

STEREO PREAMPLIFIER
C-21
SERVICE MANUAL



 **PIONEER®**

MODEL C-21 COMES IN TWO VERSIONS DISTINGUISHED AS FOLLOWS:

Type	Voltage	Remarks
KL	120V only	U.S.A. model
S	110V, 120V, 220V and 240V (Switchable)	General export model

CONTENTS

1.	SPECIFICATIONS	2
2.	FRONT PANEL FACILITIES	3
3.	CONNECTION DIAGRAM	4
4.	DISASSEMBLY	5
5.	PARTS LOCATION	6
6.	BLOCK DIAGRAM AND LEVEL DIAGRAM	8
7.	CIRCUIT DESCRIPTIONS	
7.1	Equalizer Amplifier	9
7.2	Flat Amplifier	10
7.3	Muting Circuit	10
7.4	Power Supply Circuit	11
8.	EXPLODED VIEW	12
9.	SCHEMATIC DIAGRAMS, P.C. BOARD PATTERNS AND PARTS LIST	
9.1	Schematic Diagram for KL-type	19
9.2	Schematic Diagram for S-type	21
9.3	Miscellanea	23
9.4	Flat Amplifier Assembly (AWK-055)	24
9.5	Input Assembly (AWF-025)	30
10.	PACKING	35

1. SPECIFICATIONS

Semiconductors

Transistors	36
Diodes	47

Amplifier Section

Circuitry

Equalizer Amplifier	2-stage differential amplifier Class-A SEPP with current mirror circuit
Flat Amplifier	2-stage differential amplifier Class-A SEPP with current mirror circuit

Input (Sensitivity/Impedance)

PHONO	2.5mV/100Ω, 10kΩ, 25kΩ, 50kΩ 75kΩ, 100kΩ
-------------	--

CARTRIDGE LOAD	100pF, 150pF, 200pF, 300pF, 400pF, 500pF
----------------------	---

AUX 1	150mV/50kΩ
-------------	------------

AUX 2	150mV/50kΩ
-------------	------------

TAPE PLAY	150mV/50kΩ
-----------------	------------

PHONO Overload Level

(T.H.D.: 0.01%)	300mV (1kHz)
-----------------------	--------------

Output (Level/Impedance)

TAPE REC	150mV/1kΩ
OUTPUT (R _L : 50kΩ)	1V/450Ω (rated) 20V/150Ω (max.)

Total Harmonic Distortion (20Hz to 20,000 Hz)

PHONO	0.006% (1V output, VOLUME: -20dB. GAIN CONTROL: 0dB)
-------------	--

AUX

GAIN CONTROL	Output Level			
	1V	5V	10V	20V
-6dB	0.003%	0.005%	—	—
0dB	0.005%	0.003%	0.005%	—
6dB	0.008%	0.003%	0.003%	0.005%

Frequency Response

PHONO	20Hz to 20,000Hz ±0.2dB
-------------	-------------------------

AUX	10Hz to 100,000Hz ^{+0dB} _{-0.2dB}
-----------	---

	3Hz to 300,000Hz ^{+0dB} _{-1.0dB}
--	--

Hum and Noise (IHF, short-circuited, A network)

PHONO (1V output)	80dB
-------------------------	------

AUX (1V output)	100dB
-----------------------	-------

Phono Subsonic Filter	15Hz (6dB/oct.)
-----------------------------	-----------------

Miscellaneous

Power Requirements	120V 60Hz (KL-type) 110V, 120V, 220V and 240V 50/60Hz (S-type)
--------------------------	--

Power Consumption	14 watts (UL)
-------------------------	---------------

Dimensions	420(W) x 81(H) x 357(D) mm 16-9/16 - 3-3/16 - 14-3/8 in.
------------------	---

Weight without package:	6.3kg (13 lb 14 oz)
-------------------------	---------------------

with package:	7.4kg (16 lb 5 oz)
---------------	--------------------

AC Outlets	3 (SWITCHED, KL-type) 2 (SWITCHED, S-type) 2 (UNSWITCHED)
------------------	---

Furnished Parts

Connection Cord with Pin Plugs	1
--------------------------------------	---

Operating Instructions	1
------------------------------	---

Hex. Wrench (used for fastening VOLUME knob)	1
--	---

NOTE:

Specifications and the design subject to possible modification without notice due to improvements.

2. FRONT PANEL FACILITIES

POWER SWITCH

Set this switch to the ON position and power is supplied to the C-21.

There will be no sound for a brief interval after you have set this switch to ON. This does not indicate a breakdown and it is due to the actuation of the built-in muting circuit.

TAPE SWITCH

Set this switch to the ON position to monitor the playback or recording sound when a tape deck is connected to the C-21's TAPE (REC, PLAY) terminals.

NOTE:

Set this switch to OFF (top setting) when listening to a record or a broadcast program.

VOLUME CONTROL

Use this control to adjust the output level of the OUTPUT terminals.

The dial indicates the attenuation in dB units when the maximum output level is set to 0dB. No sound will pass through the speakers when this control is set to the ∞ position on the bottom left.

CARTRIDGE LOAD SWITCHES

Use these switches to select the input resistance (ohms) and input capacitance (pF) in accordance with the specified load impedance and load capacitance of the cartridge you are using.

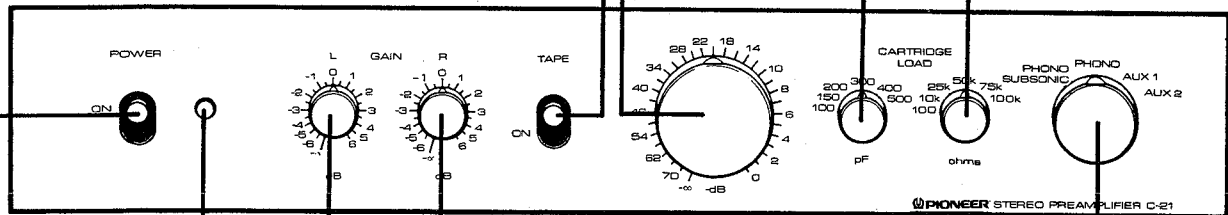

PILOT LAMP

GAIN (L, R) CONTROLS

Adjust these controls in accordance with the input sensitivity of the power amplifier (and speakers, too) connected to the C-21's OUTPUT (L, R) terminals. Output values of 1V, 2V and 0.5V can be obtained when these controls are set to 0dB (center), +6dB and -6dB, respectively, in relation to the rated inputs. When balancing the volume for the left and right channels, turn one of these controls (L or R) either clockwise or counterclockwise and adjust. If the controls are turned to the ∞ position on the bottom left, no sound will pass through the speakers.

FUNCTION SWITCH

Use this switch to select the required program source.

PHONO SUBSONIC: When listening to a record on a turntable connected to the PHONO terminals on the C-21, this switch will actuate the subsonic filter to eliminate low frequency noise caused by warp and other imperfections in the record.

PHONO: Set the switch to this position when listening to a record on a turntable which is connected to the C-21's PHONO terminals.

AUX 1: Set the switch to this position when listening to a program source on a component which is connected to the C-21's AUX 1 terminals.

AUX 2: Set the switch to this position when listening to a program source on a component which is connected to the C-21's AUX 2 terminals.

SUBSONIC FILTER

This filter attenuates frequencies lower than 15Hz by 6dB/oct, and so eliminates ultra-low-frequency noise generated by distortion and other adverse phenomena in records. Although this noise is inaudible, it is a factor which generates intermodulation distortion and can damage the speakers. When listening to records, set the FUNCTION switch to the PHONO SUBSONIC position, and this seemingly harmless noise will be cancelled out.

3. CONNECTION DIAGRAM

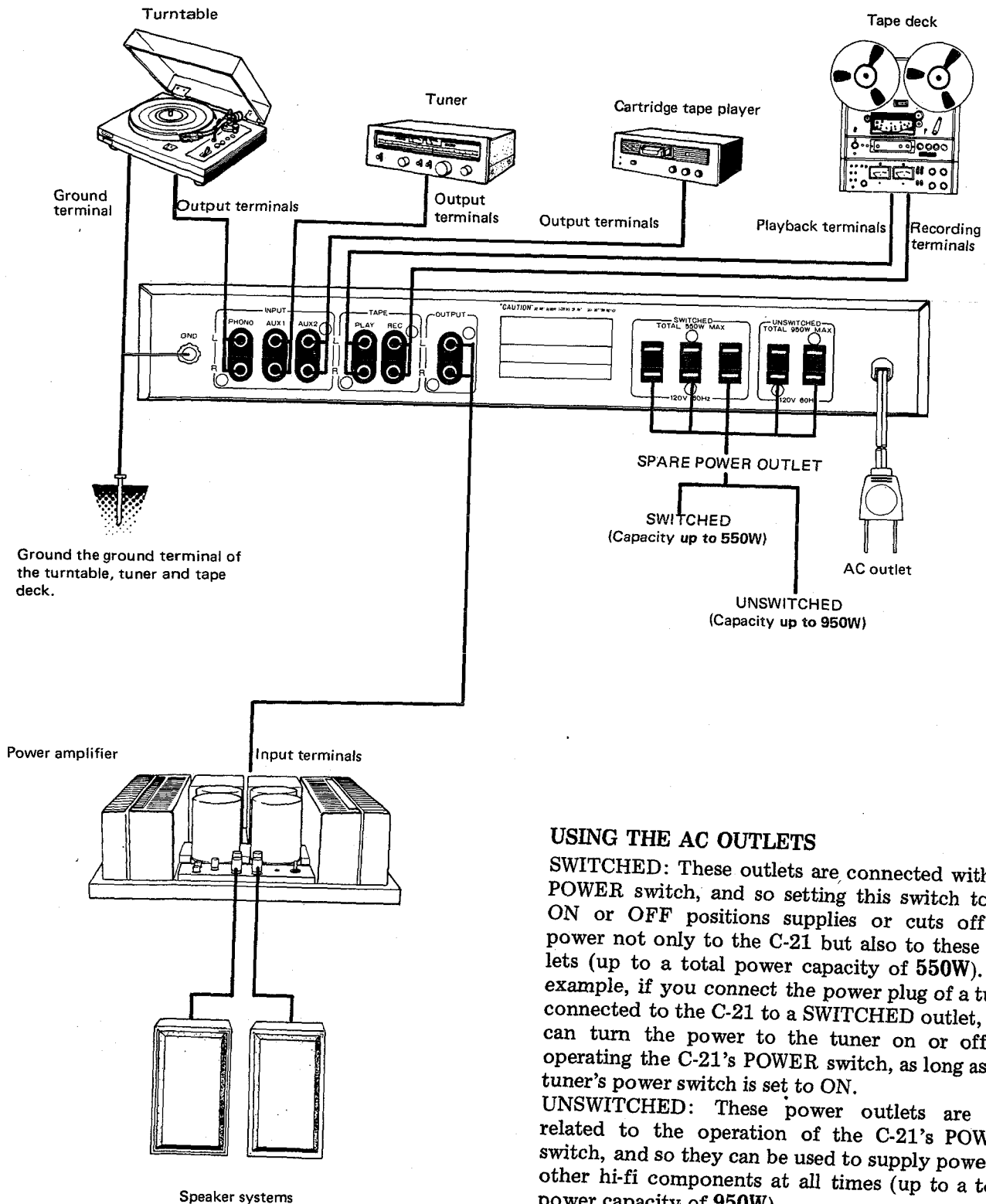

4. DISASSEMBLY

Remove the two mounting screws at each side of the top cover and remove the top cover by pulling it to the rear.

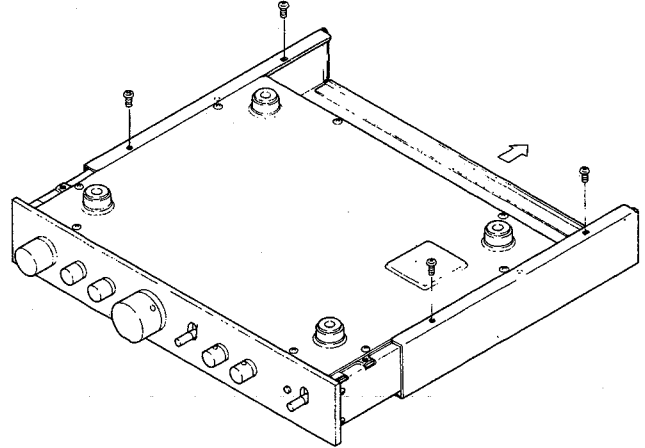

Remove the 8 mounting screws at the bottom plate and lift off the bottom plate.

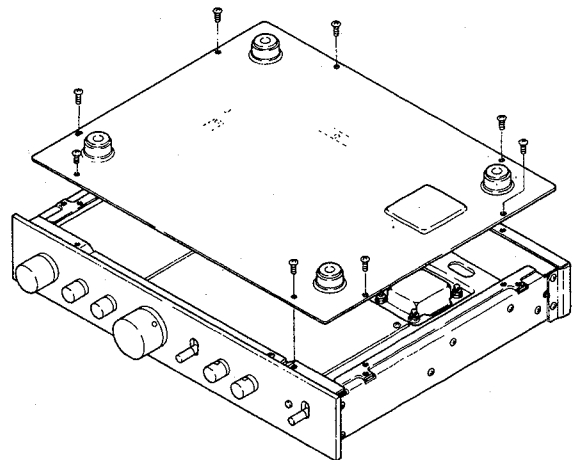

Loosen the GAIN knob and VOLUME knob set of screws and remove all the knobs. Remove the 2 mounting nuts at the front, remove the 2 screws at the top and remove the front panel by pulling it forward.

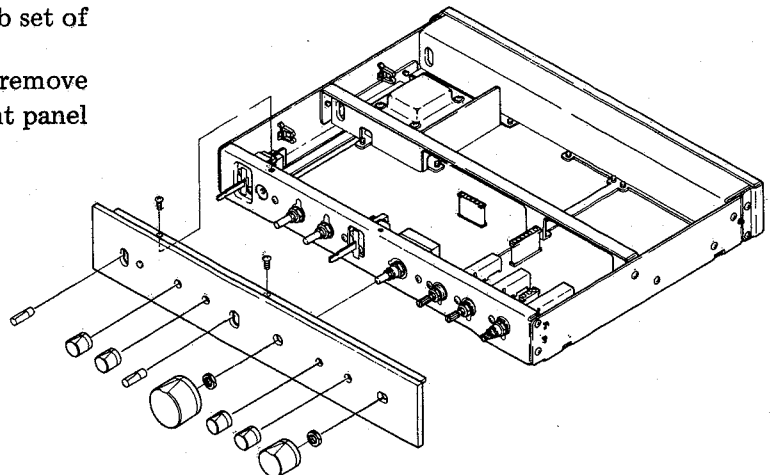

5. PARTS LOCATION

Front Panel View

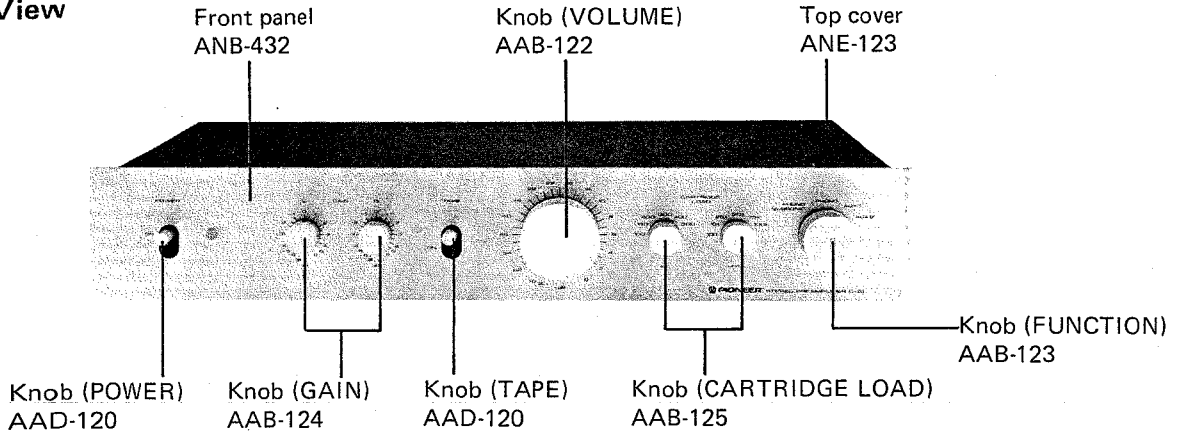

Front View with Panel Removed

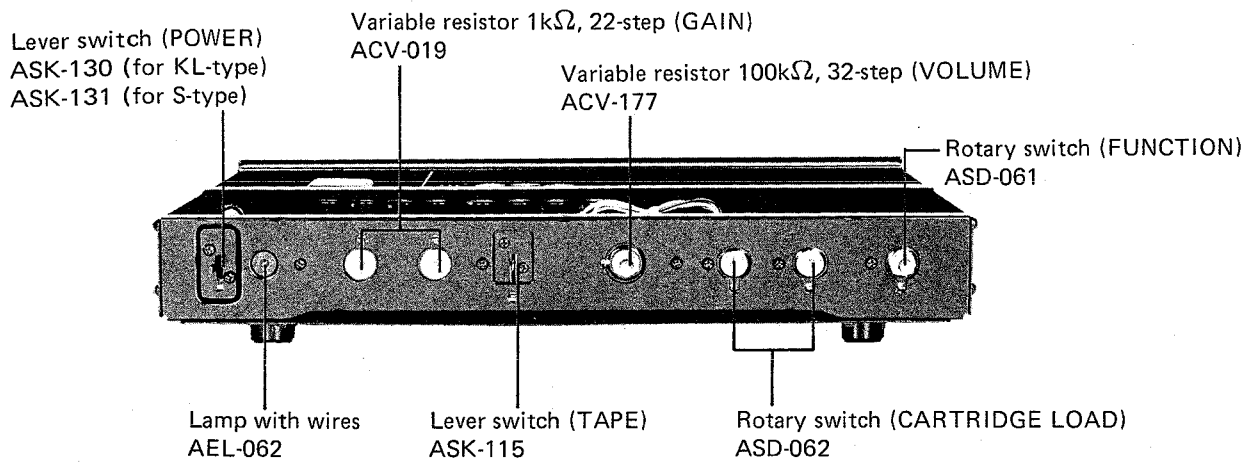

Rear View (KL-type)

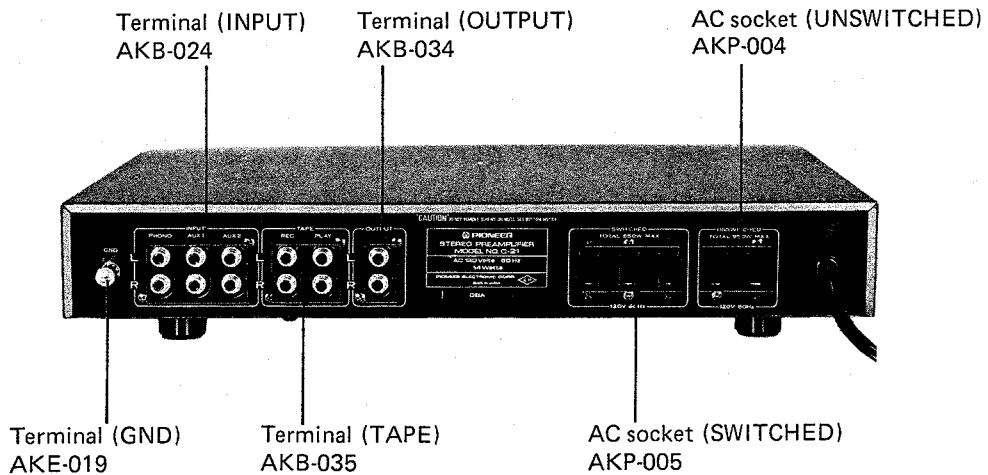

Top View

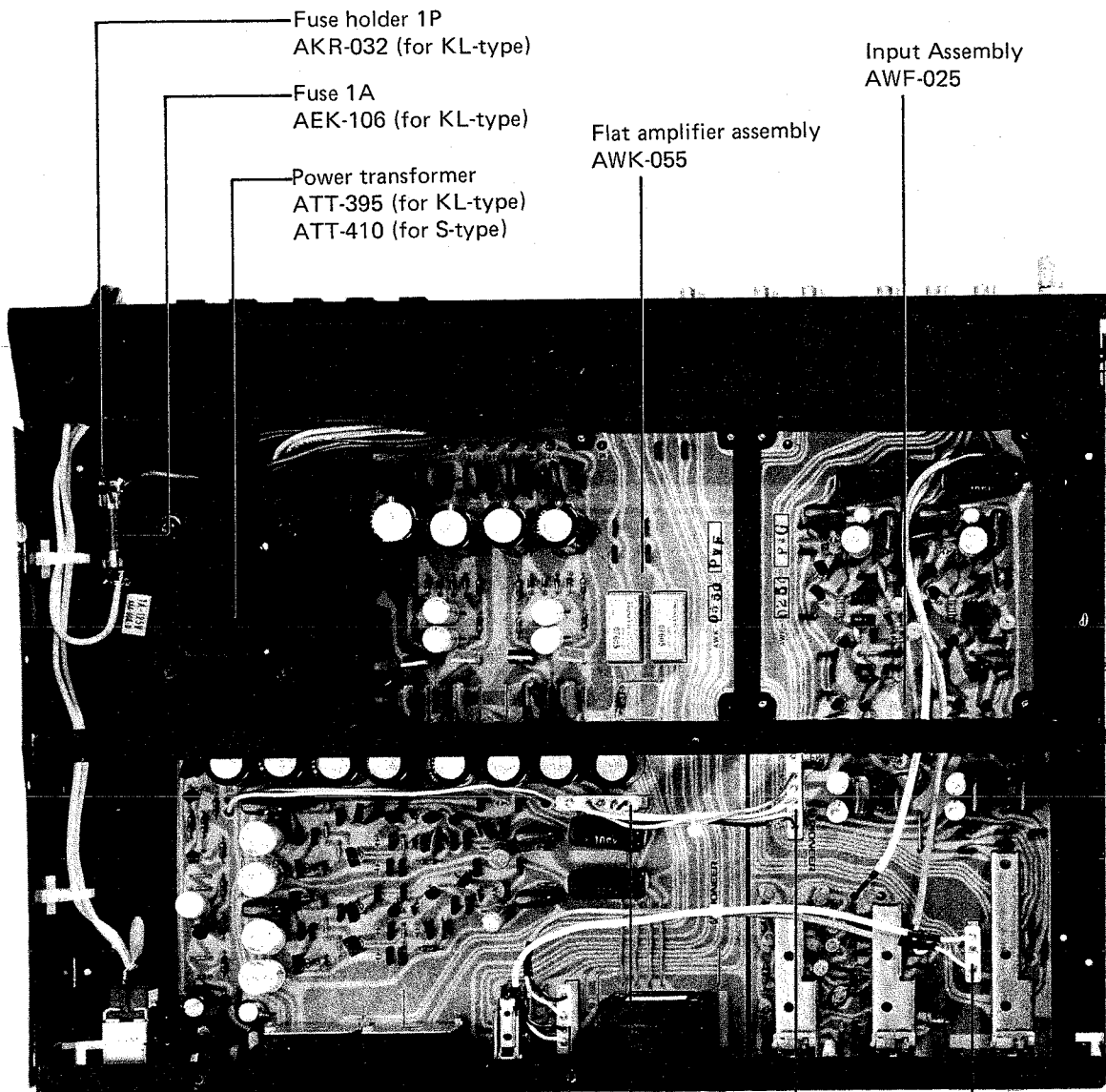

Fuse holder 1P
AKR-032 (for KL-type)

Fuse 1A
AEK-106 (for KL-type)

Power transformer
ATT-395 (for KL-type)
ATT-410 (for S-type)

Flat amplifier assembly
AWK-055

Input Assembly
AWF-025

Connector housing 4P
AKX-016
Contact
AKF-028 (x 4)

Connector housing 5P
AKX-017
Contact
AKF-028 (x 5)

Connector housing 6P
AKX-018
Contact
AKF-028 (x 6)

Connector housing 3P
AKX-015
Contact
AKF-028 (x 3)

6. BLOCK DIAGRAM AND LEVEL DIAGRAM

Block Diagram

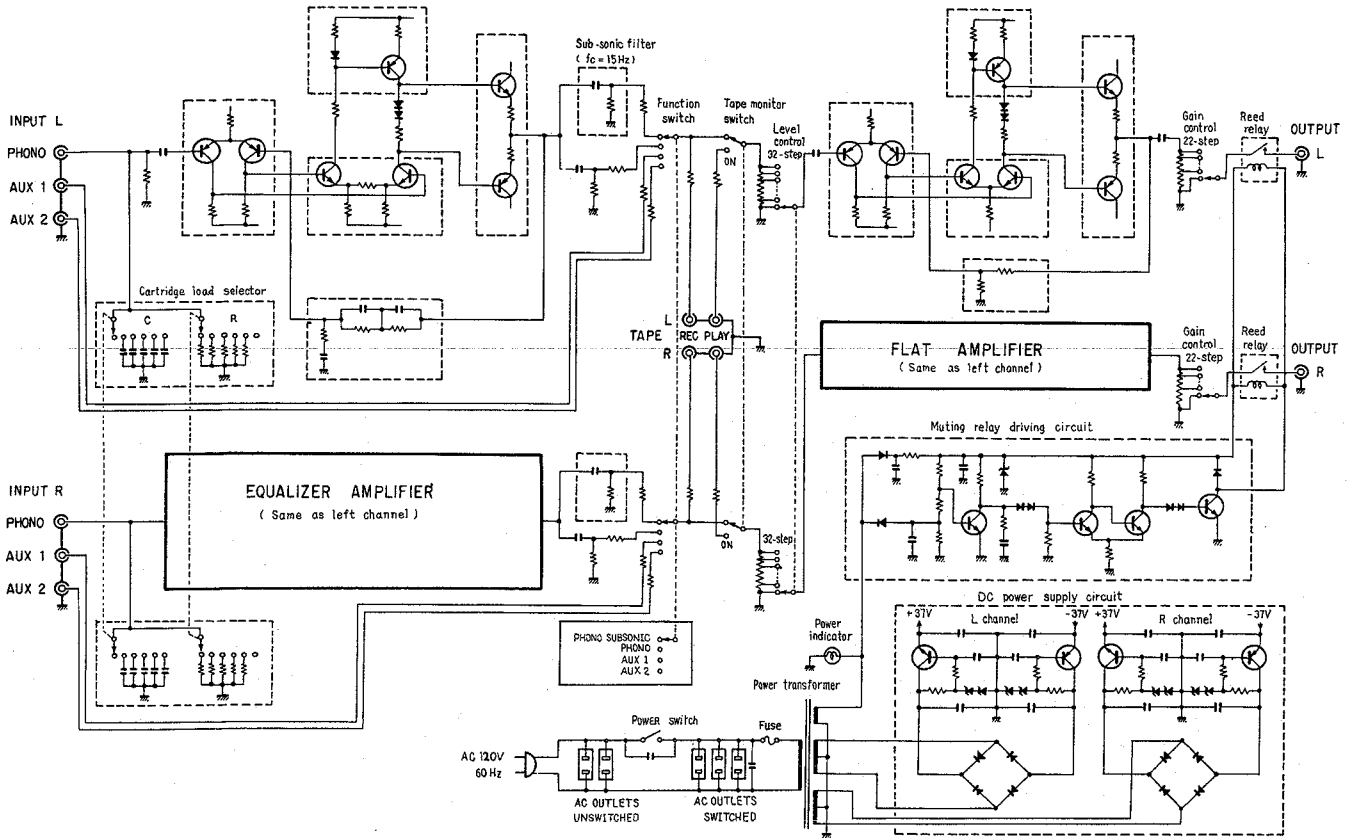

Level Diagram

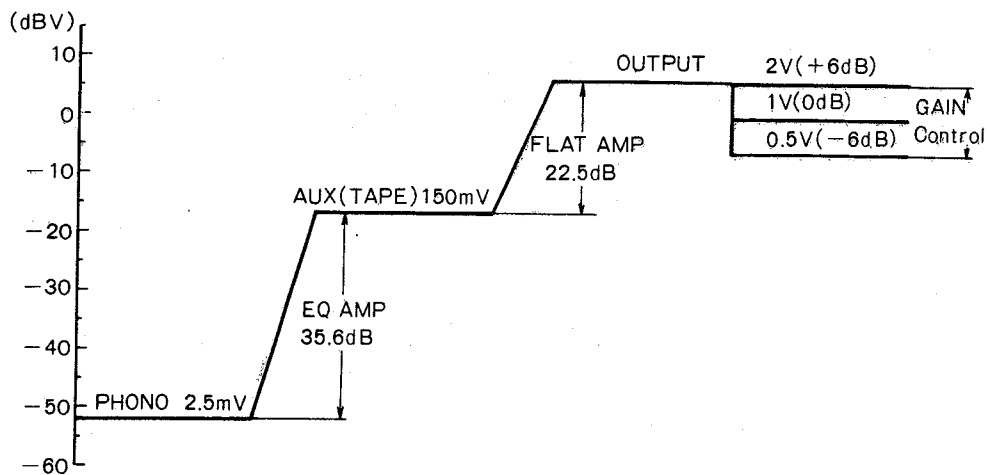

7. CIRCUIT DESCRIPTIONS

7.1 EQUALIZER AMPLIFIER

The equalizer amplifier has a 100kΩ input resistance and 100pF input capacitance. The resistors and capacitors are inserted in parallel with the input circuit and can be selected in 6 steps (R = 100Ω, 10kΩ, 25kΩ, 50kΩ, 75kΩ, 100kΩ and C = 100pF, 150pF, 200pF, 300pF, 400pF, 500pF) by means of the CARTRIDGE LOAD selector switch to ensure that the performance quality of the cartridge is exhibited to the fullest.

NOTE:

The load capacitance of the phono cartridge includes the capacitance of the connection cord in addition to the input capacitance given for this unit.

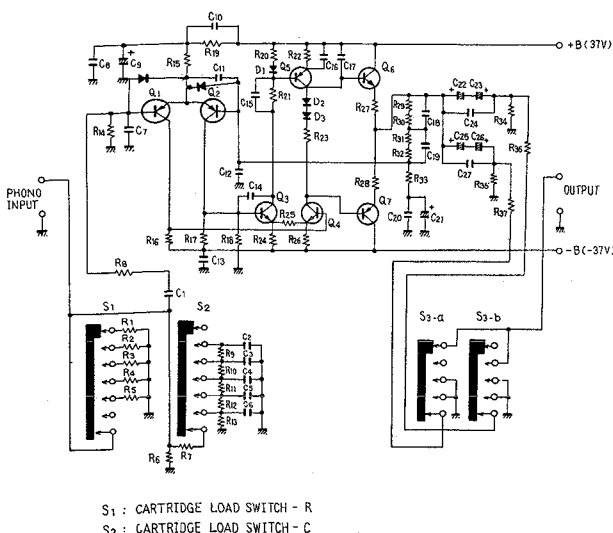

Fig. 1 Circuitry of Equalizer Amplifier

The input coupling capacitor is a polypropylene film capacitor. This capacitor has a better frequency response and temperature characteristic than electrolytic capacitors.

The first stage is a newly developed ultra-low-noise transistor differential amplifier. The use of this transistor and high negative feedback provide an SN ratio of 80dB (IHF, short circuit, A network). The second stage is a differential amplifier with current mirror, and this is operated as a push-pull amplifier. The principles of the current mirror are illustrated in Fig. 2. If the diode V_F (forward voltage, DC) and transistor V_{BE} (base to emitter voltage, DC) are assumed to be equal and I_B (base current, DC) is sufficiently lower than I₁, the relation I₁R₁ = I₂R₂ is established. Therefore,

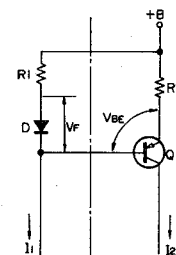

Fig. 2 Principles of Current Mirror

$I_2 = I_1 R_1 / R_2$ and a current I₂ proportional to I₁ can flow. This causes I_C (collector current, DC) of Q₅ to become proportional to Q₃; Q₄ and Q₅ are operated as a push-pull amplifier. This circuit has a good voltage utility factor and superb linearity. The final stage is a Class A symmetrical complementary SEPP circuit having a wide dynamic range and low output impedance.

The NFB circuit of this unit is shown in Fig. 3. The deviation of the equalizer characteristic of this unit is within ±0.2dB over the 20Hz ~ 20kHz range. Therefore, polypropylene capacitors having a tolerance of ±1% are used as C₁ and C₂. Moreover, R₂, R₃ are metal film resistors having a tolerance of within ±0.5% and R₁, R₄, R₅ are metal film resistors having a tolerance of within ±1%.

The output coupling capacitors are connected in series and are nonpolar. Good characteristics are obtained by connecting metallized Mylar film capacitors in parallel.

When the FUNCTION switch is set to the PHONO SUBSONIC position, the capacitance of the output coupling capacitors is made small and they are used as a 15Hz cut-off frequency, -6dB/oct slope high pass filter.

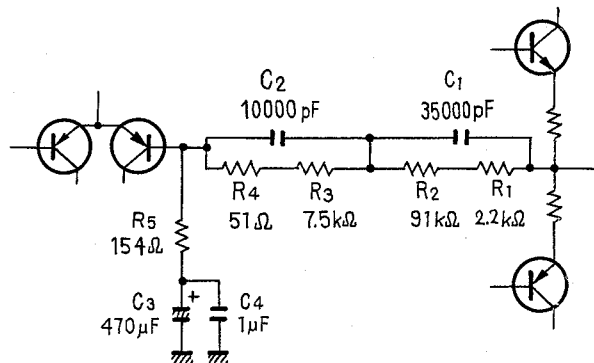

Fig. 3 NFB Circuit

The input — distortion curves are given in Fig. 4 and the frequency — equalizer deviation curve is given in Fig. 5.

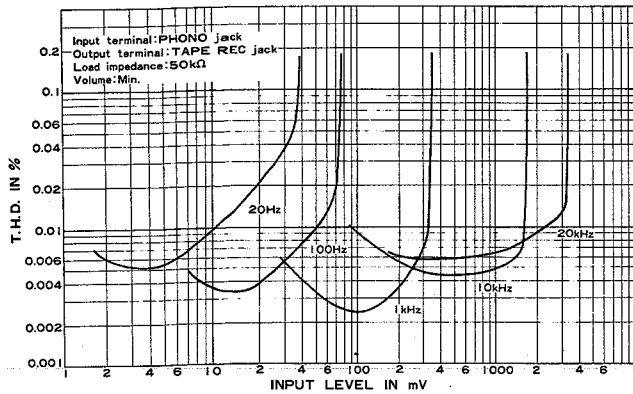

Fig. 4

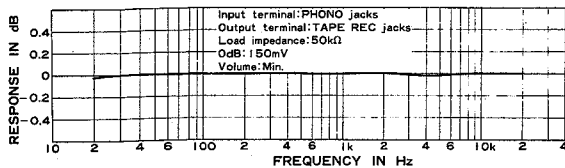

Fig. 5

7.2 FLAT AMPLIFIER (Fig. 6)

This amplifier has the same circuit construction as the equalizer amplifier. Since a large low-range gain such as that of the equalizer amplifier is unnecessary and voltage drift at the output center poses no problems, it is used as a DC amplifier. As it can function sufficiently well, even under low impedance loads, its performance is the same as that of a low output power amp. Hence, an output of 10V or greater (20Hz ~ 20kHz, T.H.D. 0.01%) is obtained even when directly coupled to a 600Ω line.

Its frequency response is given in Fig. 7 and its output voltage — distortion characteristic curves are given in Fig. 8.

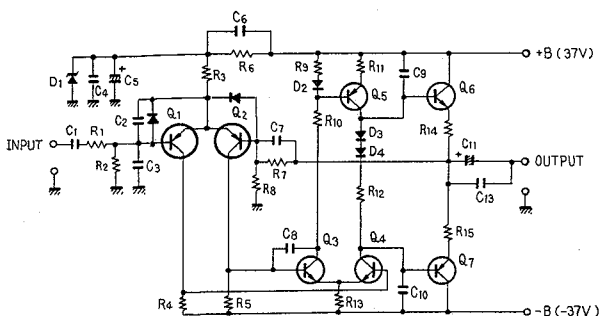

Fig. 6 Circuitry of Flat Amplifier

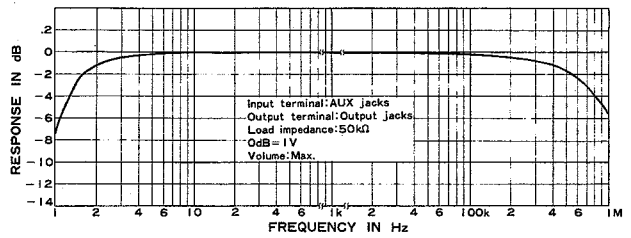

Fig. 7

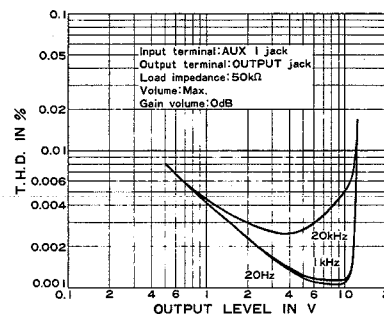

Fig. 8

7.3 MUTING CIRCUIT

A built-in muting circuit prevents unwanted noise when the power is turned ON and OFF.

This circuit opens and closes the output circuits by means of two reed relays. The contacts of the relays are closed and the output circuits are connected only during normal operation.

A one-circuit reed relay (one set of make contacts) is used. One such relay is used in each of the left and right channels.

The relay drive circuit is shown in Fig. 9. Relay coils RL1, RL2 are connected in parallel. When the power is turned OFF, the relay contacts are opened.

In Fig. 9, 7.5V (AC) are supplied when the power is turned ON.

The time constant of the negative power supply side is smaller than that of the positive side. Moreover, the values of R1 and R2 are selected (-2.9V at the anode of D1) so that Q1 is turned off during normal operation. Consequently, Q1 remains in the off state even if the power is turned ON.

Q2, Q3 constitute a Schmidt circuit. Q2 is turned off and Q3 is turned on immediately after the power is turned ON. Therefore, Q4 is in the off state, current doesn't flow in RL1, RL2 and the output circuit remains open. When C1 is charged thru R3, R4, the base potential of Q2 rises, the Schmidt circuit is inverted, Q2 is turned on and Q3 is turned off. Consequently, Q4 is turned on,

current flows in RL1, RL2 and the output circuits are closed. When the power is turned OFF, the negative power supply quickly drops to 0V. Since the positive power supply drops comparatively slowly, the base of Q1 is forward biased thru D1 and Q1 is temporarily turned on. Thereupon, the base potential of Q2 drops, the Schmidt circuit is inverted, Q2 is turned off and Q3 is turned on. Consequently, Q4 is turned off and the output circuits are opened. When Q1 is turned on, C1 is quickly discharged and the muting operation is performed again when the power is turned back ON.

7.4 POWER SUPPLY CIRCUIT

The power transformer has three secondary coils. One of these coils is for indicator lamp and muting circuit use. The other two are for left channel and right channel bridge rectification, respectively. $\pm 37V$ DC are supplied by transistor and Zener diode positive and negative voltage regulator circuits.

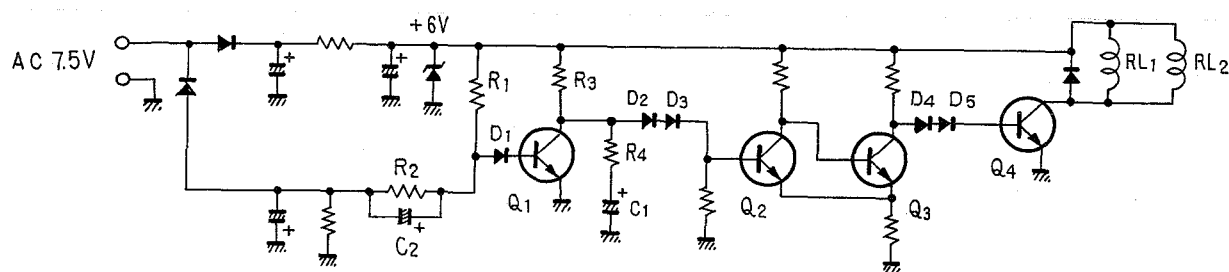





















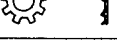

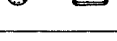
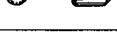
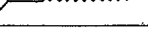

Fig. 9 Muting Circuit

8. EXPLODED VIEW

NOMENCLATURE OF SCREWS, WASHERS AND NUTS

The following symbols stand for screws, washers and nuts as shown in exploded view.

Symbol	Description	Shape
RT	Brazier head tapping screw	
PT	Pan head tapping screw	
BT	Binding head tapping screw	
CT	Countersunk head tapping screw	
TT	Truss head tapping screw	
OCT	Oval countersunk head tapping screw	
PM	Pan head machine screw	
CM	Countersunk head machine screw	
OCM	Oval countersunk head machine screw	
TM	Truss head machine screw	
BM	Binding head machine screw	
PSA	Pan head screw with spring lock washer	
PSB	Pan head screw with spring lock washer and flat washer	
PSF	Pan head screw with flat washer	

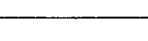
Symbol	Description	Shape
EW	E type washer	
FW	Flat washer	
SW	Spring lock washer	
N	Nut	
WN	Washer faced nut	
ITW	Internal toothed lock washer	
OTW	Outernal toothed lock washer	
SC	Slotted set screw (Cone point)	
SF	Slotted set screw (Flat point)	
HS	Hexagon socket headless set screw	
OCW	Oval countersunk head wood screw	
CW	Countersunk head wood screw	
RW	Round head wood screw	

EXAMPLE

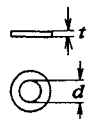
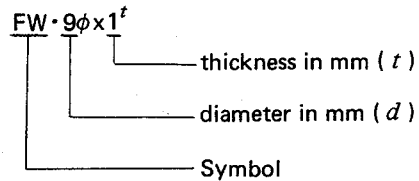
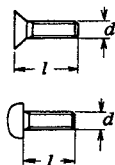
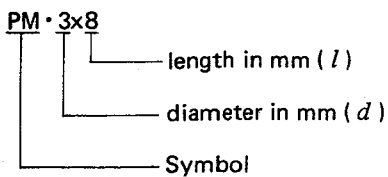

NOTE:
Parts indicated in red type cannot be supplied.

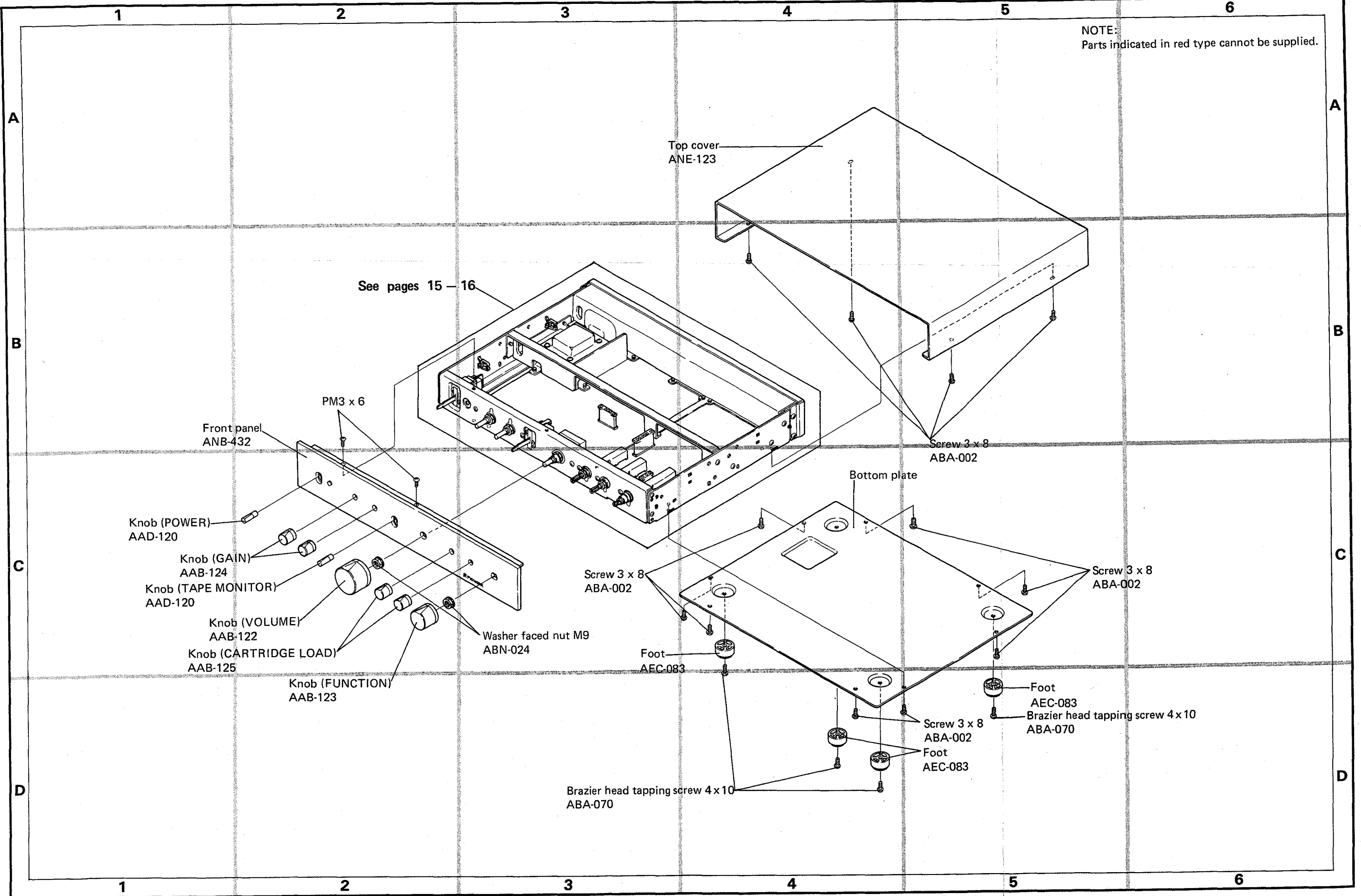

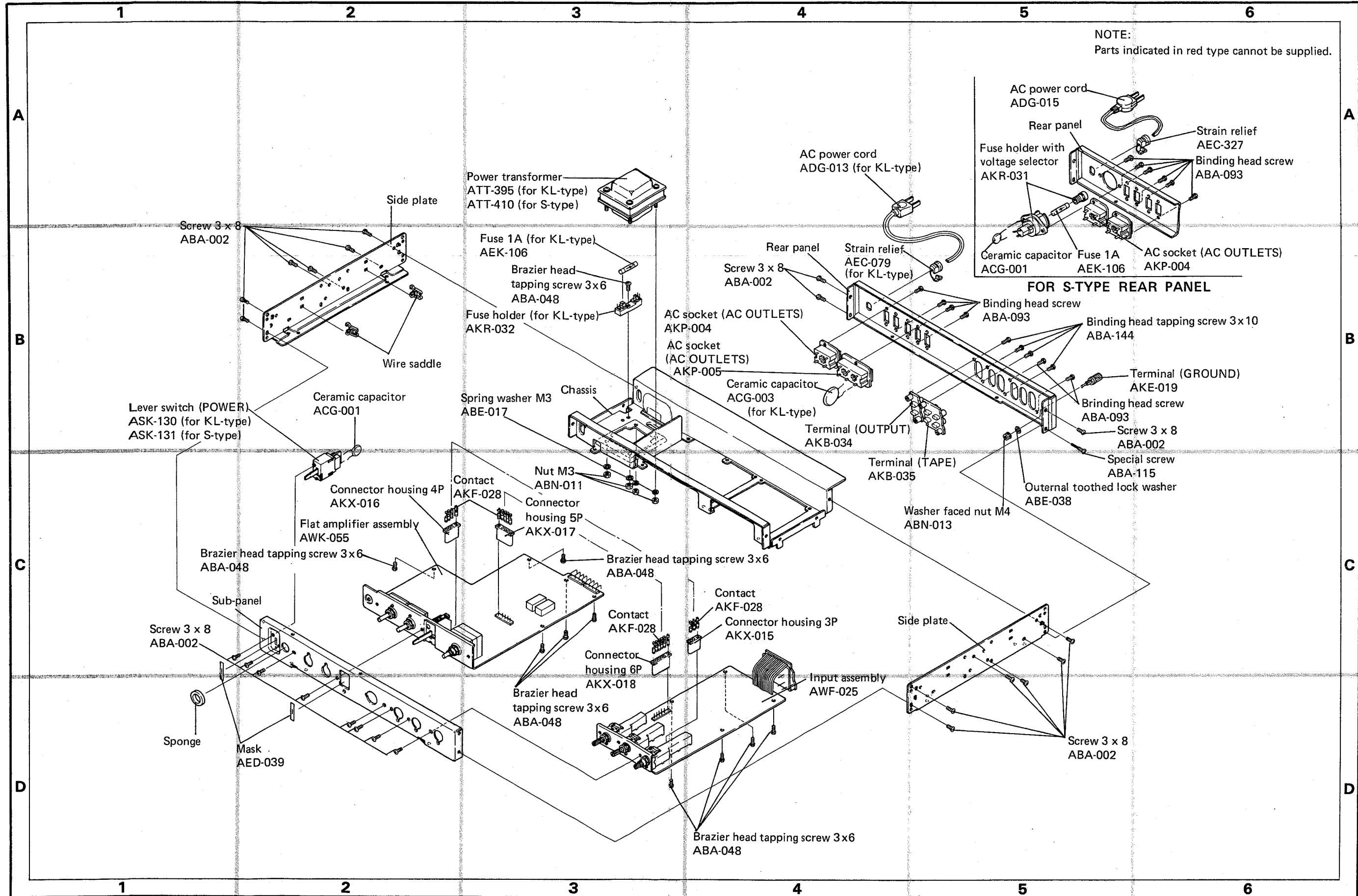

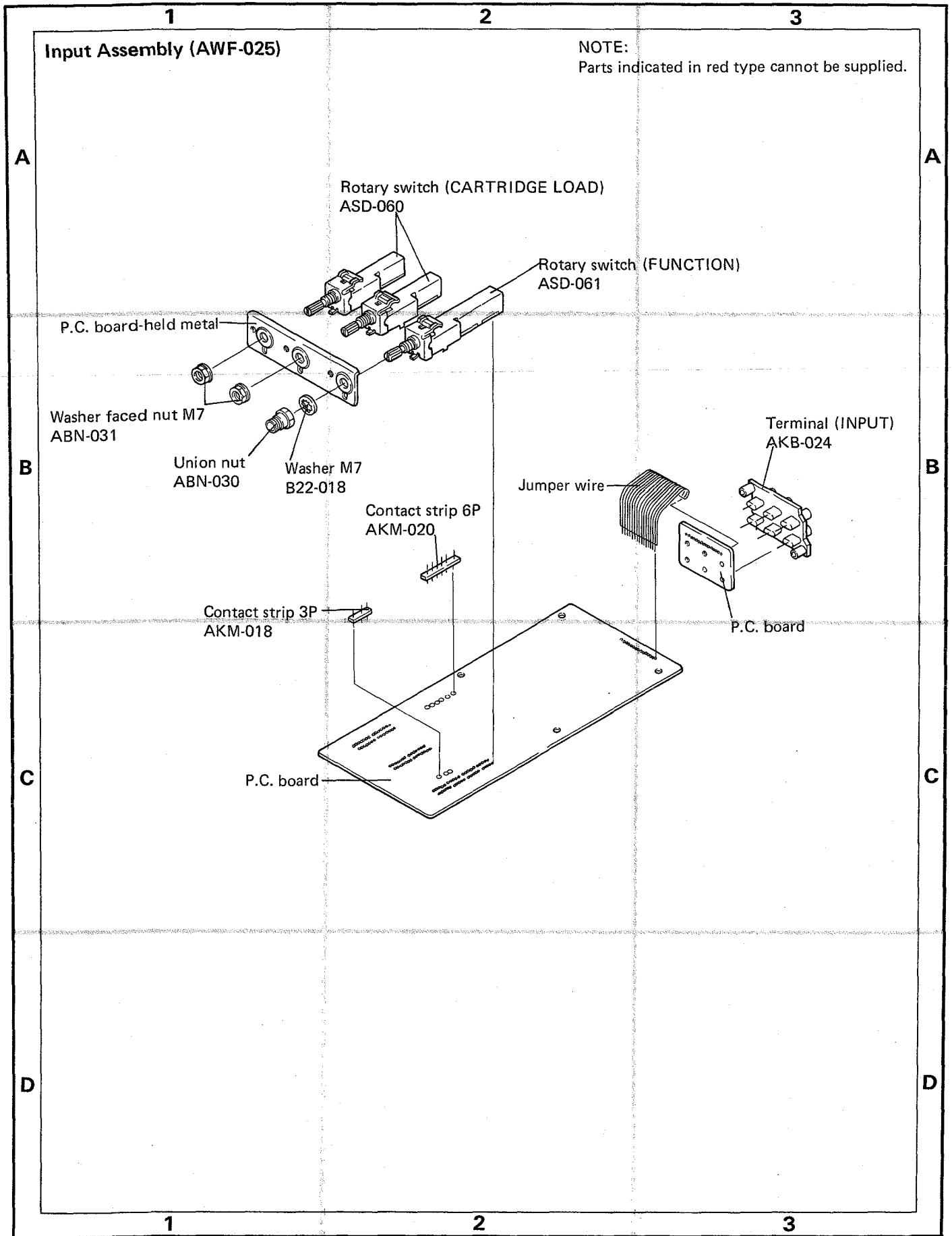

Flat Amplifier Assembly (AWK-055)

NOTE:
Parts indicated in red type cannot be supplied.

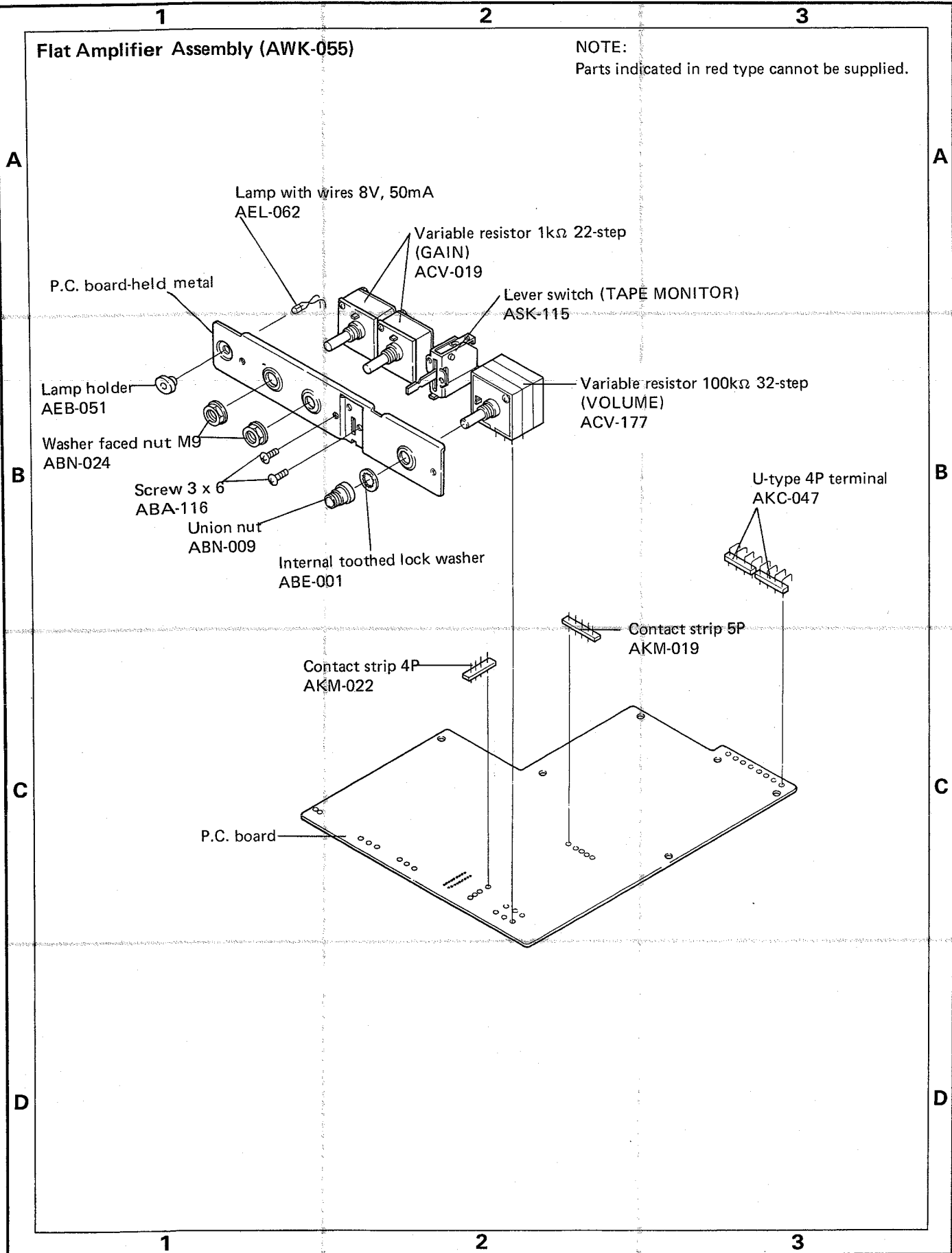

9. SCHEMATIC DIAGRAMS, P.C. BOARD PATTERNS AND PARTS LIST

9.1 SCHEMATIC DIAGRAM FOR KL-TYPE

NOTE:
The indicated semiconductors are representative ones only. Other alternative semiconductors may be used and are listed in the parts list.

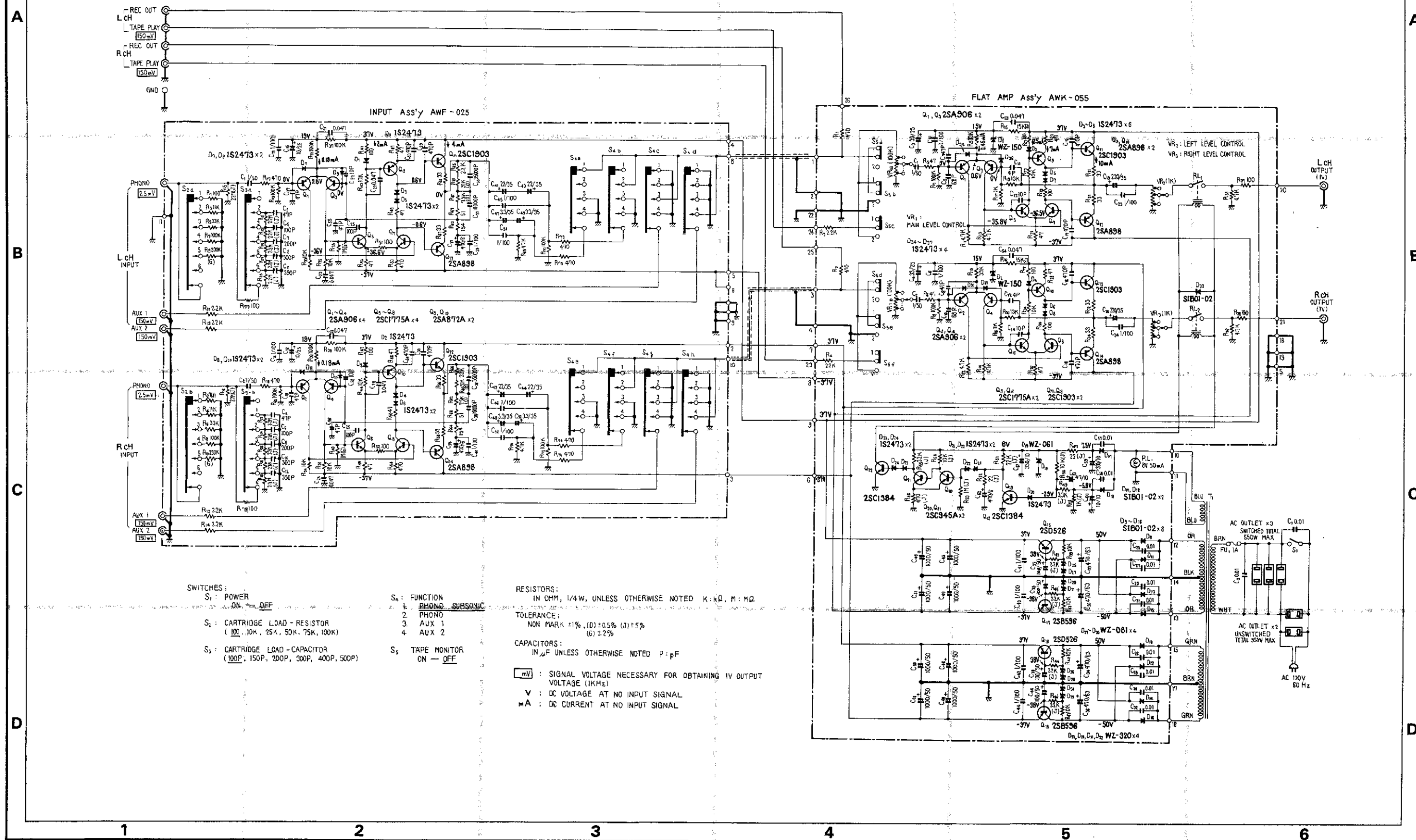

9.2 SCHEMATIC DIAGRAM FOR S-TYPE

NOTE:
The indicated semiconductors are representative ones only. Other alternative semiconductors may be used and are listed in the parts list.

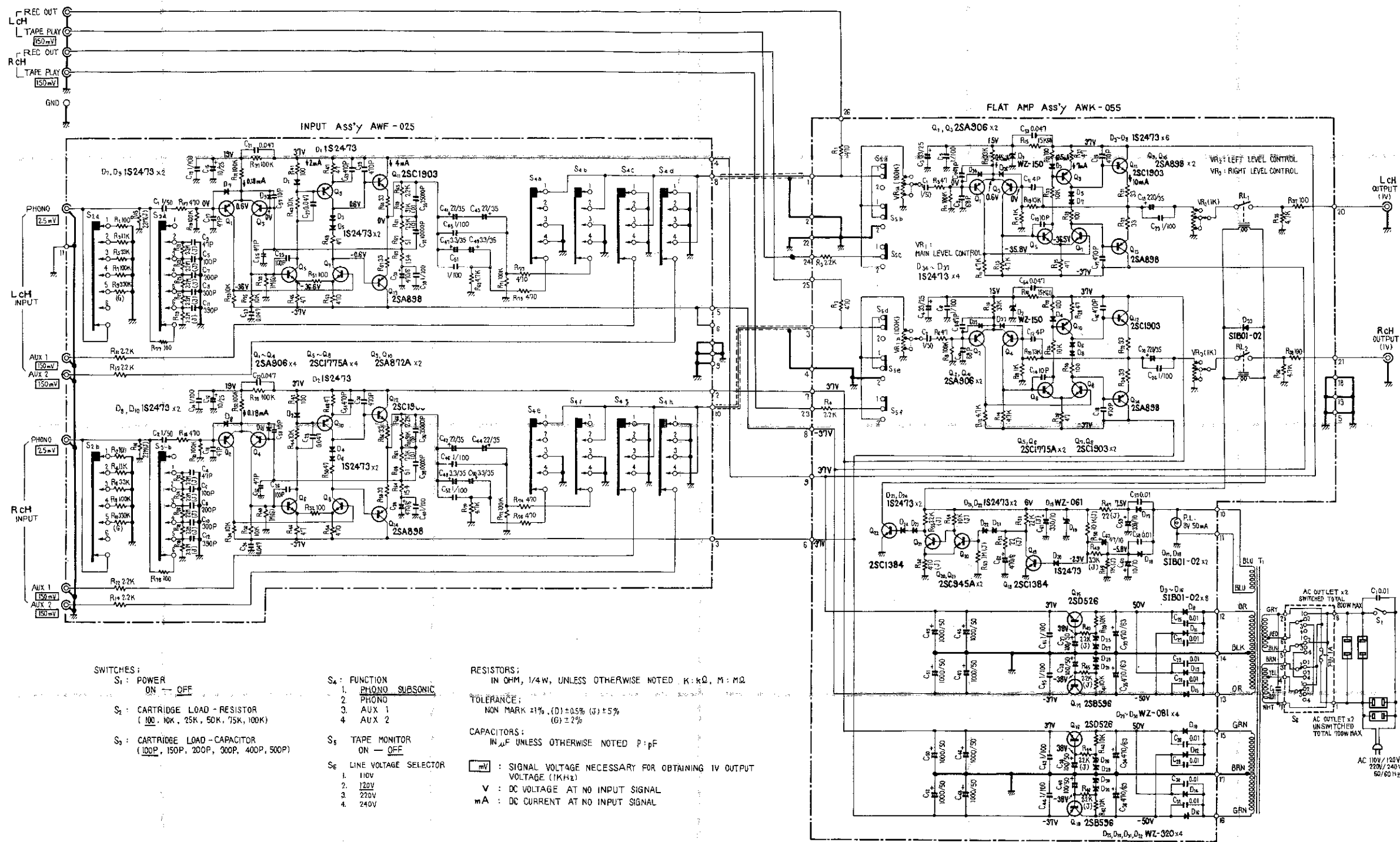

- SWITCHES:
- S₁: POWER ON - OFF
 - S₂: CARTRIDGE LOAD - RESISTOR (100, 10K, 25K, 50K, 75K, 100K)
 - S₃: CARTRIDGE LOAD - CAPACITOR (100P, 150P, 200P, 300P, 400P, 500P)
 - S₄: FUNCTION
 1. PHONO SUBSONIC
 2. PHONO
 3. AUX 1
 4. AUX 2
 - S₅: TAPE MONITOR ON - OFF
 - S₆: LINE VOLTAGE SELECTOR
 1. 110V
 2. 120V
 3. 220V
 4. 240V

RESISTORS:
IN OHM, 1/4 W, UNLESS OTHERWISE NOTED. K: KΩ, M: MΩ

TOLERANCE:
NON-MARK ±1%, (D) ±0.5%, (J) ±5%, (G) ±2%

CAPACITORS:
IN μF UNLESS OTHERWISE NOTED. P: pF

mV: SIGNAL VOLTAGE NECESSARY FOR OBTAINING 1V OUTPUT VOLTAGE (1KHz)

V: DC VOLTAGE AT NO INPUT SIGNAL

mA: DC CURRENT AT NO INPUT SIGNAL

9.3 MISCELLANEA
Miscellaneous Parts

NOTE:

- Capacitors: in μF unless otherwise noted p:pF
- Resistors: in Ω , $\frac{1}{4}W$ unless otherwise noted k:k Ω , M:M Ω

SWITCH

Symbol	Description	Part No. (KL-type)	Part No. (S-type)	Remarks
S1	Lever switch (POWER)	ASK-130	ASK-131	

CAPACITORS

Symbol	Description	Part No. (KL-type)	Part No. (S-type)	Remarks
C1	Ceramic 0.01 250V	ACG-001	ACG-001	
C2	Ceramic 0.01 125V	ACG-003	
C2	Ceramic 0.01 250V	ACG-001	

OTHERS

Symbol	Description	Part No. (KL-type)	Part No. (S-type)	Remarks
T1	Power transformer	ATT-395	ATT-410	
FU1	Fuse 1A	AEK-106	AEK-106	
	Fuse holder 1P	AKR-032	
	Plug in selector	AKR-031	with fuse holder
	AC socket (double)	AKP-004	AKP-004	
	AC socket (triple)	AKP-005	
	AC power cord	ADG-013	ADG-015	

External Appearance of Transistors

2SA906



2SA898
2SC1903

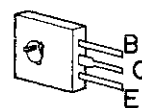

2SC1384

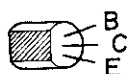

2SB507
2SB596
2SD526
2SD313R

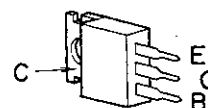

2SA872A
2SC945A
2SC1775A



9.4 FLAT AMPLIFIER ASSEMBLY (AWK-055)

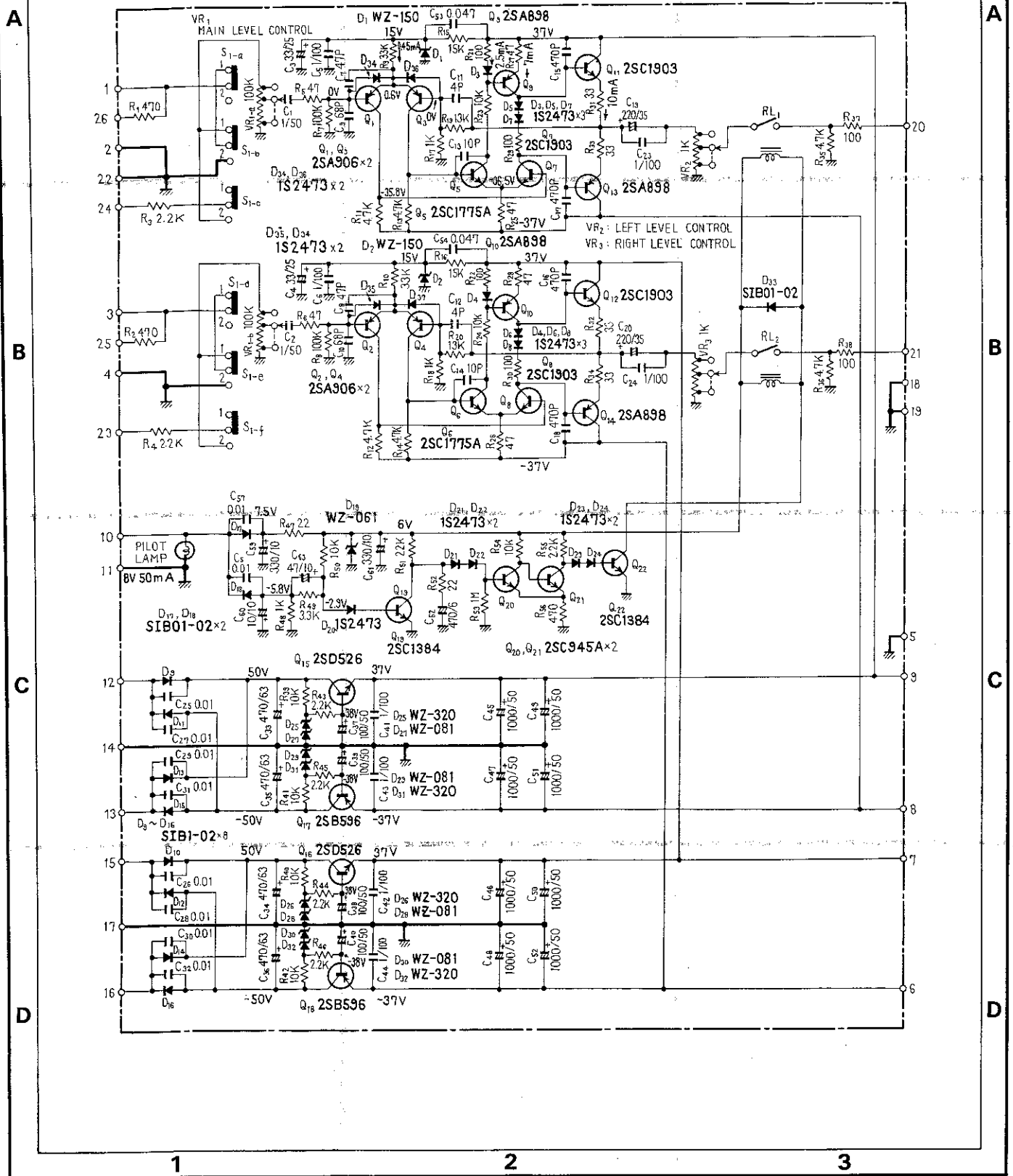

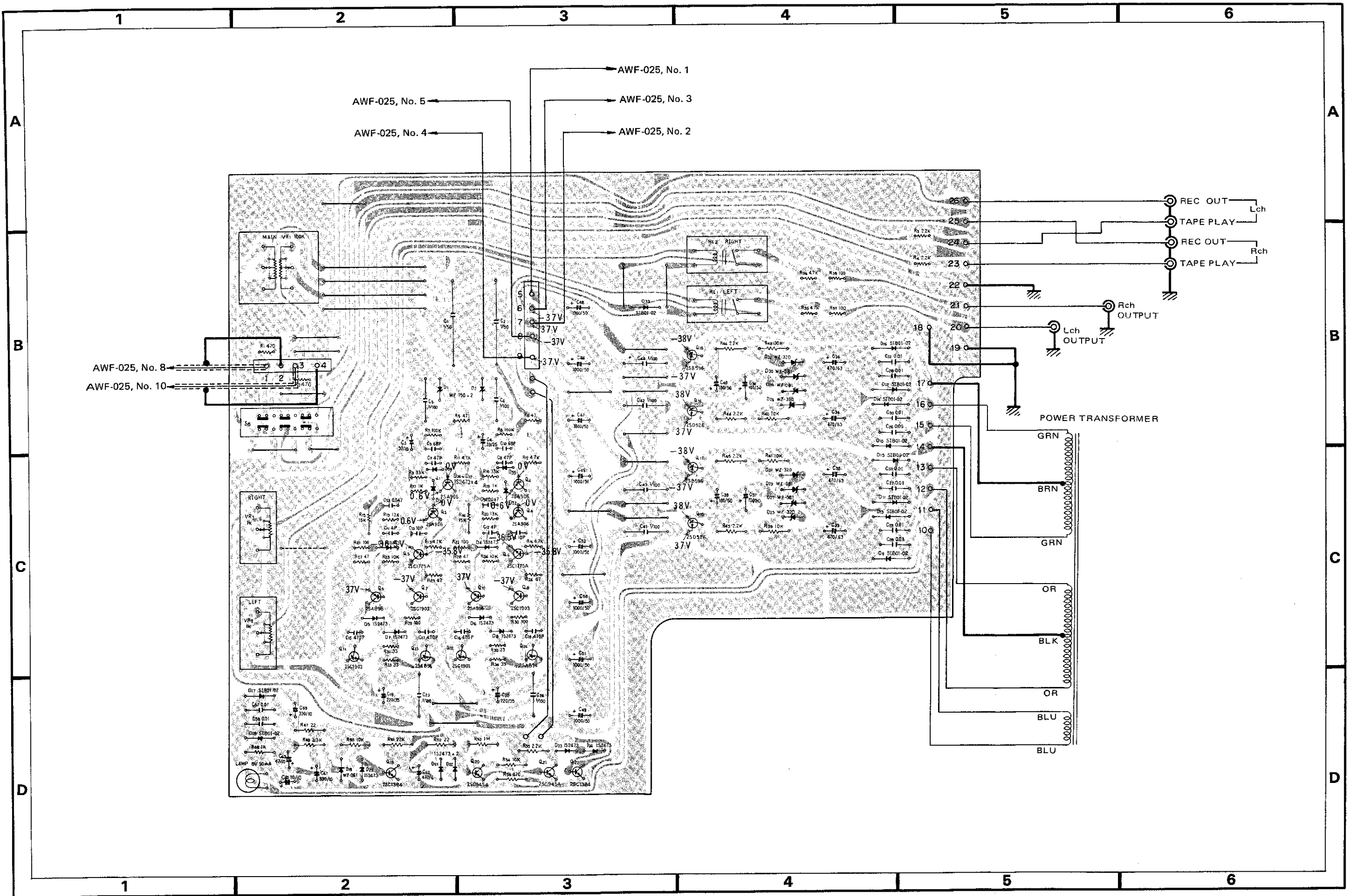

Parts List of Flat Amplifier Assembly (AWK-055)

SWITCHES

Symbol	Description	Part No.
S1	Lever switch (TAPE MONITOR)	ASK-115
RL1	Reed relay	ASR-024
RL2	Reed relay	ASR-024

OTHERS

Symbol	Description	Part No.
	Lamp with wires 8V, 50mA	AEL-062
	4P plug	AKM-022
	5P plug	AKM-019
	4P terminal (U-type)	AKC-047
	Lamp holder	AEB-051
	Union nut	ABN-009
	Washerfaced nut M9	ABN-024
	Internal toothed lock washer	ABE-001

RESISTORS

Symbol	Description	Part No.
VR1	Variable resistor 100k x 2, 32-step (VOLUME)	ACV-177
VR2	Variable resistor 1k, 22-step (GAIN)	ACV-019
VR3	Variable resistor 1k, 22-step (GAIN)	ACV-019
R1	Metal film 470 1/5W	RN1/5SQ 4700F
R2	Metal film 470 1/5W	RN1/5SQ 4700F
R3	Metal film 2.2k 1/5W	RN1/5SQ 2201F
R4	Metal film 2.2k 1/5W	RN1/5SQ 2201F
R5	Metal film 2.2k 1/5W	RN1/5SQ 2201F
R6	Metal film 47 1/5W	RN1/5SQ 0470F
R7	Metal film 100k 1/5W	RN1/5SQ 1003F
R8	Metal film 100k 1/5W	RN1/5SQ 1003F
R9	Metal film 33k 1/5W	RN1/5SQ3302F
R10	Metal film 33k 1/5W	RN1/5SQ 3302F
R11	Metal film 4.7k 1/5W	RN1/5SQ 4701F
R12	Metal film 4.7k 1/5W	RN1/5SQ 4701F
R13	Metal film 4.7k 1/5W	RN1/5SQ 4701F
R14	Metal film 4.7k 1/5W	RN1/5SQ 4701F
R15	Carbon film 15k 1/4W	RD1/4PM 153J
R16	Carbon film 15k 1/4W	RD1/4PM 153J
R17	Metal film 1k 1/5W	RN1/5SQ 1001F
R18	Metal film 1k 1/5W	RN1/5SQ 1001F
R19	Metal film 13k 1/5W	RN1/5SQ 1302F
R20	Metal film 13k 1/5W	RN1/5SQ 1302F
R21	Metal film 100 1/5W	RN1/5SQ 1000F
R22	Metal film 100 1/5W	RN1/5SQ 1000F
R23	Metal film 10k 1/5W	RN1/5SQ 1002F
R24	Metal film 10k 1/5W	RN1/5SQ 1002F
R25	Metal film 47 1/5W	RN1/5SQ 0470F

Symbol	Description	Part No.
R26	Metal film 47 1/5W	RN1/5SQ 0470F
R27	Metal film 47 1/5W	RN1/5SQ 0470F
R28	Metal film 47 1/5W	RN1/5SQ 0470F
R29	Metal film 100 1/5W	RN1/5SQ 1000F
R30	Metal film 100 1/5W	RN1/5SQ 1000F
R31	Metal film 33 1/5W	RN1/5SQ 0330F
R32	Metal film 33 1/5W	RN1/5SQ 0330F
R33	Metal film 33 1/5W	RN1/5SQ 0330F
R34	Metal film 33 1/5W	RN1/5SQ 0330F
R35	Metal film 4.7k 1/5W	RN1/5SQ 4701F
R36	Metal film 4.7k 1/5W	RN1/5SQ 4701F
R37	Metal film 100 1/5W	RN1/5SQ 1000F
R38	Metal film 100 1/5W	RN1/5SQ 1000F
R39	Carbon film 10k 1/4W	RD1/4PM 103J
R40	Carbon film 10k 1/4W	RD1/4PM 103J
R41	Carbon film 10k 1/4W	RD1/4PM 103J
R42	Carbon film 10k 1/4W	RD1/4PM 103J
R43	Carbon film 2.2k 1/4W	RD1/4PM 222J
R44	Carbon film 2.2k 1/4W	RD1/4PM 222J
R45	Carbon film 2.2k 1/4W	RD1/4PM 222J
R46	Carbon film 2.2k 1/4W	RD1/4PM 222J
R47	Carbon film 22 1/4W	RD1/4PM 220J
R48	Carbon film 1k 1/4W	RD1/4PM 102J
R49	Carbon film 3.3k 1/4W	RD1/4PM 332J
R50	Carbon film 10k 1/4W	RD1/4PM 103J
R51	Carbon film 22k 1/4W	RD1/4PM 223J
R52	Carbon film 22 1/4W	RD1/4PM 220J
R53	Carbon film 1M 1/4W	RD1/4PM 105J
R54	Carbon film 10k 1/4W	RD1/4PM 103J
R55	Carbon film 2.2k 1/4W	RD1/4PM 222J
R56	Carbon film 470 1/4W	RD1/4PM 471J

CAPACITORS

Symbol	Description	Part No.
C1	Metallized polypropylene 1 50V	ACE-016
C2	Metallized polypropylene 1 50V	ACE-016
C3	Electrolytic 33 25V	CEANL 330P 25
C4	Electrolytic 33 25V	CEANL 330P 25
C5	Metallized mylar 1 100V	ACE-008
C6	Metallized mylar 1 100V	ACE-008
C7	Polystyrene 47p 50V	CQSA 470J 50
C8	Polystyrene 47p 50V	CQSA 470J 50
C9	Polystyrene 68p 50V	CQSA 680J 50
C10	Polystyrene 68p 50V	CQSA 680J 50
C11	Ceramic 4p 50V	CCDSL 040D 50
C12	Ceramic 4p 50V	CCDSL 040D 50
C13	Polystyrene 10p 50V	CQSA 100J 50
C14	Polystyrene 10p 50V	CQSA 100J 50
C15	Polystyrene 470p 50V	CQSA 471J 50

SEMICONDUCTORS

Symbol	Description	Part No.	Symbol	Description	Part No.
C16	Polystyrene 470p 50V	CQSA 471J 50	Q1	Transistor	2SA906-G or H
C17	Polystyrene 470p 50V	CQSA 471J 50	Q2	Transistor	2SA906-G or H
C18	Polystyrene 470p 50V	CQSA 471J 50	Q3	Transistor	2SA906-G or H
C19	Electrolytic 220 35V	CEANL 221P 35	Q4	Transistor	2SA906-G or H
C20	Electrolytic 220 35V	CEANL 221P 35		* hfe of these transistors (Q1 - Q4) should have the same value.	
C21	Vacancy	Q5	Transistor	2SC1775A-E or F
C22	Vacancy	Q6	Transistor	2SC1775A-E or F
C23	Metallized mylar 1 100V	ACE-008		* hfe of these transistors (Q5, Q6) should have the same value.	
C24	Metallized mylar 1 100V	ACE-008	Q7	Transistor	2SC1903-V or B
C25	Ceramic 0.01 150V	ACG-004	Q8	Transistor	2SC1903-V or B
C26	Ceramic 0.01 150V	ACG-004	Q9	Transistor	2SA898-V or B
C27	Ceramic 0.01 150V	ACG-004	Q10	Transistor	2SA898-V or B
C28	Ceramic 0.01 150V	ACG-004		* hfe of these transistors (Q7 - Q10) should have the same value.	
C29	Ceramic 0.01 150V	ACG-004	Q11	Transistor	2SC1903-V or B
C30	Ceramic 0.01 150V	ACG-004	Q12	Transistor	2SC1903-V or B
C31	Ceramic 0.01 150V	ACG-004	Q13	Transistor	2SA898-V or B
C32	Ceramic 0.01 150V	ACG-004	Q14	Transistor	2SA898-V or B
C33	Electrolytic 470 63V	CEA 471P 63		* hfe of these transistors (Q11 - Q14) should have the same value.	
C34	Electrolytic 470 63V	CEA 471P 63	Q15	Transistor	2SD526-Y
C35	Electrolytic 470 63V	CEA 471P 63		(2SD313R-E)	
C36	Electrolytic 470 63V	CEA 471P 63	Q16	Transistor	2SD526-Y
C37	Electrolytic 100 50V	CEA 101P 50		(2SD313R-E)	
C38	Electrolytic 100 50V	CEA 101P 50	Q17	Transistor	2SB596-Y
C39	Electrolytic 100 50V	CEA 101P 50		(2SB507R-E)	
C40	Electrolytic 100 50V	CEA 101P 50	Q18	Transistor	2SB596-Y
C41	Metallized mylar 1 100V	ACE-008		(2SB507R-E)	
C42	Metallized mylar 1 100V	ACE-008		* hfe of these transistors (Q15 - Q18) should have the same value.	
C43	Metallized mylar 1 100V	ACE-008	Q19	Transistor	2SC1384-R or S
C44	Metallized mylar 1 100V	ACE-008	Q20	Transistor	2SC945A-Q or R
C45	Electrolytic 1000 50V	CEA 102P 50	Q21	Transistor	2SC945A-Q or R
C46	Electrolytic 1000 50V	CEA 102P 50	Q22	Transistor	2SC1384-R or S
C47	Electrolytic 1000 50V	CEA 102P 50	D1	Zener diode	WZ-150
C48	Electrolytic 1000 50V	CEA 102P 50	D2	Zener diode	WZ-150
C49	Electrolytic 1000 50V	CEA 102P 50	D3	Diode	1S2473
C50	Electrolytic 1000 50V	CEA 102P 50	D4	Diode	1S2473
C51	Electrolytic 1000 50V	CEA 102P 50	D5	Diode	1S2473
C52	Electrolytic 1000 50V	CEA 102P 50	D6	Diode	1S2473
C53	Mylar 0.047 50V	CQMA 473K 50	D7	Diode	1S2473
C54	Mylar 0.047 50V	CQMA 473K 50	D8	Diode	1S2473
C55	Vacancy	D9	Diode	SIB01-02 or 1S1886
C56	Vacancy	D10	Diode	SIB01-02 or 1S1886
C57	Ceramic 0.01 150V	ACG-004	D11	Diode	SIB01-02 or 1S1886
C58	Ceramic 0.01 150V	ACG-004	D12	Diode	SIB01-02 or 1S1886
C59	Electrolytic 330 10V	CEA 331P 10	D13	Diode	SIB01-02 or 1S1886
C60	Electrolytic 10 10V	CEANL 100P 10	D14	Diode	SIB01-02 or 1S1886
C61	Electrolytic 330 10V	CEA 331P 10	D15	Diode	SIB01-02 or 1S1886
C62	Electrolytic 470 6V	CEANL 471P 6	D16	Diode	SIB01-02 or 1S1886
C63	Electrolytic 47 10V	CEA 470P 10	D17	Diode	SIB01-02 or 1S1886
			D18	Diode	SIB01-02 or 1S1886
			D19	Zener diode	WZ-061
			D20	Diode	1S2473

Parts List of Factory Modification

<u>Symbol</u>	<u>Description</u>	<u>Part No.</u>
D21	Diode	1S2473
D22	Diode	1S2473
D23	Diode	1S2473
D24	Diode	1S2473
D25	Zener diode	WZ-320
D26	Zener diode	WZ-320
D27	Zener diode	WZ-081
D28	Zener diode	WZ-081
D29	Zener diode	WZ-081
D30	Zener diode	WZ-081
D31	Zener diode	WZ-320
D32	Zener diode	WZ-320
D33	Diode	SIB01-02 or 1S1886
D34	Diode	1S2473
D35	Diode	1S2473
D36	Diode	1S2473
D37	Diode	1S2473

<u>Symbol</u>	<u>Description</u>	<u>Part No.</u>
---------------	--------------------	-----------------

9.5 INPUT ASSEMBLY (AWF-025)

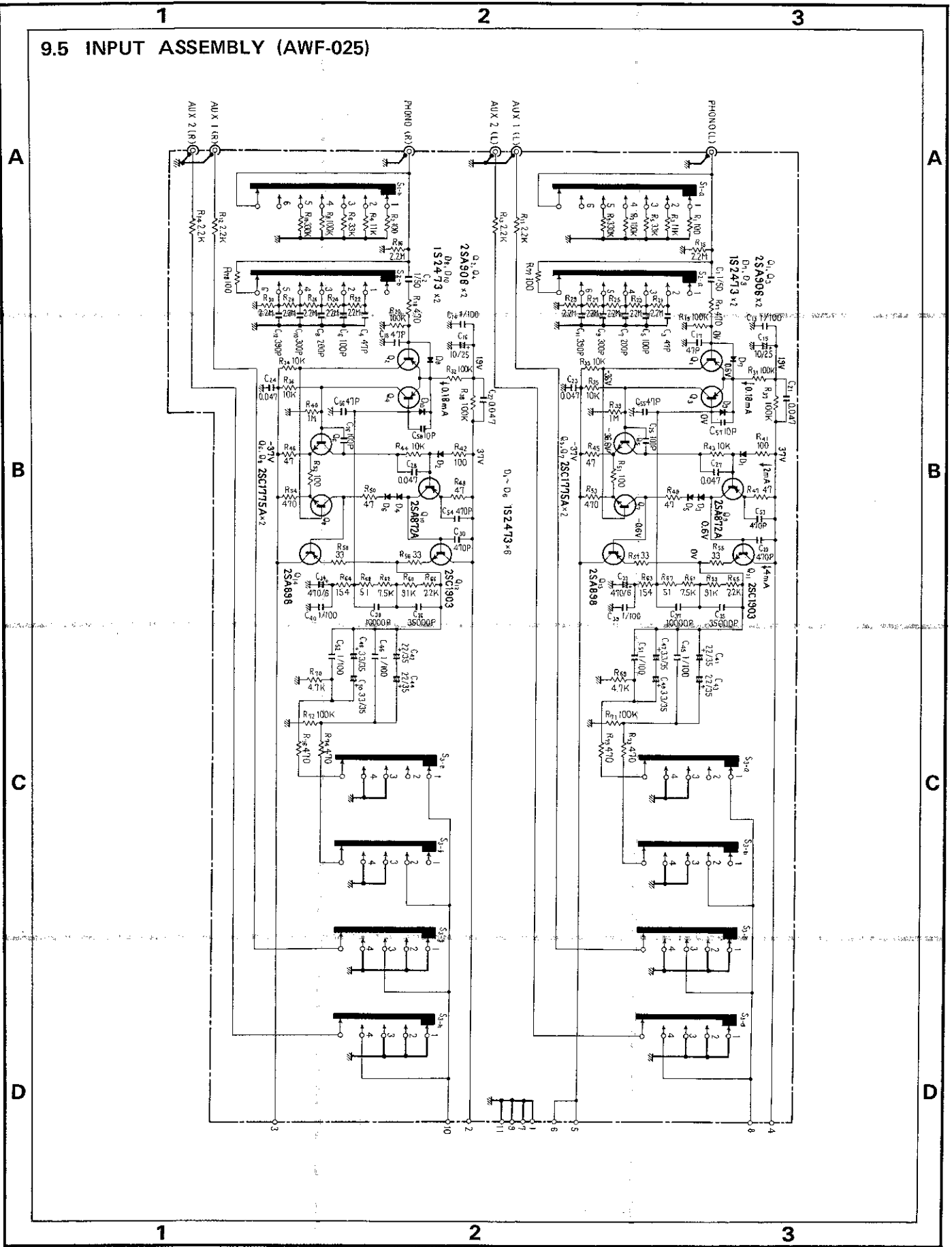

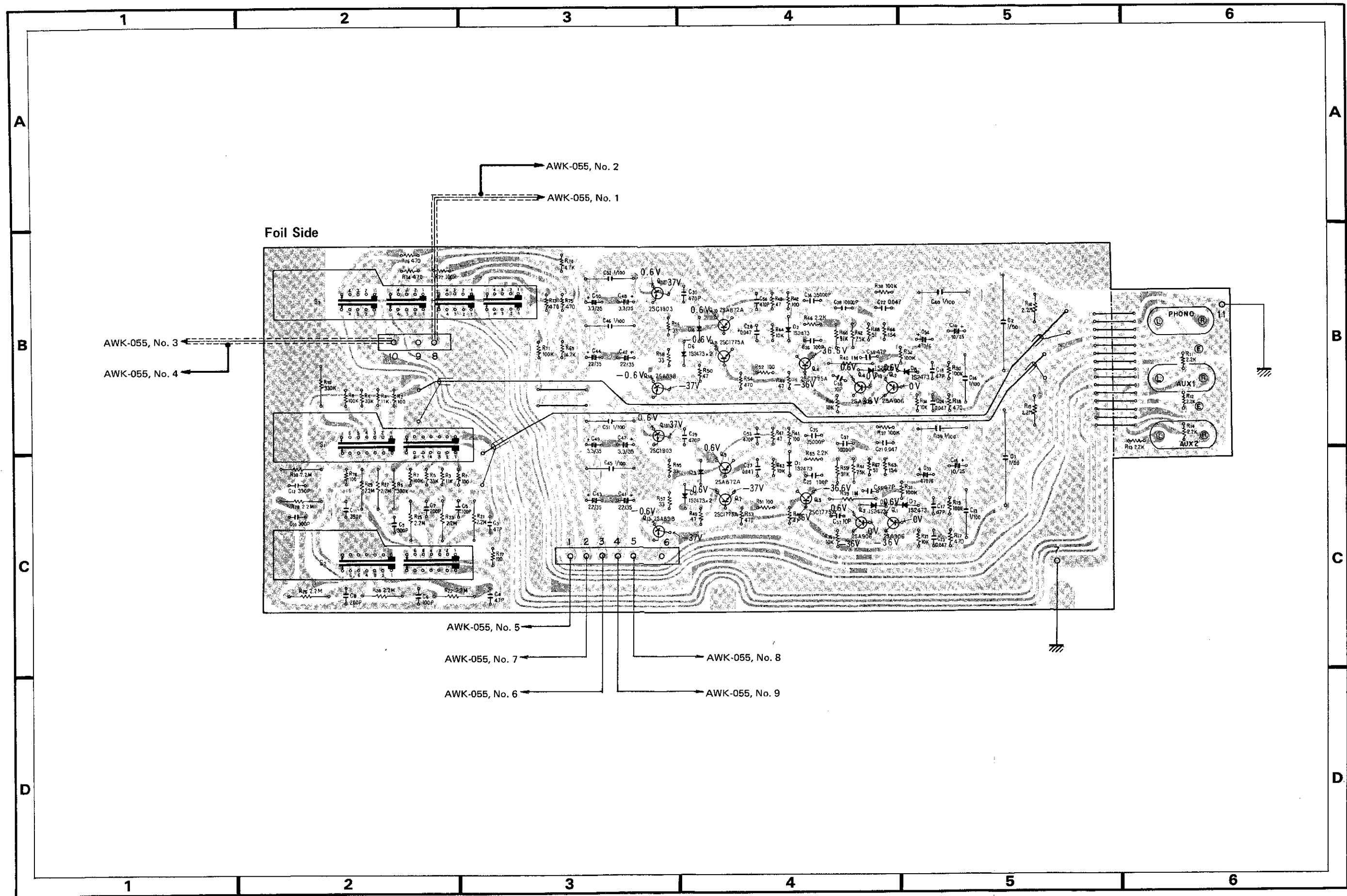

Foil Side

AWK-055, No. 2
AWK-055, No. 1

AWK-055, No. 3
AWK-055, No. 4

AWK-055, No. 5
AWK-055, No. 7
AWK-055, No. 6
AWK-055, No. 8
AWK-055, No. 9

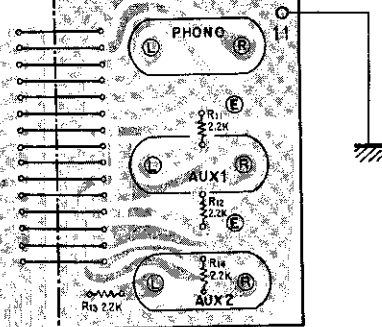

Parts List of Input Assembly (AWF-025)

SWITCHES

Symbol	Description	Part No.
S1	Rotary switch (CARTRIDGE LOAD)	ASD-062
S2	Rotary switch (CARTRIDGE LOAD)	ASD-062
S3	Rotary switch (FUNCTION)	ASD-061

OTHERS

Symbol	Description	Part No.
	Terminal (INPUT)	AKB-024
	3P plug	AKM-018
	6P plug	AKM-020
	Union nut	ABN-030
	Washer nut.M7	ABN-031
	Washer M7	B22-018

RESISTORS

Symbol	Description	Part No.
R1	Metal film 100 1/5W	RN1/5SQ 1000F
R2	Metal film 100 1/5W	RN1/5SQ 1000F
R3	Metal film 11k 1/5W	RN1/5SQ 1102F
R4	Metal film 11k 1/5W	RN1/5SQ 1102F
R5	Metal film 33k 1/5W	RN1/5SQ 3302F
R6	Metal film 33k 1/5W	RN1/5SQ 3302F
R7	Metal film 100k 1/5W	RN1/5SQ 1003F
R8	Metal film 100k 1/5W	RN1/5SQ 1003F
R9	Metal film 330k 1/4W	RN1/4PR 3303G
R10	Metal film 330k 1/4W	RN1/4PR 3303G
R11	Metal film 2.2k 1/5W	RN1/5SQ 2201F
R12	Metal film 2.2k 1/5W	RN1/5SQ 2201F
R13	Metal film 2.2k 1/5W	RN1/5SQ 2201F
R14	Metal film 2.2k 1/5W	RN1/5SQ 2201F
R15	Carbon film 2.2M 1/4W	RD1/4PS 225J
R16	Carbon film 2.2M 1/4W	RD1/4PS 225J
R17	Metal film 470 1/5W	RN1/5SQ 4700F
R18	Metal film 470 1/5W	RN1/5SQ 4700F
R19	Metal film 100k 1/5W	RN1/5SQ 1003F
R20	Metal film 100k 1/5W	RN1/5SQ 1003F
R21	Carbon film 2.2M 1/4W	RD1/4PS 225J
R22	Carbon film 2.2M 1/4W	RD1/4PS 225J
R23	Carbon film 2.2M 1/4W	RD1/4PS 225J
R24	Carbon film 2.2M 1/4W	RD1/4PS 225J
R25	Carbon film 2.2M 1/4W	RD1/4PS 225J
R26	Carbon film 2.2M 1/4W	RD1/4PS 225J
R27	Carbon film 2.2M 1/4W	RD1/4PS 225J
R28	Carbon film 2.2M 1/4W	RD1/4PS 225J
R29	Carbon film 2.2M 1/4W	RD1/4PS 225J
R30	Carbon film 2.2M 1/4W	RD1/4PS 225J

CAPACITORS

Symbol	Description	Part No.
C1	Metallized polypropylene 1 50V	ACE-016
C2	Metallized polypropylene 1 50V	ACE-016
C3	Polystyrene 47p 50V	CQSH 470J 50
C4	Polystyrene 47p 50V	CQSH 470J 50
C5	Polystyrene 100p 50V	CQSH 101J 50
C6	Polystyrene 100p 50V	CQSH 101J 50
C7	Polystyrene 200p 50V	CQSH 201J 50
C8	Polystyrene 200p 50V	CQSH 201J 50
C9	Polystyrene 300p 50V	CQSH 301J 50
C10	Polystyrene 300p 50V	CQSH 301J 50
C11	Polystyrene 390p 50V	CQSH 391J 50
C12	Polystyrene 390p 50V	CQSH 391J 50
C13	Metallized mylar 1 100V	ACE-008
C14	Metallized mylar 1 100V	ACE-008
C15	Electrolytic 10 25V	CEANL 100P 25
C16	Electrolytic 10 25V	CEANL 100p 25
C17	Polystyrene 47p 50V	CQSA 470J 50
C18	Polystyrene 47p 50V	CQSA 470J 50
C19	Vacancy
C20	Vacancy
C21	Mylar 0.047 50V	CQMA 473K 50
C22	Mylar 0.047 50V	CQMA 473K 50
C23	Mylar 0.047 50V	CQMA 473K 50
C24	Mylar 0.047 50V	CQMA 473K 50
C25	Polystyrene 100p 50V	CQSA 101J 50
C26	Polystyrene 100p 50V	CQSA 101J 50
C27	Mylar 0.047 50V	CQMA 473K 50
C28	Mylar 0.047 50V	CQMA 473K 50
C29	Polystyrene 470p 50V	CQSA 471J 50
C30	Polystyrene 470p 50V	CQSA 471J 50
C31	Vacancy
C32	Vacancy
C33	Electrolytic 470 6V	CEANL 471P 6
C34	Electrolytic 470 6V	CEANL 471P 6
C35	Polypropylene 35000p 50V	CQPA 353F 50
C36	Polypropylene 35000p 50V	CQPA 353F 50
C37	Polypropylene 10000p 50V	CQPA 103F 50
C38	Polypropylene 10000p 50V	CQPA 103F 50
C39	Metallized mylar 1 100V	ACE-008
C40	Metallized mylar 1 100V	ACE-008
C41	Electrolytic 22 35V	CEANL 220P 35
C42	Electrolytic 22 35V	CEANL 220P 35
C43	Electrolytic 22 35V	CEANL 220P 35
C44	Electrolytic 22 35V	CEANL 220P 35
C45	Metallized mylar 1 100V	ACE-008
C46	Metallized mylar 1 100V	ACE-008
C47	Electrolytic 3.3 35V	CSZA 3R3M 35
C48	Electrolytic 3.3 35V	CSZA 3R3M 35
C49	Electrolytic 3.3 35V	CSZA 3R3M 35
C50	Electrolytic 3.3 35V	CSZA 3R3M 35

SEMICONDUCTORS

Symbol	Description	Part No.
Q1	Transistor	2SA906-G or H
Q2	Transistor	2SA906-G or H
Q3	Transistor	2SA906-G or H
Q4	Transistor	2SA906-G or H
* hfe of these transistors (Q1-Q4) should have the same value.		
Q5	Transistor	2SC1775A-E or F
Q6	Transistor	2SC1775A-E or F
Q7	Transistor	2SC1775A-E or F
Q8	Transistor	2SC1775A-E or F
* hfe of these transistors (Q5-Q8) should have the same value.		
Q9	Transistor	2SA872A-E or F
Q10	Transistor	2SA872A-E or F
* hfe of these transistors (Q9, Q10) should have the same value.		
Q11	Transistor	2SC1903-V or B
Q12	Transistor	2SC1903-V or B
Q13	Transistor	2SA898-V or B
Q14	Transistor	2SA898-V or B
* hfe of these transistors (Q11-Q14) should have the same value.		
D1	Diode	1S2473
D2	Diode	1S2473
D3	Diode	1S2473
D4	Diode	1S2473
D5	Diode	1S2473
D6	Diode	1S2473
D7	Diode	1S2473
D8	Diode	1S2473
D9	Diode	1S2473
D10	Diode	1S2473

Parts List of Factory Modification

Symbol	Description	Part No.

10. PACKING

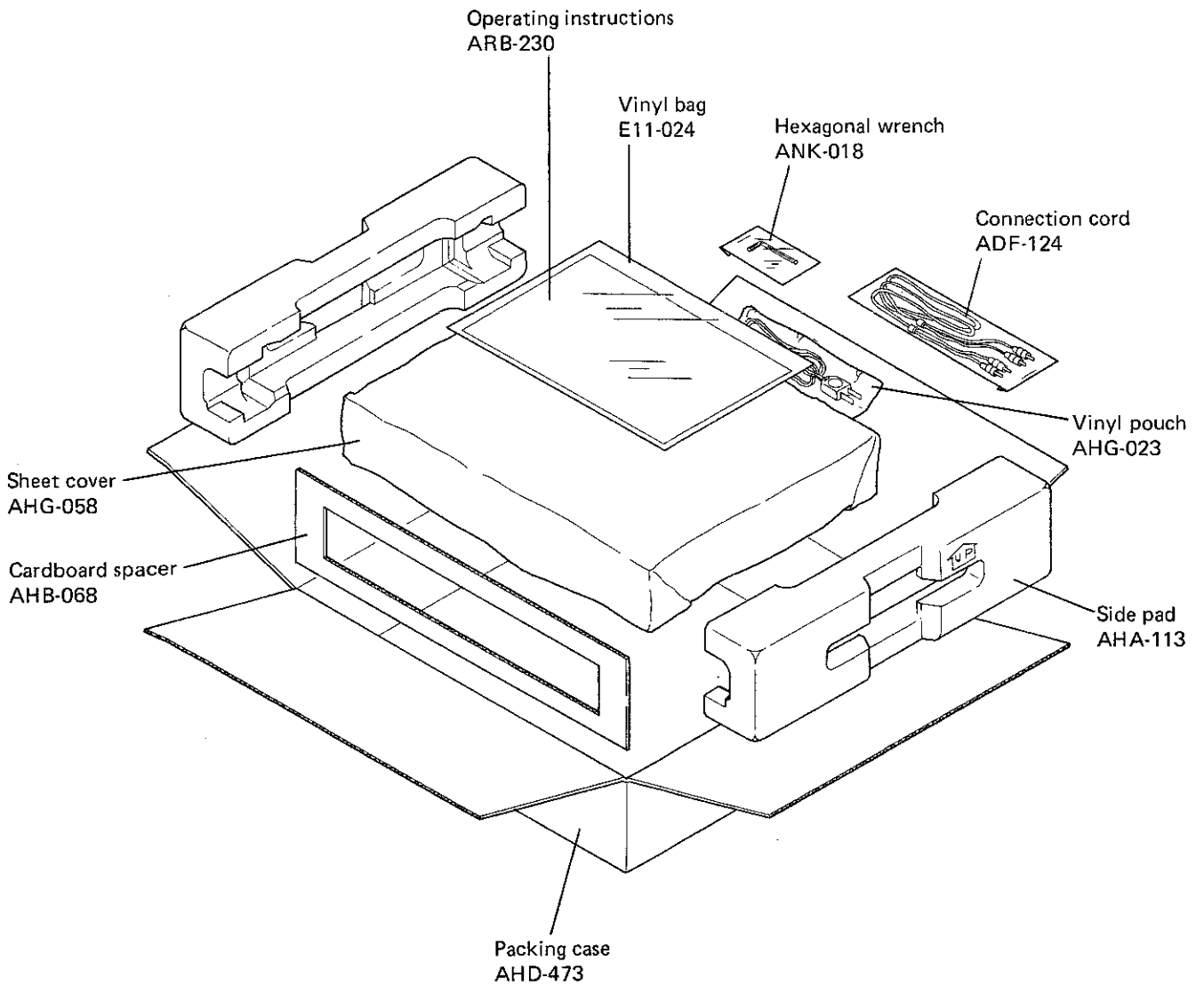

STEREO PREAMPLIFIER

C-21 KL

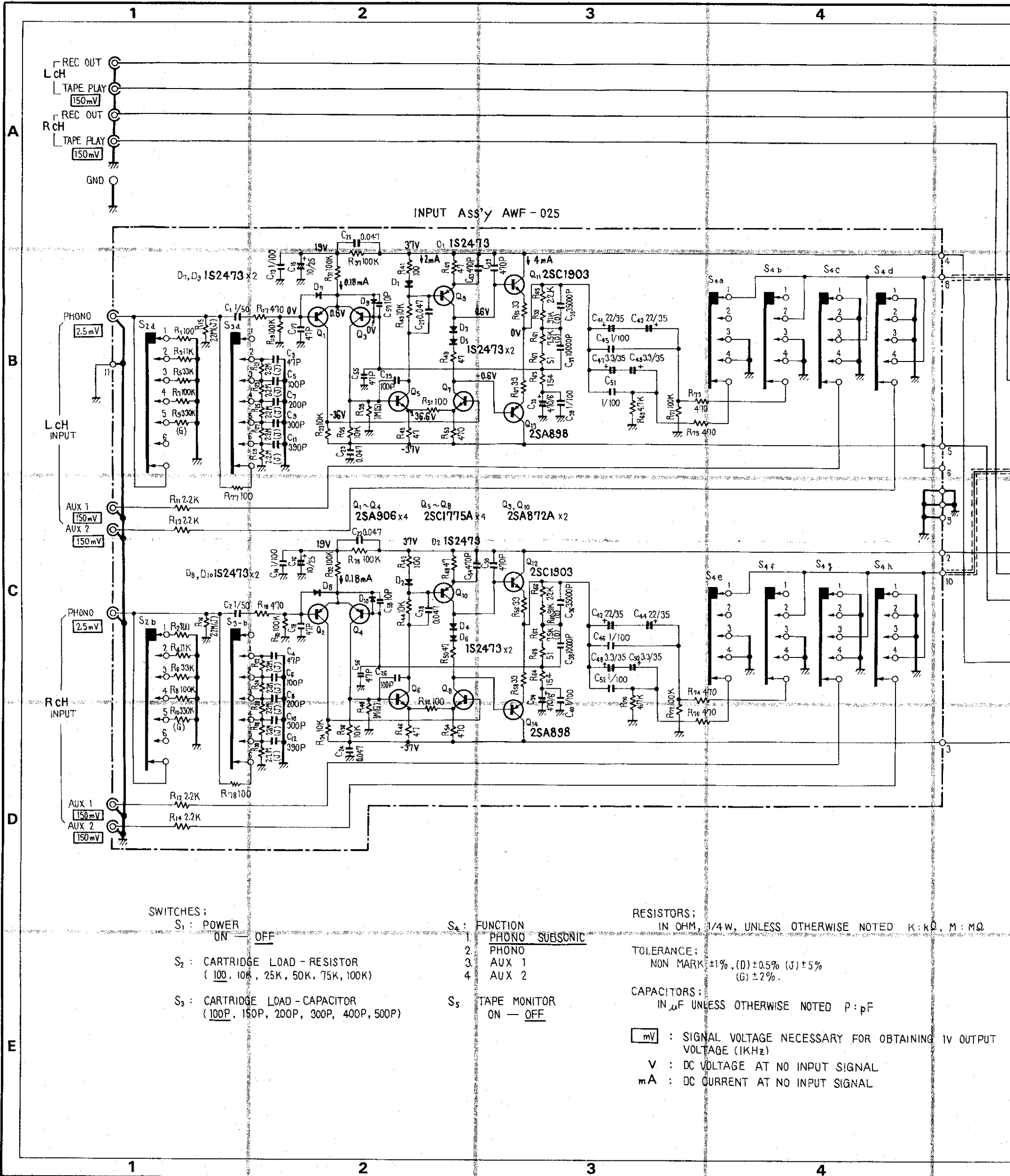

SWITCHES:
 S₁: POWER ON — OFF
 S₂: CARTRIDGE LOAD - RESISTOR (100, 10K, 25K, 50K, 75K, 100K)
 S₃: CARTRIDGE LOAD - CAPACITOR (100P, 150P, 200P, 300P, 400P, 500P)

S₄: FUNCTION
 1. PHONO SUBSONIC
 2. PHONO
 3. AUX 1
 4. AUX 2
 S₅: TAPE MONITOR ON — OFF

RESISTORS: IN OHM, 1/4W, UNLESS OTHERWISE NOTED K:kΩ, M:MΩ
 TOLERANCE: NON MARK ±1%, (D) ±0.5%, (J) ±5%, (G) ±2%.

CAPACITORS: IN μF UNLESS OTHERWISE NOTED P:pF

mV : SIGNAL VOLTAGE NECESSARY FOR OBTAINING 1V OUTPUT VOLTAGE (1KHz)
 V : DC VOLTAGE AT NO INPUT SIGNAL
 mA : DC CURRENT AT NO INPUT SIGNAL

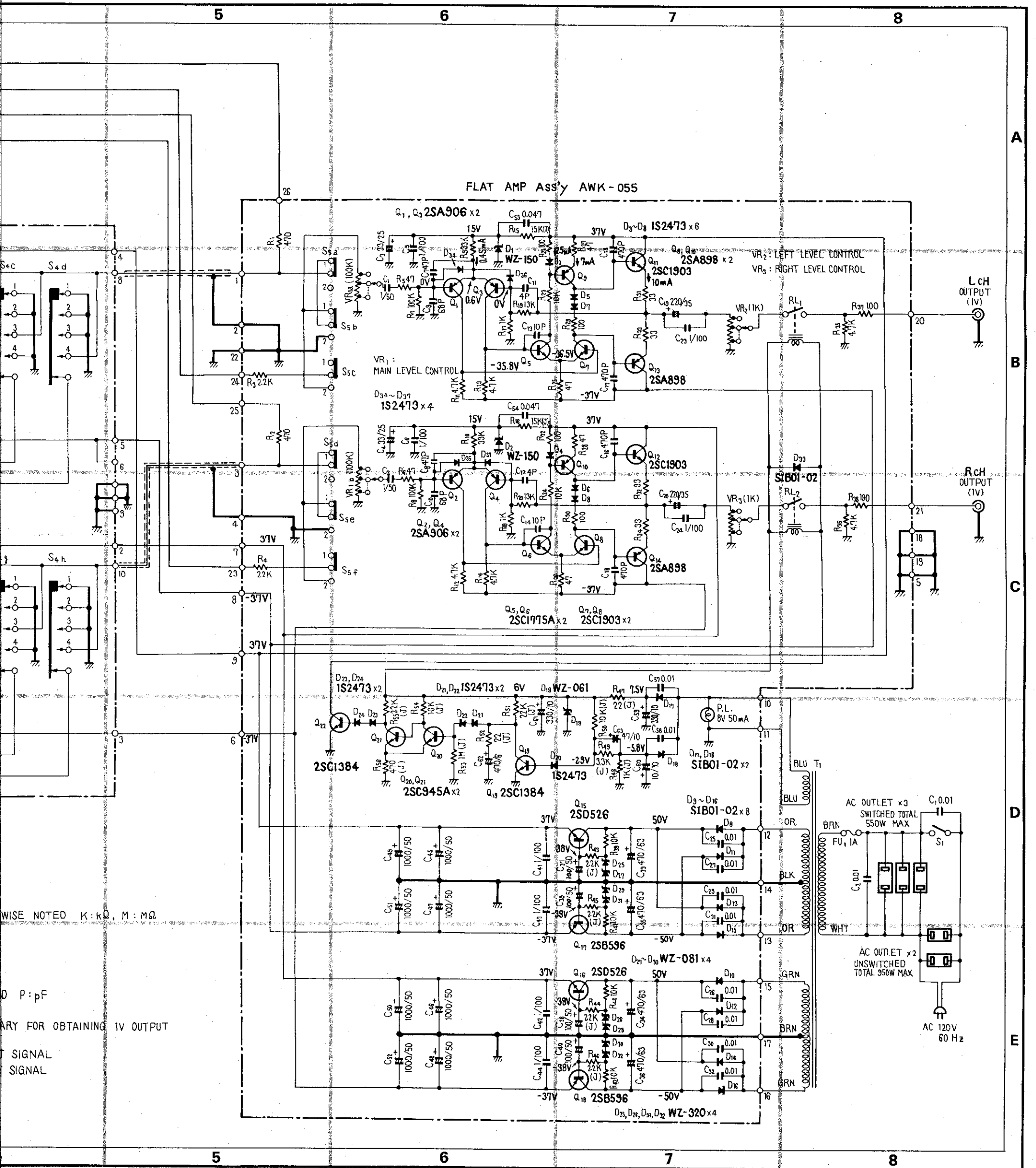

STEREO PREAMPLIFIER

C-21 S

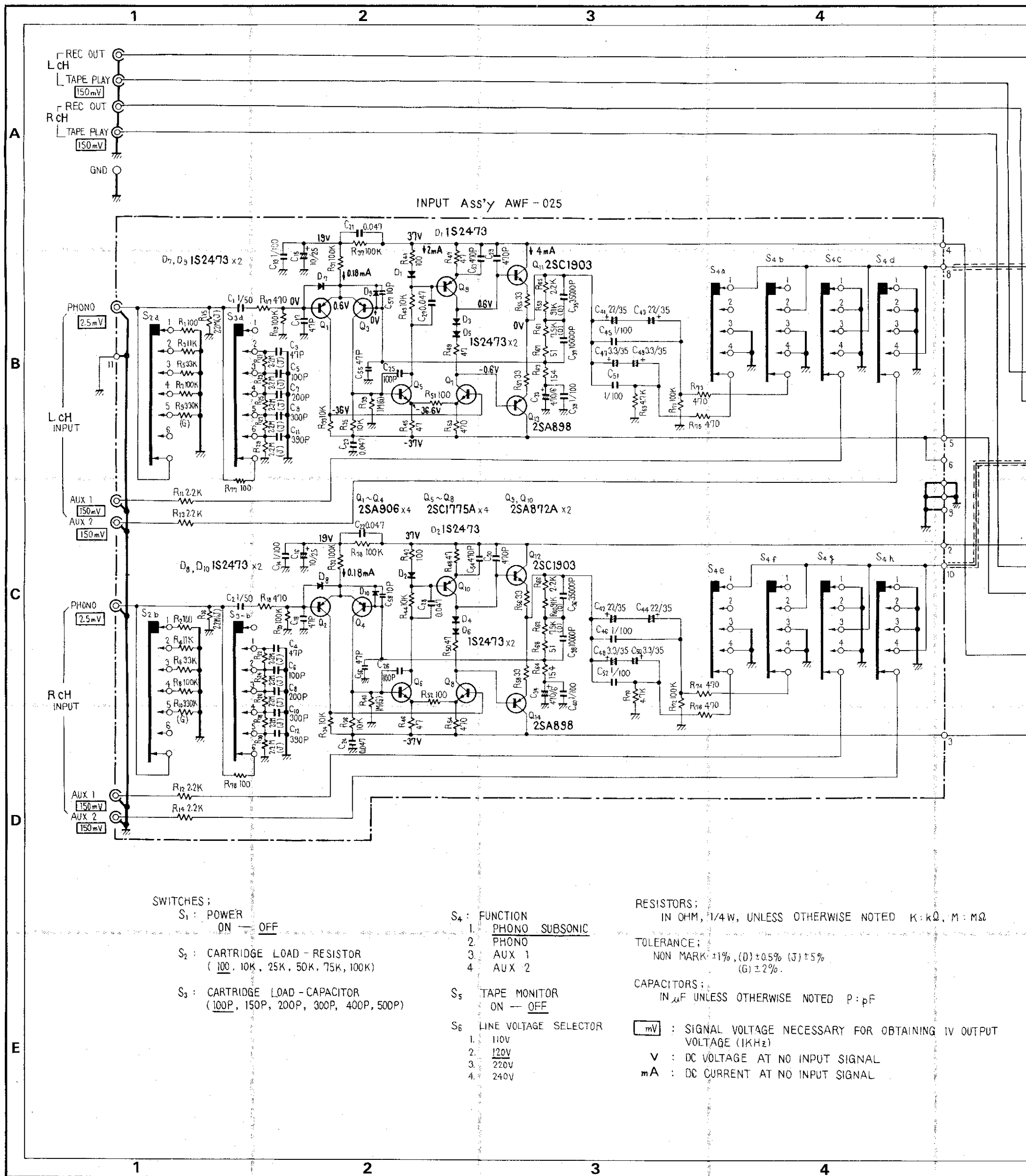

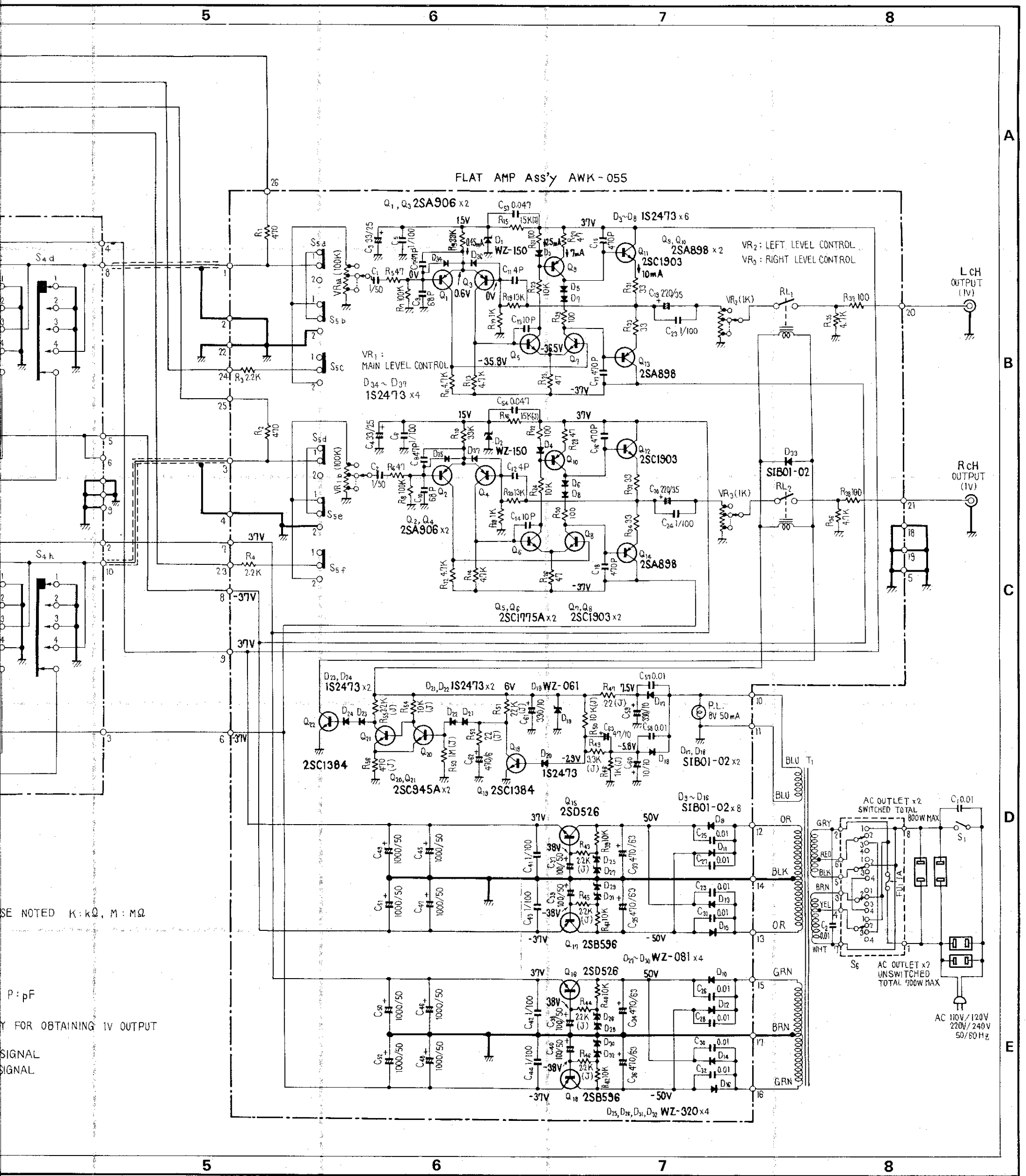

SE NOTED K:kΩ, M:MΩ

P:pF

Y FOR OBTAINING 1V OUTPUT

SIGNAL

SIGNAL