

Service Manual

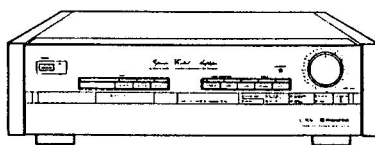

**ORDER NO.
ARP1635**

STEREO CONTROL AMPLIFIER

C-90a

MODEL C-90a HAS THREE VERSIONS:

Type	Power requirement	Export destination
HE	AC220V,240V (Switchable)*	European continent
HB	AC220V,240V (switchable)*	United Kingdom
HEZ	AC220V,240V (switchable)*	West Germany

* Change the primary wiring of the power transformer.

- This manual is applicable to the C-90a/HE,HB and HEZ types.
- For the HB and HEZ types, refer to page25.

CONTENTS

1. EXPLODED VIEWS AND PARTS LIST	2	5. P.C. BOARDS CONNECTION	
2. PACKING	8	DIAGRAM	17
3. ELECTRICAL PARTS LIST	9	6. FOR HB AND HEZ TYPES	25
4. SCHEMATIC DIAGRAM	13	7. PANEL FACILITIES	26
		8. SPECIFICATIONS	29

1. EXPLODED VIEWS AND PARTS LIST

NOTES:

- Parts without part number cannot be supplied.
- The Δ mark found on some component parts indicates the importance of the safety factor of the part. Therefore, when replacing, be sure to use parts of identical designation.
- Parts marked by "◎" are not always kept in stock. Their delivery time may be longer than usual or they may be unavailable.

Parts List of Exterior

Mark	No.	Parts No.	Description	Mark	No.	Parts No.	Description
	1	AWZ1059	Switch A assembly		101		Bottom plate
	2	AMR1159	Leg assembly		102		Spacer ring
	3	AAB1001	Knob (BALANCE, TREBLE, BASS)				
	4	AAD1012	Knob (POWER)				
	5	AAD1014	Function knob assembly A				
	6	AAD1015	Function knob assembly C				
	7	AAD1016	Knob (MUTE)				
	8	AAD1017	Knob (TONE, LOUDNESS)				
	9	AAF1012	Knob (VOLUME)				
	10	AAK1024	Arm L				
	11	AAK1025	Arm R				
	12	AAM1001	Name plate				
	13	AAN1082	Door panel				
	14	AAY-157	Knob (ADAPTOR, TAPE COPY, MODE, PHONO SELECTOR, SUBSONIC FILTER, HIGH FILTER)				
	15	AMS1033	Side board L				
	16	AMS1034	Side board R				
	17	ANE1007	Bonnet case				
	18	ABH1005	Coil spring				
	19	ABH1011	Earth spring				
	20	ADH1003	Wire (EARTH)				
	21	ABA1023	Decorative screw				
	22	BBZ30P080FZK	Screw				
	23	FBT40P080FZK	Screw				
	24	BBZ26P080FMC	Screw				
	25	NK90FUC	Nut				
	26	ABA1048	Screw				
	27	ABA1011	Screw				
	28	AED1007	Sheet				
	29	ANZ-255	Damper				
	30	ABA1006	Screw				
	31	PMZ30P060FZB	Screw				
	32	PMZ30P050FZB	Screw				
	33	ABA1050	Screw				
	34	AZN1825	Front panel assembly				
	35	PTZ20P060FMC	Screw				
	36	AED1008	Door cushion				
	37	AED1004	Cushion				
	38	AEE1003	Label				

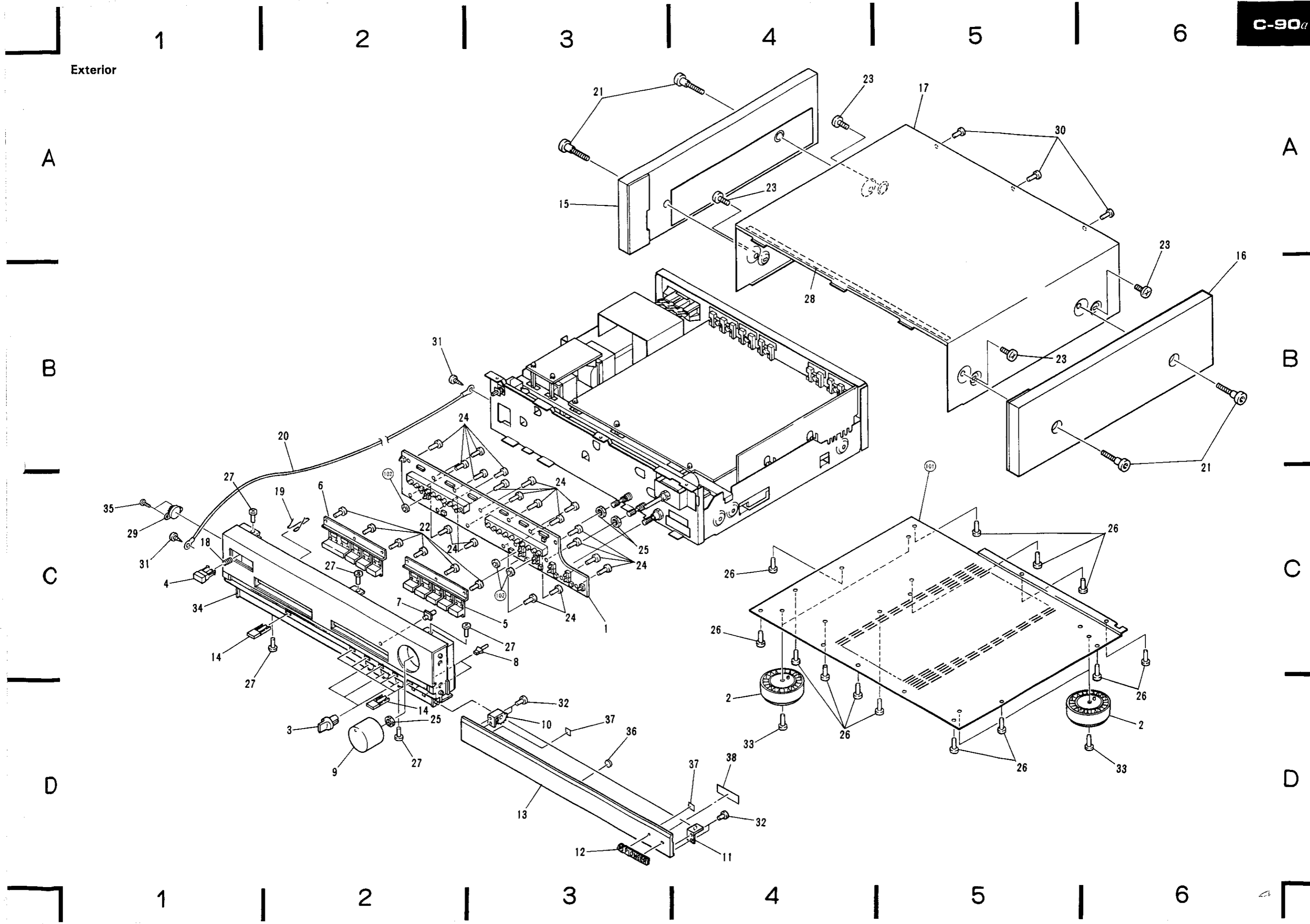

C-90a

Interior

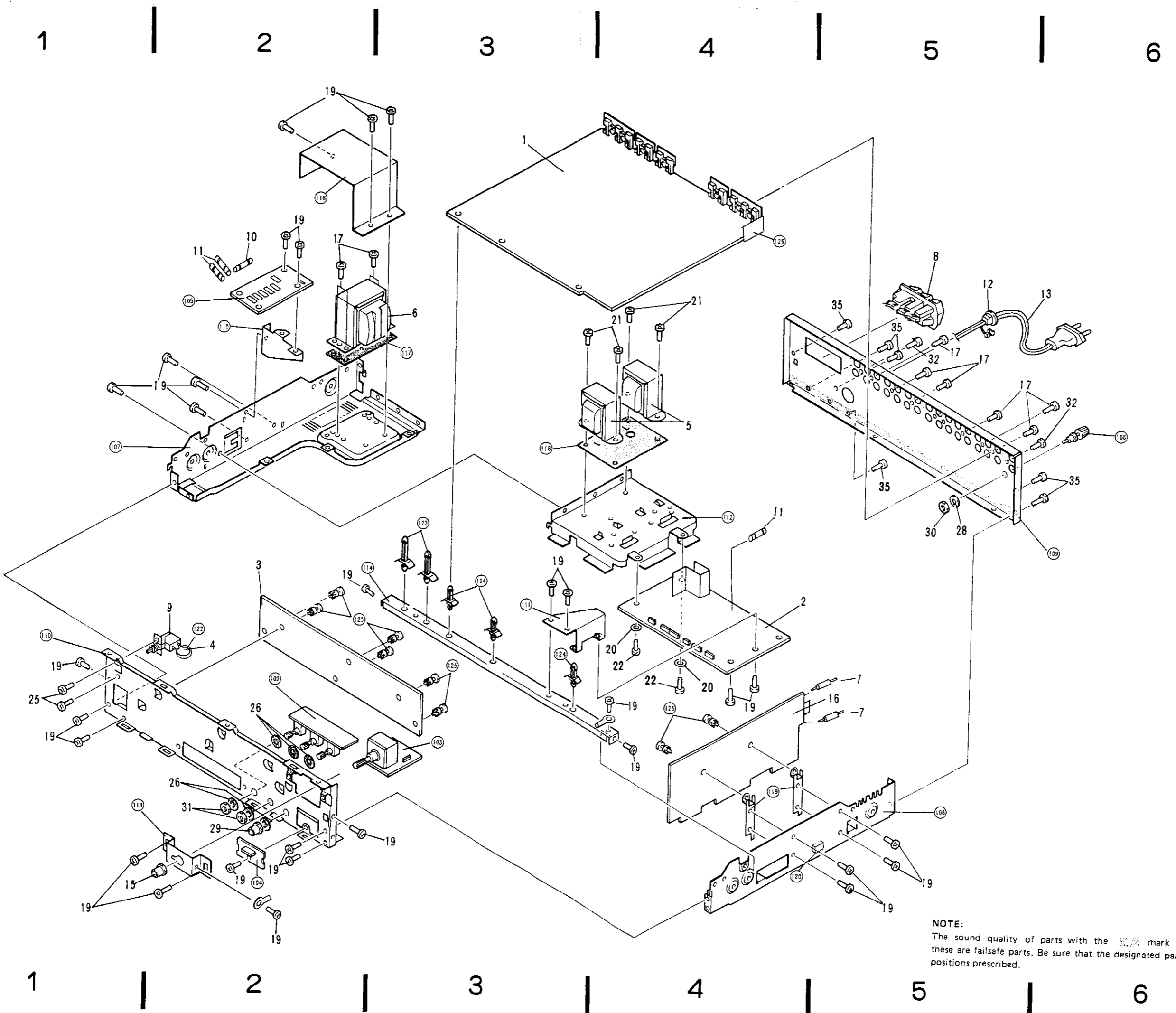

NOTE:
The sound quality of parts with the  mark denotes that these are failsafe parts. Be sure that the designated parts are in the positions prescribed.

NOTES:

- Parts without part number cannot be supplied.
- The \triangle mark found on some component parts indicates the importance of the safety factor of the part. Therefore, when replacing, be sure to use parts of identical designation.
- Parts marked by "●" are not always kept in stock. Their delivery time may be longer than usual or they may be unavailable.

Parts List of Interior

Mark	No.	Parts No.	Description	Mark	No.	Parts No.	Description
	1	AWZ2048	AF assembly		101	
	2	AWZ1049	Power supply assembly		102		VR A assembly
	3	AWZ1058	Control assembly		103		VR C assembly
\triangle	4	ACG1003	Ceramic capacitor (POWER,0.01/400V,C1)		104		Switch B assembly
\triangle	5	ATT1007	Power transformer (220V,240V,T1,T2)		105		Fuse assembly
					106		Terminal (EARTH)
\triangle	6	ATT1008	Power transformer (220V/240V,T3)		107		Transformer frame
					108		Right frame
	7	AKM-050	Plug		109		Rear panel
\triangle	8	AKP-502	AC Socket (AC OUTLET)		110		Panel stay
\triangle	9	ASG-553	Switch (POWER,S1)				
\triangle	10	AEK-401	Fuse (T500mA/250V,FU4)		111		P.C.B.Holder
					112		Transformer holder
\triangle	11	AEK-402	Fuse (T1A/250V,FU1-FU3)		113		Volume holder
\triangle	12	AEC-882	Strain relief		114		Center frame
\triangle	13	ADG1036	AC Power cord		115		P.C.B. Holder-C
	14				
	15	ABN-050	Spacer		116		Shield cover
					117		Damper plate A
	16	AWF1006	Equalizer assembly		118		Damper plate B
	17	ABA1006	Screw		119		P.C.B. Holder-B
	18	ABA1007	Screw		120		Cushion
	19	ABA1009	Screw				
	20	AEB1063	Spacer ring		121	
					122		Capacitor cover
	21	ABA1004	Screw		123		P.C.B.Support
	22	ABA-283	PWB Screw		124		P.C.B.Support
	23	PMZ30P060FZB	Screw		125		Pin grommet
	24	PTZ30P060FMC	Screw				
	25	VMZ30P060FCU	Screw		126		Shield plate
	26	ABE1001	Washer				
	27				
	28	WG70FUC	Washer				
	29	ABN-028	Nut				
	30	NK70FUC	Nut				
	31	NK90FUC	Nut				
	32	ABA-115	Screw				
	33	AED1004	Cushion				
	34				
	35	ABA1048	Screw				

2. PACKING

Parts List of Packing

Mark	No.	Parts No.	Description
	1	AHA1003	Top pad
	2	AHA1004	Bottom pad
	3	AHD1491	Packing case
	4	ADE1013	Connection cord with pin plug
	5	ARE1099	Operating instruction
101			Vinyl bag
102			Sheet

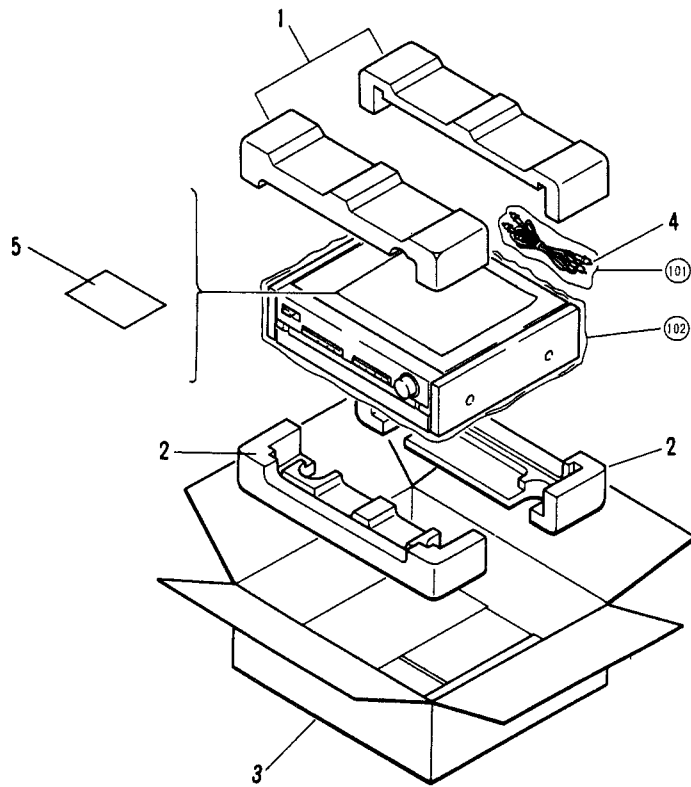

3. ELECTRICAL PARTS LIST

NOTES:

- Parts without part number cannot be supplied.
- Parts marked by "⊙" are not always kept in stock. Their delivery time may be longer than usual or they may be unavailable.
- The Δ mark found on some component parts indicates the importance of the safety factor of the part. Therefore, when replacing, be sure to use parts of identical designation.
- When ordering resistors, first convert resistance values into code form as shown in the following examples.

Ex. 1 When there are 2 effective digits (any digit apart from 0), such as 560 ohm and 47k ohm (tolerance is shown by J = 5%, and K = 10%).

560Ω	56 × 10 ¹	561.....	RD1/4PS	Ⓜ	Ⓜ	Ⓜ	J
47kΩ	47 × 10 ³	473.....	RD1/4PS	Ⓜ	Ⓜ	Ⓜ	J
0.5Ω	0R5.....		RN2H	Ⓜ	Ⓜ	Ⓜ	K
1Ω	010.....		RS1P	Ⓜ	Ⓜ	Ⓜ	K

Ex. 2 When there are 3 effective digits (such as in high precision metal film resistors).

5.62kΩ	562 × 10 ¹	5621.....	RN1/4SR	Ⓜ	Ⓜ	Ⓜ	F
--------	-----------------------	-----------	---------	---	---	---	---

Micellaneous Parts

P.C. BOARD ASSEMBLIES

Mark	Symbol & Description	Part No.
	Equalizer assembly	AWF1006
	Control assembly	AWZ1058
	Switch A assembly	AWZ1059
	AF assembly	AWZ2048
	Power supply assembly	AWZ1049
	Switch B assembly	
	VR A assembly	
	VR C assembly	
	Fuse assembly	

OTHERS

Mark	Symbol & Description	Part No.
Δ	C1 Ceramic capacitor (0.01/400V, POWER)	ACG1003
Δ	T1,T2 Power transformer (AC220V/240V)	ATT1007
Δ	T3 Power transformer (AC220V/240V)	ATT1008
Δ	S1 Push switch (POWER)	ASG-553
Δ	AC socket (OUTLET, 3P)	AKP-502
Δ	FU1-FU3 Fuse (T1A/250V)	AEK-402
Δ	FU4 Fuse (T500mA/250V)	AEK-401
	Jumper plug	AKM-050
	Earth wire	ADH1003
Δ	AC power cord	ADG1036
Δ	Strain relief	AEC-882

Equalizer assembly (AWF1006)

SEMICONDUCTORS

Mark	Symbol & Description	Part No.
	IC101,IC102	NJM5534DD
	Q117	2SA1115
	Q111,Q112	2SA965
	Q105-Q108,Q113,Q114	2SC1845
	Q109,Q110	2SC2235
	Q118,Q119	2SC2603
	Q115,Q116	2SC2878
	Q101-Q104	2SK369
	D101,D102	1SS252

RELAIIES

Mark	Symbol & Description	Part No.
	RY101-RY104 (MM/MC, MC40Ω/13Ω)	ASR1018

COILS & TYRANSFORMERS

Mark	Symbol & Description	Part No.
	L101,L102 Inductor (270μH)	ATH-132
	T101,T102 MC transformer	ATV1002

CAPACITORS

Mark	Symbol & Description	Part No.
	C117,C118 (0.03μF/100V)	ACE-094
	C119,C120 (0.12μF/100V)	ACE-095
	C140,C141	CEAS100M25
	C133-C136	CEAS470M25
	C125,C126	CEXA102M25
	C121,C122	CEYANP330M50
	C111-C114,C127,C128	CEXA100M50
	C138,C139	CEXA220M50
	C131,C132	CKCYF103Z50
	C103,C104 Mica capacitor	CMA151J500

Mark	Symbol & Description	Part No.
	C101,C102 Mica capacitor	CMA181J500
	C107,C108 (82P/100V)	ACE1025
	C123,C124 (0.015μF/100V)	ACE1030
	C115,C116	VQSA122J160
	C105,C106 (1500P/100V)	ACE1028
	C109,C110 (680P/100V)	ACE1027

RESISTORS

Mark	Symbol & Description	Part No.
	R131-R134,R161-R164	RD1/4PMFL□□□J
	R152	RD1/4PM100J
	R153-R159	RD1/8PM□□□J
	R137,R138,R141,R142,R145, R146	RDR1/2PM□□□J
	R135,R136	RDR1/2PM222F
	R145,R146	RDR1/2PM273F
	Other resistor	RDR1/4PM□□□J

OTHER

Mark	Symbol & Description	Part No.
	Terminal 2P (PHONO)	AKB1001

Control assembly (AWZ1058)

SEMICONDUCTORS

Mark	Symbol & Description	Part No.
	IC301	PDE012
	IC302,IC303	PD0012A
	IC304	M74LS42P
	Q301	2SC2458
	D301-D306	1SS131

COIL

Mark	Symbol & Description	Part No.
	L301 (1mH)	ATH-098

CAPACITORS

Mark	Symbol & Description	Part No.
	C301,C304	CEANL470M16
	C302,C303	CKDYB103K50
	C305,C306	CCDCH101J50
	C307-C309	CEAS100M25
	C311,C312	CKDYF103Z50
	C313	CKDYB103K500

RESISTORS

Mark	Symbol & Description	Part No.
	R301,R310 Resistor array	RA4S103J
	Other resistors	RD1/8PM□□□J

OTHER

Mark	Symbol & Description	Part No.
	X301 Ceramic resonator (400kHz)	ASS-046

Switch A assembly (AWZ1059)

SEMICONDUCTORS

Mark	Symbol & Description	Part No.
	D353,D355,D357,D368-D372	AEL-451
	LED (AUX3, AUX2, AUX1, TAPE2, TAPE1, TUNER, PHONO, CD)	
	D341,D343,D344,D348, D359-D367	AEL1004
	LED (MC, MM, MONO, HIGH, CUT, FILTER, SUBSONIC FILTER, TONE, MUTE, LOUDNESS)	

SWITCHES

Mark	Symbol & Description	Part No.
	S341-S343,S346-S350,S352, S355-S360 Tact switch (INPUT, TAPE MONITOR, ADAP-TOR, HIGH CUT FILTER, SUBSONIC FILTER, MODE, TAPE COPY, PHONO SEL, MUTE)	ASG-711

RESISTORS

Mark	Symbol & Description	Part No.
	R341,R345,R347,R348	RD1/8PM391J
	R342,R343 Resistor array	RA4S391J
	R346 Resistor array	RA4S391J

AF assembly (AWZ2048)

SEMICONDUCTORS

Mark	Symbol & Description	Part No.
	IC407-IC410	M520 1P
	IC405,IC406	M520 OP
	IC412	M74LS42P
	IC403,IC404	NJM5 534DD
	IC401,IC411 E-SW IC	μPD6362C
	Q433	RN1201
	Q432	RN201
	Q431	2SA1115
	Q417-Q420	2SA1145
	Q409-Q412,Q423,Q424	2SA992
	Q405-Q408,Q421,Q422,Q429, Q430	2SC1845
	Q413-Q416	2SQ705
	Q438-Q441	2SQ878
	Q427,Q428	2SJ74
	Q425,Q426	2SK170
	Q401-Q404	2SK146

Mark	Symbol & Description	Part No.
	D409-D412	AEL-398
	D422,D423	RD15EB
	D417	RD8.2EB
	D413,D416	S5566
	D419-D421	1S1555
	D401-D408	11DF2FD

RELAIES

Mark	Symbol & Description	Part No.
	RY401-RY409 Relay (MUTING, TONE, INPUT, CD, PHONO, TAPE1, ADAPTOR, TAPE2, OUTPUT)	ASR1018

CAPACITORS

Mark	Symbol & Description	Part No.
	C427,C428 (1 μ F/200V)	ACE-217
	C457,C493-C497,C499,C500	CEAS100M25
	C567,C568	CEAS470M16
	C409-C412	CEXAS331M50
	C401-C404 (470 μ F/50V)	ACH1052
	C417-C420 (330 μ F/50V)	ACH1089
	C421,C422,C429,C430	CEYANP220M50
	C413-C416,C433-C436,C441, C442	CEXA100M50
	C445-C452	CEXA2R2M50
	C453-C456	CEXA3R3M50
	C437,C438	CEXA4R7M50
	C498	CKDYB102K50
	C481,C482	CKDYB331K50
	C439,C440	CMA101J500
	C405-C408,C425,C426	ACE1014
	PP CAPACITOR (220P/100V)	
	C423,C424,C569-C572	ACE1023
	PP CAPACITOR (47P/100V)	
	C443,C444	CFTXA823J50
	C431,C432	ACE1031
	PP CAPACITOR (0.027 μ F/100V)	
	C501,C502	CKDYB103K50
	C467-C480,C487-C492	CKDYB391K50
	C485,C486	CQSXA102J160
	C483,C484	CQSXA122J160
	C465,C466	CQSXA391J160

RESISTORS

Mark	Symbol & Description	Part No.
⚠	R497 Resistor array	RA6S103J
	R553,R554	RS1LMF221J
	R465,R466	RD1/2PM822J
	R469-R496,R498,R499, R535-R542,R579,R580	RD1/8PM□□□J
⚠	R549	RD1/4PM2R2J
	R581-R584	RS1PMF4R7J
	Other resistors	RDR1/4PM□□□J

OTHERS

Mark	Symbol & Description	Part No.
	Terminal 4P (VCR/ADAPTOR/TAPE1)	AKB-115
	Terminal 6P (CD/TUNER/VDP)	AKB1002
	Terminal 6P (TAPE2/OUTPUT)	AKB1005

Power supply assembly (AWZ1049)**SEMICONDUCTORS**

Mark	Symbol & Description	Part No.
	IC201 FL Static driver IC	LC7570
	IC202 Output expander	PDO012A
	IC203 Logic IC	TC4069UBP
	Q201	2SC2705
	Q202,Q204,Q206	2SK246
	Q211,Q214,Q224-Q231	2SA1115
	Q207,Q209,Q212,Q213	2SC2603
	Q208,Q210	2SC2275A
	Q203,Q205	2SA1145
	Q232	2SC2878
	Q233,Q234	RN2203
	Q219,Q220	RN1203
	D201-D208,D226	S5566
	D209,D210	RD20ESB2
	D211	RD13EB
	D212	RD6.2EB
	D213	RD6.8EB
	D214,D221-D223,D227-D229	1SS131

CAPACITORS

Mark	Symbol & Description	Part No.
	C201,C202	CEAS471M35
	C203-C206,C209	CEAS101M25
	C207,C211	CEAS101M10
	C208	CEAS102M25
	C210	CEAS101M16
	C212 (0.047F/5.5V)	ACH-902
	C218,C219	CEAS100M25
	C220,C221,C224	CEAS010M50
	C222	CEAS100M50
	C223	CEAS4R7M50
	C225,C226	CKDYF103Z50

RESISTORS

Mark	Symbol & Description	Part No.
	R202	RS2LMF101J
	R243 Resistor array	RA8S103J
	Other resistors	RD1/8PM□□□J

Switch B assembly**SWITCHES**

Mark	Symbol & Description	Part No.
	S391,S392 Tact switch (TONE,LOUDNESS)	ASG-711

VR A assembly**CAPACITORS**

Mark	Symbol & Description	Part No.
	C551,C552	CQMXA273J100

RESISTORS

Mark	Symbol & Description	Part No.
	VR551 Variable resistor 50k Ω (BALANCE)	ACT1002
	VR552,VR553 Variable resistor 10k Ω (BASS,TREBLE)	ACT1007
	R551,R552	RDR1/4PM561J

VR C assembly**SEMICONDUCTOR**

Mark	Symbol & Description	Part No.
	D561	S5566

RELAY

Mark	Symbol & Description	Part No.
	RY561	ASR1018

CAPACITORS

Mark	Symbol & Description	Part No.
	C563,C564	CEXA010M50
	C565,C566	CKCYX104M25
	C561,C562	CQSXA152J160

RESISTORS

Mark	Symbol & Description	Part No.
	VR561 Variable resistor 15k Ω	ACW1005
	R563,R564	RDR1/4PM153J
	R561,R562	RD1/4PM751J

Fuse assembly

Mark	Symbol & Description	Part No.
------	----------------------	----------

No parts are supplied with the Fuse assembly.

4. SCHEMATIC DIAGRAM

A

B

C

D

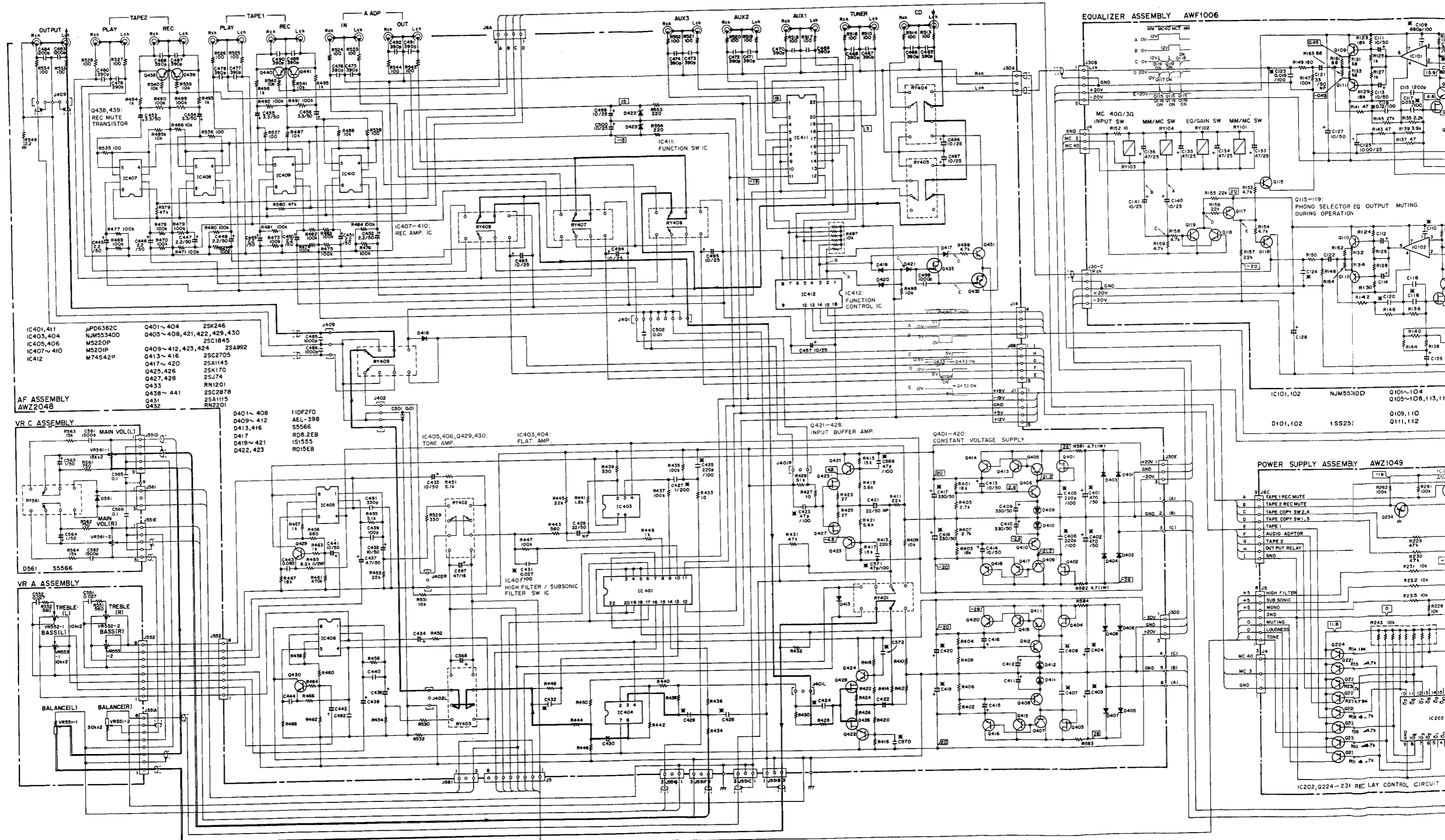

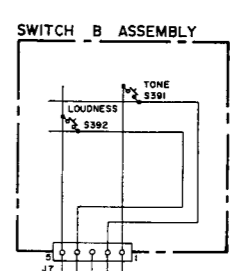
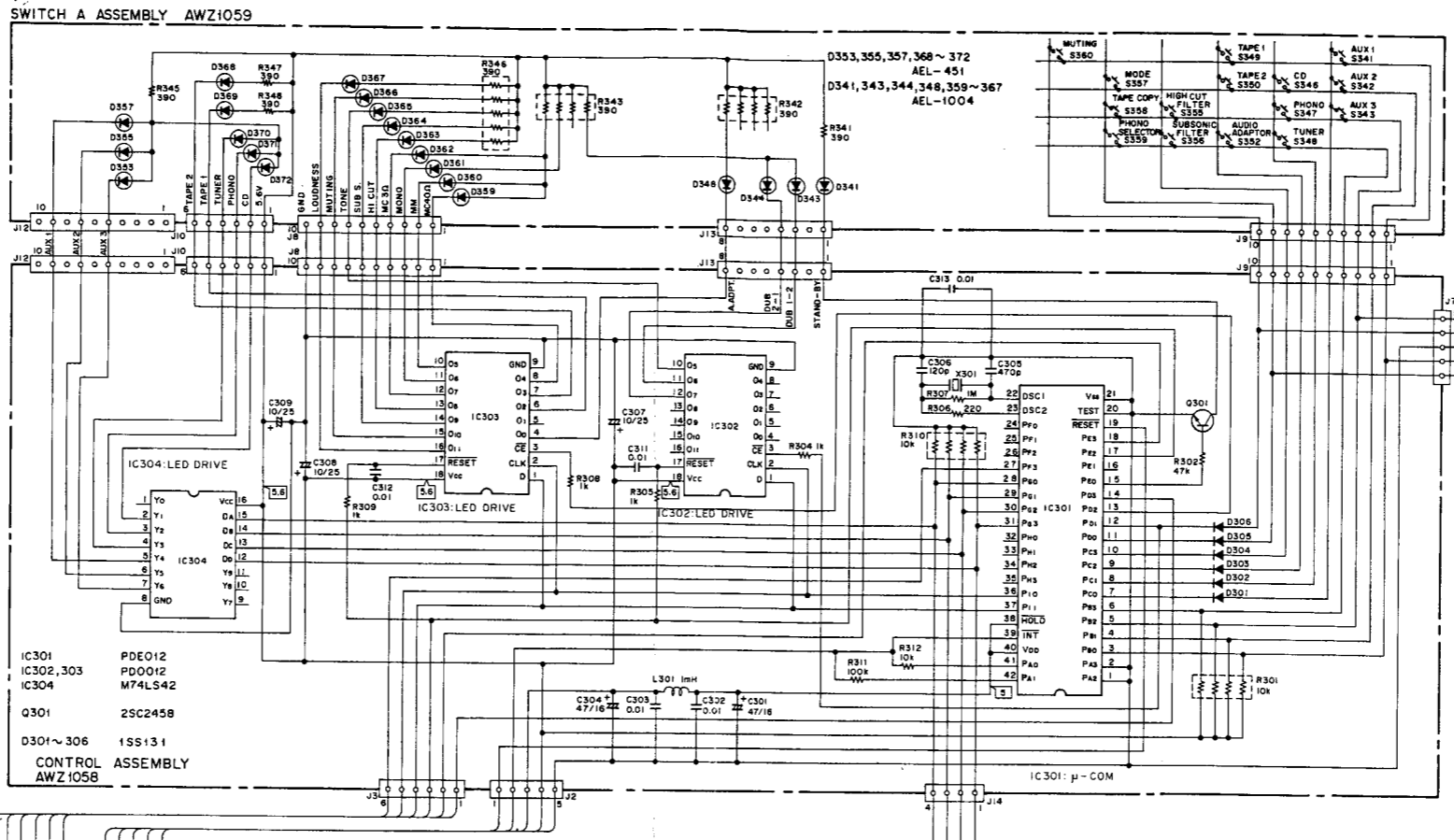
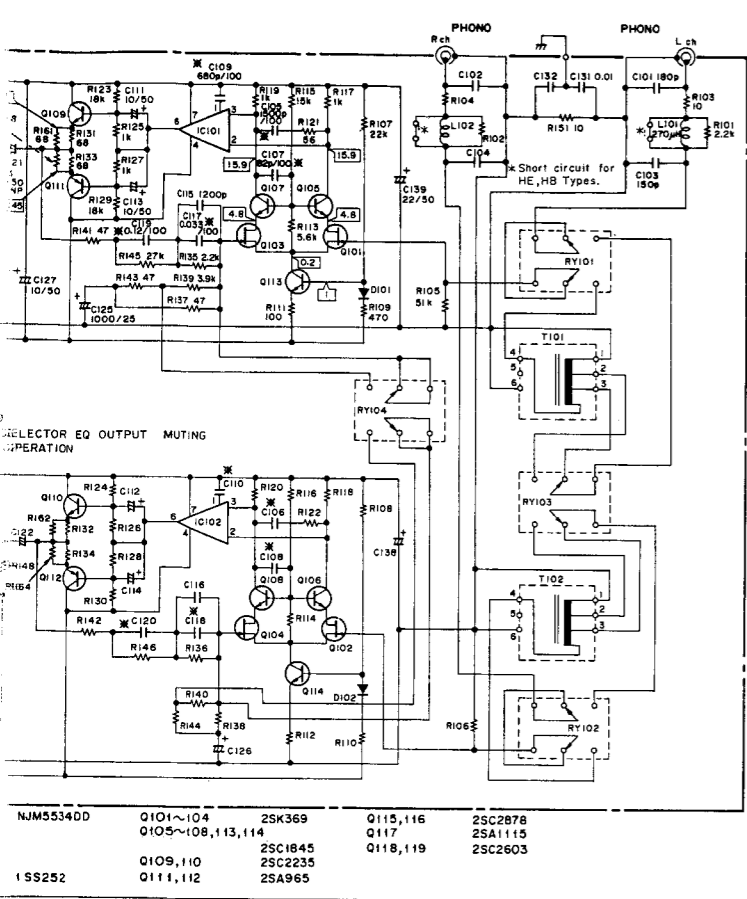

- RESISTORS:
Indicated in Ω, kΩ, MΩ, ±5% tolerance unless otherwise noted k: kΩ, M: MΩ, (F): ±1%, (G): ±2%, (K): ±10% (M): ±20% tolerance
 - CAPACITORS:
Indicated in capacity (μF)/voltage (V) unless otherwise noted μ: μF, indication without voltage is 50V except electrolytic capacitor.
 - VOLTAGE, CURRENT:
□ DC voltage (V) at no input signal
Value in () is DC voltage at rated power.
◁ mA: DC current at no input signal
 - OTHERS:
→ Signal route
⊙ Adjusting point
The Δ mark found on some component parts indicates the importance of the safety factor of the part. Therefore, when replacing, be sure to use parts of identical designation.
* marked capacitors and resistors have parts numbers.
- This is the basic schematic diagram, but the actual circuit may vary due to improvements in design.

- SWITCH & RELAY
- AF ASSEMBLY
 RY401 MUTING ON-OFF
 RY402,403 TONE ON-OFF
 RY404 FUNCTION CD-PHONO
 RY405 FUNCTION ON-OFF
 RY406 TAPE 1 ON-OFF
 RY407 ADAPTOR ON-OFF
 RY408 TAPE 2 ON-OFF
 RY409 OUTPUT ON-OFF
 RY561 LOUDNESS ON-OFF
- EQUALIZER ASSEMBLY
 RY101 MM-MC
 RY102 MM-MC
 RY103 MC40-MC3
 RY104 MM-MC
- OTHERS
 S1 POWER ON-OFF
- The underlined indicates the switch position.

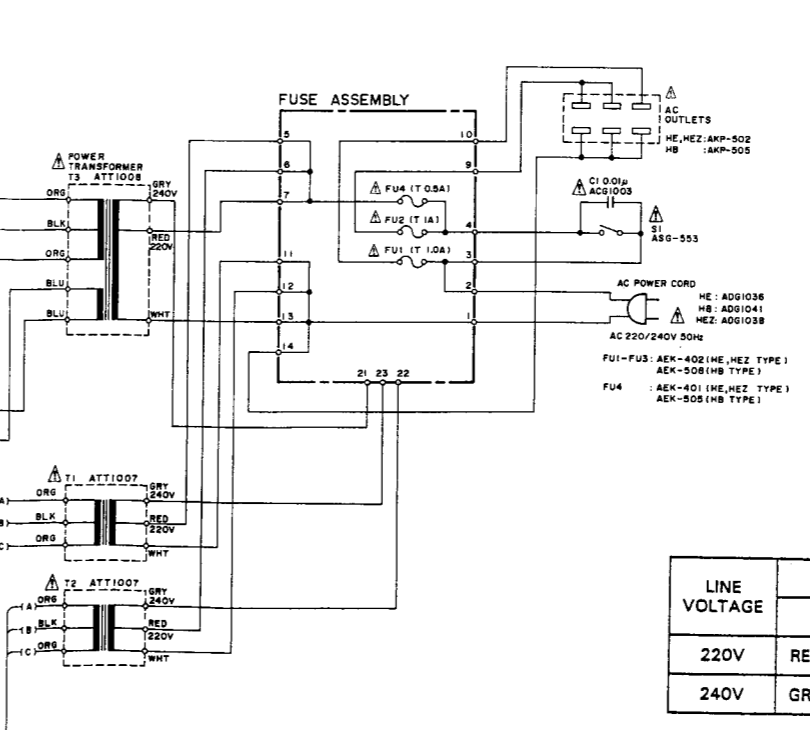
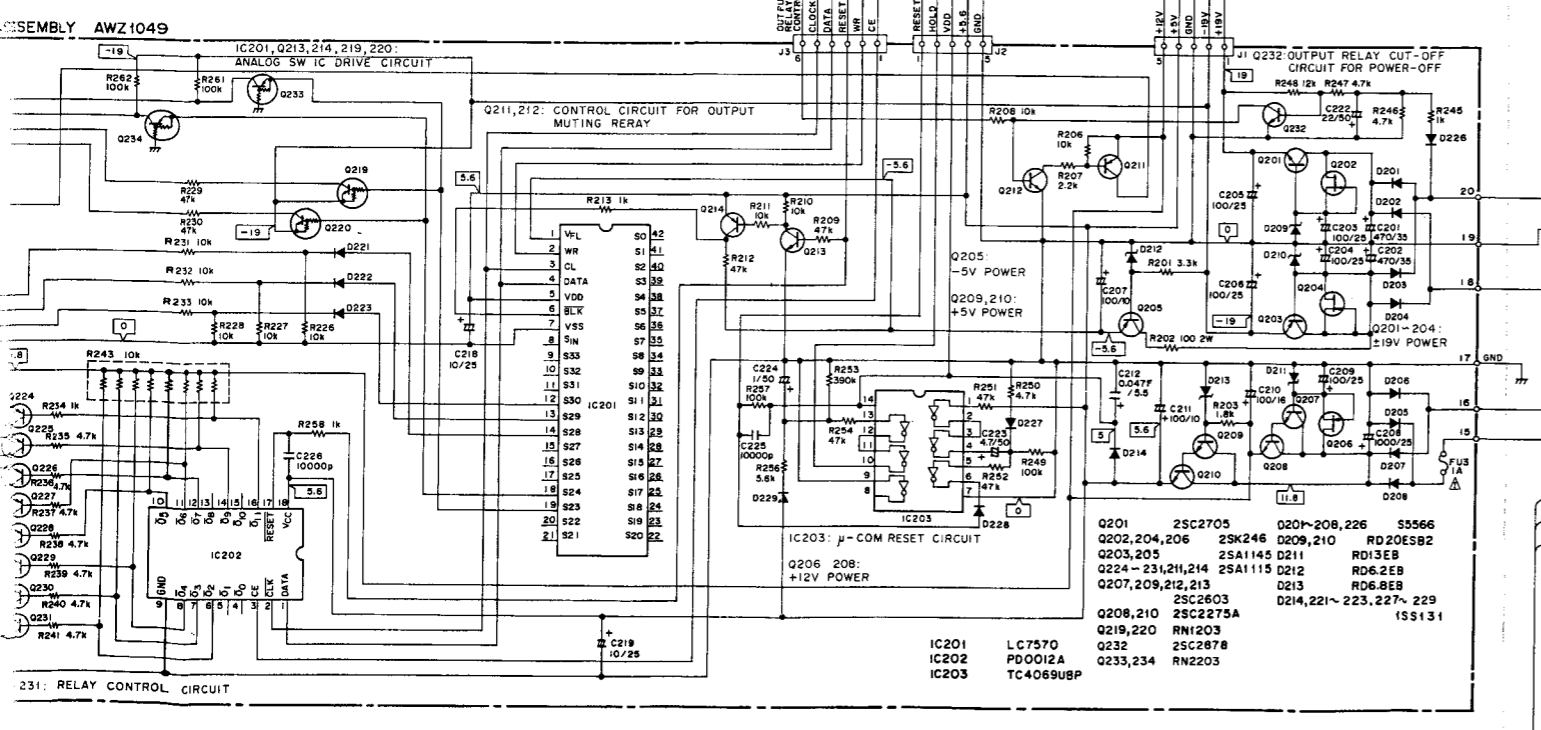

- Line voltage selection (FOR HE, HB and HEZ types)**
- Line voltage can be changed with following steps.
- Disconnect the AC power cord.
 - Remove the Bonnet case.
 - Change the connection of the power transformer lead wire.
- GRY T₁: Gray lead wire of transformer T₁
 - RED T₁: Red lead wire of transformer T₁
 - GRY T₂: Gray lead wire of transformer T₂
 - RED T₂: Red lead wire of transformer T₂
 - GRY T₃: Gray lead wire of transformer T₃
 - RED T₃: Red lead wire of transformer T₃

LINE VOLTAGE	Terminal numbers of FUSE assembly					
	5	6	7	21	22	23
220V	RED T ₁	RED T ₂	RED T ₃	GRY T ₃	GRY T ₂	GRY T ₁
240V	GRY T ₁	GRY T ₂	GRY T ₃	RED T ₃	RED T ₂	RED T ₁

4. Stick the line voltage label on the rear panel.

Part No.	Description
AAX-193	220V label
AAX-192	240V label

A

B

C

D

5. P.C.BOARDS CONNECTION DIAGRAM

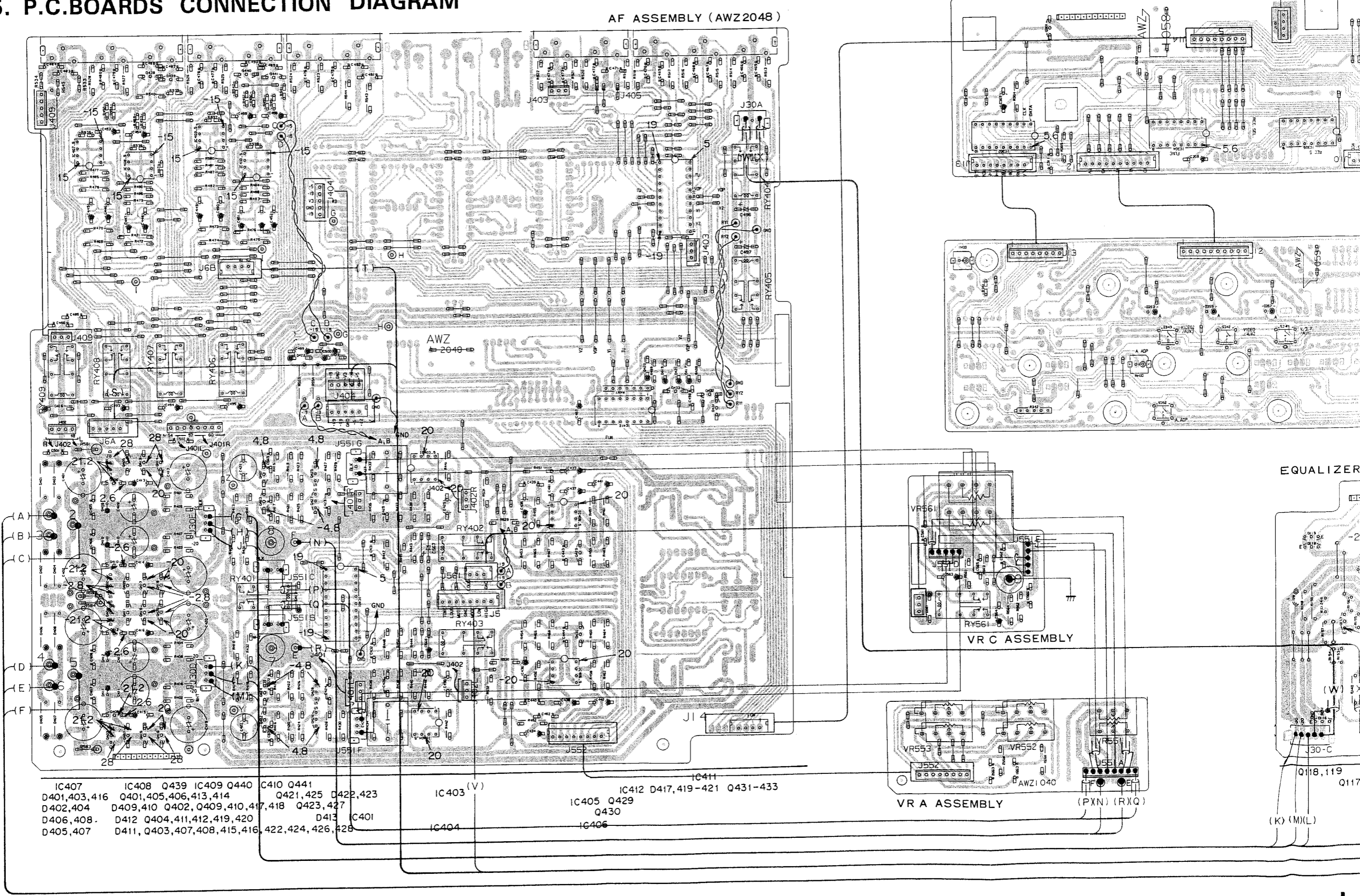

CONTROL ASSEMBLY (AWZ1058)

AF ASSEMBLY (AWZ2048)

EQUALIZER

- | | | | | | | | | |
|--------------|----------------------------|----------------------|------------------------|----------|------|------|-----------|--------------|
| IC407 | IC408 | Q439 | IC409 | Q440 | C410 | Q441 | IC403 (V) | IC411 |
| D401,403,416 | Q401,405,406,413,414 | | Q402, Q409,410,417,418 | Q423,427 | D413 | C401 | IC404 | IC412 |
| D406,408 | D412 | Q404,411,412,419,420 | | | | | | D417,419-421 |
| D405,407 | D411, Q403,407,408,415,416 | 422,424, 426, 428 | | | | | | Q431-433 |
| | | | | | | | | Q405 Q429 |
| | | | | | | | | Q430 |
| | | | | | | | | IC406 |

VR A ASSEMBLY (PXN) (RXQ)

A

B

C

D

1

2

3

4

5

6

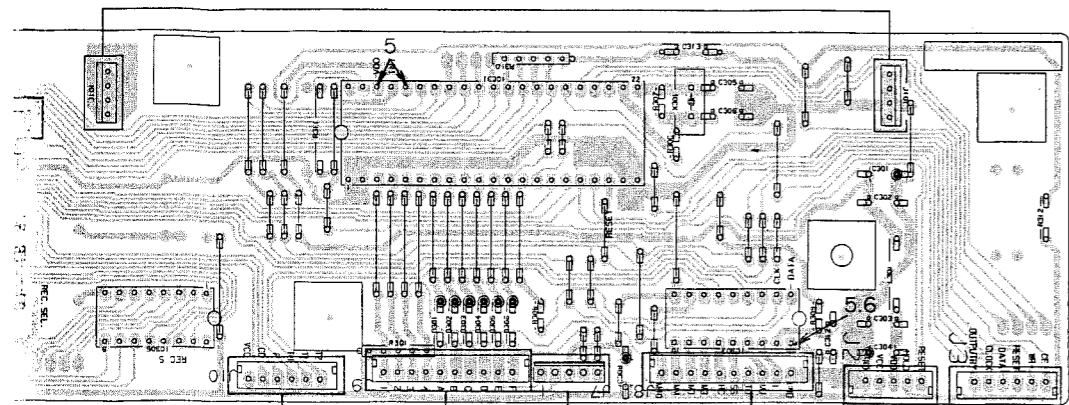

NOTE

- 1. This P.C.B. connection diagram is viewed from the parts mounted side.
- 2. The parts which have been mounted on the board can be replaced with those shown with the corresponding wiring symbols listed in the following Table.

P.C.B. pattern diagram indication	Corresponding part symbol	Part Name
		Transistor
		Resistor type transistor
		Diode

P.C.B. pattern diagram indication	Corresponding part symbol	Part Name
		Resistor
		Capacitor (Polarity)
		Capacitor (Non-polarity)

Others

P.C.B. pattern diagram indication	Part Name
IC	IC
S	Switch
RY	Relay
L	Coil
F	Filter
VR	Variable resistor or Semi-fixed resistor

- 3. The capacitor terminal marked with ⊕ (double circles) shows negative terminal.
- 4. The diode terminal marked with ⊕ (double circles) shows cathode side.
- 5. The transistor terminal to which E is affixed shows the emitter.

A

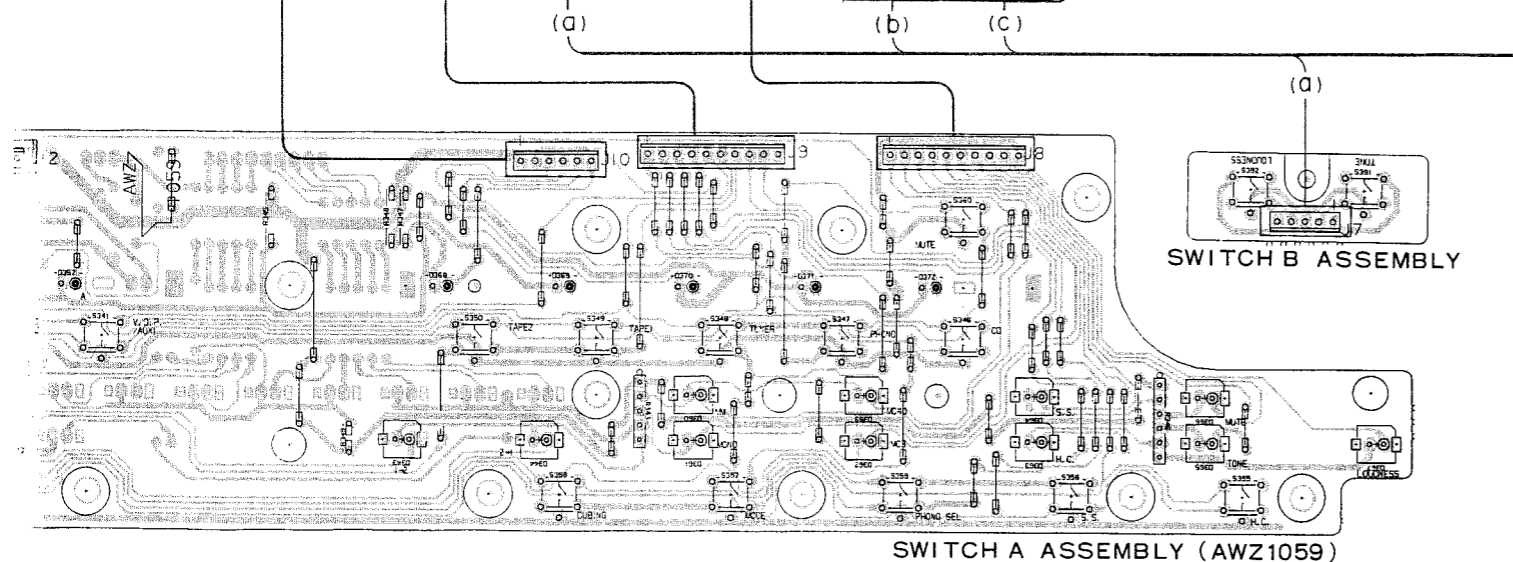

SWITCH A ASSEMBLY (AWZ1059)

SWITCH B ASSEMBLY

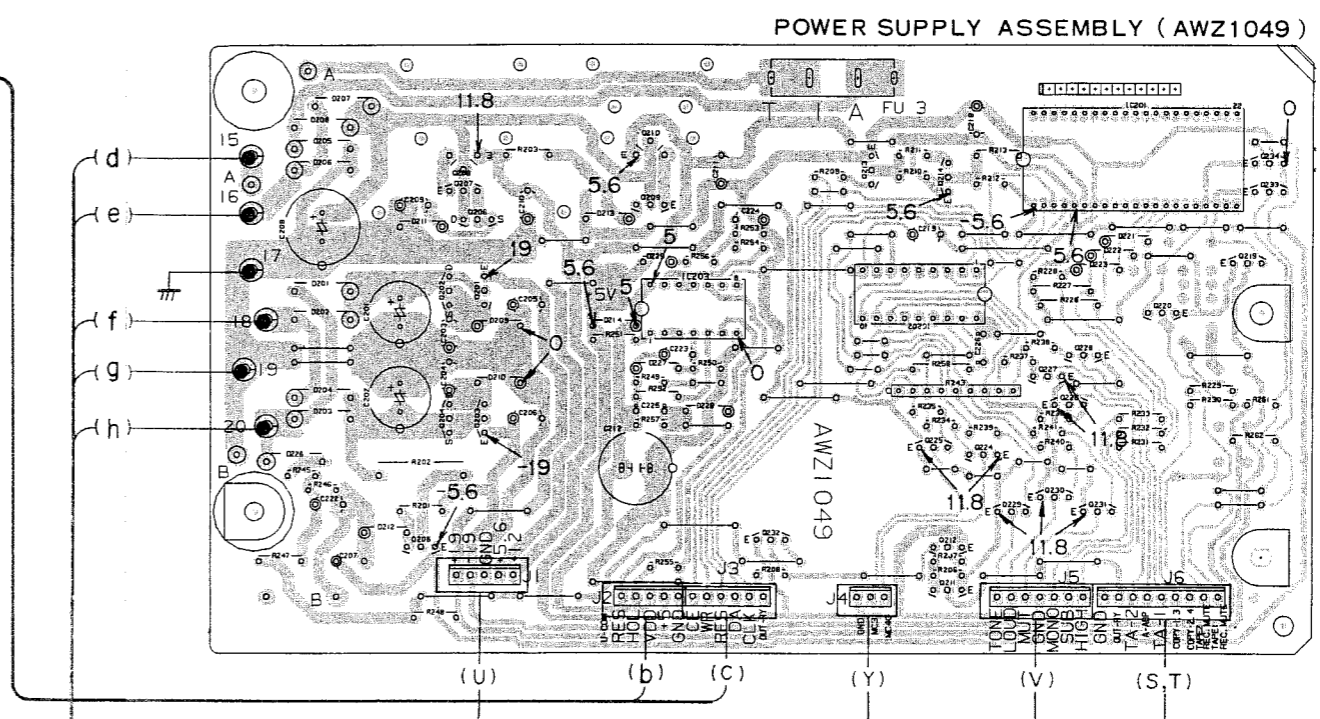

POWER SUPPLY ASSEMBLY (AWZ1049)

B

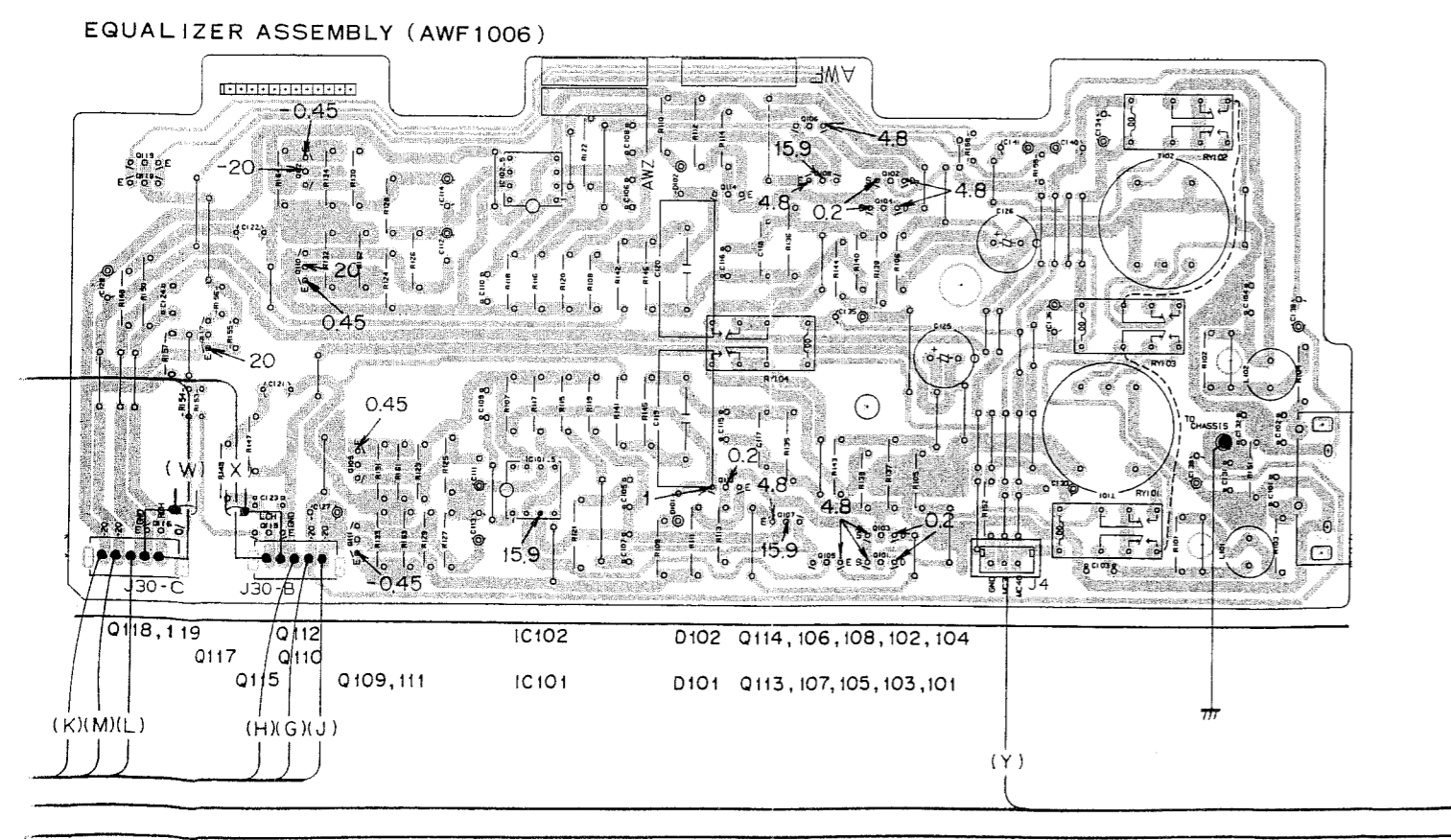

EQUALIZER ASSEMBLY (AWF1006)

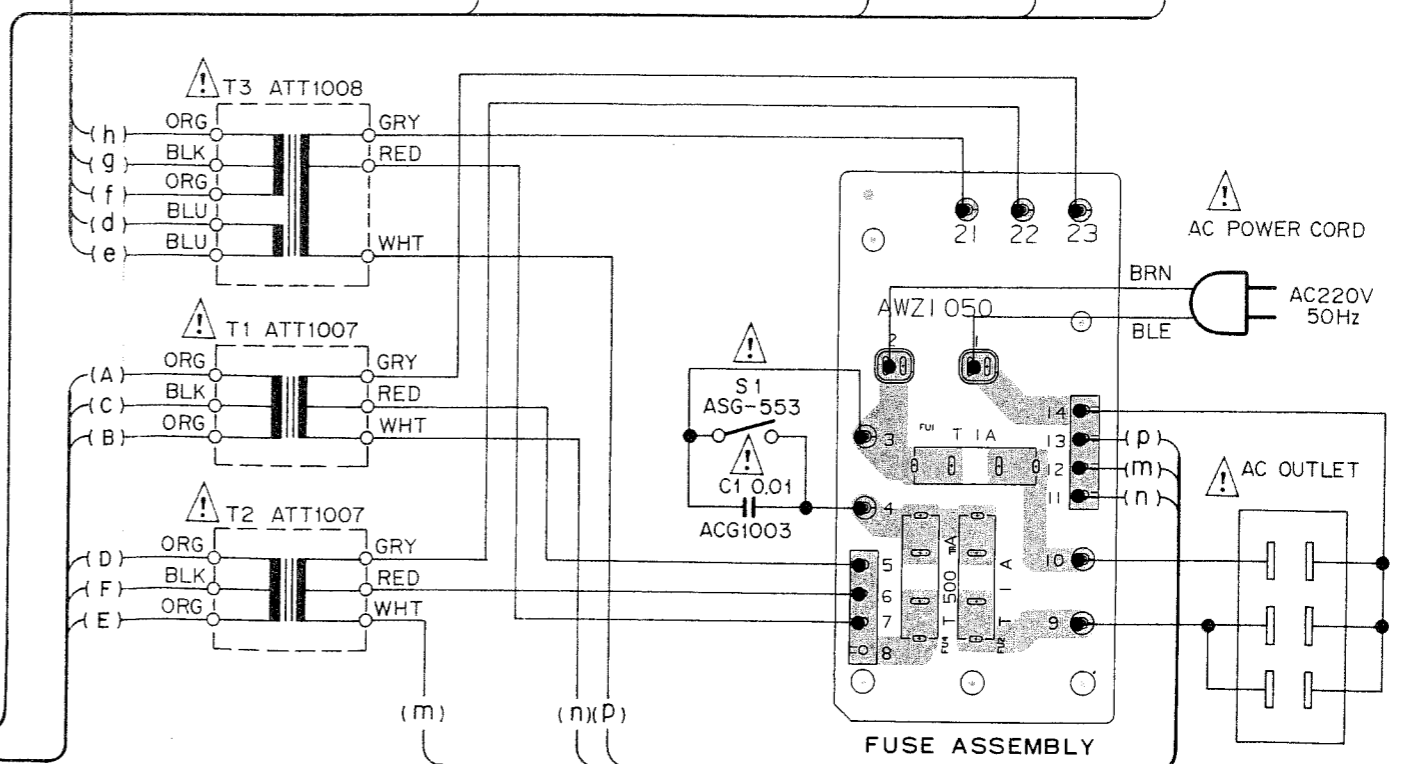

FUSE ASSEMBLY

C

D

NOTE:
This picture shows the foil side of the printed circuit.

A

POWER SUPPLY ASSEMBLY (AW21049)

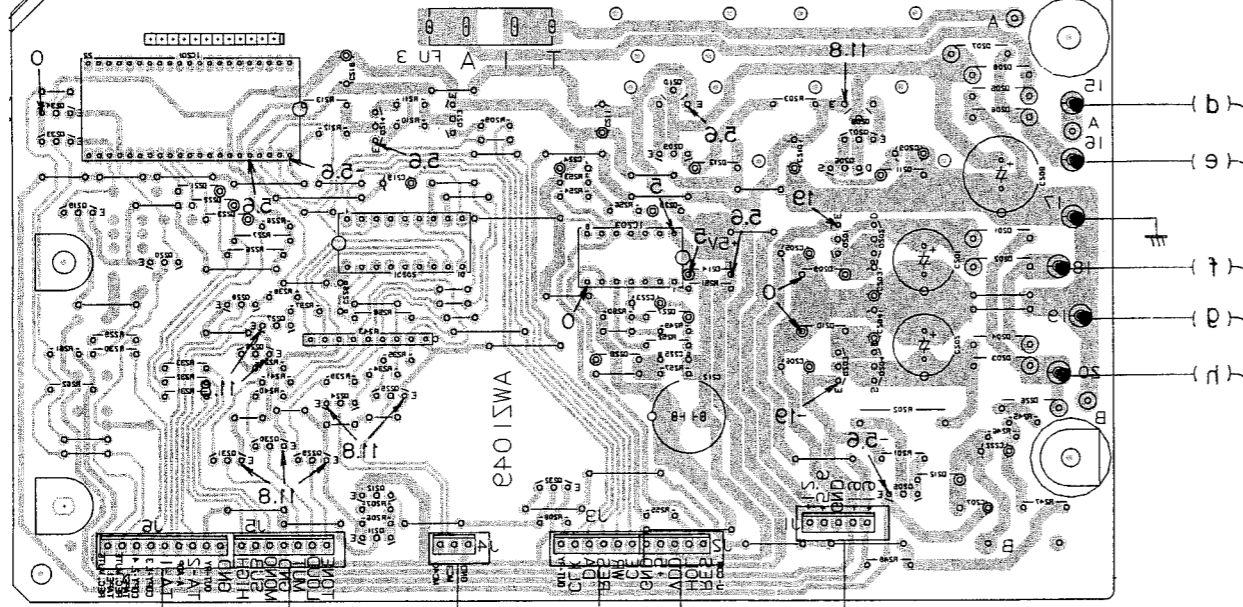

B

C

D

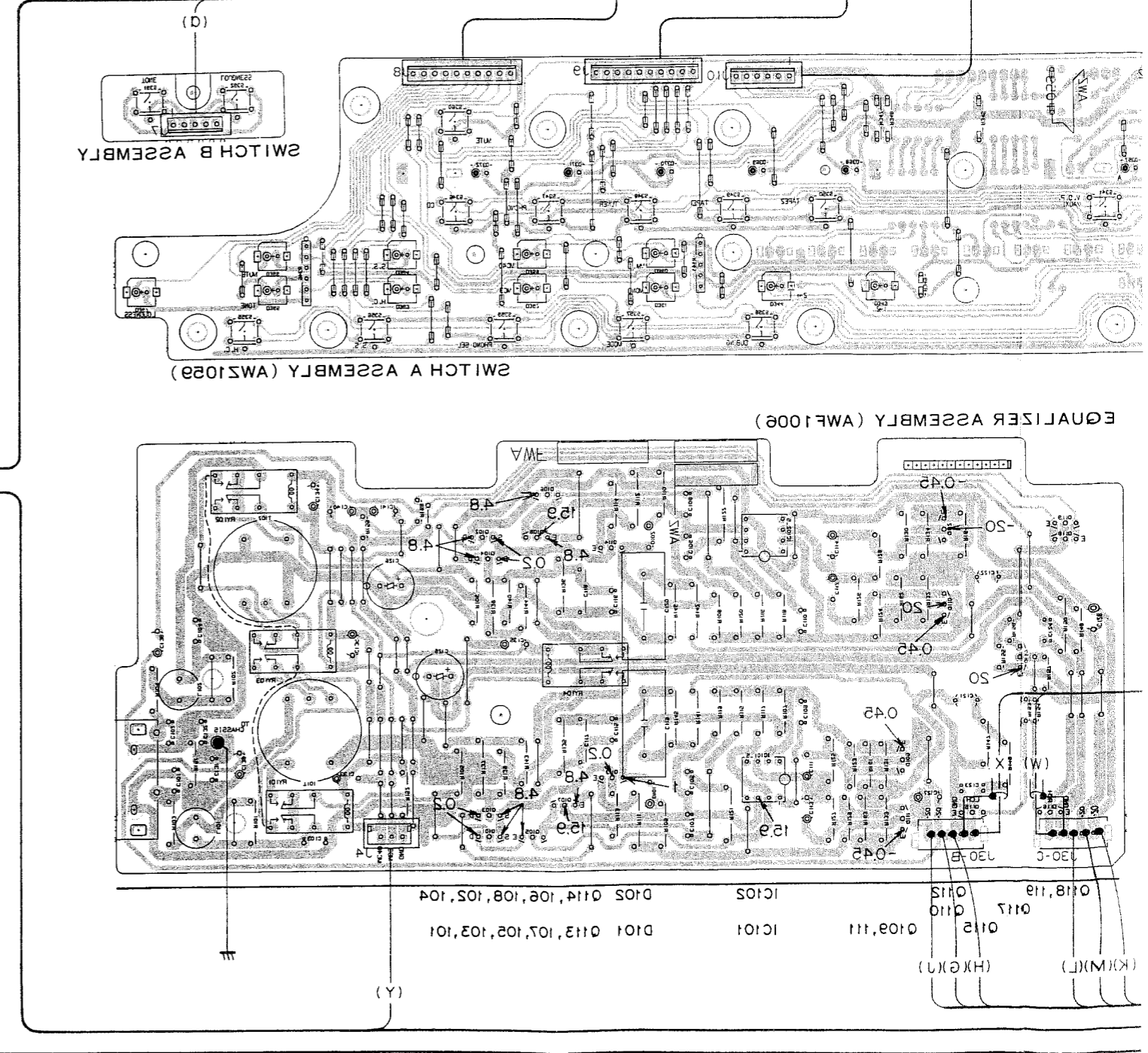
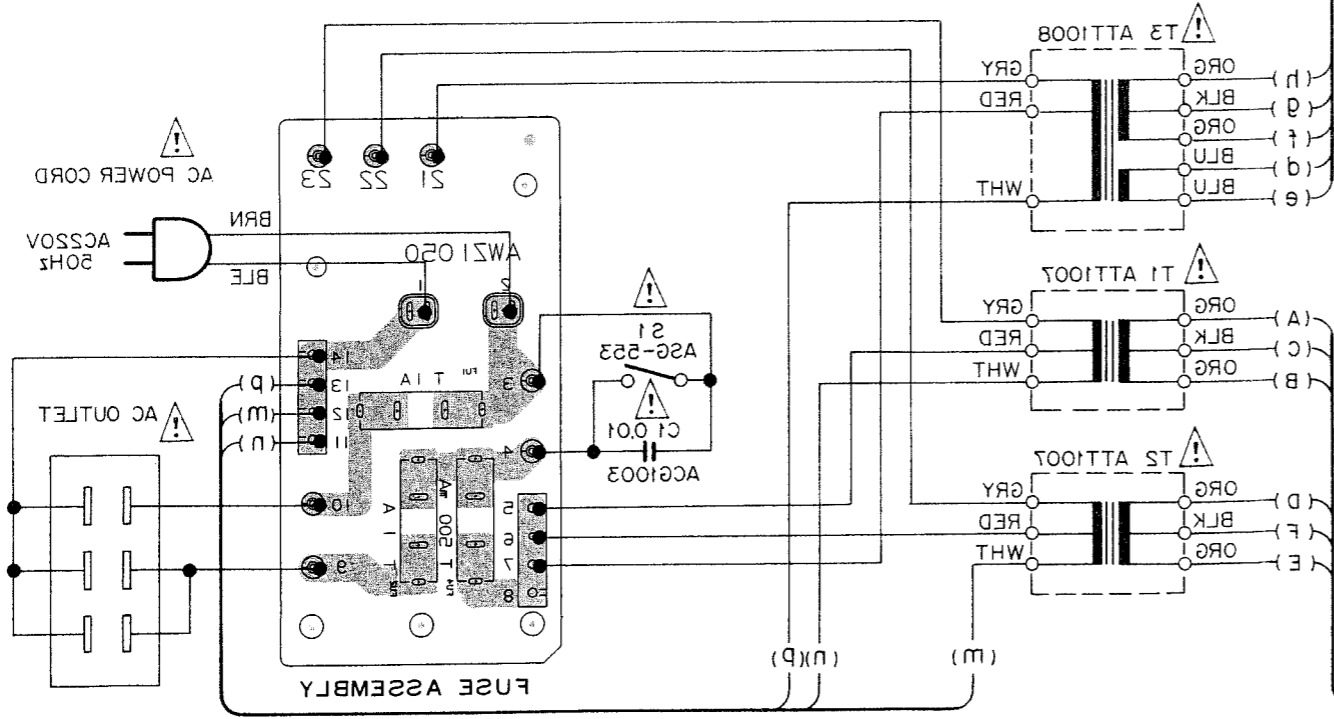

SWITCH A ASSEMBLY (AW21029)

SWITCH B ASSEMBLY

EQUALIZER ASSEMBLY (AWF1006)

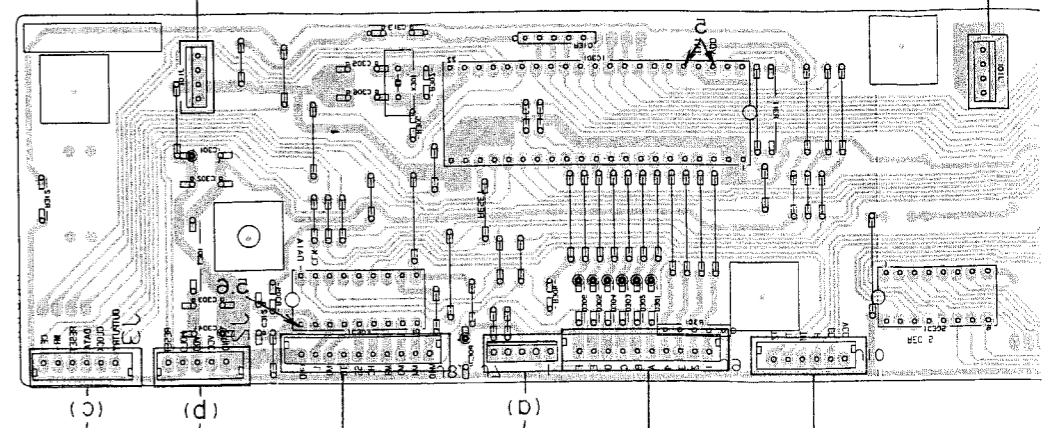

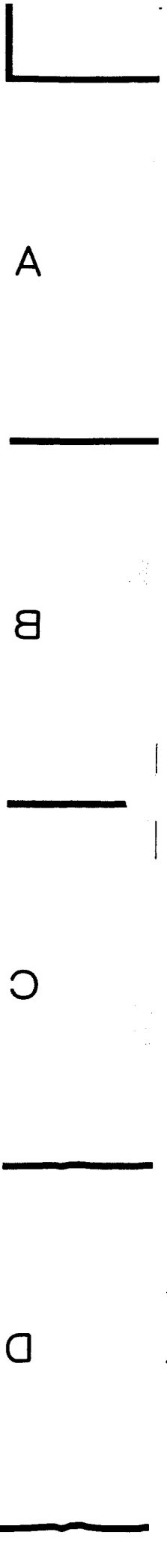

AF ASSEMBLY (WAZ5048)

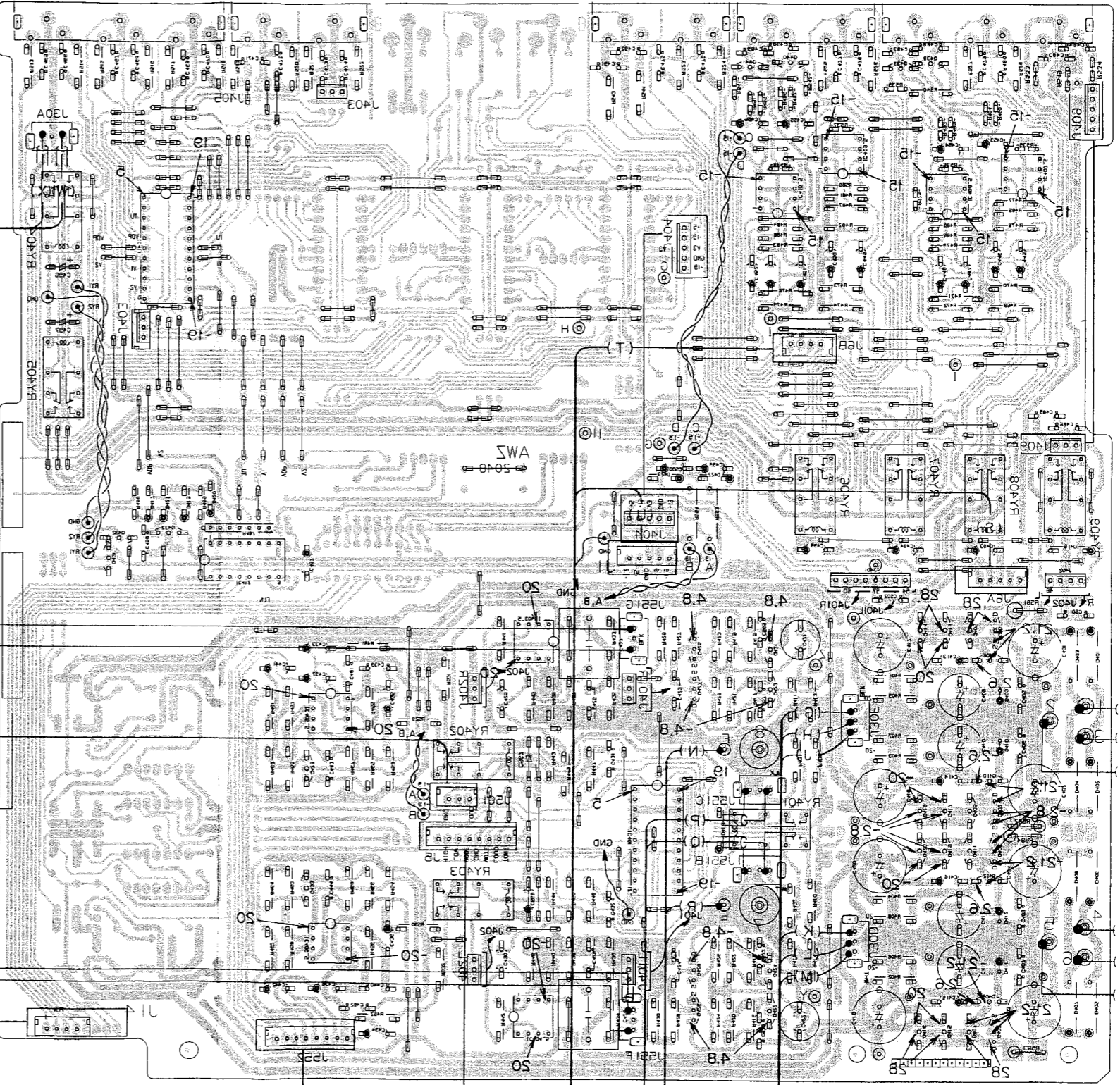

D402 402 D411 D403 403 404 405 406 407 408 409 410 411 412 413 414 415 416 417 418 419 420 421 422 423 424 425 426 427 428 429 430 431 432 433 434 435 436 437 438 439 440 441 442 443 444 445 446 447 448 449 450 451 452 453 454 455 456 457 458 459 460 461 462 463 464 465 466 467 468 469 470 471 472 473 474 475 476 477 478 479 480 481 482 483 484 485 486 487 488 489 490 491 492 493 494 495 496 497 498 499 500

CONTROL ASSEMBLY (WAZ1028)

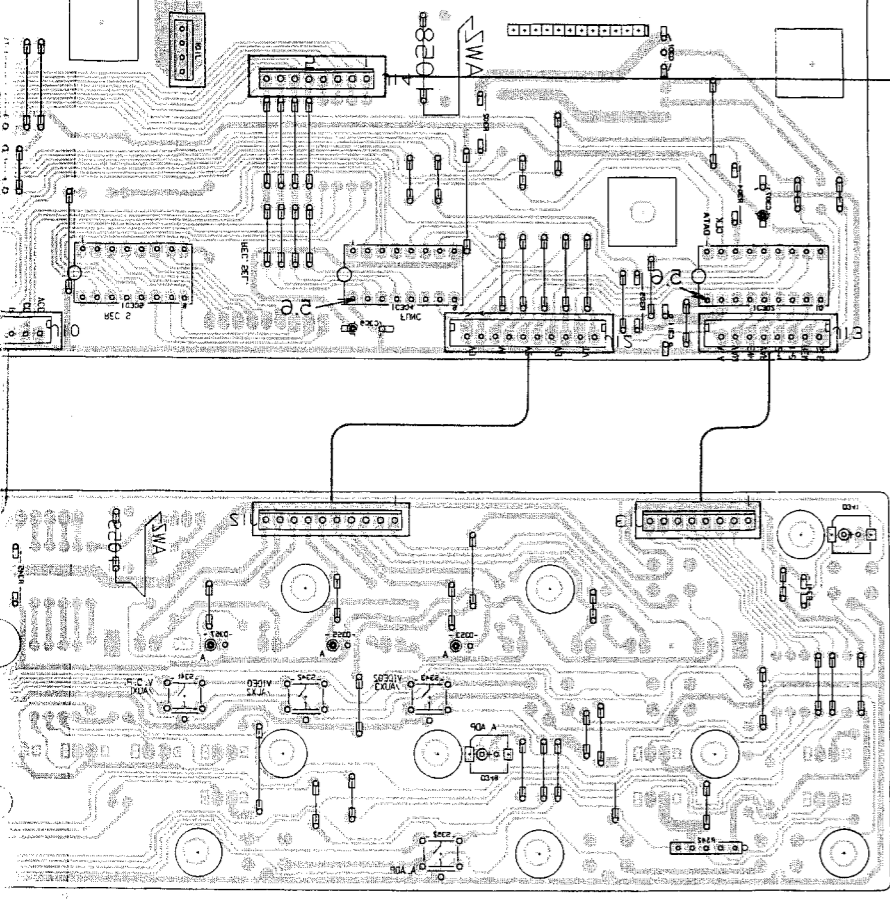

VR C ASSEMBLY

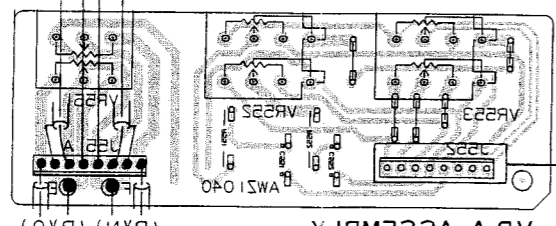

VR A ASSEMBLY

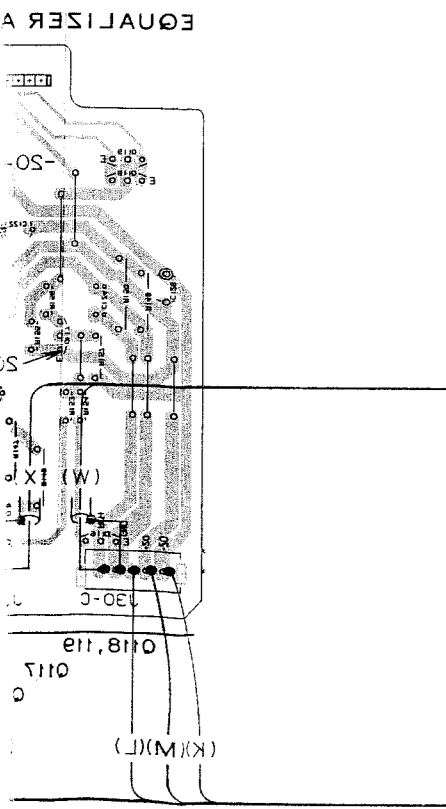

EQUALIZER A

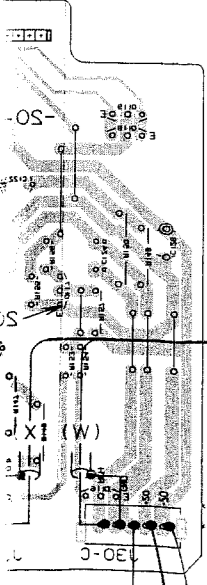

6. FOR HB AND HEZ TYPES

NOTES:

- Parts without part number cannot be supplied.
- The \triangle mark found on some component parts indicates the importance of the safety factor of the part. Therefore, when replacing, be sure to use parts of identical designation.
- Parts marked by "⊙" are not always kept in stock. Their delivery time may be longer than usual or they may be unavailable.

CONTRAST OF MISCELLANEOUS PARTS

The C-90a/HB and HEZ types are the same as the C-90a/HE type with the exception of the following sections.

Mark	Symbol & Description	Part No.			Remarks
		C-90a/ HE type	C-90a/ HB type	C-90a/ HEZ type	
\triangle	AC power cord	ADG1036	ADG1041	ADG1038	
\triangle	AC Socket (OUTLET)	AKP-502	AKP-505	AKP-502	
\triangle	Fuse (T1A/250V, FU1-FU3)	AEK-402	AEK-508	AEK-402	
\triangle	Fuse (T500mA/250V, FU4)	AEK-401	AEK-505	AEK-401	
	Screw	ABA-115	
	Operating Instruction (8-language)	ARE1099	
	Operating instruction (English)	ARB1141	
	Operating Instruction (German)	ARC1114	

7. PANEL FACILITIES

FRONT PANEL

POWER switch/indicator

Press this switch to turn this unit's power ON/OFF. When you switch the unit ON, the muting function will be activated, and the indicator will flash. Once the flashing indication changes to a steady indication, the unit will operate normally.

VOLUME control

Use to adjust the sound volume. At the [∞] position, sound will not be heard, while at the [0] position, sound volume will be at its maximum.

INPUT SELECTOR switch/indicator

Use to select playback audio components (indicator lights).

- [CD]— Compact disc player.
- [Phono]— Stereo turntable.
- [Tuner]— Tuner for listening to FM/AM broadcasts.
- [TAPE 1]— The tape deck connected to the rear panel Tape 1 terminals.
- [TAPE 2]— The tape deck connected to the rear panel Tape 2 terminals.
- [AUX 1]— The audio component connected to the rear panel AUX 1 terminals.
- [AUX 2]— The audio component connected to the rear panel AUX 2 terminals.
- [AUX 3]— The audio component connected to the rear panel AUX 3 terminals.

MUTING switch/indicator

Use to temporarily -20 dB audio signals. When this switch is pressed so that the indicator lights, the muting circuit operates to reduce the level of all audio signals by 20 dB. When set to the OFF position, the volume is returned to its previous level.

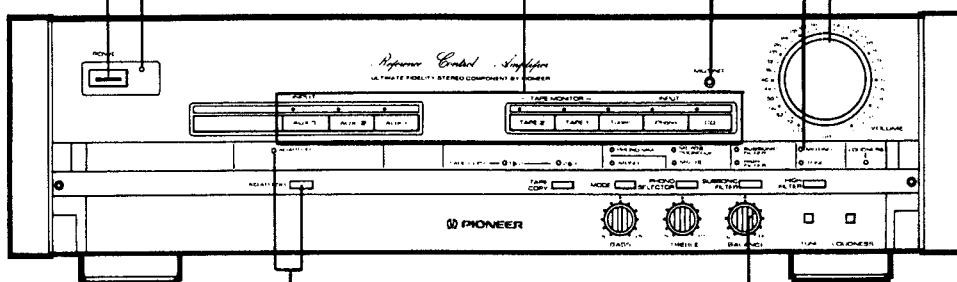

ADAPTOR switch/indicator

Normally, set this switch OFF. Set to ON when using a surround processor or graphic equalizer connected to the rear panel adaptor terminals ADAPTOR IN/OUT.

BALANCE control

Normally, leave in the center position; use it to adjust the right-left sound volume when it seems to be unevenly balanced. When the sound is too loud on the right side, turn the control in the LEFT direction; when too loud on the left side, turn the control in the RIGHT direction.

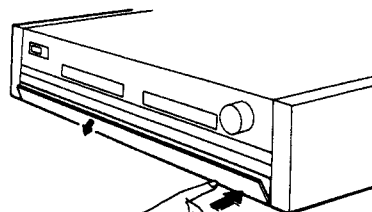

Method of opening cover

TAPE COPY switch/indicator

Use this switch when you are using two tape decks and copying one tape to another tape.

[1 ► 2]— When copying a tape in the tape deck connected to the TAPE 1 PLAY terminals to the tape deck connected to the TAPE 2 REC terminals.

[2 ► 1]— When copying a tape in the tape deck connected to the TAPE 2 PLAY terminals to the tape deck connected to the TAPE 1 REC terminals.

HIGH FILTER switch/indicator

When this switch is pressed to the ON position, the indicator lights and a high-cut filter (cutoff frequency 10 kHz) is activated.

PHONO SELECTOR switch/indicator

Set in accordance with the type of cartridge used on your turntable (the corresponding indicator will light).

[MM]— Set here when using a moving magnet cartridge, or a high-output (1mV or more) moving coil (MC) cartridge.

[MC 40 Ω]— Set here when using a moving coil cartridge with impedance of 40 Ω.

[MC 3 Ω]— Set here when using a MC cartridge with impedance of 3 Ω.

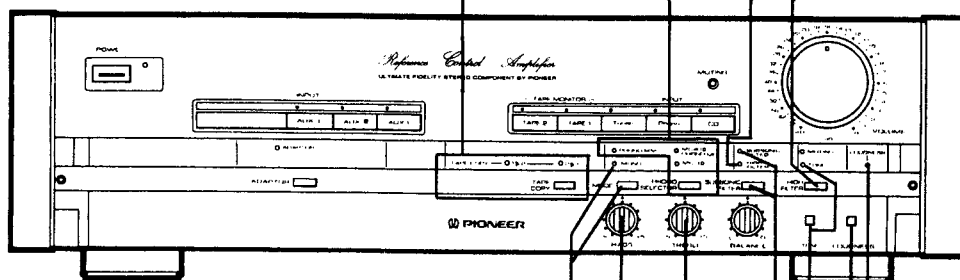
**MODE switch/indicator**

Use to select the stereo or monaural audio playback mode. Normally, this switch is not used.

When the monaural playback mode is selected, press this switch; the MODE MONO indicator will light.

SUBSONIC FILTER switch/indicator

When this switch is pressed to the ON position, the indicator lights and a subsonic filter (cutoff frequency 7 Hz) is activated. Use to remove low-frequency noise due to warped records, etc.

Tone controls

These controls can be used only when the TONE indicator is lighted.

[BASS]— Use to adjust low-frequency sounds. The center indicates the standard (flat) position. When the control is rotated to the right, low-frequency sounds are augmented; when rotated to the left, low-frequency sounds are attenuated.

[TREBLE]— Use to adjust high-frequency sounds. The center indicates the standard (flat) position. When the control is rotated to the right, high-frequency sounds are augmented; when rotated to the left, high-frequency sounds are attenuated.

TONE switch/indicator

[ON]— The TONE indicator lights, and audio inputs from all components are played back after passing through the tone control circuits. In this condition, the tone controls (BASS, TREBLE) can be used to adjust sound quality.

[OFF]— The TONE indicator goes out, and signals are played back without passing through the tone control circuits.

LOUDNESS switch/indicator

Use this switch when you wish to listen at low volume. Normally, leave it OFF.

When you turn this switch ON (indicator lights), the bass and treble will be accentuated, providing dynamic reproduction even at low volume.

REAR PANEL

NOTE:

The PHONO terminals are provided with shorting pin plugs (two). Before connecting equipment to these terminals, therefore, remove the shorting pin plugs and insert them into unused INPUT terminals.

Ground (GND) terminal

Connect to the ground terminal of your turntable.

Playback component terminals

- [PHONO]— Stereo turntable
- [CD]— Compact disc player
- [TUNER]— Tuner
- [AUX 1] } Auxiliary terminals
- [AUX 2] }
- [AUX 3] }

ADAPTOR terminals

Use to connect a surround processor, graphic equalizer, or PCM adaptor.

OUTPUT terminals

Connect to the control amplifier input terminals of power amplifier.

Tape deck terminals

- [TAPE 1]— Tape deck 1 (first deck)
 - PLAY: For playback (connect to the tape deck's PLAY terminals)
 - REC: For recording (connect to the tape deck's REC terminals)
- [TAPE 2]— Tape deck 2 (second deck)

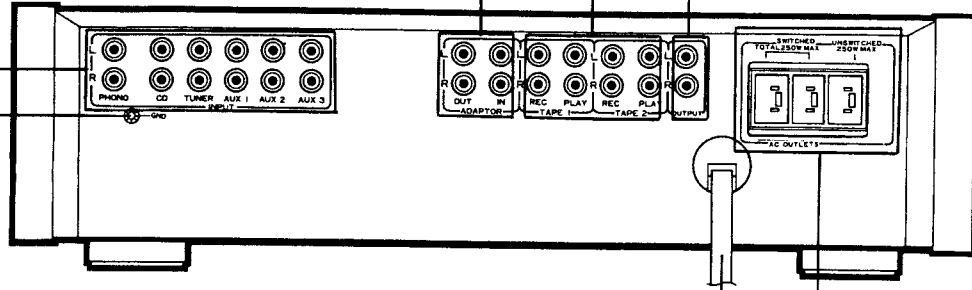

Power cord

Connect to a household wall outlet, or the power outlet of an audio timer.

AC OUTLETS (SWITCHED)

Power supplied through these outlets is turned on and off by this equipment's POWER switch. Total electrical power consumption of connected equipment should not exceed 250 W.

AC OUTLETS (UNSWITCHED)

Power flows continually to this outlet, regardless of whether this equipment is switched ON or OFF. Electrical power consumption of connected equipment should not exceed 250 W.

The equipment should be disconnected by removing the mains plug from the wall socket when not in regular use, e.g. when on vacation.

NOTE:
Do not connect appliances with high power consumption such as heaters, irons, or television sets to the AC OUTLETS in order to avoid overheating or fire risk.
This can cause this equipment to malfunction.

NOTE:

Do not connect appliances with high power consumption such as heaters, irons, or television sets to the AC OUTLETS in order to avoid overheating or fire risk.

This can cause this equipment to malfunction.

8. SPECIFICATIONS

Amplifier section

Maximum output level	
20 Hz—20 kHz, 0.01%	8 V
Harmonic distortion	
20 Hz—20 kHz, 1 V	0.002%
Intermodulation distortion (50 Hz:7 kHz = 4:1)	
1 V	0.002%
Input terminals (sensitivity/impedance)	
PHONO MM	2.5 mV/50 k Ω
PHONO MC	250 μ V/40 Ω
	125 μ V/3 Ω
TUNER, CD, TAPE PLAY, ADAPTOR	150 mV/50 k Ω
Output terminals (output level/output impedance)	
TAPE REC	150 mV/1 k Ω
OUTPUT	1 V/600 Ω
Frequency response	
PHONO MM 20 Hz—20 kHz	\pm 0.2 dB
TUNER, CD, AUX, 20 Hz—20 kHz	+0 dB
	-0.2 dB
Tone control	
BASS	\pm 9 dB, 100 Hz
TREBLE	\pm 9 dB, 10 kHz
Filter	
LOW (SUBSONIC)	7 Hz, 6 dB/oct
HIGH	10 kHz, 6 dB/oct
MUTING	-20 dB
SN ratio (short-circuit, A network)	
PHONO MM	96 dB (5 mV)
PHONO MC	86 dB (500 μ V)
TUNER, CD, TAPE PLAY, ADAPTOR	109 dB

Power section, etc.

Power requirements	AC 240 V~, 50/60 Hz
Power consumption	26 W
AC outlets	
Linked to power switch (x2)	250 W
Unlinked to power switch (x1)	250 W
External dimensions ...	457 (W) \times 404 (D) \times 133 (H) mm.
Weight	9.0 kg

Accessories

Operating Instructions	1
Pin-plug cord	1

The specifications and appearance noted above may change without notice due to improvements.

MAINTENANCE OF EXTERNAL SURFACES

- Use a polishing cloth or dry cloth to wipe off dust and dirt.
- When the surfaces are very dirty, wipe with a soft cloth dipped in some neutral cleanser diluted five or six times with water, and then wipe again with a dry cloth. Do not use furniture wax or cleaners.
- Never use thinners, benzene, insecticide sprays and other chemicals on or near this unit, since these will corrode the surfaces.

Precautions for installation

To ensure optimum sound quality, observe the following precautions.

- This unit is heavy. Be sure to install it on a firm base which can support its weight. Also, to prevent the flow of cooling air from being blocked off, do not place the unit on soft material such as a carpet or cushion, or install it in a confined space. When installing the unit in a rack, provide adequate space around it to allow heat to dissipate.
- To prevent the control amplifier from picking up noise due to leakage flux from the power amplifier when the control amplifier and power amplifier are installed adjacent to each other, install the control amplifier on the right of the power amplifier. Also, if you install the control amplifier above or below the power amplifier, place a partition between them to separate them by at least 10 cm from each other.
- Install the unit on a level surface so that the feet of the unit are all touching the installation surface.