

# Service Manual

 **PIONEER**<sup>®</sup>  
The Art of Entertainment

ORDER NO.  
RRV1615

CD AUTO CHANGER

# CAC-V180M

- Refer to the service manuals RRV1085 for CAC-V180M/WEM and ARP2122 for CJ-V50 and PD-MV55.

THIS MANUAL IS APPLICABLE TO THE FOLLOWING MODEL(S) AND TYPE(S).

Type	Model	Power Requirement	Remarks
	CAC-V180M		
WEM8	○	AC220-240V	

## CONTRAST OF MISCELLANEOUS PARTS

### NOTES:

- Parts marked by "NSP" are generally unavailable because they are not in our Master Spare Parts List.
- The  $\Delta$  mark found on some component parts indicates the importance of the safety factor of the parts. Therefore, when replacing, be sure to use parts of identical designation.
- Parts marked by "⊙" are not always kept in stock. Their delivery time may be longer than usual or they may be unavailable.

### ■ CONTRAST OF CAC-V180M/WEM8 AND CAC-V180M/WEM

CAC-V180M/WEM8 and CAC-V180M/WEM have the same construction except for the following:

Mark	Symbol & Description	Part No.		Remarks
		CAC-V180M/WEM	CAC-V180M/WEM8	
NSP	Earth Lug Assy	Not used	DDX1002	Attach to DEGT
NSP	Insulation Plate A	DEC1209	Not used	
	Shield Sheet	Not used	DEC1952	
NSP	Ferrite Clamp	Not used	DTH1177	
NSP	CE Mark Label	Not used	RRW1222	
NSP	Spacer	Not used	VEC-244	

**PIONEER ELECTRONIC CORPORATION** 4-1, Meguro 1-Chome, Meguro-ku, Tokyo 153, Japan  
**PIONEER ELECTRONICS SERVICE, INC.** P.O. Box 1760, Long Beach, CA 90801-1760, U. S. A.  
**PIONEER ELECTRONIC (EUROPE) N.V.** Haven 1087 Keetberglaan 1, 9120 Melsele, Belgium  
**PIONEER ELECTRONICS ASIACENTRE PTE. LTD.** 501 Orchard Road, #10-00 Lane Crawford Place, Singapore 0923  
**© PIONEER ELECTRONIC CORPORATION 1996**

T-SZE MAY 1996 Printed in Japan

# Service Manual

ORDER NO.  
RRV1085

CD AUTO CHANGER

# CAC-V180M

- Refer to the service manual ARP2122 for CJ-V50 and PD-MV55.

THIS MANUAL IS APPLICABLE TO THE FOLLOWING MODEL(S) AND TYPE(S).

Type	Model	Power Requirement	Remarks
	CAC-V180M		
WEM	○	AC220-240V	

- Parts of the exploded views in the Exterior section and packing are all mentioned in this manual.
- The electrical parts are mentioned by the contrast table in this manual.

## CONTENTS

1. SAFETY INFORMATION.....	2
2. CONTRAST TABLE OF ELECTRICAL PARTS.....	3
3. EXPLODED VIEW, PACKING AND PARTS LIST.....	13
4. BLOCK DIAGRAM.....	16

# 1. SAFETY INFORMATION

(FOR EUROPEAN MODEL ONLY)

**VARO!**  
AVATTAESSA JA SUOJALUKITUS OHITETTAESSA OLET ALTTIINA NÄKYMÄTTÖMÄLLE LASERSATEILYLLE. ÄLÄ KATSO SÄTEESEEN.



LASER  
Kuva 1  
Lasersateilyn varoitusmerkki

**WARNING!**  
DEVICE INCLUDES LASER DIODE WHICH EMITS INVISIBLE INFRARED RADIATION WHICH IS DANGEROUS TO EYES. THERE IS A WARNING SIGN ACCORDING TO PICTURE 1 INSIDE THE DEVICE CLOSE TO THE LASER DIODE.



LASER  
Picture 1  
Warning sign for laser radiation

**ADVERSEL:**  
USYNLIG LASERSTRÅLING VED ÅBNING NÅR SIKKERHEDSAFBRYDERE ER UDE AF FUNKTION UDGÅ UDSÆTTELSE FOR STRÅLING.

**IMPORTANT**  
THIS PIONEER APPARATUS CONTAINS LASER OF CLASS 1. SERVICING OPERATION OF THE APPARATUS SHOULD BE DONE BY A SPECIALLY INSTRUCTED PERSON.

**VARNING!**  
OSYNLIG LASERSTRÅLNING NÅR DENNA DEL ÄR ÖPPNAD OCH SPÄRREN ÄR URKOPPLAD. BETRAKTA EJ STRÅLEN.

**LASER DIODE CHARACTERISTICS**  
MAXIMUM OUTPUT POWER: 5 mw  
WAVELENGTH: 780-785 nm

## LABEL CHECK

WEM type



WEM type

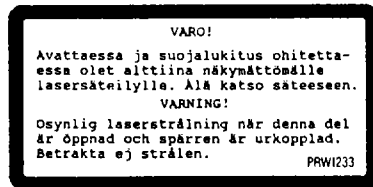

WEM type

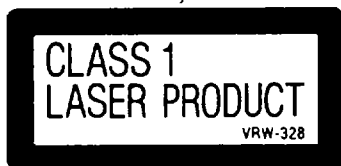
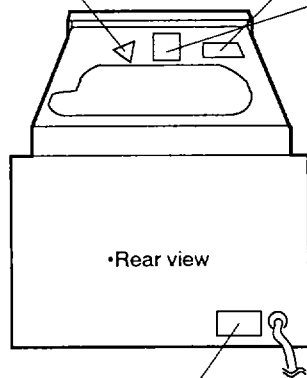
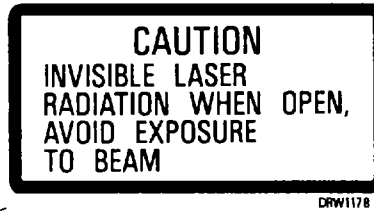

WEM type

Additional Laser Caution

1. The player microcomputer checks the inserting condition of magazines A, B and C by using the combined signals of the SENS1 (S804), SENS2 (S805), SENS3 (S806), LOCK1 (S801), LOCK2 (S802) and LOCK3 (S803) switches. It is after these three magazines are fully inserted that commands from the control microcomputer are accepted. The laser diode is turned ON for illumination by outputting the laser diode ON signal from the control microcomputer when the CLAMP switch (S1001) (DSK1001), which signals that the tray is to be pulled from the magazine and detects clamping condition, is set to ON and the player receives the "rising command" in the disc clamping condition. If no disc is available, it turns OFF after 20 seconds. The illuminated laser diode goes out when receiving a "Reject command", a "disc change command" or a "magazine eject command." The laser diode continues to oscillate when pin ② of CXA1081 (IC1) is connected to GND or to pin ③.
2. If the fault condition described in 1 is induced with the cover open and with the servo mechanism block removed to be turned over, close viewing of the objective lens with the naked eye will cause exposure to a class 1 laser beam.

## 2. CONTRAST TABLE OF ELECTRICAL PARTS

### NOTES:

- Parts marked by "NSP" are generally unavailable because they are not in our Master Spare Parts List.
- The  $\Delta$  mark found on some component parts indicates the importance of the safety factor of the part. Therefore, when replacing, be sure to use parts of identical designation.
- Parts marked by "⊙" are not always kept in stock. Their delivery time may be longer than usual or they may be unavailable.
- When ordering resistors, first convert resistance values into code form as shown in the following examples.
  - Ex.1 When there are 2 effective digits(any digit apart from 0), such as 560 ohm and 47k ohm(tolerance is shown by J=5%, and K=10%).
    - 560  $\Omega$   $\rightarrow$  56  $\times$  10<sup>1</sup>  $\rightarrow$  561..... RD1/8PM 561J
    - 47k  $\Omega$   $\rightarrow$  47  $\times$  10<sup>3</sup>  $\rightarrow$  473..... RD1/4PS 473J
    - 0.5  $\Omega$   $\rightarrow$  0R5..... RN2H 0R5K
    - 1  $\Omega$   $\rightarrow$  010..... RS1P 010K
  - Ex.2 When there are 3 effective digits(such as in high precision metal film resistors).
    - 5.62k  $\Omega$   $\rightarrow$  562  $\times$  10<sup>1</sup>  $\rightarrow$  5621..... RN1/4PC 5621F

### 2.1 CONTRAST TABLE OF ELECTRICAL PARTS

CAC - V180M/WEM and PD - MV55/WEM have the same construction except for the following :

Mark	Symbol & Description	Part No.		Remarks
		PD - MV55/WEM	CAC - V180M/WEM	
NSP	EKEY	DWS1103	Not used	* 1
	EKEY	Not used	DWS1197	
	DEGT	DWX1116	DWX1485	
⊙	ANLG	DWX1155	Not used	
	ANLG	Not used	DWX1486	
NSP	DJAK	DWX1118	Not used	* 1, * 2
NSP	PJAK	DWX1119	Not used	
NSP	RMJB	DWX1134	Not used	
	RSJB	Not used	DWX1530	
$\Delta$	AC power cord	DDG1038	PDG1003	* 2
$\Delta$	Power switch	Not used	DSA1017	
$\Delta$ NSP	Connection assembly	Not used	DKP2933	* 2

\* 1 : Refer to "2.2 PCB PARTS LIST".

\* 2 : Refer to "3.1 EXTERIOR SECTION".

#### ● DEGT

DWX1485 and DWX1116 have the same construction except for the following :

Mark	Symbol & Description	Part No.		Remarks
		DWX1116	DWX1485	
	C81	CKDYF103Z50	CKCYF103Z50	* 3
	J4 Grounding wire	Not used	XDF-511	

\* 3 : Refer to "2.3.1 OVERALL WIRING DIAGRAM".

#### ● ANLG

DWX1486 and DWX1155 have the same construction except for the following :

Mark	Symbol & Description	Part No.		Remarks
		DWX1155	DWX1486	
$\Delta$	L201 Filter	VTL-157	VTL-004	* 4
	C201, C202 (10000pF/400V)	RCG-009	VCG-048	
	C228, C229	Not used	CKPUYF473Z50	
NSP	CN207 Connector	Not used	B3B-PH-K-K	* 4
	J5, J6 Grounding wire	Not used	XDF-511	* 3
NSP	J201 Connector assembly	PA06SN-R10	PA06SN-R12	* 3
$\Delta$ NSP	CN601 Connector assembly	Not used	DKP2932	
NSP	Terminal for power supply	VKC-019	Not used	

\* 3 : Refer to "2.3.1 OVERALL WIRING DIAGRAM".

\* 4 : Refer to "2.3.3 ANLG".

Mark No.	Description	Part No.
----------	-------------	----------

**2.2 PCB PARTS LIST**

**LIST OF ASSEMBLIES**

NSP	IFJB UNIT	DWM1441
	└ EKEY	DWS1197
	└ RSJB	DWX1530

**EKEY**

**SEMICONDUCTOR**  
D601

SLC- 22VR35H3

**SWITCHES**

S601 - S603

DSG1009

**RSJB**

**SEMICONDUCTORS**

	IC501	HD151232P
△	IC503	ICP - N15
	IC502	SN74LS368AN
	Q521	2SA933S
	D520, D521	ISS254
	D501	SEL2210S

**FILTERS AND COILS**

F501 - F503  
L501, L502

VTH1001  
LFA102J

**CAPACITORS**

	C506 - C509	CEAS010M50
	C511, C512	CEAS100M16
	C514, C520	CEAS101M25
	C515	CEAS220M16
	C521, C522	CKCYB102K50
	C510, C513	CKCYF103Z50
	C501, C502 (2200p × 4)	DCG1006

**RESISTORS**

All resistors RD1/6PM□□□J

**OTHERS**

JA502	2P pin jack	DKB1031
JA501	9P D- SUB socket	DKN1051
JA503	3P mini jack	DKN1087
CN503	SP connector	W - P5104#52

2.3 SCHEMATIC AND PCB DIAGRAMS

2.3.1 OVERALL WIRING DIAGRAM

NOTE FOR SCHEMATIC DIAGRAMS (Type 4A)

1. When ordering service parts, be sure to refer to "PARTS LIST of EXPLODED VIEWS" or "PCB PARTS LIST".

2. Since these are basic circuits, some parts of them or the values of some components may be changed for improvement.

3. RESISTORS:  
Unit: k:kΩ, M:MΩ, or Ω unless otherwise noted.  
Rated power: 1/4W, 1/6W, 1/8W, 1/10W unless otherwise noted.  
Tolerance: (F): ±1%, (G): ±2%, (K): ±10%, (M): ±20% or ±5% unless otherwise noted.

4. CAPACITORS:  
Unit: p:pF or μ:F unless otherwise noted.  
Ratings: capacitor (μF) /voltage (V) unless otherwise noted.  
Rated voltage: 50V except for electrolytic capacitors.

5. COILS:  
Unit: m:mH or μ:H unless otherwise noted.

6. VOLTAGE AND CURRENT:  
□ or ← V: DC voltage (V) in PLAY mode unless otherwise noted.  
⇐ mA or ← mA: DC current in PLAY mode unless otherwise noted.  
Value in ( ) is DC current in STOP mode.

7. OTHERS:  
● or ○ : Adjusting point.  
● ◀ : Measurement point.  
• The Δ mark found on some component parts indicates the importance of the safety factor of the parts. Therefore, when replacing, be sure to use parts of identical designation.

8. SCH - □ ON THE SCHEMATIC DIAGRAM:  
• SCH-□ indicates the drawing number of the schematic diagram. (SCH stands for schematic diagram.)

9. SWITCHES (Underline indicates switch position):  
OUT OF PCB  
POWER SWITCH: POWER ON - OFF  
EKEY  
S601 : MAGAZINE EJECT 1  
S602 : MAGAZINE EJECT 2  
S603 : MAGAZINE EJECT 3

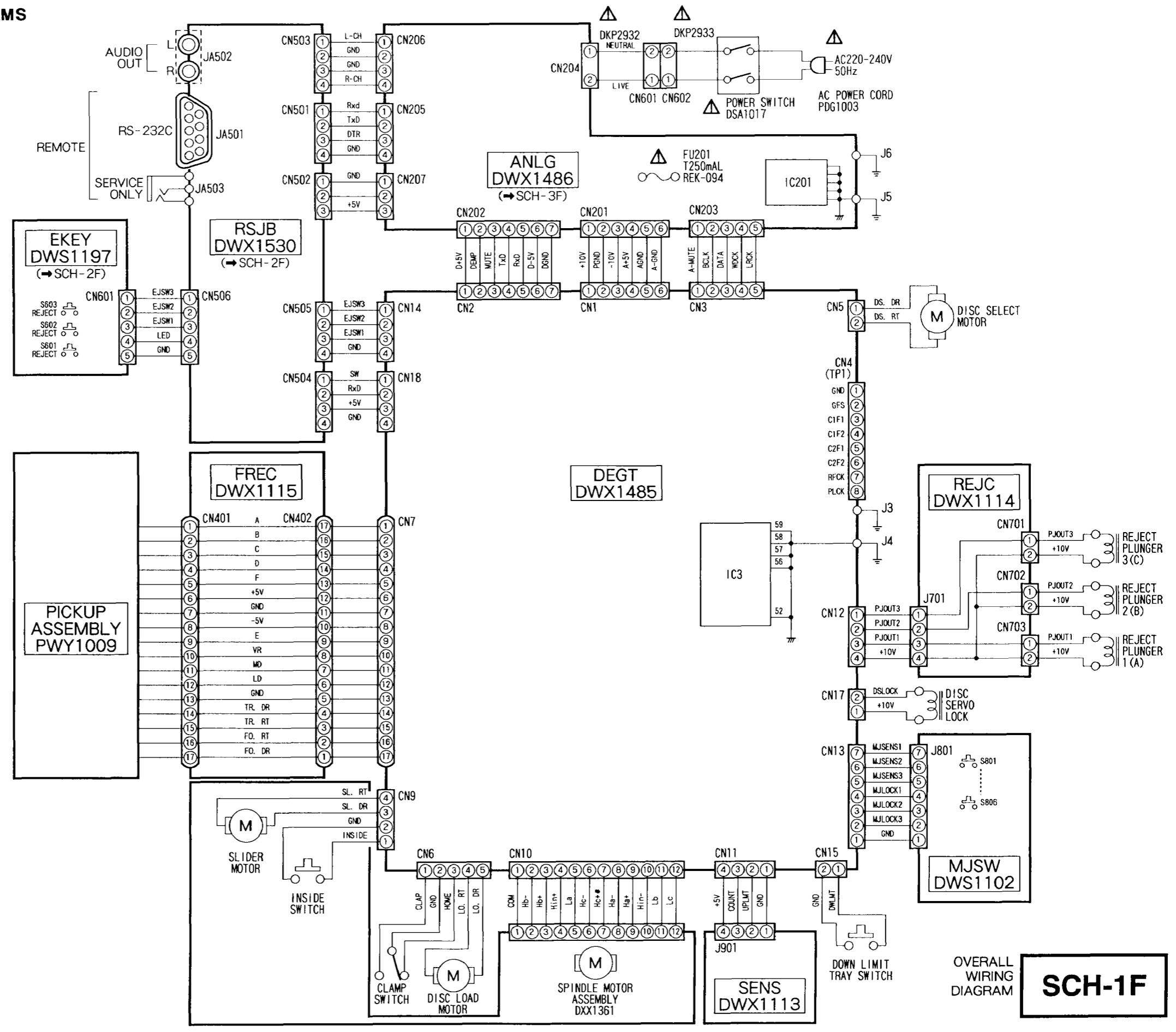

SCH-1F OVERALL WIRING DIAGRAM

OVERALL WIRING DIAGRAM SCH-1F

2.3.2 EKEY AND RSJB

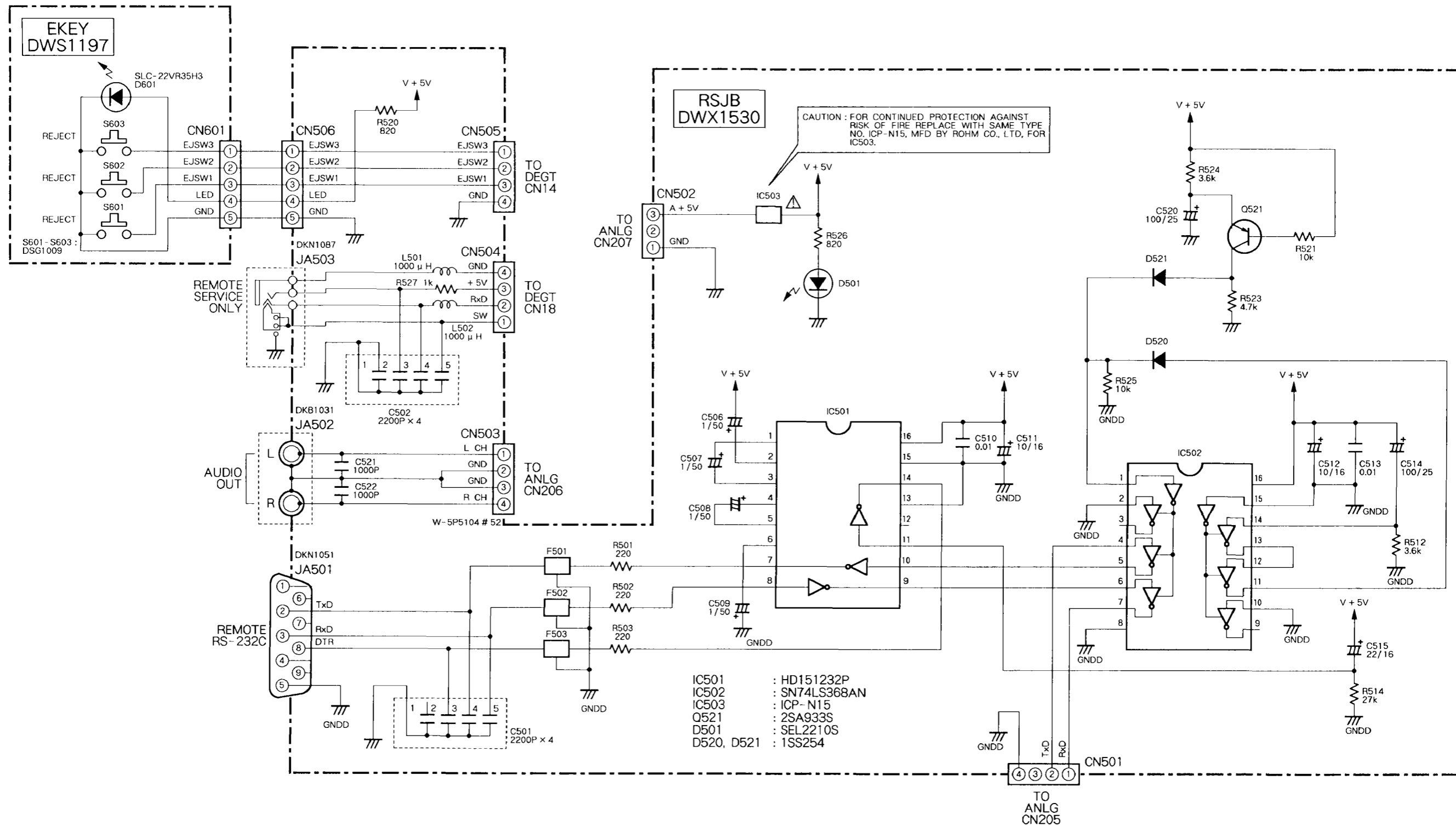

**SCH-2F**

EKEY, RSJB

**SCH-2F**

EKEY, RSJB

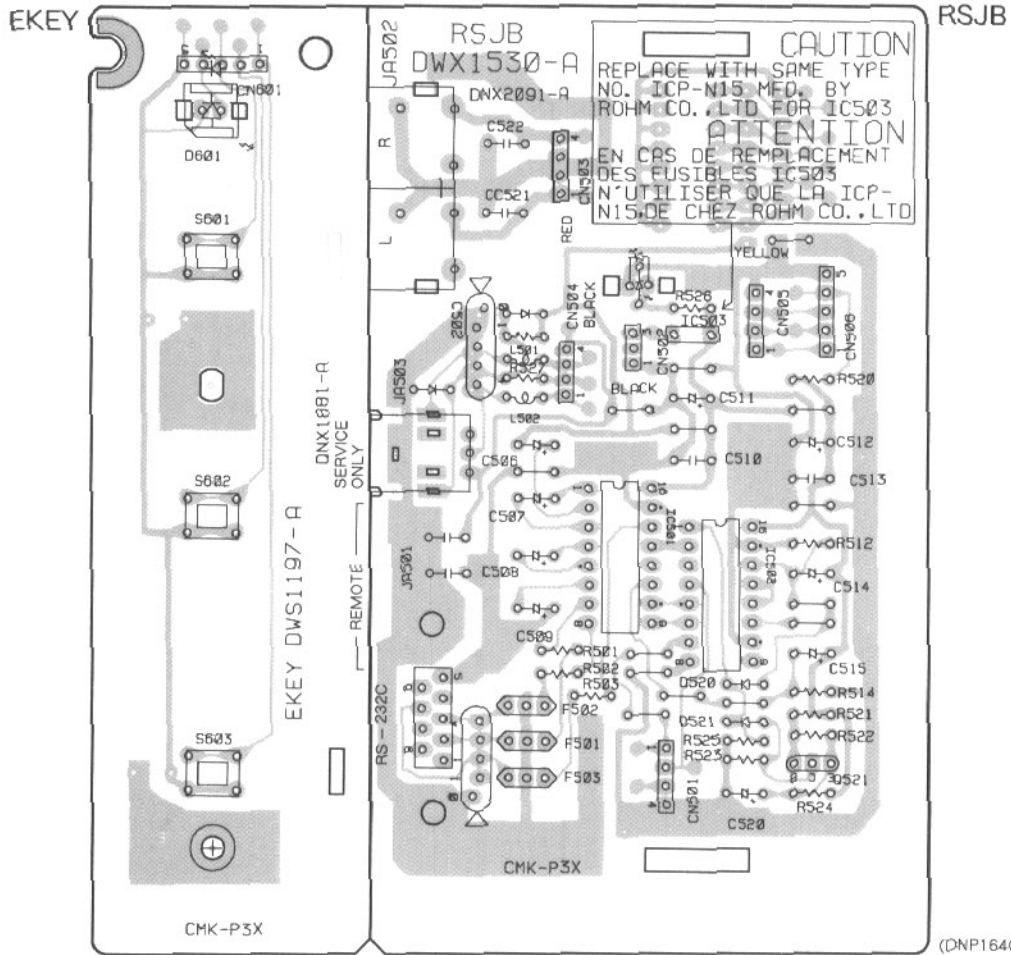

• This diagram is viewed from the mounted parts side.

NOTE FOR PCB DIAGRAMS:

1. Part numbers in PCB diagrams match those in the schematic diagrams.
2. A comparison between main parts of PCB and schematic diagrams is shown below.

NOTE FOR PCB DIAGRAMS:

1. Part numbers in PCB diagrams match those in the schematic diagrams.
2. A comparison between main parts of PCB and schematic diagrams is shown below.

Symbol in PCB Diagrams	Symbol in Schematic Diagrams	Part Name
<p>Q504</p>	<p>Q504</p>	Transistor
<p>D203</p>	<p>D203</p>	Diode
<p>C513</p>	<p>C513</p>	Capacitor (Polarized)

Symbol in PCB Diagrams	Symbol in Schematic Diagrams	Part Name
<p>B C E</p>	<p>B C E</p>	Transistor
<p>B C E</p>	<p>B C E</p>	Transistor with resistor
<p>D G S</p>	<p>D G S</p>	Field effect transistor
		Resistor array
		3-terminal regulator

3. The transistor terminal marked with E or shows the emitter.
4. The diode terminal marked with or shows cathode side.
5. The capacitor terminal marked with or shows negative terminal.



R21B

EKEY

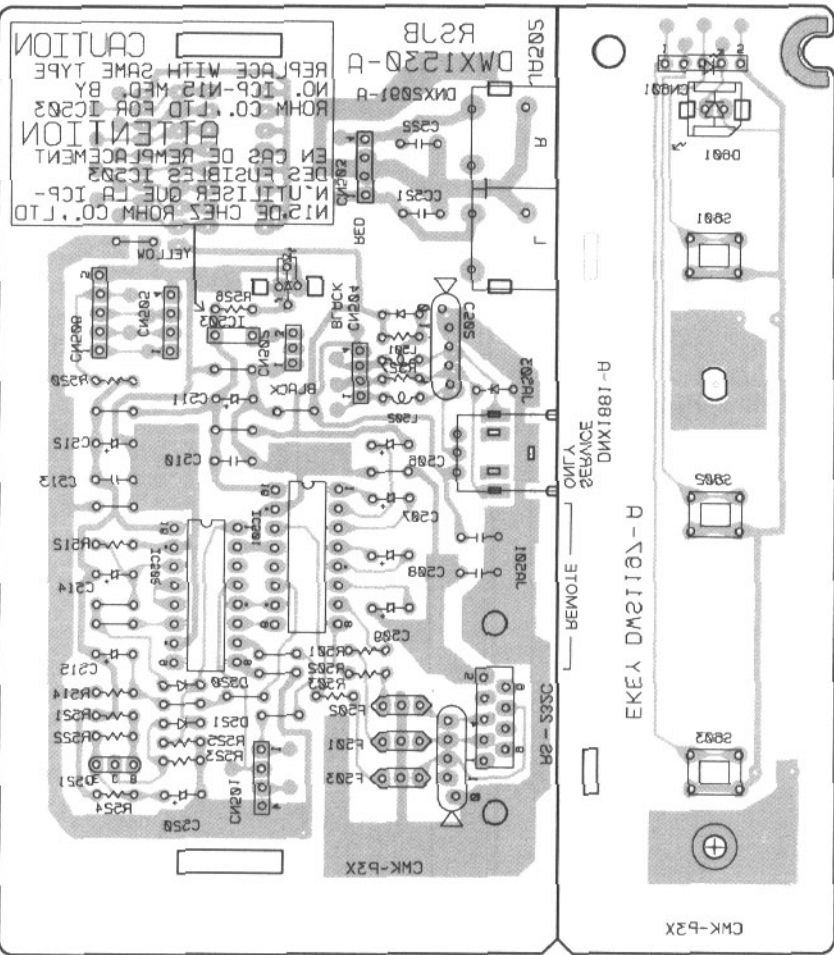

(DMP1840 - A)

• This diagram is viewed from the foil side.

A

B

C

D

2.3.3 ANLG

- The differences in the schematic and PCB diagrams between DWX1486 and DWX1155 are as follows.

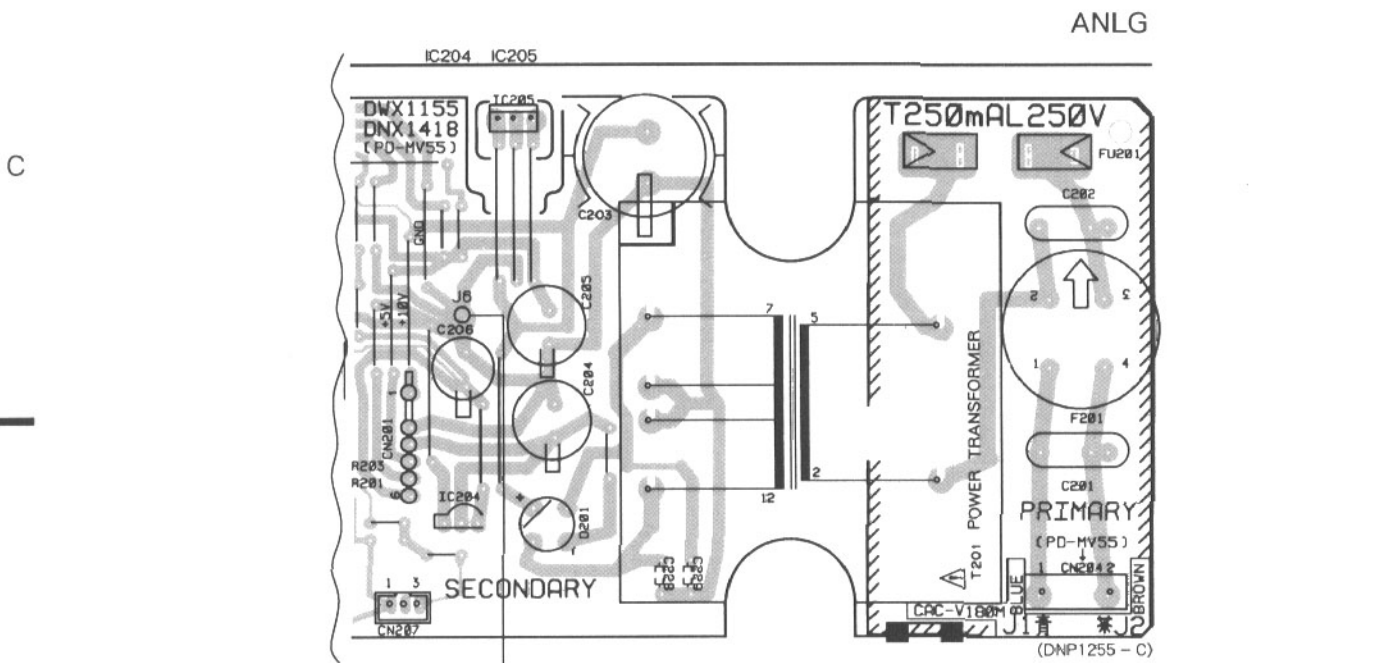
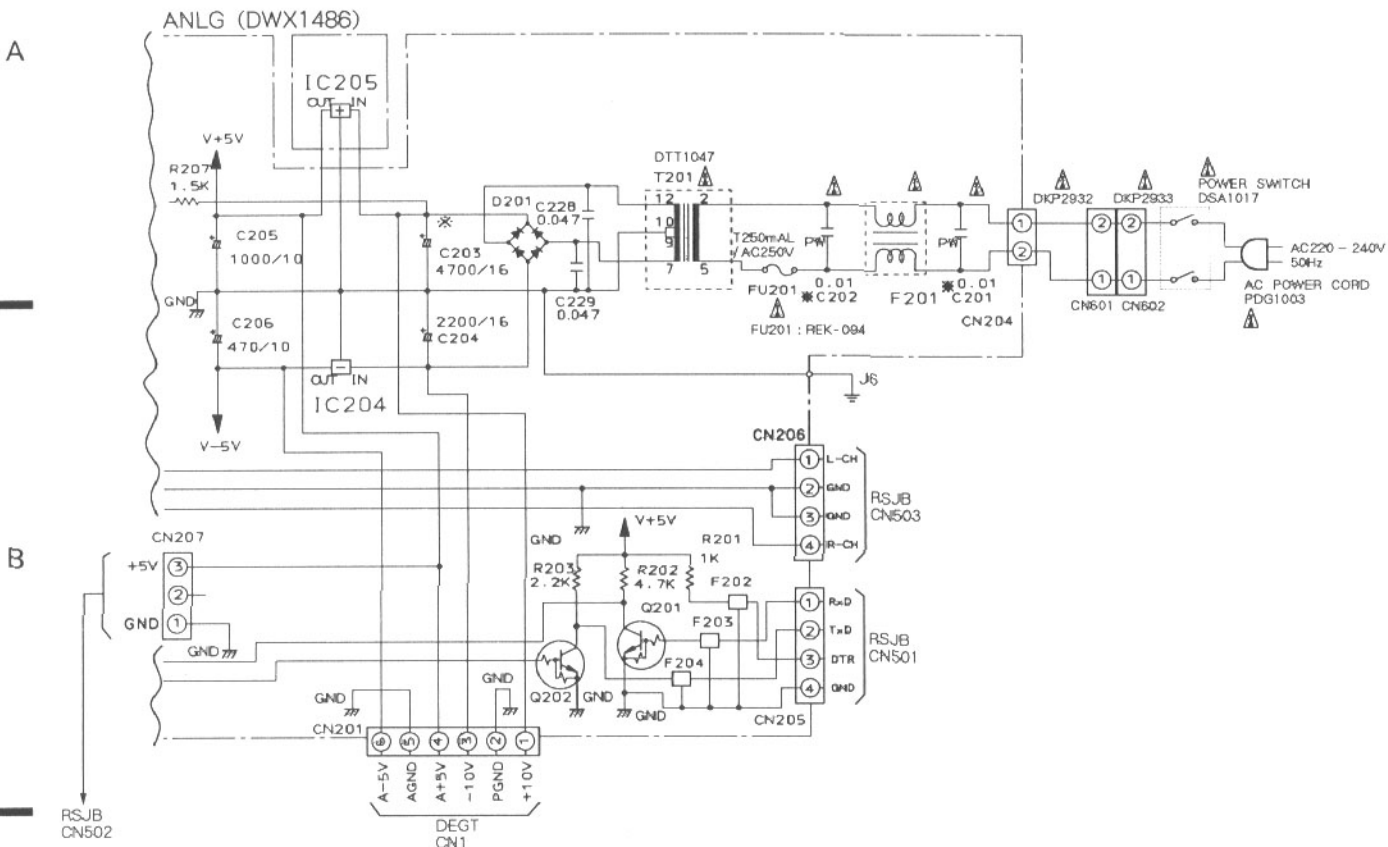

• This diagram is viewed from the mounted parts side.

SCH-3F

ANLG

SCH-3F

ANLG

A

B

C

D

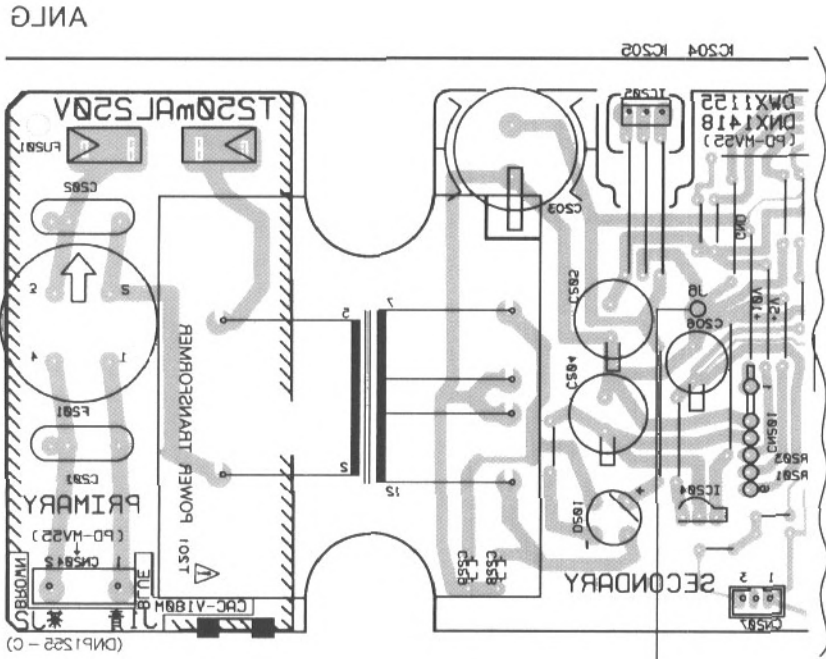

● This diagram is viewed from the foil side.

SCH-3F

SCH-3F

### 3. EXPLODED VIEW, PACKING AND PARTS LIST

**NOTES:**

- Parts marked by "NSP" are generally unavailable because they are not in our Master Spare Parts List.
- The  $\Delta$  mark found on some component parts indicates the importance of the safety factor of the part. Therefore, when replacing, be sure to use parts of identical designation.
- Parts marked by "⊙" are not always kept in stock. Their delivery time may be longer than usual or they may be unavailable.

NOTE: Screws adjacent to  $\blacktriangledown$  mark on the product are used for disassembly.

#### 3.1 EXTERIOR SECTION

**Parts List**

Mark	No.	Description	Part No.
	1	DEGT	DWX1485
	2	ANLG	DWX1486
	3	EKEY	DWS1197
	4	RSJB	DWX1530
	5	Multi mechanism assembly	DWT1023
	6	17P flexible cord	DDD1027
$\Delta$	7	AC power cord	PDG1003
$\Delta$	8	Fuse (FU201, T250mA)	REK-094
$\Delta$	9	Power transformer (T201)	DTT1047
	10	Push button	DAC1786
	11	M4 screw	DBA1071
	12	Bolt # 4-40/M3	DBA1038
	13	Front panel assembly	DXB1450
	14	Leg cap	DEC1697
	15	Bonnet assembly	DXX2116
	16	Strain relief	CM-22B
	17	.....	
	18	Cord clammer	RNH-184
	19	Screw	PMA30P060FMC
	20	Sheet	DEC1237
	21	Screw	BBZ30P060FMC
	22	Screw	BBZ30P080FMC
	23	Screw	BBZ30P080FZK
	24	Screw	BBZ40P080FMC
	25	Screw	BDZ30P060FZK
$\Delta$	26	Screw	IBZ30P080FMC
	27	Power switch	DSA1017
	28	Caution label	PRW1233
	29	Caution label(G)	VRW-329
	30	Rivet	DEC-176
	31	Screw	PCZ30P050FZK
NSP	101	Insulation plate A	DEC1209
NSP	102	Insulation plate B	DEC1210
NSP	103	Chassis	DNA1133
NSP	104	Rear panel	DNC1366
NSP	105	Bonnet	DNE1229
NSP	106	PCB holder L	DNF-180
NSP	107	Cover	DNH1818
$\Delta$ NSP	108	Connection assembly 2P	DKP2932
NSP	109	Card edge spacer	DEC1211
NSP	110	Corner post	DEC1212
NSP	111	Insulation sheet	DEC1284

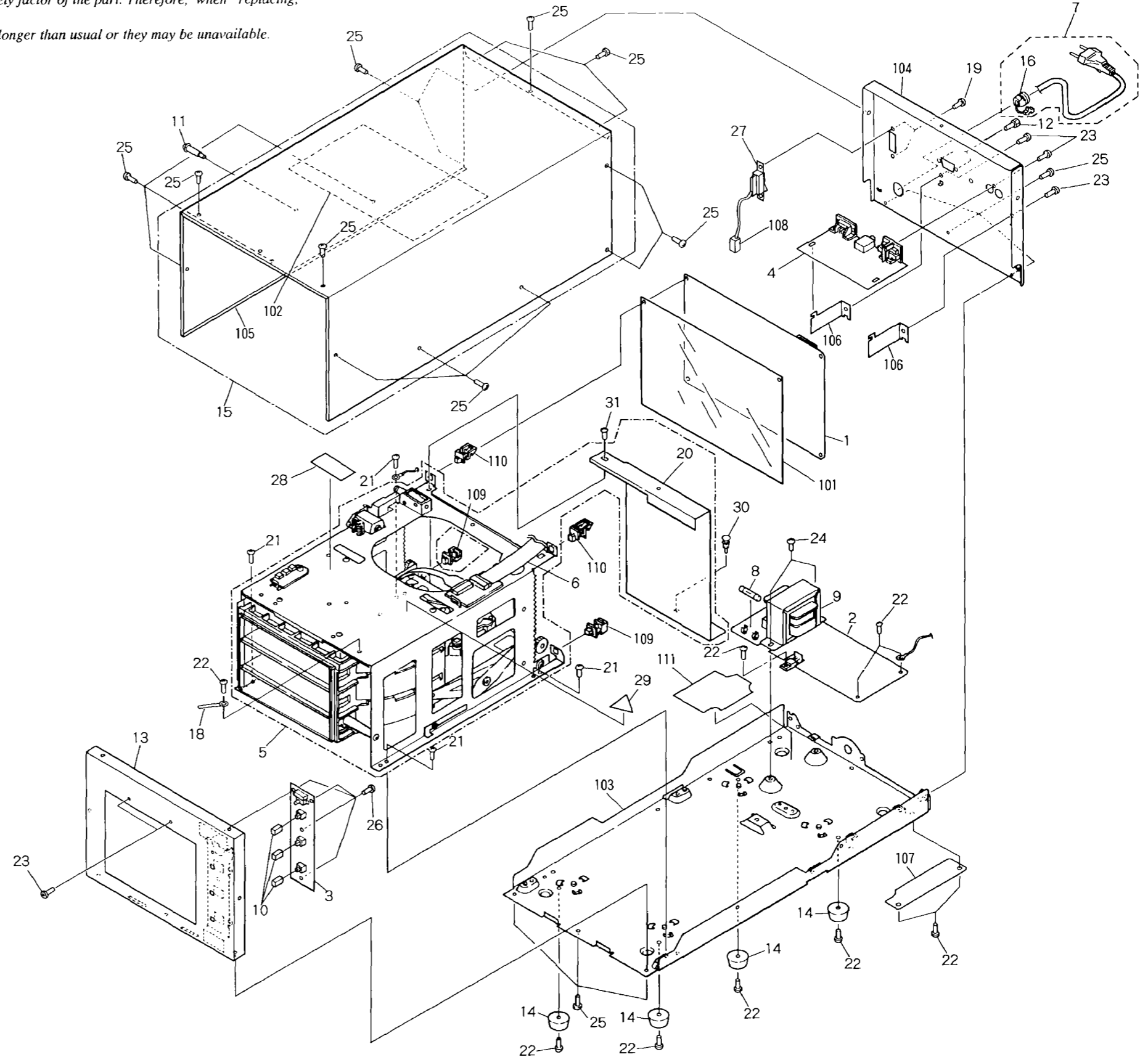

3.2 PACKING

Parts List

Mark No.	Description	Part No.
1	Top pad	DHA1204
2	Inner packing case	DHG1507
3	Packing case	DHG1508
4	Connection cord	DDE1016
5	Operating instructions (English)	DRB1174
6	Bottom pad assembly	DHA1242
7	Packing sheet	DHL1022
8	Polyethylene bag	Z21-019
9	Polyethylene bag	Z21-014
NSP 101	Air cap sheet	DHL1063
NSP 102	Magazine assembly	DXB1205
NSP 103	Shipping caution label	DRM1111

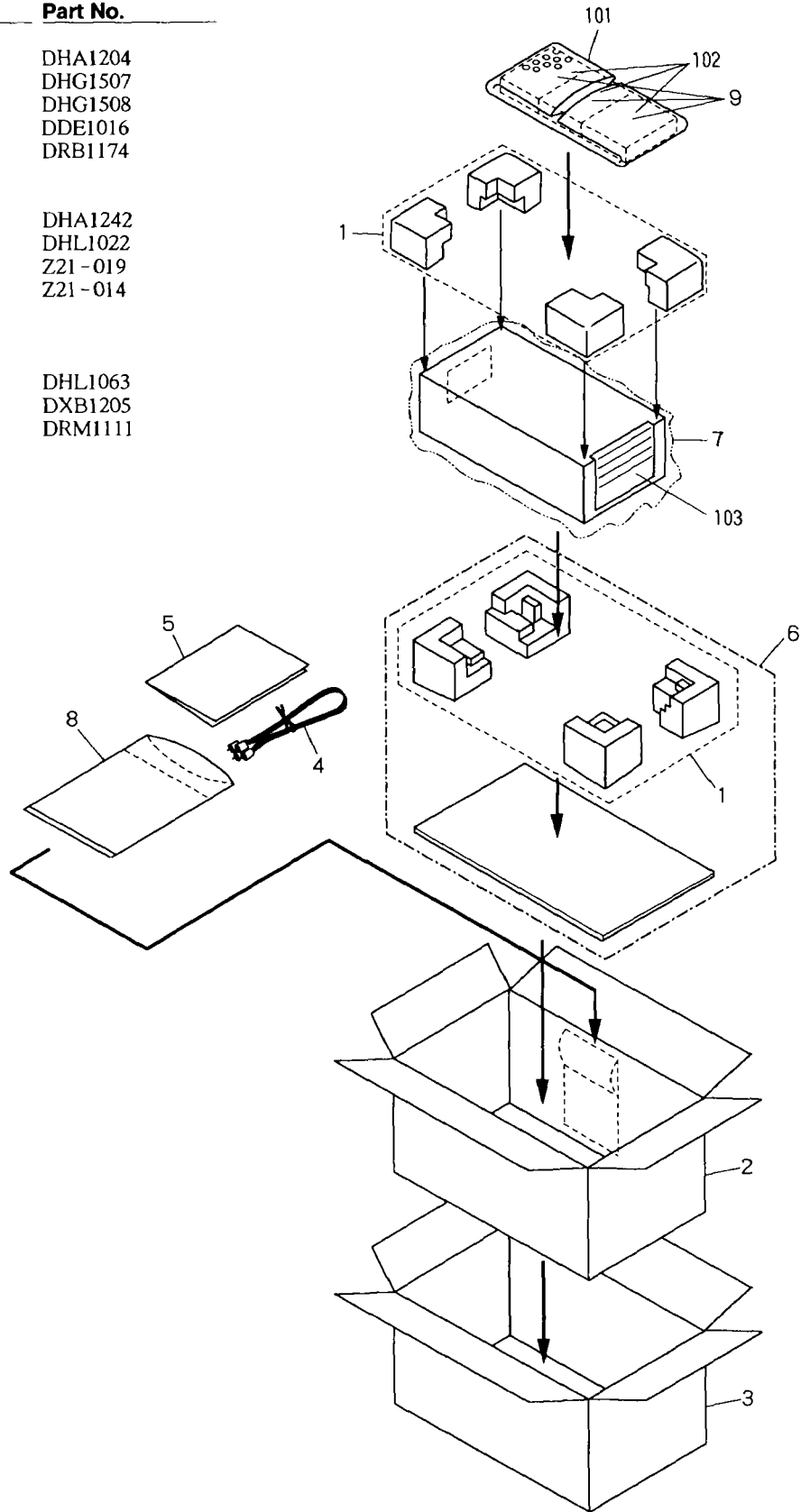

# 4. BLOCK DIAGRAM

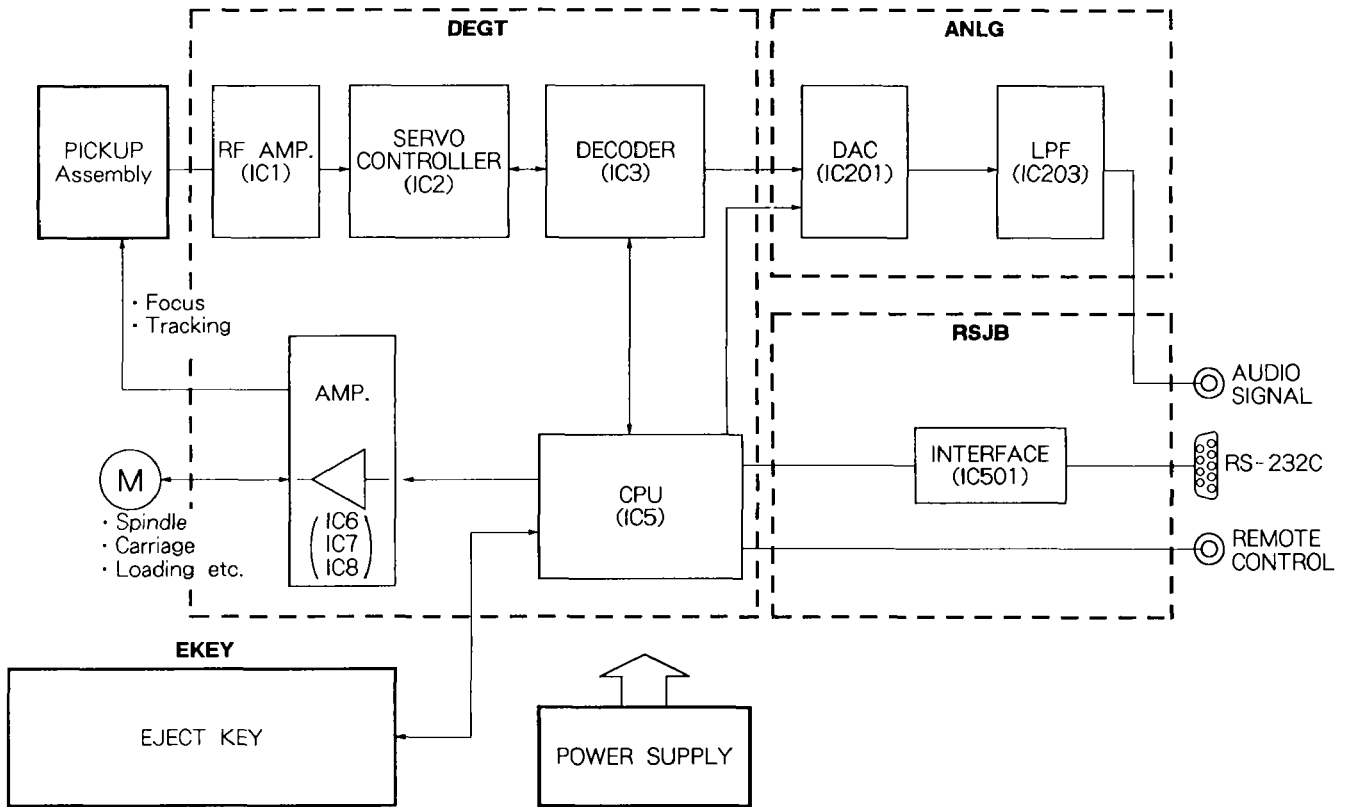

# Service Manual

(1)

ORDER NO.  
ARP2121

COMPACT DISC JUKEBOX

# CJ-V50

• Refer to the service manual ARP2122, CJ-V50.

• This manual is applicable to the HEM type.

## CONTENTS

1. SAFETY INFORMATION .....	2
2. PARTS LOCATIONS .....	4
3. DISASSEMBLY .....	11
4. P. C. BOARDS NAME .....	14
5. SERVICE MODE .....	15
6. NOTES ON REPLACING THE LITHIUM BATTERY AND RAM (IC2 : HM6225BLP-12) .....	16

# 1. SAFETY INFORMATION

## 1. SAFETY PRECAUTIONS

The following check should be performed for the continued protection of the customer and service technician.

### LEAKAGE CURRENT CHECK

Measure leakage current to a known earth ground (water pipe, conduit, etc.) by connecting a leakage current tester such as Simpson Model 229-2 or equivalent between the earth ground and all exposed metal parts of the appliance (input/output terminals, screwheads, metal overlays, control shaft, etc.). Plug the AC line cord of the appliance directly into a 120V AC 60Hz outlet and turn the AC power switch on. Any current measured must not exceed 0.5mA.

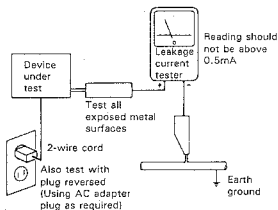

AC Leakage Test

### WARNING!

Lithium batteries. Danger of explosion. Replacement must be done by qualified personnel and only by following the instructions given in the service manual.

This warning is stated on the product or in the operating instructions. When replacing the lithium batteries, follow the note below.

Dispose of the used battery promptly. Keep away from children. Do not disassemble and do not dispose of in fire. The battery used in this device may present a fire or chemical hazard if mistreated. Do not recharge, disassemble, heat above 100°C or incinerate. Replace only with the same Part Number. Use of another battery may present a risk of fire or explosion.

Note: The lithium battery installation position is shown in the exploded view and the P.C. board pattern.

ANY MEASUREMENTS NOT WITHIN THE LIMITS OUTLINED ABOVE ARE INDICATIVE OF A POTENTIAL SHOCK HAZARD AND MUST BE CORRECTED BEFORE RETURNING THE APPLIANCE TO THE CUSTOMER.

## 2. PRODUCT SAFETY NOTICE

Many electrical and mechanical parts in the appliance have special safety related characteristics. These are often not evident from visual inspection nor the protection afforded by them necessarily can be obtained by using replacement components rated for voltage, wattage, etc. Replacement parts which have these special safety characteristics are identified in this Service Manual.

Electrical components having such features are identified by marking with a  $\Delta$  on the schematics and on the parts list in this Service Manual.

The use of a substitute replacement component which does not have the same safety characteristics as the PIONEER recommended replacement one, shown in the parts list in this Service Manual, may create shock, fire, or other hazards.

Product Safety is continuously under review and new instructions are issued from time to time. For the latest information, always consult the current PIONEER Service Manual. A subscription to, or a additional copies of, PIONEER Service Manual may be obtained at a nominal charge from PIONEER.

### ADVARSEL!

Lithiumbatteri — Eksplosionsfare ved fejlagtig håndtering. Udskiftning må kun ske med batteri af samme fabrikat og type. Levér det brugte batteri tilbage til leverandøren.

Denne advarsel er angivet på produktet eller i brugsvejledningen. Ved udskiftning af lithium batterierne følges nedenstående anvisning.

Batterierne må kun udskiftes med batterier af samme type og mærke.

### VARNING

Explosionsfara vid felaktigt batteribyte. Använd samma batterityp eller en ekvivalent typ som rekommenderas av apparattillverkaren. Kassera använt batteri enligt fabrikantens instruktion.

Denna varning finns på apparaten eller i bruksanvisningen. Följ nedanstående anvisningar vid byte av litiumbatterier. Batterierna får endast bytas ut mot litiumbatterier av samma typ och fabrikat.



(FOR EUROPEAN MODEL ONLY)

## VARO!

AVATTAESSA JA SUOJALUKITUS  
OMITETTAESSA OLET ALTTIINA  
NÄKYMÄTTÖMÄLLE LASERSÄTEILYLLE.  
ÄLÄ KATSO SÄTEESEEN.



LASER  
Kuva 1  
Lasersäteilyn  
varoituserkki

## WARNING!

DEVICE INCLUDES LASER DIODE WHICH  
EMITS INVISIBLE INFRARED RADIATION  
WHICH IS DANGEROUS TO EYES. THERE IS  
A WARNING SIGN ACCORDING TO PICTURE  
1 INSIDE THE DEVICE CLOSE TO THE LASER  
DIODE.



LASER  
Picture 1  
Warning sign for  
laser radiation

## ADVERSEL:

OSYNLIG LASERSTRÅLING VED ÅBNING  
NÅR SIKKERHEDSAFBRYDERE ER UDE AF  
FUNKTION! UNDGÅ UDSÆTTELSE FOR  
STRÅLING.

## VARNING!

OSYNLIG LASERSTRÅLING NÅR DENNA  
DEL ÄR ÖPPNAD OCH SPÄRREN  
ÄR URKOPPLAD. SETRAKTA EJ STRÅLEN.

## IMPORTANT

THIS PIONEER APPARATUS CONTAINS  
LASER OF HIGHER CLASS THAN 1.  
SERVICING OPERATION OF THE APPARATUS  
SHOULD BE DONE BY A SPECIALLY  
INSTRUCTED PERSON.

LASER DIODE CHARACTERISTICS  
MAXIMUM OUTPUT POWER: 5 mw  
WAVELENGTH: 780-785 nm

## LABEL CHECK

- MAIN SECTION (REAR SIDE)

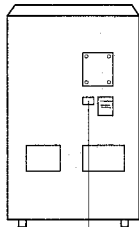

## VARO!

AVATTAESSA JA SUOJALUKITUS  
OMITETTAESSA OLET ALTTIINA  
NÄKYMÄTTÖMÄLLE LASERSÄTEILYLLE.  
ÄLÄ KATSO SÄTEESEEN.  
VARNING!  
OSYNLIG LASERSTRÅLING NÅR DENNA  
DEL ÄR ÖPPNAD OCH SPÄRREN  
ÄR URKOPPLAD. SETRAKTA EJ STRÅLEN.

PFRW203

**CAUTION**  
INVISIBLE LASER  
RADIATION WHEN OPEN,  
AVOID EXPOSURE  
TO BEAM

SFRW176

WEM type

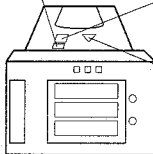

CD SECTION  
(REMOVING CONDITION  
OF THE BONNET COVER)

ADVERSEL  
OSYNLIG LASERSTRÅLING VED ÅBNING  
NÅR SIKKERHEDSAFBRYDERE ER UDE AF  
FUNKTION! UNDGÅ UDSÆTTELSE FOR  
STRÅLING.  
VORSICHT!  
UNSICHTBARE LASERSTRÅLUNG TRITT AUS,  
WEHN DECKEL  
ODER KLAPPET GEÖFFNET WIRD NICHT DEM STRAHLE  
AUSGETZT!



WEM type

**CLASS 1  
LASER PRODUCT**

PFRW-178

HEM type

## Additional Laser Caution

1. The player microcomputer checks the inserting condition of magazines A, B and C by using the combined signals of the SENS1 (S804), SENS2 (S805), SENS3 (S806), LOCK1 (S801), LOCK2 (S802) and LOCK3 (S803) switches. It is after these three magazines are fully inserted that commands from the control microcomputer are accepted. The laser diode is turned ON for illumination by outputting the laser diode ON signal from the control microcomputer when the CLAMP switch (S1001) (DSK1001), which signals that the tray is to be pulled from the magazine and detects clamping condition, is set to ON and the player receives the "rising command" in the disc clamping condition. If no disc is available, it turns OFF after 20 seconds. The illuminated laser diode goes out when receiving a "Reject command", a "disc change command" or a "magazine eject command." The laser diode continues to oscillate when pin ② of CXA1081S (IC1) is connected to GND or to pin ⑤.
2. If the fault condition described in 1 is induced with the cover open and with the servo mechanism block removed to be turned over, close viewing of the objective lens with the naked eye will cause exposure to a class 1 or higher laser beam.

## 2. PARTS LOCATIONS

### 2.1 EXTERIOR

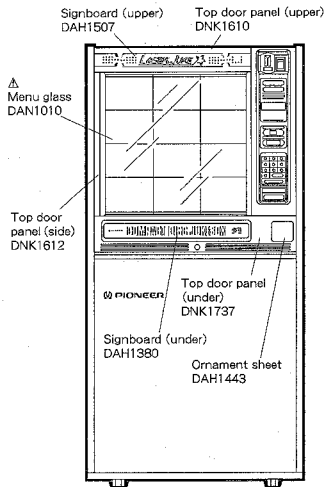

### ● OPERATION SECTION

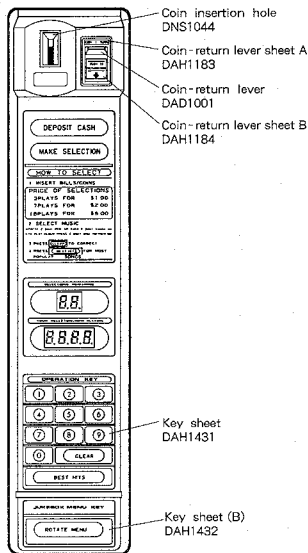

## 2.2 AMP SECTION

## ● FRONT VIEW

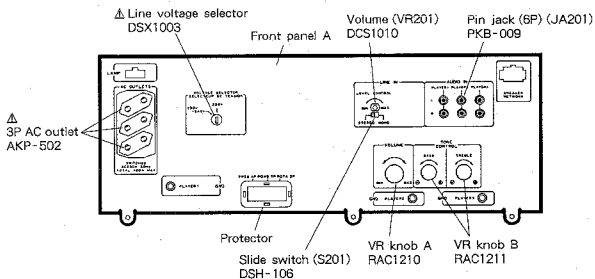

## ● REAR VIEW

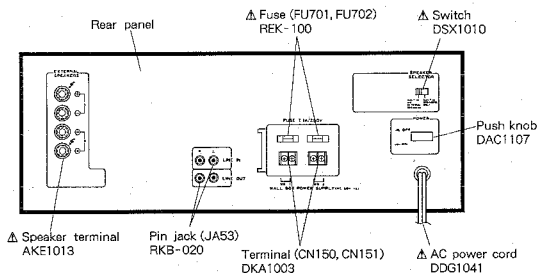

● TOP VIEW

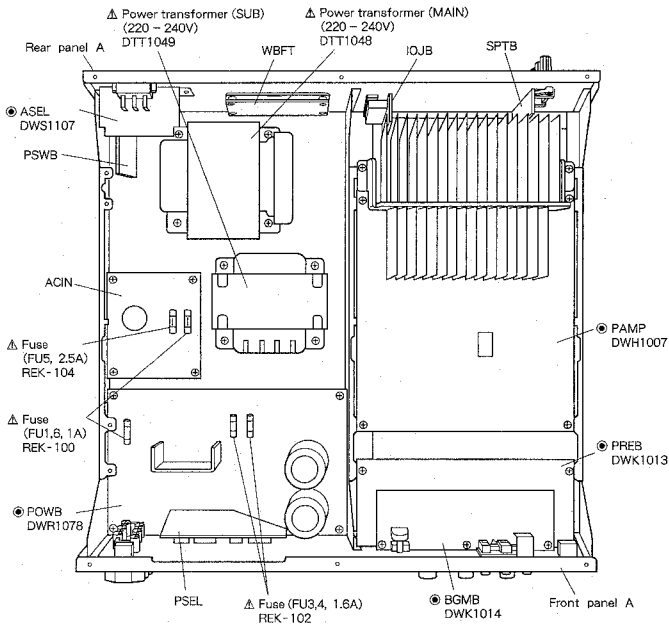

## 2.3 COMMANDER SECTION

## ● FRONT VIEW

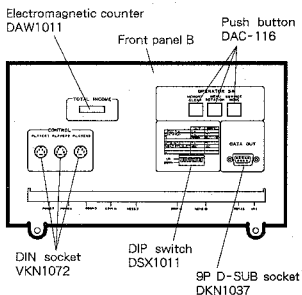

## ● REAR VIEW

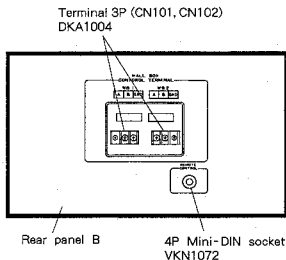

## ● TOP VIEW

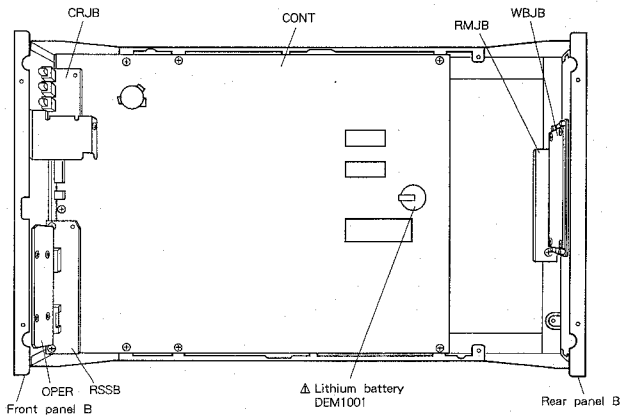

## 2.4 REMOVING CONDITION OF THE UNDER LAMP ASSEMBLY

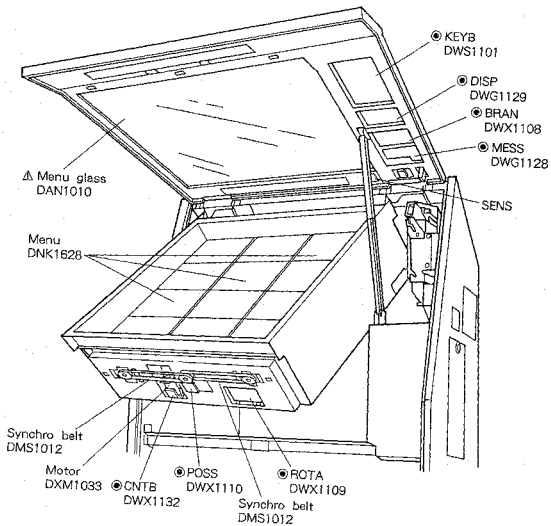

## 2.5 REMOVING CONDITION OF THE MENU BOARD

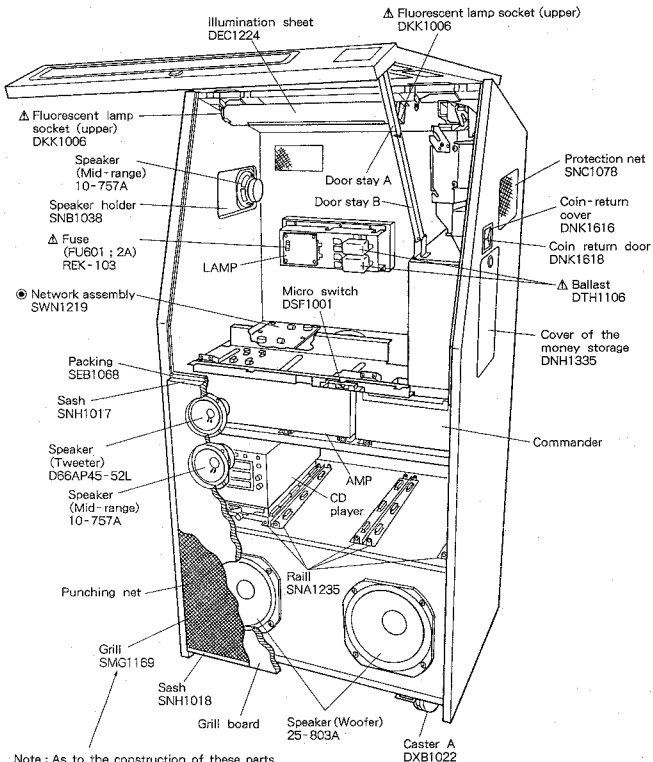

## 2.6 CD PLAYER SECTION

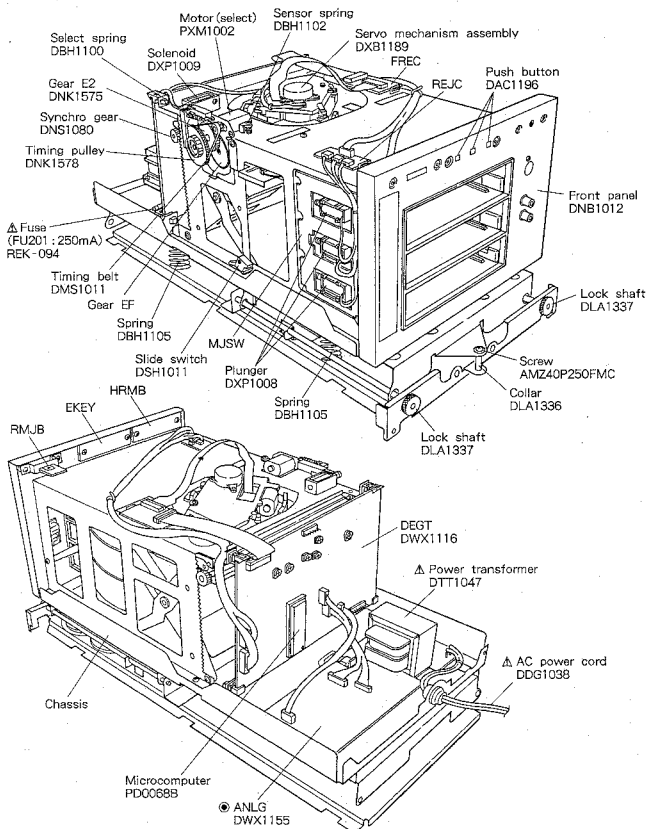



### 3. DISASSEMBLY

#### 3.1 REMOVING THE TOP DOOR ASSEMBLY

1. Open the menu door, and remove six screws ① and two R pins to remove the menu board assembly.

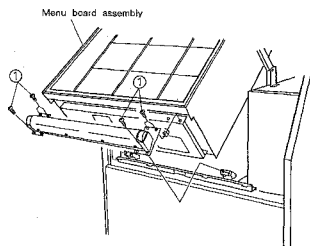

Fig. 3-1

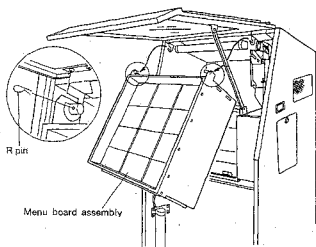

Fig. 3-2

2. Loosen four screws ② and remove two screws ③ to remove the upper lamp assembly.

3. Remove two screws ④ to remove the CA holder C assembly.

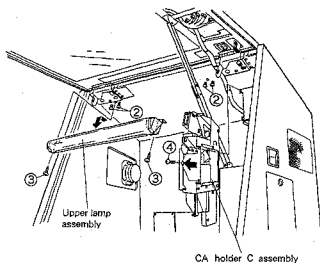

Fig. 3-3

4. Remove six screws ⑤, two screws ⑥ and two screws ⑦ to remove the top door assembly.

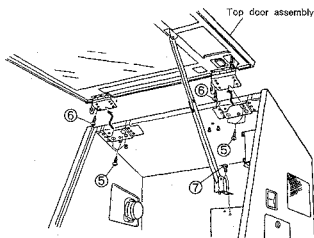

Fig. 3-4

### 3.2 REMOVING THE MENU MOTOR ASSEMBLY

1. Remove two screws ① to remove the menu motor assembly.

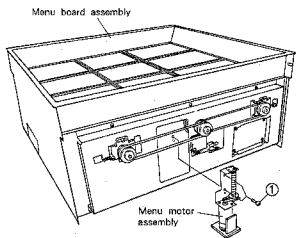

Fig. 3-5

### 3.3 REMOVING THE SYNCHRO BELT

1. Loosen two screws ① and remove two springs with plier, and remove two synchro belts by pushing the synchro pulley in the direction of arrow.

Note : When the synchro belt is replaced, be sure to perform the three surfaces of the menu synchronous adjustment.

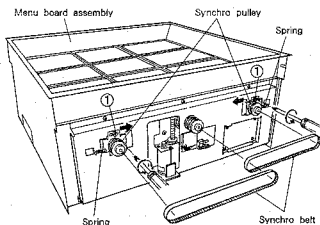

Fig. 3-6

### 3.4 REMOVING THE LAMP AND NETWORK ASSEMBLY

1. Remove six screws ① to remove the network assembly.
2. Remove four screws ② to remove the LAMP.

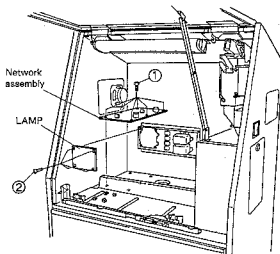

Fig. 3-7

### 3.5 REMOVING THE ROTA AND POSS

1. Remove four screws ① to remove the ROTA.
2. Remove a screw ② to remove the POSS.

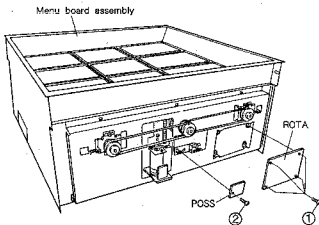

Fig. 3-8

### 3.6 REMOVING THE MESS, BRAN, DISP AND KEYB

1. Remove four screws ① to remove the MESS.
2. Remove four screws ② to remove the BRAN.
3. Remove four screws ③ to remove the DISP.
4. Remove eight screws ④ to remove the KEYB.
5. Remove two screws ⑤ to remove the SENS.

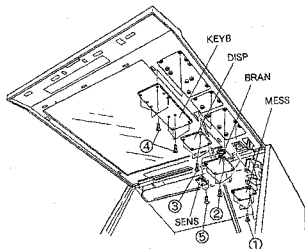

Fig. 3-9

### 3.7 REMOVING THE AMP, COMMANDER AND CD PLAYER

1. Remove three screws ① to remove the AMP.
2. Remove two screws ② to remove the commander.
3. Remove two screws ③ to remove the CD player.

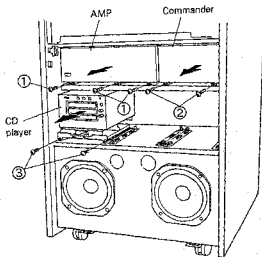

Fig. 3-10

### 3.8 REMOVING THE SPEAKER (WOOFER)

1. Remove four screws ① and disconnect the connector of speaker cord to remove the speaker.

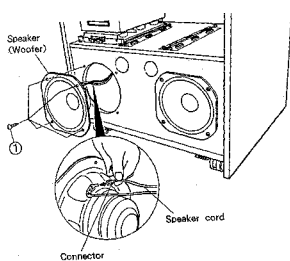

Fig. 3-11

### 3.9 REMOVING THE GLASS

1. Remove the top door assembly. (Refer to section 3.1.)
2. Set the glass side of top door assembly to the downward. Remove thirty-seven screws ① to remove the top door base, then remove the glass.

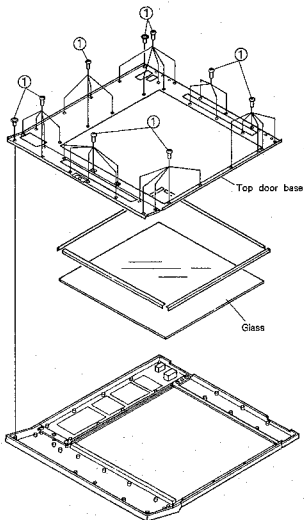

Fig. 3-12

### 3.10 REMOVING THE GLOW LAMP

Refer to the operating instructions (page 20).

## 4. P. C. BOARDS NAME

### MAIN SECTION

MESS.....MESSAGE  
 DISP.....DISPLAY  
 KEYB.....KEYBOARD  
 BRAN.....BRANCH  
 ROTA.....ROTATION  
 POSS.....POSITION SENSOR  
 LAMP.....LAMP  
 CNTB.....COUNTER BOARD  
 PAMP.....POWER AMPLIFIER  
 SPTB.....SPEAKER TERMINAL BOARD  
 PREB.....PRE AMPLIFIER BOARD  
 POWB.....POWER BOARD  
 ACIN.....AC INPUT BOARD  
 PSEL.....PRIMARY VOLTAGE SELECTOR BOARD  
 ASEL.....AMPLIFIER VOLTAGE SELECTOR BOARD  
 PSWB.....POWER SWITCH BOARD  
 CONT.....CONTROL  
 OPER.....OPERATION  
 CRJB.....CD REMOTE JACK BOARD  
 RMJB.....REMOTE CONTROL JACK BOARD  
 SENS.....SENSOR  
 WBJB.....WALL BOX JACK BOARD  
 RSSB.....RS232C AND SW BOARD  
 BGMB.....BACK GROUND MUSIC BOARD  
 IOJB.....IN OUT JACK BOARD  
 WBFT.....WALL BOX FUSE TERMINAL

### CD PLAYER SECTION

EKEY.....EJECT KEY  
 DEGT.....DIGITAL DECODING UNIT  
 ANLG.....ANALOG UNIT  
 DJAK.....DIGITAL JACK  
 PJAK.....PIN JACK  
 MJSW.....MAGAZINE EJECT SWITCH  
 SENS.....SENSOR  
 REJC.....REJECT  
 FREC.....FLEXIBLE READER CONNECTOR  
 HRMB.....HOUR METER BOARD  
 RMJB.....REMOTE JACK BOARD

## 5. SERVICE MODE

- As to using the service mode, refer to the operating instructions (pages 24 - 28).

And also as to the cord table of the service mode, refer to the operating instructions (pages 20 - 23).

- Shows the function table of the remote control (RU-V101) for service as follows. When operating the CD changer section directly, it is able to operate as shown in the below by connect the wired-remote control to the CD changer.

### 5.1 FUNCTION TABLE OF THE REMOTE CONTROL FOR SERVICE

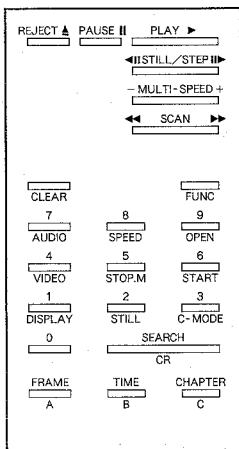

*1 REJECT	:	Spindle stop
*1 PAUSE	:	Pause
*1 PLAY	:	Play
*2 STILL/STEP		: Disc select
*2 STILL/STEP	◀	: Disc return
*2 MULTI-SPEED +		: Test command
*2 MULTI-SPEED -		: Test command
*1 SCAN	▶▶	: Scan fwd
*1 SCAN	◀◀	: Scan rev
*1 CLEAR		: Clear
*2 FRAME		: Frame set
*2 TIME		: Time set
*2 CHAPTER		: Track set
*1 SEARCH		: Search
*1 10key		: Numerical input
DISPLAY (FUNC + 1)		: no entry
STILL (FUNC + 2)		: no entry
C-MODE (FUNC + 3)		: no entry
VIDEO (FUNC + 4)		: no entry
*1 STOP.M (FUNC + 5)		: Stop marker
*1 START (FUNC + 6)		: Start
AUDIO (FUNC + 7)		: no entry
SPEED (FUNC + 8)		: no entry
*1 OPEN (FUNC + 9)		: Magazine eject

\* 1 ..... Normal function command  
 \* 2 ..... Function command is different from the LD-V530.  
 Not marked ..... No entry command

#### ● Test command

- |                             |                                 |
|-----------------------------|---------------------------------|
| 0 + MULTI-SPEED (+, -) keys | : LD-ON                         |
| 1 + MULTI-SPEED (+, -) keys | : FOCUS IN                      |
| 2 + MULTI-SPEED (+, -) keys | : Spindle kick                  |
| 3 + MULTI-SPEED (+, -) keys | : Tracking and slider servo ON  |
| 4 + MULTI-SPEED (+, -) keys | : Slider fwd (500ms)            |
| 5 + MULTI-SPEED (+, -) keys | : Slider rev (500ms)            |
| 6 + MULTI-SPEED (+, -) keys | : Tracking and slider servo OFF |
| 7 + MULTI-SPEED (+, -) keys | : Slider stop and spindle stop  |
| 8 + MULTI-SPEED (+, -) keys | : Slider stop and spindle stop  |
| 9 + MULTI-SPEED (+, -) keys | : LD-OFF                        |
- } Stop by MULTI-SPEED (+, -) key

## 6. NOTES ON REPLACING THE LITHIUM BATTERY AND RAM (IC2 : HM62256LP-12)

- When replacing the Lithium battery (DEM1001) or the RAM (IC2 : HM62256LP-12) in the CONT unit of the commander block, clear RAM data in the following manner.

If the data is not cleared, a malfunction may occur.

### ● How to clear

Ⓐ If the accessory wired-remote control of the CJ-V50A is existed, insert the wired-remote control (accessory of the CJ-V50A) to the mini DIN connector (4P) on the rear panel of the commander.

Ⓑ If the accessory wired-remote control of the CJ-V50A is not existed, connect four pins of the mini DIN connector (4P) on the RMJB unit to the chassis (GND).

1. Set the power switch to OFF and all the function switches of the commander block to ON.
2. While simultaneously pressing four keys, the volume + and - keys and the cancel A and B keys on the remote control unit, set the power switch to ON. A buzzer sounds in a few seconds, indicating that the clear operation is completed.

(Note : An error may occur if you set the power switch to OFF while pressing these four keys.)

When the data is cleared, the rate settings return to their default values and all other data become 0. Be careful when performing this operation as it sets even the non-resettable data all to 0.

# Service Manual

**PIONEER**  
The Art of Entertainment



ORDER NO.  
ARP2122

COMPACT DISC JUKEBOX

# CJ-V50 PD-MV55

- Refer to the service manual (1) ARP2121, CJ-V50.
- This manual is applicable to the CJ-V50/HEM and PD-MV55/WEM types.
- PD-MV55/WEM type is a optional CD player of the CJ-V50/HEM type.
- PD-MV55/WEM type is the same as the built-in CD player of the CJ-V50/HEM type except packing and accessory parts.
- Ce manuel pour le service comprend les explications de réglage en français.
- Este manual de servicio trata del método ajuste escrito en español.

## CONTENTS

1. SAFETY INFORMATION .....	2	6. P.C.B's PARTS LIST .....	86
2. EXPLODED VIEWS AND PARTS LIST .....	4	7. ADJUSTMENTS .....	93
3. PACKING .....	31	RÉGLAGES .....	104
4. SCHEMATIC DIAGRAMS AND P. C. BOARDS PATTERN .....	33	AJUSTES .....	115
5. BLOCK DIAGRAM .....	84	8. IC DESCRIPTION .....	126

**PIONEER ELECTRONIC CORPORATION** 4-1, Meguro 1-Chome, Meguro-ku, Tokyo 153, Japan  
**PIONEER ELECTRONICS SERVICE INC.** P.O. Box 1760, Long Beach, California 90801 U.S.A.  
**PIONEER ELECTRONICS OF CANADA, INC.** 505 Cochrane Drive, Markham, Ontario L3R 8E3 Canada  
**PIONEER ELECTRONIC [EUROPE] N.V.** Keelberglaan 1, 2740 Beveren, Belgium  
**PIONEER ELECTRONICS AUSTRALIA PTY. LTD.** 178-184 Boundary Road, Braeside, Victoria 3195, Australia TEL: [03] 580-9911  
 © PIONEER ELECTRONIC CORPORATION 1990

# 1. SAFETY INFORMATION

## 1. SAFETY PRECAUTIONS

The following check should be performed for the continued protection of the customer and service technician.

### LEAKAGE CURRENT CHECK

Measure leakage current to a known earth ground (water pipe, conduit, etc.) by connecting a leakage current tester such as Simpson Model 229-2 or equivalent between the earth ground and all exposed metal parts of the appliance (input/output terminals, screwheads, metal overlays, control shaft, etc.). Plug the AC line cord of the appliance directly into a 120V AC 60Hz outlet and turn the AC power switch on. Any current measured must not exceed 0.5mA.

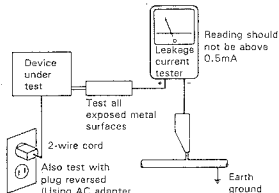

AC Leakage Test

### WARNING!

Lithium batteries. Danger of explosion. Replacement must be done by qualified personnel and only by following the instructions given in the service manual.

This warning is stated on the product or in the operating instructions. When replacing the lithium batteries, follow the note below.

Dispose of the used battery promptly. Keep away from children. Do not disassemble and do not dispose of in fire.

The battery used in this device may present a fire or chemical hazard if mistreated. Do not recharge, disassemble, heat above 100°C or incinerate. Replace only with the same Part Number. Use of another battery may present a risk of fire or explosion.

Note: The lithium battery installation position is shown in the exploded view and the P.C. board pattern.

ANY MEASUREMENTS NOT WITHIN THE LIMITS OUTLINED ABOVE ARE INDICATIVE OF A POTENTIAL SHOCK HAZARD AND MUST BE CORRECTED BEFORE RETURNING THE APPLIANCE TO THE CUSTOMER.

## 2. PRODUCT SAFETY NOTICE

Many electrical and mechanical parts in the appliance have special safety related characteristics. These are often not evident from visual inspection nor the protection afforded by them necessarily can be obtained by using replacement components rated for voltage, wattage, etc. Replacement parts which have these special safety characteristics are identified in this Service Manual.

Electrical components having such features are identified by marking with a  $\Delta$  on the schematics and on the parts list in this Service Manual.

The use of a substitute replacement component which does not have the same safety characteristics as the PIONEER recommended replacement one, shown in the parts list in this Service Manual, may create shock, fire, or other hazards.

Product Safety is continuously under review and new instructions are issued from time to time. For the latest information, always consult the current PIONEER Service Manual. A subscription to, or a additional copies of, PIONEER Service Manual may be obtained at a nominal charge from PIONEER.

### ADVARSEL!

Lithiumbatteri — Explosionsfare ved fejlagtig håndtering. Udskiftning må kun ske med batteri af samme fabrikat og type. Levér det brugte batteri tilbage til leverandøren.

Denne advarsel er angivet på produktet eller i brugsvejledningen. Ved udskiftning af lithium batterierne følges nedenstående anvisning. Batterierne må kun udskiftes med batterier af samme type og mærke.

### VARNING

Explosionsfara vid felaktigt batteribyte. Använd samma batterityp eller en ekvivalent typ som rekommenderas av apparatillverkaren. Kassera använt batteri enligt fabrikantens instruktion.

Denna varning finns på apparaten eller i bruksanvisningen. Följ nedanstående anvisningar vid byte av litiumbatterier. Batterierna får endast bytas ut mot litiumbatterier av samma typ och fabrikat.



(FOR EUROPEAN MODEL ONLY)

## VARO!

AVATTAESSA JA SUOJALUKITUS  
OHITETTAESSA OLET ALTIINA  
NÄKYMÄTTÖMÄLLE LASERSÄTEILYLLE.  
ÄLÄ KATSO SÄTEESEEN.



LASER  
Kuva 1  
Lasersäteilyn  
varoituserkki

## WARNING!

DEVICE INCLUDES LASER DIODE WHICH  
EMITS INVISIBLE INFRARED RADIATION  
WHICH IS DANGEROUS TO EYES. THERE IS  
A WARNING SIGN ACCORDING TO PICTURE  
1 INSIDE THE DEVICE CLOSE TO THE LASER  
DIODE.



LASER  
Picture 1  
Warning sign for  
laser radiation

## ADVARSEL:

USYNLIG LASERSTRÅLING VED ÅBNING  
NÅR SIKKERHEDSAFBRYDERE ER UDE AF  
FUNKTION UDGÅR UDSÆTTELSE FOR  
STRÅLING.

## VARNING!

OSYNLIG LASERSTRÅLING NÅR DENNA  
DEL ÄR ÖPPNAD OCH SPÄRREN  
ÄR URKOPPLAD. BETRÄKTA EJ STRÅLEN.

## IMPORTANT

THIS PIONEER APPARATUS CONTAINS  
LASER OF HIGHER CLASS THAN 1.  
SERVICING OPERATION OF THE APPARATUS  
SHOULD BE DONE BY A SPECIALLY  
INSTRUCTED PERSON.

## LASER DIODE CHARACTERISTICS

MAXIMUM OUTPUT POWER: 5 mw  
WAVELENGTH: 780-785 nm

## LABEL CHECK

• MAIN SECTION (REAR SIDE)

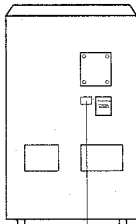

## VARO!

Avattamassa ja suoja-  
lukitus ohitettaessa olet  
alttiina näkymättömälle  
lasersäteilylle. Älä katso  
säteeseen.

## VARNING!

Osynlig laserstrålning när denna del  
är öppnad och spärren är  
urkopplad. Betrakta ej strålen.

PFR07022

**CAUTION**  
INVISIBLE LASER  
RADIATION WHEN OPEN,  
AVOID EXPOSURE  
TO BEAM

GRV1018

WEM type

**ADVARSEL**  
OSYNLIG LASERSTRÅLING VED ÅBNING NÅR SIKKERHEDS-  
AFBRYDERE ER UDE AF FUNKTION.  
UNDGÅ UDSÆTTELSE FOR STRÅLING.

**VORSICHT!**  
UNSEHBARE LASERSTRÅLUNG TRITTT AUS. WEIR DENKE  
VORER PLATZ! SCHNITT SICH NICHT DEM STRAHL AUSSETZEN!



WEM type

• CD SECTION  
(REMOVING CONDITION  
OF THE BONNET COVER)

**CLASS 1  
LASER PRODUCT**

VSW 128

HEM type

## Additional Laser Caution

- The player microcomputer checks the inserting condition of magazines A, B and C by using the combined signals of the SENS1 (S804), SENS2 (S805), SENS3 (S806), LOCK1 (S801), LOCK2 (S802) and LOCK3 (S803) switches. It is after these three magazines are fully inserted that commands from the control microcomputer are accepted. The laser diode is turned ON for illumination by outputting the laser diode ON signal from the control microcomputer when the CLAMP switch (S1001) (DSK1001), which signals that the tray is to be pulled from the magazine and detects clamping condition, is set to ON and the player receives the "rising command" in the disc clamping condition. If no disc is available, it turns OFF after 20 seconds. The illuminated laser diode goes out when receiving a "Reject command", a "disc change command" or a "magazine eject command." The laser diode continues to oscillate when pin ③ of CXA10B1S (IC1) is connected to GND or to pin ④.
- If the fault condition described in 1 is induced with the cover open and with the servo mechanism block removed to be turned over, close viewing of the objective lens with the naked eye will cause exposure to a class 1 or higher laser beam.

## 2. EXPLODED VIEWS AND PARTS LIST

### NOTES :

- Parts without part number cannot be supplied.
- The  $\Delta$  mark found on some component parts indicates the importance of the safety factor of the part. Therefore, when replacing, be sure to use parts of identical designation.
- Parts marked by "◎" are not always kept in stock. Their delivery time may be longer than usual or they may be unavailable.

### 2.1 MAIN SECTION

#### 2.1.1 EXTERIOR (1)

##### Parts List

Mark	No.	Part No.	Description	Mark	No.	Part No.	Description
	1	DAH1507	Sign board (upper)		40	SNH1018	Sash
	2	DAH1380	Sign board (under)		41	SNH1017	Sash
	3	DAH1183	Coin-return lever sheet A		42	SEB1072	Cushion
	4	DAH1443	Ornament sheet		43	SEW1014	Safety belt
	5	SBA-194	Screw		44	SEB1068	Packing
	6	DAH1431	Key sheet		45	SDF1013	Earth lug assembly
	7	DNK1236	Key knob A		46	SNA1233	Frame
	8	DNK1214	Key knob B		47	FMB50P160FZK	Screw
	9	DAH1432	Key sheet (B)		48	DEL-110	Fluorescent lamp
	10	CWC31P200FZK	Screw		49	SLH1050	Rail assembly
					50	CWC35P200FZK	Screw
	11	SNB1035	Door stopper				
	12	RWC31P200FUC	Screw		101		DS holder assembly
	13	SNB1037	Hook holder		102		Key plate (B)
	14	SNX1034	Magnet catch		103		Shield packing (B)
	15	DNK1618	Coin-return door		104		Coin guide (B)
					105		Coin-return tray
	16	DNK1616	Coin-return hole cover				
	17	DNH1335	Cover of the money storage		106		Coin box assembly
	18	DNF1258	Reinforced plate		107		Stopper B
	19	10-757A	Speaker (Mid-range)		108		Reflection plate
	20	D66AP45-52L	Speaker (Tweeter)		109		Socket holder (S)
					110		Socket holder (L)
	21	SMG1169	Grill				
	22	YE30FUC	E ring $\phi 3$		111		Lamp bracket (L)
	23	DEC1224	Illumination sheet		112		Lamp bracket (R)
$\Delta$	24	DKK1008	Fluorescent lamp socket (upper)		113		CB cushion
					114		Nut
					115		Cabinet
	25	DEC1220	Bushing				
	26	DEC-176	Plastic rivet		116		Punching net
	27	PMH30P060FMC	Screw		117		Badge
	28	TNC35P140FZK	Screw		118		Tape A
	29	SBA1061	Screw		119		Grill board
					120		Stopper A
	30	RWC35P160FZK	Screw				
	31	IPZ30P080FMC	Screw				
	32	BBZ30P060FMC	Screw				
	33	DBA1007	Screw (3.5 x 12mm)				
	34	PMB40P080FMC	Screw				
	35	IPZ30P080FMC	Screw				
	36	PMA60P100FMC	Screw				
	37	SNB1039	Catch plate L				
	38	SNB1040	Catch plate R				
	39	SNB1041	Door hinge				

## Parts List

Mark	No.	Part No.	Description
	1	DNK1627	Plate
	2	SNA1235	Rail
	3	Z5-803A	Speaker (Woofer)
	4	DSF1001	Micro switch
	5	DBH1125	O spring
	6	SNA1220	Reinforced plate
	7	DXB1022	Caster A
	8	DXB1023	Caster B
	9	YE20FUC	E ring $\phi 2$
	10	BBZ30P060FMC	Screw
	11	AMZ40F080FMC	Screw
	12	TNC35F140FZK	Screw
	13	PMH20P100FMC	Screw
	14	DBA1007	Screw (3.5 x 12mm)
	15	SBA1065	Screw
	16	PMB50P300FMC	Screw
	17	SBA-194	Screw
$\Delta$	18	DDE1034	Connection cord
	19	PDE1065	Cord with pin plug
	20	DEC1184	Shell clip
	21	YE30FUC	E ring $\phi 3$
	22	SNA1224	Earth plate
	101		Top door stay
	102		MB fixing plate
	103		Door SW cam
	104		Door switch holder assembly
	105		. . . . .
	106		Cabinet
	107		Airway cover
	108		Earth lug assembly
	109		Cord clamper
	110		R pin
	111		Magazine assembly
	112		Tape B

## 2.1.3 EXTERIOR (3)

## Parts List

Mark	No.	Part No.	Description	Mark	No.	Part No.	Description
△	1	DTH1106	Ballast		101		LAMP
△	2	DKK1001	Glow lamp socket		102		Stay A
●	3	SWN1219	Network assembly		103		Glow lamp
△	4	REK-103	Fuse (2A, FU801)		104		CA holder A
	5	10-757A	Speaker (Mid-range)		105		Hinge holder
	6	SNB1038	Speaker holder		106		Rear plate
	7	DXB1193	Hinge		107		CH lever B
	8	DBK1015	Accepter plate spring		108		CA holder C assembly
	9	BEZ30P060FMC	Screw		109		Edge guard (B)
	10	DBA1007	Screw (3.5 × 12mm)		110		Coin guide cover
	11	TNC35P140FZK	Screw		111		Insertion guide
	12	AYC30P250FMC	Screw		112		Cord clamper
	13	AMZ30P080FZK	Screw		113		HL holder assembly
	14	BSZ40P060FZK	Screw		114		CH lever assembly A
	15	BBZ40P080FMC	Screw		115		Bill holder (F)
	16	BEZ30P080FMC	Screw		116		Bill holder (L)
	17	PEZ30P120FMC	Screw		117		Bill holder (RE)
	18	DBH1037	CA spring		118		Bill holder (R)
	19	YE30FUC	E ring φ3		119		DS shaft A
	20	IPZ30P080FMC	Screw		120		DS base
	21	FMB40P080FMC	Screw		121		Door stay A
	22	AMZ40P080FMC	Screw		122		Cord clamper
	23	SNC1078	Protection net		123		DS shaft B
	24	DND1022	Door stay B		124		Tape C
					125		Tape D
					126		Coin guide (C)
					127		Ornament sash
					128		Shield packing (A)
					129		Cabinet
					130		Coin guide (D)
					131		Key plate (A)
					132		Insulation sheet

## Parts List

Mark	No.	Part No.	Description	Mark	No.	Part No.	Description
	1	DNK1633	Shaft holder		39	BBZ30P060FMC	Screw
	2	DNF1257	Corner edge		40	PMH30P060FMC	Screw
	3	DNK1629	Menu cap (L)		41	SMZ30H200FMC	Screw
	4	DNK1630	Menu cap (M)		42	BMZ26P060FMC	Screw
	5	DEC1252	Menu sheet		43	ZMD26H030FBT	Screw
	6	DNK1621	Worm wheel		44	BPZ30P080FCU	Screw
	7	DNK1626	Side ornament plate		45	AMZ30P060FZK	Screw
	8	DEC1250	Side ornament plate sheet (L)		46	ZMD40H080FBT	Screw
	9	DEC1251	Side ornament plate sheet (R)		47	DNA1070	Side frame (L)
	10	DNK1627	Ornament plate		48	DNA1071	Side frame (R)
	11	DEC1224	Illumination sheet		49	DEL-110	Fluorescent lamp
△	12	DKK1006	Fluorescent lamp socket (upper L)	●	50	DWX1110	POSS
△	13	DKK1007	Fluorescent lamp socket (under L)	●	51	DWX1109	ROTA
				●	52	DWX1132	CNTB
	14	DEC1220	Bushing		101		.....
	15	DXB-108	Bearing		102		.....
	16	DBH1107	Tension spring (under)		103		Top cover
	17	DMS1012	Synchro belt		104		.....
	18	DNK1622	Center pulley		105		.....
	19	DNK1623	Synchro pulley		106		Back frame
	20	DBH1108	Adjustment spring		107		.....
	21	DEC-176	Plastic rivet		108		Reflection plate
	22	VBN-002	Speed nut		109		Socket holder (L)
	23	DNK1632	Menu cap (U)		110		Socket holder (S)
	24	DNK1628	Menu		111		Lamp plate (L)
	25	DLA1900	Worm gear		112		Lamp plate (R)
	26	DNK1620	Pulley		113		Tension plate (under)
	27	DNK1624	Worm shaft holder		114		Under frame
	28	DMS1006	S2M timing belt		115		Adjustment plate
	29	DXB1160	Encoder disc assembly		116		Cord clamper
	30	DXM1033	Motor		117		Triangle frame (L)
	31	DXX1368	Motor assembly		118		Triangle frame (S)
	32	CEANP010M50	C70Z,C704		119		.....
	33	CGDYX104M25	C701,C703		120		Motor holder
	34	WA42D080D050	Washer		121		Sensor holder
	35	BBZ30P080FZK	Screw		122		Motor pulley
	36	BBZ40P080FMC	Screw				
	37	ZMD40H080FBT	Screw				
	38	SMZ30H120FBT	Screw				

## 2.1.5 AMP SECTION

## Parts List

Mark	No.	Part No.	Description	Mark	No.	Part No.	Description
⊙	1	DWR1078	POWB		101		ACIN
⊙	2	DWK1013	PREB		102		WBFT
⊙	3	DWH1007	PAMP		103		PSWB
△	4	REK-100	Fuse (1A, FU1,FU6,FU701,FU702)		104		• • • • •
△	5	REK-102	Fuse (1.6A, FU3,FU4)		105		SPTB
					106		IOJB
△	6	REK-104	Fuse (2.5A, FU5)		107		Side frame L
△	7	DTT1048	Main power transformer		108		Side frame R
△	8	AKP-502	3P AC outlet		109		Center frame
△	9	DDG1041	AC power cord		110		Front panel A
△	10	CM-22B	Strain relief				
	11	RAC1210	VR knob A		111		Protector
	12	RAC1211	VR knob B		112		Wire clip
	13	DLA-177	Staddle		113		Transformer frame
	14	DAC1107	Push knob		114		Cord clamper
	15	BBZ30P060FMC	Screw		115		Rear panel A
	16	BBZ30P060FZK	Screw		116		P.C.B. stopper
	17	BBZ40P060FMC	Screw		117		Heat sink
	18	BBZ30P140FMC	Screw		118		PF holder
	19	FMB40P060FMC	Screw		119		Connector assembly
	20	AMZ30P060FZK	Screw		120		Connector assembly
	21	DTT1049	Sub power transformer		121		Earth terminal
⊙	22	DWS1107	ASEL		122		PSEL
	23	DNK1893	Terminal cover		123		• • • • •
⊙	24	DWK1014	BGMB		124		Terminal holder
					125		P.C.B holder B
					126		Spacer

## Parts List

Mark	No.	Part No.	Description
	1		.....
Δ	2	DEM1001	Lithium batteries
	3	DAW1011	Electromagnetic counter
	4	DAC-118	Push button
	5		.....
	6	BBZ30P080FZK	Screw
	7	BBZ30P060FMC	Screw
	8	PMB30P060FCU	Screw
	101		RSSB
	102		CRJB
	103		OPER
	104		WBJB
	105		RMBB
	106		Front panel B
	107		P.C.B holder A
	108		Counter holder
	109		P.C.B. holder
	110		Side frame L
	111		Side frame R
	112		Reinforced frame
	113		Rear panel B
	114		Cushion
	115		CONT
	116		Bolt
	117		Cord clamper E
	118		Cord clamper
	119		P.C.B holder C
	120		Terminal holder
	121		Terminal holder
	122		Terminal holder C

## 2.1.7 TOP DOOR SECTION

## Parts List

Mark	No.	Part No.	Description	Mark	No.	Part No.	Description
⊙	1	DWG1128	MESS			101	SENS
⊙	2	DWG1129	DISP			102	Coin-return lever fixing plate
⊙	3	DWS1101	KEYB				Coin slit
	4	DAH1184	Coin-return lever sheet B			103	Top door base
	5	DAD1001	Coin-return lever			104	Top door lock plate
						105	
	6	DBH1033	Coin-return lever spring				
	7	DNS1044	Coin insertion hole			106	Lock plate stopper
	8		• • • • •			107	Cord clasper
	9	DNK1609	Operation panel			108	Glass sash
	10	DNK1610	Top door panel (upper)			109	Earth lug assembly
	11	DNK1612	Top door panel (side)				
	12	DNK1737	Top door panel (under)				
	13	DBH1034	Lock spring				
⊙	14	DWX1108	BRAN				
	15		• • • • •				
	16		• • • • •				
△	17	DAN1010	Menu glass				
	18	BPZ30P080FCU	Screw				
	19	FMH30P120FMC	Screw				
	20	IPZ30P080FMC	Screw				
	21	BBZ30P080FMC	Screw				
	22	DEC1356	IR filter				



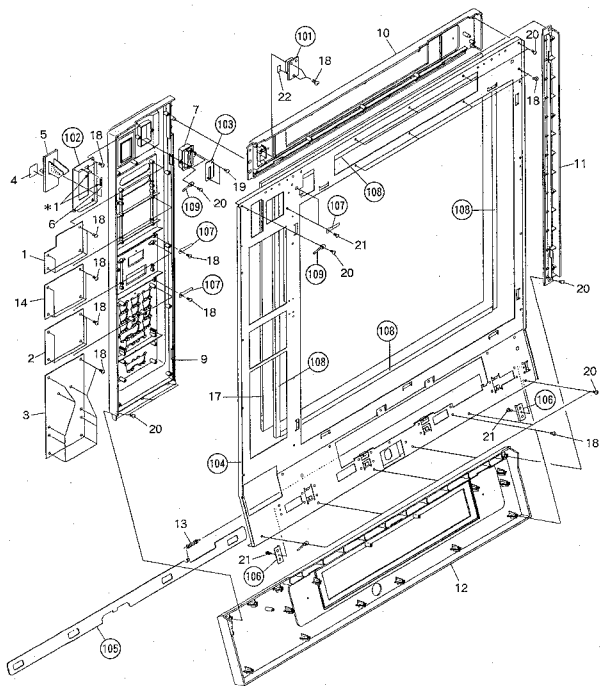

\* 1 : Silicon Adhesive GYL-014

## 2.2 CD SECTION

## 2.2.1 EXTERIOR

## Parts List

Mark	No.	Part No.	Description	Mark	No.	Part No.	Description
	1	DNE1083	Bonnet		101		Insulation plate B
	2	DXX1357	Bonnet assembly		102		HRMB
	3	DRW1151	Label A		103		EKEY
	4	DNB1012	Front panel		104		RMJB
	5	VCX-006	Hour meter		105		DJAK
	6	DAC1196	Push button		106		PJAK
	7	DTT1047	Power transformer (T201)		107		Chassis
△	8	REK-094	Fuse (250mA, FU201)		108		Upper base
△	9	DWX1155	ANLG		109		Under base
●	10	DEC-176	Plastic rivet		110		Slipping angle
	11	RNH-184	Cord clammer		111		Jack holder
	12	DLA1336	Coller		112		Insulation sheet
	13	DNK1179	SP holder				
	14	DNF1075	Plate B				
	15	DBH1106	Spring				
△	16	DDG1038	AC power cord				
	17		• • • • •				
	18	DLA1337	Lock shaft				
	19	DEB1123	Rubber washer				
	20	BBZ30P060FMC	Screw				
	21	PMZ30P040FMC	Screw				
	22	IFZ30P060FMC	Screw				
	23	AMZ30P060FMC	Screw				
	24	PMZ30P060FMC	Screw				
	25	PDZ30P050FMC	Screw				
	26	BBZ40P060FMC	Screw				
	27	AMZ40P250FMC	Screw				
	28	DDD1027	17P flexible cord				
	29	CM-22B	Strain relief				

## Parts List

Mark	No.	Part No.	Description	Mark	No.	Part No.	Description
	1	DNK1566	Lock lever		51	BMZ26P120FMC	Screw
	2	DXP1008	Plunger		52	PCZ30P050FZK	Screw
	3	DBH1101	Lock spring		53	DBA1003	Link screw
	4	PBH1015	SM spring		54	PBA1002	Floating screw
	5	DBK1028	Spring		55	PBA-125	Screw
	6	REC1005	Damper assembly		56	WT26D047D050	Washer
	7	PBH-465	Eject spring		57	WT26D047D025	Washer
	8	DMS1011	Timing belt		58	WA31D054D050	Washer
	9	DNK1578	Timing pulley		59	WA31D054D025	Washer
	10	DNK1575	Gear E2		60	YE25FUC	E ring
	11	DSH1011	Slide switch		61	WT31D054D050	Washer
	12	PXM1002	Motor (SELECT, LOADING)		62	DXP1358	Select motor assembly
	13	DBH1100	Select spring		63	DXP1009	Solenoid
	14	DNK1579	Select lever		64	BMZ26P030FMC	Screw
	15	DBH1102	Sensor spring		65	WT31D054D025	Washer
	16	RNH-184	Cord clamper		66	ZMD26H040FBT	Screw
	17	DWX1116	DEGT		67	DXB1189	Servo mechanism assembly
	18	DEC1237	Sheet		101		MJSW
	19	PNW1110	Cam		102		Side guide L
	20	PNW1111	Upper tray		103		SM select A
	21	PED1001	Cushion A		104		Top guide
	22	DNK1561	Clamper holder B		105		Side guide R
	23	DNS1080	Synchro gear		106		Center guide
	24	DNK1577	Turn drive lever		107		Eject lever
	25	DNK1574	Clamper cam		108		SM select B
	26	PYY1025	Motor assembly		109		Bottom guide
	27	DNK1573	Clamper lever		110		Guide bar
	28	DSK1001	Lever switch(S1001,CLAMP)		111		Gear EF
	29	DNK1569	Gear A		112		Gear angle
	30	DNK1570	Gear B		113		Motor base
	31	DEB1104	Belt		114		Sensor holder
	32	PNW1095	Gear pulley		115		REJC
	33	PBH1016	Clamper spring T		116		Sensor plate
	34	DBH1120	Clamper spring B		117		Main chassis
	35	DNK1572	Drive plate		118		FREC
	36	DNK1571	Drive lever		119		Insulation plate A
	37	PBP-001	Steel ball $\phi 4$		120		Card edge spacer
	38	DBH1108	Tension spring		121		Corner post
	39	DNK1568	Main gear		122		SENS
	40	PNW1107	Clamper holder T		123		.....
	41	PBP-009	Steel ball $\phi 3$		124		Upper chassis
	42	PNW1857	Clamper		125		Rubber tube
	43	DLA1296	Roller		126		Synchro shaft
	44	PEB1014	Floating rubber		127		Sub chassis
	45	DEC-176	Plastic rivet		128		Hold plate
	46	BPZ20P080FZK	Screw		129		Link plate
	47	BPZ30P100FMC	Screw		130		Link L
	48	BSZ26P040FMC	Screw		131		Link R
	49	PMZ20P030FMC	Screw		132		Motor pulley
	50	PMZ20P080FMC	Screw		133		Motor pulley

## 2.2.3 SERVO MECHANISM SECTION

## Parts List

Mark	No.	Part No.	Description
	1	CGDYX104M25	Semiconductive ceramic capacitor
	2	PEH1008	Drive spring
	3	PLA1004	Guide bar
	4	PNW1063	Carriage plate
	5	PXM1002	Motor
	6	PWY1009	Pickup assembly
	7	PMZ20P030FMC	Screw
	8	DXX1361	Spindle motor assembly
	9	PYY1025	Motor assembly
101			Motor pulley
102			Carriage M board

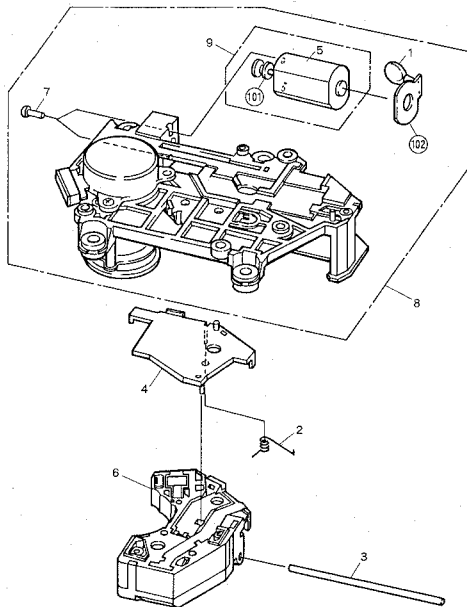

## 3. PACKING

## 3.1 MAIN SECTION

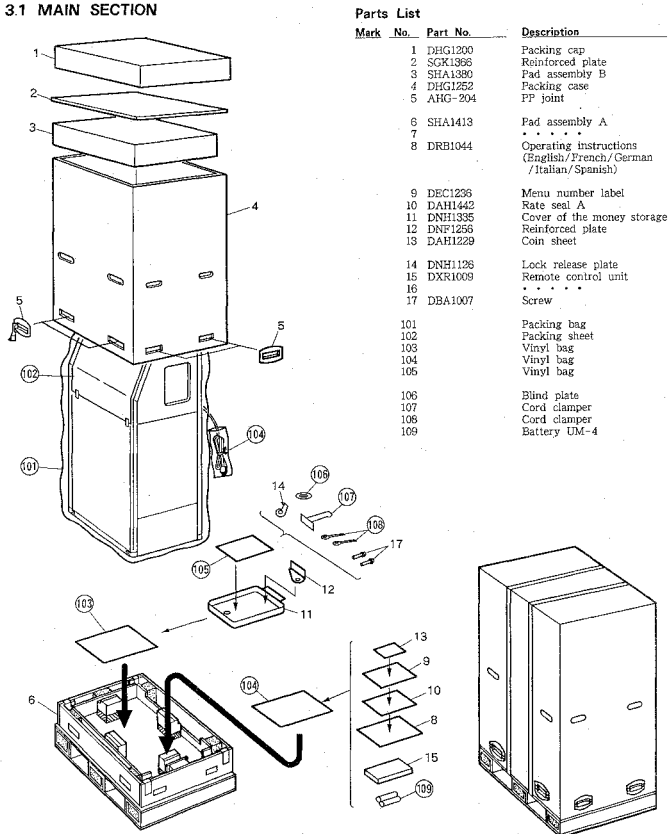

## 3.2 PACKING OF PD-MV55

## Parts List

Mark	No.	Part No.	Description
	1	DHA1086	F pad
	2	DHA1087	R pad
	3	DHG1223	Packing case
	4	DDE1034	Connection cord
	5	FDE1065	Connection cord with pin plug
	6	AMZ40P060FMC	Screw
	7	DHG1164	Case
	8	DRW1156	Label B
	9	DRB1042	Operating instructions (English/French/German/Italian/Spanish)
	10	DHC1015	Reinforcement plate
	101		Packing sheet
	102		Vinyl bag
	103		Vinyl bag
	104		Cord clasper
	105		Caution label

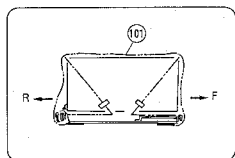

SIDE VIEW

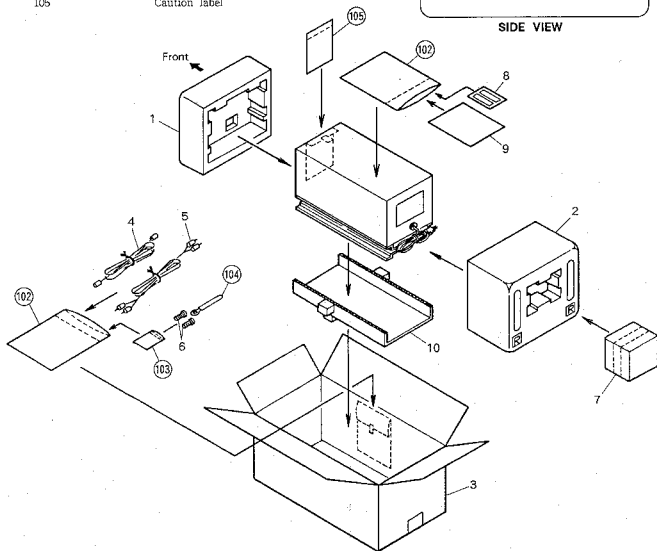

1

2

3

4

5

6

CONT

32-04 G56-057 1045-01 \*C22 105 CM-057 R6  
 047-250 000017 08-026 07 10-0 081-055 143 031-057 R6  
 08-026 07 10-0 081-055 143 031-057 R6

A

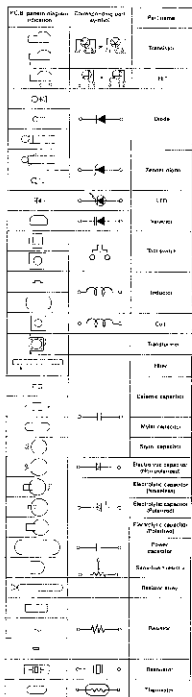

B

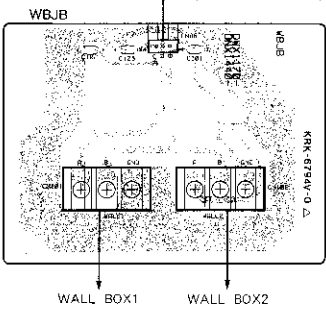

C

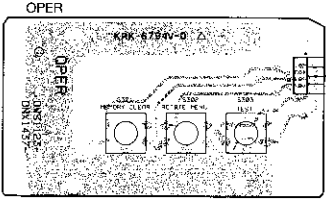

D

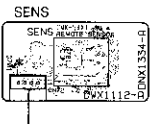

COUNTER

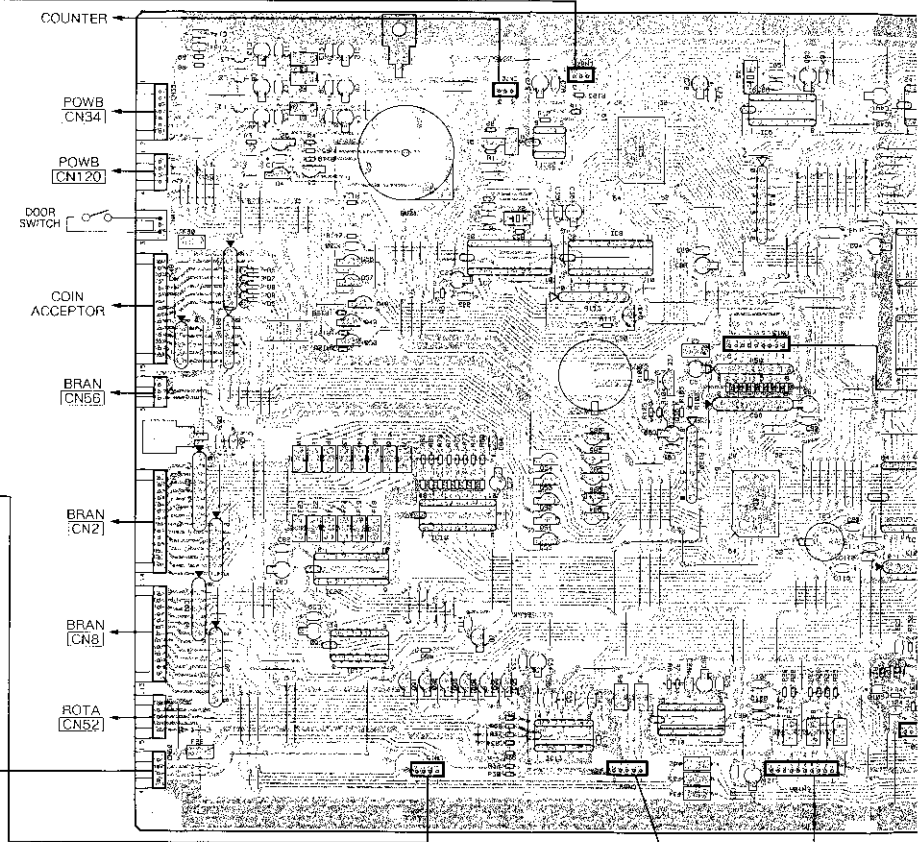
POWB  
CN34POWB  
CN120DOOR  
SWITCHCOIN  
ACCEPTORBRAN  
CN66BRAN  
CN2BRAN  
CN8ROTA  
CN52

1

2

3

4

5

6

- To PCB connector diagram - insert from the sub-assembly set.
- The part numbers have been checked on the board and the symbols on the board with the corresponding wiring numbers listed in the above table.
- The board is shown as set with "1" check - original artwork.
- The board is shown as set with "2" check - original artwork.
- The various artwork files were checked.

## 4. SCHEMATIC DIAGRAMS AND P.C. BOARDS PATTERN

### 4.1 MAIN SECTION

#### 4.1.1 OVERALL CONNECTION DIAGRAM

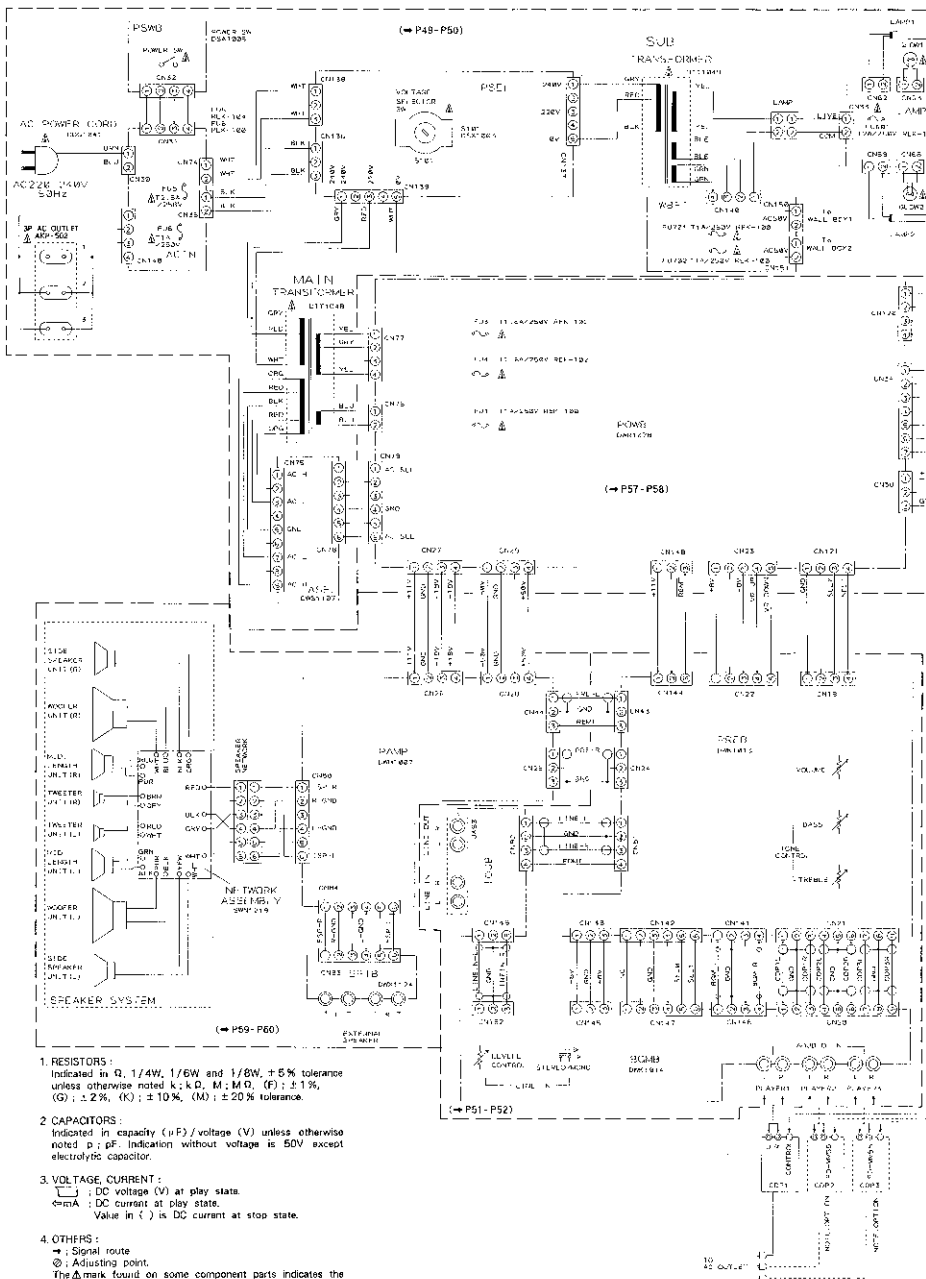



5. SWITCHES : (The underlined indicates the switch position)

MAIN SECTION  
 OUTSIDE OF P.C. BOARDS

DOOR SW

CLAMP SW  
 DOWN LIMIT TRAY SW  
 IN SIDE SW

KEY

KEYB

S301 : 1  
 S302 : 2  
 S303 : 3  
 S304 : 4  
 S305 : 5  
 S306 : 6  
 S307 : 7  
 S308 : 8  
 S309 : 9  
 S310 : 0

S311 : } CLEAR  
 S312 : }  
 S313 : }  
 S314 : } BEST HITS  
 S315 : } ROTATE MENU  
 S316 : }

ASL

SPEAKER SELECTOR SW  
 BUILT - IN AND  
 EXTERNAL  
 SPEAKERS

PSWB  
 POWER SW ON-OFF  
 OPEN

S301 : MEMORY CLEAR  
 S302 : MENU ROTATION  
 S303 : SERVICE MODE

RSSB

S1 : FUNCTION

RGMB

S201 : STEREO/MONO

S301 : A  
 S302 : B  
 S303 : C } EJECT

S801 : UP LIMIT  
 MJ5W }  
 S801 : 1 } MJ LOCK  
 S802 : 2 }  
 S803 : 3 }  
 S804 : 1 } MJ SENS  
 S805 : 2 }  
 S806 : 3 }

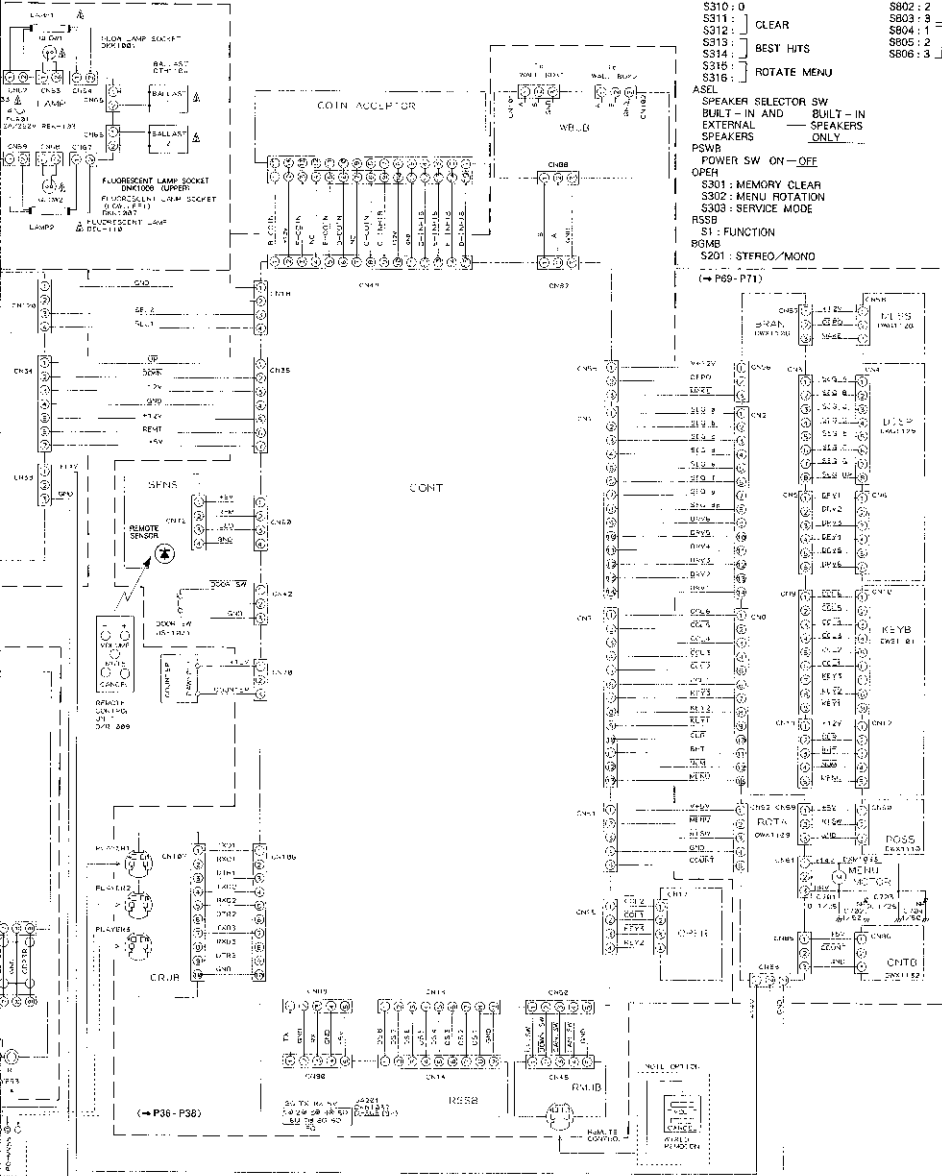

4.1.2 RSSB, CRJB, SENS, CONT, RMJB, OPER AND WBJB

A  
B  
C  
D  
E  
F

(→ P58) (→ P58)

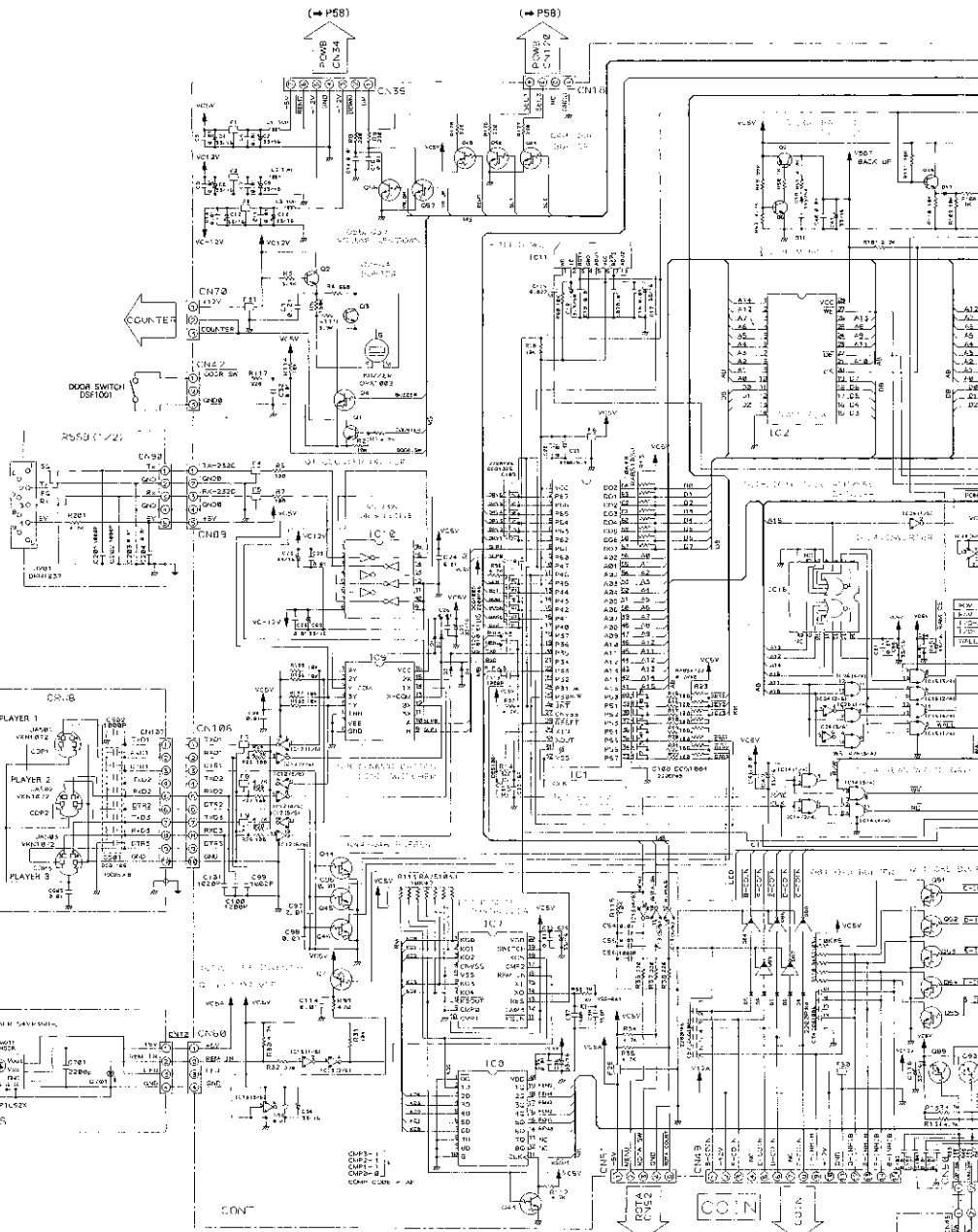

(→ P70)

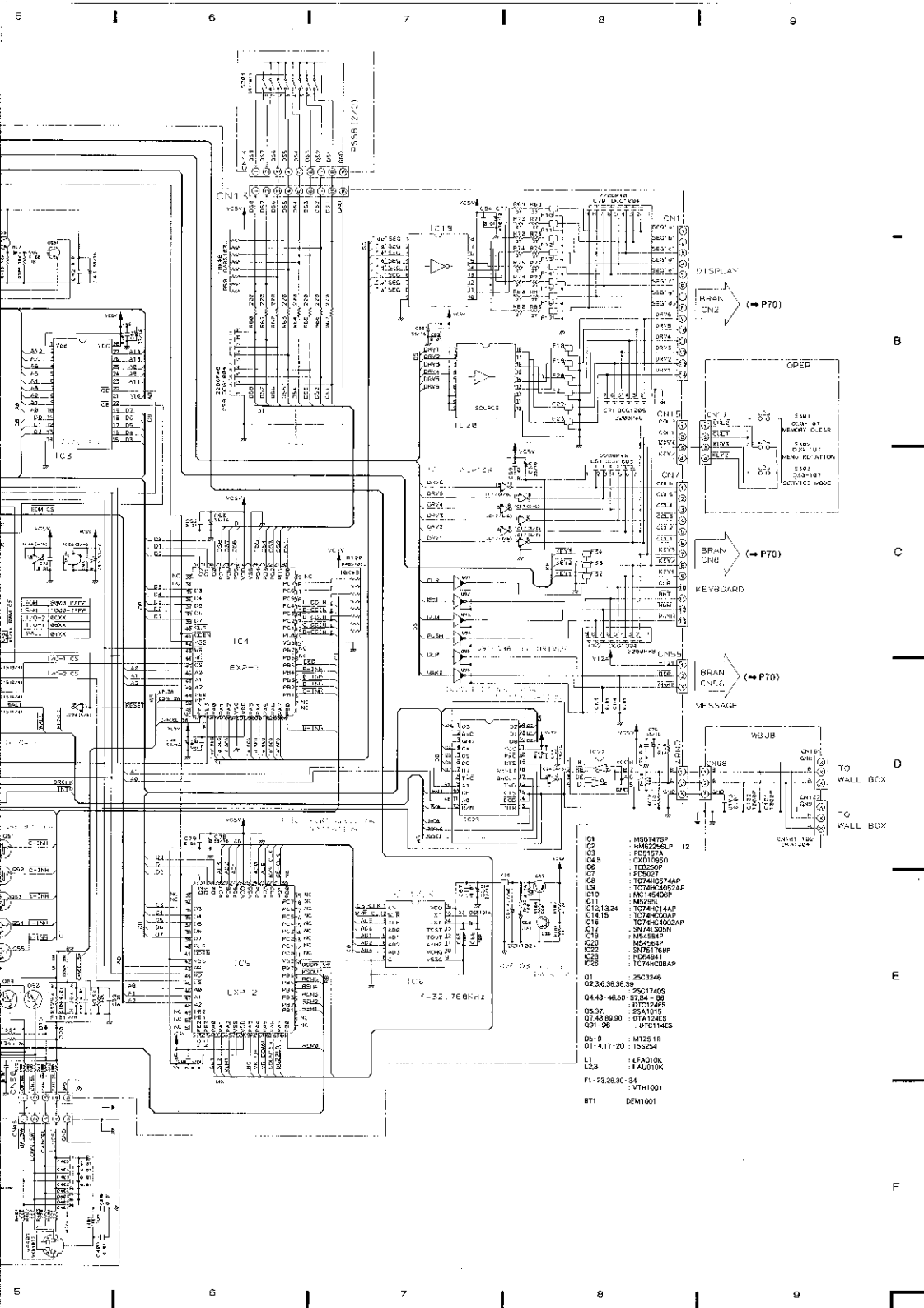

- IC1 - 74LS175P
- IC2 - 74LS260P
- IC3 - 74LS175A
- IC4 - 74LS175P
- IC5 - 74LS260P
- IC6 - 74LS175P
- IC7 - 74LS260P
- IC8 - 74LS175P
- IC9 - 74LS260P
- IC10 - 74LS175P
- IC11 - 74LS260P
- IC12 - 74LS175P
- IC13 - 74LS260P
- IC14 - 74LS175P
- IC15 - 74LS260P
- IC16 - 74LS175P
- IC17 - 74LS260P
- IC18 - 74LS175P
- IC19 - 74LS260P
- IC20 - 74LS175P
- IC21 - 74LS260P
- IC22 - 74LS175P
- IC23 - 74LS260P
- IC24 - 74LS175P
- IC25 - 74LS260P
- IC26 - 74LS175P
- IC27 - 74LS260P
- IC28 - 74LS175P
- IC29 - 74LS260P
- IC30 - 74LS175P
- IC31 - 74LS260P
- IC32 - 74LS175P
- IC33 - 74LS260P
- IC34 - 74LS175P
- IC35 - 74LS260P
- IC36 - 74LS175P
- IC37 - 74LS260P
- IC38 - 74LS175P
- IC39 - 74LS260P
- IC40 - 74LS175P
- IC41 - 74LS260P
- IC42 - 74LS175P
- IC43 - 74LS260P
- IC44 - 74LS175P
- IC45 - 74LS260P
- IC46 - 74LS175P
- IC47 - 74LS260P
- IC48 - 74LS175P
- IC49 - 74LS260P
- IC50 - 74LS175P
- IC51 - 74LS260P
- IC52 - 74LS175P
- IC53 - 74LS260P
- IC54 - 74LS175P
- IC55 - 74LS260P
- IC56 - 74LS175P
- IC57 - 74LS260P
- IC58 - 74LS175P
- IC59 - 74LS260P
- IC60 - 74LS175P
- IC61 - 74LS260P
- IC62 - 74LS175P
- IC63 - 74LS260P
- IC64 - 74LS175P
- IC65 - 74LS260P
- IC66 - 74LS175P
- IC67 - 74LS260P
- IC68 - 74LS175P
- IC69 - 74LS260P
- IC70 - 74LS175P
- IC71 - 74LS260P
- IC72 - 74LS175P
- IC73 - 74LS260P
- IC74 - 74LS175P
- IC75 - 74LS260P
- IC76 - 74LS175P
- IC77 - 74LS260P
- IC78 - 74LS175P
- IC79 - 74LS260P
- IC80 - 74LS175P
- IC81 - 74LS260P
- IC82 - 74LS175P
- IC83 - 74LS260P
- IC84 - 74LS175P
- IC85 - 74LS260P
- IC86 - 74LS175P
- IC87 - 74LS260P
- IC88 - 74LS175P
- IC89 - 74LS260P
- IC90 - 74LS175P
- IC91 - 74LS260P
- IC92 - 74LS175P
- IC93 - 74LS260P
- IC94 - 74LS175P
- IC95 - 74LS260P
- IC96 - 74LS175P
- IC97 - 74LS260P
- IC98 - 74LS175P
- IC99 - 74LS260P
- IC100 - 74LS175P

01 - 25C3246  
 02 - 36263839  
 03 - 25C17405  
 04 - 43-4620-5734-98  
 05 - 37012455  
 06 - 37012455  
 07 - 25A1015  
 08 - 25A1015  
 09 - 25A1015  
 10 - 25A1015  
 11 - 25A1015  
 12 - 25A1015  
 13 - 25A1015  
 14 - 25A1015  
 15 - 25A1015  
 16 - 25A1015  
 17 - 25A1015  
 18 - 25A1015  
 19 - 25A1015  
 20 - 25A1015  
 21 - 25A1015  
 22 - 25A1015  
 23 - 25A1015  
 24 - 25A1015  
 25 - 25A1015  
 26 - 25A1015  
 27 - 25A1015  
 28 - 25A1015  
 29 - 25A1015  
 30 - 25A1015  
 31 - 25A1015  
 32 - 25A1015  
 33 - 25A1015  
 34 - 25A1015  
 35 - 25A1015  
 36 - 25A1015  
 37 - 25A1015  
 38 - 25A1015  
 39 - 25A1015  
 40 - 25A1015  
 41 - 25A1015  
 42 - 25A1015  
 43 - 25A1015  
 44 - 25A1015  
 45 - 25A1015  
 46 - 25A1015  
 47 - 25A1015  
 48 - 25A1015  
 49 - 25A1015  
 50 - 25A1015  
 51 - 25A1015  
 52 - 25A1015  
 53 - 25A1015  
 54 - 25A1015  
 55 - 25A1015  
 56 - 25A1015  
 57 - 25A1015  
 58 - 25A1015  
 59 - 25A1015  
 60 - 25A1015  
 61 - 25A1015  
 62 - 25A1015  
 63 - 25A1015  
 64 - 25A1015  
 65 - 25A1015  
 66 - 25A1015  
 67 - 25A1015  
 68 - 25A1015  
 69 - 25A1015  
 70 - 25A1015  
 71 - 25A1015  
 72 - 25A1015  
 73 - 25A1015  
 74 - 25A1015  
 75 - 25A1015  
 76 - 25A1015  
 77 - 25A1015  
 78 - 25A1015  
 79 - 25A1015  
 80 - 25A1015  
 81 - 25A1015  
 82 - 25A1015  
 83 - 25A1015  
 84 - 25A1015  
 85 - 25A1015  
 86 - 25A1015  
 87 - 25A1015  
 88 - 25A1015  
 89 - 25A1015  
 90 - 25A1015  
 91 - 25A1015  
 92 - 25A1015  
 93 - 25A1015  
 94 - 25A1015  
 95 - 25A1015  
 96 - 25A1015  
 97 - 25A1015  
 98 - 25A1015  
 99 - 25A1015  
 100 - 25A1015

F1 - P3280-34  
 V111001  
 B11 - DEM1001

4

5

6

7

8

9

CONT

IC2507 348 IC50 081-096 IC7 IC29 034-055 IC13 IC8 028-047 IC10 IC6 IC23 IC1-IC3 090-089 036-039 IC26-IC28 IC9 IC4-IC6 IC11 K10 C5 C6 044-046

COUNTER

POWB [CN34]

POWB [CN120]

OR FC4

COIN CCEPTOR

BRAN [CN56]

BRAN [CN2]

BRAN [CN8]

ROTA [CN52]

CONT DNP1262-B  
DWG1177  
DIE 772-00-A

RSSB

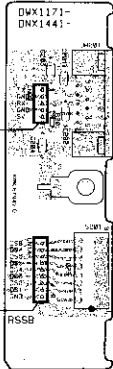

A

B

C

D

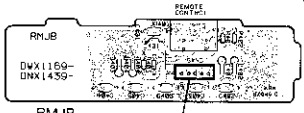

RMJB

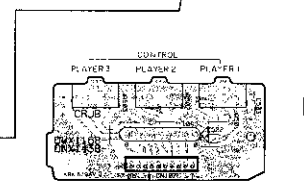

CRJB

BT

4

5

6

7

8

9

9 | 8 | 7 | 6 | 5 | 4

This P.C.B. connection diagram is viewed from the foil side.

A

B

C

D

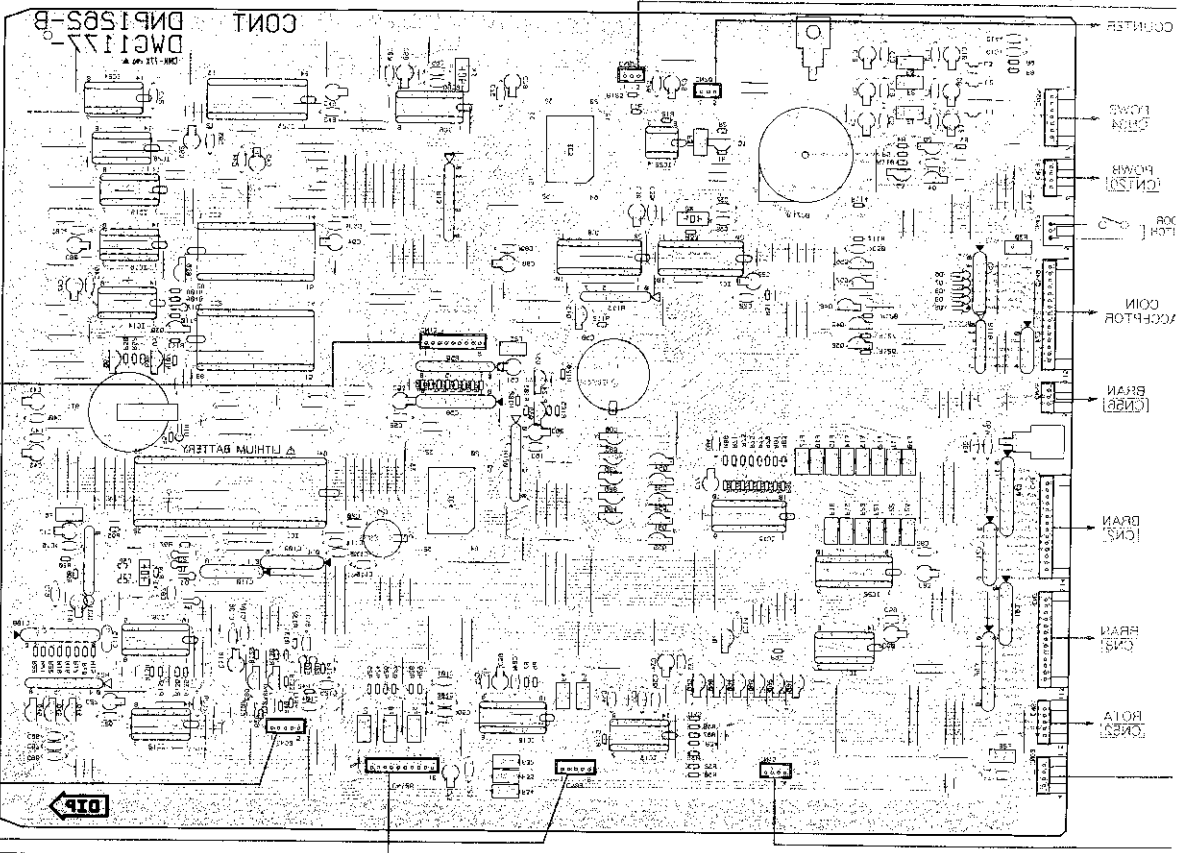
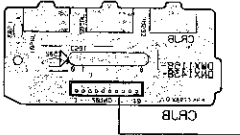
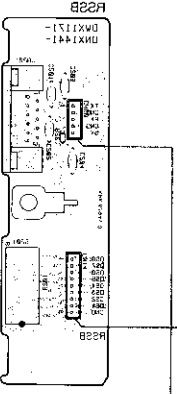

03-04 IC301C1 IC29-030C IC28-030C IC27-030C IC26-030C IC25-030C IC24-030C IC23-030C IC22-030C IC21-030C IC20-030C IC19-030C IC18-030C IC17-030C IC16-030C IC15-030C IC14-030C IC13-030C IC12-030C IC11-030C IC10-030C IC9-030C IC8-030C IC7-030C IC6-030C IC5-030C IC4-030C IC3-030C IC2-030C IC1-030C

CONT

9 | 8 | 7 | 6 | 5 | 4

CONT

49-64	98-96	10-1
100011	081-086	21
086-081	100-81	10-1
103-02	041	020-031
103	103	103
103	103	103

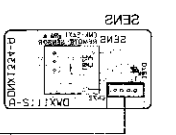
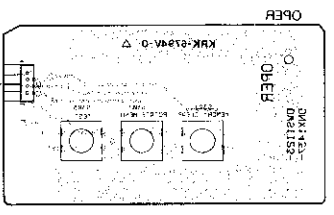
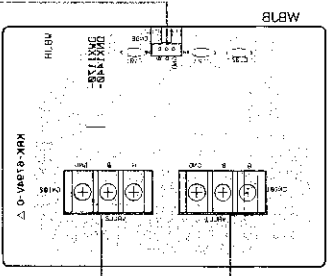
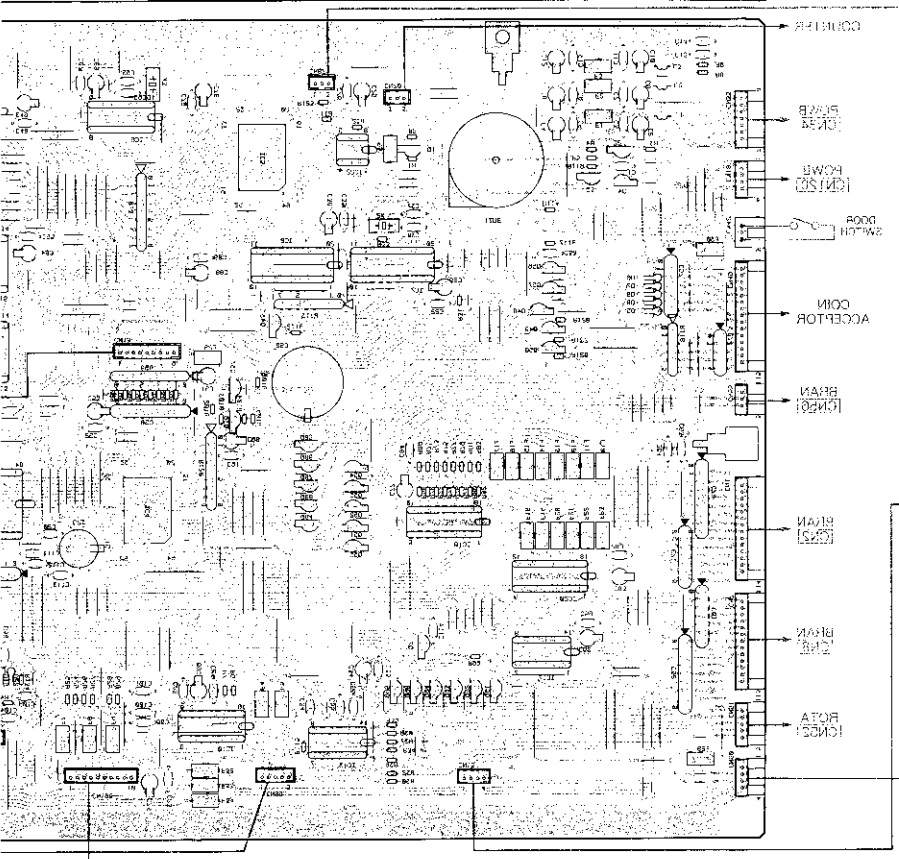

A

B

C

D

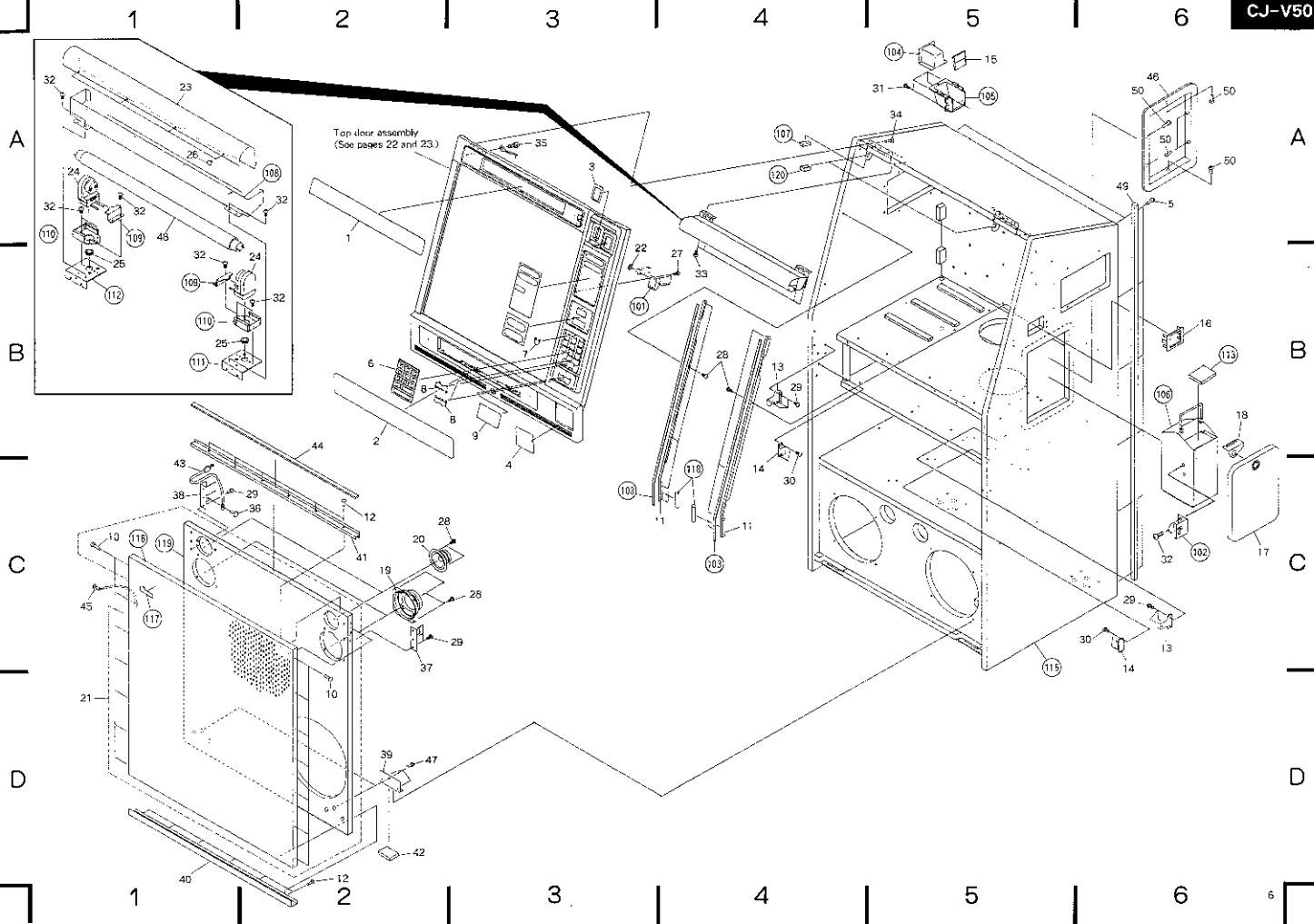

A

B

C

D

A

B

C

D

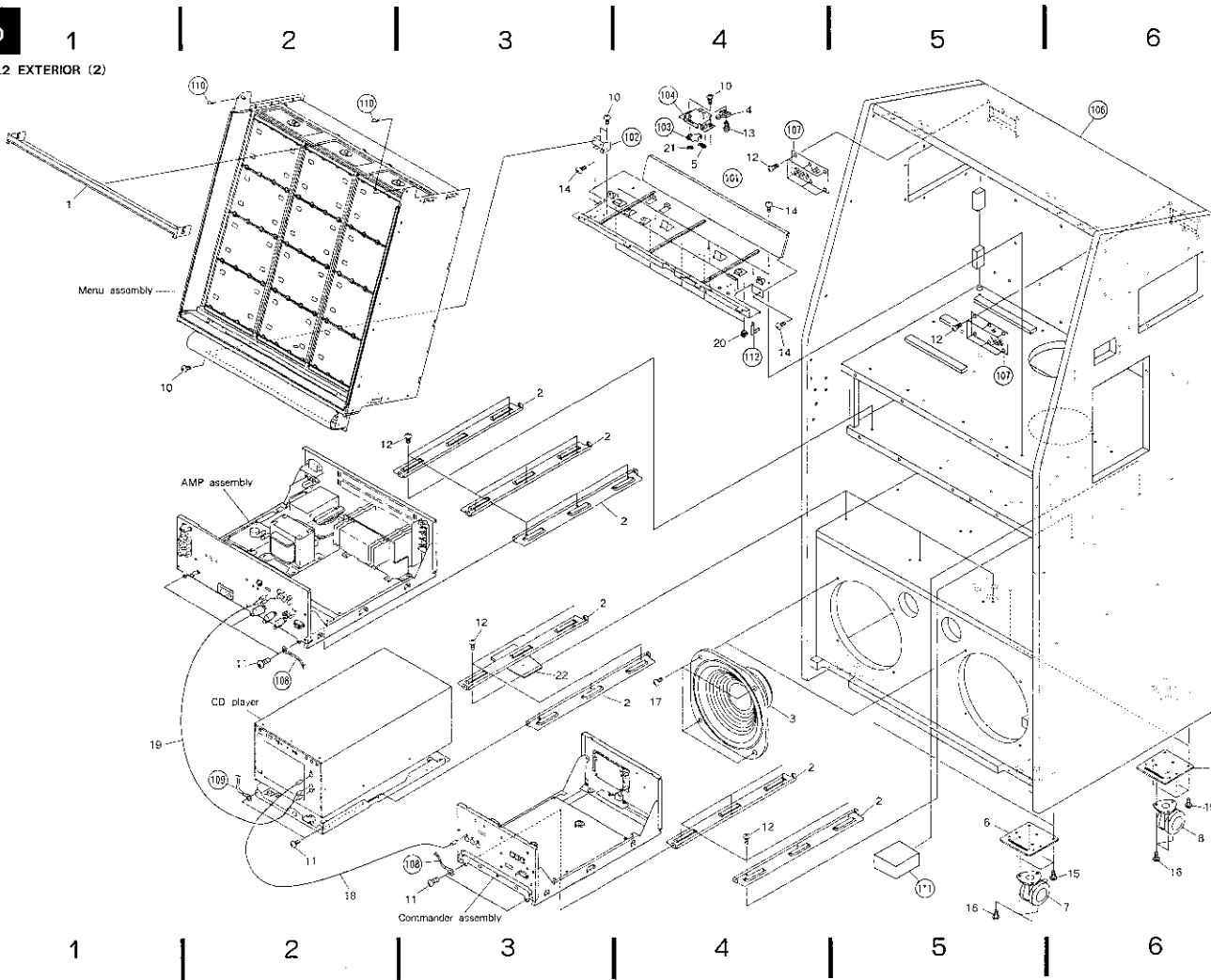



1

2

3

4

5

6

A

B

C

D

A

B

C

D

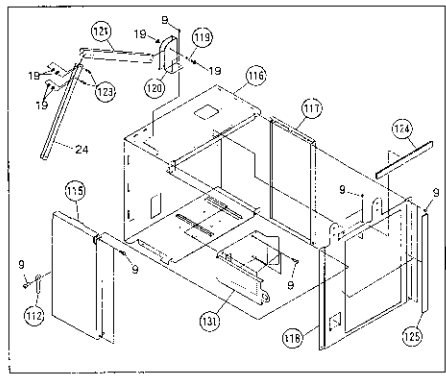
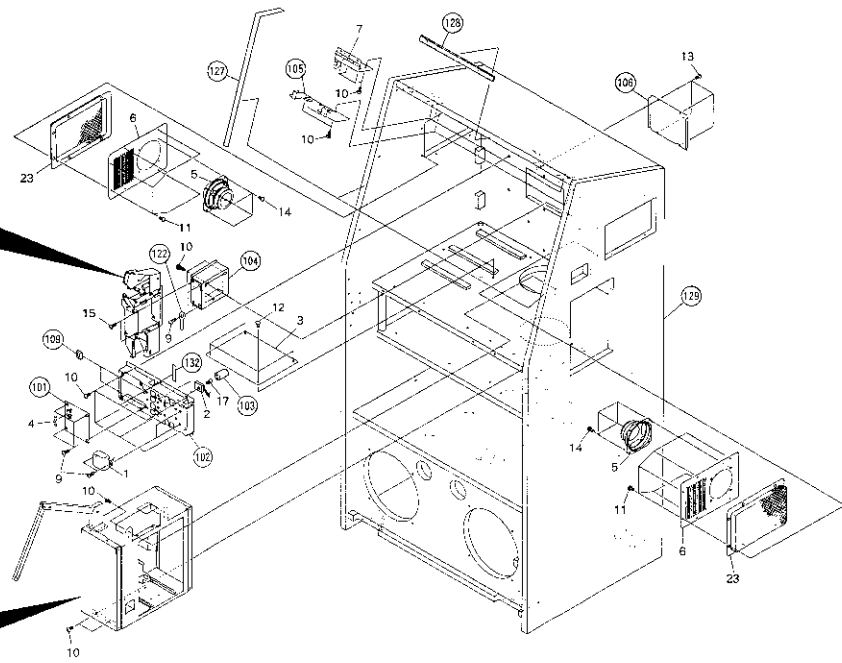
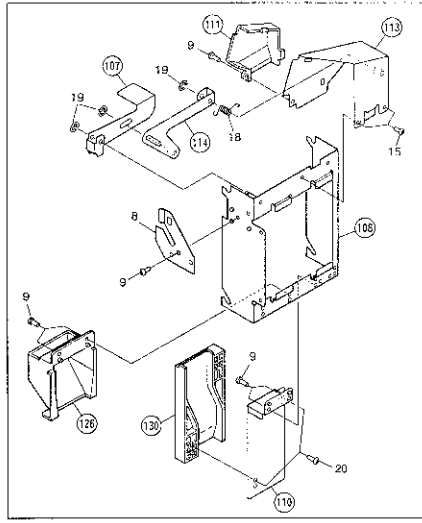

1

2

3

4

5

6

2.1.4 MENU BOARD SECTION

1 | 2 | 3 | 4 | 5 | 6

A

B

C

D

A

B

C

D

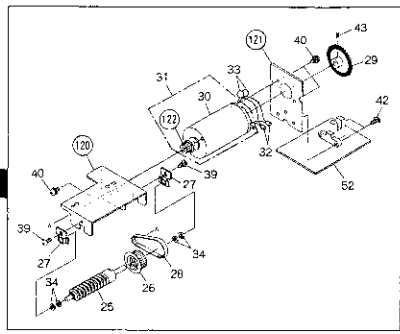
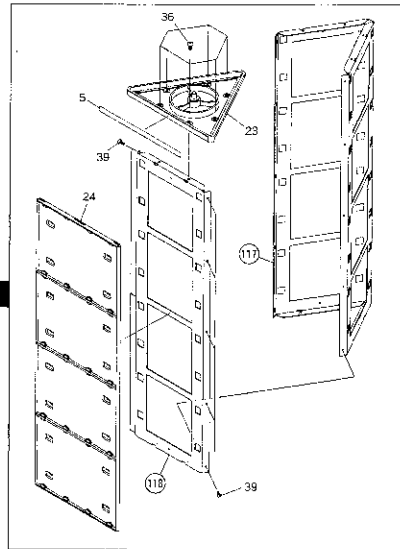
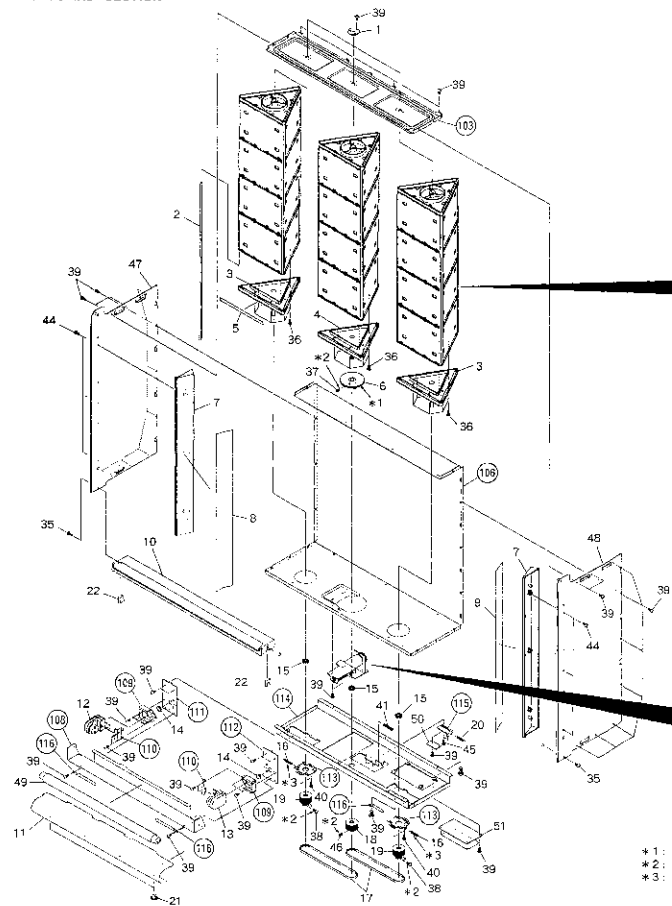

- \* 1: Froll GYA-008
- \* 2: Screw locking point
- \* 3: Silicon grease  
GYL1002 or GYA-009

1 | 2 | 3 | 4 | 5 | 6

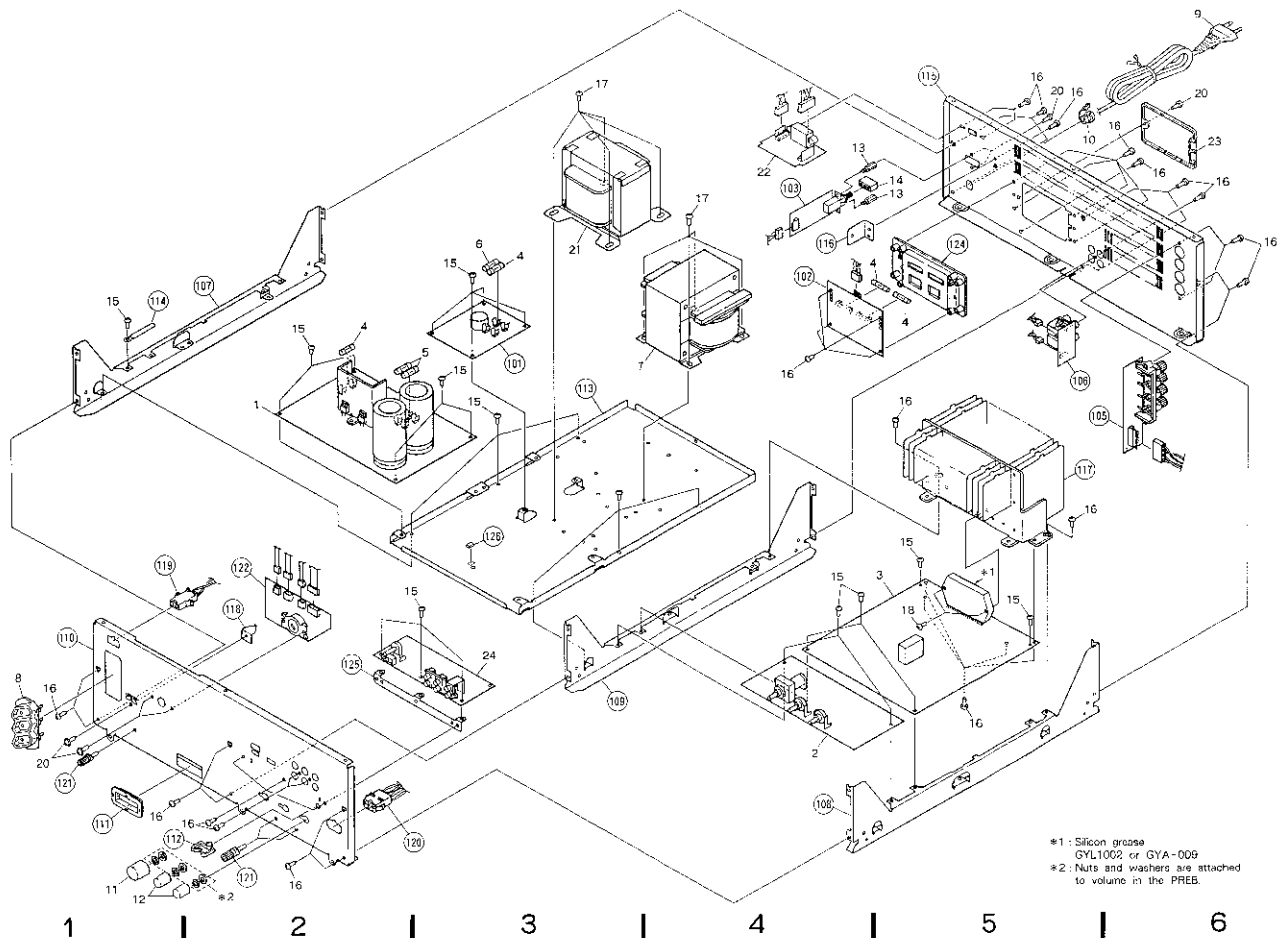

2.1.6 COMMANDER SECTION

1 | 2 | 3 | 4 | 5 | 6

A  
B  
C  
D

A  
B  
C  
D

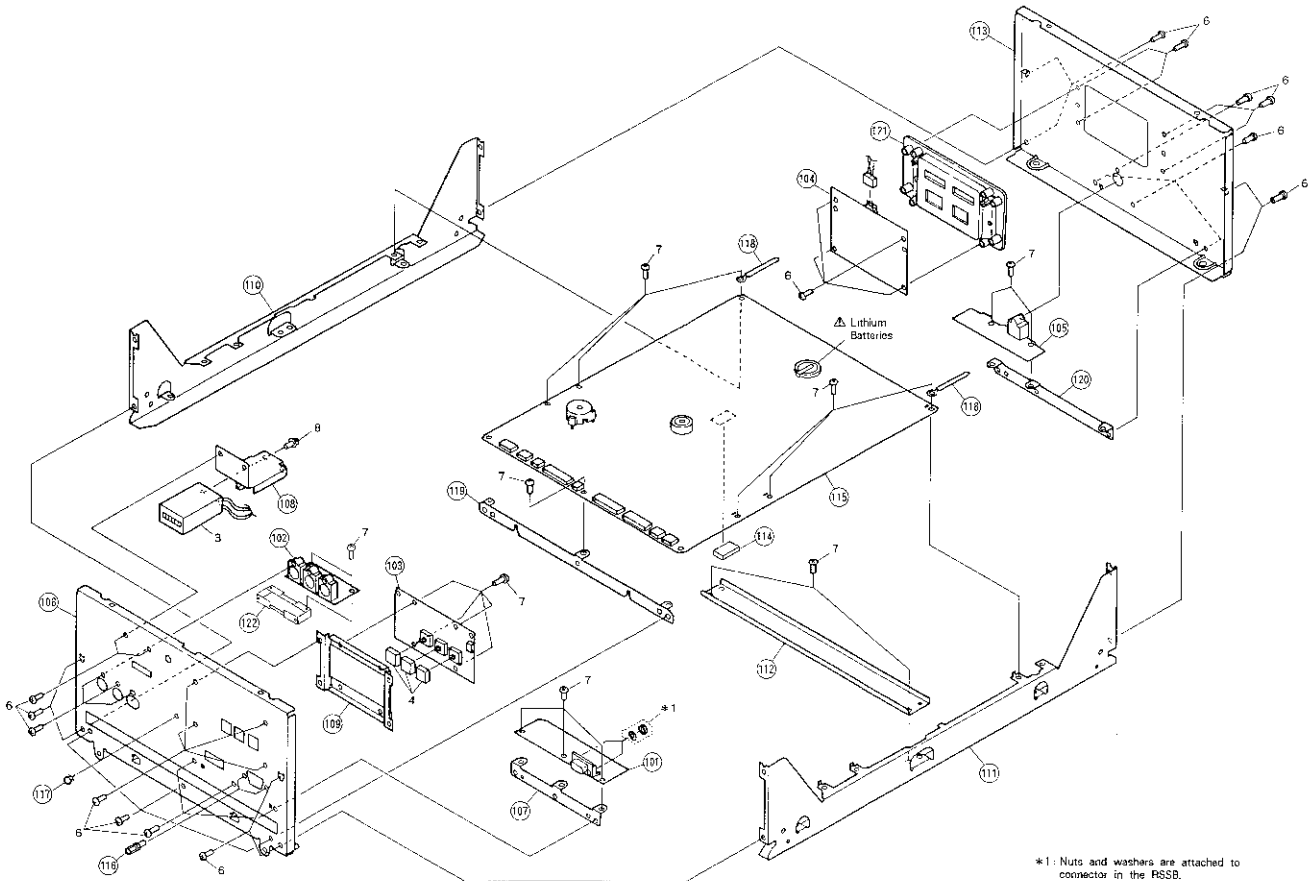

\*1: Nuts and washers are attached to connector in the RSSB.

19 | 1 | 2 | 3 | 4 | 5 | 6

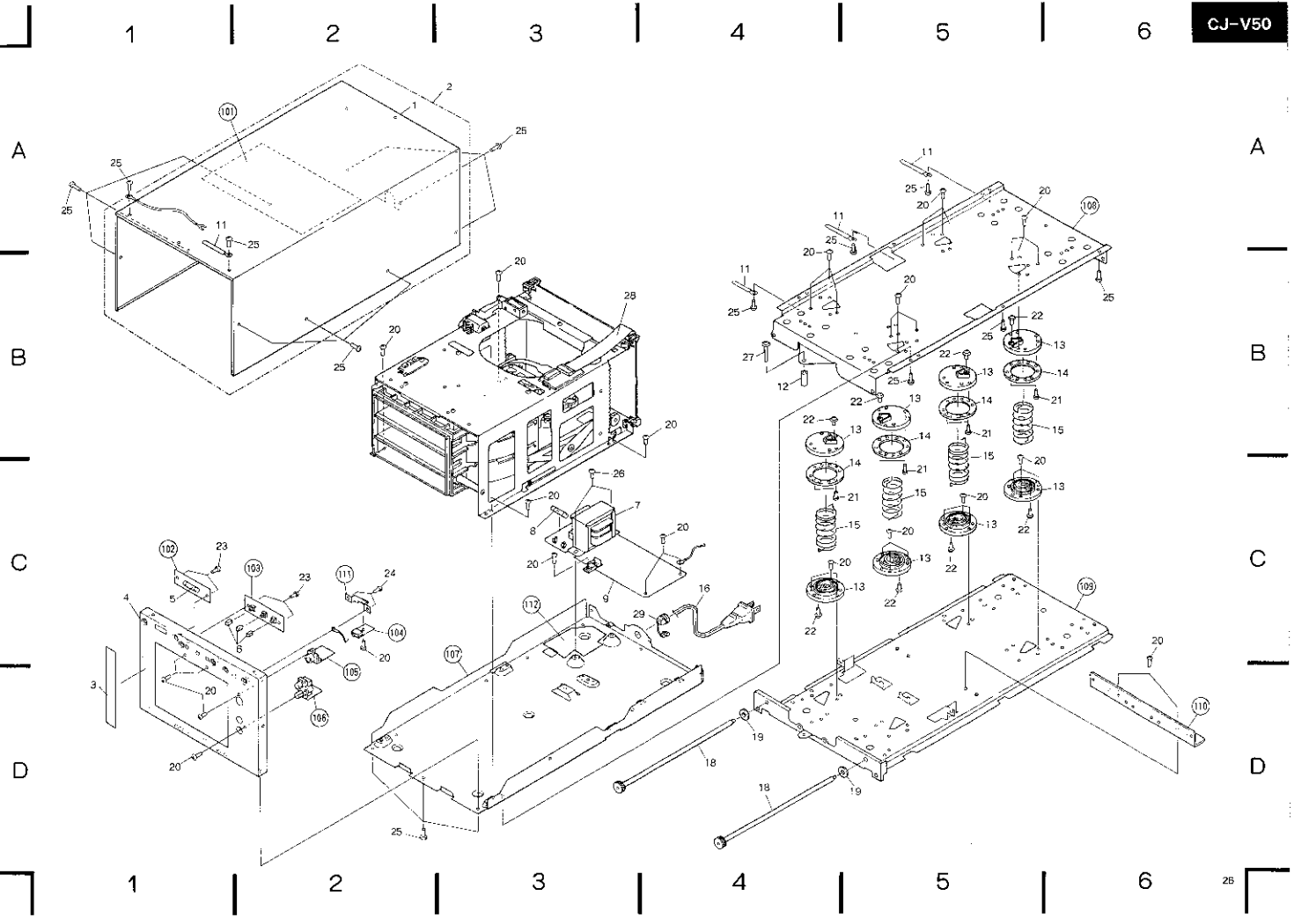

2.2.2 MECHANISM SECTION

A

B

C

D

A

B

C

D

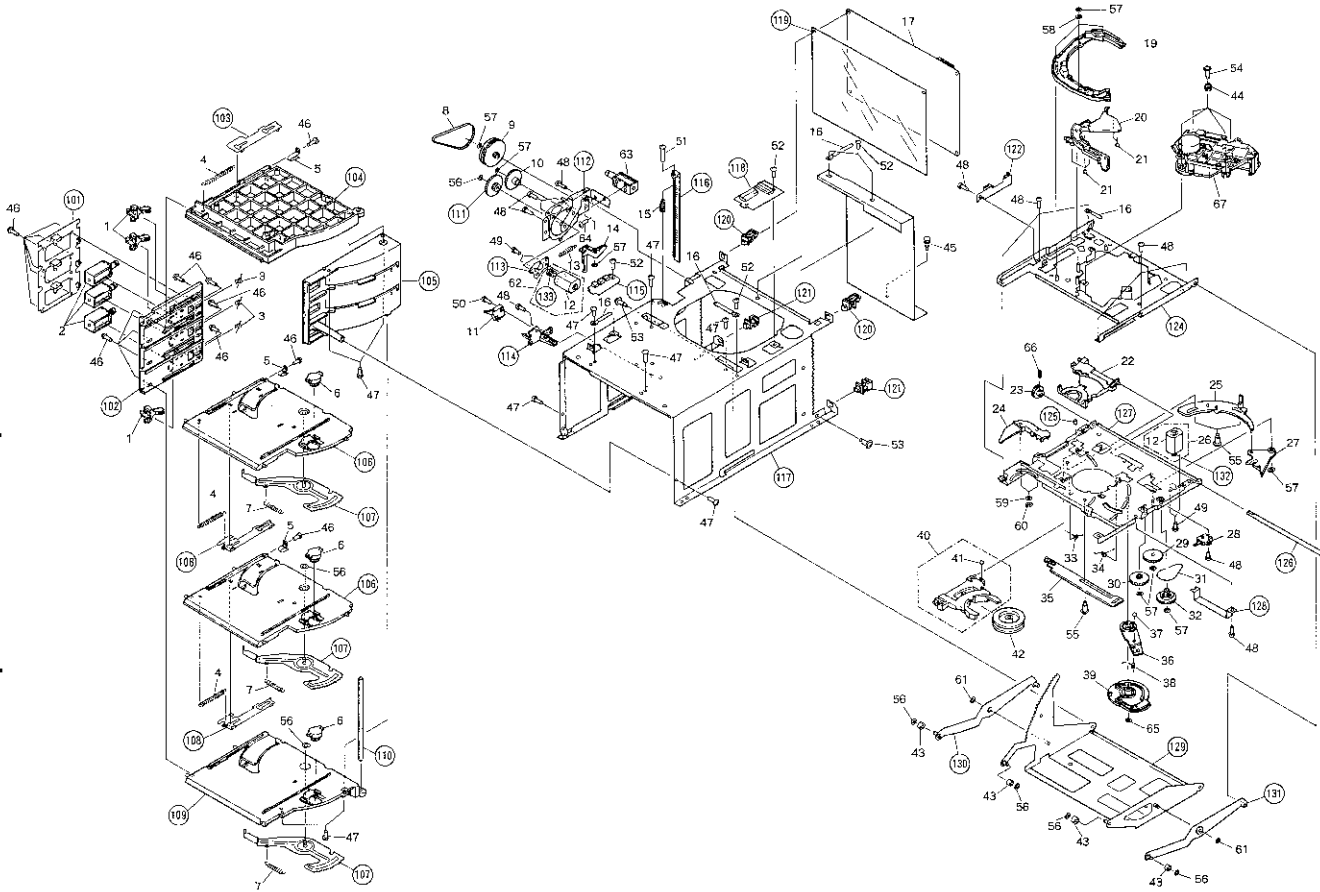

4.1.3 PSEL, ACIN, PSWB, LAMP, WBFL AND ASEL

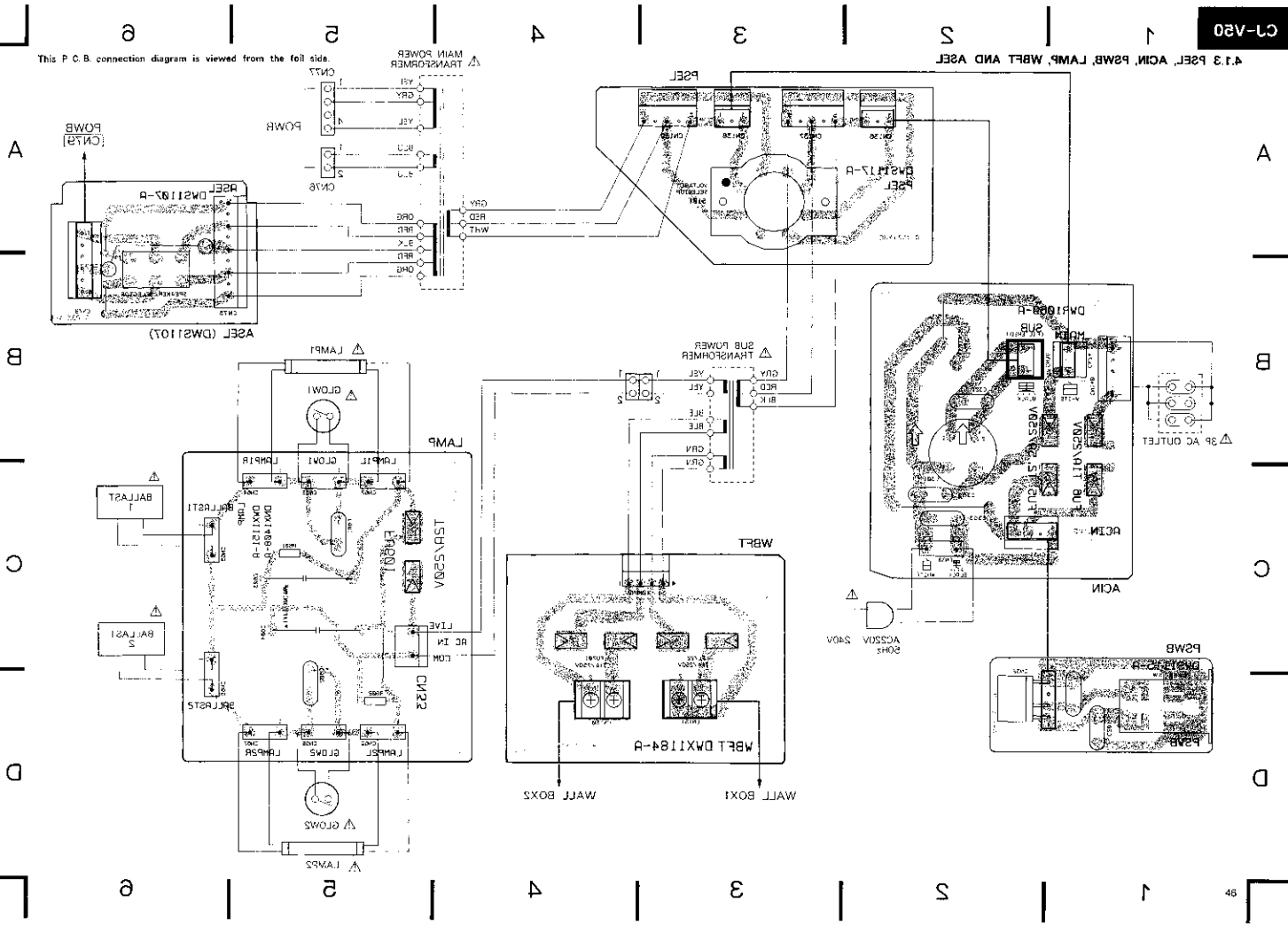

4.1.3 PSEL, ACIN, PSWB, LAMP, WBFT AND ASEL

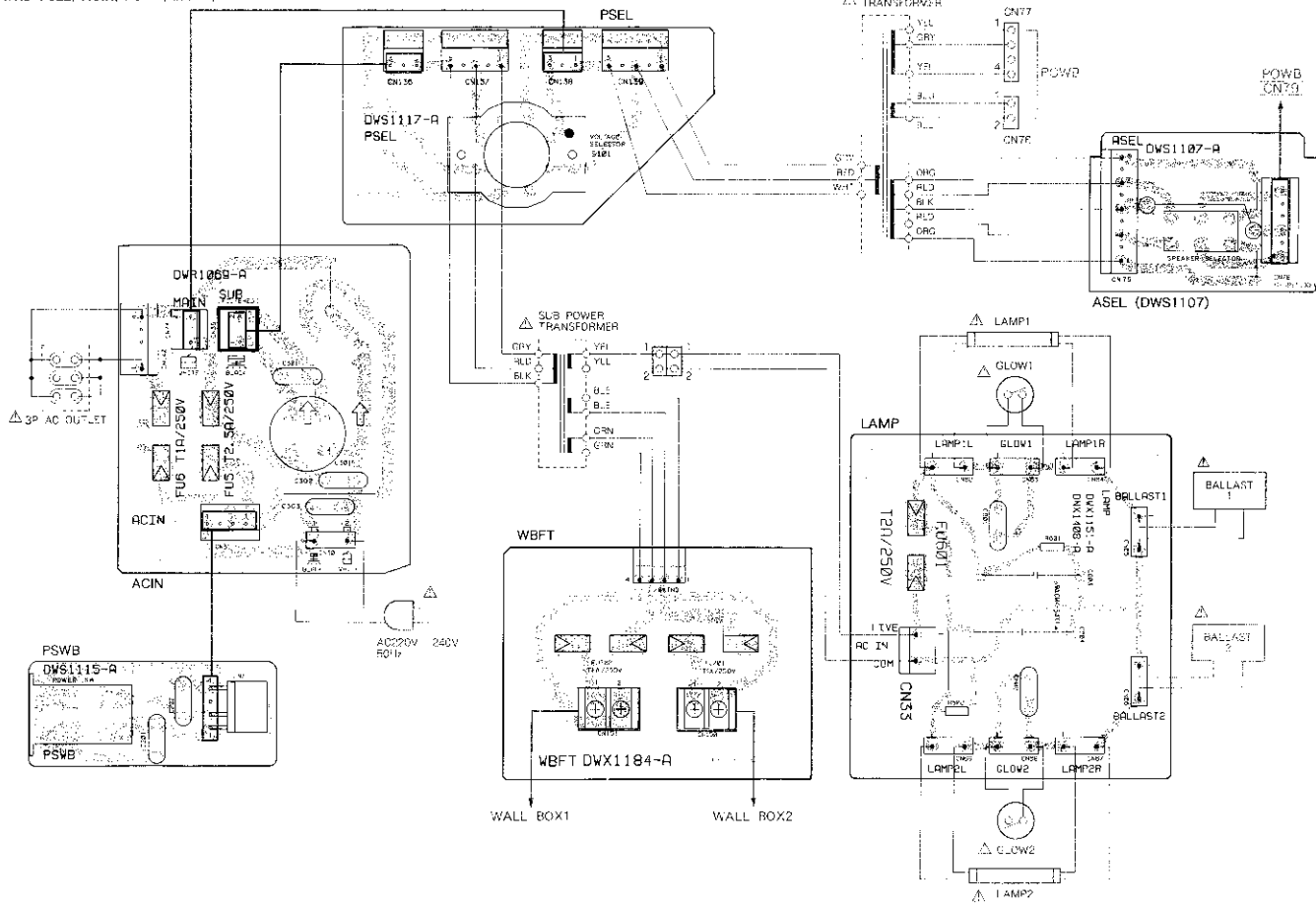



1

2

3

4

5

6

A

A

B

B

C

C

D

D

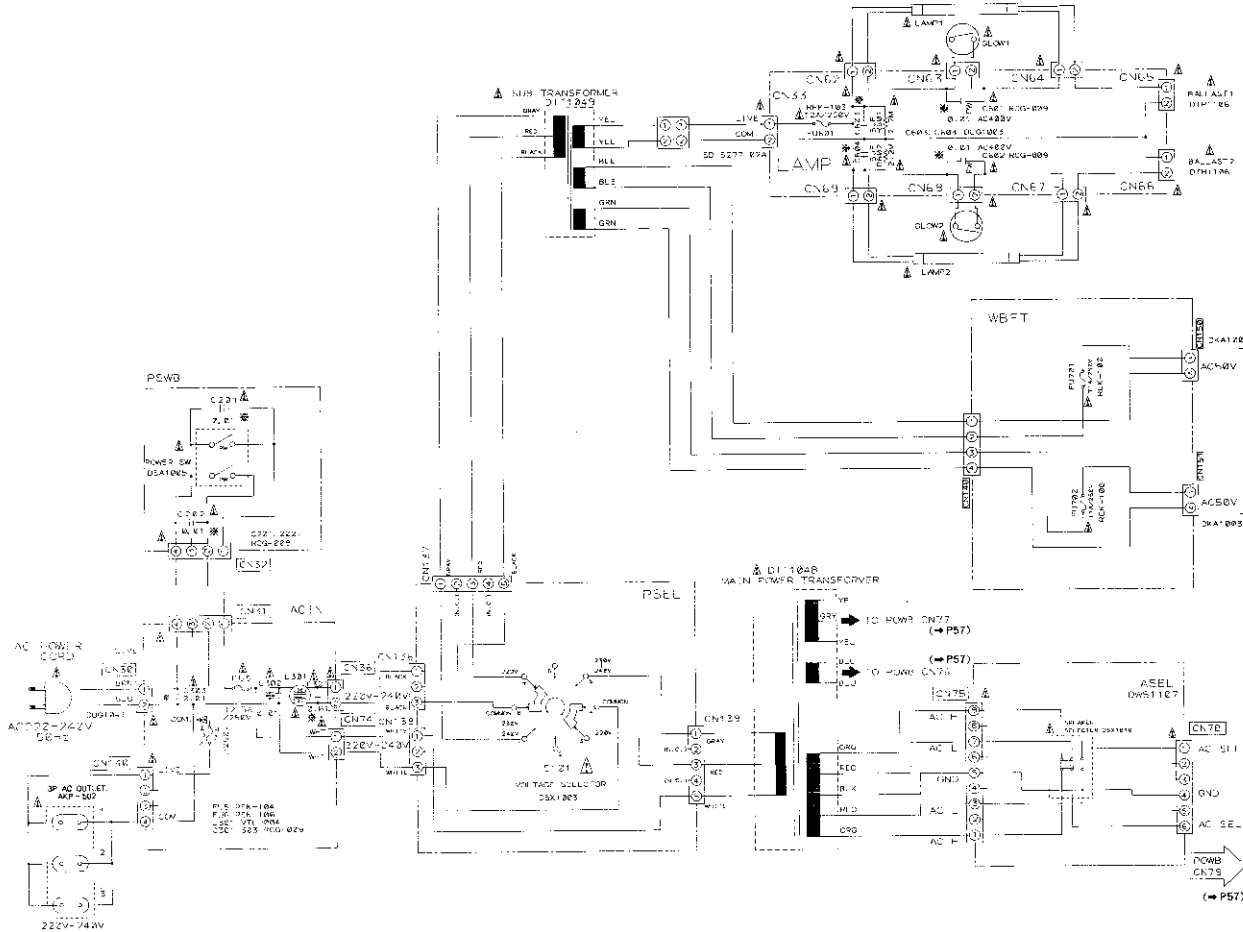

1

2

3

4

5

6

4.1.4 BGMB, PREB AND IOJB

1

2

3

4

5

6

A

A

B

B

C

C

D

D

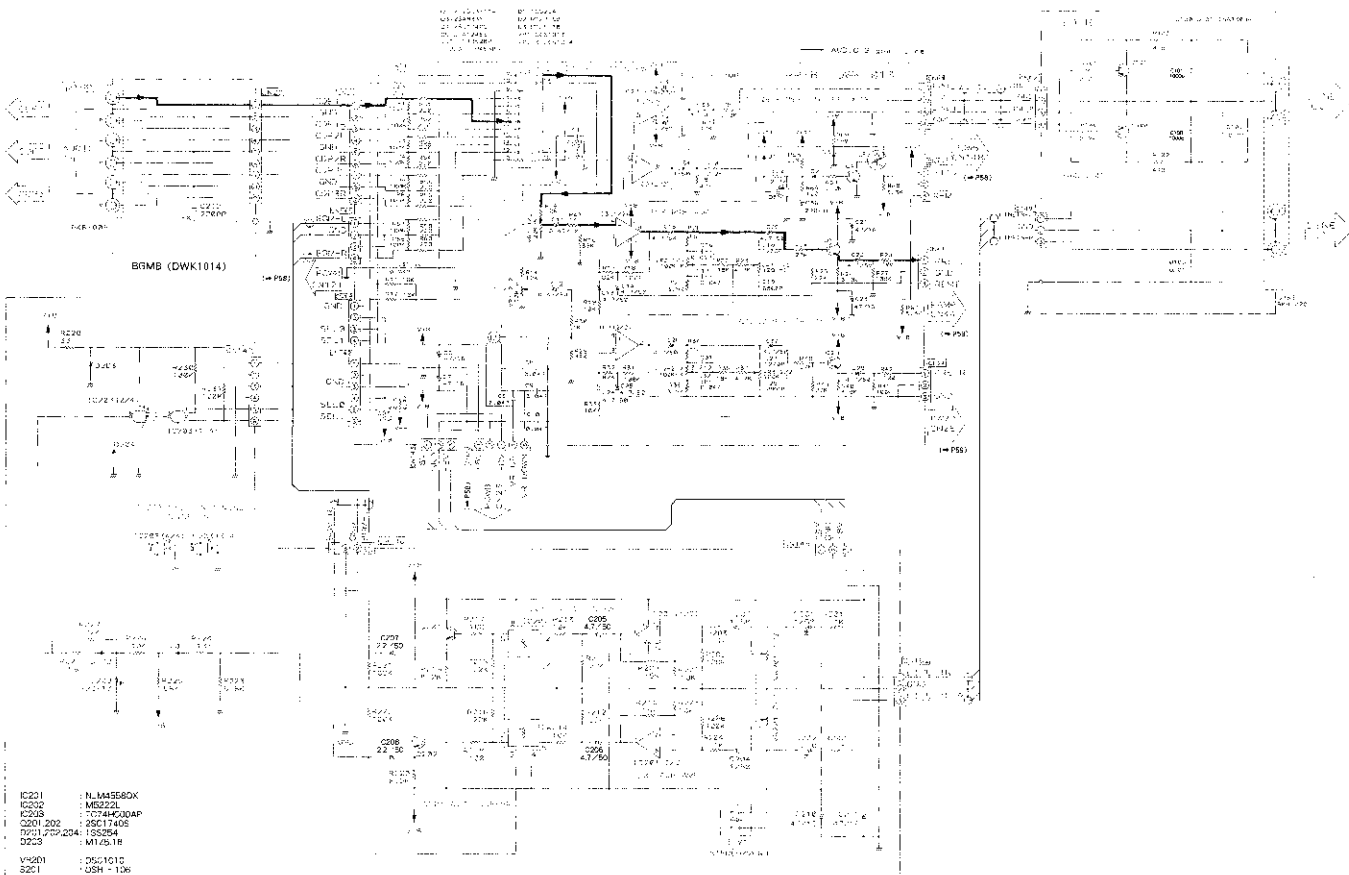

1

2

3

4

5

6

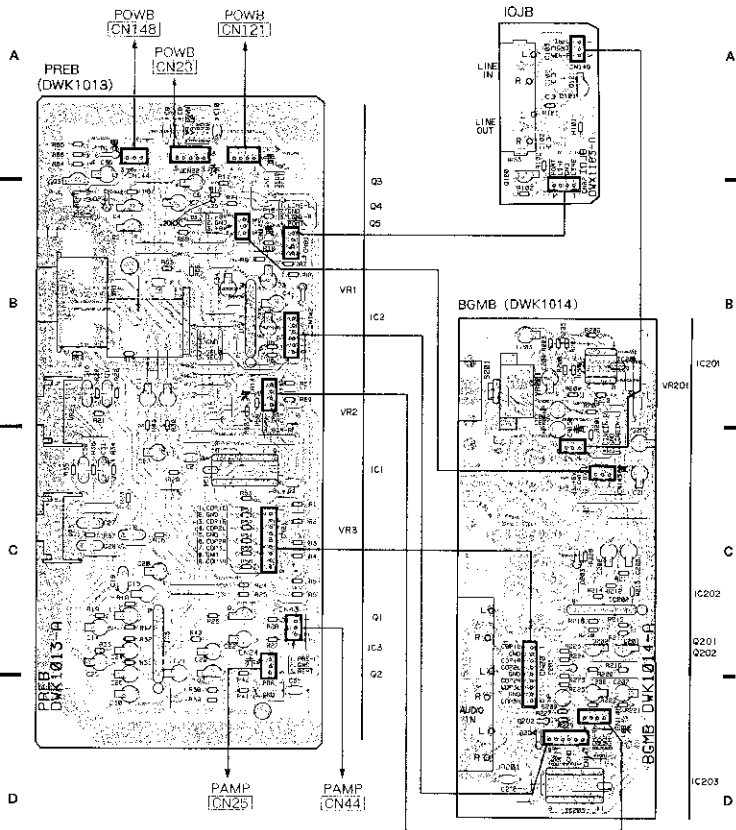

This P.C.B. connection diagram is viewed from the foil side.

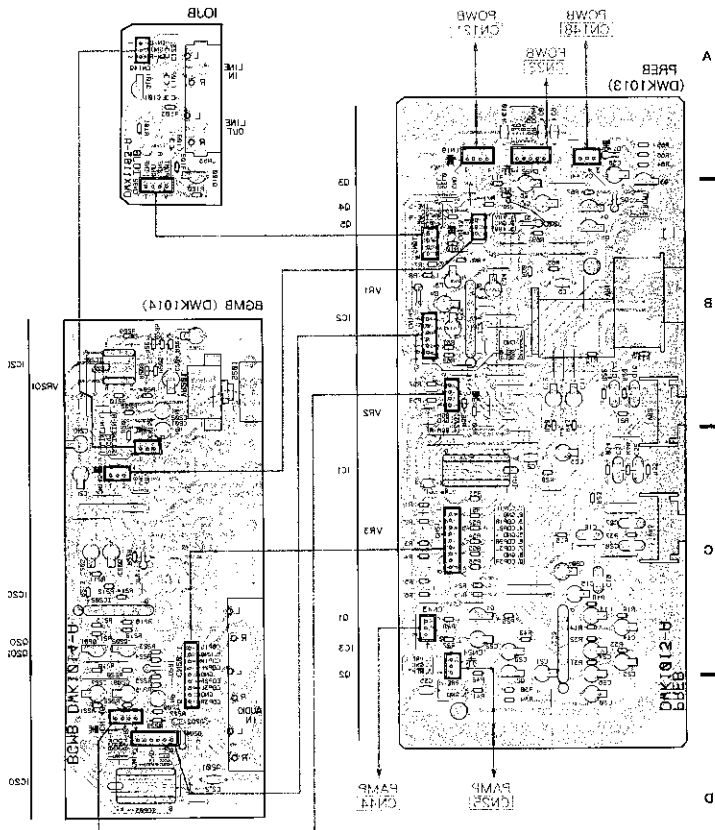

This P.C.B. connection diagram is viewed from the foil side.

4.1.5 POWER

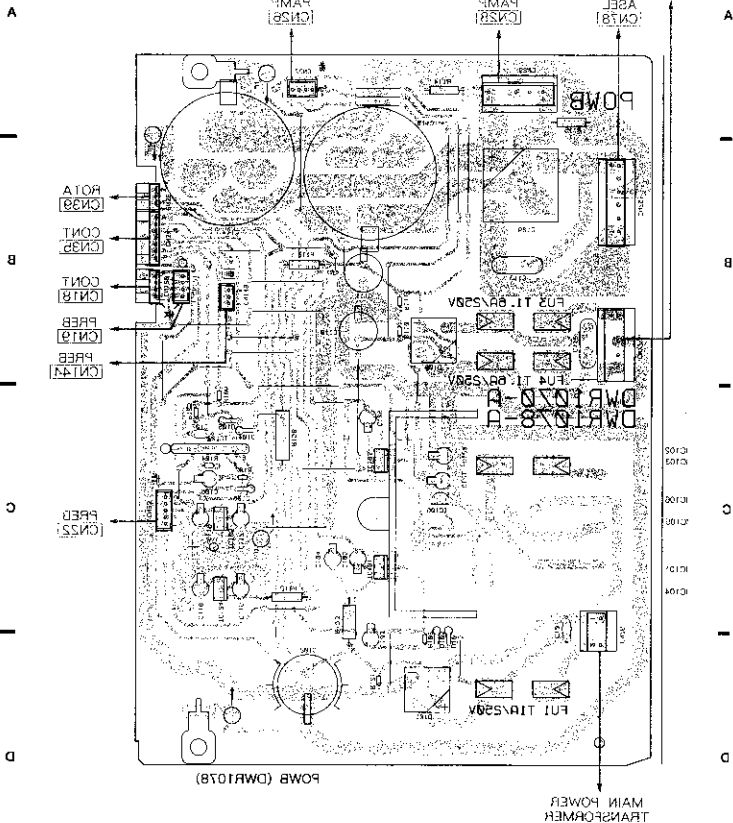
MAIN POWER  
TRANSFORMER

## 4.1.5 POWB

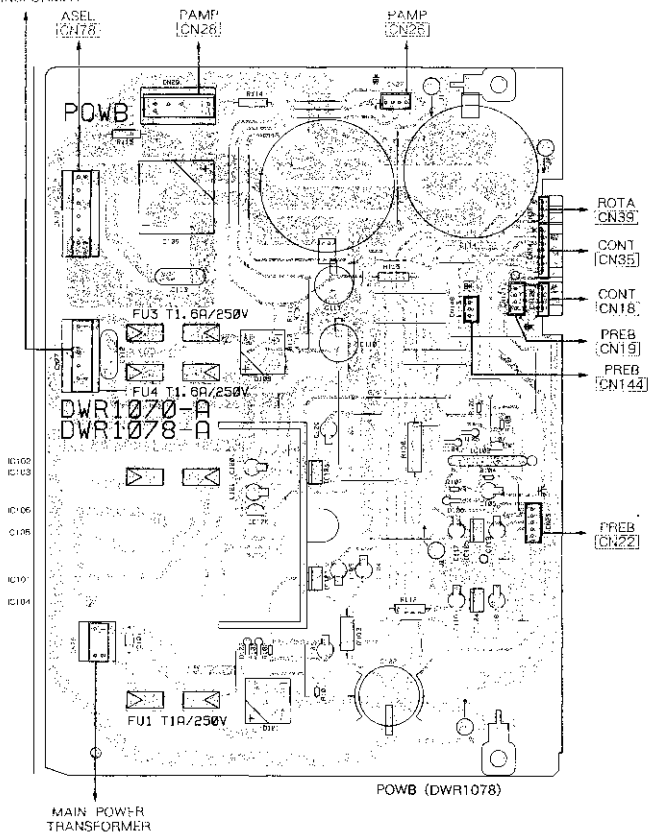
MAIN POWER  
TRANSFORMER

1 | 2 | 3 | 4 | 5 | 6

A

B

C

D

A

B

C

D

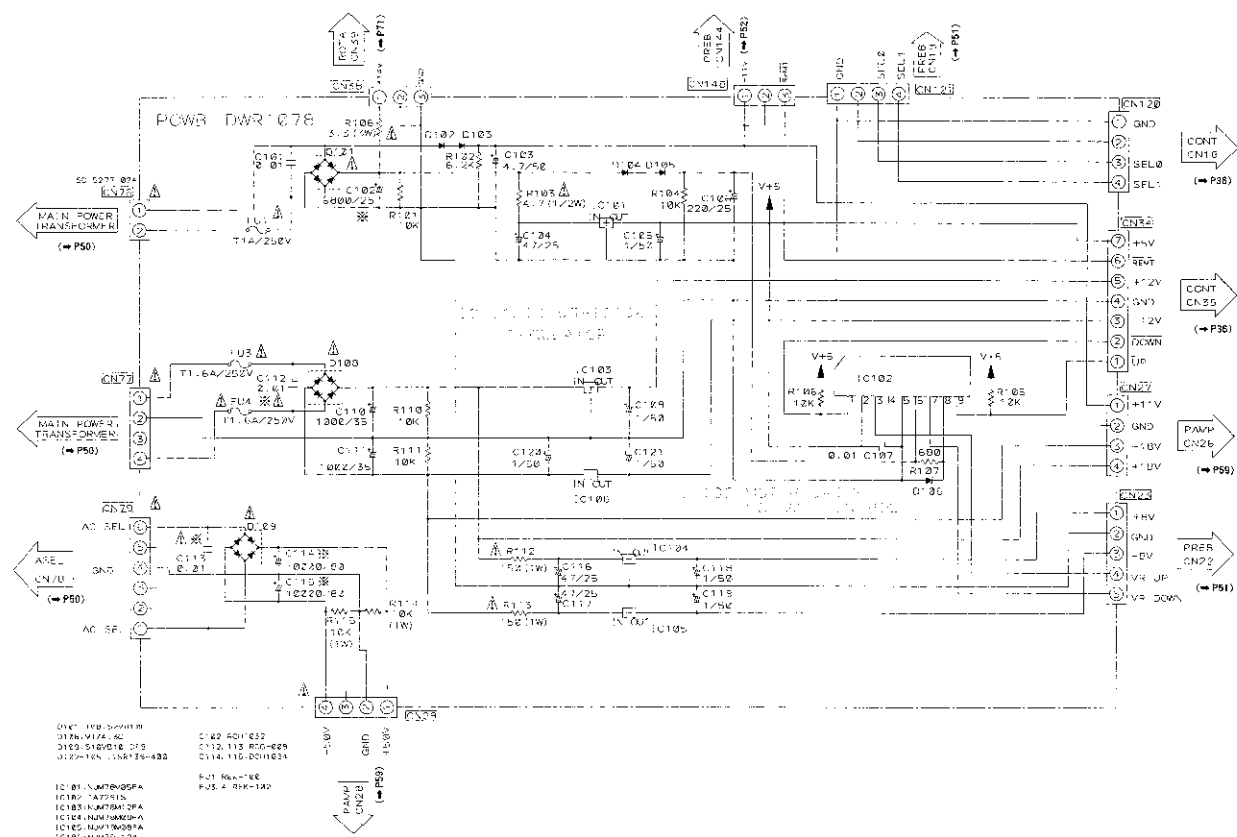

- IC101 - 118V-500V10R
- IC102 - 117V-40
- IC103 - 540V10R-015
- IC104 - 10V-10R-430
- IC105 - 115V-001103A
- IC106 - 115V-001103A
- IC107 - 115V-001103A
- IC108 - 115V-001103A
- IC109 - 115V-001103A
- IC110 - 115V-001103A
- IC111 - 115V-001103A
- IC112 - 115V-001103A
- IC113 - 115V-001103A
- IC114 - 115V-001103A
- IC115 - 115V-001103A
- IC116 - 115V-001103A
- IC117 - 115V-001103A
- IC118 - 115V-001103A
- IC119 - 115V-001103A
- IC120 - 115V-001103A
- IC121 - 115V-001103A
- IC122 - 115V-001103A
- IC123 - 115V-001103A
- IC124 - 115V-001103A
- IC125 - 115V-001103A
- IC126 - 115V-001103A
- IC127 - 115V-001103A
- IC128 - 115V-001103A
- IC129 - 115V-001103A
- IC130 - 115V-001103A
- IC131 - 115V-001103A
- IC132 - 115V-001103A
- IC133 - 115V-001103A
- IC134 - 115V-001103A
- IC135 - 115V-001103A
- IC136 - 115V-001103A
- IC137 - 115V-001103A
- IC138 - 115V-001103A
- IC139 - 115V-001103A
- IC140 - 115V-001103A

1 | 2 | 3 | 4 | 5 | 6

## 4.1.6 PAMP, SPTB AND NETWORK ASSEMBLY

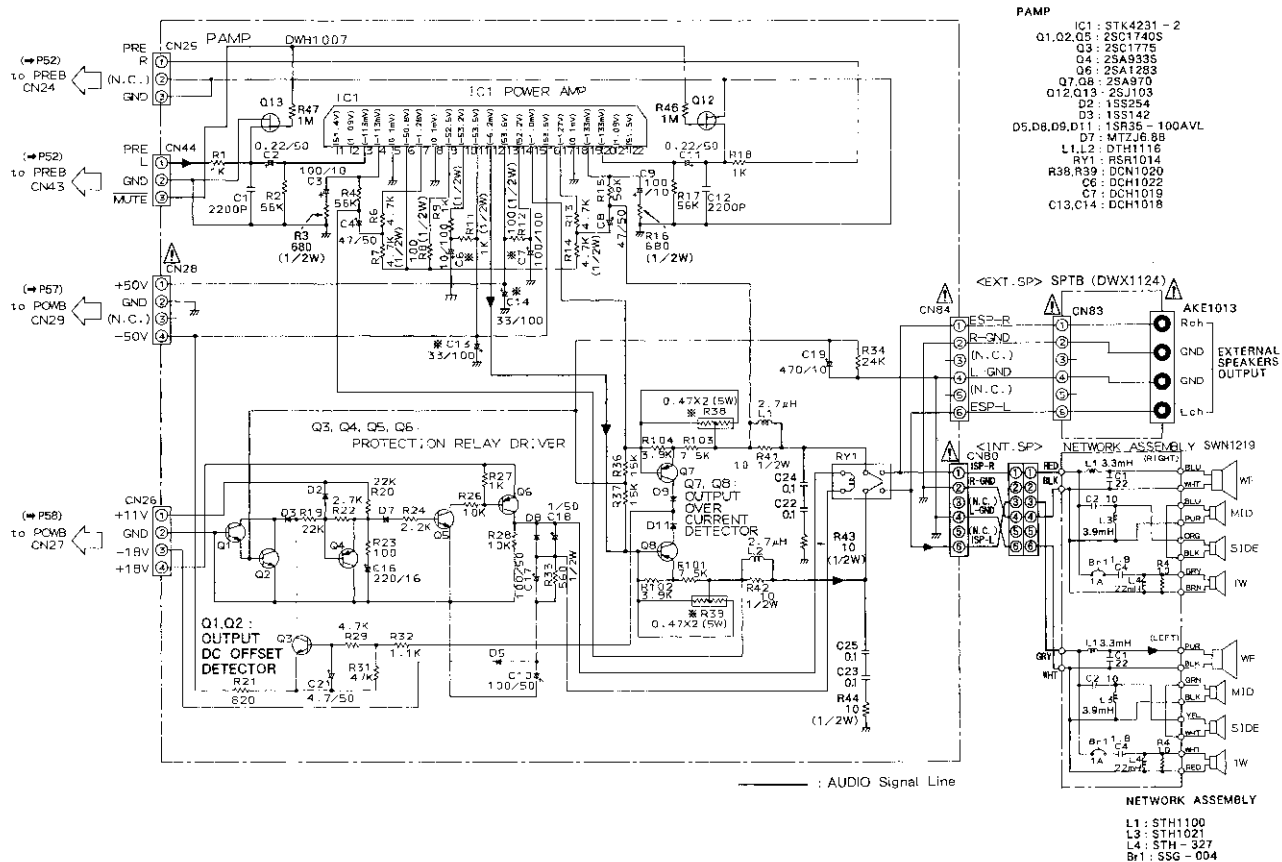



1 | 2 | 3 | 4 | 5 | 6

A

B

C

D

A

B

C

D

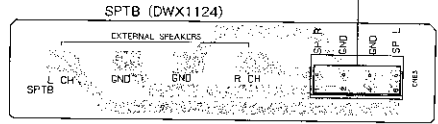
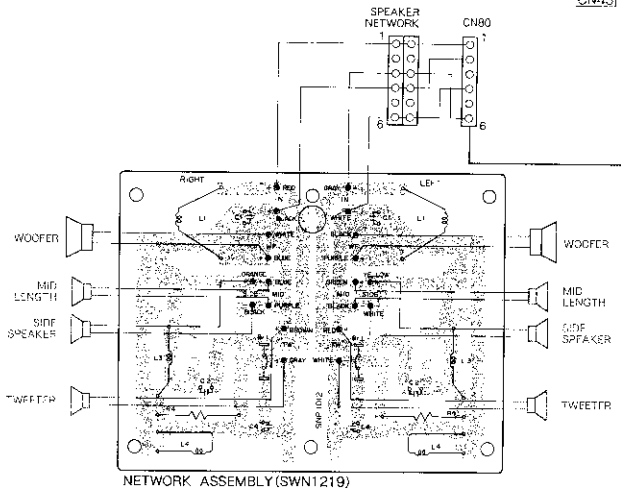
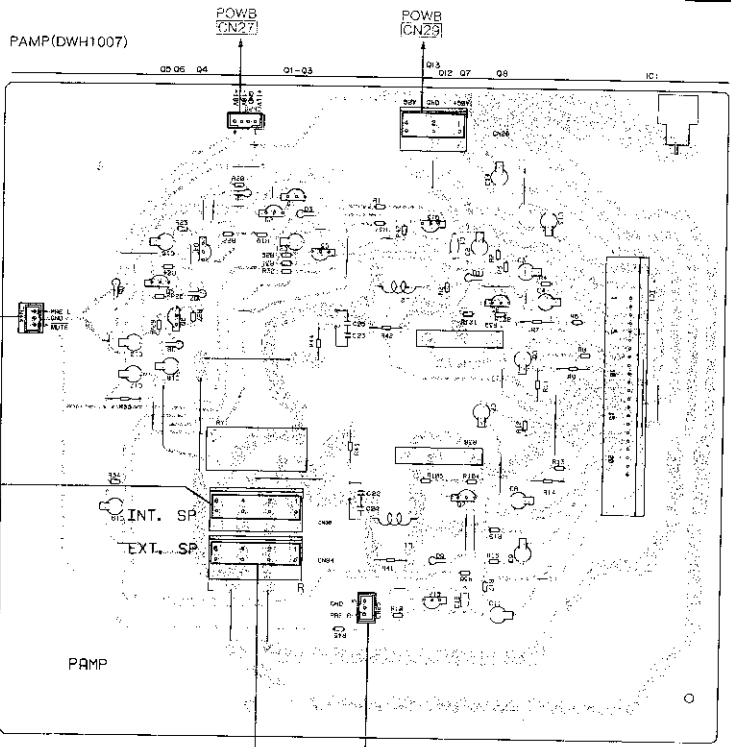

1 | 2 | 3 | 4 | 5 | 6

This P.C.B. connection diagram is viewed from the foil side.

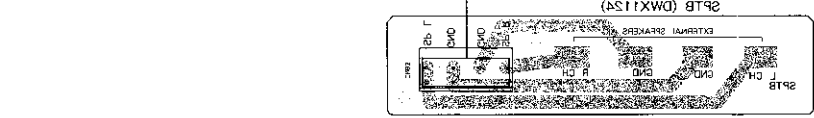
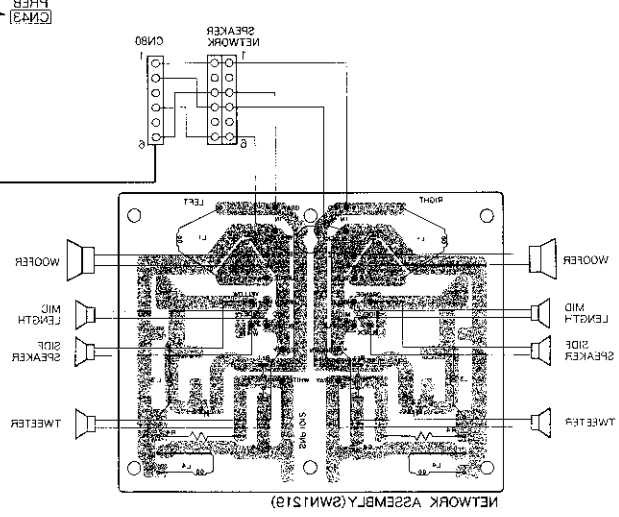
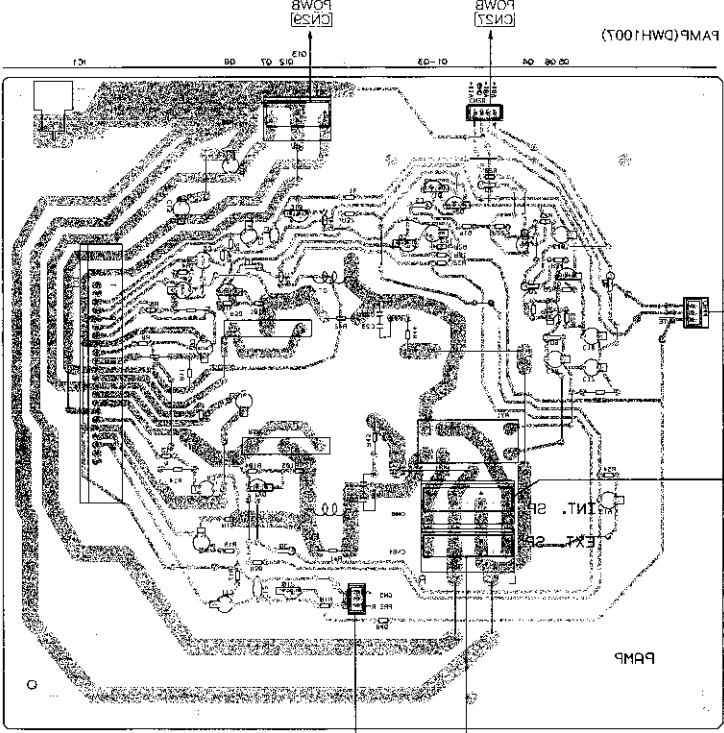

4.1.7 KEYB, BRAN, DISP, MESS, POST, CNTB AND ROTA

This P.C.B. connection diagram is viewed from the foil side.

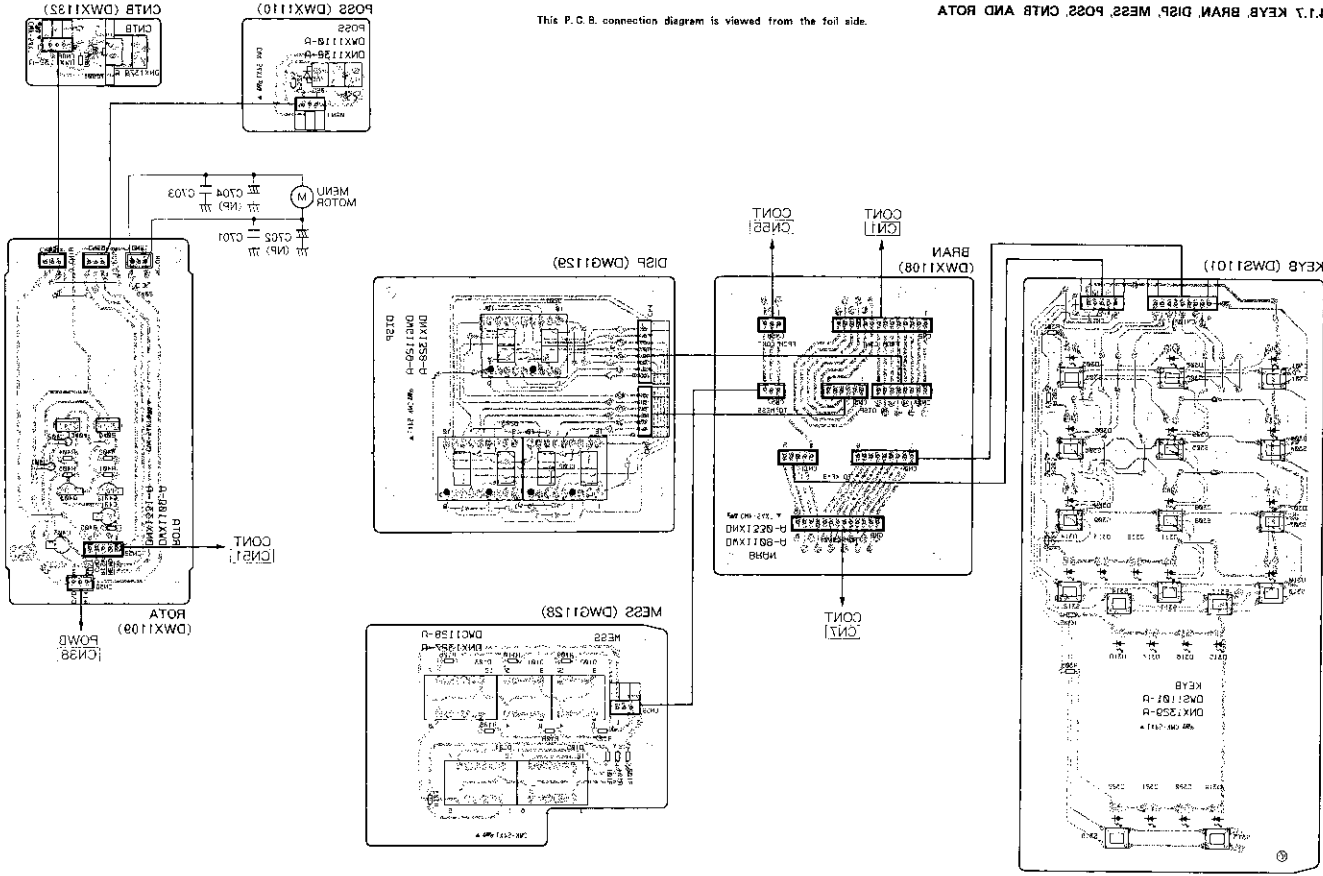

4.1.7 KEYB, BRAN, DISP, MESS, POSS, CNTB AND ROTA

A

B

C

D

KEYB (DWS1101)

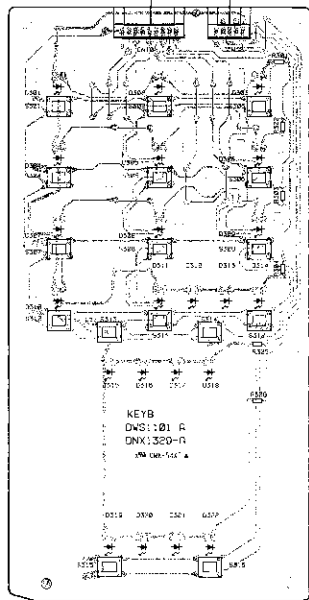

BRAN (DWX1108)

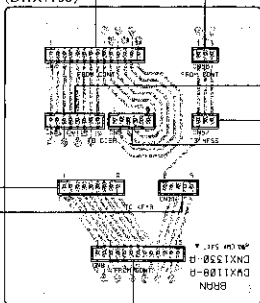

DISP (DWG1129)

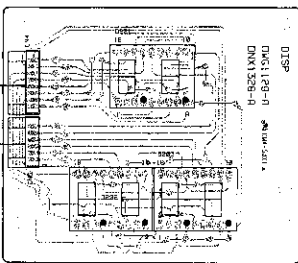

MESS (DWG1128)

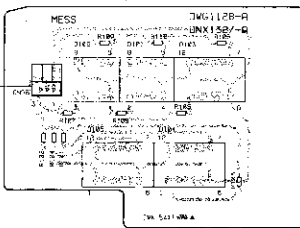

POSS (DWX1110)

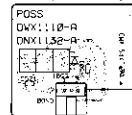

CNTB (DWX1132)

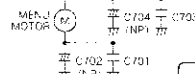

CONT [CN5]

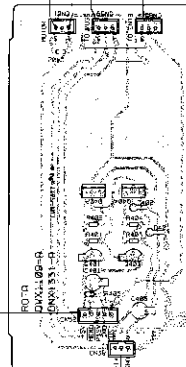

POWER [CN8]

A

B

C

D

1

2

3

4

5

6

PICKUP ASSEMBLY (PWY1009)

A

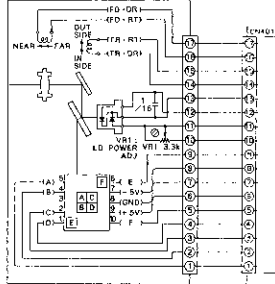

FREC

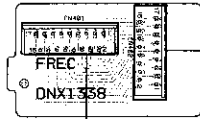

DEGT (DWX1116)

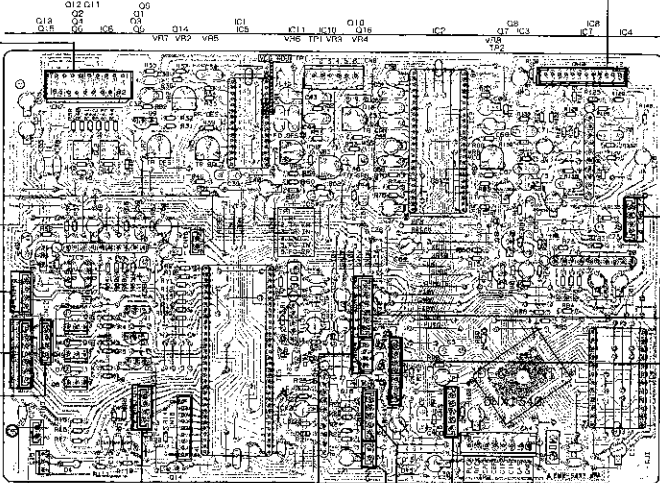

B

SENS



DOWN LIMIT TRAY SWITCH

C

MJSW

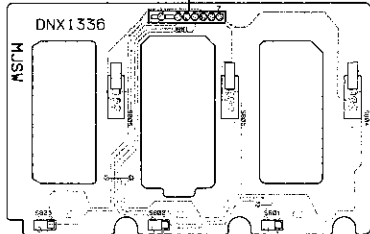

REJC

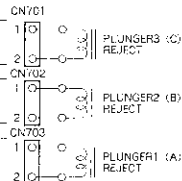

D

DISC SERVER LOCK



EKEY



RMJB

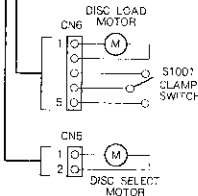

DISC LOAD MOTOR

S1001 CLAMP SWITCH

DISC SELECT MOTOR

PJAK



AN810

1

2

3

4

5

6

MESS DWG1128

BRAN  
DWX1108

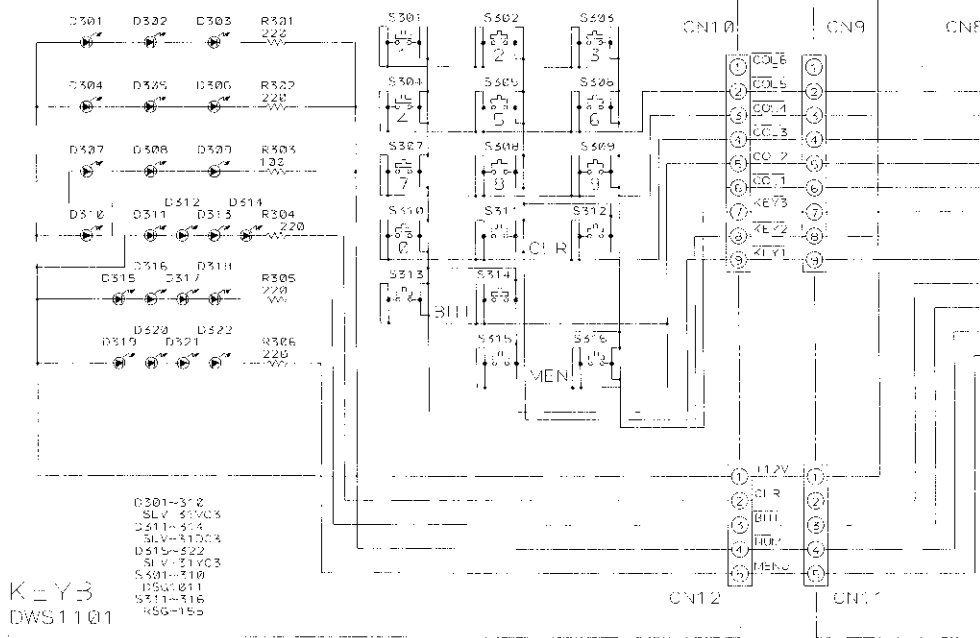
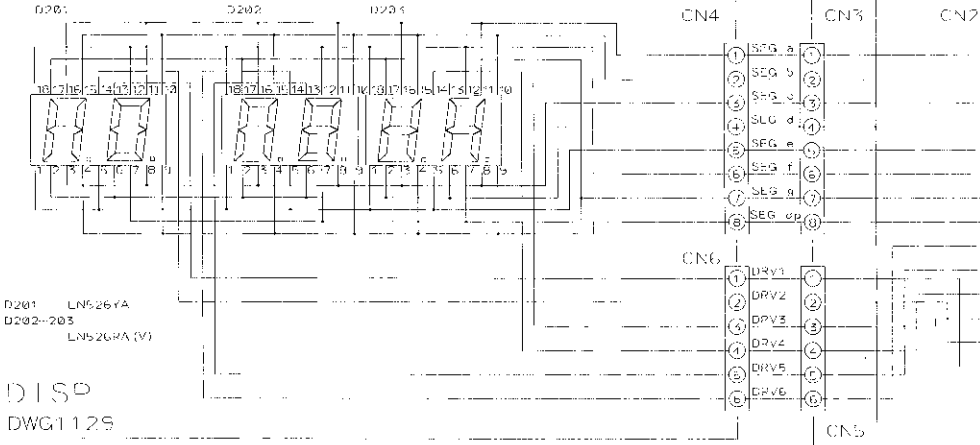
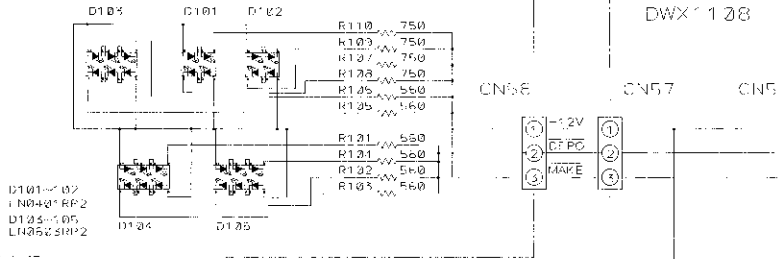

CN56

- ① V112V
- ② DFPO
- ③ MAKE



CN2

- ① SLG a
- ② SFG b
- ③ SFG c
- ④ SFG d
- ⑤ SFG e
- ⑥ SFG f
- ⑦ SFG g
- ⑧ SEG do
- ⑨ DRV6
- ⑩ DRV5
- ⑪ DRV4
- ⑫ DRV3
- ⑬ DRV2
- ⑭ DRV1



CN8

- ① CO. 6
- ② CO. 5
- ③ CO. 4
- ④ CO. 3
- ⑤ CO. 2
- ⑥ CO. 1
- ⑦ KEY3
- ⑧ KEY2
- ⑨ KEY1
- ⑩ CLR
- ⑪ SHT
- ⑫ STOP
- ⑬ MENU



POSS DWX1110

(→ P57)  
IO PCWB  
CN58

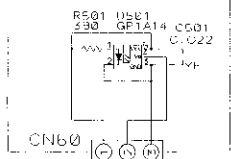

CN59

CN39

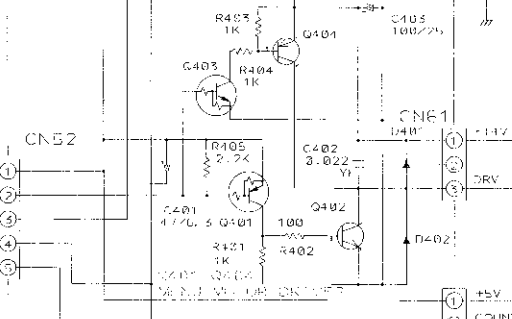

RO1A DWX1125

Q401 2SH1112 Q402 2SH1185  
 Q403 2S21752 Q404 422 15R154-400  
 R401 1K R402 1K  
 R403 1K R404 1K  
 R405 2.7K

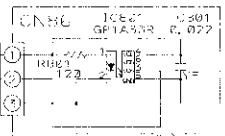

CN85

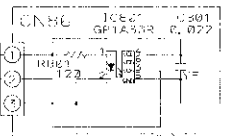

CN86

CN87

CN88

CN89

CN90

A  
B  
C  
D  
E  
F

4.2 CD SECTION

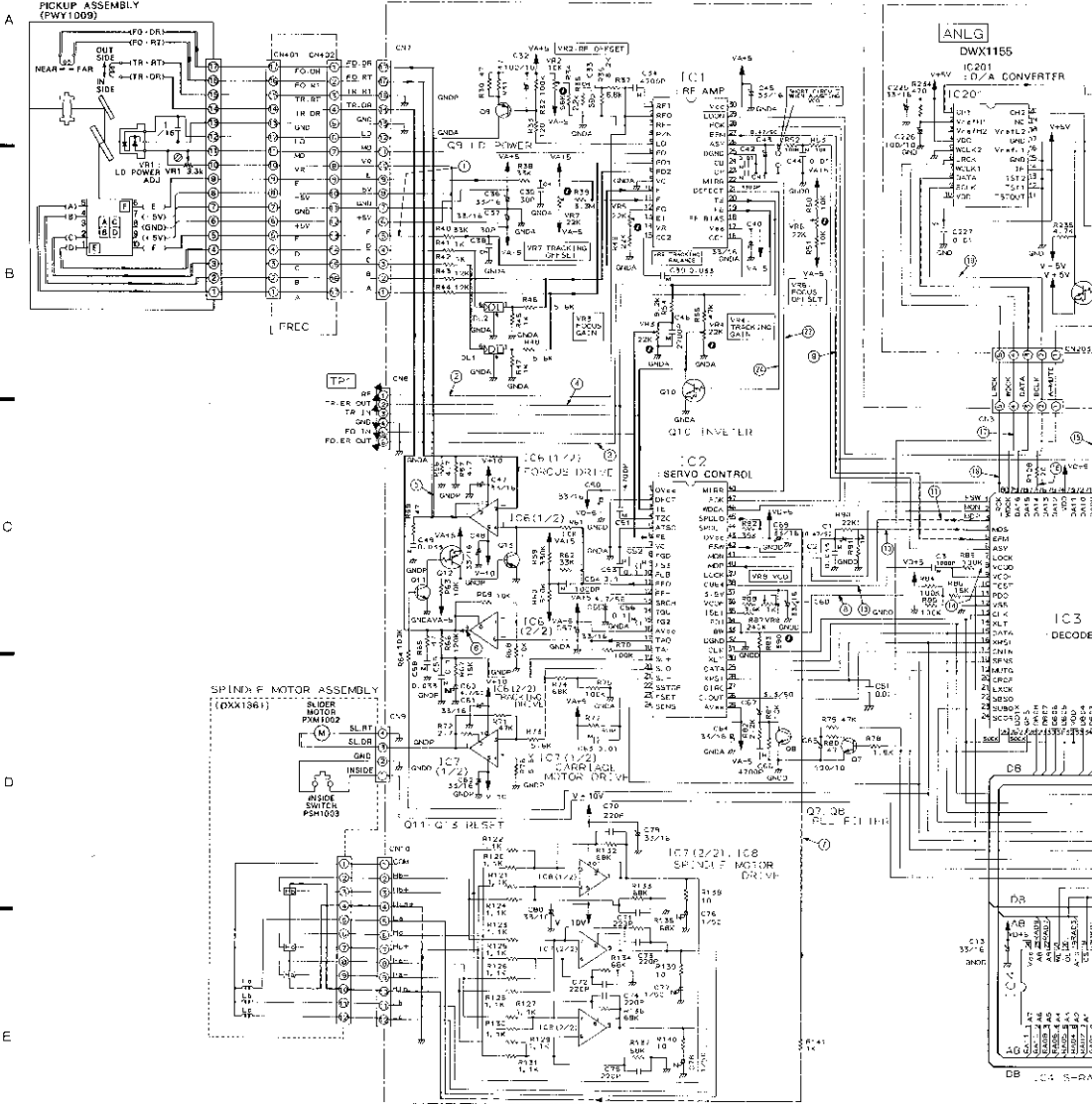

DEGT	IC1	IC2	IC3	IC4	IC5	IC6	IC7	IC8	IC9	IC10	IC11	IC12	IC13	IC14	IC15	IC16	IC17	IC18	IC19	IC20	IC21	IC22	IC23	IC24	IC25	IC26	IC27	IC28	IC29	IC30	IC31	IC32	IC33	IC34	IC35	IC36	IC37	IC38	IC39	IC40	IC41	IC42	IC43	IC44	IC45	IC46	IC47	IC48	IC49	IC50	IC51	IC52	IC53	IC54	IC55	IC56	IC57	IC58	IC59	IC60	IC61	IC62	IC63	IC64	IC65	IC66	IC67	IC68	IC69	IC70	IC71	IC72	IC73	IC74	IC75	IC76	IC77	IC78	IC79	IC80	IC81	IC82	IC83	IC84	IC85	IC86	IC87	IC88	IC89	IC90	IC91	IC92	IC93	IC94	IC95	IC96	IC97	IC98	IC99	IC100																																	
	QXA10R15	QXA10R24S	QXD113R02	QXK0810P10-12L	QD00605	TAT1208P	M516938L	Q13005	D12	D14	DTA124ES	D4-07	169254	202497	V82	V83	V84	V85	V86	V87	V88	V89	V90	V91	V92	V93	V94	V95	V96	V97	V98	V99	V100	V101	V102	V103	V104	V105	V106	V107	V108	V109	V110	V111	V112	V113	V114	V115	V116	V117	V118	V119	V120	V121	V122	V123	V124	V125	V126	V127	V128	V129	V130	V131	V132	V133	V134	V135	V136	V137	V138	V139	V140	V141	V142	V143	V144	V145	V146	V147	V148	V149	V150	V151	V152	V153	V154	V155	V156	V157	V158	V159	V160	V161	V162	V163	V164	V165	V166	V167	V168	V169	V170	V171	V172	V173	V174	V175	V176	V177	V178	V179	V180	V181	V182	V183	V184	V185	V186	V187	V188	V189	V190	V191	V192	V193	V194	V195	V196	V197	V198	V199	V200



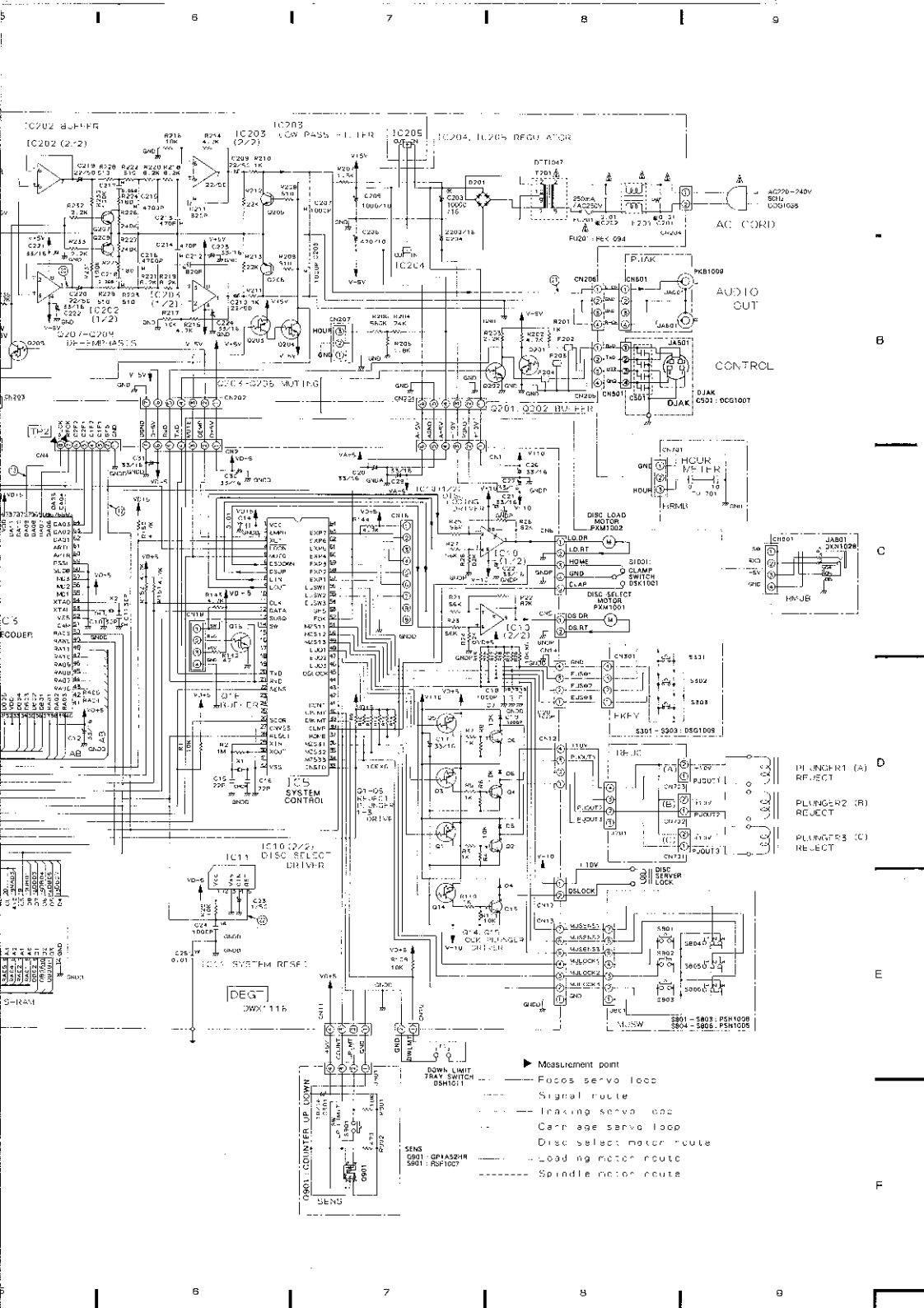

### DEGT(DWX1116)

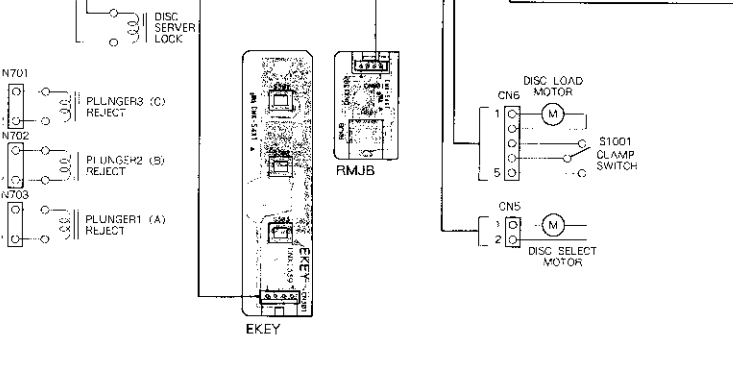
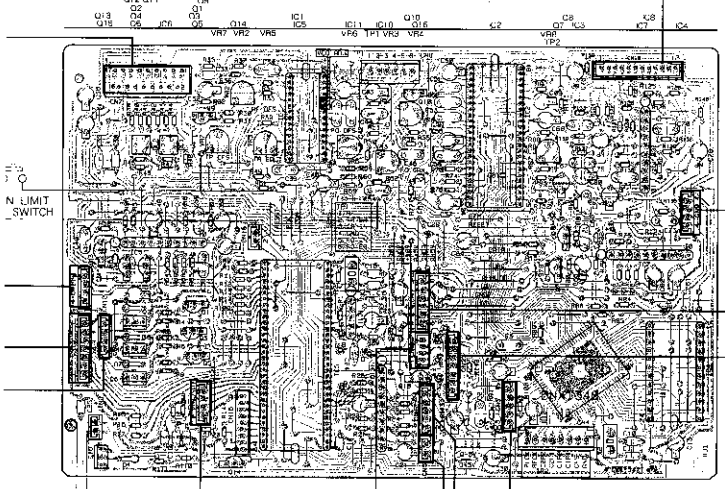

### SPINDLE MOTOR ASSEMBLY (DXX1361)

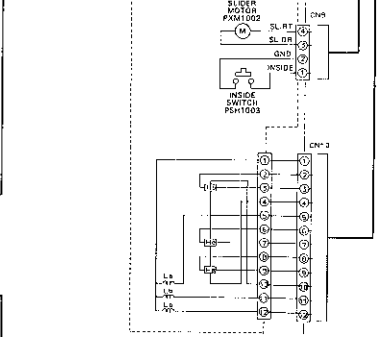

### ANLG(DWX1155)

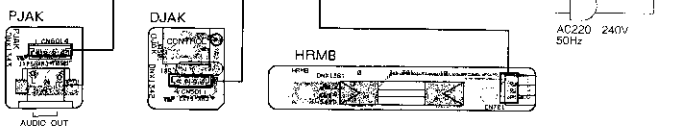
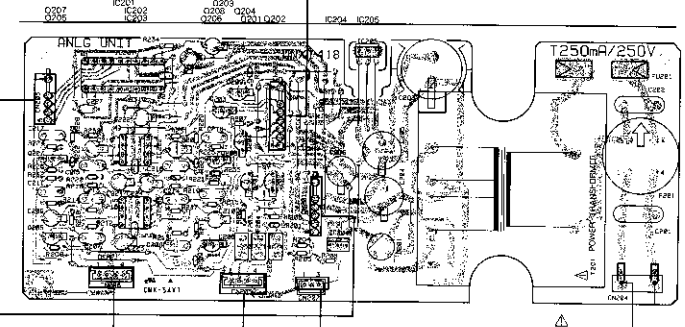

A  
B  
C  
D

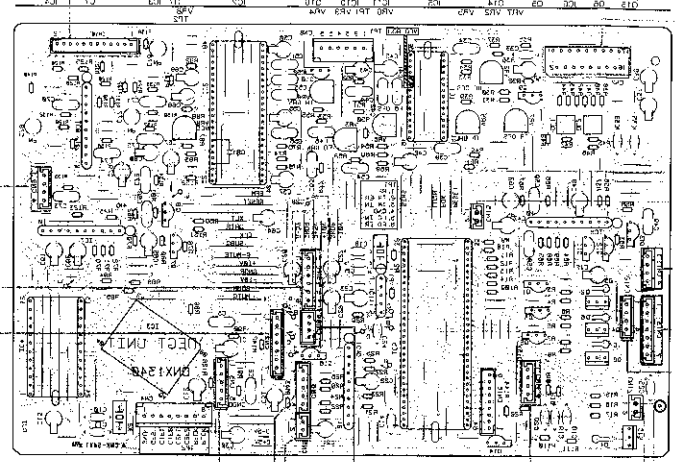

DEPT (DWX118)  
017 08 00  
015 08 00  
013 08 00  
011 08 00  
009 08 00  
007 08 00  
005 08 00  
003 08 00

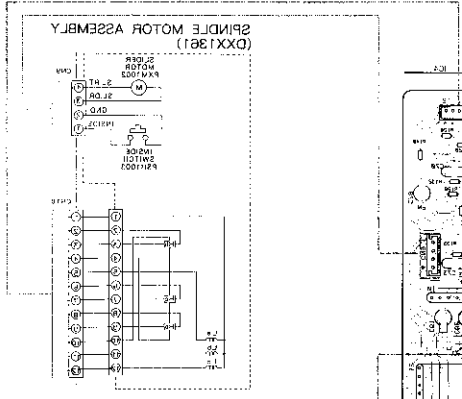

SPINDLE MOTOR ASSEMBLY  
(DXX1861)  
R241002  
R241003  
T11121  
M11101  
G.P.D.  
240V  
SW  
CH

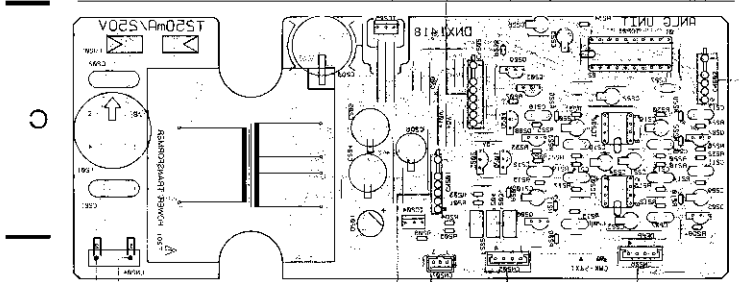

WLG (DWX128)  
0305 0505  
0300 0505  
0295 0505  
0290 0505  
0285 0505  
0280 0505  
0275 0505  
0270 0505  
0265 0505  
0260 0505  
0255 0505  
0250 0505  
0245 0505  
0240 0505  
0235 0505  
0230 0505  
0225 0505  
0220 0505  
0215 0505  
0210 0505  
0205 0505  
0200 0505  
0195 0505  
0190 0505  
0185 0505  
0180 0505  
0175 0505  
0170 0505  
0165 0505  
0160 0505  
0155 0505  
0150 0505  
0145 0505  
0140 0505  
0135 0505  
0130 0505  
0125 0505  
0120 0505  
0115 0505  
0110 0505  
0105 0505  
0100 0505  
0095 0505  
0090 0505  
0085 0505  
0080 0505  
0075 0505  
0070 0505  
0065 0505  
0060 0505  
0055 0505  
0050 0505  
0045 0505  
0040 0505  
0035 0505  
0030 0505  
0025 0505  
0020 0505  
0015 0505  
0010 0505  
0005 0505  
0000 0505

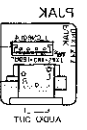
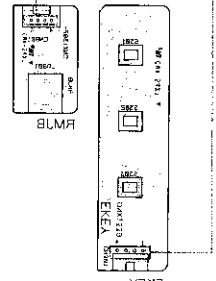

PLK VARIO UNIT

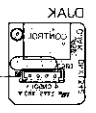

D1AK

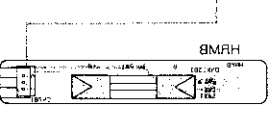

HRMB

A

B

C

D

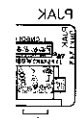
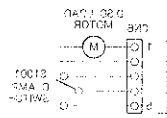
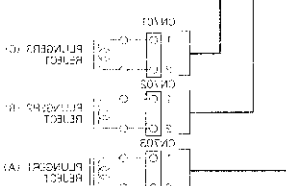
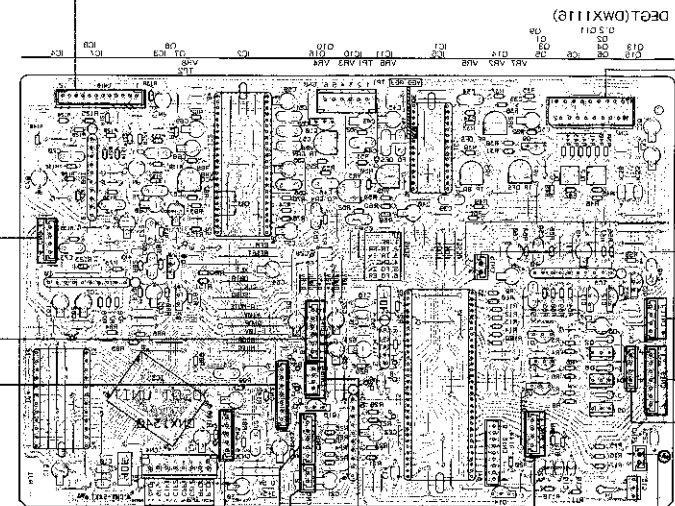
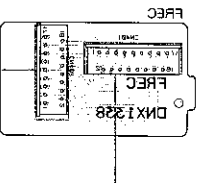
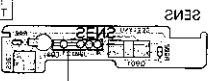
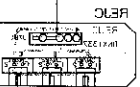
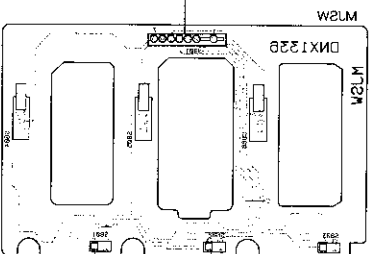
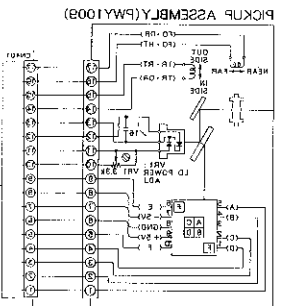

A B C D

1 2 3 4 5

1 2 3 4 5

NOTE: The circled numbers denote measuring points in the schematic diagram.

Wave Forms

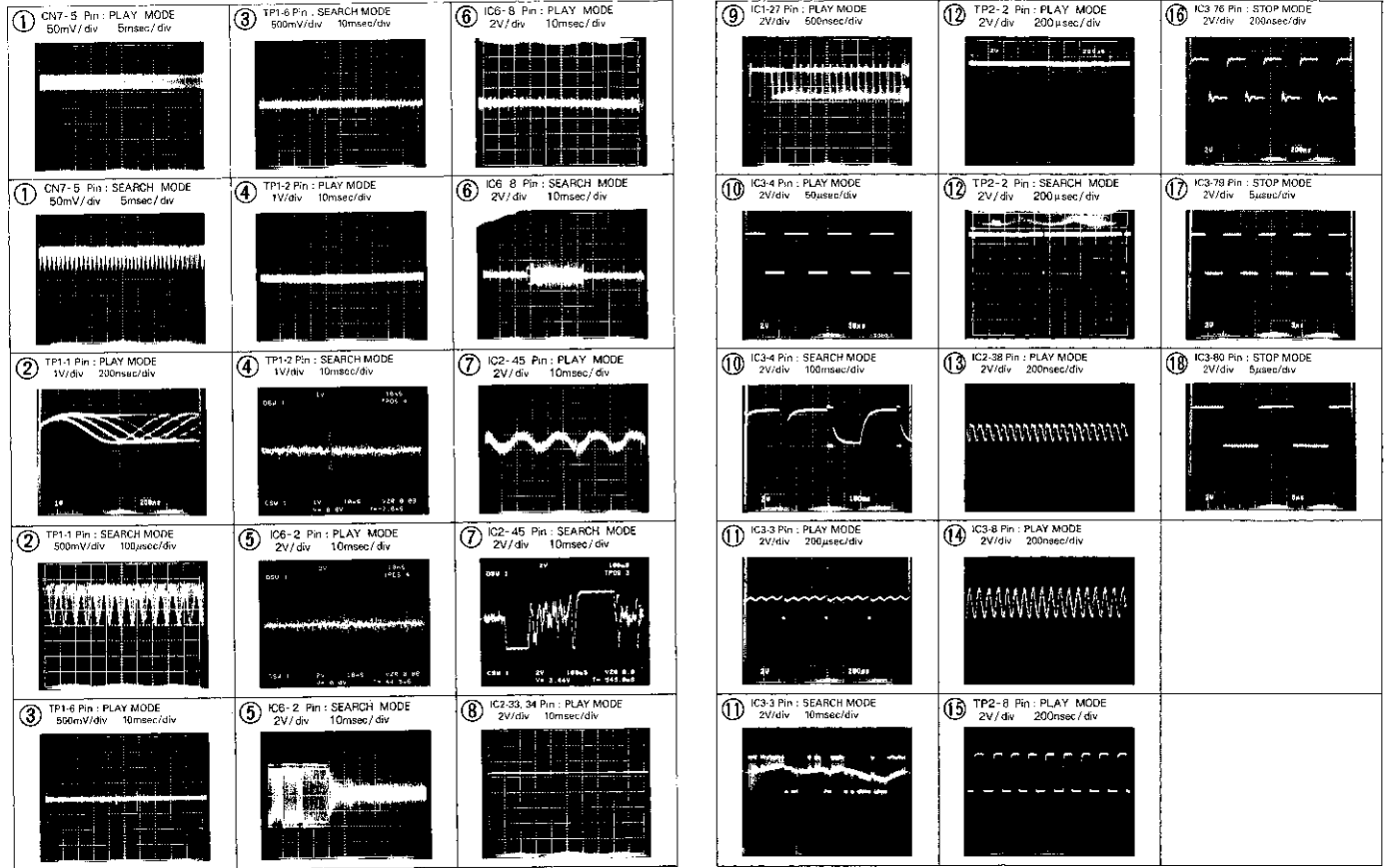

suring points in the

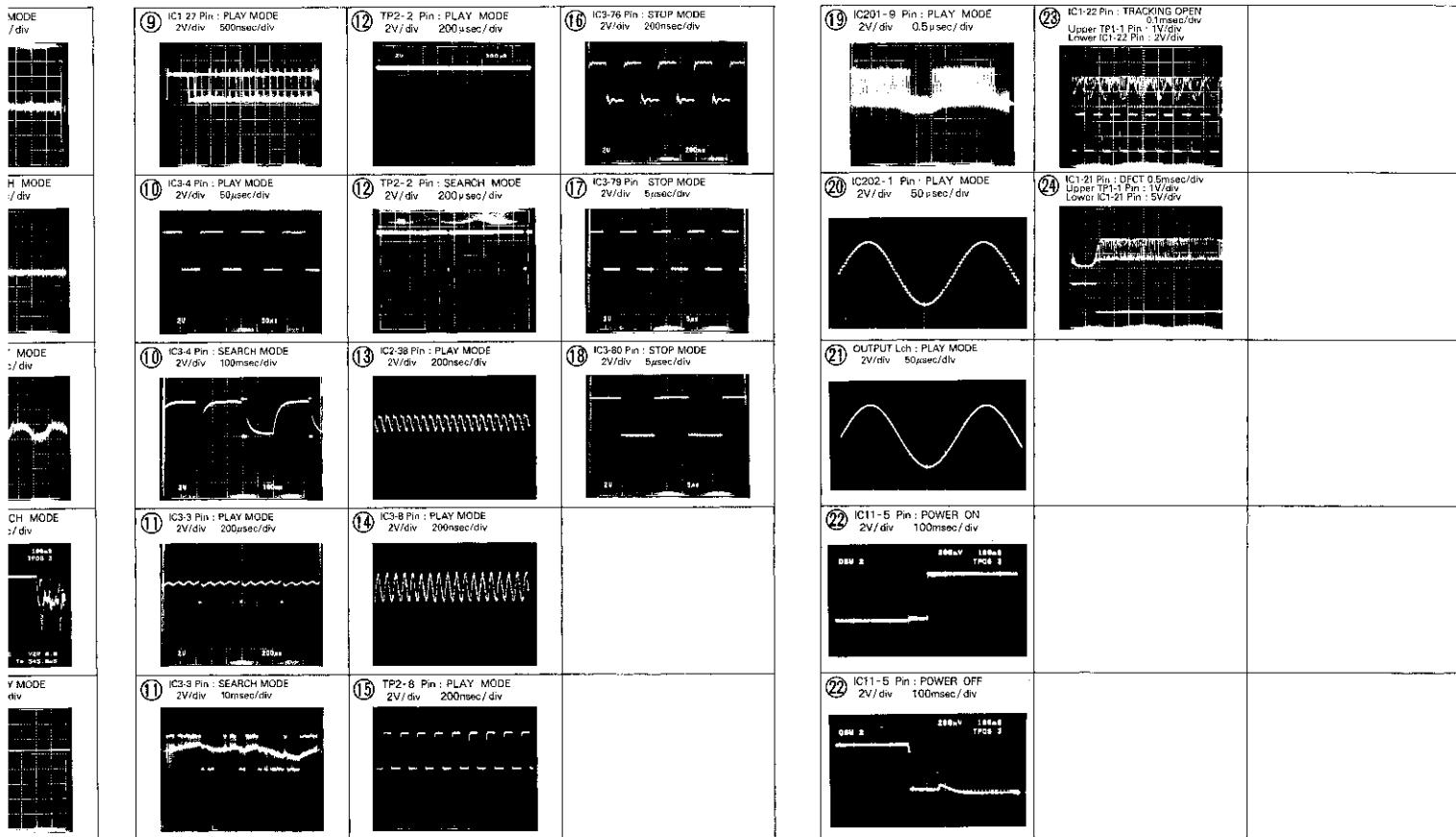

5. BLOCK DIAGRAM

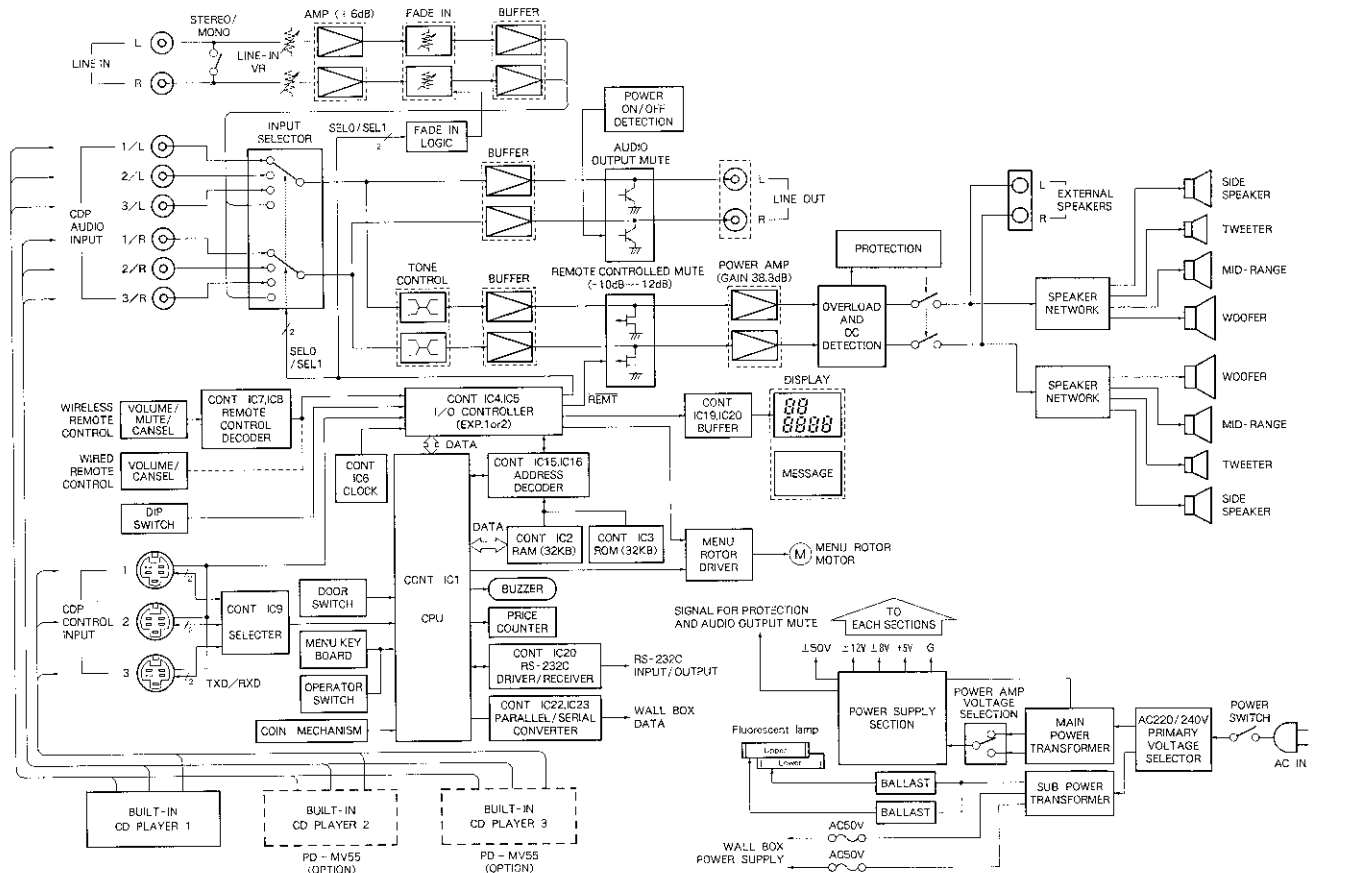

6. P. C.

MAIN SE

- NOTES :
- Parts without
  - Parts marked
  - The  $\Delta$  mark replacing, be
  - When order
- Ex.1 When  
 J...S  
 560  $\Omega$   
 47K  $\Omega$   
 0.5  $\Omega$   
 1  $\Omega$   
 Ex.2 When  
 5.62k

Mark NO

CONT SEMICONI

- IC1
- IC10
- IC11
- IC12
- IC14
- IC16
- IC17
- IC19
- IC2
- IC20
- IC22
- IC23
- IC24
- IC26
- IC3
- IC4
- IC5
- IC7
- IC8
- IC9
- G1
- G2, 3
- G3
- G31
- G3R
- G1
- Q43-
- Q4R
- Q59
- Q5
- Q50-
- Q7
- Q84-
- Q89.

## 6. P. C. B's PARTS LIST

### MAIN SECTION

#### NOTES:

- Parts without part number cannot be supplied.
- Parts marked with Ⓢ are not always kept in stock. Their delivery time may be longer than usual or they may be unavailable.
- The Δ mark found on some components indicates the importance of the safety factor of the part. Therefore, when replacing, be sure to use parts of identical designation.
- When ordering resistors, first convert resistance values into code form as shown in the following examples.
  - Ex.1 When there are 2 effective digits (any digit apart from 0): such as 560 ohm and 47k ohm (tolerance is shown by J = 5%, and K = 10%).
 

560 Ω → 56 × 10 <sup>3</sup> → 561	RD1 / 4PS 5[6]1 J
47k Ω → 47 × 10 <sup>4</sup> → 473	RD1 / 4PS 4[7]3 J
0.5 Ω → 0.05	RN2H[0]5K
1 Ω → 010	RSP1[0]10K
  - Ex.2 When there are 3 effective digits (such as in high precision metal film resistors).
 

5.62k Ω → 562 × 10 <sup>3</sup> → 5621	RN17 4SR[5]6[2]1 F
--	--------------------

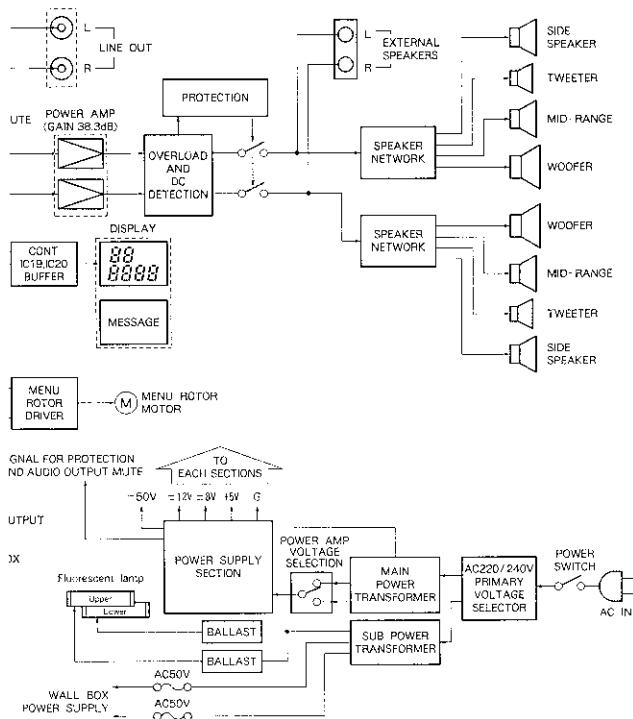

### Mark NO Description Part NO.

#### CONT

#### SEMICONDUCTORS

IC1	MS0147SP
IC10 IC	MC145408P
IC11 SYSTEM PRESET 1%	MS295L
IC12,13 LOGIC IC	TC74HC14AP
IC14,15 LOGIC IC	TC74HC00AP
IC16	TC74HC4001AP
IC17 LOGIC IC	SN74LS56N
IC19 TRANSISTOR ARRAY	MS4584P
IC2 CMOS S-DOM	DM60756LZ-12
IC20 TRANSISTOR ARRAY	MS4584P
IC22 (CC)S-422A IC	SX751758P
IC23	H8B4941
IC24 LOGIC IC	TC74HC14AP
IC26 LOGIC IC	TC74HC08AP
IC3 IC	FD6357A
IC4,5 IC	CS9396Q
IC6 (CERAMIC TIME CLOCK)	CR820P
IC7 IC	PD807
IC8	TC74HC574AP
IC9 MULTITELESEOR	TC74HC4232AP

#### Q1

Q1 TRANSISTOR	2SC3246
Q2,3 TRANSISTOR	2SC1405
Q36 TRANSISTOR	2SC1405
Q37 TRANSISTOR	2SC1415
Q38,39 TRANSISTOR	2SC1405
Q4 TRANSISTOR	DTC124ES
Q43 4E TRANSISTOR	DTC124ES
Q48 TRANSISTOR	2SC1405
Q10 TRANSISTOR	DTC124ES
Q5 TRANSISTOR	2SA1015
Q50-57 TRANSISTOR	DTC124ES
Q6 TRANSISTOR	2SC1140S
Q7 TRANSISTOR	9TA174ES
Q84-86 TRANSISTOR	JRL1240S
Q89,90 TRANSISTOR	9TA124ES

### Mark NO Description Part NO.

#### COILS AND FILTERS

L1 RADIO AL INDUCTOR	LFAD10K
L2,3 AXIAL INDUCTOR	LA610R
F1	VTH1001
F10-19	VTH1001
F2	VTH1001
F20-23	VTH1001
F25,28	VTH1001
F3	VTH1001
F30-34	VTH1001
F4-9	VTH1001

#### CAPACITORS

C1 CERAMIC CAPACITOR	CKCFY103250
C10 ELECT. CAPACITOR	CEA5330M16
C103,101 CERAMIC CAPACITOR	CKCFY103250
C102 107 CERAMIC CAPACITOR	CKCFY103250
C108 CAPACITOR ARRAY	DCE:604
C109 CAPACITOR ARRAY	30C1105
C11 CERAMIC CAPACITOR	CKCFY103250
C110 CAPACITOR ARRAY	30C1105
C111,112 CERAMIC CAPACITOR	CKCFY103250
C113 CERAMIC CAPACITOR	CKCFY103250
C14 CERAMIC CAPACITOR	CKCFY103250
C15 MYLAR FILM CAPACITOR	CMR4225150
C16,12 ELECT. CAPACITOR	CEA5330M16
C13-16 CERAMIC CAPACITOR	CKCFY103250
C17 ELECT. CAPACITOR	CEA5330M16
C18 ELECT. CAPACITOR	CEA5330M16
C19 CERAMIC CAPACITOR	CKCFY103250
C2 ELECT. CAPACITOR	CEA5330M16
C20 CERAMIC CAPACITOR	CKCFY103250
C21 ELECTROLYTIC CAPACIT	CEA5330M16



Mark No.	Description	Part No.
C22-26	CERAMIC CAPACITOR	CKCYF103Z50
C27	ELECTR. CAPACITOR	CEAS330M16
C28	CERAMIC CAPACITOR	CKCYF103Z50
C29	ELECTR. CAPACITOR	CEAS330M16
C3, 30	CERAMIC CAPACITOR	CKCYF103Z50
C31, 32	CERAMIC CAPACITOR	CCCH150J50
C33	CERAMIC CAPACITOR	CKCYF103Z50
C34	ELECTR. CAPACITOR	CEAS330M16
C35	CERAMIC CAPACITOR	CKCYF103Z50
C36	ELECTR. CAPACITOR	CEAS330M16
C37, 38	CERAMIC CAPACITOR	CCCL151J50
C39	CERAMIC CAPACITOR	CKCYF103Z50
C4	ELECTR. CAPACITOR	CEAS330M16
C40	CERAMIC CAPACITOR	CKCYF103Z50
C41	ELECTR. CAPACITOR	CEAS330M16
C42	CERAMIC CAPACITOR	CKCYF103Z50
C43	ELECTR. CAPACITOR	CEAS330M16
C44	CERAMIC CAPACITOR	CKCYF103Z50
C45	ELECTR. CAPACITOR	CEAS330M16
C46	CERAMIC CAPACITOR	CKCYF103Z50
C47	ELECTR. CAPACITOR	CEAS330M16
C48	CERAMIC CAPACITOR	CKCYF103Z50
C49	ELECTR. CAPACITOR	CEAS330M16
C5	CERAMIC CAPACITOR	CKCYF103Z50
C50	1F CAPACITOR	DGH1004
C51	ELECTR. CAPACITOR	CEAS47W50
C52	CERAMIC CAPACITOR	CKCYF103Z50
C53	ELECTR. CAPACITOR	CEAS330M16
C54, 55	CERAMIC CAPACITOR	CKCYF103Z50
C56	CERAMIC CAPACITOR	CKCYF102Z50
C57	CAPACITOR ARRAY	DCG1005
C58	CAPACITOR ARRAY	DCG1004
C59	CERAMIC CAPACITOR	CKCYF103Z50
C6, 60	ELECTR. CAPACITOR	CEAS330M16
C61	CAPACITOR ARRAY	DCG1005
C62	CAPACITOR ARRAY	DCG1004
C63, 64	CERAMIC CAPACITOR	CKCYF103Z50
C65, 66	CERAMIC CAPACITOR	CCCH100D50
C67	CERAMIC CAPACITOR	CKCYF103Z50
C68, 69	ELECTR. CAPACITOR	CEAS330M16
C7	CERAMIC CAPACITOR	CKCYF103Z50
C70	CAPACITOR ARRAY	DCG1004
C71	CAPACITOR ARRAY	DCG1005
C72	CERAMIC CAPACITOR	CKCYF103Z50
C73	ELECTR. CAPACITOR	CEAS330M16
C74	CAPACITOR ARRAY	DCG1006
C75	ELECTR. CAPACITOR	CEAS330M16
C76	CERAMIC CAPACITOR	CKCYF103Z50
C77	ELECTR. CAPACITOR	CEAS47J1M10
C78	ELECTR. CAPACITOR	CEAS330M16
C79	CERAMIC CAPACITOR	CKCYF103Z50
C8, 80	ELECTR. CAPACITOR	CEAS330M16
C81, 82	CERAMIC CAPACITOR	CKCYF103Z50
C83	ELECTR. CAPACITOR	CEAS330M16
C84-87	CERAMIC CAPACITOR	CKCYF103Z50

Mark No.	Description	Part No.
C88	ELECTR. CAPACITOR	CEAS330M16
C89, 9	CERAMIC CAPACITOR	CKCYF103Z50
C90	ELECTR. CAPACITOR	CEAS330M16
C91	CERAMIC CAPACITOR	CKCYF103Z50
C92	ELECTR. CAPACITOR	CEAS330M16
C93	CERAMIC CAPACITOR	CKCYF103Z50
C94	ELECTR. CAPACITOR	CEAS330M16
C95-98	CERAMIC CAPACITOR	CKCYF103Z50
C99	CERAMIC CAPACITOR	CKCYF102Z50

## RESISTORS

R113	RESISTOR ARRAY (10K)	RA7S108J
R118	RESISTOR ARRAY (10K)	RA5S108J
R13, 120	RESISTOR ARRAY (10K)	RA8S108J
R23	RESISTOR ARRAY (4.7K)	RA8S472J
R59	RESISTOR ARRAY (10K)	RA8S108J
Other resistors		RD1/6PM □□□ J

## OTHERS

X1	CRYSTAL RESONATOR	DSS1001
X2	CRYSTAL RESONATOR	VSS-041
X3	CRYSTAL RESONATOR	DSS1014
	PIEZOELECTRIC BUZZER	DPX1002
	IC SOCKET(28-P)	VKH-027

## ◎PAMP (DWH1007)

## SEMICONDUCTORS

IC1	AUDIO IC	SIK4231-2
Q1	TRANSISTOR	2SC1740S
Q12, 13	P-FET	ZS1103
Q2	TRANSISTOR	2SC1740S
Q3	TRANSISTOR	2SC1775
Q4	TRANSISTOR	2SA933S
Q5	TRANSISTOR	2SC1740S
Q6	TRANSISTOR	2SA1283
Q7, 8	TRANSISTOR	2SA970
D11	DIODE	1SR35-100AYL
D2	DIODE	1SS254
D3	DIODE	1SS142
D5	DIODE	1SR35-100AYL
D7	ZENER DIODE	MTZ16.8B
D8, 9	DIODE	1SR35-100AYL

## RELAY

RY1		RSR1014
-----	--	---------

## COILS

L1, 2	COIL	DTH1116
-------	------	---------

## CAPACITORS

C1	CERAMIC CAPACITOR	CKCYB222K50
C10	ELECTR. CAPACITOR	CEAS10M50
C11	ELECTR. CAPACITOR	CEASR22M50
C12	CERAMIC CAPACITOR	CKCYB222K50
C13, 14	ELECTR. CAPACITOR	DCH1018
C16	ELECTR. CAPACITOR	CEAS221M16
C17	ELECTR. CAPACITOR	CEAS10M50
C18	ELECTR. CAPACITOR	CEAS010M50
C19	ELECTR. CAPACITOR	CEAS471M10
C2	ELECTR. CAPACITOR	CEASR22M50

Mark	No.	Description	Part No.
	C21	ELECTR. CAPACITOR	CEAS4R7M50
	C22-25	AUDIO FILM CAPACITOR	CFTXA104J50
	C3	ELECTR. CAPACITOR	CEAS101M10
	C4	ELECTR. CAPACITOR	CEAS470M50
	C6	CAPACITOR (ALUMINUM)	DCH1022
	C7	ELECTR. CAPACITOR	DCH1019
	C8	ELECTR. CAPACITOR	CEAS470M50
	C9	ELECTR. CAPACITOR	CEAS101M10

## RESISTORS

	R11, 12	CARBON FILM RESISTOR	RD1/2LF□□□J
	R14	CARBON FILM RESISTOR	RD1/2LF472J
	R3, 16	CARBON FILM RESISTOR	RD1/2PMP681J
	R33	CARBON FILM RESISTOR	RD1/2LF561J
	R38, 39	RESISTOR	DCN1020
	R41-44	CARBON FILM RESISTOR	RD1/2LF100J
	R7-9	CARBON FILM RESISTOR	RD1/2LF□□□J
	Other resistors		RD1/6PM□□□J

## ACIN

## COIL

△	L301	FILTER	YTL-004
---	------	--------	---------

## CAPACITORS

△	C301-303	CAPACITOR (CERAMIC)	RCG-009
---	----------	---------------------	---------

## OTHERS

△	CN36, 74	CONNECTOR	SD-5277-02A
---	----------	-----------	-------------

## ◎ POWB (DWR1078)

## SEMICONDUCTORS

	IC101	REGULATOR IC	NJM72M05FA
	IC102	MECHANISM DRIVER IC	TA7291S
	IC103	REGULATOR IC	NJM72M12FA
	IC104	REGULATOR IC	NJM72M08FA
	IC105	REGULATOR IC	NJM72M08FA
	IC106	REGULATOR IC	NJM79L12A
△	D101	DIODE	SZYB10F
	D102-105	DIODE	1SR139-400
	D106	ZENER DIODE	MTZ4.3C
△	D108	DIODE	SZYB10F
△	D109	DIODE	S10V610-DF9

## CAPACITORS

	C101	CERAMIC CAPACITOR	CKCYF103Z50
	C102	ELECTR. CAPACITOR	RCH1032
	C103	ELECTR. CAPACITOR	CEAS4R7M50
	C104	ELECTR. CAPACITOR	CEAS470M25
	C105	ELECTR. CAPACITOR	CEAS101M50
	C106	ELECTR. CAPACITOR	CEAS221M25
	C107	CERAMIC CAPACITOR	CKCYF103Z50
	C109	ELECTR. CAPACITOR	CEAS101M50
	C110, 111	ELECTROLYTIC CAPACIT	CEAS102M35
△	C112, 113	CAPACITOR (CERAMIC)	RCG-009
	C114, 115	ELECTROLYTIC CAPACIT	DCH1034
	C116, 117	ELECTR. CAPACITOR	CEAS470M25
	C118-121	ELECTR. CAPACITOR	CEAS101M50

Mark	No.	Description	Part No.
------	-----	-------------	----------

## RESISTORS

△	R103	CARBON FILM RESISTOR	RD1/2LF4R7J
△	R112, 113	METAL OXIDE RESISTOR	RS11MF151J
	R114, 115	METAL OXIDE RESISTOR	RS11MF103J
△	R108	METAL OXIDE RESISTOR	RS3LME3R8J
	R101, 102, 104-107, 110, 111	CARBON FILM RESISTOR	RD1/4VM□□□J

## OTHERS

△	CN76	CONNECTOR	SD-5277-02A
---	------	-----------	-------------

## PSWB

## SWITCH

△	S	POWER SWITCH (POWER)	DSA1005
---	---	----------------------	---------

## CAPACITORS

△	C201, 202	CAPACITOR (CERAMIC)	RCG-009
---	-----------	---------------------	---------

## PSEL

## SWITCH

△	S101	VOLTAGE SELECTOR SW	DSX1003
---	------	---------------------	---------

## OPER

## SWITCHES

	S301-303	LIGHT ACTION SWITCH (MEMORY CLEAR, MENU ROTATION, SERVICE MODE)	DSG-107
--	----------	---	---------

## ◎ SPTB (DWX1124)

## OTHERS

△		SPEAKER TERMINAL 4-P	AKB1013
---	--	----------------------	---------

## CRJB

## CAPACITORS

	C501	CAPACITOR ARRAY	DOG-105
	C502	CERAMIC CAPACITOR	CKCYF102Z50
	C503	CERAMIC CAPACITOR	CKCYF103Z50

## OTHERS

		SOCKET (CONTROL)	YKN1072
--	--	------------------	---------

## ◎ MESS (DWG1128)

## SEMICONDUCTORS

	D101, 102	LED	LN0401RP2
	D103-105	LED	LN0603RP2

## RESISTORS

		All resistor	RD1/6PM□□□J
--	--	--------------	-------------

## ◎ ASEL (DWS1107)

## SWITCH

△	S	VOLTAGE SELECTOR SW (SPEAKER SELECTOR)	DSX1010
---	---	---	---------

Mark	No.	Description	Part No.
------	-----	-------------	----------

◎DISP (DWG1129)

SEMICONDUCTORS

D201	LED	LNS26YA
D202, 203	LED	LNS26RA(V)

◎PREB (DWK1013)

SEMICONDUCTORS

IC1	LOGIC IC	TC4052BP
IC2, 3	OP-AMP IC	NJM4558S
Q1, 2	TRANSISTOR	2SC3311A
Q3	TRANSISTOR	2SA933S
Q4	TRANSISTOR	2SC1740S
Q5	TRANSISTOR	DTA124ES
D1	DIODE	1SS254
D2	ZENER DIODE	MT27. 5B
D3	ZENER DIODE	MT25. 1B/C

CAPACITORS

C1	CERAMIC CAPACITOR	CKCYF103250
C10	CERAMIC CAPACITOR	CGCYX473M25
C11, 12	ELECTR. CAPACITOR	CEASR47M50
C13-15	ELECTR. CAPACITOR	CEAS4R7M50
C16	MYLOR FILM CAPACITOR	QOMA123J50
C17	AUDIO FILM CAPACITOR	CFTXA473J50
C18	MYLOR FILM CAPACITOR	QOMA122J50
C19	MYLOR FILM CAPACITOR	QOMA682J50
C20	CERAMIC CAPACITOR	CKCYF103250
C20	ELECTR. CAPACITOR	CEAS4R7M50
C22	ELECTR. CAPACITOR	CEAS4R7M50
C23	ELECTR. CAPACITOR	CEAS4R7M50
C24-26	ELECTR. CAPACITOR	CEAS4R7M50
C27	MYLOR FILM CAPACITOR	QOMA122J50
C28	MYLOR FILM CAPACITOR	QOMA682J50
C29	ELECTR. CAPACITOR	CEAS4R7M50
C30	ELECTR. CAPACITOR	CEAS4R7M50
C31	MYLOR FILM CAPACITOR	QOMA123J50
C32	AUDIO FILM CAPACITOR	CPTXA473J50
C33, 34	ELECTR. CAPACITOR	CEAS010M50
C35	CERAMIC CAPACITOR	CGCYX473M25
C36	ELECTR. CAPACITOR	CEAS221M16
C4	ELECTR. CAPACITOR	CEAS010M50
C5	CERAMIC CAPACITOR	CGCYX473M25
C6, 7	ELECTR. CAPACITOR	CEAS470M16
C8, 9	CERAMIC CAPACITOR	CGCYX473M25

RESISTORS

VR1	VARIABLE RESISTOR	DCS1013
VR2, 3	VARIABLE RESISTOR	DCS1014
Other resistors		RD1/6PM□□□J

WBFT

OTHERS

CN150, 151		DKA1003
------------	--	---------

Mark	No.	Description	Part No.
------	-----	-------------	----------

◎BGMB (DWK1014)

SEMICONDUCTORS

IC201	OP-AMP IC	NJM4558DX
IC202	E-VR IC	W5222L
IC203	LOGIC IC	TC74HC00AP
Q201, 202	TRANSISTOR	2SC1740S
D201, 202, 204	DIODE	1SS254
D203	ZENER DIODE	MT25. 1B

SWITCH

S201	SWITCH (STEREO/MONO)	DSH-106
------	----------------------	---------

CAPACITORS

C201, 202	ELECTR. CAPACITOR	CEANP010M50
C203, 204	ELECTR. CAPACITOR	CEAS010M50
C205, 206	ELECTR. CAPACITOR	CEAS4R7M50
C207, 208	ELECTROLYTIC CAPACIT	CEAS2R2M50
C209	ELECTROLYTIC CAPACIT	CEANP221M10
C210, 211	ELECTR. CAPACITOR	CEAL470M16
C212	CERAMIC CAPACITOR	CKDYB222K50

RESISTORS

VR201	VARIABLE RESISTOR	DCS1010
Other resistors		RD1/6PM□□□J

OTHERS

J201	PIN JACK	PKB-009
------	----------	---------

◎KEYB (DWS1101)

SEMICONDUCTORS

D301-310	LED	SLY-31MC3
D311-314	LED	SLY-31DC3
D315-322	LED	SLY-31YC3

SWITCHES

S301-310	SWITCH (1-10)	DSG1011
S311-316	SWITCH (CLEAR, BEST HITS ROTATION MENU)	RS6-155

RESISTORS

All resistors		RD1/6PM□□□J
---------------	--	-------------

RMJB

SEMICONDUCTOR

D401-404	ZENER DIODE	MTZJ5. 6B
----------	-------------	-----------

COIL

L401	AXIAL INDUCTOR	LAU010X
------	----------------	---------

CAPACITORS

C401-406	CERAMIC CAPACITOR	CKCYF103250
----------	-------------------	-------------

RESISTORS

R401-404	CARBONFILM RESISTOR	RD1/6PM221J
----------	---------------------	-------------

OTHERS

SOCKET (REMOTE CONTROL)		VKN1072
-------------------------	--	---------

Mark No.	Description	Part No.
----------	-------------	----------

**WBJB****CAPACITORS**

C101, 102	CERAMIC CAPACITOR	CKCYF102Z50
C103	CERAMIC CAPACITOR	CKCYF103Z50

**OTHERS**

CN101, 102	TERMINAL (WALL BOX CONTROL TERMINAL)	DKA1004
------------	---	---------

**RSSB****SWITCH**

S201	DIP SWITCH (FUNCTION)	DSX1011
------	-----------------------	---------

**CAPACITORS**

C201, 202	CERAMIC CAPACITOR	CKCYF102Z50
C203, 204	CERAMIC CAPACITOR	CKCYF103Z50

**RESISTOR**

R201	CARBONFILM RESISTOR	RD1/6PM472J
------	---------------------	-------------

**OTHERS**

J201	SOCKET (DATA OUT)	DKM1037
------	-------------------	---------

**IOJB****SEMICONDUCTORS**

Q100, 101	TRANSISTOR	2SA1309A
-----------	------------	----------

**CAPACITORS**

C100, 101	CERAMIC CAPACITOR	CKPUPYB102K50
C102, 103	CERAMIC CAPACITOR	CKCYF103Z50

**RESISTORS**

R100-103	CARBONFILM RESISTOR	RD1/6PM□□□J
----------	---------------------	-------------

**OTHERS**

JA53	JACK (LINE IN/OUT)	HXB-020
------	--------------------	---------

**◎BRAN (DWX1108)**

There is not supplied parts in this unit.

**◎ROTA (DWX1109)****SEMICONDUCTORS**

Q401	DIGITAL TRANSISTOR	1W4112
Q402	TRANSISTOR	2SD1762-F8
Q403	DIGITAL TRANSISTOR	1W4212
Q404	TRANSISTOR	2SB1185-F8
D401, 402	RECTIFIER DIODE	1SR159-400

**CAPACITORS**

C401	ELECTR. CAPACITOR	CEAL470M6R3
C402	CERAMIC CAPACITOR	CKPUPYF223Z25
C403	ELECTROLYTIC CAPACIT	CEAS101M25

**RESISTORS**

R401-405	CARBONFILM RESISTOR	RD1/6PM□□□J
----------	---------------------	-------------

Mark No.	Description	Part No.
----------	-------------	----------

**◎POSS (DWX1110)****SEMICONDUCTOR**

D501		GP1A14
------	--	--------

**CAPACITOR**

C501	CERAMIC CAPACITOR	CKPUPYF223Z25
------	-------------------	---------------

**RESISTOR**

R501	CARBONFILM RESISTOR	RD1/6PM391J
------	---------------------	-------------

**SENS****SEMICONDUCTOR**

D701	LED (RED)	SLR-54VR35H
------	-----------	-------------

**CAPACITOR**

C701	CERAMIC CAPACITOR	CKPUPYF223Z25
------	-------------------	---------------

**OTHERS**

	REMOTE SENSOR	GP1U50X
--	---------------	---------

**◎CNTB (DWX1132)****SEMICONDUCTOR**

IC801		GP1A30R
-------	--	---------

**CAPACITOR**

C801	CERAMIC CAPACITOR	CKPUPYF223Z25
------	-------------------	---------------

**RESISTOR**

R801	CARBONFILM RESISTOR	RD1/6PM121J
------	---------------------	-------------

**LAMP****CAPACITORS**

△ C601, 602	CAPACITOR (CERAMIC)	RCG-009
△ C603, 604	POWER CAPACITOR	DCG1003

**RESISTOR**

△ R601, 602	CARBON FILM RESISTOR	RD1/4PM225J
-------------	----------------------	-------------

**OTHERS**

△ CN33	CONNECTOR	SD-5277-02A
--------	-----------	-------------

**◎NETWORK ASSEMBLY (SWN1219)****COILS**

L1	(3.3mH)	STH1100
L3	(3.9mH)	STH1021
L4	(0.22mH)	STH-327

**CAPACITORS**

C1		CES4220KJ
C2		CES4100KJ
C4		CES4DX1R8KJ

**RESISTOR**

R4		RT10BAL100K
----	--	-------------

**OTHERS**

Br1 (1A)		SSG-004
----------	--	---------

## CD SECTION

## NOTES:

- Parts without part number cannot be supplied.
- Parts marked by "⊗" are not always kept in stock. Their delivery time may be longer than usual or they may be unavailable.
- The  $\Delta$  mark found on some component parts indicates the importance of the safety factor of the part. Therefore, when replacing, be sure to use parts of identical designation.
- When ordering resistors, first convert resistance values into code form as shown in the following examples.

Ex.1 When there are 2 effective digits (any digit apart from 0), such as 560 ohm and 47k ohm (tolerance is shown by J = 5%, and K = 10%).

560  $\Omega$   $\rightarrow$  56  $\times 10^1$   $\rightarrow$  561..... RD1/4PS 561J  
 47k  $\Omega$   $\rightarrow$  47  $\times 10^3$   $\rightarrow$  473..... RD1/4PS 473J  
 0.5  $\Omega$   $\rightarrow$  0R5 ..... RN2H 0R5K  
 1  $\Omega$   $\rightarrow$  010 ..... RS1P 010K

Ex.2 When there are 3 effective digits (such as in high precision metal film resistors).

5.62k  $\Omega$   $\rightarrow$  562  $\times 10^1$   $\rightarrow$  5621 ..... RN1/4SR 5621F

Mark	NO	Description	Part NO.	Mark	NO	Description	Part NO.
<b>EKEY</b>				C17		ELECTR. CAPACITOR	CEAS330M16
<b>SWITCHES</b>				C18, 19		CERAMIC CAPACITOR	CKCY102K50
	S301-303	SWITCH (EJECT(A, B, C))	D6G1009	C2		NYLOR FILM CAPACITOR	QMA333J50
<b>DEGT (DWX1116)</b>				C20		CERAMIC CAPACITOR	CKCY102K50
<b>SEMICONDUCTORS</b>				C21, 22		ELECTR. CAPACITOR	CEAS330M16
IC1		PRE AMP IC	CXA1081S	C23		ELECTR. CAPACITOR	CEAS10M50
IC10		POWER OP AMP	TAT256P	C24		CERAMIC CAPACITOR	CKCY102K50
IC11		SYSTEM PRESBT IC	M51953BL	C25		CERAMIC CAPACITOR	CKC1F103Z50
IC2		SERVO CONTROL IC	CXA1082AS	C26-29		ELECTR. CAPACITOR	CEAS330M16
IC3		EPW DEMODULATION IC	CXD1135QZ	C3		NYLOR FILM CAPACITOR	QMA102J50
IC4		MEMORY IC	CXK5816PN-12L	C30, 31		ELECTR. CAPACITOR	CEAS330M16
IC5		MCU	F0D068B	C32		ELECTR. CAPACITOR	CEAS101M10
IC6-8		POWER OP AMP	TAT256P	C33		CERAMIC CAPACITOR	CCCH390J50
Q1		TRANSISTOR	DTA124ES	C34		NYLOR FILM CAPACITOR	QMA472J50
Q10		TRANSISTOR	DTC124ES	C35		CERAMIC CAPACITOR	CCCH390J50
Q11		TRANSISTOR	2SC1740S	C36, 37		ELECTR. CAPACITOR	CEAS330M16
Q12		TRANSISTOR	DTA124ES	C38		CERAMIC CAPACITOR	CCCH390J50
Q13		TRANSISTOR	2SA933S	C39		NYLOR FILM CAPACITOR	QMA333J50
Q14		TRANSISTOR	DTA124ES	C40		ELECTR. CAPACITOR	CEAS330M16
Q15		TRANSISTOR	2SC249T	C41		NYLOR FILM CAPACITOR	QMA332J50
Q16		TRANSISTOR	DTC124ES	C42		NYLOR FILM CAPACITOR	QMA103J50
Q2		TRANSISTOR	2SC249T	C43		ELECTR. CAPACITOR	CEASR47M50
Q3		TRANSISTOR	DTA124ES	C44		NYLOR FILM CAPACITOR	QMA103J50
Q4		TRANSISTOR	2SC249T	C45		ELECTR. CAPACITOR	CEAS330M16
Q5		TRANSISTOR	DTA124ES	C46		NYLOR FILM CAPACITOR	QMA272J50
Q6		TRANSISTOR	2SC249T	C47, 48		ELECTR. CAPACITOR	CEAS330M16
Q7, 8		TRANSISTOR	2SC1740S	C49		NYLOR FILM CAPACITOR	QMA333J50
Q9		TRANSISTOR	2SA1399	C50		ELECTR. CAPACITOR	CEAS330M16
D4-7		DIODE	1SS254	C51		NYLOR FILM CAPACITOR	QMA472J50
<b>CAPACITORS</b>				C52, 53		NYLOR FILM CAPACITOR	QMA104J50
C1		ELECTR. CAPACITOR	CEASR47M50	C54		NYLOR FILM CAPACITOR	QMA102J50
C10, 11		CERAMIC CAPACITOR	CCCH390J50	C55		ELECTR. CAPACITOR	CEAS487M50
C12, 13		ELECTR. CAPACITOR	CEAS330M16	C56		NYLOR FILM CAPACITOR	QMA104J50
C14		CERAMIC CAPACITOR	CKC1F103Z50	C57		ELECTR. CAPACITOR	CEAS330M16
C15, 16		CERAMIC CAPACITOR	CCCH220J50	C58		NYLOR FILM CAPACITOR	QMA333J50
C59		NYLOR FILM CAPACITOR	QMA104J50	C59		NYLOR FILM CAPACITOR	QMA104J50
C60		ELECTROLYTIC CAPACIT.	CEANP47M50	C60		ELECTROLYTIC CAPACIT.	CEANP47M50
C61, 62		ELECTR. CAPACITOR	CEAS330M16	C61, 62		ELECTR. CAPACITOR	CEAS330M16
C63		NYLOR FILM CAPACITOR	QMA103J50	C63		NYLOR FILM CAPACITOR	QMA103J50
C64		ELECTR. CAPACITOR	CEAS330M16	C64		ELECTR. CAPACITOR	CEAS330M16

Mark	No.	Description	Part No.
	C65	ELECTR. CAPACITOR	CEAS101M10
	C66	MYLOR FILM CAPACITOR	CQMA47ZJ50
	C67	ELECTR. CAPACITOR	CEAS330M50
	C68, 69	ELECTR. CAPACITOR	CEAS330M16
	C70-75	CERAMIC CAPACITOR	000CH221J50
	C76-78	ELECTR. CAPACITOR	CEANP010M50
	C79, 80	ELECTR. CAPACITOR	CEAS330M16
	C81	CERAMIC CAPACITOR	CKDF103Z50

## RESISTORS

YR2	SEMI-FIXED RESISTOR	VRTB6VS103
YR3-7	VR	VRTB6VS223
YR8	VR	VRTB6VS102
Other resistors		RDI/6PM□□□J

## OTHERS

DL1, 2	DELAY LINE	FTF1012
X1	CRYSTAL RESONATOR	DSS1010
X2	CRYSTAL RESONATOR	PSS-012
CN4		B6P-SHP-1AA
CN7		5597-17APB
CN8		B6P-SHP-1AA
	IC SOCKET	VKN-029

## DIAK

## CAPACITOR

C501	CAPACITOR ARRAY	DCG1007
------	-----------------	---------

## OTHERS

JA501	SOCKET	VKN1072
-------	--------	---------

## PJAK

## OTHERS

JA601	JACK	PKB1009
-------	------	---------

## MJSW

## SWITCHES

S801-803	PUSH SWITCH (MJ LOCK (1, 2, 3))	PSH1008
S804-806	SWITCH (MJ SENS (1, 2, 3))	PSH1005

## SENS

## SEMICONDUCTOR

Q901		GPIA52HR
------	--	----------

## SWITCH

S901	(UP LIMIT)	RSP1007
------	------------	---------

## CAPACITOR

C901	ELECTROLYTIC CAPACIT	CEJA100M16
------	----------------------	------------

## RESISTORS

R901, 902	CARBONFILM RESISTER	RDI/6PM□□□J
-----------	---------------------	-------------

Mark	No.	Description	Part No.
------	-----	-------------	----------

## REJC

There is not supplied parts in this unit.

## FREC

## OTHERS

CN401, 402	CONNECTOR	5597-17APB
------------	-----------	------------

## HRMB

There is not supplied parts in this unit.

## RMJB

## OTHERS

MINI JACK 3P		DKN1028
--------------	--	---------

## ◎ANLG (DWX1155)

## SEMICONDUCTORS

IC201 D/A CONVERTER	LC7881-C
IC202, 203 LINEAR IC	NJM4558D
IC204 REGULATOR IC	NJM79M5FA
IC205 REGULATOR IC	NJM7805FA
Q201, 202 TRANSISTOR	DTC124ES
Q203 TRANSISTOR	DTA124ES
Q204 TRANSISTOR	DTC124ES
Q205, 206 TRANSISTOR	2SD1302
Q207, 208 TRANSISTOR	2SC1740S
Q209 TRANSISTOR	DTA124ES
D201 BRIDGE RECTIFIER	2W02-5008-L

## COIL AND FILTERS

L201 FILTER	VTL-157
F202-204	VTH1001

## CAPACITORS

C201, 202 CAPACITOR (CERAMIC)	RCG-009
C203 CAPACITOR (ALUMINUM)	VCH1050
C204 ELECTROLYTIC CAPACIT	CEAS222M16
C205 ELECTR. CAPACITOR	CEAS102M10
C206 ELECTR. CAPACITOR	CEAS471M10
C207, 208 MYLOR FILM CAPACITOR	CQMA102J50
C209, 210 ELECTR. CAPACITOR	CEAS220M50
C211, 212 MYLOR FILM CAPACITOR	CQMA821J50
C213, 214 MYLOR FILM CAPACITOR	CQMA471J50
C215, 216 MYLOR FILM CAPACITOR	CQMA472J50
C217, 218 MYLOR FILM CAPACITOR	CQMA683J50
C219, 220 ELECTR. CAPACITOR	CEAS220M50
C221-225 ELECTR. CAPACITOR	CEAS330M16
C226 ELECTR. CAPACITOR	CEAS101M10
C227 CERAMIC CAPACITOR	CKCF103Z50

## RESISTORS

All resistors	RDI/6PM□□□J
---------------	-------------

## 7. ADJUSTMENTS

### 7.1 MECHANICAL ADJUSTMENTS

#### 7.1.1 MAIN SECTION

##### • Synchronous adjustment of three surfaces of the menu (Fig. 7-1)

###### PREPARATIONS

- Adjust without installing the motor (menu).
- Fix the center pulley to the menu shaft with the screws.

- (1) Apply synchro belt between synchro pulley and center pulley both on the right and left sides.
- (2) While applying a spring (tension) to the underframe and tension plate, apply a tension to the synchro belt.
- (3) Fix the tension plate to the underframe with screw ①.
- (4) By placing a flat plate such as a ruler on them, align the three surfaces of the menu with each other on the same level.
- (5) Fix the menu shaft to the synchro pulley using a hexagonal wrench.
- (6) Remove the plate placed on the menu and check the following items while turning the menu by hand.
  1. Check that the three surfaces of the menu rotate smoothly.
  2. Check that all the three surfaces align with each other on the same level after turning the menu shaft once.

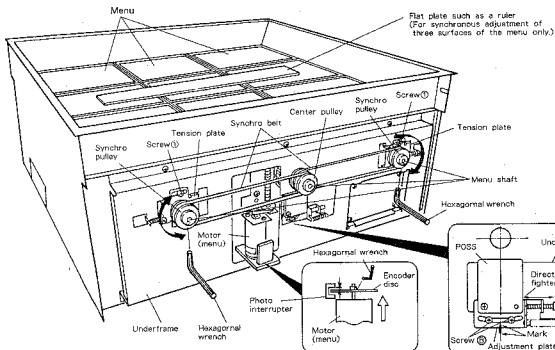

Fig. 7-1

##### • Adjustment of the stop position of menu rotation

###### PREPARATIONS

- Loosen screw ④ which holds the encoder disc using a hexagonal wrench.
- Loosen screw ⑤ which holds the adjustment plate.
- Adjust with the motor (menu) attached.

- (1) Set the gap between the encoder disc and photo interrupter of the motor (menu) to 1.2 mm. (Fig. 7-2)
- (2) Fix the screw of the encoder disc by tightening with a hex wrench.
- (3) Turn screw ⑥ so that the carved mark on the adjustment plate aligns with the underframe. Then temporarily tighten screw ④.
- (4) Push the ROTATE MENU key on the front panel of the main unit so that menu rotates. Then, perform the following adjustments depending on the condition. (Fig. 7-3)
  - When the menu stops after extending the front ..... Loosen screw ④, then tighten screw ⑥ turning it clockwise.
  - When menu stops before reaching the front ..... Loosen screw ④ and turn screw ⑥ counterclockwise to loosen it.
- (5) Turn the menu again and firmly tighten screw ④ when the menu stops directing its surfaces to the front. (Fig. 7-4 ②)
- (6) Finally, turn the menu and check that the menu stops directing all of its three surfaces to the front at every 120° rotation.

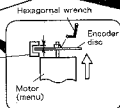

Fig. 7-2

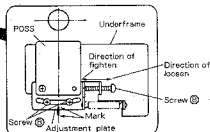

Fig. 7-3

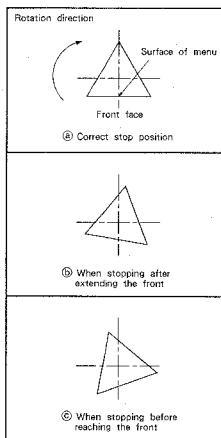

Fig. 7-4

## 7.1.2 CD SECTION

PREPARATIONS

- Set a magazine in the first and third modules of the CD main unit.
- Connect the remote control unit (RU-V101) to the CD main unit.

## 1. Rough adjustment of the select position

- Set the distance from the upper side of the sensor plate to that of the main chassis to 7mm by turning screw (A).

## 2. Adjustment of the select position

- First, proceed as follows.

- Press the 10keys in the sequence of  $\boxed{1} + \boxed{8} + \text{STILL/STEP} \blacktriangleright$  (DISC SELECT) key +  $\text{STILL/STEP} \blacktriangleleft$  (DISC RETURN) key. When the operation is completed, check that the gap between the top of the rotation lever and the upper side of the sixth tray in the magazine is  $0.3^{+0.2}_{-0}$ .

- If the distance is not within the specified range, turn screw (A) to adjust the position of the sensor plate and press the 10keys again in the sequence of  $\boxed{1} + \boxed{8} + \text{STILL/STEP} \blacktriangleright$  (DISC SELECT) key +  $\text{STILL/STEP} \blacktriangleleft$  (DISC RETURN) key until the distance comes within the specified range.

- Push the 10keys in the sequence of  $\boxed{6} + \text{STILL/STEP} \blacktriangleright$  (DISC SELECT) key +  $\text{STILL/STEP} \blacktriangleleft$  (DISC RETURN) key and check that the gap between the top of the rotation lever and the upper side of the sixth tray in the magazine is  $0.3\text{mm} \pm 0.1\text{mm}$ .

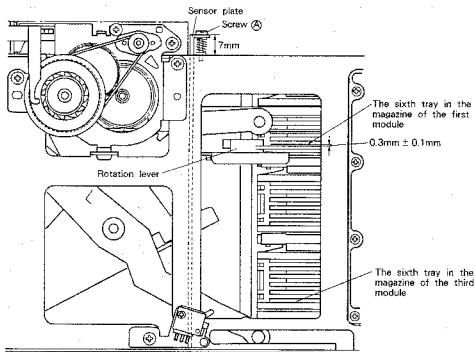

Fig. 7-5



## 7.2 ELECTRICAL ADJUSTMENTS

The adjustment items of this model should be performed in the order as shown below.

### • Adjustment and check Items

1. Tracking offset focus offset and RF offset adjustments
2. RF level adjustment
3. LD (Laser Diode) output power confirmation
4. Focus lock and spindle lock confirmation
5. Grating adjustment
6. Tracking balance adjustment
7. Tangential adjustment
8. Focus gain adjustment
9. Tracking gain adjustment
10. VCO free-run frequency adjustment
11. Method to confirm S character (FOCUS ERROR)

### • Measuring Equipment

1. Dual trace oscilloscope
2. Laser power meter
3. Test disc (YEDS-7)
4. Tracking balance adjustment filter
5. Loop gain adjustment filter
6. Signal generator
7. Frequency counter
8. Other general tools
9. Remote control unit (RU-V101)

### • Service Mode

The CD main unit can be operated independently when remote control unit (RU-V101) is connected to the unit.

For the operation, refer to Service manual (1) (ARP2047) : Service Mode (page 14).

Note: Before operating the remote control unit (RU-V101), move the mechanism by using the 10keys + STILL/STEP▶ (DISC SELECT) key to the position where the test disc has been placed.

### • Adjustment VRs and their names

- VR1 : Laser power
- VR2 : RF offset (RF. OFS)
- VR3 : Focus gain (FCS. GAN)
- VR4 : Tracking gain (TRK. GAN)
- VR5 : Tracking balance (TRK. BAL)
- VR6 : Focus offset (FCS. OFS)
- VR7 : Tracking offset (TRK. OFS)
- VR8 : VCO adjustment (VCO. ADJ)

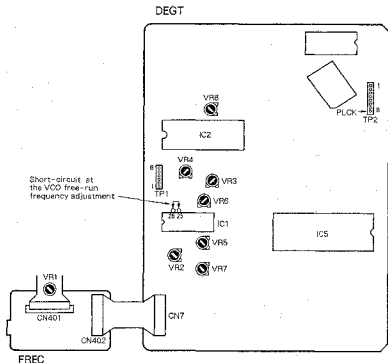
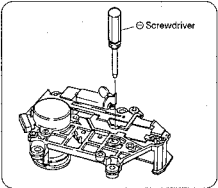
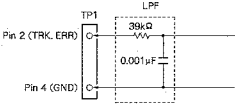

Fig. 7-6 Adjusting point

Step No.	Oscilloscope Setting		Test Points	Adjusting Points	Check items/ Adjustment specifications	Adjustment procedure
	V	H				
1	<b>TRACKING OFFSET, FOCUS OFFSET AND RF OFFSET ADJUSTMENT</b>					
			TP1 Pin 2 (TRK. ERR) TP1 Pin 6 (FCS. ERR) TP1 Pin 1 (RF OUTPUT)	VR5 (TRK. BAL.) VR7 (TRK. OFS)  VR6 (FCS. OFS)  VR2 (RF. OFS)	Tracking offset 45° 0V ± 50mV  FOCUS offset 0V ± 50mV  RF offset 100mV ± 50mV	<ul style="list-style-type: none"> <li>● Set to Service mode.</li> <li>● Turn VR5 TRK. BAL. (Tracking balance) volume clockwise 45° from the center.</li> <li>● Adjust with VR7 TRK. OFS (Tracking offset) volume so that the voltage of pin 2 TRK. ERR (Tracking error) of TP1 becomes 0V ± 50mV.</li> <li>● Adjust VR6 FCS. OFS (focus offset) so that the FCS. ERR (focus error) voltage at TP1 pin 6 becomes 0V ± 50mV.</li> <li>● Adjust VR2 RF. OFS (RF offset) so that the RF output voltage at TP1 pin 1 becomes 100mV ± 50mV.</li> </ul>
2	<b>RF LEVEL ADJUSTMENT</b>					
			TP1 Pin 1 (RF)	VR1 Laser power	1.5Vp-p $\pm \begin{smallmatrix} 0.2V \\ 0V \end{smallmatrix}$	<ul style="list-style-type: none"> <li>● Set to Service mode.</li> <li>● Play TEST disc and connect probe of an oscilloscope to pin 1 RF (RF output) of TP1 and measure the P-P voltage of RF waveform.</li> <li>● Adjust VR1 (Laser power) so that the value is within 1.5Vp-p <math>\pm \begin{smallmatrix} 0.2V \\ 0V \end{smallmatrix}</math>.</li> </ul>
3	<b>LD (LASER DIODE) OUTPUT POWER CONFIRMATION</b>					
					Confirmation : less than 0.13mW	<ul style="list-style-type: none"> <li>● Set to Service mode.</li> <li>● Press <math>\left[ \text{MULTI-SPEED+} \right]</math> key + <math>\left[ 0 \right]</math> and turn ON LD (laser diode).</li> <li>● Place sensor of the laser power meter immediately above the object lens and confirm that the output power of the LD is less than 0.13mW.</li> </ul>
4	<b>FOCUS LOCK AND SPINDLE LOCK CONFIRMATION</b>					
	0.5V/div	100msec /div	TP1 Pin 1 (RF output)		RF output exists  Normal rotation	<ul style="list-style-type: none"> <li>● Set TEST disc.</li> <li>● Set to Service mode.</li> <li>● Shift the pickup close to the center of the disc by pressing the <math>\left[ \text{MULTI-SPEED+} \right]</math> key + <math>\left[ 4 \right]</math>. * Note that this step must be performed.</li> <li>● Observe pin 1 RF (RF output) of TP1 with an oscilloscope and confirm that the RF signal is output after pressing the <math>\left[ \text{MULTI-SPEED+} \right]</math> key + <math>\left[ 1 \right]</math>.</li> <li>● Press <math>\left[ \text{MULTI-SPEED+} \right]</math> key + <math>\left[ 2 \right]</math> and be sure that the disc rotates in normal direction at almost the specified speed (as it is close to the center of the disc, the rotating speed is around 300 rpm) and not rotates abnormally or inversely.</li> </ul>

Step No.	Oscilloscope Setting		Test Points	Adjusting Points	Check items/ Adjustment specifications	Adjustment procedure										
	V	H														
<b>5 GRATING ADJUSTMENT</b>																
						 <p>Fig. 7-7</p>  <p>Fig. 7-8</p> <ul style="list-style-type: none"> <li>● Set to Service mode.</li> <li>● Shift the pickup close to the center of the disc by pressing <b>[MULTI-SPEED+]</b> key + <b>[4]</b> so that the grating adjustment screw of the pickup can be seen through the oval hole of the upper side of the servo mechanism.</li> <li>● Insert the ⊖ screwdriver into the adjusting hole from the upper side of the mechanism as shown in Fig. 7-7, and confirm that the grating screw turns.</li> <li>● Press <b>[MULTI-SPEED+]</b> key + <b>[1]</b> and <b>[MULTI-SPEED+]</b> key + <b>[2]</b> sequentially and close the focus servo and spindle servo. (Do not close the tracking servo.)</li> <li>● Observe the waveform of pin 2 TRK. ERR (Tracking error) of TP1 with an oscilloscope. At this point, insert a 4kHz cutoff low-pass filter. (Fig. 7-8)</li> </ul> <table border="1" data-bbox="153 895 559 1253"> <tr> <td>0.5V/div</td> <td>5mscc/div</td> <td>TP1 Pin 2 (TRK. ERR)</td> <td>Grating</td> <td>Null point</td> </tr> <tr> <td></td> <td></td> <td></td> <td>Grating</td> <td>Maximum amplitude</td> </tr> </table> <ul style="list-style-type: none"> <li>● Turn the ⊖ screwdriver and find null point. (Photo. 7-1)</li> <li>● Then, turn slowly the ⊖ screwdriver counterclockwise from the null point and adjust at the point where the waveform (Tracking error signal) firstly becomes maximum amplitude. (See Photo. 7-2.)</li> </ul> <p>Note:</p> <ul style="list-style-type: none"> <li>● If the ⊖ screwdriver is pressed strongly, the pickup moves toward disc center, accordingly adjustment becomes difficult.</li> <li>● Finally, be sure to confirm that the tracking error signal (at this time, 4kHz of cutoff low-pass filter is not inserted) when the pickup is moved toward the disc center and the P-P voltage of the tracking error signal at the outer circumference of the disc are not varied greatly. When the level is deviated over ±10%, adjust again by turning grating screw to the maximum error amplitude point.</li> </ul>	0.5V/div	5mscc/div	TP1 Pin 2 (TRK. ERR)	Grating	Null point				Grating	Maximum amplitude
0.5V/div	5mscc/div	TP1 Pin 2 (TRK. ERR)	Grating	Null point												
			Grating	Maximum amplitude												

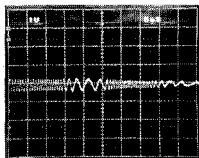

Photo. 7-1  
Null point

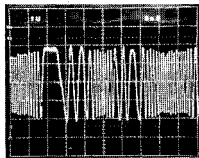

Photo. 7-2  
Maximum amplitude

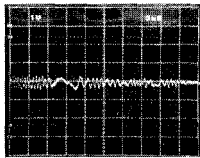
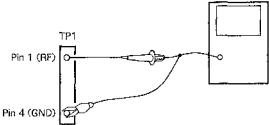
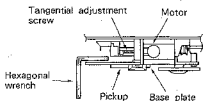

Photo. 7-3  
This is not the null-point waveform

Step No.	Oscilloscope Setting		Test Points	Adjusting Points	Check items/ Adjustment specifications	Adjustment procedure
	V	H				
<b>6 TRACKING BALANCE ADJUSTMENT</b>						
	0.5V/div	5μsec /div	TP1 Pin 2 (TRK. ERR)	VR5 (TRK. BAL)	(TRK. ERR)	<ul style="list-style-type: none"> <li>● Set the TEST disc.</li> <li>● Set to Service mode.</li> <li>● Shift the carriage close to the center of the disc by pressing <math>\left[ \text{MULTI-SPEED+} \right]</math> key + <math>\left[ 4 \right]</math>.</li> <li>● Press <math>\left[ \text{MULTI-SPEED+} \right]</math> key + <math>\left[ 1 \right]</math> and <math>\left[ \text{MULTI-SPEED+} \right]</math> key + <math>\left[ 2 \right]</math> to start turning the disc.</li> <li>● Observe pin 2 TRK. ERR (Tracking error) of TP1 with an oscilloscope and adjust with VR5 TRK. BAL (Tracking balance) volume so that the DC component of the tracking error disappears.</li> </ul> <p>Note: Before proceeding with the above adjustments, be sure to adjust the tracking error offset.</p>
	Photo. 7-4 DC elements mixed in signal				Photo. 7-5 DC elements eliminated	

Step No.	Oscilloscope Setting		Test Points	Adjusting Points	Check items/ Adjustment specifications	Adjustment procedure
	V	H				
7	<b>TANGENTIAL ADJUSTMENT</b>					
		200nsec / div	TP1 Pin 1 (RF output)	Tangential adjustment screw	Best eye pattern	<ul style="list-style-type: none"> <li>● Set the TEST disc.</li> <li>● Set to Service mode.</li> <li>● Shift the pickup close to the center of the disc by pressing <b>[MULTI-SPEED+] key + [4]</b>.</li> <li>● Press <b>[MULTI-SPEED+] key + [1]</b>, <b>[MULTI-SPEED+] key + [2]</b> and <b>[MULTI-SPEED+] key + [3]</b> sequentially, and close all the servos. (Pause indicator lights up.)</li> <li>● Observe pin 1 RF (RF output) of TP1 with an oscilloscope and adjust with the tangential screw so that the eye pattern becomes clear. (Fig. 7-9 and 7-10)</li> <li>● The adjusting point is the middle point between the point where the eye pattern becomes deteriorate by turning the tangential screw clockwise and the point where the eye pattern becomes deteriorate by turning the tangential screw counterclockwise. As a criterion, observe that the overall waveform is clear and one of the diamond shapes within the eye pattern (Photo. 7-7), and adjust at as an optimum point where the diamond shape is seen relatively fine line.</li> </ul>
						 <p style="text-align: center;">Fig. 7-9</p> <p>Note : During the adjustment, hold hexagonal wrench to upward so as to keep the pickup body not goes down.</p>



In the figure below, the top and bottom is opposite to that of the actual product.

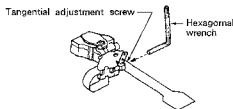

Fig. 7-10 Tangential adjustment

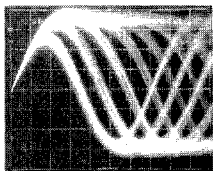

Photo. 7-6

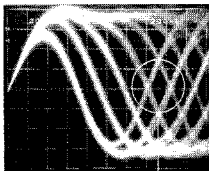

Photo. 7-7

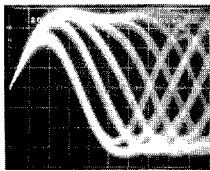

Photo. 7-8

Part to be observed



Unsatisfactory

Optimum  
adjustment

Unsatisfactory

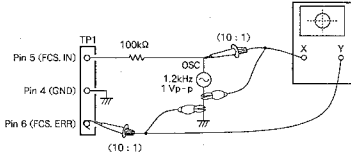
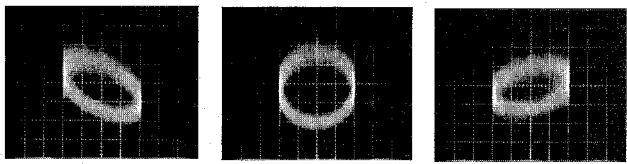
Step No.	Oscilloscope Setting		Test Points	Adjusting Points	Check items/ Adjustment specifications	Adjustment procedure
	V	H				
<b>8 FOCUS GAIN ADJUSTMENT</b>						
	20mV/div, 5mV/div. CH1 (X), CH2 (Y) (Probe 10 : 1)		X axis : TP1 Pin 5 (FCS.IN) Y axis : TP1 Pin 6 (FCS.ERR)	VR3 (FCS. GAN)	Phase difference 90°	<ul style="list-style-type: none"> <li>● In the POWER OFF state, connect an oscilloscope and oscillator as shown in Fig. 7-11.</li> <li>● Set the unit to the normal PLAY mode.</li> <li>● Turn the POWER of oscillator ON and output 1.2kHz 1Vp-p.</li> </ul> <p>Note : Depending upon oscillators, some of them output DC when their power turned ON. Therefore, it is desirable to connect oscillator after turning the power ON.</p> <ul style="list-style-type: none"> <li>● Adjust with VR3 FCS.GAN (Focus gain) volume so that the lissajous figure of the oscilloscope becomes horizontal circle (Phase difference 90°).</li> </ul>
						 <p style="text-align: center;">Fig. 7-11</p>
						 <div style="display: flex; justify-content: space-around; margin-top: 10px;"> <div style="text-align: center;"> <p>Photo. 7-9 Gain overcompensated</p> </div> <div style="text-align: center;"> <p>Photo. 7-10 Gain optimum</p> </div> <div style="text-align: center;"> <p>Photo. 7-11 Gain undercompensated</p> </div> </div>

Step No.	Oscilloscope Setting		Test Points	Adjusting Points	Check items/ Adjustment specifications	Adjustment procedure
	V	H				
<b>9 TRACKING GAIN ADJUSTMENT</b>						
	50mV/div. 5mV/div. CH1 (X). CH2 (Y) (Probe 10 : 1)	X axis : TP1 Pin 3 (TRK. IN) Y axis : TP1 Pin 2 (TRK. ERR)	VR4 (TRK. GAN)	Phase difference 90°	<ul style="list-style-type: none"> <li>● In the POWER OFF state, connect an oscilloscope and oscillator as shown in Fig. 7-12.</li> <li>● Set the unit to the normal PLAY mode.</li> <li>● Turn the POWER of oscillator ON and output 1.2kHz 2Vp-p.</li> </ul> <p>Note: Depending upon oscillators, some of them output DC when their power turned ON. Therefore, it is desirable to connect oscillator after turning the power ON.</p> <ul style="list-style-type: none"> <li>● Adjust with VR4 TRK. GAN (Tracking gain) volume so that the lissajous figure of the oscilloscope becomes horizontal circle (phase difference 90°).</li> </ul>	
						Fig. 7-12
		Photo. 7-12 Gain overcompensated	Photo. 7-13 Gain optimum		Photo. 7-14 Gain undercompensated	

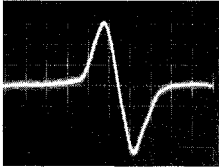

Step No.	Oscilloscope Setting		Test Points	Adjusting Points	Check items/ Adjustment specifications	Adjustment procedure
	V	H				
10	<b>VCO FREE RUN FREQUENCY ADJUSTMENT</b>					
			TP2 Pin 8 (PLCK)	VR8 (VCO, ADJ)	4.275 ± 0.01MHz	<ul style="list-style-type: none"> <li>● Set to Service mode.</li> <li>● Short-circuit between pin 25 and pin 26 of IC1 in the DEGT assembly with ⊖ screwdriver, etc. (Fig. 7-6)</li> <li>● Connect frequency counter, which is measurable over 10MHz, to pin 8 of TP2 (PLCK).</li> <li>● Adjust with VR8 VCO, ADJ (VCO adjustment) volume so that the value of frequency counter becomes 4.275 ± 0.01MHz.</li> </ul>
11	<b>METHOD TO CONFIRM S CHARACTER (FOCUS ERROR)</b>					
			TP1 Pin 6 (FCS.ERR)			<ul style="list-style-type: none"> <li>● Set to Service mode.</li> <li>● Short-circuit between pin 5 FCS.IN (Focus in) of TP1 and GND.</li> <li>● Press <b>[MULTI-SPEED+]</b> key + <b>[ ]</b> and observe the waveform of pin 6 FCS.ERR (Focus error) of TP1 at that time with an oscilloscope.</li> </ul>
						
Photo. 7-15 Focus error						

## 7. RÉGLAGES

### 7.1 RÉGLAGES MECANIQUES

#### 7.1.1 SECTION PRINCIPALE

- Réglages synchronisés de trois surfaces du menu (Fig. 7-1)

#### PRÉPARATIFS

- Ajuster sans installer le moteur (menu).
  - Fixer la poulie centrale à l'arbre de menu à l'aide des vis.
- (1) Placer des ceintures de synchronisation entre la poulie centrale et les poulies de synchronisation droite et gauche.
  - (2) Tout en appliquant une tension sur le châssis et la plaquette de tension, tirer sur la ceinture de synchronisation.
  - (3) Fixer la plaquette de tension au châssis avec une vis.
  - (4) Tout en plaçant une plaquette plate tel qu'une règle entre les surfaces du menu, les aligner au même niveau.
  - (5) Fixer l'arbre de menu à la poulie de synchronisation en utilisant la clé hexagonale.
  - (6) Retirer la plaquette placée dans le menu et vérifier les points suivants en tournant le menu à la main.
    1. Vérifier que les trois surfaces du menu pivotent de façon régulière.
    2. Vérifier que les trois surfaces sont alignées au même niveau après une rotation de l'arbre du menu.

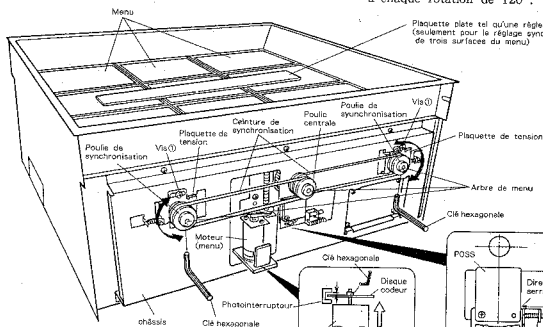

Fig. 7-1

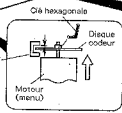

Fig. 7-2

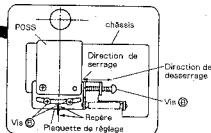

Fig. 7-3

- Réglage de la position d'arrêt de la rotation du menu (PRÉPARATIFS)

- Desserrer la vis (A) maintenant le disque codeur en utilisant la clé hexagonale.
  - Desserrer la vis (A) maintenant la plaquette de réglage. Ajuster avec le moteur (menu) joint.
- (1) Régler le jeu entre le disque codeur et le photointerrupteur du moteur (menu) à 1:1.5 mm. (Fig. 7-2)
  - (2) Fixer la vis du disque codeur en la serrant à l'aide d'une clé hexagonale.
  - (3) Tourner la vis (B) de manière à ce que le repère ciselé sur la plaquette de réglage soit alignée avec le châssis. Puis, serrer temporairement la vis (A).
  - (4) Pousser la touche ROTATE MENU sur le panneau avant de l'appareil principal de manière à faire tourner le menu. Effectuer, ensuite, les réglages suivants en fonction des conditions. (Fig. 7-3)
    - Lorsque le menu s'arrête en dépassant l'avant ..... Desserrer la vis (A), puis serrer la vis (B) en la tournant dans le sens des aiguilles d'une montre.
    - Lorsque le menu s'arrête avant d'atteindre l'avant ..... Desserrer la vis (A), puis tourner la vis (B) dans le sens contraire des aiguilles d'une montre pour la desserrer.
  - (5) Tourner le menu de nouveau, et serrer fermement la vis (A) lorsqu'il s'arrête en dirigeant ses surfaces vers l'avant. (Fig. 7-4 (A))
  - (6) Finalement, tourner le menu et vérifier qu'il s'arrête en dirigeant toutes ses trois surfaces vers l'avant à chaque rotation de 120°.

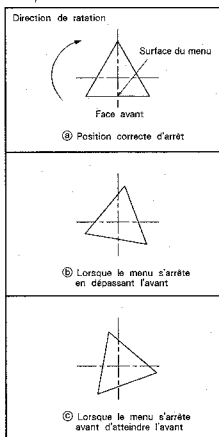

Fig. 7-4

## 7.1.2 SECTION CD

PRÉPARATIFS

- Mettre un magasin dans les première et sixième modules de l'appareil principal CD.
- Brancher la télécommande RU-V101 sur l'appareil principal CD.

1. Réglage approximatif de la position de sélection
  - (1) Régler le jeu entre le côté supérieur de la plaquette de détecteur et celui du châssis principal à 7 mm en serrant le vis Ⓐ.
  2. Réglage de la position de sélection
    - (1) Procéder comme suit :
      - ① Appuyer sur les touches par ordre [1] + [8] + STILL/STEP▶ (DISC SELECT) + STILL/STEP◀ (DISC RETURN). Après cette opération, vérifier que le jeu entre le haut du levier de rotation et le côté supérieur du sixième plateau dans le magasin est de  $0.3^{+0.2}$ .
      - ② Si le jeu est hors de la gamme spécifiée, tourner le vis Ⓐ pour régler la position de la plaquette de détecteur, et appuyer de nouveau sur les touches par ordre [1] + [8] + STILL/STEP▶ (DISC SELECT) + STILL/STEP◀ (DISC RETURN) de façon que le jeu soit dans la gamme spécifiée.
      - ③ Appuyer sur les touches par ordre [6] + STILL/STEP▶ (DISC SELECT) + STILL/STEP◀ (DISC RETURN), et vérifier que le jeu entre le haut du levier de rotation et le côté supérieur du sixième plateau dans le magasin est de  $0.3\text{mm} \pm 0.1\text{mm}$ .

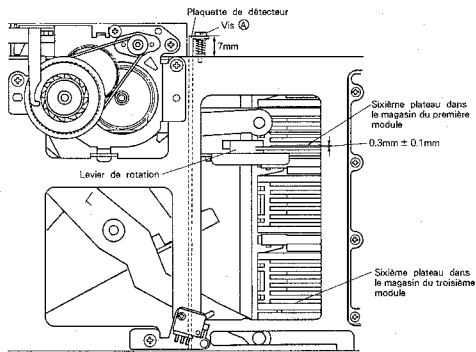

Fig. 7-5

## 7.2 RÉGLAGES ELECTRIQUES

Les réglages pour ce modèle doivent être réalisés dans l'ordre indiqué ci-dessous.

### • Réglages et vérifications à effectuer

1. Réglages de l'offset de centrage de piste, de l'offset de focalisation et de l'offset RF.
2. Réglage du niveau RF
3. Vérification de la puissance de sortie de la diode laser (LD)
4. Vérification du verrouillage de focalisation et du verrouillage de moyeu
5. Réglage du réseau
6. Réglage de l'équilibrage de centrage de piste
7. Réglage tangentiel
8. Réglage du gain de focalisation
9. Réglage du gain de centrage de piste
10. Réglage de la fréquence propre du VCO
11. Méthode de contrôle de la caractéristique S (erreur de focalisation)

### • Matériel de mesure

1. Oscilloscope double trace
2. Appareil de mesure pour puissance laser
3. Disque d'essai (YEDS-7)
4. Filtre de réglage pour équilibrage de centrage de piste
5. Filtre de réglage pour gain de boucle
6. Générateur de signal
7. Fréquence-mètre
8. Outillage général divers
9. Télécommande (RU-V101)

### • Mode d'entretien

L'appareil principal CD peut être fonctionné indépendamment quand la télécommande RU-V101 est branchée sur l'appareil. Pour les détails sur le fonctionnement, voir "Mode d'entretien" (page 14) du manuel d'entretien (1) (ARP2047).

Remarque :

Avant le fonctionnement avec la télécommande RU-V101, déplacer le mécanisme à la position où le disque d'essai est placé en appuyant sur une des touches numériques et la touche STILL/STEP▶ (DISC SELECT).

### • Dispositifs d'ajustement et no nomenclature

- VR1 : Puissance laser  
 VR2 : Offset RF (RF.OFS)  
 VR3 : Gain de focalisation (FCS.GAN)  
 VR4 : Gain de centrage de piste (TRK.GAN)  
 VR5 : Equilibrage de centrage de piste (TRK.BAL)  
 VR6 : Décalage de focalisation (FCS.OFS)  
 VR7 : Décalage de centrage de piste (TRK.OFS)  
 VR8 : Réglage du VCO (VCO.ADJ)

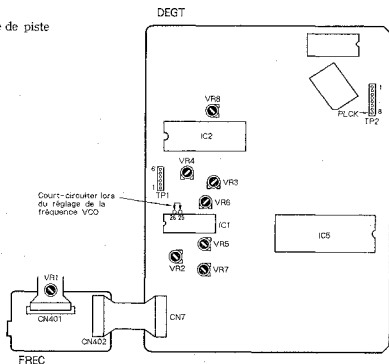
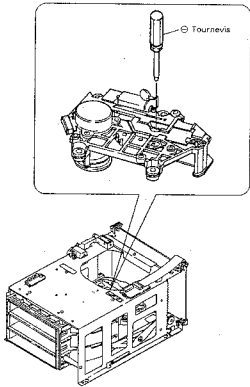
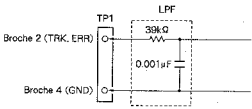

Fig. 7-6 Point de réglage

Pas No.	Réglage de l'oscilloscope		Points d'essai	Points de réglage	Points de contrôle / spécifications de réglage	Méthode de réglage
	V	H				
<b>1</b>	<b>RÉGLAGES DE L'OFFSET DE CENTRAGE DE PISTE, DE L'OFFSET DE FOCALISATION ET DE L'OFFSET RF</b>					
			TP1 Broche 2 (TRK. ERR)	VR5 (TRK. BAL)  VR7 (TRK. OFS)	Offset de centrage de piste 45°  0V ± 50mV	<ul style="list-style-type: none"> <li>Régler le mode d'essai (TEST).</li> <li>Tourner le potentiomètre VR5 TRK. BAL (équilibre de centrage de piste) de 45° depuis le centre dans le sens des aiguilles d'une montre.</li> <li>Ajuster le potentiomètre VR7 TRK. OFS (décalage de centrage de piste) de façon à ce que la tension à la broche 2 TRK. ERR (erreur de centrage de piste) de TP1 devienne égale à 0V ± 50mV.</li> </ul>
			TP1 Broche 6 (FCS. ERR)	VR6 (FCS. OFS)	Offset de focalisation 0V ± 50mV	<ul style="list-style-type: none"> <li>Régler VR6 FCS. OFS (offset de focalisation) de manière à ce que la tension de PCS. ERR (erreur de focalisation) relevée sur la broche 6 de TP1 soit de 0V ± 50mV.</li> </ul>
			TP1 Broche 1 (RF OUTPUT)	VR2 (RF. OFS)	Offset RF 100mV ± 50mV	<ul style="list-style-type: none"> <li>Régler VR2 RF. OFS (offset RF) de manière à ce que la tension de RF OUTPUT (sortie RF) relevée sur la broche 1 de TP1 soit de 100mV ± 50mV.</li> </ul>
<b>2</b>	<b>RÉGLAGE DU NIVEAU RF</b>					
			TP1 Broche 1 (RF)	VR1 Puissance laser	1,5 Vc - c $\pm$ 0,2V 0V	<ul style="list-style-type: none"> <li>Régler le mode d'essai (TEST).</li> <li>Reproduire le disque d'essai (TEST) et raccorder la sonde d'un oscilloscope à la broche 1 RF (sortie RF) de TP1 et mesurer la tension C-C de la forme d'onde RF.</li> <li>Régler VR1 (puissance laser) de façon que la tension soit de 1,5 Vc - c <math>\pm</math> 0,2V.</li> </ul>
<b>3</b>	<b>VÉRIFICATION DE LA PUISSANCE DE SORTIE DE LA DIODE LASER (LD)</b>					
					Confirmation : moins de 0,13mW	<ul style="list-style-type: none"> <li>Régler le mode d'essai (TEST).</li> <li>Appuyer sur la touche de centrage de piste arrière <math>\left[ \text{MULTI-SPEED} \right] + [0]</math> et enclencher la diode laser (LD).</li> <li>Placer le capteur de l'instrument destiné à mesurer la puissance de sortie de la diode laser (LD) est inférieure à 0,13mW.</li> </ul>
<b>4</b>	<b>VÉRIFICATION DU VERROUILLAGE DE FOCALISATION ET DU VERROUILLAGE DE MOYEU</b>					
	0,5V/div	100msec / div	TP1 Broche 1 (Sortie RF)		Présence de sortie RF  Rotation normale	<ul style="list-style-type: none"> <li>Mettre en place le disque d'essai (TEST).</li> <li>Régler le mode d'essai (TEST).</li> <li>Déplacer la tête de lecture à proximité du centre du disque en appuyant sur la touche de recherche <math>\left[ \text{MULTI-SPEED} \right] + [4]</math>.</li> <li>* Cette étape doit absolument être réalisée.</li> <li>Observer le signal RF à la broche 1 de TP1 (sortie RF) au moyen d'un oscilloscope et vérifier que le signal RF sorte après l'enfoncement de la touche d'avance de piste <math>\left[ \text{MULTI-SPEED} \right] + [1]</math>.</li> <li>Appuyer sur la touche de lecture <math>\left[ \text{MULTI-SPEED} \right] + [2]</math> et s'assurer que le disque tourne en sens normal avec approximativement la vitesse spécifiée (étant près du centre du disque, la vitesse de rotation est d'environ 300 tr/mm), sans anomalie ni inversion du sens de rotation.</li> </ul>

Pas No.	Réglage de l'oscilloscope		Points d'essai	Points de réglage	Points de contrôle / spécifications de réglage	Méthode de réglage
	V	H				
5	<b>RÉGLAGE DU RÉSEAU</b>					
						<ul style="list-style-type: none"> <li>● Régler le mode d'essai (TEST).</li> <li>● Amener la tête de lecture à proximité du centre du disque en appuyant sur la touche de recherche manuelle avant [MULTI-SPEED]-[4], de façon à ce que la vis de réglage du réseau de la tête de lecture puisse être vue à travers le trou oval situé à la partie supérieure de l'asservissement.</li> <li>● Insérer un ⊖ tournevis dans le trou de réglage depuis la partie supérieure du mécanisme, comme illustré à la figure 7-7, puis vérifier que la vis de réseau tourne.</li> <li>● Appuyer séquentiellement sur les touches de piste avant [MULTI-SPEED]-[1] et [MULTI-SPEED]-[2], et fermer les asservissements de focalisation et de moyeu. (Ne pas fermer l'asservissement de centrage de piste.)</li> <li>● Observer la forme d'onde à la broche 2 TRK.ERR (erreur de centrage de piste) de TP1 au moyen d'un oscilloscope. Introduire alors un filtre de coupure passe-bas 4 kHz. (Fig. 7-8)</li> </ul>
						 <p style="text-align: center;">Fig. 7-7</p>
						 <p style="text-align: center;">Fig. 7-8</p>
0,5V/div	5msec/div	TP1 Broche 2 (TRK.ERR)	Réseau  Réseau	Point zéro  Amplitude maximum	<ul style="list-style-type: none"> <li>● Faire tourner un ⊖ tournevis et rechercher le point zéro. (Photo 7-1)</li> <li>● Tourner ensuite lentement dans le sens contraire des aiguilles d'une montre le ⊖ tournevis depuis le point zéro et l'ajuster sur le point où la forme d'onde (signal d'erreur de centrage de piste) présente une première amplitude maximum. (Voir photo 7-2.)</li> </ul>	
					<p>Note :</p> <p>Si le ⊖ tournevis est appuyé avec force, la tête de lecture se déplace vers le centre du disque et le réglage devient difficile à effectuer.</p> <ul style="list-style-type: none"> <li>● Finalement, s'assurer que le signal d'erreur de centrage de piste (cette fois-ci le filtre de coupure passe-bas à 4kHz n'est pas introduit) n'a pas beaucoup varié lorsque la tête de lecture est déplacée vers le centre du disque, et aussi que la tension C-C du signal de centrage de piste n'a pas non plus beaucoup varié sur la circonférence extérieure du disque. Lorsque le niveau varie de plus de ±10%, recommencer le réglage en tournant la vis de réseau jusqu'au point d'amplitude d'erreur maximum.</li> </ul>	

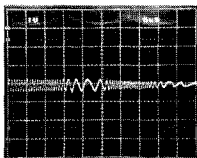

Photo. 7-1  
Point nul

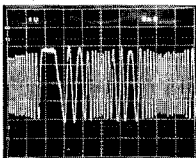

Photo. 7-2  
Amplitude maximale

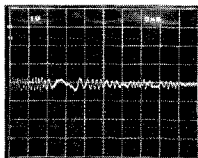

Photo. 7-3  
Ceci n'est pas la forme d'onde du point nul

Pas No.	Réglage de l'oscilloscope		Points d'essai	Points de réglage	Points de contrôle / spécifications de réglage	Méthode de réglage
	V	H				
<b>6 RÉGLAGE DE L'EQUILIBRAGE DE CENTRAGE DE PISTE</b>						
	0,5V/div	5msec /div	TP1 Broche 2 (TRK. ERR)	VR5 (TRK. BAL)	TRK. ERR	<ul style="list-style-type: none"> <li>● Mettre en place le disque d'essai (TEST).</li> <li>● Régler le mode d'essai (TEST).</li> <li>● Amener la tête de lecture à proximité du centre du disque en appuyant sur la touche de recherche manuelle avant <math>\boxed{\text{MULTI-SPEED}} + \boxed{2}</math>.</li> <li>● Appuyer sur la touche de piste avant <math>\boxed{\text{MULTI-SPEED}} + \boxed{1}</math> et sur la touche de lecture <math>\boxed{\text{MULTI-SPEED}} + \boxed{2}</math> pour faire tourner le disque.</li> <li>● Observer la broche 2 TRK. ERR (erreur de centrage de piste) de TP1 au moyen d'un oscilloscope et ajuster au moyen de potentiomètre VR5 TRK. BAL (équilibrage de centrage de piste) de façon à ce que la composante continue de l'erreur de centrage de piste disparaisse.</li> </ul> <p>Note: Avant de procéder aux ajustements ci-dessus, veiller à régler le décalage d'erreur de piste.</p>
					$A \neq B$	
					$A = B$	

Photo. 7-4 Eléments CC mêlés au signal

Photo. 7-5 Eléments CC éliminés

Pas No.	Réglage de l'oscilloscope		Points d'essai	Pointe de réglage	Points de contrôle / spécifications de réglage	Méthode de réglage
	V	H				
7	<b>RÉGLAGE TANGENTIEL</b>					
		200nsec / div	TP1 Broche 1 (sortie RF)	Vis de réglage tangentiel	Mire Best Eye	<ul style="list-style-type: none"> <li>● Mettre en place le disque d'essai (TBST)</li> <li>● Régler le mode d'essai (TEST).</li> <li>● Amener la tête de lecture à proximité du centre du disque en appuyant sur la touche de recherche manuelle avant <b>[MULTI-SPEED+] + [4]</b>.</li> <li>● Appuyer séquentiellement sur les touches d'avance de piste <b>[MULTI-SPEED+] + [1]</b>, <b>[MULTI-SPEED+] + [2]</b> et <b>[MULTI-SPEED+] + [3]</b>, et fermer tous les asservissements. (Le voyant de pause s'allume.)</li> <li>● Observer le signal RF à la broche 1 (sortie RF) de TP1 au moyen d'un oscilloscope et régler au moyen de la vis tangentielle, de façon à ce que la mire Best Eye devienne claire. (Fig. 7-9 et 7-10)</li> <li>● Le point de réglage se situe au milieu entre le point où la mire se détériore en tournant la vis tangentielle dans le sens des aiguilles d'une montre et le point où la mire se détériore en tournant la vis tangentielle dans le sens inverse des aiguilles d'une montre. Comme critère, observer que la forme d'onde globale soit claire et que l'une des formes de losange se situe dans la mire (Photo 7-7) ; réaliser le réglage en un point optimum où la forme de losange apparaît avec des traits relativement fins.</li> </ul>

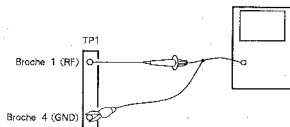
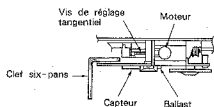

Fig. 7-9

Note : Pendant le réglage, tenir la clef six-pans vers le haut de façon à ce que le corps de la tête de lecture ne descende pas.



Dans l'illustration ci-dessous, le dessus et le dessous de l'appareil sont en réalité à l'envers.

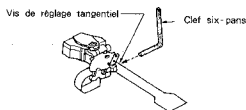

Fig. 7-10 Réglage tangentiel



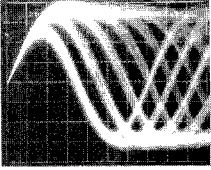

Photo. 7-6

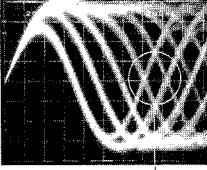

Photo. 7-7

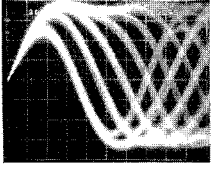

Photo. 7-8

Partie à observer



Insatisfaisant

Ajustement optimal

Insatisfaisant

Pas No.	Réglage de l'oscilloscope		Points d'essai	Points de réglage	Points de contrôle / spécifications de réglage	Méthode de réglage
	V	H				

**8 RÉGLAGE DU GAIN DE FOCALISATION**

20mV/div,  
5mV/div.  
Canal 1 (X),  
Canal 2 (Y)  
(Sonde 10 : 1)

Axe X :  
TP1  
Broche 5  
(FCS, IN)  
Axe Y :  
TP1  
Broche 6  
(FCS, ERR)

VR3  
(FCS, GAN)

Différence de phase 90°

- L'alimentation étant coupée (POWER OFF), raccorder un oscilloscope et un oscillateur de la manière indiquée à la figure 7-11.
- Régler l'appareil en mode de lecture normale.
- Enclencher l'alimentation de l'oscillateur et délivrer un signal de 1,2 kHz à 1 Vc-c.

Note: En fonction de l'oscillateur utilisé, certains appareils fournissent un courant continu lors de leur enclenchement. Par conséquent, il est préférable de raccorder l'oscillateur après avoir enclenché son alimentation.

- Ajuster le potentiomètre VR3 FCS, GAN (gain de focalisation) de façon à ce que la figure de Lissajou observée sur l'oscilloscope devienne un cercle horizontal (déphasage 90°).

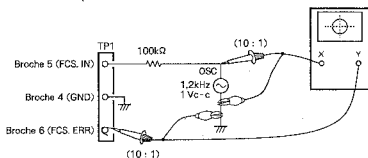

Fig. 7-11

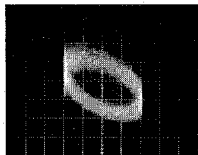

Photo. 7-9  
Gain sur-compensé

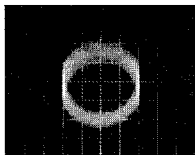

Photo. 7-10  
Gain optimal

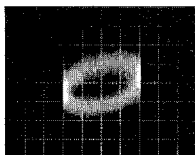
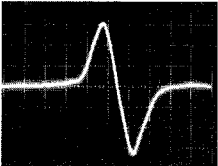

Photo. 7-11  
Gain sous-compensé

Pas No.	Réglage de l'oscilloscope		Points d'essai	Points de réglage	Points de contrôle / spécifications de réglage	Méthode de réglage
	V	H				
<b>9 RÉGLAGE DU GAIN DE CENTRAGE DE PISTE</b>						
	50mV/div. 5mV/div. Canal 1 (X). Canal 2 (Y) (Sonde 10:1)		Axe X : TP1 Broche 3 (TRK. IN) Axe Y : TP1 Broche 2 (TRK. ERR)	VR4 (TRK. GAN)	Déphasage 90°	<ul style="list-style-type: none"> <li>● L'alimentation étant coupée (POWER OFF), raccorder un oscilloscope et un oscillateur de la manière indiquée à la figure 7-12.</li> <li>● Régler l'appareil en mode de lecture normale.</li> <li>● Enclencher l'alimentation de l'oscillateur et fournir un signal de 1,2 kHz à 2 Vc-c.</li> </ul> <p>Note : En fonction de l'oscillateur utilisé, certains appareils fournissent un courant continu lors de leur enclenchement. Par conséquent, il est préférable de raccorder l'oscillateur après avoir enclenché son alimentation.</p> <ul style="list-style-type: none"> <li>● Ajuster le potentiomètre VR4 TRK GAN (gain de centrage de piste) de façon à ce que la figure de Lissajou sur l'oscilloscope devienne un cercle horizontal (déphasage 90°).</li> </ul>
						Fig. 7-12
Photo. 7-12 Gain sur-compensé		Photo. 7-13 Gain optimal		Photo. 7-14 Gain sous-compensé		

Pas No.	Réglage de l'oscilloscope		Points d'essai	Points de réglage	Points de contrôle / spécifications de réglage	Méthode de réglage
	V	H				
10	<b>RÉGLAGE DE LA FRÉQUENCE PROPRE DU VCO</b>					
			TP2 Broche 8 (PLCK)	VR8 (VCO. ADJ)	4,275 ± 0,01MHz	<ul style="list-style-type: none"> <li>● Régler le mode d'essai (TEST).</li> <li>● Court-circuiter entre broches 25 et 26 de l'IC1 dans l'assemblage DEGT à l'aide d'un ⊖ tournevis.</li> <li>● Recorder un fréquencemètre capable de mesurer au-dessus de 10 MHz à la broche 8 de TP2 (PLCK).</li> <li>● Ajuster le potentiomètre VR8 VCO ADJ (réglage du VCO) de façon à ce que la valeur indiquée par le fréquencemètre devienne égale à 4,275 ± 0,01MHz.</li> </ul>
11	<b>MÉTHODE DE CONTRÔLE DE LA CARACTÉRISTIQUE S (ERREUR DE FOCALISATION)</b>					
			TP1 Broche 6 (FCS. ERR)			<ul style="list-style-type: none"> <li>● Régler le mode d'essai (TEST).</li> <li>● Réaliser un court-circuit entre la broche 5 FCS.IN (entrée de focalisation) de TP1 et la terre GND.</li> <li>● Appuyer sur la touche d'avance de piste <b>[MULTI-SPEED] + [I]</b> et observer simultanément la forme d'onde à la broche 6 FCS.ERR (erreur de focalisation) de TP1 au moyen d'un oscilloscope.</li> </ul>
						
Photo. 7-15 Erreur de mise au point						

## 7. AJUSTES

### 7.1 AJUSTES MECÁNICOS

#### 7.1.1 SECCIÓN PRINCIPAL

##### • Tres lados de ajuste sincrónico del menú (Fig. 7-1)

##### PREPARATIVOS

- Ajuste sin instalar el motor (menú).
  - Fije la polea central al eje del menú con los tornillos.
- (1) Aplique la correa de sincronización y la polea central en ambos lados, derecho e izquierdo.
  - (2) Aplicando resorte (tensión) al armazón inferior y la placa tensora, aplique tensión a la correa de sincronización.
  - (3) Fije la placa tensora en el armazón inferior con un tornillo  $\text{D}$ .
  - (4) Colocando una placa plana, como una regla, entre ellas, alinee las tres superficies del menú entre sí de forma que queden al mismo nivel.
  - (5) Fije el eje de menú en la polea de sincronización empleando una llave hexagonal.
  - (6) Extraiga la placa colocada sobre el menú y compruebe los ítems siguientes girando manualmente el menú.
1. Compruebe si las tres superficies del menú giran sin interrupción brusca.
  2. Compruebe si todas las tres superficies del menú alinean entre sí de forma que queden al mismo nivel después de girar el eje del menú una vez.

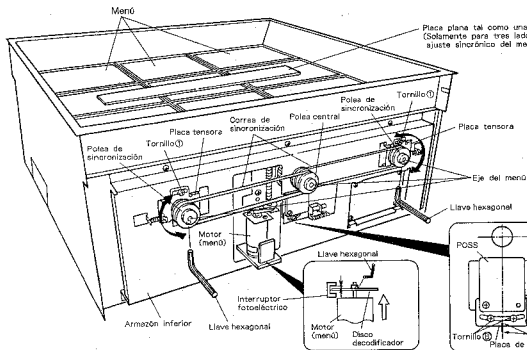

Fig. 7-1

##### • Ajuste de la posición de parada de la rotación del menú PREPARATIVOS

- Afloje el tornillo  $\text{A}$  que sostiene el disco decodificador con una llave hexagonal.
  - Afloje el tornillo  $\text{A}$  que sostiene la placa de ajuste.
  - Ajuste con el motor (menú) instalado.
- (1) Ajuste la separación entre el disco decodificador y el interruptor fotoeléctrico del motor (menú) a  $1.7_{\pm 0.05}^{\pm 0.05}$  mm. (Fig. 7-2)
  - (2) Fije el tornillo del disco decodificador apretándolo con una llave hexagonal.
  - (3) Gire el tornillo  $\text{B}$  de forma que la marca grabada en la placa de ajuste quede alineada con el armazón inferior. Después apriete temporalmente el tornillo  $\text{A}$ .
  - (4) Presione la tecla ROTATE MENU del panel frontal de la unidad principal para que el menú gire. Después realice los ajustes siguientes dependiendo de la condición. (Fig. 7-3)
    - Cuando el menú se pare después de haber pasado la parte frontal
      - ..... Afloje el tornillo  $\text{A}$  y apriete el tornillo  $\text{B}$  girándolo hacia la derecha.
    - Cuando el menú se pare antes de llegar a la parte frontal
      - ..... Afloje el tornillo  $\text{A}$  y gire el tornillo  $\text{B}$  hacia la izquierda para aflojarlo.
  - (5) Vuelva a girar el menú y apriete firmemente el tornillo  $\text{A}$  cuando el menú se pare dirigiendo sus superficies hacia la parte frontal. (Fig. 7-4  $\text{B}$ )
  - (6) Finalmente, gire el menú y compruebe si se para dirigiendo sus tres superficies hacia la parte frontal cada  $120^\circ$  de rotación.

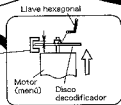

Fig. 7-2

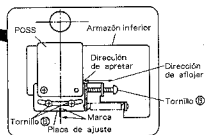

Fig. 7-3

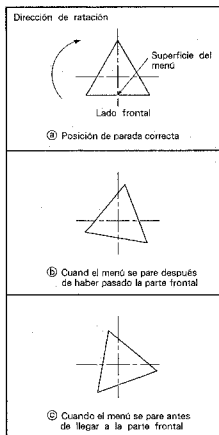

Fig. 7-4

## 7.1.2 SECCIÓN DE CD

PREPARATIVOS

- Coloque el cargador en el primer y tercer módulo de la unidad principal de CD.
- Conecte el telemando (RU-V101) a la unidad principal de CD.

1. Ajuste aproximado de la posición seleccionada
  - (1) Ajuste la distancia entre la parte superior de la placa de sensor y la del chasis principal a 7 mm girando el tornillo Ⓐ.
  2. Ajuste de la posición seleccionada
    - (1) Primero, realice el procedimiento siguiente.
      - Ⓐ Presione las teclas en el orden de [1] + [8] + STILL / STEP ► (DISC SELECT) + STILL / STEP ◀ [1] (DISC RETURN). Cuando termine la operación, compruebe si la separación entre la parte superior de la palanca de rotación y la de la sexta bandeja en el cargador es  $0,3^{+0,2}$ .
      - Ⓑ Si la separación excede a la gama especificada, gire el tornillo Ⓐ para ajustar la posición de la placa de sensor y vuelva a presionar las teclas en el orden de [1] + [8] + STILL / STEP ► (DISC SELECT) + STILL / STEP ◀ [1] (DISC RETURN) hasta que la separación se vuelva dentro de la gama especificada.
      - Ⓒ Presione las teclas en el orden de [6] + STILL / STEP ► (DISC SELECT) + STILL / STEP ◀ [1] (DISC RETURN) y compruebe si la separación entre la parte superior de la palanca de rotación y la de la sexta bandeja en el cargador es  $0,3\text{mm} \pm 0,1\text{mm}$ .

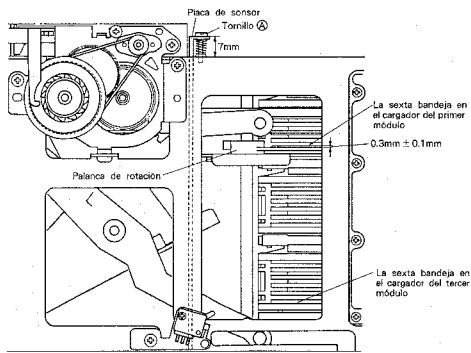

Fig. 7-5

## 7.2 AJUSTES ELECTRICOS

Los ítems de ajuste de este modelo deberán ser efectuados en el orden mostrado abajo.

### • Ítemes de ajuste y comprobación

1. Ajuste de desviación de seguimiento, foco y RF.
2. Ajuste del nivel de RF
3. Confirmación de la alimentación de salida de LD (diodo láser)
4. Confirmación de enclavamiento del enfoque y del eje
5. Ajuste del retículo
6. Ajuste del equilibrio de seguimiento
7. Ajuste tangencial
8. Ajuste de la ganancia de enfoque
9. Ajuste de la ganancia de seguimiento
10. Ajuste de la frecuencia propia de VCO
11. Método para confirmar el carácter S (error de enfoque)

### • Equipo de medición

1. Osciloscopio de doble traza
2. Medidor de alimentación del láser
3. Disco de prueba (YEDS-7)
4. Filtro de ajuste de equilibrio de seguimiento
5. Filtro de ajuste de ganancia de bucle
6. Generador de señal
7. Contador de frecuencia
8. Otras herramientas generales
9. Telemando (RU-V101)

### • Modo de operación

Si conecta el telemando (RU-V101) a la unidad principal de CD, podrá operarla a distancia.

Con respecto a la operación refiérase al manual de operación (1). (ARP2047): Modo de operación (página 14)

Nota: Antes de operar el telemando (RU-V101), mueva el mecanismo con las teclas numéricas + teclas STILL/STEP▶ (DISC SELECT) hasta la posición donde se ha colocado el disco de prueba.

### • Tores variables (VR) de ajuste y sus nombres

- VR1: Alimentación del láser  
 VR2: Compensación de RF (RF.OFS)  
 VR3: Ganancia de enfoque (FCS.GAN)  
 VR4: Ganancia de seguimiento (TRK.GAN)  
 VR5: Equilibrio de seguimiento (TRK.BAL)  
 VR6: Desviación de enfoque (FCS.OFS)  
 VR7: Desviación del seguimiento (TRK.OFS)  
 VR8: Ajuste de VCO (VCO.ADJ)

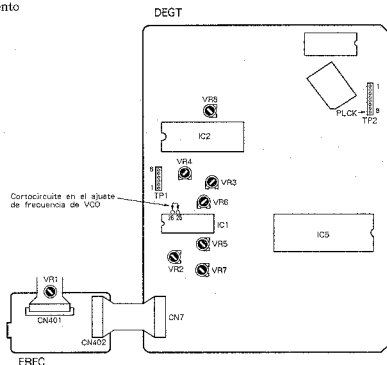
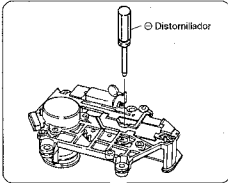
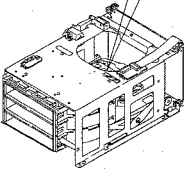
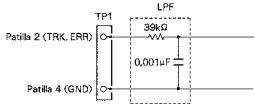

Fig. 7-6 Punto de ajuste

No. de paso	Ajuste del osciloscopio		Puntos de prueba	Puntos de ajuste	Items de verificación/ Especificaciones de ajuste	Procedimiento de ajuste
	V	H				
1	<b>AJUSTES DE LA DESVIACIÓN DE SEGUIMIENTO, FOCO Y RF</b>					
			Patilla 2 de TP1 (TRK. ERR) Patilla 6 de TP1 (FCS. ERR) Patilla 1 de TP1 (RF OUTPUT)	VR5 (TRK. BAL) VR7 (TRK. OFS) VR6 (FCS. OFS) VR2 (RF. OFS)	Desviación de seguimiento 45° $0V \pm 50mV$ Compens. de foco $0V \pm 50mV$ Compens. de RF $100mV \pm 50mV$	<ul style="list-style-type: none"> <li>● Ajuste el modo de TEST.</li> <li>● Gire el volumen de TRK. BAL (Equilibrio de seguimiento) de VR5 en el sentido de las manecillas del reloj 45° del centro.</li> <li>● Ajuste VR7 TRK. OFS (de seguimiento) de modo que el voltaje en TRK. ERR (desviación de seguimiento) de la patilla 2 de TP1 se ponga en <math>0V \pm 50mV</math>.</li> <li>● Ajuste VR6 FCS. OFS (compensación de foco) de modo que el voltaje de FCS. ERR (error de foco) en la patilla 6 de TP1 sea <math>0V \pm 50mV</math>.</li> <li>● Ajuste VR2 RF. OFS (compensación de RF) de modo que el voltaje de salida de RF en la patilla 1 de TP1 sea <math>100mV \pm 50mV</math>.</li> </ul>
2	<b>AJUSTE DEL NIVEL DE RF</b>					
			Patilla 1 de TP1 (RF)	Alimentación del laser VR1	$1.5Vp-p \pm \begin{matrix} +0.2V \\ -0V \end{matrix}$	<ul style="list-style-type: none"> <li>● Ajuste el modo de TEST.</li> <li>● Reproduzca el disco de TEST y conecte la sonda de un osciloscopio a la RF de la patilla 1 (Salida de RF) de TP1 y mida el voltaje de P-P de la forma de onda de RF.</li> <li>● Ajuste VR1 (alimentación del láser) que el valor sea <math>1.5Vp-p \pm 0V</math>.</li> </ul>
3	<b>CONFIRMACIÓN DE LA ALIMENTACIÓN DE SALIDA DE LD (DIODO LÁSER)</b>					
					Confirmación Menos de 0.13mW	<ul style="list-style-type: none"> <li>● Ajuste el modo de TEST.</li> <li>● Presione la tecla de <b>[MULTI-SPEED]+[0]</b> y encienda el LD (Diodo láser).</li> <li>● Ubique el sensor del medidor de potencia del láser inmediatamente arriba del objetivo, y confirme que la potencia de salida del LD sea menos de 0.13mW.</li> </ul>
4	<b>CONFIRMACIÓN DE ENCLAMIENTO DEL ENFOQUE Y DEL EJE</b>					
	0.5V/div	100mseg/div	Patilla 1 de TP1 (Salida de RF)		Existe salida de RF  Rotación normal	<ul style="list-style-type: none"> <li>● Ajuste del disco de TEST.</li> <li>● Ajuste el modo de TEST.</li> <li>● Cambie el captador cerca del centro del disco presionando la tecla de <b>[MULTI-SPEED]+[4]</b>.</li> <li>* Tenga en cuenta que este paso deberá ser ejecutado.</li> <li>● Observe RF (Radio frecuencia) de la patilla 1 de TP1 con un osciloscopio y confirme que se saque la señal de RF después de presionar la tecla de <b>[MULTI-SPEED]+[1]</b>.</li> <li>● Presione la tecla de <b>[MULTI-SPEED]+[2]</b> y asegúrese que el disco rota en la dirección normal casi a la velocidad especificada (tal como está cerca del centro del disco, la velocidad de rotación es alrededor de 300rpm) y que no rote anormalmente o inversamente.</li> </ul>



No. de paso	Ajuste del osciloscopio		Puntos de prueba	Puntos de ajuste	Items de verificación/ Especificaciones de ajuste	Procedimiento de ajuste
	V	H				
<b>5 AJUSTE DEL RETÍCULO</b>						
						<ul style="list-style-type: none"> <li>● Ajuste el mode TEST.</li> <li>● Cambie el captador cerca del centro del disco presionando la tecla de <b>[MULTI-SPEED]+[2]</b> de modo que el tornillo de ajuste de retículo del captador pueda ser visto a través del orificio oval en el lado superior del servomecanismo.</li> <li>● Inserte un <math>\ominus</math> destornillador en el orificio del lado superior or del mecanismo como se muestra en la Fig. 7-7, y confirme que gira el tornillo de retículo.</li> <li>● Presione la tecla de <b>[MULTI-SPEED]+[1]</b> y <b>[MULTI-SPEED]+[2]</b> secuencialmente y cierre el servo de enfoque y el del eje. (No cierre el servo de seguimiento.)</li> <li>● Observe la forma de onda en TRCK.ERR (Error de seguimiento) de la patilla 2 de TP1 con un osciloscopio. Luego inserte un filtro de paso bajo de corte. (Fig. 7-8)</li> </ul>
						  <p style="text-align: center;">Fig. 7-7</p>
						 <p style="text-align: center;">Fig. 7-8</p>
0.5V/div	5mseg /div	Patilla 2 de TP1 (TRK. ERR)	Reticulo  Reticulo	Punto cero  Amplitud máxima		<ul style="list-style-type: none"> <li>● Gire el <math>\ominus</math> destornillador y encuentre el punto cero. (Foto. 7-1)</li> <li>● Luego, gire lentamente el <math>\ominus</math> destornillador hacia el sentido contrario del reloj desde el punto cero y ajuste en el punto donde la forma de onda (Señal de error de seguimiento) primeramente se ponga a una amplitud máxima. (Vea Foto. 7-2)</li> </ul> <p>Nota :</p> <p>Si el <math>\ominus</math> destornillador se presiona fuertemente, el captador se mueve hacia el centro del disco, por consiguiente el ajuste resulta difícil.</p> <ul style="list-style-type: none"> <li>● Finalmente, asegúrese de confirmar que la señal de error de seguimiento (en este momento, no se ha insertado el filtro de paso bajo de corte de 4KHz) cuando el captador se mueve hacia el centro del disco y el voltaje de P-P de la señal de error de seguimiento en la circunferencia exterior del disco no haya variado considerablemente. Cuando se desvía el nivel arriba de <math>\pm 10\%</math>, ajuste de nuevo girando el tornillo de retículo a un punto de amplitud de error mínimo.</li> </ul>



Foto. 7-1  
Punto nulo



Foto. 7-2  
Amplitud máxima

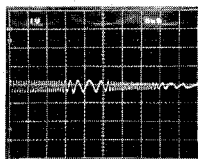

Foto. 7-3  
Esta no es la forma de onda de punto nulo

No. de peso	Ajuste del osciloscopio		Puntos de prueba	Puntos de ajuste	Items de verificación/ Especificaciones de ajuste	Procedimiento de ajuste
	V	H				
<b>6 AJUSTE DEL EQUILIBRIO DE SEGUIMIENTO</b>						
	0,5V/div	5mseg /div	Patilla 2 de TP1 (TRK. ERR)	VR5 (TRK. BAL)	TRK. ERR	<ul style="list-style-type: none"> <li>● Ajuste el disco de TEST.</li> <li>● Ajuste el mode de TEST.</li> <li>● Cambie el captador cerca del centro del disco presionando la tecla de <b>[MULTI-SPEED+] + [4]</b>.</li> <li>● Presione la tecla de <b>[MULTI-SPEED+] + [1]</b> y la tecla de <b>[MULTI-SPEED+] + [2]</b> para comenzar a voltear el disco.</li> <li>● Observe TRK. ERR (Error de seguimiento) de la patilla 2 de TP1 con un osciloscopio y ajuste con el volumen de TRK. BAL (Equilibrio de seguimiento) de VR5 de modo que la componente de CC del error de seguimiento desaparezca.</li> </ul> <p>Nota: Antes de realizar los ajustes indicados arriba, asegúrese de compensar el error de seguimiento.</p>
			<p>Foto. 7-4 Elementos de CC mezclados en la señal</p>			
			<p>Foto. 7-5 Elementos de CC eliminados</p>			

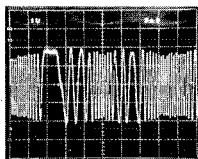
No. de paso	Ajuste del osciloscopio		Puntos de prueba	Puntos de ajuste	Items de verificación/ Especificaciones de ajuste	Procedimiento de ajuste
	V	H				
7	<b>AJUSTE TANGENCIAL</b>					
		200nseg /div	Patilla 1 de TP1 (Salida de RF)	Tornillo de ajuste de la tangencial	Mejor imagen de prueba	<ul style="list-style-type: none"> <li>● Ajuste el disco de TEST.</li> <li>● Ajuste el mode de TEST.</li> <li>● Cambie el carro cerca del centro del disco presionando la tecla de <b>[MULTI-SPEED+] + [4]</b>.</li> <li>● Presione la tecla de <b>[MULTI-SPEED+] + [1]</b>, <b>[MULTI-SPEED+] + [2]</b> y <b>[MULTI-SPEED+] + [3]</b> secuencialmente, y cierre todos los servos. (El indicador de pausa se enciende.)</li> <li>● Observe el RF de la patilla 1 (Salida de RF) de TP1 con un osciloscopio y ajuste con el tornillo de la tangencial de modo que la imagen de prueba resulte nítida. (Fig. 7-9 y 7-10)</li> <li>● El punto de ajuste es el punto medio entre el punto donde la imagen de prueba se deteriora girando el tornillo de la tangencial en el sentido de las manecillas del reloj, y el punto donde la imagen de prueba se deteriora girando el tornillo de la tangencial en contra del sentido de las manecillas del reloj. Como un criterio, observe que la forma de onda en conjunto sea nítida y que una de las figuras de diamante esté dentro de la imagen de prueba (Foto. 7-7), y ajuste al punto óptimo donde la forma de diamante se ve relativamente como una línea fina.</li> </ul>  <p style="text-align: center;">Fig. 7-9</p> <p>(Nota) Durante el ajuste, sostenga la llave hexagonal hacia arriba para evitar que el cuerpo del captador vaya hacia abajo.</p>

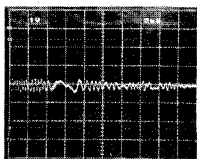
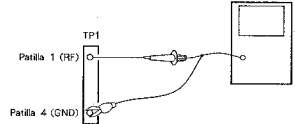
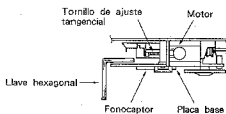

En la figura siguiente, las partes superior e inferior son copuestas a las del producto real.

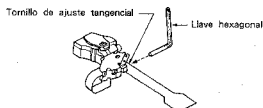

Fig. 7-10 Ajuste tangencial



Foto. 7-6



Foto. 7-7

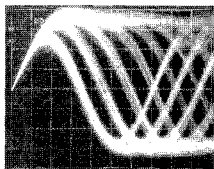

Foto. 7-8

Parte que debe observar

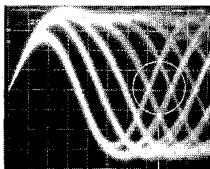

Insatisfactorio

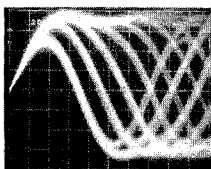
Ajuste óptimo

Insatisfactorio

No. de paso	Ajuste del osciloscopio		Puntos de prueba	Puntos de ajuste	Ítems de verificación/ Especificaciones de ajuste	Procedimiento de ajuste
	V	H				
8	<b>AJUSTE DE LA GANANCIA DE ENFOQUE</b>					
	20mV/div. 5mV/div. CH1 (X). CH2 (Y) (SONDA 10 : 1)	Eje X : Patilla 5 de TP1 (FCS.IN) Eje Y : Patilla 6 de TP1 (FCS.ERR)	VR3 (FCS.GAN)	Diferencia de fase 90°	<ul style="list-style-type: none"> <li>● En el estado de POWER OFF (apagado), conecte el osciloscopio y el oscilador como se muestra en la Fig. 7-11.</li> <li>● Ponga la unidad en el modo de reproducción (PLAY) normal.</li> <li>● Encienda el oscilador y extraiga 1.2kHz 1Vp-p.</li> </ul> <p>Nota: Dependiendo en los osciladores, algunos de ellos producen CC cuando son encendidos. Por lo tanto, es conveniente conectar el oscilador después del encendido.</p> <ul style="list-style-type: none"> <li>● Ajuste con el volumen de FCS.GAN (Ganancia de enfoque) de VR3 de modo que la figura de Lissajous del osciloscopio a ser un círculo horizontal (90° de diferencia de fase).</li> </ul>	
						Fig. 7-11
	Foto. 7-9 Ganancia sobrecompensada	Foto. 7-10 Ganancia óptima	Foto. 7-11 Ganancia subcompensada			

No. de paso	Ajuste del osciloscopio		Puntos de prueba	Puntos de ajuste	Items de verificación/ Especificaciones de ajuste	Procedimiento de ajuste
	V	H				
<b>9 AJUSTE DE LA GANANCIA DE SEGUIMIENTO</b>						
	50mV/div. 5mV/div CH1 (X). CH2 (Y) (SONDA 10:1)		Eje X : Patilla 3 de TP1 (TRK. IN) Eje Y : Patilla 2 de TP1 (TRK. ERR)	VR4 (TRK. GAN)	90° de diferencia	<ul style="list-style-type: none"> <li>En el estado de POWER OFF (apagado), conecte un osciloscopio y un oscilador como se muestra en la Fig. 7-12.</li> <li>Ponga la unidad en el modo de reproducción (PLAY) normal.</li> <li>Encienda el oscilador y extraiga 1.2 kHz 2 Vp-p.</li> </ul> <p>Nota: Dependiendo en los osciladores, algunos de ellos producen CC cuando son encendidos. Por la tanto, es conveniente conectar el oscilador después del encendido.</p> <ul style="list-style-type: none"> <li>Ajuste con el volumen de TRK. GAN de VR4 (Ganacia de seguimiento) de modo que la figura de Lissajous del osciloscopio llege a ser un círculo horizontal (90° de diferencia de fase).</li> </ul>
						Fig. 7-12



Foto. 7-12  
Ganancia sobrecompensada



Foto. 7-13  
Ganancia óptima



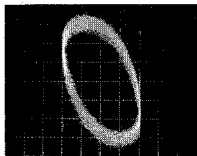

Foto. 7-14  
Ganancia subcompensada

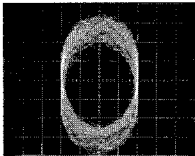
No. de paso	Ajuste del osciloscopio		Puntos de prueba	Puntos de ajuste	Items de verificación/ Especificaciones de ajuste	Procedimiento de ajuste
	V	H				
10	<b>AJUSTE DE LA FRECUENCIA PROPIA DE VCO</b>					
			Patilla 8 de TP2 (PLCK)	VR8 (VCO. ADJ)	4,275 ± 0,01MHz	<ul style="list-style-type: none"> <li>● Ajuste el modo de TEST.</li> <li>● Cortocircuite entre las patillas 25 y 26 de IC1 en el ensamblaje DEGT con un destornillador Ⓞ, etc.</li> <li>● Conecte el frecuencimetro, que pueda medir arriba de 10 MHz, a la patilla 8 de TP2 (PLCK).</li> <li>● Ajuste con el volumen VCO ADJ (ajuste de VCO) de VR8 de modo que el valor del frecuencimetro se ponga en 4,275 ± 0,01 MHz.</li> </ul>
11	<b>MÉTODO PARA CONFIRMAR EL CARÁCTER S (ERROR DE ENFOQUE)</b>					
			Patilla 6 de TP1 (FCS.ERR)			<ul style="list-style-type: none"> <li>● Ajuste el modo de TEST.</li> <li>● Haga un cortocircuito entre FCS.IN (Entrada de enfoque) de la patilla 5 de TP1 y GND.</li> <li>● Presione la tecla de <b>[MULTI-SPEED] + [I]</b> y observe la forma de onda de FCS.ERR (Error de enfoque) de la patilla 6 de TP1 con un osciloscopio.</li> </ul>
						
Foto. 7-15 Error de enfoque						

## 8. IC DESCRIPTION

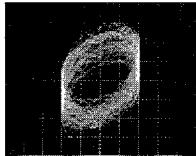
## ■ M50747SP

SYSTEM CONTROL (ROM LESS TYPE)

## ● Pin connections (Top view)

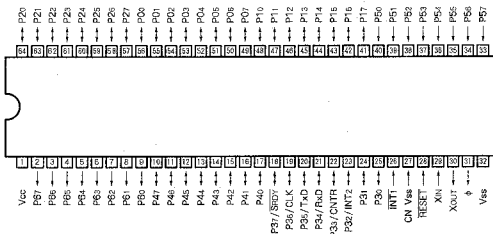

## ● Pin functions

Pin	Mark	Pin name	I/O	Function
1	Vcc	Power supply input	I	Apply +5V to Vcc.
2 - 9	P57 - P50	Output port P5	O	8 bits output port.
10 - 17	P47 - P40	Input/output port P4	I/O	8 bits input/output port.
18	P37/SRDV	Input/output port P3	I/O	8 bits input/output port. When P36, P35 and P34 is used for serial I/O, it respectively become CLK, TxD and RxD. When P37 is used for serial I/O of the clock synchronized type, it becomes SRD.V. P37 is combined with I/O terminal of timer X (CNTR). P37 is combined with lowermost interrupt.
19	P36/CLK			
20	P35/TxD			
21	P34/RxD			
22	P33/CNTR			
23	P32/INT2			
24	P31			
25	P30			
26	INT1	Interrupt input	I	Upper most interrupt input terminal.
27	CN Vss	CN Vss input	I	Connect to Vss.
28	RESET	Reset input	I	Set the "L" more than 2μs, it becomes reset state.
29	Xin	Clock input	I	Connect the crystal resonator.
30	Xout	Clock output	O	
31	φ	Timing output	O	Timing output.
32	Vss	Power supply input	I	Apply 0V to Vss.
33 - 40	P57 - P50	Input port P5	I	8 bits input port.
41 - 48	P17 - P10	Input/output port P1	I/O	8 bits input/output port.
49 - 56	P07 - P00	Input/output port P0	I/O	8 bits input/output port.
57 - 64	P27 - P20	Input/output port P2	I/O	8 bits input/output port.



■ HD64941

WALL BOX COMMUNICATION

● Pin connections (Top view)

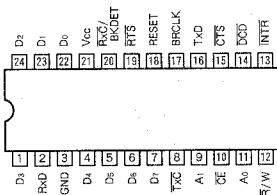

● Pin functions

Pin	Mark	Pin name	I/O	Function
1	D <sub>3</sub>	DATA BUS <sub>0</sub>	I/O	Bilateral data bus which using for data transfer with the CPU. High impedance at the reset.
4-7	D <sub>4</sub> -D <sub>7</sub>	DATA BUS <sub>7</sub>		
22-24	D <sub>0</sub> -D <sub>2</sub>	DATA BUS <sub>7</sub>		
2	RxD	RECEIVER DATA	I	Serial data input terminal to the reception section. "Mark": "H", "Space": "L"
16	TxD	TRANSMITTER DATA	O	Serial data output terminal from the transmission section. "Mark" = "H", "Space": "L" "H" at the transmission section is not operated, and "H" at the reset.
3	GND	GROUND	—	Ground
21	Vcc	POWER SUPPLY	—	+5V power supply.
8	TxC̄	TRANSMITTER CLOCK	—	Clock input terminal of the transmission section. TxD is used to synchronize with the transmission data when using the external transmission clock. TxC̄ is used for the 1X/16X clock output terminal when using the internal transmission clock. Input state at the reset.
9	A <sub>1</sub>	ADDRESS LINE c <sub>1</sub>	—	Signal for select the internal register.
11	A <sub>0</sub>			
10	CE	CHIP ENABLE	—	Addressing terminal of the CPU and internal HD64941. • When CE = L, perform the reading and writing operation to the internal register which is regulated with R/W, A <sub>0</sub> and A <sub>1</sub> • When CE = H, set the D <sub>0</sub> through D <sub>7</sub> to high impedance state.
12	R/W	READ/WRITE	—	Terminal for control the direction of the data transfer.
13	INTR	INTERRUPT	—	Output terminal of the interrupt required signal "H" at the reset.
14	DCD	DATA CARRIER DETECT	—	Detection input terminal of the data carrier. When DCD is "L", reception section is able to operate.
15	CTS	CLEAR TO SEND	—	Clear to send (transmission) input terminal. CTS have to "L" for operating the transmission section. When becomes "H" during transmit, the end of transmission after complete the character transmission in the shift register for the transmission.
17	BRCLK	BAUD RATE CLOCK	—	Clock input terminal for generating the internal baud rate, It's useless to use the external transmission and reception clocks (Tx̄C and Rx̄C.)
18	RESET	RESET	—	"0"clear terminal of the mode register 1 and 2, command register and status register.
19	RTS	REQUEST TO SEND	—	General-purpose output terminal. RTS outputs which inverting the bit 5 of the command register (CR). Usually, it is used for require the transmission.
20	RxC̄/BKDET	RECEIVER CLOCK/ BREAK DETECTION	—	Clock input terminal of reception section. Rx̄C is used to synchronize with the reception data when using the external reception clock. Rx̄C is used for the output signal of brake detection (BK-DET) and the 1X/16X clock output terminal when using the internal reception clock. Input state at the reset.

## ■ M5295L

WATCH-DOG TIMER

### ● Pin connections (Top view)

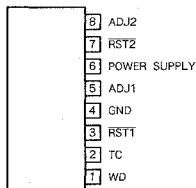

### ● Block diagram

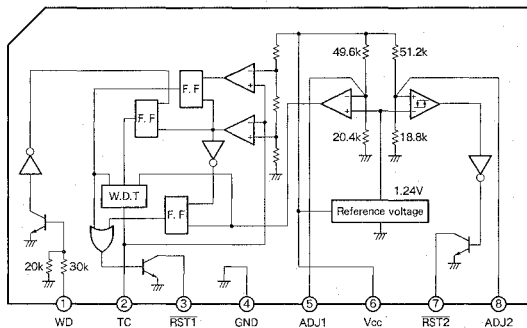

### TC74HC4002AP

DUAL 4-INPUT NOR GATE

#### Pin connections (Top view)

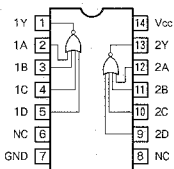

#### Truth table

A	B	C	D	Y
H	X	X	X	L
X	H	X	X	L
X	X	H	X	L
X	X	X	H	L
L	L	L	L	H

X: Don't care

### TC74HC574AP

OCTAL D-TYPE FLIP-FLOP WITH 3-STATE OUTPUT

#### Pin connections (Top view)

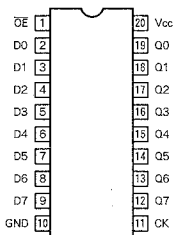

#### Truth table

INPUT			OUTPUTS
OE	CK	D	Q (S74A)
H	X	X	Z
L	$\downarrow$	X	Qn
L	$\uparrow$	L	L
L	$\uparrow$	H	H

X: Don't Care

Z: High impedance

Qn (Qn): No change

### SN75176BP

#### Pin connections (Top view)

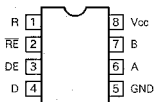

#### Truth table

INPUT		ENABLE		OUTPUTS	
D	DE	A	B	A	B
H	H	H	L	H	L
L	H	L	L	L	H
X	L	L	L	Z	Z

H = high level, L = low level,

X = irrelevant, Z = high impedance (off)