

Service Manual

ORDER NO.
ARP2617

CD AUTOCHANGER

CAC-V3200

KUC

- Refer to the service manual ARP2570 for CAC-V3000.
- This manual is applicable to CAC-V3200/KUC.

CONTRAST OF MISCELLANEOUS PARTS

NOTES:

- Parts marked by "NSP" are generally unavailable because they are not in our Master Spare Parts List.
- The \triangle mark found on some component parts indicates the importance of the safety factor of the part. Therefore, when replacing, be sure to use parts of identical designation.
- Parts marked by "●" are not always kept in stock. Their delivery time may be longer than usual or they may be unavailable.

CAC-V3200 and CAC-V3000 have the same construction except for the following :

Mark	Symbol & Description	Part No.		Remarks
		CAC-V3000	CAC-V3200	
	Top panel	DNH1687	DNH1799	
	Side panel	DNH1693	DNH1800	
	Door sash	DNH1697	DNH1801	
	Door L	DNH1771	DNH1802	
	Door escutcheon (Upper)	DNK2419	DNK2439	
	Door escutcheon (Lower)	DNK2420	DNK2440	
	Decorative panel (Upper)	DNK2421	DNK2693	
	Decorative panel (Lower)	DNK2422	DNK2694	
	Door decorative panel	DNK2423	DNK2695	
	Door (R) assembly	DXB1436	DXB1439	
	Packing case	DHG1387	DHG1491	
	Operating instructions (English)	DRB1093	DRB1129	

Service Manual

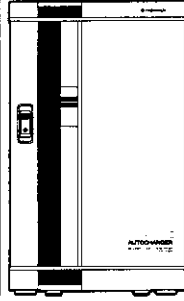

ORDER NO.
ARP2570

CD AUTOCHANGER

CAC-V3000

CAC - V3000 HAS THE FOLLOWING :

Type	Power Requirement	Remarks
HEM	AC220V - 230V, 240V (Switchable)	
KUC	AC120V only	

- This manual is applicable to CAC - V3000/HEM and KUC.
- For KUC type, refer to page 175.
- Ce manuel pour le service comprend les explications de réglage en français.
- Este manual de servicio trata del método ajuste escrito en español.

CONTENTS

1. SAFETY INFORMATION	2	8. PCB PARTS LIST	98
2. LABEL CHECK	3	9. ADJUSTMENTS	106
3. PARTS LOCATION	4	9. REGLAGES	121
4. DISASSEMBLY	7	9. AJUSTES	136
5. EXPLODED VIEWS, PACKING AND PARTS LIST	10	10. IC INFORMATION	151
6. BLOCK DIAGRAM	47	11. SERVICE MODE	164
7. SCHEMATIC AND PCB CONNECTIONS DIAGRAMS	49	12. FOR KUC TYPE	175
		13. PANEL FACILITIES	176
		14. SPECIFICATIONS	178

1. SAFETY INFORMATION

This service manual is intended for qualified service technicians; it is not meant for the casual do-it-yourselfer. Qualified technicians have the necessary test equipment and tools, and have been trained to properly and safely repair complex products such as those covered by this manual.

Improperly performed repairs can adversely affect the safety and reliability of the product and may void the warranty. If you are not qualified to perform the repair of this product properly and safely, you should not risk trying to do so and refer the repair to a qualified service technician.



WARNING

Lead in solder used in this product is listed by the California Health and Welfare agency as a known reproductive toxicant which may cause birth defects or other reproductive harm (California Health & Safety Code, Section 25249.5).

When servicing or handling circuit boards and other components which contain lead in solder, avoid unprotected skin contact with the solder. Also, when soldering do not inhale any smoke or fumes produced.



NOTICE

(FOR CANADIAN MODEL ONLY)

Fuse symbols  (fast operating fuse) and/or  (slow operating fuse) on PCB indicate that replacement parts must be of identical designation.

REMARQUE

(POUR MODÈLE CANADIEN SEULEMENT)

Les symboles de fusible  (fusible de type rapide) et/ou  (fusible de type lent) sur CCI indiquent que les pièces de remplacement doivent avoir la même désignation.

(FOR USA MODEL ONLY)

1. SAFETY PRECAUTIONS

The following check should be performed for the continued protection of the customer and service technician.

LEAKAGE CURRENT CHECK

Measure leakage current to a known earth ground (water pipe, conduit, etc.) by connecting a leakage current tester such as Simpson Model 229-2 or equivalent between the earth ground and all exposed metal parts of the appliance (input/output terminals, screwheads, metal overlays, control shaft, etc.). Plug the AC line cord of the appliance directly into a 120V AC 60Hz outlet and turn the AC power switch on. Any current measured must not exceed 0.5mA.

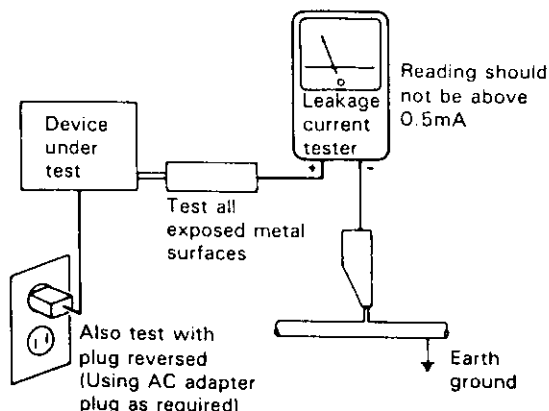

ANY MEASUREMENTS NOT WITHIN THE LIMITS OUTLINED ABOVE ARE INDICATIVE OF A POTENTIAL SHOCK HAZARD AND MUST BE CORRECTED BEFORE RETURNING THE APPLIANCE TO THE CUSTOMER.

2. PRODUCT SAFETY NOTICE

Many electrical and mechanical parts in the appliance have special safety related characteristics. These are often not evident from visual inspection nor the protection afforded by them necessarily can be obtained by using replacement components rated for voltage, wattage, etc. Replacement parts which have these special safety characteristics are identified in this Service Manual.

Electrical components having such features are identified by marking with a Δ on the schematics and on the parts list in this Service Manual.

The use of a substitute replacement component which does not have the same safety characteristics as the PIONEER recommended replacement one, shown in the parts list in this Service Manual, may create shock, fire, or other hazards.

Product Safety is continuously under review and new instructions are issued from time to time. For the latest information, always consult the current PIONEER Service Manual. A subscription to, or additional copies of, PIONEER Service Manual may be obtained at a nominal charge from PIONEER.

2. LABEL CHECK

(FOR EUROPEAN MODEL ONLY)

VARO!

AVATTAESSA JA SUOJALUKITUS
OHITETTAESSA OLET ALTTIINA
NÄKYMÄTTÖMÄLLE LASERSÄTEILYLLE.
ÄLÄ KATSO SÄTEESEEN.

ADVERSEL:

USYNLIG LASERSTRÅLING VED ÅBNING
NÅR SIKKERHEDSAFBRYDERE ER UDE AF
FUNKTION UNDGA UDSÆTTELSE FOR
STRÅLING.

VARNING!

OSYNLIG LASERSTRÅLING NÅR DENNA
DEL ÄR ÖPPNAD OCH SPÄRREN
ÄR URKOPPLAD. BETRAKTA EJ STRÅLEN.



LASER
Kuva 1
Lasersäteilyn
varoituserkki

WARNING!

DEVICE INCLUDES LASER DIODE WHICH
EMITS INVISIBLE INFRARED RADIATION
WHICH IS DANGEROUS TO EYES. THERE IS
A WARNING SIGN ACCORDING TO PICTURE
1 INSIDE THE DEVICE CLOSE TO THE LASER
DIODE.



LASER
Picture 1
Warning sign for
laser radiation

IMPORTANT

THIS PIONEER APPARATUS CONTAINS
LASER OF CLASS 1.
SERVICING OPERATION OF THE APPARATUS
SHOULD BE DONE BY A SPECIALLY
INSTRUCTED PERSON.

LASER DIODE CHARACTERISTICS

MAXIMUM OUTPUT POWER: 5 mw
WAVELENGTH: 780-785 nm

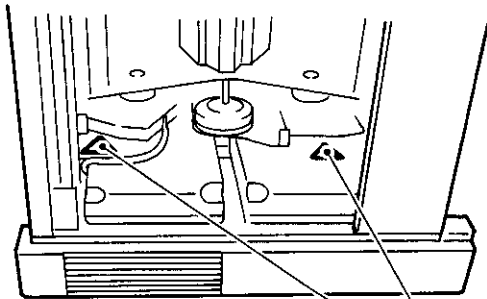

Additional Laser Caution

1. Laser Interlock Mechanism

The location of the switch (S6-8) which examines the position of the clamp is detected by the main system micro-computer. When the clamp is not closed, the laser diode will stop oscillating. The Interlock Mechanism will not operate when in the test command*.

When the 2, 3 pin of the CXA1471S (IC1) is connected to the GND, or when the 20 pin has been connected to High Level (ON), the laser diode will keep oscillating in the event of a short circuit between any of the Q1 terminals (fault condition).

2. When the CDP is being retrieved, looking directly at the objective lens from a short distance can lead to exposure to beams from the Class 1 laser.

* Refer to page 110.

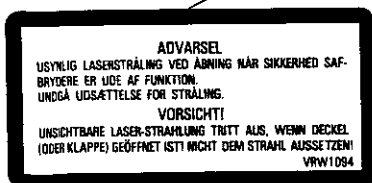
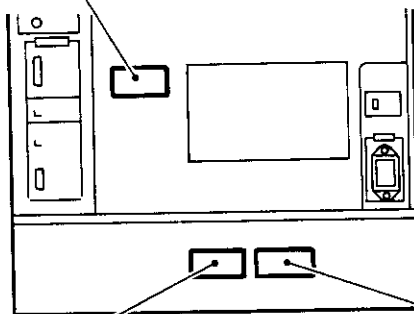

3. PARTS LOCATION

■ SEPARATE UNIT NAMES

This manual uses the following abbreviations for P. C. Board names :

CAC - V3000

Note:

When ordering service parts, be sure to refer to "PARTS LIST of EXPLODED VIEWS" or "PCB PARTS LIST".

— DACB Unit (DWM1281)	D/A Converter Board Unit
MOTHER Unit	
— SYPS Unit (DWR1134 : HEM)	System Power Supply Board Unit
(DWR1141 : KUC)	
— VCHS Unit (DWS1169 : HEM Only)	Voltage Change Switch Board Unit
— ANLG Unit (DWX1281)	Analog Audio Board Unit
— DGIF Unit (DWX1282 : HEM)	Digital Interface Board Unit
(DWX1307 : KUC)	
— XLR1 Unit (DWX1283)	XLR Connector 1 Board Unit
— XLR2 Unit (DWX1284)	XLR Connector 2 Board Unit
— CNCT Unit (DWX1286)	System Connector Board Unit
— RSIF Unit (DWX1287)	RS - 232C & 422A Interface Board Unit
— AUOB Unit (DWX1288)	Audio Output Board Unit
MAIN Unit	
— MCDR Unit (DWG1301 : HEM)	Main Control & Motor Drive Board Unit
(DWG1317 : KUC)	
— CLSB Unit (DWS1126)	Clamp Switch Board Unit
— KDSB Unit (DWS1173)	Key & Display Board Unit
— ENCB Unit (DWX1178)	Encoder Board Unit
— ILDB Unit (DWX1179)	Illumination LED Board Unit
VHIF Unit	
— VCNB Unit (DWP1025)	Vertical Control Board Unit
— VSLB Unit (DWP1026)	Vertical Sensor Left Board Unit
— VSRB Unit (DWP1027)	Vertical Sensor Right Board Unit
— CNNB Unit (DWX1180)	Connection Board Unit
— SWGB Unit (DWX1181)	Swing Board Unit
— DISP Unit (DWX1292)	Display Board Unit
PD - CACV3000 - L [CDP - 1 (L)]	
— CDPM Unit	
— CONT Unit (DWG1302)	CD Control Board Unit
— CDPS Unit (DWX1290)	CD Power Supply Board Unit
— BRAN Unit (DWX1289)	Branch Board Unit
— Servo Mechanism Assembly	
— Pick-up Assembly (PEA1030)	
PD - CACV3000 - R [CDP - 2 (R)]	
— CDPM Unit	
— CONT Unit (DWG1302)	CD Control Board Unit
— CDPS Unit (DWX1290)	CD Power Supply Board Unit
— BRAN Unit (DWX1289)	Branch Board Unit
— Servo Mechanism Assembly	
— Pick-up Assembly (PEA1030)	

FRONT SECTION

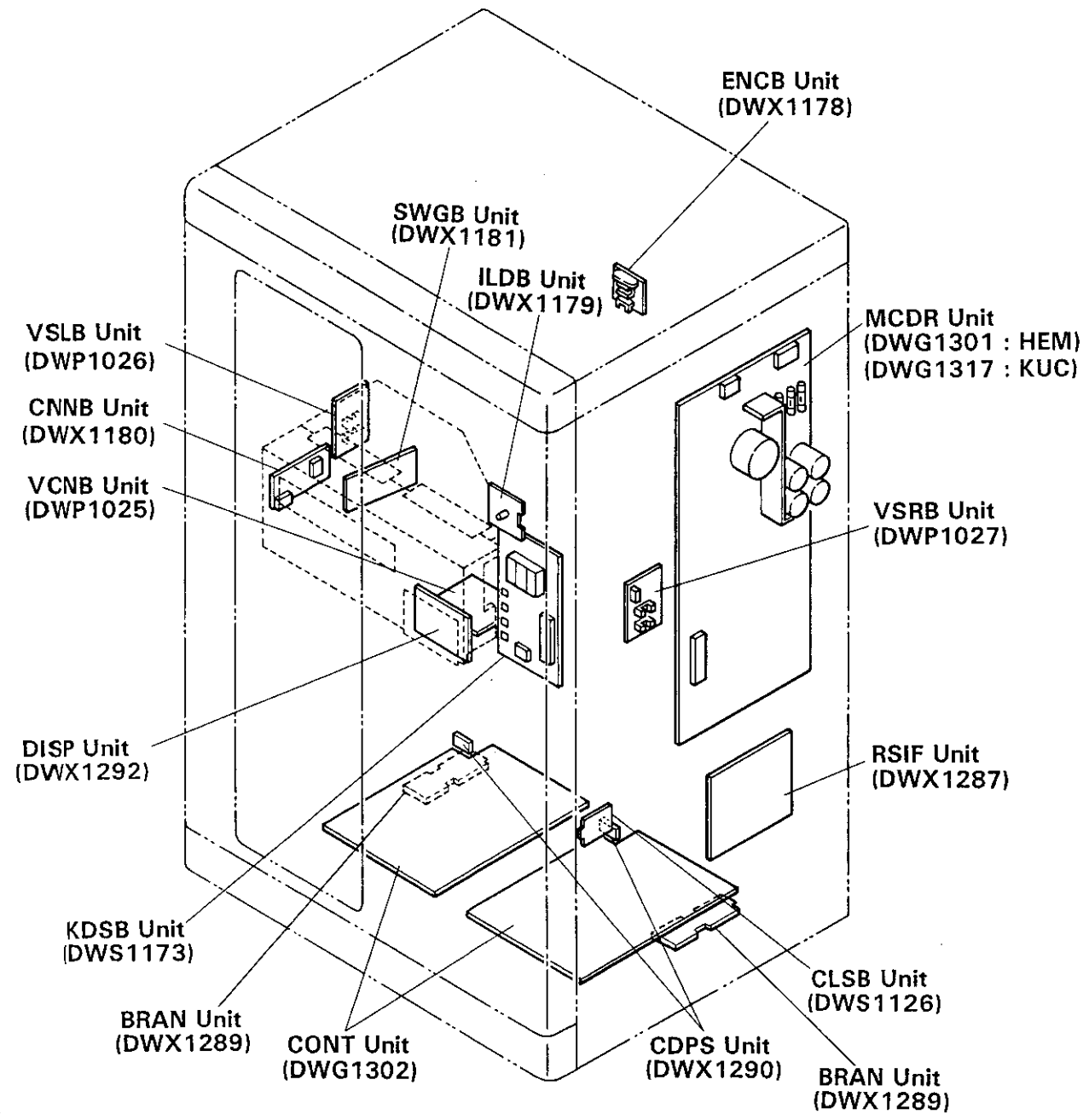

REAR SECTION

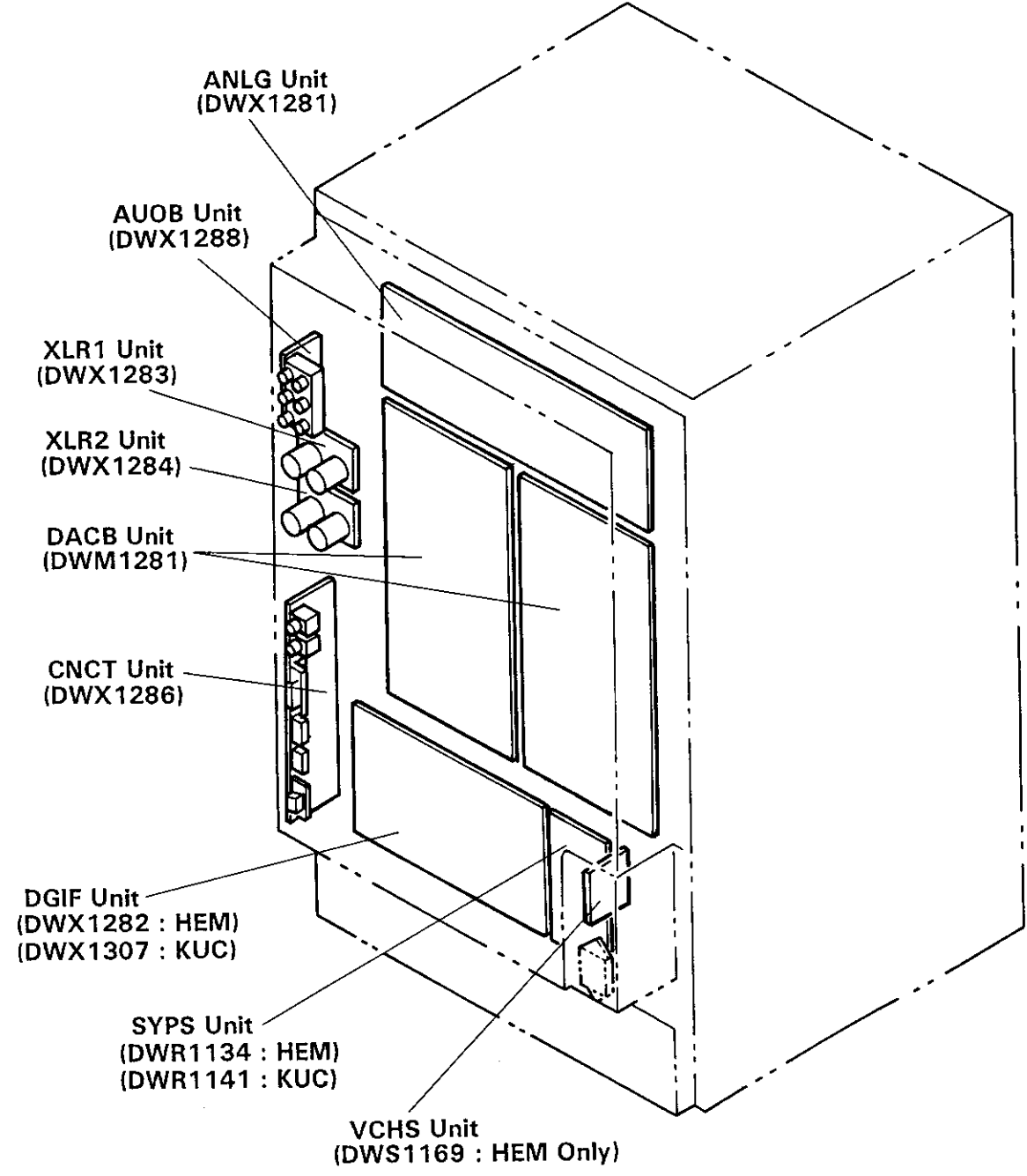

4. DISASSEMBLY

4.1 PANELS AND DOOR SECTION

1. Remove the screws attaching the top plate, side panels, etc.
2. To remove the door, unscrew the door hinge A assembly from the inside of the upper part of the door and lift the door.

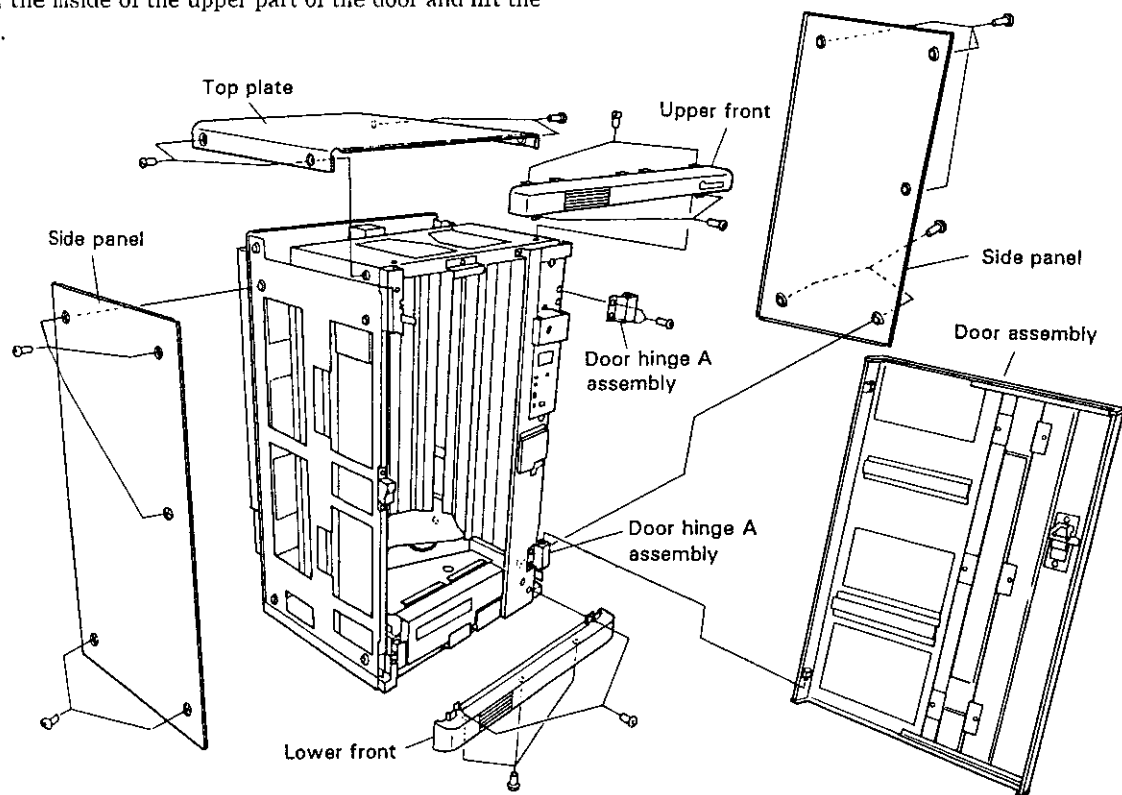

Fig. 4-1 Panels and Door Section

4.2 GEARBOX SECTION

1. Remove the screws. Unfasten the VD1 belt and spring of the VD pulley side.
2. Lift the gearbox assembly.

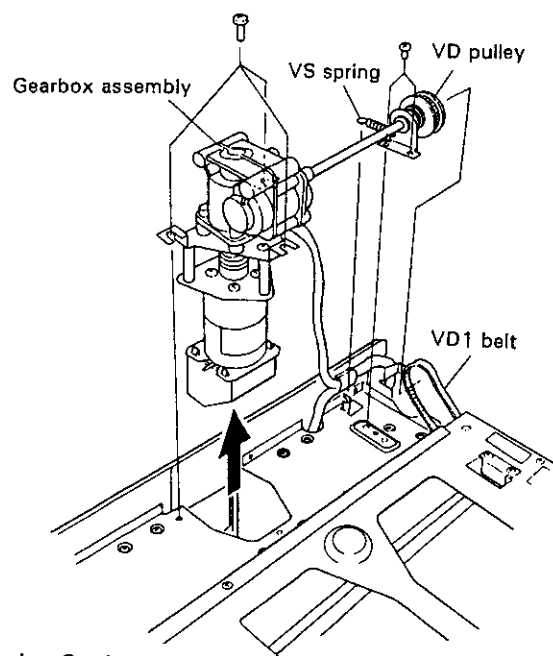

Fig. 4-2 Gearbox Section

4.3 CD PLAYER SECTION

1. Remove the CDP cover from the rear bottom.
2. Loosen the screw (A) of the front bottom. (Do not remove it.)
3. Remove the screw (B) in the lower center of the rear side and the ground terminal screw (C) of the CD player to be removed.
4. Loosen the screw (D) of the CD player to be removed.
5. Pull out the CD player.

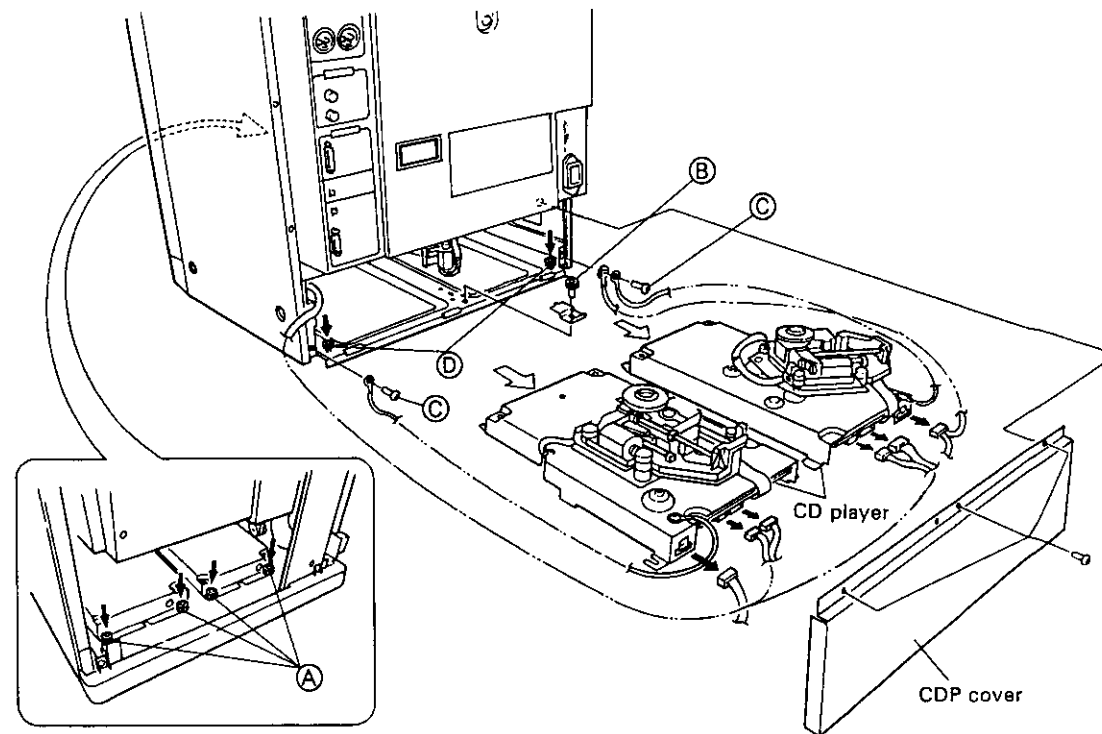

Fig. 4-3 CD Player Section

4.4 CLAMP SECTION

Perform the following steps after removing both CD players.

1. Remove the rear panel and loosen the wires.

2. Remove the screw (E) of the front bottom.
3. Remove the screw (F) of the rear bottom and the plate attaching screw (G). Pull out the clamp.

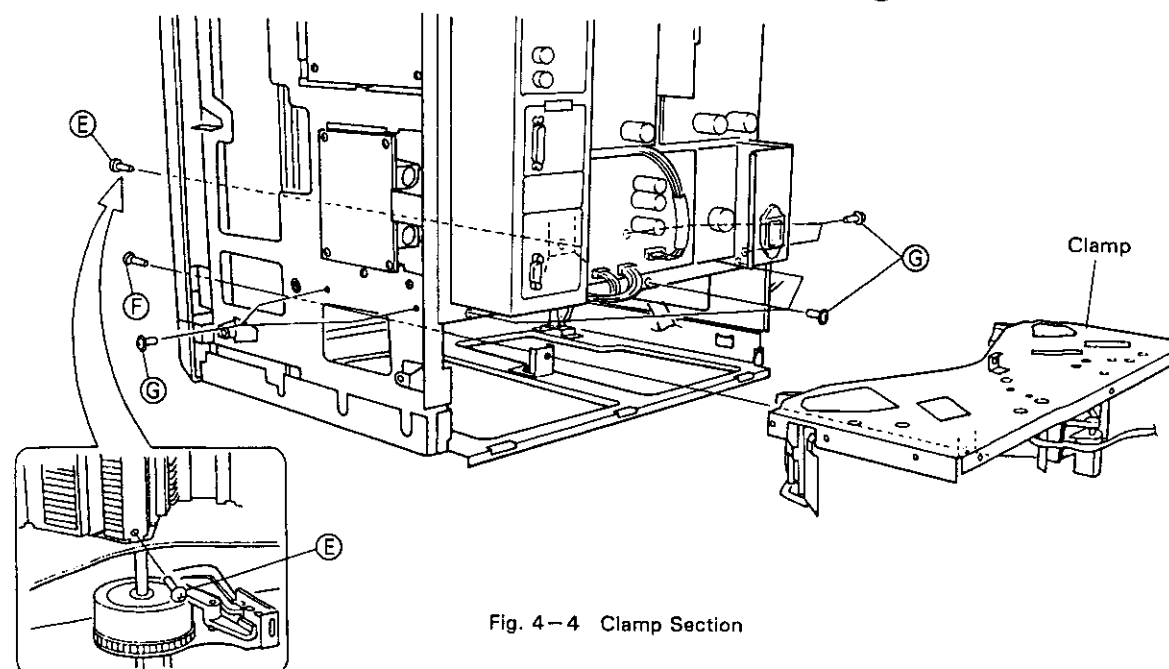

Fig. 4-4 Clamp Section

4.5 SWING ASSEMBLY SECTION

1. Remove the IL panel from the transfer mechanism assembly.
2. Remove the E washer from the swing assembly. Remove the harness from the transfer base and pull up the swing assembly.

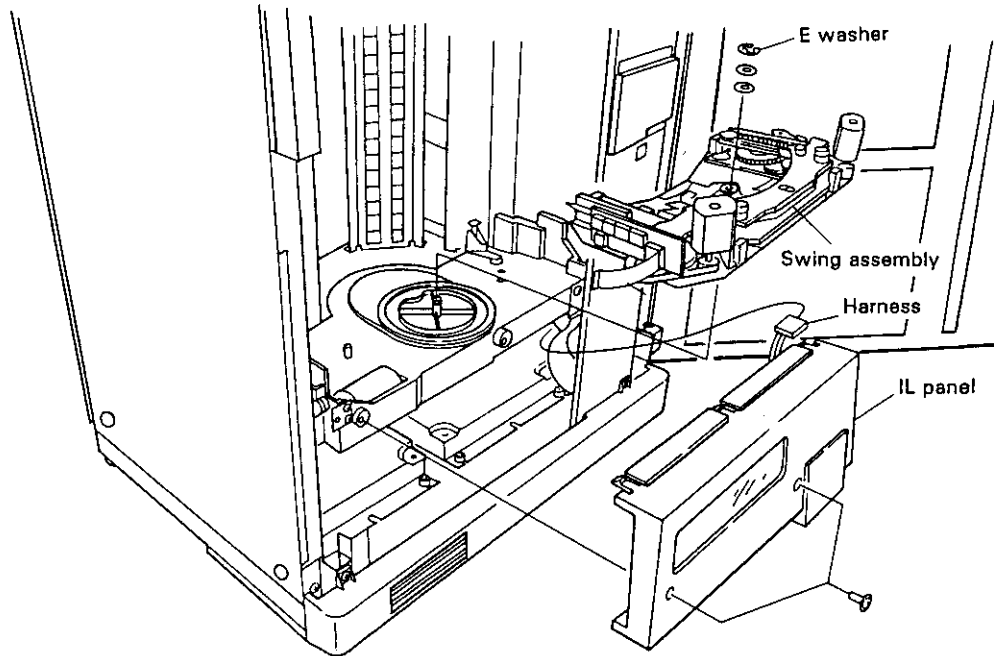

Fig. 4-5 Swing Assembly Section

4.6 SWING MOTOR ASSEMBLY (Attached under the transfer base assembly)

1. Pull out the cable from the harness guide under the transfer base assembly. Remove the supports of the harness guide from the transfer base assembly.
2. Remove the motor assembly attaching screw (H) and pull out the motor assembly.

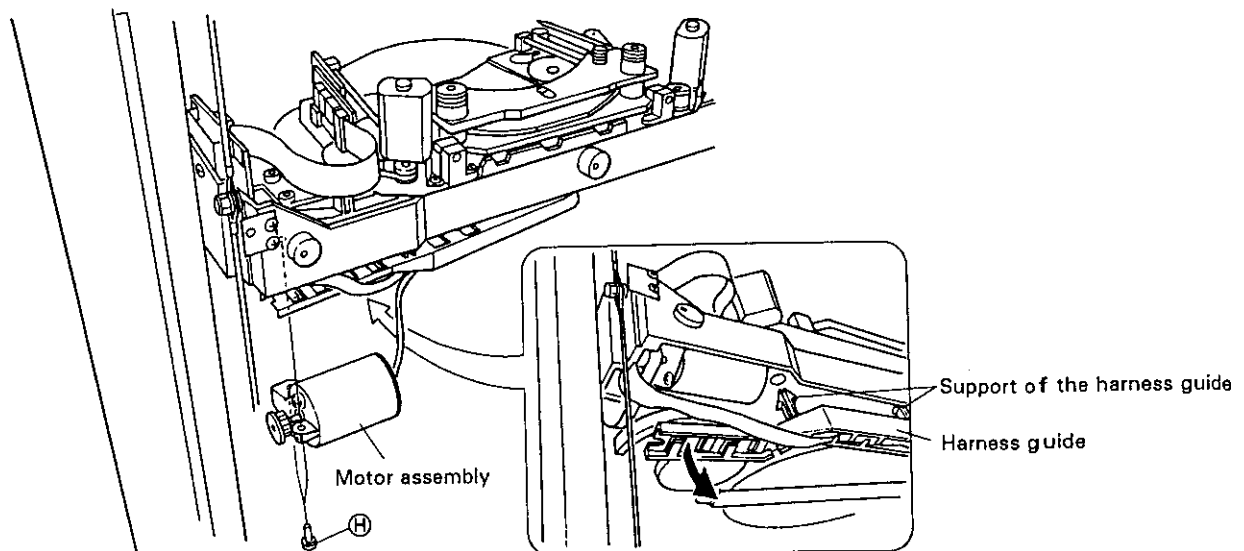

Fig. 4-6 Swing Motor Assembly

5. EXPLODED VIEWS, PACKING AND PARTS LIST

NOTES:

- Parts marked by "NSP" are generally unavailable because they are not in our Master Spare Parts List.
- The Δ mark found on some component parts indicates the importance of the safety factor of the part. Therefore, when replacing, be sure to use parts of identical designation.
- Parts marked by "☉" are not always kept in stock. Their delivery time may be longer than usual or they may be unavailable.

5.1 EXTERIOR

Parts list of Exterior

Mark	No.	Description	Parts No.
	1	CUSHION (A)	DEB1196
	2	CUSHION (B)	DEB1197
	3	INSECT SCREEN CUSHION (A)	DEB1198
	4	INSECT SCREEN CUSHION (B)	DEB1199
	5	DUMP CUSHION (A)	DEC1366
	6	DUMP CUSHION (B)	DEC1469
	7	MANUAL CONTROL PANEL	DNH1705
NSP	8	BADGE	DAM1043
	9	PACKING	DEB1153
	10	DOOR PACKING (L)	DEB1206
	11	DOOR PACKING (M)	DEB1208
	12	CDP COVER	DNH1456
	13	REAR COVER	DNH1681
	14	TOP PANEL	DNH1687
	15	SIDE PANEL	DNH1693
	16	DECORATIVE PANEL (UPPER)	DNK2421
	17	DEDORATIVE PANEL (LOWER)	DNK2422
	18	SCREW	IMT30P040FZK
	19	SCREW	BBT30P060FNI
	20	DOOR PACKING (R)	DEC1354
	21	HARNES SHEET	VEX1022

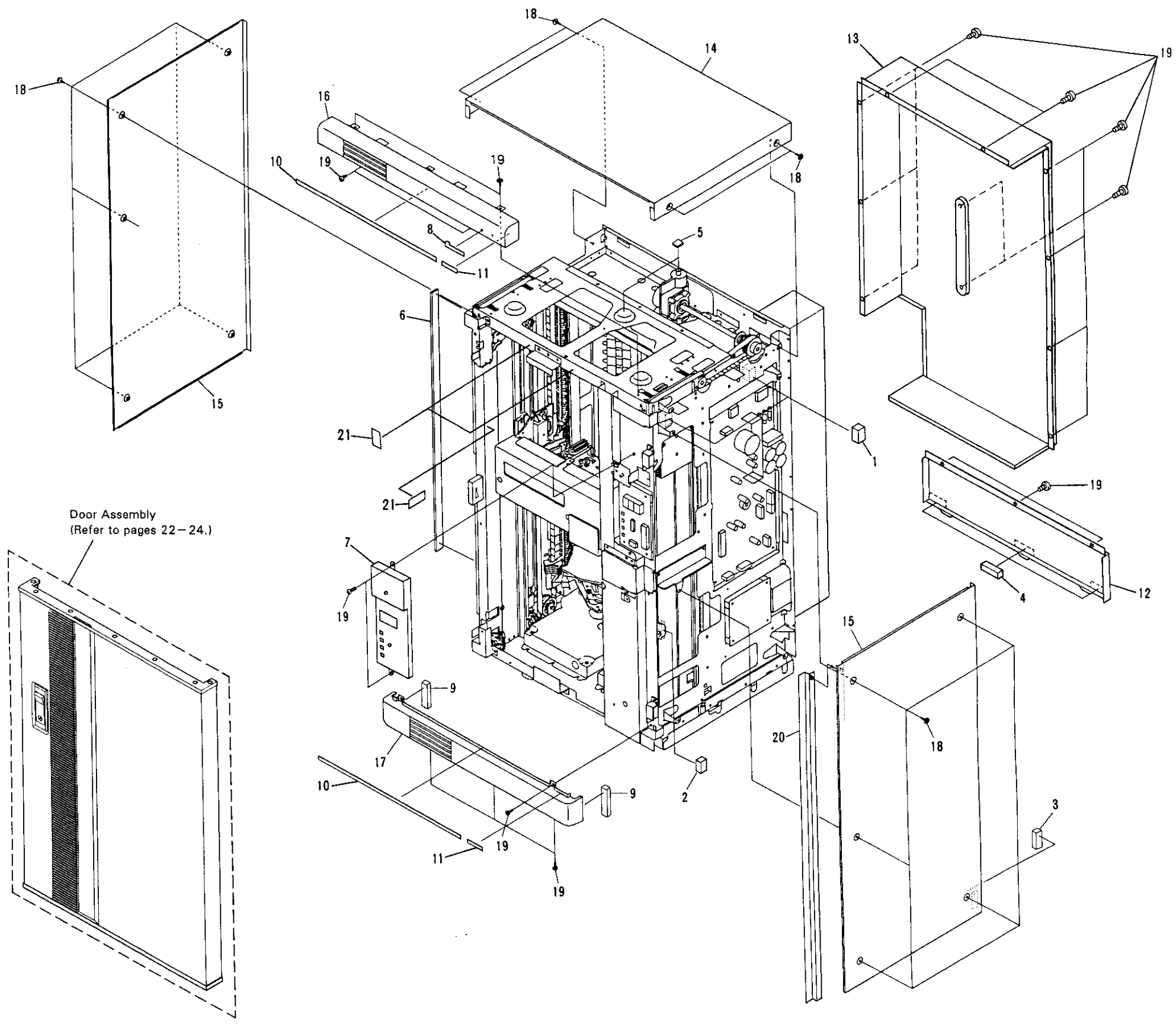

Door Assembly
(Refer to pages 22-24.)

A
B
C
D

5.2 TRANSFER BASE SECTION

A

B

C

D

A

B

C

D

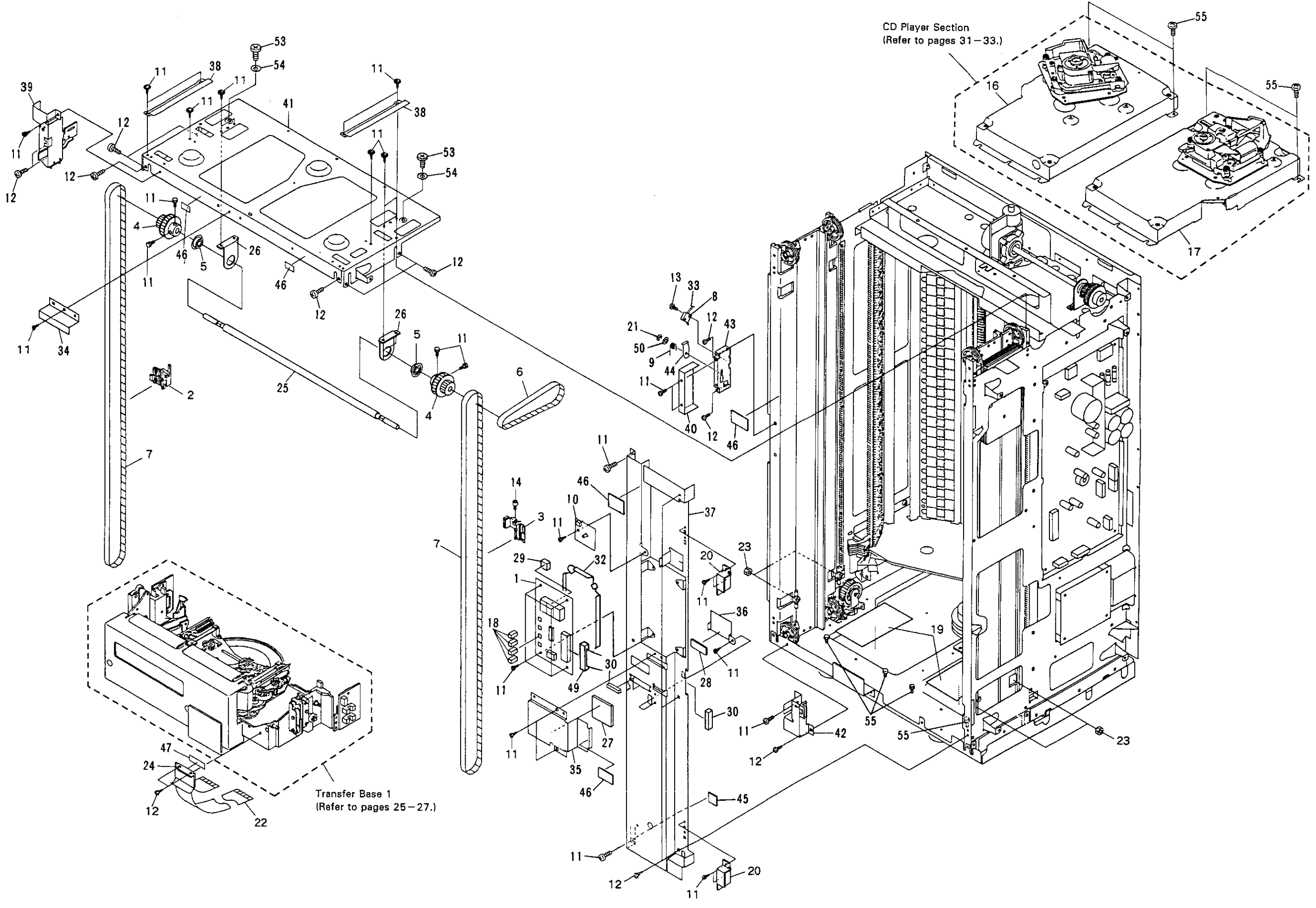

CD Player Section
(Refer to pages 31-33.)

Transfer Base 1
(Refer to pages 25-27.)

Parts list of Transfer Base Section

Mark	No.	Description	Parts No.	Mark	No.	Description	Parts No.
●	1	KDSB UNIT	DWS1173	NSP	41	TOP STAY (F)	DNH1778
	2	BELT STOPPER L	DNK1855		42	FRONT PLATE LD ASSEMBLY	DXB1385
	3	BELT STOPPER R	DNK1854		43	DOOR SW HOLDER	DXB1389
	4	VD PULLEY 1	DNK1810		44	DOOR SW PLATE SPRING ASSEMBLY	DXB1398
	5	BEARING	DXB1157	NSP	45	DUMP SHEET	VEX1021
	6	VD1 BELT	DMS1017		46	HARNESS SHEET	VEX1022
	7	S3M BELT 2	DMS1016		47	FLEXIBLE CUSHION C	DEB1151
	8	SLIDE SWITCH	VSK1003		48	AC SUB PANEL (H)	DNC1244
	9	DOOR SW SPRING	DBH1204		49	CONNECTOR ASSEMBLY	DKP1879
●	10	ILDB UNIT	DWX1179		50	WASHER	WA30F120M100
	11	SCREW	BBZ30P060FMC	△	51	SWITCH	DSA1012
	12	SCREW	AMZ30P040FMC		52	LEVER SWITCH	DSK1003
	13	SCREW	PMH20P080FMC		53	SCREW	DLA1543
	14	SCREW	SMZ30H102FBT		54	WASHER	WB50FMC
	15	SCREW	BBZ30P080FZK		55	SCREW	SMZ30H060FBT
NSP	16	CD AUTO CHANGER PLAYER (R)	PD-CACV3000-R				
NSP	17	CD AUTO CHANGER PLAYER (L)	PD-CACV3000-L				
	18	PUSH BUTTON	DAC1196				
	19	INSULATION SHEET	DEC1350				
	20	DOOR HINGE A ASSEMBLY	DXB1288				
	21	E RING	YE20FUC				
	22	FLEXIBLE CORD (23P)	DDD1061				
	23	NUT	NN30FUC				
	24	H PLATE 6	DNH1416				
	25	VD SHAFT	DLA1411				
	26	VD PLATE 1	DNH1406				
	27	FLEXIBLE CUSHION (A)	DEB1141				
	28	FLEXIBLE CUSHION (B)	DEB1142				
	29	RUBBER CUSHION	DEB1202				
	30	EDGE GUARD	DEC1317				
	31	EDGE GUARD SHEET	DEC1400				
	32	PC BLIND (B)	DEC1476				
	33	CONNECTOR ASSEMBLY	DKP2396				
	34	F STAY (T)	DNH1435				
	35	FLEXIBLE STOPPER	DNH1438				
	36	FLEXIBLE GUARD	DNH1442				
NSP	37	FRONT PLATE (R)	DNH1466				
NSP	38	T PLATE	DNH1476				
	39	FRONT PLATE LU	DNH1667				
	40	DOOR SW COVER	DNH1689				

5.3 UNDER BASE SECTION**Parts list of Under Base Section**

Mark	No.	Description	Parts No.
	1	VD PULLEY 2	DNK1809
	2	VD SHAFT 3	DLA1409
	3	FOOT (L)	DEC1322
	4	FOOT (S)	DEC1365
	5	SCREW	BBZ30P060FMC
	6	SCREW	SMZ30H060FBT
	7	VD PULLEY 2 ASSEMBLY	DXX1525
	8	CLAMPER ASSEMBLY	DXX1886
	9	SCREW	AMZ30P040FMC
	10	SCREW	BBZ30P080FMC
	11	SCREW	BBZ40P080FMC
	12	VS SPRING	DBH1143
	13	VD SPRING 4	DBH1139
	14	TENSION NUT	DLA1410
	15	VD BUSH	DNK1895
	16	VD BOLT 3 ASSEMBLY	DXB1254
	17	VD PLATE 5 ASSEMBLY	DXB1287
	18	CD HOLDER	DBK1044
	19	RUBBER CUSHION	DEB1144
	20	GEAR STAY (LOWER)	DNH1388
NSP	21	UNDER BASE	DNH1422
	22	F STAY U	DNH1436
	23	VD COVER	DNK2396
	24	PROTECT TAPE	DED1074
	25	DUMP CUSHION A	DEC1366

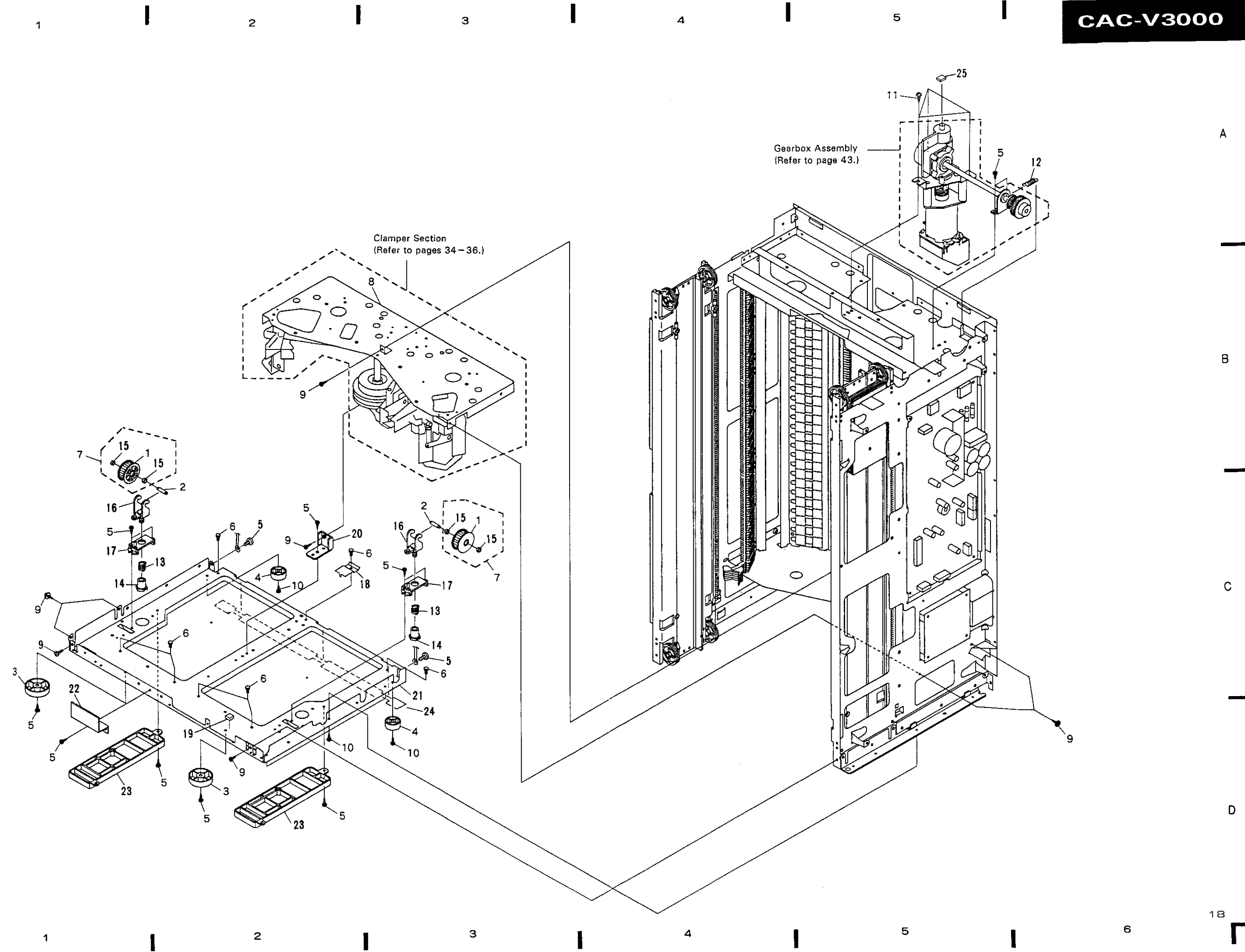

A

B

C

D

5.4 MAIN BODY SECTION

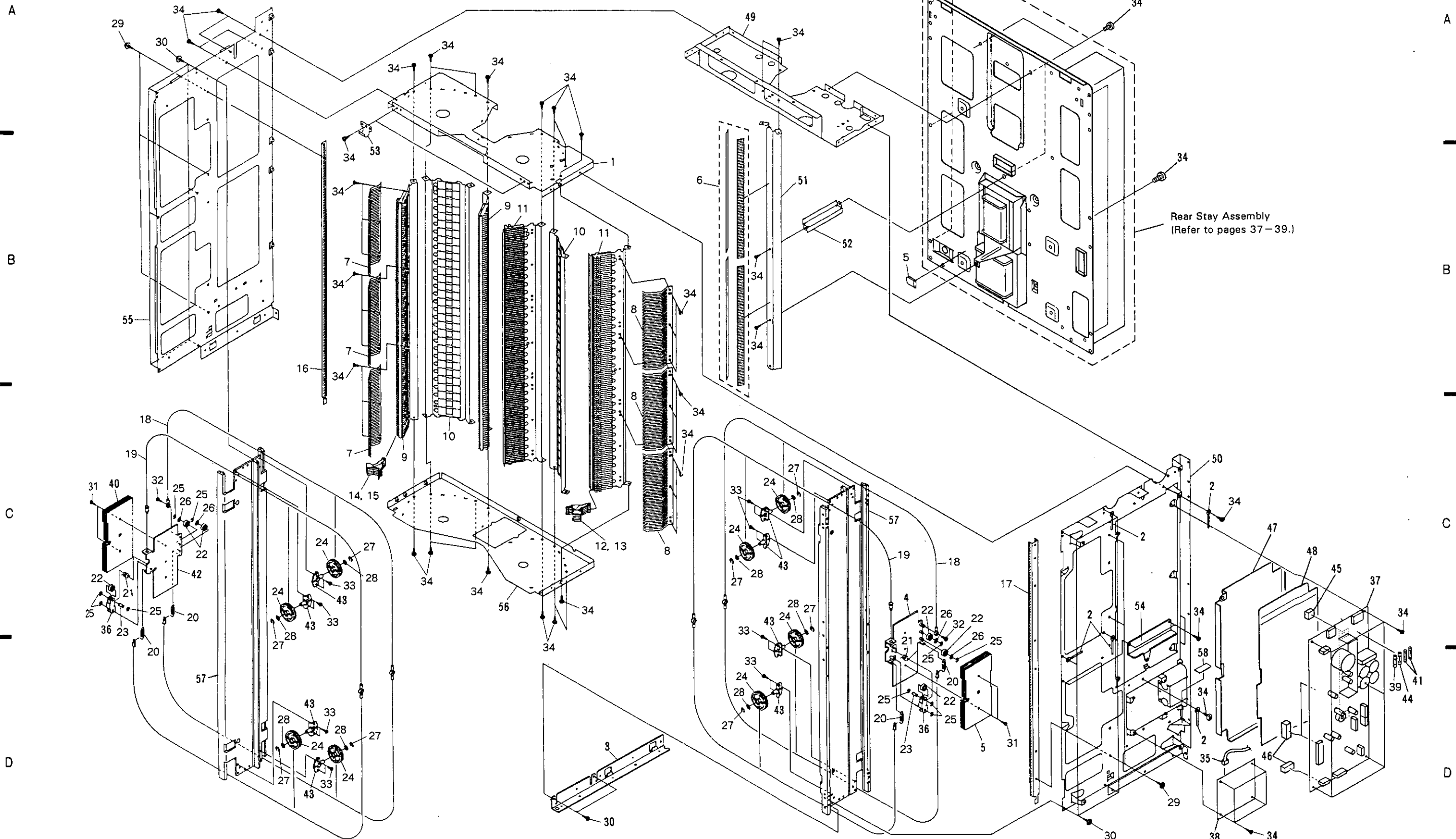

Parts list of Main Body Section

Mark	No.	Description	Parts No.	Mark	No.	Description	Parts No.
NSP	1	D STAY (T) ASSEMBLY	DXB1396	△	41	FUSE (T2AL250V, FU2, FU3)	REK - 103
	2	CORD CLAMPER	VNF - 069		42	W PLATE 1 ASSEMBLY	DXB1256
	3	U ANGLE	DNH1432		43	ROPE PLATE ASSEMBLY	DXB1258
	4	W PLATE 2 ASSEMBLY	DXB1257	△	44	FUSE (T800mAL250V, FU4)	REK - 099
	5	W PLAGE (R)	DNH1474		45	RUBBER CUSHION	DEB1202
	6	DISC ADDRESS LABEL (A)	DEC1320		46	RUBBER SPACER	DEB1210
	7	PLATE SPRING (L)	DBK1047		47	PC BLIND (A)	DEC1475
	8	PLATE SPRING (R)	DBK1048		48	PC BLIND (C)	DEC1573
	9	RACK ASSEMBLY A (L)	DNK2070	NSP	49	TOP STAY (R)	DNH1424
	10	RACK ASSEMBLY B	DNK1803	NSP	50	SIDE STAY (R)	DNH1425
	11	RACK ASSEMBLY A (R)	DNK2071	NSP	51	REINFORCEMENT STAY	DNH1430
	12	D HOLDER L (WHITE)	DNK1879		52	T STAY	DNH1431
	13	D HOLDER R (BLACK)	DNK1884		53	HOLDER STOPPER	DNH1462
	14	D HOLDER R (WHITE)	DNK1878	NSP	54	S PLATE	DNH1475
	15	D HOLDER R (BLACK)	DNK1883	NSP	55	SIDE STAY (L)	DNH1506
	16	VD ENCODER DISC 1	DNH1402		56	D STAY (U)	DNH1775
	17	VD ENCODER DISC 2	DNH1403	NSP	57	SIDE FRAME ASSEMBLY	DXB1390
	18	WIRE ASSEMBLY (A)	DXB1264		58	HARNES SHEET	VEX1022
	19	WIRE ASSEMBLY (B)	DXB1265				
	20	W2 SPRING	DBH1172				
	21	W1 SPRING	DBH1140				
	22	WEIGHT PULLEY	DNK1840				
	23	H SHAFT 9	DLA1412				
	24	ROPE PULLEY	DNK1841				
	25	E RING	YE25FUC				
	26	WASHER	WA41D065D025				
	27	E RING	YE30FUC				
	28	WASHER	WA52D080D025				
	29	SCREW	PMB26P040FCU				
	30	SCREW	AMZ30P040FMC				
	31	SCREW	CMZ30P100FMC				
	32	SCREW	PMA30P040FCU				
	33	SCREW	PMA30P050FMC				
	34	SCREW	BBZ30P060FMC				
	35	CONNECTOR ASSEMBLY	DKP2385				
	36	W PLATE 4	DNH1411				
●	37	MCDR UNIT	DWG1301				
●	38	RSIF UNIT	DWX1287				
△	39	FUSE (T5AL250V, FU5)	REK - 107				
	40	W PLATE L	DNH1473				

5.5 DOOR ASSEMBLY**Parts list of Door Assembly**

Mark	No.	Description	Parts No.
	1	DOOR PACKING	DEB1145
	2	GLASS PACKING	DEB1204
	3	RIVET	DEC1318
	4	WINDOW STOPPER	DNH1451
	5	DOOR STAY	DNH1686
	6	DOOR SASH	DNH1697
	7	DOOR L	DNH1771
	8	INDICATOR	DNK1898
	9	DOOR ESCUTCHEON (UPPER)	DNK2419
	10	DOOR ESCUTCHEON (LOWER)	DNK2420
	11	DOOR DECORATION PANEL	DNK2423
	12	DOOR HANDLE	DXB1392
	13	DOOR GLASS	DAN1019
	14	DOOR (R) ASSEMBLY	DXB1436
	15	CAUTION LABEL A	DRW1357
	16	SCREW	BBZ30P060FMC
	17	SCREW	DBA1046
NSP	18	DOOR LOCK PLATE	DNH1690
	19	EARTH SPRING	DBK1079

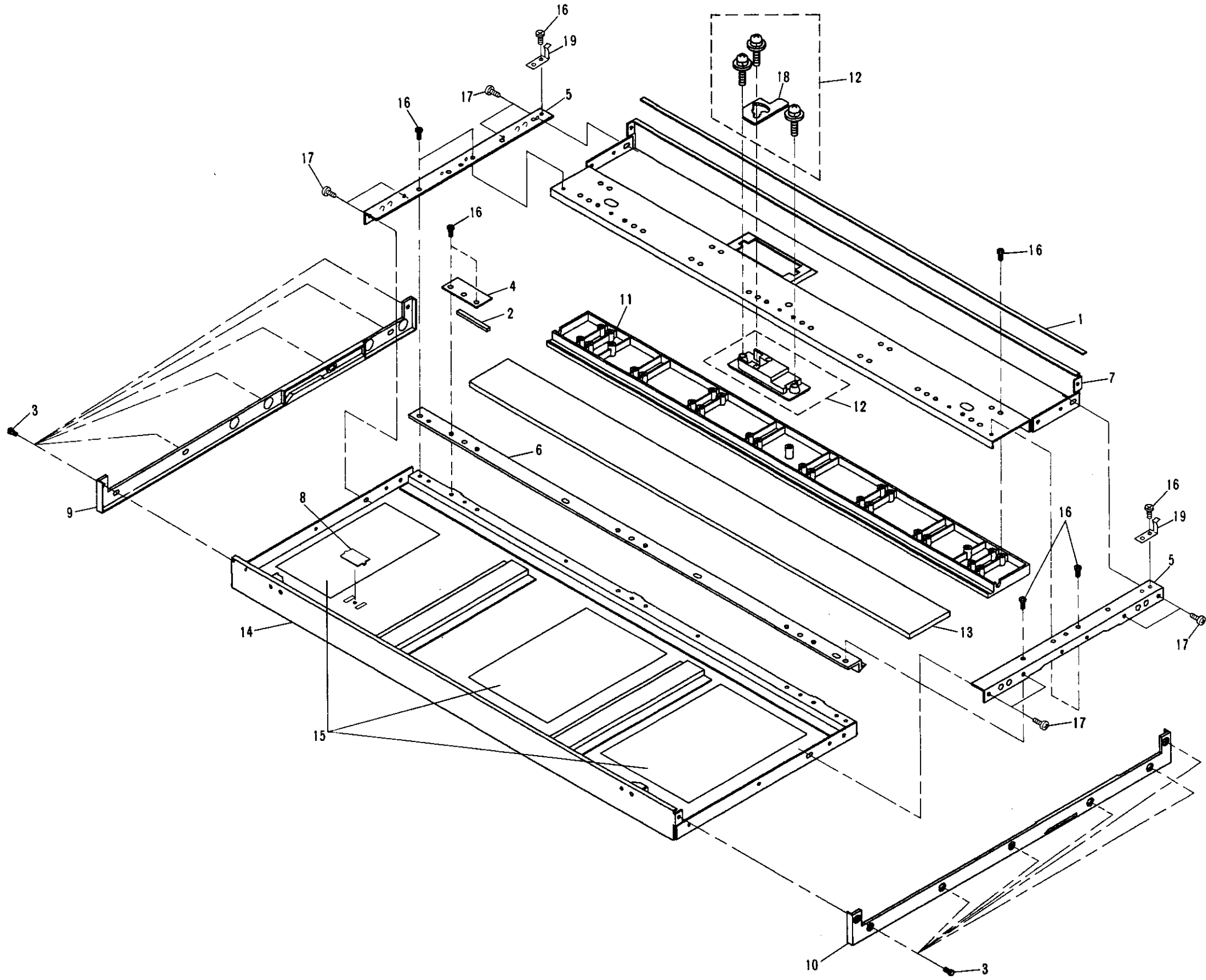

A

—

B

—

C

—

D



A

B

C

D

A

B

C

D

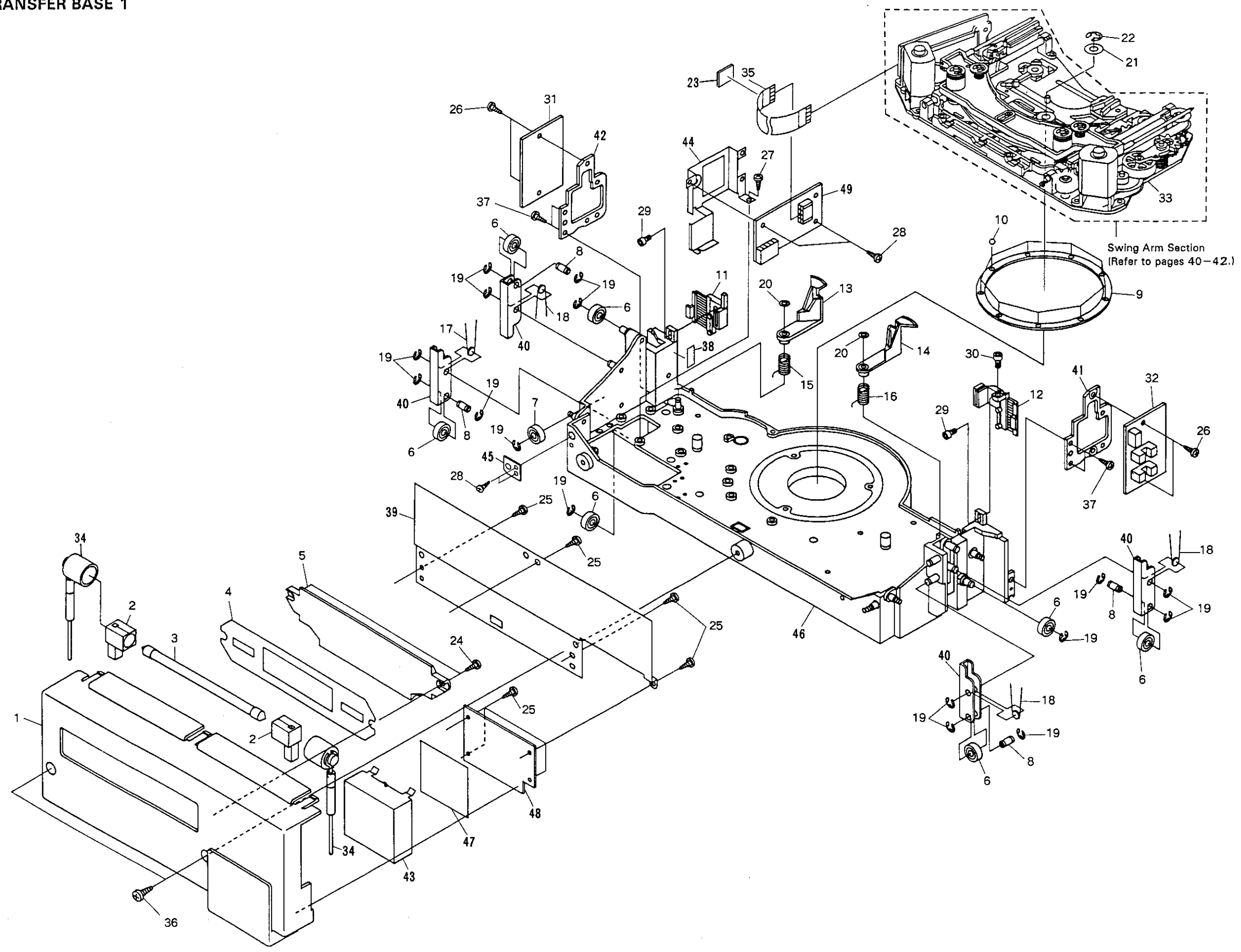

Parts list of Transfer Base 1

Mark	No.	Description	Parts No.	Mark	No.	Description	Parts No.
	1	IL PANEL	DNK2397		41	H PLATE 3	DNH1413
	2	FL SOCKET	DEB1201		42	H PLATE 4	DNH1414
	3	FLUORESCENT TUBE	DEL1009		43	SHIELD CASE 2	DNH1419
	4	IL PLATE	DAH1640		44	HAN PCB STAY	DNH1421
	5	IL LENS	DNK1857		45	SHIPPING BRACKET A	DNH1464
	6	BEARING	DXB1263		46	TRANSFER BASE ASSEMBLY	DXB1387
	7	BEARING	DXB1283		47	SHIELD PLATE	DEC1471
	8	H SHAFT 9	DLA1412	●	48	DISP UNIT	DWX1292
	9	RETAINER	DNK1849	●	49	CNNB UNIT	DWX1180
	10	STEEL BOWL	VNX1006				
	11	BELT STOPPER (L)	DNK1855				
	12	BELT STOPPER (R)	DNK1854				
	13	RELEASE LEVER (L)	DNK1881				
	14	RELEASE LEVER (R)	DNK1880				
	15	D RELEASE SPRING (L)	DBH1138				
	16	D RELEASE SPRING	DBH1137				
	17	H SPRING 2	DBH1144				
	18	H1 SPRING	DBH1136				
	19	E RING	YE25FUC				
	20	WASHER	WT26D047D025				
	21	SPRING	DBK1049				
	22	E RING	YE40FUC				
	23	FLEXIBLE CUSHION D	DEB1158				
	24	SCREW	BPZ30P060FCU				
	25	SCREW	BBZ30P080FMC				
	26	SCREW	PMH30P050FMC				
	27	SCREW	PMH30P060FMC				
	28	SCREW	PMA30P060FMC				
	29	SCREW	SMZ30H060FBT				
	30	SCREW	SMZ30H120FBT				
●	31	VSLB UNIT	DWP1026				
●	32	VSRB UNIT	DWP1027				
	33	SWING ASSEMBLY	DXX1887				
	34	FL TERMINAL ASSEMBLY	DXB1386				
	35	FLEXIBLE CORD (09P)	DDD1051				
	36	SCREW	PMH30P080FMC				
	37	SCREW	AMZ30P040FMC				
	38	HARNESS SHEET	VEX1022				
	39	IL SHASSIS	DNF1369				
	40	H PLATE 1	DNH1412				

5.7 TRANSFER BASE 2

Parts list of Transfer Base 2

Mark	No.	Description	Parts No.
	1	SW CAM GEAR	DNK1844
	2	SW ARM	DNS1124
	3	SW FOLLOWER	DNK1846
	4	SW INDUCER	DNK1847
	5	BEARING	DXB1231
	6	BEARING	DXB1176
	7	S2M TIMING BELT	DMS1006
	8	S2M PULLEY (L)	DNK1390
	9	WORM GEARS (S)	DLA1270
	10	SW GEAR 2	DNK1843
	11	SW WORM WHEEL	DNK1842
	12	DC MOTOR	DXM1037
	13	SW LEVER	DNK1848
	14	PUSH SWITCH	DSG1012
	15	RETAINER	DNK1849
	16	STEEL BOWL	VNX1006
	17	CORD CLAMPER (STEEL)	RNH - 184
	18	SCREW	PMA30P060FMC
	19	SCREW	AMZ30P120FMC
	20	S2M PULLEY (S)	DNK1389
	21	SCREW	BMZ30P060FMC
	22	SCREW	BMZ30P040FMC
	23	SCREW	PMA30P040FCU
	24	SCREW	PMB30P060FMC
	25	SCREW	PMH20P080FMC
	26	WASHER	WT26D047D025
	27	E RING	YE25FUC
	28	WASHER	WA41D065D025
	29	CERAMIC CAPACITOR	CKDYF473Z50
	30	CONNECTOR ASSEMBLY	DKP1885
	31	CONNECTOR ASSEMBLY	DKP1886
	32	CONNECTOR ASSEMBLY	DKP1896
	33	CONNECTOR ASSEMBLY	DKP1967
	34	WORM STAY	DLA1413
	35	MOTOR STAY 2	DNH1417
	36	SW GEAR STAY	DNH1768
	37	HARNESS GUIDE (A)	DNK1859
	38	HARNESS GUIDE (B)	DNK1860
	39	TURN TABLE ASSEMBLY	DXB1260
NSP	40	DUMP SHEET	VEX1021
◎	41	VCNB UNIT	DWP1025
	42	TRANSFER BASE ASSEMBLY	DXB1387

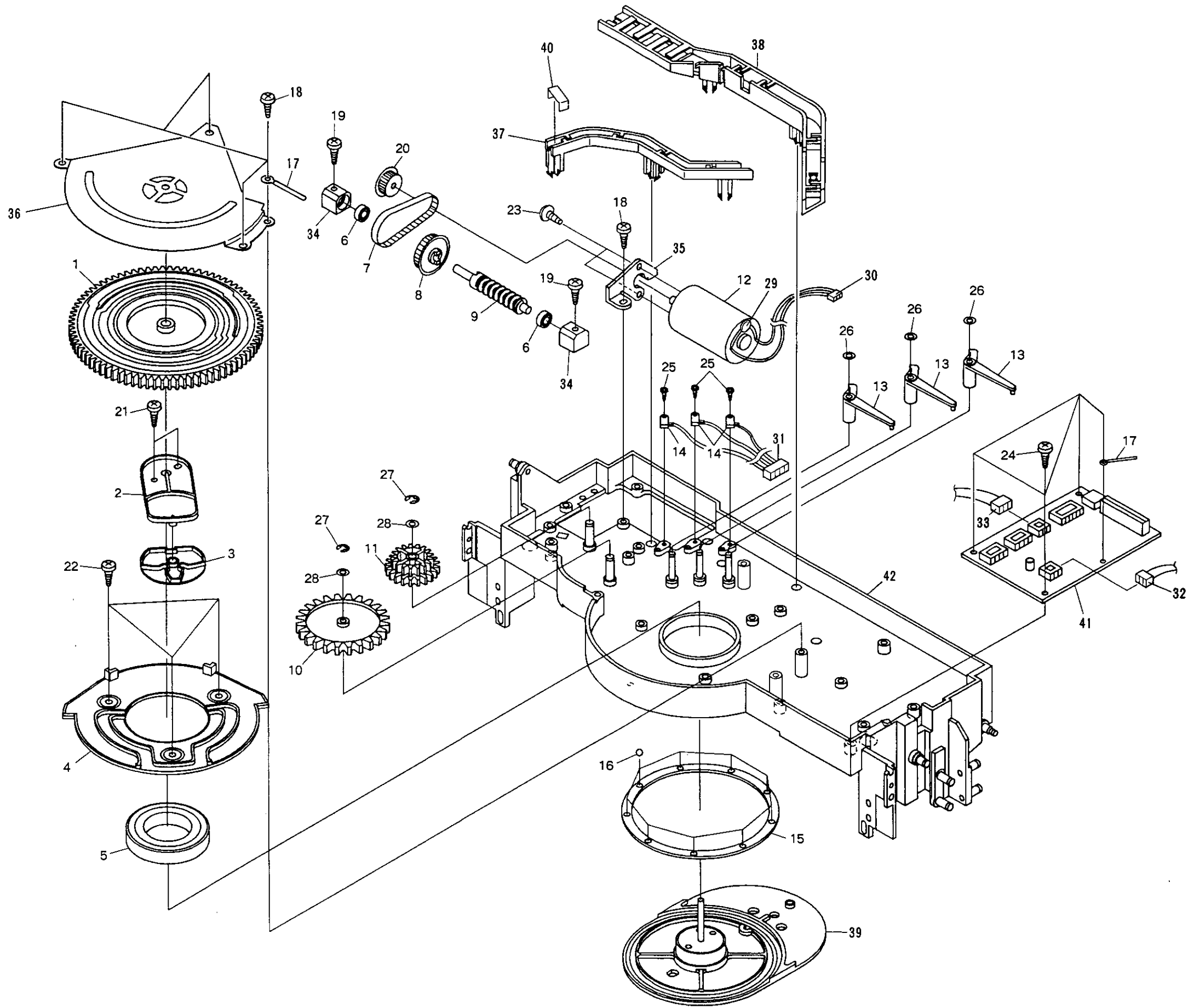

A

B

C

D

5.8 CD PLAYER SECTION

A

B

C

D

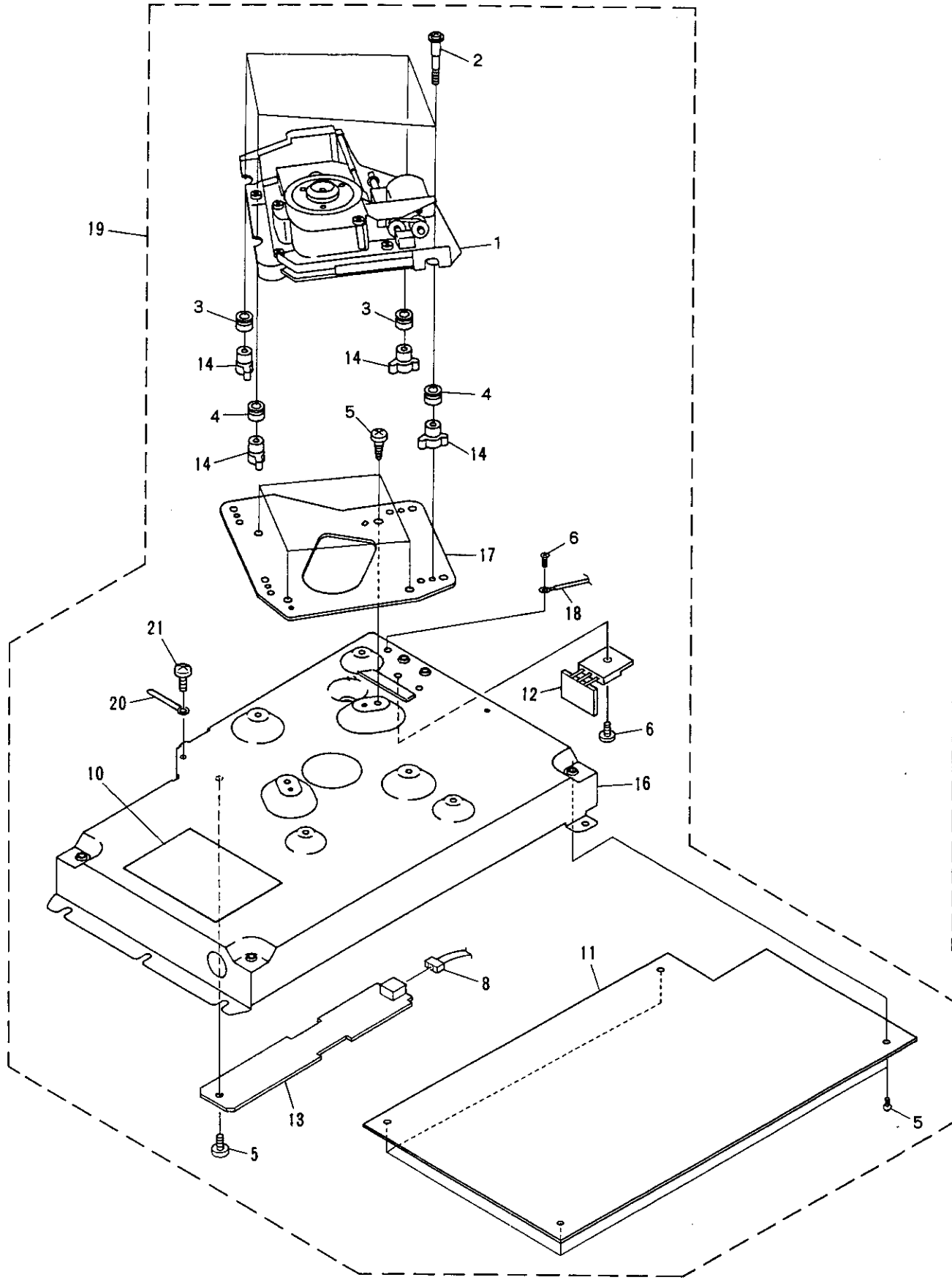

A

B

C

D

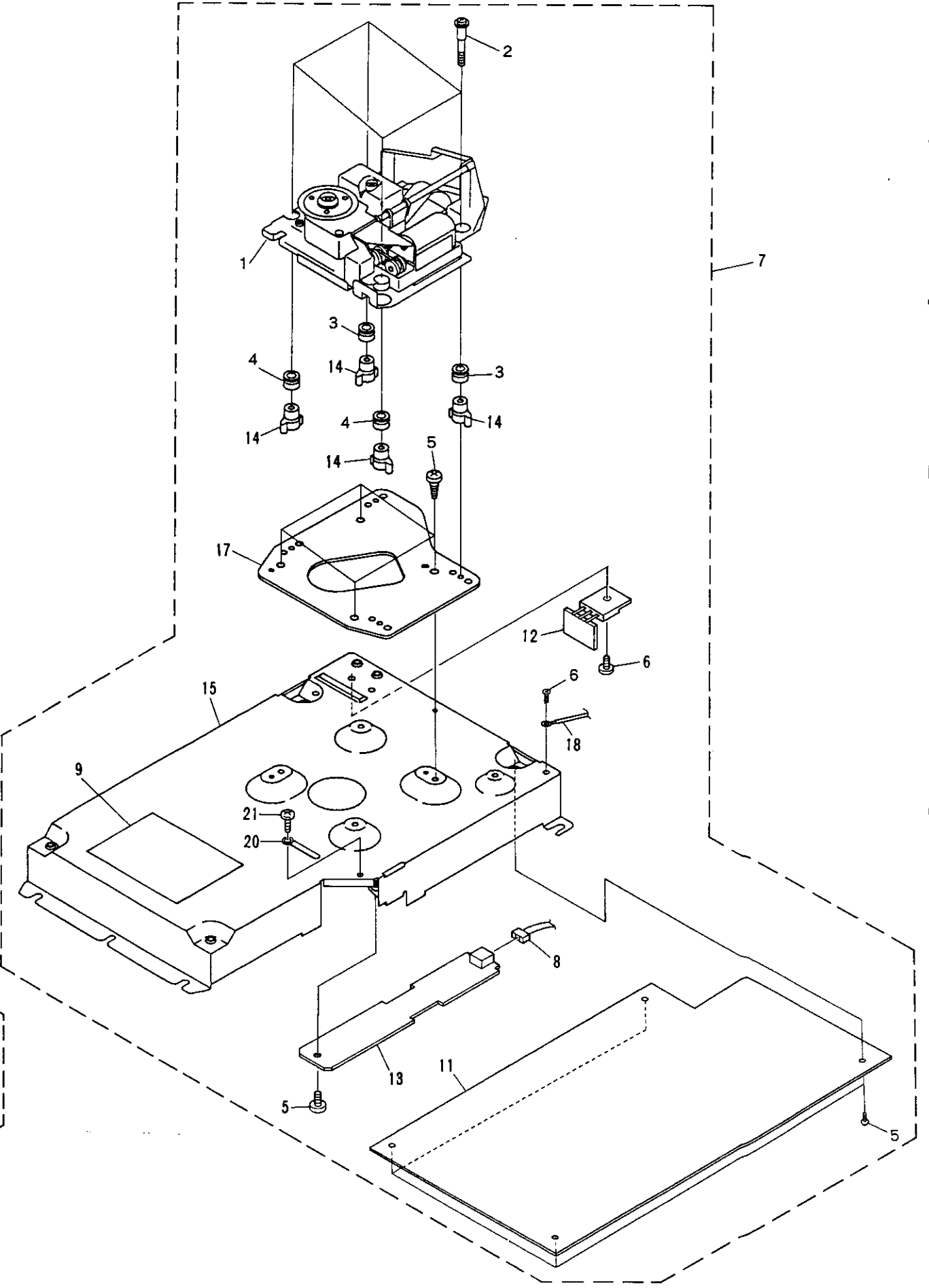

1

2

3

4

5

6

Parts list of CD Player Section

Mark	No.	Description	Parts No.
	1	SERVO MECHANISM ASSEMBLY	DXX1546
	2	SCREW	PBA1011
	3	FLOAT (RUBBER)	PEB1014
	4	FLOAT (RUBBER)	PEB1132
	5	SCREW	BBZ30P060FMC
	6	SCREW	BBZ30P080FZK
	7	PLAYER (L) ASSEMBLY	DXX1889
	8	CONNECTOR ASSEMBLY	DKP2496
	9	CAUTION LABEL (B)	DRW1358
	10	CAUTION LABEL (C)	DRW1420
●	11	CONT UNIT	DWG1302
●	12	CDPS UNIT	DWX1290
●	13	BRAN UNIT	DWX1289
NSP	14	MECHANISM SUPPORT	PNW1467
NSP	15	CDP BASE (L)	DNH1389
NSP	16	CDP BASE (R)	DNH1390
	17	CDP STAY	DNH1391
	18	EARTH LUG ASSEMBLY	DDB1012
	19	PLAYER (R) ASSEMBLY	DXX1890
	20	CORD CLAMPER	RNH-184
	21	SCREW	BBZ30P060FZK

5.9 CLAMPER SECTION

Parts list of Clamper Section

Mark	No.	Description	Parts No.	Mark	No.	Description	Parts No.
	1	SIDE RACK	DNK1789		41	SYNCHRO LEVER (R)	DXB1271
	2	CLAMPER (LOWER)	DNK1791		42	MOVING LEVER (L)	DXB1272
	3	SLIDE RACK	DNK1790		43	MOVING LEVER (R)	DXB1273
	4	REAR SP	DBH1147		44	CLAMPER HOLDER (L) ASSEMBLY	DXB1380
	5	CLAMP LEVER	DNK1792		45	CLAMPER HOLDER (R) ASSEMBLY	DXB1381
	6	CLAMP SP	DBH1128		46	CLAMPER STAY ASSEMBLY	DXB1383
	7	RACK SP	DBH1126		47	CLAMP MAGNET (FERRITE)	RMF1014
	8	DISC STOPPER (R)	DNK1794	NSP	48	YOKE (FE)	PNB1216
	9	DISC STOPPER (L)	DNK1793	NSP	49	CLSB UNIT	DWS1126
	10	CLAMPER RETAINER	DNK1801	●	50	SCREW	PMA20P040FMC
NSP	11	CLAMP MOTOR ASSEMBLY	DXX1888				
	12	MOTOR	PXM1002				
	13	SWITCH LEVER (A)	DNK1798				
	14	SWITCH LEVER (B)	DNK1799				
	15	SWITCH LEVER (C)	DNK1800				
	16	CLAMPER CAM GEAR	DNK1876				
	17	CL GEAR (A)	DNK1795				
	18	CL GEAR (C)	DNK1797				
	19	CL GEAR (B)	DNK1796				
	20	TIMING PULLEY	DNK1805				
	21	TIMING BELT	DMS1015				
	22	WASHER	WT26D047D025				
	23	WASHER	WT34D060D025				
	24	SYNCHRO SP	DBH1146				
	25	E RING	YE25FUC				
	26	POLYSLIDER WASHER	WA72D110D050				
	27	NUTS	YE40FUC				
	28	SCREW	PMB20P040FMC				
	29	SCREW	PMB30P060FMC				
	30	SCREW	AMZ30P040FMC				
	31	CORD CLAMPER (STEEL)	RNH-184				
	32	CERAMIC CAPACITOR	CKDYF103Z50				
	33	CONNECTOR ASSEMBLY	DKP2404				
	34	CONNECTOR ASSEMBLY	DKP2405				
	35	MOTOR BRACKET	DNH1386				
	36	GEAR STAY (UPPER)	DNH1387				
	37	MOTOR PULLEY	DNK1580				
	38	GEAR BASE ASSEMBLY	DXB1240				
	39	SIDE BASE	DXB1269				
	40	SYNCHRO LEVER (L)	DXB1270				

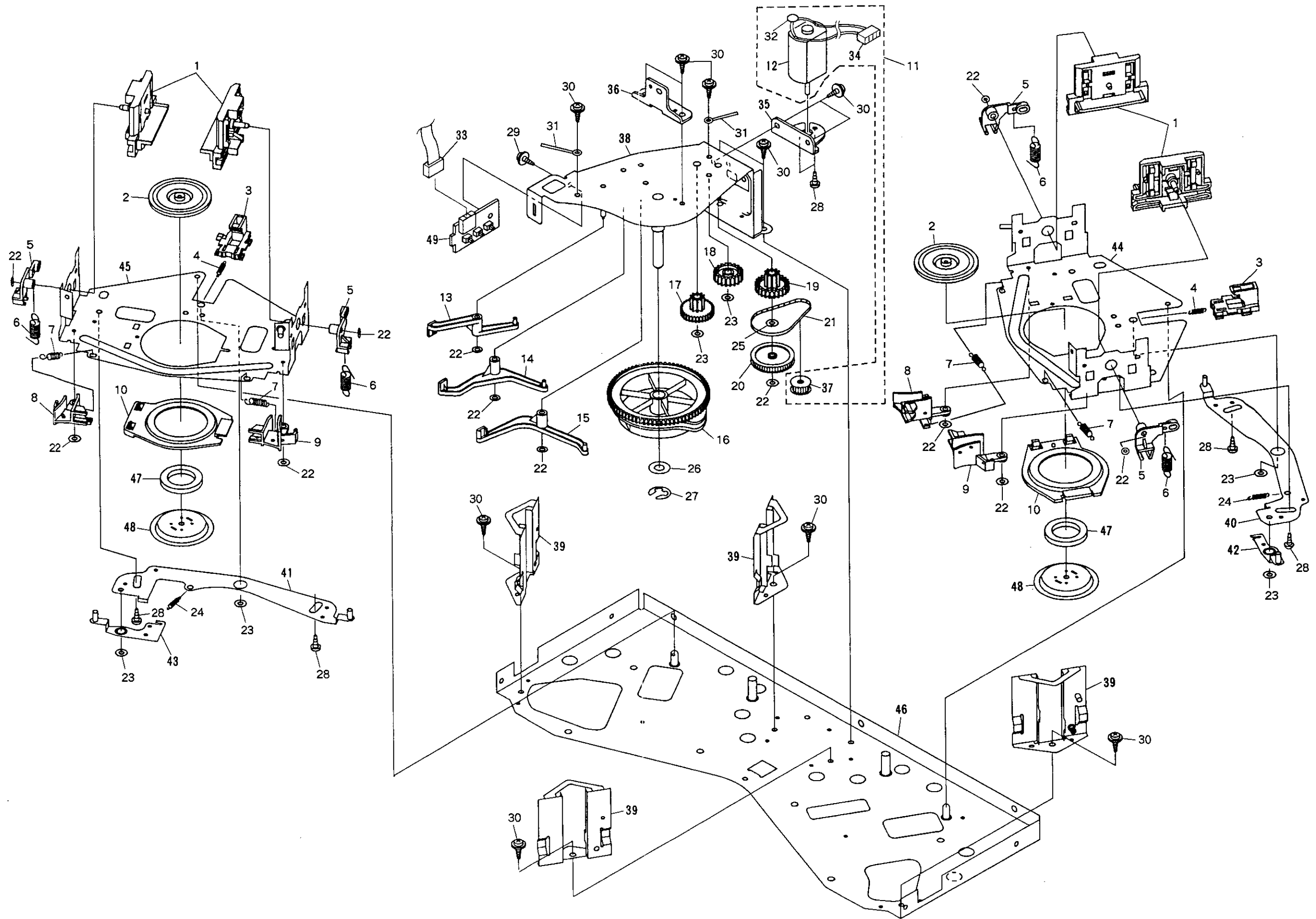

A
B
C
D

5.10 REAR STAY ASSEMBLY

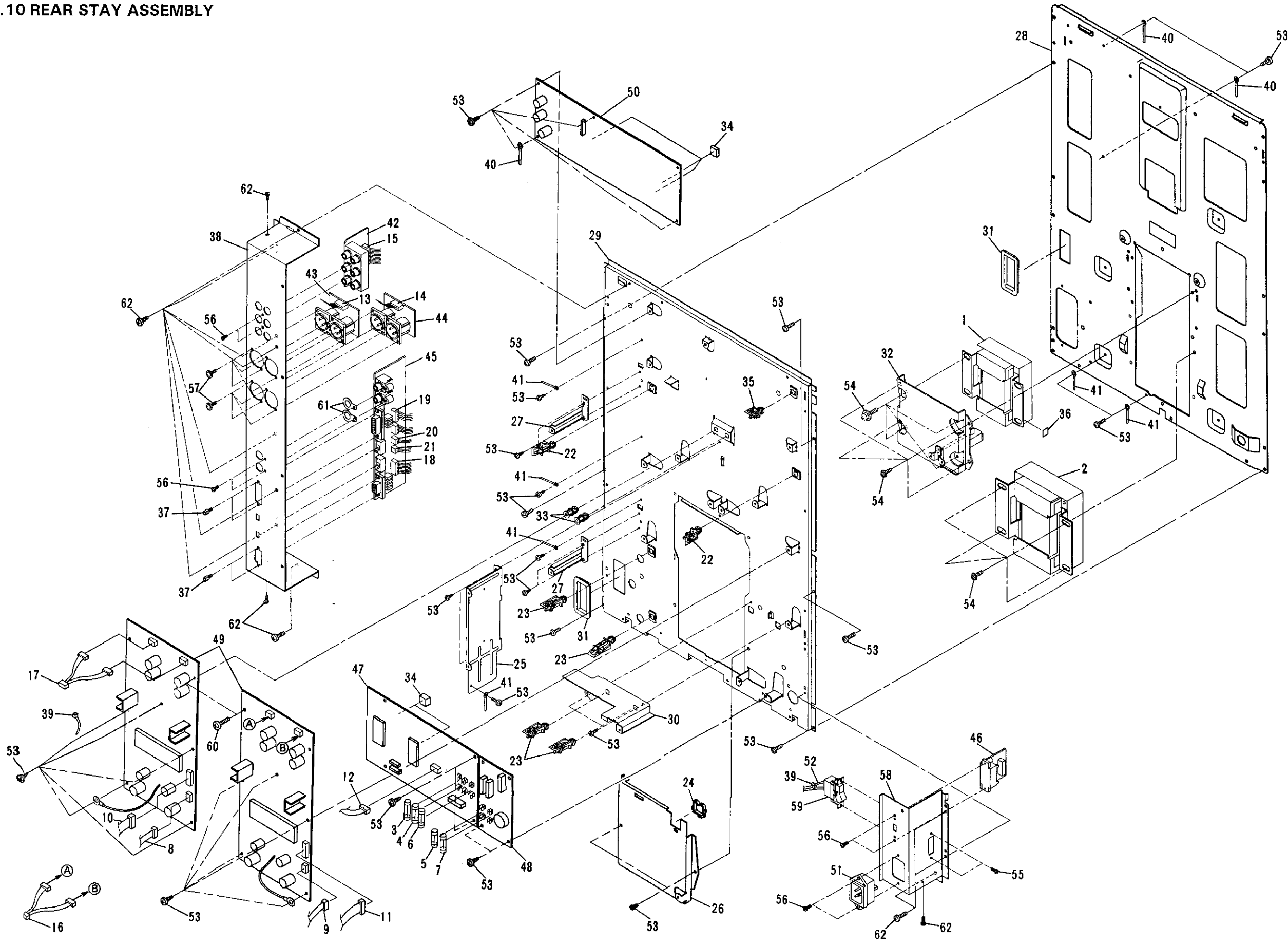

Parts list of Rear Stay Assembly

Mark	No.	Description	Parts No.	Mark	No.	Description	Parts No.
△	1	POWER TRANSFORMER (AH)	DTT1074		41	CORD CLAMPER	VNF-069
△	2	POWER TRANSFORMER (CH)	DTT1077	●	42	AUOB UNIT	DWX1288
△	3	FUSE (T630mAL250V, FU8)	REK-098	●	43	XLR1 UNIT	DWX1283
△	4	FUSE (T1AL250V, FU7)	REK-100	●	44	XLR2 UNIT	DWX1284
△	5	FUSE (T2AL250V, FU10)	REK-103	●	45	CNCT UNIT	DWX1286
△	6	FUSE (T2.5AL250V, FU6)	REK-104	●	46	VCHS UNIT	DWS1169
△	7	FUSE (T800mAL250V, FU9)	REK-099	●	47	DGIF UNIT	DWX1281
	8	CONNECTOR ASSEMBLY	DKP2386	●	48	SYPS UNIT	DWR1134
	9	CONNECTOR ASSEMBLY	DKP2387	●	49	DACB UNIT	DWM1281
	10	CONNECTOR ASSEMBLY	DKP2388	●	50	ANLG UNIT	DWX1281
	11	CONNECTOR ASSEMBLY	DKP2389	△	51	INLET ASSEMBLY 3P	DKN1075
	12	CONNECTOR ASSEMBLY	DKP2390	△	52	CONNECTOR ASSEMBLY	DKP2384
	13	CONNECTOR ASSEMBLY	DKP2391		53	SCREW	BBZ30P060FMC
	14	CONNECTOR ASSEMBLY	DKP2392		54	SCREW	ABZ40P080FMC
	15	CONNECTOR ASSEMBLY	DKP2393		55	SCREW	PMH30P080FMC
	16	CONNECTOR ASSEMBLY	DKP2394		56	SCREW	BBZ30P080FZK
	17	CONNECTOR ASSEMBLY	DKP2395		57	SCREW	PMH26P060FMC
	18	CONNECTOR ASSEMBLY	DKP2400		58	AC SUB PANEL	DNC1244
	19	CONNECTOR ASSEMBLY	DKP2441	△	59	POWER SWITCH	DSA1012
	20	CONNECTOR ASSEMBLY	DKP2442		60	SCREW	BBZ30P120FMC
	21	CONNECTOR ASSEMBLY	DKP2443		61	GROUND PLATE	ANK1074
	22	CARD EDGE SPACER	DEC1394		62	SCREW	BBT30P060FNI
	23	CARD EDGE SPACER	DEC1472				
	24	WIRE CLIP	DEC1482				
	25	SHIELD BOARD	DNH1679				
	26	TRANS COVER	DNH1680				
	27	REINFORCEMENT BRACKET	DNH1691				
	28	REAR STAY	DNH1694				
	29	PLATE (REAR)	DNH1696				
	30	SHIELD BOARD (B)	DNH1699				
NSP	31	PROTECTOR	DNK1340				
	32	TRANS HOLDER ASSEMBLY	DXB1397				
NSP	33	SPACER (PLACTIC)	PNY-404				
	34	LED SPACER	VEB1173				
NSP	35	CARD EDGE SPACER	VEC1535				
NSP	36	DUMP SHEET	VEX1021				
	37	BOLT (M2.6/M3)	DBA1037				
	38	REAR PANEL	DNC1242				
	39	CORD CLAMPER	VEC-067				
NSP	40	CORD CLAMPER	VNF-005				

5.11 SWING ARM SECTION

Parts list of Swing Arm Section

Mark	No.	Description	Parts No.	Mark	No.	Description	Parts No.
NSP	1	CHUCK MOTOR ASSEMBLY	DXX1526	46	CHUCK STAY	DLA1480	
	2	MOTOR	PXM1002	47	CHUCK SPRING 3	DBH1132	
	3	TIMING PULLEY	DNK1805	48	CHUCK BASE ASSEMBLY	DXB1301	
	4	TIMING BELT	DMS1015	49	BELT STOPPER 2	DNK1826	
	5	CSL GEAR 2	DNK1820	50	SCREW	PMA26P060FMC	
	6	C GEAR 3	DNK1825	51	SCREW	PMA26P040FMC	
	7	C GEAR 4	DNS1098	52	SCREW	PMA20P040FMC	
	8	CORD HOLDER	DNK1837	53	SCREW	BMZ26P030FMC	
	9	CORD CLIP	DNK1838	54	SCREW	PMZ20P030FMC	
	10	PUSH SWITCH	DSG1014	55	SCREW	PMZ26P040FMC	
	11	DISC SENSE LEVER	DNK1828	56	SCREW	AMZ20P030FMC	
	12	DISC HOLDER (L)	DNK1830	57	SCREW	PMA20P050FMC	
	13	LEVER SWITCH	DSK1003	58	SCREW	DBA1029	
	14	SHIELD PLATE	DEC1313	59	WASHER	WT26D0047D025	
	15	C CAM 2	DNK1831	60	E RING	YE25FUC	
16	C CAM PLATE ASSEMBLY	DXB1250	61	CHUCK WASHER	DNK1836		
17	CAM GEAR	DNK1807	62	CHUCK WASHER 2	DNK1839		
18	SLSW LEVER	DNK1827	63	SCREW	PMH26P040FMC		
19	DISC HOLDER (R)	DNK1829	64	WASHER	WA32D060D025		
20	SLF GEAR	DNK1806	65	DISC RELEASE SPRING	DBK1055		
21	SL GEAR 4	DNK1822	66	SCREW	PMB20P040FMC		
22	SW CAM (R)	DNK1832	67	WASHER	WA20D060D040		
23	THRUST STAY	DNH1401	68	SCREW	BPZ20P040FMC		
24	SW CAM (L)	DNK1833	69	CONNECTOR ASSEMBLY	DKP1887		
25	SLIDER MOTOR ASSEMBLY	DXX1527	70	CONNECTOR ASSEMBLY	DKP1888		
26	SL GEAR 5	DNK1823	71	CONNECTOR ASSEMBLY	DKP1891		
27	S2M TIMING BELT S	DMS1013	72	MOTOR STAY 1 (L)	DNH1398		
28	S2M PULLEY SL	DNK1818	73	MOTOR STAY 1 (R)	DNH1399		
29	SL ROLLER	DNK1835	74	SW PCB STAY	DNH1776		
30	SL GEAR 6	DNK1824	75	MOTOR PULLEY	DNK1580		
31	TENSION PLATE ASSEMBLY	DXB1247	76	SW BASE ASSEMBLY	DXB1388		
32	TENSIONER	DNK1817	77	SWGB UNIT	DWX1181		
33	TENSION SPRING	DBH1129	78	CLAMPER	PEC-107		
34	SL GEAR 3	DNK1821	79	WASHER	WC30FMC		
35	SHAFT (φ4)	DLA1372	80	CHUCK SPRING	DBK1050		
36	SHUFT HOLDER	DNS1092	81	SW PCB STAY (B)	DNH1777		
37	CHUCK 1 ASSEMBLY	DXB1430	82	CONNECTOR ASSEMBLY	DKP1890		
38	CHUCK SPRING 1	DBH1130	83	CONNECTOR ASSEMBLY	DKP1889		
39	CHUCK SPRING 2	DBK1131	84	CHUCK 1 RUBBER ASSEMBLY	DXX1638		
40	CHUCK SPACER	DNK1939	85	CHUCK ASSEMBLY	DXX1665		
41	RUBBER SHEET	DEB1138	86	FLEXIBLE CORD (09P)	DDD1051		
42	CHUCK 3	DNK1858					
43	CHUCK 2 ASSEMBLY	DXB1431					
44	CAM HOLDER	DNH1400					
45	CHUCK CAM	DNK1834					

●
NSP

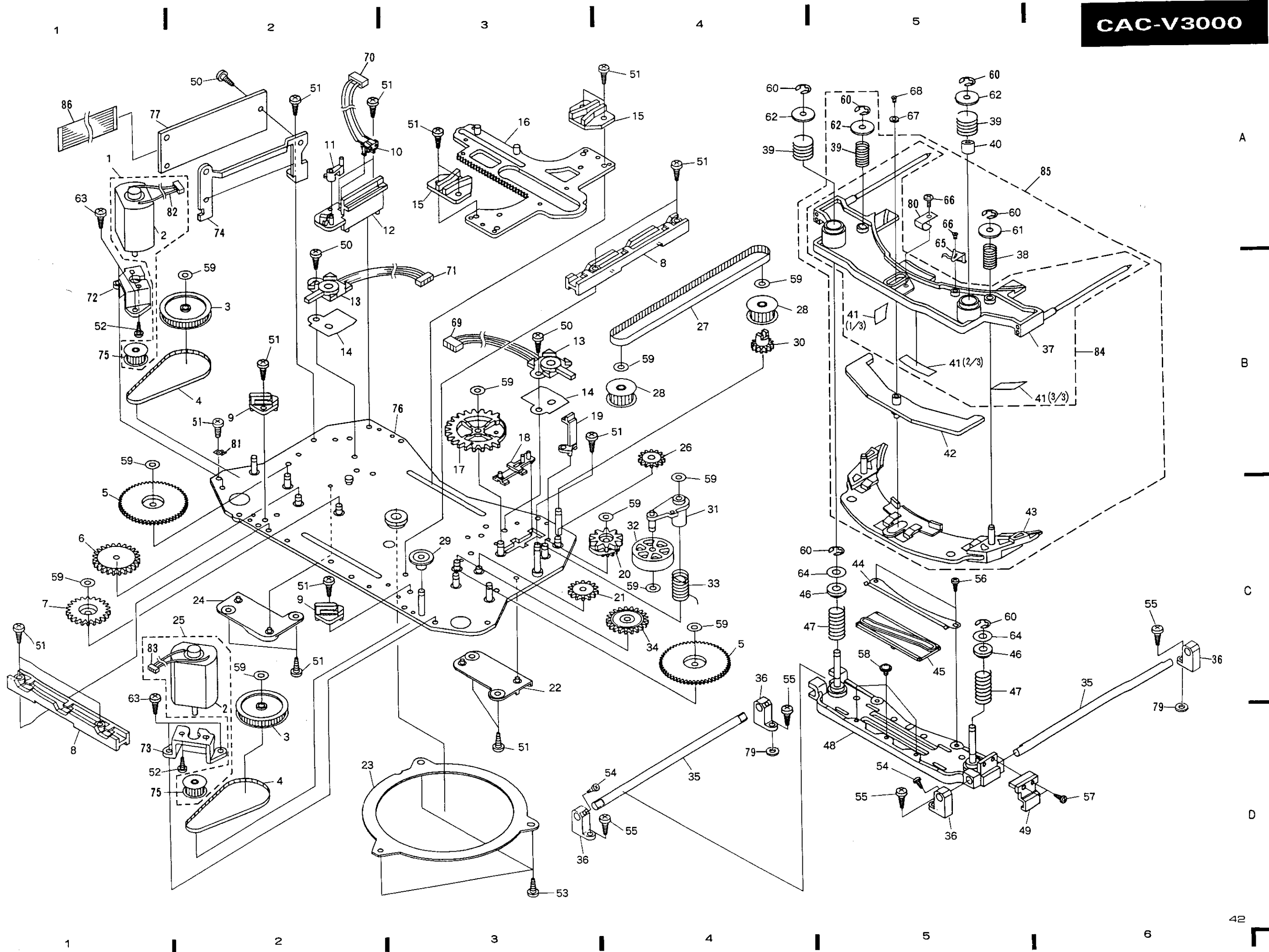

5.12 GEARBOX ASSEMBLY

Parts list of Gerabox Assembly

Mark	No.	Description	Parts No.	Mark	No.	Description	Parts No.
A	1	WORM WHEEL ASSEMBLY	DLA1523	21	CONNECTOR ASSEMBLY	DKP1882	
	2	GB SPRING	DBH1148	22	BEARING STOPPER	DLA1418	
	3	ENCORDER DISK ASSEMBLY	DXB1160	23	VM BOSS 2	DLA1498	
	4	VD MOTOR	DXM1025	24	VME PLATE	DNH1268	
	5	COUPLER	DNK1043	25	GB PLATE	DNH1433	
	6	SCREW	SMZ30H080FBT	26	M PLATE	DNH1434	
	7	SCREW	AMZ30P160FMC	27	MOTOR COVER	DNK1864	
	8	VD PULLEY 1	DNK1810	28	FLANGE	DNS1023	
	9	SCREW	ZMD26H030FBT	NSP	29	GEAR BOX	DNS1091
	10	SCREW	AMZ20P060FMC	30	BEARING	DXB1026	
	11	SCREW	AMZ30P060FMC	31	BEARING	DXB1027	
	12	SCREW	PMZ26P080FMC	32	FLANGE ASSEMBLY	DXX1892	
	13	NUT	NB26FMC	●	33	ENCB UNIT	DWX1178
	14	CORD CLAMPER (STEEL)	RNH - 184				
	15	GEAR BOX ASSEMBLY	DXX1891				
B	16	WORM GEAR ASSEMBLY	DLA1064				
	17	BEARING	DXB1157				
	18	VD PLATE 2	DNH1407				
	19	O-RING	DEB1227				
NSP	20	OIL SEAL	DEB1007				

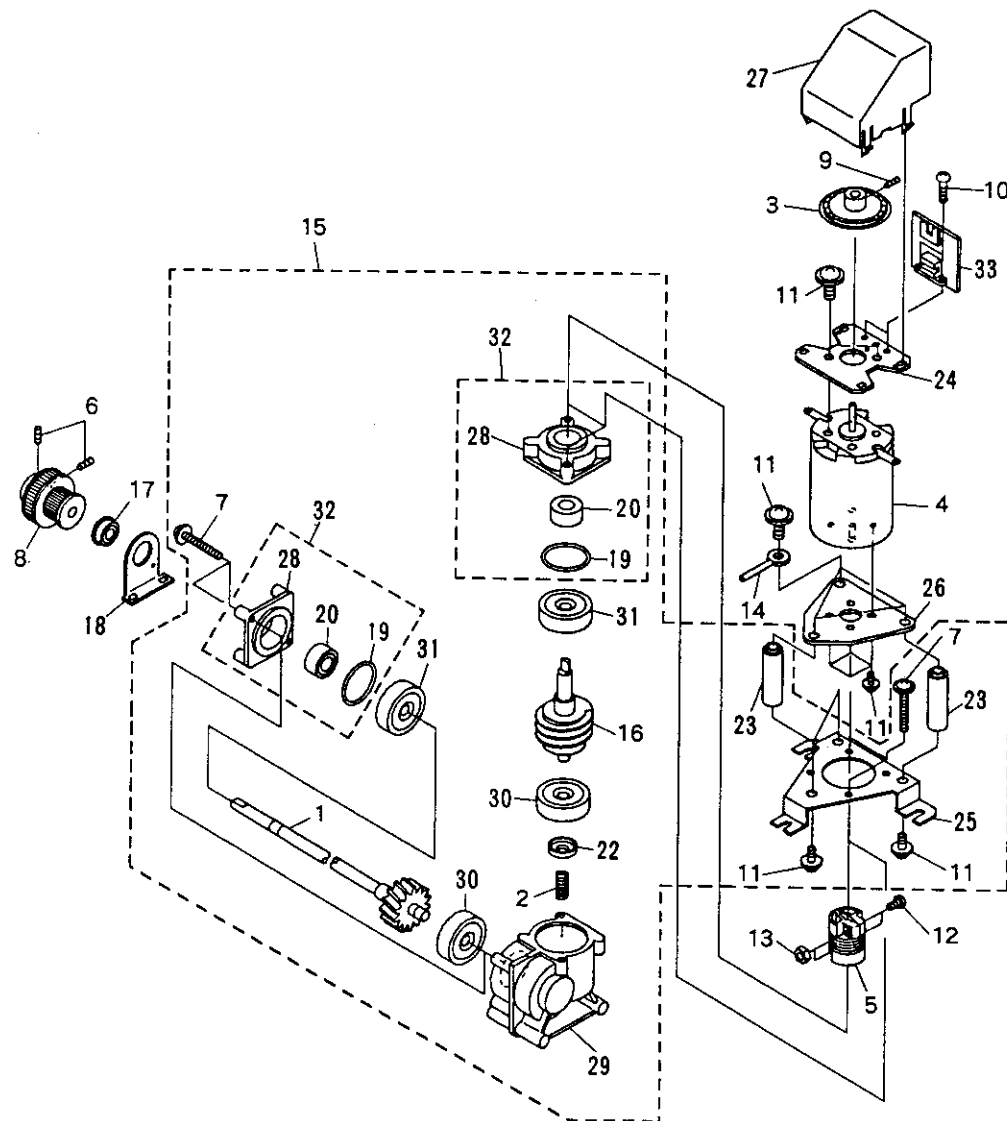

5.13 SERVO MECHANISM ASSEMBLY

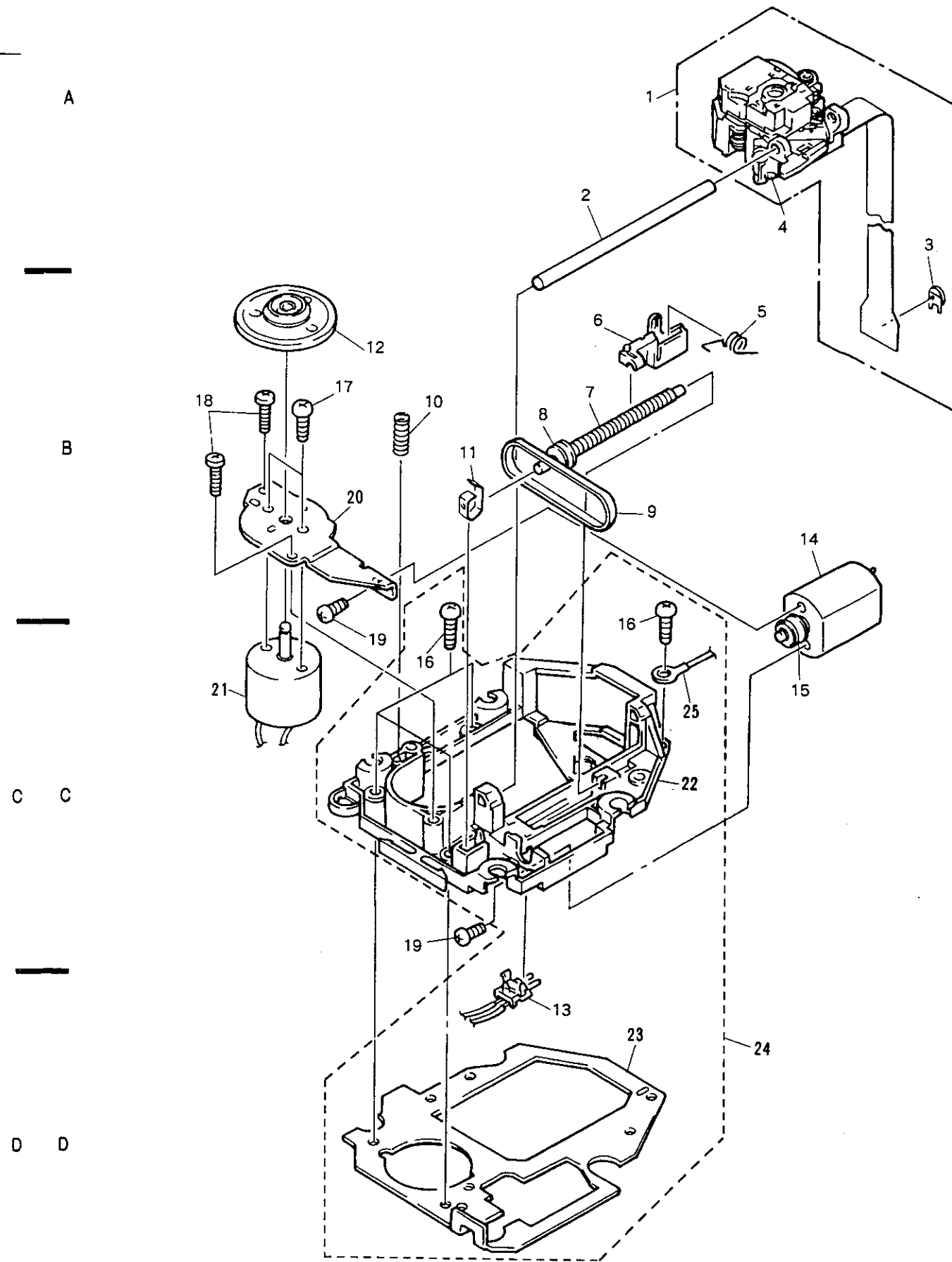

Parts list of Servo Mechanism Assembly

Mark	No.	Description	Parts No.
	1	PICK-UP ASSEMBLY	PEA1030
	2	GUIDE BAR (STEEL)	PLA1071
	3	SEMIFIXED VOLUME (VR1)	PCP1008
	4	CHIP CONDENSER (C1001)	CKSYF105Z16
	5	DRIVING SPRING (STEEL)	PBH1084
	6	HALF NUT (PLASTIC)	PNW1605
	7	DRIVING SCREW	PLA1003
	8	PULLEY	PNW1066
	9	BELT	PEB1072
	10	GROUND SPRING	PBH1009
	11	PLATE SPRING	PBK1057
	12	DISK TABLE (PC)	PNW1608
	13	PUSH SWITCH	DSG1014
	14	DC MOTOR (1.7W)	PXM1013
	15	MOTOR PULLEY (POM)	PNW1634
	16	SCREW	PBZ30P080FMC
	17	SCREW	JFZ20P030FNI
	18	SCREW	BPZ20P080FZK
	19	SCREW	PMZ20P030FMC
NSP	20	MOTOR BASE (FE)	PNB1211
NSP	21	SPINDLE MOTOR	DXM1042
NSP	22	MECHA CHASSIS (ABS)	PNW1604
NSP	23	MECHA BASE (FE)	PNB1212
NSP	24	MECHA BASE ASSEMBLY	PXA1305
NSP	25	GROUND LEAD UNIT (300V)	PDF1087

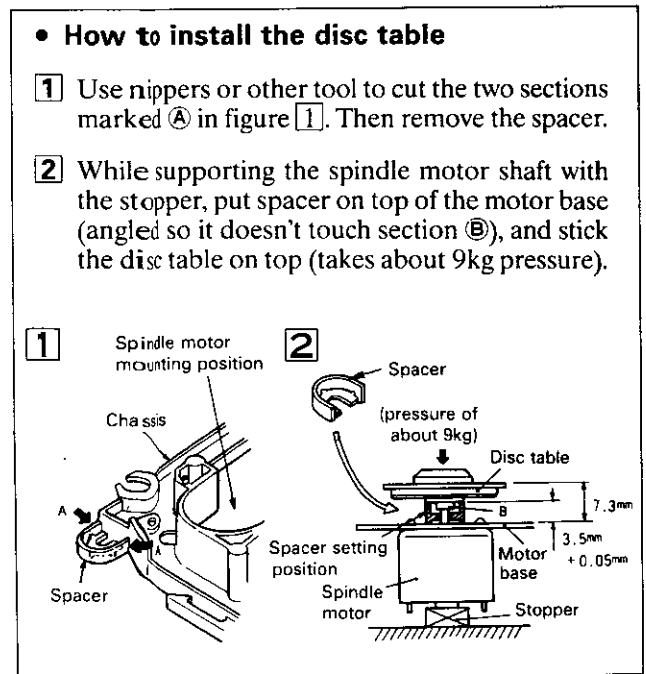

5.14 PACKING

Parts list of Packing

Mark	No.	Description	Parts No.	Mark	No.	Description	Parts No.
A	1	CAUTION	DRM1074		11	PAD RU	DHA1187
	2	CORD WITH PLUG	DDE1016		12	PAD RD	DHA1188
	3	STATIC DISCHARGER	DED1073		13	PAD F	DHA1189
	4	OPERATING INSTRUCTIONS	DRB1088		14	PAD FD	DHA1215
	5	LOCK	DXC1003		15	PACKING CASE	DHG1386
△	6	AC CORD	ODG1003		16	INNER CASE	DHG1389
NSP	7	VINYL BAG	VHL-014		17	PACKING SHEET	DHL1054
NSP	8	VINYL BAG 100×230×0.018	Z21-010		18	STATIC ERASE INSTRUCTIONS	DRW1439
NSP	9	VINYL BAG 165×200×0.03	Z21-014				
NSP	10	VINYL BAG 240×190×0.05	Z21-020				

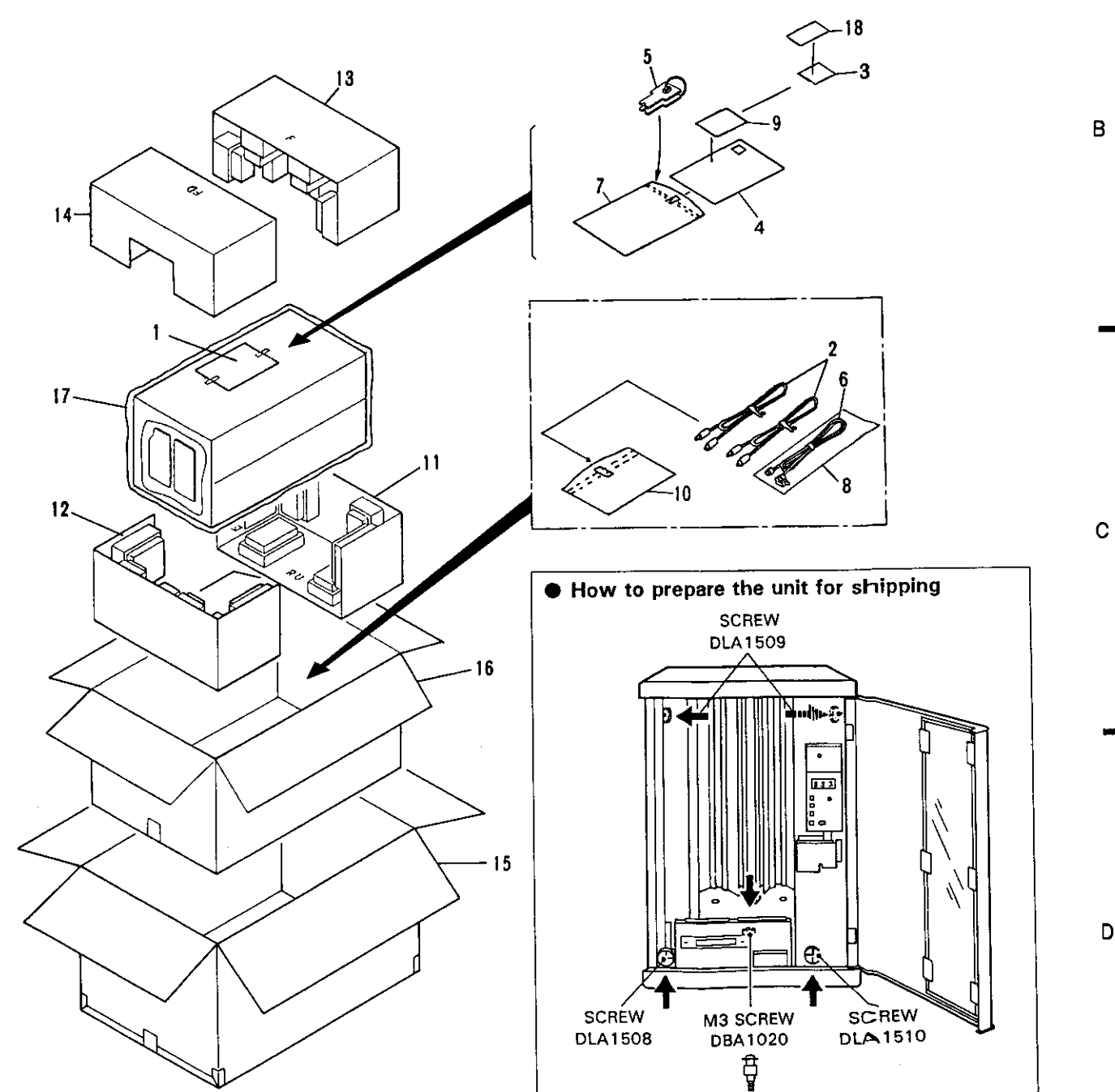

6. BLOCK DIAGRAM

A

B

C

D

A

B

C

D

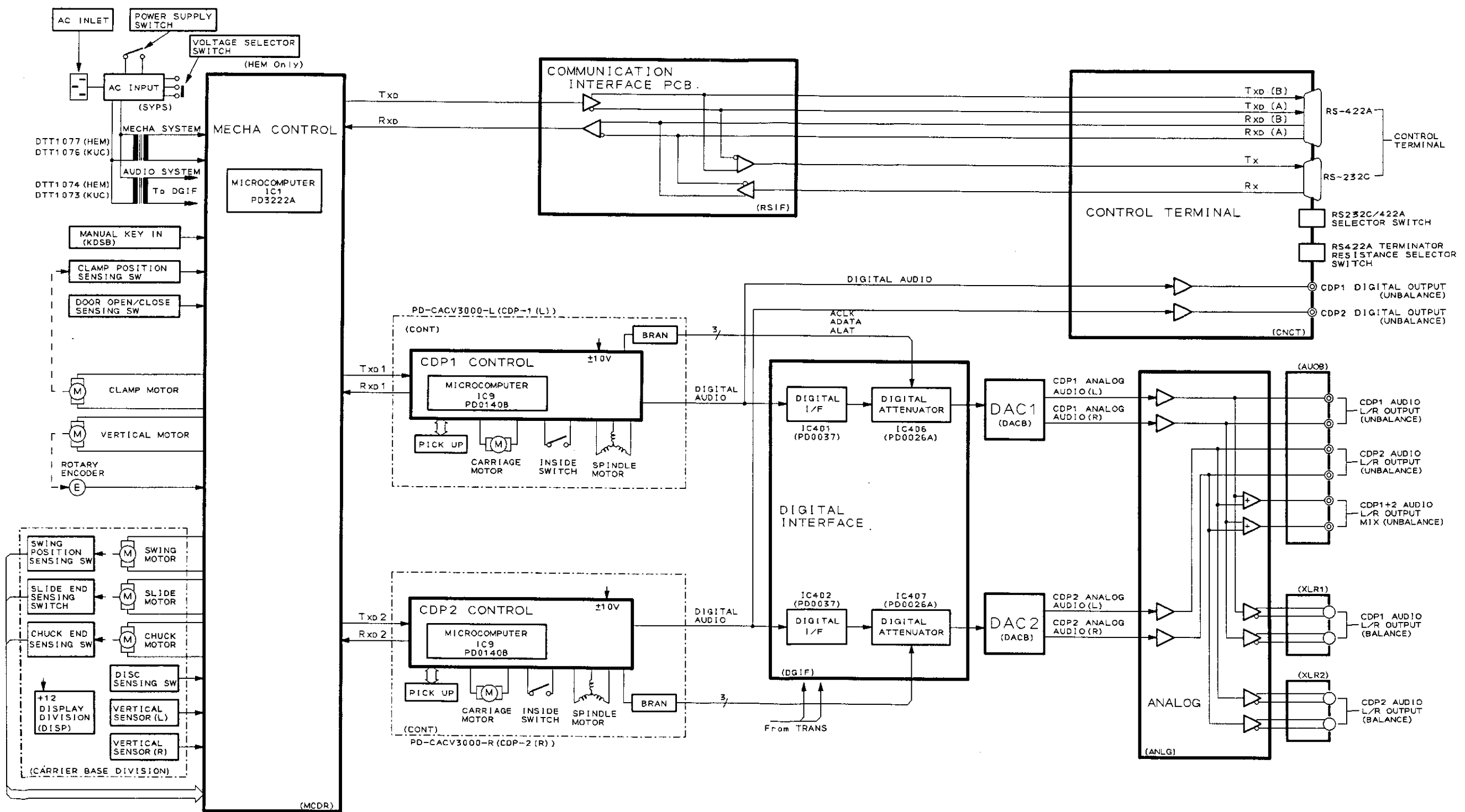

7. SCHEMATIC AND PCB CONNECTIONS DIAGRAMS

7.1 OVERALL SCHEMATIC DIAGRAM

A
B
C
D
E
F

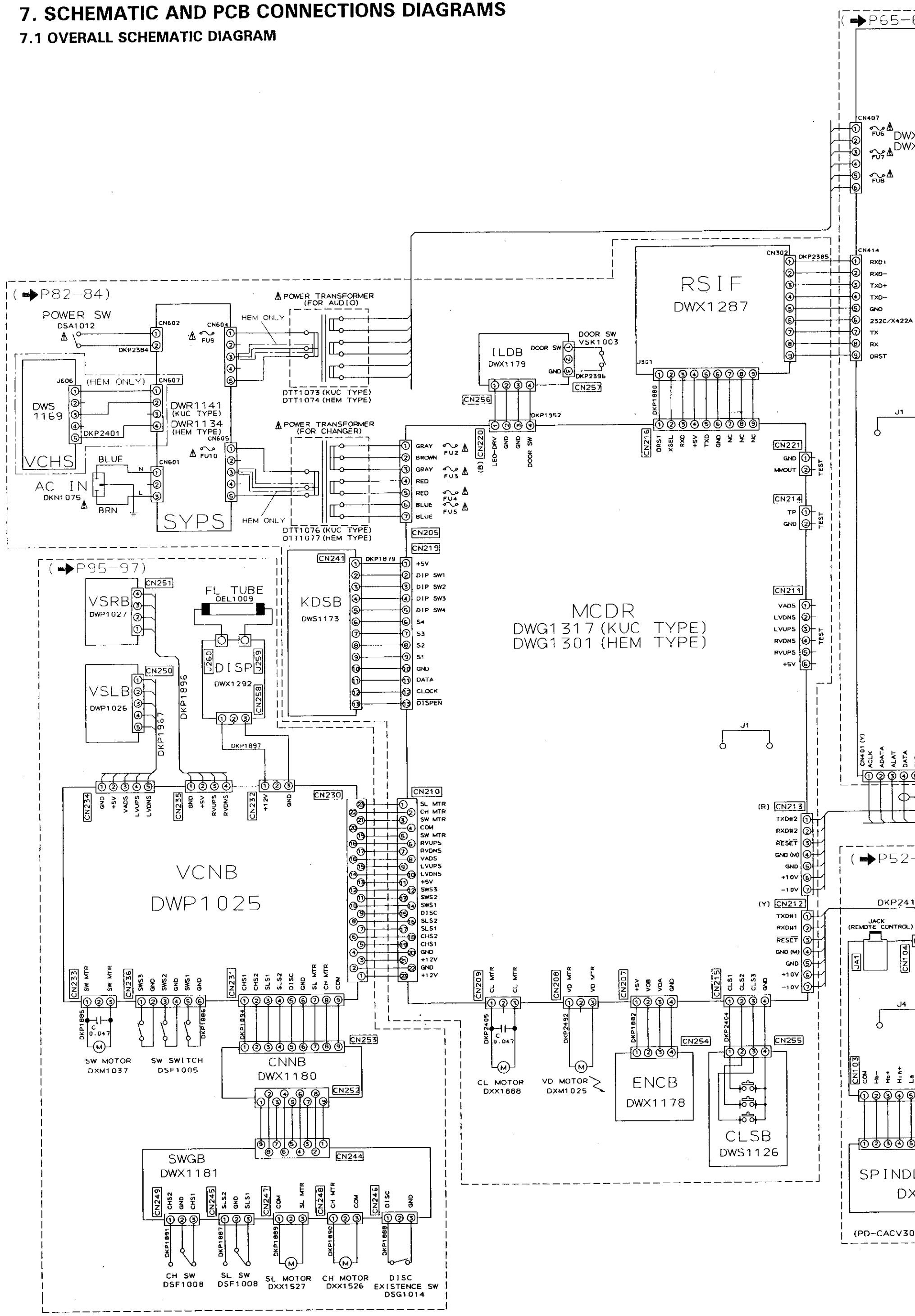

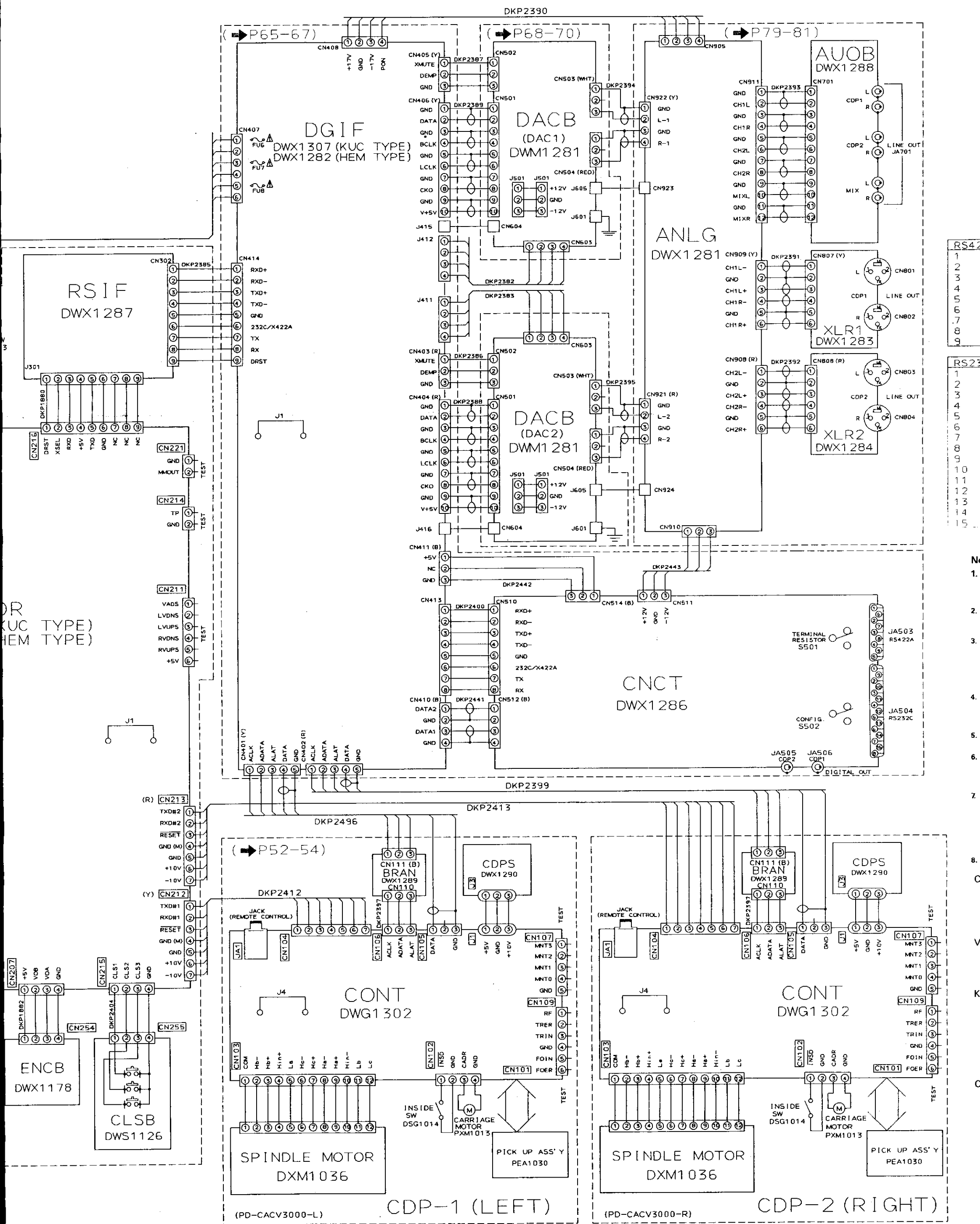

RS42

1
2
3
4
5
6
7
8
9

RS23

1
2
3
4
5
6
7
8
9
10
11
12
13
14
15

No

1.
2.
3.
4.
5.
6.
7.
8.
9.
10.
11.
12.
13.
14.
15.

V

1
2
3
4
5
6
7
8
9
10
11
12
13
14
15

K

1
2
3
4
5
6
7
8
9
10
11
12
13
14
15

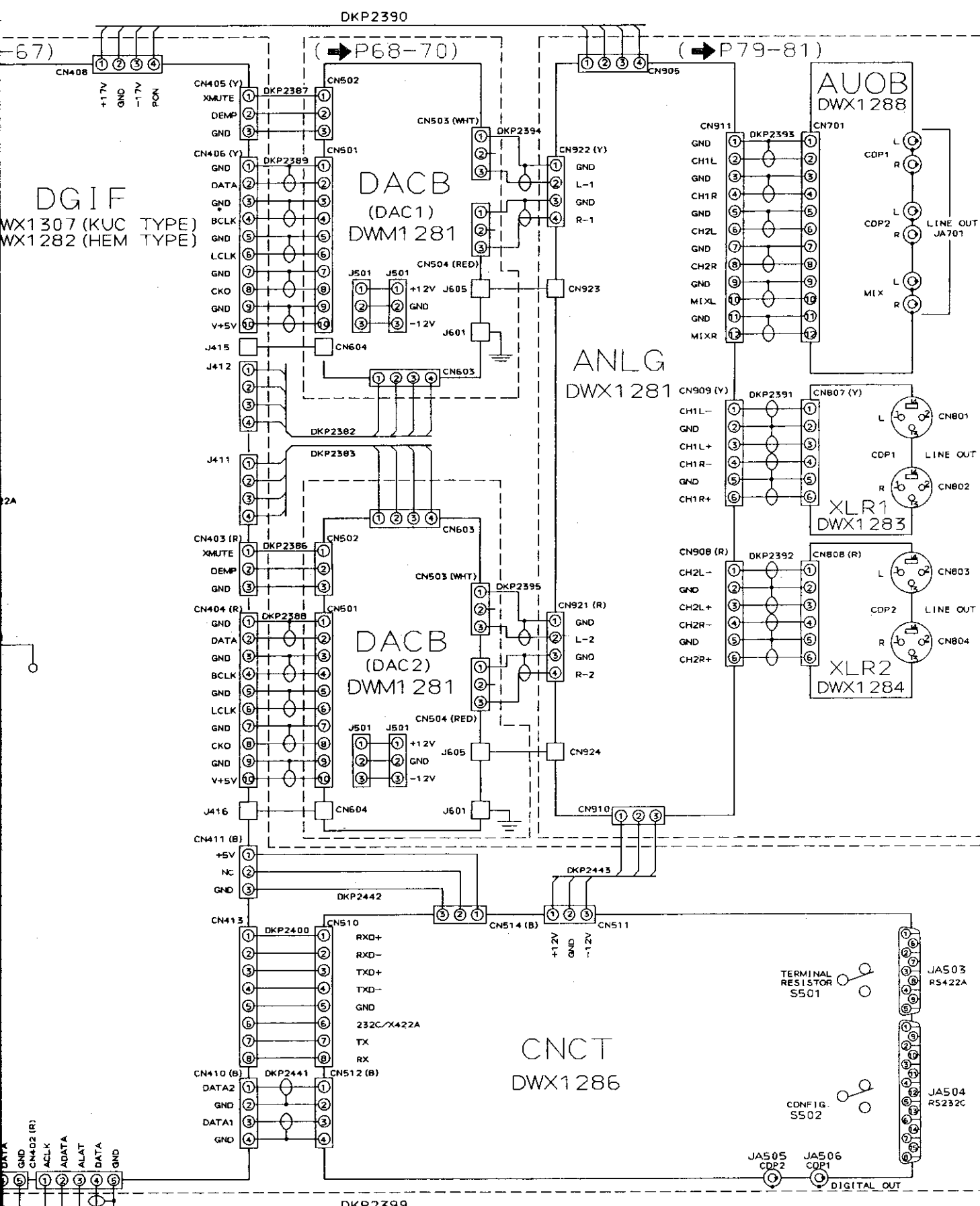

RS422A (9P)

1	GND
2	TXD (A)
3	RXD (A)
4	GND
5	NC
6	GND
7	TXD (B)
8	RXD (B)
9	GND

RS232C (15P)

1	GND
2	TX
3	RX
4	DTR
5	NC
6	NC
7	NC
8	NC
9	NC
10	NC
11	GND
12	NC
13	NC
14	NC
15	GND

- Note:** (Type 2)
- When ordering service parts, be sure to refer to "PARTS LIST of EXPLODED VIEWS" or "PCB PARTS LIST".
 - Since these are basic circuits, some parts of them or the values of some components may be changed for improvement.
 - RESISTORS:**
Unit: k:K Ω , M:M Ω , or Ω unless otherwise noted.
Rated power: 1/4W, 1/6W, 1/8W, 1/10W unless otherwise noted.
Tolerance: (F): $\pm 1\%$, (G): $\pm 2\%$, (K): $\pm 10\%$, (M): $\pm 20\%$ or $\pm 5\%$ unless otherwise noted.
 - CAPACITORS:**
Unit: p:pF or μ F unless otherwise noted.
Ratings: capacitor (μ F)/ voltage (V) unless otherwise noted.
Rated voltage: 50V except for electrolytic capacitors.
 - COILS:**
Unit: m:mH or μ H unless otherwise noted.
 - VOLTAGE AND CURRENT:**
 \square : DC voltage (V) at no input signal unless otherwise noted.
 \square : mA or - mA : DC current at no input signal unless otherwise noted.
 - OTHERS:**
• \rightarrow : Signal route.
• \odot : Adjusting point.
• ∇ (Red) : Measurement point.
• The Δ mark found on some component parts indicates the importance of the safety factor of the parts. Therefore, when replacing, be sure to use parts of identical designation.
 - SWITCHES** (Underline indicates switch position):

- CLSB UNIT**
- S6 PUSH SWITCH
 - S7 PUSH SWITCH
 - S8 PUSH SWITCH
- VCHS UNIT**
- S601 VOLTAGE SELECTOR
220 - 230V/240V
- KDSB UNIT**
- S1 TACT SWITCH
 - S2 TACT SWITCH
 - S3 TACT SWITCH
 - S4 TACT SWITCH
 - S5 DIP SWITCH
- CNCT UNIT**
- S501 TERMINAL RESISTOR ON/OFF
 - S502 CONFIG. RS - 232C/RS - 422A

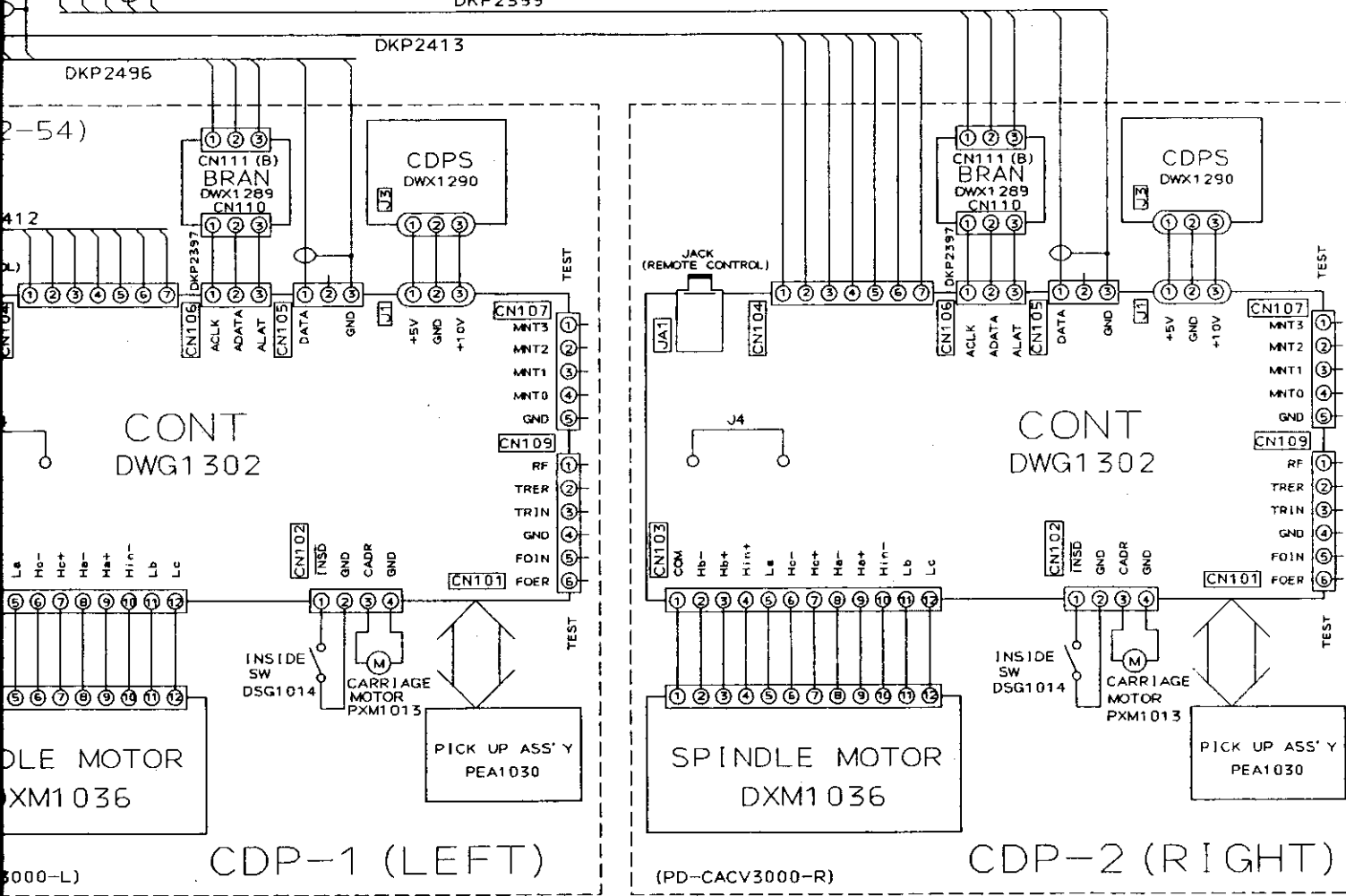

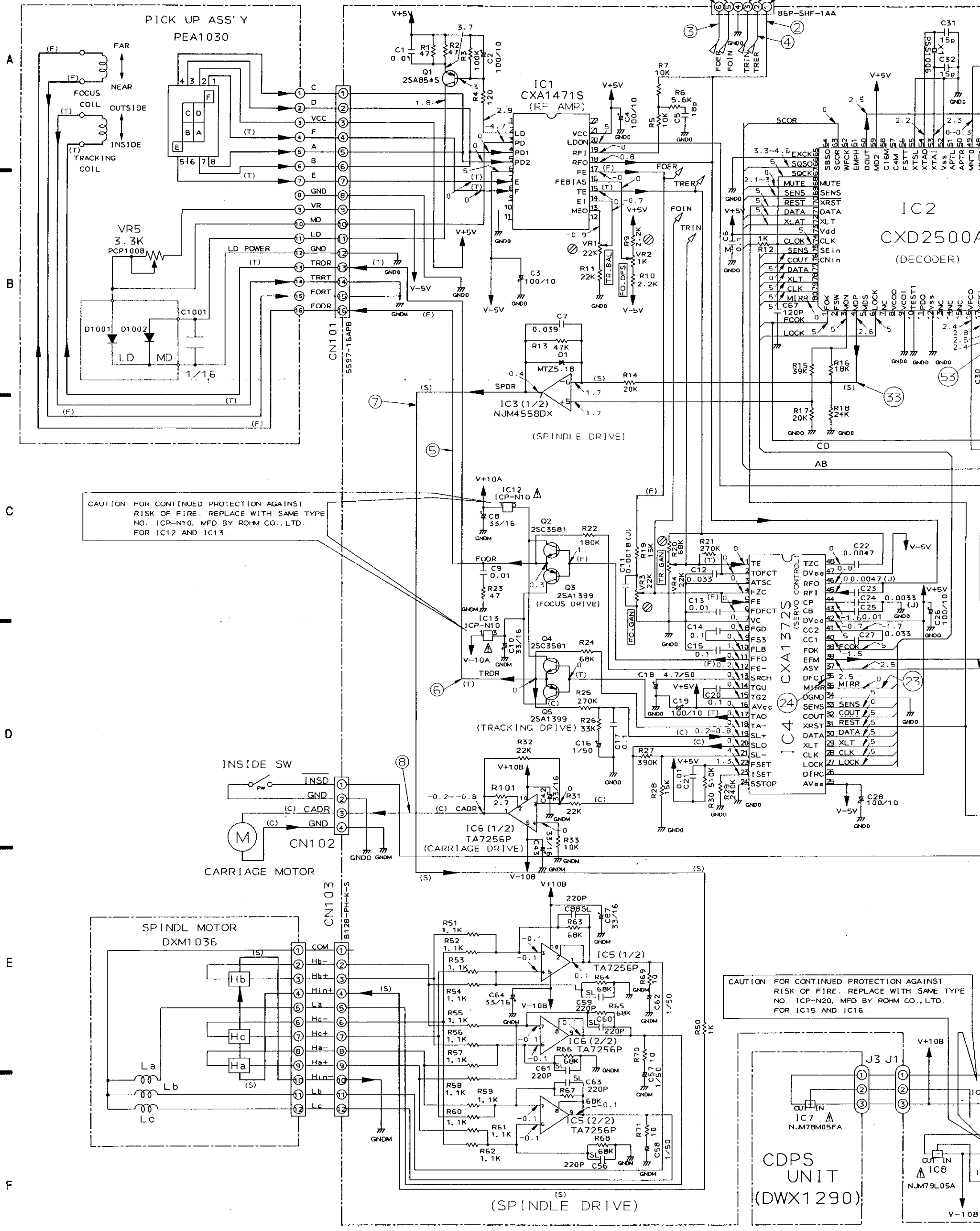

CAUTION: FOR CONTINUED PROTECTION AGAINST RISK OF FIRE, REPLACE WITH SAME TYPE NO. ICP-N10, MFD BY ROHM CO., LTD. FOR IC12 AND IC13.

CAUTION: FOR CONTINUED PROTECTION AGAINST RISK OF FIRE, REPLACE WITH SAME TYPE NO. ICP-N20, MFD BY ROHM CO., LTD. FOR IC15 AND IC16.

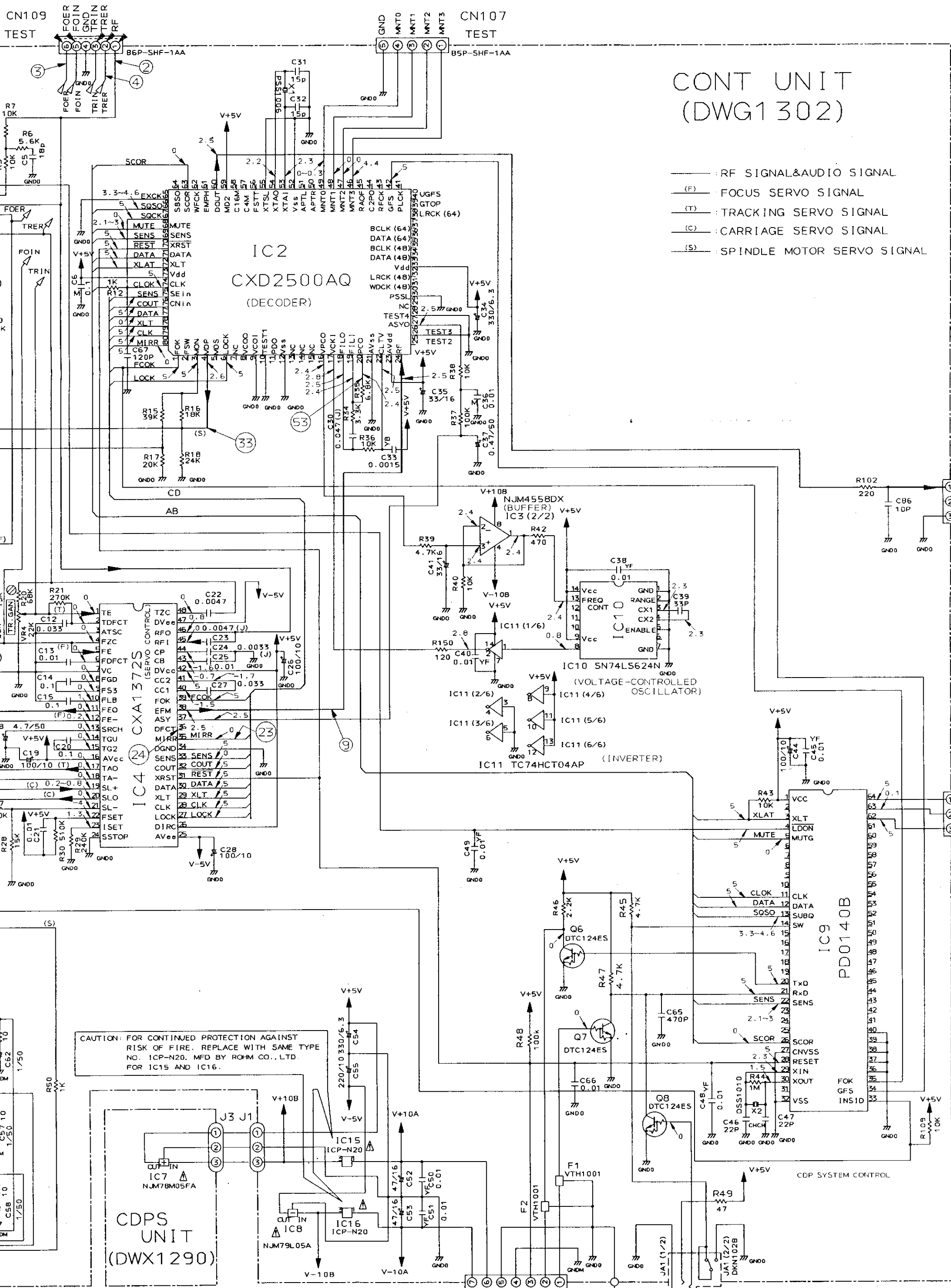

CONT UNIT (DWG1302)

- RF SIGNAL & AUDIO SIGNAL
- (F) FOCUS SERVO SIGNAL
- (T) TRACKING SERVO SIGNAL
- (C) CARRIAGE SERVO SIGNAL
- (S) SPINDLE MOTOR SERVO SIGNAL

CAUTION: FOR CONTINUED PROTECTION AGAINST RISK OF FIRE, REPLACE WITH SAME TYPE NO. ICP-N20, MFD BY ROHM CO., LTD. FOR IC15 AND IC16.

CDPS UNIT (DWX1290)

JACK (FOR REMOTE CONTROL)

TO MCDR UNIT CN212 (CN213) (P84)

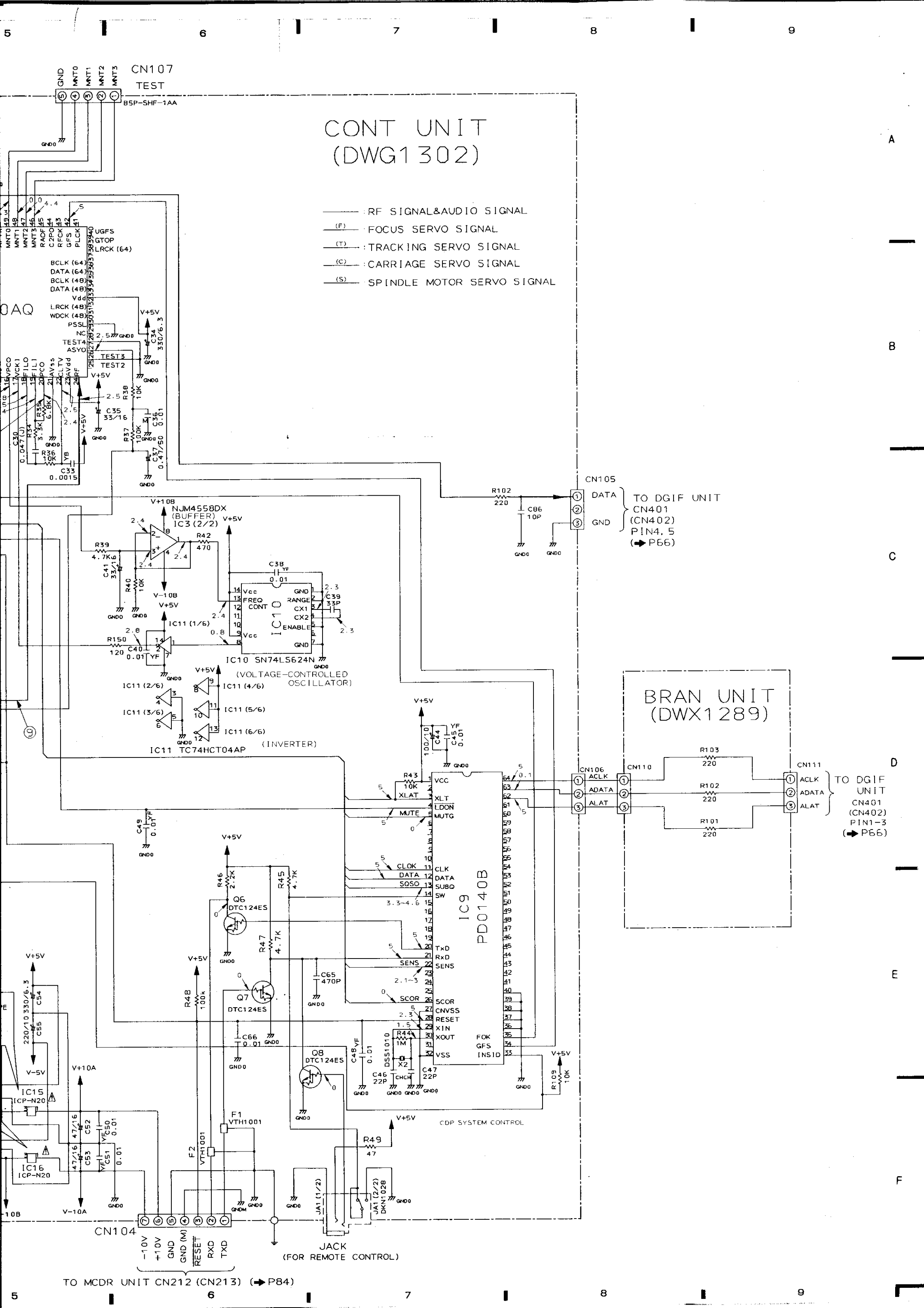

NOTE: The encircled numbers denote measuring points in the schematic diagram.

*1: FOCUS CLOSS: Press the "1 + MULTI-SPEED" key without loading the disc.

Wave Forms

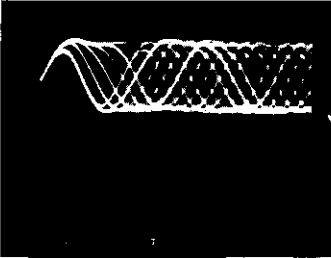
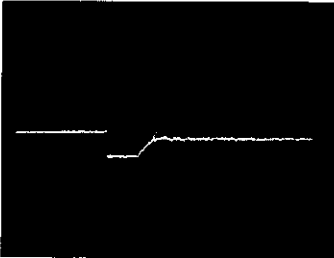
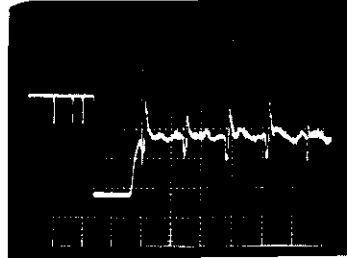
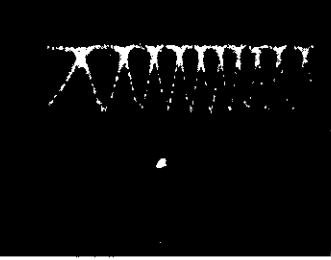
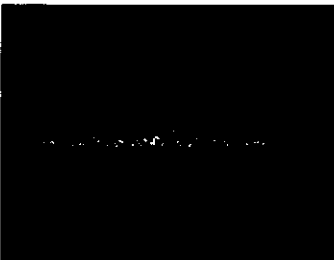
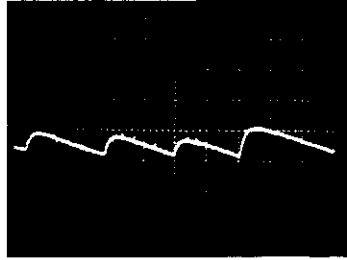
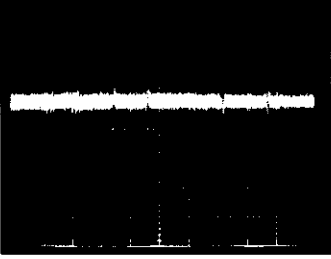
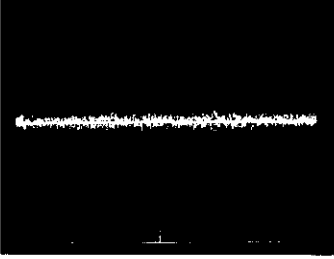
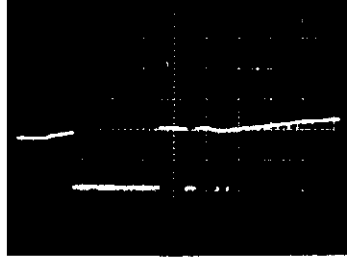
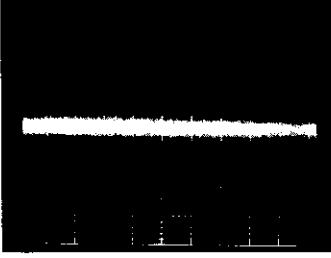
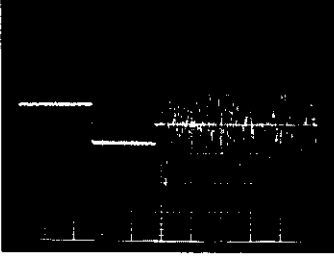
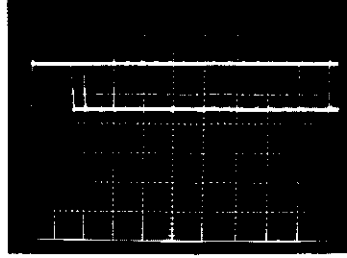
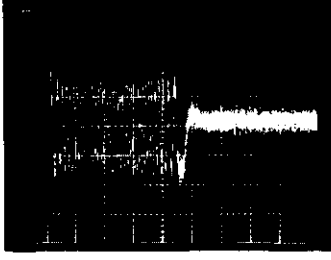
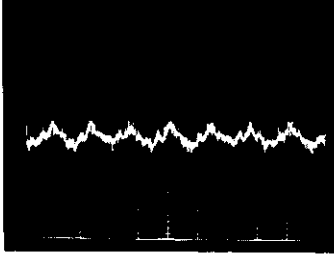
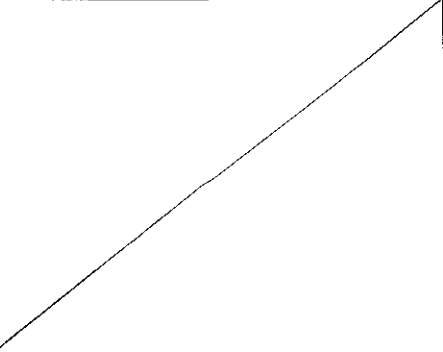
<p>② CN109 Pin 1 : PLAY MODE (RF) 500mV/div 500nsec/div</p>  <p style="text-align: right;">- GND</p>	<p>⑤ Q2 Emitter : FOCUS CLOSS (*1) MODE (FODR) 1V/div 200msec/div</p>  <p style="text-align: right;">- GND</p>	<p>⑦ IC3 Pin 7 : SEARCH MODE (SPDR) 2V/div 50msec/div</p>  <p style="text-align: right;">- GND</p>
<p>② CN109 Pin 1 : SEARCH MODE (RF) 500mV/div 200μsec/div</p>  <p style="text-align: right;">- GND</p>	<p>⑤ Q2 Emitter : PLAY MODE (FODR) 1V/div 200msec/div</p>  <p style="text-align: right;">- GND</p>	<p>⑧ IC6 Pin 1 : PLAY MODE (CADR) 1V/div 2S/div</p>  <p style="text-align: right;">- GND</p>
<p>③ CN109 Pin 6 : PLAY MODE (FOER) 100mV/div 10msec/div</p>  <p style="text-align: right;">- GND</p>	<p>⑥ Q4 Emitter : PLAY MODE (TRDR) 500mV/div 1msec/div</p>  <p style="text-align: right;">- GND</p>	<p>⑧ IC6 Pin 1 : SEARCH MODE (CADR) 2V/div 200msec/div</p>  <p style="text-align: right;">- GND</p>
<p>④ CN109 Pin 2 : PLAY MODE (TRER) 1V/div 10msec/div</p>  <p style="text-align: right;">- GND</p>	<p>⑥ Q4 Emitter : SEARCH MODE (TRDR) 500mV/div 1msec/div</p>  <p style="text-align: right;">- GND</p>	<p>⑨ IC4 Pin 38 : PLAY MODE (EFM) 2V/div 500nsec/div</p>  <p style="text-align: right;">- GND</p>
<p>④ CN109 Pin 2 : SEARCH MODE (TRER) 1V/div 1msec/div</p>  <p style="text-align: right;">- GND</p>	<p>⑦ IC3 Pin 7 : PLAY MODE (SPDR) 1V/div 50msec/div</p>  <p style="text-align: right;">- GND</p>	

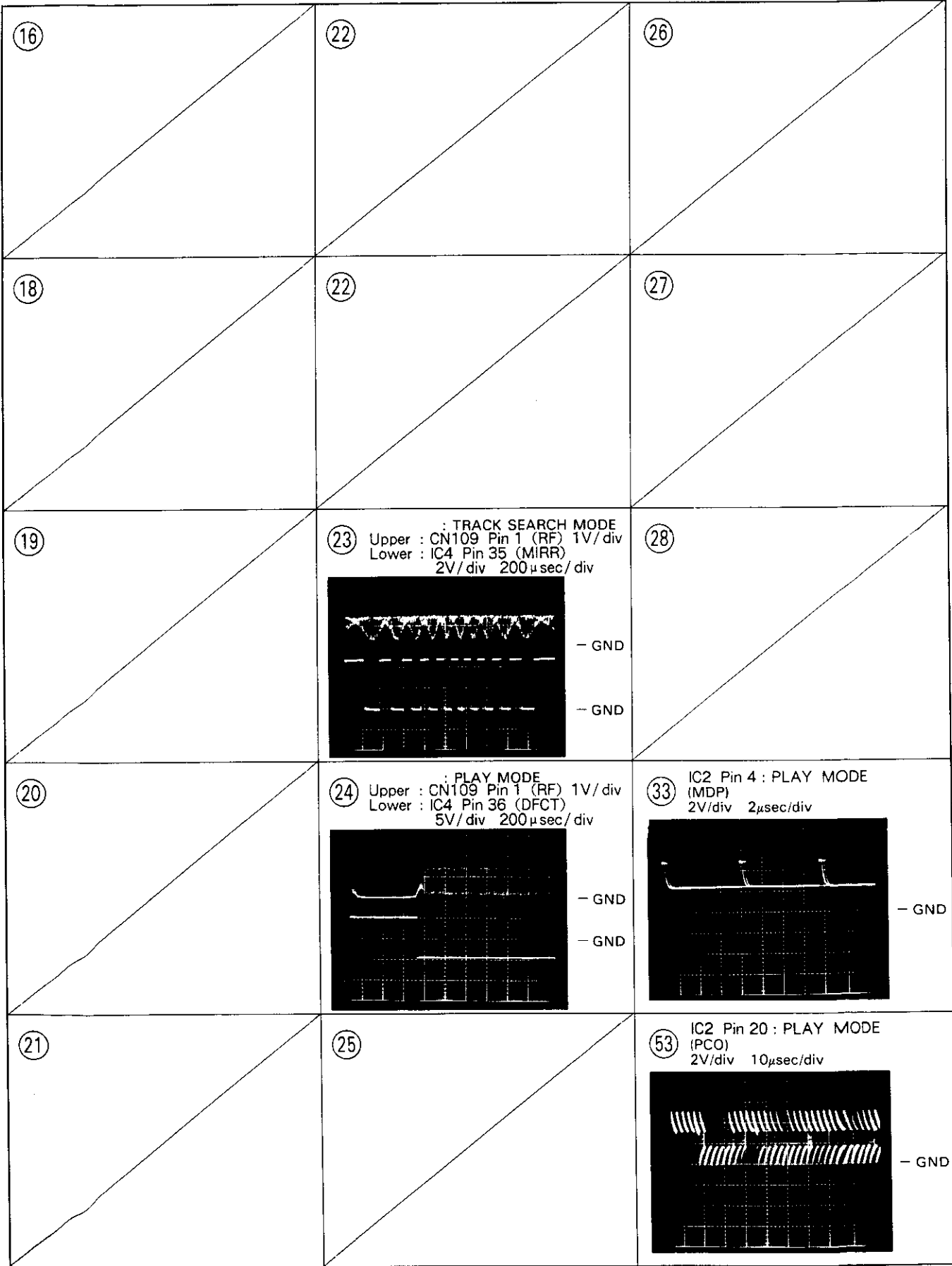

This P. C. B connection diagram is viewed from the parts mounted side.

CONT

IC1	IC3	IC5	IC11
Pin No	Pin No	Pin No	Pin No
1	1-3	1-2	1
2	4	3-4	2
3	5-6	5	3-14
4,5	7	6,7	
6	8	8,9	
7,8	10	10	

Voltage			
01	02	03	04
3.7	0.3	3	1.8
0.5	0	0	
0.5	0	5	0
0.8		0	5

IC2	IC4	IC6	IC9
Pin No	Pin No	Pin No	Pin No
1	14,15	15	1-2
2	17-19	16	3,4
3	20	17	5
4	21	18	5
5	22	19	5-10
6	23	20	11,12
7-15	24,25	21	13
16	26-31	22	14-19
17	32	23	20,21
18	33	24	22
19	34	25	23-25
20	35	26	27
21	36	27	26
22	37,38	28	28
23	39	29	29
24	40	30	29
25,26	41	31-33	30
27	42	34	30
28-41	43	35-61	34
42	44	52	34
43-45	45	53	34
46	46	54	34
47,48	47	54	5
49	48		5
50-52			5
53			5
54			5
55-59			5
60			5
61,62			5
63			5
64			5

IC10
Pin No
1-2
3-4
5-7
8
9-12
13
14

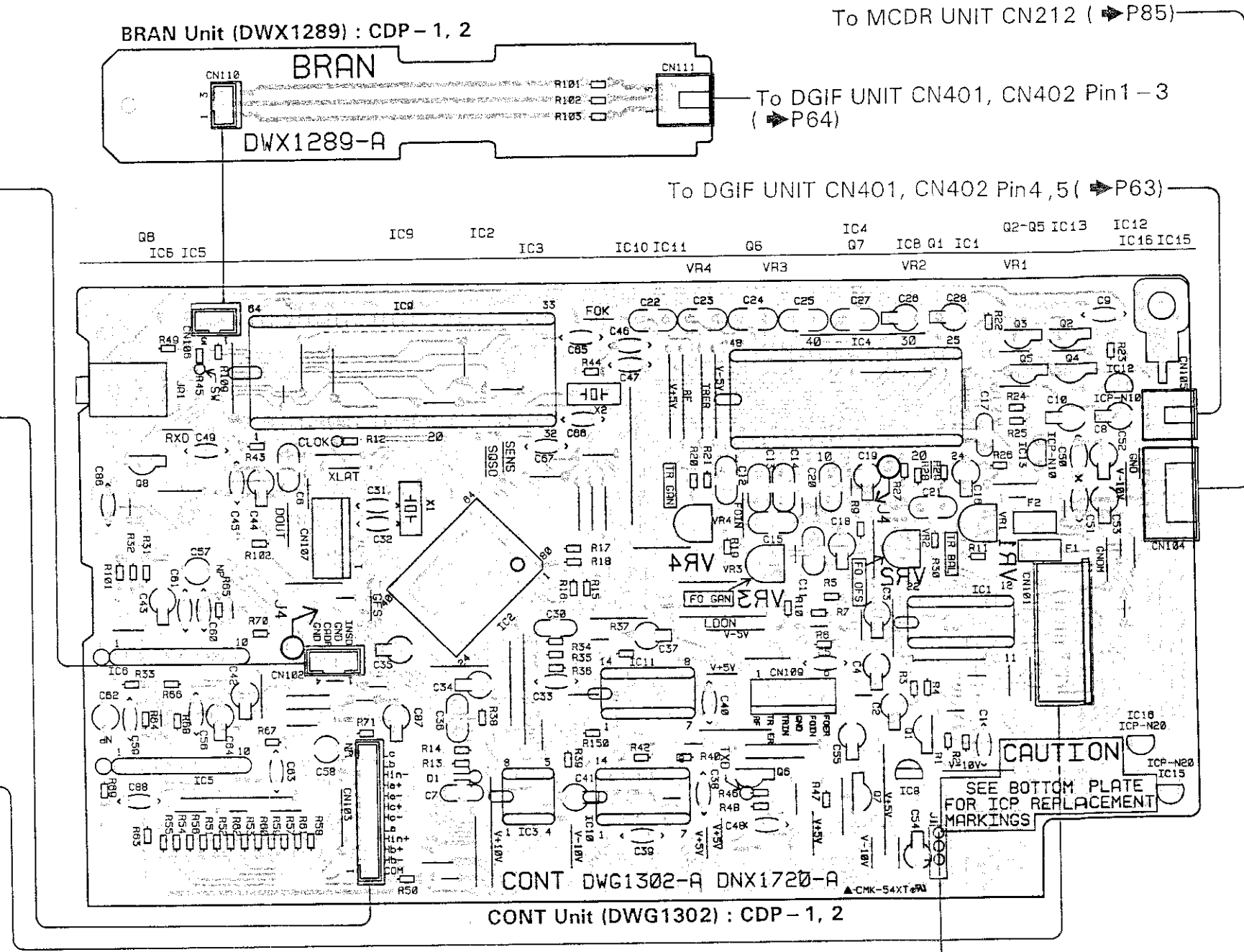
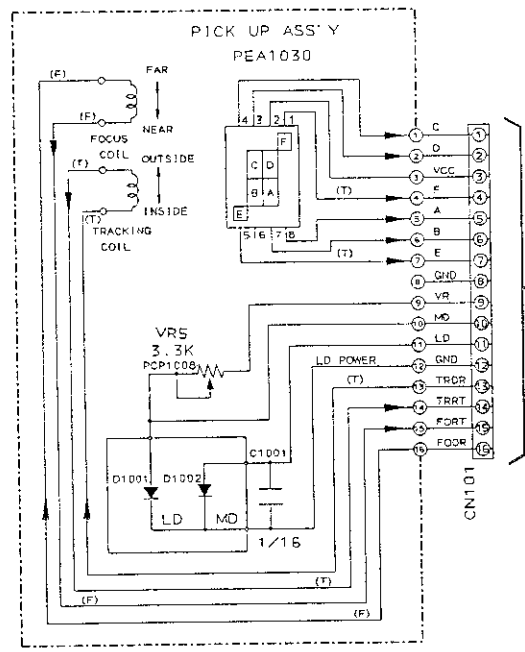
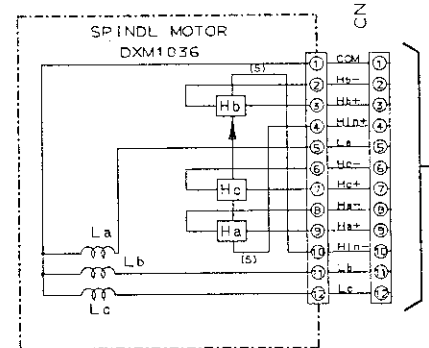
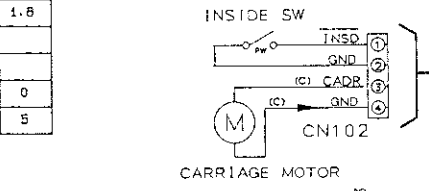

P.C.B. pattern diagram indication	Corresponding part symbol	Part name	P.C.B. pattern diagram indication	Corresponding part symbol	Part name	P.C.B. pattern diagram indication	Corresponding part symbol	Part name	P.C.B. pattern diagram indication	Corresponding part symbol	Part name
[Symbol]	[Symbol]	Transistor	[Symbol]	[Symbol]	Ceramic capacitor	[Symbol]	[Symbol]	Sem-fixed resistor	[Symbol]	[Symbol]	Varactor
[Symbol]	[Symbol]	FET	[Symbol]	[Symbol]	Mylar capacitor	[Symbol]	[Symbol]	Resistor array	[Symbol]	[Symbol]	Inductor
[Symbol]	[Symbol]	Diode	[Symbol]	[Symbol]	Silver capacitor	[Symbol]	[Symbol]	Resistor	[Symbol]	[Symbol]	Coil
[Symbol]	[Symbol]	Zener diode	[Symbol]	[Symbol]	Electrolytic capacitor (Non-polarized)	[Symbol]	[Symbol]	Resistor	[Symbol]	[Symbol]	Transformer
[Symbol]	[Symbol]	LED	[Symbol]	[Symbol]	Electrolytic capacitor (Polarized)	[Symbol]	[Symbol]	Resistor	[Symbol]	[Symbol]	Filer
[Symbol]	[Symbol]		[Symbol]	[Symbol]	Electrolytic capacitor (Polarized)	[Symbol]	[Symbol]	Thermistor	[Symbol]	[Symbol]	
[Symbol]	[Symbol]		[Symbol]	[Symbol]	Electrolytic capacitor (Polarized)	[Symbol]	[Symbol]	Tact switch	[Symbol]	[Symbol]	
[Symbol]	[Symbol]		[Symbol]	[Symbol]	Power capacitor	[Symbol]	[Symbol]		[Symbol]	[Symbol]	

- This P.C.B. connection diagram is viewed from the parts mounted side.
- The parts which have been mounted on the board can be replaced with those shown with the corresponding wiring symbols listed in the above Table.
- The capacitor terminal marked with \ominus shows negative terminal.
- The diode marked with \square shows cathode side.
- The transistor terminal marked with \square shows emitter.

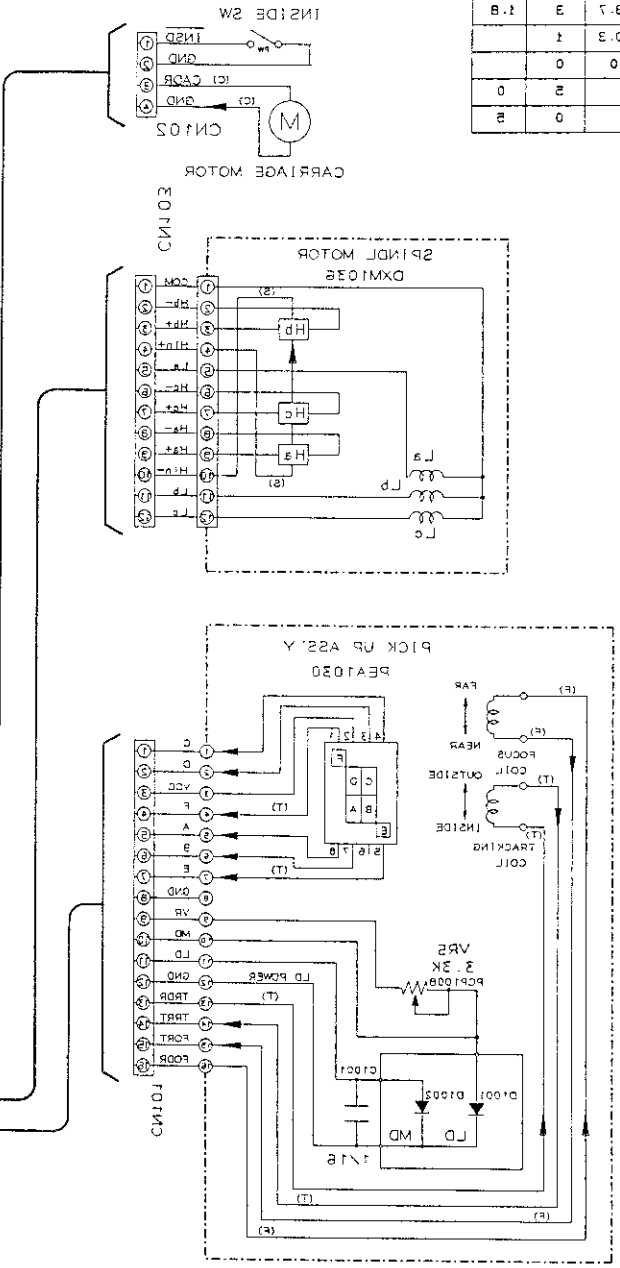
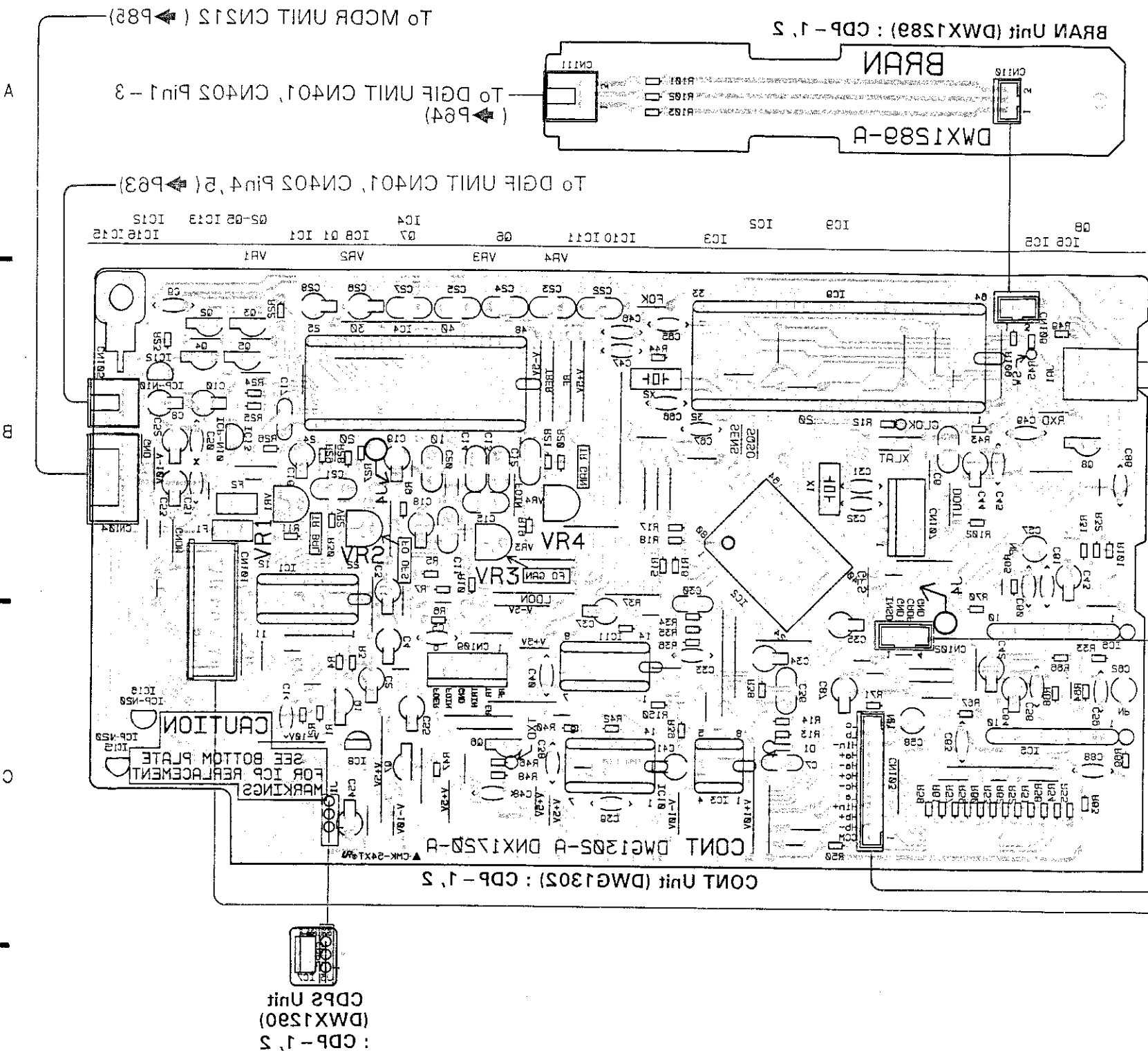

IC1	Pin No	Voltage
1	1	5.4
2	2	5.8
3	3	-4.7
4	4	2.8
5	5	1.7
6	6	-0.1
7	7	-0.4
8	8	0.1
9	9	0.1
10	10	0
11	11	0
12	12	0
13	13	0
14	14	0
15	15	0
16	16	0
17	17	0
18	18	0
19	19	0
20	20	0
21	21	0
22	22	0
23	23	0
24	24	0
25	25	0
26	26	0
27	27	0
28	28	0
29	29	0
30	30	0
31	31	0
32	32	0
33	33	0
34	34	0
35	35	0
36	36	0
37	37	0
38	38	0
39	39	0
40	40	0
41	41	0
42	42	0
43	43	0
44	44	0
45	45	0
46	46	0
47	47	0
48	48	0
49	49	0
50	50	0
51	51	0
52	52	0
53	53	0
54	54	0
55	55	0
56	56	0
57	57	0
58	58	0
59	59	0
60	60	0
61	61	0
62	62	0
63	63	0
64	64	0

IC2	Pin No	Voltage
1	1	5.4
2	2	5.8
3	3	-4.7
4	4	2.8
5	5	1.7
6	6	-0.1
7	7	-0.4
8	8	0.1
9	9	0.1
10	10	0
11	11	0
12	12	0
13	13	0
14	14	0
15	15	0
16	16	0
17	17	0
18	18	0
19	19	0
20	20	0
21	21	0
22	22	0
23	23	0
24	24	0
25	25	0
26	26	0
27	27	0
28	28	0
29	29	0
30	30	0
31	31	0
32	32	0
33	33	0
34	34	0
35	35	0
36	36	0
37	37	0
38	38	0
39	39	0
40	40	0
41	41	0
42	42	0
43	43	0
44	44	0
45	45	0
46	46	0
47	47	0
48	48	0
49	49	0
50	50	0
51	51	0
52	52	0
53	53	0
54	54	0
55	55	0
56	56	0
57	57	0
58	58	0
59	59	0
60	60	0
61	61	0
62	62	0
63	63	0
64	64	0

IC3	Pin No	Voltage
1	1	5.4
2	2	5.8
3	3	-4.7
4	4	2.8
5	5	1.7
6	6	-0.1
7	7	-0.4
8	8	0.1
9	9	0.1
10	10	0
11	11	0
12	12	0
13	13	0
14	14	0
15	15	0
16	16	0
17	17	0
18	18	0
19	19	0
20	20	0
21	21	0
22	22	0
23	23	0
24	24	0
25	25	0
26	26	0
27	27	0
28	28	0
29	29	0
30	30	0
31	31	0
32	32	0
33	33	0
34	34	0
35	35	0
36	36	0
37	37	0
38	38	0
39	39	0
40	40	0
41	41	0
42	42	0
43	43	0
44	44	0
45	45	0
46	46	0
47	47	0
48	48	0
49	49	0
50	50	0
51	51	0
52	52	0
53	53	0
54	54	0
55	55	0
56	56	0
57	57	0
58	58	0
59	59	0
60	60	0
61	61	0
62	62	0
63	63	0
64	64	0

IC4	Pin No	Voltage
1	1	5.4
2	2	5.8
3	3	-4.7
4	4	2.8
5	5	1.7
6	6	-0.1
7	7	-0.4
8	8	0.1
9	9	0.1
10	10	0
11	11	0
12	12	0
13	13	0
14	14	0
15	15	0
16	16	0
17	17	0
18	18	0
19	19	0
20	20	0
21	21	0
22	22	0
23	23	0
24	24	0
25	25	0
26	26	0
27	27	0
28	28	0
29	29	0
30	30	0
31	31	0
32	32	0
33	33	0
34	34	0
35	35	0
36	36	0
37	37	0
38	38	0
39	39	0
40	40	0
41	41	0
42	42	0
43	43	0
44	44	0
45	45	0
46	46	0
47	47	0
48	48	0
49	49	0
50	50	0
51	51	0
52	52	0
53	53	0
54	54	0
55	55	0
56	56	0
57	57	0
58	58	0
59	59	0
60	60	0
61	61	0
62	62	0
63	63	0
64	64	0

7.3 DGIF UNIT AND CNCT UNIT

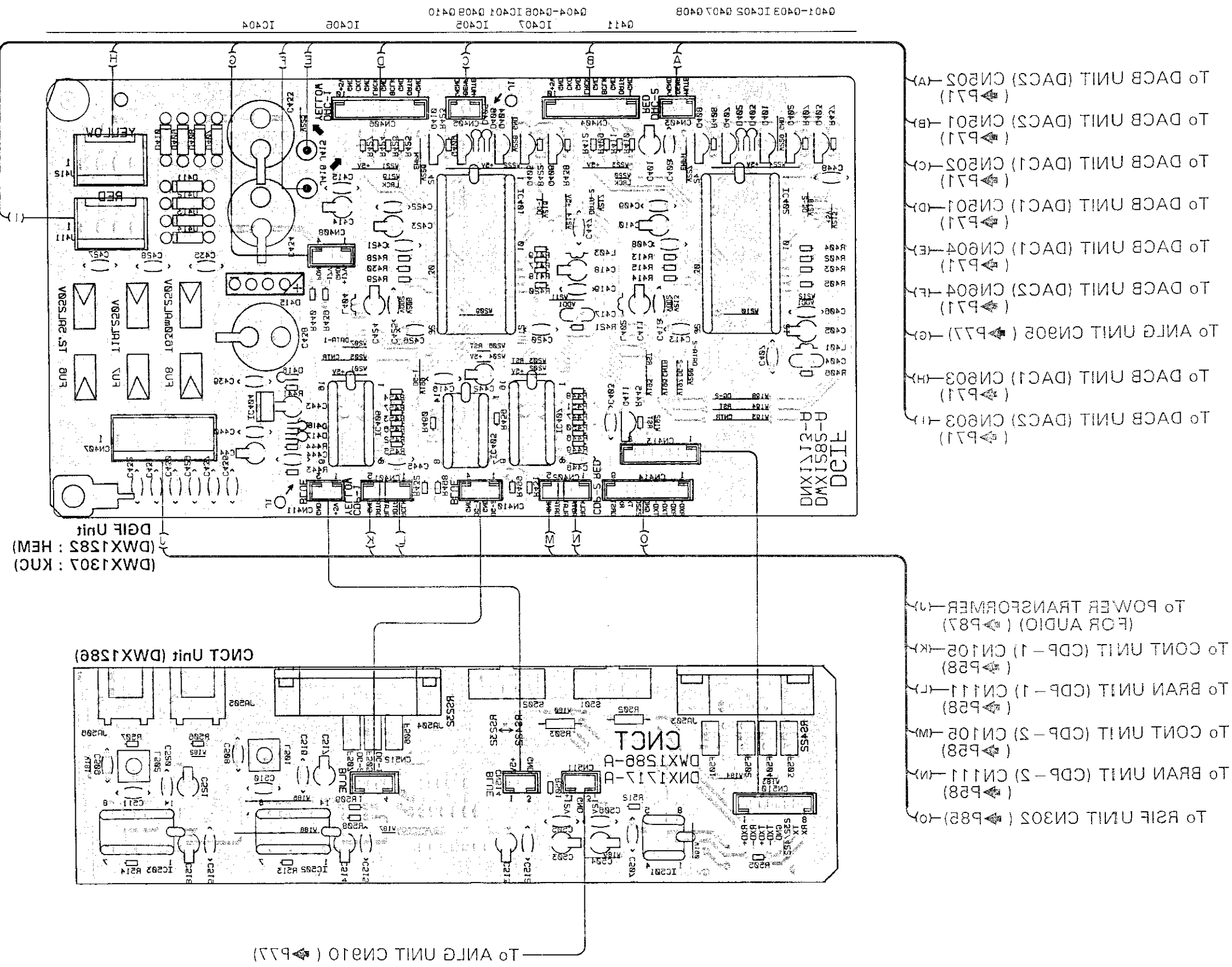

TO DACB UNIT (DAC1) CN803 (H)
 (P71)
 TO DACB UNIT (DAC2) CN804 (F)
 (P71)
 TO DACB UNIT (DAC1) CN804 (E)
 (P71)
 TO DACB UNIT (DAC1) CN501 (D)
 (P71)
 TO DACB UNIT (DAC1) CN502 (C)
 (P71)
 TO DACB UNIT (DAC2) CN501 (B)
 (P71)
 TO DACB UNIT (DAC2) CN505 (A)
 (P71)

TO RSIE UNIT CN305 (P88) (F)
 (P88)
 TO BRAIN UNIT (CDP-2) CN111 (M)
 (P88)
 TO CONT UNIT (CDP-2) CN108 (W)
 (P88)
 TO BRAIN UNIT (CDP-1) CN111 (L)
 (P88)
 TO CONT UNIT (CDP-1) CN108 (K)
 (P88)
 TO POWER TRANSFORMER (FOR AUDIO) (P87)
 (P87)

TO ANLG UNIT CN910 (P77)

(DMX1301 : KUC)
 (DMX1385 : HEM)
 DGIF Unit

CNCT Unit (DMX1386)

IC201

Pin No	Volts
1	5.2
2	5.2
3	5.2
4	5.2
5	5.2
6	5.2
7	5.2
8	5.2

IC205

Pin No	Volts
1	5.2
2	5.2
3	5.2
4	5.2
5	5.2
6	5.2
7	5.2
8	5.2

IC401

Pin No	Volts
1	5.2
2	5.2
3	5.2
4	5.2
5	5.2
6	5.2
7	5.2
8	5.2

IC408

Pin No	Volts
1	5.2
2	5.2
3	5.2
4	5.2
5	5.2
6	5.2
7	5.2
8	5.2

IC407

Pin No	Volts
1	5.2
2	5.2
3	5.2
4	5.2
5	5.2
6	5.2
7	5.2
8	5.2

Pin No	Volts
1	5.2
2	5.2
3	5.2
4	5.2
5	5.2
6	5.2
7	5.2
8	5.2

IC409

Pin No	Volts
1	5.2
2	5.2
3	5.2
4	5.2
5	5.2
6	5.2
7	5.2
8	5.2

This P. C. B. connection diagram is viewed from the foil side.

- A To DACB UNIT (DAC2) CN502 (A) (P71)
- A To DACB UNIT (DAC2) CN501 (B) (P71)
- A To DACB UNIT (DAC1) CN502 (C) (P71)
- A To DACB UNIT (DAC1) CN501 (D) (P71)
- A To DACB UNIT (DAC1) CN604 (E) (P71)
- A To DACB UNIT (DAC2) CN604 (F) (P71)
- B To ANLG UNIT CN905 (G) (P77)
- B To DACB UNIT (DAC1) CN603 (H) (P71)
- B To DACB UNIT (DAC2) CN603 (I) (P71)
- C To POWER TRANSFORMER (FOR AUDIO) (J) (P87)
- C To CONT UNIT (CDP-1) CN105 (K) (P58)
- C To BRAN UNIT (CDP-1) CN111 (L) (P58)
- C To CONT UNIT (CDP-2) CN105 (M) (P58)
- C To BRAN UNIT (CDP-2) CN111 (N) (P58)
- D To RSIF UNIT CN302 (O) (P85)
- To ANLG UNIT CN910 (P77)

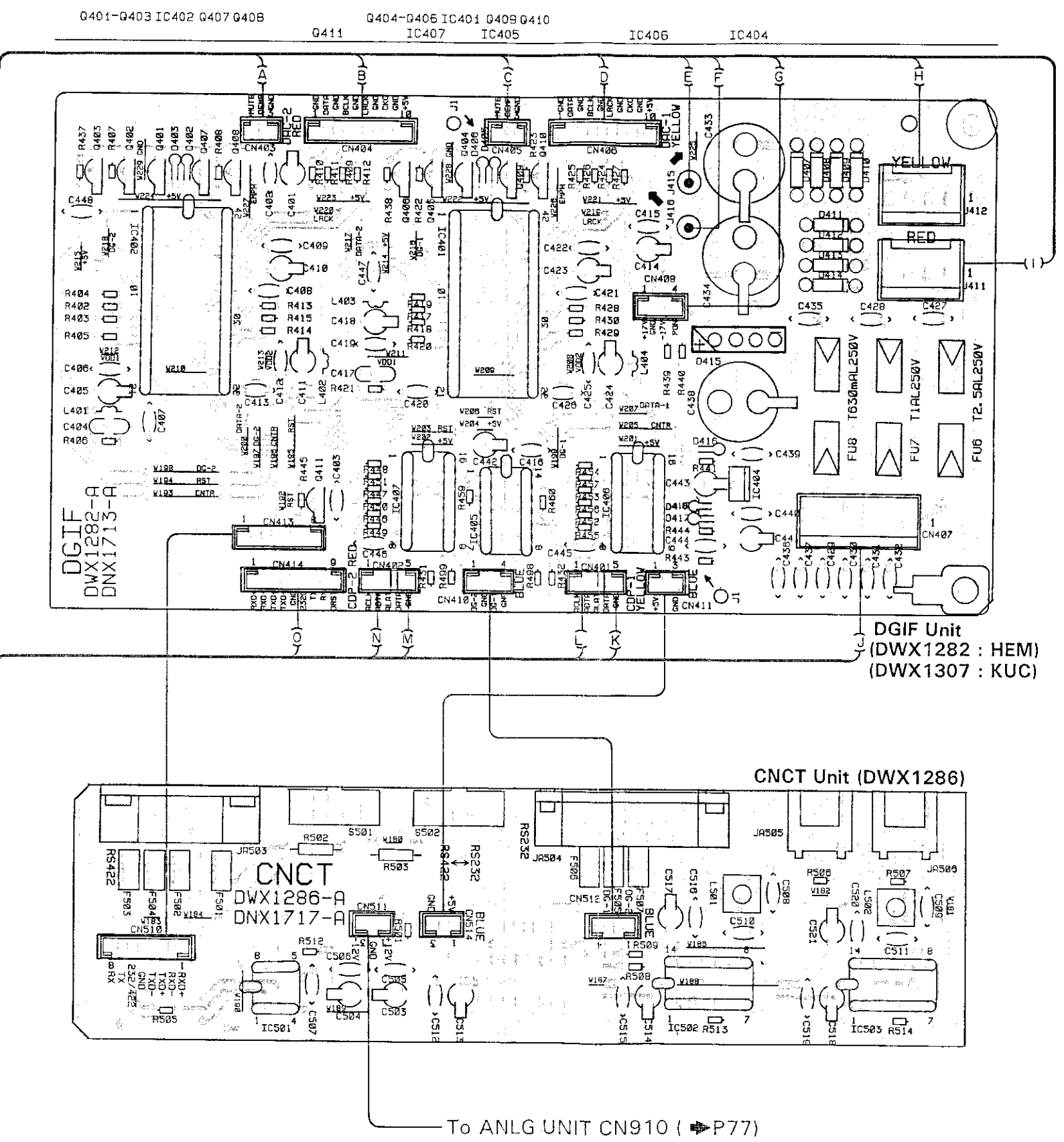

CNCT
IC501

Pin No	Voltage
1	
2	4.1
3	4.9
4	
5	-2.7
6	
7	-11
8	

IC502

Pin No	Voltage
1-6	2.5
7	
B-13	2.5
14	

DGIF
IC401

Pin No	Voltage
1	2.5
2-8	
9	1.5
10, 11	
12	5
13-30	
31	2.4
32	0
33	
34	2.5
35-42	

IC406

Pin No	Voltage
1, 2	
3	5
4	0
5	5
6	0.1
7	5
B-12	
13	2.5
14	0
15	2.4
16	

IC402

Pin No	Voltage
1	2.5
2-5	
6, 7	2.5
8	
9	1.5
10, 11	
12	5
13, 14	
15	0.7
16	2
17	5
18, 19	
20-23	0.7
24	
25	2.2
26	5
27	2
28	0.7
29	2
30	2.2
31	2.4
32	0
33, 34	2.5
35	
36-38	0
39-42	

IC407

Pin No	Voltage
1, 2	
3	5
4-12	
13	2.5
14	0
15	2.4
16	

	Voltage		
	E	B	C
Q401	0	3.7	0
Q402	3.7	0	0
Q403	0	5	0
Q404	0	3.7	0
Q405	3.7	0	0
Q406	0	5	0
Q407	5	-12	0
Q408	0	5	0
Q409	5	-12	0
Q410	0	5	0
Q411	0	5	0

IC405

Pin No	Voltage
1-6	2.5
7	
8	
9-13	2.5
14	

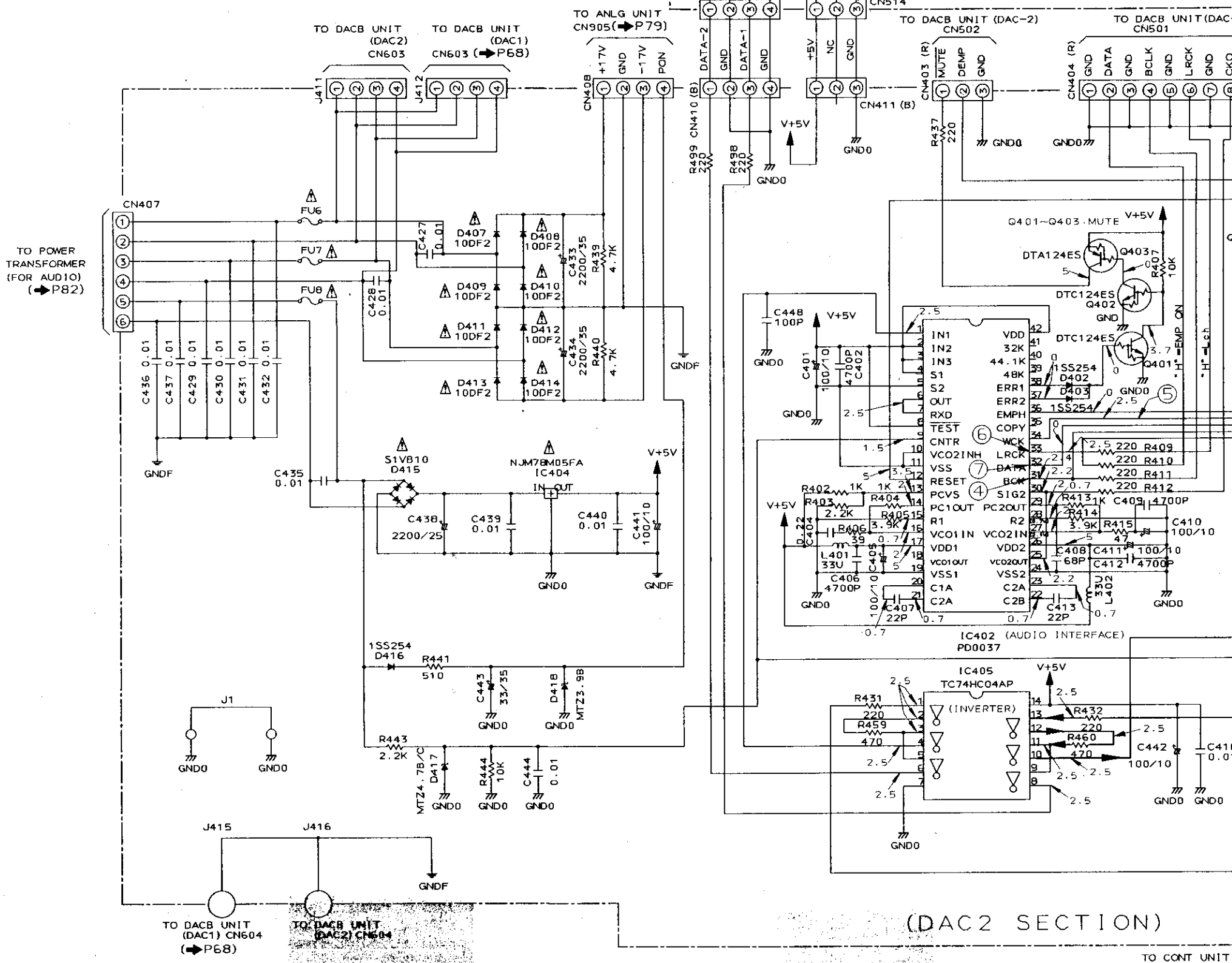
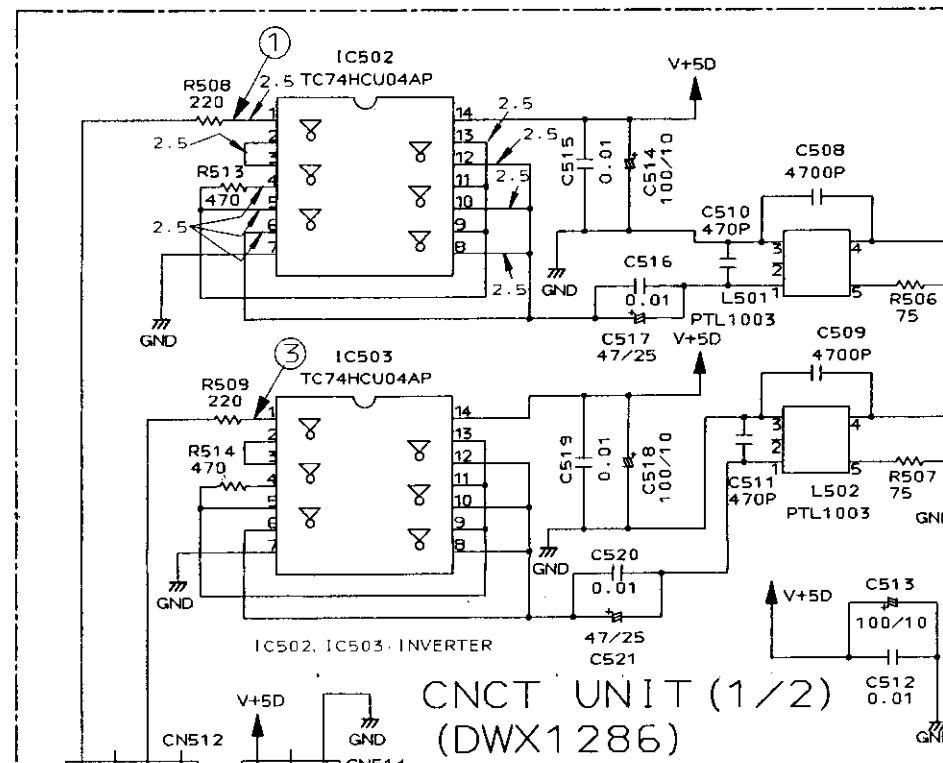
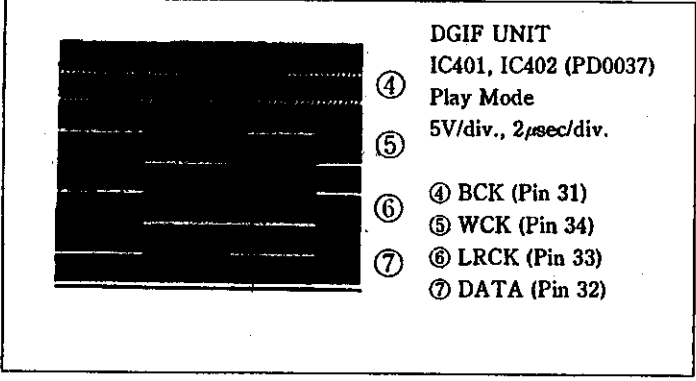
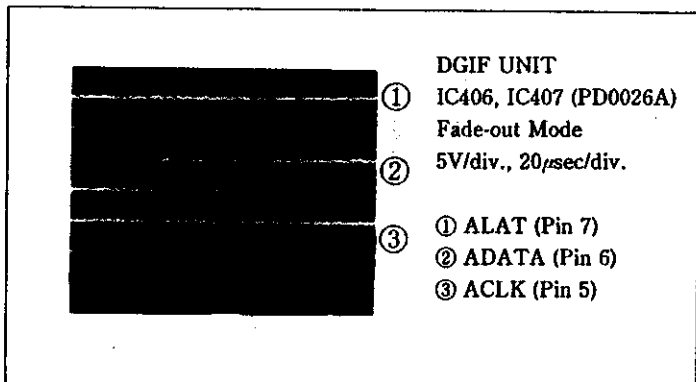

A
 B
 C
 D
 E
 F

CNCT UNIT
Power ON : 200nsec/div.

- ① IC502 - Pin 1
5V/div.
- ② Digital Output (CDP-2)
1V/div.
- ③ IC503 - Pin 1
5V/div.
- ④ Digital Output (CDP-1)
1V/div.

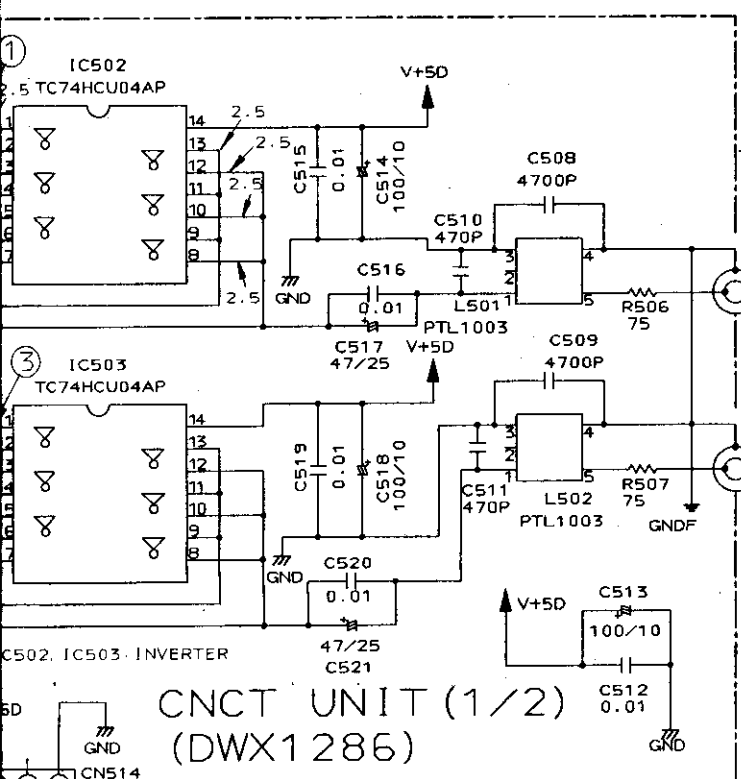

	HEM	KUC
FU6	T2.5AL250V REK-104	4A/125V DEK1020
FU7	T1AL250V REK-100	1.6A/125V DEK1015
FU8	T630mAL250V REK-098	800mA/125V DEK1010

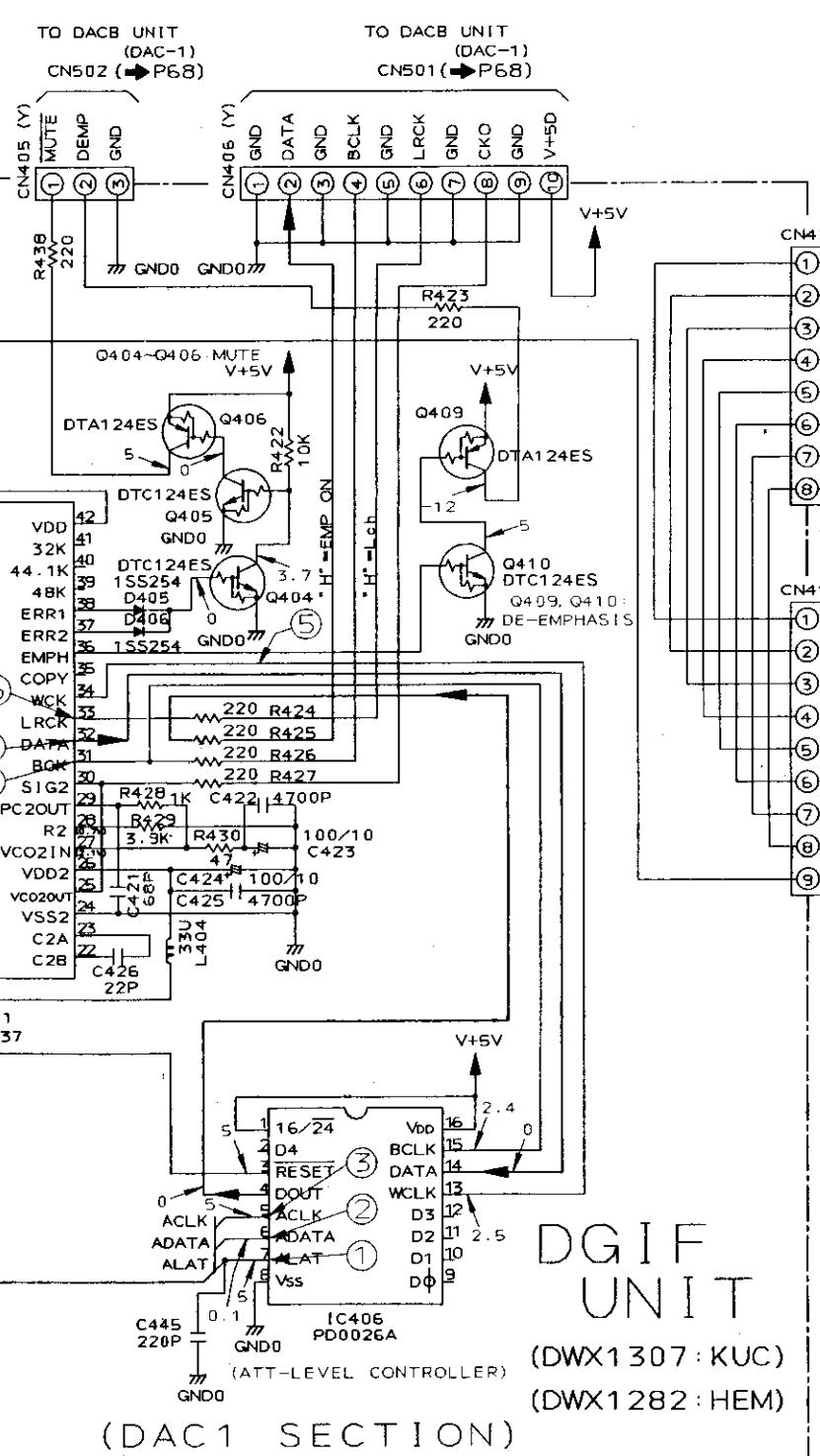
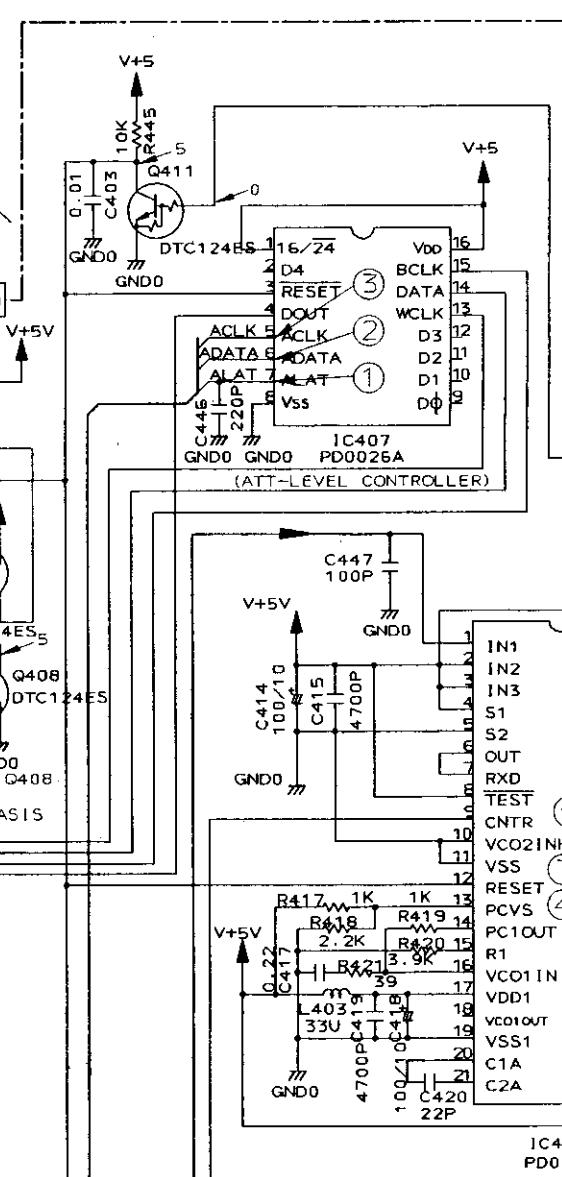
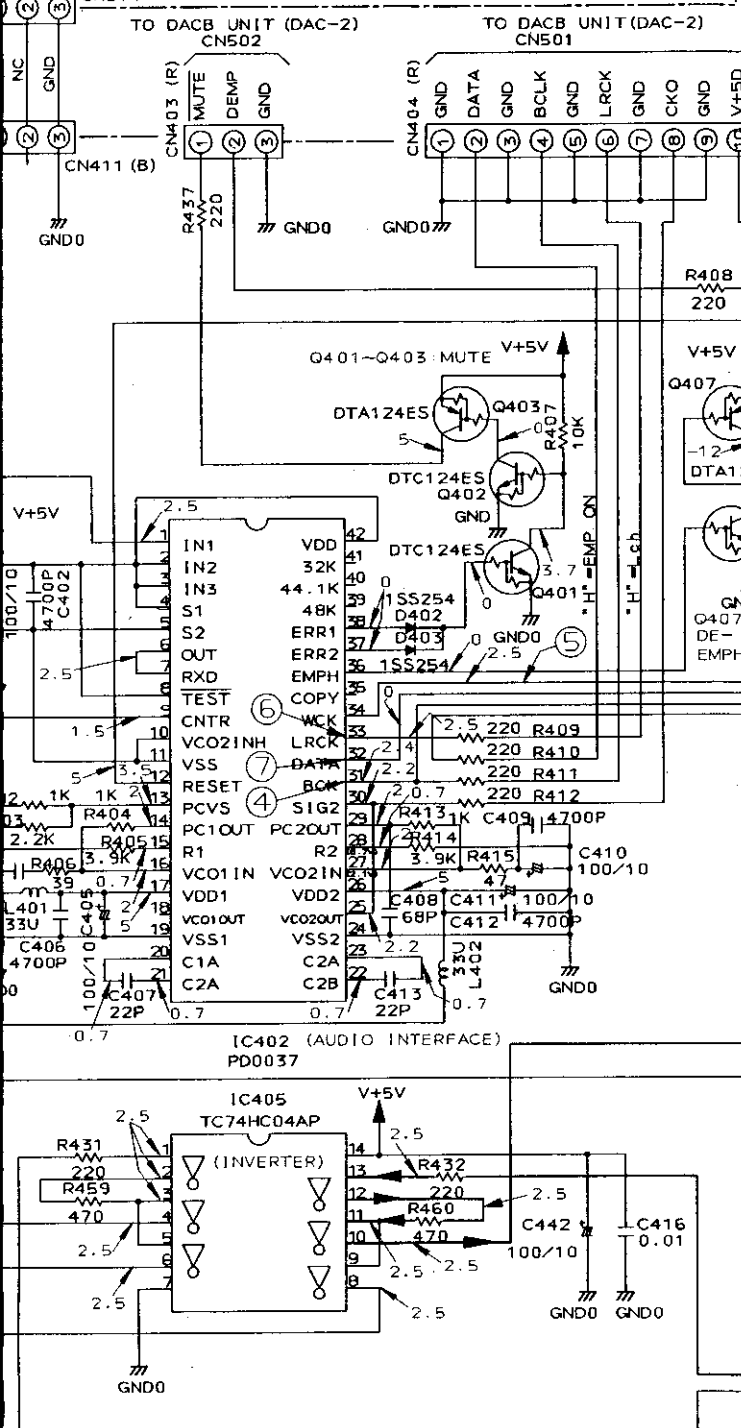

DIGIF UNIT
(DWX1307: KUC)
(DWX1282: HEM)

(DAC2 SECTION)

(DAC1 SECTION)

TO CONT UNIT CN105 (CDP-2)
TO BRAN UNIT CN111 (CDP-2)

TO BRAN UNIT CN111 (CDP-1) (→P54)
TO CONT UNIT CN105 (CDP-1) (→P54)

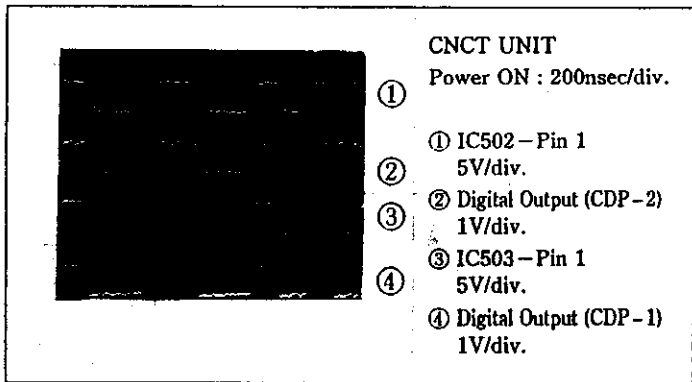

AUDIO SIGNAL

	HEM	KUC
FU6	T2.5A/250V REK-104	4A/125V DEK1020
FU7	T1A/250V REK-100	1.6A/125V DEK1015
FU8	T630mA/250V REK-098	800mA/125V DEK1010

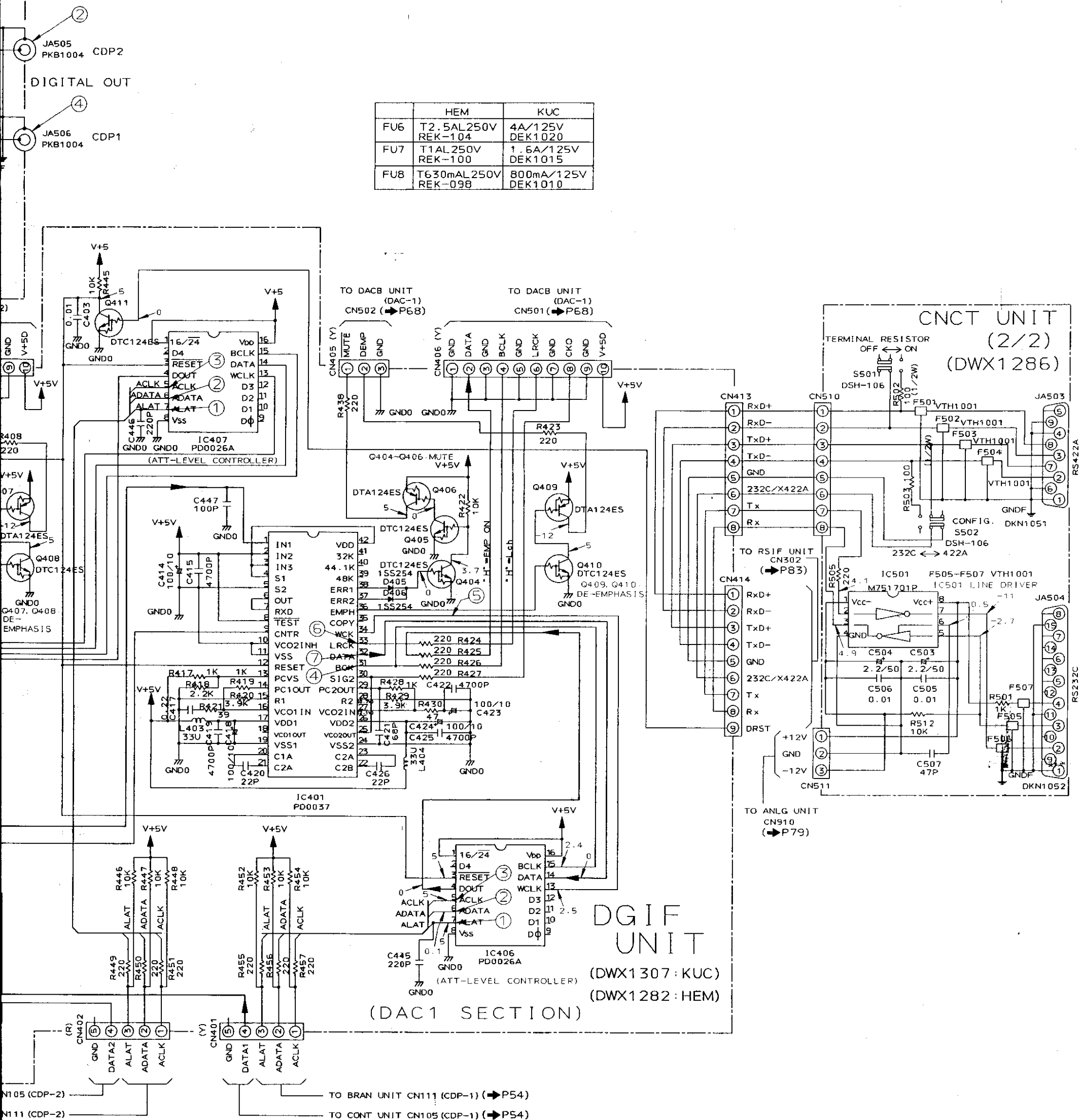

A
B
C
D
E
F

7.4 DACB UNIT

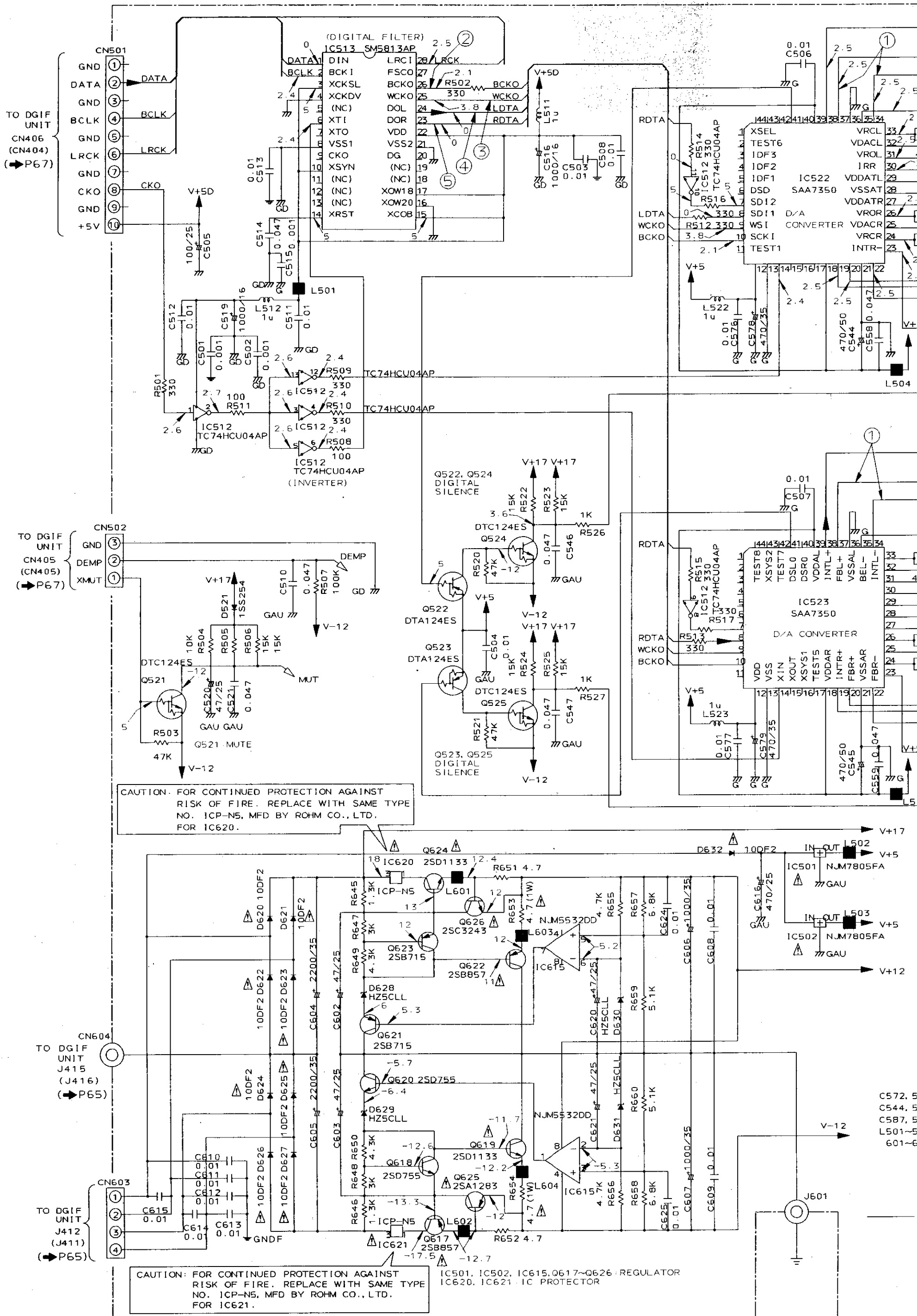

CAUTION: FOR CONTINUED PROTECTION AGAINST RISK OF FIRE, REPLACE WITH SAME TYPE NO. ICP-N5, MFD BY ROHM CO., LTD. FOR IC620.

CAUTION: FOR CONTINUED PROTECTION AGAINST RISK OF FIRE, REPLACE WITH SAME TYPE NO. ICP-N5, MFD BY ROHM CO., LTD. FOR IC621.

C572, 5
C544, 5
C587, 5
L501-5
L501-6
601-6

DACB U
(DWM12)

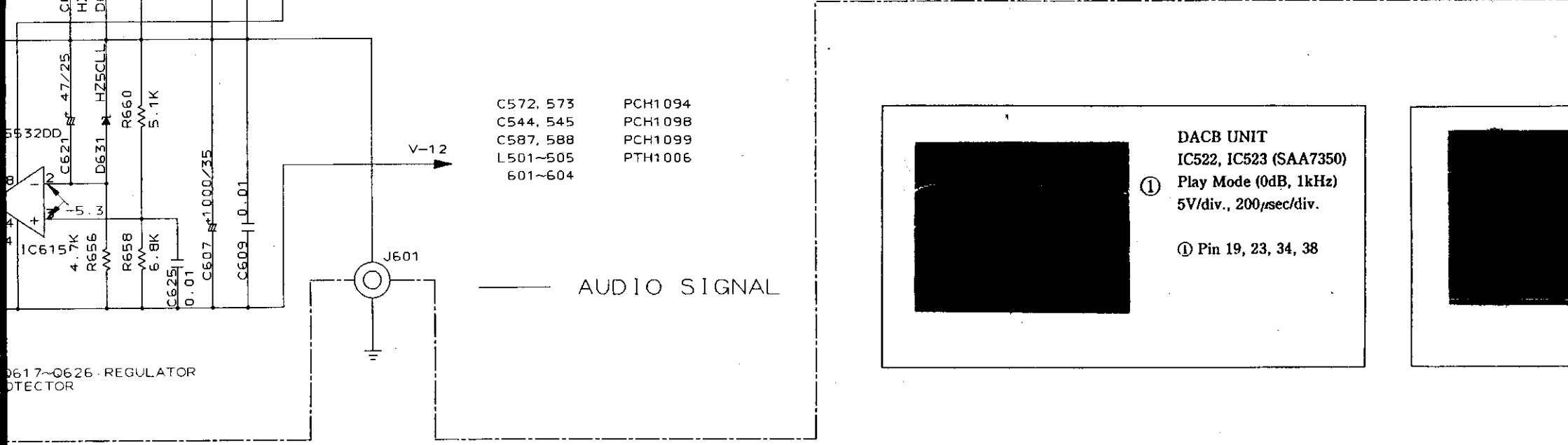
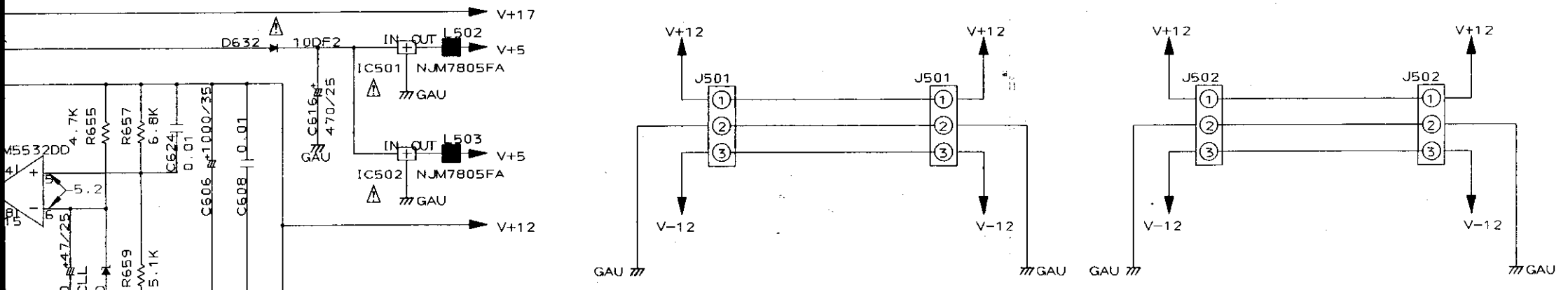
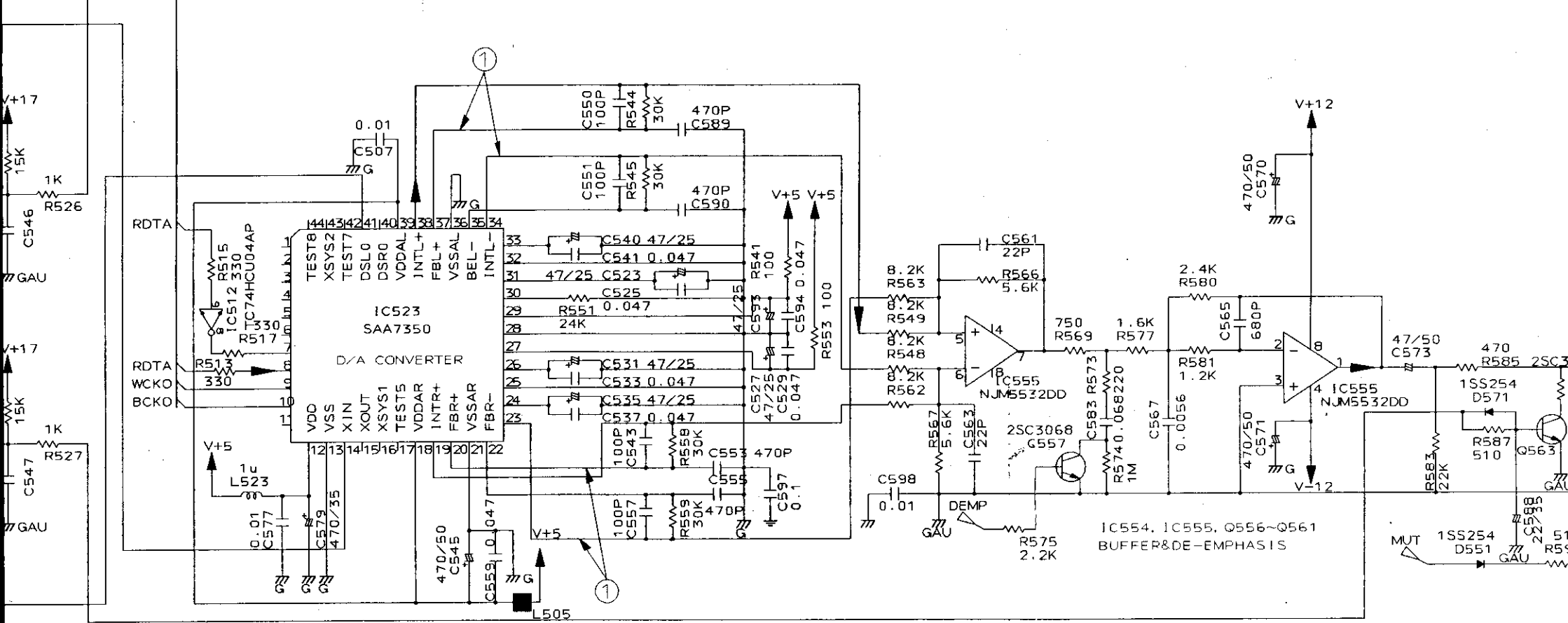
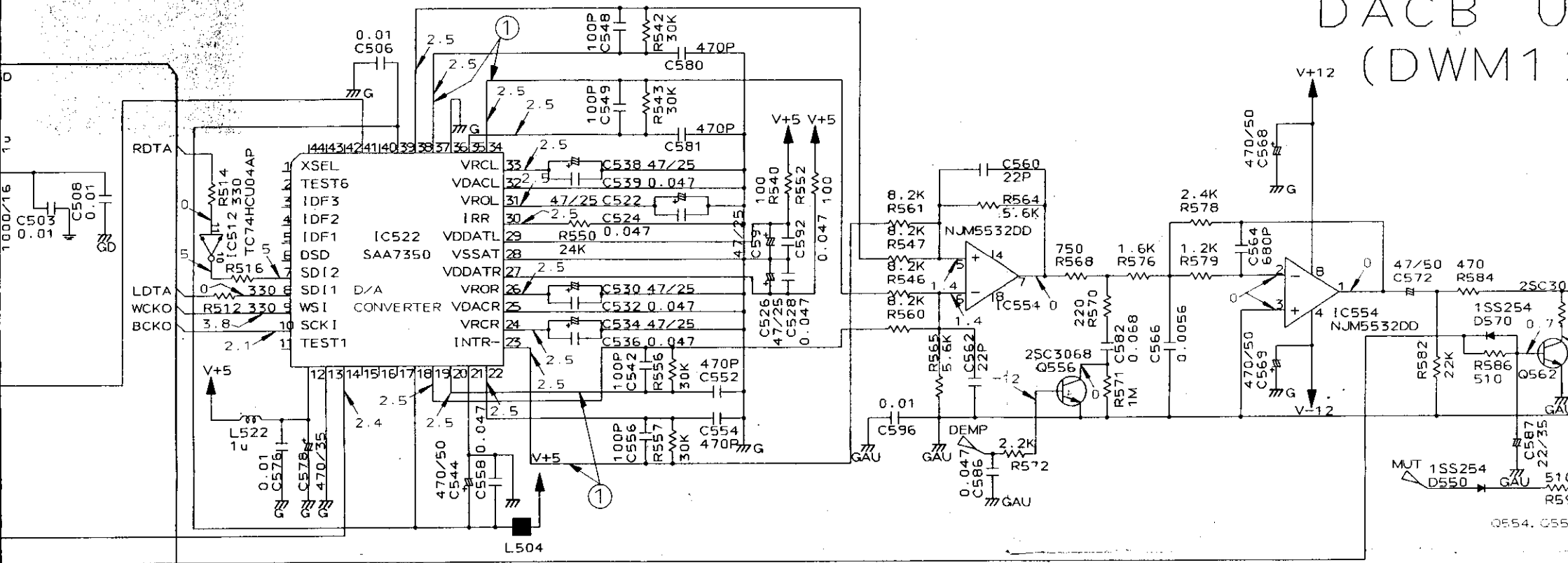

DACB UNIT
IC522, IC523 (SAA7350)

① Play Mode (0dB, 1kHz)
5V/div., 200μsec/div.

① Pin 19, 23, 34, 38

DACB UNIT (DWM1281)

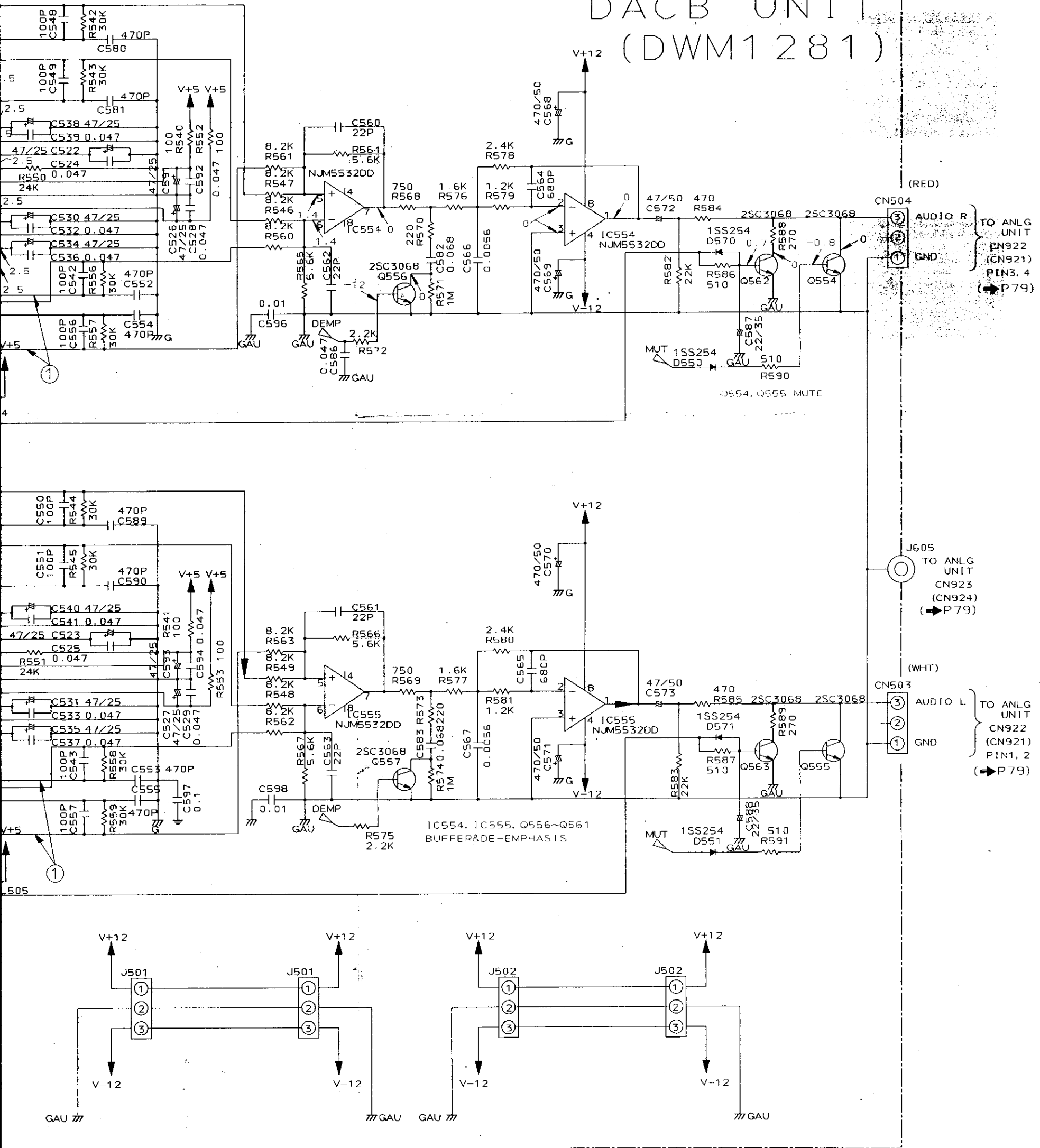

573 PCH1094
545 PCH1098
588 PCH1099
505 PTH1006
604

AUDIO SIGNAL

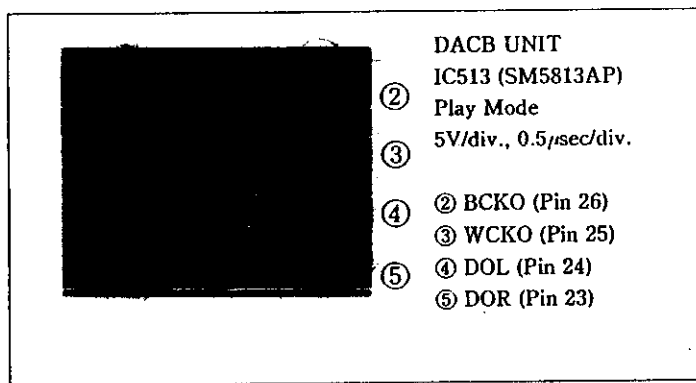
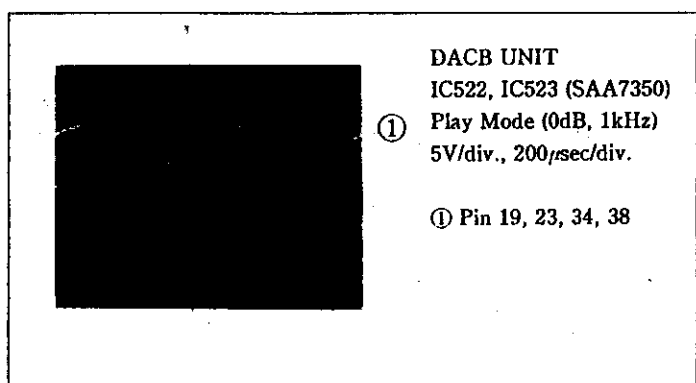

Q624 IC620 Q626 Q621-Q623 Q521-Q525 IC512 IC501 IC522
 Q617 IC621 Q625 IC615 Q618-Q620 IC513 IC502 IC523 IC554 Q556 Q562 Q554
 IC555 Q557 Q563 Q555

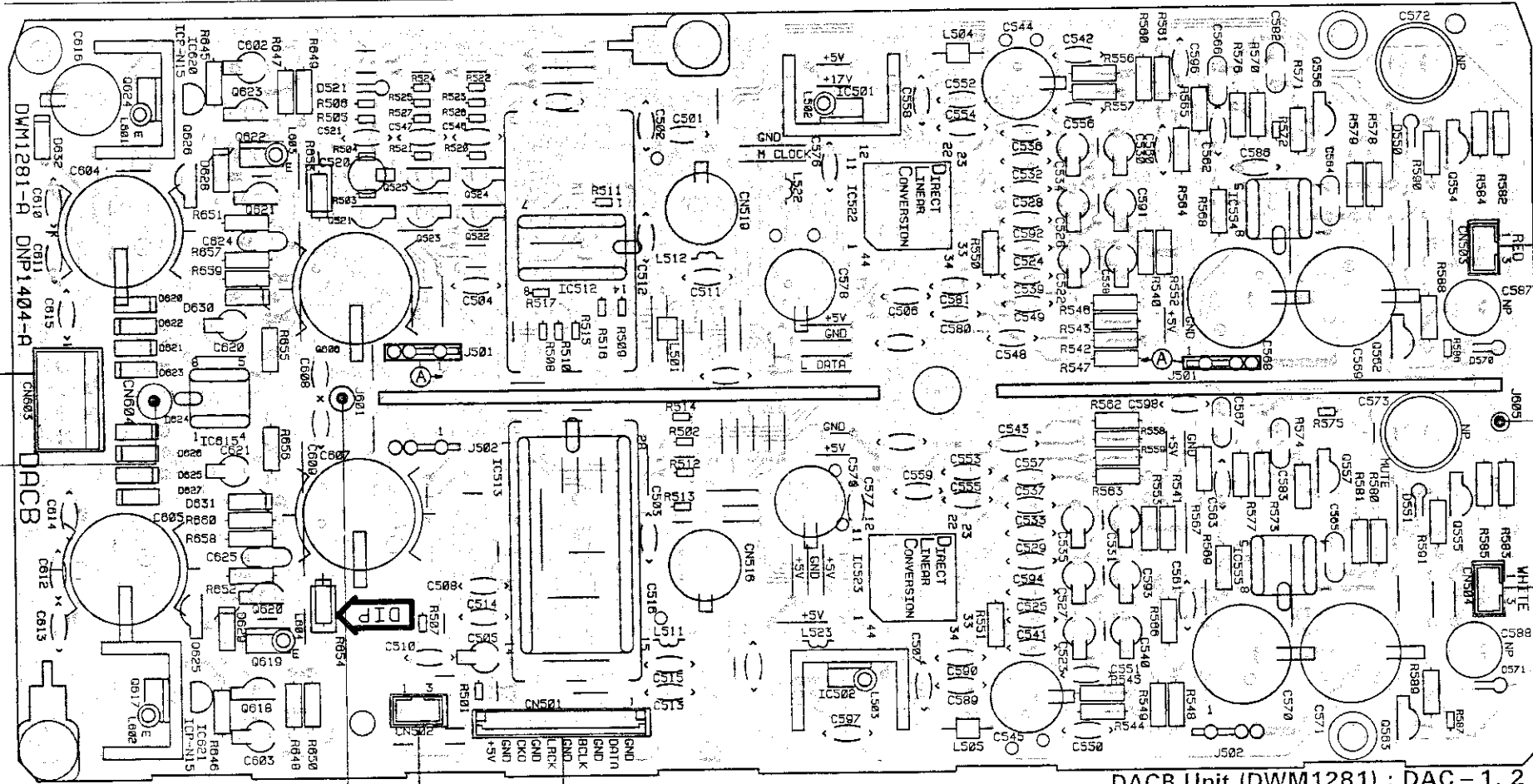

DACB Unit (DWM1281) : DAC - 1, 2

To DGIF UNIT J411, J412 (P64)

To DGIF UNIT J415, J416 (P64)

To ANLG UNIT CN921, CN922 Pin1, 2 (P77)

To ANLG UNIT CN923, CN924 (P77)

To ANLG UNIT CN921, CN922 Pin3, 4 (P77)

DACB

IC512	IC522	IC615
Pin No	Pin No	Pin No
1	1-6	1
2	7	2,3
3	8	4
4	9	5,6
5	10	7
6	11-13	8
7-9	14	IC620
10	15-18	Pin No Voltage
11	19-20	1
12	21	3
13	22-24	IC621
14	25	Pin No Voltage
	26	1
	27-29	3
	30, 31	
	32	
	33-35	
	36	
	37-40	
	41	
	42-44	
	IC554	
	Pin No Voltage	
	1-3	
	4	
	5,6	
	7	
	8	
	9	
	10	
	11	
	12	
	13	
	14	
	15	
	16	
	17	
	18	
	19	
	20	
	21	
	22	
	23	
	24	
	25	
	26	
	27	
	28	
	29	

To DGIF UNIT CN403, CN405 (P63)

To DGIF UNIT CN404, CN406 (P63, 64)

P.C.B. pattern diagram indication	Corresponding part symbol	Part name	P.C.B. pattern diagram indication	Corresponding part symbol	Part name	P.C.B. pattern diagram indication	Corresponding part symbol	Part name	P.C.B. pattern diagram indication	Corresponding part symbol	Part name
		Transistor			Ceramic capacitor			Semi-fixed resistor			Varactor
		FET			Mylar capacitor			Resistor array			Inductor
		Diode			Styrol capacitor			Resistor			Coil
		Zener diode			Electrolytic capacitor (Non polarized)			Resonator			Transformer
		LED			Electrolytic capacitor (Noiseless)			Thermistor			Filter
					Electrolytic capacitor (Polarized)			Tact switch			
					Power capacitor						

- This P.C.B. connection diagram is viewed from the parts mounted side.
- The parts which have been mounted on the boards can be replaced with those shown with the corresponding wiring symbols listed in the above Table.
- The capacitor terminal marked with shows negative terminal.
- The diode marked with shows cathode side.
- The transistor terminal marked with shows emitter.

This P. C. B connection diagram is viewed from the parts mounted side.

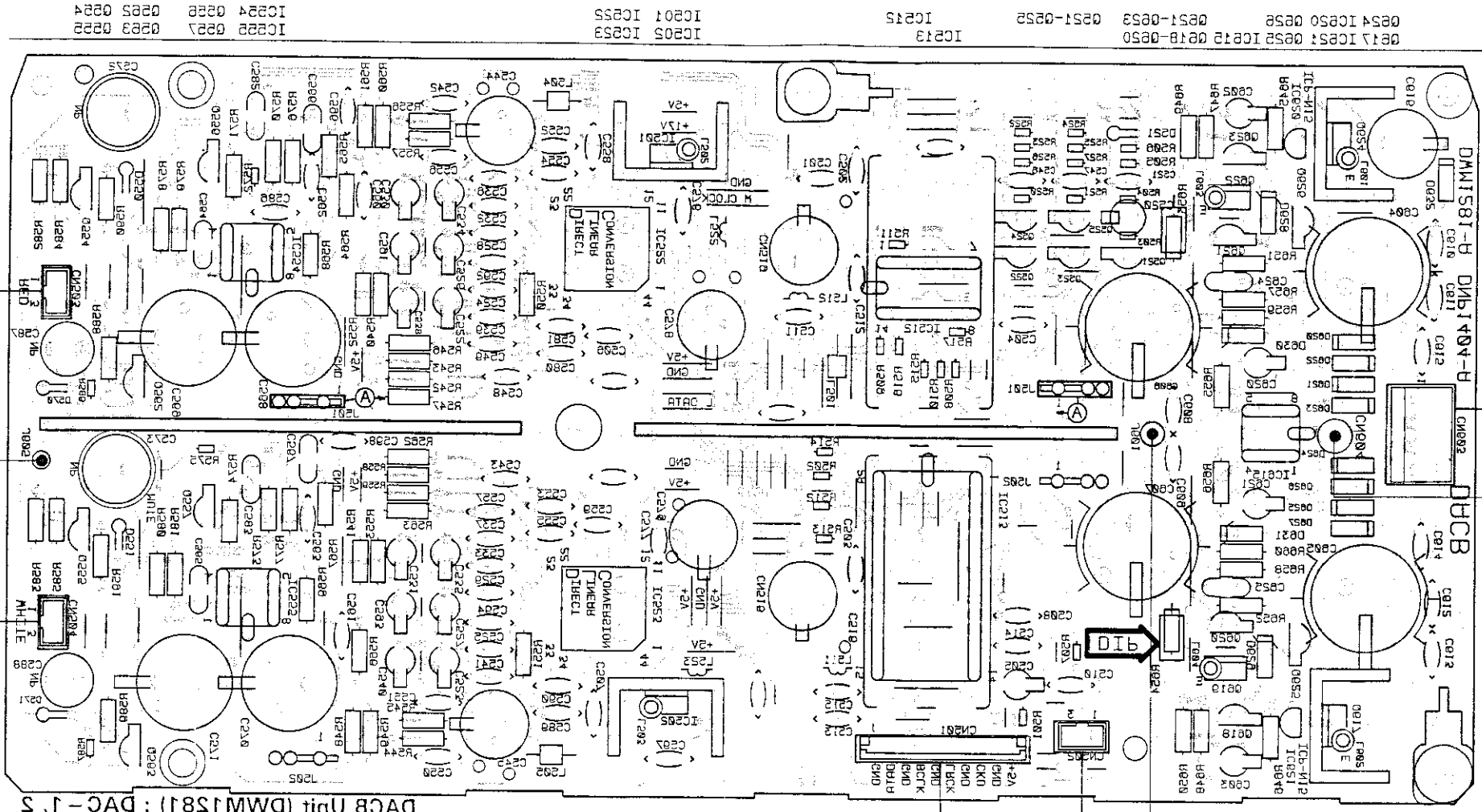

A

B

C

D

73

This P. C. B. connection diagram is viewed from the foil side.

IC213 IC215 IC205 IC253 IC201 IC255 IC222 IC227 IC224 IC228 IC229 IC225 IC226 IC223 IC221 IC220 IC219 IC218 IC217 IC216 IC215 IC214 IC213 IC212 IC211 IC210 IC209 IC208 IC207 IC206 IC205 IC204 IC203 IC202 IC201 IC200 IC199 IC198 IC197 IC196 IC195 IC194 IC193 IC192 IC191 IC190 IC189 IC188 IC187 IC186 IC185 IC184 IC183 IC182 IC181 IC180 IC179 IC178 IC177 IC176 IC175 IC174 IC173 IC172 IC171 IC170 IC169 IC168 IC167 IC166 IC165 IC164 IC163 IC162 IC161 IC160 IC159 IC158 IC157 IC156 IC155 IC154 IC153 IC152 IC151 IC150 IC149 IC148 IC147 IC146 IC145 IC144 IC143 IC142 IC141 IC140 IC139 IC138 IC137 IC136 IC135 IC134 IC133 IC132 IC131 IC130 IC129 IC128 IC127 IC126 IC125 IC124 IC123 IC122 IC121 IC120 IC119 IC118 IC117 IC116 IC115 IC114 IC113 IC112 IC111 IC110 IC109 IC108 IC107 IC106 IC105 IC104 IC103 IC102 IC101 IC100 IC99 IC98 IC97 IC96 IC95 IC94 IC93 IC92 IC91 IC90 IC89 IC88 IC87 IC86 IC85 IC84 IC83 IC82 IC81 IC80 IC79 IC78 IC77 IC76 IC75 IC74 IC73 IC72 IC71 IC70 IC69 IC68 IC67 IC66 IC65 IC64 IC63 IC62 IC61 IC60 IC59 IC58 IC57 IC56 IC55 IC54 IC53 IC52 IC51 IC50 IC49 IC48 IC47 IC46 IC45 IC44 IC43 IC42 IC41 IC40 IC39 IC38 IC37 IC36 IC35 IC34 IC33 IC32 IC31 IC30 IC29 IC28 IC27 IC26 IC25 IC24 IC23 IC22 IC21 IC20 IC19 IC18 IC17 IC16 IC15 IC14 IC13 IC12 IC11 IC10 IC9 IC8 IC7 IC6 IC5 IC4 IC3 IC2 IC1

IC213	IC215	IC205	IC253	IC201	IC255	IC222	IC227	IC224	IC228	IC229	IC225	IC226	IC223	IC221	IC220	IC219	IC218	IC217	IC216	IC215	IC214	IC213	IC212	IC211	IC210	IC209	IC208	IC207	IC206	IC205	IC204	IC203	IC202	IC201	IC200	IC199	IC198	IC197	IC196	IC195	IC194	IC193	IC192	IC191	IC190	IC189	IC188	IC187	IC186	IC185	IC184	IC183	IC182	IC181	IC180	IC179	IC178	IC177	IC176	IC175	IC174	IC173	IC172	IC171	IC170	IC169	IC168	IC167	IC166	IC165	IC164	IC163	IC162	IC161	IC160	IC159	IC158	IC157	IC156	IC155	IC154	IC153	IC152	IC151	IC150	IC149	IC148	IC147	IC146	IC145	IC144	IC143	IC142	IC141	IC140	IC139	IC138	IC137	IC136	IC135	IC134	IC133	IC132	IC131	IC130	IC129	IC128	IC127	IC126	IC125	IC124	IC123	IC122	IC121	IC120	IC119	IC118	IC117	IC116	IC115	IC114	IC113	IC112	IC111	IC110	IC109	IC108	IC107	IC106	IC105	IC104	IC103	IC102	IC101	IC100	IC99	IC98	IC97	IC96	IC95	IC94	IC93	IC92	IC91	IC90	IC89	IC88	IC87	IC86	IC85	IC84	IC83	IC82	IC81	IC80	IC79	IC78	IC77	IC76	IC75	IC74	IC73	IC72	IC71	IC70	IC69	IC68	IC67	IC66	IC65	IC64	IC63	IC62	IC61	IC60	IC59	IC58	IC57	IC56	IC55	IC54	IC53	IC52	IC51	IC50	IC49	IC48	IC47	IC46	IC45	IC44	IC43	IC42	IC41	IC40	IC39	IC38	IC37	IC36	IC35	IC34	IC33	IC32	IC31	IC30	IC29	IC28	IC27	IC26	IC25	IC24	IC23	IC22	IC21	IC20	IC19	IC18	IC17	IC16	IC15	IC14	IC13	IC12	IC11	IC10	IC9	IC8	IC7	IC6	IC5	IC4	IC3	IC2	IC1
58	57	56	55	54	53	52	51	50	49	48	47	46	45	44	43	42	41	40	39	38	37	36	35	34	33	32	31	30	29	28	27	26	25	24	23	22	21	20	19	18	17	16	15	14	13	12	11	10	9	8	7	6	5	4	3	2	1	0	-1	-2	-3	-4	-5	-6	-7	-8	-9	-10	-11	-12	-13	-14	-15	-16	-17	-18	-19	-20	-21	-22	-23	-24	-25	-26	-27	-28	-29	-30	-31	-32	-33	-34	-35	-36	-37	-38	-39	-40	-41	-42	-43	-44	-45	-46	-47	-48	-49	-50	-51	-52	-53	-54	-55	-56	-57	-58																																																																																																																						

A

B

C

D

73

7.5 ANLG UNIT, AUOB UNIT, XLR1 UNIT AND XLR2 UNIT

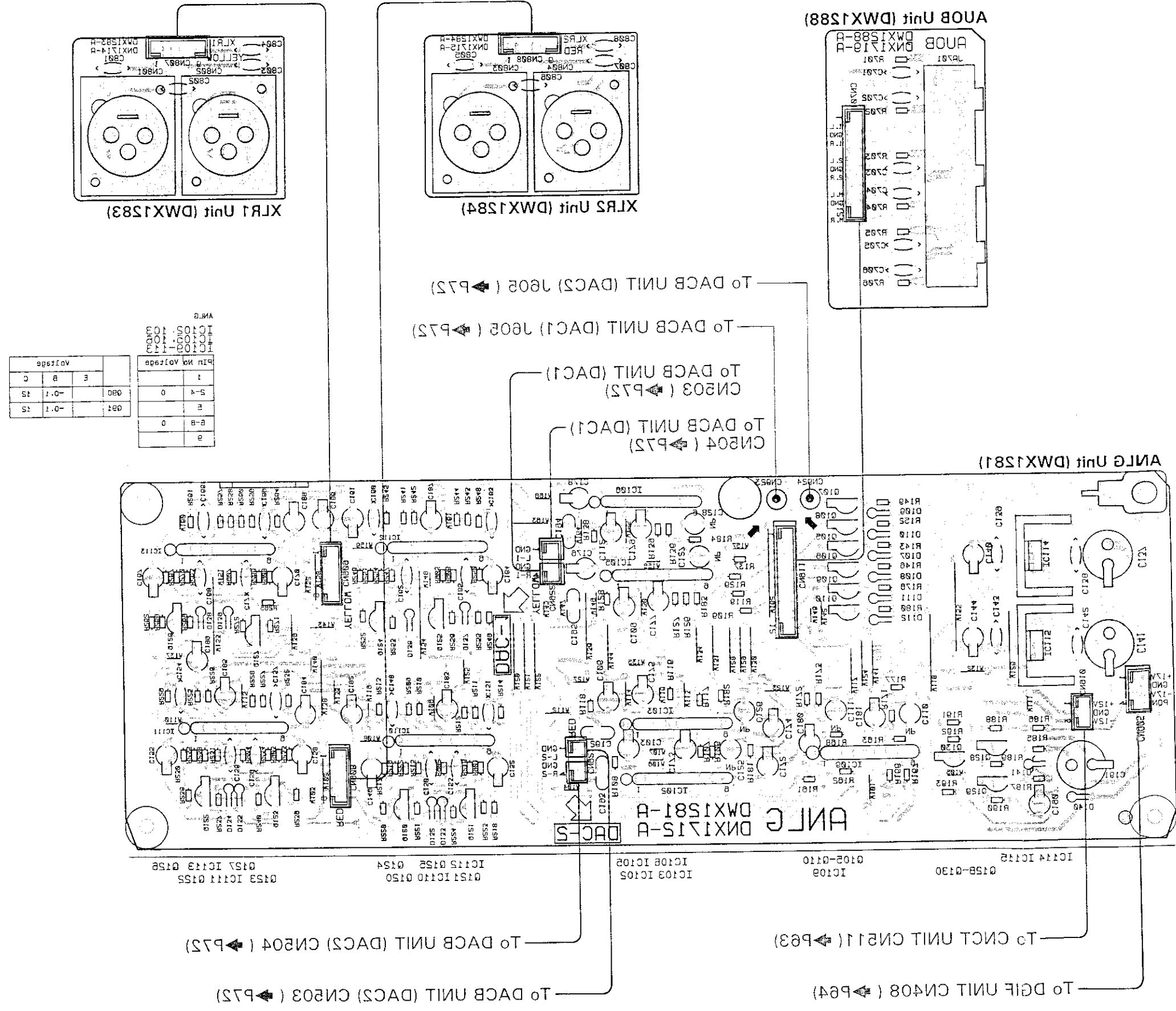

ANLG

IC140	0100	1000
IC100	0100	1000
IC100	0100	1000
IC100	0100	1000
IC100	0100	1000

IC100	0100	1000
IC100	0100	1000
IC100	0100	1000
IC100	0100	1000
IC100	0100	1000

This P. C. B. connection diagram is viewed from the foil side.

AUOB Unit (DWX1288)

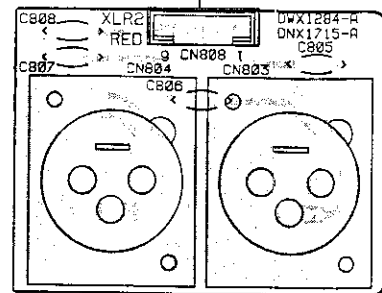
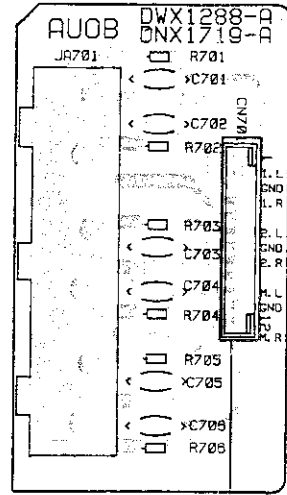

XLR2 Unit (DWX1284)

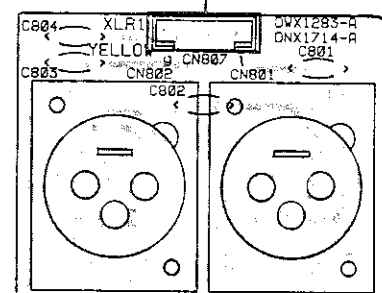

XLR1 Unit (DWX1283)

To DACB UNIT (DAC2) J605 (▶P72)

To DACB UNIT (DAC1) J605 (▶P72)

To DACB UNIT (DAC1) CN503 (▶P72)

To DACB UNIT (DAC1) CN504 (▶P72)

ANLG

IC1010	100
IC1009	100
IC1008	114
IC1007	114
Pin No	Voltage
1	
2-4	0
5	
6-8	0
9	

Voltage	Voltage		
	E	B	C
Q90		-0.1	12
Q91		-0.1	12

ANLG Unit (DWX1281)

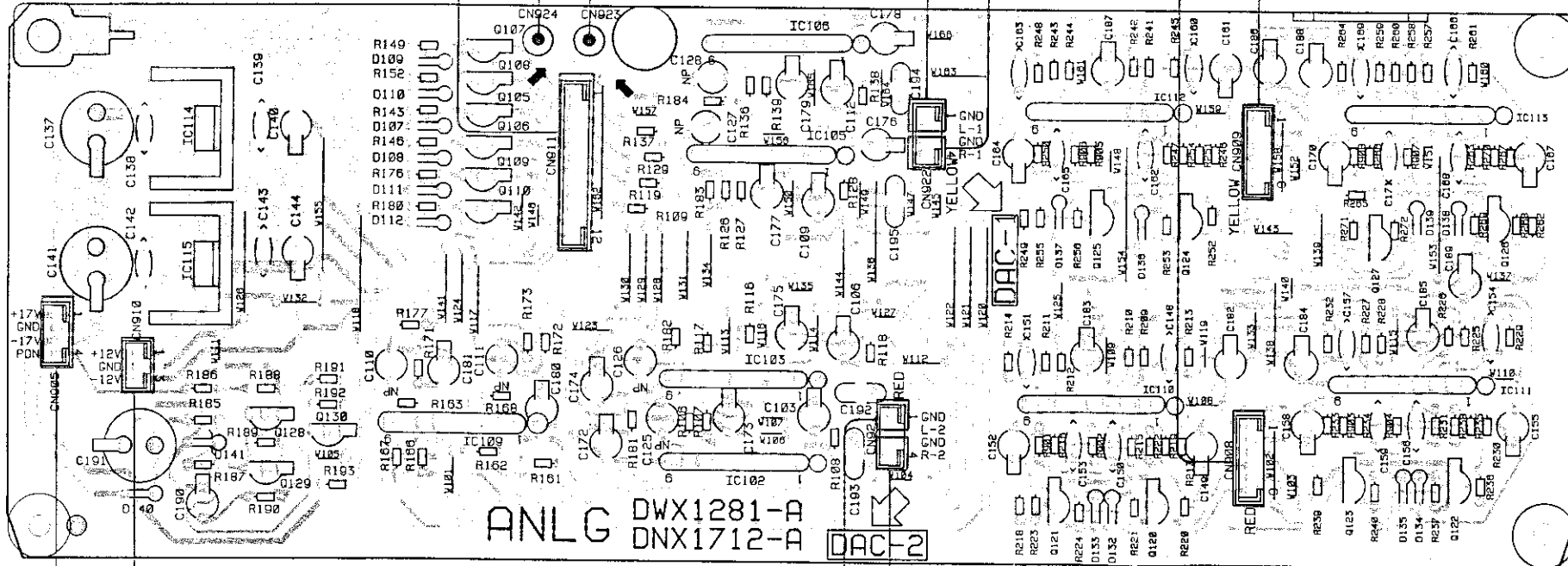

To CNCT UNIT CN511 (▶P63)

To DGIF UNIT CN408 (▶P64)

To DACB UNIT (DAC2) CN504 (▶P72)

To DACB UNIT (DAC2) CN503 (▶P72)

PCB pattern diagram indication	Corresponding part symbol	Part name
		Transistor
		FET
		Diode
		Zener diode
		LED
		Varactor
		Tact switch
		Inductor
		Coil
		Transformer
		Filter
		Ceramic capacitor
		Mylar capacitor
		Styrol capacitor
		Electrolytic capacitor (Non polarized)
		Electrolytic capacitor (Noiseless)
		Electrolytic capacitor (Polarized)
		Electrolytic capacitor (Polarized)
		Power capacitor
		Semi-fixed resistor
		Resistor array
		Resistor
		Resonator
		Thermistor

- This PCB connection diagram is viewed from the parts mounted side.
- The parts which have been mounted on the board can be replaced with those shown with the corresponding wiring symbols listed in the above table.
- The capacitor terminal marked with shows negative terminal.
- The diode marked with shows cathode side.
- The transistor terminal marked with shows emitter.

This P. C. B connection diagram is viewed from the parts mounted side.

A
B
C
D
E
F

ANLG UNIT (DWX1281)

IC102, IC103, IC105, IC106: BUFFER

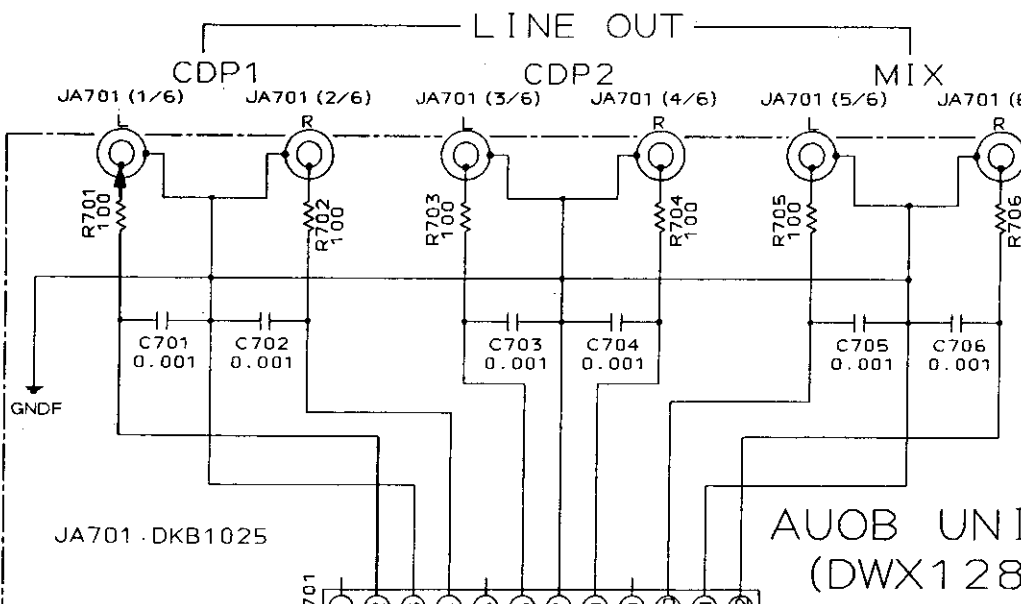
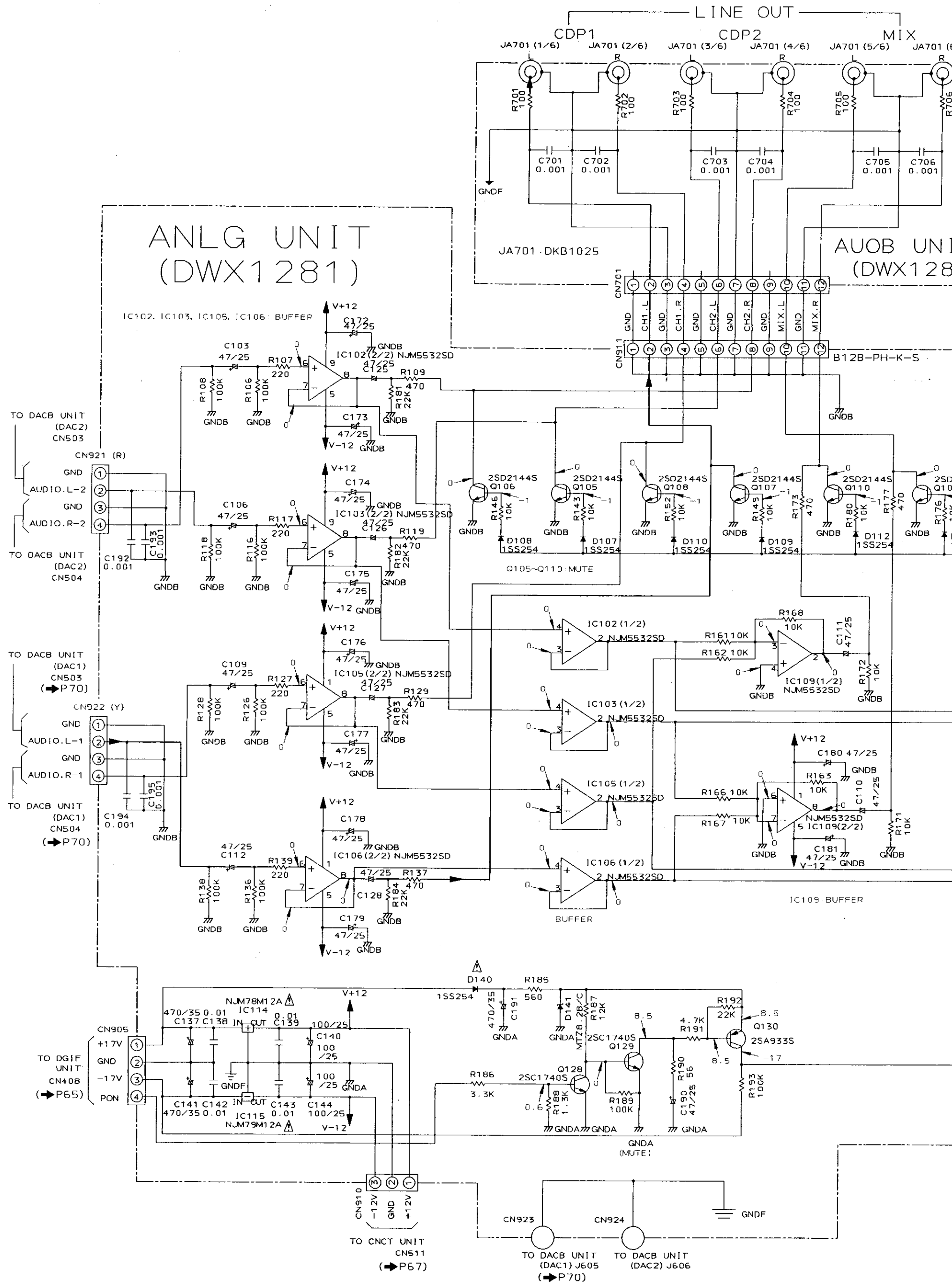

AUOB UNIT (DWX128)

JA701-DKB1025

B12B-PH-K-S

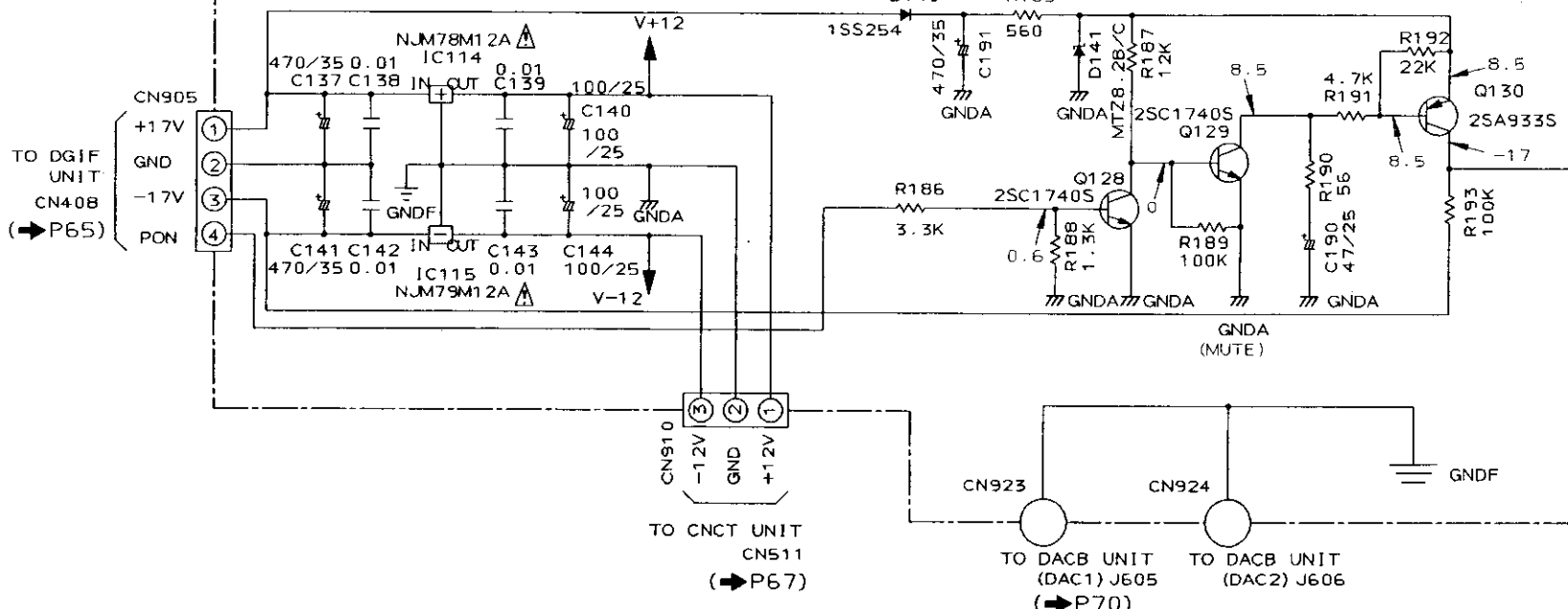
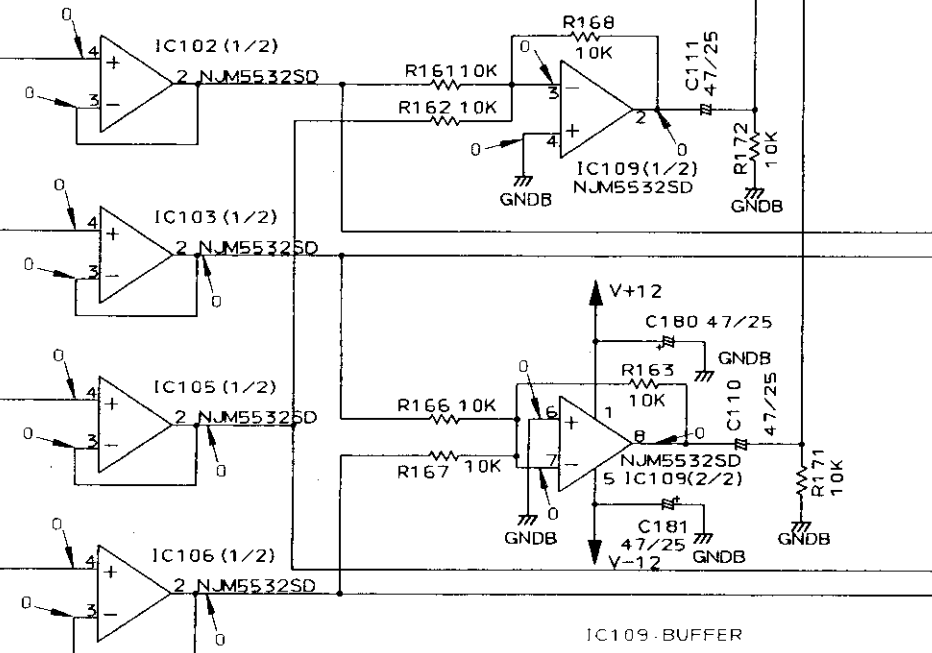
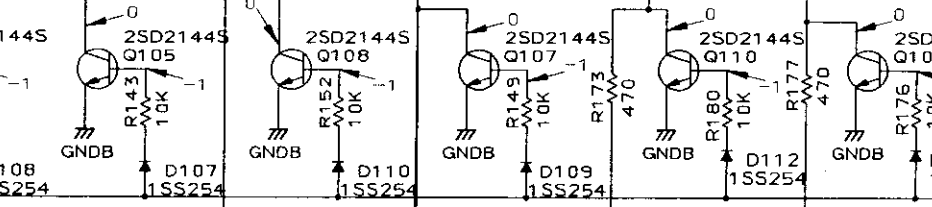

LINE OUT

CDP2

MIX

AUOB UNIT (DWX1288)

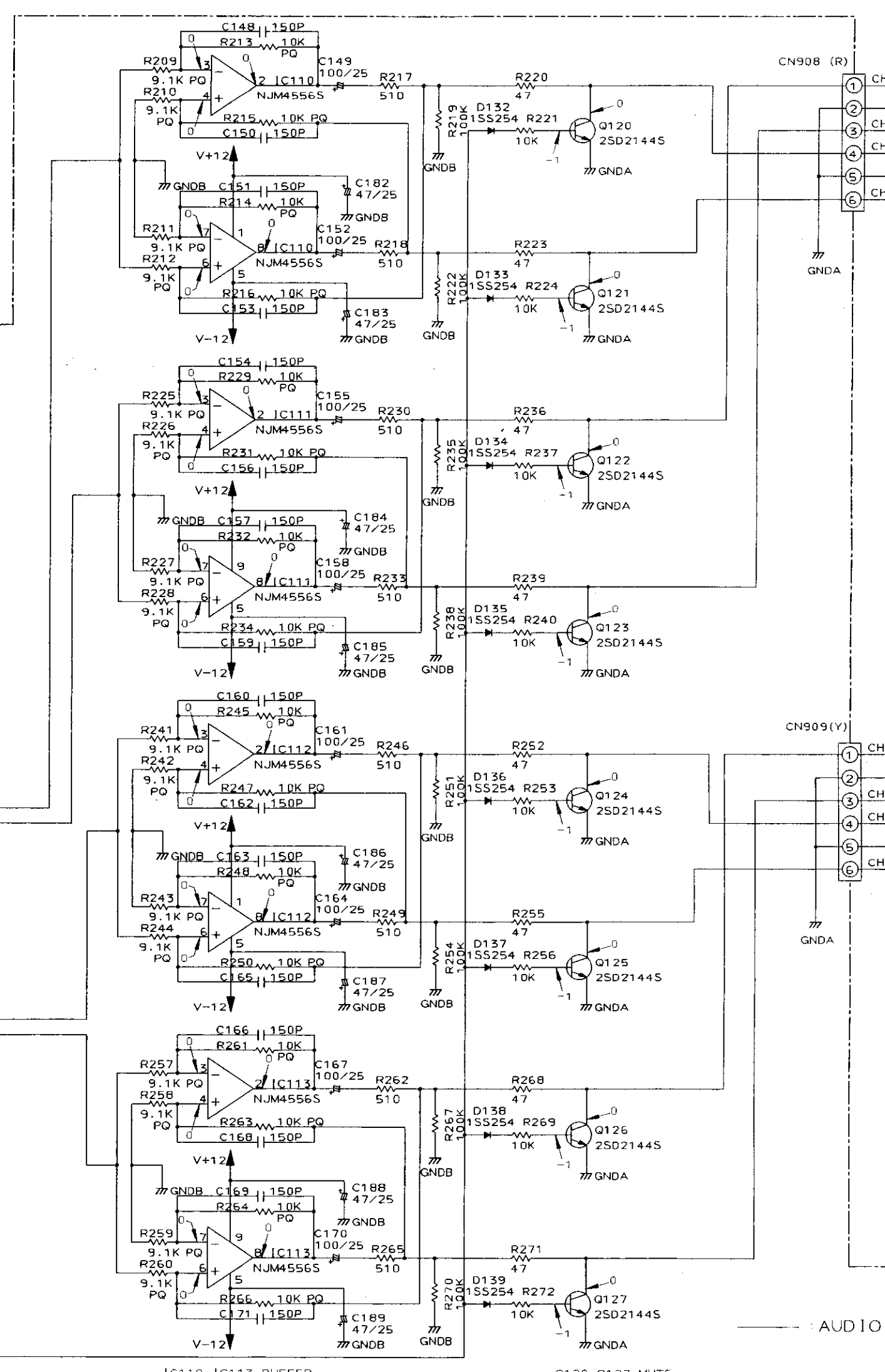
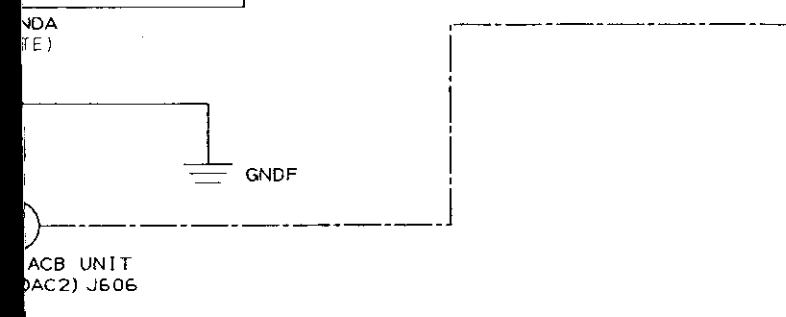
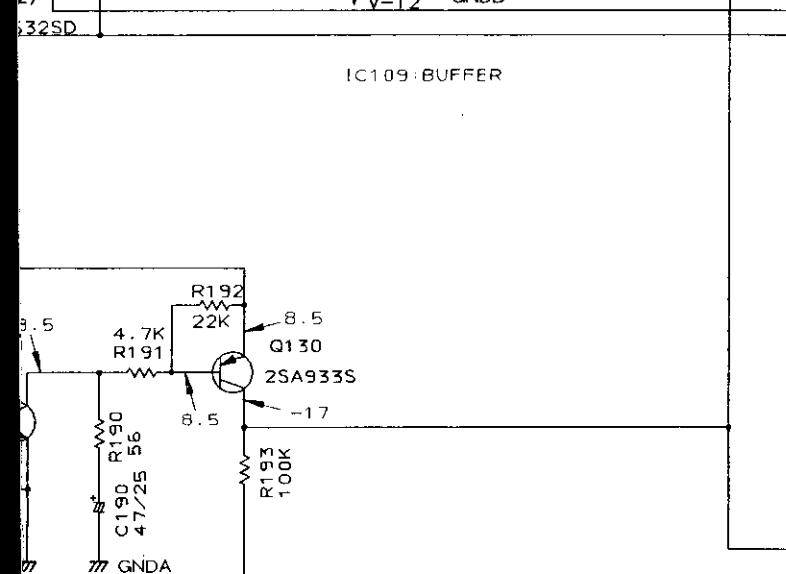
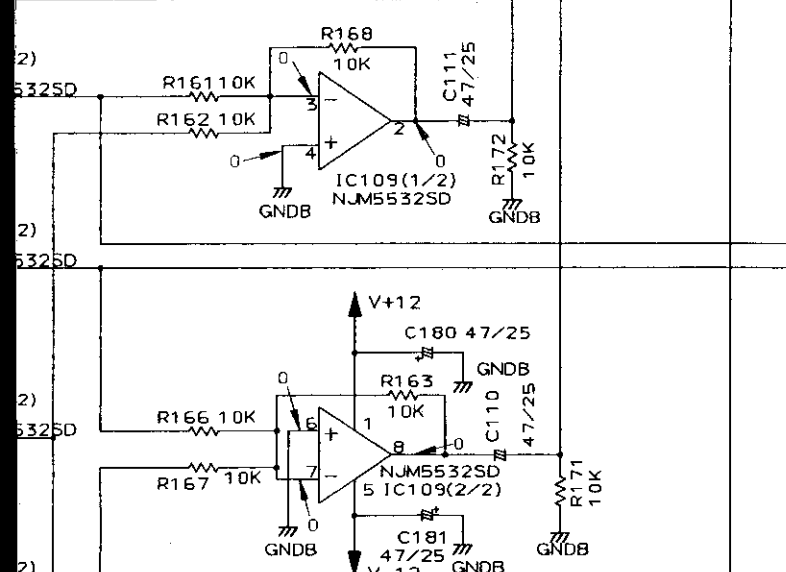
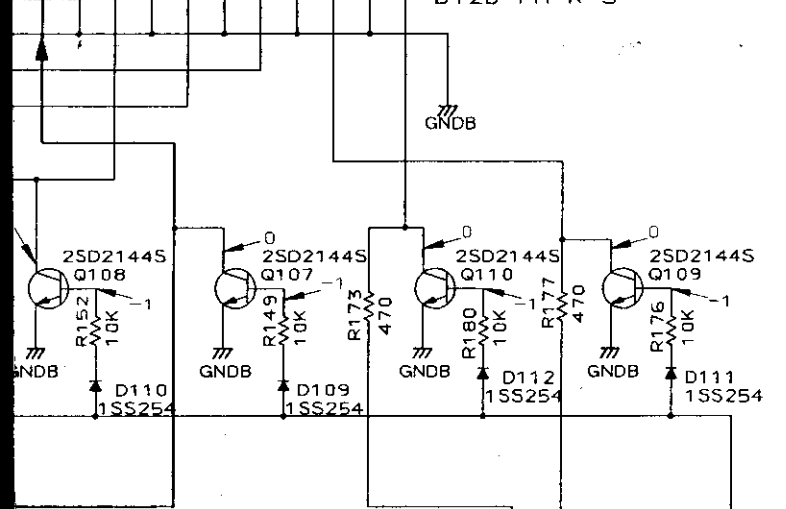
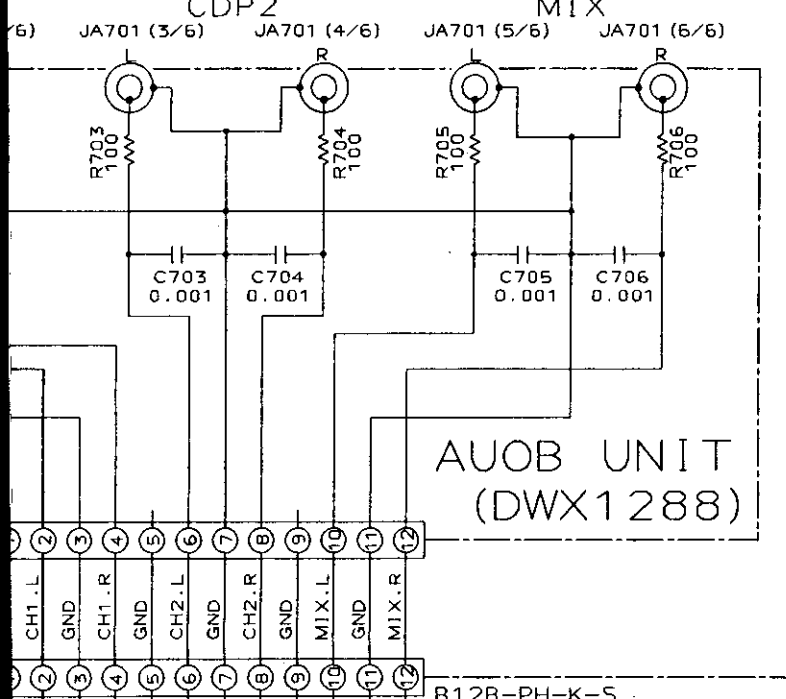

AUDIO S

(6/6)

IT (88)

2SD2144S 09
10K
D111 1SS254

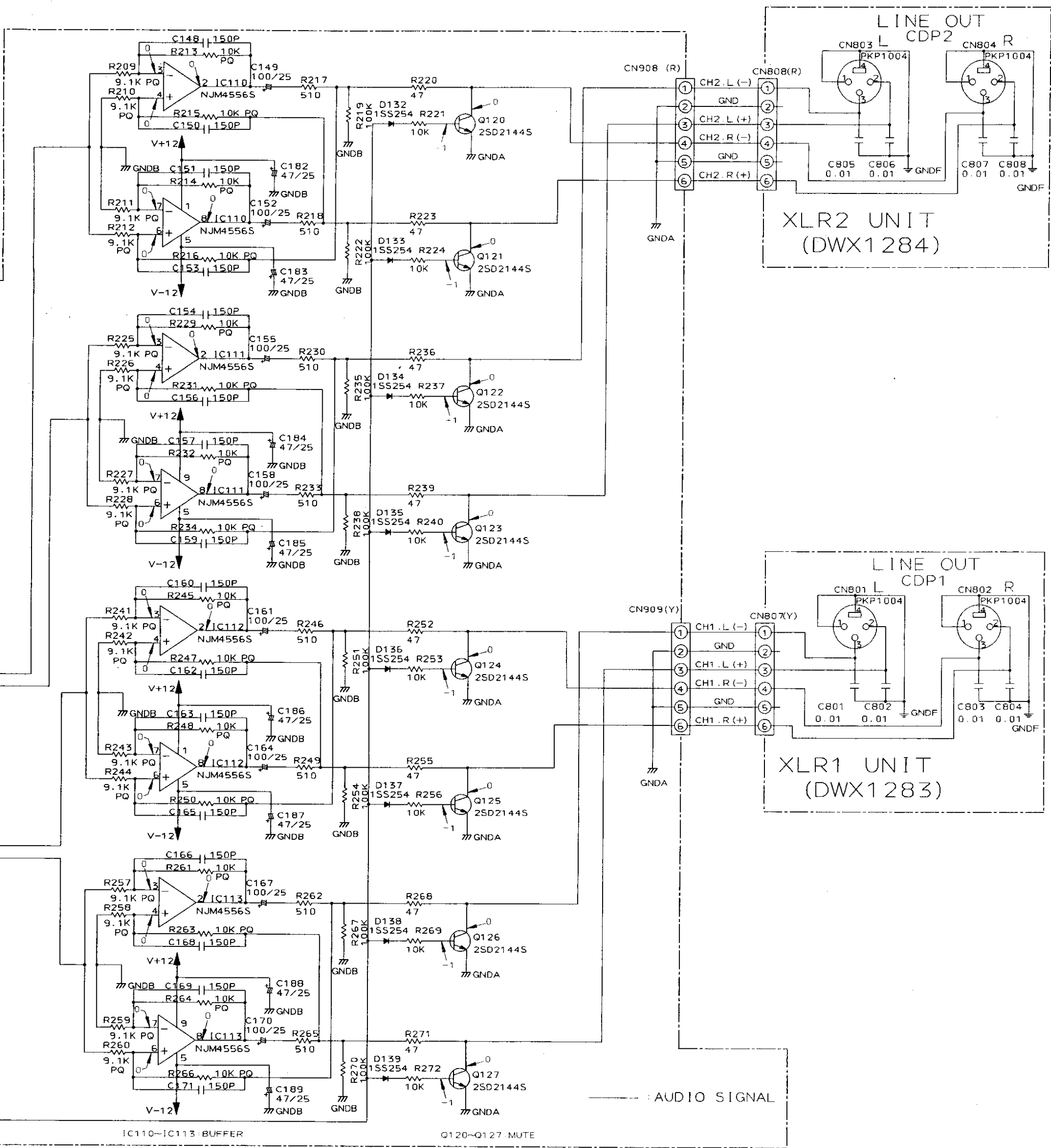

IC110~IC113: BUFFER

Q120~Q127: MUTE

AUDIO SIGNAL

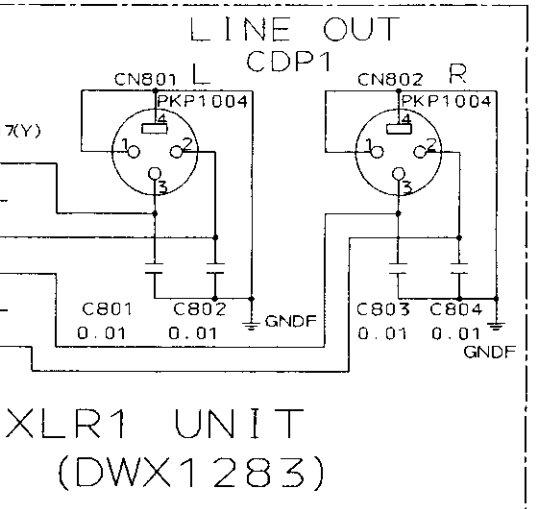
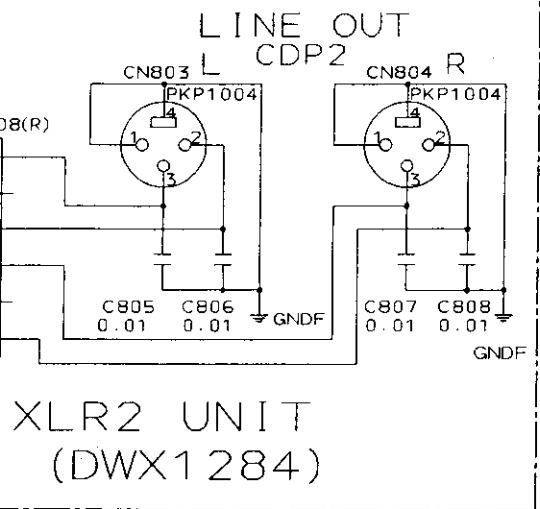

7.6 MCDR UNIT, KDSB UNIT, ILDB UNIT, RSIF UNIT, ENCB UNIT, CLSB UNIT, SYPS UNIT AND VCHS UNIT

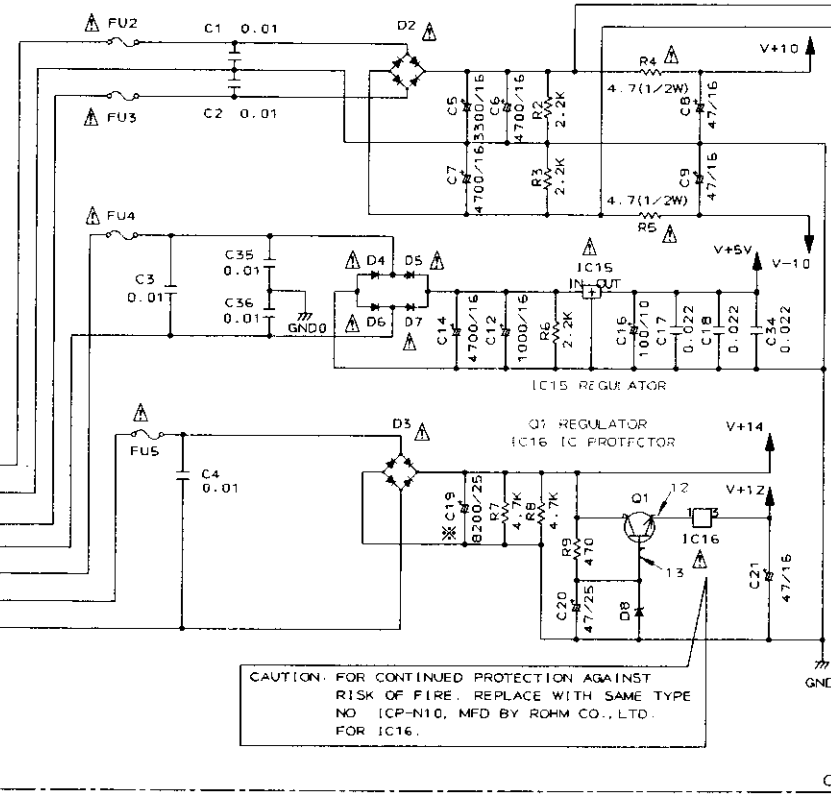
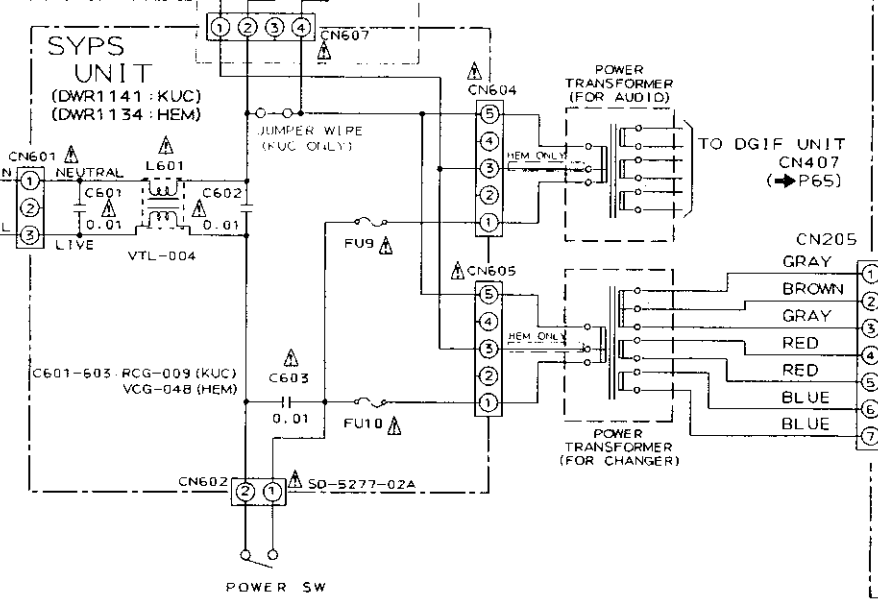
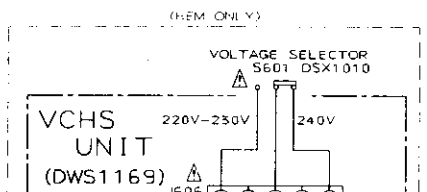
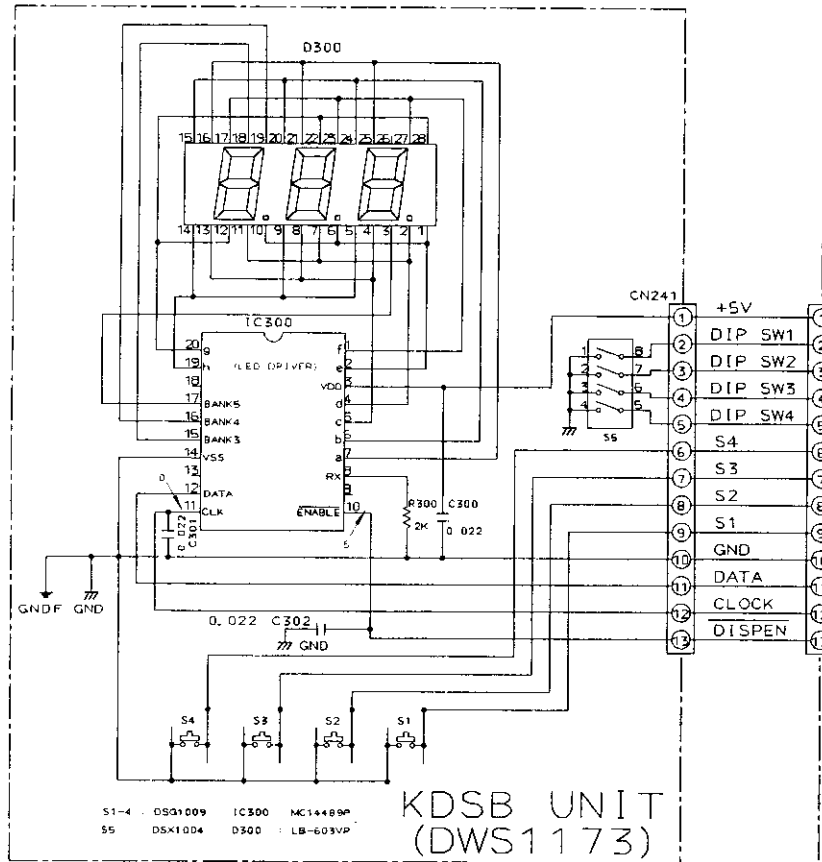
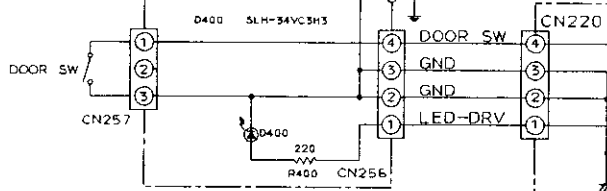
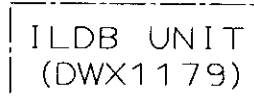
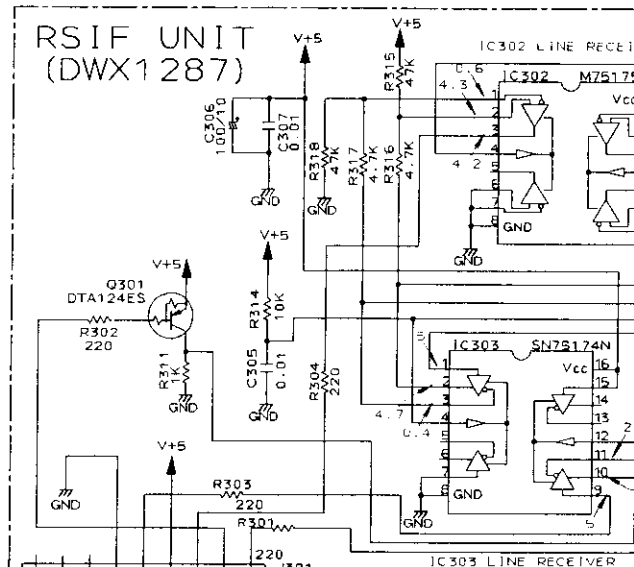
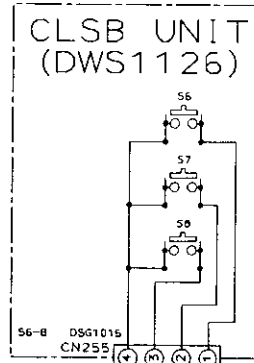
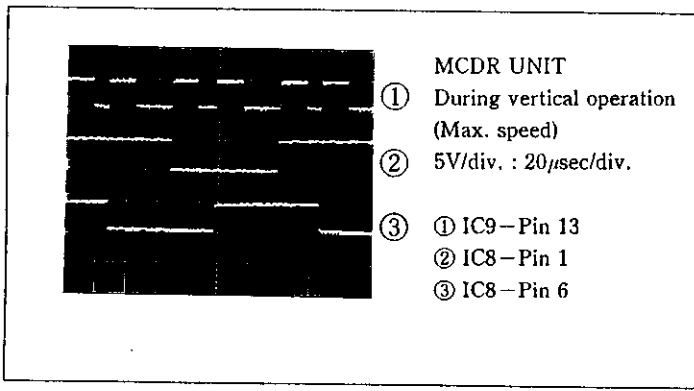

CAUTION: FOR CONTINUED PROTECTION AGAINST RISK OF FIRE, REPLACE WITH SAME TYPE NO. ICP-F10, MFD BY ROHM CO., LTD. FOR IC16.

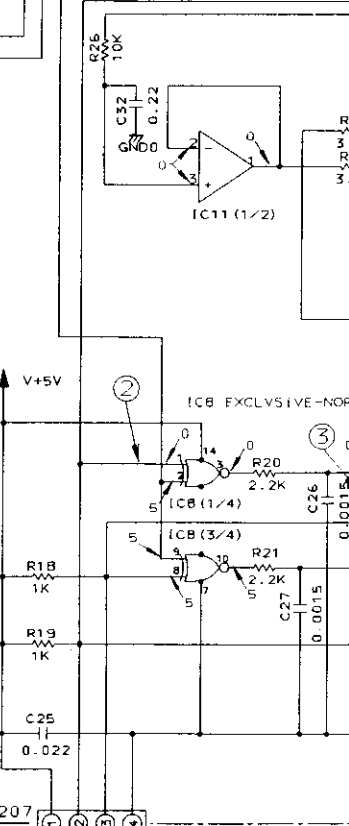

	DWM1283-A HEM	DWM1287-A KUC
FU2	T2AL250V	3.15A/125V
FU3	REK-103	DEK1019
FU4	T800mAL250V REK-099	1.25A/125V DEK1013
FU5	T5AL250V REK-107	8A/125V DEK1025
FU9	REK-099	DEK1013
FU10	T800mAL250V REK-103	1.25A/125V DEK1017
	T2AL250V	2.5A/125V

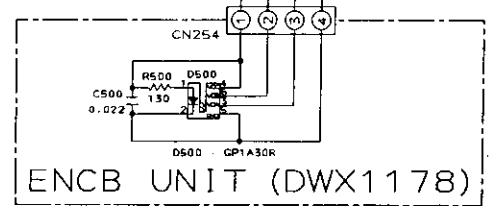

RSIF UNIT (DWX1287)

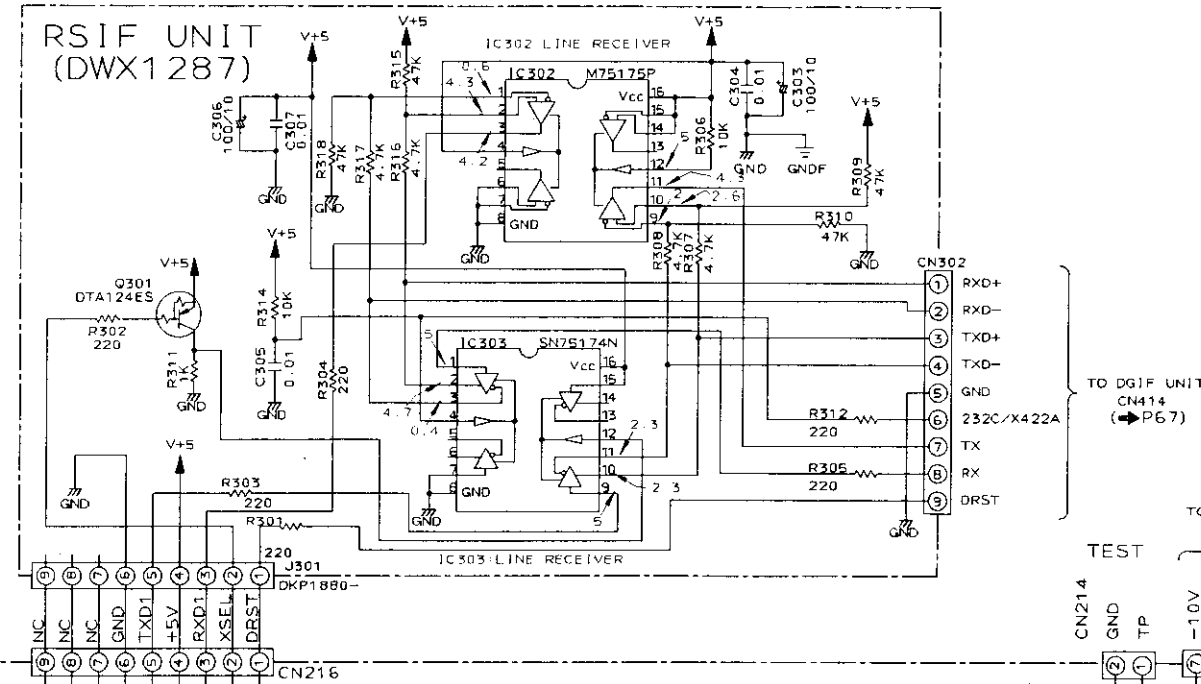

MCDR UNIT

- ④ IC12 10/sec/div. During vertical operation (Max. speed)
- ⑤ ④ Pin 1 : 5V/div.
- ⑥ ⑤ Pin 7 : 1V/div.
- ⑦ ⑥ Pin 6 : 1V/div.

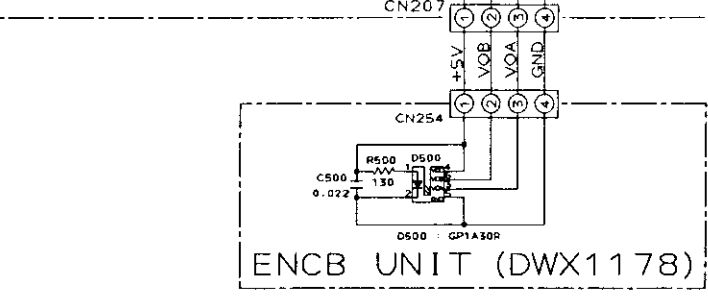
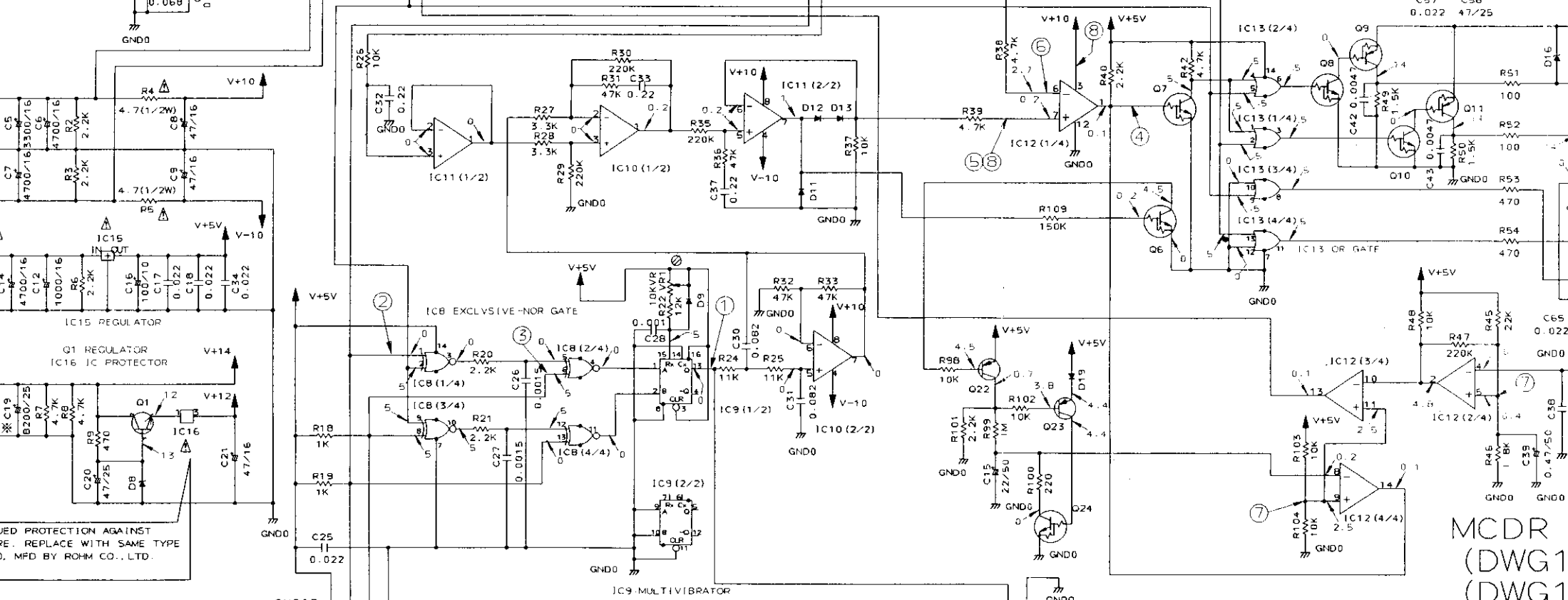
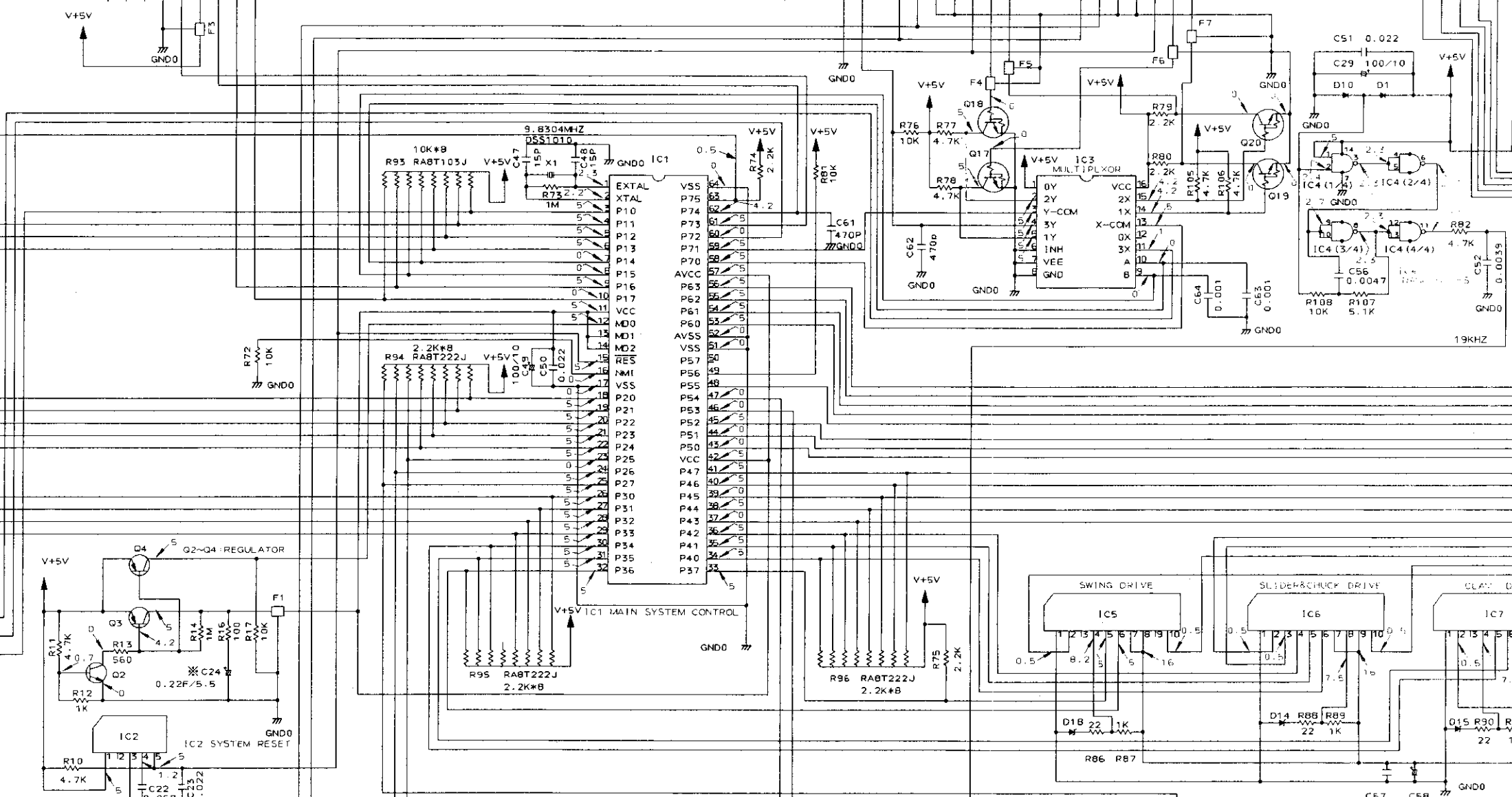
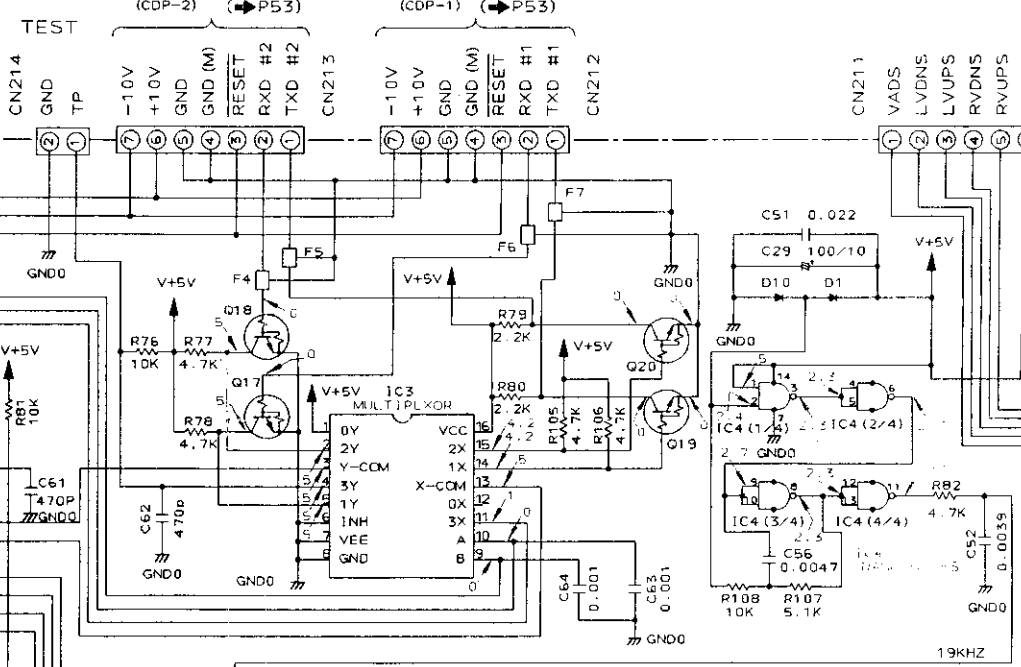

IC1	PSS222A	Q1	2SD1266	F1-7	VTH
IC2	M51953BL	Q2	2SC1740S		
IC3	TC74HC0052AP	Q3, 4	2SA1015	C5	DCH
IC4	TC74HC00AP	Q6, 7, 8, 10	DTA124ES	C7, 6, 14	DCH
IC5, 7	TA7291P	17-20, 24		C19	DCH
IC6	TA7288P	Q9, 11, 12	DTA124ES	C24	DCH
IC8	TC4077BP			C44	DCH
IC9	TC74HC123AP	Q22, 23	2SA9335		
IC10, 11	NJM4565DA	D1, 9, 10, 11-13, 19	15S254		
IC12	BA10339	D2	8BA-402		
IC13	TC74HC32AP	D3	8BA-406B		
IC14	4AM12	D4-7	15R139-403		
IC15	LM2940CT-5.0	D8	MT213A/B		
IC16	ICP-N10	D14-17	MT27.5B/C		
IC17	ICP-N38	D18	MT28.2B		

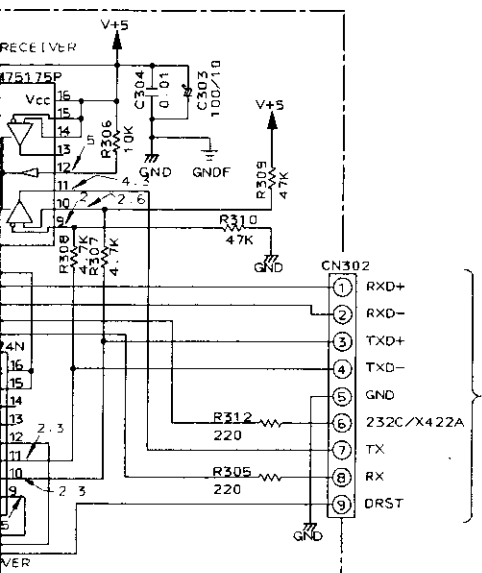

MCDR UNIT
 ④ IC12 10μsec/div.
 During vertical operation
 (Max. speed)
 ⑤
 ⑥ ④ Pin 1 : 5V/div.
 ⑤ Pin 7 : 1V/div.
 ⑥ Pin 6 : 1V/div.

MCDR UNIT
 IC12
 During vertical operation
 (Max. speed)
 ⑦ 10V/div., 20μsec/div.
 ⑦ Pin 5, 9 (Raise)
 ⑧ Pin 3, 7 (Lower)

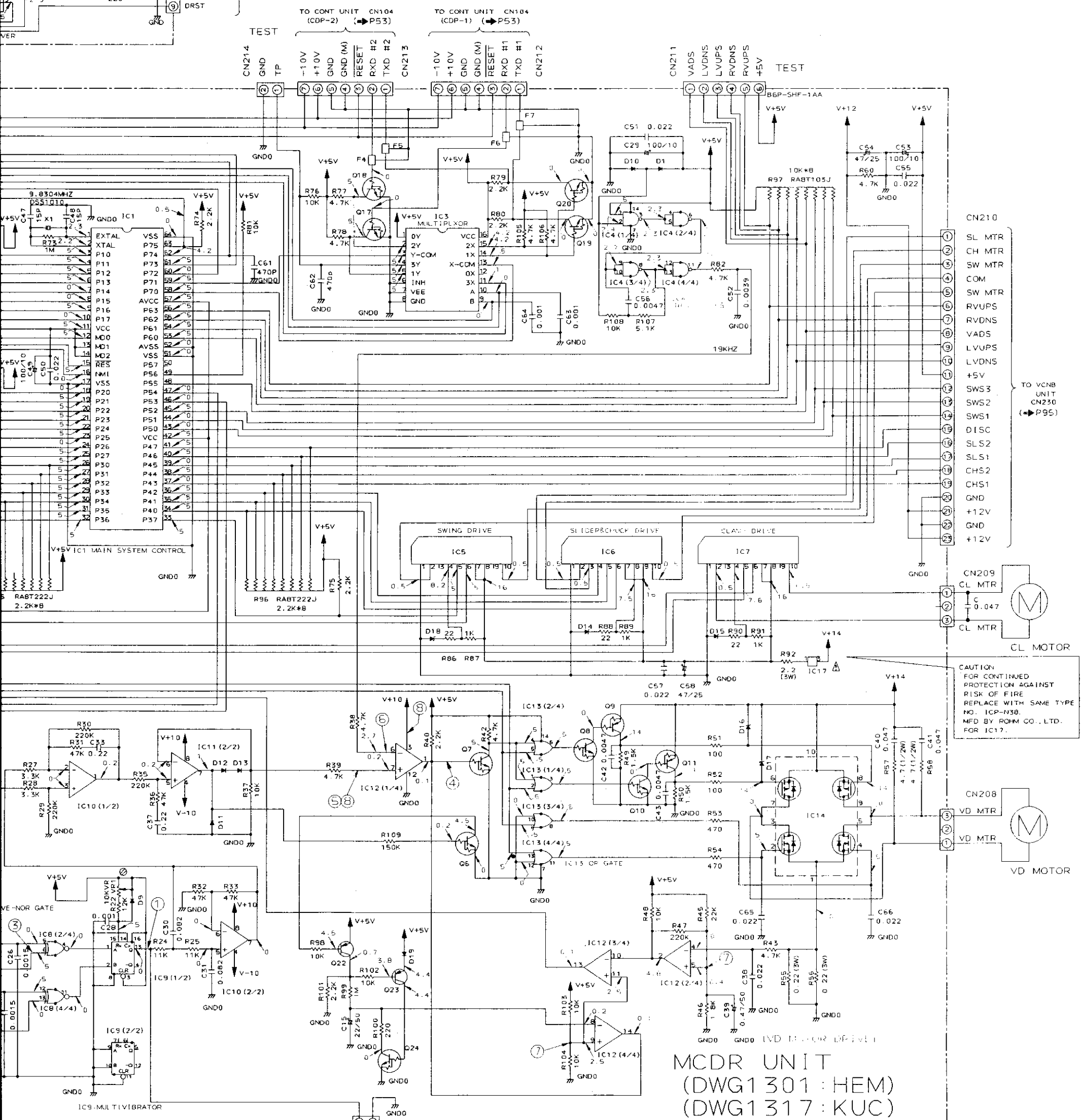

MCDR UNIT
 (DWG1301:HEM)
 (DWG1317:KUC)

TEST

IC1	-PDS222A	O1	-25D1266	F1-7	VTH1001
IC2	-M51953BL	O2	-25C17405	C5	DCH1023
IC3	-TC74HC4052AP	O3, 4	-25A1015	C7, 6, 14	DCH1024
IC4	-TC74HC00AP	O6, 7, 8, 10	-DTC124ES	C19	-DCH1035
IC5, 7	-TA7291P	17-20, 24		C24	-DCH1037
IC6	-TA7288P	O9, 11, 12	-DTA124ES	C44	-DCG1004
IC8	-TC4077BP				
IC9	-TC74HC123AP	Q22, 23	-25A9335	X1	-DSS1010
IC10, 11	-N.M.4565DA	D1, 9, 10, 11-13, 19	-15S254		
IC12	-BA10539	O2	-RBA-402		
IC13	-TC74HC32AP	O3	-RBA-406B		
IC14	-4AM12	O4-7	-15R139-400		
IC15	-LM2940CT-5.0	O8	-MTZ15A/B		
IC16	-1CP-N10	D14-17	-MTZ7.5B/C		
IC17	-1CP-N38	D18	-MTZ8.2B		

A
 B
 C
 D
 E
 F

RSIF Unit (DWX1287)

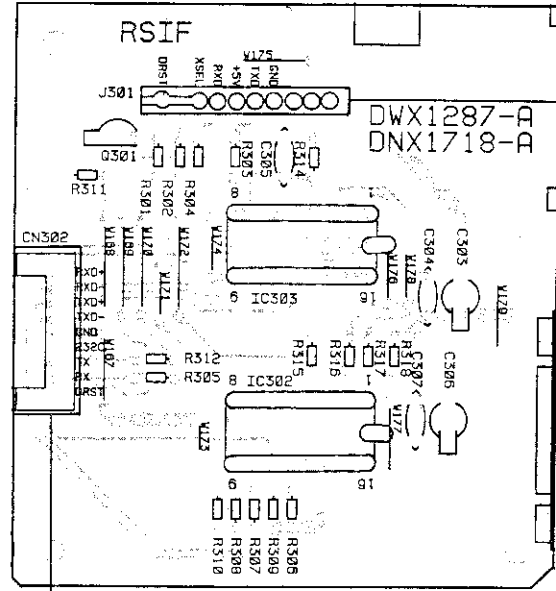

IC302		IC303	
Pin No	Voltage	Pin No	Voltage
1	0.6	1	5
2	4.3	2	4.7
3	4.2	3	0.4
4-8		4-8	
9	2	9	5
10	2.6	10, 11	2.3
11	4.3		
12	5		

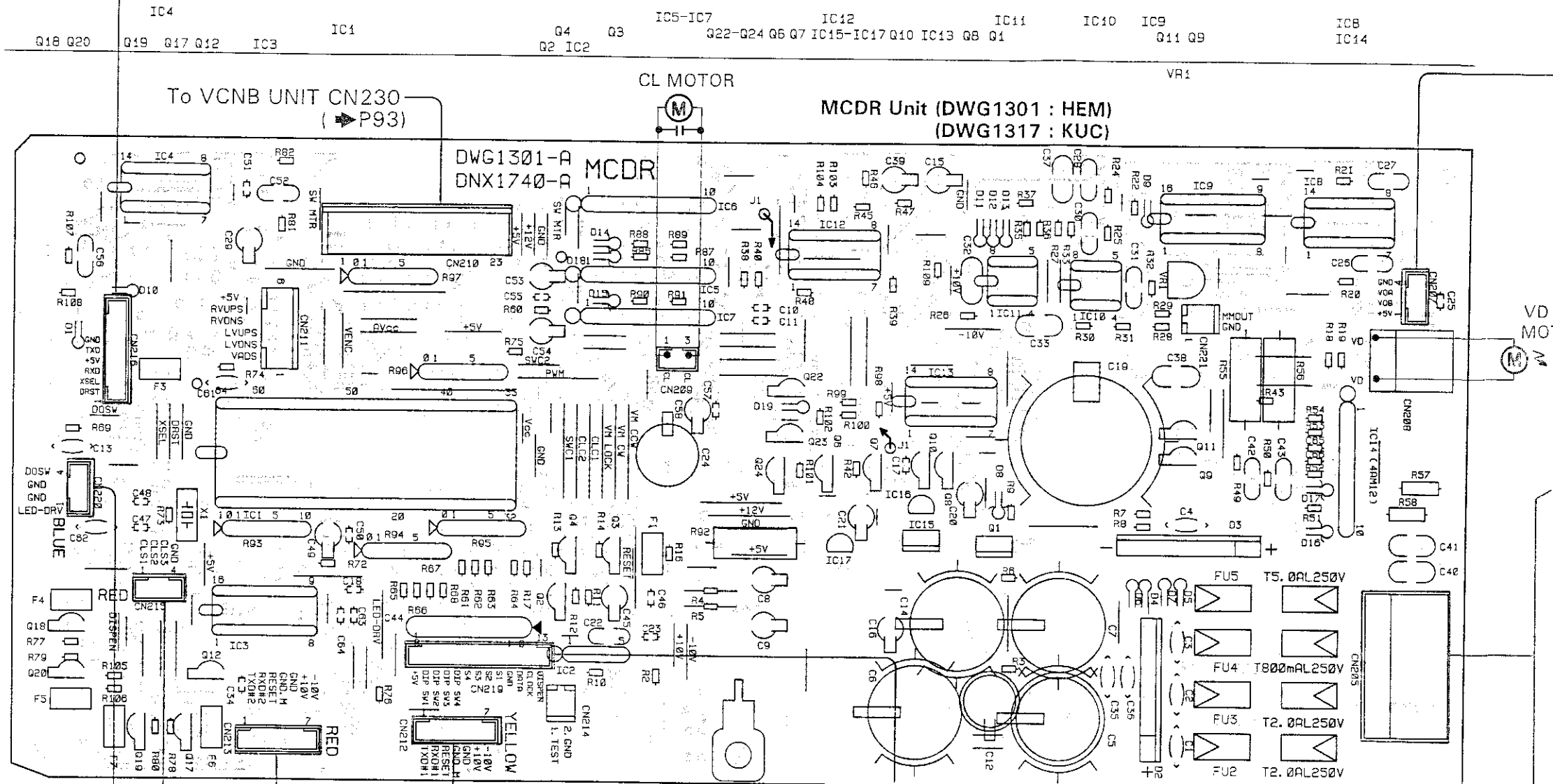

IC1		IC4		ICB		IC13	
Pin No	Voltage	Pin No	Voltage	Pin No	Voltage	Pin No	Voltage
1	2.3	1	5	1	0	1-6	5
2	2.2	2	2.4	2	5	7	0
3-6	5	3-5	2.3	3-5	0	8-9	5
7-8	0	6	2.7	6	5	10	0
9	5	7		7		11	5
10	0	8	2.3	8-10	5	12	0
11-12	5	9-11	2.7	11	0	13	5
13-14		12-13	2.3	12	5	14	
15	5	14	5	13	0		
16-17	0			14			
18-22	5						
23	0						
24-36	5						
37	0						
38	5						
39	0						
40-42	5						
43-44	0						
45	5						
46-47	0						
48-50							
51-52	0						
53-59	5						
60	0						
61	5						
62	4.2						
63	0.5						
64	0						

IC5		IC9		IC14	
Pin No	Voltage	Pin No	Voltage	Pin No	Voltage
1	0.5	1-3	0	1	0
2	0.5	4-14	5	2-3	0
3	0	15	5	4	5
4	0.2	16	0	5	0
5	0.5			6	14
6	0.5			7	0
7	15			8	14
8	7.5			9	0
9	16			10	0.5
10	0.5				

IC2		IC7		IC10	
Pin No	Voltage	Pin No	Voltage	Pin No	Voltage
1	5	1	0.5	1	0.2
2-3		2	0.5	2-3	0
4	1.2	3		4	
5	5	4	7.6	5-7	0
		5-6	5	8	
		7-8	16		
		9			
		10	0.5		

IC3		IC12		Voltage	
Pin No	Voltage	Pin No	Voltage		
1		1	0.1	01	12
2-5	5	2	4.8	02	0
6-8		3		03-4	5
9-10	0	4	0	05	0.2
11	1	5	0.4	06	0
12		6	2.7	07	0
13	5	7	0.2	08	5
14-15	4.2	8		09	0
16		9	2.5	10	14
		10	4.8	Q10	5
		11	2.5	Q11	0
		12		Q12	5
		13-14	0.1	Q17-18	0
				Q19-20	0
				Q22	4.5
				Q23	4.4
				Q24	4.4

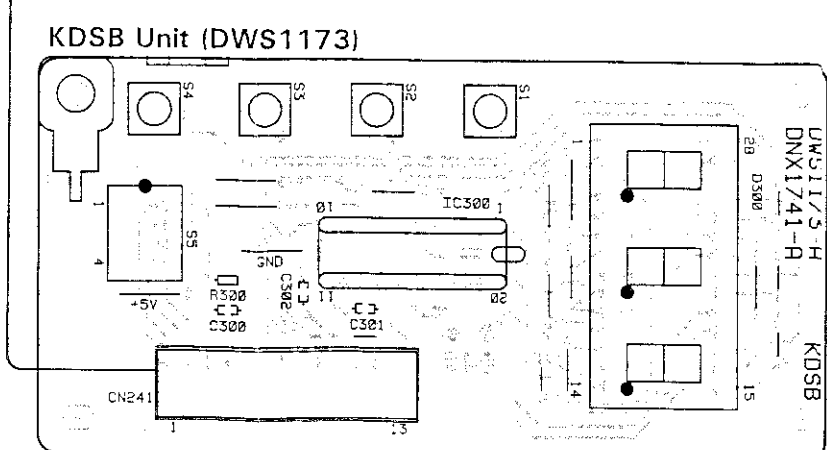
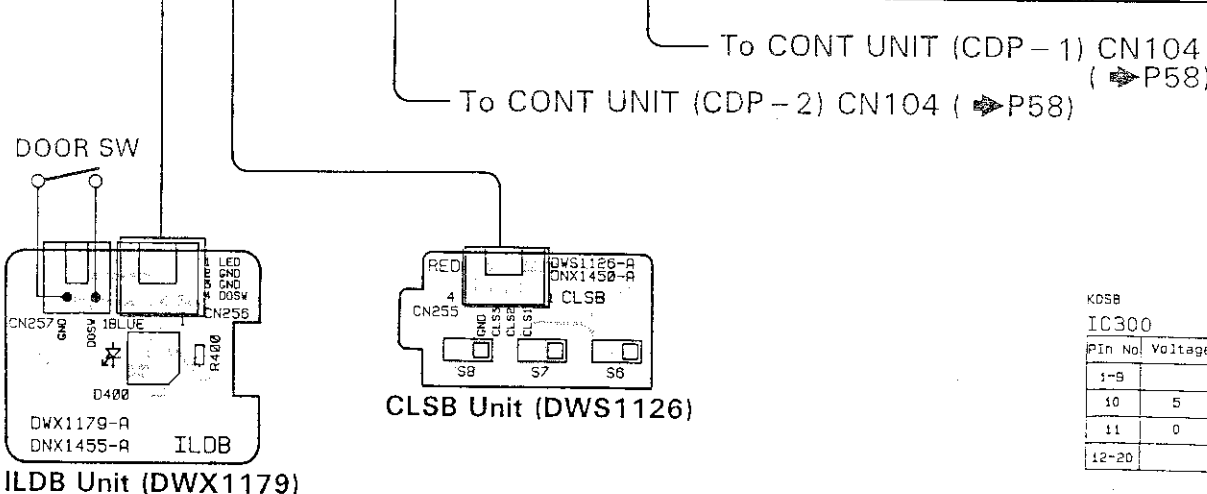

This P. C. B connection diagram is viewed from the parts mounted side.

To DGIF UNIT CN407 (P64)

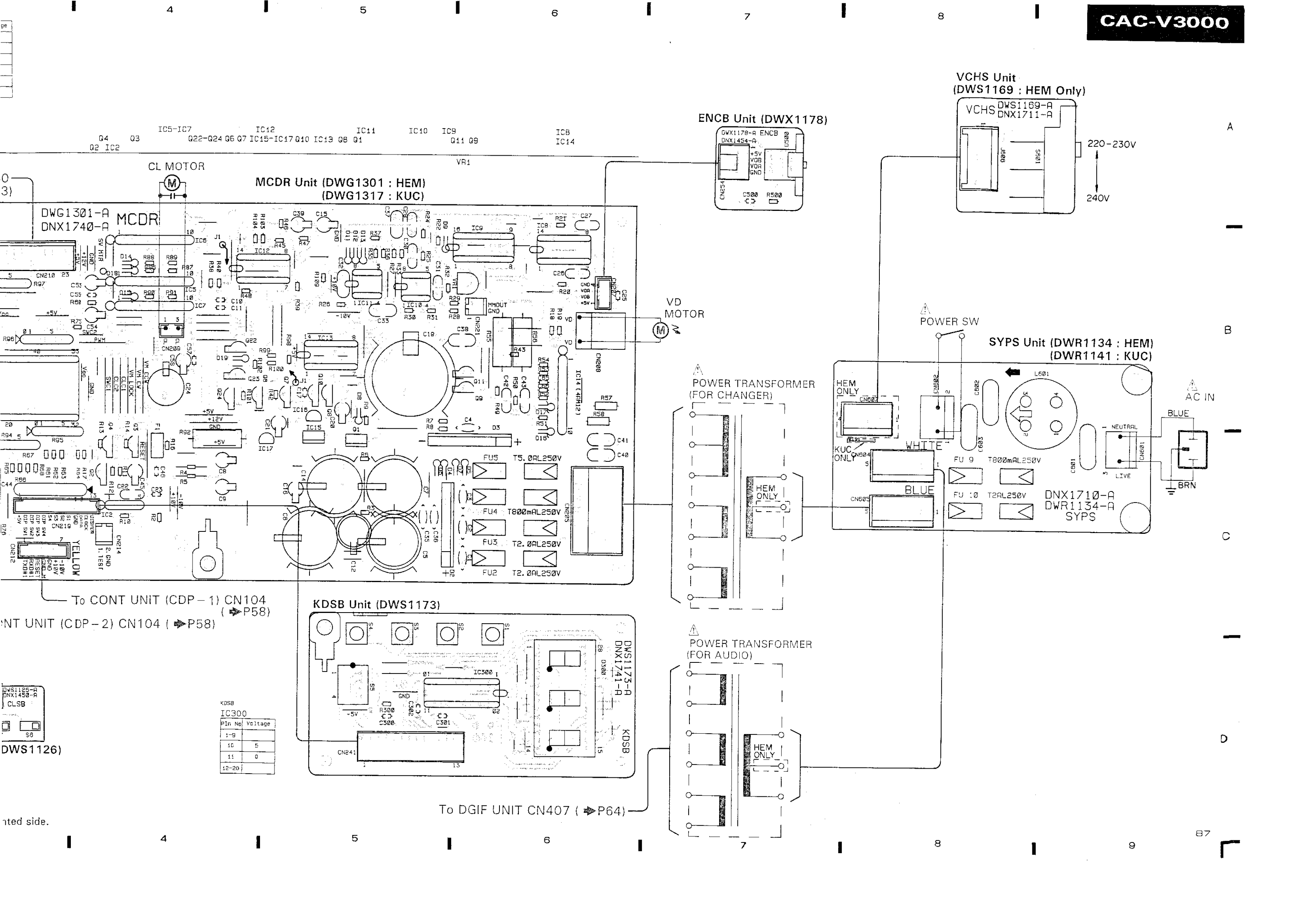

IC5-IC7 Q22-Q24 Q6 Q7 IC15-IC17 Q10 IC13 Q8 Q1 IC8 IC14
 Q4 Q3 Q2 IC2

**MCDR Unit (DWG1301 : HEM)
 (DWG1317 : KUC)**

ENCB Unit (DWX1178)

**VCHS Unit
 (DWS1169 : HEM Only)**

**SYPS Unit (DWR1134 : HEM)
 (DWR1141 : KUC)**

KDSB Unit (DWS1173)

**POWER TRANSFORMER
 (FOR CHANGER)**

**POWER TRANSFORMER
 (FOR AUDIO)**

POWER SW

AC IN

To CONT UNIT (CDP-1) CN104 (P58)
 CONT UNIT (CDP-2) CN104 (P58)

To DGIF UNIT CN407 (P64)

KDSB
IC300

Pin No.	Voltage
1-9	5
10	5
11	0
12-20	

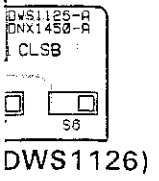

nted side.

A
 B
 C
 D

A

B

C

D

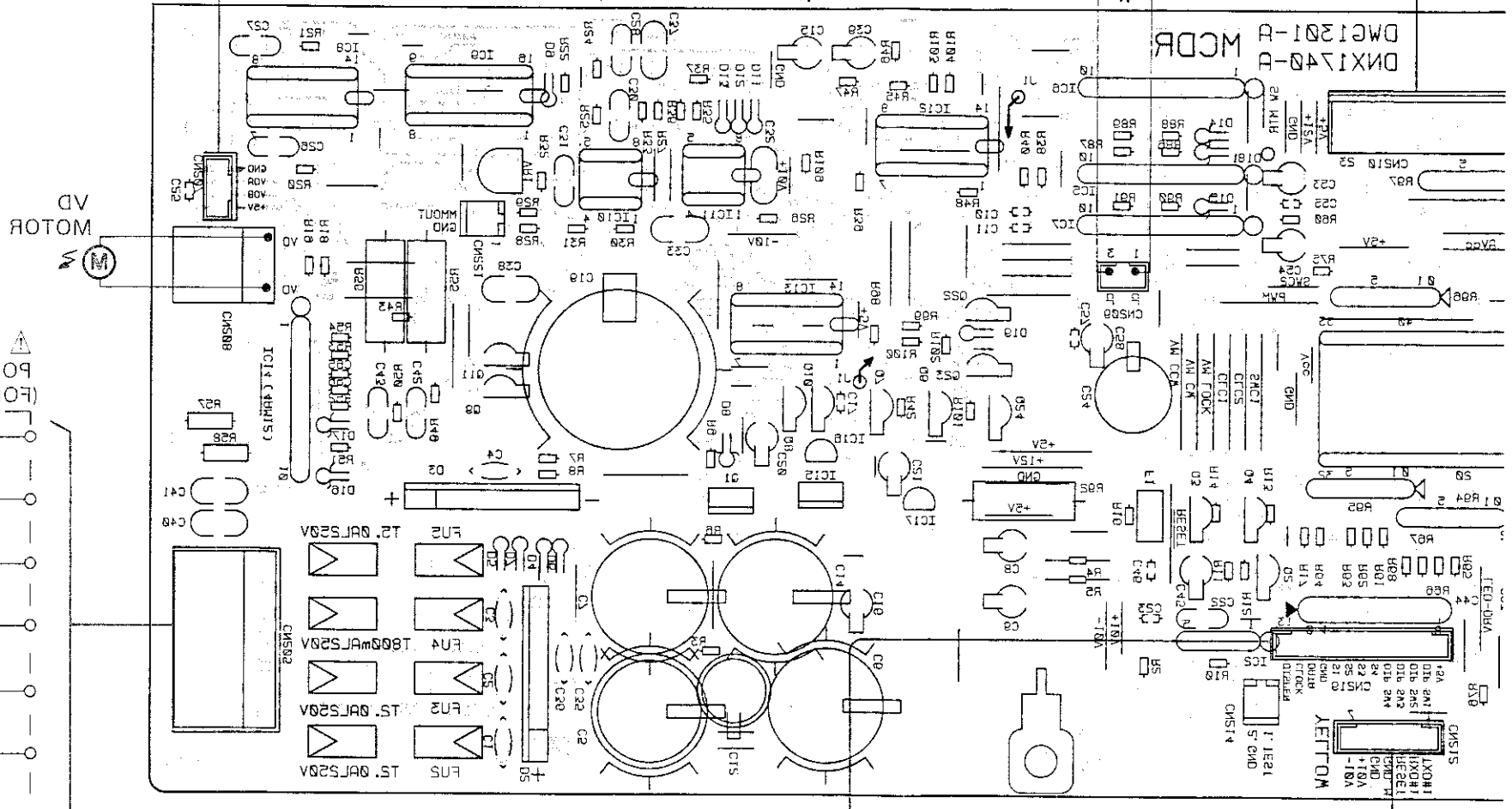
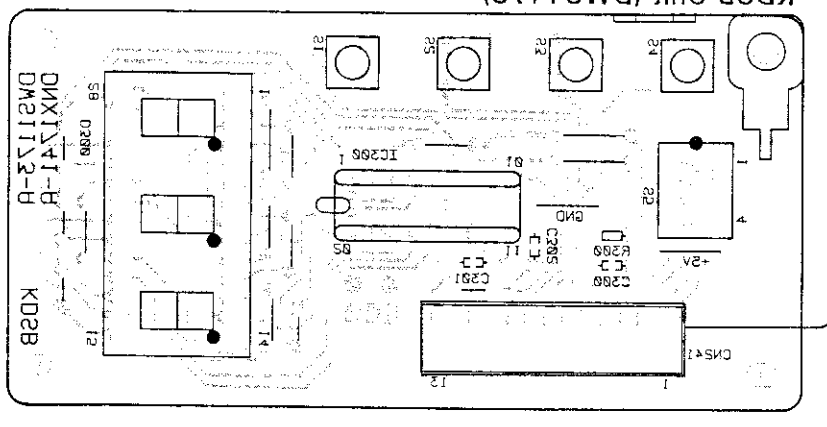
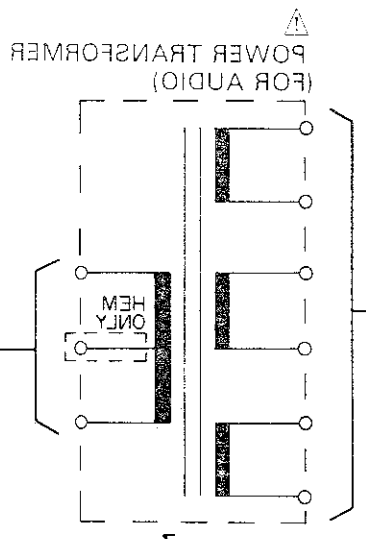
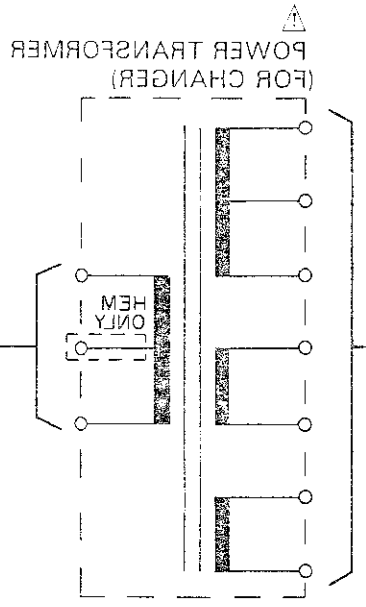
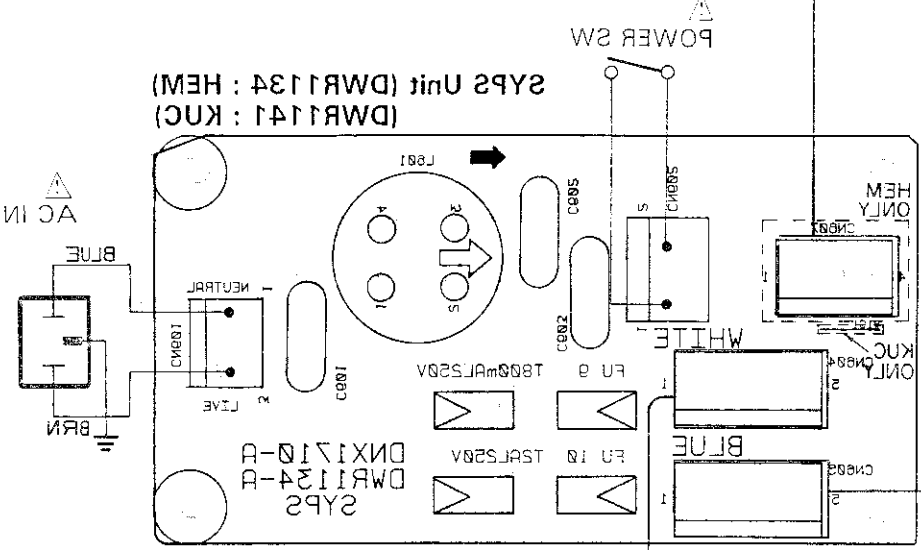
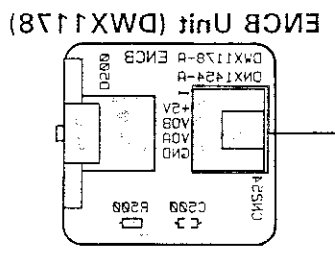
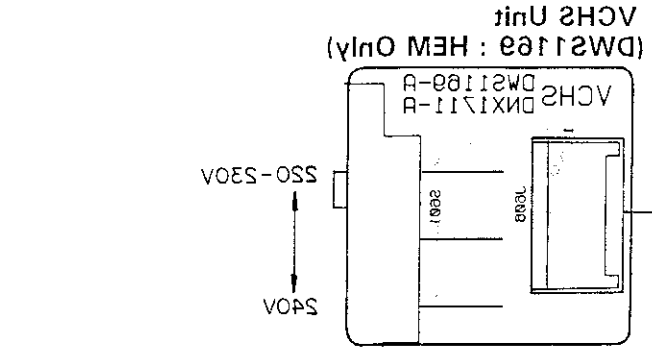

Pin No	Voltage
1	0
2	0
3	0
4	0
5	0
6	0
7	0
8	0
9	0
10	0
11	0
12	0
13	0
14	0
15	0
16	0
17	0
18	0
19	0
20	0
21	0
22	0
23	0
24	0
25	0
26	0
27	0
28	0
29	0
30	0
31	0
32	0
33	0
34	0
35	0
36	0
37	0
38	0
39	0
40	0
41	0
42	0
43	0
44	0
45	0
46	0
47	0
48	0
49	0
50	0

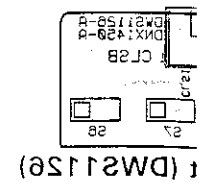

Page	Rev
1	1
2	1
3	1
4	1
5	1
6	1
7	1
8	1
9	1
10	1
11	1
12	1
13	1
14	1
15	1
16	1
17	1
18	1
19	1
20	1
21	1
22	1
23	1
24	1
25	1
26	1
27	1
28	1
29	1
30	1
31	1
32	1
33	1
34	1
35	1
36	1
37	1
38	1
39	1
40	1
41	1
42	1
43	1
44	1
45	1
46	1
47	1
48	1
49	1
50	1

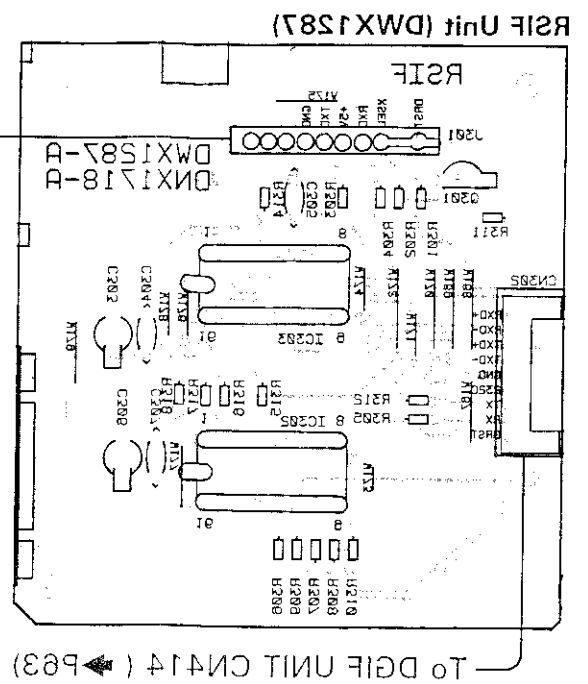

IC1	IC2	IC3	IC4	IC5	IC6	IC7	IC8	IC9	IC10	IC11	IC12	IC13	IC14	IC15	IC16	IC17	IC18	IC19	IC20	IC21	IC22	IC23	IC24	IC25	IC26	IC27	IC28	IC29	IC30	IC31	IC32	IC33	IC34	IC35	IC36	IC37	IC38	IC39	IC40	IC41	IC42	IC43	IC44	IC45	IC46	IC47	IC48	IC49	IC50	IC51	IC52	IC53	IC54	IC55	IC56	IC57	IC58	IC59	IC60	IC61	IC62	IC63	IC64	IC65	IC66	IC67	IC68	IC69	IC70	IC71	IC72	IC73	IC74	IC75	IC76	IC77	IC78	IC79	IC80	IC81	IC82	IC83	IC84	IC85	IC86	IC87	IC88	IC89	IC90	IC91	IC92	IC93	IC94	IC95	IC96	IC97	IC98	IC99	IC100
1	2	3	4	5	6	7	8	9	10	11	12	13	14	15	16	17	18	19	20	21	22	23	24	25	26	27	28	29	30	31	32	33	34	35	36	37	38	39	40	41	42	43	44	45	46	47	48	49	50	51	52	53	54	55	56	57	58	59	60	61	62	63	64	65	66	67	68	69	70	71	72	73	74	75	76	77	78	79	80	81	82	83	84	85	86	87	88	89	90	91	92	93	94	95	96	97	98	99	100

IC303	IC304	IC305	IC306	IC307	IC308	IC309	IC310	IC311	IC312	IC313	IC314	IC315	IC316	IC317	IC318	IC319	IC320	IC321	IC322	IC323	IC324	IC325	IC326	IC327	IC328	IC329	IC330	IC331	IC332	IC333	IC334	IC335	IC336	IC337	IC338	IC339	IC340	IC341	IC342	IC343	IC344	IC345	IC346	IC347	IC348	IC349	IC350	IC351	IC352	IC353	IC354	IC355	IC356	IC357	IC358	IC359	IC360	IC361	IC362	IC363	IC364	IC365	IC366	IC367	IC368	IC369	IC370	IC371	IC372	IC373	IC374	IC375	IC376	IC377	IC378	IC379	IC380	IC381	IC382	IC383	IC384	IC385	IC386	IC387	IC388	IC389	IC390	IC391	IC392	IC393	IC394	IC395	IC396	IC397	IC398	IC399	IC400		
1	2	3	4	5	6	7	8	9	10	11	12	13	14	15	16	17	18	19	20	21	22	23	24	25	26	27	28	29	30	31	32	33	34	35	36	37	38	39	40	41	42	43	44	45	46	47	48	49	50	51	52	53	54	55	56	57	58	59	60	61	62	63	64	65	66	67	68	69	70	71	72	73	74	75	76	77	78	79	80	81	82	83	84	85	86	87	88	89	90	91	92	93	94	95	96	97	98	99	100

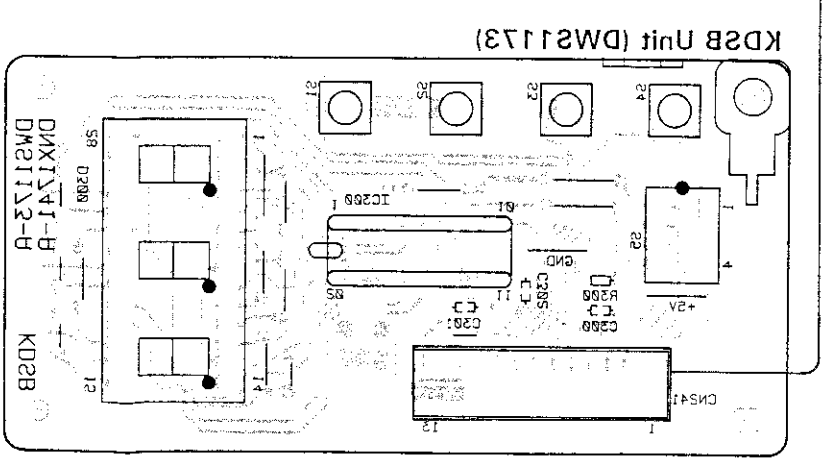
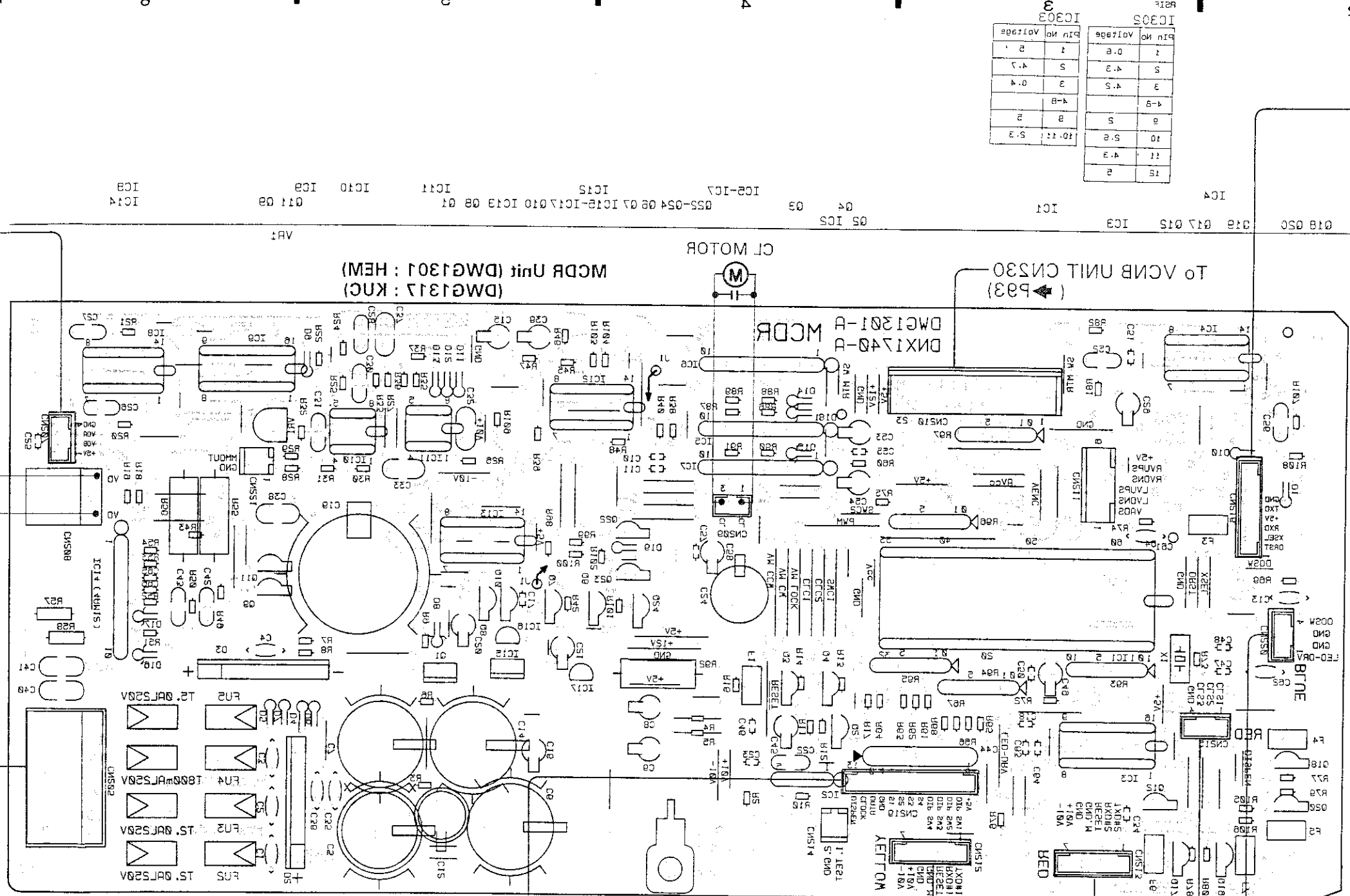

IC300	IC301	IC302	IC303	IC304	IC305	IC306	IC307	IC308	IC309	IC310	IC311	IC312	IC313	IC314	IC315	IC316	IC317	IC318	IC319	IC320	IC321	IC322	IC323	IC324	IC325	IC326	IC327	IC328	IC329	IC330	IC331	IC332	IC333	IC334	IC335	IC336	IC337	IC338	IC339	IC340	IC341	IC342	IC343	IC344	IC345	IC346	IC347	IC348	IC349	IC350	IC351	IC352	IC353	IC354	IC355	IC356	IC357	IC358	IC359	IC360	IC361	IC362	IC363	IC364	IC365	IC366	IC367	IC368	IC369	IC370	IC371	IC372	IC373	IC374	IC375	IC376	IC377	IC378	IC379	IC380	IC381	IC382	IC383	IC384	IC385	IC386	IC387	IC388	IC389	IC390	IC391	IC392	IC393	IC394	IC395	IC396	IC397	IC398	IC399	IC400
1	2	3	4	5	6	7	8	9	10	11	12	13	14	15	16	17	18	19	20	21	22	23	24	25	26	27	28	29	30	31	32	33	34	35	36	37	38	39	40	41	42	43	44	45	46	47	48	49	50	51	52	53	54	55	56	57	58	59	60	61	62	63	64	65	66	67	68	69	70	71	72	73	74	75	76	77	78	79	80	81	82	83	84	85	86	87	88	89	90	91	92	93	94	95	96	97	98	99	100	

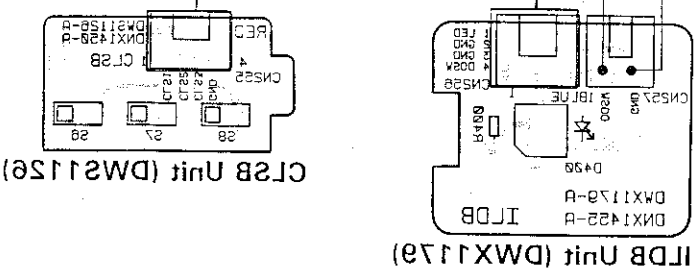

This P. C. B. connection diagram is viewed from the foil side.

TO DIGE UNIT CN407 (P64)

TO CONT UNIT (CDP-1) CN104 (P58)
 TO CONT UNIT (CDP-2) CN104 (P58)

TO DIGE UNIT CN414 (P83)

TO VCNB UNIT CN230 (P93)

MCDR Unit (DWG1301 : KUC)

CL MOTOR

IC1 IC2 IC3 IC4 IC5 IC6 IC7 IC8 IC9 IC10 IC11 IC12 IC13 IC14 IC15 IC16 IC17 IC18 IC19 IC20 IC21 IC22 IC23 IC24 IC25 IC26 IC27 IC28 IC29 IC30 IC31 IC32 IC33 IC34 IC35 IC36 IC37 IC38 IC39 IC40 IC41 IC42 IC43 IC44 IC45 IC46 IC47 IC48 IC49 IC50 IC51 IC52 IC53 IC54 IC55 IC56 IC57 IC58 IC59 IC60 IC61 IC62 IC63 IC64 IC65 IC66 IC67 IC68 IC69 IC70 IC71 IC72 IC73 IC74 IC75 IC76 IC77 IC78 IC79 IC80 IC81 IC82 IC83 IC84 IC85 IC86 IC87 IC88 IC89 IC90 IC91 IC92 IC93 IC94 IC95 IC96 IC97 IC98 IC99 IC100

VAR1

RSIF Unit (DWX1587)

IC1 IC2 IC3 IC4 IC5 IC6 IC7 IC8 IC9 IC10 IC11 IC12 IC13 IC14 IC15 IC16 IC17 IC18 IC19 IC20 IC21 IC22 IC23 IC24 IC25 IC26 IC27 IC28 IC29 IC30 IC31 IC32 IC33 IC34 IC35 IC36 IC37 IC38 IC39 IC40 IC41 IC42 IC43 IC44 IC45 IC46 IC47 IC48 IC49 IC50 IC51 IC52 IC53 IC54 IC55 IC56 IC57 IC58 IC59 IC60 IC61 IC62 IC63 IC64 IC65 IC66 IC67 IC68 IC69 IC70 IC71 IC72 IC73 IC74 IC75 IC76 IC77 IC78 IC79 IC80 IC81 IC82 IC83 IC84 IC85 IC86 IC87 IC88 IC89 IC90 IC91 IC92 IC93 IC94 IC95 IC96 IC97 IC98 IC99 IC100

7.7 VCNB UNIT, CNNB UNIT, SWGB UNIT, VSLB UNIT, VSRB UNIT AND DISP UNIT

0210

020	B	-0.1	15
021	C	-0.1	15

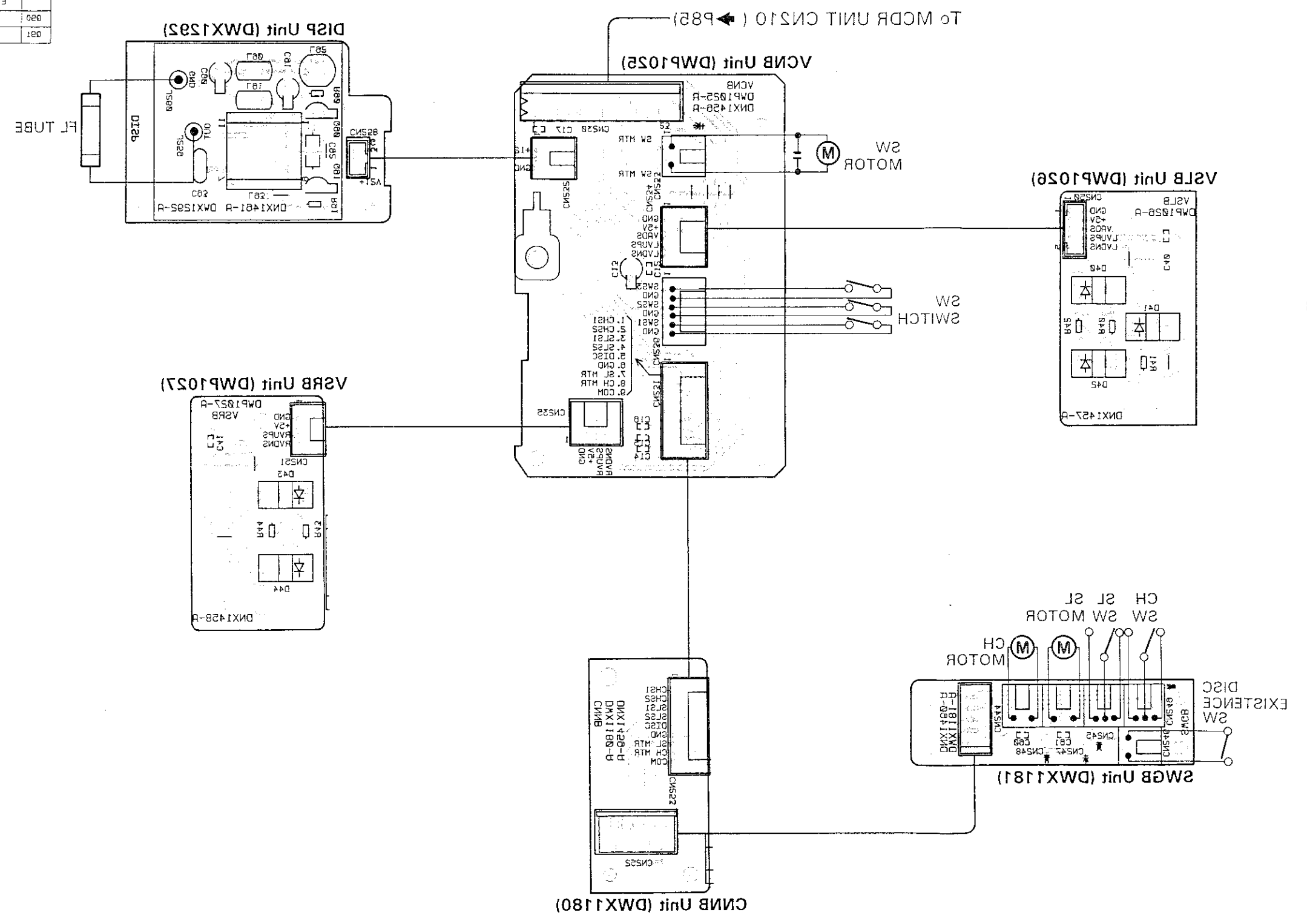

This P. C. B. connection diagram is viewed from the foil side.

A

B

C

D

To MCDR UNIT CN210 (→ P85)

VCNB Unit (DWP1025)

DISP Unit (DWX1292)

DISP	Voltage		
	E	B	C
090		-0.1	12
091		-0.1	12

FL TUBE

VSLB Unit (DWP1026)

SW SWITCH

VSRB Unit (DWP1027)

CNNB Unit (DWX1180)

SWGB Unit (DWX1181)

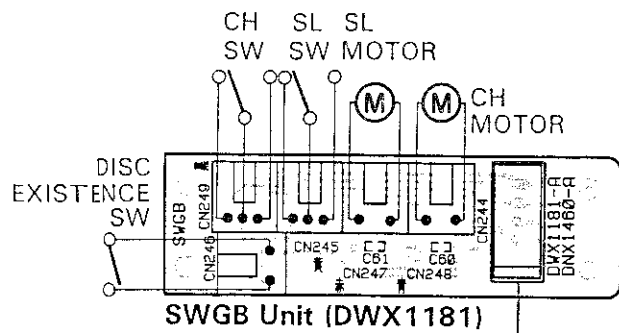

P.C.B. pattern diagram indication	Corresponding part symbol	Part name
		Transistor
		FET
		Diode
		Zener diode
		LED
		Varactor
		Tact switch
		Inductor
		Coil
		Transformer
		Filter
		Ceramic capacitor
		Mylar capacitor
		Styro capacitor
		Electrolytic capacitor (Non polarized)
		Electrolytic capacitor (Polarized)
		Electrolytic capacitor (Polarized)
		Power capacitor
		Semi-fixed resistor
		Resistor array
		Resistor
		Resonator
		Thermistor

A

B

C

D

This P. C. B connection diagram is viewed from the parts mounted side.

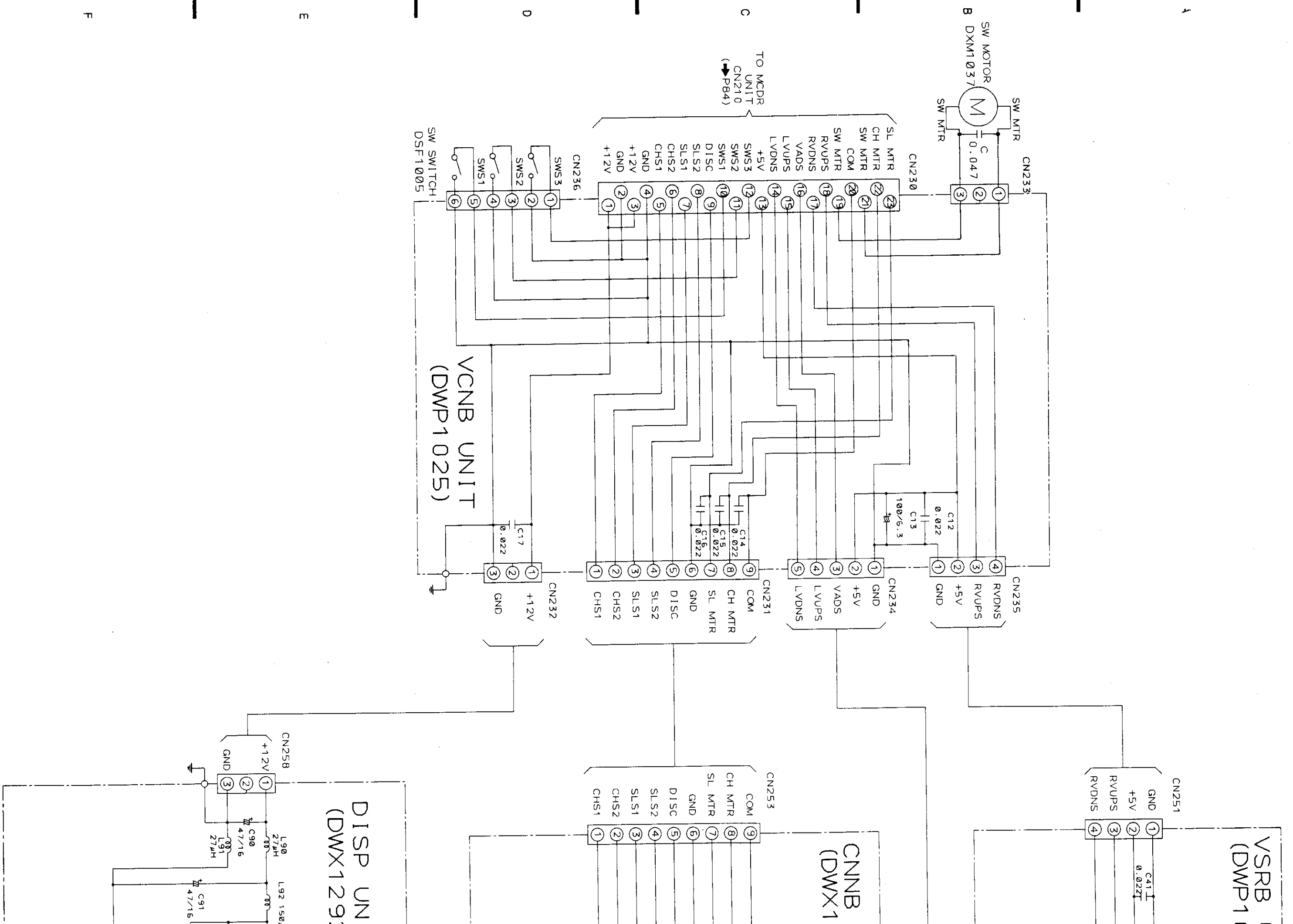

F

E

D

C

B

A

VSRB UNIT (DWP1027)

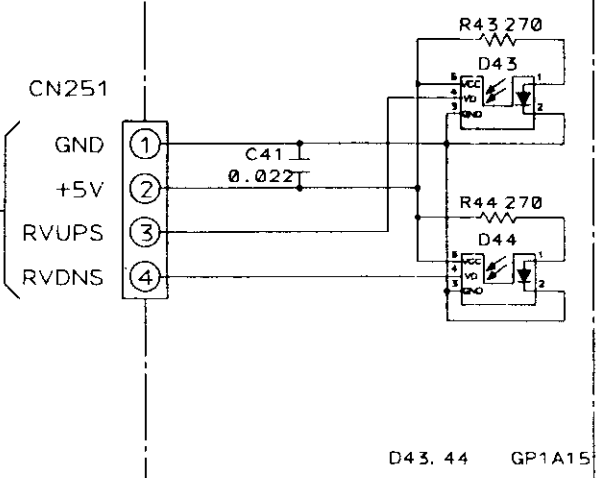

VSLB UNIT (DWP1026)

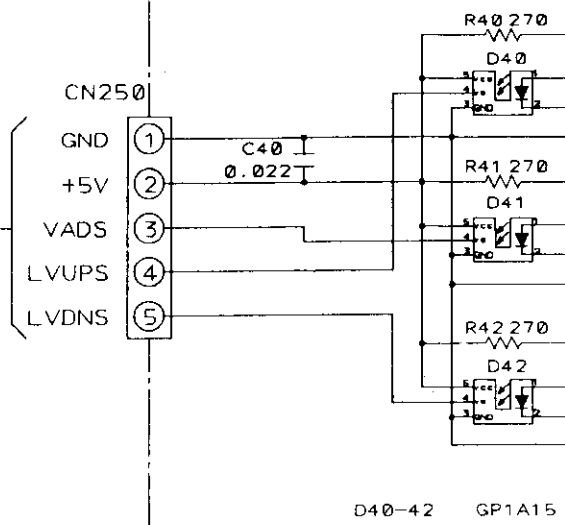

CNNB UNIT (DWX1180)

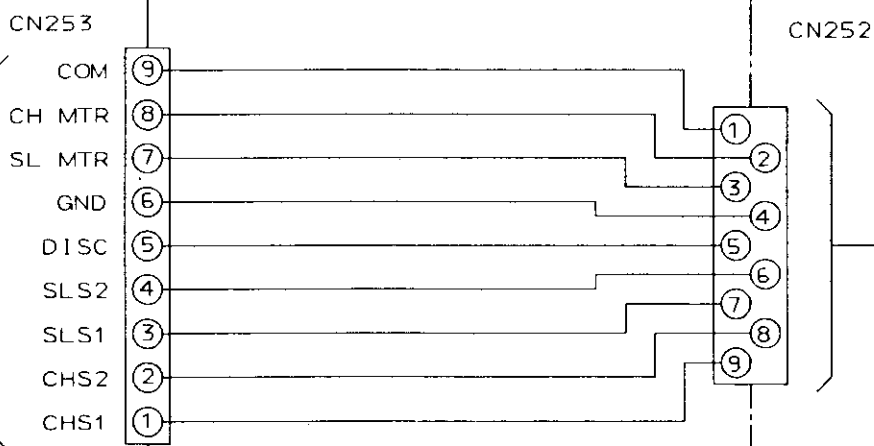

SWGB UNIT (DWX1181)

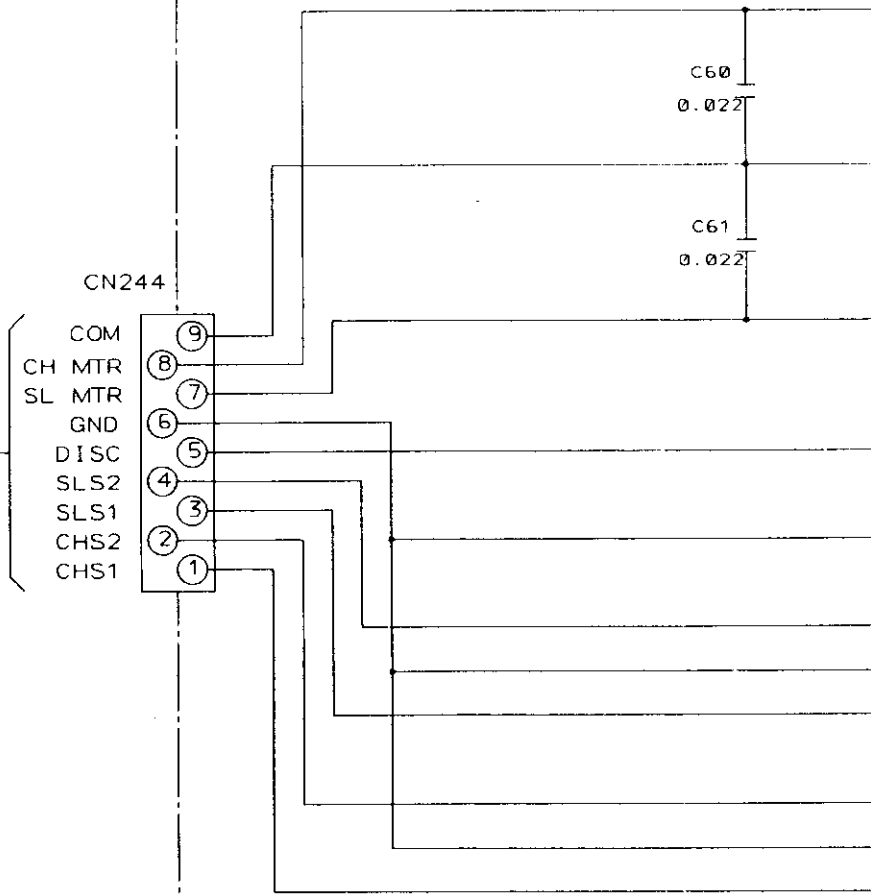

DISP UNIT (DWX1292)

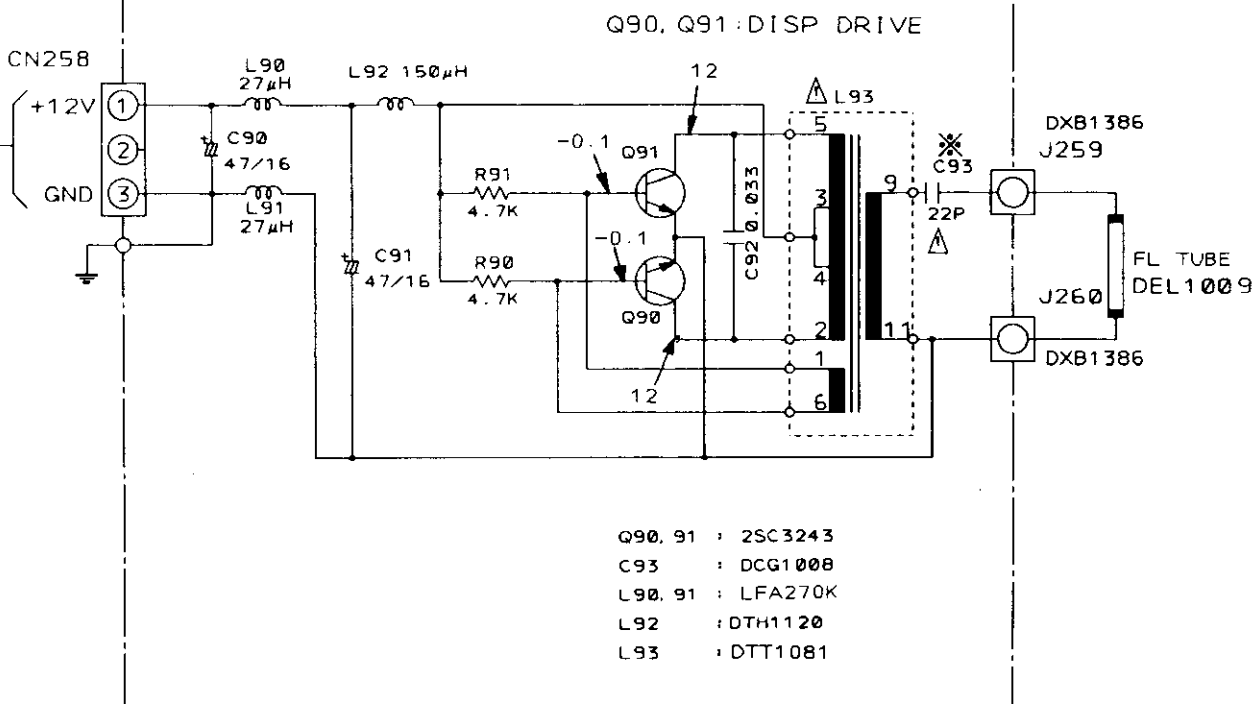

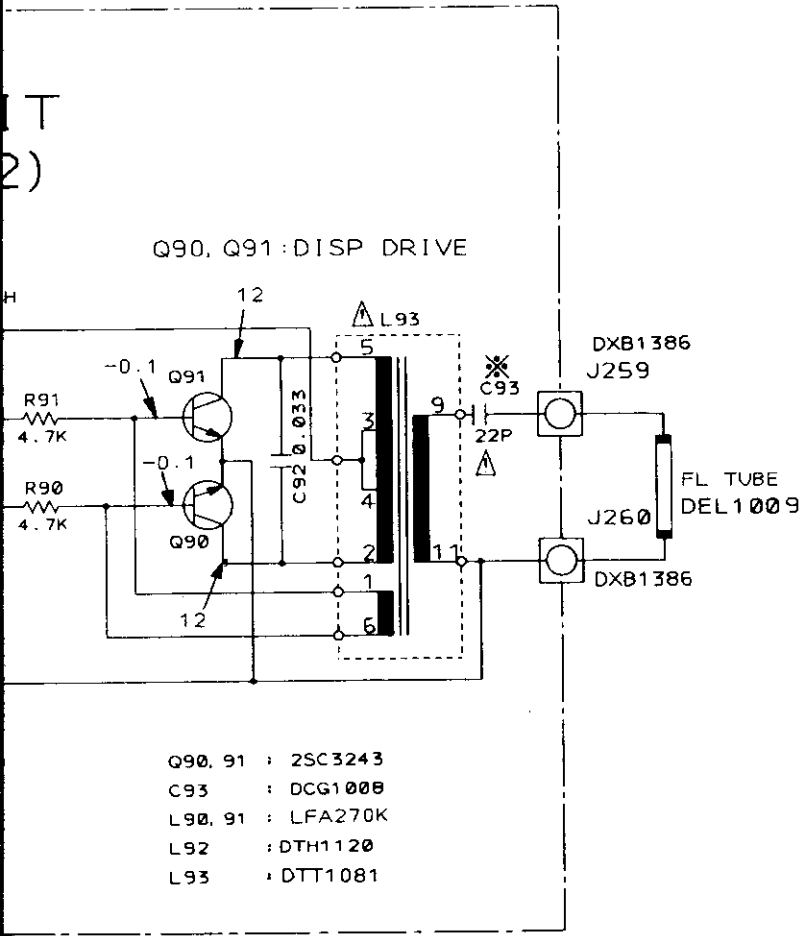
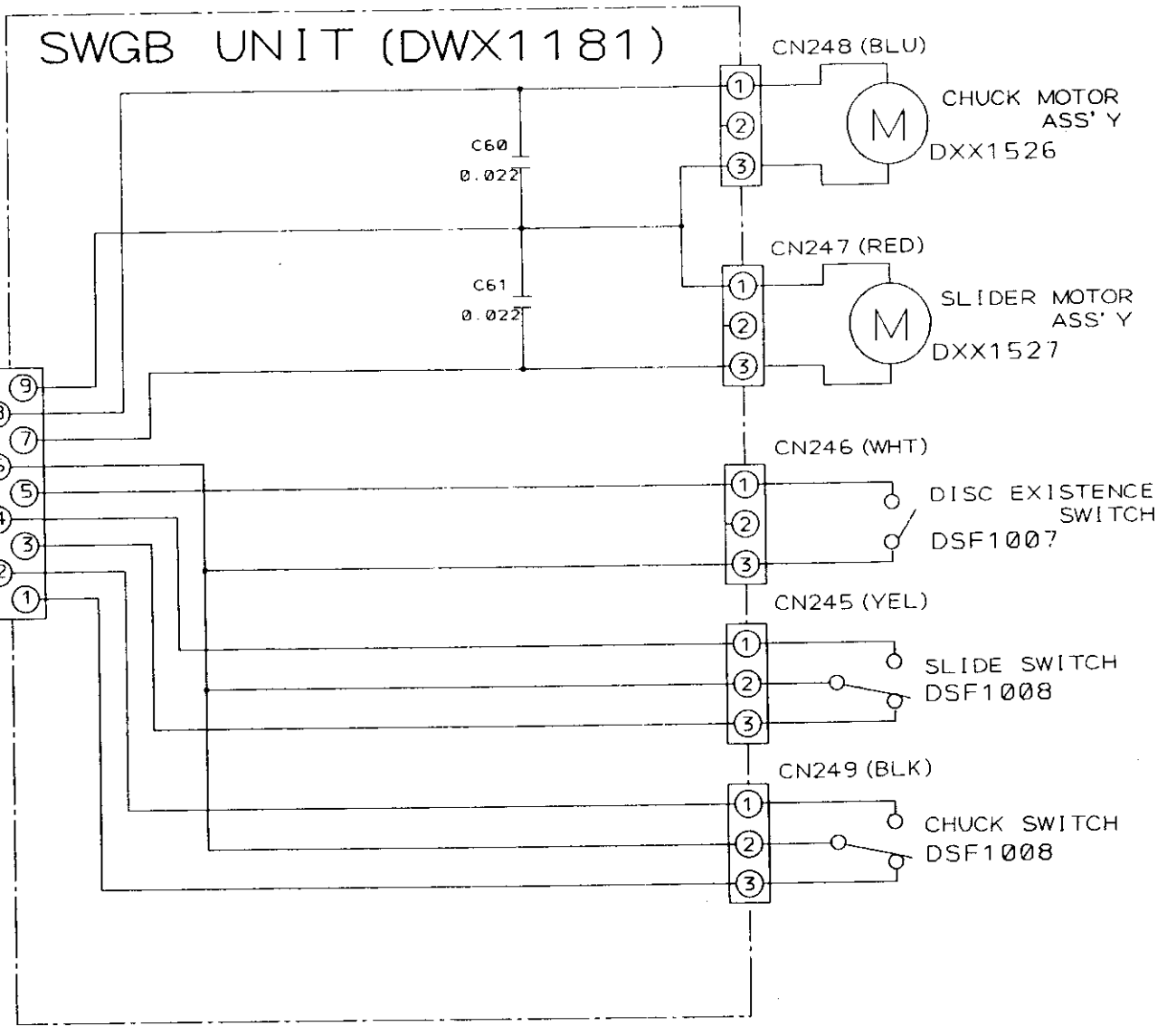
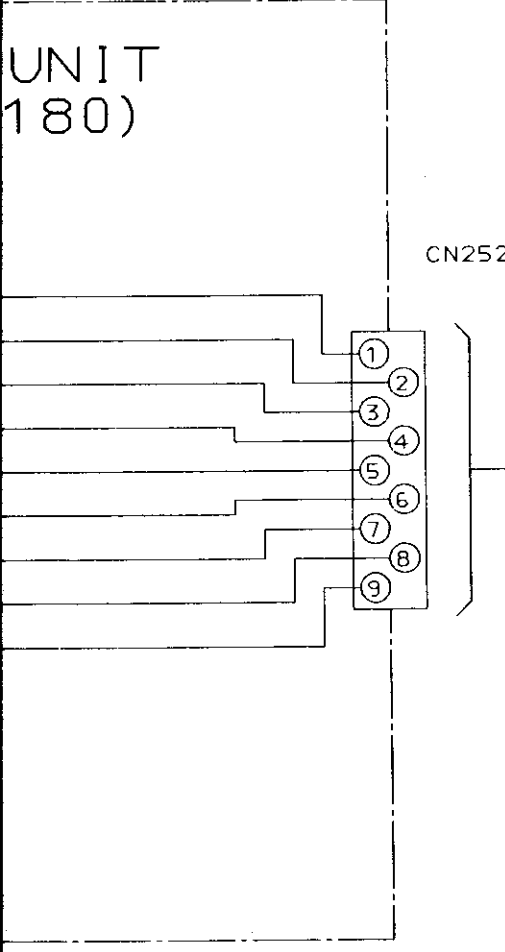
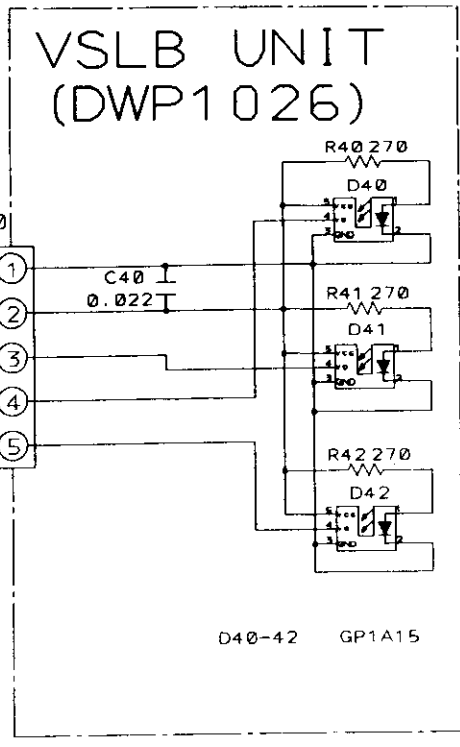
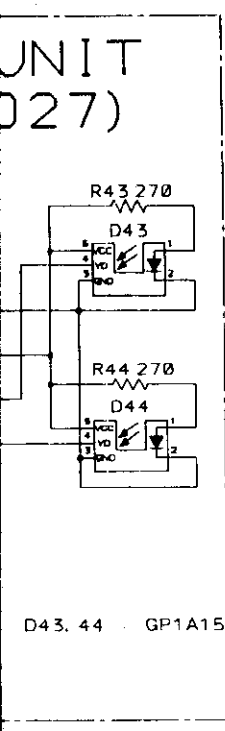

A
B
C
D
E
F

CAC-V3000

8. PCB PARTS LIST

NOTES:

- Parts marked by "NSP" are generally unavailable because they are not in our Master Spare Parts List.
- The Δ mark found on some component parts indicates the importance of the safety factor of the part. Therefore, when replacing, be sure to use parts of identical designation.
- Parts marked by "●" are not always kept in stock. Their delivery time may be longer than usual or they may be unavailable.
- When ordering resistors, first convert resistance values into code form as shown in the following examples.

Ex. 1 When there are 2 effective digits (any digit apart from 0), such as 560 ohm and 47k ohm (tolerance is shown by J = 5%, and K = 10%).

560 Ω \rightarrow 56 \times 10¹ \rightarrow 561 RD1/8PM \square \square \square J
 47k Ω \rightarrow 47 \times 10³ \rightarrow 473 RD1/4PS \square \square \square J
 0.5 Ω \rightarrow 0R5 RN2H \square \square \square K
 1 Ω \rightarrow 010 RS1P \square \square \square K

Ex. 2 When there are 3 effective digits (such as in high precision metal film resistors).

5.62k Ω \rightarrow 562 \times 10¹ \rightarrow 5621 RN1/4PC \square \square \square F

Mark No.	Description	Parts No.	Mark No.	Description	Parts No.	Mark No.	Description	Parts No.
LIST OF ASSEMBLIES			IC3	MULTIPLEXOR	TC74HC4052AP	C15	ELECT. CAPACITOR	CEAS220M50
●	MCDR UNIT	DWG1301	IC4	LOGIC IC	TC74HC00AP	C16	ELECT. CAPACITOR	CEAS101M10
●	CONT UNIT	DWG1302	IC5	LINEAR IC	TA7291P	C17, 18	CERAMIC CAPACITOR	CKPUYF223Z25
●	DACB UNIT	DWM1281	IC6	MOTOR DRIVER IC	TA7288P	C19	ELECT. CAPACITOR	DCH1035
●	VCNB UNIT	DWP1025	IC7	LINEAR IC	TA7291P		(8200/25)	
●	VSLB UNIT	DWP1026	IC8	IC	TC4077BP	C2	CERAMIC CAPACITOR	CKCYF103Z50
●	VSRB UNIT	DWP1027	IC9	CMOS, IC	TC74HC123AP	C20	ELECT. CAPACITOR	CEAS470M25
●	SYPS UNIT	DWR1134	Q1	TRANSISTOR	2SD1266	C21	ELECT. CAPACITOR	CEAS470M16
●	CLSB UNIT	DWS1126	Q10	TRANSISTOR	DTC124ES	C22	AUDIO FILM CAPACITOR	CFTXA683J50
●	VCHS UNIT	DWS1169	Q11, 12	TRANSISTOR	DTA124ES	C23	CERAMIC CAPACITOR	CKPUYF223Z25
●	KDSB UNIT	DWS1173	Q17-19	TRANSISTOR	DTC124ES	C24	CAPACITOR (0.22F)	DCH1037
●	ENCB UNIT	DWX1178	Q2	TRANSISTOR	2SC1740S	C25	CERAMIC CAPACITOR	CKPUYF223Z25
●	ILDB UNIT	DWX1179	Q20	TRANSISTOR	DTC124ES	C26, 27	MYLAR FILM CAPACITOR	CQMA152J50
●	CNNB UNIT	DWX1180	Q22, 23	TRANSISTOR	2SA933S	C28	MYLAR FILM CAPACITOR	CQMA102J50
●	SWG B UNIT	DWX1181	Q24	TRANSISTOR	DTC124ES	C29	ELECT. CAPACITOR	CEAS101M10
●	ANLG UNIT	DWX1281	Q3, 4	TRANSISTOR	2SA1015	C3	CERAMIC CAPACITOR	CKCYF103Z50
●	DGIF UNIT	DWX1282	Q6-8	TRANSISTOR	DTC124ES	C30, 31	AUDIO FILM CAPACITOR	CFTXA823J50
●	XLR1 UNIT	DWX1283	Q9	TRANSISTOR	DTA124ES	C32, 33	AUDIO FILM CAPACITOR	CFTXA224J50
●	XLR2 UNIT	DWX1284	D1	DIODE	1SS254	C34	CERAMIC CAPACITOR	CKPUYF223Z25
●	CNCT UNIT	DWX1286	D10-13	DIODE	1SS254	C35, 36	CERAMIC CAPACITOR	CKCYF103Z50
●	RSIF UNIT	DWX1287	D14-17	ZENER DIODE	MTZ7.5B	C37	AUDIO FILM CAPACITOR	CFTXA224J50
●	AUOB UNIT	DWX1288	D18	ZENER DIODE	MTZ8.2B	C38	MYLAR FILM CAPACITOR	CQMA223J50
●	BRAN UNIT	DWX1289	D19	DIODE	1SS254	C39	ELECT. CAPACITOR	CEASR47M50
●	CDPS UNIT	DWX1290	Δ D2	DIODE BRIDGE	RBA-402	C4	CERAMIC CAPACITOR	CKCYF103Z50
●	DISP UNIT	DWX1292	Δ D3	DIODE	RBA-406B	C40, 41	MYLAR FILM CAPACITOR	CQMA473J50
MCDR UNIT			Δ D4-7	RECTIFIER DIODE	1SR139-400	C42, 43	MYLAR FILM CAPACITOR	CQMA472J50
SEMICONDUCTORS			D8	ZENER DIODE	MTZ13A	C44	CAPACITOR ARRAY	DCG1004
IC1	MICRO-COMPUTER IC	PD3222A	D9	DIODE	1SS254	C45	(2200p \times 8)	
IC10	LINEAR IC	NJM4565D	COILS			C46	ELECT. CAPACITOR	CEAS101M10
IC11	LINEAR IC	NJM4565D	F1	FILTER	VTH1001	C47, 48	CERAMIC CAPACITOR	CKPUYF223Z25
IC12	COMPARATOR	BA10339	F3-7	FILTER	VTH1001	C49	AXIAL CAPACITOR	CCPUSL150J50
IC13	LOGIC IC	TC74HC32AP	CAPACITORS			C5	ELECT. CAPACITOR	CEAS101M10
IC14	POWER MOSFET ARRAY	4AM12	C1	CERAMIC CAPACITOR	CKCYF103Z50	C50, 51	CAPACITOR (3300/16)	DCH1023
IC15	IC	LM2940CT-5.0	C10, 11	CERAMIC CAPACITOR	CKPUYF223Z25	C52	CERAMIC CAPACITOR	CKPUYF223Z25
Δ IC16	IC PROTECTOR	ICP-N10	C12	ELECT. CAPACITOR	CEAS102M16	C53	MYLAR FILM CAPACITOR	CQMA392J50
Δ IC17	IC PROTECTOR	ICP-N38	C13	CERAMIC CAPACITOR	CKCYF222Z50	C54	ELECT. CAPACITOR	CEAS101M10
IC2	SYSTEM PRESET IC	M51953BL	C14	CAPACITOR (4700/16)	DCH1024	C55	ELECT. CAPACITOR	CEAS470M25
						C56	ELECT. CAPACITOR	CEAS470M25
						C57	CERAMIC CAPACITOR	CKPUYF223Z25
						C58	MYLAR FILM CAPACITOR	CQMA472J50
						C6	CAPACITOR (4700/16)	DCH1024
						C61, 62	CERAMIC CAPACITOR	CKDYB471K50
						C63, 64	CERAMIC CAPACITOR	CKPUYB102K50
						C65, 66	CERAMIC CAPACITOR	CKPUYF223Z25
						C7	CAPACITOR (4700/16)	DCH1024
						C8, 9	ELECT. CAPACITOR	CEAS470M16

Mark No.	Description	Parts No.	Mark No.	Description	Parts No.	Mark No.	Description	Parts No.
C15	ELECT. CAPACITOR	CEAS220M50	RESISTORS			C14, 15	MYLAR FILM CAPACITOR	CQMA104K50
C16	ELECT. CAPACITOR	CEAS101M10	VR1	SEMI-FIXED RESISTOR	VRTB6VS103	C16	ELECT. CAPACITOR	CEAS010M50
C17, 18	CERAMIC CAPACITOR	CKPUYF223Z25				C17	MYLAR FILM CAPACITOR	CQMA104K50
C19	ELECT. CAPACITOR (8200/25)	DCH1035	R32, 33	METALFILM RESISTOR	RN1/6PQ4702F	C18	ELECT. CAPACITOR	CEAS4R7M50
C2	CERAMIC CAPACITOR	CKCYF103Z50	R4, 5	CARBON FILM RESISTOR	RD1/2LF4R7J	C19, 2	ELECT. CAPACITOR	CEAS101M10
C20	ELECT. CAPACITOR	CEAS470M25	R55, 56	METAL OXIDE RESISTOR	RS3LMFR22J	C20	MYLAR FILM CAPACITOR	CQMA104K50
C21	ELECT. CAPACITOR	CEAS470M16	R57, 58	CARBON FILM RESISTOR	RD1/2PMF4R7J	C21	MYLAR FILM CAPACITOR	CQMA103K50
C22	AUDIO FILM CAPACITOR	CFTXA683J50	R92	METAL OXIDE RESISTOR	RS3LMF2R2J	C22	MYLAR FILM CAPACITOR	CQMA472K50
C23	CERAMIC CAPACITOR	CKPUYF223Z25	R93	RESISTOR ARRAY (10k)	RA8T103J	C23	MYLAR FILM CAPACITOR	CQMA472J50
C24	CAPACITOR (0.22F)	DCH1037	R94-96	RESISTOR ARRAY (10k)	RA8T222J	C24	MYLAR FILM CAPACITOR	CQMA332J50
C25	CERAMIC CAPACITOR	CKPUYF223Z25	R97	RESISTOR ARRAY (10k)	RA8T103J	C25	MYLAR FILM CAPACITOR	CQMA103K50
C26, 27	MYLAR FILM CAPACITOR	CQMA152J50		Other resistors	RD1/6PM□□□□	C26	ELECT. CAPACITOR	CEAS101M10
C28	MYLAR FILM CAPACITOR	CQMA102J50	OTHERS			C27	MYLAR FILM CAPACITOR	CQMA333K50
C29	ELECT. CAPACITOR	CEAS101M10	X1	CRYSTAL RESONATOR (9.8304MHz)	DSS1010	C28, 3	ELECT. CAPACITOR	CEAS101M10
C3	CERAMIC CAPACITOR	CKCYF103Z50	CN211	6P TOP POST	B6P-SHF-1AA	C30	MYLAR FILM CAPACITOR	CQMA473J50
C30, 31	AUDIO FILM CAPACITOR	CFTXA823J50	CONT UNIT			C31, 32	CERAMIC CAPACITOR	CCCCH150J50
C32, 33	AUDIO FILM CAPACITOR	CFTXA224J50	SEMICONDUCTORS			C33	CERAMIC CAPACITOR	CKCYB152K50
C34	CERAMIC CAPACITOR	CKPUYF223Z25	IC1	PRE AMP IC	CXA1471S	C34	ELECT. CAPACITOR	CEAS331M6R3
C35, 36	CERAMIC CAPACITOR	CKCYF103Z50	IC10	VCO	SN74LS624N	C35	ELECT. CAPACITOR	CEAS330M16
C37	AUDIO FILM CAPACITOR	CFTXA224J50	IC11	LOGIC IC	TC74HCT04AP	C36	MYLAR FILM CAPACITOR	CQMA103K50
C38	MYLAR FILM CAPACITOR	CQMA223J50	△ IC12, 13	IC PROTECTOR	ICP-N10	C37	ELECT. CAPACITOR	CEASR47M50
C39	ELECT. CAPACITOR	CEASR47M50	△ IC15, 16	IC PROTECTOR	ICP-N20	C38	CERAMIC CAPACITOR	CKCYF103Z50
C4	CERAMIC CAPACITOR	CKCYF103Z50	IC2	EFM DEMODULATION IC	CXD2500AQ	C39	CERAMIC CAPACITOR	CCCCH330J50
C40, 41	MYLAR FILM CAPACITOR	CQMA473J50	IC3	OP-AMP IC	NJM4558DX	C4	ELECT. CAPACITOR	CEAS101M10
C42, 43	MYLAR FILM CAPACITOR	CQMA472J50	IC4	SERVO IC	CXA1372S	C40	CERAMIC CAPACITOR	CKCYF103Z50
C44	CAPACITOR ARRAY (2200p × 8)	DCG1004	IC5, 6	POWER OP AMP	TA7256P	C41-43	ELECT. CAPACITOR	CEAS330M16
C45	ELECT. CAPACITOR	CEAS101M10	△ IC8	REGULATOR IC	NJM79L05A	C44	ELECT. CAPACITOR	CEAS101M10
C46	CERAMIC CAPACITOR	CKPUYF223Z25	IC9	MICRO-COMPUTER IC	PD0140B	C45	CERAMIC CAPACITOR	CKCYF103Z50
C47, 48	AXIAL CAPACITOR	CCPUSL150J50	Q1	TRANSISTOR	2SA854S	C46, 47	CERAMIC CAPACITOR	CCCCH220J50
C49	ELECT. CAPACITOR	CEAS101M10	Q2	TRANSISTOR	2SC3581	C48, 49	CERAMIC CAPACITOR	CKCYF103Z50
C5	CAPACITOR (3300/16)	DCH1023	Q3	TRANSISTOR	2SA1399	C5	CERAMIC CAPACITOR	CCCCH180J50
C50, 51	CERAMIC CAPACITOR	CKPUYF223Z25	Q4	TRANSISTOR	2SC3581	C50, 51	CERAMIC CAPACITOR	CKCYF103Z50
C52	MYLAR FILM CAPACITOR	CQMA392J50	Q5	TRANSISTOR	2SA1399	C52, 53	ELECT. CAPACITOR	CEAS470M16
C53	ELECT. CAPACITOR	CEAS101M10	Q6-8	TRANSISTOR	DTC124ES	C54	ELECT. CAPACITOR	CEAS331M6R3
C54	ELECT. CAPACITOR	CEAS470M25	D1	ZENER DIODE	MTZJ5.1B	C55	ELECT. CAPACITOR	CEAS221M10
C55	CERAMIC CAPACITOR	CKPUYF223Z25	COILS			C56	CERAMIC CAPACITOR	CCCSL221J50
C56	MYLAR FILM CAPACITOR	CQMA472J50	F1, 2	FILTER	VTH1001	C57, 58	ELECT. CAPACITOR	CEANP010M50
C57	CERAMIC CAPACITOR	CKPUYF223Z25	CAPACITORS			C59	CERAMIC CAPACITOR	CCCSL221J50
C58	ELECT. CAPACITOR	CEAS470M25	C1	CERAMIC CAPACITOR	CKCYF103Z50	C6	MYLAR FILM CAPACITOR	CQMA104K50
C6	CAPACITOR (4700/16)	DCH1024	C10	ELECT. CAPACITOR	CEAS330M16	C60, 61	CERAMIC CAPACITOR	CCCSL221J50
C61, 62	CERAMIC CAPACITOR	CKDYB471K50	C11	MYLAR FILM CAPACITOR	CQMA182J50	C62	ELECT. CAPACITOR	CEANP010M50
C63, 64	CERAMIC CAPACITOR	CKPUYB102K50	C12	MYLAR FILM CAPACITOR	CQMA333K50	C63	CERAMIC CAPACITOR	CCCSL221J50
C65, 66	CERAMIC CAPACITOR	CKPUYF223Z25	C13	MYLAR FILM CAPACITOR	CQMA103K50	C64	ELECT. CAPACITOR	CEAS330M16
C7	CAPACITOR (4700/16)	DCH1024				C65	CERAMIC CAPACITOR	CKCYB471K50
C8, 9	ELECT. CAPACITOR	CEAS470M16				C66	CERAMIC CAPACITOR	CKCYF103Z50
						C67	CERAMIC CAPACITOR	CCCSL121J50
						C7	MYLAR FILM CAPACITOR	CQMA393K50

Mark No.	Description	Parts No.	Mark No.	Description	Parts No.	Mark No.	Description	Parts No.
RESISTORS			C14, 15	MYLAR FILM CAPACITOR	CQMA104K50	C8	ELECT. CAPACITOR	CEAS330M16
VR1	SEMI-FIXED RESISTOR	VRTB6VS103	C16	ELECT. CAPACITOR	CEAS010M50	C86	CERAMIC CAPACITOR	CCCCH100D50
R32, 33	METAL FILM RESISTOR	RN1/6PQ4702F	C17	MYLAR FILM CAPACITOR	CQMA104K50	C87	ELECT. CAPACITOR	CEAS330M16
R4, 5	CARBON FILM RESISTOR	RD1/2LF4R7J	C18	ELECT. CAPACITOR	CEAS4R7M50	C88	CERAMIC CAPACITOR	CCCSL221J50
R55, 56	METAL OXIDE RESISTOR	RS3LMFR22J	C19, 2	ELECT. CAPACITOR	CEAS101M10	C9	CERAMIC CAPACITOR	CKCYF103Z50
R57, 58	CARBON FILM RESISTOR	RD1/2PMF4R7J	C20	MYLAR FILM CAPACITOR	CQMA104K50	RESISTORS		
R92	METAL OXIDE RESISTOR	RS3LMF2R2J	C21	MYLAR FILM CAPACITOR	CQMA103K50	VR1	VR (22k)	VRTB6VS223
R93	RESISTOR ARRAY (10k)	RA8T103J	C22	MYLAR FILM CAPACITOR	CQMA472K50	VR2	VR (1k)	VRTB6VS102
R94-96	RESISTOR ARRAY (10k)	RA8T222J	C23	MYLAR FILM CAPACITOR	CQMA472J50	VR3, 4	VR (22k)	VRTB6VS223
R97	RESISTOR ARRAY (10k)	RA8T103J	C24	MYLAR FILM CAPACITOR	CQMA332J50	Other resistors RD1/6PM□□□J		
	Other resistors	RD1/6PM□□□J	C25	MYLAR FILM CAPACITOR	CQMA103K50	OTHERS		
OTHERS			C26	ELECT. CAPACITOR	CEAS101M10	CN101	CONNECTOR	5597-16APB
X1	CRYSTAL RESONATOR (9.8304MHz)	DSS1010	C27	MYLAR FILM CAPACITOR	CQMA333K50	CN107	5P TOP POST (NH)	B5P-SHF-1AA
CN211	6P TOP POST	B6P-SHF-1AA	C28, 3	ELECT. CAPACITOR	CEAS101M10	CN109	6P TOP POST	B6P-SHF-1AA
FRONT UNIT			C30	MYLAR FILM CAPACITOR	CQMA473J50		MINI JACK 3P	DKN1028
SEMICONDUCTORS			C31, 32	CERAMIC CAPACITOR	CCCCH150J50	X1	XTAL RES (OSC) (16.9344MHz)	PSS1006
IC1	PRE AMP IC	CXA1471S	C33	CERAMIC CAPACITOR	CKCYB152K50	X2	CRYSTAL RESONATOR (9.8304MHz)	DSS1010
IC10	VCO	SN74LS624N	C34	ELECT. CAPACITOR	CEAS331M6R3	DACB UNIT		
IC11	LOGIC IC	TC74HCT04AP	C35	ELECT. CAPACITOR	CEAS330M16	SEMICONDUCTORS		
IC12, 13	IC PROTECTOR	ICP-N10	C36	MYLAR FILM CAPACITOR	CQMA103K50	△ IC501, 502	REGULATOR IC	NJM7805FA
IC15, 16	IC PROTECTOR	ICP-N20	C37	ELECT. CAPACITOR	CEASR47M50	IC512	LOGIC IC	TC74HCU04AP
IC2	EFM DEMODULATION IC	CXD2500AQ	C38	CERAMIC CAPACITOR	CKCYF103Z50	IC513	IC	SM5813AP
IC3	OP-AMP IC	NJM4558DX	C39	CERAMIC CAPACITOR	CCCCH330J50	IC522, 523	IC	SAA7350
IC4	SERVO IC	CXA1372S	C40	ELECT. CAPACITOR	CEAS101M10	IC554, 555	OP-AMP IC	NJM5532DD
IC5, 6	POWER OP AMP	TA7256P	C41-43	ELECT. CAPACITOR	CEAS330M16	△ IC615	OP-AMP IC	NJM5532DD
IC8	REGULATOR IC	NJM79L05A	C44	ELECT. CAPACITOR	CEAS101M10	IC620, 621	IC PROTECTOR	ICP-N5
IC9	MICRO-COMPUTER IC	PD0140B	C45	CERAMIC CAPACITOR	CKCYF103Z50	Q521	TRANSISTOR	DTC124ES
Q1	TRANSISTOR	2SA854S	C46, 47	CERAMIC CAPACITOR	CCCCH220J50	Q522, 523	TRANSISTOR	DTA124ES
Q2	TRANSISTOR	2SC3581	C48, 49	CERAMIC CAPACITOR	CKCYF103Z50	Q524, 525	TRANSISTOR	DTC124ES
Q3	TRANSISTOR	2SA1399	C5	CERAMIC CAPACITOR	CCCCH180J50	Q554-557	TRANSISTOR	2SC3068
Q4	TRANSISTOR	2SC3581	C50, 51	CERAMIC CAPACITOR	CKCYF103Z50	Q562, 563	TRANSISTOR	2SC3068
Q5	TRANSISTOR	2SA1399	C52, 53	ELECT. CAPACITOR	CEAS470M16	△ Q617	TRANSISTOR	2SB857
Q6-8	TRANSISTOR	DTC124ES	C54	ELECT. CAPACITOR	CEAS331M6R3	Q618	TRANSISTOR	2SD755
D1	ZENER DIODE	MTZJ5.1B	C55	ELECT. CAPACITOR	CEAS221M10	△ Q619	POWER TRANSISTOR	2SD1133
COILS			C56	CERAMIC CAPACITOR	CCCSL221J50	Q620	TRANSISTOR	2SD755
F1, 2	FILTER	VTH1001	C57, 58	ELECT. CAPACITOR	CEANP010M50	Q621	TRANSISTOR	2SB715
CAPACITORS			C59	CERAMIC CAPACITOR	CCCSL221J50	△ Q622	TRANSISTOR	2SB857
C1	CERAMIC CAPACITOR	CKCYF103Z50	C6	MYLAR FILM CAPACITOR	CQMA104K50	Q623	TRANSISTOR	2SB715
C10	ELECT. CAPACITOR	CEAS330M16	C60, 61	CERAMIC CAPACITOR	CCCSL221J50	△ Q624	POWER TRANSISTOR	2SD1133
C11	MYLAR FILM CAPACITOR	CQMA182J50	C62	ELECT. CAPACITOR	CEANP010M50	△ Q625	TRANSISTOR	2SA1283
C12	MYLAR FILM CAPACITOR	CQMA333K50	C63	CERAMIC CAPACITOR	CCCSL221J50	△ Q626	TRANSISTOR	2SC3243
C13	MYLAR FILM CAPACITOR	CQMA103K50	C64	ELECT. CAPACITOR	CEAS330M16	D521	DIODE	1SS254
			C65	CERAMIC CAPACITOR	CKCYB471K50	D550, 551	DIODE	1SS254
			C66	CERAMIC CAPACITOR	CKCYF103Z50	D570, 571	DIODE	1SS254
			C67	CERAMIC CAPACITOR	CCCSL121J50	△ D620-627	DIODE	10DF2
			C7	MYLAR FILM CAPACITOR	CQMA393K50	D628-631	ZENER DIODE	HZ5CLL

Mark No.	Description	Parts No.	Mark No.	Description	Parts No.
COILS			C566, 567	AUDIO FILM CAPACITOR	CFTXA562J50
L501-505	AMOLPHOUS BEAD	PTH1006	C568-571	ELECT. CAPACITOR	CENA471M50
L511, 512	AXIAL INDUCTOR	LAU010K	C572, 573	ELECT. CAPACITOR (47/50)	PCH1094
L522, 523	AXIAL INDUCTOR	LAU010K	C576, 577	AUDIO FILM CAPACITOR	CFTXA103J50
L601-604	AMOLPHOUS BEAD	PTH1006	C578, 579	ELECT. CAPACITOR	CENA471M35
CAPACITORS			C580, 581	PL. STYRENE CAPACITOR	CQSF471J50
C501, 502	AUDIO FILM CAPACITOR	CFTXA102J50	C582, 583	AUDIO FILM CAPACITOR	CFTXA683J50
C503, 504	AUDIO FILM CAPACITOR	CFTXA103J50	C586	AUDIO FILM CAPACITOR	CFTXA473J50
C505	ELECT. CAPACITOR	CENA101M25	C587, 588	ELECT. CAPACITOR (220/35)	PCH1099
C506-508	AUDIO FILM CAPACITOR	CFTXA103J50	C589, 590	PL. STYRENE CAPACITOR	CQSF471J50
C510	AUDIO FILM CAPACITOR	CFTXA473J50	C591	ELECT. CAPACITOR	CENA470M25
C511-513	AUDIO FILM CAPACITOR	CFTXA103J50	C592	AUDIO FILM CAPACITOR	CFTXA473J50
C514	AUDIO FILM CAPACITOR	CFTXA473J50	C593	ELECT. CAPACITOR	CENA470M25
C515	AUDIO FILM CAPACITOR	CFTXA102J50	C594	AUDIO FILM CAPACITOR	CFTXA473J50
C516, 519	ELECT. CAPACITOR	CENA102M16	C596	AUDIO FILM CAPACITOR	CFTXA103J50
C520	ELECT. CAPACITOR	CENA470M25	C597	AUDIO FILM CAPACITOR	CFTXA104J50
C521	AUDIO FILM CAPACITOR	CFTXA473J50	C598	AUDIO FILM CAPACITOR	CFTXA103J50
C522, 523	ELECT. CAPACITOR	CENA470M25	C602, 603	ELECT. CAPACITOR	CENA470M25
C524, 525	AUDIO FILM CAPACITOR	CFTXA473J50	C604, 605	ELECT. CAPACITOR	CENA222M35
C526, 527	ELECT. CAPACITOR	CENA470M25	C606, 607	ELECT. CAPACITOR	CENA102M35
C528, 529	AUDIO FILM CAPACITOR	CFTXA473J50	C608-615	AUDIO FILM CAPACITOR	CFTXA103J50
C530, 531	ELECT. CAPACITOR	CENA470M25	C616	ELECT. CAPACITOR	CEAS471M25
C532, 533	AUDIO FILM CAPACITOR	CFTXA473J50	C620, 621	ELECT. CAPACITOR	CENA470M25
C534, 535	ELECT. CAPACITOR	CENA470M25	C624, 625	AUDIO FILM CAPACITOR	CFTXA103J50
C536, 537	AUDIO FILM CAPACITOR	CFTXA473J50	RESISTORS		
C538	ELECT. CAPACITOR	CENA470M25	R540, 541	CARBON FILM RESISTOR	RDR1/4PM101J
C539	AUDIO FILM CAPACITOR	CFTXA473J50	R542-545	CARBON FILM RESISTOR	RDR1/4PM303J
C540	ELECT. CAPACITOR	CENA470M25	R546-549	CARBON FILM RESISTOR	RDR1/4PM822J
C541	AUDIO FILM CAPACITOR	CFTXA473J50	R550, 551	CARBON FILM RESISTOR	RDR1/4PM243J
C542, 543	PL. STYRENE CAPACITOR	CQSF101J50	R552, 553	CARBON FILM RESISTOR	RDR1/4PM101J
C544, 545	ELECTR. CAPACITOR (470/50)	PCH1098	R556-559	CARBON FILM RESISTOR	RDR1/4PM303J
C546, 547	AUDIO FILM CAPACITOR	CFTXA473J50	R560-563	CARBON FILM RESISTOR	RDR1/4PM822J
C548-551	PL. STYRENE CAPACITOR	CQSF101J50	R564-567	CARBON FILM RESISTOR	RDR1/4PM562J
C552-555	PL. STYRENE CAPACITOR	CQSF471J50	R568, 569	CARBON FILM RESISTOR	RDR1/4PM751J
C556, 557	PL. STYRENE CAPACITOR	CQSF101J50	R570	CARBON FILM RESISTOR	RDR1/4PM221J
C558, 559	AUDIO FILM CAPACITOR	CFTXA473J50			
C560-563	PL. STYRENE CAPACITOR	CQSF220K50			
C564, 565	AUDIO FILM CAPACITOR	CFTXA681J50			

Mark No.	Description	Parts No.
R571	CARBON FILM RESISTOR	RDR1/4PM105J
R573	CARBON FILM RESISTOR	RDR1/4PM221J
R574	CARBON FILM RESISTOR	RDR1/4PM105J
R576, 577	CARBON FILM RESISTOR	RDR1/4PM162J
R578	CARBON FILM RESISTOR	RDR1/4PM242J
R579	CARBON FILM RESISTOR	RDR1/4PM122J
R580	CARBON FILM RESISTOR	RDR1/4PM242J
R581	CARBON FILM RESISTOR	RDR1/4PM122J
R582, 583	CARBON FILM RESISTOR	RDR1/4PM223J
R584, 585	CARBON FILM RESISTOR	RDR1/4PM471J
R588, 589	CARBON FILM RESISTOR	RDR1/4PM271J
R590, 591	CARBON FILM RESISTOR	RDR1/4PM511J
R645, 646	CARBON FILM RESISTOR	RDR1/4PM132J
R647, 648	METAL FILM RESISTOR	RN1/4PQ3001F
R649, 650	METAL FILM RESISTOR	RN1/4PQ4301F
R651, 652	CARBON FILM RESISTOR	RDR1/4PM4R7J
△ R653, 654	METAL OXIDE RESISTOR	RS1LMF4R7J
R655, 656	CARBON FILM RESISTOR	RDR1/4PM472J
R657, 658	CARBON FILM RESISTOR	RDR1/4PM682J
R659, 660	CARBON FILM RESISTOR	RDR1/4PM512J
	Other resistors	RD1/6PM□□□J
OTHERS		
△ SCREW	IBZ30P100FCC	
△ CN603	4P TOP POST (VH)	B4P-VH
J	CONNECTOR ASSY	DKP2408

VCNB UNIT

CAPACITORS

C12	CERAMIC CAPACITOR	CKPUYF223Z25
C13	ELECTR. CAPACITOR	CEAL101M6R3
C14-17	CERAMIC CAPACITOR	CKPUYF223Z25

VSLB UNIT

SEMICONDUCTORS

D40-42	PHOTO INTERRUPTER	GP1A15
--------	-------------------	--------

CAPACITORS

C40	CERAMIC CAPACITOR	CKPUYF223Z25
-----	-------------------	--------------

Mark No.	Description	Parts No.
RESISTORS		
R40-42	CARBON FILM RESISTOR	RD1/6PM271J

VSRB UNIT

SEMICONDUCTORS

D43, 44	PHOTO INTERRUPTER	GP1A15
---------	-------------------	--------

CAPACITORS

C41	CERAMIC CAPACITOR	CKPUYF223Z25
-----	-------------------	--------------

RESISTORS

R43, 44	CARBON FILM RESISTOR	RD1/6PM271J
---------	----------------------	-------------

SYPS UNIT

COILS

△ L601	FILTER	VTL-004
--------	--------	---------

CAPACITORS

△ C601-603	CAPACITOR (0.01/400)	VCG-048
------------	----------------------	---------

OTHERS

△ CN602	CONNECTOR	SD-5277-02A
---------	-----------	-------------

CLSB UNIT

SWITCHES

S6-8	PUSH SWITCH	DSG1015
------	-------------	---------

VCHS UNIT

SWITCH

△ S601	VOLTAGE SELECTOR SW	DSX1010
--------	---------------------	---------

OTHERS

△ J606	CONNECTOR ASSY	DKP2401
--------	----------------	---------

KDSB UNIT

SEMICONDUCTORS

IC300	IC	MC14489P
-------	----	----------

D300	LED	LB-603VP
------	-----	----------

SWITCHES

S1-4	SWITCH	DSG1009
S5	DIP SW 4P	DSX1004

CAPACITORS

C300-302	CERAMIC CAPACITOR	CKPUYF223Z25
----------	-------------------	--------------

RESISTORS

R300	CARBON FILM RESISTOR	RD1/6PM202J
------	----------------------	-------------

Mark No.	Description	Parts No.	Mark No.	Description	Parts No.
ENCB UNIT			C141	ELECT. CAPACITOR	CEAS471M35
SEMICONDUCTORS			C142, 143	CERAMIC CAPACITOR	CKCYF103Z50
IC500	PHOTO INTERRUPTER	GP1A30R	C144	ELECT. CAPACITOR	CEAS101M25
CAPACITORS			C148	CERAMIC CAPACITOR	CCCSL151J50
C500	CERAMIC CAPACITOR	CKPUYF223Z25	C149	ELECT. CAPACITOR	CEAS101M25
RESISTORS			C150, 151	CERAMIC CAPACITOR	CCCSL151J50
R500	CARBON FILM RESISTOR	RD1/6PM131J	C152	ELECT. CAPACITOR	CEAS101M25
ILDB UNIT			C153, 154	CERAMIC CAPACITOR	CCCSL151J50
SEMICONDUCTORS			C155	ELECT. CAPACITOR	CEAS101M25
D400	LED	SLH-34VC3H3-S	C156, 157	CERAMIC CAPACITOR	CCCSL151J50
RESISTORS			C158	ELECT. CAPACITOR	CEAS101M25
R400	CARBON FILM RESISTOR	RD1/6PM221J	C159, 160	CERAMIC CAPACITOR	CCCSL151J50
CNNB UNIT			C161	ELECT. CAPACITOR	CEAS101M25
CNNB unit has no service parts.			C162, 163	CERAMIC CAPACITOR	CCCSL151J50
SWGB UNIT			C164	ELECT. CAPACITOR	CEAS101M25
SWITCHES			C165, 166	CERAMIC CAPACITOR	CCCSL151J50
C60, 61	CERAMIC CAPACITOR	CKPUYF223Z25	C167	ELECT. CAPACITOR	CEAS101M25
ANLG UNIT			C168, 169	CERAMIC CAPACITOR	CCCSL151J50
SEMICONDUCTORS			C170	ELECT. CAPACITOR	CEAS101M25
IC102, 103	OP-AMP IC	NJM5532SD	C171	CERAMIC CAPACITOR	CCCSL151J50
IC105, 106	OP-AMP IC	NJM5532SD	C172-190	ELECT. CAPACITOR	CEAS470M25
IC109	OP-AMP IC	NJM5532SD	C191	ELECT. CAPACITOR	CEAS471M35
IC110-113	OP-AMP IC	NJM4556S	RESISTORS		
△ IC114	REGULATOR IC	NJM78M12FA	R209-212	METALFILM RESISTOR	RN1/6PQ9101F
△ IC115	REGULATOR IC	NJM79M12FA	R213-216	METALFILM RESISTOR	RN1/6PQ1002F
Q105-110	TRANSISTOR	2SD2144S	R225-228	METALFILM RESISTOR	RN1/6PQ9101F
Q120-127	TRANSISTOR	2SD2144S	R229	METALFILM RESISTOR	RN1/6PQ1002F
Q128, 129	TRANSISTOR	2SC1740S	R231, 232	METALFILM RESISTOR	RN1/6PQ1002F
Q130	TRANSISTOR	2SA933S	R234	METALFILM RESISTOR	RN1/6PQ1002F
D107-112	DIODE	1SS254	R241-244	METALFILM RESISTOR	RN1/6PQ9101F
D132-139	DIODE	1SS254	R245	METALFILM RESISTOR	RN1/6PQ1002F
△ D140	DIODE	1SS254	R247, 248	METALFILM RESISTOR	RN1/6PQ1002F
D141	ZENER DIODE	MTZ8. 2B	R250	METALFILM RESISTOR	RN1/6PQ1002F
CAPACITORS			R257-260	METALFILM RESISTOR	RN1/6PQ9101F
C103, 106	ELECT. CAPACITOR	CEAS470M25	R261	METALFILM RESISTOR	RN1/6PQ1002F
C109	ELECT. CAPACITOR	CEAS470M25	R263, 264	METALFILM RESISTOR	RN1/6PQ1002F
C110, 111	ELECT. CAPACITOR	CEANP470M25	R266	METALFILM RESISTOR	RN1/6PQ1002F
C112	ELECT. CAPACITOR	CEAS470M25	Other resistors		
C125-128	ELECT. CAPACITOR	CEANP470M25	RD1/6PM□□□J		
C137	ELECT. CAPACITOR	CEAS471M35			
C138, 139	CERAMIC CAPACITOR	CKCYF103Z50			
C140	ELECT. CAPACITOR	CEAS101M25			

Mark No.	Description	Parts No.
DGIF UNIT		
SEMICONDUCTORS		
IC401, 402	DIGITAL I. F. IC	PD0037
IC404	REGULATOR IC	NJM78M05FA
IC405	LOGIC IC	TC74HC04AP
IC406, 407	DIG-ATT IC	PD0026A
Q401, 402	TRANSISTOR	DTC124ES
Q403	TRANSISTOR	DTA124ES
Q404, 405	TRANSISTOR	DTC124ES
Q406, 407	TRANSISTOR	DTA124ES
Q408	TRANSISTOR	DTC124ES
Q409	TRANSISTOR	DTA124ES
Q410	TRANSISTOR	DTC124ES
Q411	TRANSISTOR	DTC124ES
D402, 403	DIODE	1SS254
D405, 406	DIODE	1SS254
D407-414	DIODE	10DF2
D415	BRIDGE STACK	S1VB10/F03
D416	DIODE	1SS254
D417	ZENER DIODE	MTZ4.7B
D418	ZENER DIODE	MTZ3.9B
COILS		
L401-404	AXIAL INDUCTOR	LAU330J
CAPACITORS		
C401	ELECT. CAPACITOR	CEAS101M10
C402	CERAMIC CAPACITOR	CKCYF472Z50
C403	CERAMIC CAPACITOR	CKCYF103Z50
C404	AUDIO FILM CAPACITOR	CFTXA224J50
C405	ELECT. CAPACITOR	CEAS101M10
C406	CERAMIC CAPACITOR	CKCYF472Z50
C407	CERAMIC CAPACITOR	CCCSL220J50
C408	CERAMIC CAPACITOR	CCCSL680J50
C409	CERAMIC CAPACITOR	CKCYF472Z50
C410, 411	ELECT. CAPACITOR	CEAS101M10
C412	CERAMIC CAPACITOR	CKCYF472Z50
C413	CERAMIC CAPACITOR	CCCSL220J50
C414	ELECT. CAPACITOR	CEAS101M10
C415	CERAMIC CAPACITOR	CKCYF472Z50
C416	CERAMIC CAPACITOR	CKCYF103Z50
C417	AUDIO FILM CAPACITOR	CFTXA224J50
C418	ELECT. CAPACITOR	CEAS101M10
C419	CERAMIC CAPACITOR	CKCYF472Z50
C420	CERAMIC CAPACITOR	CCCSL220J50
C421	CERAMIC CAPACITOR	CCCSL680J50
C422	CERAMIC CAPACITOR	CKCYF472Z50
C423, 424	ELECT. CAPACITOR	CEAS101M10
C425	CERAMIC CAPACITOR	CKCYF472Z50
C426	CERAMIC CAPACITOR	CCCSL220J50
C427-432	CERAMIC CAPACITOR	CKCYF103Z50
C433, 434	ELECT. CAPACITOR	CEAS222M35
C435-437	CERAMIC CAPACITOR	CKCYF103Z50
C438	ELECT. CAPACITOR	CEAS222M25

Mark No.	Description	Parts No.
C439, 440	CERAMIC CAPACITOR	CKCYF103Z50
C441, 442	ELECT. CAPACITOR	CEAS101M10
C443	ELECT. CAPACITOR	CEAS330M35
C444	CERAMIC CAPACITOR	CKCYF103Z50
C445, 446	CERAMIC CAPACITOR	CCCSL221J50
C447, 448	CERAMIC CAPACITOR	CCCSL101J50
RESISTORS		
	All resistors	RD1/6PM□□□□
OTHERS		
J411	CONNECTOR ASSY	DKP2383
J412	CONNECTOR ASSY	DKP2382
J415, 416	CONNECTOR ASSY	DKP2407
XLR1 UNIT		
CAPACITORS		
C801-804	CERAMIC CAPACITOR	CKCYF103Z50
OTHERS		
CN801, 802	3P RECEPTACLE	PKP1004
XLR2 UNIT		
CAPACITORS		
C805-808	CERAMIC CAPACITOR	CKCYF103Z50
OTHERS		
CN803, 804	3P RECEPTACLE	PKP1004
CNCT UNIT		
SEMICONDUCTORS		
IC501	LINE DRIVER	M751701P
IC502, 503	LOGIC IC	TC74HCU04AP
SWITCHES		
S501, 502	SWITCH	DSH-106
COILS		
F501-507	FILTER	VTH1001
L501, 502	COIL	PTL1003
CAPACITORS		
C503, 504	ELECT. CAPACITOR	CEAS2R2M50
C505, 506	CERAMIC CAPACITOR	CKCYF103Z50
C507	CERAMIC CAPACITOR	CCCSL470J50
C508, 509	CERAMIC CAPACITOR	CKCYF472Z50
C510, 511	CERAMIC CAPACITOR	CKCYB471K50
C512	CERAMIC CAPACITOR	CKCYF103Z50
C513, 514	ELECT. CAPACITOR	CEAS101M10
C515, 516	CERAMIC CAPACITOR	CKCYF103Z50
C517	ELECT. CAPACITOR	CEAS470M25
C518	ELECT. CAPACITOR	CEAS101M10
C519, 520	CERAMIC CAPACITOR	CKCYF103Z50
C521	ELECT. CAPACITOR	CEAS470M25

Mark No. Description Parts No.

RESISTORS

R502, 503 CARBON FILM RESISTOR RD1/2PMF101J
 Other resistors RD1/6PM□□□J

OTHERS

JA503 D-SUB SOCKET 9P DKN1051
 JA504 D-SUB SOCKET 15P DKN1052
 JA505, 506 JACK PKB1004

RSIF UNIT

SEMICONDUCTORS

IC302 IC M75175P
 IC303 LOGIC IC SN75174N
 Q301 TRANSISTOR DTA124ES

CAPACITORS

C303 ELECT. CAPACITOR CEAS101M10
 C304, 305 CERAMIC CAPACITOR CKCYF103Z50
 C306 ELECT. CAPACITOR CEAS101M10
 C307 CERAMIC CAPACITOR CKCYF103Z50

RESISTORS

All resistors RD1/6PM□□□J

OTHERS

J301 CONNECTOR ASSY DKP1880

AUOB UNIT

CAPACITORS

C702-706 CERAMIC CAPACITOR CKCYF102Z50

RESISTORS

R701-706 CARBON FILM RESISTOR RD1/6PM101J

OTHERS

JA701 JACK DKB1025

BRAN UNIT

RESISTORS

R101-103 CARBON FILM RESISTOR RD1/6PM221J

CDPS UNIT

SEMICONDUCTOR

△ IC7 REGULATOR IC NJM78M05FA

DISP UNIT

SEMICONDUCTORS

Q90, 91 TRANSISTOR 2SC3243

Mark No. Description Parts No.

COILS

L90, 91 RADIAL INDUCTOR LFA270K
 L92 INDUCTOR DTH1120
 L93 TRANSFORMER DTT1081

CAPACITORS

C90, 91 ELECTR. CAPACITOR CEAL470M16
 C92 PL. PROPYtene CQPYA333J2A
 CAPACIT
 C93 CAPACITOR (22p) DCG1008

RESISTORS

R90, 91 CARBON FILM RESISTOR RD1/6PM472J

OTHERS

INSULATION SHEET DEC1471
 FL TERMINAL ASS'Y DXB1386

9. ADJUSTMENTS

9.1 HORIZONTAL ADJUSTMENT OF THE TRANSFER BASE ASSEMBLY

(Fig. 9-1)

1. Remove approximately 10 CDs from the bottom of the right and left rack assemblies.
2. Set the system to the Super Manual mode (see "11. ① Super Manual mode"), then move the transfer base assembly downwards.
3. Place a metal ruler on the left side (A) of the D-stay (U). Adjust the height of the transfer base assembly to the D-stay (U).
4. Place the metal ruler on the right side (B) of the D-stay (U). Modify the height of the transfer base assembly by adjusting the screw (C) of the belt stopper (R). Height difference between the right and left transfer base assemblies must be within 0.1 mm.

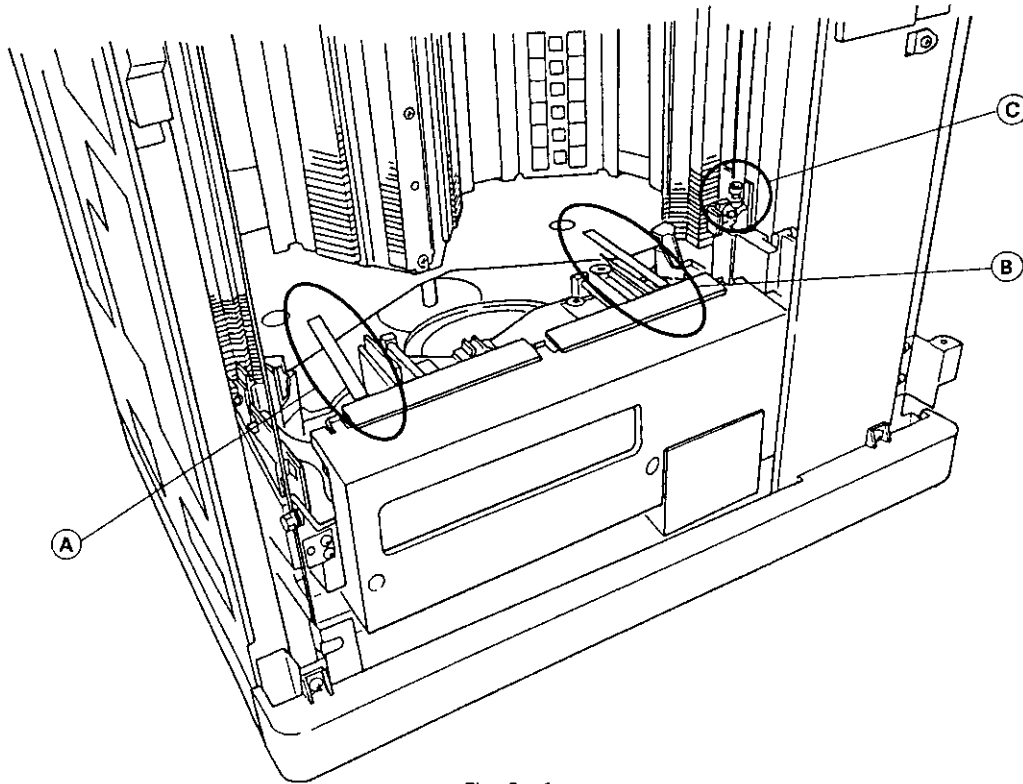

Fig. 9-1

9.2 ADJUSTING THE SPEED OF THE VD (VERTICAL) MOTOR

1. Make the connection as shown in Fig. 9-2.
2. Set the system to the Super Manual mode (see "11. ① Super Manual mode"), then turn all DIP switches (S5 on the KDSB unit) to OFF (VD motor will be selected).
3. Rotate the VD motor by pressing S1 or S2 of the KDSB unit.
4. Adjust VR1 so that the waveform of the oscilloscope becomes $t = 17 \pm 0.5 \mu\text{sec}$ (see Fig. 9-3).

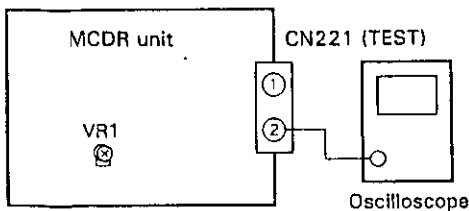

Fig. 9-2 Connection

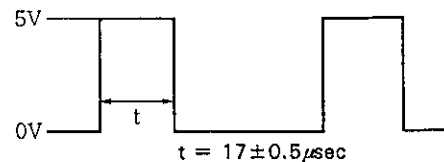

Fig. 9-3 Waveform

9.3 ADJUSTING THE HEIGHT OF THE ENCODER PLATE

● **Left Rack Assembly**

1. Set the system to the Manual mode (see "11. ② Manual mode"), then move the transfer base assembly to the CD installation address #79.
2. Swing the assembly towards the left rack assembly.
3. Adjust the VD encoder 1 (left) so that the chuck stay, chuck 1 assembly and chuck spring 3 will be inoperative when the arrow shaft is activated. (See Fig. 9-4 and 9-5 and Table 9-1.)
4. After adjustment, move the transfer base assembly vertically and confirm the height at the address #79.
5. Repeat the same for confirming the height at the CD installation addresses #1, #12, #50 and #150.

● **Right Rack Assembly**

1. Make the adjustment in the same manner as with the left rack assembly, except that the CD installation address is #229.
2. Also confirm the height at the CD installation addresses #151, #200 and #300.

NOTE :

If the CD touches the partition of the rack assembly (A) even though the arrow shaft is in the center position, the chuck may defective, the arrow shaft may be bent or the disc is distorted.

A : The VD encoder adjustment position is too high.
(→ Lower the VD encoder plate.)

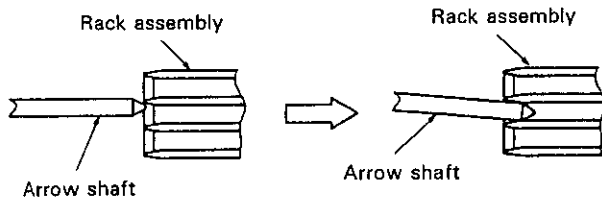

B : Proper adjustment

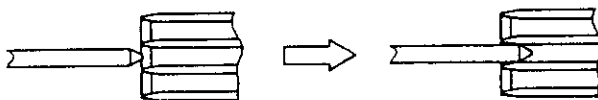

C : The VD encoder adjustment position is too low.
(→ Raise the VD encoder plate.)

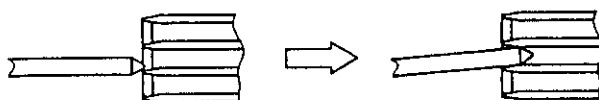

Adjust so that the arrow shaft and the rack assembly are positioned as shown in (B) above (see Fig. 9-5).

Fig. 9-4

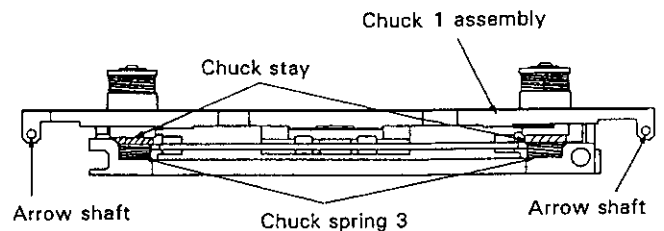
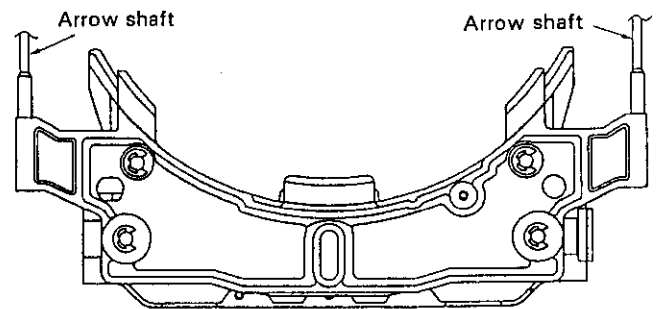

Fig. 9-5

The chuck stay and the chuck 1 assembly function as shown in the table below when the arrow shaft is inserted into the rack assembly.

	Chuck Stay	Chuck 1 Assembly	Chuck Spring 3
Fig. 9-4 A	Lowers.	Lowers.	Contracts.
Fig. 9-4 B	Does not operate.	Does not operate.	Does not operate.
Fig. 9-4 C	Does not operate.	Raises.	Does not operate.

Table 9-1

9.4 ADJUSTMENT OF THE CD PLAYER

CD players may operate improperly or do not operate at all if they are improperly or inadequately adjusted, even though no defect can be found in the pick-up and circuitry. Be sure to adjust correctly according to the adjustment procedure.

1. Adjustment Items / Check Points and Sequence

Sequence	Item	Test Point	Adjustment Point
1	Focus offset adjustment	CN109, Pin 6 (FOER)	VR2 (FO. OFS)
2	Grating adjustment	CN109, Pin 2 (TRER)	Grating adjusting slit
3	Tracking error balance adjustment	CN109, Pin 2 (TRER)	VR1 (TR. BAL)
4	Pick-up radial/tangential tilt adjustment	CN109, Pin 1 (RF)	Radial tilt adjusting screw, tangential tilt adjusting screw
5	RF level adjustment	CN109, Pin 1 (RF)	VR5 (RF level)
6	Focus servo loop gain adjustment	CN109, Pin 5 (FOIN) CN109, Pin 6 (FOER)	VR3 (FO. GAN)
7	Tracking servo loop gain adjustment	CN109, Pin 3 (TRIN) CN109, Pin 2 (TRER)	VR4 (TR. GAN)
8	Focus error signal confirmation	CN109, Pin 6 (FOER)	———

● Abbreviation Table

FOER	: Focus Error	FO. OFS	: Focus Offset
FOIN	: Focus In	TR. BAL	: Tracking Balance
TRIN	: Tracking In	FO. GAN	: Focus Servo Loop Gain
TRER	: Tracking Error	TR. GAN	: Tracking Servo Loop Gain

2. Instruments and Tools

Use the following instruments and tools for adjustment :

1. Dual trace oscilloscope (10 : 1 probe)
2. Low-frequency oscillator
3. Test disc (YEDS-7)
4. Low-pass filter (39 k Ω + 0.001 μ F)
5. Resistor (100 k Ω)
6. Standard tools

3. CD Player Setting

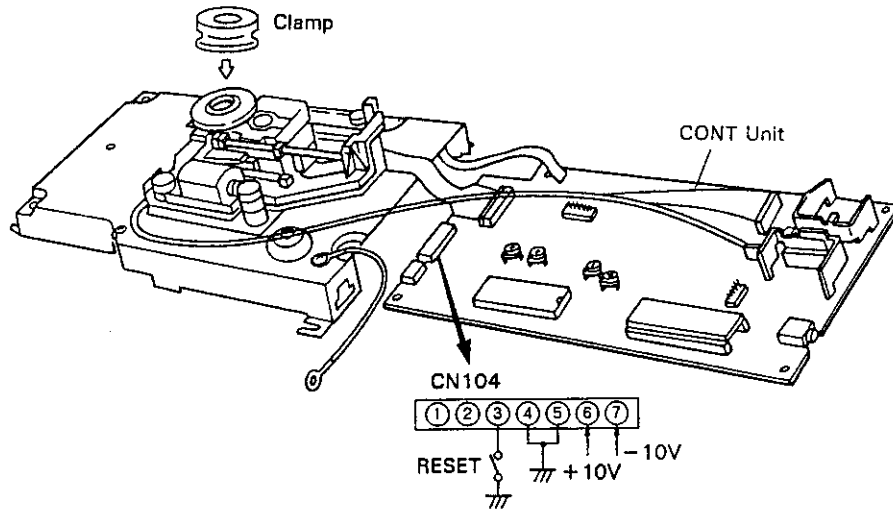

4. Positions of the Test Points and Adjusting VR

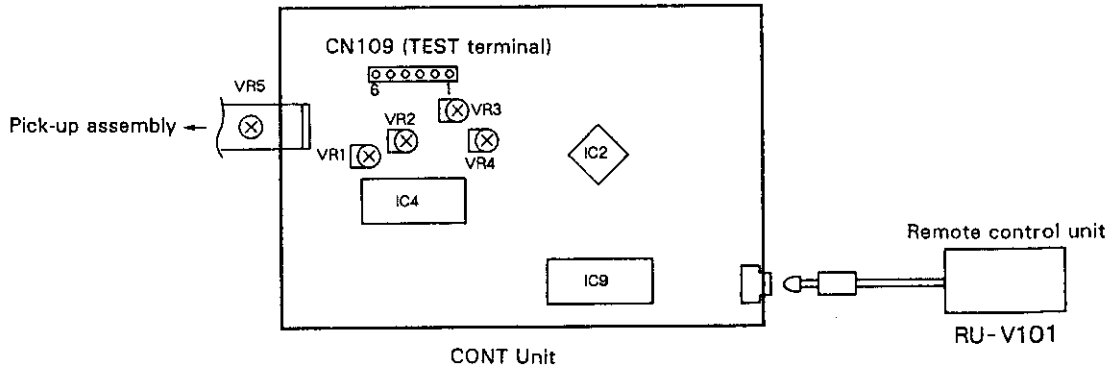

Fig. 1 Adjustment Points

5. Notes

1. Use an oscilloscope with a probe ratio of 10 : 1.
2. All control knob positions (set values) of the oscilloscope shown in this adjustment procedure are based on the condition using an oscilloscope with a probe ratio of 10 : 1.

● FUNCTION OF THE SERVICE REMOTE CONTROL UNIT

The CD player (PD-CACV3000) of the CD Auto Changer (CAC-V3000) can be directly operated by using the remote control unit (RU-V101). The remote control unit has the following functions :

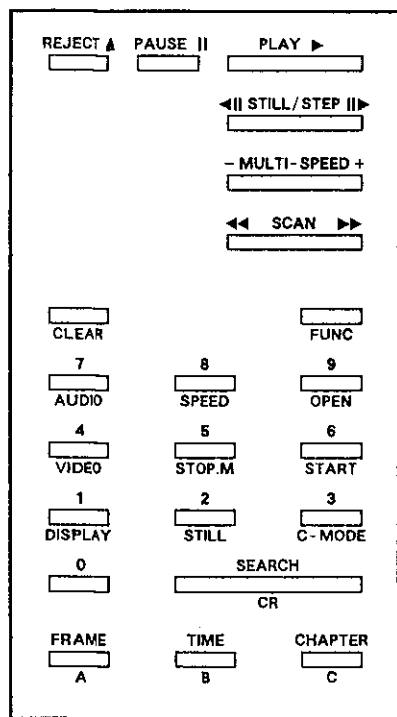

RU-V101

REJECT	:	Spindle stop
PAUSE	:	Pause
PLAY	:	Play
STILL/STEP	:	Disc select
STILL/STEP	:	Disc return
MULTI-SPEED +	:	Test command
MULTI-SPEED -	:	Test command
SCAN	:	Scan FWD
SCAN	:	Scan REV
CLEAR	:	Clear
FRAME	:	Specifies a block.
TIME	:	Specifies the time.
CHAPTER	:	Specifies a track.
SEARCH	:	Search
10 key	:	To enter numbers.
DISPLAY (FUNC + 1)	:	No entry
STILL (FUNC + 2)	:	No entry
C-MODE (FUNC + 3)	:	No entry
VIDEO (FUNC + 4)	:	Volume set
STOP. M (FUNC + 5)	:	Stop marker
START (FUNC + 6)	:	Start
AUDIO (FUNC + 7)	:	Fade IN/OUT Start
SPEED (FUNC + 8)	:	Speed control
OPEN (FUNC + 9)	:	No entry
B (FUNC + TIME)	:	Fade time set

● Test Command

- 0 + MULTI-SPEED (+, -) key : Laser diode (LD) ON
- 1 + MULTI-SPEED (+, -) key : Focus servo close
- 2 + MULTI-SPEED (+, -) key : Spindle kick
- 3 + MULTI-SPEED (+, -) key : Tracking, slider servo ON
- 4 + MULTI-SPEED (+, -) key : Slider FWD key
 Pressing the Slider FWD key once will move the pickup by approximately half of the full stroke.
- 5 + MULTI-SPEED (+, -) key : Slider REV key
 Pressing the Slider REV key once will move the pickup by approximately half of the full stroke.
- 6 + MULTI-SPEED (+, -) key : Tracking, slider servo OFF
- 7 + MULTI-SPEED (+, -) key : Slider stop, spindle stop
- 8 + MULTI-SPEED (+, -) key : Slider stop, spindle stop
- 9 + MULTI-SPEED (+, -) key : Focus servo open

● Usage of the SPEED Command

Based on the assumption that normal speed equals 100, the speed rate of 90 to 110 is expressed as -10 to +10%.

Example : Changing the speed by -10%

[9] + [0] + [FUNC] + [8]

Note :

- The changed speed will not return to normal by pressing the REJECT button. To resume normal speed, press the Disc Select key.
- Always press the Disc Select key after pressing the Disc Return key. Otherwise the system will not accept commands.

● To Check the Digital Attenuator

Attenuation level and Fade time are able to set. Fade In/Out function is also executed by this remote controller.

Example 1 : Set the fade time to 10 seconds.

[1] + [0] + [FUNC] + [TIME]

Example 2 : Attenuation level maximum. (mute)

[0] + [FUNC] + [4]

Example 3 : Start the Fade-in.

[2] + [5] + [5] + [FUNC] + [7]

Note :

The digital attenuation is valid for the built-in D/A convertor. So use the analog output to check this function.

1. Focus Offset Adjustment

<ul style="list-style-type: none"> ● Purpose : To adjust the DC offset voltage of the focus error amplifier to -50mV. ● Symptom of improper adjustment : The player does not focus in. RF signal is dirty. 	
<ul style="list-style-type: none"> ● Instrument connection ● Setting ● Player condition ● Adjustment point ● Disc 	<ul style="list-style-type: none"> ● Connect the oscilloscope to Pin 6 (FOER) of CN109. ● 5mV/div, 10mS/div, DC mode ● Stop (only the power supply is ON) ● VR2 (FO. OFS) ● Not necessary
<ul style="list-style-type: none"> ● Connection 	
<ul style="list-style-type: none"> ● Procedure <p>Adjust VR2 (FO. OFS) to set the voltage of Pin 6 (FOER) of CN109 to $-50 \pm 50\text{mV}$.</p>	

2. Grating Adjustment

Grating Adjustment 1/2

- Purpose : To adjust the two laser beam spots for tracking error generation to the optimum angle on the track.
- Symptom of improper adjustment : The player does not start playback. Does not perform track search. Skips track(s).

- | | |
|--|---|
| <ul style="list-style-type: none"> ● Instrument connection ● Setting ● Player condition ● Adjustment point ● Disc | <ul style="list-style-type: none"> ● Connect the oscilloscope to Pin 2 (TRER) of CN109 via the low-pass filter. (see Fig. 2) ● 50 mV/div, 5 mS/div, DC mode ● Focus and spindle servos closed. Tracking servo open. ● Grating adjusting slit of the pickup. ● YEDS-7 |
|--|---|

● Connection

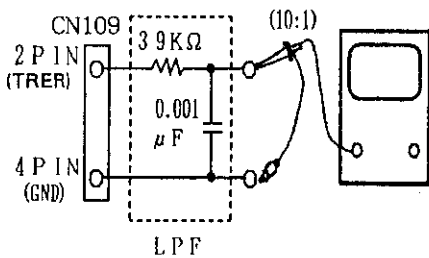
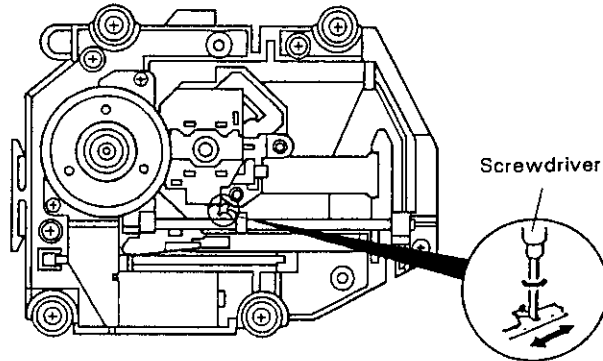

Fig. 2



Adjustment Point

● Procedure

1. Move the pickup to the proximity of the outer edge of the disc by using the "4 + MULTI-SPEED" or "5 + MULTI-SPEED" key.
2. Press the "1 + MULTI-SPEED" key, then "2 + MULTI-SPEED" key to close the focus and spindle servos.
3. Insert a screwdriver into the grating adjusting slit. Adjust grating and find the null point. See the next page for more details.
4. Slowly turning the screwdriver counterclockwise from the null point will gradually increase the amplitude of the waveform. Continued turning of the screwdriver will decrease the waveform amplitude again. Turn the screwdriver counterclockwise from the null point to find the first maximum point of waveform amplitude.

(Reference)

Fig. 3 shows the relationship between the tracking beam angle to the track and the waveform.

● How to find the null point

Insert a screwdriver into the grating adjusting slit and change the grating angle. By this method, the tracking error signal amplitude of Pin 2 of CN109 can be changed. There are several points where the waveform amplitude decreases within the variable range of grating. Among these points, only one point allows the envelope to be smooth. This means that the three laser beams divided by the grating are on the same track (see Fig. 3).

This point is called null point. Adjust the grating to find the null point and use it as the reference position for grating adjustment.

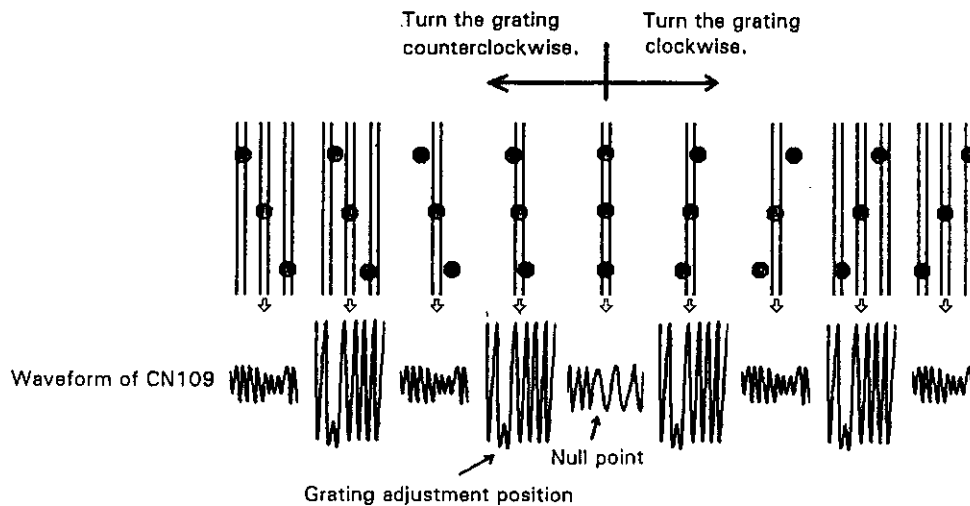
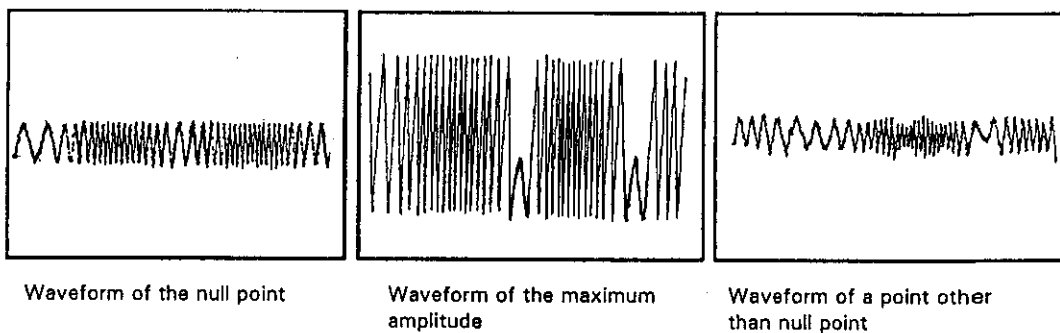

Fig. 3



Note :

The amplitude of the tracking error signal is approximately $3 V_{p-p}$. If the amplitude is extremely small ($2 V_{p-p}$) (using LPF of $39 \text{ k}\Omega + 0.001 \mu\text{F}$), the lens may be not clean or the pickup is malfunctioning.

If the amplitude of the error signal fluctuates more than 10% between the inner most edge and outer most edge of a disc, the grating is not adjusted to the optimum point. Adjust the grating correctly.

3. Tracking Error Balance Adjustment

- Purpose : To correct the sensitivity levels of the tracking photodiode to the same level.
- Symptom of improper adjustment : The player does not start playback. Does not perform track search.

- Instrument connection
- Setting
- Player condition
- Adjustment point
- Disc

- Connect the oscilloscope to Pin 2 (TRER) of CN109 (the low-pass filter may be used).
- 50 mV/div, 5 mS/div, DC mode
- Focus and spindle servos closed. Tracking servo open.
- VR1 (TR. BAL)
- YEDS-7

- Connection

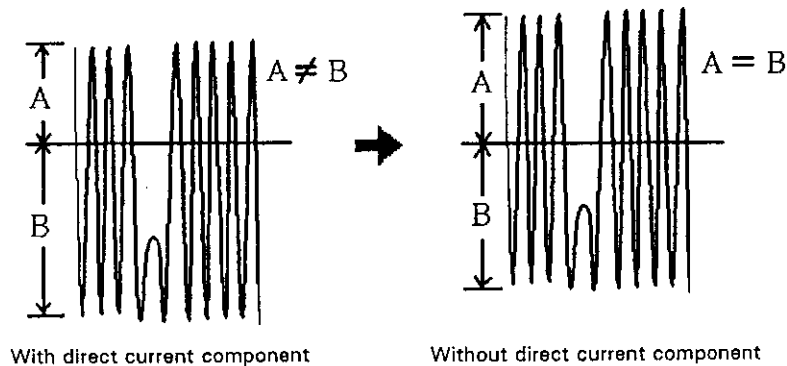

● Procedure

1. Move the pickup to the center between the inner and outer edges of the disc (R = 35 mm) by using the "4 + MULTI-SPEED" or "5 + MULTI-SPEED" key.
2. Press the "1 + MULTI-SPEED" key, then "2 + MULTI-SPEED" key to close the focus and spindle servos.
3. Align the bright line (GND) of the oscilloscope with the center of the oscilloscope screen, and change to the DC mode.
4. Adjust VR1 (TR. BAL) to make the amplitude of the positive side the same as the negative side of the tracking error signal of Pin 2 (TRER) of CN109 (so that there is no DC component).

4. Pick-up Radial/Tangential Tilt Adjustment

Pick-up Radial/Tangential Tilt Adjustment 1/2

- Purpose : To adjust the angle of the pickup to the disc, and optimize the RF signal to be read by irradiating the laser beam vertically to the disc.
- Symptom of improper adjustment : Skipping sound. Some discs cannot be played back.

- Instrument connection
- Setting
- Player condition
- Adjustment point
- Disc

- Connect the oscilloscope to Pin 1 (RF) of CN109.
- 20 mV/div, 200 nS/div, AC mode
- Play
- The radial tilt adjusting screw and the tangential tilt adjusting screw of the pickup.
- YEDS-7

- Connection

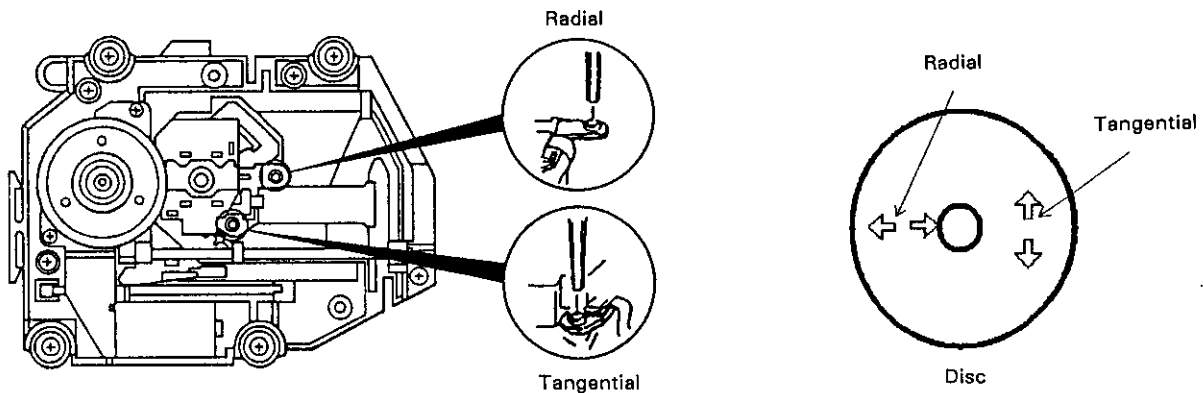

Fig. 4

Adjustment Point

- Procedure

1. Move the pickup to the proximity of the outer edge of the disc by using the "4 + MULTI-SPEED" key. Press the "1 + MULTI-SPEED", "2 + MULTI-SPEED" and "3 + MULTI-SPEED" keys in sequence to close the focus, spindle and tracking servos and set the player to the play mode.
2. Use a hexagon wrench (3 mm) to adjust the radial tilt adjusting screw so that the eye pattern (diamond-shaped waveform that appears in the center of the RF signal) is shown most clearly.
3. Use the hexagon wrench to adjust the tangential tilt adjusting screw so that the eye pattern is shown most clearly (see Fig. 5).

4. Adjust again the radial tilt adjusting screw, then the tangential tilt adjusting screw so that the eye pattern is shown most clearly. If necessary, adjust the two adjusting screws alternately so that the eye pattern is shown most clearly.

Note :

Radial and tangential refer to the directions in relation to the discs, as shown in Fig. 4.

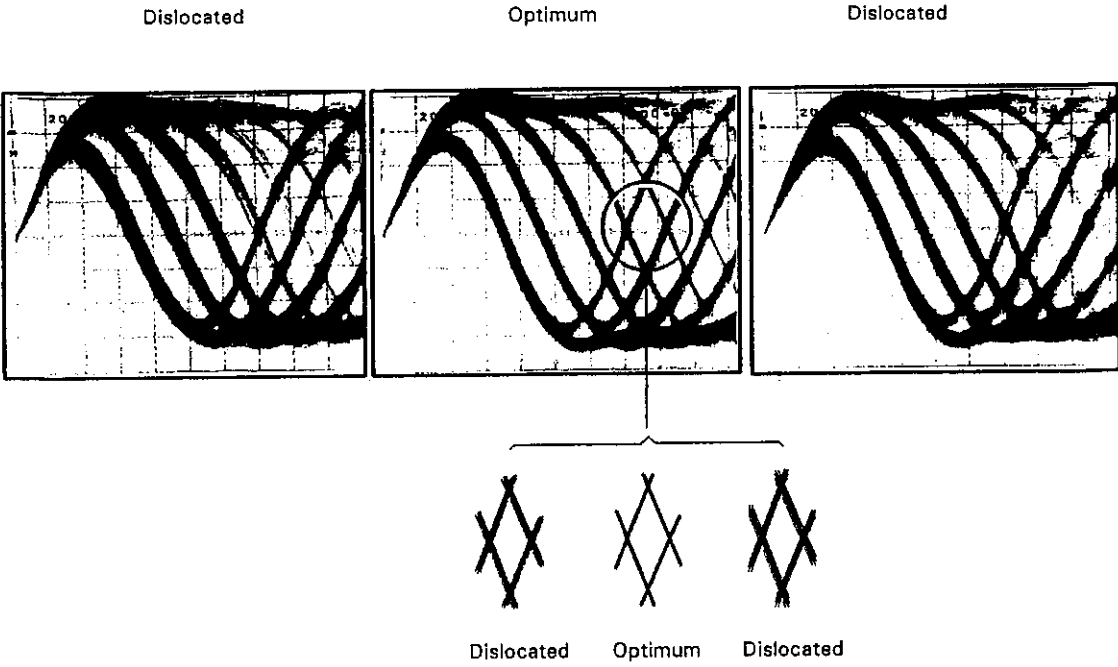

Fig. 5

5. RF Level Adjustment

<ul style="list-style-type: none"> ● Purpose : To optimize the amplitude of the playback RF signal. ● Symptom of improper adjustment : The player does not play back. Does not perform search. 	
<ul style="list-style-type: none"> ● Instrument connection ● Setting ● Player condition ● Adjustment point ● Disc 	<ul style="list-style-type: none"> ● Connect the oscilloscope to Pin 1 (RF) of CN109. ● 50 mV/div, 10 mS/div, AC mode ● Play ● VR5 (laser power) ● YEDS-7
<ul style="list-style-type: none"> ● Connection 	
<ul style="list-style-type: none"> ● Procedure <ol style="list-style-type: none"> 1. Move the pickup to the center between the inner and outer edges of the disc ($R = 35 \text{ mm}$) by using the "4 + MULTI-SPEED" or "5 + MULTI-SPEED" key. Press the "1 + MULTI-SPEED", "2 + MULTI-SPEED" and "3 + MULTI-SPEED" keys in sequence to close the servos and set the player to the play mode. 2. Adjust VR5 to set the amplitude of the RF signal to 1.2 $V_{p-p} + 0.3/-0.1 \text{ V}$. 	

6. Focus Servo Loop Gain Adjustment

- Purpose : To adjust the loop gain of the focus servo to the optimum value.
- Symptom of improper adjustment : The player does not start playback. The focus actuator sound is high.

- | | |
|--|--|
| <ul style="list-style-type: none"> ● Instrument connection ● Setting ● Player condition ● Adjustment point ● Disc | <ul style="list-style-type: none"> ● See Fig. 6. ● CH1 : 20 mV/div, X-Y mode CH2 : 5 mV/div ● Play ● VR3 (FO. GAN) ● YEDS-7 |
|--|--|

- Connection

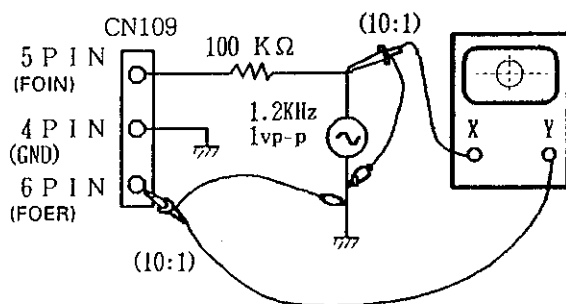
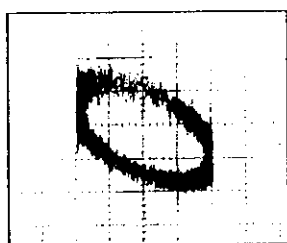
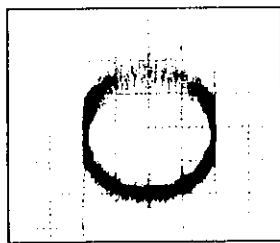

Fig. 6



Gain is too large.



Optimum gain

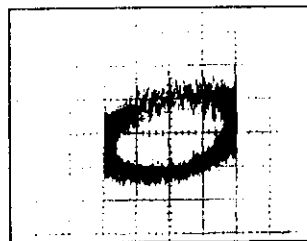

Gain is too small.

● Procedure

1. Set the output of the AF oscillator to 1.2 kHz and 1 V_{p-p}.
2. Move the pickup to the center between the inner and outer edges of the disc (R = 35 mm) by using the "4 + MULTI-SPEED" or "5 + MULTI-SPEED" key. Press the "1 + MULTI-SPEED", "2 + MULTI-SPEED" and "3 + MULTI-SPEED" keys in sequence to close the servos and set the player to the play mode.
3. Adjust VR3 (FO. GAN) so that the Lissajous's waveforms become symmetric to the X and Y axes, respectively.

7. Tracking Servo Loop Gain Adjustment

- Purpose : To adjust the loop gain of the tracking servo to the optimum value.
- Symptom of improper adjustment : The player does not start playback. The actuator sound is high during searching. Skips track(s).

- Instrument connection
- Setting
- Player condition
- Adjustment point
- Disc

- See Fig. 7.
- CH1 : 50 mV/div, X-Y mode CH2 : 5 mV/div
- Play
- VR4 (TR. GAN)
- YEDS-7

- Connection

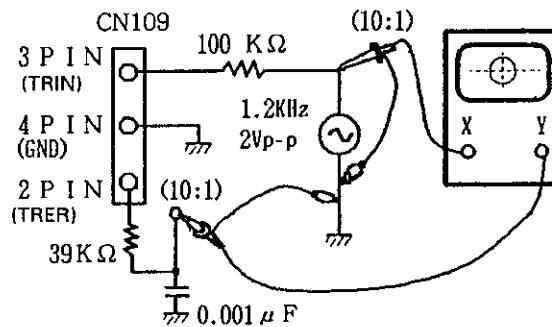
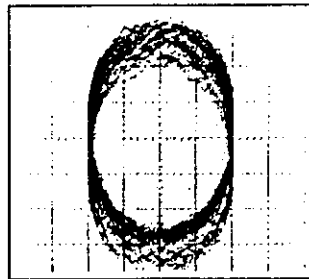

Fig. 7



Gain is too large.



Optimum gain

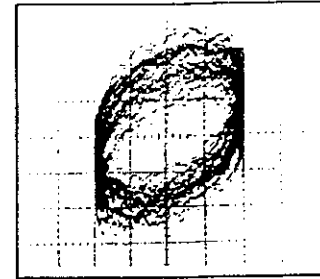

Gain is too small.

- Procedure

1. Set output of the AF oscillator to 1.2 kHz and 2 Vp-p.
2. Move the pickup to the center between the inner and outer edges of the disc (R = 35 mm) by using the "4 + MULTI-SPEED" or "5 + MULTI-SPEED" key. Press the "1 + MULTI-SPEED", "2 + MULTI-SPEED" and "3 + MULTI-SPEED" keys in sequence to close the servos and set the player to the play mode.
3. Adjust VR4 (TR. GAN) so that the Lissajous's waveforms become symmetric to the X and Y axes, respectively.

8. Focus Error Signal Confirmation

● Purpose : To evaluate the pickup by observing the focus error signal. Whether the pickup is faulty or not faulty can be decided from the level of amplitude of the tracking error signal (see "Tracking error balance adjustment") and by confirming the waveform of the focus error signal.

● Symptom of improper adjustment :

- Instrument connection
- Setting
- Player condition
- Adjustment point
- Disc

- Connect the oscilloscope to Pin 6 (FOER) of CN109.
- 100 mV/div, 5 mS/div, DC mode
- Stop
- None
- YEDS-7

● Connection

● Procedure

1. Connect Pin 5 of CN109 to GND.
2. Insert a disc.
3. Pressing the "1 + MULTI-SPEED" key while watching the oscilloscope screen allows you to observe for an instant the waveform shown in Fig. 8. Confirm that the amplitude is 2.5 V_{p-p} or larger and the amplitude of the positive side is approximately the same as the negative side. Note that the waveform is displayed only for an instant when the "1 + MULTI-SPEED" key is pressed. Press the key as many times as needed until the waveform can be confirmed.

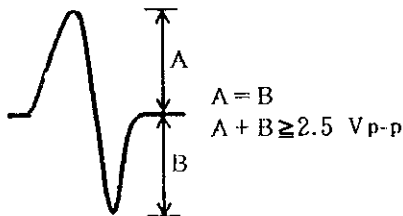

Fig. 8

[Evaluation of the pickup]

Evaluate the pickup after all adjustments are made correctly. If the evaluation result is as listed below, the pickup may be defective.

- ① The amplitude of the tracking error signal is extremely small (2 V_{p-p} or smaller).
- ② The amplitude of the focus error signal is extremely small (2.5 V_{p-p} or smaller).
- ③ The amplitude of the positive side of the focus error signal is excessively asymmetric from the negative side (more than 2 : 1).
- ④ RF signal is too small (0.8 V_{p-p} or smaller). The signal does not reach the specified value even after adjusting VR 5 (laser power).

9. REGLAGES

9.1 REGLAGE HORIZONTAL DE L'ENSEMBLE DE BASE DE TRANSFERT

(Fig. 9-1)

1. Retirer environ 10 CD du bas des ensembles de support droit et gauche.
2. Régler le système au mode Super Manuel (voir "11. ① Mode Super Manuel"), puis abaisser l'ensemble de base de transfert.
3. Placer une règle métallique sur le côté gauche (A) de l'armature en forme de D (U). Régler la hauteur de l'ensemble de base de transfert d'après l'armature en forme de D (U).
4. Placer la règle métallique sur le côté droit (B) de l'armature en forme de D (U). Modifier la hauteur de l'ensemble de base de transfert en ajustant la vis (C) de la butée de courroie (R). La différence de hauteur entre les ensembles de base de transfert droit et gauche doit être dans les 0,1 mm.

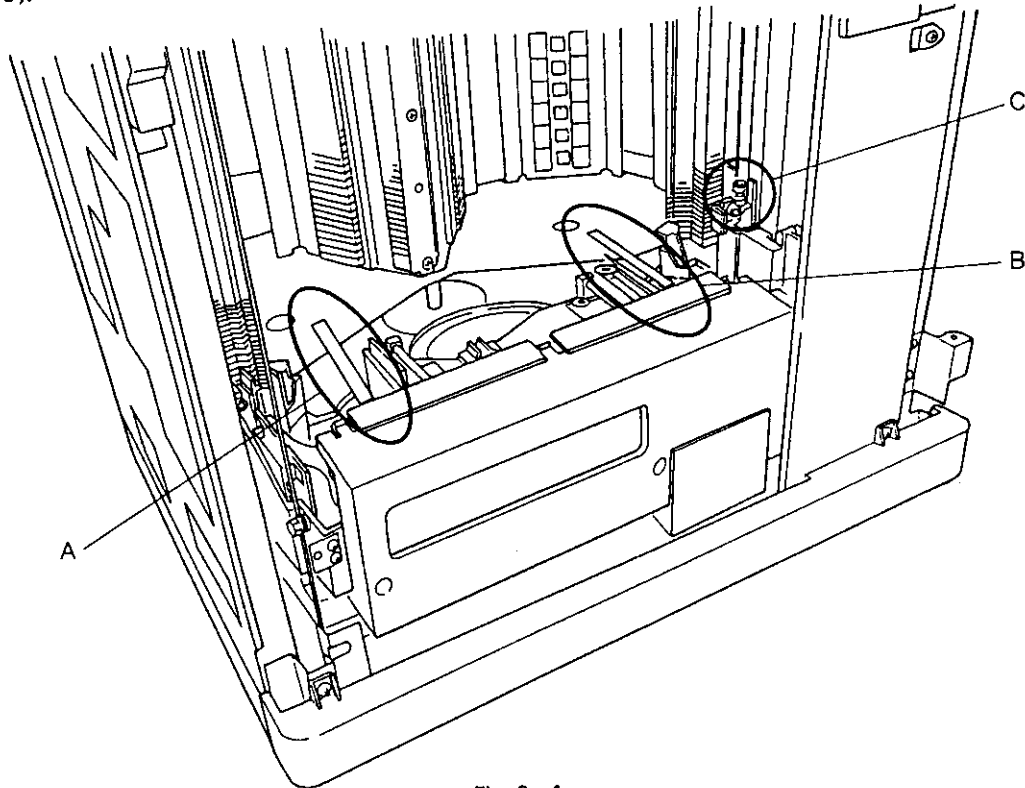

Fig. 9-1

9.2 REGLAGE DE LA VITESSE DU MOTEUR VD (VERTICAL)

1. Procéder à la connexion de la manière indiquée à la Fig. 9-2.
2. Régler le système au mode Super Manuel (voir "11. ① Mode Super Manuel"), puis désenclencher tous les commutateurs DIP (S5 l'unité KDSB) (le moteur VD sera sélectionné).
3. Faire tourner le moteur VD en maintenant S1 ou S2 de l'unité KDSB enfoncé.
4. Ajuster VR1 pour que la forme d'onde de l'oscilloscope devienne $t = 17 \pm 0,5 \mu\text{sec.}$ (voir Fig. 9-3).

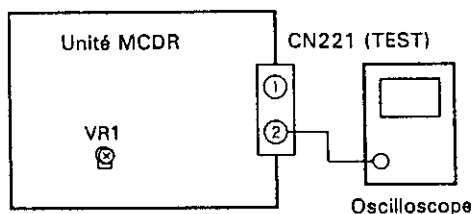

Fig. 9-2 Connexion

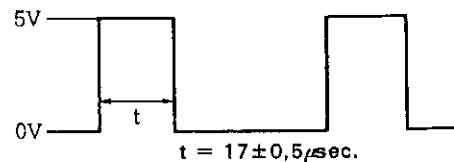

Fig. 9-3 Forme d'onde

9.3 REGLAGE DE LA HAUTEUR DE LA PLAQUE D'ENCODEUR VD

● **Ensemble de Support Gauche**

1. Régler le système au mode Manuel (voir "11. ② Mode Manuel"), puis déplacer l'ensemble de base de transfert à l'adresse d'installation de CD #79.
2. Faire basculer l'ensemble vers l'ensemble de support gauche.
3. Ajuster l'encodeur VD 1 (gauche) pour que l'armature à mandrin, l'ensemble 1 de mandrin et le ressort de mandrin 3 ne soient pas fonctionnels lorsque l'arbre à flèche est activé. (Voir les Fig. 9-4 et 9-5 et le Tableau 9-1.)
4. Après le réglage, déplacer verticalement l'ensemble de base de transfert et confirmer la hauteur au niveau de l'adresse #79.
5. Répéter la même procédure pour confirmer la hauteur au niveau des adresses d'installation de CD #1, #12, #50 et #150.

● **Ensemble de Support Droit**

1. Procéder au réglage de la même manière qu'avec l'ensemble de support gauche, sauf que l'adresse d'installation de CD est #229.
2. Confirmer également la hauteur au niveau des adresses d'installation de CD #151, #200 et #300.

REMARQUE :

Si le CD touche la partie de l'ensemble de support (A), même avec l'arbre à flèche en position centrale, le mandrin peut être défectueux, l'arbre à flèche tordu ou le disque déformé.

A : La position de réglage de l'encodeur VD est trop élevée. (→ Abaisser la plaque de l'encodeur VD.)

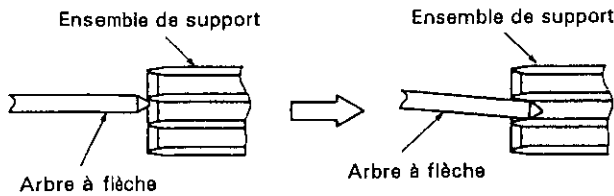

B : Réglage correct

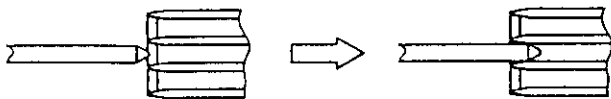

C : La position de réglage de l'encodeur VD est trop basse. (→ Relever la plaque de l'encodeur VD.)

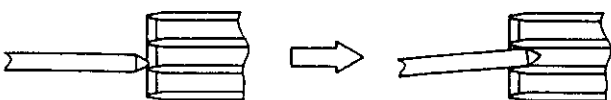

Ajuster pour que l'arbre à flèche et l'ensemble de support soient placés de la manière indiquée dans (B) ci-dessus (voir Fig. 9-5).

Fig. 9-4

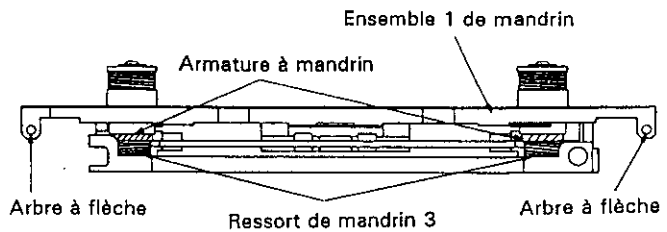
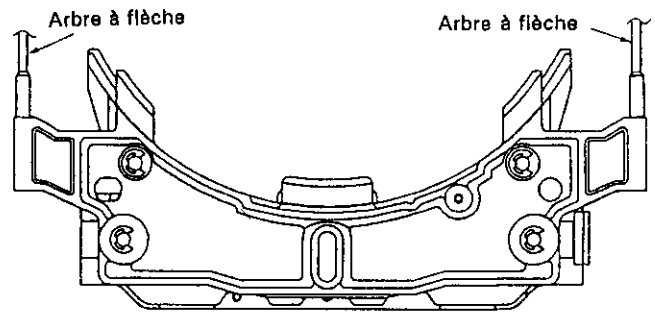

Fig. 9-5

L'armature à mandrin et l'ensemble 1 de mandrin fonctionnent de la manière indiquée dans le tableau ci-dessous lorsque l'arbre à flèche est inséré dans l'ensemble de support.

	Armature à Mandrin	Ensemble 1 de Mandrin	Ressort de Mandrin 3
Fig. 9-4 A	Abaisse.	Abaisse.	Contracte.
Fig. 9-4 B	Ne fonctionne pas.	Ne fonctionne pas.	Ne fonctionne pas.
Fig. 9-4 C	Ne fonctionne pas.	Relève.	Ne fonctionne pas.

Tableau 9-1

9.4 REGLAGE DU LECTEUR DE CD

Les lecteurs de CD peuvent mal fonctionner ou ne pas fonctionner du tout s'ils sont mal ou incorrectement ajustés, bien qu'aucun défaut ne puisse être trouvé dans le capteur et les circuits électriques. Toujours ajuster correctement en fonction de la procédure d'ajustement.

1. Articles de Réglage/Points de Contrôle et Séquence

Séquence	Article	Point d'essai	Point de réglage
1	Réglage du décalage de mise au point	CN109, Broche 6 (FOER)	VR2 (FO. OFS)
2	Réglage de la grille	CN109, Broche 2 (TRER)	Fente de réglage de la grille
3	Réglage de l'équilibre d'erreur d'alignement	CN109, Broche 2 (TRER)	VR1 (TR. BAL)
4	Réglage de l'inclinaison radiale/tangentielle du capteur	CN109, Broche 1 (RF)	Vis de réglage d'inclinaison radiale, vis de réglage d'inclinaison tangentielle
5	Réglage du niveau HF	CN109, Broche 1 (RF)	VR5 (niveau HF)
6	Réglage du gain de boucle du servo de mise au point	CN109, Broche 5 (FOIN) CN109, Broche 6 (FOER)	VR3 (FO. GAN)
7	Réglage du gain de boucle du servo d'alignement	CN109, Broche 3 (TRIN) CN109, Broche 2 (TRER)	VR4 (TR. GAN)
8	Confirmation du signal d'erreur de mise au point	CN109, Broche 6 (FOER)	—

● Table des abréviations

FOER	: Erreur de Mise au Point	FO. OFS	: Décalage de Mise au Point
FOIN	: Entrée Mise au Point	TR. BAL	: Equilibre D'alignement
TRIN	: Entrée Alignement	FO. GAN	: Gain de Boucle Servo de Mise au Point
TRER	: Erreur D'alignement	TR. GAN	: Gain de Boucle Servo D'alignement

2. Instruments et Outils

Utiliser les instruments et outils suivants pour le réglage.

1. Oscilloscope à double tracé (sonde 10 : 1)
2. Oscilloscope à basse fréquence
3. Disque d'essai (YEDS-7)
4. Filtre passe-bas (39 k Ω + 0,001 μ F)
5. Résistance (100 k Ω)
6. Outils standard

3. Réglage du Lecteur de CD

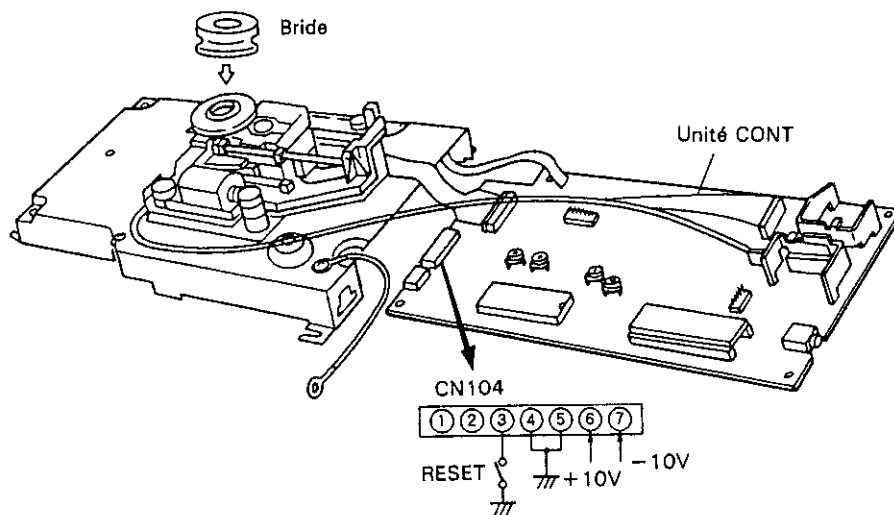

4. Positions des Points D'essai et Réglage de VR

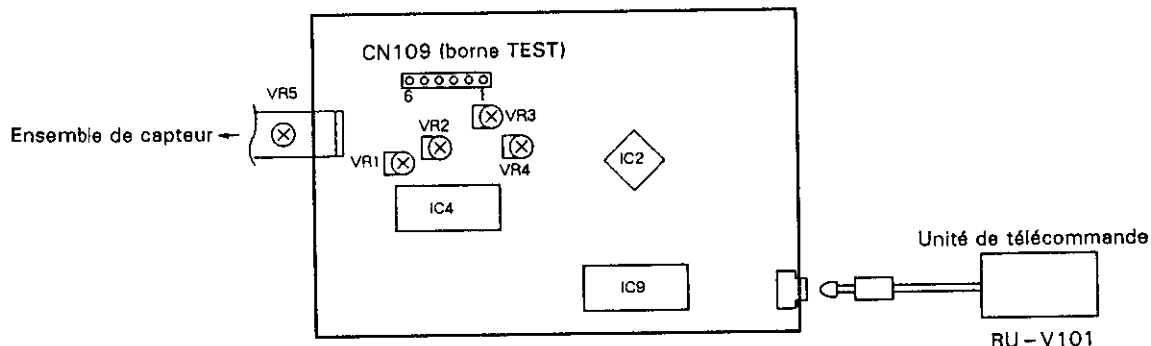

Unité CONT
Fig. 1 Points de réglage

5. Remarques

1. Utiliser un oscilloscope ayant un rapport de sonde de 10 : 1.
2. Toutes les positions du bouton de commande (valeurs réglées) de l'oscilloscope indiquées dans cette procédure de réglage sont basées sur les conditions d'utilisation d'un oscilloscope ayant un rapport de sonde de 10 : 1.

● **FONCTIONS DE L'UNITÉ DE TÉLÉCOMMANDE DE SERVICE**

Le lecteur de CD (PD-CACV3000) du changeur automatique de CD (CAC-V3000) peut être directement actionné en utilisant l'unité de télécommande (RU-V101). L'unité de télécommande possède les fonctions suivantes :

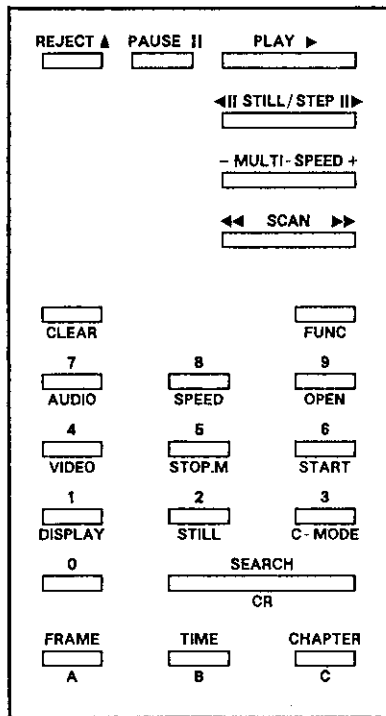

RU-V101

- REJECT : Arrêt de l'axe
- PAUSE : Pause
- PLAY : Reproduction
- STILL/SEPT III▶ : Sélection de disque
- STILL/SEPT ◀III : Retour de disque
- MULTI-SPEED + : Commande d'essai
- MULTI-SPEED - : Commande d'essai
- SCAN ▶▶ : Balayage en avant
- SCAN ◀◀ : Balayage en arrière
- CLEAR : Effacement
- FRAME : Spécifie un bloc.
- TIME : Spécifie l'heure.
- CHAPTER : Spécifie une piste.
- SEARCH : Recherche
- 10 key : Pour entrer des chiffres.
- DISPLAY (FUNC + 1) : Pas d'entrée
- STILL (FUNC + 2) : Pas d'entrée
- C-MODE (FUNC + 3) : Pas d'entrée
- VIDEO (FUNC + 4) : Réglage du volume
- STOP.M (FUNC + 5) : Marqueur d'arrêt
- START (FUNC + 6) : Démarrage
- AUDIO (FUNC + 7) : Lacement du fondu de début et de fin
- SPEED (FUNC + 8) : Contrôle de vitesse
- OPEN (FUNC + 9) : Pas d'entrée
- B (FUNC + TIME) : Réglage de la durée du fondu

● **Commande D'essai**

- Touche 0 + MULTI-SPEED (+, -) : Diode laser (LD) allumée
- Touche 1 + MULTI-SPEED (+, -) : Fermeture de servo de mise au point
- Touche 2 + MULTI-SPEED (+, -) : Secousse d'axe
- Touche 3 + MULTI-SPEED (+, -) : Alignement, servo curseur activé
- Touche 4 + MULTI-SPEED (+, -) : Une pression sur la touche d'avance de curseur déplace le capteur d'environ la moitié de la pleine course.
- Touche 5 + MULTI-SPEED (+, -) : Une pression sur la touche de recul de curseur déplace le capteur d'environ la moitié de la pleine course.
- Touche 6 + MULTI-SPEED (+, -) : Alignement, servo curseur désactivé
- Touche 7 + MULTI-SPEED (+, -) : Arrêt de curseur, arrêt d'axe
- Touche 8 + MULTI-SPEED (+, -) : Arrêt de curseur, arrêt d'axe
- Touche 9 + MULTI-SPEED (+, -) : Ouverture de servo de mise au point

● **Utilisation de la Commande SPEED**

En se basant sur la supposition que la vitesse normale est égale à 100, le rapport de vitesse de 90 à 110 est exprimé avec -10% à +10%.

Exemple : Changement de la vitesse de -10%

+ + +

Remarque :

- La vitesse changée ne revient pas à la normale en appuyant sur la touche REJECT. Pour revenir à la vitesse normale, appuyer sur la touche de sélection de disque.
- Toujours appuyer sur la touche de sélection de disque après une pression sur la touche de retour de disque. Sinon, le système n'accepte pas les commandes.

● **Contrôle de L'atténuateur de Signal**

Le niveau d'atténuation et la durée de fondu peuvent être réglés. La fonction de fondu peut également être commandée à l'aide de cette télécommande.

Exemple 1 : Règle la durée de fondu à 10 secondes.

+ + +

Exemple 2 : Niveau d'atténuation maximal. (sourdine)

+ +

Exemple 3 : Lance le fondu de début.

+ + + +

Remarque :

L'atténuation numérique est valable pour le convertisseur N/A intégré. Utiliser la sortie analogique pour contrôler cette fonction.

1. Réglage du Décalage de Mise au Point

- But : Régler la tension de décalage c.c. de l'amplificateur d'erreur de mise au point à -50 mV.
- Symptômes en cas de mauvais ajustement : Le lecteur ne met pas au point. Le signal HF est trouble.

- Connexion de l'instrument
- Réglage
- Etat du lecteur
- Point de réglage
- Disque

- Connecter l'oscilloscope à la Broche 6 (FOER) de CN109.
- 5 mV/div., 10 mS/div., mode c.c.
- Arrêt (seule l'alimentation est mise)
- VR2 (FO. OFS)
- Pas nécessaire

- Connexion

- Procédure

Ajuster VR2 (FO. OFS) pour régler la tension de la Broche 6 (FOER) de CN109 à -50 ± 50 mV.

2. Réglage de la Grille

Réglage de la Grille 1/2

- But : Régler les deux points du faisceau laser de génération d'erreur d'alignement à un angle optimum sur la piste.
- Symptômes en cas de mauvais ajustement : Le lecteur ne commence pas la reproduction. N'effectue pas la recherche de piste. Saute une(des) piste(s).

● Connexion de l'instrument

- Réglage
- Etat du lecteur
- Point de réglage
- Disque

● Connecter l'oscilloscope à la Broche 2 (TRER) de CN109 via le filtre passe-bas (voir Fig. 2)

- 50 mV/div., 5 mS/div., mode c.c.
- Servos de mise au point et d'axe fermés. Servo d'alignement ouvert.
- Fente de réglage de grille du capteur.
- YEDS-7

● Connexion

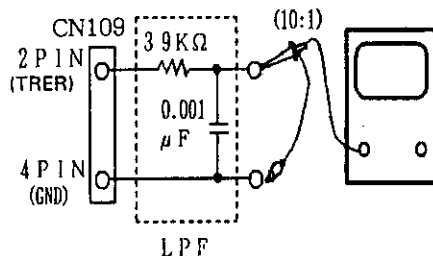
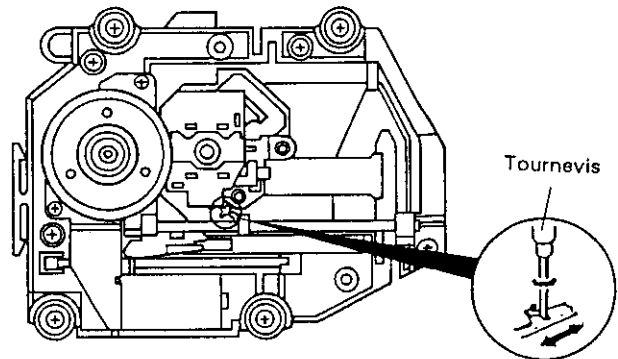

Fig. 2



Point de réglage

● Procédure

1. Déplacer le capteur à proximité du bord externe du disque en utilisant la touche "4 + MULTI-SPEED" ou "5 + MULTI-SPEED".
2. Appuyer sur la touche "1 + MULTI-SPEED", puis sur la touche "2 + MULTI-SPEED" pour fermer les servos de mise au point et d'axe.
3. Introduire un tournevis dans la fente de réglage de grille.
Ajuster la grille et trouver le point nul. Voir à la page suivante pour plus de détails.
4. Une rotation lente du tournevis dans le sens inverse des aiguilles d'une montre à partir du point nul augmente progressivement l'amplitude de la forme d'onde. Une rotation continue du tournevis rediminue l'amplitude de la forme d'onde. Tourner le tournevis dans le sens inverse des aiguilles d'une montre à partir du point nul pour trouver le premier point maximum d'amplitude de forme d'onde.

(Référence)

La Fig. 3 indique la relation entre l'angle de faisceau d'alignement à la piste et la forme d'onde.

● **Comment trouver le point nul**

Introduire un tournevis dans la fente de réglage de grille et changer l'angle de grille. Avec cette méthode, l'amplitude du signal d'erreur d'alignement de la Broche 2 de CN109 peut être changée. Il y a plusieurs points où l'amplitude de la forme d'onde diminue dans la gamme de grille variable. Parmi ces points, un seul permet à l'enveloppe d'être régulière. Ceci signifie que les trois faisceaux laser divisés par la grille sont sur la même piste (voir Fig. 3).

Ce point est appelé le point nul. Régler la grille pour trouver le point nul et l'utiliser comme position de référence pour le réglage de la grille.

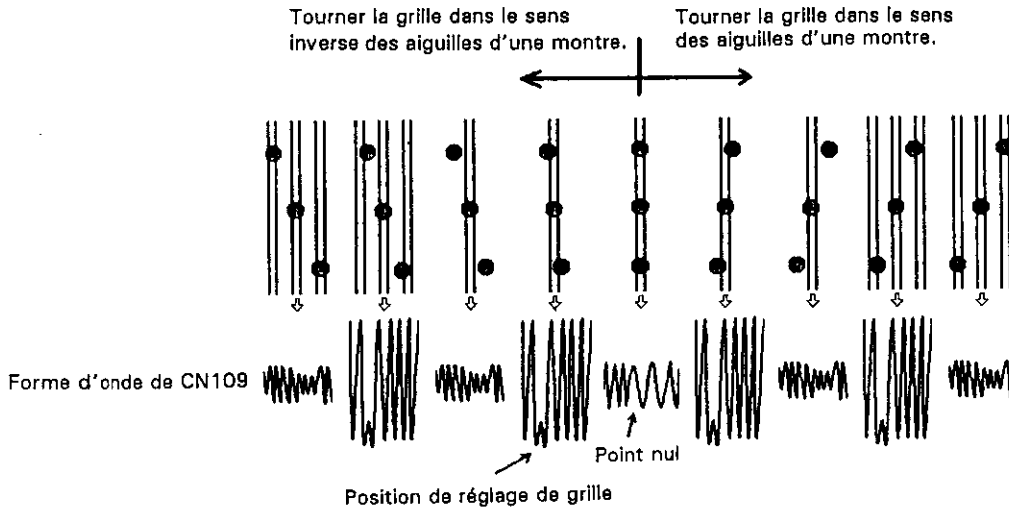
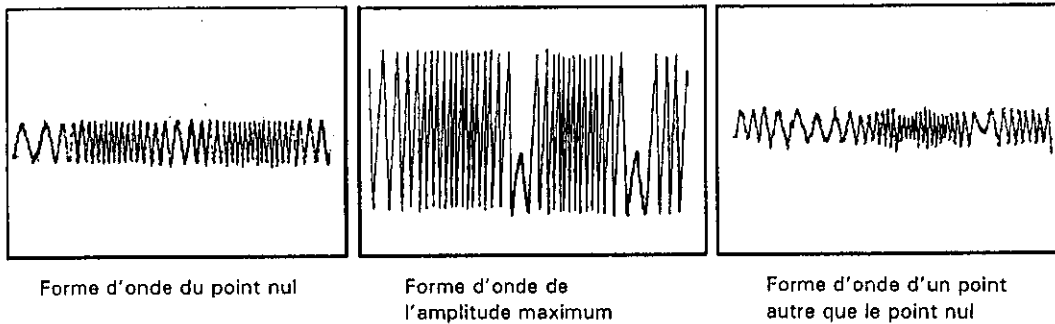

Fig. 3



Remarque :

L'amplitude du signal d'erreur d'alignement est d'approximativement 3 Vc-c. Si l'amplitude est très petite (2 Vc-c) (en utilisant un LPF (filtre passe-bas) de 39 kΩ + 0,001 μF), la lentille peut ne pas être propre ou le capteur peut ne pas fonctionner.

Si l'amplitude du signal d'erreur fluctue de plus de 10% entre les bords interne et externe d'un disque, la grille n'est pas ajustée au point maximum. Ajuster correctement la grille.

3. Réglage D'équilibre D'erreur D'alignement

- But : Corriger les niveaux de sensibilité de la photodiode d'alignement au même niveau.
- Symptômes en cas de mauvais ajustement : Le lecteur ne commence pas la reproduction. N'effectue pas la recherche de piste.

- | | |
|---|---|
| <ul style="list-style-type: none"> ● Connexion de l'instrument ● Réglage ● Etat du lecteur ● Point de réglage ● Disque | <ul style="list-style-type: none"> ● Connecter l'oscilloscope à la Broche 2 (TRER) de CN109 (le filtre passe-bas peut être utilisé). ● 50 mV/div., 5 mS/div., mode c.c. ● Servos de mise au point et d'axe fermés. Servo d'alignement ouvert. ● VR1 (TR. BAL) ● YEDS-7 |
|---|---|

- Connexion

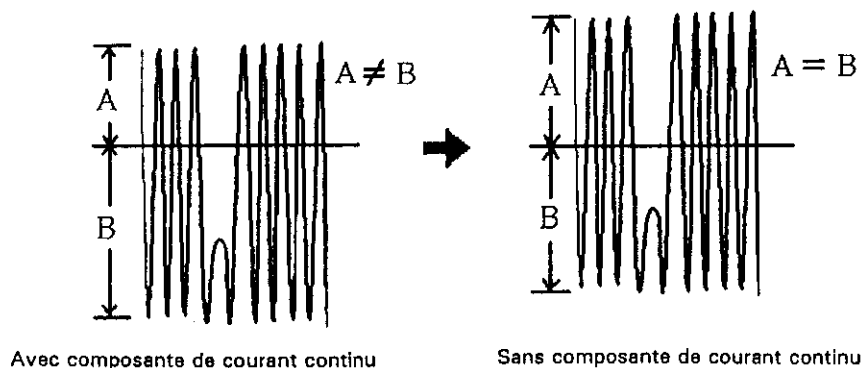

- Procédure
1. Déplacer le capteur au centre entre les bords interne et externe du disque ($R = 35 \text{ mm}$) en utilisant la touche "4 + MULTI-SPEED" ou "5 + MULTI-SPEED".
 2. Appuyer sur la touche "1 + MULTI-SPEED", puis sur la touche "2 + MULTI-SPEED" pour fermer les servos de mise au point et d'axe.
 3. Aligner la ligne claire (GND) de l'oscilloscope sur le centre de l'écran de l'oscilloscope, et passer au mode c.c..
 4. Ajuster VR1 (TR. BAL) pour rendre l'amplitude du côté positif identique au côté négatif du signal d'erreur d'alignement de la Broche 2 (TRER) de CN109 (pour qu'il n'y ait pas de composante CC).

4. Réglage de L'inclinaison Radiale/Tangentielle du Capteur

Réglage de L'inclinaison Radiale/Tangentielle du Capteur 1/2

- But : Ajuster l'angle du capteur par rapport au disque, et optimiser le signal HF à lire en irradiant verticalement le faisceau laser par rapport au disque.
- Symptômes en cas de mauvais ajustement : Saut du son. Certains disques ne peuvent pas être reproduits.

- Connexion de l'instrument
- Réglage
- Etat du lecteur
- Point de réglage
- Disque

- Connecter l'oscilloscope à la Broche 1 (RF) de CN109.
- 20 mV/div., 200 nS/div., mode c.a.
- Reproduction
- Vis de réglage d'inclinaison radiale et vis de réglage d'inclinaison tangentielle du capteur.
- YEDS-7

● Connexion

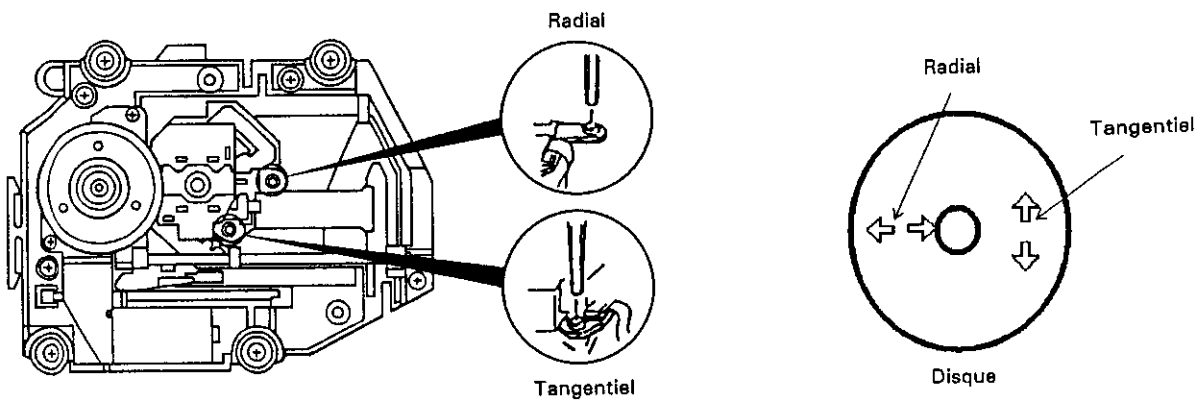

Point de réglage

Fig. 4

● Procédure

1. Déplacer le capteur à proximité du bord externe du disque en utilisant la touche "4 + MULTI-SPEED". Appuyer en séquence sur les touches "1 + MULTI-SPEED", "2 + MULTI-SPEED" et "3 + MULTI-SPEED" pour fermer les servos de mise au point, d'axe et d'alignement et régler le lecteur au mode de reproduction.
2. Utiliser une clé hexagonale (3 mm) pour régler la vis de réglage d'inclinaison radiale de manière à ce que le modèle d'oeil (forme d'onde en forme de diamant qui apparaît au centre du signal HF) soit le mieux indiqué.
3. Utiliser la clé hexagonale pour régler la vis de réglage d'inclinaison tangentielle de manière à ce que le modèle d'oeil soit le mieux indiqué (voir Fig. 5).

4. Ajuster de nouveau la vis de réglage d'inclinaison radiale, puis la vis de réglage d'inclinaison tangentielle de manière à ce que le modèle d'oeil soit le mieux indiqué. Si nécessaire, ajuster alternativement les deux vis de réglage de manière à ce que le modèle d'oeil soit le mieux indiqué.

Remarque :

Radial et tangentiel se rapportent aux directions en relation avec les disques, de la manière indiquée dans la Fig. 4.

Réglage de L'inclinaison Radiale/Tangentielle du Capteur 2/2

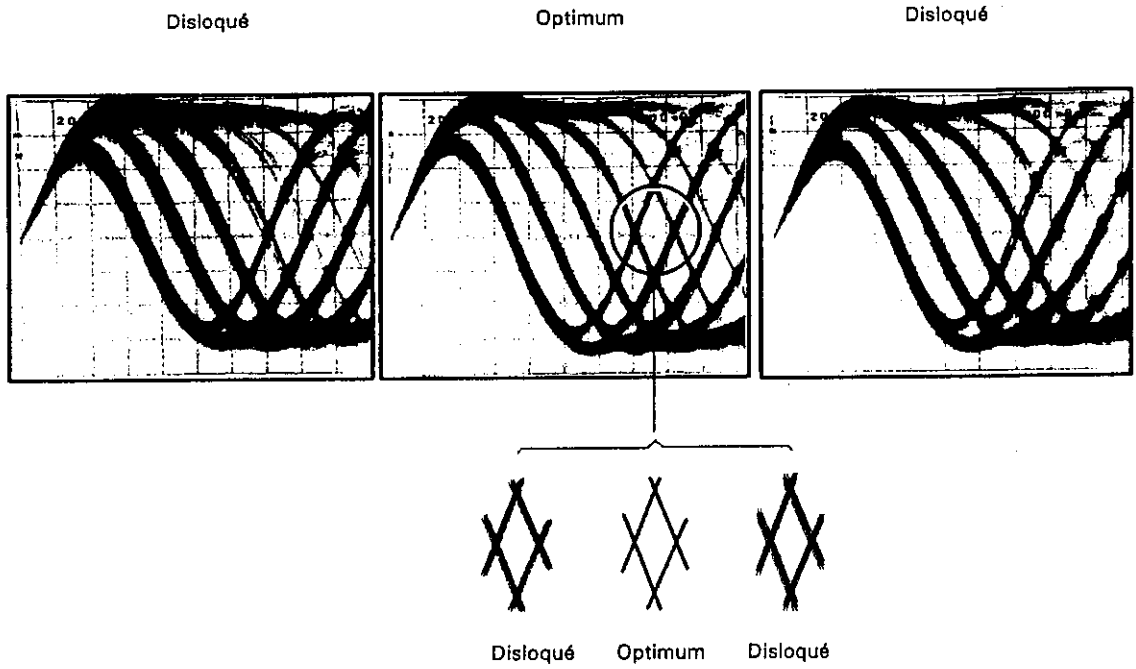

Fig. 5

5. Réglage du niveau HF

- But : Optimiser l'amplitude du signal HF de reproduction.
- Symptômes en cas de mauvais ajustement : Le lecteur ne reproduit pas. N'effectue pas la recherche.

- | | |
|---|---|
| <ul style="list-style-type: none">● Connexion de l'instrument● Réglage● Etat du lecteur● Point de réglage● Disque | <ul style="list-style-type: none">● Connecter l'oscilloscope à la Broche 1 (RF) de CN109.● 50 mV/div., 10 mS/div., mode c.a.● Reproduction● VR5 (puissance laser)● YEDS-7 |
|---|---|

- Connexion

- Procédure

1. Déplacer le capteur au centre entre les bords interne et externe du disque ($R = 35 \text{ mm}$) en utilisant la touche "4 + MULTI-SPEED" ou "5 + MULTI-SPEED". Appuyer en séquence sur les touches "1 + MULTI-SPEED", "2 + MULTI-SPEED" et "3 + MULTI-SPEED" pour fermer les servos et régler le lecteur au mode de reproduction.
2. Ajuster VR5 pour régler l'amplitude du signal HF à 1,2 V_{c-c} +0,3/-0,1 V.

6. Réglage du Gain de Boucle du Servo de Mise au Point

- But : Régler le gain de boucle du servo de mise au point à la valeur optimum.
- Symptômes en cas de mauvais ajustement : Le lecteur ne commence pas la reproduction. Le son du dispositif de commande de mise au point est haut.

- Connexion de l'instrument
- Réglage
- Etat du lecteur
- Point de réglage
- Disque

- Voir Fig. 6.
- CH1 : 20 mV/div., mode X-Y CH2 : 5 mV/div.
- Reproduction
- VR3 (FO. GAN)
- YEDS-7

- Connexion

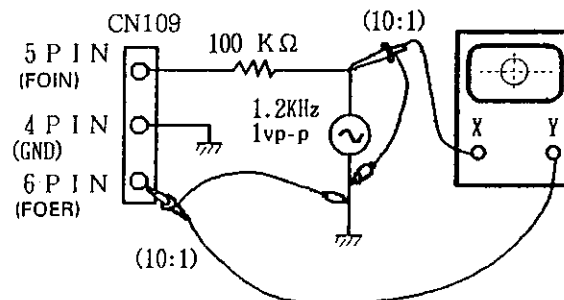
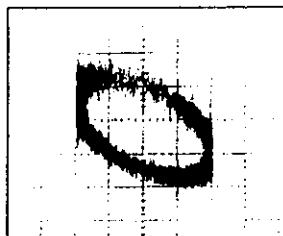
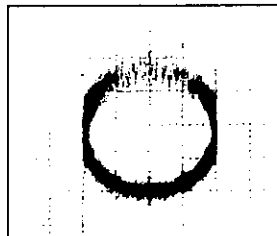

Fig. 6



Le gain est trop important.



Gain optimum

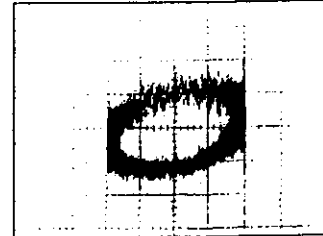

Le gain est trop petit.

- Procédure

1. Régler la sortie de l'oscillateur AF à 1,2 kHz et 1 Vc-c.
2. Déplacer le capteur au centre entre les bords interne et externe du disque ($R = 35$ mm) en utilisant la touche "4 + MULTI-SPEED" ou "5 + MULTI-SPEED". Appuyer en séquence sur les touches "1 + MULTI-SPEED", "2 + MULTI-SPEED" et "3 + MULTI-SPEED" pour fermer les servos et régler le lecteur au mode de reproduction.
3. Ajuster VR3 (FO. GAN) pour que les formes d'onde de Lissajou deviennent respectivement symétriques aux axes X et Y.

7. Réglage du Gain de Boucle du Servo D'alignement

- But : Régler le gain de boucle du servo d'alignement à la valeur optimum.
- Symptômes en cas de mauvais ajustement : Le lecteur ne commence pas la reproduction. Le son du dispositif de commande de mise au point est haut pendant la recherche. Saute une(des) piste(s).

- Connexion de l'instrument
- Réglage
- Etat du lecteur
- Point de réglage
- Disque

- Voir Fig. 7.
- CH1 : 50 mV/div., mode X-Y CH2 : 5 mV/div.
- Reproduction
- VR4 (TR. GAN)
- YEDS-7

● Connexion

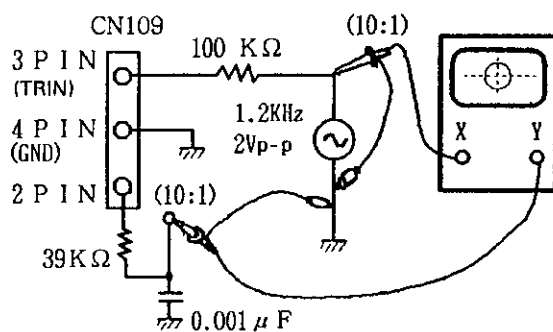
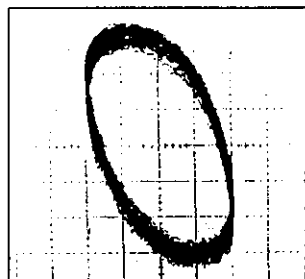
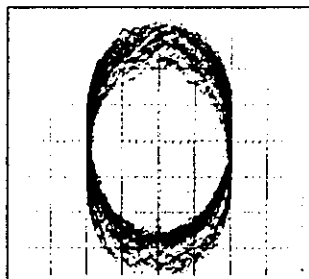

Fig. 7



Le gain est trop important.



Gain optimum

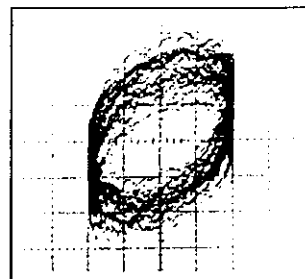

Le gain est trop petit.

● Procédure

1. Régler la sortie de l'oscillateur AF à 1,2 kHz et 2 Vc-c.
2. Déplacer le capteur au centre entre les bords interne et externe du disque (R = 35 mm) en utilisant la touche "4 + MULTI-SPEED" ou "5 + MULTI-SPEED". Appuyer en séquence sur les touches "1 + MULTI-SPEED", "2 + MULTI-SPEED" et "3 + MULTI-SPEED" pour fermer les servos et régler le lecteur au mode de reproduction.
3. Ajuster VR4 (TR. GAN) pour que les formes d'onde de Lissajou deviennent respectivement symétriques aux axes X et Y.

8. Confirmation du Signal D'erreur de Mise au Point

- But : Evaluer le capteur en observant le signal d'erreur de mise au point. Que le capteur soit défectueux ou non peut être décidé à partir du niveau d'amplitude du signal d'erreur d'alignement (Voir "Réglage de l'équilibre d'erreur d'alignement") et en confirmant la forme d'onde du signal d'erreur de mise au point.
- Symptômes en cas de mauvais ajustement :

- Connexion de l'instrument
- Réglage
- Etat du lecteur
- Point de réglage
- Disque

- Connecter l'oscilloscope à la Broche 6 (FCS ERR) de CN109.
- 100 mV/div., 5 mS/div., mode c.c.
- Arrêt
- Aucun
- YEDS-7

- Connexion

● Procédure

1. Connecter la broche 5 de CN109 à GND.
2. Insérer un disque.
3. Une pression sur la touche "1 + MULTI-SPEED" tout en observant l'écran de l'oscilloscope vous permet d'observer pendant un instant la forme d'onde indiquée à la Fig. 8. Confirmer que l'amplitude est de 2,5 Vc-c ou plus et que l'amplitude du côté positif est approximativement la même que du côté négatif. Remarquer que la forme d'onde n'est affichée que pendant un instant lorsque la touche "1 + MULTI-SPEED" est enfoncée. Appuyer autant de fois que nécessaire sur la touche jusqu'à ce que la forme d'onde puisse être confirmée.

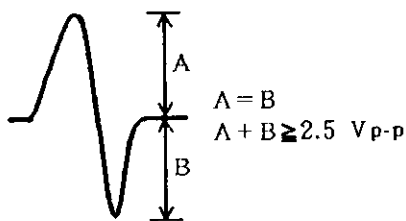

Fig. 8

[Evaluation du capteur]

Evaluer le capteur après avoir procédé correctement à tous les réglages. Si le résultat de l'évaluation est comme indiqué ci-dessous, le capteur peut être défectueux.

- ① L'amplitude du signal d'erreur d'alignement est extrêmement petite (2 Vc-c ou moins).
- ② L'amplitude du signal d'erreur de mise au point est extrêmement petite (2,5 Vc-c ou moins).
- ③ L'amplitude du côté positif du signal d'erreur de mise au point est extrêmement asymétrique du côté négatif (plus de 2 : 1).
- ④ Le signal HF est trop petit (0,8 Vc-c ou moins). Le signal n'atteint pas la valeur spécifiée, même après le réglage de VR5 (puissance laser).

9. AJUSTES

9.1 AJUSTE HORIZONTAL DEL CONJUNTO DE LA BASE DE TRANSFERENCIA (Fig. 9-1)

1. Extraiga aproximadamente 10 discos compactos de los conjuntos de bastidor derecho e izquierdo.
2. Ajuste el sistema al modo Super Manual (vea el apartado "11. ① Modo Super Manual"), y mueva entonces el conjunto de la base de transferencia hacia abajo.
3. Coloque una regla metálica en el lado izquierdo (A) del soporte D (U). Ajuste la altura del conjunto de la base de transferencia al soporte D (U).
4. Coloque la regla metálica en el lado derecho (B) del soporte D (U). Modifique la altura del conjunto de la base de transferencia ajustando el tornillo (C) del tope de la correa (R). La diferencia de altura entre los conjuntos de base de transferencia derecho e izquierdo debe estar dentro de 0,1 mm.

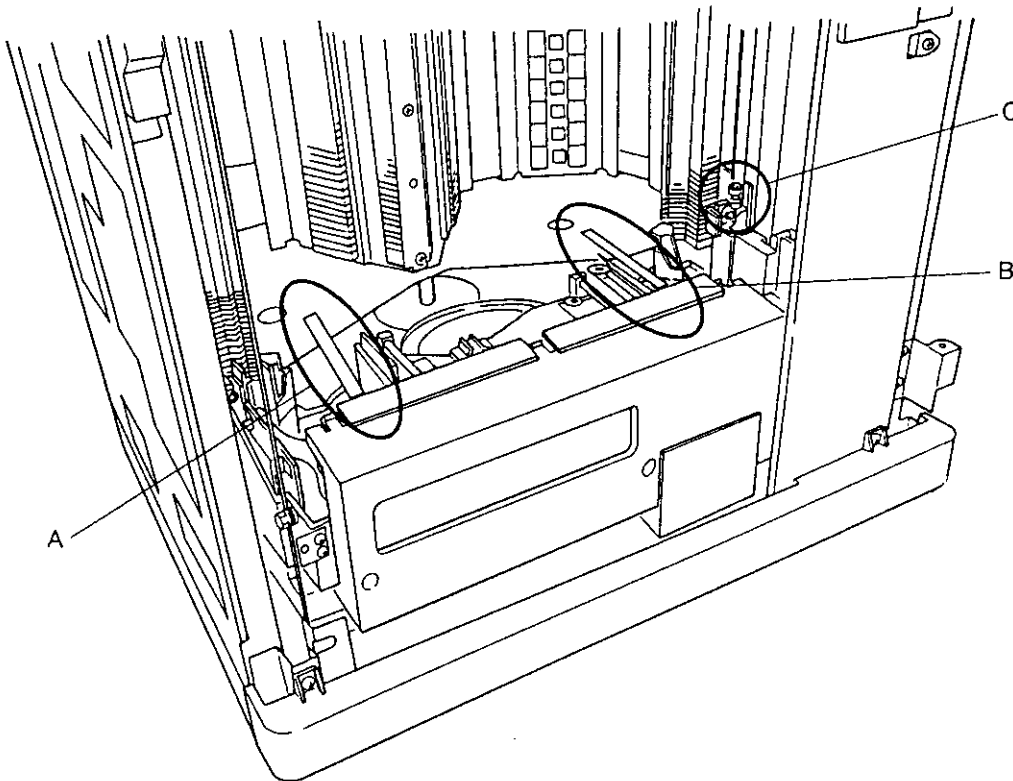

Fig. 9-1

9.2 AJUSTE DE LA VELOCIDAD DEL MOTOR VD (VERTICAL)

1. Haga la conexión como se muestra en la Fig. 9-2.
2. Ajuste el sistema al modo Super Manual (vea el apartado "11. ① modo Super Manual"), y ponga todos los interruptores DIP (S5 de la unidad KDSB) en la posición OFF (se seleccionará el motor VD).
3. Gire el motor VD presionado S1 ó S2 de la unidad KDSB.
4. Ajuste VR1 de modo que la forma de onda del osciloscopio pase a ser $t = 17 \pm 0,5 \mu\text{seg.}$ (vea la Fig. 9-3).

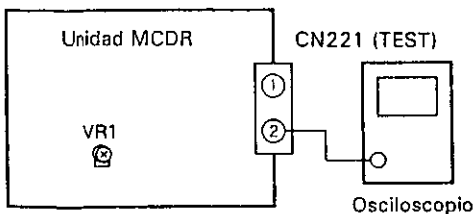

Fig. 9-2 Conexión

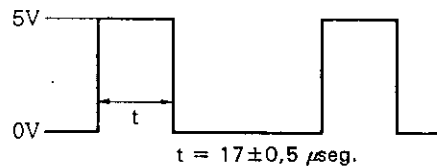

Fig. 9-3 Forma de onda

9.3 AJUSTE DE LA ALTURA DE LA PLACA DEL CODIFICADOR VD

● **Conjunto del Bastidor Izquierdo**

1. Ajuste el sistema al modo Manual (vea el apartado "11. ② modo Manual"), y entonces mueva el conjunto de la base de transferencia a la dirección N.º 79 de instalación de CD.
2. Oscile el conjunto hacia el conjunto del bastidor izquierdo.
3. Ajuste el codificador VD 1 (izquierdo) de modo que el soporte del plato, conjunto del plato 1 y resorte del plato 3 queden inoperativos cuando se active el eje de la flecha. (Vea las Fig. 9-4 y 9-5 y la Tabla 9-1.)
4. Después de ajustar, mueva el conjunto de la base de transferencia verticalmente y confirme la altura en la dirección N.º 79.
5. Repita lo mismo para confirmar la altura en las direcciones de instalación de CD N.º 1, 12, 50, y 150.

A : La posición de ajuste del codificador VD es demasiado alta (→ Baje la placa del codificador VD.)

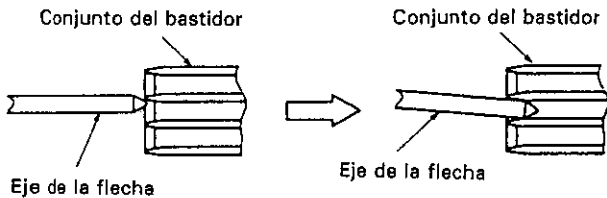

B : Ajuste correcto



C : La posición de ajuste del codificador VD es demasiado baja (→ Suba la placa del codificador VD.)



Ajuste de modo que el eje de la flecha y el conjunto del bastidor queden situados como se muestra en (B) de arriba (vea la Fig. 9-5).

Fig. 9-4

● **Conjunto del Bastidor Derecho**

1. Haga el ajuste del mismo modo que con el conjunto del bastidor izquierdo, a excepción de que la dirección de instalación de CD es la N.º 229.
2. Confirme también la altura en las direcciones de instalación de CD N.º 151, 200, y 300.

NOTA :

Si el CD toca la división del conjunto del bastidor (A) aunque el eje de la flecha esté en la posición central, el plato puede estar defectuoso, el eje de la flecha puede estar doblado o el disco deformado.

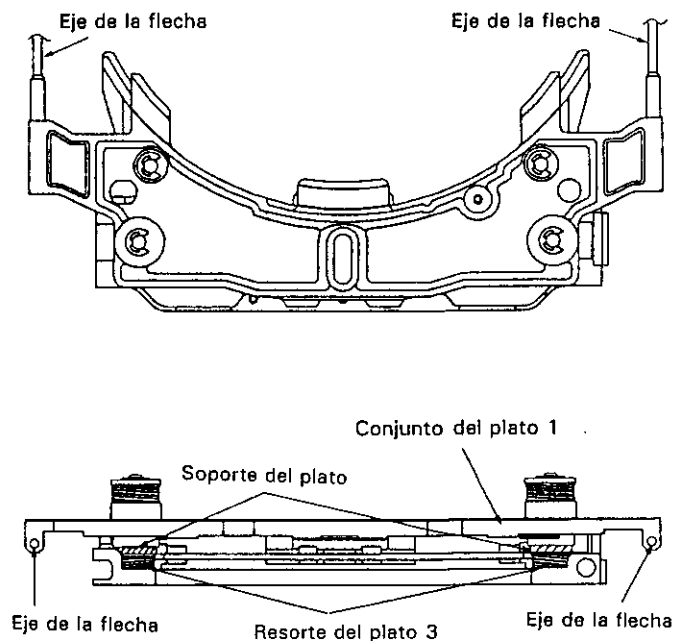

Fig. 9-5

El soporte de plato y el conjunto del plato 1 funcionan como se muestra en la tabla siguiente cuando se inserta el eje de flecha en el conjunto del bastidor.

	Soporte del Plato	Conjunto del Plato 1	Resorte del Plato 3
Fig. 9-4 A	Baja	Baja	Se contrae
Fig. 9-4 B	No opera	No opera	No opera
Fig. 9-4 C	No opera	Sube	No opera

Tabla 9-1

9.4 AJUSTE DEL REPRODUCTOR DE CD

Los reproductores de CD pueden operar incorrectamente o no operar en absoluto si se ajustan incorrectamente, aunque no pueda encontrarse ningún defecto en el fonocaptor y circuitos. Asegúrese de ajustar correctamente de acuerdo con el procedimiento de ajuste.

1. Ítemes de Ajuste / Puntos de Comprobación y Secuencia

Secuencia	Ítem	Punto de prueba	Punto de ajuste
1	Ajuste de descentramiento de enfoque	CN109, Patilla 6 (FOER)	VR2 (FO. OFS)
2	Ajuste de reticulado	CN109, Patilla 2 (TRER)	Ranura de ajuste de reticulado
3	Ajuste del balance de error de seguimiento	CN109, Patilla 2 (TRER)	VR1 (TR. BAL)
4	Ajuste de la inclinación radial/tangencial del fonocaptor	CN109, Patilla 1 (RF)	Tornillo de ajuste de inclinación radial, tornillo de ajuste de inclinación tangencial
5	Ajuste del nivel de RF	CN109, Patilla 1 (RF)	VR5 (nivel de RF)
6	Ajuste de la ganancia del bucle servo de enfoque	CN109, Patilla 5 (FOIN) CN109, Patilla 6 (FOER)	VR3 (FO. GAN)
7	Ajuste de la ganancia del bucle servo de seguimiento	CN109, Patilla 3 (TRIN) CN109, Patilla 2 (TRER)	VR4 (TR. GAN)
8	Confirmación de la señal de error de enfoque	CN109, Patilla 6 (FOER)	_____

● Tabla de Abreviaturas

FOER	: Error de Enfoque	FO. OFS	: Descentramiento de Enfoque
FOIN	: Entrada de Enfoque	TR. BAL	: Balance de Seguimiento
TRIN	: Entrada de Seguimiento	FO. GAN	: Ganancia del Servobucle de Enfoque
TRER	: Error de Seguimiento	TR. GAN	: Ganancia del Servobucle de Seguimiento

2. Instrumentos y Herramientas

Emplee los instrumentos y herramientas siguientes para el ajuste :

1. Osciloscopio de trazado doble (sonda de 10 : 1)
2. Oscilador de baja frecuencia
3. Disco de prueba (YEDS-7)
4. Filtro de paso bajo (39 k Ω + 0,001 μ F)
5. Resistor (100 k Ω)
6. Herramientas estándar

3. Ajuste del Reproductor de CD

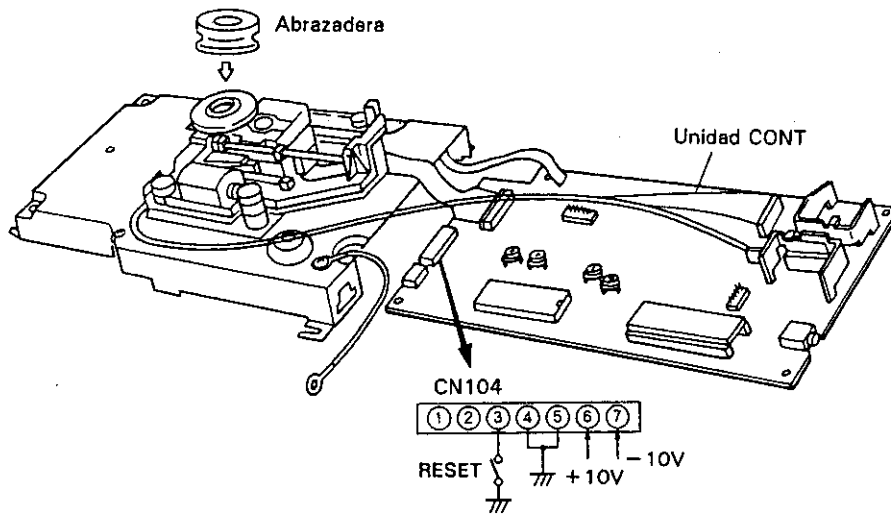

4. Posiciones de Los Puntos de Prueba y VR de Ajuste

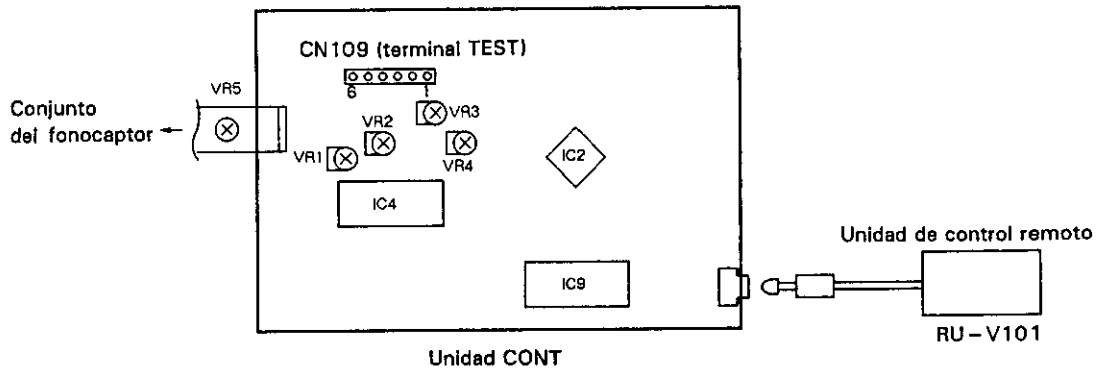

Fig. 1 Puntos de Ajuste

5. Notas

1. Emplee un osciloscopio con una relación de sonda de 10 : 1.
2. Todas las posiciones de los mandos de control (valores ajustados) del osciloscopio mostrado en este procedimiento de ajuste se basan en la condición del empleo de un osciloscopio con una relación de sonda de 10 : 1.

● FUNCIONES DE LA UNIDAD DE CONTROL REMOTO DE SERVICIO

El reproductor de CD (PD-CACV3000) del Cargador automático de CD (CAC-V3000) puede operarse directamente empleando la unidad de control remoto (RU-V101). La unidad de control remoto tiene las funciones siguientes :

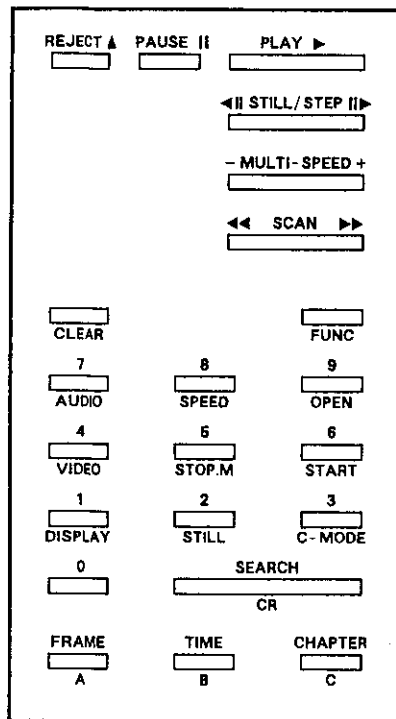

RU-V101

REJECT ▲	: Parada del pivote
PAUSE II	: Pausa
PLAY ▶	: Reproducción
◀ II STILL / STEP II ▶	: Selección de disco
◀ II STILL / STEP II ▶	: Retorno de disco
- MULTI-SPEED +	: <input type="checkbox"/> Comando de prueba
MULTI-SPEED -	
◀◀ SCAN ▶▶	: Exploración en avance
SCAN ▶▶	: Exploración en inversión
SCAN ◀◀	
CLEAR	: Borrado
FRAME	: Especifica un bloque
TIME	: Especifica el tiempo
CHAPTER	: Especifica una canción
SEARCH	: Búsqueda
10 teclas	: Para introducir números
DISPLAY (FUNC + 1)	: Sin entrada
STILL (FUNC + 2)	: Sin entrada
C-MODE (FUNC + 3)	: Sin entrada
VIDEO (FUNC + 4)	: Volumen ajustado
STOP.M (FUNC + 5)	: Marcador de parada
START (FUNC + 6)	: Inicio
AUDIO (FUNC + 7)	: Inicio de Entrada/Salida de fundido
SPEED (FUNC + 8)	: Control de velocidad
OPEN (FUNC + 9)	: Sin entrada
B (FUNC + TIME)	: Ajuste del tiempo de fundido

● Comando de Prueba

- Tecla 0 + MULTI-SPEED (+, -) : Diodo láser (LD) activado
- Tecla 1 + MULTI-SPEED (+, -) : Cierre de servoenfoco
- Tecla 2 + MULTI-SPEED (+, -) : Golpe de pivote
- Tecla 3 + MULTI-SPEED (+, -) : Seguimiento, servo de deslizador activado
- Tecla 4 + MULTI-SPEED (+, -) : Al presionar la tecla FWD del deslizador una vez se moverá el fonocaptor aproximadamente la mitad de una carrera completa.
- Tecla 5 + MULTI-SPEED (+, -) : Al presionar la tecla REV del deslizador una vez se moverá el fonocaptor aproximadamente la mitad de una carrera completa.
- Tecla 6 + MULTI-SPEED (+, -) : Seguimiento, servo de deslizador desactivado
- Tecla 7 + MULTI-SPEED (+, -) : Parada de deslizador, parada de pivote
- Tecla 8 + MULTI-SPEED (+, -) : Parada de deslizador, parada de pivote
- Tecla 9 + MULTI-SPEED (+, -) : Abertura de servoenfoco

● Empleo del Comando SPEED

Suponiendo que la velocidad normal es igual a 100, la velocidad de 90 a 110 se expresa como -10 a +10%.

Ejemplo : Cambio de la velocidad en -10%

9 + **0** + **FUNC** + **8**

Nota :

- La velocidad cambiada no retornará a la normal al presionar el botón REJECT. Para reanudar la velocidad normal, presione la tecla de selección de disco.
- Presione siempre la tecla de selección de disco después de haber presionado la tecla de retorno de disco. De lo contrario, el sistema no aceptará los comandos.

● Para Comprobar el Atenuador Digital

Pueden ajustarse el nivel de atenuación y el tiempo de fundido. La función de fundido de aparición/desaparición gradual también se ejecuta con este controlador remoto.

Ejemplo 1 : Ajuste el tiempo de fundido a 10 segundos.

1 + **0** + **FUNC** + **TIME**

Ejemplo 2 : Nivel maximo de atenuación. (silenciamiento)

0 + **FUNC** + **4**

Ejemplo 3 : Inicie la aparición gradual.

2 + **5** + **5** + **FUNC** + **7**

Nota :

La atenuación digital es válida para el convertidor D/A incorporado. Por lo tanto, emplee la salida analógica para comprobar esta función.

1. Ajuste del Descentramiento de Enfoque

<ul style="list-style-type: none"> ● Propósito : Para ajustar la tensión de descentramiento de CC del amplificador de error de enfoque a $= 50 \text{ mV}$. ● Síntoma de ajuste incorrecto : El reproductor no enfoca. La señal de RF no es clara. 	
<ul style="list-style-type: none"> ● Conexión del instrumento ● Ajuste ● Condición del reproductor ● Punto de ajuste ● Disco 	<ul style="list-style-type: none"> ● Conecte el osciloscopio a la patilla 6 (FOER) de CN109. ● 5 mV/div, 10 mS/div, modo de CC ● Parada (sólo la alimentación está conectada) ● VR2 (FO. OFS) ● No es necesario
<ul style="list-style-type: none"> ● Conexión 	
<ul style="list-style-type: none"> ● Procedimiento <p>Ajuste VR2 (FO. OFS) para ajustar la tensión de la patilla 6 (FOER) de CN109 a $-50 \pm 50 \text{ mV}$.</p>	

2. Ajuste de Reticulado

Ajuste de Reticulado 1/2

- Propósito : Ajustar los dos puntos del haz de láser para seguimiento de la generación de errores al ángulo óptimo en la pista.
- Síntoma de ajuste incorrecto : El reproductor no inicia la reproducción. No efectúa la búsqueda de canciones. Salta canciones.

- Conexión del instrumento
- Ajuste
- Condición del reproductor
- Punto de ajuste
- Disco

- Conecte el osciloscopio a la patilla 2 (TRER) de CN109 a través del filtro de paso bajo (vea la Fig. 2).
- 50 mV/div, 5 mS/div, modo de CC
- Servos de enfoque y de pivote cerrados. Servo de seguimiento abierto.
- Ranura de ajuste de reticulado del fonocaptor.
- YEDS-7

- Conexión

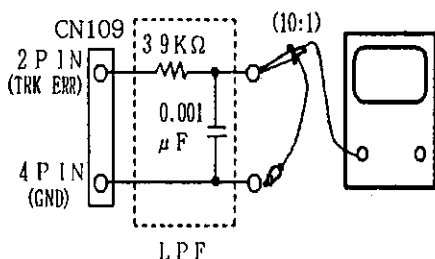
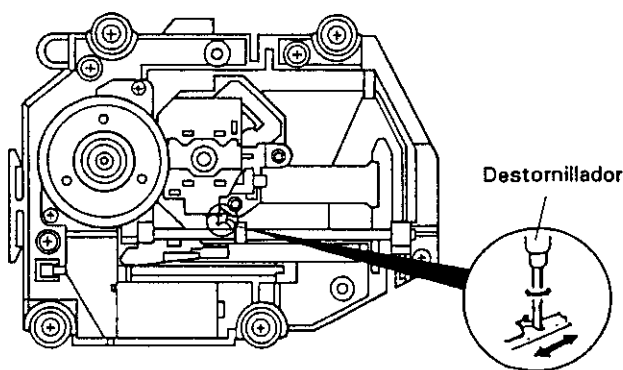

Fig. 2



Punto de ajuste

- Procedimiento

1. Mueva el fonocaptor cerca del borde del disco empleando la tecla "4 + MULTI-SPEED" ó "5 + MULTI-SPEED".
2. Presione tecla "1 + MULTI-SPEED", y luego la tecla "2 + MULTI-SPEED" para cerrar los servos de enfoque y del pivote.
3. Inserte el destornillador en la ranura de ajuste del reticulado. Ajuste el reticulado y encuentre el punto nulo. Para más detalles, vea la página siguiente.
4. Girando lentamente el destornillador hacia la izquierda desde el punto nulo se incrementará gradualmente la amplitud de la forma de onda. Si se sigue girando el destornillador, se reducirá de nuevo la amplitud de la forma de onda.
Gire el destornillador hacia la izquierda desde el punto nulo para encontrar el primer punto máximo de amplitud de forma de onda.

(Referencia)

La Fig. 3 muestra la relación entre el ángulo del haz de seguimiento con la pista y la forma de onda.

● **Cómo encontrar el punto nulo**

Inserte el destornillador en la ranura de ajuste del reticulado y cambie el ángulo del reticulado. Con este método, puede cambiarse la amplitud de la señal de error de seguimiento de la patilla 2 de CN109. Hay varios puntos donde la amplitud de forma de onda se reduce con el margen variable del reticulado. Entre estos puntos, sólo un punto permite que la envolvente sea uniforme. Esto significa que los tres haces de láser divididos por el reticulado están en la misma pista (vea la Fig. 3).

Este punto se denomina punto nulo. Ajuste el reticulado para encontrar el punto nulo y empleelo como posición de referencia para el ajuste del reticulado.

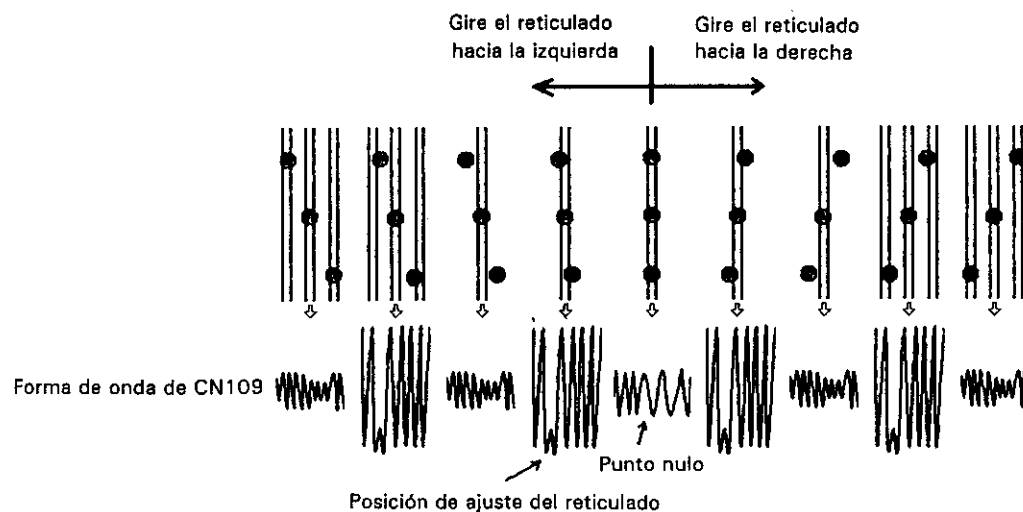
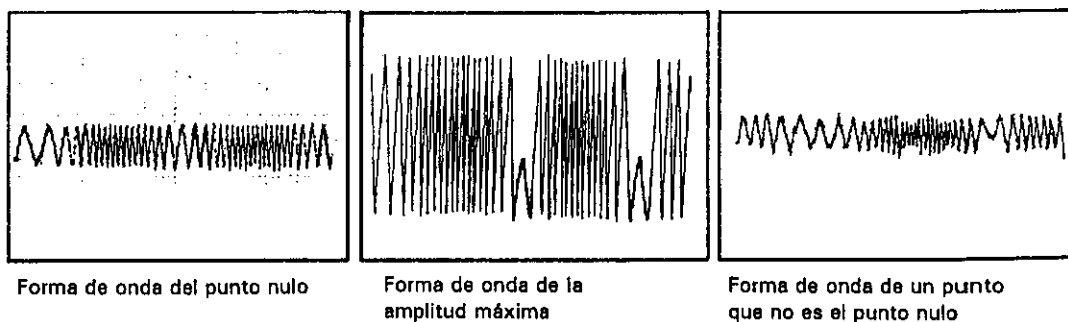

Fig. 3



Nota :

La amplitud de la señal de error de seguimiento es aproximadamente de $3 V_p - p$. Si la amplitud es muy pequeña ($2 V_p - p$) (empleando LPF de $39 \text{ k}\Omega + 0,001 \mu\text{F}$), la lente puede no estar limpia o el fonocaptor puede funcionar mal.

Si la amplitud de la señal de error fluctúa más del 10% entre los bordes interior y exterior de un disco, significa que el reticulado no está ajustado en el punto óptimo. Ajuste el reticulado correctamente.

3. Ajuste del Balance de Error de Seguimiento

- Propósito : Corregir los niveles de sensibilidad del fotodiodo de seguimiento al mismo nivel.
- Síntoma de ajuste incorrecto : El reproductor no inicia la reproducción. No efectúa la búsqueda de canciones.

- | | |
|---|--|
| <ul style="list-style-type: none"> ● Conexión del instrumento ● Ajuste ● Condición del reproductor ● Punto de ajuste ● Disco | <ul style="list-style-type: none"> ● Conecte el osciloscopio a la patilla 2 (TRER) de CN109 (puede usarse el filtro de paso bajo). ● 50 mV/div, 5 mS/div, modo de CC ● Servos de enfoque y de pivote cerrados. Servo de seguimiento abierto. ● VR1 (TR. BAL) ● YEDS-7 |
|---|--|

- Conexión

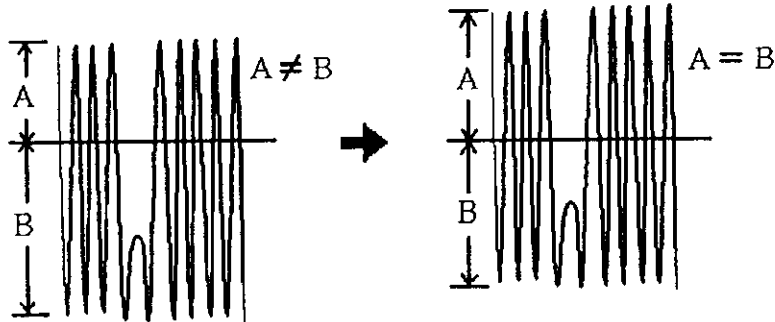

Con componente de corriente continua

Sin componente de corriente continua

- Procedimiento

1. Mueva el fonocaptor al centro entre la circunferencia interior y los bordes exteriores del disco (R = 35 mm) empleando la tecla "4 + MULTI-SPEED" ó "5 + MULTI-SPEED".
2. Presione tecla "1 + MULTI-SPEED", y luego la tecla "2 + MULTI-SPEED" para cerrar los servos de enfoque y del pivote.
3. Alinee la línea brillante (GND) del osciloscopio con el centro de la pantalla del osciloscopio, y cambie al modo de CC.
4. Ajuste VR1 (TR. BAL) para hacer la amplitud del lado positivo igual que la del lado negativo de la señal de error de seguimiento de la patilla 2 (TRER) de CN109 (de modo que no haya componente de CC).

4. Ajuste de la Inclineración Radial/Tangencial del Fonocaptor Ajuste de la Inclineración Radial/Tangencial del Fonocaptor 1/2

- Propósito : Ajustar el ángulo del fonocaptor con el disco, y optimizar la señal de RF a leerse irradiando verticalmente el haz de láser al disco.
- Síntoma de ajuste incorrecto : Se salta sonido. Algunos discos no pueden reproducirse.

- Conexión del instrumento
- Ajuste
- Condición del reproductor
- Punto de ajuste
- Disco

- Conecte el osciloscopio a la patilla 1 (RF) de CN109.
- 20 mV/div, 200 nS/div, modo de CA
- Reproducción
- El tornillo de ajuste de la inclinación radial y tornillo de ajuste de la inclinación tangencial del fonocaptor.
- YEDS-7

- Conexión

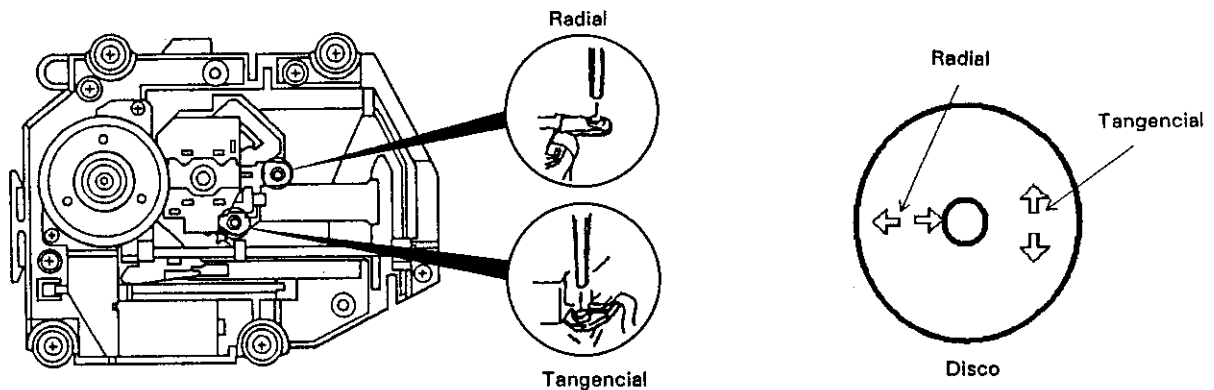

Fig. 4

● Procedimiento

1. Mueva el fonocaptor cerca del borde exterior del disco empleando la tecla "4 + MULTI-SPEED". Presione tecla "1 + MULTI-SPEED", la tecla "2 + MULTI-SPEED", y "3 + MULTI-SPEED" en secuencia para cerrar los servos de enfoque, del pivote y de seguimiento y ajustar el reproductor al modo de reproducción.
2. Emplee una llave hexagonal (3 mm) para ajustar el tornillo de ajuste de inclinación radial de modo que el patrón de ojo (forma de onda en forma de diamante que aparece en el centro de la señal de RF) se vea con la mayor claridad.
3. Emplee la llave hexagonal para ajustar el tornillo de ajuste de inclinación tangencial de modo que el patrón de ojo se muestre con la mayor claridad (vea la Fig. 5).

4. Ajuste de nuevo el tornillo de ajuste de inclinación radial, y luego el tornillo de ajuste de inclinación tangencial de modo que el patrón de ojo se muestre con la mayor claridad. Si es necesario, ajuste los dos tornillos de ajuste de forma alternada de modo que el patrón del ojo se muestre con la mayor claridad.

Nota :

Radial y tangencial se refieren a las direcciones con relación a los discos, como se muestra en la Fig. 4.

Ajuste de la Inclinación Radial/Tangencial del Fonocaptor 2/2

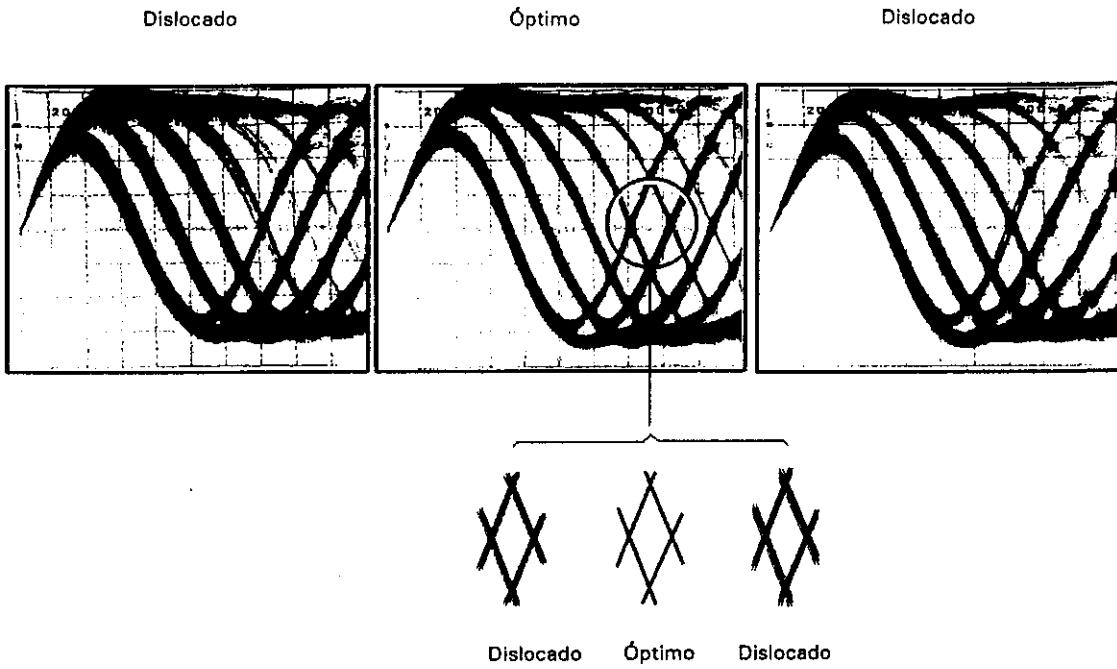

Fig. 5

5. Ajuste del Nivel de RF

- Propósito : Optimizar la amplitud de la señal de RF reproducida.
- Síntoma de ajuste incorrecto : El reproductor no inicia la reproducción. No efectúa la búsqueda de canciones.

- Conexión del instrumento
- Ajuste
- Condición del reproductor
- Punto de ajuste
- Disco

- Conecte el osciloscopio a la patilla 1 (RF) de CN109.
- 50 mV/div, 10 mS/div, modo de CA
- Reproducción
- VR5 (alimentación de láser)
- YEDS-7

- Conexión

- Procedimiento

1. Mueva el fonocaptor al centro entre los bordes interior y exterior del disco ($R = 35 \text{ mm}$) empleando la tecla "4 + MULTI-SPEED" ó "5 + MULTI-SPEED". Presione tecla "1 + MULTI-SPEED", la tecla "2 + MULTI-SPEED", y "3 + MULTI-SPEED" en secuencia para cerrar los servos y ajustar el reproductor al modo de reproducción.
2. Ajuste VR5 para ajustar la amplitud de la señal RF a 1,2 V_{p-p} +0,3/-0,1 V.

6. Ajuste de la Ganancia del Bucle del Servo de Enfoque

- Propósito : Ajustar la ganancia del bucle del servo de enfoque al valor óptimo.
- Síntoma de ajuste incorrecto : El reproductor no inicia la reproducción. El sonido del activador de enfoque es alto.

- Conexión del instrumento
- Ajuste
- Condición del reproductor
- Punto de ajuste
- Disco

- Vea la Fig. 6.
- CH1 : 20 mV/div, modo X-Y CH2 : 5 mV/div
- Reproducción
- VR3 (FO. GAN)
- YEDS-7

- Conexión

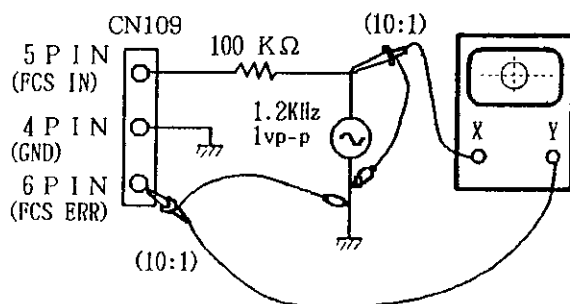
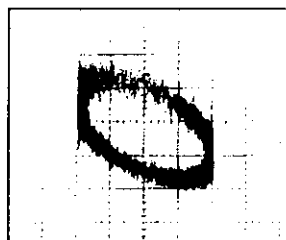

Fig. 6



Ganancia excesiva



Ganancia óptima

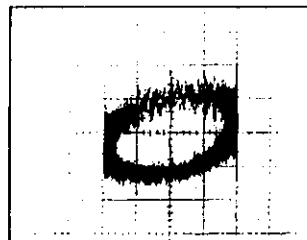

Ganancia insuficiente

- Procedimiento

1. Ajuste la salida del oscilador de AF a 1,2 kHz y 1 V_{p-p}.
2. Mueva el fonocaptor al centro entre los bordes interior y exterior del disco (R = 35 mm) empleando la tecla "4 + MULTI-SPEED" ó "5 + MULTI-SPEED". Presione tecla "1 + MULTI-SPEED", la tecla "2 + MULTI-SPEED", y "3 + MULTI-SPEED" en secuencia para cerrar los servos y ajustar el reproductor al modo de reproducción.
3. Ajuste VR3 (FO. GAN) de modo que las formas de onda de Lissajous sean simétricas a los ejes X y Y, respectivamente.

7. Ajuste de la Ganancia del Bucle del Servo de Seguimiento

- Propósito : Ajustar la ganancia del bucle del servo de seguimiento al valor óptimo.
- Síntoma de ajuste incorrecto : El reproductor no inicia la reproducción. El sonido del activador es alto durante la búsqueda. Se saltan pistas.

- Conexión del instrumento
- Ajuste
- Condición del reproductor
- Punto de ajuste
- Disco

- Vea la Fig. 7.
- CH1 : 50 mV/div, modo X-Y CH2 : 5 mV/div
- Reproducción
- VR4 (TR. GAN)
- YEDS-7

- Conexión

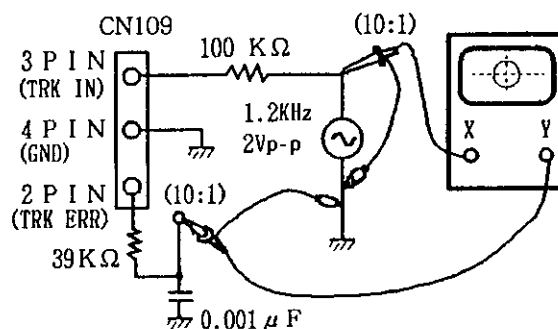
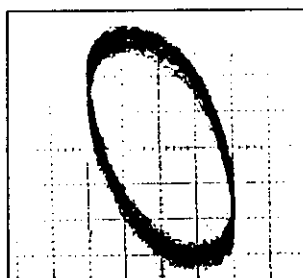
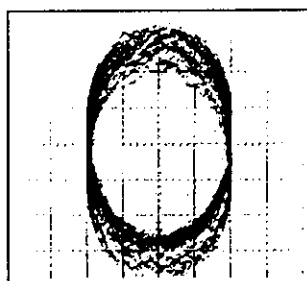

Fig. 7



Ganancia excesiva



Ganancia óptima



Ganancia insuficiente

- Procedimiento

1. Ajuste la salida del oscilador de AF a 1,2 kHz y 2 Vp-p.
2. Mueva el fonocaptor al centro entre los bordes interior y exterior del disco (R = 35 mm) empleando la tecla "4 + MULTI-SPEED" ó "5 + MULTI-SPEED". Presione tecla "1 + MULTI-SPEED", la tecla "2 + MULTI-SPEED", y "3 + MULTI-SPEED" en secuencia para cerrar los servos y ajustar el reproductor al modo de reproducción.
3. Ajuste VR4 (TR. GAN) de modo que las formas de onda de Lissajous sean simétricas a los ejes X y Y, respectivamente.

8. Confirmación de la Señal de Error de Enfoque

<ul style="list-style-type: none"> ● Propósito : Evaluar el fonocaptor observando la señal de error de enfoque. Podrá decidirse si el fonocaptor está o no defectuoso partiendo del nivel de amplitud de la señal de error de seguimiento (vea "Ajuste del balance de la forma de onda de seguimiento") y confirmando la forma de onda de la señal de error de enfoque. ● Síntoma de ajuste incorrecto : 	
<ul style="list-style-type: none"> ● Conexión del instrumento ● Ajuste ● Condición del reproductor ● Punto de ajuste ● Disco 	<ul style="list-style-type: none"> ● Conecte el osciloscopio a la patilla 6 (FOER) de CN109. ● 100 mV/div, 5 mS/div, modo de CC ● Parada ● Ninguno ● YEDS - 7
<ul style="list-style-type: none"> ● Conexión 	
<ul style="list-style-type: none"> ● Procedimiento <ol style="list-style-type: none"> 1. Conecte la patilla 5 de CN109 a GND. 2. Inserte un disco. 3. Presionando la tecla "1 + MULTI-SPEED" mientras mira la pantalla del osciloscopio le permitirá observar durante un instante la forma de onda mostrada en la Fig. 8. Confirme que la amplitud sea de 2,5 V_{p-p} o mayor y que la amplitud del lado positivo sea aproximadamente igual que la del lado negativo. Tenga presente que la forma de onda se visualiza sólo durante un instante cuando se presiona la tecla "1 + MULTI-SPEED". Presione la tecla tantas veces como sea necesario hasta poder confirmar la forma de onda. 	<p>[Evaluación del fonocaptor]</p> <p>Evalúe el fonocaptor después de haber efectuado correctamente todos los ajustes. Si el resultado de la evaluación es como se indica abajo, el fonocaptor puede estar defectuoso.</p> <ol style="list-style-type: none"> ① La amplitud de la señal de error de seguimiento es muy pequeña (2 V_{p-p} o menor). ② La amplitud de la señal de error de enfoque es muy pequeña (2,5 V_{p-p} o menor). ③ La amplitud del lado positivo de la señal de error de enfoque es excesivamente asimétrica desde el lado negativo (más de 2 : 1). ④ La señal de RF es demasiado pequeña (0,8 V_{p-p} o menor). La señal no llega al valor especificado ni después del ajuste de VR5 (alimentación de láser).

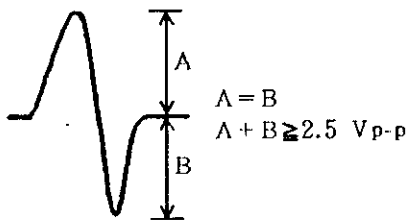

Fig. 8

10. IC INFORMATION

- The information shown in the list is basic information and may not correspond exactly to that shown in the schematic diagrams.

10.1 PD0026A (DGIF UNIT : IC406, IC407)

● Digital Attenuator IC

● Block Diagram

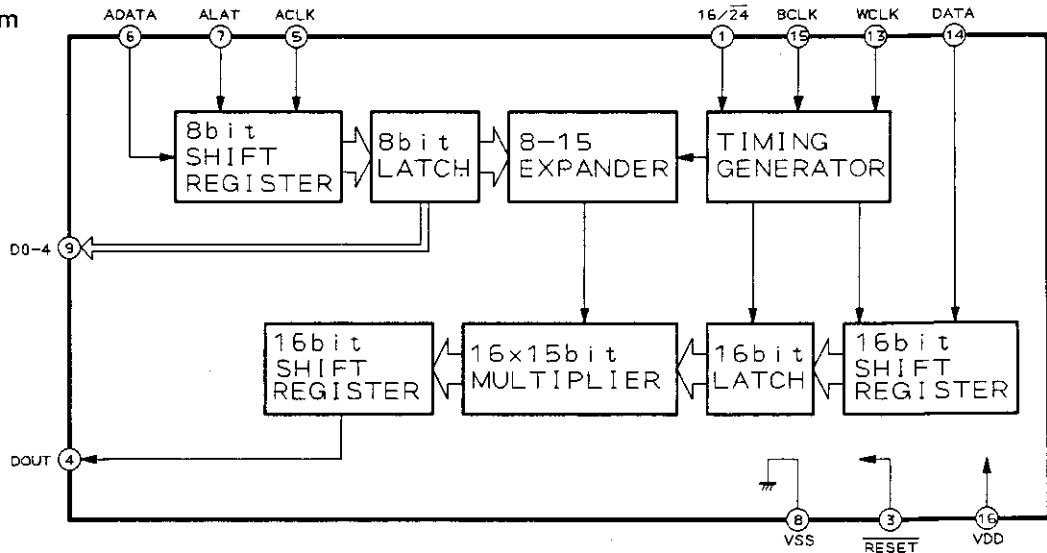

● Pin Function

No.	Symbol	Terminal Name	I/O	Description
1	16/24	16/24	I	Changes the DATA format.
2	D4	ATTENUATION DATA 4	O	Displays the attenuation level (0 to -36 dB). Open drain output.
3	RESET	RESET	I	Resets the inside of IC (attenuation level = 0dB).
4	DOUT	DATA OUT	O	Outputs 16-bit serial data (complement of 2, MSB fast).
5	ACLK	ATTENUATION CLOCK	I	Clock signal for writing the attenuation level.
6	ADATA	ATTENUATION DATA	I	Inputs the attenuation level data (binary, MSB fast).
7	ALAT	ATTENUATION LATCH PULSE	I	Inputs the attenuation level latch pulse.
8	VSS			Ground terminal.
9	D0	ATTENUATION DATA 0	O	Displays the attenuation level (0dB). Open drain output.
10	D1	ATTENUATION DATA 1	O	Displays the attenuation level (0 to -6dB). Open drain output.
11	D2	ATTENUATION DATA 2	O	Displays the attenuation level (0 to -12dB). Open drain output.
12	D3	ATTENUATION DATA 3	O	Displays the attenuation level (0 to -24dB). Open drain output.
13	WCLK	WORD CLOCK	I	Word clock input.
14	DATA	DATA	I	Inputs 16-bit serial data (complement of 2, MSB fast).
15	BCLK	BIT CLOCK	I	Bit clock input.
16	VDD			Power supply.

10.2 PD3222A (MCDR UNIT : IC1)

- Micro-computer
- Pin Assignment

Note :
 (H) or 1 : 5V
 (L) or 0 : 0V
 (M) : Motor

Master Clock 9.8304MHz 

When transmitting the data for Display : (L)
 (Asynchronous serial communication direction selector)

IFSEL1	IFSEL2	Mode
1	0	CDP-1 (Left)
0	1	CDP-2 (Right)
1	1	RXD2 - Not used TXD2 - Data for Display

Set the RS-422A driver to active when the transmission is performed.

This is the reset signal for IC401, IC402, IC406 and IC407 of the DGIF unit.

Indicator (L) : ON

KDSB unit Dip SW (S5) Input

When VD (M) Lock (MCDR unit IC14, FET ARRAY I_{AVE} ≈ 3.1A or more) is (H)

(PWM drive for VD (M) by IC14)

VMCCW	VMCW	VD (M)
0	1	Transfer base UP (CCW)
1	0	Transfer base Down (CW)
1	1	Brake

KDSB unit S1-S4 Input

(CL (M) drive by IC7)

CLC1	CLC2	CL (M)
0	1	CCW
1	0	CW
1	1	Brake

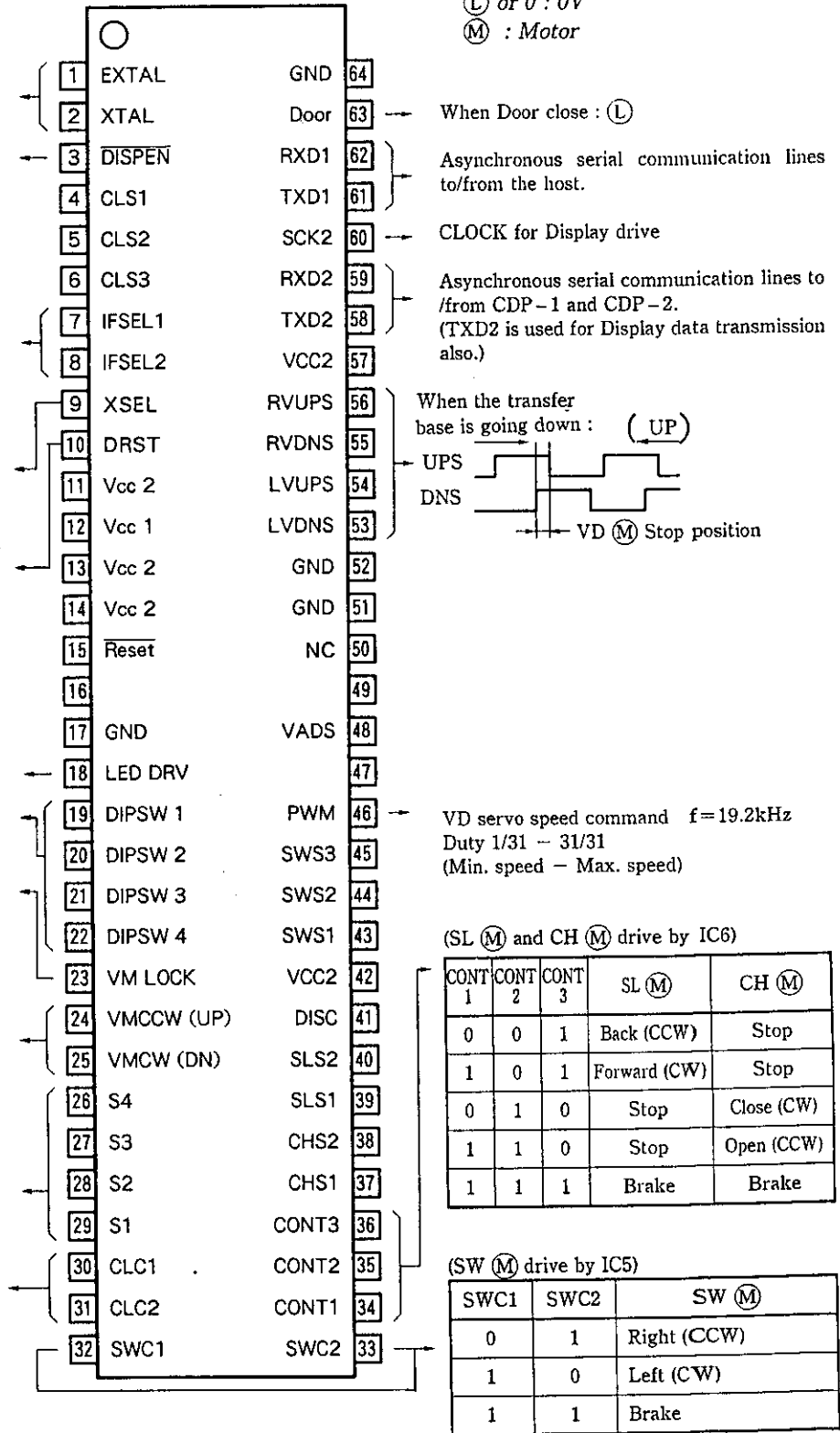

● Block Diagram

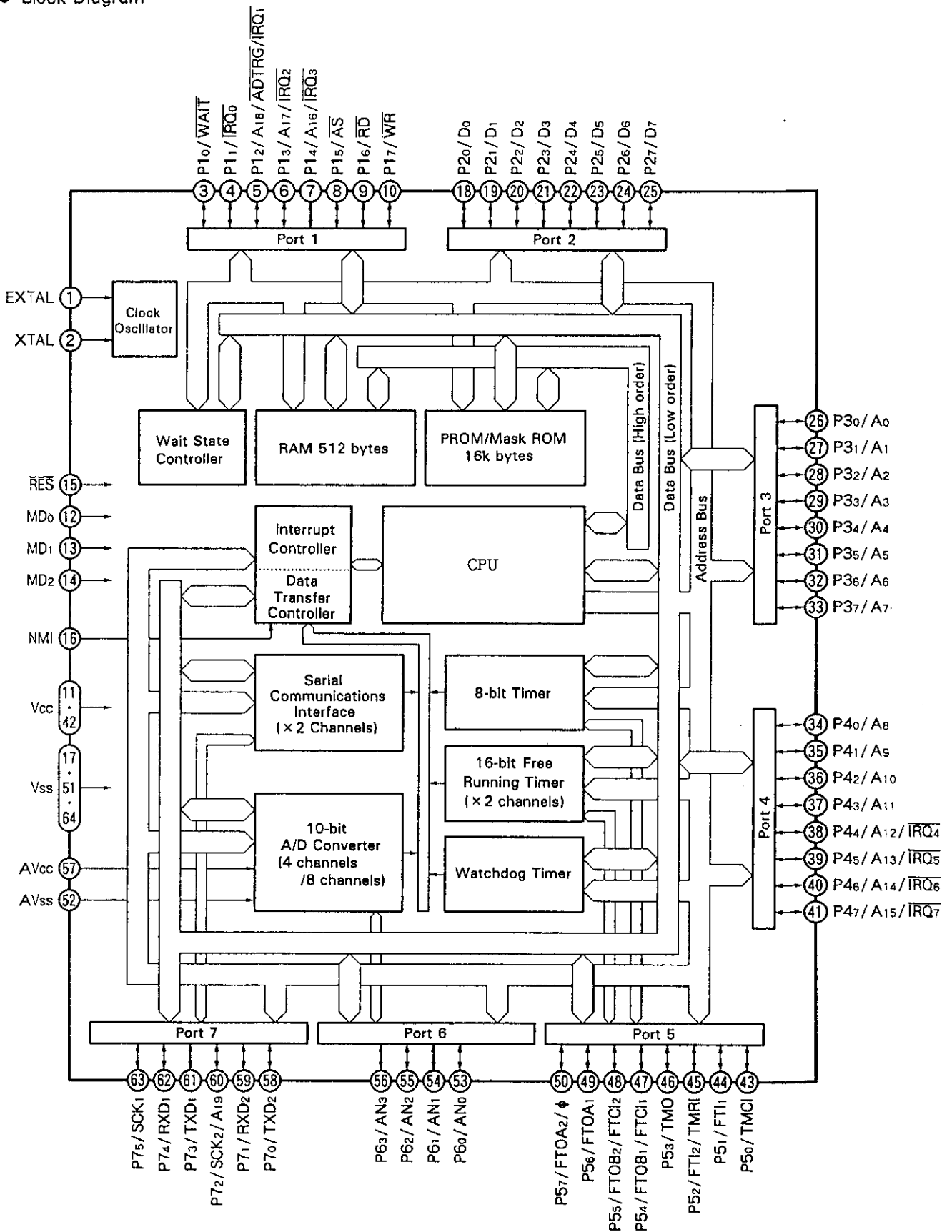

10.3 SAA7350 (DACB UNIT : IC522, IC523)

- Stereo CMOS DAC
- Block Diagram

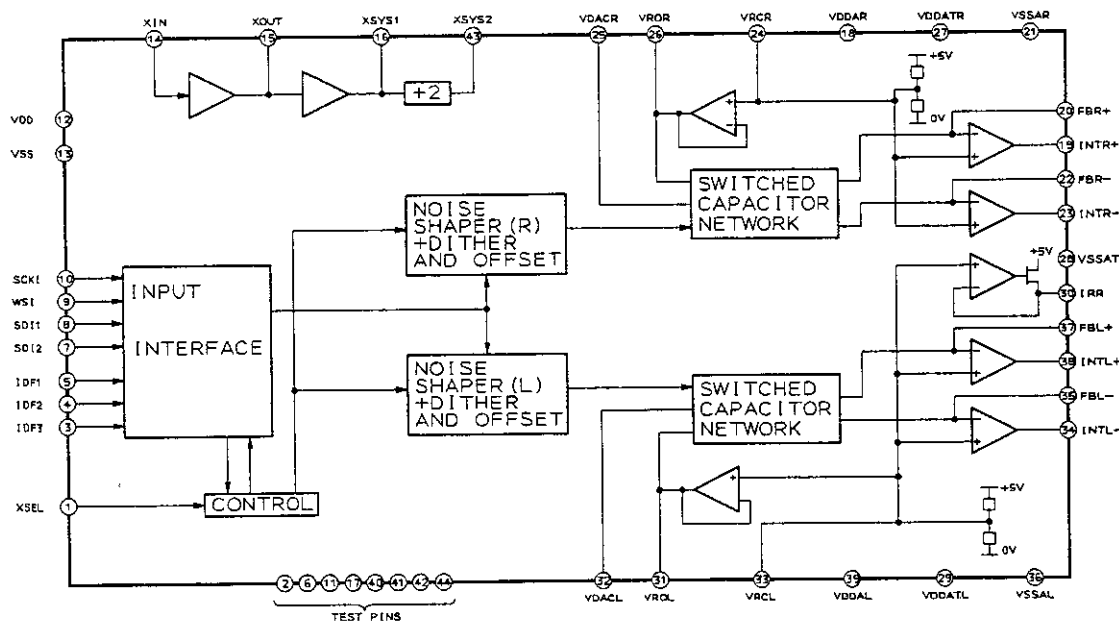

● Pin Function

No.	Terminal Name	I/O	Description
1	XSEL		Crystal frequency select. This pin is used to select the master crystal frequency as follows : XSEL HIGH = 384fs XSEL LOW = 256fs This pin defaults to XSEL HIGH when not connected.
2	TEST6		Test 6 : This pin should be left open circuit.
3	IDF3	I	Input data format. These three pins determine the input format the device is to operate in (see functional description). If unconnected these pins will default HIGH (i. e. burst clock mode).
4	IDF2	I	
5	IDF1	I	
6	TEST4	-	Test 4 : This pin should be left open circuit
7	SDI2	I	Serial Data Input. Used in simultaneous mode only (for the right channel signal). When not used, this pin will be internally pulled high.
8	SDI1	I	Serial Data Input. This should be a 16, 18 or 20-bit linear 2's complement PCM signal. In simultaneous mode this pin is used for the left channel signal.
9	WSI	I	Serial input Word Select signal. Signifies whether data word is for the left or right channel. Can be either fs, 2fs, 4fs or 8fs where fs is the system sampling frequency. fs can lie between 16kHz and 53kHz.
10	SCK1	I	Bit clock input for the serial input interface.
11	TEST1	-	Test 1. This pin should be left open circuit.
12	VDD	-	+5V power supply for the digital section.
13	VSS	-	Ground connection for the digital section.

No.	Terminal Name	I/O	Description
14	XIN	I	Crystal Oscillator Input.
15	XOUT	O	Crystal Oscillator Output.
16	XSYS1	O	Buffered Oscillator Output.
17	TEST5	-	Test 5. In normal operation this pin should be tied LOW.
18	VDDAR		Analogue 5V supply for right channel.
19	INTR +	O	Output from the Right Positive switched-capacitor integrator. Input to differential op-amp.
20	FBR +		Feedback connection for the Right positive switched-capacitor integrator.
21	VSSAR		0V supply for right channel.
22	FBR -		Feedback connection for the Right Negative switched-capacitor integrator.
23	INTR -	O	Output from the Right Negative switched-capacitor integrator. Input to differential op-amp.
24	VRCR	I	High impedance voltage reference for right channel inputs. Typically VDDAR/2.
25	VDACR		Reference Voltage Supply for Right channel DAC's. Normally this will be connected to VSS.
26	VROR	O	Right channel Voltage Reference Output. Typically VDDAR/2.
27	VDDATR		5V supply for right channel analogue timing.
28	VSSAT		0V supply for left and right channel analogue.
29	VDDATL		5V supply for left channel analogue timing.
30	IRR		24k Ω bias resistor connection for the reference current generator circuit.
31	VROL	O	Left channel Voltage Reference Output. Typically VDDAL/2.
32	VDACL		Reference Voltage Supply for Left channel DAC. Normally this will be connected to VSS.
33	VRCL	I	High impedance voltage reference for left channel inputs and for bias current generator. Typically VDDAL/2.
34	INTL -	O	Output from the Left Negative switched-capacitor integrator. Input to differential op-amp.
35	FBL -		Feedback connection for the Left Negative switched-capacitor integrator.
36	VSSAL		0V supply for left channel.
37	FBL +		Feedback connection for the Left Positive switched-capacitor integrator.
38	INTL +	O	Output from the Left Positive switched-capacitor integrator. Input to differential op-amp.
39	VDDAL		Analogue 5V supply for left channel.
40	TEST2	-	Test 2 : This pin should be left open circuit.
41	TEST3	-	Test 3 : This pin should be left open circuit.
42	TEST7	-	Test 7 : This pin should be left open circuit.
43	XSYS2	O	Output clock at a frequency of half the master clock frequency.
44	TEST8	-	Test 8 : This pin should be left open circuit.

10.4 CXD2500AQ (CONT UNIT : IC2)

● Decoder

● Block Diagram

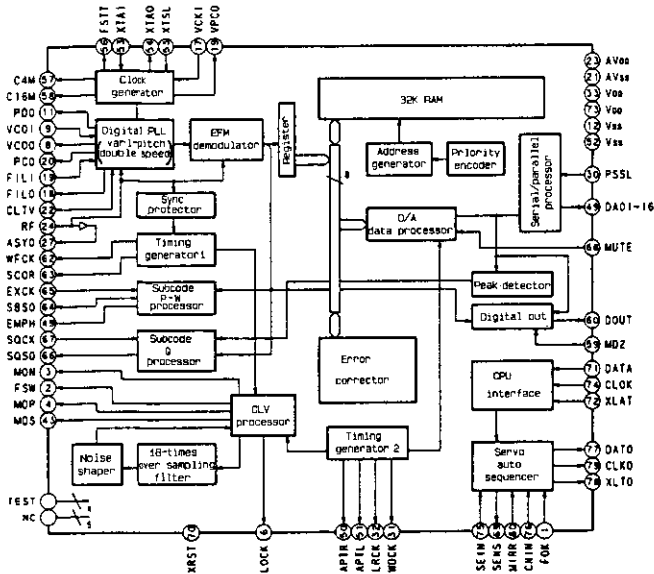

● Pin Function

No.	Terminal Name	I/O	Description
1	FOK	I	Focus OK input terminal. Used for SENS output and the servo auto sequencer.
2	FSW	O	Output to switch the spindle motor output filter.
3	MON	O	ON/OFF control output of the spindle motor.
4	MDP	O	Servo control of the spindle motor.
5	MDS	O	Servo control of the spindle motor.
6	LOCK	O	Samples GFS at 460Hz and outputs "H" when GFS is in the H mode. Outputs "L" when receiving the L signal continuously eight times.
7	NC	-	---
8	VCOO	O	Oscillation circuit output for analog EFM PLL.
9	VCOI	I	Oscillation circuit input for analog EFM PLL. $f_{clock} = 8.6436\text{MHz}$
10	TEST	I	TEST terminal normal GND.
11	PD0	O	Charge pump output for analog EFM PLL.
12	V _{SS}	-	GND
13			
14	NC	-	---
15			

No.	Terminal Name	I/O	Description
16	VPCO	O	PLL charge pump output for variable pitch.
17	VCKI	I	Clock input from external VCO for variable pitch. $f_{center} = 16.9344\text{MHz}$
18	FILO	O	Master PLL (slave = digital PLL) filter output
19	FILI	I	Master PLL filter input
20	PCO	O	Master PLL charge pump output
21	AV _{SS}	-	Analog GND
22	CLTV	I	Master VCO control voltage input
23	AV _{DD}	-	Analog power supply (+5V)
24	RF	I	EFM signal input
25	TEST2	I	Connect to GND.
26	TEST3	I	
27	ASYO	O	EFM full swing output (L = V _{SS} , H = V _{DD})
28	TEST4	I	Connect to GND.
29	NC	-	---
30	PSSL	I	Audio data output mode switching input. Serial output by the L mode. Parallel output by the H mode.
31	WDCK	O	D/A interface for 48-bit slot. Word clock $f = 2F_s$.
32	LRCK	O	D/A interface for 48-bit slot. LR clock $f = F_s$.
33	V _{DD}	-	Power supply (+5V)
34	DA16	O	DA16 (MSB) output when PSSL = 1. Serial data (2s'COMP, MSB fast) of the 48-bit slot when PSSL = 0.
35	DA15	O	DA15 output when PSSL = 1. Bit clock of the 48-bit slot when PSSL = 0.
36	DA14	O	DA14 output when PSSL = 1. Serial data (2s'COMP, LSB fast) of the 64-bit slot when PSSL = 0.
37	DA13	O	DA13 output when PSSL = 1. Bit clock of the 64-bit slot when PSSL = 0.
38	DA12	O	DA12 output when PSSL = 1. LR clock of the 64-bit slot when PSSL = 0.

No.	Terminal Name	I/O	Description
39	DA11	O	DA11 output when PSSL = 1. GTOP output when PSSL = 0.
40	DA10	O	DA10 output when PSSL = 1. XUGF output when PSSL = 0.
41	DA09	O	DA09 output when PSSL = 1. XPLCK output when PSSL = 0.
42	DA08	O	DA08 output when PSSL = 1. GFS output when PSSL = 0.
43	DA07	O	DA07 output when PSSL = 1. RFCK output when PSSL = 0.
44	DA06	O	DA06 output when PSSL = 1. C2P0 output when PSSL = 0.
45	DA05	O	DA05 output when PSSL = 1. XRAOF output when PSSL = 0.
46	DA04	O	DA04 output when PSSL = 1. MNT3 output when PSSL = 0.
47	DA03	O	DA03 output when PSSL = 1. MNT2 output when PSSL = 0.
48	DA02	O	DA02 output when PSSL = 1. MNT1 output when PSSL = 0.
49	DA01	O	DA01 output when PSSL = 1. MNT0 output when PSSL = 0.
50	APTR	O	Aperture compensation control output. H mode when Rch.
51	APTL	O	Aperture compensation control output. H mode when Lch.
52	Vss	-	GND
53	XTAI	I	16.9344MHz Xtal oscillation circuit input or 33.8688MHz.
54	XTAO	O	16.9344MHz Xtal oscillation circuit output.
55	XTSL	I	Xtal select input terminal. Changes to the L mode when Xtal is 16.9344MHz. Changes to the H mode when Xtal is 33.8688MHz.
56	FSTT	O	2/3 divider output of terminals 53 and 54. Does not change with the variable pitch.
57	C4M	O	4.2336MHz output. Changes simultaneously with the variable pitch.
58	C16M	O	16.9344MHz output. Changes simultaneously with the variable pitch.

No.	Terminal Name	I/O	Description
59	MD2	I	Digital-out ON/OFF control. Is turned ON by the H signal. Is turned OFF by the L signal.
60	DOUT	O	Digital-out output terminal.
61	EMPH	O	Outputs "H" when emphasis exists in the playback disc. Outputs "L" when no emphasis exists in the playback disc.
62	WFCK	O	WFCK (Write Frame Clock) output.
63	SCOR	O	Outputs "H" when the system detects either subcode synchro S0 or S1.
64	SBSO	O	Sub P -- W serial output.
65	EXCK	I	Clock input for SBSO lead out.
66	SQSO	O	SubQ 80-bit and PCM peak. Level data 16-bit output.
67	SQCK	I	Clock input for SQSO lead out.
68	MUTE	I	Is muted by the H signal. Muting is canceled by the L signal.
69	SENS	-	SENS output. Outputs to CPU.
70	XRST	I	System reset. Resets by the L signal.
71	DATA	I	Serial data input from CPU.
72	XLAT	I	Latch input from CPU. Latches serial data at the trailing edge.
73	VDD	-	Power supply (+5V)
74	CLOK	I	Serial data transfer clock input from CPU.
75	SEIN	I	SENSE input from SSP.
76	CNIN	I	Track jumps counting signal input
77	DATO	O	Serial data output to SSP.
78	XLTO	O	Serial data latch output to SSP. Latches serial data at the trailing edge.
79	CLKO	O	Serial data transfer clock output to SSP.
80	MIRR	I	Mirror signal input. For a jump more than 128 tracks using the auto sequencer.

10.5 PD0037 (DGIF UNIT : IC401, IC402)

- Digital Interface Receiver
- Block Diagram

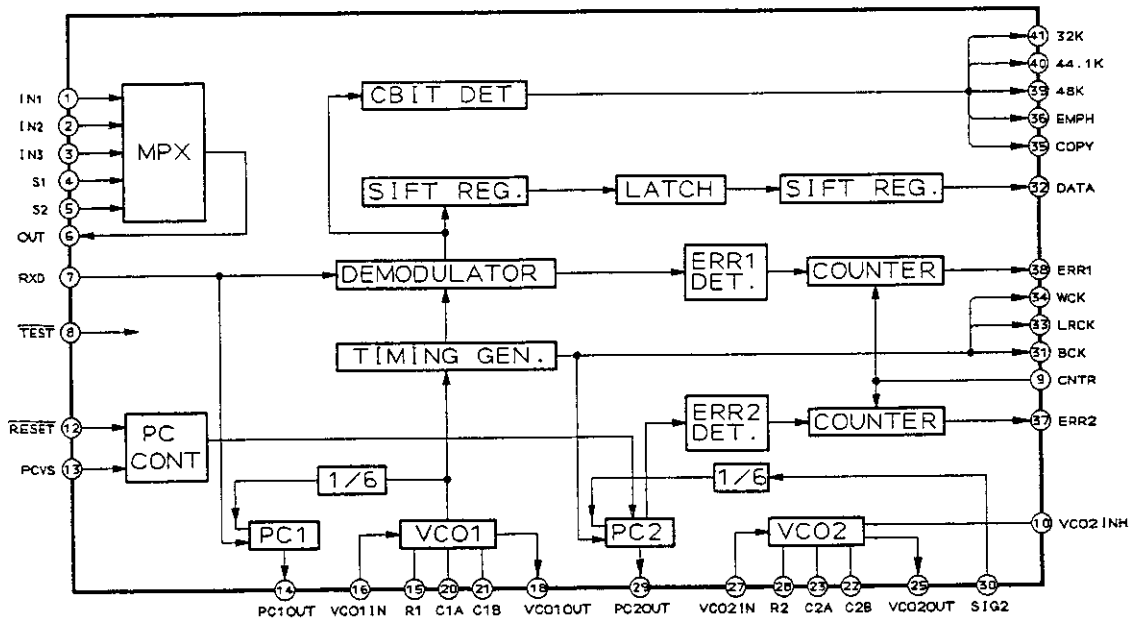

● Pin Function

No.	Terminal Name	I/O	Description
1	IN1	I	Data input 1
2	IN2	I	Data input 2
3	IN3	I	Data input 3
			Digital audio data input in the EIAJ format. (TTL level)
4	S1	I	Input selector 1 (TTL level)
5	S2	I	Input selector 2 (TTL level)
6	OUT	O	MPX output of data.
7	RXD	I	Data input. Normally connect to OUT. (CMOS level)
8	TEST	I	Test mode input. Normally fixed to "H." Contains pull-up resistance. (TTL level)
9	CNTR	I	Counter clock input for setting output time for ERR1 and ERR2. (CMOS level)
10	VC02 INH	I	For stopping VCO2 oscillation. Stops oscillation by the "H" signal. (TTL level)
11	VSS	-	Logic VSS.
12	RESET	I	Power ON reset input. (CMOS level)
13	PCVS	I	Input for setting VCO1 and VCO2 free-running frequency.

No.	Terminal Name	I/O	Description
14	PC1 OUT	O	Phase comparator 1 output.
15	R1	-	Terminal to connect the VCO1 adjusting resistance.
16	VC01IN	I	VCO1 control voltage input.
17	VDD1	-	VCO1 VDD
18	VC01 OUT	O	VCO1 output (384fs)
19	VSS1	-	VCO1 VSS
20	C1 A	-	VCO1 adjusting capacity connection terminal.
21	C1 B	-	
22	C2 B	-	VCO2 adjusting capacity connection terminal.
23	C2 A	-	
24	VSS2	-	VCO2 VSS
25	VC02 OUT	O	VCO2 output (384fs)
26	VDD2	-	VCO2 VDD
27	VC02 IN	I	VCO2 control voltage input.

No.	Terminal Name	I/O	Description
28	R2	-	Terminal to connect the VCO2 adjusting resistance.
29	PC2 OUT	O	Phase comparator 2 output.
30	SIG2	I	V input of the phase comparator 2. Normally connect to VCO2 OUT. (CMOS level)
31	BCK	O	Demodulation data bit clock output.
32	DATA	O	Demodulation audio data output.
33	LRCK	O	Demodulation data L/R channel output. (H = L channel)
34	WCK	O	Demodulation data word clock output.
35	COPY	O	COPY information output. Enables copy by the "H" signal.
36	EMPH	O	Emphasis information output. (H = Emphasis exists.)
37	ERR2	O	2nd PLL UNLOCK output. (H = UNLOCK)

No.	Terminal Name	I/O	Description
38	ERR1	O	1st PLL data reading error output. (H = Error detected.)
39	48K	O	Sampling frequency information output. Open drain for the LED driver. "L" active.
40	44.1K		
41	32K		
42	VDD	-	Logic VDD.

● Input Selector

S2	S1	OUT
L	L	L
L	H	IN1
H	L	IN2
H	H	IN3

Terminals not used for IN1 to IN3 are fixed either in the "H" or "L" mode.

10.6 CXA1372S (CONT UNIT : IC4)

● Block Diagram

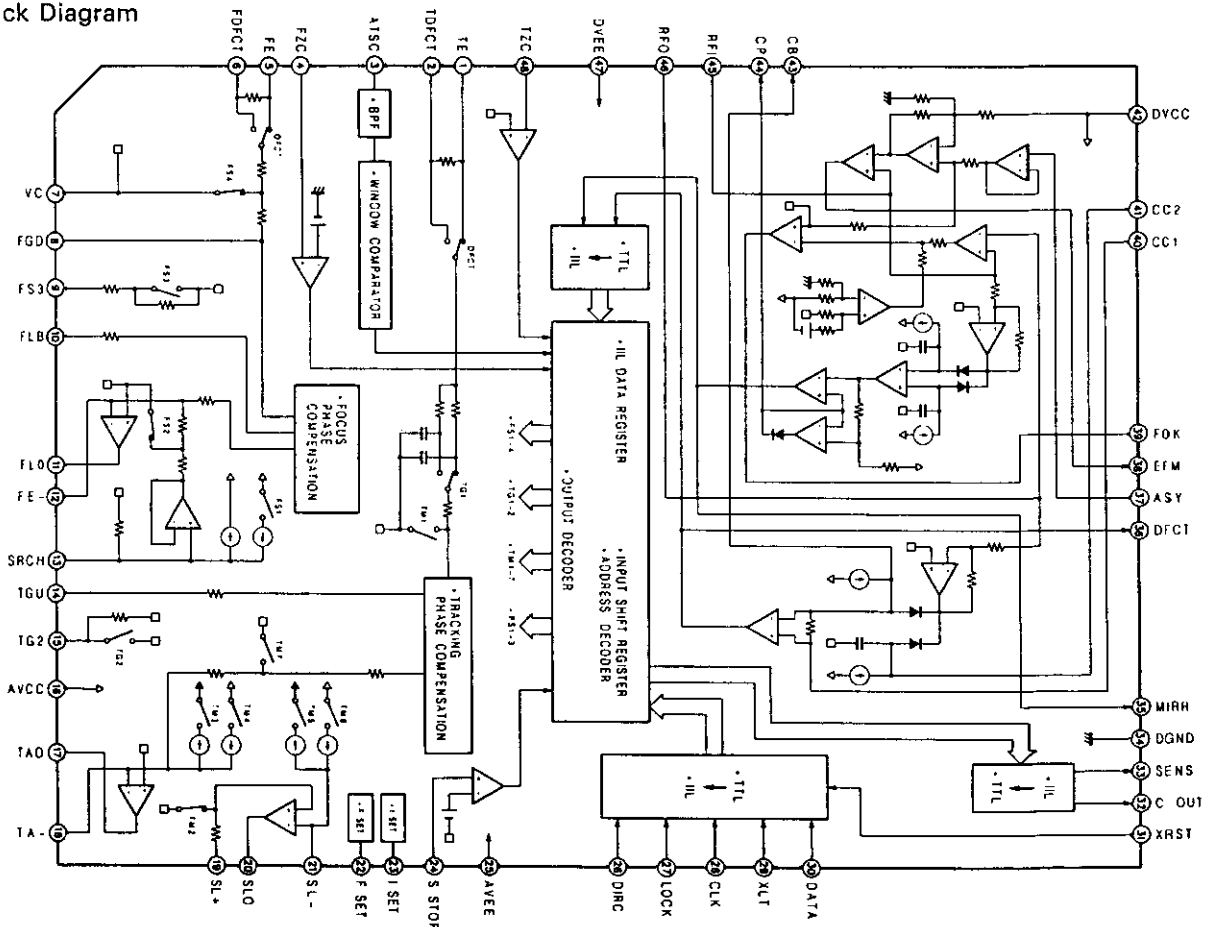

10.7 SM5813AP (DACB : IC513)

- Digital Filter
- Block Diagram

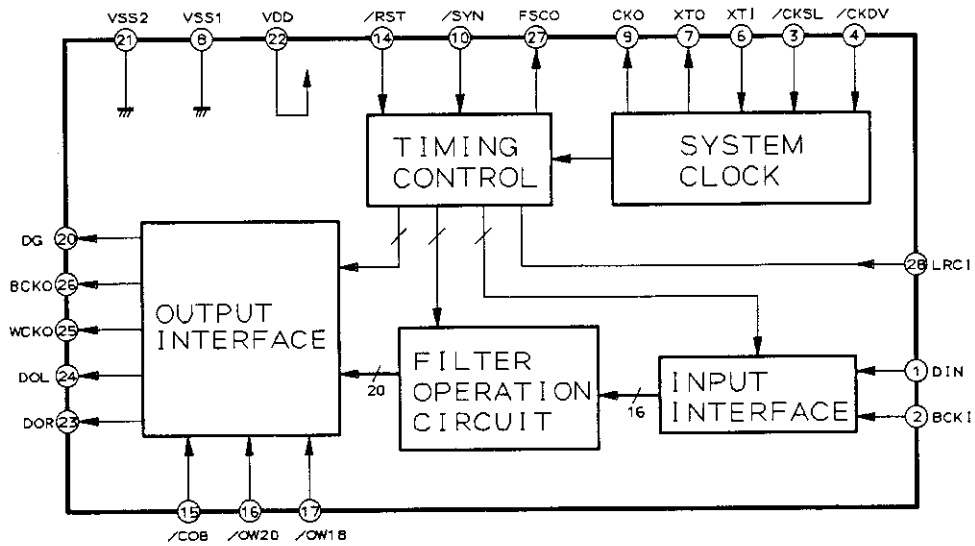

● Pin Function

No.	Terminal Name	I/O	Description
1	DIN	I	Input data
2	BCKI	I	Bit clock of input data.
3	/CKSL	I	Selects the input frequency of the XTI terminal. (See the description of the Pin6 XTI terminal.)
4	/CKDV	I	
5	(NC)	-	---
6	XTI	I	Oscillator input terminal. (192fs : /CKSL = H, /CKDV = H) (384fs : /CKSL = H, /CKDV = L) (256fs : /CKSL = L, /CKDV = H) (512fs : /CKSL = L, /CKDV = L)
7	XTO	O	Oscillator output terminal.
8	VSS1	-	GND terminal 1
9	CKO	O	Oscillator output clock (frequency is the same as with the XTI terminal).
10	/SYN	I	Selects between the jitter-free mode and the forced synchronous mode. H = Jitter-free mode L = Forced synchronous mode
11	(NC)	-	---
12			
13			
14	/RST	I	System reset. H = Normal operation L = System reset

No.	Terminal Name	I/O	Description												
15	/COB	I	Selects between a complement of 2 and COB. H = Complement of 2 L = COB												
16	/OW20	I	Selects the output bits. <table border="1" style="margin-left: 20px;"> <thead> <tr> <th>OUTPUT BIT</th> <th>16</th> <th>18</th> <th>20</th> </tr> </thead> <tbody> <tr> <td>/OW18</td> <td>H</td> <td>L</td> <td>H</td> </tr> <tr> <td>/OW20</td> <td>H</td> <td>H</td> <td>L</td> </tr> </tbody> </table>	OUTPUT BIT	16	18	20	/OW18	H	L	H	/OW20	H	H	L
OUTPUT BIT	16	18	20												
/OW18	H	L	H												
/OW20	H	H	L												
17	/OW18	I													
18	(NC)	-	---												
19															
20	DG	O	Degitch control clock												
21	VSS2	-	GND terminal 2												
22	VDD	-	Power supply terminal (5V)												
23	DOR	O	Rch octuple over-sampling output data												
24	DOL	O	Lch octuple over-sampling output data												
25	WCKO	O	Word clock of output data												
26	BCKO	O	Bit clock of output data												
27	FSCO	O	Internal operation timing clock for fs cycle.												
28	LRCI	I	Sample rate (fs) clock of input data H = Lch L = Rch												

Note : "fs" stands for the sample frequency of input data.

10.8 LB – 603VP (KDSB UNIT : D300)

- LED
- Pin Assignment

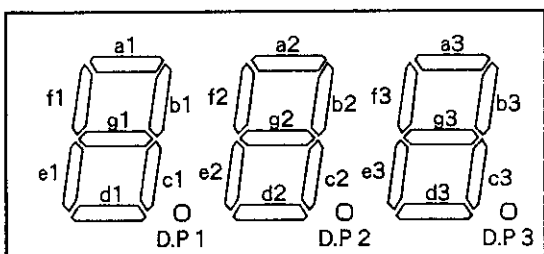

● Schematic Diagram

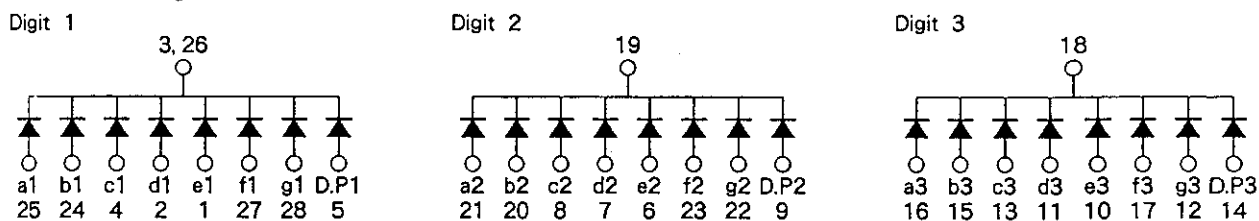

● Pin Function

Pin	Address	Pin	Address
1	Segment " e1 " Anode	15	Segment " b3 " Anode
2	Segment " d1 " Anode	16	Segment " a3 " Anode
3	Digit. 1 Common Cathode	17	Segment " f3 " Anode
4	Segment " c1 " Anode	18	Digit. 3 Common Cathode
5	D. P 1 Anode	19	Digit. 2 Common Cathode
6	Segment " e2 " Anode	20	Segment " b2 " Anode
7	Segment " d2 " Anode	21	Segment " a2 " Anode
8	Segment " c2 " Anode	22	Segment " g2 " Anode
9	D. P 2 Anode	23	Segment " f2 " Anode
10	Segment " e3 " Anode	24	Segment " b1 " Anode
11	Segment " d3 " Anode	25	Segment " a1 " Anode
12	Segment " g3 " Anode	26	Digit. 1 Common Cathode
13	Segment " c3 " Anode	27	Segment " f1 " Anode
14	D. P 3 Anode	28	Segment " g1 " Anode

10.9 4AM12 (MCDR UNIT : IC14)

- High-speed Power Switching
- Pin Assignment
- Block Diagram

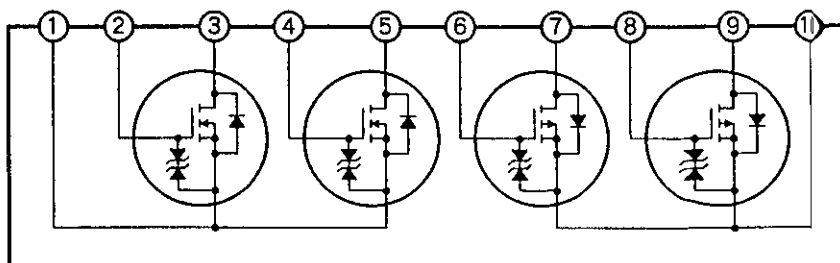
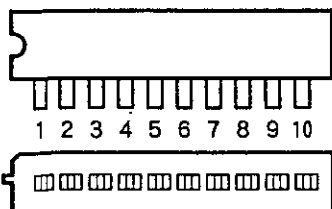

10.10 CXA1471S (CONT UNIT : IC1)

- RF Amp
- Block Diagram

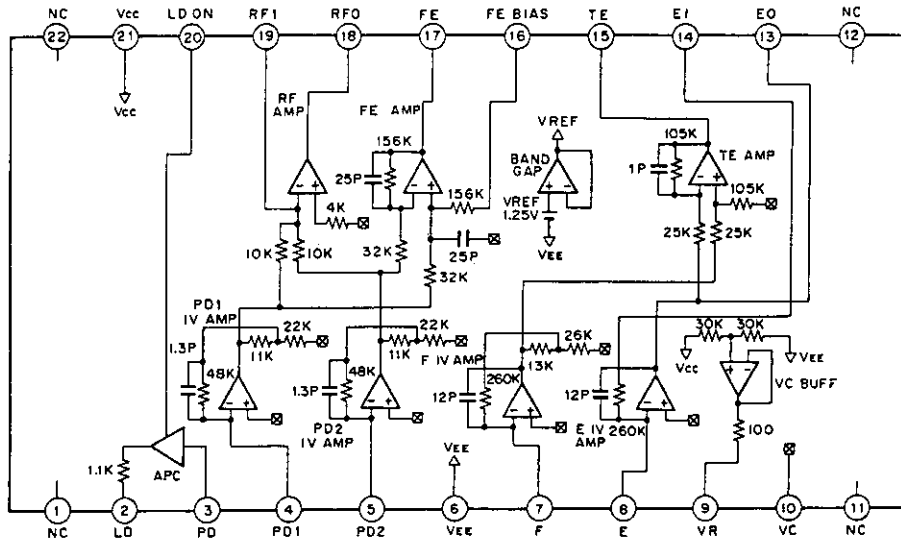

10.11 M75175P (RSIF UNIT : IC302)

- Quadruple Differential Line Receiver
- Pin Assignment

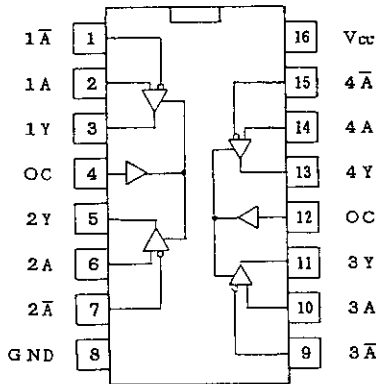

10.12 SN75174N (RSIF UNIT IC303)

- Line Driver
- Pin Assignment
- Truth Table

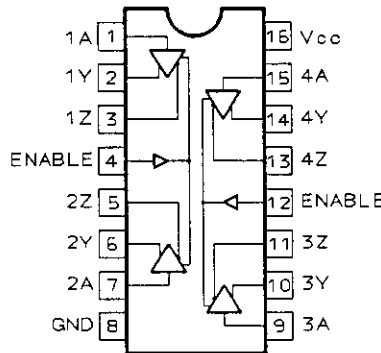

INPUT	ENABLE	OUTPUTS	
		Y	Z
H	H	H	L
L	H	L	H
X	L	Z	Z

H = TTL high level.
 L = TTL low level.
 X = irrelevant.
 Z = high impedance(off)

- Function Table

Input		Output	
A	A-bar	OC	Y
$V_{ID} > V_{TH}$		H	H
$V_{TL} < V_{ID} < V_{TH}$		H	*
$V_{ID} < V_{TL}$		H	L
X		L	Z

Note)
 V_{ID} : (Voltage applied to A) – (Voltage applied to A)
 V_{TH} : 0.2V
 V_{TL} : -0.2V
 X : Either 'H' or 'L.'
 * : State of Y is not defined.
 Z : Indicates high impedance.

10.13 BA10339 (MCDR UNIT : IC12)

- Quad Comparator
- Block Diagram

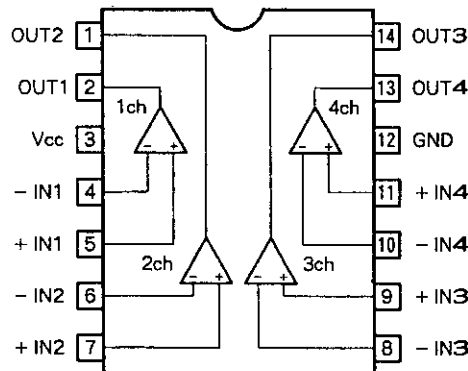

10.14 MC14489P (KDSB UNIT : IC300)

- Multifunction OED Display/Lamp Driver CMOS
- Pin Assignment
- Block Diagram

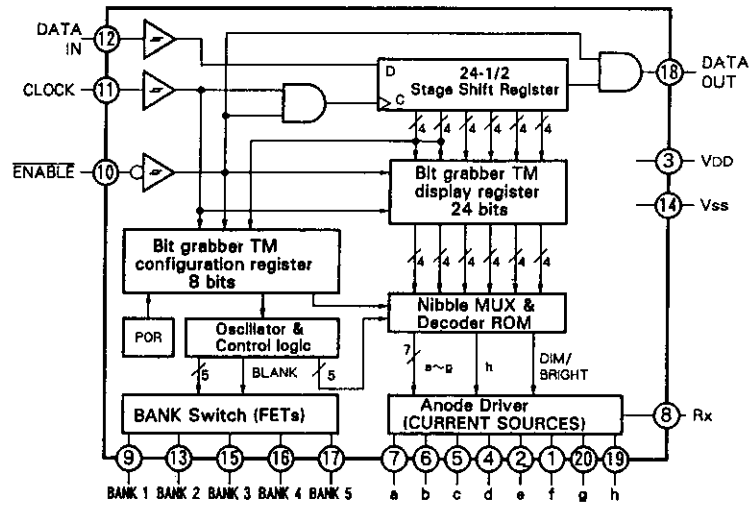
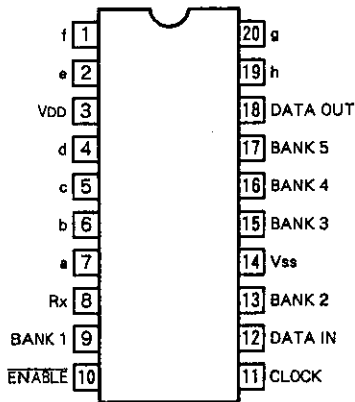

10.15 PD0140B (CONT UNIT : IC9)

- CDP System Control
- Pin Function

No.	Terminal Name	I/O	Description
1	Vcc	O	+5V
2	-	O	NC
3	XLT	O	Latch signal output for communication with CXD2500AQ.
4	LDON	O	Laser diode control output H : Diode ON
5	MUTEG	O	Mute control output H : Mute ON
6-10	-	O	NC
11	CLK	O	Clock signal output for communication with CXD2500AQ.
12	DATA	O	Data transmission to CXD2500AQ.
13	SUBQ	I	Subcode input
14	SW	I	External/Remote control input H : Remote control input
15-19	-	O	NC
20	TxD	O	Asynchronous serial communications with system micro-computer.
21	RxD	I	
22	SENS	I	SENS input from CXD2500AQ
23-25	-	O	NC
26	SCOR	I	Subcode ready signal input H : Ready

No.	Terminal Name	I/O	Description
27	CNVss		GND
28	RESET		
29	XIN		Master clock 9.8304MHz
30	XOUT		
31	-	O	NC
32	Vss		GND
33	INSD	I	Inside switch input L : Inside
34	GFS	I	Spindle monitor input H : OK
35	FOK	I	Focus monitor input H : OK
36-40	-	I	GND
41-48	-	O	NC
49-56	-	O	
57-61	-	O	
62	ALAT	O	Latch signal output to the digital attenuator
63	ADAT	O	Data output to the digital attenuator
64	ACLK	O	Communication clock signal output to the digital attenuator

11. SERVICE MODE

1. OPERATION MODE

The operation mode is divided into two types, User mode and Service mode.

Mode switching process is in the Initial setting mode, where the set reads which buttons are pressed and which bits of a DIP switch are set.

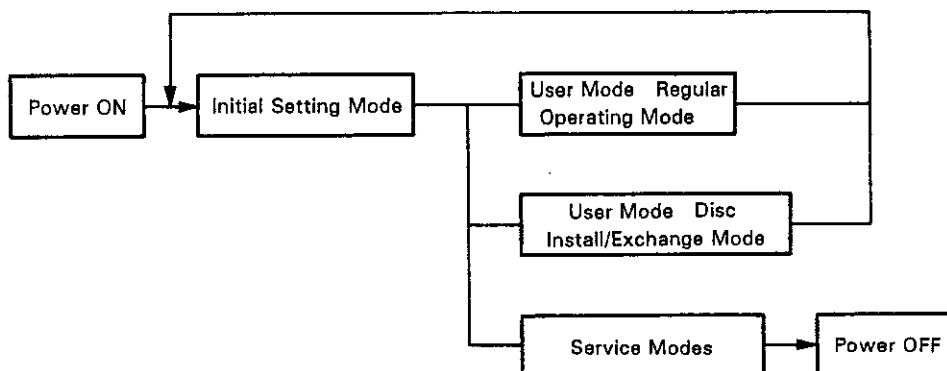

The user mode has the regular operation mode, which is controlled by the host computer, and the disc install and disc exchange modes. A restart can be performed from the initial setting mode by opening the door, switching the DIP switch setting, and closing the door because the mode settings are determined by the DIP switch setting.

For details, see the instruction manual.

Indicator

In addition to the ON and OFF conditions, the lamp can also flash rapidly or slowly. Always observe the indicator during operation. Because the meaning of the indicator is very important.

● Fast Flashing

The lamp flashes quickly when the door is open to indicate that it must be closed. For example, when the manual mode is entered, a request to close the door is indicated when the initialization is not completed. When this occurs, a start up operation must be performed after the completing the initialization. In the disc install/exchange mode, a request is issued to close the door because the mechanism operation cannot be performed when the door is open.

When the door is closed, a request is made to open the door. When a series of operation is completed in the disc install/exchange mode and the next operation is necessary, a request is made to open the door. If an error occurs, a request is made to open the door and display the error message. And in that case, the lamp continues to flash rapidly after the door is closed.

● Slow Flashing

The lamp flashes slowly to indicate that the mechanism is operating. Be careful not to open the door by mistake when the mechanism is operating. This condition is also seen while the initial setting mode is executed.

● OFF Condition

This lamp indicates that the door is closed. (User mode)

● ON Condition

This lamp lights to indicate that the door is open (User mode). If the service mode is entered, the indicator lamp stays ON even when the door is closed. This enables external verification that the door was closed by mistake when the service mode is entered.

2. SERVICE MODE

The following eight modes compose the service mode.

- ① SUPER MANUAL MODE
- ② MANUAL MODE
- ③ ERROR HISTORY REFERENCE MODE
- ④ PLAYER ADDRESS SETTING MODE
- ⑤ COUNTER READ MODE
- ⑥ LOOP BACK TEST MODE
- ⑦ SOFTWARE VERSION REFERENCE MODE
- ⑧ SCREENING MODE

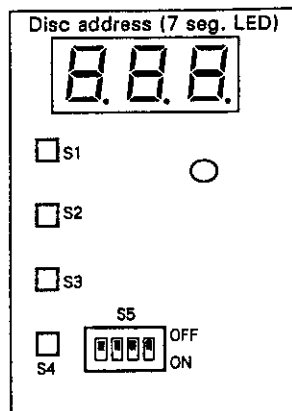

Fig. 1 KDSB unit

The tactile switches (S1 to S4) in the KDSB unit, the dip switches (S5) and the power switch are used to enter the service mode. Turn on the power while pressing some tactile switches. The various independent operations are performed depending on the combined pattern of switches that are pressed (except in the screening mode). When shifting to other modes, turn the power switch OFF one time and then turn it ON again. The operation will not shift to another mode if the power switch is not turned ON again. (Refer to Fig. 1 and 2.)





No.	Mode	How to Enter Each Service Mode.	No.	Mode	How to Enter Each Service Mode.
1	SUPER MANUAL MODE	Press  + Power Switch ON.	5	COUNTER READ MODE	Press  + Power Switch ON.
2	MANUAL MODE	Press  + Power Switch ON.	6	LOOP BACK TEST MODE	Press  + Power Switch ON.
3	ERROR HISTORY REFERENCE MODE	Press  + Power Switch ON.	7	SOFTWARE VERSION REFERENCE MODE	Press  + Power Switch ON.
4	PLAYER ADDRESS SETTING MODE	Press  + Power Switch ON.	8	SCREENING MODE	 + Power Switch ON.

Fig. 2

Precaution

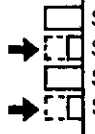
The user mode of the CAC-V3000 is designed so the mechanism operation cannot be performed when the door is opened to ensure user safety. However, in the service mode, the mechanism operates when the door is opened because the mechanism control is operated by the operation buttons inside the door. Read this manual adequately to understand the operations and perform them correctly.

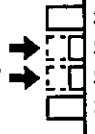
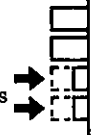
The screening mode can only operate if the door is opened or closed when DIP switch number 4 is ON.

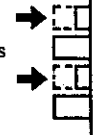
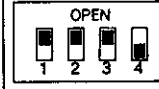
The screening mode is a provisional function that is used in manufacturing processing and should not be used by the regular user.

The mechanism operates in the following service modes.

- Manual mode
- Super manual mode
- Screening mode

① Super Manual Mode

It is possible to monitor the whole sensors on the operating mechanism. Those are seen on the LEDs. And also each motor that drives the mechanism is able to control individually.

1) Start-up Operation

While pressing all switches S1 to S4, turn the power switch ON.

2) Sensor ON/OFF Verification

Each segment of the seven-segment LED are assigned to each sensor. See Fig. 3 and Table 2 to 8.

※ The logical levels of each segment are as follows.

- Segment lights : 1
- Segment goes off : 0
- LED brightness decreases : CLS3 = 0
- LED brightness increases : CLS3 = 1

3) Drive Motor Select

Select the drive motor by setting the DIP switch's bit. (Refer to Table 1)

Switches S1 and S2 are used to drive the motor. The motor is driven while the switch is pressed without any relation to the sensor value.

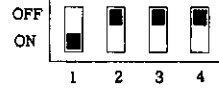
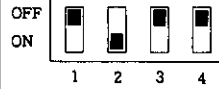
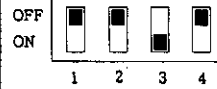
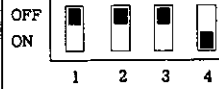
Switch	Motor and Direction of the Operation				
	Vertical Motor	Clamp Motor	Swing Motor	Chuck Motor	Slide Motor
S1	Upward	Clockwise direction	Right	Close	Forward
S2	Downward	Counterclockwise direction	Left	Open	Backward
S5	 All switches : OFF	 S5-1 only : ON	 S5-2 only : ON	 S5-3 only : ON	 S5-4 only : ON

Note :

To protect the mechanism, the motor does not operate under the following conditions.

- Chuck operation is not possible if the slide mechanism is in the middle position.
- The slide mechanism cannot extend if the swing arm is not stopped in the right or left position.
- Swing operation is not possible if the slide mechanism has not retracted.

Table 1

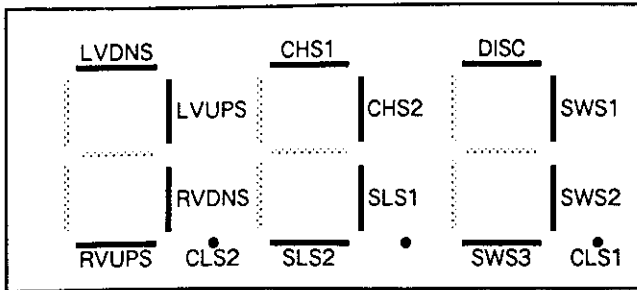

Note : CLS3 determines the brightness of the entire LEDs.

- LVDNS) Left vertical position detection sensor (See Table 2)
- LVUPS) Left vertical position detection sensor (See Table 2)
- RVDNS) Right vertical position detection sensor (See Table 3)
- RVUPS) Right vertical position detection sensor (See Table 3)
- CHS1) Chuck motor end detection switch (See Table 5)
- CHS2) Chuck motor end detection switch (See Table 5)
- SLS1) Slide motor end detection switch (See Table 4)
- SLS2) Slide motor end detection switch (See Table 4)
- DISC : Disc presence detection switch (See Table 6)
- SWS1) Swing motor stop position detection switch (See Table 7)
- SWS2) Swing motor stop position detection switch (See Table 7)
- SWS3) Swing motor stop position detection switch (See Table 7)
- CLS1) Clamp motor stop position detection switch
- CLS2) Clamp motor stop position detection switch
- CLS3) Clamp motor stop position detection switch

Fig. 3 LED Light Position

Left Vertical Position Detection Sensor Value	
LVUPS	
LVDNS	
Mechanism operation	Lower Stop position Raise

Table 2

Right Vertical Position Detection Sensor Value	
RVUPS	
RVDNS	
Mechanism operation	Lower Stop position Raise

Table 3

Slide Motor End Detection Sensor Value	
SLS 1	
SLS 2	
Mechanism position	Retract Extend

Table 4

Chuck Motor End Detection Sensor Value	
CHS 1	
CHS 2	
Mechanism position	Open Close

Table 5

CD Presence Detection Switch	
DISC	
	Loaded Not loaded.

Table 6

Swing Motor Stop Position Detection Switch Value	
SWS 1	
SWS 2	
SWS 3	
Mechanism position	Left end Center Right end

Table 7

Clamp Motor Stop Position Detection Switch Value																
CLS 1																
CLS 2																
CLS 3																
Clamper (left) Clamper (right) Motor rotation direction	<table border="0"> <tr> <td>OPEN</td> <td>CLOSE</td> <td>CLOSE</td> <td>OPEN</td> <td>OPEN</td> </tr> <tr> <td>OPEN</td> <td>OPEN</td> <td>CLOSE</td> <td>CLOSE</td> <td>OPEN</td> </tr> <tr> <td>⇐ Counterclockwise direction</td> <td></td> <td></td> <td></td> <td>Clockwise direction ⇒</td> </tr> </table>	OPEN	CLOSE	CLOSE	OPEN	OPEN	OPEN	OPEN	CLOSE	CLOSE	OPEN	⇐ Counterclockwise direction				Clockwise direction ⇒
OPEN	CLOSE	CLOSE	OPEN	OPEN												
OPEN	OPEN	CLOSE	CLOSE	OPEN												
⇐ Counterclockwise direction				Clockwise direction ⇒												

Table 8

② Manual Mode

1) Start-up Operation

While pressing both S1 and S2, turn the power switch ON.

If the manual mode is entered, the LED usually displays [n1]. However, a sequence number is displayed when the set starts just after a malfunction has occurred.

※ In some cases, a request is made for the initial setting to ensure safe operation. Close the door if the indicator flashes rapidly. The lamp will flash slowly and operation will be executed same as the initial settings. The indicator lamp goes off when the initial setting is completed. After the power is shut off, open the door, and turn the power on while pressing switches S1 and S2 again.

2) Usage

- The disc setup operations can be executed for each step from n1 to n14 for S3 (Refer to Tables 9 and 10). The transfer base vertical operation is performed by switches S1 and S2.
- The disc return operation is executed for each step from r14 to r1 for switch S4. (Refer to Tables 9 and 10). The transfer base vertical operation is performed by switches S1 and S2. If switch S4 is pressed to return the CD to the incorrect rack in [r7], the correct address is displayed on the LED.
- S1, S2 can directly control the drive motor at each step. (see Table 10)
- The selection of the CD player and the side of the rack can be performed by bit 1 of S5 (DIP switches). If the right side is selected the period next to the numeral LED lights. (Refer to Fig. 4.) But this selection is only possible at sequence numbers [1], [7] and [14].

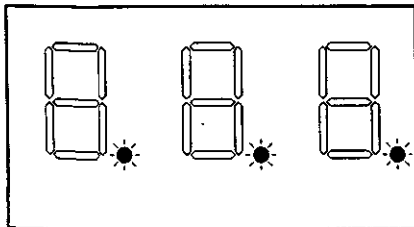
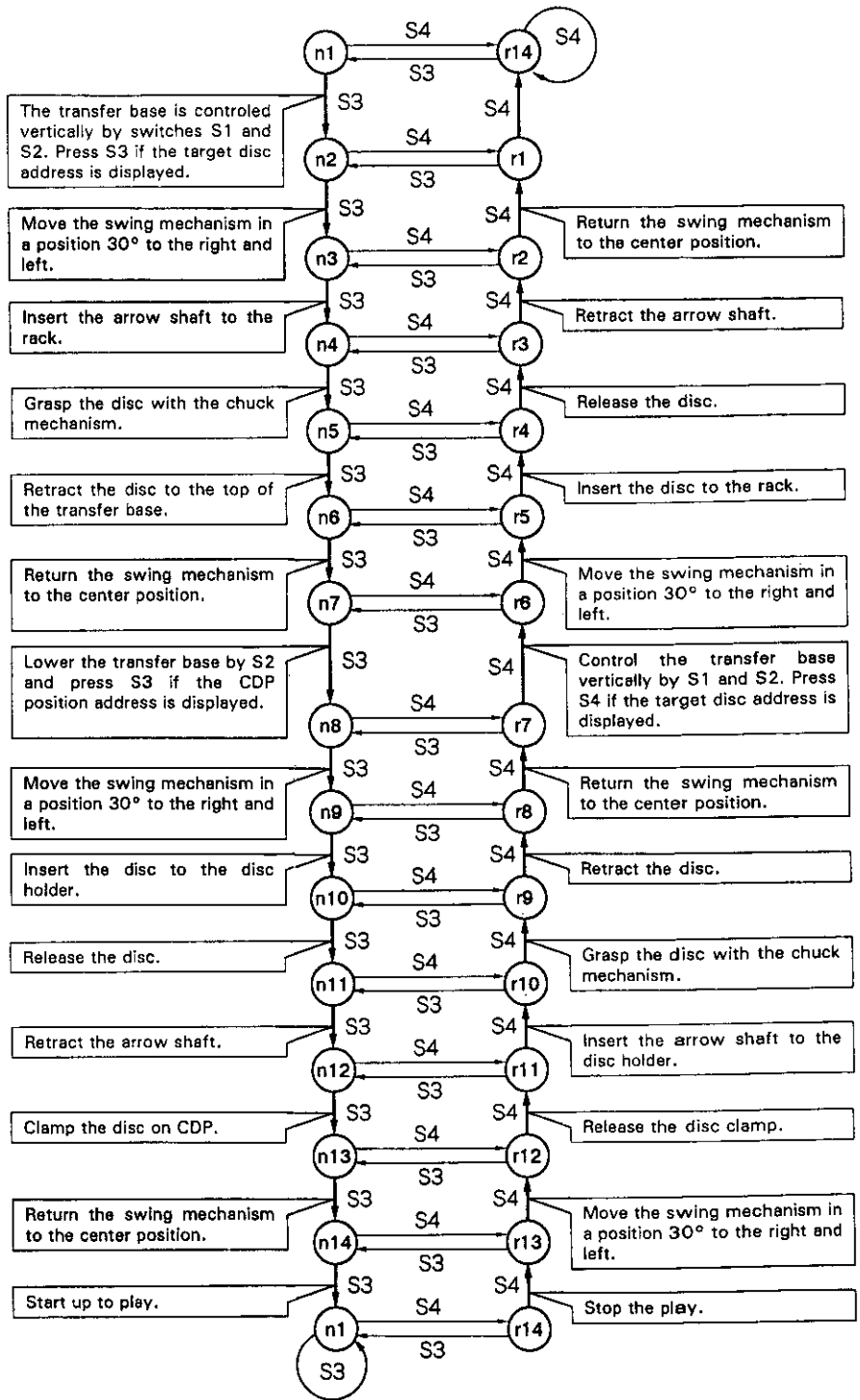

Fig. 4 The period lights.



Note : CDP is an abbreviation for CD player.

Table 9 Manual Mode Operation sequences

Operation	S1-ON	S2-ON	LED Displays
Vertical	Shift to upper direction.	Shift to lower direction.	The current address
Swing	Shift to right direction.	Shift to left direction.	Flash when the mechanism is not on the correct position.
Slide	Forward	Backward	
Chuck	Close	Open	
Clamp	* Clockwise turn	* Counterclockwise turn	

* Refer to Table 8.

Table 10-1 Tactile Switch Functions

Operation	S3-ON	S4-ON
Disc setup	After the step operation is completed, a value of one is added to the sequence number.	A value of one is subtracted from the sequence number and the operation condition is changed to [Disc Return].
Disc return	A value of one is added to the sequence number and the operation condition is changed to [Disc Setup].	After the step operation is completed, a value of one is subtracted from the sequence number.

Table 10-2 Tactile Switch Functions

Operation	Sequence	Operation Contents	Explanation
Disc setup	n 1	Vertical	The transfer base is controled vertically by switches S1 and S2. Press S3 if the target disc address is displayed. Move the swing mechanism in a position 30° to the right and left. Insert the arrow shaft. Grasp the disc with the chuck mechanism. Retract the disc to the top of the transfer base. Return the swing mechanism to the center position. Lower the transfer base by S2 and press S3 if the CDP position address is displayed. Move the swing mechanism in a position 30° to the right and left. Insert the disc to the disc holder. Release the disc. Retract the arrow shaft. Clamp the disc on CDP. Return the swing mechanism to the center position.
	n 2	Swing	
	n 3	Slide	
	n 4	Chuck	
	n 5	Slide	
	n 6	Swing	
	n 7	Vertical	
	n 8	Swing	
	n 9	Slide	
	n10	Chuck	
	n11	Slide	
	n12	Clamp	
	n13	Swing	
Disc return	r14	Vertical	Stop the play. Move the swing mechanism in a position 30° to the right and left. Release the disc clamp. Insert the arrow shaft to the disc holder. Grasp the disc with the chuck mechanism. Retract the disc. Return the swing mechanism to the center position. Control the transfer base vertically by S1 and S2. Press S4 if the target disc address is displayed. Move the swing mechanism in a position 30° to the right and left. Insert the disc to the rack. Release the disc. Retract the arrow shaft. Return the swing mechanism to the center position.
	r13	Swing	
	r12	Clamp	
	r11	Slide	
	r10	Chuck	
	r 9	Slide	
	r 8	Swing	
	r 7	Vertical	
	r 6	Swing	
	r 5	Slide	
	r 4	Chuck	
	r 3	Slide	
	r 2	Swing	

Table 11 Operation Sequence Chart

③ Error History Reference Mode

Up to eight error events can be recorded. The most recent event is recorded as number one. When the number of events exceeds eight, the oldest one is shifted out (deleted.)

1) Start-up Operation

While pressing switches S3 and S4, turn the power switch ON. The LED display flashes [E --] slowly.

2) Usage

Operations are performed according to the functions shown in Table 12.

Switch	Function	Contents
S1	One is added to the error history pointer.	The error history pointer (1 to 8) is displayed when the switch is pressed. The error number (Table 13) is displayed when the switch is released.
S2	One is subtracted from the error history pointer.	The error history pointer (1 to 8) is displayed when the switch is pressed. The error number (Table 13) is displayed when the switch is released.
S3	Call the detailed error data. (Invalid when detailed error data was not recorded.)	The vertical address where the error occurred is displayed while the switch is pressed. (The disc address is displayed if a CDP error occurs.) When the switch is released, the sequence number when the error occurred is displayed. (The CD player error message is displayed if a CDP error occurs.) * If switch S3 is pressed again, the error history pointer and the error number display returns.
S4	Clear the error history.	Press this switch more than four seconds, then the flash cycle speed increases and the entire error history is cleared.

Note : CDP is an abbreviation for CD player.

Table 12

Error No.	Error Name	Contents
E71	PLAYER STATUS ERROR ※ Only detected in screening mode.	The CDP does not enter the correct operation status. ● An error occurs when the anticipated operation status is not set even after waiting approximately five minutes.
E72	TOC READ ERROR ※ Only detected in screening mode.	The TOC data of the disc was not be able to read. ● The disc is abnormal or the CDP is malfunctioning.
E81	NO PLAYER AVAILABLE	There is no CDP available. ● Both CDPs are checked in the initial setting mode. If both represent E89, then it turns to E81.
E82	BUFFER OVERFLOW	The data from the CDP was not processed. ● The decoding process of the data from the CDP was not completed quickly enough. ● But receive buffer is auto maticaly cleared communicates and the set continues to work.
E83 E84	PLAYER ERROR PROTOCOL ERROR ※ Only detected in screening mode.	The disc cannot be played normally. The CDP communication is not operating normally. ● This error does not in the normal mode because the host computer communicates directly with the CDP. ● The error code from the CDP is recorded as the detailed error data. (Refer to Table 14.)
E85	BUFFER OVERFLOW	The data from the host was not processed. ● The decoding process of the data from the host was not completed in time or the length of the command line was too long. ● A value of E00 is returned to the host.

Error No.	Error Name	Contents
E86	NOT SAFE TO SWING	The condition for the swing operation is not ensured. <ul style="list-style-type: none"> ● An attempt was made to perform a swing operation in [n8], but the clamper was not open completely.
E87	NOT SAFE TO SLIDE	The condition for the slide operation is not ensured. <ul style="list-style-type: none"> ● An attempt was made to perform a slide operation in [n9] or [r11], but the clamper was not open completely. ● The swing operation is not performed correctly.
E88	VERSION MISMATCH	The CDP microprocessor program did not match the expected version. <ul style="list-style-type: none"> ● Load the correct version.
E89	NO RESPONSE	A transmission was performed for the CDP but an answer was not returned within 250 ms. <ul style="list-style-type: none"> ● The CDP unit is not installed. ● The communication line is not connected correctly. ● Control was performed by the incorrect communication mode.
E90	BACKUP DATA IS INCORRECT.	The contents of the backup memory are corrupted. <ul style="list-style-type: none"> ● Special bytes of memory are checked during the initial setting. If the contents have been changed, clear all backed up data. The error was recorded after this processing was completed. ● The super capacitor is faulty. ● The microprocessor was not inserted correctly. ● The player is not powered for a long period of time (more than a month).
E91	MECHANICAL TIMEOUT ※ The sequence number is recorded as detailed error data.	The operation was not completed even if the maximum permissive time was exceeded. <ul style="list-style-type: none"> ● The maximum permissive times for each mechanism are as follows. Vertical operation : 20.0 seconds Swing operation : 3.0 seconds Slide operation : 3.0 seconds Chuck operation : 1.5 seconds Clamp operation : 2.0 seconds ● Suspected causes Motor or Driver is faulty. Position sensors are faulty. Overload due to faulty operation position. ● If it occurs in [n3], it returns to [r1] and tries this step again. The value E91 remains in the error history. If an error occurs again, operation stops.
E92	THE DISC CANNOT CHUCK.	The disc was not be able to pick up. <ul style="list-style-type: none"> ● If it occurs in [n5], operation does not stop, because the disc may not enter the rack correctly. ● If it occurs in [r9], a retry operation is attempted up to a maximum of four times. If the operation fails five times consecutively, this is regarded as an error and operation stops. This is recorded as only one error.
E93	RETURN ADDRESS IS LOST.	The address of the disc on the transfer base is not known. <ul style="list-style-type: none"> ● The contents of memory are faulty. (An error code of E90 is recorded also.) ● The disc presence sensor is faulty.
E94	VERTICAL MOVING NG.	The vertical motor locks for more than 10 seconds. <ul style="list-style-type: none"> ● The mechanism sticks into the top or bottom end because the vertical address was not read correctly. ● The motor control circuit is faulty. ※ The address in the detailed error data was the address currently read by the microprocessor. Compare the actual address.

Error No.	Error Name	Contents
E95	SOFTWARE TROUBLE	It was determined that a dangerous condition occurred because the program malfunctioned. ● A stack overflow occurred when there were numerous errors.

※ When an error occurred in the screening mode, it does not reset in the initial setting mode even when the power is turned on again (error lock). In that case, enter to the error history mode, after removing or repairing the cause of the error. Press switch S4. The error number that is displayed is cleared.

Note : CDP is an abbreviation for CD player.

Table 13 Error Number Chart

Error No.	Error Name	Contents
00E	COMMUNICATION ERROR	Communication line error ● Framing error ● Buffer overflow
04E	FEATURE NOT AVAILABLE	Attempt was made to execute unavailable feature. ● Incorrect command mnemonic. ● Not available in this mode.
06E	MISSING ARGUMENT	Required parameter is not specified.
11E	DISC NOT EXIST	No disc is mounted.
12E	ADDRESS ERROR	Search address cannot be found.
13E	DEFOCUSING ERROR	Defocus occurred.
14E	SPINDLE UNLOCK	Spindle is unlocked.
96E	START-UP ERROR	Start-up operation cannot be performed.
99E	PLAYER PANIC	Unrecoverable error occurred in the player. ● Disc play cannot be continued. ● Player is not correctly connected.

Table 14 Player Error Messages

④ Player Address Setting Mode

When the unit is shipped from the factory, player address [1] is assigned to the left player and player address [2] is assigned to the right player. When a system is designed using two or more changers, the addresses of these players must differ. In this case, enter the player address setting mode and change the player addresses.

1. While pressing S1 and S3 simultaneously, turn the power switch ON. The left players address will be displayed in the following format. The address of the right player cannot be displayed. The address of the right player is set by adding one to the value of the left player.

1 This is the factory setting.
The setting can be changed to a maximum value of 98.

2. The numeric value can be changed by pressing switch S3 for the one's value and switch S2 for the 10's value. The brightness of the display decreases when the change operation starts.

13 Left player [13],
Right player [14]

3. If S4 (ENTER) is pressed, the player address that is displayed is recorded and the display brightness returns to the original level. When the number was 00 or 99, the brightness stays at the low level to indicate that the player address setting was not accepted.

⑤ Counter Read Mode

The number of mechanism operations is recorded in order to perform periodic maintenance of the mechanisms. The count corresponds to the number of times a disc was picked up from the disc rack. This is regarded as equivalent to the number of selections that were performed. Multiply the average performance time and calculate the player operation time. The operation time of both players cannot be calculated separately. The display is represented in the following formats.

The high-order unit are displayed.
--3 The unit represents the number of 1,000's and the maximum value is 999.

The lower-order units are displayed.
020 The unit represents the number of ones and the maximum value is 999.
 Three digits are always displayed.

1. If the power switch is turned ON while pressing switches S2 and S4 simultaneously, this mode is entered and the value of the high order digits is displayed.
2. If the buttons for S1 to S4 are pressed in any order, the low-order digits are displayed as long as the buttons are pressed. The high-order digits are displayed when the buttons are released.

⑥ Loop-back Test Mode

This mode is used to perform a hardware test of the communication interface. The RX and TX are looped at the external control terminal.

1. If the power switch is turned ON while pressing switches S2 and S3 simultaneously, this mode is entered and the following is displayed.

The left digit of the display represents the low-order four bits of the ASCII code that is transmitted.
0-- A value of 30H is transmitted in the initial condition.

2. The right digit displays the low order 4 bits of the ASCII code that is input to RX. As a result, [0 - 0] is displayed if a serial control terminal is connected to produce a loop-back using the special short-circuited connector.
3. A value of one is added to the left digit if S1 is pressed. When the switch is released, a value of one is added to the ASCII code and then it is transmitted. The transmission and reception can be checked by performing this procedure from values of [0 - 0], [1 - 1], [2 - 2] to [F - F]. Data that is transmitted can be in the range from 30H to 5FH. When the host is connected, the corresponding ASCII code is transmitted to it.

※ Short-circuited connection for the loop-back.

Short pins 2 and 3 in the RS-232C cable. Short pins 2 and 3, 7 and 8 in the RS422A cable.

Note :

Check the RS422A and RS232C separately. If both connection terminals are short-circuited simultaneously, the display will not be correct.

⑦ Software Version Reference Mode

The software version of the programmed system microprocessor can be verified in this mode.

1. If the power switch is turned ON while pressing switches S2 and S3 simultaneously, this mode is entered and the system microprocessor version is displayed as shown in the following format.

4.13

2. If small changes are performed, a separate revision number is assigned to that version. When there is a revision number, the version number is displayed only while any button is being pressed and the revision number appears when the button is released.

⑧ Screening Mode

There is a special service mode called the screening mode. The mechanism can be operated automatically for a long period of time in a previously determined sequence in this mode. And there are four different types of disc accessing depending on the DIP switch-patterns.

So it is very important that the initial disc installing before entering this mode matches the DIP switch-patterns as shown in the following table and explanation. Otherwise, it may cause the mechanical malfunctions. Be especially careful to use this mode.

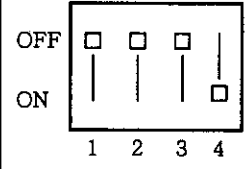
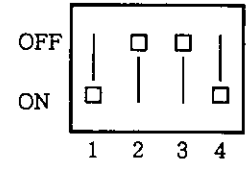
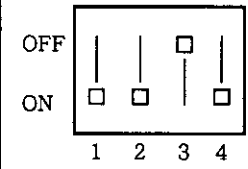
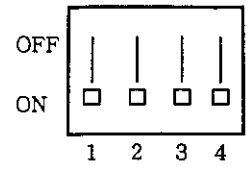
DIP Switch Bit Pattern (S5)				
The number of required CDs.	8	4	300	4
The addresses to install them	#1 to #4 and #151 to #154	#1, #2 and #151, #152	#1 to #300 (All racks)	#3, #148 and #153, #298
Other disc racks	must be clear.	must be clear.	——	may be OK as they are.
After each play, the disc is returned to	another rack.	another rack.	original rack.	original rack.

Note :

- During the screening operation, the number of screening operations is displayed on the LED. Numbers greater than 1,000 are indicated by the lighting patterns of the periods in the LED display as shown below.

[0 0 0.] : 1,000

[0 0. 0] : 2,000

- When the number of operations reaches 2048, it stops. The LED displays [End] when the performance is completed and the transfer base assembly stops at the shipping position. All errors are cleared at this time. The player address returns to the value that was set when the player was shipped from the factory.
- If an error occurs during screening, the LED alternately displays the error number, screening number and operation sequence when the error occurred.

12. FOR KUC TYPE

NOTES:

- Parts marked by "NSP" are generally unavailable because they are not in our Master Spare Parts List.
- The Δ mark found on some component parts indicates the importance of the safety factor of the part. Therefore, when replacing, be sure to use parts of identical designation.
- Parts marked by "●" are not always kept in stock. Their delivery time may be longer than usual or they may be unavailable.

CONTRAST OF MISCELLANEOUS PARTS

CAC - V3000/KUC and CAC - V3000/HEM have the same construction except for the following :

Mark	Symbol & Description	Part No.		Remarks
		CAC - V3000/HEM	CAC - V3000/KUC	
●	SYPS unit	DWR1134	DWR1141	
●	VCHS unit	DWS1169	
●	DGIF unit	DWX1282	DWX1307	* 1
●	MCDR unit	DWG1301	DWG1317	* 2
Δ	Power transformer (AH : 220-230, 240V)	DTT1074	
Δ	Power transformer (AK : 120V)	DTT1073	
Δ	Power transformer (CH : 220-230, 240V)	DTT1077	
Δ	Power transformer (CK : 120V)	DTT1076	
Δ	FU2, FU3 Fuse (T2AL250V)	REK - 103	
Δ	FU2, FU3 Fuse (3.15A/125V)	DEK1019	
Δ	FU4, FU9 Fuse (T800mAL250V)	REK - 099	
Δ	FU4, FU9 Fuse (1.25A/125V)	DEK1013	
Δ	FU5 Fuse (T5AL250V)	REK - 107	
Δ	FU5 Fuse (8A/125V)	DEK1025	
Δ	FU6 Fuse (T2.5AL250V)	REK - 104	
Δ	FU6 Fuse (4A/125V)	DEK1020	
Δ	FU7 Fuse (T1AL250V)	REK - 100	
Δ	FU7 Fuse (1.6A/125V)	DEK1015	
Δ	FU8 Fuse (T630mAL250V)	REK - 098	
Δ	FU8 Fuse (800mA/125V)	DEK1010	
Δ	FU10 Fuse (T2AL250V)	REK - 103	
Δ	FU10 Fuse (2.5A/125V)	DEK1017	
Δ	AC Power cord	ODG1003	DDG1057	
	AC Sub panel	DNC1244	DNC1243	
	Bolt	DBA1037	DBA1038	
	Packing case	DHG1386	DHG1387	
	Operating instructions (English)	DRB1093	
	Operating instructions (English, French, German, Italian, Spanish)	DRB1088	
	FUSE caution label	DRW1381	
	ICP caution label A	DRW1382	
	ICP caution label C	DRW1384	

* 1 : Although DGIF unit (DWX1307) and DGIF unit (DWX1282) are different in part number, they have the same service parts.
 * 2 : Although MCDR unit (DWG1317) and MCDR unit (DWG1301) are different in part number, they have the same service parts.

SYPS UNIT

SYPS unit (DWR1141) and SYPS unit (DWR1134) have the same construction except for the following :

Mark	Symbol & Description	Part No.		Remarks
		DWR1134	DWR1141	
Δ	C601-C603 (0.01)	VCG-048	RCG-009	

13. PANEL FACILITIES

FRONT VIEW

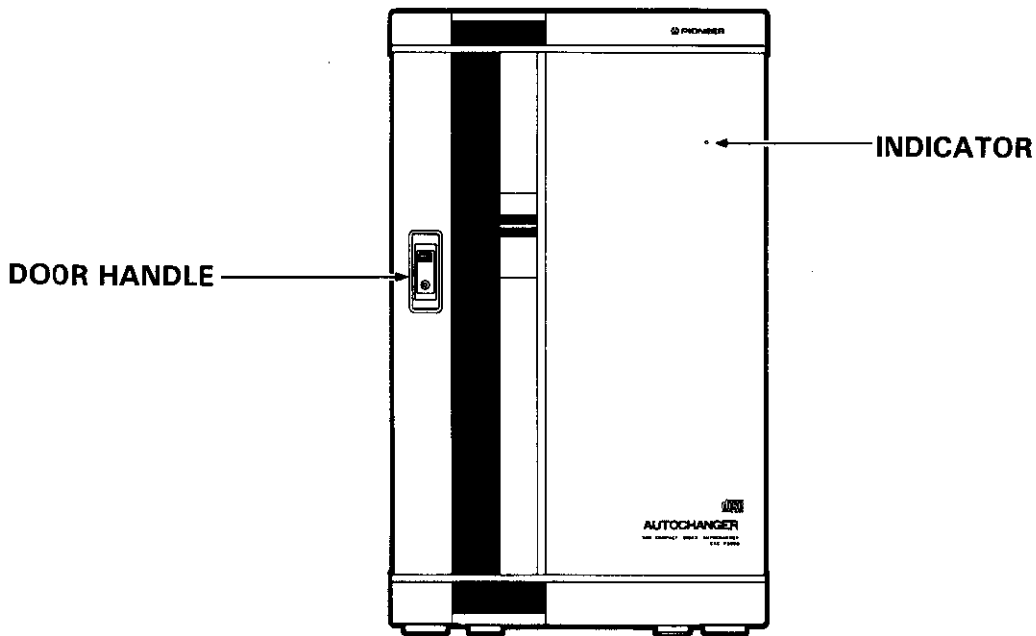

INSIDE VIEW

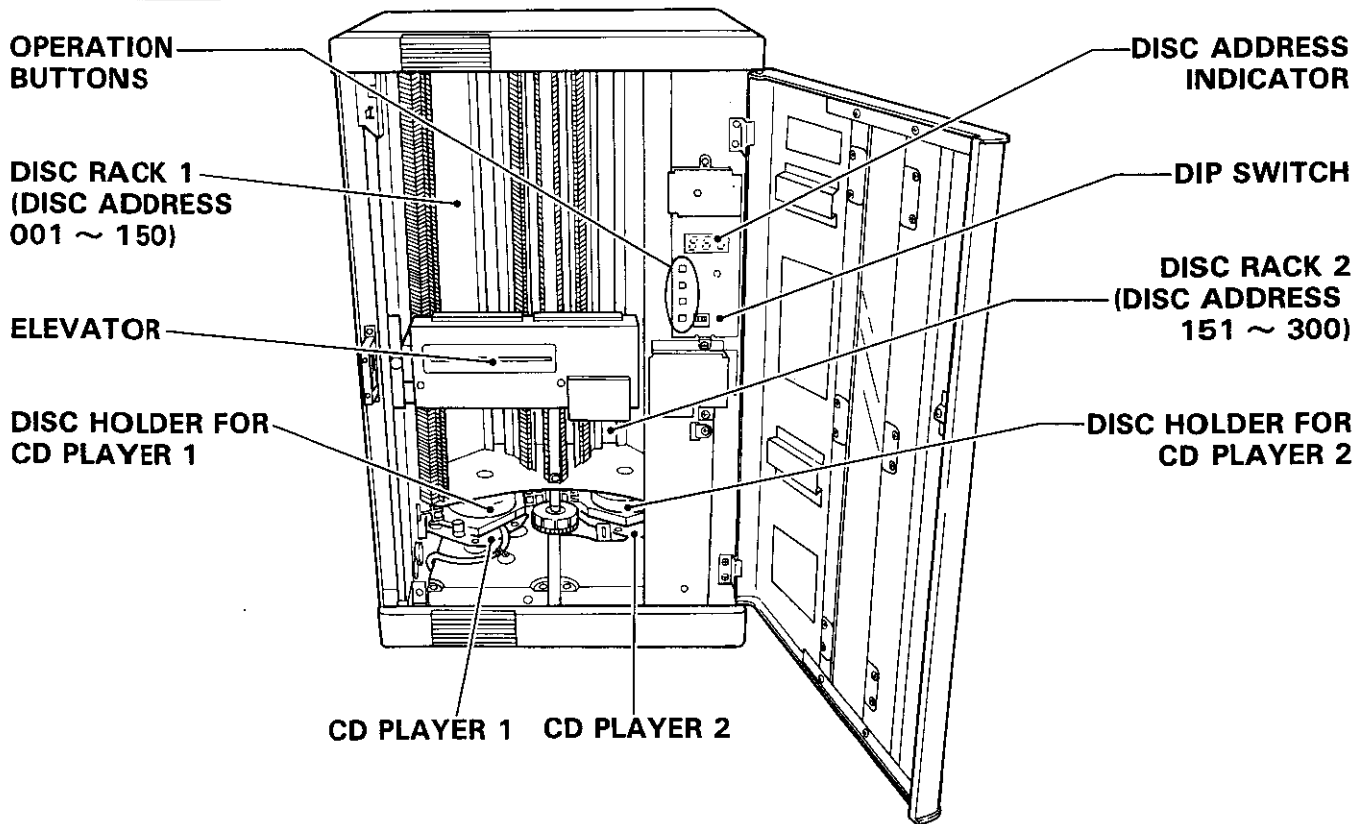

REAR VIEW

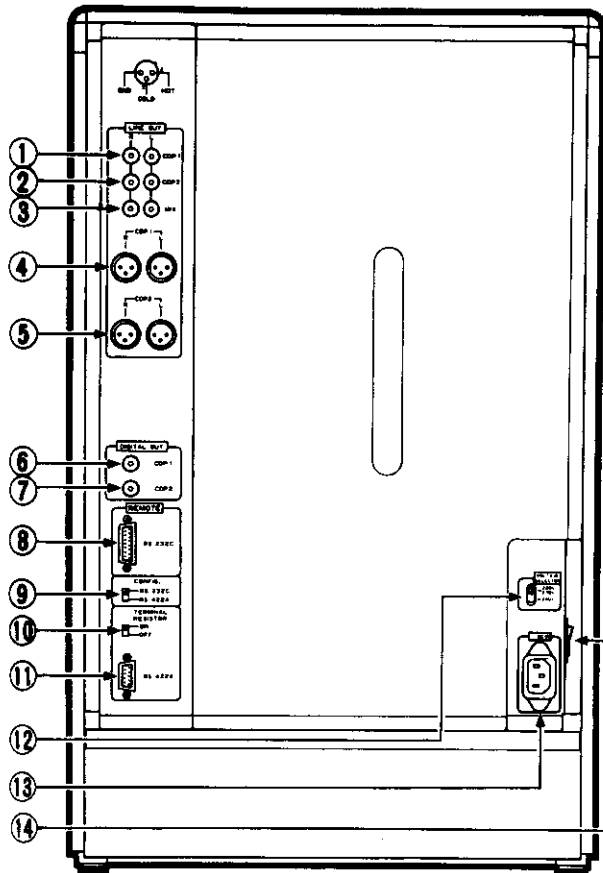

① **LINE OUT CDP1 jacks**
(RCA pin-jack, unbalanced)

Outputs analog audio signals from CD player 1

② **LINE OUT CDP2 jacks**
(RCA pin-jack, unbalanced)

Outputs analog audio signals from CD player 2

③ **LINE OUT MIX jacks**
(RCA pin-jack, unbalanced)

Outputs analog signals by mixing audio signals from CD players 1 and 2

④ **LINE OUT CDP1 jacks**
(XLR-3•32, balanced)

Outputs analog audio signals from CD player 1

⑤ **LINE OUT CDP2 jacks**
(XLR-3•32, balanced)

Outputs analog audio signals from CD player 2

⑥ **DIGITAL OUT CDP1 jack**
(RCA pin-jack, unbalanced)

Outputs digital audio signals from CD player 1

⑦ **DIGITAL OUT CDP2 jack**
(RCA pin-jack, unbalanced)

Outputs digital audio signals from CD player 2

⑧ **RS-232C connector**

RS-232C interface for connection to a computer or controller. See page 10 for more details.

⑨ **RS-232C/RS-422A switch**

Switches the interface from RS-232C to RS-422A and vice versa

⑩ **RS-422A TERMINAL RESISTOR switch**

Switches input impedance. Turn to ON when you use RS-422A interface.

⑪ **RS-422A connector**

RS-422A interface for connection to a computer or controller. See page 10 for more details.

⑫ **VOLTAGE SELECTOR switch**

Switches the voltage from 220-230 V to 240 V and vice versa

⑬ **~ AC inlet**

⑭ **Power switch**

14. SPECIFICATIONS

FOR HEM TYPE

General

System	CD auto changer
Power supply	AC 220 – 230/240 V, 50/60 Hz
Power consumption	64 W
Weight	28.5 kg
Dimensions	360 (W) x 360 (D) x 590 (H) mm
Allowable operating temperature range	+5 to +35°C
Allowable operating humidity range	5 to 90% (no condensation)
Storage temperature	-40 to +60°C

Discs

..... 12 cm CDs

Connection terminals

Players 1 and 2 unbalanced output	
Output level	2.2 ±0.5 Vrms
Output impedance	1 kΩ or lower
Signal-to-noise ratio	110 dB
Frequency response	20 Hz to 20 kHz ±0.5 dB
Distortion	0.007% at 1 kHz
Channel separation	103 dB
Remained noise	100 μVrms or less
Level difference between right and left	1.5 dB or less
Players 1 and 2 balanced output	
Output level	+4 $\pm_{-2.2}^{1.8}$ dBm
Players 1 and 2 mix unbalanced output	
Output level	2.2 ±0.5 Vrms
Output impedance	1 kΩ or lower

Function

Disc storage Max. 300 discs

Accessories

Audio cable (4 m)	2
Door key (for locking the front door)	2
Electrostatic charge removal sheet	1
Power cord	1
Operating Instructions	1

NOTE:

Specifications and design subject to possible modifications without notice, due to improvements.

FOR KUC TYPE

General

System	CD auto changer
Power supply	AC 120 V, 60 Hz
Power consumption	60 W
Weight	28.5 kg (62 lb 13oz)
Dimensions	360 (W) x 360 (D) x 590 (H) mm 14-3/16 (W) x 14-3/16 (D) x 23-1/4 (H) in
Allowable operating temperature range	+5 to +35°C (41 to 95°F)
Allowable operating humidity range	5 to 90% (no condensation)
Storage temperature	-40 to +60°C (-40 to 140°F)

Discs

..... CD (5-inch only)

Connection terminals

Players 1 and 2 unbalanced output	
Output level	2.2 ±0.5 Vrms
Output impedance	1 kΩ or lower
Signal-to-noise ratio	110 dB
Frequency response	20 Hz to 20 kHz ±0.5 dB
Distortion	0.007% at 1 kHz
Channel separation	103 dB
Remained noise	100 μVrms or less
Level difference between right and left	1.5 dB or less
Players 1 and 2 balanced output	
Output level	+4 $\pm_{-2.2}^{1.8}$ dBm
Players 1 and 2 mix unbalanced output	
Output level	2.2 ±0.5 Vrms
Output impedance	1 kΩ or lower

Function

Disc storage Max. 300 discs

Accessories

Audio cable (13 feet)	2
Door key (for locking the front door)	2
Electrostatic charge removal sheet	1
Power cord	1
Operating Instructions	1

NOTE:

Specifications and design subject to possible modifications without notice, due to improvements.

Maintenance:

In order to ensure the save and correct function of this unit, we recommend regular maintenance. Extended service life can be expected if maintained properly.