

Service Manual

PIONEER
The Art of Entertainment

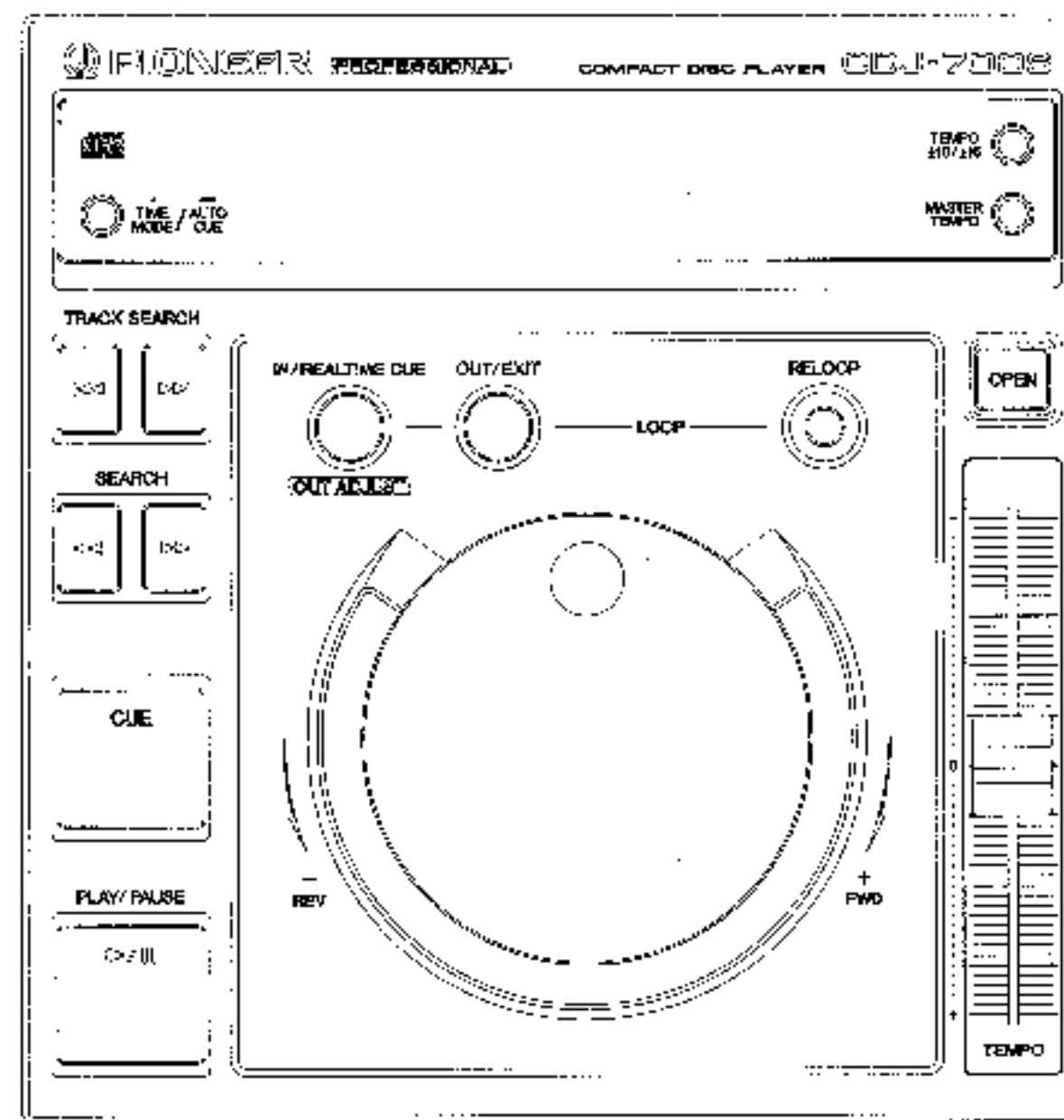

ORDER NO.
RRV1846

COMPACT DISC PLAYER

CDJ-700S

CDJ-500S

THIS MANUAL IS APPLICABLE TO THE FOLLOWING MODEL(S) AND TYPE(S).

Type	Model		Power Requirement	The voltage can be converted by the following method.
	CDJ - 700S	CDJ - 500S		
KUC	O	—	AC120V	—
HY	—	O	AC220 – 230V/240V	With the voltage selector
SL	—	O	AC110V/120V/220 – 230V/240V	With the voltage selector

CONTENTS

1. SAFETY INFORMATION	2
2. EXPLODED VIEWS AND PARTS LIST	4
3. SCHEMATIC DIAGRAM	12
4. PCB CONNECTION DIAGRAM	30
5. PCB PARTS LIST	40
6. ADJUSTMENT	43
7. GENERAL INFORMATION	50
7.1 PARTS	50
7.1.1 IC	50
7.1.2 DISPLAY	53
7.2 DIAGNOSIS	54
7.2.1 ERROR CODE DISPLAY	54
7.2.2 DISASSEMBLY	54
7.3 BLOCK DIAGRAM	56
8. PANEL FACILITIES AND SPECIFICATIONS	57

PIONEER ELECTRONIC CORPORATION

4-1, Meguro 1-Chome, Meguro-ku, Tokyo 153, Japan

PIONEER ELECTRONICS SERVICE, INC. P.O.Box 1760, Long Beach, CA 90801-1760, U.S.A.

PIONEER ELECTRONIC [EUROPE] N.V. Haven 1087, Keetberglaan 1, 9120 Melsele, Belgium

PIONEER ELECTRONICS ASIACENTRE PTE. LTD. 501 Orchard Road, #10-00 Lane Crawford Place, Singapore 0923

1. SAFETY INFORMATION

This service manual is intended for qualified service technicians; it is not meant for the casual do-it-yourselfer. Qualified technicians have the necessary test equipment and tools, and have been trained to properly and safely repair complex products such as those covered by this manual.

Improperly performed repairs can adversely affect the safety and reliability of the product and may void the warranty. If you are not qualified to perform the repair of this product properly and safely, you should not risk trying to do so and refer the repair to a qualified service technician.

WARNING

Lead in solder used in this product is listed by the California Health and Welfare agency as a known reproductive toxicant which may cause birth defects or other reproductive harm (California Health & Safety Code, Section 25249.5).

When servicing or handling circuit boards and other components which contain lead in solder, avoid unprotected skin contact with the solder. Also, when soldering do not inhale any smoke or fumes produced.

NOTICE

(FOR CANADIAN MODEL ONLY)

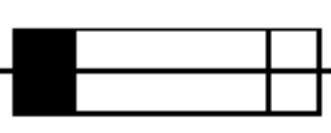
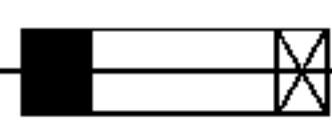
Fuse symbols  (fast operating fuse) and/or  (slow operating fuse) on PCB indicate that replacement parts must be of identical designation.

REMARQUE

(POUR MODÈLE CANADIEN SEULEMENT)

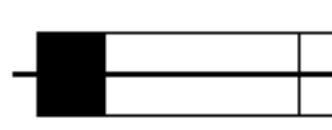
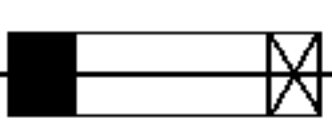
Les symboles de fusible  (fusible de type rapide) et/ou  (fusible de type lent) sur CCI indiquent que les pièces de remplacement doivent avoir la même désignation.

(FOR USA MODEL ONLY)

1. SAFETY PRECAUTIONS

The following check should be performed for the continued protection of the customer and service technician.

LEAKAGE CURRENT CHECK

Measure leakage current to a known earth ground (water pipe, conduit, etc.) by connecting a leakage current tester such as Simpson Model 229-2 or equivalent between the earth ground and all exposed metal parts of the appliance (input/output terminals, screwheads, metal overlays, control shaft, etc.). Plug the AC line cord of the appliance directly into a 120V AC 60 Hz outlet and turn the AC power switch on. Any current measured must not exceed 0.5 mA.

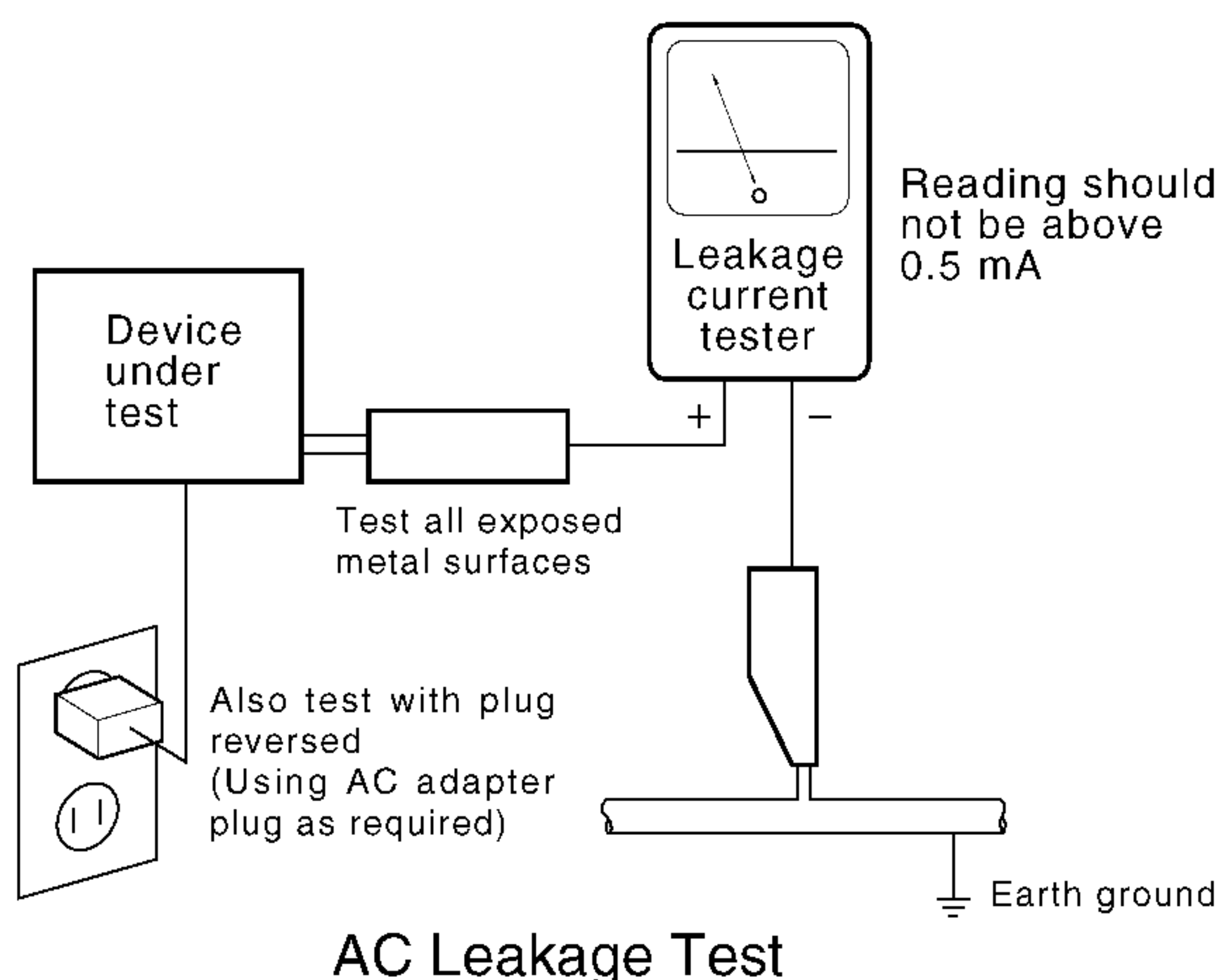

ANY MEASUREMENTS NOT WITHIN THE LIMITS OUTLINED ABOVE ARE INDICATIVE OF A POTENTIAL SHOCK HAZARD AND MUST BE CORRECTED BEFORE RETURNING THE APPLIANCE TO THE CUSTOMER.

2. PRODUCT SAFETY NOTICE

Many electrical and mechanical parts in the appliance have special safety related characteristics. These are often not evident from visual inspection nor the protection afforded by them necessarily can be obtained by using replacement components rated for voltage, wattage, etc. Replacement parts which have these special safety characteristics are identified in this Service Manual.

Electrical components having such features are identified by marking with a  on the schematics and on the parts list in this Service Manual.

The use of a substitute replacement component which does not have the same safety characteristics as the PIONEER recommended replacement one, shown in the parts list in this Service Manual, may create shock, fire, or other hazards.

Product Safety is continuously under review and new instructions are issued from time to time. For the latest information, always consult the current PIONEER Service Manual. A subscription to, or additional copies of, PIONEER Service Manual may be obtained at a nominal charge from PIONEER.

LABEL CHECK (for CDJ - 500S /HY and CDJ - 500S /SL)

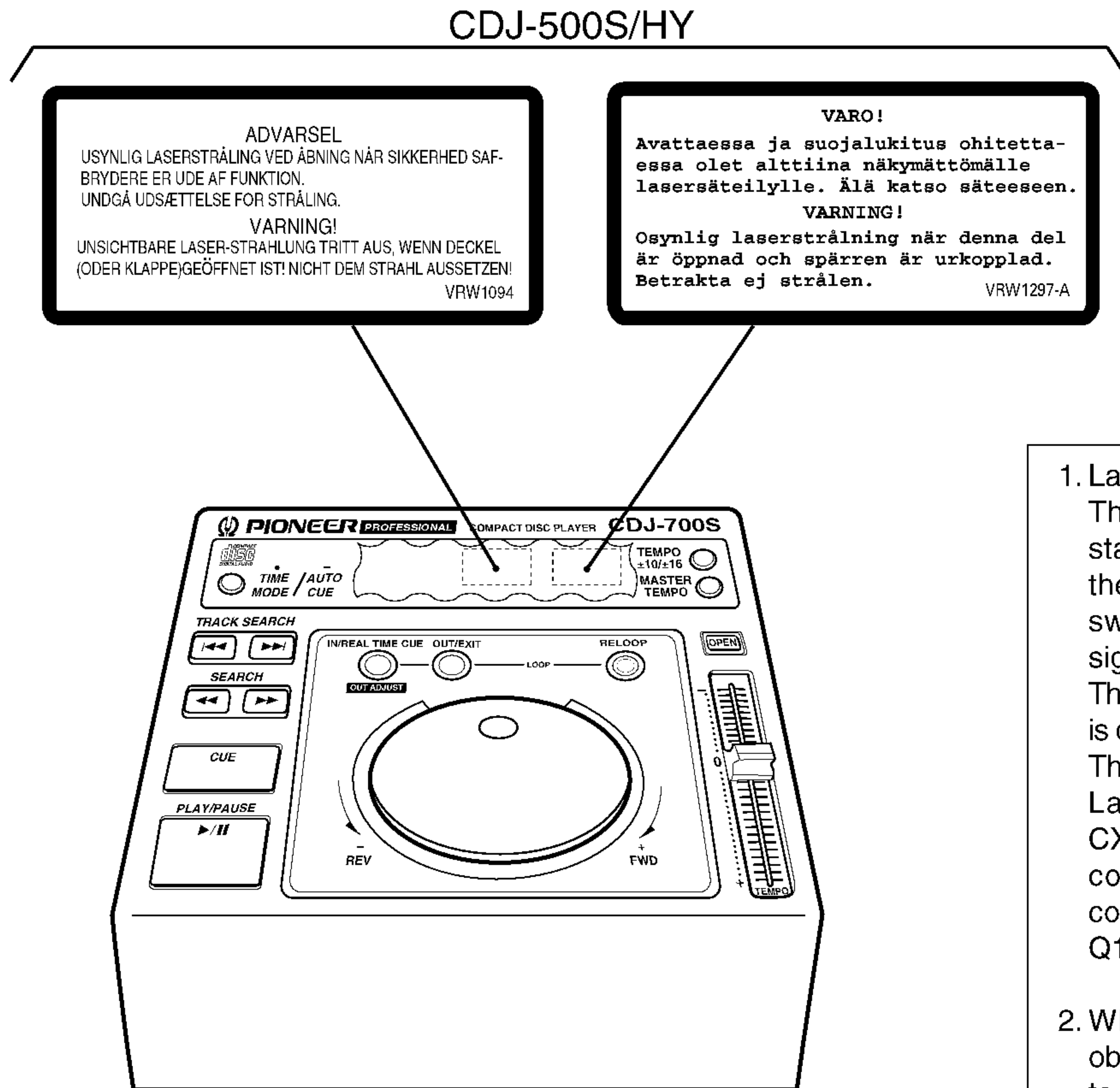

Additional Laser Caution

1. Laser Interlock Mechanism

The position of the switch (S651) for detecting loading state is detected by the system microprocessor, and the design prevents laser diode oscillation when the switch (S651) is not on $\overline{\text{CLMP}}$ terminal side ($\overline{\text{CLMP}}$ signal is OFF or high level).

Thus, the interlock will no longer function if the switch (S651) is deliberately set to $\overline{\text{CLMP}}$ terminal side. (low level)

The interlock also does not function in the test mode *. Laser diode oscillation will continue, if pin 33 of CXA1782CQ (IC101) on the MAIN BOARD ASSY is connected to GND, or pin 23 of IC701 (LDON) is connected to low level (ON), or else the terminals of Q101 are shorted to each other (fault condition).

2. When the cover is opened, close viewing of the objective lens with the naked eye will cause exposure to a Class 1 laser beam.

* : Refer to page 44.

CDJ-700S,CDJ-500S

2. EXPLODED VIEWS AND PARTS LIST

- NOTES:**
- Parts marked by "NSP" are generally unavailable because they are not in our Master Spare Parts List.
 - The Δ mark found on some component parts indicates the importance of the safety factor of the parts. Therefore, when replacing, be sure to use parts of identical designation.
 - Screws adjacent to \blacktriangledown mark on the product are used for disassembly.

2.1 PACKING

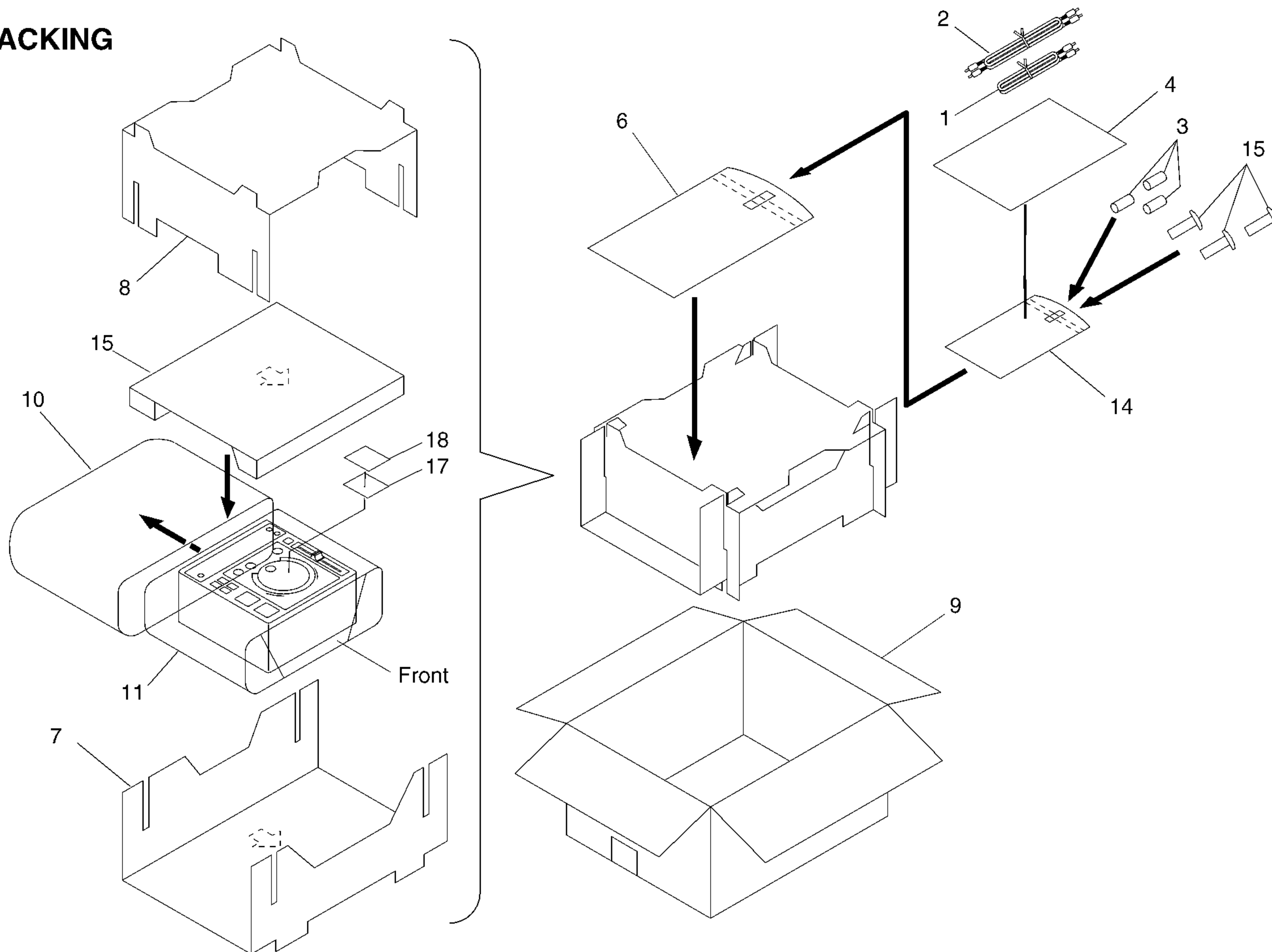

(1) PARTS LIST

Mark	No.	Description	Parts No.	Mark	No.	Description	Parts No.
	1	Control Cable	PDE1247		11	Seat (550×550×0.5)	Z23 - 026
	2	Audio Cable	VDE1033		12	
	3	Spacers for Rack Mounting	DLA1837		13	
	4	Operating Instructions	See Contrast table (2)	NSP	14	Polyethylene Bag (50×70×0.03)	Z21 - 002
	5			15	Screw for Rack Mounting	IBZ30P100FCC
	6	Polyethylene Bag (0.03×230×340)	Z21 - 038		16	Pad (C)	DHA1400
	7	Pad (A)	DHA1390		17	Silicagel	AEN7001
	8	Pad (B)	DHA1391		18	Caution SG	DRM1199
	9	Packing Case	See Contrast table (2)				
	10	Polyethylene Bag	DHL1106				

(2) CONTRAST TABLE

CDJ-500S/HY, SL and CDJ-700S/KUC are constructed the same except for the following:

Mark	No.	Symbol and Description	Part No.			Remarks
			CDJ-700S/KUC	CDJ-500S/HY	CDJ-500S/SL	
	4	Operating Instructions (English)	DRB1215	Not used	Not used	
	4	Operating Instructions (English/French/German/Italian/Dutch/Spanish)	Not used	DRB1214	Not used	
	4	Operating Instructions (English/Spanish/Chinese)	Not used	Not used	DRB1220	
	9	Packing Case	DHG1783	DHG1785	DHG1784	

CDJ-700S, CDJ-500S

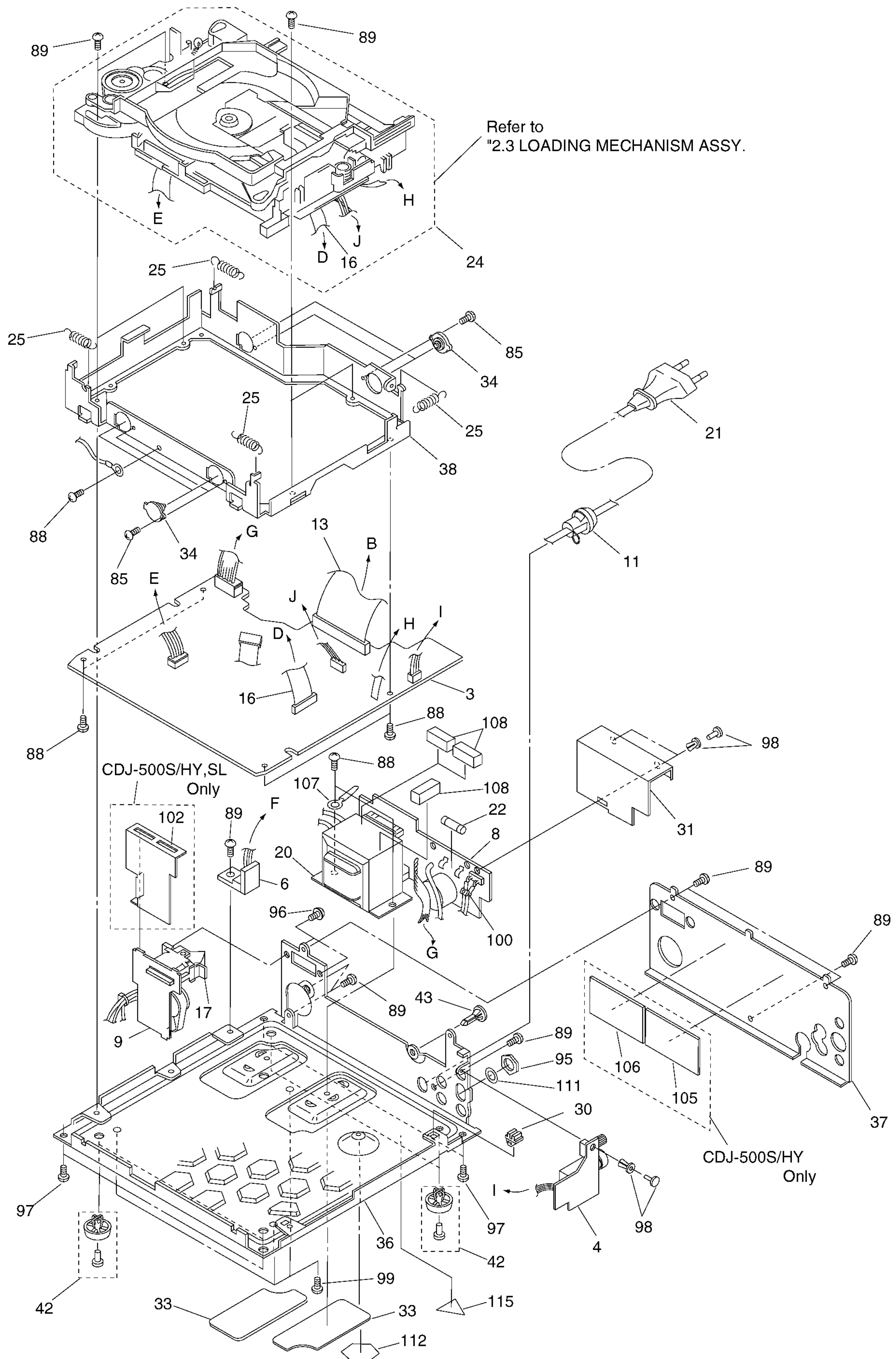

(1) EXTERIOR SECTION PARTS LIST

Mark	No.	Description	Parts No.	Mark	No.	Description	Parts No.
NSP	1	DOOR BOARD ASSY	DWS1289		56	Door Spring A	DBH1379
NSP	2	LED B BOARD ASSY	DWX1819		57	Door Spring B	DBH1396
	3	MAIN BOARD ASSY	DWX1821		58	J Spring	DBH1385
	4	H.P BOARD ASSY	DWX1822		59	Door Stopper A	DNF1576
NSP	5	LED A BOARD ASSY	DWX1824		60	Door Stopper B	DNF1577
NSP	6	REGULATOR BOARD ASSY	DWX1825		61	Door Shaft Holder A	DNK3431
	7	FUNCTION BOARD ASSY	DWG1497		62	Door Shaft Holder B	DNK3432
NSP	8	TRANS BOARD ASSY	See Contrast table (2)		63	Door Shaft Holder C	DNK3436
NSP	9	POWER SW BOARD ASSY	See Contrast table (2)		64	Clamper Cover	DNK3442
NSP	10	SLIDER BOARD ASSY	DWX1823		65	Roller Holder Assy	DXB1645
	11	Cord Stopper	See Contrast table (2)		66	Clamper Assy	DXB1655
	12	12P F.F.C/60V	DDD1118	NSP	67	Clamper Plate	DNE1289
	13	38P F.F.C/60V	DDD1119	NSP	68	Weight	DNH2300
NSP	14	Cord With Plug	DE005VF0	NSP	69	Clamper	DNK3439
	15	Connector Assembly	DKP3368		70	Lock Hook Spring	DBH1383
	16	S Flexible L	DNP1811		71	Lock Hook Plate	DNH2286
△	17	S1 Switch	DSA1024		72	Lock Hook Assy	DXB1647
	18	Push Switch	DSG1012		73	Damp Sheet	VEX1021
	19	Lever Switch	DSK1003		74	Loop Knob	DAC1878
△	20	Power Transformer	See Contrast table (2)		75	Reloop Knob	DAC1879
△	21	AC Power Cord	See Contrast table (2)		76	Knob A	DAC1880
△	22	FU1 Fuse	See Contrast table (2)		77	Knob B	DAC1881
NSP	23	UL1571, AWG28	ZWNP1571G-28-4-14A		78	Knob C	DAC1882
NSP	24	Loading Mechanism Assy	DXA1830		79	Display Plate	DAH1854
	25	Float Spring	DBH1382		80	Slide Sheet	DAH1855
	26	VR Spring	DBK1088		81	Slide Knob	DNK2936
	27	Earth Lead Unit	DDF1010		82	Jog Dial	DNK3438
	28	Earth Lead Unit	DDF1011		83	Control Panel	See Contrast table (2)
	29			84	65 Label	See Contrast table (2)
	30	Assy Table	DEC1231		85	Screw	AMZ20P040FMC
	31	AC Cover	DEC2131		86	Screw	AMZ30P040FMC
	32	Flexible Cover	DEC2133		87	Screw	BBZ26P060FMC
	33	Bottom Cover	DEC2134		88	Screw	BBZ30P060FMC
	34	Damper	DEC2136		89	Screw	BBZ30P080FZK
	35	Connector Cover	DEC2138		90	Screw	BMZ20P060FMC
NSP	36	Chassis	DNA1220		91	Screw	BPZ26P060FNI
NSP	37	Rear Panel	See Contrast table (2)		92	Screw	BPZ26P080FZK
	38	Mechanism Base	DNF1572		93	Screw	BPZ30P060FZK
	39	Damper Plate	DNF1574		94	Screw	BPZ30P080FMC
	40	VR Plate	DNF1575		95	Nut	NKX2FUC
	41	Gear Damper	DXB1648		96	Screw	PMH30P060FMC
	42	Foot	REC-434		97	Screw	PPZ30P080FZK
	43	Locking Card Spacer	VEC1596		98	Rivet	RBM-003
	44	Thrust Stay	DNH2288		99	Screw	BBZ30P040FCC
	45	Smoother	DNK2933		100	Binder	ZCA-SKB90BK
	46	Retainer	DNK3430		101	Slider Assy-s	DXX2396
	47	Ball	VNX1006		102	Switch Cover	See Contrast table (2)
	48	Guide Cushion	DEC2161		103	
	49	Air Seal A	See Contrast table (2)		104	
	50	Air Seal B	See Contrast table (2)		105	Caution Label (HE)	See Contrast table (2)
	51	Air Seal C	See Contrast table (2)		106	Caution Label	See Contrast table (2)
	52	Air Seal D	See Contrast table (2)	NSP	107	Binder	ZCB-4772B
	53	Door Arm	DNF1573		108	Stop Cushion B	DEC2199
	54	Door Cover	DNH2287		109	Knob Cushion	DEC2180
	55	Door	DNK3435		110	Stop Cushion A	DEC2184

CDJ-700S,CDJ-500S

Mark	No.	Description	Parts No.
	111	Washer	DBE1010
	112	Bottom Cover B	DEC2192
	113	TAPE (BLACK)	DEH1016
	114	Hook Stopper	DEB1376
	115	IBM Label	DRW1566

(2) EXTERIOR SECTION CONTRAST TABLE

CDJ-500S/HY, SL and CDJ-700S/KUC are constructed the same except for the following:

Mark	No.	Symbol and Description	Part No.			Remarks
			CDJ-700S/KUC	CDJ-500S/HY	CDJ-500S/SL	
NSP	8	TRANS BOARD ASSY	DWR1284	DWR1286	DWR1286	
NSP	9	POWER SW BOARD ASSY	DWS1290	DWS1287	DWS1286	
△	11	Cord Stopper	CM – 22C	CM – 22B	CM – 22B	
△	20	Power Transformer (AC120V)	DTT1144	Not used	Not used	
△	20	Power Transformer (AC220 – 230V/240V)	Not used	DTT1146	Not used	
△	20	Power Transformer (AC110V/120V/220 – 230V/240V)	Not used	Not used	DTT1143	
△	21	AC Power Cord	PDG1015	PDG1003	PDG1003	
△	22	FU1 Fuse (500mA)	VEK1009	Not used	Not used	
△	22	FU1 Fuse (T250mA)	Not used	AEK1048	AEK1048	
	37	Rear Panel	DNC1458	DNC1460	DNC1459	
	49	Air Seal A	DEC2197	Not used	Not used	
	49	Air Seal E	Not used	DEC2198	DEC2198	
	50	Air Seal B	DEC2193	Not used	Not used	
	50	Air Seal F	Not used	DEC2195	DEC2195	
	51	Air Seal C	DEC2194	Not used	Not used	
	51	Air Seal G	Not used	DEC2196	DEC2196	
	52	Air Seal D	DEC2175	Not used	Not used	
	52	Air Seal H	Not used	DEC2179	DEC2179	
	83	Control Panel	DNK3471	DNK3437	DNK3437	
	84	65 Label	ORW1069	Not used	Not used	
	102	Switch Cover	Not used	DEC2137	DEC2137	
	105	Caution Label (HE)	Not used	VRW1297	Not used	
	106	Caution Label	Not used	VRW1094	Not used	

2.3 LOADING MECHANISM ASSY

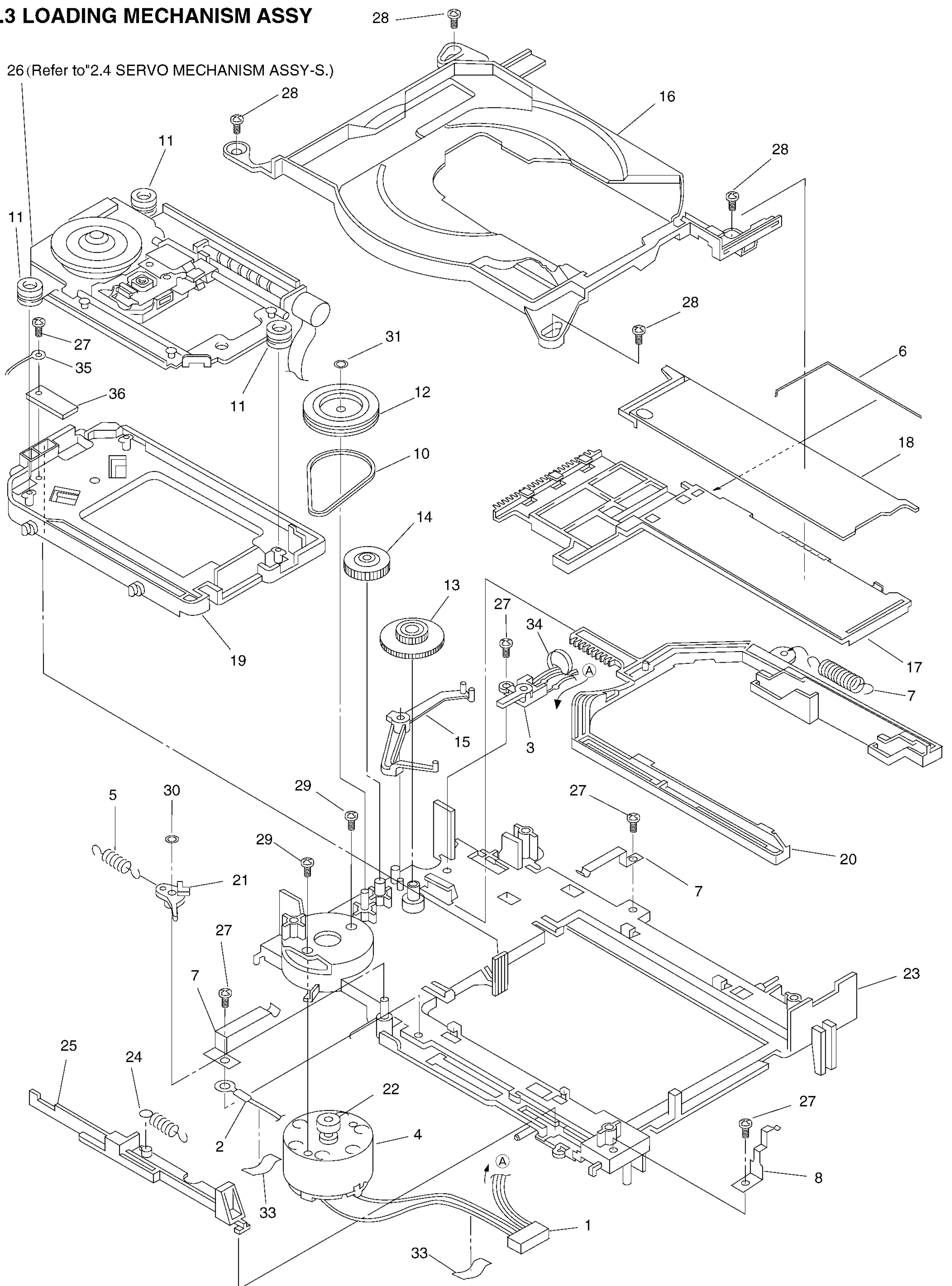

CDJ-700S,CDJ-500S

● LOADING MECHANISM ASSY SECTION PARTS LIST

Mark	No.	Description	Parts No.
NSP	1	Connector Assembly	DDE1111
	2	Cord With Plug	DDF1010
	3	Lever Switch	DSK1003
	4	DC Motor/0.75W	PXM1010
	5	Cancel Lever Spring	DBH1386
	6	Spring	DBH1388
	7	Mechanism Stopper Spring A	DBK1135
	8	Mechanism Stopper Spring B	DBK1136
	9	
	10	Belt	DEB1316
	11	Mount Bush	DEB1328
	12	Gear Pulley	DNK3099
	13	Drive Gear	DNK3100
	14	Loading Gear	DNK3101
	15	SW Lever	DNK3425
	16	Tray	DNK3426
	17	Shatter A	DNK3427
	18	Shatter B	DNK3428
	19	Servo Mechanism Base	DNK3429
	20	Drive Cam	DNK3433
	21	Cancel Lever	DNK3440
	22	Pulley	DNK3444
	23	Loading Base Assy	DXB1646
	24	Drive Lever Spring	DBH1384
	25	Hook Drive Lever	DNK3434
	26	Servo Mechanism Assy – S	DXX2409
	27	Screw	BPZ26P060FZK
	28	Screw	BPZ30P080FMC
	29	Screw	PMZ26P040FMC
	30	Washer	WT16D032D025
	31	Washer	WT21D050D050
	32	Screw	IBZ30P060FMC
	33	Tape	DEC1204
	34	Binder	ZCA – SKB90BK
	35	Earth Lead Unit	DDF1010
	36	Schlegel S	DEC2181
	37	Came Spring	DBH1395

2.4 SERVO MECHANISM ASSY-S

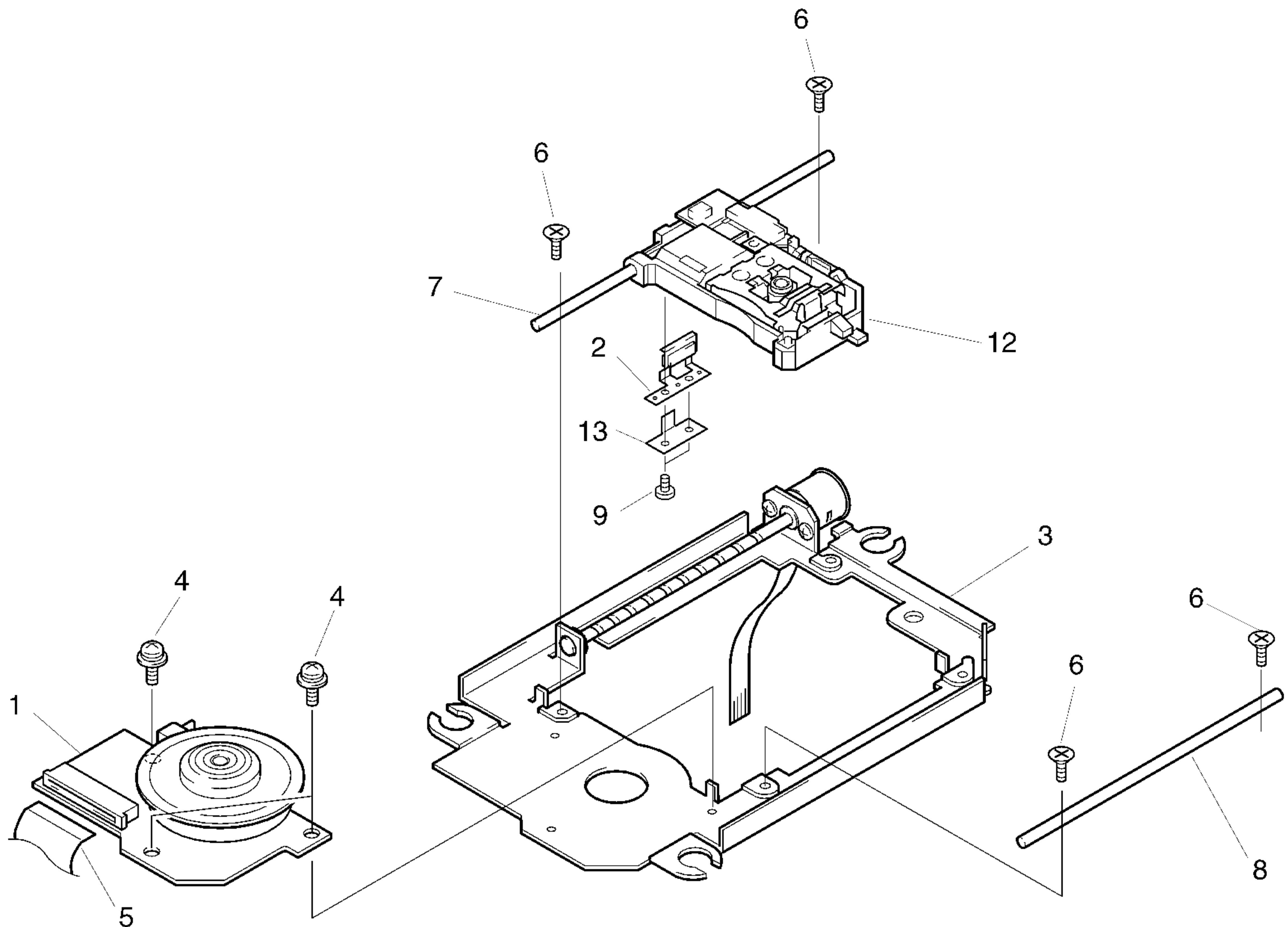

● PARTS LIST

Mark	No.	Description	Parts No.
	1	Spindle motor assy	DXM1084
	2	Screw guide	DNK3238
	3	Pulsemotor frame	DXM1085
	4	Screw	PMH20P040FMC
	5	SPD Card	DDX1165
	6	Screw	CMZ20P060FMC
	7	Guide shaft	DLA1731
	8	Sub guide shaft	DLA1372
	9	Screw	ABA7022
	10	
	11	
NSP	12	Pickup assy	DWY1067
	13	Guide spring	DBK1122

3. SCHEMATIC DIAGRAM

Note : When ordering service parts, be sure to refer to "EXPLODED VIEWS and PARTS LIST" or "PCB PARTS LIST"

3.1 OVERALL CONNECTION DIAGRAM

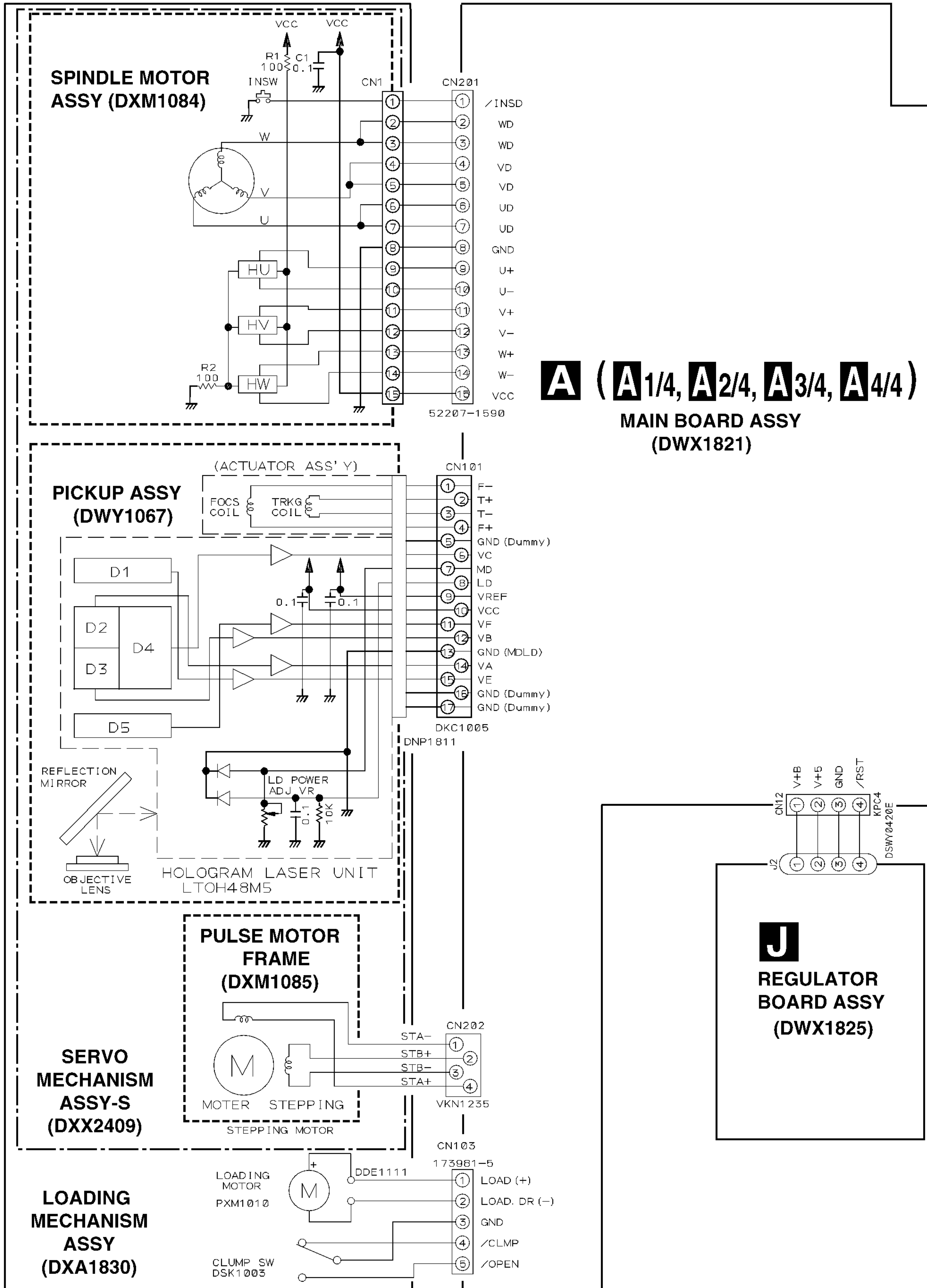

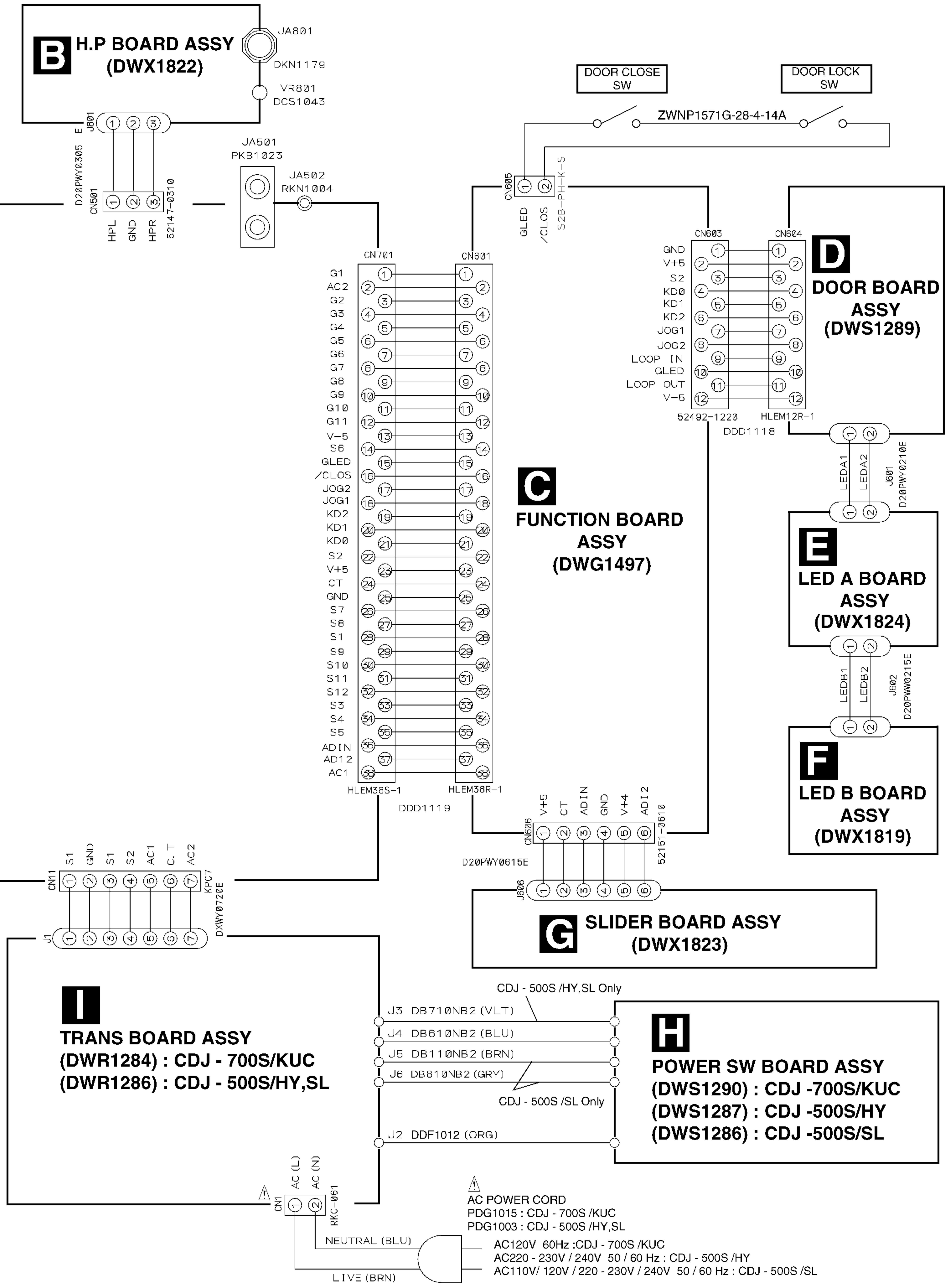

Note		CAPACITOR	
RESISTOR		No mark electrolytic:	CEAS (μ F)
No mark	: Carbon film resistor (Ω)	JA	: CEJA (F)
No mark	\square : 1/10W	No mark ceramic	: CKSQYF (μ F)
COIL		YB	: CKSQYB (μ F)
No mark	: LAU (H)	TL	: CFTLA (μ F)
LC	: LCTA (H)	CH	: CCSQCH (F)

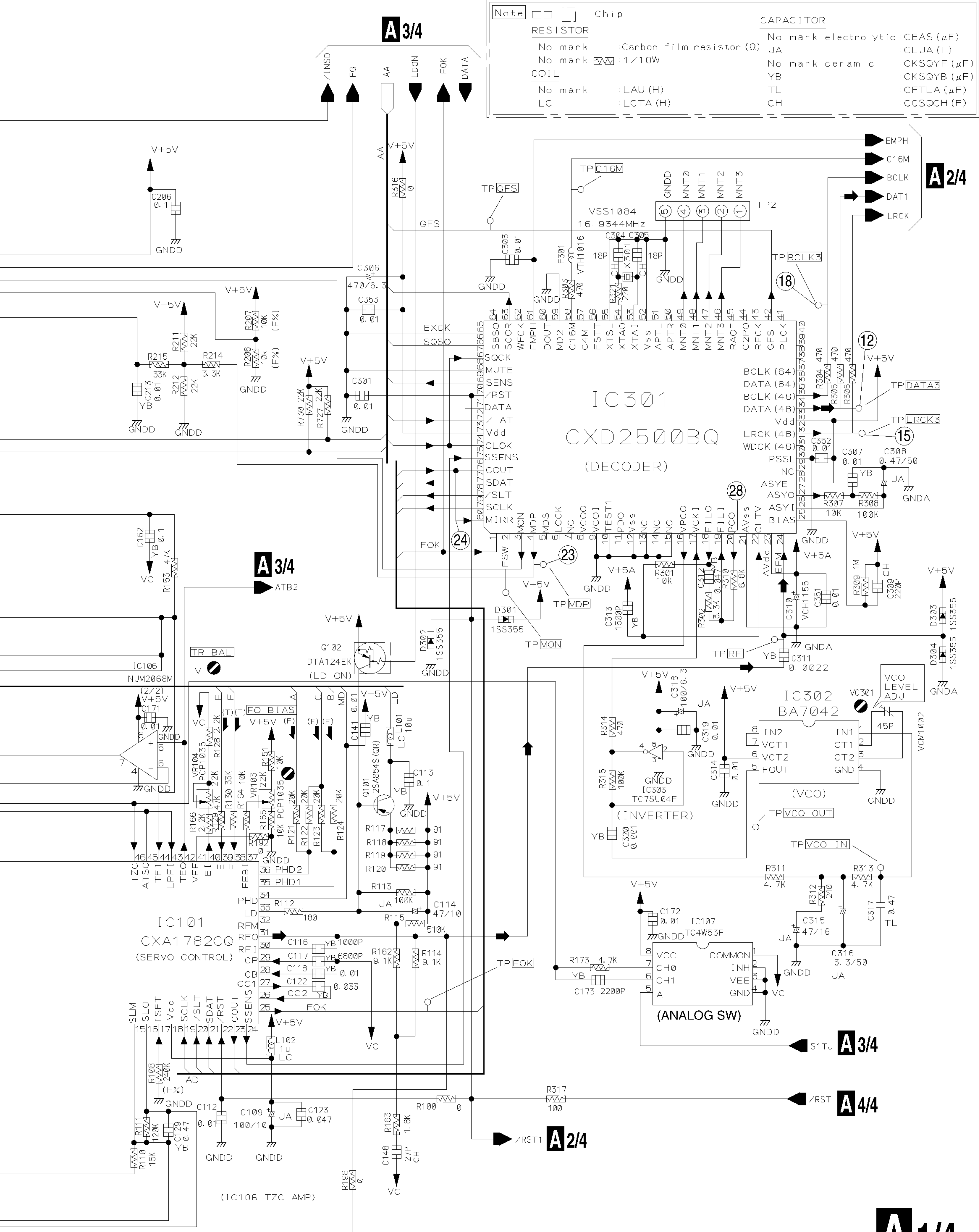

CDJ-700S, CDJ-500S

3.3 MAIN BOARD ASSY(2/4) AND H.P BOARD ASSY

A2/4 MAIN BOARD ASSY (DWX1821)

SIGNAL ROUTE
 ➔ : RF & AUDIO SIGNAL

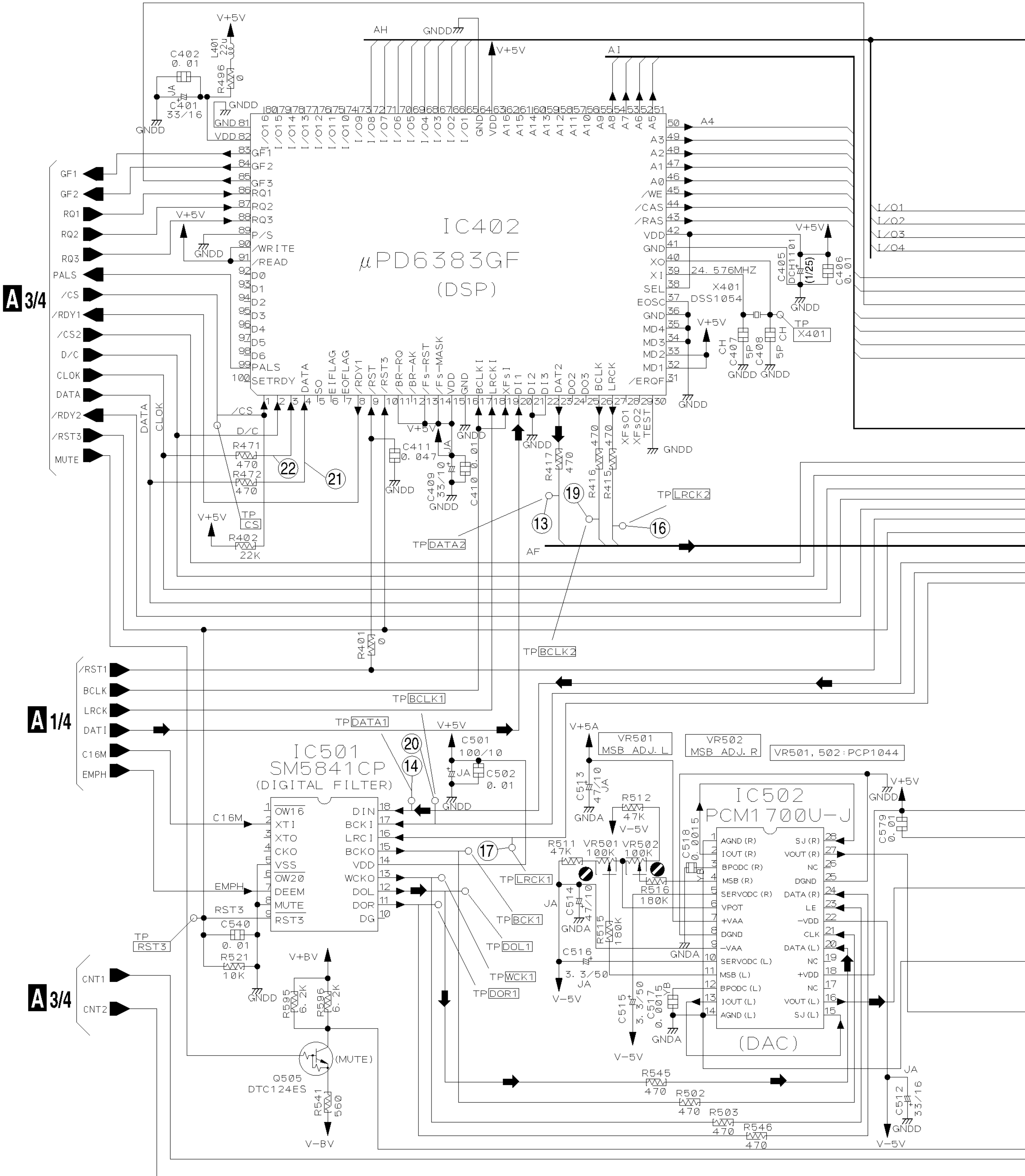

RESISTOR		CAPACITOR	
No mark	: Carbon film resistor (Ω)	No mark electrolytic	: CEAS (μ F)
No mark	\sim : 1/4W	JA	: CEJA (μ F)
VM	: RD1/4VM (Ω)	No mark ceramic	: CKSQYF (μ F)
COIL		YB	: CKSQYB (μ F)
No mark	: LAU (H)	CH	: CCSQCH (F)
		M	: CQMA (μ F)

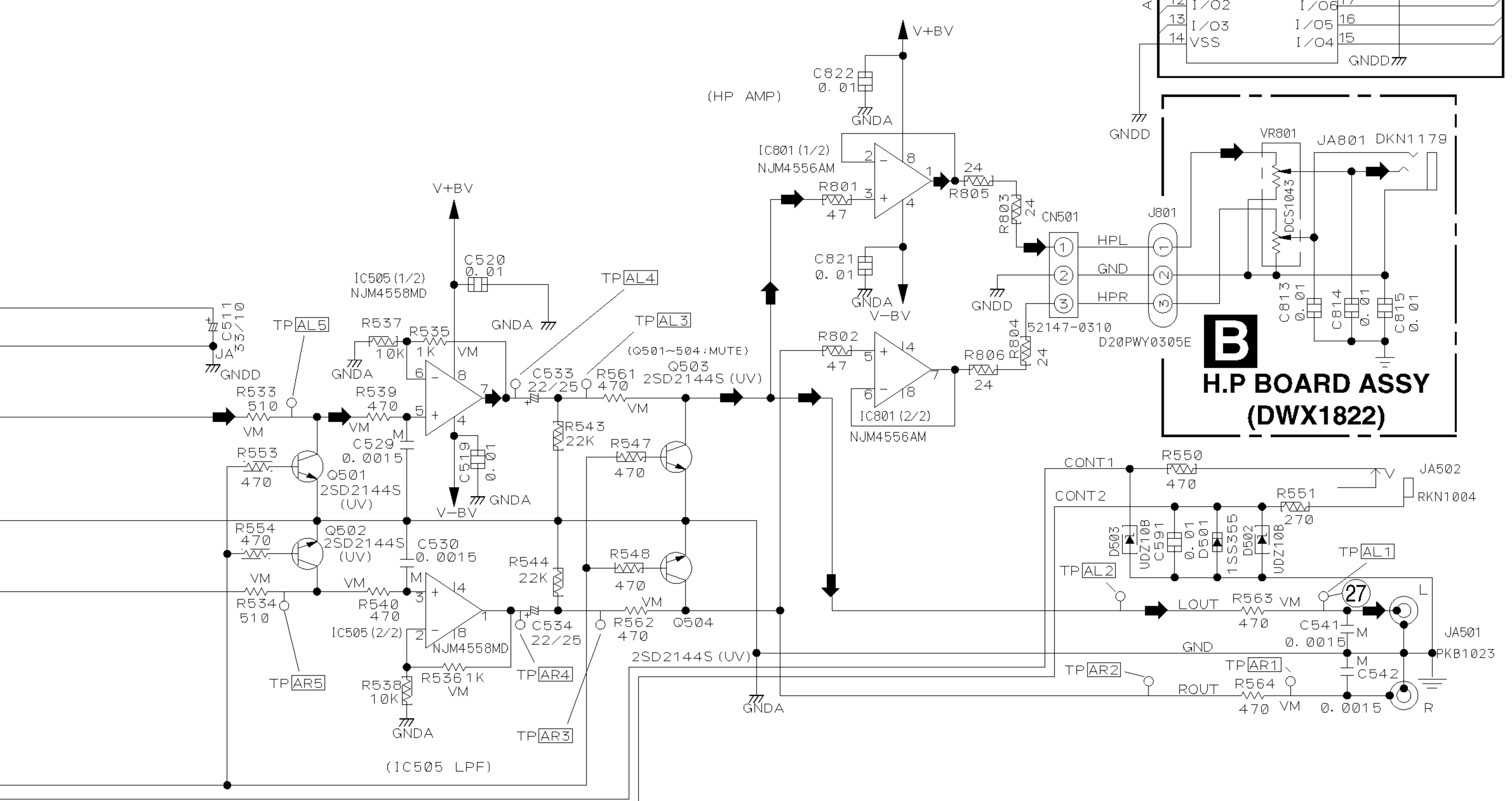
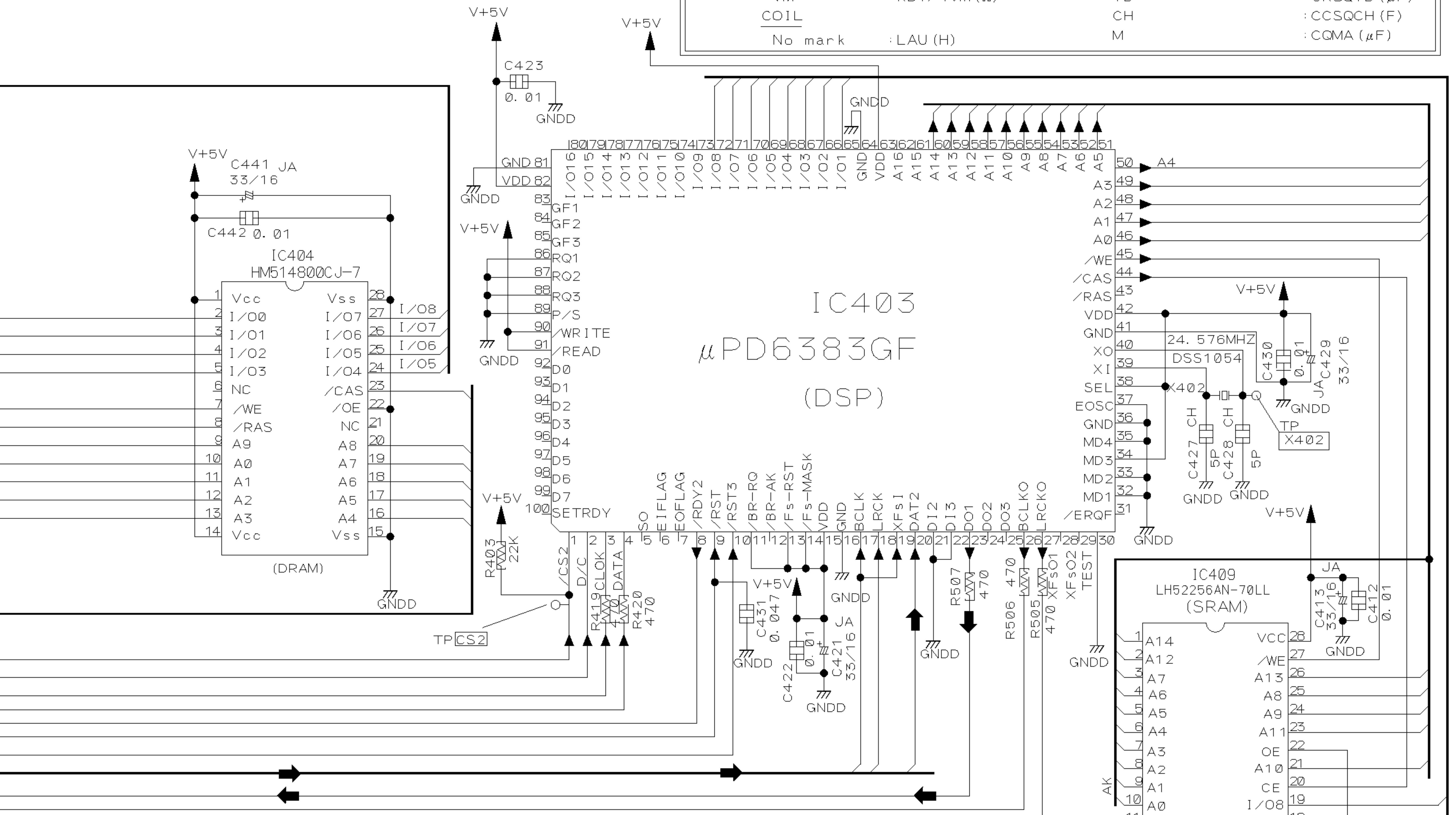

CDJ-700S, CDJ-500S

3.4 MAIN BOARD ASSY(3/4)

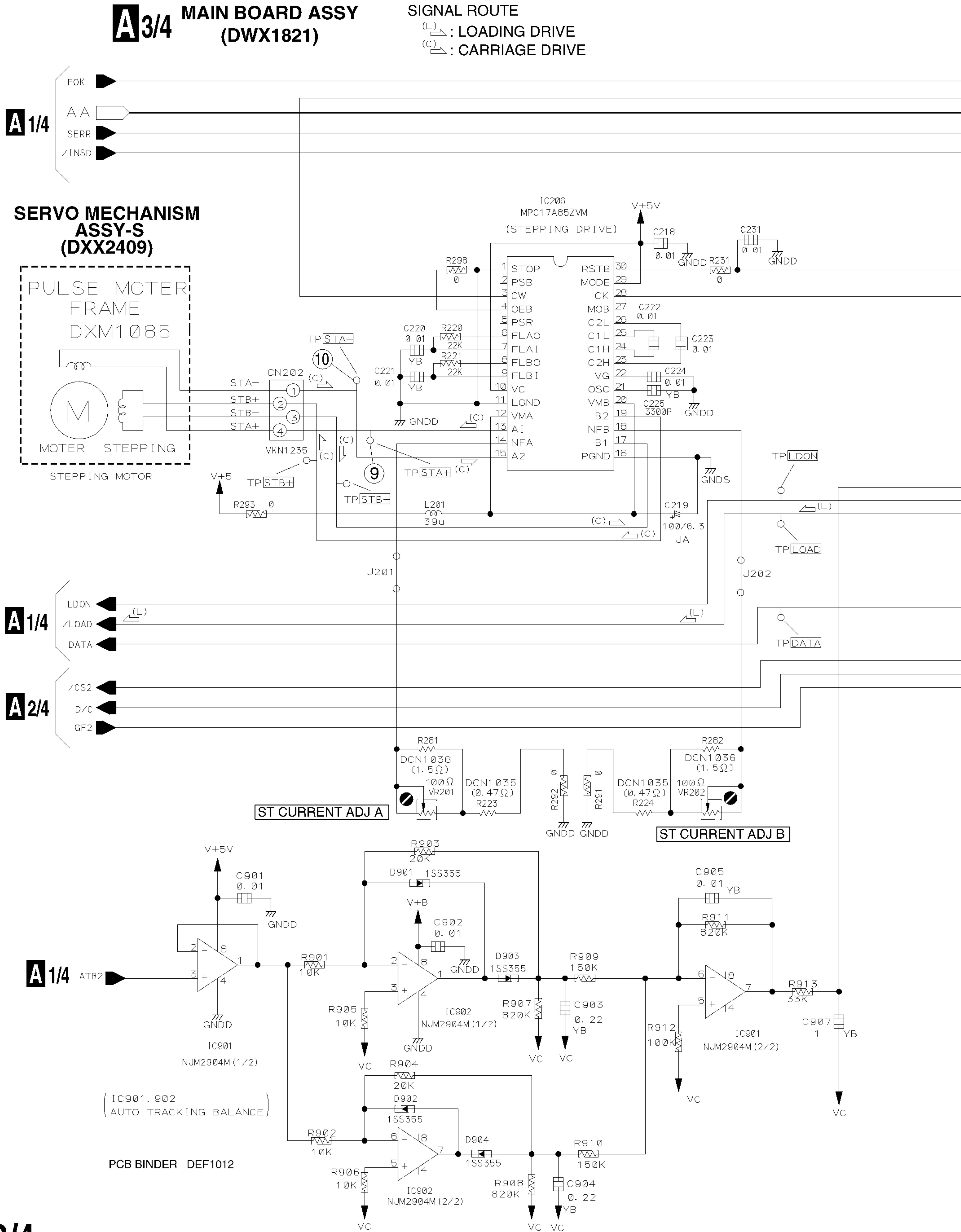

CDJ-700S, CDJ-500S

3.5 FUNCTION BOARD ASSY, DOOR BOARD ASSY, LED A BOARD ASSY, LED B BOARD ASSY AND SLIDER BOARD ASSY

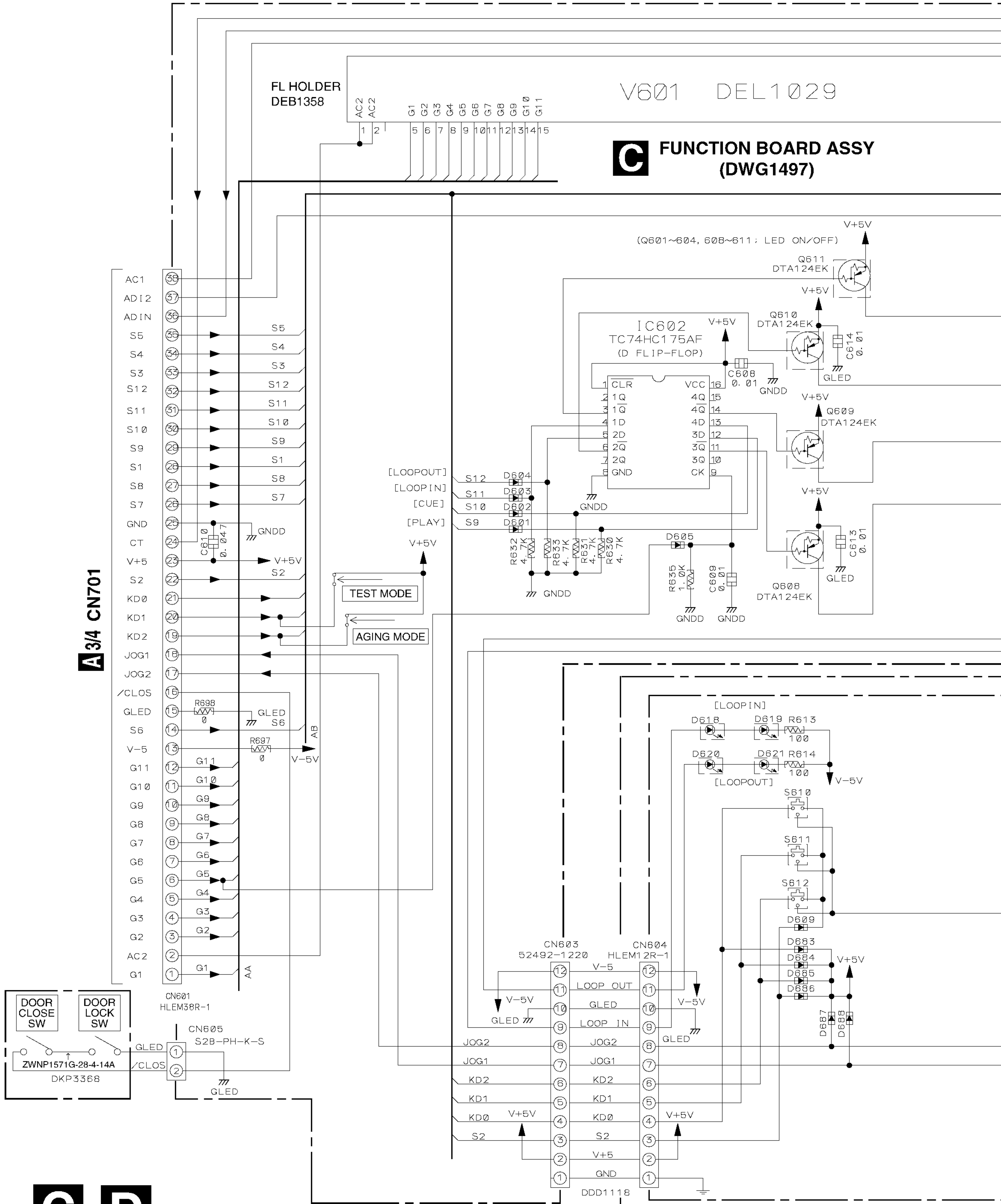

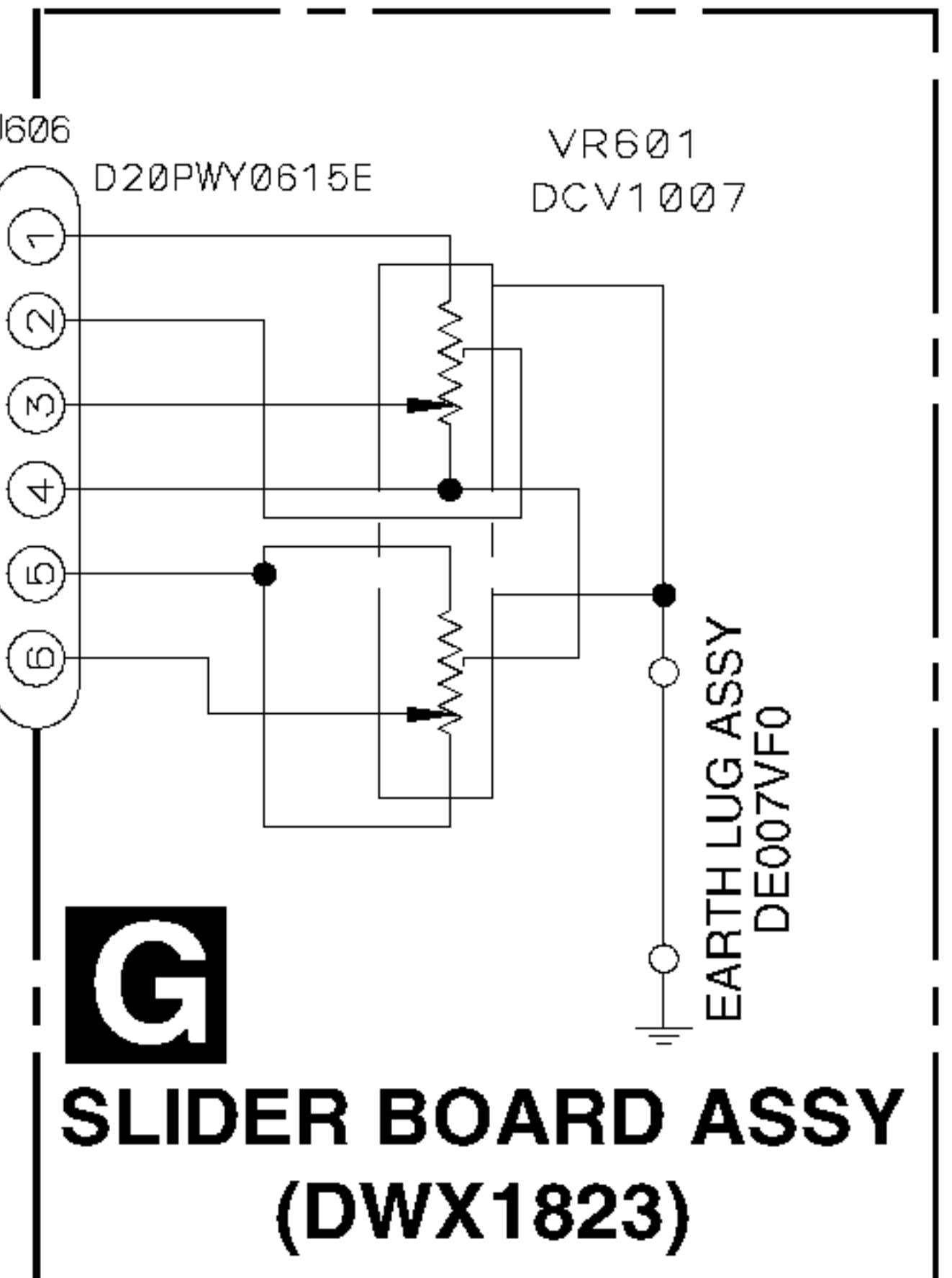
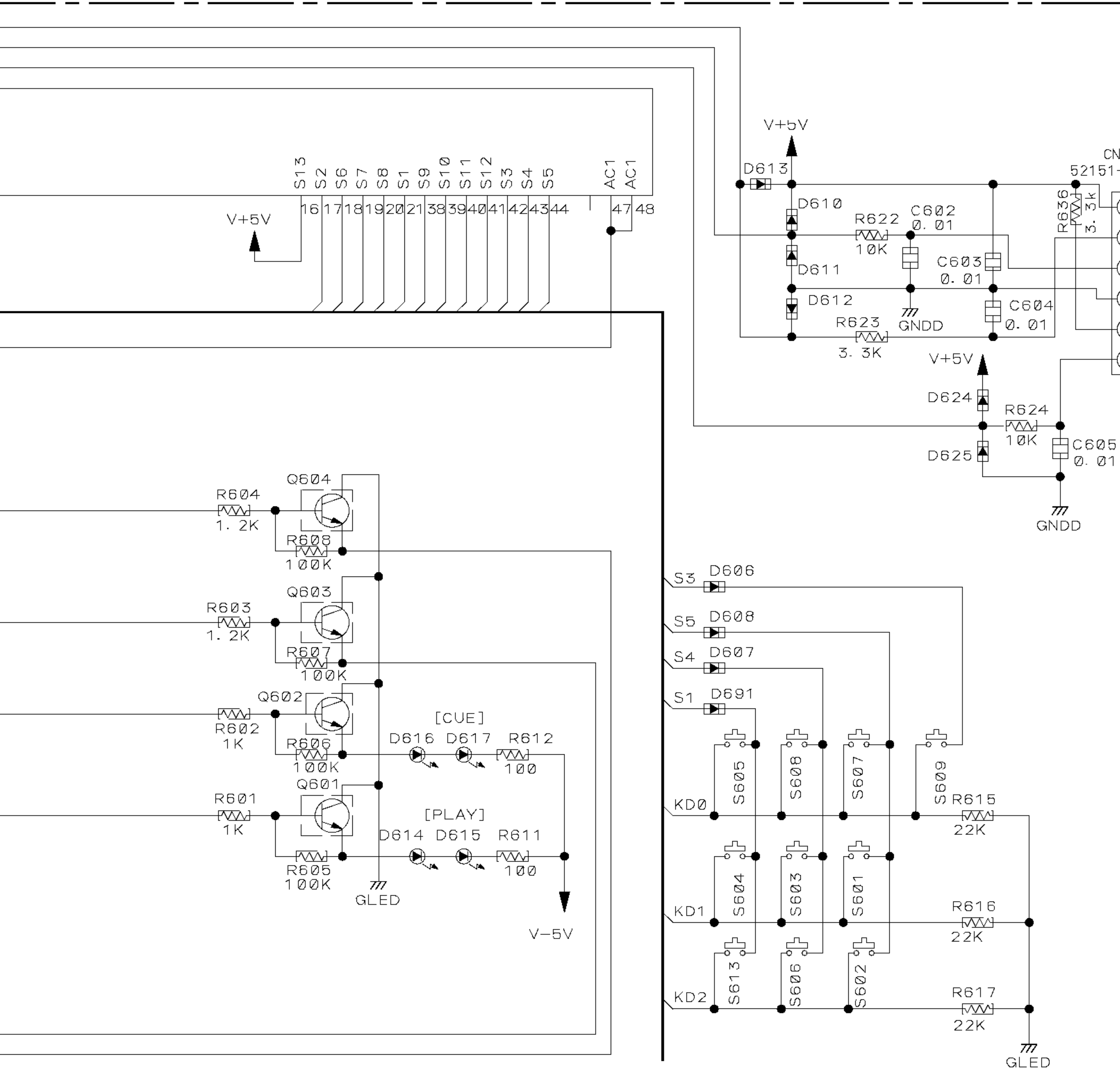

Note

SWITCH

S601	S602	
S604	S605	RSG1030
S603	S606	DSG1056
S607	S608	PSG1006
S609	S613	
S610	S612	DSG1061
S611		

DIODE

D614, D615	GL5EG8
D616, D617	GL5HY8
D618~D621	LT1H40A
D689, D690	MPY4361F
No Mark	1SS355

TRANSISTOR

Q501~Q604	2SC2412K (R/S)
Q608~Q611	DTA124EK

CAPACITOR No mark: μF

No mark	
ceramic	CKSQYF

RESISTOR Ω

No mark	Carbon film resistor
No mark	1/10W

COIL

No mark	LCTA (H)
---------	----------

FUNCTION BOARD ASSY

- S601 : TRKB
- S602 : SCNB
- S603 : PLAY
- S604 : TRKF
- S605 : SCNF
- S606 : CUE
- S607 : TEMPO
- S608 : MASTER T.
- S609 : EJECT
- S613 : TIME

DOOR BOARD ASSY

- S610 : LOOPIN
- S611 : LOOPOUT
- S612 : RELOOP

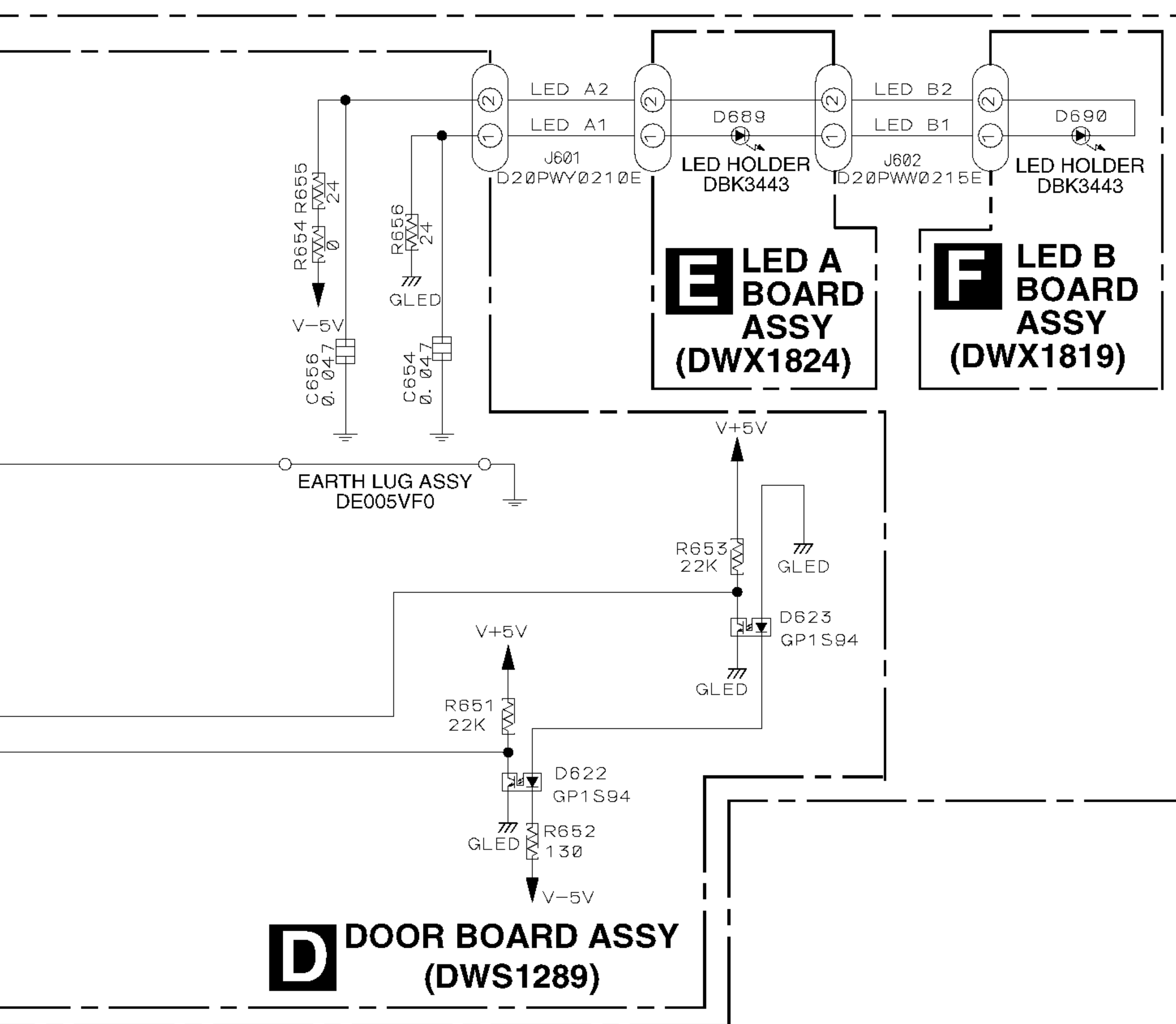

D DOOR BOARD ASSY (DWS1289)

CDJ-700S,CDJ-500S

3.6 MAIN BOARD ASSY(4/4), POWER SW BOARD ASSY, TRANS BOARD ASSY AND REGULATOR BOARD ASSY

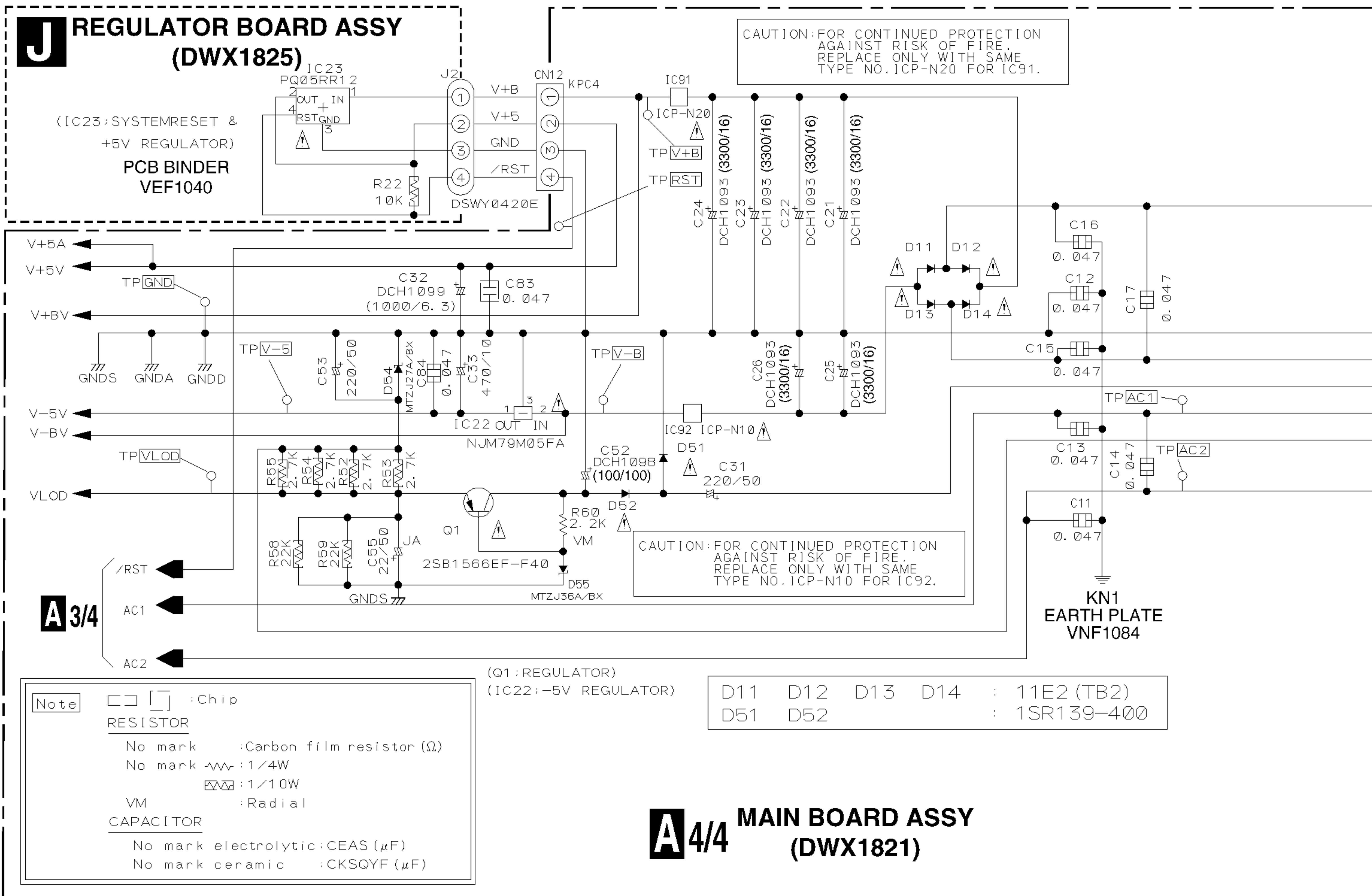
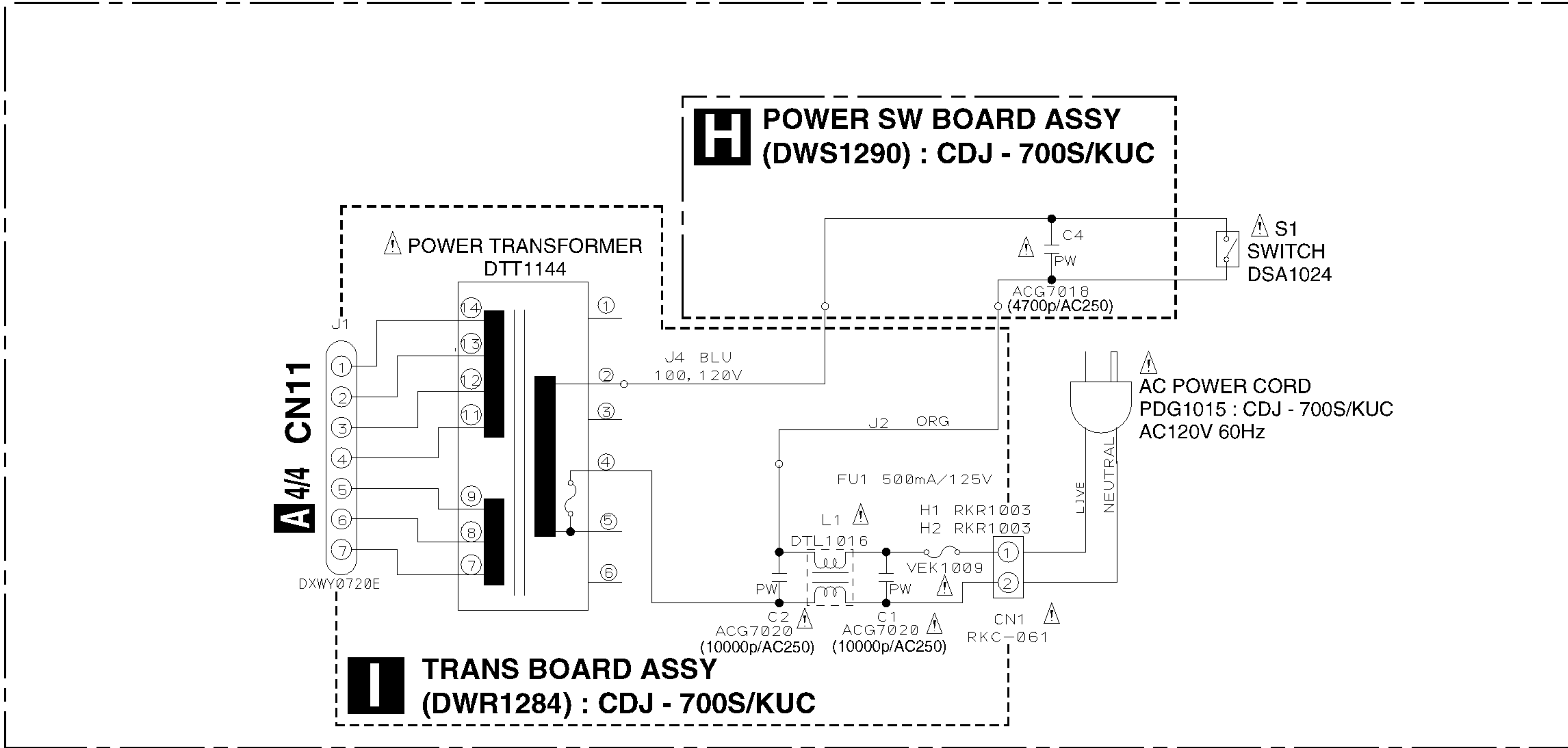

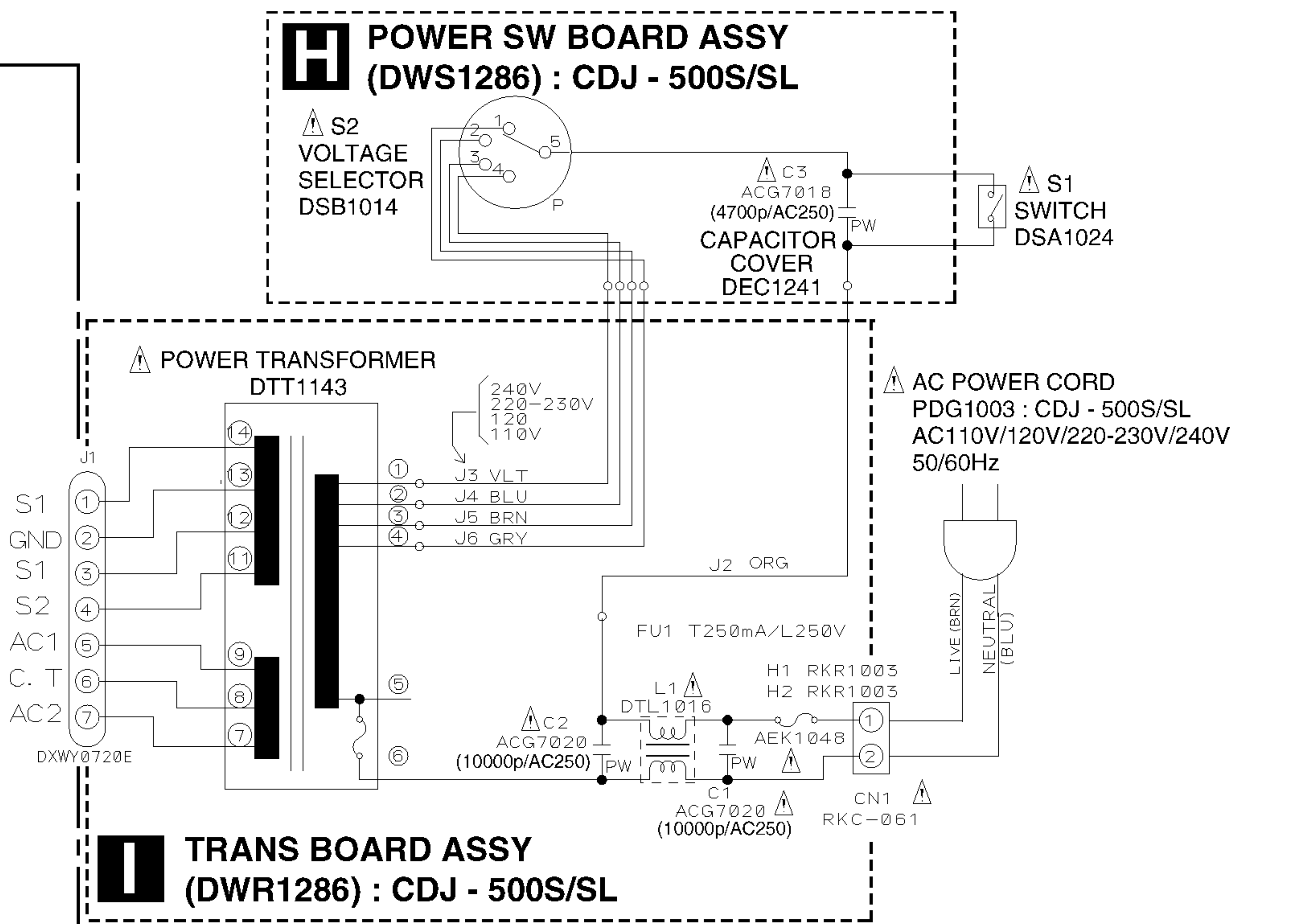
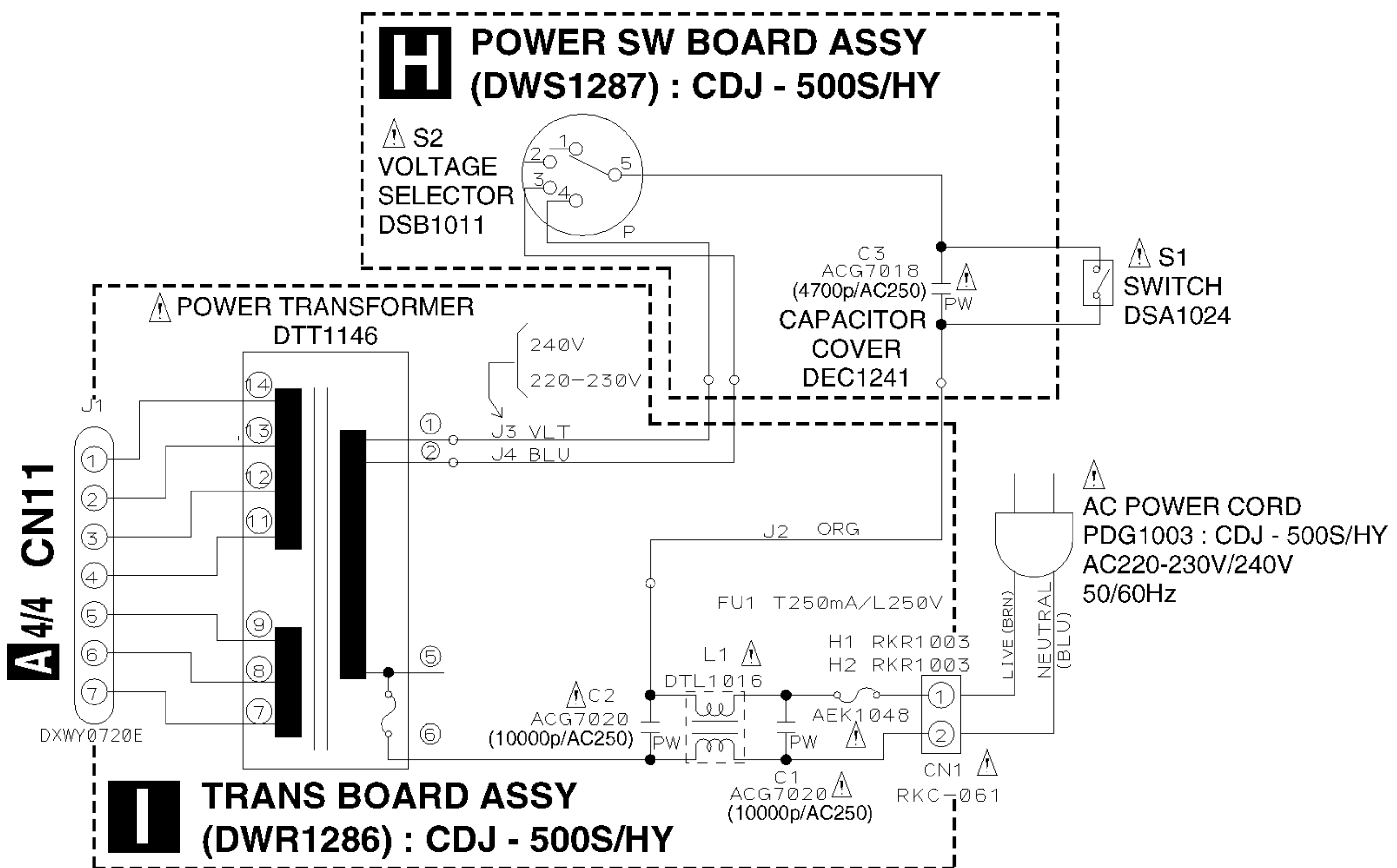

BOARD IN JUMPER

J2 ORG DDF1012	J5 BRN DB110NB2
J3 VLT DB710NB2	J6 GRY DB810NB2
J4 BLU DB610NB2	

● NOTE FOR FUSE REPLACEMENT

CAUTION — FOR CONTINUED PROTECTION AGAINST RISK OF FIRE, REPLACE ONLY WITH SAME TYPE AND RATINGS ONLY.

CDJ-700S,CDJ-500S

VOLTAGES (V) OF MAIN BOARD ASSY SECTION

Note : Voltages are in the PLAY mode.

IC101 (CXA1782CQ)

1	+2.4
2	+2.5
3	+2.4
4	+2.5
5	+2.4
6	+2.4
7	+2.5
8	+2.7
9	+2.4
10	+2.5
11	+0.8
12	+2.5
13	+2.5
14	+2.4
15	+2.5
16	+2.5
17	+1.2
18	+4.9
19	+4.8
20	+4.9
21	0
22	0
23	+0.1
24	+1.3
25	+4.9
26	+1.4
27	+1.5
28	+2.3
29	+2.0
30	+2.4
31	+3.1
32	+2.5
33	+3.0
34	0
35	+2.5
36	+2.5
37	+2.5
38	+2.5
39	+2.5
40	+2.2
41	0
42	+2.5
43	+2.5
44	+2.4
45	+2.5
46	0
47	+2.4
48	+2.5

IC102 (LA6520)

1	+1.9
2	+1.9
3	0
4	+0.1
5	+1.6
6	+1.6
7	+1.6
8	+1.6
9	0
10	0
11	0
12	+7.2
13	-8.2
14	-8.2

IC103 (NJM2068M)

1	+2.5
2	+2.5
3	+2.5
4	0
5	+2.5
6	+2.5
7	+2.5
8	+4.9

IC104 (NJM2904M)

1	+2.5
2	+2.5
3	+2.5
4	0
5	+2.5
6	+2.5
7	+2.5
8	+4.9

IC105 (TC4W66F)

1	+2.6
2	+2.5
3	0
4	0
5	+2.5
6	+2.5
7	0
8	+4.9

IC106 (NJM2068M)

1	+2.4
2	+2.4
3	+2.4
4	0
5	+2.5
6	+2.5
7	+2.5
8	+4.9

IC107 (TC4W53F)

1	+2.5
2	0
3	0
4	0
5	0
6	0
7	0
8	+4.9

IC201 (BA6849FP)

1	0
2	+5.9
3	0
4	+5.9
5	0
6	0
7	+5.9
8	0
9	+2.5
10	+2.5
11	+2.4
12	+2.5
13	+2.5
14	+2.5
15	+0.5
16	0
17	+0.6
18	0
19	0
20	0
21	+2.6
22	+2.5
23	+4.9
24	+2.4
25	+4.9
26	+7.2
27	+7.2
28	+7.2
29	0
30	0

IC206 (MPC17A85ZVM)

1	0
2	+4.5
3	+4.9
4	0
5	+1.5
6	+0.5
7	+0.5
8	+0.1
9	+0.4
10	+4.9
11	0
12	+4.7
13	+0.6
14	0
15	+1.1
16	0
17	+3.1
18	+0.1
19	+0.5
20	+4.7
21	+1.4
22	+14.1
23	+11.9
24	+7.2
25	+2.4
26	+2.4
27	+4.9
28	0
29	+4.9
30	+5.0

IC301 (CXD2500BQ)

1	+4.9	41	+2.3
2	+0.1	42	+4.9
3	+4.9	43	+2.5
4	+2.7	44	0
5	0	45	+4.9
6	+4.9	46	+4.4
7	0	47	0
8	+4.9	48	0
9	0	49	0
10	0	50	+1.2
11	0	51	+1.2
12	0	52	0
13	0	53	+2.5
14	0	54	+2.5
15	0	55	0
16	+2.6	56	+2.8
17	+2.5	57	+2.3
18	0	58	+1.4
19	+2.6	59	0
20	+2.6	60	0
21	0	61	0
22	+2.5	62	+2.5
23	+4.9	63	0
24	+2.5	64	0
25	+0.9	65	0
26	+2.5	66	+4.1
27	+2.5	67	+4.8
28	+4.9	68	0
29	0	69	+0.6
30	0	70	+5.0
31	+2.5	71	+0.1
32	+2.5	72	+4.9
33	0	73	+4.9
34	+2.5	74	+4.8
35	+2.4	75	+1.3
36	+2.5	76	+0.1
37	+2.4	77	+0.1
38	+2.5	78	+4.9
39	0	79	+4.8
40	+4.9	80	+0.1

IC302 (BA7042)

1	+2.6
2	+2.1
3	+2.1
4	0
5	+3.9
6	+5.0
7	+2.6
8	+2.6

IC303 (TC7SU04F)

1	0
2	+2.6
3	0
4	+2.6
5	+4.9

IC402 (μPD6383GF)

1	+4.9	51	0
2	+4.9	52	0
3	+4.9	53	0
4	+0.1	54	0
5	+0.8	55	0
6	+0.1	56	0
7	+4.7	57	0
8	+4.9	58	0
9	+5.0	59	0
10	+5.0	60	0
11	+4.7	61	0
12	+4.7	62	+4.7
13	+4.7	63	+4.7
14	+4.7	64	0
15	+4.7	65	+0.4
16	0	66	+0.4
17	+2.4	67	+0.4
18	+2.5	68	+0.4
19	+2.4	69	+0.4
20	+2.5	70	+0.4
21	0	71	+0.4
22	0	72	+0.4
23	+2.4	73	0
24	+3.0	74	0
25	+2.9	75	0
26	+2.4	76	0
27	+2.4	77	0
28	0	78	0
29	0	79	0
30	0	80	0
31	+4.72	81	0
32	+4.72	82	+4.7
33	+4.72	83	+4.7
34	0	84	0
35	0	85	+4.7
36	0	86	0
37	0	87	0
38	+4.72	88	+4.9
39	+2.5	89	0
40	+2.5	90	+4.7
41	0	91	+4.7
42	+4.7	92	0
43	+4.7	93	+4.7
44	+4.7	94	0
45	+4.7	95	+4.7
46	+4.7	96	+4.7
47	0	97	+4.7
48	0	98	0
49	0	99	+4.7
50	0	100	+4.6

CDJ-700S,CDJ-500S

IC403 (μ PD6383GF)

1	+4.8	51	+4.7
2	+4.8	52	+4.7
3	+4.8	53	0
4	0	54	0
5	0	55	0
6	0	56	+4.7
7	+4.7	57	+4.7
8	+4.7	58	0
9	+5.0	59	0
10	+4.9	60	0
11	+4.7	61	0
12	+4.7	62	0
13	+4.7	63	+4.7
14	+4.7	64	0
15	+4.7	65	0
16	0	66	0
17	+2.3	67	0
18	+2.3	68	0
19	+2.3	69	0
20	+2.3	70	+0.3
21	0	71	+0.3
22	0	72	+0.3
23	+2.3	73	0
24	+2.9	74	+4.7
25	+2.1	75	0
26	+2.3	76	+4.7
27	0	77	+4.7
28	0	78	0
29	0	79	+4.7
30	0	80	0
31	+4.7	81	0
32	0	82	+4.7
33	0	83	+4.7
34	0	84	+4.7
35	0	85	0
36	0	86	0
37	0	87	0
38	+4.7	88	0
39	+2.5	89	0
40	+2.5	90	+4.7
41	0	91	+4.7
42	+4.7	92	0
43	+4.7	93	0
44	+4.7	94	0
45	0	95	+4.7
46	0	96	+4.7
47	0	97	0
48	+4.7	98	+4.7
49	+4.7	99	0
50	+4.7	100	+4.6

IC404 (HM514800CJ)

1	+4.7
2	+2.4
3	+2.4
4	+2.3
5	+2.3
6	0
7	+4.6
8	+2.3
9	+4.6
10	+2.1
11	+2.5
12	+2.4
13	+2.4
14	+4.7
15	0
16	+2.4
17	+2.4
18	+2.4
19	+2.2 - +2.4
20	+2.2 - +2.4
21	0
22	0
23	+4.5
24	+2.2
25	+2.2
26	+2.2
27	+2.2
28	0

IC409 (LH52256AN-70LL)

1	+0.2
2	+2.4
3	+2.4
4	+2.4
5	+2.4
6	+2.4
7	+2.4
8	+2.4
9	+2.4
10	+3.8
11	+0.3
12	+3.4
13	+0.3
14	0
15	+3.5
16	+3.0
17	+0.2
18	+0.2
19	+3.6
20	+4.3
21	+2.4
22	0
23	+2.5
24	+2.4
25	+2.4
26	+2.4
27	+4.6
28	+4.7

IC502 (PCM1700U)

1	0
2	0
3	+3.1
4	-4.5
5	-1.7
6	-4.2
7	+4.9
8	0
9	-5.0
10	-1.7
11	-4.5
12	+3.2
13	0
14	0
15	0
16	0
17	0
18	+4.7
19	0
20	+1.7
21	+1.7
22	-5.0
23	+3.5
24	+1.7
25	0
26	0
27	0
28	0

IC501 (SM5841CP)

1	+4.6
2	+2.4
3	+2.0
4	+2.4
5	0
6	+4.6
7	0
8	0
9	+4.9
10	+2.9
11	+1.7
12	+1.7
13	+3.5
14	+4.7
15	+1.5
16	+2.3
17	+2.3
18	+2.3

IC505 (NJM4558MD)

1	0
2	0
3	0
4	-8.4
5	0
6	0
7	0
8	+7.4

VOLTAGES (V) OF FUNCTION BOARD ASSY SECTION

Note : Voltages are in the PLAY mode.

IC701 (PD4842A)

1	-30.1	41	+4.9
2	-30.1	42	0
3	-30.1	43	0
4	-30.0	44	0
5	-30.0	45	+0.1
6	-30.1	46	+0.1
7	-30.1	47	+2.5
8	+4.9	48	0
9	0	49	+4.7
10	+4.9	50	0
11	+4.8	51	+4.9
12	+4.9	52	+4.9
13	+4.8	53	+0.6
14	+4.8	54	0
15	+0.1	55	0
16	+4.1	56	+4.9
17	+5.0	57	+4.9
18	+4.9	58	0
19	+4.9	59	0
20	0	60	0
21	+4.9	61	0
22	+2.4	62	0
23	+4.9	63	+4.7
24	+2.2	64	-10 - 0
25	0	65	-10 - 0
26	+2.5	66	-10 - 0
27	+2.5	67	-10 - 0
28	+2.4	68	-10 - 0
29	+4.9	69	-10 - 0
30	+4.9	70	-25 - -20
31	+4.9	71	-33.1
32	0	72	-26.1
33	0	73	0
34	+2.3	74	-26.1
35	+2.4	75	-22.7
36	+4.9	76	-23.4
37	+4.9	77	-30.1
38	0	78	-30.1
39	+4.9	79	-30.1
40	+4.8	80	-30.0

IC801 (NJM4556AM)

1	0
2	0
3	0
4	-8.4
5	0
6	0
7	0
8	+7.4

IC901 (NJM2904M)

1	+2.5
2	+2.5
3	+2.5
4	0
5	+2.4
6	+2.5
7	+2.2
8	+4.9

IC902 (NJM2904M)

1	+2.2
2	+2.5
3	+2.4
4	0
5	+2.5
6	+2.5
7	+2.6
8	+7.4

IC602 (TC74HC175AF)

1	+4.9
2	0 - +5.0
3	0 - +5.0
4	+1.8
5	+1.3
6	+4.9
7	+4.9
8	0
9	+0.3
10	0
11	0
12	+0.7 - +1.1
13	+1.4
14	0
15	+4.9
16	+4.9

CDJ-700S, CDJ-500S

Waveforms

Note : The encircled numbers denote measuring points in the schematic diagram.

*1 14T-JUMP : After switching to the pause mode, Press the manual search key.

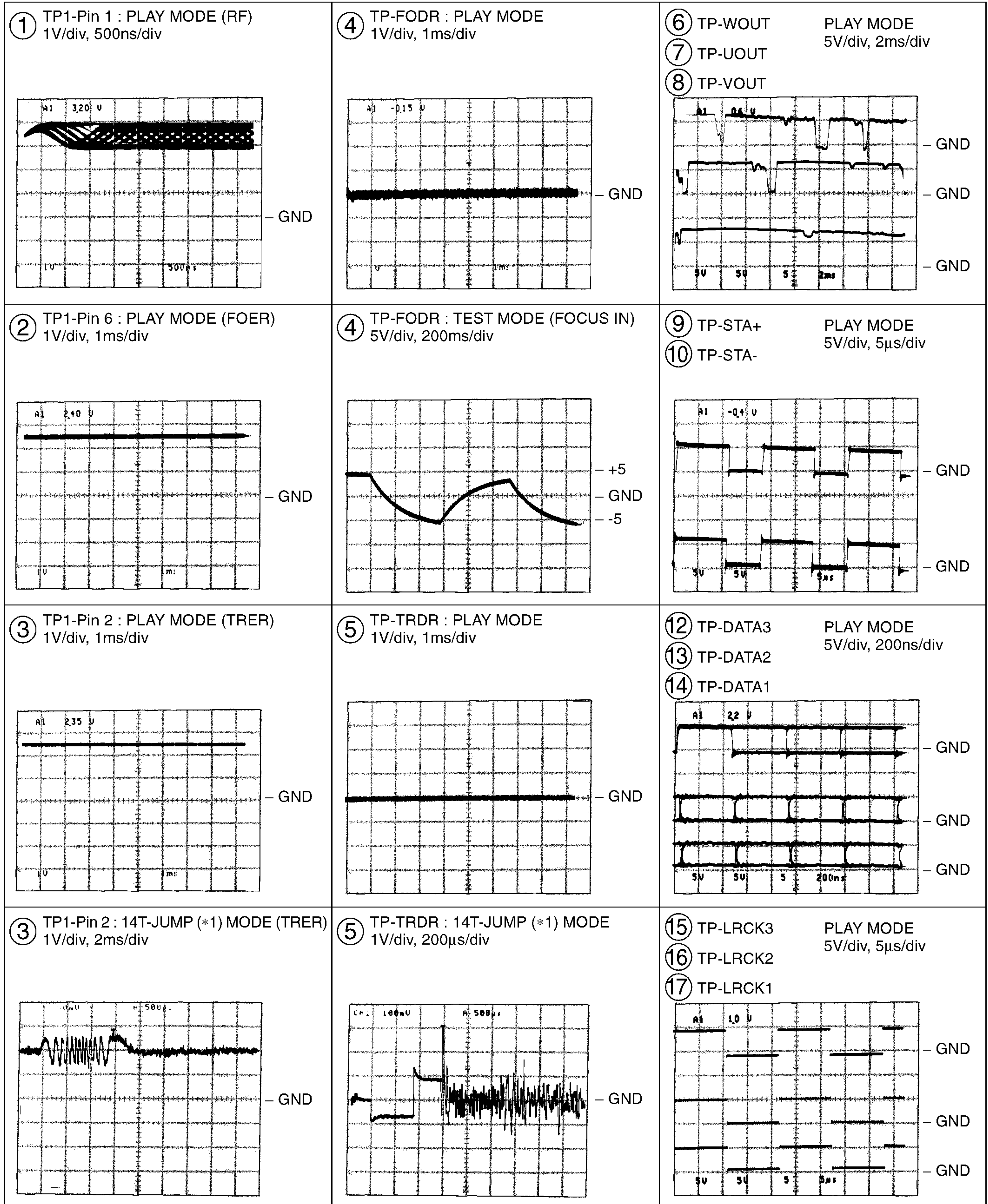

- ⑱ TP-BCLK3 PLAY MODE
5V/div, 200ns/div
- ⑲ TP-BCLK2
- ⑳ TP-BCLK1

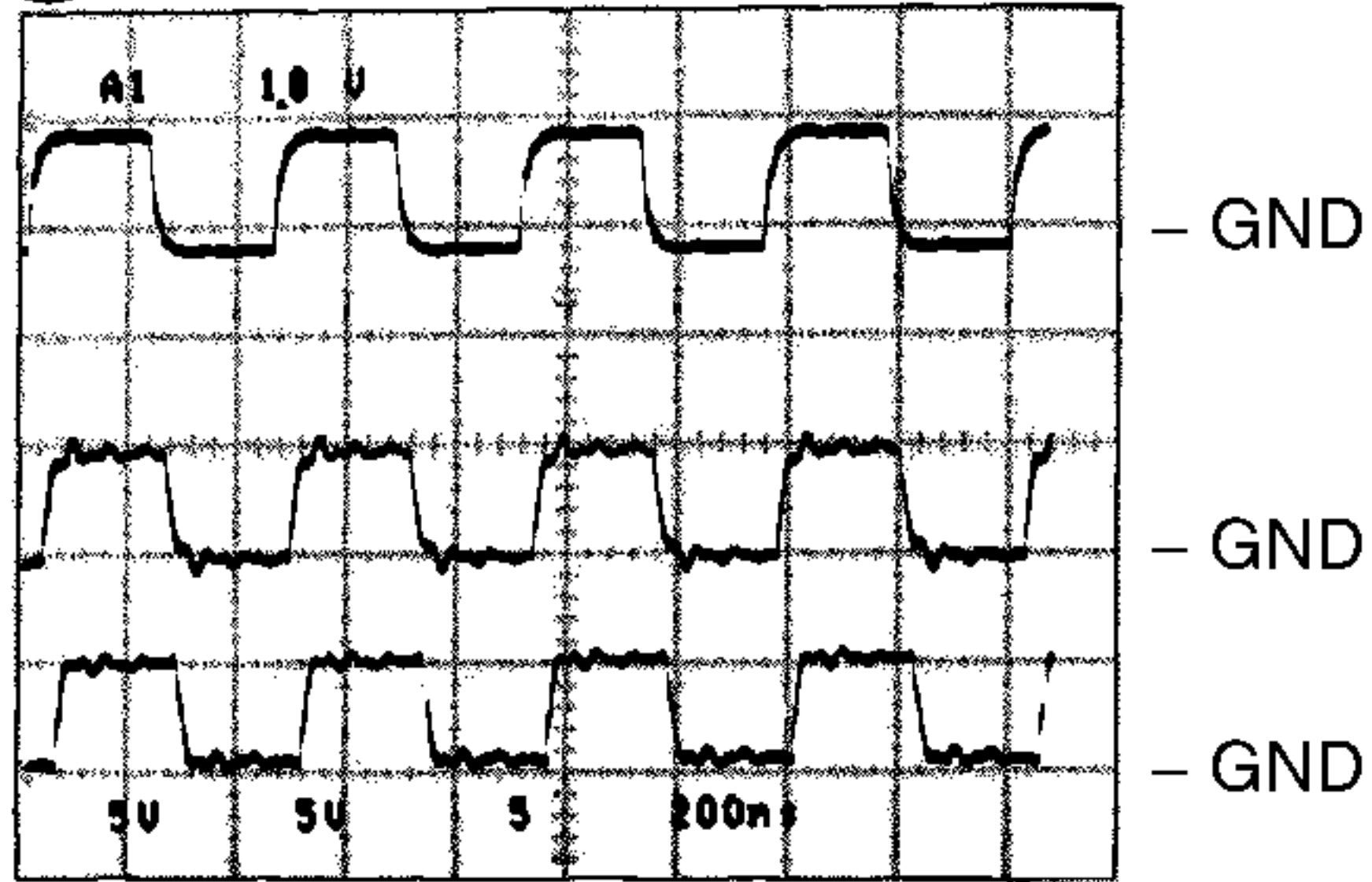

- ㉔ IC301-Pin80(MIRR) : 14T-JUMP (*1) MODE
2V/div, 100μs/div

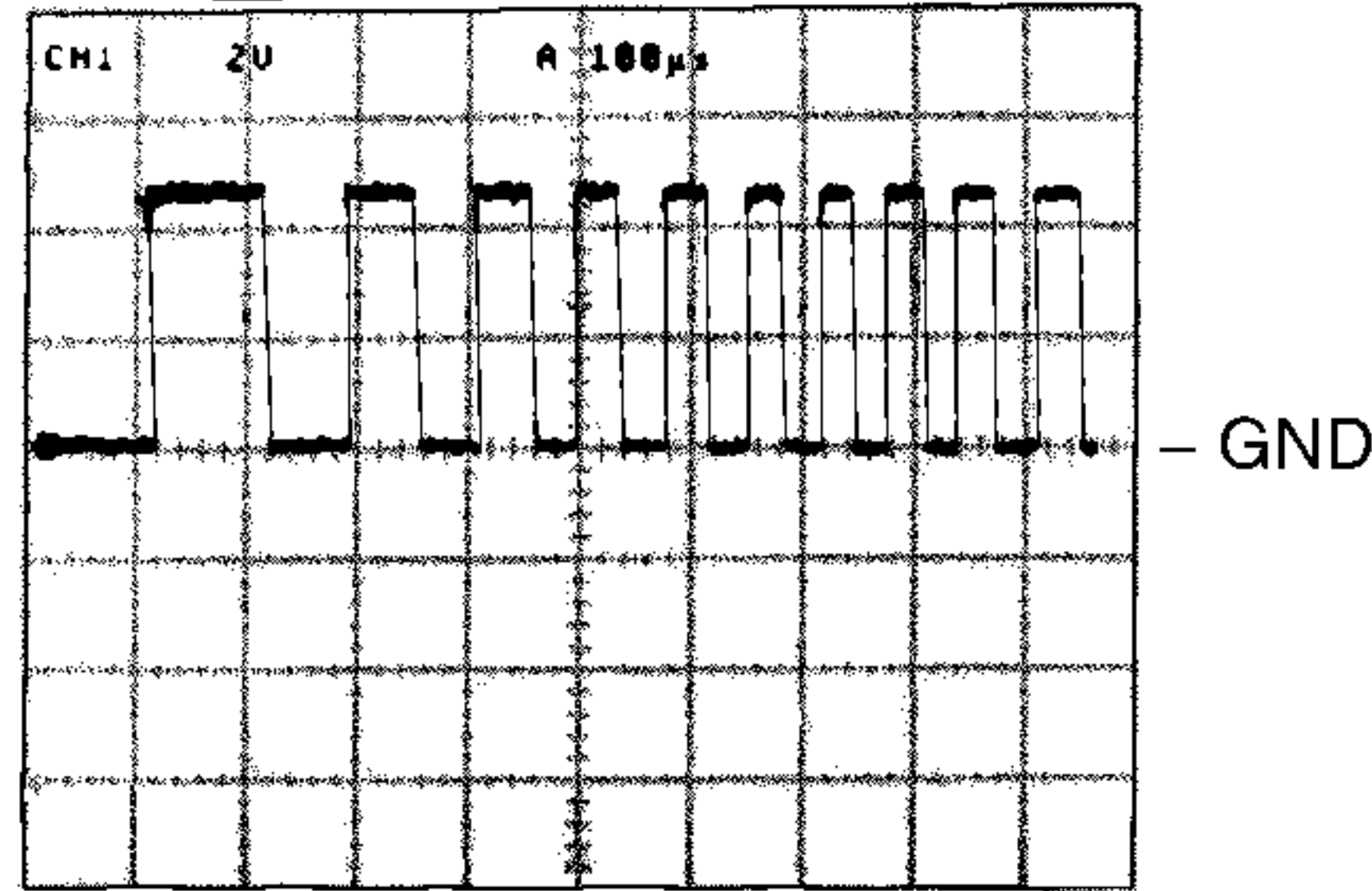

- ㉖ IC701-Pin36(/RST3) : POWER OFF MODE
2V/div, 100μs/div

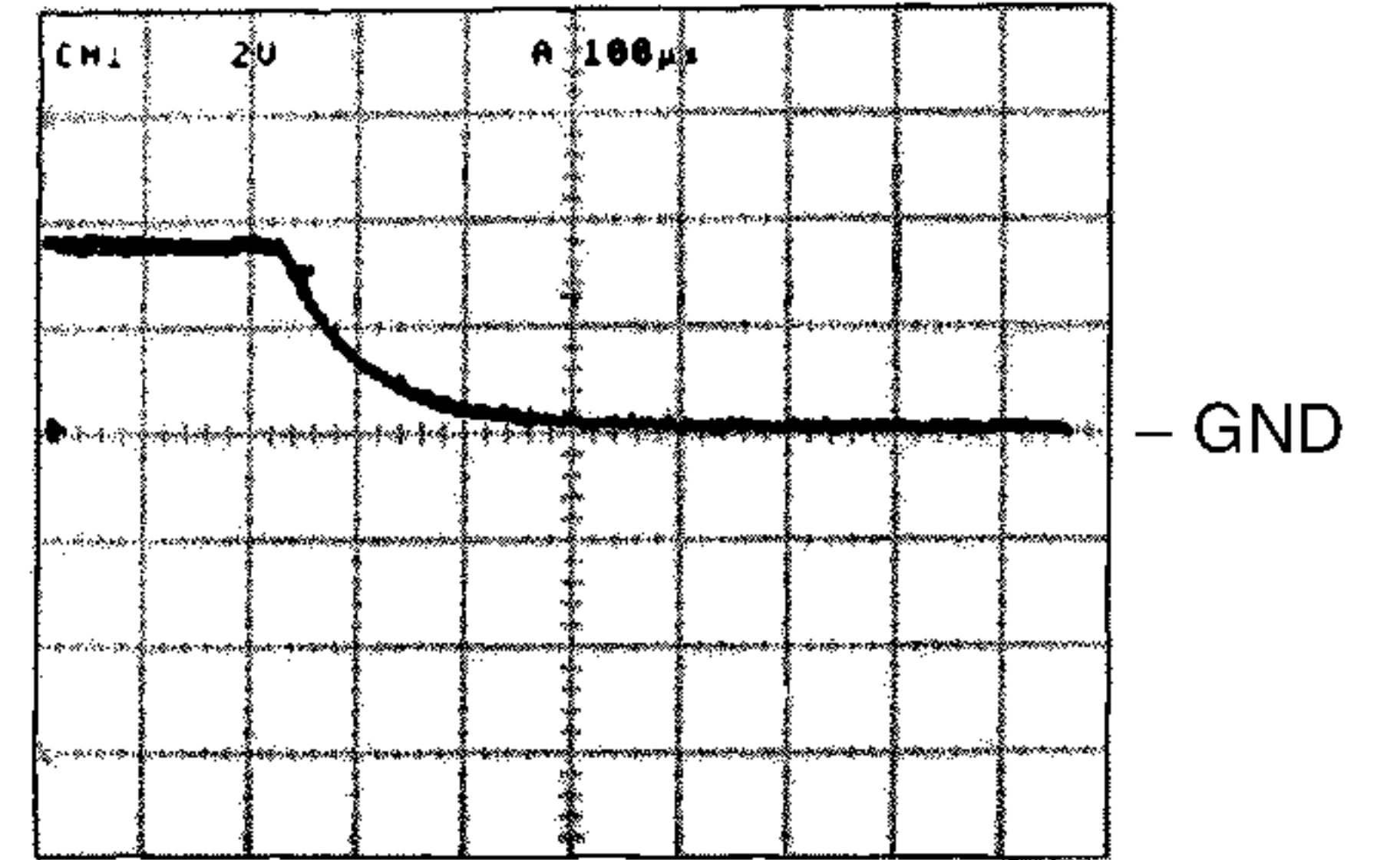

- ㉑ IC402-Pin4(DATA) PLAY MODE
2V/div, 100μs/div
- ㉒ IC402-Pin3(CLOK)

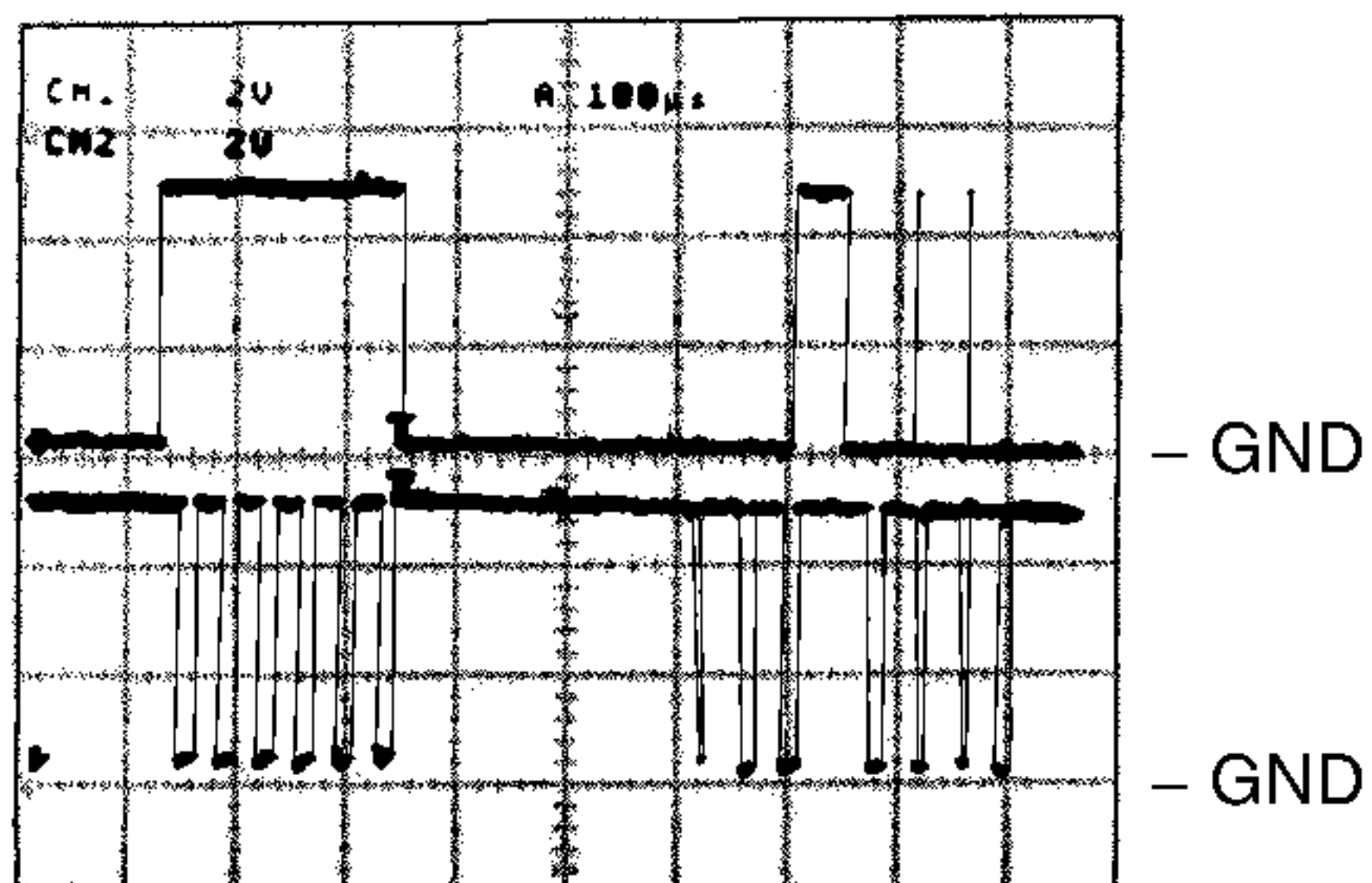

- ㉕ IC701-Pin17(RST) : POWER ON MODE
2V/div, 5ms/div

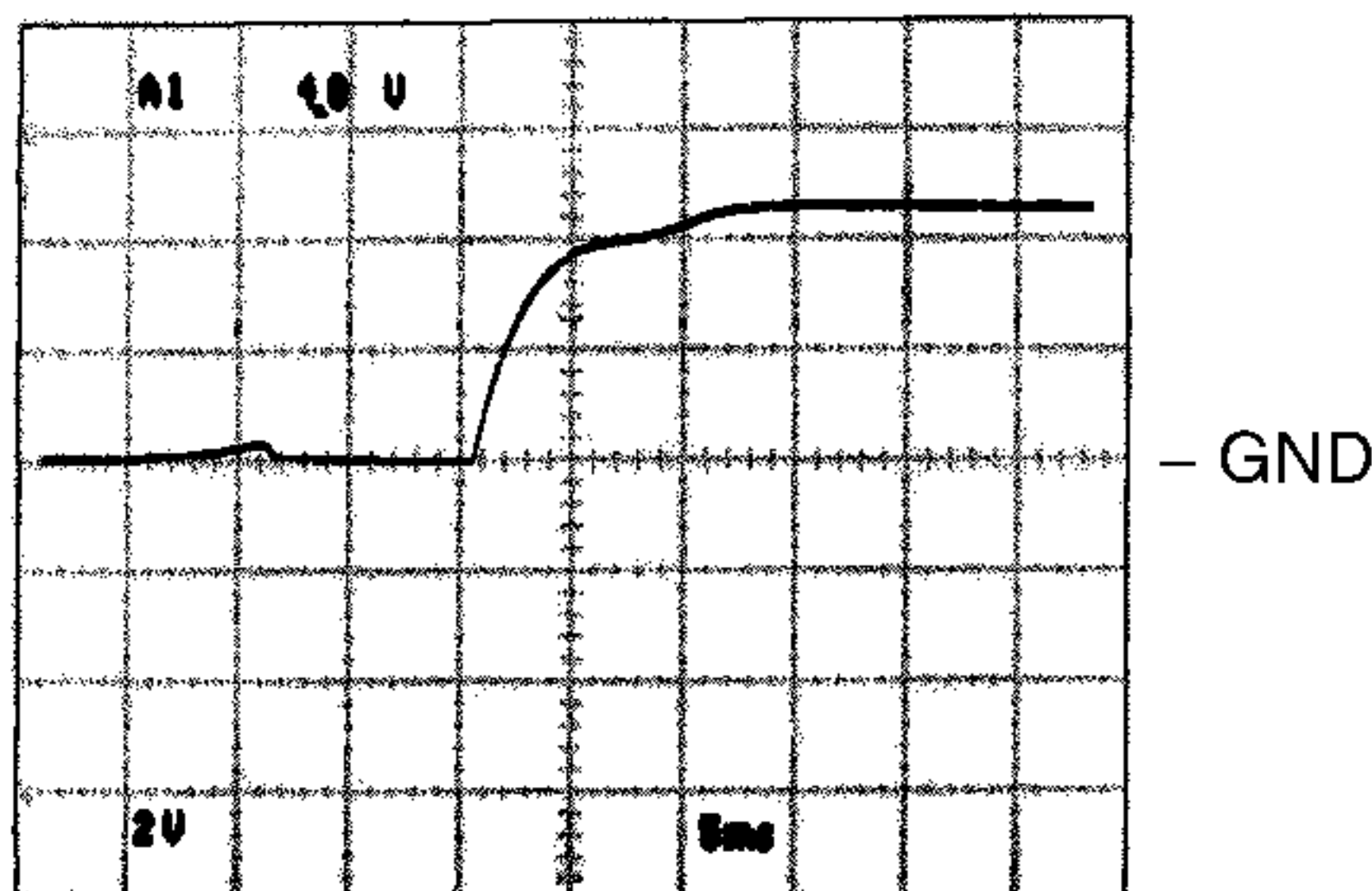

- ㉗ TP-AL1 : PLAY MODE (1kHz)
2V/div, 200μs/div

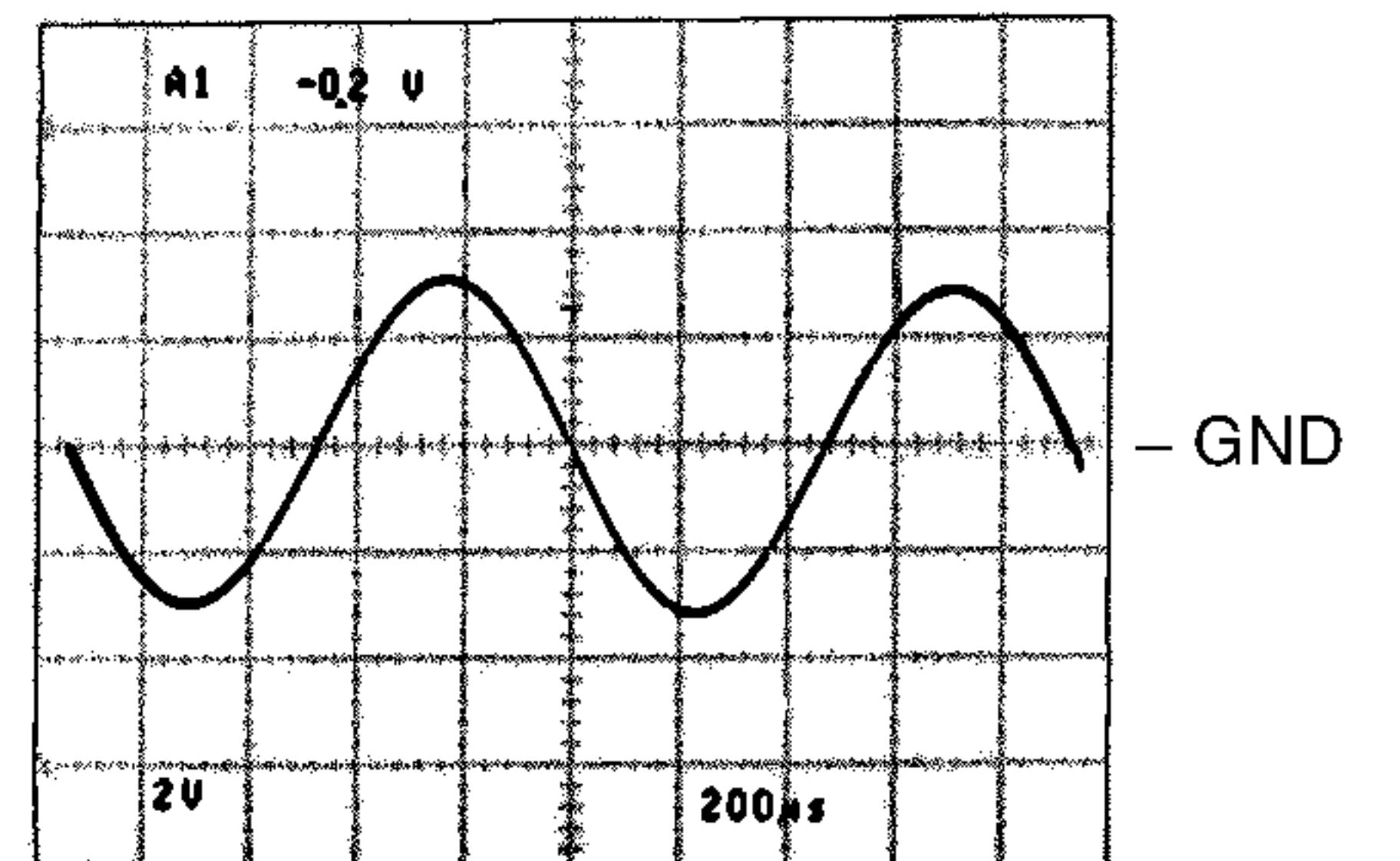

- ㉓ TP-MDP : PLAY MODE
2V/div, 2μs/div

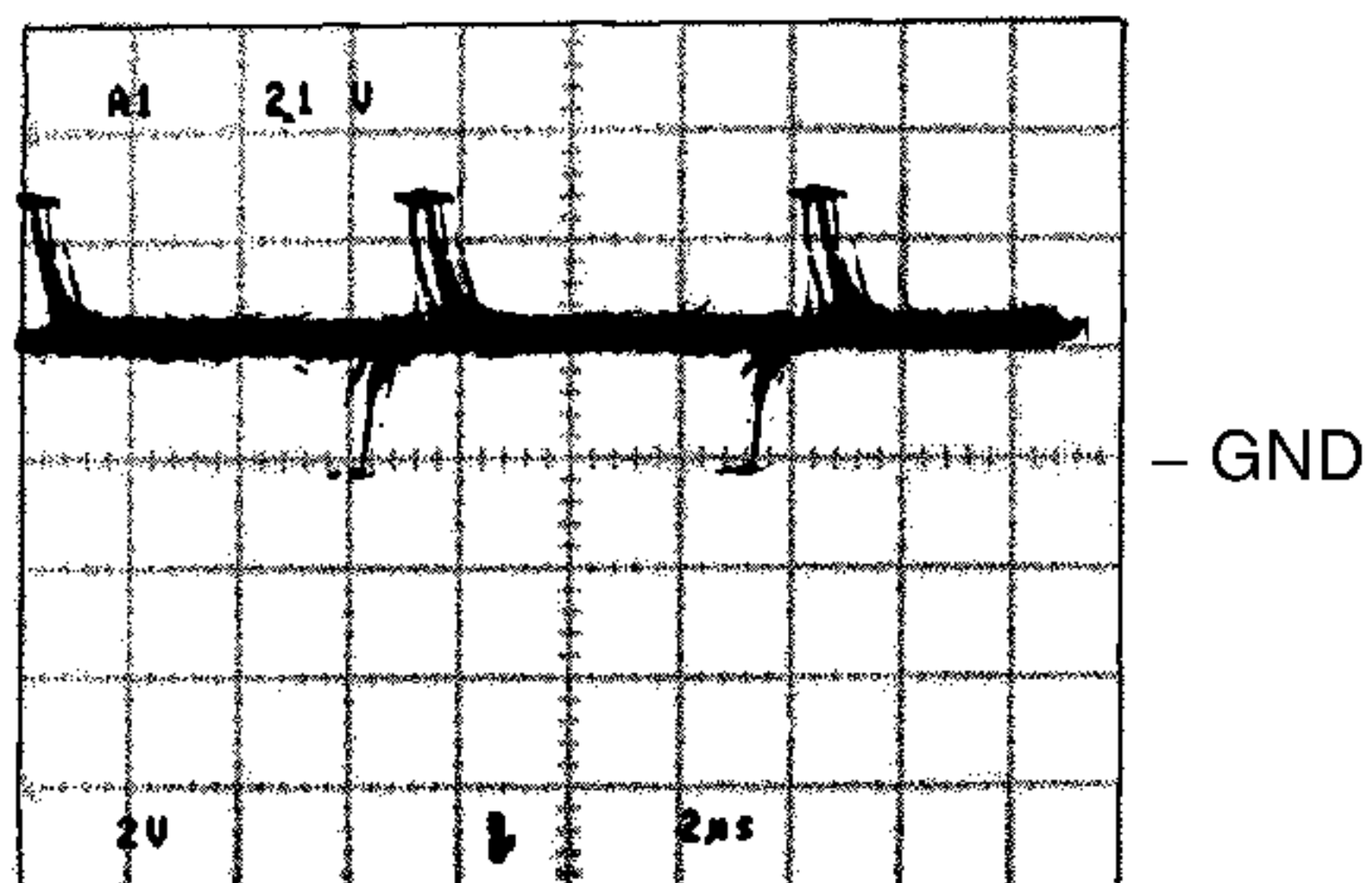

- ㉕ IC701-Pin17(RST) : POWER OFF MODE
2V/div, 10ms/div

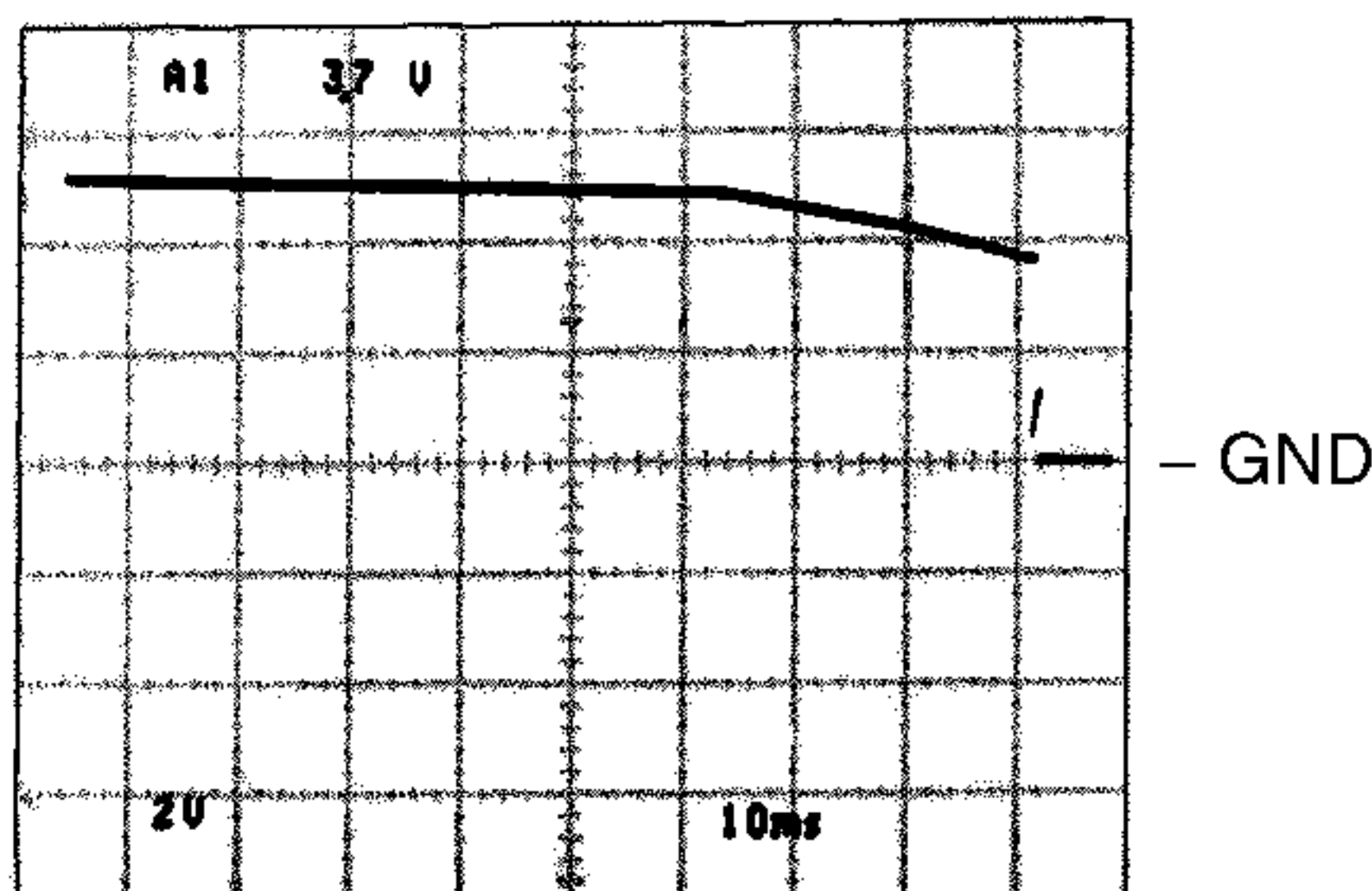

- ㉘ IC301-Pin20(PCO) : PLAY MODE
2V/div, 2μs/div

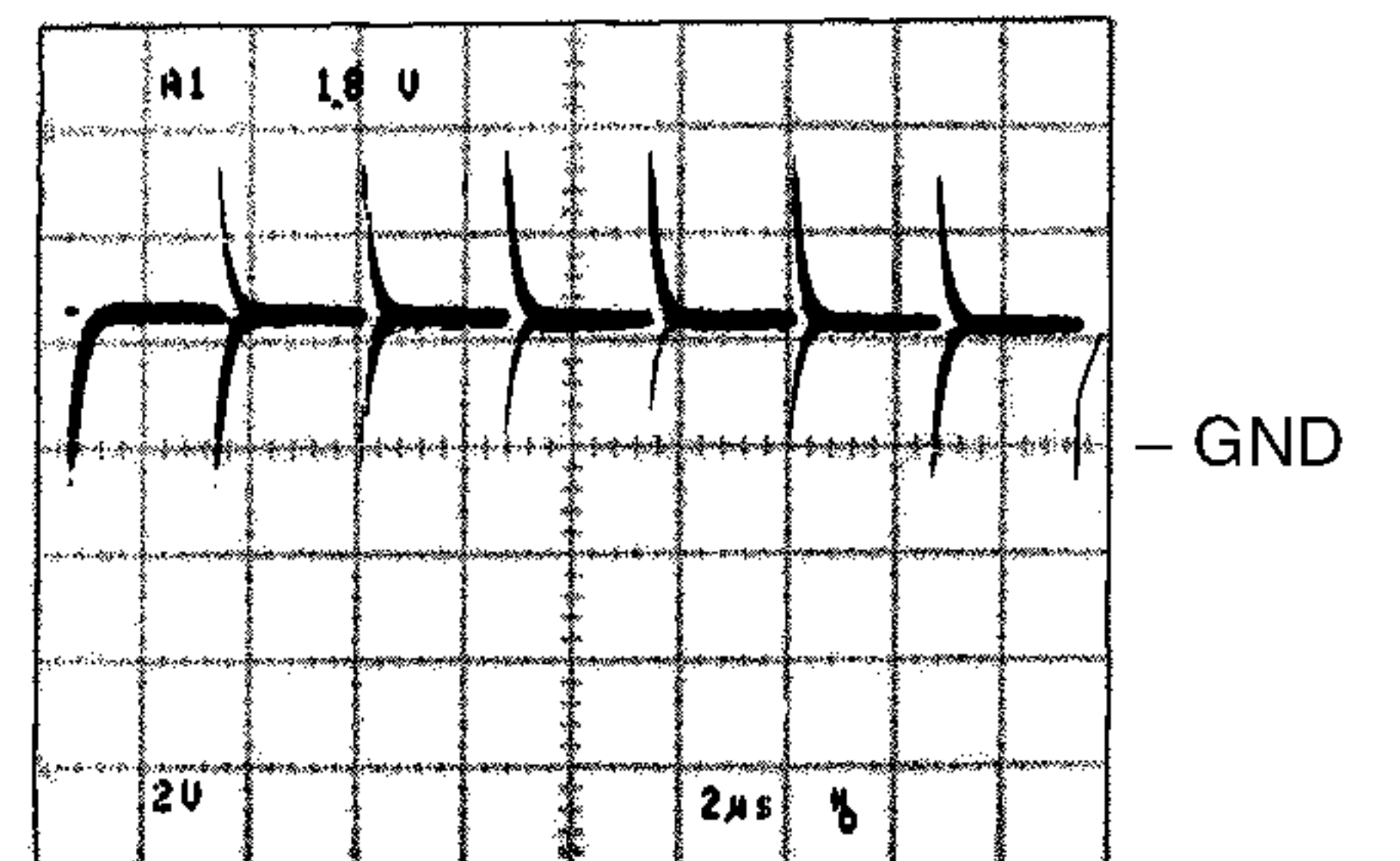

- ㉔ IC301-Pin80(MIRR) : PLAY MODE
2V/div, 100μs/div

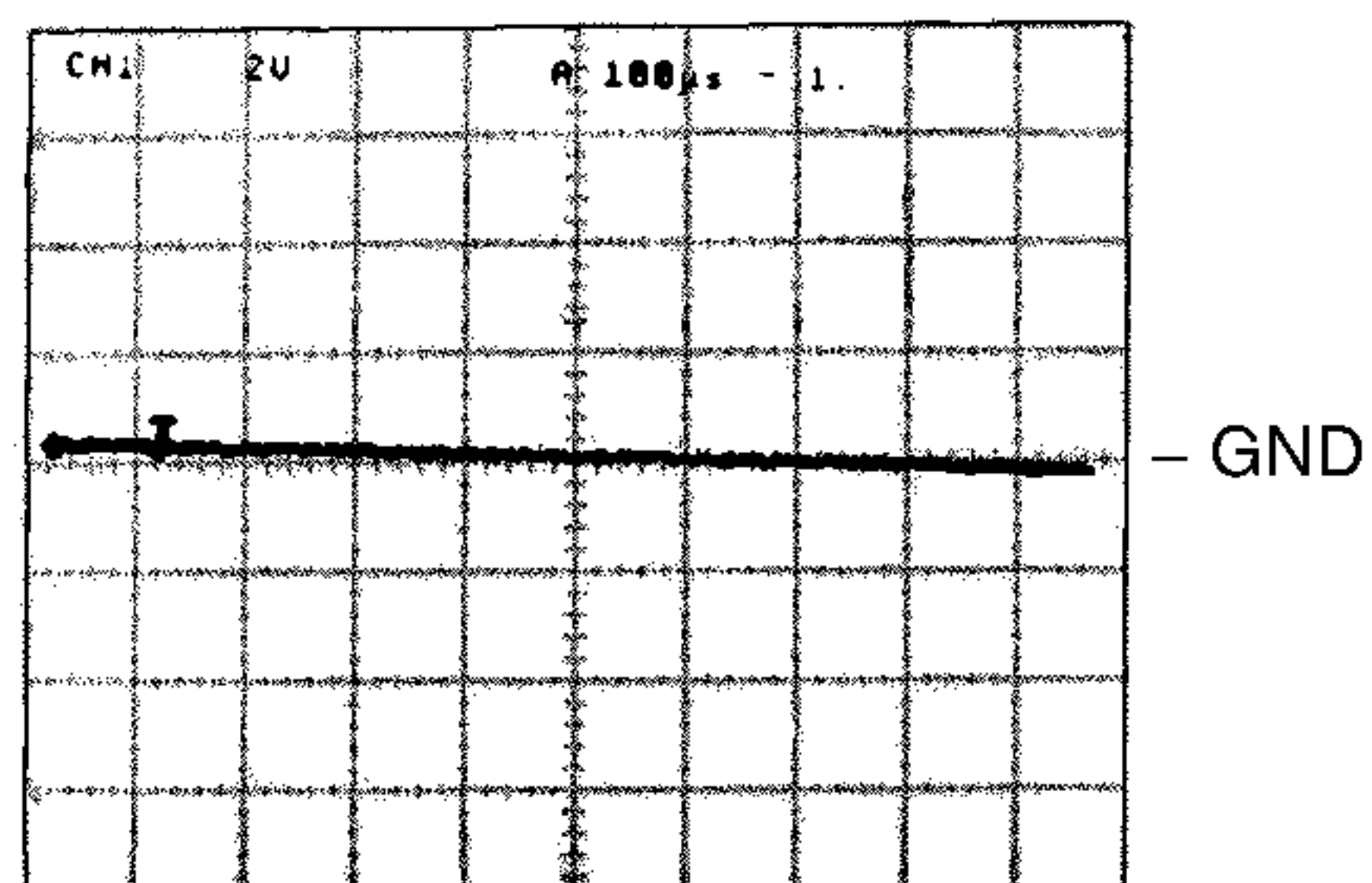

- ㉖ IC701-Pin36(RST3) : POWER ON MODE
2V/div, 2μs/div

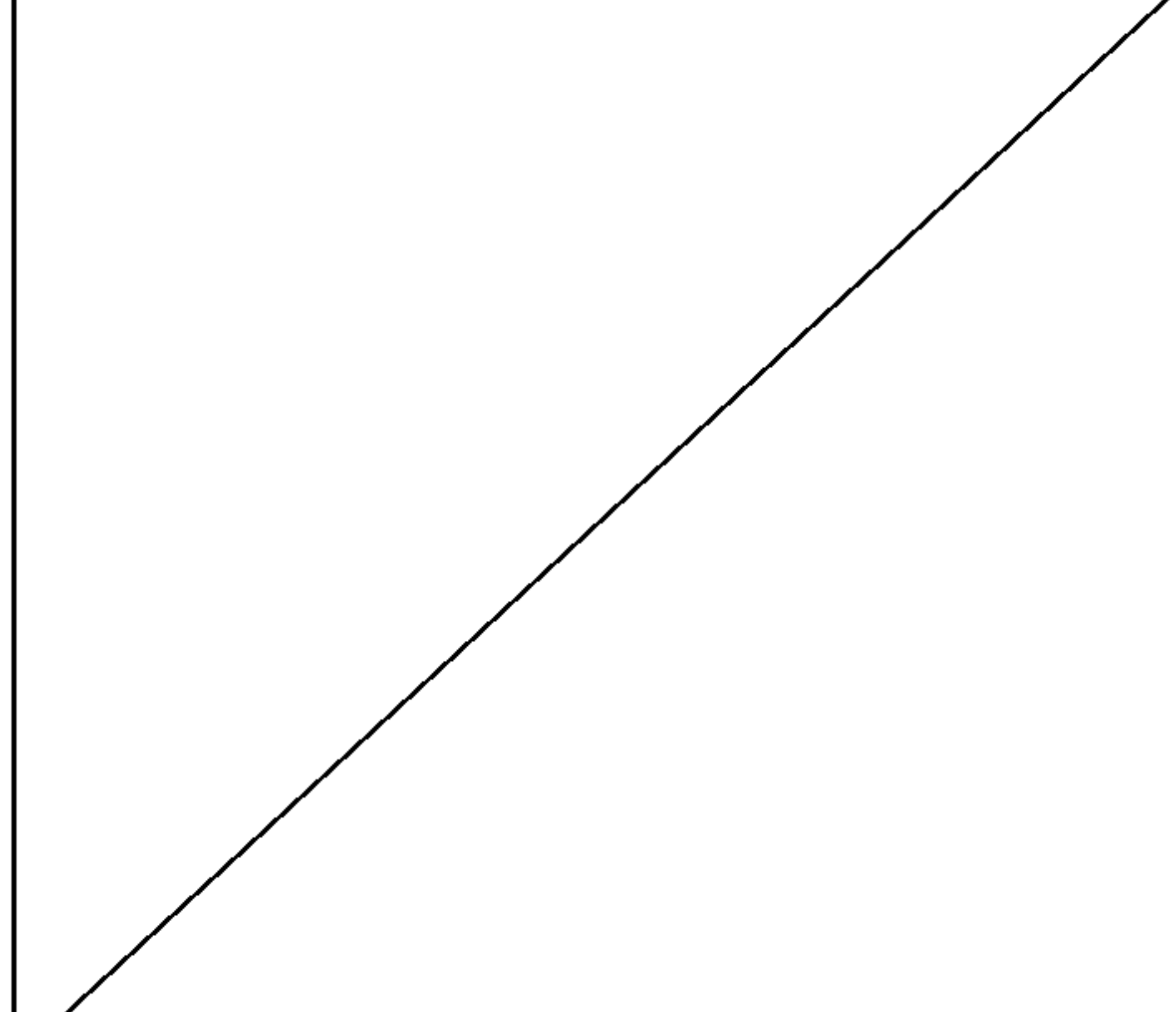
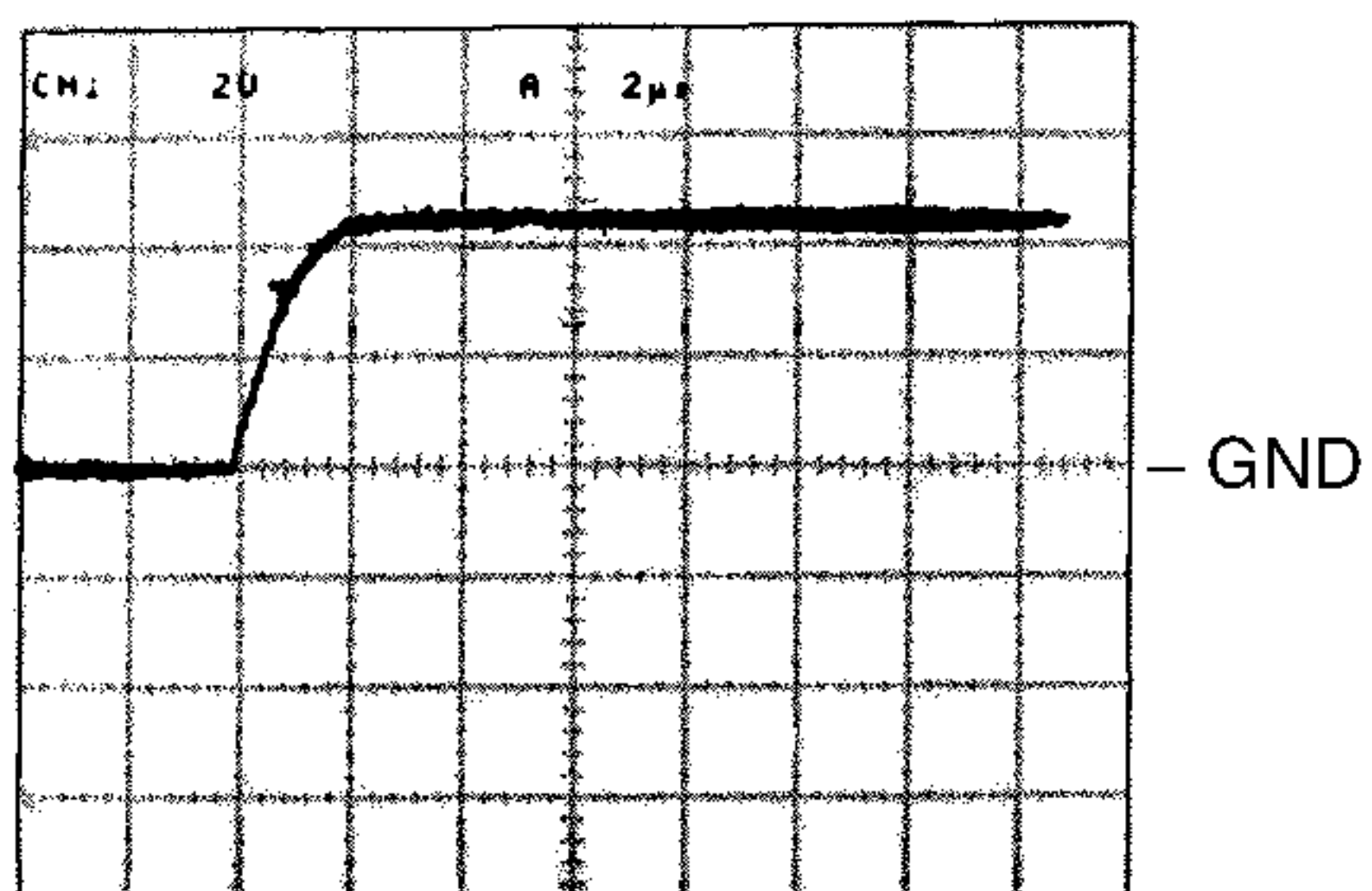

4. PCB CONNECTION DIAGRAM

4.1 MAIN BOARD ASSY

NOTE FOR PCB DIAGRAMS

1. Part numbers in PCB diagrams match those in the schematic diagrams.
2. A comparison between the main parts of PCB and schematic diagrams is shown below.

Symbol in PCB Diagrams	Symbol in Schematic Diagrams	Part Name
		Transistor
		Transistor with resistor
		Field effect transistor
		Resistor array
		3-terminal regulator

3. The parts mounted on this PCB include all necessary parts for several destination.
For further information for respective destinations, be sure to check with the schematic diagram.

4. Viewpoint of PCB diagrams

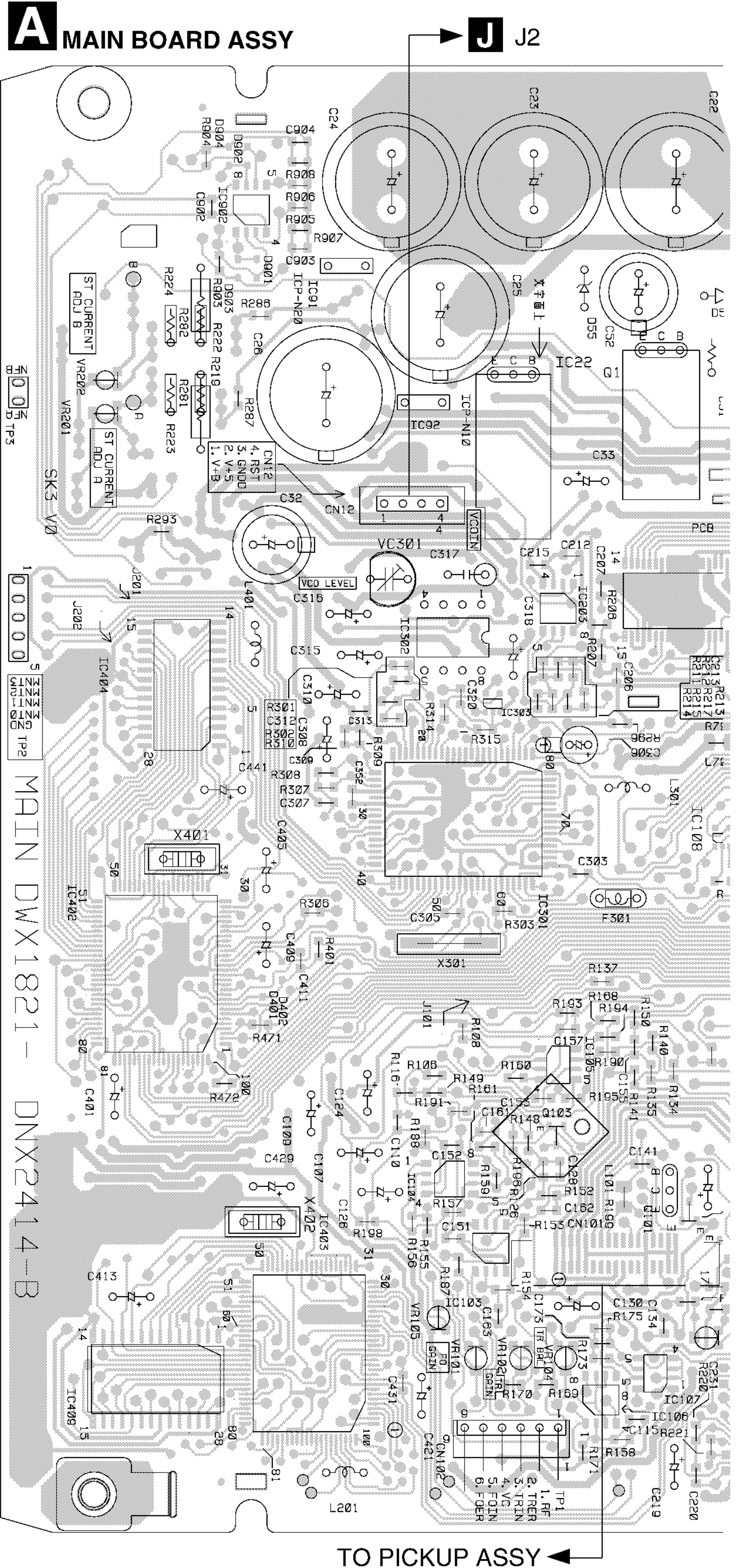
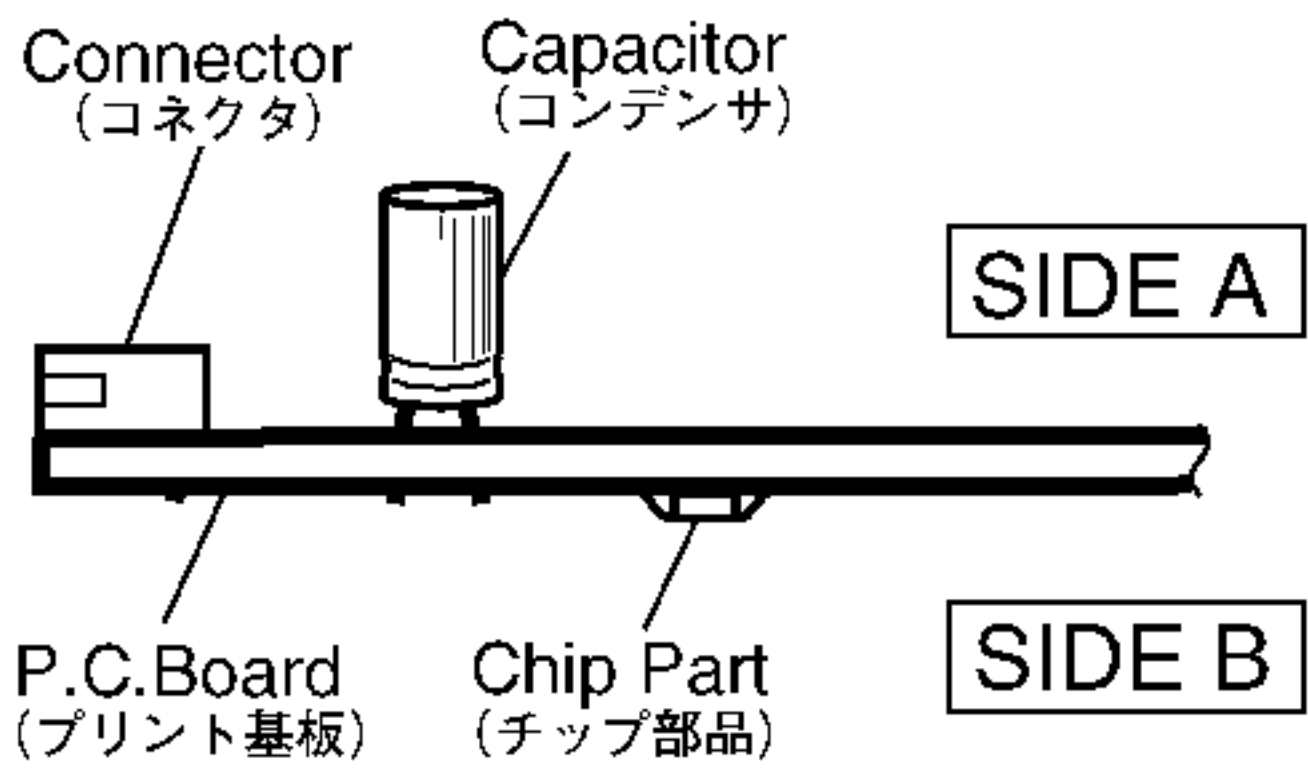

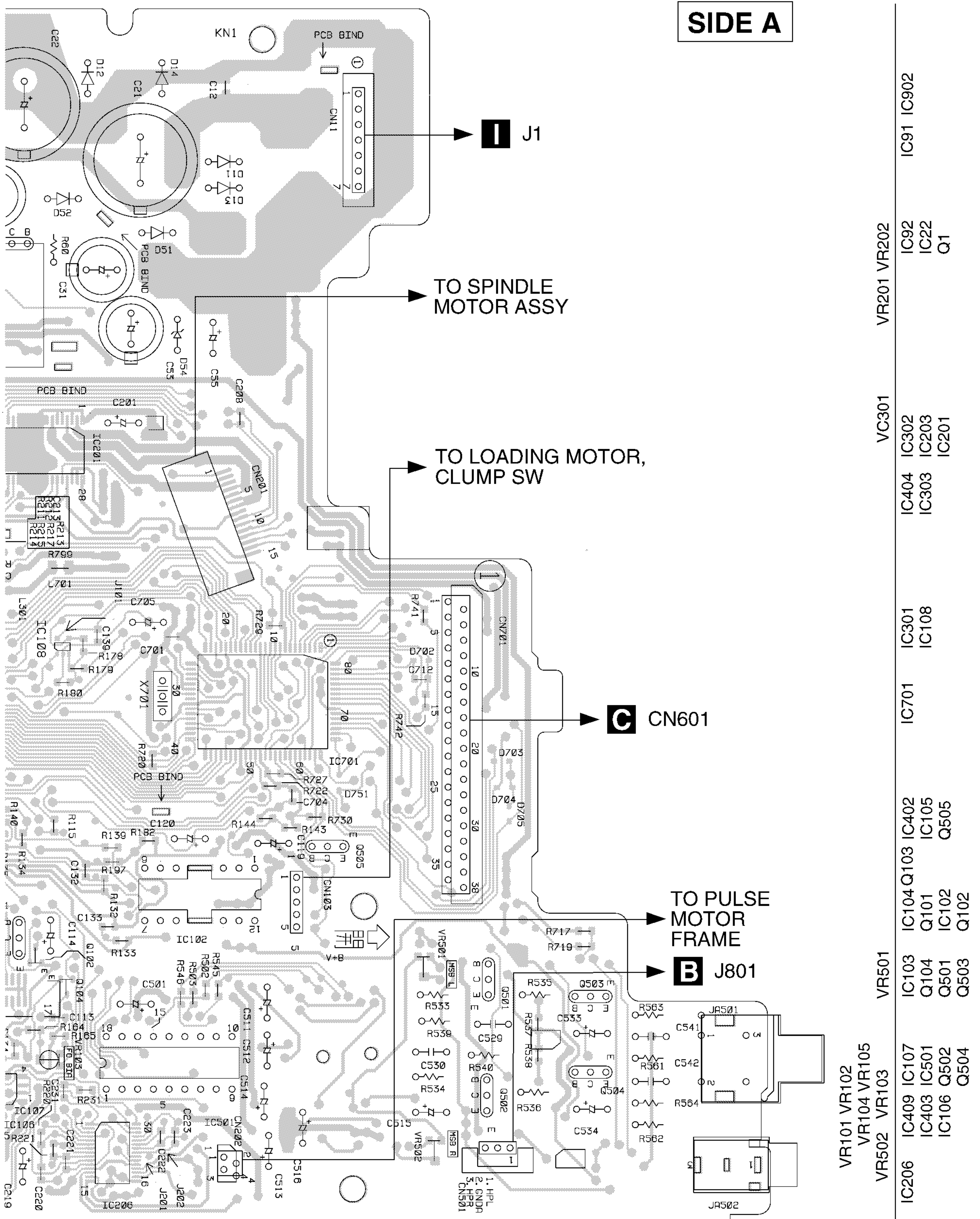

DNP1834-B

A MAIN BOARD ASSY

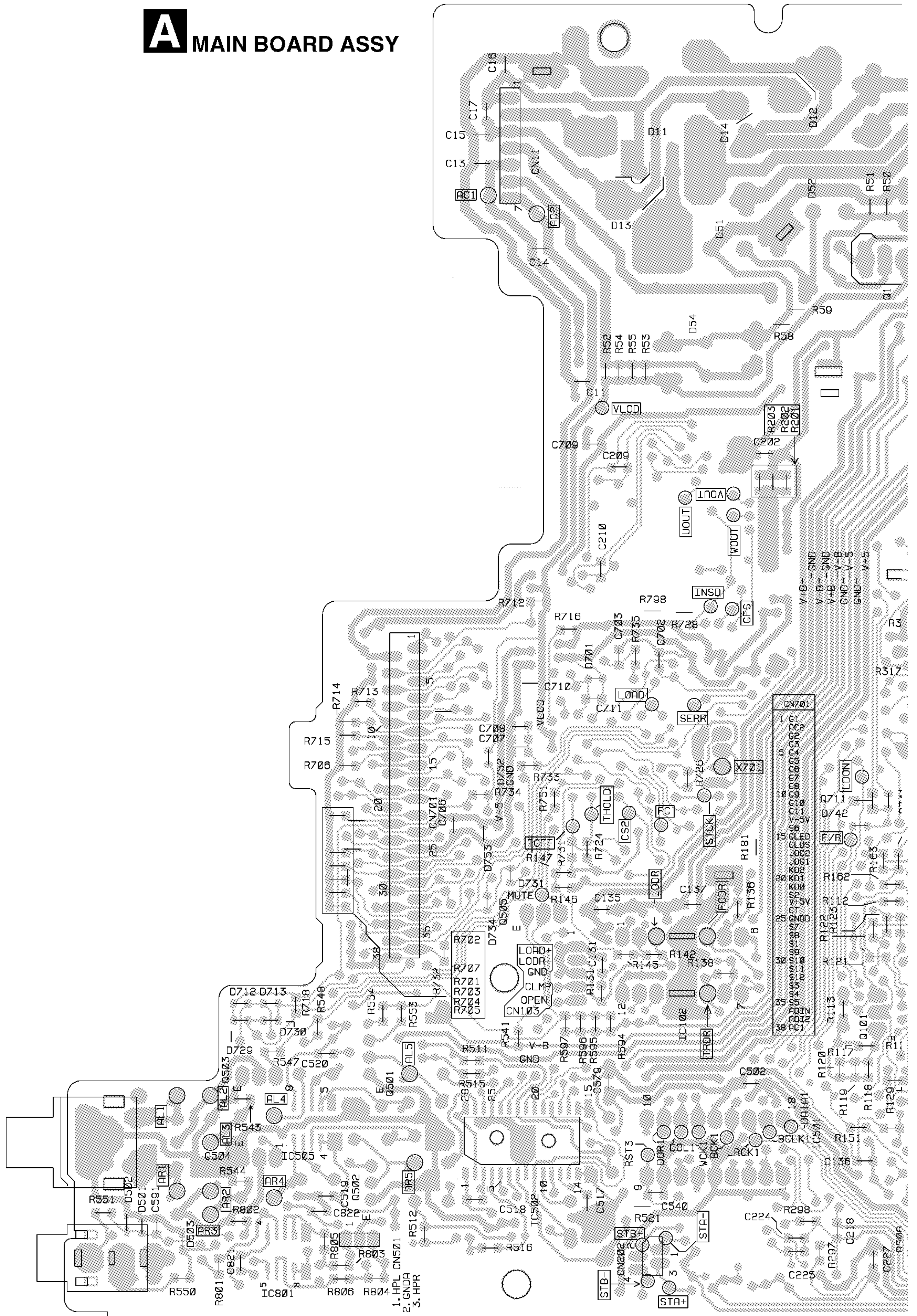

CDJ-700S, CDJ-500S

4.2 H.P BOARD ASSY, FUNCTION BOARD ASSY, DOOR BOARD ASSY, LED A BOARD ASSY, LED B BOARD ASSY AND SLIDER BOARD ASSY

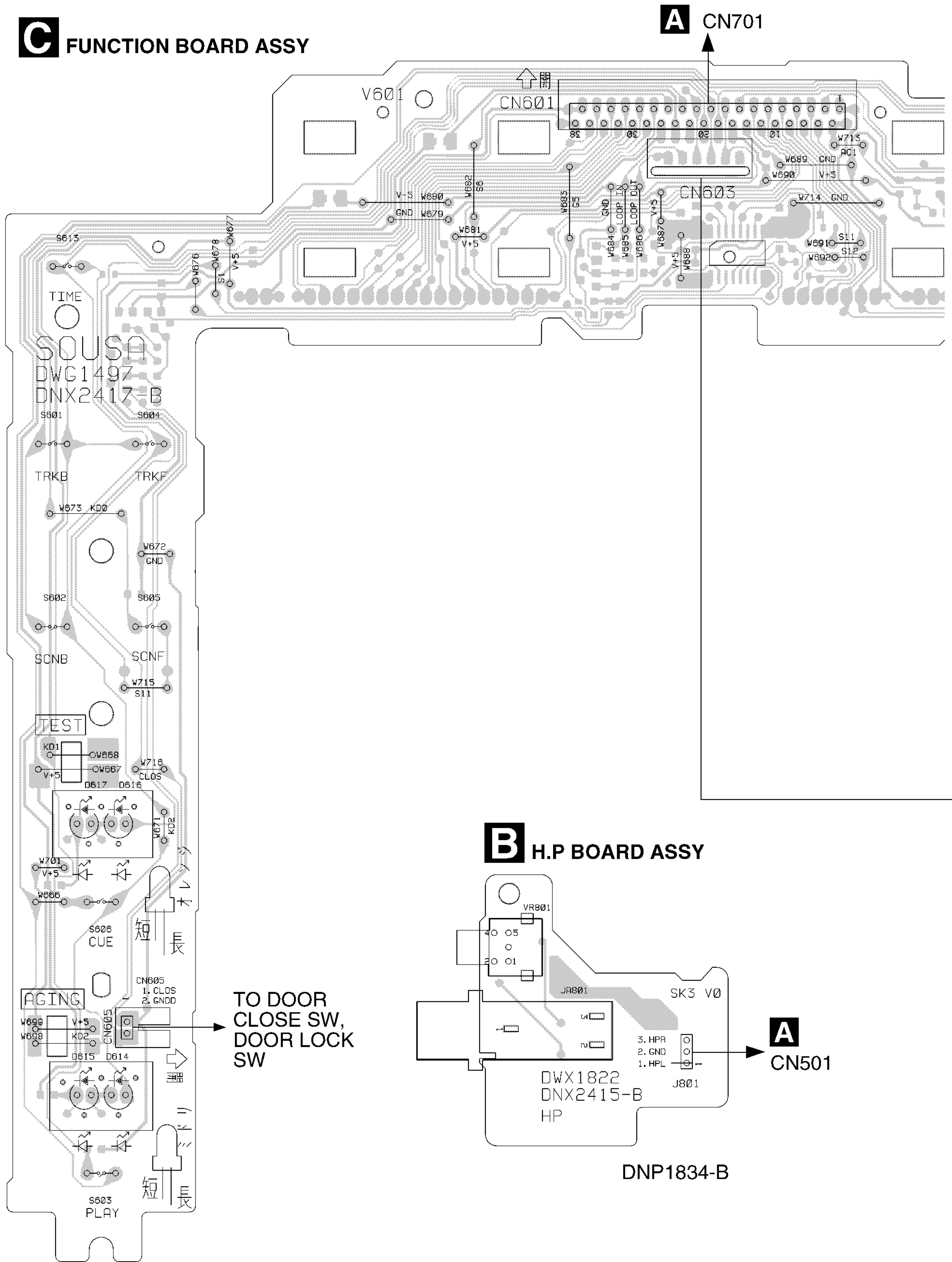

SIDE A

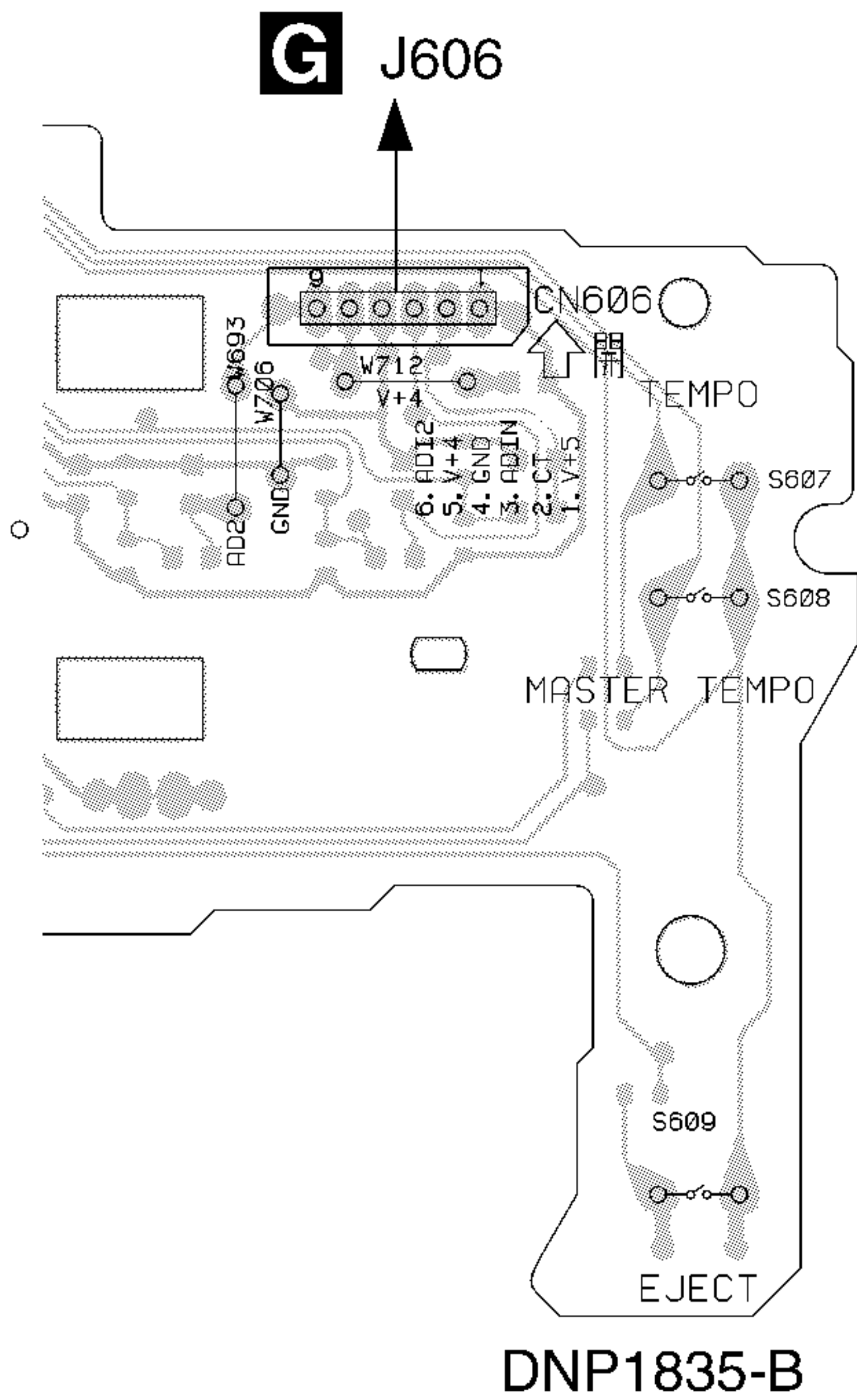

E LED A BOARD ASSY

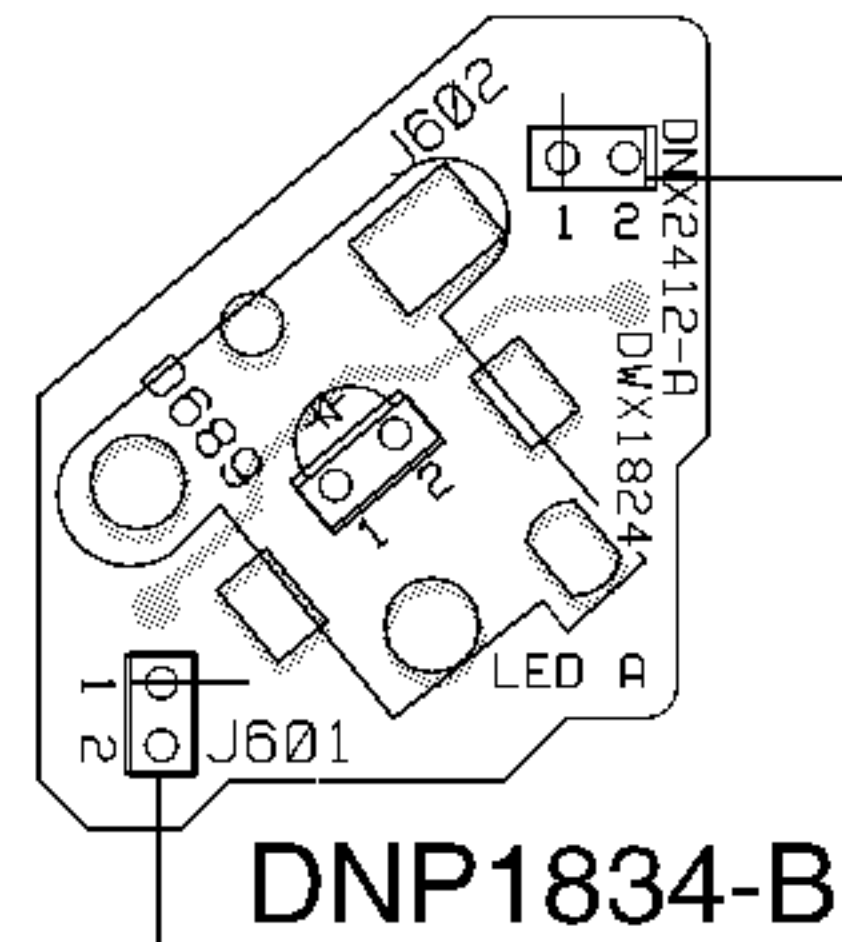

F LED B BOARD ASSY

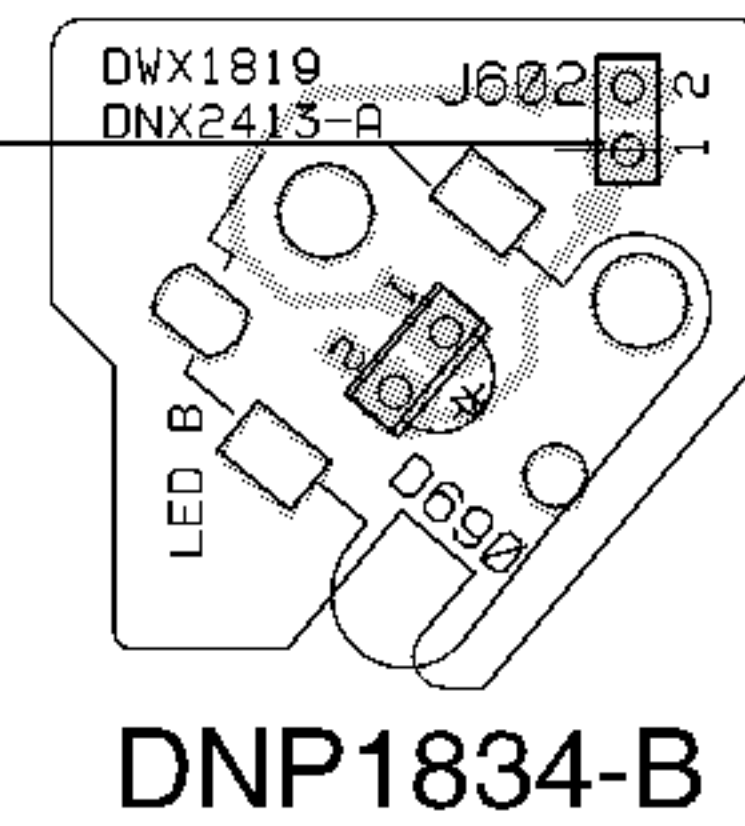

D DOOR BOARD ASSY

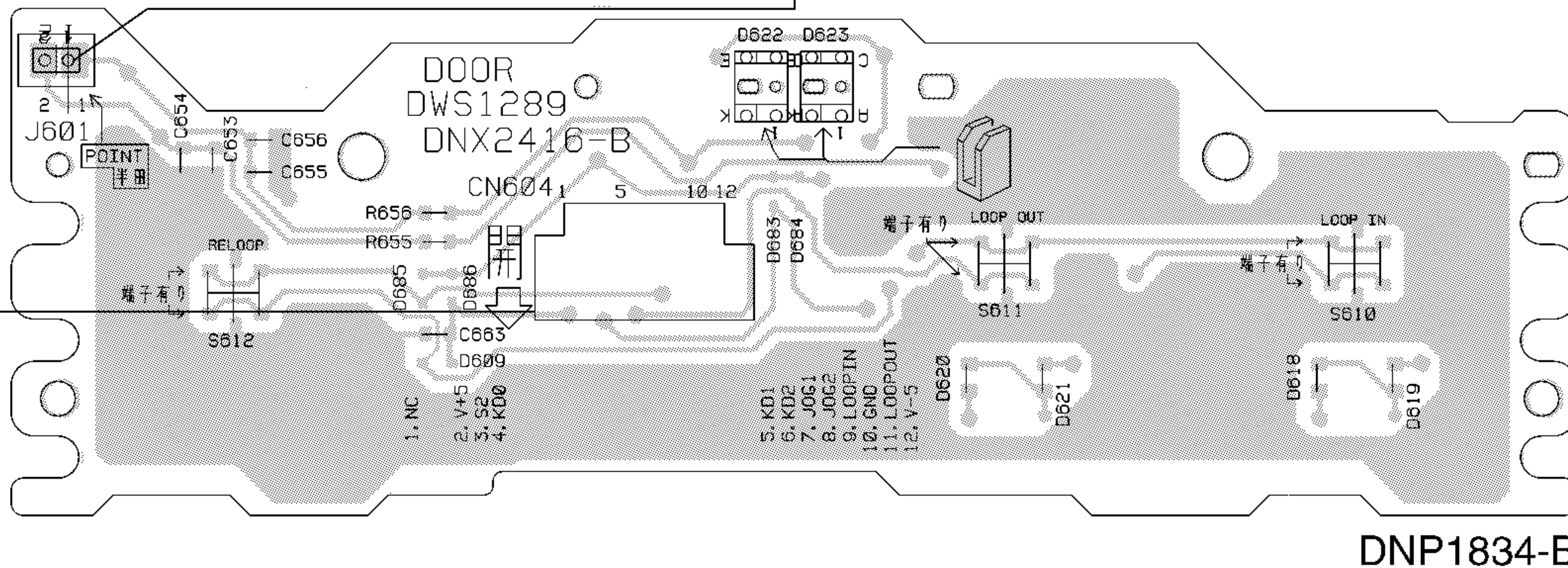

G SLIDER BOARD ASSY

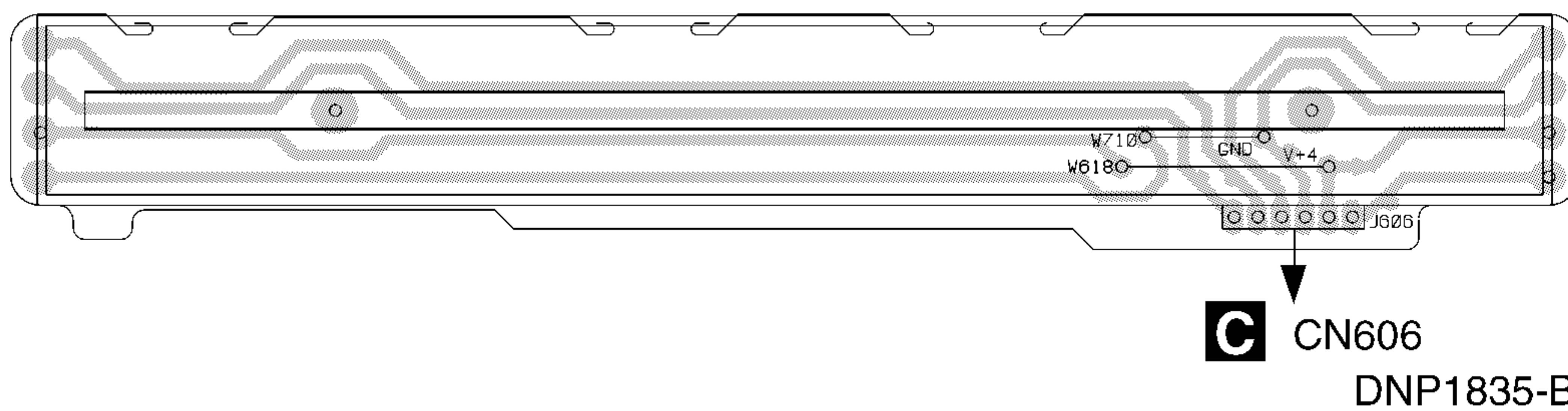

F LED B BOARD ASSY

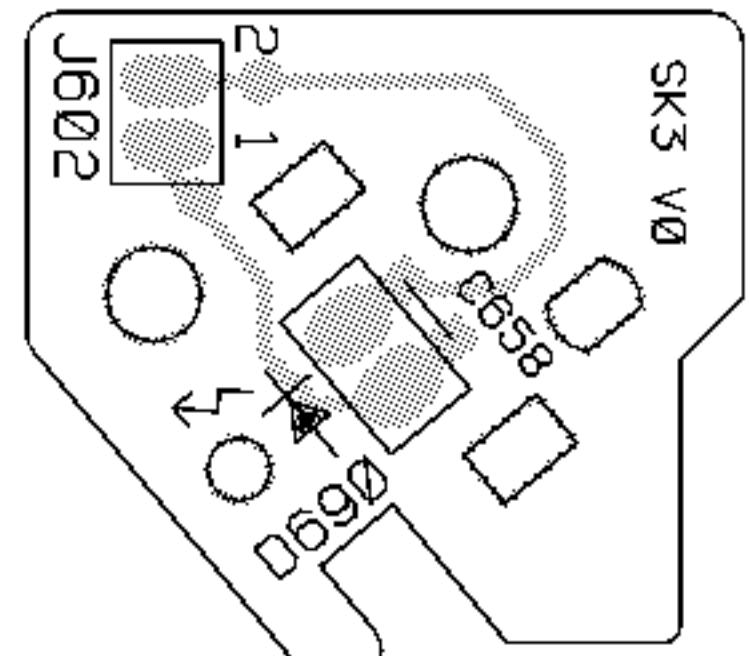

DNP1834-B

E LED A BOARD ASSY

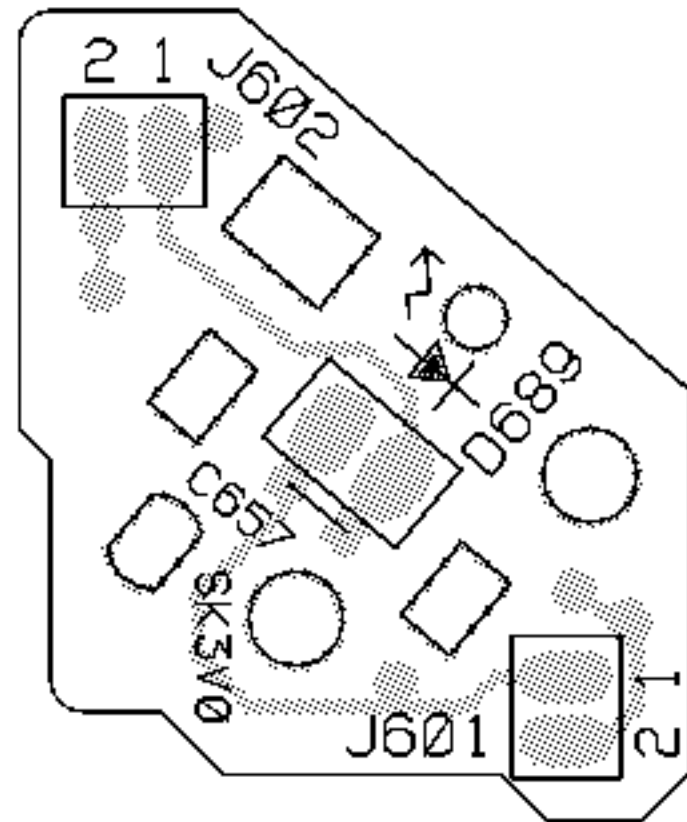

DNP1834-B

C FUNCTION BOARD ASSY

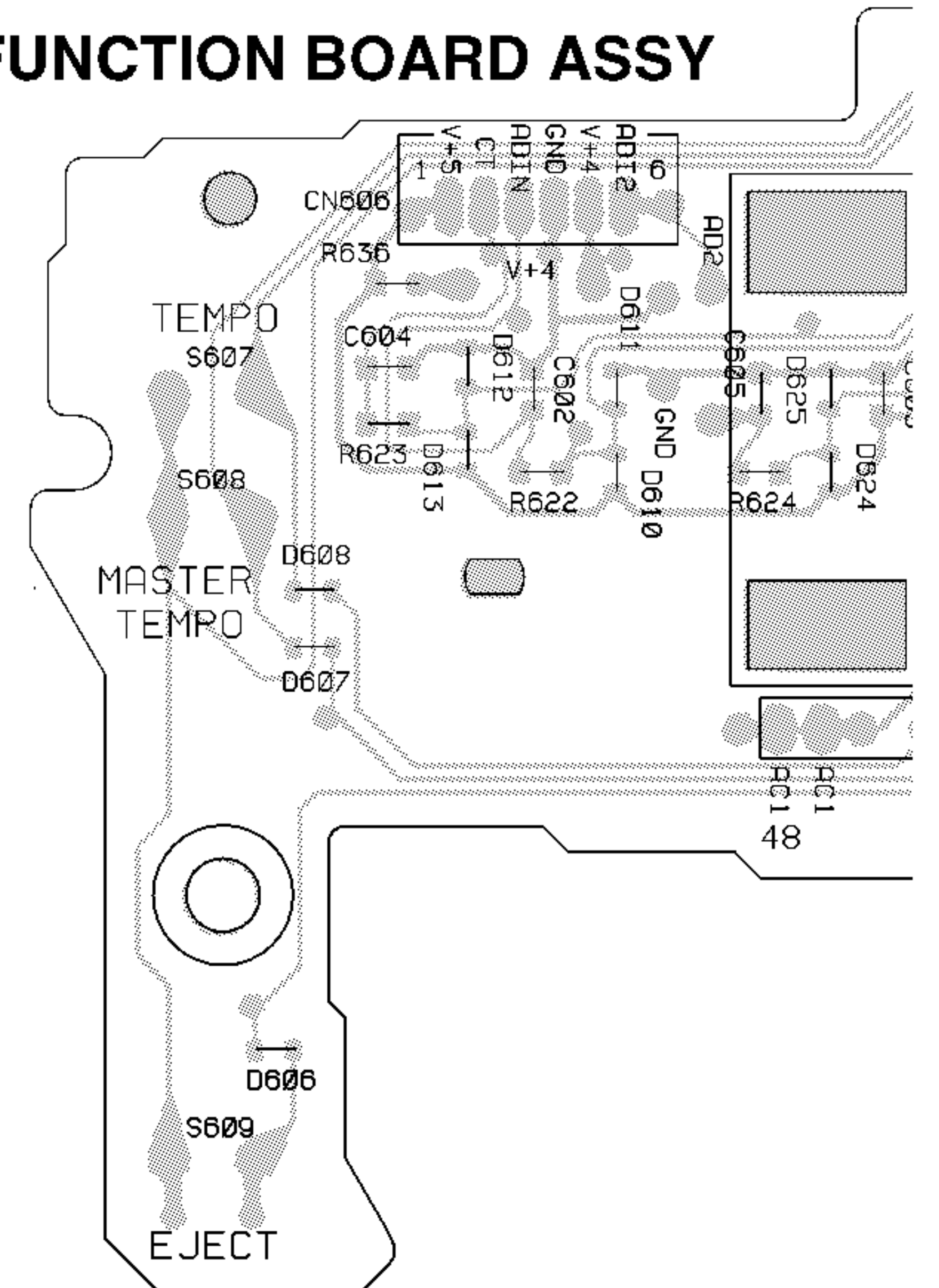

D DOOR BOARD ASSY

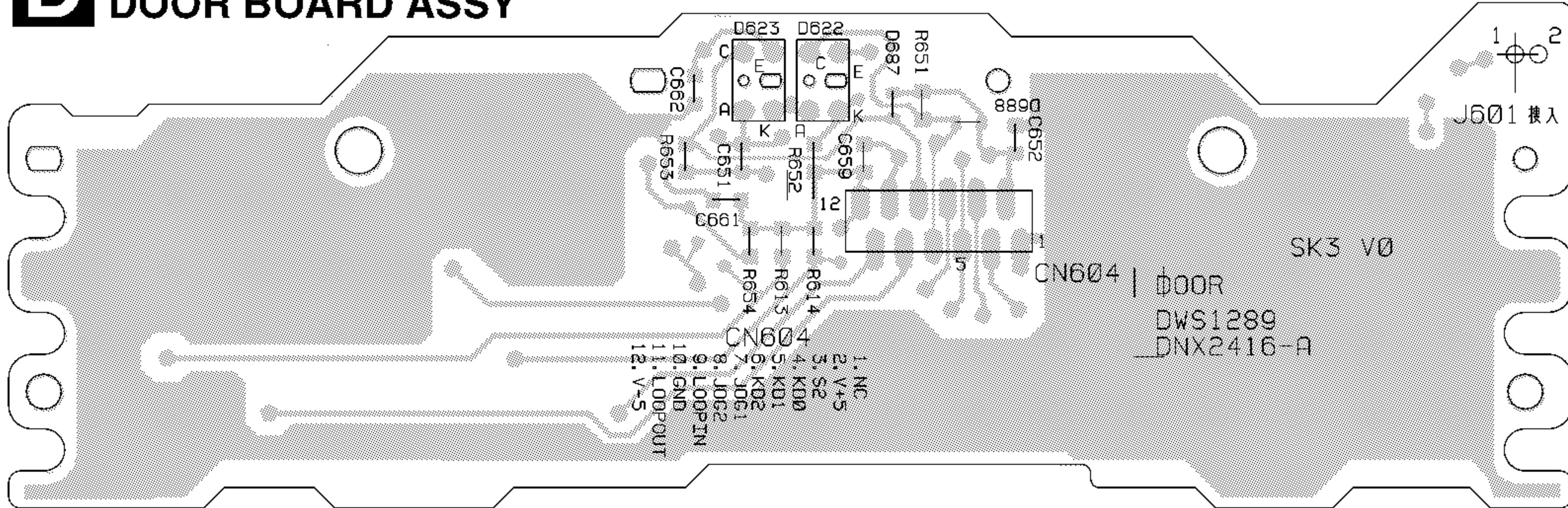

DNP1834-B

G SLIDER BOARD ASSY

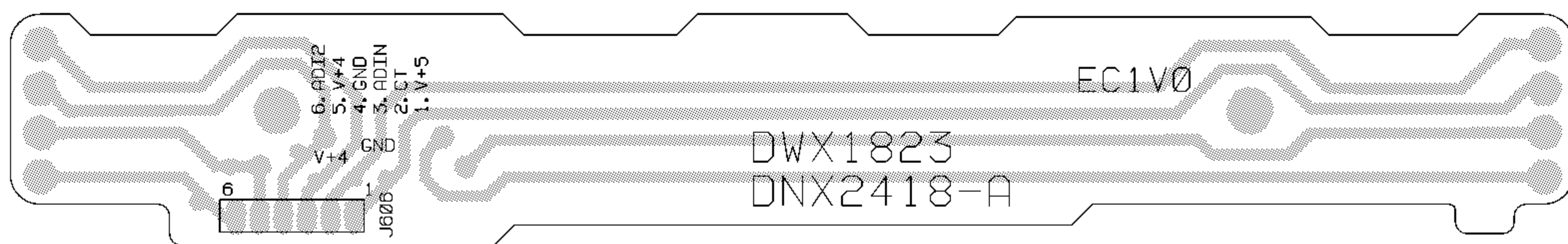

DNP1835-B

SIDE B

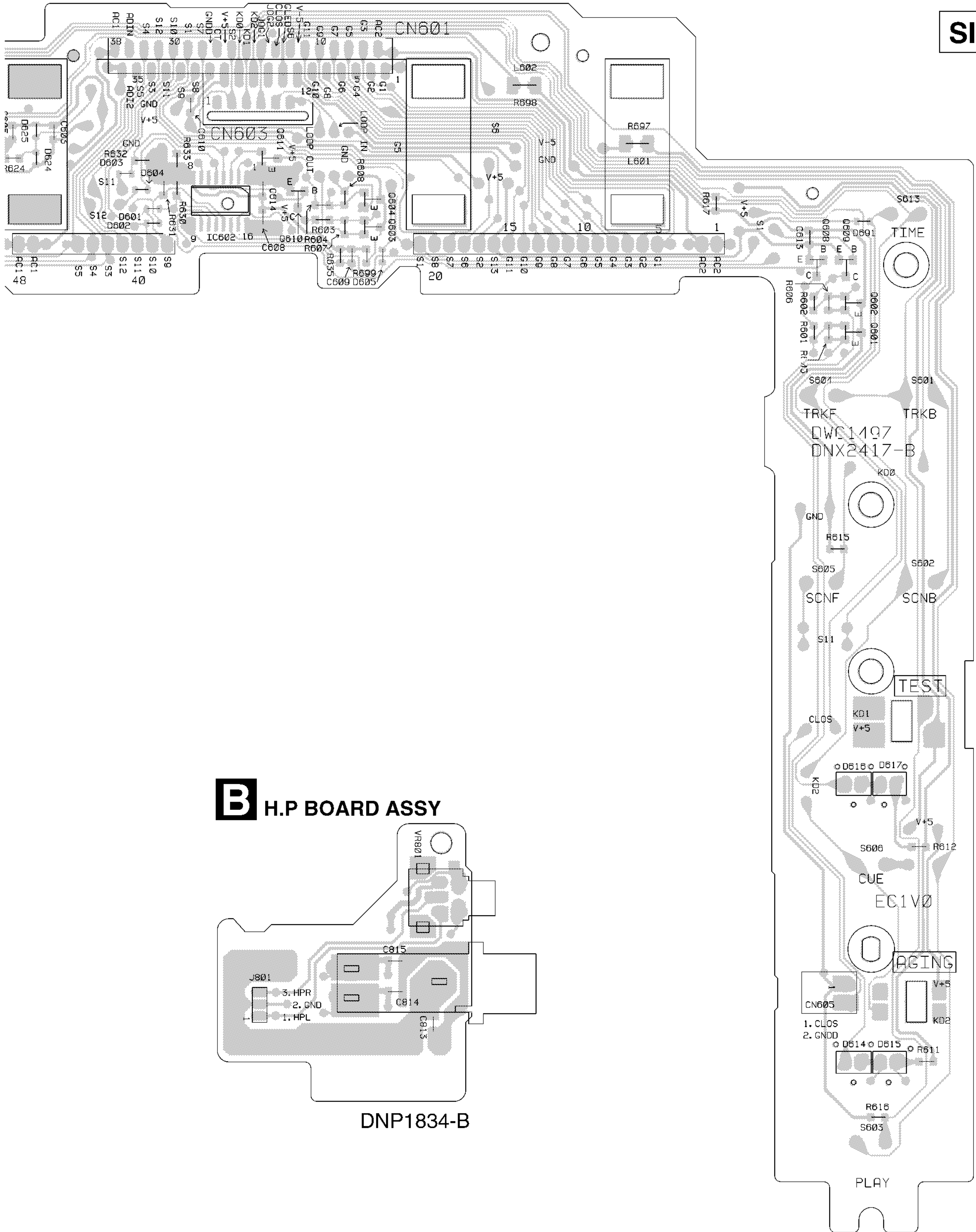

- Q611
- IC602
- Q610
- Q604
- Q603
- Q608
- Q609
- Q602
- Q601

B H.P BOARD ASSY

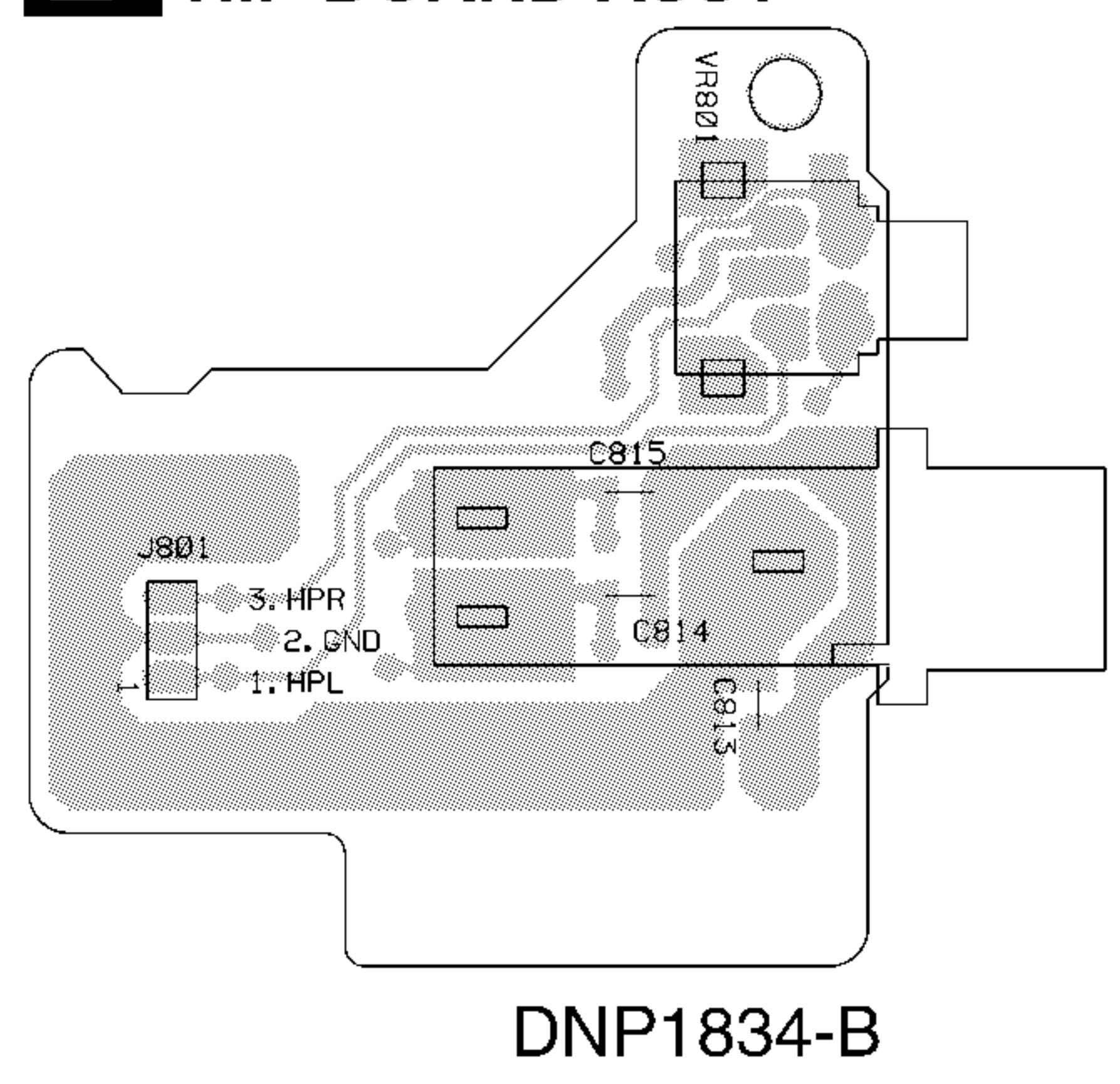

DNP1834-B

DNP1835-B

B C

CDJ-700S, CDJ-500S

4.3 POWER SW BOARD ASSY, TRANS BOARD ASSY AND REGULATOR BORD ASSY

CDJ-700S/KUC

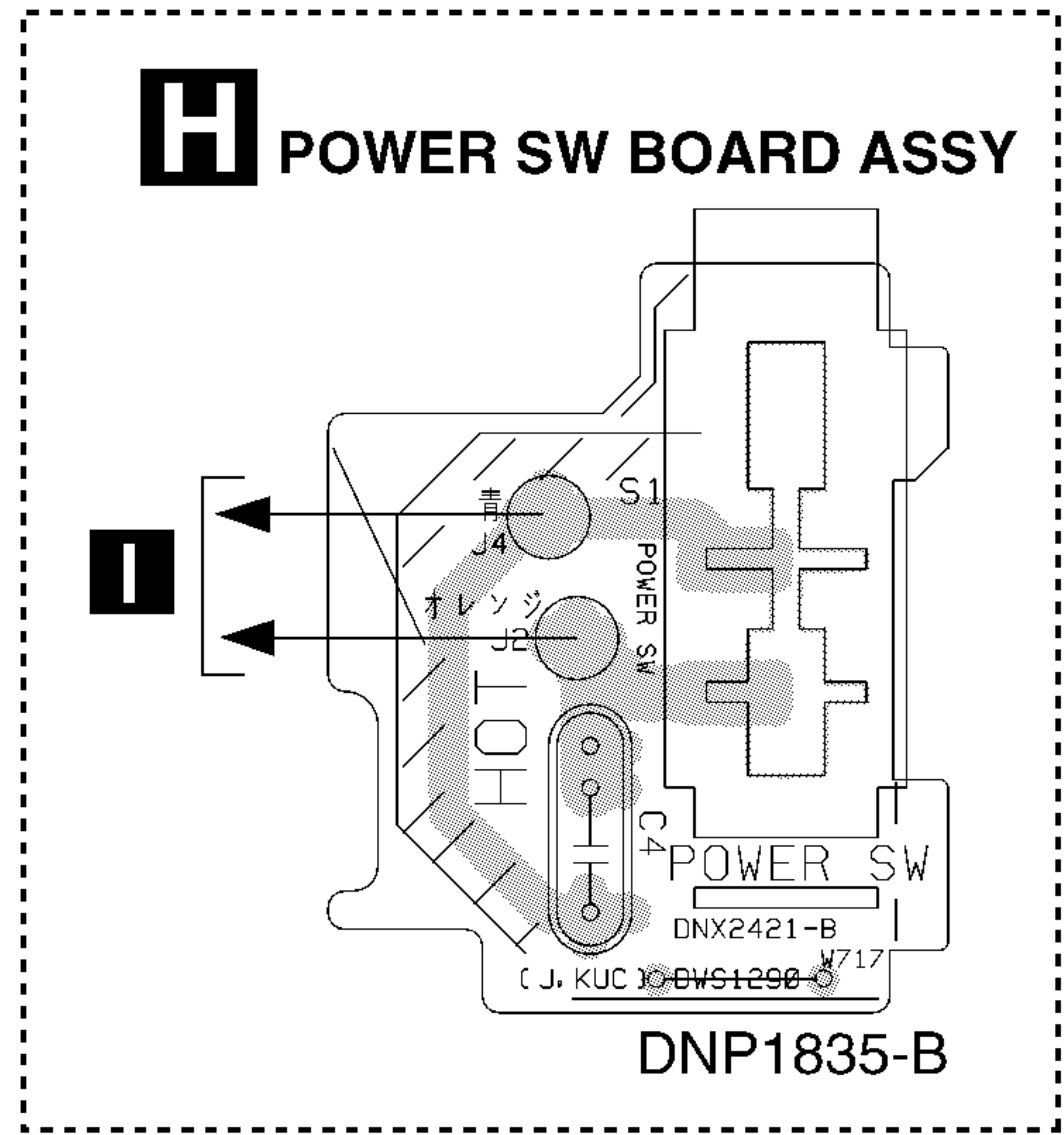

CDJ-500S/HY,SL

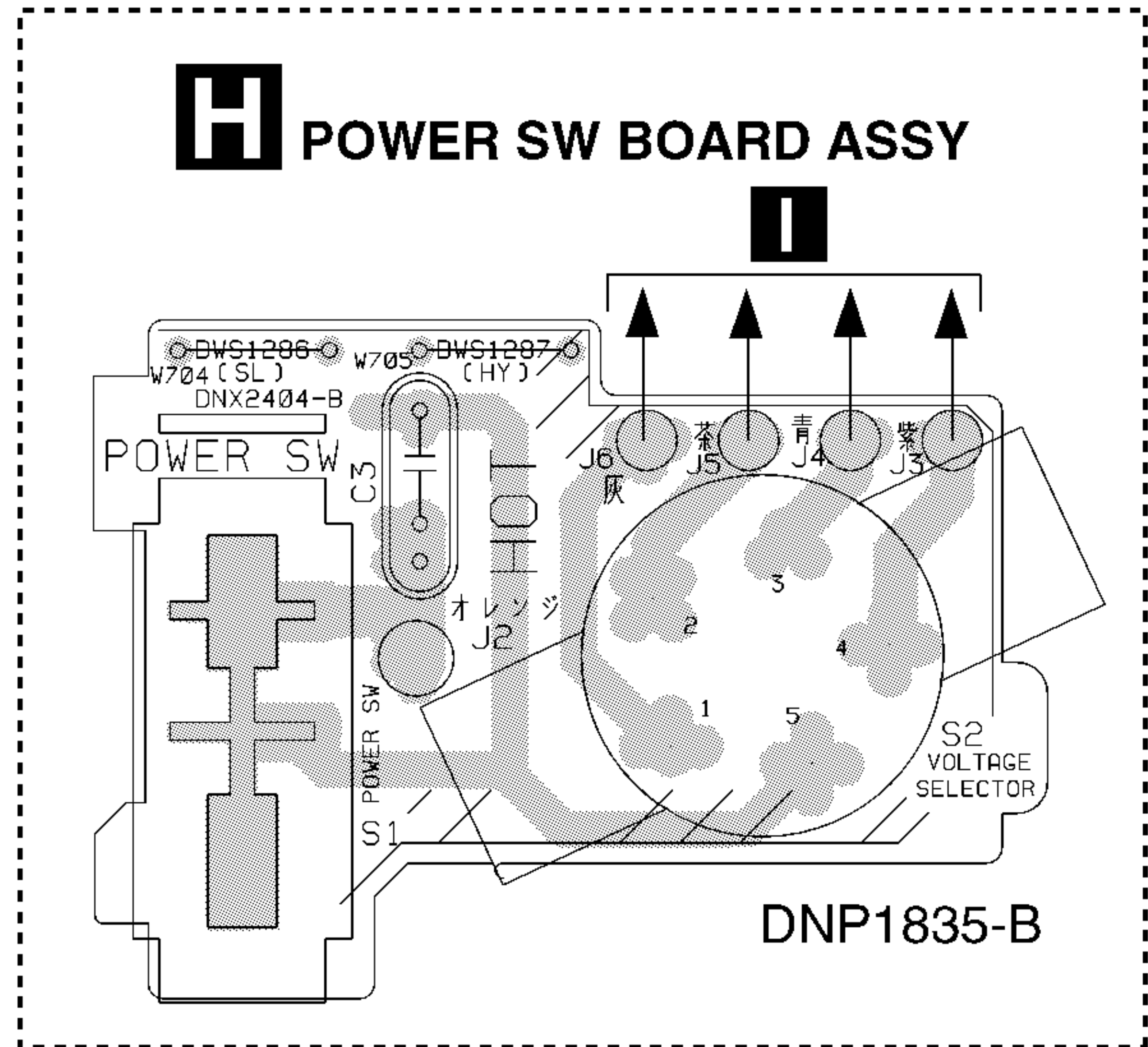

I TRANS BOARD ASSY

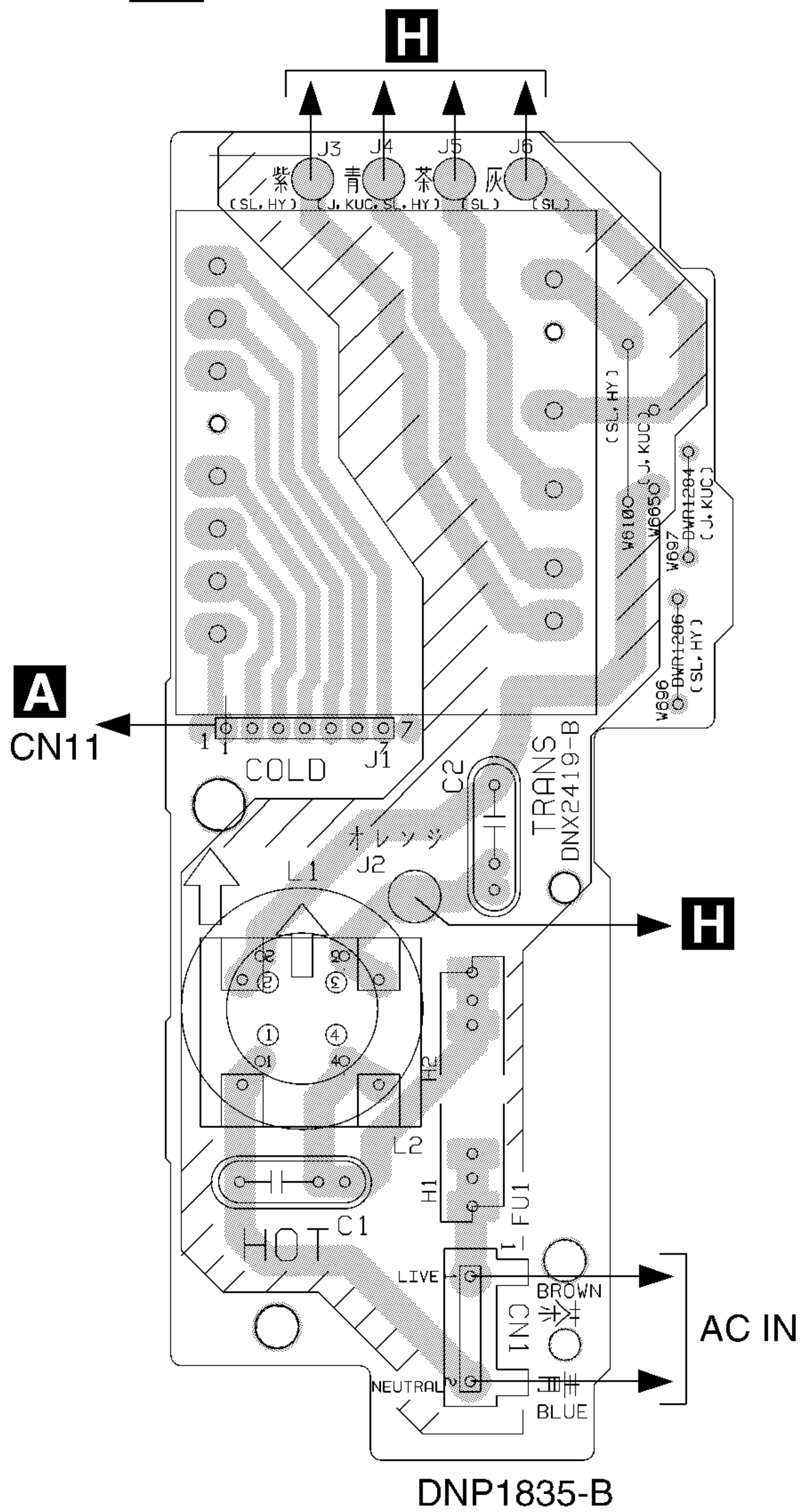

SIDE A

J REGULATOR BOARD ASSY

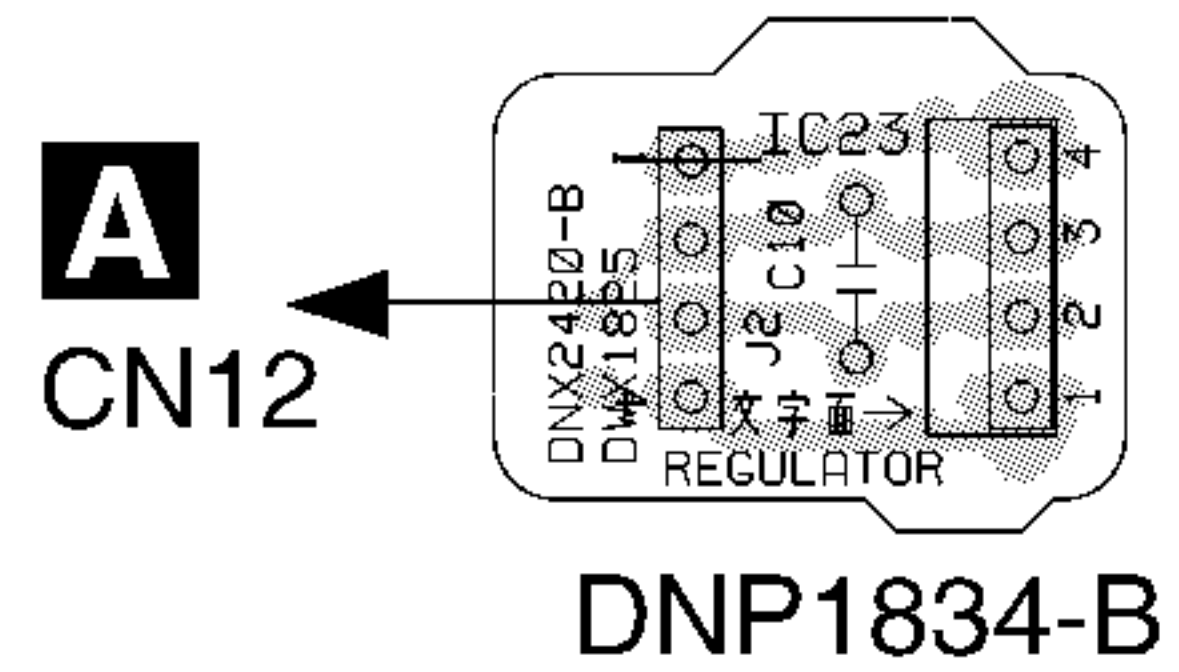

CDJ-500S/HY,SL

H POWER SW BOARD ASSY

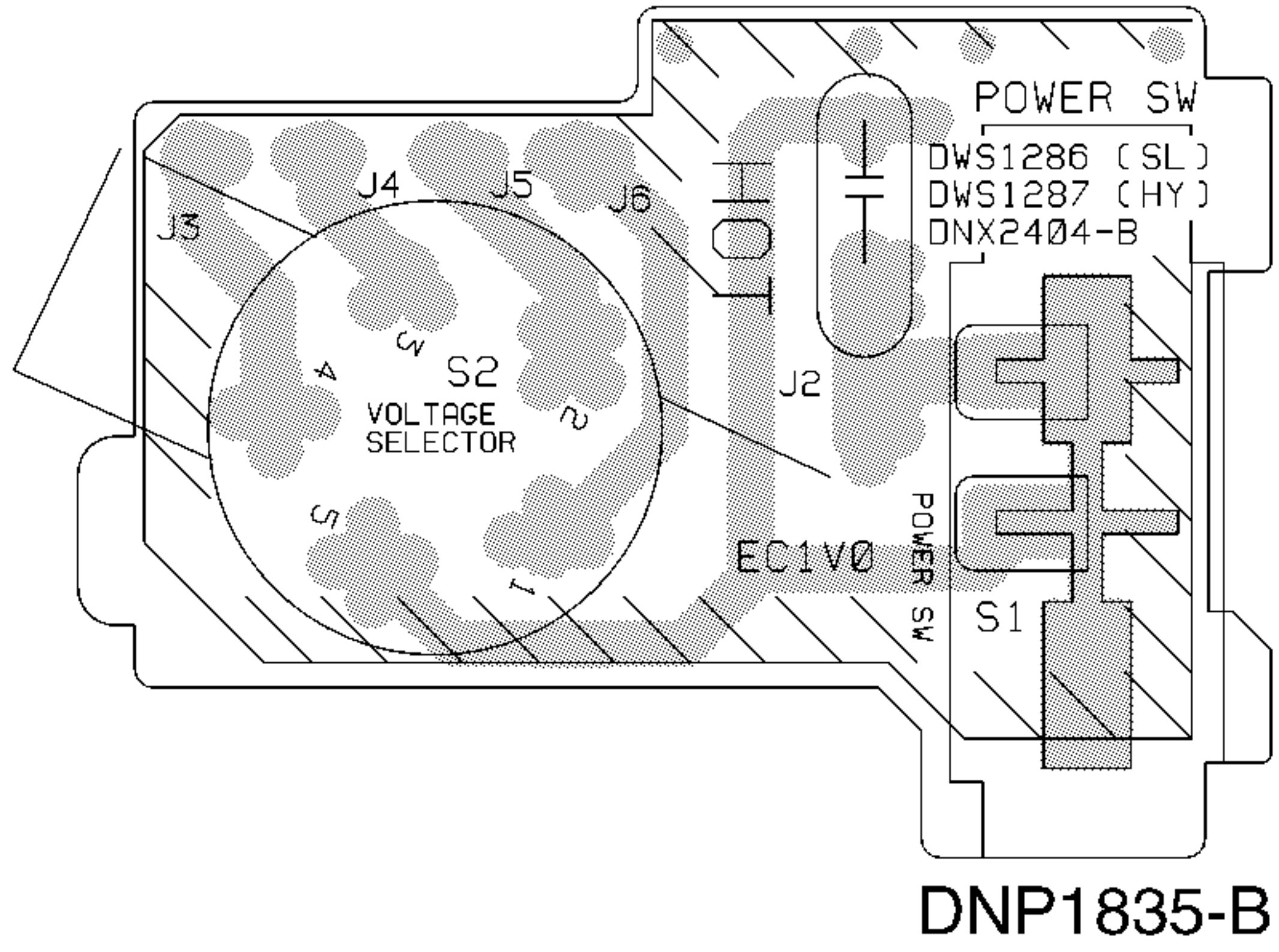

CDJ-700S/KUC

H POWER SW BOARD ASSY

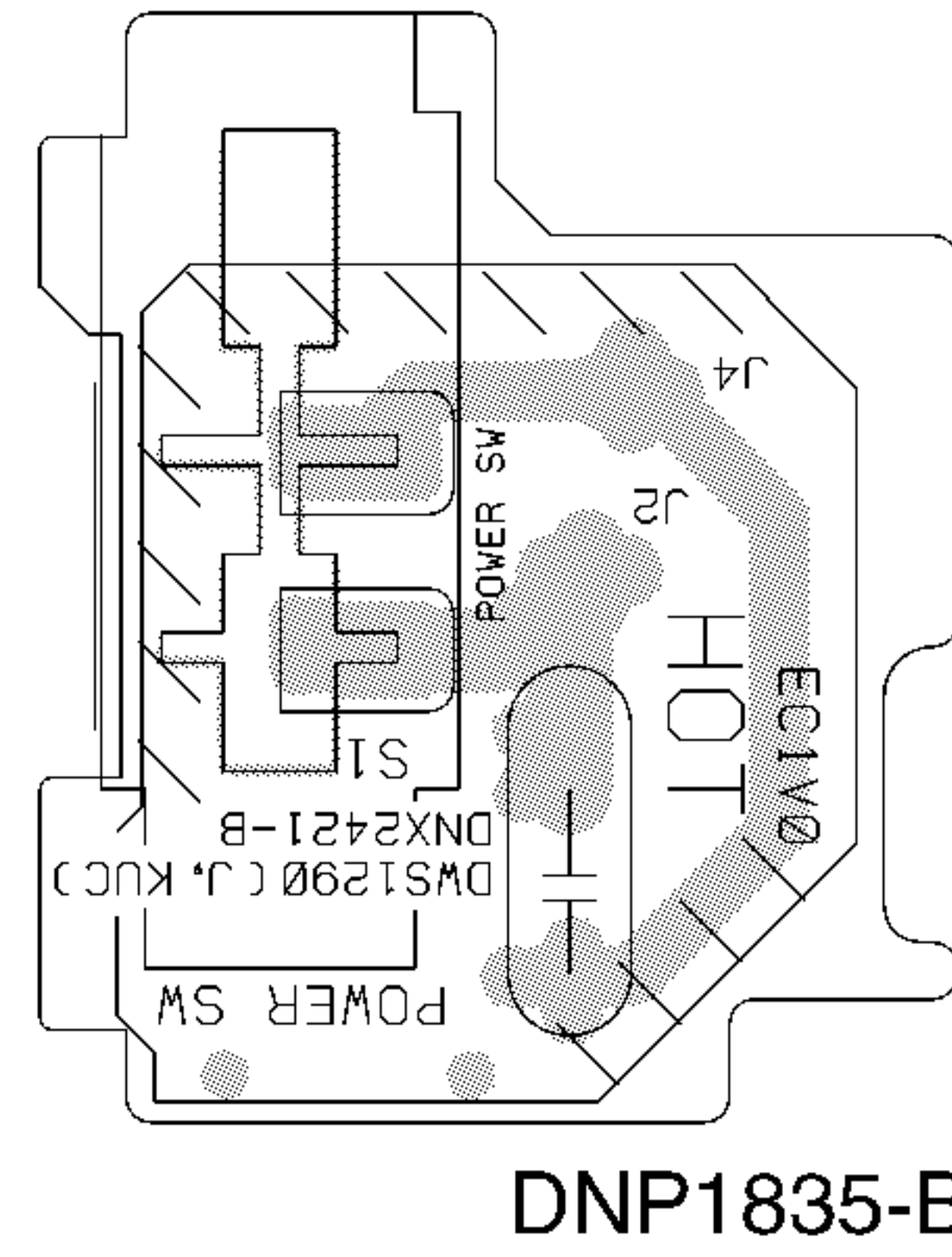

SIDE B

J REGULATOR BOARD ASSY

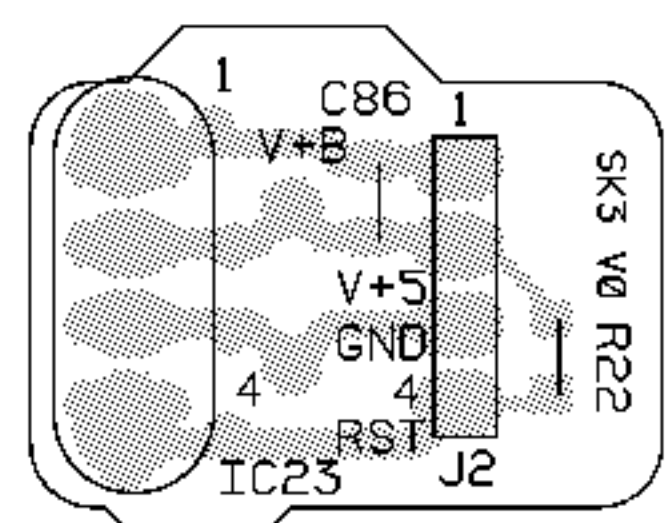

DNP1834-B

I TRANS BOARD ASSY

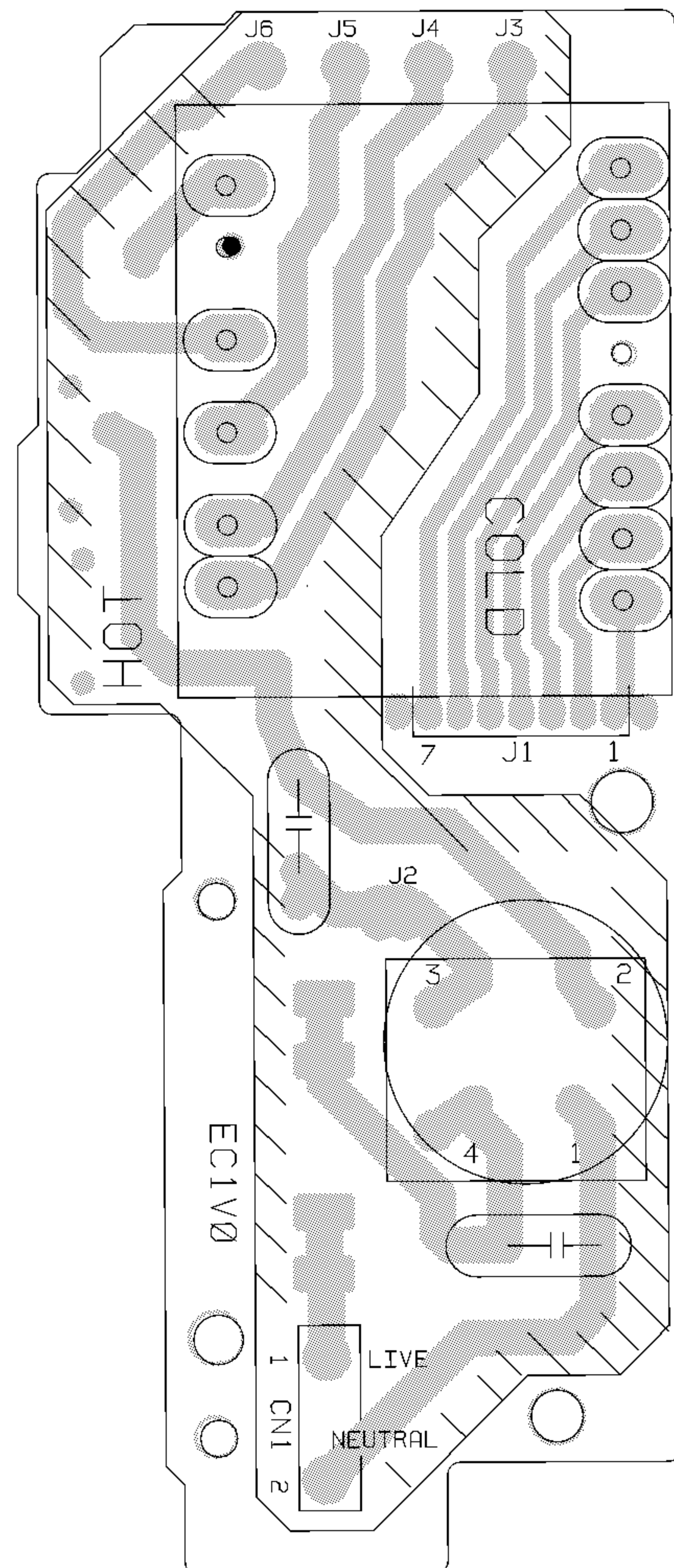

DNP1835-B

CDJ-700S,CDJ-500S

5. PCB PARTS LIST

NOTES: • Parts marked by "NSP" are generally unavailable because they are not in our Master Spare Parts List.

• The Δ mark found on some component parts indicates the importance of the safety factor of the part. Therefore, when replacing, be sure to use parts of identical designation.

• When ordering resistors, first convert resistance values into code form as shown in the following examples.

Ex.1 When there are 2 effective digits (any digit apart from 0), such as 560 ohm and 47k ohm (tolerance is shown by J = 5%, and K = 10%).

560 Ω	\rightarrow	56 \times 10 ¹	\rightarrow	561	RD1/4PU	$\boxed{5}$ $\boxed{6}$ $\boxed{1}$ J
47k Ω	\rightarrow	47 \times 10 ³	\rightarrow	473	RD1/4PU	$\boxed{4}$ $\boxed{7}$ $\boxed{3}$ J
0.5 Ω	\rightarrow	R50			RN2H	\boxed{R} $\boxed{5}$ $\boxed{0}$ K
1 Ω	\rightarrow	1R0			RS1P	$\boxed{1}$ \boxed{R} $\boxed{0}$ K

Ex.2 When there are 3 effective digits (such as in high precision metal film resistors).

5.62k Ω	\rightarrow	562 \times 10 ¹	\rightarrow	5621	RN1/4PC	$\boxed{5}$ $\boxed{6}$ $\boxed{2}$ $\boxed{1}$ F
----------------	---------------	------------------------------	---------------	------------	---------	---------------------------------------------------

■ LIST OF WHOLE PCB ASSEMBLIES

CDJ-500S/HY, SL and CDJ-700S/KUC are constructed the same except for the following:

Mark	Symbol and Description	Part No.			Remarks
		CDJ-700S/KUC	CDJ-500S/HY	CDJ-500S/SL	
NSP	MOTHER BOARD ASSY	DWM2068	DWM2068	DWM2068	
NSP	— DOOR BOARD ASSY	DWS1289	DWS1289	DWS1289	
NSP	— LED B BOARD ASSY	DWX1819	DWX1819	DWX1819	
NSP	— MAIN BOARD ASSY	DWX1821	DWX1821	DWX1821	
NSP	— H.P BOARD ASSY	DWX1822	DWX1822	DWX1822	
NSP	— LED A BOARD ASSY	DWX1824	DWX1824	DWX1824	
NSP	— REGULATOR BOARD ASSY	DWX1825	DWX1825	DWX1825	
	SUB BOARD ASSY	DWX1820	DWX1812	DWX1811	
NSP	— FUNCTION BOARD ASSY	DWG1497	DWG1497	DWG1497	
NSP	— TRANS BOARD ASSY	DWR1284	DWR1286	DWR1286	*
NSP	— POWER SW BOARD ASSY	DWS1290	DWS1287	DWS1286	
NSP	— SLIDER BOARD ASSY	DWX1823	DWX1823	DWX1823	

Note * : Although DWR1284 and DWR1286 are different in part number, they consist of the same components.

■ CONTRAST OF PCB ASSEMBLIES

POWER SW BOARD ASSY

DWS1287, DWS1286 and DWS1290 are constructed the same except for the following:

Mark	Symbol and Description	Part No.			Remarks
		DWS1290	DWS1287	DWS1286	
Δ	C3 (4700pF/AC250V) C4 (4700pF/AC250V) S2	Not used ACG7018 Not used	ACG7018 Not used DSB1011	ACG7018 Not used DSB1014	

■ PARTS LIST FOR CDJ-700S/KUC

Mark No. Description Parts No.

D DOOR BOARD ASSY

SEMICONDUCTORS

D609, D683 – D688	1SS355
D622, D623	GP1S94
D618 – D621	LT1H40A

SWITCHES AND RELAYS

S610 – S612	DSG1061
-------------	---------

CAPACITORS

C654, C656	CKSQYF473Z50
------------	--------------

Mark No. Description Parts No.

RESISTORS

All Resistors	RS1/10S□□□J
---------------	-------------

OTHERS

CN604	CONNECTOR 12P	HLEM12R – 1
-------	---------------	-------------

F LED B BOARD ASSY

SEMICONDUCTORS

D690	MPY4361F
------	----------

Mark	No.	Description	Parts No.	Mark	No.	Description	Parts No.
A MAIN BOARD ASSY							
SEMICONDUCTORS							
	IC201		BA6849FP	C109, C501			CEJA101M10
	IC302		BA7042	C201			CEJA101M16
	IC101		CXA1782CQ	C124, C126, C130, C219, C318			CEJA101M6R3
	IC301		CXD2500BQ	C705			CEJA101M6R3
	IC404		HM514800CJ - 7	C55			CEJA220M50
△	IC92		ICP - N10	C409, C511			CEJA330M10
△	IC91		ICP - N20	C119, C120, C401, C413, C421			CEJA330M16
△	IC102		LA6520	C429, C441, C512			CEJA330M16
	IC409		LH52256AN - 70LL	C316, C516			CEJA3R3M50
	IC206		MPC17A85ZVM	C114, C513, C514			CEJA470M10
	IC103, IC106		NJM2068M	C315			CEJA470M16
	IC104, IC901, IC902		NJM2904M	C107			CEJA4R7M35
	IC801		NJM4556AM	C308			CEJAR47M50
	IC505		NJM4558MD	C317			CFTLA474J50
△	IC22		NJM79M05FA	C110, C116, C320			CKSQYB102K50
	IC502		PCM1700U - J	C118, C131 - C133, C213, C104, C141			CKSQYB103K50
	IC701		PD4842A	C220, C221, C307, C704, C905			CKSQYB103K50
	IC501		SM5841CP	C102, C103, C105, C108, C113			CKSQYB104K25
	IC107		TC4W53F	C128, C161, C162, C207			CKSQYB104K25
	IC105		TC4W66F	C907			CKSQYB105K10
	IC303		TC7SU04F	C711, C712			CKSQYB122K50
	IC402, IC403		UPD6383GF	C313, C517, C518			CKSQYB152K50
	Q101		2SA854S	C106, C173, C311			CKSQYB222K50
△	Q1		2SB1566	C163, C903, C904			CKSQYB224K16
	Q103		2SD2114K	C225			CKSQYB332K50
	Q501 - Q504		2SD2144S	C122			CKSQYB333K50
	Q102		DTA124EK	C111			CKSQYB473K25
	Q505		DTC124ES	C101, C312, C703			CKSQYB473K50
△	D11 - D14		11E2	C129, C174			CKSQYB474K16
△	D51, D52		1SR139 - 400	C125			CKSQYB562K50
	D301 - D304, D501, D701 - D705		1SS355	C117, C153			CKSQYB682K50
	D712, D713, D729 - D731, D734		1SS355	C127			CKSQYB683K25
	D901 - D904		1SS355	C112, C135, C137			CKSQYF103Z50
	D54		MTZJ27A/BX	C152, C157, C171, C172			CKSQYF103Z50
	D55		MTZJ36A/BX	C218, C222 - C224, C231, C301			CKSQYF103Z50
	D502, D503		UDZ10B	C303, C314, C319, C351 - C353			CKSQYF103Z50
				C402, C406, C410, C412			CKSQYF103Z50
				C422, C423, C430, C442, C502			CKSQYF103Z50
				C519, C520, C540, C579, C591			CKSQYF103Z50
				C702, C821, C822, C901, C902			CKSQYF103Z50
				C202, C206, C208 - C210			CKSQYF104Z25
				C11, C12, C123, C13 - C15			CKSQYF473Z50
				C151, C158, C159, C16, C17			CKSQYF473Z50
				C411, C431, C701, C706, C709			CKSQYF473Z50
				C83, C84			CKSQYF473Z50
				C707, C708			CKSQYF474Z16
				C529, C530, C541, C542			CQMA152J50
				C21 - C26 (3300μF/16V)			DCH1093
				C52 (100μF/10V)			DCH1098
				C32 (1000μF/6.3V)			DCH1099
				C405 (1μF/25V)			DCH1101
				C310 (10μF/6.3V)			VCH1155
				VC301			VCM1002
	C304, C305		CCSQCH180J50				
	C309		CCSQCH221J50				
	C115, C148		CCSQCH270J50				
	C407, C408, C427, C428		CCSQCH5R0C50				
	C121		CCSQCH680J50				
	C533, C534		CEAS220M25				
	C31, C53		CEAS221M50				
	C515		CEAS3R3M50				
	C33		CEAS471M10				
	C306		CEAS471M6R3				

CDJ-700S,CDJ-500S

Mark No. Description Parts No.

RESISTORS

R402, R403 RD1/4PU223J
 R535, R536 RD1/4VM102J
 R60 RD1/4VM222J
 R539, R540, R561 – R564 RD1/4VM471J
 R533, R534 RD1/4VM511J

R223, R224 (0.47Ω, 1/4W) DCN1035
 R281, R282 (1.5Ω, 1/4W) DCN1036
 R206, R207 RS1/10S1002F
 R108 RS1/10S2403F
 VR101 – VR104 (22kΩ) PCP1035

VR501, VR502 (100kΩ) PCP1044
 VR201, VR202 (100Ω) PCP1038

Other Resistors RS1/10S□□□J

OTHERS

CN103 MT 5P CONNECTOR 173981 – 5
 CN501 3P JUMPER CONNECTOR 52147 – 0310
 CN201 CONNECTOR 52207 – 1590
 PCB BINDER DEF1012
 CN101 CONNECTOR (17P) DKC1005

X401, X402 CERAMIC RESONATOR DSS1054
 (24.576MHz)
 CN701 CONNECTOR HLEM38S – 1
 CN12 CONNECTOR(4P) KPC4
 CN11 CONNECTOR(7P) KPC7

JA501 JACK PKB1023
 JA502 JACK RKN1004
 PCB BINDER VEF1040
 CN202 4P CONNECTOR VKN1235
 KN1 EARTH METAL FITTING VNF1084

X701 CERAMIC RESONATOR VSS1014
 (4.19MHz)
 X301 CRYSTAL RESONATOR VSS1084
 (16.9344MHz)

B H.P BOARD ASSY

CAPACITORS

C813 – C815 CKSQYF103Z50

RESISTORS

VR801 (5kΩ – B) DCS1043

OTHERS

JA801 JACK DKN1179

E LED A BOARD ASSY

SEMICONDUCTORS

D689 MPY4361F

J REGULATOR BOARD ASSY

SEMICONDUCTORS

△ IC23 PQ05RR12

Mark No. Description Parts No.

RESISTORS

All Resistors RS1/10S□□□J

C FUNCTION BOARD ASSY

SEMICONDUCTORS

IC602 TC74HC175AF
 Q601 – Q604 2SC2412K
 Q608 – Q611 DTA124EK
 D601 – D608, D610 – D613 1SS355
 D624, D625, D691 1SS355

D614, D615 GL5EG8
 D616, D617 GL5HY8

SWITCHES AND RELAYS

S603, S606 DSG1056
 S607 – S609, S613 PSG1006
 S601, S602, S604, S605 RSG1030

CAPACITORS

C602 – C605, C608, C609 CKSQYF103Z50
 C613, C614 CKSQYF103Z50
 C610 CKSQYF473Z50

RESISTORS

All Resistors RS1/10S□□□J

OTHERS

CN606 6PJUMPER CONNECTOR 52151 – 0610
 CN603 CONNECTOR 12P 52492 – 1220
 FL HOLDER DEB1358
 V601 FL INDICATOR TUBE DEL1029
 CN601 CONNECTOR HLEM38R – 1
 CN605 KR CONNECTOR S2B – PH – K – S

I TRANS BOARD ASSY

COILS AND FILTERS

△ L1 LINE FILTER (L=800μH) DTL1016

CAPACITORS

△ C1, C2 (10000pF/AC250V) ACG7020

OTHERS

J1 PARALLEL CORD DXWY0720E
 △ TERMINAL RKC – 061
 H1, H2 HOLDER RKR1003

H POWER SW BOARD ASSY

CAPACITORS

△ C4 (4700pF/AC250V) ACG7018

OTHERS

△ J2 DDF1012

G SLIDER BOARD ASSY

RESISTORS

VR601 (50kΩ – B×2) DCV1007

OTHERS



J606 PARALLEL WIRE D20PWY0615E

6. ADJUSTMENT

6.1 ELECTRIC ADJUSTMENTS

6.1.1 PREPARATIONS

1.1 Jigs and Measuring Instruments

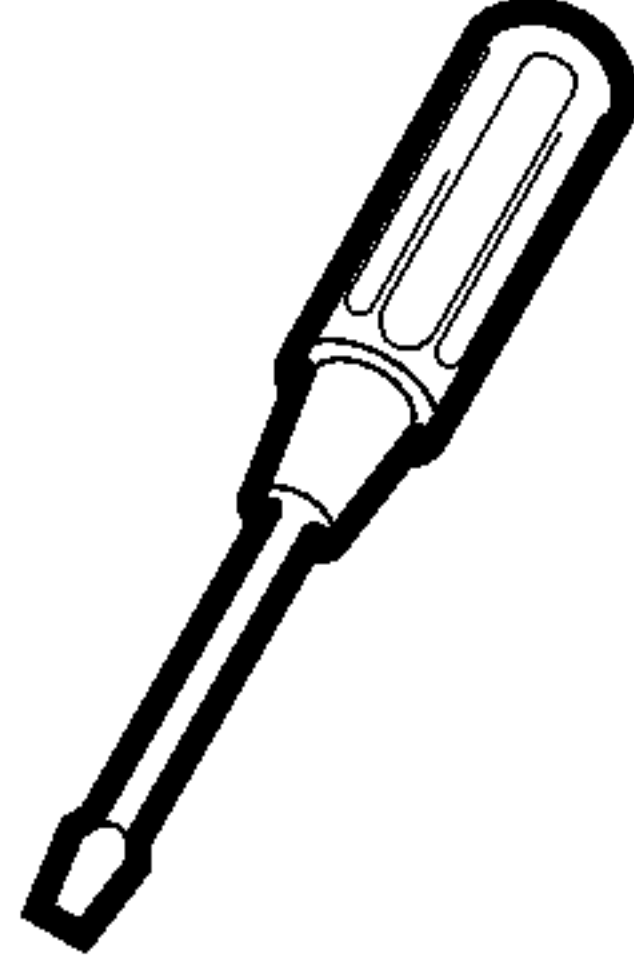
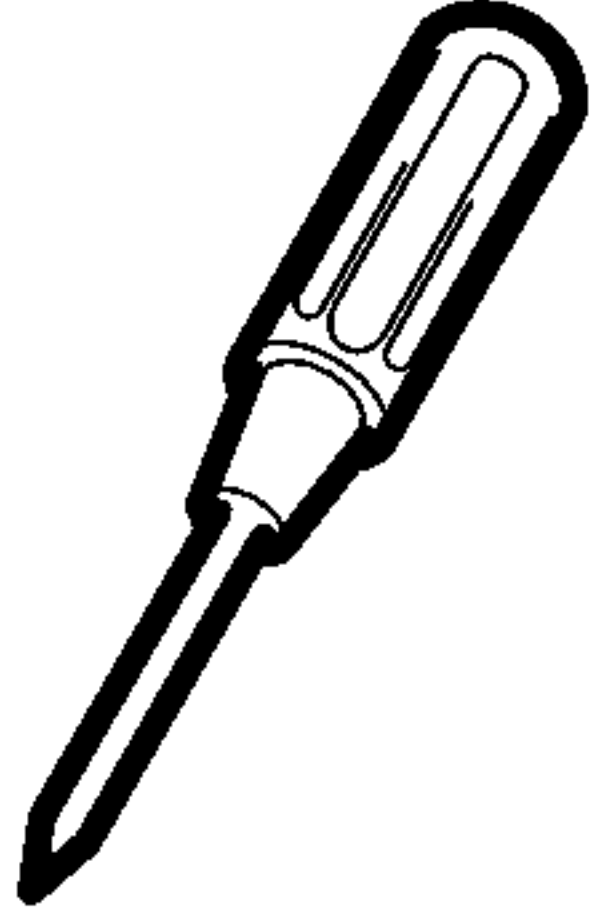
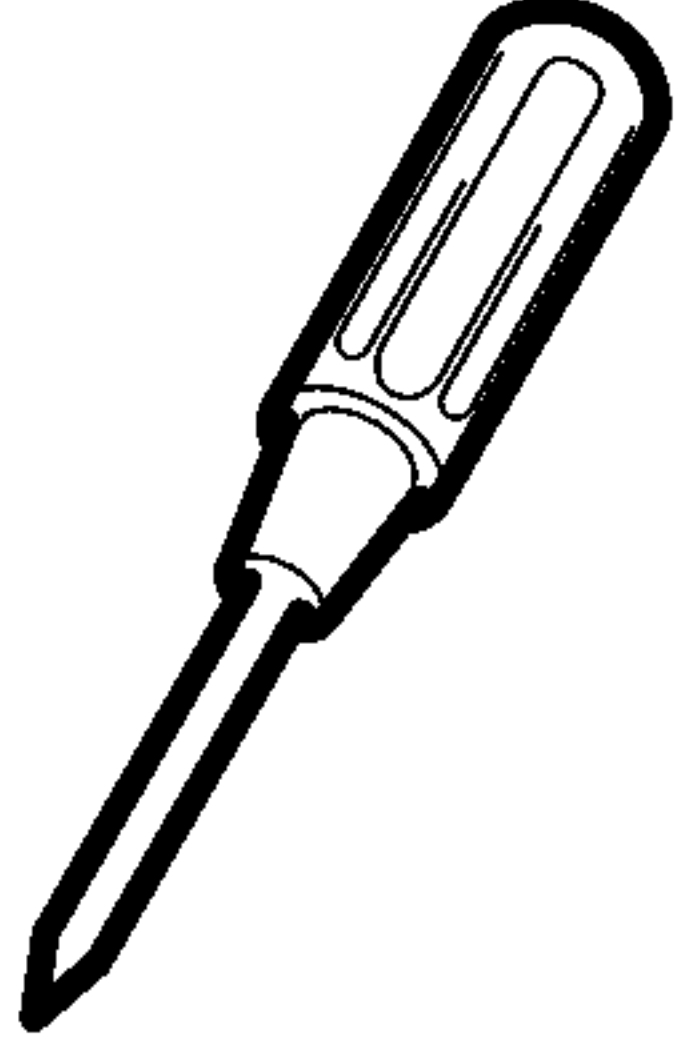
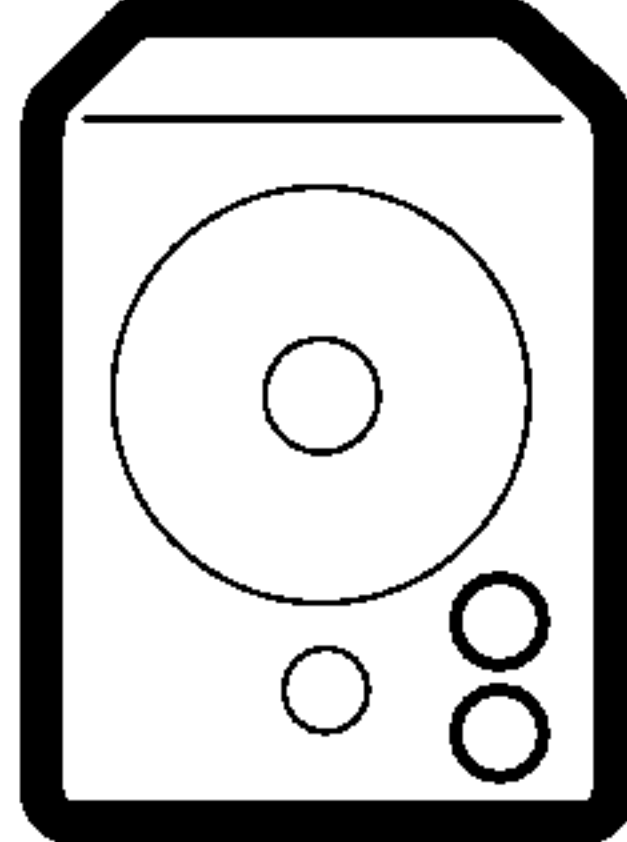
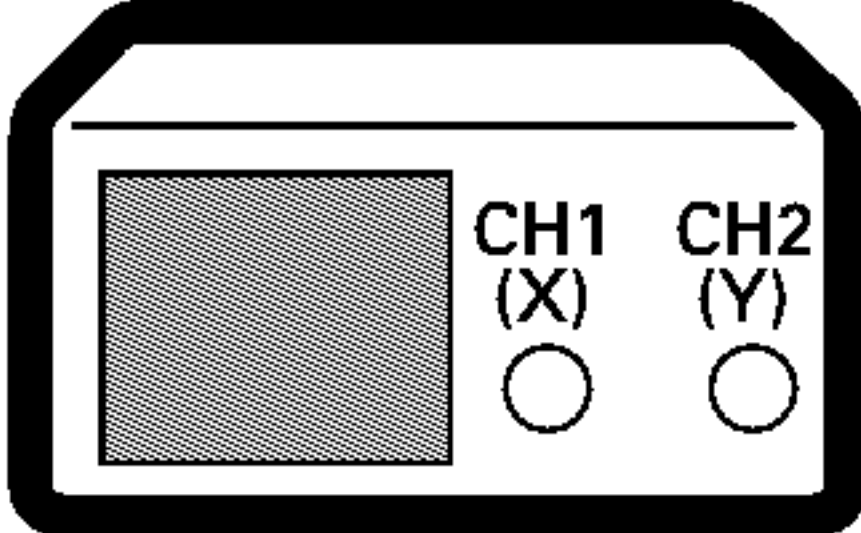
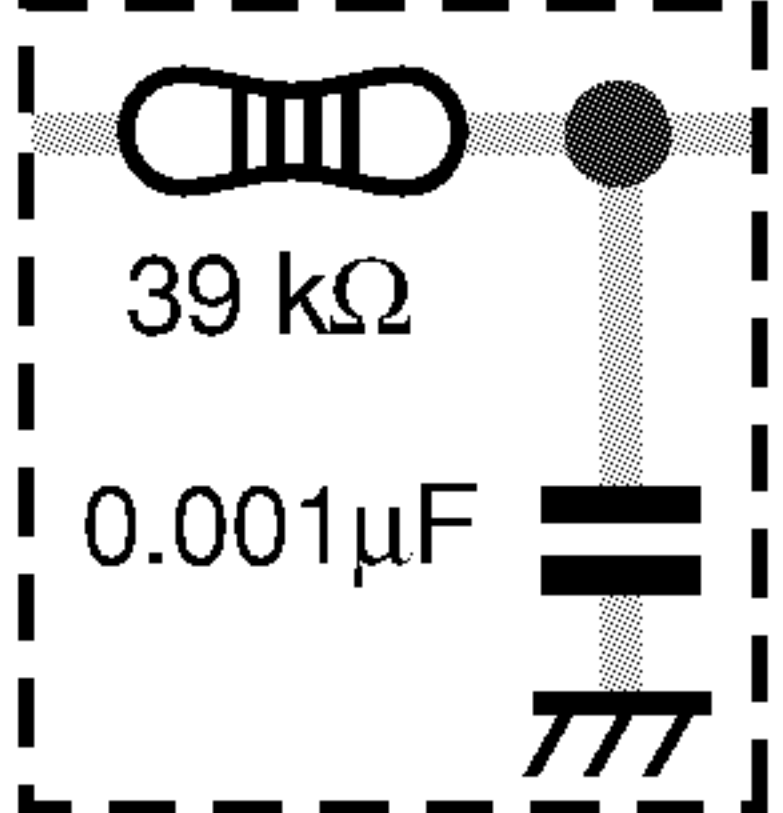
 <p>8-cm DISC (With at least about 20 minutes recording)</p>	 <p>CD TEST DISC (YEDS-7)</p>	 <p>⊖ Precise screwdriver</p>	 <p>⊖ screwdriver (small)</p>	 <p>⊕ screwdriver (medium)</p>
	 <p>⊕ screwdriver (large)</p>	 <p>Low-frequency oscillator</p>	 <p>Dual-trace oscilloscope (10 : 1 probe)</p>	 <p>Low pass filter^① (39 kΩ + 0.001μF)</p>

1.2 Necessary Adjustment Points

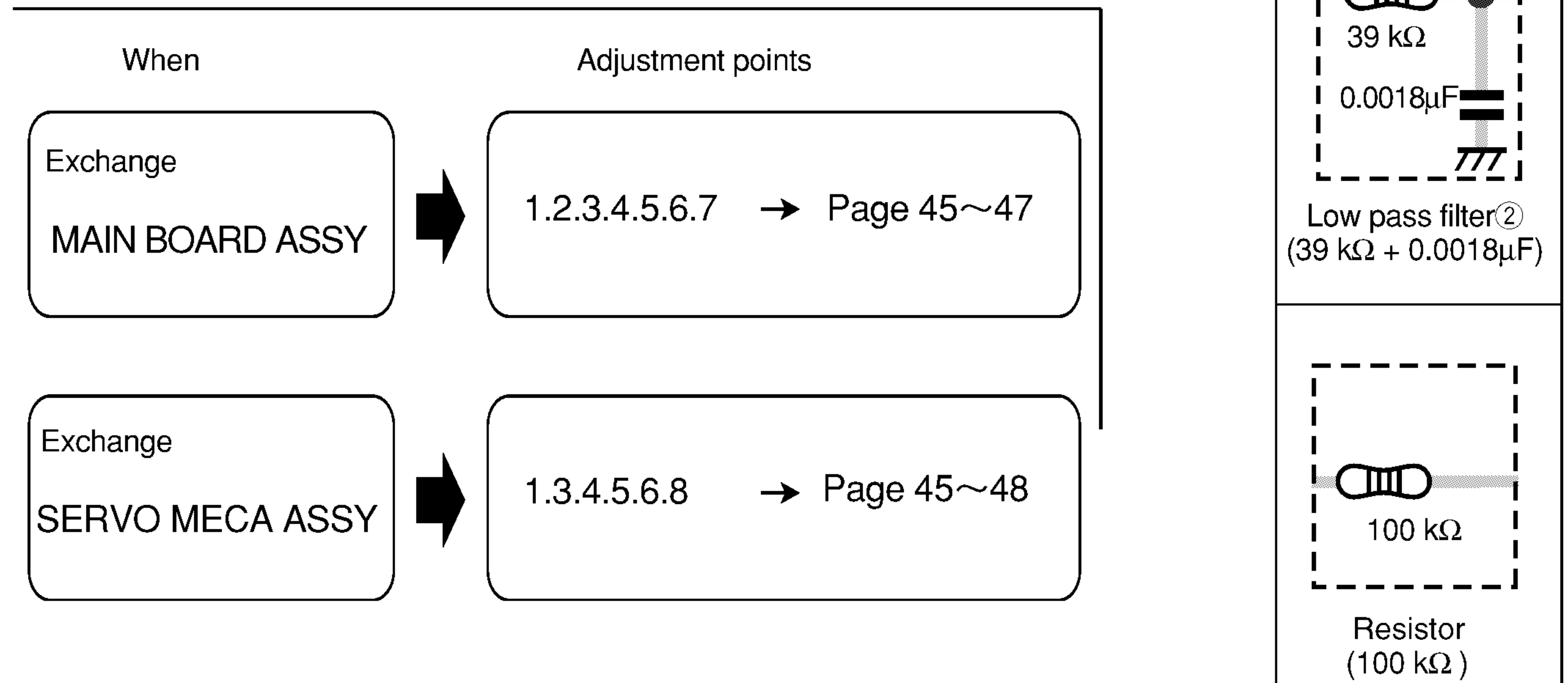

6.1.2 ADJUSTMENT

Precautions for Test Mode

- (1) If a soiled or damaged disc is played back and a GFS error is generated, the system may not perform a STOP operation and may run out of control, although muting ON/OFF will be performed. If the system does run out of control, press the CUE key to switch the power OFF.
- (2) Do NOT press any key while an OPEN/CLAMP, SPINDLE KICK, or FOCUS SEARCH operation is in progress. Be sure to wait until the operation is completed before calling the next operation.
- (3) Key operation can be done only when the servo mechanism is in the Clamped position (door closed).

1. How to Start/Cancel Test Mode

TEST MODE: ON

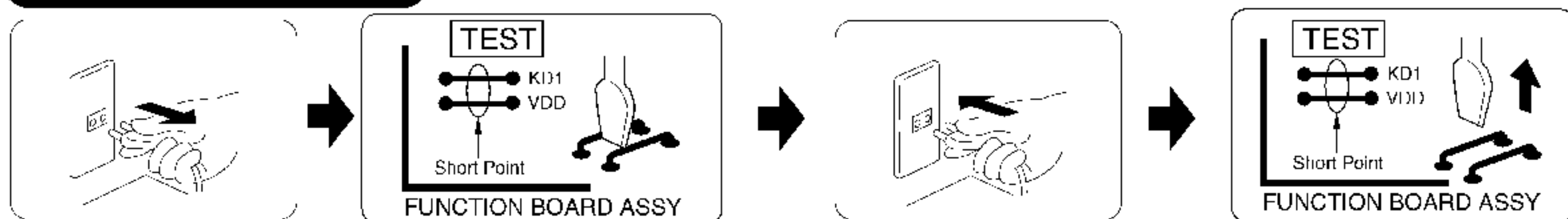

TEST MODE: PLAY

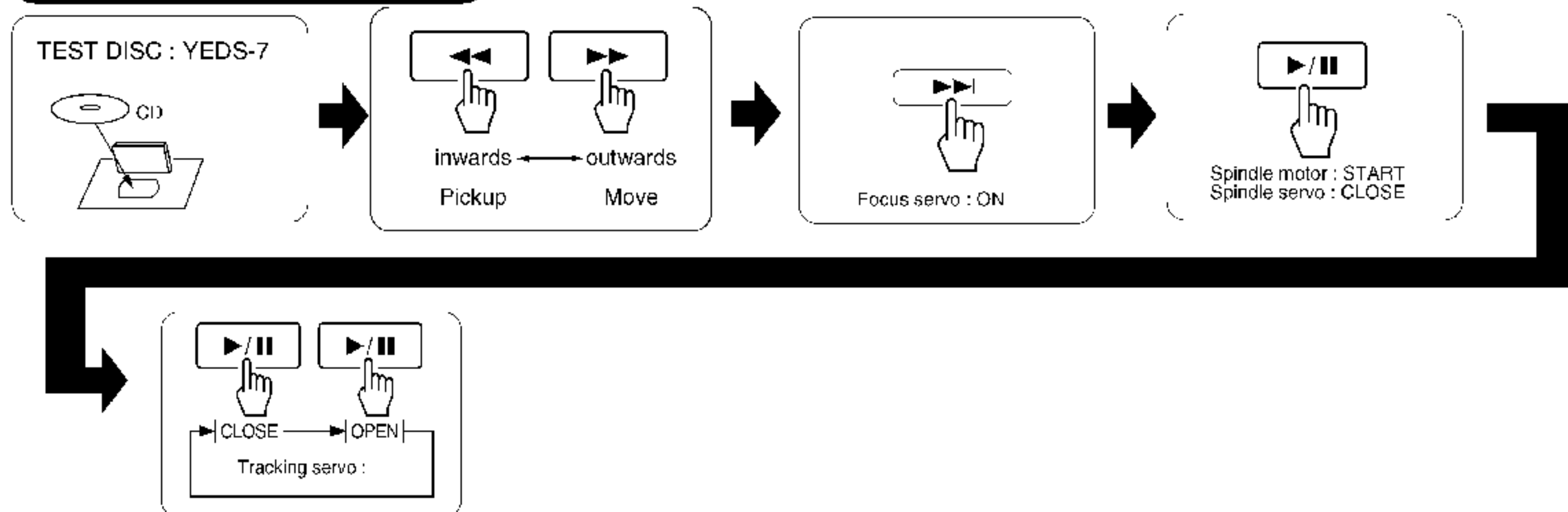

TEST MODE: DISPLAY

Switch status display

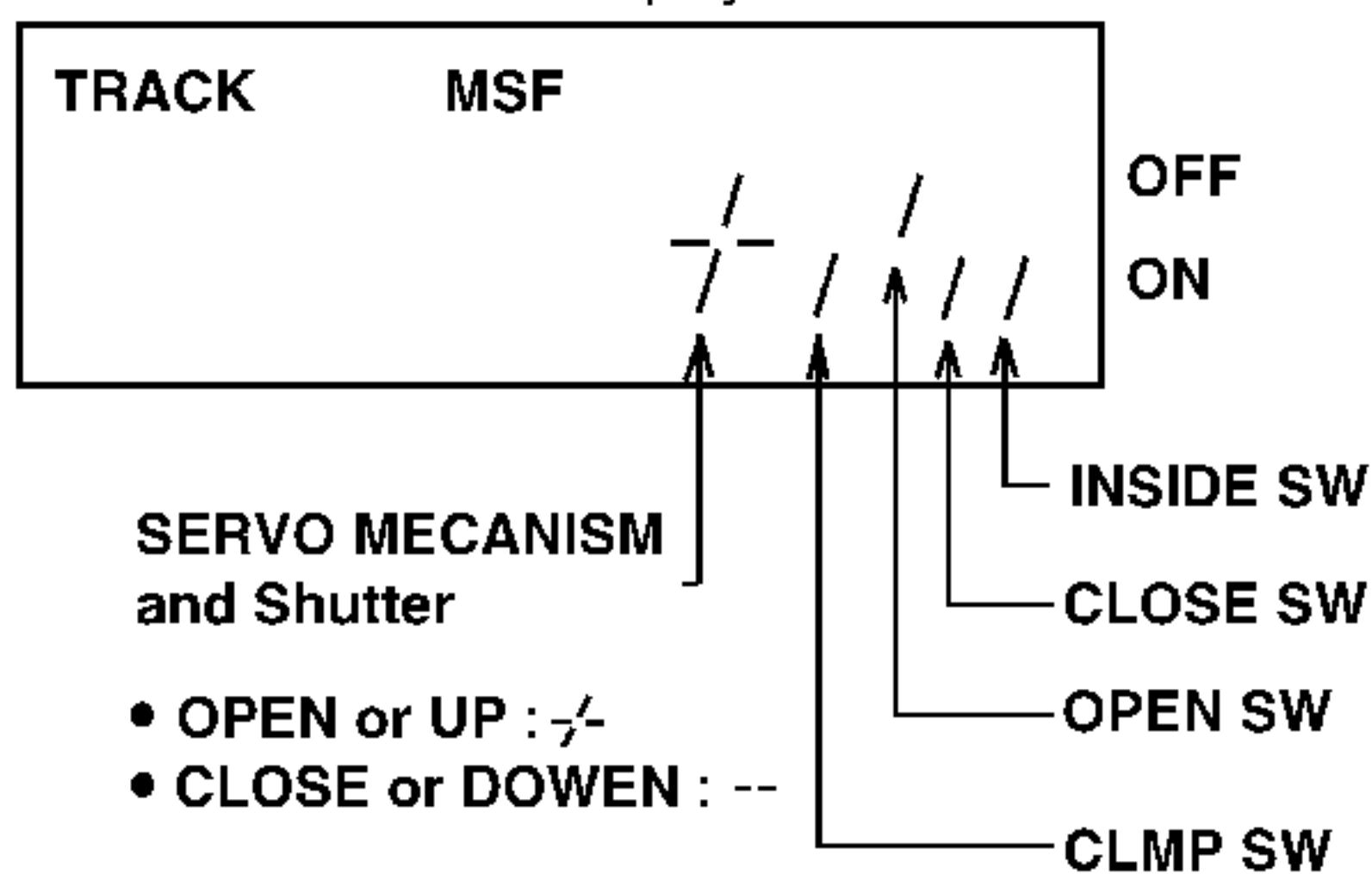

TEST MODE: STOP → CANCEL

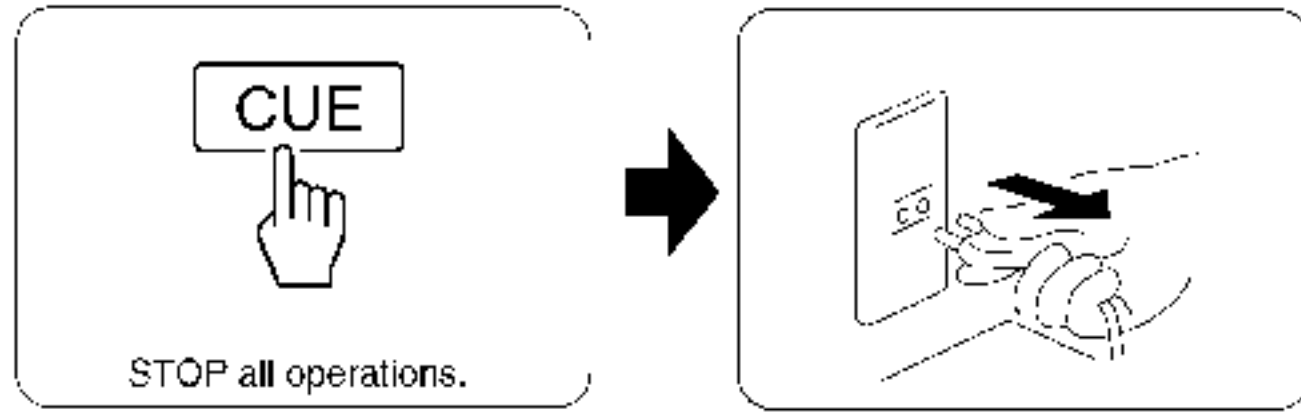

2. Adjustment Locations

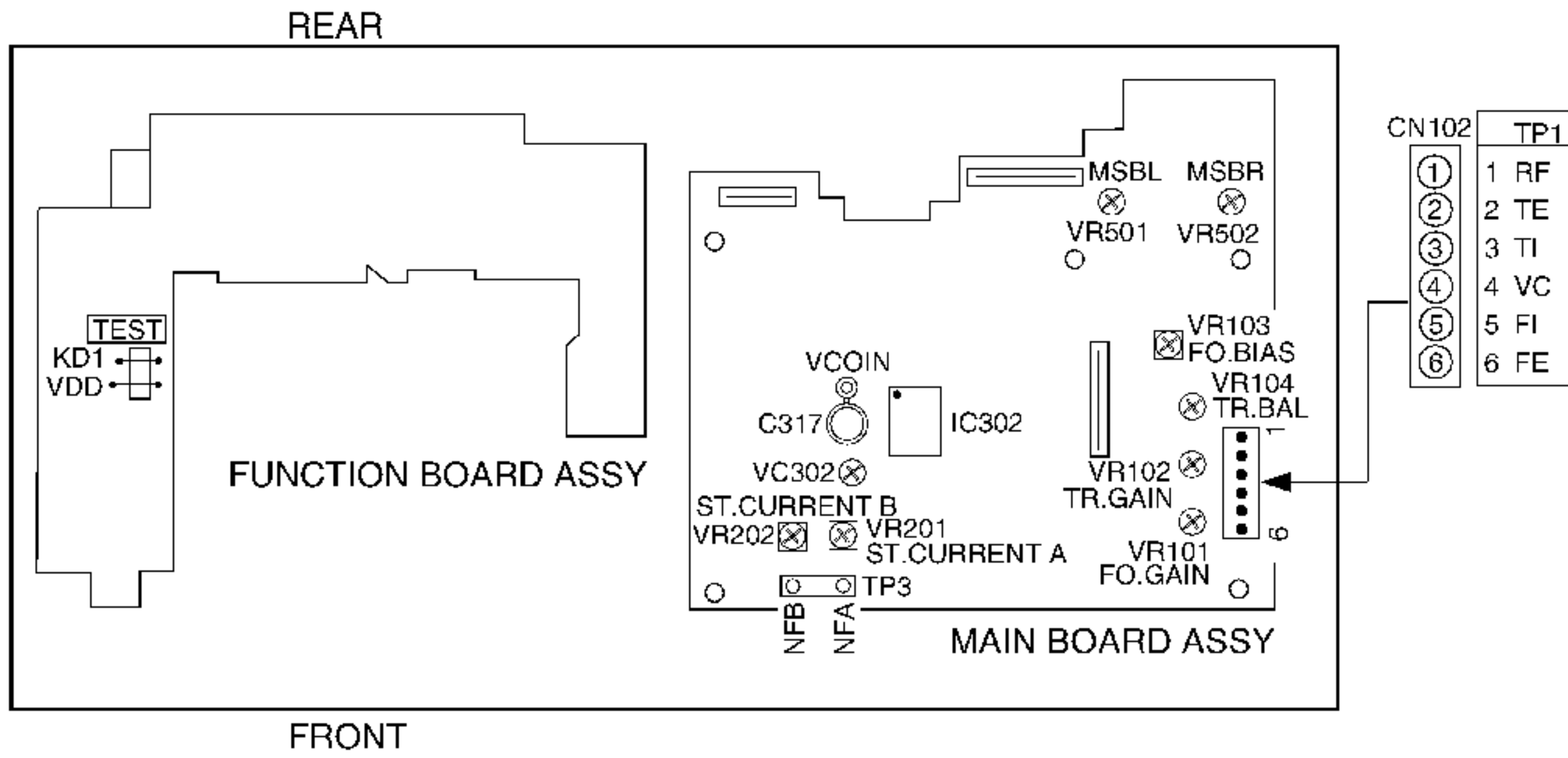

CDJ-700S, CDJ-500S

6.2 CHECK AND ADJUSTMENTS

1. Focus BIAS Adjustment

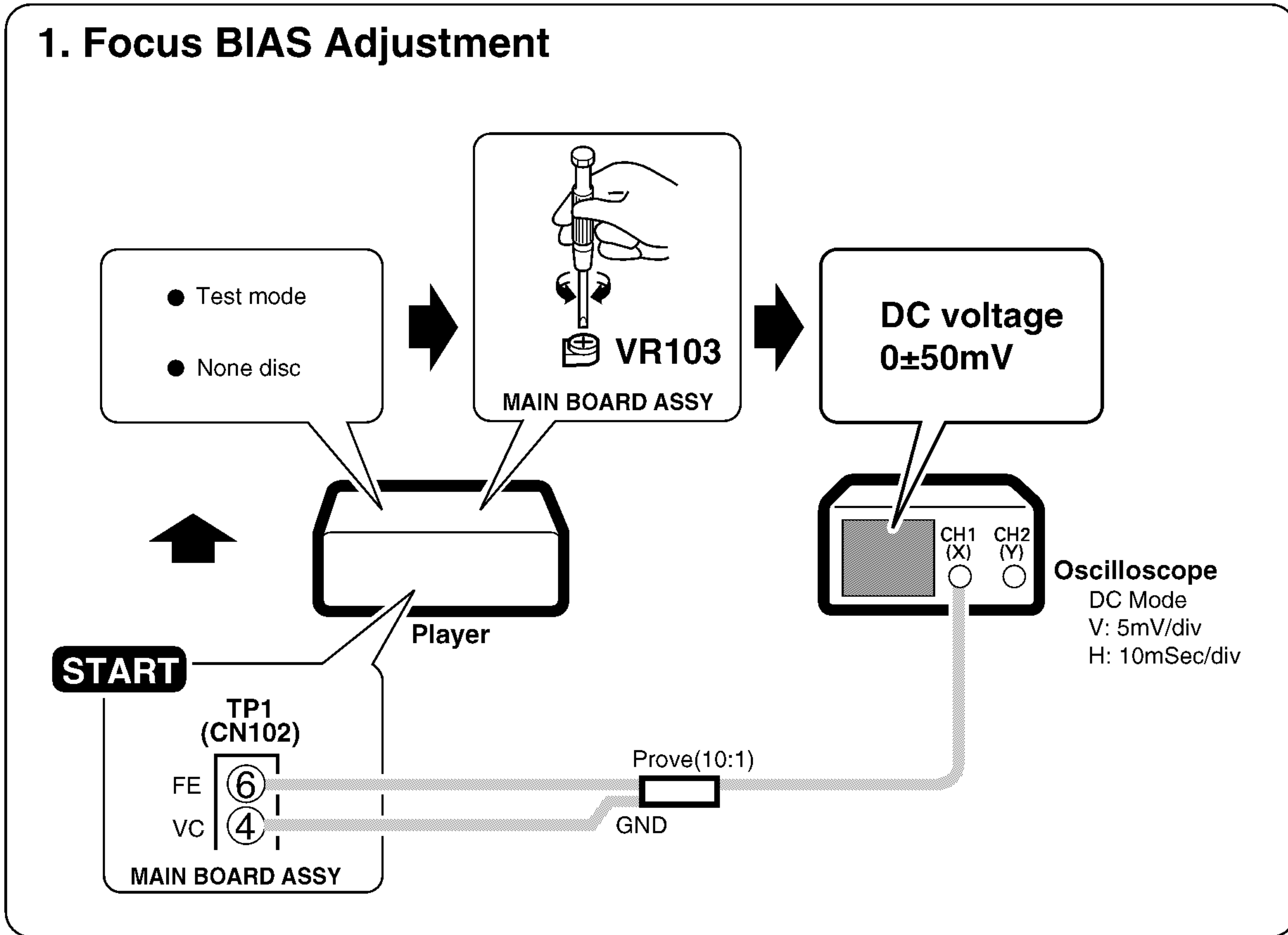

2. Vco Adjustment

Note : Adjustment of VC301 may not be made if the LOADING MECHANISM ASSY is installed. Before adjustment, remove the LOADING MECHANISM ASSY.

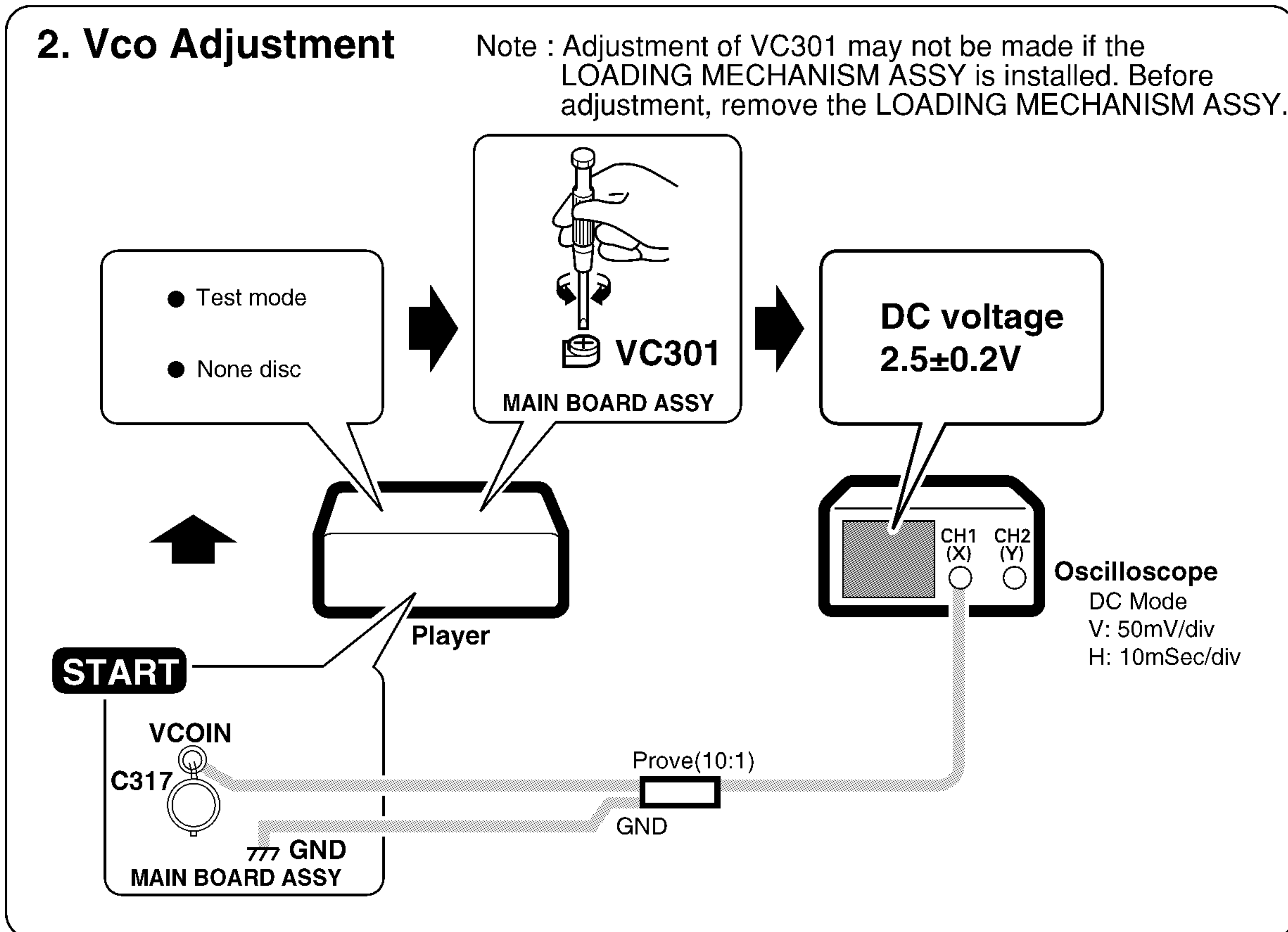

3. RF LEVEL ADJUSTMENT

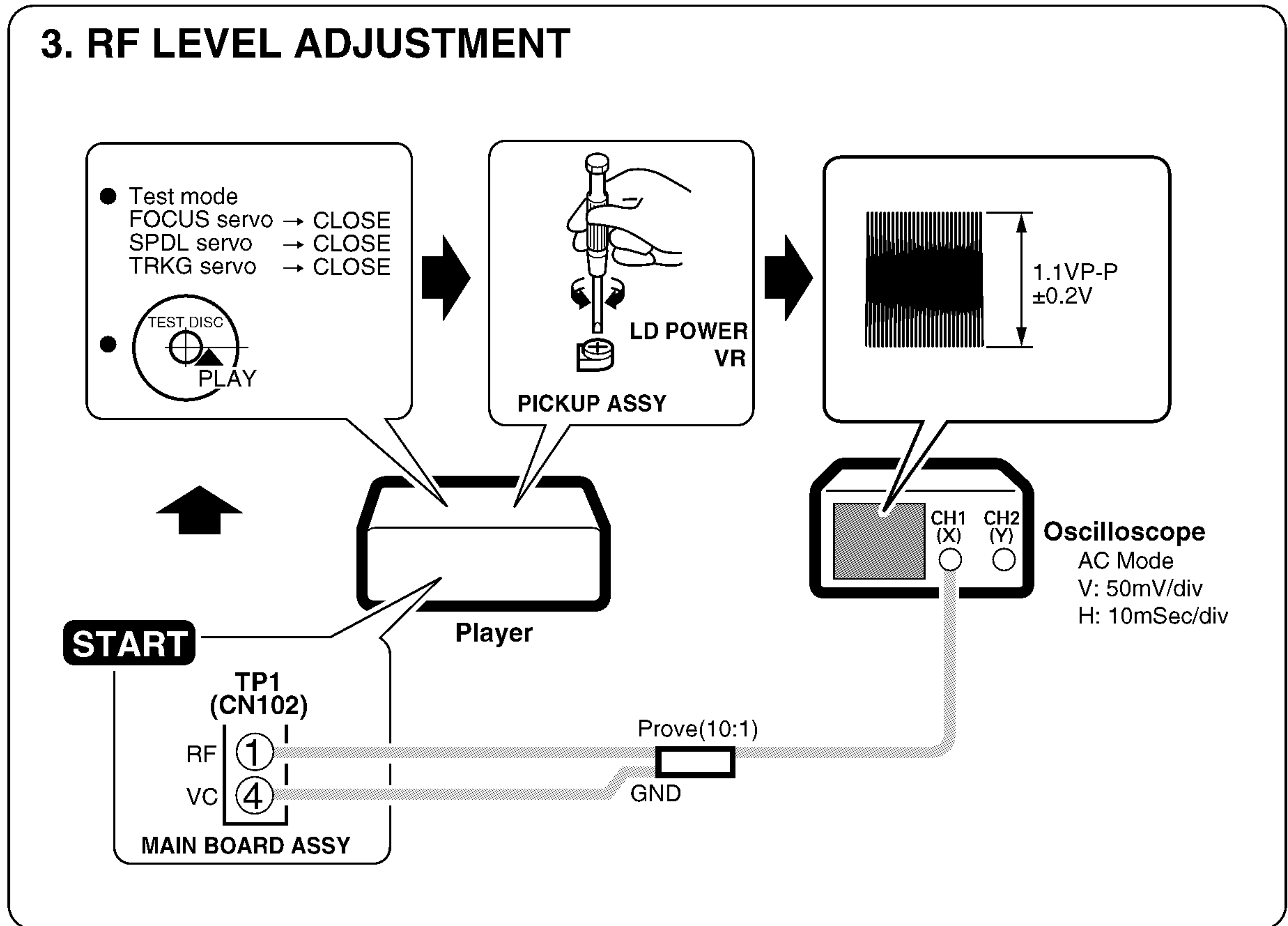

4. Tracking Error Barance Adjustment

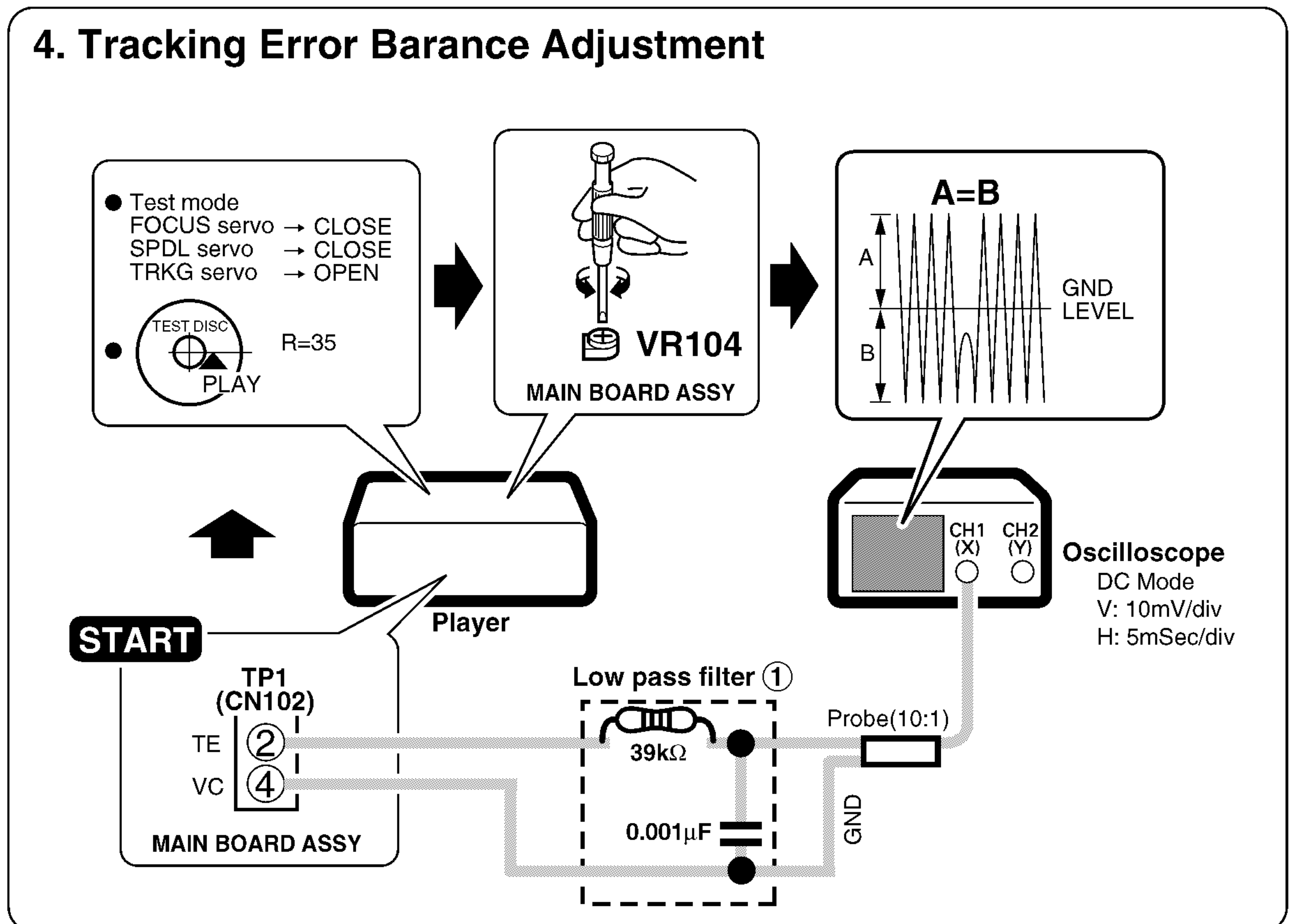

5. Focus Servo Loop Gain Adjustment

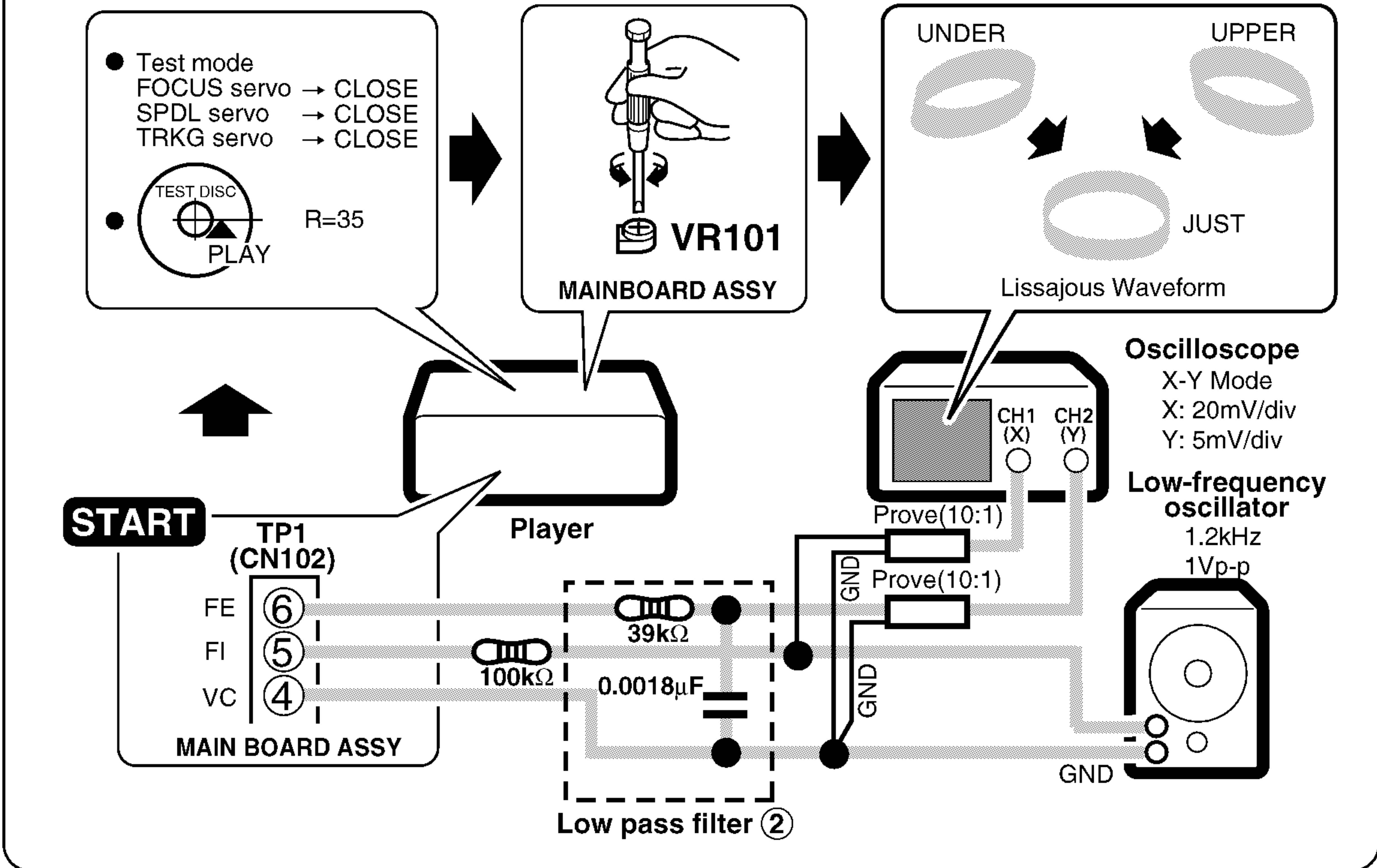

6. Tracking Servo Loop Gain Adjustment

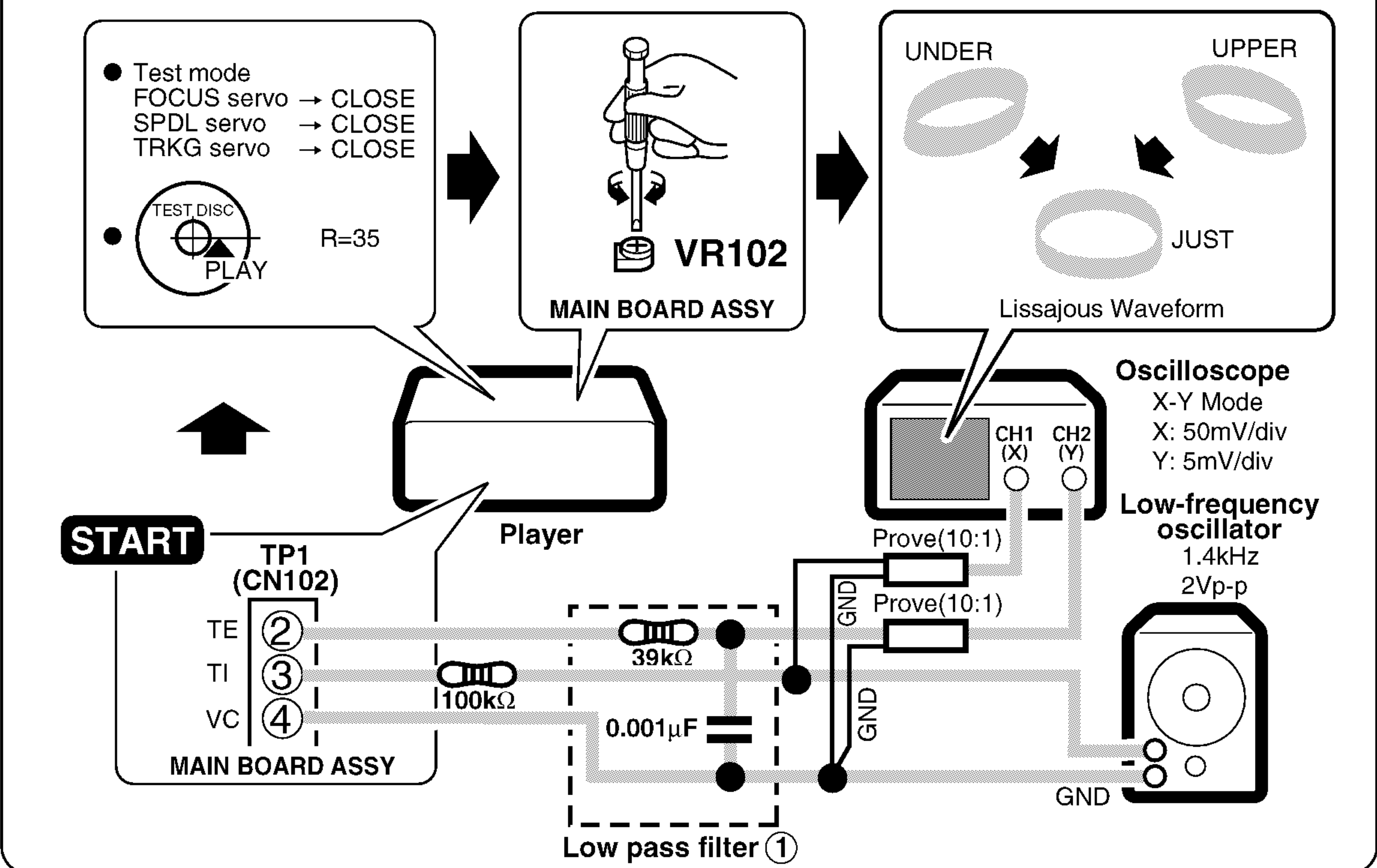

7. MSB Adjustment

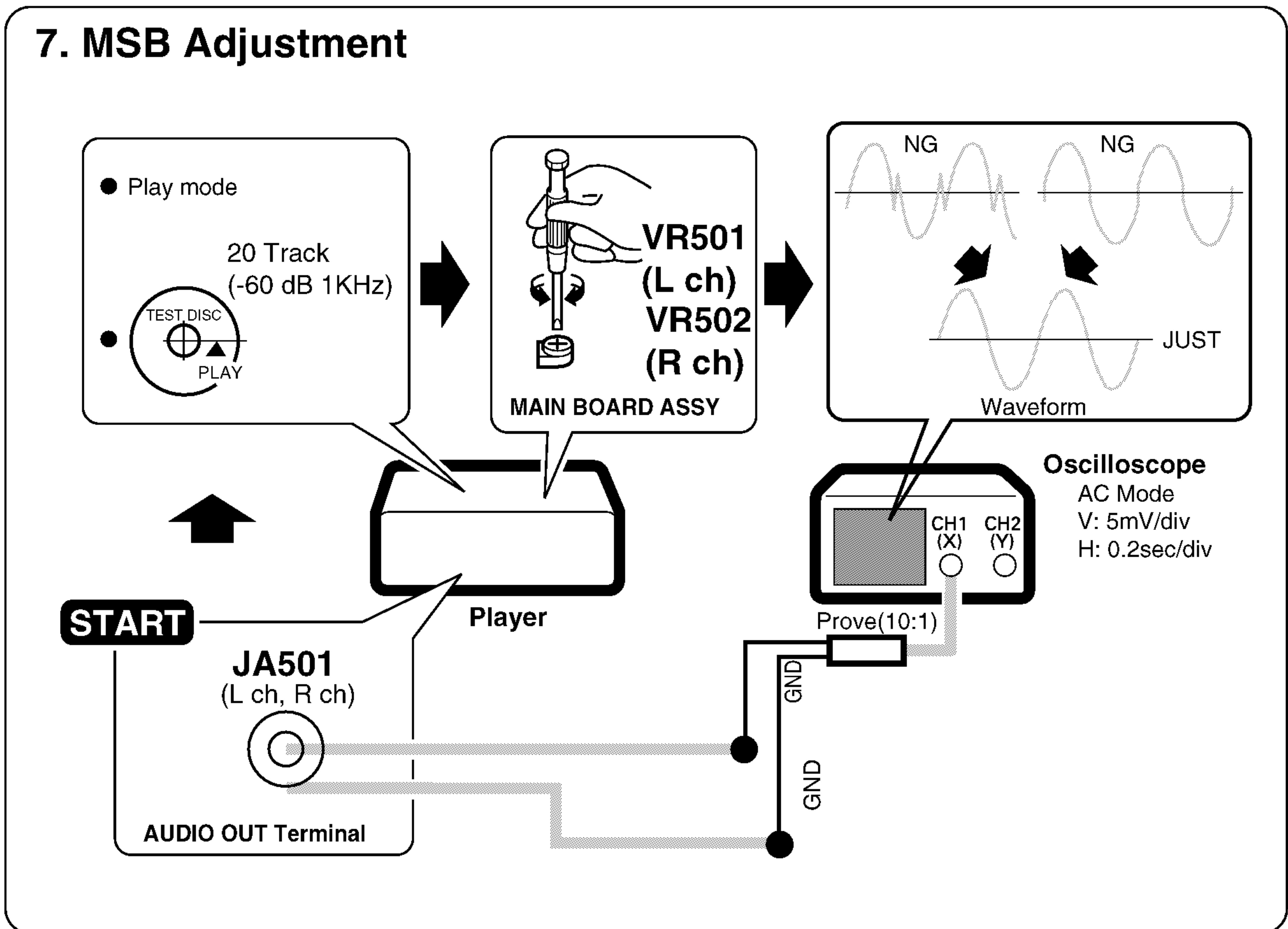

8. Stepper Current Adjustment

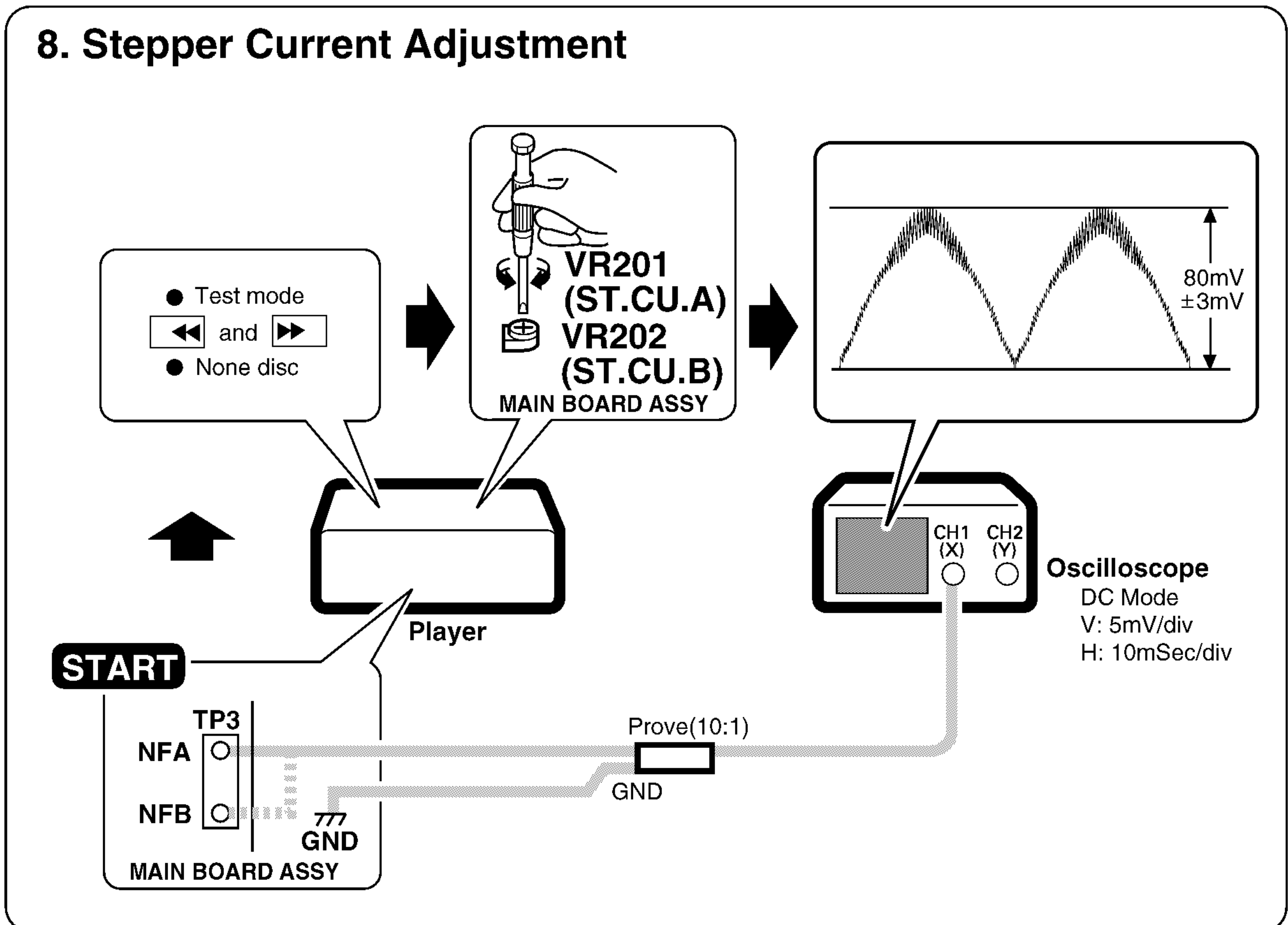

CDJ-700S,CDJ-500S

7. GENERAL INFORMATION

7.1 PARTS

7.1.1 IC

■ MPC17A85ZVM (IC206:MAIN BOARD ASSY)

● STEPPING DRIVER IC

● Pin Assignment (Top View)

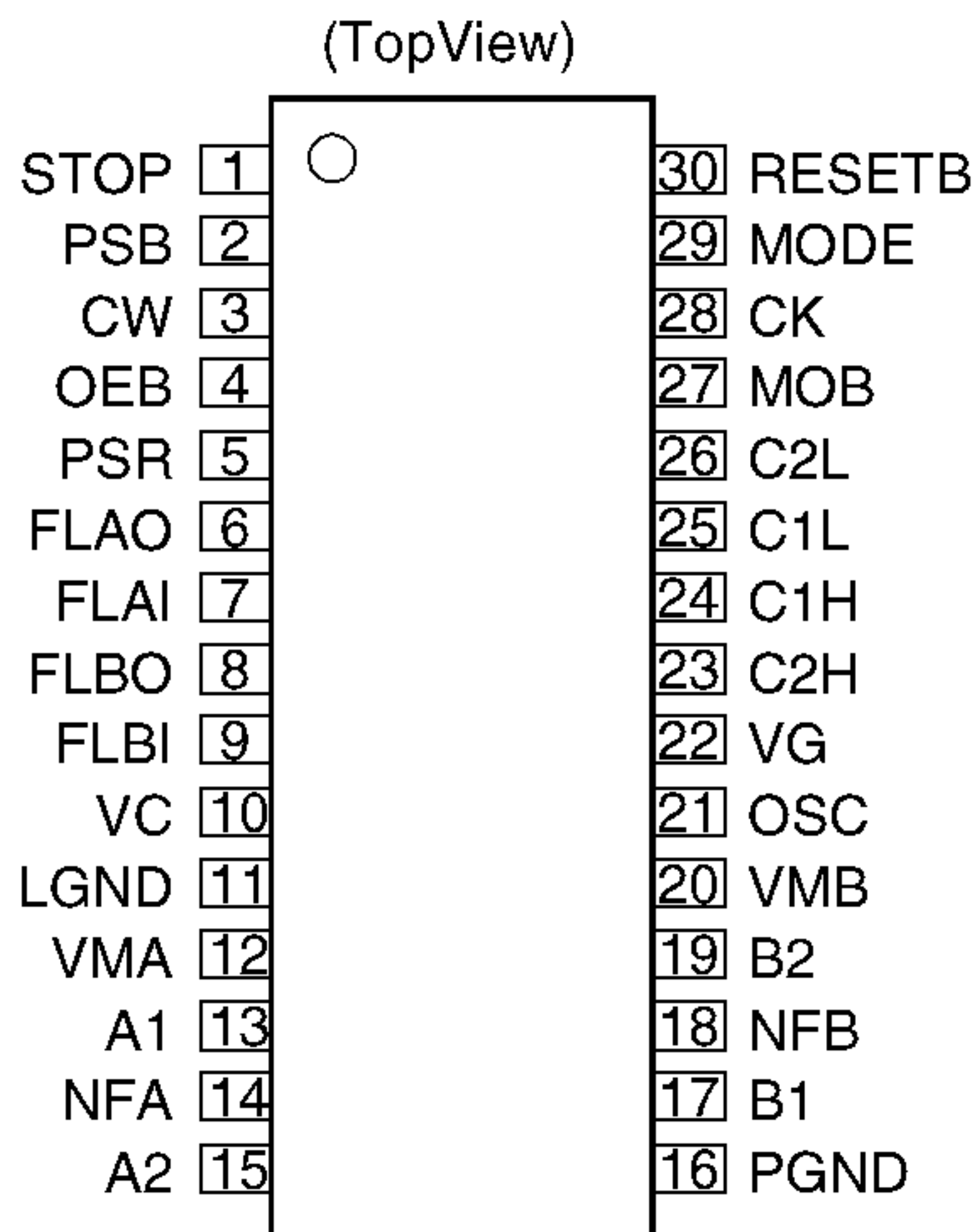

● Block Diagram

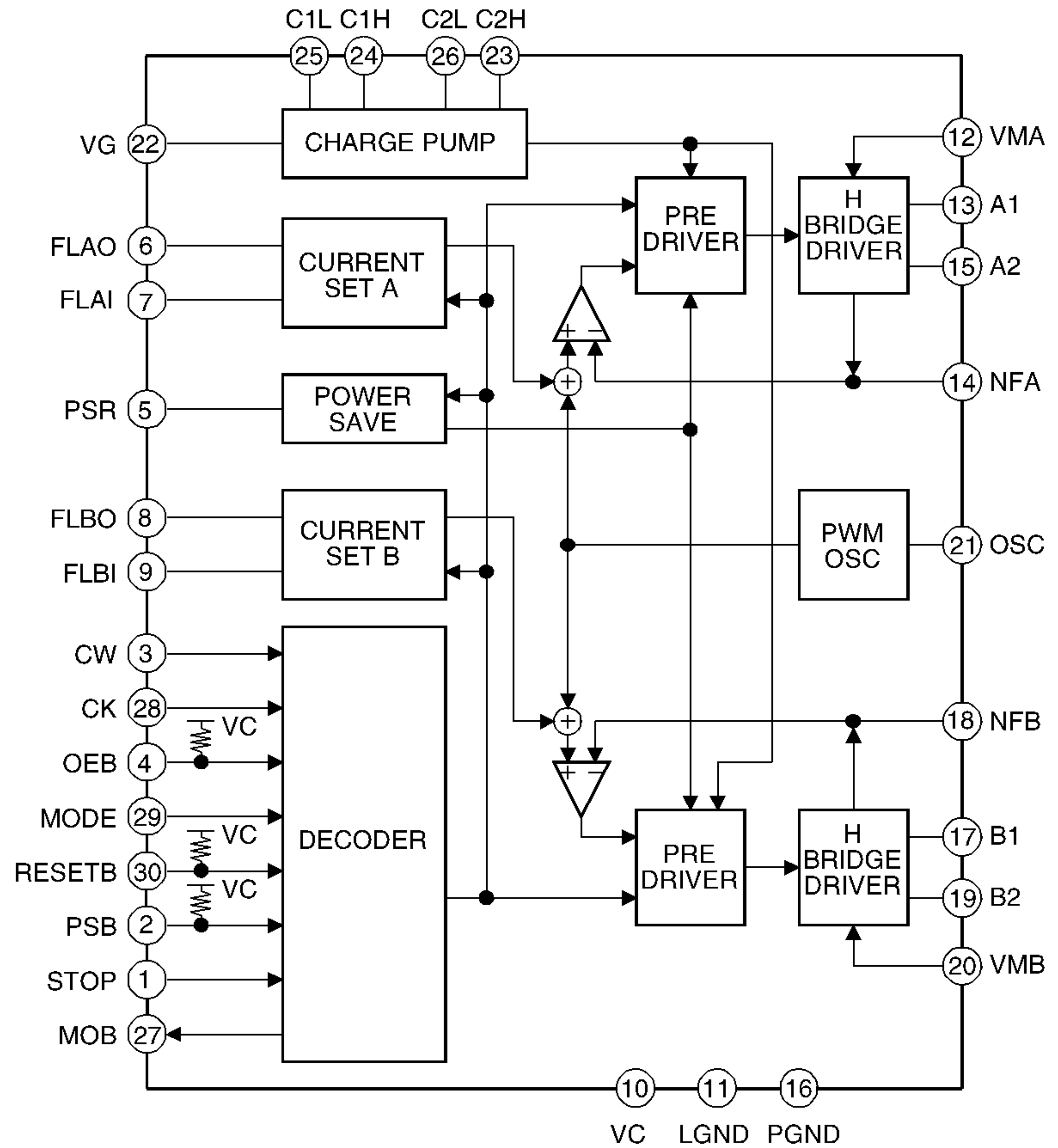

● Pin Function

No.	Pin Name	Function
1	STOP	STOP pin. When H, STOP state remains in force until MOB is L.
2	PSB	Power Save mode pin. When L, Power Save mode remains in force until MOB is L.
3	CW	Forward/reverse toggle pin.
4	OEB	Output enable pin.
5	PSR	Power Save current-setting pin.
6	FLAO	Filter-connection pin.
7	FLAI	
8	FLBO	
9	FLBI	
10	VC	Power pin for the control section.
11	LGND	Control section ground.
12	VMA	Power pin for the power section. (channel A)
13	A1	A-phase output pin.
14	NFA	A-phase feedback resistance connection pin.
15	A2	A-phase output pin.

No.	Pin Name	Function
16	PGND	Power section ground.
17	B1	B-phase output pin.
18	NFB	B-phase feedback resistance connection pin.
19	B2	B-phase output pin.
20	VMB	Power pin for the power section. (channel B)
21	OSC	Capacitor connection pin.
22	VG	Capacitor connection pin for the charge pump. VG voltage input pin.
23	C2H	Step-up capacitor connection pin.
24	C1H	
25	C1L	
26	C2L	
27	MOB	Phase-detection monitor pin.
28	CK	Clock input pin.
29	MODE	Mode-toggle pin. (32/64 steps) H : 64, L : 32
30	RESETB	Reset pin. L : reset

- The information shown in the list is basic information and may not correspond exactly to that shown in the schematic diagrams.

■ PD4842A (IC701 : MAIN BOARD ASSY)

● SYSTEM CONTROL μ COM

● Pin Assignment(Top View)

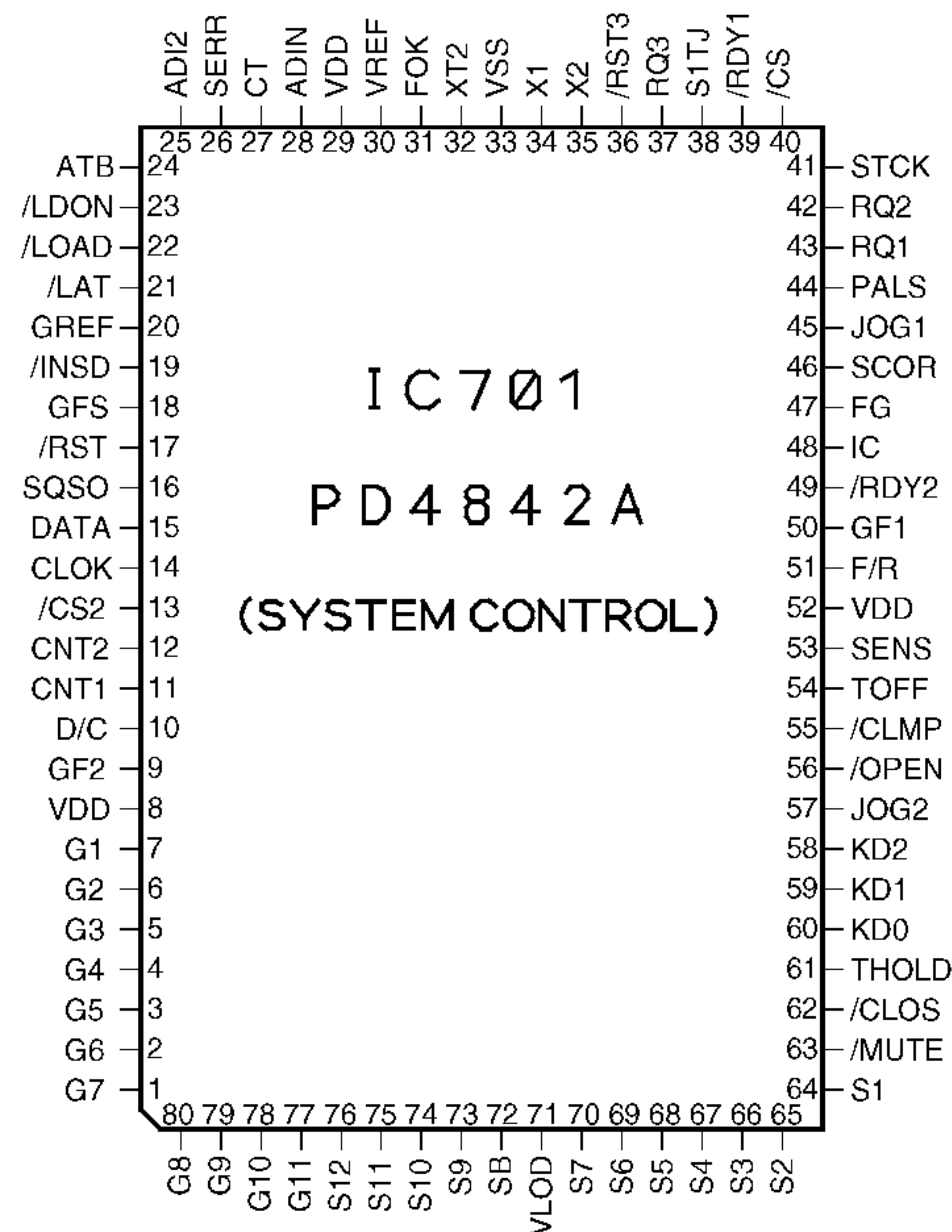

● Pin Function

No.	Port	Pin Name	I/O	Function
1	FIP6	GRID 7	OUT	FL grid output 7.
2	FIP5	GRID 6	OUT	FL grid output 6.
3	FIP4	GRID 5	OUT	FL grid output 5.
4	FIP3	GRID 4	OUT	FL grid output 4.
5	FIP2	GRID 3	OUT	FL grid output 3.
6	FIP1	GRID 2	OUT	FL grid output 2.
7	FIP0	GRID 1	OUT	FL grid output 1.
8	VDD	VDD	-	Connect to VDD.
9	P27	GF2 (SAMP)	IN-	DSP memory sampling.
10	P26	C/D	OUT	DSP command/data selection. (L : command)
11	P25	CNT1	IN	External control I/O.
12	P24	CNT2	IN	External control input.
13	P23	CS2	OUT	DSP chip select 2. (L : select)
14	SCK1	CLOK	OUT	Serial clock. (for CXD2500 & DSP)
15	SO1	DATA	OUT	Serial data output. (for CXD2500 & DSP)
16	SI1	SQSO	IN	Sub-code Q serial data input.
17	RESET	RST	IN	CPU reset. (L : reset)
18	P74	GFS	IN	Frame sync lock input. (H : OK, L : NG)
19	P73	INSD	IN	Slider inside switch input. (L : inside)
20	AVSS	GND ref	-	Ground potential for the A/D converter.
21	P17	XLAT	OUT	LSI control data latch pulse.
22	P16	LOAD	IN	Shutter motor output. (IN : STOP)
23	P15	LDON	OUT	Laser diode output. (L : OFF, H : ON)
24	P14	ATB	IN	A/D input for ATB. (above 0.5 V : ATB, below : no ATB)
25	P13	ADI2	IN	Slider voltage input.
26	P12	SERR	IN	A/D input to control the stepping motor.
27	P11	CT	IN	Slider center tap voltage input.
28	P10	ADIN	IN	Slider voltage input.
29	AVDD	VDD	-	Analog power for the A/D converter.

CDJ-700S,CDJ-500S

No.	Port	Pin Name	I/O	Function
30	AVREF	VDD ref	-	Standard voltage input for the A/D converter.
31	P04	FCOK	IN	Focus OK input. (H : OK, L : NG)
32	XT2	XT2	-	Not used.
33	VSS	GND	-	Connect to ground.
34	X1	X1	-	Oscillator pulses for the main system. (4.194304 MHz)
35	X2	X2	-	Oscillator pulses for the main system. (4.194304 MHz)
36	P37	RST3	OUT	Reset output for peripheral ICs. (for digital filter and DSP [L : reset])
37	P36	RQ3 (PLAY)	OUT	DSP memory play.
38	P35	S1TJ	OUT	Servo control output.
39	P34	RDY	IN	DSP READY input. (L : READY)
40	P33	CS	OUT	DSP chip select. (L : select)
41	P32	STCK	OUT	Stepping motor control output.
42	P31	RQ2 (WRIT)	OUT	DSP memory write (H : write).
43	P30	RQ1 (READ)	OUT	DSP memory read (H : read).
44	INTP3	PALS	IN	Interrupt input for RAM-internal display pulses.
45	INTP2	JOG1	IN	Interrupt input for jog dial pulses.
46	INTP1	SCOR	IN	Interrupt input for sub-code sync.
47	INTP0	FG	IN	FG pulse input.
48	IC	IC	-	Connect to ground.
49	P72	RDY2	IN	DSP READY 2 input. (L : READY)
50	P71	GF1 (CMP)	IN	DSP data compare input. (H : comparing)
51	P70	F/R	OUT	Stepping motor forward/reverse output.
52	VDD	VDD	-	Connect to VDD.
53	P127	SENS	IN	LSI operation status input.
54	P126	TOFF	OUT	Analog switch output. (H/L for tracking ON/OFF, H : track counter search)
55	P125	CLMP	IN	Clamping completed switch input.
56	P124	OPEN	IN	Switch input for servo mechanism down completed.
57	P123	JOG2	IN	Jog dial pulse input.
58	P122	KD2	IN	Key-scan data input.
59	P121	KD1	IN	
60	P120	KD0	IN	
61	P117	THOLD	OUT	Analog switch output. (1, 14, 30Tr JUMP : L)
62	P116	CLOS	IN	Switch input for door close completed.
63	P115	MUTE	OUT	Muting output. (L : on, H : off)
64	FIP22	SEG 1	OUT	FL segment output 1.
65	FIP21	SEG 2	OUT	FL segment output 2.
66	FIP20	SEG 3	OUT	FL segment output 3.
67	FIP19	SEG 4	OUT	FL segment output 4.
68	FIP18	SEG 5	OUT	FL segment output 5.
69	FIP17	SEG 6	OUT	FL segment output 6.
70	FIP16	SEG 7	OUT	FL segment output 7.
71	VLOAD	VLOAD	-	Connected to FIP controller/driver pull-down resistance. (-31V)
72	FIP15	SEG 8	OUT	FL segment output 8.
73	FIP14	SEG 9	OUT	FL segment output 9.
74	FIP13	SEG 10	OUT	FL segment output 10.
75	FIP12	SEG 11	OUT	FL segment output 11.
76	FIP11	SEG 12	OUT	FL segment output 12.
77	FIP10	GRID 11	OUT	FL grid output 11.
78	FIP9	GRID 10	OUT	FL grid output 10.
79	FIP8	GRID 9	OUT	FL grid output 9.
80	FIP7	GRID 8	OUT	FL grid output 8.

7.1.2 DISPLAY

■ DEL1029(V601:FUNCTION BOARD ASSY)

● FL TUBE

PIN ASSIGNMENT

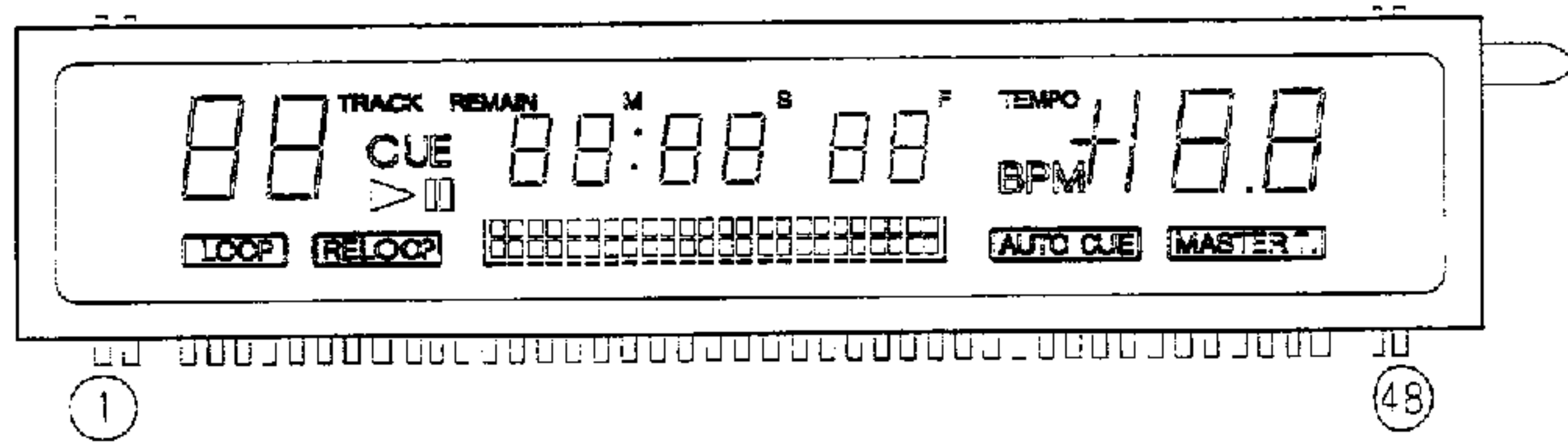

ANODE GRID ASSIGNMENT

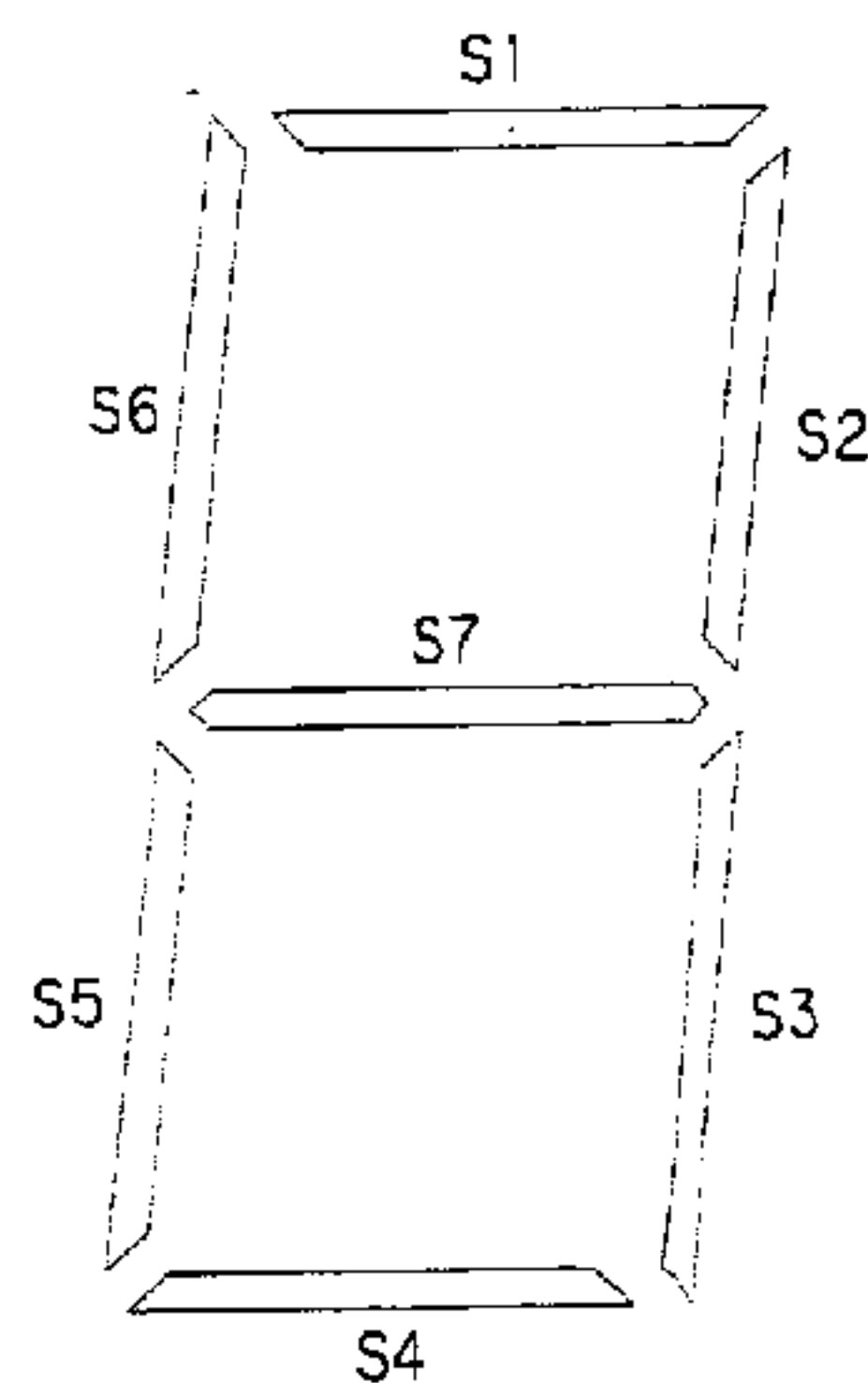
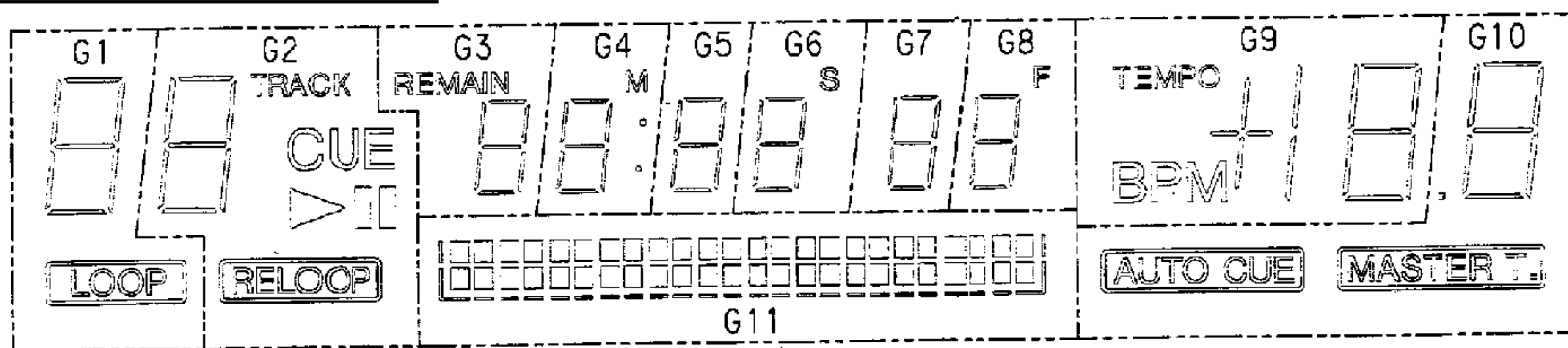

G1~G10

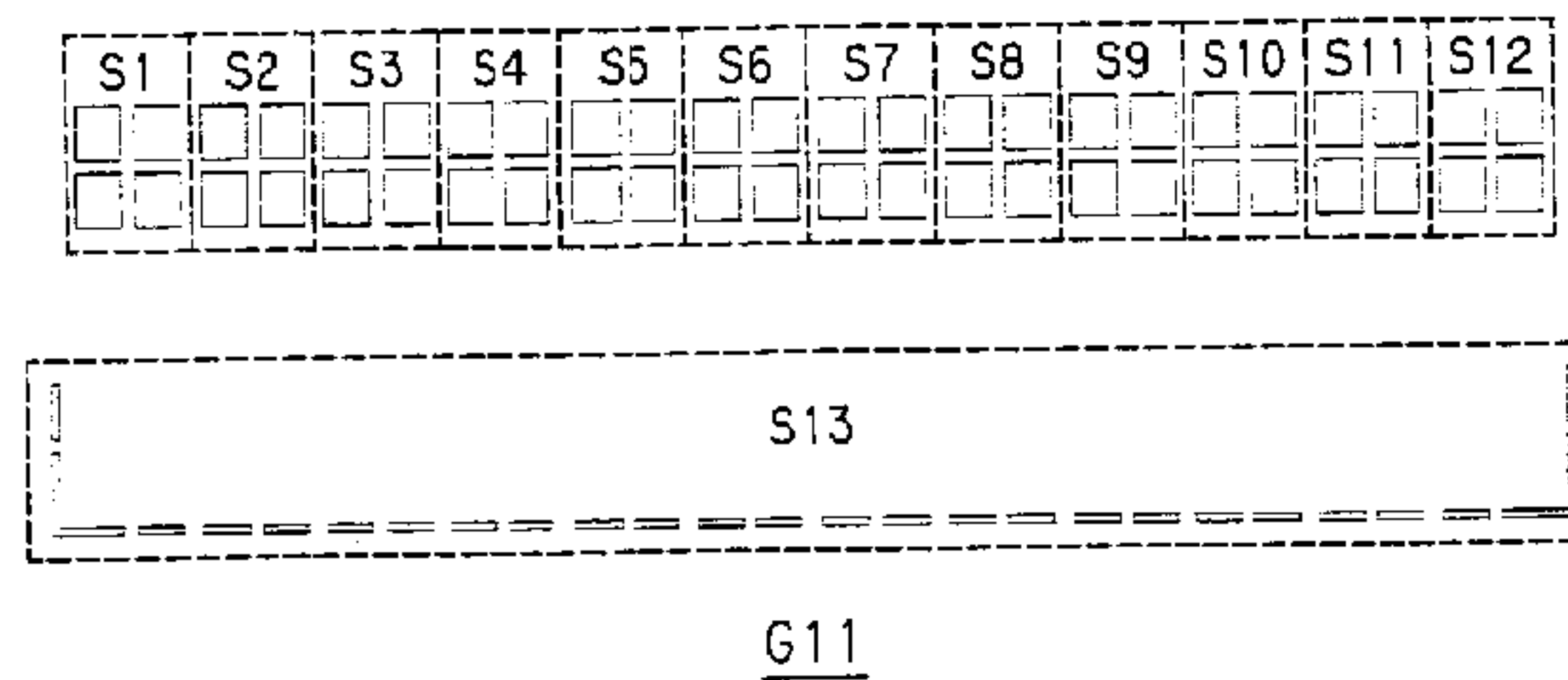

G11

	G1	G2	G3	G4	G5	G6	G7	G8	G9	G10	G11
S1	S1	S1	S1	S1	S1	S1	S1	S1	S1	S1	⎓
S2	S2	S2	S2	S2	S2	S2	S2	S2	S2	S2	⎓
S3	S3	S3	S3	S3	S3	S3	S3	S3	S3	S3	⎓
S4	S4	S4	S4	S4	S4	S4	S4	S4	S4	S4	⎓
S5	S5	S5	S5	S5	S5	S5	S5	S5	S5	S5	⎓
S6	S6	S6	S6	S6	S6	S6	S6	S6	S6	S6	⎓
S7	S7	S7	S7	S7	S7	S7	S7	S7	S7	S7	⎓
S8	⎓	>	⎓	.	⎓	S	⎓	⎓	+	MASTER	⎓
S9	⎓	CUE	⎓	M	⎓	⎓	⎓	⎓	+	⎓	⎓
S10	LOOP	⎓	REMAIN	⎓	⎓	⎓	⎓	⎓	⎓	AUTO CUE	⎓
S11	⎓	RELOOP	⎓	⎓	⎓	⎓	⎓	F	BPM	⎓	⎓
S12	⎓	TRACK	⎓	⎓	⎓	⎓	⎓	⎓	TEMPO	⎓	⎓
S13	⎓	⎓	⎓	⎓	⎓	⎓	⎓	⎓	⎓	⎓	⎓

PIN CONNECTION

Pin No.	1	2	3	4	5	6	7	8	9	10	11	12	13	14	15	16	17
Assignment	F1	F1	NP	NL	G1	G2	G3	G4	G5	G6	G7	G8	G9	G10	G11	S13	S2

Pin No.	18	19	20	21	22 ~ 37	38	39	40	41	42	43	44	45	46	47	48
Assignment	S6	S7	S8	S1	NL	S9	S10	S11	S12	S3	S4	S5	NL	NP	F2	F2

F:Filament G1~G11:Grid S1~S13:Anode NP:No Pin NL:No Lead

CDJ-700S, CDJ-500S

7.2 DIAGNOSIS

7.2.1 ERROR CORD DISPLAY

■ Error display

When the player detects an error during operation, it will immediately stop and display an error code in the display window.

Displayed error code number	Type of error	Error contents	Possible Cause → Remedy
E-72 01	TOC READ ERROR	TOC data cannot be read after 20 seconds	The disc is soiled.
E-72 02	FG PULSE ERROR	Disc is rotating, but rotation cannot be ascertained.	Either IC201 (spindle driver IC) or Pin 47 of IC701 (control microprocessor) is damaged.
E-83 01	PLAYER ERROR	Disc loaded cannot be played properly (GFS NG:2sx3).	The disc is soiled. The disc is scarred.
E-83 02	PLAYER ERROR	Disc loaded cannot be played properly (FOCUS NG:0.1sx3)	The disc is soiled. The disc is scarred.
E-91 01	MECHANICAL TIME OUT	Mechanical operation did not end in allotted time (CLAMP:4s)	The loading mechanism is defective.
E-91 02	MECHANICAL TIME OUT	Mechanical operation did not end in allotted time (OPEN: 4s)	The door opening/closing mechanism is defective. An object is placed on the door.
E-91 03	MECHANICAL TIME OUT	Mechanical operation did not end in allotted time (INSIDE: 5s)	The servo mechanism is defective.

7.2.2 DISASSEMBLY

■ REMOVING THE CONTROL PANEL (Fig 1)

1. Switch the power ON, then press the EJECT button to open the door. (CAUTION 1)
2. Disconnect the power cable from the AC outlet.
3. Remove the 4 screws ① securing the control panel.
4. Put the control panel back the chassis. Be careful to injure.

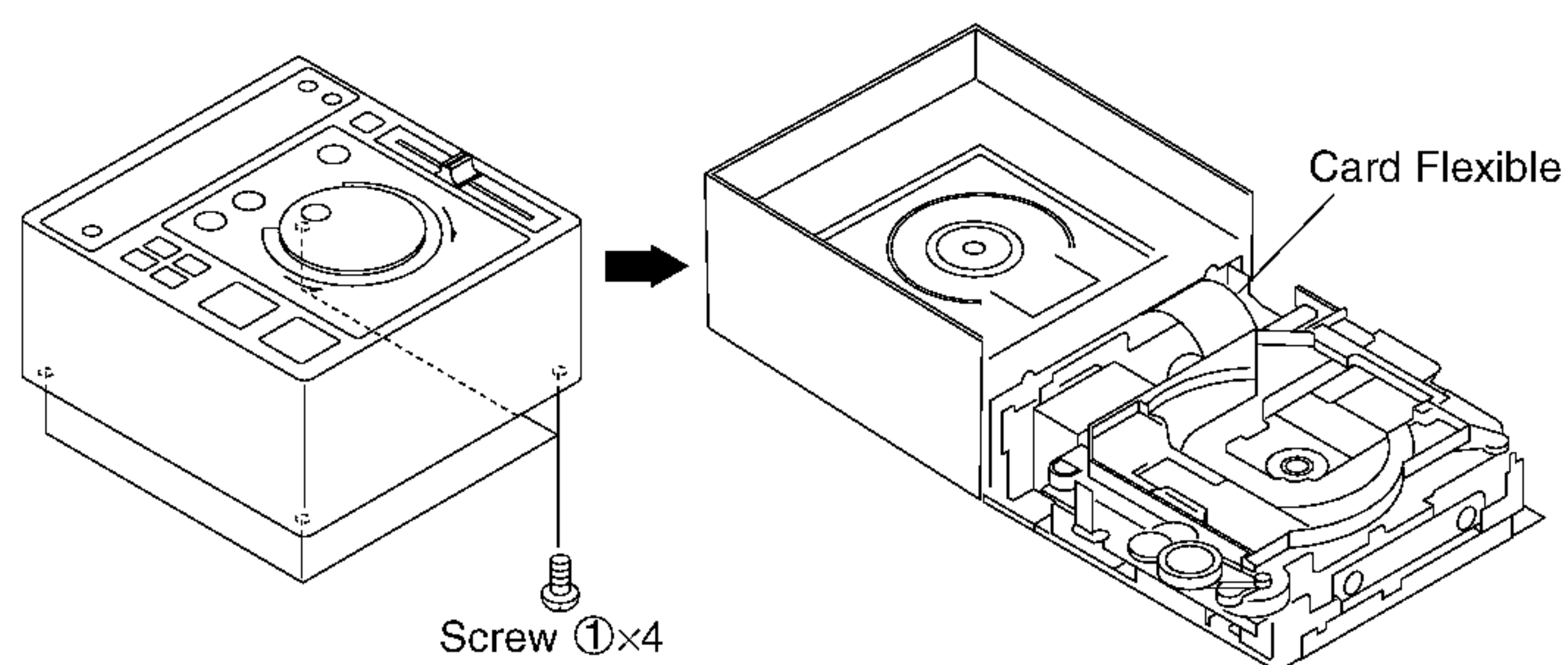

Fig 1

<< PRECAUTIONS >>

Be sure to disconnect the power cable from the AC outlet whenever removing the card flexible cable from the connector for maintenance, etc. Hold the both sides of the card flexible cable with both hands to disconnect the cable straight. (Even if the power has been switched OFF, previously charged voltage may remain in the capacitor, etc. If the electrodes of the card flexible cable and those of the connector come in contact by accident, a malfunction may occur.)

■ (CAUTION 1) IMPORTANT

HOW TO OPEN THE DOOR DURING AN EMERGENCY (Fig 2)

If the door does not open for some reasons when the EJECT button is pressed, use the following steps to open the door manually.

1. Disconnect the power cable from the AC outlet.
2. Make a key by using a paper clip or similar material. (A metal stick 1mm in diameter and 50mm in length may be used.)
3. Insert the key perpendicularly into the hole as shown in the illustration above, then push down the key toward the right. The lock hook assy can now be shifted to open the door.

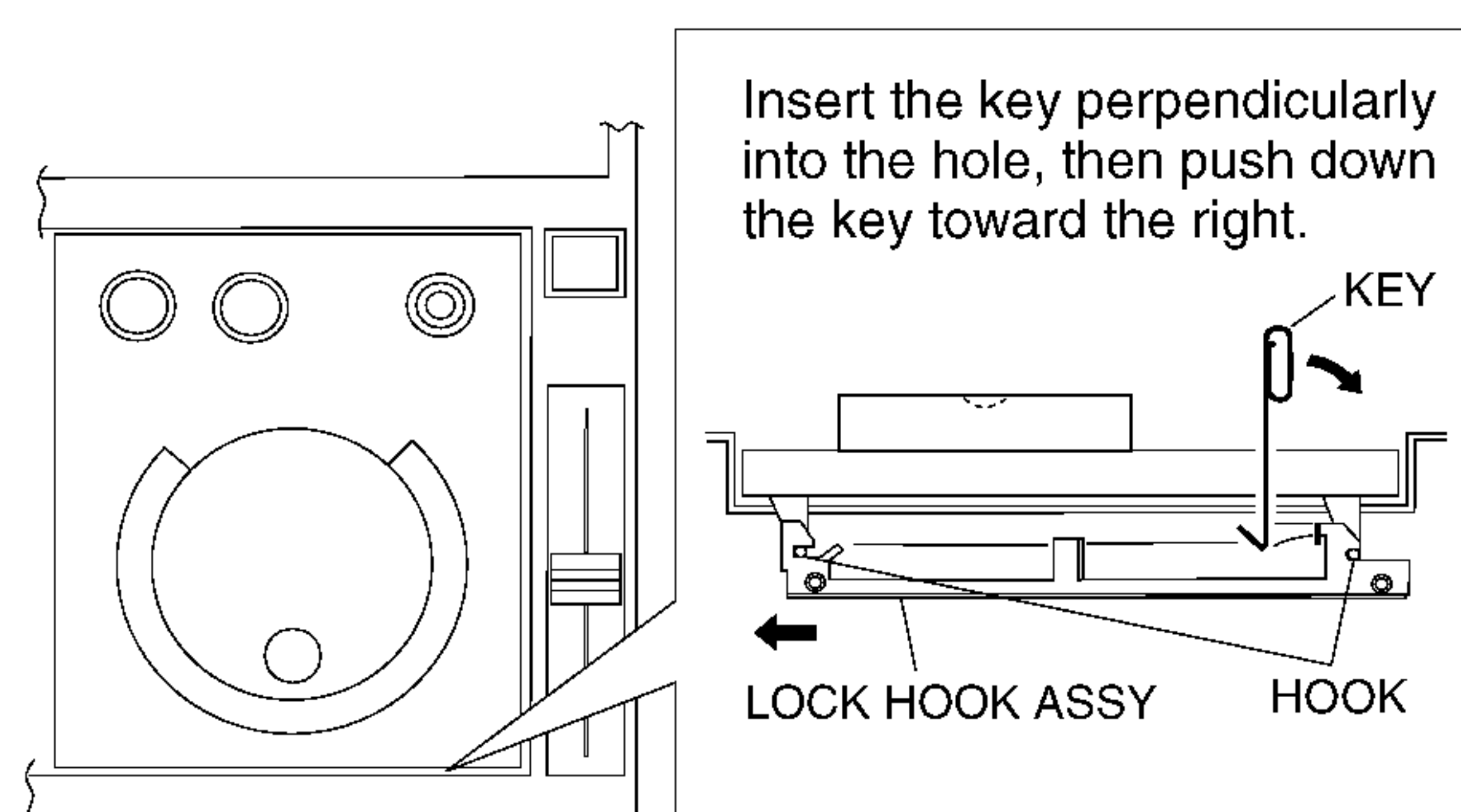
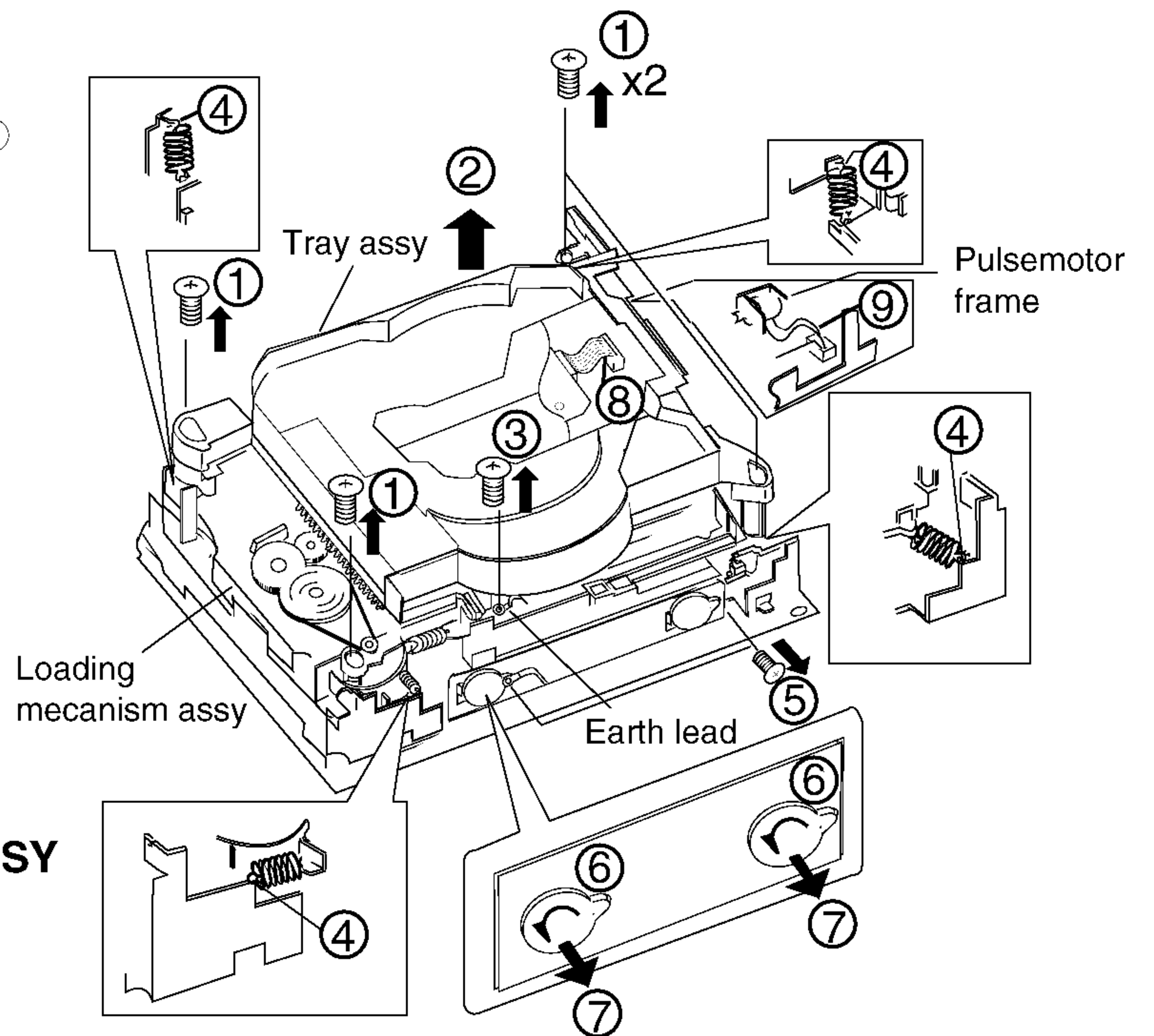

Fig 2

■ REMOVING THE TRAY ASSY (Fig 3)

1. Remove the 4 screws ① that secure the tray.
2. Remove the tray assy from the loading mechanism assy. ②



■ REMOVING THE LOADING MECANISM ASSY (Fig 3)

1. Remove the tray assy. ①, ②
2. Remove the earth lead screw ③.
3. Remove the springs on the other side ④ in 4 places.
4. Remove the bushing dampers in 2 places ⑥, ⑦ by turning them counterclockwise.
5. Remove the S flexible L ⑧.
6. Remove the flexible ⑨ of the pulse motor frame.

Fig 3

■ REMOVING THE CLAMPER ASSY (Fig 4)

1. Remove the 3 screws ① that secure the clamper cover.
2. Remove the clamper cover ②.
3. Remove the clamper assy.

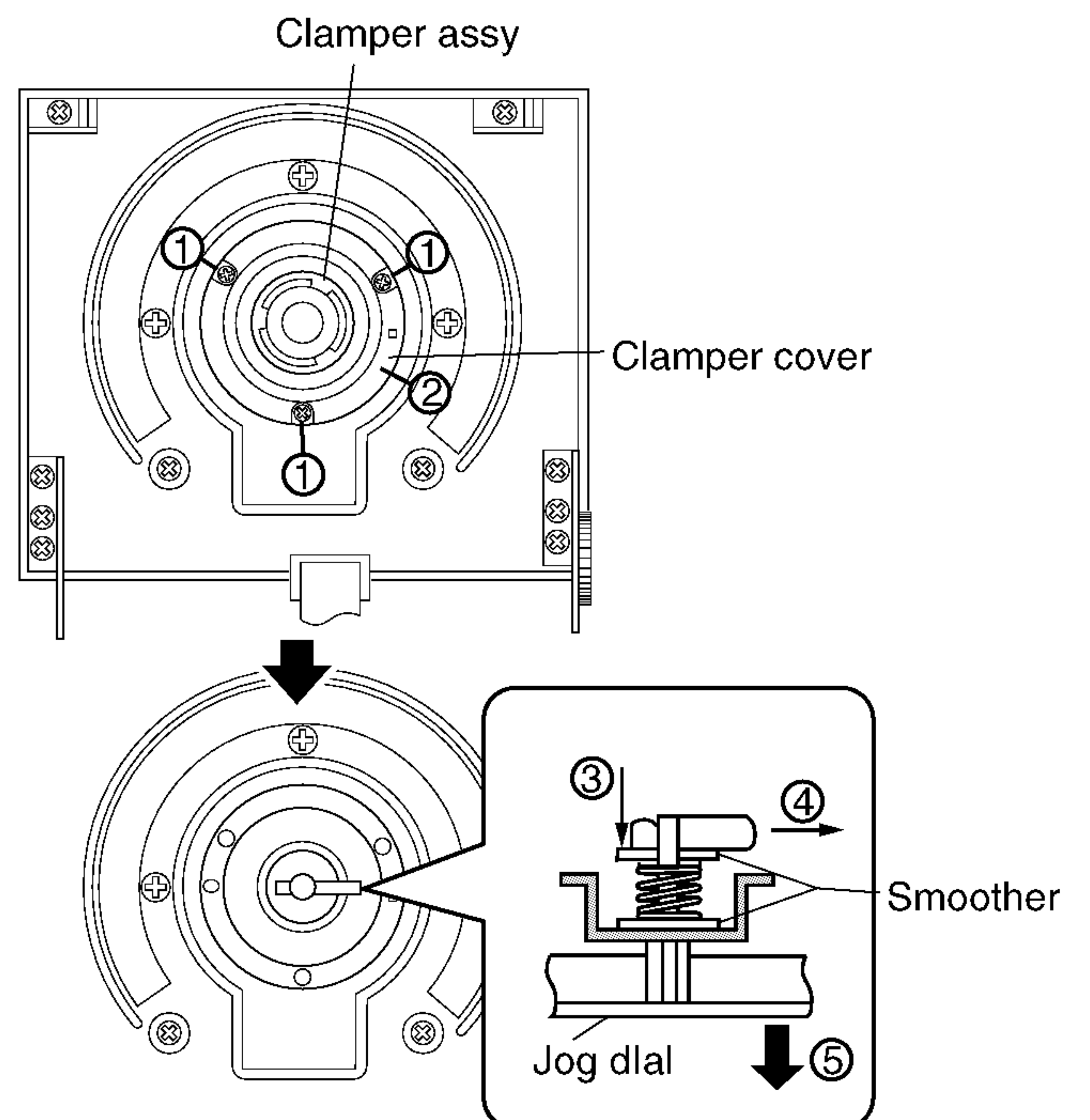

■ REMOVING THE JOGDIAL (Fig 4)

1. Remove the clamper assy. ①, ②
2. Depressing the thrust stays ③, pull out ④.
3. Remove the jog dial ⑤.

Fig 4

CDJ-700S, CDJ-500S

7.3 BLOCK DIAGRAM

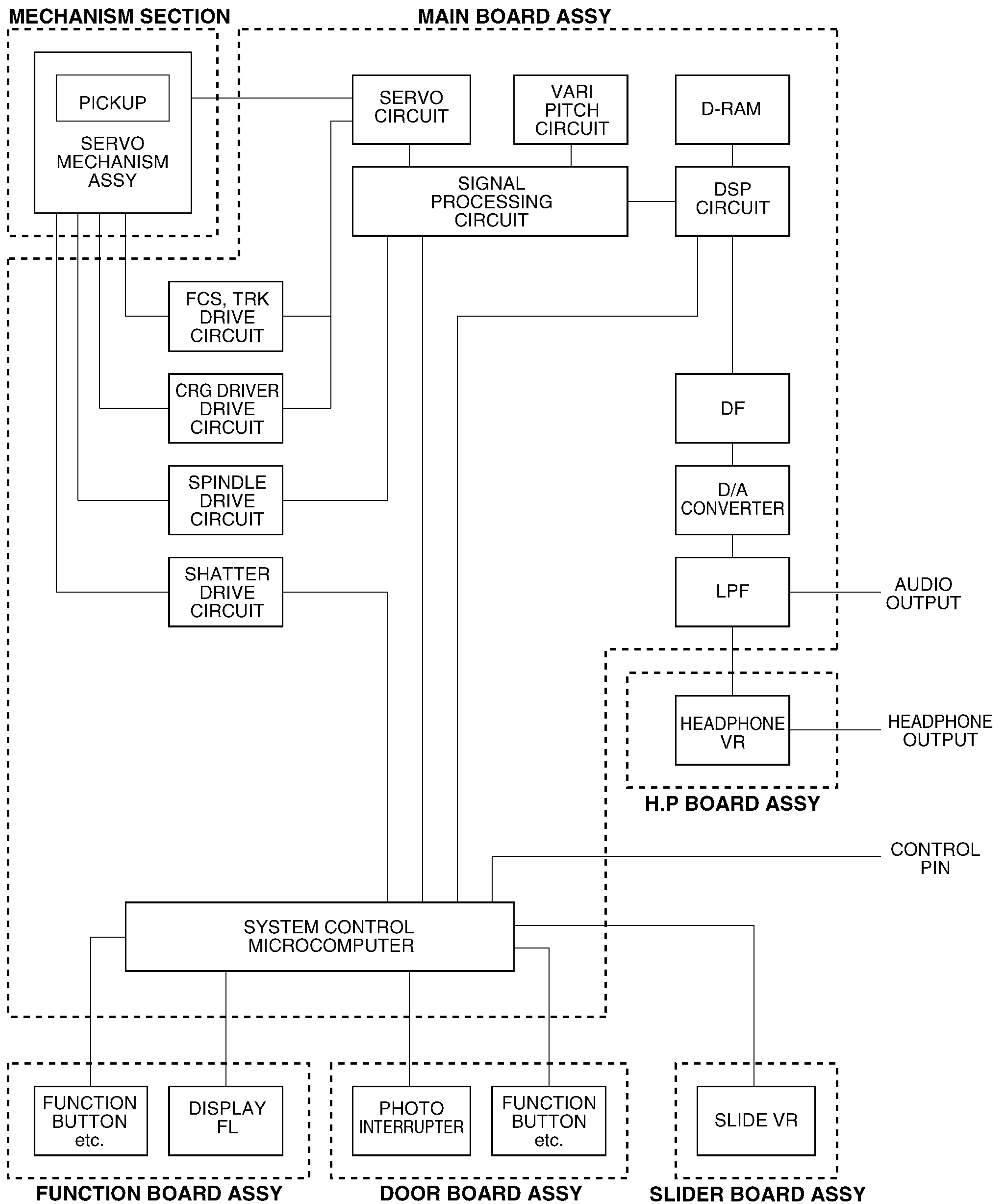

8. PANEL FACILITIES AND SPECIFICATIONS

■ FRONT PANEL

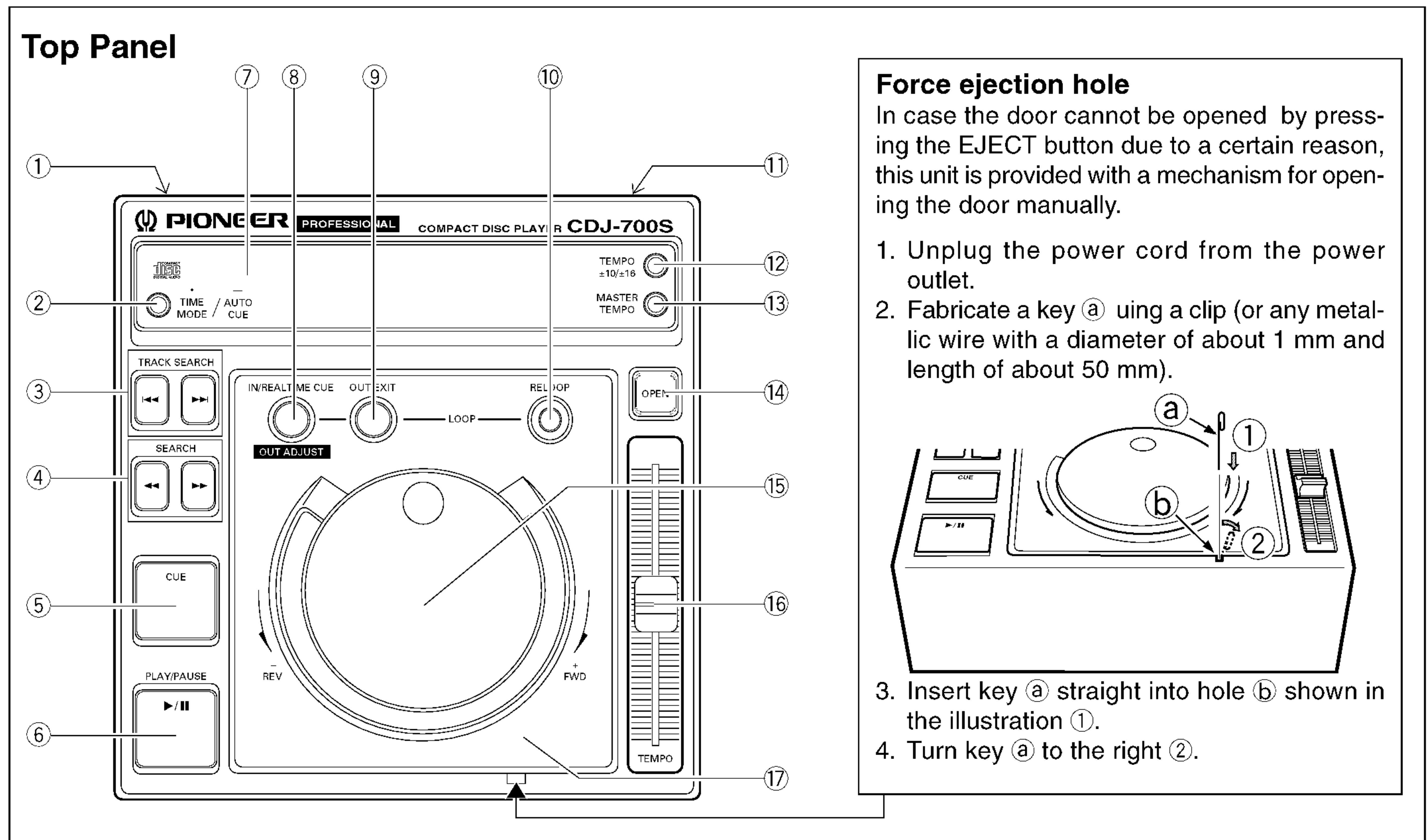

Force ejection hole

In case the door cannot be opened by pressing the EJECT button due to a certain reason, this unit is provided with a mechanism for opening the door manually.

1. Unplug the power cord from the power outlet.
2. Fabricate a key ① using a clip (or any metallic wire with a diameter of about 1 mm and length of about 50 mm).

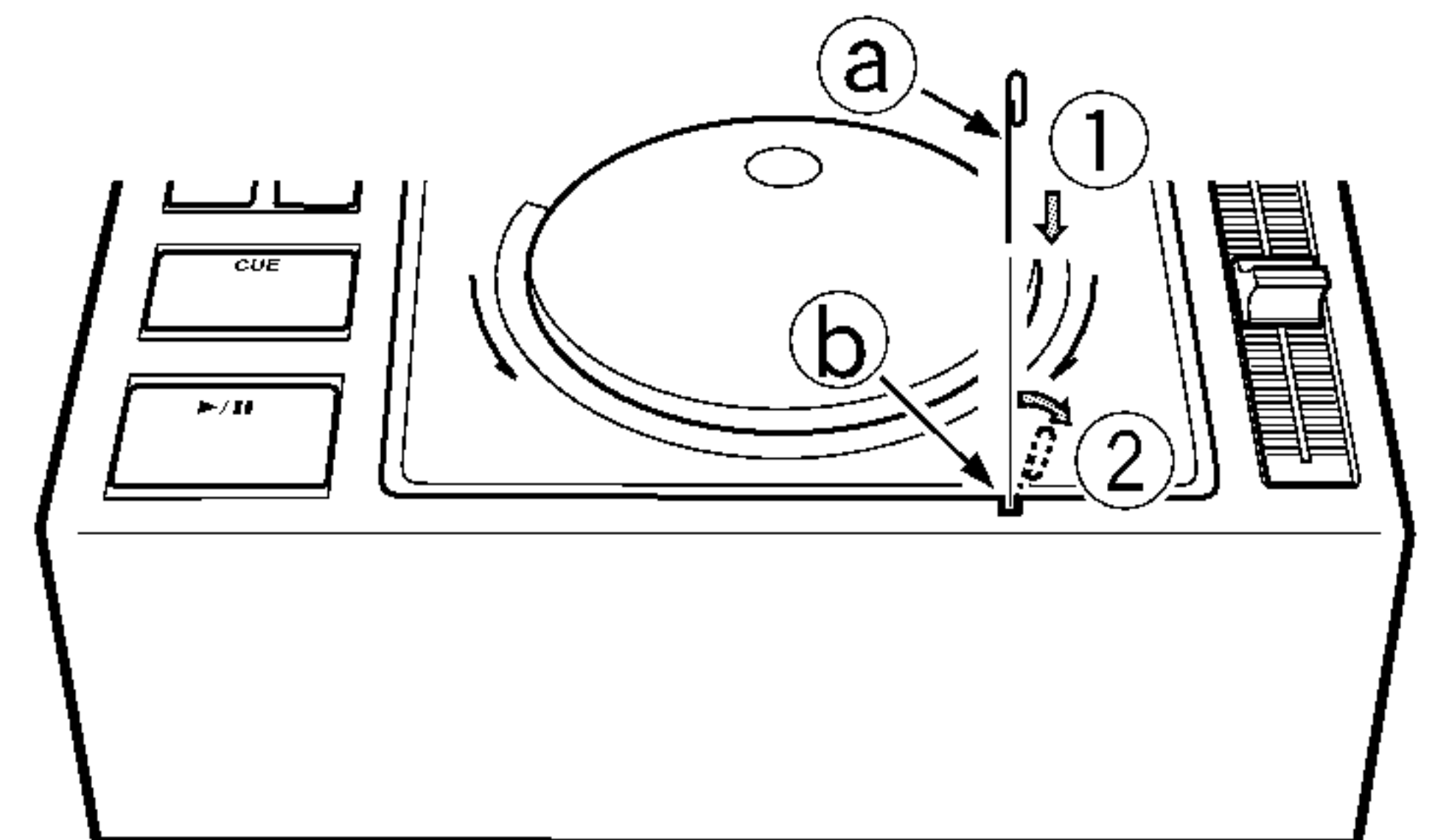

3. Insert key ① straight into hole ② shown in the illustration ①.
4. Turn key ① to the right ②.

- | | |
|-----------------------------------------------------------------------------------------------------------------------------------------------------------------------------------------------------------------------------------------------------------------------------------------------------------------------------------------------------------------------------------------------------------------------------------------------------------------------------------------------------------------------------------------------------------------------------------------------------------------------------------------------------------------------------------------------------------------------------------------------------------------------------------------------------------------------------------------------------------------------------------------------------------------------------------------------------------------------------------------------------------------|-----------------------------------------------------------------------------------------------------------------------------------------------------------------------------------------------------------------------------------------------------------------------------------------------------------------------------------------------------------------------------------------------------------------------------------------------------------------------------------------------------------------------------------------------------------------------------------------------------------------------------------------------------------------------------------------------------------------------------------------------------------------------------------------------------------------------------------------------------------------------------------------------------------------------------------------------------------------------------------------------------------------------------|
| <p>① POWER switch
(Located on rear panel)
Provides electrical power to the player.</p> <p>② TIME MODE/AUTO CUE button
Two functions are available.</p> <p>[Time display]
Each time this button is pressed, the time display changes between the elapsed playback time of the track (TIME) and the remaining playback time of the track (REMAIN).
● The REMAIN display appears when power is turned ON.</p> <p>[Auto Cue function]
When a disc is initially loaded or when performing track search, this function automatically stores the cue point (the point immediately preceding actual sound output) in memory.
● The Auto Cue function defaults to OFF when power is first turned on.</p> <p>③ TRACK SEARCH buttons (◀◀, ▶▶)</p> <p>④ SEARCH buttons (◀, ▶)</p> <p>⑤ CUE button/indicator
Three functions are available.</p> <p>[Cue Point Memory]</p> <p>[Back Cue]</p> <p>[Cue Point Sampler]</p> | <p>⑥ PLAY/PAUSE button/indicator (▶/)</p> <p>⑦ Display window</p> <p>⑧ LOOP IN/REAL TIME CUE/OUT ADJUST button</p> <p>⑨ LOOP OUT/EXIT button</p> <p>⑩ RELOOP button</p> <p>⑪ Headphones jack, Level control (HEADPHONE, HEADPHONE VOLUME)
Located on rear panel.
● The headphone jack is provided only to allow confirmation of the disc sound; as a result, the volume provided by the headphone output may seem insufficient when listening within a disco or other environment characterized by high sound volume.</p> <p>⑫ TEMPO control range button (TEMPO±10/±16)
Each time this button is pressed, the tempo adjustment range produced by the TEMPO control slider toggles between the two range ±10% and ±16%. When the range is switched, the newly selected range (10.0 or 16.0) flashes on the display for about two seconds.
● The adjustment range defaults to ±10% when power is first turned ON.</p> <p>⑬ MASTER TEMPO button</p> |
|-----------------------------------------------------------------------------------------------------------------------------------------------------------------------------------------------------------------------------------------------------------------------------------------------------------------------------------------------------------------------------------------------------------------------------------------------------------------------------------------------------------------------------------------------------------------------------------------------------------------------------------------------------------------------------------------------------------------------------------------------------------------------------------------------------------------------------------------------------------------------------------------------------------------------------------------------------------------------------------------------------------------|-----------------------------------------------------------------------------------------------------------------------------------------------------------------------------------------------------------------------------------------------------------------------------------------------------------------------------------------------------------------------------------------------------------------------------------------------------------------------------------------------------------------------------------------------------------------------------------------------------------------------------------------------------------------------------------------------------------------------------------------------------------------------------------------------------------------------------------------------------------------------------------------------------------------------------------------------------------------------------------------------------------------------------|

CDJ-700S, CDJ-500S

⑭ OPEN button (▲)

Press this button to open the disc compartment door.

- When pressed during playback, disc rotation stops before the door opens.

⑮ Jog dial (+ FWD/ - REV)

⑯ TEMPO control knob

The playback tempo can be changed with this knob. The center clicked position is for normal playback tempo. If you slide the knob (down) towards you (+ side), the music tempo quickens. If the knob is away from you (- side), the music tempo slows.

⑰ Disc compartment door

Press the EJECT button to open the door. To close the door, push gently on the front of the door.

■ DISPLAY

Display Window

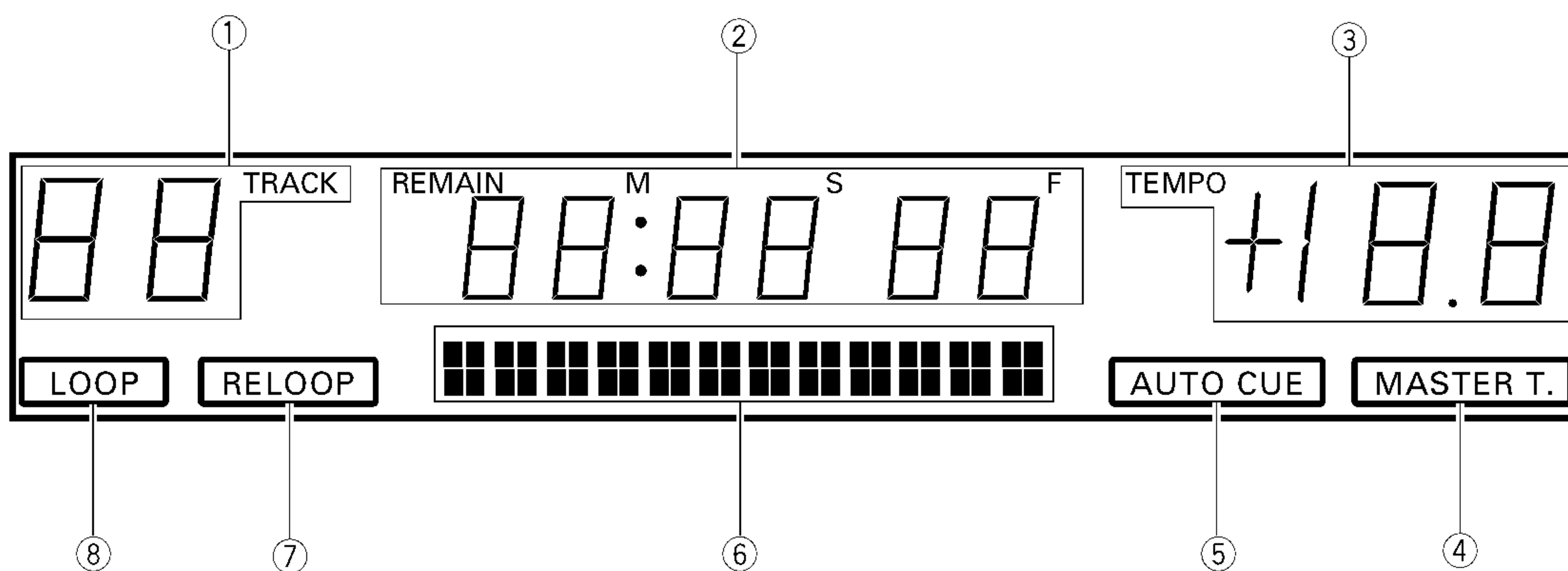

① TRACK number display

Displays the current number of the track playing.

② Time display (REMAIN)

The elapsed playback time of the track being played or the remaining playback time of the track being played (REMAIN) is displayed in minutes (M) and seconds (S), or frames (F).

③ Playback tempo (TEMPO) display

The playback tempo adjusted with the TEMPO control knob is displayed (up to $\pm 10\%$ or $\pm 16\%$) in steps of 0.1%.

④ MASTER T. indicator

Lights when the MASTER TEMPO function is used.

⑤ AUTO CUE indicator

Lights when the AUTO CUE function is used.

⑥ Playback address display

The elapsed playback time or remaining playback time of the track playing is roughly indicated with the full-scaled bar graph.

- When no disc is in the disc compartment off
- When displaying elapsed playback time lights up from the left side
- When displaying remaining playback time turns off from the left side
- When remaining playback time is less than 30 seconds blinks

⑦ RELOOP indicator

Lights when loop playback is possible. The loop-in point (start point) and loop-out point (end point) are stored in memory.

⑧ LOOP indicator

Lights during loop playback.

■ SPECIFICATIONS

1. General

System	Compact disc digital audio system
Power requirements	AC 120 V, 60 Hz
Power consumption	19 W
Operating temperature	+5°C – +35°C (+41°F – +95°F)
Operating humidity	5% – 85%
(There should be no condensation of moisture.)	
Weight	2.6 kg (5 lbs 12 oz)
Dimensions	217 (W) × 227.7 (D) × 98 (H) mm 8-1/2 (W) × 8-15/16 (D) × 3-7/8 (H) in.

2. Audio section

Frequency response	20 Hz – 20 kHz (EIAJ)
Signal-to-noise ratio	106 dB or more (EIAJ)
Dynamic range	96 dB or more (EIAJ)
Channel separation	98 dB or more (EIAJ)
Total harmonic distortion	0.004% or less (EIAJ)
Output level	2.0 V
Channels	2-channel (stereo)

3. Accessories

● Operating instructions	1
● Audio cable	1
● Control cable	1
● Screws for rack mounting	3
● Spacers for rack mounting	3
● Limited warranty	1

NOTE:

Specifications and design are subject to possible modification without notice.