

Service Manual

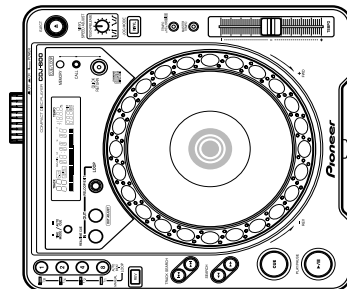

CDJ-800

ORDER NO.
RRV2690

COMPACT DISC PLAYER

CDJ-800

THIS MANUAL IS APPLICABLE TO THE FOLLOWING MODEL(S) AND TYPE(S).

Model	Type	Power Requirement	Remarks
CDJ-800	KUCXJ	AC120V	
CDJ-800	WYXJ	AC220-240V	



For details, refer to "Important symbols for good services" .

SAFETY INFORMATION



This service manual is intended for qualified service technicians ; it is not meant for the casual do-it-yourselfer. Qualified technicians have the necessary test equipment and tools, and have been trained to properly and safely repair complex products such as those covered by this manual.

Improperly performed repairs can adversely affect the safety and reliability of the product and may void the warranty. If you are not qualified to perform the repair of this product properly and safely, you should not risk trying to do so and refer the repair to a qualified service technician.



WARNING

This product contains lead in solder and certain electrical parts contain chemicals which are known to the state of California to cause cancer, birth defects or other reproductive harm.

Health & Safety Code Section 25249.6 – Proposition 65



NOTICE

(FOR CANADIAN MODEL ONLY)

Fuse symbols  (fast operating fuse) and/or  (slow operating fuse) on PCB indicate that replacement parts must be of identical designation.

REMARQUE

(POUR MODÈLE CANADIEN SEULEMENT)

Les symboles de fusible  (fusible de type rapide) et/ou  (fusible de type lent) sur CCI indiquent que les pièces de remplacement doivent avoir la même désignation.

(FOR USA MODEL ONLY)

1. SAFETY PRECAUTIONS

The following check should be performed for the continued protection of the customer and service technician.

LEAKAGE CURRENT CHECK

Measure leakage current to a known earth ground (water pipe, conduit, etc.) by connecting a leakage current tester such as Simpson Model 229-2 or equivalent between the earth ground and all exposed metal parts of the appliance (input/output terminals, screwheads, metal overlays, control shaft, etc.). Plug the AC line cord of the appliance directly into a 120V AC 60Hz outlet and turn the AC power switch on. Any current measured must not exceed 0.5mA.

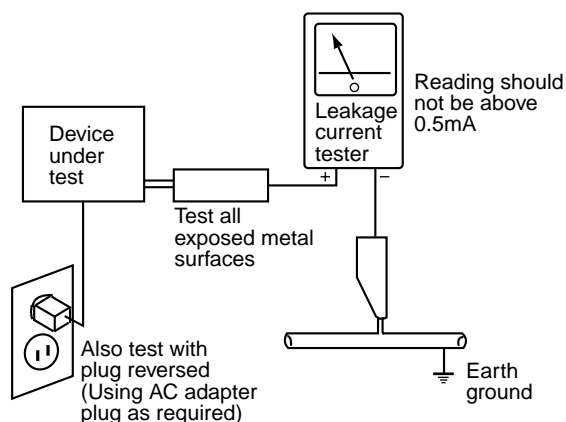

AC Leakage Test

ANY MEASUREMENTS NOT WITHIN THE LIMITS OUTLINED ABOVE ARE INDICATIVE OF A POTENTIAL SHOCK HAZARD AND MUST BE CORRECTED BEFORE RETURNING THE APPLIANCE TO THE CUSTOMER.

2. PRODUCT SAFETY NOTICE

Many electrical and mechanical parts in the appliance have special safety related characteristics. These are often not evident from visual inspection nor the protection afforded by them necessarily can be obtained by using replacement components rated for voltage, wattage, etc. Replacement parts which have these special safety characteristics are identified in this Service Manual.

Electrical components having such features are identified by marking with a Δ on the schematics and on the parts list in this Service Manual.

The use of a substitute replacement component which does not have the same safety characteristics as the PIONEER recommended replacement one, shown in the parts list in this Service Manual, may create shock, fire, or other hazards.

Product Safety is continuously under review and new instructions are issued from time to time. For the latest information, always consult the current PIONEER Service Manual. A subscription to, or additional copies of, PIONEER Service Manual may be obtained at a nominal charge from PIONEER.

IMPORTANT

THIS PIONEER APPARATUS CONTAINS LASER OF CLASS 1.
SERVICING OPERATION OF THE APPARATUS SHOULD BE DONE BY A SPECIALLY INSTRUCTED PERSON.

LASER DIODE CHARACTERISTICS

MAXIMUM OUTPUT POWER: 5 mW
WAVELENGTH: 780 – 785 nm

WARNING !

The AEL(accessible emission level) of the laser power output is less then **CLASS 1** but the laser component is capable of emitting radiation exceeding the limit for **CLASS 1**.

A specially instructed person should servicing operation of the apparatus.

LABEL CHECK**CDJ-800 WYXJ : Types Only****VARO!**

Avattaessa ja suojalukitus ohitettaessa olet alttiina näkymättömille lasersäteilylle. Älä katso säteeseen.

WARNING!

Osynlig laserstrålning när denna del är öppnad och spårren är urkopplad. Betrakta ej strålen.

VHW1287-A

ADVARSEL

USYNLIG LASERSTRÅLING VED ÅBNING NÅR SIKKERHED SAF-BRYDERE ER UDE AF FUNKTION. UNDGÅ UDSÆTTELSE FOR STRÅLING.

VORSICHT!

UNSIHTBARE LASER-STRÅHLUNG TRITTS AUS, WENN DECKEL (ODER KLAPPE) GEÖFFNET IST! NICHT DEM STRAHL AUSSETZEN!

VHW1094

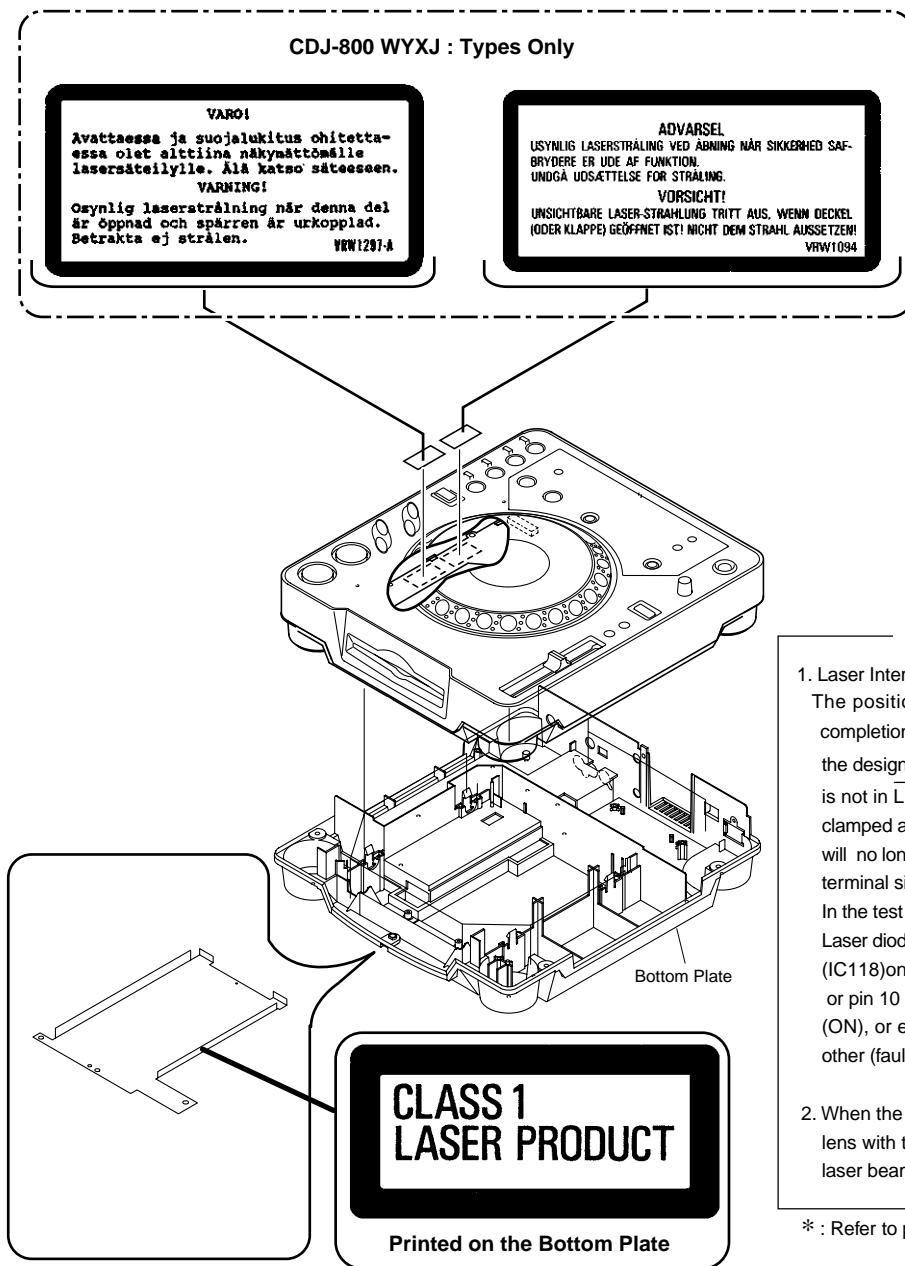
**Additional Laser Caution****1. Laser Interlock Mechanism**

The position of the switch (S1901) for detecting loading completion is detected by the system microprocessor, and the design prevents laser diode oscillation when the switch is not in LPS1 terminal side (when the mechanism is not clamped and LPS1 signal is high level.) Thus, the interlock will no longer function if the switch is deliberately set to LPS1 terminal side. (if LPS1 signal is low level).

In the test mode* the interlock mechanism will not function. Laser diode oscillation will continue, if pin 9 of TA2153FN (IC118) on the MAIN ASSY is connected to GND, or pin 10 of IC118 (LDON) is connected to low level (ON), or else the terminals of Q110 are shorted to each other (fault condition).

2. When the cover is opened, close viewing of the objective lens with the naked eye will cause exposure to a Class 1 laser beam.

* : Refer to page 53.

[Important symbols for good services]

In this manual, the symbols shown-below indicate that adjustments, settings or cleaning should be made securely. When you find the procedures bearing any of the symbols, be sure to fulfill them:

1. Product safety



You should conform to the regulations governing the product (safety, radio and noise, and other regulations), and should keep the safety during servicing by following the safety instructions described in this manual.

2. Adjustments



To keep the original performances of the product, optimum adjustments or specification confirmation is indispensable. In accordance with the procedures or instructions described in this manual, adjustments should be performed.

3. Cleaning



For optical pickups, tape-deck heads, lenses and mirrors used in projection monitors, and other parts requiring cleaning, proper cleaning should be performed to restore their performances.

4. Shipping mode and shipping screws



To protect the product from damages or failures that may be caused during transit, the shipping mode should be set or the shipping screws should be installed before shipping out in accordance with this manual, if necessary.

5. Lubricants, glues, and replacement parts



Appropriately applying grease or glue can maintain the product performances. But improper lubrication or applying glue may lead to failures or troubles in the product. By following the instructions in this manual, be sure to apply the prescribed grease or glue to proper portions by the appropriate amount. For replacement parts or tools, the prescribed ones should be used.

[NOTES ON SERVICING]

■ CLEANING



Before shipping out the product, be sure to clean the following positions by using the prescribed cleaning tools:

Position to be cleaned	Cleaning tools
Pickup lenses	Cleaning liquid : GEM1004 Cleaning paper : GED-008

5 6 7 8

CONTENTS

- SAFETY INFORMATION.....2
- 1. SPECIFICATIONS6
- 2. EXPLODED VIEWS AND PARTS LIST8
 - 2.1 PACKING8
 - 2.2 EXTERIOR SECTION10
 - 2.3 CONTROL PANEL SECTION.....12
 - 2.4 SLOT-IN MECHANISM SECTION14
- 3. BLOCK DIAGRAM AND SCHEMATIC DIAGRAM16
 - 3.1 BLOCK DIAGRAM16
 - 3.2 OVERALL WIRING DIAGRAM18
 - 3.3 MAIN ASSY(1/2).....20
 - 3.4 MAIN ASSY(2/2).....22
 - 3.5 AC IN, TRNS, SECB and REGB ASSYS.....24
 - 3.6 MFLB, SLMB and KSWB ASSYS.....26
 - 3.7 JFLB, SLDB and JOGB ASSYS28
- 4. PCB CONNECTION DIAGRAM35
 - 4.1 MAIN ASSY36
 - 4.2 AC IN and TRNS ASSYS.....38
 - 4.3 SECB, REGB and SLMB ASSYS40
 - 4.4 MFLB and KSWB ASSYS.....42
 - 4.5 SLDB, JOGB and JFLB ASSYS46
- 5. PCB PARTS LIST50
- 6. ADJUSTMENT54
- 7. GENERAL INFORMATION55
 - 7.1 DIAGNOSIS55
 - 7.1.1 SERVICE MODE55
 - 7.1.2 POWER ON SEQUENCE.....60
 - 7.1.3 DISASSEMBLY62
 - 7.2 PARTS65
 - 7.2.1 IC65
 - 7.2.2 DISPLAY75
- 8. PANEL FACILITIES76

A
B
C
D
E
F

CDJ-800

5 6 7 8

5

1. SPECIFICATIONS

1. General

System Compact disc digital audio system
 Power requirements (KUCXJ)AC 120 V, 60 Hz
 Power requirements(WYXJ)AC 220 -240V, 50/60 Hz
 Power consumption (KUCXJ)18 W
 Power consumption(WYXJ)21 W
 Operating temperature +5°C to +35°C
 Operating humidity 5% to 85%
 (There should be no condensation of moisture.)
 Weight3.9 kg (8.6 lb)
 Dimensions 305 (W)x 344.1 (D) x 108.5 (H) mm
 12 - 5/8 (W) x 13 -17/32 (D)x 4 - 1/4 (H) in

2. Audio section

Frequency response4 Hz to 20 kHz
 Signal-to-noise ratio115 dB or more (JEITA)
 Distortion0.006% (JEITA)

3. Accessories

- Operating instructions 1
- Power cord..... 1
- Audio cable 1
- Control cord..... 1
- Forced eject pin 1
 (housed in a groove in the bottom panel)
- Warranty(KUCXJ) 1

NOTE:

Specifications and design are subject to possible modification without notice.

Accessories

Audio Cable
 (VDE1052) L=1.5m



Power Cord
 (ADG1154 : WYXJ)
 (ADG7021 : KUCXJ)



Forced Eject Pin
 (housed in a groove in
 the bottom panel)
 (DEX1008)

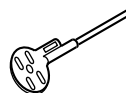

Control Cord
 (PDE-319) L=1 m





5



6



7



8



A



B



C



D



E



F



5



6

CDJ-800



7





8

7



2. EXPLODED VIEWS AND PARTS LIST

- NOTES:
- Parts marked by "NSP" are generally unavailable because they are not in our Master Spare Parts List.
 - The  mark found on some component parts indicates the importance of the safety factor of the part. Therefore, when replacing, be sure to use parts of identical designation.
 - Screws adjacent to  mark on product are used for disassembly.
 - For the applying amount of lubricants or glue, follow the instructions in this manual.
(In the case of no amount instructions, apply as you think it appropriate.)

2.1 PACKING

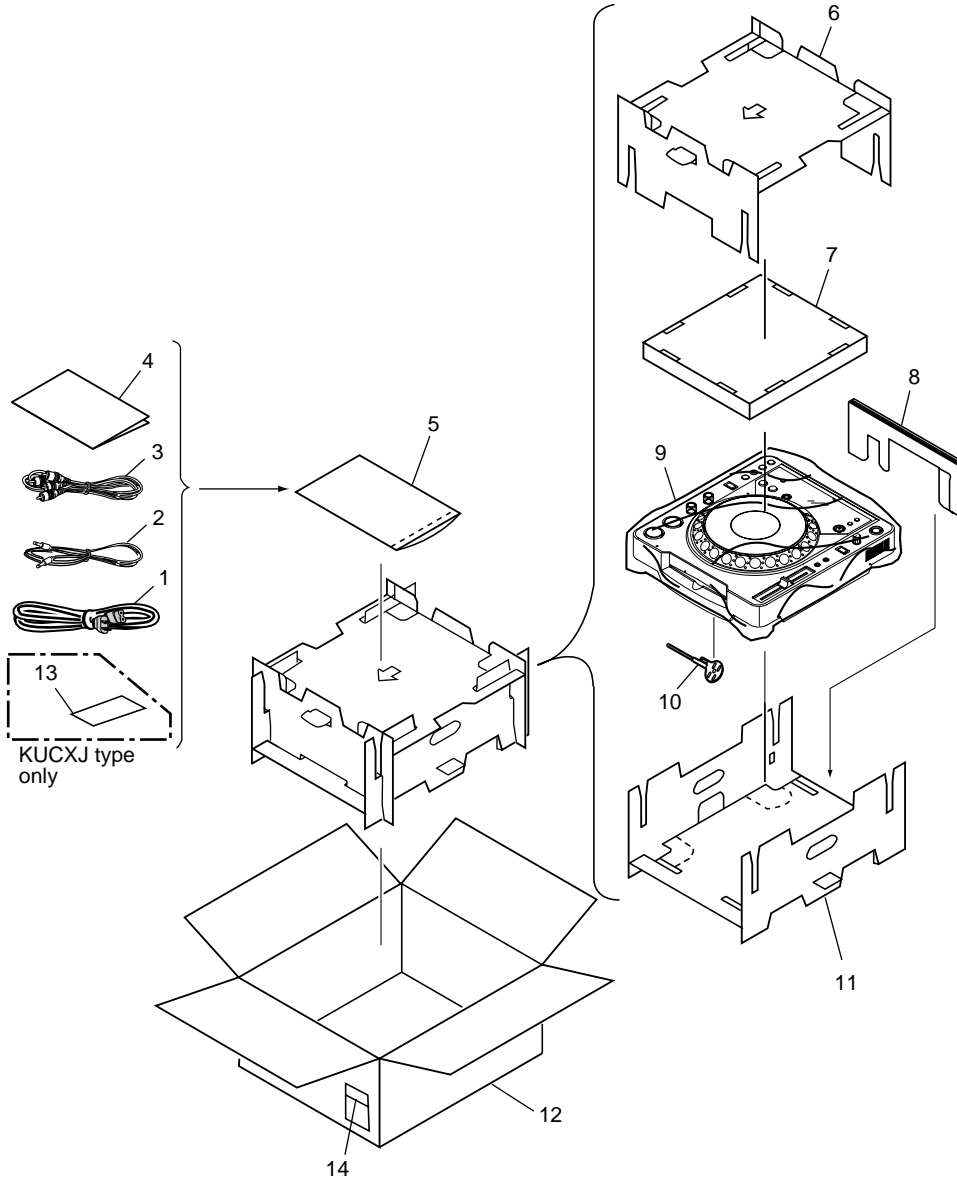

PACKING parts List

<u>Mark No.</u>	<u>Description</u>	<u>Part No.</u>	<u>Mark No.</u>	<u>Description</u>	<u>Part No.</u>
⚠ 1	AC Power Cord	See Contrast table(2)	9	Sheet	RHX1006
2	Control Cord	PDE-319	10	Push Rod	DEX1008
3	Audio Cord	VDE1052			
4	Operating Instructions	See Contrast table(2)	11	Pad A	DHA1555
5	Polyethylene Bag	Z21-038	12	Packing Case	See Contrast table(2)
			NSP 13	Warranty Card	See Contrast table(2)
6	Pad B	DHA1556	NSP 14	Label	VRW1629
7	Pad C	DHA1557			
8	Pad D	DHA1558			

(2) CONTRAST TABLE

CDJ-800/KUCXJ and WYXJ types are constructed the same except for the following:

Mark	No.	Symbol and Description	Part No.	
			KUCXJ	WYXJ
⚠	1	AC Power Cord	ADG7021	ADG1154
	4	Operating Instructions (KUCXJ)	DRB1333	Not used
	4	Operating Instructions (WYXJ)	Not used	DRB1332
	12	Packing Case	DHG2291	DHG2290
	NSP 13	Warranty Card	ARY7043	Not used

2.2 EXTERIOR SECTION

A

Refer to "2.3 CONTROL PANEL SECTION".

B

C

D

E

F

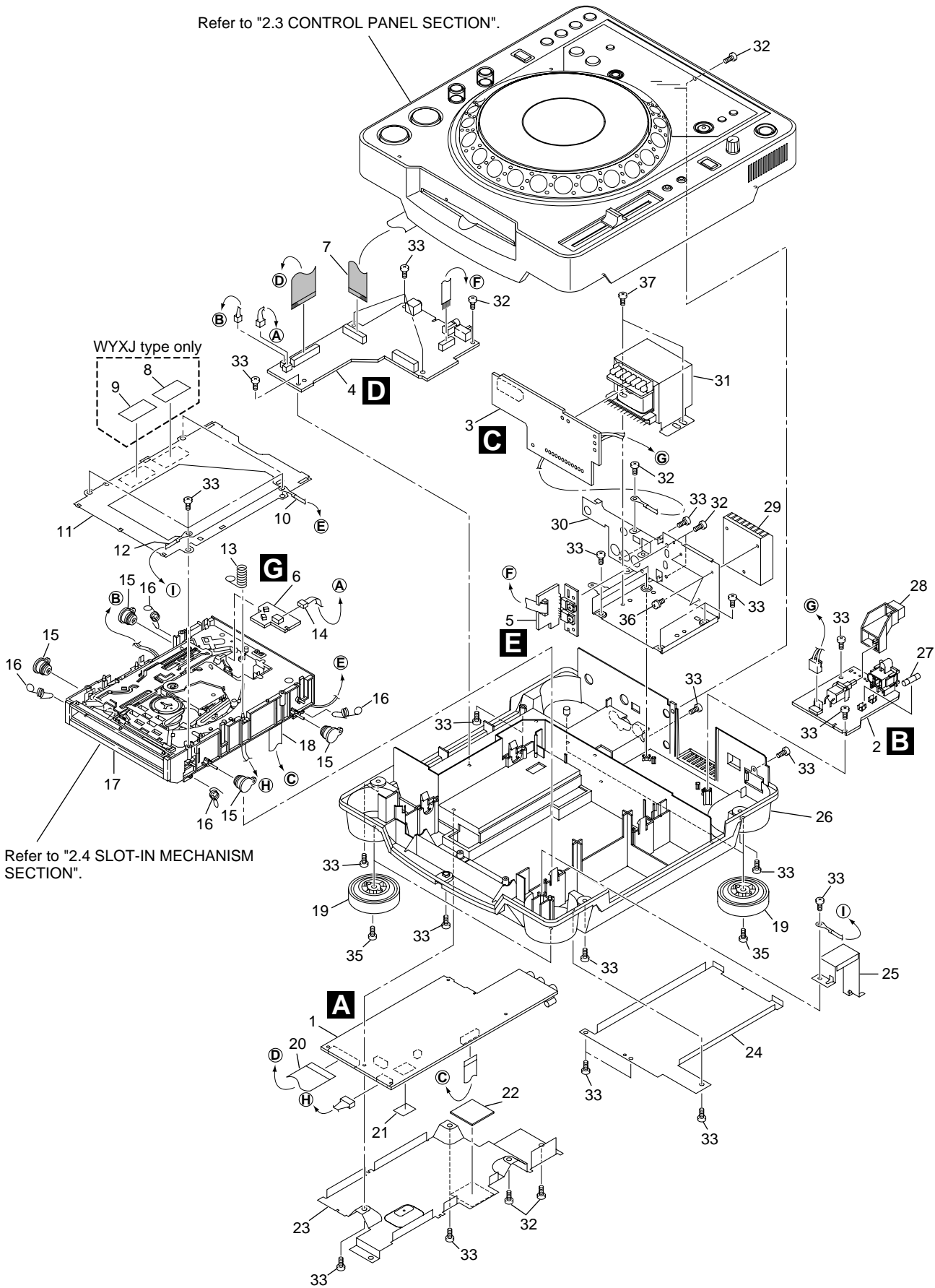

Refer to "2.4 SLOT-IN MECHANISM SECTION".

EXTERIOR SECTION parts List

Mark No.	Description	Part No.	Mark No.	Description	Part No.
1	MAIN Assy	DWG1563	20	25P F•F•C/60V	DDD1223
2	AC IN Assy	See Contrast table(2)			
3	TRNS Assy	DWR1364	NSP 21	Silicon Rubber D5 L	DEB1456
4	SECB Assy	DWR1361	22	Bottom Cushion S4	DEC2506
5	REGB Assy	DWR1362	23	Bottom Plate P	DNH2531
			24	Bottom Plate M	DNH2546
6	SLMB Assy	DWS1322	25	Earth Plate	DNH2532
7	19P F•F•C/60V	DDD1222			
8	Caution Label	See Contrast table(2)	NSP 26	Chassis	See Contrast table(2)
9	Caution Label HE	See Contrast table(2)	⚠ 27	FU11 Fuse	See Contrast table(2)
10	Earth Lead Unit	PDF1104	28	Power Knob	DAC2073
			29	Heat Sink	DNG1086
11	Mecha Plate	DNH2339	30	Trans Plate	DNH2529
NSP 12	Cord with Plug	DE010VF0			
13	Earth Spring	DBH1398	⚠ 31	T21 Power Transformer	See Contrast table(2)
14	Connector Assy	PG03KK-E22	32	Screw	BBZ30P080FMC
15	Damper	CNV6011	33	Screw	BPZ30P080FZK
			34	
16	Float Spring G5	DBH1494	35	Screw	IPZ30P100FMC
NSP 17	Slot-in Mecha S4 Assy	DXA1946			
18	Lead Card 16P	DDD1221	36	Screw	PMA30P060FMC
19	Insulator Assy	DXA1945	37	Screw	BBZ40P060FMC

(2) CONTRAST TABLE

CDJ-800/KUCXJ and WYXJ types are constructed the same except for the following:

Mark	No.	Symbol and Description	Part No.	
			KUCXJ	WYXJ
	2	AC IN Assy	DWR1366	DWR1363
	8	Caution Label	Not used	VRW1094
	9	Caution Label HE	Not used	PRW1233
NSP	26	Chassis	DNK4060	DNK4059
⚠	27	FU11 Fuse (1.6A/125V)	REK1077	Not used
⚠	27	FU11 Fuse (T800mA/L250V)	Not used	REK1021
⚠	31	T21 Power Transformer	DTT1169	DTT1168

2.3 CONTROL PANEL SECTION



*1 Lubricating oil : ZLB-PN397B

A

B

C

D

E

F

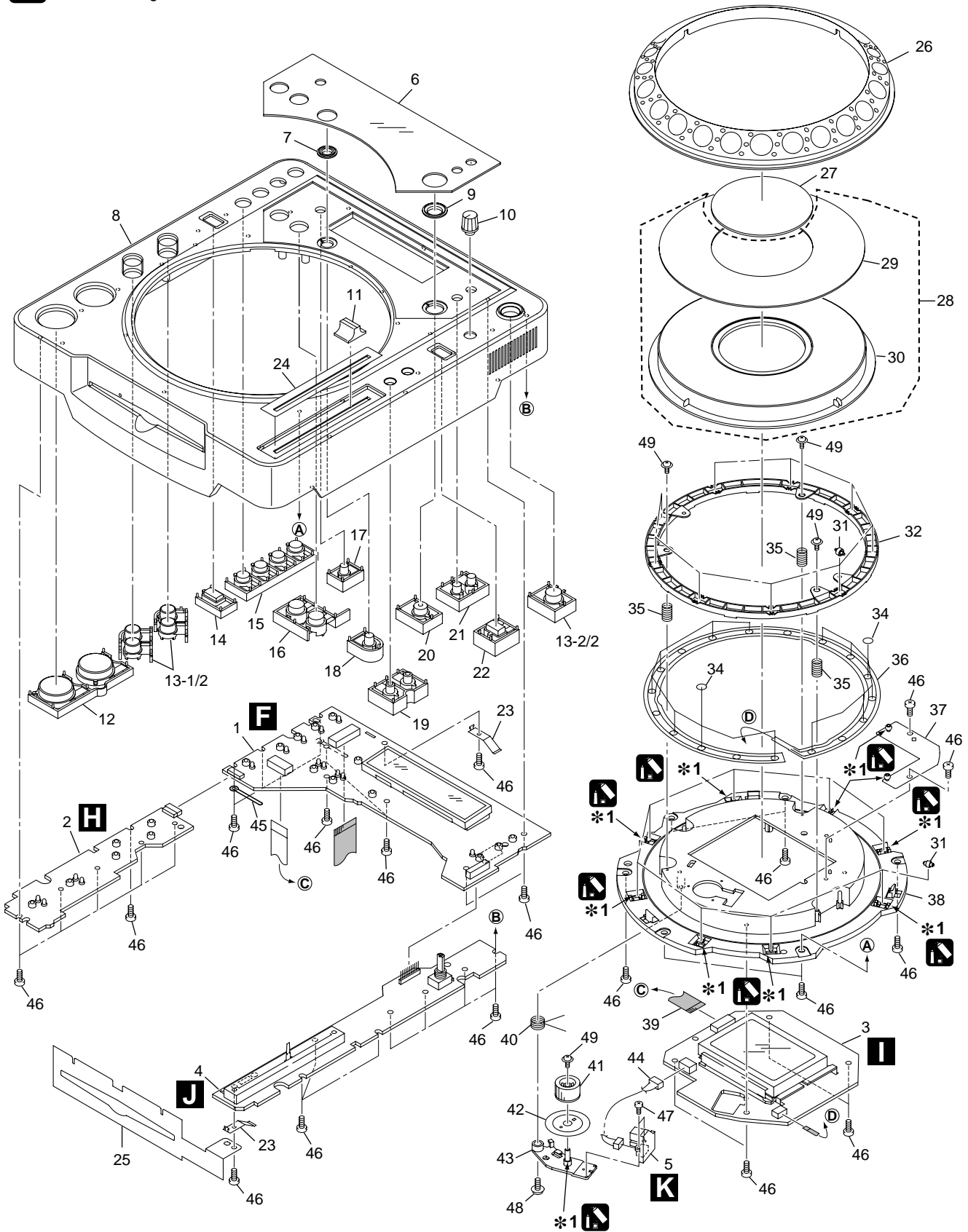

CONTROL PANEL SECTION parts List

<u>Mark No.</u>	<u>Description</u>	<u>Part No.</u>	
1	MFLB Assy	DWG1564	A
2	KSWB Assy	DWS1321	
3	JFLB Assy	DWG1565	
4	SLDB Assy	DWS1323	
5	JOGB Assy	DWG1566	
6	Display Panel	DAH2139	
7	RELOOP Guard	DNK4057	
8	Control Panel	DNK4054	
9	QR Guard	DNK4058	
10	Rotary Knob C	DAA1143	
11	Slide Knob	DAC2067	B
12	PLAY Knob	DAC2059	
13	SET Knob (EJECT)	DAC2060	
14	REVERSE Knob	DAC2068	
15	AUTO BEAT LOOP Knob	DAC2069	
16	LOOP Knob	DAC2066	
17	TIME MODE Knob	DAC2065	
18	RELOOP Knob	DAC2064	
19	TEMPO Knob	DAC2061	
20	QUICK RETURN Knob	DAC2070	C
21	CALL Knob	DAC2062	
22	VINYL Knob	DAC2063	
23	Earth Plate (CU)	DBK1224	
24	Slide Sheet 1C	DAH1988	
25	Vessel Sheet	DEC2495	
26	JOG B	DNK4068	
27	JOG Panel	DAH2182	
28	JOG Assy-S	DXX2521	
29	JOG Plate	DAH2052	D
30	JOG A	DNK4067	
31	Roller A Assy	DXB1773	
32	SW Ring	DNK4070	
33		
34	SW Cushion HH48	DEC2523	
35	SW Spring	DBH1514	
36	Sheet SW	DSX1060	
37	JOG Stay Assy	DXB1774	
38	JOG Holder	DNK4069	E
39	13P F•F•C/60V	DDD1220	
40	Arm Spring	DBH1503	
41	D Gear	DNK4066	
42	ENC Plate	DEC2498	
43	Gear Arm	DNK4065	
44	Connector Assy	PF04PP-B07	
45	Cord Clamper	RNH-184	
46	Screw	BPZ30P080FZK	F
47	Screw	BPZ20P060FMC	
48	Screw	IPZ30P100FMC	
49	Screw	PBA1062	

2.4 SLOT-IN MECHANISM SECTION

A

B

C

D

E

F

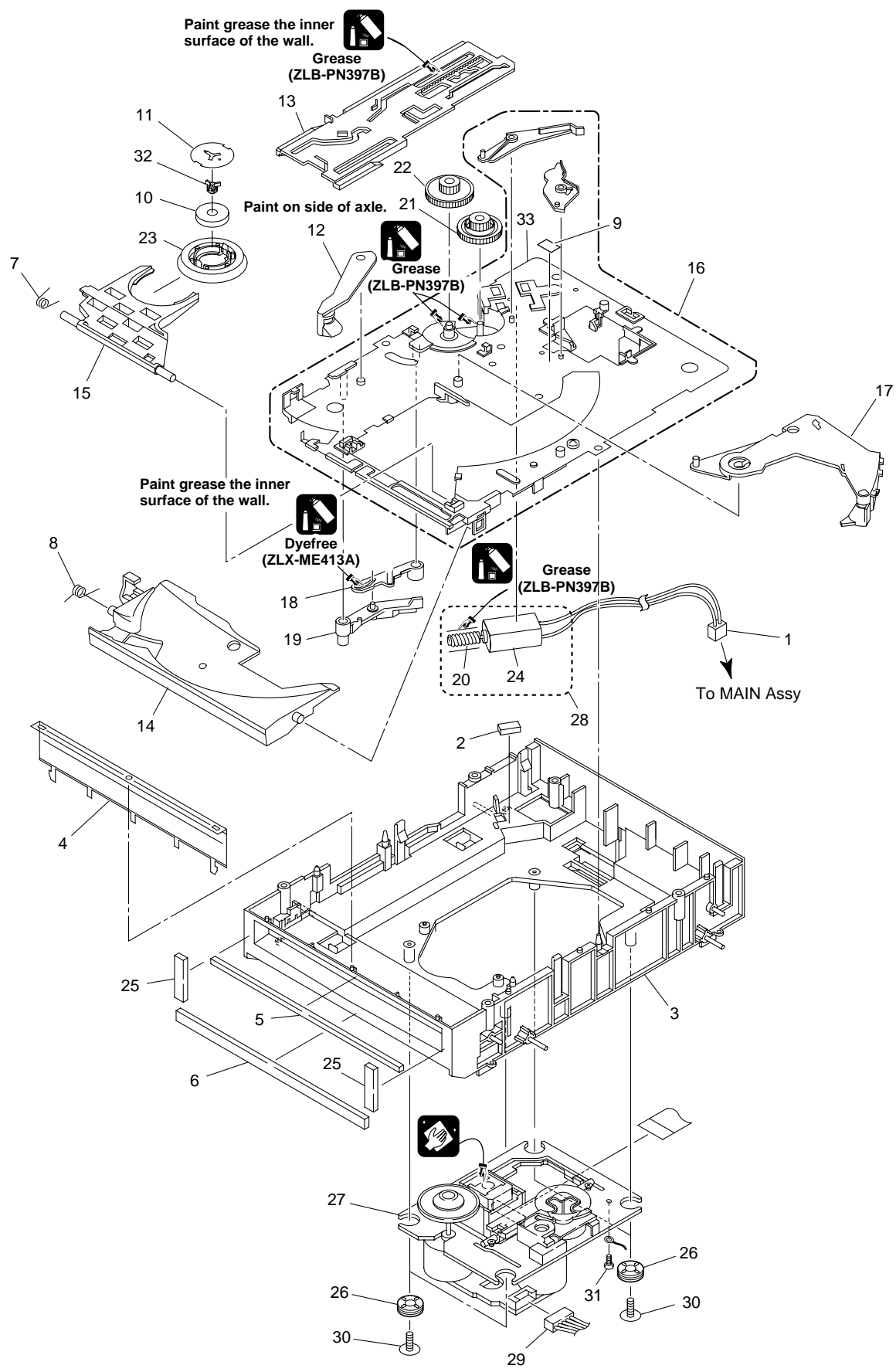

SLOT-IN MECHANISM SECTION parts List

<u>Mark No.</u>	<u>Description</u>	<u>Part No.</u>
1	Connector Assy	DKP3522
2	Spacer Por (T3)	DEB1566
3	Float Base S4 Assy	DXB1772
4	Front Sheet	DED1132
5	Vessel Cushion A	DEC2455
6	Vessel Cushion B	DEC2456
7	Clamp Spring	DBH1374
8	Guide Spring	DBH1375
9	SW. Lever Spacer (Pet)	DEC2420
10	Clamp Magnet	DMG1009
11	Yoke S4	DNH2528
12	Loading Lever	DNK3406
13	Main Cam	DNK3407
14	Disc Guide	DNK3478
15	Clamp Arm	DNK3576
16	Loading Base Assy-S	DEA1022
17	Eject Lever	DNK3684
18	Lever AP	DNK3835
19	Lever BP	DNK3836
NSP 20	Worm Gear	DNK3410
21	Loading Gear	DNK3409
22	Drive Gear	DNK3565
23	Clamper S4	DNK4072
NSP 24	DC Motor	DXM1173
25	Vessel Cushion C	DEC2457
26	Float Rubber S4	DEB1568
27	CD Mechanism	DXA-DA114
28	DC Motor Assy-S	DXX2510
29	Connector Assy (6P)	PF06PP-B25
30	Screw DM	DBA1104
31	Screw	BBZ20P040FMC
32	Centering Guide	DNK4073
NSP 33	Loading Base	DNK3637

A

B

C

D

E

F

3. BLOCK DIAGRAM AND SCHEMATIC DIAGRAM

3.1 BLOCK DIAGRAM

A

B

C

D

E

F

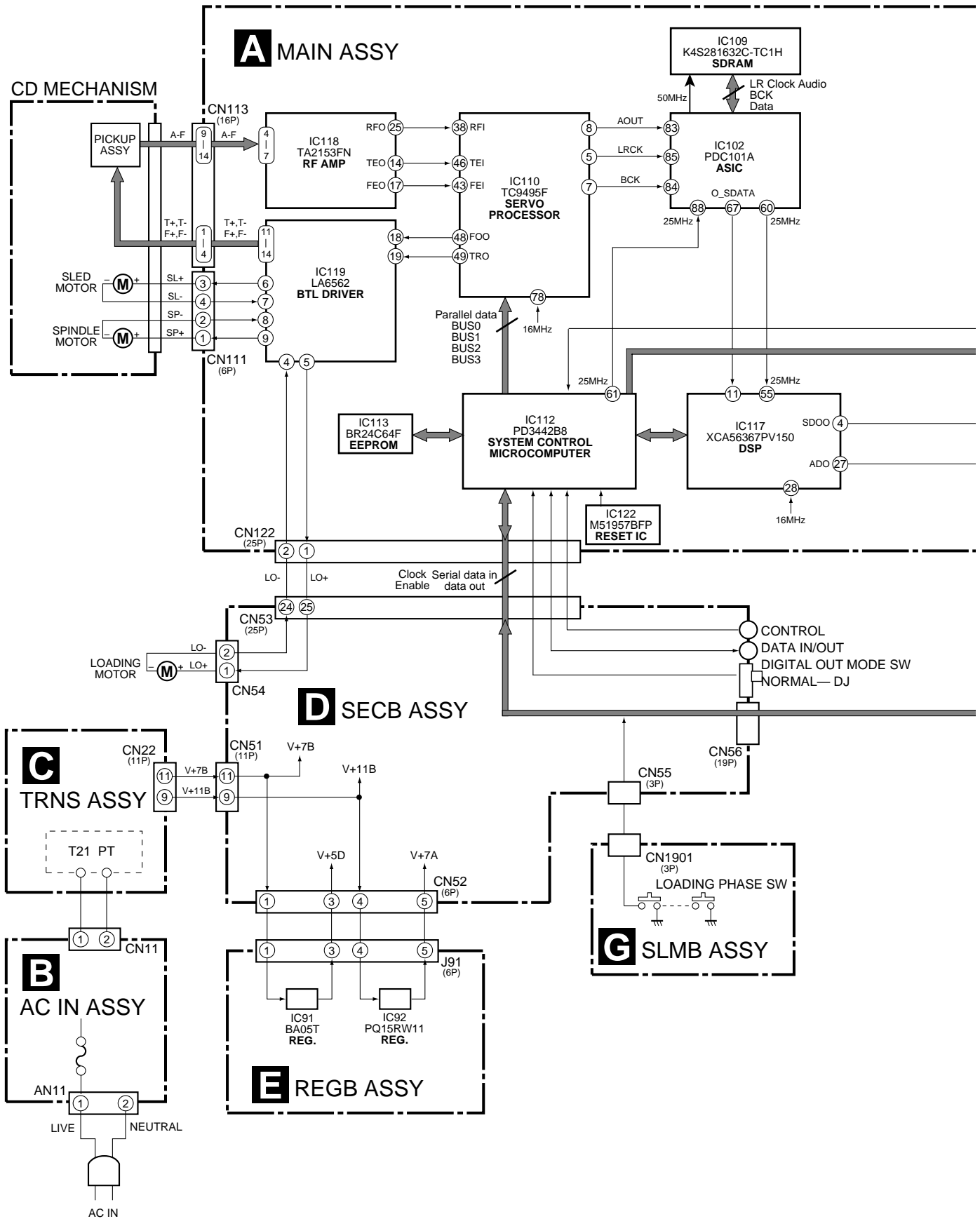

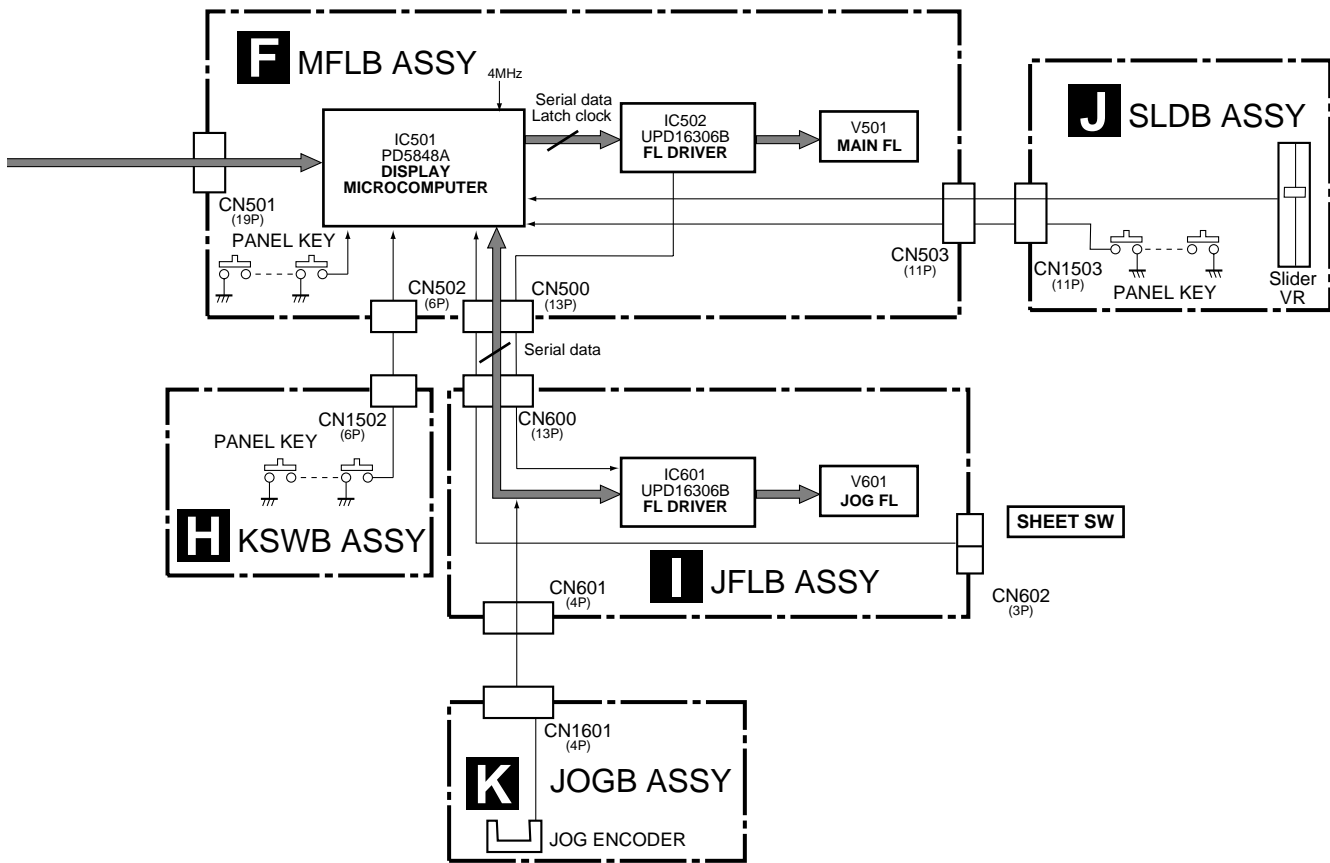
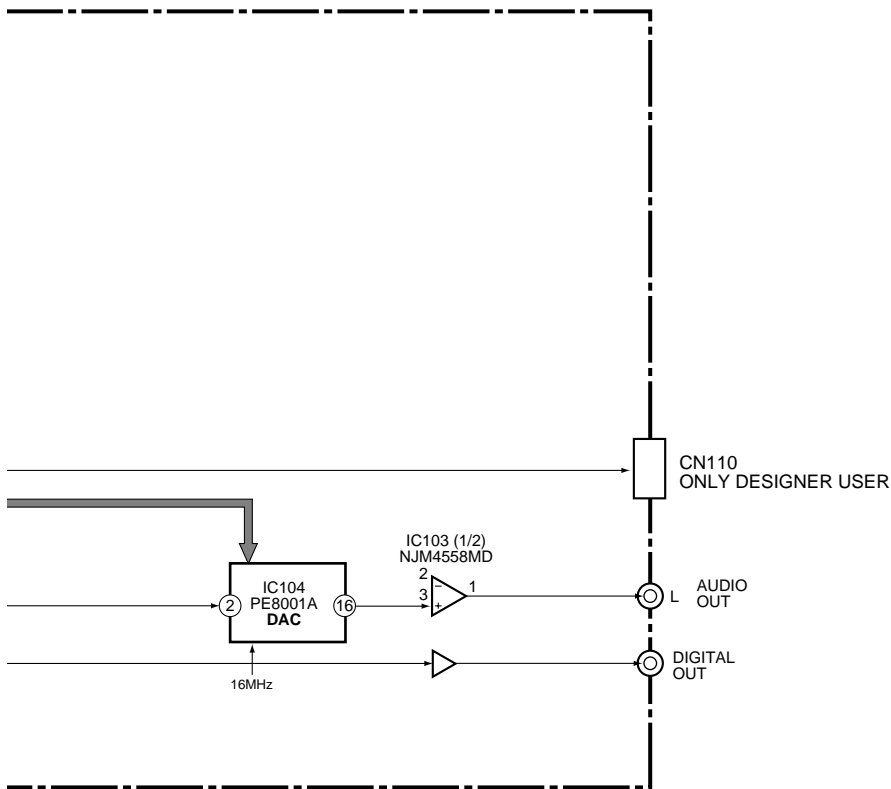

3.2 OVERALL WIRING DIAGRAM

A

B

C

D

E

F

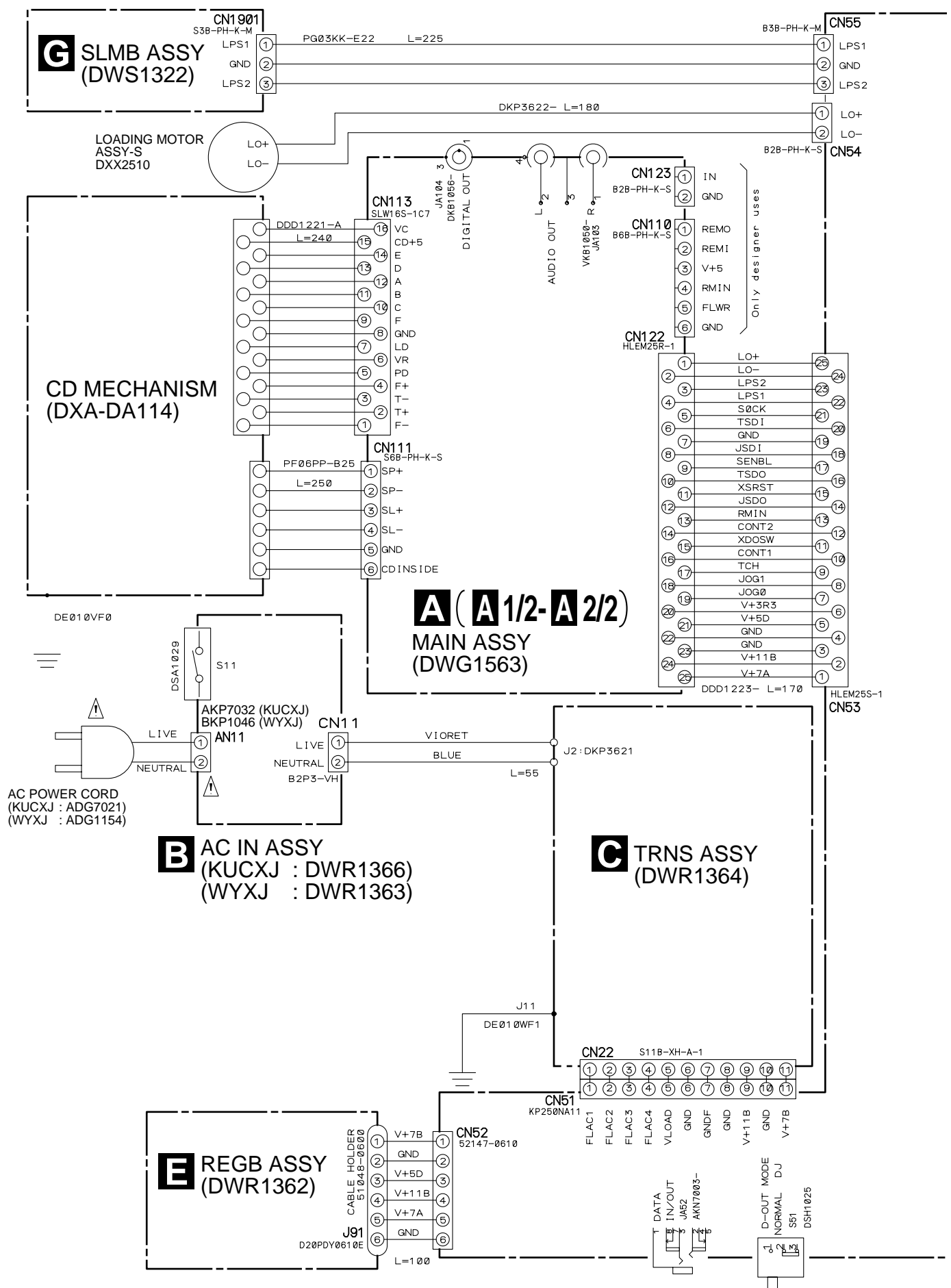

Note : When ordering service parts, be sure to refer to "EXPLODED VIEWS and PARTS LIST" or "PCB PARTS LIST".

D SECB ASSY (DWR1361)

H KSWB ASSY (DWS1321)

J SLDB ASSY (DWS1323)

F MFLB ASSY (DWG1564)

I JFLB ASSY (DWG1565)

K JOGB ASSY (DWG1566)

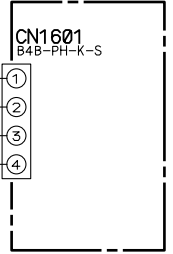
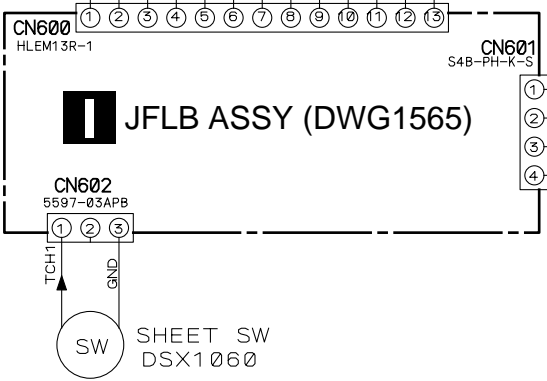
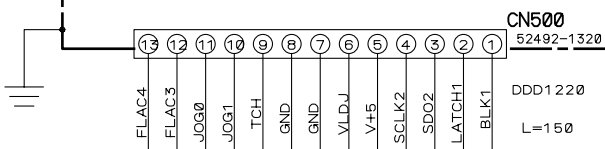
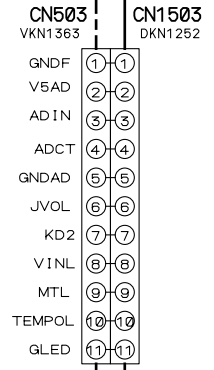
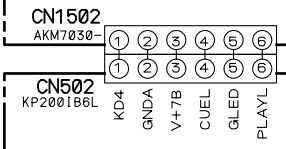
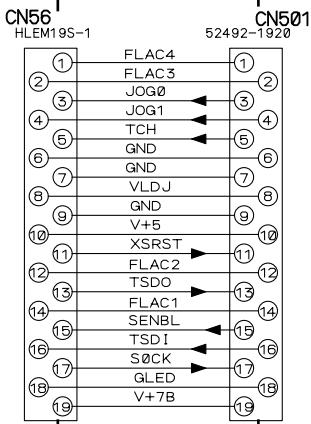

3.3 MAIN ASSY(1/2)

A

B

C

D

E

F

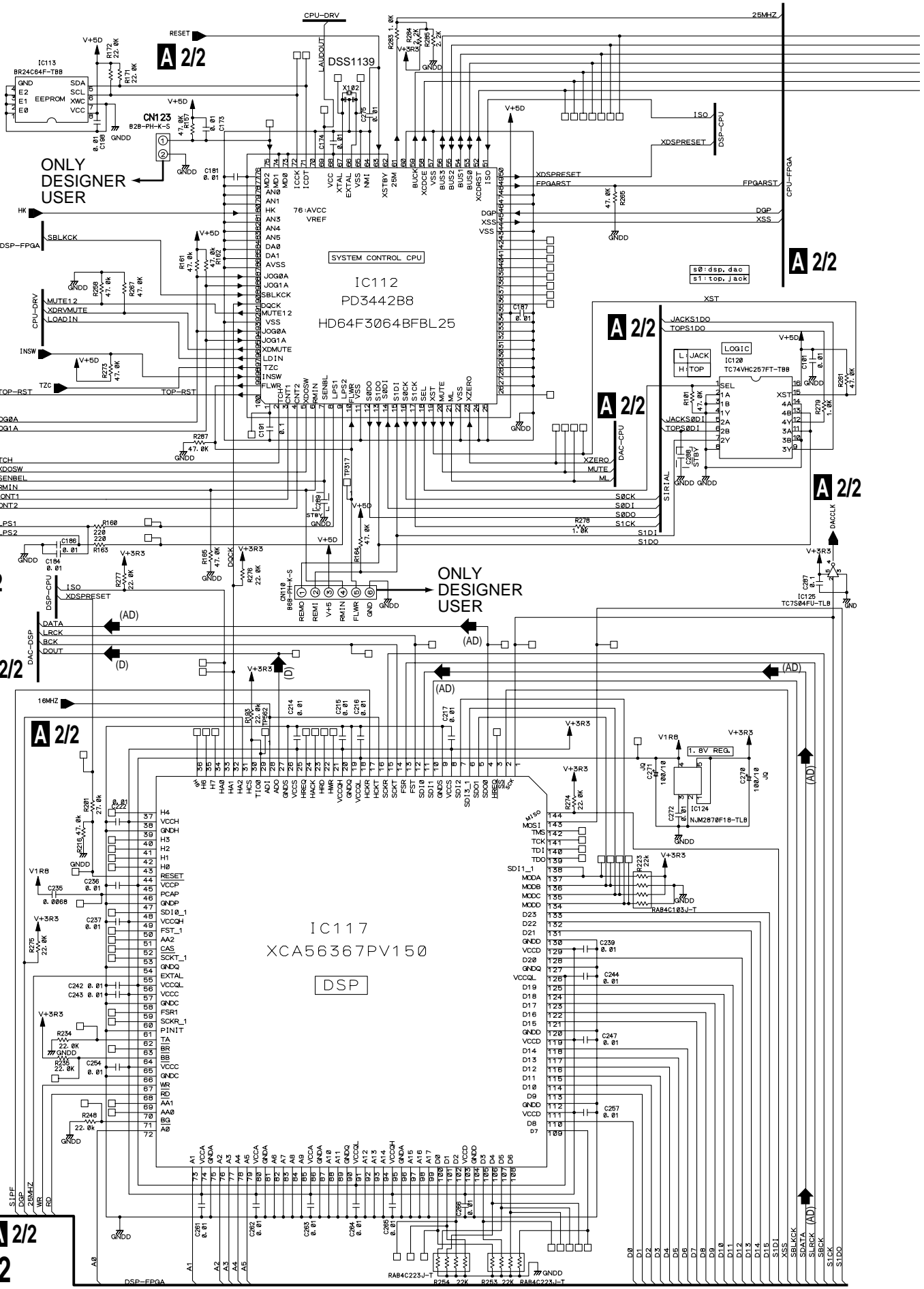

1

2

3

4

A 1/2 MAIN ASSY (DWG1563)

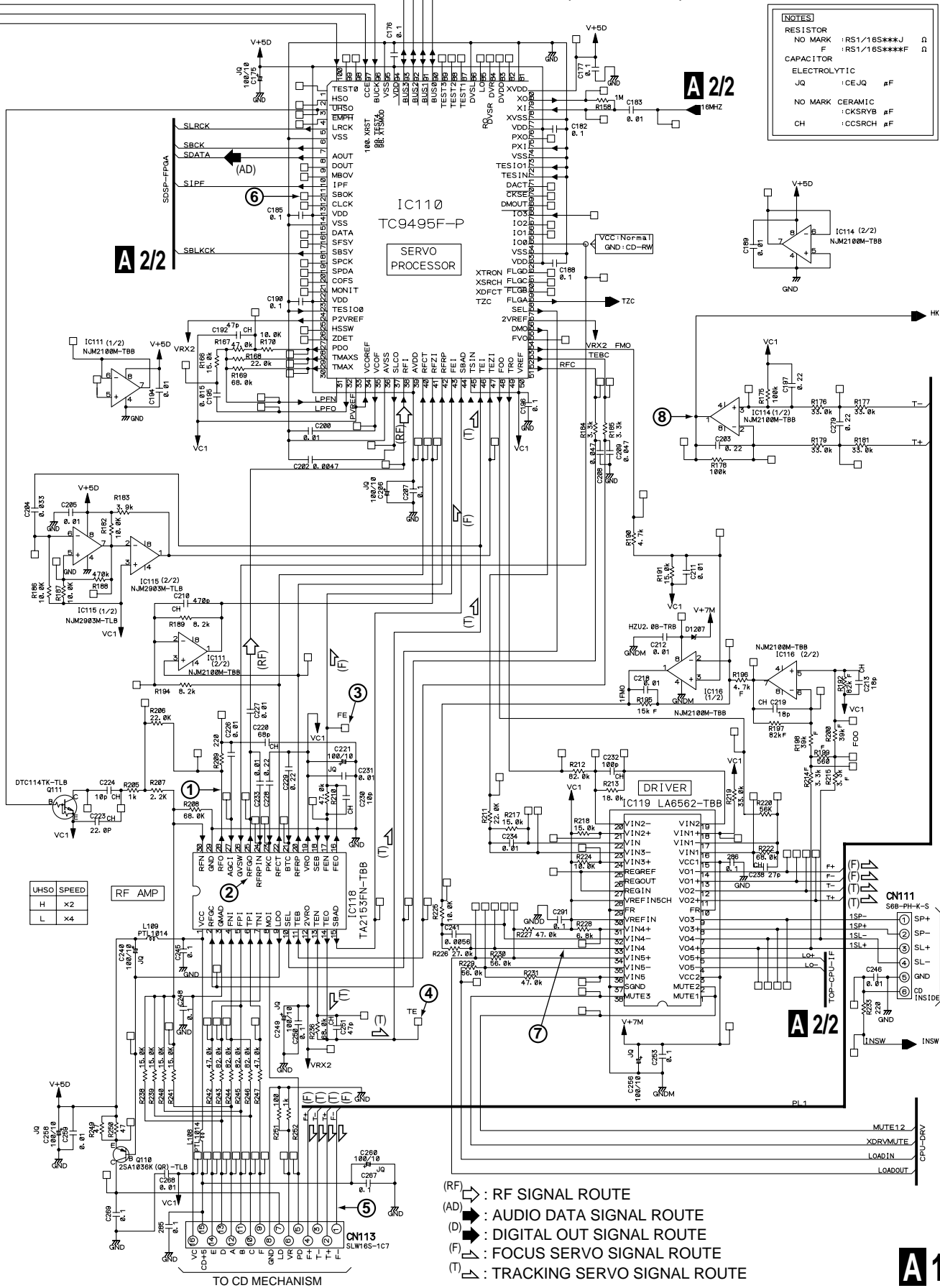

NOTES	
RESISTOR	
NO MARK	: RS1/16S***J Ω
F	: RS1/16S***F Ω
CAPACITOR	
ELECTROLYTIC	
JQ	: CEJQ μF
NO MARK	: CERSYB μF
CH	: CCSRCH μF

UHSO SPEED	
H	X2
L	X4

- (RF) : RF SIGNAL ROUTE
- (AD) : AUDIO DATA SIGNAL ROUTE
- (D) : DIGITAL OUT SIGNAL ROUTE
- (F) : FOCUS SERVO SIGNAL ROUTE
- (T) : TRACKING SERVO SIGNAL ROUTE

A 1/2

3.4 MAIN ASSY(2/2)

A
B
C
D
E
F

A 2/2
MAIN ASSY
(DWG1563)

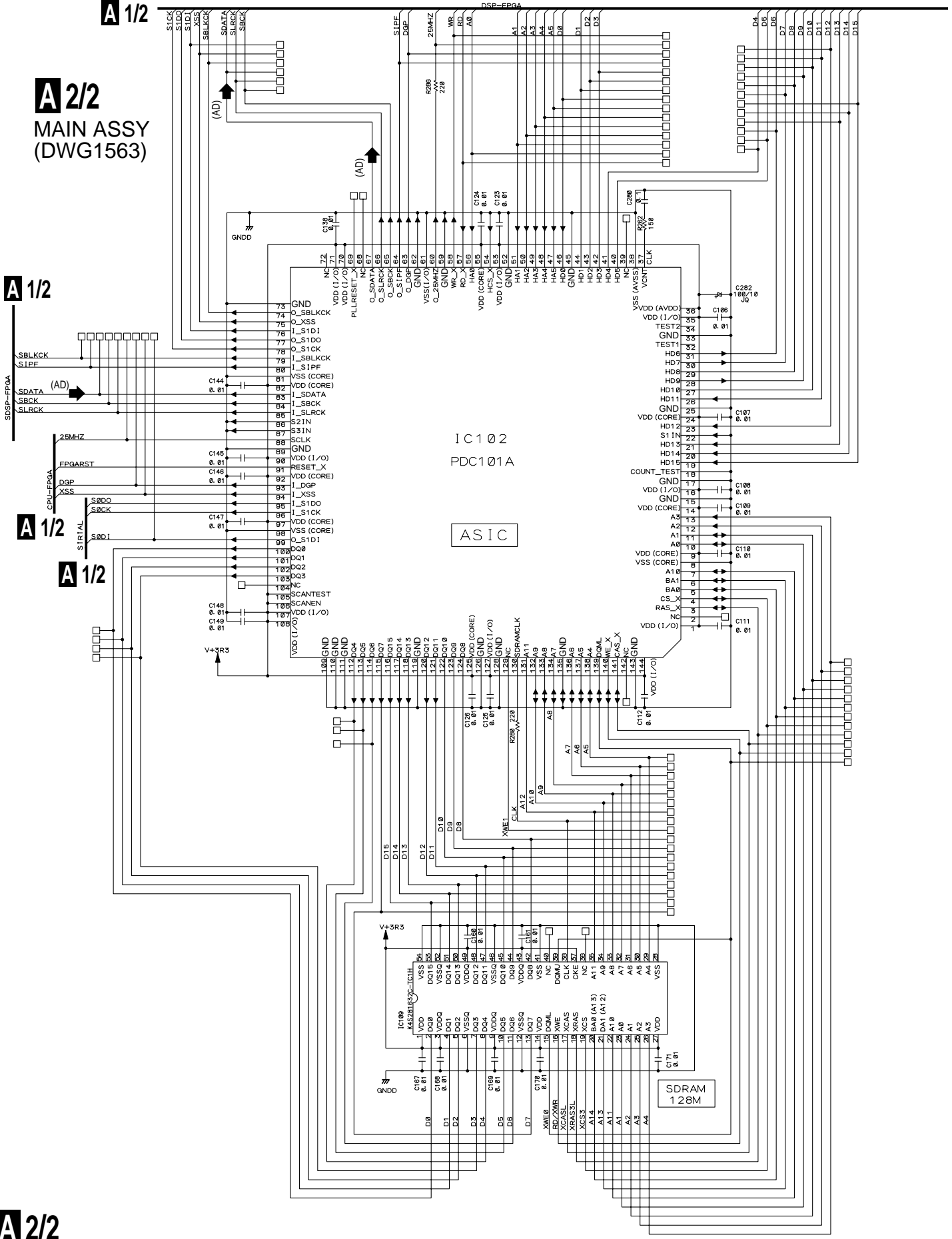

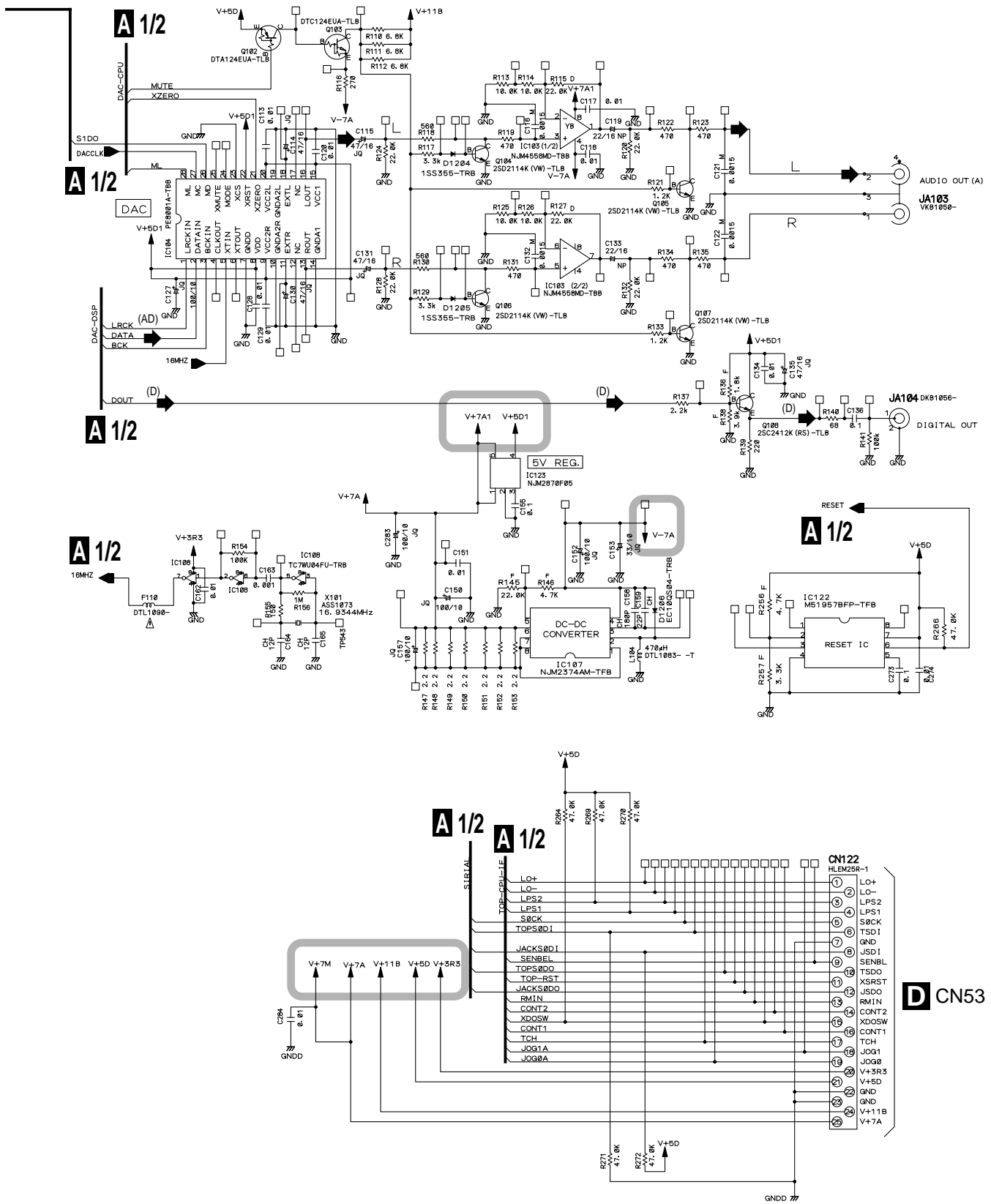

RESISTOR		CAPACITOR		NO MARK CERAMIC	
NO MARK	:RS1/16S***J Ω	NO MARK	:CEAT μF	CH	:CCSRCH μF
F	:RS1/16S***F Ω	JQ	:CEJQ μF	M	:CQMA μF
D	:RS1/16S***D Ω	NP	:CEJNP μF	[]	IS STANBY

- ➡ : AUDIO SIGNAL ROUTE
- (AD) ➡ : AUDIO DATA SIGNAL ROUTE
- (D) ➡ : DIGITAL OUT SIGNAL ROUTE

: The power supply is shown with the marked box.

A 2/2

3.5 AC IN, TRNS, SECB and REGB ASSYS

A

B

C

D

E

F

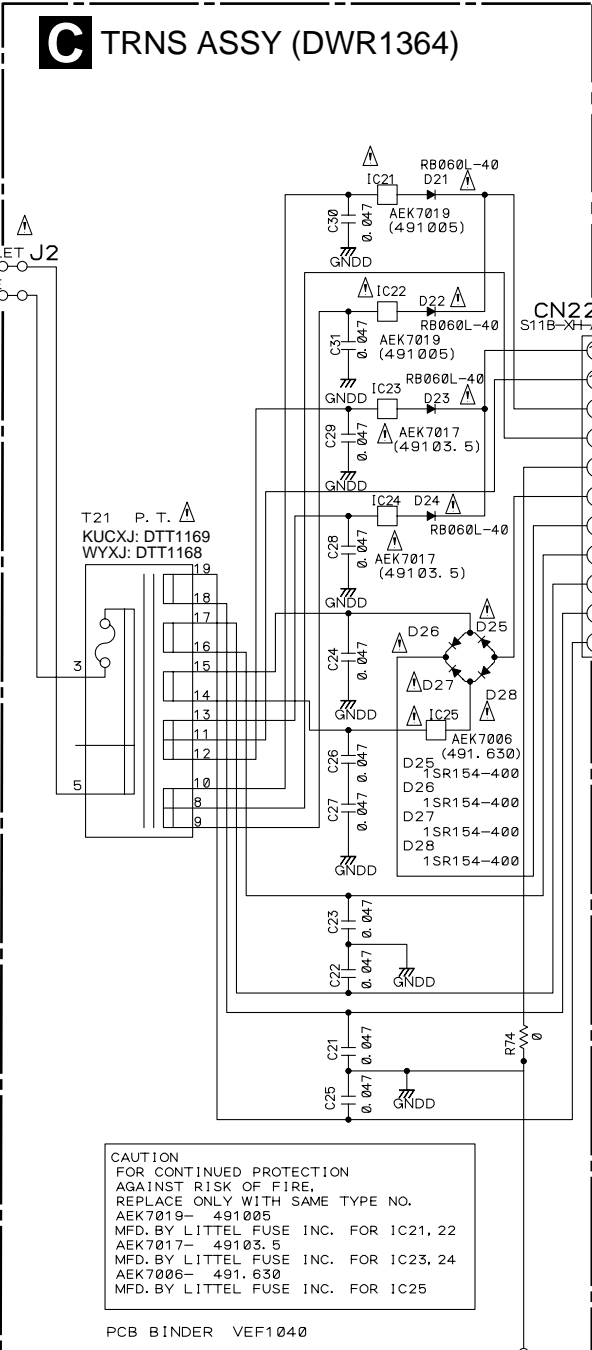
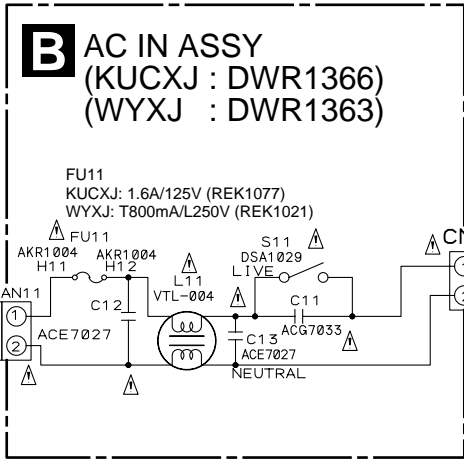

CAUTION
 FOR CONTINUED PROTECTION
 AGAINST RISK OF FIRE,
 REPLACE ONLY WITH SAME TYPE NO.
 AEK7019- 491005
 MFD. BY LITTEL FUSE INC. FOR IC21, 22
 AEK7017- 49103.5
 MFD. BY LITTEL FUSE INC. FOR IC23, 24
 AEK7006- 491.630
 MFD. BY LITTEL FUSE INC. FOR IC25

• NOTE FOR FUSE REPLACEMENT

CAUTION -FOR CONTINUED PROTECTION AGAINST RISK OF FIRE.
 REPLACE WITH SAME TYPE AND RATINGS ONLY.

THE MARK FOUND ON SOME COMPONENT PARTS INDICATES THE IMPORTANCE OF THE SAFETY FACTOR OF THE PARTS. THEREFORE, WHEN REPLACING, BE SURE TO USE PARTS OF IDENTICAL DESIGNATION.

Notes		
RESISTOR		
VM	:RD1/2VM****J	Ω
D	:RS1/16S****D	Ω
NO MARK	:RS1/16S****J	Ω
CAPACITOR		
NO MARK ELECTROLYTIC	:CEAT	μF
NO MARK CERAMIC	:CKSRYB	μF



3.6 MFLB, SLMB and KSWB ASSYS

F MFLB ASSY (DWG1564)

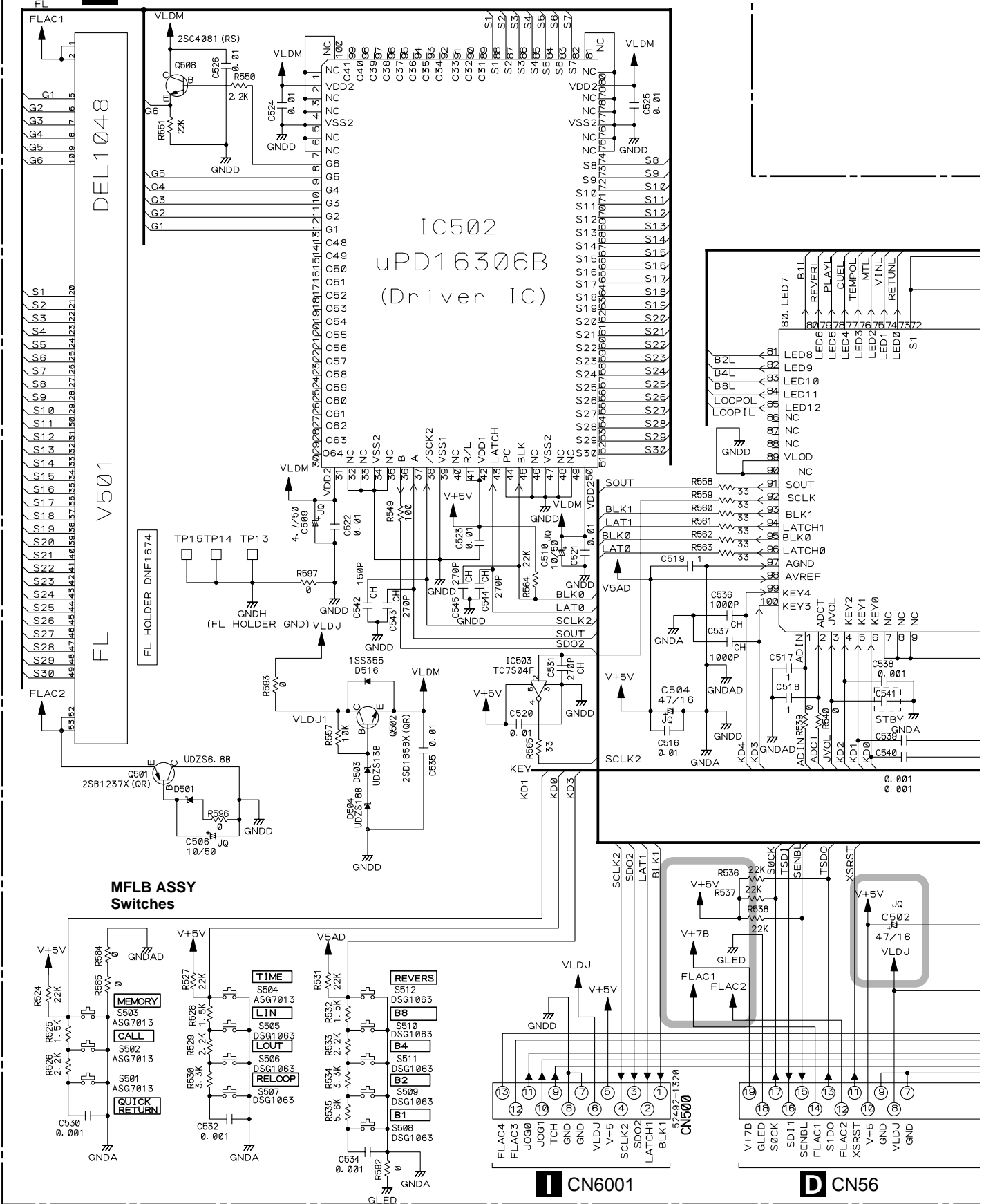

G SLMB ASSY (DWS1322)

H KSWB ASSY (DWS1321)

D CN55

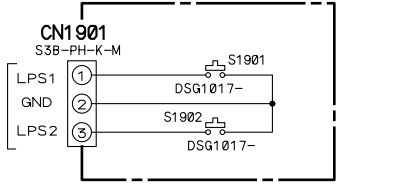

H CN502

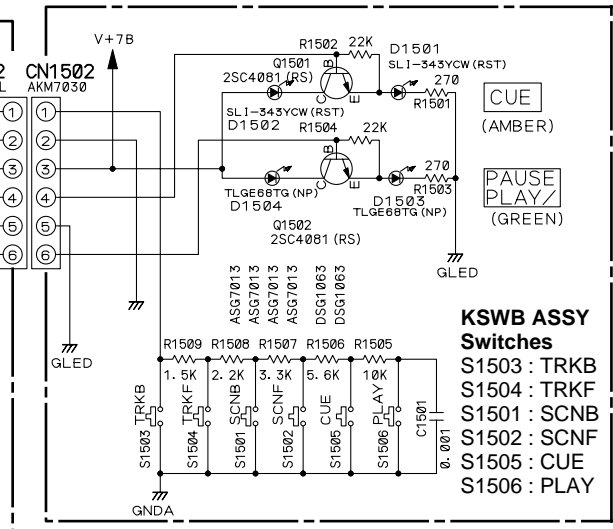

KSWB ASSY Switches
 S1503 : TRKB
 S1504 : TRKF
 S1501 : SCNB
 S1502 : SCNF
 S1505 : CUE
 S1506 : PLAY

Display Micro Computer

IC501 PD5848A (M38B79MFH-FP)

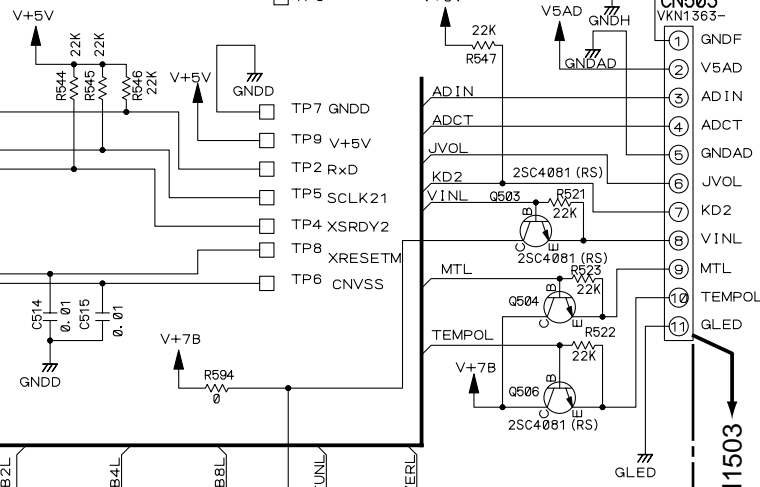
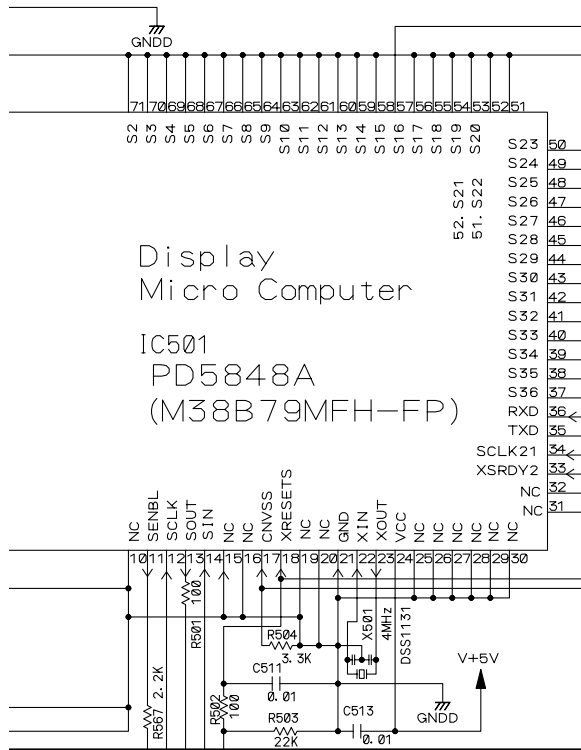

J CN1503

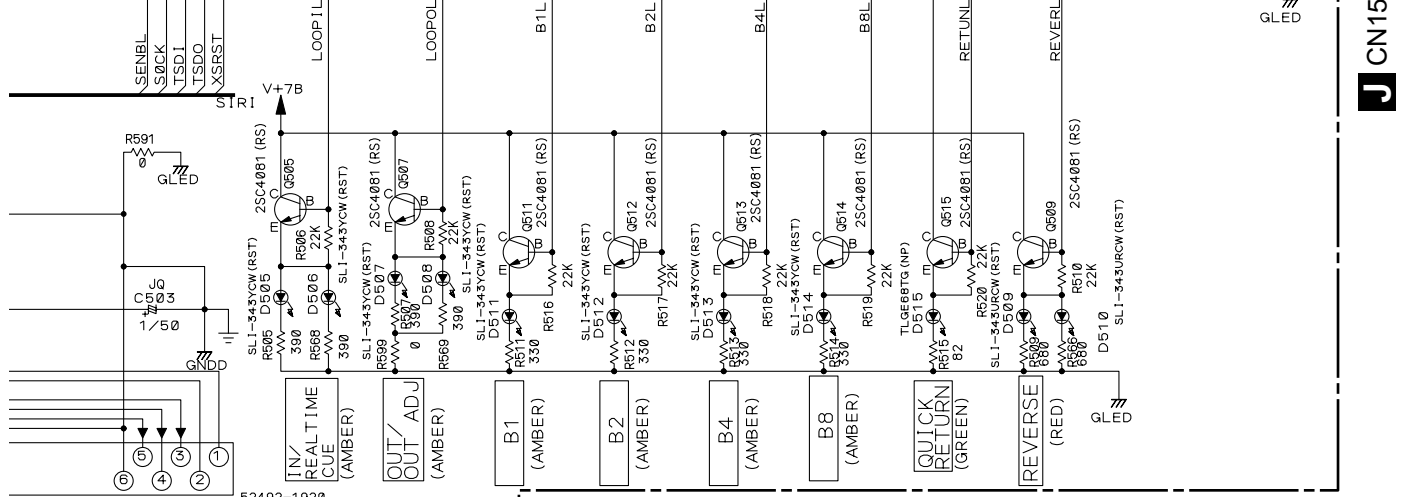

Notes		
RESISTORS	NO MARK	:RS1/16S***J
CAPACITOR	NO MARK	:CKSRBYB μF
	CH	:CCSRCH F
	JQ	:CEJQ μF

O : The power supply is shown with the marked box.

F G H

3.7 JFLB, SLDB and JOGB ASSYS

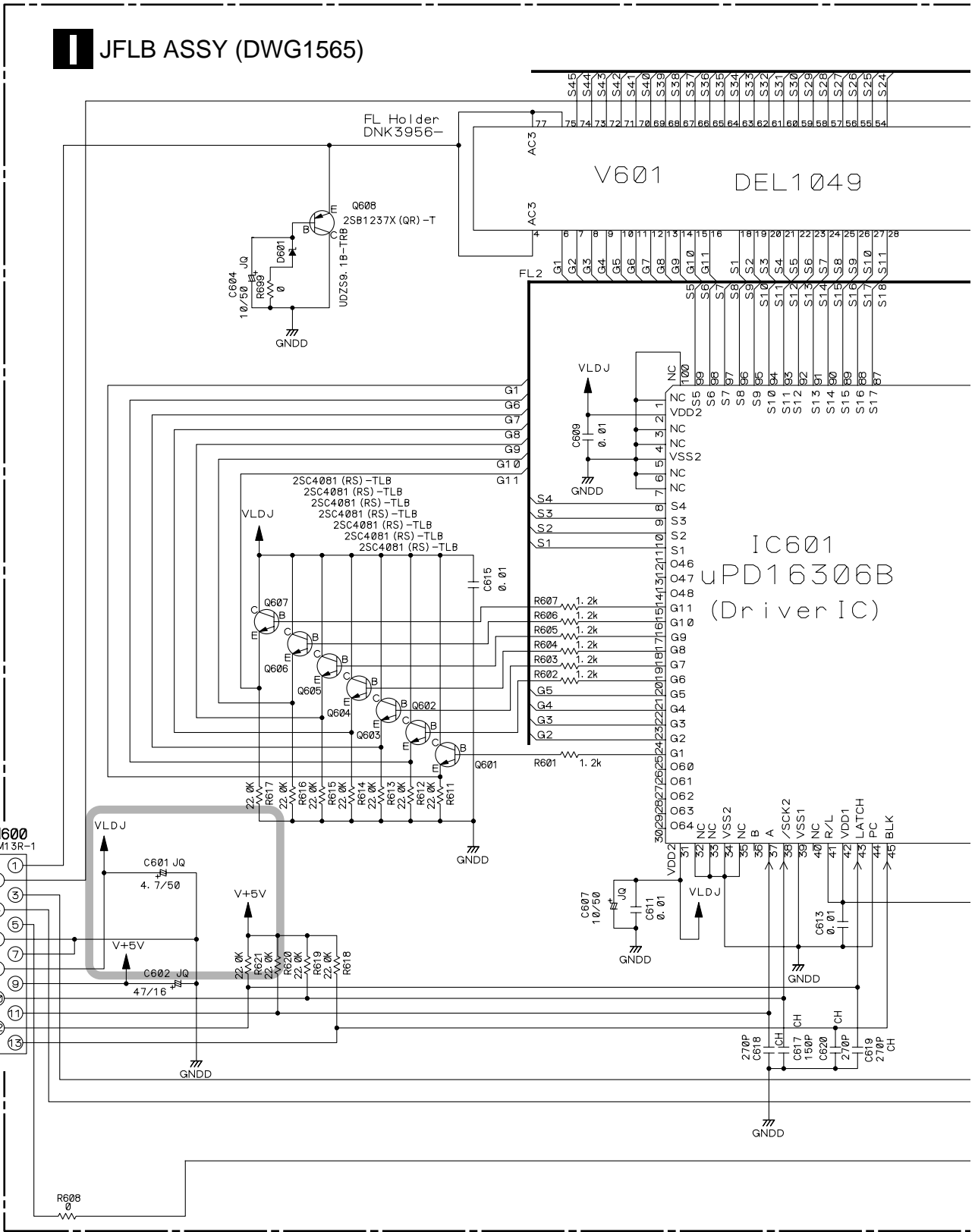

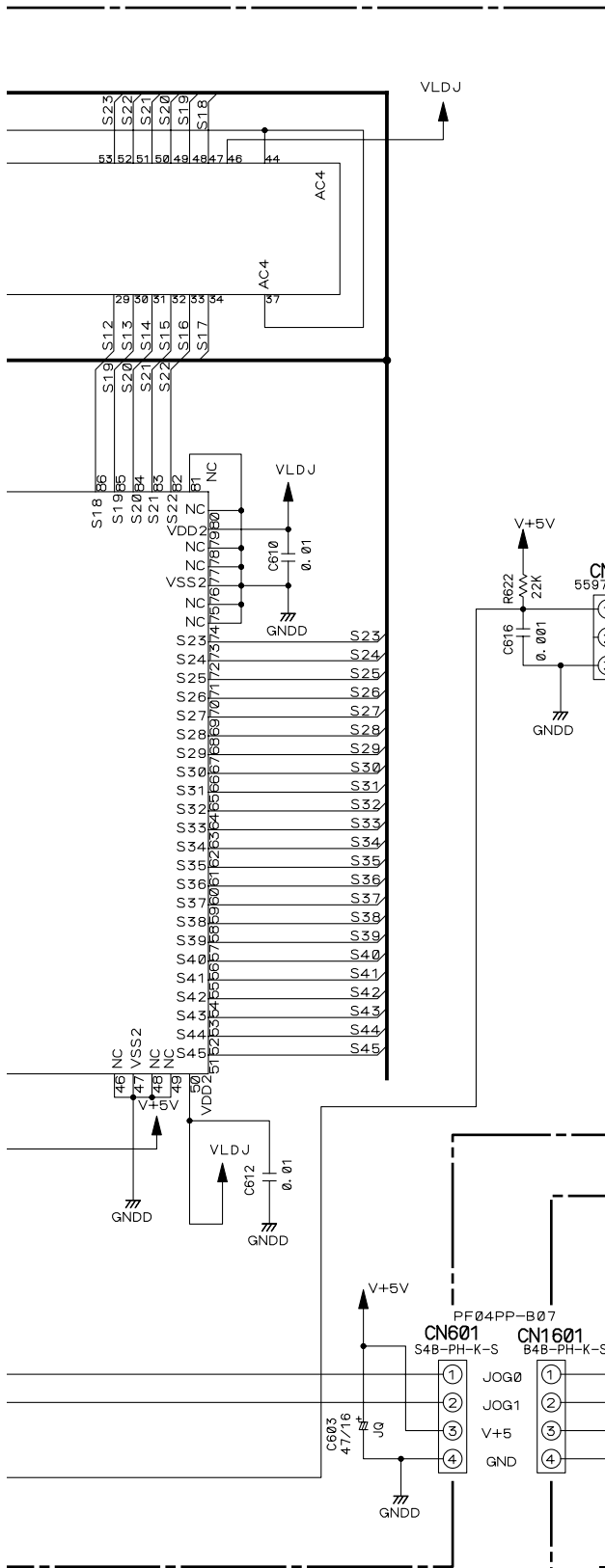

J SLDB ASSY (DWS1323)

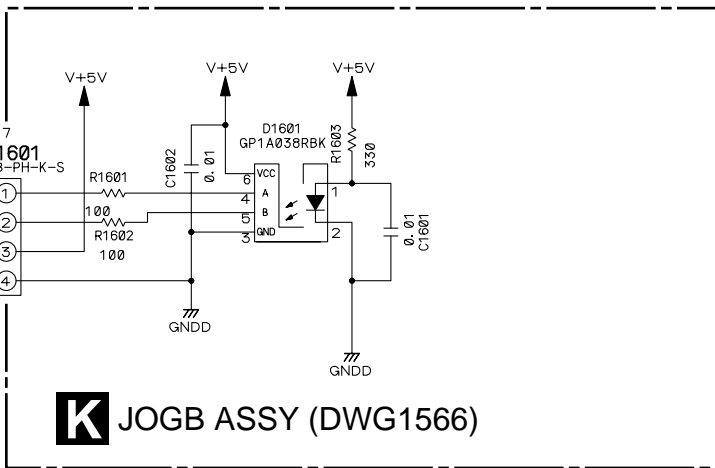
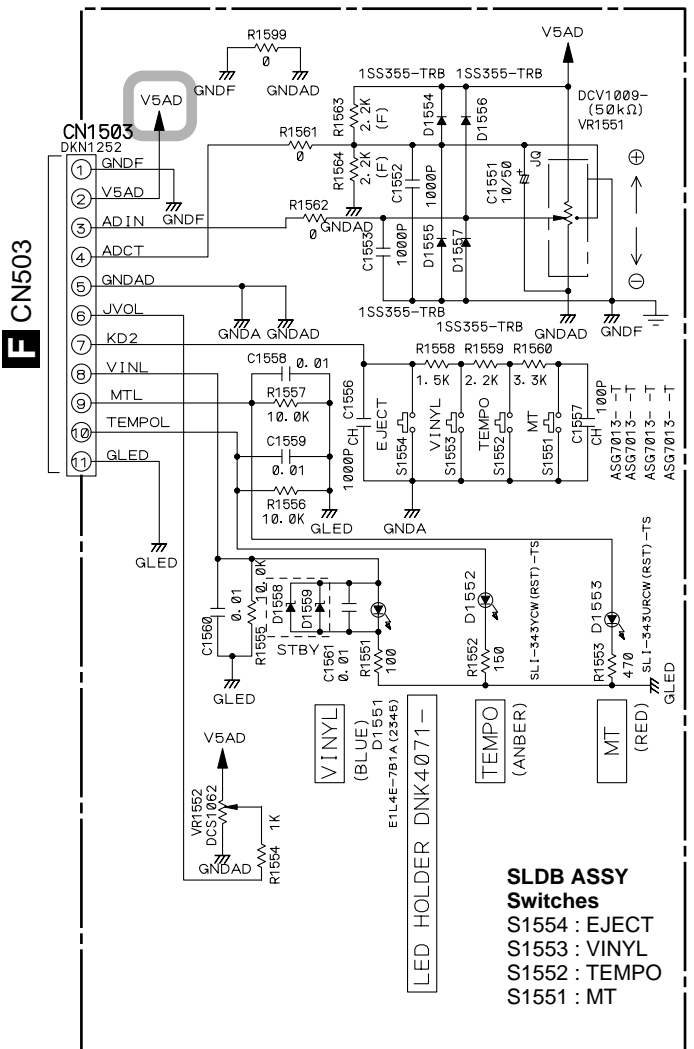

K JOGB ASSY (DWG1566)

: The power supply is shown with the marked box.



Waveforms

A 1/2 MAIN ASSY

A

B

C

D

E

F

<p>① IC118-28 pin (RFO) V: 500mV/div. H: 100nS/div.</p> <p>② IC118-25 pin (ARF) V: 500mV/div. H: 100nS/div.</p>	<p>• Mode: STD 905 play</p>	<p>④ IC118-14 pin (TEO) V: 0.5V/div. H: 1mS/div.</p> <p>⑤ IC113-1 pin (T+) V: 1V/div. H: 1mS/div.</p>	<p>⑥ IC110-12 pin (SBOK) V: 5V/div. H: 1mS/div.</p> <p>• Mode: SR Single jump (reverse side only)</p>

<p>① IC118-28 pin (RFO) V: 200mV/div. H: 100nS/div.</p> <p>② IC118-25 pin (ARF) V: 200mV/div. H: 100nS/div.</p>	<p>• Mode: STD RW play</p>	<p>④ IC118-14 pin (TEO) V: 1V/div. H: 0.5S/div.</p> <p>⑤ IC113-1 pin (T+) V: 2V/div. H: 0.5S/div.</p>	<p>⑥ IC110-12 pin (SBOK) V: 5V/div. H: 0.5S/div.</p> <p>• Mode: Start up</p>

<p>③ IC118-16 pin (FEO) V: 0.5V/div. H: 5mS/div.</p> <p>• When pressing the remote control unit in the test mode (7+TM)</p>	<p>④ IC118-14 pin (TEO) V: 1V/div. H: 2mS/div.</p> <p>⑤ IC113-1 pin (T+) V: 2V/div. H: 2mS/div.</p>	<p>⑦ IC119-33 pin (SLV) V: 1V/div. H: 2mS/div.</p> <p>⑧ IC114-1 pin (HK) V: 1V/div. H: 2mS/div.</p>	<p>• Mode: 16MF 16 track Multi-jump forward</p>

<p>④ IC118-14 pin (TEO) V: 0.5V/div. H: 5mS/div.</p> <p>Mode: T-OPEN</p>	<p>④ IC118-14 pin (TEO) V: 1V/div. H: 0.2S/div.</p> <p>⑤ IC113-1 pin (T+) V: 2V/div. H: 0.2S/div.</p>	<p>⑦ IC119-33 pin (SLV) V: 1V/div. H: 0.2S/div.</p> <p>⑧ IC114-1 pin (HK) V: 1V/div. H: 0.2S/div.</p>	<p>• Mode: FS-F Track 1 to 16 search</p>

Voltages

A 1/2 MAIN ASSY

IC110 (TC9495F-P)

Pin No	Voltage (V)
1	5
2	5
3	0-5
4	0
5	0-5
6	0
7	0-5
8	0-5
9	0
10	0
11	0-5
12	0-5
13	0-5
14	5
15	0
16	0-5
17	0-5
18	0-5
19	0-5
20	0-5
21	0-5
22	0-5
23	5
24	0
25	4.2
26	2.1
27	5
28	0-5
29	2.1
30	2.1
31	2.1
32	2.1
33	2.1
34	2.1
35	1.6
36	0
37	2.1
38	2.1
39	5
40	2.6
41	3.3
42	2.6
43	2.1
44	2.6
45	2.1
46	2.1
47	1-4.2
48	2.1
49	2.1
50	2.1
51	0-5
52	0-5
53	0-5
54	2.1
55	2.3
56	4.2
57	5
58	0-5
59	5
60	0-5

Pin No	Voltage (V)
61	0-5
62	5
63	0
64	5
65	0
66	0
67	0
68	5
69	5
70	5
71	0
72	0
73	0
74	0
75	5
76	5
77	0
78	2.2
79	2.3
80	5
81	0
82	0
83	0
84	0
85	0
86	0
87	5
88	5
89	5
90	0-5
91	0-5
92	0-5
93	0-5
94	5
95	0
96	0-5
97	0-5
98	5
99	5
100	0-5

IC112 (PD3442A8)

Pin No	Voltage (V)
1	3.3
2	0-5
3	0-5
4	0-5
5	0-5
6	0-5
7	0-5
8	0-5
9	0-5
10	0-5
11	0
12	0-5
13	0-5
14	0-5
15	0-5
16	0-5
17	0-5
18	0-5
19	0-5
20	0-5
21	0-5
22	0
23	0-5
24	0
25	0
26	0
27	0
28	0
29	0
30	0
31	0
32	0
33	0
34	0
35	5
36	0-5
37	0-5
38	0-5
39	0-5
40	0-5
41	0-5
42	0-5
43	0-5
44	0
45	0-5
46	0-3.3
47	0
48	0
49	0-5
50	0-5
51	0-3.3
52	0-5
53	0-5
54	0-5
55	0-5
56	0-5
57	0
58	0-5
59	0-5
60	0

Pin No	Voltage (V)
61	2.5
62	5
63	0-5
64	0
65	0
66	2.6
67	2.6
68	5
69	0-5
70	0
71	0-5
72	0-5
73	5
74	5
75	5
76	5
77	0
78	0
79	0
80	0-5
81	0-5
82	0-5
83	0-5
84	0-5
85	0-5
86	0-5
87	0-5
88	0-5
89	0-5
90	0-5
91	0-3.3
92	0-5
93	0
94	0-5
95	0-5
96	0-5
97	0-5
98	0-5
99	0-5
100	0-5

IC117 (XCA56367PV150)

Pin No	Voltage (V)
1	0-3.3
2	0-3.3
3	0
4	0-3.3
5	0-3.3
6	0-3.3
7	0-3.3
8	3.3
9	0
10	0-3.3
11	0-3.3
12	0-3.3
13	0-3.3
14	0-3.3
15	0-3.3
16	0-3.3
17	0-3.3
18	1.8
19	0
20	3.3
21	0
22	0
23	0
24	0
25	3.3
26	0
27	0-3.3
28	0-3.3
29	3.3
30	3.3
31	0-3.3
32	0-3.3
33	0-3.3
34	0
35	0
36	0
37	0
38	3.3
39	0
40	0
41	0
42	0
43	0
44	0-3.3
45	1.8
46	0
47	0
48	0
49	3.3
50	0
51	3.3
52	3.3
53	0
54	0
55	1.6
56	1.8
57	3.3
58	0
59	0
60	0

Pin No	Voltage (V)
61	0
62	0
63	3.3
64	3.3
65	3.3
66	0
67	0-3.3
68	0-3.3
69	3.3
70	3.3
71	0
72	0-3.3
73	0-3.3
74	3.3
75	0
76	0-3.3
77	0-3.3
78	0-3.3
79	0-3.3
80	3.3
81	0
82	0
83	0
84	0
85	0
86	3.3
87	0
88	0
89	0
90	0
91	1.8
92	0
93	0
94	0
95	3.3
96	0
97	0
98	0
99	0
100	0-3.3
101	0-3.3
102	0-3.3
103	3.3
104	0
105	0-3.3
106	0-3.3
107	0-3.3
108	0-3.3
109	0-3.3
110	0-3.3
111	3.3
112	0
113	0-3.3
114	0-3.3
115	0-3.3
116	0-3.3
117	0-3.3
118	0-3.3
119	3.3
120	0

Pin No	Voltage (V)
121	0-3.3
122	0-3.3
123	0-3.3
124	0-3.3
125	0-3.3
126	1.8
127	0
128	0-3.3
129	3.3
130	0
131	0-3.3
132	0-3.3
133	0-3.3
134	0-3.3
135	0-3.3
136	0-3.3
137	0-3.3
138	0-3.3
139	0
140	3.3
141	3.3
142	3.3
143	0-3.3
144	0-3.3

A 1/2 MAIN ASSY**IC118 (TA2153FN)**

Pin No	Voltage (V)
1	5
2	0-5
3	2.1
4	2.2
5	2.2
6	2.1
7	2.4
8	0
9	0-5
10	0-5
11	1.9
12	4.2
13	2.1
14	2.1
15	2.6
16	2.1
17	2.1
18	0
19	2.1
20	2.7
21	3.3
22	2.6
23	1.9
24	2.1
25	2.1
26	5
27	2.1
28	1.7
29	0
30	2.1

IC119 (LA6565)

Pin No	Voltage (V)
1	0-5
2	0-5
3	7.2
4	3.3
5	3.3
6	3.3
7	3.3
8	2.5
9	4.2
10	0
11	3.7
12	3.7
13	3.9
14	3.5
15	7.2
16	2.2
17	2.1
18	2.2
19	2.1
20	2.1
21	2.1
22	1.9
23	2.1
24	2.1
25	1.1
26	1.8
27	1.1
28	2.1
29	0
30	2.1
31	2.1
32	2.1
33	2.1
34	3.4
35	5
36	5
37	0
38	0-5

A 2/2 MAIN ASSY**IC102 (PDC101A)**

Pin No	Voltage (V)
1	3.3
2	0
3	0-3.3
4	0-3.3
5	0-3.3
6	0-3.3
7	0-3.3
8	0
9	3.3
10	0-3.3
11	0-3.3
12	0-3.3
13	0-3.3
14	3.3
15	0
16	3.3
17	0
18	0
19	0-3.3
20	0-3.3
21	0-3.3
22	0
23	0-3.3
24	3.3
25	0
26	0-3.3
27	0-3.3
28	0-3.3
29	0-3.3
30	0-3.3
31	0-3.3
32	0
33	0
34	0
35	3.3
36	3.3
37	1.1
38	0
39	0
40	0-3.3
41	0-3.3
42	0-3.3
43	0-3.3
44	0-3.3
45	0
46	0-3.3
47	0-3.3
48	0-3.3
49	0-3.3
50	0-3.3
51	0-3.3
52	0
53	3.3
54	0
55	3.3
56	0-3.3
57	0-3.3
58	0-3.3
59	0
60	0-3.3

Pin No	Voltage (V)
61	0
62	0
63	0-3.3
64	0-3.3
65	0-3.3
66	0-3.3
67	0-3.3
68	0
69	3.3
70	3.3
71	3.3
72	0
73	0
74	0-3.3
75	0-3.3
76	0-3.3
77	0-3.3
78	0-3.3
79	0-5
80	0-5
81	0
82	3.3
83	0-5
84	0-5
85	0-5
86	0
87	0
88	2
89	0
90	3.3
91	0-5
92	3.3
93	0-3.3
94	0-5
95	0-5
96	0-5
97	3.3
98	0
99	0-3.3
100	0-3.3
101	0-3.3
102	0-3.3
103	0-3.3
104	0
105	3.3
106	3.3
107	3.3
108	3.3
109	0
110	0
111	0
112	0-3.3
113	0-3.3
114	0-3.3
115	0-3.3
116	0-3.3
117	0-3.3
118	0-3.3
119	0
120	0-3.3

Pin No	Voltage (V)
121	0-3.3
122	0-3.3
123	0-3.3
124	0-3.3
125	3.3
126	0
127	3.3
128	0
129	0-3.3
130	1.3
131	0-3.3
132	0-3.3
133	0-3.3
134	0-3.3
135	0
136	0-3.3
137	0-3.3
138	0-3.3
139	0-3.3
140	0-3.3
141	0-3.3
142	0
143	0
144	3.3

IC104 (PE8001A)

Pin No	Voltage (V)
1	0-3.3
2	0-3.3
3	0-3.3
4	1.8
5	1.8
6	3.5
7	0
8	5
9	5
10	0
11	2.5
12	0
13	0-5
14	0
15	5
16	0-5
17	0
18	2.5
19	0
20	5
21	0-5
22	5
23	0
24	5
25	5
26	0-5
27	0-3.3
28	0-5

IC109 (K4S281632C-TC1H)

Pin No	Voltage (V)
1	3.3
2	0-3.3
3	3.3
4	0-3.3
5	0-3.3
6	0
7	0-3.3
8	0-3.3
9	3.3
10	0-3.3
11	0-3.3
12	0
13	0-3.3
14	3.3
15	0-3.3
16	0-3.3
17	0-3.3
18	0-3.3
19	0-3.3
20	0-3.3
21	0-3.3
22	0-3.3
23	0-3.3
24	0-3.3
25	0-3.3
26	0-3.3
27	3.3
28	0
29	0-3.3
30	0-3.3
31	0-3.3
32	0-3.3
33	0-3.3
34	0-3.3
35	0-3.3
36	0
37	3.3
38	1.5
39	0-3.3
40	0
41	0
42	0-3.3
43	3.3
44	0-3.3
45	0-3.3
46	0
47	0-3.3
48	0-3.3
49	3.3
50	0-3.3
51	0-3.3
52	0
53	0-3.3
54	0

IC122 (M51957BFP)

Pin No	Voltage (V)
1	0
2	2.1
3	0
4	0
5	1.3
6	5
7	5
8	0

F MFLB ASSY

IC501 (PD3848A)

Pin No	Voltage (V)
1	0
2	42
3	0
4	0
5	0
6	0
7	0
8	0-42
9	0-42
10	0-42
11	0-42
12	0
13	0
14	0
15	0-42
16	0-42
17	0-42
18	0-42
19	0-42
20	0-42
21	0-42
22	0-42
23	0-42
24	0-42
25	0-42
26	0
27	0
28	0
29	0
30	0
31	42
32	0
33	0
34	0
35	0
36	0-5
37	0-5
38	0-5
39	0
40	0
41	5
42	5
43	0-5
44	0
45	0-5
46	0
47	0
48	0
49	0
50	42
51	0-42
52	0-42
53	0-42
54	0-42
55	0-42
56	0-42
57	0-42
58	0-42
59	0-42
60	0-42

IC502 (UPD16306B)

Pin No	Voltage (V)
1	0
2	31
3	0
4	0
5	0
6	0
7	0
8	0-31
9	0-31
10	0-31
11	0-31
12	0-31
13	0-31
14	0
15	0
16	0
17	0
18	0
19	0
20	0
21	0
22	0
23	0
24	0
25	0
26	0
27	0
28	0
29	0
30	0
31	0
32	0
33	0
34	0
35	0
36	0-5
37	0-5
38	0-5
39	0
40	31
41	5
42	5
43	0-5
44	0
45	0-5
46	0
47	0
48	0
49	0
50	31
51	0-31
52	0-31
53	0-31
54	0-31
55	0-31
56	0-31
57	0-31
58	0-31
59	0-31
60	0-31

I JFLB ASSY

IC601 (UPD16306B)

Pin No	Voltage (V)	Pin No	Voltage (V)
1	0-5	61	0
2	2.5	62	0
3	0-5	63	0
4	0-5	64	0
5	0-5	65	0
6	0-5	66	0
7	0	67	0
8	0	68	0
9	0	69	0
10	0-5	70	0
11	0-5	71	0
12	0-5	72	0
13	0-5	73	0-5
14	0	74	0-5
15	0	75	0-5
16	0	76	0-5
17	0-5	77	0-5
18	0	78	0-5
19	0	79	0-5
20	0	80	0-5
21	2.1	81	0-5
22	2.4	82	0-5
23	5	83	0-5
24	0	84	0-5
25	0	85	0-5
26	0	86	0
27	0	87	0
28	0	88	0-5
29	0	89	0
30	0	90	0
31	0	91	0-5
32	0	92	0-5
33	5	93	0-5
34	5	94	0-5
35	0	95	0-5
36	5	96	0-5
37	0	97	0
38	0	98	5
39	0	99	0-5
40	0	100	0-5
41	0		
42	0		
43	0		
44	0		
45	0		
46	0		
47	0		
48	0		
49	0		
50	0		
51	0		
52	0		
53	0		
54	0		
55	0		
56	0		
57	5		
58	0		
59	0		
60	0		

1

2

3

4

A

B

C

D

E

F

1

2

3

4











CDJ-800

4. PCB CONNECTION DIAGRAM

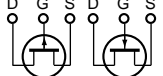
NOTE FOR PCB DIAGRAMS :

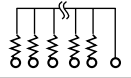
1. Part numbers in PCB diagrams match those in the schematic diagrams.
2. A comparison between the main parts of PCB and schematic diagrams is shown below.

Symbol In PCB Diagrams	Symbol In Schematic Diagrams	Part Name
		Transistor
		Transistor with resistor
		Field effect transistor
		Resistor array
		3-terminal regulator

3. The parts mounted on this PCB include all necessary parts for several destinations.
For further information for respective destinations, be sure to check with the schematic diagram.
4. View point of PCB diagrams.

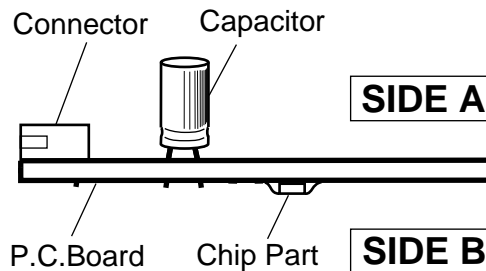

4.1 MAIN ASSY

SIDE A

SIDE A

A MAIN ASSY

A

B

C

D

E

F

To CD Mech
anism

D CN53

(DNP2035-A)

A

A

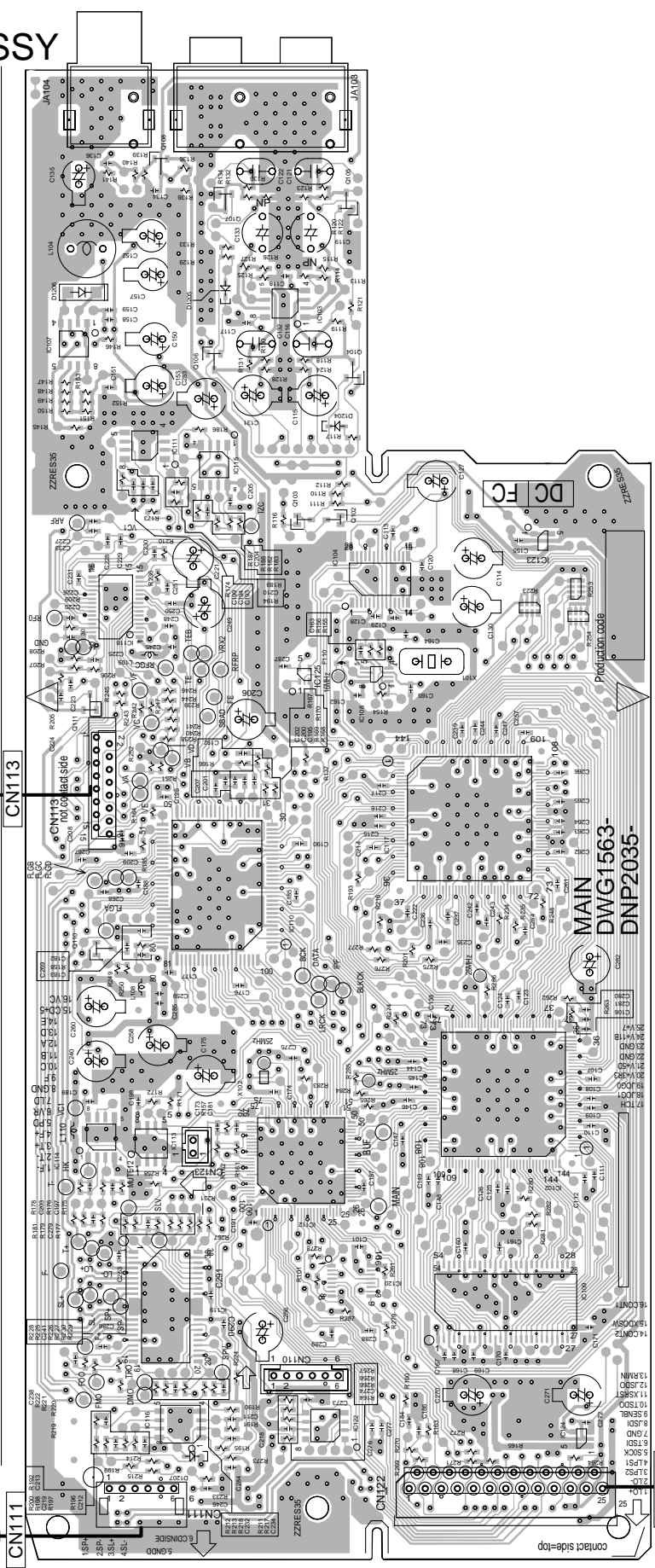

SIDE B

SIDE B

A MAIN ASSY

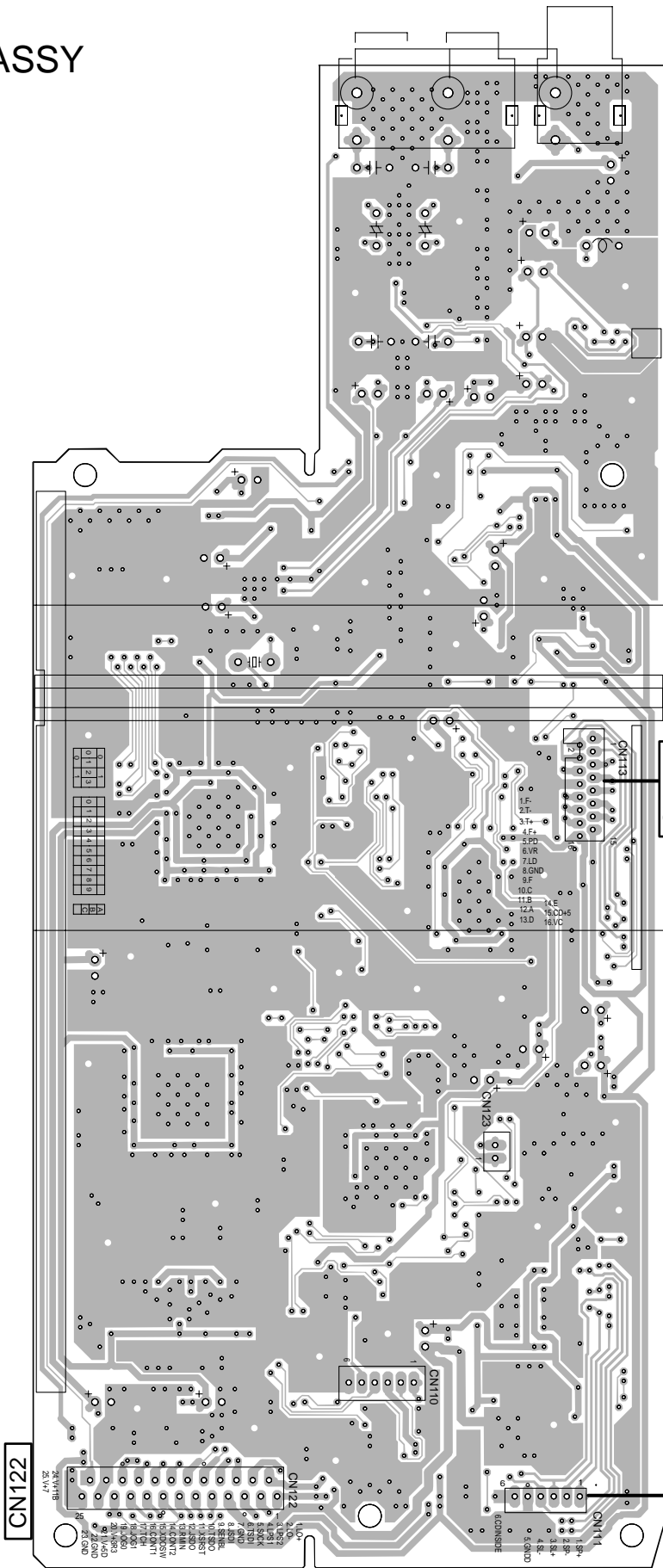

To Mechanism

To Mechanism

(DNP2035-A)

A

A

4.2 AC IN and TRNS ASSYS

SIDE A

SIDE A

B AC IN ASSY

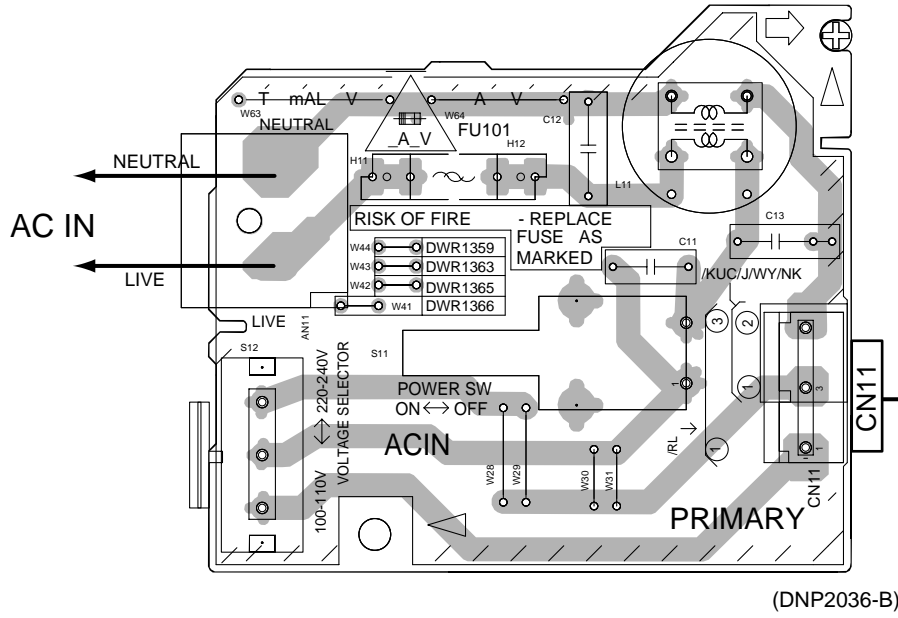

C TRNS ASSY

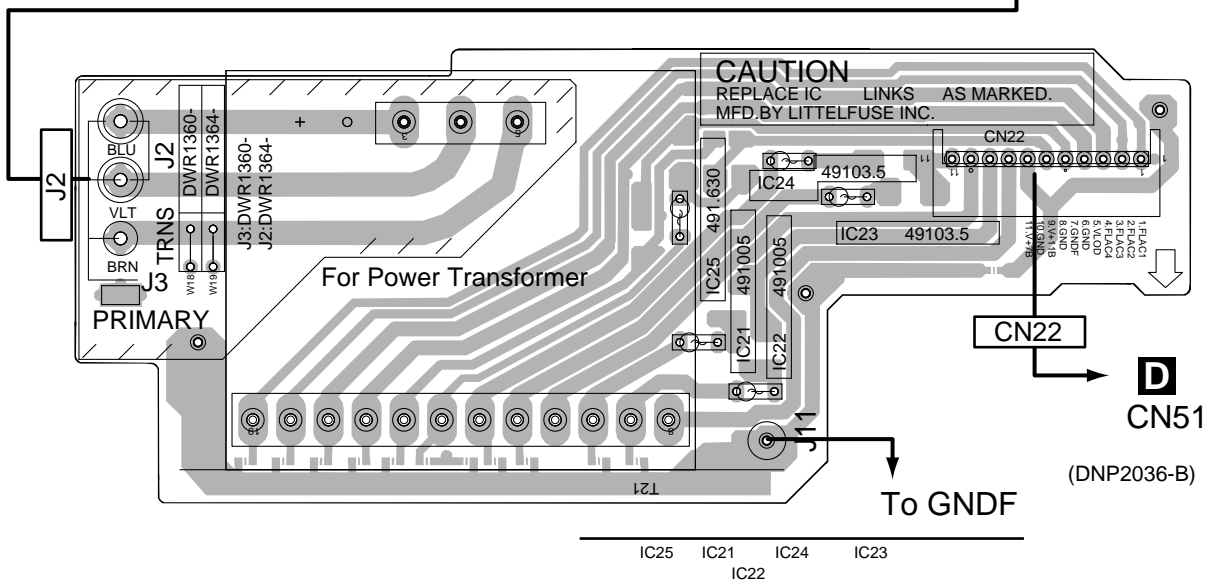

B C

B C

SIDE B

SIDE B

B AC IN ASSY

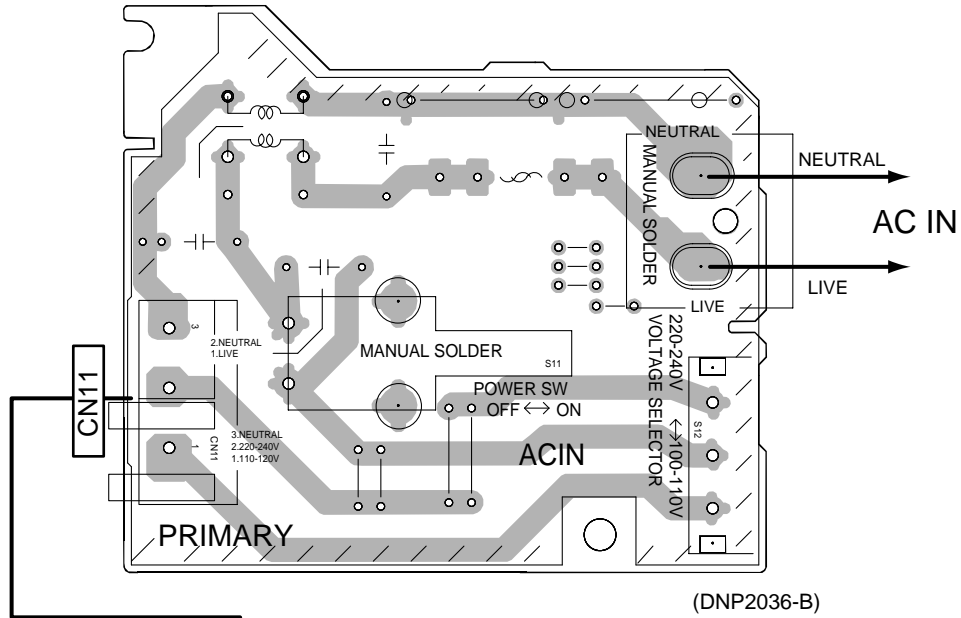

C TRNS ASSY

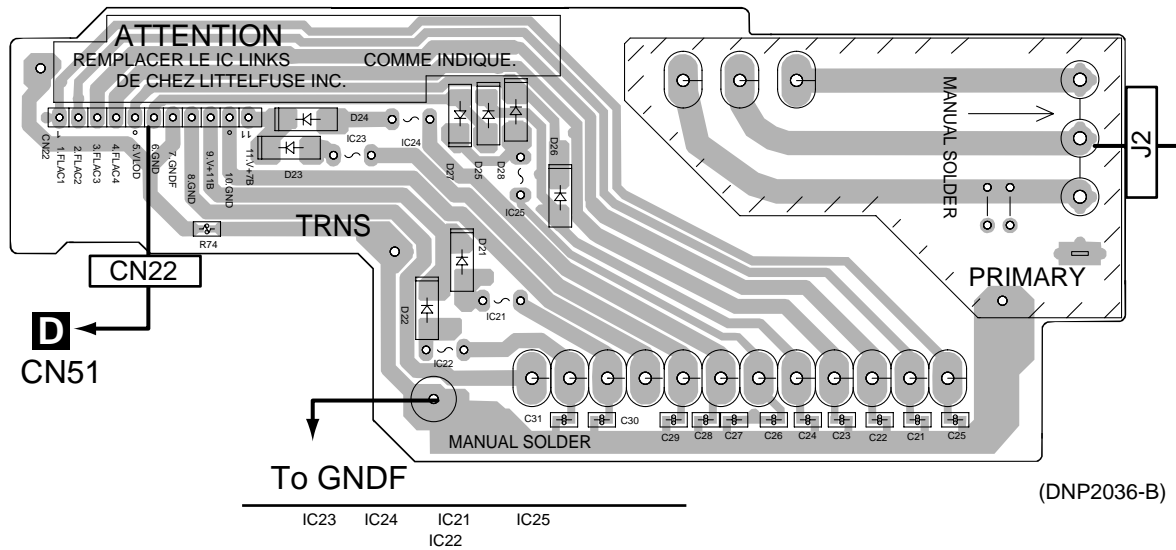

B C

B C

4.3 SECB, REGB and SLMB ASSYS

SIDE A

SIDE A

D SECB ASSY

E REGB ASSY

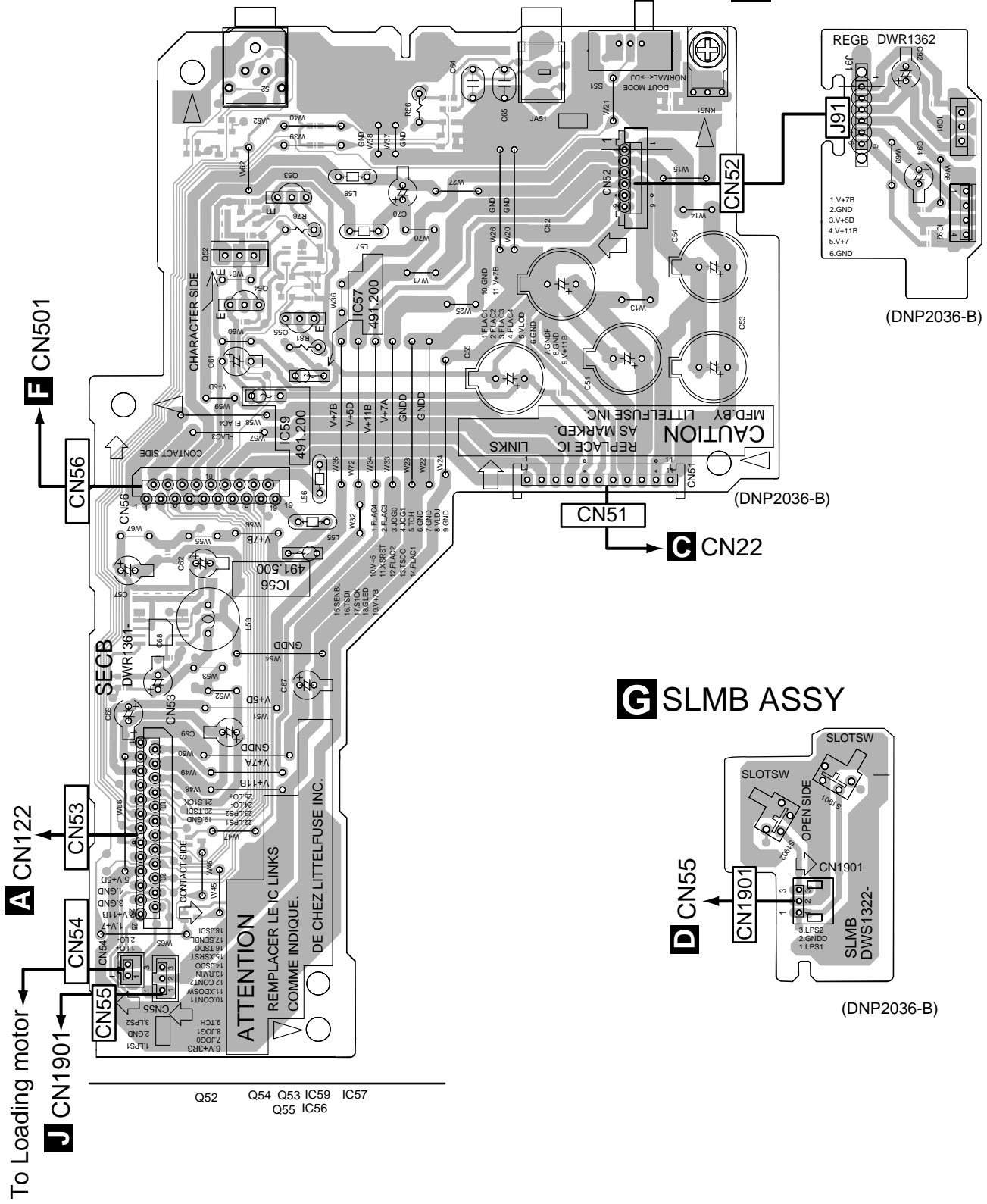

A CN122
J CN1901
 To Loading motor

DEG

DEG

SIDE B

SIDE B

D SECB ASSY

E REGB ASSY

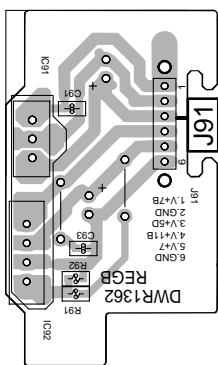

G SLMB ASSY

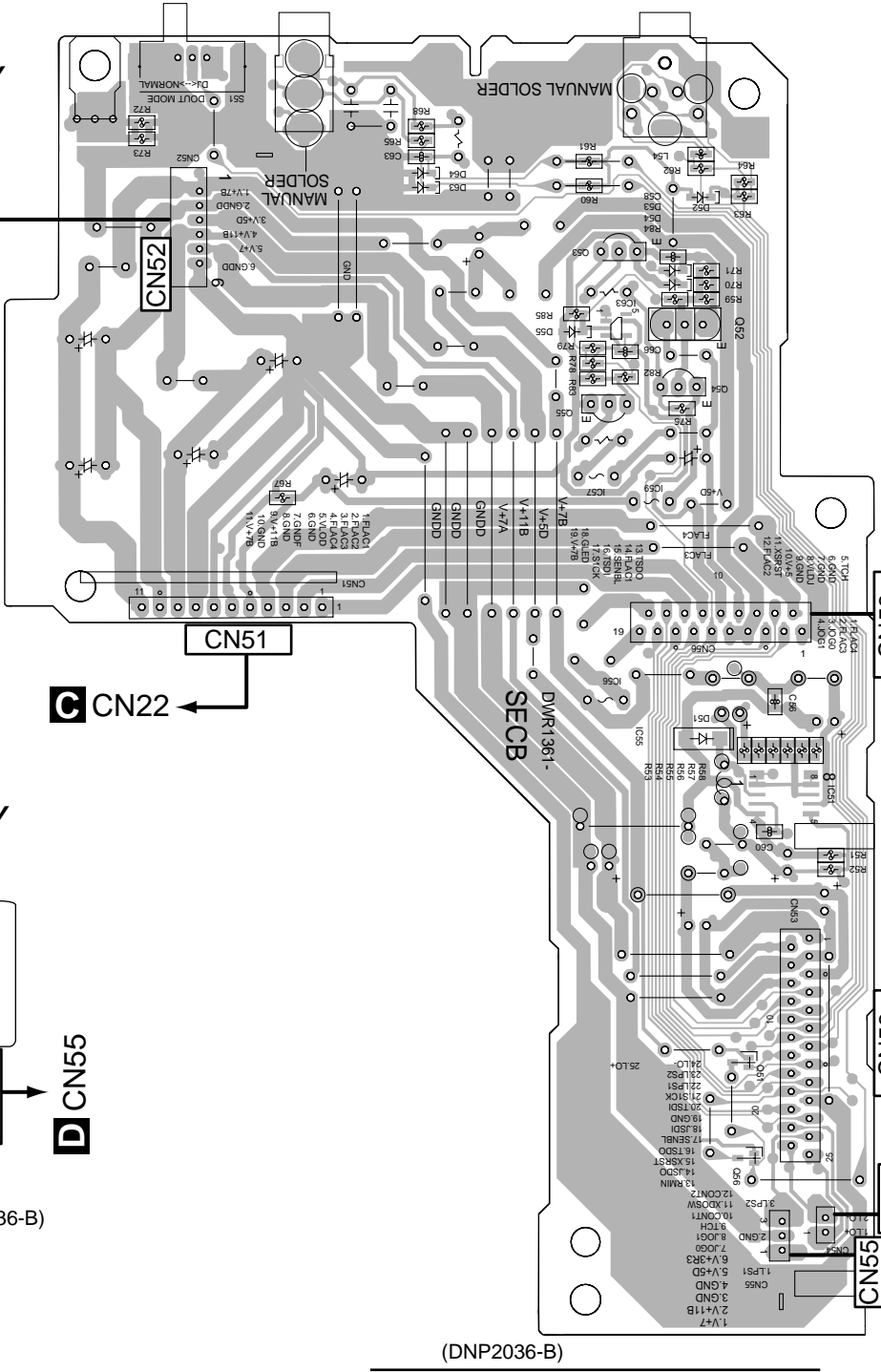
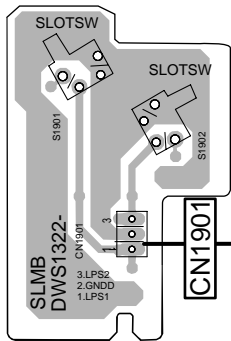

F CN501

C CN22

D CN55

CN53

CN54

CN55

CN56

J CN1901 To Loading motor

DEG

DEG

4.4 MFLB and KSWB ASSYS

SIDE A

F MFLB ASSY

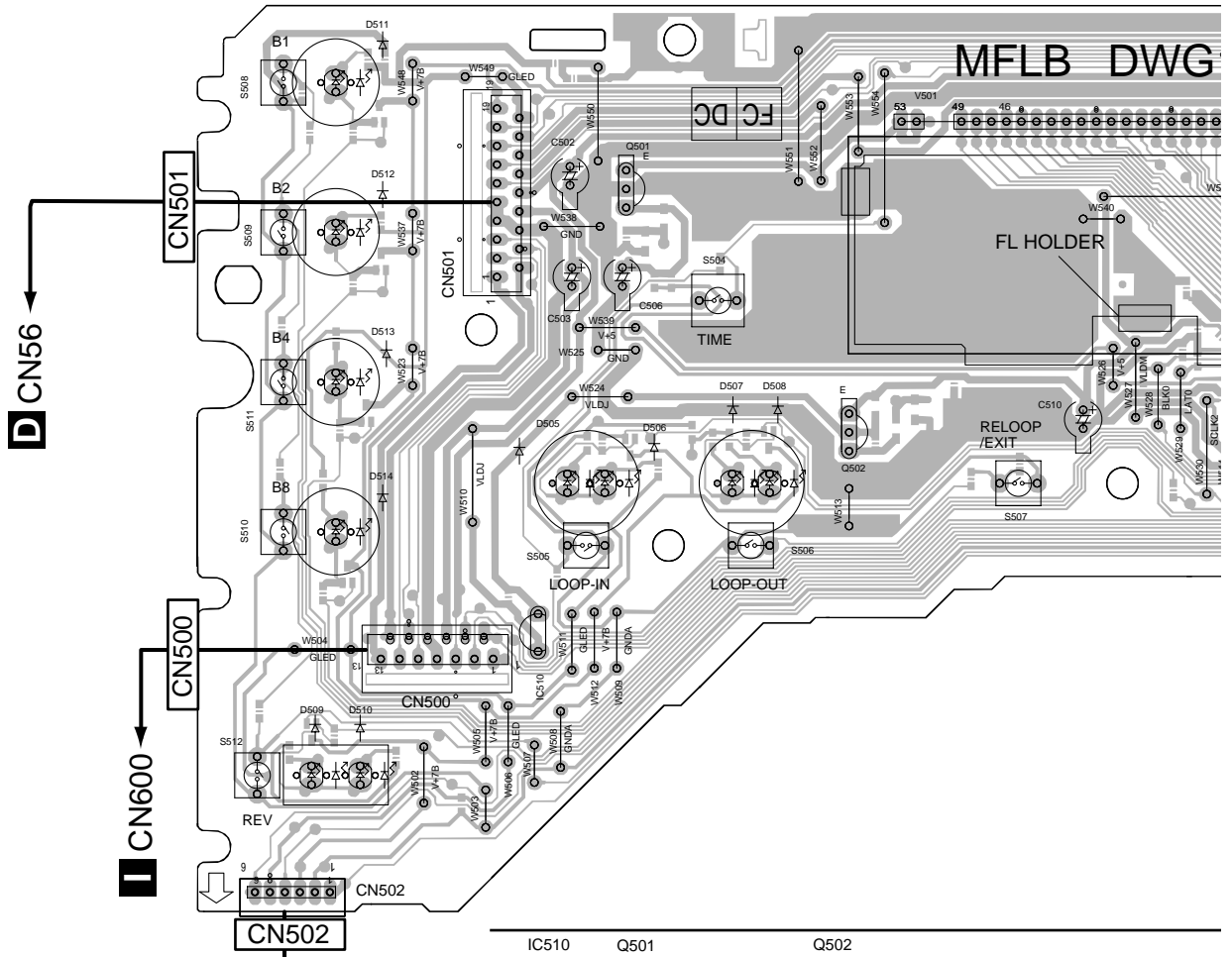

H KSWB ASSY

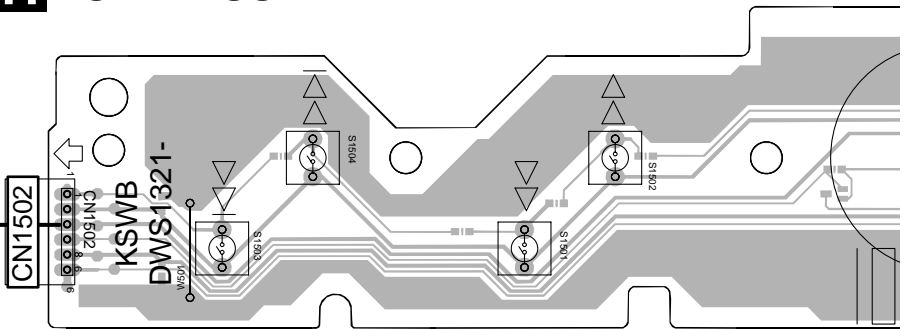

SIDE A

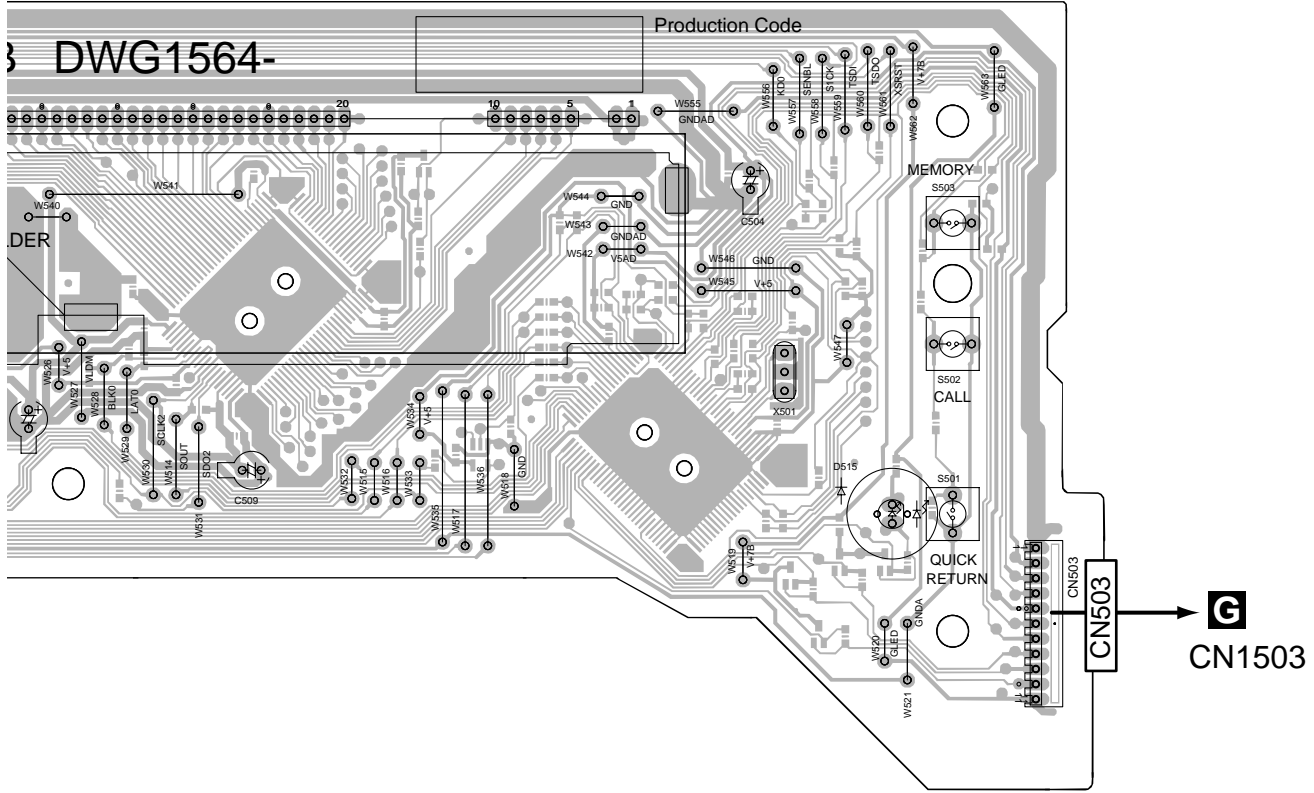

(DNP2036-B)

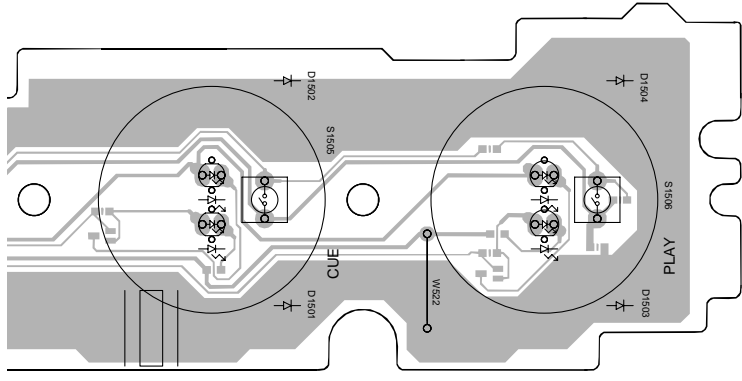

(DNP2036-B)

SIDE B

F MFLB ASSY

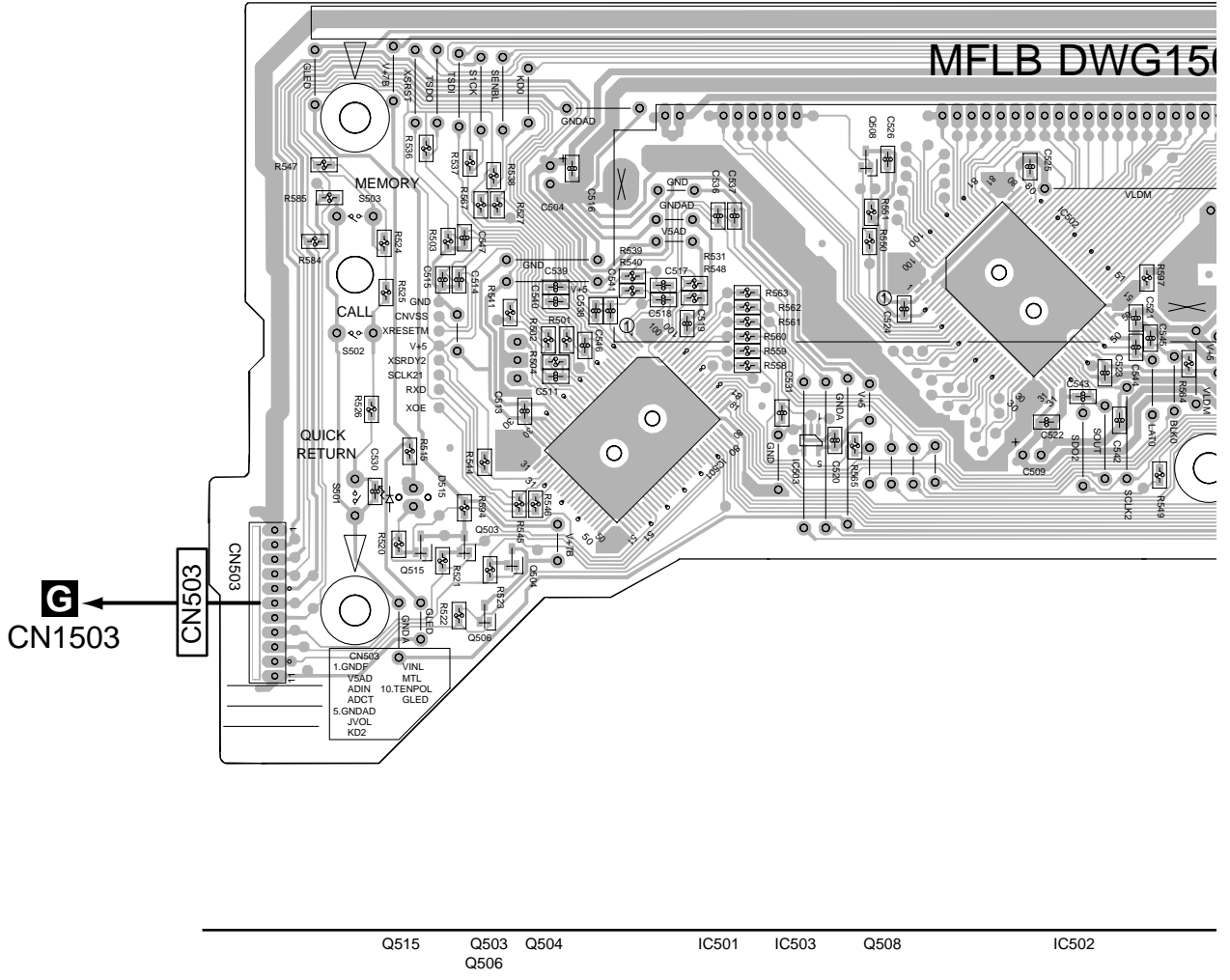

H KSWB ASSY

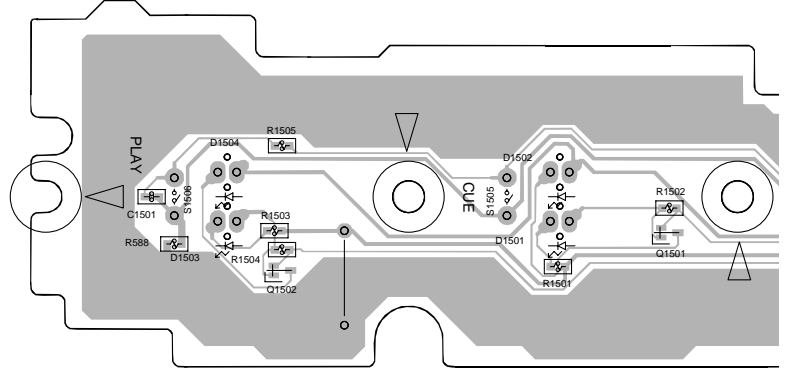

SIDE B

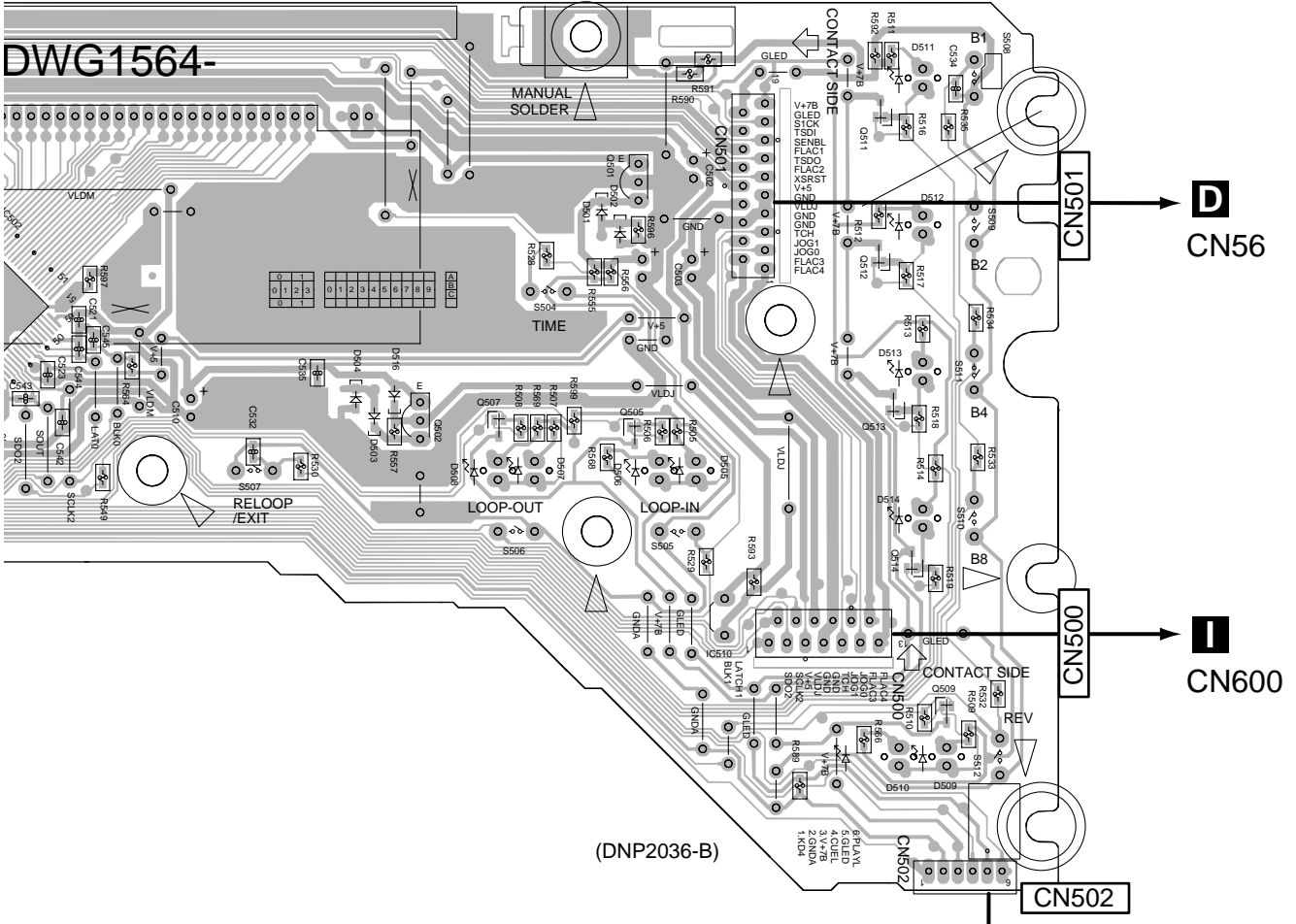

Q502 Q507 Q505 Q511 Q514 Q509
Q512 Q513

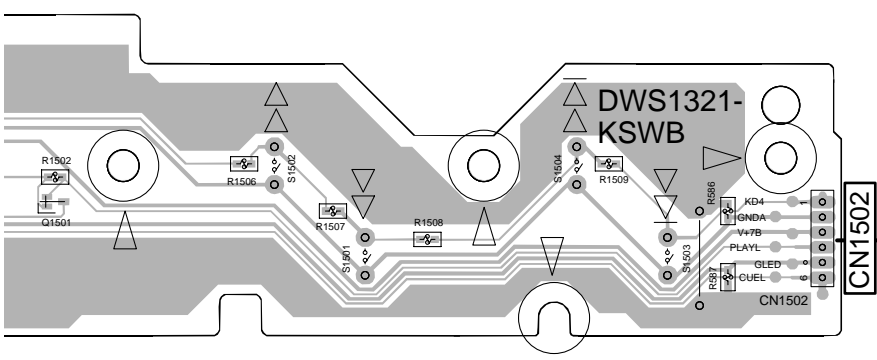

(DNP2036-B)



4.5 SLDB, JOGB and JFLB ASSYS

SIDE A

I JFLB ASSY

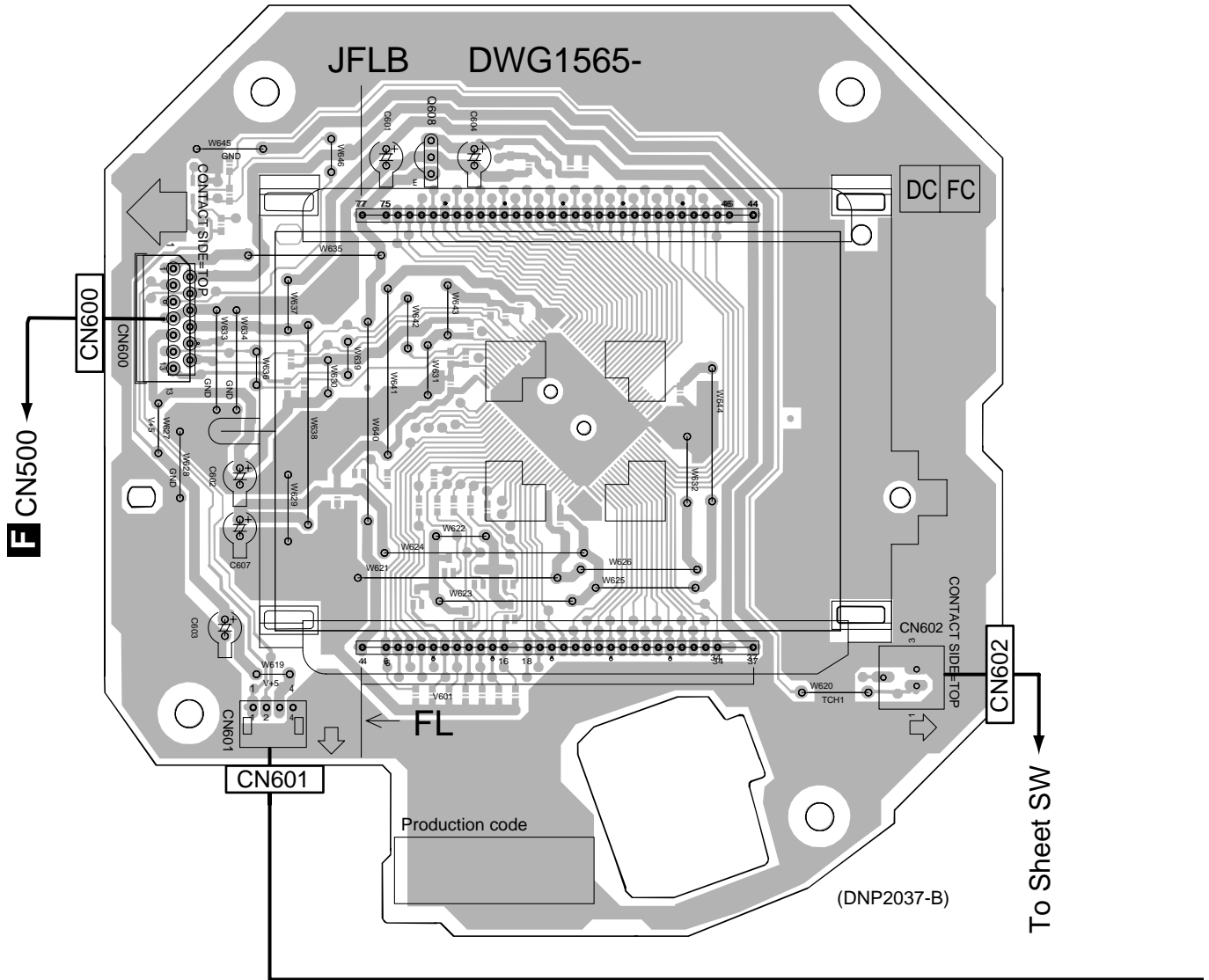

J SLDB ASSY

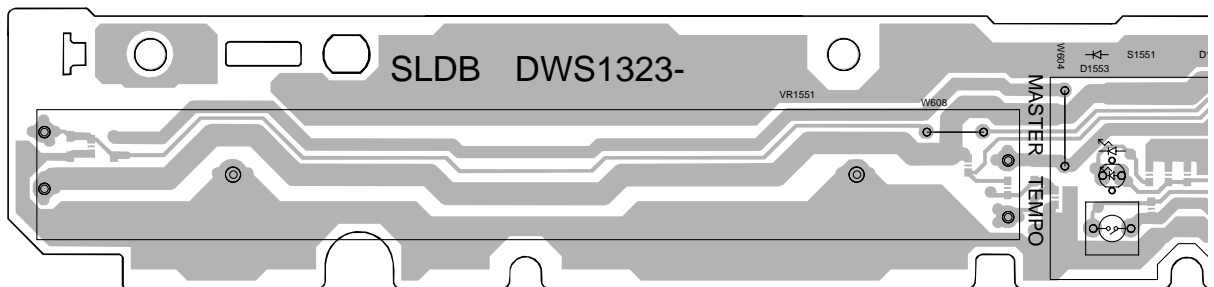

SIDE A

K JOGB ASSY

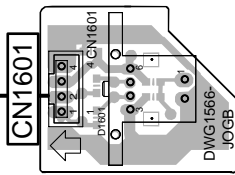

(DNP2037-B)

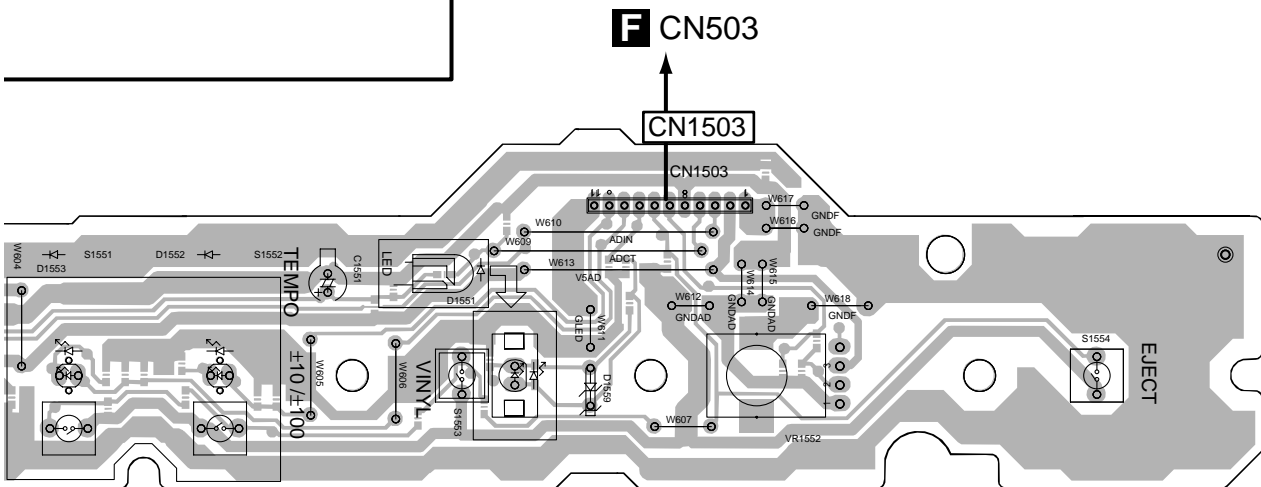

F CN503

CN1503

(DNP2037-B)

SIDE B

J JFLB ASSY

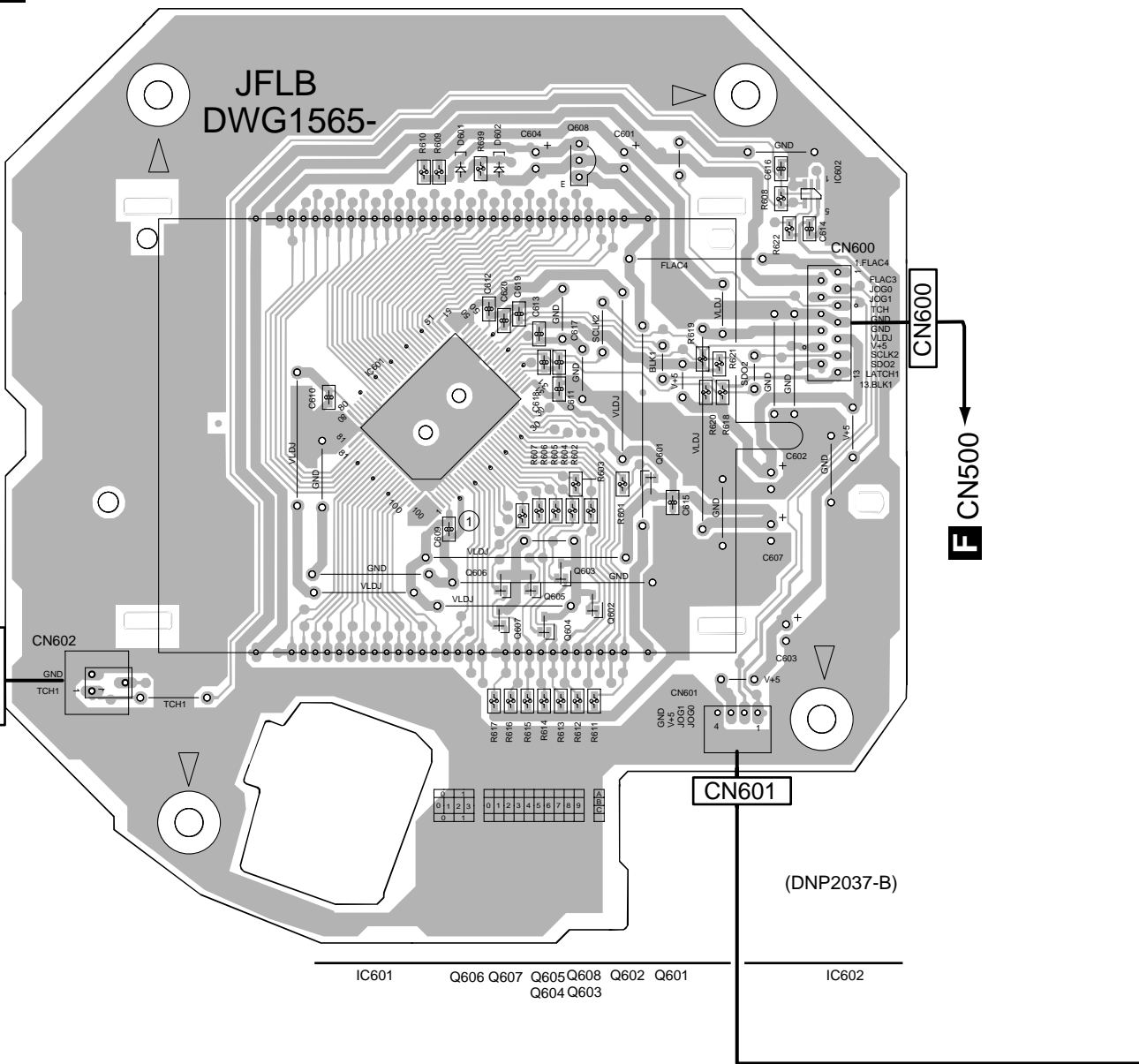

J SLDB ASSY

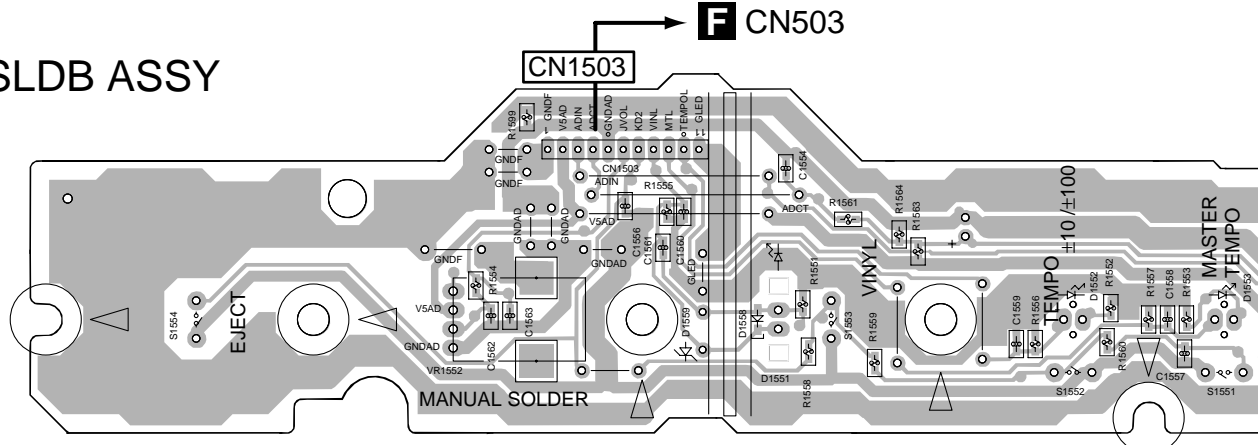

J **I**

SIDE B

A

B

K JOGB ASSY

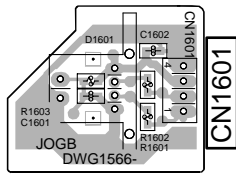

(DNP2037-B)

C

D

E



(DNP2037-B)

F

J K

5. PCB PARTS LIST

NOTES: ● Parts marked by "NSP" are generally unavailable because they are not in our Master Spare Parts List.

● The Δ mark found on some component parts indicates the importance of the safety factor of the part. Therefore, when replacing, be sure to use parts of identical designation.

● When ordering resistors, first convert resistance values into code form as shown in the following examples.

Ex.1 When there are 2 effective digits (any digit apart from 0), such as 560 ohm and 47k ohm (tolerance is shown by J=5% and K=10%).

560 Ω \rightarrow 56 x 10¹ \rightarrow 561 RD1/4PU $\overline{561}J$

47k Ω \rightarrow 47 x 10³ \rightarrow 473 RD1/4PU $\overline{473}J$

0.5 Ω \rightarrow R50 RN2H $\overline{R50}K$

1 Ω \rightarrow 1R0 RS1P $\overline{1R0}K$

Ex.2 When there are 3 effective digits (such as in high precision metal film resistors).

5.62k Ω \rightarrow 562 x 10¹ \rightarrow 5621 RN1/4PC $\overline{5621}F$

LIST OF ASSEMBLIES

Mark No.	Description	Part No.
	1..MAIN Assy	DWG1563
NSP	1..DISP Assy (WYXJ)	DWM2147
NSP	1..DISP Assy (KUCXJ)	DWM2149
	2..MFLB Assy	DWG1564
	2..SECB Assy	DWR1361
	2..REGB Assy	DWR1362
	2..TRNS Assy	DWR1364
	2..AC IN Assy (KUCXJ)	DWR1366
	2..AC IN Assy (WYXJ)	DWR1363
	2..KSWB Assy	DWS1321
	2..SLMB Assy	DWS1322
NSP	1..SUB Assy	DWM2146
	2..JFLB Assy	DWG1565
	2..JOGB Assy	DWG1566
	2..SLDB Assy	DWS1323

Mark No.	Description	Part No.
	Q108	2SC2412K
	Q104-Q107	2SD2114K
	Q102	DTA124EUA
	Q111	DTC114TK
	Q103	DTC124EUA

	D1204, D1205	1SS355
	D1206	EC10QS04
	D1207	HZU2.0B

COILS AND FILTERS

	L104 (470uH)	DTL1083
	F110 (Ferrite core)	DTL1090
	L108, L109 (Chip beads)	PTL1014

CAPACITORS

	C224, C230	CCSRCH100D50
	C232	CCSRCH101J50
	C164, C165	CCSRCH120J50
	C213, C219	CCSRCH180J50
	C158	CCSRCH181J50
	C159, C223	CCSRCH220J50
	C238	CCSRCH270J50
	C192, C251	CCSRCH470J50
	C210	CCSRCH471J50
	C220	CCSRCH680J50

	C150, C152, C157	CEAT101M10
	C127, C175, C206, C221, C240	CEJQ101M10
	C249, C256, C258, C260	CEJQ101M10
	C270, C271, C282, C283	CEJQ101M10
	C153	CEJQ330M10

	C114, C115, C130, C131, C135	CEJQ470M16
	C119, C133	CEJQNP220M16
	C163	CKSRYB102K50
	C101, C106-C113, C117, C118	CKSRYB103K50
	C120, C123-C126, C128, C129	CKSRYB103K50

	C134, C138, C144-C149, C151	CKSRYB103K50
	C160-C162, C167-C171	CKSRYB103K50
	C173, C174, C181, C183, C184	CKSRYB103K50
	C186, C187, C189, C194, C198	CKSRYB103K50
	C200, C205, C211, C212	CKSRYB103K50

	C214-C218, C222, C226, C227	CKSRYB103K50
	C233, C234, C236, C237, C239	CKSRYB103K50
	C242-C244, C246, C247, C254	CKSRYB103K50
	C257, C259, C261-C266, C272	CKSRYB103K50
	C274, C275, C284	CKSRYB103K50

	C136, C155, C176, C177, C182	CKSRYB104K25
	C185, C188, C190, C191, C196	CKSRYB104K25
	C207, C231, C245, C248, C250	CKSRYB104K25

MAIN ASSY SEMICONDUCTORS

A MAIN ASSY SEMICONDUCTORS

IC113	BR24C64F
IC109	K4S281632C-TC1H
IC119	LA6562
IC122	M51957BFP
IC111, IC114, IC116	NJM2100M
IC107	NJM2374AM
IC123	NJM2870F05
IC124	NJM2870F18
IC115	NJM2903M
IC103	NJM4558MD
IC112	PD3442B8
IC102	PDC101A
IC104	PE8001A
IC118	TA2153FN
IC120	TC74VHC257FT
IC125	TC7S04FU
IC108	TC7WU04FU
IC110	TC9495F-P
IC117	XCA56367PV150
Q110	2SA1036K

<u>Mark No.</u>	<u>Description</u>	<u>Part No.</u>
C253, C267-C269, C273, C280 C285-C287, C291		CKSRYB104K25 CKSRYB104K25
C195 C197, C203, C228, C229, C279 C204 C202 C208, C209		CKSRYB153K50 CKSRYB224K16 CKSRYB333K16 CKSRYB472K50 CKSRYB473K50
C241 C235 C116, C121, C122, C132		CKSRYB562K50 CKSRYB682K50 CQMA152J50

RESISTORS

R223, R253, R254 R195 R136 R115, R127 R145		RAB4C223J RS1/16S1502F RS1/16S1801F RS1/16S2202D RS1/16S2202F
R214, R215, R257 R138 R198, R200 R146, R196, R256 R199		RS1/16S3301F RS1/16S3901F RS1/16S3902F RS1/16S4701F RS1/16S5600F
R192, R197 Other Resistors		RS1/16S8202F RS1/16S###J

OTHERS

X101 CRYSTAL RES. (16.93MHz) CN123 KR CONNECT POST 2P CN110 KR CONNECT POST 6P JA104 1P PINJACK X102 CERAMIC RES.(24.57MHz)		ASS1073 B2B-PH-K-S B6B-PH-K-S DKB1056 DSS1139
CN122 CONNECTOR 25P CN111 CONNECTOR 6P CN113 FFC CONNECTOR JA103 2P JACK		HLEM25R-1 S6B-PH-K-S SLW16S-1C7 VKB1050

**F MFLB ASSY
SEMICONDUCTORS**

IC501 IC503 IC502 Q501 Q503, Q504, Q505		PD5848A TC7S04F UPD16306B 2SB1237X 2SC4081
Q506, Q507 Q508, Q509 Q511, Q512, Q513 Q514, Q515 Q502		2SC4081 2SC4081 2SC4081 2SC4081 2SD1858X
D516 D509, D510 D505, D506, D507 D508, D511 D512, D513, D514		1SS355 SLI-343URCW SLI-343YCW SLI-343YCW SLI-343YCW
D515 D503 D504 D501		TLGE68TG UDZS13B UDZS18B UDZS6.8B

COILS AND FILTERS

X501 CERAMIC RES.(4MHz)		DSS1131
-------------------------	--	---------

SWITCHES AND RELAYS

<u>Mark No.</u>	<u>Description</u>	<u>Part No.</u>
S501, S502, S503, S504 S505, S506, S507, S508 S509, S510, S511, S512		ASG7013 DSG1063 DSG1063

CAPACITORS

C536, C537 C542 C531, C543, C544, C545 C506, C510 C502, C504		CCSRCH102J50 CCSRCH151J50 CCSRCH271J50 CEJQ100M50 CEJQ470M16
C503 C509 C530, C532, C534, C538, C539 C540 C511, C513, C514, C515, C516		CEJQ1R0M50 CEJQ4R7M50 CKSRYB102K50 CKSRYB102K50 CKSRYB103K50
C520, C521, C522, C523, C524 C525, C526, C535 C517, C518, C519		CKSRYB103K50 CKSRYB103K50 CKSRYB105K6R3

RESISTORS

Other Resistors		RS1/16S###J
-----------------	--	-------------

OTHERS

CN500 13P CONNECTOR CN501 19P CONNECTOR V501 FL DISPLAY FL HOLDER CN502 6P SOCKET CN503 11P CONNECTOR		52492-1320 52492-1920 DEL1048 DNF1674 KP200IB6L VKN1363
--	--	--

**D SECB ASSY
SEMICONDUCTORS**

⚠ IC56 ⚠ IC57, IC59 IC51 IC63 Q54		AEK7005 AEK7023 NJM2374AM TC7S04F 2SB1238X
Q53, Q55 ⚠ Q52 Q51 Q56 D52		2SD1859X 2SD2012 DTA143EUA DTC124EUA 1SS355
D51 D63, D64 D53 D54 D55		EC10QS04 UDZS10B UDZS20B UDZS22B UDZS5.1B

COILS AND FILTERS

L53 (82uH) L55, L56, L57, L58 (Ferrite beads) L54 (Chip beads)		DTL1104 VTH1020 VTL1084
--	--	-------------------------------

SWITCHES AND RELAYS

S51		DSH1025
-----	--	---------

CAPACITORS

C60 C57, C59, C62, C67, C68 C69, C70 C61		CCSRCH331J50 CEAT101M10 CEAT101M10 CEAT1R0M50
C55 C51, C52		CEAT221M2A CEAT222M25

Mark No.	Description	Part No.
C53, C54		CEAT332M16
C58		CKSRYB103K50
C56, C63, C66		CKSRYB104K25

RESISTORS

R76		RD1/2VM103J
R66		RD1/2VM271J
R81		RD1/2VM470J
R51		RS1/16S2002D
R52		RS1/16S3302D

Other Resistors		RS1/16S###J
-----------------	--	-------------

OTHERS

CN52 6P JUMPER CONN.		52147-0610
52 MINI JACK		AKN7003
CN54 KR CONN. POST		B2B-PH-K-S
CN55 3P CONN. POST		B3B-PH-K-M
CN56 19P FFC CONN.		HLEM19S-1

CN53 25P CONNECTOR		HLEM25S-1
CN51 11P SOCKET		KP250NA11
JA51 REMOCON JACK		PKN1004
PCB BINDER		VEF1040
KN51 EARTH METAL FITT.		VNF1084

REGB ASSY SEMICONDUCTORS

⚠ IC91		BA05T
⚠ IC92		PQ15RW11

CAPACITORS

C92		CEAT101M10
C94		CEAT470M16
C91, C93		CKSRYB103K50

RESISTORS

R92		RS1/16S2201D
R91		RS1/16S3901D

OTHERS

91 6P CABLE HOLDER		51048-0600
J91 6P JUMPER WIRE		D20PDY0610E
REGURATOR PLATE		DNH2533

TRANS ASSY SEMICONDUCTORS

⚠ IC25		AEK7006
⚠ IC23, IC24		AEK7017
⚠ IC21, IC22		AEK7019
⚠ D25, D26, D27, D28		1SR154-400
⚠ D21, D22, D23, D24		RB060L-40

CAPACITORS

C21, C22, C23, C24, C25		CKSRYB473K50
C26, C27, C28, C29		CKSRYB473K50
C30, C31		CKSRYB473K50

RESISTORS

Other Resistors		RS1/16S###J
-----------------	--	-------------

OTHERS

⚠ J2 CONNECTOR ASSY		DKP3621
CN22 11P CONNECTOR		S11B-XH-A-1
PCB BINDER		VEF1040

AC IN ASSY(for KUCXJ type)

Mark No.	Description	Part No.
----------	-------------	----------

COILS AND FILTERS

⚠ L11		VTL-004
-------	--	---------

SWITCHES AND RELAYS

⚠ S11		DSA1029
-------	--	---------

CAPACITORS

⚠ C12, C13 (Film capa.)		ACE7027
⚠ C11 (10000P/AC250V)		ACG7033

OTHERS

⚠ AN11 POWER SOCKET		AKP7032
H11, H12 FUSE CLIP		AKR1004
⚠ CN11 2P-VH CONNECTOR		B2P3-VH

AC IN ASSY (for WYXJ type)**COILS AND FILTERS**

⚠ L11		VTL-004
-------	--	---------

SWITCHES AND RELAYS

⚠ S11		DSA1029
-------	--	---------

CAPACITORS

⚠ C12, C13 (Film capa.)		ACE7027
⚠ C11 (10000P/AC250V)		ACG7033

OTHERS

H11, H12 FUSE CLIP		AKR1004
⚠ CN11 2P-VH CONNECTOR		B2P3-VH
⚠ AN11 POWER SOCKET		BKP1046

KSWB ASSY SEMICONDUCTORS

Q1501, Q1502		2SC4081
D1501, D1502		SLI-343YCW
D1503, D1504		TLGE68TG

SWITCHES AND RELAYS

S1501, S1502, S1503, S1504		ASG7013
S1505, S1506		DSG1063

CAPACITORS

C1501		CKSRYB102K50
-------	--	--------------

RESISTORS

Other Resistors		RS1/16S###J
-----------------	--	-------------

OTHERS

CN1502 6P PLUG		AKM7030
----------------	--	---------

JFLB ASSY SEMICONDUCTORS

IC601		UPD16306B
Q608		2SB1237X
Q601, Q602, Q603, Q604, Q605		2SC4081
Q606, Q607		2SC4081
D601		UDZS9.1B

CAPACITORS

C617		CCSRCH151J50
C618, C619, C620		CCSRCH271J50
C604, C607		CEJQ100M50
C601		CEJQ1R0M50
C602, C603		CEJQ470M16

C616		CKSRYB102K50
------	--	--------------

<u>Mark No.</u>	<u>Description</u>	<u>Part No.</u>
C609, C610, C611, C612, C613 C615		CKSRYB103K50 CKSRYB103K50

RESISTORS

Other Resistors	RS1/16S###J
-----------------	-------------

OTHERS

CN602 CONNECTOR	5597-03APB
V601 FL DISPLAY	DEL1049
FL HOLDER	DNK3956
CN600 13P CONNECTOR	HLEM13R-1
CN601 KR CONNECTOR	S4B-PH-K-S

**SLMB ASSY
SWITCHES AND RELAYS**

S1901, S1902	DSG1017
--------------	---------

OTHERS

CN1901 KR CONNECTOR	S3B-PH-K-M
---------------------	------------

**JOGB ASSY
SEMICONDUCTORS**

D1601	GP1A038RBK
-------	------------

CAPACITORS

C1601, C1602	CKSRYB103K50
--------------	--------------

RESISTORS

Other Resistors	RS1/16S###J
-----------------	-------------

OTHERS

CN1601 KR CONNECTOR	B4B-PH-K-S
---------------------	------------

**SLDB ASSY
SEMICONDUCTORS**

DD1554, DD1555, D1556, D1557	1SS355
D1551	E1L4E-7B1A
D1553	SLI-343URCW
D1552	SLI-343YCW

SWITCHES AND RELAYS

S1551, S1552, S1553, S1554	ASG7013
----------------------------	---------

CAPACITORS

C1557	CCSRCH101J50
C1556	CCSRCH102J50
C1551	CEJQ100M50
C1552, C1553	CKSRYB102K50
C1558, C1559, C1560, C1561	CKSRYB103K50

RESISTORS

R1563, R1564	RS1/16S2201F
VR1552 10kB	DCS1062
VR1551 VR slide(50k)	DCV1009
Other Resistors	RS1/16S###J

OTHERS

CN1503 PLUG	DKN1252
-------------	---------

6. ADJUSTMENT

A

There is no information to be shown in this chapter.

B

C

D

E

F

7. GENERAL INFORMATION

7.1 DIAGNOSIS

7.1.1 SERVICE MODE

1. Service Mode Summary

This unit is controlled with two microcomputers. One microcomputer performs the button input and indication of FL and LED (display section), and the other microcomputer drives the player (player section).
Test mode is prepared in each microcomputer.

① Confirmation mode of the button of display section and display function

It is the mode which confirms button input and display function.

② The mode which confirms the operation of the player section (use the remote control unit)

Connect the remote control unit (RU-V101) to the data copy terminal of the player, and confirms the operation.

③ Version confirmation mode

Can confirm software version of each microcomputer.

2. Confirmation Mode of the Button of Display Section and Display Function

Enter this mode when turns the power on while pressing the [MEMORY] key and [TIME] key simultaneously.

It can light display part in this mode partially as follows. And it can perform each button and the input of volume and indication normally. Further, display lights while pressing the button.

	Button	Display
LED	QUICK RETURN	Light LED of QUICK RETURN
	AUTO BEAT (1, 2, 4, 8)	Light LED of each beat
	REVERSE	Light LED of REVERSE
	CUE	Light LED of CUE
	PLAY/PAUSE	Light LED of PLAY/PAUSE
	LOOP IN	Light LED of LOOP IN
	LOOP OUT	Light LED of LOOP OUT
	JOG MODE	Light LED of VINYL
	TEMPO RANGE	Light LED of TEMPO RANGE
	MASTER TEMPO	Light LED of MASTER TEMPO
FL	TRACK/SEARCH - FWD	Light "REMAIN", "M", ":", "88" of a minute and "8" of high-order digit of a second
	TRACK/SEARCH - REV	Light "88" of the track number, "A. COU" and "QUICK RETURN"
	SEARCH - FWD	Light "S", "F", "8" of low order digit of a second and "88" of a frame
	SEARCH -REV	Light all of Playing bar and frame
	TIME MODE/AUTO CUE	Light "+1888%" of tempo, "888" of BPM, "WIDE", "MT" and "BPM"
	RELOOP/EXIT	Light all FLs, JOG-FLs and LEDs of the main unit
	CALL	Light all the rotation display parts of JOG-FL
	MEMORY	Light all CUE point marks of JOG-FL
	EJECT	Light "VINYL" character and a frame (blue) of the JOG-FL center
	JOG ADJUST VOLUME	Goes out the ring A of JOG-FL when the volume position is less than the center. And light it when it is more than the center.
	SLIDER VOLUME	Goes out the ring B of JOG-FL when the volume position is less than the center. And light it when it is more than the center.

3. Confirmation Mode of the Operation with the Player being Simple

Connect the remote control unit (RU-V101) to DATA IN/OUT terminal of the Rear panel, and confirms the operation. These commands test a mechanism and servo system mainly. Therefore, DJ function such as scan or tempo does not work. Prepare only a command that searches arbitrary music and playback the audio.

Connect the remote control unit, and enter this mode when turns the power on while pressing the [MEMORY] key and [REVERSE] key simultaneously.

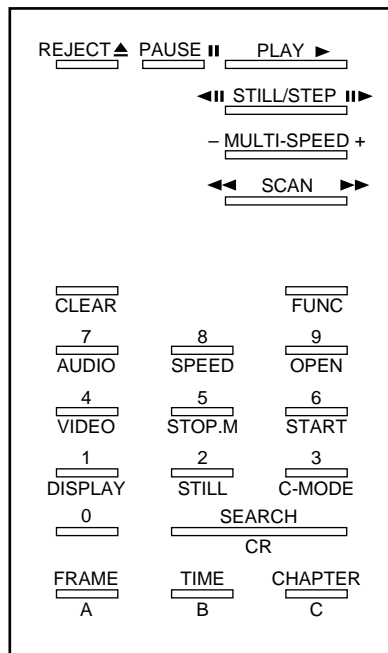

Function	Button corresponding to RU-V101
A Time mode set	TIME
Track mode set	CHAPTER
Block mode set	FRAME
Play	PLAY
Reject	REJECT
Pause	PAUSE
Search	SEARCH
Eject	OPEN (FUNC + 9)
Audio Play	AUDIO (FUNC + 7)
Test/Normal Mode Change	C-MODE (FUNC + 3)
Servo All Off	0 + TIME
Focus On	1 + TIME
Spindle Kick, Tracking On/Off	2 + TIME
Tracking Off	3 + TIME
Slide FWD	4 + TIME
Slide REV	5 + TIME
Search TR No.2	6 + TIME
Pickup Up/Down	7 + TIME

• Specification method of addressing modes in the search

There are three ways of search methods of time search, track search and block search in this unit. It is necessary to specify each mode when performs each search. After specified the mode once, mode is maintained till modifies it next.

• Time search (A Time mode set)

Set absolute time (minute, second) in the address mode.

Examples: When search for 2 minutes 34 seconds

Press buttons of [TIME], [0], [2], [3], [4] and [SEARCH] in order.

• Track search (Track mode set)

Set track number in the address mode.

Examples: When search for track 5

Press buttons of [CHAPTER], [5] and [SEARCH] in order.

• Block search (Block mode set)

Set block in the address mode.

Examples: When search for 2 minutes 34 seconds 56 frame

Press buttons of [FRAME], [0], [2], [3], [4], [5], [6] and [SEARCH] in order.

• Player operation command

(Play)

Set up and play. (it is not audio playback)

In addition, release it if it is the pause state.

(Reject)

Stop

(Pause)

Pauses at the position.

(Eject)

In the playback state or stop state, perform the disc eject.

(Audio Play)

Audio playbacks the arbitrary music.

It is necessary for this command that Player is set up beforehand. Please execute (Play) first.

(Reject) Stop by the command.

Examples: When audio playbacks at track 8 Press buttons of [8], [AUDIO], ([FUNC] and [7]) in order.

• Test operation command

It can control servo operation finely.

Be careful not to damage the player by mistake the usage of test command.

(Test/Normal Mode Change)

[C-MODE] Switch the Test mode/Normal mode by [FUNC] and [3] buttons.

Can use only commands of 7TM from 0TM in the test mode.

(Servo All Off)

During servo ON, turn all servos OFF when pressing the [0] and [TIME] buttons in order.

(Focus On)

During CD STOP, turns the LD ON when pressing [1] and [TIME] buttons in order, and perform the autofocus.

(Spindle Kick, Tracking ON/Off)

During tracking servo OFF, perform the spindle kick and turn the automatic adjustment processing and tracking servo ON when pressing [2] and [TIME] buttons in order.

Also during tracking servo ON, turn the tracking servo OFF when pressing [2] and [TIME] buttons in order.

(Tracking OFF)

During tracking servo ON, turn the tracking servo OFF when pressing [3] and [TIME] buttons in order.

(Slide FWD)

During tracking servo ON, turn the tracking servo OFF and move the slider in the FWD direction when pressing [4] and [TIME] buttons in order.

(Slide REV)

During tracking servo ON, turn the tracking servo OFF and move the slider in the REV direction when pressing [5] and [TIME] buttons in order.

(Search TR No.2)

During CD STOP, perform the following operations when pressing [6] and [TIME] buttons in order.

LD ON → Autofocus → Spindle kick → Automatic adjustment processing → Second tune search → Tracking servo ON
When performed Tracking OFF, there is the case that cannot rise up in this command. In that case please repeat once again.

(Pickup UP/DOWN)

During CD STOP, turn the LD ON and move the pickup up and down when pressing [7] and [TIME] buttons in order.

Do not close the focus.

* When rise by a step with the test mode, input a command by pressing buttons of [0], [TIME], [1], [TIME], [2] and [TIME] in order.

4. Version confirmation mode

Confirm the software version of each microcomputer.

• Symptom of the microcomputer software version of the display section

Turn the power on while pressing the [MEMORY] and [TRACK-SEARCH-REV] buttons, then two figures character is displayed at the track number display section. This shows a version. (First edition is as 10)

• Symptom of the microcomputer software version of the player section

In the normal use, three figures of numbers are displayed at the tempo display section that continues pressing the [RELOOP] button for 10 seconds. This shows a version. (First edition is as 1.00)

5. Error display list

When normal operation is not completed in normal use, indicate the following error code in the display section.

It can confirm the history of error contents till 16 histories when enter the version confirmation mode of the foregoing paragraph.

In this mode In this mode, display the error content in the "minute" display section (M) and display the memory address of microcomputer in the "second + frame" display section (S, F). (hexadecimal number)

Address changes when rotating the jog dial, and check range of DF20H-DF2FH. (initial value is DF20H)

DF20H is the newest, and DF2FH is the oldest error contents. The latest error is stored into DF20H.

Error Code	Error Name	Error Contents
E-7201	TOC READ ERROR	26: Cannot lead TOC data
E-8301	PLAYER ERROR (Abnormality of raising up)	12: Specified address were not able to search 15: Address is not readable 22: Focus servo cannot close 91: Pickup does not return to the internal periphery of the disc } (* Note)
E-8302	PLAYER ERROR (Abnormality of playback)	12: Specified address were not able to search 15: Address is not readable 22: Focus servo cannot close
E-8303	PLAYER ERROR (Buffer writing abnormality)	99: Abnormality of buffer write
E-9101	MECHANICAL TIME OUT	90: Abnormality of disc loading mechanism (Timeout)

* Note: When these error occurred before recognizing disc to be a CD, eject the disc automatically.

Then, error code is not displayed, but please refer to the error contents which are stored into the memory.

■ Chart of a remote control unit function of CDJ-800

* Caution in the remote control unit use: Please connect to the DATA IN/OUT terminal before turning the power on.

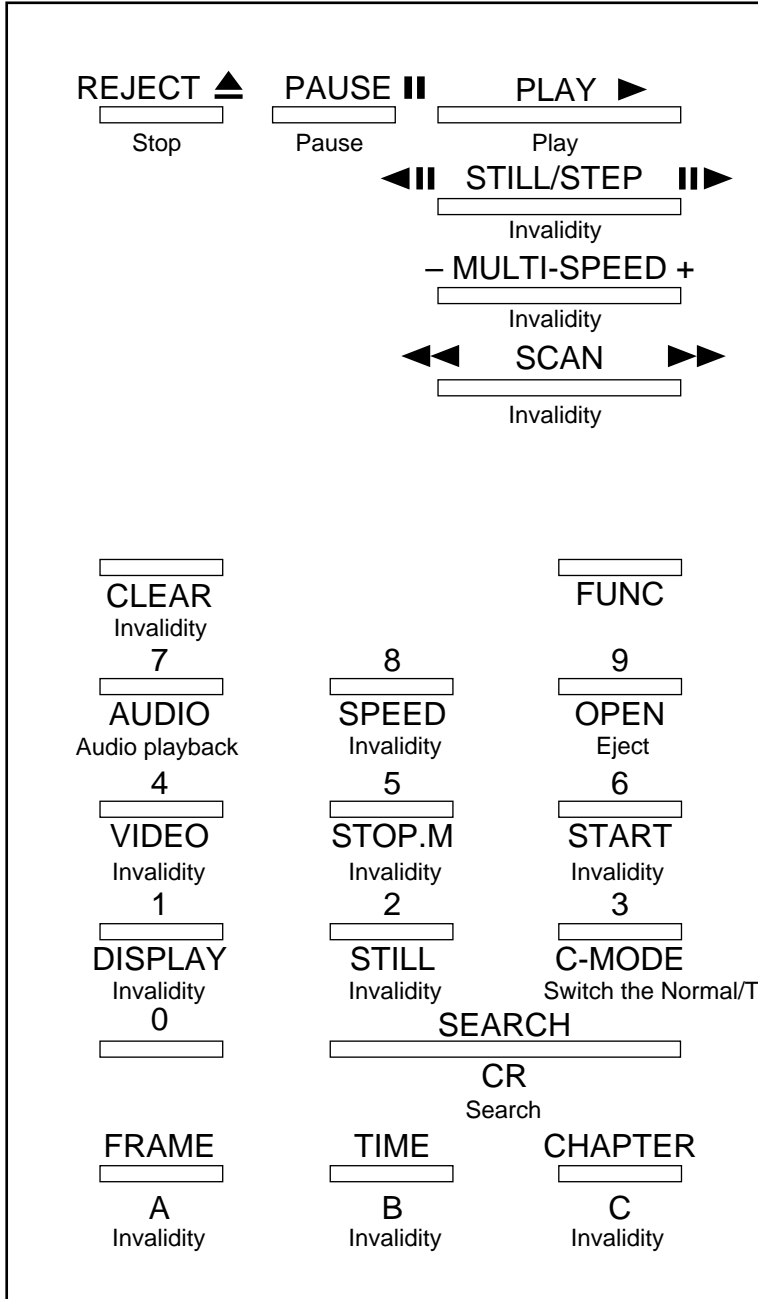

7.1.2 POWER ON SEQUENCE

A
B
C
D
E
F

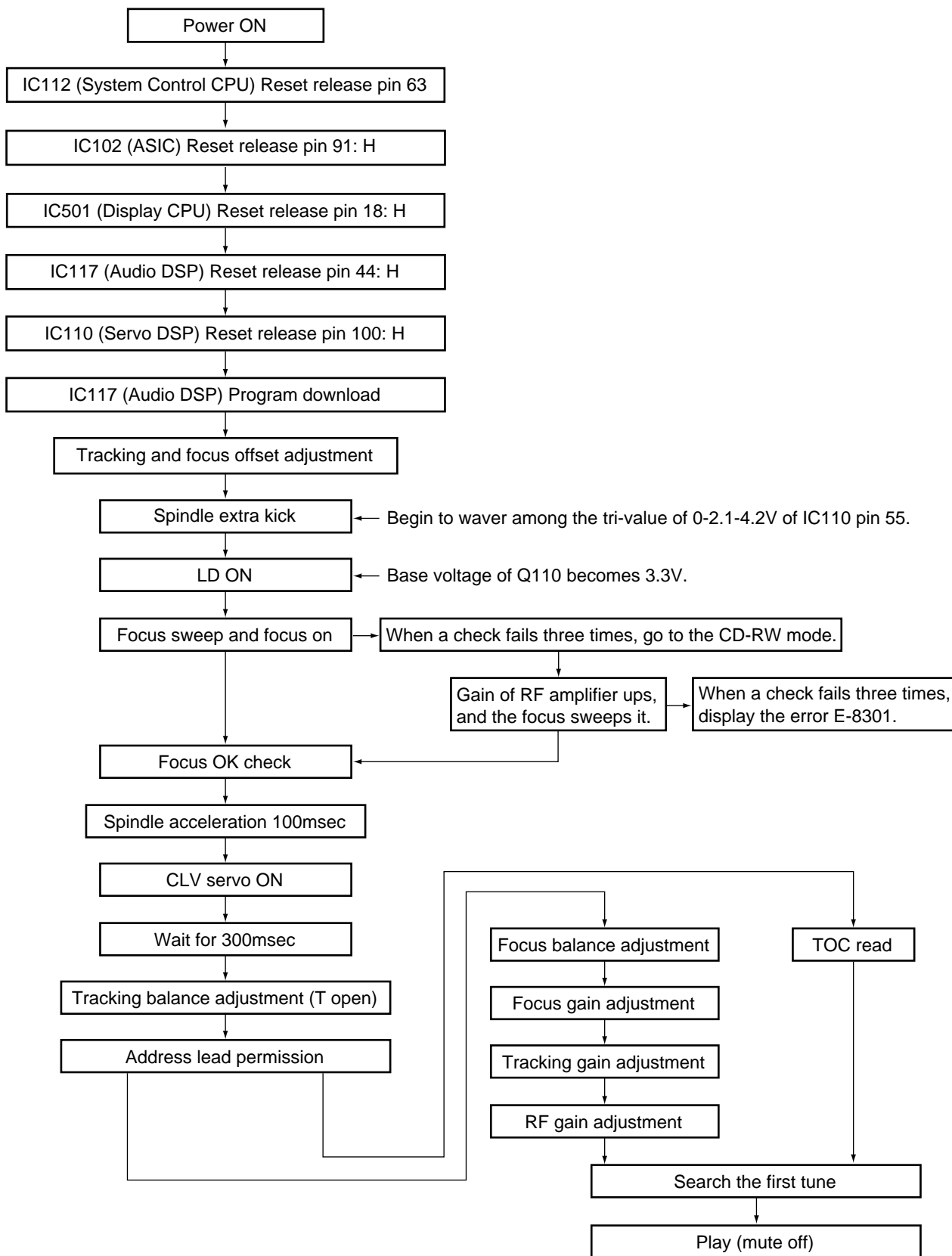

GOOD OR BAD JUDGEMENT METHOD OF THE PICKUP

1. LD current : 20 to 80mA TYP : 40 to 50mA
 Measure both end of R249 on the MAIN Assy in the play state. (Fig. 1)
 There must be the value that divided the measured value with 23.5 Ω within the numerical value mentioned above.
2. Focus coil DC resistor : 7.0 ± 1.0 Ω
 Pull out the flexible cable from the side of the pickup Assy.
 Measure the resistance value between the feet(F+, F-) of the posts.
 It must be within the above mentioned value.
3. Tracking coil DC resistor : 6.0 ± 1.0 Ω
 Pull out the flexible cable from the side of the pickup Assy.
 Measure the resistance value between the feet(T+, T-) of the posts.
 It must be within the above mentioned value.

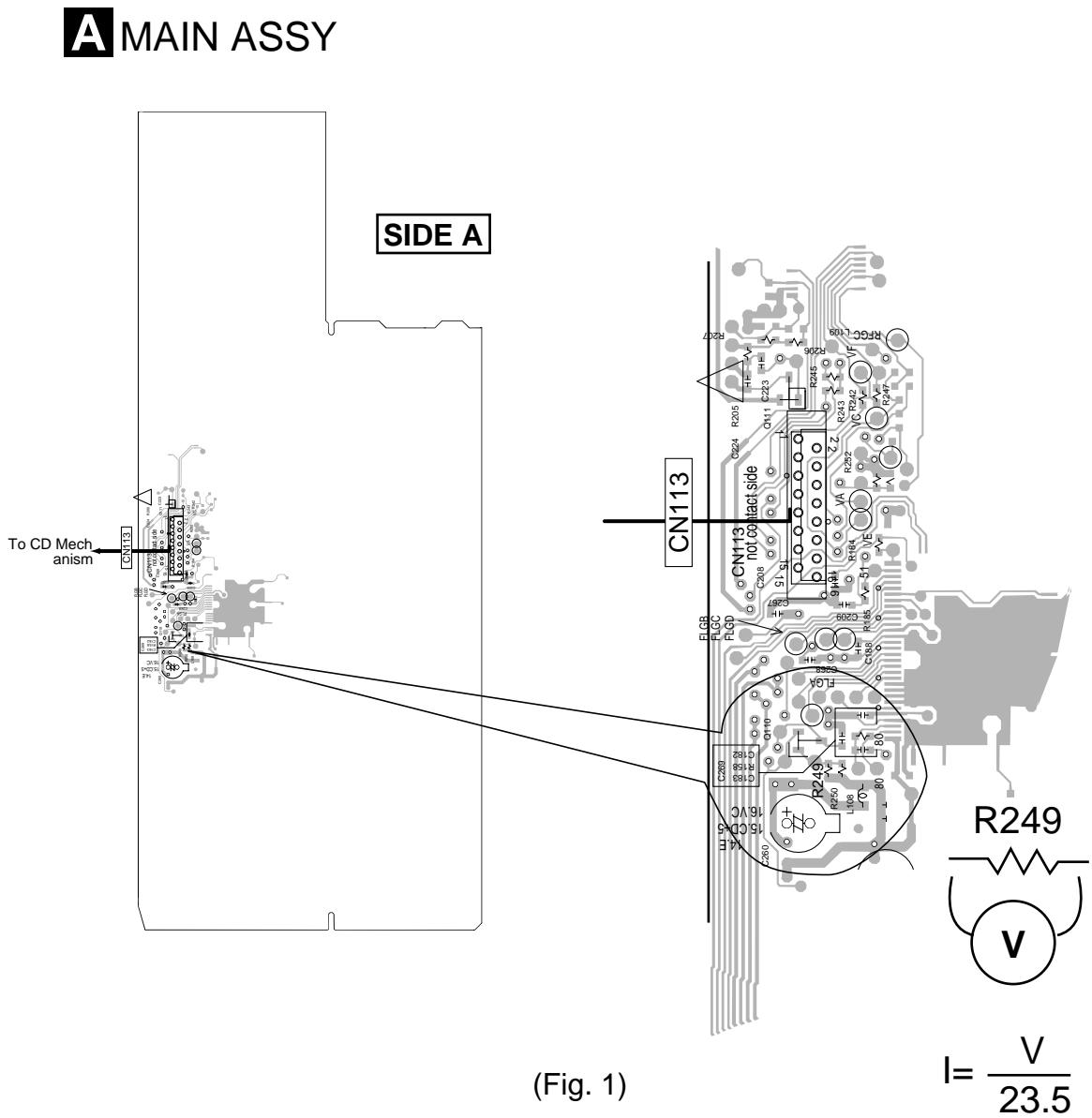

7.1.3 DISASSEMBLY

1 MAIN Assy

- ① Remove three screws to remove the Bottom Plate M.
- ② Remove four screws to remove the Bottom Plate P.

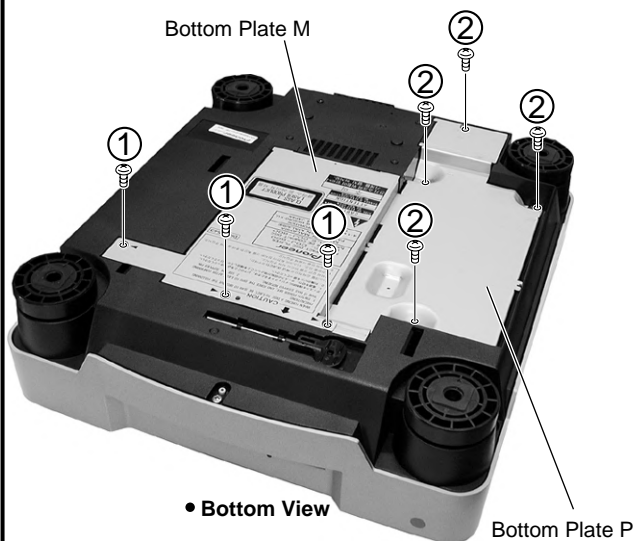

- ③ Remove two screws.



- ④ Disconnect two flexible cables and a connector.
- ⑤ Remove the MAIN Assy.

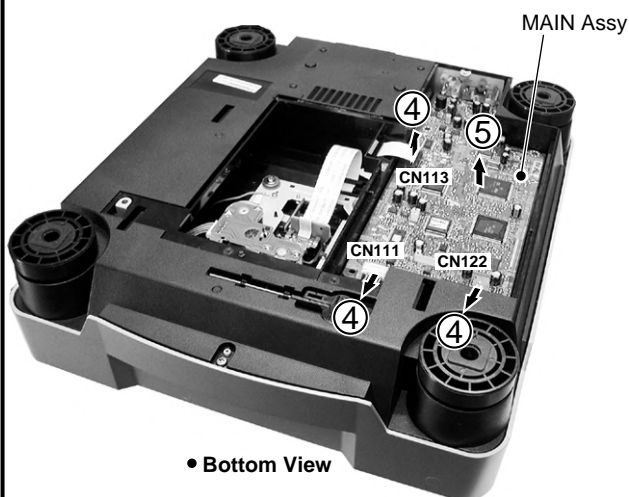

2 CD Mechanism

- ① Remove three screws to remove the Bottom Plate M.

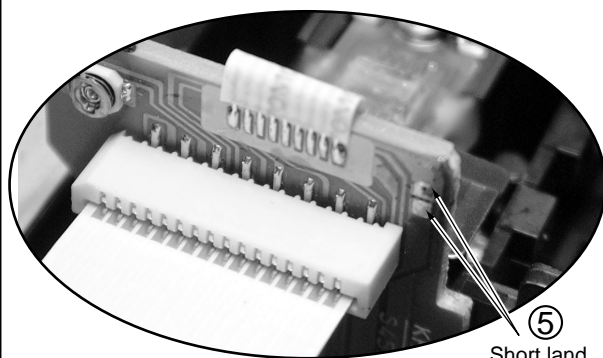

- ② Remove a screw.
- ③ Remove four screws.
- ④ Disconnect a spindle connector.
- ⑤ Disconnect a pickup flexible cable
[Caution in the Mechanism Assy replacement]
• When removing the Mechanism Assy, short-circuit a LD Short land ⑤ before disconnecting a flexible cable from the connector.
- ⑥ Remove the CD Mechanism.
• When installing the Mechanism Assy, release the short-circuit of LD Short land ⑤ after connecting the flexible cable to the connector. (For LD fracture prevention)

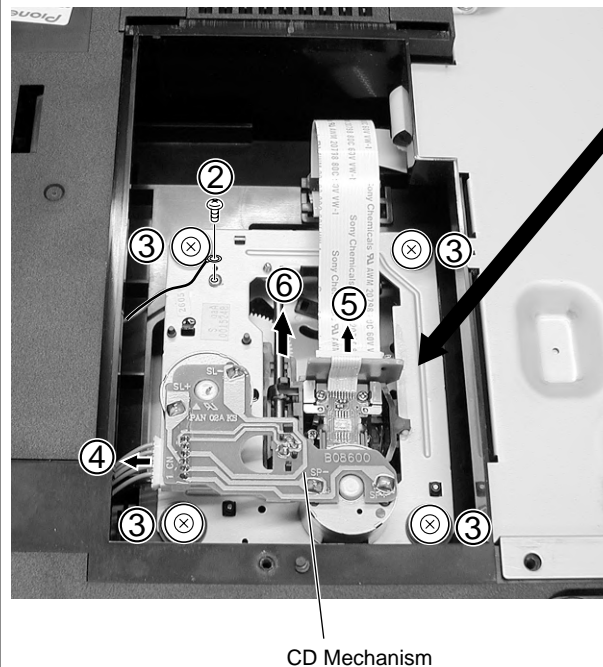

3 Control Panel Section

① Remove five screws.

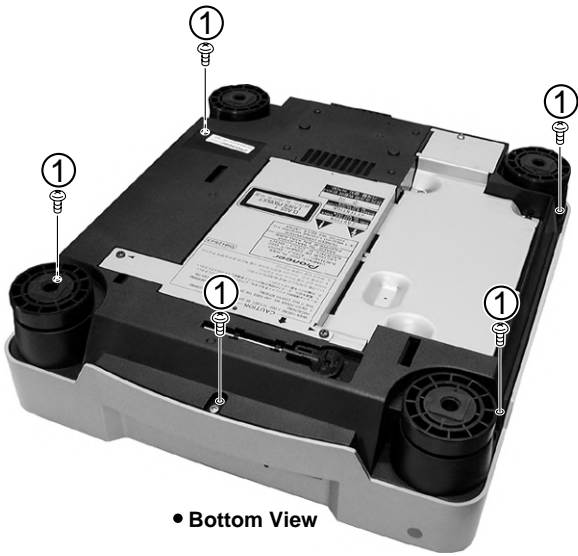

② Remove a screw.



③ Remove the Control Panel Section.

④ Disconnect a flexible cable.

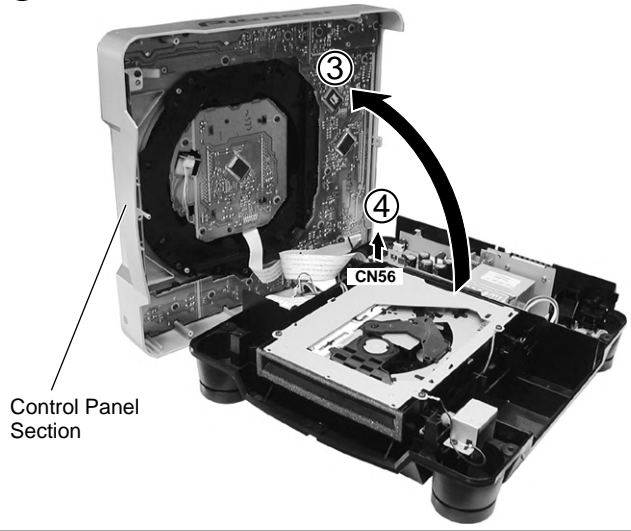

4 JOG Section

① Release a Cord Clamper.

② Disconnect a flexible cable.

③ Remove six screws.

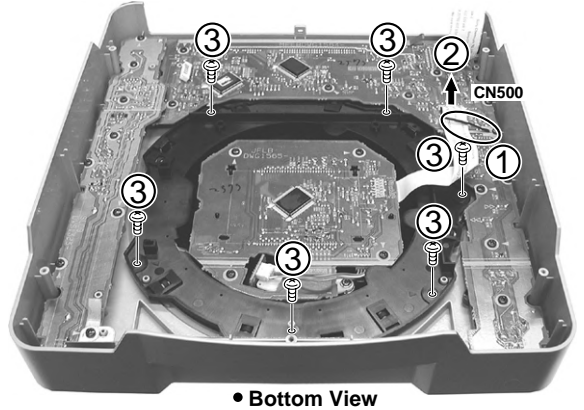

④ Unhook three hooks.

⑤ Remove the JOG B and JOG A.

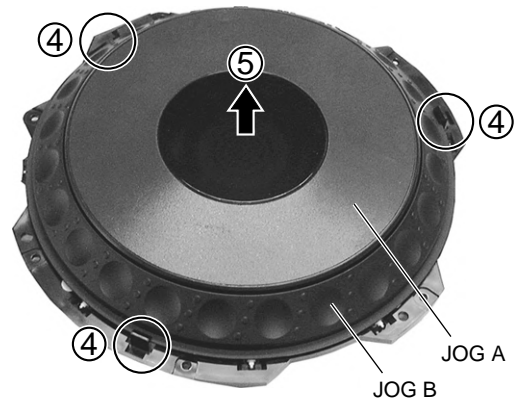

⑥ Remove three screws to remove the SW Ring.

Caution (*) :
Be careful not to lose the SW spring.

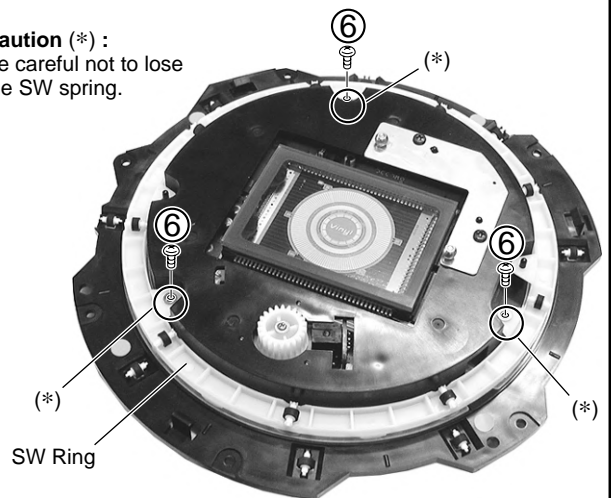

Caution in Sheet SW Installation

- ① Be careful not to bend and fold the Sheet SW.
- ② Confirm that the dust or trash does not adhere to pasting side (JOG Holder).
In addition, when tearing off the former Sheet SW and putting a new part, completely wipe the JOG Holder off with alcohol so that paste does not remain on the pasting side of JOG Holder.
- ③ When putting the Sheet SW, match the position not to run aground on rib of the internal circumference of JOG Holder.
- ④ Sheet SW pushes all the sides including the point of contact fully, and put it. (No good air getting into it.)
(When the air got into it, remove it and replace the new one. Do not recycle it.)
- ⑤ Put the SW Cushion HH48 on direction arrow part (12 places) of the Sheet SW.
- ⑥ When inserting a cable in connector, release a lock by all means, and connector locks after inserting it.

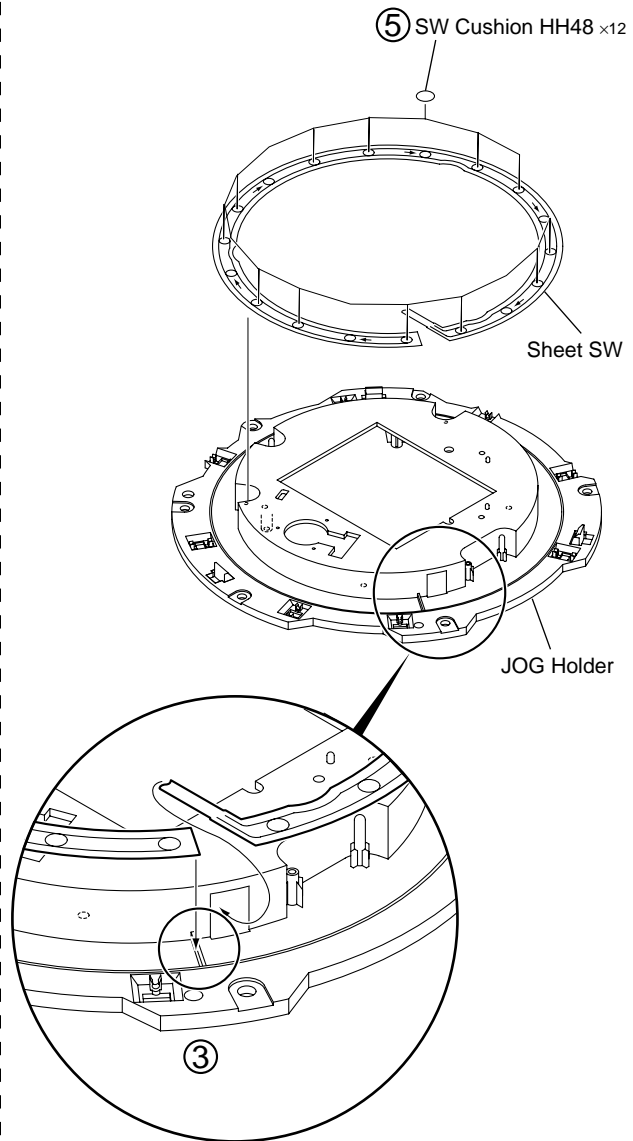

Caution in Roller A Assy Installation

- ① Apply a grease to the shaft bearing section of JOG Holder side and SW Ring side.
(Apply it to two places for roller one.)
(Be careful so that grease does not adhere to rubber section of the roller.)

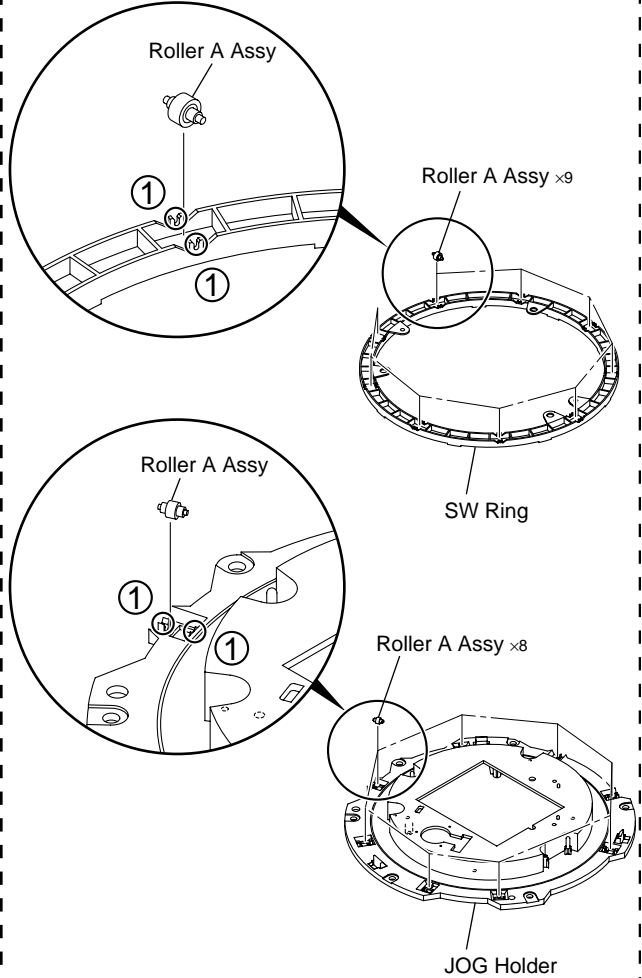

7.2 PARTS

7.2.1 IC

The information shown in the list is basic information and may not correspond exactly to that shown in the schematic diagrams.

List of IC

PD3442B8, PD101A, NJM2374AM, NJM2870F05

PD3442B8 (MAIN ASSY : IC112)

SYSTEM CONTROL Microcomputer

Pin Assignment (Top view)

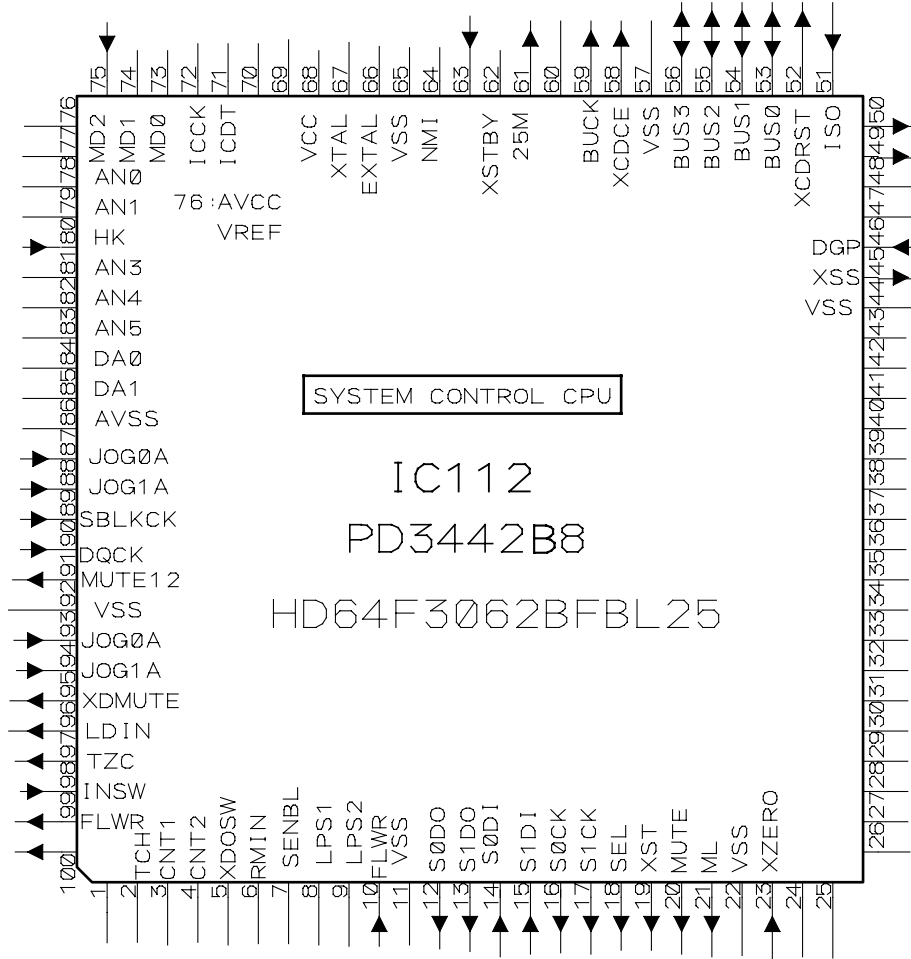

• Pin Function

No.	Pin Name	I/O	Description
1	Vcc	-	By the capacitor (0.1μF) It GND-connects.
2	TCH	I	JIG touch sensor input
3	CNT1	I/O	Control 1 input and output terminal
4	CNT2	I	Control 2 input terminal
5	XDOSW	I	Digital OUT ON/OFF SW detection
6	RMIN	I	For a RS232C input
7	SELBL	I	The enable output to host CPU
8	LPS1	I	A loading mechanism's condition
9	LPS2	I	
10	FLWR	I	The terminal which detects a flash write-in permission signal
11	Vss	-	Digital GND
12	S0DO	O	The serial output terminal to DSP
13	S1DO	O	A serial output besides a controller
14	S0DI	I	The serial input from DSP
15	S1D1	I	A serial input besides a controller
16	S0CK	O	The serial clock to DSP
17	S1CK	O	A serial clock besides a controller
18	SEL	O	Reset to FPGA
19	XST	O	Reset to circumference IC
20	MUTE	O	Line OUT output MUTE
21	ML	O	The reset terminal for DAC
22	Vss	-	Digital GND
23	XZERO	O	The terminal for repealing zero detection
24	NC	-	
25	NC	-	-
26	NC	-	-
27	NC	-	-
28	NC	-	-
29	NC	-	-
30	NC	-	-
31	NC	-	-
32	NC	-	-
33	NC	-	-
34	NC	-	-
35	Vcc	-	Power supply (Digital 5V)
36	A0	-	FPGA interface (data bus)
37	A1	-	
38	A2	-	
39	A3	-	
40	A4	-	

• Pin Function

No.	Pin Name	I/O	Description
41	NC	O	It connects with GND.
42	NC	I	
43	NC	I	
44	Vss	-	Digital (GND)
45	XSS	O	Motorola DSP (preceding paragraph) Interface
46	DGP	I	Motorola DSP (preceding paragraph) Interface
47	NC	I	
48	NC	I	
49	FPGARST	O	FPGA program permission signal
50	XDSPRESET	O	Motorola DSP (latter part) Interface reset
51	ISO	I	
52	XCDRST	O	TC9495F reset (H: reset)
53	BUS0	I/O	TC9495F microcomputer I/F data 0
54	BUS1	I/O	TC9495F microcomputer I/F data 1
55	BUS2	I/O	TC9495F microcomputer I/F data 2
56	BUS3	I/O	TC9495F microcomputer I/F data 3
57	Vss	-	Digital GND
58	XCDCE	O	TC9495F chip enable signal
59	BUCK	O	TC9495F microcomputer I/F clock signal
60	Vss	-	Digital GND
61	25M	O	Clock output (25MHz) to FPGA and DSP
62	XSTBY	I	Low power consumption mode
63	XRST	I	Hard reset
64	NMI	I	Compulsive interruption
65	Vss	-	Digital GND
66	EXTAL	I	Crystal oscillation
67	XTAL	I	
68	Vcc	-	Digital 5V
69	NC	O	-
70	XSRD	O	FPGA Read
71	ICDT	O	EEPROM data output
72	ICCK	O	EEPROM clock output
73	MD0	I	CPU mode setup
74	MD1	I	
75	MD2	I	
76	Avcc	-	The power supply terminal of A/D conversion machine, and D/A conversion machine
77	VREF	-	The standard voltage input terminal of A/D conversion machine, and D/A conversion machine
78	AN0	-	It connects with GND.
79	AN1	-	It connects with GND.
80	HK	I	It connects with GND.

• Pin Function

No.	Pin Name	I/O	Description
81	AN3	I	It connects with GND.
82	AN4	I	
83	AN5	I	
84	DA0	O	
85	DA1	O	
86	AVss	-	The grand terminal of A/D conversion machine, and D/A conversion machine
87	JOG0A	I	JOG pulse input 0A
88	JOG1A	I	JOG pulse input 1A
89	SBLKCK	I	Motorola DSP (preceding paragraph) Interface
90	DQCK	I	Motorola DSP (preceding paragraph) Interface
91	MUTE12	I	Driver IC mute control
92	Vss	-	GND
93	JOG0A	I	JOG pulse input 0A
94	JOG1A	I	JOG pulse input 1A
95	XDMUTE	O	Data OUT output MUTE
96	LDIN	O	Slider data value
97	TZC	O	TC9495F zero detecting flag
98	IN SW	I	Slider Inside detection switch
99	FLWR	O	FL Wright
100	TOP-RST	O	Reset output for Topcpu

■ PD101A (MAIN ASSY : IC102)

• ASIC Microcomputer

● Pin Function(1/4)

No.	Pin Name	I/O	Description
1	VDD(I/O)	-	Power supply (3.3V) for I/O
2	NC	-	NC
3	RAS X	O	SDRAM row address strobe
4	CS_X	O	Chip select (for SDRAM)
5	BA0	O	SDRAM bank address
6	BA1	O	SDRAM bank address
7	A10	O	SDRAM address bus
8	GND	-	GND for core
9	VDD(core)	-	Power supply (3.3V) for core
10	A0	O	SDRAM address bus
11	A1	O	SDRAM address bus
12	A2	O	SDRAM address bus
13	A3	O	SDRAM address bus
14	VDD(core)	-	Power supply (3.3V) for core
15	GND	I	GND D
16	VDD (I/O)	-	Power supply (3.3V) for I/O
17	GND	-	GND for I/O
18	COUNT_TEST	I	Count test pin
19	HD15	I/O	DSP Data bus
20	HD14	I/O	DSP Data bus
21	HD13	I/O	DSP Data bus
22	S1 IN	I	PLL TEST terminal
23	HD12	I/O	DSP Data bus
24	VDD (core)	-	Power supply (3.3V) for core
25	GND	-	GND for core
26	HD11	I/O	DSP Data bus
27	HD10	I/O	
28	HD9	I/O	
29	HD8	I/O	
30	HD7	I/O	
31	HD6	I/O	
32	TEST1	I	PLL TEST terminal
33	GND	-	GND for I/O
34	TEST2	I	PLL TEST terminal
35	VDD (I/O)	-	Power supply (3.3V) for I/O
36	AVDD (AVss)	-	Power supply for PLL
37	VCNT	-	PLL terminal
38	AVSS (AVSS)	-	GND for PLL
39	NC	-	NC
40	HD5	I/O	DSP Data bus

• Pin Function(2/4)

No.	Pin Name	I/O	Description
41	HD4	I/O	DSP Data bus
42	HD3	I/O	DSP Data bus
43	HD2	I/O	DSP Data bus
44	HD1	I/O	DSP Data bus
45	GND	-	GND for CORE
46	HD0	I/O	DSP Data bus
47	HA5	I	DSP Address bus
48	HA4	I	DSP Address bus
49	HA3	I	DSP Address bus
50	HA2	I	DSP Address bus
51	HA1	I	DSP Address bus
52	GND	-	GND for I/O
53	VDD (I/O)	-	Power supply (3.3V) for I/O
54	HCS_X	I	DSP chip selection
55	VDD (core)	-	Power supply (3.3V) for CORE
56	HA0	I	DSP Address bus
57	RD_X	I	DSP read strobe signal
58	WR_X	I	DSP write strobe signal
59	GND	-	GND for CORE
60	0_25M	O	Clock output (25MHz)
61	GND	-	GND for I/O
62	GND	I	GND D
63	O_DGP	O	5-3v converte output
64	O_SIPF	O	5-3v converte output
65	O_SBCK	O	5-3v converte output
66	O_SLRCK	O	5-3v converte output
67	O_SDATA	O	5-3v converte output
68	NC		NC
69	PLLRESET-X	I	PLL Reset input
70	VDD (I/O)	-	Power supply (3.3V) for I/O
71	VDD (I/O)	-	Power supply (3.3V) for I/O
72	NC		NC
73	GND	-	GND for I/O
74	O_SBLKCK	O	5-3v converte output
75	O_XSS	O	5-3v converte output
76	I_SIDI	I	5-3v converte input
77	O_SIDI	O	5-3v converte output
78	O_SICK	O	5-3v converte output
79	I_SBLKCK	I	5-3v converte input
80	I_SIPF	I	5-3v converte input

• Pin Function(3/4)

No.	Pin Name	I/O	Description
81	GND	-	GND for CORE
82	VDD (core)	-	Power supply (3.3V) for CORE
83	I_SDATA	I	5-3v Switching input
84	I_SBCK	I	5-3v Switching input
85	I_SLRCK	I	5-3v Switching input
86	S21N	I	PLL TEST terminal
87	S31N	I	PLL TEST terminal
88	SCLK	I	System clock
89	GND	-	GND for I/O
90	VDD (I/O)	-	Power supply (3.3V) for I/O
91	RESET_X	I	System reset
92	VDD (core)	-	Power supply (3.3V) for CORE
93	I_DGP	I	5-3v Switching input
94	I_XSS	I	5-3v Switching input
95	I_SIDO	I	5-3v Switching input
96	I_SICK	I	5-3v Switching input
97	VDD (core)	-	Power supply (3.3V) for CORE
98	GND	-	GND for CORE
99	O_SIDI	I/O	SDRAM Data bus
100	DQ0	I/O	SDRAM Data bus
101	DQ1	I/O	SDRAM Data bus
102	DQ2	I/O	SDRAM Data bus
103	DQ3	I/O	SDRAM Data bus
104	NC	-	NC
105	SCANTEST	I	Test terminal
106	SCANEN	I	Test terminal
107	VDD (I/O)	-	Power supply (3.3V) for I/O
108	VDD (I/O)	-	Power supply (3.3V) for I/O
109	GND	-	GND for CORE
110	GND	-	GND for I/O
111	GND	-	GND for I/O
112	DQ4	I/O	SDRAM Data bus
113	DQ5	I/O	SDRAM Data bus
114	DQ6	I/O	SDRAM Data bus
115	DQ7	I/O	SDRAM Data bus
116	DQ15	I/O	SDRAM Data bus
117	DQ14	I/O	SDRAM Data bus
118	DQ13	I/O	SDRAM Data bus
119	GND	-	GND for I/O
120	DQ12	I/O	SDRAM Data bus

A

• Pin Function (4/4)

No.	Pin Name	I/O	Description
121	DQ11	I/O	SDRAM interface Data bus
122	DQ10	I/O	SDRAM interface Data bus
123	DQ9	I/O	SDRAM interface Data bus
124	DQ8	I/O	SDRAM interface Data bus
125	VDD (core)	-	Power supply (3.3V) for CORE
126	GND	-	GND for CORE
127	VDD (I/O)	-	Power supply (3.3V) for I/O
128	GND	-	GND for I/O
129	NC	-	NC
130	SDRAMCLK	O	SDRAM Clock
131	A11	O	SDRAM interface Address bus
132	A9	O	SDRAM interface Address bus
133	A8	O	SDRAM interface Address bus
134	A7	O	SDRAM interface Address bus
135	GND	-	GND for I/O
136	A6	O	SDRAM interface Address bus
137	A5	O	SDRAM interface Address bus
138	A4	O	SDRAM interface Address bus
139	DQML	O	SDRAM Data mask
140	WE_X	O	SDRAM Write enable
141	CAS_X	O	SDRAM column address strobe
142	NC	-	NC
143	GND	-	GND for I/O
144	VDD (I/O)	-	Power supply (3.3V) for I/O

■ NJM2374AM (MAIN ASSY : IC107)

● DC-DC CONVERTER

● Block Diagram

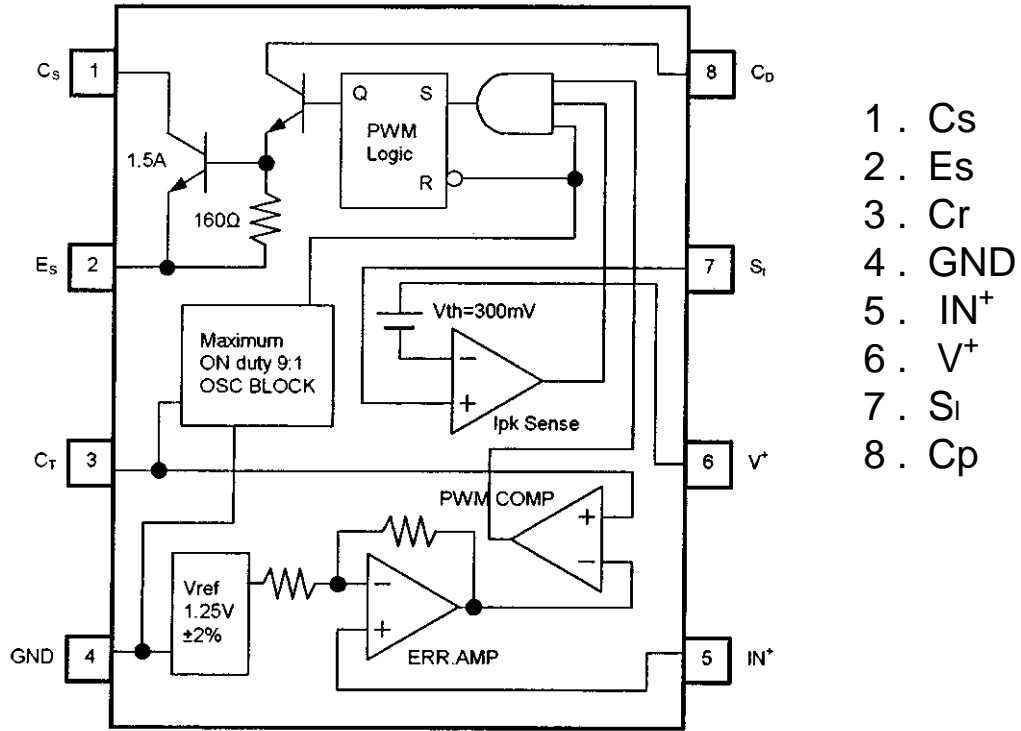

- 1. C_s
- 2. E_s
- 3. C_r
- 4. GND
- 5. IN^+
- 6. V^+
- 7. S_i
- 8. C_p

● Pin Arrangement

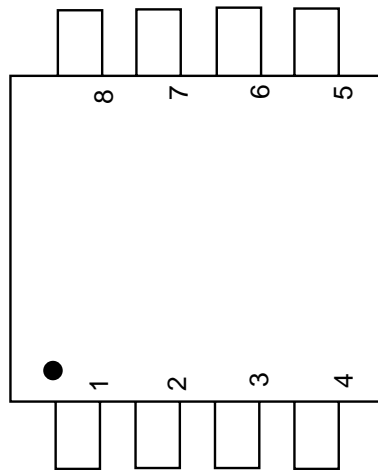

■ NJM2870F05 (MAIN ASSY : IC123)

● 5V Regulator

● Pin Configuration

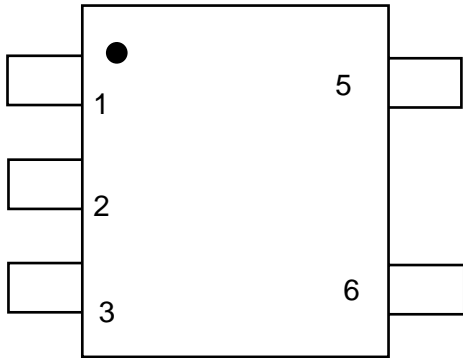

PIN FUNCTION

- 1 . CONTROL
- 2 . GND
- 3 . NOISE BYPASS
- 4 . Vout
- 5 . Vin

● Block Diagram

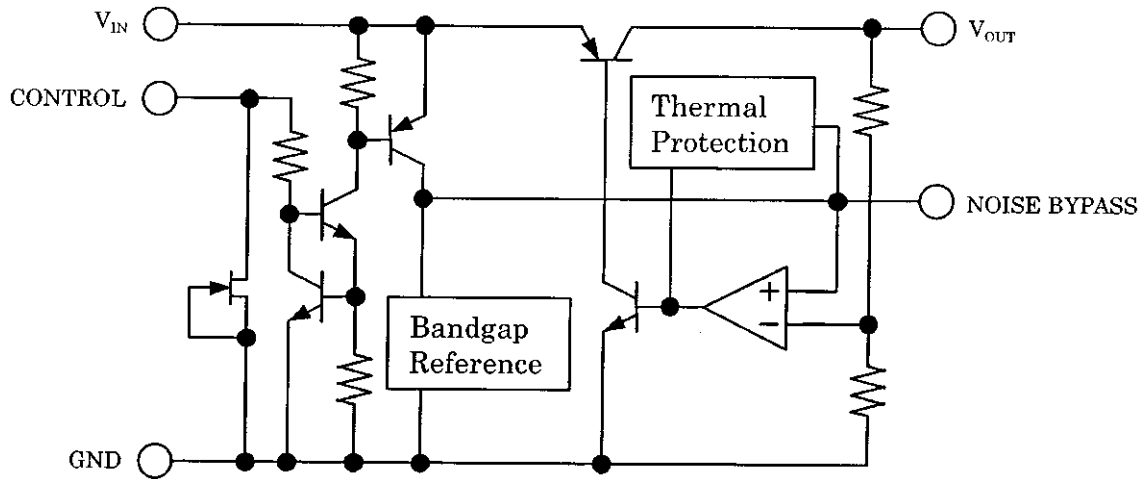

8. PANEL FACILITIES

8.1 PANEL FACILITIES

■ Front Panel

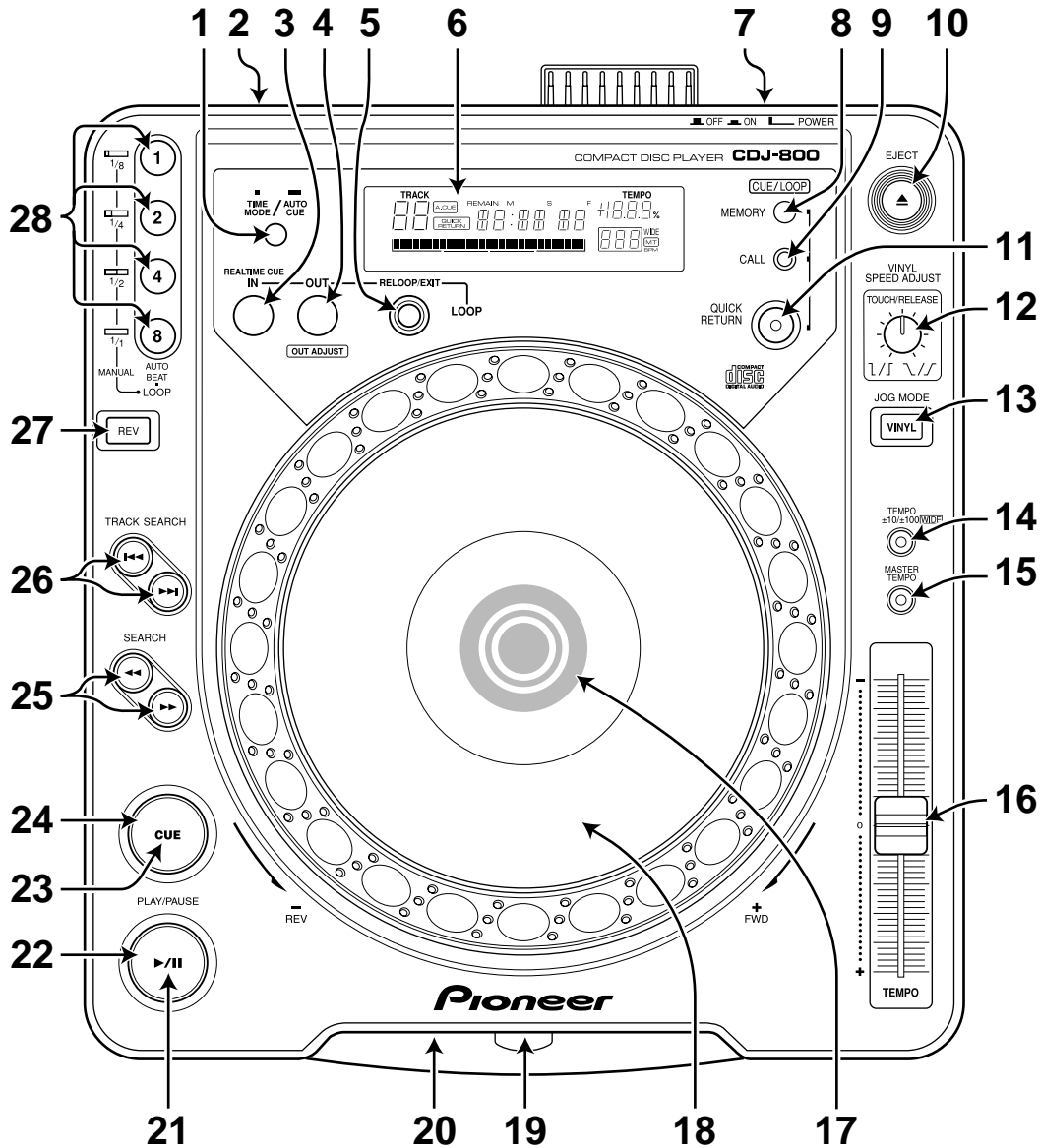

1. TIME MODE/AUTO CUE button (*)

TIME MODE:

Each time this button is pressed, the time display changes between elapsed playback time and remaining playback time (REMAIN) of each track.

- The **TIME MODE** is stored in memory and persists even when the power is turned off.

AUTO CUE:

Hold down this key for 1 second or longer to toggle between **AUTO CUE** on and off.

- **AUTO CUE** on/off status is stored in memory and persists even when the power is turned off.

2 DIGITAL OUT MODE switch (DJ/NORMAL)

This switch is located on the unit's rear panel. When set to DJ, the DIGITAL OUT connector outputs audio data alone. When set to NORMAL, digital data (including sub-codes) is output, but the unit's DJ functions are not supported (operation buttons marked with the asterisk (*) are disabled).

No sound will be produced in the Pause mode.

3 LOOP IN/REALTIME CUE button / indicator (*)

Real-time cue
Enter loop in point

4 LOOP OUT (OUT ADJUST) button / indicator (*)

Enter loop out point
Loop out point adjust

5 RELOOP/EXIT button (*)**6 Display****7 POWER switch (OFF /ON **)

This switch is located on the rear panel of the unit.

8 CUE/LOOP MEMORY button (*)

Stores Cue points and Loop points in internal memory.

9 CUE/LOOP CALL button (*)

Calls Cue points and Loop points stored in internal memory.

10 EJECT button ()

When this button is pressed the disc is ejected through the disc loading slot when it stops rotating.

11 QUICK RETURN button / Indicator (*)

If this switch is set to ON when the JOG MODE is set to VINYL, pressing the surface of the Jog dial will cause play to return quickly to the cue point .

12 VINYL SPEED ADJUST TOUCH/RELEASE dial (*)

This dial control is used to adjust the deceleration speed from play to full stop when the JOG MODE is set to VINYL and the Jog dial surface is pressed, and also the acceleration speed from full stop to play when the user's finger is removed from the surface of the Jog dial .

13 JOG MODE VINYL button / indicator (*)

VINYL mode: when the surface of the Jog dial is pressed during playback, playback stops and if the dial is rotated, music is output according to the speed the dial is turned.

- The JOG MODE is stored in memory and remains in memory even if the power is turned off.

CDJ mode: above operation is not performed even when the Jog dial surface is pressed.

14 TEMPO control range button / indicator (±10/±100 WIDE) (*)

Each time this button is pressed, the variable range of the TEMPO control slider changes between ± 10% and ±100%; when set to ±100 WIDE, the button indicator lights.

15 MASTER TEMPO button / indicator (*)

Each press of the button turns the master tempo function on or off.

16 TEMPO control slider (*)

Slide the knob towards you (+) to increase the tempo and slide it away from you (-) to decrease it.

17 Jog Dial Display**18 Jog dial (+FWD/-REV) (*)****19 Disc loading slot****20 Force ejection hole****21 PLAY/PAUSE indicator (/II)**

Lights during play and flashes during pause.

22 PLAY/PAUSE button (/II)**23 CUE indicator (*)**

Lights when a Cue point is set.
Flashes in pause mode.

24 CUE button (*)

Cue point settings
Cue point sampler
Back cue

25 SEARCH buttons (, )**26 TRACK SEARCH buttons (, )****27 Reverse button / indicator (REV) (*)**

When this button is pressed, its indicator lights and the unit is set to reverse play.

28 AUTO BEAT LOOP buttons / indicators (1, 2, 4, 8) (*)

(MANUAL 1/8, 1/4, 1/2, 1/1)

When this button is pressed, auto loop play is performed based on the track's BPM (1 beat, 2 beats, 4 beats or 8 beats).

When a loop has been set manually, the button operates as a loop shortening button (1=1/8, 2=1/4, 4=1/2, 8=1/1).

Display

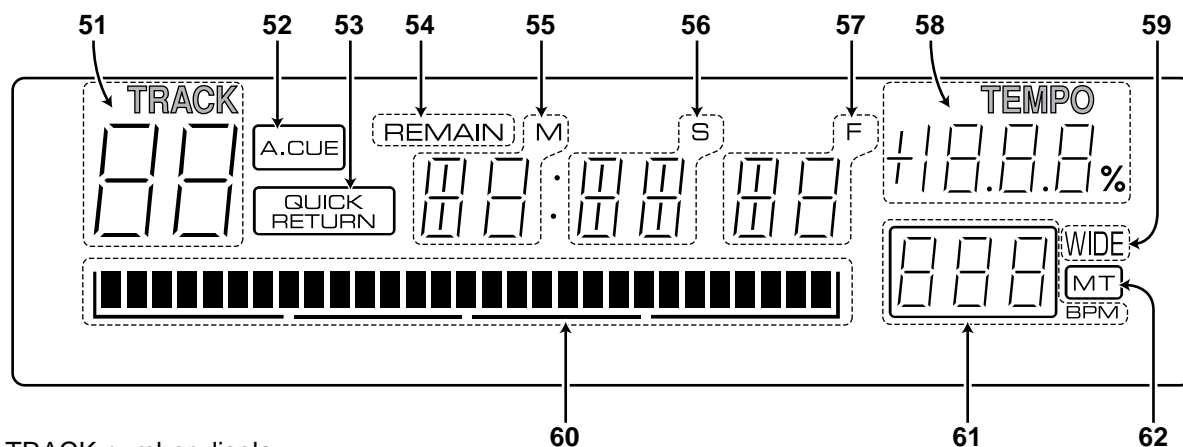

51 TRACK number display

Displays TRACK numbers.

52 Auto cue indicator (A. CUE)

Lights when auto cue is on.

53 QUICK RETURN indicator

Lights when QUICK RETURN function is ON.

54 REMAIN indicator

Indicates that track remaining time is being displayed.

55 Time display (min) (M)

56 Time display (sec) (S)

57 Frame display (F)

One second is 75 frames.

58 TEMPO display

Displays how much change is being applied to playback speed by the TEMPO control slider.

59 Tempo control range indicator (WIDE)

Lights when TEMPO $\pm 10/\pm 100$ WIDE button is set to " ± 100 WIDE".

60 Playback address display

Indicates elapsed playback time and remaining playback time in an easy to grasp 1-track full scale bar graph.

- The 1-track full scale mode shows elapsed time by lit segments from the left.
- The 1-track full scale mode shows remaining time by unlit segments from the left.
- When the remaining time is 30 seconds or less, the display flashes gently and the flashing becomes faster when there is 15 seconds or less left.

61 BPM counter

Indicates BPM for the current track.

The BPM counter may sometimes not be able to measure the BPM of a track.

62 Master tempo indicator (MT)

Lights when the master tempo function is on.

Jog Dial Display

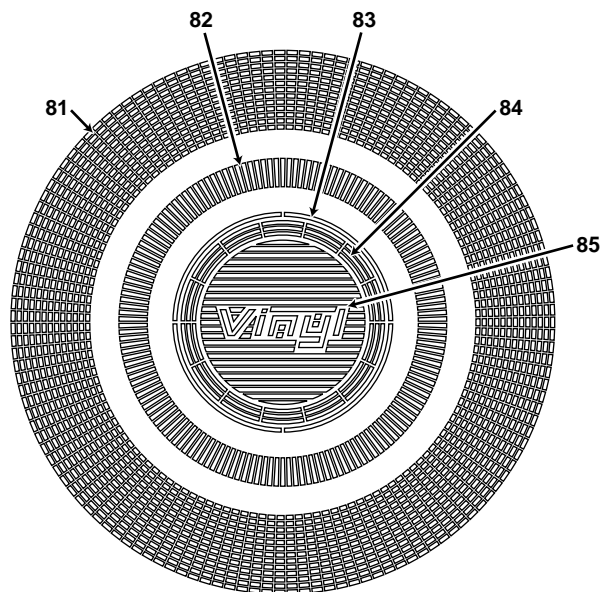

81 Operation display

Indicates play position in frames 135 frames for one full rotation. Turns during playback and stops during pause.

82 Cue point position indicator

Indicates the current cue point position.

83 Display the condition of the audio memory

When set in the audio memory display mode the light will flash when recording.

84 Jog touch detection indicator

In the VINYL mode, this indicator lights when the surface of the Jog dial is pressed.

85 VINYL mode display.

Lights up in the VINYL mode.