

# Service Manual

**Pioneer**

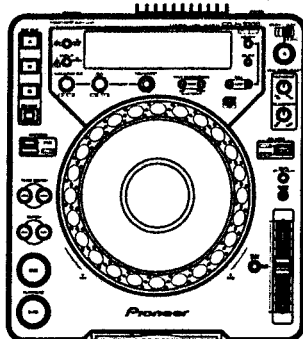

ORDER NO.  
RRV2468

COMPACT DISC PLAYER

# CDJ-1000

THIS MANUAL IS APPLICABLE TO THE FOLLOWING MODEL(S) AND TYPE(S).

Type	Model	Power Requirement	Remarks
	CDJ-1000		
KUC	○	AC120V	
TL	○	AC110- 240V	
WY	○	AC220- 240V	

## CONTENTS

1. SAFETY INFORMATION .....	2	7.1 DIAGNOSIS .....	59
2. EXPLODED VIEWS AND PARTS LIST .....	4	7.1.1 SERVICE MODE .....	59
3. BLOCK DIAGRAM AND SCHEMATIC DIAGRAM .....	12	7.1.2 ERROR DISPLAY .....	61
4. PCB CONNECTION DIAGRAM .....	38	7.1.3 DISASSEMBLY .....	62
5. PCB PARTS LIST .....	52	7.1.4 PART REPLACEMENT METHOD OF JOG SECTION .....	66
6. ADJUSTMENT .....	57	7.1.5 ABOUT ELECTRIC DISCHARGE .....	69
7. GENERAL INFORMATION .....	59	7.1.6 SEQUENCE AFTER THE POWER ON .....	70
		7.2 PARTS .....	71
		7.2.1 IC .....	71
		8. PANEL FACILITIES AND SPECIFICATIONS .....	87

**PIONEER ELECTRONIC CORPORATION** 4-1, Meguro 1-chome, Meguro-ku, Tokyo 153-8654, Japan  
**PIONEER ELECTRONICS SERVICE, INC.** P.O. Box 1760, Long Beach, CA 90801-1760, U.S.A.  
**PIONEER ELECTRONIC NV** Haven 1087, Keetberglaan 1, 9120 Melsele, Belgium  
**PIONEER ELECTRONICS ASIACENTRE PTE. LTD.** 253 Alexandra Road, #04-01, Singapore 159936  
 ©PIONEER ELECTRONIC CORPORATION 2001

# 1. SAFETY INFORMATION

This service manual is intended for qualified service technicians; it is not meant for the casual do-it-yourselfer. Qualified technicians have the necessary test equipment and tools, and have been trained to properly and safely repair complex products such as those covered by this manual. Improperly performed repairs can adversely affect the safety and reliability of the product and may void the warranty. If you are not qualified to perform the repair of this product properly and safely, you should not risk trying to do so and refer the repair to a qualified service technician.



**WARNING**

This product contains lead in solder and certain electrical parts contain chemicals which are known to the state of California to cause cancer, birth defects or other reproductive harm.

Health & Safety Code Section 25249.6 – Proposition 65



**NOTICE**

(FOR CANADIAN MODEL ONLY)

Fuse symbols  (fast operating fuse) and/or  (slow operating fuse) on PCB indicate that replacement parts must be of identical designation.

**REMARQUE**

(POUR MODÈLE CANADIEN SEULEMENT)

Les symboles de fusible  (fusible de type rapide) et/ou  (fusible de type lent) sur CCI indiquent que les pièces de remplacement doivent avoir la même désignation.

(FOR USA MODEL ONLY)

## 1. SAFETY PRECAUTIONS

The following check should be performed for the continued protection of the customer and service technician.

### LEAKAGE CURRENT CHECK

Measure leakage current to a known earth ground (water pipe, conduit, etc.) by connecting a leakage current tester such as Simpson Model 229-2 or equivalent between the earth ground and all exposed metal parts of the appliance (input/output terminals, screwheads, metal overlays, control shaft, etc.). Plug the AC line cord of the appliance directly into a 120V AC 60 Hz outlet and turn the AC power switch on. Any current measured must not exceed 0.5 mA.

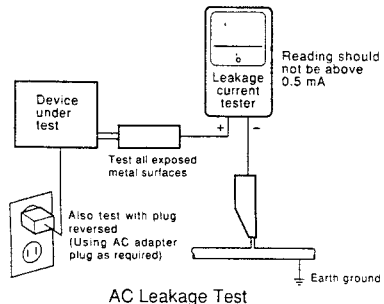

ANY MEASUREMENTS NOT WITHIN THE LIMITS OUTLINED ABOVE ARE INDICATIVE OF A POTENTIAL SHOCK HAZARD AND MUST BE CORRECTED BEFORE RETURNING THE APPLIANCE TO THE CUSTOMER.

## 2. PRODUCT SAFETY NOTICE

Many electrical and mechanical parts in the appliance have special safety related characteristics. These are often not evident from visual inspection nor the protection afforded by them necessarily can be obtained by using replacement components rated for voltage, wattage, etc. Replacement parts which have these special safety characteristics are identified in this Service Manual.

Electrical components having such features are identified by marking with a  $\Delta$  on the schematics and on the parts list in this Service Manual.

The use of a substitute replacement component which does not have the same safety characteristics as the PIONEER recommended replacement one, shown in the parts list in this Service Manual, may create shock, fire, or other hazards.

Product Safety is continuously under review and new instructions are issued from time to time. For the latest information, always consult the current PIONEER Service Manual. A subscription to, or additional copies of, PIONEER Service Manual may be obtained at a nominal charge from PIONEER.

**IMPORTANT**

THIS PIONEER APPARATUS CONTAINS LASER OF CLASS 1. SERVICING OPERATION OF THE APPARATUS SHOULD BE DONE BY A SPECIALLY INSTRUCTED PERSON.

**LASER DIODE CHARACTERISTICS**

MAXIMUM OUTPUT POWER: 5 mW  
WAVELENGTH: 780 – 785 nm

**WARNING !**

The AEL(accessible emission level) of the laser power output is less than CLASS 1 but the laser component is capable of emitting radiation exceeding the limit for CLASS 1.  
A specially instructed person should servicing operation of the apparatus.

## LABEL CHECK (for CDJ-1000/ TL and WY types)

CDJ-1000/ TL and WY Types Only

**VARO!**

Avvattamassa ja suojaohitus ohitettavissa olti alittina säilyttämättömiä laserlaitteita. Älä katso silmiin.

**VAROING!**

Omplyy laserstråling när denna del är öppnad och spårren är urkopplad. Beträkta ej strålen.

VW1227-1

**ADVARSEL**

USTRYLJIG LASERSTRÅLING VED ÅBNING NÅR SIKKERHEDSFAKTORENE ER UDEN FORBUDNING. UNDGÅ UDSÆTTELSE FOR STRÅLING.

**VORSICHT!**

UNTERSCHIEDLICHE LASERSTRÄHLUNG TRITTT AUF. WENN SICHERHEITSKLAPPEN GEÖFFNET WIRD NICHT DEN STRAHLEN AUSSETZEN.

VW1054

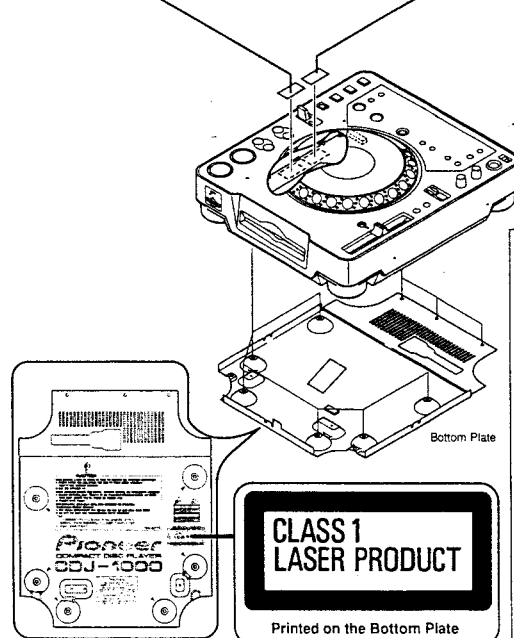

### Additional Laser Caution

- Laser Interlock Mechanism**  
The position of the switch (S1) for detecting loading completion is detected by the system microprocessor, and the design prevents laser diode oscillation when the switch is not in LPS1 terminal side (when the mechanism is not clamped and LPS1 signal is high level.) Thus, the interlock will no longer function if the switch is deliberately set to LPS1 terminal side. (if LPS1 signal is low level).  
In the test mode\* the interlock mechanism will not function. Laser diode oscillation will continue, if pin 33 of CXA1782CQ (IC101) on the MOTHER BOARD ASSY is connected to GND, or pin 43 of IC701 (LDON) is connected to low level (ON), or else the terminals of Q101 are shorted to each other (fault condition).
- When the cover is opened, close viewing of the objective lens with the naked eye will cause exposure to a Class 1 laser beam.

\* : Refer to page 57.

## 2. EXPLODED VIEWS AND PARTS LIST

- NOTES: ● Parts marked by "NSP" are generally unavailable because they are not in our Master Spare Parts List.  
 ● The Δ mark found on some component parts indicates the importance of the safety factor of the part.  
 Therefore, when replacing, be sure to use parts of identical designation.  
 ● Screws adjacent to ▼ mark on the product are used for disassembly.

### 2.1 PACKING

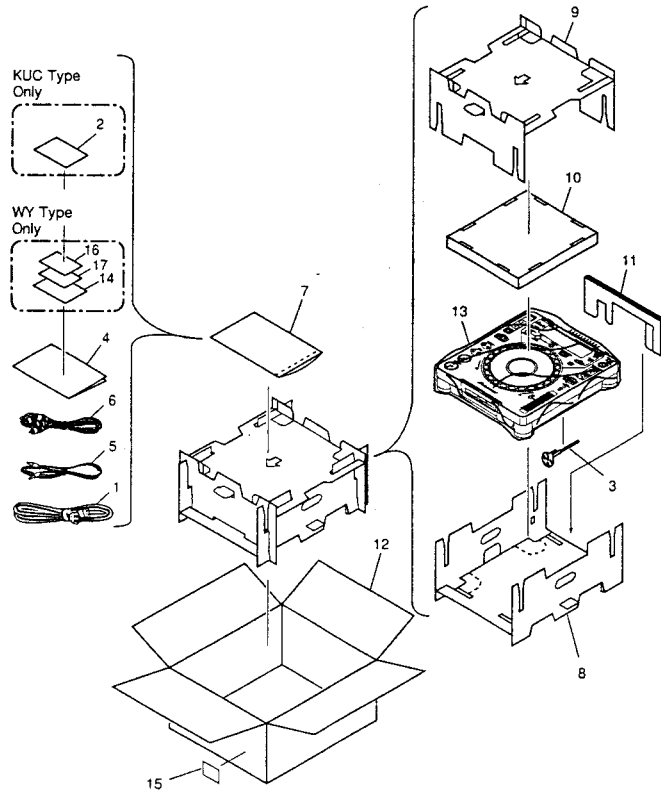

### (1) PACKING PARTS LIST

Mark	No.	Description	Part No.
Δ	1	Power Cord	See Contrast table (2)
NSP	2	Warranty Card	See Contrast table (2)
	3	Forced Eject Pin	DEX1013
	4	Operating Instructions	See Contrast table (2)
	5	Control Cord (L= 1m)	PDE1247
	6	Audio Cable (L = 1.5m)	VDE1033
NSP	7	Polyethylene Bag (0.03 × 230 × 340)	Z21-038
	8	Pad (A)	DHA1518
	9	Pad (B)	DHA1519
	10	Pad (C)	DHA1523
	11	Pad (D)	DHA1524
	12	Packing Case	See Contrast table (2)
	13	Sheet	RHX1006
NSP	14	Mini Catalogue	See Contrast table (2)
NSP	15	Label	See Contrast table (2)
NSP	16	Pamphlet	See Contrast table (2)
NSP	17	MMC Catalog	See Contrast table (2)

### (2) CONTRAST TABLE

CDJ-1000/KUC, TL and WY types are constructed the same except for the following :

Mark	No.	Symbol and Description	Part No.			Remarks
			KUC Type	TL Type	WY Type	
Δ	1	Power Cord	ADG7021	ADG1154	ADG1154	
NSP	2	Warranty Card	ARY7043	Not used	Not used	
	4	Operating Instructions (English)	DRB1297	Not used	Not used	
	4	Operating Instructions (English/ Spanish)	Not used	DRB1299	Not used	
	4	Operating Instructions (English/ French /German/ Italian/ Dutch/ Spanish)	Not used	Not used	DRB1298	
NSP	12	Packing Case	DHG2145	DHG2146	DHG2129	
NSP	14	Mini Catalogue	Not used	Not used	DRY1194	
NSP	15	Label	VRW1629	Not used	Not used	
NSP	16	Pamphlet	Not used	Not used	DRY1188	
NSP	17	MMC Catalog	Not used	Not used	DRY1195	

2.2 EXTERIOR (1/2) SECTION

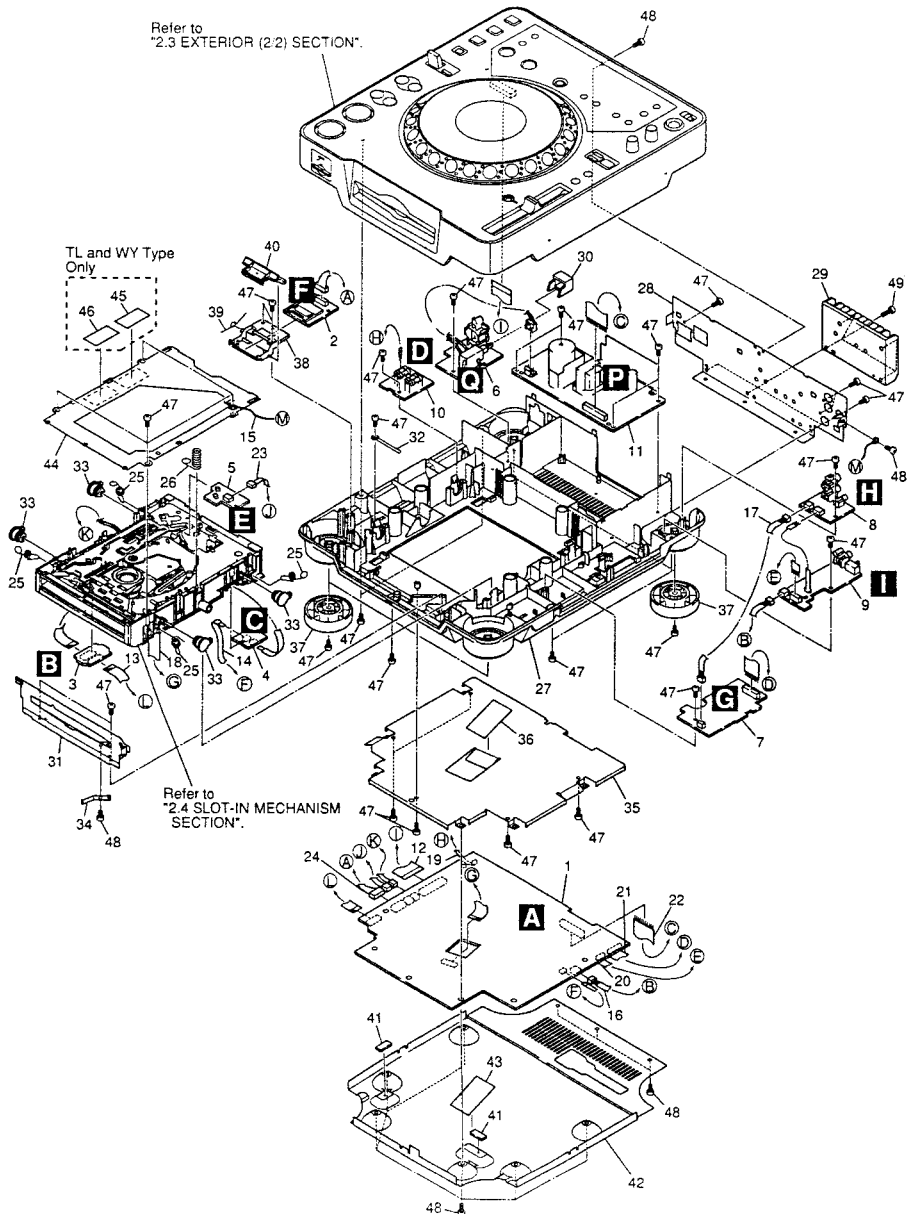

(1) EXTERIOR (1/2) SECTION PARTS LIST

Mark	No.	Description	Part No.	Mark	No.	Description	Part No.
	1	MAIN Assy	DWX2161		26	Earth Spring	DBH1398
	2	MMCB Assy	DWX2169		27	Chassis	DNK3869
	3	SPCN Assy	DWX2170	NSP	28	Rear Panel	See Contrast table (2)
	4	STCN Assy	DWX2171		29	Heat Sink	DNG1081
	5	SLMB Assy	DWX1309		30	Power Knob	DAC1895
	6	PSWB Assy	See Contrast table (2)		31	Front Plate	DNH2480
	7	DABB Assy	DWX2162		32	Cord Clamper	RNH-184
	8	JACB Assy	DWX2163		33	Damper	CNV6011
	9	DOUT Assy	DWX2164		34	Earth Plate (CU)	VBK1070
	10	FLRB Assy	DWX2166		35	Shield Case	DNH2481
Δ	11	SW POWER SUPPLY Assy	DWR1344		36	Shield Cushion	DEC2445
	12	25P Flexible Cable/60V	DDD1189		37	Insulator Assy	DXA1904
	13	12P Flexible Cable/60V	DDD1190		38	Memory Holder	DNK3884
	14	4P Flexible Cable/60V	DDD1191		39	Flap Spring	DBH1487
	15	Earth Lead Unit/300V	DDF1015		40	SD Flap	DNK3883
	16	Connector Assy 3P	DKP3546	NSP	41	Silicone Rubber D5L	DEB1456
	17	Connector Assy 3P	DKP3548		42	Bottom Plate	DNH2479
	18	FPC D5 Slot	DNP1951		43	Bottom Cushion	DEC2444
	19	Jumper Wire 03P	D20PYY0310E		44	Mecha Plate	DNH2339
	20	Jumper Wire 05P	D20PYY0510E		45	Caution Label	See Contrast table (2)
	21	Jumper Wire 09P	D20PYY0910E	NSP	46	Caution Label HE	See Contrast table (2)
	22	Jumper Wire 15P	D20PYY1510E		47	Screw	BPZ30P080FZK
	23	Connector Assy	PF03PP-B30		48	Screw	BBZ30P060FZK
	24	Connector Assy	PG07KK-F15		49	Screw	BBZ30P120FZK
	25	Float Spring (G5)	DBH1485				

(2) CONTRAST TABLE

CDJ-1000/KUC. TL and WY types are constructed the same except for the following :

Mark	No.	Symbol and Description	Part No.			Remarks
			KUC Type	TL Type	WY Type	
NSP	6	PSWB Assy	DWS1312	DWS1311	DWS1311	
	28	Rear Panel	DNC1576	DNC1577	DNC1567	
	45	Caution Label	Not used	VRW1094	VRW1094	
NSP	46	Caution Label HE	Not used	VRW1297	VRW1297	

2.3 EXTERIOR (2/2) SECTION

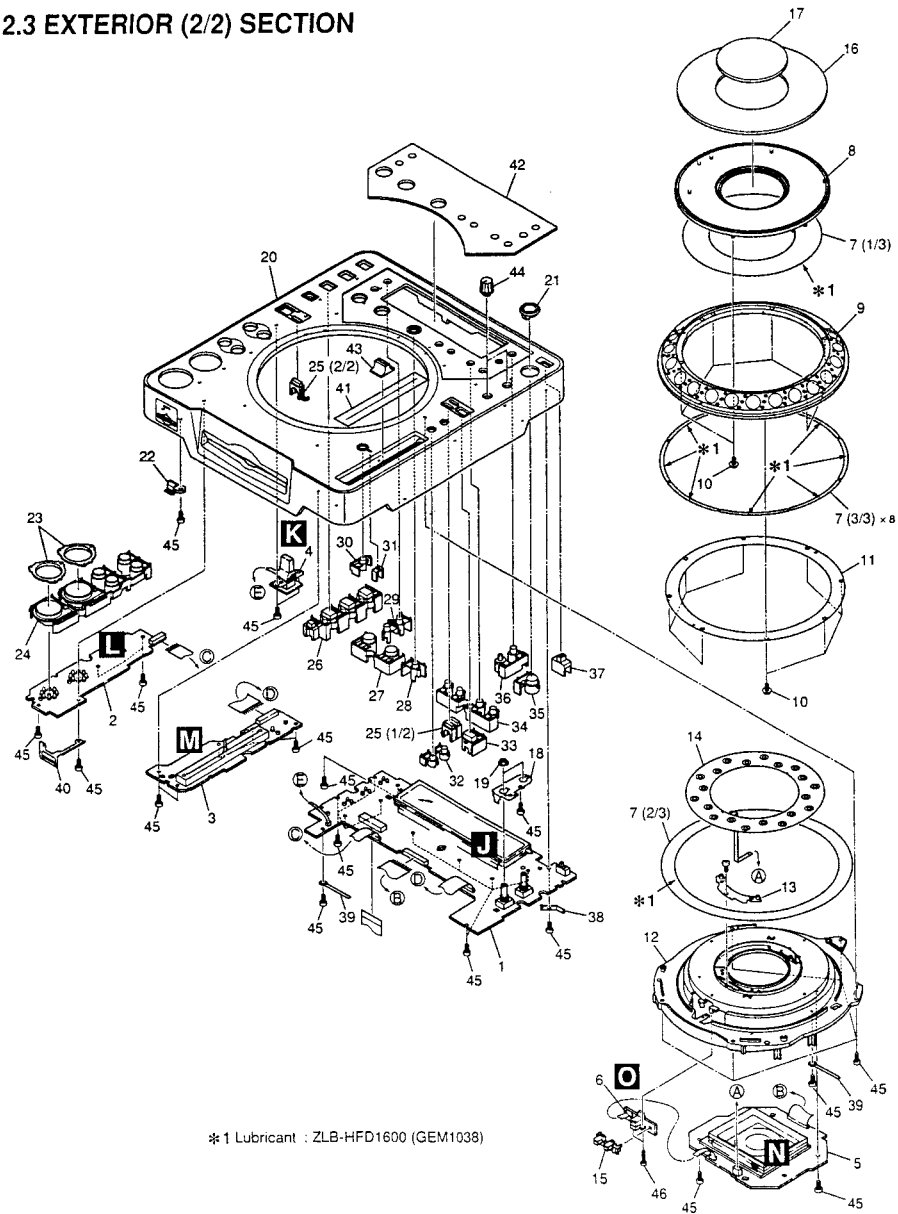

● EXTERIOR (2/2) SECTION PARTS LIST

Mark	No.	Description	Part No.
	1	MFLB Assy	DWG1548
	2	KSWB Assy	DWS1307
	3	SLDB Assy	DWS1308
	4	RSWB Assy	DWS1310
	5	JFLB Assy	DWG1549
	6	JOGB Assy	DWG1550
	7	JOG Sheet Assy	DXB1757
	8	JOG Dial A	DNK3870
	9	JOG Dial B	DNK3871
	10	Screw	PBA1062
	11	Encoder Plate	DEC2425
	12	JOG Holder	DNK3872
	13	JOG Stay Assy	DXB1760
	14	Sheet SW	DSX1057
	15	Encoder Guide	DNK3873
	16	JOG Plate	DAH2052
	17	JOG Panel	DAH2051
	18	VR Stay	DNF1663
	19	Flange Nut (M9)	DBN1004
	20	Control Panel	DNK3875
	21	Eject Guard	DNK3958
	22	Card Lens	DNK3885
	23	Ring Lens	DNK3880
	24	Set Knob (PLAY) Assy	DXB1750
	25	Mode Lens	DNK3881
	26	Set Knob (HS)	DAC1986
	27	Set Knob (LOOP)	DAC1995
	28	Re-loop Knob	DAC1992
	29	Set Knob (TIME)	DAC1991
	30	Tempo Reset Knob	DAC1993
	31	Tempo Lens	DNK3882
	32	Set Knob (MT)	DAC1987
	33	Mode Select Knob	DAC1989
	34	Set Knob (SC)	DAC1988
	35	Eject Knob	DAC1990
	36	Set Knob (MEMO)	DAC1994
	37	Slide SW Knob	DAC1926
NSP	38	Earth Plate (CU)	VBK1070
	39	Cord Clamper	Z09-061
	40	Card Plate	DBK1212
	41	Slide Sheet 1C	DAH1988
	42	Display Panel	DAH2022
	43	Slide Knob	DNK2936
	44	Rotary Knob C	DAA1143
	45	Screw	BPZ30P080FZK
	46	Screw	BPZ20P120FMC

2.4 SLOT-IN MECHANISM SECTION

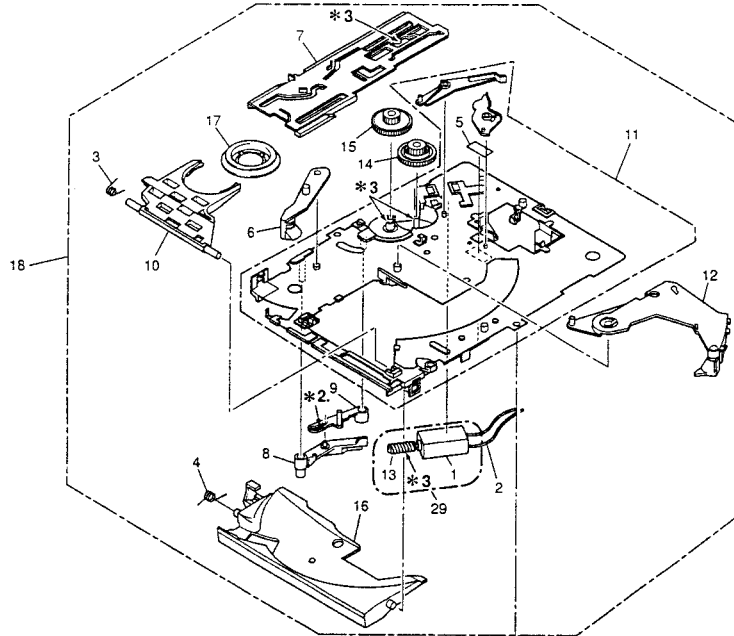

Refer to  
"2.5 TRAVERSE MECHANISM ASSY-S"

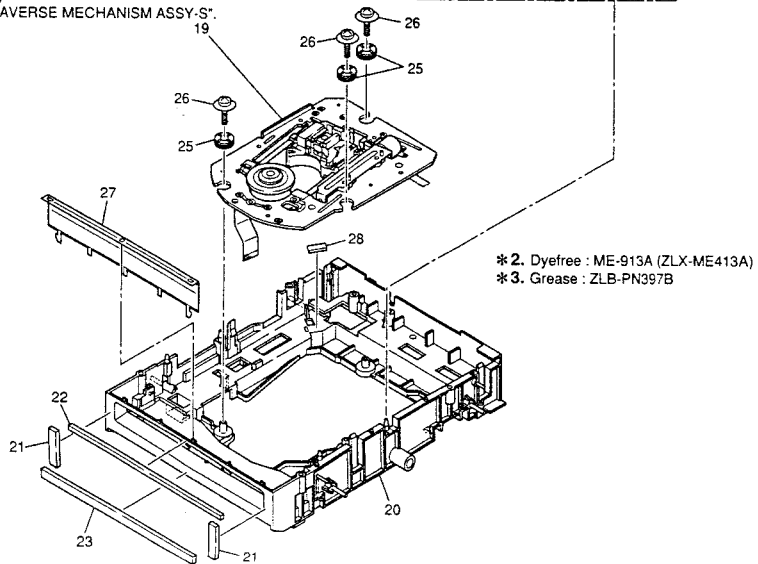

● SLOT-IN MECHANISM SECTION PARTS LIST

Mark	No.	Description	Part No.	Mark	No.	Description	Part No.
NSP	1	DC Motor	DXM1093	16	Disc Guide	DNK3914	
	2	Connector Assy	PF02PY-B32	17	Clamper D4 Assy	DXA1881	
	3	Clamp Spring	DBH1374	18	Slot-in Mechanism G5 Assy	DXA1906	
	4	Guide Spring	DBH1375	19	Traverse Mechanism Assy-S	DXX2502	
	5	SW Lever Spacer (PET)	DEC2420	20	Float Base (G5) Assy	DXB1748	
	6	Loading Lever	DNK3406	21	Vessel Cushion C	DEC2424	
	7	Main Cam	DNK3407	22	Vessel Cushion A	DEC2257	
	8	Lever B	DNK3558	23	Vessel Cushion B	DEC2258	
	9	Lever A	DNK3564	24	*****		
	10	Clamp Arm	DNK3576	25	Float Rubber D3	DEB1404	
	11	Loading Base Assy-S	DEA1022	26	Float Fastener	DBA1139	
	12	Eject Lever	DNK3684	27	Front Sheet	DED1132	
NSP	13	Worm Gear	DNK3910	28	Spacer POR (T3)	DEB1467	
	14	Loading Gear	DNK3911	29	Loading Motor Assy-S	DEA1008	
	15	Drive Gear	DNK3912				

2.5 TRAVERSE MECHANISM ASSY-S

● TRAVERSE MECHANISM ASSY-S PARTS LIST

Mark	No.	Description	Part No.
NSP	1	Spindle Motor	DXM1138
NSP	2	Stepping Motor	DXM1142
NSP	3	Pickup Assy	VWY1069
NSP	4	Adjust Screw	DBA1119
NSP	5	Precision Screw	DBA1124
NSP	6	Skew Spring	DBH1437
NSP	7	Joint Spring	DBK1188
NSP	8	Guide Shaft	DLA1840
NSP	9	Slider G4	DNK3733
NSP	10	Mechanism Frame G5	DNK3776
NSP	11	Joint	DNK3777
	12	Screw	BPZ20P080FMC
	13	Screw	BPZ26P080FMC

\*4. Screw Lock #300UB: ZBA-300UB  
\*5. Grease: ZLB-PN397B  
\*6. Grease: ZLB-PN948P

### 3. BLOCK DIAGRAM AND SCHEMATIC DIAGRAM

#### 3.1 BLOCK DIAGRAM

A

B

C

D

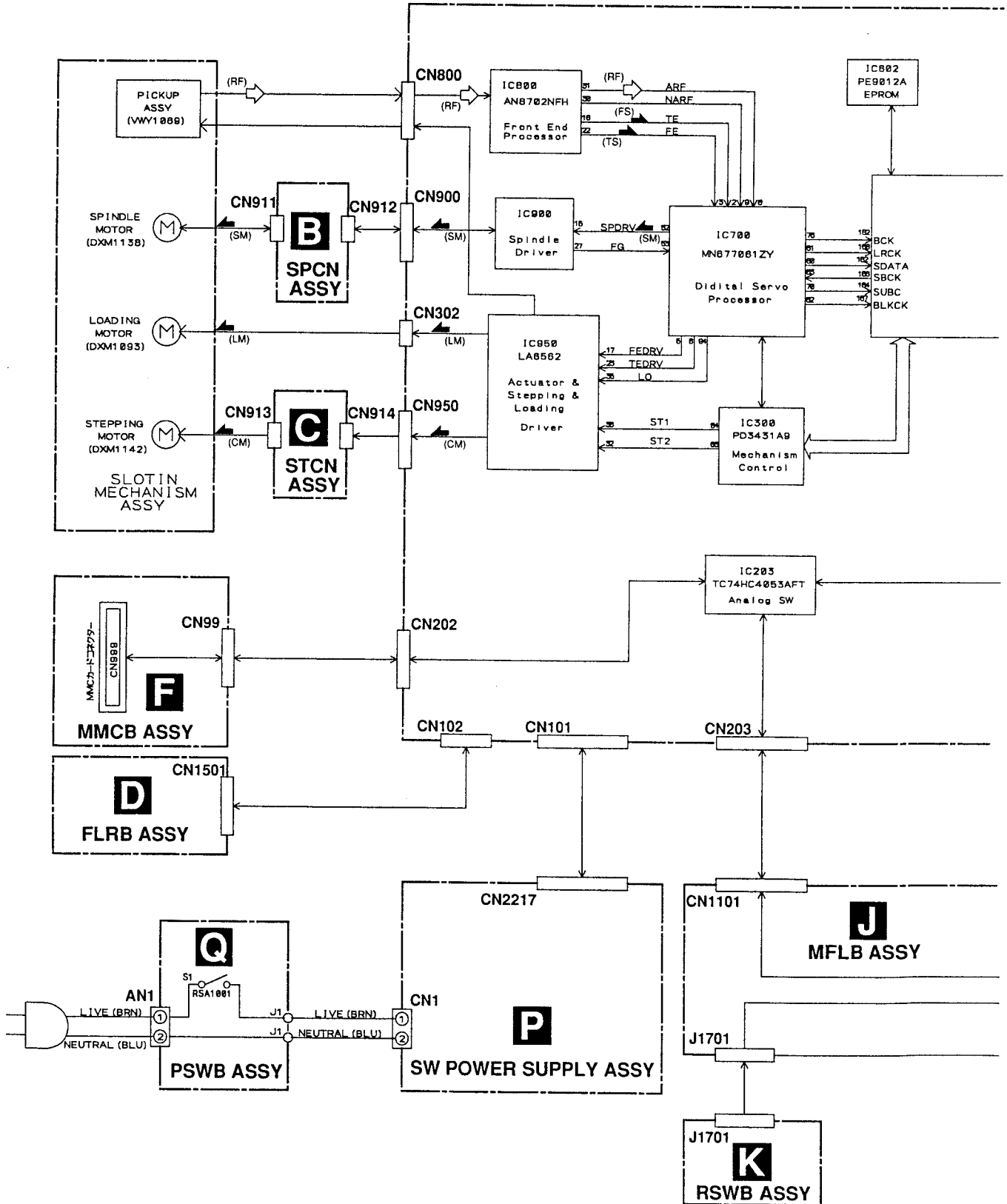

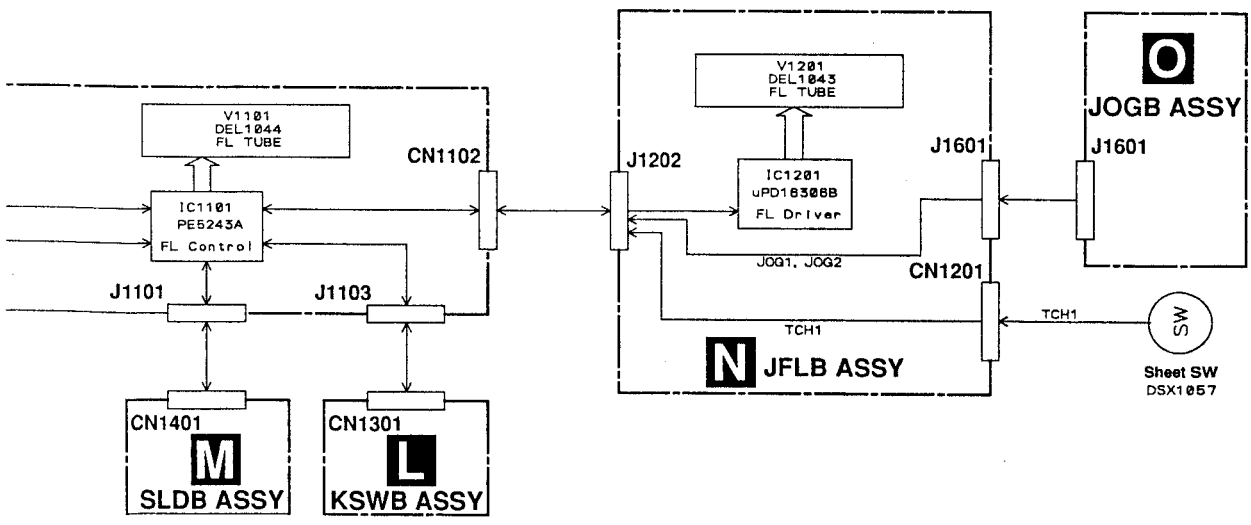
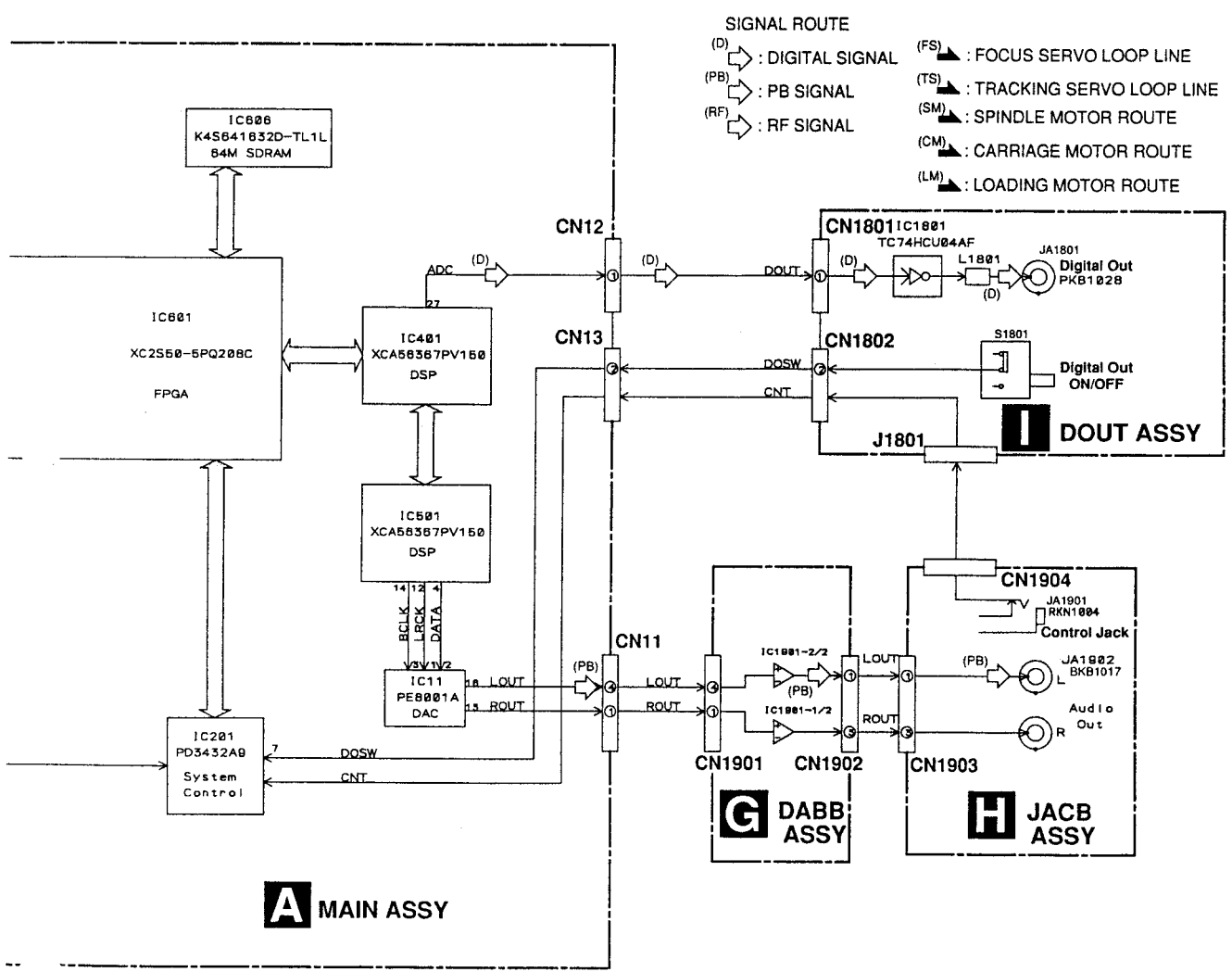



3.2 OVERALL WIRING DIAGRAM

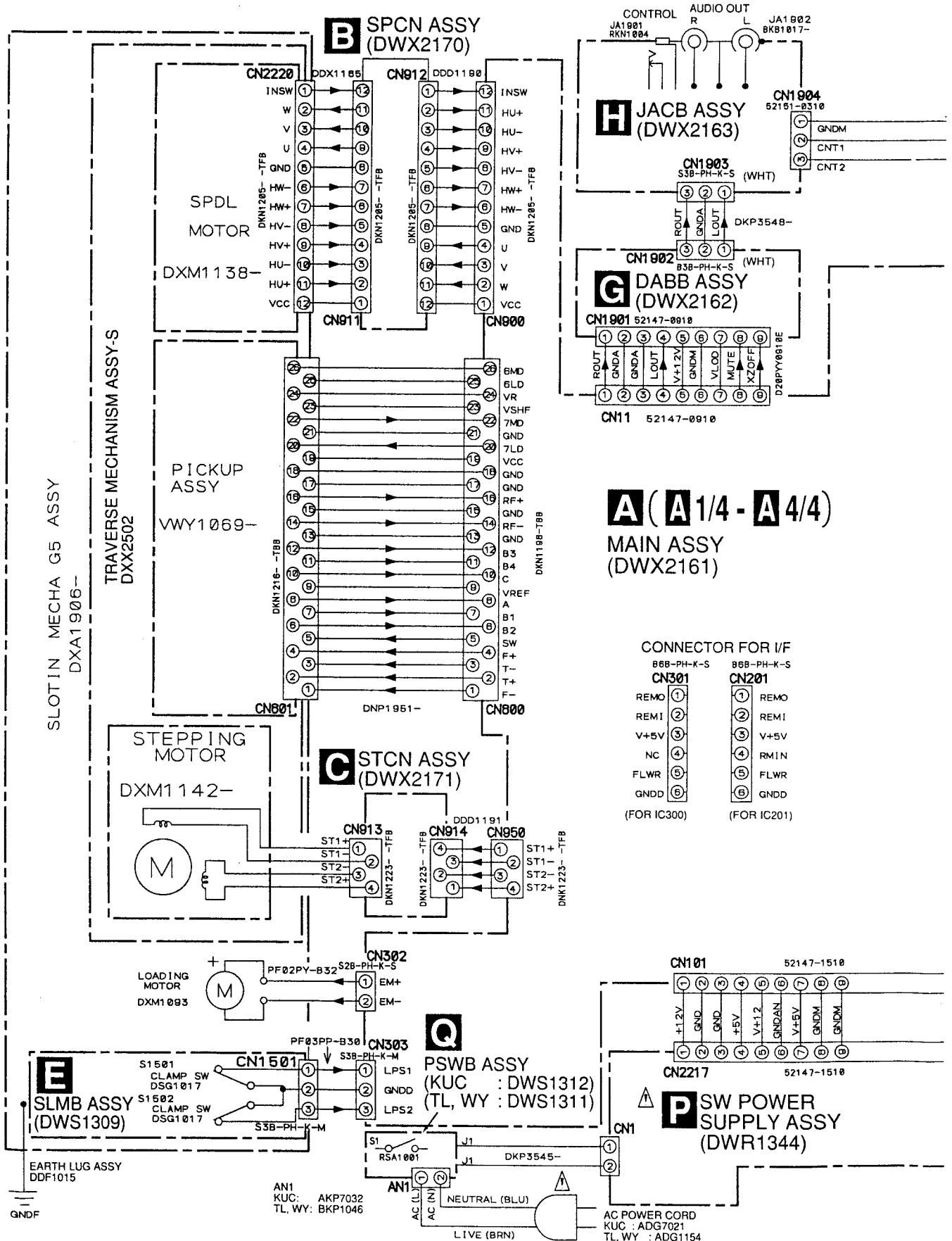

**A (A1/4 - A4/4)**  
**MAIN ASSY**  
 (DWX2161)

CONNECTOR FOR I/F

868-PH-K-S		868-PH-K-S	
CN301		CN201	
REMO	①	REMO	①
REM1	②	REM1	②
V+5V	③	V+5V	③
NC	④	RM1N	④
FLWR	⑤	FLWR	⑤
GNDD	⑥	GNDD	⑥

(FOR IC300)                      (FOR IC201)

Note : When ordering service parts, be sure to refer to "EXPLODED VIEWS and PARTS LIST" or "PCB PARTS LIST".

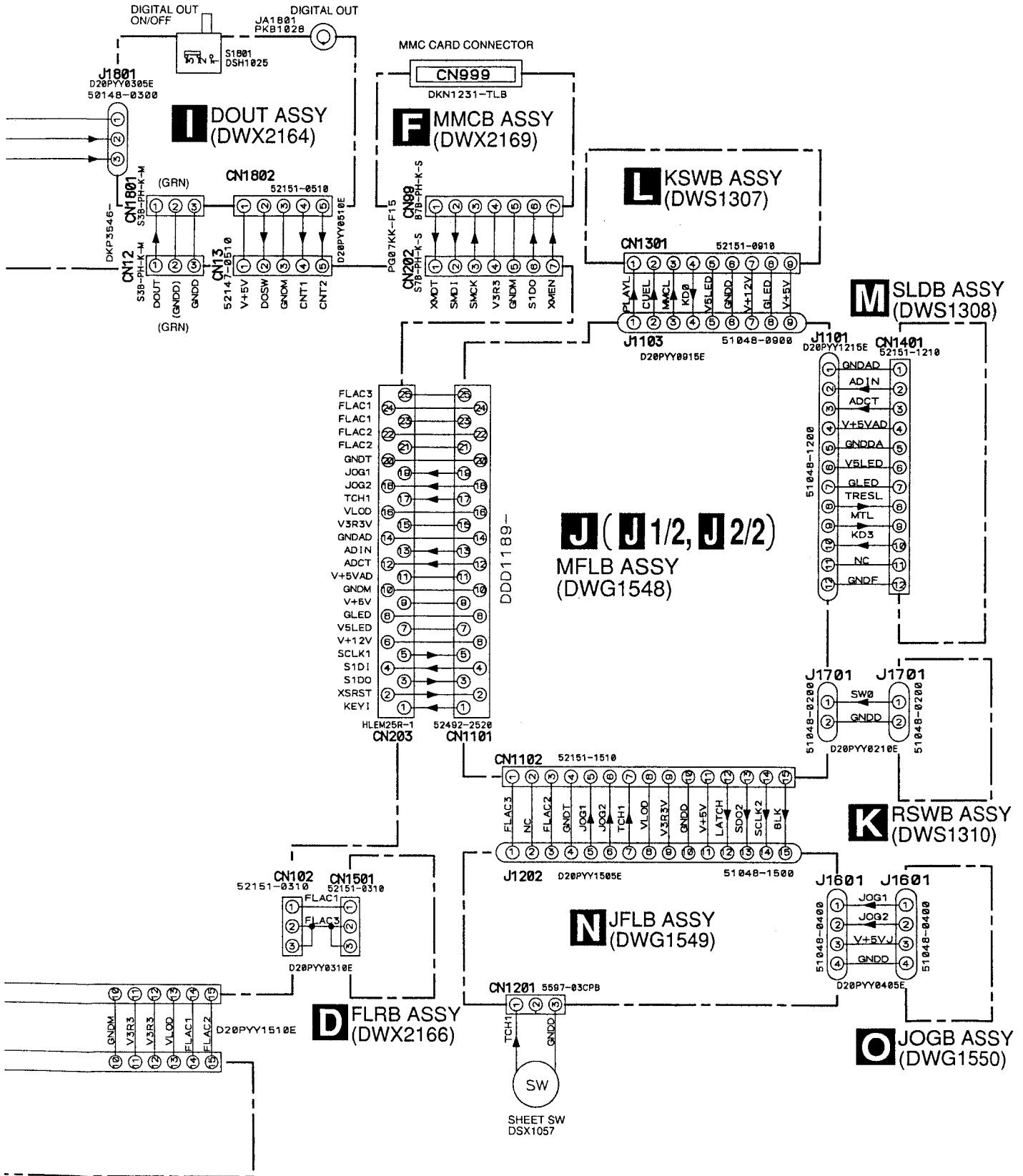

3.3 MAIN (1/4), SPCN and STCN ASSYS

A 1/4 MAIN ASSY (DWX2161)

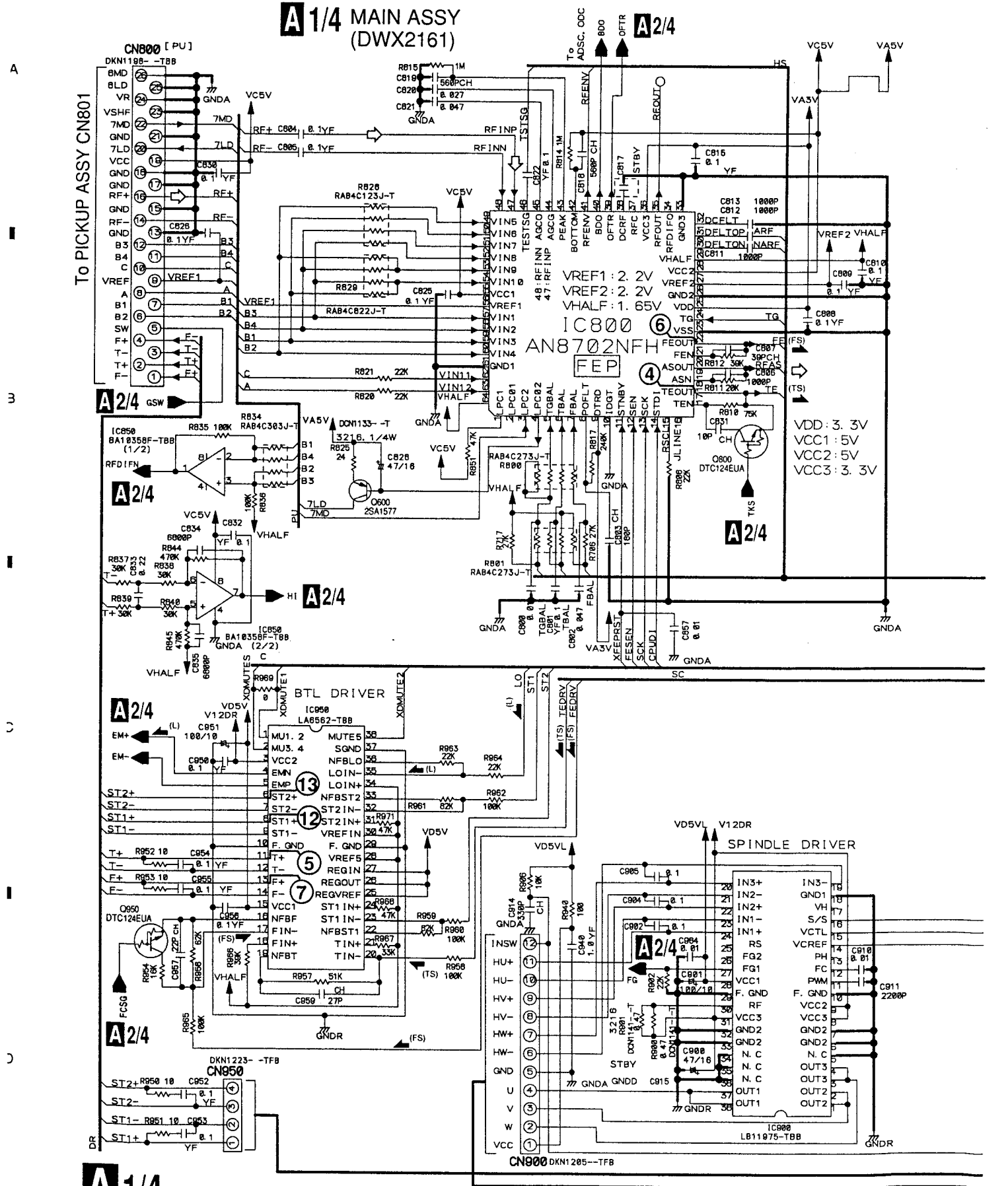

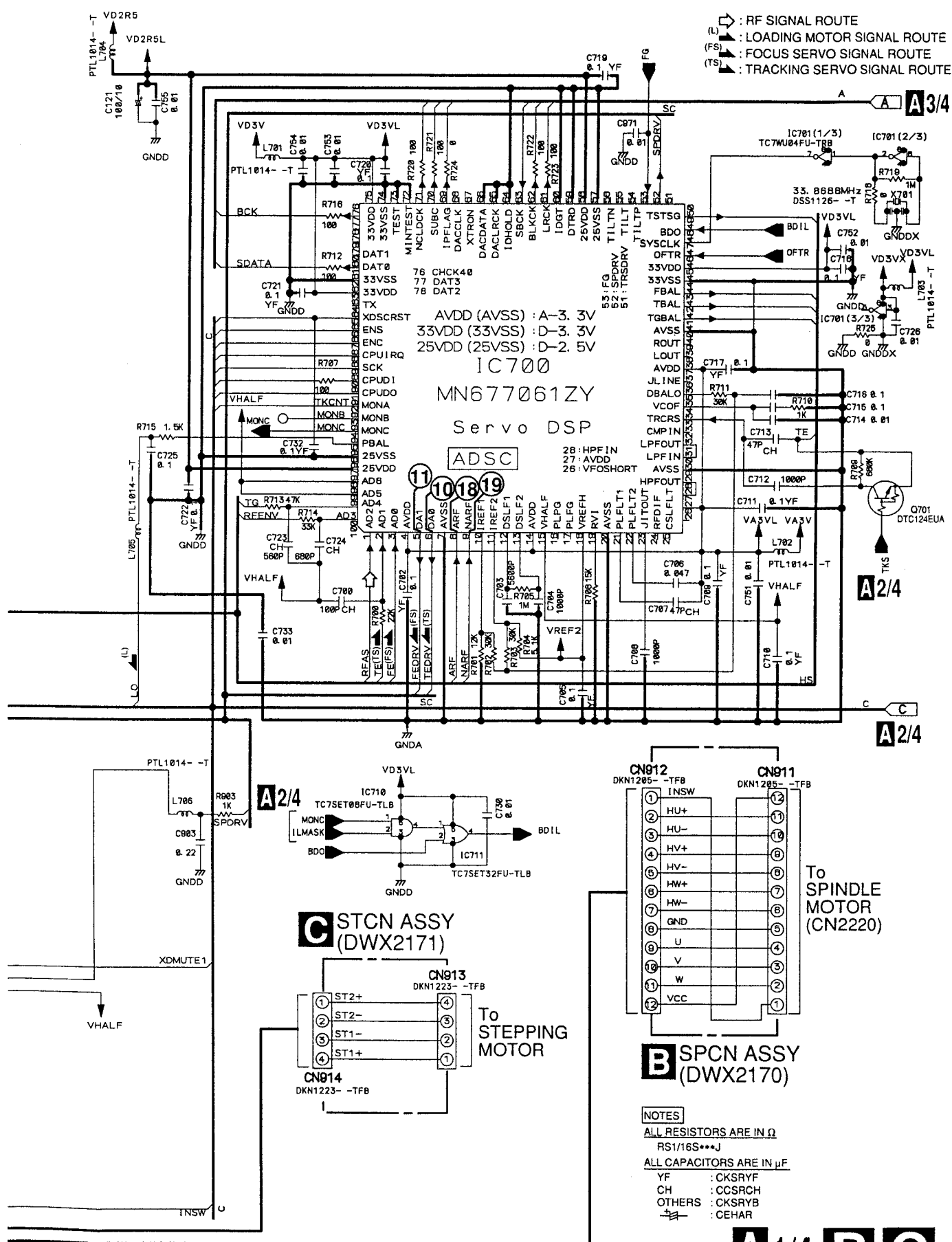

**NOTES**  
 ALL RESISTORS ARE IN Ω  
 RS1/16S\*\*\*J  
 ALL CAPACITORS ARE IN μF  
 YF : CKSRYF  
 CH : CCSRCH  
 OTHERS : CKSRYB  
 ⚡ : CEHAR

**A1/4 B C**

3.4 MAIN (2/4), FLRB and SLMB ASSYS

**A** 2/4 MAIN ASSY (DWX2161)

**E** SLMB ASSY (DWS1309)

**NOTES**

- ALL RESISTORS ARE IN  $\Omega$   
RS1/16S\*\*\*J
- ALL CAPACITORS ARE IN  $\mu F$
- YF : CKSRYF
- CH : CCSRCH
- OTHERS : CKSRYB
- DIODE : CEHAR
- DIODE : 1SS355

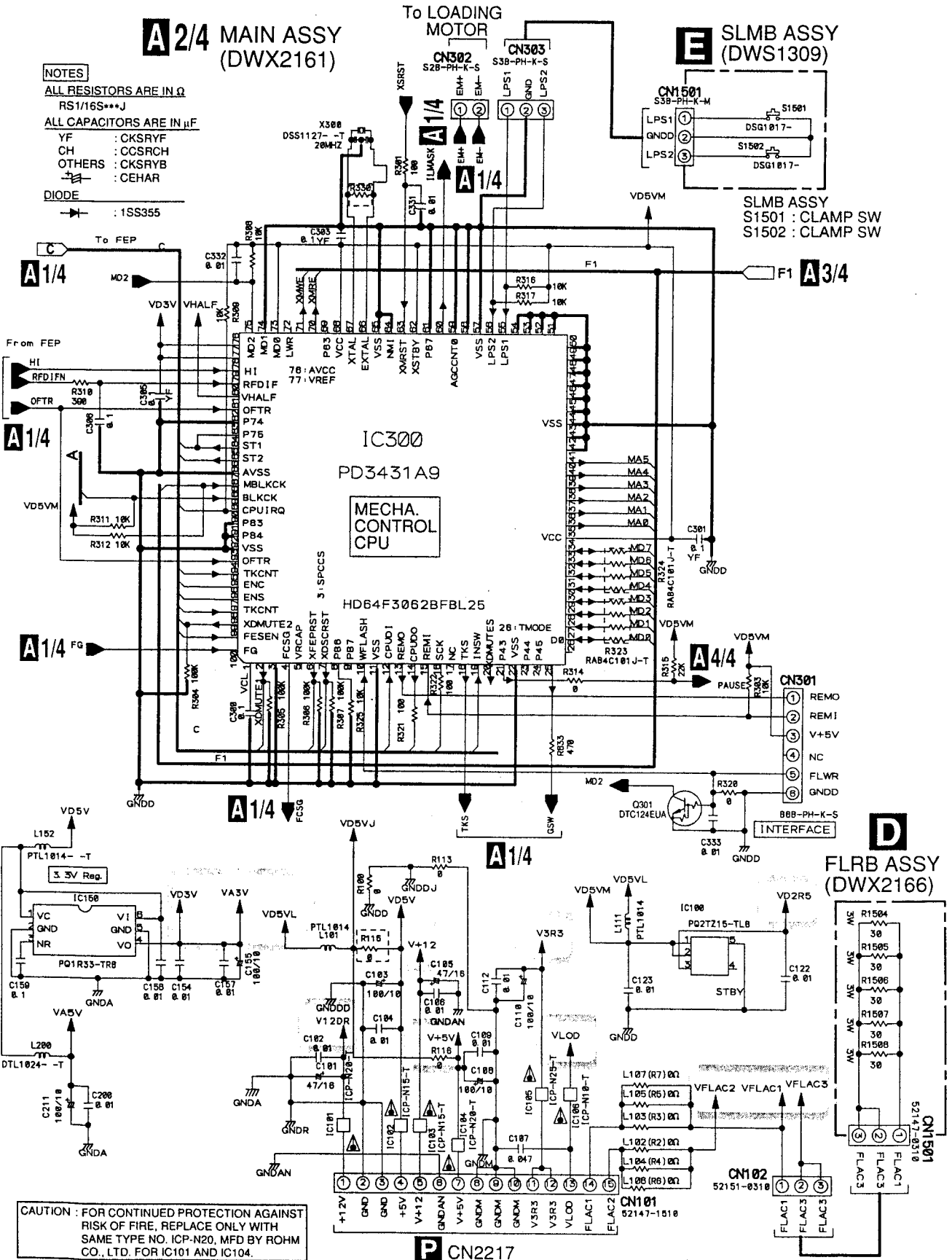

CAUTION : FOR CONTINUED PROTECTION AGAINST RISK OF FIRE, REPLACE ONLY WITH SAME TYPE NO. ICP-N20, MFD BY ROHM CO., LTD. FOR IC101 AND IC104.

**P** CN2217





The power supply is shown with the marked box.

- NOTES**  
 ALL RESISTORS ARE IN Ω  
 RS1/16S\*\*\*J  
 ALL CAPACITORS ARE IN μF  
 YF : CKSRYF  
 CH : CCSRCH  
 OTHERS : CKSRYB  
 ⚡ : CEHAR

- ➡ : PB AUDIO SIGNAL ROUTE  
 (D) ➡ : DIGITAL DATA SIGNAL ROUTE

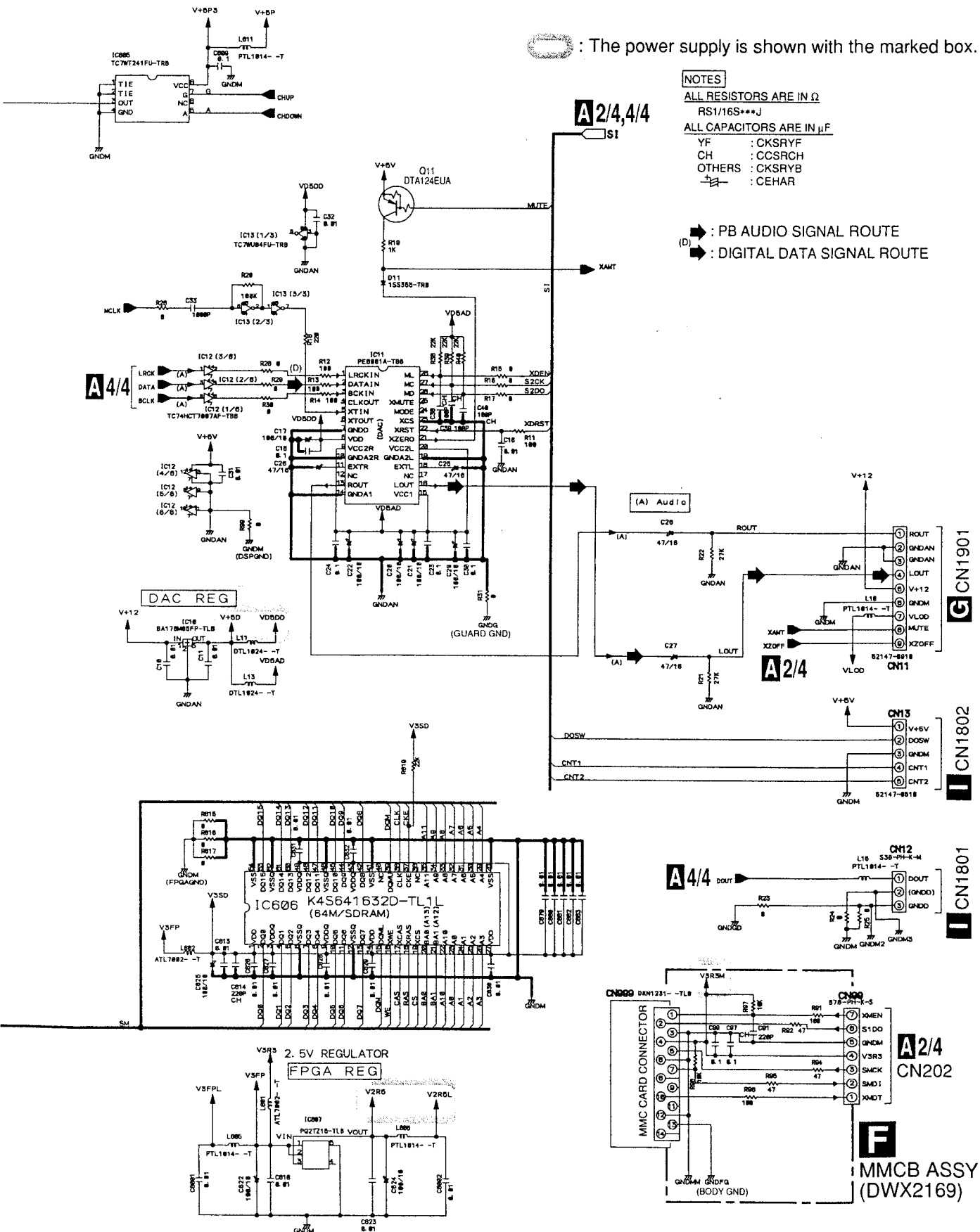



3.6 MAIN ASSY (4/4)

A

U

C

D

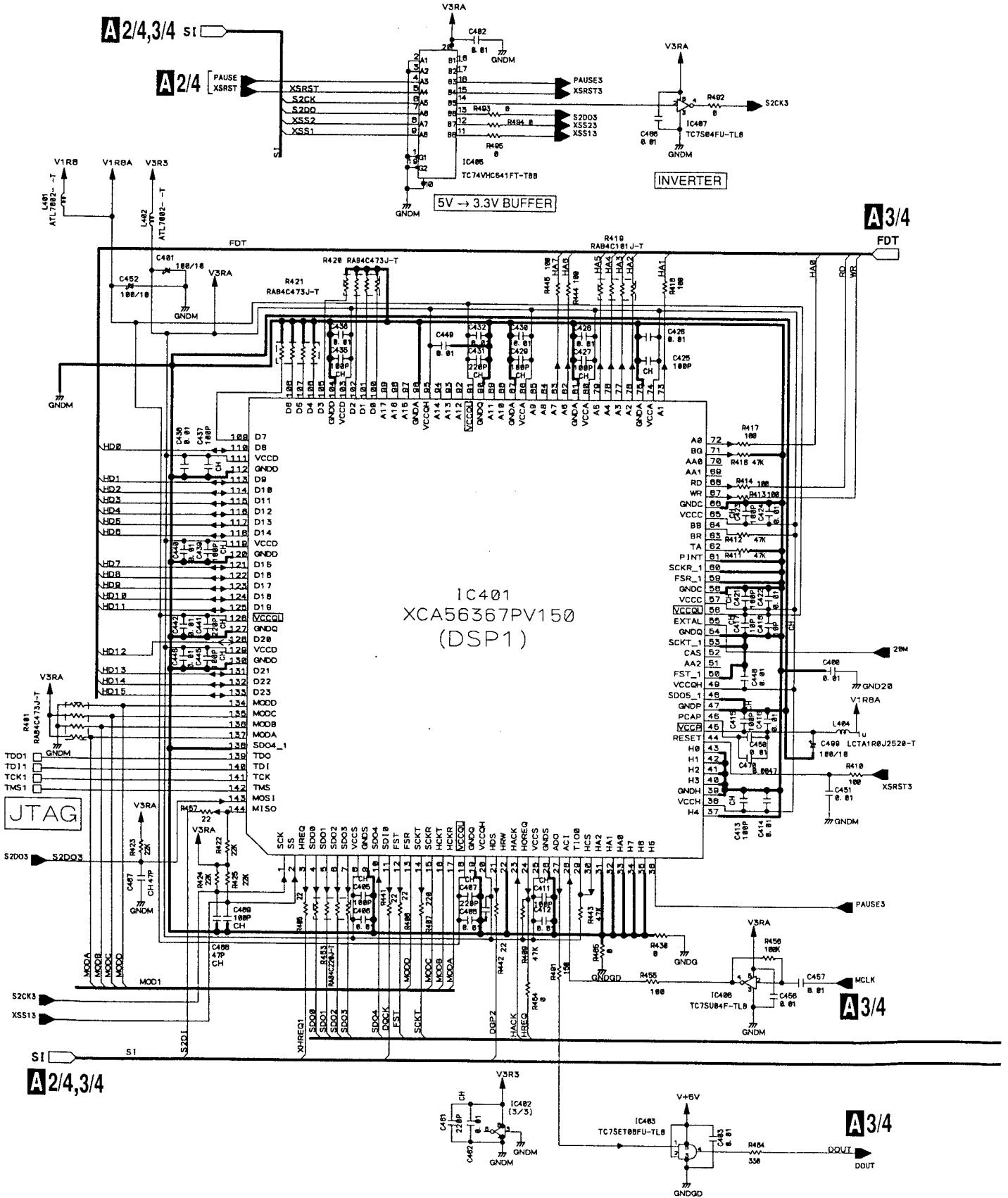

# A 4/4 MAIN ASSY (DWX2161)

: The power supply is shown with the marked box.

(D) : DIGITAL DATA SIGNAL ROUTE

### NOTES

ALL RESISTORS ARE IN  $\Omega$

RS1/16S\*\*\*J

ALL CAPACITORS ARE IN  $\mu F$

YF : CKSRYF

CH : CCSRCH

OTHERS : CKSRYB

CEHAR

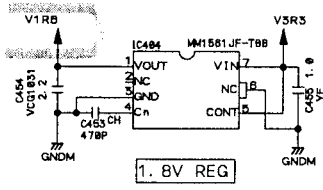

1.8V REG

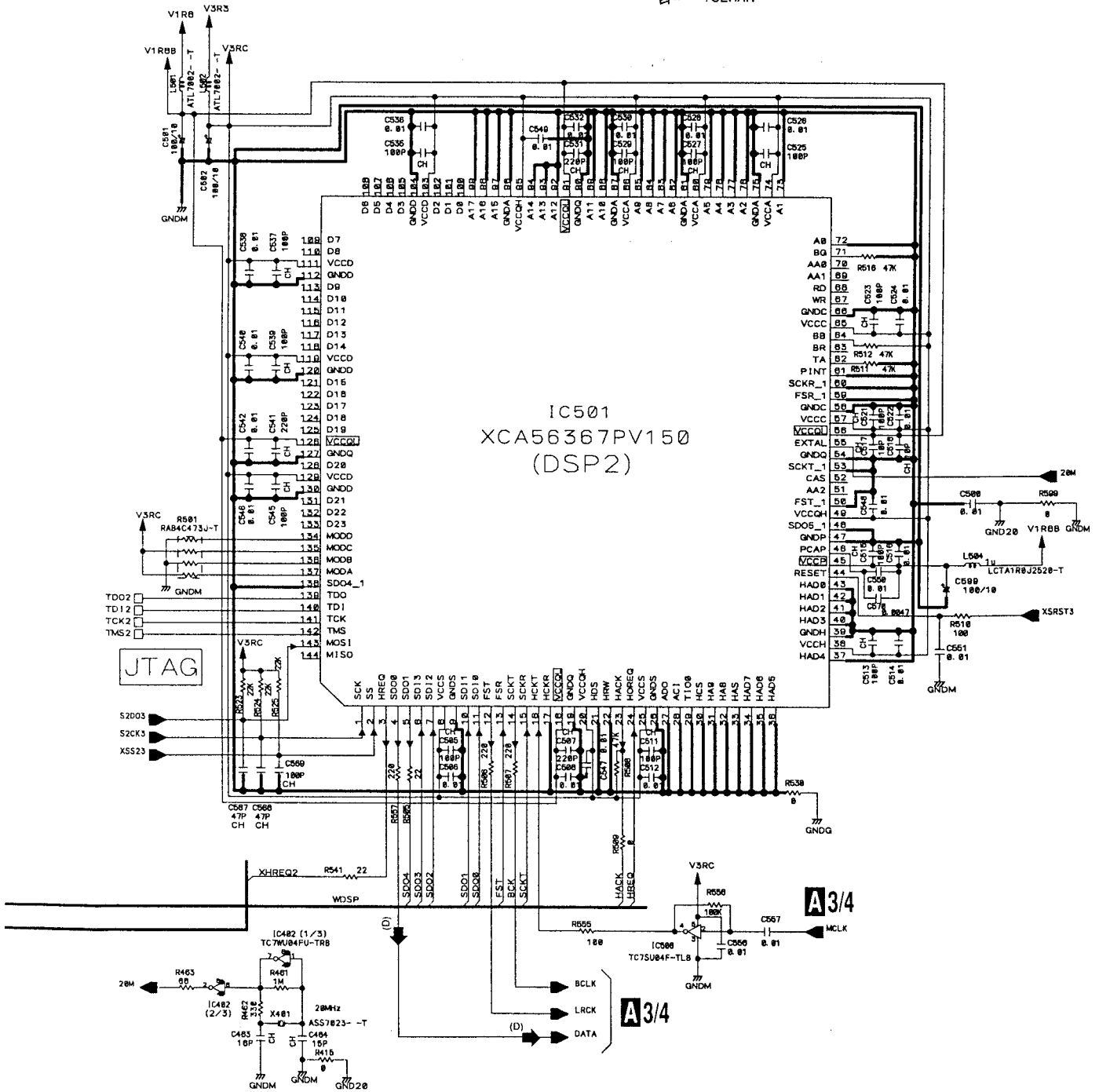

### 3.7 DABB, JACB and DOUT ASSYS

A

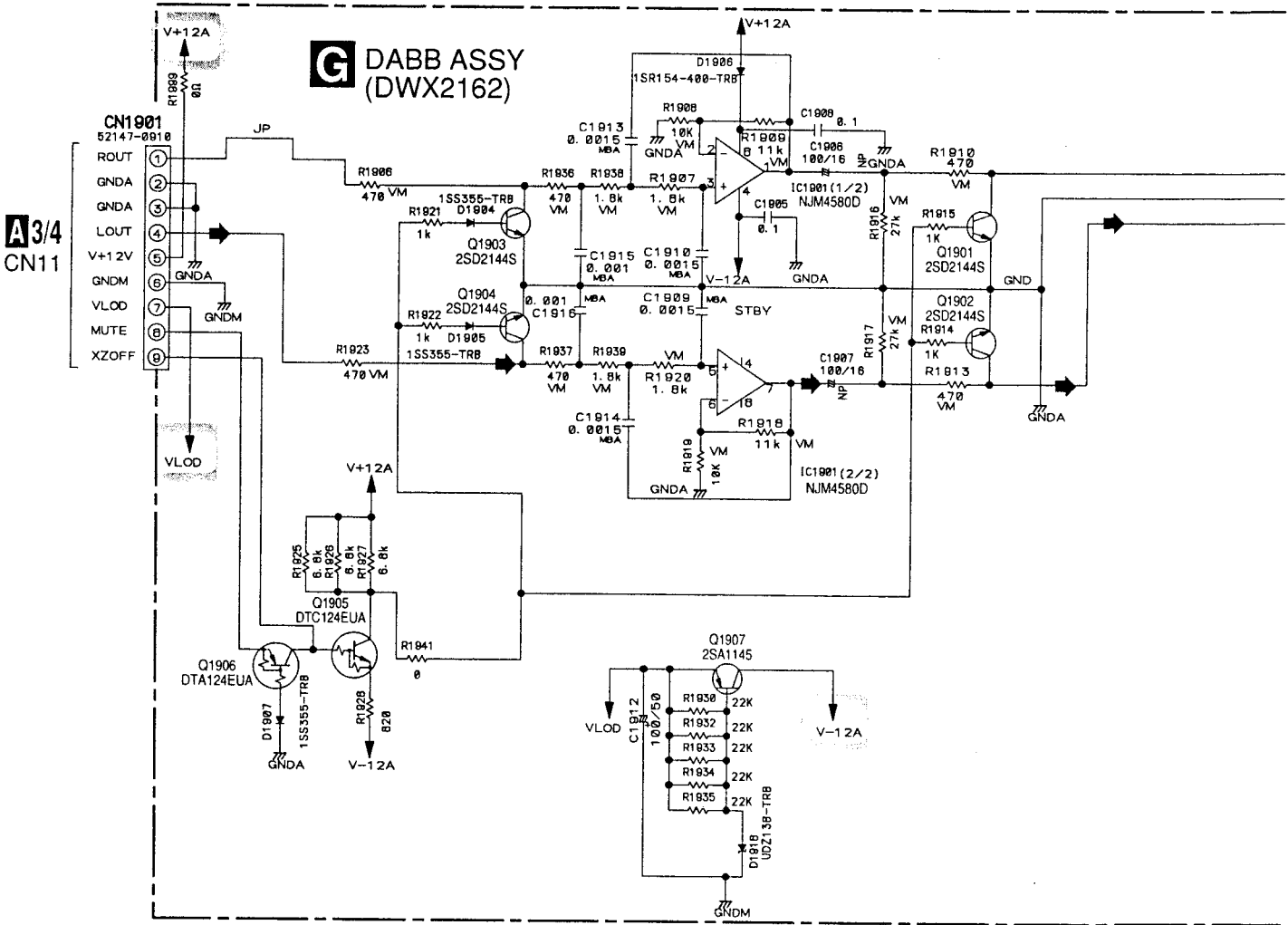

B

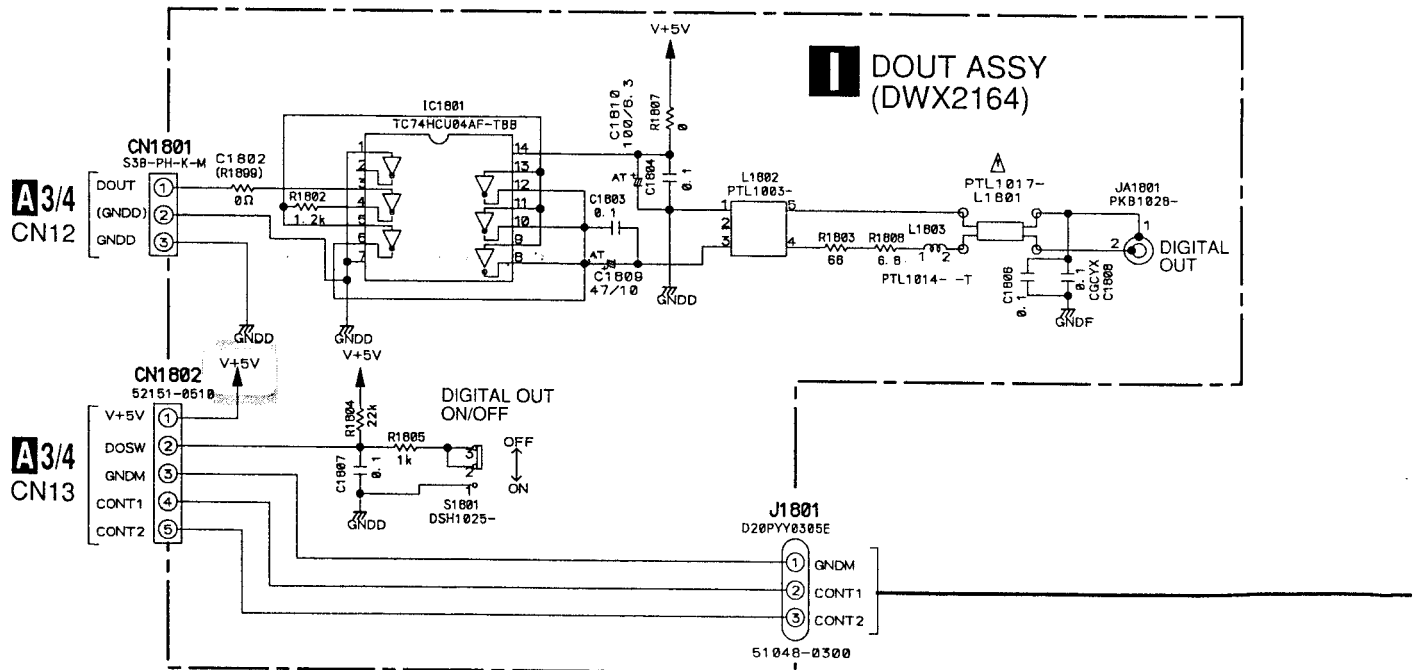

C

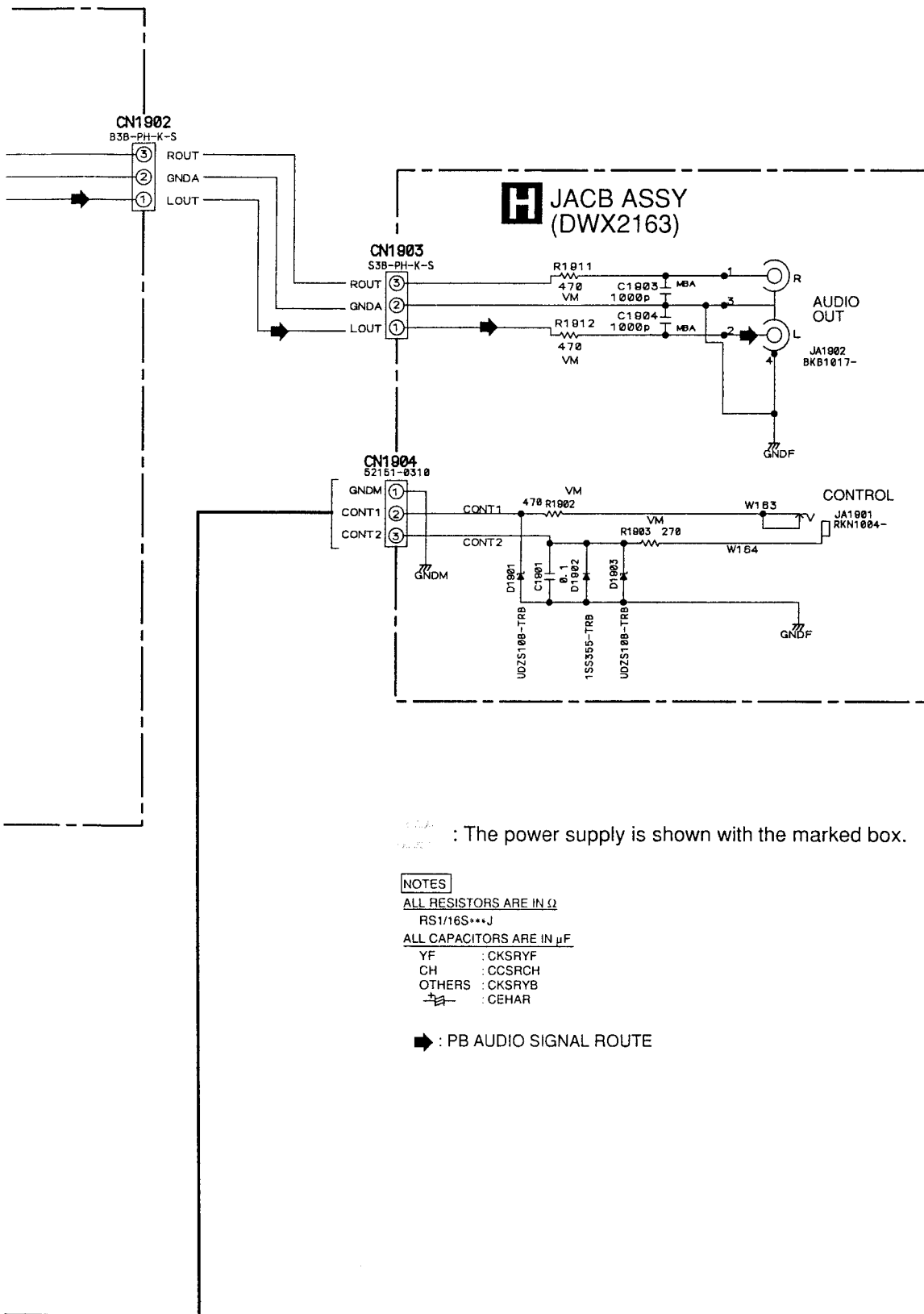

⎓ : The power supply is shown with the marked box.

**NOTES**

ALL RESISTORS ARE IN  $\Omega$

RS1/16S\*\*\*J

ALL CAPACITORS ARE IN  $\mu F$

YF : CKSRYF

CH : CCSRCH

OTHERS : CKSRYB

: CEHAR

➡ : PB AUDIO SIGNAL ROUTE



3.8 MFLB (1/2) and RSWB ASSYS

J1/2 MFLB ASSY (DWG1548)

The power supply is shown with the marked box.

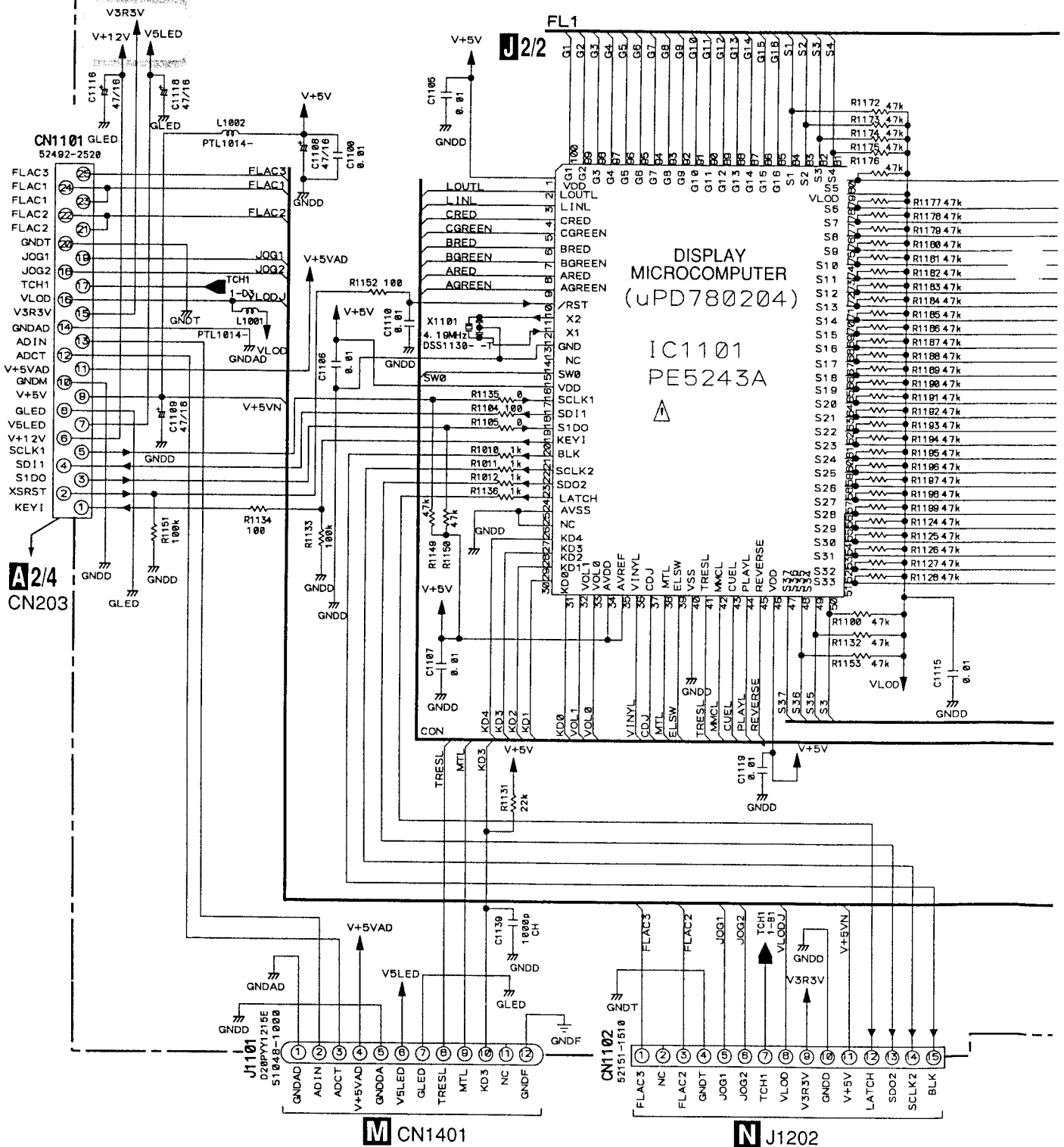

- SWITCHES
- |           |             |             |             |                   |               |
|-----------|-------------|-------------|-------------|-------------------|---------------|
| MFLB ASSY | S1106       | : ▲ (EJECT) | S1113       | : IN/REALTIME CUE |               |
| S1101     | : A         | S1107       | : SELECT    | S1114             | : LOOP OUT    |
| S1102     | : B         |             | VINYL - CDJ | S1115             | : RELOOP/EXIT |
| S1103     | : C         | S1109       | : ◀ CALL    | S1116             | : ◀ WAVE      |
| S1104     | : DISPLAY   | S1110       | : CALL ▶    | S1117             | : WAVE ▶      |
|           | TEXT/WAVE   | S1111       | : MEMORY    | S1118             | : EJECT LOCK  |
| S1105     | : TIME MODE | S1112       | : DELETE    | S1119             | : SELECT      |
- RSWB ASSY  
S1701 : FWD - REV

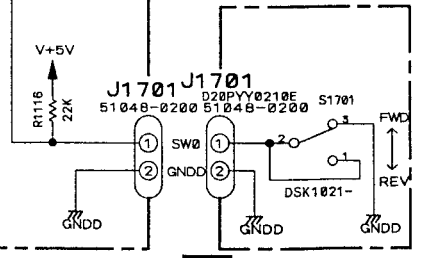
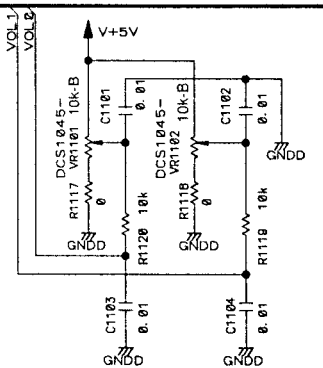
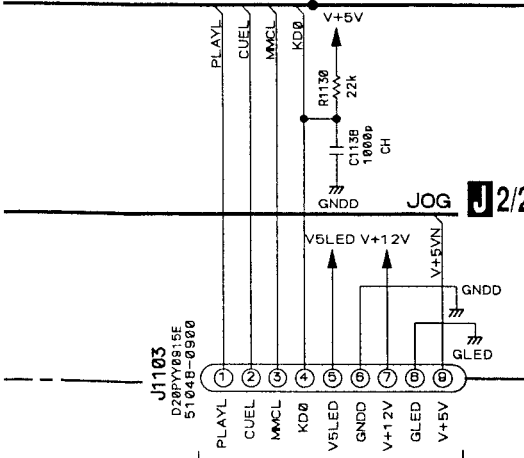
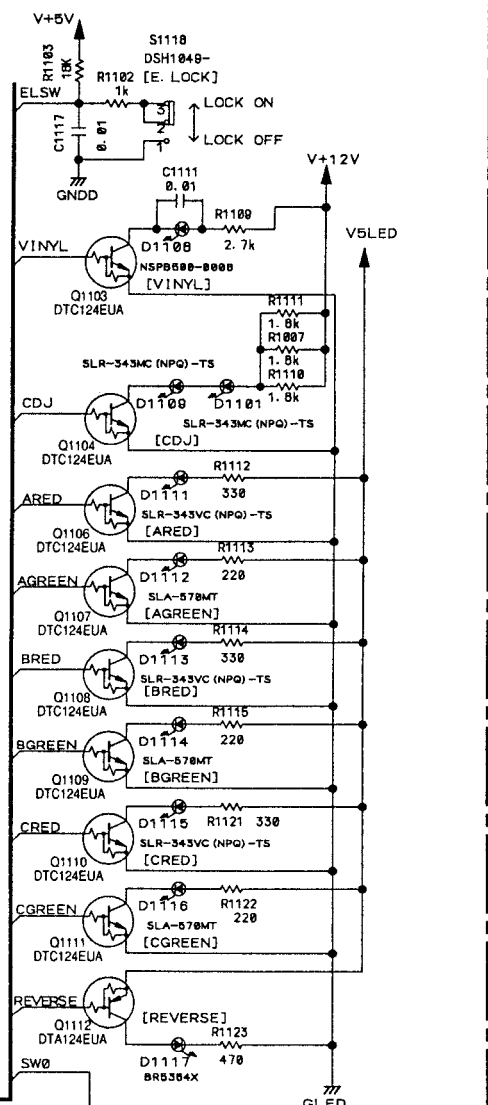
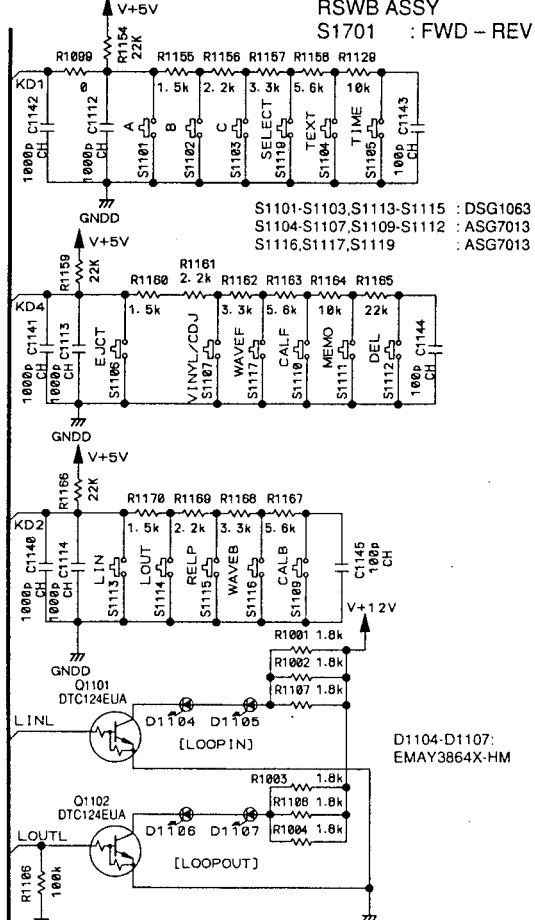
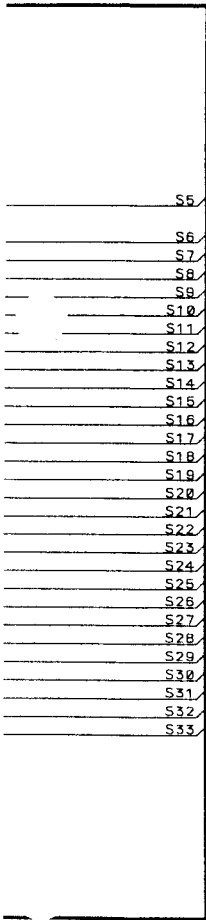

**NOTES**  
ALL RESISTORS ARE IN Ω  
RS116S\*\*\*J  
ALL CAPACITORS ARE IN μF  
YF : CKSRYF  
CH : CCSRCH  
OTHERS : CKSRYB  
—|— : CEHAR

**K** RSWB ASSY (DWS1310)

**L** CN1301

**J1/2** **K** 27

3.9 MFLB ASSY (2/2)

A

B

C

D

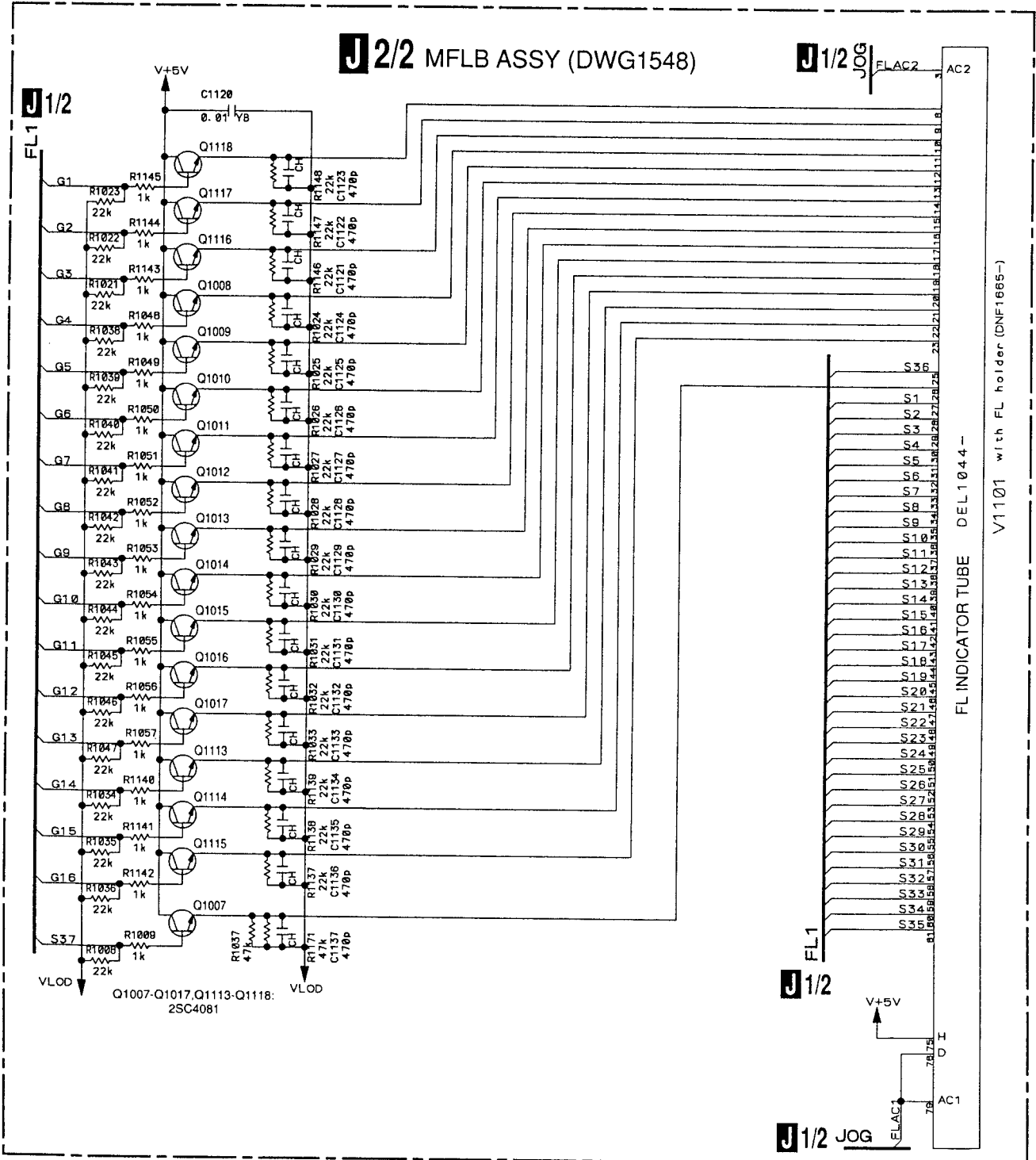

- NOTES**
- ALL RESISTORS ARE IN  $\Omega$
  - RS1/16S\*\*\*J
  - ALL CAPACITORS ARE IN  $\mu F$
  - YF : CKSRYF
  - CH : CCSRCH
  - OTHERS : CKSRYB
  - : CEHAR

### 3.10 KSWB and SLDB ASSYS

J1/2  
J1103

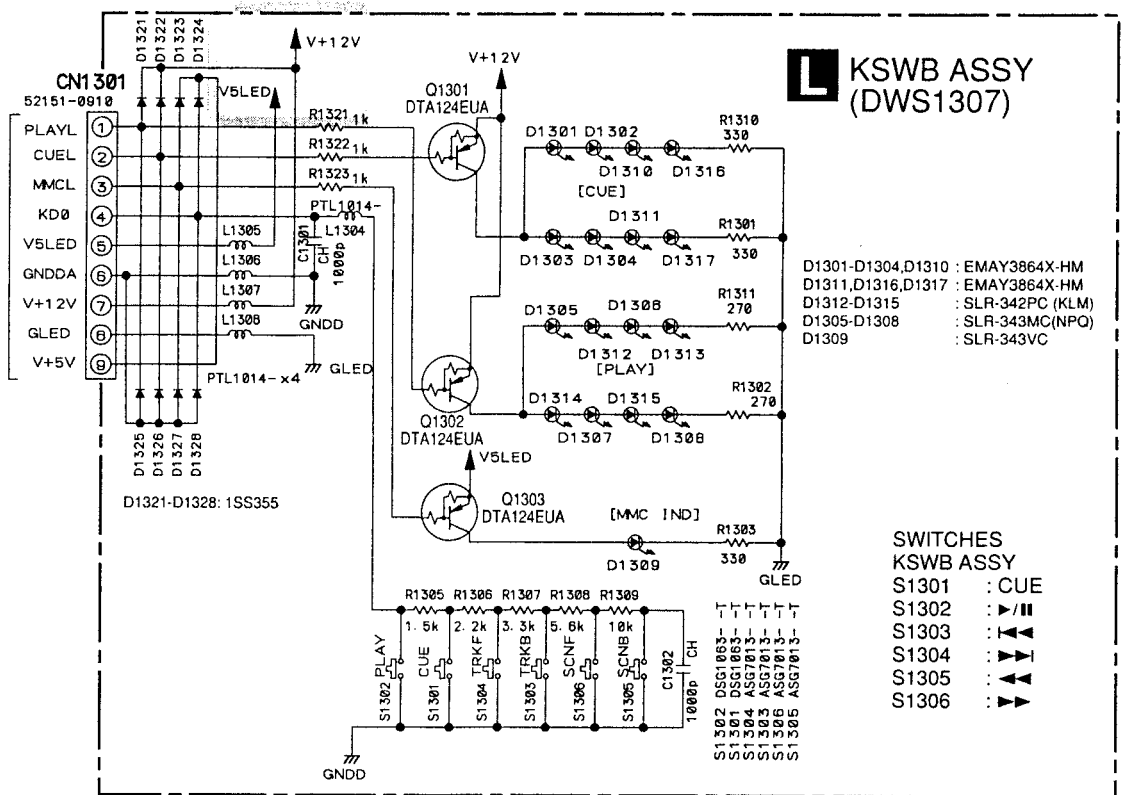

J1/2  
J1101

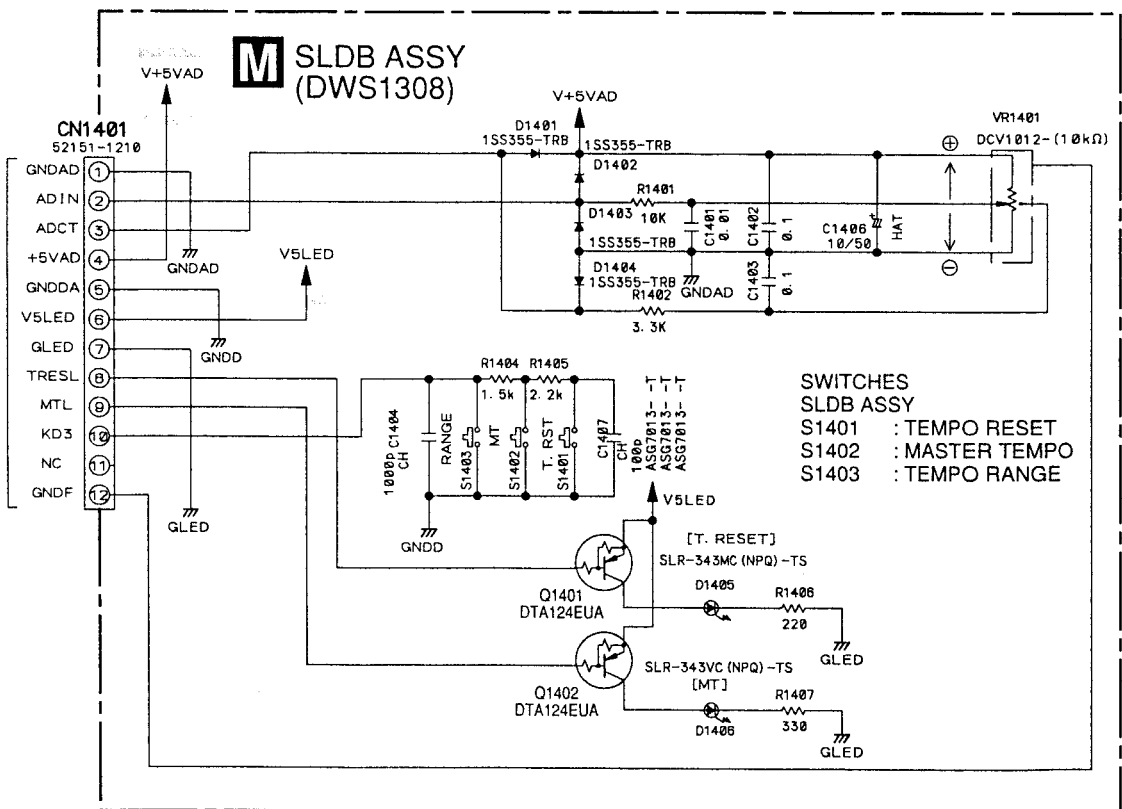

: The power supply is shown with the marked box.



3.11 JFLB and JOGB ASSYS

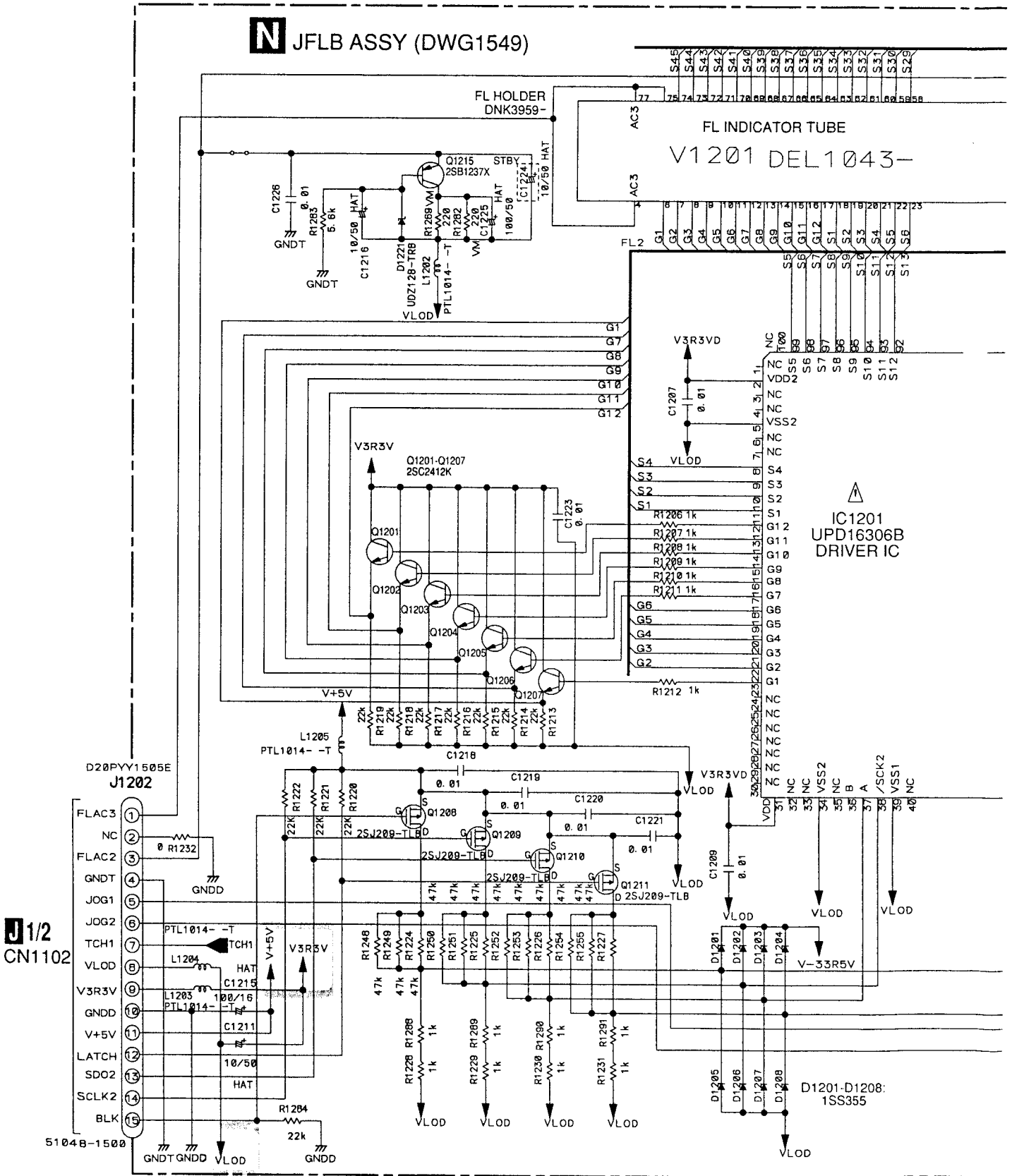

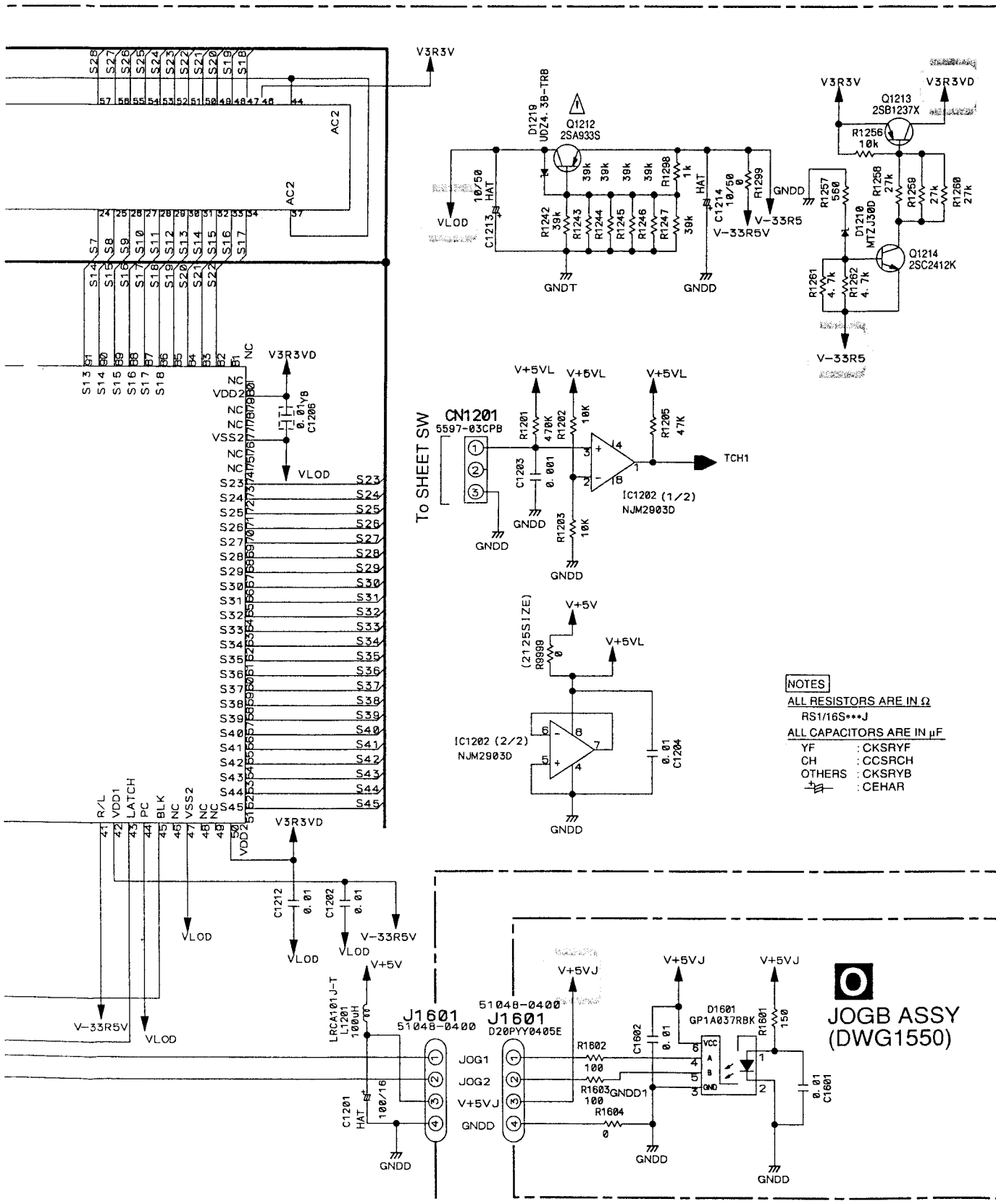

- NOTES**
- ALL RESISTORS ARE IN  $\Omega$
  - RS1/16S\*\*\*J
  - ALL CAPACITORS ARE IN  $\mu F$
  - YF : CKSRYP
  - CH : CCSRCH
  - OTHERS : CKSRYP
  - : CEHAR

: The power supply is shown with the marked box.

**NO**

3.12 SW POWER SUPPLY and PSWB ASSYS

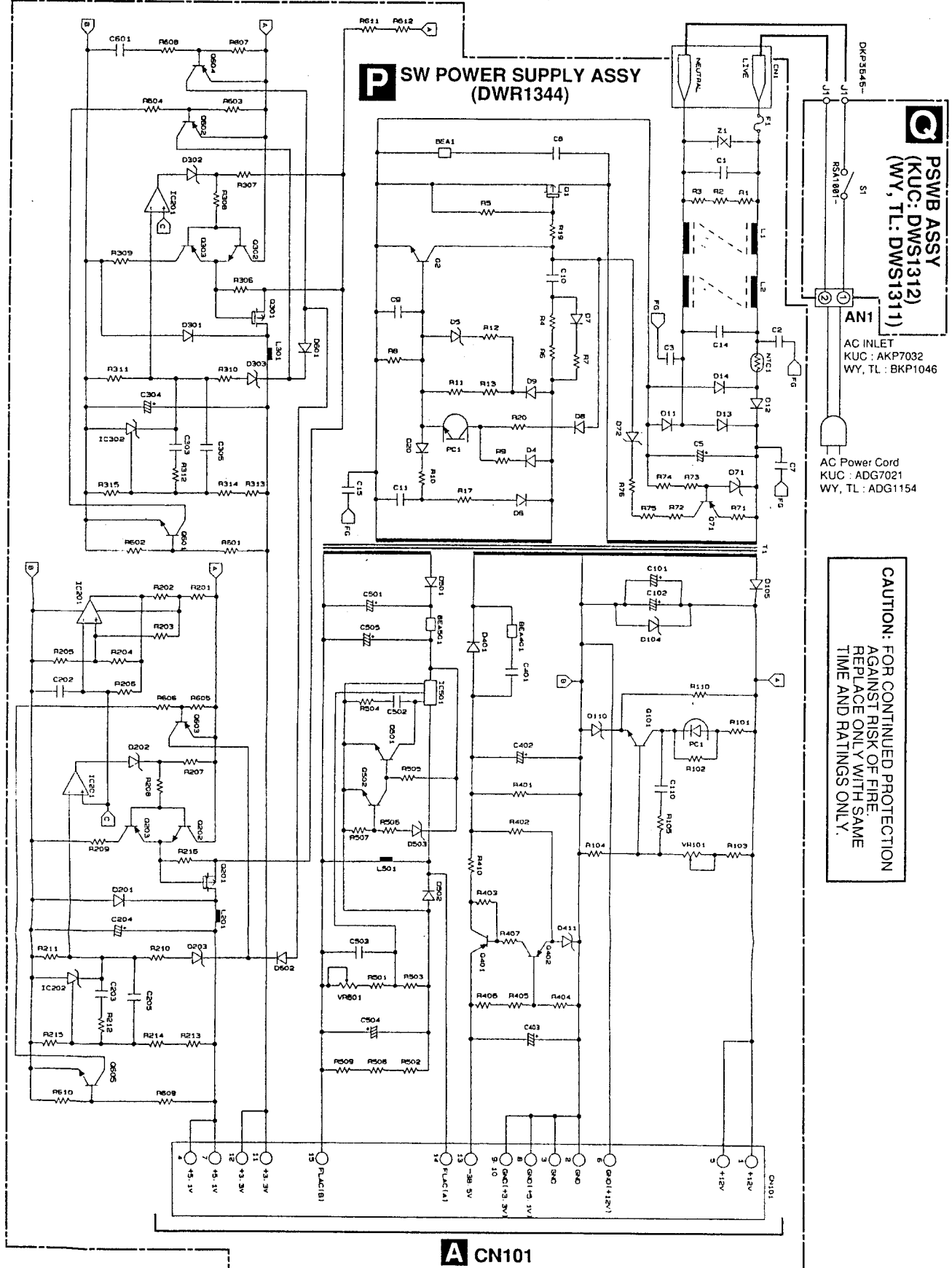

**P** SW POWER SUPPLY ASSY (DWR1344)

**Q** PSWB ASSY (KUC: DWS1312) (WY, TL: DWS1311)



AC INLET  
KUC: AKF7032  
WY, TL: BKP1046

AC Power Cord  
KUC: ADG7021  
WY, TL: ADG1154

**CAUTION: FOR CONTINUED PROTECTION AGAINST RISK OF FIRE REPLACE ONLY WITH SAME TIME AND RATINGS ONLY.**

**A** CN101

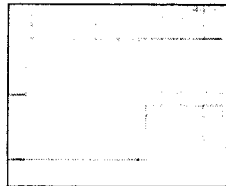
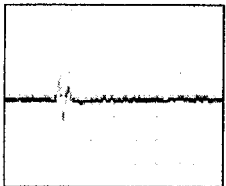
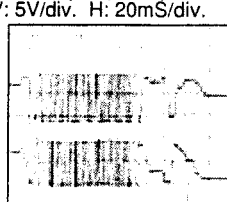
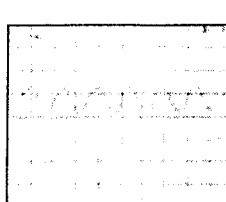
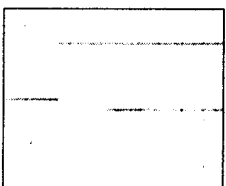
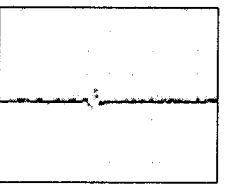
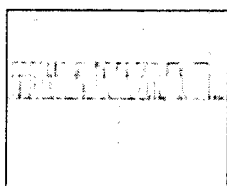
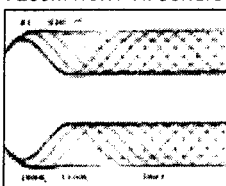
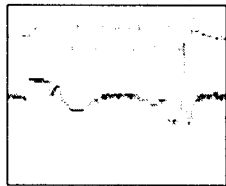
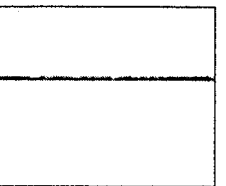
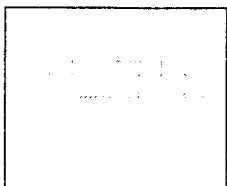
■ Waveforms

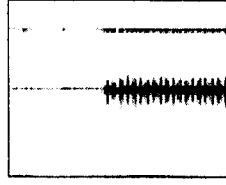
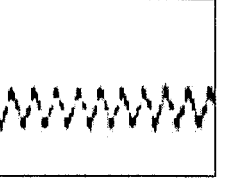
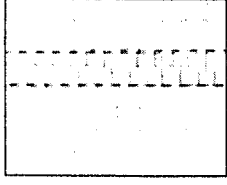
<p><b>A2/4 MAIN ASSY</b> Mode: Power ON</p> <p>① IC201- 63pin (XRST) V: 2V/div. H: 20mS/div.</p> <p>② IC201- 19pin (XSRST) V: 2V/div. H: 20mS/div.</p> 	<p><b>A1/4 MAIN ASSY</b></p> <p>Mode: 1trak Jump</p> <p>④ IC800- 18pin (TE) V: 500mV/div. H: 500μS/div.</p> 	<p><b>A1/4 MAIN ASSY</b></p> <p>Mode: Search</p> <p>⑫ IC950- 8pin (ST1+) V: 5V/div. H: 20mS/div.</p> <p>⑬ IC950- 6pin (ST2+) V: 5V/div. H: 20mS/div.</p> 	<p><b>A3/4 MAIN ASSY</b></p> <p>Mode: Play</p> <p>⑰ IC604- 3pin (VCOOUT) V: 2V/div. H: 20nS/div.</p> 
<p><b>A2/4 MAIN ASSY</b></p> <p>Mode: Power ON</p> <p>① IC201- 63pin (XRST) V: 2V/div. H: 50mS/div.</p> <p>③ IC201- 18pin (XFRST) V: 2V/div. H: 50mS/div.</p> 	<p><b>A1/4 MAIN ASSY</b></p> <p>Mode: Focus UP/Down</p> <p>⑥ IC800- 22pin (FE) V: 200mV/div. H: 500μS/div.</p> 	<p><b>A3/4 MAIN ASSY</b></p> <p>Mode: Play</p> <p>⑭ IC601- 162pin (SDATA) V: 2V/div. H: 1μS/div.</p> 	<p><b>A1/4 MAIN ASSY</b></p> <p>Mode: 3100rpm/ Inside Play</p> <p>⑱ IC700- 8pin (ARF) V: 200mV/div. H: 50nS/div.</p> <p>⑲ IC700- 9pin (NARF) V: 200mV/div. H: 50nS/div.</p> 
<p><b>A1/4 MAIN ASSY</b></p> <p>Mode: Search</p> <p>④ IC800- 18pin (TE) V: 1V/div. H: 200μS/div.</p> <p>⑤ IC950- 11pin (T+) V: 500mV/div. H: 200μS/div.</p> 	<p><b>A1/4 MAIN ASSY</b></p> <p>Mode: Play</p> <p>⑩ IC700- 6pin (TEDRV) V: 200mV/div. H: 5μS/div.</p> 	<p><b>A3/4 MAIN ASSY</b></p> <p>Mode: Play</p> <p>⑮ IC601- 182pin (BCK) V: 2V/div. H: 500nS/div.</p> 	
<p><b>A1/4 MAIN ASSY</b></p> <p>Mode: Focus</p> <p>⑥ IC800- 22pin (FE) V: 1V/div. H: 50mS/div.</p> <p>⑦ IC950- 13pin (F+) V: 1V/div. H: 50mS/div.</p> 	<p><b>A1/4 MAIN ASSY</b></p> <p>Mode: Play</p> <p>⑪ IC700- 5pin (FEDRV) V: 100mV/div. H: 20mS/div.</p> 	<p><b>A3/4 MAIN ASSY</b></p> <p>Mode: Play</p> <p>⑯ IC601- 168pin (LRCK) V: 2V/div. H: 5μS/div.</p> 	

■ Waveforms (1/4)

**A** 1/4 MAIN ASSY

IC700 (MN677061ZY)

Pin No.	Voltage (V)
1	2.2
2	1.65
3	1.65
4	3.3
5	1 to 2.2
6	1.65
7	0
8	1.65
9	1.65
10	1.65
11	1.65
12	1.65
13	1.65
14	3.3
15	1.65
16	0
17	0
18	2.2
19	1.2
20	0
21	1
22	1
23	1.65
24	0
25	0
26	0
27	3.3
28	0
29	0
30	0
31	0
32	0
33	0
34	1.65
35	1
36	0 to 1.65
37	0
38	3.3
39	0
40	0
41	0
42	1.65
43	1.65 to 3.3
44	1.65 to 3.3
45	0
46	3.3
47	0 to 3.3
48	0 to 3.3
49	0
50	0
51	0
52	0 to 3.3
53	0 to 3.3
54	0
55	0
56	0
57	0
58	2.5
59	0
60	0
61	0 to 3.3
62	0 to 3.3
63	0 to 3.3
64	0
65	0
66	0
67	0
68	0
69	0 to 3.3
70	0 to 3.3
71	0 to 3.3
72	0
73	0
74	0
75	3.3
76	0 to 3.3
77	0
78	0
79	0
80	0 to 3.3
81	0
82	3.3
83	0
84	0 to 5
85	5
86	0 to 5
87	0 to 3.3
88	0 to 5
89	0 to 5
90	0 to 3.3

IC700 (MN677061ZY)

Pin No.	Voltage (V)
91	0 to 3.3
92	0
93	0
94	0 to 3.3
95	0
96	2.5
97	1.65
98	1.65
99	1.65
100	2.2

IC701 (TC7WU04FU)

Pin No.	Voltage (V)
1	0 to 3.3
2	0 to 3.3
3	3.3
4	0
5	0
6	0.5 to 2.5
7	0 to 3.3
8	3.3

IC710 (TC7SET08FU)

Pin No.	Voltage (V)
1	0
2	0
3	0
4	0
5	3.3

IC711 (TC7SET32FU)

Pin No.	Voltage (V)
1	0
2	0
3	0
4	0
5	3.3

IC800 (AN8702NFH)

Pin No.	Voltage (V)
1	5
2	0
3	0
4	3.3
14	0 to 5
15	1.2
16	0
17	1.65
18	1 to 2
19	1.65
20	2 to 2.2
21	1.65
22	1.65
23	0
24	1.65
25	3.3
26	0
27	2.2
28	5
29	1.65
30	1.65 to 2.2
31	1.65 to 2.2
32	1.8
33	0
34	0
35	0
36	3.3
37	0
38	0
39	0 to 3.3
40	0
41	3.3
42	1.2
43	1.65
44	2.2
45	2.2
46	2.2
47	1.65 to 2.2
48	1.65 to 2.2
49	2.2
50	2.2
51	2.2
52	2.2
53	2.2
54	2.2
55	5
56	2.2
57	2.2
58	2.2
59	2.2
60	2.2
61	0
62	2.2
63	2.2
64	1.651

IC850 (BA10358F)

Pin No.	Voltage (V)
1	1.65
2	2.2
3	2.2
4	0
5	2.2
6	2.2
7	2.2
8	5

IC900 (LB11975)

Pin No.	Voltage (V)
1	0 to 12
2	0 to 12
3	0 to 12
4	0 to 12
5	0
6	0
7	0
8	12
9	12
10	0
11	1.65 to 3.3
12	1.65 to 3.3
13	0
14	1.65
15	14.65
16	5
17	0
18	0
19	1.65
20	1.65
21	1.65
22	1.65
23	1.65
24	1.65
25	5
26	5
27	5
28	1.65
29	0
30	1.65
31	1.65
32	1.65
33	1.65
34	1.65
35	0
36	1.65
37	0
38	0

IC950 (LA6562)

Pin No.	Voltage (V)
1	5
2	5
3	12
4	5
5	5
6	7.5
7	3.5
8	6.5
9	5
10	0
11	2 to 3.3
12	2 to 3.3
13	1.65 to 3.3
14	1.65 to 3.3
15	5
16	1 to 2
17	1.65
18	1.65
19	1.65
20	1.65
21	1.65
22	1.65
23	1.65
24	1.65
25	5
26	5
27	5
28	1.65
29	0
30	1.65
31	1.65
32	1.65
33	1.65
34	1.65
35	0
36	1.65
37	0
38	0

**A** 2/4 MAIN ASSY

IC100 (PQ2TZ15)

Pin No.	Voltage (V)
1	5
2	5
3	2.5
4	0
5	0

IC150 (PQ1R33)

Pin No.	Voltage (V)
1	5
2	0
3	1.2
4	3.3
5	0
6	5

IC202 (BR24C64F)

Pin No.	Voltage (V)
1	0
2	0
3	0
4	0
5	5
6	5
7	0
8	5

IC203 (TC74HC4053AFT)

Pin No.	Voltage (V)
1	5
2	0 to 5
3	5
4	0 to 5
5	0 to 5
6	0
7	0
8	0
9	0
10	0
11	0
12	0 to 5
13	5
14	0 to 5
15	0 to 5
16	5

IC204 (TC7SET08FU)

Pin No.	Voltage (V)
1	0 to 3.3
2	5
3	0
4	0 to 5
5	5

IC205 (TC74VHC08FT)

Pin No.	Voltage (V)
1	0
2	0
3	0
4	0 to 5
5	3.3
6	0 to 3.3
7	0
8	0 to 3.3
9	3.3
10	3.3
11	0 to 3.3
12	0 to 5
13	3.3
14	3.3

IC206 (PQ1R33)

Pin No.	Voltage (V)
1	5
2	0
3	1.2
4	3.3
5	0
6	5

■ Waveforms (2/4)

**A** 2/4 MAIN ASSY

IC300 (PD3431A9)	
Pin No.	Voltage (V)
1	3.3
2	0 to 5
3	0
4	0
5	0
6	0 to 5
7	0 to 5
8	0
9	0
10	0
11	0
12	0 to 5
13	5
14	0 to 3.3
15	5
16	0 to 5
17	0
18	5
19	0 to 5
20	0 to 5
21	0 to 5
22	0
23	0
24	0
25	0
26	0 to 5
27	0 to 5
28	0 to 5
29	0 to 5
30	0 to 5
31	0 to 5
32	0 to 5
33	0 to 5
34	5
35	0 to 5
36	0 to 5
37	0 to 5
38	0 to 5
39	0 to 5
40	0 to 5
41	0
42	0
43	0
44	0
45	0
46	0
47	0
48	0
49	0
50	0
51	0
52	0
53	0
54	0
55	0 to 5
56	0 to 5
57	0
58	0
59	0
60	0 to 5
61	0
62	5
63	0 to 5
64	0
65	0
66	1.65 to 3.3
67	1.65 to 3.3
68	5
69	0
70	0 to 5
71	0 to 5
72	0
73	5
74	0
75	5
76	3.3
77	3.3
78	1.65
79	1.65
80	1.65
81	0 to 3.3
82	0
83	0 to 5
84	0 to 5
85	0 to 5
86	0
87	0 to 3.3
88	0 to 3.3
89	0 to 5
90	0

IC300 (PD3431A9)	
Pin No.	Voltage (V)
91	0
92	0
93	0 to 3.3
94	0 to 3.3
95	0 to 3.3
96	0 to 3.3
97	0 to 3.3
98	0 to 5
99	5
100	0 to 3.3

IC201 (PD3432A9)	
Pin No.	Voltage (V)
1	3.3
2	0 to 5
3	0 to 5
4	0 to 5
5	0 to 5
6	0 to 5
7	0 to 5
8	0 to 5
9	0 to 5
10	0
11	0
12	0 to 5
13	0 to 5
14	0 to 5
15	0 to 5
16	0 to 5
17	0 to 5
18	0 to 5
19	0 to 5
20	0 to 5
21	0
22	0
23	0
24	5
25	0 to 5
26	0
27	0 to 5
28	0 to 5
29	0 to 5
30	0 to 5
31	0 to 5
32	0 to 5
33	0 to 5
34	0 to 5
35	5
36	0 to 5
37	0 to 5
38	0 to 5
39	0 to 5
40	0 to 5
41	0
42	0
43	0
44	0
45	0
46	0
47	0
48	0
49	0
50	0
51	0
52	0
53	0
54	0
55	0 to 5
56	0 to 5
57	0
58	0
59	0 to 5
60	0 to 3.3
61	0
62	5
63	0 to 5
64	0
65	0
66	1.65 to 3.3
67	1.65 to 3.3
68	5
69	0
70	0 to 5
71	0 to 5
72	0
73	5
74	0
75	5

IC600 (M51957BFP)	
Pin No.	Voltage (V)
1	0
2	1.2
3	0
4	0
5	1.2
6	5
7	5
8	0

IC201 (PD3432A9)	
Pin No.	Voltage (V)
76	5
77	5
78	2.5
79	2.5
80	0
81	0
82	0
83	0
84	0
85	0
86	0
87	0 to 5
88	0 to 5
89	0 to 3.3
90	0
91	0
92	0
93	0 to 5
94	0 to 5
95	0 to 5
96	0 to 5
97	5
98	0
99	0 to 5
100	0 to 3.3

**A** 3/4 MAIN ASSY

IC10 (BA178M05EP)	
Pin No.	Voltage (V)
1	12
2	0
3	5

IC11 (PE8001A)	
Pin No.	Voltage (V)
1	0 to 5
2	0 to 5
3	0 to 5
4	0
5	0 to 5
6	0
7	0
8	5
9	5
10	0
11	0
12	0
13	0
14	0
15	5
16	0
17	0
18	0
19	0
20	5
21	0 to 5
22	0 to 5
23	0
24	0
25	0
26	0 to 5
27	0 to 5
28	0 to 5

IC12 (TC74HCT7007AF)	
Pin No.	Voltage (V)
1	0 to 3.3
2	0 to 5
3	0 to 3.3
4	0 to 5
5	0 to 3.3
6	0 to 5
7	0
8	0
9	0
10	0
11	0
12	0
13	0
14	5

IC13 (TC7WU04FU)	
Pin No.	Voltage (V)
1	0 to 5
2	0 to 5
3	0
4	0
5	0
6	0 to 5
7	0 to 5
8	5

IC606 (K4S641632D)	
Pin No.	Voltage (V)
1	3.3
2	0 to 3.3
3	3.3
4	0 to 3.3
5	0 to 3.3
6	0
7	0 to 3.3
8	0 to 3.3
9	3.3
10	0 to 3.3
11	0 to 3.3
12	0
13	0 to 3.3
14	3.3
15	0
16	0 to 3.3
17	0 to 3.3
18	0 to 3.3
19	0
20	0
21	0
22	0 to 3.3
23	0 to 3.3
24	0 to 3.3
25	0 to 3.3
26	0 to 3.3
27	3.3
28	0
29	0 to 3.3
30	0 to 3.3
31	0 to 3.3
32	0 to 3.3
33	0 to 3.3
34	0 to 3.3
35	0 to 3.3
36	0
37	2 to 2.2
38	0 to 3.3
39	0
40	0
41	0
42	0 to 3.3
43	3.3
44	0 to 3.3
45	0 to 3.3
46	0
47	0 to 3.3
48	0 to 3.3
49	3.3
50	0 to 3.3
51	0 to 3.3
52	0
53	0 to 3.3
54	0

IC607 (PQ2TZ15)	
Pin No.	Voltage (V)
1	3.3
2	3.3
3	2.5
4	0
5	0

IC608 (TC7WU04FU)	
Pin No.	Voltage (V)
1	0.5 to 3.3
2	0 to 3.3
3	0
4	0
5	0 to 3.3
6	0 to 3.3
7	0 to 3.3
8	3.3

IC609 (NJM78L05UA)	
Pin No.	Voltage (V)
1	5
2	0
3	12

IC610 (TC7SH08FU)	
Pin No.	Voltage (V)
1	5
2	3.3
3	0
4	3.3
5	3.3

IC611 (TC7SU04FU)	
Pin No.	Voltage (V)
1	0
2	1.2 to 1.65
3	0
4	0 to 3.3
5	3.3

IC612 (TC7WU04FU)	
Pin No.	Voltage (V)
1	0 to 3.3
2	0 to 3.3
3	0
4	0
5	0
6	0 to 3.3
7	0 to 3.3
8	3.3

IC602 (PE9012A)	
Pin No.	Voltage (V)
1	0
2	0

IC604 (TLC2932IPW)	
Pin No.	Voltage (V)
1	5
2	0
3	0 to 5
4	0
5	0
6	0
7	0
8	0
9	5
10	0
11	0
12	3.3
13	2.5
14	5

IC605 (TC7WT241FU)	
Pin No.	Voltage (V)
1	0
2	0
3	3.3 to 5
4	0
5	0 to 3.3
6	0
7	0
8	5

# CDJ-1000

## ■ Voltage (3/4)

### A 3/4 MAIN ASSY

Pin No.	Voltage (V)
1	0
2	0
3	0 to 3.3
4	0 to 3.3
5	0 to 3.3
6	0 to 3.3
7	0 to 3.3
8	0 to 3.3
9	0 to 3.3
10	0 to 3.3
11	0
12	3.3
13	2.5
14	0 to 3.3
15	0 to 3.3
16	0 to 3.3
17	0 to 3.3
18	0 to 3.3
19	0
20	0 to 3.3
21	0 to 3.3
22	0 to 3.3
23	0 to 3.3
24	0 to 3.3
25	0
26	3.3
27	0 to 3.3
28	2.5
29	0 to 3.3
30	0 to 3.3
31	0 to 3.3
32	0
33	0 to 3.3
34	0 to 3.3
35	0 to 3.3
36	0 to 3.3
37	0 to 3.3
38	2.5
39	3.3
40	0
41	0 to 3.3
42	0 to 3.3
43	0 to 3.3
44	0 to 3.3
45	0 to 3.3
46	0 to 3.3
47	0 to 3.3
48	0 to 3.3
49	0 to 3.3
50	0
51	0
52	0
53	3.3
54	3.3
55	2.5
56	0
57	0 to 5
58	0 to 5
59	0 to 5
60	0 to 5
61	0 to 5
62	0 to 5
63	0 to 5
64	0
65	3.3
66	2.5
67	0 to 5
68	0 to 5
69	0 to 5
70	0 to 5
71	0 to 5
72	0
73	0 to 5
74	0
75	0
76	2.5
77	0 to 3.3
78	3.3
79	0
80	0 to 3.3
81	0
82	0
83	0 to 3.3
84	0 to 3.3
85	0
86	0
87	0 to 5
88	0 to 5
89	0 to 5
90	0

Pin No.	Voltage (V)
91	2.5
92	3.3
93	0
94	0
95	0
96	0
97	0
98	0
99	0
100	0
101	0
102	0 to 3.3
103	0
104	3.3
105	3.3
106	3.3
107	3.3
108	0 to 3.3
109	0 to 3.3
110	0 to 3.3
111	0 to 3.3
112	0 to 3.3
113	0 to 3.3
114	0 to 3.3
115	0 to 3.3
116	0
117	3.3
118	2.5
119	0 to 3.3
120	0 to 3.3
121	0 to 3.3
122	0 to 3.3
123	0 to 3.3
124	0
125	0 to 3.3
126	0 to 3.3
127	0 to 3.3
128	2.5
129	0
130	3.3
131	0
132	0 to 3.3
133	0 to 3.3
134	0 to 3.3
135	0 to 3.3
136	0 to 3.3
137	0
138	0 to 3.3
139	0 to 3.3
140	0 to 3.3
141	0 to 3.3
142	0 to 3.3
143	2.5
144	3.3
145	0
146	0
147	0
148	0
149	0
150	0
151	0
152	0
153	0 to 3.3
154	0
155	0 to 3.3
156	3.3
157	0
158	0
159	0
160	3.3
161	3.3
162	0 to 3.3
163	0 to 3.3
164	0 to 3.3
165	0 to 3.3
166	0 to 3.3
167	0 to 3.3
168	0 to 3.3
169	0
170	3.3
171	2.5
172	0
173	0
174	0
175	0
176	0 to 3.3
177	0
178	0 to 5
179	0 to 5
180	0

Pin No.	Voltage (V)
181	0
182	0 to 3.3
183	0
184	3.3
185	0 to 3.3
186	2.5
187	0 to 5
188	0 to 5
189	0 to 5
190	0
191	0 to 5
192	0 to 5
193	0 to 5
194	0 to 5
195	0 to 5
196	2.5
197	3.3
198	0
199	0 to 5
200	0 to 5
201	0 to 5
202	0 to 5
203	0 to 5
204	0 to 5
205	0
206	0 to 3.3
207	0
208	3.3

### A 4/4 MAIN ASSY

Pin No.	Voltage (V)
1	0 to 3.3
2	0 to 3.3
3	0 to 3.3
4	0 to 3.3
5	0 to 3.3
6	0 to 3.3
7	0 to 3.3
8	3.3
9	0 to 3.3
10	0 to 3.3
11	0 to 3.3
12	0 to 3.3
13	1.8
14	0 to 3.3
15	0 to 3.3
16	3.3
17	0 to 3.3
18	1.8
19	0
20	3.3
21	0
22	0
23	0 to 3.3
24	3.3
25	3.3
26	0
27	0 to 3.3
28	0 to 3.3
29	0 to 3.3
30	0 to 3.3
31	0
32	0
33	0
34	0
35	0
36	0
37	0
38	3.3
39	0
40	0
41	0
42	0
43	0
44	3.3
45	1.8
46	0 to 3.3
47	0
48	0
49	3.3
50	0
51	0
52	0
53	0
54	0
55	0 to 3.3
56	1.8
57	3.3
58	0
59	0
60	0
61	0
62	0
63	0
64	0 to 3.3
65	3.3
66	0
67	0 to 3.3
68	0 to 3.3
69	0
70	0
71	0 to 3.3
72	0 to 3.3
73	0 to 3.3
74	3.3
75	0
76	0 to 3.3
77	0 to 3.3
78	0 to 3.3
79	0 to 3.3
80	3.3
81	0

Pin No.	Voltage (V)
82	0 to 3.3
83	0 to 3.3
84	0
85	0
86	3.3
87	0
88	0
89	0
90	0
91	1.8
92	0
93	0
94	0
95	3.3
96	0
97	0
98	0 to 3.3
99	0 to 3.3
100	0 to 3.3
101	0
102	0
103	3.3
104	0
105	0
106	0
107	0
108	0
109	0
110	0 to 3.3
111	3.3
112	0
113	0 to 3.3
114	0 to 3.3
115	0 to 3.3
116	0 to 3.3
117	0 to 3.3
118	0 to 3.3
119	3.3
120	0
121	0 to 3.3
122	0 to 3.3
123	0 to 3.3
124	0 to 3.3
125	0 to 3.3
126	1.8
127	0
128	0 to 3.3
129	3.3
130	0
131	0 to 3.3
132	0 to 3.3
133	0 to 3.3
134	3.3
135	3.3
136	3.3
137	3.3
138	0
139	0
140	3.3
141	3.3
142	3.3
143	0 to 3.3
144	0 to 3.3

Pin No.	Voltage (V)
1	0 to 3.3
2	0 to 3.3
3	0
4	0
5	3.3
6	0 to 3.3
7	0 to 3.3
8	3.3

Pin No.	Voltage (V)
1	0 to 3.3
2	5
3	0
4	0 to 5
5	5

Pin No.	Voltage (V)
1	1.8
2	0
3	0
4	0.5
5	3.3
6	0
7	3.3

Pin No.	Voltage (V)
1	0
2	0
3	0
4	5
5	0 to 5
6	0 to 5
7	0 to 5
8	0 to 5
9	0 to 5
10	0
11	3.3
12	0 to 3.3
13	0 to 3.3
14	0 to 3.3
15	3.3

Pin No.	Voltage (V)
1	0 to 5
2	0 to 5
3	0
4	0 to 3.3
5	3.3

Pin No.	Voltage (V)
1	0
2	0 to 3.3
3	0
4	0 to 3.3
5	3.3

Pin No.	Voltage (V)
1	0 to 5
2	0 to 5
3	0
4	0 to 3.3
5	3.3

■ Voltage (4/4)

**A** 4/4 MAIN ASSY

IC501(XCA56367PV150)

Pin No.	Voltage (V)
1	0 to 3.3
2	0 to 3.3
3	0 to 3.3
4	0 to 3.3
5	0 to 3.3
6	0 to 3.3
7	0 to 3.3
8	3.3
9	0
10	0 to 3.3
11	0 to 3.3
12	0 to 3.3
13	0 to 3.3
14	0 to 3.3
15	0 to 3.3
16	0 to 3.3
17	0
18	1.8
19	0
20	3.3
21	0
22	0
23	3.3
24	0 to 3.3
25	3.3
26	0
27	0
28	0
29	0
30	0
31	0
32	0
33	0
34	0
35	0
36	0
37	0
38	3.3
39	0
40	0
41	0
42	0
43	0
44	0 to 3.3
45	1.8
46	0
47	0
48	0
49	3.3
50	0
51	0
52	0
53	0
54	0
55	0 to 3.3
56	1.8
57	3.3
58	0
59	0
60	0
61	0
62	0
63	0
64	3.3
65	3.3
66	0
67	0
68	0
69	0
70	0
71	0
72	0
73	0
74	3.3
75	0
76	0
77	0
78	0
79	0
80	3.3
81	0
82	0
83	0
84	0
85	0
86	3.3
87	0
88	0
89	0
90	0

IC501(XCA56367PV150)

Pin No.	Voltage (V)
91	1.8
92	0
93	0
94	0
95	3.3
96	0
97	0
98	0
99	0
100	0
101	0
102	0
103	3.3
104	0
105	0
106	0
107	0
108	0
109	0
110	0
111	3.3
112	0
113	0
114	0
115	0
116	0
117	0
118	0
119	3.3
120	0
121	0
122	0
123	0
124	0
125	0
126	1.8
127	0
128	0
129	3.3
130	0
131	0
132	0
133	0
134	0
135	3.3
136	0
137	3.3
138	0
139	0
140	3.3
141	3.3
142	3.3
143	0
144	0

**J** 1/2 MFLB ASSY

IC1101 (PE5243A)

Pin No.	Voltage (V)
1	5
2	0 to 5
3	0 to 5
4	0 to 5
5	0 to 5
6	0 to 5
7	0 to 5
8	0 to 5
9	0 to 5
10	0 to 5
11	0 to 5
12	0 to 5
13	0
14	0
15	0 to 5
16	5
17	0 to 5
18	0 to 5
19	0 to 5
20	0 to 5
21	0 to 5
22	0 to 5
23	0 to 5
24	0 to 5
25	0
26	0
27	0 to 5
28	0 to 5
29	0 to 5
30	0 to 5
31	0 to 5
32	0 to 5
33	0 to 5
34	5
35	5
36	0 to 5
37	0 to 5
38	0 to 5
39	0 to 5
40	0
41	0 to 5
42	0 to 5
43	0 to 5
44	0 to 5
45	0 to 5
46	5
47	-38.5 to 5
48	-38.5 to 5
49	-38.5 to 5
50	-38.5 to 5
51	-38.5 to 5
52	-38.5 to 5
53	-38.5 to 5
54	-38.5 to 5
55	-38.5 to 5
56	-38.5 to 5
57	-38.5 to 5
58	-38.5 to 5
59	-38.5 to 5
60	-38.5 to 5
61	-38.5 to 5
62	-38.5 to 5
63	-38.5 to 5
64	-38.5 to 5
65	-38.5 to 5
66	-38.5 to 5
67	-38.5 to 5
68	-38.5 to 5
69	-38.5 to 5
70	-38.5 to 5
71	-38.5 to 5
72	-38.5 to 5
73	-38.5 to 5
74	-38.5 to 5
75	-38.5 to 5
76	-38.5 to 5
77	-38.5 to 5
78	-38.5 to 5
79	-38.5 to 5
80	-38.5
81	-38.5 to 5
82	-38.5 to 5
83	-38.5 to 5
84	-38.5 to 5
85	-38.5 to 5
86	-38.5 to 5
87	-38.5 to 5
88	-38.5 to 5
89	-38.5 to 5
90	-38.5 to 5

IC1101 (PE5243A)

Pin No.	Voltage (V)
91	-38.5 to 5
92	-38.5 to 5
93	-38.5 to 5
94	-38.5 to 5
95	-38.5 to 5
96	-38.5 to 5
97	-38.5 to 5
98	-38.5 to 5
99	-38.5 to 5
100	-38.5 to 5

**N** JFLB ASSY

IC1201 (UPD16036B)

Pin No.	Voltage (V)
1	0
2	3.3
3	0
4	0
5	-38.5
6	0
7	0
8	-38.5 to 3.3
9	-38.5 to 3.3
10	-38.5 to 3.3
11	-38.5 to 3.3
12	-38.5 to 3.3
13	-38.5 to 3.3
14	-38.5 to 3.3
15	-38.5 to 3.3
16	-38.5 to 3.3
17	-38.5 to 3.3
18	-38.5 to 3.3
19	-38.5 to 3.3
20	-38.5 to 3.3
21	-38.5 to 3.3
22	-38.5 to 3.3
23	-38.5 to 3.3
24	0
25	-38.5 to 3.3
26	-38.5 to 3.3
27	-38.5 to 3.3
28	-38.5 to 3.3
29	-38.5 to 3.3
30	-38.5 to 3.3
31	3.3
32	0
33	0
34	-38.5
35	0
36	0
37	-38.5 to -33.5
38	-38.5 to -33.5
39	-38.5
40	0
41	-33.5
42	-33.5
43	-38.5 to -33.5
44	-38.5
45	-38.5 to -33.5
46	0
47	-38.5
48	0
49	0
50	3.3
51	-38.5 to 3.3
52	-38.5 to 3.3
53	-38.5 to 3.3
54	-38.5 to 3.3
55	-38.5 to 3.3
56	-38.5 to 3.3
57	-38.5 to 3.3
58	-38.5 to 3.3
59	-38.5 to 3.3
60	-38.5 to 3.3
61	-38.5 to 3.3
62	-38.5 to 3.3
63	-38.5 to 3.3
64	-38.5 to 3.3
65	-38.5 to 3.3
66	-38.5 to 3.3
67	-38.5 to 3.3
68	-38.5 to 3.3
69	-38.5 to 3.3
70	-38.5 to 3.3
71	-38.5 to 3.3
72	-38.5 to 3.3
73	-38.5 to 3.3
74	0
75	0
76	-38.5
77	0
78	0
79	3.3
80	0
81	0
82	-38.5 to 3.3
83	-38.5 to 3.3
84	-38.5 to 3.3
85	-38.5 to 3.3
86	-38.5 to 3.3
87	-38.5 to 3.3
88	-38.5 to 3.3
89	-38.5 to 3.3
90	-38.5 to 3.3

IC1201 (UPD16036B)

Pin No.	Voltage (V)
91	-38.5 to 3.3
92	-38.5 to 3.3
93	-38.5 to 3.3
94	-38.5 to 3.3
95	-38.5 to 3.3
96	-38.5 to 3.3
97	-38.5 to 3.3
98	-38.5 to 3.3
99	-38.5 to 3.3
100	0

IC1202 (NJM2903D)

Pin No.	Voltage (V)
1	5
2	2.5
3	4.5
4	0
5	0
6	0
7	0
8	5

**D** DOUT ASSY

IC1801 (TC74HCU04AF)

Pin No.	Voltage (V)
1	0
2	0
3	0 to 5
4	0 to 5
5	0 to 5
6	0 to 5
7	0
8	0 to 5
9	0 to 5
10	0 to 5
11	0 to 5
12	0 to 5
13	0 to 5
14	5







**D** FLRB ASSY

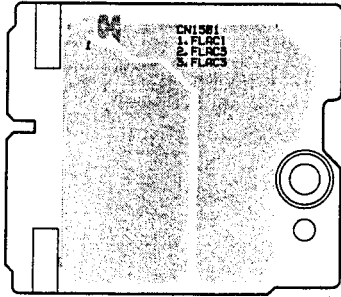

**E** SLMB ASSY

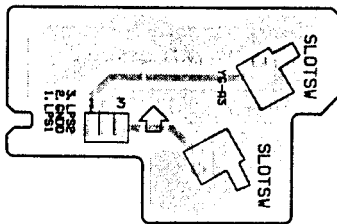

**F** MMCB ASSY

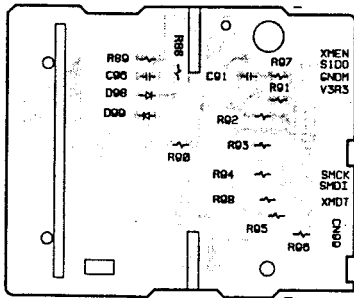

(DNP-1986B)

**SIDE B**

**B** SPCN ASSY

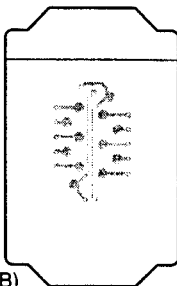

(DNP-1986B)

**A** MAIN ASSY

• This PCB is a four-layered board.

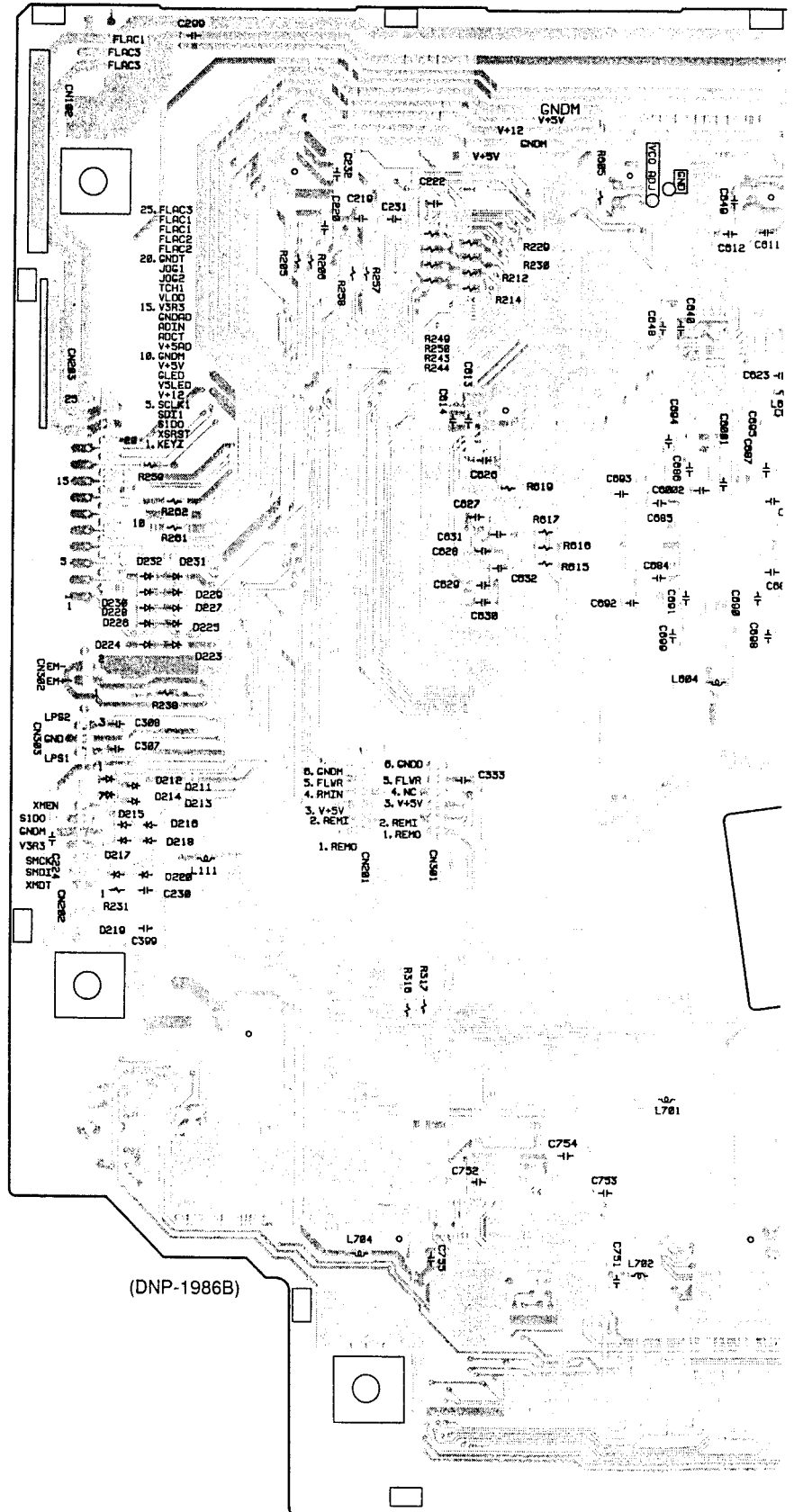

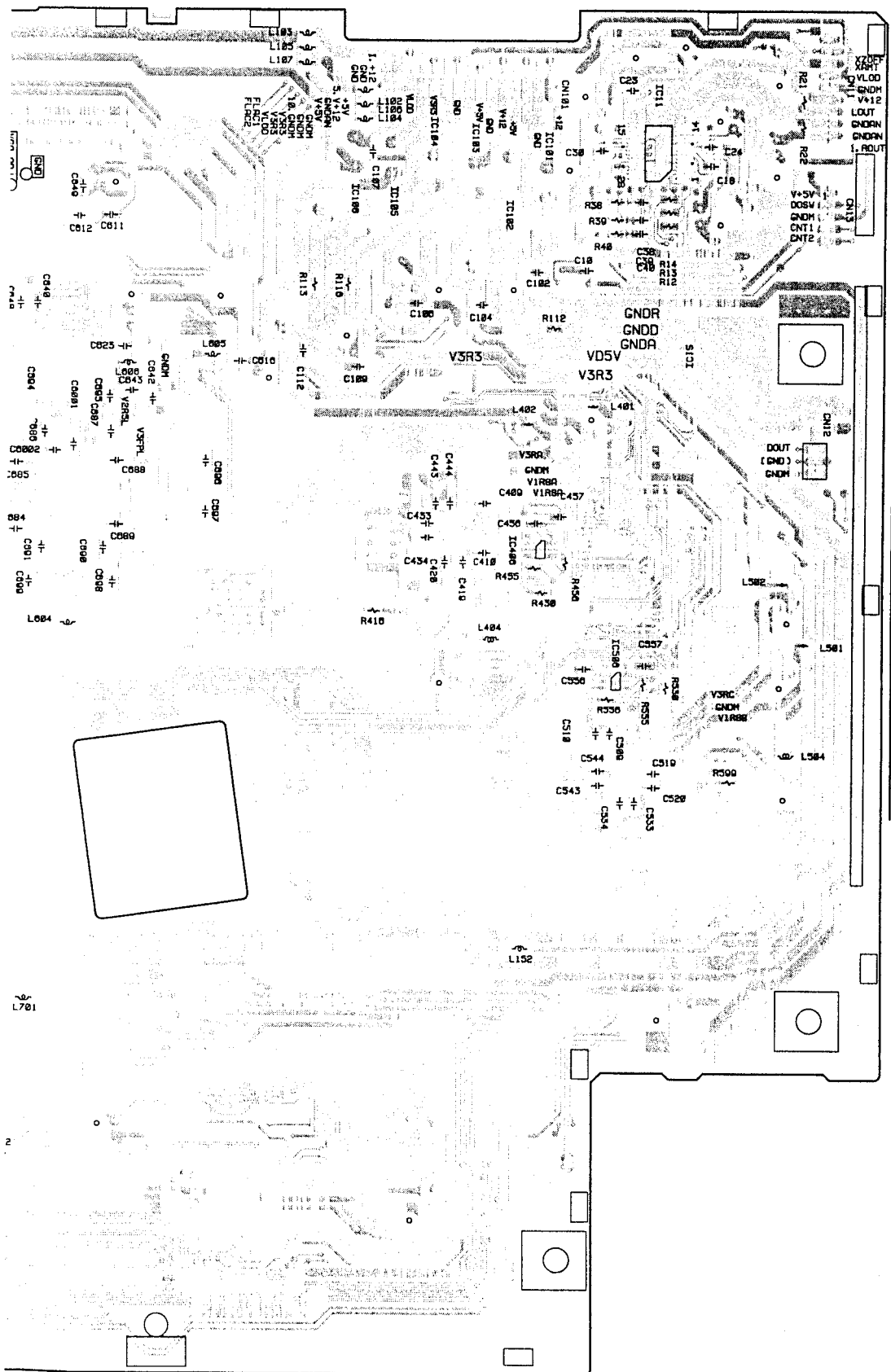

IC11

IC406

IC506

**SIDE B**

4.2 JABB, JACB and DOUT ASSYS

**SIDE A**

A

**H** JACB ASSY

**G** DABB ASSY

**A** CN11

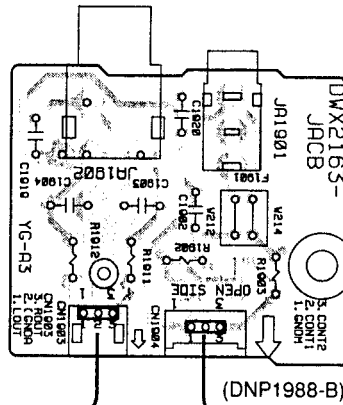
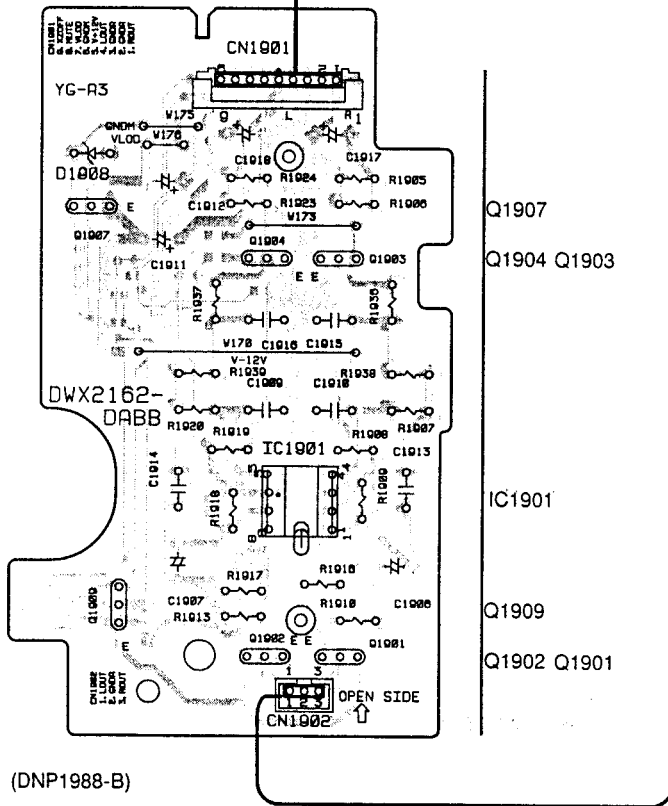

**I** DOUT ASSY

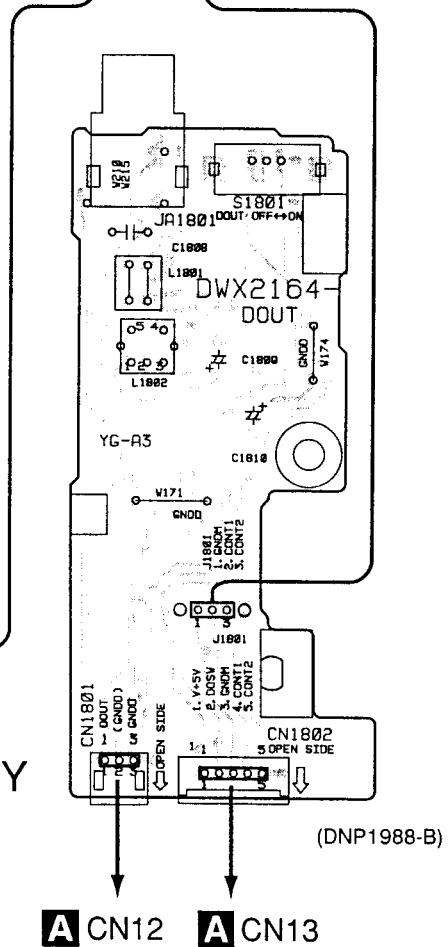

B

C

D



### 4.3 MFLB, RSWB, KSWB and SLDB ASSYS

**A**  
**SIDE A**

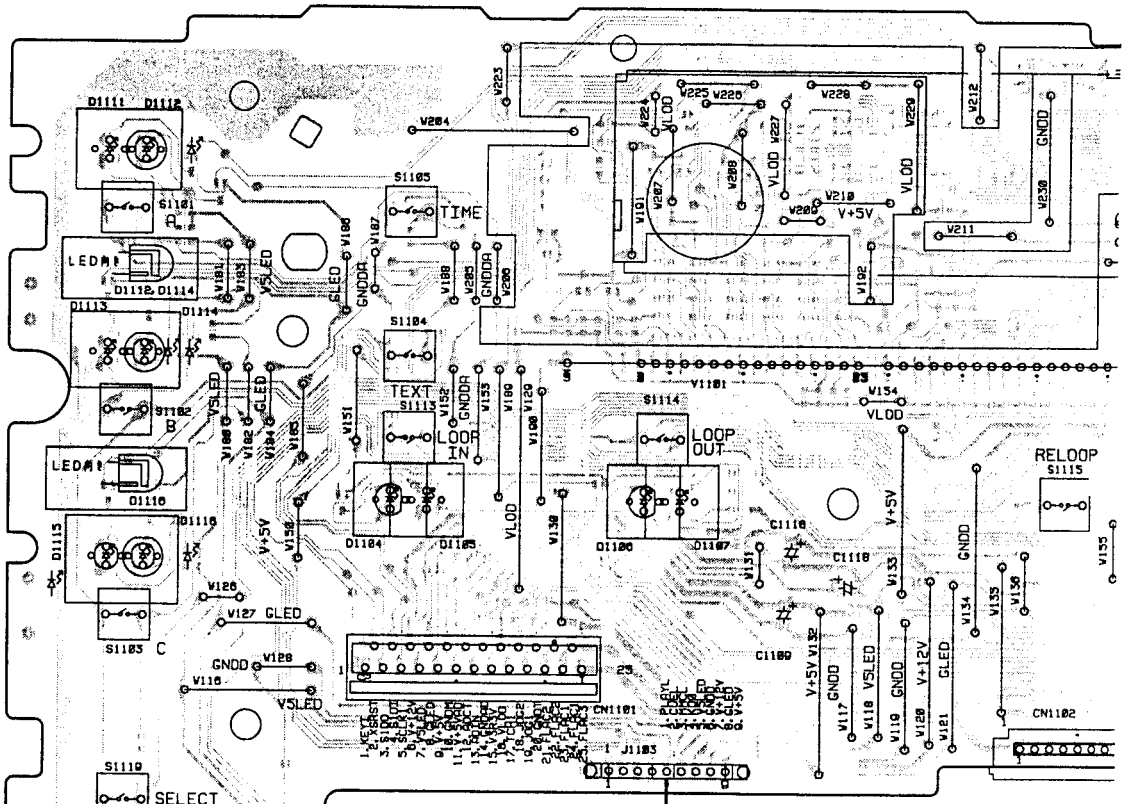

**K** RSWB ASSY

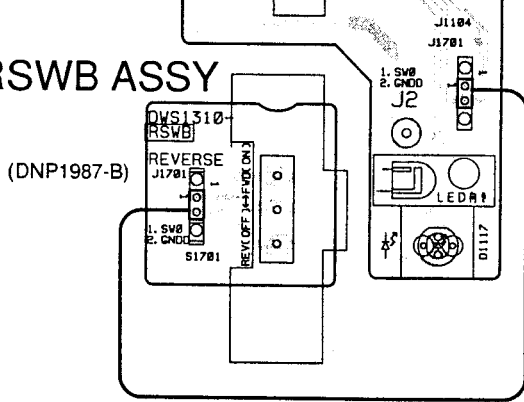

**N** J1

**L** KSWB ASSY

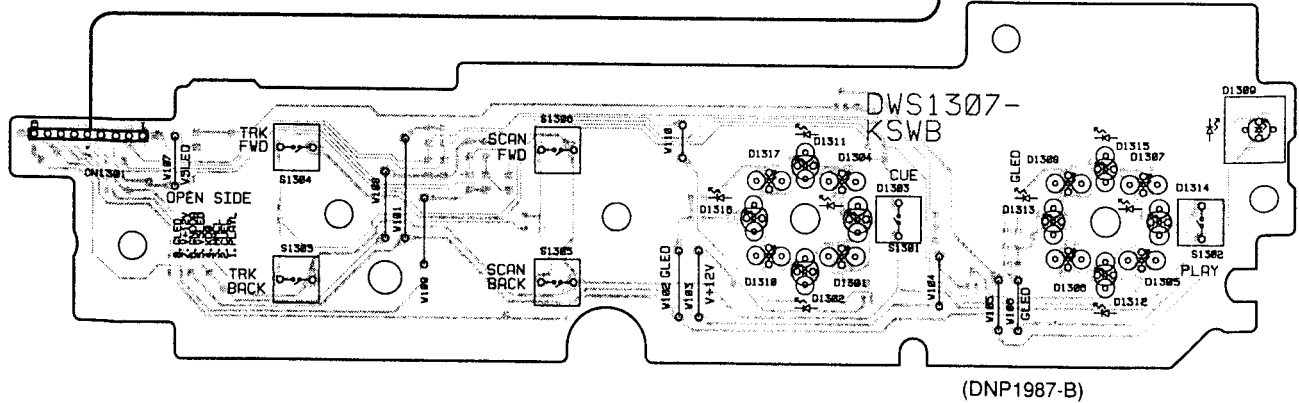

**J** **K** **L**

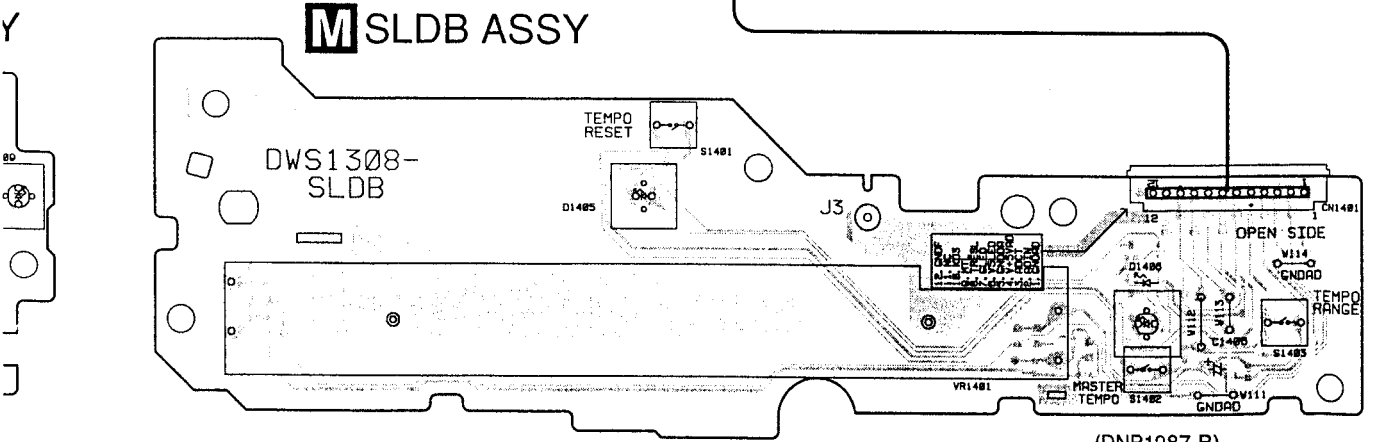
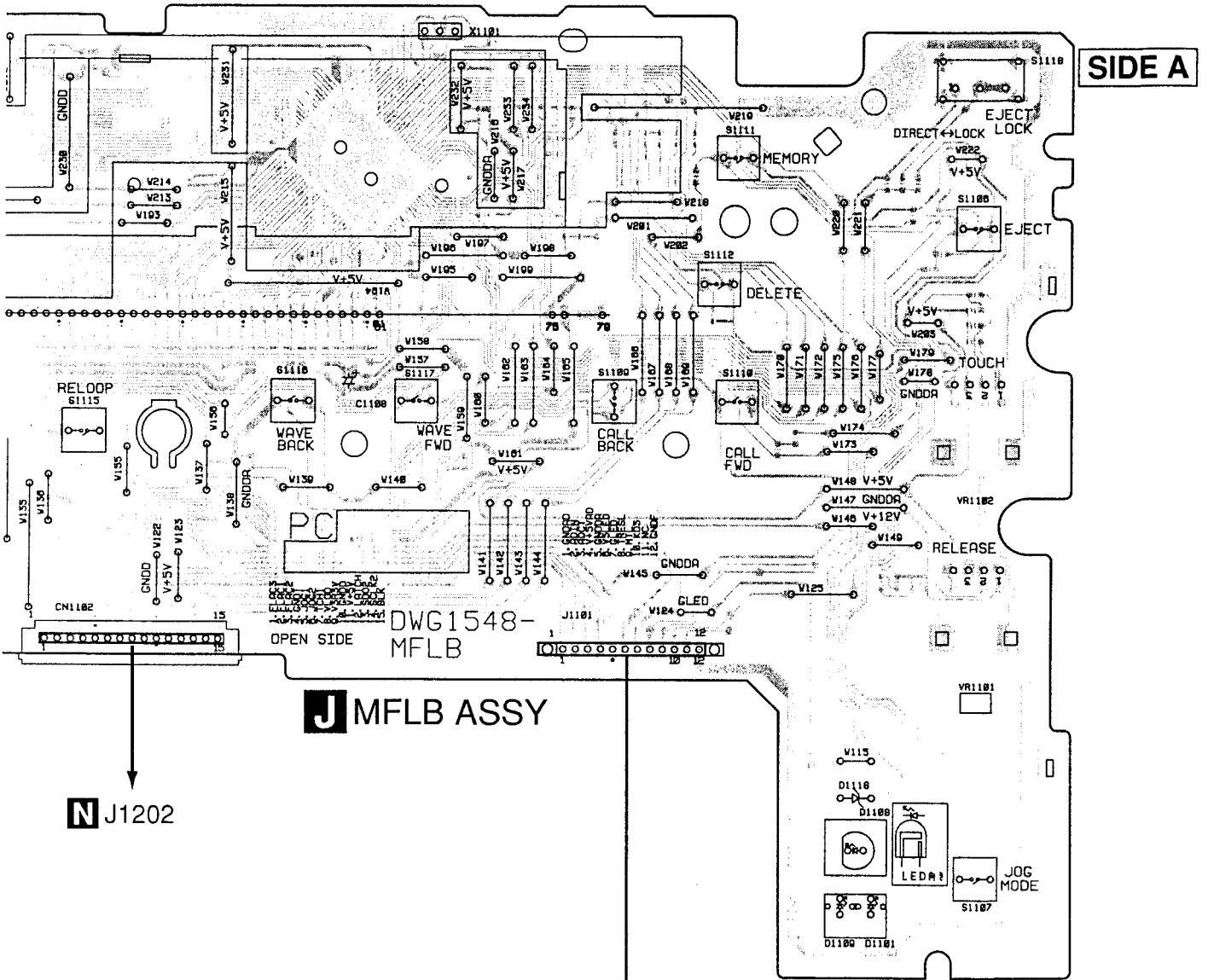

(DNP1987-B)



A

**J** MFLB ASSY

**SIDE B**

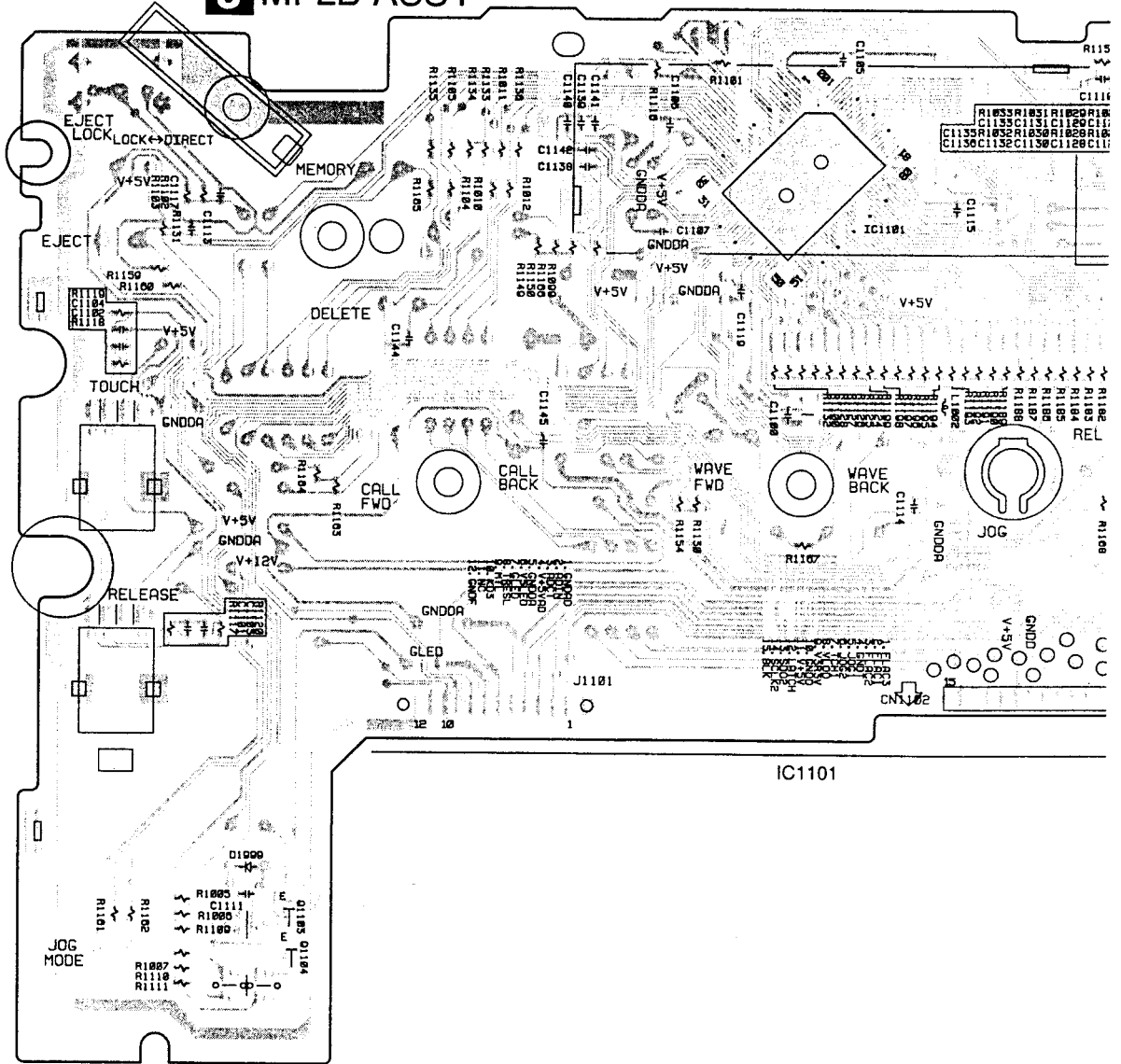

(DNP1987-B)

Q1103  
Q1104

3

C

**M** SLDB ASSY

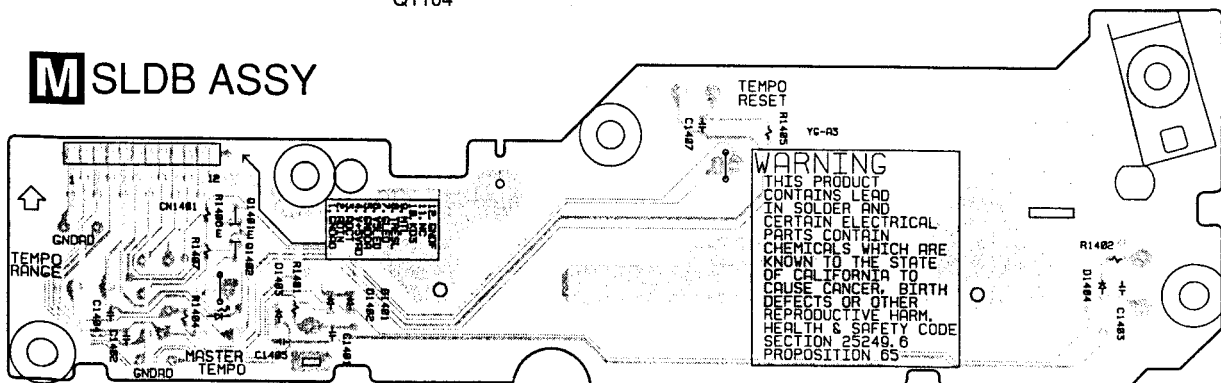

(DNP1987-B)

Q1401  
Q1402

SIDE B

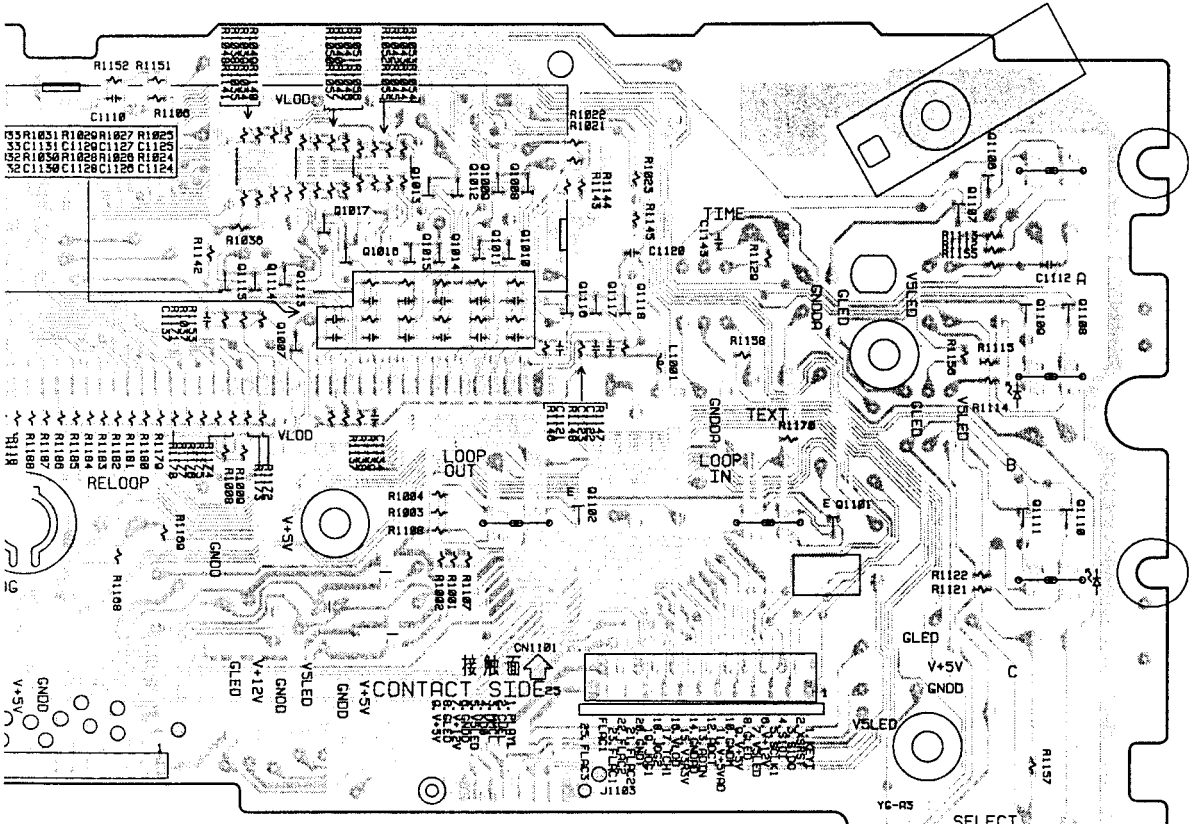

Q1007 Q1013 Q1009  
 Q1017 Q1012 Q1008 Q1102  
 Q1114 Q1016 Q1115 Q1011 Q1116 Q1118  
 Q1115 Q1113 Q1015 Q1014 Q1010 Q1117

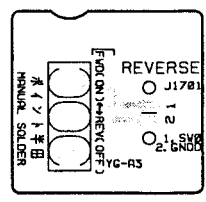
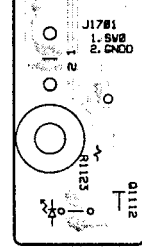

**K**  
 RSWB  
 ASSY

Q1106  
 Q1107 Q1109 Q1108  
 Q1101 Q1111 Q1110  
 Q1112

**L** KSWB ASSY

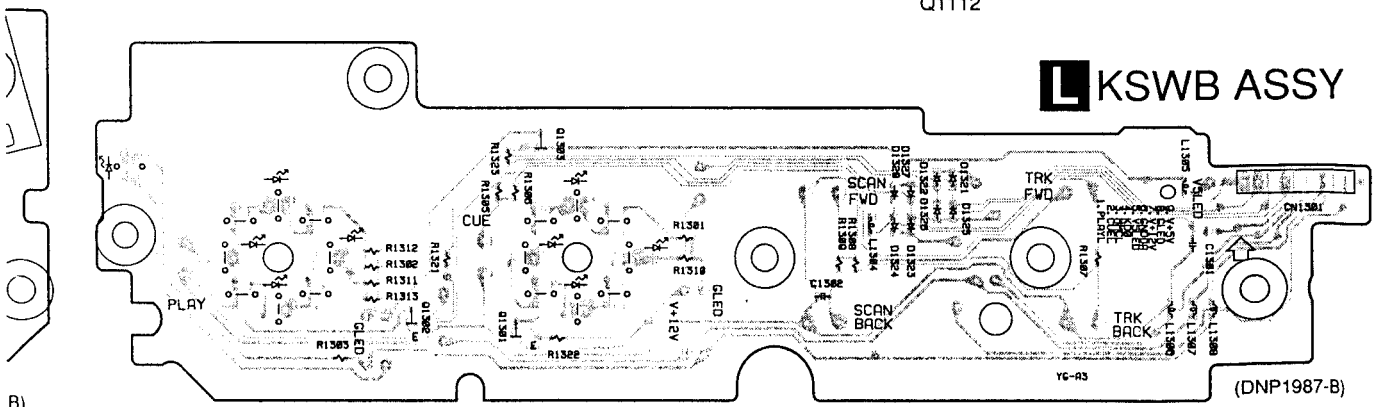

Q1302 Q1301 Q1303

**J K L** 47

### 4.4 JFLB and JOGB ASSYS

**SIDE A**

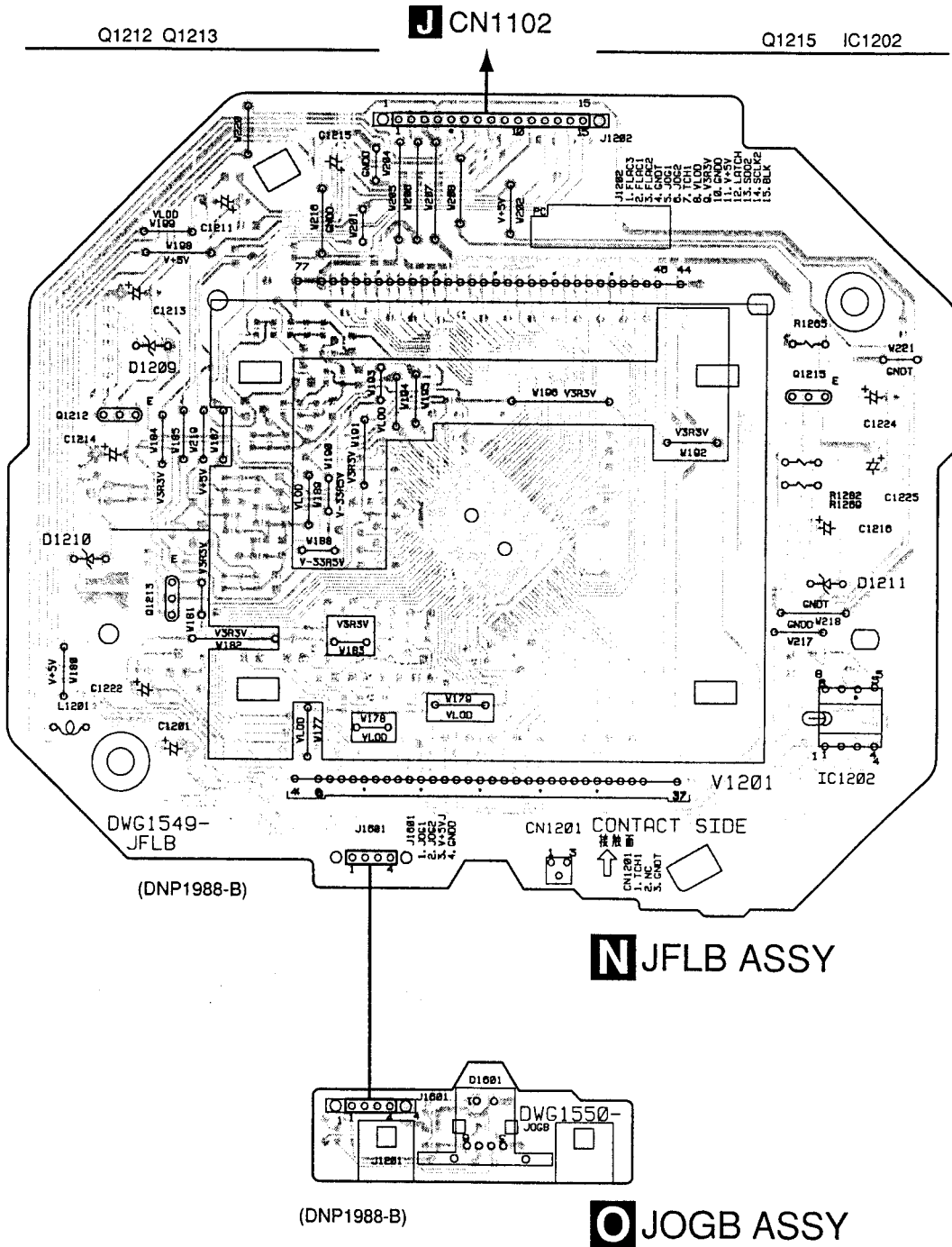

SIDE B

Q1211 Q1209  
Q1202 Q1204 Q1205 Q1210  
IC1201 Q1201 Q1203 Q1206 Q1207 Q1214

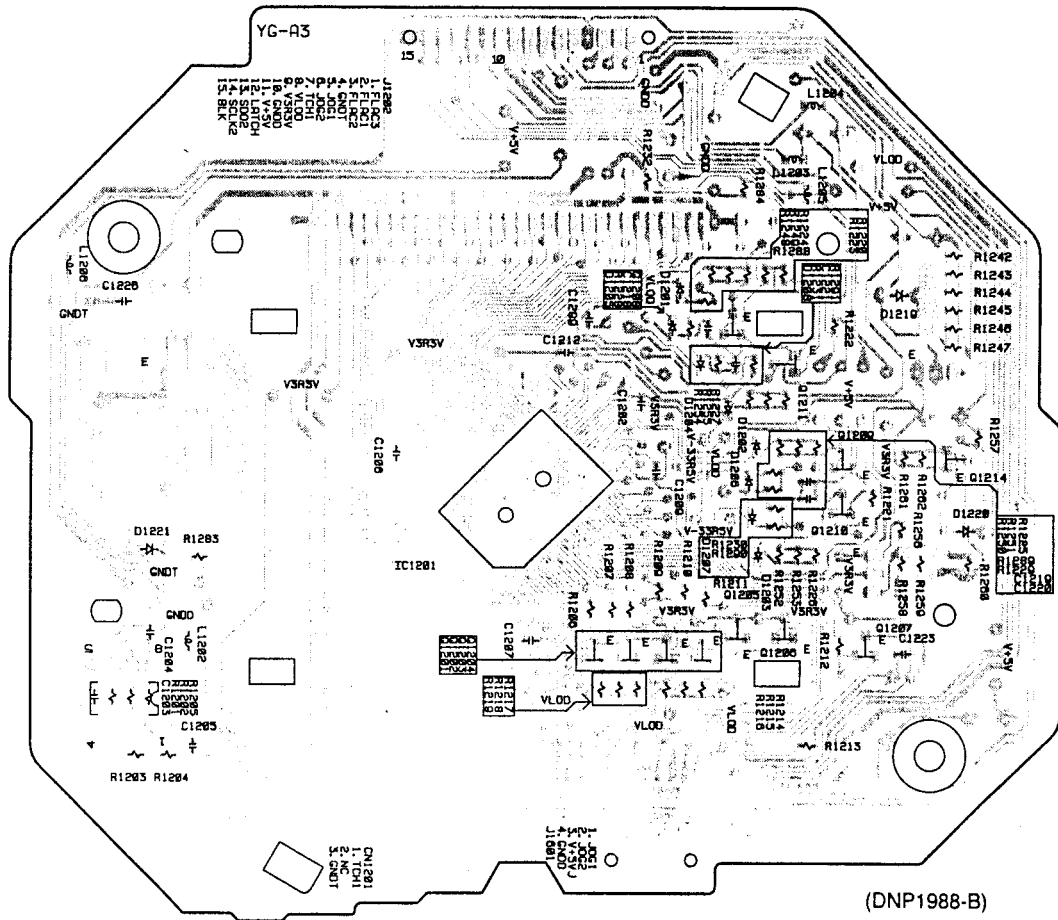

N JFLB ASSY

O JOGB ASSY

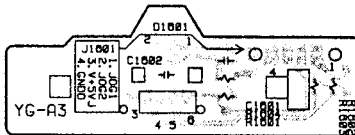

### 4.5 POWER SUPPLY and PSWB ASSYS

**SIDE A**

**P** POWER SUPPLY ASSY

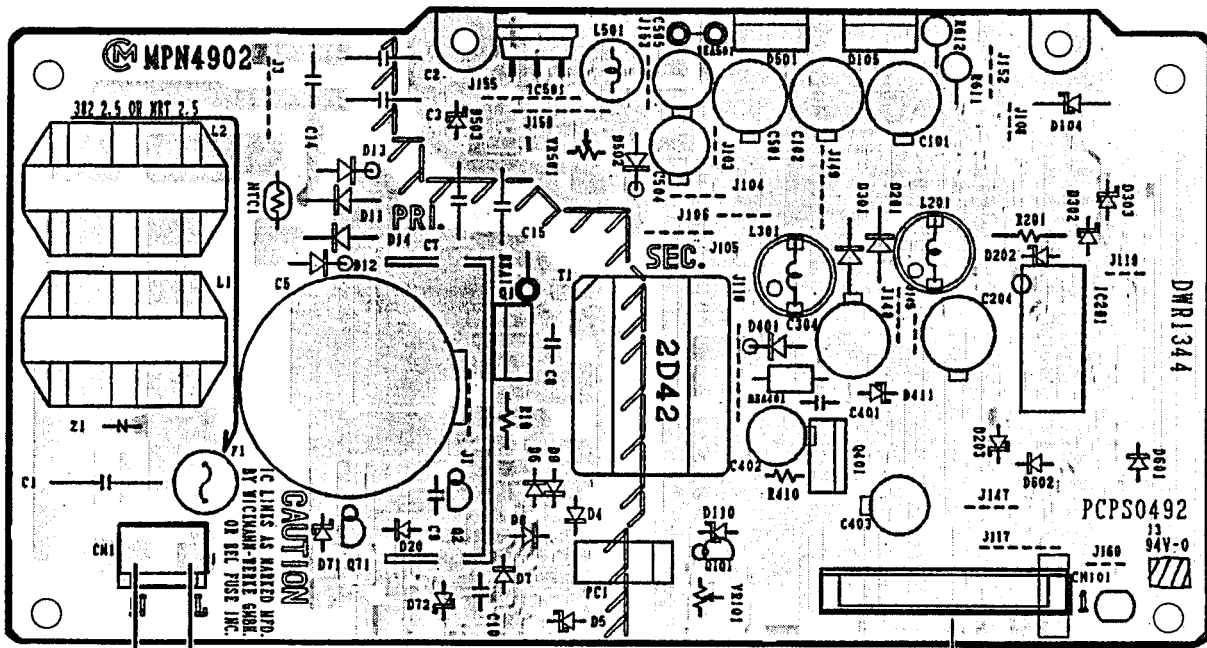

**A** CN101

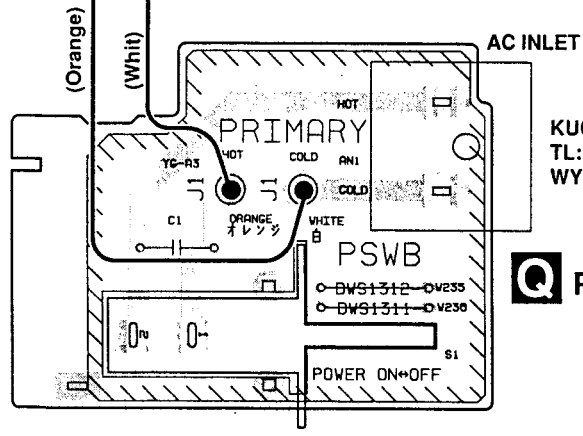

**Q** PSWB ASSY

SIDE B

**P** POWER SUPPLY ASSY

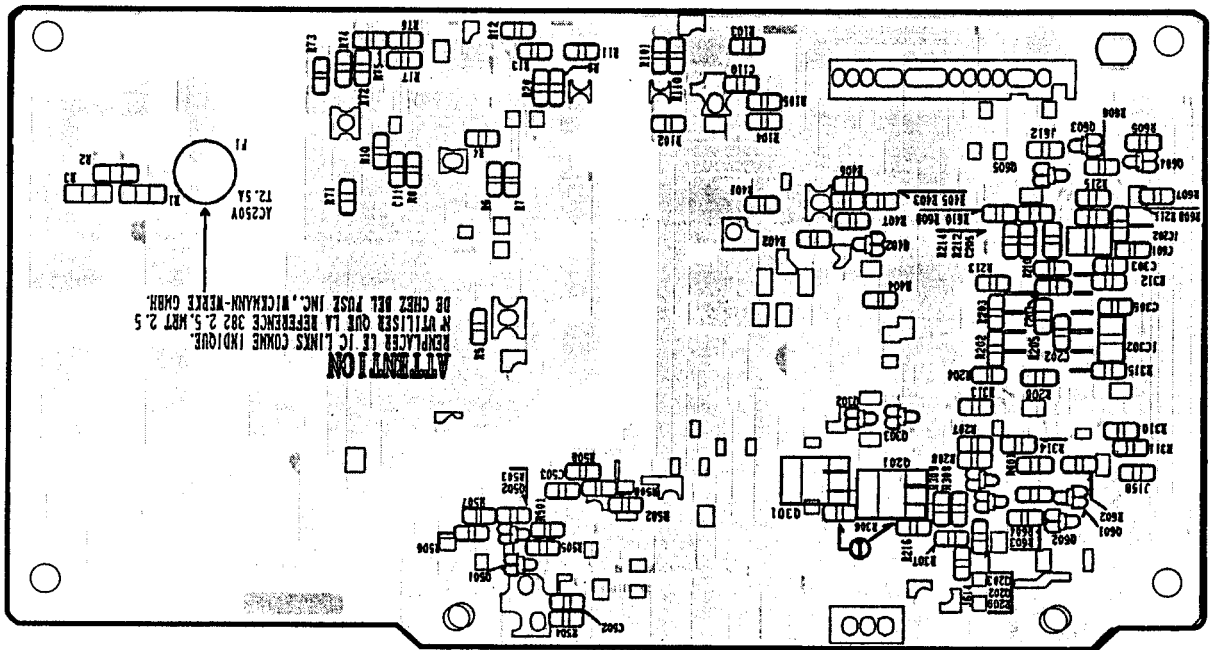

### 5. PCB PARTS LIST

- NOTES:**
- Parts marked by "NSP" are generally unavailable because they are not in our Master Spare Parts List.
  - The  $\Delta$  mark found on some component parts indicates the importance of the safety factor of the part. Therefore, when replacing, be sure to use parts of identical designation.
  - When ordering resistors, first convert resistance values into code form as shown in the following examples.
    - Ex.1 When there are 2 effective digits (any digit apart from 0), such as 560 ohm and 47k ohm (tolerance is shown by J=5%, and K=10%).
      - 560  $\Omega$   $\rightarrow$  56  $\times$  10<sup>1</sup>  $\rightarrow$  561 ..... RD114PU [5] [6] [1] J
      - 47k  $\Omega$   $\rightarrow$  47  $\times$  10<sup>3</sup>  $\rightarrow$  473 ..... RD114PU [4] [7] [3] J
      - 0.5  $\Omega$   $\rightarrow$  R50 ..... RN2H [R] [5] [0] K
      - 1  $\Omega$   $\rightarrow$  1R0 ..... RS1P [1] [R] [0] K
    - Ex.2 When there are 3 effective digits (such as in high precision metal film resistors).
      - 5.62k  $\Omega$   $\rightarrow$  562  $\times$  10<sup>1</sup>  $\rightarrow$  5621 ..... RN114PC [5] [6] [2] [1] F

### • LIST OF WHOLE PCB ASSEMBLIES

Mark	Symbol and Description	Part No.			Remarks		
		CDJ-1000/ KUC	CDJ-1000/ TL	CDJ-1000/ WY			
NSP	MOTHER ASSY	DWM2123	DWM2123	DWM2123			
	└ MAIN ASSY	DWX2161	DWX2161	DWX2161			
	└ MMCB ASSY	DWX2169	DWX2169	DWX2169			
	└ SPCN ASSY	DWX2170	DWX2170	DWX2170			
	└ STCN ASSY	DWX2171	DWX2171	DWX2171			
NSP	DISP ASSY	DWM2126	DWM2124	DWM2124			
	└ MFLB ASSY	DWG1548	DWG1548	DWG1548			
	└ KSWB ASSY	DWS1307	DWS1307	DWS1307			
	└ SLDB ASSY	DWS1308	DWS1308	DWS1308			
	└ SLMB ASSY	DWS1309	DWS1309	DWS1309			
	└ RSWB ASSY	DWS1310	DWS1310	DWS1310			
	└ PSWB ASSY	DWS1312	DWS1311	DWS1311			
	NSP	SUB ASSY	DWM2125	DWM2125		DWM2125	*1
		└ JFLB ASSY	DWG1549	DWG1549		DWG1549	
		└ JOGB ASSY	DWG1550	DWG1550		DWG1550	
└ DABB ASSY		DWX2162	DWX2162	DWX2162			
└ JACB ASSY		DWX2163	DWX2163	DWX2163			
└ DOUT ASSY		DWX2164	DWX2164	DWX2164			
└ FLRB ASSY		DWX2166	DWX2166	DWX2166			
$\Delta$ SW POWER SUPPLY ASSY		DWR1344	DWR1344	DWR1344			

\*1: For PSWB ASSY, Refer to "CONTRAST OF PCB ASSEMBLIES" and "PARTS LIST FOR CDJ-1000/KUC".

### • CONTRAST OF PCB ASSEMBLIES

#### P PSWB ASSY

DWS1312 and DWS1311 are constructed the same except for the following:

Mark	Symbol and Description	Part No.		Remarks
		DWS1312	DWS1311	
	AN 1 (AC SOCKET)	AKP7032	Not used	
	AN 1 (1P AC INLET)	Not used	BKP1046	

### • PARTS LIST FOR CDJ-1000/KUC

Mark	No.	Description	Part No.	Mark	No.	Description	Part No.
<b>A MAIN ASSY</b>							
<b>SEMICONDUCTORS</b>							
		IC800	AN8702NFH			C 417, C 418, C 517, C 518, C 638	CCSRCH100D50
		IC850	BA10358F			C 831	CCSRCH100D50
		IC10	BA178M05FP			C 221, C 223, C 38-C 40, C 405	CCSRCH101J50
		IC202	BR24C64F			C 411, C 413, C 415, C 421, C 423	CCSRCH101J50
$\Delta$		IC106 (I = 0.4A)	ICP-N10			C 425, C 427, C 429, C 435, C 437	CCSRCH101J50
$\Delta$		IC102, IC103 (I = 0.6A)	ICP-N15			C 439, C 445, C 469, C 505, C 511	CCSRCH101J50
$\Delta$		IC101, IC104 (I = 0.8A)	ICP-N20			C 513, C 515, C 521, C 523, C 525	CCSRCH101J50
$\Delta$		IC105 (I = 1A)	ICP-N25			C 527, C 529, C 535, C 537, C 539	CCSRCH101J50
		IC606	K4S641632D-TL1L			C 545, C 569, C 700	CCSRCH101J50
		IC950	LA6562			C 635, C 637	CCSRCH120J50
		IC900	LB11975			C 603, C 633	CCSRCH121J50
		IC600	M51957BFP-TFB			C 464, C 634	CCSRCH150J50
		IC404	MM1561JF			C 463	CCSRCH180J50
		IC700	MN677061ZY			C 803	CCSRCH181J50
		IC609	NJM78L05UA			C 957	CCSRCH220J50
		IC300	PD3431A9			C 407, C 431, C 441, C 461, C 507	CCSRCH221J50
		IC201	PD3432A9			C 531, C 541, C 614	CCSRCH221J50
		IC11	PE8001A			C 959	CCSRCH270J50
		IC602	PE9012A			C 649	CCSRCH271J50
		IC150, IC206	PQ1R33			C 914	CCSRCH331J50
		IC100, IC607	PQ2TZ15			C 807	CCSRCH390J50
		IC203	TC74HC4053AFT			C 467, C 468, C 567, C 568, C 707	CCSRCH470J50
		IC12	TC74HC7007AF			C 713	CCSRCH470J50
		IC205	TC74VHC08FT			C 453	CCSRCH471J50
		IC405	TC74VHC541FT			C 723, C 818, C 819	CCSRCH561J50
		IC407	TC7S04FU			C 724	CCSRCH681J50
		IC204, IC403, IC710	TC7SET08FU			C 103, C 108, C 110, C 121, C 155	CEHAR101M10
		IC711	TC7SET32FU			C 17, C 20, C 201, C 21, C 211	CEHAR101M10
		IC610	TC7SH08FU			C 22, C 29, C 401, C 452, C 499	CEHAR101M10
		IC406, IC506	TC7SU04F			C 501, C 502, C 599, C 602, C 622	CEHAR101M10
		IC611	TC7SU04FU			C 624, C 625, C 901, C 951	CEHAR101M10
		IC605	TC7WT241FU			C 101, C 105, C 25-C 28, C 828	CEHAR470M16
		IC13, IC402, IC608, IC612, IC701	TC7WU04FU			C 900	CEHAR470M16
		IC604	TLC2932PW			C 33, C 704, C 708, C 712, C 806	CKSRBY102K50
		IC801	XC2S50-5PQ208C			C 811-C 813	CKSRBY102K50
		IC401, IC501	XCA56367PV150			C 10, C 102, C 104, C 106, C 109	CKSRBY103K50
		Q 600	2SA1577			C 11, C 112, C 122, C 123, C 154	CKSRBY103K50
		Q 204	2SC4081			C 157, C 158, C 16, C 200	CKSRBY103K50
		Q 11, Q 202	DTA124EUA			C 202, C 203, C 205-C 210	CKSRBY103K50
		Q 201, Q 203, Q 301, Q 701, Q800	DTC124EUA			C 217, C 218, C 225, C 226	CKSRBY103K50
		Q 950	DTC124EUA			C 230-C 233, C 31, C 32	CKSRBY103K50
		D 11, D 203-D 232	1SS355			C 331-C 333, C 400, C 402, C 406	CKSRBY103K50
						C 408, C 412, C 414, C 416, C 422	CKSRBY103K50
						C 424, C 426, C 428, C 430, C 432	CKSRBY103K50
						C 436, C 438, C 440, C 442	CKSRBY103K50
<b>COILS AND FILTERS</b>							
		L 401, L 402, L 601, L 602	ATL7002			C 446-C 451, C 456, C 457, C 462	CKSRBY103K50
		L 11, L 13, L 200	DTL1024			C 466, C 500, C 506, C 508, C 512	CKSRBY103K50
		L 404, L 504	LCTA1RQJ2520			C 514, C 516, C 522, C 524, C 526	CKSRBY103K50
		L 10, L 101, L 111, L 15, L 152	PTL1014			C 528, C 530, C 532, C 536, C 538	CKSRBY103K50
		L 201, L 600, L 603-L 611	PTL1014			C 540, C 542, C 546-C 551	CKSRBY103K50
		L 701-L 705	PTL1014			C 556, C 557, C 6001, C 6002, C 601	CKSRBY103K50
						C 604, C 607, C 613, C 615, C 616	CKSRBY103K50
						C 618, C 623, C 626-C 632, C 636	CKSRBY103K50
						C 641-C 644, C 651-C 683, C 714	CKSRBY103K50
						C 726, C 730, C 733, C 751-C 755	CKSRBY103K50

Mark	No.	Description	Part No.
	C 800, C 857, C 910, C 964 C 159, C 18, C 204, C 213, C 215 C 228, C 23, C 24, C 30, C 300 C 306, C 605, C 608-C 610, C 612 C 620, C 621, C 715, C 716, C 725	CKSRYB103K50 CKSRYB104K16 CKSRYB104K16 CKSRYB104K16 CKSRYB104K16	
	C 902, C 904, C 905 C 229, C 600, C 640, C 648 C 911 C 606, C 639, C 833, C 903 C 820	CKSRYB104K16 CKSRYB105K6R3 CKSRYB222K50 CKSRYB224K10 CKSRYB273K16	
	C 470, C 570 C 706, C 802, C 821 C 703 C 834, C 835 C 301, C 303, C 305, C 702, C 705	CKSRYB472K50 CKSRYB473K25 CKSRYB562K50 CKSRYB682K50 CKSRYF104Z25	
	C 709-C 711, C 717-C 722, C 732 C 801, C 804, C 805, C 808-C 810 C 815, C 822, C 825, C 826, C 830 C 832, C 950, C 952-C 956 C 455, C 940	CKSRYF104Z25 CKSRYF104Z25 CKSRYF104Z25 CKSRYF104Z25 CKSRYF105Z10	
	C 454 (2.2μF/10V)	VCG1031	
<b>RESISTORS</b>			
	R 825 (47Ω) R 900, R 901 (4.7Ω) R 323, R 324, R 419, R 654-R 657 R 681, R 682 R 828	DCN1133 DCN1141 RAB4C101J RAB4C101J RAB4C123J	
	R 453 R 800, R801 R 834 R 218, R 401, R 420, R421, R501 R 829 R 1-R 7 R 604 R 806 R 605 VR601 (4.7KΩ)	RAB4C220J RAB4C273J RAB4C303J RAB4C473J RAB4C822J RS1/10S0R0J RS1/16S1502F RS1/16S2202F RS1/16S8202F VCP1172	
	Other Resistors	RS1/16S□□□ J	
<b>OTHERS</b>			
	X 401 X 701 X 201, X 300 X 601 X 602	ASS7023 DSS1126 DSS1127 RSS1055 VSS1086	
	CN13 5P JUMPER CONNECTOR CN11 9P JUMPER CONNECTOR CN101 15P JUMPER CONNECTOR CN102 3P JUMPER CONNECTOR CN201, CN301 KR CONNECTOR	52147-0510 52147-0910 52147-1510 52151-0310 B6B-PH-K	
	CN900 12P FFC CONNECTOR CN950 4P FFC CONNECTOR CN203 25P CONNECTOR CN302 CONNECTOR POST CN12, CN303 CONNECTOR POST	DKN1205 DKN1223 HLEM25R-1 S2B-PH-K S3B-PH-K	
	CN202 CONNECTOR POST	S7B-PH-K	

Mark	No.	Description	Part No.
<b>B</b>		<b>SPCN ASSY</b>	
		<b>OTHERS</b> CN911, CN912 12P CONNECTOR	DKN1205
<b>C</b>		<b>STCN ASSY</b>	
		<b>OTHERS</b> CN913, CN914 4P CONNECTOR	DKN1223
<b>D</b>		<b>FLRB ASSY</b>	
		<b>RESISTORS</b> R 1504-R 1508	RS3LMF300J
		<b>OTHERS</b> CN1501 3P JUMPER CONNECTOR	52147-0310
<b>E</b>		<b>SLMB ASSY</b>	
		<b>SWITCHES</b> S 1501, S 1502	DSG1017
		<b>OTHERS</b> CN1501 KR CONNECTOR POST	S3B-PH-K
<b>F</b>		<b>MCCB ASSY</b>	
		<b>CAPACITORS</b> C 91 C 99 C 97	CCSRCH221J50 CKSRYB103K50 CKSRYB104K16
		<b>RESISTORS</b> Other Resistors	RS1/16S□□□ J
		<b>OTHERS</b> CN99 CONNECTOR POST CN999 SD CONNECTOR	B7B-PH-K DKN1231
<b>G</b>		<b>DABB ASSY</b>	
		<b>SEMICONDUCTORS</b> IC1901 Q 1907 Q 1906 Q 1901 -Q 1904 Q 1905	NJM4580D 2SA1145 DTA124EUA 2SD2144S DTC124EUA
		D 1906 D 1904, D 1905, D 1907 D 1918	1SR154-400 1SS355 UDZ13B
		<b>CAPACITORS</b> C 1906, C 1907 C 1912 C 1905, C 1908 C 1915, C 1916 C 1909, C 1910, C 1913, C 1914	CEANP101M16 CEAT101M50 CKSRYB104K16 CQMB102J50 CQMB152J50
		<b>RESISTORS</b> R 1908, R 1919 R 1909, R 1918 R 1907, R 1920, R 1936, R 1939 R 1916, R 1917 R 1906, R 1910, R 1913, R 1923	RD1/2VM103J RD1/2VM113J RD1/2VM182J RD1/2VM273J RD1/2VM471J

Mark	No.	Description	Part No.
	R 1936, R 1937 Other Resistors	RD1/2VM471J RS1/16S□□□ J	
	<b>OTHERS</b> CN1901 9P JUMPER CONNECTOR CN1902 CONNECTOR POST	52147-0910 B3B-PH-K	
<b>H</b>		<b>JACB ASSY</b>	
		<b>SEMICONDUCTORS</b> D 1902 D 1901, D 1903	1SS355 UDZS10B
		<b>CAPACITORS</b> C 1901 C 1903, C 1904	CKSRYB104K16 CQMB102J50
		<b>RESISTORS</b> R 1903 R 1902, R 1911, R 1912	RD1/2VM271J RD1/2VM471J
		<b>OTHERS</b> CN1904 3PJUMPER CONNECTOR JA1902 2P PIN JACK JA1901 REMOCON JACK CN1903 CONNECTOR POST	52151-0310 BKB1017 RKN1004 S3B-PH-K
<b>I</b>		<b>DOUT ASSY</b>	
		<b>SEMICONDUCTORS</b> IC1801	TC74HCU04AF
		<b>COILS AND FILTERS</b> L 1802 L 1803 L 1801	PTL1003 PTL1014 PTL1017
		<b>SWITCHES AND RELAYS</b> S 1801	DSH1025
		<b>CAPACITORS</b> C 1810 C 1809 C 1808 C 1802 C 1803, C 1804, C 1806, C 1807	CEAT101M6R3 CEAT470M10 CGCYX104M16 CKSRYB102K50 CKSRYB104K16
		<b>RESISTORS</b> Other Resistors	RS1/16S□□□ J
		<b>OTHERS</b> 0 J 1801 JA1801 CN1801	3P CABLE HOLDER JUMPER WIRE 1P JACK CONNECTOR POST
		51048-0300 D20PYY0305E PKB1028 S3B-PH-K	

Mark	No.	Description	Part No.
<b>J</b>		<b>MFLB ASSY</b>	
		<b>SEMICONDUCTORS</b> △ IC1101 Q 1007-Q 1017, Q 1113-Q 1118 Q 1112 Q 1101-Q 1104, Q 1106-Q 1111 D 1117	PE5243A 2SC4081 DTA124EUA DTC124EUA BR5364X
		D 1104-D 1107 D 1108 D 1112, D 1114, D 1116 D 1101, D 1109 D 1111, D 1113, D 1115	EMAY3864X-HM NSPB500-0008 SLA570MT SLR-343MC SLR-343VC
		<b>COILS AND FILTERS</b> L 1001, L 1002	PTL1014
		<b>SWITCHES</b> S 1104-S 1107, S 1109-S 1112 S 1116, S 1117, S 1119 S 1101-S 1103, S 1113-S 1115 S 1118	ASG7013 ASG7013 DSG1063 DSH1049
		<b>CAPACITORS</b> C 1143-C 1145 C 1112-C 1114, C 1138-C 1142 C 1121-C 1137 C 1108, C 1109, C 1116, C 1118 C 1100-C 1107, C 1110, C 1111, C 1115	CCSRCH101J50 CCSRCH102J50 CCSRCH471J50 CEHAR470M16 CKSRYB103K50
		C 1117, C 1119, C 1120	CKSRYB103K50
		<b>RESISTORS</b> VR1101, VR1102 (10KΩ-B) Other Resistors	DCS1045 RS1/16S□□□ J
		<b>OTHERS</b> X 1101 4.19MHz 0 2P CABLE HOLDER 0 9P CABLE HOLDER 0 12P CABLE HOLDER CN1101 25P CONNECTOR	DSS1130 51048-0200 51048-0900 51048-1200 52492-2520
		J 1103 9P JUMPER WIRE J 1101 12P JUMPER WIRE V 1101 FL INDICATOR TUBE 0 FL HOLDER	D20PYY0915E D20PYY1215E DEL1044 DNF1665
<b>K</b>		<b>RSWB ASSY</b>	
		<b>SWITCHES</b> S 1701	DSK1021
		<b>OTHERS</b> 0 J 1701	2P CABLE HOLDER 2P JUMPER WIRE
		51048-0200 D20PYY0210E	



Mark No. Description Part No.

**L KSWB ASSY**  
SEMICONDUCTORS

Q 1301-Q 1303	DTA124EUA
D 1321-D 1328	1SS355
D 1301-D 1304, D 1310, D 1311	EMAY3864X-HM
D 1316, D 1317	EMAY3864X-HM
D 1312-D 1315	SLR-342PC
D 1305-D 1308	SLR-343MC
D 1309	SLR-343VC

**COILS AND FILTERS**  
L 1304-L 1308

PTL1014

**SWITCHES**

S 1303-S 1306	ASG7013
S 1301, S 1302	DSG1063

**CAPACITORS**

C 1302	CCSRCH101J50
C 1301	CCSRCH102J50

**RESISTORS**

Other Resistors	RS1/16S□□□ J
-----------------	--------------

**OTHERS**

CN1301 9P JUMPER CONNECTOR	52151-0910
----------------------------	------------

**M SLDB ASSY**  
SEMICONDUCTORS

Q 1401, Q 1402	DTA124EUA
D 1401-D 1404	1SS355
D 1405	SLR-343MC
D 1406	SLR-343VC

**SWITCHES**

S 1401-S 1403	ASG7013
---------------	---------

**CAPACITORS**

C 1407	CCSRCH101J50
C 1404	CCSRCH102J50
C 1406	CEHAT100M50
C 1401	CKSRBYB103K50
C 1402, C 1403	CKSRBYB104K16

**RESISTORS**

VR1401 (10kΩ-B)	DCV1012
Other Resistors	RS1/16S□□□ J

**N JFLB ASSY**  
SEMICONDUCTORS

△ IC1202	NJM2903D
△ IC1201	UPD16306B
△ Q 1212	2SA933S
Q 1201-Q 1207, Q 1214	2SC2412K
Q 1208-Q 1211	2SJ209
Q 1213, Q1215	2SB1237X
D 1201-D 1208	1SS355
D 1210	MTZJ30D
D 1221	UDZ12B
D 1219	UDZ4.3B

Mark No. Description Part No.

**COILS AND FILTERS**

L 1201	LRCA101J
L 1202-L 1205	PTL1014

**CAPACITORS**

C 1211, C 1213, C 1214, C 1216, C 1224	CEHAT100M50
C 1201, C 1215	CEHAT101M16
C 1225	CEHAT101M50
C 1203	CKSRBYB102K50
C 1202, C 1204, C 1206, C 1207, C 1209	CKSRBYB103K50
C 1212, C 1218-C 1221, C 1223, C 1226	CKSRBYB103K50

**RESISTORS**

R 1269, R 1282	RD1/2VM221J
R 9999	RS1/10S0R□ J
Other Resistors	RS1/16S□□□ J

**OTHERS**

0	4P CABLE HOLDER	51048-0400
CN1201	FPC CONNECTOR	5597-03CPB
J 1202	15P JUMPER WIRE	D20PY1505E
V 1201	FL INDICATOR TUBE	DEL1043
0	FL HOLDER	DNK3959

**O JOGB ASSY**  
SEMICONDUCTORS

D 1601	GP1A037RBK
--------	------------

**CAPACITORS**

C 1601, C 1602	CKSRBYB103K50
----------------	---------------

**RESISTORS**

Other Resistors	RS1/16S□□□ J
-----------------	--------------

**OTHERS**

0	4P CABLE HOLDER	51048-0400
J 1601	4P JUMPER WIRE	D20PY0405E

**P SW POWER SUPPLY ASSY**  
There is no service parts.

**Q PSWB ASSY**

△ S 1	RSA1001
-------	---------

**OTHERS**

△ AN1	POWER SOCKET	AKP7032
△ J 1	CONNECTOR ASSY	DKP3545
0	PCB BINDER	VEF1040

**6. ADJUSTMENT**

**6.1 ADJUSTMENT ITEMS AND LOCATION**

■ Adjustment Points (PCB Part)

**A MAIN ASSY**

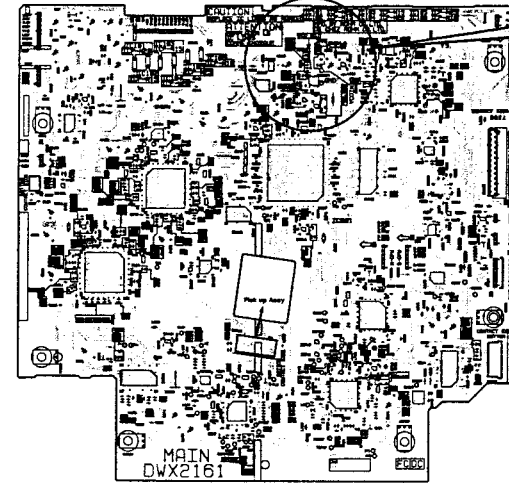

SIDE A

■ Adjustment Items

[Electrical Part]

- ① VCO Free-running Adjustment

**6.2 JIGS AND MEASURING INSTRUMENTS**

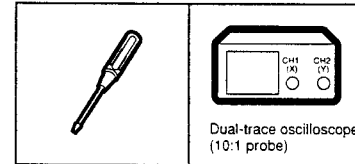

**6.3 NECESSARY ADJUSTMENT POINTS**

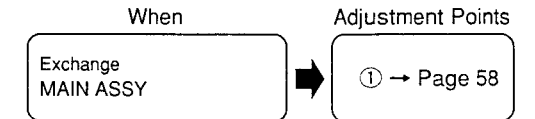

6.4 ELECTRICAL ADJUSTMENT

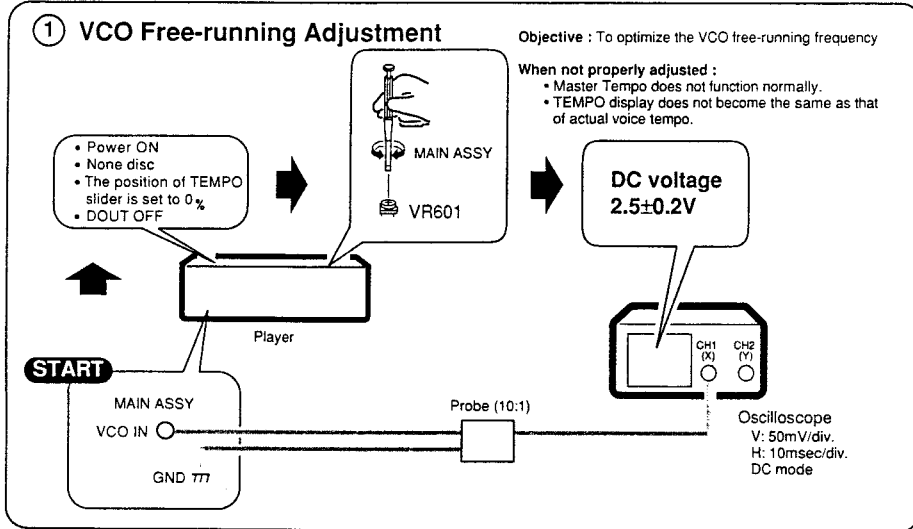

7.1 GENERAL INFORMATION

7.1 DIAGNOSIS

7.1.1 SERVICE MODE

7.1.1.1 HOW TO START / CANCEL SERVICE MODE

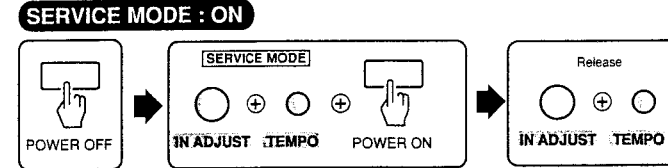

**SERVICE MODE : CANCEL**

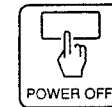

7.1.1.2 OPERATION IN SERVICE MODE

- In the service mode, can check "LED and FL displays" partially as follows.
- In addition, it lights while pressing the key.

**LED CHECK**

Key Name	LED lighting
① HOT CUE -A	<b>A</b> (Green)
② HOT CUE -B	<b>B</b> (Green)
③ HOT CUE -C	<b>C</b> (Green)
④ REC MODE	<b>A B C</b> (Red) (Red) (Red)
⑤ DIRECTION (SW)	<b>REV</b>
⑥ CUE	<b>CUE</b>
⑦ PLAY/PAUSE	<b>▶/  </b> <b>CARD</b>
⑧ IN ADJUST	<b>IN ADJUST</b>
⑨ OUT ADJUST	<b>OUT ADJUST</b>
⑩ JOG MODE	<b>CDJ</b>
⑪ TEMPO	<b>VINYL</b>
⑫ MASTER TEMPO	<b>MASTER TEMPO</b>
⑬ TEMPO RESET	<b>TEMPO RESET</b>

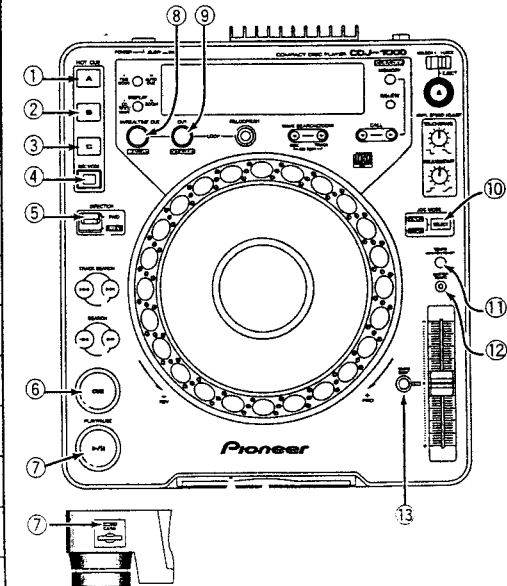

**FL CHECK**

Key Name	FL lighting Position
▶▶	A-1, P-1
◀◀	A-2, P-2
◀◀	B-1, P-3
▶▶	B-2, P-4
TIME MODE/AUTO CUE	C
DISPLAY	D
RELOOP/ EXIT	E
WAVE - FWD	F
WAVE - REV	G
CALL - FWD	H
CALL - REV	I
DELETE	J
MEMORY	All of FL, P: Jog-FL and LED light up.
EJECT LOCK (SW)	L
EJECT	M
MEMORY JOG ADJUST -TOUCH (VOL)	Right from VR Center N
MEMORY JOG ADJUST -RELEASE (VOL)	Right from VR Center O

• Key Position

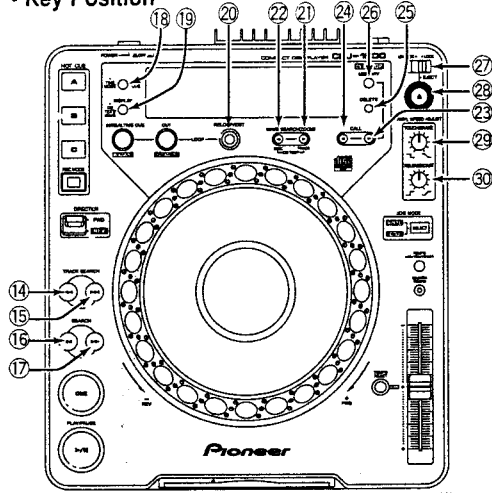

• FL lighting Position (Jog- FL DISPLAY)

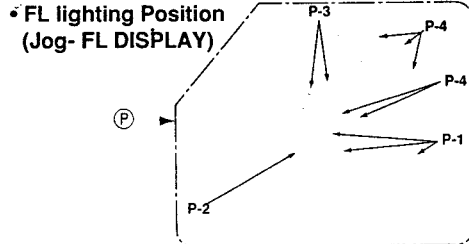

(FL DISPLAY)

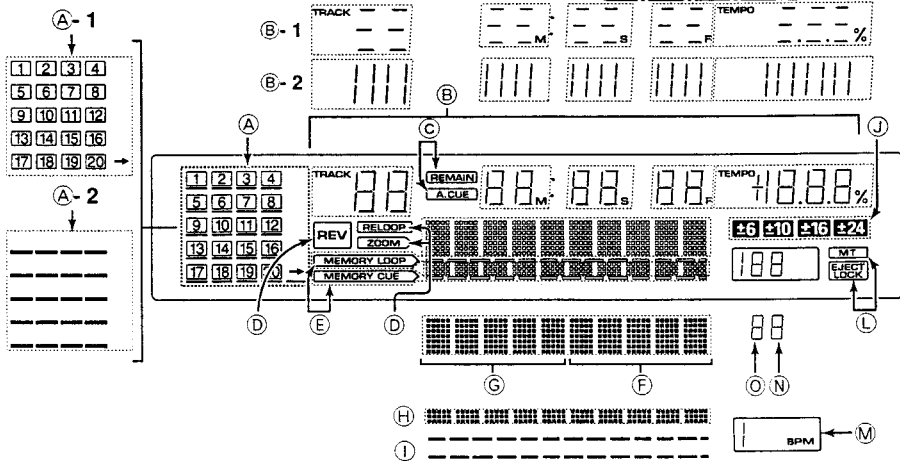

**7.1.2 ERROR DISPLAY**

• When trouble occurred in the player operation in the normal use, display the error code in FL a second and a frames. In addition, can display a history of error content.

1. Display the software version to display part of minute, second and frame that continues pressing RELOOP button for 10 seconds.
2. RAM address (FFEF20-FFFFFF) of the microcomputer inside and the content (00-FF) display it with a hexadecimal number to character display section when turns the Jog Dial.
3. Display 16 histories of the latest error content in RAM address (FFF020-FFF02F).

• Error Code Table

Error Code	Error Name	Error Content
E - 7201	TOC READ ERROR	26: Cannot lead TOC data
E - 8301	PLAYER ERROR (Abnormality of raising up)	11: All the error stop before disc distinction is this error. 20: Spindle does not turn 21: No disc (Focus servo error small) 24: Address is not readable
E - 8302	PLAYER ERROR (Abnormality of playback)	12: Specified address were not able to search 15: Address is not readable 22: Focus servo cannot close 23: Tracking servo cannot close
E - 8303	PLAYER ERROR (Abnormality of buffer write)	99: Abnormality of buffer write
E - 9101	MECHANICAL TIME OUT	90: Abnormality of the disc loading mechanism (Timeout)

■ Error display explanation

1. Soft version display

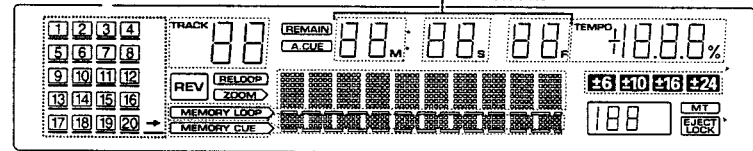
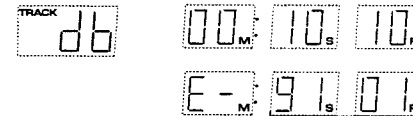

2. RAM address and Contents display



3. Error history display



7.1.3 DISASSEMBLY

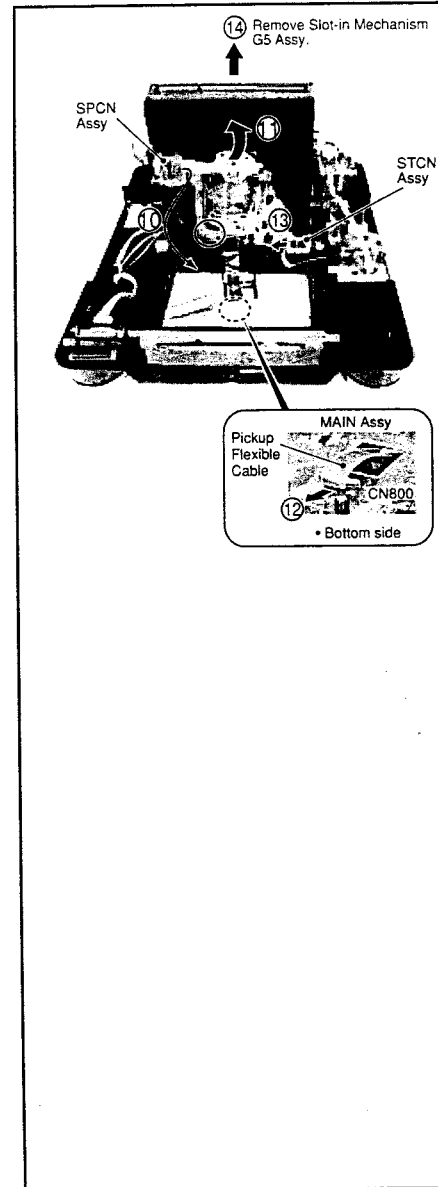
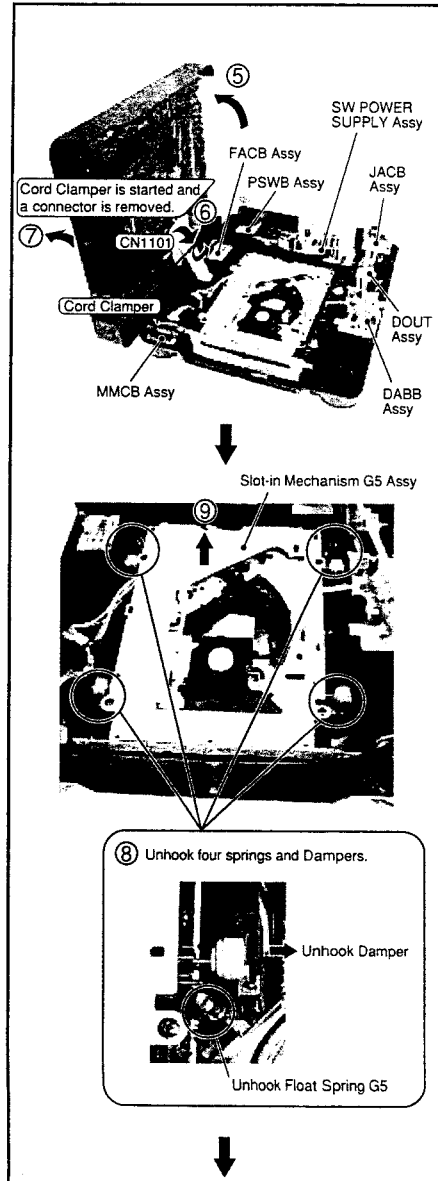
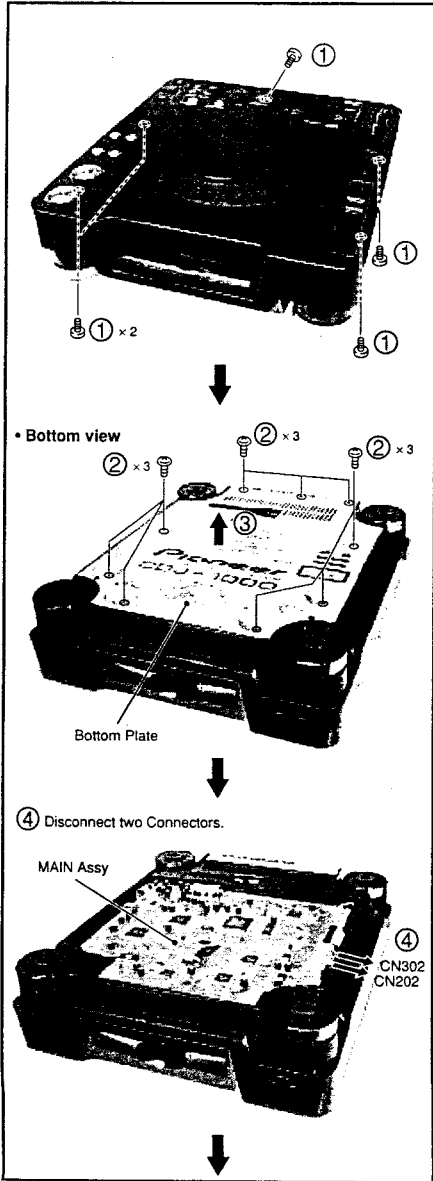

■ Traverse Mechanism Assy

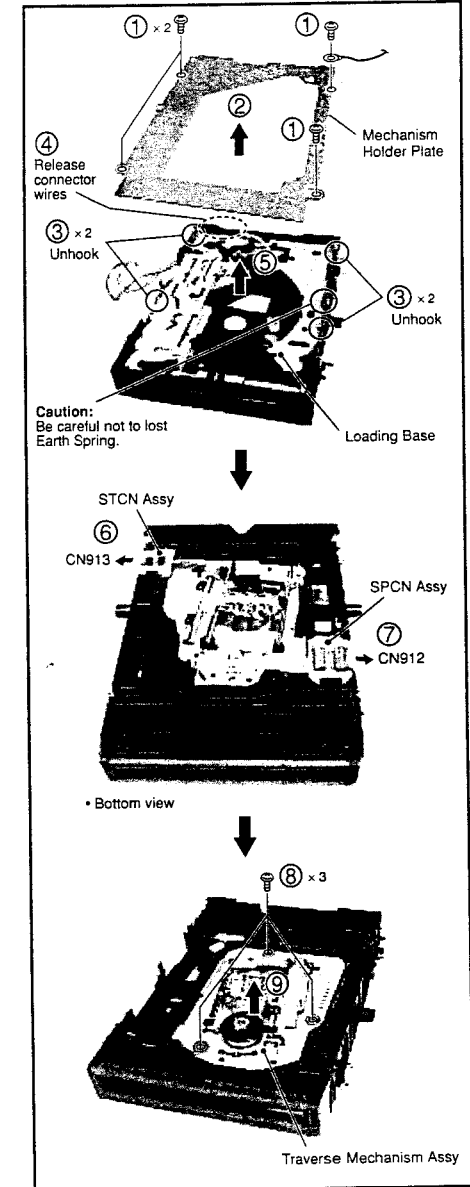

■ JOG Dial Section

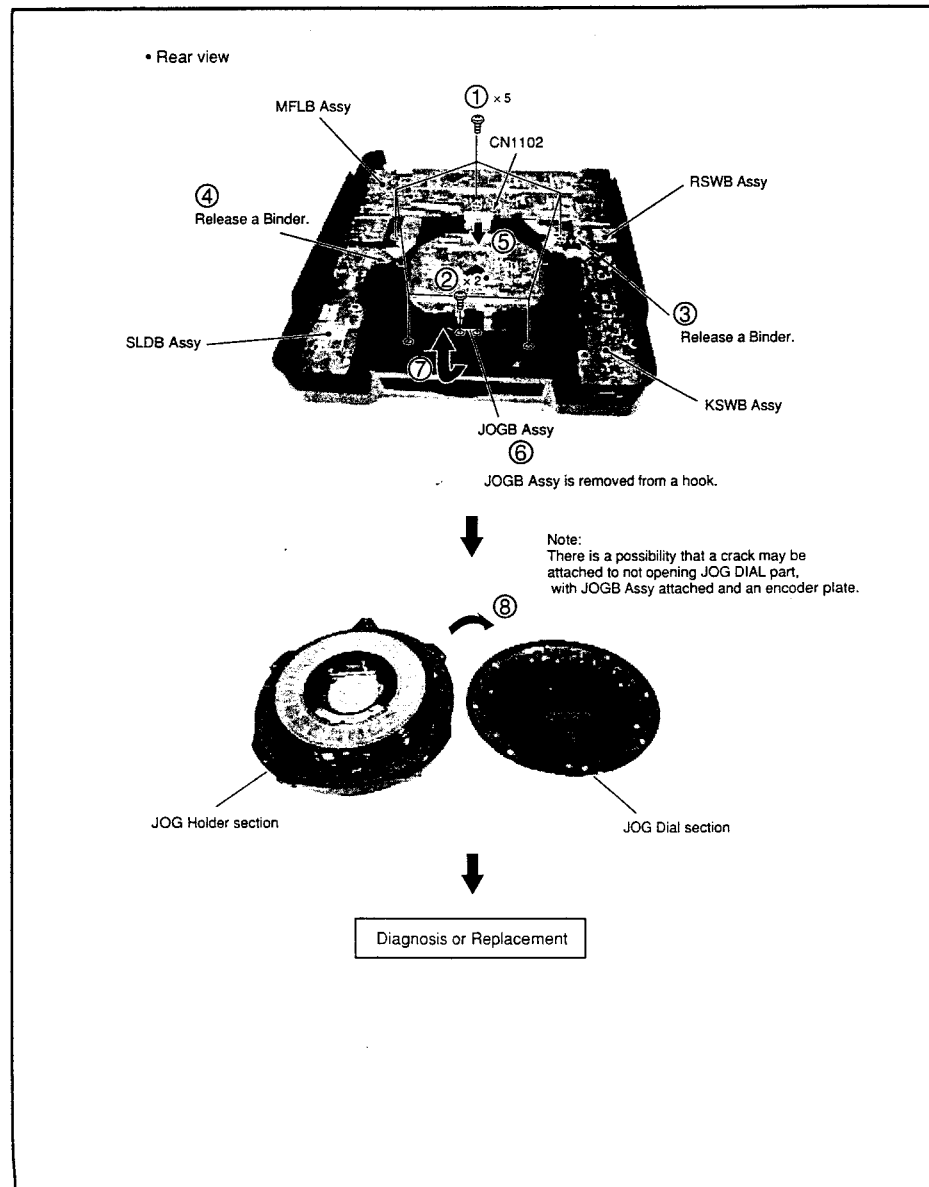

■ The processing method of each wire rod

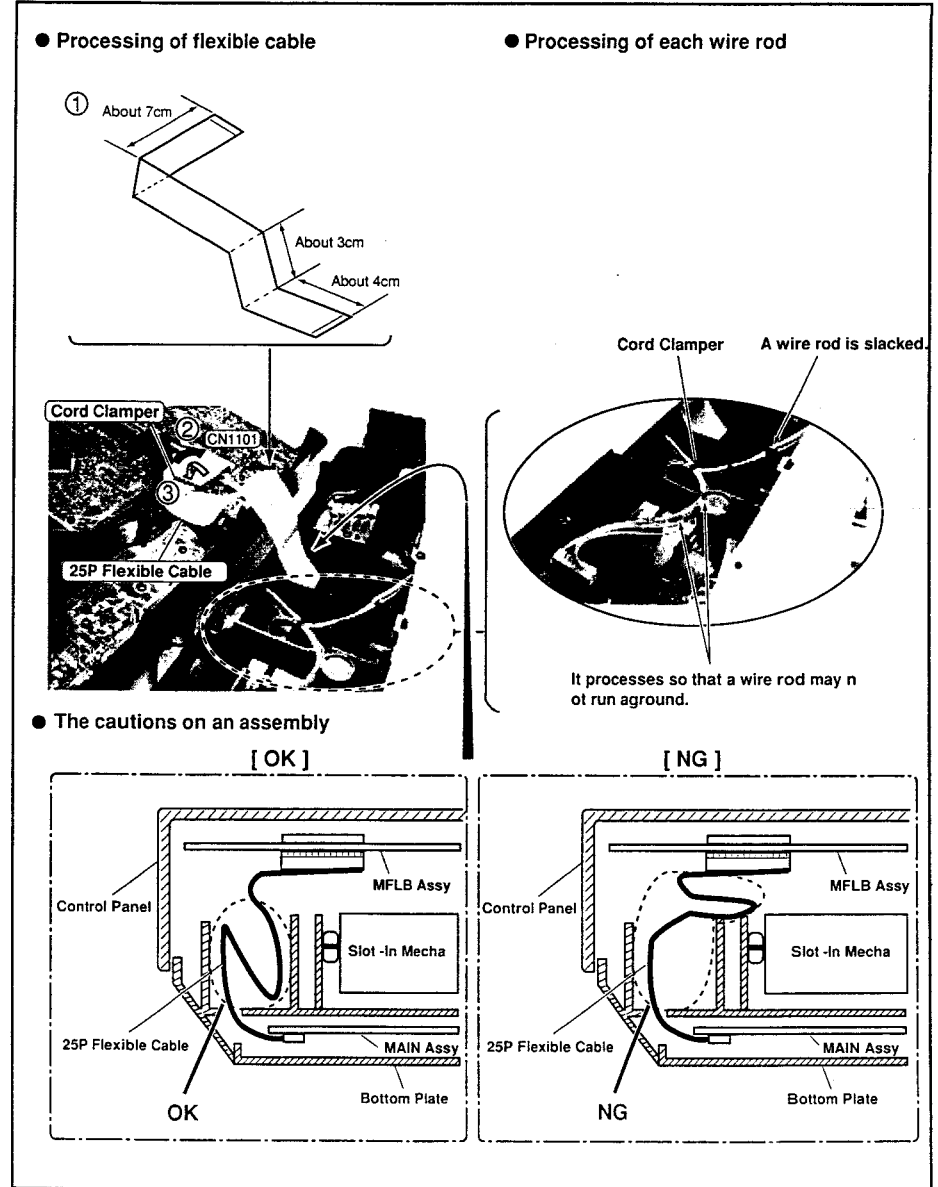

7.1.4 Part Replacement Method of JOG Section

7.1.4.1 A part to Replace in Part Replacement Simultaneously

		Replacement Part							
		Sheet SW (DSX1057)	JOG Sheet A (DXB1757)	JOG Sheet B (DXB1757)	JOG Sheet C (DXB1757)	JOG Plate (DAH2052)	JOG Holder (DNK3672)	JOG Dial A (DNK3670)	JOG Dial B (DNK3671)
A Part to Replace Simultaneously	Sheet SW								
	JOG Sheet A					○	○	○	
	JOG Sheet B						○		
	JOG Sheet C								○
	JOG Plate		○					○	
	JOG Holder			○					
	JOG Dial A		○			○			
	JOG Dial B				○				

Note  : Do not need to replace the JOG Holder when replacing the Sheet SW. However, be careful so that paste does not remain on the former Sheet SW.

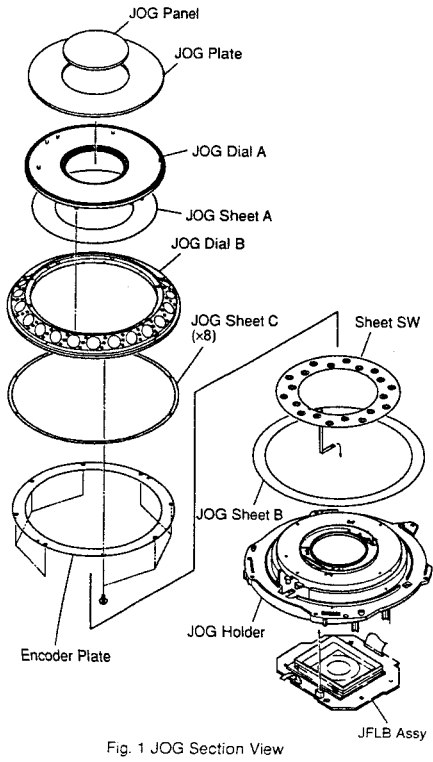

Fig. 1 JOG Section View

7.1.4.2 Caution in Sheet SW Installation

- ① Be careful not to bend and fold the Sheet SW.
  - ② Confirm that the dust or trash does not adhere to pasting side (JOG Holder).
- In addition, when tear off the former Sheet SW and put a new part, completely wipe the JOG Holder off with alcohol so that paste does not remain on the pasting side of JOG Holder.
- ③ Bend a cable of the Sheet SW in a right angle in difference in grade shape, and put it in corner hole of the JOG Holder. (Fig. ②)
  - ④ When put the Sheet SW, match the position not to run aground on rib of the internal circumference of JOG Holder. (Fig. ③)
  - ⑤ Sheet SW pushes all the sides including the point of contact fully, and put it. (No good air getting into it.)
  - ⑥ When insert a cable in connector, release a lock by all means, and connector locks after inserting it.
  - ⑦ A cable performs styling as shown in Fig. ③ after installing the JFLB Assy (DWG1549).

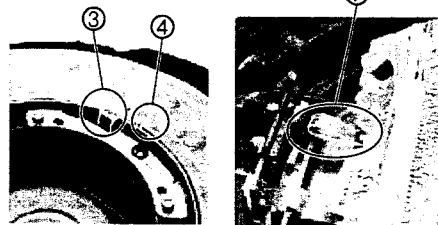

Fig. ②

Fig. ③ (Bottom View)

- ⑧ It assembles so that an encoder plate may go into the slot of the encoder guide of JOGB Assy.

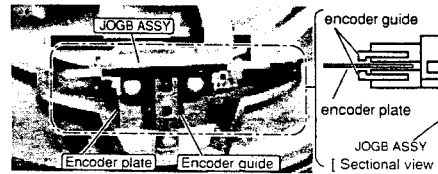

Fig. ③ [Sectional view]

7.1.4.3 Caution in JOG Sheet A Pasting

- ① Be careful not to bend and fold the JOG Sheet A.
- ② Put a lubricant (GEM1038) on the sheet.
- ③ Confirm that the dust or trash do not adhere to pasting side (JOG Dial A).
- ④ Match JOG Sheet A with marking of inner and outer circumference for pasting of JOG Dial A. (Fig. ④)
- ⑤ Put it to push you out of the inner circumference toward the periphery. (No good air getting into it.)

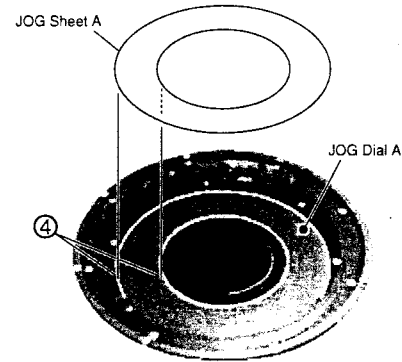

Fig. ④ (Bottom View)

7.1.4.4 Caution in JOG Sheet B Pasting

- ① Be careful not to bend and fold the JOG Sheet B.
- ② Put a lubricant (GEM1038) on the sheet.
- ③ Confirm that the dust or trash do not adhere to pasting side (JOG Holder).
- ④ Pasting method: Two places have this side with 90°. Paste it while matching with a guide of rib, and match a round. (Fig. ⑤)
- ⑤ Put it to push you out of the inner circumference toward the periphery. (No good air getting into it.) (Fig. ⑥)

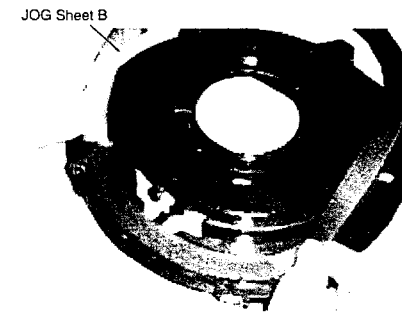

Fig. ⑤

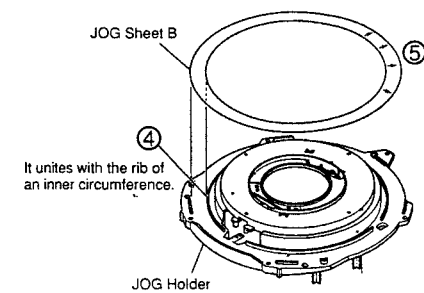

Fig. ⑥

7.1.4.5 Caution in JOG Sheet C Pasting

- ① Be careful not to bend and fold the JOG Sheet C.
- ② Put a lubricant (GEM1038) on the sheet.
- ③ Confirm that the dust or trash do not adhere to pasting side (JOG Dial B).
- ④ Pasting method: Match the inside diameter direction with edge side of the inside diameter of JOG Dial B, and match eight places of periphery directions in rib. (No good JOG Dial B protruding outward) (Fig. 7)

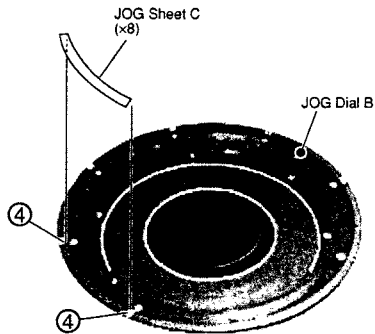

Fig. 7 (Bottom View)

7.1.4.6 Caution in JOG Plate pasting

- ① Confirm that the dust or trash do not adhere to pasting side (JOG Dial A).
- ② JOG Plate matches it with rib of the inner circumference of JOG Dial A, and put it. However, be careful not to run aground on the rib. (Fig. 8)
- ③ Be careful so that air gets into it, and the appearance of sheet does not wave.

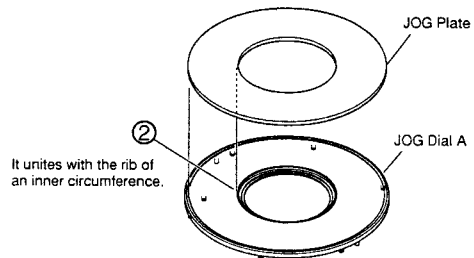
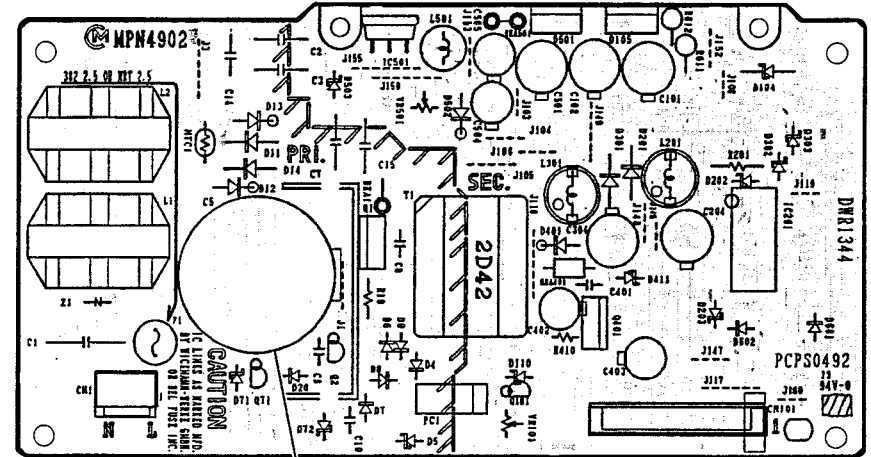

Fig. 8

7.1.5 About electric discharge

- To the capacitor (C5) of a switching circuit part, it is in power supply OFF. (after 5 minutes) Although remained abbreviation 20V, there is no danger of an electric shock.

**P** POWER SUPPLY ASSY



C5

7.1.6 SEQUENCE AFTER THE POWER ON

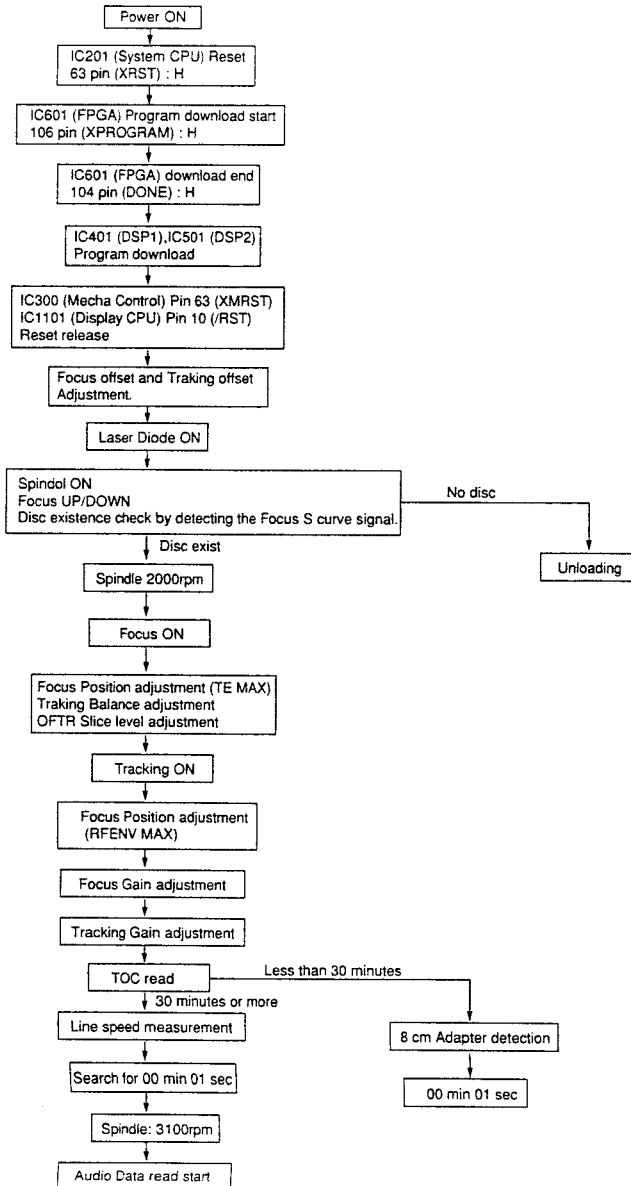

7.2 PARTS

7.2.1 IC

The information shown in the list is basic information and may not correspond exactly to that shown in the schematic diagrams.

•List of IC

NJM2903D, UPD16306BGF, MM1561JF, XCA56367PV150, PD3431A9, PD3432A9, PE5243A

■ NJM2903D (JFLB ASSY : IC1202)

• Comparator

● Block Diagram

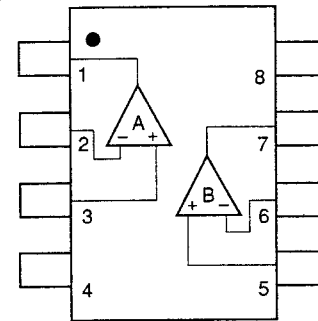

- 1 . A OUTPUT
- 2 . A - INPUT
- 3 . A + INPUT
- 4 . GND
- 5 . B + INPUT
- 6 . B - INPUT
- 7 . B OUTPUT
- 8 . V<sup>+</sup>

■ UPD16306B (JFLB ASSY : IC1201)

• Output VFD Driver

● Block Diagram

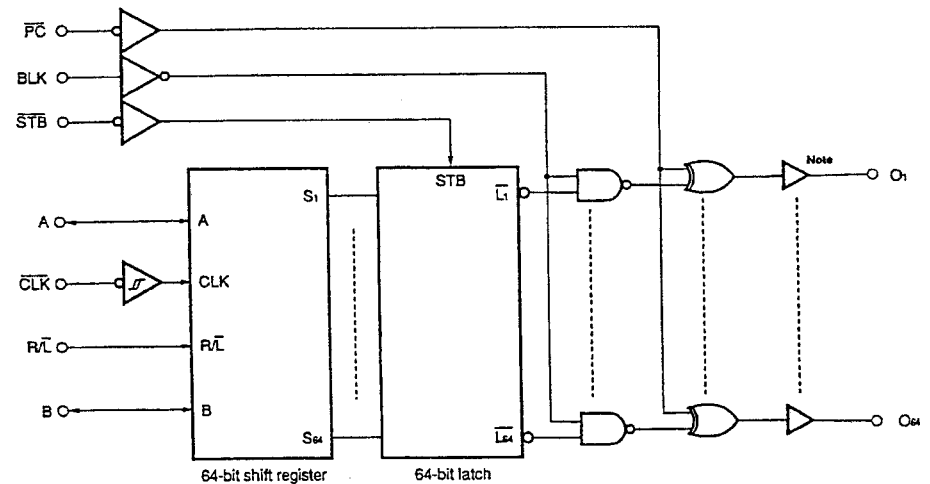

Note High-voltage CMOS drivers (80 V, ±50 mAmax.)



■ MM1561JF (MAIN ASSY : IC404)

• 500mA Regulator

● Block Diagram

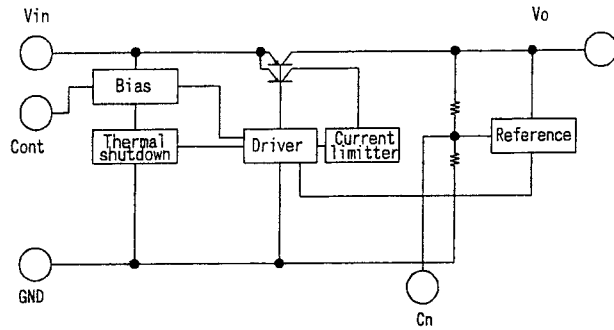

● Pin Function

PIN No.	PIN NAME	FUNCTIONS	INTERNAL EQUIVALENT CIRCUIT						
1	Vout	Output pin							
2	NC	No connection	-						
3	GND	Ground	-						
4	Cn	Noise decrease pin							
5	Cont	Control pin <table border="1" style="margin-left: 20px;"> <tr> <td>Cont</td> <td>出力 Output</td> </tr> <tr> <td>H</td> <td>ON</td> </tr> <tr> <td>L</td> <td>OFF</td> </tr> </table>	Cont	出力 Output	H	ON	L	OFF	
Cont	出力 Output								
H	ON								
L	OFF								
6	Sub	Substrate The 6pin must be connected to GND.	-						
7	Vin	Input pin							

● Pin Arrangement

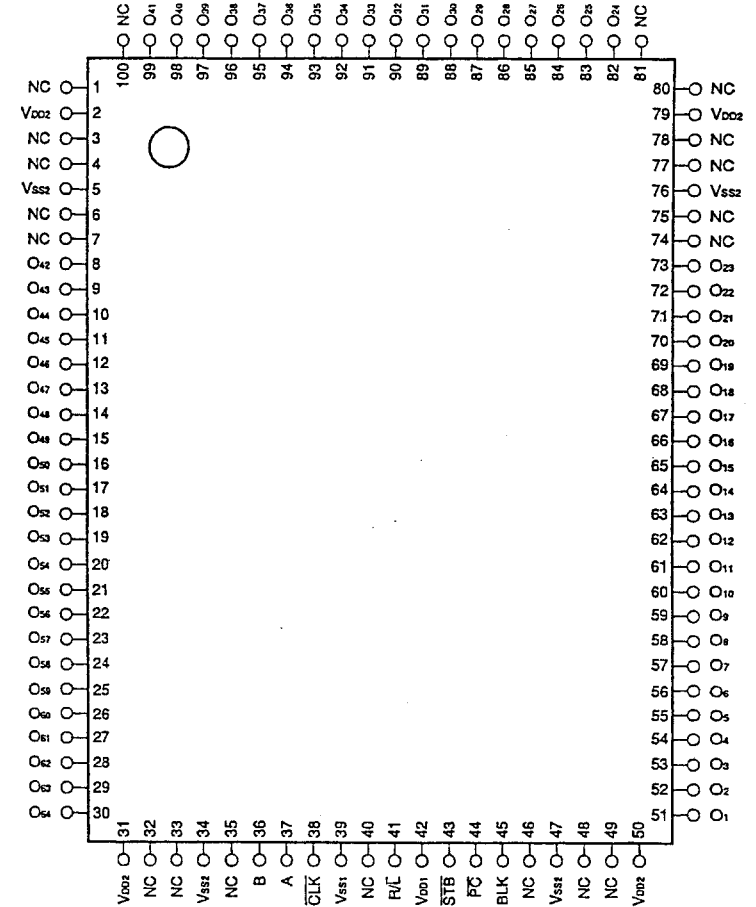

- Cautions**
1. Be sure to leave pin 40 open because it is connected to the lead frame.
  2. Be sure to use all the V<sub>DD1</sub>, V<sub>DD2</sub>, V<sub>SS1</sub>, and V<sub>SS2</sub> pins. Keep the V<sub>SS1</sub> and V<sub>SS2</sub> pins at the same voltage level.
  3. Supply power to V<sub>DD1</sub>, logic inputs, and V<sub>DD2</sub> in this order to protect the device from destruction due to latch up. Turn off power in the reverse order. Observe these power sequences even during a transition period.
  4. Since  $\mu$ PD16306B have a CMOS structure, be careful about electrical static destruction.

● Pin Function

Symbol	Pin Name	Pin Number	Description
P C	Polarity reverse input	44	PC=H: all output polarities reverse
B L K	Blanking input	45	BLK=H: all drive output=H or L
STB	Latch strobe input	43	L:data through, H:data hold
A	Right data I/O	37	R/L=H A:input B:output
B	Left data I/O	36	R/L=L A:output B:input
CLK	Clock input	38	Executes shift at falling edge
R/L	Shift direction control input	41	H:right shift mode A → O <sub>64</sub> ...O <sub>1</sub> → B L:left shift mode B → O <sub>64</sub> ...O <sub>1</sub> → A
O <sub>1</sub> ~O <sub>64</sub>	High voltage output	51to73,82to99 8to30	8 0 V、5 0 m A <sub>MAX.</sub>
V <sub>DD1</sub>	Logic power supply	42	5 V ± 1 0 %
V <sub>DD2</sub>	Drive power supply	2,31,50,79	1 0 ~ 7 0 V
V <sub>SS1</sub>	Logic ground	39	connect to system ground
V <sub>SS2</sub>	Drive ground	5,34,47,76	connect to system ground
NC	Vacant pin	1,3,4,6,7,32,33,35 40,46,48,49,74,75 77,78,80,81,100	No Connection Be sure to leave pin 40 open.

■ XCA56367PV150 (MAIN ASSY : IC401, IC501)

• 24-Bit Digital Signal Processor

● Block Diagram

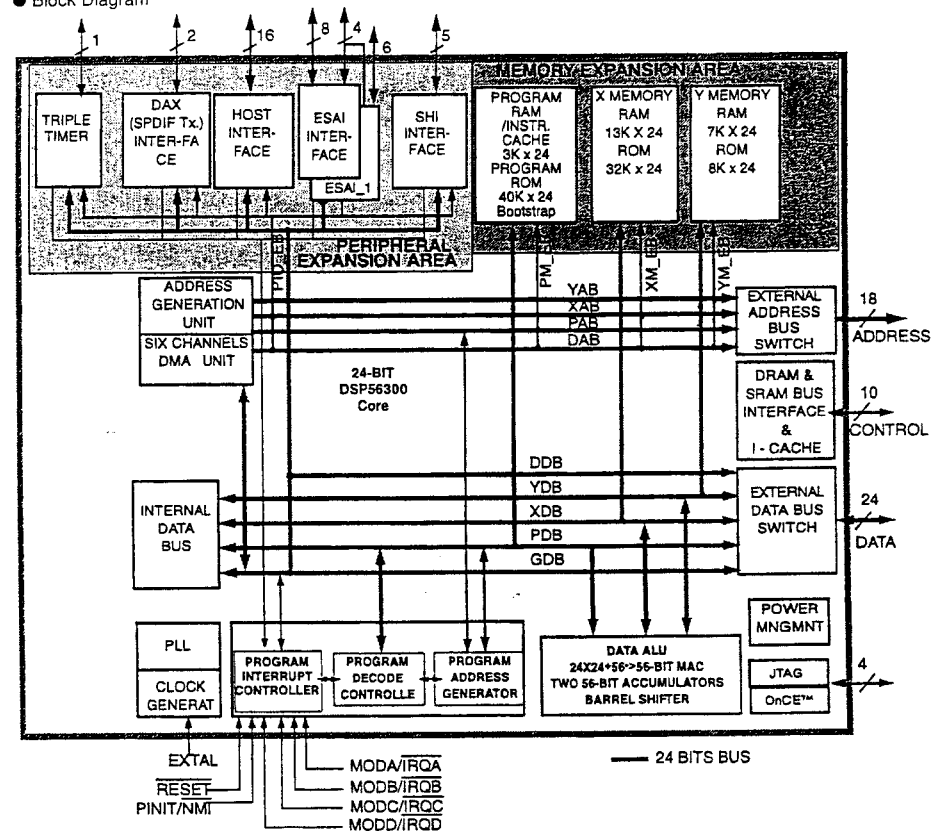

## ● Pin Function

Signal Name	Pin No.	Signal Name	Pin No.	Signal Name	Pin No.	Signal Name	Pin No.
A0	72	D9	113	GNDS	9	SD00/SD00_1	4
A1	73	D10	114	GNDS	26	SD01/SD01_1	5
A2	76	D11	115	HA8/HA1	32	SD02/SD13/SD02_1/SD13_1	6
A3	77	D12	116	HA9/HA2	31	SD03/SD12/SD03_1/SD12_1	7
A4	78	D13	117	HACK/HRRQ	23	SD04/SD11	10
A5	79	D14	118	HAD0	43	SD04_1/SD11_1	138
A6	82	D15	121	HAD1	42	SD05/SD10	11
A7	83	D16	122	HAD2	41	SD05_1/SD10_1	48
A8	84	D17	123	HAD3	40	SS#/HA2	2
A9	85	D18	124	HAD4	37	TA#	62
A10	88	D19	125	HAD5	36	TCK	141
A11	89	D20	128	HAD6	35	TDI	140
A12	92	D21	131	HAD7	34	TDO	139
A13	93	D22	132	HAS/HA0	33	TIO0	29
A14	94	D23	133	HCKR	17	TMS	142
A15	97	EXTAL	55	HCKT	16	VCCA	74
A16	98	FSR	13	HCS/HA10	30	VCCA	80
A17	99	FSR_1	59	HDS/HWR	21	VCCA	86
AA0	70	FST	12	HOREQ/HTRQ	24	VCCC	57
AA1	69	FST_1	50	HREQ#	3	VCCC	65
AA2	51	GND A	75	HRW/HRD	22	VCCD	103
AC1	28	GND A	81	MODA/IRQA#	137	VCCD	111
ADO	27	GND A	87	MODB/IRQB#	136	VCCD	119
BB#	64	GND A	96	MODC/IRQC#	135	VCCD	129
BG#	71	GND C	58	MODD/IRQD#	134	VCCH	38
BR#	63	GND C	66	MISO/SDA	144	VCCQH	20
CAS#	52	GND D	104	MOS/HA0	143	VCCQH	95

Signal Name	Pin No.	Signal Name	Pin No.	Signal Name	Pin No.	Signal Name	Pin No.
D0	100	GND D	112	PCAP	46	VCCQH	49
D1	101	GND D	120	PINIT/NMI#	61	VCCQL	18
D2	102	GND D	130	RD#	68	VCCQL	56
D3	105	GND H	39	RESET#	44	VCCQL	91
D4	106	GND P	47	SCK/SCL	1	VCCQL	126
D5	107	GND Q	19	SCKR	15	VCCP	45
D6	108	GND Q	54	SCKR_1	60	VCCS	8
D7	109	GND Q	90	SCKT	14	VCCS	25
D8	110	GND Q	127	SCKT_1	53	WR#	67

■ PD3431A9 (MAIN ASSY : IC300)

• Mecha. Control CPU

● Pin Function (1/3)

No.	Mark	Pin Name	I/O	Description
1	Vcc	-	-	Power supply (VD5V)
2	PB0	XDMUTE1	O	Driver IC mute control (0: MUTE 1: MUTE release)
3	PB1	-	I	It connects with Vss.
4	PB2	FCSG	O	A focus gain is changed.
5	PB3	CRC	O	CRC check result of a sub code (NG 1: 0: O.K.)
6	PB4	XFEP RST	O	FEP reset pulse (0: Reset 1: Reset release)
7	PB5	XDSCRST	O	ADSC reset pulse (0: Reset 1: Reset release)
8	PB6	LDONM	I	LD ON (0: usually 1: LD on-mode)
9	PB7	-	O	NC
10	FEW	WFLASH	I	The write-in enable signal of a flash memory
11	Vss	-	-	GND
12	TxD0	CPUDTIN	O	The serial output to FEP/ADSC
13	TxD1	REMO	O	The serial output to a personal computer/remote control
14	RxD0	CPUDTOUT	I	The serial input from FEP/ADSC
15	RxD1	REMI	I	The serial input to a personal computer/remote control
16	SCK0	SCK	O	The serial communication clock with FEP/ADSC
17	P95	WFLASH	O	The write-in control signal of a flash memory
18	P40	TKS	O	The slice level of TE is chosen. (zero: high-speed 1: low speed)
19	P41	INSW	I	Slider Inside detection switch
20	P42	XDMUTES	O	Stepper control
21	P43	DSPSTOP	O	Read-out of DSP is forbidden.
22	Vss	-	-	GND
23	P44	-	O	NC
24	P45	-	O	NC
25	P46	GSW	O	OEIC gain selection (0: Low 1: Hi)
26	P47	TMODE	I	Test mode (0: It shifts to test mode)
27	D0	D0	I/O	Data bus
28	D1	D1	I/O	
29	D2	D2	I/O	
30	D3	D3	I/O	
31	D4	D4	I/O	
32	D5	D5	I/O	
33	D6	D6	I/O	
34	D7	D7	I/O	
35	Vcc	-	-	Power supply (VD5V)
36	A0	A0	O	Address bus
37	A1	A1	O	
38	A2	A2	O	
39	A3	A3	O	
40	A4	A4	O	

● Pin Function (2/3)

No.	Mark	Pin Name	I/O	Description
41	A5	A5	O	Address bus
42	A6	-	I	It connects with Vss.
43	A7	-	I	
44	Vss	-	-	GND
45	A8	-	I	It connects with Vss.
46	A9	-	I	
47	A10	-	I	
48	A11	-	I	
49	A12	-	I	
50	A13	-	I	
51	A14	-	I	
52	A15	-	I	
53	A16	-	I	
54	A17	-	I	
55	P52	LPS1	I	A loading mechanism's condition
56	P53	LPS2	I	
57	Vss	-	-	GND
58	WAIT	-	I	It connects with Vss.
59	P61	-	I	
60	P62	ILMASK	O	The mask of the Interruption circuit is carried out.
61	P67	-	I	It connects with Vss.
62	STBY	XSTBY	I	It connects with Vss.
63	RES	XMRST	I	Reset input (0:reset 1:reset release)
64	NMI	NMI	I	It connects with Vss.
65	Vss	Vss	-	GND
66	EXTAL	EXTAL	I	(20MHz)
67	XTAL	XTAL	I	(20MHz)
68	Vcc	Vcc	-	Power supply (VD5V)
69	AS	-	O	NC
70	RD	XRD	O	Read strobe signal
71	S39/PE7	XWR	O	Write strobe signal
72	VDD4	-	O	NC
73	S40/PF0	MD0	I	CPU mode setup
74	S41/PF1	MD1	I	
75	S42/PF2	MD2	I	
76	S43/PF3	-	-	Power supply (VD3V)
77	S44/PF4	-	-	
78	S45/PF5	HI	I	Function (Analog)
79	S46/PF6	RFDIF	I	
80	S47/PF7	VHALF	I	Function

● Pin Function (3/3)

No.	Mark	Pin Name	I/O	Description
81	AN3	OFTR	I	Function
82	P74	-	I	It connects with Vss.
83	AN5	P75	I	The monitor of ST1
84	DA0	ST1	O	Stepper drive (analog)
85	DA1	ST2	O	
86	AVss	-	-	Analog GND
87	IRQ0	MBLKCK	I	The interruption demand from FPGA
88	IRQ1	BLKCK	I	
89	IRQ2	CPUIRQ	I	
90	P83	-	I	It connects with Vss.
91	P84	-	I	
92	Vss	-	-	GND
93	PA0	OFTR	I	Function
94	TCLKB	TKCNT	I	Track pulse input (pulse width is measured and speed is detected)
95	PA2	ENC	O	Serial input enable of ADSC CIRC part (0: permission 1: prohibition)
96	PA3	ENS	O	Serial input enable of ADSC part (0: permission 1: prohibition)
97	PA4	TKCNT	I	Track pulse input
98	PA5	XDMUTE2	O	Driver IC mute control (0:MUTE 1:MUTE release)
99	PA6	FESEN	O	FEP serial input enable (0: permission 1: prohibition)
100	TIOC2	FG	I	FG pulse input

■ PD3431A9 (MAIN ASSY : IC201)

● System Control CPU

● Pin Function (1/3)

No.	Pin Name	I/O	Description
1	Vcc	-	By the capacitor (0.1μF) It GND-connects.
2	DGP2	I	Motorola DSP (preceding paragraph) Interface
3	XHREQ1	I	
4	XHREQ2	I	Motorola DSP (latter part) Interface
5	XSS1	O	Motorola DSP (preceding paragraph) Interface
6	XSS2	O	Motorola DSP (latter part) Interface
7	DOSW	I	Digital OUT ON/OFF SW detection
8	CNT2	I	Control 2 input terminal
9	CNT1	I/O	Control 1 input and output terminal
10	WFILSH	I	The terminal which detects a flash write-in permission signal
11	Vss	-	Digital GND
12	S2DO	O	The serial output terminal to DSP
13	S1DO	O	A serial output besides a controller
14	S2DI	I	The serial input from DSP
15	S1DI	I	A serial input besides a controller
16	S2CK	O	The serial clock to DSP
17	S1CK	O	A serial clock besides a controller
18	XFRST	O	Reset to FPGA
19	XSRST	O	Reset to circumference IC
20	ASWC	O	Serial change SW enable
21	MUTE	O	Line OUT output MUTE
22	Vss	-	Digital GND
23	MON2	O	Monitor terminal 2
24	XZOFF	O	The terminal for repealing zero detection
25	XDRST	O	The reset terminal for DAC
26	NC	-	-
27	D0	-	FPGA interface (data bus)
28	D1	-	
29	D2	-	
30	D3	-	
31	D4	-	
32	D5	-	
33	D6	-	
34	D7	-	
35	Vcc	-	Power supply (VD5V)
36	A0	-	FPGA interface (data bus)
37	A1	-	
38	A2	-	
39	A3	-	
40	A4	-	

● Pin Function (2/3)

No.	Pin Name	I/O	Description
41	NC	O	It connects with GND.
42	NC	I	
43	NC	I	
44	Vss	-	Digital (GND)
45	NC	I	It connects with GND.
46	NC	I	
47	NC	I	
48	NC	I	
49	NC	I	
50	NC	I	
51	NC	I	
52	NC	I	
53	NC	I	
54	NC	I	
55	KEY1	I	The key processing demand from front CPU
56	TCH	I	JIG touch sensor input
57	Vss	-	Digital GND
58	NC	I	It connects with GND.
59	XMDT	I	MMC detection signal
60	DONE	O	The initialization end signal from FPGA
61	20M	I	It connects with GND.
62	STBY	I	Low power consumption mode
63	XRST	I	Hard reset
64	NMI	I	Compulsive interruption
65	Vss	-	Digital GND
66	EXTAL	I	Crystal oscillation
67	XTAL	I	
68	Vcc	-	Digital 5V
69	NC	O	-
70	XSRD	O	FPGA Read
71	XSWR	O	FPGA Write
72	NC	O	-
73	MD0	I	CPU mode setup
74	MD1	I	
75	MD2	I	
76	Avcc	-	The power supply terminal of A/D conversion machine, and D/A conversion machine
77	VREF	-	The standard voltage input terminal of A/D conversion machine, and D/A conversion machine
78	ADCT	I	Slider center value
79	ADIN	I	Slider data value
80	NC	I	It connects with GND.

● Pin Function (3/3)

No.	Pin Name	I/O	Description
81	NC	I	It connects with GND.
82	NC	I	
83	NC	I	
84	NC	O	
85	NC	O	
86	AVss	-	The grand terminal of A/D conversion machine, and D/A conversion machine
87	JOG1	I	JOG pulse input 1
88	JOG2	I	JOG pulse input 2
89	DQCK	I	Motorola DSP (preceding paragraph) interface
90	NC	I	It connects with GND.
91	RMIN	I	For a RS232C input
92	Vss	-	GND
93	XMEN	I	MMC chip enable
94	XDEN	I	DAC communication enable
95	ICDT	O	EEPROM data output
96	ICCK	O	EEPROM clock output
97	HRST	I	MMC hard reset output
98	NC	O	It connects with GND.
99	XPRGM	O	FPGA program permission signal
100	XINT	I	-

■ PE5243A (MFLB ASSY : IC1101)

• Disply Control CPU

● Pin Function (1/3)

No.	Mark	Pin Name	I/O	Description
1	VDD	-	-	Power supply (VD5V)
2	P37	LED15, Model distinction	O	LOUT, and NEXT / NET distinction
3	P36/BUZ	LED14	I	LIN
4	P35/PCL	LED13	O	CRED
5	P34/TI2	LED12	O	CGREEN
6	P33/TI1	LED11	O	BRED
7	P32/TO2	LED10	O	BGREEN
8	P31/TO1	LED9	O	ARED
9	P30/TO0	LED8	O	AGREEN
10	RESET	RESET	I	RESET
11	X2	CLOCK	-	(5MHz)
12	X1	CLOCK	-	(5MHz)
13	IC	GND	-	-
14	XT2	NC	-	-
15	P04/XT1	SW0	I	Reverse Switch
16	VDD	-	-	-
17	P27/SCK0	SCLK1	I	The clock input from host CPU
18	P26/SO0/SB1	SDO1	O	The data output to host CPU
19	P25/SI0/SB0	SDI1	I	The data input from host CPU
20	P24/BUSY	ENABLE	O	The enable output to host CPU
21	P23/STB	BLK	O	The blank output to FL drive
22	P22/SCK1	SCLK2	O	The clock output to FL driver
23	P21/SO1	SDO2	O	The strike robe to FL driver
24	P20/SI1	STB	O	NC
25	Avss	GND	-	GND
26	P17/ANI7	LED5	I	-
27	P16/ANI6	KEYAD5	I	Key input
28	P15/ANI5	KEYAD4	I	
29	P14/ANI4	KEYAD3	I	
30	P13/ANI3	KEYAD2	I	
31	P12/ANI2	KEYAD1	I	
32	P11/ANI1	VOL1	I	Turntable VOL
33	P10/ANI0	VOL2	I	
34	AVDD	VDD	-	Power supply (+5V)
35	AVREF	VDD	-	
36	P03/INT3/CI0	LED16	O	VINYL
37	P02/INTP2	LED7	O	CDJ
38	P01/INTP1	LED6	O	MT
39	P00/INTP/TI0	ELSW	I	Eject Switch
40	Vss	-	-	-

● Pin Function (2/3)

No.	Mark	Pin Name	I/O	Description	
41	P74	LED4	O	TRES	
42	P73	LED3	O	MMC	
43	P72	LED2	O	CUE	
44	P71	LED1	O	PLAY	
45	P70	LED0	O	REVERSE	
46	VDD	-	-	Power supply (5V)	
47	P127/FIP52	S37	O	FL display	
48	P126/FIP51	S36	O		
49	P125/FIP50	S35	O		
50	P124/FIP49	S34	O		
51	P123/FIP48	S33	O		
52	P122/FIP47	S32	O		
53	P121/FIP46	S31	O		
54	P120/FIP45	S30	O		
55	P117/FIP44	S29	O		
56	P116/FIP43	S28	O		
57	P115/FIP42	S27	O		
58	P114/FIP41	S26	O		
59	P113/FIP40	S25	O		
60	P112/FIP39	S24	O		
61	P111/FIP38	S23	O		
62	P110/FIP37	S22	O		
63	P107/FIP36	S21	O		
64	P106/FIP35	S20	O		
65	P105/FIP34	S19	O		
66	P104/FIP33	S18	O		
67	P103/FIP32	S17	O		
68	P102/FIP31	S16	O		
69	P101/FIP30	S15	O		
70	P100/FIP29	S14	O		
71	P97/FIP28	S13	O		
72	P96/FIP27	S12	O		
73	P95/FIP26	S11	O		
74	P94/FIP25	S10	O		
75	P93/FIP24	S9	O		
76	P92/FIP23	S8	O		
77	P91/FIP22	S7	O		
78	P90/FIP21	S6	O		
79	VLOAD	-	-		-
80	P87/FIP20	S5	O		FL display

● Pin Function (3/3)

No.	Mark	Pin Name	I/O	Description
81	P86/FIP19	S4	○	FL display
82	P85/FIP18	S3	○	
83	P84/FIP17	S2	○	
84	P83/FIP16	S1	○	
85	P82/FIP15	G16	○	
86	P81/FIP14	G15	○	
87	P80/FIP13	G14	○	
88	FIP12	G13	○	
89	FIP11	G12	○	
90	FIP10	G11	○	
91	FIP9	G10	○	
92	FIP8	G9	○	
93	FIP7	G8	○	
94	FIP6	G7	○	
95	FIP5	G6	○	
96	FIP4	G5	○	
97	FIP3	G4	○	
98	FIP2	G3	○	
99	FIP1	G2	○	
100	FIP0	G1	○	

## 8. PANEL FACILITIES AND SPECIFICATIONS

### 8.1 PANEL FACILITIES

■ Front Panel

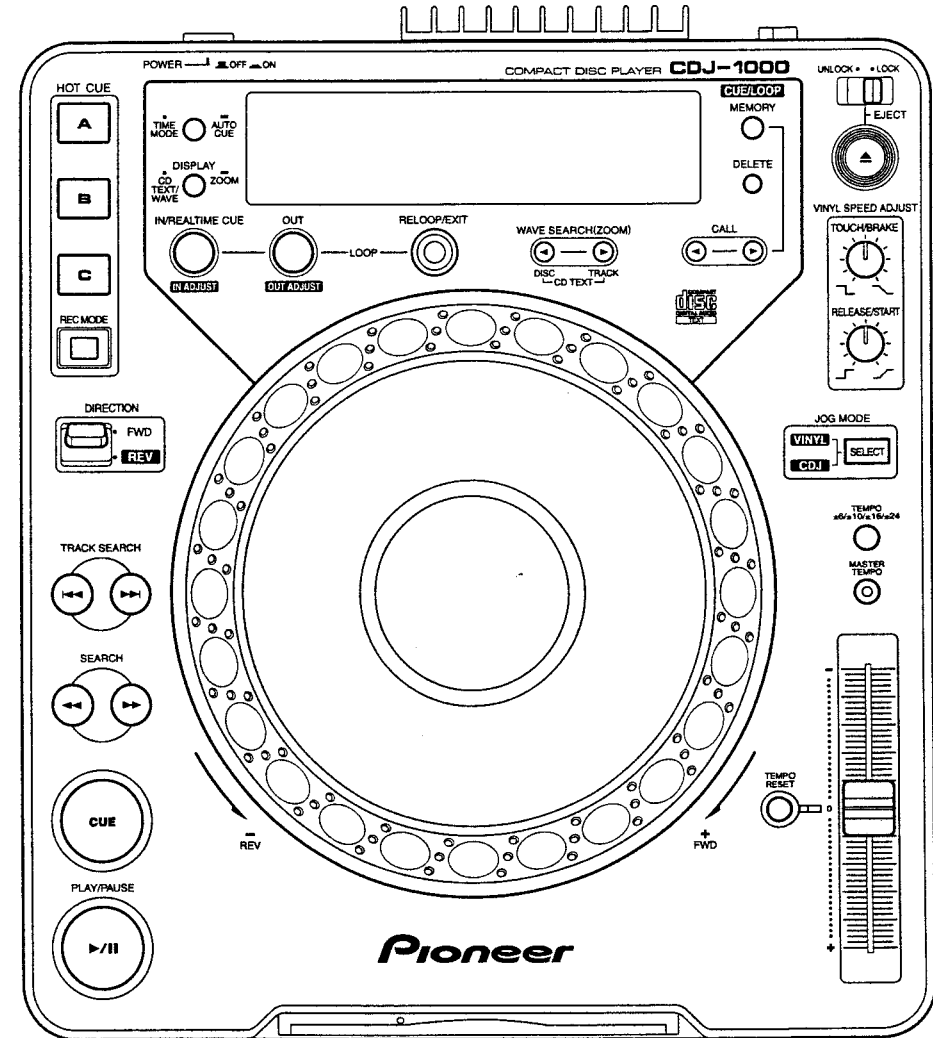



buttons indicated by \* cannot be used in digital mode.

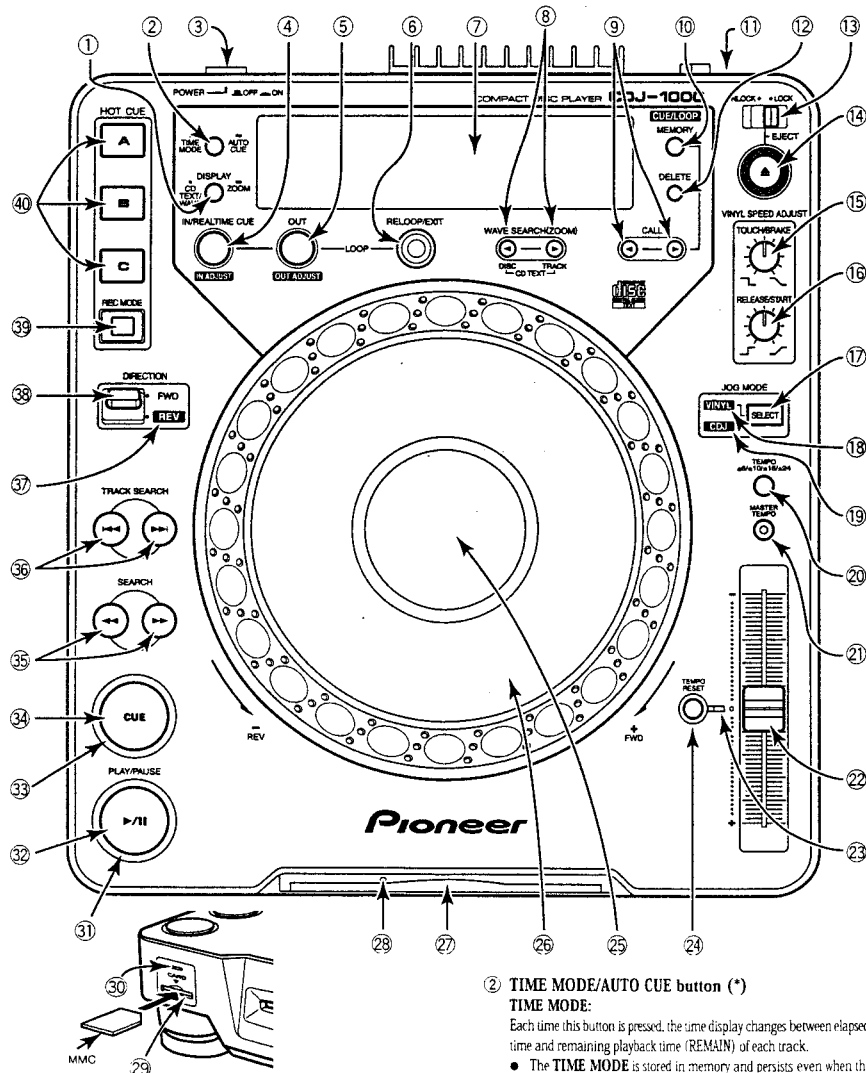

① **DISPLAY CD TEXT/WAVE (ZOOM) button (\*)**

Each press of this button toggles the display between WAVE display and CD-TEXT disc/track title display. When the button is held down for 1 second or longer, the WAVE display cycles between: the 1 track full-scale and 2x zoom scale.

② **TIME MODE/AUTO CUE button (\*)**

**TIME MODE:**  
Each time this button is pressed, the time display changes between elapsed playback time and remaining playback time (REMAIN) of each track.

- The **TIME MODE** is stored in memory and persists even when the power is turned off.

**AUTO CUE:**  
Hold down this key for 1 second or longer to toggle between **AUTO CUE** on and off. P.11

- **AUTO CUE** on/off status is stored in memory and persists even when the power is turned off.

③ **POWER switch OFF / ON**

This switch is located on the rear panel of the unit.

④ **LOOP IN/REALTIME CUE/IN ADJUST button/indicator (\*)**

**Real-time cue**  
Enter loop in point  
Loop in point adjust

⑤ **LOOP OUT/OUT ADJUST button/indicator (\*)**

Enter loop out point  
Loop out point adjust

⑥ **RELOOP/EXIT button (\*)**

⑦ **Display**

⑧ **WAVE SEARCH (ZOOM)/CD TEXT buttons (◀, ▶) (\*)**

This button moves the displayed area when WAVE is in zoom display mode. In the TEXT display mode, pressing the ◀ button will display the disc title and pressing the ▶ button will display the track title.

⑨ **CUE/LOOP CALL buttons (◀, ▶) (\*)**

Calls Cue points and Loop points stored in internal memory or external memory (when a memory card is inserted). (When a memory card is inserted, the external memory takes precedence.)

⑩ **CUE/LOOP MEMORY button (\*)**

Stores Cue points and Loop points in internal memory or external memory (when a memory card is inserted). (When a memory card is inserted, the external memory takes precedence.)

⑪ **Digital Mode switch (ON/OFF)**

This switch is located on the rear panel of the unit. Set to ON when the digital output is to be used. When set to On, the DJ functions do not function. (Functions marked \* do not operate in this mode.) And the muted pause mode is used instead of the audible pause mode.

⑫ **CUE/LOOP DELETE button (\*)**

Deletes Cue points or Loop points stored in internal memory or external memory (when memory card is inserted). (When a memory card is inserted, the external memory takes precedence.)

⑬ **EJECT UNLOCK/LOCK switch**

**UNLOCK:** In this mode the disc can be ejected even during playback.  
**LOCK:** In this mode, the disc cannot be ejected during playback. The disc can be ejected when in pause mode.

⑭ **EJECT button (▲)**

When this button is pressed the disc is ejected through the disc insertion slot when it stops rotating. When the **EJECT UNLOCK/LOCK** switch is set to [LOCK] position, the disc can only be ejected when in pause mode.

⑮ **VINYL SPEED ADJUST TOUCH/BRAKE dial (\*)**

When the **JOG MODE SELECT** button is set to [VINYL] position, you can use this dial to adjust the speed by which the playback stops when the surface of the Jog dial is pressed. Playback stops faster as the dial is turned counterclockwise and stops slower as the dial is turned clockwise.

⑯ **VINYL SPEED ADJUST RELEASE/START dial (\*)**

When the **JOG MODE SELECT** button is set to [VINYL] position, you can use this dial to adjust the speed by which playback starts after you take your hand off the surface of the Jog dial. Playback starts normal speed faster as the dial is turned counterclockwise and takes longer time to return to normal speed when turned clockwise.

⑰ **JOG MODE SELECT button (\*)**

**VINYL mode:** when the surface of the Jog dial is pressed during playback, playback stops and if the dial is rotated, music is output according to the speed the dial is turned.

- The **JOG MODE** is stored in memory and remains in memory even if the power is turned off.

**CDJ mode:** above operation is not performed even when the Jog dial surface is pressed.

⑱ **VINYL indicator (\*)**

This indicator lights when the **JOG MODE** is in VINYL mode.

⑲ **CDJ indicator (\*)**

This indicator lights when the **JOG MODE** is in CDJ mode.

⑳ **TEMPO Control Range button ±6/±10/±16/±24 (\*)**

Each time the button is pressed, the range changes (±6%/±10%/±16%/±24%).

㉑ **MASTER TEMPO button/indicator (\*)**

Each press of the button turns the master tempo function on or off.

㉒ **Tempo Control knob (\*)**

Slide the knob towards you (+) to increase the tempo and slide it away from you (-) to decrease it.

㉓ **Tempo Reset indicator (\*)**

Shows that the tempo has been reset to [0] (normal tempo) regardless of the position of the **Tempo Control knob**.

㉔ **TEMPO RESET button (\*)**

Resets the tempo to [0] (normal tempo) regardless of the position of the **Tempo Control knob**. Press button once more to release it.

㉕ **Jog Dial Display**

㉖ **Jog dial (+FWD/-REV) (\*)**

㉗ **Disc Loading Slot**

㉘ **Force Ejection Hole**

㉙ **Memory Card Loading Slot**

㉚ **Memory Card indicator**

Lights when the MMC card is being accessed.  
• Do not remove the card or turn off the power when this lamp is on.

㉛ **Play/Pause indicator (▶/||) (\*)**

Lights during play and flashes during pause.

㉜ **PLAY/PAUSE button (▶/||) (\*)**

㉝ **CUE indicator (\*)**

Lights when a Cue point is set and a search is not being performed. Flashes in pause mode.

㉞ **CUE button (\*)**

Cue point settings  
Cue point sampler  
Back cue

㉟ **SEARCH button (◀◀, ▶▶) (\*)**

㊱ **TRACK SEARCH button (◀◀, ▶▶) (\*)**

㊲ **Reverse indicator (REV) (\*)**

Lights when the **DIRECTION FWD/REV** switch is set to reverse.

㊳ **DIRECTION FWD/REV switch (\*)**

Plays tracks backwards when set to the [REV] position (forward position).

㊴ **HOT CUE REC MODE button (\*)**

Switches **HOT CUE** button function (REC/CALL).  
• It is set to call when the power is turned on.

㊵ **HOT CUE A, B, C button/indicator**

It is set to hot cue point recording mode when A, B and C light in red. It is set to call mode when A, B and C light in green. When the button is pressed, playback starts from the hot cue point. It is off when no hot cue point has been recorded.

■ Display

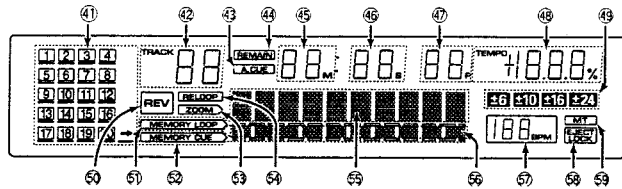

- 41 **Calendar display (1 - 20, →)**  
TRACK numbers beyond the current track lights. When the next track is 21 or beyond, → lights. When Cue points or loops are stored, an underscore lights in the corresponding TRACK numbers.
- 42 **TRACK Number indicator**  
Displays TRACK numbers.
- 43 **Auto Cue indicator (A. CUE)**  
Lights when auto cue is on.
- 44 **REMAIN indicator**  
Indicates that track remaining time is being displayed.
- 45 **Time display (min) (M)**
- 46 **Time display (sec) (S)**
- 47 **Frame display (F)**  
One second is 75 frames.
- 48 **Playback Tempo display (TEMPO)**  
Indicates the rate of change in the playback tempo.
- 49 **Tempo Adjustment Range indicator (±6, ±10, ±16, ±24)**  
Indicates the variable range of the Tempo Control knob selected with the TEMPO Control Range button.
- 50 **Reverse indicator (REV)**  
Indicates that the DIRECTION FWD/REV switch is set to reverse ([REV] position).
- 51 **MEMORY LOOP indicator**  
Displays the selected track loop memory position above the playback address display (13 points). Even when there may be several memory points in the same block, only one lights.
- 52 **MEMORY CUE indicator**  
Displays the selected cue memory positions under the playback address display (13 points). Even when there may be several memory points in the same block, only one lights.
- 53 **ZOOM indicator**  
Indicates that WAVE is indicated in zoom mode.
- 54 **RELOOP indicator**  
Lights when the unit is in reloop standby or performing a loop.

- 55 **Wave/Text display**  
When WAVE is displayed the music level of the current track.  
The level is indicated either in 1-track full scale, or zoom when only part of the track is shown. In the zoom mode, the display area is moved using the WAVE SEARCH (ZOOM) buttons (←, →).  
CD TEXT will be displayed in the TEXT mode.  
The contents of the display is the disc title and track title in English upto a maximum of 48 letters which can be scrolled.
- 56 **Playback Address display**  
Indicates elapsed playback time and remaining playback time in an easy to grasp 1-track full scale or 2x zoom scale bar graph.
  - The 1-track full scale mode shows elapsed time by lit segments from the left.
  - The 1-track full scale mode shows remaining time by unlit segments from the left.
  - When the remaining time is 30 seconds or less, the display flashes gently and the flashing becomes faster when there is 15 seconds or less left.
  - In the 2x zoom scale mode, only the playback position is lit for the WAVE display.
- 57 **BPM Counter**  
Indicates BPM for the current track.  
The BPM counter may sometimes not be able to measure the BPM of a track.
- 58 **EJECT LOCK indicator**  
Lights when the EJECT UNLOCK/LOCK switch is set to the [LOCK] position.
- 59 **Master Tempo indicator (MT)**  
Lights when the master tempo function is on.

■ Jog Dial Display

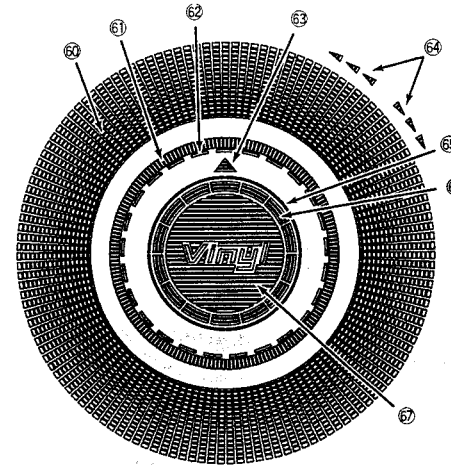

- 60 **Operation display**  
Indicates play position in frames 135 frames for one full rotation. Turns during playback and stops during pause.
- 61 **All Track display**  
Indicates track currently being played.
- 62 **Memory Cue/ Loop display**  
Lights when there is a MEMORY CUE or LOOP in a track.
- 63 **All Track Display Reference Point**  
Displays the first track starting point of the disc.
- 64 **Direction display**  
This display the direction of the playback.
- 65 **Display the condition of the audio memory**  
When set in the audio memory display mode the light will flash when recording.
- 66 **Displays the condition of the VINYL mode movement**  
Lights up when there is a pause or when the Jog dial is touched in the VINYL mode.
- 67 **VINYL mode display.**  
Lights up in the VINYL mode.

8.2 SPECIFICATIONS

■ CDJ-1000/ KUC type

1. General

System ..... Compact disc digital audio system  
 Power requirements ..... AC 120 V, 60 Hz  
 Power consumption ..... 33 W  
 Operating temperature ..... +5°C – +35°C  
 Operating humidity ..... 5% – 85%  
 (There should be no condensation of moisture.)  
 Weight ..... 4.2 kg (9.26 lb)  
 Dimensions ..... 320 (W) x 370 (D) x 105 (H) mm  
 12 – 5/8 (W) x 14 – 9/16 (D) x 4 – 1/8 (H) in

2. Audio section

Frequency response ..... 4 Hz – 20 kHz  
 Signal-to-noise ratio ..... 115 dB or more (EIAJ)  
 Distortion ..... 0.006% (EIAJ)

■ CDJ-1000/ WY type

1. General

System ..... Compact disc digital audio system  
 Power requirements ..... AC 220 -240V, 50/60 Hz  
 Power consumption ..... 31 W  
 Operating temperature ..... +5°C – +35°C  
 Operating humidity ..... 5% – 85%  
 (There should be no condensation of moisture.)  
 Weight ..... 4.2 kg (9.26 lb)  
 Dimensions ..... 320 (W) x 370 (D) x 105 (H) mm  
 12 – 5/8 (W) x 14 – 9/16 (D) x 4 – 1/8 (H) in

2. Audio section

Frequency response ..... 4 Hz – 20 kHz  
 Signal-to-noise ratio ..... 115 dB or more (EIAJ)  
 Distortion ..... 0.006% (EIAJ)

■ CDJ-1000/ TL type

1. General

System ..... Compact disc digital audio system  
 Power requirements ..... AC 220 -240V, 50/60 Hz  
 Power consumption ..... 31 W  
 Operating temperature ..... +5°C – +35°C  
 Operating humidity ..... 5% – 85%  
 (There should be no condensation of moisture.)  
 Weight ..... 4.2 kg  
 Dimensions ..... 320 (W) x 370 (D) x 105 (H) mm

2. Audio section

Frequency response ..... 4 Hz – 20 kHz  
 Signal-to-noise ratio ..... 115 dB or more (EIAJ)  
 Distortion ..... 0.006% (EIAJ)

■ Accessories

3. Accessories

• Operating instructions ..... 1  
 • Power cord ..... 1  
 • Audio cable ..... 1  
 • Control cord ..... 1  
 • Forced eject pin  
 (housed in a groove in the bottom panel) ..... 1  
 • Limited warranty ..... 1

NOTE:

Specifications and design are subject to possible modification without notice.

3. Accessories

• Operating instructions ..... 1  
 • Power cord ..... 1  
 • Audio cable ..... 1  
 • Control cord ..... 1  
 • Forced eject pin  
 (housed in a groove in the bottom panel) ..... 1  
 • Limited warranty ..... 1

NOTE:

Specifications and design are subject to possible modification without notice.

3. Accessories

• Operating instructions ..... 1  
 • Power cord ..... 1  
 • Audio cable ..... 1  
 • Control cord ..... 1  
 • Forced eject pin  
 (housed in a groove in the bottom panel) ..... 1

NOTE:

Specifications and design are subject to possible modification without notice.

Service Manual

COMPACT DISC PLAYER

CDJ-1000

ORDER NO.  
RRV2574

THIS MANUAL IS APPLICABLE TO THE FOLLOWING MODEL(S) AND TYPE(S).

Type	Model	Power Requirement	Remarks
	CDJ-1000		
KUCXJ	○	AC120V	
TLBXJ	○	AC110V- 240V	
WYXJ	○	AC220- 240V	

● This service manual should be used together with the following manual(s):

Model No.	Order No.	Remarks
CDJ-1000/ KUC, TL, WY	RRV2468	5335

Audio Cable  
(VDE1033) L=1.5m



Control Cord  
(PDE1247) L=1 m



Power Cord  
(KUC type : ADG7021  
TL, WY type: ADG1154)



Forced Eject Pin  
(DEX1013)



# 1. CONTRAST OF MISCELLANEOUS PARTS

NOTES: ● Parts marked by "NSP" are generally unavailable because they are not in our Master Spare Parts List.

● The  $\Delta$  mark found on some component parts indicates the importance of the safety factor of the part.

Therefore, when replacing, be sure to use parts of identical designation.

● Screws adjacent to  $\nabla$  mark on product are used for disassembly.

● Reference Nos. indicate the pages and Nos. in the service manual for the base model.

● When ordering resistors, first convert resistance values into code form as shown in the following examples.

Ex.1 When there are 2 effective digits (any digit apart from 0), such as 560 ohm and 47k ohm (tolerance is shown by J=5%, and K=10%).

560  $\rightarrow$  56 x 10<sup>1</sup>  $\rightarrow$  561  $\rightarrow$  RD114PU561J

47k  $\rightarrow$  47 x 10<sup>3</sup>  $\rightarrow$  473  $\rightarrow$  RD114PU473J

0.5  $\rightarrow$  R50  $\rightarrow$  RN2H1R50K

1  $\rightarrow$  1R0  $\rightarrow$  RS1P1R10K

Ex.2 When there are 3 effective digits (such as in high precision metal film resistors).

5.62k  $\rightarrow$  562 x 10<sup>1</sup>  $\rightarrow$  5621  $\rightarrow$  RN114PC5621F

## ■ CONTRAST TABLE

CDJ-1000/KUCXJ and CDJ-1000/KUC are constructed the same except for the following :

Ref. No.	Mark	Symbol and Description	Part No.		Remarks
			CDJ-1000/ KUC	CDJ-1000/ KUCXJ	
<b>PACKING</b>					
P5 - 4		Operating Instructions (English)	DRB1297	DRB1311	
P5 - 5		Control Cord (L=1m)	PDE1247	PDE1267	
P5 - 6		Audio Cable (L=1.5m)	VDE1033	VDE1052	
P5 - 8		Pad (A)	DHA1518	DHA1533	
P5 - 9		Pad (B)	DHA1519	DHA1534	
P5 - 10		Pad (C)	DHA1523	DHA1535	
P5 - 11		Pad (D)	DHA1524	DHA1536	
P5 - 12		Packing Case	DHG2145	DHG2188	
<b>Exterior (1/2)</b>					
P7 - 12		25P Flexible Cable/60V	DDD1189	DDD1196	
P7 - 13		12P Flexible Cable/60V	DDD1190	DDD1197	
P7 - 14		4P Flexible Cable/60V	DDD1191	DDD1198	
P7 - 15		Earth Lead Unit/300V	DDF1015	DDF1024	
P7 - 16		Connector Assy 3P	DKP3546	DKP3562	
P7 - 17		Connector Assy 3P	DKP3548	DKP3561	
P7 - 18	NSP	FPC D5 Slot	DNP1951	DNP1948	
P7 - 29		Heat Sink	DNG1081	DNG1082	
P7 - 42		Bottom Plate	DNH2479	DNH2510	
<b>Exterior (2/2)</b>					
P9 - 9		Jog Dial B	DNK3871	DNK3990	
P9 - 24		Set Knob (Play) Ass'y	DXB1750	DXB1762	
P9 - 39	NSP	Cord Clamper	Z09-061	ZCB-069Z	

## ■ CONTRAST TABLE

CDJ-1000/TLBXJ and CDJ-1000/TL are constructed the same except for the following :

Ref. No.	Mark	Symbol and Description	Part No.		Remarks
			CDJ-1000/ TL	CDJ-1000/ TLBXJ	
<b>PACKING</b>					
P5 - 4		Operating Instructions (English, Spanish)	DRB1299	DRB1312	
P5 - 5		Control Cord (L=1m)	PDE1247	PDE1267	
P5 - 6		Audio Cable (L=1.5m)	VDE1033	VDE1052	
P5 - 8		Pad (A)	DHA1518	DHA1533	
P5 - 9		Pad (B)	DHA1519	DHA1534	
P5 - 10		Pad (C)	DHA1523	DHA1535	
P5 - 11		Pad (D)	DHA1524	DHA1536	
P5 - 12		Packing Case	DHG2146	DHG2189	
<b>Exterior (1/2)</b>					
P7 - 12		25P Flexible Cable/60V	DDD1189	DDD1196	
P7 - 13		12P Flexible Cable/60V	DDD1190	DDD1197	
P7 - 14		4P Flexible Cable/60V	DDD1191	DDD1198	
P7 - 15		Earth Lead Unit/300V	DDF1015	DDF1024	
P7 - 16		Connector Assy 3P	DKP3546	DKP3562	
P7 - 17		Connector Assy 3P	DKP3548	DKP3561	
P7 - 18	NSP	FPC D5 Slot	DNP1951	DNP1948	
P7 - 29		Heat Sink	DNG1081	DNG1082	
P7 - 42		Bottom Plate	DNH2479	DNH2510	
P7 - 45		Label	VRW1697	DRW2102	
<b>Exterior (2/2)</b>					
P9 - 9		Jog Dial B	DNK3871	DNK3990	
P9 - 24		Set Knob (Play) Ass'y	DXB1750	DXB1762	
P9 - 39	NSP	Cord Clamper	Z09-061	ZCB-069Z	

## ■ CONTRAST TABLE

CDJ-1000/WYXJ and CDJ-1000/WY are constructed the same except for the following :

Ref. No.	Mark	Symbol and Description	Part No.		Remarks
			CDJ-1000/ WY	CDJ-1000/ WYXJ	
<b>Packing</b>					
P5 - 4		Operating Instructions (English, French, German, Italian, Dutch, Spanish)	DRB1298	DRB1310	
P5 - 5		Control Cord (L=1m)	PDE1247	PDE1267	
P5 - 6		Audio Cable (L=1.5m)	VDE1033	VDE1052	
P5 - 8		Pad (A)	DHA1518	DHA1533	
P5 - 9		Pad (B)	DHA1519	DHA1534	
P5 - 10		Pad (C)	DHA1523	DHA1535	
P5 - 11		Pad (D)	DHA1524	DHA1536	
P5 - 12		Packing Case	DHG2129	DHG2187	
P5 - 14	NSP	Mini Catalogue	DRY1194	Not used	
<b>EXTERIOR (1/2)</b>					
P7 - 12		25P Flexible Cable/60V	DDD1189	DDD1196	
P7 - 13		12P Flexible Cable/60V	DDD1190	DDD1197	
P7 - 14		4P Flexible Cable/60V	DDD1191	DDD1198	
P7 - 15		Earth Lead Unit/300V	DDF1015	DDF1024	
P7 - 16		Connector Assy 3P	DKP3546	DKP3562	
P7 - 17		Connector Assy 3P	DKP3548	DKP3561	
P7 - 18	NSP	FPC D5 Slot	DNP1951	DNP1948	
P7 - 29		Heat Sink	DNG1081	DNG1082	
P7 - 42		Bottom Plate	DNH2479	DNH2510	
P7 - 46		Caution Label HE	VRW1297	PRW1233	
<b>Exterior (2/2)</b>					
P9 - 9		Jog Dial B	DNK3871	DNK3990	
P9 - 24		Set Knob (Play) Ass'y	DXB1750	DXB1762	
P9 - 39	NSP	Cord Clamper	Z09-061	ZCB-069Z	