

Service Manual

Pioneer

CDX-FM1259/X1N/UC

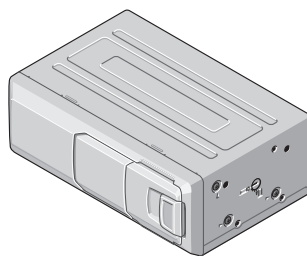

ORDER NO.
CRT2320

UNIVERSAL MULTI-CD SYSTEM

CDX-FM1259

CDX-FM1257

X1N/UC

X1N/UC,ES



- See the separate manual CX-938(CRT2357) for the CD mechanism description, disassembly and circuit description.
- The CD mechanism employed in this model is one of C8 series.

CONTENTS

1. SAFETY INFORMATION	2	7. GENERAL INFORMATION	43
2. EXPLODED VIEWS AND PARTS LIST	3	7.1 PARTS	43
3. SCHEMATIC DIAGRAM	12	7.1.1 IC.....	43
4. PCB CONNECTION DIAGRAM	24	7.1.2 DISPLAY	49
5. ELECTRICAL PARTS LIST	32	7.2 DIAGNOSIS	50
6. ADJUSTMENT.....	36	7.2.1 DISASSEMBLY	50
		7.2.2 TEST MODE	52
		7.3 BLOCK DIAGRAM	58
		8. OPERATIONS AND SPECIFICATIONS.....	60

PIONEER ELECTRONIC CORPORATION 4-1, Meguro 1-Chome, Meguro-ku, Tokyo 153-8654, Japan
PIONEER ELECTRONICS SERVICE INC. P.O.Box 1760, Long Beach, CA 90801-1760 U.S.A.
PIONEER ELECTRONIC [EUROPE] N.V. Haven 1087 Keetberglaan 1, 9120 Melsele, Belgium
PIONEER ELECTRONICS ASIACENTRE PTE.LTD. 253 Alexandra Road, #04-01, Singapore 159936

● **CD Player Service Precautions**

1. For pickup unit(CXX1285) handling, please refer to"Disassembly"(See page 50). During replacement, handling precautions shall be taken to prevent an electrostatic discharge(protection by a short pin).
2. During disassembly, be sure to turn the power off since an internal IC might be destroyed when a connector is plugged or unplugged.
3. Please checking the grating after changing the pick-up unit (See page 37).
4. Since these screws protects the mechanism during transport, be sure to affix it when it is transported for repair, etc.

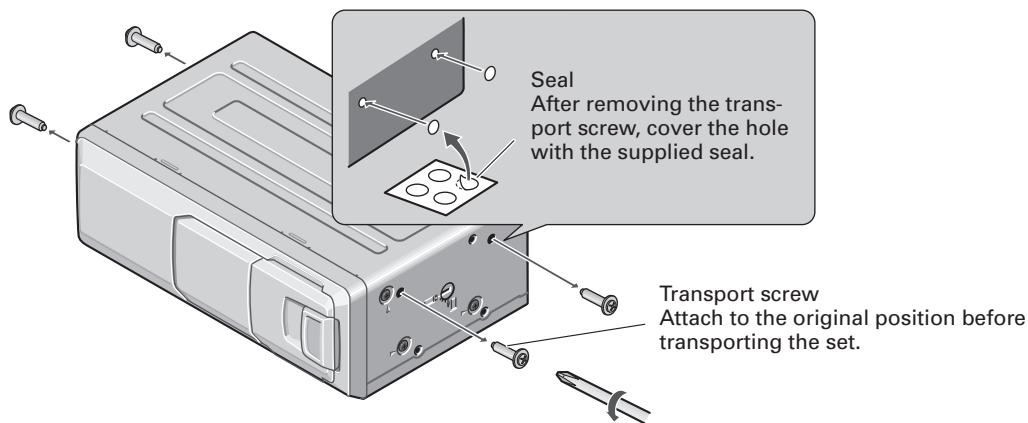

A transport screw has been attached to the set in order to protect it during transportation. After removing the transport screw, cover the hole with the supplied seal. Be sure to remove the transport screw before mounting the set. The removed transport screw should be retained in the accessory bag for use the next time the set is transported.

1. SAFETY INFORMATION

1.1 CDX-FM1259/X1N/UC,CDX-FM1257/X1N/UC

CAUTION

This service manual is intended for qualified service technicians; it is not meant for the casual do-it-yourselfer. Qualified technicians have the necessary test equipment and tools, and have been trained to properly and safely repair complex products such as those covered by this manual. Improperly performed repairs can adversely affect the safety and reliability of the product and may void the warranty. If you are not qualified to perform the repair of this product properly and safely; you should not risk trying to do so and refer the repair to a qualified service technician.

WARNING

This product contains lead in solder and certain electrical parts contain chemicals which are known to the state of California to cause cancer, birth defects or other reproductive harm.
Health & Safety Code Section 25249.6 - Proposition 65

2. EXPLODED VIEWS AND PARTS LIST

2.1 PACKING

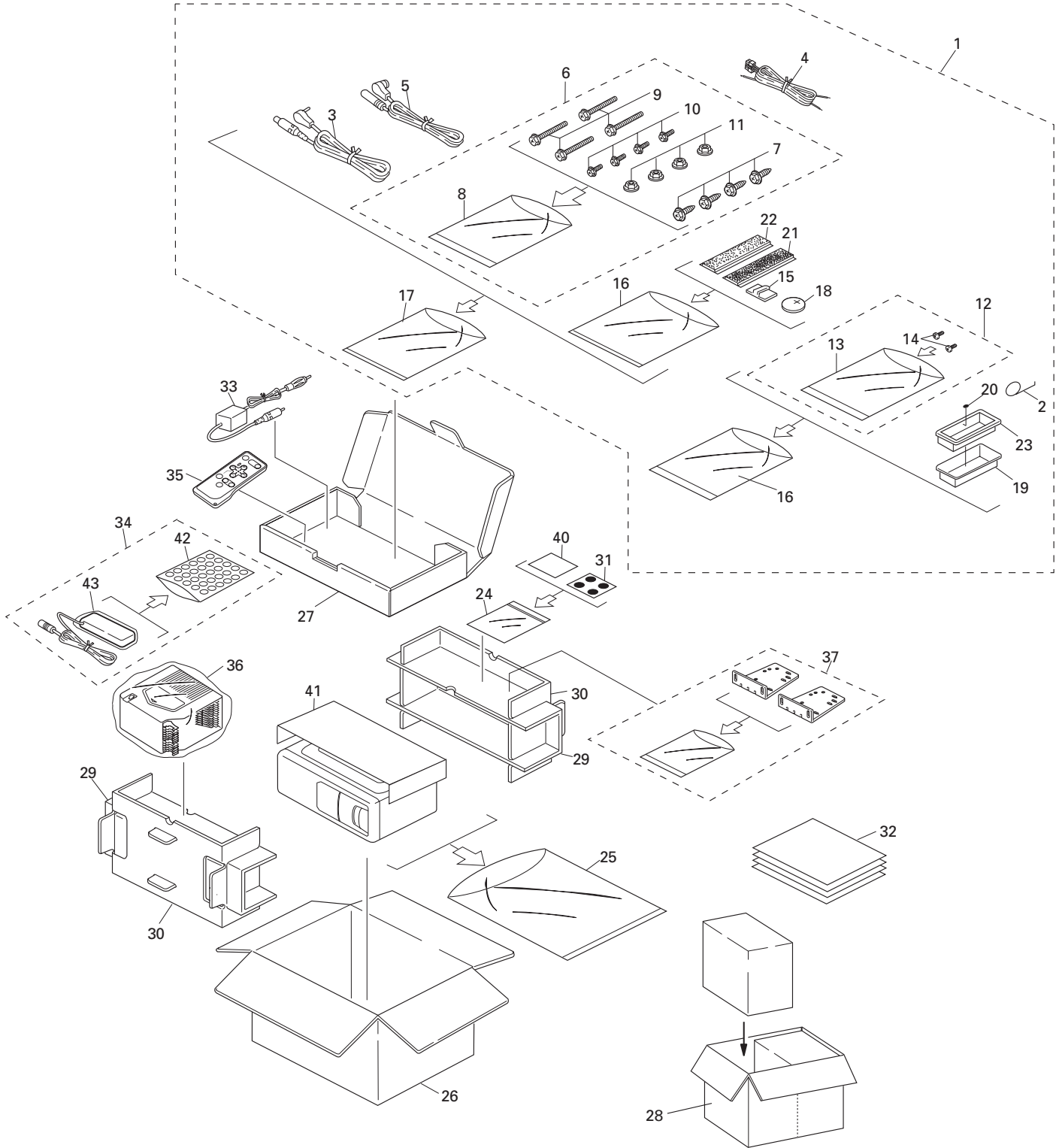

NOTE:

- Parts marked by "*" are generally unavailable because they are not in our Master Spare Parts List.
- Screws adjacent to ∇ mark on the product are used for disassembly.

● PACKING SECTION PARTS LIST

Mark No.	Description	Part No.		
		CDX-FM1259/X1N/UC	CDX-FM1257/X1N/UC	CDX-FM1257/X1N/ES
1	Accessory Assy	CEA2494	CEA2494	CEA2495
2	Spring	CBH-865	CBH-865	CBH-865
3	Cord	CDE4289	CDE4289	CDE4289
4	Cord	CDE5812	CDE5812	CDE5812
5	Cord	CDE5814	CDE5814	CDE5814
6	Screw Assy	CEA1962	CEA1962	CEA1962
7	Screw	CBA1295	CBA1295	CBA1295
* 8	Polyethylene Sheet	CNM5158	CNM5158	CNM5158
9	Screw	HMB60P500FMC	HMB60P500FMC	HMB60P500FMC
10	Screw	HMF40P080FZK	HMF40P080FZK	HMF40P080FZK
11	Nut	NF60FMC	NF60FMC	NF60FMC
12	Screw Assy	CEA1965	CEA1965	CEA1965
* 13	Polyethylene Bag	CEG-127	CEG-127	CEG-127
14	Screw	IMS30P050FZK	IMS30P050FZK	IMS30P050FZK
15	Clamper	CEF1010	CEF1010	CEF1010
* 16	Polyethylene Bag	CEG-158	CEG-158	CEG-158
17	Polyethylene Bag	CEG1185	CEG1185	*E36-622
18	Battery	CEX1030	CEX1030	CEX1030
19	Bracket	CNC8061	CNC8061	CNC8061
20	Cushion	CNM3182	CNM3182	CNM3182
21	Fastener(Soft)	CNM3872	CNM3872	CNM3872
22	Fastener(Rough)	CNM4041	CNM4041	CNM4041
23	Panel	CNS5428	CNS5428	CNS5428
* 24	Polyethylene Bag	CEG1099	CEG1099	CEG1099
25	Polyethylene Bag	CEG1174	CEG1174	CEG1026
26	Carton	CHG3721	CHG3720	CHG3722
27	Sub Carton	CHG3729	CHG3728	CHG3730
28	Contain Box	CHL3721	CHL3720	CHL3722
29	Protector	CHP2136	CHP2136	CHP2136
30	Protector	CHP2137	CHP2137	CHP2137
31	Seal	CNM5599	CNM5599	CNM5599
32-1	Installation Manual	CRD2874	CRD2874	CRD2877
32-2	Owner's Manual	CRD2873	CRD2875	CRD2876
* 32-3	Warranty Card	CRY1070	Not used	Not used
* 32-4	Caution Card	CRP1205	CRP1205	CRP1205
33	Antenna Select Assy	CWM6445	CWM6445	CWM6445
34	Display Assy	CXB3242	CXB3241	CXB3241
35	Remote Control Assy	CXB3262	CXB3261	CXB3261
36	Magazine Assy	CXB4028	CXB4028	CXB4028
37	Angle Assy	CXB3589	CXB3589	CXB3589

Mark No.	Description	Part No.		
		CDX-FM1259/X1N/UC	CDX-FM1257/X1N/UC	CDX-FM1257/X1N/ES
38			
39			
*	40 Caution Card	CRP1090	CRP1090	CRP1090
*	41 Caution Card	CRP1196	CRP1196	CRP1196
	42 Air Cushioned Bag	CEG1055	CEG1055	CEG1055
	43 Cover	CEG1062	CEG1062	CEG1062

● **Owner's Manual**

Model	Part No.	Language
CDX-FM1259/X1N/UC	CRD2873	English, French
CDX-FM1257/X1N/UC	CRD2875	English, French
CDX-FM1257/X1N/ES	CRD2876	English, Spanish, Portuguese(B), Arabic

● **Installation Manual**

Model	Part No.	Language
CDX-FM1259/X1N/UC	CRD2874	English, French
CDX-FM1257/X1N/UC	CRD2874	English, French
CDX-FM1257/X1N/ES	CRD2877	English, Spanish, Portuguese(B), Arabic

2.2 EXTERIOR

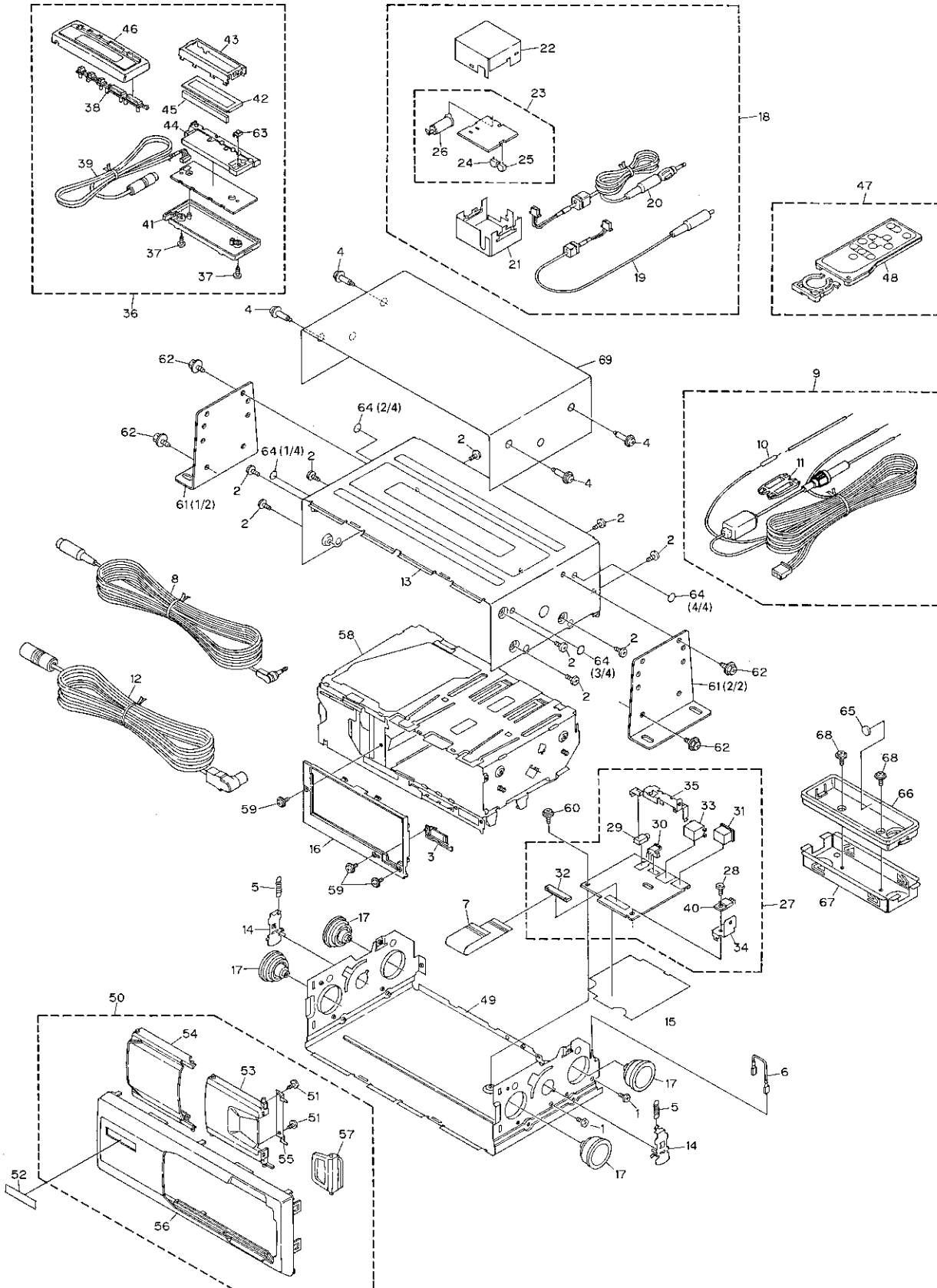

(1) EXTERIOR SECTION PARTS LIST

Mark No.	Description	Part No.	Mark No.	Description	Part No.
1	Screw	BMZ26P040FMC	36	Display Assy	See Contrast table(2)
2	Screw	BMZ30P040FZK	37	Screw	BPZ20P100FZK
3	Button	CAC4632	38	Button	CAC5887
4	Screw	CBA1353	39	Cord	CDE5834
5	Spring	CBH1862	40	Transistor(Q801)	2SD2396
6	Connector	CDE5525	41	Cover	CNS5223
7	Connector	CDE5833	42	LCD(LCD901)	CAW1514
8	Cord	CDE4289	43	Holder	CNC8062
9	Cord	CDE5812	44	Lighting Conductor	CNV5594
10	Resistor	RS1/2PMF102J	45	Rubber	CNV5599
11	Cap	CNS1472	46	Grille Unit	See Contrast table(2)
12	Cord	CDE5814	47	Remote Control Assy	See Contrast table(2)
13	Upper Case	CNB2393	48	Cover	CNS4948
14	Arm	CNC8058	49	Lower Case Unit	CXB3398
15	Insulator	CNM6074	50	Grille Unit	See Contrast table(2)
16	Panel	CNS5218	51	Screw	BPZ20P080FMC
17	Damper	CNV5227	52	Sheet	See Contrast table(2)
18	Antenna Select Assy	CWM6445	53	Door	CAT2052
19	Cord	CDE4087	54	Door	CAT2053
20	Antenna Cable	CDH1207	55	Holder	CNC8141
21	Chassis	CNA1555	56	Grille	See Contrast table(2)
22	Case	CNB1764	57	Lever	CNS5394
23	Antenna Select Unit	CWX2200	58	CD Mechanism Module	See Contrast table(2)
24	Plug(CN502)	CKS1222	59	Screw	IMS20P035FZK
25	Plug(CN501)	CKS2812	60	Screw	IMS26P040FMC
26	Antenna Jack(CN503)	CKX1006	61	Angle Assy	CXB3589
27	Extension Unit	CWX2304	62	Screw	HMF40P080FZK
28	Screw	BMZ26P060FMC	63	IC(IC902)	TSOP1840SB1
29	Jack(CN401)	CKN1022	64	Seal	CNM5599
30	Plug(CN801)	CKS-460	65	Cushion	CNM3182
31	Connector(CN802)	CKS3195	66	Panel	CNS5428
32	Connector(CN201)	CKS4019	67	Bracket	CNC8061
33	Connector(CN803)	CKS3407	68	Screw	IMS30P050FZK
34	Holder	CNC8060	* 69	Caution Card	CRP1196
35	Holder	CNC8069			

(2) CONTRAST TABLE

CDX-FM1259/X1N/UC, CDX-FM1257/X1N/UC and CDX-FM1257/X1N/ES are constructed the same except for the following:

Mark No.	Symbol and Description	Part No.		
		CDX-FM1259/X1N/UC	CDX-FM1257/X1N/UC	CDX-FM1257/X1N/ES
36	Display Assy	CXB3242	CXB3241	CXB3241
46	Grille Unit	CXB3821	CXB3820	CXB3820
47	Remote Control Assy	CXB3262	CXB3261	CXB3261
50	Grille Unit	CXB4382	CXB4381	CXB4381
52	Sheet	CAH1685	CAH1682	CAH1682
56	Grille	CNS5226	CNS5306	CNS5306
58	CD Mechanism Module	CXK4916	CXK4915	CXK4915

2.3 CD MECHANISM MODULE

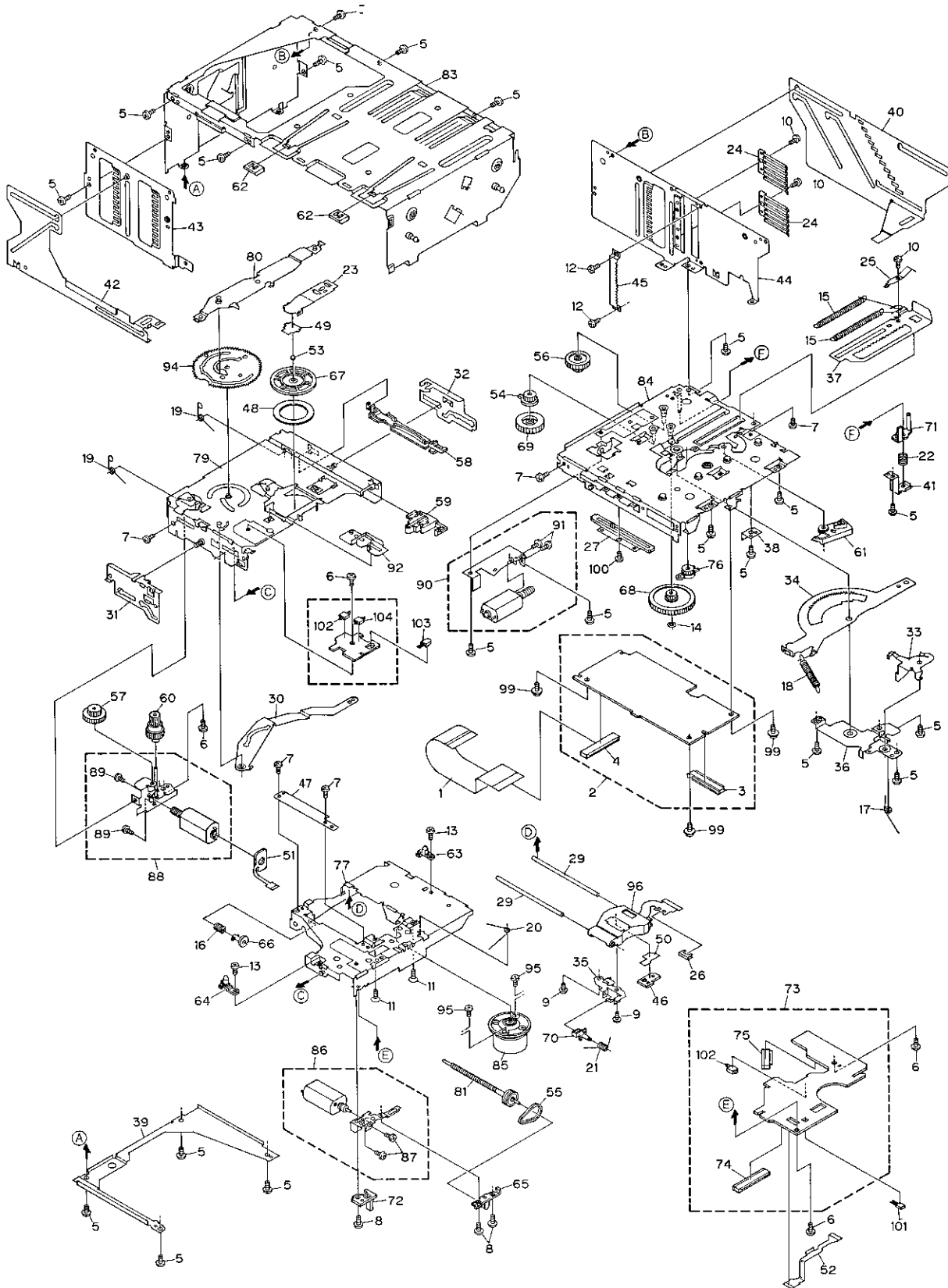

(1) CD MECHANISM MODULE SECTION PARTS LIST

Mark No.	Description	Part No.	Mark No.	Description	Part No.
1	Connector	CDE6069	46	Plate	CNC8375
2	CD Core Unit(C8)	See Contrast table(2)	47	Cover	CNC8434
3	Connector(CN701)	CKS1963	48	Sheet	CNM6009
4	Connector(CN101)	CKS2272	49	Spacer	CNM6146
5	Screw	BMZ20P025FMC	50	Sheet	CNM6296
6	Screw	CBA1037	51	PCB	CNP5227
7	Screw	CBA1041	52	PCB	CNP5228
8	Screw	CBA1176	53	Ball	CNR1189
9	Screw	CBA1362	54	Gear	CNR1531
10	Screw	CBA1387	55	Belt	CNT1086
11	Screw	CBA1470	56	Gear	CNV5472
12	Screw	CBA1476	57	Gear	CNV5473
13	Screw	CBA1486	58	Rail	CNV5474
14	Washer	CBF1038	59	Lever	CNV5475
15	Spring	CBH1867	60	Gear	CNV5477
16	Spring	CBH2172	61	Arm	CNV5478
17	Spring	CBH2173	62	Holder	CNV5480
18	Spring	CBH2174	63	Guide	CNV5481
19	Spring	CBH2175	64	Guide	CNV5482
20	Spring	CBH2177	65	Holder	CNV5483
21	Spring	CBH2178	66	Holder	CNV5484
22	Spring	CBH2179	67	Clamper	CNV5485
23	Spring	CBL1390	68	Gear	CNV5486
24	Spring	CBL1392	69	Gear	CNV5562
25	Spring	CBL1404	70	Holder	CNV5563
26	Short Pin	CBL1239	71	Stopper	CNV5564
27	Volume(VR801)	CCW1024	72	Lighting Conductor	CNV5785
28	••••		73	Mechanism PCB	CWX2303
29	Shaft	CLA3304	74	Connector(CN801)	CKS1965
30	Arm	CNC7901	75	Connector(CN802)	CKS3486
31	Lever	CNC7905	76	Damper Unit	CXA7159
32	Lever	CNC7906	77	Chassis Unit	CXB2850
33	Arm	CNC7908	78	••••	
34	Arm	CNC7909	79	Chassis Unit	CXB2851
35	Holder	CNC7911	80	Arm Unit	CXB2855
36	Holder	CNC7912	81	Screw Unit	CXB2857
37	Lever	CNC7919	82	••••	
38	Stopper	CNC7920	83	Frame Unit	CXB4427
39	Frame	CNC7921	84	Magazine Holder Unit	CXB2859
40	Lever	CNC7922	85	Motor Unit(M851)(SPINDLE)	CXB3003
41	Bracket	CNC7923	86	Motor Unit(M854)(CARRIAGE)	CXB3004
42	Lever	CNC7924	87	Screw	JFZ20P025FMC
43	Frame	CNC7927	88	Motor Unit(M853)(TRAY)	CXB4421
44	Frame	CNC7928	89	Screw	JFZ20P025FMC
45	Bracket	CNC8355	90	Motor Unit(M852)(ELV)	CXB3006

Mark No.	Description	Part No.
91	Screw	JFZ20P025FMC
92	Lever Unit	CXB3938
93	
94	Gear Unit	CXB4338
95	Screw	JGZ17P025FZK
96	Pickup Unit(Service)	CXX1285
97	
98	
99	Screw	IMS26P040FMC
100	Screw	JFZ20P025FNI
101	Photo-transistor(Q851)	PT4800
102	Spring Switch(S851,S853)	CSN1051
103	LED(D851)	CN504-2
104	Spring Switch(S852)	CSN1052

(2) CONTRAST TABLE

CDX-FM1259/X1N/UC, CDX-FM1257/X1N/UC and CDX-FM1257/X1N/ES are constructed the same except for the following:

Mark No.	Symbol and Description	Part No.		
		CDX-FM1259/X1N/UC	CDX-FM1257/X1N/UC	CDX-FM1257/X1N/ES
2	CD Core Unit(C8)	CWX2276	CWX2275	CWX2275

2.4 MAGAZINE ASSY

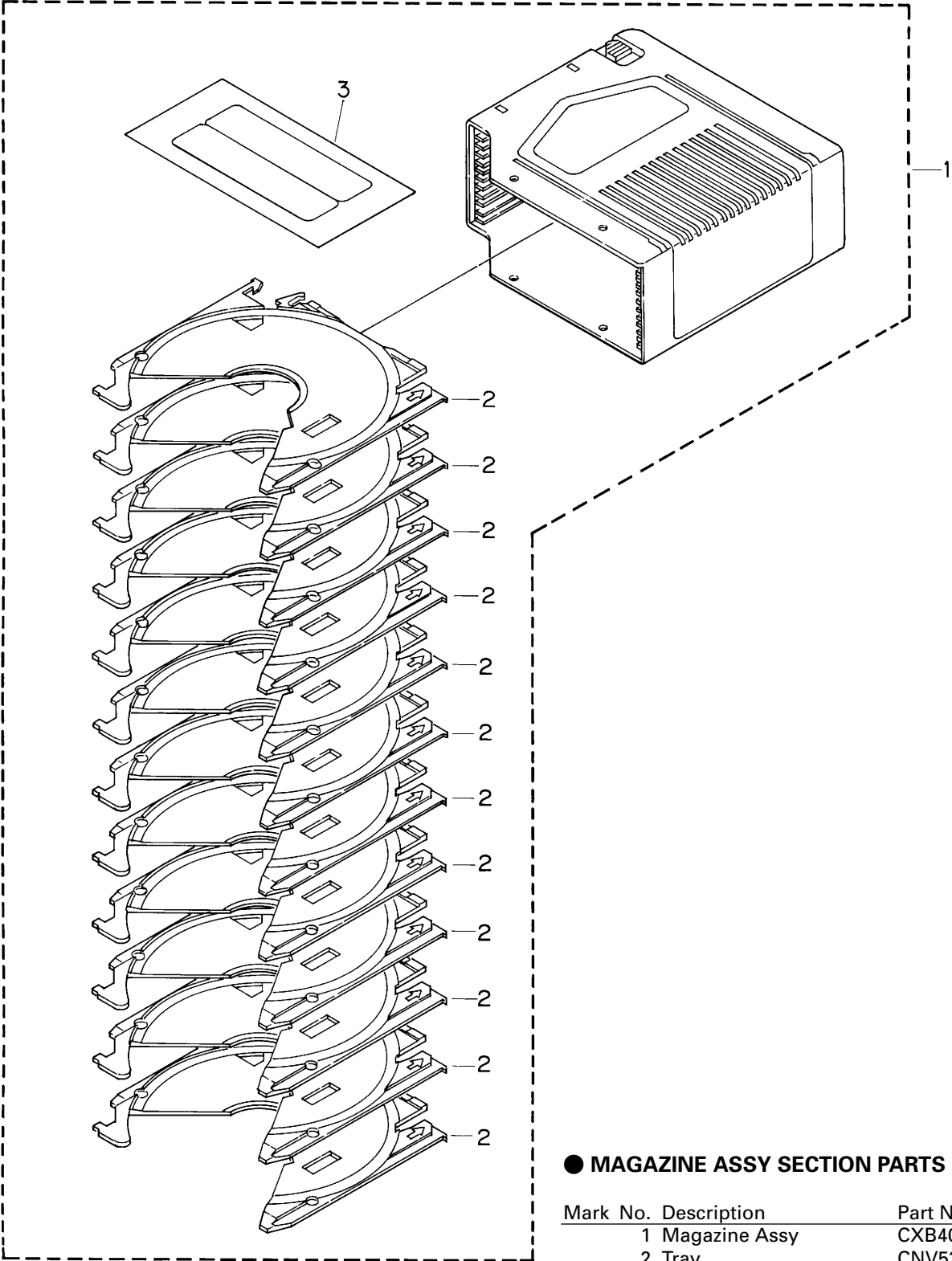

● MAGAZINE ASSY SECTION PARTS LIST

Mark No.	Description	Part No.
1	Magazine Assy	CXB4028
2	Tray	CNV5341
3	Label	CRW1396

3. SCHEMATIC DIAGRAM

3.1 OVERALL CONNECTION DIAGRAM

Note: When ordering service parts, be sure to refer to "EXPLODED VIEWS AND PARTS LIST" or "ELECTRICAL PARTS LIST".

A

B

C

D

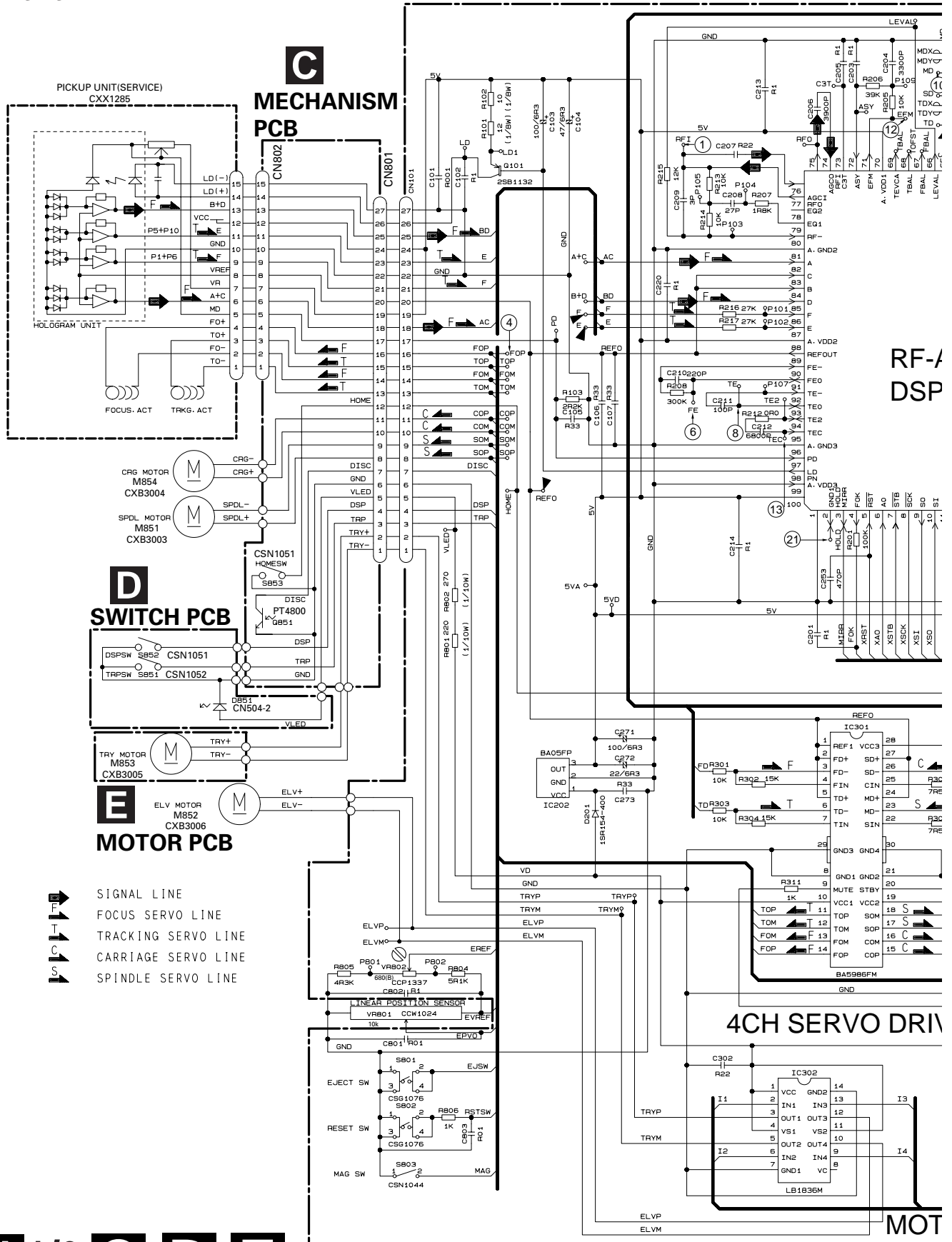

NOTE :

□ Symbol indicates a resistor.
 No differentiation is made between chip resistors and discrete resistors.

—|— Symbol indicates a capacitor.
 No differentiation is made between chip capacitors and discrete capacitors.

Decimal points for resistor and capacitor fixed values are expressed as:
 2.2→2R2
 0.022→R022

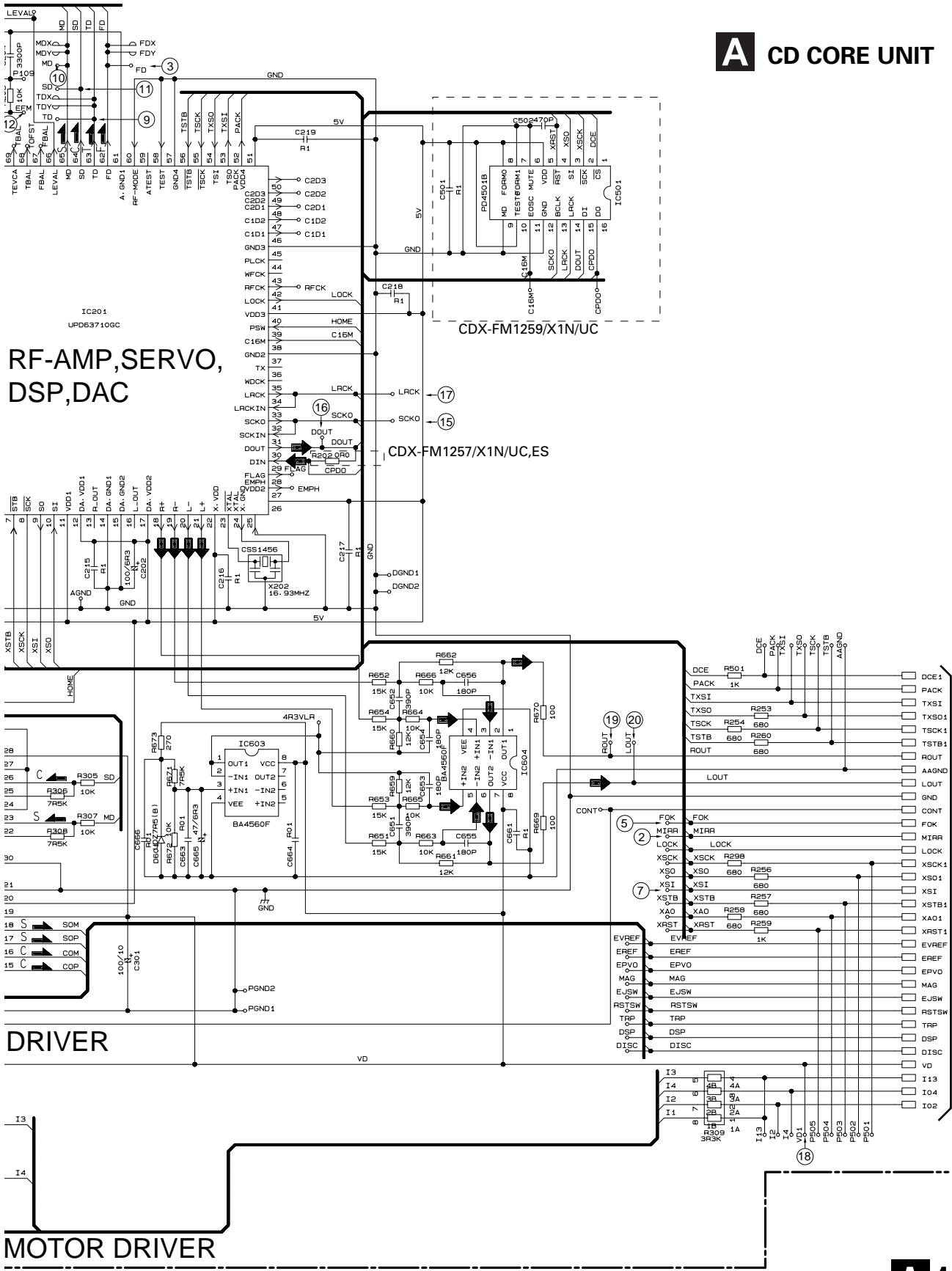

RF-AMP, SERVO, DSP, DAC

DRIVER

MOTOR DRIVER

A CD CORE UNIT

A2/2

A1/2

A

B

C

D

A

B

C

D

A1/2

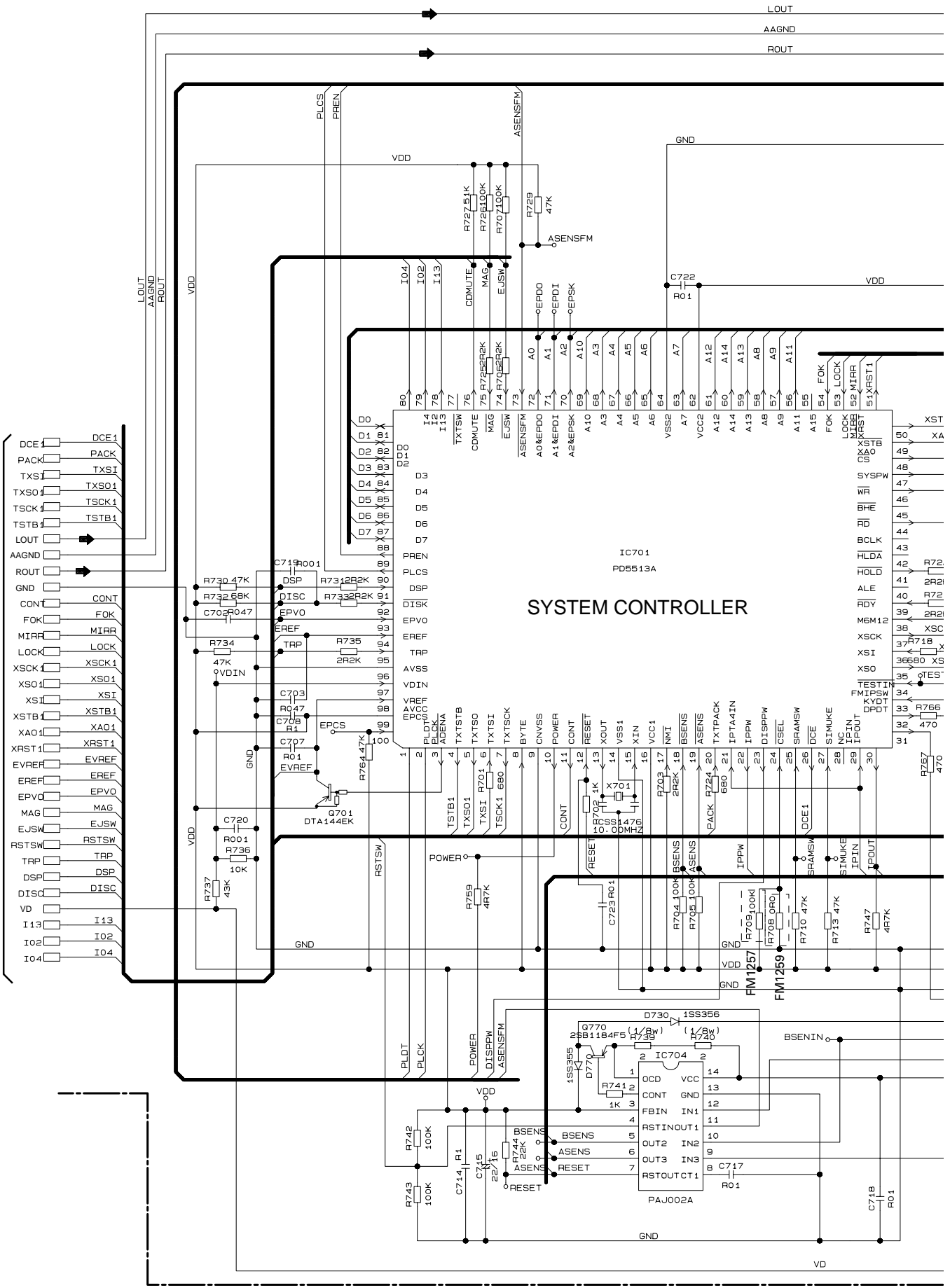

SYSTEM CONTROLLER

IC701 PD5513A

1

2

3

4

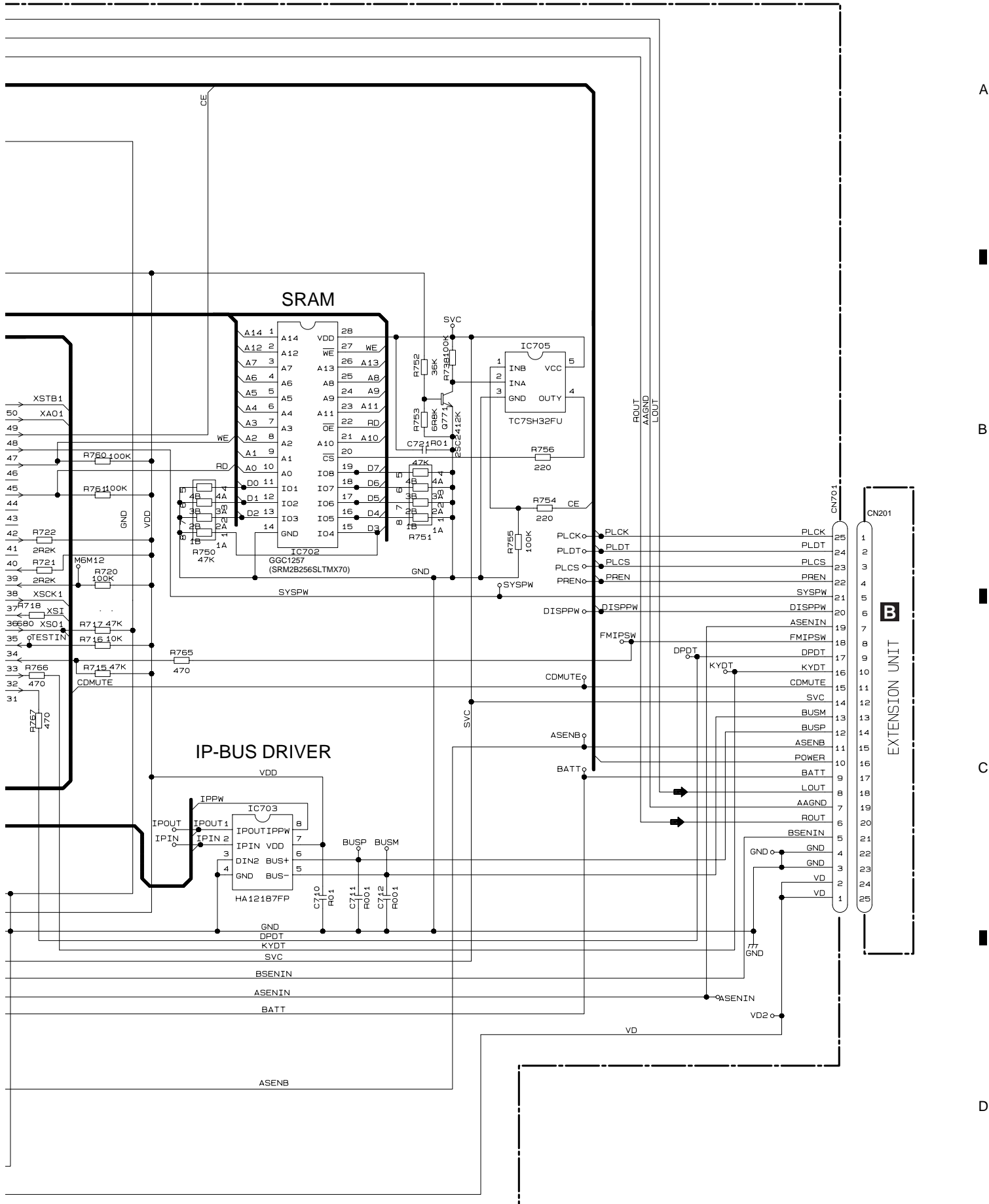

Note:1. The encircled numbers denote measuring pointes in the circuit diagram.
 2. Reference voltage
 REFO:2.5V

● Waveforms

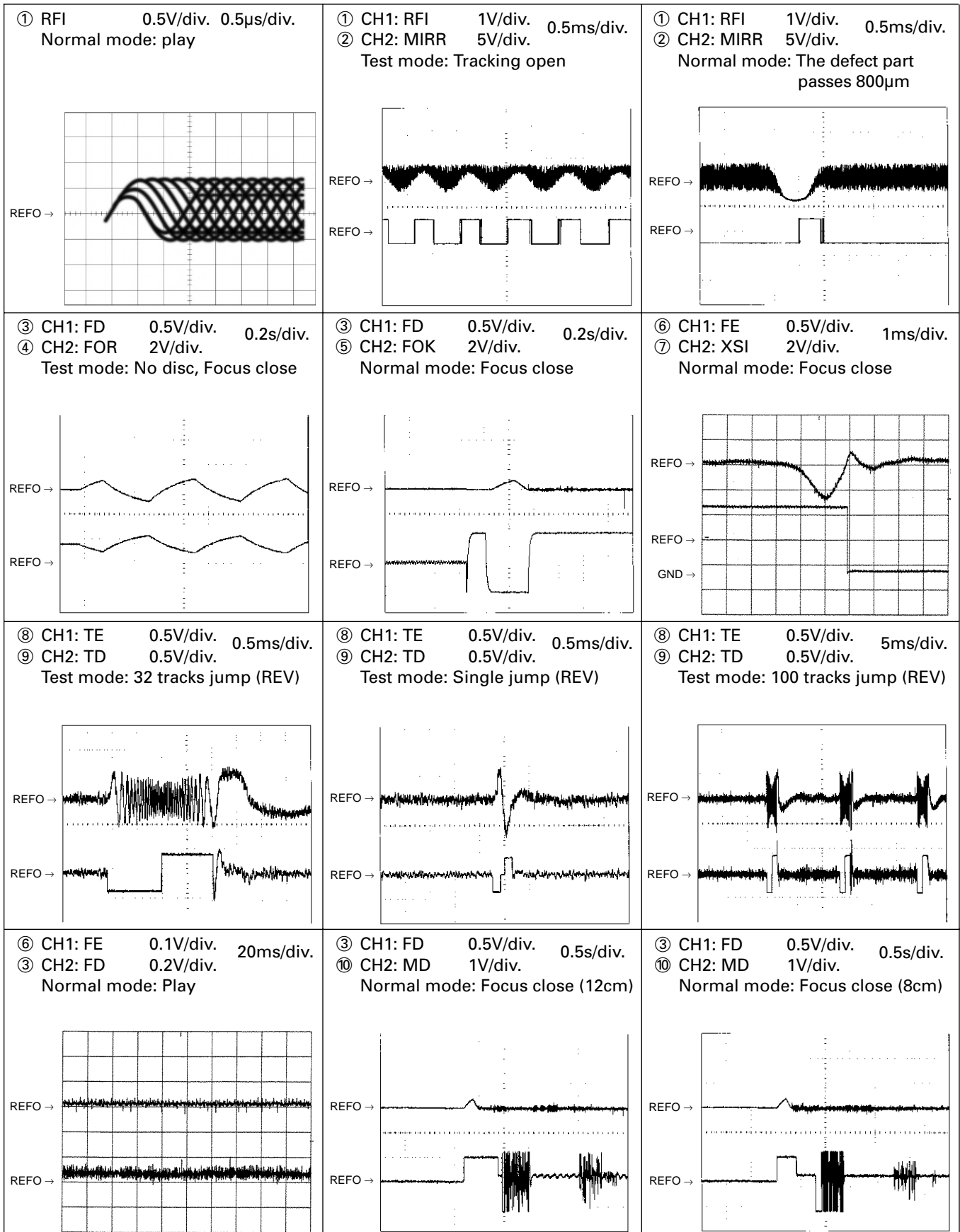

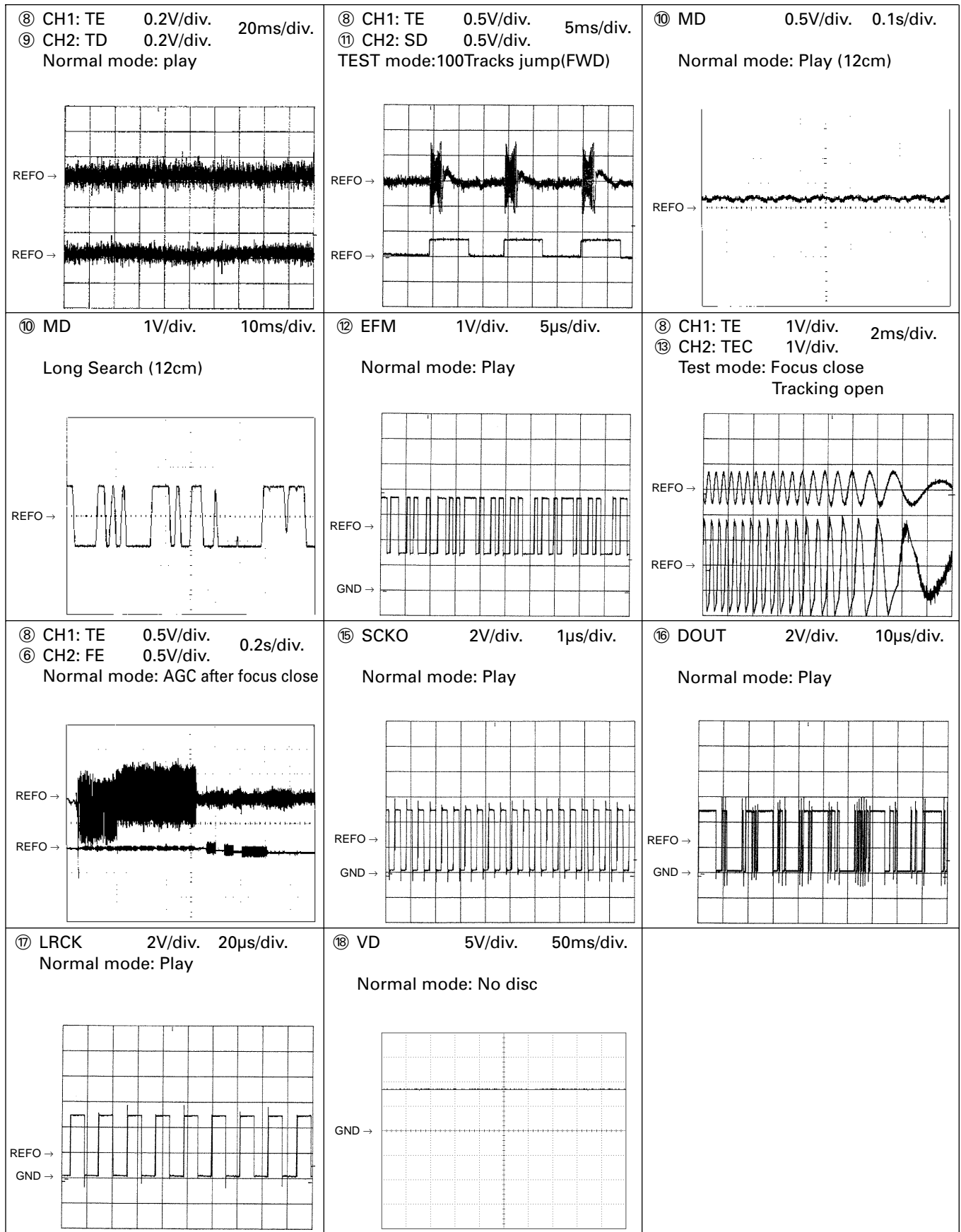

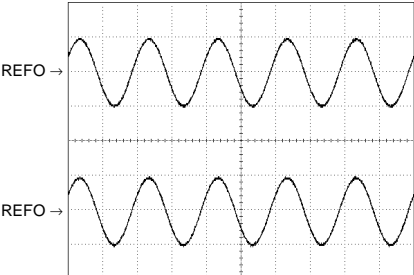
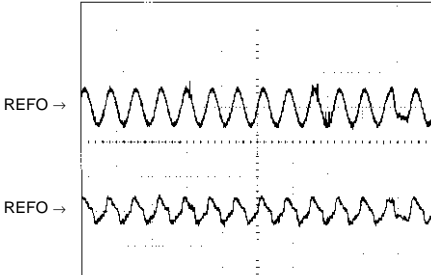
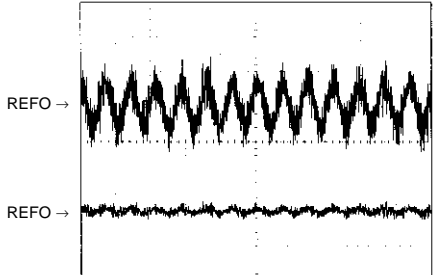
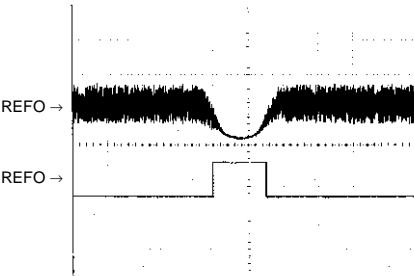
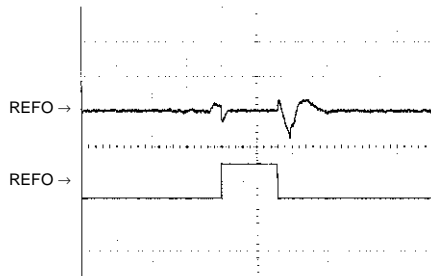
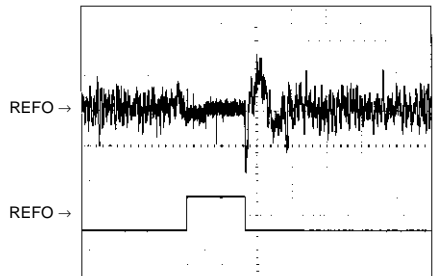
<p>⑱ CH1: R OUT 2V/div. 500μs/div. ⑳ CH2: L OUT 2V/div. Normal mode: Play (1kHz 0dB)</p> 	<p>⑥ CH1: FE 0.2V/div. 1ms/div. ③ CH2: FD 0.5V/div. Normal mode: During AGC</p> 	<p>⑧ CH1: TE 0.2V/div. 1ms/div. ⑨ CH2: TD 0.5V/div. Normal mode: During AGC</p> 
<p>① CH1: RFI 1V/div. 0.5ms/div. ② CH2: HOLD 5V/div. Normal mode: The defect part passes 800μm(B.D)</p> 	<p>③ CH1: FD 1V/div. 0.5ms/div. ② CH2: HOLD 5V/div. Normal mode: The defect part passes 800μm(B.D)</p> 	<p>⑨ CH1: TD 0.1V/div. 0.5ms/div. ② CH2: HOLD 5V/div. Normal mode: The defect part passes 800μm(B.D)</p> 

3.2 EXTENSION UNIT

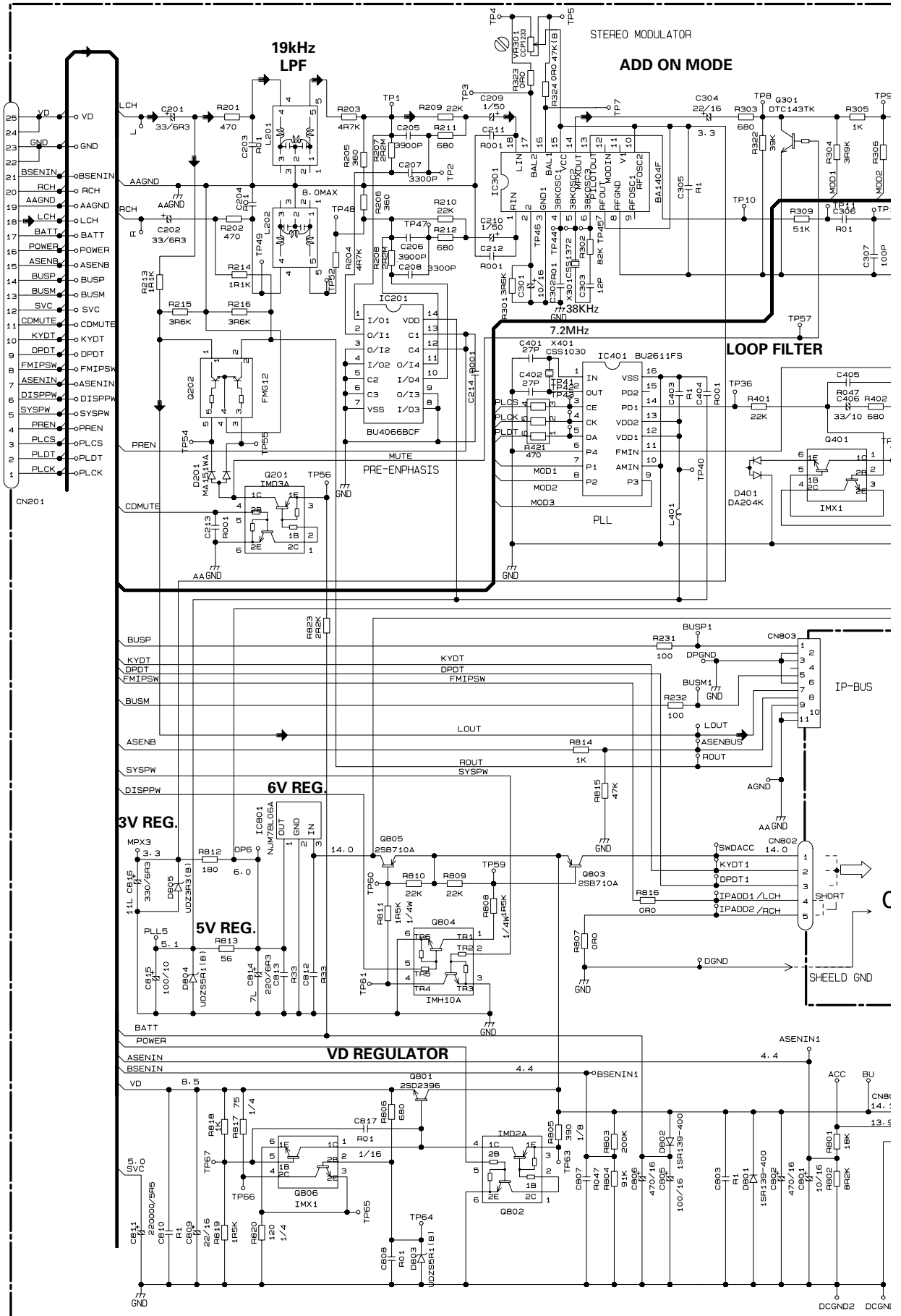

A
CN701

B

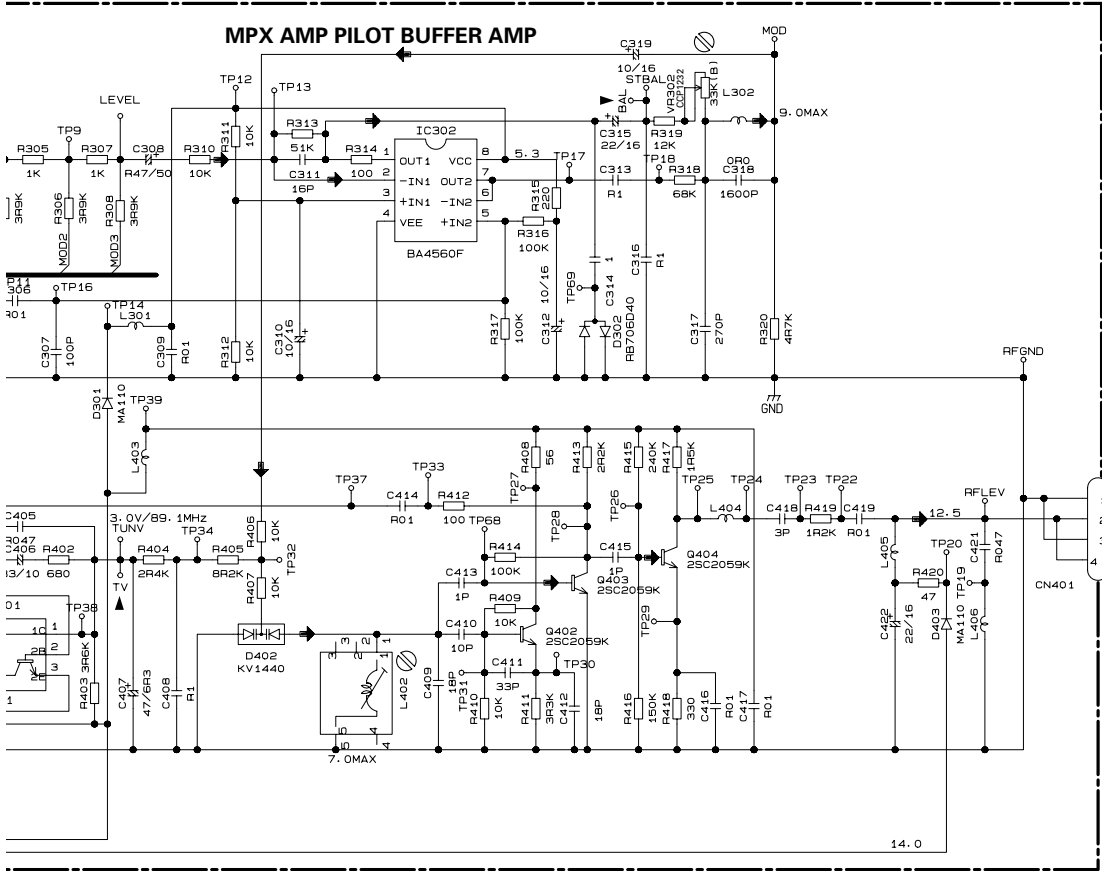

The Δ mark found on some component parts indicates the importance of the safety factor of the part. Therefore, when replacing, be sure to use parts of identical designation.

IP-BUS

F
CN501

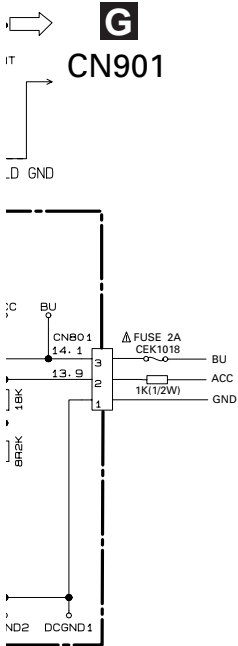

B EXTENSION UNIT

B

3.3 ANTENNA SELECT UNIT

A

B

C

D

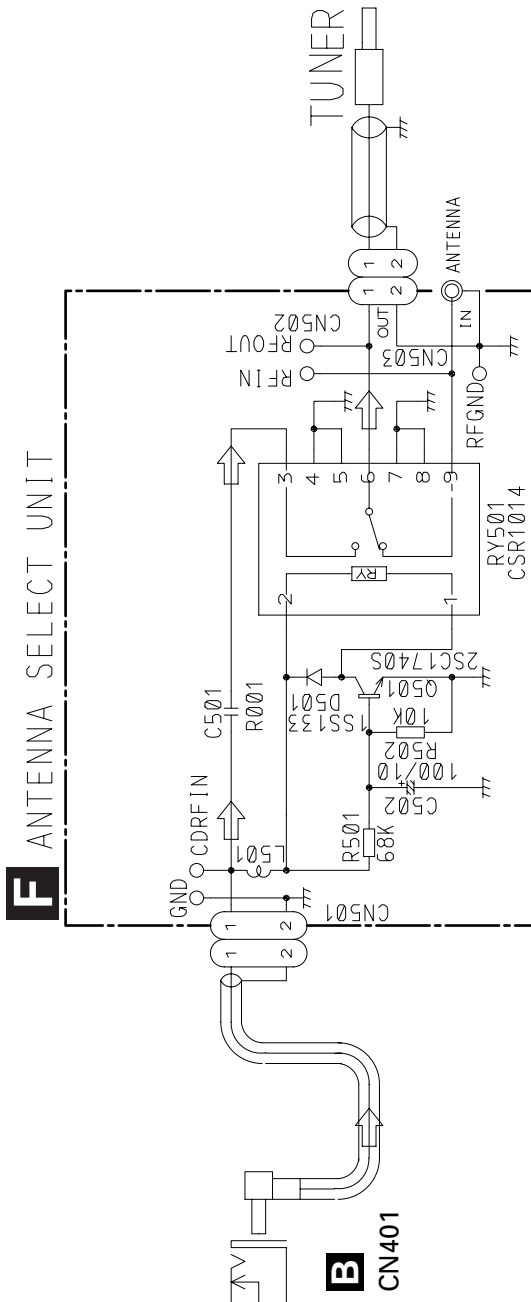

3.4 DISPLAY ASSY

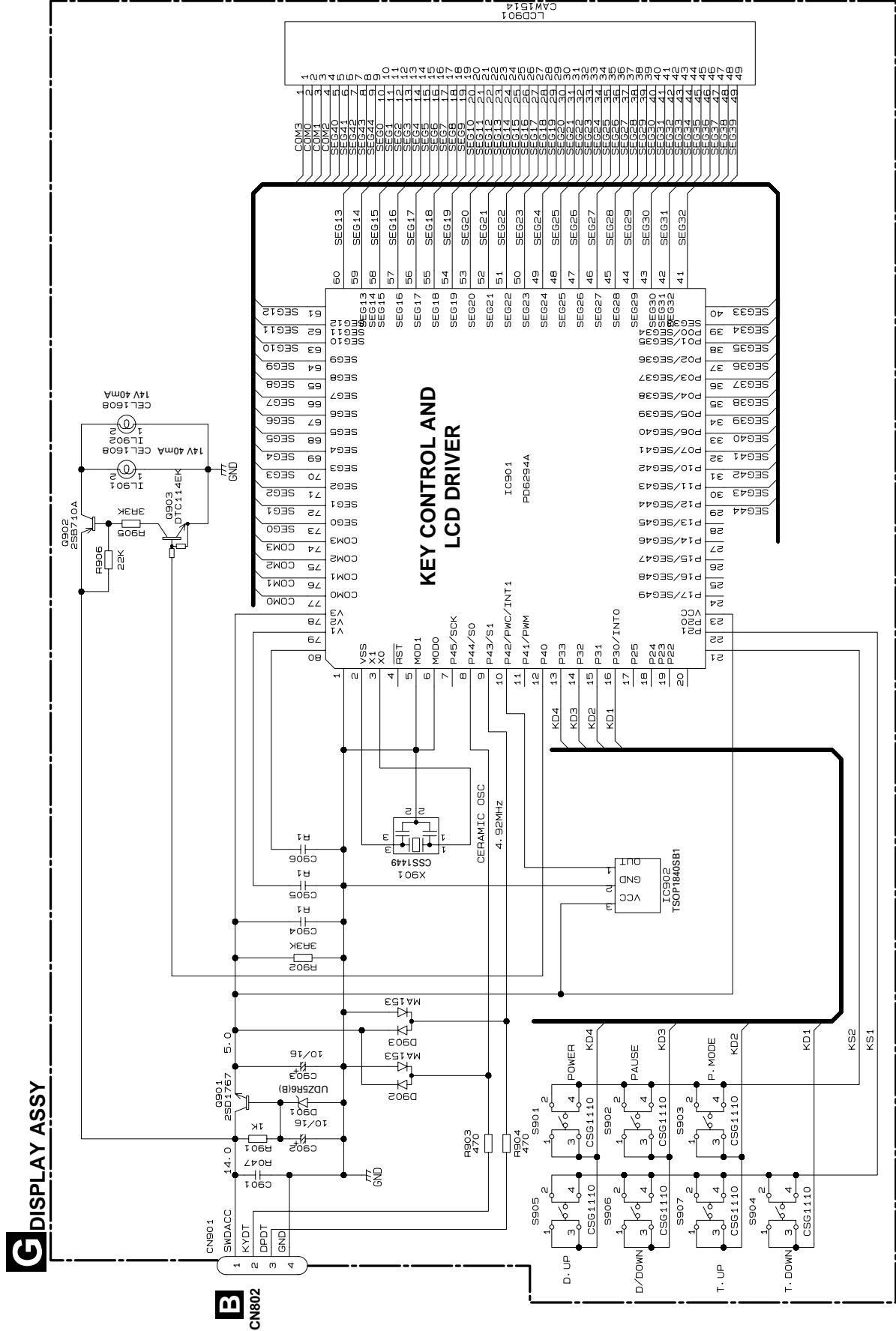

4. PCB CONNECTION DIAGRAM

4.1 CD CORE UNIT

NOTE FOR PCB DIAGRAMS

- The parts mounted on this PCB include all necessary parts for several destination.
- For further information for respective destinations, be sure to check with the schematic diagram.

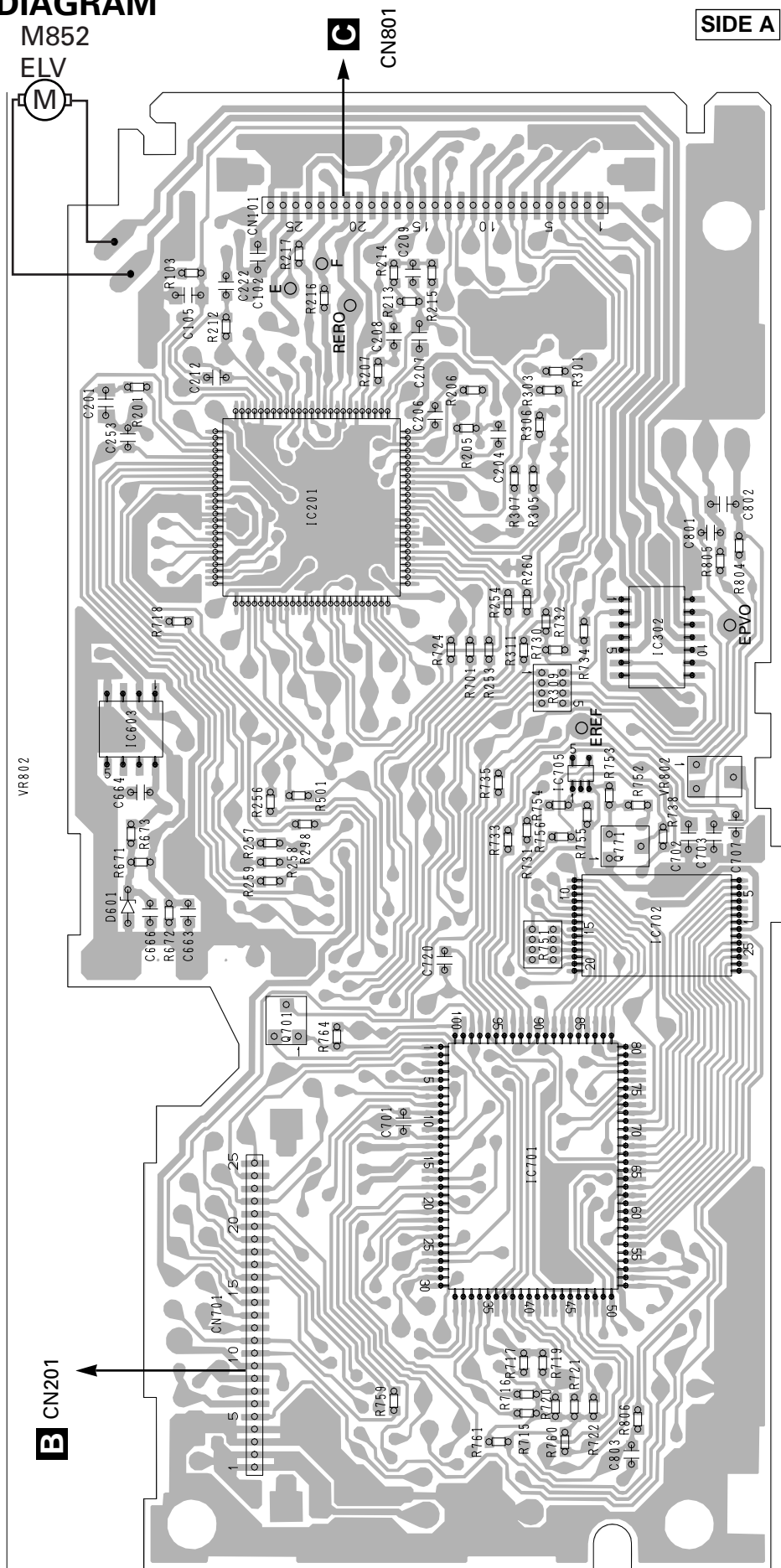

SIDE A

A CD CORE UNIT

B CN201

SIDE B

B EXTENSION UNIT

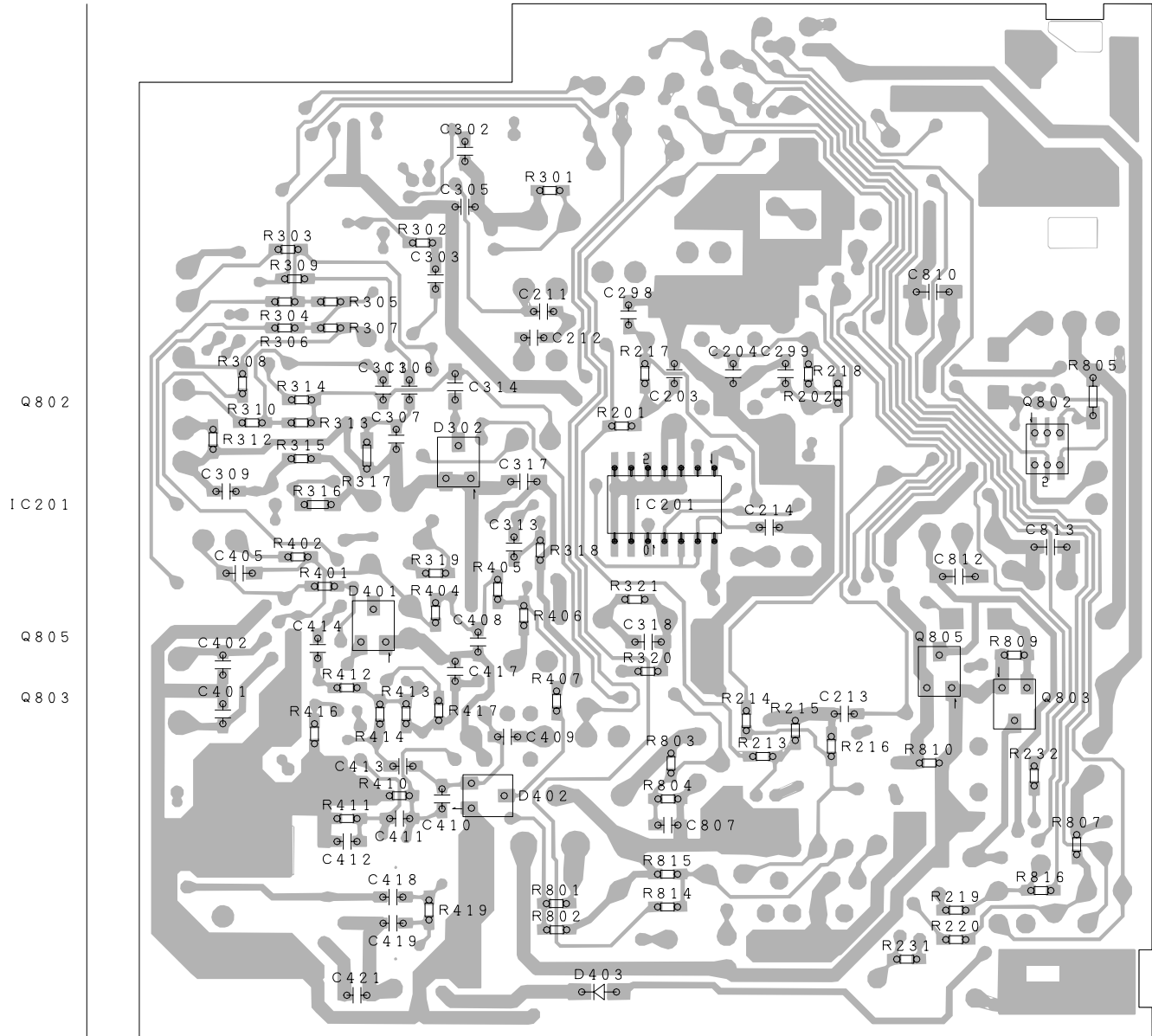

4.3 MECHANISM PCB

C MECHANISM PCB

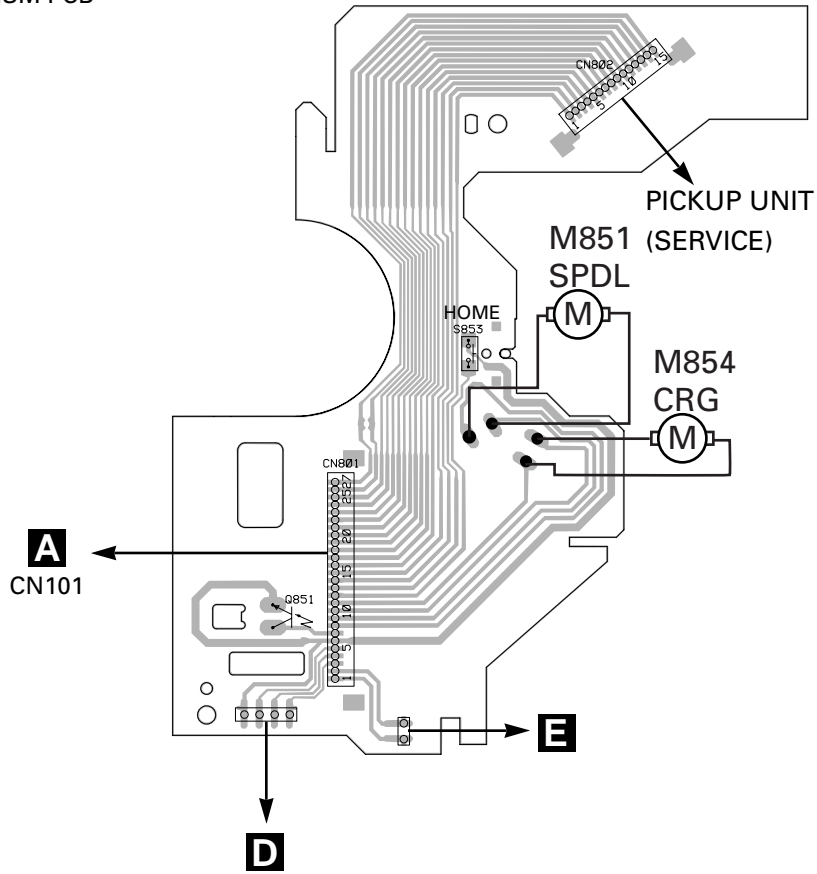

4.4 SWITCH PCB

D SWITCH PCB

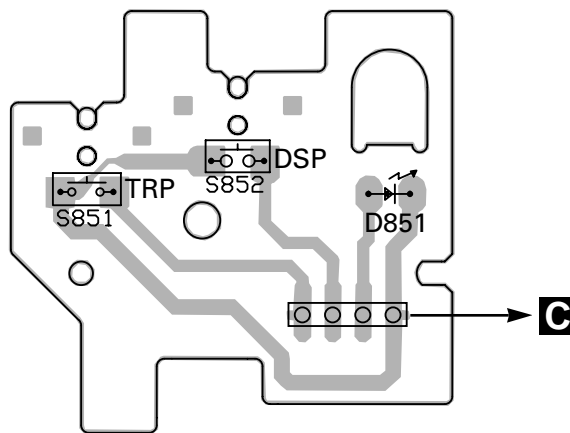

4.5 MOTOR PCB

E MOTOR PCB

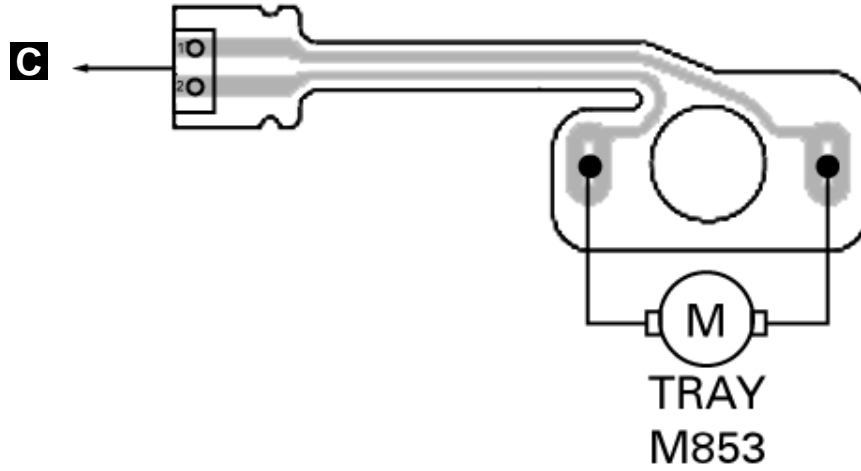

4.6 ANTENNA SELECT UNIT

F ANTENNA SELECT UNIT

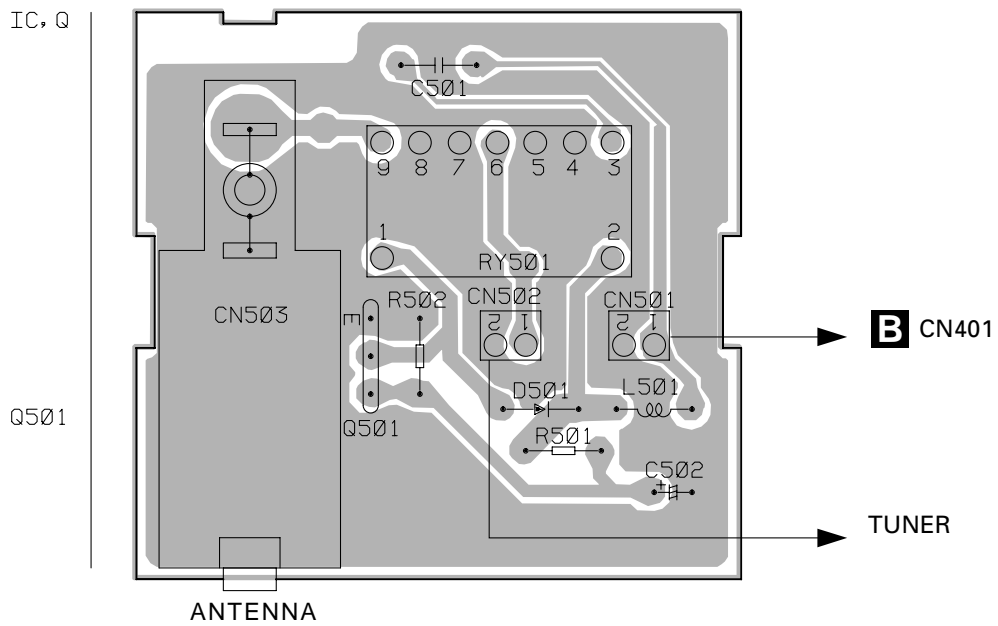

4.7 DISPLAY ASSY

SIDE A

A

B

C

D

DISPLAY ASSY

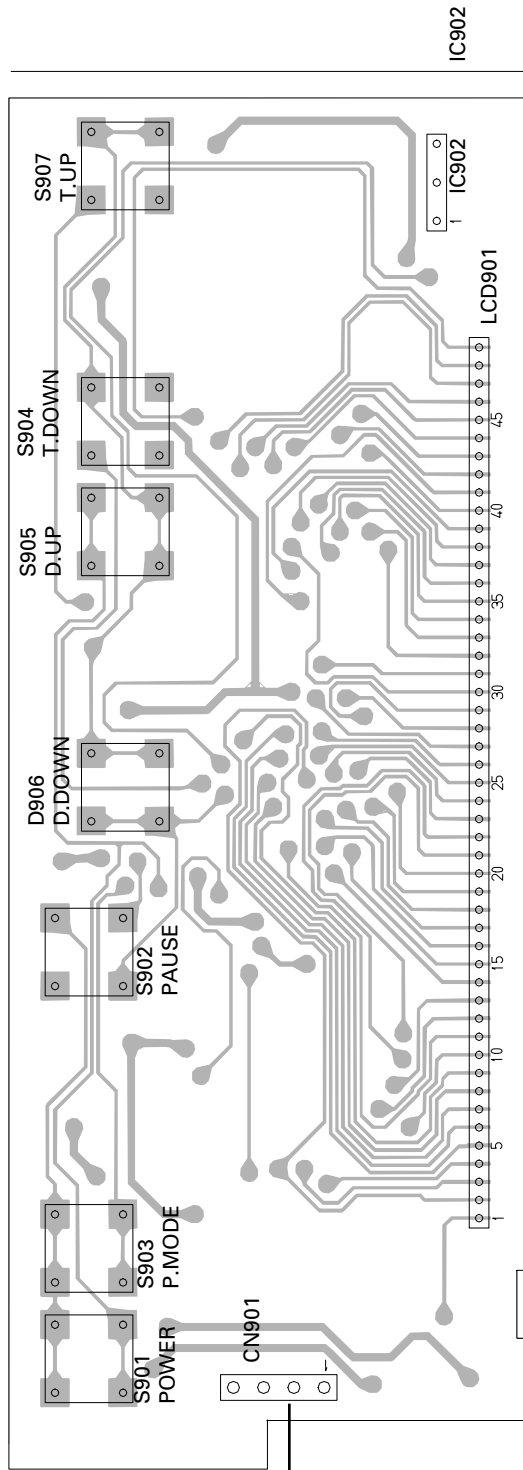

SIDE B

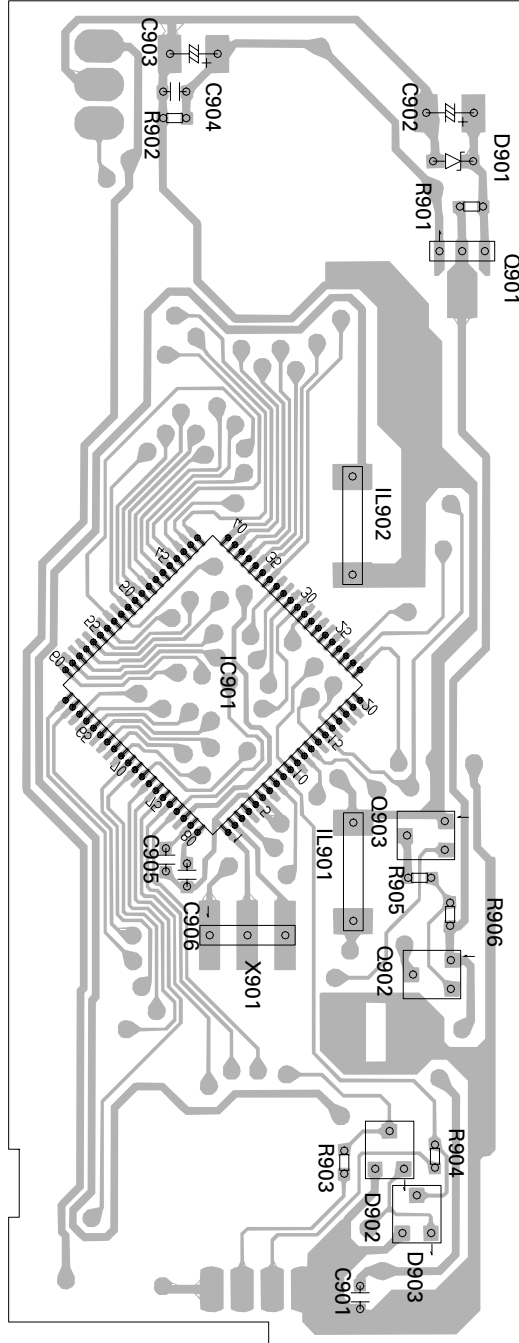

DISPLAY ASSY



Q901
Q903 Q902
IC901

A B C D



1 2 3 4

5. ELECTRICAL PARTS LIST

NOTE:

- Parts whose parts numbers are omitted are subject to being not supplied.
- The part numbers shown below indicate chip components.

Chip Resistor

RS1/OSOOOJ,RS1/OOSOOOJ

Chip Capacitor (except for CQS.....)

CKS....., CCS....., CSZS.....

====Circuit Symbol and No.====Part Name	Part No.	====Circuit Symbol and No.====Part Name	Part No.
B Unit Number : CWX2304		R 206	RS1/16S361J
Unit Name : Extension Unit		R 207	RS1/16S225J
MISCELLANEOUS		R 208	RS1/16S225J
IC 201 IC	BU4066BCF	R 209	RS1/16S223J
IC 301 IC	BA1404F	R 210	RS1/16S223J
IC 302 IC	BA4560F	R 211	RS1/16S681J
IC 401 IC	BU2611FS	R 212	RS1/16S681J
IC 801 IC	NJM78L06A	R 213	RS1/16S112J
		R 214	RS1/16S112J
		R 215	RS1/16S362J
Q 201 Transistor	IMD3A		
Q 202 Transistor	FMG12	R 216	RS1/16S362J
Q 301 Transistor	DTC143TK	R 231	RS1/16S101J
Q 401 Transistor	IMX1	R 232	RS1/16S101J
Q 402 Transistor	2SC2059K	R 301	RS1/16S362J
		R 302	RS1/16S823J
Q 403 Transistor	2SC2059K		
Q 404 Transistor	2SC2059K	R 303	RS1/16S681J
Q 801 Transistor	2SD2396	R 304	RS1/16S392J
Q 802 Transistor	IMD2A	R 305	RS1/16S102J
Q 803 Transistor	2SB710A	R 306	RS1/16S392J
		R 307	RS1/16S102J
Q 804 Transistor	IMH10A		
Q 805 Transistor	2SB710A	R 308	RS1/16S392J
Q 806 Transistor	IMX1	R 309	RS1/16S513J
D 201 Chip Diode	MA151WA	R 310	RS1/16S103J
D 301 Diode	MA110	R 311	RS1/16S103J
		R 312	RS1/16S103J
D 302 Diode	RB706D40		
D 401 Diode	DA204K	R 313	RS1/16S513J
D 402 Diode	KV1440	R 314	RS1/16S101J
D 403 Diode	MA110	R 315	RS1/16S221J
D 801 Diode	1SR139-400	R 316	RS1/10S104J
		R 317	RS1/10S104J
D 802 Diode	1SR139-400		
D 803 Diode	UDZS5R1(B)	R 318	RS1/16S683J
D 804 Diode	UDZS5R1(B)	R 319	RS1/16S123J
D 805 Diode	UDZ3R3(B)	R 320	RS1/16S472J
L 201 Filter	CTF1333	R 322	RS1/16S393J
		R 323	RS1/16S0R0J
L 202 Filter	CTF1333		
L 301 Inductor	LCTB2R2K2125	R 324	RS1/16S0R0J
L 302 Inductor	CTF1302	R 401	RS1/16S223J
L 401 Inductor	LCTB2R2K2125	R 402	RS1/16S681J
L 402 Coil	CTC1079	R 403	RS1/16S362J
		R 404	RS1/16S242J
L 403 Inductor	LCTB2R2K2125		
L 404 Inductor	LCTA1R0J3225	R 405	RS1/16S822J
L 405 Inductor	LCTA101J3225	R 406	RS1/16S103J
L 406 Inductor	LCTAR68J3225	R 407	RS1/16S103J
X 301 Radiator 38.000kHz	CSS1372	R 408	RS1/16S560J
		R 409	RS1/16S103J
X 401 Crystal Resonator 7.2MHz	CSS1030		
VR 301 Semi-fixed 47kΩ(B)	CCP1233	R 410	RS1/16S103J
VR 302 Semi-fixed 33kΩ(B)	CCP1232	R 411	RS1/16S332J
		R 412	RS1/16S101J
		R 413	RS1/16S222J
		R 414	RS1/16S104J
RESISTORS			
R 201	RS1/16S471J		
R 202	RS1/16S471J	R 415	RS1/16S244J
R 203	RS1/16S472J	R 416	RS1/16S154J
R 204	RS1/16S472J	R 417	RS1/16S152J
R 205	RS1/16S361J	R 418	RS1/16S331J
		R 419	RS1/16S122J

====Circuit Symbol and No.====Part Name	Part No.	====Circuit Symbol and No.====Part Name	Part No.
R 420	RS1/16S470J	C 408	CKSRYB104K16
R 421	RA3C471J	C 409	CCSRCH180J50
R 801	RS1/16S183J	C 410	CCSRCH100D50
R 802	RS1/16S822J	C 411	CCSRCH330J50
R 803	RS1/16S204J	C 412	CCSRCH180J50
R 804	RS1/16S913J	C 413	CCSRCK1R0C50
R 805	RS1/8S391J	C 414	CKSRYB103K50
R 806	RS1/16S681J	C 415	CCSRCK1R0C50
R 807	RS1/16S0R0J	C 416	CKSRYB103K50
R 808	RS1/4S152J	C 417	CKSRYB103K50
R 809	RS1/16S223J	C 418	CCSRJ3R0C50
R 810	RS1/16S223J	C 419	CKSRYB103K50
R 811	RS1/4S152J	C 421	CKSRYB473K16
R 812	RS1/16S181J	C 422	CEAL220M16
R 813	RS1/16S560J	C 801	CEAL100M16
R 814	RS1/16S102J	C 802	470µF/16V
R 815	RS1/16S473J	C 803	CCH1183
R 816	RS1/16S0R0J	C 805	CKSRYB104K16
R 817	RS1/4S750J	C 806	470µF/16V
R 818	RS1/16S102J	C 807	CEJA101M16
R 819	RS1/16S152J	C 808	CCH1183
R 820	RS1/4S121J	C 809	CKSRYB473K16
R 823	RS1/10S222J	C 810	CKSRYB103K50
CAPACITORS		C 811	0.22F/5.5V
C 201	CEAL330M6R3	C 812	CKSQYB104K16
C 202	CEAL330M6R3	C 813	CKSQYB334K16
C 203	CKSRYB103K50	C 814	CKSQYB334K16
C 204	CKSRYB103K50	C 815	CEJA221M6R3
C 205	CKSRYB392K50	C 816	CEJA101M10
C 206	CKSRYB392K50	C 817	CEAS331M6R3
C 207	CKSRYB332K50	C 817	CKSRYB103K50
C 208	CKSRYB332K50	A Unit Number : CWX2276(CDX-FM1259/X1N/UC)	
C 209	CEAL1R0M50	Unit Name : CD Core Unit	
C 210	CEAL1R0M50	CWX2275(CDX-FM1257/X1N/UC,ES)	
MISCELLANEOUS			
C 211	CKSRYB102K50	IC 201	IC
C 212	CKSRYB102K50	IC 202	IC
C 213	CKSRYB102K50	IC 301	IC
C 214	CKSRYB102K50	IC 302	IC
C 301	CEAL100M16	IC 501	IC(CDX-FM1259/X1N/UC)
C 302	CKSRYB103K50	IC 603	IC
C 303	CCSRCH120J50	IC 604	IC
C 304	CEAL220M16	IC 701	IC
C 305	CKSRYB104K16	IC 702	IC (SRM2B256SLTMX70)
C 306	CKSRYB103K50	IC 703	IC
C 307	CCSRCH101J50	IC 704	IC
C 308	CEALR47M50	IC 705	IC
C 309	CKSRYB103K50	Q 101	Transistor
C 310	CEAL100M16	Q 701	Transistor
C 311	CCSRCH160J50	Q 770	Transistor
C 312	CEAL100M16	Q 771	Transistor
C 313	CKSRYB104K16	D 201	Diode
C 314	CKSQYB105K16	D 601	Diode
C 315	CEAL220M16	D 730	Diode
C 316	CKSRYB104K16	D 770	Diode
C 317	CCSQCH271J50	X 202	Ceramic Resonator16.93MHz
C 318	CCSQCH162J50	X 701	Ceramic Resonator10.00MHz
C 319	CEAL100M16	S 801	Push Switch(EJECT)
C 401	CCSRCH270J50	S 802	Push Switch(RESET)
C 402	CCSRCH270J50	S 803	Spring Switch(MAG)
C 403	CKSRYB104K16	VR 802	Semi-fixed 680Ω(B)
C 404	CKSRYB102K50		
C 405	CKSQYB473K16		
C 406	CEALNP330M10		
C 407	CEAL470M6R3		

====Circuit Symbol and No.====Part Name	Part No.	====Circuit Symbol and No.====Part Name	Part No.
RESISTORS			
R 101	RS1/8S120J	R 718	RS1/16S681J
R 102	RS1/8S100J	R 720	RS1/16S104J
R 103	RS1/16S222J	R 721	RS1/16S222J
R 201	RS1/16S104J	R 722	RS1/16S222J
R 202 (CDX-FM1257/X1N/UC,ES)	RS1/16S0R0J	R 724	RS1/16S681J
R 205	RS1/16S103J	R 725	RS1/16S222J
R 206	RS1/16S393J	R 726	RS1/16S104J
R 207	RS1/16S182J	R 727	RS1/16S513J
R 208	RS1/16S304J	R 729	RS1/16S473J
R 212	RS1/16S0R0J	R 730	RS1/16S473J
R 213	RS1/16S103J	R 731	RS1/16S222J
R 214	RS1/16S103J	R 732	RS1/16S683J
R 215	RS1/16S123J	R 733	RS1/16S222J
R 216	RS1/16S273J	R 734	RS1/16S473J
R 217	RS1/16S273J	R 735	RS1/16S222J
R 253	RS1/16S681J	R 736	RS1/16S103J
R 254	RS1/16S681J	R 737	RS1/16S433J
R 256	RS1/16S681J	R 738	RS1/16S104J
R 257	RS1/16S681J	R 739	RS1/8S2R0J
R 258	RS1/16S681J	R 740	RS1/8S2R0J
R 259	RS1/16S102J	R 741	RS1/16S102J
R 260	RS1/16S681J	R 742	RS1/16S104J
R 298	RS1/16S681J	R 743	RS1/16S104J
R 301	RS1/16S103J	R 744	RS1/16S223J
R 302	RS1/16S153J	R 747	RS1/16S472J
R 303	RS1/16S103J	R 750	RA4C473J
R 304	RS1/16S153J	R 751	RA4C473J
R 305	RS1/16S103J	R 752	RN1/16SE3602D
R 306	RS1/16S752J	R 753	RN1/16SE6801D
R 307	RS1/16S103J	R 754	RS1/16S221J
R 308	RS1/16S752J	R 755	RS1/16S104J
R 309	RA4C332J	R 756	RS1/16S221J
R 311	RS1/16S102J	R 759	RS1/16S472J
R 501	RS1/16S102J	R 760	RS1/16S104J
R 651	RSK1/16S153J	R 761	RS1/16S104J
R 652	RSK1/16S153J	R 764	RS1/16S473J
R 653	RSK1/16S153J	R 765	RS1/16S471J
R 654	RSK1/16S153J	R 766	RS1/16S471J
R 659	RSK1/16S123J	R 767	RS1/16S471J
R 660	RSK1/16S123J	R 801	RS1/10S221J
R 661	RSK1/16S123J	R 802	RS1/10S271J
R 662	RSK1/16S123J	R 804	RS1/16S512J
R 663	RSK1/16S103J	R 805	RS1/16S432J
R 664	RSK1/16S103J	R 806	RS1/16S102J
R 665	RSK1/16S103J	CAPACITORS	
R 666	RSK1/16S103J	C 101	CKSRYB102K50
R 669	RS1/16S101J	C 102	CKSQYB104K25
R 670	RS1/16S101J	C 103	CEV101M6R3
R 671	RS1/16S752J	C 104	CEV470M6R3
R 672	RS1/16S103J	C 105	CKSQYB334K16
R 673	RS1/16S271J	C 106	CKSQYB334K16
R 701	RS1/16S681J	C 107	CKSQYB334K16
R 702	RS1/16S102J	C 201	CKSQYB104K25
R 703	RS1/16S222J	C 202	CEV101M6R3
R 704	RS1/16S104J	C 203	CKSQYB104K25
R 705	RS1/16S104J	C 204	CKSRYB332K50
R 706	RS1/16S222J	C 205	CKSQYB104K25
R 707	RS1/16S104J	C 206	CKSRYB392K50
R 708 (CDX-FM1259/X1N/UC)	RS1/16S0R0J	C 207	CKSQYB224K16
R 709 (CDX-FM1257/X1N/UC,ES)	RS1/16S104J	C 208	CCSRCH270J50
R 710	RS1/16S473J	C 209	CCSRCJ3R0C50
R 713	RS1/16S473J	C 210	CCSRCH221J50
R 715	RS1/16S473J	C 211	CCSRCH101J50
R 716	RS1/16S103J	C 212	CKSRYB682K50
R 717	RS1/16S473J	C 213	CKSQYB104K25

====Circuit Symbol and No.====	Part Name	Part No.
C 214		CKSQYB104K25
C 215		CKSQYB104K25
C 216		CKSQYB104K25
C 217		CKSQYB104K25
C 218		CKSQYB104K25
C 219		CKSQYB104K25
C 220		CKSQYB104K25
C 253		CKSRYP471K50
C 271		CEV101M6R3
C 272	22μF/6.3V	CCH1300
C 273		CKSQYB334K16
C 301		CEV101M10
C 302		CKSQYB224K16
C 501	(CDX-FM1259/X1N/UC)	CKSQYB104K25
C 502	(CDX-FM1259/X1N/UC)	CKSRYP471K50
C 651		CCSRCH391J50
C 652		CCSRCH391J50
C 653		CCSRCH181J50
C 654		CCSRCH181J50
C 655		CCSRCH181J50
C 656		CCSRCH181J50
C 661		CKSQYB104K25
C 663		CKSRYP103K25
C 664		CKSRYP103K25
C 665		CEV470M6R3
C 666		CKSRYP103K25
C 702		CKSQYB473K16
C 703		CKSQYB473K16
C 707		CKSRYP103K25
C 708		CKSQYB104K25
C 710		CKSRYP103K25
C 711		CKSRYP102K50
C 712		CKSRYP102K50
C 714		CKSQYB104K25
C 715		CSZST220M16
C 717		CKSRYP103K25
C 718		CKSRYP103K25
C 719		CKSRYP102K50
C 720		CKSRYP102K50
C 721		CKSRYP103K25
C 722		CKSRYP103K25
C 723		CKSRYP103K25
C 801		CKSRYP103K25
C 802		CKSQYB104K25
C 803		CKSRYP103K25

G Unit Number : CXB3242(CDX-FM1259/X1N/UC)
 CXB3241(CDX-FM1257/X1N/UC,ES)
 Unit Name : Display Assy

MISCELLANEOUS

IC 901	IC	PD6294A
IC 902	IC	TSOP1840SB1
Q 901	Transistor	2SD1767
Q 902	Transistor	2SB710A
Q 903	Transistor	DTC114EK
D 901	Diode	UDZS5R6(B)
D 902	Diode	MA153
D 903	Diode	MA153
X 901	Ceramic Resonator 4.9152MHz	CS51449
S 901	Switch	CSG1110
S 902	Switch	CSG1110
S 903	Switch	CSG1110
S 904	Switch	CSG1110
S 905	Switch	CSG1110
S 906	Switch	CSG1110

====Circuit Symbol and No.====	Part Name	Part No.
S 907	Switch	CSG1110
IL 901	Lamp 14V 40mA	CEL1608
IL 902	Lamp 14V 40mA	CEL1608
LCD 901	LCD	CAW1514

RESISTORS

R 901		RS1/16S102J
R 902		RS1/16S332J
R 903		RS1/16S471J
R 904		RS1/16S471J
R 905		RS1/16S332J
R 906		RS1/16S223J

CAPACITORS

C 901		CKSRYP473K16
C 902		CSZSR100M16
C 903		CSZSR100M16
C 904		CKSRYP104K16
C 905		CKSRYP104K16
C 906		CKSRYP104K16

F Unit Number : CWX2200
 Unit Name : Antenna Select Unit

MISCELLANEOUS

Q 501	Transistor	2SC1740S
D 501	Diode	1SS133
L 501	Ferri-Inductor	LAU4R7K
RY 501	Relay	CSR1014

RESISTORS

R 501		RD1/4PU683J
R 502		RD1/4PU103J

CAPACITORS

C 501		CKCYB102K50
C 502		CEAL101M10

C Unit Number :
 Unit Name : Mechanism PCB

Q 851	Photo-transistor	PT4800
S 853	Spring Switch(HOME)	CSN1051

D Unit Number :
 Unit Name : Switch PCB

D 851	LED	CN504-2
S 851	Spring Switch(DSP)	CSN1051
S 852	Spring Switch(TAP)	CSN1052

E Unit Number :
 Unit Name : Motor PCB

M 853	Motor(TRAY)	CXB3005
-------	-------------	---------

Miscellaneous Parts List

M 851	Pickup Unit(P8)(Service)	CXX1285
M 852	Motor(SPINdle)	CXB3003
M 852	Motor(ELEVATION)	CXB3006
M 854	Motor(CARRIAGE)	CXB3004
VR 801	Volume 10kΩ	CCW1024

6. ADJUSTMENT

6.1 MODULATOR ADJUSTMENT

● Connection Diagram

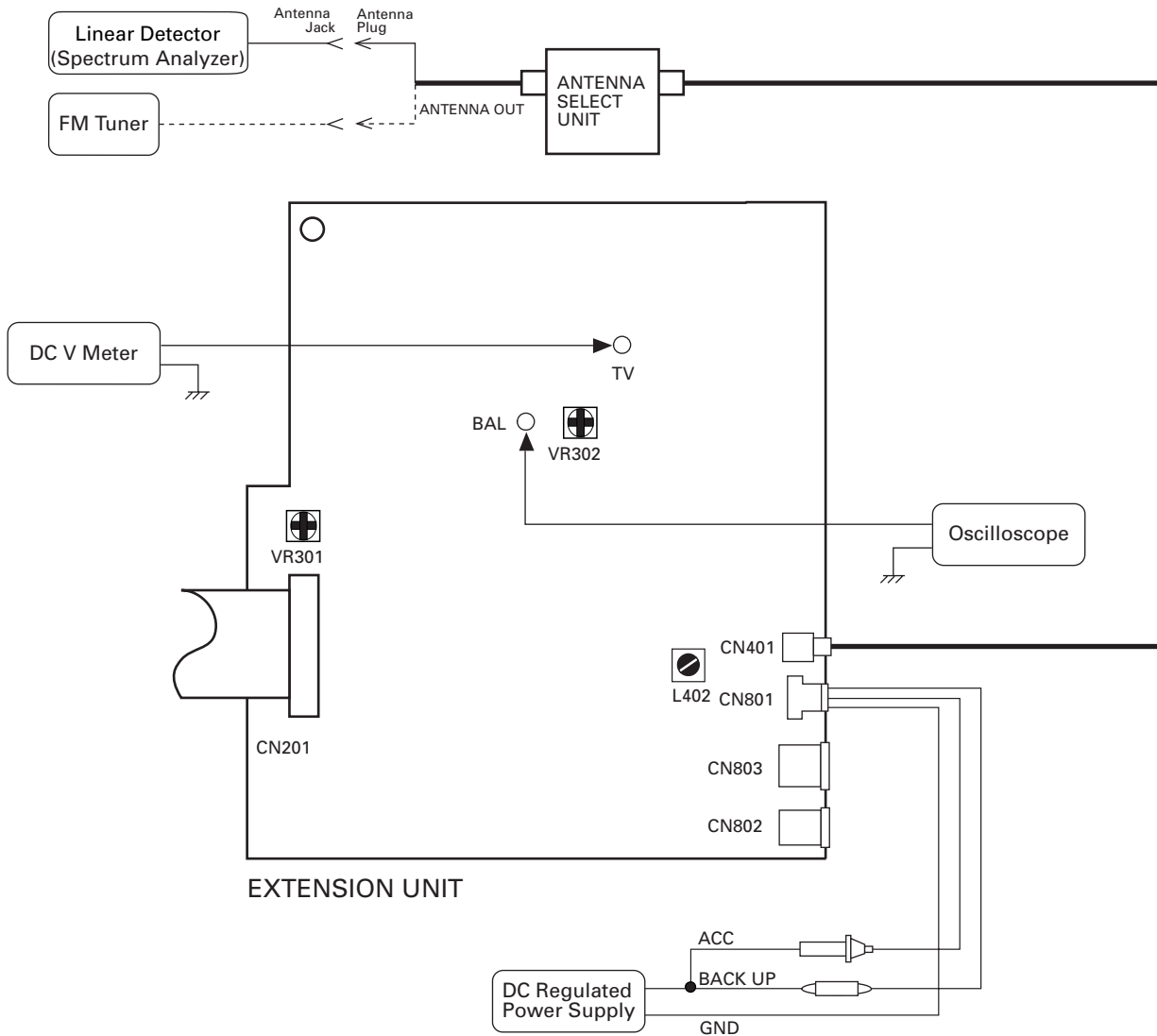

● Adjustment

Note: When adjusting, the frequency is made 89.1MHz.

	CD Signal	Adjusting Point	Adjustment Method	Notes
Tuning Voltage Adjustment	-∞	L402	DC V Meter: 3.0V±0.1V	
Balance Adjustment	-∞	VR301	Oscilloscope: 38kHz signal becomes minimum	
Modulation Adjustment	400Hz 0dB (*1) or 500Hz 0dB	VR302	Linear Detector (Spectrum Analyzer): 135±5kHz	LEVEL = 7

*1 : L and R are input at the same time.

6.2 CHECKING THE GRATING

● Checking the Grating After Changing the Pickup Unit

• Note :

CD mechanism modules the grating angle of the pickup unit cannot be adjusted after the pickup unit is changed. The pickup unit in the CD mechanism module is adjusted on the production line to match the CD mechanism module and is thus the best adjusted pickup unit for the CD mechanism module. Changing the pickup unit is thus best considered as a last resort. However, if the pickup unit must be changed, the grating should be checked using the procedure below.

• Purpose :

To check that the grating is within an acceptable range.

• Symptoms of Mal-adjustment :

If the grating is off by a large amount symptoms such as being unable to close tracking, being unable to perform track search operations, or track searching taking a long time, may appear.

• Method :

- | | |
|-----------------------|----------------------------|
| • Measuring Equipment | • Oscilloscope, Two L.P.F. |
| • Measuring Points | • E, F, REFO |
| • Disc | • ABEX TCD-784 |
| • Mode | • TEST MODE |

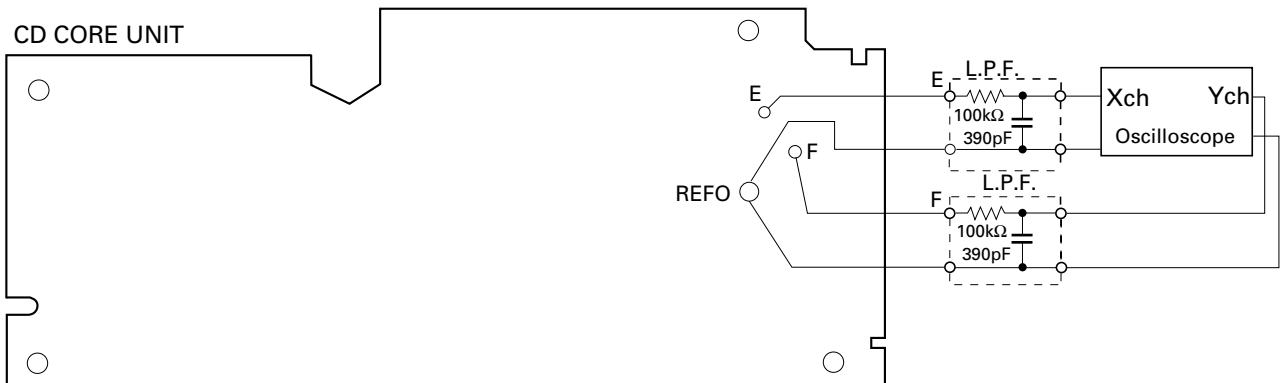

• Checking Procedure

1. Enter Test mode, then select Multi-CD player and switch the 5V regulator on.
2. Using the **TRK+** and **TRK-** buttons, move the pickup unit to the innermost track.
3. Press key **9** to close focus, the display should read "91". Press key **9** 2 times. Enter Rough Servo mode. Press key **8** to implement the tracking balance adjustment the display should now read "81".
4. As shown in the diagram above, monitor the L.P.F. outputs using the oscilloscope and check that the phase difference is within 75° . Refer to the photographs supplied to determine the phase angle.
5. If the phase difference is determined to be greater than 75° try changing the pickup unit to see if there is any improvement. If, after trying this a number of times, the grating angle does not become less than 75° then the mechanism should be judged to be at fault.

• Note

Because of eccentricity in the disc and a slight misalignment of the clamping center the grating waveform may be seen to "wobble" (the phase difference changes as the disc rotates). The angle specified above indicates the average angle.

• Hint

Change the disc changes the clamp position and may decrease the "wobble".

Grating waveform

Ech→ Xch 20mV/div, AC
Fch→ Ych 20mV/div, AC

0°

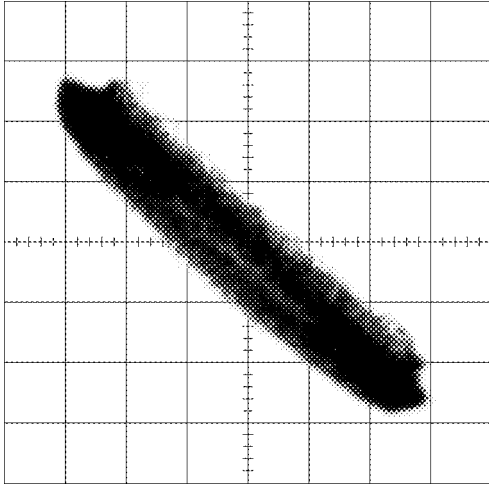

30°

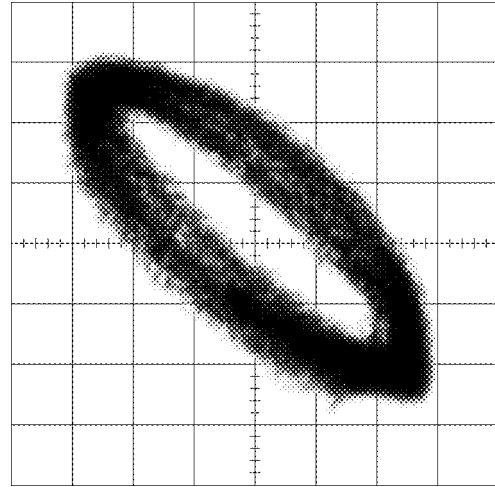

45°

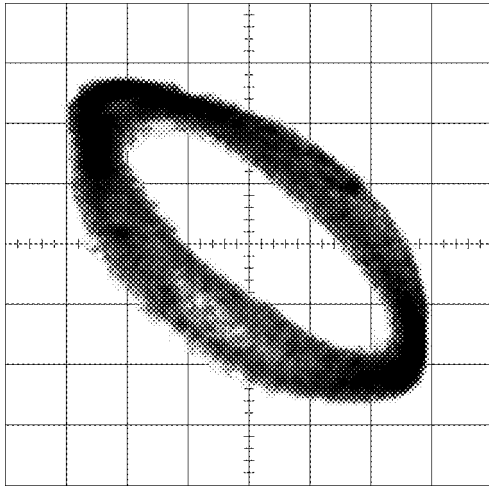

60°

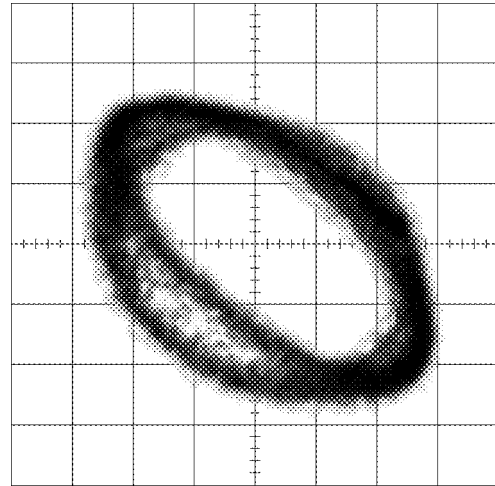

75°

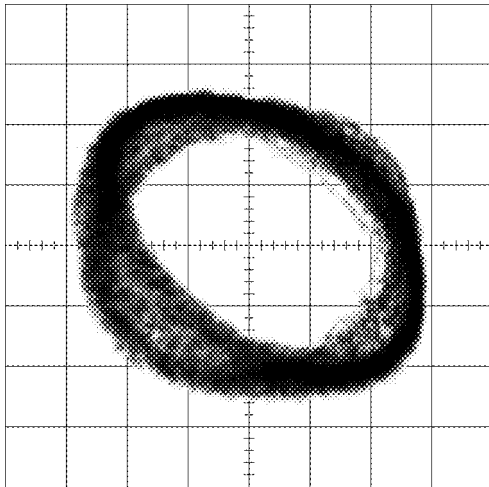

90°

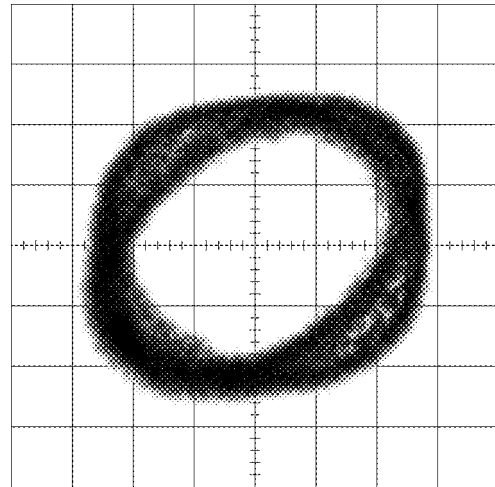

6.3 ADJUSTMENT OF ELEVATION WHEN THE CD CORE UNIT HAS BEEN REMOVED FOR MAINTENANCE

● Adjustment When Error Code 60 is Displayed Because of Malfunctioning Elevation

• Note :
 This mechanism is detects the height of the stage using slide-variable resistance.
 To absorb dislocation of the stage height caused by differences in the mechanism and the CD core unit, adjustment must be made for each CD-mechanism module using a variable resistor.
 Normally, readjustment is not needed, as this has been adjusted at the factory. However, adjustment of elevation is required according to the procedure explained below if an elevation error has occurred or if the CD core unit has been removed.

• Purpose :
 To adjust and confirm whether or not elevation operates correctly.

• Adjustment Method :
• Measuring Equipment: Oscilloscope, One L.P.F.
• Measuring Points : EREF, EPVO
• Setting : Without a magazine in Test mode
 With the mechanism placed upside-down (Place the CD mechanism module so that the CD core unit is above.)

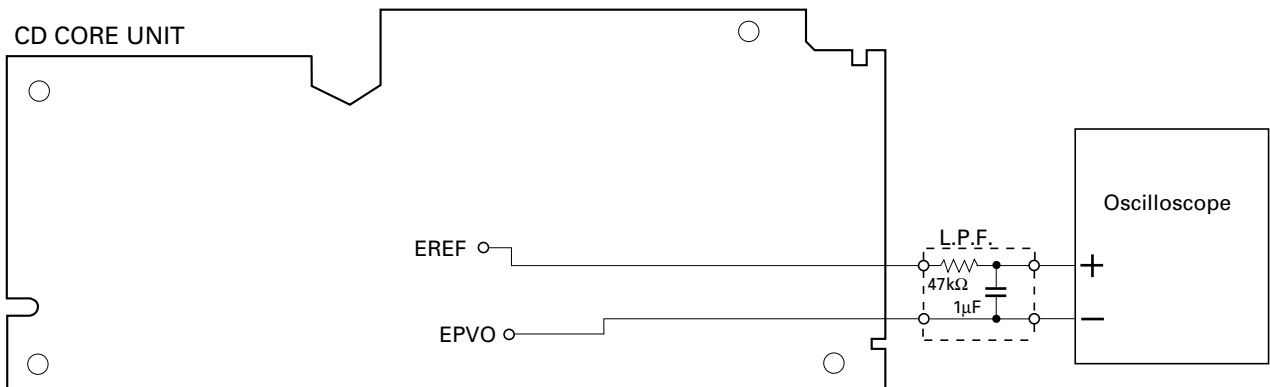

• Confirmation Procedure

1. Enter Test mode, then select Multi-CD player.
2. Press key 7 to enter Mechanism Test mode.
3. Press key 12 twice to specify the amount of movement.

Examples of display

TRACK	FUNCTION
	1

TRACK	FUNCTION
72	00' 00"

The amount of movement changes each time key 12 is pressed.

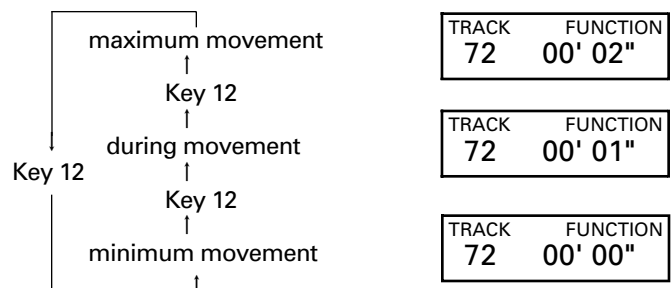

Examples of display

4. Press key **9** to set ELV/TRAY mode to TRAY.

TRACK	FUNCTION
72	01' 02"

5. Press key **FF** to release the clamp and return the tray to the magazine.

Release the clamp

6. Press key **9** to enter Elevation Move mode.

TRACK	FUNCTION
72	00' 02"

7. Use key **FF/REV** to operate elevation and set it to the graduation of the sixth step (Fig. 1).

8. Make the adjustment.

Use VR802 to adjust the difference in potential between EREF and EPVO to 0 ± 10 mV.

9. When adjustment is completed, press key **BAND** to exit Mechanism Test mode.

TRACK	FUNCTION
72	00' 02"

10. Confirm operation of the mechanism.

Place the mechanism horizontally (CD core unit below). Take care not to short-circuit the PCB.

TRACK	FUNCTION
	' "

11. Confirm the height of the stage. Use the Disc \pm key to select Disc No.6.

Check if the stopper bend of the clamp lever is engaged in the groove of the frame stopper (Fig. 2-4).

TRACK	FUNCTION
04	00' 00"

• **Note :**

The stopper bend will be pressed downward into the groove for final clamping. Confirm the engagement position of the stopper bend.

- If the stopper bend is engaged in the center and pressed downward, adjustment is completed. Go to step 15.
- If the stopper bend is dislocated, check the amount of dislocation by following steps 12 to 14.

12. To see the amount of dislocation, place the mechanism upside-down.
If the stopper bend has been dislocated in the direction of the first CD, turn VR802 to the left(Fig. 2).

To lower the stage toward the twelfth step by 0.1 mm, reduce the voltage of EREF (adjusted in step 8) by 10 mV.

If the stopper bend has been dislocated in the direction of the twelfth CD, turn VR802 to the right(Fig. 4).

To raise the stage toward the first step by 0.1 mm, increase the voltage of EREF (adjusted in step 8) by 10 mV.

13. Place the mechanism horizontal. Go back to step 11 to reconfirm the stage height.

14. When adjustment of the stage height is completed, proceed as follows:

15. Press the **EJECT** switch.

16. Once operation of the mechanism has stopped, turn the power OFF.

17. Wait more than one minute after the power is turned off, then turn the power ON and insert a magazine.

18. Check if the mechanism operates correctly with the first, sixth, seventh and twelfth CDs.

19. If the mechanism operates properly, adjustment is completed. If the mechanism operates improperly, make the adjustment again.

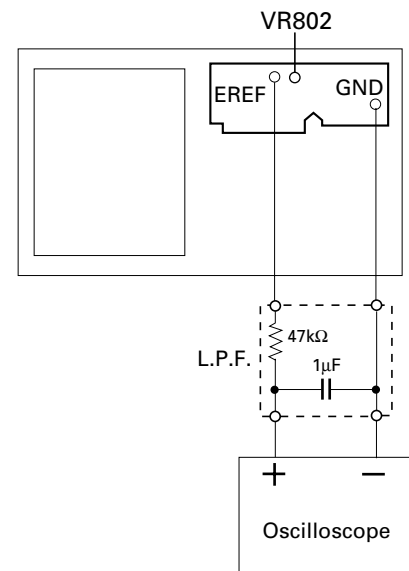

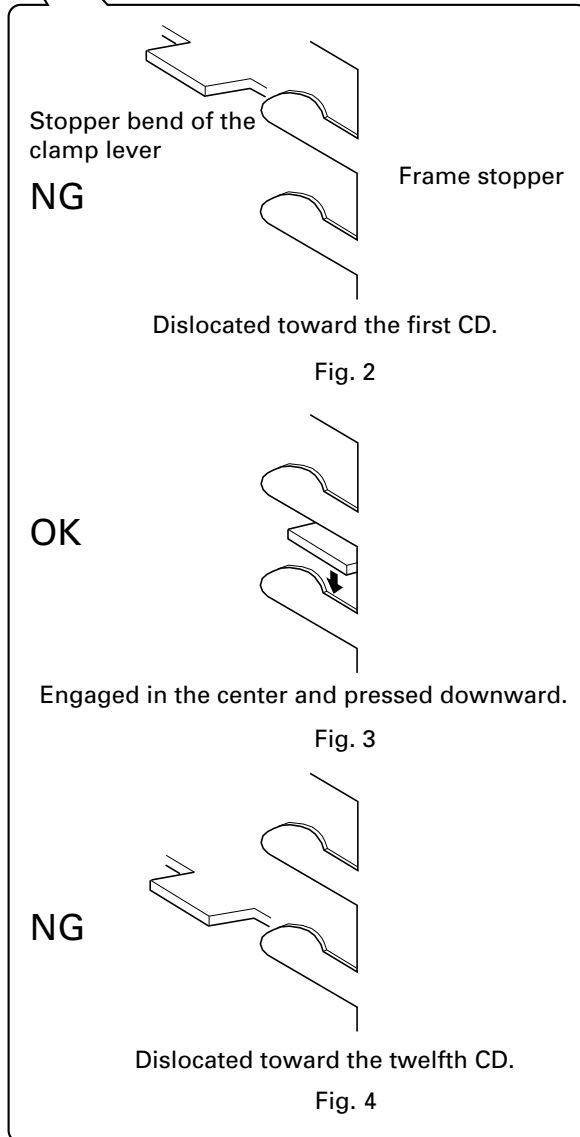
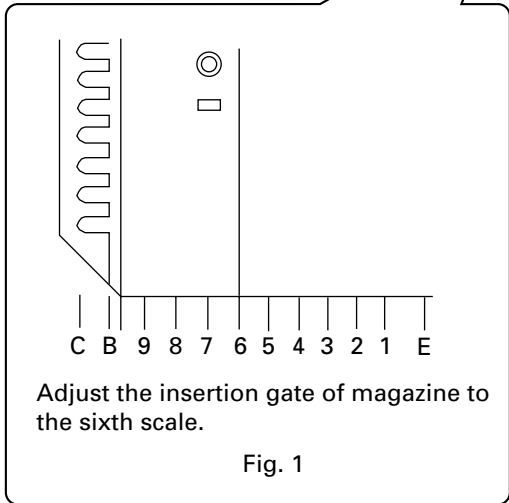
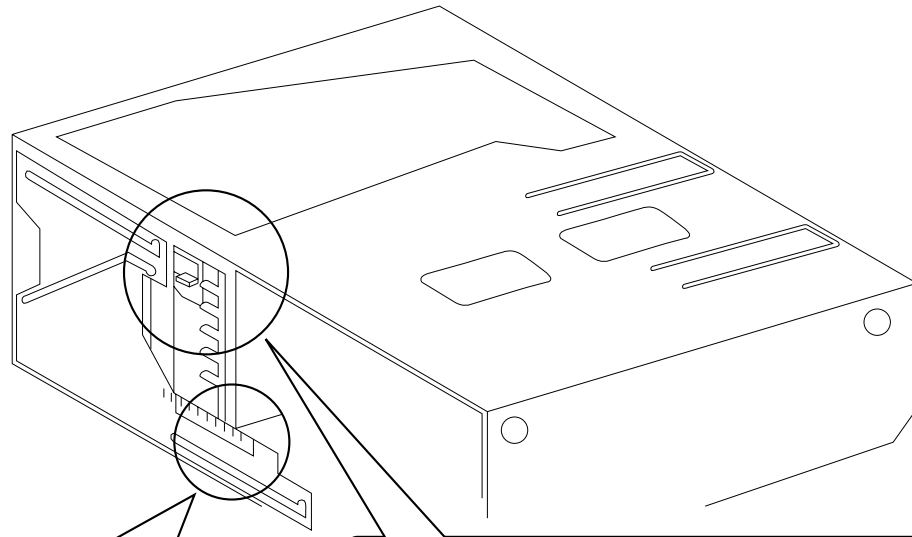

7. GENERAL INFORMATION

7.1 PARTS

7.1.1 IC

● Pin Functions (UPD63710GC)

Pin No.	Pin Name	I/O	Function and Operation
1	GND		Logic circuit GND
2	HOLD	I/O	Defect detection output
3	MIRR	I/O	MIRR output
4	FOK	O	RFOK signal output
5	RST	I	Reset signal input
6	A0	I	Command/parameter identification signal input
7	STB	I	Data strobe signal input
8	SCK	I	Clock signal input for serial data input/output
9	SO	O	Serial data and status signal output
10	SI	I	Serial data input
11	VDD		Positive power supply terminal to logic circuit
12	DA.VDD		Positive power supply terminal to D/A converter
13	NC		Not used
14, 15	DA.GND		D/A converter GND
16	NC		Not used
17	DA.VDD		Positive power supply terminal to D/A converter
18	R+	O	Right channel audio data output
19	R-	O	Right channel audio data output
20	L-	O	Left channel audio data output
21	L+	O	Left channel audio data output
22	X.VDD		Positive power supply terminal to crystal oscillation circuit
23	XTAL	O	Crystal oscillator connect pin
24	XTAL	I	Crystal oscillator connect pin
25	X.GND		Crystal oscillation circuit GND
26	VDD		Positive power supply terminal to logic circuit
27	EMPH	O	Output pin for the pre-emphasis data in the sub-Q code
28	FLAG	O	Flag output pin to indicate that audio data currently being output consists of noncorrectable data
29	DIN	I	Serial data input to internal DAC
30	DOUT	O	Serial audio data output
31	SCKIN	I	Serial clock input to internal DAC
32	SCKO	O	Audio data that is output from DOUT changes at rising edge of this clock
33	LRCKIN	I	LRCK signal input to internal DAC
34	LRCK	O	Signals to distinguish the right and left channels of the audio data output from DOUT
35	WDCK	O	Output double the frequency of LRCK
36	TX	O	Digital audio interface data output
37	GND		Logic circuit GND
38	C16M	O	Oscillator clock buffering output
39	LIMIT	I	Status of the pin is output at Bit 5 of the status output
40	VDD		Positive power supply terminal to logic circuit
41	LOCK	O	EFM synchronous detection signal
42	RFCK	O	Frame synchronous signal of XTAL-system
43	WFCK	O	Frame synchronous signal of PLL-system
44	PLCK	O	Monitor pin of bit clock
45	GND		Logic circuit GND
46	C1D1	O	Output pin for indicating the C1 error correction results
47	C1D2	O	Output pin for indicating the C1 error correction results
48	C2D1	O	Output pin for indicating the C2 error correction results
49	C2D2	O	Output pin for indicating the C2 error correction results
50	C2D3	O	Output pin for indicating the C2 error correction results
51	VDD		Positive power supply terminal to logic circuit

Pin No.	Pin Name	I/O	Function and Operation
52	PACK	O	CD-TEXT PACK synchronous signal
53	TSO	O	CD-TEXT data serial output
54	TSI	I	CD-TEXT control parameter serial input
55	T \overline SCK	I	CD-TEXT serial clock input
56	TSTB	I	CD-TEXT parameter strobe signal input
57	GND		Logic circuit GND
58	TEST	I	Test pin
59	ATEST	I/O	Test pin
60	RFMODE	I	Use/not use select for internal RF amplifier
61	A.GND		Analog circuit GND
62	FD	O	Focus drive output
63	TD	O	Tracking drive output
64	SD	O	Sled drive output
65	MD	O	Spindle drive output
66	DACO	O	DAC output for adjustment
67	FBAL	O	DAC output for adjustment
68	TBAL	O	DAC output for adjustment
69	TEVCA	O	DAC output for adjustment
70	A.VDD		Power supply terminal to analog circuit
71	EFM	O	EFM signal output
72	ASY	I	EFM comparator reference voltage input
73	C3T		3T detection capacitor additional pin
74	RFI	I	RF signal input for EFM data regulation
75	AGCO	O	RF signal output of after gain adjustment
76	AGCI	I	RF-AGC amplifier input
77	RFO	O	RF summing amplifier output
78	EQ2		RF amplifier equalizer parts additional pin
79	EQ1		RF amplifier equalizer parts additional pin
80	RF-	I	RF summing amplifier inverted input
81	A.GND		Analog circuit GND
82	A	I	Photo detector A input
83	C	I	Photo detector C input
84	B	I	Photo detector B input
85	D	I	Photo detector D input
86	F	I	Photo detector F input
87	E	I	Photo detector E input
88	A.VDD		Positive power supply terminal to analog circuit
89	REFOUT	O	Reference electric potential output
90	FE-	I	Focus error amplifier inverted input
91	FEO	I/O	Focus error amplifier output
92	TE-	I	Tracking error amplifier inverted input
93	TEO	I/O	Tracking error amplifier output
94	TE2	I/O	Tracking error output of after amplification
95	TEC	I	Tracking comparator input
96	A.GND		Analog circuit GND
97	PD	I	PD detection signal input for LD output monitor
98	LD	O	LD control current output
99	PN	I	APC circuit control polarity set pin
100	A.VDD		Positive power supply terminal to analog circuit

*UPD63710GC

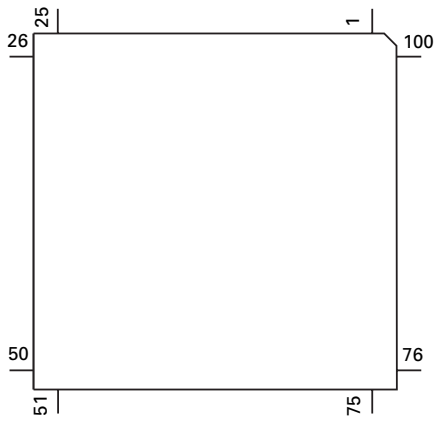

IC's marked by* are MOS type.

Be careful in handling them because they are very liable to be damaged by electrostatic induction.

BA05FP

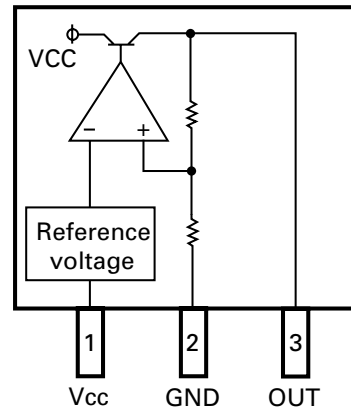

BA5986FM

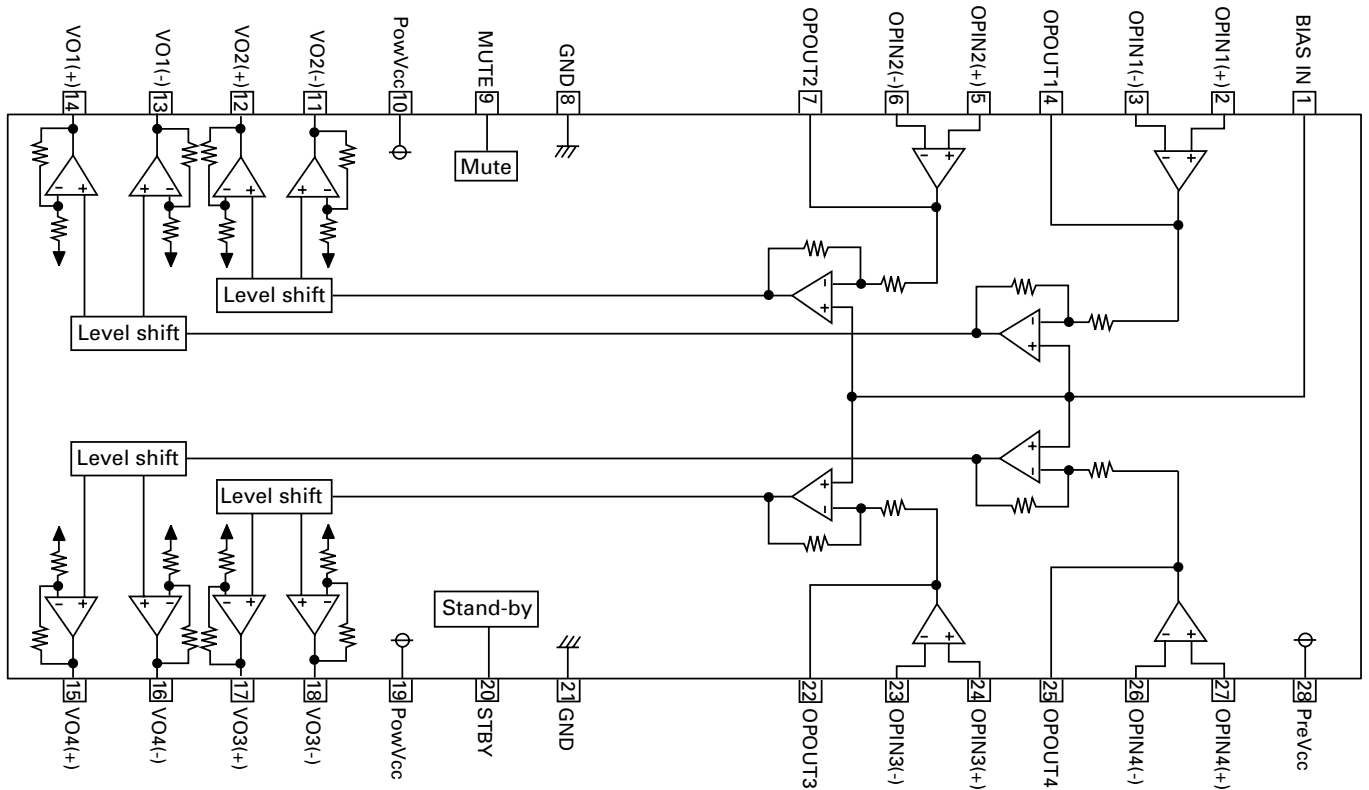

● Pin Functions (PD5513A)

Pin No.	Pin Name	I/O	Format	Function and Operation
1	PLDT	O	C	PLL data output
2	PLCK	O	C	PLL clock output
3	ADENA	O	C	A/D reference voltage output
4	TXTSTB	O	C	TEXT parameter output
5	TXTSO	O	C	TEXT control parameter serial output
6	TXTSI	I		TEXT data serial input
7	TXTSCK	O	C	TEXT clock output
8	BYTE	I		VCC joint
9	CNVSS	I		VSS joint
10	POWER	O	C	CD +5V control
11	CONT	O	C	Servo driver output control
12	RESET			Reset input
13	XOUT	O		Crystal oscillating element connection pin
14	VSS			GND
15	XIN	I		Crystal oscillating element connection pin
16	VCC			VDD
17	NMI	I		Pull up
18	BSENS	I		Back up power sense input
19	ASENS	I		Acc sense input
20	TXTPACK	I		TEXT PACK interrupt input
21	IPTA4IN	I		IPIN joint
22	IPPW	O	C	Power supply control output for IP BUS interface IC
23	DISPPW	O	C	Key/Display microcomputer supply control
24	CSEL	I		Compression select
25	SRAMSW	I		When there is SRAM, "H"
26	CCS	O	C	IP-BUS chip select
27	SIMUKE	I		Destination information input
28	NC			Not used
29	IPIN	I		Data input from IP BUS interface IC
30	IPOUT	O	C	Data output for IP BUS interface IC
31	DPDT	O	C	Display data output
32	KYDT	I		Key data input
33	FMIPSW	I		FM/IP BUS select switch
34	TESTIN	I		Test program mode input
35	XSO	O	NM	LSI data output
36	XSI	I		LSI data input
37	XSCK	O	NM	LSI clock output
38	M6M12	I		6/12 disc select input
39-43	NC			Not used
44	RD	O	C	SRAM enable output
45	NC			Not used
46	WR	O	C	SRAM write enable output
47	SYSPW	O	C	System power supply control output
48	CS	O	C	SRAM chip select
49	XAO	O	C	CD LSI data discernment control signal output
50	XSTB	O	C	CD LSI strobe output
51	XRST	O	C	CD LSI reset output
52	MIRR	I		Mirror detector input
53	LOCK	I		Spindle lock detector input
54	FOK	I		FOK signal input
55	NC			Not used
56	A11	O	C	SRAM address bus output
57	A9	O	C	SRAM address bus output
58	A8	O	C	SRAM address bus output
59	A13	O	C	SRAM address bus output
60	A14	O	C	SRAM address bus output
61	A12	O	C	SRAM address bus output
62	VCC			VDD

Pin No.	Pin Name	I/O	Format	Function and Operation
63	A7	O	C	SRAM address bus output
64	VSS			GND
65-68	A6-A3	O	C	SRAM address bus output
69	A10	O	C	SRAM address bus output
70	A2 & (EPSK)	O	C	SRAM address bus output and (E2PROM clock output)
71	A1 & (EPDI)	O/I	C	SRAM address bus output and (E2PROM data input)
72	A0 & (EPDO)	O	C	SRAM address bus output and (E2PROM data output)
73	ASENSFM	I		Select FM="ASENS"
74	EJSW	I		Eject key switch interrupt input
75	MAG	I		Magazine lock switch interrupt input
76	CDMUTE	O	C	CD mute output
77	NC			Not used
78	I13	O	C	Motor driver control output
79	I2	O	C	Motor driver control output
80	I4	O	C	Motor driver control output
81-88	D0-D7	I/O	C	SRAM data bus
89	PREN	O	C	Preemphasis select output
90	PLCS	O	C	PLL chip select output
91	DSP	I		DISC detect timing input
92	DISK			Disc detector input
93	ELVPVO	I		Voltage input from ELV position sense
94	ELVREF	I		ELV reference voltage input
95	TRP	I		Tray position input
96	AVSS	I		A/D GND
97	VDIN			Power supply short sensor input
98	VREF	I		A/D converter reference voltage input
99	AVCC			A/D VCC
100	EPCS	I/O	C	E2PROM detect input , Chip select output

*PD5513A

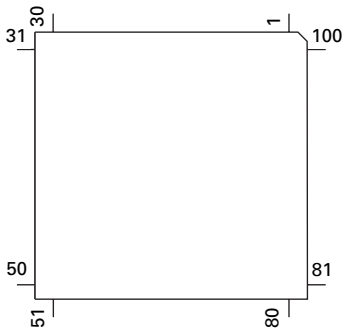

Format	Meaning
C	C MOS
NM	Middle resistivity N channel open drain

TC7SH32FU

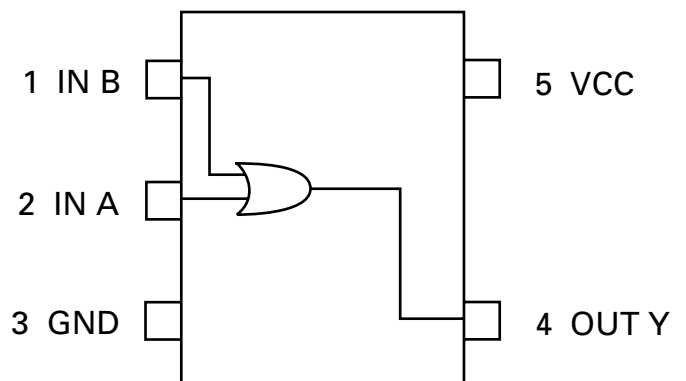

● Pin Functions (PD6294A)

Pin No.	Pin Name	I/O	Function and Operation
1	VSS		GND
2	X1		Crystal oscillator connection pin
3	X0		Crystal oscillator connection pin
4	RST	I	System reset
5,6	MODE1,0		GND
7	GRN/AMB	O	GREEN/AMBER select output
8	SO	O	UART output
9	SI	I	UART output
10	REMIN	I	Remote control signal input
11	RVER		Not used
12	NC		Not used
13-16	KDT4-1	I	Key data input
17-22	KST6-1	O	Key strobe output
23	VCC		5V
24-73	SEG49-0	O	LCD segment output
74-77	COM3-0	O	Common driver output
78-80	V3-1		LCD bias power supply

*PD6294A

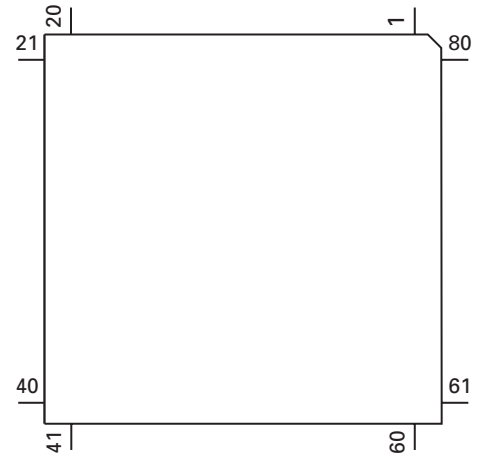

TSOP1840SB1

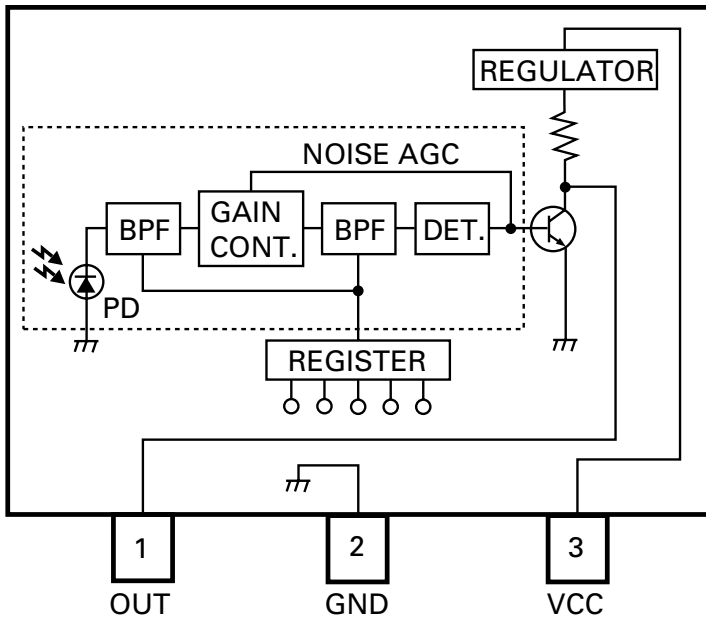

7.1.2 DISPLAY

● CAW1514

SEGMENT

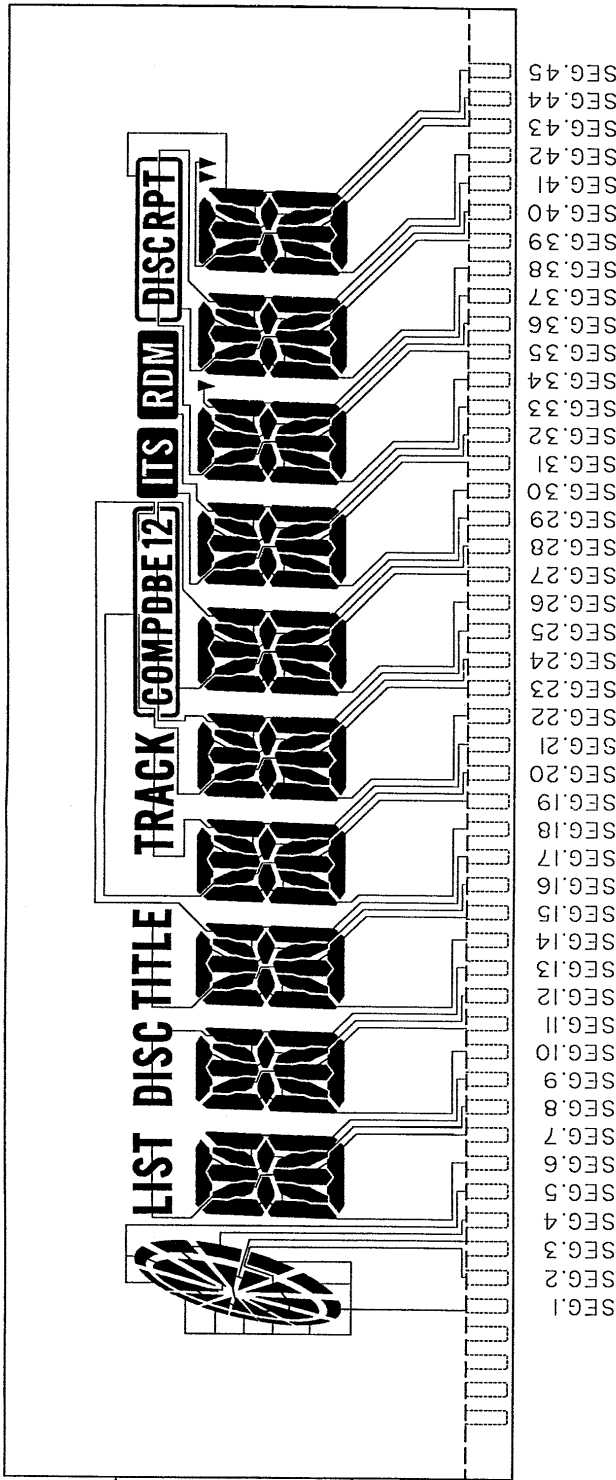

COMMON

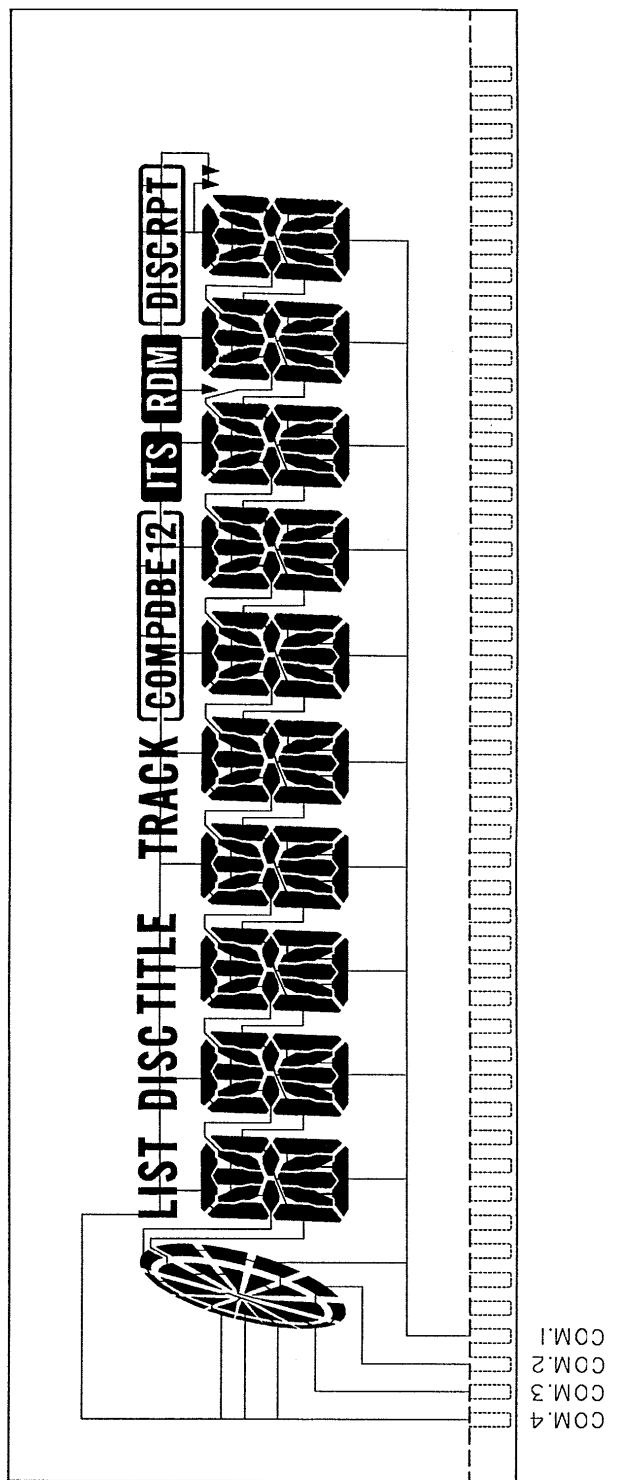





7.2 DIAGNOSIS

7.2.1 DISASSEMBLY

● Removing the Upper Case(not shown)

1. Remove the night screws.
2. Remove the Upper Case.



● Removing the CD Mechanism Module

-  Remove the four dampers(Fig.5).
-  Disconnect the connector(Fig.5).
-  Remove the two springs(Fig.5).
-  Disconnect the connector and then remove the CD Mechanism Module(Fig.6).

● Removing the Grille Unit(not shown)

- 1.Press the two tabs indicated by arrows and then pull out the Grille Unit(Exterior section parts list No.50).

● Removing the Extension Unit(Fig.7)

-  Remove the two screws.
-  Remove the screw.
-  Remove the claw and remove the Extension Unit.

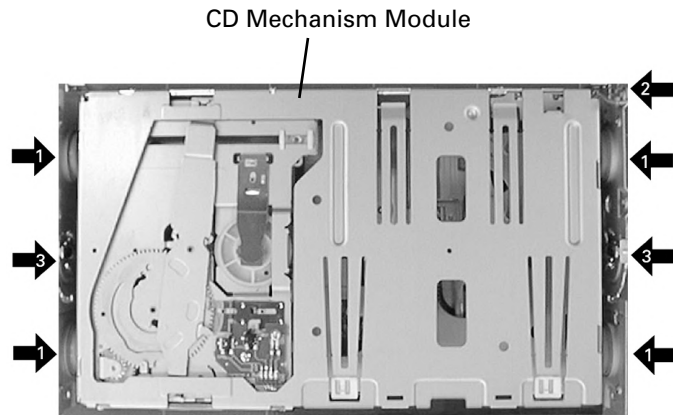

Fig.5

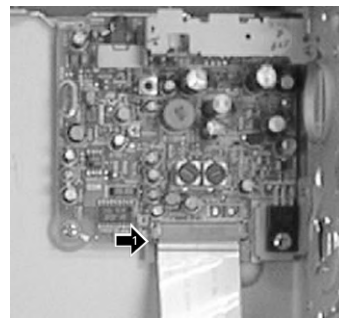
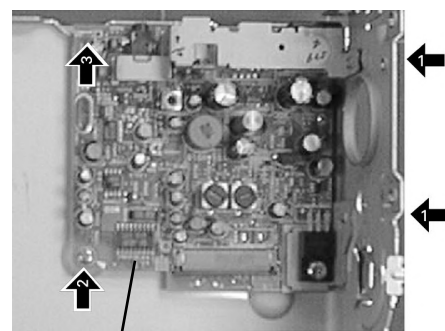

Fig.6



Extension Unit

Fig.7

● Removing the Pickup Unit

1. Insert the short pin from the pickup unit in the flexible substrate.
2. Remove the flexible substrate from the connector.
3. Remove the flexible card from the connector.
4. Remove the lead wires to which the spindle motor and carriage motor assy were soldered.
5. Remove the two screws and lift the relay substrate up as shown in the figure on the upper right. At this time, make sure that the flexible tray motor printed circuit board and flexible relay card are not pulled excessively.

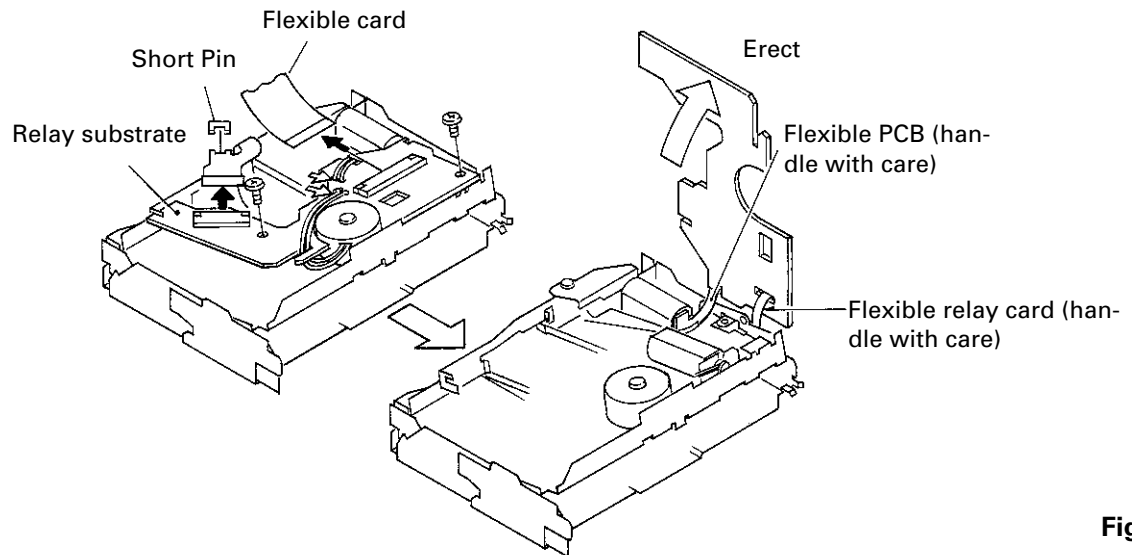

Fig.8

6. Remove screw A and then remove the carriage motor assy, lighting conductor, feed screw holder, feed screw and belt (see Fig. 9).
7. Remove screw B on the main side and the pickup unit together with the guide shaft (see Fig. 9).

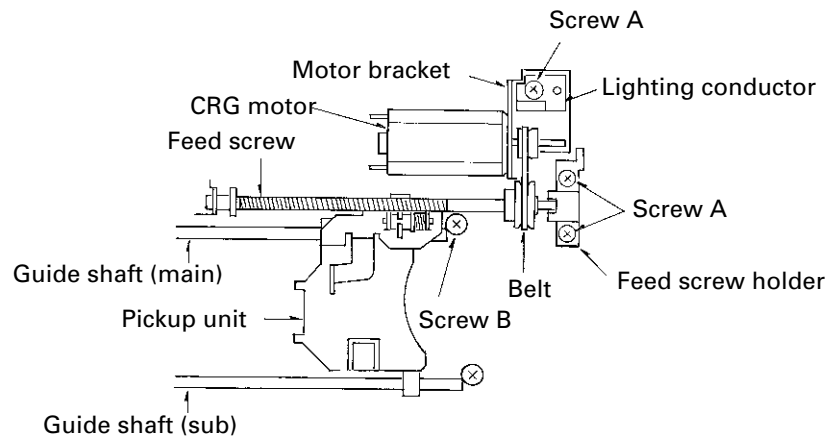

Fig.9

7.2.2 TEST MODE

● CD Test Mode

1) Precautions

- This unit uses a single power supply (+5V) for the regulator. The signal reference potential, therefore, is connected to REFO(approx. 2.5V) instead of GND.

If REFO and GND are connected to each other by mistake during adjustments, not only will it be impossible to measure the potential correctly, but the servo will malfunction and a severe shock will be applied to the pick-up. To avoid this, take special note of the following.

Do not connect the negative probe of the measuring equipment to REFO and GND together. It is especially important not to connect the channel 1 negative probe of the oscilloscope to REFO with the channel 2 negative probe connected to GND.

Since the frame of the measuring instrument is usually at the same potential as the negative probe, change the frame of the measuring instrument to floating status.

If by accident REFO comes in contact with GND, immediately switch the regulator or power OFF.

- Always make sure the regulator is OFF when connecting and disconnecting the various filters and wiring required for measurements.
- Before proceeding to further adjustments and measurements after switching regulator ON, let the player run for about one minute to allow the circuits to stabilize.
- Since the protective systems in the unit's software are rendered inoperative in test mode, be very careful to avoid mechanical and /or electrical shocks to the system when making adjustment.
- Disc detection during tray extraction and return operations is performed by means of the photo transistor in this unit. Consequently, if the inside of the unit is exposed to a strong light source with the outer casing removed for repairs or adjustment, the following malfunctions may occur:
 - *Even with a disc loaded, the unit detects "no disc" and cannot start play.
 - *Although a 12-cm disc is loaded, the unit detects "8cm disc" mistakenly.

When the unit malfunctions this way, either re-position the light source, move the unit or cover the photo transistor.
- During exchanging discs, do not press the keys for the discs to be exchanged.

2) Test Mode

This mode is used for adjusting the CD mechanism module of the device.

- Test mode starting procedure
Reset while pressing the **4** and **6** keys together.
- Test mode cancellation
Switch ACC, back-up OFF.
- If the 8 or 9 key is pressed while focus search is in progress, immediately turn the power off (otherwise the actuator may be damaged due to the lens stuck).
- Jump operation of TRs other than 100TR continues after releasing the key. CRG move and 100TR jump operations are brought into the "Tracking close" status when the key is released.
- Powering Off/On resets the jump mode to "Single TR (91)", the RF AMP gain setting to 0 dB, and the automatic adjustment value to the initial value.
- During exchanging discs, do not press the keys for the discs to be exchanged.

Key to adjustment text inside (12 keys type)	HEAD UNIT (6 keys type)
BAND	BAND
TRK+/FF	TRK+/FF
TRK-/REV	TRK-/REV
7	1
8	2
9	3
10	4
11	5
12	6
DISC-	DISC-
SOURCE ON/OFF	SOURCE ON/OFF

● Flow Chart

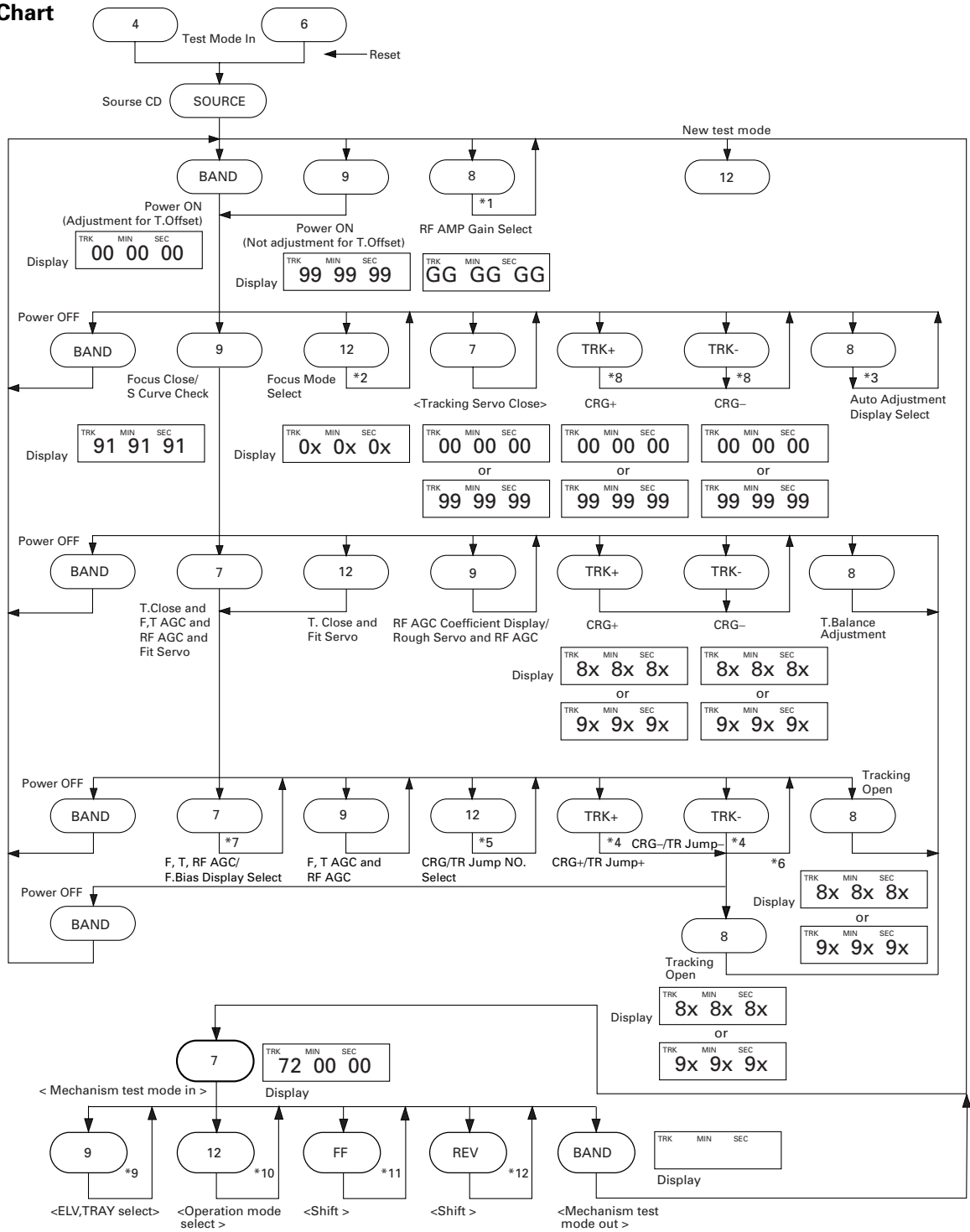

*1 → TYP → +6dB → +12dB
 Display 06 06 06 12 12 12

*2 → Focus Close → S Curve Check
 Display 00 00 00 01 01 01
 (99 99 99)

*3 → F.Offset Display → RF.Offset Display → F.Cansel Display

$$F.Cancel Value = \{Top Rank 8bit of Set Value (7F [H] to 80 [H]) + 128\} / 4$$

$$= 63 [D] to (32 [D]) to 00 [D]$$

*4 Single TR/32TR/100TR

*5 → Single TR → 32TRK → 100TRK → CRG Move
 Display 9x(8x):91(81) 92(82) 93(83) 94(84)

*6 CRG Move, 100TR Jump Only

*7 → TRK, MIN, SEC → F.AGC Gain → T.AGC Gain → RF AGC Gain

$$(F,T.AGC Gain = (Present Value/Initial Value) \times 20)$$

*8 Voltage of CRG Motor = 2 [V]

*9 ELV motor select → TRAY motor select
 Display 72 00 0x 72 10 0x

*10 8ms pulse drive → 24ms pulse drive → DC drive
 Display 72 00 00 72 00 01 72 00 02

48ms pulse drive → 100ms pulse drive → DC drive
 Display 72 10 00 72 10 01 72 10 02

*11 ELV select : ELV down (Disc 12 → 1)
 TRAY select : TRAY out

*12 ELV select : ELV up (Disc 1 → 12)
 TRAY select : TRAY in

● **Error Messages**

If a CD is not operative or stopped during operation due to an error, the error mode is turned on and cause(s) of the error is indicated with a corresponding number. This arrangement is intended at reducing nonsense calls from the users and also for facilitating trouble analysis and repair work in servicing.

(1) Basic Indication Method

1) When SERRORM is selected for the CSMOD (CD mode area for the system), error codes are written to DMIN (minutes display area) and DSEC (seconds display area). The same data is written to DMIN and DSEC. DTNO remains in blank as before.

2) Head unit display examples

Depending on display capability of LCD used, display will vary as shown below. xx contains the error number.

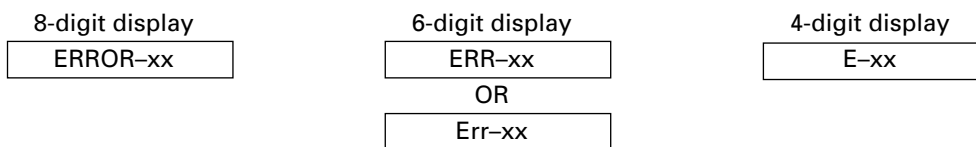

* When the system is manufactured for an OEM basis, the error display will be configured according to the customer specification.

(2) Error Code List

Code	Class	Displayed error code	Description of the code and potential cause(s)
10	Electricity	Carriage Home NG	CRG can't be moved to inner diameter. CRG can't be moved from inner diameter. → Failure on home switch or CRG move mechanism.
11	Electricity	Focus Servo NG	Focusing not available. → Stains on rear side of disc or excessive vibrations on REWRITABLE.
12	Electricity	Spindle Lock NG Subcode NG RF AMP NG	Spindle not locked. Sub-code is strange (not readable). → Failure on spindle, stains or damages on disc, or excessive vibrations. A disc not containing CD-R data is found. Turned over disc are found, though rarely. → Failure on home switch or CRG move mechanism. An appropriate RF AMP gain can't be determined. → CD signal error.
17	Electricity	Setup NG	APC protection doesn't work. Focus can be easily lost. → Damages or stains on disc, or excessive vibrations.
30	Electricity	Search Time Out	Failed to reach target address. → CRG tracking error or damages on disc.
A0	System	Power Supply NG	Power (VD) is ground faulted. → Failure on SW transistor or power supply (failure on connector).
A1	System	Mechanism power failure	Mechanism elevation reference voltage is out of prescription. → EREF adjustment VR and/or power abnormal.
50	Mechanism	An error upon ejection	MAG switch release time has time out. Elevation time out when eject.
60	Mechanism	An error while putting in and out the tray	Tray in / out time has time out. Tray is caught when put in.

Code	Class	Displayed error code	Description of the code and potential cause(s)
70	Mechanism	An error upon elevation	Elevation time has time out.
80	Mechanism	An error with an empty magazine inserted	No disc is available.

Remarks: Unreadable TOC does not constitute an error. An intended operation continues in this case.

A newly designed head unit must conform to the example given above.

Upper digits of an error code are subdivided as shown below:

1x: Setup relevant errors, 3x: Search relevant errors, 3x: Search relevant errors, Ax: Other errors.

● New Test Mode

M-CD plays the same way as before.

If an error such as off focus, spindle unlocking, unreadable sub-code, or sound skipping occurs after setup, its cause and time occurred (in absolute time) are displayed.

During setup, operational status of the control software (internal RAM: CPOINT) is displayed.

These displays and functions are prepared for enhancing aging in the servicing and efficiency of trouble analysis.

(1) Shifting to the New Test Mode

- ① Turn on the current test mode by starting the reset from the 4 and 6 keys together.
- ② Select M-CD for the source through the specified procedure including use of the [SOURCE] key. Then, press the 12 key while maintaining the regulator turned off.
- ③ After the above operations, the new test mode remains on irrespective of whether the M-CD is turned on or off.
You can reset the new test mode by turning on the reset start.

* With some products, the new test mode can be reset through the same operations as that employed for shifting to the STBY mode (while maintaining the Acc turned off).

(2) Key Correspondence

Key (Example)	Test mode		New test mode	
	Power Off	Power On	In-play	Error Production
BAND	To power on (offset adjustment performed)	To power off	–	Time/Err.No. switching
UP	–	FWD-Kick	FF/TR+	–
DOWN	–	REV-Kick	REV/TR-	–
7	–	T.Close (AGC performed) /parameter display switching	Scan	–
8	RF AMP gain switching	Parameter display switching /T.BAL adjustment/T.Open	Mode	–
9	To power on (offset adjustment not performed)	F.Close/RF AGC/F.T.AGC	–	–
10	–	F.Open	–	–
11	–	Jump Off	–	–
12	–	F.Mode switching /T.Close (no AGC)/Jump switching	Auto/Manu	T.No./Time switching

Key (Example)	Mechanism Test Mode
BAND	Back to the test mode
UP	Playing the mechanism
DOWN	Playing the mechanism
7	Mechanism test mode in
8	–
9	TRAY/ELV select
10	–
11	–
12	Operation step select

Note: Eject and CD on/off is performed in the same procedure as that for the normal mode.

(3) Cause of Error and Error Code

Code	Class	Contents	Description and cause
40	Electricity	Off focus detected.	FOK goes low. → Damages/stains on disc, vibrations or failure on servo.
41	Electricity	Spindle unlocked.	FOK = Low continued for 50 msec. → Damages/stains on disc, vibrations or failure on servo.
42	Electricity	Sub-code unreadable.	Sub-code was unreadable for 50 msec. → Damages/stains on disc, vibrations or failure on servo.
43	Electricity	Sound skipping detected.	Last address memory function was activated. → Damages/stains on disc, vibrations or failure on servo.

Note: Mechanical errors during aging are not displayed.

The error codes should be indicated in the same way as in the normal mode.

(4) Display of Operational Status (CPOINT) during Setup

Status No.	Contents	Protective action
00	CD+5V ON process in progress.	None
01	Servo LSI initialization (1/3) in progress.	None
02	Servo LSI CRAM initialization in progress.	None
03	Servo LSI initialization (2/3) in progress.	None
04	Offset adjustment (1/3) in progress.	None
05	Offset adjustment (2/3) in progress.	None
06	Offset adjustment (3/3) in progress.	None
07	FZD adjustment in progress.	None
08	Servo LSI initialization (3/3) in progress.	None
10	Carriage move to home position started.	None
11	Carriage move to home position started.	None
12	Carriage is moving toward inner diameter.	Specified 10 seconds has been passed or failure on home switch.
13	Carriage is moving toward outer diameter.	Specified 10 seconds has been passed or failure on home switch.
14	Carriage outer kick in progress.	None
15	Carriage outer diameter feed (1 second) in progress.	None
20	Servo close started.	None
21	Pre-processing for focus search started.	None
22	Spindle rotation and focus search started.	None
23	Waiting for focus close (XSI=Low).	Specified focus search time has been passed.
24	Standing by after focus close is over.	Specified focus search time has been passed.
25	Focus search preprocessing is in progress while setup protection is turned on.	None

Status No.	Contents	Protective action
26	Focus search preprocessing is in progress while focus recovery is turned on.	None
27	Wait time after focus close is set up.	Off focus.
28	Standing by after focus close is over.	Off focus.
29	Setup (1/2) before T balance adjustment is started.	Off focus.
30	Setup (2/2) before T balance adjustment is started.	Off focus.
31	T balance adjustment started.	Off focus.
32	T balance adjustment (1/2).	Off focus.
33	T balance adjustment (2/2).	Off focus.
34	Waiting for spindle rotation to end. Spindle rough servo.	Off focus.
35	Standing by after spindle rough servo is over.	Off focus.
36	RF AGC started.	Off focus.
37	RF AGC started.	Off focus.
38	RF AGC ending process in progress.	Off focus.
39	Tracking close in progress.	Off focus.
40	Standing by after tracking is closed. Carriage closing in progress.	Off focus.
41	Focus/tracking AGC started.	Off focus.
42	Focus AGC started.	Off focus.
43	Focus AGC in progress.	Off focus.
44	Tracking AGC in progress.	Off focus.
45	Standing by after focus/tracking AGC are over.	Off focus.
46	Spindle processes applicable servo.	Off focus.
47	Check for servo close is started.	Off focus.
48	Check of LOCK pin started.	Off focus or spindle not locked.
49	RF AGC started.	Off focus.
50	RF AGC in progress.	Off focus.
51	Standing by after RF AGC is over.	Off focus.

(5) Display Examples

1) During Setup (When status no. = 11)

TRK No.	MIN.	SEC.
11	11'	11"

2) During Operation (TOC read, TRK search, Play, FF and REV)

The same as in the normal mode.

3) When a Protection Error Occurred

Switch to the following displays (A) and (B) using the [BAND] switch:

(A) Error occurrence timing display in absolute time.

An example: Error occurred in 12th tune at 34'56" in absolute time.

TRK No.	MIN.	SEC.
12	34'	56"

(B) Error No. display

An example: Error #40 (Off focus is detected)

ERROR-40

7.3 BLOCK DIAGRAM

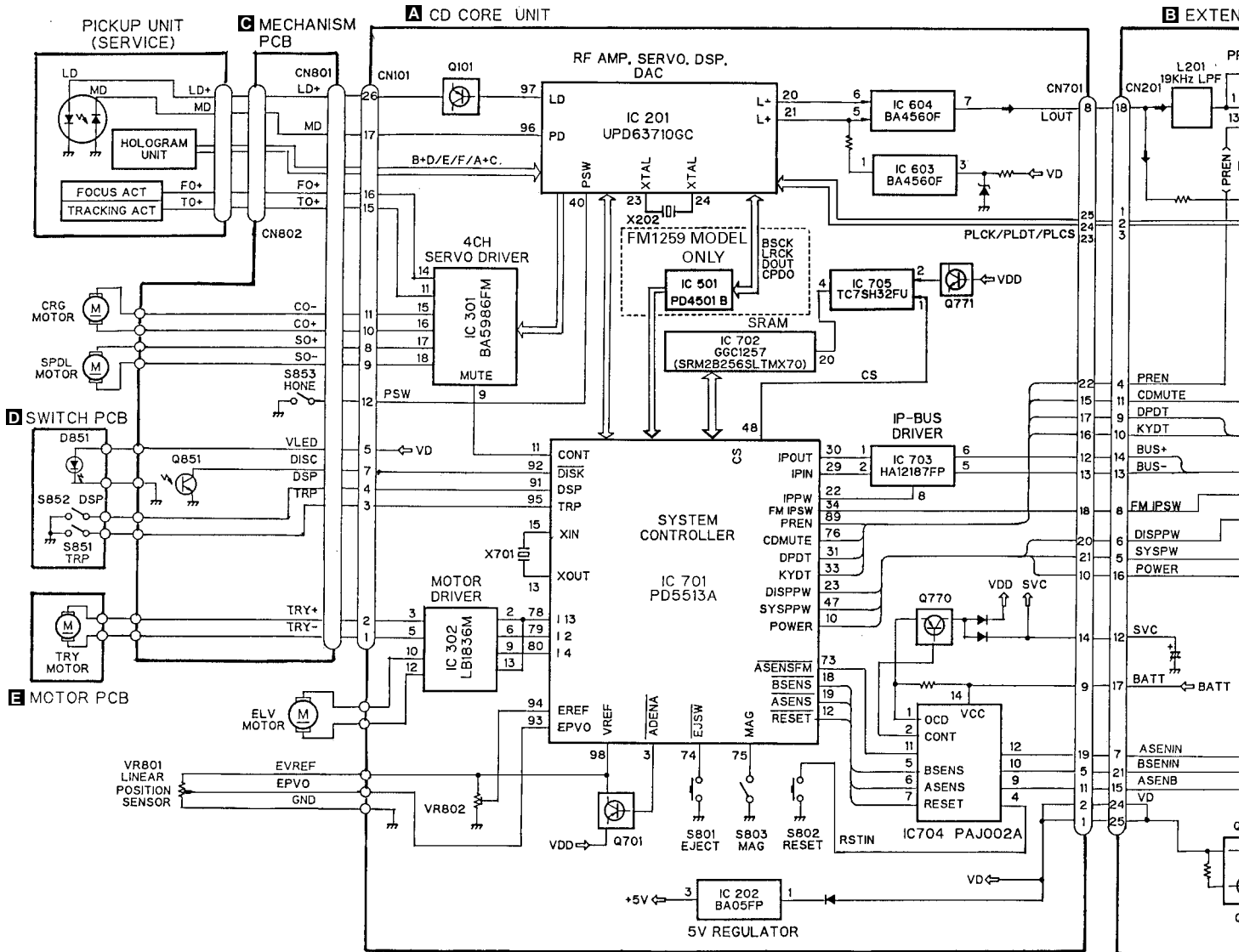

XTENSION UNIT

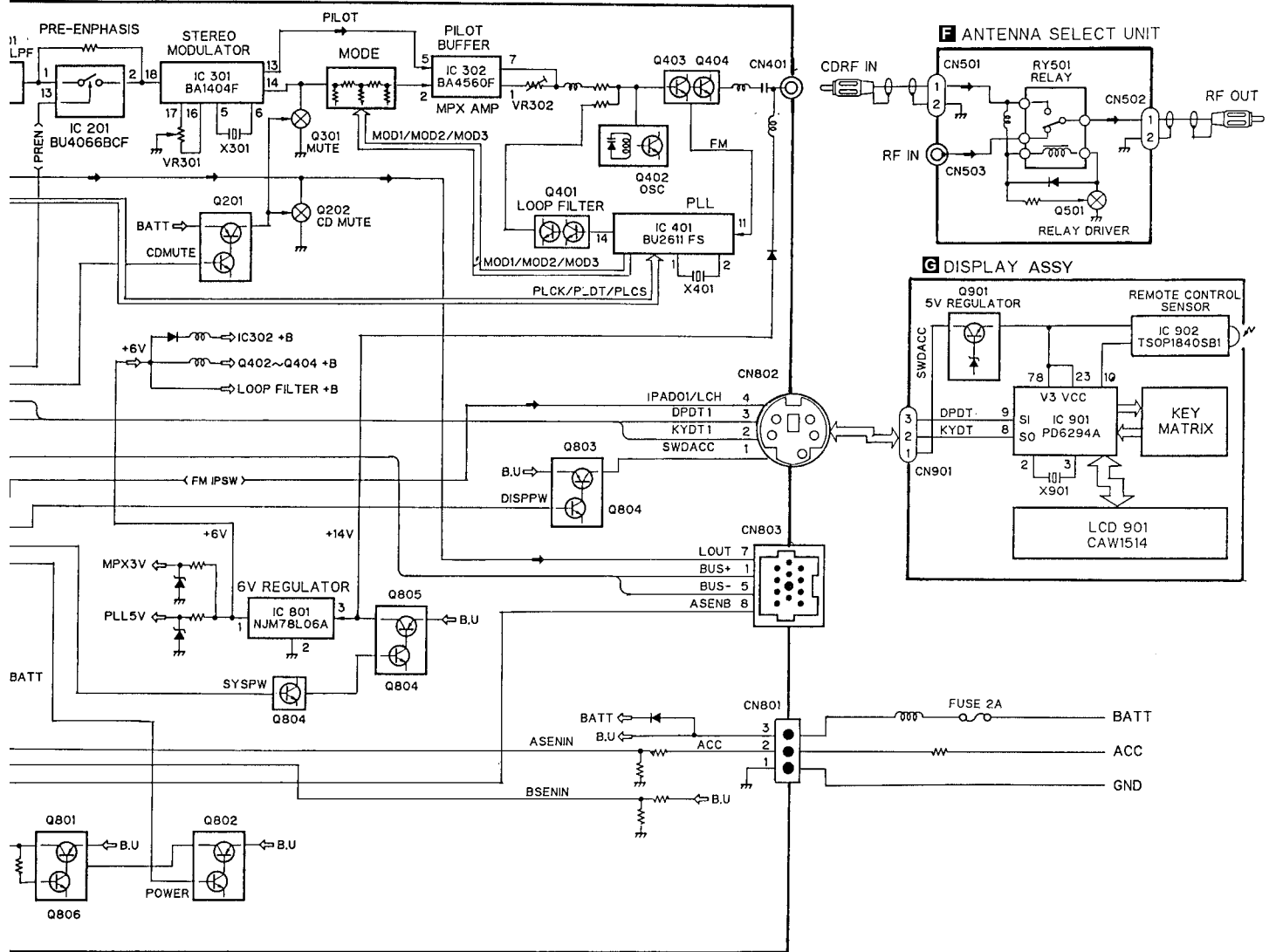

8. OPERATIONS AND SPECIFICATIONS

8.1 OPERATIONS

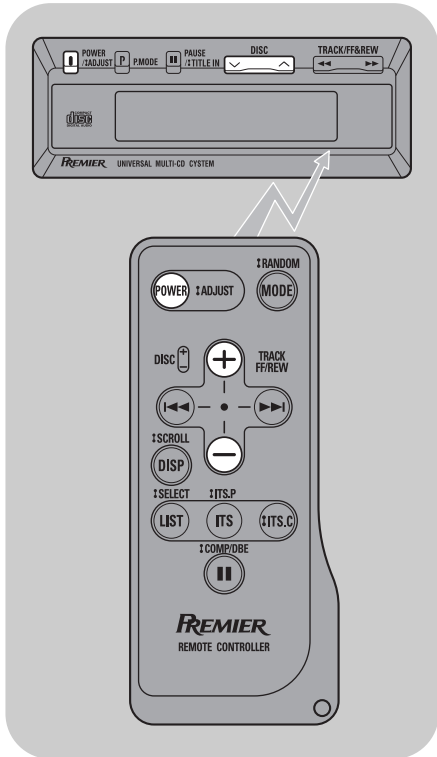

Start the CD player

1. Switch the radio on and tune to Modulating Frequencies.

- The initial value is 89.1 MHz.
- If your radio does not have muting, there may be some noise before power switch of control unit is ON. If this happens, turn down the volume of the radio.



or



2. Press button to switch on and start the player.

Disc Number Search



or



Disc Number

+ : increase the number.

- : decrease the number.

Parts for connection

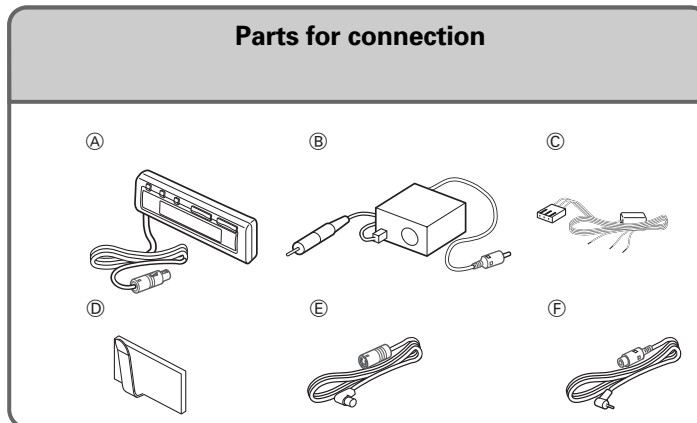

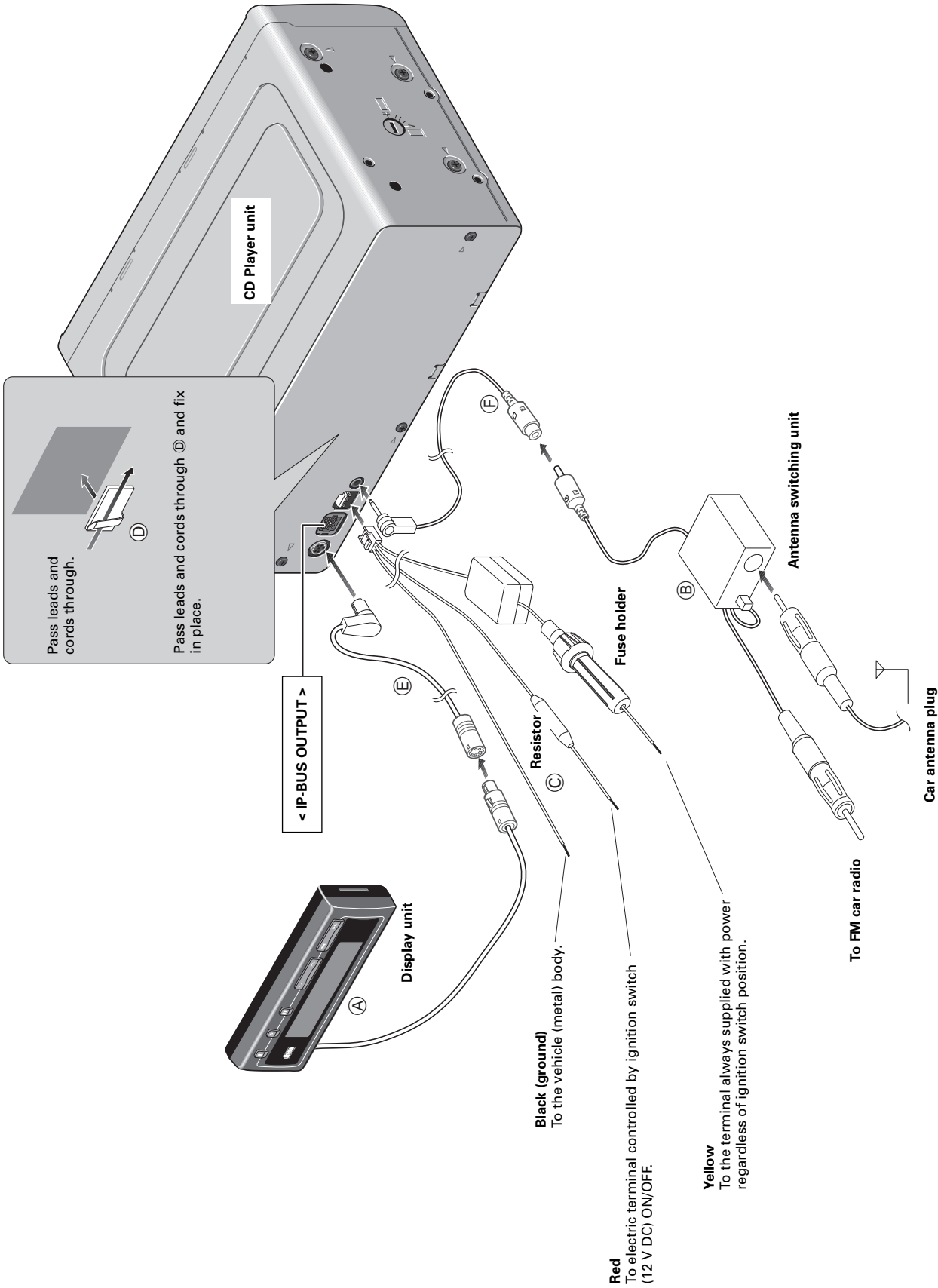

8.2 SPECIFICATIONS

CD Player unit

System Compact disc audio system
Usable discs Compact Disc
Signal format
..... Sampling frequency: 44.1 kHz
..... Number of quantization bits: 16; linear
Power source
..... 14.4 V DC (10.8 — 15.1 V allowable)
Max. current consumption 1.0 A
Weight 2.2 kg (4.9 lbs)
Dimensions
..... 257 (W) × 94 (H) × 172 (D) mm
..... [10-1/8 (W) × 3-11/16 (H) × 6-3/4 (D) in]
FM modulator usable frequency
..... 87.9/88.1/88.3/88.5/88.7/88.9/89.1
..... /89.3/89.5/89.7/89.9/90.1 MHz

Antenna Switching unit

Weight 140 g (0.3 lbs)
Dimensions
..... 45 (W) × 25 (H) × 43 (D) mm
..... [1-3/4 (W) × 1 (H) × 1-5/8 (D) in]

Display unit

Weight 78 g (0.1 lbs)
Dimensions
..... 100 (W) × 37 (H) × 18 (D) mm
..... [3-15/16 (W) × 1-7/16 (H) × 5/8 (D) in]

Remote Controller unit

Power source
..... Battery (CR2032)
Weight (including battery)
..... 15 g (0.03 lbs)
Dimensions
..... 39 (W) × 92 (H) × 6 (D) mm
..... [1-9/16 (W) × 3-5/8 (H) × 1/4 (D) in]

Note:

Specifications and the design are subject to possible modification without prior notice due to improvements.