

Service Manual

PIONEER
The Art of Entertainment

• CDX-M8036ZT/E

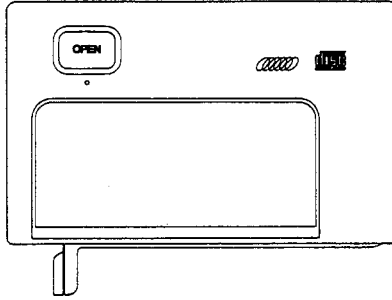

ORDER NO.
CRT1487

CD PLAYER

CDX-M8036ZT E

CDX-M9171ZT-91 E

COMPACT
disc
DIGITAL AUDIO

NOTE:

● Refer to the service manual CDX-M30/UC (CRT1463) for finding circuit and mechanism description which are not shown in this manual.

● These models have been installed in LEXUS LS400.

	CDX-M8036ZT/E	CDX-M9171ZT-91/E
Part No.	86270-50030	86275-50060

CONTENTS

1. SPECIFICATIONS.....	2	9. CONNECTION DIAGRAM(1).....	39
2. TRANSPORTATION SCREWS.....	3	10. SCHEMATIC CIRCUIT DIAGRAM(1).....	43
3. SAFETY INFORMATION.....	4	11. SCHEMATIC CIRCUIT DIAGRAM(2).....	46
4. GENERAL GUIDE.....	5	12. CONNECTION DIAGRAM(2).....	49
5. CONNECTOR FUNCTION DESCRIPTION.....	5	13. CHASSIS EXPLODED VIEW.....	52
6. DISASSEMBLY.....	6	14. CD MECHANISM UNIT EXPLODED VIEW.....	56
7. BLOCK DIAGRAM.....	9	15. ELECTRICAL PARTS LIST.....	60
8. ADJUSTMENT.....	11		

PIONEER ELECTRONIC CORPORATION 4-1, Meguro 1-Chome, Meguro-ku, Tokyo 153, Japan
PIONEER ELECTRONICS SERVICE INC. P.O. Box 1760, Long Beach, California 90801 U.S.A.
PIONEER ELECTRONICS OF CANADA, INC. 300 Allstate Parkway Markham, Ontario L3R 0P2 Canada
PIONEER ELECTRONIC [EUROPE] N.V. Haven 1087 Keetberglaan 1, 9120 Melsele, Belgium
PIONEER ELECTRONICS AUSTRALIA PTY. LTD. 178-184 Boundary Road, Braeside, Victoria 3195, Australia TEL: [03] 580-9911
 © PIONEER ELECTRONIC CORPORATION 1992

FA AUG. 1992 Printed in Japan

● CD Player Service Precautions

1. Since these screws protect the mechanism during transport, be sure to affix it when it is transported for repair, etc.
2. For pickup unit handling, please refer to "Disassembly". During replacement, handling precautions shall be taken to prevent an electrostatic discharge (protection by a short pin).
3. During disassembly, be sure to turn the power off since an internal IC might be destroyed when a connector is plugged or unplugged.

2. TRANSPORTATION SCREWS

Removal of Screws

Be sure to remove transportation screws (red) ①, ② and ④ in this order and cover the screw holes with seals ③ before mounting the set. Peel off adhesive tape to remove the transportation pin ①. **The removed screws (red) and the pin will be required if you transport the player again later. Keep them in the bag for keeping transportation screws.**

Reinstallation of Screws

Be sure to reinstall the transportation screws (red) in the procedure described below before re-transporting the set. Incorrect order of reinstallation or use of different screws may cause the set to fail.

1. Let the set operate the beginning of a disc and stop operation within 10 seconds thereafter before removing the set.
2. Remove the magazine and then the set.
3. Reinstall the transportation screws in the reverse order (④, ② and ①) of removal. Fasten the transportation pin ① with adhesive tape.

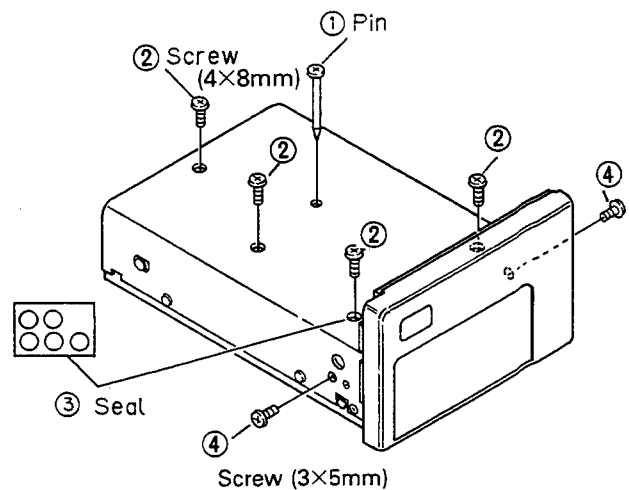

Fig. 1

3. SAFETY INFORMATION

1. Safety Precautions for those who Service this Unit.

- Follow the adjustment steps (see pages 11 through 25) in the service manual when servicing this unit. When checking or adjusting the emitting power of the laser diode exercise caution in order to get safe, reliable results.

Caution:

1. During repair or tests, minimum distance of 13cm from the focus lens must be kept.
2. During repair or tests, do not view laser beam for 10 seconds or longer.

2. A "CLASS 1 LASER PRODUCT" label is affixed to the rear of the player.

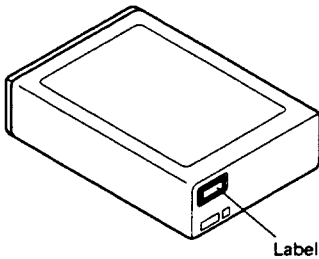

Fig. 2

3. The triangular label is attached to the mechanism unit frame.

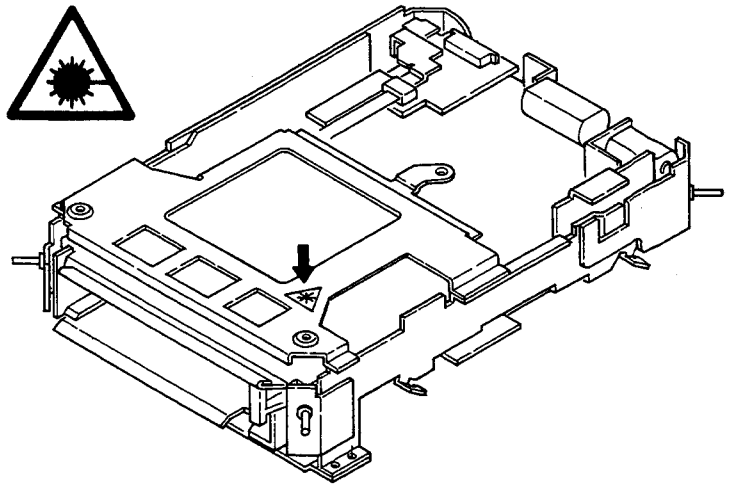

Fig. 3

4. Specifications of Laser Diode

Specifications of laser radiation fields to which human access is possible during service.

- Wavelength = 785 nanometers
- Radiant power = 69.7 microwatts (Through a circular aperture stop having a diameter of 80 millimeters)
- 0.55 microwatts (Through a circular aperture stop having a diameter of 7 millimeters)

4. GENERAL GUIDE

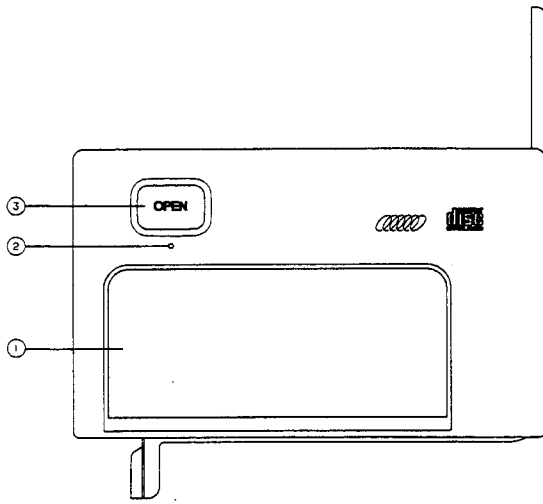

Fig. 4

① Door

Be sure never to leave the door open.

② Clear button

If the power does not switch on or if the compact disc player does not operate when the button on the multi-CD controller is pressed, or if the multi-CD controller display is incorrect, press this button on the player with the tip of a pencil to restore normal operation.

③ Door open/eject button

Press this button to open the door ① and eject the magazine. (Hold down the button for at least 0.3 seconds.)

5. CONNECTOR FUNCTION DESCRIPTION

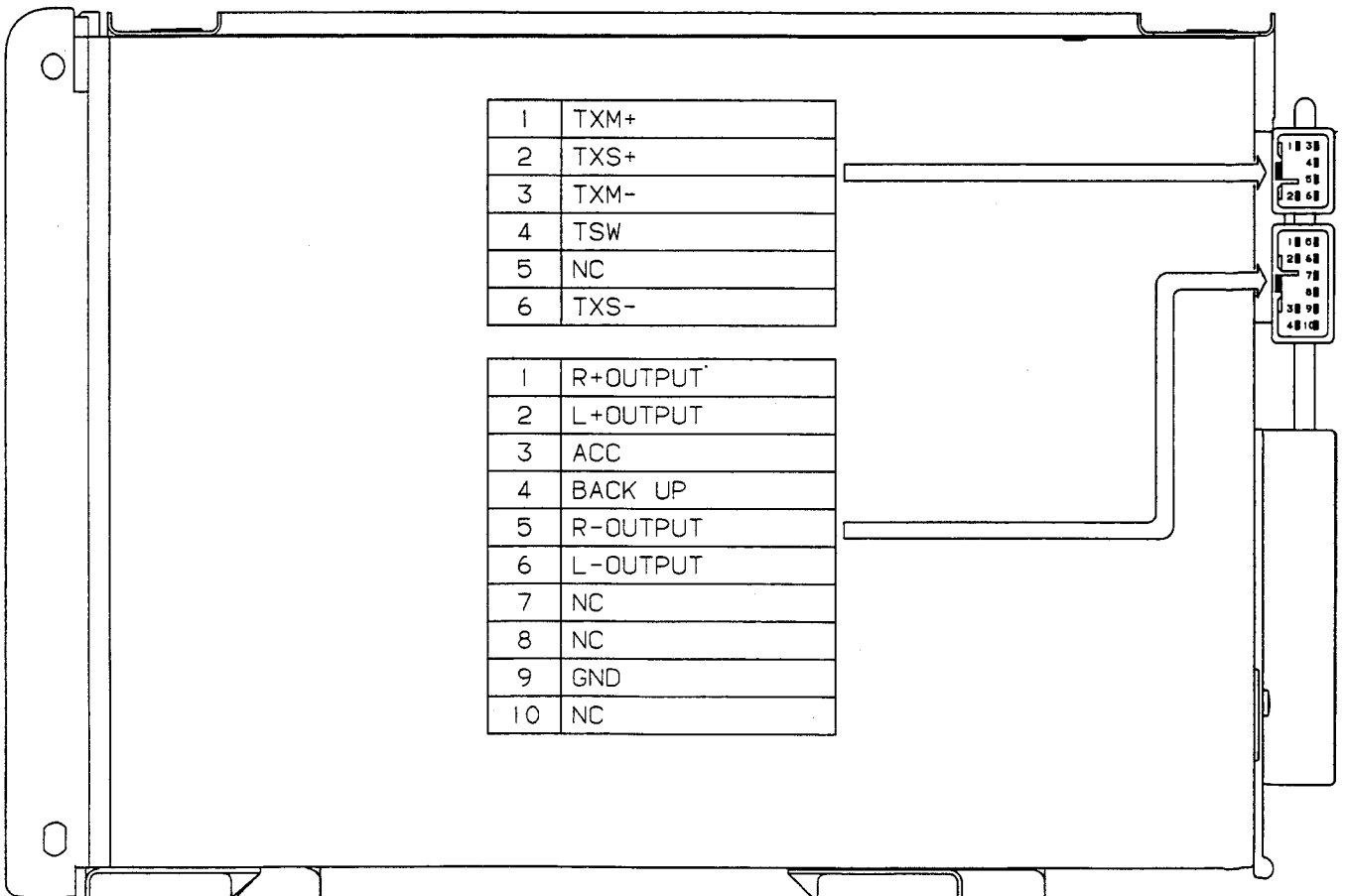

Fig. 5

6. DISASSEMBLY

● Removing the Bracket

1. Remove the six screws A and remove the bracket.

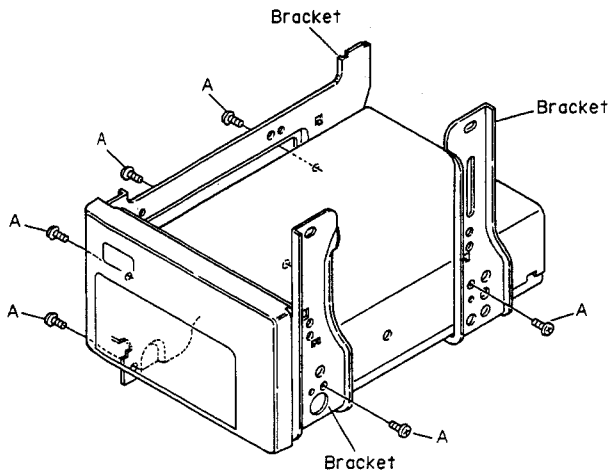

Fig. 6

● Removing the Grille Assy and Lower Case

1. Remove the four stoppers.
2. Remove the cover and remove the cushion.
3. Remove the clamper and remove the connector.
4. Remove the grille assy.
5. Remove the two screws A and remove the lower case.

NOTE: Reassemble the cover before reassembling the upper case.

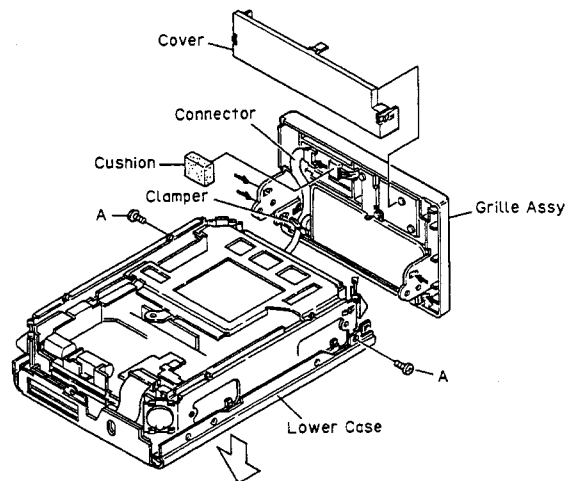

Fig. 8

● Removing the Upper Case

1. Remove the screw A and remove the holder.
2. Remove the screw B and remove the holder.
3. Disconnect the two connectors.
4. Remove the five screws C and remove the upper case.

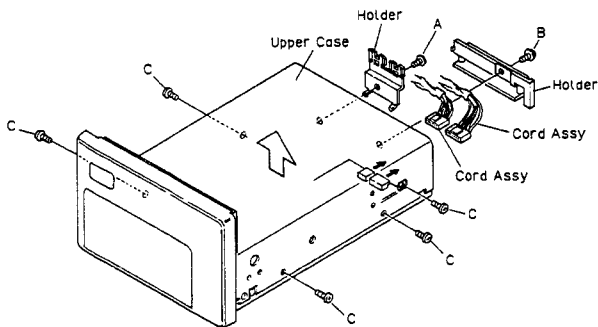

Fig. 7

● Removing the Chassis L and Chassis R

1. Remove the four screws A.
2. Disconnect the two connectors.
3. Remove the sub chassis.
4. Disconnect the two connectors.
5. Remove the four damper holders and remove the four dampers.
6. Remove the four springs.
7. Remove the chassis L and remove the chassis R.

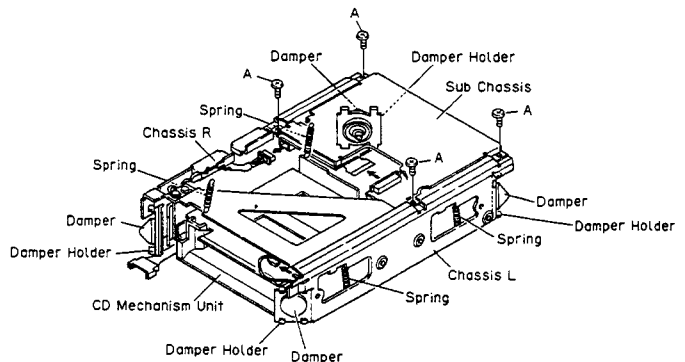

Fig. 9

NOTE: Use utmost care to mount the spring.

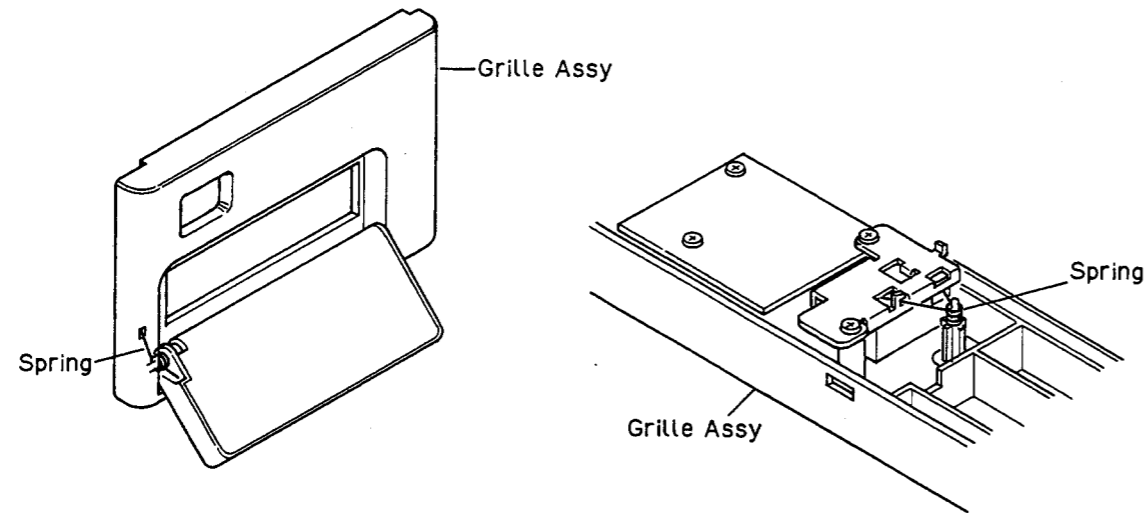

Fig. 10

• CN351
Before disconnecting the CN351 connector (PU unit connector), attach a short pin as illustrated.

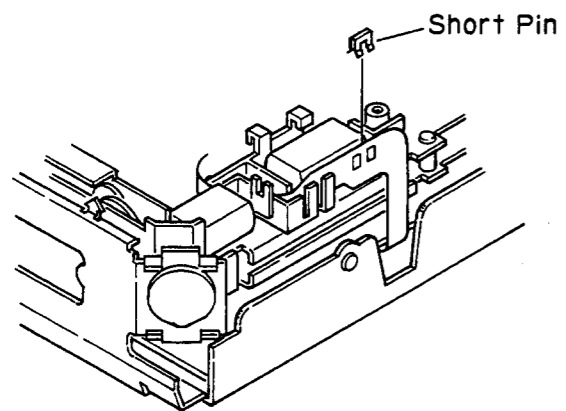

Fig. 11

7. BLOCK DIAGRAM

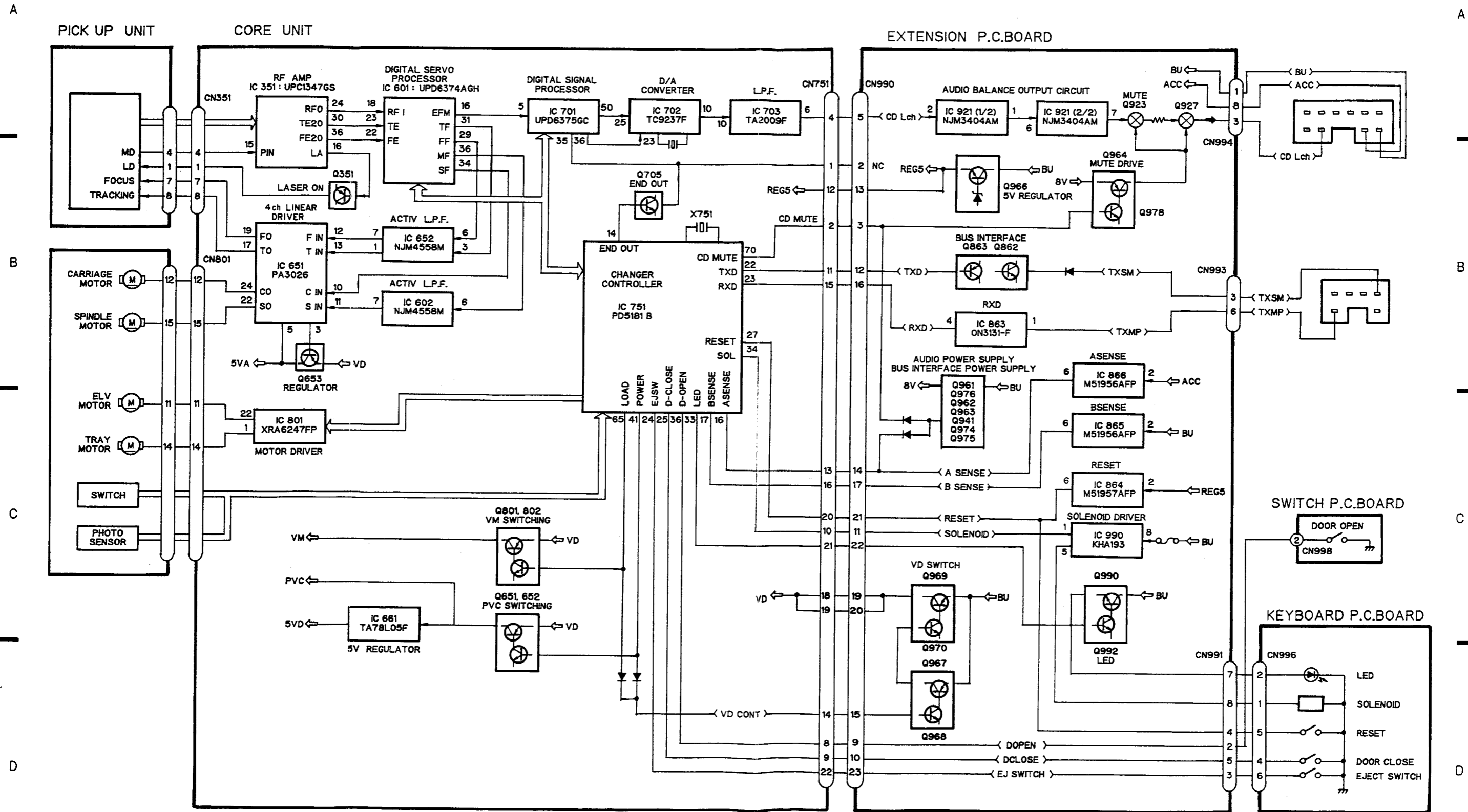

Fig. 12

8. ADJUSTMENT

1)Precautions

- This unit uses a single power supply (+5V) for the regulator. The signal reference potential, therefore, is connected to REFOUT (approx. 2.5V) instead of GND.

If REFOUT and GND are connected to each other by mistake during adjustments, not only will it be impossible to measure the potential correctly, but the servo will malfunction and a severe shock will be applied to the pick-up. To avoid this, take special note of the following.

Do not connect the negative probe of the measuring equipment to REFOUT and GND together. It is especially important not to connect the channel 1 negative probe of the oscilloscope to REFOUT with the channel 2 negative probe connected to GND.

And since the frame of the measuring instrument is usually at the same potential as the negative probe, change the frame of the measuring instrument to floating status.

If by accident REFOUT comes in contact with GND, immediately switch the regulator or power OFF.

- Always make sure the regulator is OFF when connecting and disconnecting the various filters and wiring required for measurements.
- Before proceeding to further adjustments and measurements after switching regulator ON, let the player run for about one minute to allow the circuits to stabilize.
- Since the protective systems in the unit's software are rendered inoperative in test mode, be very careful to avoid mechanical and /or electrical shocks to the system when making adjustment.
- When loading and unloading discs during adjustment procedures, always wait for the disc to be properly clamped or ejected before pressing the another key. Otherwise, there is risk of the actuator being destroyed.
- Turn power off when pressing the button TRACK > or the button TUNE ∨ key for focus search in the test mode. (Or else lens may stick and the actuator may be damaged.)

2)Test mode

The model CDX-M8036ZT is adjusted in a combination with the multiple CD control head (KEH-M8171ZT.). Each regulator key should be operated at the head. With the KEH-M8171ZT taken up for reference, a description will be given below concerning how to enter into the test mode, including key operations. The key in the adjustment text is also one of the KEH-M8171ZT keys.

- How to enter into the test mode

Switch back-up ON while pressing the CD and SCAN keys together.

- Resetting the test mode

Switch the KEH-M8171ZT and CDX-M8036ZT back-up OFF.

- Role to be played by each key in the test mode

Key	Function
RANDOM	Regulator ON/OFF
TRACK >	FWD Kick
TUNE ∨	REV Kick
TUNE ^	Tracking close
TRACK <	Tracking open
RPT	Focus close
SCAN	Disc change

● **Measuring Equipment and Jigs**

Adjustment	• Measuring equipment&jigs
Grating Adjustment	• Oscilloscope,clock driver,grating adjustment filter (bandpass filter)(GGF133),AC millivoltmeter • SONY TYPE 4 (or TYPE 3) • Extension Cable:GGF1157,GGF1158 • DIN Cord:GGF1159 •Relay P.C.Board:GGF1156
Tangential Skew Check	•Oscilloscope,screwdriver •SONY TYPE 4 (or TYPE 3) • Extension Cable:GGF1157,GGF1158 • DIN Cord:GGF1159 • Relay P.C.Board:GGF1156
Grating Adjustment	• Oscilloscope,clock driver,two low-pass filters • SONY TYPE 4 (or TYPE 3) • Extension Cable:GGF1157,GGF1158 • DIN Cord:GGF1159 •Relay P.C.Board:GGF1156
FE Bias Adjustment	Oscilloscope,volume adjustment driver SONY TYPE 4 (or TYPE 3) • Extension Cable:GGF1157,GGF1158 • DIN Cord:GGF1159 •Relay P.C.Board:GGF1156
RF Offset Adjustment	Oscilloscope,volume adjustment driver SONY TYPE 4 (or TYPE 3) • Extension Cable:GGF1157,GGF1158 • DIN Cord:GGF1159 •Relay P.C.Board:GGF1156
TE Offset Adjustment-1	DC voltmeter or oscilloscope,volume adjustment driver • Extension Cable:GGF1157,GGF1158 • DIN Cord:GGF1159 •Relay P.C.Board:GGF1156
Tracking Balance Adjustment-1	Oscilloscope,volume adjustment driver SONY TYPE 4 (or TYPE 3) • Extension Cable:GGF1157,GGF1158 • DIN Cord:GGF1159 •Relay P.C.Board:GGF1156
Focus Servo Loop Gain Adjustment	Oscillator,gain adjustment filter (GGF-065),Oscilloscope, dual meter milli-voltmeter,volume adjustment driver SONY TYPE 4 (or TYPE 3) • Extension Cable:GGF1157,GGF1158 • DIN Cord:GGF1159 •Relay P.C.Board:GGF1156
Tracking Servo Loop Gain Adjustment	Oscillator,gain adjustment filter (GGF-065),Oscilloscope, dual meter milli-voltmeter,volume adjustment driver SONY TYPE 4 (or TYPE 3) • Extension Cable:GGF1157,GGF1158 • DIN Cord:GGF1159 •Relay P.C.Board:GGF1156
TE Offset Adjustment-2	DC voltmeter,volume adjustment driver • Extension Cable:GGF1157,GGF1158 • DIN Cord:GGF1159 •Relay P.C.Board:GGF1156
Tracking Balance Adjustment-2	Oscilloscope,volume adjustment driver SONY TYPE 4 (or TYPE 3) • Extension Cable:GGF1157,GGF1158 • DIN Cord:GGF1159 •Relay P.C.Board:GGF1156

● **Adjustment Points**

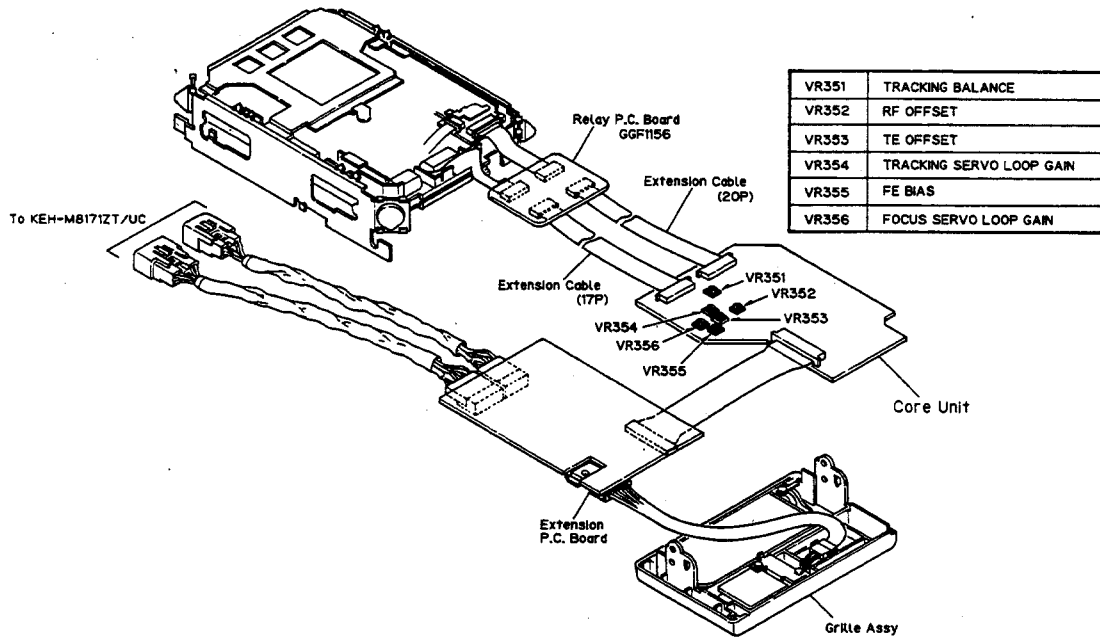

Fig. 13

● **Test Point**

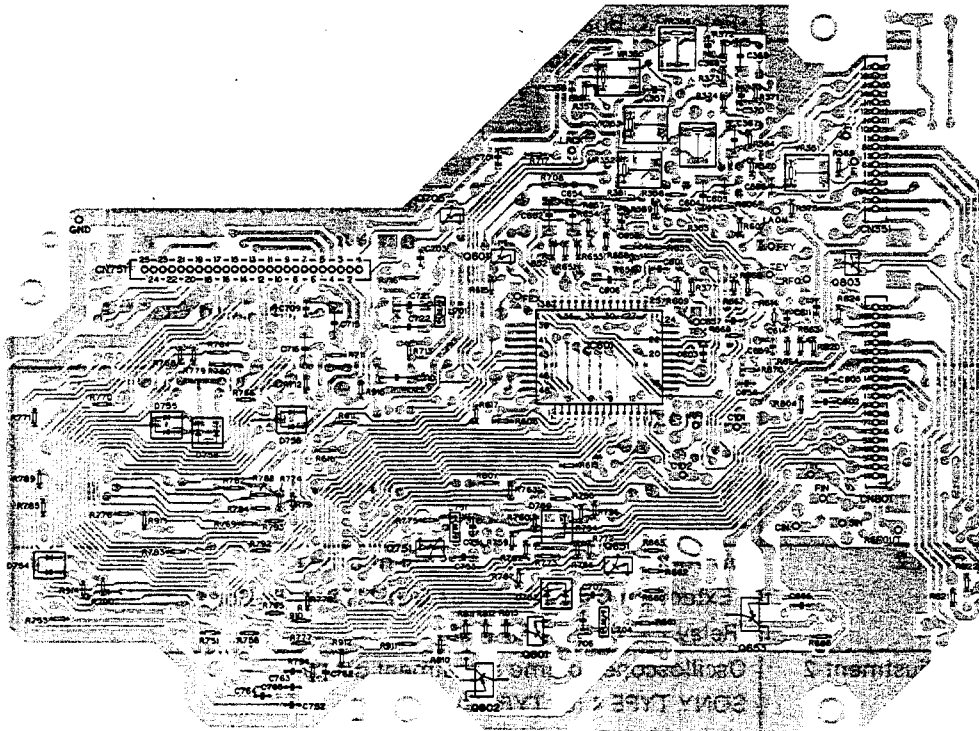

Fig. 14

8.1 Grating Adjustment (Rough adjustment)

- Purpose: The grating may need adjustment in a replaced pick-up unit.
- Maladjustment symptoms: No disc playback; track jumping.

- | | |
|---|---|
| <ul style="list-style-type: none"> • Measuring equipment / jigs • Measuring point • Test disc and setting • Adjustment position | <ul style="list-style-type: none"> • Oscilloscope, clock driver, grating adjustment filter (bandpass filter)(GGF-133), AC millivoltmeter • TEY • SONY TYPE 4 (or TYPE 3) • Test mode • Pick-up grating adjustment hole |
|---|---|

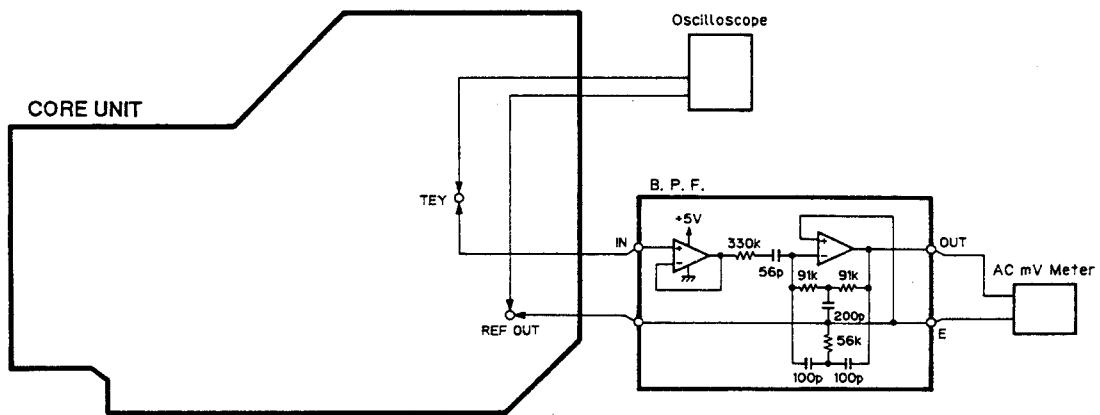
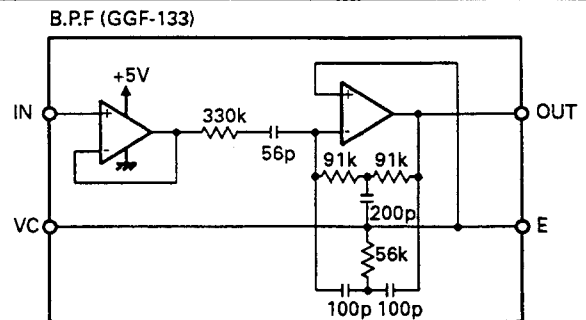

Fig. 15

Adjustment Procedure

1. In the test mode, set a test desc-loaded magazine and select the tray with a test disc.
2. Switch regulator ON.
3. Using the TRACK > or TUNE v key, move the pick-up to about the center of the test disc.
4. Press the RPT key to close focus.
5. While monitoring the TEY filter output by AC milli-voltmeter, turn the grating adjustment hole slowly. The AC voltage increases and decreases while turning the screw. Search for the minimum voltage level. (This corresponds to the position where the grating is on a track, and is referred to as the null point.)
6. Then while monitoring TEY by oscilloscope, turn the driver slowly clockwise from the null point (as seen from under the pick-up) until the first waveform peak amplitude is reached.



8.2 Trangular Skew Check

- Purpose: To check whether tangential skew has been misaligned or not when replacing the pick-up unit.
- Maladjustment symptoms: No disc playback, track jumping.

- | | |
|---|--|
| <ul style="list-style-type: none"> • Measuring equipment / jigs • Measuring point • Test disc and setting • Adjustment position | <ul style="list-style-type: none"> • Oscilloscope, screwdriver • RFO • SONY TYPE 4 (or TYPE 3) • Normal mode • Pick-up tangential adjustment screw |
|---|--|

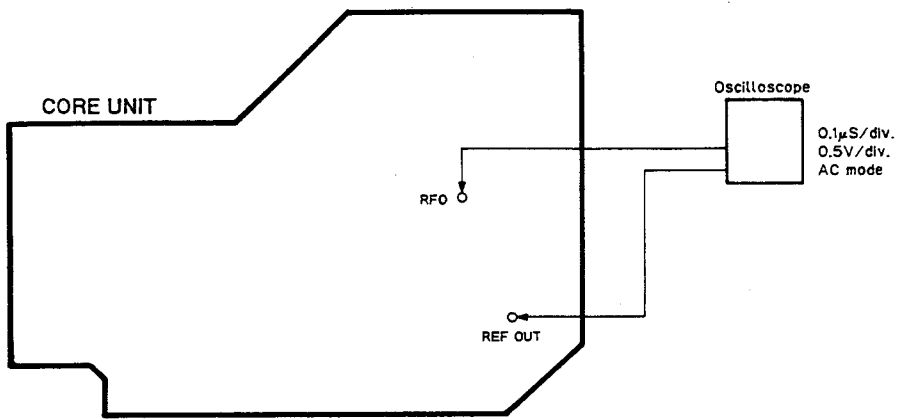

Fig. 16

Adjustment Procedure

1. Play tune TNO 12 in normal mode. (TYPE 3: TNO 14)
2. Adjust the tangential adjustment screw so that the RF wave-form will have a level maximized and an eye pattern clearly viewed. Turn the adjustment screw both clockwise and counterclockwise to points where the eye pattern deteriorates, and take the midway point as the adjustment point. As a general guide, look for an overall clear wave-form, and one of the diamond shapes in the eye pattern. The diamond shapes should appear in fine lines at the point of optimum adjustment. Take care not to knock the pick-up with the screwdriver at this stage. (This kind of accident can result in loss of focus.) (See Fig. 17, 18)
3. Apply "screw-lock" to the tangential adjustment screw.
4. After adjusting tangential skew, also adjust the grating.

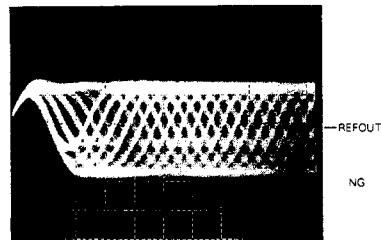

Fig. 17

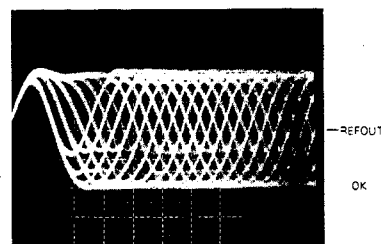

Fig. 18

0.5V/div.
0.5µs/div.
DC mode

8.3 Granting Adjustment (Fine adjustment)

- Purpose: The grating may need adjustment in a replaced pick-up unit.
- Maladjustment symptoms: No disc playback, track jumping.

- | | |
|---|--|
| <ul style="list-style-type: none"> • Measuring equipment / jigs • Measuring point • Test disc and setting • Adjustment position | <ul style="list-style-type: none"> • Oscilloscope, clock driver, two low-pass filters • E LPF output, F LPF output • SONY TYPE 4 (or TYPE 3) • Test mode • Pick-up grating adjustment hole |
|---|--|

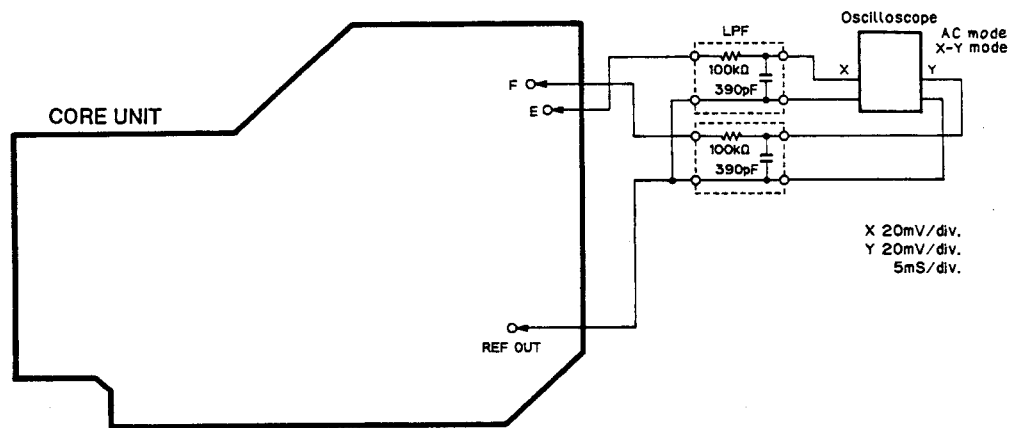

Fig. 19

Adjustment Procedure

1. Connect a low-pass filter as shown in the above diagram.
2. Switch regulator ON in test mode, and load a disc.
3. Using the TRACK > or TUNE < key, move the pick-up to about the center of the test disc.
4. Press the RPT key to close focus.
5. Using the driver, adjust the Lissajous figure to a single line (or as close as possible).
6. Switch regulator OFF and remove the filters.

TEY waveform 5ms/div, 500mV/div

Nul Point

Lissajous figure (AC input)
Horizontal axis E 20mV/div
Vertical axis F 20mV/div

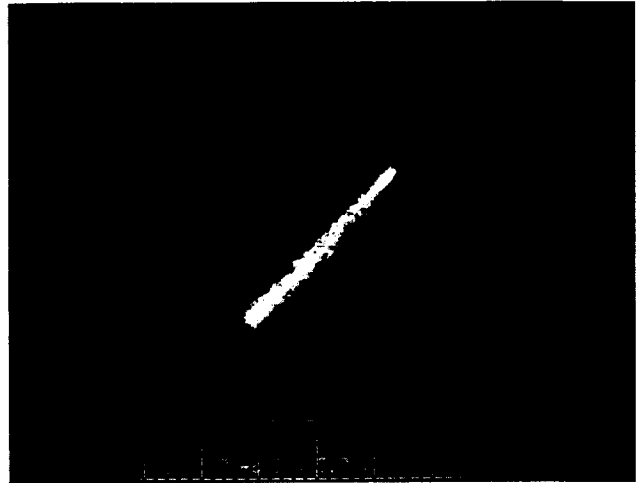
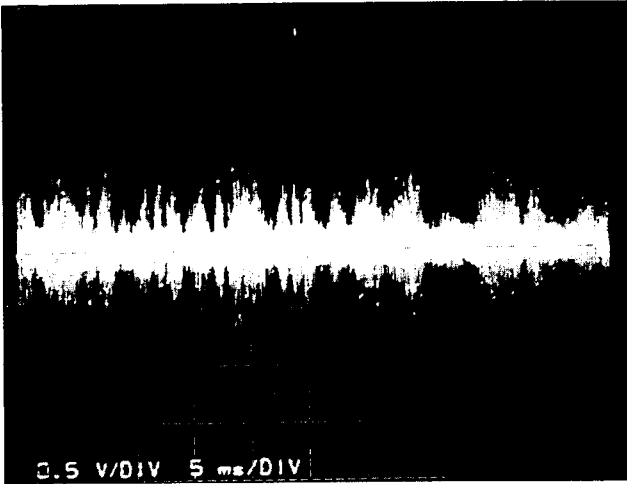

Fig. 20

Fig. 21



"Rough" adjustment

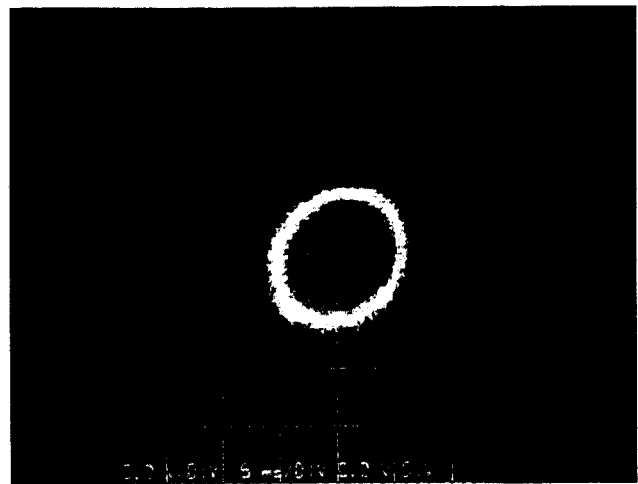
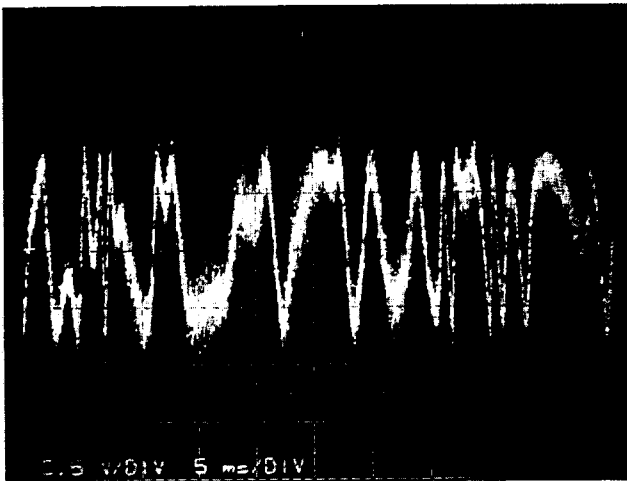

Fig. 22

Fig. 23



Final adjustment

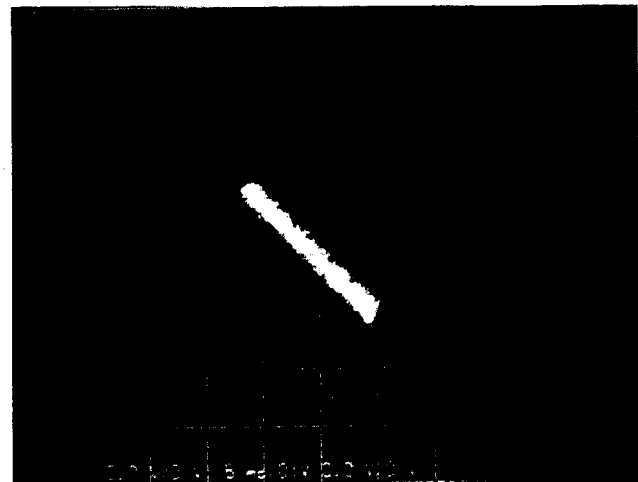
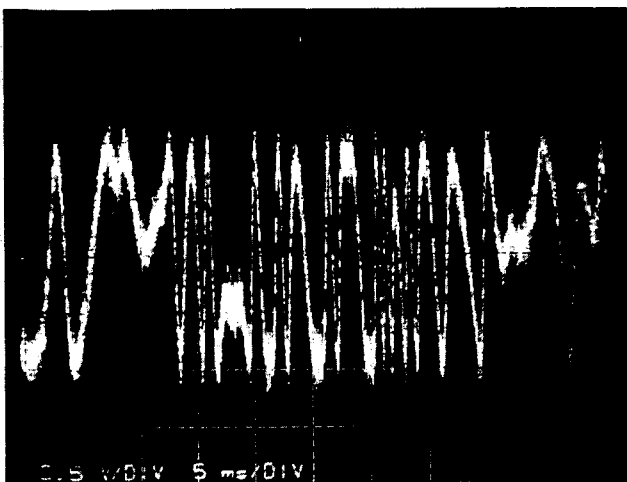

Fig. 24

Fig. 25

8.4 FE Bias Adjustment

- Purpose: To adjust the focus servo bias to an optimum value.
- Maladjustment symptoms: Focus closing difficulty, poor playability.

- | | |
|---|--|
| <ul style="list-style-type: none"> • Measuring equipment / jigs • Measuring point • Test disc and setting • Adjustment position | <ul style="list-style-type: none"> • Oscilloscope, volume adjustment driver • RFO • SONY TYPE 4 (or TYPE 3) • Normal mode • VR355(FEB) |
|---|--|

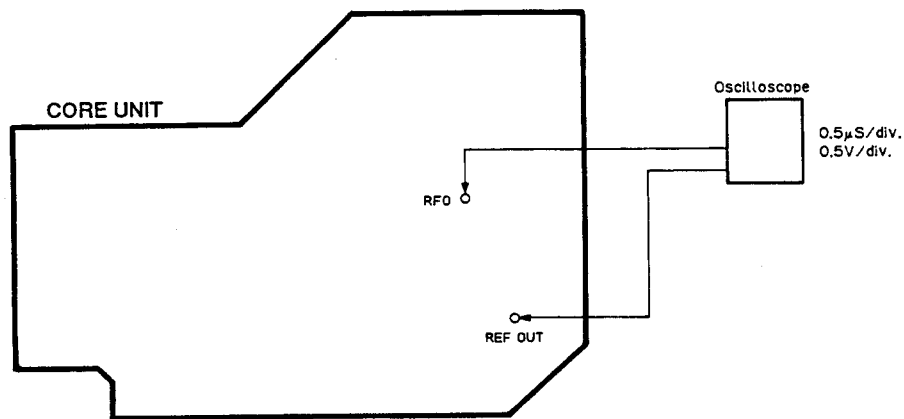

Fig. 26

Adjustment Procedure

1. Play tune TNO 12 in normal mode.(TYPE 3:TNO 14)
2. Observe RFO in respect to REFOUT in the oscilloscope, and adjust VR355(FEB) to obtain maximum RF and optimum eye pattern. (See Fig.27,28)

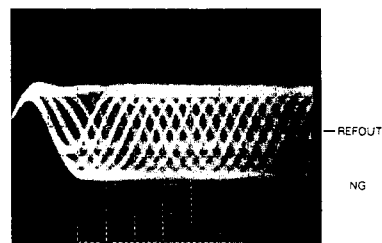

Fig. 27

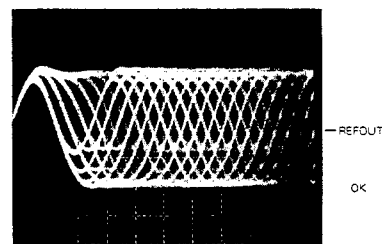

Fig. 28

0.5V/div.
0.5µs/div.
DC mode

8.5 RF Offset Adjustment

- Purpose: To adjust the RF amplifier offset to a suitable value.
- Maladjustment symptoms: Focus closure fails readily.

- | | |
|---|--|
| <ul style="list-style-type: none"> • Measuring equipment / jigs • Measuring point • Test disc and setting • Adjustment position | <ul style="list-style-type: none"> • Oscilloscope, volume adjustment driver • RFO • SONY TYPE 4 (or TYPE 3) • Normal mode • VR352(RFO) |
|---|--|

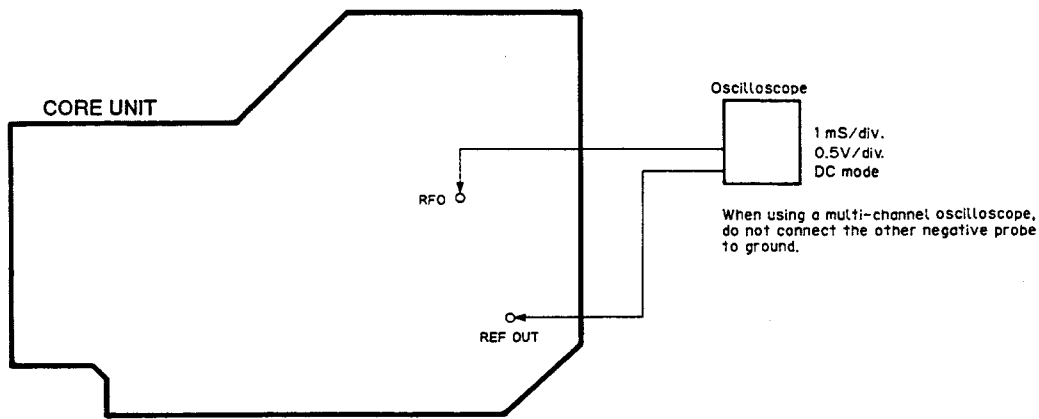
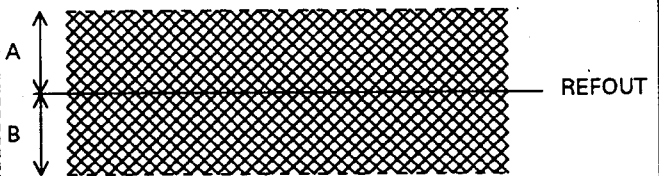

Fig. 29

Adjustment Procedure

1. Play tune TNO 12 in normal mode. (TYPE 3:TNO 14)
2. Use VR352 to adjust the RFO waveform so that REFOUT appears at the center. (A-B must not exceed 100 mV.)



8.6 TE Offset Adjustment- 1

- Purpose: To adjust the electrical offset of the tracking servo to zero.
- Maladjustment symptoms: Search times too long, carriage run-away.

- | | |
|---|---|
| <ul style="list-style-type: none"> • Measuring equipment / jigs • Measuring point • Test disc and setting • Adjustment position | <ul style="list-style-type: none"> • DC voltmeter or oscilloscope, volume adjustment driver • TEY • Empty magazine • Test mode • VR353(TEO) |
|---|---|

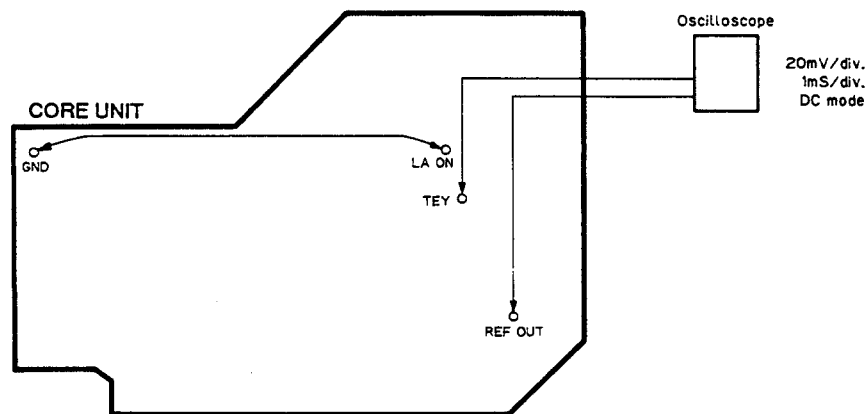

Fig. 30

Adjustment Procedure

1. Connect LAON to GND.
2. Switch regulator ON while in test mode.
3. Using VR353(TEO), adjust the TEY output DC voltage in reference to REFOUT to a value of $0 \pm 25\text{mV}$.
4. Switch regulator OFF.
5. Remove LAON to GND.

8.7 Tracking Balance Adjustment- 1

- Purpose: To adjust the tracking servo offset to zero.
- Maladjustment symptoms: Search times too long,poor playability,carriage run-away.

- | | |
|---|---|
| <ul style="list-style-type: none"> • Measuring equipment / jigs • Measuring point • Test disc and setting • Adjustment position | <ul style="list-style-type: none"> • Oscilloscope,volume adjustment driver • TEY (Tracking error signal) • SONY TYPE 4 (or TYPE 3) • Test mode • VR351(T.BAL) |
|---|---|

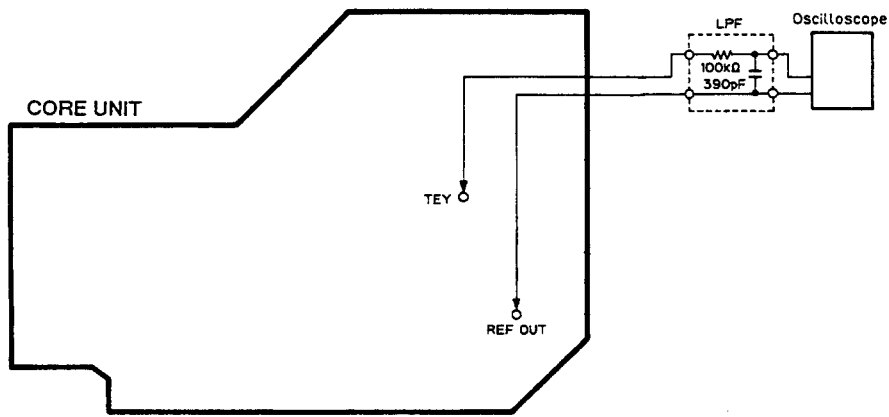

Fig. 31

Adjustment Procedure

1. After checking that regulator is OFF,connect the low-pass filter as shown in the diagram.
2. Set the test disc (SONY TYPE 4). Switch regulator ON.
3. Using the TRACK > or TUNE v key,move the pick-up to about the center of the signal surface.
4. Press the RPT key to close focus.
5. Using an oscilloscope,observe the TEY signal in respect to REFOUT. Then adjust VR351(T.BAL) to set the positive and negative amplitudes to the same levels.(See Fig.32-34)
6. Switch the power OFF.

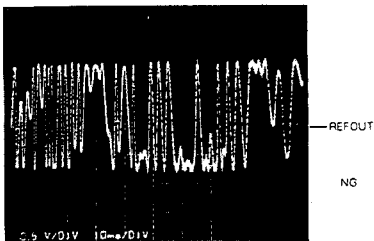

Fig. 32

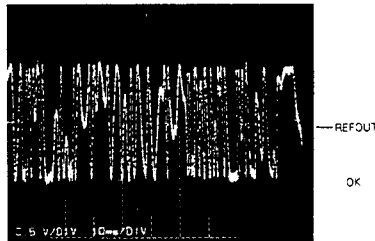

Fig. 33

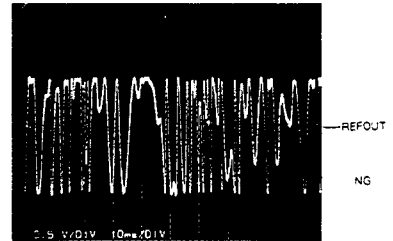

Fig. 34

8.8 Focus Servo Loop Gain Adjustment

- Purpose: To adjust the focus servo loop gain to an optimum value.
- Maladjustment symptoms: Poor playability, reduced resistance to vibration, focus closure fails readily.

- | | |
|---|--|
| <ul style="list-style-type: none"> • Measuring equipment / jigs • Measuring point • Test disc and setting • Adjustment position | <ul style="list-style-type: none"> • Oscillator, gain adjustment filter (GGF-065), dual meter milli-voltmeter, oscilloscope, volume adjustment driver • FEX, FEY • SONY TYPE 4 (or TYPE 3) • Normal mode • VR356(FG) |
|---|--|

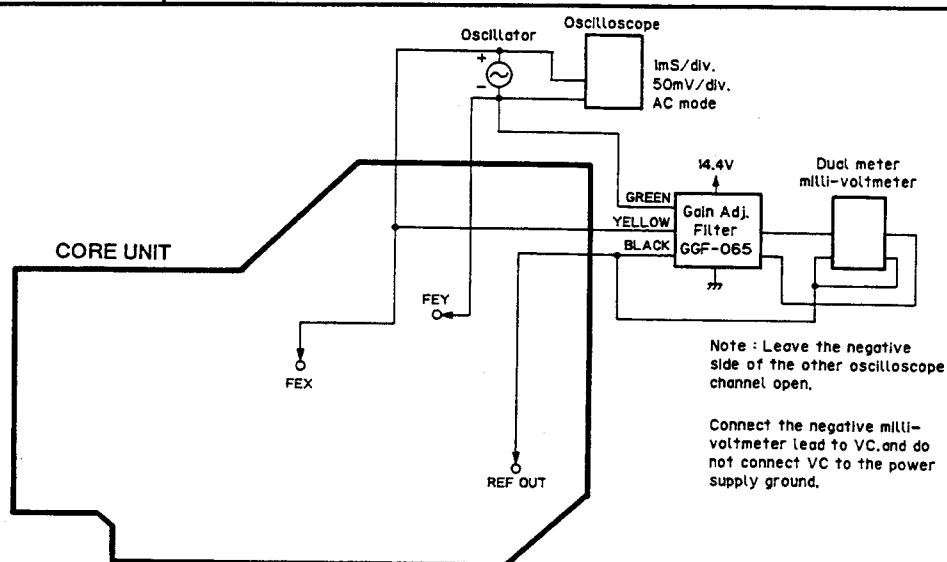

Fig. 35

Adjustment Procedure

1. After checking that the power is OFF, connect the gain adjustment filter and measuring equipment as shown in the above diagram.
2. Play tune TNO 12 in normal mode. (TYPE 3: TNO 14)
3. Set the oscillator to 1kHz, and observe the FEX/FEY output in the oscilloscope. Adjust the oscillator output to obtain a FEX/FEY output of 100mVp-p.
4. Adjust VR356(FG) to obtain a milli-voltmeter difference of 0 ± 0.5 dB.

8.9 Tracking Servo Loop Gain Adjustment

- Purpose: To adjust the tracking servo loop gain to an optimum value.
- Maladjustment symptoms: Poor playability, reduced resistance to vibration.

- | | |
|---|--|
| <ul style="list-style-type: none"> • Measuring equipment / jigs • Measuring point • Test disc and setting • Adjustment position | <ul style="list-style-type: none"> • Oscillator, gain adjustment filter (GGF-065), dual meter milli-voltmeter, oscilloscope, volume adjustment driver • TEX, TEY • SONY TYPE 4 (or TYPE 3) • VR354(TG) |
|---|--|

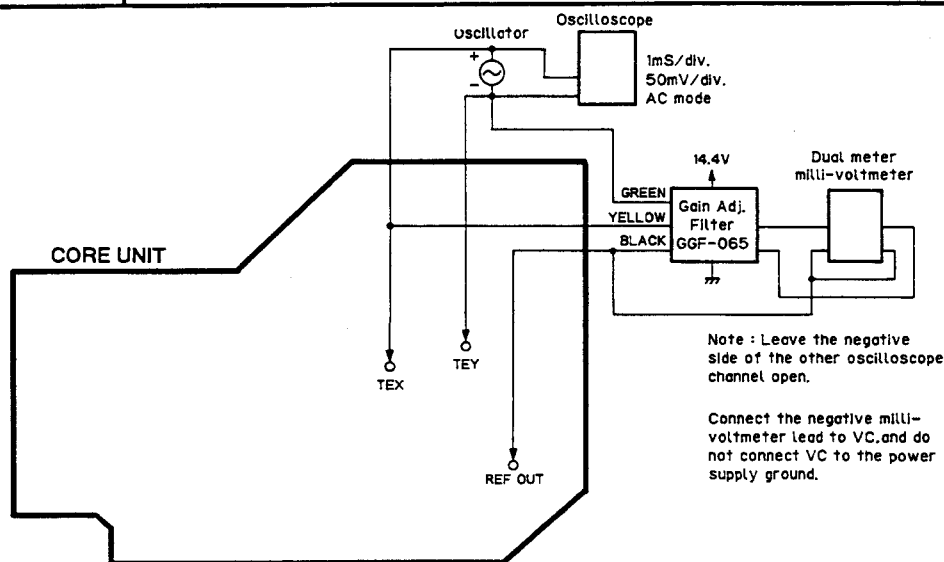

Fig. 36

Adjustment Procedure

1. After checking that the power is OFF, connect the gain adjustment filter and measuring equipment as shown in the above diagram.
2. Play tune TNO 12 in normal mode. (TYPE 3:TNO 14)
3. Set the oscillator to 1.4kHz, and observe the TEX/TEY output in the oscilloscope. Adjust the oscillator output to obtain a TEX/TEY output of 300mVp-p.
4. Adjust VR354(TG) to obtain a milli-voltmeter difference of 0 ± 0.5 dB.

8.10 TE Offset Adjustment- 2

<ul style="list-style-type: none"> • Purpose: To adjust the electrical offset of the tracking servo to zero. • Maladjustment symptoms: Search times too long, carriage run-away. 	
<ul style="list-style-type: none"> • Measuring equipment / jigs • Measuring point • Test disc and setting • Adjustment position 	<ul style="list-style-type: none"> • DC voltmeter, volume adjustment driver • TEY • No Disc • Test mode • VR353
<p>Adjustment Procedure</p> <p>Same as for TE offset adjustment-1, but with the DC voltage of the TEY output adjusted to $0 \pm 50\text{mV}$. The purpose of this additional adjustment is to correct any deviations generated when carrying out the tracking balance and tracking servo loop gain adjustments after completing TE offset adjustment-1.</p>	

8.11 Tracking Balance Adjustment- 2

<ul style="list-style-type: none"> • Purpose: To adjust the tracking servo offset to zero. • Maladjustment symptoms: Search times too long, poor playability, carriage run-away. 	
<ul style="list-style-type: none"> • Measuring equipment / jigs • Measuring point • Test disc and setting • Adjustment position 	<ul style="list-style-type: none"> • Oscilloscope, volume adjustment driver • TEY • SONY TYPE 4 (or TYPE 3) • Test mode • VR351
<p>Adjustment Procedure</p> <p>Steps 1 thru 5 same as tracking balance adjustment-1.</p> <p>6. Check that the level difference between the positive and negative amplitudes of the TEY signal is within 5% (See Fig.32-34). If greater than 5%, adjust with VR351.</p> <p>7. If further adjustment was necessary in step 6, repeat TE offset adjustment-2.</p>	

• ICs

UPC1347GS

VCC	1	36	FE20
BP	2	35	FE2-
BPO	3	34	FE10
WC+	4	33	FE1+
WC-	5	31	FE2+
GND	6	32	VREF2
QDH	7	30	TE20
QDO	8	29	TE2-
A	9	28	TE10
C	10	27	APCO
B	11	26	TE2+
D	12	25	APC-
E	13	24	RFO
F	14	23	NC
PIN	15	22	RF-
LA	16	21	RFS
LAON	17	20	RF+
VREF1	18	19	GND2

• Pin Functions (UPC1347GS)

Pin No	Pin Name	I/O	Function and Operation
1	VCC		
2	BP-	Input	Vibration detect amplifier 1 inverter input
3	BPO	Output	Vibration detect amplifier 1 output
4	WC+	Input	Window comparator non-inverting input
5	WC-	Input	Window comparator inverter input
6	GND		GND
7	QDH	Input	Vibration detect amplifier 3 non-inverting input
8	QDO	Output	Vibration detect amplifier 3 output
9	A	Input	A signal input
10	C	Input	C signal input
11	B	Input	B signal input
12	D	Input	D signal input
13	E	Input	E signal input
14	F	Input	F signal input
15	PIN	Input	APC circuit PD amplifier input
16	LA	Output	APC circuit LD amplifier output
17	LAON		Laser diode ON/OFF switching
18	VREF1		Reference voltage
19	GND2		GND
20	RF+	Input	RF amplifier non-inverting input
21	RFS	Output	RF summing virtual output
22	RF-	Input	RF amplifier inverter input
23	NC		
24	RFO	Output	RF amplifier output
25	APC-	Input	APC circuit PD amplifier inverter input
26	TE2+	Input	Tracking error amplifier 2 non-inverting input
27	APCO	Output	APC circuit PD amplifier output
28	TE10	Output	Tracking error amplifier 1 output
29	TE2-	Input	Tracking error amplifier 2 inverter input
30	TE20	Output	Tracking error amplifier 2 output
31	VREF2		Reference voltage
32	FE2+	Input	Focus error amplifier 2 non-inverting input
33	FE1+	Input	Focus error amplifier 1 non-inverting input
34	FE10	Output	Focus error amplifier 1 output
35	FE2-	Input	Focus error amplifier 2 inverter input
36	FE20	Output	Focus error amplifier 2 output

UPD6374AGH

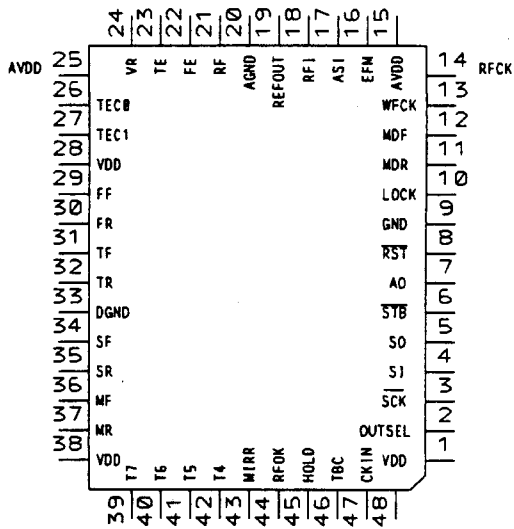

NJM4558M

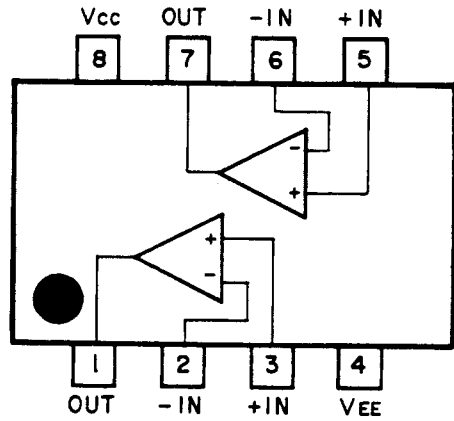

PA3026

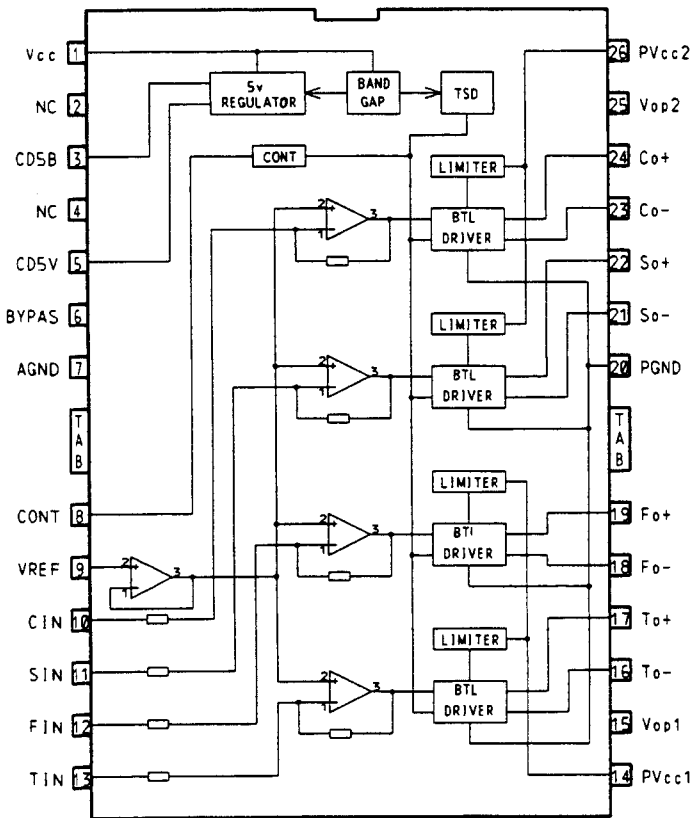

TA78L05F

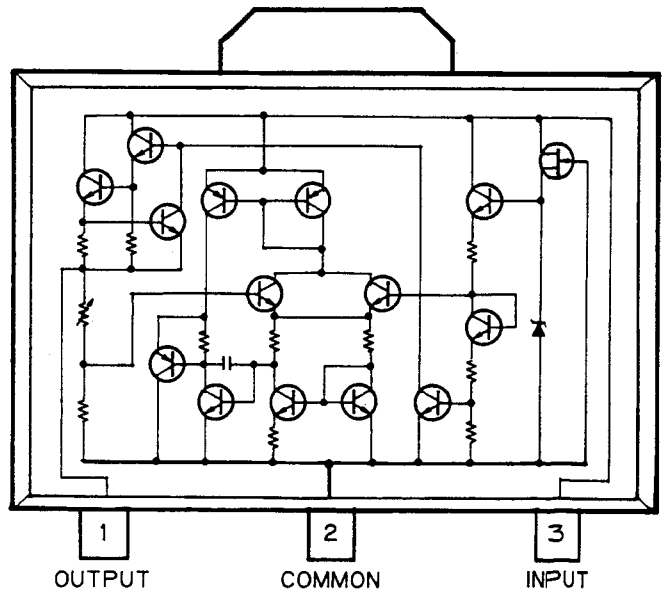

● Pin Functions (UPD6375GC)

Pin No	Pin Name	I/O	Function and Operation
1	NC		
2	WDCK	Output	Output terminal for signal having double the frequency of LRCK
3	C4LR	Output	Output terminal for signal having four the frequency of LRCK
4	RFCK	Output	Oscillation clock divider signal, output terminal for signal giving one-frame synchronization
5	EFMI	Input	EFM signal input terminal
6	TEST		TEST
7	VSS		GND
8	C1D1	Output	Output terminal indicating C1 error correction status
9	C1D2	Output	
10	C2D1	Output	Output terminal indicating C2 error correction status
11	C2D2	Output	
12, 13	NC		
14	STBY	Input	Standby input terminal. STBY=H stops clock oscillation
15	NC		
16	PLK1	Output	VCO output terminal for use in analog PLL selection
17	VDD		VDD
18	PLK8	Input	VCO clock input terminal for use in analog PLL selection
19	PLCK	Output	Bit clock monitor terminal
20	VSS		GND
21	POUT	Output	Output terminal for phase comparison between EFM signal and bit clock
22	WFCK	Output	Signal issuing one-frame period (approximately 7.35kHz) by bit clock dividing signal
23	VDD		5 V
24	MD	Output	Signal indicating spindle motor CLV servo control output status
25	MDF	Output	Spindle motor CLV servo control positive direction output terminal
26	MDR	Output	Spindle motor CLV servo control negative direction output terminal
27	LOCK	Output	Becomes "H" when the synchronization signal and frame counter output coincide at EFM demodulator
28	RST	Input	Reset signal input terminal
29	AO	Input	Control signal distinguishing data from microcomputer
30	STB	Input	Signal latching within this LSI the serial data fetched from SI terminal
31	SO		Serial data input terminal
32	SI	Input	Input terminal fro data from microcomputer
33	VSS		GND
34	SCK	Input	Clock input terminal for serial data input
35	TX	Output	Digital audio interface data output terminal
36	MUTE/EMPH	Output	Output terminal for mute command decoding signal or sub-Q command pre-emphasis data
37	SFSY	Output	Signal indicating subcode one-frame synchronization
38	SBSY	Output	Signal indicating head of subcode block
39	SBCK	Input	Subcode data read clock input terminal
40	SBSO	Output	Subcode data output terminal
41	VDD		5 V
42	XTAL	Output	Oscillation continuation terminal
43	XTAL	Input	Oscillation continuation terminal

Pin No	Pin Name	I/O	Function and Operation
44	VSS		GND
45	C16M	Output	Oscillation clock output terminal
46	VDD		5 V
47	C4M	Output	1/4 cycle output terminal for oscillation clock signals
48	FLAG	Output	Flag signal indicating that the current audio data output consists of incorrectable data
49	SCKO	Output	Clock output terminal for audio serial data
50	DOUT	Output	Serial audio data output terminal
51	LRCK	Output	Signal distinguishing between left and right channel DOUT terminal output
52	NC		

UPD6375GC

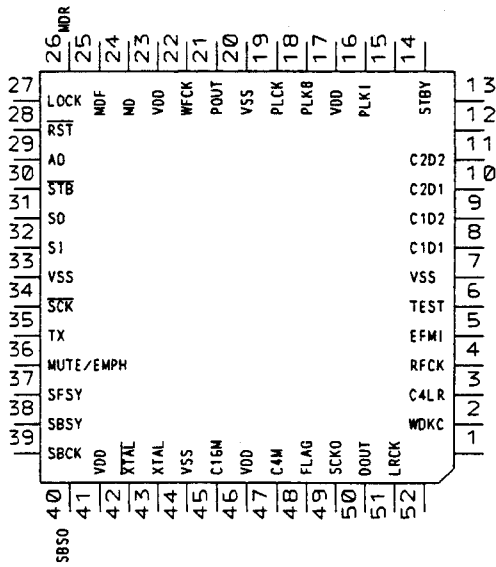

TC9237F

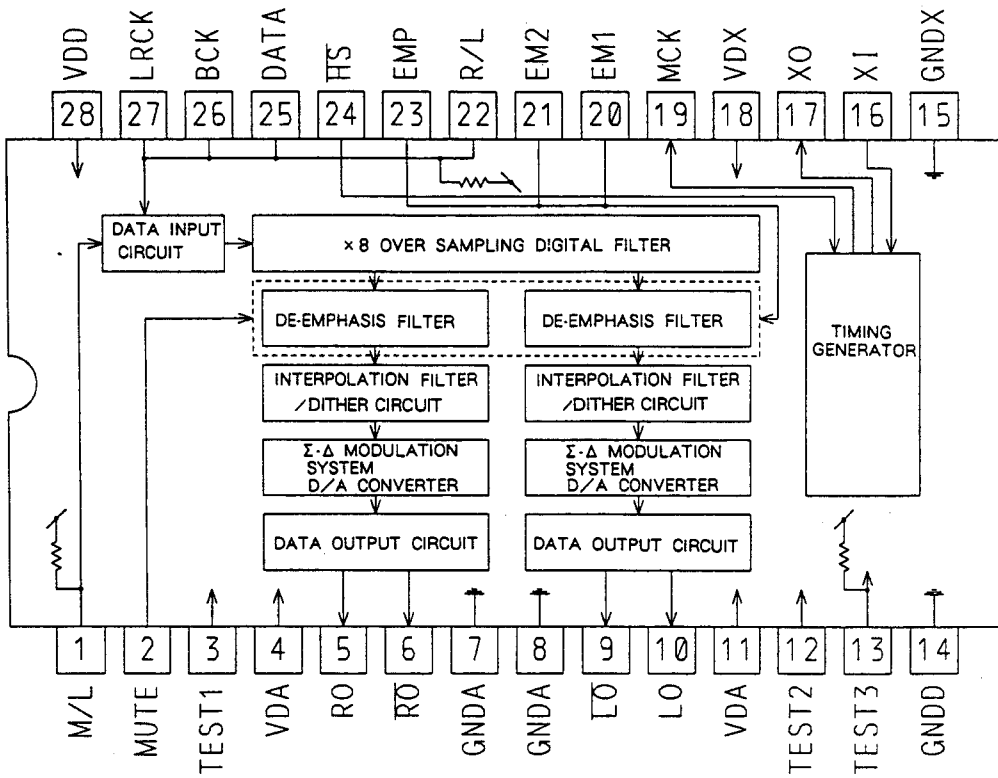

TA2009F

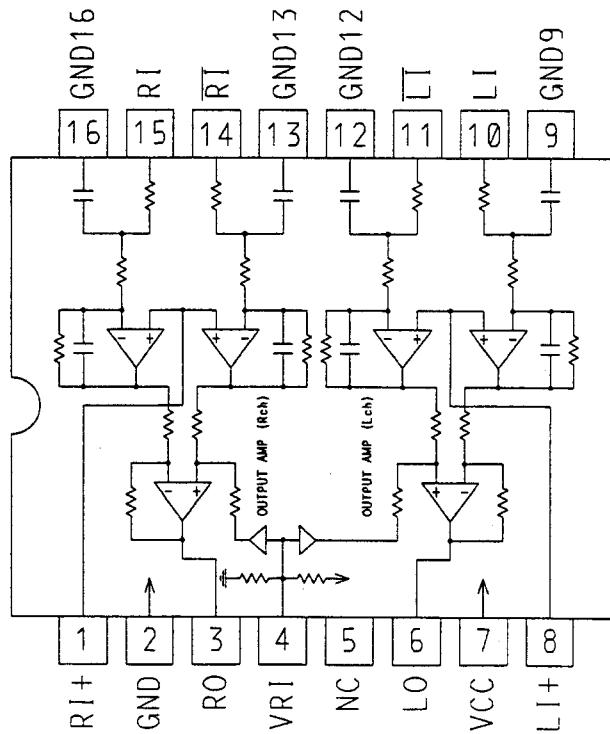

● Pin Functions (PD5181B)

Pin No.	Pin Name	I/O	I/O Format	Function and Operation
1	TIN	Input		Disc position detector switch
2	TEMP			Temperature detector
3	VMIN			Mechanism power supply detector input
4	C/D	Output	NM	Command/data appointment output
5	DCS	Output	NM	Chip select output
6	DRDY	Input		Ready input
7	DRST	Output	NM	Reset output
8	AO	Output	NM	LSI data control signal
9	XSCK	Input/ Output		LSI clock input/output
10	XSO	Output	NM	LSI data output
11	XSI	Input	NM	LSI data input
12	STB	Output	C	LSI strobe output
13	RST	Output	C	Reset output pin
14	ENDOUT	Output	C	Digital output enable signal
15	NC			
16	ASENS	Input		Acc sense input
17	BSENS	Input		Back up power sense input pin
18-21	NC			
22	TXD	Output	C	Bus communication data output
23	RXD	Input		Bus communication data input
24	EJSW	Input		Eject signal input
25	D. CLOSE	Input		Door close detect input
26	CNVSS			GND
27	RESET	Input		Reset input
28	FECNT	Output	C	DEFECT port
29	NC			Not used
30	XIN	Input		Crystal oscillating element connection pin
31	XOUT	Output	C	Crystal oscillating element connection pin
32	VSS			GND
33	LED	Output		LED signal output
34	SDL	Output		Door solenoid control output
35	MAG			Magazine rock switch
36	DOPEN	Input		Door open detect input
37-40	NC			
41	POWER	Output	C	CD +5V control
42	CONT	Output	C	Servo driver power supply control
43-56	NC			
57	HOLD	Output	C	Hold control output
58	TBC	Output	C	Tracking bank switching output
59	NC			Not used
60	MIRR	Input		Mirror detector input
61	LOCK	Input		Spindle lock detector input
62	FOK	Input		FOK signal input
63	HOME	Input		Home position detector input
64	NC			Not used

Pin No.	Pin Name	I/O	I/O Format	Function and Operation
65	LOAD	Output	C	Mechanism power supply control
66-68	I2-10	Output	C	Motor driver control
69	OPTSW	Input		Digital output ON/OFF input
70	CDMUTE	Output	C	CD mute output
71	ADENA	Output	C	A/D reference voltage output
72	TESTIN	Input		Test program mode input
73	VCC			Back up 5V
74	VREF	Input		A/D reference voltage input
75	AVSS			A/D GND
76	CSEL			Compression select
77	EJP			Eject position switch
78	DISC	Input		Disc detector input
79	TSEL	Input		Tray position detector photosensor
80	TOUT	Input		Tray position detector switch

I/O Format	Meaning
C	CMOS output
NM	Middle resistivity N channel open drain

*PD5181B

IC's marked by * are MOS type.
Be careful in handling them because they are very liable to be damaged by electrostatic induction.

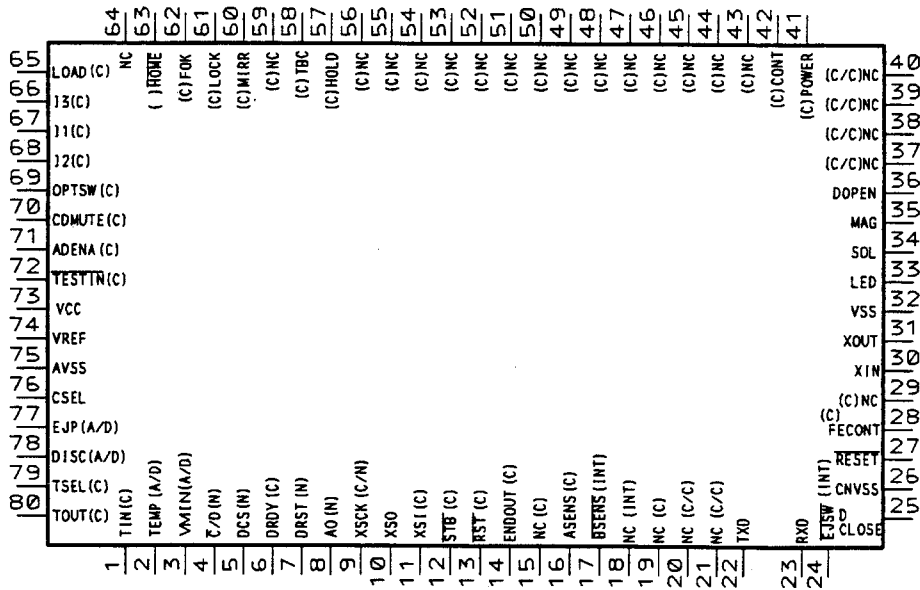

XRA6247FP

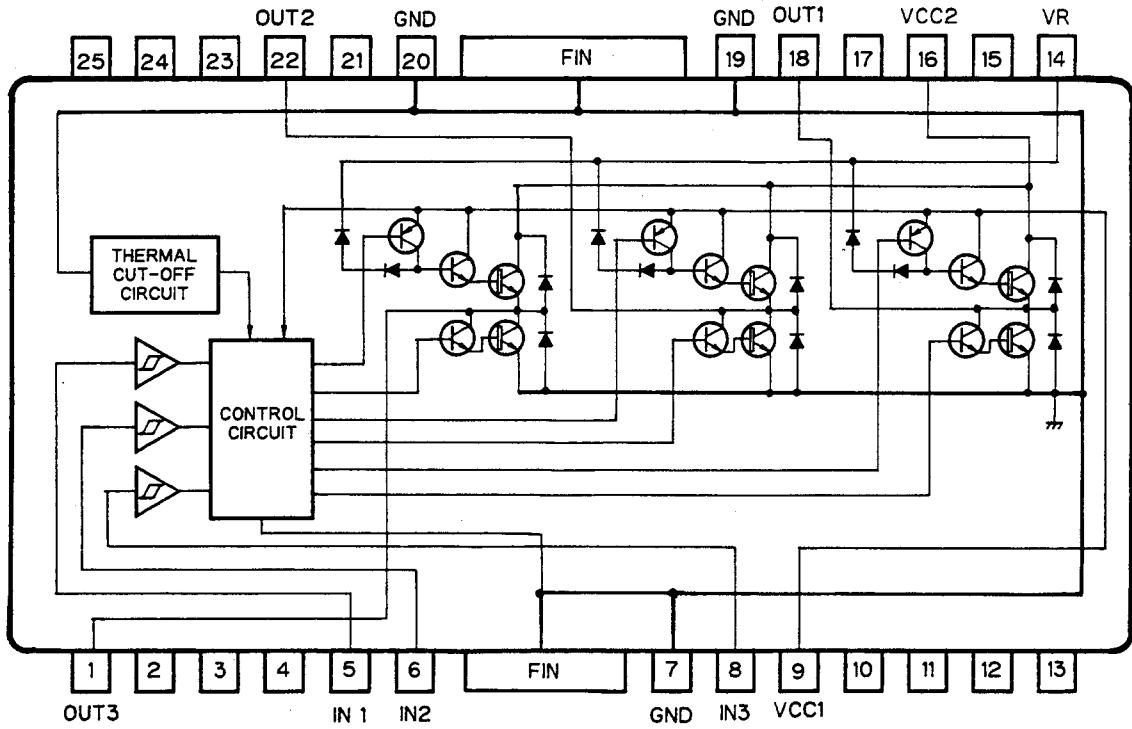

ON3131-F

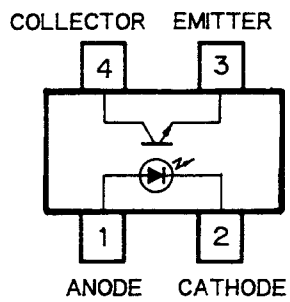

M51957AFP

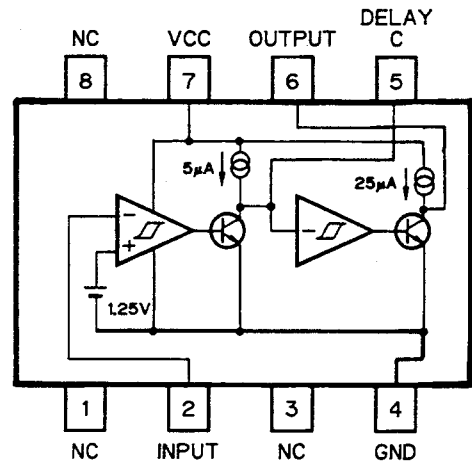

M51958AFP

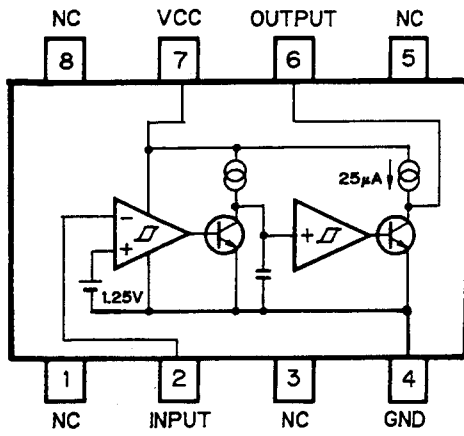

NJM3404AM

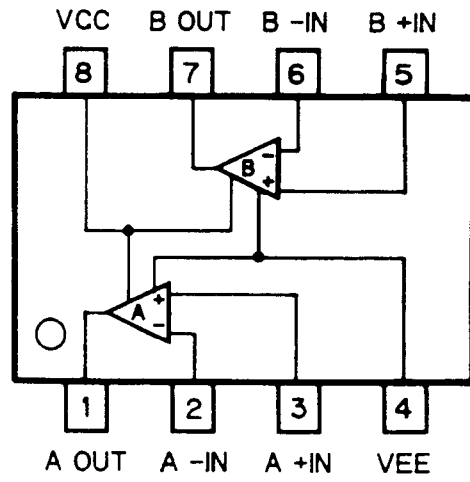

KHA193

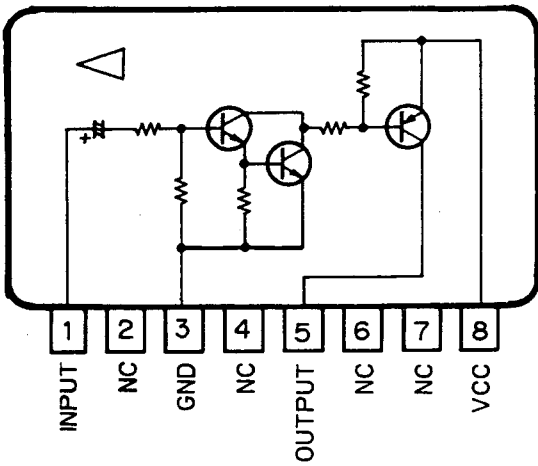

Note: 1. The encircled numbers denote measuring points in the circuit diagram.
 2. Reference voltage
 REFOUT: 2.5V

• Wave Forms

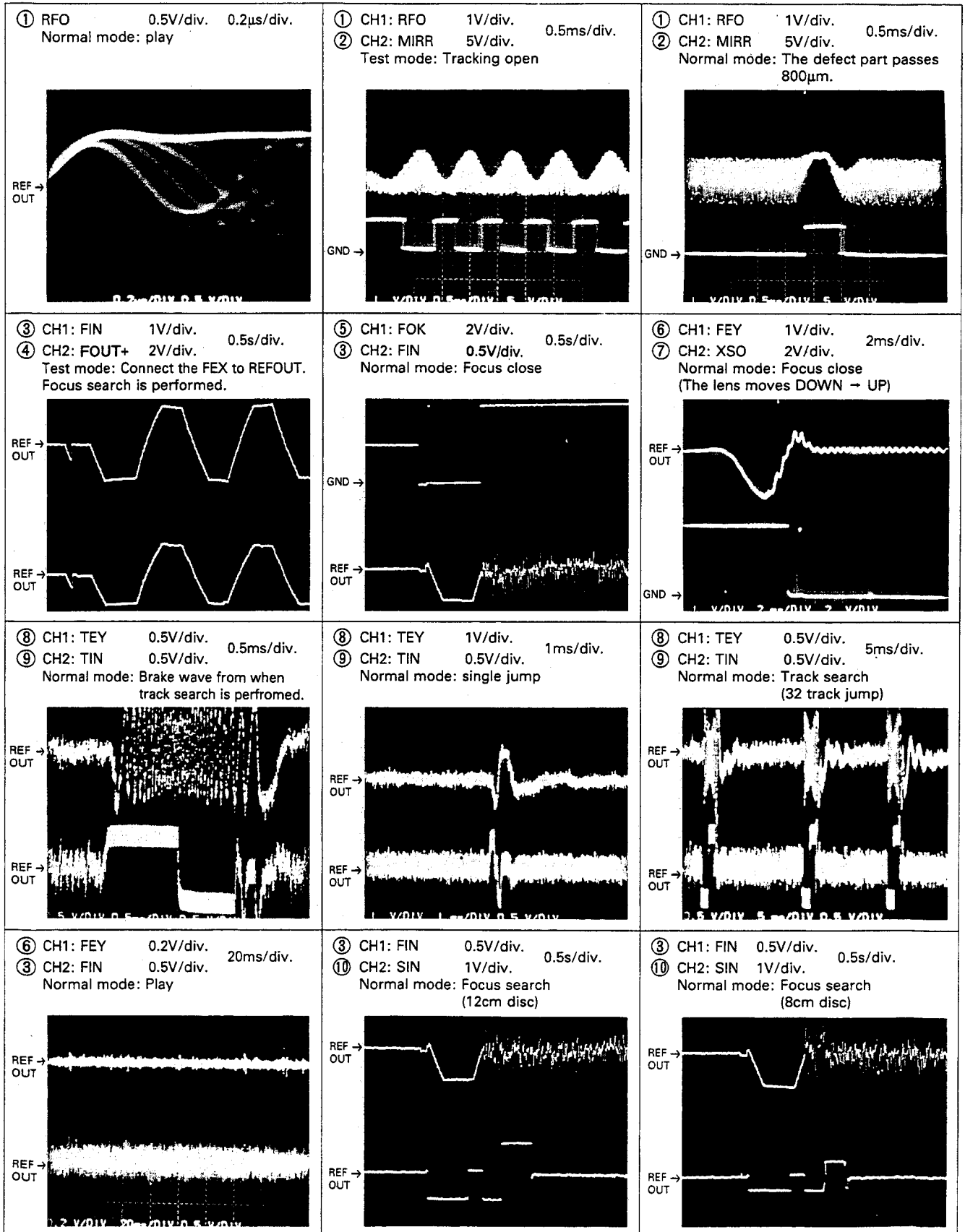

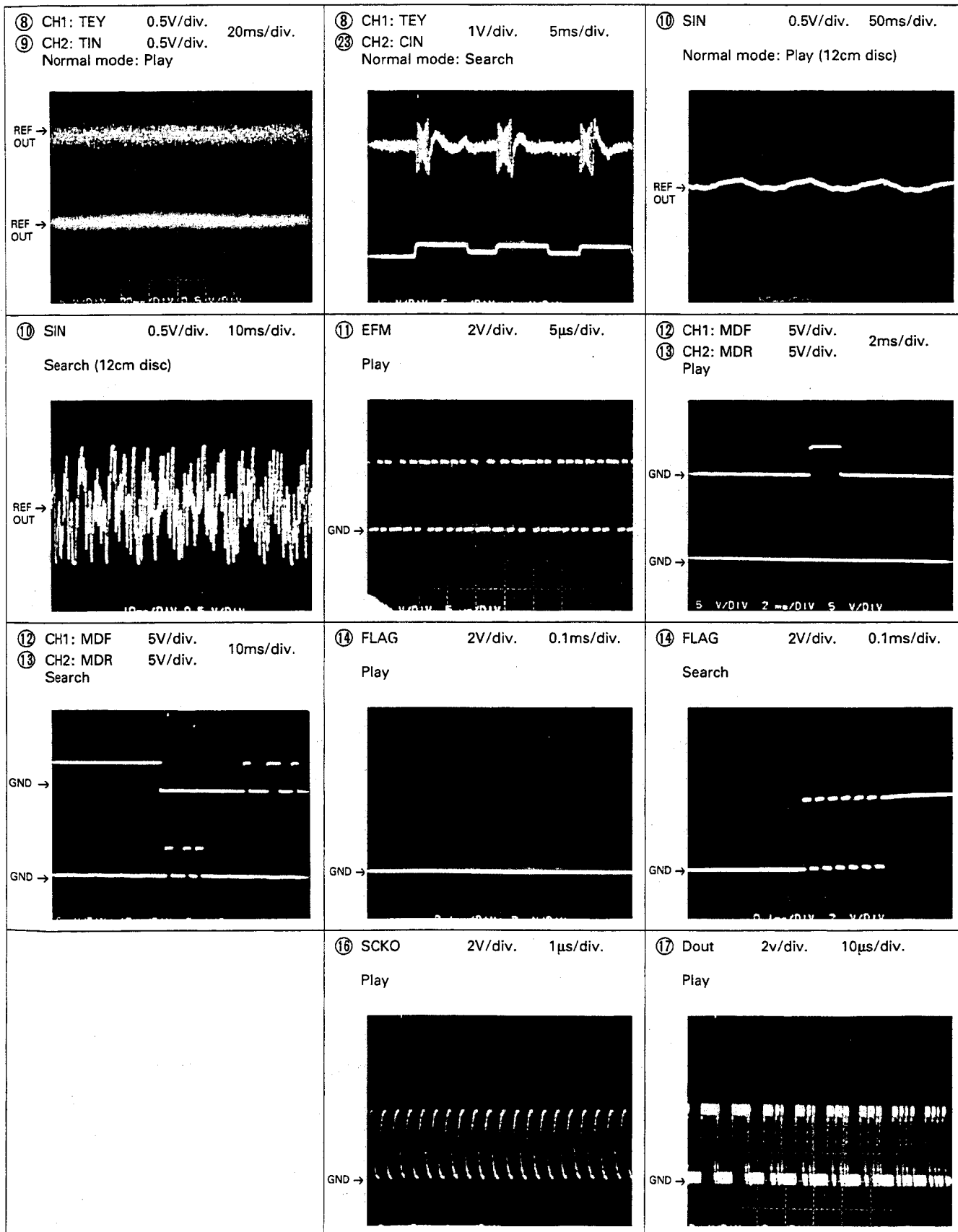

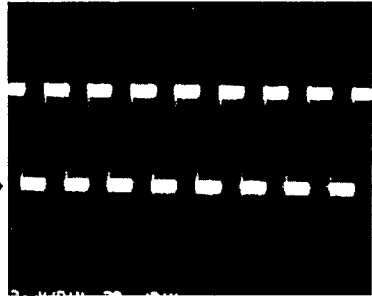
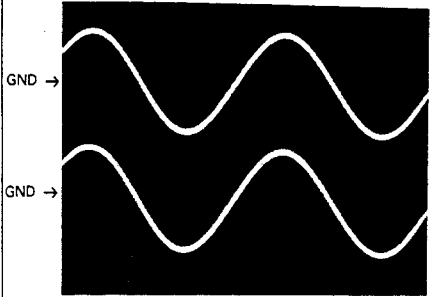
<p>⑱ LRCK 2V/div. 20μs/div.</p> <p>Play</p> 	<p>⑳ CH1: L 1V/div. 0.2ms/div.</p> <p>㉑ CH2: R 1V/div.</p> <p>Play (1kHz)</p> 	

9. CONNECTION DIAGRAM (1)

CORE UNIT

IC, Q	IC703	IC751	IC702	Q705	Q802	Q601	Q751	IC661	Q801	IC701	IC601	Q651	IC
ADJ											VR355	VR353	VR356
											VR352	VR354	

PU UNIT

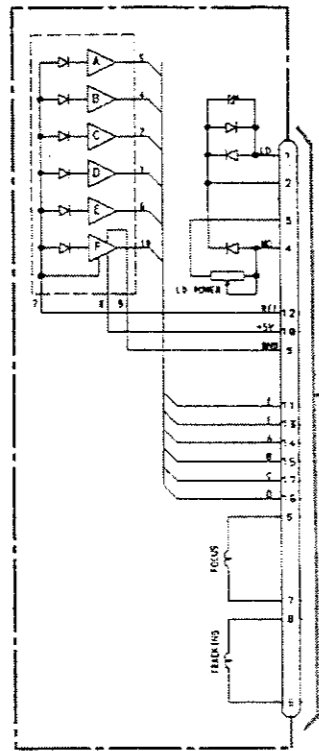

TO
EXTENSION
P.C. BOARD
CN990

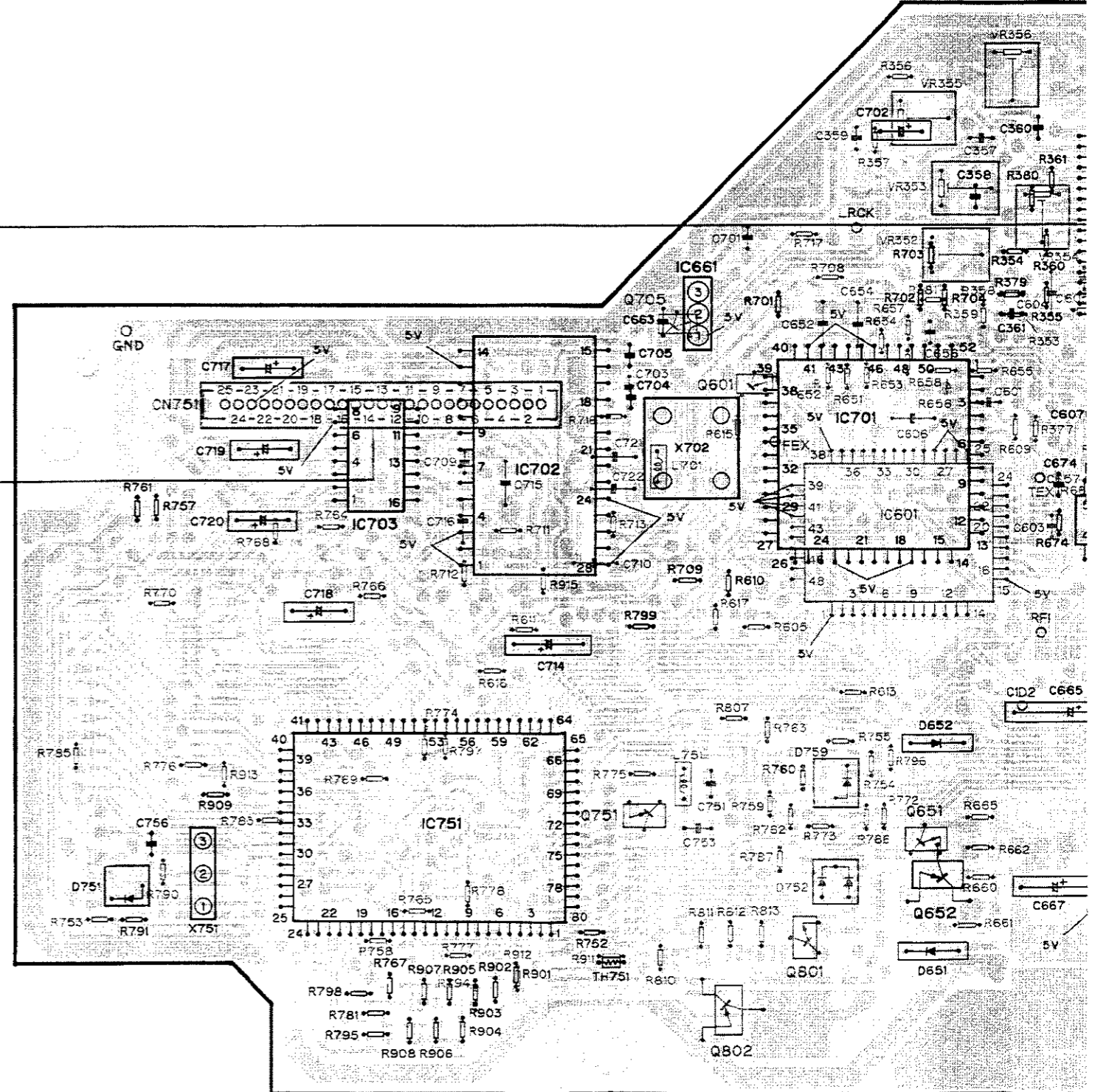

Q651 IC351
 IC701 IC601 Q652 IC652 Q653 IC602 IC651 IC801 Q351
 VR355 VR353 VR356 VR351
 VR352 VR354

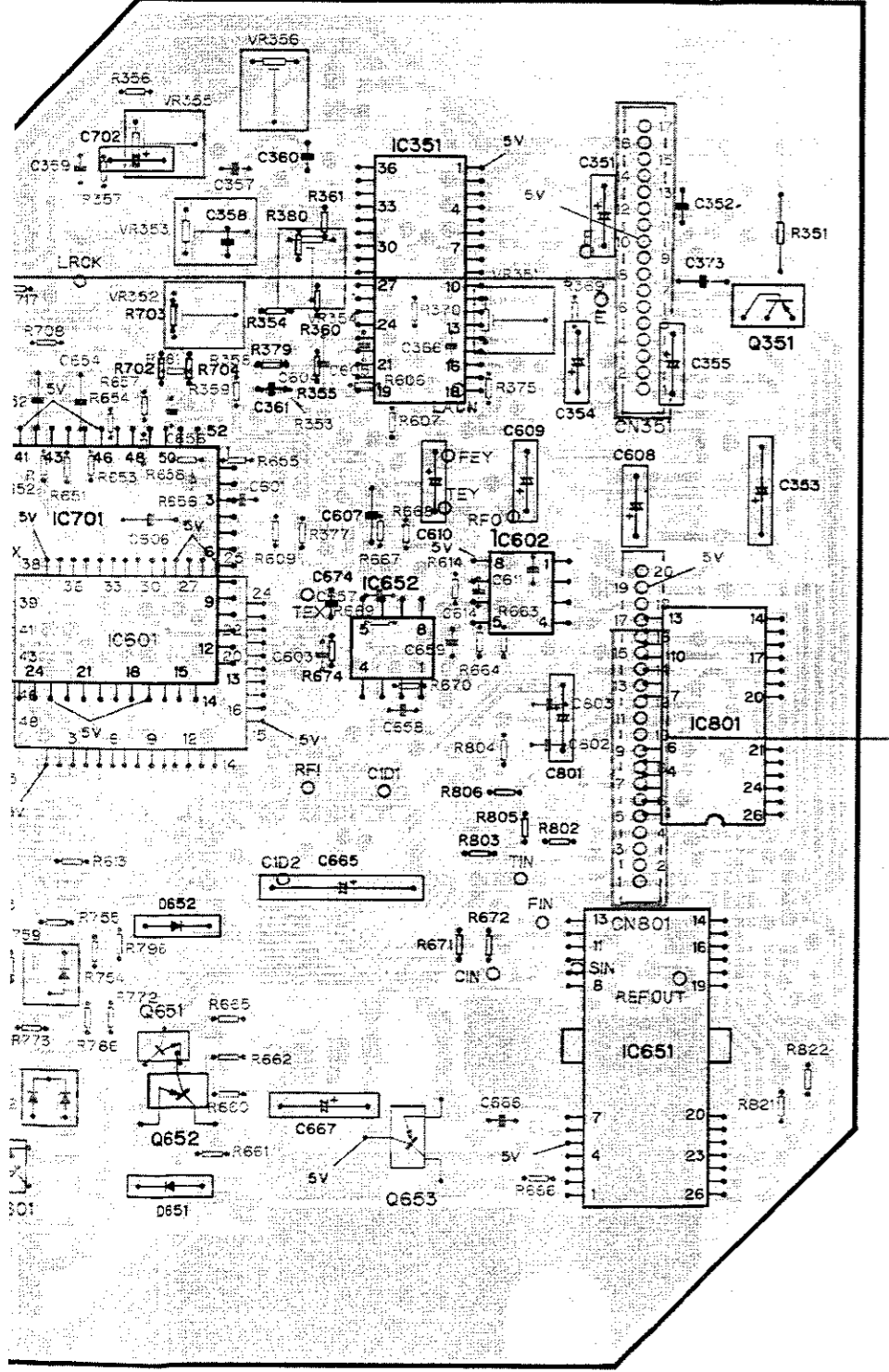
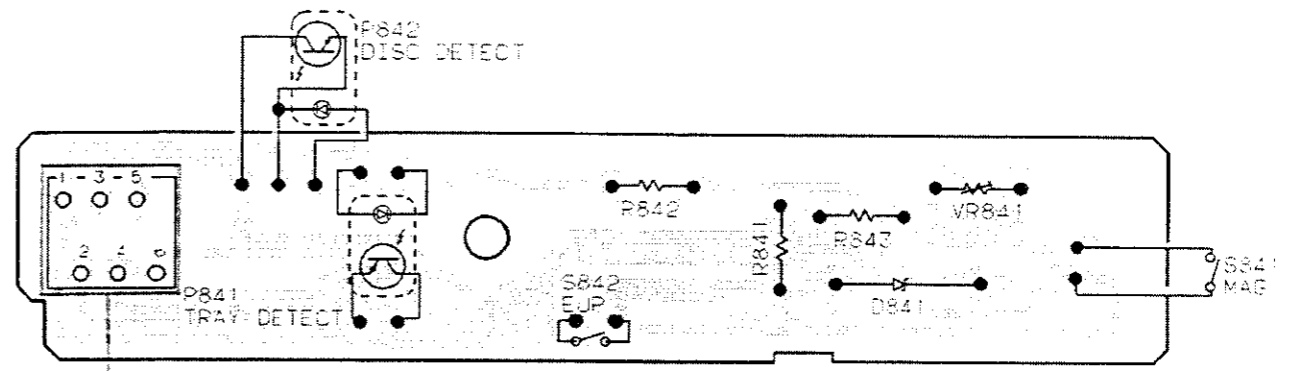

PHOTO P.C. BOARD



MECHANISM P.C. BOARD

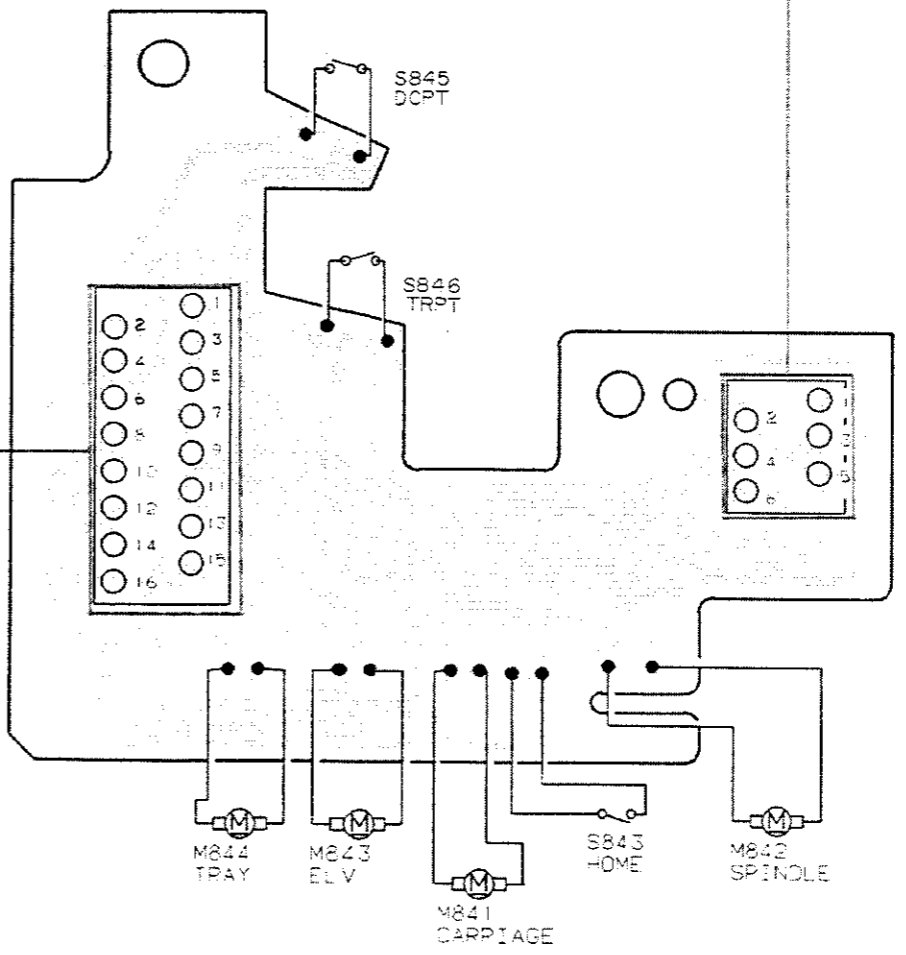
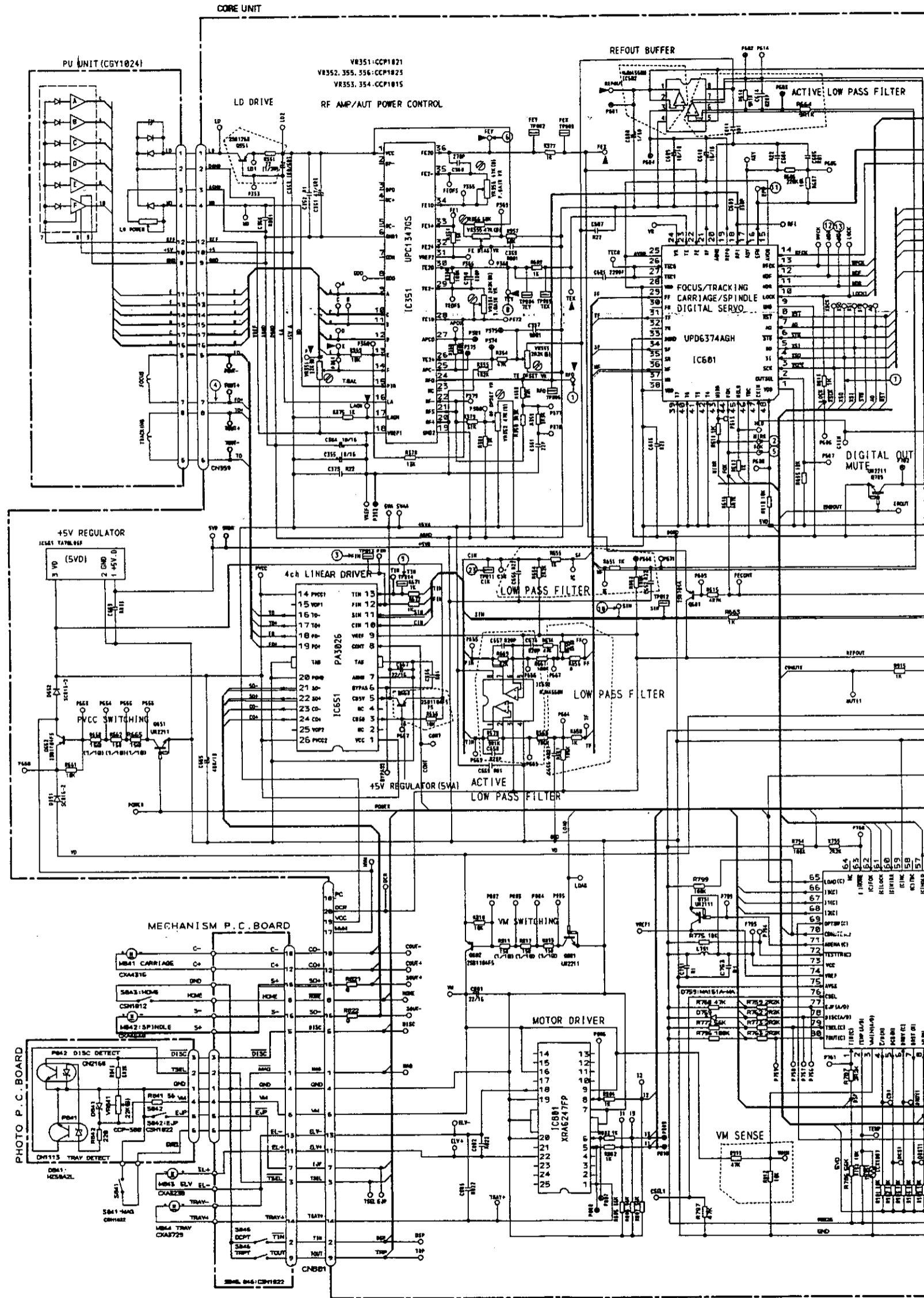

Fig. 37

10. SCHEMATIC CIRCUIT DIAGRAM (1)



EXTENSION P.C. BOARD

A

B

C

D

E

F

SWITCH P.C. BOARD

KEYBOARD P.C. BOARD

46

TO CORE UNIT

- (NC)
- (NC)
- CDMUTE
- DGND
- L
- AGND
- R
- (NC)
- DDPEN
- OCLOSE
- SOL
- TXD
- REGS
- ASENS
- VDCONT
- RXD
- BSENS
- (NC)
- VD
- VD
- RESET
- LED
- EJSW
- (NC)
- GND
- GND

- 1 CN998
- 2
- 3
- 4
- 5 AL
- 6
- 7 AR
- 8
- 9 OPEN
- 10
- 11 CLOSE
- 12
- 13
- 14
- 15
- 16
- 17
- 18
- 19
- 20
- 21
- 22
- 23 EJSW
- 24
- 25
- 26

- 1 CN991
- 2 GND
- 3 DDOPEN
- 4 EJSW
- 5 RESET
- 6 OCLOSE
- 7 GND
- 8 SOL
- 9
- 10
- 11
- 12
- 13
- 14
- 15
- 16
- 17
- 18
- 19
- 20
- 21
- 22
- 23
- 24
- 25
- 26

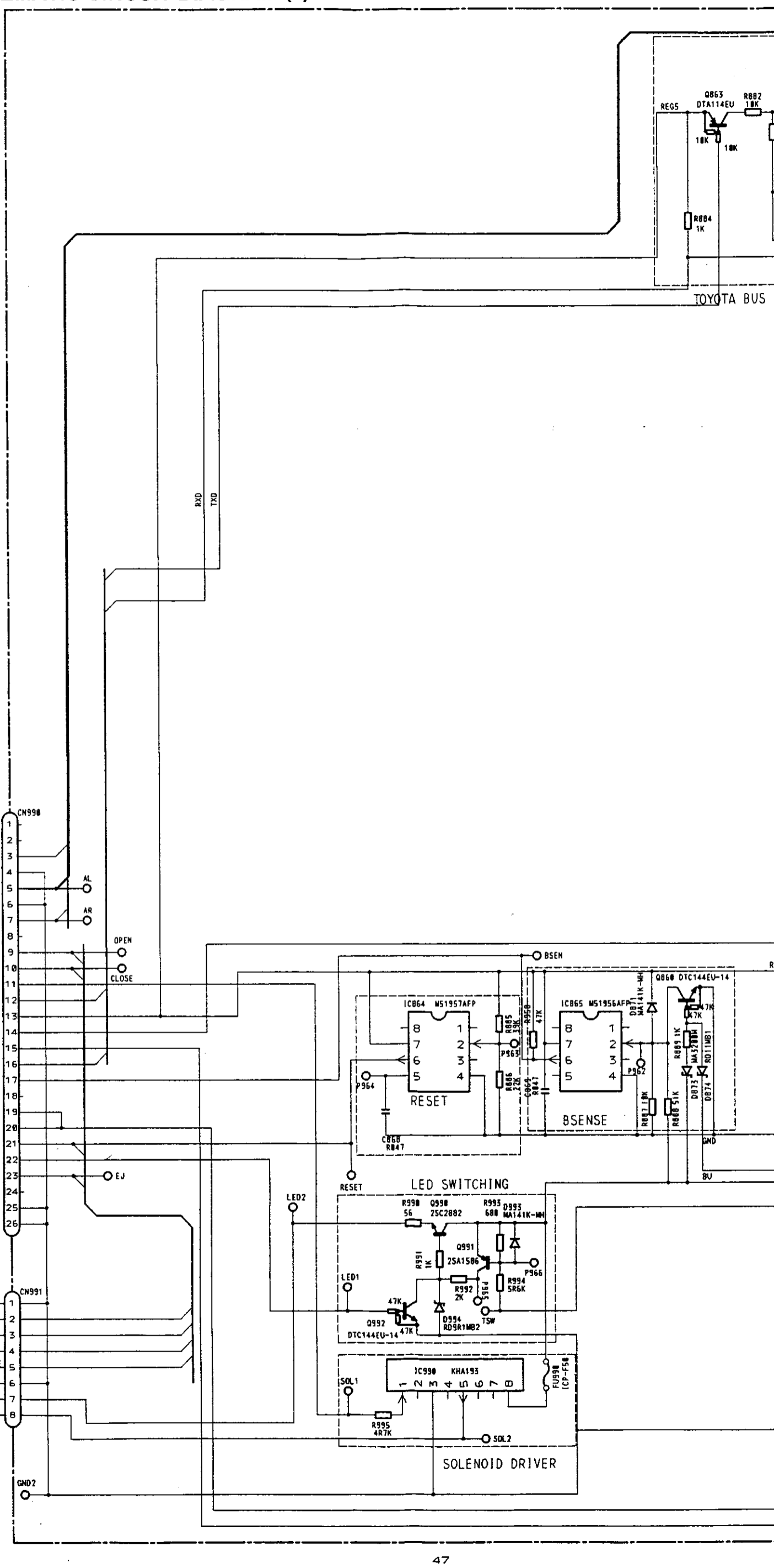
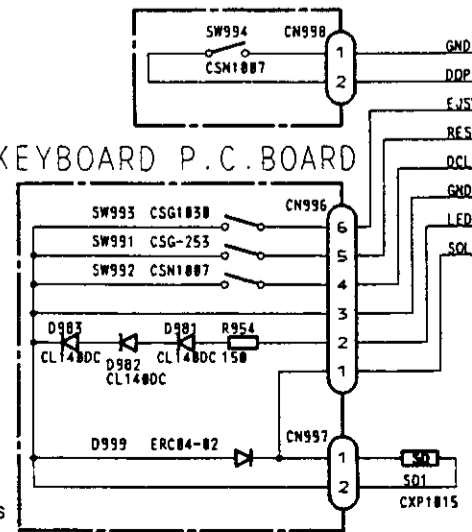

2

3

47

4

5

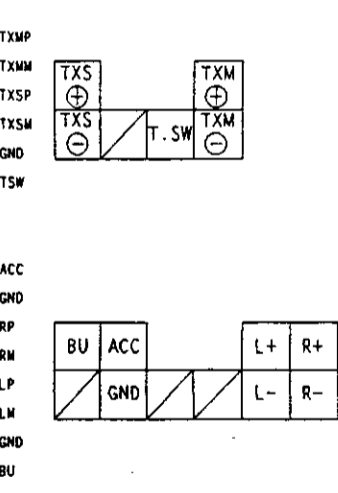
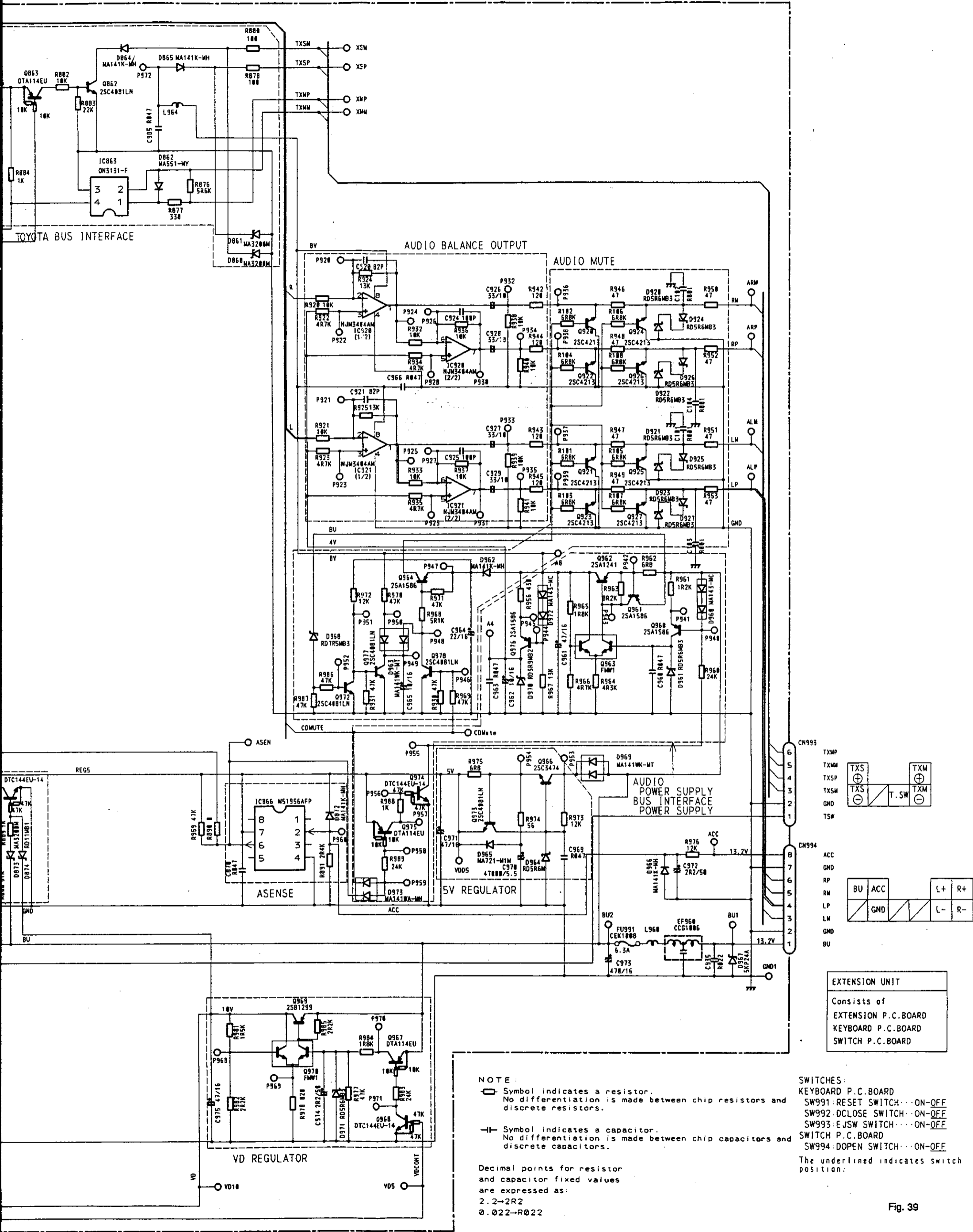

EXTENSION UNIT
 Consists of
 EXTENSION P.C.BOARD
 KEYBOARD P.C.BOARD
 SWITCH P.C.BOARD

NOTE:
 □ Symbol indicates a resistor.
 No differentiation is made between chip resistors and discrete resistors.
 ⊕ Symbol indicates a capacitor.
 No differentiation is made between chip capacitors and discrete capacitors.
 Decimal points for resistor and capacitor fixed values are expressed as:
 2.2-2R2
 0.022-R022

SWITCHES:
 KEYBOARD P.C. BOARD
 SW991: RESET SWITCH... ON-OFF
 SW992: DCLOSE SWITCH... ON-OFF
 SW993: EJSW SWITCH... ON-OFF
 SWITCH P.C. BOARD
 SW994: DOPEN SWITCH... ON-OFF
 The underlined indicates switch position:

Fig. 39

12. CONNECTION DIAGRAM (2)

KEYBOARD P.C. BOARD

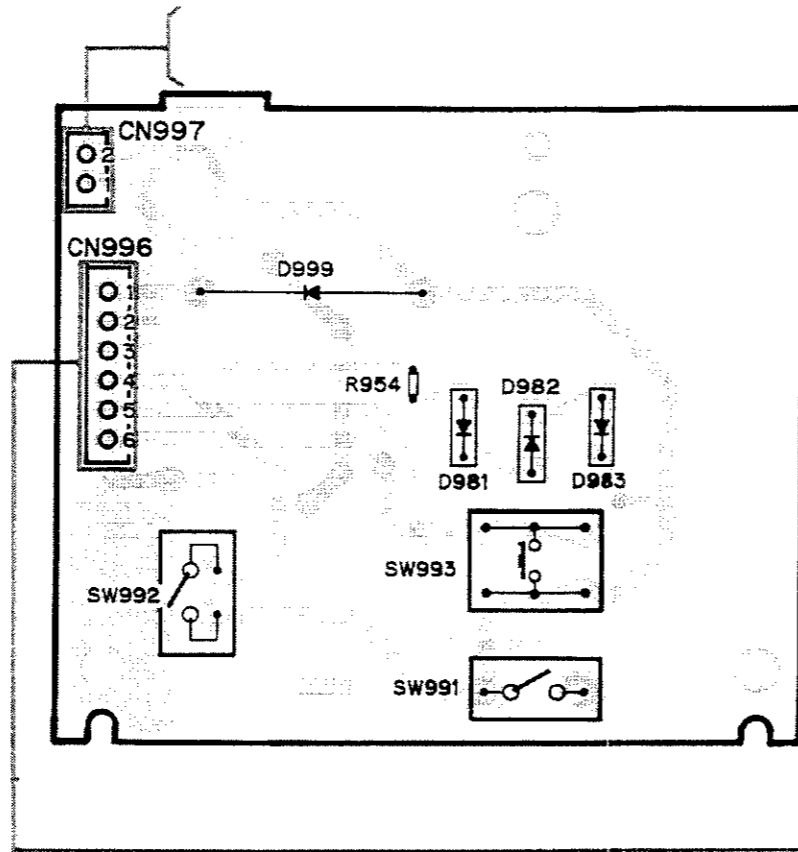

SWITCH P.C. BOARD

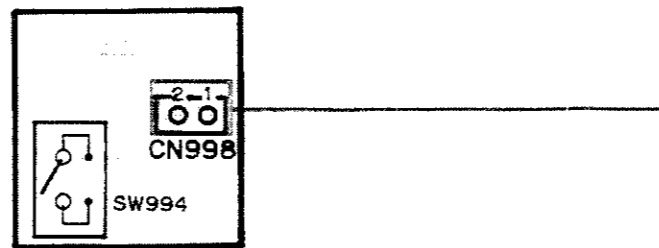

EXTENSION P.C. BOARD

Q975 Q967
 Q974 Q969 IC990 Q990 IC865 Q9
 Q960 Q962 Q978 Q862 Q966
 IC921 Q923 Q927 Q961 Q922 IC864 Q991 IC8
 Q977 Q972 Q964 Q920 Q963 Q976 IC866
 IC, Q Q921 Q925 Q924 IC920 Q926 Q970 Q863 Q968

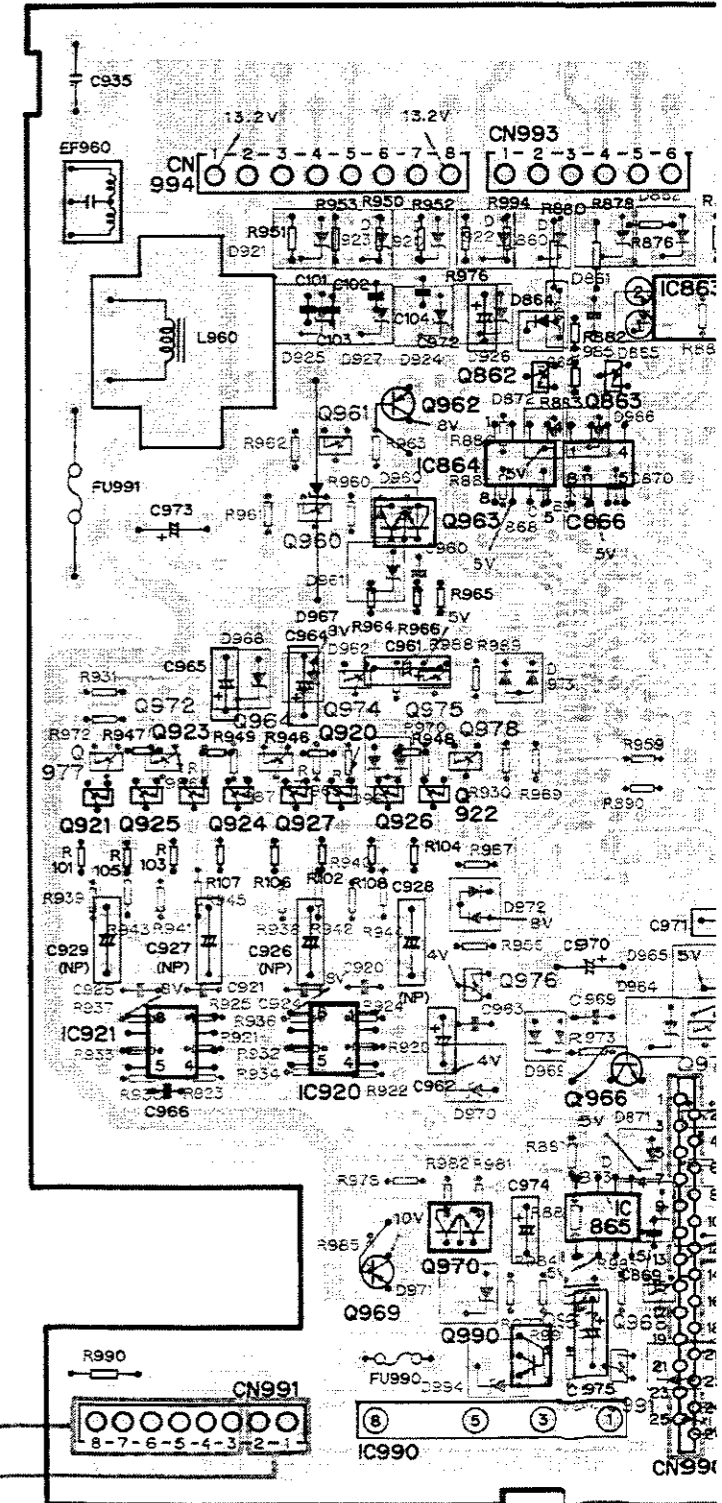

EXTENSION P.C. BOARD

Q975 Q967
 Q974 Q969 IC990 Q990 IC865 Q860
 Q960 Q962 Q978 Q862 Q966
 IC921 Q923 Q927 Q961 Q922 IC864 Q991 IC863
 Q977 Q972 Q964 Q920 Q963 Q976 IC866 Q973
 IC, Q Q921 Q925 Q924 IC920 Q926 Q970 Q863 Q968 Q992

RD

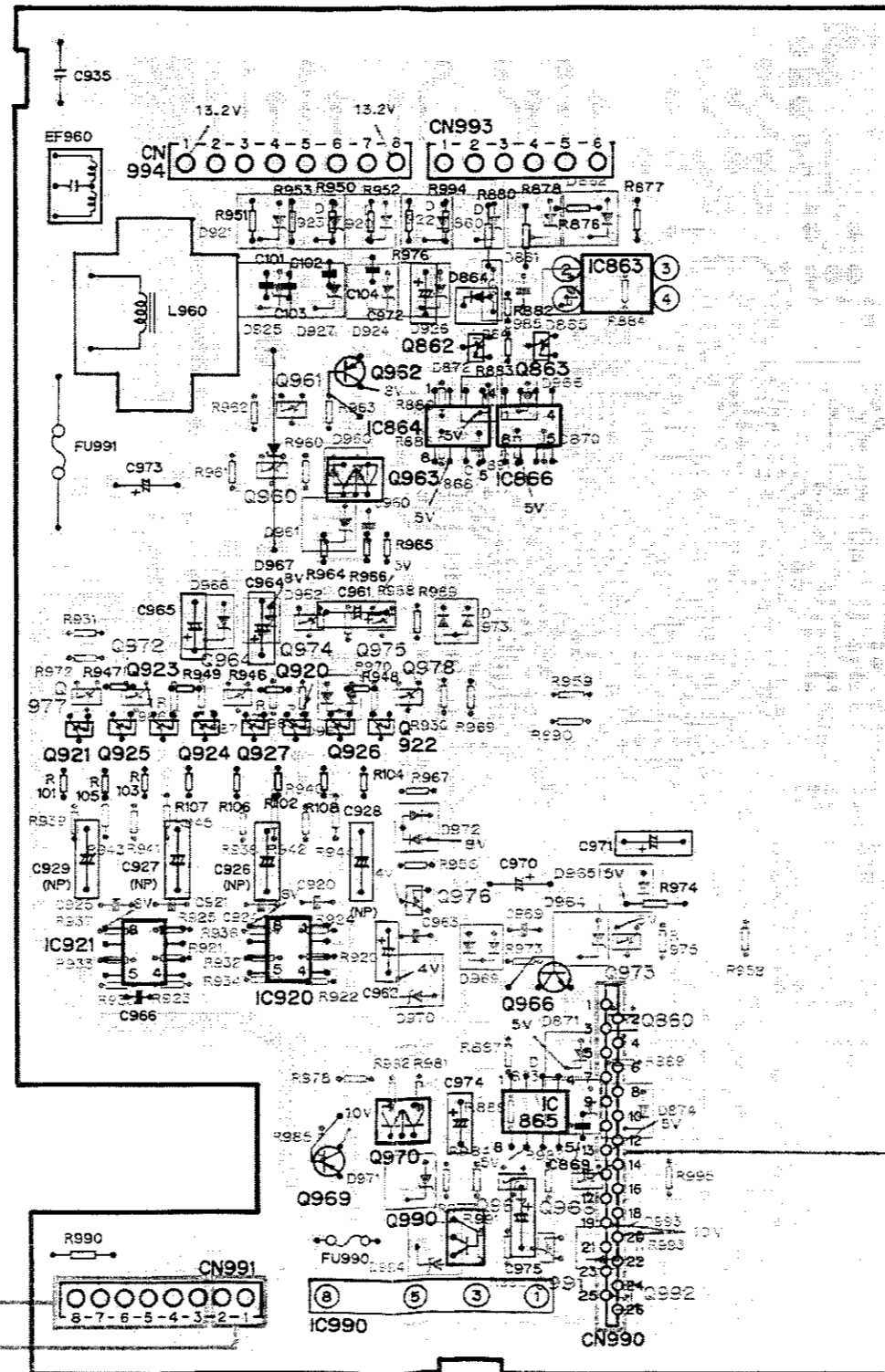
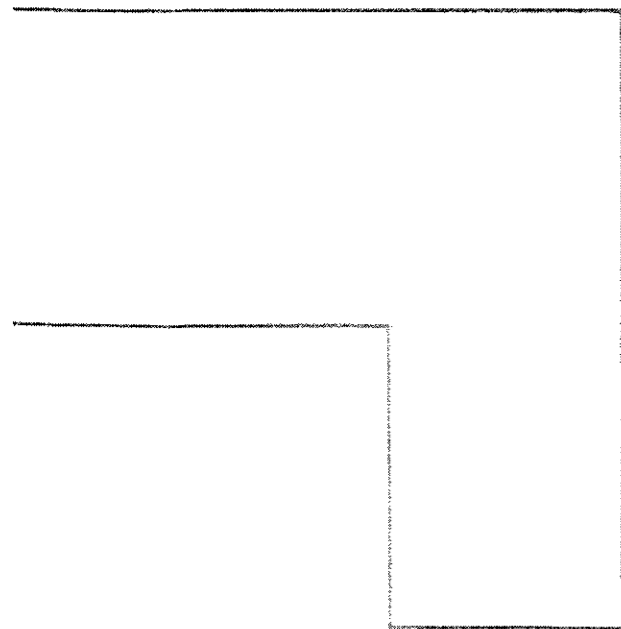
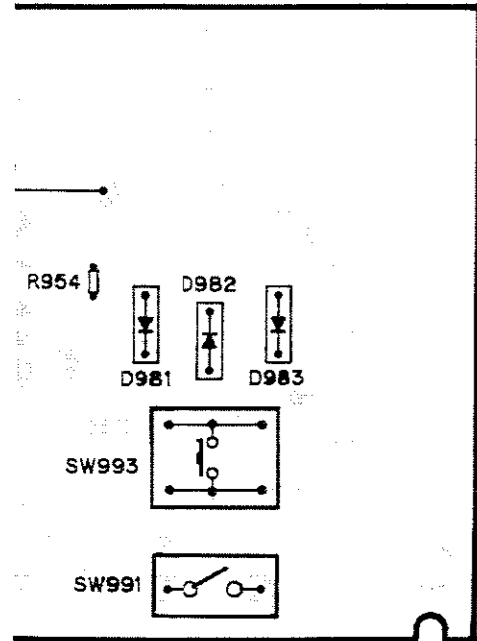
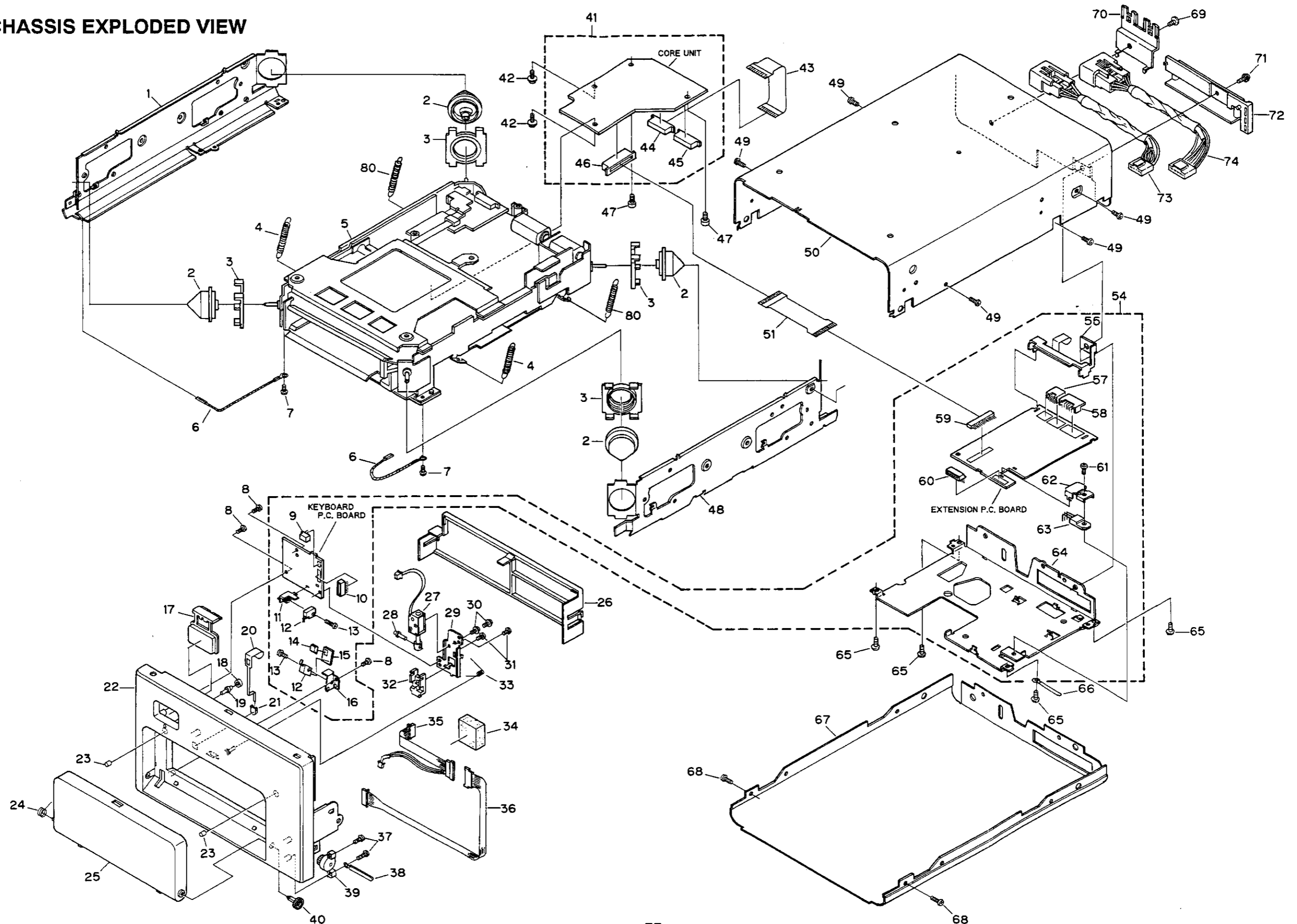

Fig. 40

13. CHASSIS EXPLODED VIEW



A
B
C
D

7 8 9

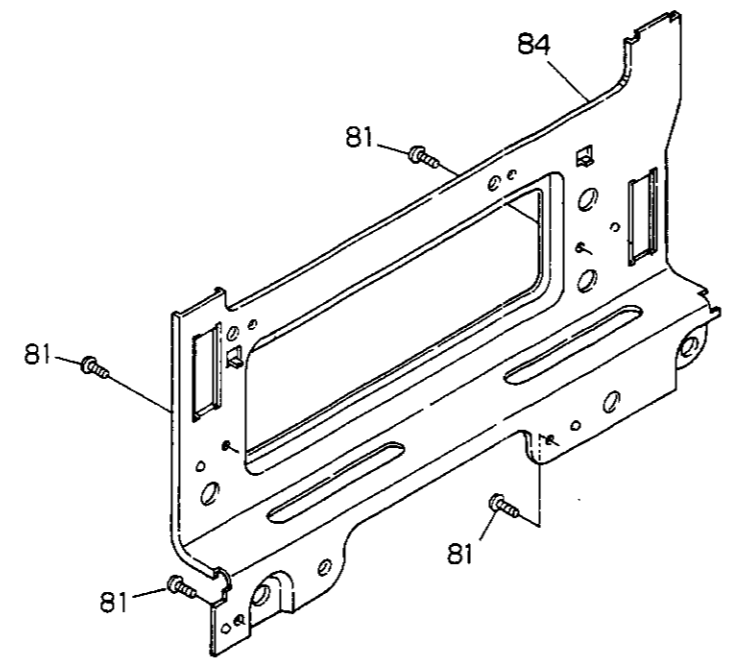

A

B

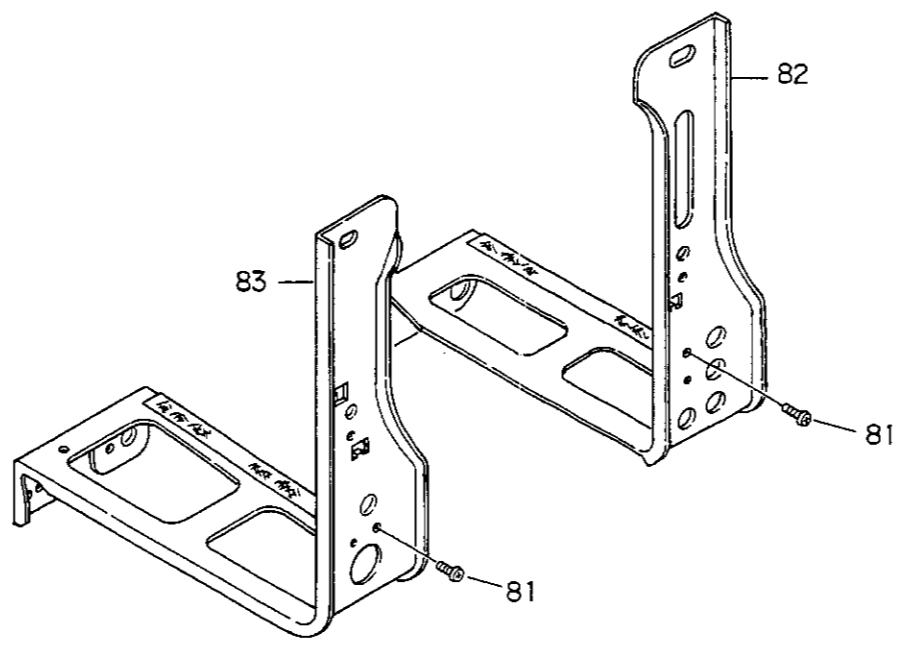

C

D

Fig. 41

54 7 8 9

● Parts List

NOTES:

- Parts marked by “*” or “*” are generally unavailable because they are not in our Master Spare Parts List.
- Parts marked by “●” are not always kept in stock. Their delivery time may be longer than usual or they may be unavailable.

Mark No.	Description	Part No.	Mark No.	Description	Part No.
*	1 Chassis L	CNC4338	●	41 Core Unit	CWX1433
	2 Damper	CNV3219		42 Screw	PMS26P050FMC
	3 Damper Holder	CNV2894	*	43 P. C. Board	CNP3188
	4 Spring	CBH1471		44 Connector (20P) (CN801)	CKS1958
●	5 CD Mechanism Unit	CXK2660		45 Connector (17P) (CN351)	CKS1955
	6 Connector	CDE2949		46 Connector (25P) (CN751)	CKS2271
	7 Screw	BMZ26P040FMC		47 Screw (M2.6×6)	CBA1181
	8 Screw (M2.6×8)	CBA1161	*	48 Chassis R	CNC4337
	9 Plug (2P) (CN997)	CKS1632		49 Screw	BMZ30P050FMC
	10 Plug (6P) (CN996)	CKS1039	*	50 Case	CNB1496
*	11 Holder	CNC3731	*	51 P. C. Board	CNP3189
	12 Switch (SW992, 994) (DOPEN, DCLOSE)	CSN1007		52, 53	
	13 Screw (M1.7×5.5)	CBA1070	●	54 Extension Unit	CWX1435
	14 Plug (2P) (CN998)	CKS1049	*	55 Holder	CNC4163
*	15 P. C. Board	CNP2955		56	
				57 Connector (6P) (CN993)	CKS2400
*	16 Holder	CNC3730		58 Connector (8P) (CN994)	CKS2401
	17 Button (OPEN)	CAC2920 3660		59 Connector (26P) (CN990)	CKS1964
*	18 Cushion	CNM2628		60 Plug (8P) (CN991)	CKS1055
	19 Button (CLEAR)	CAC2921		61 Screw (M2.6×8)	CBA1186
	20 Arm	CBL1144	*	62 TR Bracket	CNC3993
	21 Cap	CNV3220		63 Transistor (Q969)	2SB1299
	22 Grille	CNS2221	*	64 Sub Chassis	CNC3995
*	23 Cushion	CNM2828		65 Screw	BMZ30P040FMC
	24 Spring	CBH1408		66 Clamper	HEF-102
	25 Door Assy	CXA5250	*	67 Case	CNB1497
	26 Cover	CNV2763		68 Screw	BMZ30P050FMC
	27 Solenoid	CXP1015		69 Screw	BMZ30P050FMC
	28 Shaft	CLA1972	*	70 Holder	CNC3807
*	29 Holder	CNC3733		71 Screw	PMS30P080FMC
	30 Screw	PMS20P025FMC		72 Holder	CNV3218
	31 Screw (M2.6×8)	CBA1161		73 Cord Assy	CDE3833
	32 Holder	CNV2832		74 Cord Assy	CDE3837
	33 Spring	CBH1438		75-79	
*	34 Cushion	CNM3206		80 Spring	CBH1379
	35 Connector	CDE3293		81 Screw	BMZ30P060FMC
	36 Connector	CDE3608	*	82 Bracket	CNC3805
	37 Screw (M2×8)	CBA1203	*	83 Bracket	CNC3804
	38 Clamper	CEF-008	*	84 Bracket	CNC4655
	39 Damper Unit	CXA4423			
	40 Gear	CNV2830			

14. CD MECHANISM UNIT EXPLODED VIEW

● Parts List

Mark No.	Description	Part No.	Mark No.	Description	Part No.
1	Screw	BMZ26P030FMC	41	Guide	CNV2739
2	Holder Spring	CBH1324	*	42 Clamper Bracket Unit	CXA3237
3	Spring Holder	CNC3054		43 Spring	CBH1436
4	Gathering P.C. Board	CNX1850		44 Cushion	CNM2555
5	Screw(M1.7×6)	CBA1163		45 Lower Chassis Unit	CXA4372
6	Switch(S841)	CSH1022		46 Damper Bracket Unit	CXA4381
7	Spring(M2×3)	CBA1152		47 Damper Bracket Unit	CXA4376
8	Clamper	CNV2722		48 Clamper Arm Unit	CXA4958
9	Connector	CDE2701		49 Clamper Arm Bracket Unit	CXA4378
10	Lock Arm	CNV3215		50 Clamp Spring	CBH1321
11	Roller	CLA2034		51 Lever	CNC3038
12	Lock Spring	CBH1320		52 Connector(6P)	CKS1526
13	Screw(M2×4.5)	CBA1075		53 Connector(16P)	CKS1536
14	Magazine Guide	CNV2369		54 Gathering P.C. Board	CNX1906
15	Screw(M2×3)	CBA1077		55 Plug(2P)	CKS1049
16	Screw	PMS20P025FMC		56 Plug(4P)	CKS1051
17	Spring	CBL1145		57 Roller	CLA1846
18	Spring Bracket	CNC4323		58 Cam Lever Unit	CXA4012
19	Magazine Holder	CNC4287		59 Screw(M2.6×5)	CBA1180
20	Side Frame Unit	CXA4373		60 Cam Arm	CNV2736
21	Washer	YE15FUC		61 Cam Lever Bracket	CNC3682
22	Arm	CNV2352		62 SW Arm	CNV2964
23	Screw(M2×5)	CBA1080		63 SW Arm	CNV2959
24	Arm Guide	CNV2372		64 Spring	CBH1104
25	Roller	CLA1846		65 CRG Holder	CNV2961
26	Spring	CBL1134		66 Belt	CNT1053
27	Lower Frame	CNC3456		67 Screw Unit	CXA2375
28	Screw	PMS20P030FMC		68 Motor Unit(M841 CARRIAGE)	CXA4316
29	Connector	CDE3464		69 Screw	CBA-098
30	Upper Frame	CNC3960		70 Screw(M2×6)	CBA1004
31	Spring	CBH1466		71 Switch(S843)	CSN1012
32	EJ Spring	CBH1365		72 Gathering P.C. Board	CNX1862
33	Magazine Holder Unit	CXA5249		73 CRG Bracket	CNC3961
34	Screw(M1.7×5.5)	CBA1070		74 Disc-up Spring	CBH1442
35	Damper Unit	CXA3242	*	75 Sheet	CNM3241
36	Connector	CDE3466	*	76 Disc-up Guide Unit	CXA4377
37	Magazine Guide	CNV2734	*	77 Sheet	CNM3178
38	Clamper Bracket Assy	CXA4039	*	78 Sheet	CNM3241
39	Spacer	CNM1787		79 Disc-up Guide Assy	CXA4384
40	Ball	CNR1079		80 Switch(S845, 846)	CSN1022

Mark No.	Description	Part No.	Mark No.	Description	Part No.
81	Cam Gear Bracket	CNC3964	121	Connector	CDE3151
82	Screw(M2×5)	CBA1054	122	Guide	CNV2958
83	Cam Gear	CNV2963	123	Connector	CDE3150
84	Roller	CLA1977	124	Motor Unit(M843 ELV)	CXA3238
85	Disc-up Arm Unit	CXA4382	125	ELV Bracket Unit	CXA4380
86	Shaft	CLA1962	126	Gear	CNV2962
87	Washer	YE20FUC	127	Washer	CBF1038
88	Disc-up Bracket Unit	CXA4375	128	Gear	CNV2363
89	CRG Holder	CNV2965	129	Gear	CNV2371
90	Spring	CBL1135	130	Gear	CNV2364
91	Motor Unit(M842 SPINDLE)	CXA4540	* 131	Disc Guide	CNV2966
92	Rack	CNV2972	* 132	Sheet	CNM3179
93	Spring	CBH1432	133	Disc Guide Assy	CXA4383
94	Guide	CNV2971	134	Sheet	CNM2553
95	Wheel	CNV2359	135	P. C. Board	CNP2820
96	Gear	CNV2360	136	Spacer	CNV2365
97	Main Chassis Unit	CXA4371	137	Photo-interrupter(P842)	ON2160
98	Spring	CBL1133	138	Gathering P. C. Board	CNX1794
99	Cover	CNC3968	139	Plug(6P)	CKS1526
100	Screw	HBA-258	140	Photo-interrupter(P841)	ON1113
101	Screw(M2×3)	CBA1062	141	Screw(M1.7×6)	CBA1163
102	CRG Holder Unit	CXA4379	142	Switch(S842 EJP)	CSH1022
103	Spacer	CNT1052	143	TSEL Bracket	CNC4072
104	Cushion	CNV1863	144	Washer	CBE1027
105	PU Unit	CGY1024	145	Spring Holder	CNC3054
106	Screw	JGZ20P070FNI	146	Roller	CLA2036
107	Holder	CNC4073	147	Spacer	CNM3340
108	Spring	CBL1138	148	Screw(M2×2.5)	CBA1076
109	Screw	JFZ14P016FNI	149	
110	Spring	CBH1430	150	Screw	PMS20P030FMC
111	Holder Unit	CXA4675			
112	Screw	JFZ17P030FNI			
113	Weight	CNC4116			
114	Shaft	CLA2027			
115	Arm Unit	CXA3995			
116	Washer	YE20FUC			
117	Washer	YE25FUC			
118	Lever Unit	CXA3542			
119	TRY Bracket	CNC3963			
120	TRAY Motor Unit(M844)	CXA3729			

• CD Mechanism Unit

A

B

C

D

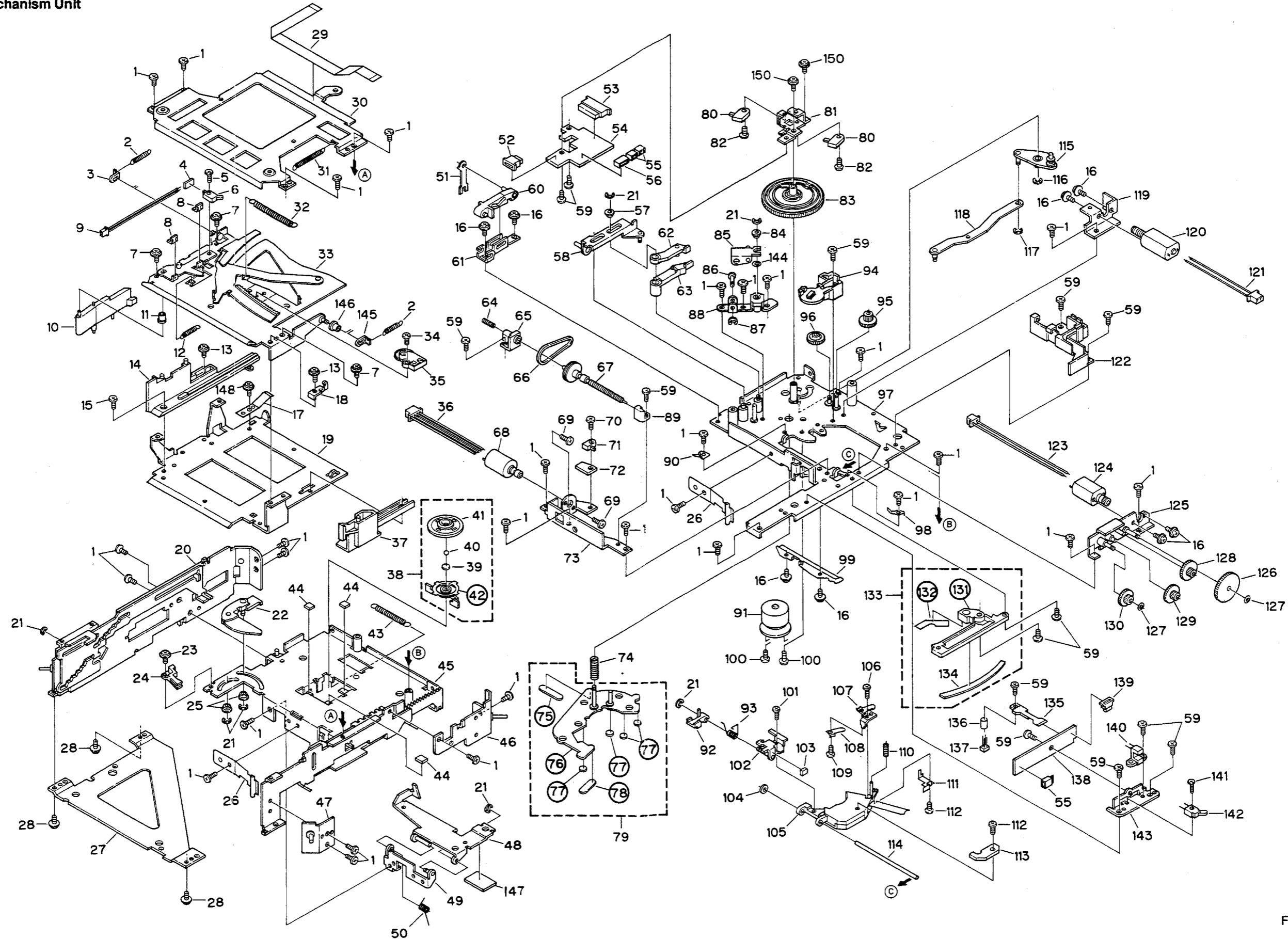

Fig. 42

15. ELECTRICAL PARTS LIST

NOTE:

- Parts whose parts numbers are omitted are subject to being not supplied.
- The part numbers shown below indicate chip components.

Chip Resistor

RS1/□S□□□□J, RS1/□□S□□□□J

Chip Capacitor (except for CQS.....)

CKS....., CCS....., CSZS.....

Unit Number :
Unit Name : Core Unit

MISCELLANEOUS

-----Circuit Symbol & No. Part	Name-----	Part No.
IC 351	UPC1347GS	
IC 601	UPD6374AGH	
IC 602 652	NJM4558M	
IC 651	PA3026	
IC 661	TA78L05F	
IC 701	UPD6375GC	
IC 702	TC9237F	
IC 703	TA2009F	
IC 751	PD5181B	
IC 801	XRA6247FP	
Q 351	2SB1260	
Q 601	2SB709A	
Q 651 705 801	UN2211	
Q 652	2SB1184F5	
Q 653 802	2SB1184F5	
Q 751	UN2111	
D 651 652	SC016-2	
D 751	MA151A-MA	
D 752	MA151WK-MT	
D 759	MA151A-MA	
L 701	Inductor	LCTBR39K2125
L 751	Inductor	LCTBR39K2125
TH 751	Thermister	CCX1007
X 702	Crystal Resonator 16.9344MHz	CSS1067
X 751	4.9152MHz	CSS1084
VR 351	Semi-fixed 22kΩ	CCP1021
VR 352 355	Semi-fixed 47kΩ (B)	CCP1023
VR 353 354	Semi-fixed 2.2kΩ (B)	CCP1015
VR 356	Semi-fixed 47kΩ (B) Checker Tip	CCP1023 CKF1025
RESISTORS		
R 351	RS1/2S220J	
R 353	RS1/16S623J	
R 354	RS1/16S473J	
R 355	RS1/16S122J	
R 356 357	RS1/16S683J	
R 358 359	RS1/16S332J	
R 360	RS1/16S684J	
R 361	RS1/16S153J	
R 369 605 607 661 666 713 775 810 912	RS1/16S103J	
R 370 381	RS1/16S133J	
R 615 616	RS1/16S472J	
R 375 377 609 611 613 651 653 658	RS1/16S102J	
R 379	RS1/16S513J	
R 380 761 767 799	RS1/16S104J	
R 606	RS1/16S224J	

-----Circuit Symbol & No. Part	Name-----	Part No.
R 610 901 902 903 904 905 908		RS1/16S103J
R 614		RS1/16S912J
R 617 716 804 915		RS1/16S102J
R 652 657		RS1/16S162J
R 654		RS1/16S222J
R 655		RS1/16S332J
R 656		RS1/16S0R0J
R 660 662 665 811 812 813		RS1/10S151J
R 663		RS1/16S102J
R 664		RS1/16S912J
R 667		RS1/16S104J
R 668		RS1/16S752J
R 669		RS1/16S823J
R 670		RS1/16S912J
R 671 672 702 703 704 791 802 803		RS1/16S102J
R 674		RS1/16S473J
R 701		RS1/16S272J
R 708		RS1/16S201J
R 709		RS1/16S0R0J
R 711 712		RS1/16S100J
R 717 764 768 770 776 778 783 785		RS1/16S0R0J
R 752		RS1/16S153J
R 753 760 769 774 797 911		RS1/16S473J
R 754 777 796		RS1/16S104J
R 755 758 759 762 763 765 773 787 913		RS1/16S222J
R 757 906 907 909		RS1/16S222J
R 766 772 786 790 807		RS1/16S563J
R 781		RS1/16S473J
R 794		RS1/16S563J
R 795		RS1/16S473J
R 798		RS1/16S104J
R 805 806		RS1/16S563J
R 821 822		RS1/16S0R0J
CAPACITORS		
C 351 717		CEV470M6R3
C 352		CKSQYB104K25
C 353 714		CEV101M6R3
C 354 355 609 610 702 719 720		CEV100M16
C 357 359 366		CKSRYB102K50
C 358		CCSRCH331J50
C 360		CCSRCH271J50
C 361		CCSRCH220J50
C 373 607		CKSYB224K25
C 601		CKSRYB222K50
C 603		CCSRCH331J50
C 604 606 652 654 710 715 716 721 722		CKSYB224K25
C 605 611 659 666 709		CKSRYB103K25
C 608		CEV010M50
C 614		CKSRYB821K50
C 656		CKSQYB273K25
C 657 658		CKSRYB821K50
C 663		CKSQYB333K25
C 665	400 μF/10V	CCH1120
C 667		CSZST220M16

-----Circuit Symbol & No. Part	Name-----	Part No.	-----Circuit Symbol & No. Part	Name-----	Part No.
C 674		CKSRYB821K50	R 883		RS1/10S223J
C 703		CCSRCH470J50	R 884		RS1/10S102J
C 704 705		CCSRCH080D50	R 885		RS1/10S393J
C 718		CEV330M6R3	R 886		RS1/10S223J
C 751 753		CKSQYB104K25	R 887 920 921 932 933 938 939 940 941		RS1/10S103J
C 756		CKSRYB472K50	R 888		RS1/10S513J
C 801		CEV220M16	R 889 988 991		RS1/10S102J
C 802 803		CKSQYB223K25	R 890		RS1/10S0R0J
			R 891		RS1/10S242J
			R 922 923 934 935 995		RS1/10S472J
			R 924 925 967		RS1/10S133J
			R 930 931 958 959 969 970 971 977 986 987		RS1/10S473J
			R 936 937		RS1/10S103J
			R 942 943 944 945		RS1/8S121J
			R 946 947 948 949		RS1/10S470J
			R 950 951 952 953		RS1/4S470J
			R 954		RS1/10S151J
			R 956		RS1/10S431J
			R 960 983 989		RS1/10S243J
			R 961		RS1/10S122J
			R 962 975		RS1/10S6R8J
			R 963		RS1/10S822J
			R 964		RS1/10S432J
			R 965		RS1/10S182J
			R 966		RS1/10S472J
			R 968		RS1/10S512J
			R 972 973		RS1/10S123J
			R 974		RS1/2S560J
			R 976		RS1/4S123J
			R 978		RS1/10S821J
			R 981		RS1/10S152J
			R 982 985		RS1/10S222J
			R 984		RS1/10S182J
			R 990		RS1/2S560J
			R 992		RS1/10S202J
			R 993		RS1/10S681J
CAPACITORS					
			C 101 102 103 104		CKSQYB102K50
			C 868 870 960 963 969 985		CKSQYB473K50
			C 869 966		CKSQYB473K50
			C 920 921		CCSQCH820J50
			C 924 925		CCSQCH101J50
			C 926 927 928 929		CEVNP330M10
			C 935		CKDYF223Z50
			C 961 971 975		CEV470M16
			C 962		CEV100M16
			C 964		CEV220M16
			C 965		CEV100M16
			C 970	47000 μF/5.5V	CCL1015
			C 972 974		CEV2R2M50
			C 973	470 μF/16V	CCH1080
			Unit Number : Unit Name : Mechanism P.C.Board		
			S 843	Switch (Home)	CSN1012
			S 845 846	Switch (DCPT,TRPT)	CSN1022
			M 841	Motor Unit (Carriage)	CXA4316
			M 842	Motor Unit (Spindle)	CXA4540
			M 843	Motor Unit (ELV)	CXA3238
			M 844	TRAY Motor Unit	CXA3729
RESISTORS					
			R 101 102 103 104 105 106 107 108		RS1/10S682J
			R 876 994		RS1/4S562J
			R 877		RS1/4S331J
			R 878 880		RS1/2S101J
			R 882		RS1/10S103J

Extension Unit
Consists of
● Extension P.C.Board
● Keyboard P.C.Board
● Switch P.C.Board

MISCELLANEOUS

IC 863		ON3131-F
IC 864		M51957AFP
IC 865 866		M51956AFP
IC 920 921		NJM3404AM
IC 990	HIC	KHA193

Q 860 968 974 992		DTC144EU-14
Q 862		2SC4081LN
Q 863		DTA114EU
Q 920 921 922 923 924 925 926 927		2SC4213
Q 960 961 964 976 991		2SA1586
Q 962		2SA1241
Q 963 970		FMW1
Q 966		2SC3474
Q 967 975		DTA114EU
Q 969		2SB1299
Q 972 973 977 978		2SC4081LN
Q 990		2SC2882
D 860 861 873		MA3200M
D 862		MA551-MY
D 864		MA141K-MH

D 865 871 872 962 966 993		MA141K-MH
D 874		RD11MB1
D 920 921 922 923 924 925 926 961 964 971		RD5R6MB3
D 927		RD5R6MB3
D 960 972		MA143-MC
D 963 969		MA141WK-MT
D 965		MA721-M1M
D 967		5KP24A
D 968		RD7R5MB3
D 970		RD3R9MB2
D 973		MA141WA-MN
D 981 982 983	LED	CL140DC
D 994		RD9R1M
D 999		ERC04-02
L 960	Choke Coil	CTH1047

L 964	Inductor	LCTBR33K3216
SW991	Switch (RESET)	CSG-253
SW992 994	Switch (DCLOSE,DOPEN)	CSN1007
SW993	Switch (EJSW)	CSG1030
FU 990	Fuse	ICP-F50
FU 991	Fuse 6.3A	CEK1008
EF 960	EMI Filter	CCG1006

-----Circuit Symbol & No. Part Name----- Part No.

Unit Number :

Unit Name : Photo P.C.Board

D 841		HZS9A2L
VR 841	Semi-fixed 22kΩ (B)	CCP-380
S 841	Switch (MAG)	CSH1022
S 842	Switch (EJP)	CSH1022
P 841	Photo-Interrupter	# N1113
P 842	Photo-Interrupter	# N2160
R 841		RD1/4PS560JL
R 842		RD1/4PS221JL
R 843		RD1/4PS622JL

Miscellaneous Parts List

SO 1	Solenoid PUUnit	CXP1015 CGY1024
------	--------------------	--------------------

Service Manual

PIONEER®
The Art of Entertainment

PION-03692

• CDX-M30

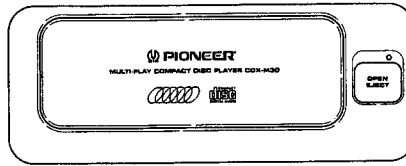

ORDER NO.
CRT1463

MULTI-PLAY COMPACT DISC PLAYER

CDX-M30

CDX-M33 US

UC, EW, ES

COMPACT
disc
DIGITAL AUDIO

CONTENTS

1. TRANSPORTATION SCREWS.....	2	10. CONNECTION DIAGRAM(2).....	48
2. SAFETY INFORMATION.....	3	11. SCHEMATIC CIRCUIT DIAGRAM(2).....	51
3. GENERAL GUIDE.....	4	12. CD MECHANISM UNIT EXPLODED VIEW.....	57
4. CONNECTING THE UNITS.....	4	13. CABINET EXPLODED VIEW.....	61
5. DISASSEMBLY.....	5	14. CHASSIS EXPLODED VIEW.....	62
6. BLOCK DIAGRAM.....	7	15. MAGAZINE EXPLODED VIEW.....	66
7. ADJUSTMENT.....	9	16. PACKING METHOD.....	67
8. CONNECTION DIAGRAM(1).....	41	17. ELECTRICAL PARTS LIST.....	69
9. SCHEMATIC CIRCUIT DIAGRAM(1).....	45	18. CIRCUIT DESCRIPTION.....	71

SPECIFICATIONS

General

System.....	Compact disc audio system
Usable discs.....	Compact Disc
Signal format.....	Sampling frequency: 44.1 kHz Number of quantization bits: 16; linear
Power source.....	14.4 V DC (10.8-15.6 allowable)
Max. current consumption.....	0.9 A
Weight.....	3.0 kg
Dimensions.....	200 (W) × 75 (H) × 295 (D) mm

Audio

Frequency characteristics.....	5-20,000 Hz (±1 dB)
Signal-to-noise ratio.....	97 dB (1 kHz) (IEC-A Network)
Dynamic range.....	94 dB (1 kHz)
Output level.....	500 mV (1 kHz, 0 dB)
Number of channels.....	2 (stereo)

Note:

Specifications and the design are subject to possible modification without prior notice due to improvements.

PIONEER ELECTRONIC CORPORATION 4-1, Meguro 1-Chome, Meguro-ku, Tokyo 153, Japan
PIONEER ELECTRONICS SERVICE INC. P.O. Box 1760, Long Beach, California 90801 U.S.A.
PIONEER ELECTRONICS OF CANADA, INC. 300 Allstate Parkway Markham, Ontario L3R 0P2 Canada
PIONEER ELECTRONIC [EUROPE] N.V. Haven 1087 Keetberglaan 1, 9120 Melsele, Belgium
PIONEER ELECTRONICS AUSTRALIA PTY. LTD. 178-184 Boundary Road, Braeside, Victoria 3195, Australia TEL: [03] 580-9911
 © PIONEER ELECTRONIC CORPORATION 1992

● **CD Player Service Precautions**

1. Since these screws protect the mechanism during transport, be sure to affix it when it is transported for repair, etc.
2. For pickup unit handling, please refer to "Disassembly". During replacement, handling precautions shall be taken to prevent an electrostatic discharge (protection by a short pin).
3. During disassembly, be sure to turn the power off since an internal IC might be destroyed when a connector is plugged or unplugged.

1. TRANSPORTATION SCREWS

Removal of Screws

Be sure to remove transportation screws (red) ① and ② in this order and cover the screw holes with seals ③ before mounting the set. Peel off adhesive tape to remove the transportation pin ①. **The removed screws (red) and the pin will be required if you transport the player again later. Keep them in the bag for keeping transportation screws.**

Reinstallation of Screws

Be sure to reinstall the transportation screws (red) in the procedure described below before re-transporting the set. Incorrect order of reinstallation or use of different screws may cause the set to fail.

1. Let the set operate the beginning of a disc and stop operation within 10 seconds thereafter before removing the set.
 2. Remove the magazine and then the set.
 3. Reinstall the transportation screws in the reverse order (② and ①) of removal. Fasten the transportation pin ① with adhesive tape.
- Before screwing in the transportation screws, position the player vertically.

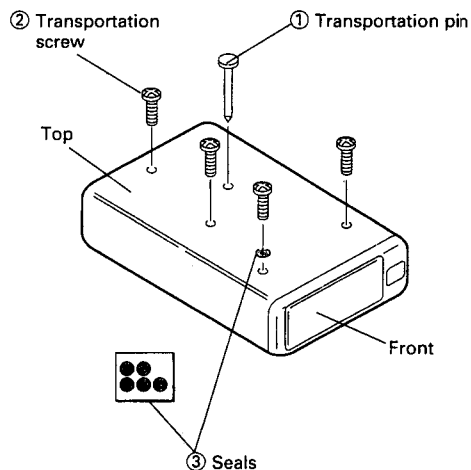

2. SAFETY INFORMATION

2.1 CDX-M30/EW

1. Safety Precautions for those who Service this Unit.

- Follow the adjustment steps (see pages 9 through 27) in the service manual when servicing this unit. When checking or adjusting the emitting power of the laser diode exercise caution in order to get safe, reliable results.

Caution:

1. During repair or tests, minimum distance of 13cm from the focus lens must be kept.
2. During repair or tests, do not view laser beam for 10 seconds or longer.

2. A "CLASS 1 LASER PRODUCT" label is affixed to the rear of the player.

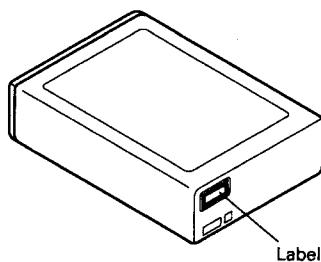

Fig. 1

3. The triangular label is attached to the mechanism unit frame.

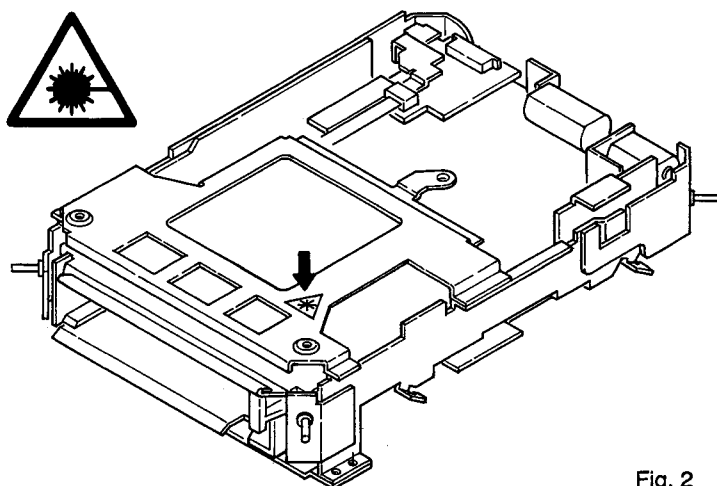

Fig. 2

4. Specifications of Laser Diode

Specifications of laser radiation fields to which human access is possible during service.

Wavelength	= 785 nanometers
Radiant power	= 69.7 microwatts (Through a circular aperture stop having a diameter of 80 millimeters)
	0.55 microwatts (Through a circular aperture stop having a diameter of 7 millimeters)

2.2 CDX-M30/UC,CDX-M33/UC

CAUTION

This service manual is intended for qualified service technicians; it is not meant for the casual do-it-yourselfer. Qualified technicians have the necessary test equipment and tools, and have been trained to properly and safely repair complex products such as those covered by this manual.

Improperly performed repairs can adversely affect the safety and reliability of the product and may void the warranty. If you are not qualified to perform the repair of this product properly and safely, you should not risk trying to do so and refer the repair to a qualified service technician.

WARNING

Lead in solder used in this product is listed by the California Health and Welfare agency as a known reproductive toxicant which may cause birth defects or other reproductive harm (California Health & Safety Code, Section 25249.5). When servicing or handling circuit boards and other components which contain lead in solder, avoid unprotected skin contact with the solder. Also, when soldering do not inhale any smoke or fumes produced.

3. GENERAL GUIDE

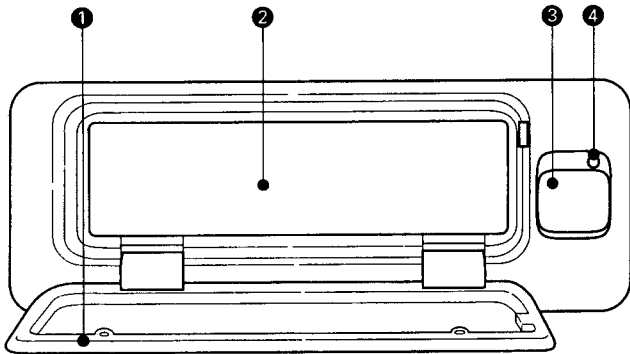

Fig. 3

1 Door

Be sure never to leave the door open.

2 Compact disc magazine slot

3 Door open/eject button

Press this button to open the door 1 and eject the magazine.

4 Clear button

If the power does not switch on or if the compact disc player does not operate when the button on the multi-CD controller is pressed, or if the multi-CD controller display is incorrect, press this button on the player with the tip of a pencil to restore normal operation. **Always press the clear button on the multi-CD controller, too, after pressing this button.**

The Magazine Type Multi-Play CD players with  mark and the Magazines with the same mark are compatible for 5-inch (12 cm) discs.

Precautions when using 8-cm (3-inch) CDs

- The magazine supplied with this CD player is for 12-cm (5-inch) CDs only. Do not put 8-cm (3-inch) CDs in the magazine, even with adapters, as they may cause a failure.
- To play 8-cm CDs, use the optional JD-M308 magazine, which holds six 8-cm CDs. The JD-M108 magazine for six 8-cm CDs cannot be used with this player.

4. CONNECTING THE UNITS

- Before mounting, remove the transportation screws (see page 2) and connect the units temporarily. Check that the units are connected correctly by operating the multi-CD controller.
- Be sure to properly connect the color-coded leads. Failure to do so can cause malfunctions.
- When connecting the cords, be sure to fix them firmly with clamps or tape. Be sure to protect the cords from damage by taping them at places where they will contact burr.
- After connection is complete, press the clear buttons on the player and the multi-CD controller with the tip of a pencil.
- Wire all connecting cords so that they stay well clear of high-temperature areas such as the heater outlet.
- Do not drill a hole into the engine compartment to connect the orange power cable directly to the battery.
- Be sure to connect the ground lead (black) to the vehicle body or some other metal part that is properly grounded to the chassis. If the ground lead is not properly connected, noise may occur or the player or multi-CD controller may not operate correctly.

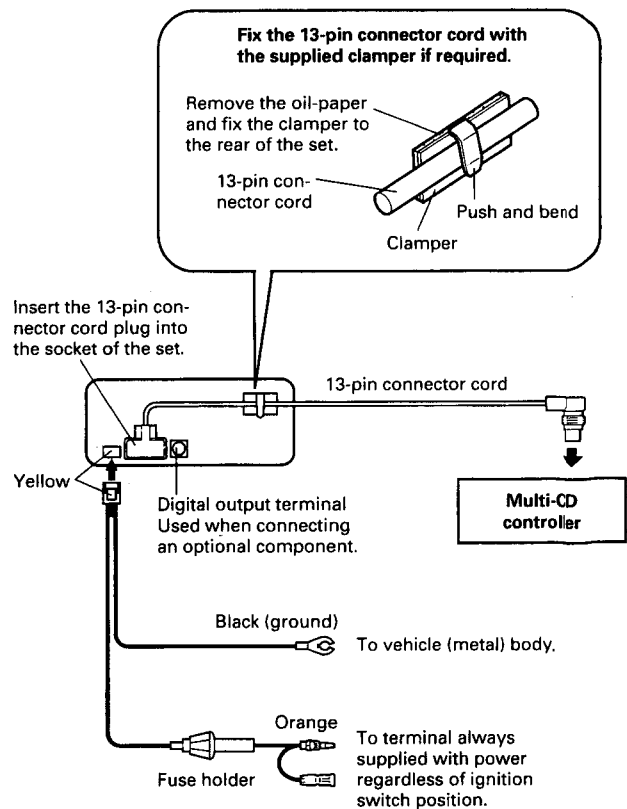

Fig. 4

5. DISASSEMBLY

● Case

1. Unfasten six screws A and then remove the upper case.
2. Unfasten four screws B and then remove the lower case.

● Grille Assy

1. Unlock four catches and dismount the grille assembly.

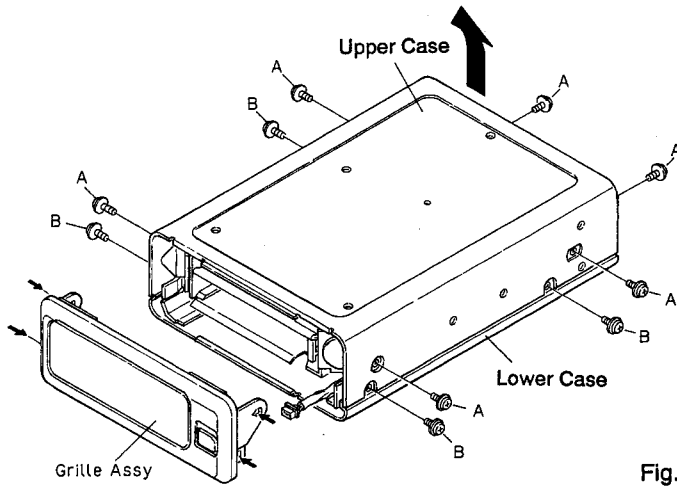

Fig. 5

● Chassis L,R

1. Unfasten four screws.
2. Disconnect two connectors and remove the sub chassis.
3. Remove the damper holder.
4. Remove the spring.
5. Remove chassis L.
6. Remove chassis R.

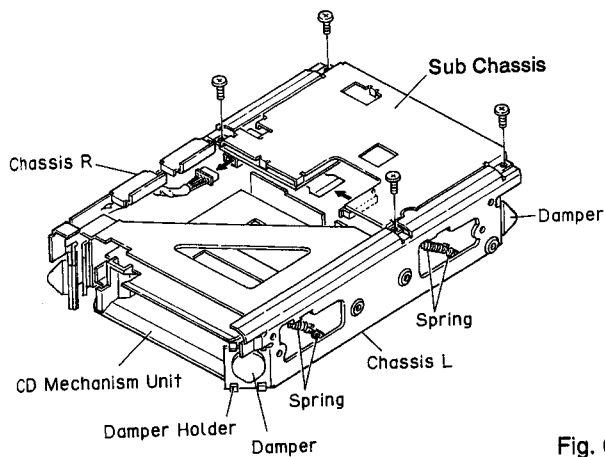

Fig. 6

● **CN351**

Before disconnecting the CN351 connector (PU unit connector), attach a short pin as illustrated.

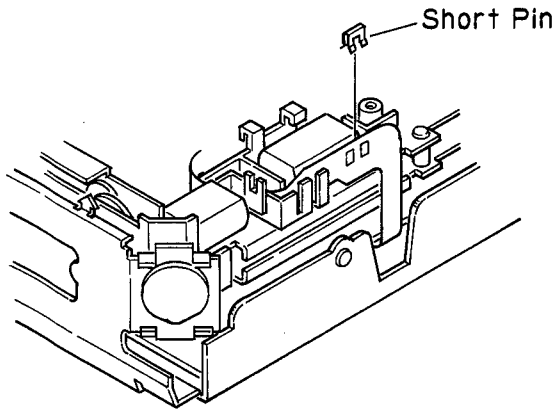

Fig. 7

6. BLOCK DIAGRAM

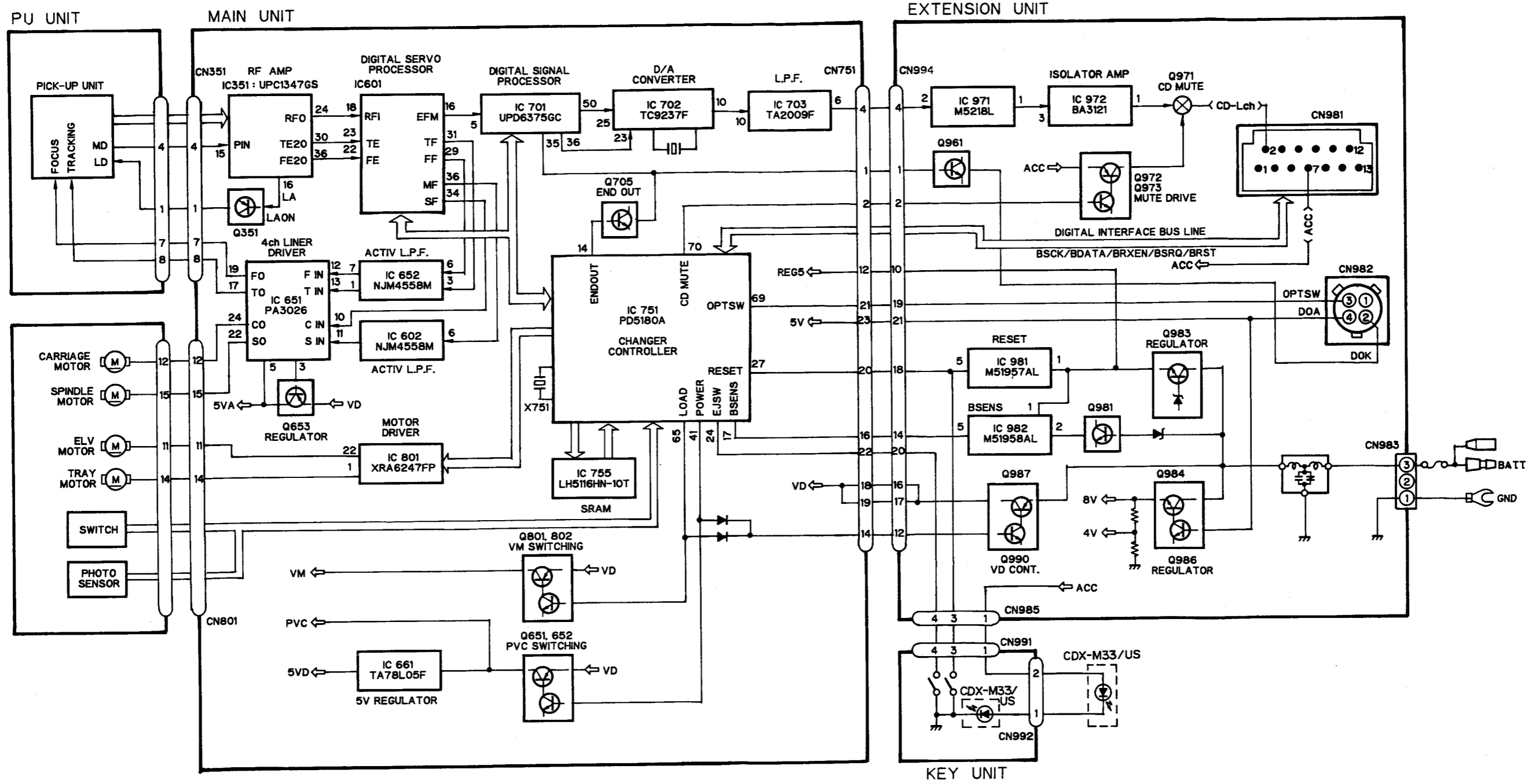

Fig. 8

7. ADJUSTMENT

1)Precautions

- This unit uses a single power supply (+5V) for the regulator. The signal reference potential, therefore, is connected to REFOUT (approx. 2.5V) instead of GND.

If REFOUT and GND are connected to each other by mistake during adjustments, not only will it be impossible to measure the potential correctly, but the servo will malfunction and a severe shock will be applied to the pick-up. To avoid this, take special note of the following.

Do not connect the negative probe of the measuring equipment to REFOUT and GND together. It is especially important not to connect the channel 1 negative probe of the oscilloscope to REFOUT with the channel 2 negative probe connected to GND.

And since the frame of the measuring instrument is usually at the same potential as the negative probe, change the frame of the measuring instrument to floating status.

If by accident REFOUT comes in contact with GND, immediately switch the regulator or power OFF.

- Always make sure the regulator is OFF when connecting and disconnecting the various filters and wiring required for measurements.
- Before proceeding to further adjustments and measurements after switching regulator ON, let the player run for about one minute to allow the circuits to stabilize.
- Since the protective systems in the unit's software are rendered inoperative in test mode, be very careful to avoid mechanical and/or electrical shocks to the system when making adjustment.
- When loading and unloading discs during adjustment procedures, always wait for the disc to be properly clamped or ejected before pressing the another key. Otherwise, there is risk of the actuator being destroyed.
- Turn power off when pressing the button ►► or the button ◄◄ key for focus search in the test mode. (Or else lens may stick and the actuator may be damaged.)

2)Test mode

The model CDX-M30, M33 is adjusted in a combination with the multiple CD control head (FH-M75, FH-M70, DEH-M980RDS, etc.). Each regulator key should be operated at the head. With the FH-M75, M70 taken up for reference, a description will be given below concerning how to enter into the test mode, including key operations. The key in the adjustment text is also one of the FH-M75, M70 keys.

- How to enter into the test mode

While pressing keys 4 and 6 at a time, press the back-up ON or clear button ON the FH-M75, M70.

- Resetting the test mode

Press the clear button ON the FH-M75, M70. Subsequently press the clear button ON the CDX-M30, M33. Or turn off the CDX-M30, M33 and the FH-M75, M70 back-up and wait for about one minute.

- Role to be played by each key in the test mode

A function key permits you to select the CD multi-player, single CD player, deck, TV or tuner.

Key	Function
BAND/REL	Regulator ON/OFF
►►	FWD Kick
◄◄	REV Kick
EJECT	EJECT
F·3	Jump mode
F·1	Tracking close
F·4	Tracking open
F·2	Focus close
CD	CD ON/OFF

- SINGLE/10TRK/32TRK will continue to operate even after the key is released. Tracking closed the moment C-MOVE is released.
- JUMP MODE resets to SINGLE as soon as power is off.

• Flow Chart

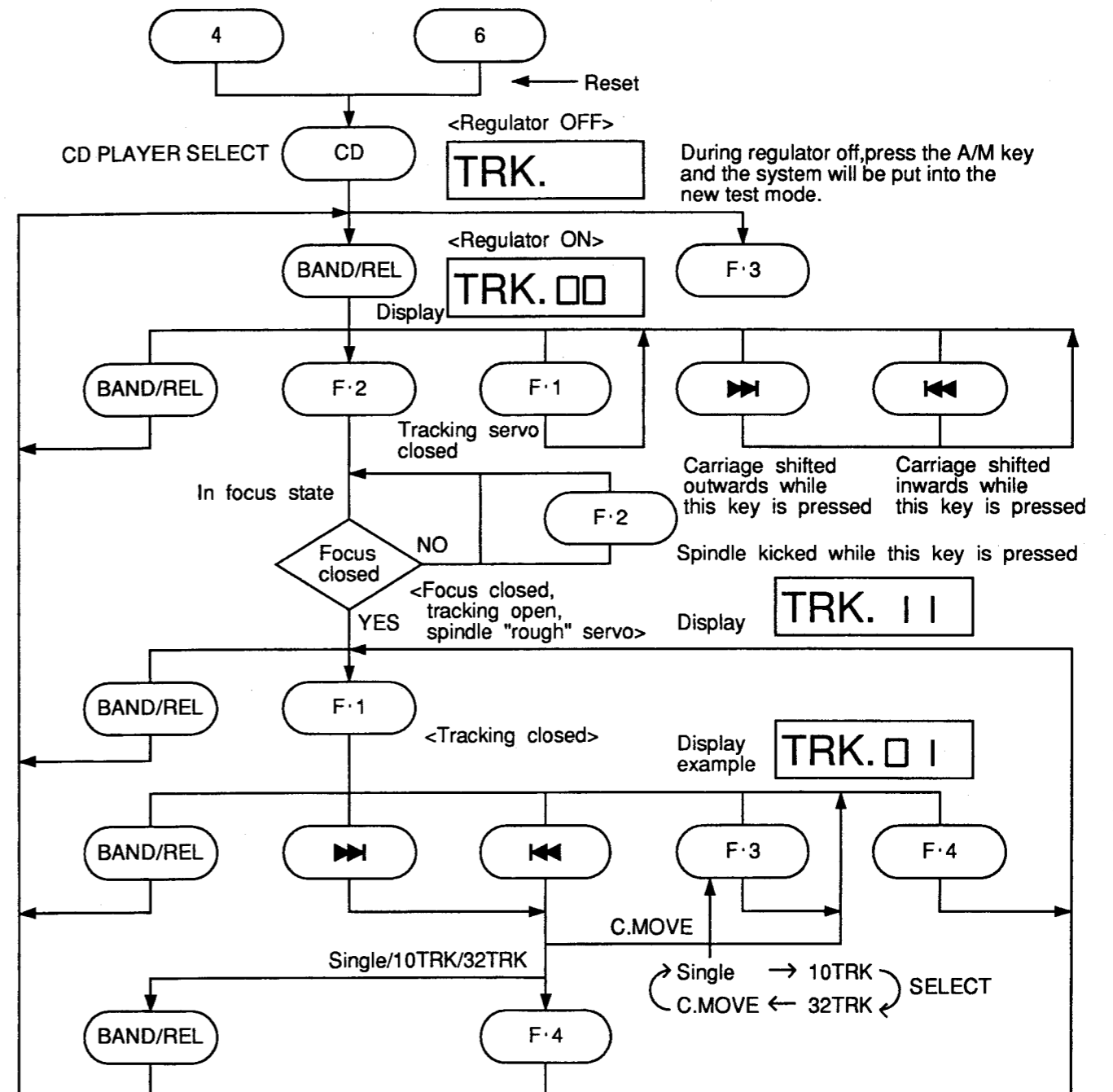

● Measuring Equipment and Jigs

Adjustment	<ul style="list-style-type: none"> • Measuring equipment&jigs
Grating Adjustment	<ul style="list-style-type: none"> • Oscilloscope,clock driver,grating adjustment filter (bandpass filter)(GGF133),AC millivoltmeter • SONY TYPE 4 (or TYPE 3) • Extension Cable:GGF1157,GGF1158 • DIN Cord:GGF1159 •Relay P.C.Board:GGF1156
Tangential Skew Check	<ul style="list-style-type: none"> •Oscilloscope,screwdriver •SONY TYPE 4 (or TYPE 3) • Extension Cable:GGF1157,GGF1158 • DIN Cord:GGF1159 • Relay P.C.Board:GGF1156
Grating Adjustment	<ul style="list-style-type: none"> • Oscilloscope,clock driver,two low-pass filters • SONY TYPE 4 (or TYPE 3) • Extension Cable:GGF1157,GGF1158 • DIN Cord:GGF1159 •Relay P.C.Board:GGF1156
FE Bias Adjustment	<ul style="list-style-type: none"> Oscilloscope,volume adjustment driver SONY TYPE 4 (or TYPE 3) • Extension Cable:GGF1157,GGF1158 • DIN Cord:GGF1159 •Relay P.C.Board:GGF1156
RF Offset Adjustment	<ul style="list-style-type: none"> Oscilloscope,volume adjustment driver SONY TYPE 4 (or TYPE 3) • Extension Cable:GGF1157,GGF1158 • DIN Cord:GGF1159 •Relay P.C.Board:GGF1156
TE Offset Adjustment-1	<ul style="list-style-type: none"> DC voltmeter or oscilloscope,volume adjustment driver • Extension Cable:GGF1157,GGF1158 • DIN Cord:GGF1159 •Relay P.C.Board:GGF1156
Tracking Balance Adjustment-1	<ul style="list-style-type: none"> Oscilloscope,volume adjustment driver SONY TYPE 4 (or TYPE 3) • Extension Cable:GGF1157,GGF1158 • DIN Cord:GGF1159 •Relay P.C.Board:GGF1156
Focus Servo Loop Gain Adjustment	<ul style="list-style-type: none"> Oscillator,gain adjustment filter (GGF-065),Oscilloscope, dual meter milli-voltmeter,volume adjustment driver SONY TYPE 4 (or TYPE 3) • Extension Cable:GGF1157,GGF1158 • DIN Cord:GGF1159 •Relay P.C.Board:GGF1156
Tracking Servo Loop Gain Adjustment	<ul style="list-style-type: none"> Oscillator,gain adjustment filter (GGF-065),Oscilloscope, dual meter milli-voltmeter,volume adjustment driver SONY TYPE 4 (or TYPE 3) • Extension Cable:GGF1157,GGF1158 • DIN Cord:GGF1159 •Relay P.C.Board:GGF1156
TE Offset Adjustment-2	<ul style="list-style-type: none"> DC voltmeter,volume adjustment driver • Extension Cable:GGF1157,GGF1158 • DIN Cord:GGF1159 •Relay P.C.Board:GGF1156
Tracking Balance Adjustment-2	<ul style="list-style-type: none"> Oscilloscope,volume adjustment driver SONY TYPE 4 (or TYPE 3) • Extension Cable:GGF1157,GGF1158 • DIN Cord:GGF1159 •Relay P.C.Board:GGF1156

● Adjustment Points

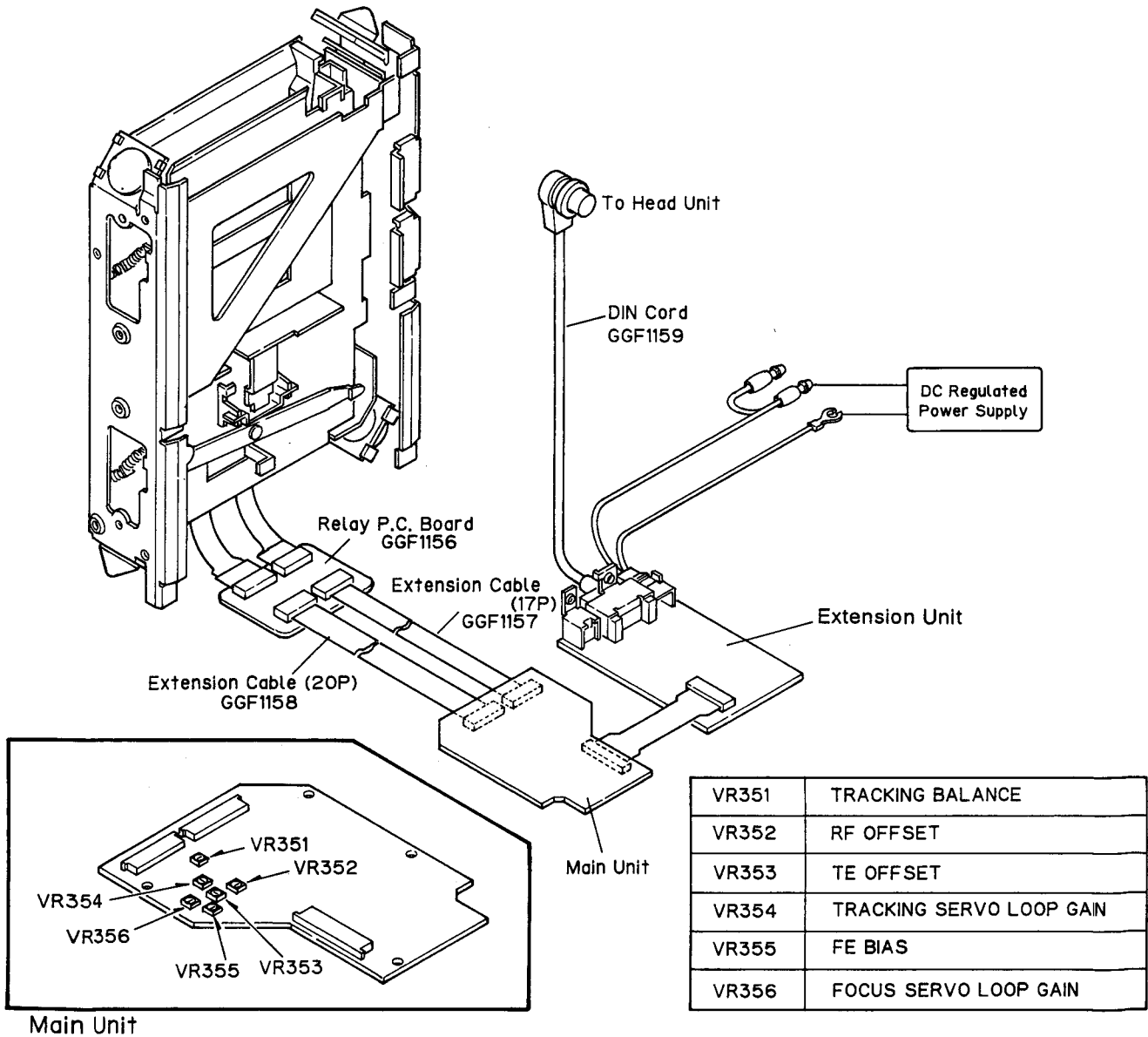

Fig. 9

7.1 Grating Adjustment (Rough adjustment)

- Purpose: The grating may need adjustment in a replaced pick-up unit.
- Maladjustment symptoms: No disc playback; track jumping.

<ul style="list-style-type: none"> • Measuring equipment / jigs • Measuring point • Test disc and setting • Adjustment position 	<ul style="list-style-type: none"> • Oscilloscope, clock driver, grating adjustment filter (bandpass filter)(GGF-133), AC millivoltmeter • TEY • SONY TYPE 4 (or TYPE 3) • Test mode • Pick-up grating adjustment hole
---	--

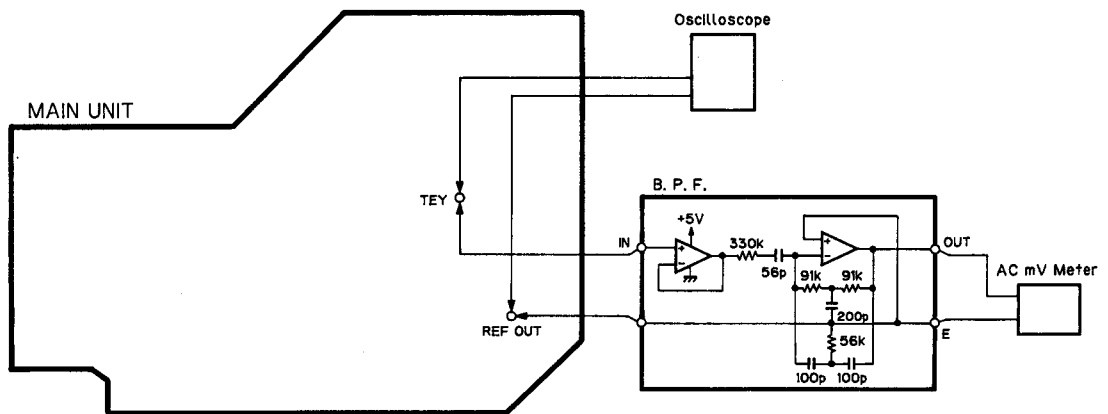
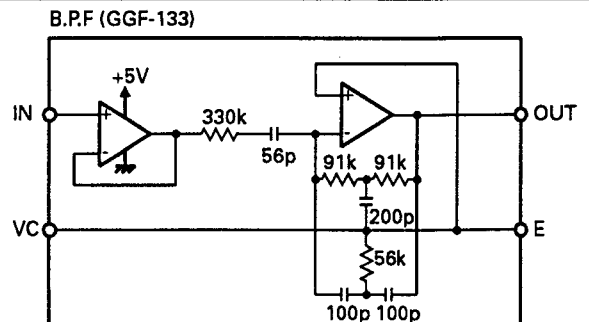

Fig. 10

Adjustment Procedure

1. In the test mode, set a test desc-loaded magazine and select the tray with a test disc.
2. Switch regulator ON.
3. Using the ►► or ◄◄ key, move the pick-up to about the center of the test disc.
4. Press the F•2 key to close focus.
5. While monitoring the TEY filter output by AC milli-voltmeter, turn the grating adjustment hole slowly. The AC voltage increases and decreases while turning the screw. Search for the minimum voltage level. (This corresponds to the position where the grating is on a track, and is referred to as the null point.)
6. Then while monitoring TEY by oscilloscope, turn the driver slowly clockwise from the null point (as seen from under the pick-up) until the first waveform peak amplitude is reached.



7.2 Tangential Skew Check

- Purpose: To check whether tangential skew has been misaligned or not when replacing the pick-up unit.
- Maladjustment symptoms: No disc playback; track jumping.

- | | |
|---|---|
| <ul style="list-style-type: none"> • Measuring equipment / jigs • Measuring point • Test disc and setting • Adjustment position | <ul style="list-style-type: none"> • Oscilloscope, screwdriver • RFO • SONY TYPE 4 (or TYPE 3) • Normal mode • Pick-up tangential adjustment screw |
|---|---|

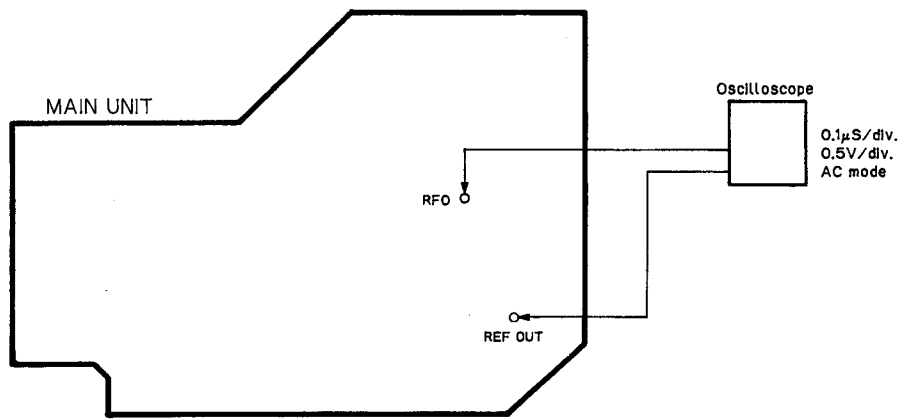

Fig.11

Adjustment Procedure

1. Play tune TNO 12 in normal mode.(TYPE 3:TNO 14)
2. Adjust the tangential adjustment screw so that the RF wave-form will have a level maximized and an eye pattern clearly viewed. Turn the adjustment screw both clockwise and counterclockwise to points where the eye pattern deteriorates, and take the midway point as the adjustment point. As a general guide, look for an overall clear wave-form, and one of the diamond shapes in the eye pattern. The diamond shapes should appear in fine lines at the point of optimum adjustment. Take care not to knock the pick-up with the screwdriver at this stage. (This kind of accident can result in loss of focus.) (See Fig.12,13)
3. Apply "screw-lock" to the tangential adjustment screw.
4. After adjusting tangential skew, also adjust the grating.

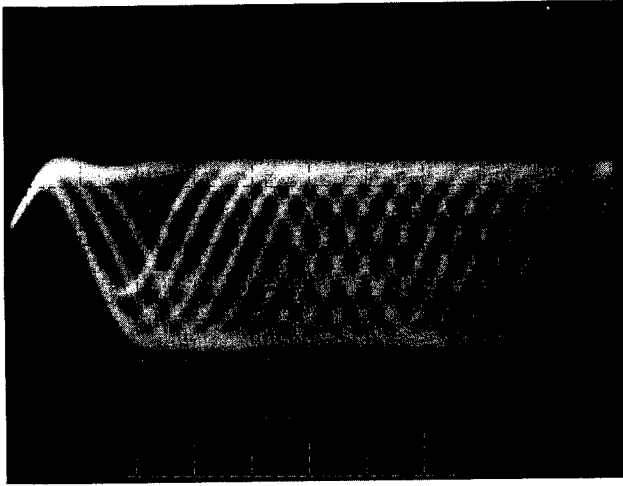

Fig. 12

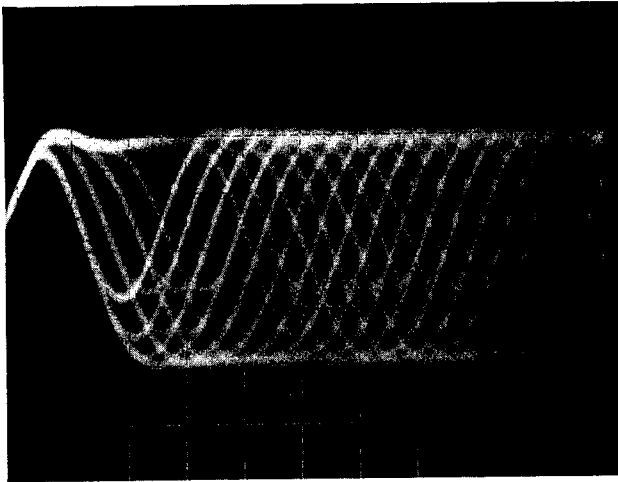

Fig. 13

0.5V/div.
0.5 μ s/div.
DC mode

7.3 Grating Adjustment (Fine adjustment)

- Purpose: The grating may need adjustment in a replaced pick-up unit.
- Maladjustment symptoms: No disc playback; track jumping.

- | | |
|---|---|
| <ul style="list-style-type: none"> • Measuring equipment / jigs • Measuring point • Test disc and setting • Adjustment position | <ul style="list-style-type: none"> • Oscilloscope, clock driver, two low-pass filters • E LPF output, F LPF output • SONY TYPE 4 (or TYPE 3) • Test mode • Pick-up grating adjustment hole |
|---|---|

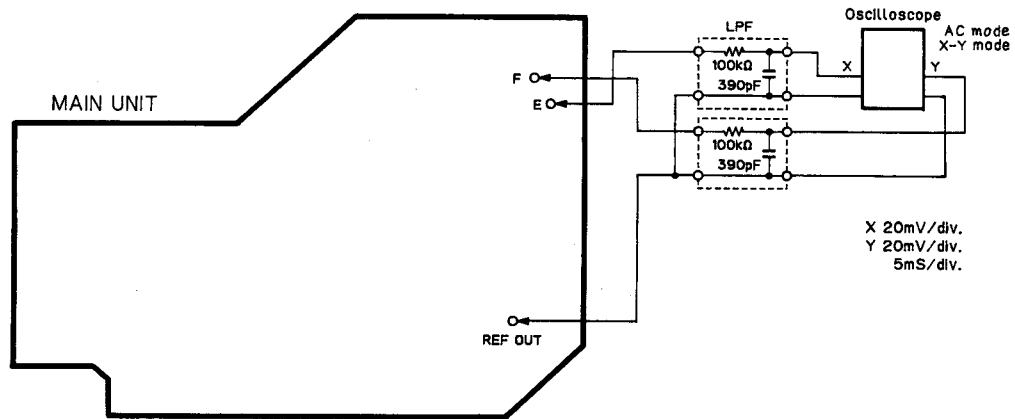

Fig. 14

Adjustment Procedure

1. Connect a low-pass filter as shown in the above diagram.
2. Switch regulator ON in test mode, and load a disc.
3. Using the \blacktriangleright or \blacktriangleleft key, move the pick-up to about the center of the test disc.
4. Press the F•2 key to close focus.
5. Using the driver, adjust the Lissajous figure to a single line (or as close as possible).
6. Switch regulator OFF and remove the filters.

TEY waveform 5ms/div, 500mV/div

Nul Point

Lissajous figure (AC input)
Horizontal axis E 20mV/div
Vertical axis F 20mV/div

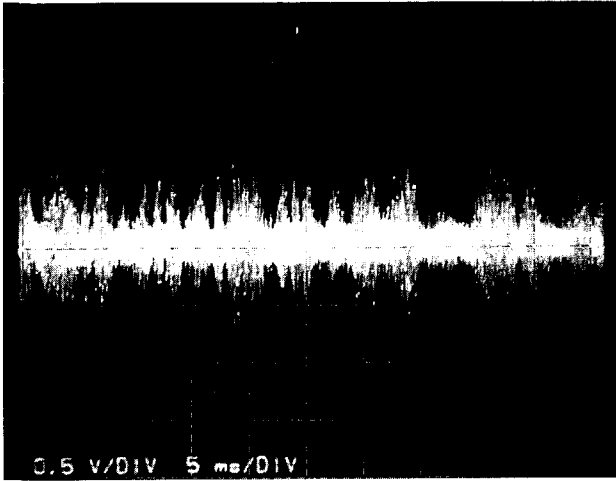

Fig. 15

Fig. 16



"Rough" adjustment

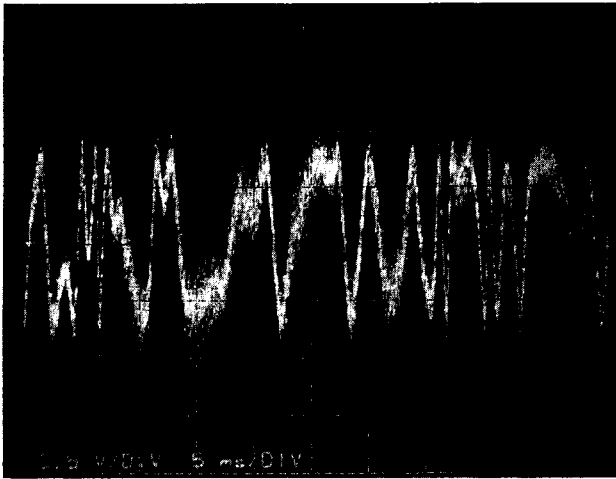

Fig. 17

Fig. 18



Final adjustment

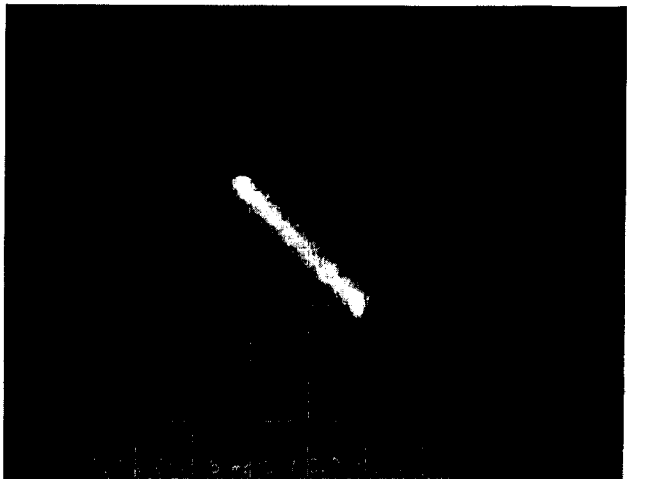
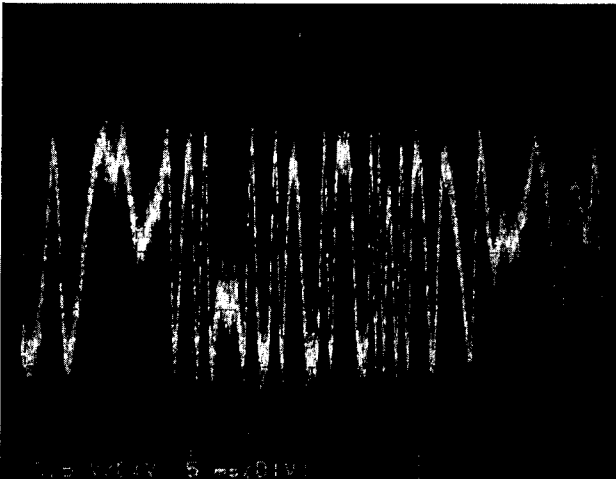

Fig. 19

Fig. 20

7.4 FE Bias Adjustment

- Purpose: To adjust the focus servo bias to an optimum value.
- Maladjustment symptoms: Focus closing difficulty, poor playability.

- | | |
|---|--|
| <ul style="list-style-type: none"> • Measuring equipment / jigs • Measuring point • Test disc and setting • Adjustment position | <ul style="list-style-type: none"> • Oscilloscope, volume adjustment driver • RFO • SONY TYPE 4 (or TYPE 3) • Normal mode • VR355(FEB) |
|---|--|

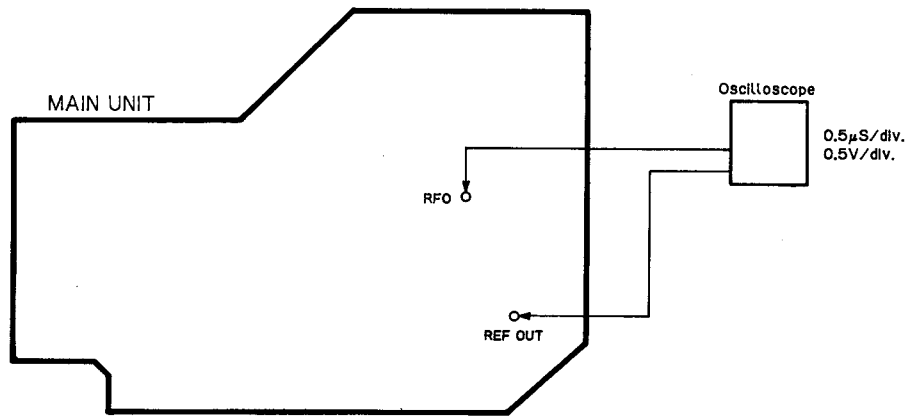

Fig.21

Adjustment Procedure

1. Play tune TNO 12 in normal mode.(TYPE 3:TNO 14)
2. Observe RFO in respect to REFOUT in the oscilloscope, and adjust VR355(FEB) to obtain maximum RF and optimum eye pattern. (See Fig.22,23)

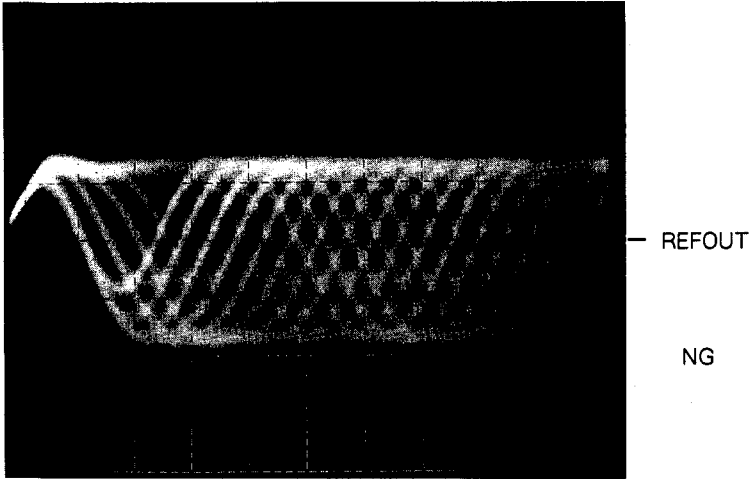

Fig. 22

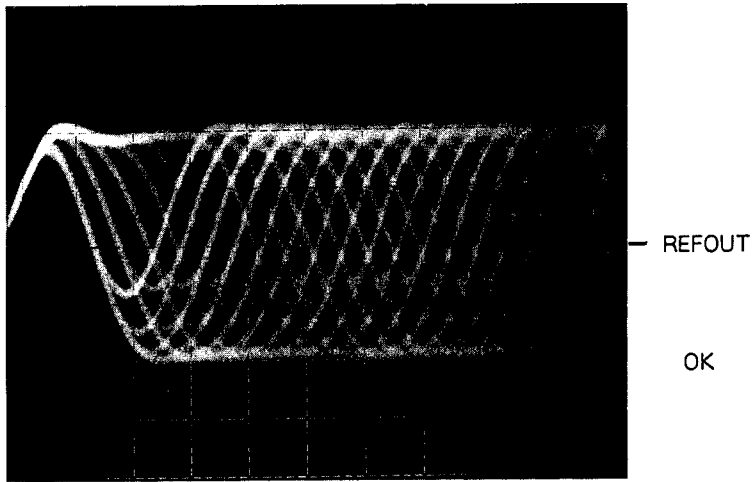

Fig. 23

0.5V/div.
0.5 μ s/div.
DC mode

7.5 RF Offset Adjustment

- Purpose: To adjust the RF amplifier offset to a suitable value.
- Maladjustment symptoms: Focus closure fails readily.

- | | |
|---|--|
| <ul style="list-style-type: none"> • Measuring equipment / jigs • Measuring point • Test disc and setting • Adjustment position | <ul style="list-style-type: none"> • Oscilloscope, volume adjustment driver • RFO • SONY TYPE 4 (or TYPE 3) • Normal mode • VR352(RFO) |
|---|--|

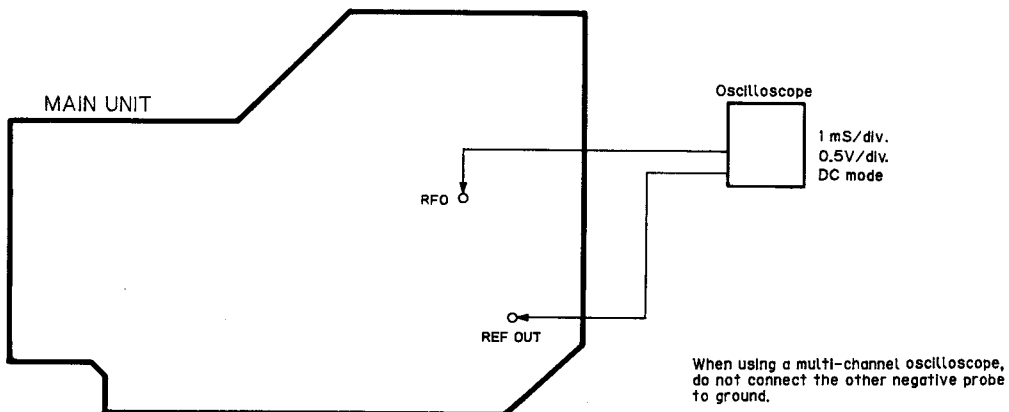
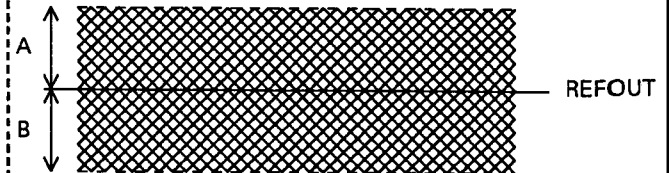

Fig.24

Adjustment Procedure

1. Play tune TNO 12 in normal mode. (TYPE 3:TNO 14)
2. Use VR352 to adjust the RFO waveform so that REFOUT appears at the center. (A-B must not exceed 100 mV.)



7.6 TE Offset Adjustment-1

- Purpose: To adjust the electrical offset of the tracking servo to zero.
- Maladjustment symptoms: Search times too long, carriage run-away.

- | | |
|---|---|
| <ul style="list-style-type: none"> • Measuring equipment / jigs • Measuring point • Test disc and setting • Adjustment position | <ul style="list-style-type: none"> • DC voltmeter or oscilloscope, volume adjustment driver • TEY • Empty magazine • Test mode • VR353(TEO) |
|---|---|

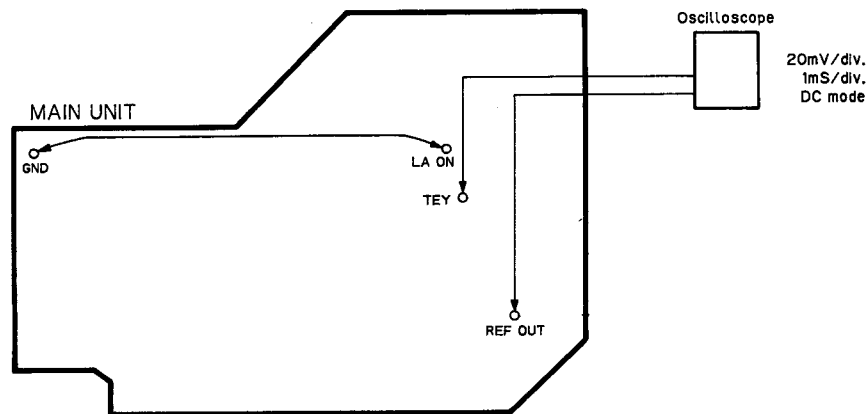

Fig.25

Adjustment Procedure

1. Connect LAON to GND.
2. Switch regulator ON while in test mode.
3. Using VR353(TEO), adjust the TEY output DC voltage in reference to REFOUT to a value of $0 \pm 25\text{mV}$.
4. Switch regulator OFF.
5. Remove LAON to GND.

7.7 Tracking Balance Adjustment-1

- Purpose: To adjust the tracking servo offset to zero.
- Maladjustment symptoms: Search times too long, poor playability, carriage run-away.

- | | |
|---|--|
| <ul style="list-style-type: none"> • Measuring equipment / jigs • Measuring point • Test disc and setting • Adjustment position | <ul style="list-style-type: none"> • Oscilloscope, volume adjustment driver • TEY (Tracking error signal) • SONY TYPE 4 (or TYPE 3) • Test mode • VR351(T.BAL) |
|---|--|

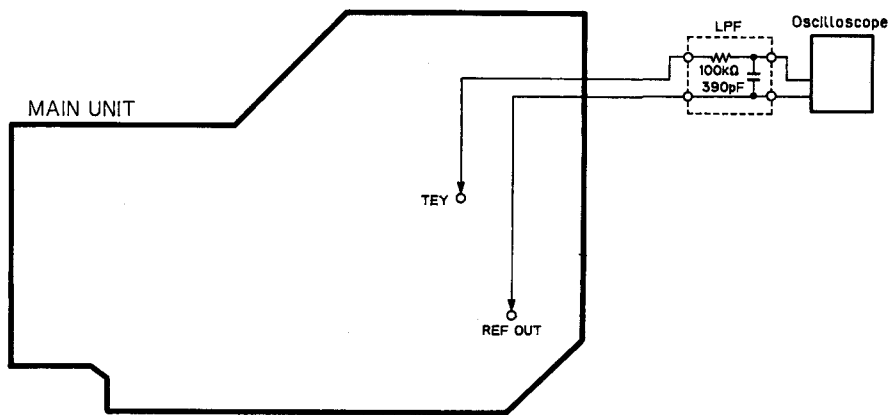

Fig.26

Adjustment Procedure

1. After checking that regulator is OFF, connect the low-pass filter as shown in the diagram.
2. Set the test disc (SONY TYPE 4). Switch regulator ON.
3. Using the ►► or ◄◄ key, move the pick-up to about the center of the signal surface.
4. Press the F-2 key to close focus.
5. Using an oscilloscope, observe the TEY signal in respect to REFOUT. Then adjust VR351(T.BAL) to set the positive and negative amplitudes to the same levels. (See Fig.27-29)
6. Switch the power OFF.

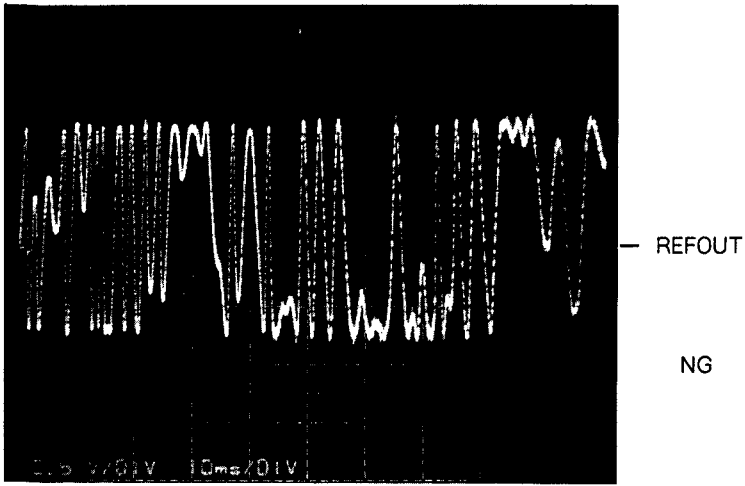

Fig. 27

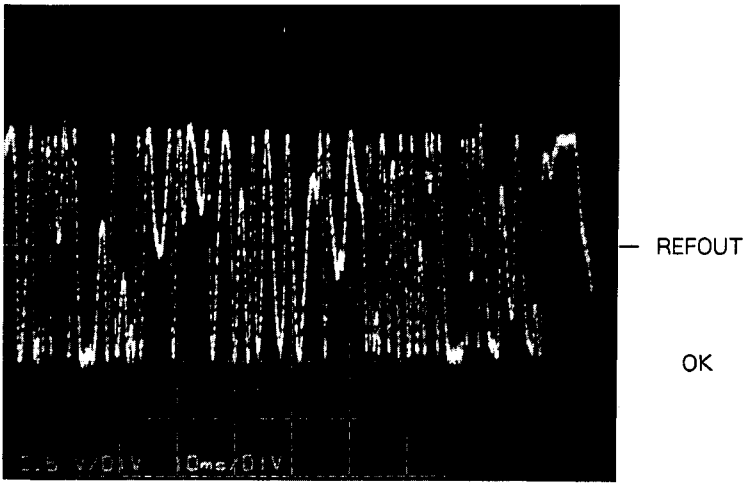

Fig. 28

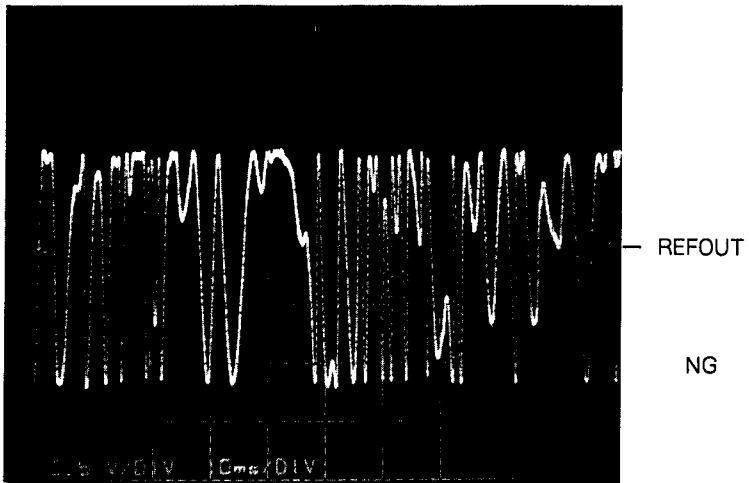

Fig. 29

7.8 Focus Servo Loop Gain Adjustment

- Purpose: To adjust the focus servo loop gain to an optimum value.
- Maladjustment symptoms: Poor playability, reduced resistance to vibration, focus closure fails readily.

- | | |
|---|--|
| <ul style="list-style-type: none"> • Measuring equipment / jigs • Measuring point • Test disc and setting • Adjustment position | <ul style="list-style-type: none"> • Oscillator, gain adjustment filter (GGF-065), dual meter milli-voltmeter, oscilloscope, volume adjustment driver • FEX, FEY • SONY TYPE 4 (or TYPE 3) • Normal mode • VR356(FG) |
|---|--|

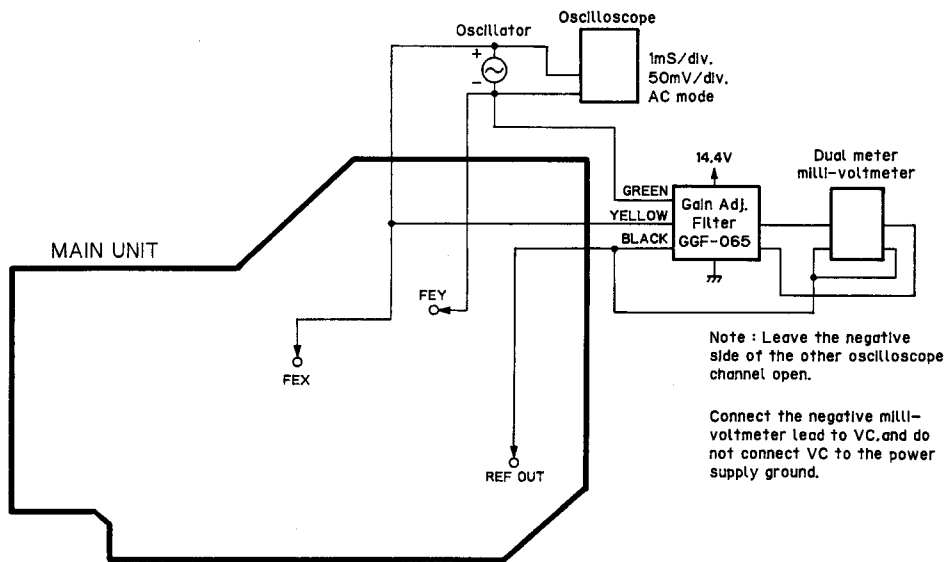

Fig.30

Adjustment Procedure

1. After checking that the power is OFF, connect the gain adjustment filter and measuring equipment as shown in the above diagram.
2. Play tune TNO 12 in normal mode. (TYPE 3:TNO 14)
3. Set the oscillator to 1kHz, and observe the FEX/FEY output in the oscilloscope. Adjust the oscillator output to obtain a FEX/FEY output of 100mVp-p.
4. Adjust VR356(FG) to obtain a milli-voltmeter difference of 0 ± 0.5 dB.

7.9 Tracking Servo Loop Gain Adjustment

- Purpose: To adjust the tracking servo loop gain to an optimum value.
- Maladjustment symptoms: Poor playability, reduced resistance to vibration.

- | | |
|---|---|
| <ul style="list-style-type: none"> • Measuring equipment / jigs • Measuring point • Test disc and setting • Adjustment position | <ul style="list-style-type: none"> • Oscillator, gain adjustment filter (GGF-065), dual meter milli-voltmeter, oscilloscope, volume adjustment driver • TEX, TEY • SONY TYPE 4 (or TYPE 3) • Normal mode • VR354(TG) |
|---|---|

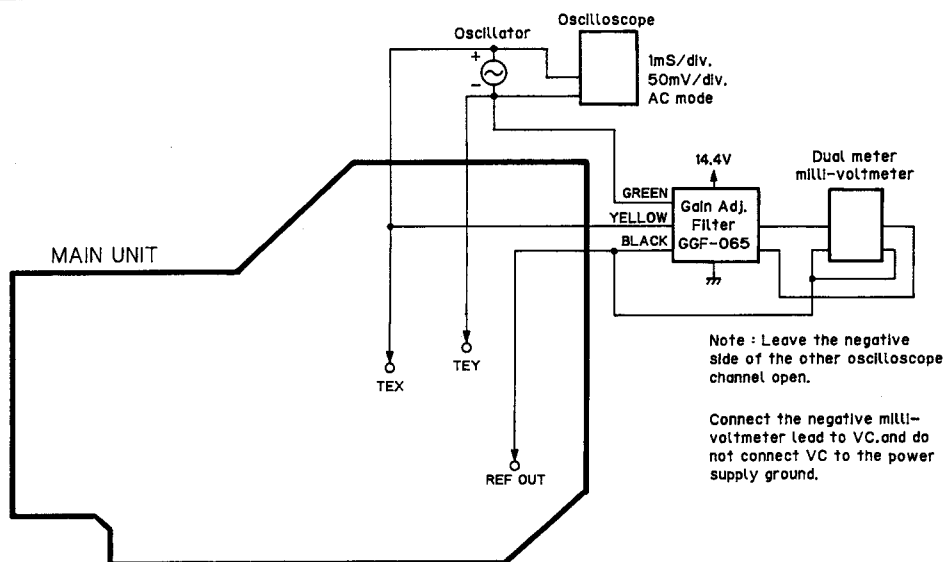

Fig.31

Adjustment Procedure

1. After checking that the power is OFF, connect the gain adjustment filter and measuring equipment as shown in the above diagram.
2. Play tune TNO 12 in normal mode. (TYPE 3:TNO 14)
3. Set the oscillator to 1.4kHz, and observe the TEX/TEY output in the oscilloscope. Adjust the oscillator output to obtain a TEX/TEY output of 300mVp-p.
4. Adjust VR354(TG) to obtain a milli-voltmeter difference of $0 \pm 0.5\text{dB}$.

7.10 TE Offset Adjustment-2

- Purpose: To adjust the electrical offset of the tracking servo to zero.
- Maladjustment symptoms: Search times too long, carriage run-away.

- | | |
|---|---|
| <ul style="list-style-type: none"> • Measuring equipment / jigs • Measuring point • Test disc and setting • Adjustment position | <ul style="list-style-type: none"> • DC voltmeter, volume adjustment driver • TEY • No Disc • Test mode • VR353 |
|---|---|

Adjustment Procedure

Same as for TE offset adjustment-1, but with the DC voltage of the TEY output adjusted to $0 \pm 50\text{mV}$. The purpose of this additional adjustment is to correct any deviations generated when carrying out the tracking balance and tracking servo loop gain adjustments after completing TE offset adjustment-1.

7.11 Tracking Balance Adjustment-2

<ul style="list-style-type: none"> • Purpose: To adjust the tracking servo offset to zero. • Maladjustment symptoms: Search times too long, poor playability, carriage run-away. 	
<ul style="list-style-type: none"> • Measuring equipment / jigs • Measuring point • Test disc and setting • Adjustment position 	<ul style="list-style-type: none"> • Oscilloscope, volume adjustment driver • TEY • SONY TYPE 4 (or TYPE 3) • Test mode • VR351
<p>Adjustment Procedure</p> <p>Steps 1 thru 5 same as tracking balance adjustment-1.</p> <p>6. Check that the level difference between the positive and negative amplitudes of the TEY signal is within 5% (See Fig.27-29). If greater than 5%, adjust with VR351.</p> <p>7. If further adjustment was necessary in step 6, repeat TE offset adjustment-2.</p>	

• ICs

IC351 : UPC1347GS

VCC	1	36	FE20
BP	2	35	FE2-
BPO	3	34	FE10
WC+	4	33	FE1+
WC-	5	31	FE2+
GND	6	32	VREF2
QDH	7	30	TE20
QDO	8	29	TE2-
A	9	28	TE10
C	10	27	APCO
B	11	26	TE2+
D	12	25	APC-
E	13	24	RFO
F	14	23	NC
PIN	15	22	RF-
LA	16	21	RFS
LAON	17	20	RF+
VREF1	18	19	GND2

• Pin Functions (UPC1347GS)

Pin No	Pin Name	I/O	Function and Operation
1	VCC		
2	BP-	Input	Vibration detect amplifier 1 inverter input
3	BPO	Output	Vibration detect amplifier 1 output
4	WC+	Input	Window comparator non-inverting input
5	WC-	Input	Window comparator inverter input
6	GND		GND
7	QDH	Input	Vibration detect amplifier 3 non-inverting input
8	QDO	Output	Vibration detect amplifier 3 output
9	A	Input	A signal input
10	C	Input	C signal input
11	B	Input	B signal input
12	D	Input	D signal input
13	E	Input	E signal input
14	F	Input	F signal input
15	PIN	Input	APC circuit PD amplifier input
16	LA	Output	APC circuit LD amplifier output
17	LAON		Laser diode ON/OFF switching
18	VREF1		Reference voltage
19	GND2		GND
20	RF+	Input	RF amplifier non-inverting input
21	RFS	Output	RF summing virtual output
22	RF-	Input	RF amplifier inverter input
23	NC		
24	RFO	Output	RF amplifier output
25	APC-	Input	APC circuit PD amplifier inverter input
26	TE2+	Input	Tracking error amplifier 2 non-inverting input
27	APCO	Output	APC circuit PD amplifier output
28	TE10	Output	Tracking error amplifier 1 output
29	TE2-	Input	Tracking error amplifier 2 inverter input
30	TE20	Output	Tracking error amplifier 2 output
31	VREF2		Reference voltage
32	FE2+	Input	Focus error amplifier 2 non-inverting input
33	FE1+	Input	Focus error amplifier 1 non-inverting input
34	FE10	Output	Focus error amplifier 1 output
35	FE2-	Input	Focus error amplifier 2 inverter input
36	FE20	Output	Focus error amplifier 2 output

IC601 : GGF9001

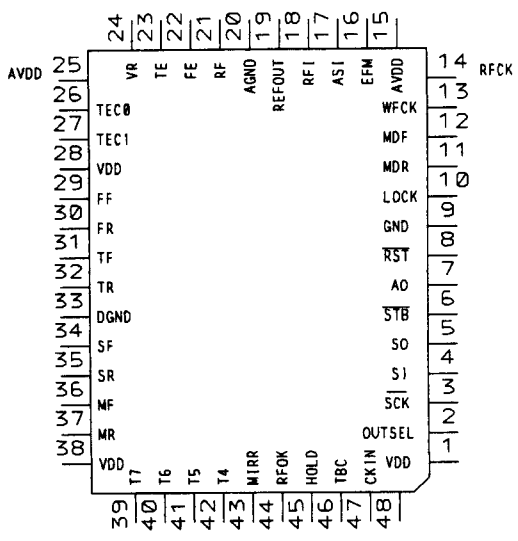

IC602, 652 : RC4558M

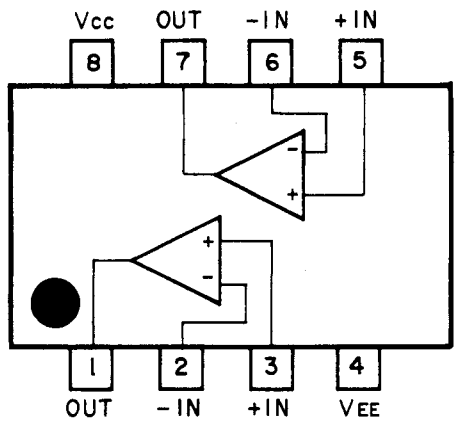

IC651 : PA3026

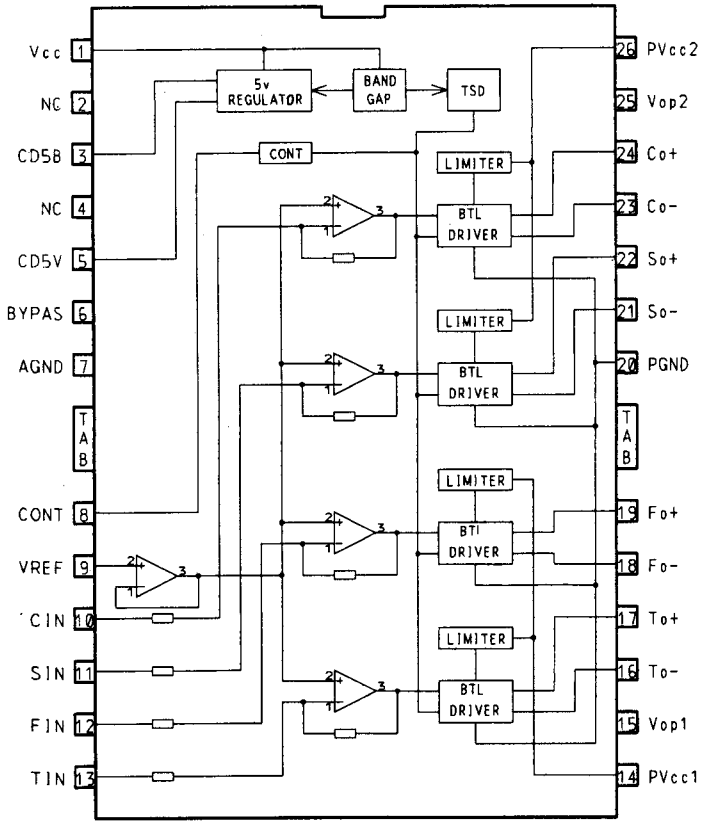

IC661 : TA78L05F

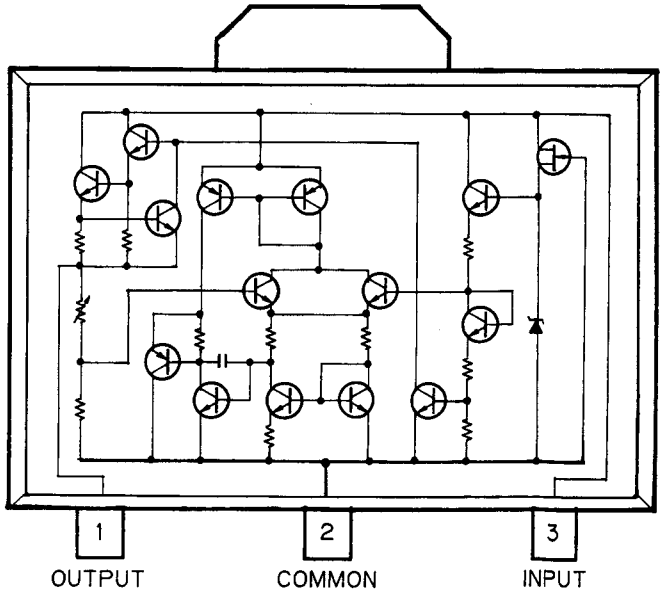

• Pin Functions (UPD6375GC)

Pin No	Pin Name	I/O	Function and Operation
1	NC		
2	WDCK	Output	Output terminal for signal having double the frequency of LRCK
3	C4LR	Output	Output terminal for signal having four the frequency of LRCK
4	RFCK	Output	Oscillation clock divider signal, output terminal for signal giving one-frame synchronization
5	EFMI	Input	EFM signal input terminal
6	TEST		TEST
7	VSS		GND
8	C1D1	Output	Output terminal indicating C1 error correction status
9	C1D2	Output	
10	C2D1	Output	
11	C2D2	Output	
12, 13	NC		
14	STBY	Input	Standby input terminal. STBY=H stops clock oscillation
15	NC		
16	PLK1	Output	VCO output terminal for use in analog PLL selection
17	VDD		VDD
18	PLK8	Input	VCO clock input terminal for use in analog PLL selection
19	PLCK	Output	Bit clock monitor terminal
20	VSS		GND
21	POUT	Output	Output terminal for phase comparison between EFM signal and bit clock
22	WFCK	Output	Signal issuing one-frame period (approximately 7.35kHz) by bit clock dividing signal
23	VDD		5 V
24	MD	Output	Signal indicating spindle motor CLV servo control output status
25	MDF	Output	Spindle motor CLV servo control positive direction output terminal
26	MDR	Output	Spindle motor CLV servo control negative direction output terminal
27	LOCK	Output	Becomes "H" when the synchronization signal and frame counter output coincide at EFM demodulator
28	RST	Input	Reset signal input terminal
29	AO	Input	Control signal distinguishing data from microcomputer
30	STB	Input	Signal latching within this LSI the serial data fetched from SI terminal
31	SO		Serial data input terminal
32	SI	Input	Input terminal fro data from microcomputer
33	VSS		GND
34	SCK	Input	Clock input terminal for serial data input
35	TX	Output	Digital audio interface data output terminal
36	MUTE/EMPH	Output	Output terminal for mute command decoding signal or sub-Q command pre-emphasis data
37	SFSY	Output	Signal indicating subcode one-frame synchronization
38	SBSY	Output	Signal indicating head of subcode block
39	SBCK	Input	Subcode data read clock input terminal
40	SBSO	Output	Subcode data output terminal
41	VDD		5 V
42	XTAL	Output	Oscillation continuation terminal
43	XTAL	Input	Oscillation continuation terminal

Pin No	Pin Name	I/O	Function and Operation
44	VSS		GND
45	C16M	Output	Oscillation clock output terminal
46	VDD		5 V
47	C4M	Output	1/4 cycle output terminal for oscillation clock signals
48	FLAG	Output	Flag signal indicating that the current audio data output consists of incorrectable data
49	SCKO	Output	Clock output terminal for audio serial data
50	DOUT	Output	Serial audio data output terminal
51	LRCK	Output	Signal distinguishing between left and right channel DOUT terminal output
52	NC		

IC701 : UPD6375GC

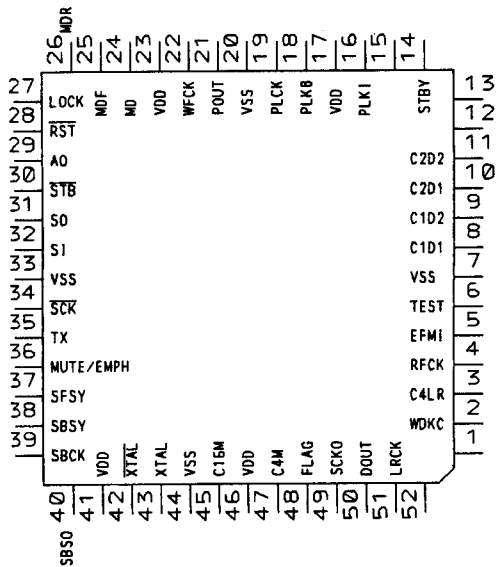

IC702 : TC9237F

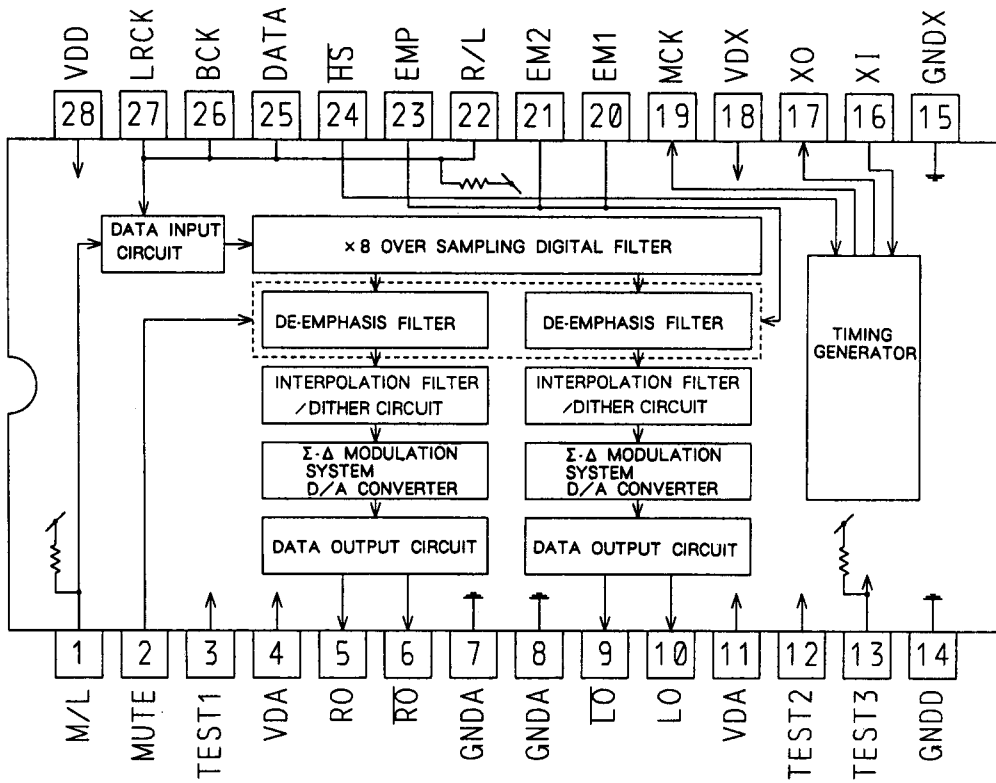

IC703 : TA2009F

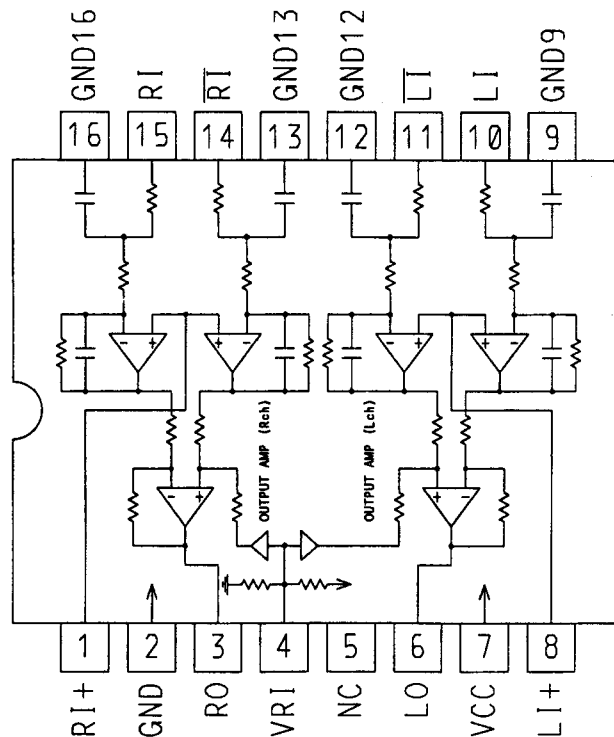

●Pin Functions (PD5180A)

Pin No.	Pin Name	I/O	I/O Format	Function and Operation
1	TIN	Input		Disc position detector switch
2	TEMP			Temperature detector
3	VMIN			Mechanism power supply detector input
4	C/D	Output	NM	Command/data appointment output
5	DCS	Output	NM	Chip select output
6	DRDY	Input		Ready input
7	DRST	Output	NM	Reset output
8	AO	Output	NM	LSI data control signal
9	XSCK	Input/ Output		LSI clock input/output
10	XSO	Output	NM	LSI data output
11	XSI	Input	NM	LSI data input
12	STB	Output	C	LSI strobe output
13	RST	Output	C	Reset output pin
14	ENDOUT	Output	C	Digital output enable signal
15, 16	NC			
17	BSENS	Input		Back up power sense input pin
18	BRST	Input		Bus communication reset input pin
19	BSRQ	Output	C	Bus communication service request output pin
20	BRXEN	Input/ Output	C	Bus communication reception enable input pin
21	BSCK	Input/ Output	C	Bus serial clock input/output
22	BSO	Output	C	Serial data output pin
23	BSI	Input		Bus serial data input
24	EJSW	Input		Eject signal input
25	MAG	Input		Magazine lock switch
26	CNVSS			GND
27	RESET	Input		Reset input
28	FECNT	Output	C	DEFECT port
29	NC			Not used
30	XIN	Input		Crystal oscillating element connection pin
31	XOUT	Output	C	Crystal oscillating element connection pin
32	VSS			GND
33-40	D7-D0	Input/ Output		External RAM data line
41	POWER	Output	C	CD +5V control
42	CONT	Output	C	Servo driver power supply control
43	WE	Output	C	External RAM write enable
44	PROT	Output	C	External RAM output enable
45	CS	Output	C	External RAM chip select
46-56	A10-A0	Output	C	External RAM address line
57	HOLD	Output	C	Hold control output
58	TBC	Output	C	Tracking bank switching output
59	NC			Not used
60	MIRR	Input		Mirror detector input
61	LOCK	Input		Spindle lock detector input
62	FOK	Input		FOK signal input
63	HOME	Input		Home position detector input
64	NC			Not used

Pin No.	Pin Name	I/O	I/O Format	Function and Operation
65	LOAD	Output	C	Mechanism power supply control
66-68	I2-I0	Output	C	Motor driver control
69	OPTSW	Input		Digital output ON/OFF input
70	CDMUTE	Output	C	CD mute output
71	ADENA	Output	C	A/D reference voltage output
72	TESTIN	Input		Test program mode input
73	VCC			Back up 5V
74	VREF	Input		A/D reference voltage input
75	AVSS			A/D GND
76	CSEL			Compression select
77	EJP			Eject position switch
78	DISK	Input		Disc detector input
79	TSEL	Input		Tray position detector photosensor
80	TOUTS	Input		Tray position detector switch

I/O Format	Meaning
C	CMOS output
NM	Middle resistivity N channel open drain

*IC751 : PD5180A

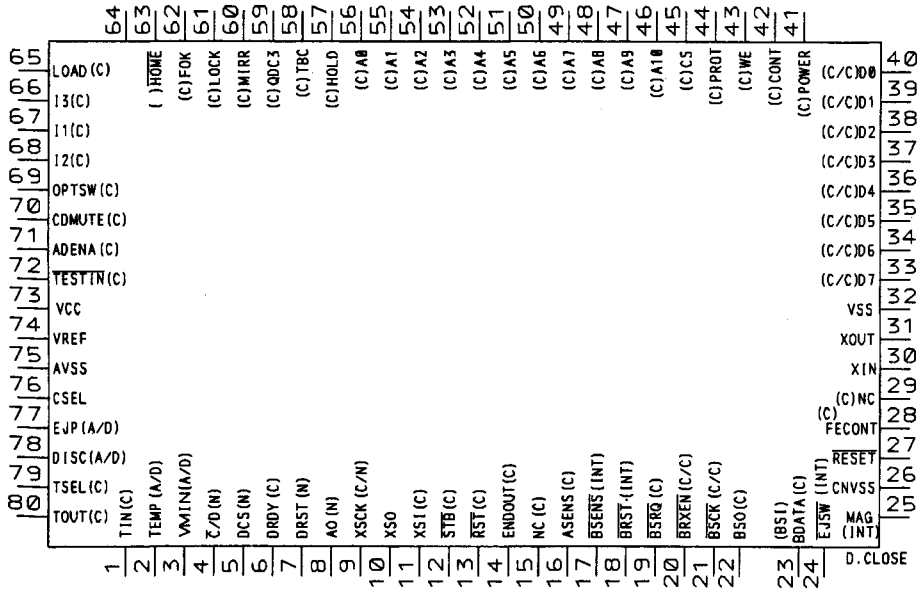

IC's marked by * are MOS type.
Be careful in handling them because they are very liable to be damaged by electrostatic induction.

IC755 : LH5116HN-10T

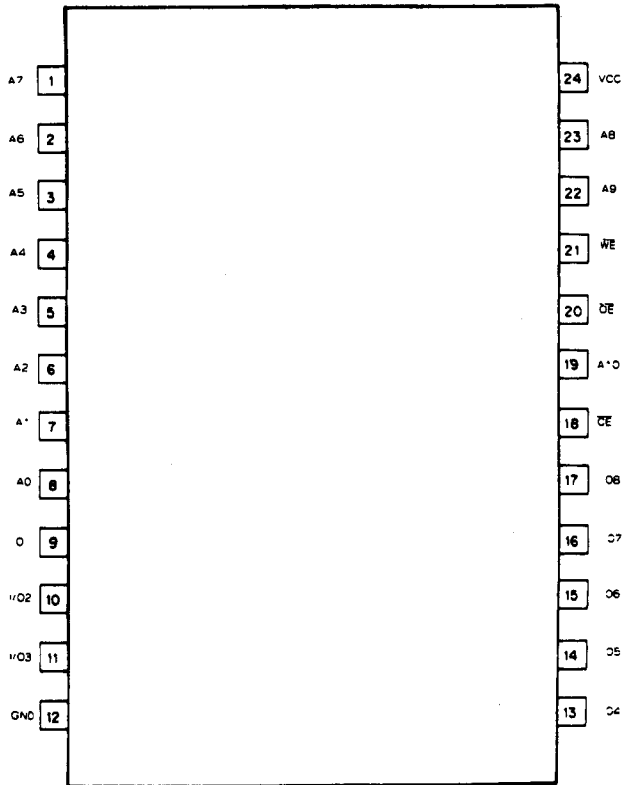

IC801 : XRA6247FP

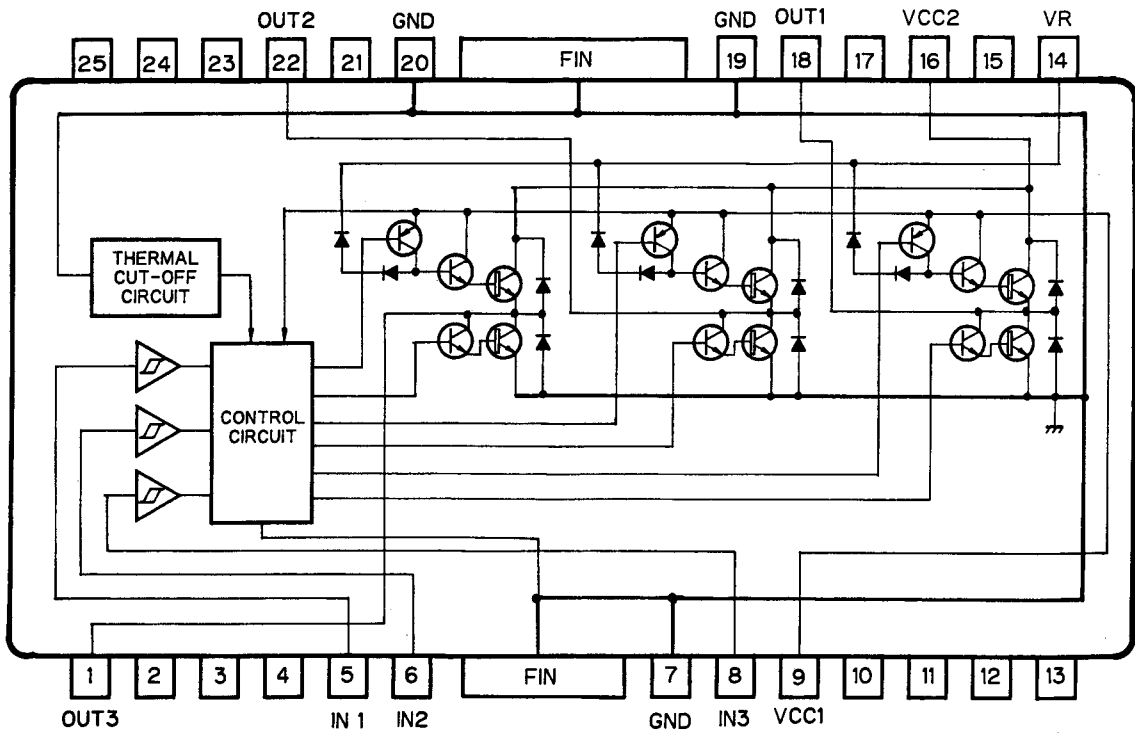

IC971 : M5218AL

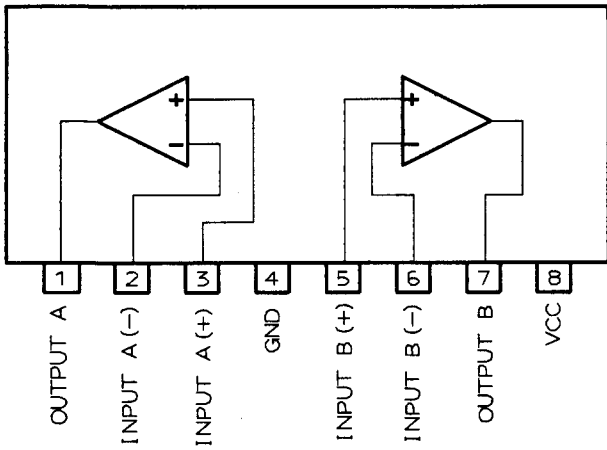

IC972 : BA3121

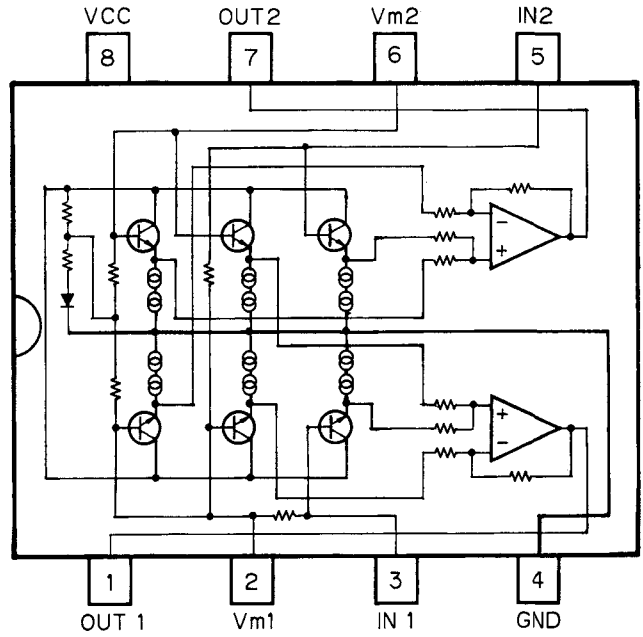

IC981 : M51957AL

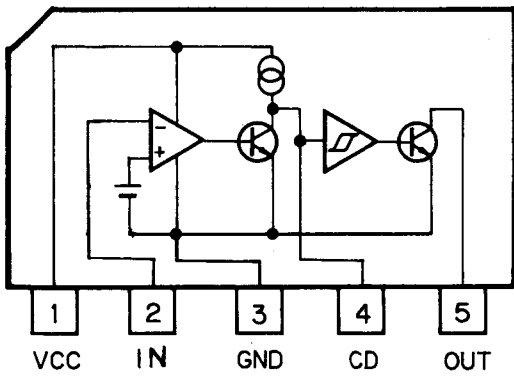

IC982 : M51958AL

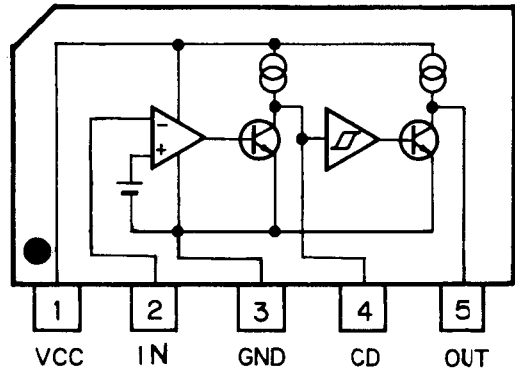

Note: 1. The encircled numbers denote measuring pointes in the circuit diagram.
 2. Reference voltage
 REFOUT: 2.5V

• Wave Forms

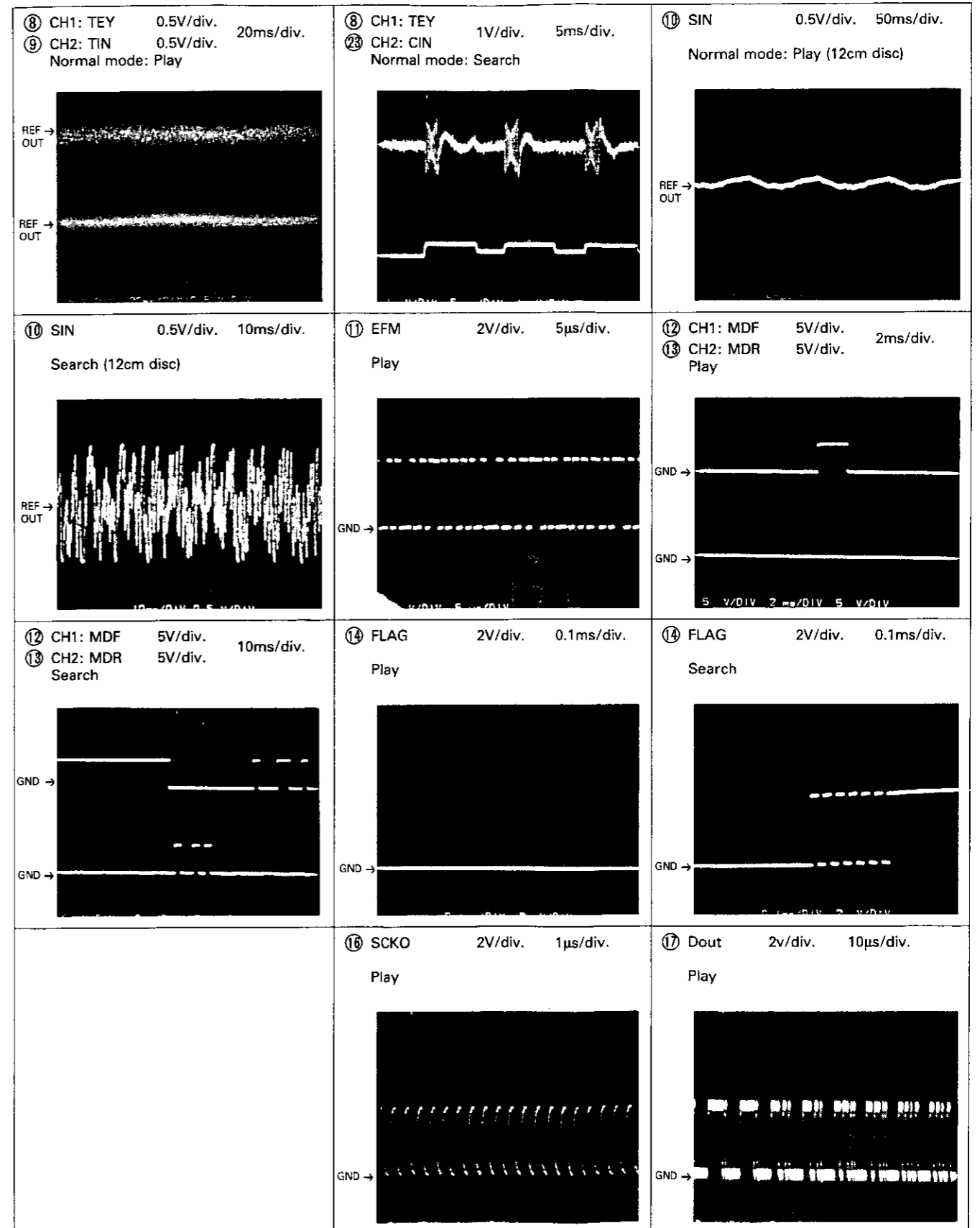
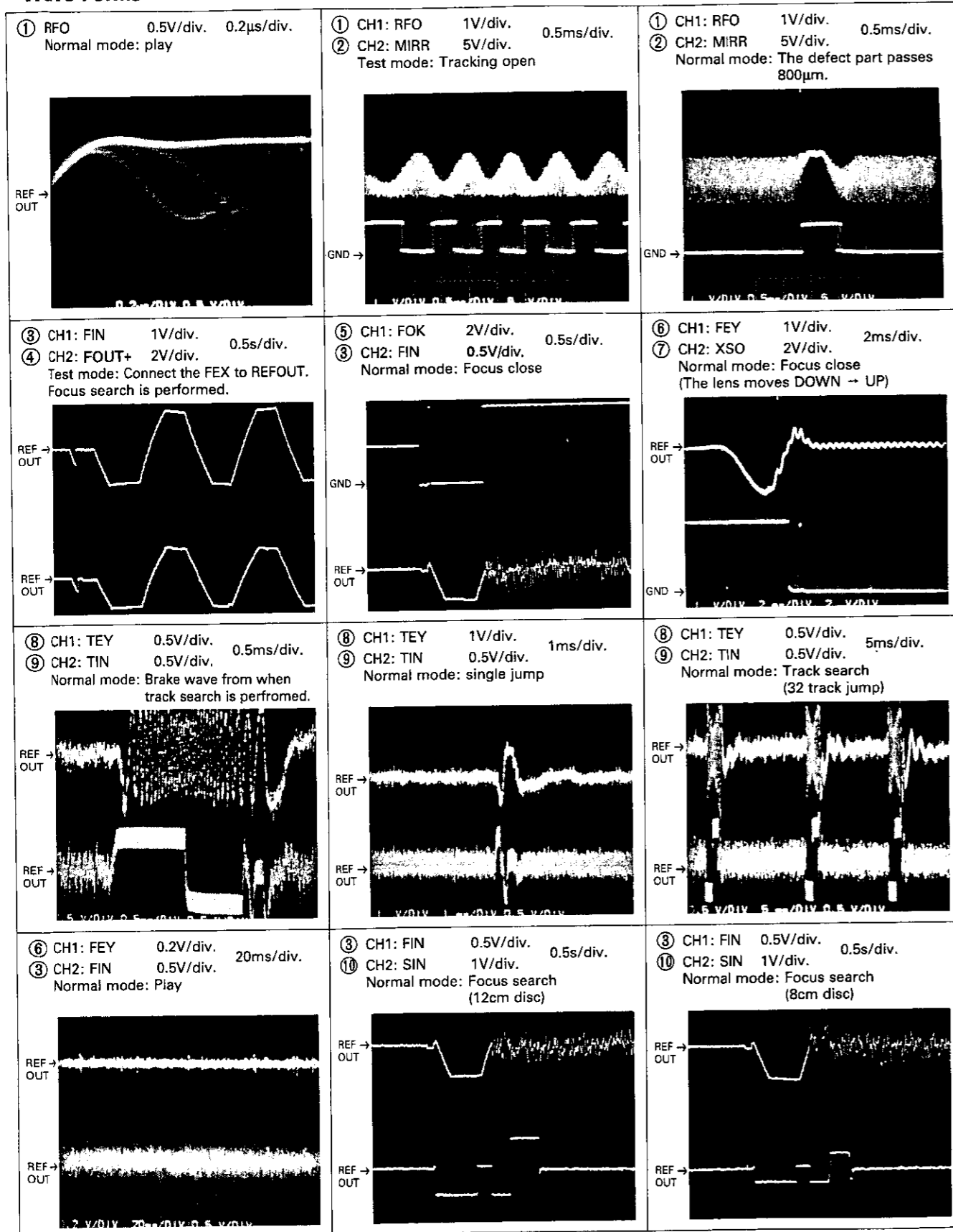

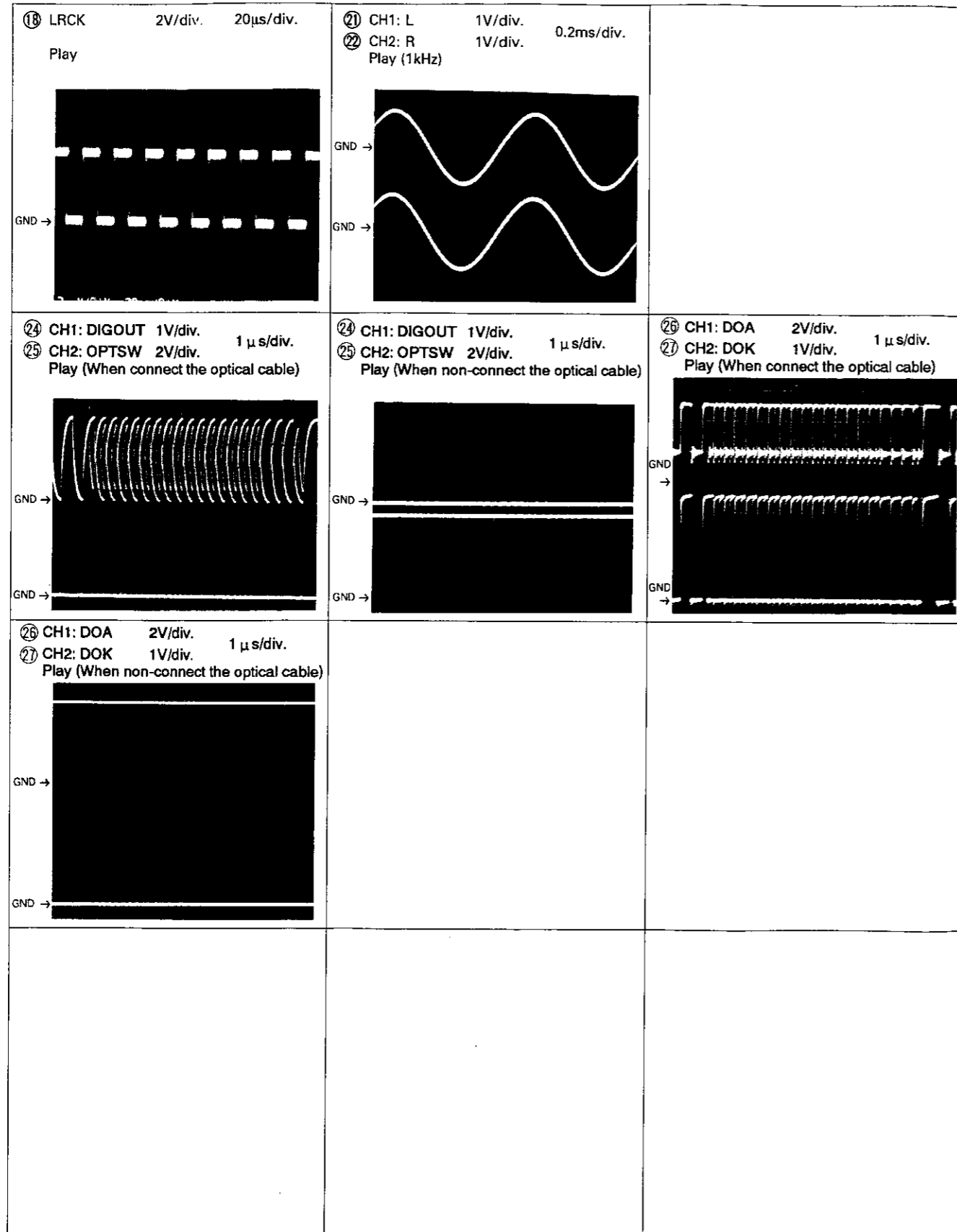

8. CONNECTION DIAGRAM (1)

MAIN UNIT

IC, Q	IC755	IC703 IC751	IC702	Q705 Q802 Q601	Q751 IC661 IC704 Q801 IC701 IC601 Q6E	Q651
ADJ						VR355 VR352

PU UNIT

A

B

C

D

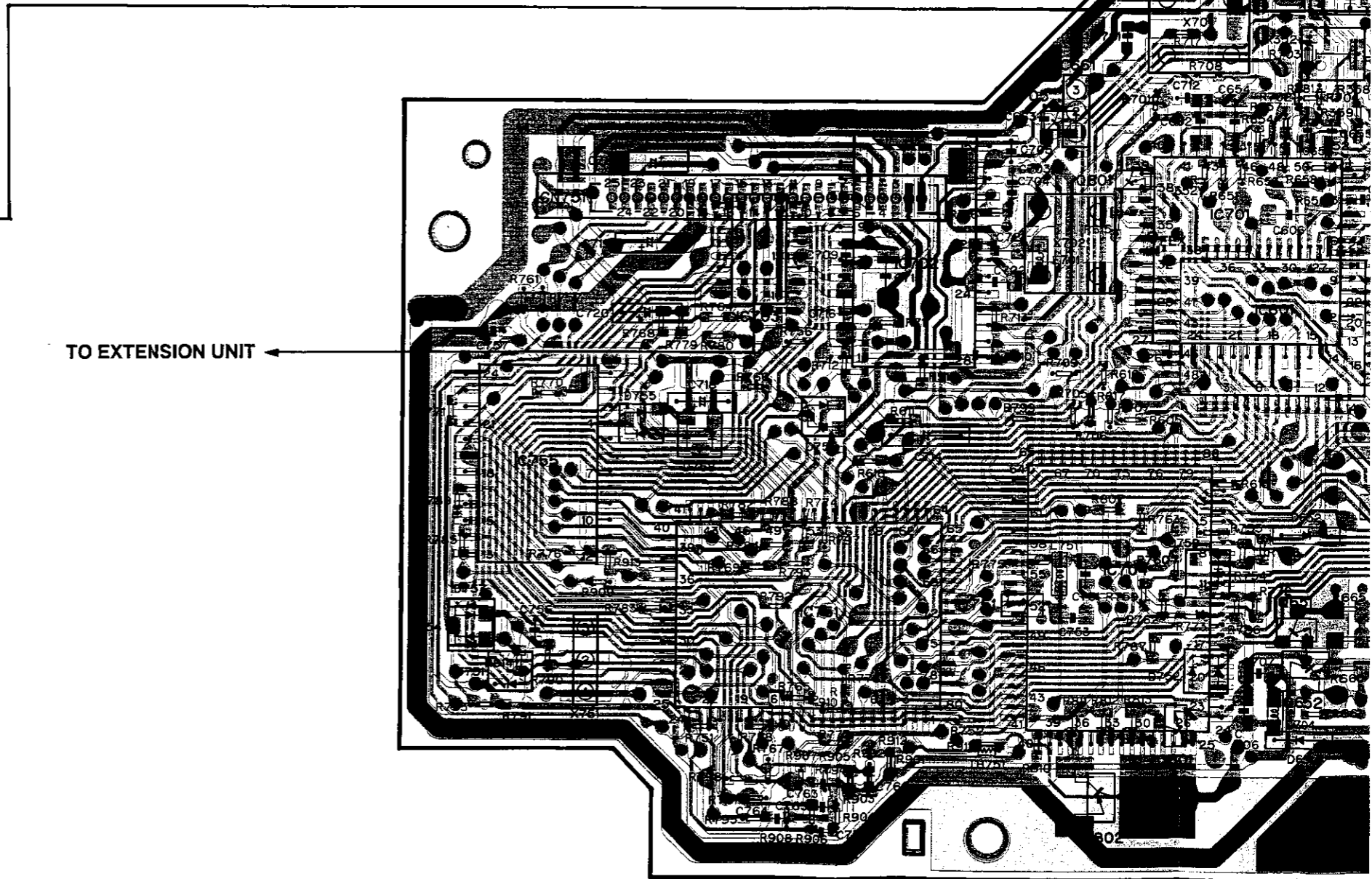
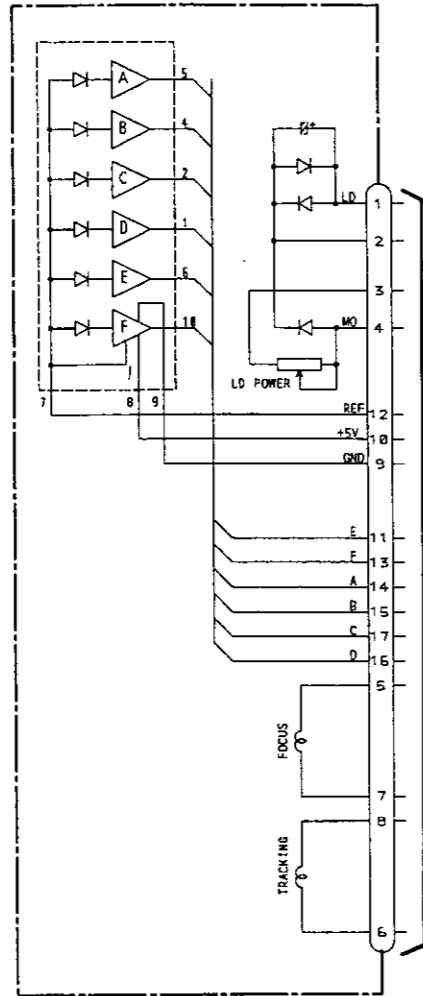

TO EXTENSION UNIT

Q2 Q601 Q651 IC351
 IC704 Q801 IC701 IC601 Q652 IC652 Q653 IC602 Q803 IC651 IC801 Q351

VR355 VR353 VR356 VR351
 VR352 VR354

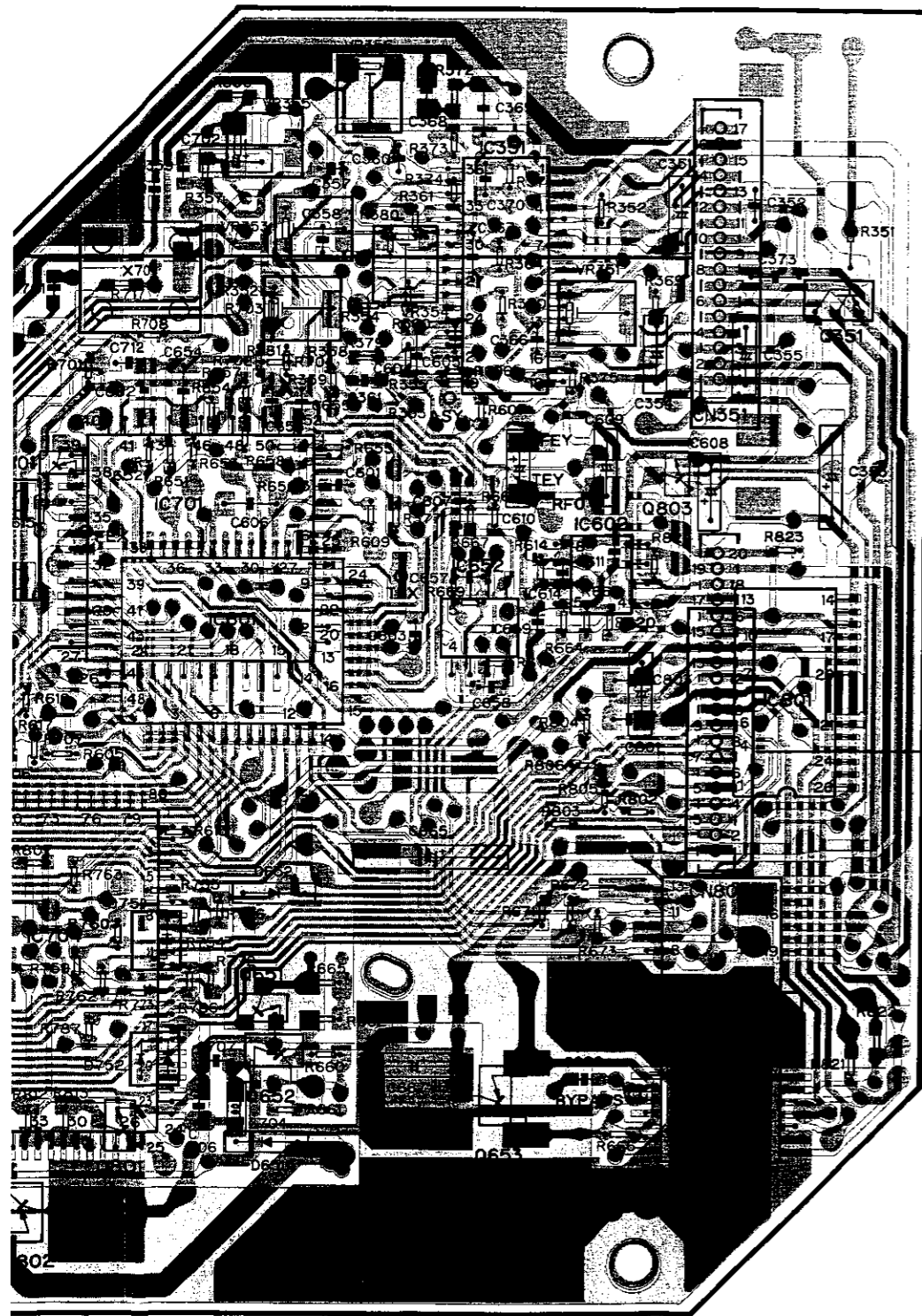
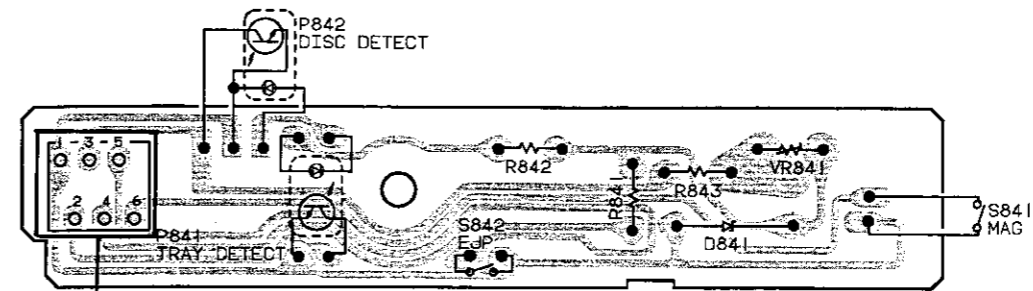
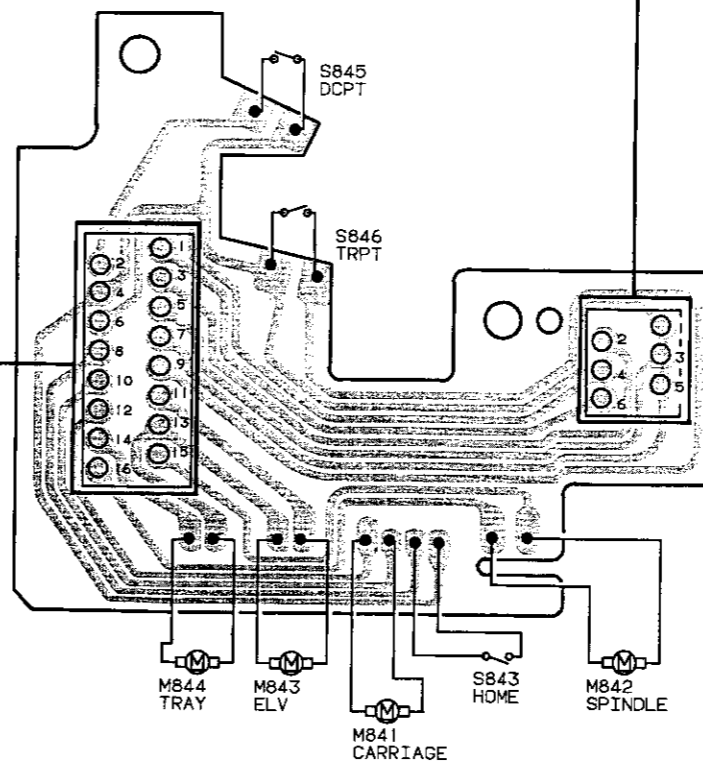

PHOTO P.C. BOARD



MECHANISM P.C. BOARD



A

B

C

D

Fig. 32

9. SCHEMATIC CIRCUIT DIAGRAM (1)

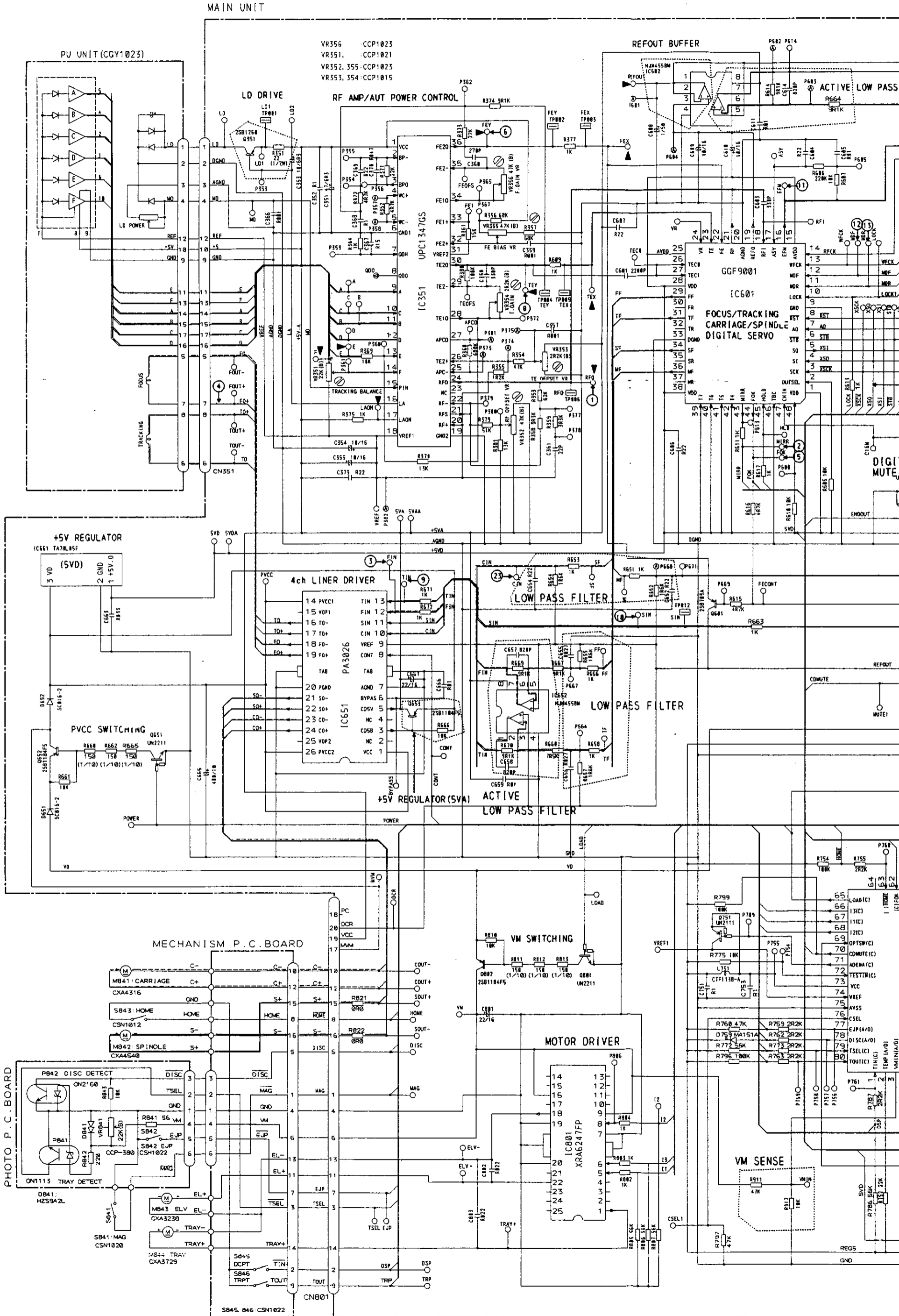

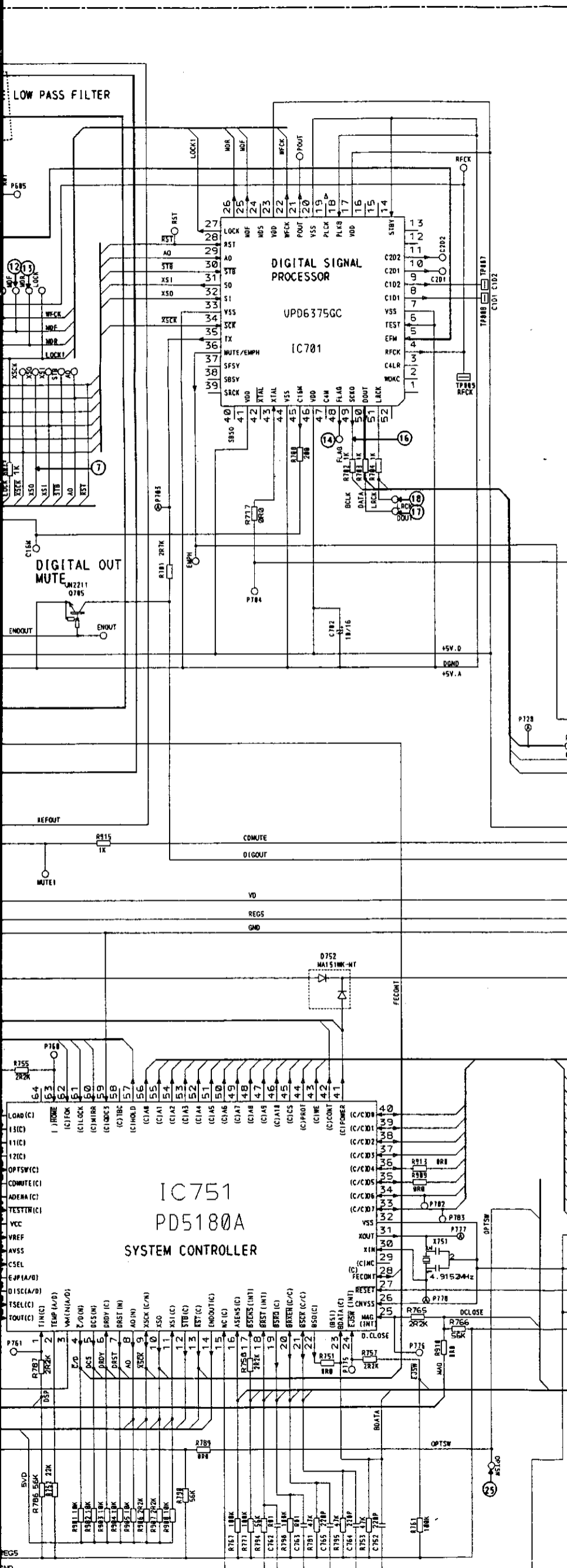

- SWITCHES**
MECHANISM P.C. BOARD
SB45: DCPN SWITCH... ON-OFF
SB46: TRPN SWITCH... ON-OFF
PHOTO P.C. BOARD
SB41: MAG SWITCH... ON-OFF
SB42: EJP SWITCH... ON-OFF
MISCELLANEOUS
SB43: HOME SWITCH... ON-OFF

The underlined indicates the switch position.

- NOTE:**
- Symbol indicates a resistor. No differentiation is made between chip resistors and discrete resistors.
 - |— Symbol indicates a capacitor. No differentiation is made between chip capacitors and discrete capacitors.

- SIGNAL LINE
- - - FOCUS SERVO LINE
- FOCUS SERVO LINE
- - - TRACKING SERVO LINE
- TRACKING SERVO LINE
- SPINDLE SERVO LINE

Decimal points for resistor and capacitor fixed values are expressed as:
2.2→2R2
0.022→R022

TO EXTENSION UNIT

Fig. 33

10. CONNECTION DIAGRAM (2)

• CDX-M30/UC, EW, ES

A

B

C

D

KEY UNIT

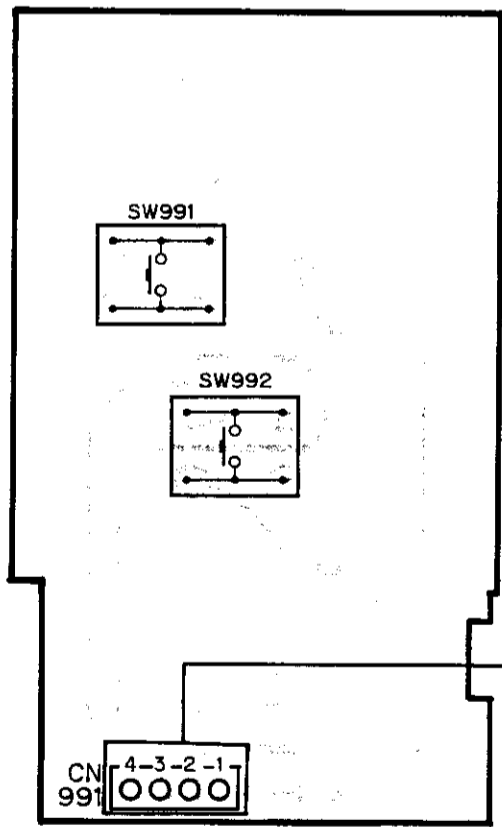

EXTENSION UNIT

IC, Q	Q992	IC982	IC971	Q98
Q981	Q987	Q981	Q991	Q990

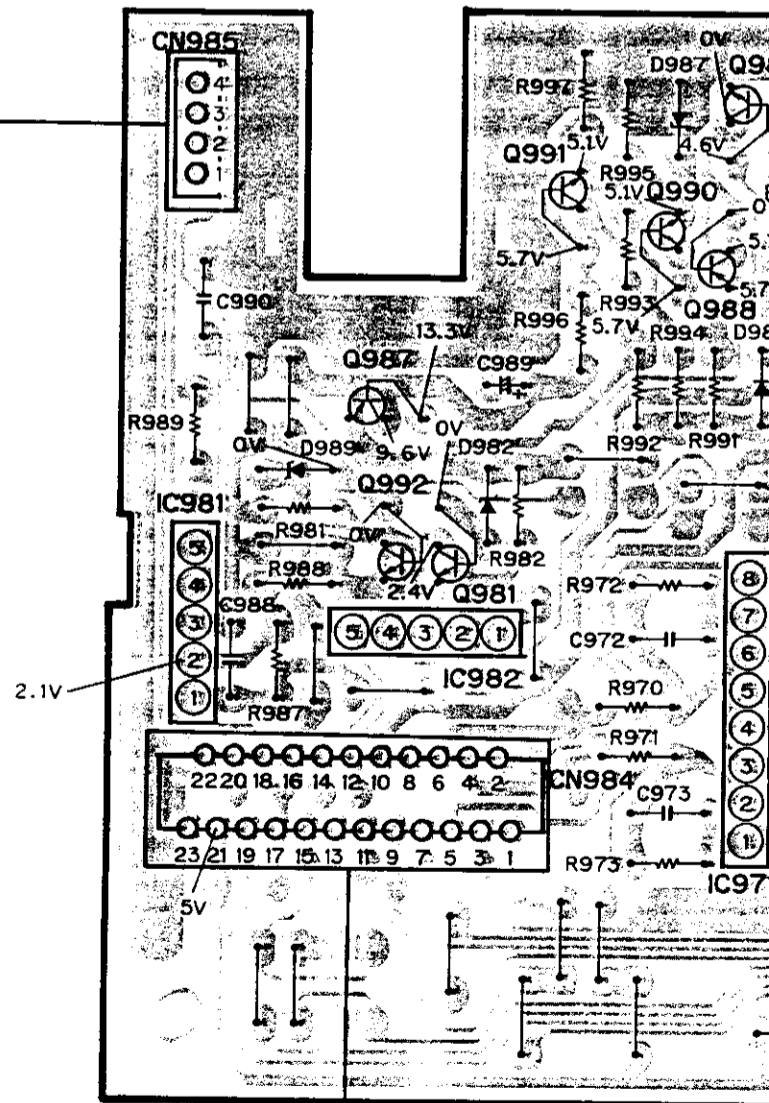

TO MAIN UNIT

71 Q989 IC972 Q985 Q970 Q971
 90 Q988 Q983 Q986 Q984 Q972 Q973 Q961

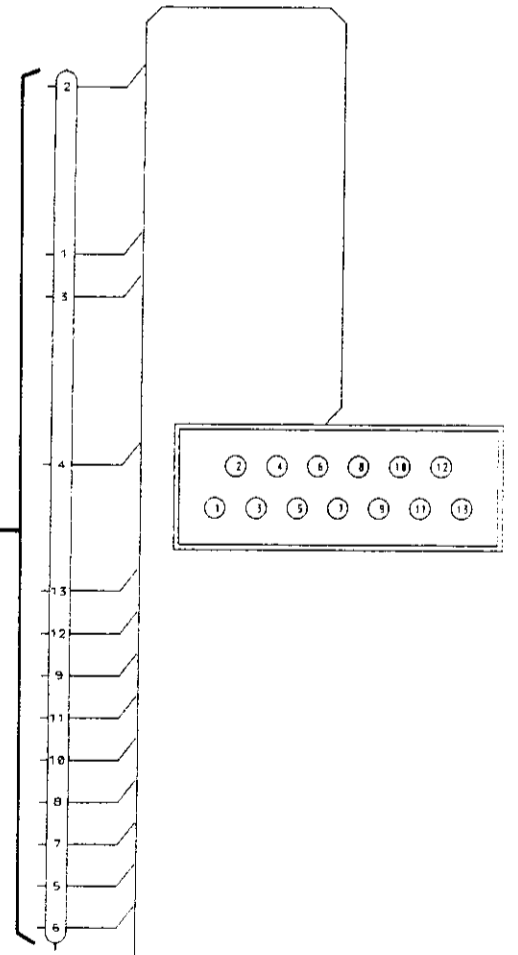
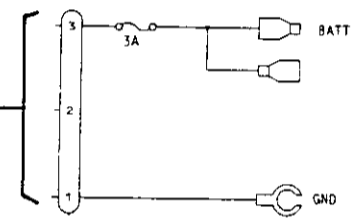
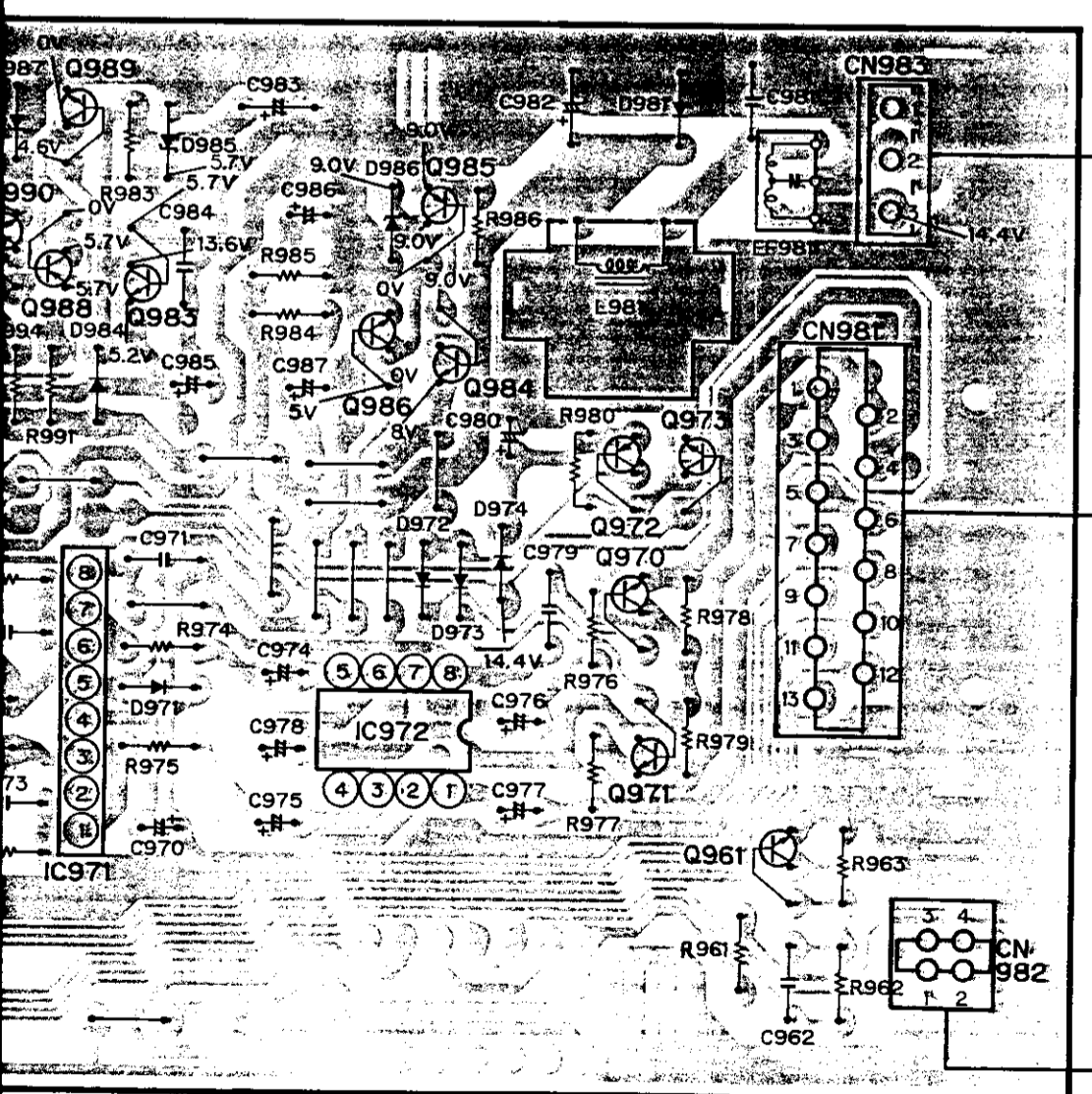
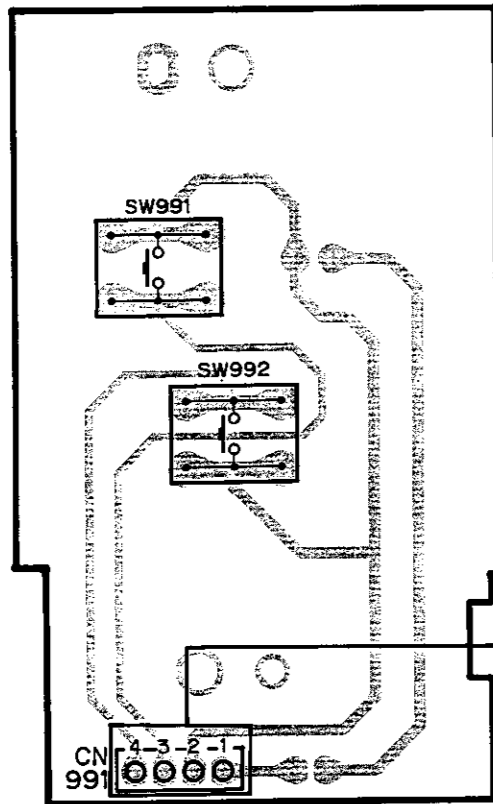

Fig. 34

10. CONNECTION DIAGRAM (2)

● CDX-M30/UC, EW, ES

KEY UNIT



EXTENSION UNIT

IC, Q IC981	Q992 IC982 Q987 Q981 Q991	IC971 Q989 Q990 Q988 Q983	IC972 Q985 Q986 Q984	Q970 Q971 Q972 Q973 Q961
-------------	------------------------------	------------------------------	-------------------------	-----------------------------

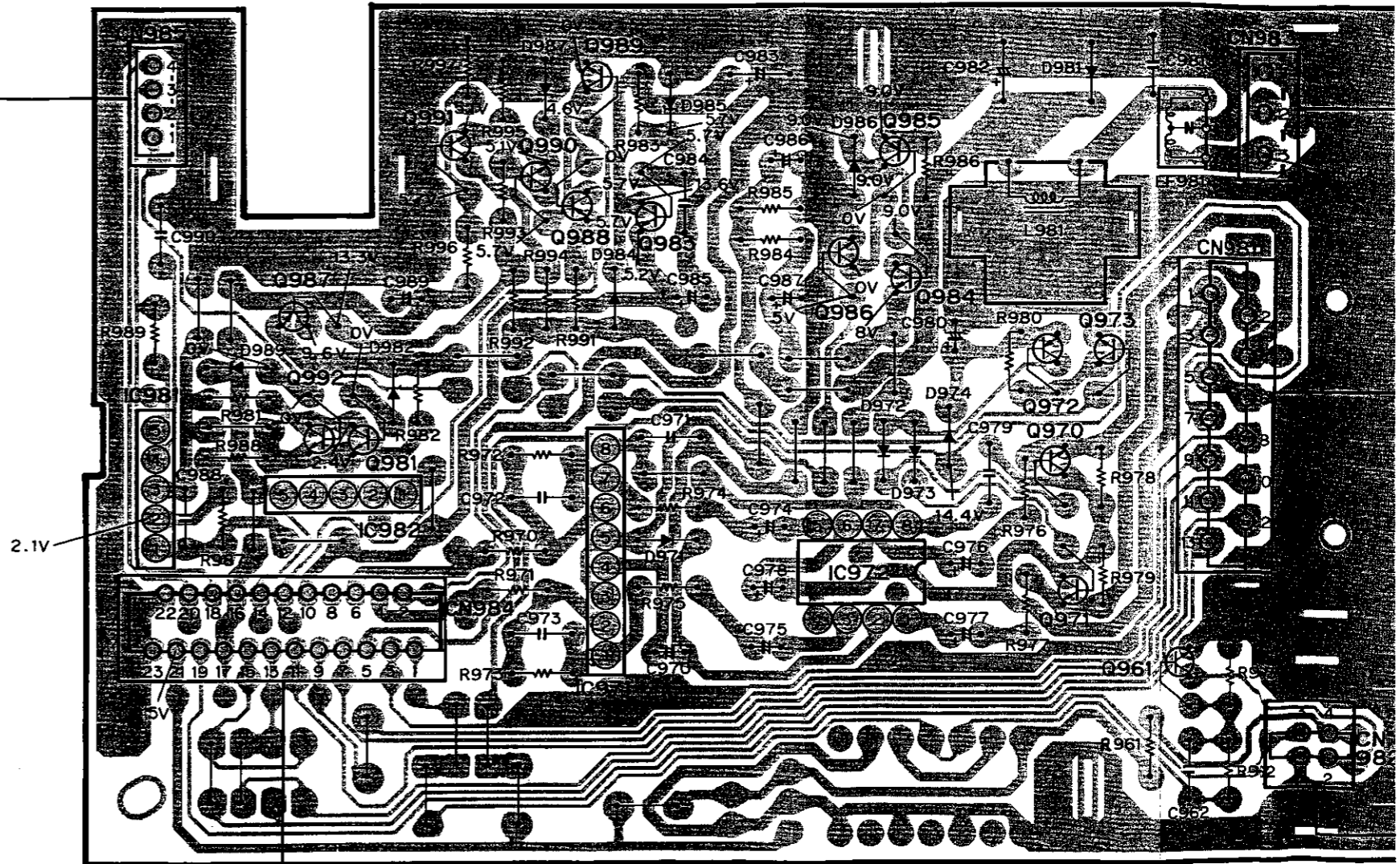

TO MAIN UNIT

11. SCHEMATIC CIRCUIT DIAGRAM (2)

• CDX-M30/US, EW, ES

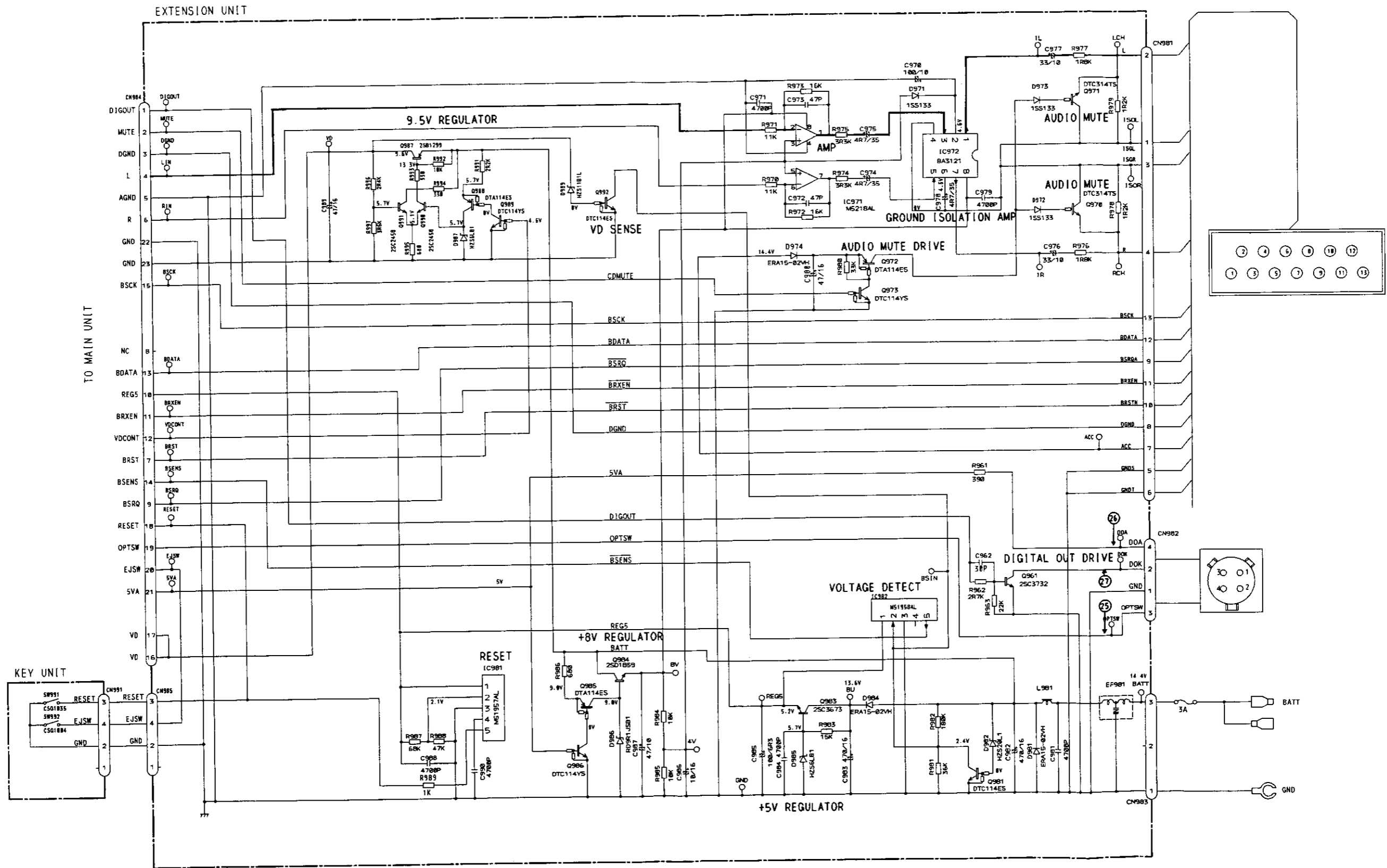

Fig. 35

A

B

C

D

EXTENSION UNIT

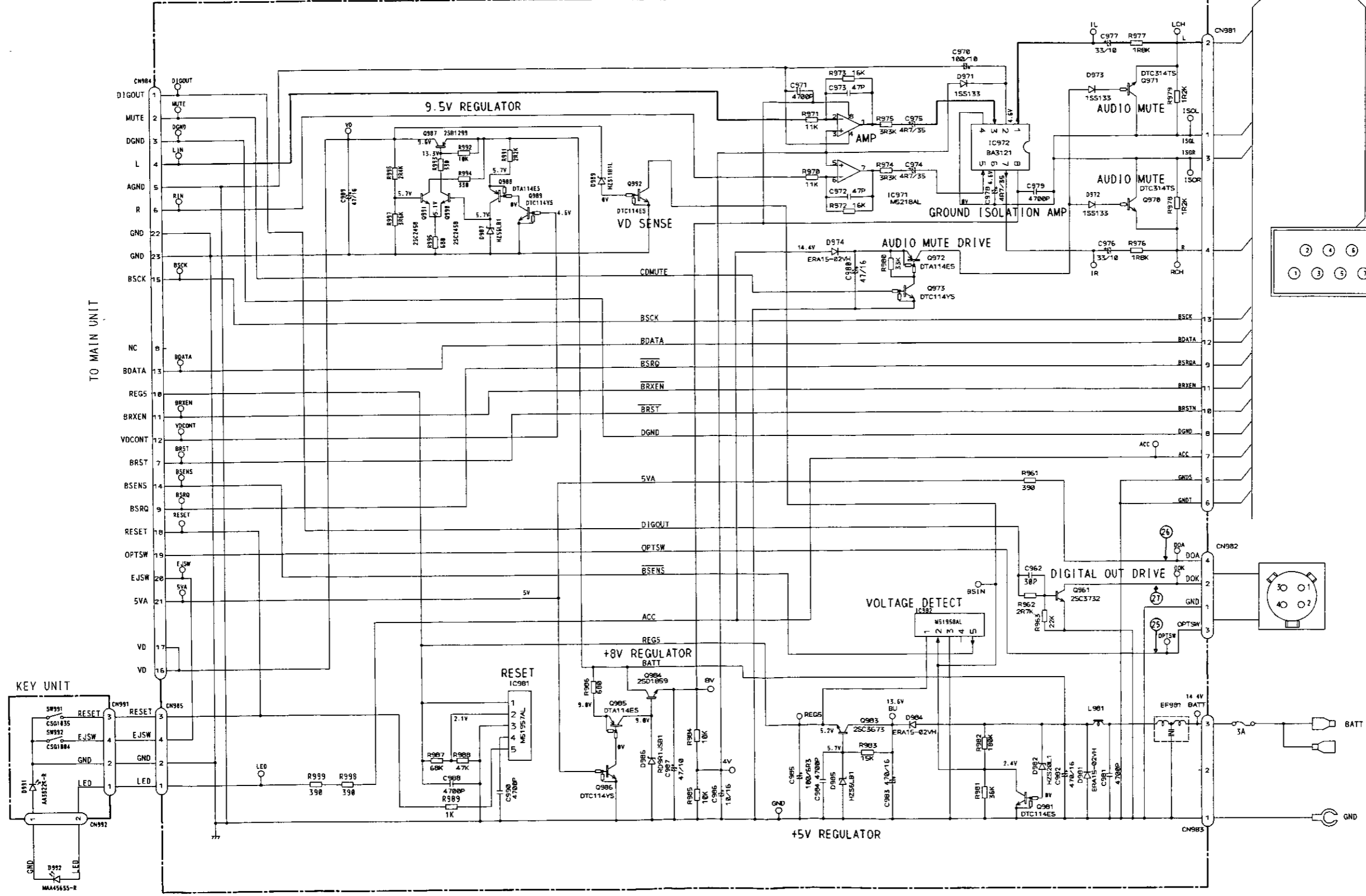

A

B

C

D

Fig. 36

•CDX-M33/US

A

EXTENSION UNIT

IC, Q IC981	Q992 IC982 Q987 Q981 Q991	IC971 Q989 Q990 Q988 Q983	IC972 Q985 Q986 Q984	Q970 Q971 Q972 Q973 Q961
-------------	------------------------------	------------------------------	-------------------------	-----------------------------

KEY UNIT

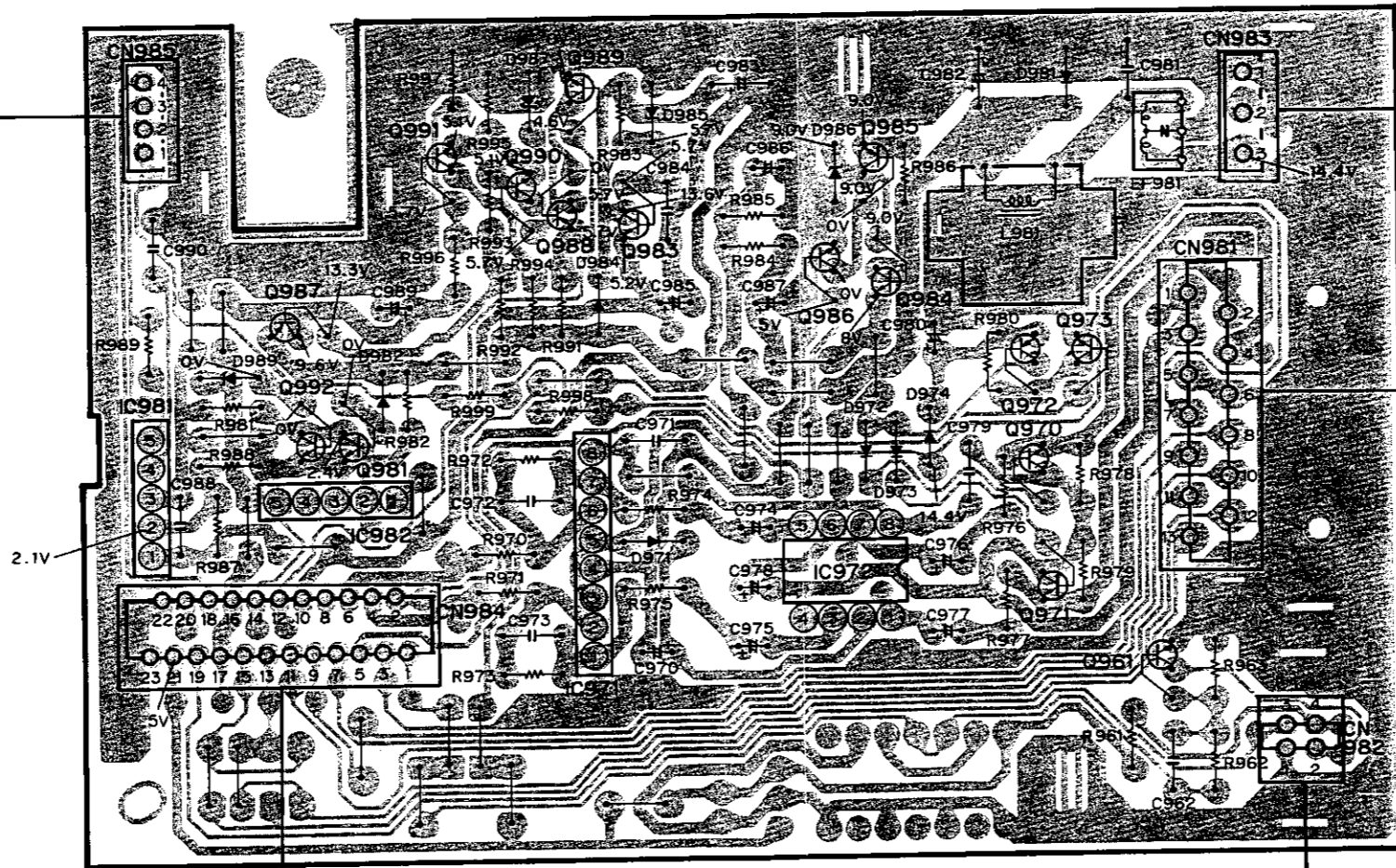
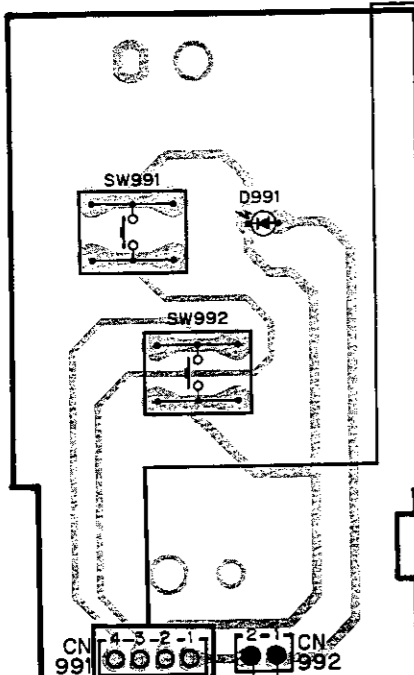

2.1V

TO MAIN UNIT

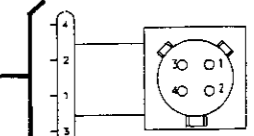
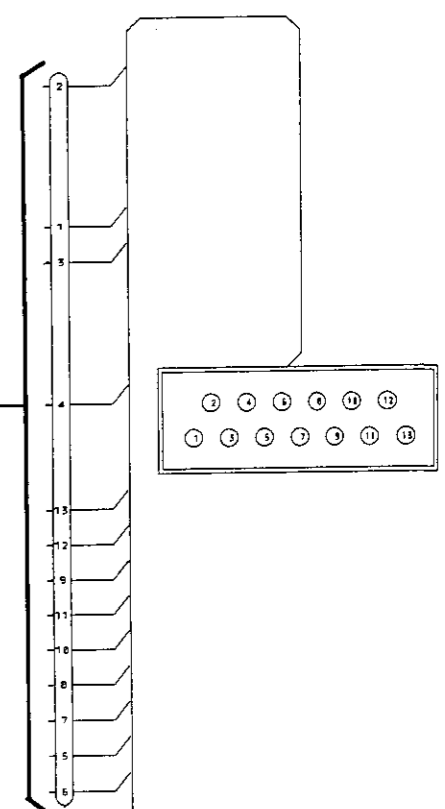
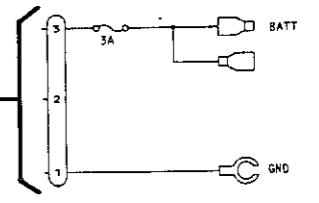

B

C

D

A

B

C

D

Fig. 27

12. CD MECHANISM UNIT EXPLODED VIEW

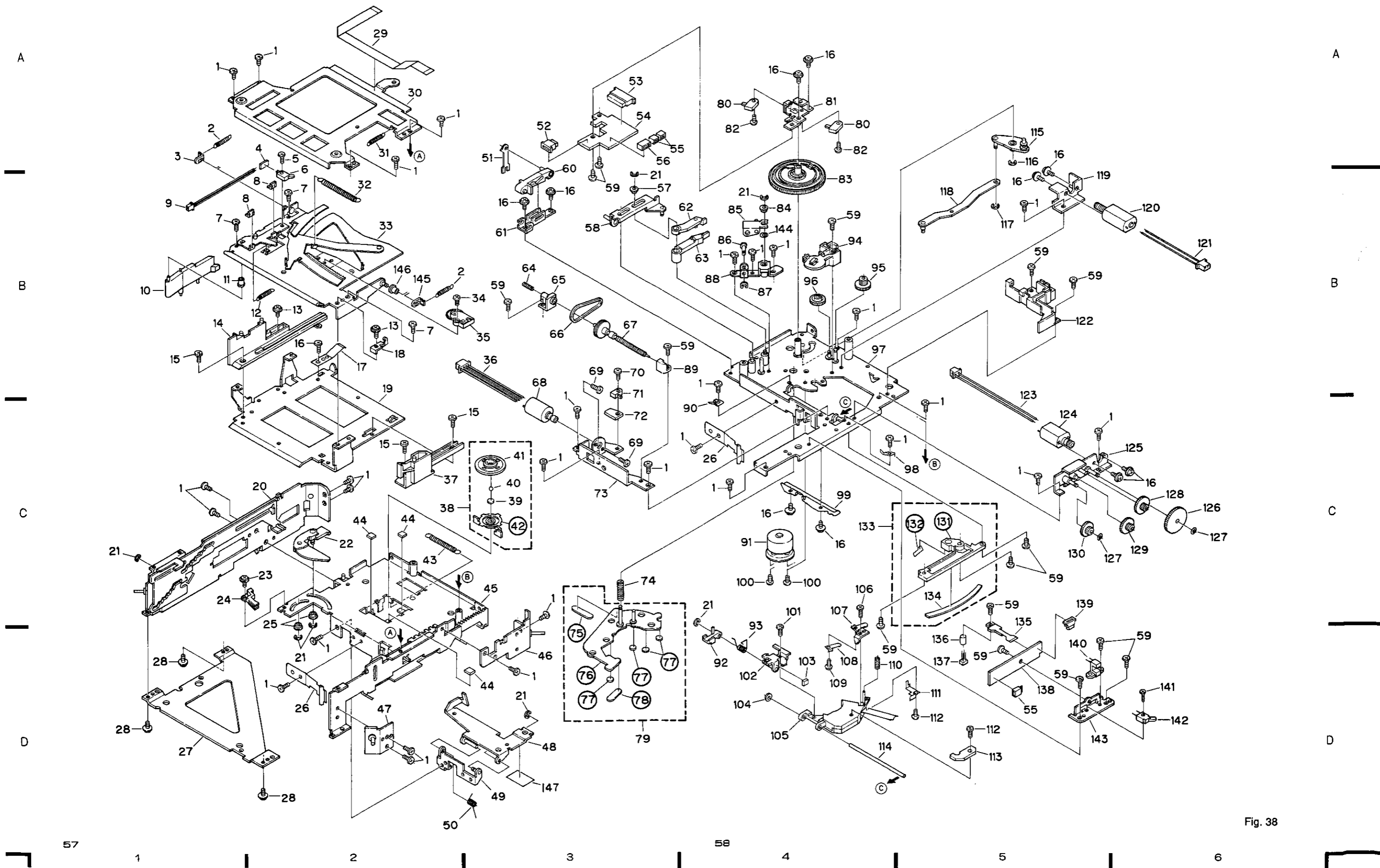

Fig. 38

NOTE:

- The parts marked with "⊙" may need long time to supply and their supply is subject to refuse as the case may be.
- Because the parts with encircled number shown on the dismantling drawing are not spare parts, we are unable to supply them in principle.

● Parts List

Mark No.	Description	Part No.	Mark No.	Description	Part No.	Mark No.	Description	Part No.	Mark No.	Description	Part No.
1	Screw	BMZ26P030FMC	41	Guide	CNV2739	81	Cam Gear Bracket	CNC3964	116	Washer	YE20FUC
2	Holder Spring	CBH1324	42	Clamper Bracket Unit	CXA3237	82	Screw (M2×5)	CBA1054	117	Washer	YE25FUC
3	Spring Holder	CNC3054	43	Spring	CBH1436	83	Cam Gear	CNV2963	118	Lever Unit	CXA3542
4	Gathering P. C. Board	CNX1840	44	Cushion	CNM2555	84	Collar	CLA1977	119	TRY Bracket	CNC3963
5	Screw (M1.7×5.5)	CBA1070	45	Lower Chassis Unit	CXA4372	85	Disc UP Arm Unit	CXA4382	120	TRAY Motor Unit (M844)	CXA3729
6	Switch (S841)	CSN1020	46	Damper Bracket Unit	CXA4381	86	Shaft	CLA1962	121	Connector	CDE3151
7	Spring (M2×3)	CBA1152	47	Damper Bracket Unit	CXA4376	87	Washer	YE20FUC	122	Guide	CNV2958
8	Clamper	CNV2722	48	Clamper Arm Unit	CXA4958	88	Disc-up Bracket Unit	CXA4375	123	Connector	CDE3150
9	Connector	CDE2701	49	Clamper Arm Bracket Unit	CXA4378	89	CRG Holder	CNV2965	124	Motor Unit (M843 ELV)	CXA3238
10	Lock Arm	CNV3215	50	Clamp Spring	CBH1321	90	Spring	CBL1135	125	ELV Bracket Unit	CXA4380
11	Roller	CLA2034	51	Lever	CNC3038	91	Motor Unit (M842)	CXA4540	126	Gear	CNV2962
12	Lock Spring	CBH1320	52	Plug (6P)	CKS1526	92	Rack	CNV2972	127	Washer	CBF1038
13	Screw	CBA1075	53	Plug	CKS1536	93	Spring	CBH1432	128	Gear	CNV2363
14	Magazine Guide	CNV2369	54	Gathering P. C. Board	CNX1778	94	Guide	CNV2971	129	Gear	CNV2371
15	Screw (M2×3)	CBA1077	55	Plug (2P)	CKS1049	95	Wheel	CNV2359	130	Gear	CNV2364
16	Screw	PMS20P025FMC	56	Plug (4P)	CKS1051	96	Gear	CNV2360	131	Disc Guide	CNV2966
17	Spring	CBL1145	57	Collar	CLA1846	97	Main Chassis Unit	CXA4371	132	Sheet	CNM3179
18	Spring Bracket	CNC4323	58	Cam Lever Unit	CXA4012	98	Spring	CBL1133	133	Disc Guide Assy	CXA4383
19	Magazine Holder	CNC4287	59	Screw (M2.6×5)	CBA1180	99	Cover	CNC3968	134	Sheet	CNM2553
20	Side Frame Unit	CXA4373	60	Cam Arm	CNV2736	100	Screw	HBA-258	135	P. C. Board	CNP2806
21	Washer	YE15FUC	61	Cam Lever Bracket	CNC3682	101	Screw (M2×3)	CBA1062	136	Spacer	CNV2365
22	Arm	CNV2352	62	SW Arm	CNV2964	102	CRG Holder Unit	CXA4379	137	Photo-interrupter (P842)	ON2160
23	Screw (M2×5)	CBA1080	63	SW Arm	CNV2959	103	Spacer	CNT1052	138	Gathering P. C. Board	CNX1780
24	Arm Guide	CNV2372	64	Spring	CBH1104	104	Cushion	CNV1863	139	Plug (4P)	CKS1526
25	Roller	CLA1846	65	CRG Holder	CNV2961	105	PU Unit	CGY1023	140	Photo-interrupter (P841)	ON1113
26	Spring	CBL1134	66	Belt	CNT1053	106	Screw	JGZ20P070FNI	141	Screw (M1.7×6)	CBA1163
27	Lower Frame	CNC3456	67	Screw Unit	CXA2375	107	Holder	CNC4073	142	Switch (S842 EJP)	CSH1022
28	Screw	PMS20P030FMC	68	Motor Unit (M841)	CXA4316	108	Spring	CBL1138	143	TSEL Bracket	CNC4072
29	Connector	CDE3464	69	Screw	CBA-098	109	Screw	JFZ14P016FNI	144	Washer	CBE1027
30	Upper Frame	CNC3960	70	Screw (M2×6)	CBA1004	110	Spring	CBH1430	145	Spring Holder	CNC3054
31	Spring	CBH1466	71	Switch (S843)	CSN1012	111	Holder Unit	CXA4675	146	Roller	CLA2036
32	EJ Spring	CBH1402	72	P. C. Board	CNP2803	112	Screw	JFZ17P030FNI			
33	Magazine Holder Unit	CXA4729	73	CRG Bracket	CNC3961	113	Weight	CNC4116			
34	Screw	CBA1070	74	Disc UP Spring	CBH1442	114	Shaft	CLA1197			
35	Damper Unit	CXA3242	75	Sheet	CNM3241	115	Arm Unit	CXA3995			
36	Connector	CDE3466	76	Disc-up Guide Unit	CXA4377						
37	Magazine Guide	CNV2734	77	Sheet	CNM3178						
38	Clamper Bracket Assy	CXA4039	78	Sheet	CNM3241						
39	Spacer	CNM1787	79	Disc-up Guide Assy	CXA4384						
40	Ball	CNR1079	80	Switch (S845.846)	CSN1022						

13. CABINET EXPLODED VIEW

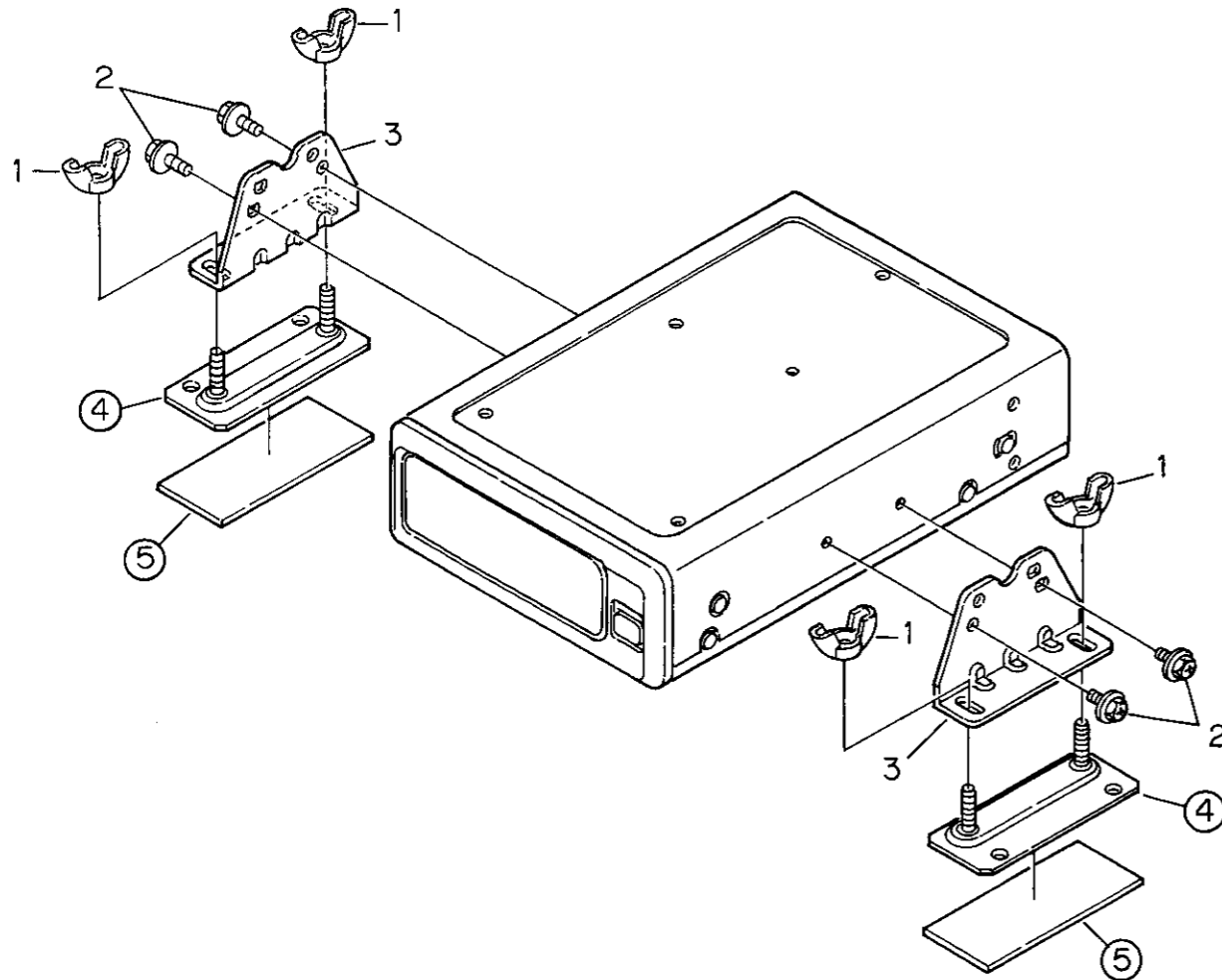

● Parts List

Mark No.	Description	Part No.
1	Nut	NR60FZK
2	Screw	HMF40P080FZK
3	Angle	CNB1634
4	Base(M30/EW, ES)	CNC4349
5	Cushion(M30/EW, ES)	CNM2647

14. CHASSIS EXPLODED VIEW

● Parts List

Mark No.	Description	Part No.	Mark No.	Description	Part No.
1	Cushion	CNM2488	33	Connector	CKS1955
2	Shaft	CLA1949	34	Connector	CKS2271
3	Shaft	CLA2038	35	Spacer	CNM3339
4	Door	CAT1435	36	Screw	PMS26P050FMC
5	Spring	CBH1428	● 37	Extension Unit	CWX1374
6	Stopper	CNV2905	38	Plug(4P)	CKS1634
7	Spring	CBH1426	39	TR Bracket	CNC3993
8	Chassis L	CNC3846	40	Screw	CBA1181
9	Damper	CNV3219	41	Chassis R	CNC3845
10	Damper Holder	CNV2894	42	Clamper	HEF-102
11	Spring	CBH1379	43	Connector(4P)	CDE3671
● 12	CD Mechanism Unit	CXK2600	44	P.C. Board	CNP2717
13	Screw(M2.6×8)	CBA1161	45	Lower Case	CNB1568
14	Spring Holder	CNC3972	46	Sub Chassis	CNC3995
15	Spacer	CNM3211	47	Screw	BMZ30P040FMC
16	Button(OPEN, EJECT)	CAC3153	48	Holder	CNC3994
17	Lever	CNV2903	49	Connector	CKS2104
18	Spring	CBH1427	50	Connector(23P)	CKS2226
19		51	Plug(4P)	CKS1051
20	Transistor(Q987)	2SB1299	52	DIN Cord	CDE3485
21-23		53	Cord	CDE3741
24	Screw	PMS30P040FZK	54	Screw	BMZ30P040FZK
25	Screw(Transportation)	BMZ40P080FRD	55	Connector Bracket	CNC3847
26	Pin(Transportation)	CLA1969	56	Connector	CKS2101
27	Upper Case	CNB1567	57	Plug	CKS2372
28	P.C. Board	CNP3042	58	Screw(M2.6×8)	CBA1186
29	Connector	CDE2949	59	
30	Screw	BMZ26P040FMC	60	Grille	CNS2380
● 31	Main Unit	CWX1373	61	Grille Assy	CXA4679
32	Connector	CKS1958	62	Spacer	CNM3452
			63	Cushion	CNM3328
			64	Spacer	CNM3208

Fig. 39

● Chassis

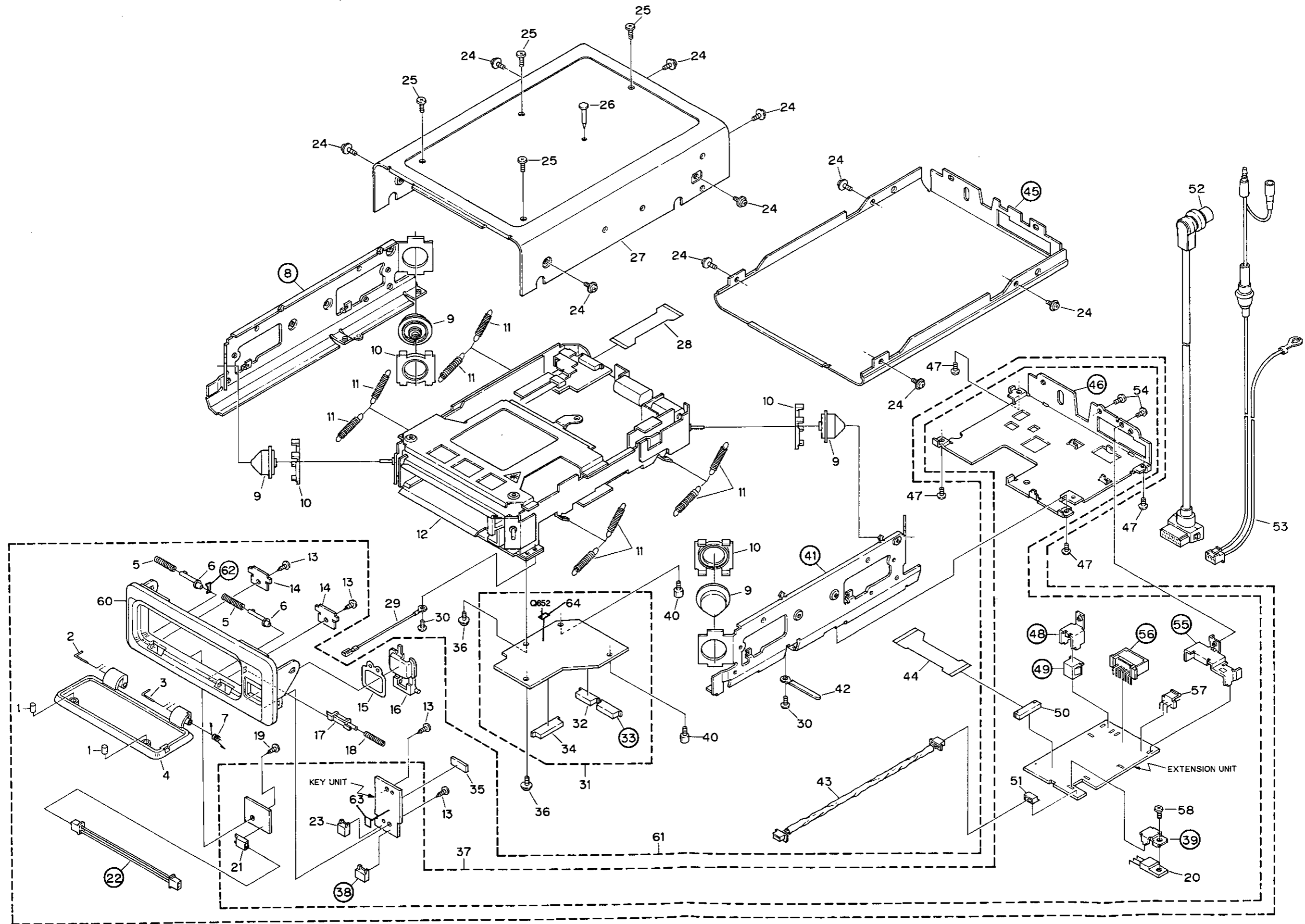
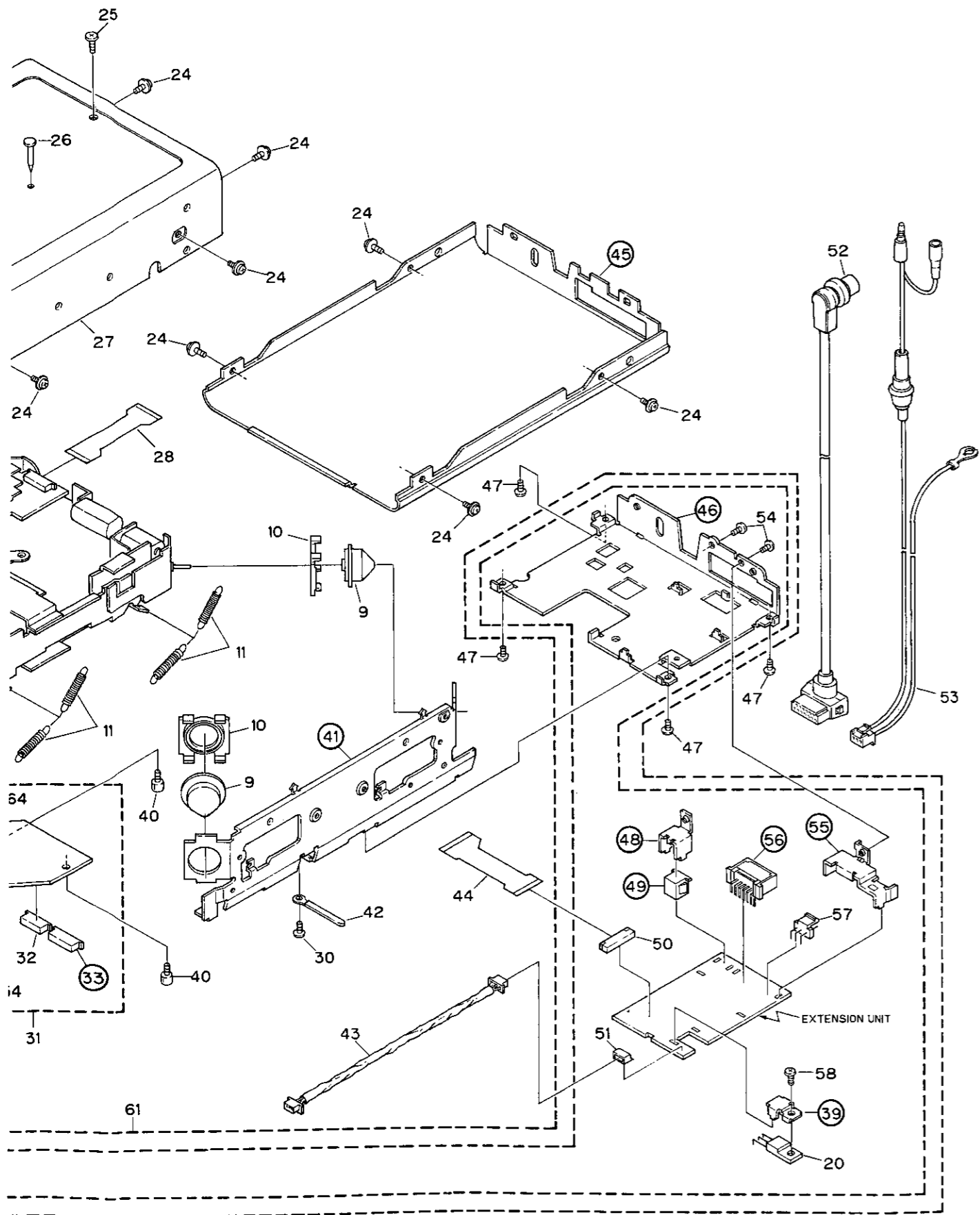

Fig. 40



Note:
 • The CDX-M33/US, CDX-M30/EW and CDX-M30/ES Parts Lists enumerate the parts which differ from those enumerated in the CDX-M30/UC Parts List only. The parts other than those enumerated in the former are identical with those in the latter, to which you are requested to refer, accordingly. The CDX-M30/UC Parts List is given on page 62.

	M30/UC	M33/US	M30/EW	M30/ES
Mark No. Description	Part No.	Part No.	Part No.	Part No.
4 Door	CAT1435	CAT1437	CAT1435	CAT1435
16 Button	CAC3153	CAC3022	CAC3153	CAC3153
19 Screw	CBA1161
21 Plug	CKS1049
22 Connector	CDE3746
23 Plug	CKS1632
27 Upper Case	CNB1567	CNB1570	CNB1569	CNB1567
● 37 Extension Unit	CWX1374	CWX1444	CWX1374	CWX1374
45 Lower Case	CNB1568	CNB1571	CNB1568	CNB1568
53 Cord	CDE3741	CDE3741	CDE3742	CDE3741
60 Grille	CNS2380	CXA4431 (Grille Unit)	CNS2380	CNS2380
61 Grille Assy	CXA4679	CXA4680	CXA4679	CXA4679

Fig. 40

15. MAGAZINE (PXA1356) EXPLODED VIEW

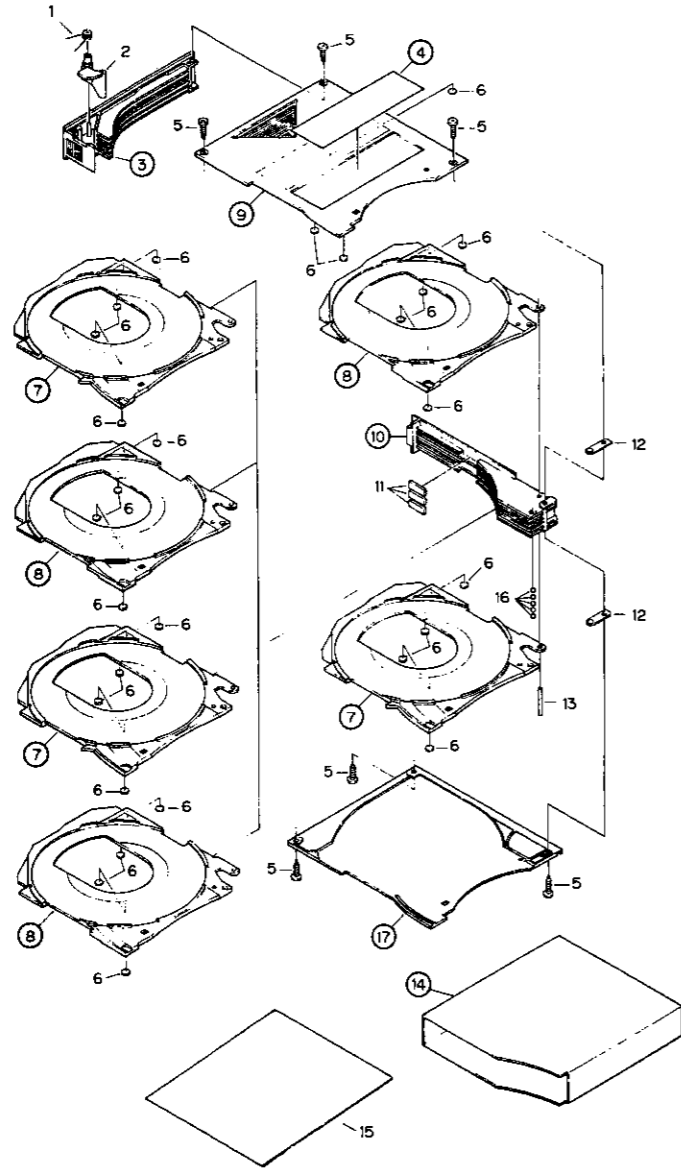

Fig. 41

● Parts List

Mark No.	Description	Part No.	Mark No.	Description	Part No.
1	Spring M	PBH1067	11	Cushion Rubber	PNM1011
2	Lever	PNW1386	12	Spring	PBK-085
3	Case F	PNW1799	13	Shaft	PLB-281
4	Caution Label	PRW1139	14	PP Case	PHN1031
5	Screw	BPZ20P080FZK	15	Label	PRW1197
6	Cushion	PED-049	16	Ball	PBP-005
7	Tray A	PNW1935	17	Case B	PNW1596
8	Tray B	PNW1936			
9	Case T	PNW1126			
10	Case L	PNW1800			

16. PACKING METHOD

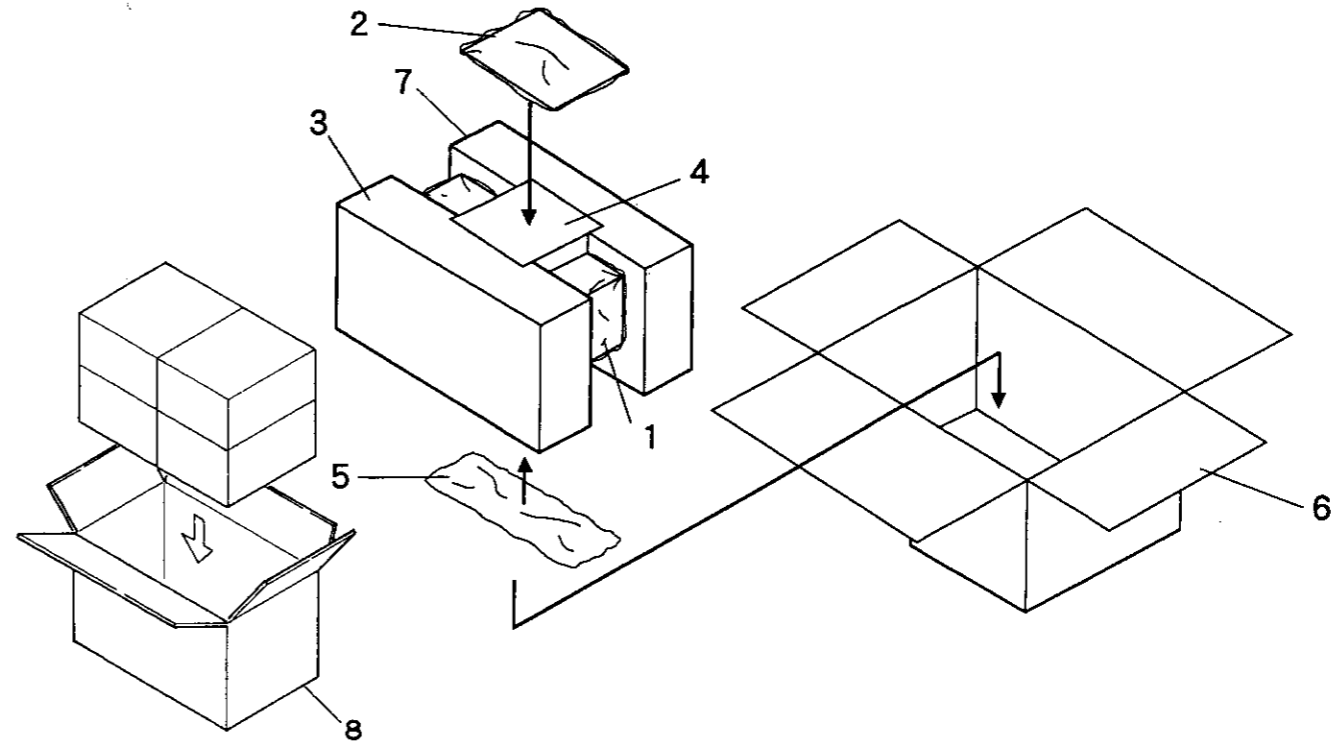

Fig. 42

● Parts List (CDX-M30/UC)

Mark No.	Description	Part No.	Mark No.	Description	Part No.
1	Cover	CEG1091	5-3-6	Screw(×1)	PMB50Y160FMC
	Caution Card	CRP1098	5-3-7	Nut(×1)	NF40FMC
	Sheet	CNM2887	5-3-8	Nut(×1)	NF50FMC
*	Caution Card(Screw)	CRP1090	5-3-9	Nut(×4)	NR60FZK
*	Polyethylene Bag	CEG1099	5-3-10	Washer(×1)	WS40FMC
2	Polyethylene Bag	E36-618	5-4	Cord	CDE3741
2-1	Owner's Manual	CRD1554	5-5	Angle(×2)	CNB1634
2-2		5-6	
*	2-3 Card	ARY1048	5-7	Polyethylene Bag	E36-622
3	Styrofoam	CHP1313	* 5-8	Clamper	CEF1010
4	Magazine	PXA1356	6	Carton	CHG2157
5	Accessory Assy	CEA1713	7	Styrofoam	CHP1312
5-1	DIN Cord	CDE3485	8	Contain Box	CHL2157
5-2	Strap	CNF-111			
*	5-3 Screw Assy	CEA1563			
5-3-1	Screw for Strap(×1)	CBA-028			
5-3-2	Screw(×4)	CBA1069			
* 5-3-3	Polyethylene Bag	E36-615			
5-3-4	Screw(×4)	HMB60P500FZK			
5-3-5	Screw(×4)	HMF40P080FZK			

Note:
● The dif
The in
The

Mar
*

2-1

Pa
CRI
CRI
CRI
CRI
CRI

16. PACKING METHOD

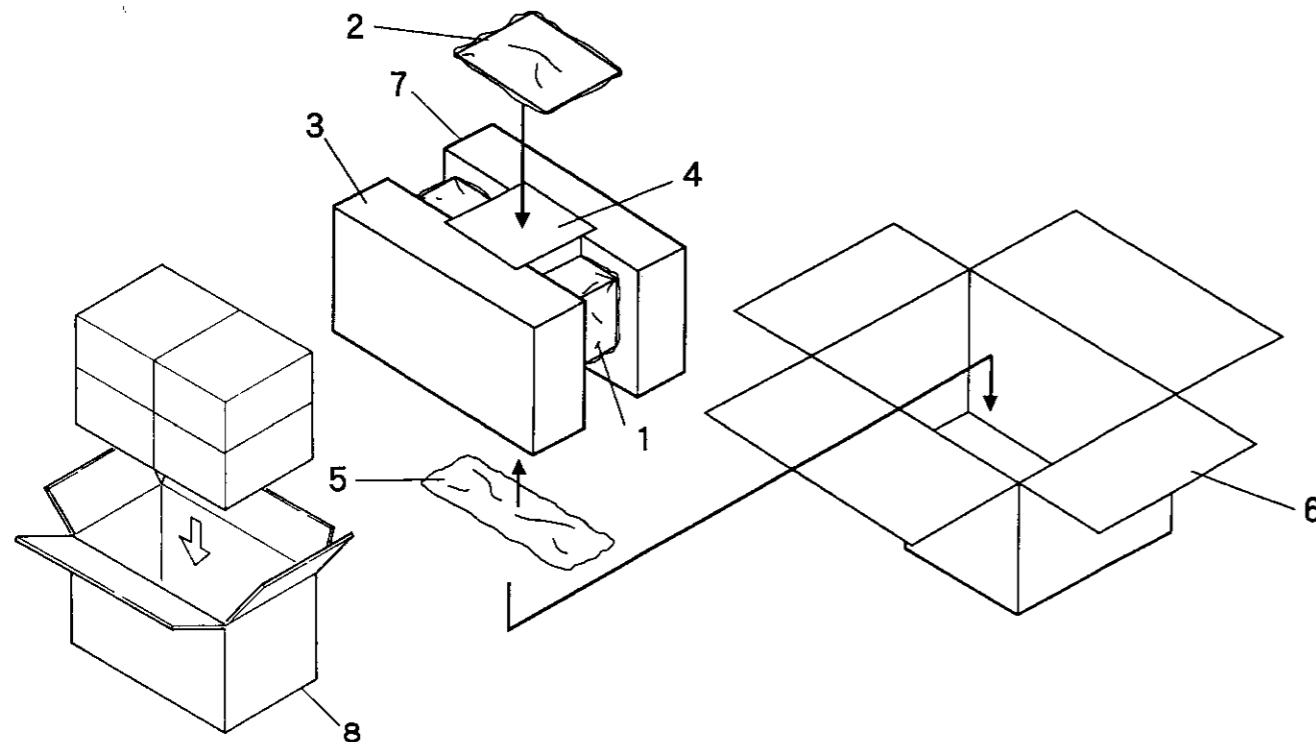

Fig. 42

● Parts List (CDX-M30/UC)

Mark No.	Description	Part No.	Mark No.	Description	Part No.
	1 Cover	CEG1091	5-3-6	Screw(×1)	PMB50Y160FMC
	Caution Card	CRP1098	5-3-7	Nut(×1)	NF40FMC
	Sheel	CNM2887	5-3-8	Nut(×1)	NF50FMC
*	Caution Card(Screw)	CRP1090	5-3-9	Nut(×4)	NR60FZK
*	Polyethylene Bag	CEG1099	5-3-10	Washer(×1)	WS40FMC
	2 Polyethylene Bag	E36-618	5-4	Cord	CDE3741
	2-1 Owner's Manual	CRD1554	5-5	Angle(×2)	CNB1634
	2-2		5-6	
*	2-3 Card	ARY1048	5-7	Polyethylene Bag	E36-622
	3 Styrofoam	CHP1313	*	5-8 Clamper	CEF1010
	4 Magazine	PXA1356	6	Carton	CHG2157
	5 Accessory Assy	CEA1713	7	Styrofoam	CHP1312
	5-1 DIN Cord	CDE3485	8	Contain Box	CHL2157
	5-2 Strap	CNF-111			
*	5-3 Screw Assy	CEA1563			
	5-3-1 Screw for Strap(×1)	CBA-028			
	5-3-2 Screw(×4)	CBA1069			
*	5-3-3 Polyethylene Bag	E36-615			
	5-3-4 Screw(×4)	HMB60P500FZK			
	5-3-5 Screw(×4)	HMF40P080FZK			

Note:

- The CDX-M33/US, CDX-M30/EW and CDX-M30/ES Parts Lists enumerate the parts which differ from those enumerated in the CDX-M30/UC Parts List only. The parts other than those enumerated in the former are identical with those in the latter, to which you are requested to refer, accordingly. The CDX-M30/UC Parts List is given on page 67.

	M30/UC	M33/US	M30/EW	M30/ES
Mark No. Description	Part No.	Part No.	Part No.	Part No.
1 Sheel	CNM2887	CNM2916	CNM2887	CNM2887
2-1 Owner's Manual	CRD1554	CRB1235	CRD1555	CRD1557
Owner's Manual	CRD1556
2-2 Cushion(×2)	CNM2647	CNM2647
* 2-3 Card	ARY1048	ARY1048	CRY-062
5 Accessory Assy	CEA1713	CEA1713	CEA1715	CEA1714
5-4 Cord	CDE3741	CDE3741	CDE3742	CDE3741
5-6 Base	CNC4349	CNC4349
6 Carton	CHG2157	CHG2156	CHG2158	CHG2159
8 Contain Box	CHL2157	CHL2156	*CHL2158	*CHL2159

2-1 Owner's Manual

Part No.	Model	Language
CRB1235	CDX-M33/US	English
CRD1554	CDX-M30/UC	English, French
CRD1555	CDX-M30/EW	English, French, German, Spanish, Portuguese
CRD1556	CDX-M30/EW	Swedish, Norwegian, Dutch, Italian, Finnish
CRD1557	CDX-M30/ES	English, French, Spanish, Arabic

17. ELECTRICAL PARTS LIST

NOTE:

- Parts whose parts numbers are omitted are subject to being not supplied.
- The part numbers shown below indicate chip components.

Chip Resistor

RS1/□S□□□□J,RS1/□□S□□□□J

Chip Capacitor (except for CQS.....)

CKS....., CCS....., CSZS.....

Unit Number :
Unit Name :Main Unit

MISCELLANEOUS

-----Circuit Symbol & No. Part	Name-----	Part No.
IC 351		UPC1347GS
IC 601	(UPD6374GH-501)	GGF9001
IC 602 652		RC4558M
IC 651		PA3026
IC 661		TA78L05F
IC 701		UPD6375GC
IC 702		TC9237F
IC 703		TA2009F
IC 751		PD5180A
IC 755		LH5116HN-10T
IC 801		XRA6247FP
Q 351		2SB1260
Q 601		2SB709A
Q 651 705 801		UN2211
Q 652		2SB1184F5
Q 653 802		2SB1184F5
Q 751		UN2111
D 651		SC016-2
D 652		SC016-2
D 751		MA151A-MA
D 752		MA151WK-MT
D 754 755 756 758		MA153-MC
D 757		MA153-MC
D 759		MA151A-MA
L 701 751	Inductor	CTF1138
X 702	Crystal Resonator	CSS1067
X 751		CSS1084
VR 351	Semi-fixed 22kΩ (B)	CCP1021
VR 352 355 356	Semi-fixed 47kΩ (B)	CCP1023
VR 353 354	Semi-fixed 2.2kΩ (B)	CCP1015

RESISTORS

R 351		RS1/2S220J
R 352		RS1/16S472J
R 353		RS1/16S623J
R 354 781 795		RS1/16S473J
R 355		RS1/16S122J
R 356 357		RS1/16S683J
R 358 359		RS1/16S332J
R 360		RS1/16S684J
R 361		RS1/16S153J
R 364		RS1/16S102J
R 369 605 607 661 666 713 775 810		RS1/16S103J
R 370		RS1/16S133J
R 371 373		RS1/16S223J
R 372 615 616		RS1/16S472J
R 374 614 664 667 669 670		RS1/16S912J

-----Circuit Symbol & No. Part	Name-----	Part No.
R 375 377 609 611 613 651 653 656 658 663		RS1/16S102J
R 379		RS1/16S513J
R 380		RS1/16S104J
R 381		RS1/16S133J
R 606		RS1/16S224J
R 610 901 902 903 904 905		RS1/16S103J
R 617 915		RS1/16S102J
R 652 654 655 657		RS1/16S162J
R 660 662 665		RS1/10S151J
R 668		RS1/16S752J
R 671 672 702 703 704 791 802 803		RS1/16S102J
R 701		RS1/16S272J
R 708		RS1/16S201J
R 709 909		RS1/16S0R0J
R 711 712		RS1/16S100J
R 716 804		RS1/16S102J
R 717 751 789 821 822 910 913		RS1/16S0R0J
R 752		RS1/16S223J
R 753 760 797 911		RS1/16S473J
R 754 777 782 784 788 796		RS1/16S104J
R 755 758 759 762 763 765 773 787		RS1/16S222J
R 756		RS1/16S681J
R 757		RS1/16S222J
R 761 767 798 799		RS1/16S104J
R 766 772 786 790 794 807		RS1/16S563J
R 770 771 779 780		RS1/16S681J
R 792		RS1/16S101J
R 805 806		RS1/16S563J
R 811 812 813		RS1/10S151J
R 906 907		RS1/16S222J
R 908		RS1/16S103J
R 912		RS1/16S103J

CAPACITORS

C 351 717		CE/470M6R3
C 352		CKSQYB104K25
C 353 714		CE/101M6R3
C 354 355 609 610 702		CE/100M16
C 357 359 366		CKSRYB102K50
C 358		CCSRCH331J50
C 360		CCSRCH271J50
C 361		CCSRCH220J50
C 367		CKSYB154K25
C 368 751 753		CKSQYB104K25
C 369 604 606 652 654 710 715 716 721 722		CKSYB224K25
C 370		CKSQYB473K25
C 373 607		CKSYB224K25
C 601		CKSRYB222K50
C 603		CCSRCH331J50
C 605 611 659 666 709 762 763		CKSRYB103K25
C 608		CE/010M50
C 614 657 658		CKGRYB821K50
C 655 656		CKSQYB273K25
C 663		CKSQYB333K25

====Circuit Symbol & No. Part	Name=====	Part No.
C 665	400 μ F/10V	CCH1120
C 667		CSZST220M16
C 703		CCSRCH470J50
C 704 705		CCSRCH080D50
C 718		CEV330M6R3
C 719 720		CEV100M16
C 752 764 765		CCSRCH221J50
C 756		CKSRYPB472K50
C 757		CKSRYPB103K25
C 801		CEV220M16
C 802 803		CKSQYB223K25
Unit Number :		
Unit Name :Extension Unit		
MISCELLANEOUS		
IC 971		M5218AL
IC 972		BA3121
IC 981		M51957AL
IC 982		M51958AL
Q 970 971		DTC314TS
Q 972 985 988		DTA114ES
Q 973 986 989		DTC114YS
Q 981 992		DTC114ES
Q 983		2SC3673
Q 984		2SD1859
Q 987		2SB1299
Q 990 991		2SC2458
D 971 972 973		1SS133
D 974 981 984		ERA15-02VH
D 982		HZS20L1
D 985 987		HZS6LB1
D 986		RD9R1JSB1
D 989		HZS11B1L
L 981	Choke Coil	CTH1047
EF 981	EMI Filter	CCG1006
RESISTORS		
R 970 971		RD1/4PS113JL
R 972 973		RD1/4PS163JL
R 974 975		RD1/4PS332JL
R 976 977		RD1/4PS182JL
R 978 979		RD1/4PS122JL
R 980		RD1/4PS333JL
R 981		RD1/4PS363JL
R 982		RD1/4PS184JL
R 983		RD1/4PS153JL
R 984 985 992		RD1/4PS103JL
R 986 995		RD1/4PS681JL
R 987		RD1/4PS683JL
R 988		RD1/4PS473JL
R 989		RD1/4PS102JL
R 991		RD1/4PS222JL
R 993 994		RD1/4PS331JL
R 996		RD1/4PS242JL
R 997		RD1/4PS362JL
R 998 999(CDX-M33/US)		RD1/4PS391JL
CAPACITORS		
C 970		CEA101M10LL
C 971 979 981 984 988		CKCYB472K50
C 972 973		CCCCH470J50
C 974 975		CEA4R7M35LL
C 976 977		CEA330M10LL
C 978		CEA4R7M35LL
C 980 989		CEA470M16LL
C 982 983	470 μ F/16V	CCH1080
C 985		CEA101M6R3LL
C 986		CEA100M16LL

====Circuit Symbol & No. Part	Name=====	Part No.
C 987		CEA470M10LL
C 990		CKCYB472K50
Unit Number :		
Unit Name :Key Unit		
D991(CDX-M33/US)		AA3822K-R
SW991	Switch(Reset)	CSG1035
SW992	Switch(Eject)	CSG1004
Unit Number:		
Unit Name :Mechanism P.C.Board		
S 843	Switch(Home)	CSN1012
S 845 846	Switch(DCPT,TRPT)	CSN1022
M 841	Motor Unit(Carriage)	CXA4316
M 842	Motor Unit(Spindle)	CXA4540
M 843	Motor Unit(ELV)	CXA3238
M 844	TRAY Motor Unit	CXA3729
Unit Number:		
Unit Name :Photo P.C.Board		
D 841		HZS9A2L
VR 841	Semi-fixed 22k Ω (B)	CCP-380
S 841	Switch(MAG)	CSN1020
S 842	Switch(EJP)	CSH1022
P 841	Photo-Interrupter	ON1113
P 842	Photo-Interrupter	ON2160
R 841		RD1/4PS560JL
R 842		RD1/4PS221JL
R 843		RD1/4PS103JL
Miscellaneous Parts List		
PU Unit		
D992(CDX-M33/US)		CGY1023
		MAA4565S-R

18. CIRCUIT DESCRIPTION

1. Preamplifier Stage

This unit processes a pickup output signal to make signals for subsequent stages, i.e. servo unit, modulator unit and control unit. The signal from the pickup is converted on an I-V basis in a photodetector-built-in preamplifier inside the pickup.

Besides, an addition is made to the signal in an RF amplifier (IC351) to obtain RF, FE and TE signals.

The preamplifier unit has a configuration with one-chip IC UPD1347GS mainly employed. It is described in detail below.

The present system, which is of single power (+5 V) type, has 2.5 volts available for both RF Amplifier Reference Voltage V_{ref} and other signal circuit reference voltage REFOUT. Voltages referred to below are to be expressed in Unit [REFOUT]. (A voltage based on a reference value of 0 (V) is to be expressed in Unit [V].) The IC is a 36-pin flat package, which has an internal configuration as shown in Fig. 43.

This IC is described below concerning its internal component parts.

(NOTE) Pin 18 on IC351 has V_{ref} (2.5 V), which in turn serves as the reference voltage in the RF amplifier. For measurements, adjustments, etc., apply REFOUT obtained by passing REFO of Pin 19 on IC601 through a buffer.

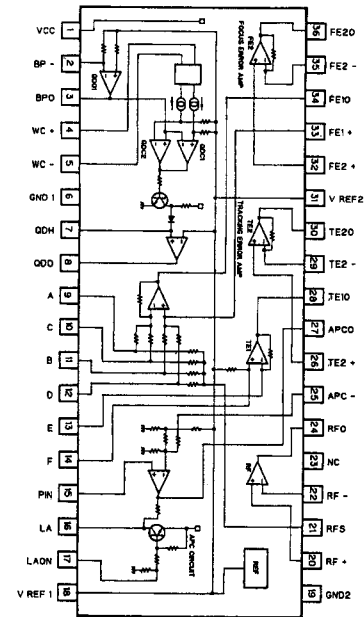

Fig. 43 Block diagram

(1) RF amplifier

Photodetector Outputs A, B, C and D are added in amplifier (1) so that $(A + B + C + D)$ will be outputted to RFO. (This terminal permits an eye pattern to be checked.) RFO output voltage $VRFO$ has lowfrequency components as follows:

$$VRFO_{[REFOUT]} = -[(R358 + R353)/10 k] \times (A + B + C + D)$$

For RFO output (Pin 24, an RF output at a level of $VRFO = 1.9 V_{p-p}$, AC., is available, with REFOUT at the center.

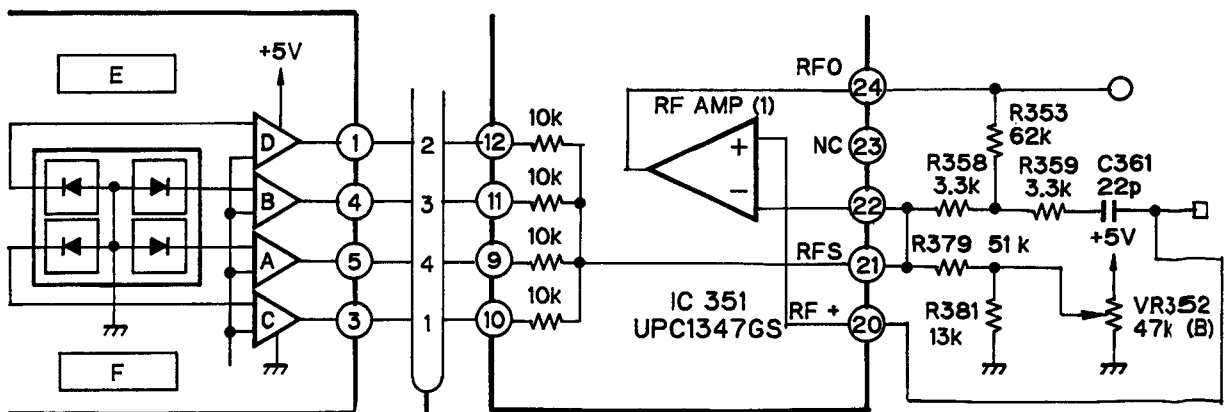

Fig. 44 Block diagram

(2) Focus error amplifier

Photodetector outputs A, B, C and D are inputted to both differential and focus-error amplifiers so that A + C - B - D will be outputted.

An FE output volatage (low frequency) will be :

$$V_{FE} = 5 \times 25 \text{ k} / R_A \times (A + C - B - D)_{[REFOUT]}$$

An FE output (Pin 36) of about 2.5 (V) is available as an S-shaped curve.

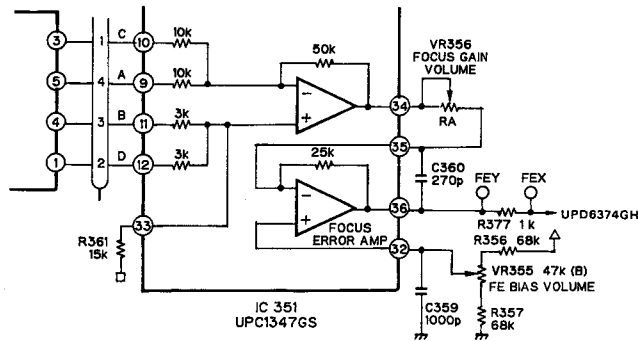

Fig. 45 Focus error amplifier

(4) APC circuit

A laser diode, if driven at a constant current, will have a negative temperature curve with a large optical output. It is necessary, therefore, to control the current with a monitor photodiode so that a constant output will be available. This is an APC circuit. The present system has LDI set to approximately 50 thru 60 mA.

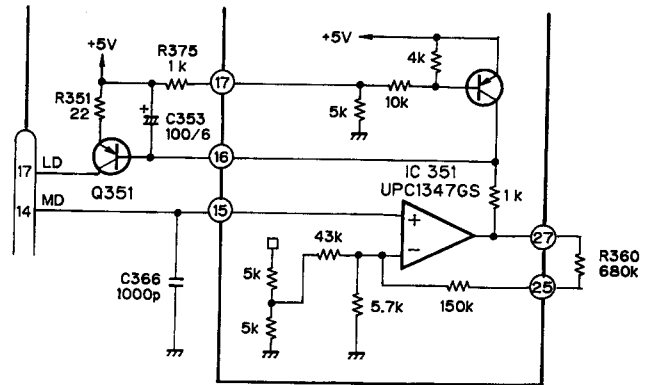

Fig. 47 APC circuit

(3) Tracking error amplifier

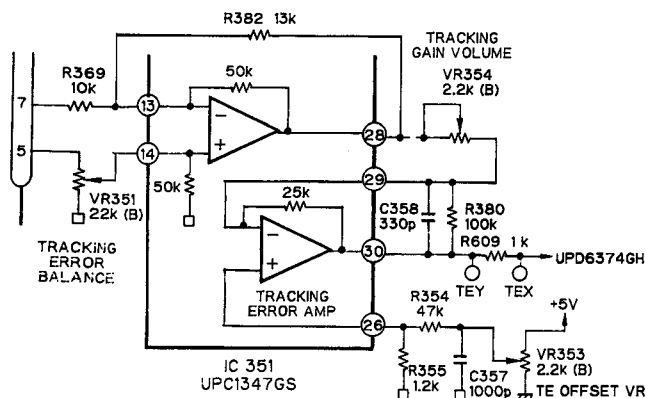

Fig. 46 Tracking error amplifier

The side-spot voltages inputted to E and F are amplified in differential and tracking-error amplifiers so that an output (E-F) can be obtained.

$$V_{TE} = 50 \text{ k} / 13 \text{ k} / 10 \text{ k} \times 100 \text{ k} / 25 \text{ k} / R_B \times (E-F)_{[REFOUT]}$$

The TE offset VR, moreover, is to cancel a DC offset from the preamplifier to the servo amplifier while the TE balance VR is to adjust the tracking signal symmetry. These are the prerequisites to mainly perform an operation of tracking normally. A tracking error of approximately 2 (v) p-p' is available as an output of pin 30.

2. Servo Stage

This unit has FE, TE and RF outputs received as its inputs from the RF amplifier. And the analog signals are converted to the digital ones, which are in turn used to execute the servo operations of focus tracking, carriage and spindle and the servo control of in-focus track jump, etc. subject to an instruction from the system microcomputer. IC UPD6374GH (48 pins, flat package) is mainly employed, with the block diagram given in Fig. 48. In addition, this IC has an automatic sequencer built in to perform track jumps, etc; based on the serial data transferred from the system microcomputer. The servo unit is described below on a component by component basis.

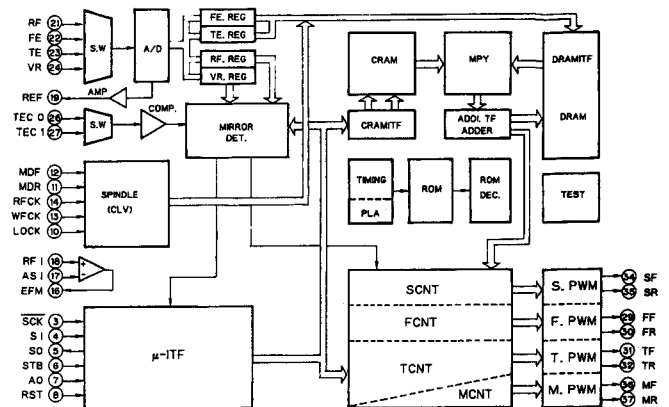
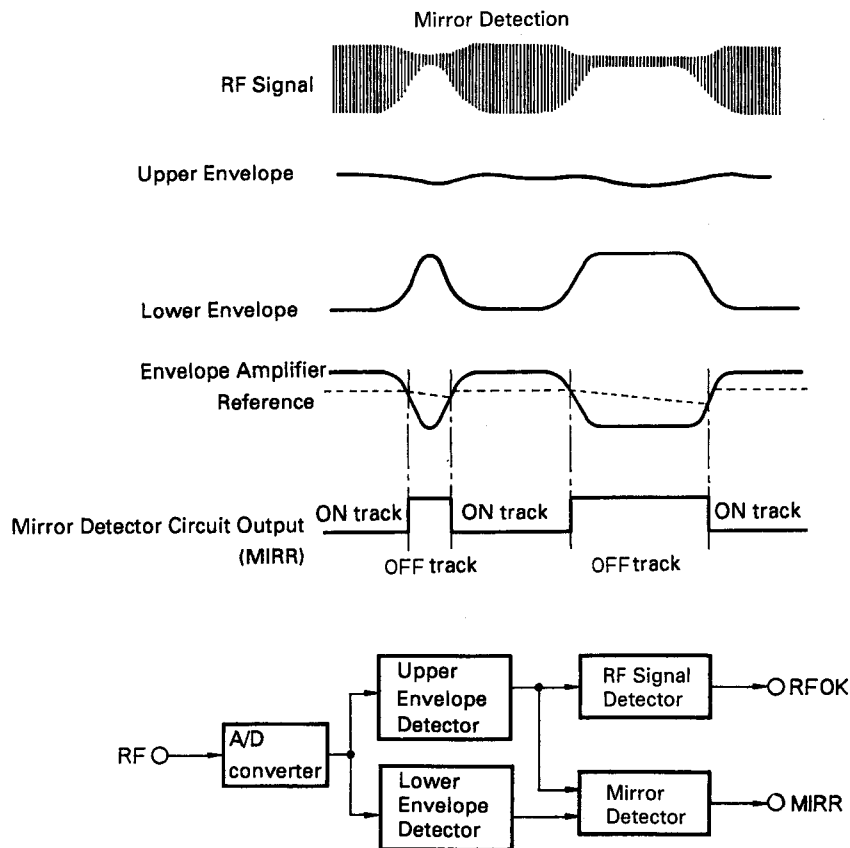

Fig. 48 UPD6374GH Block diagram

(1) Mirror circuit

The mirror detector circuit is to determine an on-track or off-track status by detecting a mirror status, with an envelope amplitude extracted from an RF signal. For the reference to detect a lack of amplitude, the envelope amplitude is held at the peak with a sufficient

large time constant and multiplied by two-thirds to obtain the reference value. Should an RF signal have no amplitude available (with the focus servo removed), the mirror detector circuit has an output (MIRR) go "H."



RF detector / mirror detector circuit block diagram

Fig. 49 Mirror circuit

(2) Focus OK circuit

The FOK circuit compares the upper envelope of an RF signal with the value set by the microcomputer and outputs a result of such comparison at the FOK terminal. ("H" is outputted, with [RF signal's upper envelope] > [set value].)

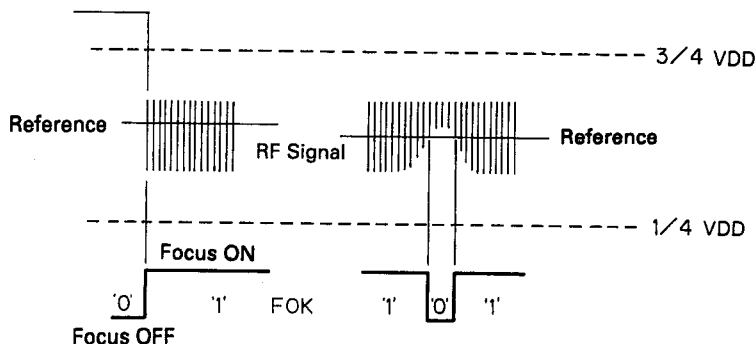

Fig. 50

(3) EFM comparator

The EFM comparator is to digitize an RF signal. Since its error rate increases under the influence of an asymmetry generated, the EFM output signal is made to pass through a low-pass filter by making use of the fact that a bit is generated at a probability of 50 %. And the signal so filtrated is taken for a comparison level. The present system has a low-pass filter cut off $f_c = 3.3$ (Hz) for C604 and R606 and $f_c = 1.6$ (kHz) for C605 and R607.

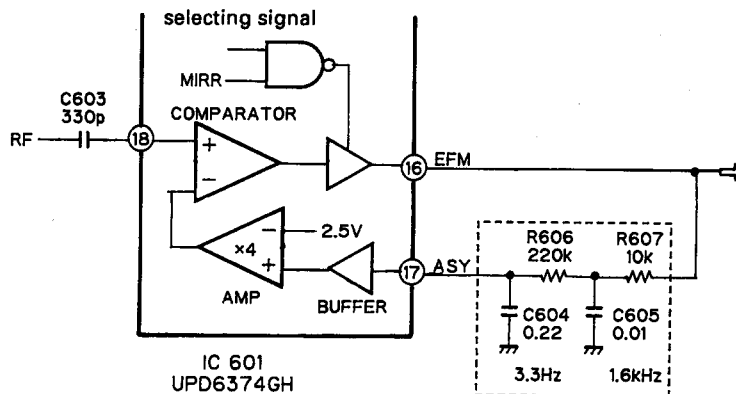

Fig. 51 EFM comparator

(4) Command code

A list of the commands used in the present system is given below.

10H	SK	TM	TEH	FR	TK	TB	T CNT	BRK
11H	FON	TON	SON	MON	FST	DFCT	JSK	TAB
12H	SLED NON-SENSITIVE AREA				HSL	SCV	RFP	TFP
13H	FOK LEVEL				FSPV 1	FSPV 0	T1	T0
14H	00 (h)							
15H	0	0	0	0	0	TCS	CV2	E3EN
16H	0	0	0	0	FPW	TPW	SPW	MPW

20H	TRACK KICK LEVEL a			
21H	TRACK KICK LEVEL b			
22H	TRACK KICK TIME A			
23H	TRACK KICK TIME B		TRAVERSE COUNTER N (H)	
24H	TRAVERSE COUNTER N (L)			
25H	SLED KICK LEVEL	SL1	SL0	0 0

<Description of Functions>

- SK:** sled kick control; the sled is kicked at a value set in 25 H, when SK is set to "1."
- TM:** tracking mute control
With TM = "1," the tracking output is put by TEH into either PRECEDING VALUE HOLD or REFERENCE HOLD (Data 00 value) mode.
With TM "0," a result of tracking and filtration is outputted (in the normal mode).
- TEH:** error hold control upon track jump
With SK = TM = "1," the tracking output has PRECEDING VALUE HOLD or REFERENCE HOLD mode selected.
REFERENCE HOLD, with TEH = "0" and PRECEDING VALUE HOLD, with TEH = "1"
- FR:** output level polarity control upon tracking and upon sled kicking
With FR = "0," a value available at output level registers (20,21 and 25 H) is multiplied by -1 and outputted.
With FR = "1," an output level register is outputted unchangedly.
- TK:** controlling both track jump trigger and traverse counter load; it has two meanings according to the T. CNT bit.
With T.CNT = "0," set the TK bit to "1" and the track jump sequencer will start.
With T.CNT = "1," set the TK bit to "1" and the traverse counter will be loaded with Values 23 H and 24 H.
- BRK:** half-wave brake circuit control
With BRC = "1," the half-wave brake is ON.
- TB:** selecting a tracking filter coefficient bank:
With TB = "0," the tracking filter bank goes 0.
With TB = "1," the tracking filter bank goes 1.
FON, TON, SON and MON: servo output (PWM output) on/off control
With any = "1," the PWM output is on.
With any = "0," the PWM output has stopped.
With PWM output stopped, a high impedance is outputted with the PWM in the single-phase 3-value output mode.

- FST:** focus search control
With FST = "1," a focus search will be started if FON = 1.
- DFCT:** tracking output hold control with flaw detected
With DFCT = "1," the tracking hold is outputted upon detection of flaw.
- JSK:** sled kick control upon jump
With JSK = "1," the sled is kicked at a level set in 25 H for a duration of the track jump.
- TAB:** track jump sequencer operation abort control
With TAB = "1," the track jump sequencer stops operating.
SLED NON-SENSITIVE AREA: A sled dead zone is controlled at an absolute value of 4 bits.
- HSL:** selecting the tracking output hold control
With HSL = "0," the tracking output hold is controlled by a missing FOK signal.
With HSL = "1," the tracking output hold is controlled by means of an external hold.
- SCV:** selecting a sled servo control with CLV lock
With SCV = "0," the sled servo is turned off (with PWM output stopped) to unlock CLV.
With SCV = "1," the sled servo is normally on, irrespective of whether or not CLV is locked.
- RFP:** selecting the polarity of data to an RFP processor system (circuits to generate FOK, MIRR, etc.)
- TFP:** selecting the polarity of a tracking error zero cross (TEC) signal
- FOK LEVEL:** setting a reference value in the RF detector circuit
- FSPW1, FSPW0:** selecting a PWM output carrier
FSPW0: changing a motor system PWM carrier 88.2 kHz with FSPW0 = "0" and 22.05 kHz with FSPW0 = "1."
FSPW1: changing an actuator system PWM carrier 88.2 kHz with FSPW1 = "0" and 176.4 kHz with FSPW1 = "1."

T1, T0: square wave cycle upon focus search

SETTING		CYCLE
T0	T1	
0	0	approx. 0.74 sec. ($2^{16}/F_s$)
0	1	approx. 1.49 sec. ($2^{17}/F_s$)
1	0	approx. 2.97 sec. ($2^{18}/F_s$)
1	1	approx. 5.94 sec. ($2^{19}/F_s$)

20 H, 21 H:

register to set a kick level upon track jump

22 H, 23 H:

register to set a kick time upon track jump

Kick Time = (set value + 1) × 1/F_s (11.3 μs)

23H, 24H:

traverse counter setting register

25H: sled kick setting register

SLED KIK LEVEL:

sled kick level setting register

SL1, SL0:

selecting SLED FULL KICK or SHORT mode

SL1	SL0	MODE
0	1	short
1	0	full kick
0	0	normal kick

TCS: selecting the tracking zero cross comparator
TECO input, with TCS = "0" and
TEC1 input, with TCS = "1"

CV2: selecting the sensitivity of CLV error detector
with speed doubled
Normal speed selected, with CV2 = "0" and
Double speed selected, with CV2 = "1"

E3EN: controlling the function of protecting EFM ≤
3T upon high-speed access
protector off, with E3EN = "0" and Protector
on, with E3EN = "1."

(5) Focus servo system

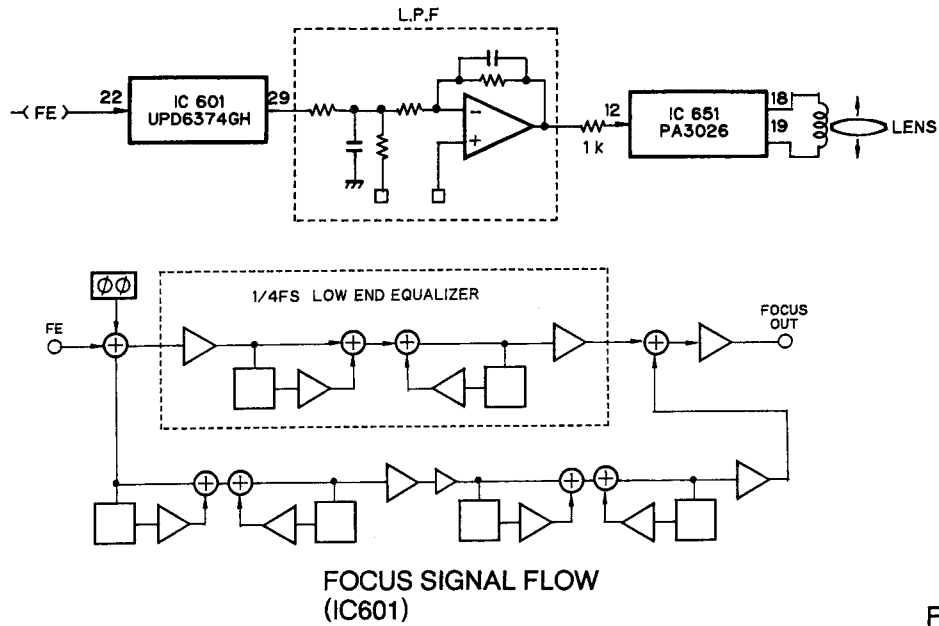

Fig. 52

The digital loop filter is built in the interior of the IC. Sending a coefficient from the microcomputer will allow you to obtain a desired equalizer curve. The present system has an equalizer curve shown in Fig. 56.

a) In-focus

In the in-focus sequence, the lens is driven into a focus S-curve (approx. 10 μm) to close the servo loop on an in-focus basis. A flow of signals in focus is shown in Fig. 53.

The search voltage is designed to fall within a range of the lens drive distance ± 1.0 mm, being entirely dependent upon the sensitivity of a focus actuator. In the present system, both gain (voltage) and time constant are determined according to a coefficient from the microcomputer, based on the pulse in a specified cycle, which has been set in a register. The timing in which a focus is to be closed, moreover, is generated, based on the value which has been set as referred to in a signal flow shown in Fig. 54.

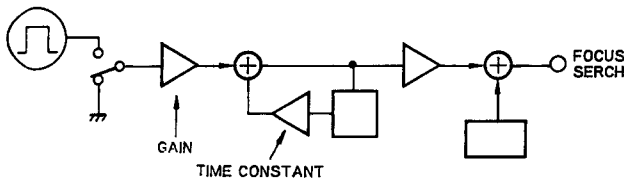

Fig. 53

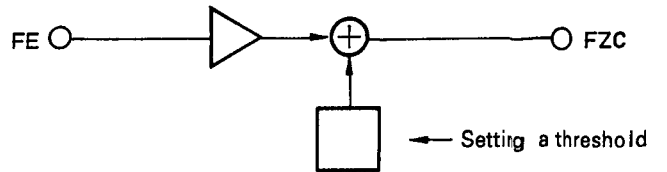

Fig. 54

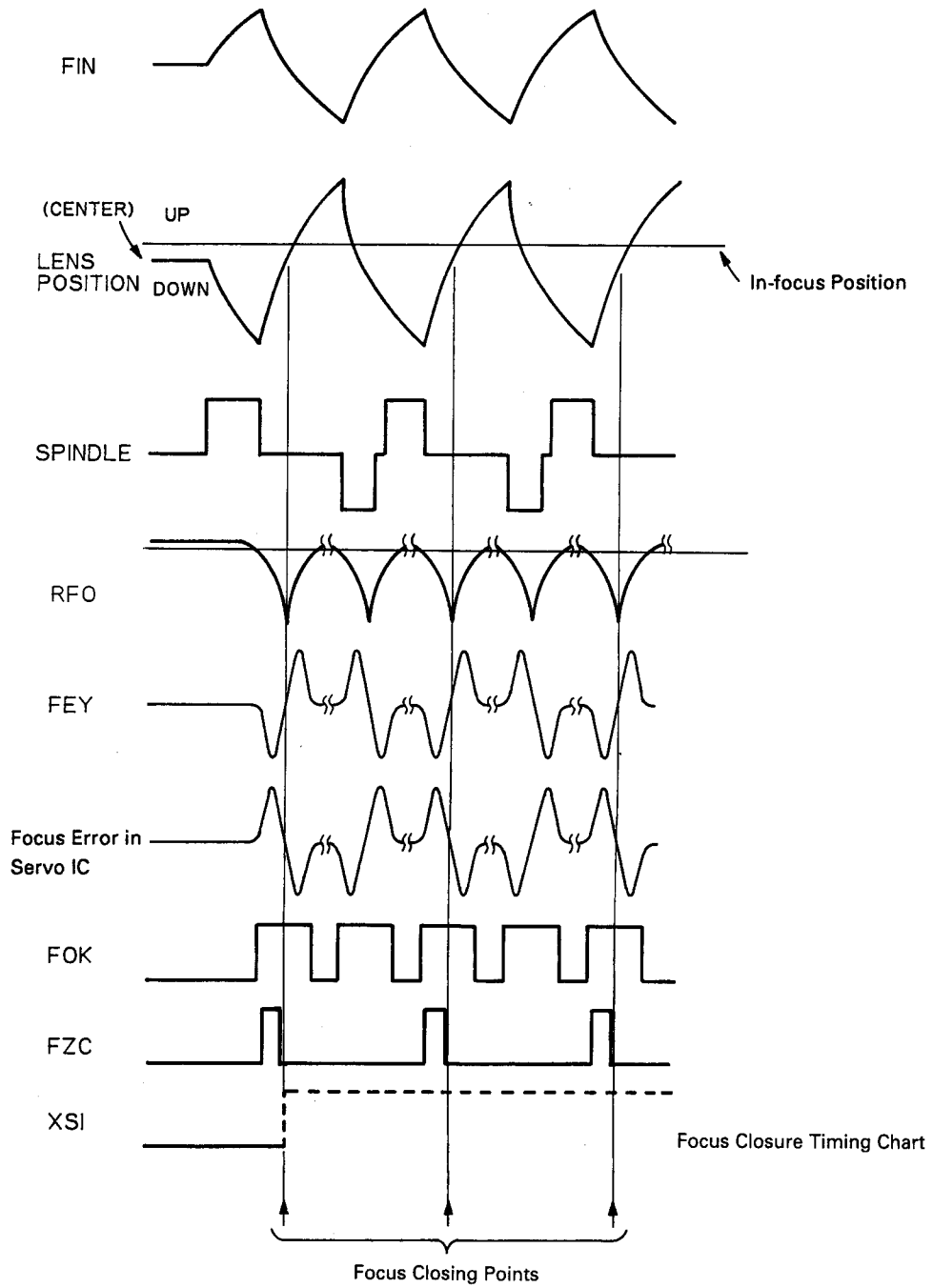

Fig. 55

(6) Focus equalizer

The present system permits a specific equalizer curve to be obtained according to the coefficient sent from the microcomputer. A digital filter built in IC UPD6374GH and an active filter mounted in the exterior are used to obtain a specified equalizer curve.

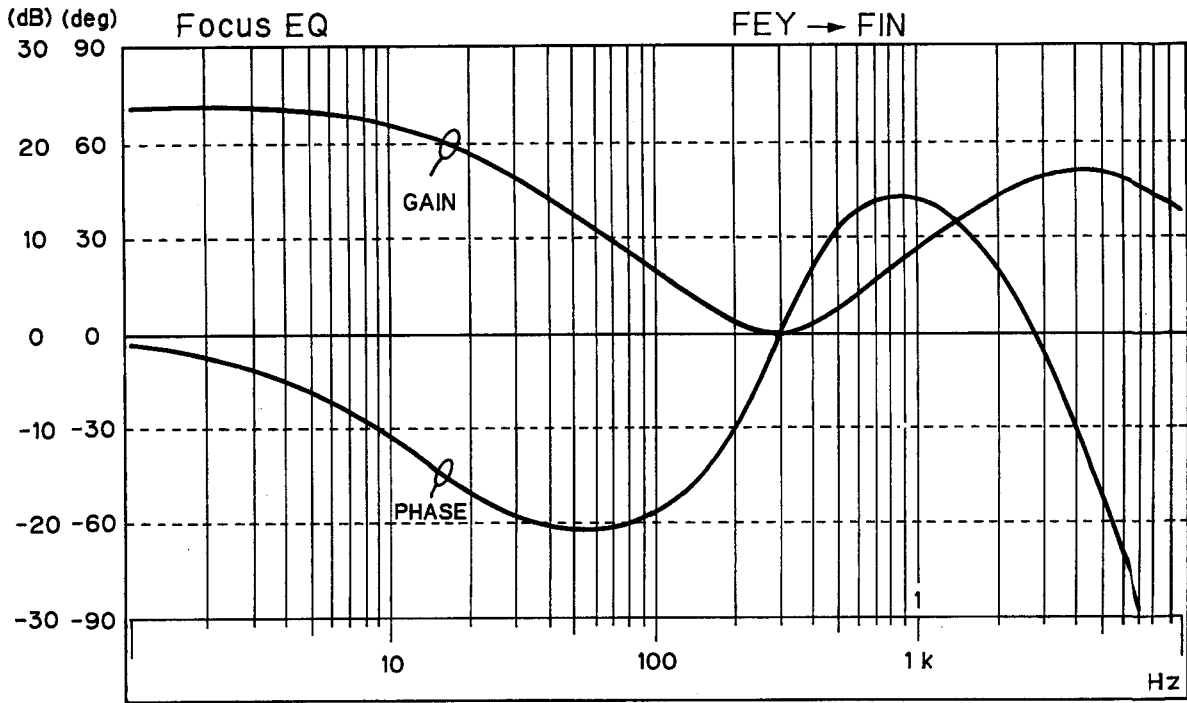

Fig. 56 Focus equalizer (Example)

(7) Tracking carriage servo system

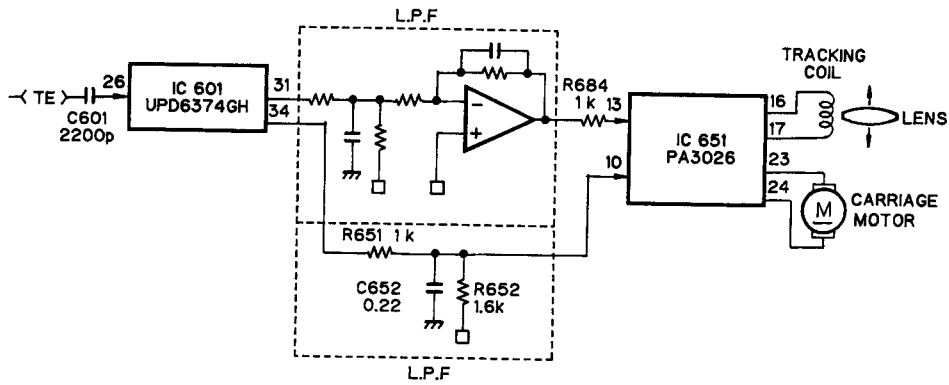

Fig. 57 Tracking carriage servo block diagram

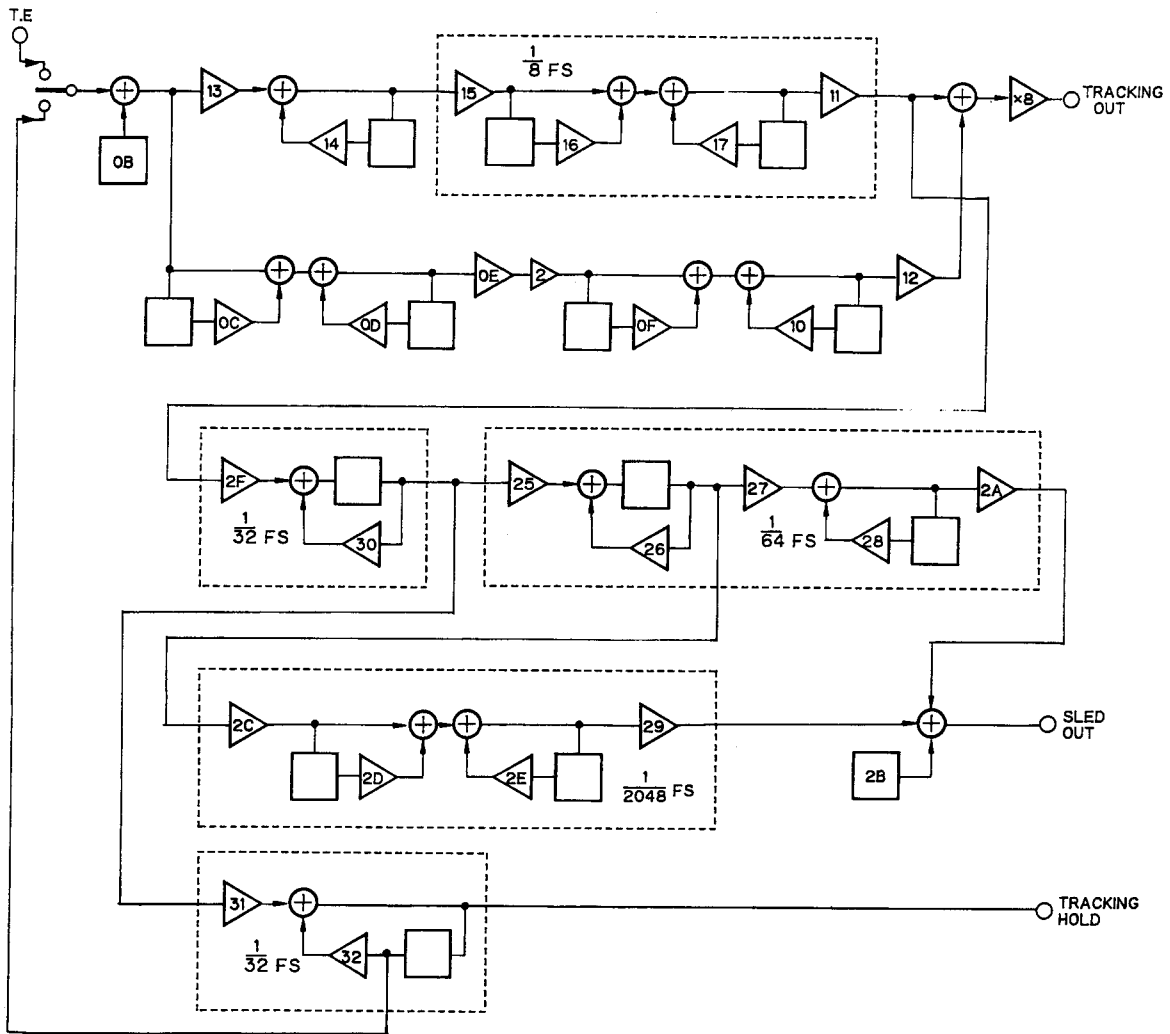

Fig. 58 Tracking carriage signal flow chart (IC601)

Shown in Fig. 57, 58 are a block diagram of the tracking carriage servo system and a flow of signals in IC UPD6374GH. To make a track jump either forward or reverse, tracking kick and brake voltages and carriage kick and brake voltages are set in related registers beforehand. A jump forward or reverse is made at the voltage which has been set in an instruction from the microcomputer.

a) Tracking equalizer

In the present system, a digital filter is built in IC UPD6374HG, allowing a specific equalizer curve to be obtained according to the coefficient sent from the microcomputer. And a passive filter is externally mounted. These two filters are used to obtain a specified equalizer curve. To allow a stable pull-in throughout

the search, moreover, the equalizer curve applied is so set as to obtain a higher level of gain than that during the play.

Fig. 59 shows the tracking equalizer curves observed during both play and search.

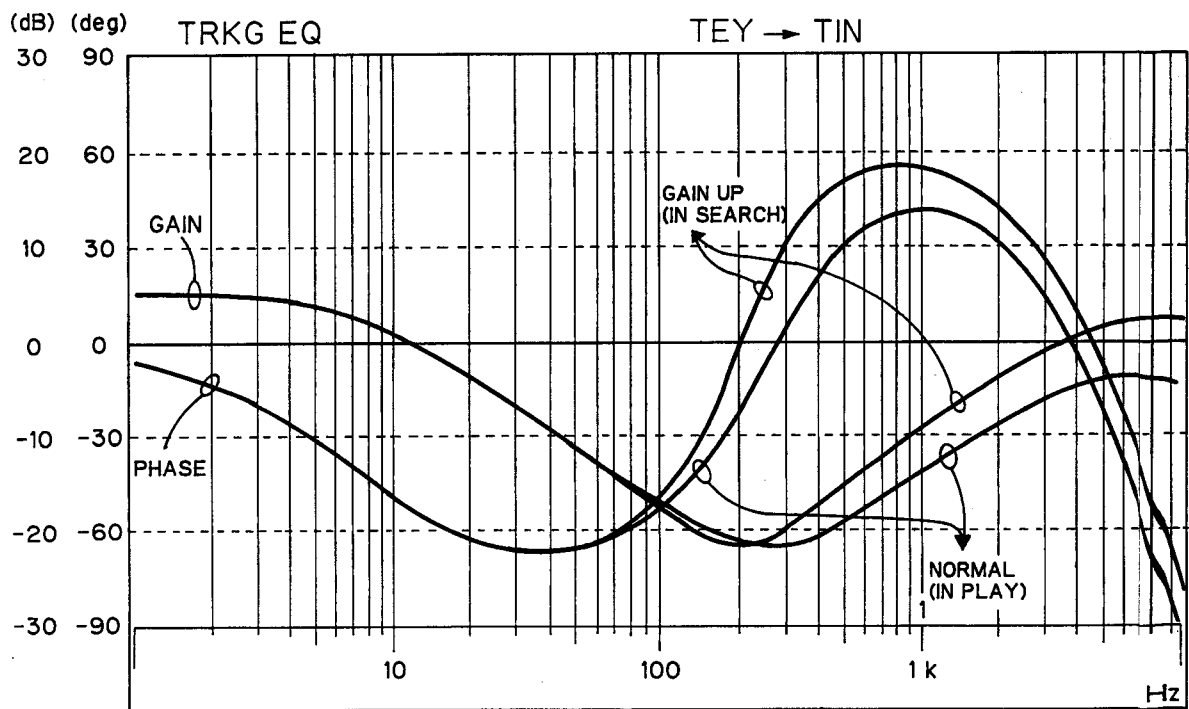

Fig. 59 Tracking equalizer (Example)

b) Brake Circuit (Fig. 60)

Since the actuator is put into a non-linear status in the in-focus mode or in the track-jump mode, the pull in the servo loop turns out very poor after completion of a jump. While both pickup and disc are relatively moving, the brake circuit permits tracking to be closed smoothly. The direction in which both pickup and disc are moving is detected, based on a phase relation between MIRR

and tracking error signals. With an accelerating component only cut off the tracking error, the decelerating component only is used while repeating the ON/OFF operations of servo on a chopper basis.

Thus, a stable pull in the servo loop is performed. This circuit's ON/OFF operations are controlled by the microcomputer.

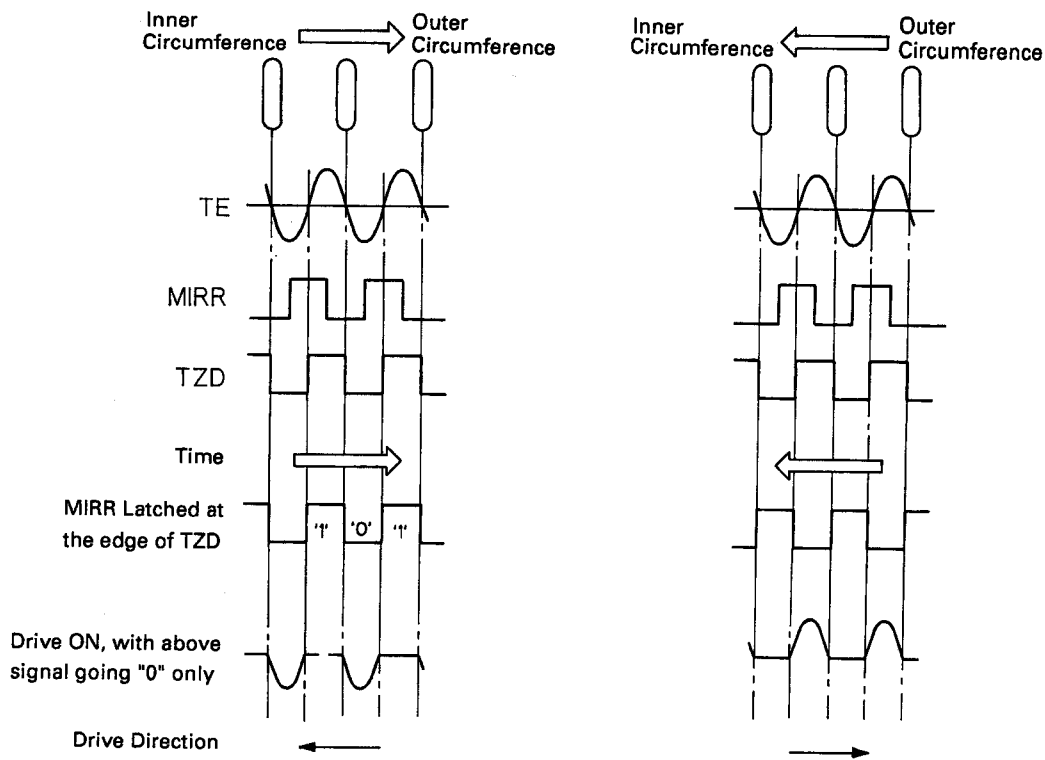

Fig. 60 Brake circuit operation

c) Carriage equalizer

As shown in the signal flow, the carriage servo system takes for an input the voltage at which the tracking actuator is driven. Based on the equalizer curves shown in Fig. 61, moreover, the system obtains those components which are required to feed the carriage. In the

present system, a threshold voltage is set beforehand so as to turn on the carriage servo when the tracking actuator has a lens deflection fall outside the range of approximately ± 30 tracks in relation to the low-pass filter output at the tracking drive voltage.

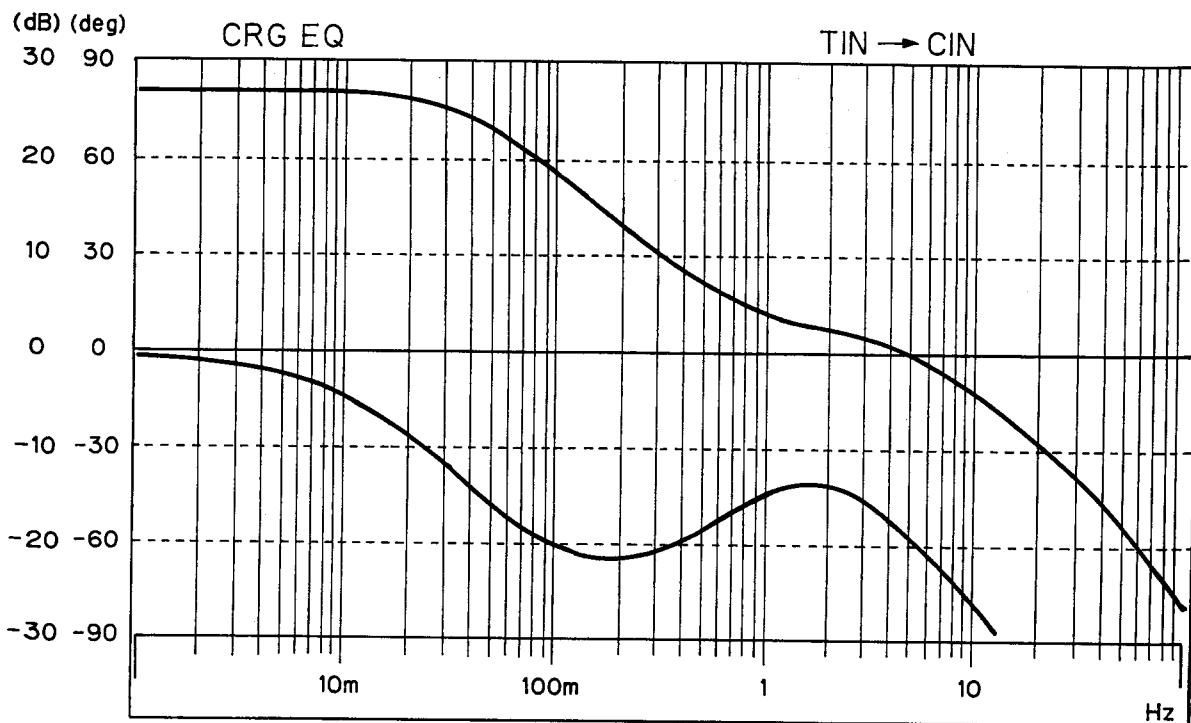

Fig. 61 Carriage equalizer (Example)

(8) Track Jump

The present system is jumping tracks 1, 10 and 32 subject to an automatic sequence of the UPD6374GH. The 64, 80 track jumps conventionally available have been substituted for $32TRK \times 2$ and $32TRK \times 3$, accordingly. Fig.62, 63 shows a timing chart of the 1, 10 and 32 track jumps.

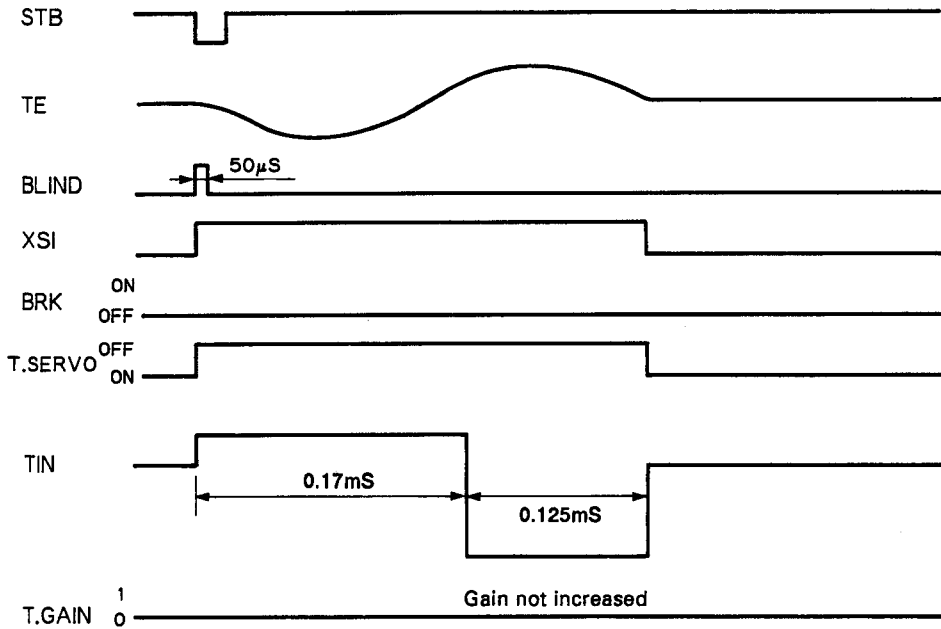

Fig. 62 Single jump

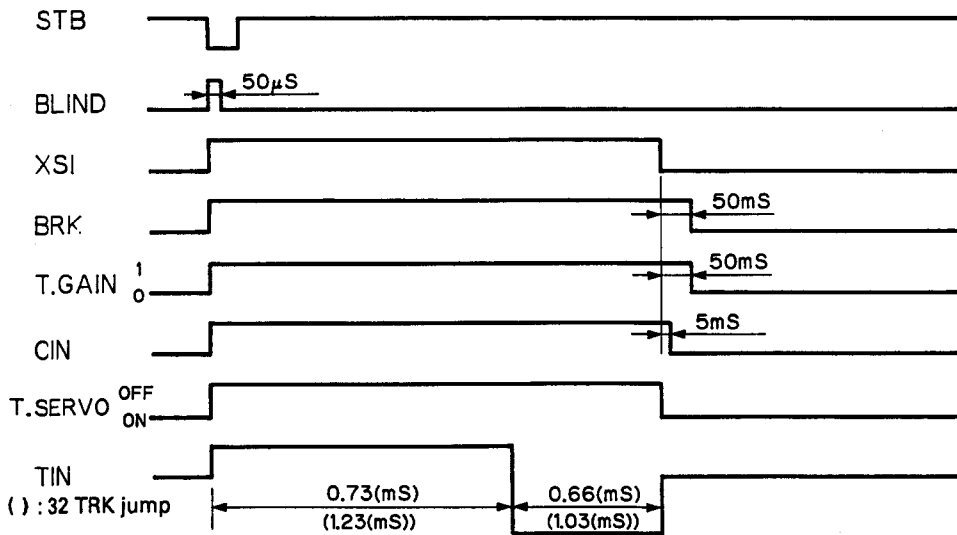

Fig. 63 10/32 Track jump

a) Track jump counter

When tracks are consecutively crossed, a tracking error signal will not fail to cross the DC offset point in both on- and off-track modes as shown in Fig. 64. This point, therefore, is used to determine either on- or off-track so as to count the number of cycles in which the on-track is switched over to the off-track. A count value is set by the microcomputer. And this count value is given priority to the kick-setting time.

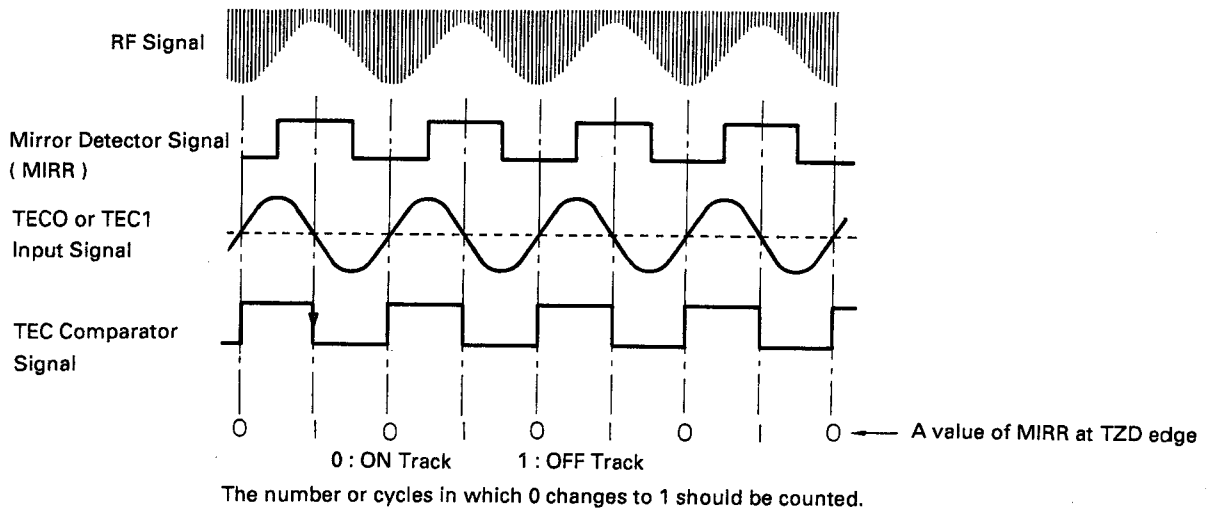
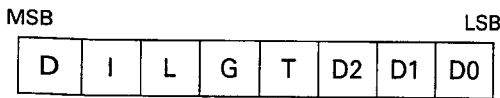

Fig. 64 Track count jump

3. CLV Control Stage

(1) CLV control command and CLV mode command



D	0	RFCK/4 and WFCK/4	Select a steady servo phase comparison signal.
	1	RFCK/8 and WFCK/8	
I	0	RFCK/16	Select a bottom hold cycle of pull-in and rough servos.
	1	RFCK/32	
L	0	MDF, MDR (H, Z) outputs	Select an MDF/MDR output terminal selecting method.
	1	MDF, MDR (H, L) outputs	
G	0	-12 dB	Select the gain of pull-in and rough servos.
	1	0 dB	
T	0	RFCK/2	Select a peak hold cycle of pull-in servo.
	1	RFCK/4	

D2	D1	D0	MDF	MDR	Control Status
0	0	0	L	L	stop
0	0	1	H	L	kick
0	1	0	L	H	brake
0	1	1	L	L	stop
1	0	0	L/H	L/H	pull-in servo
1	0	1	L/H	L/H	rough servo
1	1	0	L/H	L/H	steady servo
1	1	1	L/H	L/H	applied servo

• Pull-in Servo

This servo is used to pull the spindle motor speed into a specified number of revolutions. With a cycle of 8.6436 MHz reckoned as T, we can get "22T" (synchronous signal) as the maximum inversion interval of an EFM signal at the specified number of revolutions. Therefore, determine the EFM signal's maximum inversion interval and compare it with "22T" so that we can detect whether the motor speed is higher or lower than the specified number of revolution.

EFM SIGNAL MAX. INVERSION INTERVAL	MDF TERMINAL	MDR TERMINAL	MOTOR SPEED
"21T" and below	L(Z)	H	high
"22T"	L(Z)	L(Z)	
"23T" and above	H	L(Z)	low

Z: High impedance

• Rough Servo

This servo is used for the high-speed access in which the carriage is moved at a high speed, with focus servo ON and tracking servo OFF.

• Steady Servo

This servo is used to maintain the spindle motor speed at a specified number of revolutions. It is outputted as a result of comparing the phase between WFCK/4 and RFCK/4 or between WFCK/8 and RFCK/8.

• Application Servo

This is the CLV servo mode available during the normal operation. In the EFM demodulator block, every WFCK/16 is sampled to determine whether or not the frame synchronizing signal coincides with an output of the internal frame counter. As a result, a signal is generated to show whether or not they are coincident. Once this signal has been found not incident in eight consecutive cycles, the status is first determined asynchronous. Under any other conditions, the status is deemed synchronous. The CLV application servo mode automatically selects the pull-in servo in the asynchronous status and the steady servo in the synchronous status. This feature is not employed in the present system.

• Test Mode

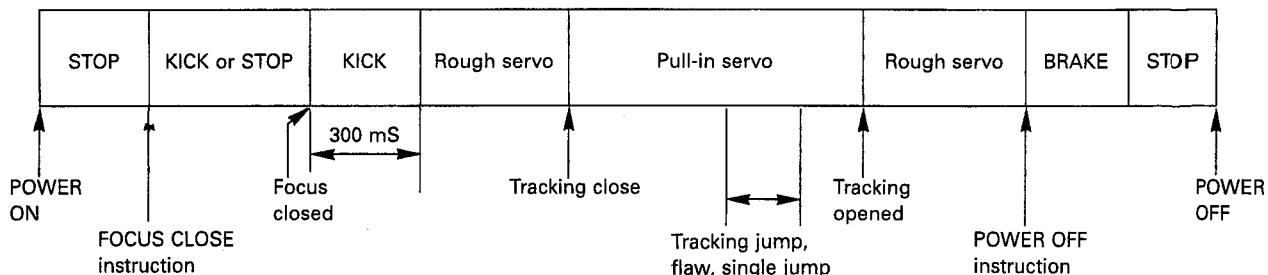

• Normal Mode

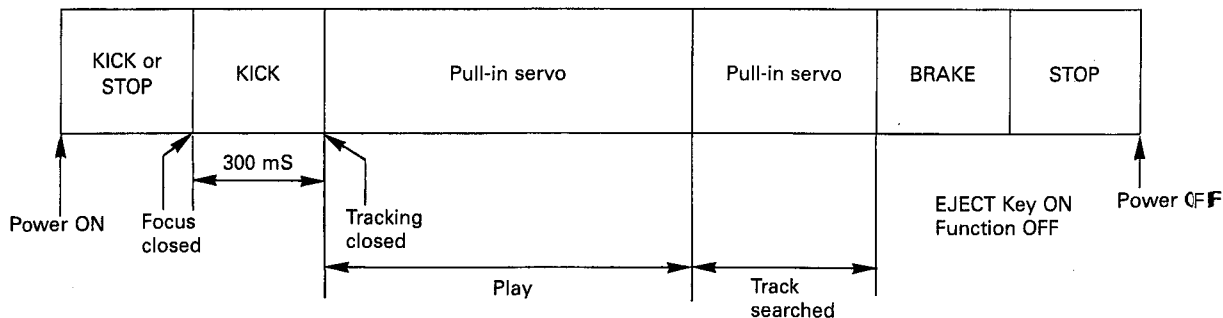

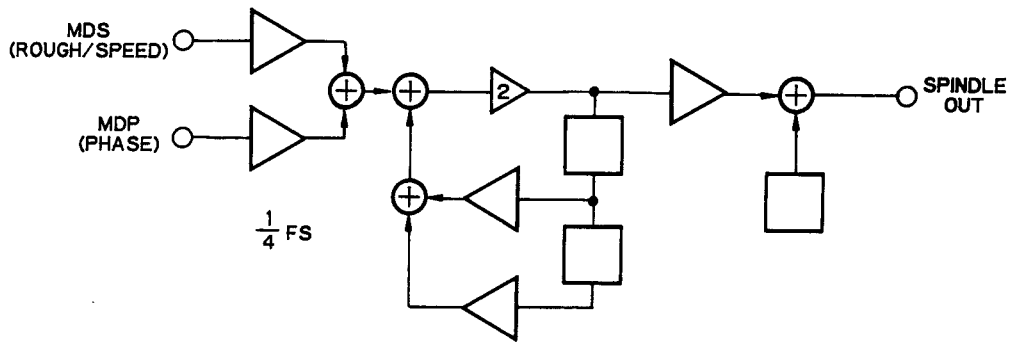

Fig. 65 Spindle signal flow chart (IC601)

(2) PLL stage

The present system employs a digital PLL circuit illustrated below. This PLL circuit operates so as to lock the rising edge of a PLCK and the edge of an EFM signal. And it has a resolution of as high as approximately eight times $1T$ ($T = \text{EFM signal's bit rate} = 1/4.3218 \text{ MHz}$). Both frequency divider output frequency and EFM bit rate have their errors automatically regulated to adjust the mean free-run frequency to the bit rate.

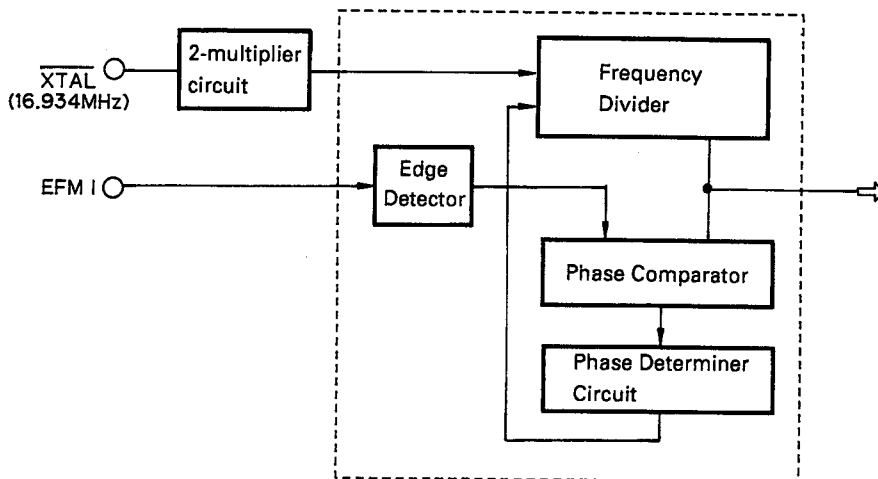

Fig. 66 Digital PLL block diagram (IC701)

4. Power Supply Stage

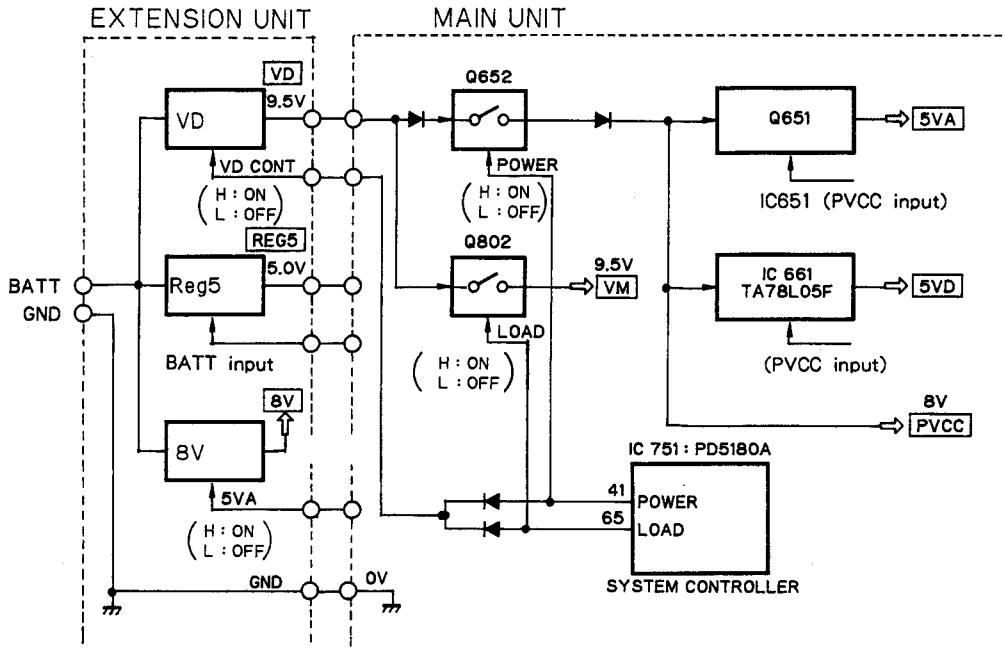

Fig. 67

The -5V power is available in two types; 5VA and 5VD. The 5VA is used to supply power to the pickup LD and to the preamplifier system and the 5VD to other LSIs.

The VM is used to supply power to the mechanism-driver IC (IC801). No output is available as long as mechanisms are operating.

The REG5 is used to supply power to the system controller (IC751 and 755) while outputting normally. The 8V is used for the auto system circuit (amplifier and isolator) in the extended unit and not supplied to the main unit.

It should be noted that the Q987 in the VD circuit has a very high temperature.

5. Optical Digital Output Circuit

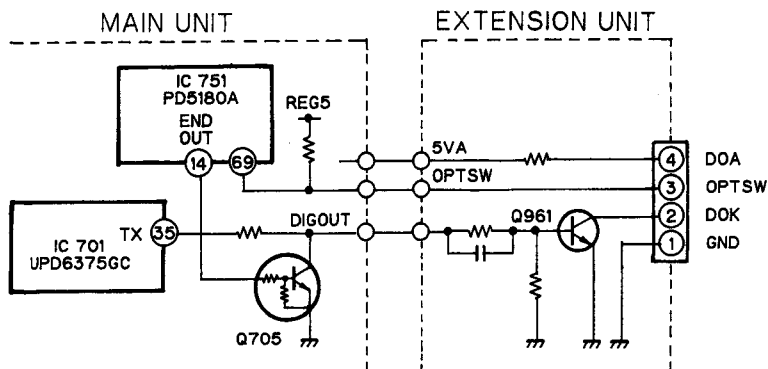

Fig. 68

The optical digital output circuit has a configuration as illustrated. Originally, its output is normally available at the TX terminal on the IC701. With effects of noise, etc. taken into consideration, however, the Q785 is employed to control muting so that the optical digital output circuit will output only when an optical cable is

connected. Once the optical cable has been inserted, the OPT switch will change from H to L. This is detected by the IC751 to turn ⑭ ENDOUT from H to L, thereby resetting the MUTE mode. With the optical cable removed, the system will operate reversely to change the DIGOUT over to L.

6. New Test Mode (FH-M70+CDX-M30)

The new test mode performs more or less the same operations as the normal mode PLAY, but is able to carry out a more detailed analysis of error stop causes. During setup, it displays the operation status of the CD control software. After setup, it displays the causes, time of occurrence, and disc number of protection operations, errors, and time-out of FOK, LOCK, sub-code readability and un-readability, sound dropping, mechanism error, etc. (However, only with the combination of head units manufactured after Autumn 1991.)

The following new test mode keys are examples when combined with FH-M70.

• New Test Mode (aging operation and setup analysis)

The CD, either single or multiple, plays in the normal mode. After being set up, it will display FOK (focus), LOCK (spindle), subcode, sound skip, protection against a mechanical error or the like, occurrence of an error, cause and time of an expiry, if any, (and disc number in the multi-mode).

During the setup, the CD software operation status (internal RAM and C-point) is displayed.

The software on the head unit side does not involve any special problem but runs normally.

Since it is necessary to cope with the error number display function.

(1) How to Put in the NEW TEST Mode

See the test mode flow chart Page 10.

(2) Relations of keys between TEST and NEW TEST Modes.

P-BUS Commands	Keys	Test Mode		New Test Mode	New Test Mode
		Regulator OFF	Regulator ON	Play in progress	Error Protection } Talking place
B0	BAND/REL	Regulator ON	Regulator OFF	BAND/REL	Time of occurrence } Selected Cause of error
B1	▶▶	—	FWD-KICK	▶▶	—
B2	◀◀	—	REV-KICK	◀◀	—
B3	F · 1	—	TRACKING CLOSE	F · 1	—
B4	F · 4	—	TRACKING OPEN	F · 4	—
B5	F · 2	—	FOCUS CLOSE	F · 2	—
B6	—	—	FOCUS OPEN	—	—
B7	—	—	Jump-OFF	—	—
B8	F · 3	To new Test Mode	Jump-Mode selected	F · 3	Occurrence TNo } Selected Time of occurrence

Operations, such as EJECT, CD ON/OFF, etc. are to be performed normally

(3) Error Cause (Error Number) Code

Error Code	Classification	Mode	Description	Cause/Detail
40	ELECTRIC	PLAY	FOK – L 100 ms	Put out of focus Spindle unlocked Subcode fails to read Last address memory operated Scar, Stain, Vibration, Servo defect, etc...
41	↑	↑	LOCK – L 100 ms	
42	↑	↑	Subcode unacceptable 500 ms	
43	↑	↑	Sound skipped	

*With CD single, no mechanical error is displayed while aging. The error code is identical with those in the normal mode.

(4) Indicating an Operation Status During Setup

Status No.	Description	Protection operation
01	Carriage home mode started	None
02	Carriage moving on the internal circumference	10-second time out
03	Carriage moving on the external circumference	10-second time out
11	Setup started	None
12	Spindle turn/Focus search started	None
13	Waiting for focus closing	Failure to focus closing
14	Spindle kicked and focus checked	Out of focus
15	Tracking closed and focus checked	Out of focus
17	Carriage closed and focus checked	Out of focus
18	Lock subcode } Waiting	Failure to lock, Subcode failed to read out of focus
19	End	None

(5) Example of 7-segment Display**(a) SET UP in progress**

TRACK	MIN	SEC	
11	11	11	
TRACK			While in the TEST MODE, a status number is indicated in TNO, MIN and SEC.
11			
MIN	SEC		
11	11		

(b) Operation (PLAY, SEARCH, etc.) in progress Perfectly identical with that in the multi mode.

(c) Protection/Error upon occurrence

ERROR-XX	While in the error mode, an error
Err-XX, ERR-XX	number is displayed in MIN and
E-XX	SEC.

Select the display with the BAND/REL key.

TRACK	MIN	SEC	
10	40	05	
TRACK			While in the PLAY MODE, an absolute time is indicated in TNO, MIN and SEC.
10			
MIN	SEC		
40	05		Select the display with the F · 3 key.