

Service Manual

ORDER NO.
CRT1572

MULTI-COMPACT DISC PLAYER

CDX-P11 EW

COMPACT
disc
DIGITAL AUDIO

- This additional service manual is designed to be used together with Model CDX-P600/EW Service Manual CRT1558. Refer to it for finding parts numbers and adjustment ,etc. which are not shown in this manual.

EXPLODED VIEW PARTS LIST

● Parts List (Page 1-36)

Mark No. Description	CDX-P600/EW	CDX-P11/EW
	Part No.	Part No.
8 Upper Case	CNB1783	CNB1796
15 Main Unit	CWX1631	CWX1724
26 Door	CAT1592	CAT1600
29 Grille	CNS2914	CNS2951
31 Extension Unit	CWX1694	CWX1723

PACKING METHOD

● Parts List (Page 2-9)

Mark No. Description	CDX-P600/EW	CDX-P11/EW
	Part No.	Part No.
1-2 Polyethylene Bag	CEG1116
1-3 Owner's Manual	CRD1698
Owner's Manual	CRD1699
* 1-4 Card	CRY-062
17 Carton	CHG2390	CHG2461
18 Contain Box	CHL2390	CHL2461

ELECTRICAL PARTS LIST

●Parts List (Page 1-31) (Main Unit)

Circuit Symbol & No. Part	CDX-P600/EW	CDX-P11/EW
	Part No.	Part No.
IC751	PD5262A	PD5271A
IC752	LH5160HN-10L
Q781	UN2211
R782,784,788	RS1/16S104J
R922	RS1/16S104J
C757	CKSRYB103K50

●Parts List (Page 1-31) (Extension Unit)

Circuit Symbol & No. Part	CDX-P600/EW	CDX-P11/EW
	Part No.	Part No.
Q1731	2SC3673
D1731	HZS6LB1
SW1751	CSH1035
R1736	RS1/10S101J
R1737	RD1/4PS153JL
R1738	RS1/8S101J
R1751	RD1/4PS102JL
R1752,1753,1754	RD1/4PS513JL
R1755	RS1/10S102J
C1733	CCL1027
C1736	CEA010M50LS2
C1738	CKSQYB103K25

●Parts Position

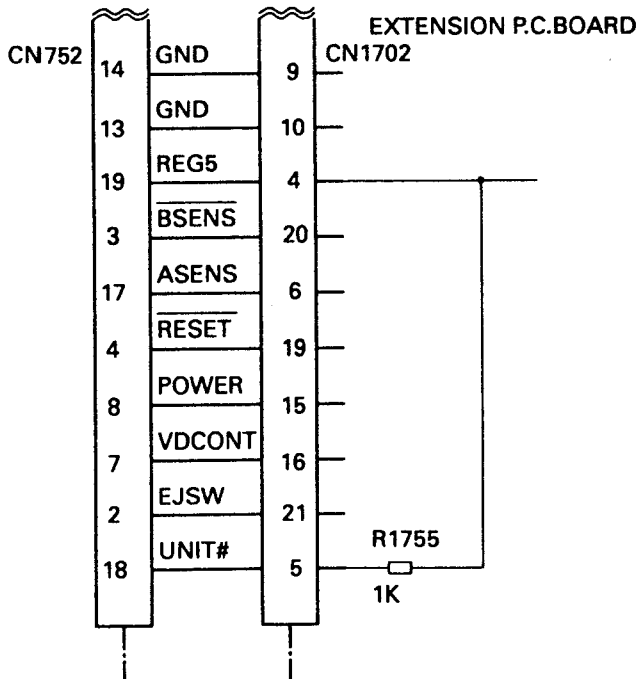

CHAPTER 1

1. SAFETY INFORMATION

1.1 CDX-P600/UC,P606/UC

CAUTION

This service manual is intended for qualified service technicians; it is not meant for the casual do-it-yourselfer. Qualified technicians have the necessary test equipment and tools, and have been trained to properly and safely repair complex products such as those covered by this manual. Improperly performed repairs can adversely affect the safety and reliability of the product and may void the warranty. If you are not qualified to perform the repair of this product properly and safely; you should not risk trying to do so and refer the repair to a qualified service technician.

WARNING

Lead in solder used in this product is listed by the California Health and Welfare agency as a known reproductive toxicant which may cause birth defects or other reproductive harm (California Health & Safety Code, Section 25249.5). When servicing or handling circuit boards and other components which contain lead in solder, avoid unprotected skin contact with the solder. Also, when soldering do not inhale any smoke or fumes produced.

1.2 CDX-P600/EW

1. Safety Precautions for those who Service this Unit.

- Follow the adjustment steps (see pages 1-8 through 1-26) in the service manual when servicing this unit. When checking or adjusting the emitting power of the laser diode exercise caution in order to get safe, reliable results.

Caution:

1. During repair or tests, minimum distance of 13cm from the focus lens must be kept.
 2. During repair or tests, do not view laser beam for 10 seconds or longer.
2. A "CLASS 1 LASER PRODUCT" label is affixed to the rear of the player.
3. The triangular label is attached to the mechanism unit frame.

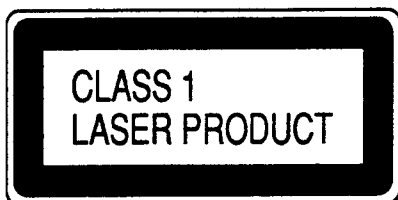

Fig.1

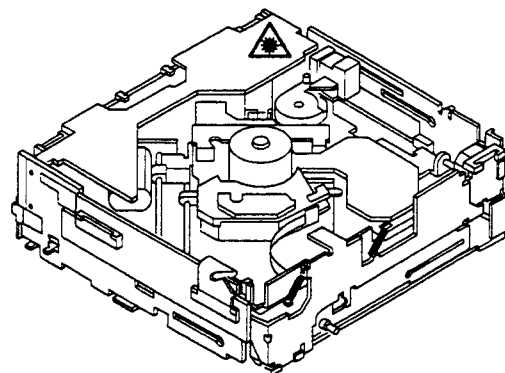

Fig.2

4. Specifications of Laser Diode

Specifications of laser radiation fields to which human access is possible during service.

Wavelength = 785 nanometers

Radiant power = 69.7 microwatts(Through a circular aperture stop having a diameter of 80 millimeters)
0.55 microwatts(Through a circular aperture stop having a diameter of 7 millimeters)

2. OPERATIONS AND CONNECTION

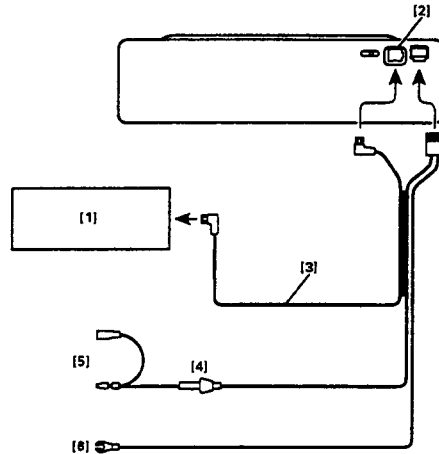

Fig. 3

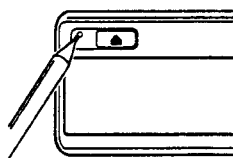

Fig. 4

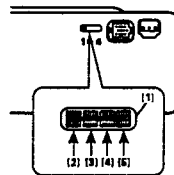

Fig. 5

Connecting the Units

- Before mounting, remove the transportation pin (See "Transportation pin".) and connect the units temporarily. Check that the units are connected correctly by operating the multi-CD controller.
- After connection is complete, press the clear buttons on the player and the multi-CD controller with the tip of a pencil.
- Be sure to connect the ground lead (black) to the vehicle body or some other metal part that is properly grounded to the chassis. If the ground lead is not properly connected, noise may occur or the player or multi-CD controller may not operate correctly.
- This unit is for vehicles with a 12-volt battery and negative grounding. Before installing it in a recreational vehicle, truck, or bus, check the battery voltage.
- To avoid shorts in the electrical system, be sure to disconnect the battery (-) cable before beginning installation.
- Check whether installation and wiring have been completed correctly. Replace the removed car components, then connect the end of the cable to the negative (-) terminal of the battery.
- Secure the wiring with cable clamps or adhesive tape. To protect the wiring, wrap adhesive tape around them where they lie against metal parts.
- Route and secure all wiring so it cannot touch any moving parts, such as the gear shift, handbrake, and seat rails. Do not route wiring in places that get hot, such as near the heater outlet. If the insulation of the wiring melts or gets torn, there is a danger of the wiring short-circuiting to the vehicle body.
- Don't pass the orange lead through a hole into the engine compartment to connect to the battery. This will damage the lead insulation and cause a very dangerous short.
- Do not shorten any leads. If you do, the protection circuit may fail to work when it should.
- Never feed power to other equipment by cutting the insulation of the power supply lead of the unit and tapping into the lead. The current capacity of the lead will be exceeded, causing over heating.
- Replace fuses only with the types stipulated on the fuse holder.

(Fig. 3)

[1] Multi CD controller or Multiple installation adapter (such as CD-P44)

[2] IP-BUS output (black)

Connect the black connector of the cable to this connector.

[3] IP-BUS cable

[4] Fuse holder

[5] Orange

To the terminal always supplied with power regardless of ignition switch position.

[6] Black (ground)

To the vehicle (metal) body.

Pressing the clear button

If the power does not switch on or if the compact disc player does not operate when the button on the multi-CD controller is pressed, or if the multi-CD controller display is incorrect, press this button on the player with the tip of a pencil to restore normal operation. (This button is located inside the door.) Always press the clear button on the multi-CD controller, too, after pressing this button. (Fig. 4)

- If the clear button is pressed when the player contains a magazine or the ignition switch is set to the ON or ACC position, the CD title display and ITS memory are cleared.

Changing the Address Switch

- This unit can be connected from the second to fourth multi-CD players by using the separately sold multiple installation adapter (CD-P44). Each multi-CD player has an address switch so that the multiple installation adapter can identify which player is which. Set the address switch for each player as shown in Fig. 5.
- See the instruction manual for the multiple installation adapter (CD-P44) when you connect multi-CD players using the adapter.

(Fig. 5)

[1] Address switch

This switch can be set to address 1,2,3, or 4, starting from the left.

- [2] Address 1
- [3] Address 2
- [4] Address 3
- [5] Address 4

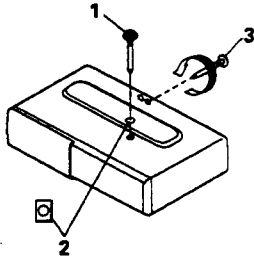

Fig. 6

Transportation pin

Removing the transportation pin

(Fig. 6)

A transportation pin is installed to protect the player during transportation. Before mounting the player, remove the transportation pin and cover the hole with the supplied adhesive seal. Screw the removed transportation pin into the specified hole; it will be needed if you retransport the player.

1. Peel off adhesive tape and remove the pin.
2. Cover the hole with the seal provided.
3. Screw the pin into the left-side hole of the 2 holes.

Reinstalling the pin

(Fig. 7)

To transport the player, reinstall the transportation pin as follows:

Before removing the player

Play back the first track of a disc, and stop within 10 seconds. Remove the magazine, wait about 10 seconds, then remove the player.

1. Remove the pin.
2. Insert the pin in its original position, and fix it with Scotch tape.

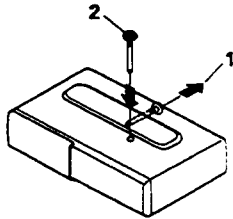

Fig. 7

3. DISASSEMBLY

● Removing the Case

1. Unfasten six screws A and then remove the upper case.
2. Unfasten four screws B and then remove the lower case.

● Removing the Grille Assy

1. Unlock four catches and dismount the grille assy.

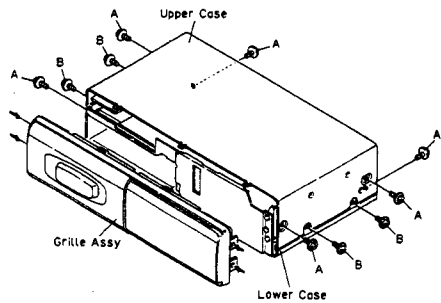

Fig.8

● Removing the Bracket L,R

1. Unfasten six screws.
2. Remove bracket L.
3. Remove bracket R.

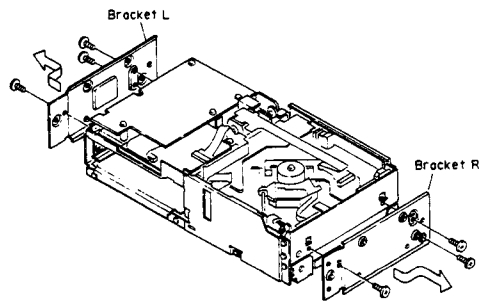

Fig.9

● Removing the Extension P.C.Board

1. Unfasten four screws.
2. Remove the connector.
3. Remove the extension P.C.Board.

NOTE: Be sure to screw in order of 1-4.

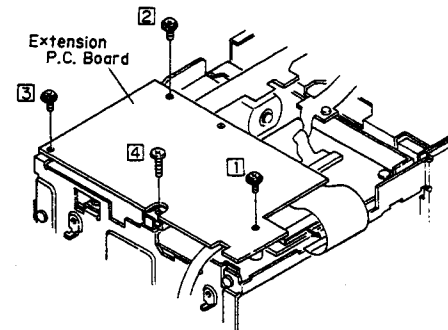

Fig.10

● CN351

Before disconnecting the CN351 connector (PU unit connector), attach a short pin as illustrated.

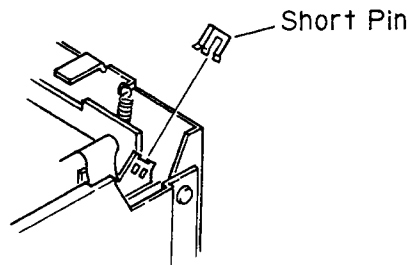

Fig.11

● Removing the Main Unit

1. Unfasten three screws.
2. Remove the three connectors.
3. Remove the main unit.

NOTE: Be sure to screw in order of 1-3.

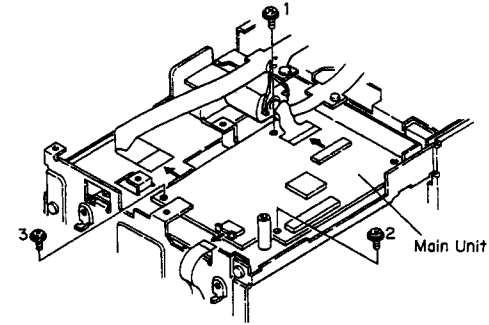

Fig.12

4. ADJUSTMENT

1) Precautions

This unit uses a single power supply (+5V) for the regulator. The signal reference potential, therefore, is connected to REFOUT (approx. 2.5V) instead of GND. If REFOUT and GND are connected to each other by mistake during adjustments, not only will it be impossible to measure the potential correctly, but the servo will malfunction and a severe shock will be applied to the pick-up. To avoid this, take special note of the following.

Do not connect the negative probe of the measuring equipment to REFOUT and GND together. It is especially important not to connect the channel 1 negative probe of the oscilloscope to REFOUT with the channel 2 negative probe connected to GND.

And since the frame of the measuring instrument is usually at the same potential as the negative probe, change the frame of the measuring instrument to floating status.

If by accident REFOUT comes in contact with GND, immediately switch the regulator or power OFF.

Always make sure the regulator is OFF when connecting and disconnecting the various filters and wiring required for measurements.

Before proceeding to further adjustments and measurements after switching regulator ON, let the player run for about one minute to allow the circuits to stabilize.

Since the protective systems in the unit's software are rendered inoperative in test mode, be very careful to avoid mechanical and / or electrical shocks to the system when making adjustment.

When loading and unloading discs during adjustment procedures, always wait for the disc to be properly clamped or ejected before pressing the another key. Otherwise, there is risk of the actuator being destroyed.

Turn power off when pressing the button TRACK UP or the button TRACK DOWN key for focus search in the test mode. (Or else lens may stick and the actuator may be damaged.)

2) Test mode

This unit is adjusted in a combination with the multiple CD control unit (KEH-P5000, etc.). Each regulator key should be operated at the unit. With the KEH-P5000 taken up for reference, a description will be given below concerning how to enter into the test mode, including key operations. The key in the adjustment text is also one of the KEH-P5000 keys.

How to enter into the test mode
While pressing keys 4 and 6 at a time, press the back-up ON or clear button ON the KEH-P5000.

Resetting the test mode
Press the clear button ON the KEH-P5000. Subsequently press the clear button ON this unit. Or turn off this unit and the KEH-P5000 back-up and wait for about one minute.

a) CD multi-player

Key	Function
BAND	Regulator ON / OFF
TRACK UP	FWD kick
TRACK DOWN	REV kick
7/F1	Tracking close
8/F2	Tracking open
9/F3	Focus close
10/F4	Focus open
11/F5	Jump-Off
12/F6	1/10/32 jump / carriage move switching

- SINGLE / 10TRK / 32TRK will continue to operate even after the key is released. Tracking closed the moment C-MOVE is released.
- With two or more players connected, disconnect any other CD multi-players and connect one changer only to the control unit. Unless the address switch is positioned at ONE, the system cannot be put into the test mode.

● Flow Chart

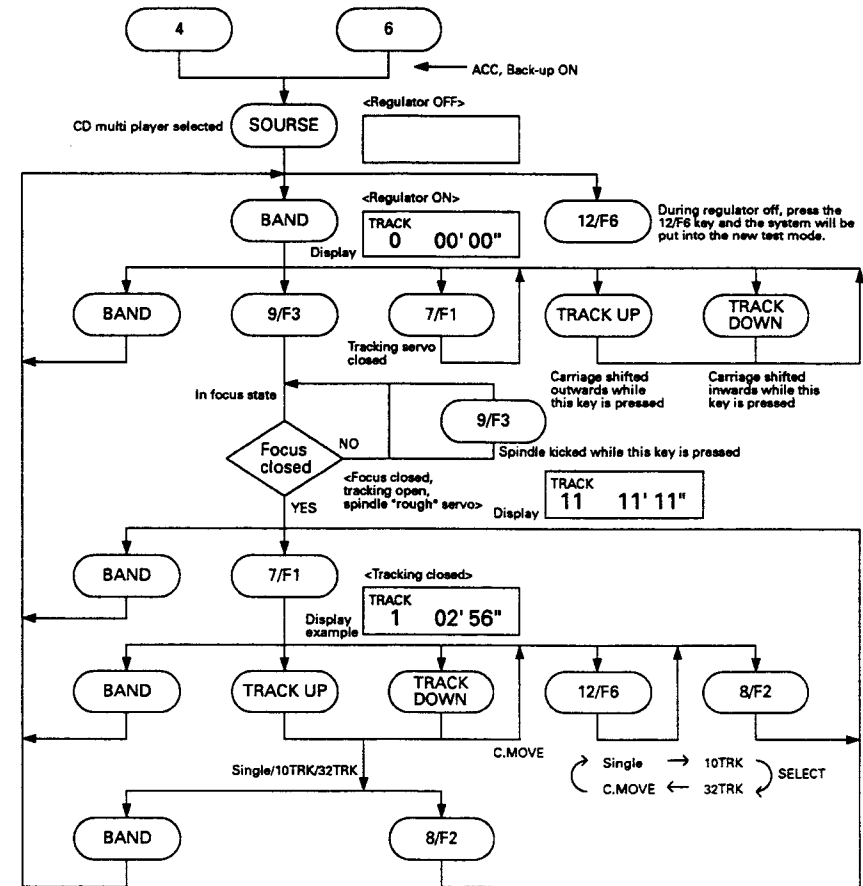

● Measuring Equipment and Jigs

Adjustment	• Measuring equipment&jigs
1 Grating Adjustment-1 (Rough adjustment)	<ul style="list-style-type: none"> • Oscilloscope, clock driver, grating adjustment filter (bandpass filter)(GGF-133), AC milli-voltmeter • SONY TYPE 4 (or ABEX TCD-782) • Extension Cable:GGD1023
2 Tangential Skew Check	<ul style="list-style-type: none"> • Oscilloscope, screwdriver • SONY TYPE 4 (or ABEX TCD-782) • Extension Cable:GGD1023
3 Grating Adjustment-1 (Fine adjustment)	<ul style="list-style-type: none"> • Oscilloscope, clock driver, two low-pass filters • SONY TYPE 4 (or ABEX TCD-782) • Extension Cable:GGD1023
4 Grating Adjustment-2	<ul style="list-style-type: none"> • Oscilloscope, grating adjustment driver, low-pass filter • SONY TYPE 4 (or ABEX TCD-782) • Extension Cable:GGD1023
5 FE Bias Adjustment	<ul style="list-style-type: none"> • Oscilloscope, volume adjustment driver • SONY TYPE 4 (or ABEX TCD-782) • Extension Cable:GGD1023
6 RF Offset Adjustment	<ul style="list-style-type: none"> • Oscilloscope, volume adjustment driver • SONY TYPE 4 (or ABEX TCD-782) • Extension Cable:GGD1023
7 TE Offset Adjustment-1	<ul style="list-style-type: none"> • DC voltmeter or oscilloscope, volume adjustment driver • Extension Cable:GGD1023
8 Tracking Balance Adjustment-1	<ul style="list-style-type: none"> • Oscilloscope, volume adjustment driver • SONY TYPE 4 (or ABEX TCD-782) • Extension Cable:GGD1023
9 Focus Servo Loop Gain Adjustment-1	<ul style="list-style-type: none"> • Oscillator, gain adjustment filter (GGF-065), oscilloscope, dual meter milli-voltmeter, volume adjustment driver • SONY TYPE 4 (or ABEX TCD-782) • Extension Cable:GGD1023
10 Focus Servo Loop Gain Adjustment-2	<ul style="list-style-type: none"> • Oscillator, gain adjustment filter, oscilloscope, volume adjustment driver • SONY TYPE 4 (or ABEX TCD-782) • Extension Cable:GGD1023
11 Tracking Servo Loop Gain Adjustment-1	<ul style="list-style-type: none"> • Oscillator, gain adjustment filter (GGF-065), oscilloscope, dual meter milli-voltmeter, volume adjustment driver • SONY TYPE 4 (or ABEX TCD-782) • Extension Cable:GGD1023
12 Tracking Servo Loop Gain Adjustment-2	<ul style="list-style-type: none"> • Oscillator, gain adjustment filter, oscilloscope, volume adjustment driver • SONY TYPE 4 (or ABEX TCD-782) • Extension Cable:GGD1023
13 TE Offset Adjustment-2	<ul style="list-style-type: none"> • DC voltmeter or oscilloscope, volume adjustment driver • Extension Cable:GGD1023

Adjustment	• Measuring equipment&jigs
14 Checking FEY Level	<ul style="list-style-type: none"> • Oscilloscope • SONY TYPE 4 (or ABEX TCD-782) • Extension Cable:GGD1023
15 Tracking Balance Adjustment-2 and Checking TEY Level	<ul style="list-style-type: none"> • Oscilloscope, volume adjustment driver • SONY TYPE 4 (or ABEX TCD-782) • Extension Cable:GGD1023

● Adjustment Points

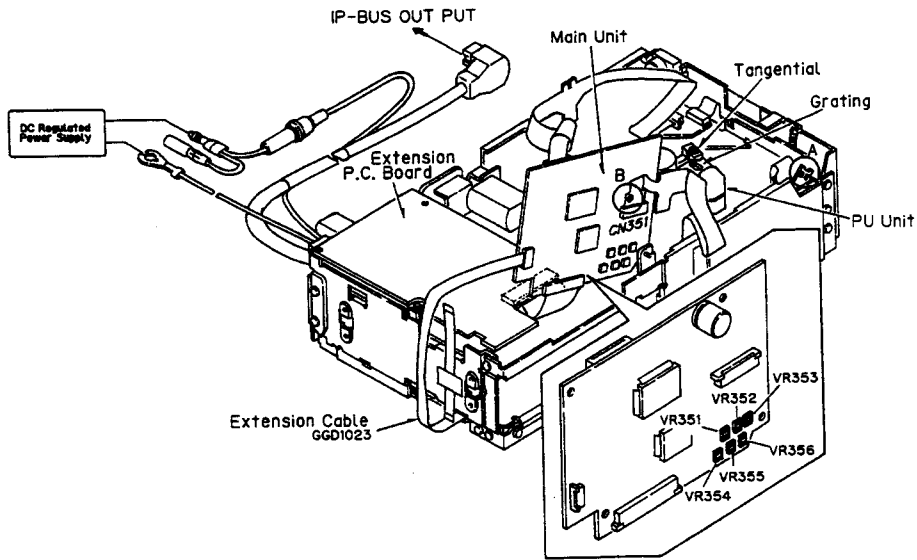

Fig.13

VR351	FE BIAS
VR352	RF OFFSET
VR353	TE OFFSET
VR354	TRACKING BALANCE
VR355	FOCUS SERVO LOOP GAIN
VR356	TRACKING SERVO LOOP GAIN

Note: When pulling out the connector CN351, be sure to install a short pin in section A. Alternatively, the land in section B may be short-circuited (by soldering or the like). When the connector is inserted, be sure to disconnect it before the power is turned on.

● Test Point

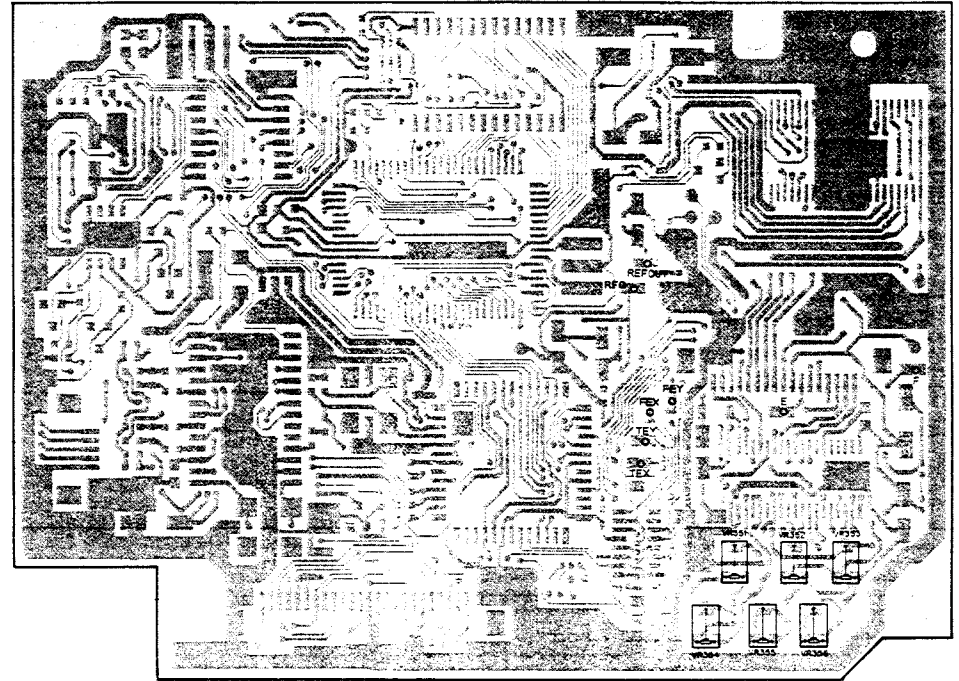
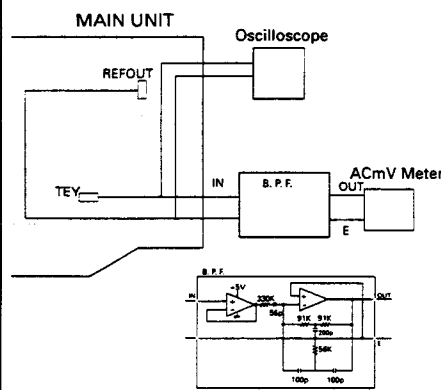

Fig.14

1 Grating Adjustment-1 (Rough adjustment)

- Grating Adjustment-1 (rough adjustment and fine adjustment) may be performed in Grating Adjustment-2.
- **Purpose:**
The grating may need adjustment in a replaced pick-up unit.
- **Maladjustment symptoms:**
No disc playback, track jumping.

- **Measuring equipment / jigs:**
Oscilloscope, clock driver, grating adjustment filter (bandpass filter) (GGF-133), AC milli-voltmeter
- **Measuring point:**
TEY
- **Test disc and setting:**
SONY TYPE 4 (or ABEX TCD-782) Test mode
- **Adjustment position:**
Pick-up grating adjustment hole



- Adjustment Procedure**
1. In the test mode, set a test disc-loaded magazine and select the tray with a test disc.
 2. Switch regulator ON.
 3. Using the TRACK UP or TRACK DOWN key, move the pick-up to about the center of the test disc.
 4. Press the 9/F3 key to close focus.
 5. While monitoring the TEY filter output by AC milli-voltmeter, turn the grating adjustment hole slowly. The AC voltage increases and decreases while turning the screw. Search for the minimum voltage level. (This corresponds to the position where the grating is on a track, and is referred to as the null point.)
 6. Then while monitoring TEY by oscilloscope, turn the driver slowly clockwise from the null point (as seen from under the pick-up) until the first waveform peak amplitude is reached.

2 Tangential Skew Check

- **Purpose:**
To check whether tangential skew has been misaligned or not when replacing the pick-up unit.
- **Maladjustment symptoms:**
No disc playback, track jumping.

- **Measuring equipment / jigs:**
Oscilloscope, screwdriver
- **Measuring point:**
RFO
- **Test disc and setting:**
SONY TYPE 4 (or ABEX TCD-782) Normal mode
- **Adjustment position:**
Pick-up tangential adjustment screw

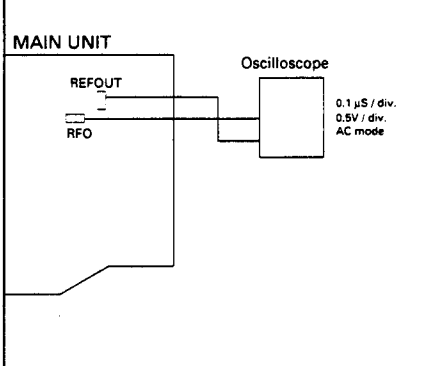

- Adjustment Procedure**
1. Play tune TNO 12 in normal mode. (ABEX TCD-782:TNO19)
 2. Adjust the tangential adjustment screw so that the RF wave-form will have a level maximized and an eye pattern clearly viewed. Turn the adjustment screw both clockwise and counterclockwise to points where the eye pattern deteriorates, and take the midway point as the adjustment point. As a general guide, look for an overall clear waveform, and one of the diamond shapes in the eye pattern. The diamond shapes should appear in fine lines at the point of optimum adjustment. Take care not to knock the pick-up with the screwdriver at this stage. (This kind of accident can result in loss of focus.) (See Waveform 1,2)
 3. Apply "screw-lock" to the tangential adjustment screw.
 4. After adjusting tangential skew, also adjust the grating.

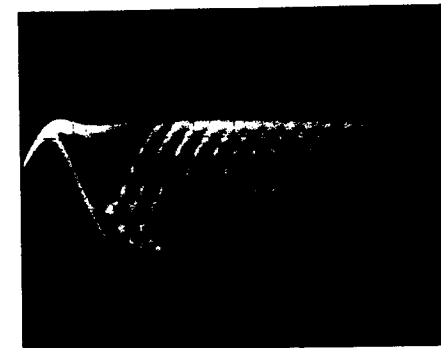

Waveform 1

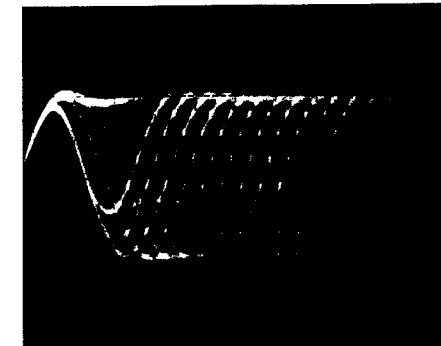

Waveform 2

0.5V/div.
0.5μs/div.
DC mode

3 Grating Adjustment-1(Fine adjustment)

- **Purpose:**
The grating may need adjustment in a replaced pick-up unit.
- **Maladjustment symptoms:**
No disc playback, track jumping.

- **Measuring equipment / jigs:**
Oscilloscope, clock driver, two low-pass filters
- **Measuring point:**
E LPF output, F LPF output
- **Test disc and setting:**
SONY TYPE 4 (or ABEX TCD-782) Test mode
- **Adjustment position:**
Pick-up grating adjustment hole

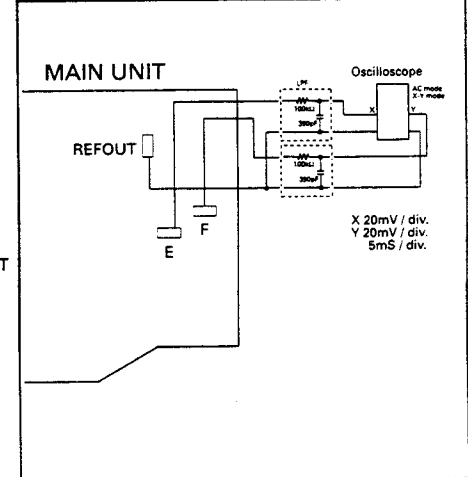

- Adjustment Procedure**
1. Connect a low-pass filter as shown in the above diagram.
 2. Switch regulator ON in test mode, and load a disc.
 3. Using the TRACK UP or TRACK DOWN key, move the pick-up to about the center of the test disc.
 4. Press the 9/F3 key to close focus.
 5. Using the driver, adjust the Lissajous figure to a single line (or as close as possible). (See Waveform 8)
 6. Switch regulator OFF and remove the filters.

TEY waveform 5ms/div.,500mV/div.

Nul Point

Lissajous figure(AC input)
Horizontal axis E 20mV/div.
vertical axis F 20mV/div.

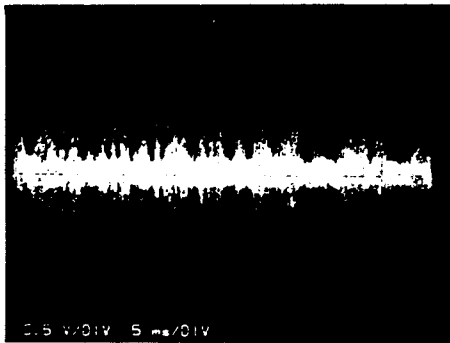

Waveform 3



Waveform 4

"Rough" adjustment

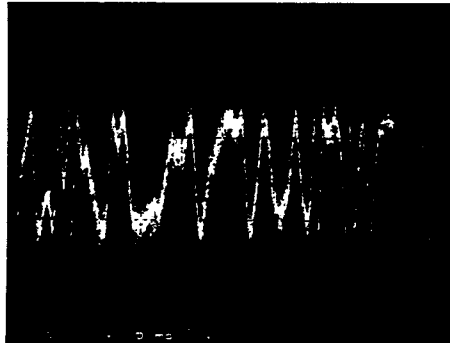

Waveform 5

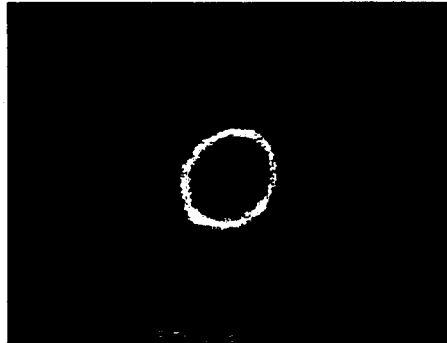

Waveform 6

Final adjustment

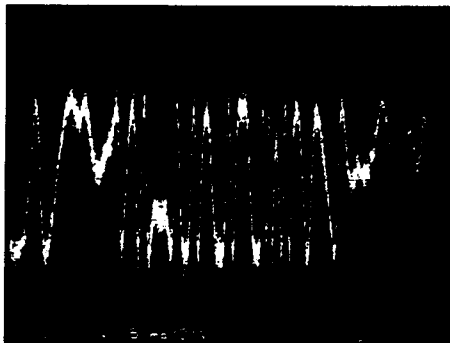

Waveform 7

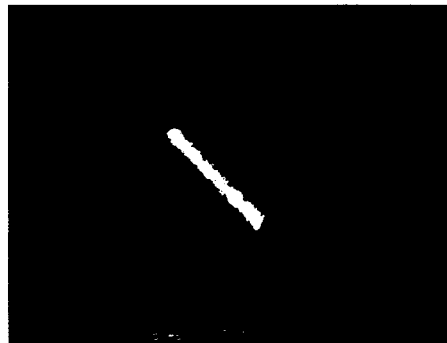

Waveform 8

4 Grating Adjustment-2

- Grating Adjustment-2 may be performed in Grating Adjustment-1 (rough adjustment and fine adjustment).
- Purpose:
The grating may need adjustment in a replaced pick-up unit.
- Maladjustment symptoms:
No disc playback, track jumping.

• Measuring equipment / jigs:
Oscilloscope, grating adjustment driver, low-pass filter

• Measuring point:
TEY

• Test disc and setting:
SONY TYPE 4 (or ABEX TCD-782) Test mode

• Adjustment position:
Pick-up grating adjustment hole

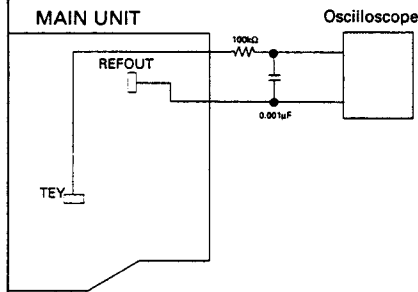

Adjustment Procedure

1. In the test mode, set a test disc-loaded magazine and select the tray with a test disc.
2. Switch regulator ON.
3. Using the TRACK UP or TRACK DOWN key, move the pick-up to center of the test disc.
4. Press the 9/F3 key to close focus.
5. Insert the adjusting screwdriver in the slit for the pick-up grating adjustment and adjust the grating to seek out the null point. For details, see following page.
6. As the screwdriver is slowly turned clockwise from the null point, the amplitude of the waveform increases gradually. As the screwdriver continues to be turned, the amplitude of the waveform decreases again. Adjust the grating to a point at which the amplitude of the waveform first reaches the maximum while the screwdriver is turned clockwise from the null point.

● How to seek the null point

When the screwdriver is inserted in the slit for grating adjustment while the angle of the grating is varied, the amplitude of the TEY tracking error signal varies. There are 5 or 6 positions where the amplitude of the waveform is decreased in the grating variable range. In only one of the waveform amplitude diminishing positions, the envelope is made smooth. This position denotes the state where three laser beams divided by the grating are aligned right on the same track. This position is referred to as the null point. Adjust the grating to seek out the null point which is used as a reference position in performing the grating adjustment.

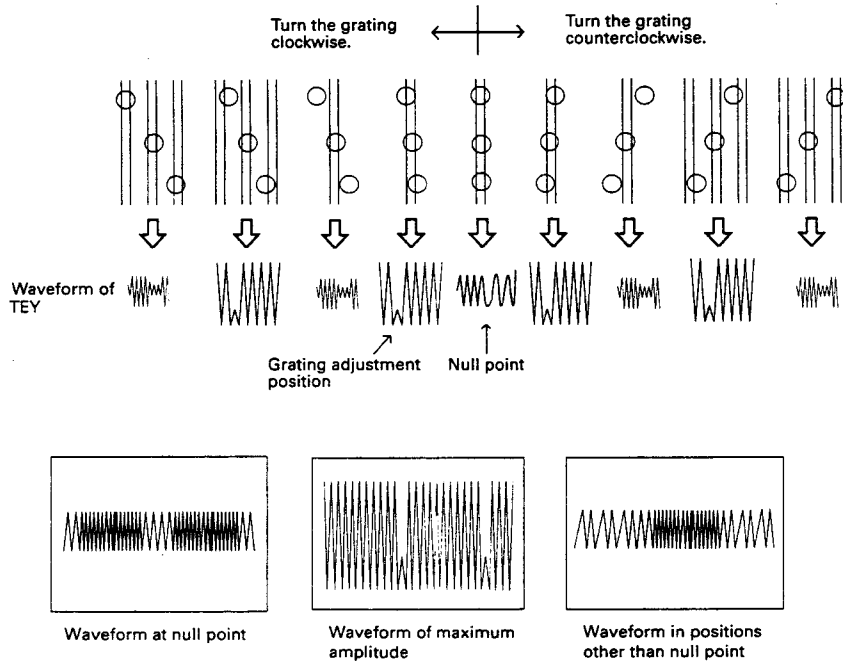

5 FE Bias Adjustment

- Purpose:
To adjust the focus servo bias to an optimum value.
- Maladjustment symptoms:
Focus closing difficulty, poor playability.
- Measuring equipment / jigs:
Oscilloscope, volume adjustment driver
- Measuring point:
RFO
- Test disc and setting:
SONY TYPE 4 (or ABEX TCD-782) Normal mode
- Adjustment position:
VR351 (FEB)

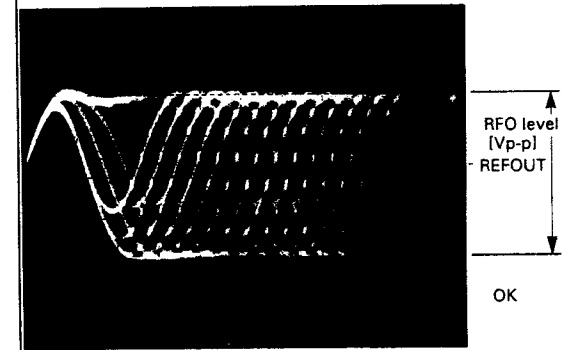
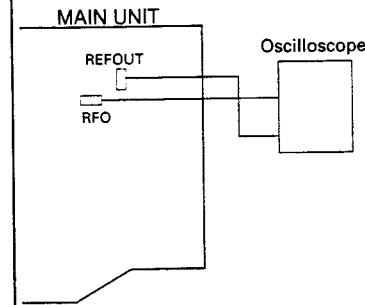
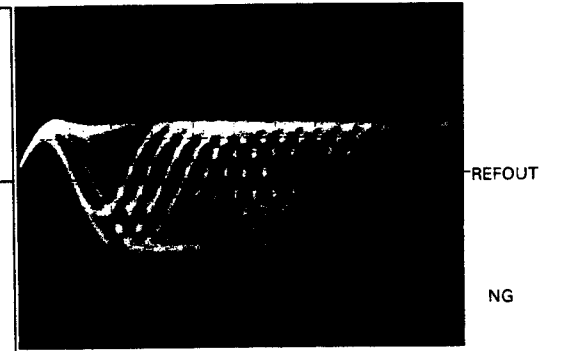

Adjustment Procedure

1. Play tune TNO 12 in normal mode.(ABEX TCD-782:TNO 19)
2. Observe RFO in respect to REFOUT in the oscilloscope, and adjust VR351 (FEB) to obtain maximum RF and optimum eye pattern.(See Waveform 9,10)
3. After adjustment, measure the RFO output level shown in Waveform 10 and take actions shown below.

Output level	Action
2.6Vp-p more than	Replace the pick-up
1.2Vp-p - 2.6Vp-p	Normal
1.2Vp-p less than	Replace the pick-up

0.5V/div.
0.5μs/div.
DC mode



6 RF Offset Adjustment

- **Purpose:**
To adjust the RF amplifier offset to a suitable value.
- **Maladjustment symptoms:**
Focus closure fails readily.

- **Measuring equipment / jigs:**
Oscilloscope, volume adjustment driver
- **Measuring point:**
RFO
- **Test disc and setting:**
SONY TYPE 4 (or ABEX TCD-782) Normal mode
- **Adjustment position:**
VR352 (RFO)

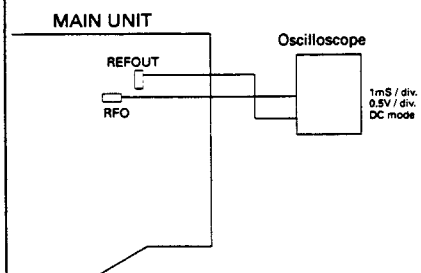

When using a multi-channel oscilloscope, do not connect the other negative probe to ground.

Adjustment Procedure

1. Play tune TNO 12 in normal mode.(ABEX TCD-782:TNO 19)
2. Using VR352 to adjust the RFO waveform so that REFOUT appears at the center.(A-B must not exceed 100 mV.)



7 TE Offset Adjustment-1

- **Purpose:**
To adjust the electrical offset of the tracking servo to zero.
- **Maladjustment symptoms:**
Search times too long, carriage run-away.

- **Measuring equipment / jigs:**
DC voltmeter or oscilloscope, volume adjustment driver
- **Measuring point:**
TEY
- **Test disc and setting:**
Empty magazine Test mode
- **Adjustment position:**
VR353

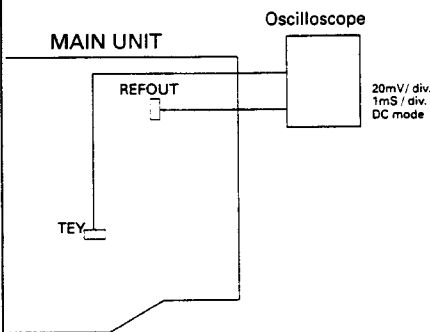

Adjustment Procedure

1. Select a tray without a disc, while in test mode.
2. Switch regulator ON.
3. Using VR353, adjust the TEY output DC voltage in reference to REFOUT to a value of 0 ± 25 mV.
4. Switch regulator OFF.

8 Tracking Balance Adjustment-1

- **Purpose:**
To adjust the tracking servo offset to zero.
- **Maladjustment symptoms:**
Search times too long, poor playability, carriage run-away.

- **Measuring equipment / jigs:**
Oscilloscope, volume adjustment driver
- **Measuring point:**
TEY (Tracking error signal)
- **Test disc and setting:**
SONY TYPE 4 (or ABEX TCD-782) Test mode
- **Adjustment position:**
VR354 (T.BAL)

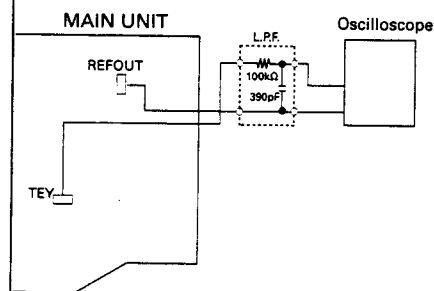

Adjustment Procedure

1. After checking that regulator is OFF, connect the low-pass filter as shown in the diagram.
2. Set the test disc. Switch regulator ON.
3. Using the TRACK UP or TRACK DOWN key, move the pick-up to about the center of the signal surface.
4. Press the 9/F3 key to close focus.
5. Using an oscilloscope, observe the TEY signal in respect to REFOUT.
Then adjust VR354 (T.BAL) to set the positive and negative amplitudes to the same levels.
(See Waveform 11-13)
6. Switch the power OFF.

TEY waveform
0.5V/div.
10ms/div.

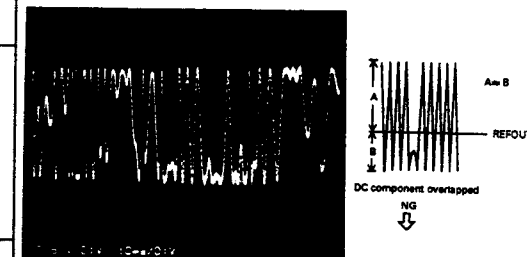

Waveform 11

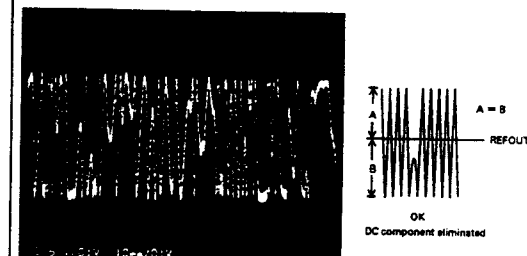

Waveform 12

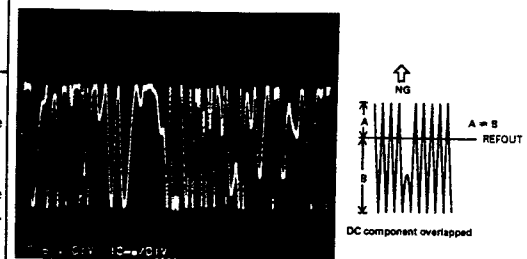

Waveform 13

9 Focus Servo Loop Gain Adjustment-1

• Focus Servo Loop Gain Adjustment-1 may be performed in Focus Servo Loop Gain Adjustment-2.
 • **Purpose:**
 To adjust the focus servo loop gain to an optimum value.
 • **Maladjustment symptoms:**
 Poor playability, reduced resistance to vibration, focus closure fails readily.

• **Measuring equipment / jigs:**
 Oscillator, gain adjustment filter (GGF-065), oscilloscope, dual meter milli-voltmeter, volume adjustment driver
 • **Measuring point:**
 FEX, FEY
 • **Test disc and setting:**
 SONY TYPE 4 (or ABEX TCD-782) Normal mode
 • **Adjustment position:**
 VR355

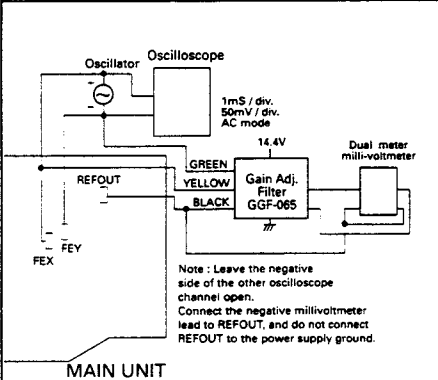

Adjustment Procedure

1. After checking that the power is OFF, connect the gain adjustment filter and measuring equipment as shown in the above diagram.
2. Play tune TNO 12 in normal mode.(ABEX TCD-782:TNO 19)
3. Set the oscillator to 1kHz, and observe the FEX/FEY output in the oscilloscope. Adjust the oscillator output to obtain a FEX/FEY output of 100mVp-p.
4. Adjust VR355 to obtain a milli-voltmeter difference of $0 \pm 0.5dB$.

10 Focus Servo Loop Gain Adjustment-2

• **Purpose:**
 To adjust the focus servo loop gain to an optimum value.
 • **Maladjustment symptoms:**
 Poor playability, reduced resistance to vibration, focus closure fails readily.

• **Measuring equipment / jigs:**
 Oscillator, gain adjustment filter, oscilloscope
 • **Measuring point:**
 FEX, FEY
 • **Test disc and setting:**
 SONY TYPE 4 (or ABEX TCD-782) Normal mode
 • **Adjustment position:**
 VR355

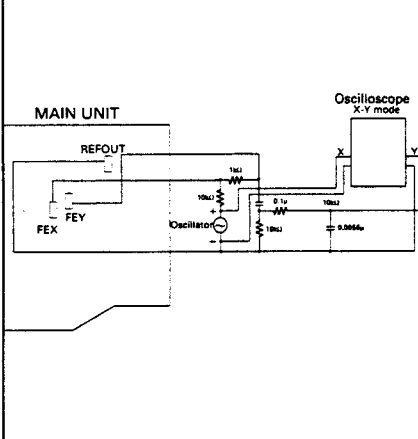

Adjustment Procedure

1. After checking that the power is OFF, connect the gain adjustment filter and measuring equipment as shown in the above diagram.
2. Play tune TNO 12 in normal mode.(ABEX TCD-782:TNO 19)
3. Set the oscillator at 1kHz and adjust the output of the oscillator to 2Vp-p.
4. Adjust VR355 to make the Lissajou's figure of waveform symmetrical about X and Y axes respectively.

11 Tracking Servo Loop Gain Adjustment-1

• Tracking Servo Loop Gain Adjustment-1 may be performed in Tracking Servo Loop Gain Adjustment-2.
 • **Purpose:**
 To adjust the tracking servo loop gain to an optimum value.
 • **Maladjustment symptoms:**
 Poor playability, reduced resistance to vibration.

• **Measuring equipment / jigs:**
 Oscillator, gain adjustment filter(GGF-065), oscilloscope, dual meter milli-voltmeter, volume adjustment driver
 • **Measuring point:**
 TEX, TEY
 • **Test disc and setting:**
 SONY TYPE 4 (or ABEX TCD-782) Normal mode
 • **Adjustment position:**
 VR356

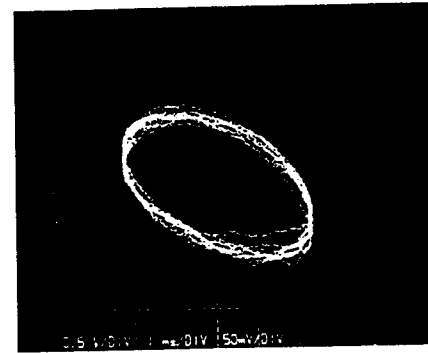

High-level gain

Focus
 X=0.5V/div.
 Y=50mV/div.
 1ms/div.

Waveform 14

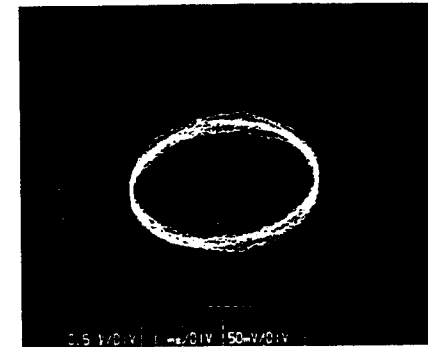

Optimum gain

Waveform 15

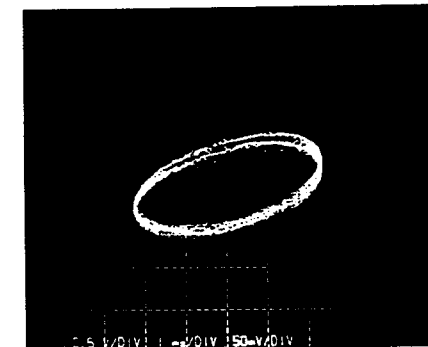

Low-level gain

Waveform 16

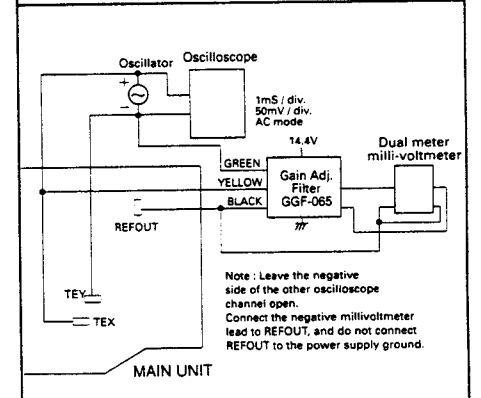

Adjustment Procedure

1. After checking that the power is OFF, connect the gain adjustment filter and measuring equipment as shown in the above diagram.
2. Play tune TNO 12 in normal mode.(ABEX TCD-782:TNO 19)
3. Set the oscillator to 1.4kHz, and observe the TEX/TEY output in the oscilloscope. Adjust the oscillator output to obtain a TEX/TEY output of 300mVp-p.
4. Adjust VR356 to obtain a milli-voltmeter difference of $0 \pm 0.5dB$.

12 Tracking Servo Loop Gain Adjustment-2

- **Purpose:**
To adjust the tracking servo loop gain to an optimum value.
- **Maladjustment symptoms:**
Poor playability, reduced resistance to vibration.

- **Measuring equipment / jigs:**
Oscillator, gain adjustment filter, oscilloscope
- **Measuring point:**
TEX, TEY
- **Test disc and setting:**
SONY TYPE 4 (or ABEX TCD-782) Normal mode
- **Adjustment position:**
VR356

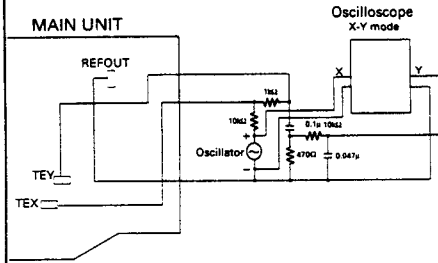

Adjustment Procedure

1. After checking that the power is OFF, connect the gain adjustment filter and measuring equipment as shown in the above diagram.
2. Play tune TNO 12 in normal mode.(ABEX TCD-782:TNO19)
3. Set the oscillator at 1.4kHz and adjust the output of the oscillator to 5Vp-p.
4. Adjust VR356 to make the Lissajou's figure of waveform symmetrical about X and Y axes respectively.

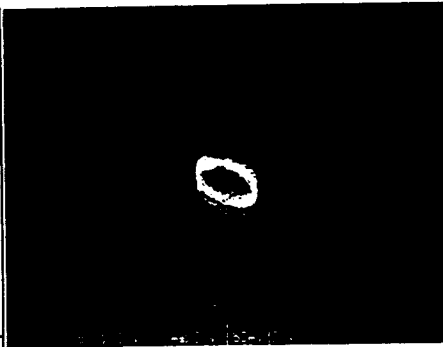

High-level gain

Tracking
X=5V/div.
Y=50mV/div.
2ms/div.

Waveform 17

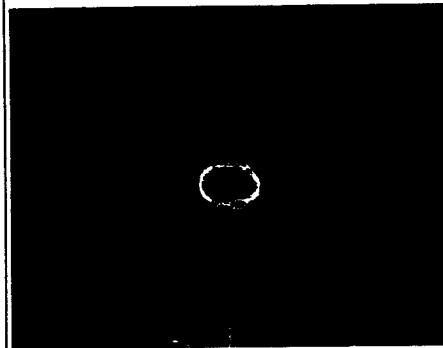

Optimum gain

Waveform 18

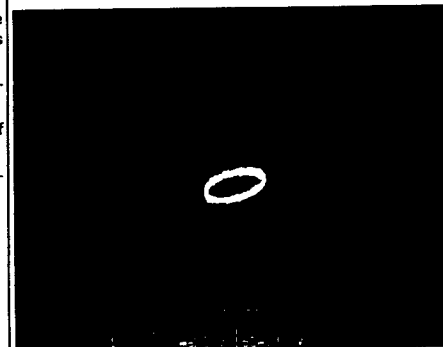

Low-level gain

Waveform 19

13 TE Offset Adjustment-2

- **Purpose:**
To adjust the electrical offset of the tracking servo to zero.
- **Maladjustment symptoms:**
Search times too long, carriage run-away.

- **Measuring equipment / jigs:**
DC voltmeter or oscilloscope, volume adjustment driver
- **Measuring point:**
TEY
- **Test disc and setting:**
No Disc Test mode
- **Adjustment position:**
VR353

Adjustment Procedure

Same as for TE offset adjustment-1, but with the DC voltage of the TEY output adjusted to $0 \pm 50mV$. The purpose of this additional adjustment is to correct any deviations generated when carrying out the tracking balance and tracking servo loop gain adjustments after completing TE offset adjustment-1.

14 Checking FEY Level

- **Purpose:**
Check the focus error level.
- **If the level is insufficient:**
Focus is hard to close and the playability is worsened.

- **Measuring equipment / jigs:**
Oscilloscope
- **Measuring point:**
FEY
- **Test disc and setting:**
SONY TYPE 4 (or ABEX TCD-782) Test mode

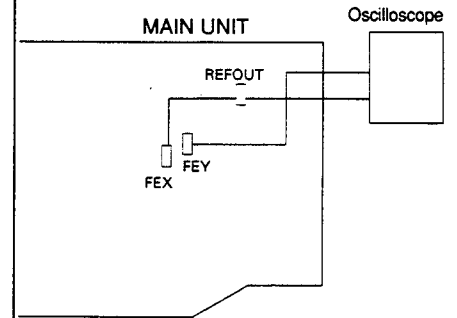

Checkout Procedure(This checkout always must be performed after gain adjustment.)

1. Connect the oscilloscope to REFOUT and FEY. Connect FEX to REFOUT.
2. In the test mode, set a test disc-loaded magazine and select a tray with a test disc.
3. Switch regulator ON.
4. Using the TRACK UP or TRACK DOWN key, move the pick-up to the center of the test disc.
5. Press the 9/F3 key to close focus. During this action, the disc repeats acceleration and deceleration.
6. Observe the FEY waveform and measure the FEY level.
7. Switch regulator OFF.
8. Disconnect FEX and REFOUT.

Normal level of FEY: $2.6Vp-p \pm 0.6Vp-p$
If the level is less than the above, examine the peripheral circuits of the unit or replace the pick-up.

15 Tracking Balance Adjustment-2 and Checking TEY Level



Waveform 20

- **Purpose:**
To adjust the tracking servo offset to zero.
- **Maladjustment symptoms:**
Search times too long, poor playability, carriage run-away.

- **Measuring equipment / jigs:**
Oscilloscope, volume adjustment driver
- **Measuring point:**
TEY (Tracking error signal) L.P.F. output

- **Test disc and setting:**
SONY TYPE 4 (or ABEX TCD-782) Test mode
- **Adjustment position:**
VR354

Adjustment Procedure
Steps 1 through 5 are the same as the steps taken in the tracking balance adjustment-1.

6. Check to see that the level of positive and negative amplitudes of TEY signal. If there is deviation, make adjustment using VR354.
7. After adjustment measure the TEY level. (Measurement always should be made after the tracking gain adjustment is completed. Before the adjustment, normal level measurement cannot be achieved.)

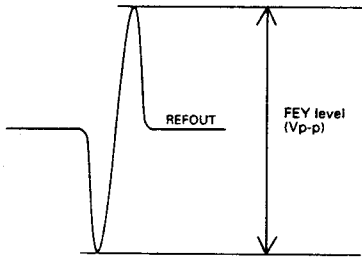

In addition to the waveform shown above, the FEY level output produces another waveform like $-A_1$. However, take measurement only of the above figure of waveform.

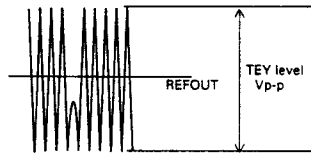

Normal range of TEY level: $2.0 \pm 0.5V_{p-p}$
If the level is out of the above range, examine the peripheral circuits of the unit or replace the pick-up.

- ICs
- Pin Functions (PD5262A)

Pin No.	Pin Name	I/O	I/O Format	Function and Operation
1	TIN	I	C	Tray position input
2	TEMP			Temperature detector
3	VDIN			Power supply short sensor input
4	RSTN	O	NM	Reset output
5	MIRR	I	NM	Mirror detector input
6	LOCK	I	NM	Spindle lock detector input
7	FOK	I	NM	FOK signal input
8	A0	O	NM	LSI data control signal
9	XSCK	I/O	C/NM	LSI clock input/output
10	XSO	O	NM	LSI data output
11	XSI	I	C	LSI data input
12	STB	O	C	LSI strobe output
13	RST	O	C	LSI reset output
14	CCS	O	C	IP-BUS chip select
15	CPW	O	C	IP-BUS power control
16	ASENS	I		ACC power sense input
17	BSENS	I		Back up power sense input
18	CIRQ	I		IP-BUS interrupt input
19	CCD	O	C	IP-BUS command / data appointment
20	CRW	O	C	IP-BUS read / wright appointment
21	CSCK	O	C	IP-BUS clock output
22	CSO	O	C	IP-BUS data output
23	CSI	I	C	IP-BUS data input
24	EJSW	I		Eject key switch interrupt input
25	MAG	I		Magazine lock switch interrupt input
26	CNVCC	I		GND
27	RESET	I		Reset input
28	EJLED	O	C	LED output for eject
29	CRST	O	C	IP-BUS reset output
30	XIN	I		Crystal oscillating element connection pin
31	XOUT	O		Crystal oscillating element connection pin
32	VSS			GND
33-40	D7-D0	I/O	C	External RAM data line
41	WE	O	C	External RAM write enable
42	PROT	O	C	External RAM output enable
43	CS	O	C	External RAM chip select
44-56	A12-A0	O	C	External RAM address line
57	EJP	I	C	Eject position switch
58	6/12	I	C	6/12 switching input
59	FECNT	I/O	C	DEFECT port
60	POWER	O	C	CD +5V control
61	CONT	O	C	Servo driver power supply control
62	NC	I	C	Pull down
63	HOME	I	C	Home position detector input
64	OPTSW	I	C	Digital output ON/OFF input
65	LOAD	O	C	Mechanism power supply control
66	I3	O	C	Motor driver control output
67	I1	O	C	Motor driver control output
68	I2	O	C	Motor driver control output
69	ENDOUT	O	C	Digital output enable signal
70	CDMUTE	O	C	CD mute output

Pin No.	Pin Name	I/O	I/O Format	Function and Operation
71	ADENA	O	C	A/D reference voltage output
72	TESTIN	I	C	Test program mode input
73	VCC			5V
74	VREF	I		A/D converter reference voltage input
75	AVSS	I		A/D GND
76	UNIT#H			UNIT # input
77	UNIT#L		C	UNIT # input
78	DISK			Disc detector input
79	TSEL	I	C	Tray position detector photo sensor
80	TOUT	I	C	Disc sensor timing input

I/O Format	Meaning
C	C MOS
NM	Middle resistivity N channel open drain

IC's marked by* are MOS type.
Be careful in handing them because they are very liable to be damaged by electrostatic induction.

*PD5262A

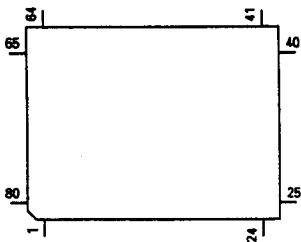

PA0051AM

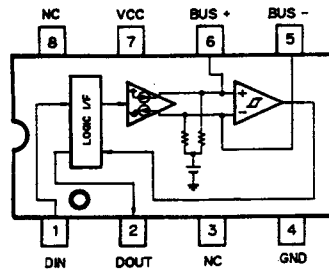

PD4308AM

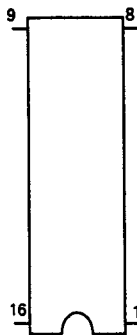

● Pin Functions (PD4308AM)

Pin	Pin Name	I/O	Function and Operation
1	IPSCK	I/O	Clock input/output
2	IPSI	I	Data input
3	IPSO	O	Data output
4	IPIRQ	I	Interrupt input
5	IPRW	O	Read / write output
6	X1		Crystal oscillator connection pin
7	X0		Crystal oscillator connection pin
8	GND		GND
9	RX	I	Data input
10	TX	O	Data output
11	NC		Not used
12	IPCD	O	Command/data output
13	IPCS	O	Chip select output
14	IPRST	O	Reset output
15,16	VDD		Power supply

● Pin Functions (SM5871AS)

Pin No.	Pin Name	I/O	Function and Operation
1	XTO	O	Oscillation output
2	XVSS		Crystal VSS (0V)
3	DS	IP	Normal / high-speed play mode select (DS=L : Normal play mode) (DS=H : High-speed play mode)
4	CKO	O	Oscillation output clock (DS=L : 384fs), (DS=H : 192fs)
5	TSTN	IP	Test : H
6	MODN	IP	Mode control
7	ATTN	IP	Soft mute control
8	LRCI	IP	Input data sample rate (fs) clock : H=Lch, L=Rch
9	BCKI	IP	Input data bit clock
10	DIN	IP	Input data
11	DFS1	IP	De-emphasis control 1
12	DFS2	IP	De-emphasis control 2
13	MUTEO	O	Infinity zero detector output
14	RSTN	IP	System reset : H=Normal motion, L=System reset
15	DVSS		Digital GND (0V)
16	DVDD		Digital VDD (5V)
17	AVDD1		Anaioque VDD 1 (5V)
18	LO	O	Lch PWM output (+)
19	AVSS1		Analogue GND 1 (0V)
20	LON	O	Lch PWM output (-)
21	AVDD2		Analogue VDD 2 (5V)
22	AVDD3		Analogue VDD 3 (5V)
23	RON	O	Rch PWM output (-)
24	AVSS2		Analogue GND 2 (0V)
25	RO	O	Rch PWM output (+)
26	AVDD4		Analogue VDD 4 (5V)
27	XVDD		Crystal VDD (5V)
28	XTI	I	Oscillation input (384fs : DS=L), (192fs : DS=H)

ATTN	SELECT	MODN	
		H	L
H		Soft mute cancel motion	Soft mute motion hold (fix)
L		Soft mute motion	

DFS2	SELECT	DFS1	
		L	H
L		De-emphasis ON 44.1kHz	De-emphasis OFF
H		De-emphasis ON 48.0kHz	De-emphasis ON 32.0kHz

*SM5871AS

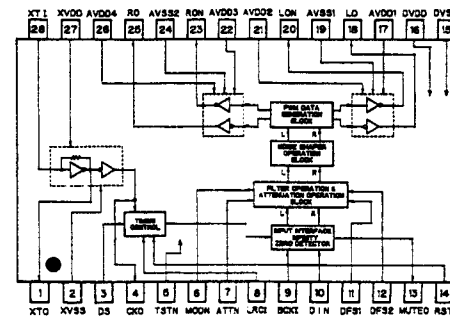

*LH-5160HN-10L

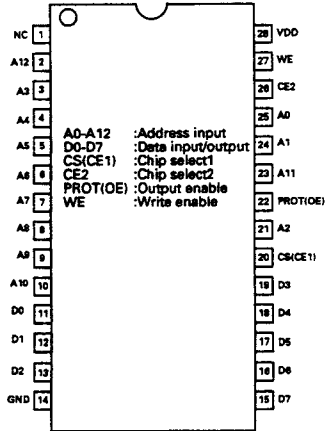

XRA4560F
XRA4560

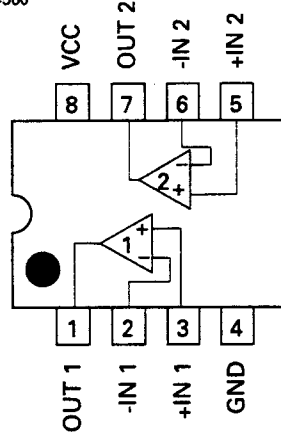

● Pin Functions (PAJ001A)

Pin No.	Pin Name	I/O	Function and Operation
1	GND		IC P.C. Board (SUB) electric potential / The lowest electric potential of IC
2	VDD1	O	Microcomputer 5V power supply output
3	RSTIN	I	Microcomputer reset control (VSL) detector input
4	VDD2	O	Microcomputer pull up resistance 5V power supply output
5	OUT2	O	Attenuation power detector 2 output
6	OUT3	O	Attenuation power detector 3 output
7	RSTOUT	O	Microcomputer reset control output
8	CT1		Microcomputer reset delay time constant terminal
9	IN3	I	Attenuation power detector 3 input
10	CF		Reference filter capacitor connection terminal
11	OUT1	O	Attenuation power detector 1 output
12	IN1	I	Attenuation power detector 1 input
13	IN2	I	Attenuation power detector 2 input
14	VCC		IC power supply input / The highest electric potential of IC

PAJ001A

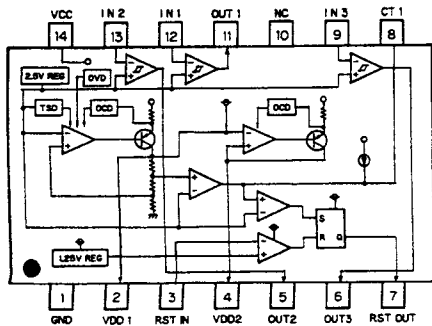

5. ELECTRICAL PARTS LIST

NOTES:

- Parts whose parts numbers are omitted are subject to being not supplied.
- The part numbers shown below indicate chip components.

Chip Resistor
RS1/0S000J, RS1/00S000J
Chip Capacitor (except for CQS.....)
CKS....., CCS....., CSZS.....

Circuit Symbol & No.	Part Name	Part No.	Circuit Symbol & No.	Part Name	Part No.
Unit Number : CWX1631 Unit Name : Main Unit			R 611 702 703 704 802 803	RS1/16S102J	
			R 614 664	RS1/16S912J	
			R 615 616 661 810	RS1/16S472J	
			R 652	RS1/16S162J	
			R 653 736 740 741 742 743 744 745 755 757	RS1/16S222J	
MISCELLANEOUS					
IC 351	UPC1347GS				
IC 801	UPD6374AGH		R 655	RS1/16S362J	
IC 602 652	XRA4558F		R 656 669	RS1/16S183J	
IC 651	PA3026		R 660 662 665 811 812 813	RS1/10S131J	
IC 661	TA78L05F		R 679	RS1/16S333J	
			R 706	RS1/16S201J	
IC 701	UPD6376GC				
IC 702	SM5871AS		R 718 719	RS1/16S101J	
IC 707	XRA4560F		R 721	RS1/16S471J	
IC 706	TA78L05F		R 722 723 724 725 778	RS1/16S103J	
IC 751	PD5262A		R 726 727 728 729	RS1/16S752J	
			R 730 731	RS1/16S163J	
IC 752	LH5160HN-10L		R 732 733	RS1/16S163J	
IC 754	PD4308AM		R 734	RS1/16S472J	
IC 756	PA0061AM		R 752	RS1/16S123J	
IC 801	XRA8247FP		R 758 759 762 763 765 766 773 787 931 932	RS1/16S222J	
Q 351	2SB1260		R 766 786 790	RS1/16S563J	
Q 601	2SB709A				
Q 651 725 781 801	UN2211		R 797	RS1/16S473J	
Q 652 653 802	2SB1184F5		R 799	RS1/16S513J	
Q 721	DTA123JK		R 805 806 807	RS1/16S583J	
Q 722	DTC144EK		R 821 822	RS1/16S0R0J	
			R 825 826	RS1/10S241J	
Q 723	2SC4453				
Q 724	DTC114YK		R 835 836	RS1/10S241J	
Q 751	UN2111		R 911	RS1/16S433J	
D 651 652	SC016-2		R 916	RS1/16S0R0J	
D 751	MA151A-MA		R 922	RS1/16S104J	
			R 918	RS1/16S154J	
D 752	MA151WK-MT				
X 702	Crystal Resonator 16.9344MHz		R 927	RS1/16S104J	
X 751	Ceramic Resonator 8.000MHz				
X 752	Ceramic Resonator 12.563MHz				
VR 351 352 355	Semi-fixed 47kΩ(B)				
			CAPACITORS		
VR 353 356	Semi-fixed 2.2kΩ(B)		C 351	CEV470M6R3	
VR 354	Semi-fixed 22kΩ(B)		C 352 751	CKSQYB104K16	
	Checker Chip		C 353 732	CEV101M6R3	
			C 354 355 608 609 610	CEV100M16	
			C 357 359 366	CKSRYB102K50	
			RESISTORS		
R 353	RS1/16S622J		C 358 603	CKSRYB331K50	
R 354 746 747 748 749 750 751 753 756 760	RS1/16S473J		C 360	CKSRYB271K50	
R 355	RS1/16S122J		C 361	CCSRC220J50	
R 356 357 658	RS1/16S683J		C 373	CKSQYB224K16	
R 358 359 654	RS1/16S332J		C 801	CKSRYB222K50	
R 360	RS1/16S684J		C 604 652 654	CKSQYB224K16	
R 361	RS1/16S153J		C 605 606 611 615 616 618 619 661 666 742	CKSRYB103K50	
R 369 605 607 666 678 720 775 905 908 912	RS1/16S103J		C 614	CKSRYB21K50	
R 370 381	RS1/16S133J		C 617 702 708 709 724 744 757	CKSRYB103K60	
R 375 377 609 613 651 663 671 672 791 804	RS1/16S102J		C 655	CKSQYB333K25	
R 379	RS1/16S513J		C 657	CKSRYB391K50	
R 380 754 761 767 772 777 782 784 788 796	RS1/16S104J		C 658	CKSQYB272K50	
R 382	RS1/16S100J		C 663	CKSQYB333K25	
R 383	RS1/8S120J		C 665	CCH1120	
R 606	RS1/16S224J		C 667 801	CEV220M16	

Circuit Symbol & No. Part Name	Part No.
C 720	CKSYB224K16
C 725 726	CKSRVB102K50
C 727	CKSRVB102K50
C 728 729	CCSRCH680J50
C 730 731	CKSYB104K16
C 733 734	CCSRCH221J50
C 737 738	CCSRCH680J50
C 739 740	CCSRCH680J50
C 741	CKSYB224K16
C 743	CKSRVB103K50
C 756	CKSRVB472K50
C 758	CKSYB104K16
C 759	CKSQYB104K16
C 802 803	CKSQYB223K50
Unit Number : CWX1694	
Unit Name : Extension Unit	
MISCELLANEOUS	
IC1601	XRA4560
IC1731	PAJ001A
Q1601 1602	2SD1048
Q1603 1722	DTA144EK
Q1604 1711 1721	DTC114YK
Q1712	DTA114EK
Q1713	2SB1299
Q1714 1715 1761	2SC2458
Q1723	2SD1859
Q1731	2SC3673
D1601 1602	1SS133
D1603 1701 1703	1SR139
D1621 1622	RD18LSB1
D1711	HZS6LB1
D1721	HZS6LB3
D1722 1723	HZS5LLA
D1731	HZS6LB1
L1701	Choke Coil
SW1751	Switch (ADDRESS)
SW17521753	Switch (EJSW,RESET)
EF1701	EMI Filter
CCG1006	
RESISTORS	
R1601 1602 1607 1608	RD14PS562JL
R1603 1604	RD14PS682JL
R1609 1610	RD14PS102JL
R1611 1612	RD14PS432JL
R1613 1614	RD14PS562JL
R1615 1712 1735	RD14PS103JL
R1621 1622	RD14PS101JL
R1701 1731 1733	RD14PS104JL
R1702	RD14PS184JL
R1711	RD14PS222JL
R1713 1714	RD14PS331JL
R1715	RD14PS681JL
R1716	RD14PS242JL
R1717	RD14PS362JL
R1721 1723 1724	RD14PS432JL
R1722	RD14PS101JL
R1732	RD14PS104JL
R1734 1751	RD14PS102JL
R1736	RS110S101J
R1737	RD14PS153JL
R1738	RS18S101J
R1752 1753 1754	RD14PS513JL
R1781	RD14PS433JL
R1782	RD14PS273JL
R1784	RS110S104J

Circuit Symbol & No. Part Name	Part No.
CAPACITORS	
C1603 1604	CCSOCH331J50
C1605 1606	CCSOCL222J50
C1607 1608	CEA330M10LL
C1609	CKSYB103K25
C1610 1723	CEA101M10LL
C1621 1622	CCSCH471J50
C1701	CKSQYB472K50
C1702	CEAS471M16
C1703	CCH-114
C1704 1711 1721 1722 1734 1738	CKSQYB103K25
C1705 1713	CEA3R3M50LL
C1712	CEA220M10LL
C1726 1727	CEA3R3M60LS
C1731	CEAR47M50LS2
C1732	CEA470M6R3LS
C1733	2200µF/25V
C1736	
C1737	
C1739	
Unit Number :	
Unit Name : Mechanism P.C.Board	
S 805	Switch (HOME)
CSN1012	
Unit Number :	
Unit Name : Photo P.C.Board	
D 1	LED
S 801 802	Switch (RSTP,MAG)
BR4361F	
CSN1012	
Miscellaneous Parts List	
D 2	LED
S 803 804	Switch (TRP,DSP)
P 801 802	Photo Transistor
M 1	Motor Unit (Spindle)
M 2	Motor Unit (Elevation)
M 3	Motor Unit (Loading)
M 4	Motor Unit (Carriage)
PU Unit	
BR4361F	
CSN1012	
PT4800	
CXA4540	
CXA5325	
CXA5324	
CXA4649	
CGY1027	

6. CIRCUIT DESCRIPTION

● Indicating An Error Number

If the CD should fail to operate, or if an error has taken place during the operation and resulted in an error, the player will enter into the error mode. And the cause of such error is numerically indicated. This is aimed at assisting an analysis or a repair.

(1) Basic Means of Display

•With ERROR indicated in "MODE" on IP-BUS Display date, an error code is transmitte by the use of MIN and SEC. Identical date are transmitted with MIN and SEC.

•Examples of Display

E-XX	(4 digits)
Err-XX	(6 digits)
ERR-XX	(6 digits)
ERROR-XX	(8 digits)

(2) Error Codes

Error Code	Classification	Description	Detail / Cause
10	ELECTRIC	Carriage home failure	Unmovable to and from the inner circumference → Home switch failed and / or carriage improper moved
11	ELECTRIC	Focus failure	Focussing failed → Disc scarred or stained on the back or vibrating hard
12	ELECTRIC	SETUP failure	Spindle failed to lock or subcode extraordinary → Spindle defective, disc scarred or stained or vibrating hard
14	ELECTRIC	Blank Disc	Unrecorded CD-R The disc has been in inserted upside down
30	ELECTRIC	Search time out	Target address failed to reach → Carriage / tracking improperly and / or disc scarred
A0	SYSTEM / MECHANISM	Power failure	Mechanism drive power supply VM short sense or no power supply → Switching transistor defective and / or power abnormal or LOAD terminal failure
50	MECHANISM	An error upon ejection	MAG SW release time has time out Elevation time out when eject
60	MECHANISM	An error while putting in and out the tray	Tray in / out time has time out Tray is caught when put in
70	MECHANISM	An error upon elevation	Elevation time has time out
80	MECHANISM	An error with an empty magazine inserted	No disc is available

* Setup means a series of operations after focusing up to sound output.

● **New Test Mode (IP-BUS System)**

[Objective]

This feature is for performing failure analysis in aging.

Control is performed by the head unit (when the head unit enters the test mode).

Unless an abnormal event occurs, the operation is almost the same as normal CD-Multi operation. In case an error such as the servo error should occur, the operation stops with the indication of the replay time at the error without performing normal recovery.

[Main functions]

- (1) When a CD is set up, the operation status is displayed.
- (2) If the servo error occurs during play, the operation stops with the indication of the replay time at the error. By pressing a particular key, the display indicating an error cause and replay time can be changed.
- (3) Single unit operation is allowed. Disc change, normal play, TR+/-, FF/REW, play mode switching and random play may be performed.

[Details of operation]

(1) How to initiate the new test mode

First initiate the test mode, then select the CD-Multi.

When the jump changeover key is pressed with the power supply to the servo system being OFF, the CD-Multi enters the new test mode.

Because the head unit cannot know that the CD-Multi has entered the new test mode, the head unit is still placed in the test mode and outputs a command in the test mode when requested by pressing a particular key.

(2) How to leave the new test mode

After executing the hard reset of the head unit, the hard reset of the CD-Multi should be performed.

(3) Indicating an Operation Status During Setup

Status No.	Description	Protection operation
01	Carriage home mode started	None
02	Carriage moving on the internal circumference	10-second time out, home switch defect
03	Carriage moving on the external circumference	10-second time out, home switch defect
11	Setup started	None
12	Spindle turn / Focus search started	None
13	Waiting for focus closing	Failure to focus closing
14	Spindle kicked and focus checked	Out of focus
15	Tracking closed and focus checked	Out of focus
17	Carriage closed and focus checked	Out of focus
18	Lock and subcode waiting	Failure to lock, subcode failed to read out of focus
19	End	None

(4) Error Code Description

Code	Classification	Description	Cause / Detail
40	ELECTRIC	Put out of focus detect	FOK=L 100ms → Scar, Stain, Vibration, Servo defect
41	ELECTRIC	Spindle unlocked detect	LOCK=L 150ms → Scar, Stain, Vibration, Servo defect
42	ELECTRIC	Subcode unacceptable detect	Subcode fails to read 500ms → Scar, Stain, Vibration, Servo defect
43	ELECTRIC	Sound skipped	Last address memory operated → Scar, Stain, Vibration, Servo defect

(5) Operation of keys between TEST and NEW TEST Modes

Command Code	Test Mode		New Test Mode
	Name	Operation	Operation
15 00	DDCN	Servo power supply ON / OFF	— (Error stop time / cause select)
15 01	FWDKCK	FWD-KICK	TR+ / FF
15 02	REVKCK	REV-KICK	TR- / REW
15 03	TRKCLS	TRACKING CLOSE	—
15 04	TRKOPN	TRACKING OPEN	PLAY mode select
15 05	FCSCLS	FOCUS CLOSE	—
15 06	FCSOPN	FOCUS OPEN	RANDOM
15 07	JMPOFF	JUMP OFF	—
15 08	CRGTRK	1/10/32 jump and carriage move select	AUTO / MANUAL select

7. EXPLODED VIEW PARTS LIST

● Chassis (Exploded View : Page 2-3)

NOTES:

- Parts marked by "*" are generally unavailable because they are not in our Master Spare Parts List.
- Parts marked by "⊙" are not always kept in stock. Their delivery time may be longer than usual or they may be unavailable.

● Parts List (CDX-P600/UC)

Mark No.	Description	Part No.	Mark No.	Description	Part No.
1	Screw	BMZ26P030FMC	26	Door	CAT1592
2	Screw	BMZ26P080FMC	27	*****	
3	Cord	CDE4211	28	*****	
4	*****		29	Grille	CNS2914
5	*****		30	*****	
6	Pin	CLA2163	31	Extension Unit	CWX1694
7	Lower Case	CNB1654	32	Connector (CN801) (5P)	CKS1943
8	Upper Case	CNB1783	33	Connector (CN351) (17P)	CKS1955
9	Bracket R	CNC4445	34	Connector (CN752) (24P)	CKS1962
10	Bracket L	CNC4444	35	Connector (CN901) (16P)	CKS2495
11	Insulator	CNM3828	36	Connector (CN804) (16P)	CKS1954
* 12	Seal	CNM3848	37	Plug (CN1701) (3P)	CKS-460
13	Insulator	CNM3779	38	*****	
14	P.C.Board	CNP3500	39	Connector (CN1702) (22P)	CKS1542
15	Main Unit	CWX1631	40	*****	
⊙ 16	CD Mechanism Unit	CXK2750	41	Connector (CN1601) (11P)	CKS2479
17	*****		42	Heat Sink	CNC4447
18	Screw	PMS26P040FMC	43	Earth Plate	CNC4650
19	Screw	PMS30P040FZK	44	*****	
20	Screw (M6x16)	CBA1295	45	Connector Bracket	CNC5181
21	Screw	HMB60P500FMC	46	Transistor (Q1713)	2SB1299
22	Screw	HMF40P080FZK	47	Button	CAC3571
23	Nut	NF60FMC	48	Holder	CNC5043
24	Angle	CNB1765			
25	Screw	BPZ26P080FMC			

• The CDX-P600/EW,ES,CDX-P606/UC and CDX-P600/X1B/EW Parts Lists enumerate the parts which differ from those enumerated in the CDX-P600/UC Parts List only. The parts other than those enumerated in the former are identical with those in the latter, to which you are requested to refer, accordingly. The CDX-P600/UC Parts List is given on page 1-36.

Mark No.	Description	CDX-P600/UC	CDX-P600/EW	CDX-P600/ES	CDX-P606/UC	CDX-P600/X1B/EW
		Part No.	Part No.	Part No.	Part No.	Part No.
3	Cord	CDE4211	CDE4210	CDE4211	CDE4211	CDE4210
7	Lower Case	CNB1654	CNB1654	CNB1654	CNB1782	CNB1654
8	Upper Case	CNB1783	CNB1783	CNB1783	CNB1800	CNB1783
16	CD Mechanism Unit	⊙ CXK2750	⊙ CXK2750	⊙ CXK2750	⊙ CXK2750	CXK2755
26	Door	CAT1592	CAT1592	CAT1592	CAT1602	CAT1592
29	Grille	CNS2914	CNS2914	CNS2914	CNS2852	CNS2914
47	Button	CAC3571	CAC3571	CAC3571	CAC3840	CAC3571

● CD Mechanism Unit (Exploded View : Page 2-5)

● Parts List

Mark No.	Description	Part No.	Mark No.	Description	Part No.
1	Screw	BMZ20P025FMC	41	Spring	CBL1181
2	Screw	BMZ20P030FMC	42	Spring	CBL1156
3	*****		43	Spring	CBL1157
4	Screw	BMZ26P030FMC	44	Spring	CBL1158
5	Screw	BMZ26P050FMC	45	Connector (5P)	CDE3905
6	LED (D1,2)	BR4361F	46	PU Unit	CGY1027
7	Screw (M2x4)	CBA1015	47	Connector (6P)	CKS1944
8	Screw (M2x2.5)	CBA1037	48	Connector (15P)	CKS1953
9	Screw (M2x7)	CBA1060	49	Connector (17P) (CN1,2)	CKS1955
10	Screw (M2x3)	CBA1062	50	Connector (5P)	CKS2208
11	Screw (M1.7x5.5)	CBA1070	51	Shaft	CLA2027
12	Screw (M2x3)	CBA1077	52	Shaft	CLA2123
13	*****		53	Shaft	CLA2126
14	Screw (M2x6)	CBA1229	54	Roller	CLA2127
15	Screw (M2x2.5)	CBA1251	55	Roller	CLA2159
16	Washer	CBF1037	56	Shaft	CLA2160
17	Washer	CBF1038	57	Collar	CLA2161
18	Spring	CBH1430	58	Shaft	CLA2210
19	Spring	CBH1488	59	Shaft	CLA2213
20	Spring	CBH1489	60	Shaft	CLA2239
21	Spring	CBH1490	61	Holder	CNC4073
22	Spring	CBH1491	62	Weight	CNC4551
23	Spring	CBH1492	63	Bracket	CNC4602
24	Spring	CBH1493	64	Arm	CNC4606
25	Spring	CBH1494	65	Holder	CNC4626
26	Spring	CBH1495	66	Side Frame (L)	CNC4649
27	Spring	CBH1497	67	R Frame	CNC4646
28	Spring	CBH1498	68	Scale	CNC4647
29	Spring	CBH1499	69	Bracket	CNC4630
30	Spring	CBH1585	70	CM Bracket	CNC4631
31	Spring	CBH1501	71	Bracket	CNC4632
32	Spring	CBH1507	72	Arm	CNC4634
33	Spring	CBH1504	73	Arm	CNC4635
34	Spring	CBH1505	74	Arm	CNC4636
35	Spring	CBH1506	75	TG Plate	CNC4637
36	Spring	CBH1537	76	Bracket	CNC4642
37	Spring	CBH1538	77	Frame	CNC4851
38	Spring	CBH1563	78	Frame	CNC4854
39	Spring	CBH1569	79	Cover	CNC4955
40	Spring	CBL1138	80	Frame	CNC4967

Mark No.	Description	Part No.	Mark No.	Description	Part No.	Mark No.	Description	Part No.	Mark No.	Description	Part No.
81	Spacer	CNM1787	121	Gear	CNV3382	161	Screw Unit	CXA5302	186	Screw	JFZ14P016FNI
82	Sheet	CNM3567	122	Gear	CNV3383	162	Arm Unit	CXA5303	187	****	
83	****		123	Gear	CNV3384	163	Bracket Unit	CXA5304	188	****	
84	P.C.Board	CNP3223	124	Guide	CNV3385	164	Bracket Unit	CXA5305	189	****	
85	P.C.Board	CNP3225	125	Arm	CNV3386	165	Holder Unit	CXA5308	190	Screw	JFZ20P025FNI
86	P.C.Board	CNP3226	126	Roller	CNV3387	166	Frame Unit	CXA5320	191	Screw	JGZ20P070FNI
87	Ball	CNR1189	127	Wheel	CNV3526	167	Arm Unit	CXA5311	192	Screw	PMS20P025FMC
88	Gear	CNR1289	128	Arm	CNV3546	168	Arm Unit	CXA5313	193	Photo Transistor (P801,802)	PT4800
89	Gear	CNR1290	129	Cover	CNV3547	169	Bracket Unit	CXA5314	194	Washer	YE15FUC
90	Gear	CNR1304	130	Holder	CNV3548	170	Arm Unit	CXA5315	195	Washer	YE20FUC
91	Guide	CNR1309	131	Damper	CNV3353	171	Main Frame Unit	CXA5316	196	Washer	YE25FUC
92	Holder	CNR1310	132	Holder	CNV3584	172	Lever Unit	CXA5317	197	Sheet	CNM3798
93	Holder	CNR1311	133	Plate	CNV3629	173	Magazine Holder Unit	CXA5321	198	Bracket	CNC5028
94	Belt	CNT1047	134	Composite P.C.Board	CNX1986	174	Upper Frame Unit	CXA5319	199	Insulator	CNM3786
95	Holder	CNV3622	135	****		175	Bracket Unit	CXA5322	200	Sheet	CNM3817
96	Arm	CNV3354	136	Composite P.C.Board	CNX2067	176	Motor Unit (Loading) (M3)	CXA5324	201	Screw	BMZ26P040FMC
97	Lock	CNV3355	137	Composite P.C.Board	CNX1995	177	Gear	CNV3365	202	Screw (M2x2.5)	CBA1041
98	Screw Bearing	CNV3356	138	Composite P.C.Board	CNX1996	* 178	Motor	CXM1069	203	Screw (M2.6x3)	CBA1065
99	Holder	CNV3357	139	Composite P.C.Board	CNX1997	179	Motor Unit (Elevation) (M2)	CXA5325	204	****	
100	Roller	CNV3358	140	Composite P.C.Board	CNX1998	180	Gear	CNV3381	205	Screw	JFZ17P025FNI
101	Cam	CNV3359	141	Composite P.C.Board	CNX1999	* 181	Motor	CXM1061	206	Screw	JFZ17P035FNI
102	Guide	CNV3360	142	Switch (S801,802,803,804,805)	CSN1012	182	Whom Bracket Unit	CXA5326	207	Screw	JFZ20P030FNI
103	Guide	CNV3361	143	Motor Unit (Spindle) (M1)	CXA4540	183	Arm Unit	CXA6362	208	Sheet	CNM3826
104	Holder	CNV3362	144	Motor Unit (Carriage) (M4)	CXA4649	184	Damper Unit	CXA5631	209	Roller	CLA2266
105	Holder	CNV3363	145	Stage Chassis Unit	CXA5287	185	Clamper	HEF-102	210	Spring	CBH1579
106	****		146	****							
107	Gear	CNV3366	147	Mode Ring Unit	CXA5288						
108	Gear	CNV3367	148	Steer R Unit	CXA5289						
109	Gear	CNV3368	149	LM Bracket Unit	CXA5290						
110	Gear	CNV3371	150	Rink Unit	CXA5291						
111	TRYD Gear	CNV3372	151	Lever Unit	CXA5292						
112	CUPM Gear	CNV3373	152	Arm Unit	CXA5293						
113	Clamper UP Gear	CNV3374	153	Gear Arm Unit	CXA5294						
114	Guide	CNV3375	154	Arm Unit	CXA5295						
115	Guide	CNV3376	155	Plate Unit	CXA5296						
116	Arm	CNV3377	156	TG Bracket Unit	CXA5297						
117	Arm	CNV3378	157	CRG Chassis Unit	CXA5298						
118	Guide	CNV3379	158	Bracket Unit	CXA5299						
119	Guide	CNV3380	159	Arm Unit	CXA5300						
120	****		160	Arm Unit	CXA5301						

Service Manual

MULTI-COMPACT DISC PLAYER

CDX-P600 UC,EW,ES
CDX-P600 X1B/EW
CDX-P606 UC



- See the service manual CDX-M6/UC,EW (CRT1522) for the circuit description.
- See the separate manual CX-613 (CRT1518) for the CD mechanism description.

CHAPTER 2

CONTENTS

1. EXPLODED VIEW	2-2
2. PACKING METHOD	2-9
3. CONNECTION DIAGRAM(1).....	2-15
4. SCHEMATIC CIRCUIT DIAGRAM(1).....	2-19
5. SCHEMATIC CIRCUIT DIAGRAM(2).....	2-22
6. CONNECTION DIAGRAM(2).....	2-25
7. BLOCK DIAGRAM	2-27

1. EXPLODED VIEW

● Magazine Assy (CXA5483)

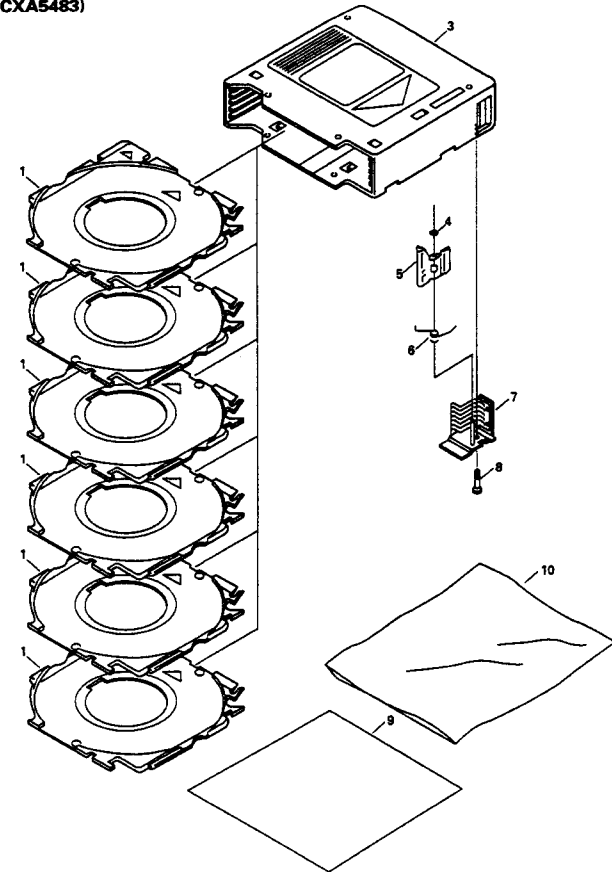

Fig.1

● Parts List

Mark No.	Description	Part No.	Mark No.	Description	Part No.
1	Tray Unit	CXA5484	* 6	Spring	CBH1522
2		* 7	Bracket Unit	CXA5481
* 3	Case Unit	CXA5479	* 8	Screw (M2x13)	CBA1272
4	Washer	CBF1039	* 9-1	Owner's Manual	CRD1639
* 5	Arm	CNV3468	* 9-2	Label	CRW1248
			* 10	Polyethylene Bag	CEG1156

● Chassis (Parts List : Page 1-36)

A
B
C
D

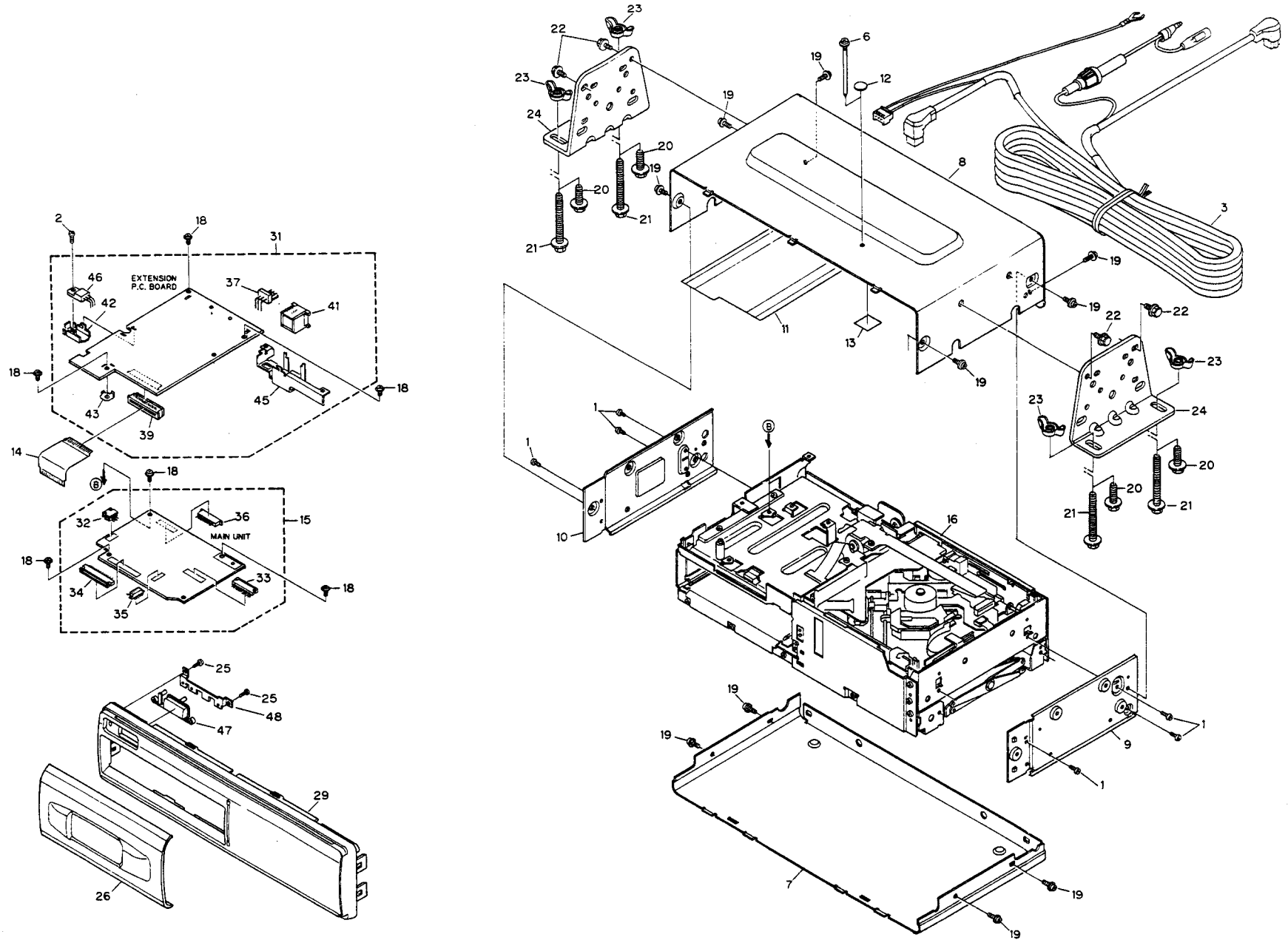

Fig.2

A

B

C

D

A

B

C

D

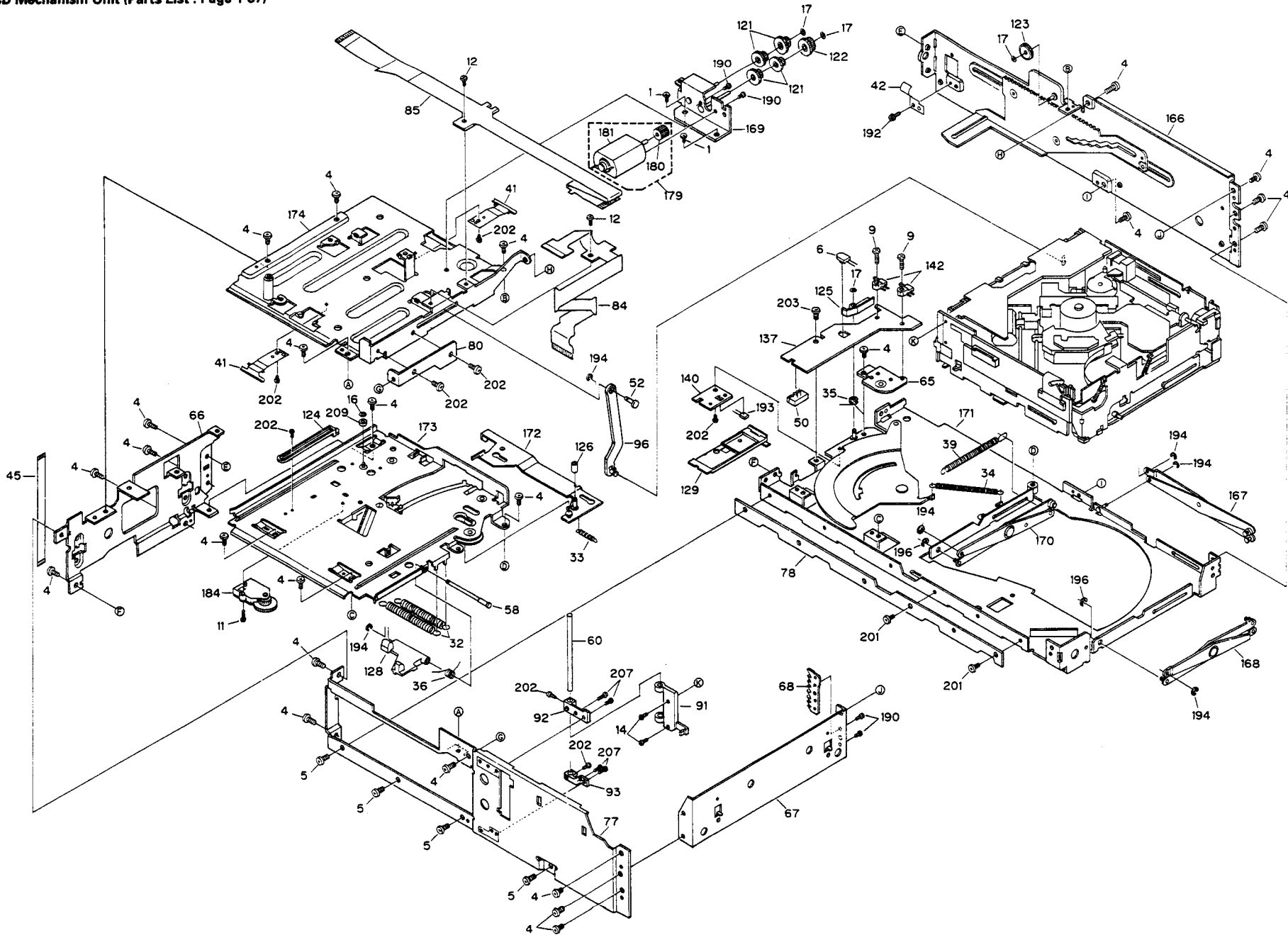

Fig.3

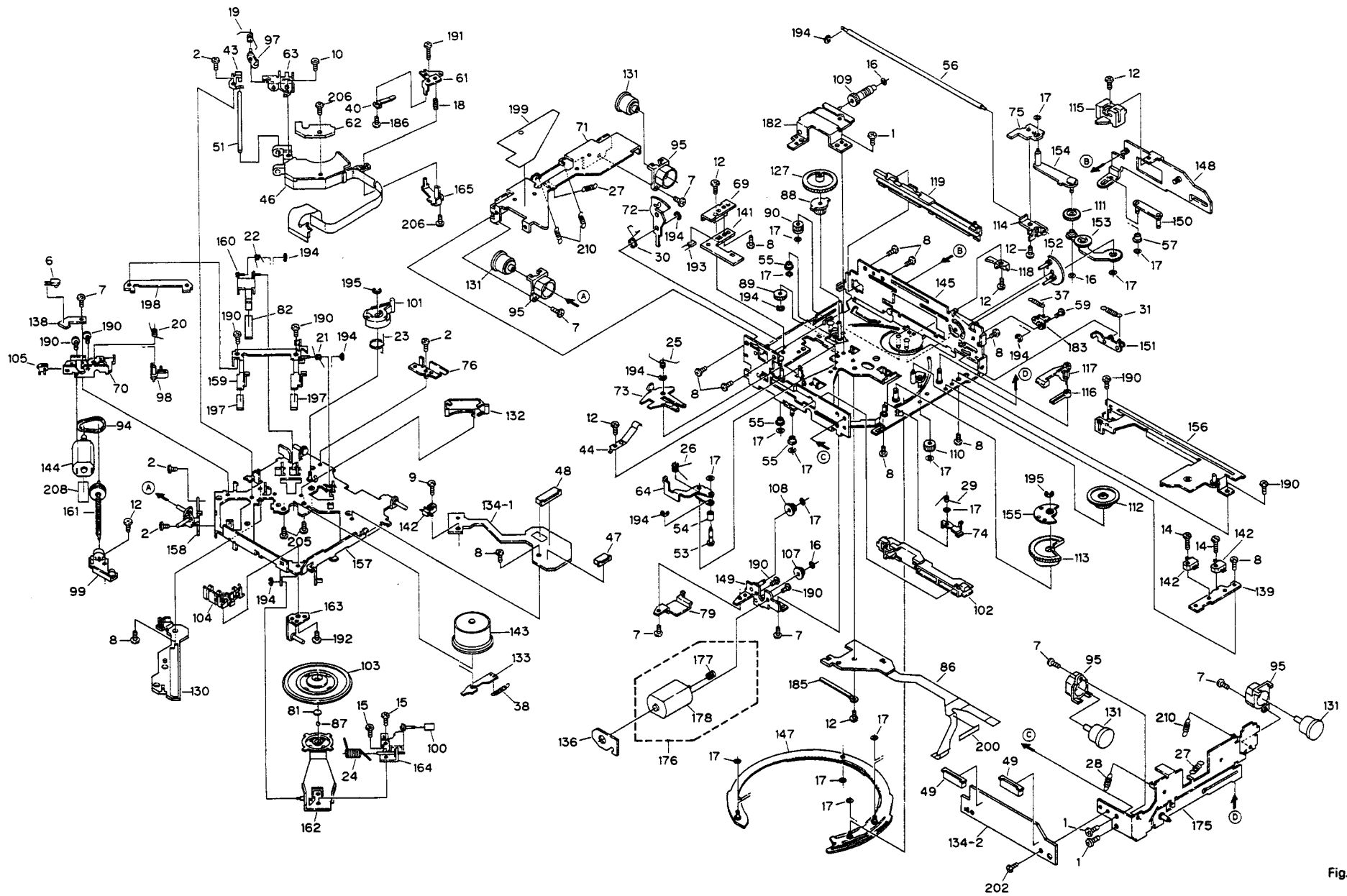

Fig.4

2. PACKING METHOD

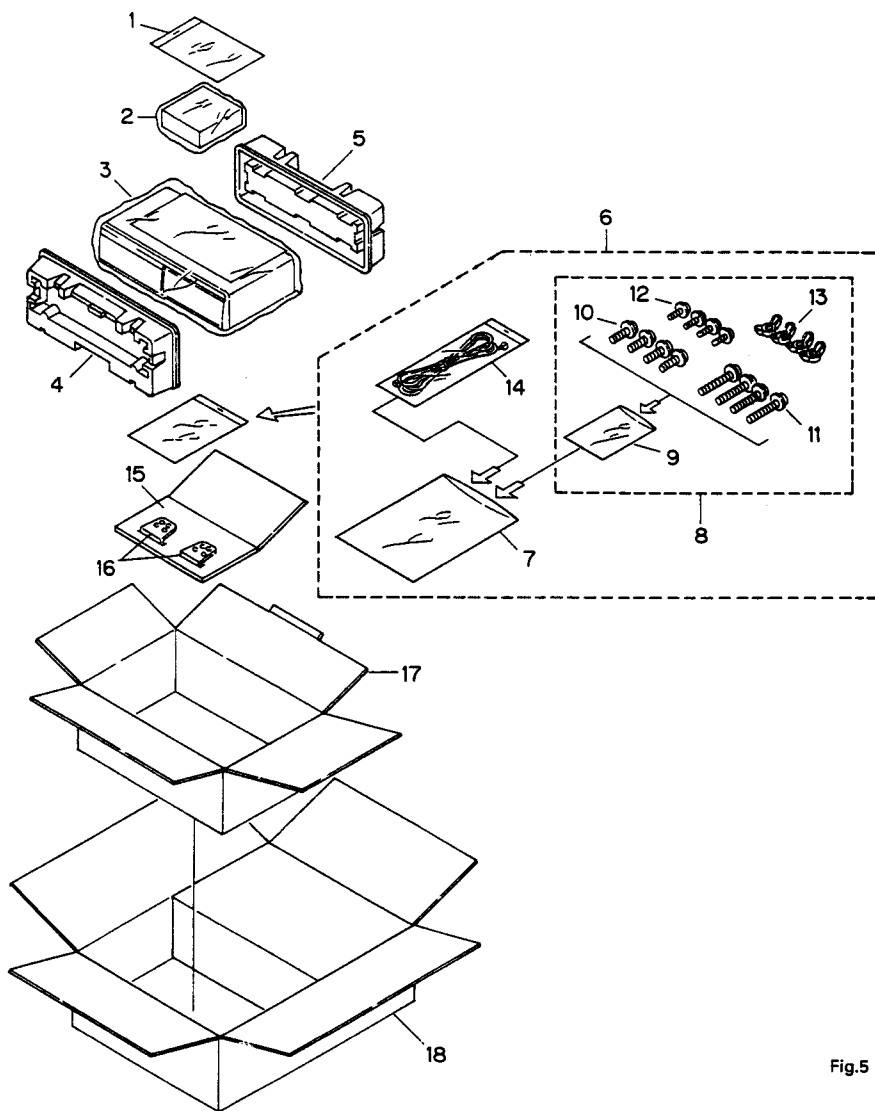

Fig.5

● Parts List (CDX-P600/UC)

Mark No.	Description	Part No.	Mark No.	Description	Part No.
* 1-1	Card	ARY1048	12	Screw	HMF40P080FZK
1-2	Polyethylene Bag	CEG1116	13	Nut	NR60FMC
1-3	Owner's Manual	CRD1700	14	Cord	CDE4211
2	Magazine Assy	CXA5483	15	Spacer	CHW1317
3-1	Cover	CEG1149	16	Angle	CNB1765
* 3-2	Seal	CNM3648	17	Carton	CHG2391
* 3-3	Caution Card	CRP1112	18	Contain Box	CHL2391
4	Protector	CHP1538			
5	Protector	CHP1539			
6	Accessory Assy	CEA1923			
* 7	Polyethylene Bag	E36-622			
8	Screw Assy	CEA1962			
* 9	Polyethylene Bag	E36-615			
10	Screw (M6x16)	CBA1295			
11	Screw	HMB60P500FMC			

• The CDX-P600/EW,ES,CDX-P606/UC and CDX-P600/X1B/EW Parts Lists enumerate the parts which differ from those enumerated in the CDX-P600/UC Parts List only. The parts other than those enumerated in the former are identical with those in the latter, to which you are requested to refer, accordingly. The CDX-P600/UC Parts List is given on page 2-10.

Mark No.	Description	CDX-P600/UC	CDX-P600/EW	CDX-P600/ES	CDX-P606/UC	CDX-P600/X1B/EW
		Part No.	Part No.	Part No.	Part No.	Part No.
* 1-1	Card	ARY1048	*****	*****	*****	*****
1-2	Polyethylene Bag	CEG1116	CEG1116	CEG1116	CEG1116	* UEG-004
1-3	Owner's Manual	CRD1700	*****	*****	*****	*****
	Owner's Manual	*****	CRD1698	*****	*****	CRD1698
	Owner's Manual	*****	CRD1699	*****	*****	CRD1699
	Owner's Manual	*****	*****	CRD1697	*****	*****
	Owner's Manual	*****	*****	*****	CRD1735	*****
* 1-4	Card	*****	CRY-062	*****	*****	URY-001
* 1-5	Warranty Card	*****	*****	*****	CRY1070	*****
3-1	Cover	CEG1149	CEG1149	CEG1149	CEG1149	* UEG-003
4	Protector	CHP1538	CHP1538	CHP1538	CHP1538	*****
5	Protector	CHP1539	CHP1539	CHP1539	CHP1539	*****
	Protector	*****	*****	*****	*****	UHP-008(x2)
6	Accessory Assy	CEA1923	CEA1922	CEA1923	CEA1923	CEA1922
* 7	Polyethylene Bag	E36-622	E36-622	E36-622	E36-622	UEG-002
14	Cord	CDE4211	CDE4210	CDE4211	CDE4211	CDE4210
17	Carton	CHG2391	CHG2390	CHG2392	CHG2452	UHG-017
18	Contain Box	CHL2391	CHL2390	CHL2392	CHL2452	UHL-001

1-3 Owner's Manual

Part No.	Model	Language
CRD1700	CDX-P600/UC	English,French
CRD1698	CDX-P600/EW,CDX-P600/X1B/EW	English,Italian,French,German,Dutch
CRD1699	CDX-P600/EW,CDX-P600/X1B/EW	Spanish,Portuguese,Swedish,Norwegian,Finnish
CRD1697	CDX-P600/ES	English,French,German,Spanish,Arabic
CRD1735	CDX-P606/UC	English,French

● Wave Forms

Note: 1. The encircled numbers denote measuring points in the circuit diagram.
 2. Reference voltage REFOUT: 2.5V

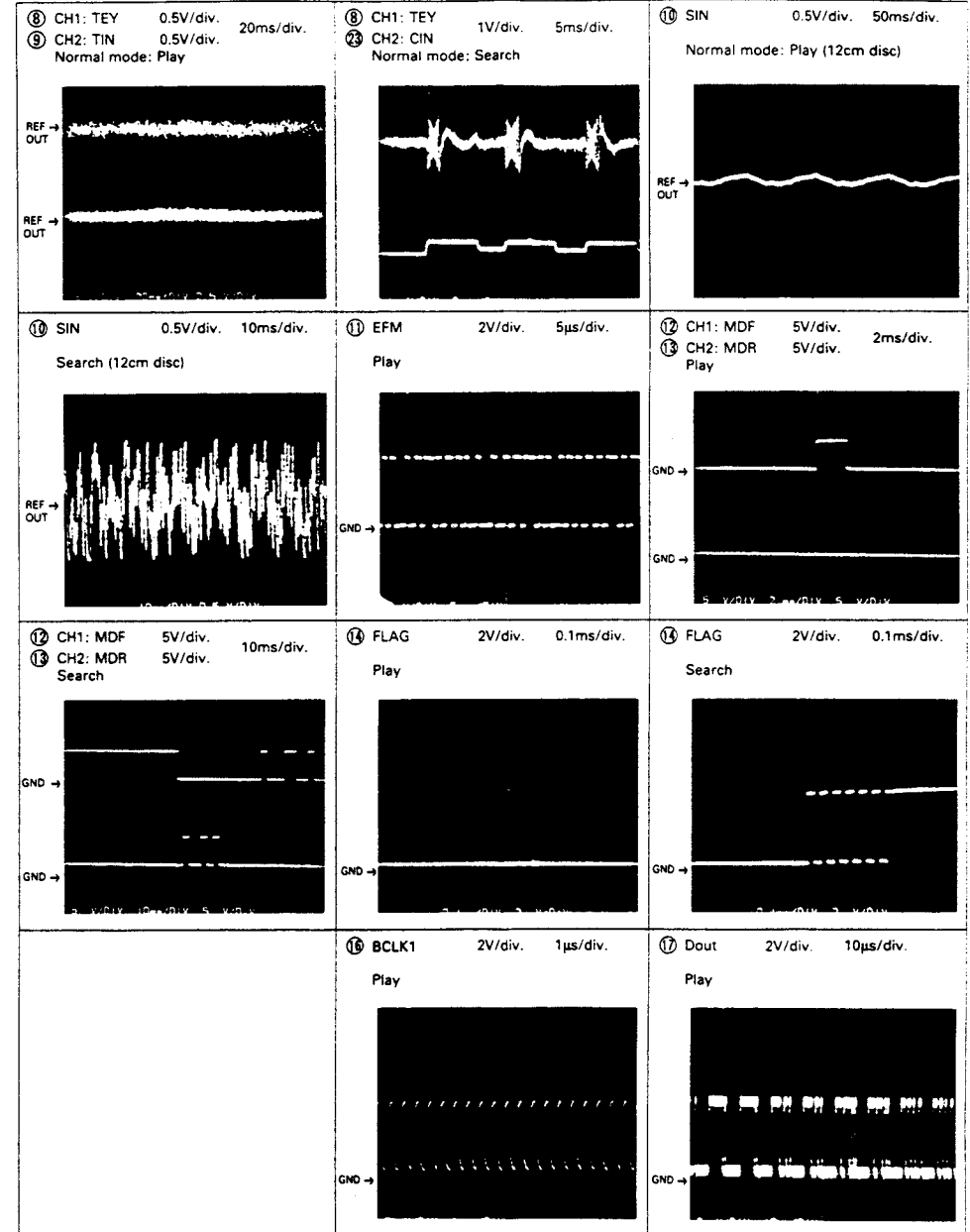
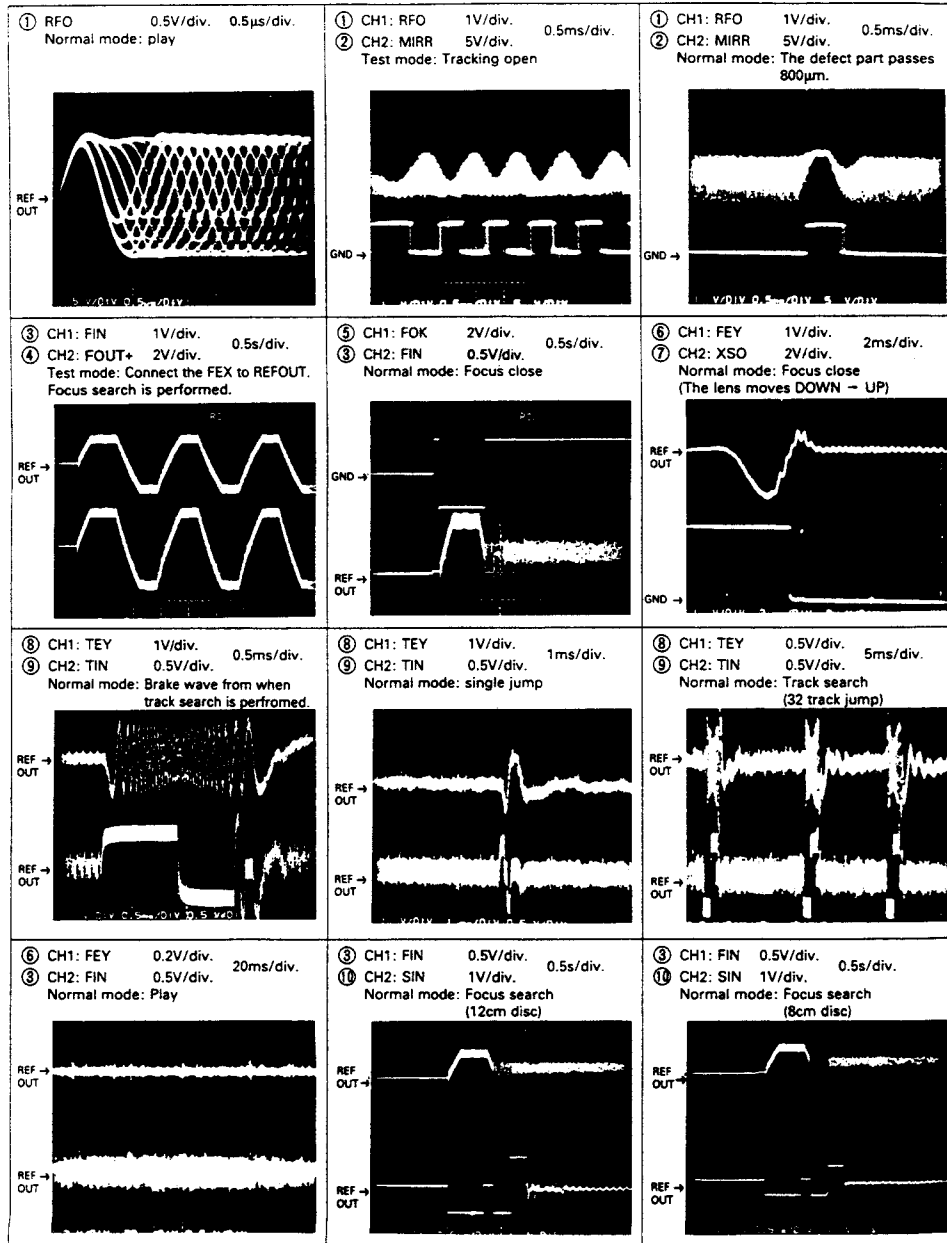

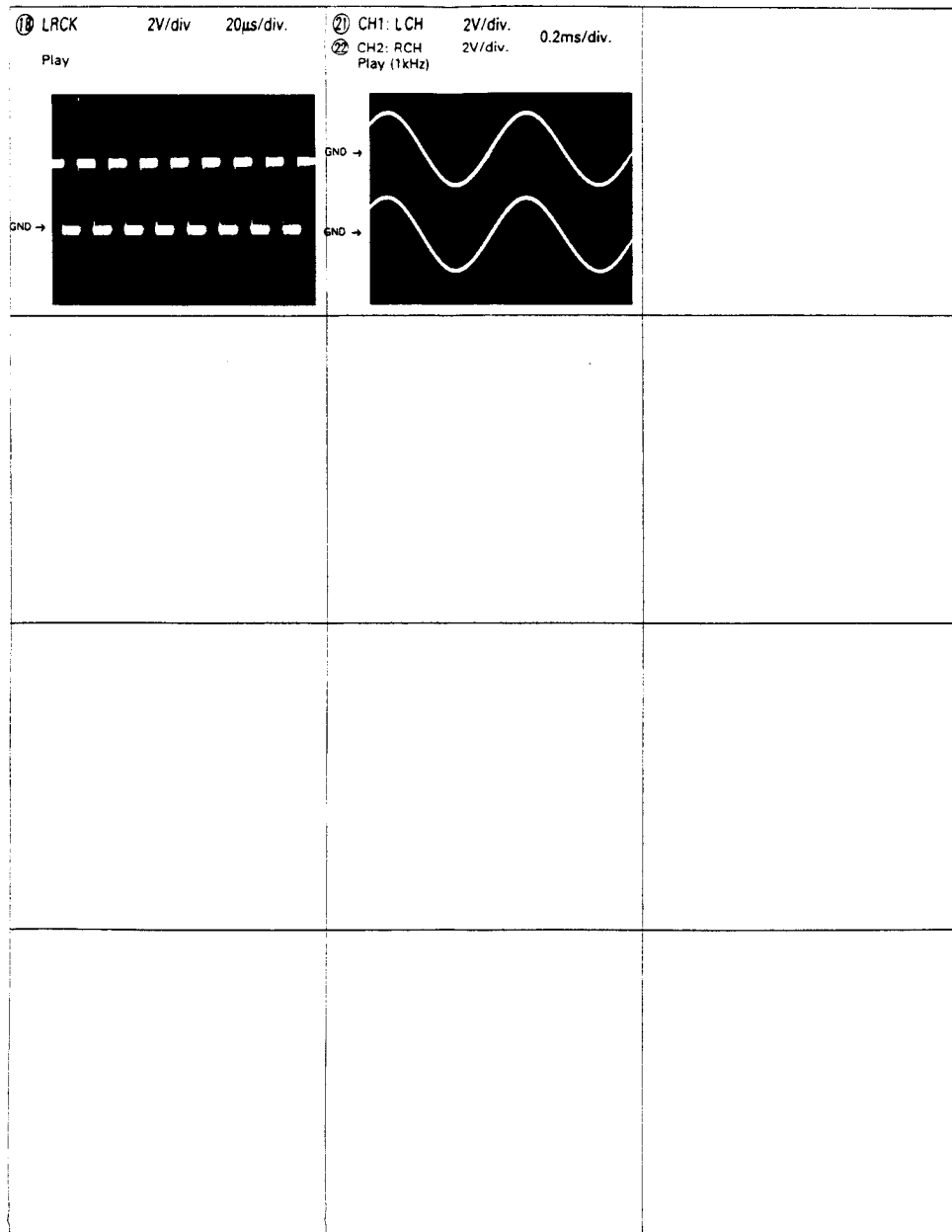

3. CONNECTION DIAGRAM(1)

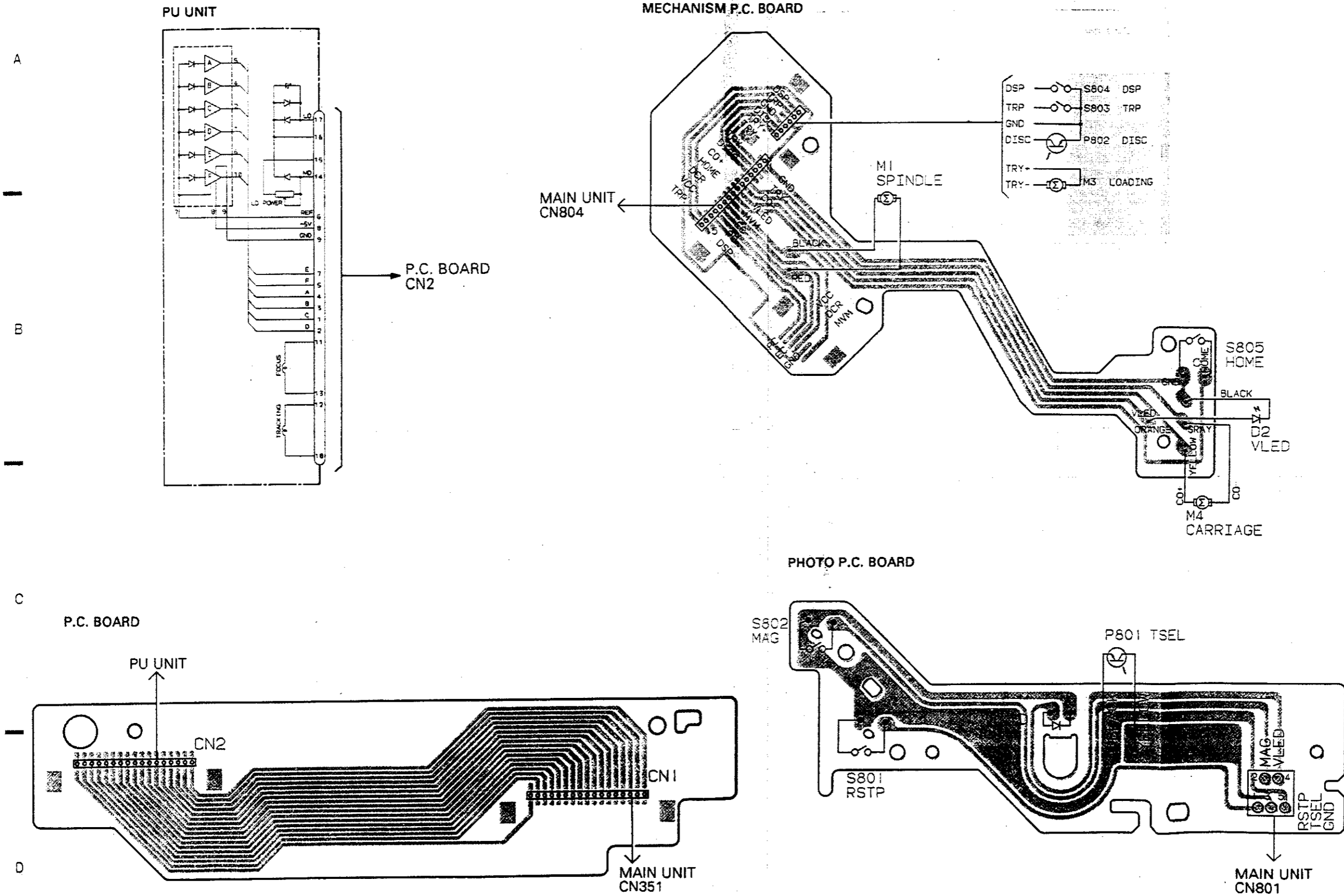

MAIN UNIT

IC, Q ADJ

MECHANISM P.C. BOARD

IC752

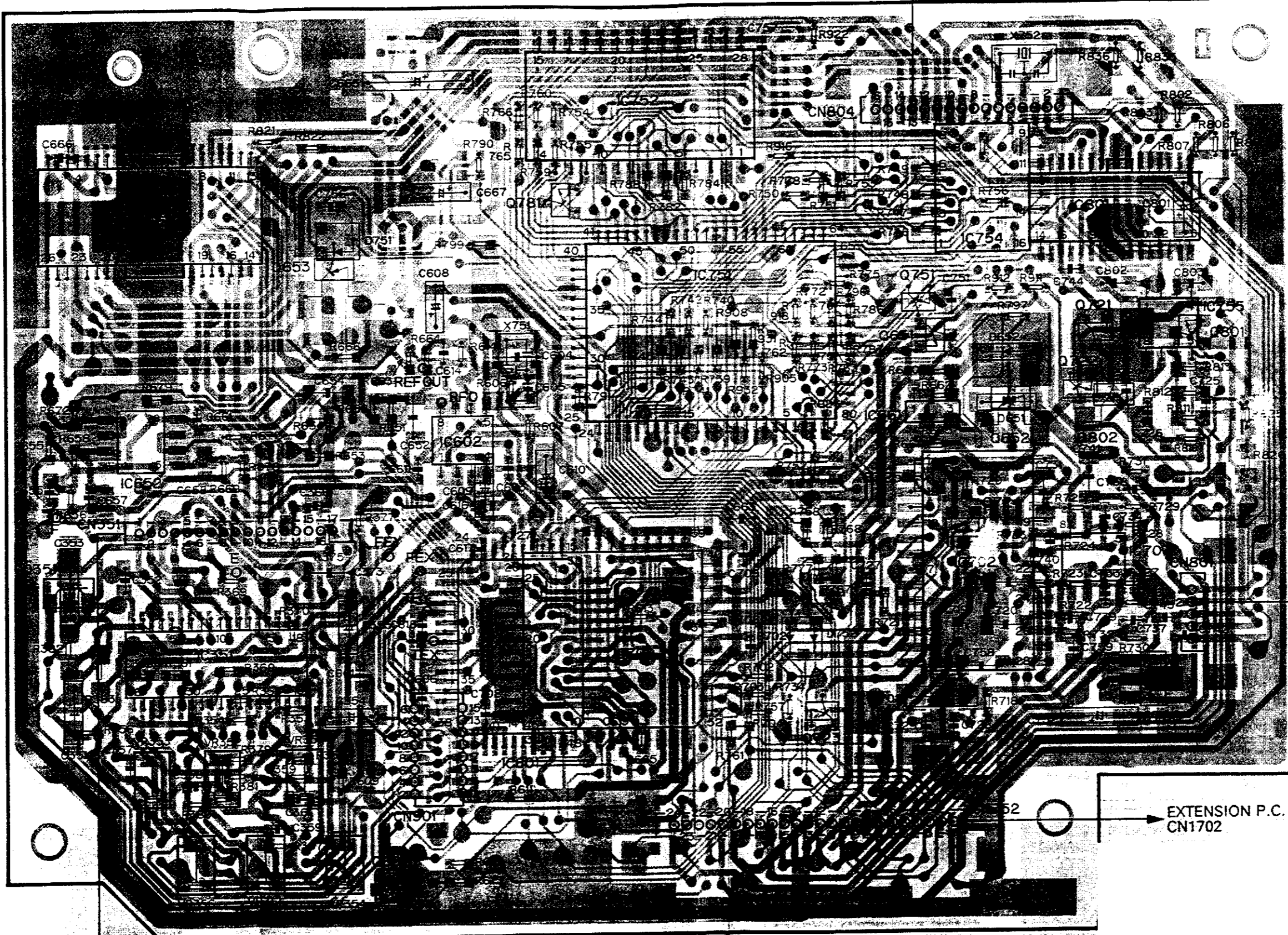

- Q781
- IC651
- IC754
- IC801
- Q653
- Q751
- Q721 IC755
- Q651 Q801
- IC751
- Q722
- Q802
- Q652
- IC661
- IC652
- IC602
- Q725
- Q724
- IC702
- IC707
- Q351
- IC601
- IC701
- IC351
- IC708
- Q723
- VR353
- VR352
- VR351
- VR356
- VR355
- VR354
- Q601

PHOTO P.C. BOARD

EXTENSION P.C. BOARD CN1702

P.C. BOARD CN1

Fig. 6

4. SCHEMATIC CIRCUIT DIAGRAM(1)

- SIGNAL LINE
- - - FOCUS SERVO LINE
- · - · TRACKING SERVO LINE
- · - · CARRIAGE SERVO LINE
- · - · SPINDLE SERVO LINE

PU UNIT (CGY1027) P.C. BOARD

MAIN UNIT

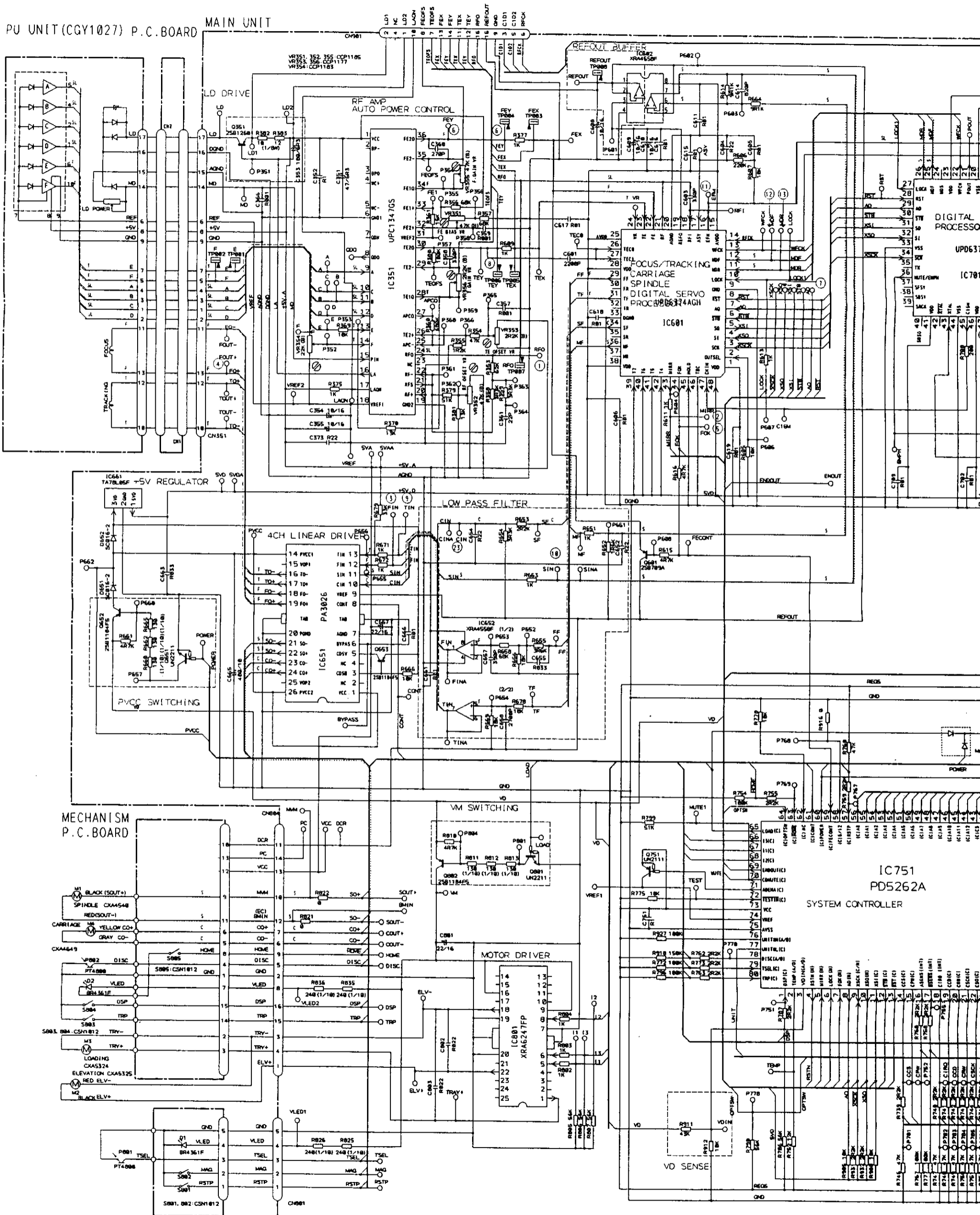

PHOTO P.C. BOARD

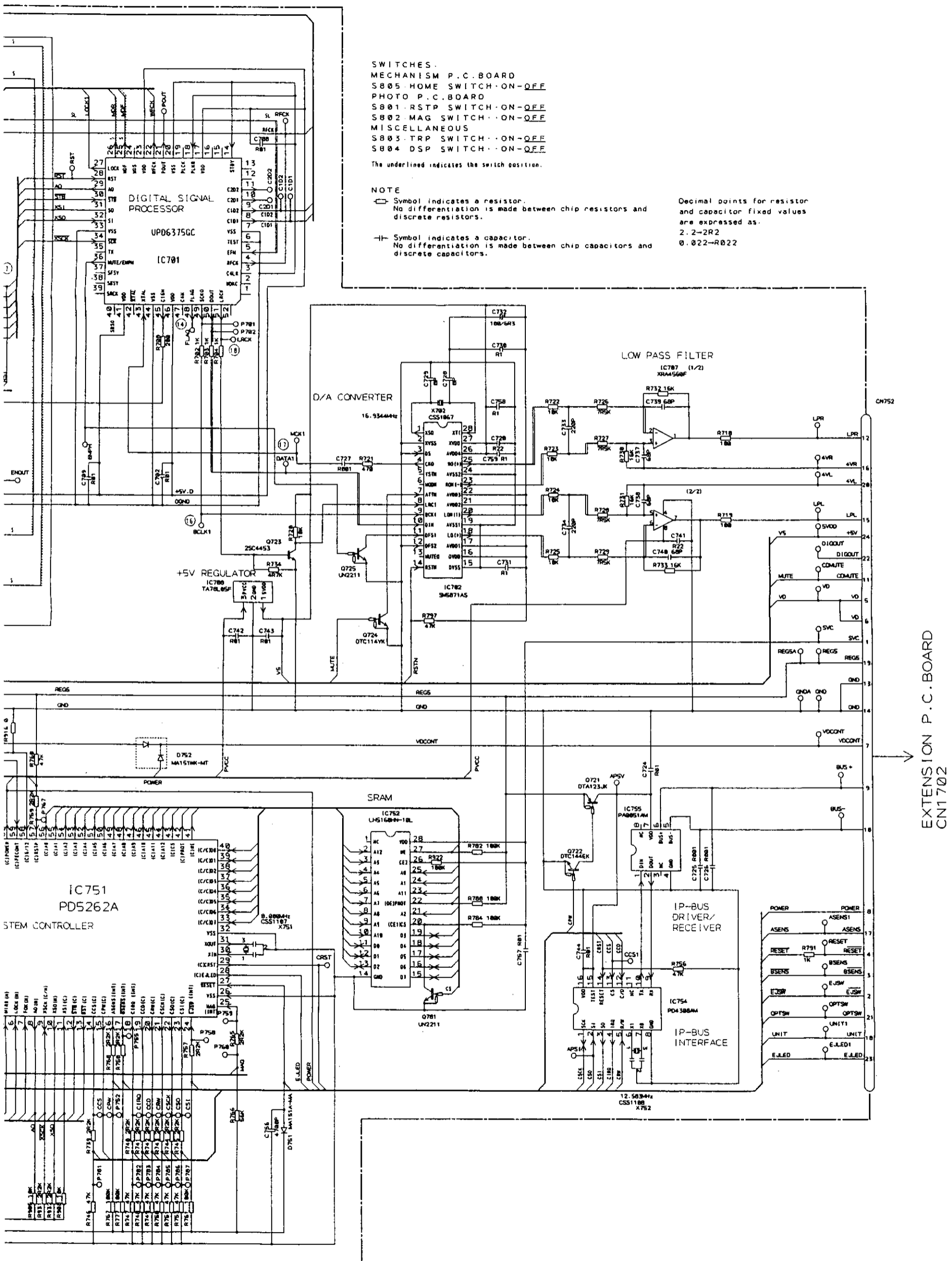

Fig.7

5. SCHEMATIC CIRCUIT DIAGRAM(2)

MAIN UNIT

EXTENSION P.C.BOARD

A
B
C
D
E

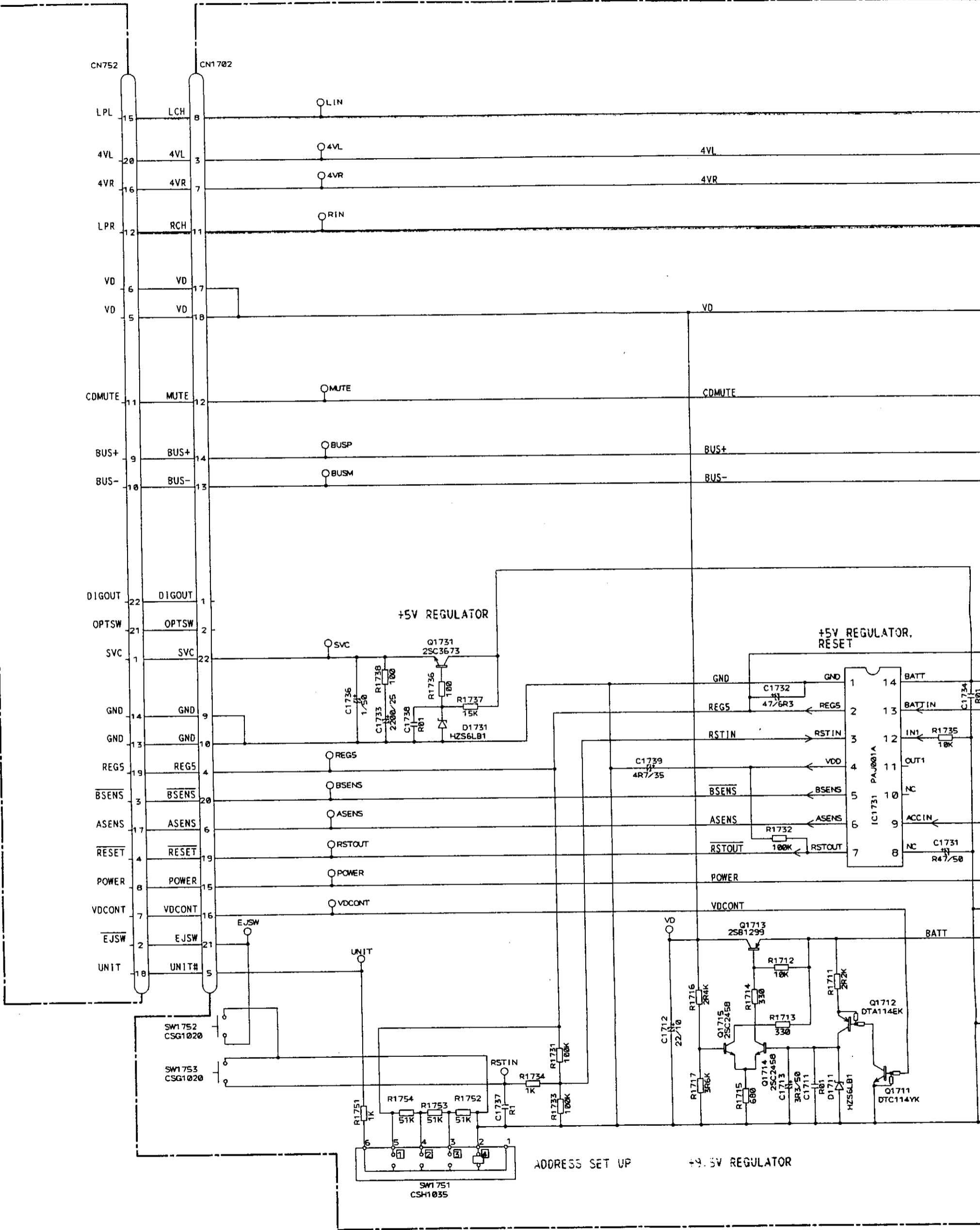

NOTE:
 □ Symbol indicates a resistor.
 No differentiation is made between chip resistors and discrete resistors.
 □-□ Symbol indicates a capacitor.
 No differentiation is made between chip capacitors and discrete capacitors.

Decimal point
and capacitor
values
are expressed
as
2.2-2R2
0.022-R02

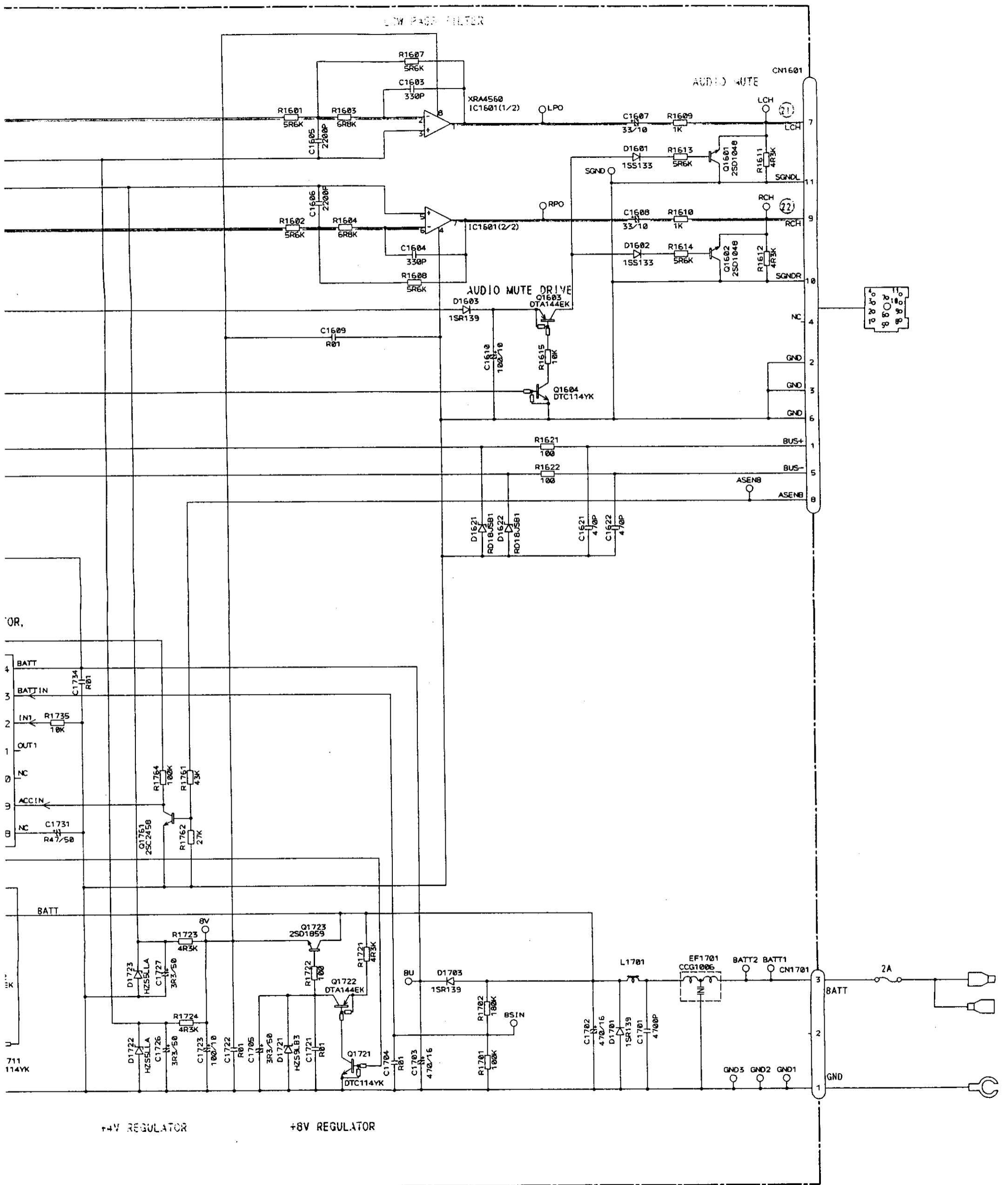

Decimal points for resistor and capacitor fixed values are expressed as:
 2.2→2R2
 0.022→R022

Fig.8

6. CONNECTION DIAGRAM(2)

EXTENSION P.C. BOARD

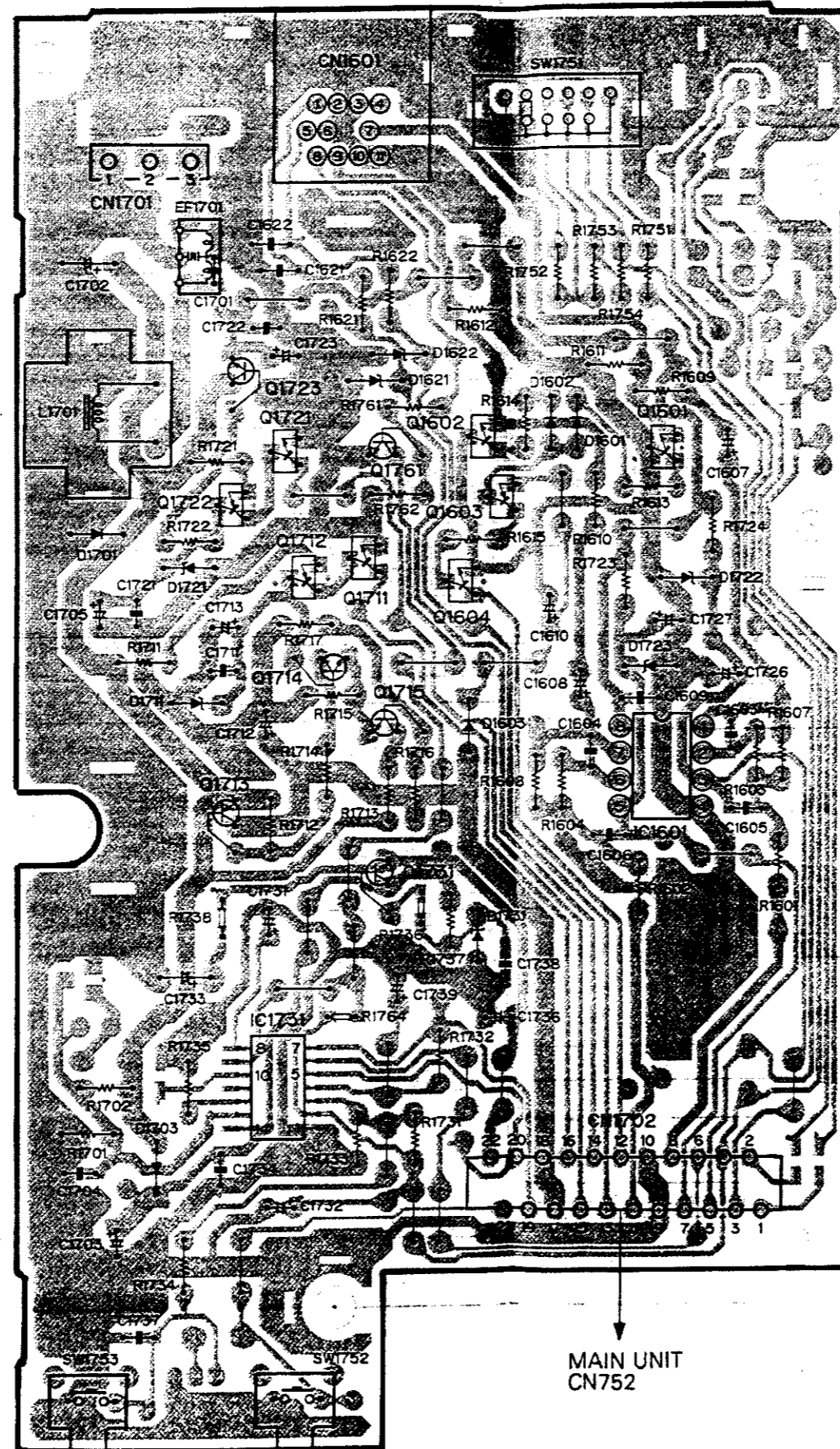

IC, Q

- Q1723
- Q1602 Q1761
- Q1721 Q1601
- Q1722 Q1603
- Q1711
- Q1712 Q1604
- Q1714
- Q1715
- IC1601
- Q1713
- Q1731
- IC1731

A
B
C
D

MAIN UNIT
CN752

Fig.9

7. BLOCK DIAGRAM

A

B

C

D

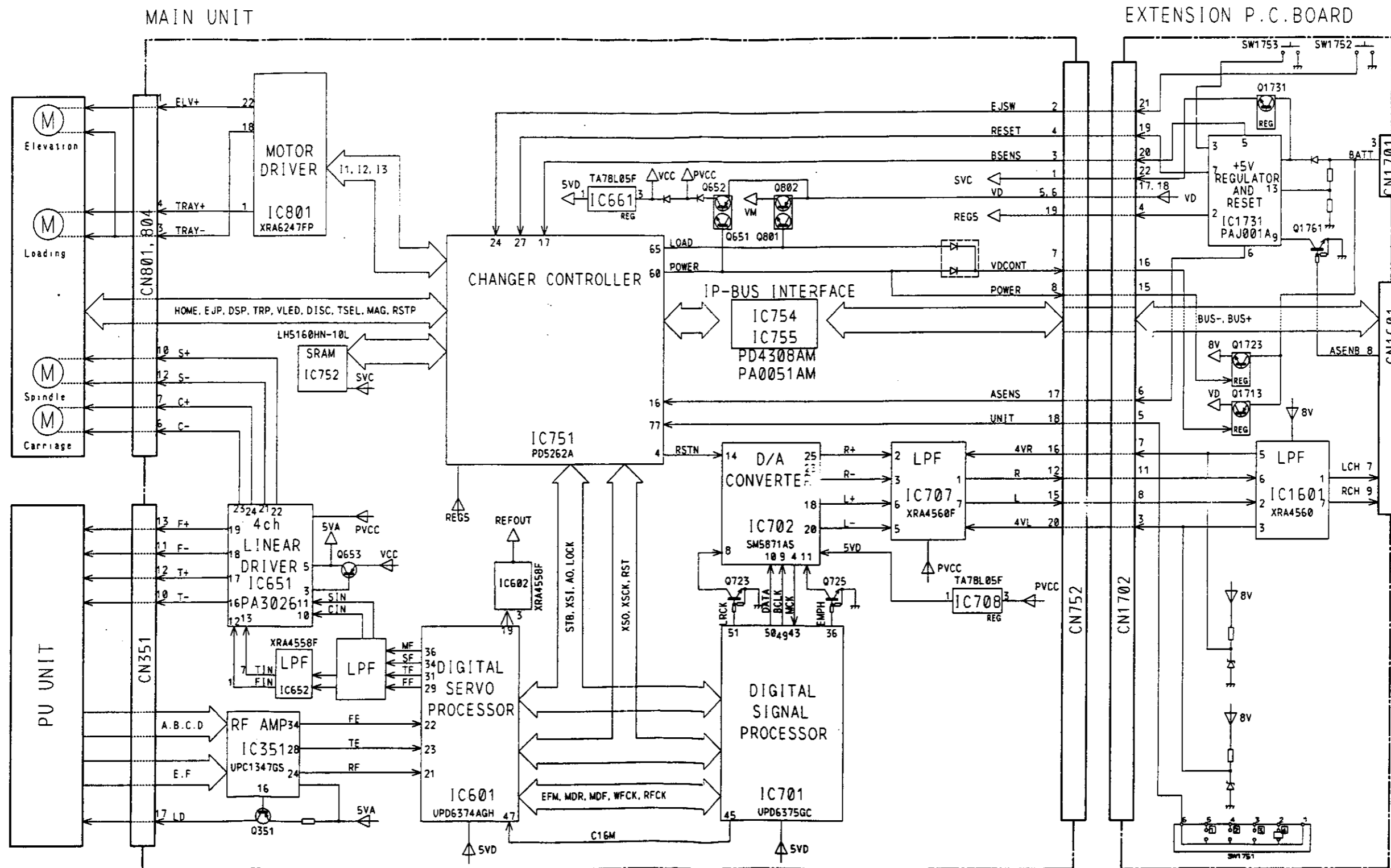

A

B

C

D

Fig.10