

# Service Manual

**PIONEER**  
The Art of Entertainment



ORDER NO.  
**CRT1633**

MULTI-COMPACT DISC PLAYER

# CDX-P22

**EW**

**COMPACT**  
**disc**  
**DIGITAL AUDIO**

- This additional service manual is designed to be used together with Model CDX-P610/EW Service Manual CRT1632. Refer to it for finding parts numbers and adjustment ,etc. which are not shown in this manual.

## EXPLODED VIEW PARTS LIST

### ● Parts List (Page 1-39)

Mark No. Description	CDX-P610/EW	CDX-P22/EW
	Part No.	Part No.
5 Upper Case	CNB1886	CNB1872
6 Lower Case	CNB1815	CNB1885
8 Main Unit	CWX1721	CWX1762 (Serial No. 11001~)
		CWX1869 (Serial No. ~11000)
9 Extension Unit	CWX1729	CWX1802
15 Angle	CNB1874	CNB1765
27 Button	CAC3982	CAC4130
28 Door	CAT1624	CAT1641
30 Grille	CNS3092	CNS3160

## PACKING METHOD

### ● Parts List (Page 2-8)

\*:Non spare part

Mark No. Description	CDX-P610/EW	CDX-P22/EW
	Part No.	Part No.
1-1 Polyethylene Bag	CEG1116	.....
1-2 Owner's Manual	CRD1776	.....
Owner's Manual	CRD1777	.....
* 1-3 Warranty Card	CRY1071	.....
7 Carton	CHG2507	CHG2511
8 Accessory Assy	CEA2019	CEA2020
8-2 Angle(X2)	CNB1874	CNB1765
9 Contain Box	CHL2507	CHL2511

**PIONEER ELECTRONIC CORPORATION** 4-1, Meguro 1-Chome, Meguro-ku, Tokyo 153, Japan

**PIONEER ELECTRONICS SERVICE INC.** P.O.Box 1760, Long Beach, California 90801 U.S.A.

**PIONEER ELECTRONICS OF CANADA, INC.** 300 Allstate Parkway Markham, Ontario L3R OP2 Canada

**PIONEER ELECTRONIC [EUROPE] N.V.** Haven 1087 Keetberglaan 1, 9120 Melsele, Belgium

**PIONEER ELECTRONICS AUSTRALIA PTY.LTD.** 178-184 Boundary Road, Braeside, Victoria 3195, Australia TEL:[03]580-9911

© **PIONEER ELECTRONIC CORPORATION 1994**

K-FFS.OCT.1994 Printed in Japan

## ● Pin Functions (PD5292A)

Pin No.	Pin Name	I/O	I/O Format	Function and Operation
1	TIN	I	C	Disc sensor timing input
2	TEMP			Temperature detector
3	VDIN	I		Power supply short sensor input
4	CLAMP	I	C	Tray position input
5	CSI	I	C	IP-BUS data input
6	CSO	O	C	IP-BUS data output
7	APPW	O	C	IP-BUS driver power supply control output
8	AO	O	C	Control signal distinguishing from LSI
9	XSCK	I/O	C	LSI clock input/output
10	XSO	O	C	LSI data output
11	XSI	I	C	LSI data input
12	STB	O	C	LSI Strobe output
13	RST	O	C	LSI reset output
14	NC			Not used
15	DACRST	O	C	D/A converter reset output
16	ASENS	I		ACC power sense input
17	BSENS	I		Back up power sense input
18-23	NC			Not used
24	EJSW	I		Eject key switch interrupt input
25	MAG	I		Magazine lock switch interrupt input
26	NC			GND
27	RESET	I		Reset input
28	POWER	O	C	CD +5V control
29	CONT	O	C	Servo driver power supply control
30	XIN	I		Crystal oscillating element connection pin
31	XOUT	O		Crystal oscillating element connection pin
32	VSS			GND
33-56	NC			Not used
57	EJP	I	C	Reset position switch
58,59	NC			Not used
60	MIRR	I	C	Mirror detector input
61	LOCK	I	C	Spindle lock detector input
62	FOK	I	C	FOK signal input
63	HOME	I	C	Home position detector input
64	OPTSW	I	C	Digital output ON/OFF input
65	LOAD	O	C	Mechanism power supply control
66	I3	O	C	Motor driver control output
67	I1	O	C	Motor driver control output
68	I2	O	C	Motor driver control output
69	I4	O	C	Motor driver control output
70	CDMUTE	O	C	CD mute output
71	ADENA	O	C	A/D reference voltage output
72	TESTIN	I	C	Test program mode input
73	VCC			Back up 5V
74	VREF	I		A/D converter reference voltage input
75	AVSS	I		A/D GND
76	UNIT			Not used
77	6/12	I	C	6/12 switching input
78	DISK	I		Disc detector input
79	TSEL			Tray position detector photo sensor
80	NC			Not used

I/O Format	Meaning
C	C MOS output

\*PD5292A

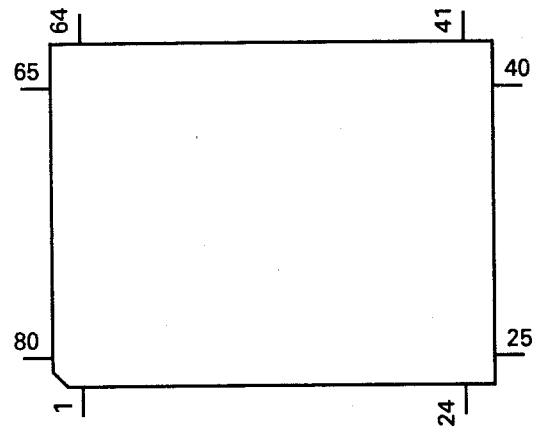

IC's marked by\* are MOS type.  
Be careful in handing them because they are very  
liable to be damaged by electrostatic induction.

## ELECTRICAL PARTS LIST

### NOTE:

- Parts whose parts numbers are omitted are subject to being not supplied.
- The part numbers shown below indicate chip components.

Chip Resistor

RS1/OSOOOJ,RS1/OOSOOOJ

Chip Capacitor (except for CQS.....)

CKS....., CCS....., CSZS.....

====Circuit Symbol & No. Part Name====	Part No.	====Circuit Symbol & No. Part Name====	Part No.
Unit Number : Unit Name : Extension P.C.Board			
MISCELLANEOUS			
Q 1693 1697 Q 1696 Q 1698 1699 Q 1799 Q 1906	DTA144ES DTC114YS DTC343TS 2SC2458 2SB942	R 1001 R 1002 R 1003 R 1004 1768 R 1005	RD1/4PS220JL RD1/4PS0R0JL RD1/4PS103JL RS1/16S102J RS1/16S823J
Q 1907 1908 D 1698 1699 D 1798 1799 D 1901 1903 L 1901	2SD1859 1SS133 RD18JSB1 ERA15-02VH CTH1129	R 1006 R 1007 R 1011 1012 R 1013 1024 1025 R 1014 1410	RS1/16S182J RS1/16S333J RS1/16S683J RD1/4PS102JL RS1/16S473J
Choke Coil		R 1018 R 1019 1401 1407 1716 R 1020 R 1021 1701 R 1022 1408	RD1/4PS622JL RS1/16S563J RS1/16S622J RS1/16S513J RS1/16S133J
RESISTORS			
R 1695 1910 R 1696 1697 R 1698 1699 R 1795 1796 1908 R 1798	RD1/4PS103JL RD1/4PS332JL RD1/4PS112JL RD1/4PS101JL RD1/4PS273JL	R 1027 R 1028 R 1201 1406 1411 1605 1606 1607 1608 1702 1712 1741 R 1402 1403 1613 1614 1615 1616 R 1404	RS1/16S183J RS1/16S822J RS1/16S103J RS1/16S163J RS1/16S753J
R 1799 R 1906 R 1907 R 1909 1911 R 1912	RD1/4PS433JL RD1/4PS104JL RD1/4PS204JL RD1/4PS201JL RD1/4PS241JL	R 1405 1708 R 1409 R 1412 R 1601 R 1602	RS1/16S433J RS1/16S153J RS1/16S152J RS1/16S0R0J RS1/16S471J
R 1913 R 1914 R 1915	RD1/4PS681JL RD1/4PS511JL RD1/4PS104JL	R 1609 1610 1611 1612 R 1617 1618 1769 R 1619 R 1703 1704 R 1705 1713 1715 1718 1721 1730 1731 1732 1733 1734	RS1/16S752J RS1/16S101J RS1/16S102J RS1/16S154J RS1/16S104J
CAPACITORS			
C 1698 1699 C 1798 1799 C 1901 1905 C 1904 C 1906	CEA330M10LL CKPYB471K50L CCH1183 CEA220M10LL CCH1183	R 1706 R 1709 1710 1714 1722 1729 1735 1744 1745 R 1717 R 1719 1742 R 1747 1748	RS1/16S104J RS1/16S222J RS1/16S123J RS1/16S0R0J RS1/16S104J
C 1907	CKPYB102K50L	R 1756 R 1767 R 1771 R 1801 1802	RS1/16S104J RD1/4PS3R9JL RS1/16S102J RD1/4PS391JL
Unit Number : CWX1762 (Serial No. 11001~) Unit Name : Main Unit			
MISCELLANEOUS			
IC 1001 IC 1201 IC 1401 IC 1601 IC 1602	UPC2571GS UPD63700GF XRA6797FP SM5874AM XRA4560F	C 1001 1008 1010 1011 1708 1709 C 1002 C 1003 1021 1602 1603 1604 1605 C 1004 C 1005	CKSRYB102K50 CEA101M6R3LL CKSQYB104K16 CEA470M6R3LL CCSRCH101J50
IC 1603 IC 1701 IC 1703 IC 1704 IC 1801	NJM78L05A PD5292A PA0051AM PAJ002A LB1836M	C 1006 1023 C 1007 C 1009 C 1013 1701 1705 1707 C 1014	CKSRYB561K50 CKSYB334K16 CCSRCH181J50 CKSRYB103K25 CCSRCH220J50
Q 1001 Q 1401 1709 Q 1701 Q 1703 Q 1704 1707 1801	2SA1015 2SB1238 DTA144ES DTC144ES DTA123JS	C 1015 1201 1202 C 1018 C 1022 C 1026 C 1203	CKSYF105Z16 CEA220M6R3LL CKSRYB332K50 CKSRYB103K25 CKSRYB471K50
Q 1708 1802 D 1401 1402 1403 X 1601 X 1701 S 1701 1702	DTC114YS ERA15-02VH CSS1328 CSS1310 CSG1059	C 1401 C 1402 C 1403 C 1404 1405 C 1406 1407	CSZA220M10 CKSQYB103K50 CKSQYB153K50 CEAS221M10 CKSRYB152K50
VR1001 VR1002 VR10031004	Semi-fixed 2.2kΩ (B) Semi-fixed 22kΩ (B) Semi-fixed 47kΩ (B)	C 1408 C 1806 1607 C 1608 C 1609 1610 C 1611 1612 1613 1614	CKSRYB271K50 CCSRCH470J50 CEA101M6R3LL CCSRCH221J50 CCSRCH680J50

====Circuit Symbol & No. Part Name====	Part No.	====Circuit Symbol & No. Part Name====	Part No.
C 1616 C 1617 1618 C 1703 C 1706 C 1710	CKSYB224K16 CKSRYB103K25 CASA330M10 CKSRYB103K50 CKSRYB103K25	R 1006 R 1007 R 1011 1012 R 1013 1024 1025 R 1014 1410	RS1/16S182J RS1/16S333J RS1/16S683J RD1/4PS102JL RS1/16S473J
C 1802	CEA220M16LL	R 1018 R 1019 1401 1407 1716 R 1020 R 1021 1701 R 1022 1408	RD1/4PS622JL RS1/16S563J RS1/16S622J RS1/16S103J RS1/16S163J RS1/16S753J
Unit Number : Unit Name : P.C.Board			
C 801 802	CKSQYB102K50	R 1027 R 1028 R 1201 1406 1411 1605 1606 1607 1608 1702 1712 1741 R 1402 1403 1613 1614 1615 1616 R 1404	RS1/16S183J RS1/16S822J RS1/16S103J RS1/16S163J RS1/16S753J
Unit Number : Unit Name : Mechanism P.C.Board			
D 802 S 805	LED Switch(Home)	R 1405 1708 R 1409 R 1412 R 1601 1719 1742 R 1602	BR4361F CSN1012
Unit Number : Unit Name : Photo P.C.Board			
D 801 S 801 S 802	LED Switch(RSTP) Switch(MAG)	R 1609 1610 1611 1612 R 1617 1618 1769 R 1619 R 1703 R 1704	BR4361F CSN1025 CSN1012
Miscellaneous Parts List			
M 802 M 803 M 801 M 804 P 801 802	PU Unit Motor Unit(ELV) Motor Unit(Tray) Motor Unit(Spindle) Motor Unit(Carriage) Photo-Transistor	R 1705 1706 1713 1715 1718 1721 1730 1731 1732 1733 R 1709 1710 1714 1722 1729 1735 1744 1745 R 1717 R 1734 1737 1738 1739 R 1747 1748	CGY1036 CXA6978 CXA6977 CXA6991 CXA4649 PT4800
S 803 804	Switch(TRP,DSP)	R 1756 R 1767 R 1771 R 1801 1802	CSN1012
Unit Number : CWX1869 (Serial No. ~11000) Unit Name : Main Unit			
MISCELLANEOUS			
IC 1001 IC 1201 IC 1401 IC 1601 IC 1602	UPC2571GS UPD63700GF1 XRA6797FP SM5874AM XRA4560F	C 1001 1008 1010 1011 1708 1709 C 1002 C 1003 1021 1602 1603 1604 1605 C 1004 C 1005	CKSRYB102K50 CEA101M6R3LL CKSQYB104K16 CEA470M6R3LL CCSRCH101J50
IC 1603 IC 1701 IC 1703 IC 1704 IC 1801	NJM78L05A PD5292A PA0051AM PAJ002A LB1836M	C 1006 1023 C 1007 C 1009 C 1013 1701 1702 1705 1707 C 1014	CKSRYB561K50 CKSYB334K16 CCSRCH181J50 CKSRYB103K25 CCSRCH220J50
Q 1001 Q 1401 1709 Q 1701 Q 1703 Q 1704 1707 1801	2SA1015 2SB1238 DTA144ES DTC144ES DTA123JS	C 1015 1201 1202 C 1018 C 1022 C 1026 C 1203	CKSYF105Z16 CEA220M6R3LL CKSRYB332K50 CKSRYB103K25 CKSRYB471K50
Q 1708 1802 D 1401 1402 1403 X 1601 X 1701 S 1701 1702	DTC114YS ERA15-02VH CSS1328 CSS1310 CSG1059	C 1401 C 1402 C 1403 C 1404 1405 C 1406 1407	CSZA220M10 CKSQYB103K50 CKSQYB153K50 CEAS221M10 CKSRYB152K50
VR1001 VR1002 VR10031004	Semi-fixed 2.2kΩ (B) Semi-fixed 22kΩ (B) Semi-fixed 47kΩ (B)	C 1408 C 1606 1607 C 1608 C 1609 1610 C 1611 1612 1613 1614	CKSRYB271K50 CCSRCH470J50 CEA101M6R3LL CCSRCH221J50 CCSRCH680J50
R 1001 R 1002 R 1003 R 1004 1768 R 1005	RD1/4PS220JL RD1/4PS0R0JL RD1/4PS103JL RS1/16S102J RS1/16S823J	C 1616 C 1617 1618 C 1703 C 1704 C 1706	CKSYB224K16 CKSRYB103K25 CASA330M10 CEA221M6R3LL CKSRYB103K50
C 1710		C 1710 C 1802	CKSRYB103K25 CEA220M16LL

CONNECTION DIAGRAM(1)

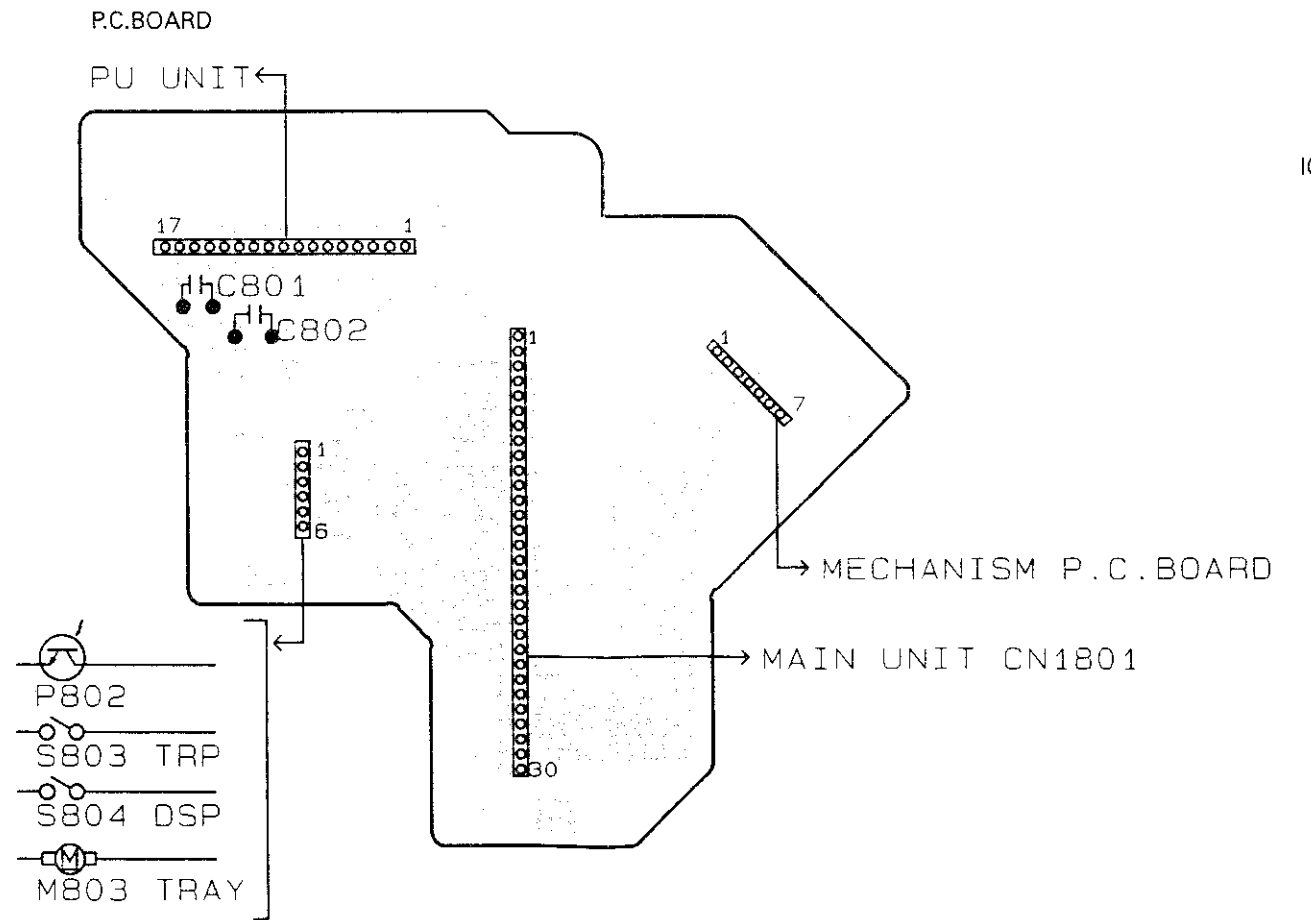
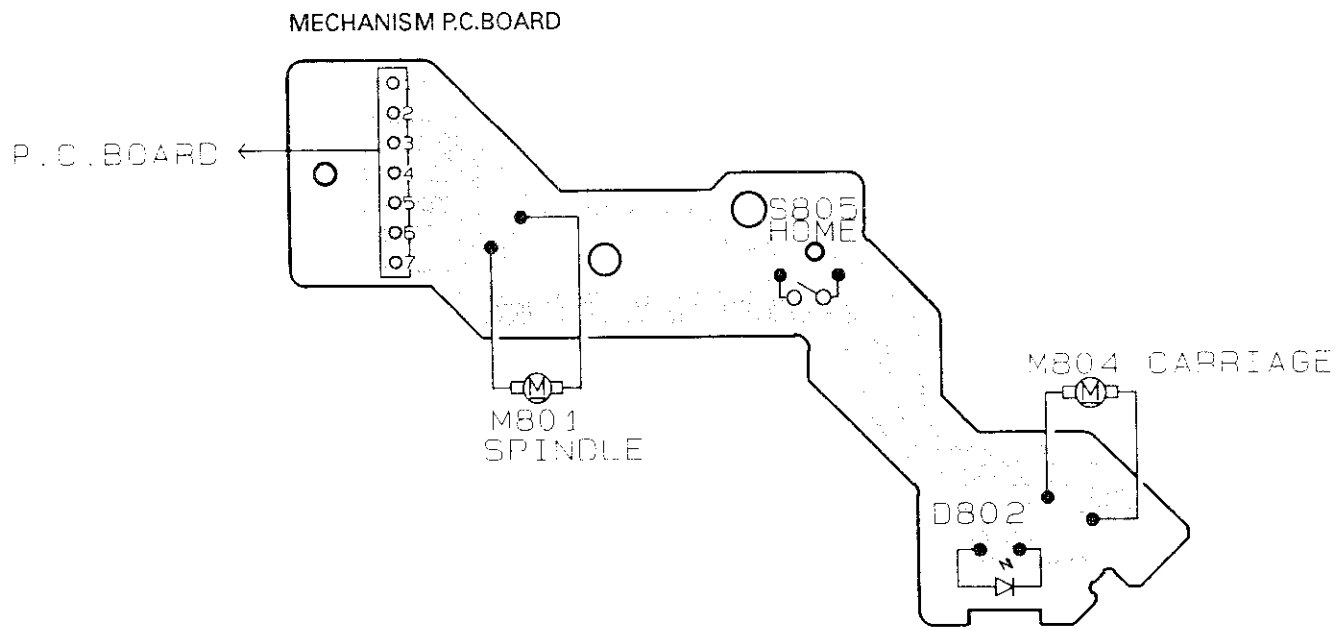
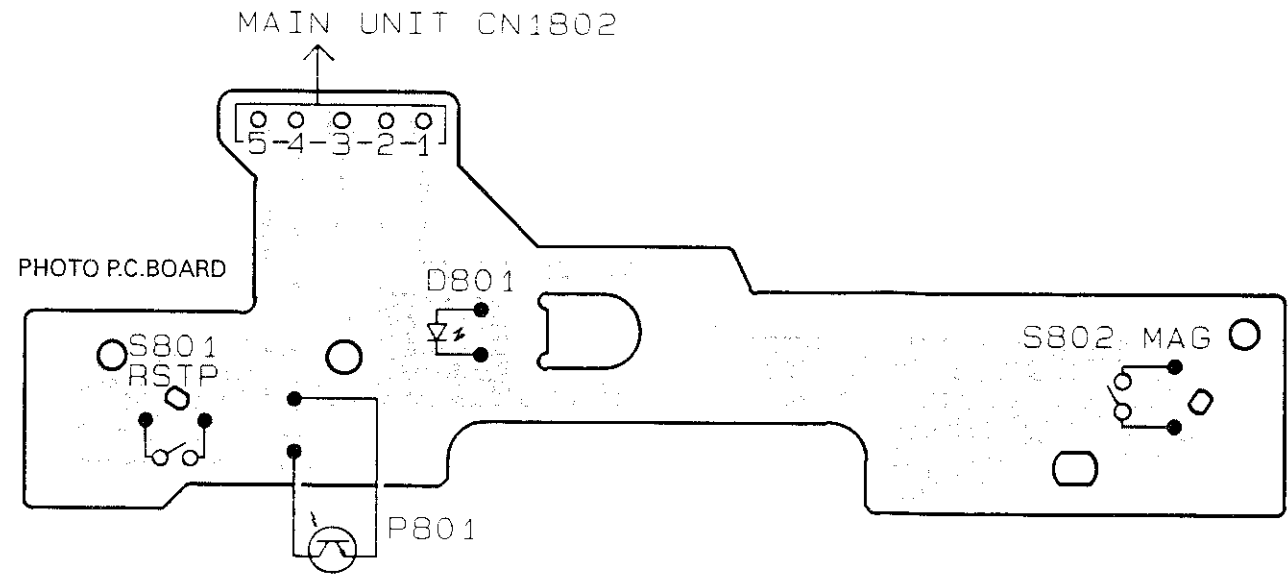
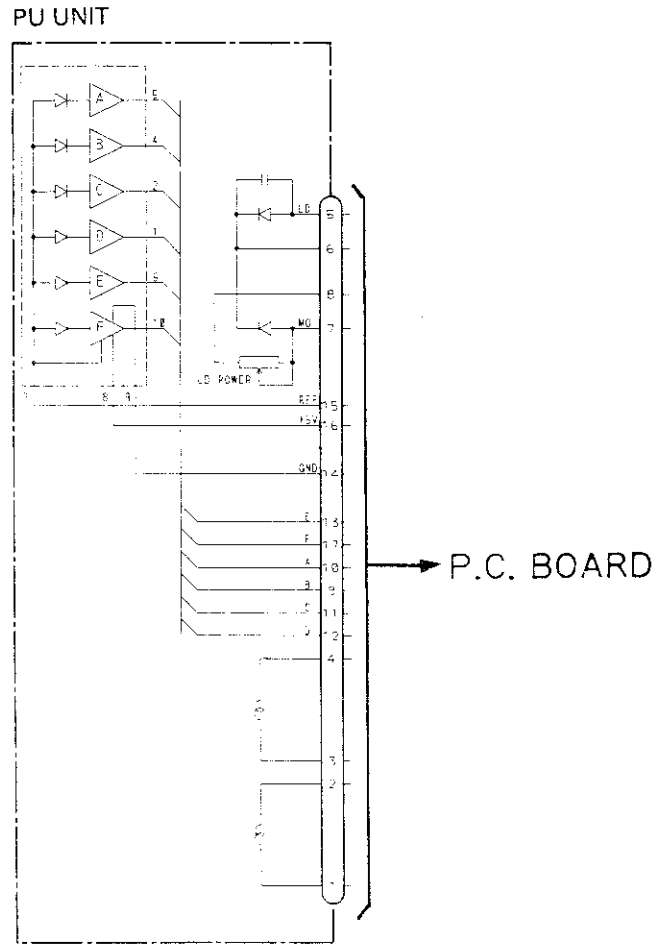

MAIN UNIT (Serial No. 11001~)

M802 ELV

P.C. BOARD

- IC, Q ADJ
- VR1001
- VR1002
- VR1003
- VR1004
- IC1801
- Q1801
- Q1802
- Q1701
- IC1001
- IC1201
- IC1701
- Q1001
- IC1703
- IC1601
- IC1603
- Q1703
- Q1708
- Q1704
- Q1707
- IC1401
- Q1709
- IC1602
- IC1704
- Q1401
- SM P.C. BOARD
- CN1801

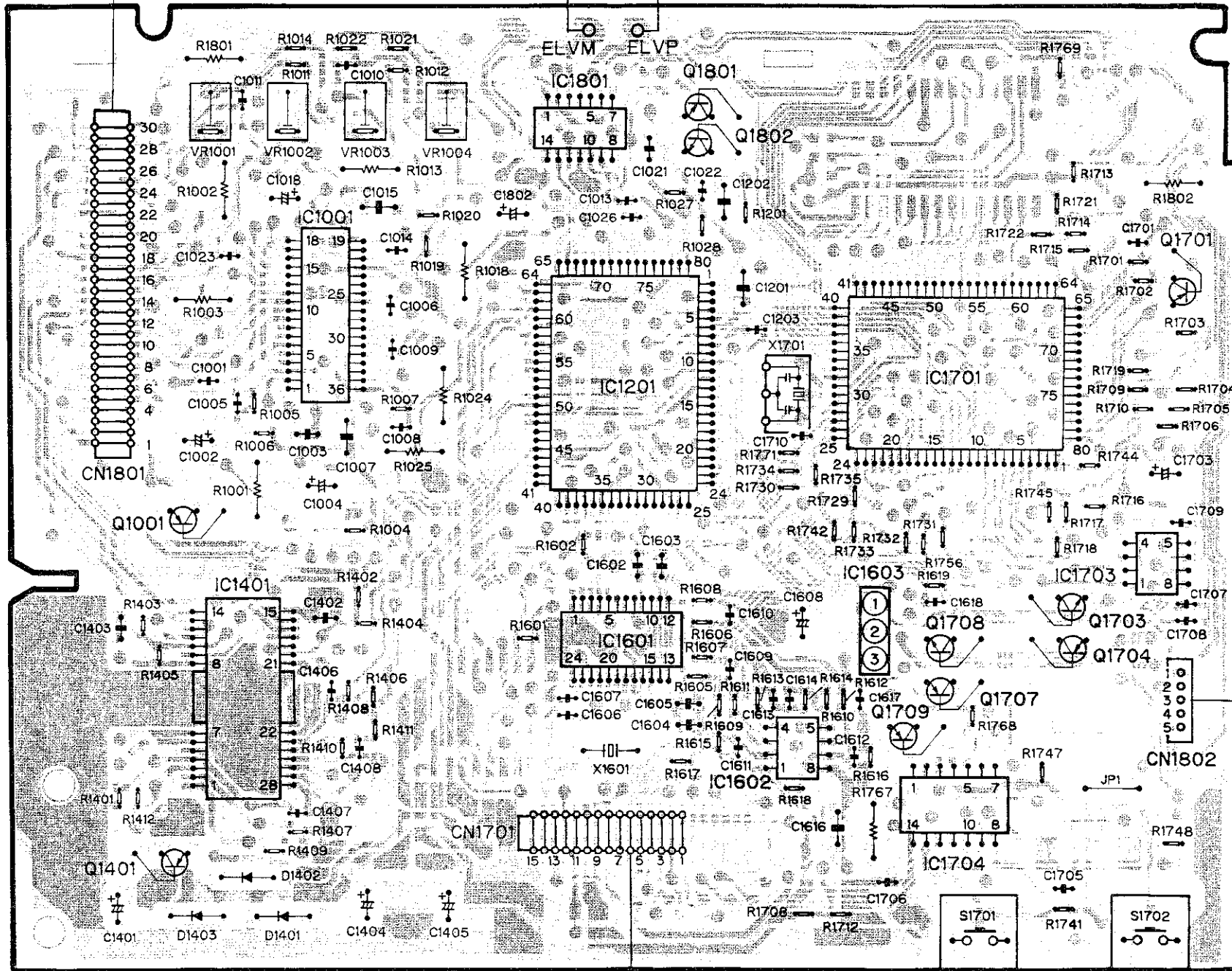

PHOTO P.C. BOARD

EXTENSION P.C. BOARD  
CN1697

Fig.1

# SCHEMATIC CIRCUIT DIAGRAM(1)

- SL — SIGNAL LINE
- F — FOCUS SERVO LINE
- T — TRACKING SERVO LINE
- C — CARRIAGE SERVO LINE
- S — SPINDLE SERVO LINE

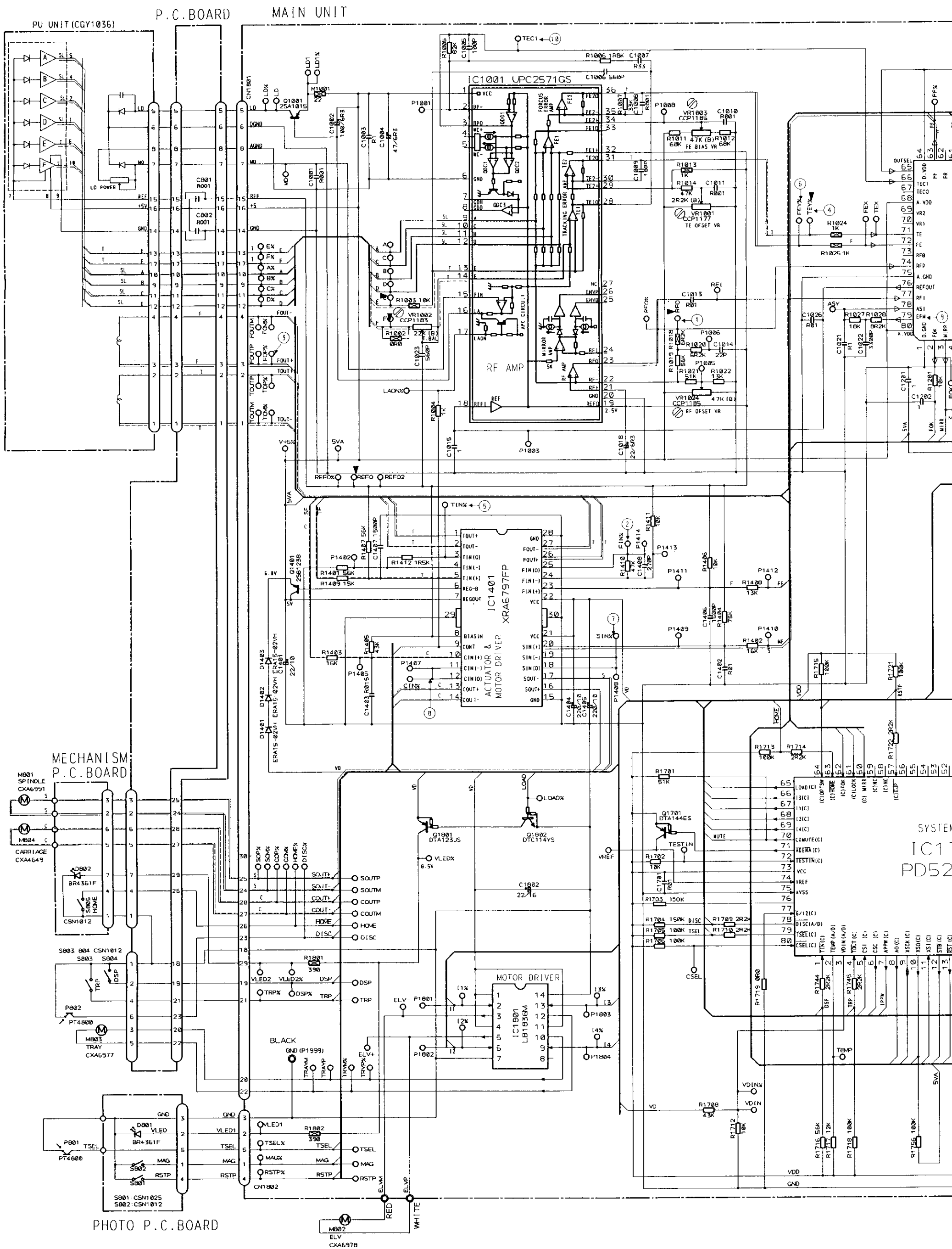

SYSTEM  
IC17  
PD52

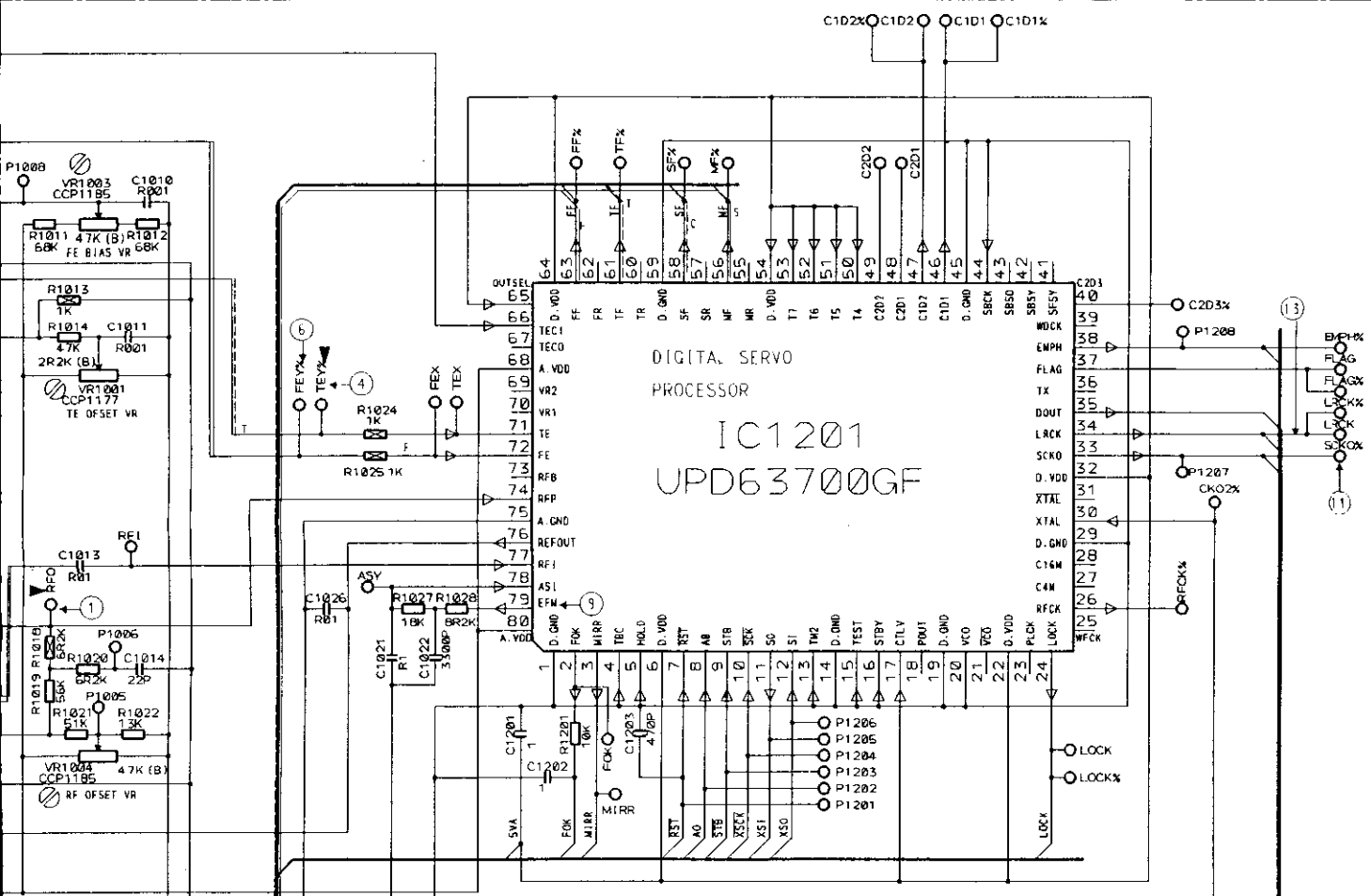

NOTE:  
 □ Symbol indicates a resistor. No differentiation is made between chip discrete resistors.  
 —||— Symbol indicates a capacitor. No differentiation is made between chip discrete capacitors.  
 Decimal points for resistor and capacitor fixed values are expressed as:  
 2.2-2R2  
 0.022-R022

SWITCH  
 MECHA  
 SB05  
 PHOTO  
 SB01  
 SB02  
 MISCE  
 SB03  
 SB04  
 The underl

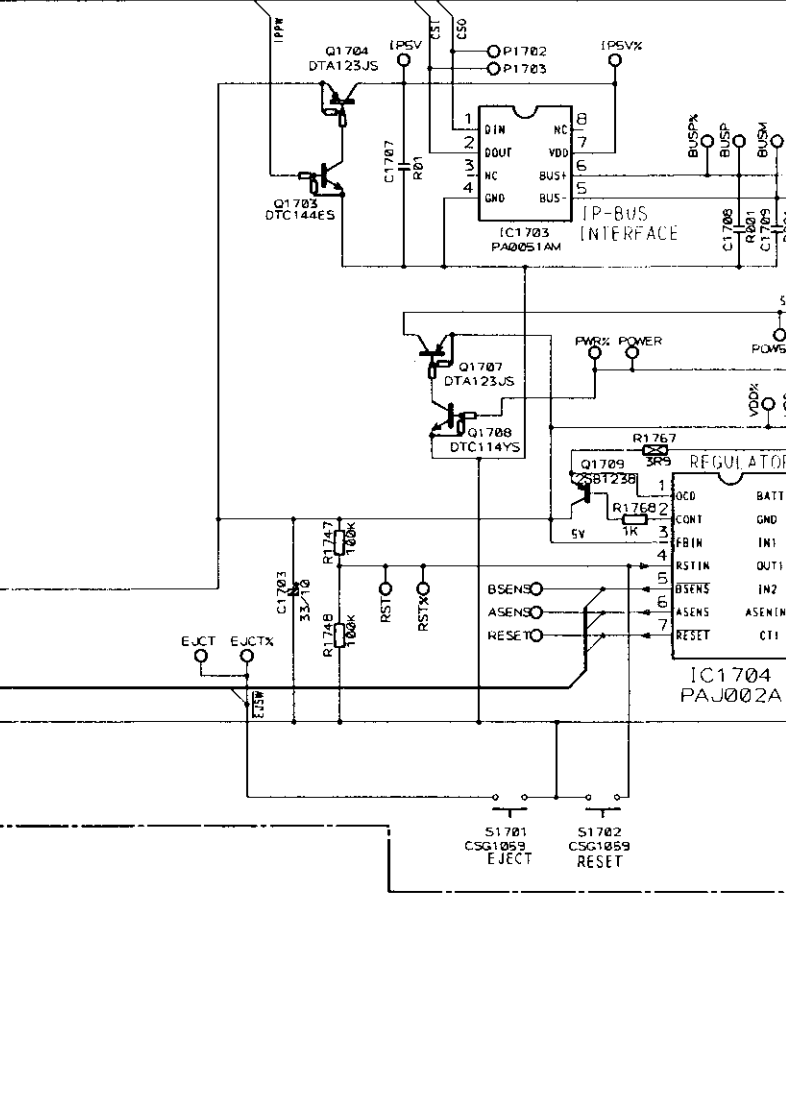
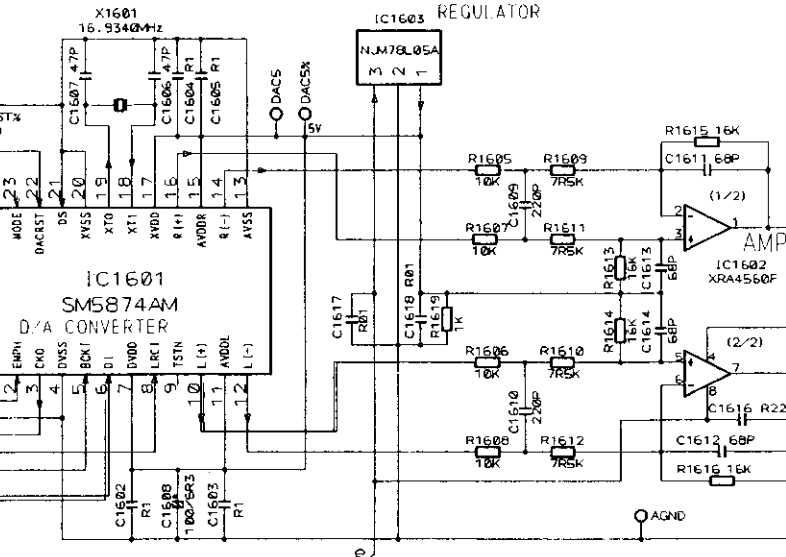
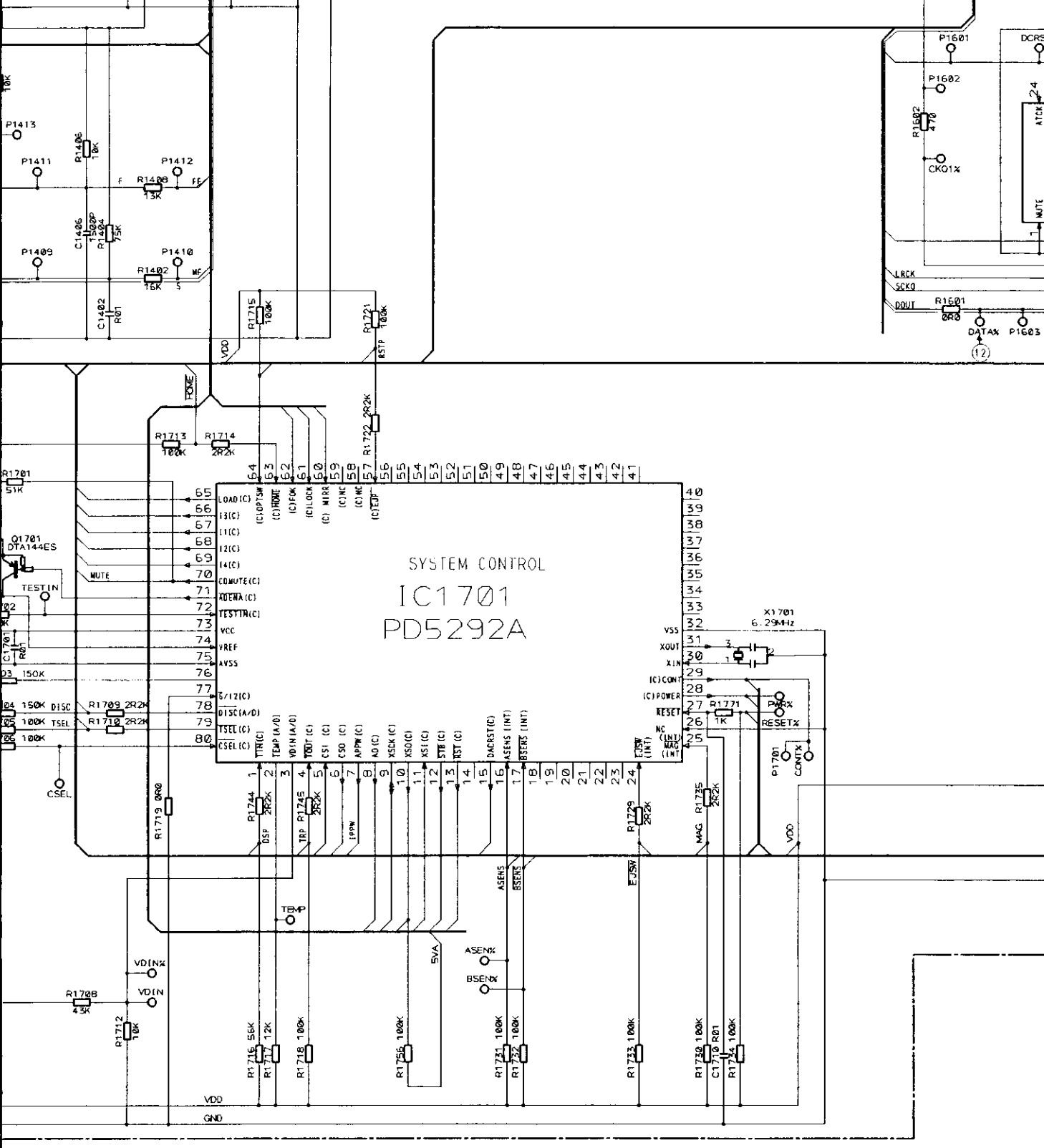



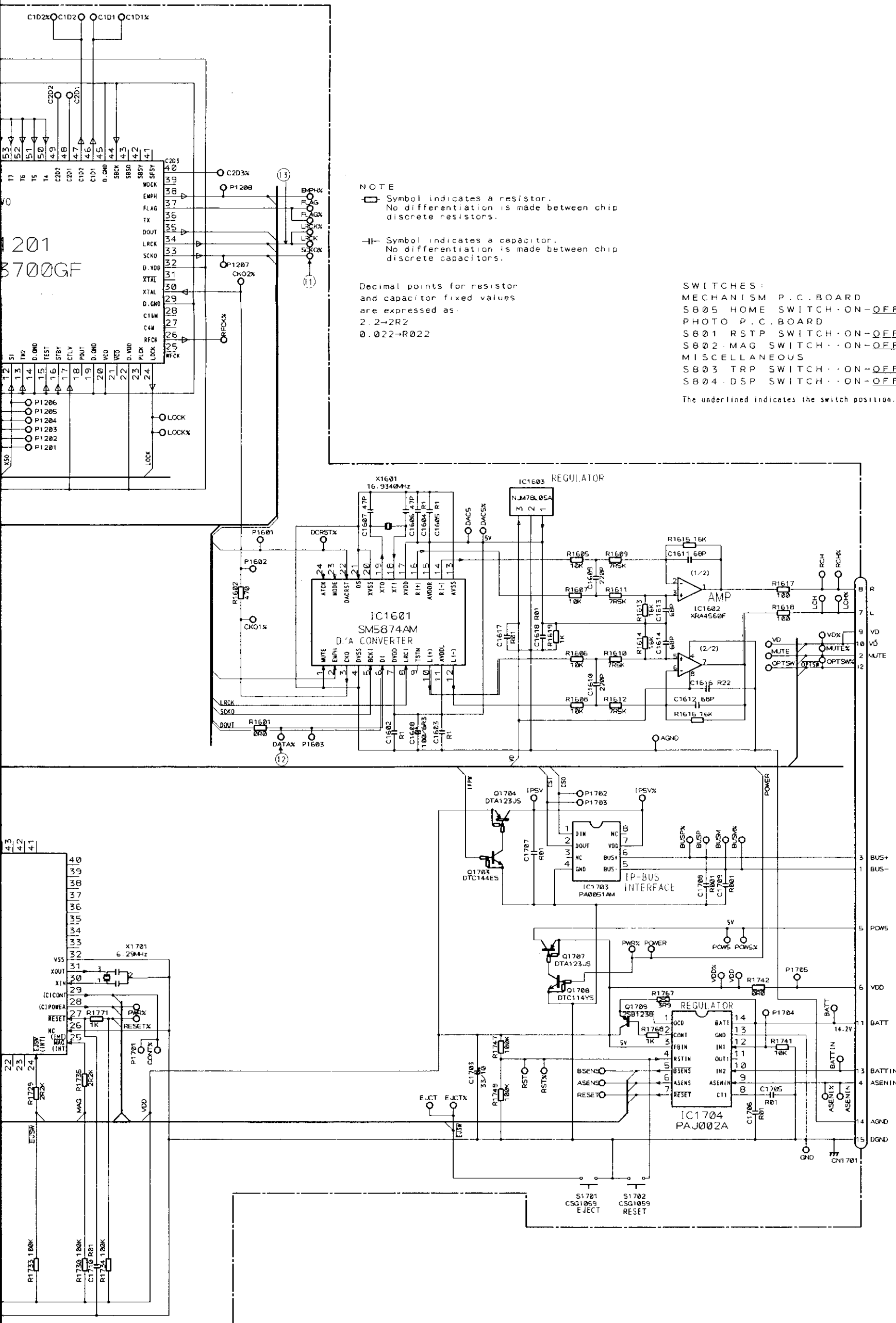

NOTE  
 □ Symbol indicates a resistor.  
 No differentiation is made between chip discrete resistors.

▯ Symbol indicates a capacitor.  
 No differentiation is made between chip discrete capacitors.

Decimal points for resistor and capacitor fixed values are expressed as:  
 2.2→2R2  
 0.022→R022

SWITCHES:  
 MECHANISM P.C. BOARD  
 SB05 HOME SWITCH · ON-OFF  
 PHOTO P.C. BOARD  
 SB02 · MAG SWITCH · ON-OFF  
 SB03 TRP SWITCH · ON-OFF  
 MISCELLANEOUS  
 SB04 · DSP SWITCH · ON-OFF  
 The underlined indicates the switch position.

Fig.2

A

B

C

D

E

F

SCHEMATIC CIRCUIT DIAGRAM(2)

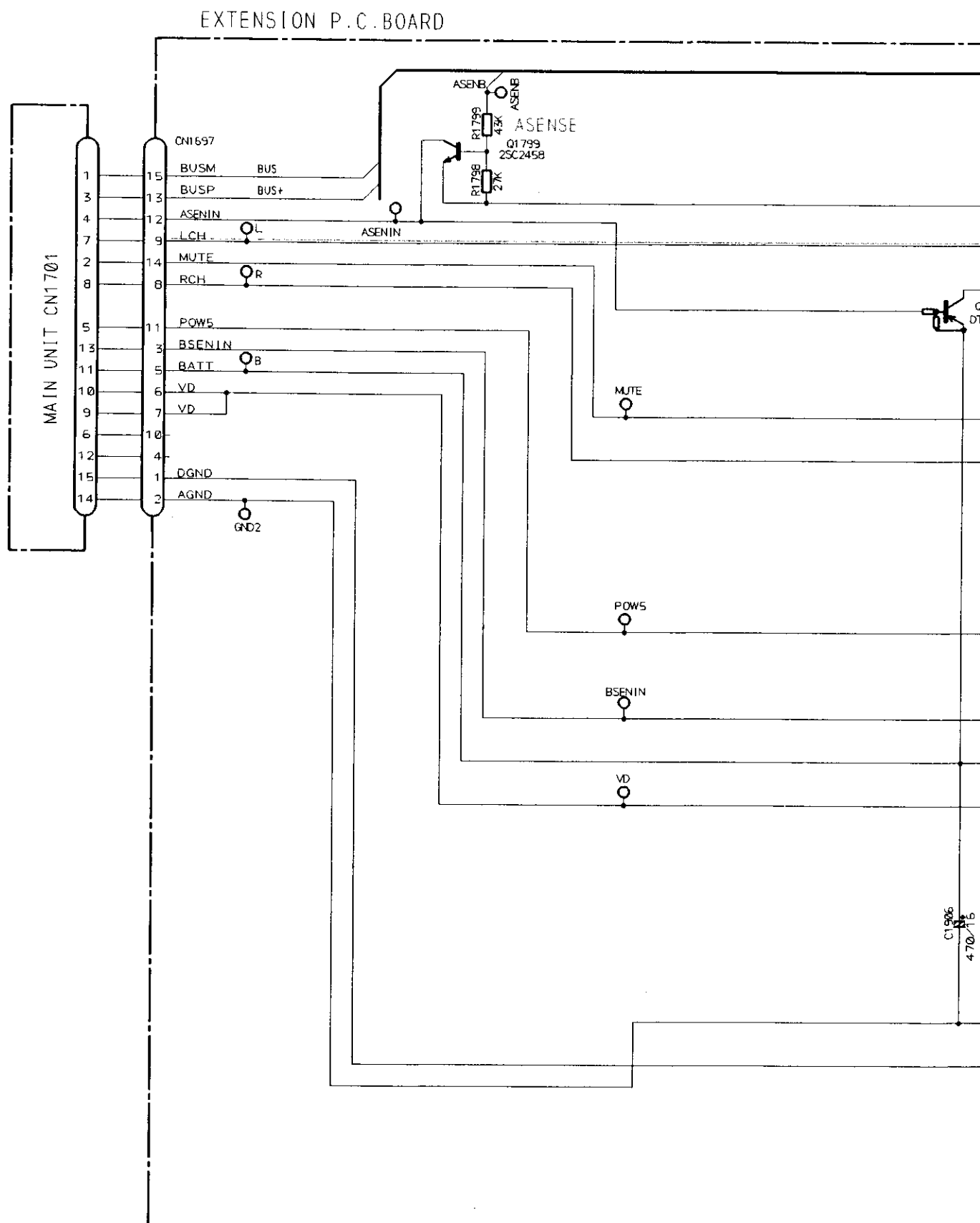

4

5

6

7

8

ARD

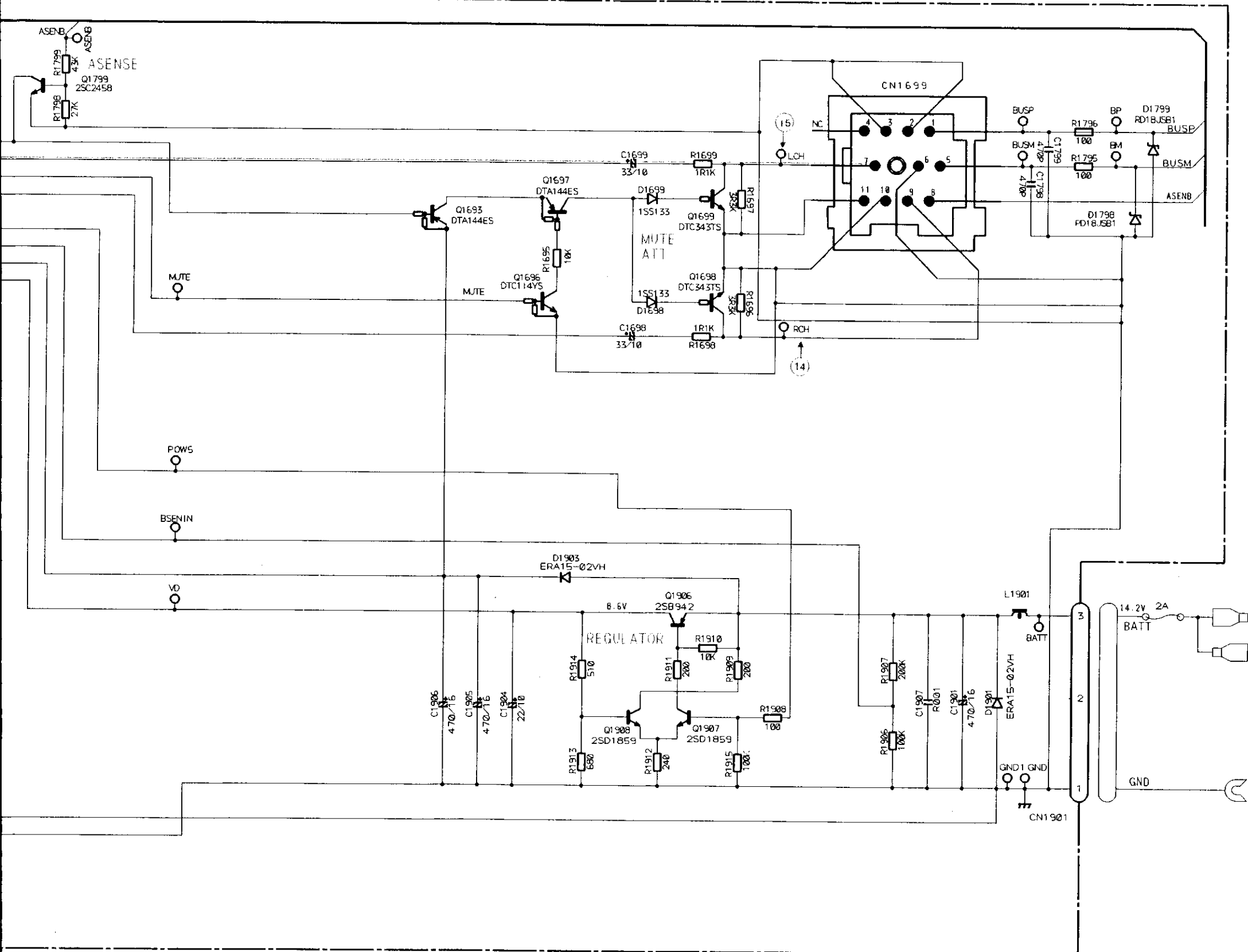

15

4

5

6

16

7

8

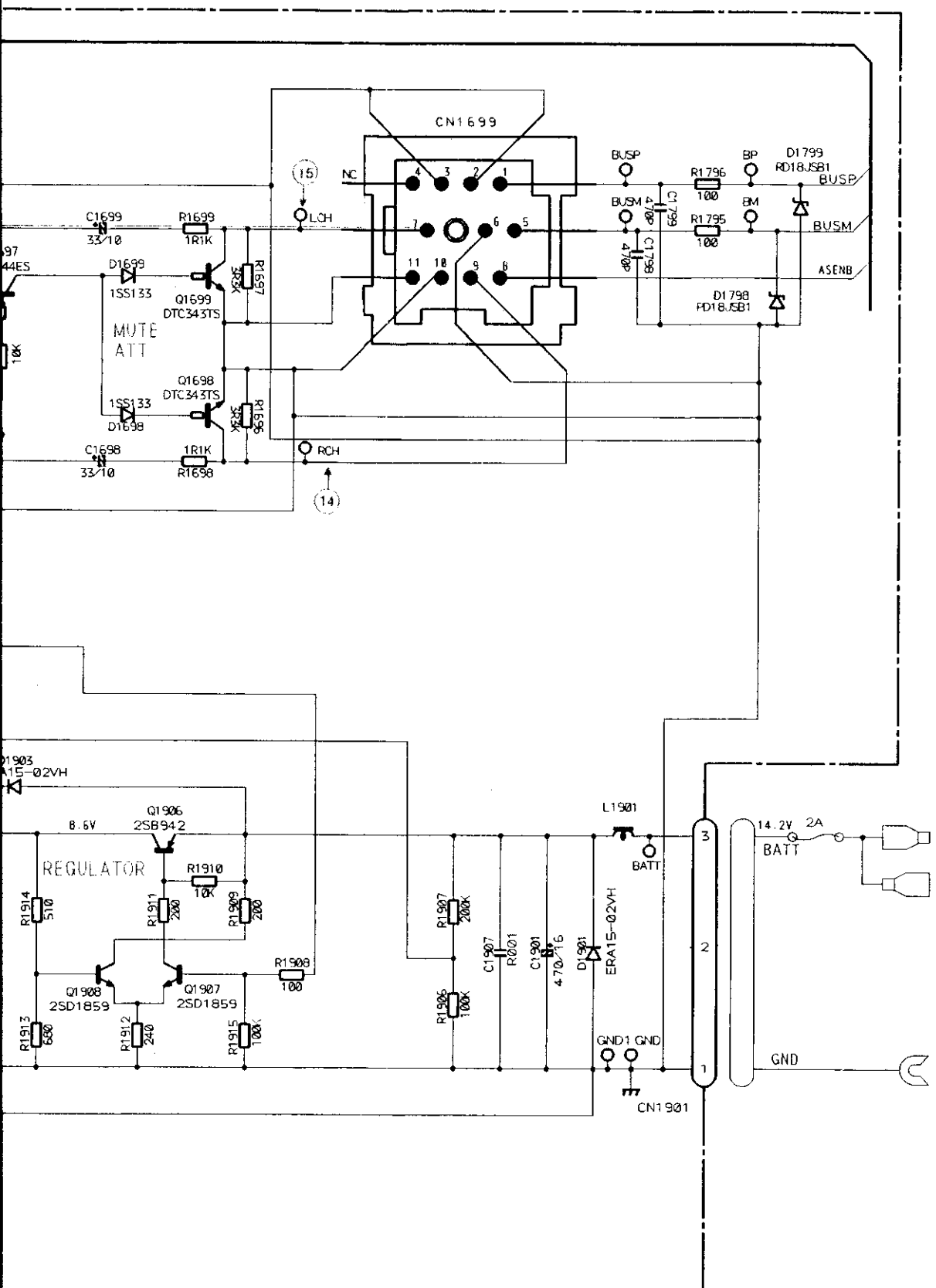

Fig.3

CONNECTION DIAGRAM(2)

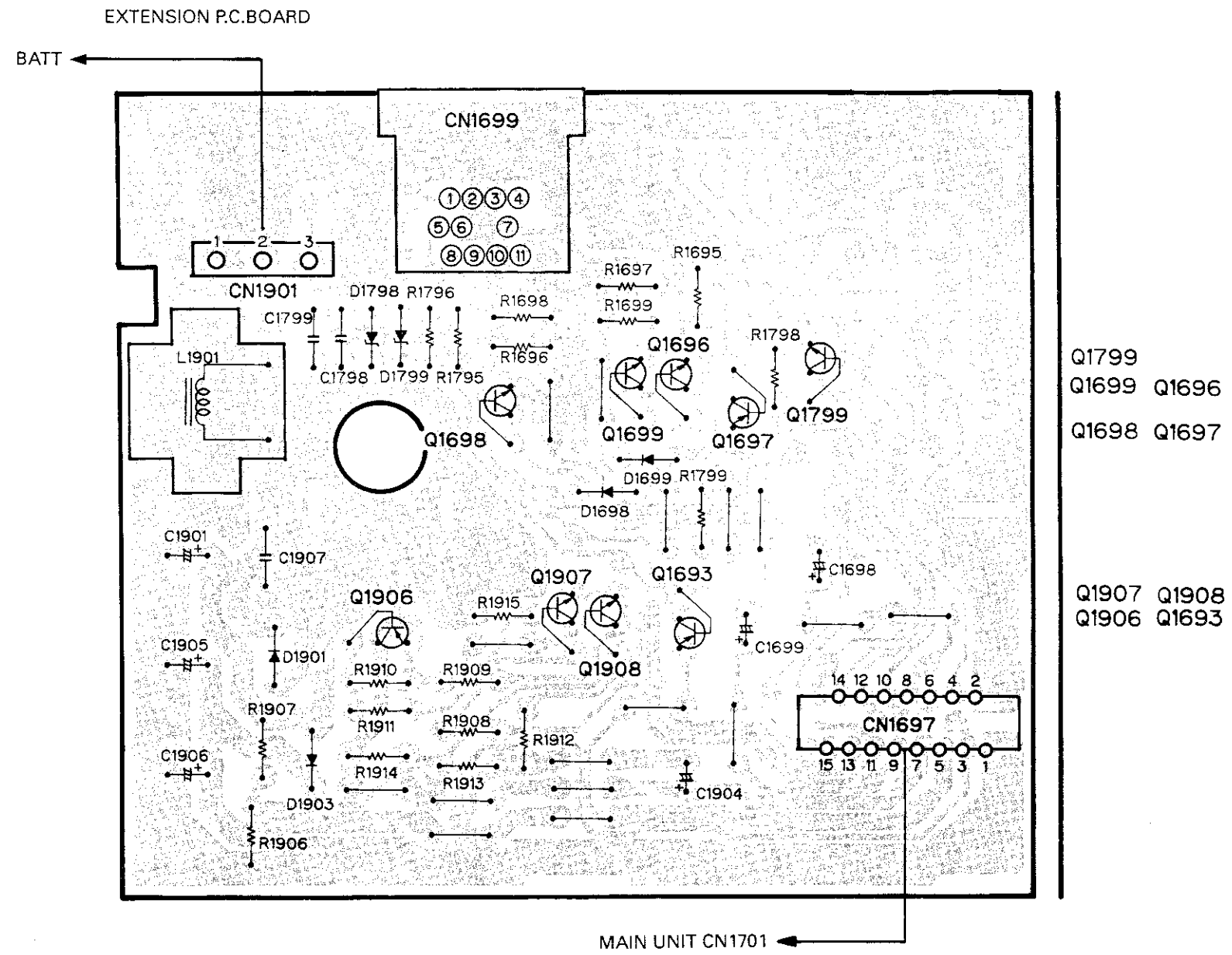

Fig.4

MAIN UNIT (Serial No. ~11000)

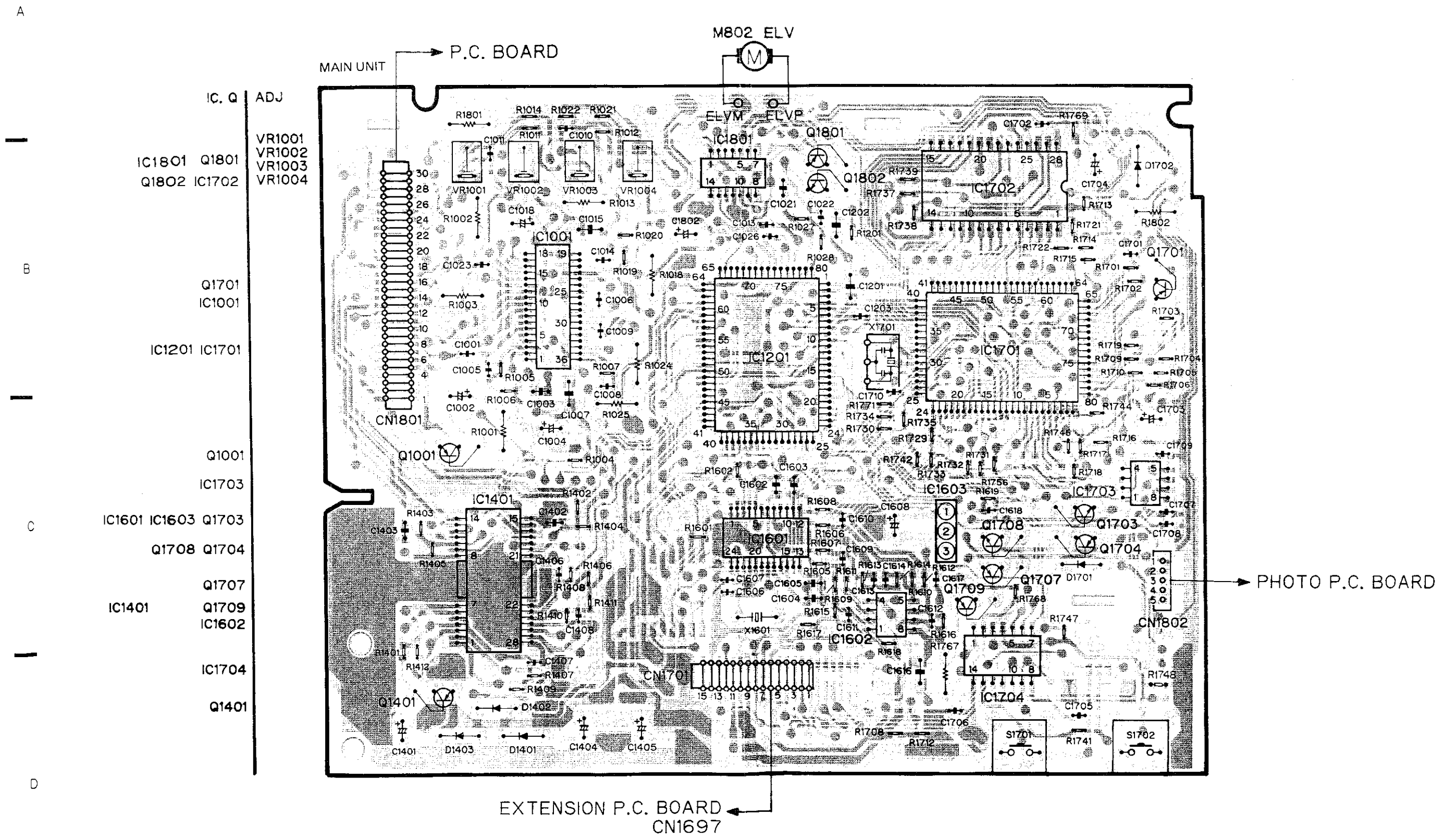
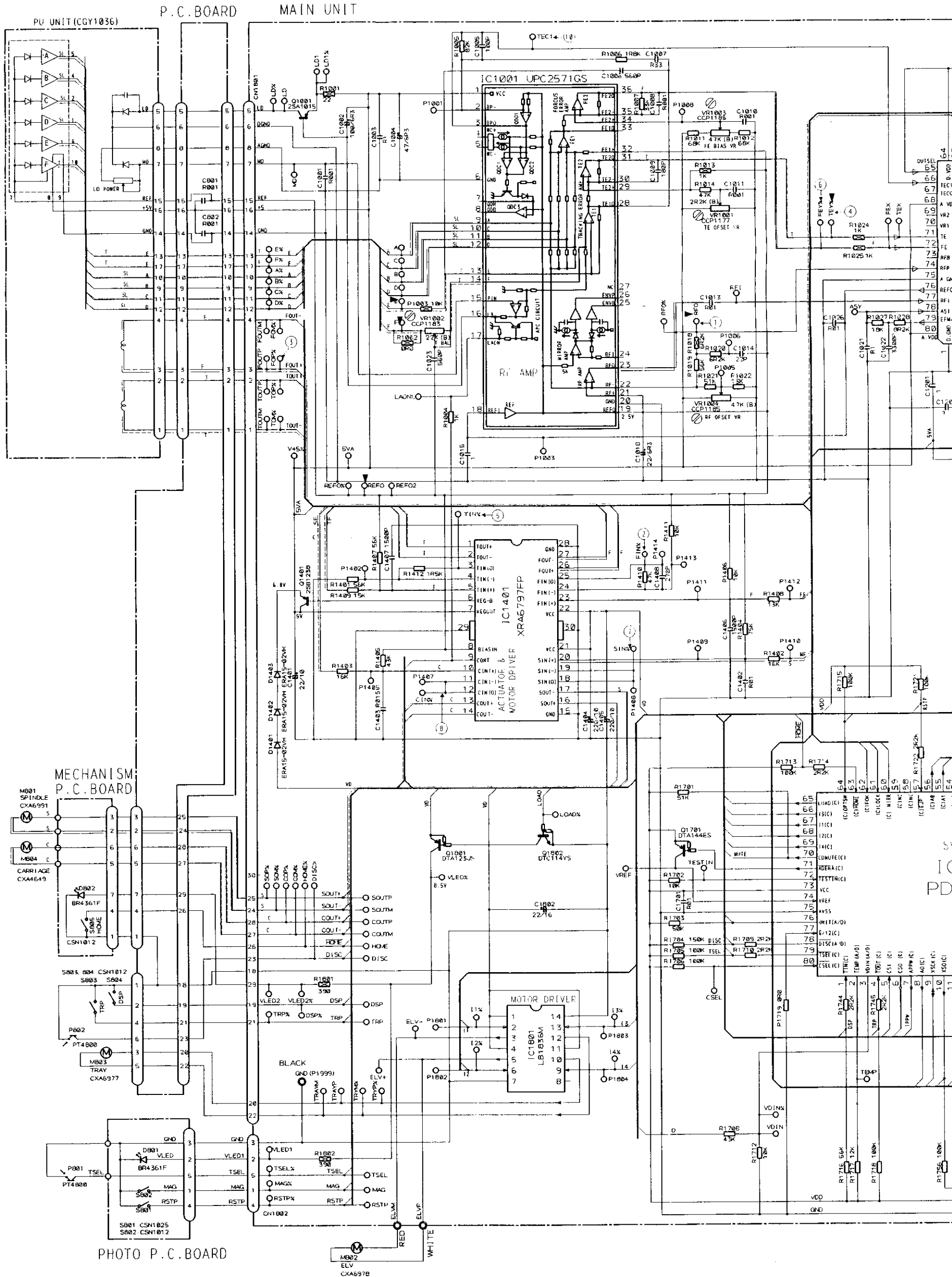
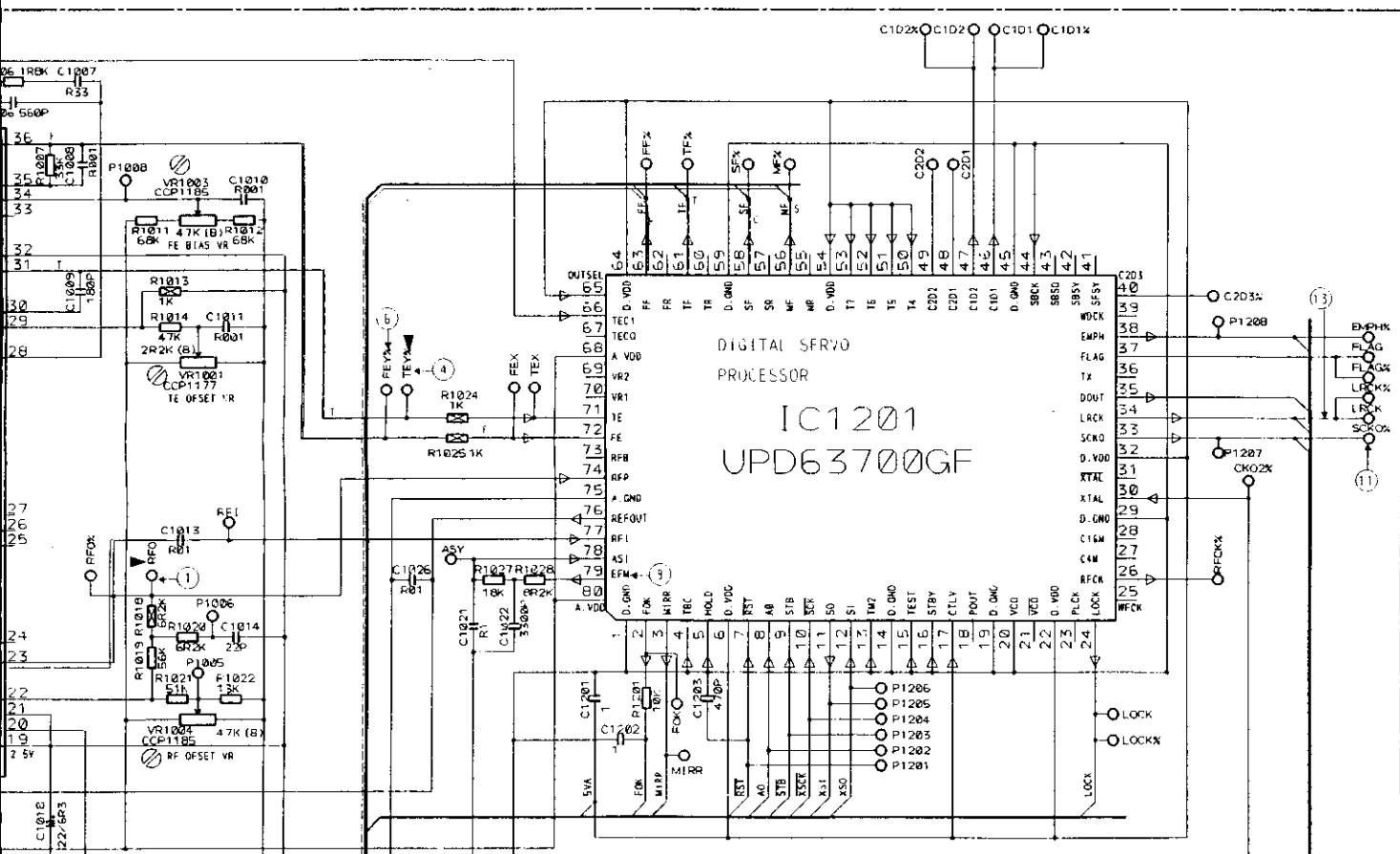

Fig.5

# MAIN UNIT (Serial No. ~11000)

- SL — SIGNAL LINE
- F — FOCUS SERVO LINE
- T — TRACKING SERVO LINE
- C — CARRIAGE SERVO LINE
- S — SPINDLE SERVO LINE





NOTE:  
 □ Symbol indicates a resistor.  
 No differentiation is made between chip discrete resistors.  
 ▭ Symbol indicates a capacitor.  
 No differentiation is made between chip discrete capacitors.

Decimal points for resistor and capacitor fixed values are expressed as:  
 0.2-2R2  
 0.022-R022

SWITCHES  
 MECHANIS  
 S805-HOM  
 PHOTO P.  
 S801-RST  
 S802-MAG  
 MISCELLA  
 S803-TRP  
 S804-DSP  
 The underlined

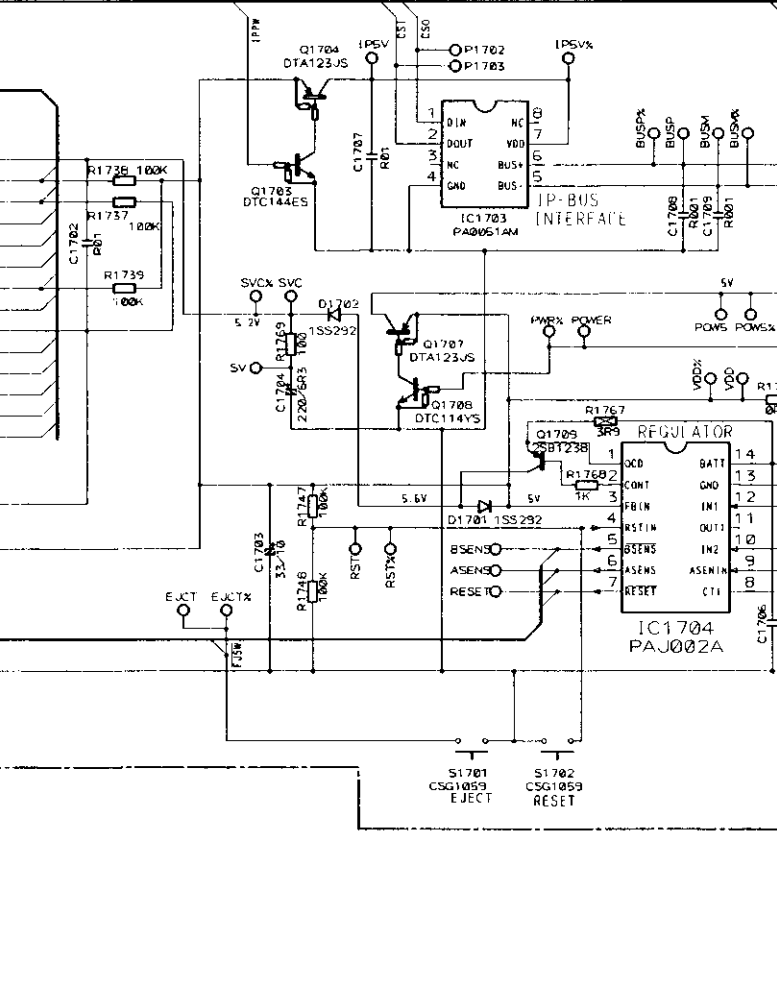
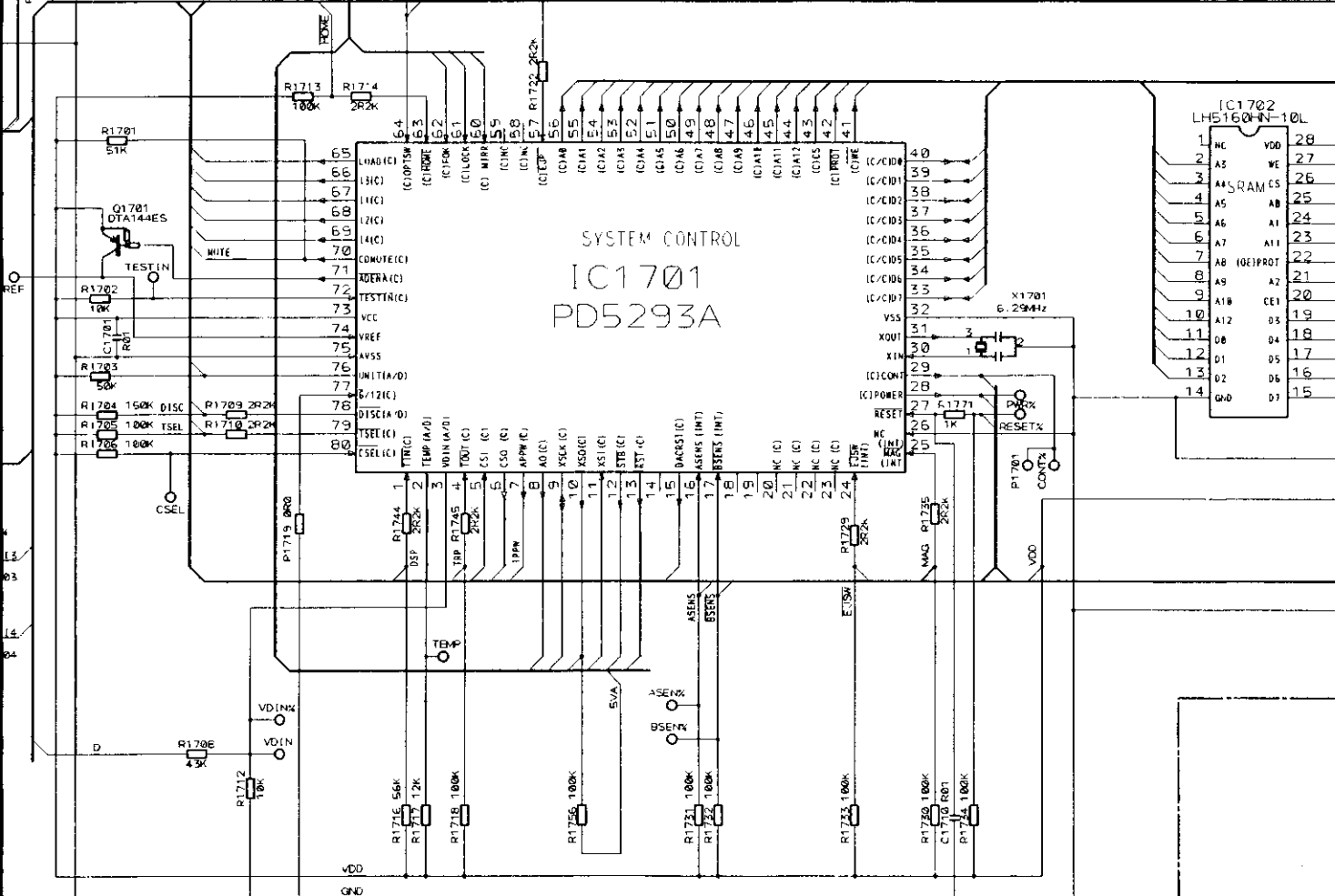
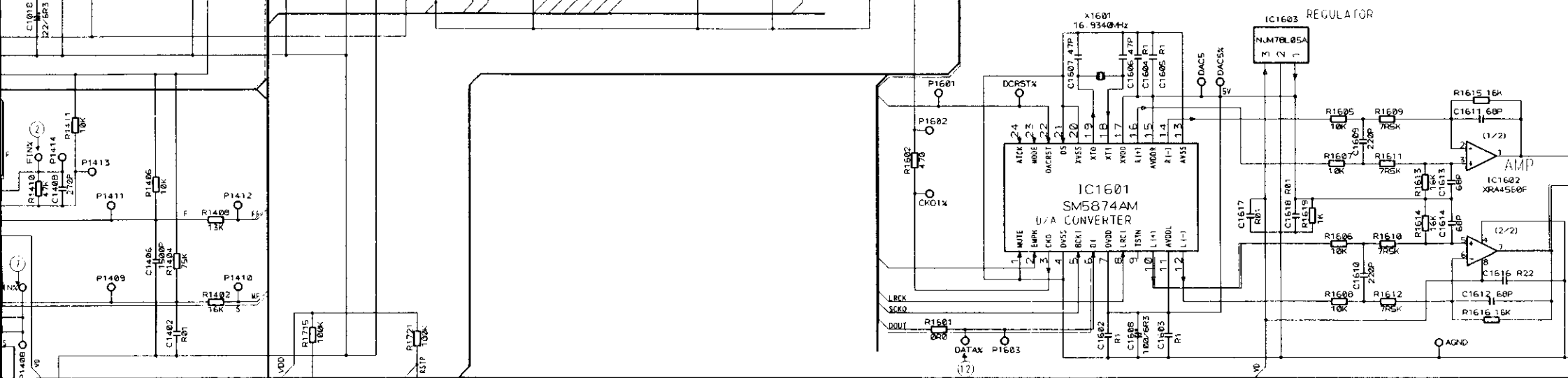



A

B

C

D

E

F

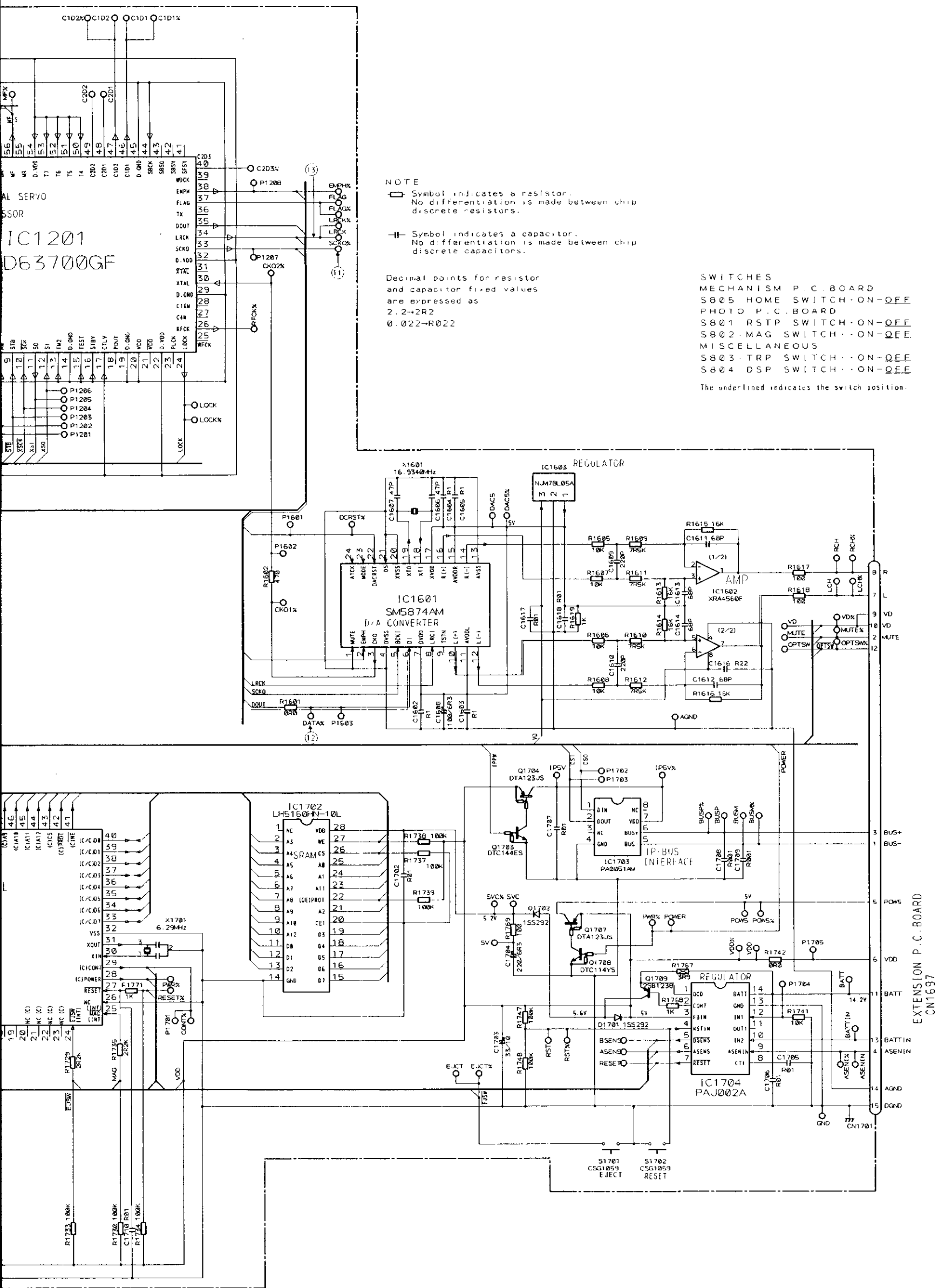

Fig.6

## SAFETY INFORMATION

### 1. Safety Precautions for those who Service this Unit.

- Follow the adjustment steps in the service manual when servicing this unit. When checking or adjusting the emitting power of the laser diode exercise caution in order to get safe, reliable results.

#### Caution:

1. During repair or tests, minimum distance of 13cm from the focus lens must be kept.
  2. During repair or tests, do not view laser beam for 10 seconds or longer.
2. A "CLASS 1 LASER PRODUCT" label is affixed to the rear of the player.
3. The triangular label is attached to the mechanism unit frame.

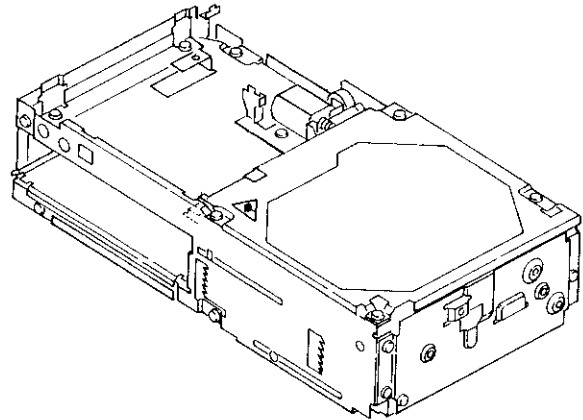

### 4. Specifications of Laser Diode

Specifications of laser radiation fields to which human access is possible during service.

Wavelength = 785 nanometers

Radiant power = 69.7 microwatts(Through a circular aperture stop having a diameter of 80 millimeters)  
0.55 microwatts(Through a circular aperture stop having a diameter of 7 millimeters)



# Service Manual

-CDX-P610



ORDER NO.  
**CRT1632**

The chapter 1 of this Service Manual will not be reprinted. On your additional orders, we may supply only the chapter 2. For the chapter 1, please make copies and attach to the chapter 2 at your side if necessary.

## MULTI-COMPACT DISC PLAYER

# CDX-P616 UC

# CDX-P610 UC,EW,ES

# CDX-P610 X1B/EW

- See the separate manual CX-624 (CRT1631) for the CD mechanism description and disassembly.
- The CD mechanism employed in this model is one of CX-624 series.

### SPECIFICATIONS

#### General

System ..... Compact disc audio system  
 Usable discs ..... Compact Disc  
 Signal format ..... Sampling frequency: 44.1 kHz  
   Number of quantization bits: 16; linear  
 Power source ..... 14.4 V DC  
   (10.8 - 15.6 V allowable)  
 Max. current consumption ..... 1.0 A  
 Weight ..... 2.4 kg (5.3 lbs.)  
 Dimensions ..... 275 (W) × 69 (H) × 155 (D) mm  
   [10-7/8 (W) × 2-3/4 (H) × 6-1/8 (D) in.]

#### Audio

Frequency characteristics ..... 5 - 20,000 Hz ( 1 dB)  
 Signal-to-noise ratio ..... 92 dB (1 kHz) (IHF-A Network)  
 Distortion ..... 0.006 %  
 Dynamic range ..... 90 dB (1 kHz)  
 Output level ..... 1,000 mV (1 kHz, 0 dB)  
 Number of channels ..... 2 (stereo)

These specifications were determined and are presented in accordance with specification standards established by the Ad Hoc Committee of Car Stereo Manufacturers.

#### Note:

Specifications and design are subject to possible modification without prior notice due to improvements.

### CONTENTS

#### CHAPTER 1

- 1. SAFETY INFORMATION.....1-2
- 2. OPERATIONS AND CONNECTION .....1-3
- 3. DISASSEMBLY .....1-4
- 4. ADJUSTMENT .....1-5
- 5. CIRCUIT DESCRIPTION .....1-18
- 6. EXPLODED VIEW PARTS LIST .....1-39
- 7. ELECTRICAL PARTS LIST .....1-42

#### CHAPTER 2

- 1. EXPLODED VIEW .....2-3
- 2. PACKING METHOD .....2-8
- 3. CONNECTION DIAGRAM(1).....2-13
- 4. SCHEMATIC CIRCUIT DIAGRAM(1).....2-17
- 5. SCHEMATIC CIRCUIT DIAGRAM(2).....2-20
- 6. CONNECTION DIAGRAM(2).....2-23
- 7. BLOCK DIAGRAM .....2-25

#### PIONEER ELECTRONIC CORPORATION

4-1, Meguro 1-Chome, Meguro-ku, Tokyo 153, Japan

PIONEER ELECTRONICS SERVICE INC. P.O.Box 1760, Long Beach, California 90801 U.S.A.

PIONEER ELECTRONICS OF CANADA, INC. 300 Allstate Parkway Markham, Ontario L3R 0P2 Canada

PIONEER ELECTRONIC [EUROPE] N.V. Haven 1087 Keetberglaan 1, 9120 Melsele, Belgium

PIONEER ELECTRONICS AUSTRALIA PTY.LTD. 178-184 Boundary Road, Braeside, Victoria 3195, Australia TEL:(03)580-9911

© PIONEER ELECTRONIC CORPORATION 1994

K-FFS.OCT. 1994 Printed in Japan

# CHAPTER 1

## 1. SAFETY INFORMATION

### 1.1 CDX-P616/UC,P610/UC

#### **CAUTION**

This service manual is intended for qualified service technicians; it is not meant for the casual do-it-yourselfer. Qualified technicians have the necessary test equipment and tools, and have been trained to properly and safely repair complex products such as those covered by this manual. Improperly performed repairs can adversely affect the safety and reliability of the product and may void the warranty. If you are not qualified to perform the repair of this product properly and safely; you should not risk trying to do so and refer the repair to a qualified service technician.

#### **WARNING**

Lead in solder used in this product is listed by the California Health and Welfare agency as a known reproductive toxicant which may cause birth defects or other reproductive harm (California Health & Safety Code, Section 25249.5). When servicing or handling circuit boards and other components which contain lead in solder, avoid unprotected skin contact with the solder. Also, when soldering do not inhale any smoke or fumes produced.

### 1.2 CDX-P610/EW,X1B/EW

#### 1. Safety Precautions for those who Service this Unit.

- Follow the adjustment steps (see pages 1-5 through 1-14) in the service manual when servicing this unit. When checking or adjusting the emitting power of the laser diode exercise caution in order to get safe, reliable results.

#### Caution:

1. During repair or tests, minimum distance of 13cm from the focus lens must be kept.
  2. During repair or tests, do not view laser beam for 10 seconds or longer.
2. A "CLASS 1 LASER PRODUCT" label is affixed to the rear of the player.
3. The triangular label is attached to the mechanism unit frame.

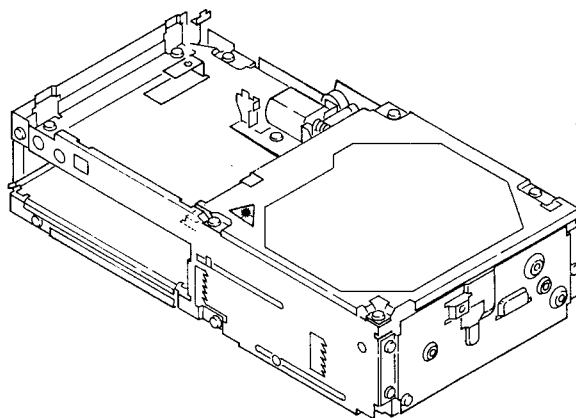

#### 4. Specifications of Laser Diode

Specifications of laser radiation fields to which human access is possible during service.

Wavelength = 785 nanometers

Radiant power = 69.7 microwatts(Through a circular aperture stop having a diameter of 80 millimeters)  
0.55 microwatts(Through a circular aperture stop having a diameter of 7 millimeters)

## 2. OPERATIONS AND CONNECTION

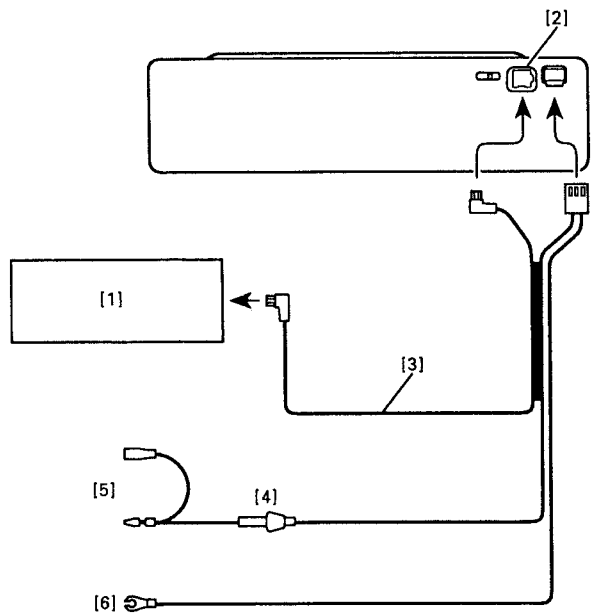

Fig.1

(Fig. 1)

[1] Multi CD controller or Multiple installation adapter (such as CD-P44)

[2] IP-BUS output (black)

Connect the black connector of the cable to this connector.

[3] IP-BUS cable

To prevent incorrect connection, the input side of the IP-BUS connector is colored in blue, and the output side in black. Connect the connectors of the same colors correctly.

[4] Fuse holder

[5] Orange

To the terminal always supplied with power regardless of ignition switch position.

[6] Black (ground)

To the vehicle (metal) body.

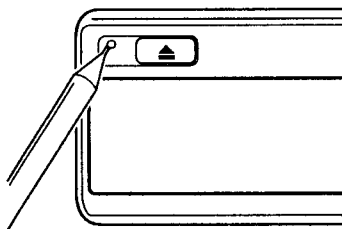

Fig.2

### Pressing the clear button

If the power does not switch on or if the compact disc player does not operate when the button on the multi-CD controller is pressed, or if the multi-CD controller display is incorrect, press this button on the player with the tip of a pencil to restore normal operation. (This button is located inside the door.) Always press the clear button on the multi-CD controller, too, after pressing this button (Fig. 2).

- If the clear button is pressed when the player contains a magazine or the ignition switch is set to the ON or ACC position, the CD title display and ITS memory are cleared.

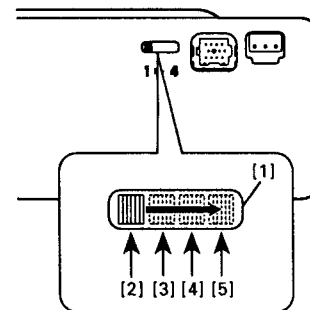

Fig.3

### Changing the Address Switch

- This unit can be connected from the second to fourth multi-CD players by using the separately sold multiple installation adapter (CD-P44). Each multi-CD player has an address switch so that the multiple installation adapter can identify which player is which. Set the address switch for each player as shown in Fig. 3.
- See the instruction manual for the multiple installation adapter (CD-P44) when you connect multi-CD players using the adapter.

(Fig. 3)

[1] Address switch

This switch can be set to address 1, 2, 3, or 4, starting from the left.

[2] Address 1

[3] Address 2

[4] Address 3

[5] Address 4

### 3. DISASSEMBLY

#### ● Removing the Case

1. Remove the five screws.
2. Remove the upper case and lower case.

#### ● Removing the Grille Assy

1. Press the four tabs indicated by arrows and then pull out the grille assy.

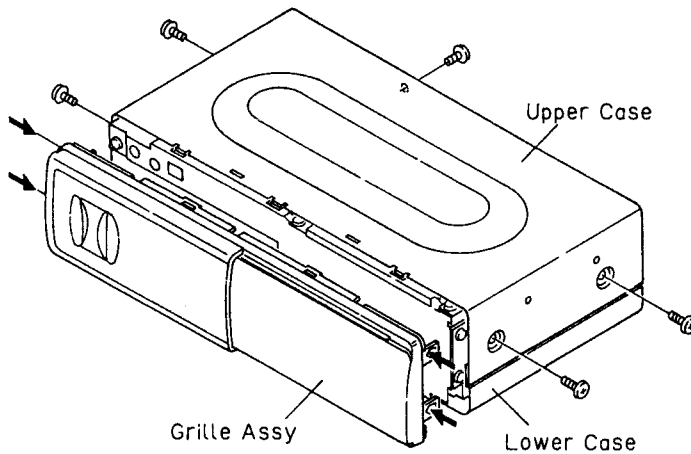

Fig.4

#### ● Removing the Extension P.C.Board

1. Remove the one screw.
2. Unbend the tab A until straight.
3. Remove the extension p.c.board.

#### ● Removing the Main Unit

1. Remove the one screw.
2. Unbend the tab B until straight.
3. Remove the main unit.

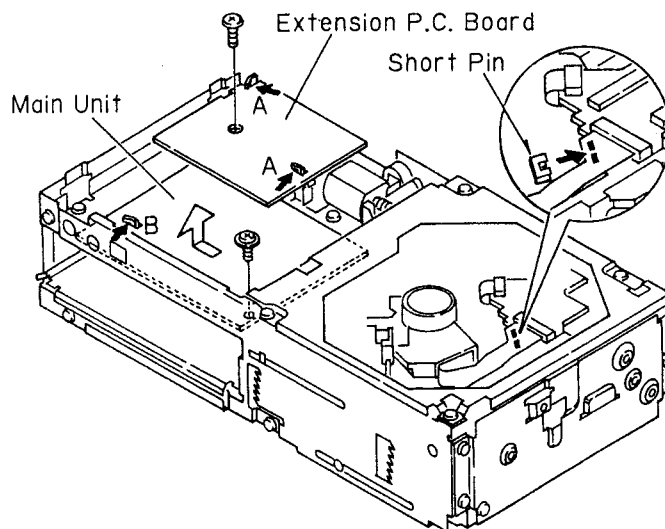

Fig.5

Before disconnecting the connector(PU unit connector), attach a short pin as illustrated.

## 4. ADJUSTMENT

### 4.1 CD ADJUSTMENT

#### 1)Precautions

- This unit uses a single power supply (+5V) for the regulator. The signal reference potential, therefore, is connected to REFO(approx. 2.5V) instead of GND. If REFO and GND are connected to each other by mistake during adjustments, not only will it be impossible to measure the potential correctly, but the servo will malfunction and a severe shock will be applied to the pick-up. To avoid this, take special note of the following.
  - Do not connect the negative probe of the measuring equipment to REFO and GND together. It is especially important not to connect the channel 1 negative probe of the oscilloscope to REFO with the channel 2 negative probe connected to GND.
  - Since the frame of the measuring instrument is usually at the same potential as the negative probe, change the frame of the measuring instrument to floating status.
  - If by accident REFO comes in contact with GND, immediately switch the regulator or power OFF.
- Always make sure the regulator is OFF when connecting and disconnecting the various filters and wiring required for measurements.
- Before proceeding to further adjustments and measurements after switching regulator ON, let the player run for about one minute to allow the circuits to stabilize.
- Since the protective systems in the unit's software are rendered inoperative in test mode, be very careful to avoid mechanical and /or electrical shocks to the system when making adjustment.
- This unit is adjusted in a combination with the CD control unit (KEH-P7000, etc.). Each regulator key should be operated at the unit.
  - With the KEH-P7000 taken up for reference, a description will be given below concerning how to enter into the test mode, including key operations. The key in the adjustment text is also one of the KEH-P7000 keys.
- How to enter into the test mode
  - Switch ACC, back-up ON while pressing the 4 and 6 keys together.
- Resetting the test mode
  - Switch ACC, back-up Off.
- Disc detection during loading and eject operations is performed by means of a photo transistor in this unit. Consequently, if the inside of the unit is exposed to a strong light source when the outer casing is removed for repairs or adjustment, the following malfunctions may occur.
  - \*During PLAY, even if the eject button is pressed, the disc will not be ejected and the unit will remain in the PLAY mode.
  - \*The unit will not load a disc.
    - When the unit malfunctions this way, either re-position the light source, move the unit or cover the photo transistor.
- When loading and unloading discs during adjustment procedures, always wait for the disc to be properly clamped or ejected before pressing another key. Otherwise, there is a risk of the actuator being destroyed.
- Turn power off when pressing the button **FF** or the button **REV** key for focus search in the test mode. (Or else lens may stick and the actuator may be damaged.)
- SINGLE/4TRK/10TRK/32TRK will continue to operate even after the key is released. Tracking is closed the moment C-MOVE is released.
- JUMP MODE resets to SINGLE as soon as power is switched off.

● Flow Chart

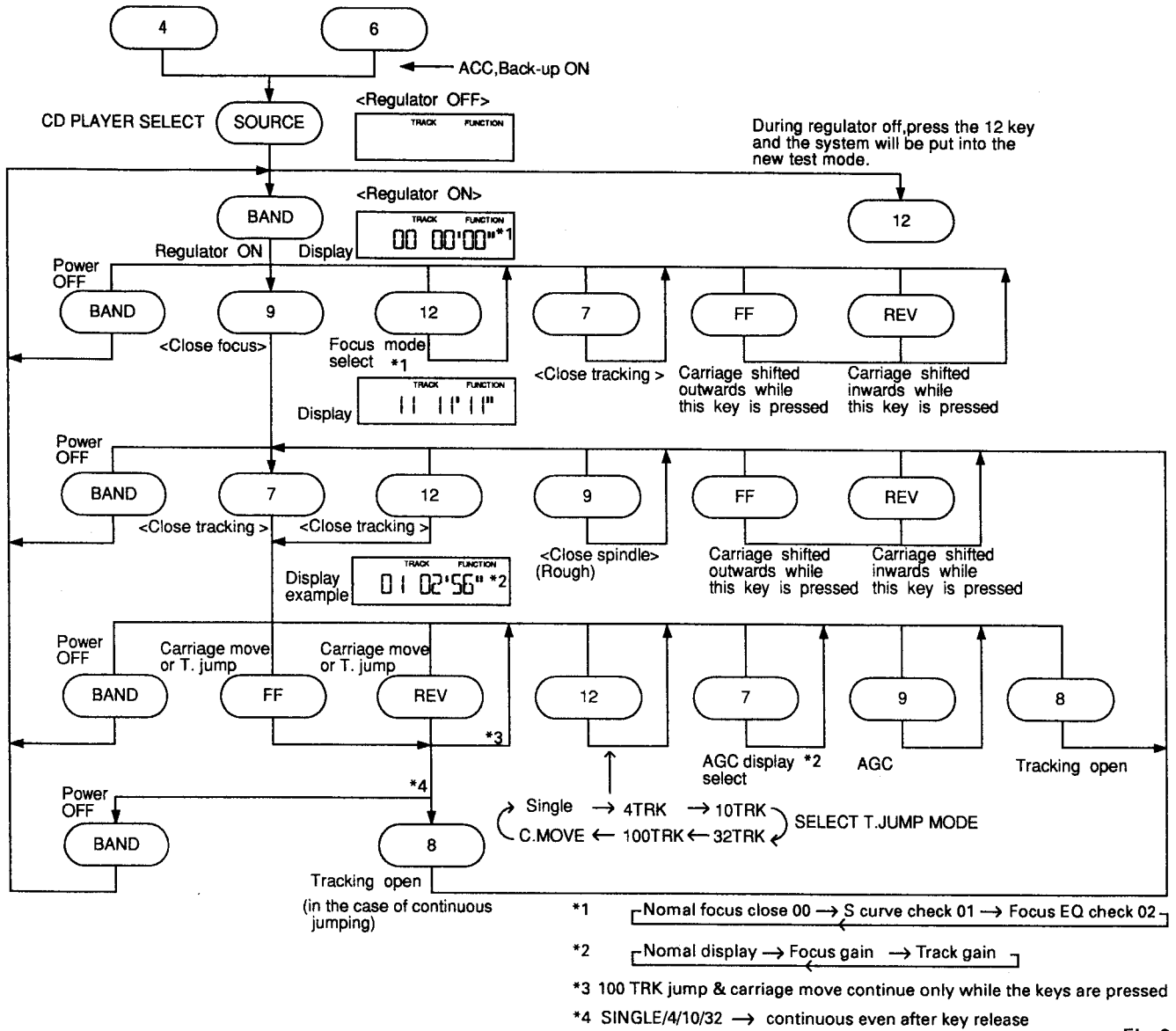

Fig.6

● Measuring Equipment and Jigs

Adjustment	Measuring equipment & jigs
1 Tracking Error Offset Adjustment 1	DC V Meter
2 Grating Check / Adjustment 1	Oscilloscope, ABEX TCD-784 (or SONY TYPE 4), Two L.P.F., Clock Driver
3 Grating Adjustment 2	Oscilloscope, Grating Adjustment Filter (B.P.F.), mV Meter, ABEX TCD-784 (or SONY TYPE 4), Two L.P.F., Clock Driver
4 Tracking Balance Adjustment 1	Oscilloscope, Low-pass Filter, ABEX TCD-784 (or SONY TYPE 4)
5 Focus Bias Adjustment	Oscilloscope, ABEX TCD-784 (or SONY TYPE 4)
6 RFO Offset Adjustment	Oscilloscope, ABEX TCD-784 (or SONY TYPE 4)
7 Tracking Error Offset Adjustment 2	DC V Meter
8 Tracking Balance Adjustment 2	Oscilloscope, Low-pass Filter, ABEX TCD-784 (or SONY TYPE 4)



● Adjustment Point and Test Point

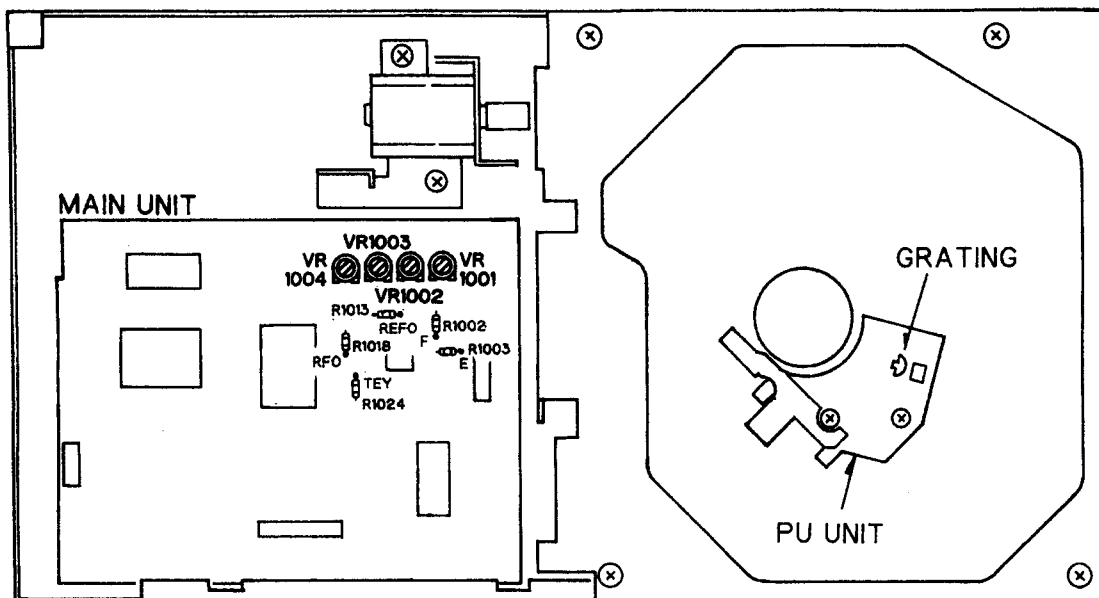

VR1001	TRACKING ERROR OFFSET
VR1002	TRACKING BALANCE
VR1003	FOCUS ERROR BIAS
VR1004	RFO OFFSET

Fig.7

### 1 Tracking Error Offset Adjustment 1

· **Purpose :**  
To adjust the offset of the tracking pre-amp to zero.

· **Symptoms of Mal-adjustment :**  
Track search NG, Carriage runaway, Poor playability.

· **Measuring Equipment / Jig** · DC V Meter

· **Measuring Point** · TEY

· **Test Disc , Mode** · No disc, TEST MODE

· **Adjustment Point** · VR1001(TE OFFSET VR)

MAIN UNIT

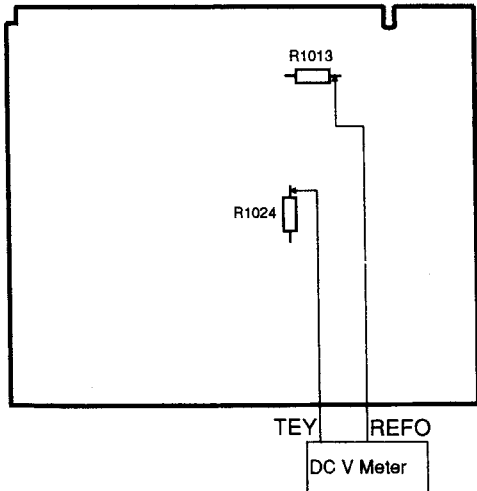

**Adjustment Procedure**

1. Switch the regulator on.
2. Using VR1001, adjust TEY to  $0 \pm 25\text{mV}$  w.r.t. REFO.

### 2 Grating Check / Adjustment 1

· **Purpose :**  
To check that the PU grating is correctly aligned after the PU unit has been replaced.

· **Symptoms of Mal-adjustment :**  
Unable to play disc, track skip during search, search NG.

· **Measuring Equipment / Jig** · Oscilloscope, Two L.P.F., Clock Driver

· **Measuring Point** · E, F

· **Test Disc , Mode** · ABEX TCD-784 (or SONY TYPE 4), TEST MODE

· **Adjustment Point** · Grating hole

MAIN UNIT

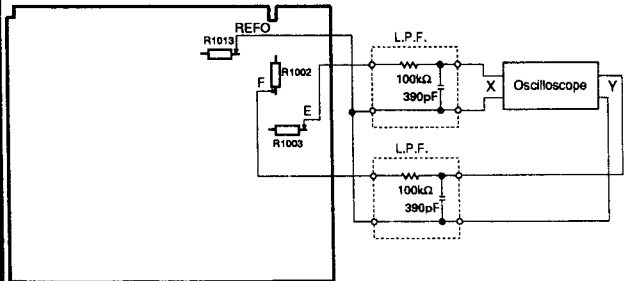

**Adjustment Procedure**

1. Load disc and switch regulator on.
2. Position the PU in the center of the disc using the **FF & REV** keys.
3. Press key **9** to close focus and once more to close spindle.
4. Referring to the photographs given check that the grating is within  $\pm 45^\circ$ . If not, it should be possible to make a fine adjustment to the grating by slowly tuning the grating screw. If, however during the adjustment the lissajous figure is seen to "FLIP" then the null point must be found and the adjustment made from there(see next section).

Lissajous figure (AC input)  
Horizontal axis E 10mV/div.  
Vertical axis F 10mV/div.



60°=NG

Waveform 1

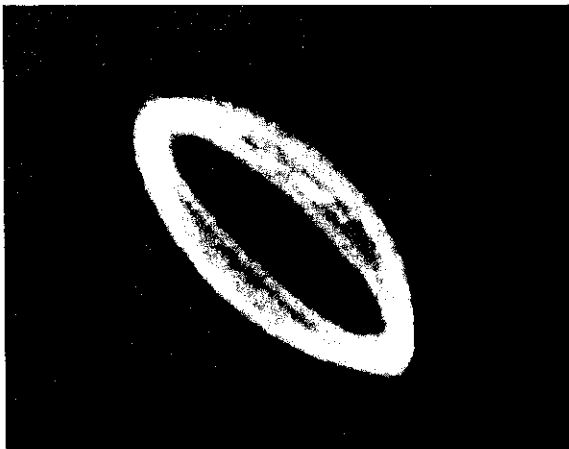

45°=OK  
(Limit)

Waveform 2

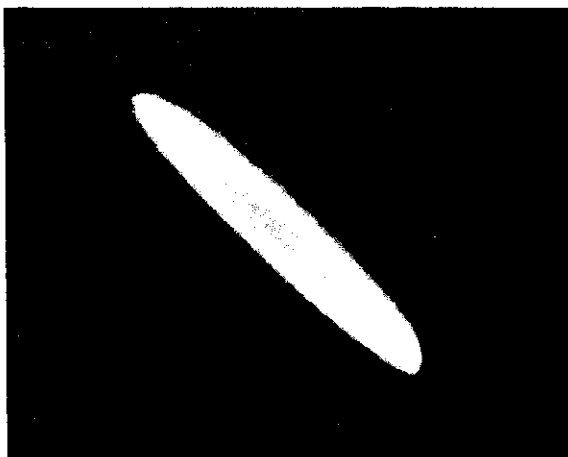

0°=BEST  
(Doesn't become  
a single line due  
to eccentricity)

Waveform 3

### 3 Grating Adjustment 2

<b>Purpose :</b> This needs to be done if the previous adjustment was unsuccessful.	
<b>Symptoms of Mal-adjustment :</b> Unable to play disc, track skipping, track search NG.	
<b>Measuring Equipment / Jig</b>	· Oscilloscope, Grating Adjustment filter (B.P.F.), mV Meter, Two L.P.F., Clock Driver
<b>Measuring Point</b>	· TEY, E, F
<b>Test Disc , Mode</b>	· ABEX TCD-784 (or SONY TYPE 4), TEST MODE
<b>Adjustment Point</b>	· Grating hole

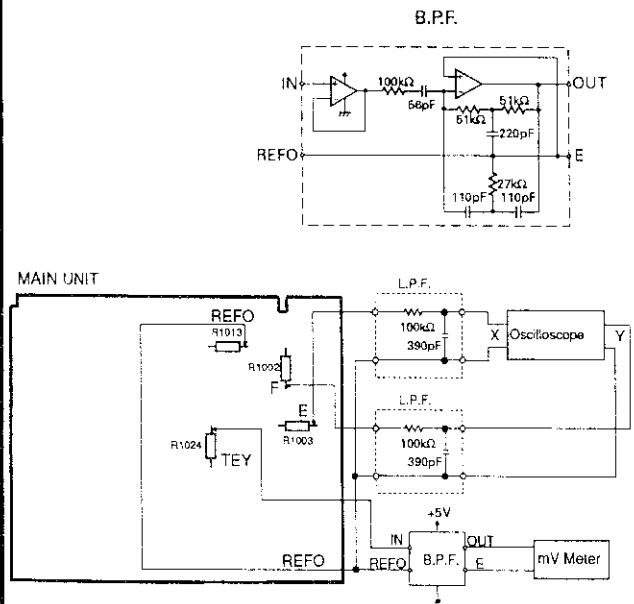

#### Adjustment Procedure

1. Load disc and switch regulator on.
2. Position the PU unit in the center of the disc using the **FF & REV** keys.
3. Press key **9** to close focus and press once more to close spindle.
4. While monitoring the output of the B.P.F. connected to TEY, slowly turn the grating screw. The output voltage should pass through many minimums; search for the minimum which is clearly smaller than the rest - this is the "null point", where the E & F sub-beams are lined up with the tracks on the disc.
5. From this null point, turn the grating screw clockwise (as seen from the underside of the PU unit) until the lissajous waveform is a single line (or close as possible) as shown in the photograph.

Lissajous figure (AC input)  
Horizontal axis E 10mV/div.  
Vertical axis F 10mV/div.  
Null Point=180°

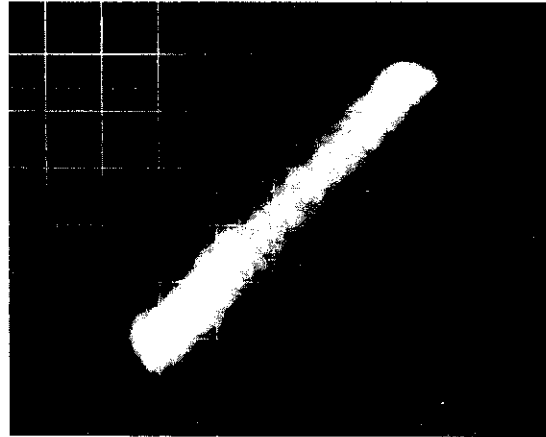

Waveform 4

"Rough" adjustment=90°

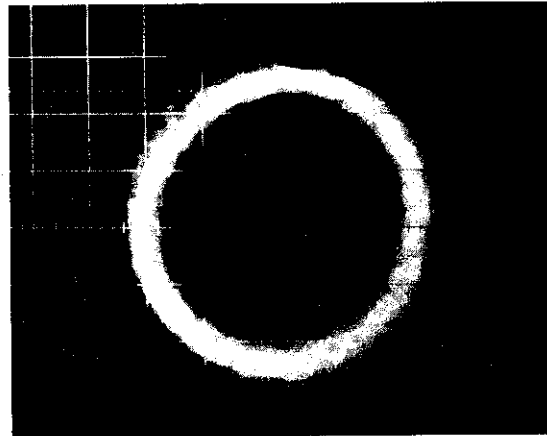

Waveform 5

Final adjustment=0°

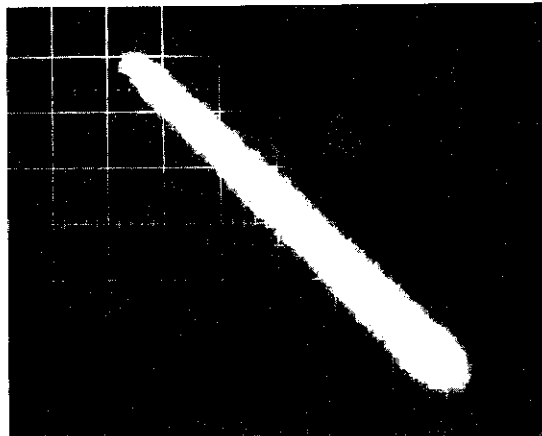

Waveform 6

### 4 Tracking Balance Adjustment 1

<b>Purpose :</b> To equate the sensitivity of the F channel to that of the E channel.	
<b>Symptoms of Mal-adjustment :</b> Track search NG, Poor playability carriage runaway.	
<b>Measuring Equipment / Jig</b>	· Oscilloscope, L.P.F.
<b>Measuring Point</b>	· TEY
<b>Test Disc , Mode</b>	· ABEX TCD-784 (or SONY TYPE 4), TEST MODE
<b>Adjustment Point</b>	· VR1002 (T.BAL VR)

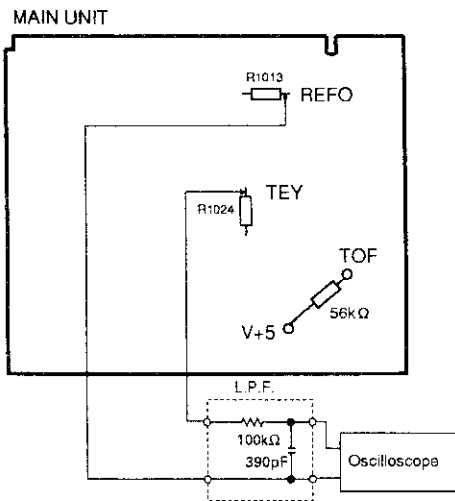

Pull up the TOF terminal to the V+5 terminal with a 56kΩ resistor. (This is in order to cancel lens offset in the tracking direction.) (Sub-number of the main unit's p.c.board is -C and after.)  
NOTE: If the sub-number of the main unit's p.c.board is -B, it means there is no TOF terminal, so instead of attaching a pull-up resistor, adjust the item by tilting 45° in the direction where the grille is lifted.

#### Adjustment Procedure

1. Load disc and switch the regulator on.
2. Position the PU unit in the center of the disc using the **FF & REV** keys.
3. Close focus by pressing key **9**.
4. Observing the TEY waveform on the oscilloscope, adjust VR1002 until the positive and negative halves have the same amplitude (see waveform 7-9).

#### Check

After adjustment the TEY waveform should have an amplitude of  $1.5 \pm 0.65$  Vpp (ABEX TCD-784 or SONY TYPE 4) (Providing focus bias is OK)

DC Mode  
0.5V/div.  
5ms/div.

+5% NG

REFO →

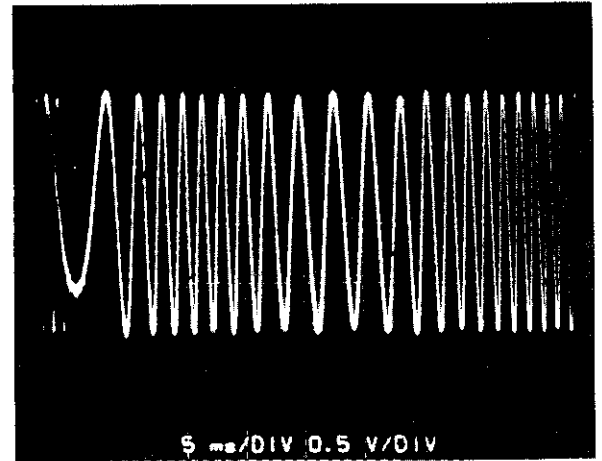

Waveform 7

±0% OK

REFO →

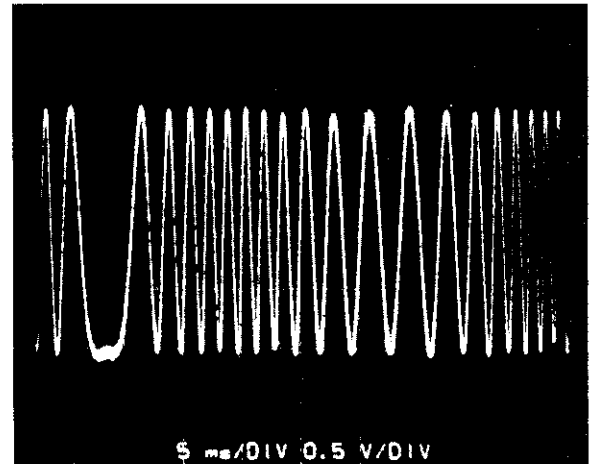

Waveform 8

-5% NG

REFO →

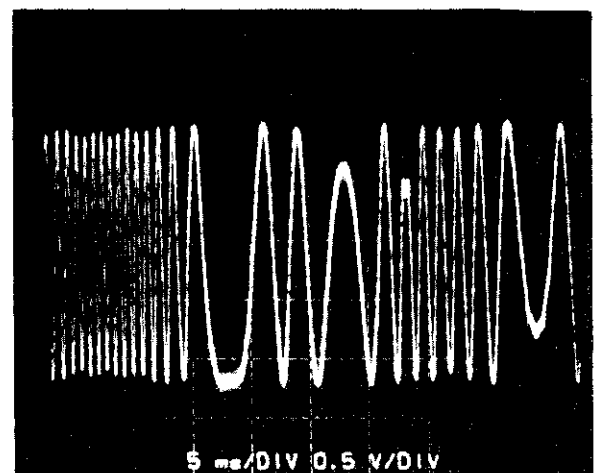

Waveform 9

### 5 Focus Bias Adjustment

**Purpose :**  
To adjust the focus servo reference so that the RF waveform is an optimum.

**Symptoms of Mal-adjustment :**  
Difficulty in closing focus, poor playability.

**Measuring Equipment / Jig** · Oscilloscope

**Measuring Point** · RFO

**Test Disc , Mode** · ABEX TCD-784 (or SONY TYPE 4),  
NORMAL MODE

**Adjustment Point** · VR1003 (FE BIAS VR)

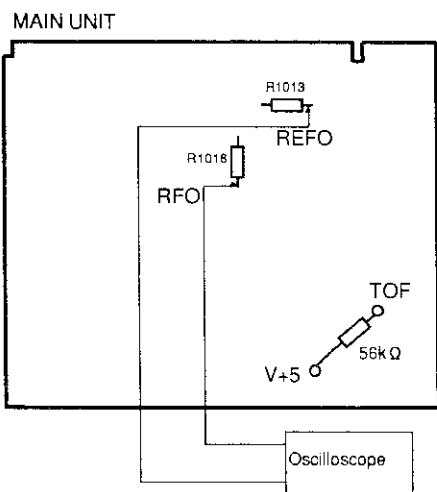

Pull up the TOF terminal to the V+5 terminal with a 56kΩ resistor.  
(This is in order to cancel lens offset in the tracking direction.)  
(Sub-number of the main unit's p.c.board is -C and after.)  
NOTE: If the sub-number of the main unit's p.c.board is -B, it means there is no TOF terminal, so instead of attaching a pull-up resistor, adjust the item by tilting 45° in the direction where the grille is lifted.

**Adjustment Procedure**

1. Play track number 18.
2. Adjust VR1003 so that the RFO waveform amplitude is a maximum and eye pattern is optimum.

**Check**

- After adjustment the RFO waveform should have an amplitude of  $1.7 \pm 0.65$  Vpp (ABEX TCD-784 or SONY TYPE 4)
3. Remove the pull-up resistor after completing adjustment.

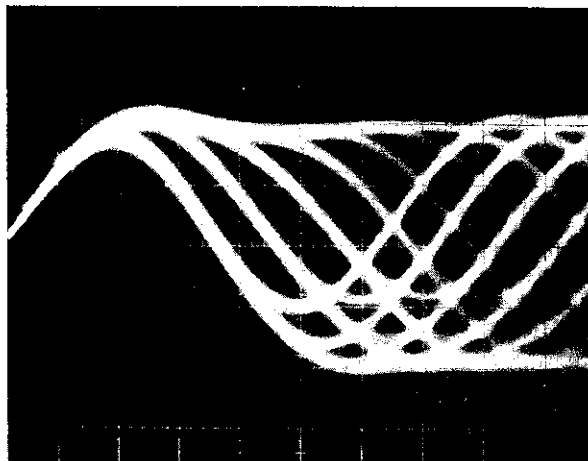

OK



Waveform 10

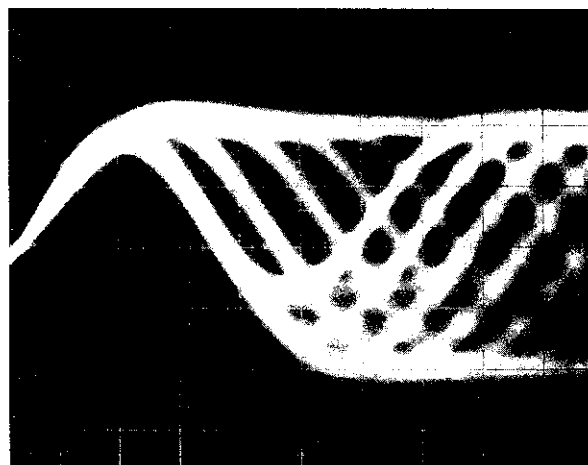

NG

AC Mode Before adjustment Waveform 11

### 6 RFO Offset Adjustment

<p>· <b>Purpose</b> To adjust the RFO waveform offset to an optimum.</p> <p>· <b>Symptoms of Mal-adjustment</b> Difficulty in closing focus, poor playability.</p>	
<p>· <b>Measuring Equipment / Jig</b></p> <p>· <b>Measuring Point</b></p> <p>· <b>Test Disc , Mode</b></p> <p>· <b>Adjustment Point</b></p>	<p>· Oscilloscope</p> <p>· RFO</p> <p>· ABEX TCD-784 (or SONY TYPE 4), NORMAL MODE</p> <p>· VR1004 (RFO OFFSET VR)</p>

MAIN UNIT

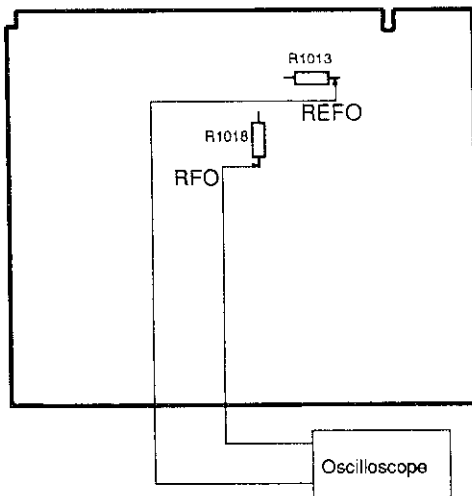

#### Adjustment Procedure

1. Make sure the TOF terminal's pull-up resistor has been disconnected.
2. Play track number 18.
3. Adjust VR1004 so that the peak value of the upper envelope of the RFO waveform is at +1.1VDC w.r.t. REFO(See waveform 12-14).

DC Mode  
0.2V/div.  
0.5µs/div.

+100mV NG

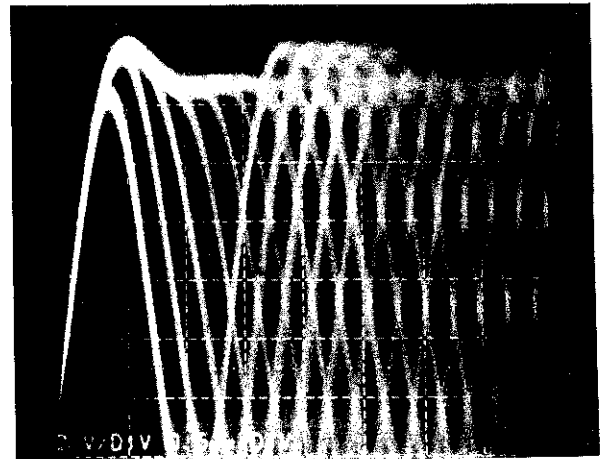

Waveform 12

REFO →

OK

1.1V

REFO →

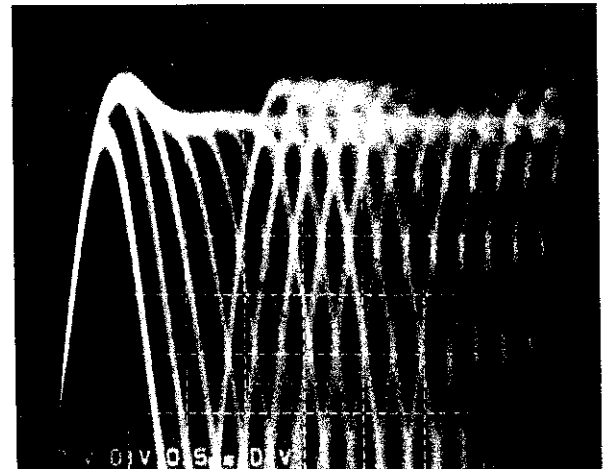

Waveform 13

-100mV NG

REFO →

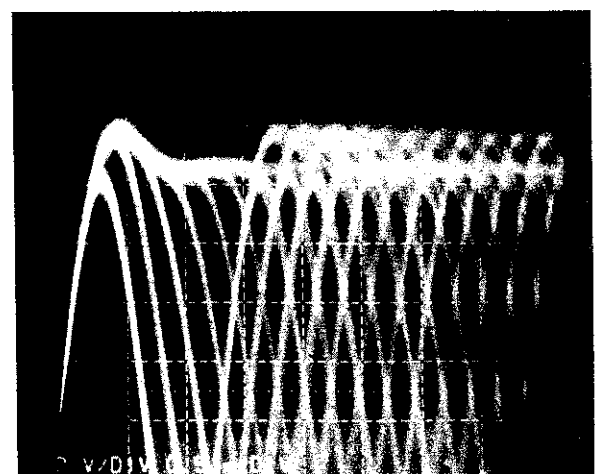

Waveform 14

### 7 Tracking Error Offset Adjustment 2

<p><b>·Purpose :</b> To check the offset of the tracking pre-amp is zero and adjust if necessary.</p> <p><b>·Symptoms of Mal-adjustment :</b> Track search NG, Carriage runaway, Poor playability.</p>	
<p><b>·Measuring Equipment / Jig</b></p>	<p>·DC V Meter</p>
<p><b>·Measuring Point</b></p>	<p>·TEY</p>
<p><b>·Test Disc , Mode</b></p>	<p>·No disc, TEST MODE</p>
<p><b>·Adjustment Point</b></p>	<p>·VR1001(TE OFFSET VR)</p>

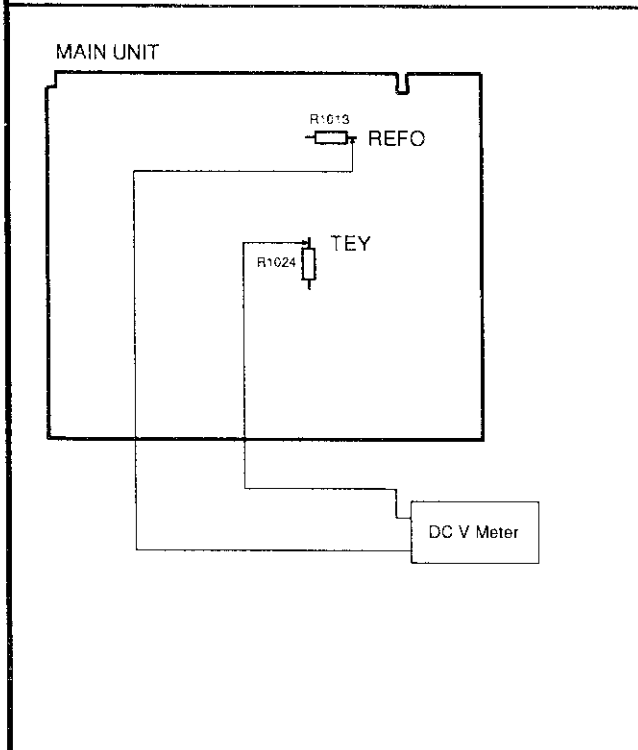

<p><b>Adjustment Procedure</b></p> <ol style="list-style-type: none"> <li>1. Switch the regulator on.</li> <li>2. Using VR1001, adjust TEY to <math>0 \pm 25\text{mV}</math> w.r.t. REFO.</li> </ol>	
--	--

### 8 Tracking Balance Adjustment 2

<p><b>·Purpose :</b> To equate the sensitivity of the F channel to that of the E channel. This needs only be done if the TE OFFSET volume was re-adjusted in the previous step.</p> <p><b>·Symptoms of Mal-adjustment:</b> Track search NG, Poor playability, carriage runaway.</p>	
<p><b>·Measuring Equipment / Jig</b></p>	<p>·Oscilloscope, L.P.F.</p>
<p><b>·Measuring Point</b></p>	<p>·TEY</p>
<p><b>·Test Disc , Mode</b></p>	<p>·ABEX TCD-784 (or SONY TYPE 4), TEST MODE</p>
<p><b>·Adjustment Point</b></p>	<p>·VR1002 (T.BAL VR)</p>

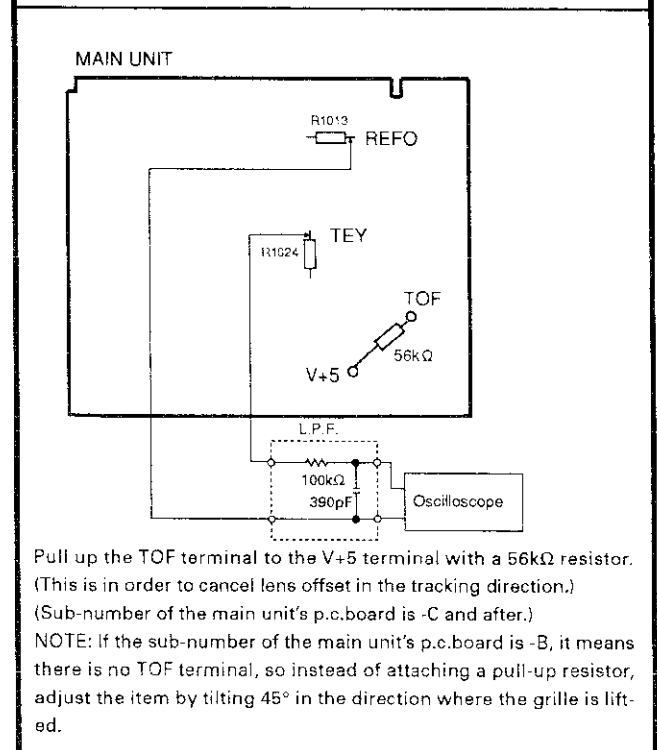

<p>Pull up the TOF terminal to the V+5 terminal with a 56kΩ resistor. (This is in order to cancel lens offset in the tracking direction.) (Sub-number of the main unit's p.c.board is -C and after.)</p> <p>NOTE: If the sub-number of the main unit's p.c.board is -B, it means there is no TOF terminal, so instead of attaching a pull-up resistor, adjust the item by tilting 45° in the direction where the grille is lifted.</p>	
<p><b>Adjustment Procedure</b></p> <ol style="list-style-type: none"> <li>1. Load disc and switch the regulator on.</li> <li>2. Position the PU unit in the center of the disc using the FF &amp; REV keys.</li> <li>3. Close focus by pressing key 9.</li> <li>4. Observing the TEY waveform on the oscilloscope, adjust VR1002 until the positive and negative halves have the same amplitude (See waveform 7-9).</li> </ol>	
<p><b>Check</b></p> <p>After adjustment the TEY waveform should have an amplitude of <math>1.5 \pm 0.65 \text{ Vpp}</math> (ABEX TCD-784 or SONY TYPE 4)</p> <ol style="list-style-type: none"> <li>5. Remove the pull-up resistor after completing adjustment.</li> </ol>	



## 4.2 NEW TEST MODE

### ● New Test Mode(aging operation and setup analysis)

The single CD player plays in normal mode. After being set up, it will display FOK (focus), LOCK (spindle), subcode, sound skip, protection against a mechanical error or the like, occurrence of an error, cause and time of an expiry, if any, (and disc number)

During the setup, the CD software operation status (internal RAM and C-point)is displayed.

#### (1) How to enter NEW TEST Mode

See the test mode flow chart Page 1-6.

#### (2) Relations of keys between TEST and NEW TEST Modes

Keys	Test Mode		New Test Mode	
	Regulator OFF	Regulator ON	PLAY in progress	Error Occurred, Protection Activated
BAND	Regulator ON	Regulator OFF	—	Time of occurrence/ cause of error select
FF	—	FWD-Kick	FF/TR+	—
REV	—	REV-Kick	REV/TR-	—
7	—	Tracking close	SCAN	—
8	—	Tracking open	MODE	—
9	—	Focus close	—	—
12	To New Test Mode	Jump Mode Select	AUTO/MANU	TRACK No./ time of occurrence select

Operations,such as EJECT, CD ON/OFF, etc. are performed normally

#### (3) Error Cause (Error Number) Code

Error Code	Classification	Mode	Description	Cause/Detail	Scratch, Stain, Vibration, Servo defect, etc...
40	ELECTRIC	PLAY	FOK=L 100ms	Put out of focus	
41	ELECTRIC	PLAY	LOCK=L 100ms	Spindle unlock	
42	ELECTRIC	PLAY	Subcode unacceptable 500ms	Failed to read subcode	
43	ELECTRIC	PLAY	Sound skipped	Last address memory operated	

#### (4) Indicating an Operation Status During Setup

Status No.	Description	Protection operation
01	Carriage home mode started	None
02	Carriage moving inwards	10-second time out, Home switch failed
03	Carriage moving outwards	10-second time out, Home switch failed
05	Carriage moving outwards	None
11	Setup started	None
12	Spindle turn/Focus search started	None
13	Waiting for focus closure (XSI=L)	Failure to close focus
10,14	Waiting for focus closure (FOK=H)	Failure to close focus
15, 16, 17	Focus closed, Tracking open	Focus disrupted
18	During focus AGC	Focus disrupted
19	During tracking AGC	Disrupted focus
20	Waiting for MIRR, LOCK or subcode read Carriage closed, SPINDLE=ADAPTIVE	Focus disrupted, MIRR NG, Failure to lock, failed to read subcode

**(5) Example of Display.**

·SET UP in progress  
8 digits

TNo.	Min	Sec
11	11	11

4 digits(Auto)

TNo.
11

4 digits(Manual)

Min	Sec
11	11

·Operation (PLAY, SEARCH, etc.) in progress perfectly identical with that in the normal mode.

·Protection/Error upon occurrence(4 digits display)

(a) Error number indicated

E-xx
------

Select the display with the BAND key.

(b) Track number indicated

TNo.
10

(c) Absolute time indicated

Min	Sec
40	05

Select the display with the 12 key.

·Protection/Error upon occurrence(8 digits display)

(a) Error number indicated

ERROR-xx
----------

Select the display with the BAND key.

(b) Track number and  
absolute time indicated

TNo.	Min	Sec
10	40	05

### ● Error Number Indication

If the CD should fail to operate or if an error has taken place during operation the player will enter into the error mode, and the cause of the error will be numerically indicated.

This is aimed at assisting in analysis or repair.

#### (1) Basic Means of Display

·Examples of Display            E-XX

#### (2) Error Codes

Error Code	Classification	Description	Cause/Detail
10	ELECTRIC	Carriage home failure	Carriage doesn't move to or from the innermost position →Home switch failed and/or carriage immobile
11	ELECTRIC	Focus failure	Focus failed →Defects, disc upside-down, severe vibration
12	ELECTRIC	SETUP failure Subcode failure	Spindle failed to lock or subcode unreadable →Spindle defective, defect, severe vibration
14	ELECTRIC	Mirror failure	Unrecorded CD-R The disc is upside-down, defects, vibration
17	ELECTRIC	Set up failure	AGC protect failed →Defects, disc upside-down, severe vibration
30	ELECTRIC	Search time out	Failed to reach target address →Carriage/tracking defective and/or defects
A0	SYSTEM	Power failure	Power overvoltage or short circuit detected →Switching transistor defective and/or power abnormal
50	MECHANISM	An error upon ejection	MAG switch release time has time out Elevation time out when eject
60	MECHANISM	An error while putting in and out the tray	Tray in / out time has time out Tray is caught when put in
70	MECHANISM	An error upon elevation	Elevation time has time out
80	MECHANISM	An error with an empty magazine inserted	No disc is available

## 5. CIRCUIT DESCRIPTION

### 5.1 PRE-AMPLIFIER STAGE (UPC2571GS)

The optical signals are converted to voltage signals using an i/v amplifier inside the PU unit.

These voltage signals (A - F) are further processed by this pre-amp stage.

The pre-amplifier performs the following tasks

- Automatic power control of the PU unit's laser diode.
- Generation of an equalized RF signal from the photo-detector outputs (A - D).
- Generation of a focus error signal from the photo-detector outputs (A - D).
- Generation of a tracking error signal from the photo-detector outputs (E & F).
- Generation of a tracking zero crossing signal from the photo-detector outputs (E & F).

This IC runs from a single voltage supply (+5V). The reference voltage for this IC, the PU unit, and all the servo circuitry is REFO. This is obtained from pin 19 of the pre-amp ; which in turn is derived from the output REFOUT of the servo LSI, IC1201, UPD63700GF. The voltages REFOUT and REFO should be at +2.5V DC with respect to GND. All measurements and observations should be made using REFO as the reference as this is a buffered output. Care should be taken not to inadvertently short REFO to GND.

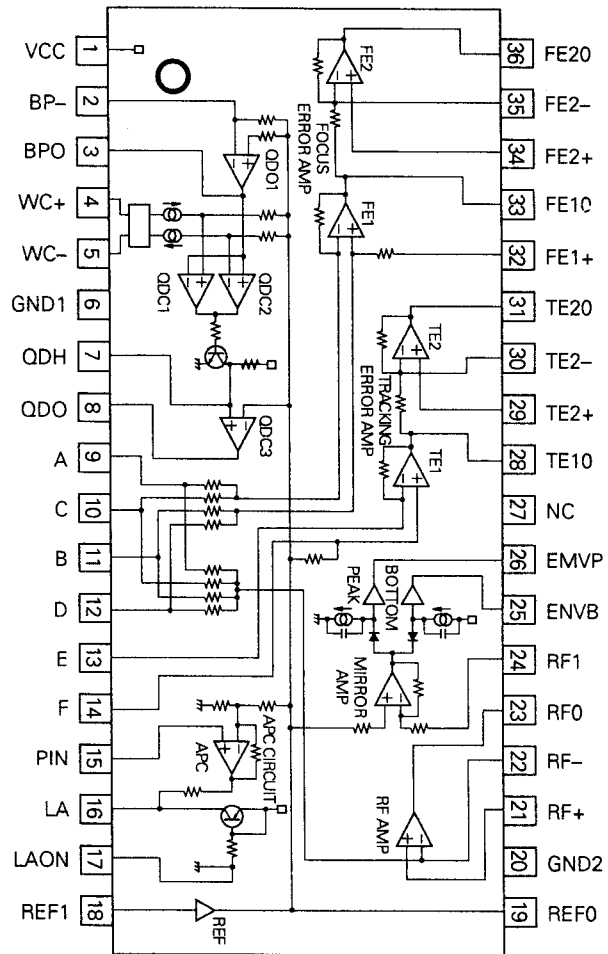

Fig.8 : UPC2571GS BLOCK DIAGRAM

#### 1) Automatic Power Control (APC)

The laser diode's junction voltage varies greatly with temperature ; causing large output variations in optical power. To avoid this, a monitor diode is used in a feedback circuit to keep the optical power constant. As two different manufacturer's laser diodes are used the LD current falls into two broad bands : approx. 40mA and approx. 60mA.

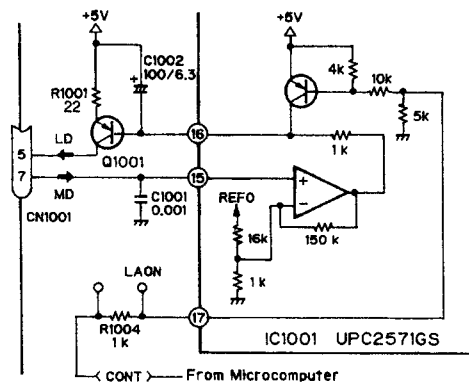

Fig.9 : APC CIRCUIT

### 2) RF Amplifier

This performs a simple summation of the photo-detector outputs A,B,C & D, amplifies, and equalizes to produce the RF signal at RFO. The RF eye pattern may be monitored here. The RFO OFFSET volume is used to ensure that the RFO waveform has the correct offset relative to the FOK threshold level inside the servo LSI UPD63700GF. The FOK signal is used in the focus close sequence, and during play to control the defect circuit inside the UPD63700GF.

The AC coupled RFO signal, RFI, is used by the UPD63700GF to generate the EFM signal which is used in turn by the DSP spindle CLV control sections.

For low frequency signals :

$$VRFO = (A+B+C+D) \times (R1018+R1019)/10k = (A+B+C+D) \times 6.22$$

The RFO waveform should have an amplitude of approx. 1.9Vpp, with it's upper envelope at +1.1V DC w.r.t. REFO.

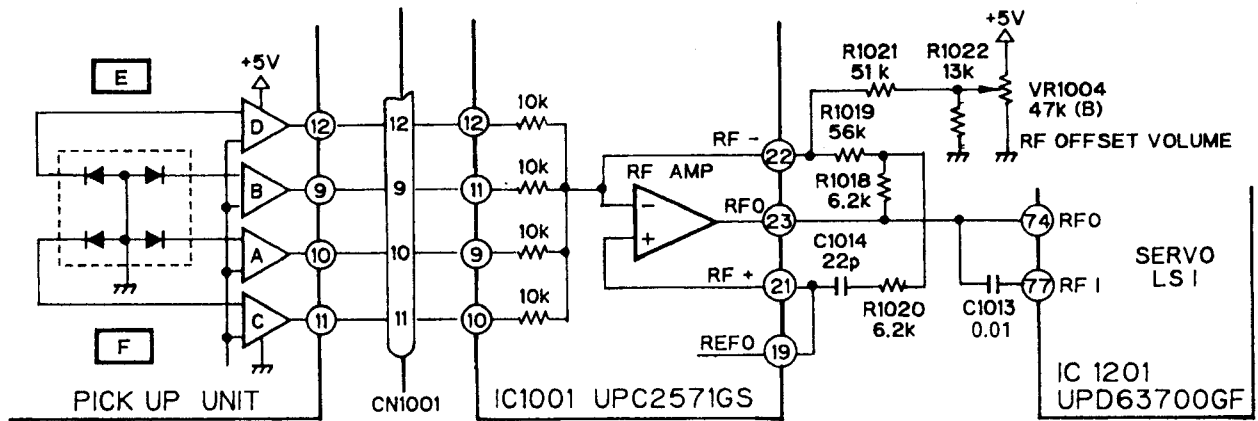

Fig.10 : RFO AMPLIFIER

### 3) Focus Error Amplifier

This produces a focus error signal used as the basis for the focus servo.

$$VFEY = ( (A+C)-(B+D) ) \times 5 \times (R1007//20k)/10k$$

$$= FE \times 6.23 \quad (FE = \text{PU unit focus error})$$

The S-Curve at FEY should have an amplitude of approx. 1.9Vpp.

The second amplifier stage is also a low pass filter,  $f_c=11\text{kHz}$ , and has a bias volume adjustment. This adjustment is used to vary the reference bias level of the focus servo loop and is adjusted to obtain an optimum eye pattern at RFO.

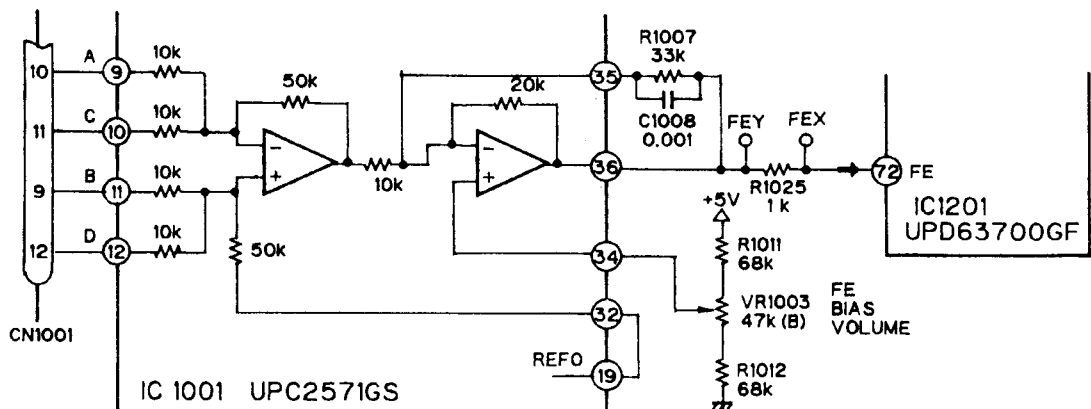

Fig.11 : FOCUS ERROR AMPLIFIER

**4) Tracking Error Amplifier**

This produces the tracking error signal used in the tracking servo loop.

$$V_{TEY} = (25 \times E) - (25 \times F \times 2 \times 10k / (T.BAL+10k))$$

Normally, the sensitivity of E & F are the same and T.BAL=10k

$$\Rightarrow V_{TEY} = 25 \times (E-F)$$

If, however, the E and F sensitivities are different the T.BAL volume can be used to cancel out the unbalance. The offset adjustment TE OFFSET is to cancel any DC offsets from the photo-detectors or op-amps to ensure the reference bias for the servo loop is at zero. Maladjustment of either of these pre-sets will result in poor tracking performance and susceptibility to skipping.

For a typical unit, the TEY level should be approx. 1.8 Vpp.

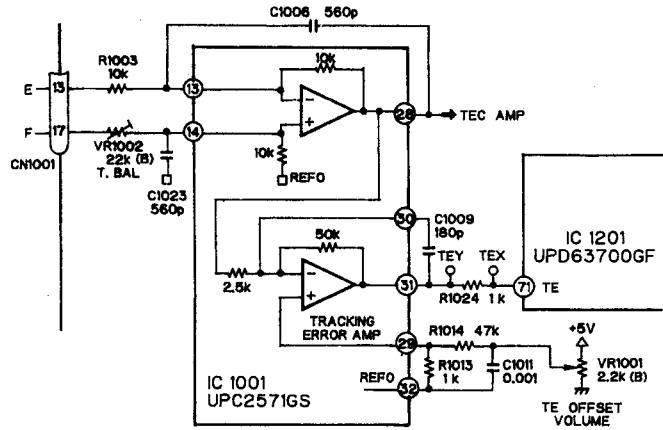

Fig.12 : TRACKING ERROR AMPLIFIER

**5) Tracking Zero Crossing Amplifier**

TEC1 is basically an amplified, AC coupled, version of the TEY waveform. It is used by the servo LSI IC1201, UPD63700GF to locate the zero crossing points of the TEY signal to :

- 1) Determine how many tracks have been crossed during track jumping or a carriage move operation.
- 2) Determine in which direction the lens is moving when attempting to close tracking. This is used in the "tracking brake" circuit described later.

For signals in the range 500Hz - 5kHz :

$$V_{TEC1} = R1005/R1006 \times (E-F) = 45.5 \times (E-F)$$

Typically TEC1 is around 4.2Vpp, this means that the TEC1 signal level may be greater than the saturation limit of the op-amp and the signal will clip. However, since the servo LSI only uses the zero-crossing points, this is not critical.

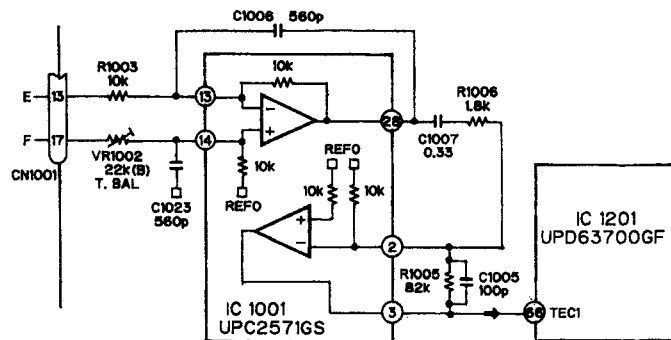

Fig.13 : TRACKING ZERO CROSSING AMPLIFIER

## 5.2 SERVO STAGE (UPD63700GF)

All the servo equalization & sequencing, such as focus closing, track jumping, carriage moving etc. are performed in this LSI, as well as all the DSP functions : data decoding, error protection, interpolation etc. The signals FE & TE are digitized and processed by the servo block to produce the focus, tracking & carriage drive signals, in a PWM format.

The RFI signal is converted to the EFM signal which is decoded by the DSP block to produce an audio signal ; during this process, a spindle servo error signal is also generated and used by the servo block to produce a spindle drive signal, again in PWM form.

The PWM waveforms are filtered, to remove the PWM carrier, amplified by the driver IC1401 XRA6797FP, and output to the corresponding actuators.

### 1) Focus Servo System

The main focus equalization takes place inside the UPD63700GF (figure 14). The equalizer response can be measured between FEX and FIN and has the shape shown in figure 15.

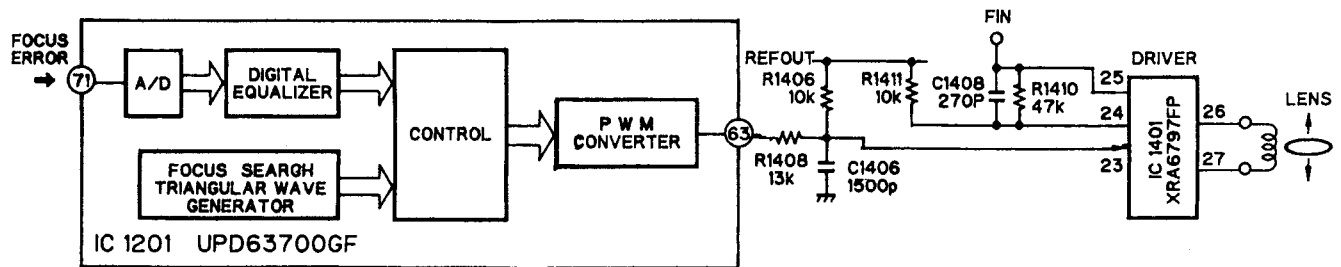

Fig.14 : FOCUS SERVO BLOCK DIAGRAM

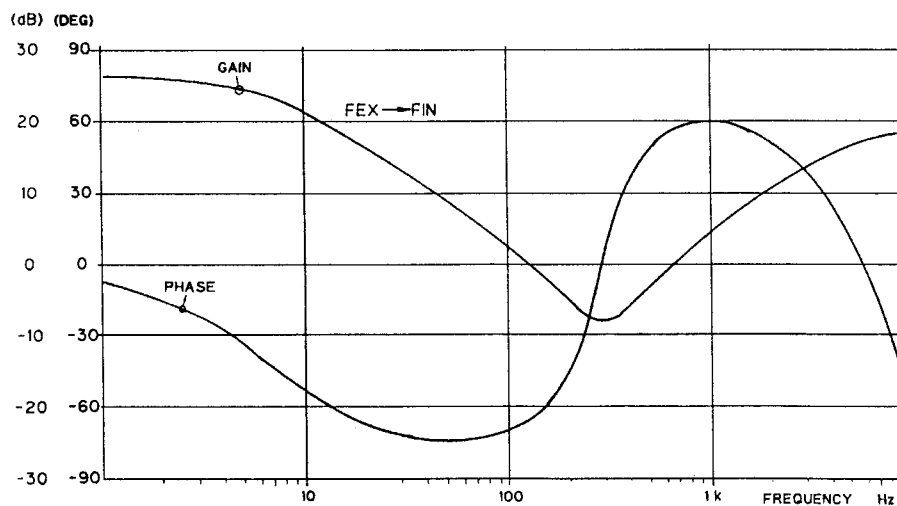

Fig.15 : FOCUS EQUALIZER

In order to smoothly close focus the lens must first be within approx. 5µm of the "just focused" position. This position is achieved by a focus search sequence. The lens is moved up and down using a triangular wave search voltage while the spindle motor is kicked and kept rotating at an appropriate speed. The servo LSI monitors the FE and RFO signals and, at an appropriate point, automatically closes focus.

The conditions for focus close are :

- 1) The lens is moving from a far to a near position relative to the disc,
- 2) FOK = HIGH (5V),
- 3) FZD (IC internal signal) was latched high and
- 4) FE = 0 (w.r.t. REFO).

When the focus servo closes, the servo LSI's serial data

output port, XSO, will show a high-low transition. This is received by the microcomputer as an indication that the servo loop was closed and after about 25mS it begins monitoring the FOK output, via a LPF, to verify that focus is still closed ; in the event of FOK becoming low for an appreciable time, the microcomputer will take appropriate action.

The various signal levels which contribute to focus close are shown in figure 16, which shows the case where focus close has been inhibited.

In TEST MODE, using FOCUS CLOSE MODE 1, conditions 2 & 3 can be inhibited to allow the S-Curve, focus search voltage and the actual lens movement to be observed at ease.

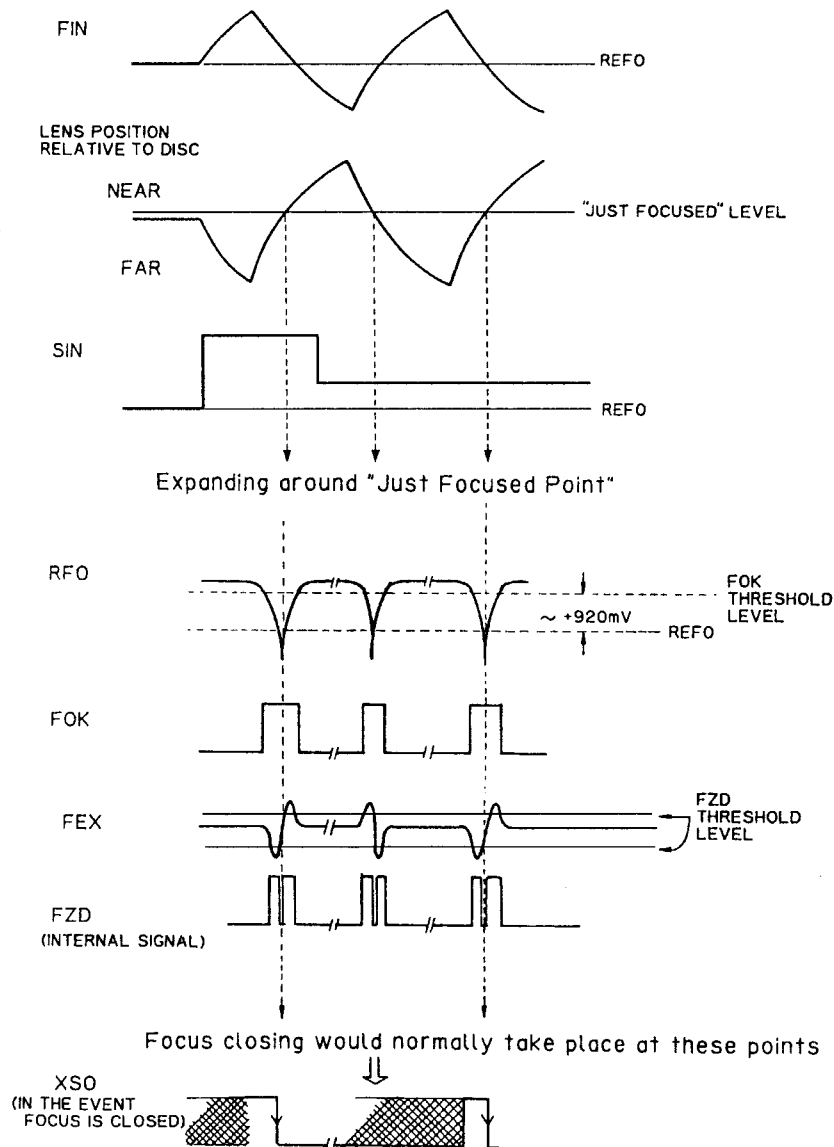

Fig.16 : FOCUS CLOSING SEQUENCE



a) FOK CIRCUIT

The FOK circuit inside the servo LSI compares the lower envelope of the RFO signal with a threshold level fixed by the microcomputer. Should the envelope level fall below this FOK level then FOK becomes high. This is used during focus close as stated and also during play to control a defect circuit, which switches the focus &

tracking servos into a hold mode should the RFO envelope become disrupted by dirt, grease etc, thus increasing the player's defect response (figure 17). The FOK threshold is approx. +920mV w.r.t. REFO. It is for this reason that the upper envelope should be adjusted to +1.1V DC w.r.t. REFO.

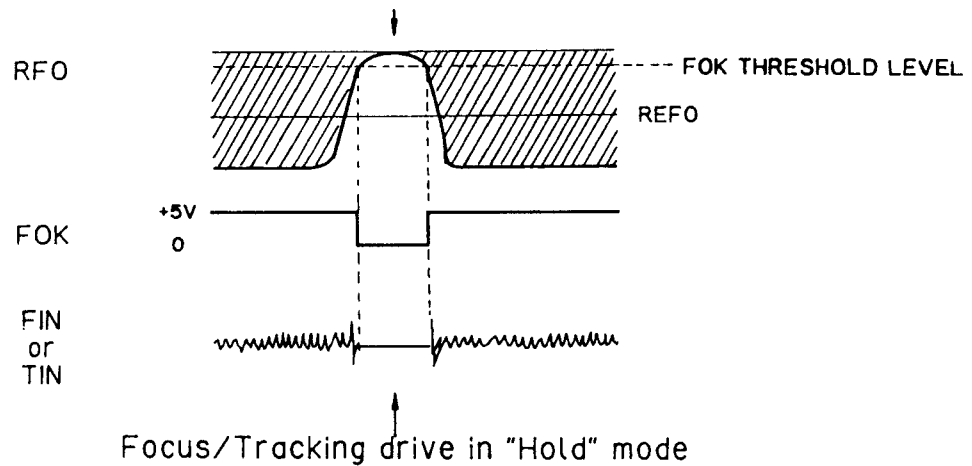

Fig.17 : DEFECT CIRCUIT

b) FZD CIRCUIT

The FZD circuit inside the servo IC compares the absolute value of the FE signal to a threshold value and outputs a high/low signal which is then used in the focus close sequence as stated.

At power on, the microcomputer switches the laser diode off and reads the value of the FE bias via the servo LSI's A/D port. The FZD threshold is set 200mV above this bias level.

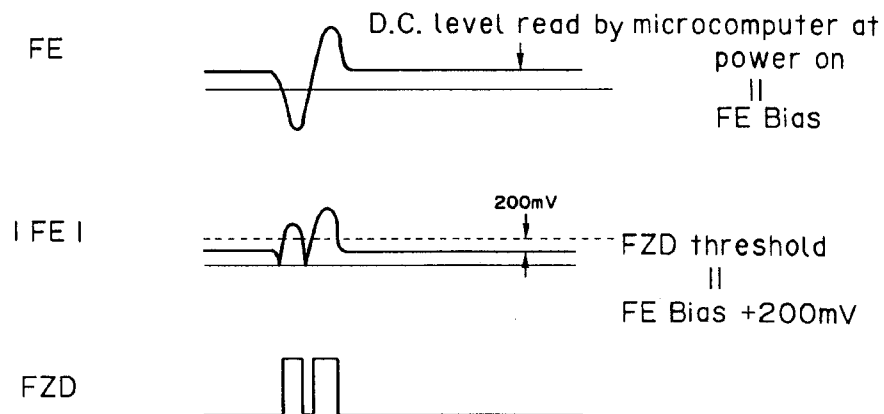

Fig.18 : FZD CIRCUIT

## 2) Tracking Servo System

The main tracking equalization takes place inside the UPD63700GF (figure 19 ). The equalizer response can be measured between TEX and TIN and will have the shape shown in figure 20.

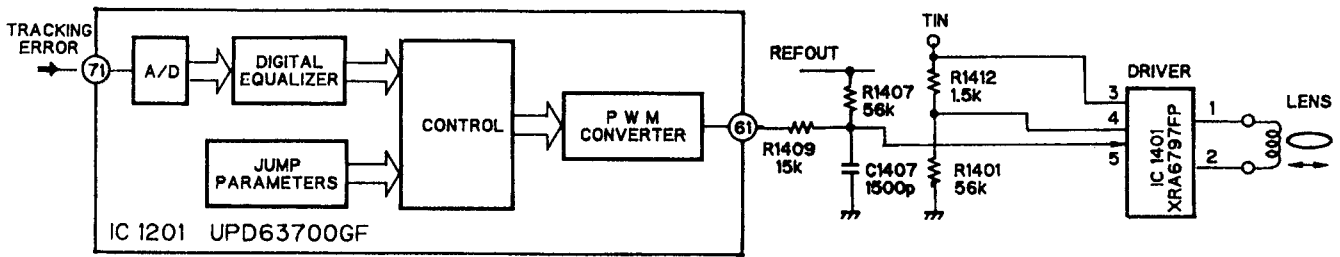

Fig.19 : TRACKING SERVO BLOCK DIAGRAM

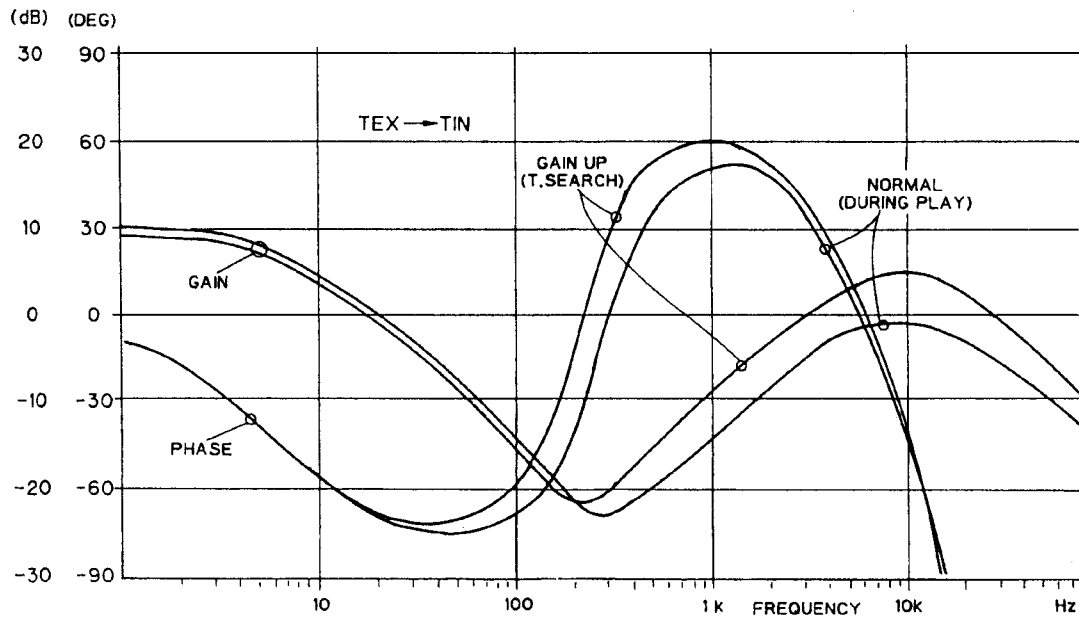

Fig.20 : TRACKING EQUALIZER

a) Track Jumping

Track jumping is performed automatically by the servo LSI upon receipt of the appropriate command from the microcomputer. The present microcomputer is programmed to use 1,4,10 & 32 track jump commands to achieve searching. The 32 track jump command may be used in pairs (64 tracks) or triplets (100 track) as required. In TEST MODE the 1,4,10,32 & 100 track jump and carriage move sequences may be observed by selecting the appropriate mode.

Note that the number of tracks jumped is controlled by setting an internal counter to half the total value and then counting this down using the zero crossing edges of TEC1. Once the counter is at zero, a brake pulse of

fixed duration is output to bring the lens to a halt; allowing tracking to be closed and normal play to continue.

For a fixed period of time after a multi-track jump has been performed, a "tracking brake" circuit is activated in conjunction with a "gain-up" equalizer to ensure that the servo achieves stabilization before entering normal play.

Manual track search, in normal mode, uses a group of single track jumps to achieve FWD/REV at approx. ten times normal play speed.

The figures 21 & 22 show the timing charts for the single-track jump and multi-track jump commands.

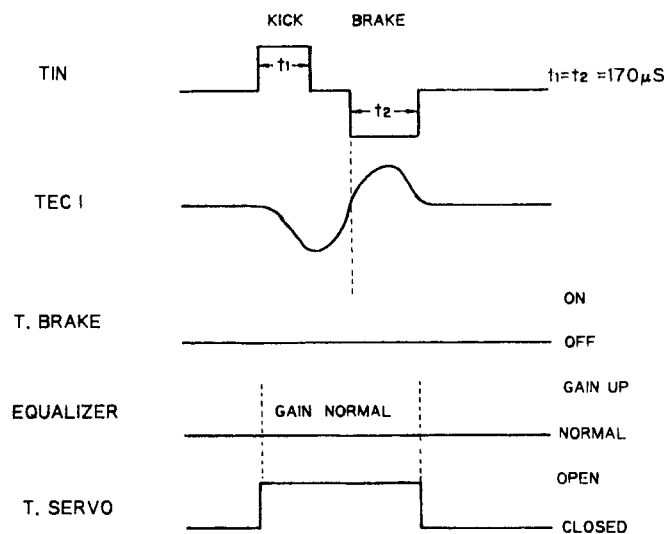

Fig.21 : SINGLE TRACK JUMP

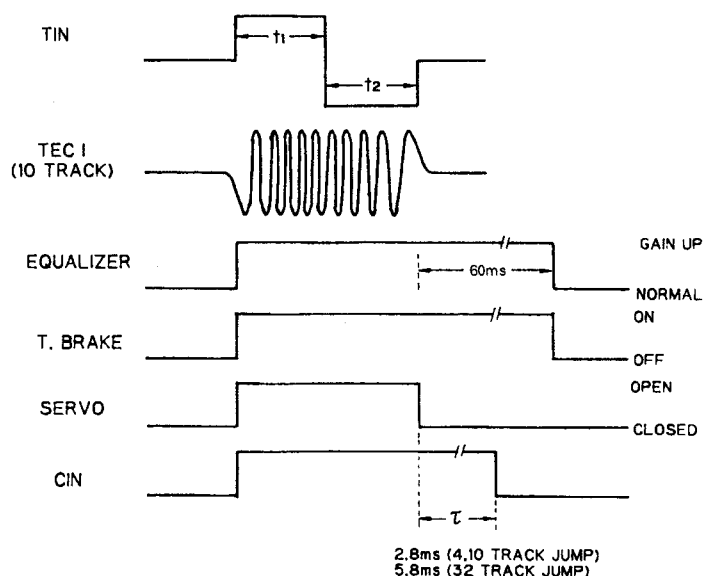
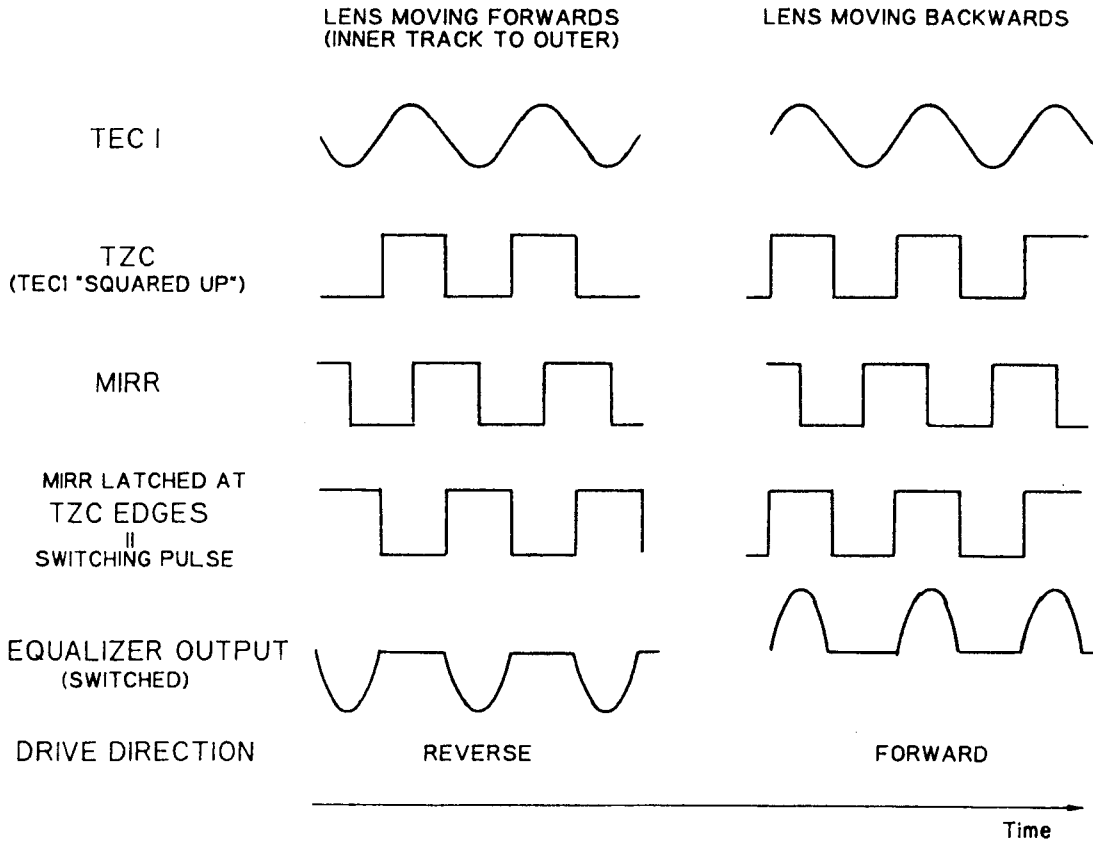

Fig.22 : MULTI TRACK JUMP

b) Tracking Brake Circuit (Figure 23)

This relies on determining which direction the lens is moving and only outputting the portion of the drive waveform which acts to oppose this motion. Direction

of motion is deduced from TEC1 and the MIRR signal and knowledge of their phase relation.



Note : Equalizer output assumed to have same phase as TEC1.

Fig.23 : TRACKING BRAKE CIRCUIT

c) MIRROR Circuit

The MIRR circuit indicates if the laser beam is on or off track.

MIRR = 'H' => off track, MIRR = 'L' => on track.

MIRR is generated by detecting the upper and lower envelopes of the RFO waveform and producing a difference signal which is then compared with a peak-held version of itself to determine if the envelope size has dropped below a certain percentage.

If so, this is assumed to be due to the beam going off-track ; in practice dirt on the disc can also give the same effect (see figure 24).

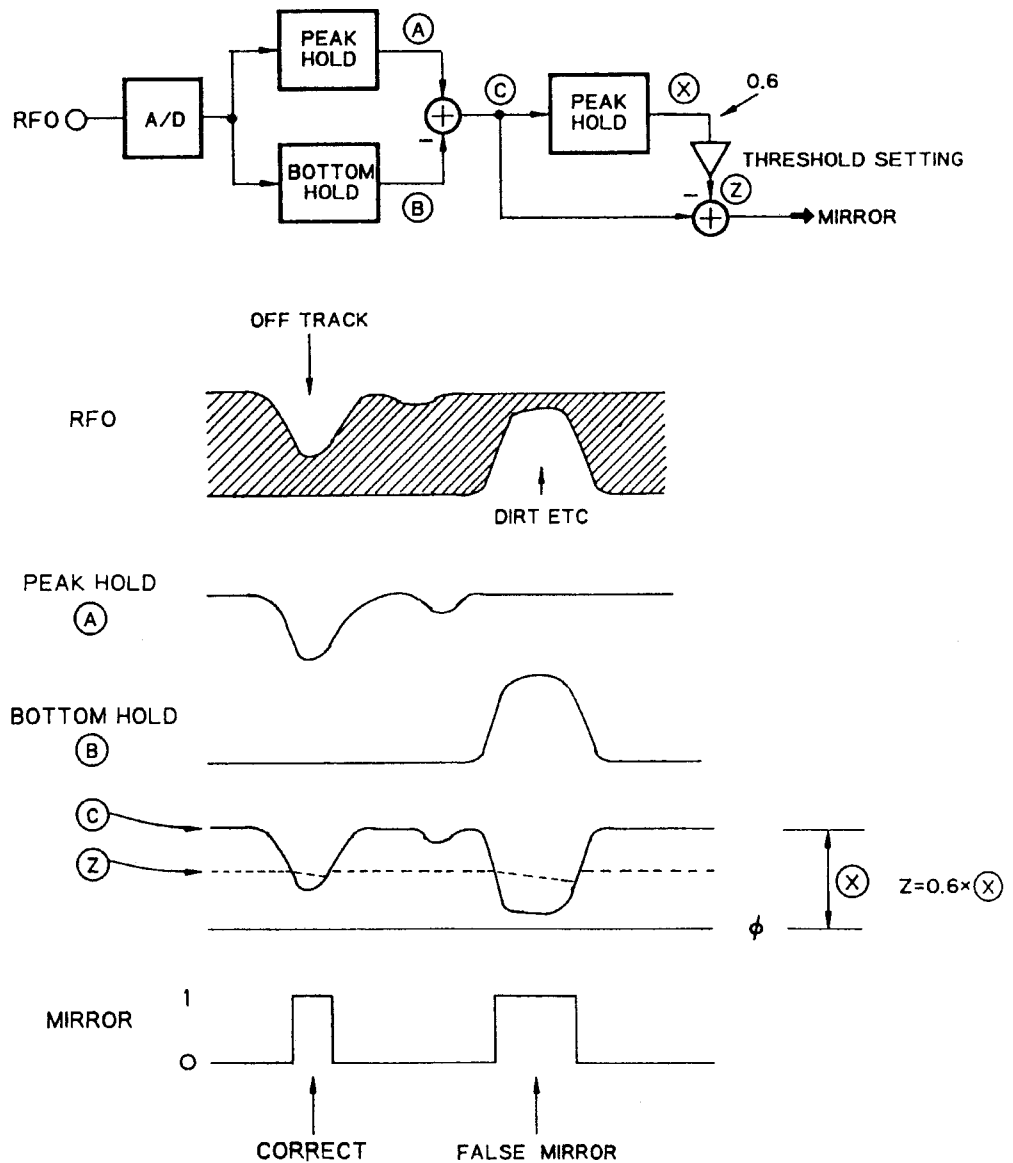

Fig.24 : MIRROR CIRCUIT & SIGNAL DIAGRAM

### 3) Carriage Servo System

The carriage servo system takes its input from the low frequency component of the tracking equalizer output. This is amplified and equalized, and the output fed to the carriage motor via the PWM converter, LPF and driver IC. The gain of the equalizer is set so that when the lens is offset from its center by a set amount the voltage at the carriage motor is enough to overcome friction and move the carriage forward.

Because the carriage motor will only begin moving when the applied voltage is great enough to overcome friction the drive voltage is cut-off inside the servo LSI until it reaches an appropriate level ; thus saving on wasted power dissipation.

Due to eccentricity of the disc etc. the threshold level may be crossed several times before the carriage assembly actually moves. This can result in a series of pulses being applied to the carriage motor.

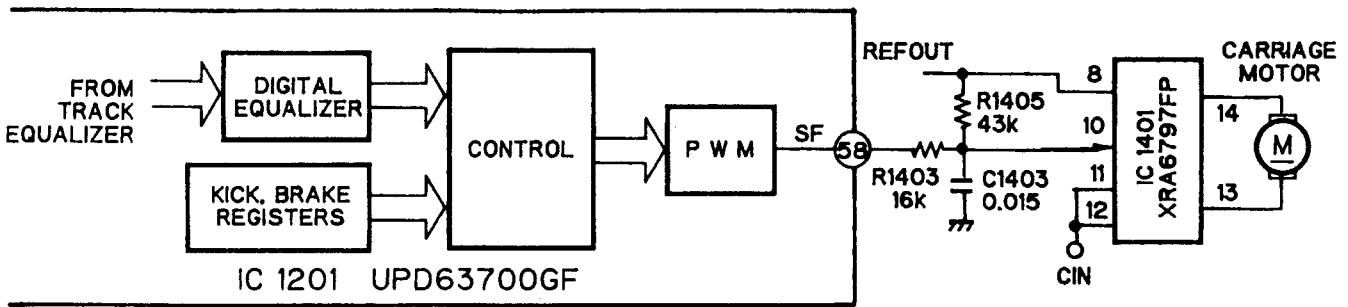

Fig.25 : CARRIAGE SERVO CIRCUIT

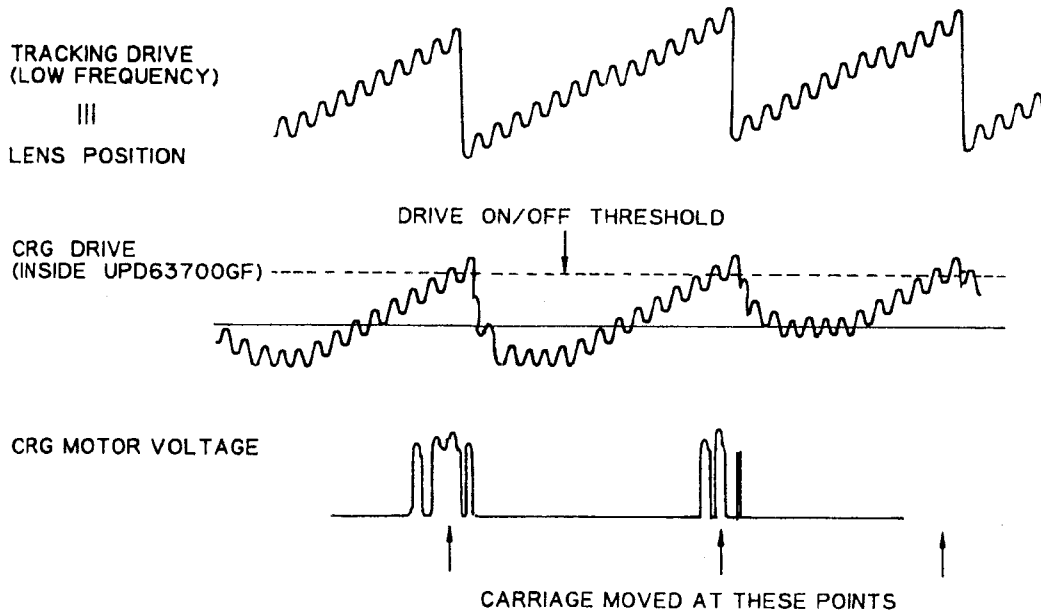

Fig.26 : CARRIAGE WAVEFORM

#### 4) Spindle Servo

The spindle servo has a number of different modes :

- (i) Kick : Used at set-up to bring the spindle up to speed from stand-still.
- (ii) Offset : This is used i) At set-up, after spindle kick and before AGC has finished.  
ii) During play if focus is suddenly disrupted.
- (iii) Adaptive Servo : This is the CLV mode which ensures that the linear velocity of the disc as seen by the laser spot is kept constant. During play, a timing signal is extracted from the EFM signal and used to generate speed and phase error signals. These error signals are summed and fed into a servo equalizer to produce a drive signal via the PWM converter.
- (iv) Brake : This is used to bring the disc to a stop quickly, for ejection or when CD source is deselected or for any other reason. The servo LSI puts out a brake level and monitors the EFM signal. When the longest pattern in the EFM signal is longer than a fixed amount an internal flag is set. By monitoring this flag the microcomputer can judge when the disc has stopped and proceed to eject etc. If this flag is not set within a certain time limit the servo is switched to STOP mode and eject is implemented after a wait period.

- (v) Stop : This occurs at power on or during disc eject. The spindle motor voltage is zero.
- (vi) Rough : This is used in normal mode to control the linear velocity of the disc when the carriage is being moved for fast access. A speed signal is deduced from the EFM waveform and input to the spindle equalizer. This mode should be used in TEST MODE to perform the grating adjustment.

##### a) EFM Comparator

This circuit 'squares' up the analog RF signal into a digital EFM signal. In order to ensure minimum errors it is necessary to use a feedback circuit to match the DC level of the threshold to the center of the RF waveform. This circuit (shown in the spindle servo block diagram) uses the fact that the EFM signal should have no DC component. By feeding back the EFM signal's DC level the threshold level changes until the DC level is zero and the threshold, by definition, is at the exact center of the RFI waveform. The filtering in the feedback has been adjusted to ensure minimum error.

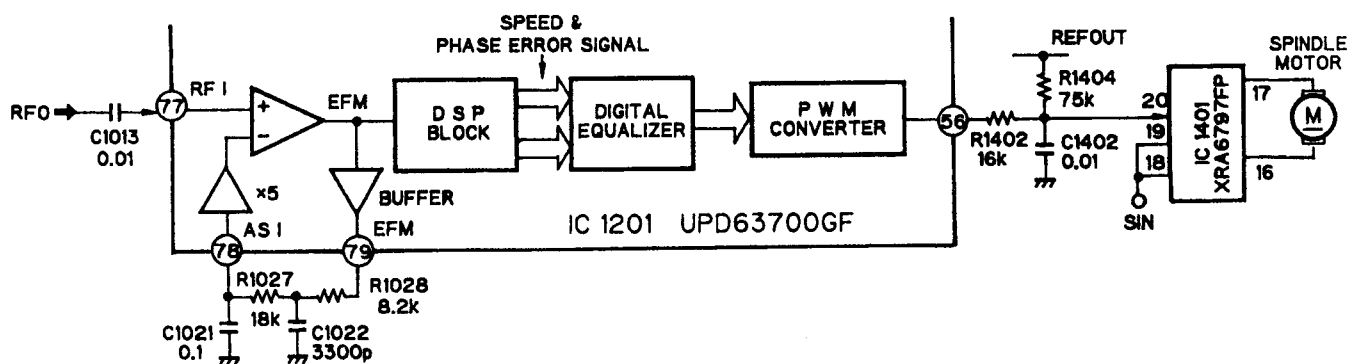

(EFM Compalator Circuit)

Fig.27 : SPINDLE CIRCUIT

● Normal Mode

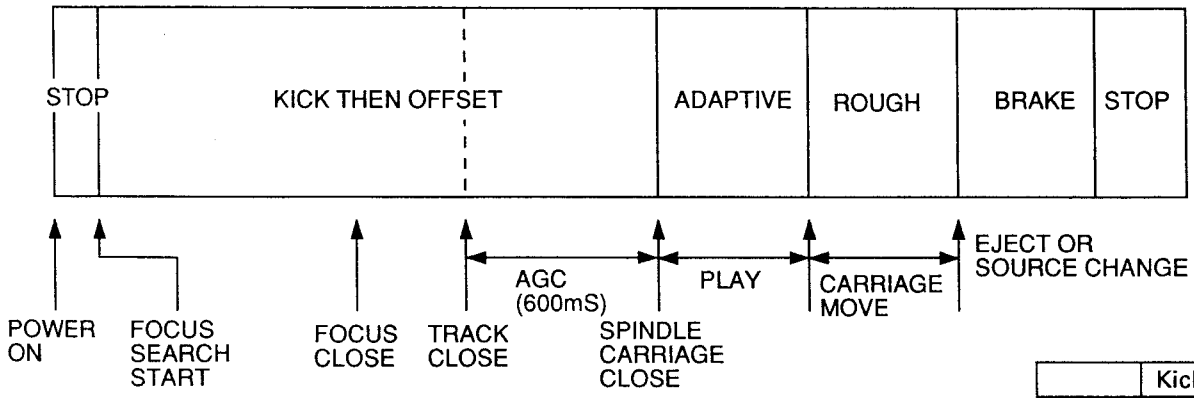

	Kick Time
12cm	800mS
8cm	300mS

● Test Mode

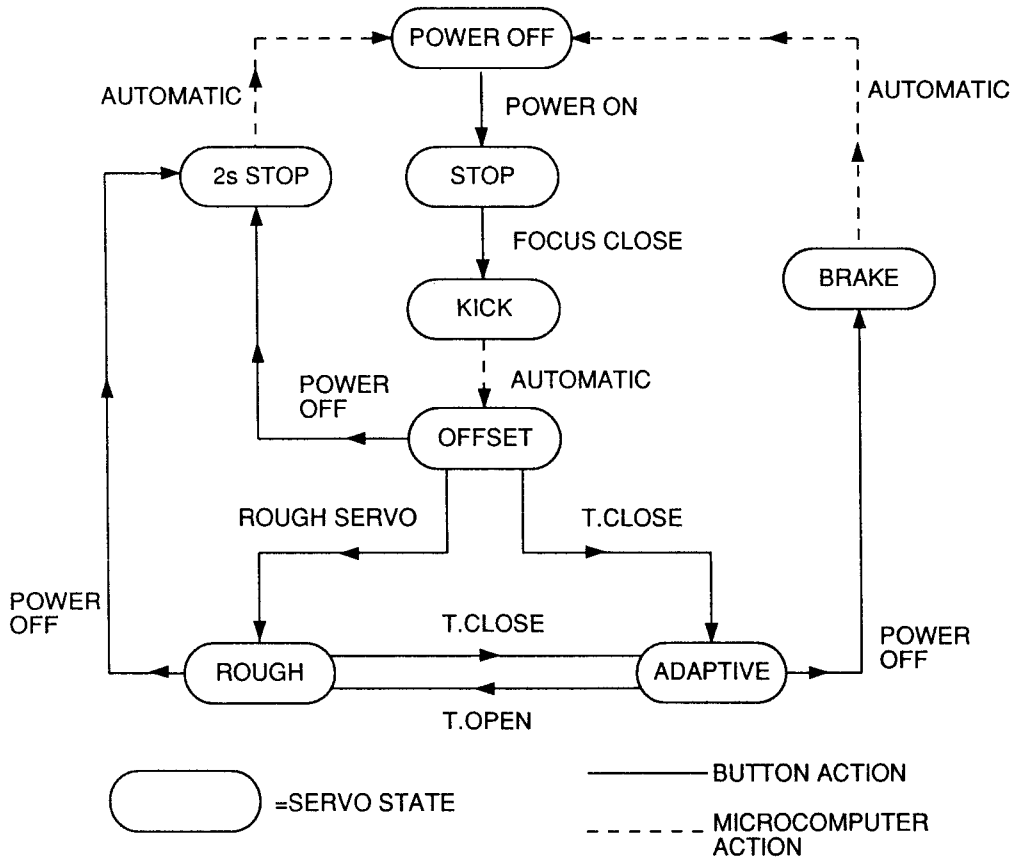

Fig.28 : SPINDLE SERVO MODES



**5) Automatic Gain Control (AGC)**

The servo LSI UPD63700GF contains a new function which allows the microcomputer to automatically adjust the gain of the focus and tracking servos every time a new disc is inserted or the CD source is selected. The block diagram of the AGC circuit is shown in figure 29. Basically, a small disturbance signal is inserted into the servo loop at a fixed frequency and the response of the loop is measured via the filtered signals G1 and G2. For a properly adjusted servo loop the amplitudes of G1 and G2 should be equal. The microcomputer reads in these values, does a simple calculation and adjusts the loop gain appropriately.

In order to achieve a high degree of accuracy this adjustment is performed a number of times.

As long as there is power supplied to the microcomputer it remembers the previous adjustment point and uses this as a starting point. Thus, should the system degrade with time (actuator sensitivity, dirt build-up, circuit degradation etc.) the microcomputer can follow this trend and keep the loop gain optimized.

If power to the microcomputer is removed, it forgets the previous adjustment point and assumes a default value.

At shipping the CD player will be within 5dB of this default and no problems should occur. For an older player however this is not so and it is possible that servo closure may not take place immediately. In this case, the microcomputer adjusts the gain 'blind', searching for a stable point.

In TEST MODE, the result of the AGC can be monitored. Once tracking close (with AGC) has been performed the set can be made to display the present value of the gain block. The default value is displayed as '20', which is the value a typical PU unit, PCB & test disc would result in. If for some reason the loop gain had dropped by, say, 6dB (1/2 the typical value) then the gain block will be adjusted during AGC to twice its default value ; resulting in a gain of '40'. Similarly a set with a loop gain twice the typical will display '10' as the present gain.

Using this, it is possible to 'measure' the loop gain of the servo without the need for any instrumentation. The players shipped from the factory are checked with a test disc so that the value of the gain block after AGC is within the range 11 - 45.

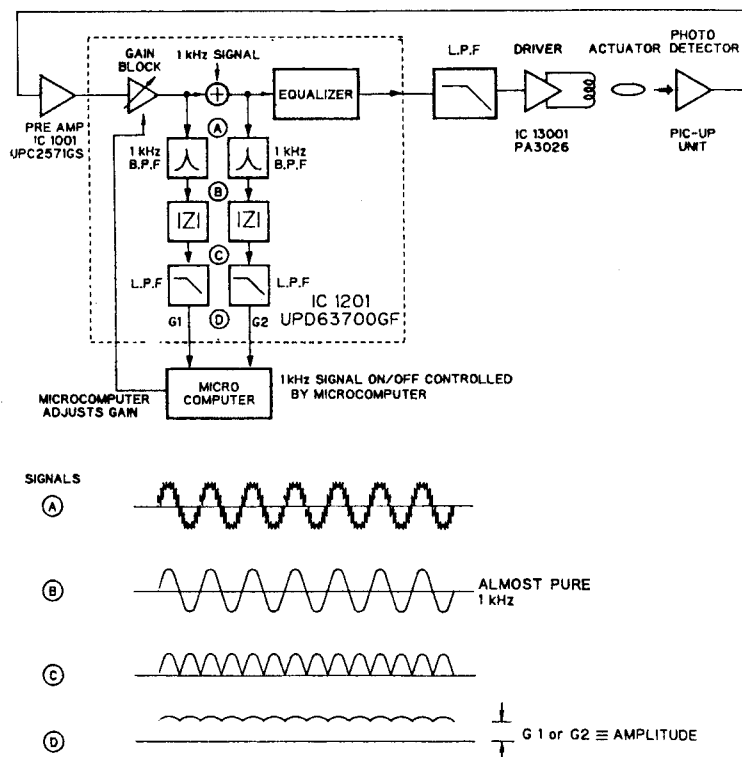

Fig.29 : AGC BLOCK DIAGRAM

### 5.3 Power Source Configuration

The power source for this system consists of seven separate sources which are the SVC (5.2V), VDD (5.0V), VLED (8.5V), 5VA (5.0V), DAC5 (5.0V), VD (8.6V), and POW5 (5.0V) power sources.

**SVC:** Power source for SRAM (IC1702). Even if BU is cut off by diode switching, the charge voltage of C1704 (electrolytic capacitor) maintains SRAM's power supply for one day (minimum 2 V) and saves data of the ITS and title memories.

**VDD:** Power source for the microcomputer (IC1701). Constantly outputs power as long as the BU created by the IC power source PAJ002A is connected.

**VLED:** Power supply for the two LEDs for the elevation (vertical movement) sensor and disc sensor. The LEDs light during mechanical movement, and are controlled by LOAD.

**5VA:** Consists of power source for IC1001, IC1201 and the LD of the PU unit, plus the regulator circuit for IC1401 (XRA6797FP) and an external transistor. The 5VA power supply outputs power when VD is turned on.

**DAC5:** Consists of the IC1601 (D/A converter IC) and audio midpoint voltage, plus regulator IC from VD. The DAC5 power supply outputs power when VD is turned on.

**VD:** Main power supply for the system. Power is output when POW5, having switched VDD by POWER, reaches the reference voltage and is triggered.

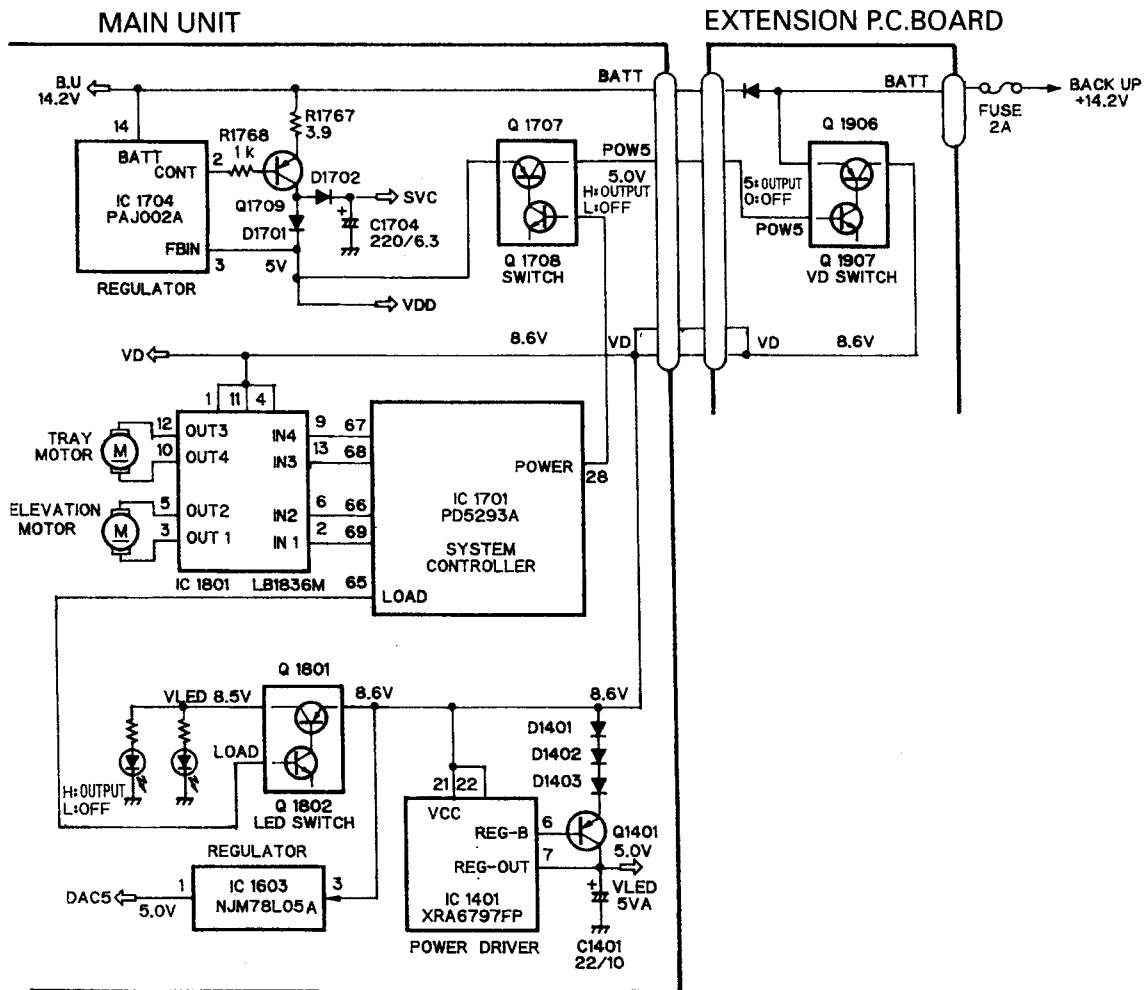

Fig.30

### 5.4 Mechanical Function

#### 1) Elevation (Figure 31)

When BU is turned on, the elevator moves upward until RSTP becomes L. The elevator stops at L. This is the 6th position (reset position). While counting the number of L of TSEL, the elevator subsequently transfers to the position of the requested number of discs (place where TSEL is L). The TSEL waveform is detected by LED and photo transistor. MAG become L when the magazine is inserted. If there is no magazine, MAG becomes H. Even after magazine eject, the mechanism constantly detects the reset position and stops here.

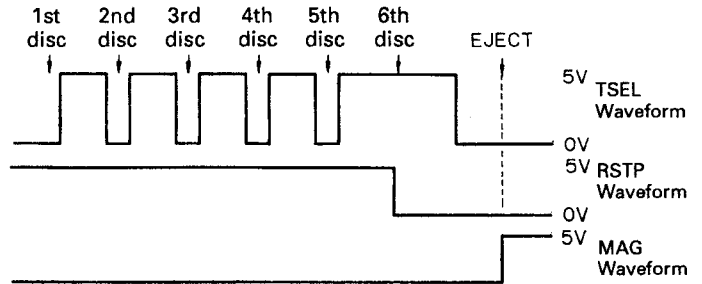

Fig.31

#### 2) Tray extension and retreat (Figure 32)

The series of movements consisting of storing the tray in the magazine, extending and retreating the tray, and completion of clamping is determined by the microcomputer according to the DSP and TRP waveforms. The motors are driven by the 2-circuit motor drivers IC1801 (LB1836M) for locomoting the elevator and trays. Forward and reverse are carried out by drive instructions from the microcomputer through a combination of H and L of four lines (I1, I2, I3, I4).

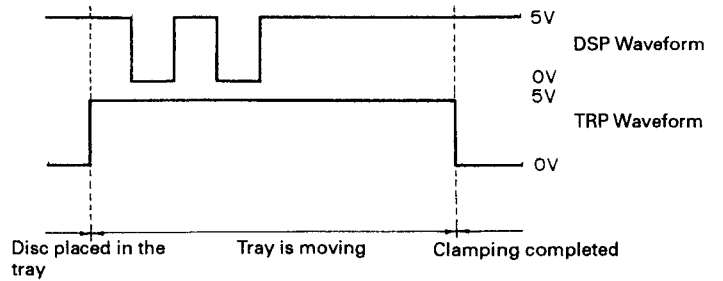

Fig.32

#### 3) Disc detection (Figure 33)

DSP is not only used for the previously mentioned extension and retreat of trays, but is also used for timing of decisions of whether the tray contains a disc or not, and whether the disc is a 12 or 8 cm disc. A series of disc detection operations are carried out while trays are pulled out of the magazine. For disc detection, an LED and photo transistor are provided above and

below the tray. Presence of the disc is determined according to whether the light passes through the tray (disc waveform is L) or is blocked by the disc (disc waveform is H).

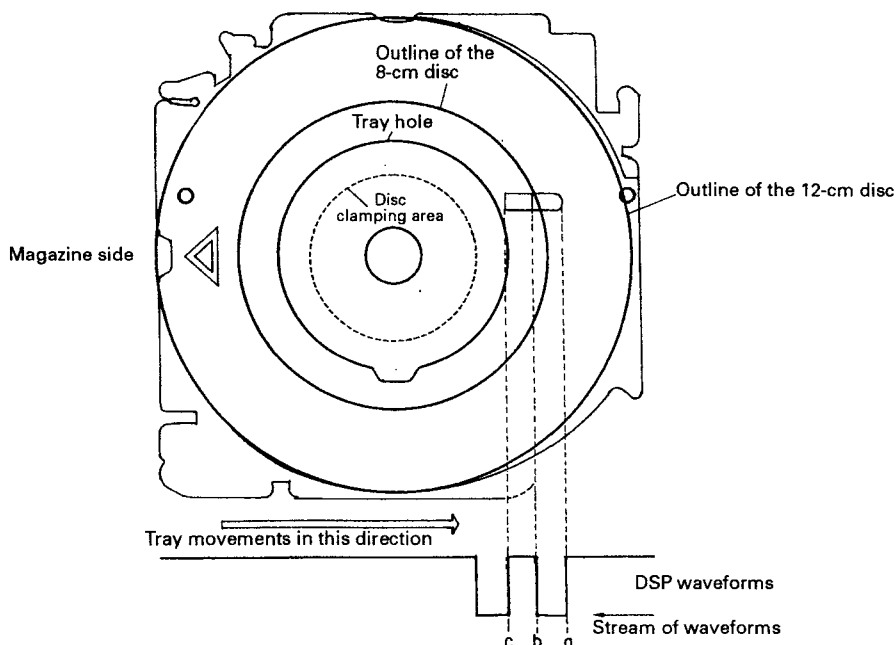

Fig.33

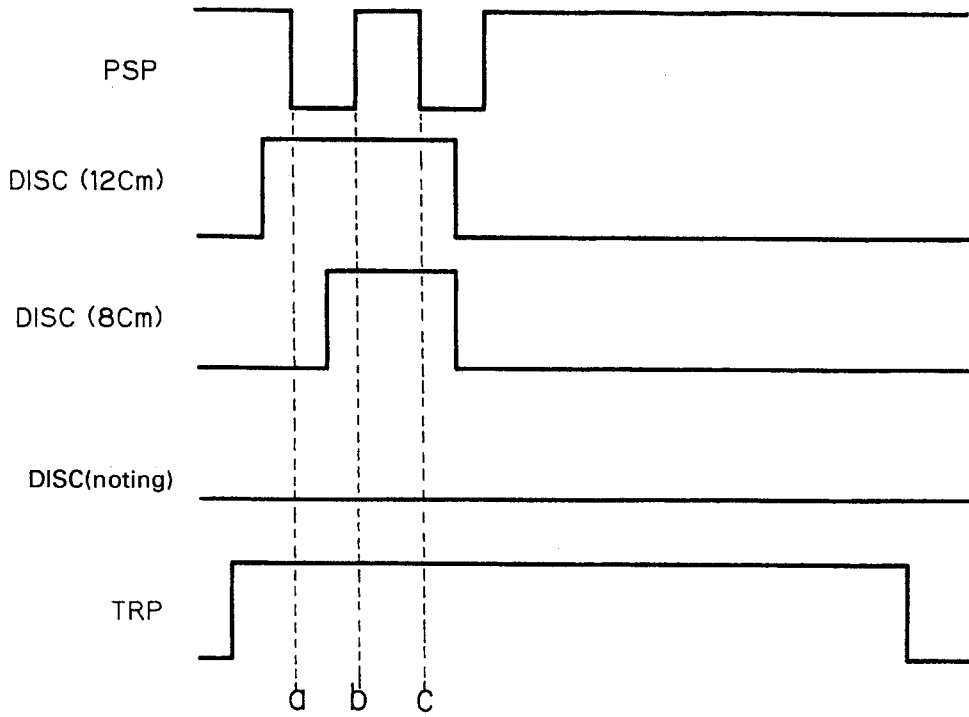

Fig.34

The flow of the waveform is opposite that of the previously mentioned DSP waveform.

Disc waveform is continuously detected during the periods of a-b and b-c:

If L is detected at least once, that period is L.

If L is not detected at least once, that period is H.

	a-b	b-c
12Cm	H	H
8Cm	L	H
Disc (nothing)	L	L

However, regardless of whether a-b is H or L, if b-c is L, all trays are determined to be empty.

● ICs

● Pin Functions (SM5874AM)

Pin No.	Pin Name	I/O	Function and Operation
1	MUTE	I	Mode H: Soft mute ON/OFF Mode L: Attenuator level DOWN/UP
2	EMPH	I	De-emphasis ON/OFF terminal
3	CKO	O	Oscillation output clock
4	DVSS		Digital GND (0V)
5	BCKI	I	Input data bit clock
6	DI	I	Serial data input
7	DVDD		Digital VDD (5V)
8	LRCI	I	Input data sample rate (fs) clock
9	TSTN	I	Test
10	L(+)	O	Lch analogue output (+)
11	AVDDL		Analogue VDD
12	L(-)	O	Lch analogue output (-)
13	AVSS	I	Analogue VSS
14	R(-)	O	Rch analogue output (-)
15	AVDDR		Analogue VDD
16	R(+)	O	Rch analogue output (+)
17	XVDD		Crystal VDD (5V)
18	XTI	I	Oscillation input
19	XTO	O	Oscillation output
20	XVSS		Crystal VSS (0V)
21	DS	I	Normal / high-speed play mode select
22	DACRST	O	Reset output
23	MODE	I	Soft mute / attenuator mode select
24	ATCK	I	Attenuator level clock

IC's marked by\* are MOS type.

Be careful in handling them because they are very liable to be damaged by electrostatic induction.

\*SM5874AM

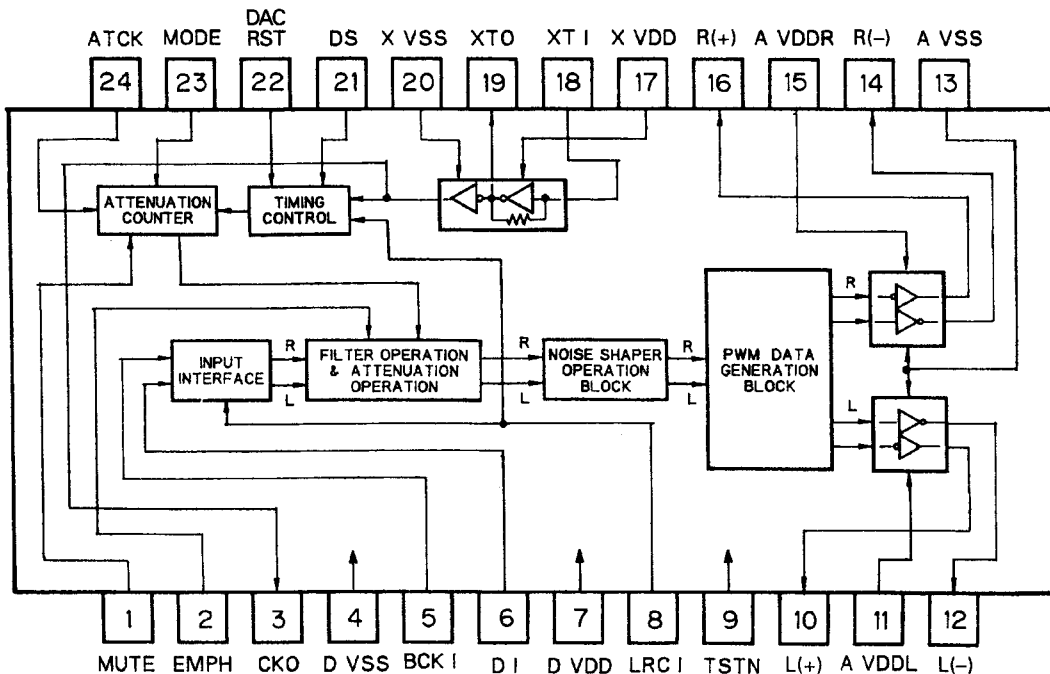

● **Pin Functions (PD5293A)**

Pin No.	Pin Name	I/O	I/O Format	Function and Operation
1	TIN	I	C	Tray position input
2	TEMP	I		Temperature detector
3	VDIN	I		Power supply short sensor input
4	TOUT	I	C	Disc sensor timing input
5	CSI	I	C	IP-BUS data input
6	CSO	O	C	IP-BUS data output
7	APPW	O	C	IP-BUS driver power supply control output
8	AO	O	C	Control signal distinguishing from LSI
9	XSCK	I/O	C	LSI clock input/output
10	XSO	O	C	LSI data output
11	XSI	I	C	LSI data input
12	STB	O	C	LSI strobe output
13	RST	O	C	LSI reset output
14	DCE	O	C	Chip enable output
15	DACRST	O	C	D/A converter reset output
16	ASENS	I		ACC power sense input
17	BSENS	I		Back up power sense input
18	DMUTE	O	C	Mute output
19	DRST	O	C	Reset output
20-23	NC			Not used
24	EJSW	I		Eject key switch interrupt input
25	MAG	I		Magazine lock switch interrupt input
26	NC			Not used
27	RESET	I		Reset input
28	POWER	O	C	CD +5V control
29	CONT	O	C	Servo driver power supply control
30	XIN	I		Crystal oscillating element connection pin
31	XOUT	O		Crystal oscillating element connection pin
32	VSS			GND
33-40	D7-D0	I/O	C	External RAM data
41	WE	O	C	External RAM write enable
42	PROT	O	C	External RAM output enable
43	CS	O	C	External RAM chip select
44-56	A12-A0	O	C	External RAM address
57	EJP	I	C	Reset position switch
58,59	NC			Not used
60	MIRR	I	C	Mirror detector input
61	LOCK	I	C	Spindle lock detector input
62	FOK	I	C	FOK signal input
63	HOME	I	C	Home position detector input
64	OPTSW	I	C	Digital output ON/OFF input
65	LOAD	O	C	Mechanism power supply control
66	I3	O	C	Motor driver control output
67	I1	O	C	Motor driver control output
68	I2	O	C	Motor driver control output
69	I4	O	C	Motor driver control output
70	CDMUTE	O	C	CD mute output
71	ADENA	O	C	A/D reference voltage output
72	TESTIN	I	C	Test program mode input
73	VCC			Back up 5V
74	VREF	I		A/D converter reference voltage input
75	AVSS	I		A/D GND
76	UNIT	I		Unit input
77	6/12	I	C	6/12 switching input
78	DISK			Disc detector input
79	TSEL	I		Tray position detector photo sensor
80	CSEL	I	C	Compression select

I/O Format	Meaning
C	C MOS

PAJ002A

\*PD5293A

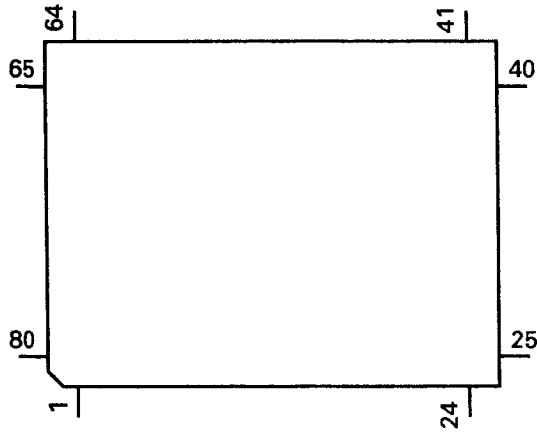

XRA6797FP

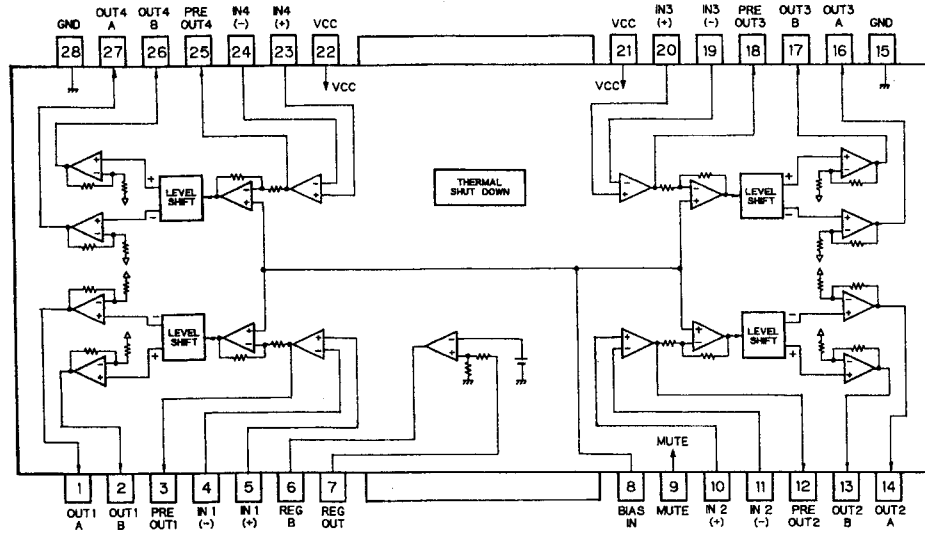
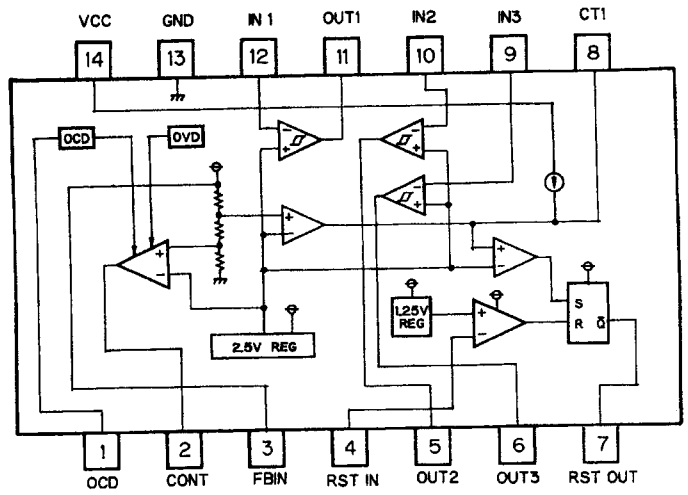

LB1836M

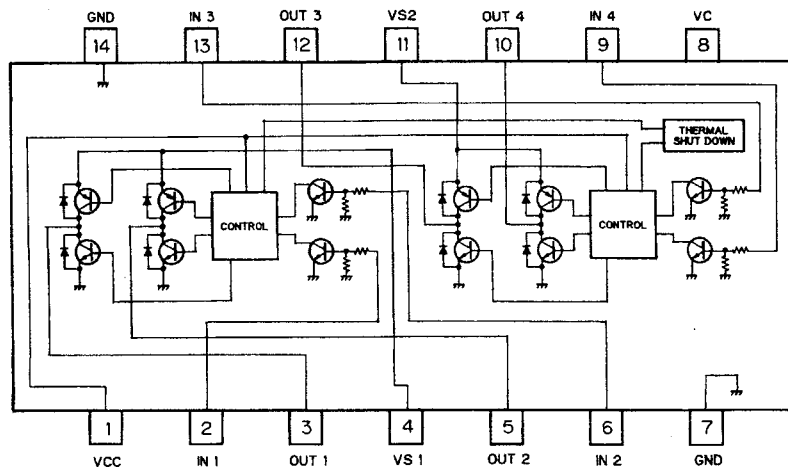

● Pin Functions (PD4501A)

Pin No.	Pin Name	I/O	Function and Operation
1	CBNK2/ $\overline{CS}$	I	CROM bank select signal input/Chip select
2	CBNK1/ $\overline{SCK}$	I	CROM bank select signal input/Clock
3	CBNK0/SI	I	CROM bank select signal input/Data
4	RST	I	Reset signal input
5	VDD		Power supply
6	MUTE	I	Mute control input
7	FORM1	I	Bit clock rate select signal input
8	FORM0	I	Bit clock rate select signal input
9	MD/TEST1	I	CROM bank select /test mode select
10	TEST0	I	Test mode select
11	EOOSC	I	External clock input
12	GND		GND
13	BCLK	I	Bit clock signal input
14	LRCK	I	L/R clock signal input
15	DI	I	Audio data serial input
16	DO	O	Audio data serial output

\*PD4501A (CDX-P616)

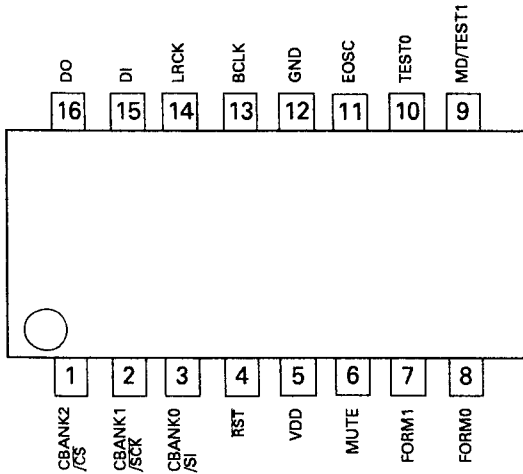



## 6. EXPLODED VIEW PARTS LIST

### NOTE:

- Parts marked by "\*" are generally unavailable because they are not in our Master Spare Parts List.
- Parts marked by "⊙" are not always kept in stock. Their delivery time may be longer than usual or they may be unavailable.
- Chassis(Exploded View:Page 2-7)

### ● Parts List

Mark No.	Description	Part No.
1	Screw	BMZ26P080FMC
2	Screw	BSZ30P055FZK
3	Cord (P616/UC,P610/UC,ES) Cord (P610/EW,X1B/EW)	CDE4211  CDE4210
4	Connector	CDE4372
5	Upper Case	CNB1886
6	Lower Case	CNB1815
7	Insulator	CNM3987
8	Main Unit(P616) Main Unit(P610)	CWX1761 CWX1721
9	Extension Unit	CWX1729
10	CD Mechanism Unit	CXK4000
11	Screw	PMS26P040FMC
12	Earth Plate	CNC5769
13	Screw	HMF40P080FZK
14	.....	
15	Angle	CNB1874
16	.....	
17	Connector(CN1701)	CKS2764
18	Connector(CN1801)	CKS2779
19	Connector(CN1802)	CKS3127
20	Heat Sink	CNC4447
21	Connector Bracket	CNC5570
22	Connector(CN1697)	CKS2218
23	Connector(CN1699)	CKS2479
24	Plug(CN1901)	CKS-460
25	Transistor(Q1906)	2SB942
26	Screw	BPZ26P080FMC
27	Button	CAC3982
28	Door(P616) Door(P610)	CAT1650 CAT1624
29	Holder	CNC5362
30	Grille Unit(P616) Grille Unit(P610)	CXA7758 CXA7757
31	Connector	CDE4366

● **CD Mechanism Unit(Exploded View:Page 2-4)**

● **Parts List**

Mark No.	Description	Part No.	Mark No.	Description	Part No.
1	Screw	BMZ20P030FMC	49	Lever	CNC5166
2	Screw	BMZ20P025FMC	50	Arm	CNC5168
3	Screw(M2.6×3)	CBA1065	51	Arm	CNC5169
4	LED	BR4361F	52	Bracket	CNC5170
5	.....		53	CM Bracket	CNC5171
6	Screw	CBA1041	54	Cover	CNC5172
7	Screw	CBA1077	55	Upper Frame	CNC5175
8	Screw	CBA1086	56	Main Frame	CNC5176
9	Screw	CBA1229	57	Side Frame	CNC5178
10	Screw	CBA1243	58	Bracket	CNC5462
11	Washer	CBF1038	59	Cover	CNC5567
12	Spring	CBH1488	60	Cover	CNC5576
13	Spring	CBH1497	61	Lever	CNC5678
14	Spring	CBH1498	62	Plate	CNC5782
15	.....		63	Spacer	CNM1787
16	Spring	CBH1588	64	Sheet	CNM3897
17	Spring	CBH1589	65	Sheet	CNM4337
18	Spring	CBH1744	66	Insulator	CNM4266
19	Spring	CBH1592	67	P.C.Board	CNP3642
20	Spring	CBH1593	68	P.C.Board	CNP3730
21	Spring	CBH1594	69	Belt	CNT1047
22	Spring(Silver)	CBH1596	70	Rack	CNV3355
23	Spring	CBH1597	71	Holder	CNV3363
24	Spring	CBH1599	72	Gear	CNV3753
25	Spring	CBH1604	73	Gear	CNV3754
26	Spring	CBH1605	74	Guide	CNV3756
27	Spring(Silver)	CBH1606	75	Arm	CNV3757
28	Spring(Brown)	CBH1607	76	Arm	CNV3758
29	Spring	CBH1631	77	Arm	CNV4185
30	Spring(Black)	CBH1633	78	Worm Wheel	CNV3761
31	Spring	CBH1667	79	Gear	CNR1382
32	Spring	CBH1706	80	Gear	CNV3763
33	Spring	CBH1721	81	Gear	CNV3764
34	Spring	CBL1157	82	Gear	CNV3765
35	Arm	CBL1186	83	Gear	CNV3766
36	Arm	CBL1187	84	Gear	CNV3767
37	Spring	CBL1210	85	Arm	CNV3769
38	Connector	CDE4244	86	Guide	CNV3770
39	.....		87	Guide	CNV3771
40	PU Unit	CGY1036	88	Guide	CNV3772
41-44	.....		89	Guide	CNV3773
45	Shaft	CLA2027	90	Arm	CNV3775
46	Shaft	CLA2322	91	Bearing	CNV3778
47	Shaft	CLA2345	92	Holder	CNV3779
48	Link	CNC5150	93	Damper	CNV3780

Mark No.	Description	Part No.	Mark No.	Description	Part No.
94	Cam	CNV3781	145	Screw	JFZ20P014FMC
95	Guide	CNV3784	146	Washer	CBF1002
96	Guide	CNV3785			
97	Arm	CNV3787			
98	Plate	CNV3912			
99	Arm	CNV3914			
100	Composite P.C.Board	CNX2236			
101	.....				
102	Composite P.C.Board	CNX2237			
103	.....				
104,105	.....				
106	Switch(S802-805)	CSN1012			
107	Switch(S801)	CSN1029			
108	P.C.Board Unit	CWX1809			
109	Connector(6P)	CKS1944			
110	Connector(17P)	CKS1955			
111	Connector(30P)	CKS1968			
112	Connector(7P)	CKS2406			
113	Motor Unit(M804)	CXA4649			
114	Damper Unit	CXA6443			
115	Stage Chassis Unit	CXA6608			
116	CRG Chassis Unit	CXA6609			
117	Steer Unit	CXA6610			
118	Bracket Unit	CXA6611			
119	Magazine Holder Unit	CXA6612			
120	Lever Unit	CXA6613			
121	Lower Cover Unit	CXA6614			
122	Bracket Unit	CXA6615			
123	Cam Ring Unit	CXA6616			
124	Lever Unit	CXA6619			
125	Lever Unit	CXA6620			
126	Link Unit	CXA6621			
127	Arm Unit	CXA6622			
128	Arm Unit	CXA6623			
129	Arm Unit	CXA6624			
130	Frame Unit	CXA6625			
131	Lever Unit	CXA6626			
132	Motor Unit(M803)	CXA6977			
133	Motor Unit(M802)	CXA6978			
134	Screw Unit	CXA6990			
135	Motor Unit(M801)	CXA6991			
136	Arm Unit	CXA7153			
137	.....				
138	Clamper Unit	CXA7632			
139,140	.....				
141	Screw	JFZ17P025FNI			
142	Screw	JFZ20P025FNI			
143	Photo-transistor (P801,802)	PT4800			
144	Spring	CBH1741			

## 7. ELECTRICAL PARTS LIST

**NOTE:**

- Parts whose parts numbers are omitted are subject to being not supplied.
- The part numbers shown below indicate chip components.

Chip Resistor

RS1/OSOOOJ,RS1/OOSOOOJ

Chip Capacitor (except for CQS.....)

CKS....., CCS....., CSZS.....

====Circuit Symbol & No. Part Name====	Part No.	====Circuit Symbol & No. Part Name====	Part No.
Unit Number :		IC 1704	PAJ002A
Unit Name : Extension P.C.Board		IC 1801	LB1836M
MISCELLANEOUS		Q 1001	2SA1015
Q 1693 1697	DTA144ES	Q 1401 1709	2SB1238
Q 1696	DTC114YS	Q 1701	DTA144ES
Q 1698 1699	DTC343TS	Q 1703	DTC144ES
Q 1799	2SC2458	Q 1704 1707 1801	DTA123JS
Q 1906	2SB942	Q 1708 1802	DTC114YS
Q 1907 1908	2SD1859	D 1401 1402 1403	ERA15-02VH
D 1698 1699	1SS133	D 1701 1702	1SS292
D 1798 1799	RD18JSB1	X 1601	Resonator 16.9340MHz
D 1901 1903	ERA15-02VH	X 1701	Ceramic Resonator
L 1901	CTH1129	S 1701 1702	Switch(EJECT,RESET)
SW1799	Switch(Address)	VR1001	Semi-fixed 2.2kΩ (B)
		VR1002	Semi-fixed 22kΩ (B)
		VR1003 1004	Semi-fixed 47kΩ (B)
RESISTORS		RESISTORS	
R 1695 1910	RD1/4PS103JL	R 1001	RD1/4PS220JL
R 1696 1697	RD1/4PS332JL	R 1002	RD1/4PS0R0JL
R 1698 1699	RD1/4PS112JL	R 1003	RD1/4PS103JL
R 1791	RD1/4PS102JL	R 1004 1768	RS1/16S102J
R 1792 1793 1794	RD1/4PS513JL	R 1005	RS1/16S823J
R 1795 1796 1908	RD1/4PS101JL	R 1006	RS1/16S182J
R 1798	RD1/4PS273JL	R 1007	RS1/16S333J
R 1799	RD1/4PS433JL	R 1011 1012	RS1/16S683J
R 1906	RD1/4PS104JL	R 1013 1024 1025	RD1/4PS102JL
R 1907	RD1/4PS204JL	R 1014 1410	RS1/16S473J
R 1909 1911	RD1/4PS201JL	R 1018	RD1/4PS622JL
R 1912	RD1/4PS241JL	R 1019 1401 1407 1716	RS1/16S563J
R 1913	RD1/4PS681JL	R 1020	RS1/16S622J
R 1914	RD1/4PS511JL	R 1021 1701	RS1/16S513J
R 1915	RD1/4PS104JL	R 1022 1408	RS1/16S133J
CAPACITORS		R 1027	RS1/16S183J
C 1698 1699	CEA330M10LL	R 1028	RS1/16S822J
C 1798 1799	CKPYB471K50L	R 1201 1406 1411 1605 1606 1607 1608 1702 1712 1741	RS1/16S103J
C 1901 1905	CCH1183	R 1402 1403 1613 1614 1615 1616	RS1/16S163J
C 1904	CEA220M10LL	R 1404	RS1/16S753J
C 1906	CCH1183	R 1405 1708	RS1/16S433J
C 1907	CKPYB102K50L	R 1409	RS1/16S153J
Unit Number : CWX1761(CDX-P616/UC)		R 1412	RS1/16S152J
Unit Name : Main Unit		R 1602	RS1/16S471J
MISCELLANEOUS		R 1609 1610 1611 1612	RS1/16S752J
IC 1001	UPC2571GS	R 1617 1618 1769	RS1/16S101J
IC 1201	UPD63700GF	R 1619	RS1/16S102J
IC 1301	PD4501A	R 1704	RS1/16S154J
IC 1401	XRA6797FP	R 1705 1713 1715 1718 1721 1730 1731 1732 1733 1734	RS1/16S104J
IC 1601	SM5874AM	R 1707	RS1/16S0R0J
IC 1602	XRA4560F	R 1709 1710 1714 1722 1729 1735 1744 1745	RS1/16S222J
IC 1603	NJM78L05A	R 1717	RS1/16S123J
IC 1701	PD5293A	R 1719 1742 1766	RS1/16S0R0J
IC 1702	LH5160HN-10L	R 1737 1738 1739	RS1/16S104J
IC 1703	PA0051AM	R 1747 1748	RS1/16S104J

====Circuit Symbol & No. Part Name====	Part No.	====Circuit Symbol & No. Part Name====	Part No.
R 1756	RS1/16S104J	<b>RESISTORS</b>	
R 1767	RD1/4PS3R9JL	R 1001	RD1/4PS220JL
R 1771	RS1/16S102J	R 1002	RD1/4PS0R0JL
R 1801 1802	RD1/4PS391JL	R 1003	RD1/4PS103JL
<b>CAPACITORS</b>		R 1004 1768	RS1/16S102J
C 1001 1008 1010 1011 1708 1709	CKSRYP102K50	R 1005	RS1/16S823J
C 1002	CEA101M6R3LL	R 1006	RS1/16S182J
C 1003 1021 1602 1603 1604 1605	CKSQYB104K16	R 1007	RS1/16S333J
C 1004	CEA470M6R3LL	R 1011 1012	RS1/16S683J
C 1005	CCSRCH101J50	R 1013 1024 1025	RD1/4PS102JL
C 1006 1023	CKSRYP561K50	R 1014 1410	RS1/16S473J
C 1007	CKSYB334K16	R 1018	RD1/4PS622JL
C 1009	CCSRCH181J50	R 1019 1401 1407 1716	RS1/16S563J
C 1013 1301 1701 1702 1705 1707	CKSRYP103K25	R 1020	RS1/16S622J
C 1014	CCSRCH220J50	R 1021 1701	RS1/16S513J
C 1015 1201 1202	CKSYF105Z16	R 1022 1408	RS1/16S133J
C 1018	CEA220M6R3LL	R 1027	RS1/16S183J
C 1022	CKSRYP332K50	R 1028	RS1/16S822J
C 1026	CKSRYP103K25	R 1201 1406 1411 1605 1606 1607 1608 1702 1712 1741	RS1/16S103J
C 1203	CKSRYP471K50	R 1402 1403 1613 1614 1615 1616	RS1/16S163J
C 1302	CEA470M6R3LL	R 1404	RS1/16S753J
C 1401	CSZA220M10	R 1405 1708	RS1/16S433J
C 1402	CKSQYB103K50	R 1409	RS1/16S153J
C 1403	CKSQYB153K50	R 1412	RS1/16S152J
C 1404 1405	CEAS221M10	R 1601	RS1/16S0R0J
C 1406 1407	CKSRYP152K50	R 1602	RS1/16S471J
C 1408	CKSRYP271K50	R 1609 1610 1611 1612	RS1/16S752J
C 1606 1607	CCSRCH470J50	R 1617 1618 1769	RS1/16S101J
C 1608	CEA101M6R3LL	R 1619	RS1/16S102J
C 1609 1610	CCSRCH221J50	R 1704	RS1/16S154J
C 1611 1612 1613 1614	CCSRCH680J50	R 1705 1713 1715 1718 1721 1730 1731 1732 1733 1734	RS1/16S104J
C 1616	CKSYB224K16	R 1706	RS1/16S104J
C 1617 1618	CKSRYP103K25	R 1709 1710 1714 1722 1729 1735 1744 1745	RS1/16S222J
C 1703	CASA330M10	R 1717	RS1/16S123J
C 1704	CEA221M6R3LL	R 1719 1742 1766	RS1/16S0R0J
C 1706	CKSRYP103K50	R 1737 1738 1739	RS1/16S104J
C 1710	CKSRYP103K25	R 1747 1748	RS1/16S104J
C 1802	CEA220M16LL	R 1756	RS1/16S104J
Unit Number : CWX1721(CDX-P610/UC,EW,X1B/EW,ES)		R 1767	RD1/4PS3R9JL
Unit Name : Main Unit		R 1771	RS1/16S102J
		R 1801 1802	RD1/4PS391JL
<b>MISCELLANEOUS</b>		<b>CAPACITORS</b>	
IC 1001	UPC2571GS	C 1001 1008 1010 1011 1708 1709	CKSRYP102K50
IC 1201	UPD63700GF	C 1002	CEA101M6R3LL
IC 1401	XRA6797FP	C 1003 1021 1602 1603 1604 1605	CKSQYB104K16
IC 1601	SM5874AM	C 1004	CEA470M6R3LL
IC 1602	XRA4560F	C 1005	CCSRCH101J50
IC 1603	NJM78L05A	C 1006 1023	CKSRYP561K50
IC 1701	PD5293A	C 1007	CKSYB334K16
IC 1702	LH5160HN-10L	C 1009	CCSRCH181J50
IC 1703	PA0051AM	C 1013 1701 1702 1705 1707	CKSRYP103K25
IC 1704	PAJ002A	C 1014	CCSRCH220J50
IC 1801	LB1836M	C 1015 1201 1202	CKSYF105Z16
Q 1001	2SA1015	C 1018	CEA220M6R3LL
Q 1401 1709	2SB1238	C 1022	CKSRYP332K50
Q 1701	DTA144ES	C 1026	CKSRYP103K25
Q 1703	DTC144ES	C 1203	CKSRYP471K50
Q 1704 1707 1801	DTA123JS	C 1401	CSZA220M10
Q 1708 1802	DTC114YS	C 1402	CKSQYB103K50
D 1401 1402 1403	ERA15-02VH	C 1403	CKSQYB153K50
D 1701 1702	1SS292	C 1404 1405	CEAS221M10
X 1601	CSS1328	C 1406 1407	CKSRYP152K50
X 1701	CSS1310	C 1408	CKSRYP271K50
S 1701 1702	CSG1059	C 1606 1607	CCSRCH470J50
VR1001	CCP1177	C 1608	CEA101M6R3LL
VR1002	CCP1183	C 1609 1610	CCSRCH221J50
VR10031004	CCP1185	C 1611 1612 1613 1614	CCSRCH680J50
	Resonator 16.9340MHz		
	Ceramic Resonator		
	Switch(EJECT,RESET)		
	Semi-fixed 2.2kΩ (B)		
	Semi-fixed 22kΩ (B)		
	Semi-fixed 47kΩ (B)		

# CDX-P616,P610

====Circuit Symbol & No. Part Name====	Part No.	
C 1616	CKSYB224K16	
C 1617 1618	CKSRYB103K25	
C 1703	CASA330M10	
C 1704	CEA221M6R3LL	
C 1706	CKSRYB103K50	
C 1710	CKSRYB103K25	
C 1802	CEA220M16LL	
Unit Number :		
Unit Name : P.C.Board		
C 801 802	CKSQYB561K50	
Unit Number :		
Unit Name : Mechanism P.C.Board		
D 802	LED	BR4361F
S 805	Switch(Home)	CSN1012
Unit Number :		
Unit Name : Photo P.C.Board		
D 801	LED	BR4361F
S 801	Switch(RSTP)	CSN1025
S 802	Switch(MAG)	CSN1012
Miscellaneous Parts List		
	PU Unit	CGY1036
M 802	Motor Unit(ELV)	CXA6978
M 803	Motor Unit(Tray)	CXA6977
M 801	Motor Unit(Spindle)	CXA6991
M 804	Motor Unit(Carriage)	CXA4649
P 801 802	Photo-Transistor	PT4800
S 803 804	Switch(TRP,DSP)	CSN1012

# Service Manual

ORDER NO.  
**CRZ1632**

The chapter 1 of this Service Manual will not be reprinted. On your additional orders, we may supply only the chapter 2. For the chapter 1, please make copies and attach to the chapter 2 at your side if necessary.

**MULTI-COMPACT DISC PLAYER**

**CDX-P616 UC**  
**CDX-P610 UC,EW,ES**  
**CDX-P610 X1B/EW**



- See the separate manual CX-624 (CRT1631) for the CD mechanism description and disassembly.
- The CD mechanism employed in this model is one of CX-624 series.

## CHAPTER 2

### CONTENTS

#### CHAPTER 2

1. EXPLODED VIEW .....	2-3
2. PACKING METHOD .....	2-8
3. CONNECTION DIAGRAM(1).....	2-13
4. SCHEMATIC CIRCUIT DIAGRAM(1).....	2-17
5. SCHEMATIC CIRCUIT DIAGRAM(2).....	2-20
6. CONNECTION DIAGRAM(2).....	2-23
7. BLOCK DIAGRAM .....	2-25

# 1. EXPLODED VIEW

## ● Magazine Assy(CXA5483)

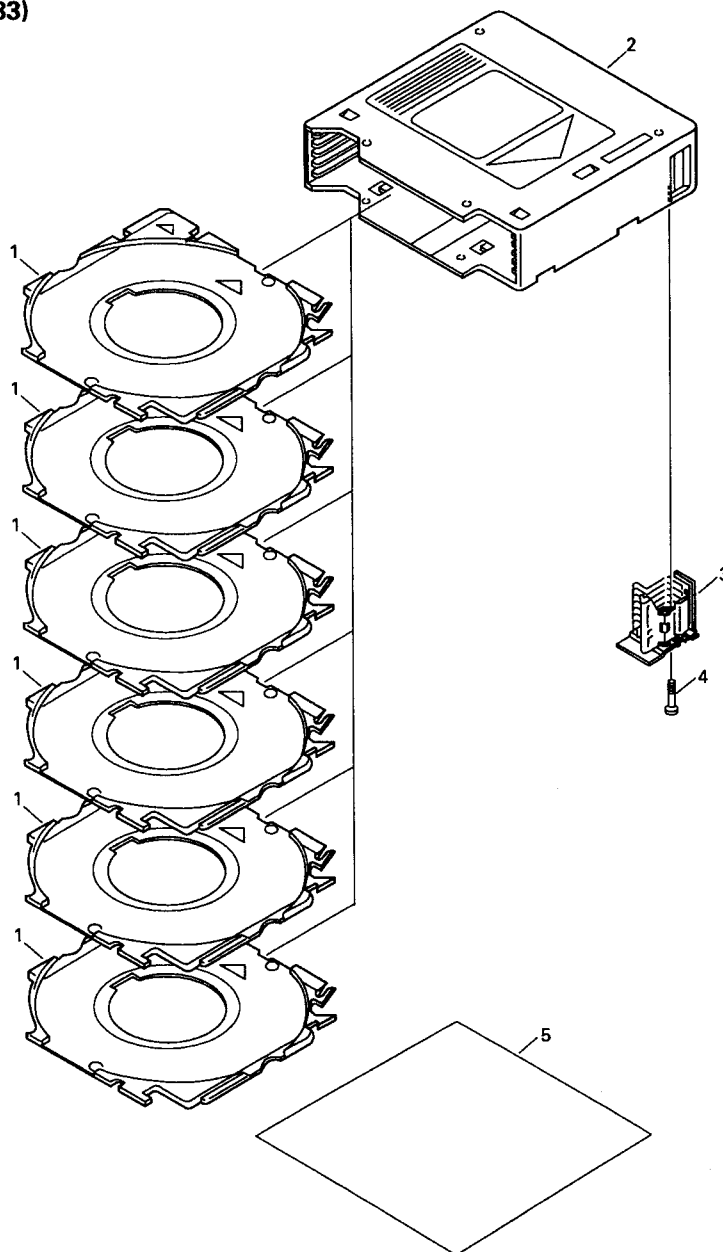

Fig.1

## ● Parts List

Mark No.	Description	Part No.
1	Tray Unit	CXA5484
2	Case Unit	CXA5479
3	Bracket Assy	CXA5480
4	Screw(M2x13)	CBA1272
5-1	Owner's Manual	CRD1639
5-2	Label	CRW1248



● CD Mechanism Unit(Parts List:Page 1-40)

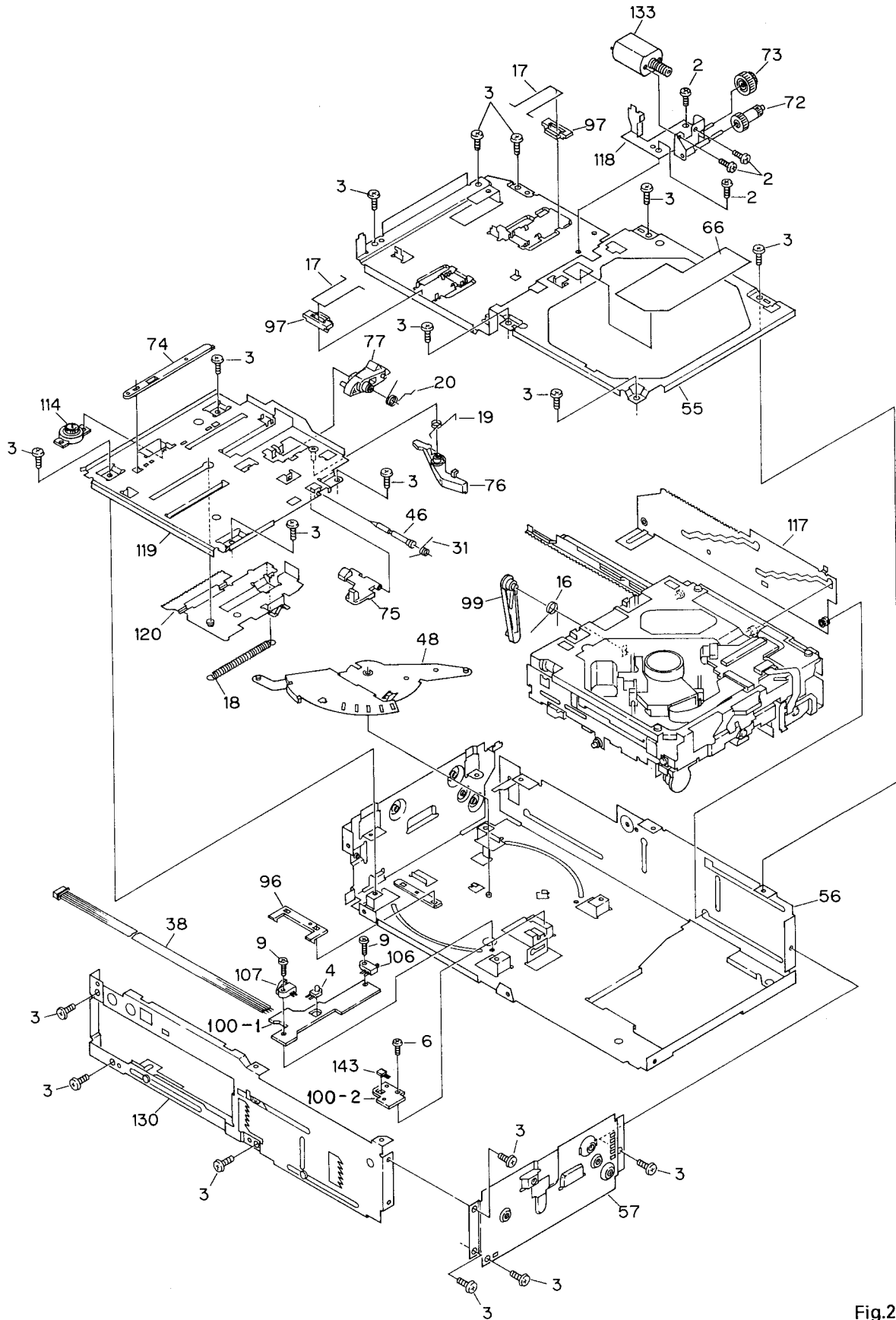

A

B

C

D

Fig.2

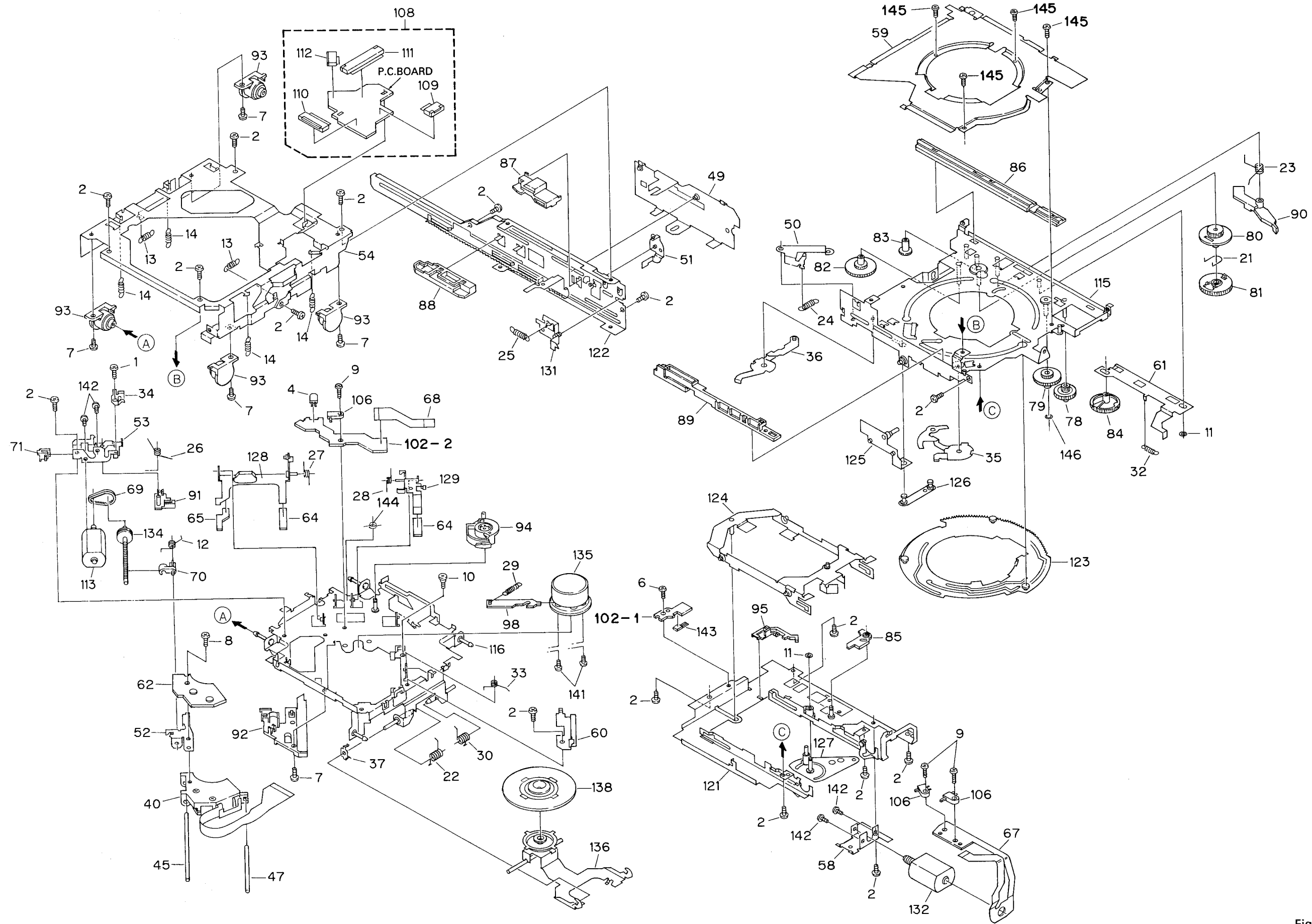

Fig.3

● Chassis(Parts List:Page 1-39)

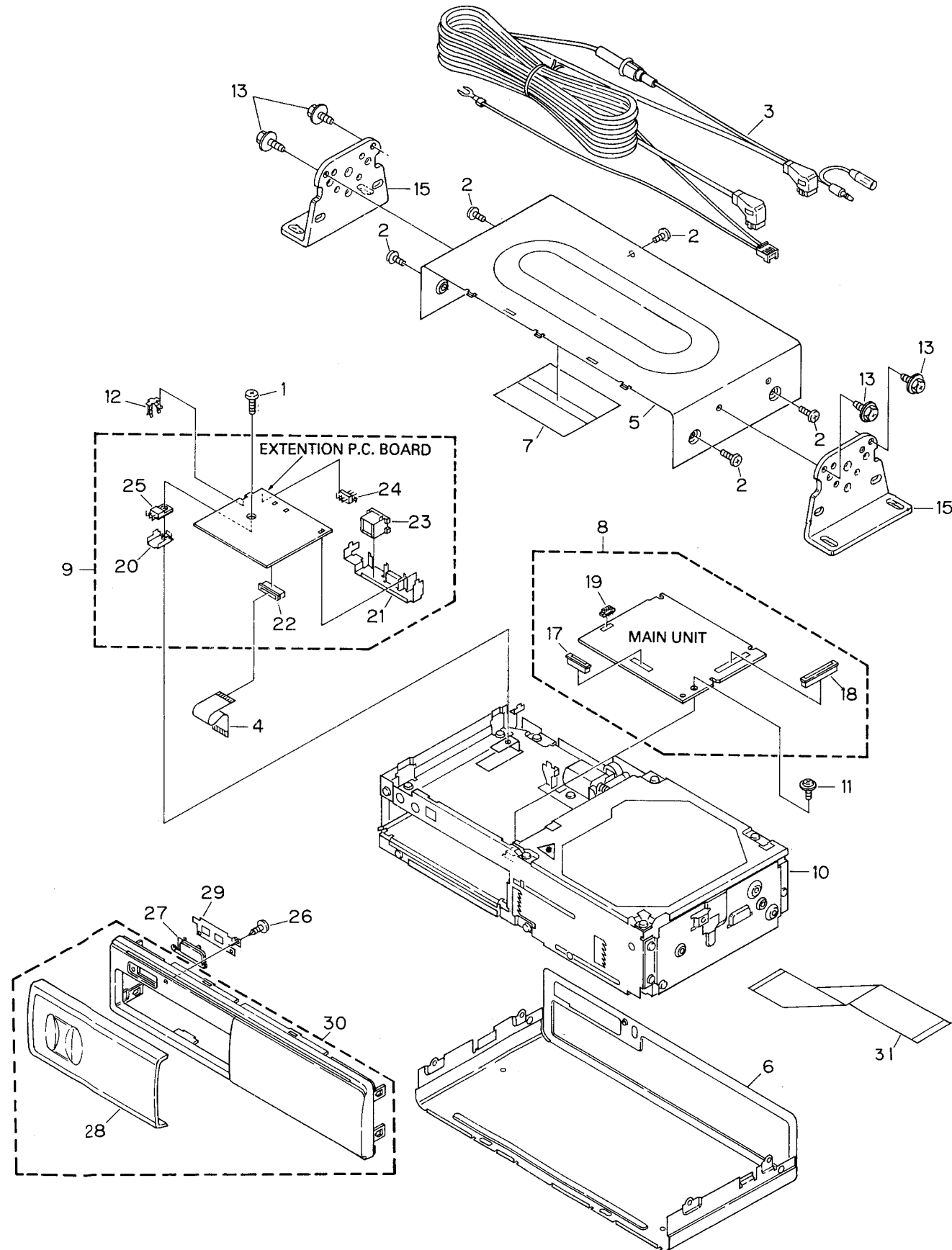

Fig.4

2. PACKING METHOD

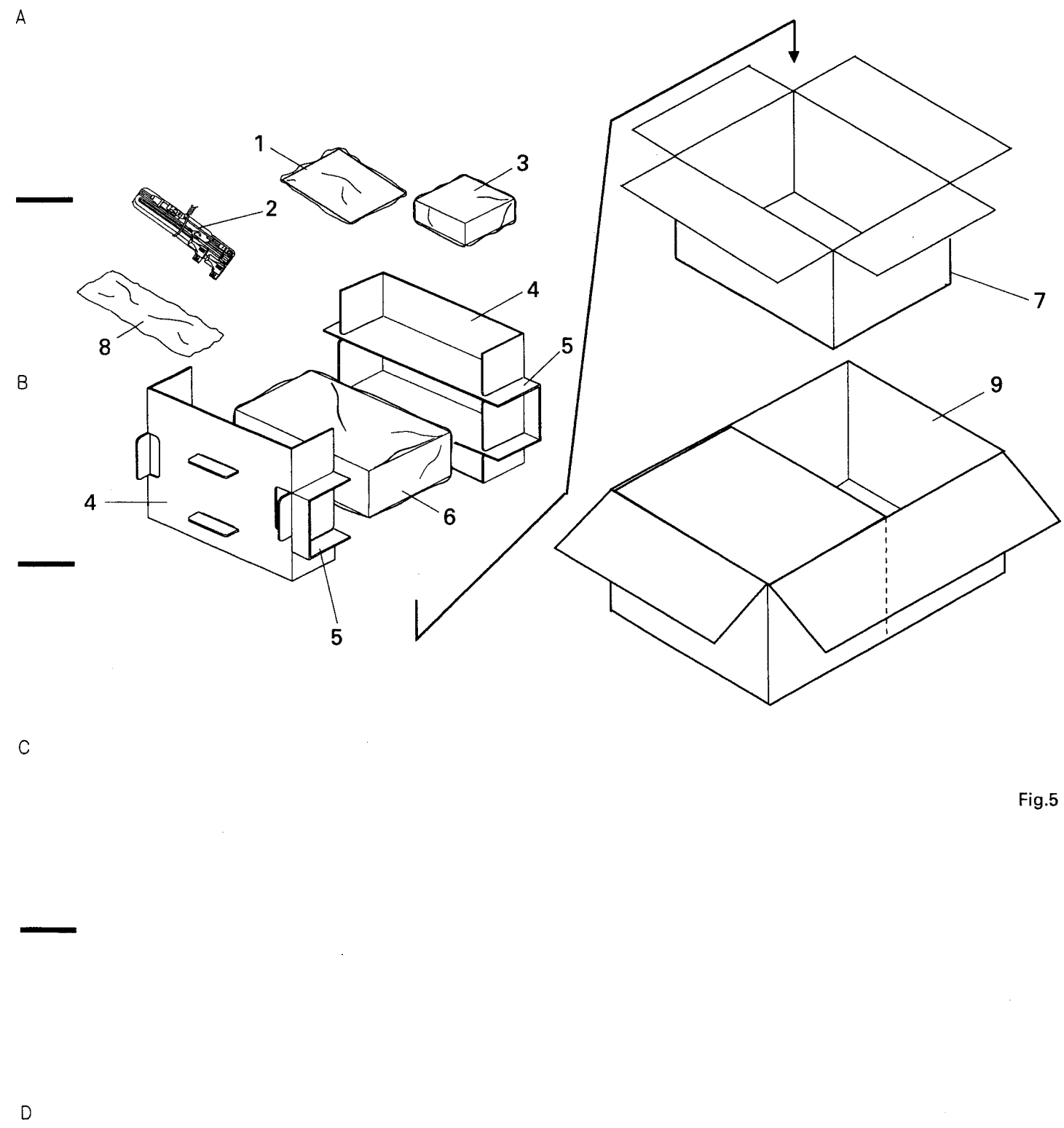

Fig.5

● Parts List(CDX-P616/UC)

Mark No.	Description	Part No.	Mark No.	Description	Part No.
1-1	Polyethylene Bag	CEG1116	8-1	Screw Assy	CEA1962
1-2	Owner's Manual	CRD1780	8-1-1	Screw(x4)	CBA1295
* 1-3	Warranty Card	CRY1070	* 8-1-2	Polyethylene Bag	E36-615
2	Cord	CDE4211	8-1-3	Screw(x4)	HMB60P500FMC
3	Magazine Assy	CXA5483	8-1-4	Screw(x4)	HMF40P080FZK
4	Protector	CHP1662	8-1-5	Nut(x4)	NF60FMC
5	Protector	CHP1661	8-2	Angle(x2)	CNB1874
6	Polyethylene Bag	CEG1174	* 8-3	Polyethylene Bag	E36-634
7	Carton	CHG2510	9	Contain Box	CHL2510
8	Accessory Assy	CEA2019			

• The CDX-P610/UC,EW,ES and CDX-P610/X1B/EW Parts Lists enumerate the parts which differ from those enumerated in the CDX-P616/UC Parts List only. The parts other than those enumerated in the former are identical with those in the latter, to which you are requested to refer, accordingly. The CDX-P616/UC Parts List is given on page 2-9.

Mark No.	Description	CDX-P616/UC Part No.	CDX-P610/UC Part No.	CDX-P610/EW Part No.	CDX-P610/ES Part No.	CDX-P610/X1B/EW Part No.
1-1	Polyethylene Bag	CEG1116	CEG1116	CEG1116	.....	*UEG-004
1-2	Owner's Manual	CRD1780	CRD1778	CRD1777	CRD1779	CRD1777
				CRD1776		CRD1776
* 1-3	Warranty Card	CRY1070	.....	CRY1071	.....	URY-001
2	Cord	CDE4211	CDE4211	CDE4210	CDE4211	CDE4210
6	Polyethylene Bag	CEG1185	CEG1185	CEG1042	CEG1042	UEG-003
7	Carton	CHG2510	CHG2508	CHG2507	CHG2509	CHG2507
9	Contain Box	CHL2510	CHL2508	CHL2507	CHL2509	CHL2507
* Card		.....	ARY1048	.....	.....	.....

● Owner's Manual

Part No.	Model	Language
CRD1776	CDX-P610/EW	English,Italian,French,German,Dutch
CRD1777	CDX-P610/EW	Spanish,Portuguese,Swedish,Norwegian,Finnish
CRD1778	CDX-P610/UC	English,French
CRD1779	CDX-P610/ES	English,French,German,Spanish,Arabic
CRD1780	CDX-P616/UC	English,French

Note: 1. The encircled numbers denote measuring points in the circuit diagram.  
2. Reference voltage  
REFO: 2.5V

● Waveforms

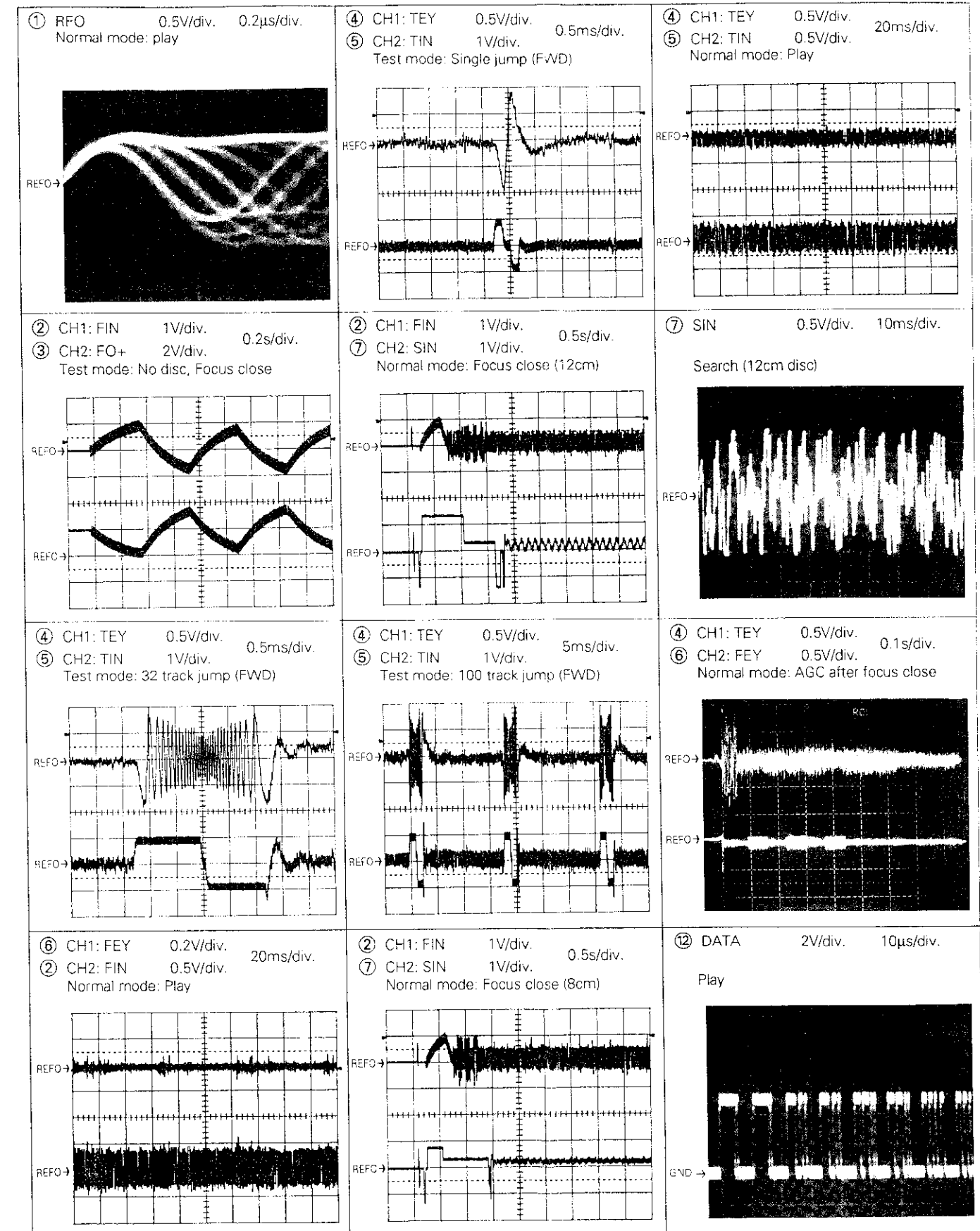

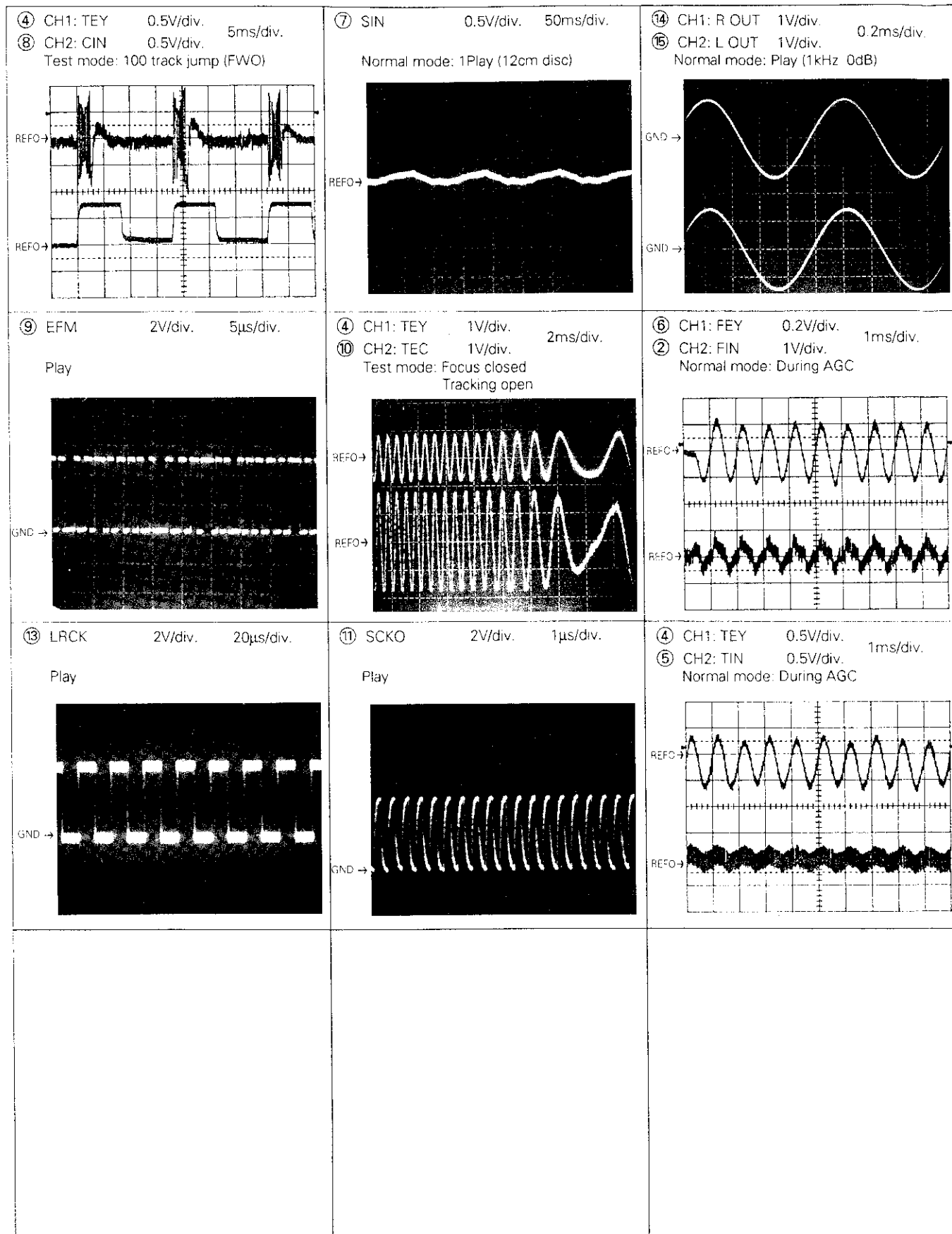

3. CONNECTION DIAGRAM(1)

A

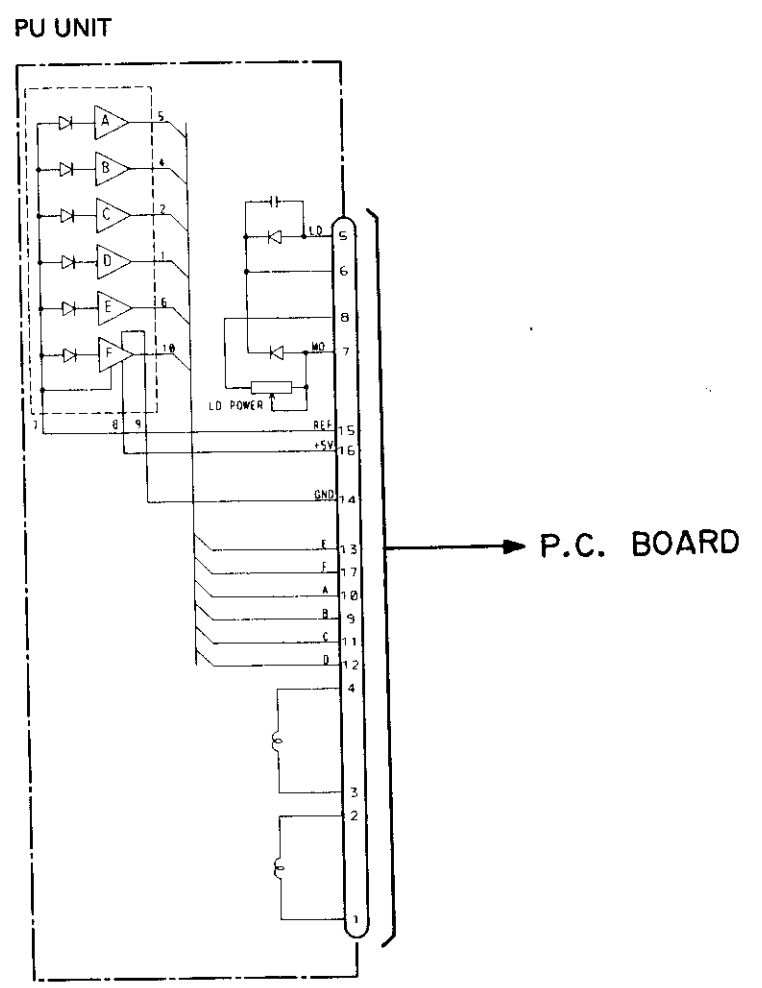

B

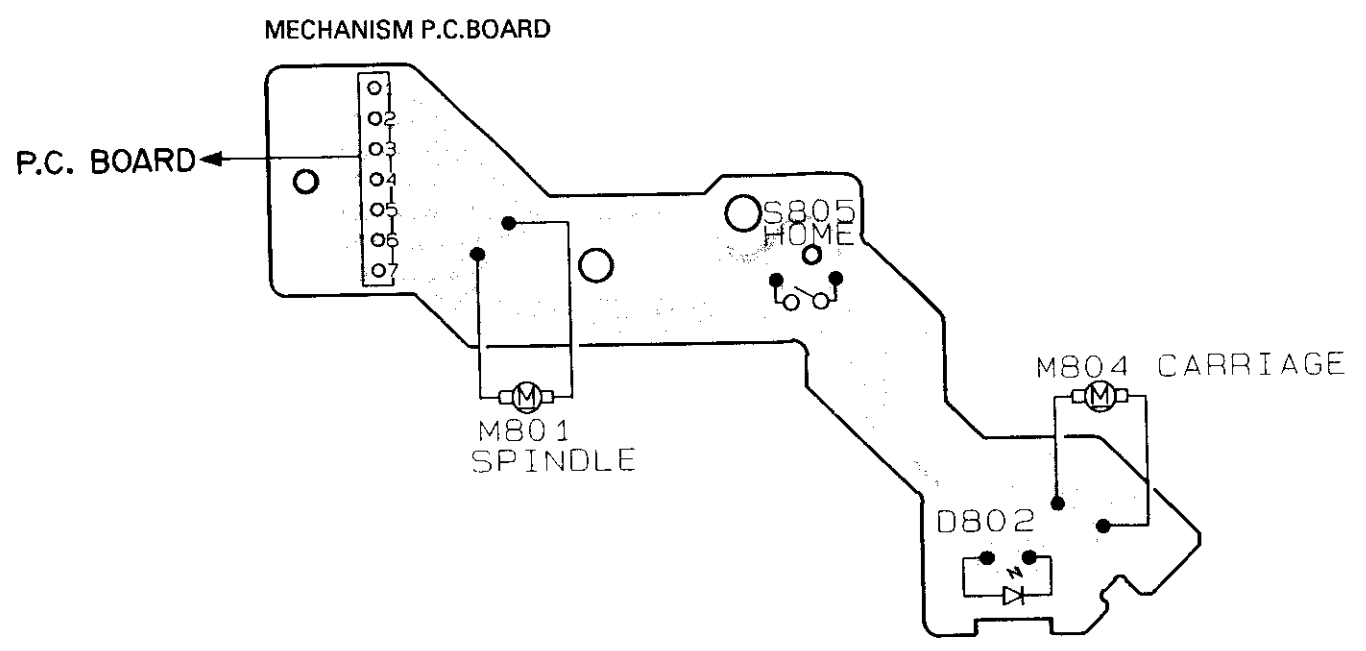

C

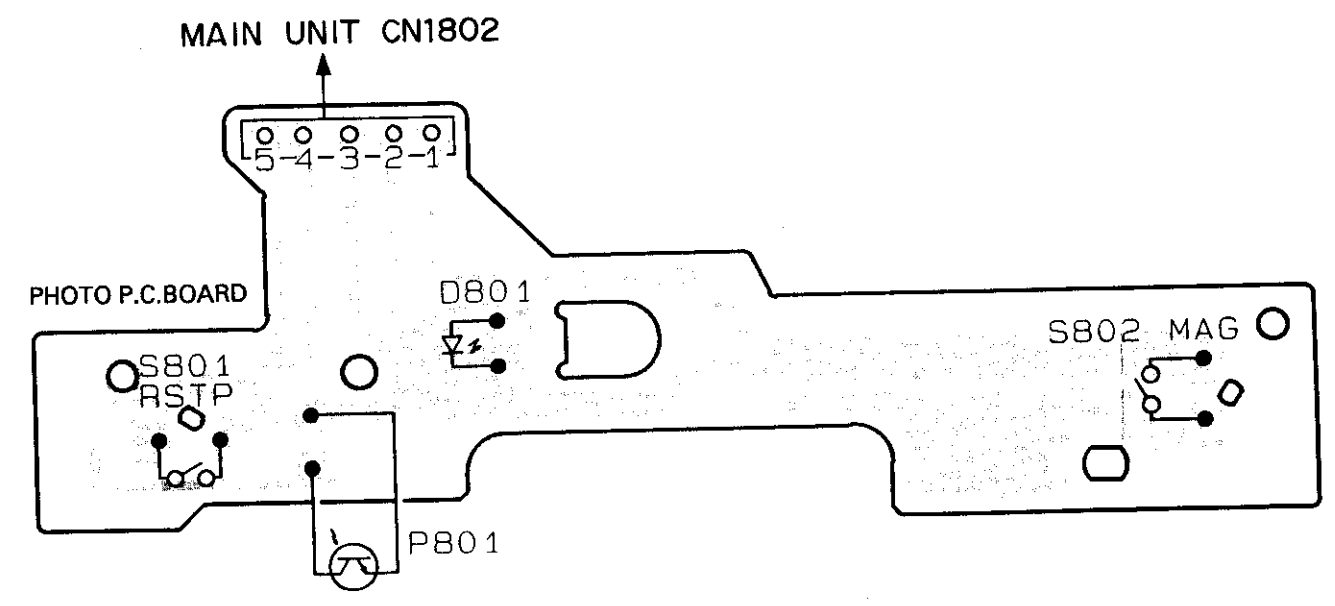

D

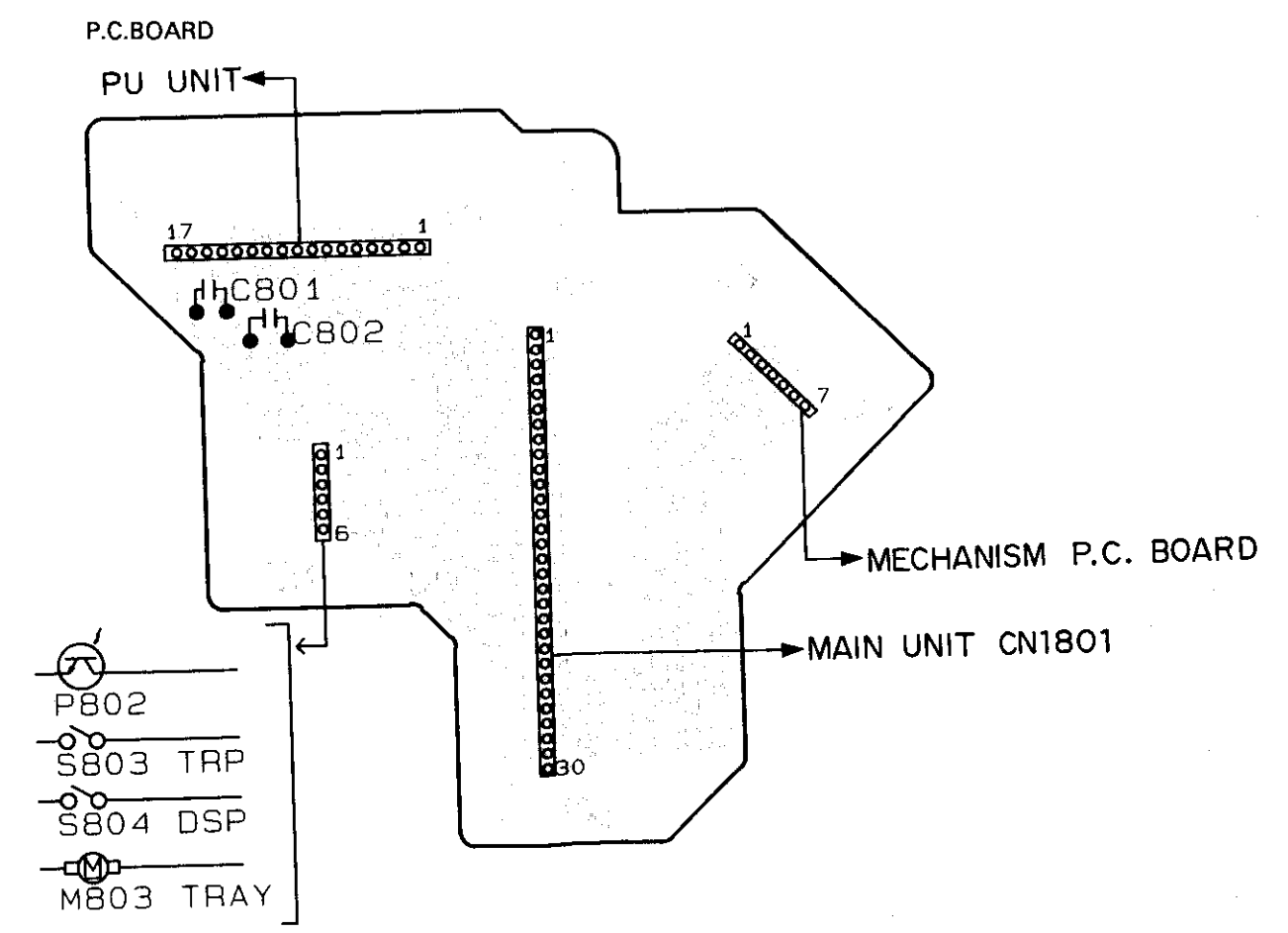

1

2

3

4

5

6

AGE

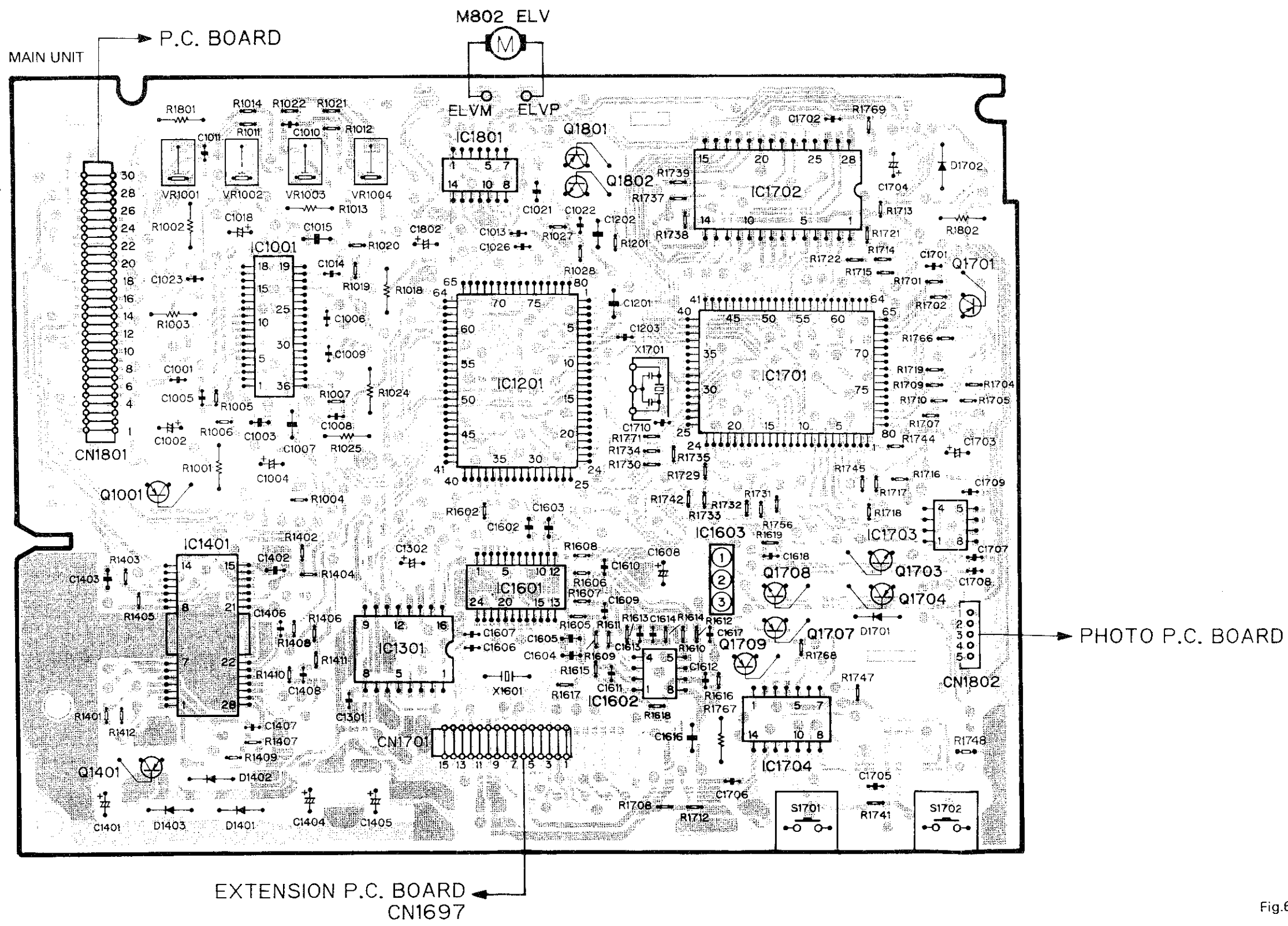

- | IC, Q  | ADJ    |
|--------|--------|
| IC1801 | VR1001 |
| Q1801  | VR1002 |
| Q1802  | VR1003 |
| IC1702 | VR1004 |
| Q1701  |        |
| IC1001 |        |
| IC1201 |        |
| IC1701 |        |
| Q1001  |        |
| IC1703 |        |
| IC1601 |        |
| IC1603 |        |
| Q1703  |        |
| Q1708  |        |
| Q1704  |        |
| Q1707  |        |
| IC1401 |        |
| IC1301 |        |
| Q1709  |        |
| IC1602 |        |
| IC1704 |        |
| Q1401  |        |
| CN1801 |        |

Fig.6

# 4. SCHEMATIC CIRCUIT DIAGRAM(1)

- S --- SIGNAL LINE
- F --- FOCUS SERVO LINE
- T --- TRACKING SERVO LINE
- L --- LARRIAGE SERVO LINE
- S --- SPINDLE SERVO LINE

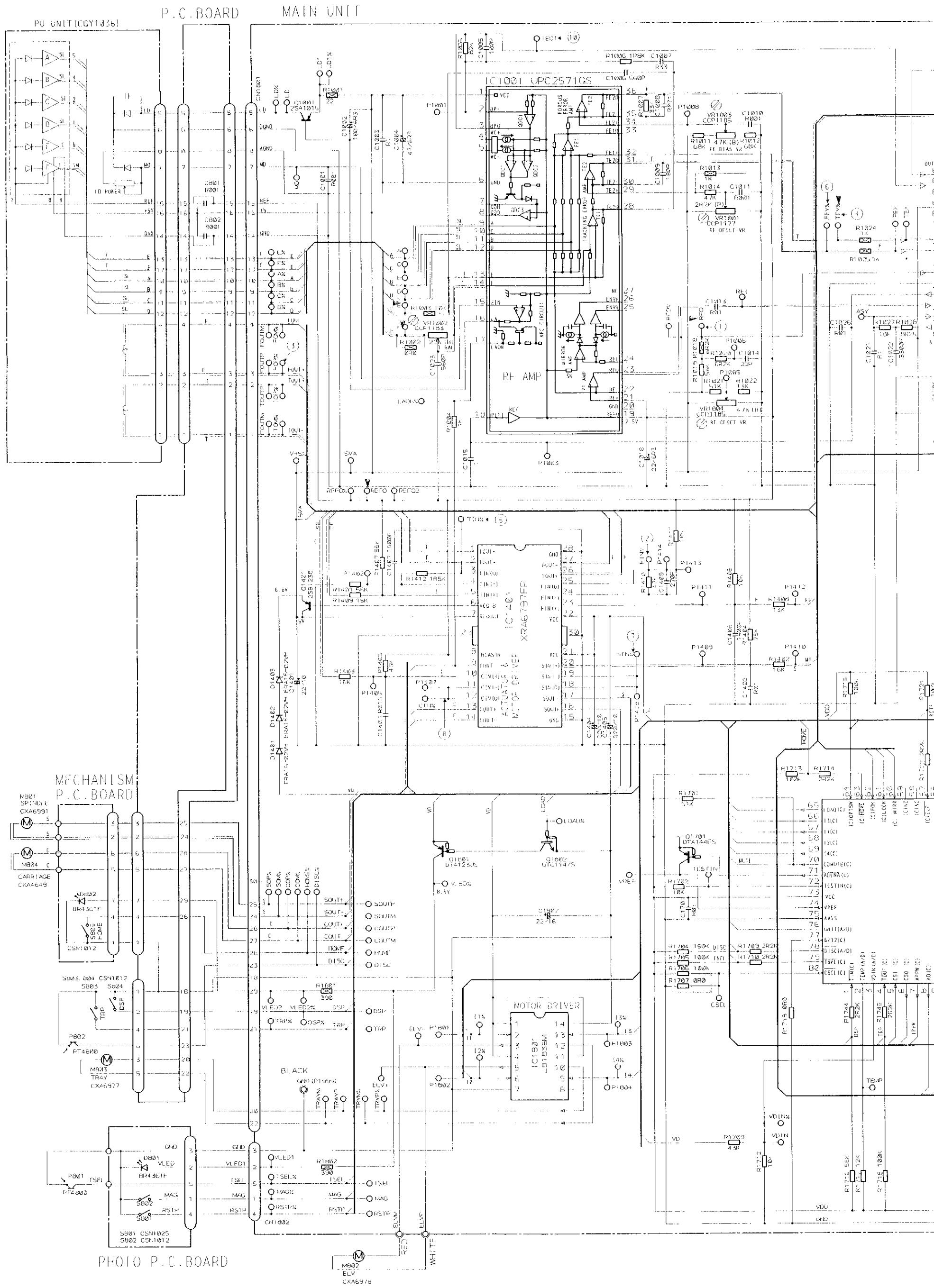



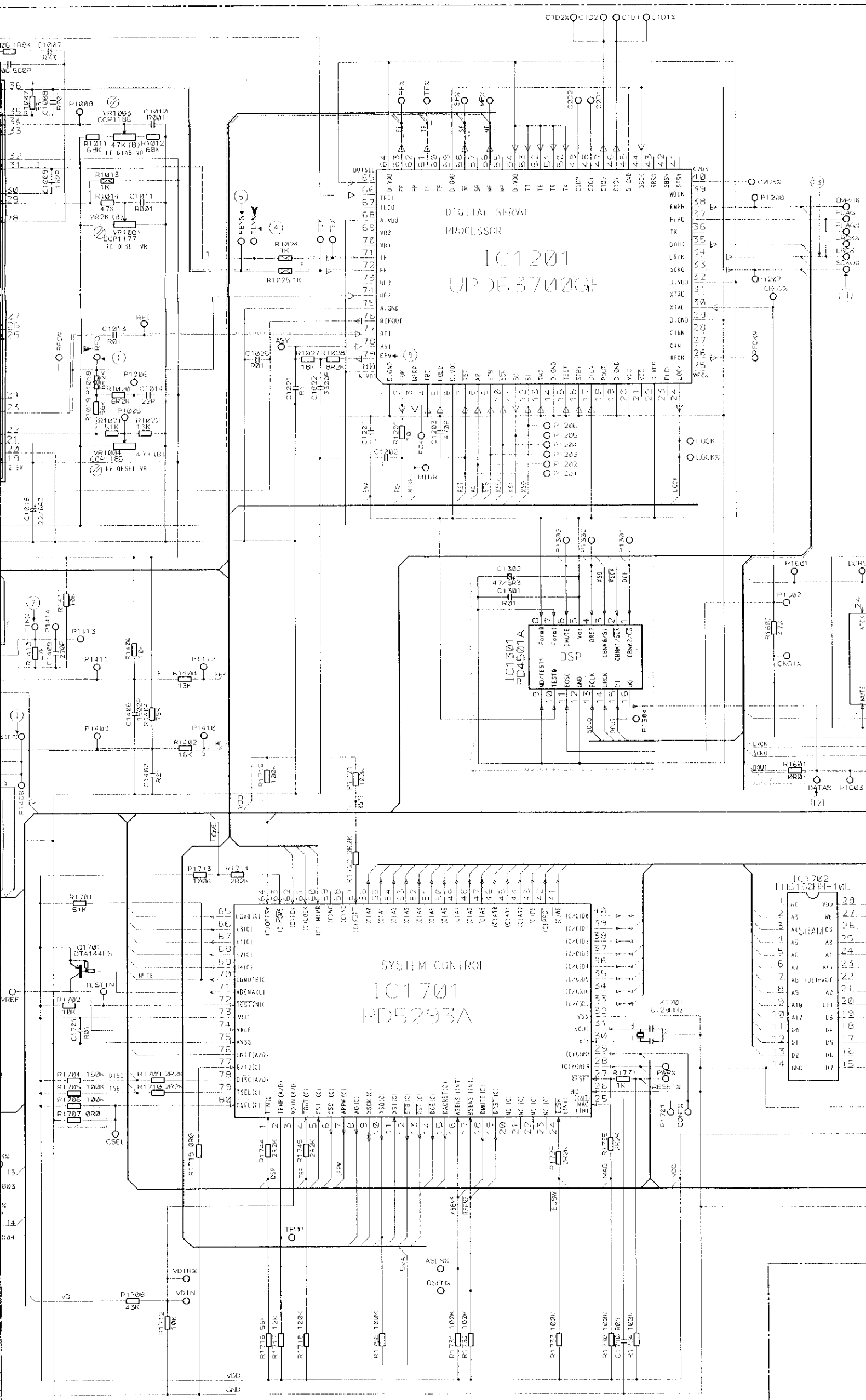

IC1501	CDX-P610	CDX-P616
R1601	0	PD4581A
R1706	100K	
R1781	0	
C1501	0	
C1502		47/603

NOTE

□ Symbol indicates a resistor. No differentiation is made between chip discrete resistors.

⊃ Symbol indicates a capacitor. No differentiation is made between chip discrete capacitors.

Decimal points for resistor and capacitor fixed values are expressed as:  
 2.2 → R22  
 0.022 → R022

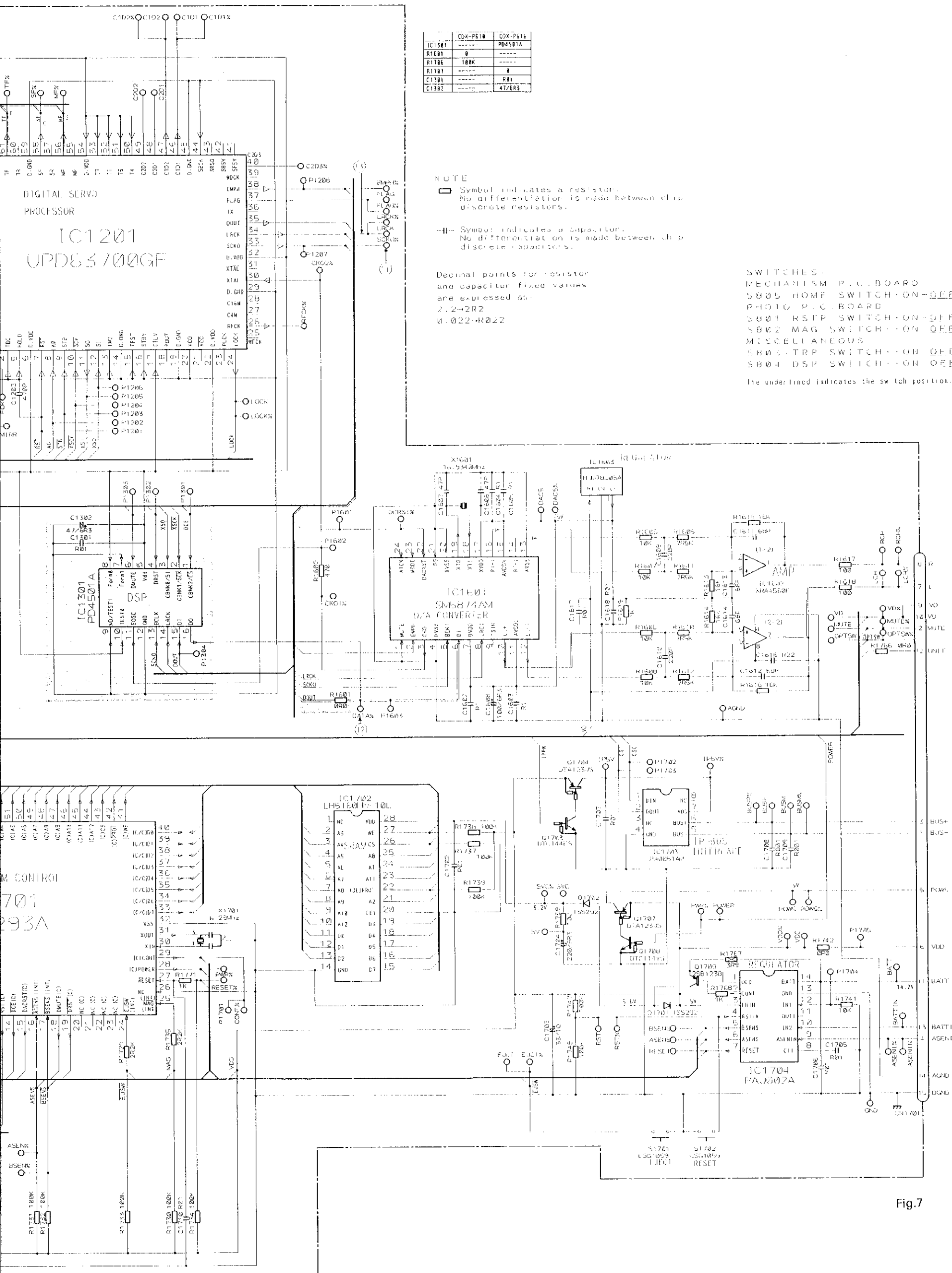

	CDX-P616	CDX-P610
IC1601	8	PD4501A
R1601	8	
R1706	100K	
R1707	8	
C1502		8
C1503		47/63

NOTE  
 □ Symbol indicates a resistor.  
 No differentiation is made between chip and discrete resistors.

⊞ Symbol indicates a capacitor.  
 No differentiation is made between chip and discrete capacitors.

Decimal points for resistor and capacitor fixed values are expressed as:  
 2.2-2R2  
 0.022-R022

SWITCHES -  
 MECHANISM P.C. BOARD  
 S805 HOME SWITCH - ON OFF  
 PHOTO P.C. BOARD  
 S801 RSTP SWITCH - ON OFF  
 S802 MAG SWITCH - ON OFF  
 MISCELLANEOUS  
 S803 TRP SWITCH - ON OFF  
 S804 DSP SWITCH - ON OFF

The underlined indicates the switch position.

Fig.7

5. SCHEMATIC CIRCUIT DIAGRAM(2)

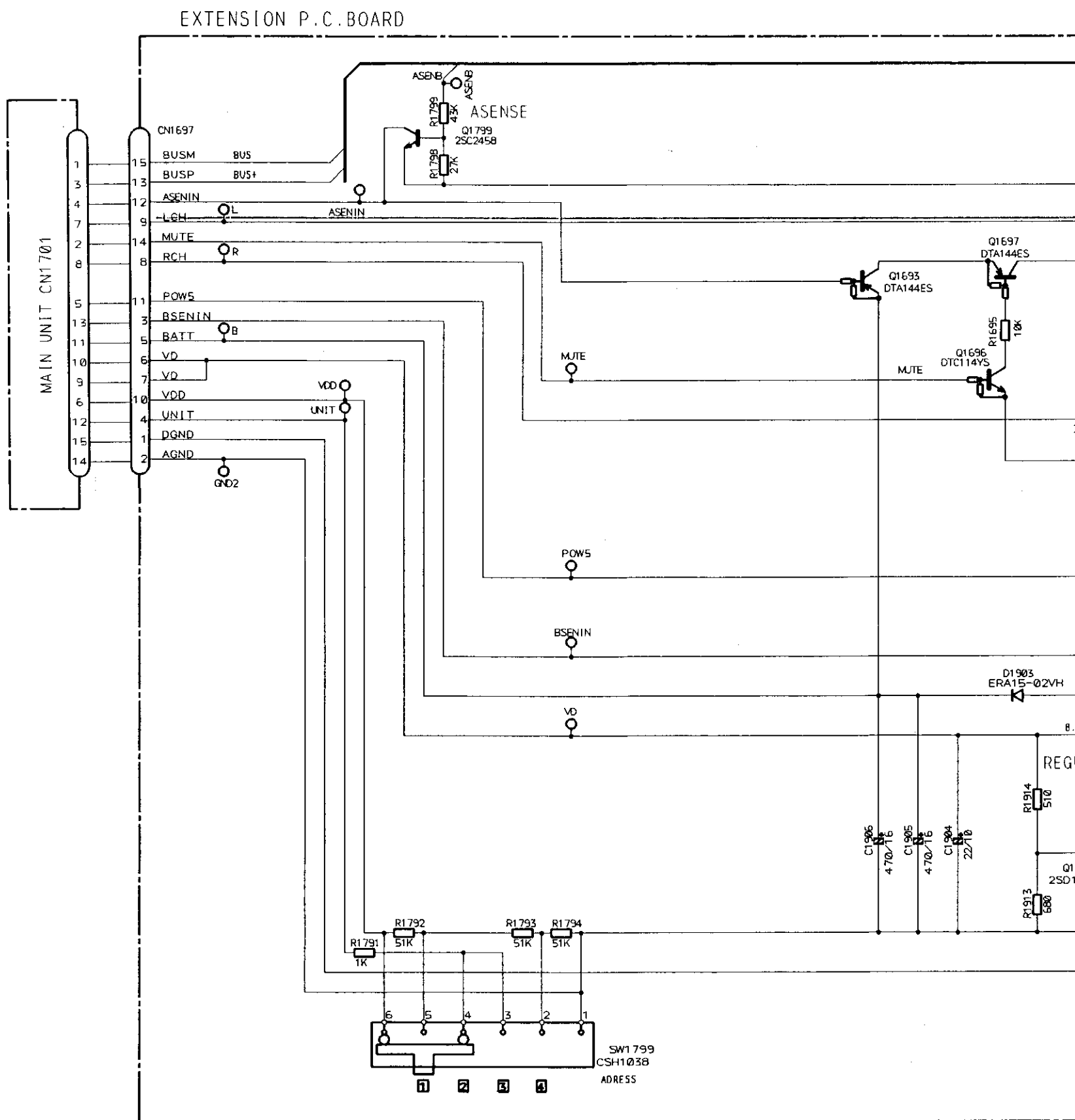

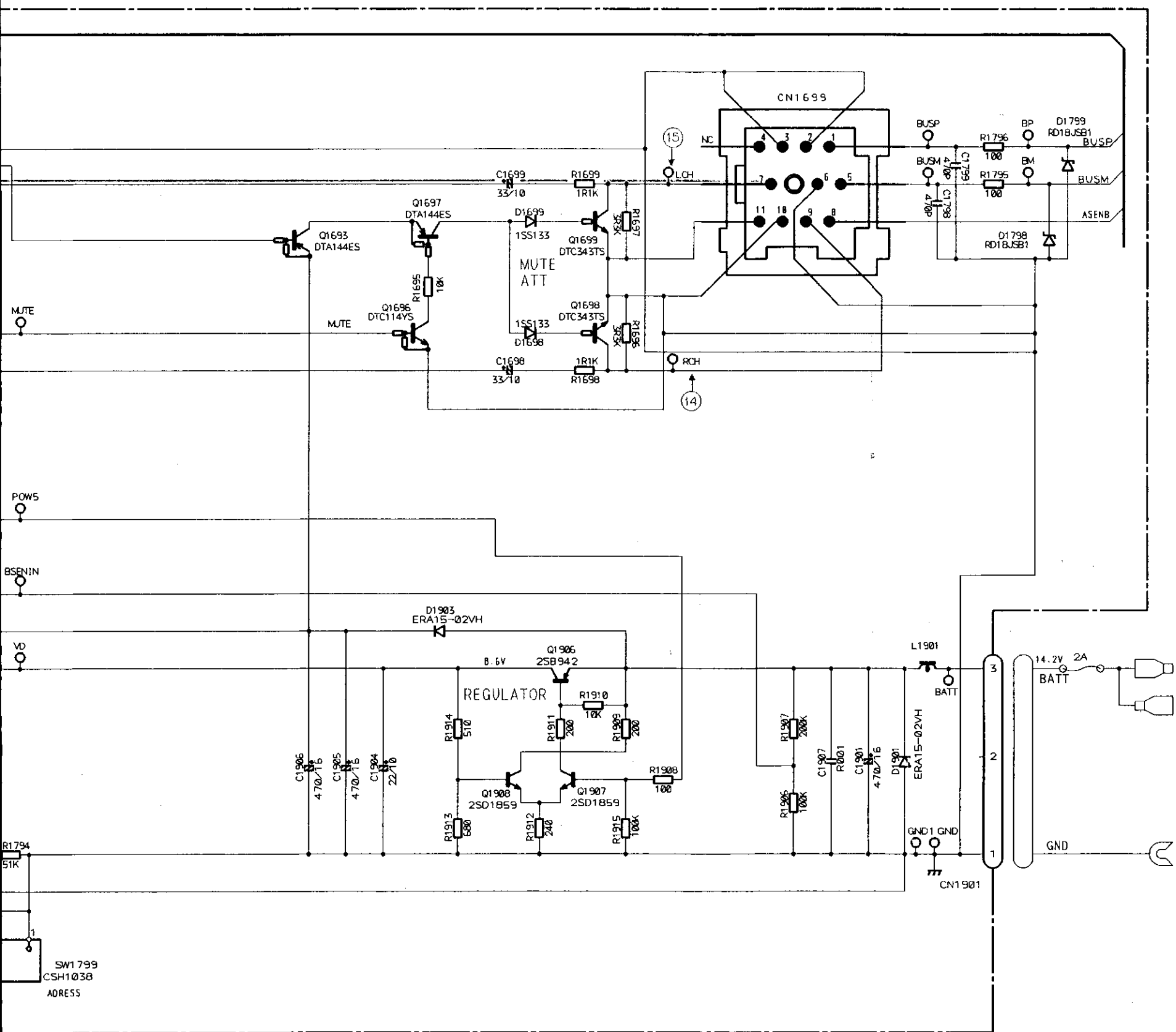

Fig.8

6

7

8

9

A

B

C

D

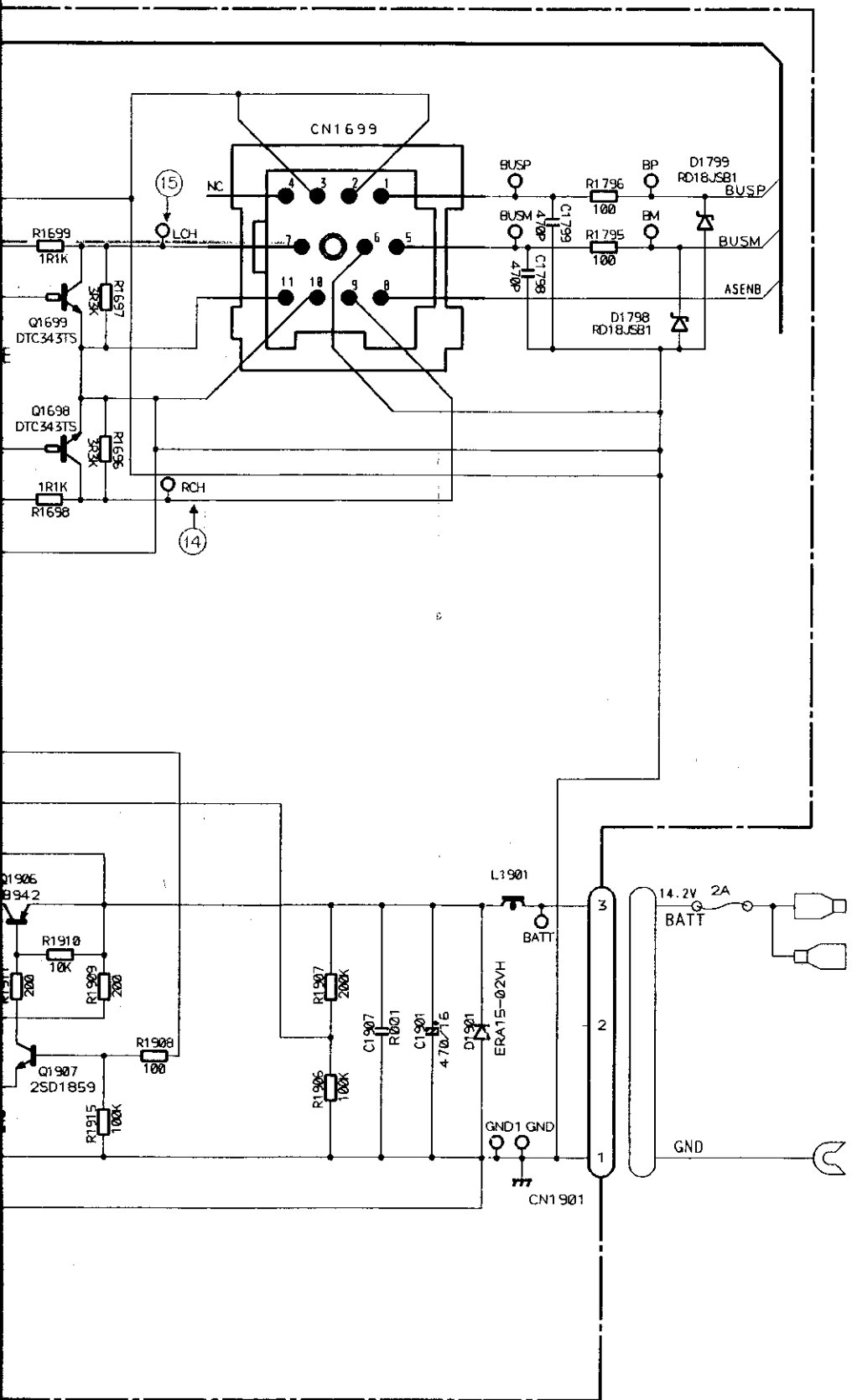

Fig.8

6

7

8

9

6. CONNECTION DIAGRAM(2)

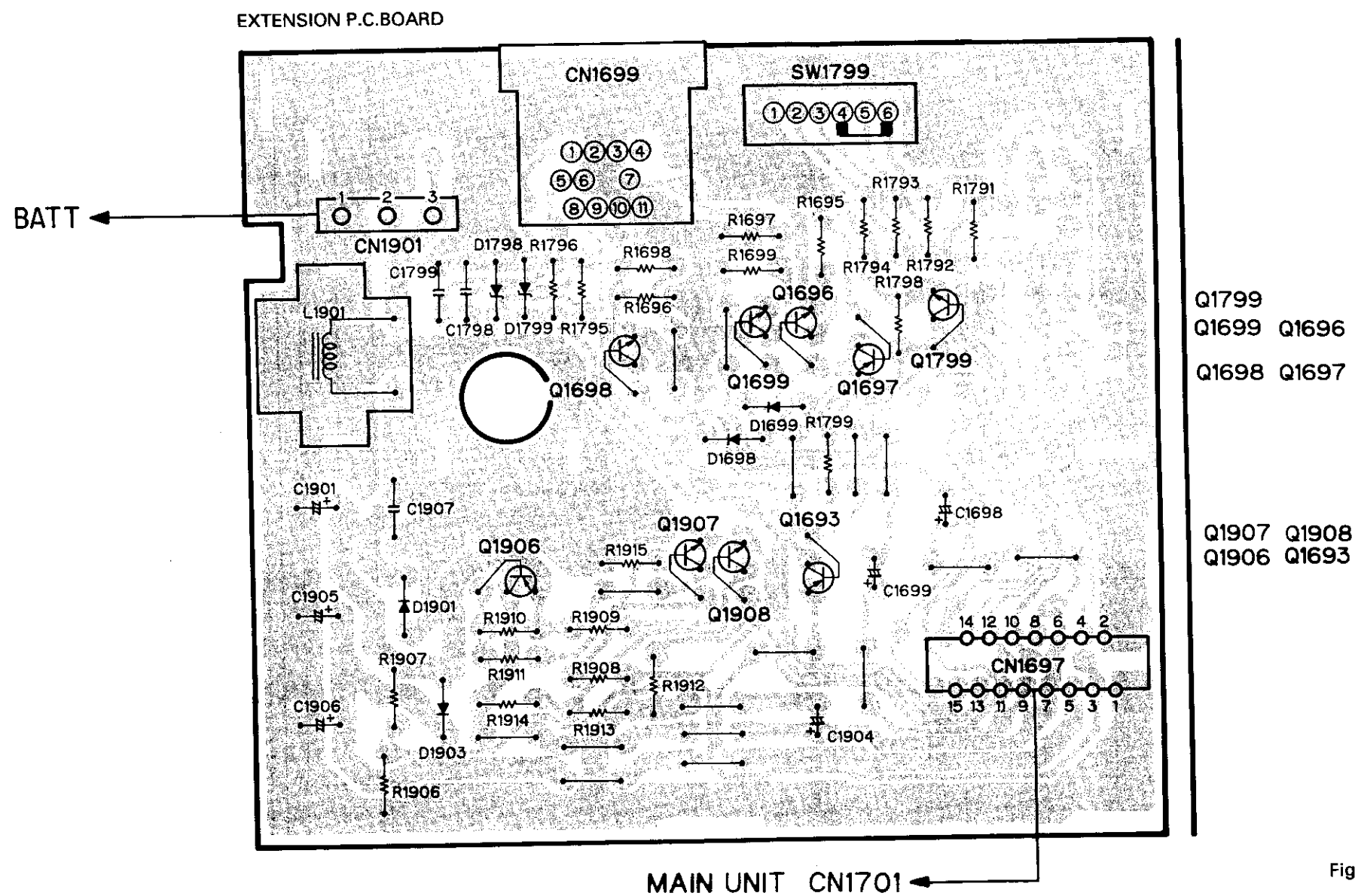

Fig.9

7. BLOCK DIAGRAM

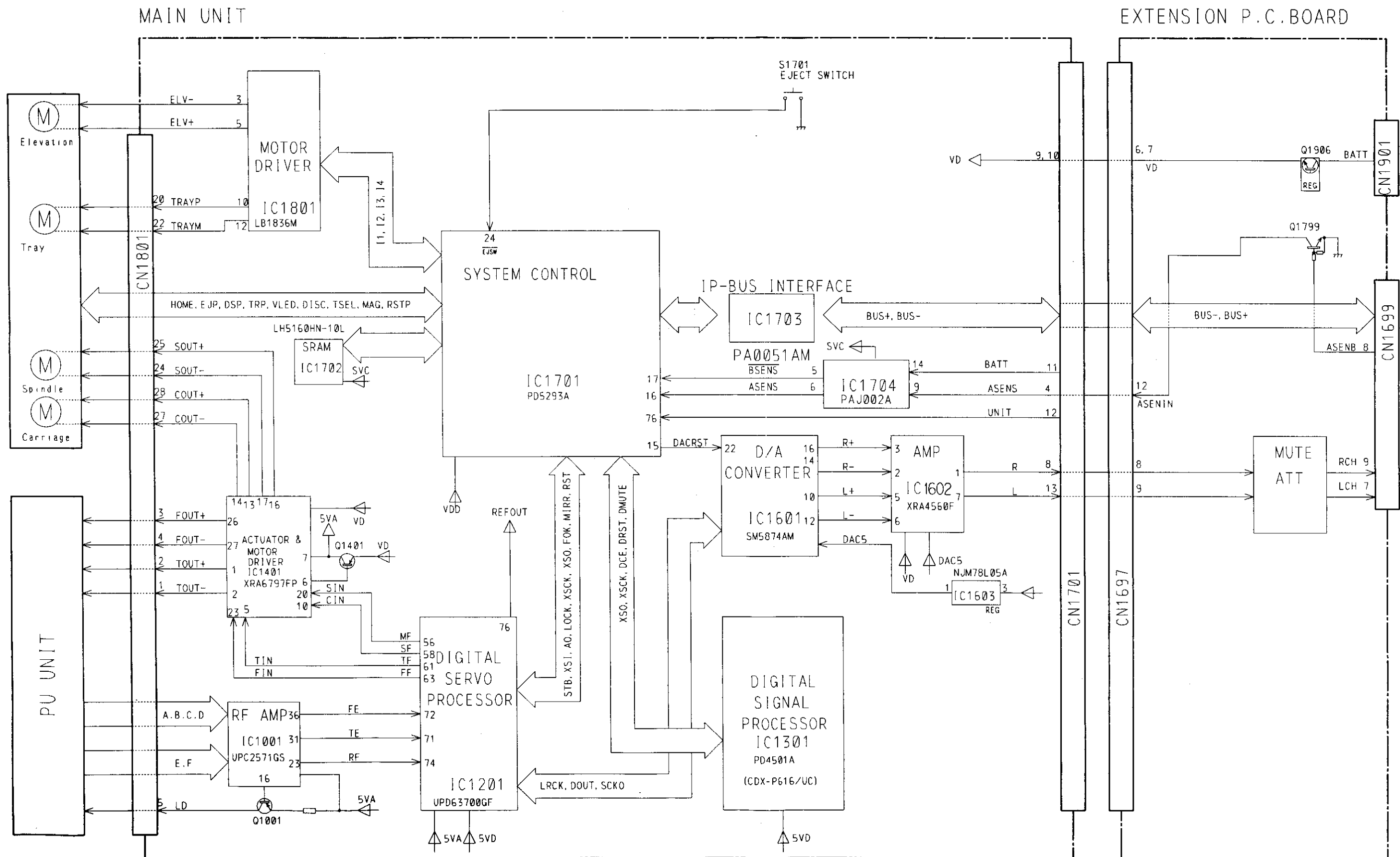

Fig.10