

# Service Manual

ORDER NO.  
ARP2343

COMPACT DISC JUKEBOX

# CJ-V55LR

KU

- Refer to the service manuals ARP1913 for CJ-V55 (PD-MV55) and ARP1912 for CJ-V55 (SERVICE MANUAL (1)).
- This manual is applicable to KU type.
- The CJ-V55LR mainly differs from the CJ-V55 in having two CD players, a coin acceptor and a bill acceptor.

## CONTRAST OF MISCELLANEOUS PARTS

**NOTES:**

- Parts without part number cannot be supplied.
- The  $\Delta$  mark found on some component parts indicates the importance of the safety factor of the part. Therefore, when replacing, be sure to use parts of identical designation.
- Parts marked by "⊙" are not always kept in stock. Their delivery time may be longer than usual or they may be unavailable.

CJ-V55LR/KU and CJ-V55/KUC have the same construction except for the following:

Mark	Symbol & Description	Part No.		Remarks
		CJ-V55 /KUC type	CJ-V55LR /KU type	
	Pad	••••	DHA1157	1
	Packing case	DHG1229	DHG1320	2
	Packing cap	DHG1200	DHG1326	3
	Accessories case	••••	DHK1055	4
	Coin acceptor	••••	DXB-134	5
	Bill acceptor	••••	DXB1360	6

Note: The numbers shown in the "Remarks" column refer to those in the figures in the subsequent pages.

• COIN ACCEPTOR

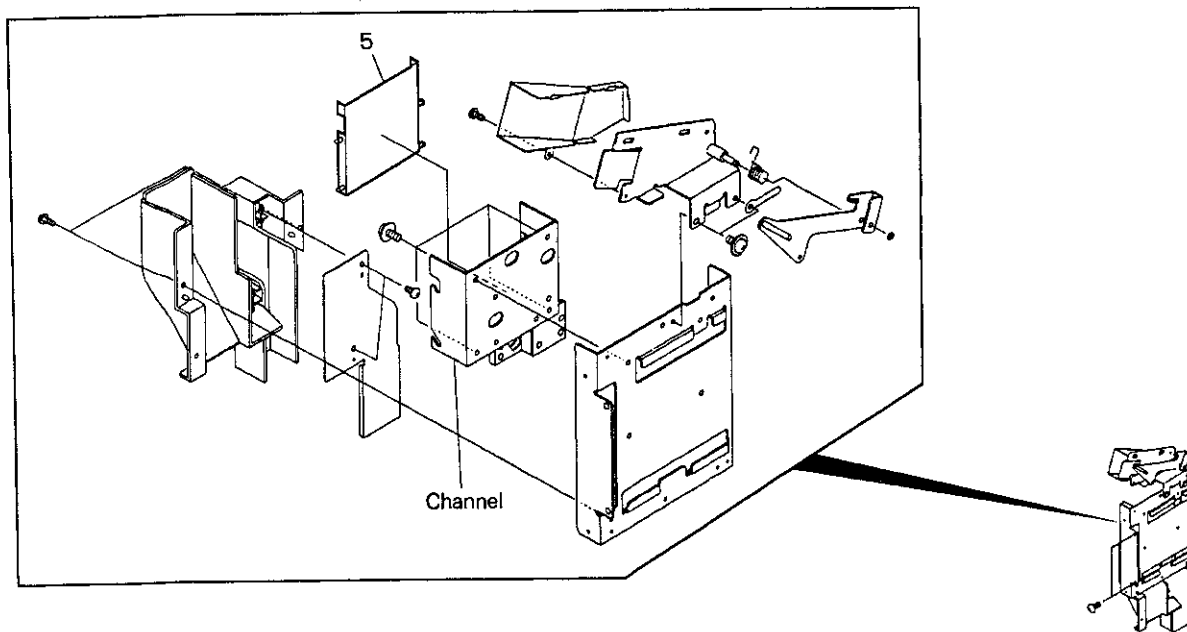

• BILL ACCEPTOR

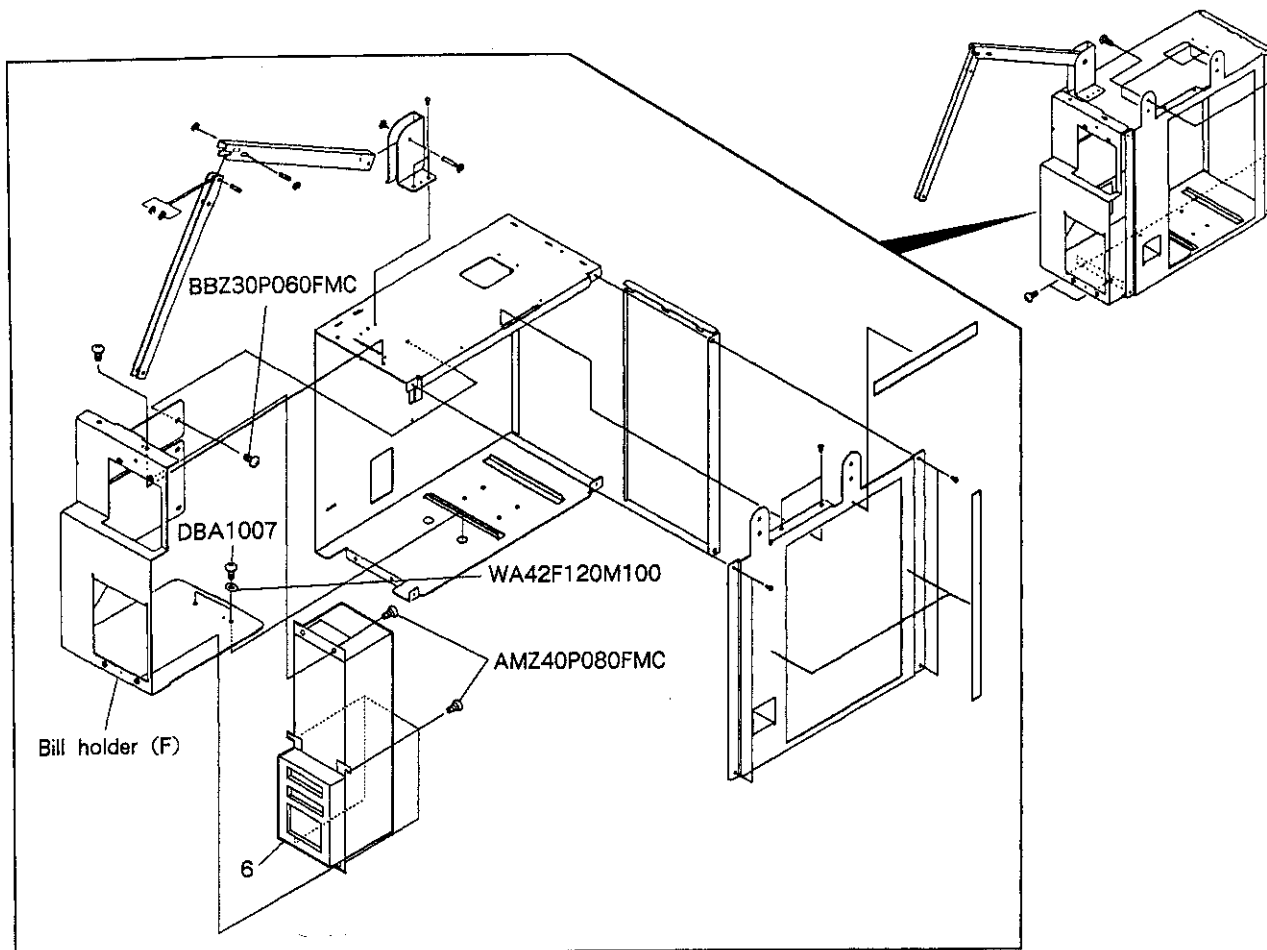

• PACKING

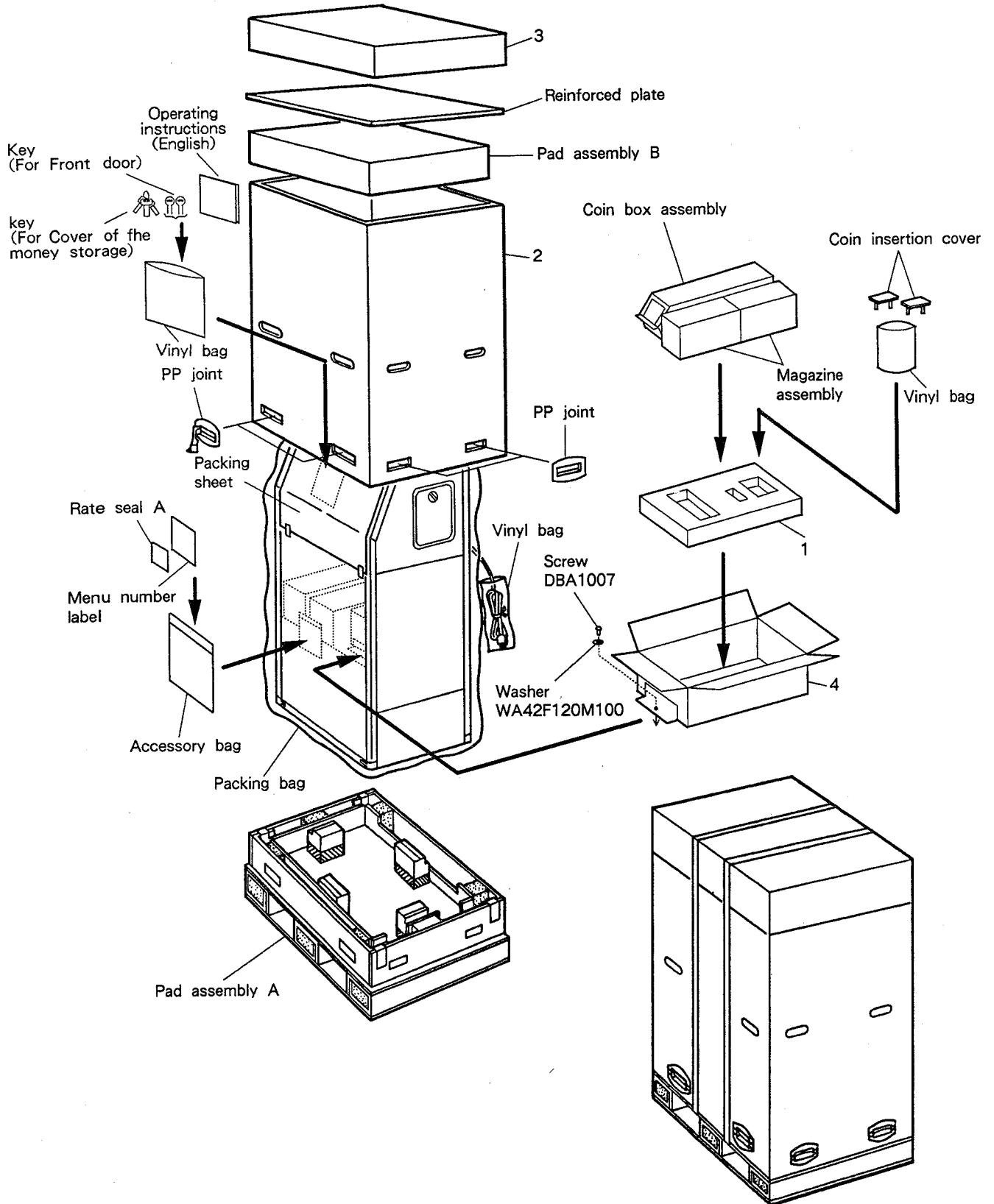

# Service Manual

 **PIONEER®**  
The future of sound and vision.

3076

(1)

ORDER NO.  
ARP1912

COMPACT DISC JUKEBOX

# CJ-V55

• Refer to the service manual ARP1913, CJ-V55.

• This manual is applicable to the KUC type.

## CONTENTS

1. SAFETY INFORMATION.....	2
2. PARTS LOCATIONS.....	3
3. DISASSEMBLY .....	10
4. P.C. BOARDS NAME.....	13
5. SERVICE MODE.....	14

**PIONEER ELECTRONIC CORPORATION** 4-1, Meguro 1-Chome, Meguro-ku, Tokyo 153, Japan  
**PIONEER ELECTRONICS SERVICE INC.** P.O. Box 1760, Long Beach, California 90801 U.S.A.  
**PIONEER ELECTRONICS OF CANADA, INC.** 505 Cochrane Drive, Markham, Ontario L3R 8E3 Canada  
**PIONEER ELECTRONIC [EUROPE] N.V.** Keetberglaan 1, 2740 Beveren, Belgium  
**PIONEER ELECTRONICS AUSTRALIA PTY. LTD.** 178-184 Boundary Road, Braeside, Victoria 3195, Australia TEL: [03] 580-9911  
© PIONEER ELECTRONIC CORPORATION 1990

IFI JAN. 1990 Printed in Japan

3076

## 1. SAFETY INFORMATION

(FOR USA MODEL ONLY)

### 1. SAFETY PRECAUTIONS

The following check should be performed for the continued protection of the customer and service technician.

#### LEAKAGE CURRENT CHECK

Measure leakage current to a known earth ground (water pipe, conduit, etc.) by connecting a leakage current tester such as Simpson Model 229-2 or equivalent between the earth ground and all exposed metal parts of the appliance (input/output terminals, screwheads, metal overlays, control shaft, etc.). Plug the AC line cord of the appliance directly into a 120V AC 60Hz outlet and turn the AC power switch on. Any current measured must not exceed 0.5mA.

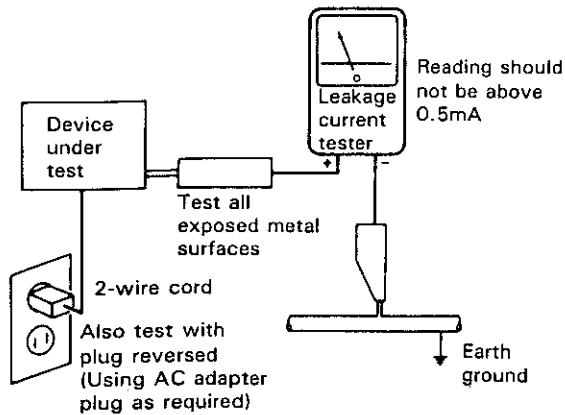

AC Leakage Test

ANY MEASUREMENTS NOT WITHIN THE LIMITS OUTLINED ABOVE ARE INDICATIVE OF A POTENTIAL SHOCK HAZARD AND MUST BE CORRECTED BEFORE RETURNING THE APPLIANCE TO THE CUSTOMER.

### 2. PRODUCT SAFETY NOTICE

Many electrical and mechanical parts in the appliance have special safety related characteristics. These are often not evident from visual inspection nor the protection afforded by them necessarily can be obtained by using replacement components rated for voltage, wattage, etc. Replacement parts which have these special safety characteristics are identified in this Service Manual.

Electrical components having such features are identified by marking with a  $\Delta$  on the schematics and on the parts list in this Service Manual.

The use of a substitute replacement component which does not have the same safety characteristics as the PIONEER recommended replacement one, shown in the parts list in this Service Manual, may create shock, fire, or other hazards.

Product Safety is continuously under review and new instructions are issued from time to time. For the latest information, always consult the current PIONEER Service Manual. A subscription to, or additional copies of, PIONEER Service Manual may be obtained at a nominal charge from PIONEER.

## 2. PARTS LOCATIONS

### 2.1 EXTERIOR

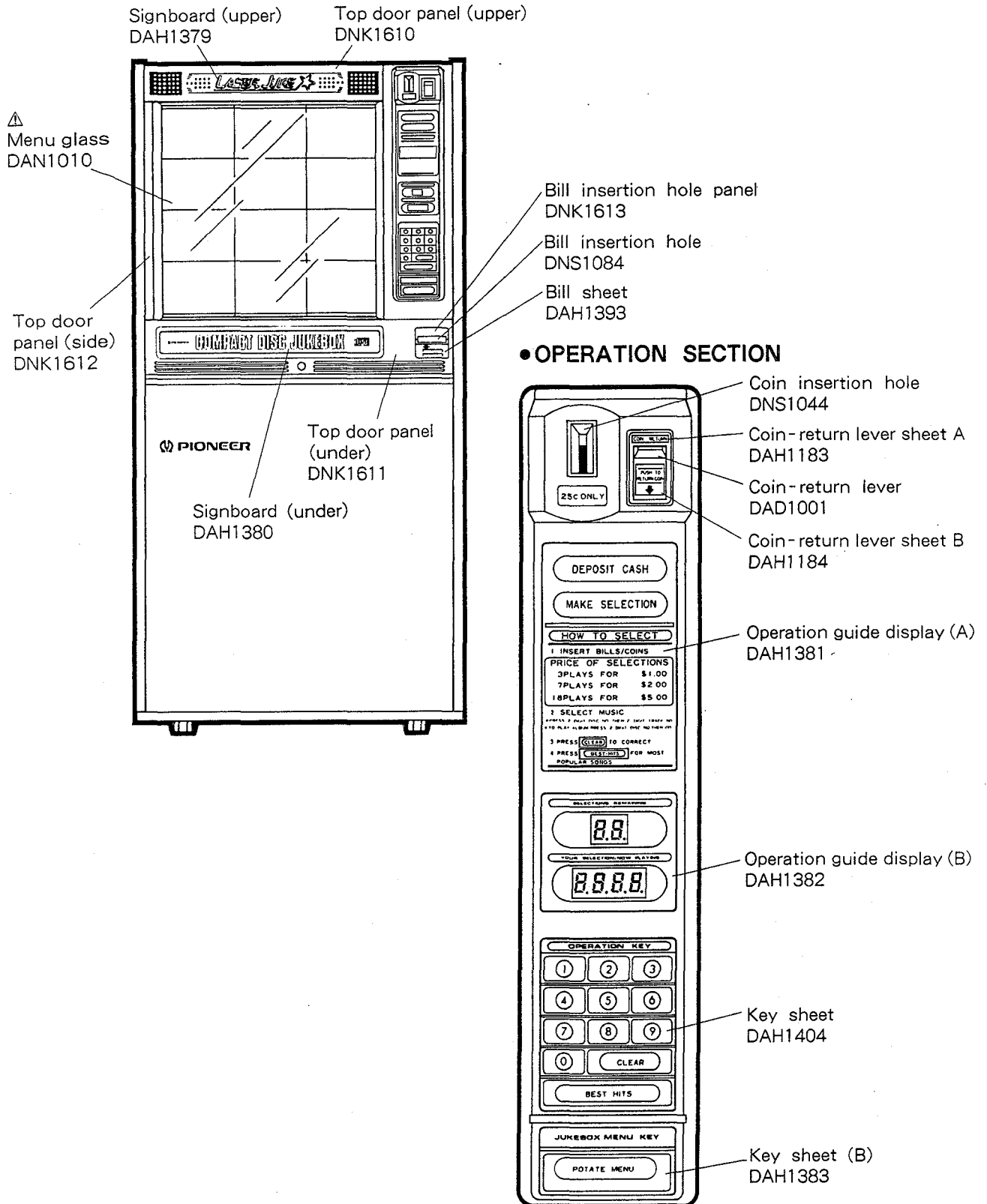

2.2 AMP SECTION

• FRONT VIEW

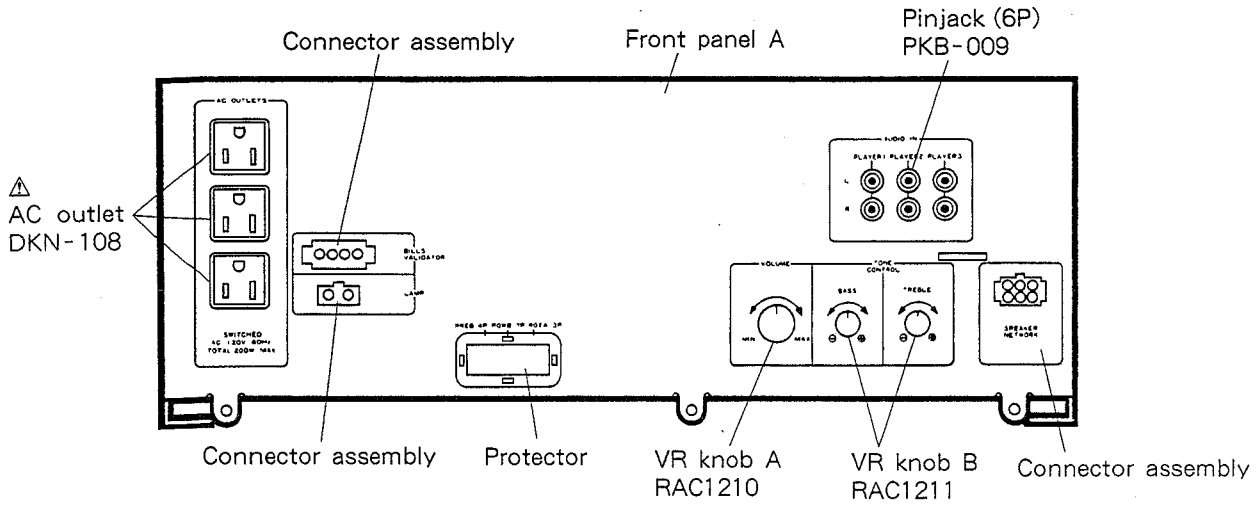

• REAR VIEW

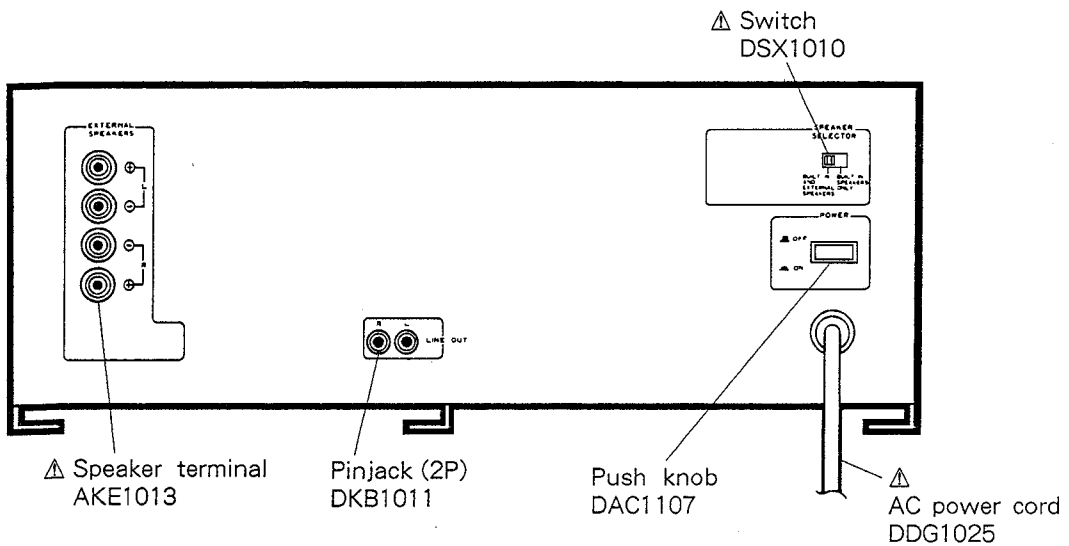

● TOP VIEW

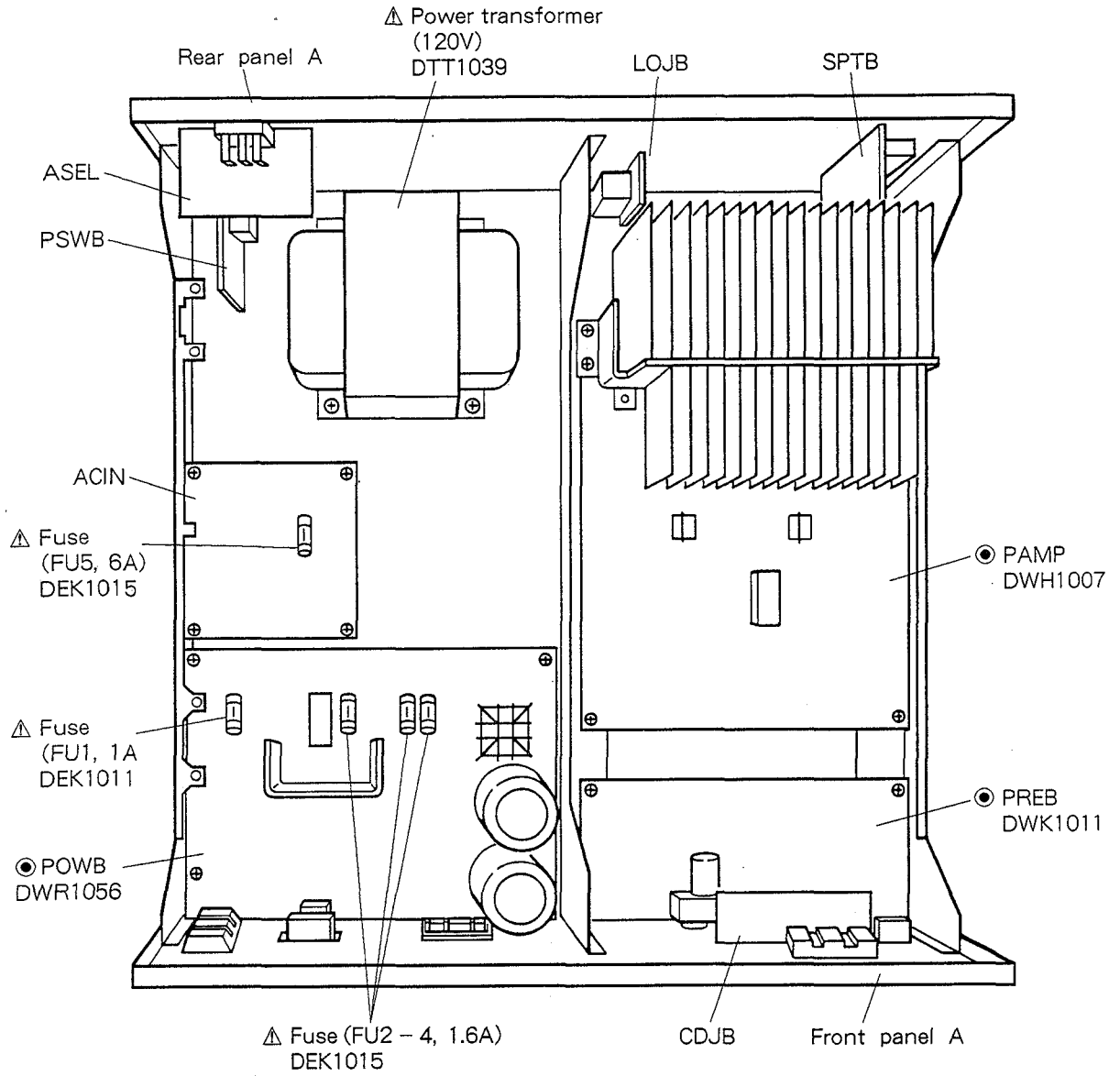



### 2.3 COMMANDER SECTION

● FRONT VIEW

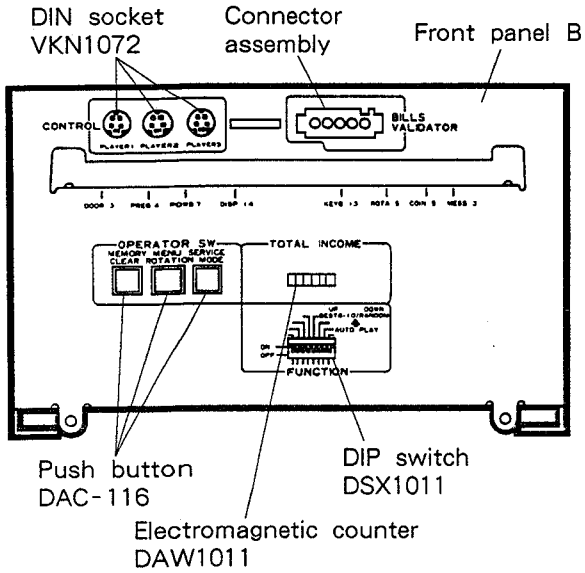

● REAR VIEW

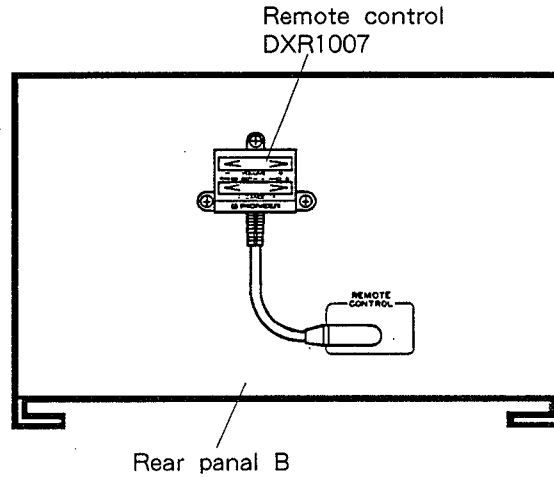

● TOP VIEW

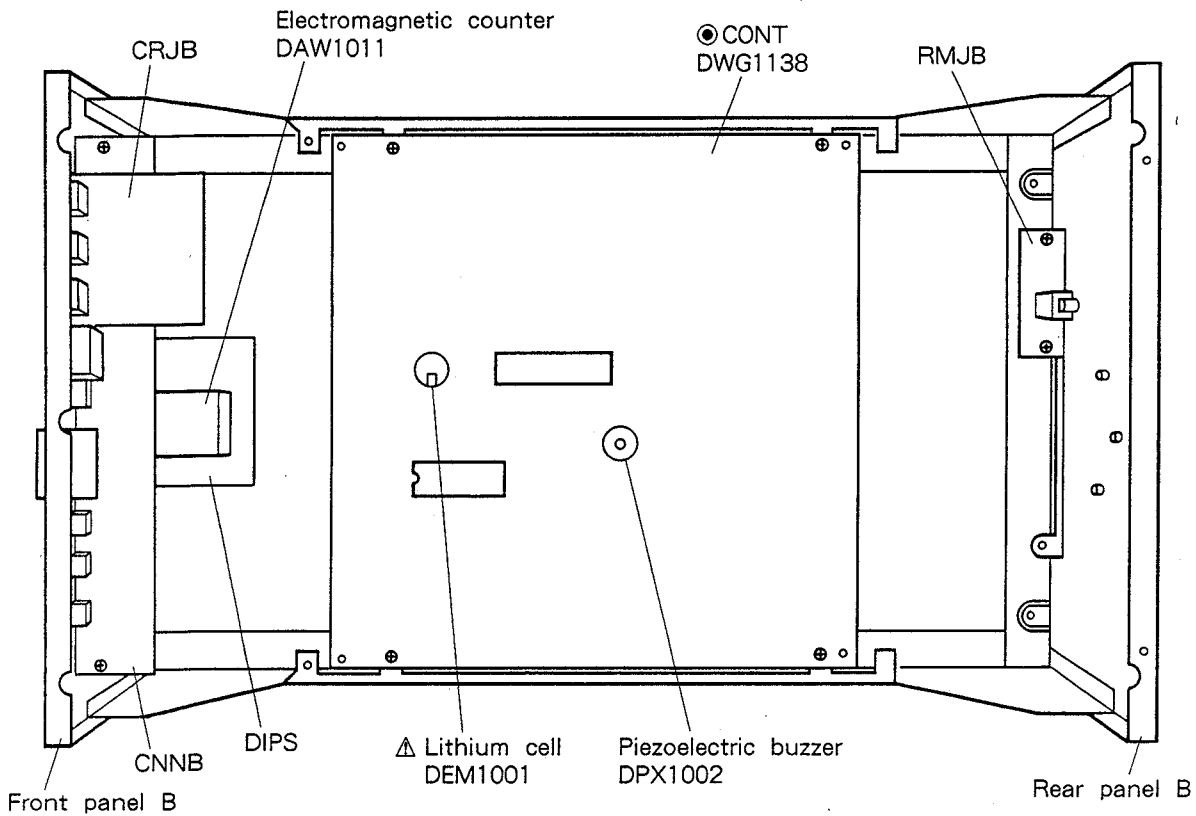

2.4 REMOVING CONDITION OF THE UNDER LAMP ASSEMBLY

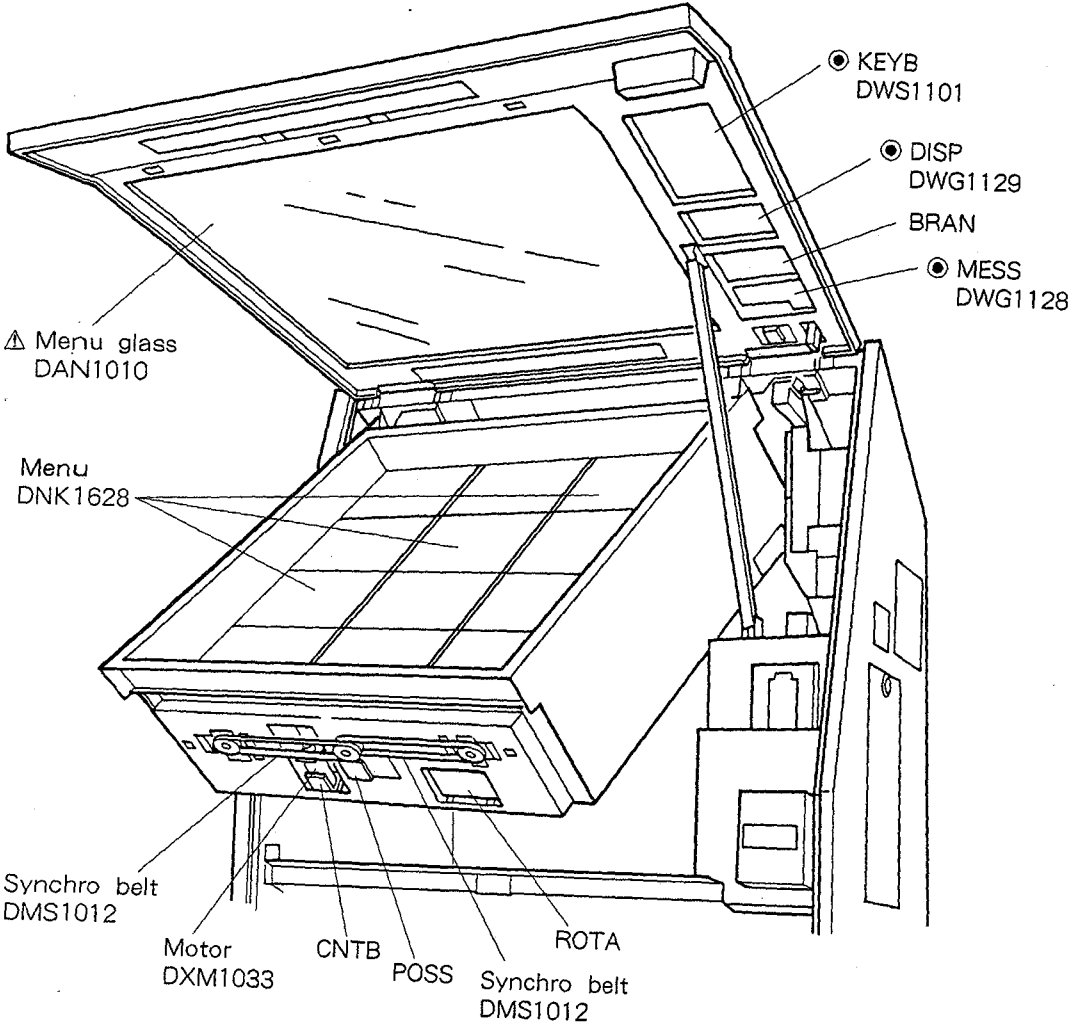

## 2.5 REMOVING CONDITION OF THE MENU BOARD

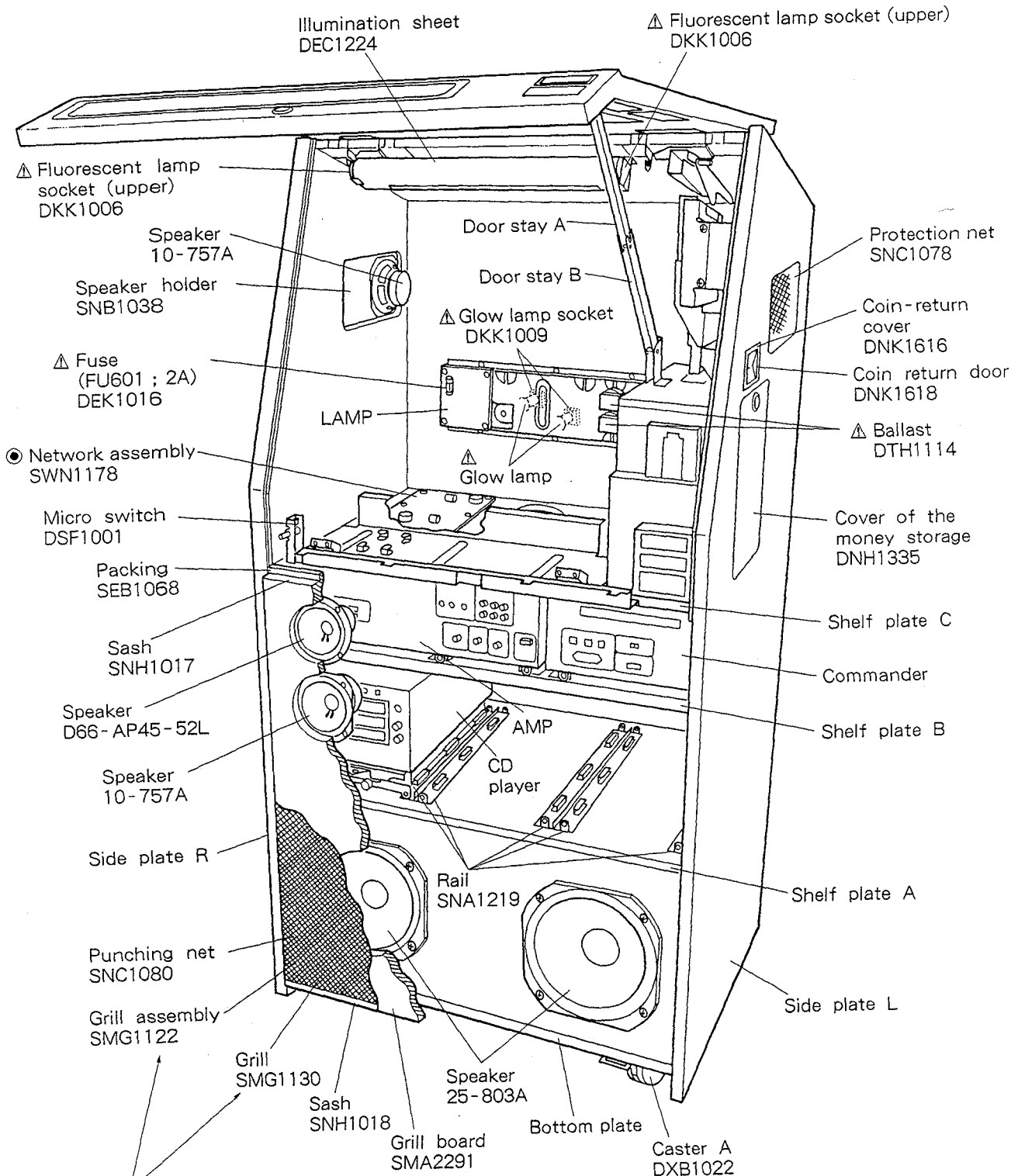

Note : As to the construction of these parts, refer to the exploded view.

2.6 CD PLAYER SECTION

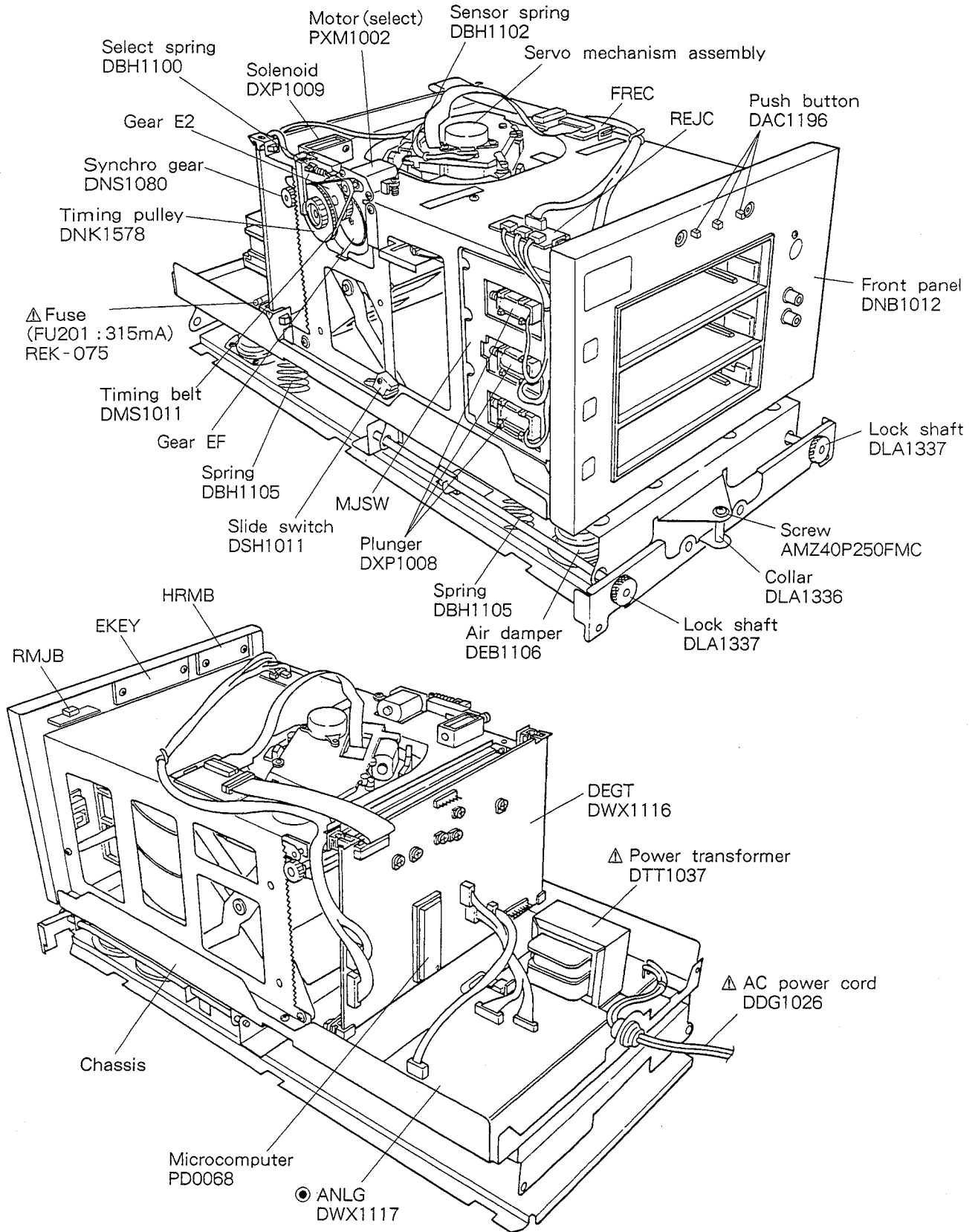

### 3. DISASSEMBLY

#### 3.1 REMOVING THE TOP DOOR ASSEMBLY

1. Open the menu door, and remove six screws ① and two R pins to remove the menu board assembly.

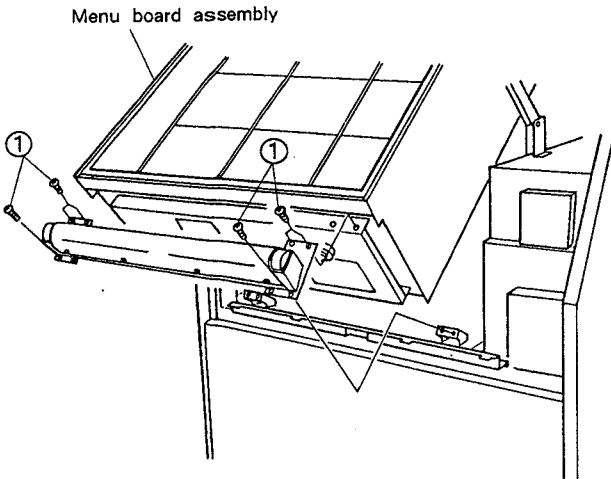

Fig. 3-1

2. Loosen four screws ② and remove two screws ③ to remove the upper lamp assembly.  
3. Remove two screws ④ to remove the CA holder (B) assembly.

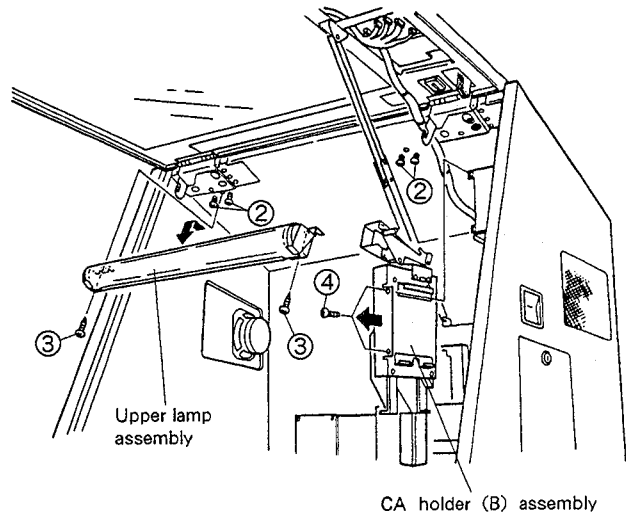

Fig. 3-3

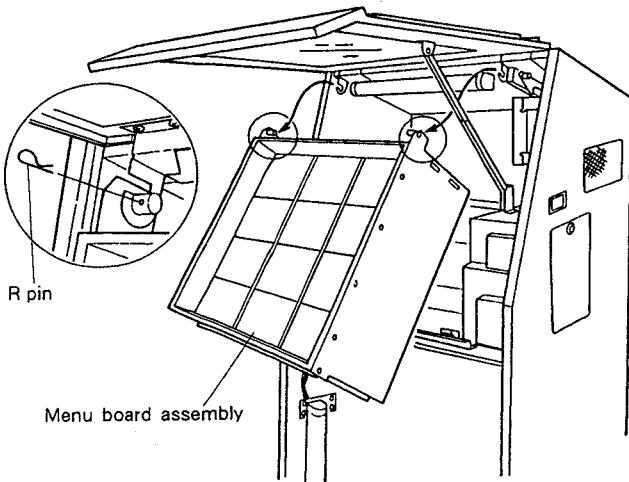

Fig. 3-2

4. Remove six screws ⑤, two screws ⑥ and two screws ⑦ to remove the top door assembly.

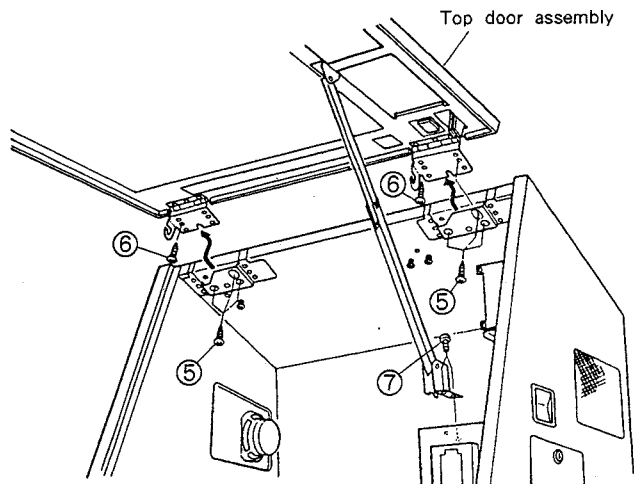

Fig. 3-4

### 3.2 REMOVING THE MENU MOTOR ASSEMBLY

1. Remove two screws ① to remove the menu motor assembly.

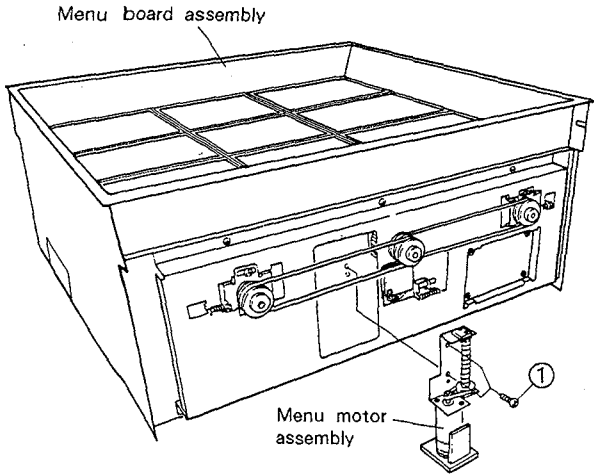

Fig. 3-5

### 3.4 REMOVING THE LAMP AND NETWORK ASSEMBLY

1. Remove six screws ① to remove the network assembly.
2. Remove four screws ② to remove the LAMP.

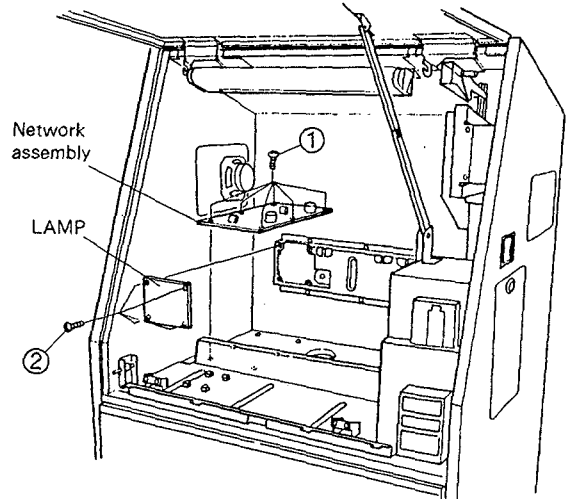

Fig. 3-7

### 3.3 REMOVING THE SYNCHRO BELT

1. Loosen two screws ① and remove two springs with plier, and remove two synchro belts by pushing the synchro pulley in the direction of arrow.

Note : When the synchro belt is replaced, be sure to perform the three sides of the menu synchronous adjustment.

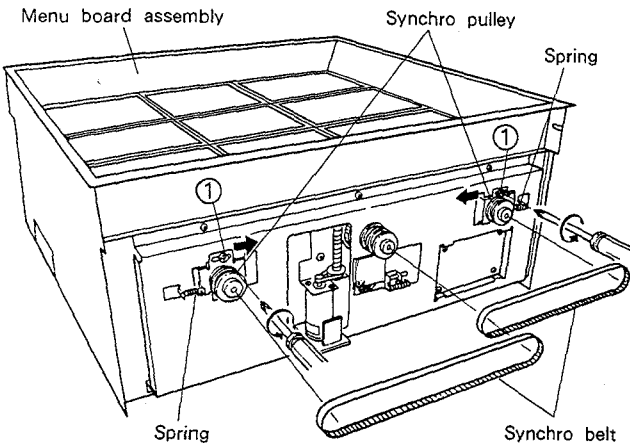

Fig. 3-6

### 3.5 REMOVING THE ROTA AND POSS

1. Remove four screws ① to remove the ROTA.
2. Remove a screw ② to remove the POSS.

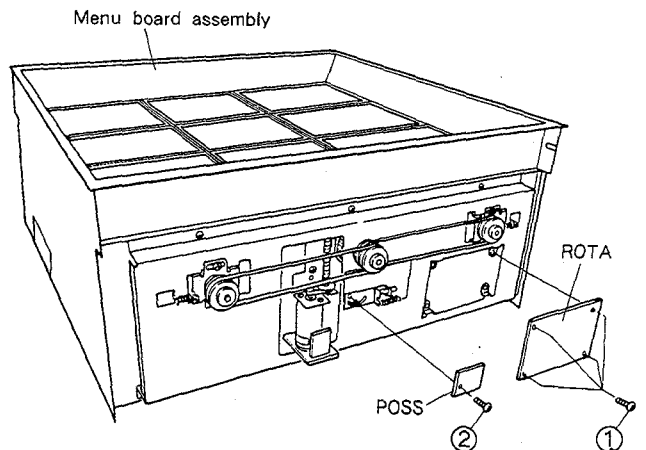

Fig. 3-8

### 3.6 REMOVING THE MESS, BRAN, DISP AND KEYB

1. Remove four screws ① to remove the MESS.
2. Remove four screws ② to remove the BRAN.
3. Remove four screws ③ to remove the DISP.
4. Remove eight screws ④ to remove the KEYB.

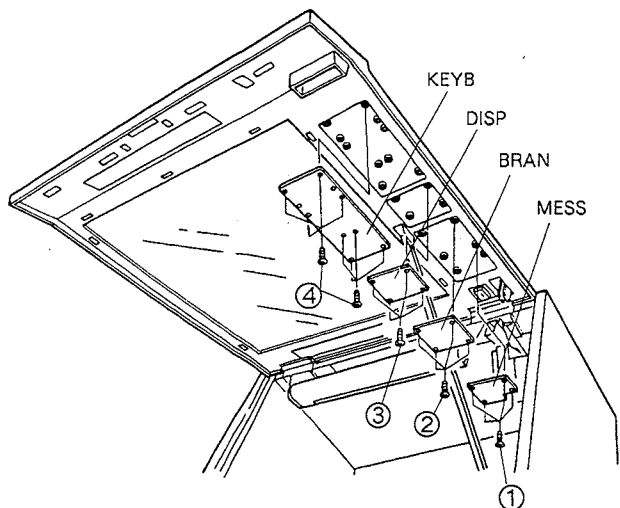

Fig. 3-9

### 3.8 REMOVING THE SPEAKER (WOOFER)

1. Remove four screws ① and disconnect the connector of speaker cord to remove the speaker.

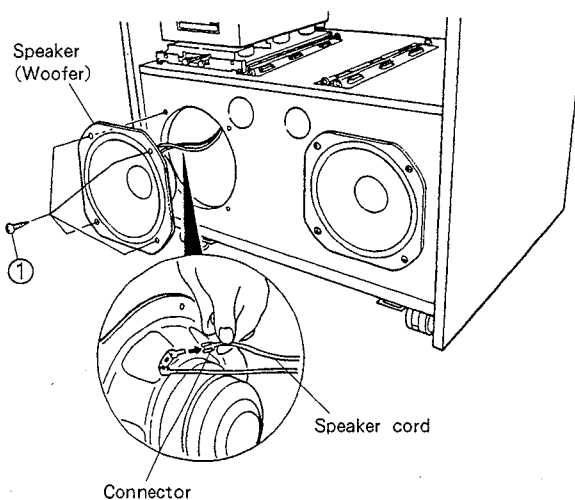

Fig. 3-11

### 3.7 REMOVING THE AMP, COMMANDER AND CD PLAYER

1. Remove three screws ① to remove the AMP.
2. Remove two screws ② to remove the commander.
3. Remove two screws ③ to remove the CD player.

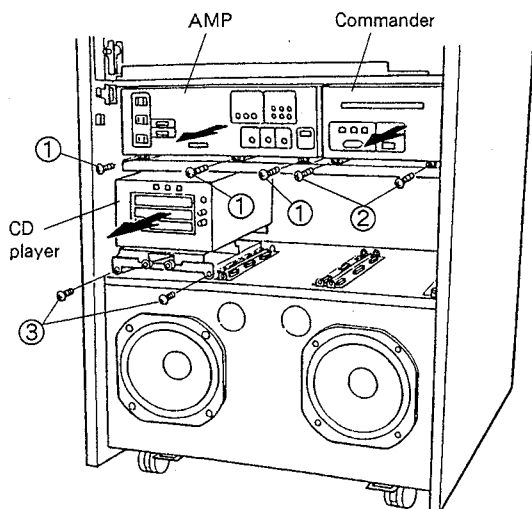

Fig. 3-10

### 3.9 REMOVING THE GLASS

1. Remove the top door assembly. (Refer to section 3.1.)
2. Set the glass side of top door assembly to the downward. Remove thirty-seven screws ① to remove the top door base, then remove the glass.

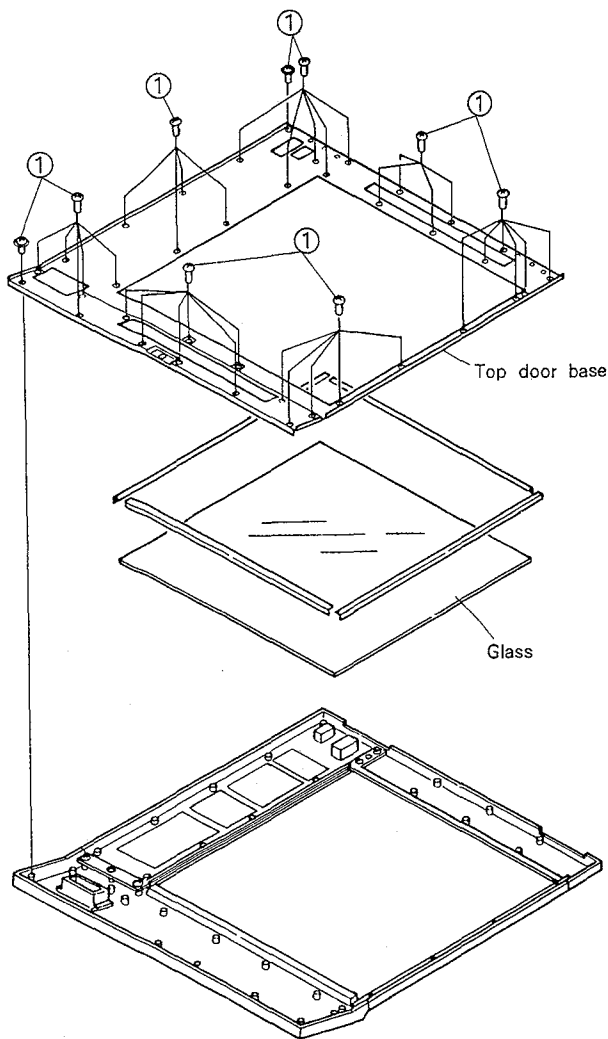

Fig. 3-12

### 3.10 REMOVING THE GLOW LAMP

Refer to the operating instructions (page 20).

## 4. P. C. BOARDS NAME

### MAIN SECTION

MESS.....MESSAGE  
 DISP.....DISPLAY  
 KEYB.....KEYBOARD  
 BRAN.....BRANCH  
 ROTA.....ROTATION  
 POSS.....POSITION SENSOR  
 LAMP.....LAMP  
 CNTB.....COUNTER BOARD  
 PAMP.....POWER AMPLIFIER  
 SPTB.....SPEAKER TERMINAL BOARD  
 LOJB.....LINE OUT JACK BOARD  
 PREB.....PRE AMPLIFIER BOARD  
 POWB.....POWER BOARD  
 ACIN.....AC INPUT BOARD  
 ASEL.....AMPLIFIER VOLTAGE SELECTOR BOARD  
 PSWB.....POWER SWITCH BOARD  
 CDJB.....CD JACK BOARD  
 CONT.....CONTROL  
 OPER.....OPERATION  
 DIPS.....DIP SWITCH  
 CRJB.....CD REMOTE JACK BOARD  
 RMJB.....REMOTE CONTROL JACK BOARD  
 CNNB.....CONNECTION BOARD

### CD PLAYER SECTION

EKEY.....EJECT KEY  
 DEGT.....DIGITAL DECODING UNIT  
 ANLG.....ANALOG UNIT  
 DJAK.....DIGITAL JACK  
 PJAK.....PIN JACK  
 MJSW.....MAGAZINE EJECT SWITCH  
 SENS.....SENSOR  
 REJC.....REJECT  
 FREC.....FLEXIBLE READER CONNECTOR  
 HRMB.....HOUR METER BOARD  
 RMJB.....REMOTE JACK BOARD



## 5. SERVICE MODE

- As to using the service mode, refer to the operating instructions (pages 23 - 26).  
And also as to the cord table of the service mode, refer to the operating instructions (pages 20 - 22).
- Shows the function table of the remote control (RU-V101) for service as follows. When operating the CD changer section directly, it is able to operate as shown in the below by connect the wired-remote control to the CD chager.

### 5.1 FUNCTION TABLE OF THE REMOTE CONTROL FOR SERVICE

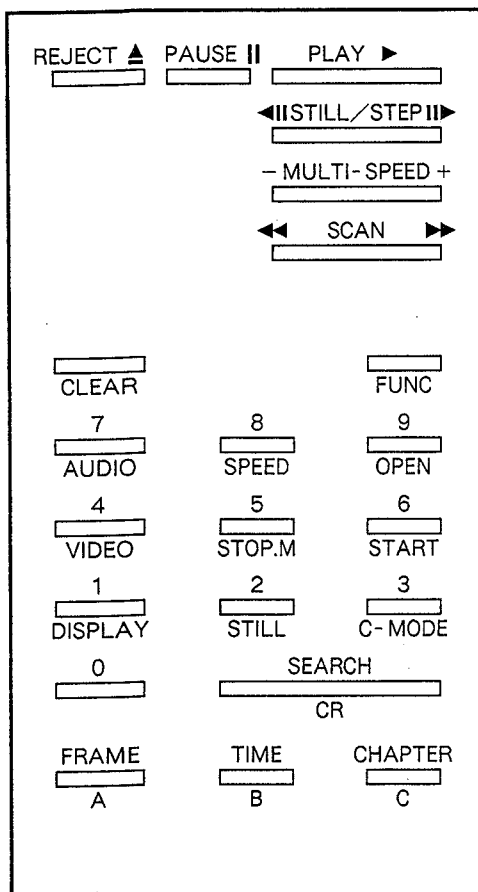

*1 REJECT		: Spinde stop
*1 PAUSE		: Pause
*1 PLAY		: Play
*2 STILL/STEP	▶▶▶	: Disc select
*2 STILL/STEP	◀◀◀	: Disc return
*2 MULTI-SPEED +		: Test command
*2 MULTI-SPEED -		: Test command
*1 SCAN	▶▶▶	: Scan fwd
*1 SCAN	◀◀◀	: Scan rev
*1 CLEAR		: Clear
*2 FRAME		: Frame set
*2 TIME		: Time set
*2 CHAPTER		: Track set
*1 SEARCH		: Search
*1 10key		: Numerical input
DISPLAY	(FUNC + 1)	: no entry
STILL	(FUNC + 2)	: no entry
C-MODE	(FUNC + 3)	: no entry
VIDEO	(FUNC + 4)	: no entry
*1 STOP.M	(FUNC + 5)	: Stop marker
*1 START	(FUNC + 6)	: Start
AUDIO	(FUNC + 7)	: no entry
SPEED	(FUNC + 8)	: no entry
*1 OPEN	(FUNC + 9)	: Magazine eject

\* 1 .....Normal function command  
 \* 2 .....Function command is different from the LD-V530.  
 Not marked .....No entry command

#### ● Test command

- 0 + MULTI-SPEED (+, -) keys : LD-ON
- 1 + MULTI-SPEED (+, -) keys : FOCUS IN
- 2 + MULTI-SPEED (+, -) keys : Spindle kick
- 3 + MULTI-SPEED (+, -) keys : Tracking and slider servo ON
- 4 + MULTI-SPEED (+, -) keys : Slider fwd (500ms)
- 5 + MULTI-SPEED (+, -) keys : Slider rev (500ms) ] Stop by MULTI-SPEED (+, -) key
- 6 + MULTI-SPEED (+, -) keys : Tracking and slider servo OFF
- 7 + MULTI-SPEED (+, -) keys : Slider stop and spindle stop
- 8 + MULTI-SPEED (+, -) keys : Slider stop and spindle stop
- 9 + MULTI-SPEED (+, -) keys : LD-OFF

# Operating Instructions

## COMPACT DISC JUKEBOX

# CJ-V55

LASER JUKE 

COMPACT  
disc  
DIGITAL AUDIO



Thank you for buying this PIONEER product. Please read through these operating instructions so you will know how to operate your model properly. After you have finished reading the instructions, put them away in a safe place for future reference. In some countries or regions, the shape of the power plug and power outlet may sometimes differ from that shown in the explanatory drawings. However, the method of connecting and operating the unit is the same.

### IMPORTANT NOTICE

RECORD THE MODEL NUMBER AND SERIAL NUMBER OF THIS EQUIPMENT BELOW. THE NUMBERS ARE ON THE REAR PANEL.

MODEL NO. CJ-V55

SERIAL NO. \_\_\_\_\_

KEEP THESE NUMBERS FOR FUTURE USE.

### WARNING:

TO PREVENT FIRE OR SHOCK HAZARD, DO NOT EXPOSE THIS APPLIANCE TO RAIN OR MOISTURE.

[For Canadian models]

### CAUTION:

TO PREVENT ELECTRIC SHOCK DO NOT USE THIS (POLARIZED) PLUG WITH AN EXTENSION CORD, RECEPTACLE OR OTHER OUTLET UNLESS THE BLADES CAN BE FULLY INSERTED TO PREVENT BLADE EXPOSURE.

### ATTENTION:

POUR PREVENIR LES CHOCS ELECTRIQUES NE PAS UTILISER CETTE FICHE POLARISEE AVEC UN PROLONGATEUR UNE PRISE DE COURANT OU UNE AUTRE SORTIE DE COURANT, SAUF SI LES LAMES PEUVENT ETRE INSEREES A FOND SANS EN LAISSER AUCUNE PARTIE A DECOUVERT.

## CONTENTS

CAUTIONS ON INSTALLATION .....	4	
CARE OF DISCS .....	4	
<b>PREPARATION</b>		
HOW TO OPEN THE MENU DOOR .....	5	
HOW TO OPEN THE MAIN UNIT DOOR .....	5	
REMOVING THE TRANSPORT SCREWS FROM THE CD PLAYER .....	6	
CONNECTION .....	6	
ATTACHING THE COIN ACCEPTOR .....	8	
ATTACHING THE BILL ACCEPTOR .....	8	
INSTALLING THE LOCK ON THE CHARGE STORAGE COVER .....	10	
INSTALLING DISCS TO THE MAGAZINE .....	10	
ATTACHING THE MENU SHEET .....	12	
INSTALLING THE LOCK TO THE MENU DOOR .....	12	
CASTER LOCKING .....	13	
SETTING OF THE FUNCTION SWITCHES .....	13	
NAME AND FUNCTION OF EACH PART .....		14
OPERATION .....	17	
REPLACING THE MENU AND DISC .....	18	
ADDING A CD PLAYER .....	18	
REMOVING COINS/BILLS .....	19	
<b>MAINTENANCE</b>		
CHANGING THE FLUORESCENT LAMPS .....	19	
CHANGING THE GLOW LAMP .....	20	
<b>SERVICE MODE</b>		
HOW TO USE SERVICE MODE .....	20	
ERROR CODE .....	26	
TROUBLESHOOTING .....	27	
SPECIFICATIONS .....	28	

## IMPORTANT



The lightning flash with arrowhead, within an equilateral triangle, is intended to alert the user of the presence of uninsulated "dangerous voltage" within the product's enclosure that may be of sufficient magnitude to constitute a risk of electric shock to persons.



**CAUTION:**  
TO PREVENT THE RISK OF ELECTRIC SHOCK, DO NOT REMOVE COVER (OR BACK). NO USER-SERVICEABLE PARTS INSIDE. REFER SERVICING TO QUALIFIED SERVICE PERSONNEL.



The exclamation point within an equilateral triangle is intended to alert the user of the presence of important operating and maintenance (servicing) instructions in the literature accompanying the appliance.

# SAFETY INSTRUCTIONS

**READ INSTRUCTIONS** — All the safety and operating instructions should be read before the appliance is operated.

**RETAIN INSTRUCTIONS** — The operating instructions should be retained for future reference.

**HEED WARNING** — All warnings on the appliance and in the operating instructions should be adhered to.

**FOLLOW INSTRUCTIONS** — All operating and use instructions should be followed.

**WATER AND MOISTURE** — The appliance should not be used near water — for example, near a bathtub, washbowl, kitchen sink, laundry tub, in a wet basement, or near a swimming pool, etc.

**LOCATION** — The appliance should be installed in a stable location.

**WALL OR CEILING MOUNTING** — The appliance should not be mounted to a wall or ceiling.

**VENTILATION** — The appliance should be situated so that its location or position does not interfere with its proper ventilation. For example, the appliance should not be situated on a bed, sofa, rug, or similar surface that may block the ventilation openings; or, placed in a built-in installation, such as a bookcase or cabinet that may impede the flow of air through the ventilation openings.

**HEAT** — The appliance should be situated away from heat sources such as radiators, heat registers, stoves, or other appliances (including amplifiers) that produce heat.

**POWER SOURCES** — The appliance should be connected to a power supply only of the type described in the operating instructions or as marked on the appliance.

**POWER-CORD PROTECTION** — Power-supply cords should be routed so that they are not likely to be walked on or pinched by items placed upon or against them, paying particular attention to cords at plugs, convenience receptacles, and the point where they exit from the appliance.

**POLARIZATION** — If your purchased product is provided with a polarized power plug, please read the following instructions. This product is equipped with a polarized alternating current line plug (a plug having one blade wider than the other). This plug will fit into the power outlet only one way. This is a safety feature. If you are unable to insert the plug fully into the outlet, try reversing the plug. If the plug should still fail to fit, contact your electrician to replace your obsolete outlet. Do not defeat the safety purpose of the polarized plug.

**CLEANING** — The appliance should be cleaned only with a polishing cloth or a soft dry cloth. Never clean with furniture wax, benzene, insecticides or other volatile liquids since they may corrode the cabinet.

**POWER LINES** — An outdoor antenna should be located away from power lines.

**NONUSE PERIODS** — The power cord of the appliance should be unplugged from the outlet when left unused for a long period of time.

**OBJECT AND LIQUID ENTRY** — Care should be taken so that objects do not fall and liquids are not spilled into the enclosure through openings.

**DAMAGE REQUIRING SERVICE** — The appliance should be serviced by a Pioneer authorized service center or qualified service personnel when:

- The power-supply cord or the plug has been damaged; or
- Objects have fallen, or liquid has been spilled into the appliance; or
- The appliance has been exposed to rain; or
- The appliance does not appear to operate normally or exhibits a marked change in performance; or
- The appliance has been dropped; or the enclosure damaged.

**SERVICING** — The user should not attempt to service the appliance beyond that described in the operating instructions. For all other servicing, contact the nearest Pioneer authorized service center.

**OUTDOOR ANTENNA GROUNDING** — If an outside antenna is connected to the antenna terminal, be sure the antenna system is grounded so as to provide some protection against voltage surges and built up static charges.

In the U.S.A. section 810 of the National Electrical Code, ANSI/NFPA No. 70-1984, provides information with respect to proper grounding of the mast and supporting structure, grounding of the lead-in wire to an antenna discharge unit, size of grounding conductors, location of antenna discharge unit, connection to grounding electrodes, and requirements for the grounding electrode. See Fig. A.

**CART** — An appliance and cart combination should be moved with care. Quick stops, excessive force, and uneven surfaces may cause the appliance and cart combination to overturn.

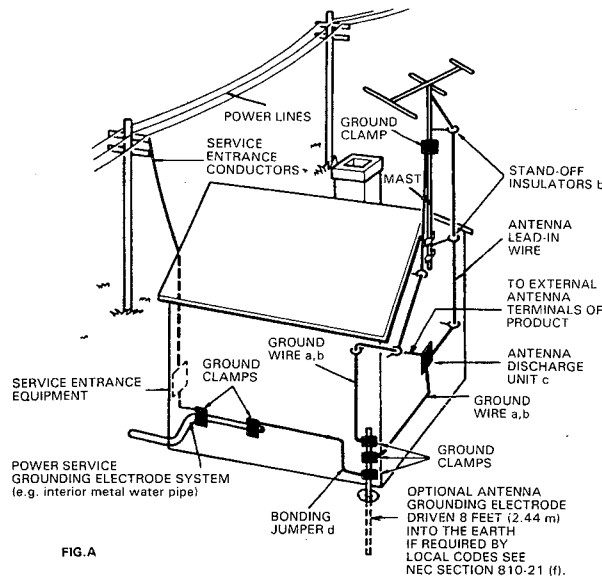

FIG. A

- a) Use No. 10 AWG (5.3 mm<sup>2</sup>) copper, No. 8 AWG (8.4 mm<sup>2</sup>) aluminum, No. 17 AWG (1.0 mm<sup>2</sup>) copper-clad steel, bronze wire, or larger as ground wire.
  - b) Secure antenna lead-in and ground wires to house with stand-off insulators spaced from 4 feet (1.22 meters) to 6 feet (1.83 meters) apart.
  - c) Mount antenna discharge unit as closely as possible to where lead-in enters house.
  - d) Use jumper wire not smaller than No. 6 AWG (13.3 mm<sup>2</sup>) copper, or the equivalent, when a separate antenna-grounding electrode is used.
- See NEC Section 810-21 (j).

**CAUTION: USE OF CONTROL OR ADJUSTMENT OR PERFORMANCE OF PROCEDURES OTHER THAN THOSE SPECIFIED HEREIN MAY RESULT IN HAZARDOUS RADIATION EXPOSURE.**

**USE OF OPTICAL INSTRUMENTS WITH THIS PRODUCT WILL INCREASE EYE HAZARDS.**

**[For Canadian model]**

This digital apparatus does not exceed the Class B limits for radio noise emissions from digital apparatus set out in the Radio Interference Regulations of the Canadian Department of Communications.

**[Pour le modèle Canadien]**

L'interférence, radioélectrique générée par cet appareil numérique de type B ne dépasse pas les limites énoncées dans le Règlement sur les perturbations radioélectriques, section appareil numérique, du Ministère des Communications.

**INFORMATION TO USER [FOR U.S. MODEL]**

This equipment generates and uses radio frequency energy and if not installed and used properly, that is, in strict accordance with the manufacturer's instructions, may cause interference to radio and television reception. It has been type tested and found to comply with the limits for a Class B computing device in accordance with the specifications in Subpart J of Part 15 of FCC Rules, which are designed to provide reasonable protection against such interference in a residential installation. However, there is no guarantee that interference will not occur in a particular installation.

If this equipment does cause interference to radio or television reception, which can be determined by turning the equipment off and on, the user is encouraged to try to correct the interference by one or more of the following measures:

- reorient the receiving antenna
- relocate this equipment with respect to the receiver
- move this equipment away from the receiver
- plug this equipment into a different outlet so that equipment and receiver are on different branch circuits.

If necessary, the user should consult the dealer or an experienced radio/television technician for additional suggestions. The user may find the following booklet prepared by the Federal Communications Commission helpful:

"How to Identify and Resolve Radio-TV Interference Problems".

This booklet is available from the US Government Printing Office, Washington, D.C., 20402, Stock No. 004-000-00345-4.

*The above instructions apply only to units which will be operated in the United States.*

**POWER-CORD CAUTION**

Handle the power cord by the plug. Do not pull out the plug by tugging the cord and never touch the power cord when your hands are wet as this could cause a short circuit or electric shock. Do not place the unit, a piece of furniture, etc., on the power cord, or pinch the cord. Never make a knot in the cord or tie it with other cords. The power cords should be routed such that they are not likely to be stepped on. A damaged power cord can cause fire or give you an electrical shock. Check the power cord once in a while. When you find it damaged, ask your nearest PIONEER authorized service center or your dealer for a replacement.

# CAUTIONS ON INSTALLATION CARE OF DISCS

Select a horizontal and stable place. Avoid the following:

- ① Exposed to direct sunlight
- ② Installation near a toilet or kitchen
- ③ Exposed to a spotlight
- ④ Installation near a refrigerator, dimmer, air-conditioning equipment or other large electrical appliances
- ⑤ Installation near neon signs
- ⑥ Installation on a non-horizontal place with a weak floor  
Where the floor is not horizontal, insert a hard plate or something similar beneath the casters.
- ⑦ Installation in a place where it is difficult to carry out coin/bill collection, servicing or maintenance.

## Condensation

In winter, if this system is brought from outdoors into a heated room or the temperature of the room where this system is installed is raised quickly, the operation unit or lens will be covered by condensation.

When covered by condensation, this system cannot read and play laser beam signals.

Keep this system at room temperature for one to two hours depending on the degree of condensation and the condensation will evaporate, making this system ready for playing.

Other symptoms similar to condensation may also occur at places exposed directly to a cooler or air-conditioner in summer. In such a case, move this system to another location.

## Special cautions on setting

- ① **Power capacity**  
Supply power from a wall outlet that allows a safe supply of power equal to or more than the total power consumption of all equipment you will use.
- ② **Connection cord**  
Prevent the weight or tensile force of the cord from being applied to the plug of the connection cord.
- ③ **Grounding**  
Where no earth leakage breaker is available, connect the grounding conductor to the earth.
- ④ **Confirmation after setting**  
**Be sure to confirm the following:**
  - Casters are locked.
  - The menu sheet matches the discs.
  - The external speaker phase is properly set and the right and left speakers are positioned properly.

Our company will not be responsible for any accident or other damage due to an improper fixing condition, fixing with insufficient strength, accident, or other similar circumstances.

- With this unit, use discs which display the mark shown below.



- When holding discs, do not touch their signal surfaces. Hold the edges, or one edge and the center hole.



- Do not affix labels or adhesive tape to the label surfaces. Also, do not scratch or damage the label.
- Discs rotate at high speed inside the player. Do not use damaged (cracked or warped) discs.

## CLEANING DISCS

- The presence of fingerprints or smudges on the surface of the disc will not directly affect the recorded signals; but depending on the degree of contamination, the brightness of the light reflected from the signal surfaces may be reduced, causing degradation of sound quality.

Always keep your discs clean by wiping them gently with a soft cloth from the inner edge toward the outer perimeter.

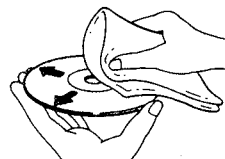

- If a disc becomes very dirty, wet a soft cloth in water. After wringing it out well, wipe the dirt away gently, and then remove any water drops with another soft dry cloth.
- Do not use record cleaning sprays of anti-static agents on discs. Also, never clean discs with benzene, thinner, or other volatile solvents which may cause damage to the disc surface.

## STORING DISCS

(Storing without using the six-disc magazine)

- Discs are made of the same kinds of plastic used for conventional analog audio records. Be careful not to allow discs to warp; always store discs in their cases vertically, avoiding locations with heat or humidity, or extremely low temperatures. Avoid leaving discs in cars and on the seats being exposed to direct sunlight. This can be harmful to your discs.
- Always read and abide by the precautionary notes listed on the disc labels.

## PREPARATION

### HOW TO OPEN THE MENU DOOR

- ① Push the lever with a screwdriver through the lock installing hole towards the right and release the lock.
- ② Hold the menu door up and make sure that it is fastened to the arm.

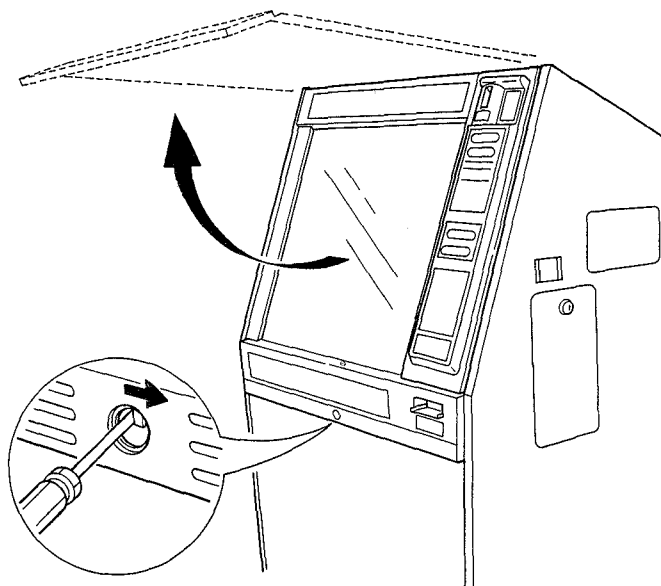

### HOW TO OPEN THE MAIN UNIT DOOR

- The upper part of the main unit door is held to the main unit with a magnet. To open it, pull the upper part towards you.
- A string is attached as stopper on the left side.
- To remove the main unit door for connection etc., hold the door up, and pull the two projections located on the bottom of the door out of the slit.
- When working on the inside of the main unit, put the removed main unit door beside the right side of the unit. Be careful not to disturb the connection cable.

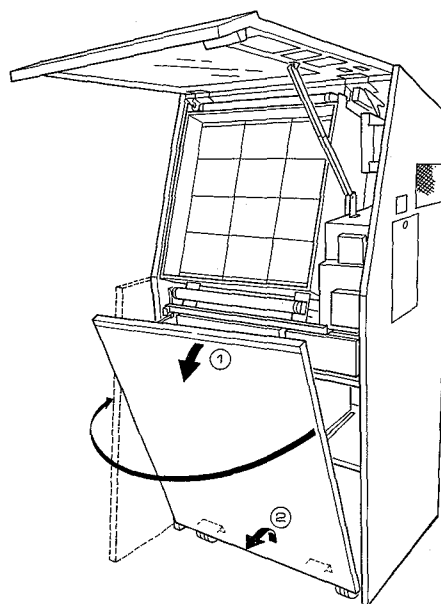

# REMOVING THE TRANSPORT SCREWS FROM THE CD PLAYER

The vibration-protection of the CD player is fixed with three screws for shipping.

- ① Remove the screws and spacer on the front center.  
(Keep the removed screws in the pocket inside the main unit door in case it becomes necessary to move the unit again.)
- ② Remove those screws on both sides of the front, and install them to the holes indicated by the arrows.

When transporting the CD player, make sure to install the screws for protection.

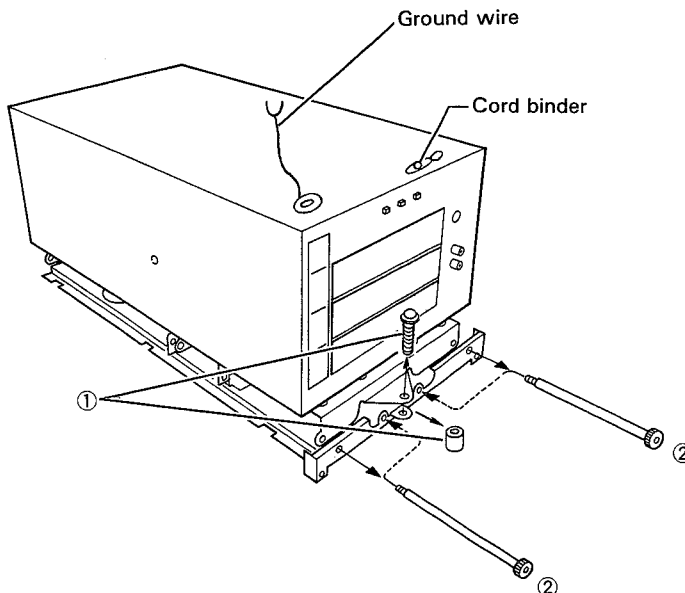

## CONNECTION

### CONNECTING THE CD PLAYER

- ① Connect the CD player's CONTROL jack to the controller's CONTROL jack with the supplied control cord.
- ② Connect the CD player's AUDIO OUT jacks to the amplifier's INPUT jack with the supplied audio cord.
- ③ Connect the CD player's power cord to the AC OUTLET of the amplifier section.
- ④ Connect the ground wire to the ground terminal.

### CONNECTING THE EXTERNAL SPEAKERS

- External speakers can be connected to the EXTERNAL SPEAKERS terminals located on the rear of the main unit.
- Connect the "+" terminals on this unit to the "+" terminals on the speakers, and the "-" terminals on the unit to the "-" terminals on the speakers.

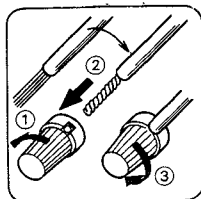

- ① Loosen cap.
- ② Insert wire.
- ③ Tighten cap.

### NOTE:

Do not allow any of the cord's conductors to protrude from the terminals or touch any other conductors. Malfunctions or breakdowns may occur when conductors come into contact with each other.

### Speaker impedance

Connect speaker systems with a nominal impedance of between 8 and 16 ohms.

### Setting of speaker selector switch

When using only the built-in speakers, set the switch to the right. When using both built-in and external speakers, set the switch to the left side.

### When combining with other devices (such as an amplifier)

Connect the LINE OUT jack located on the rear panel to the input jack of the other device.

### CONNECTING THE POWER CORD

After completing connection of all signal lines, connect the power cord to the wall outlet.

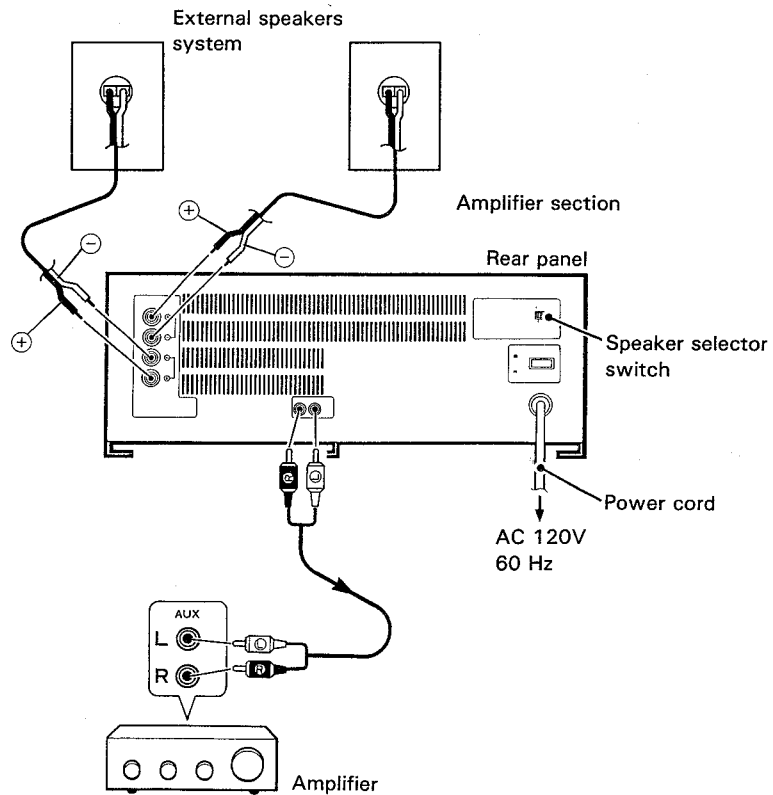
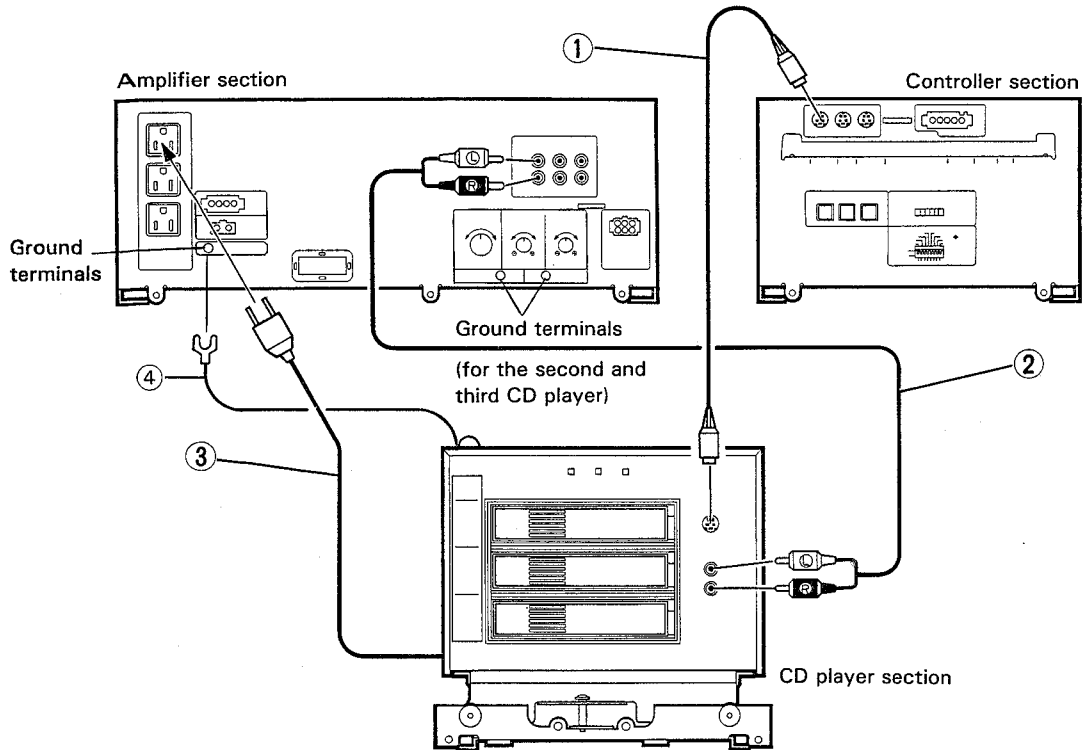



# ATTACHING THE COIN ACCEPTOR

When using coins for the CD jukebox, the coin acceptor must be installed.

Install the coin acceptor.  
Insert the upper part first.

\* Use an N-530-A made by CONLUX USA for the coin acceptor.

**CAUTION**  
THIS INSTALLATION SHOULD BE MADE BY A QUALIFIED SERVICE PERSON AND SHOULD CONFIRM TO ALL LOCAL CODES.

To prevent coin input, install the supplied stopper in the the coin slot.

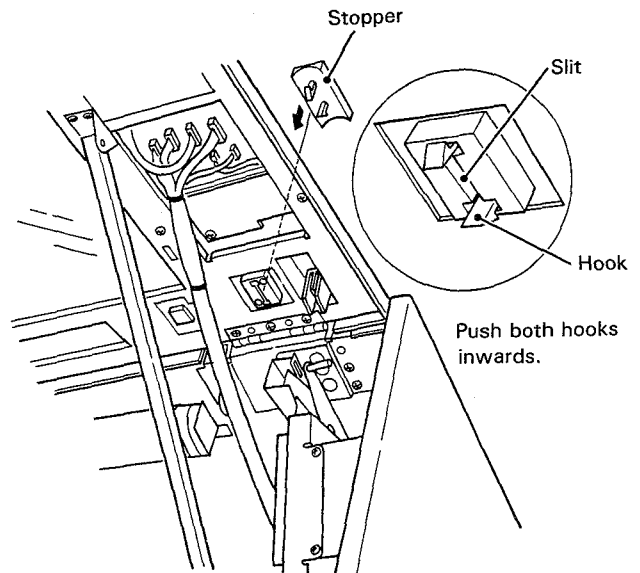
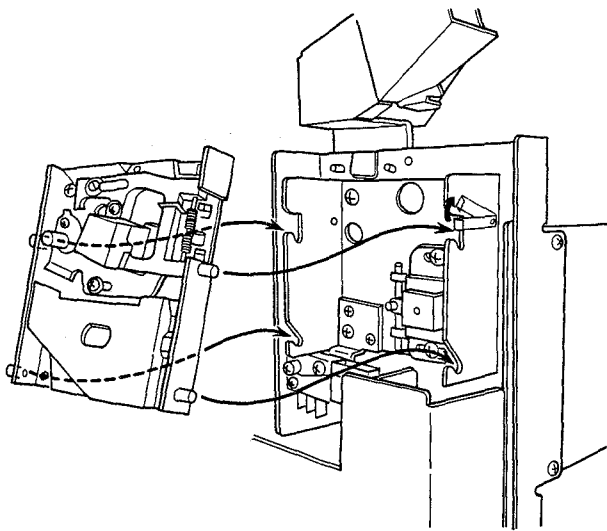

# ATTACHING THE BILL ACCEPTOR

When using bills for the CD jukebox, the bill acceptor must be installed.

**CAUTION**  
THIS INSTALLATION SHOULD BE MADE BY A QUALIFIED SERVICE PERSON AND SHOULD CONFIRM TO ALL LOCAL CODES.

① Open the cover of the money storage located on the right side of the CD jukebox from the front.

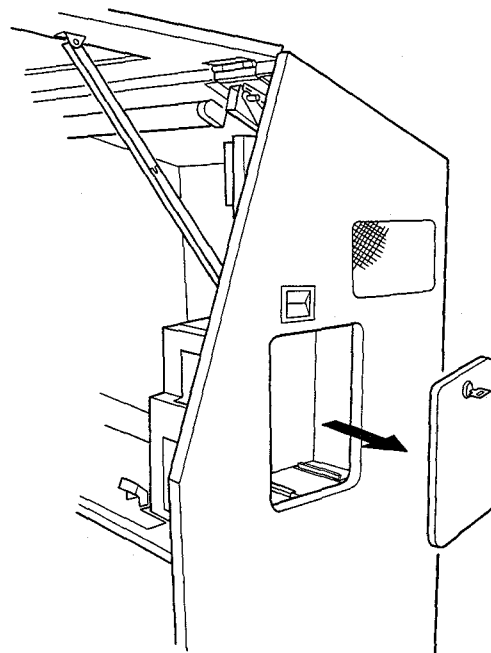

## ATTACHING THE BILL ACCEPTOR

- ② Take out the bill holder, and install the bill acceptor.

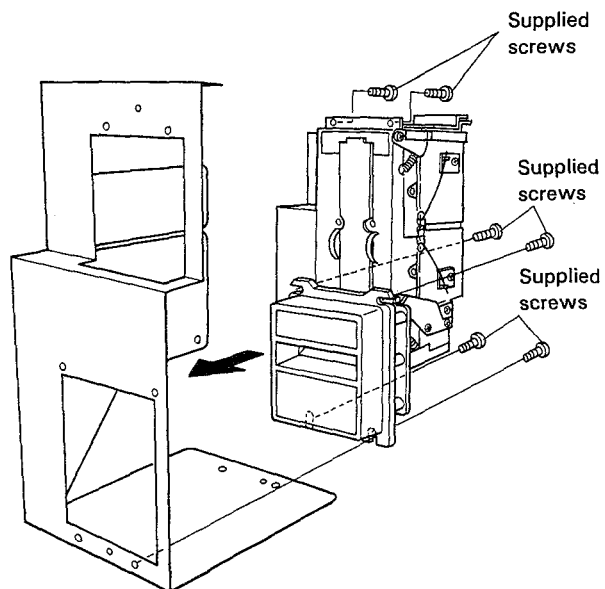
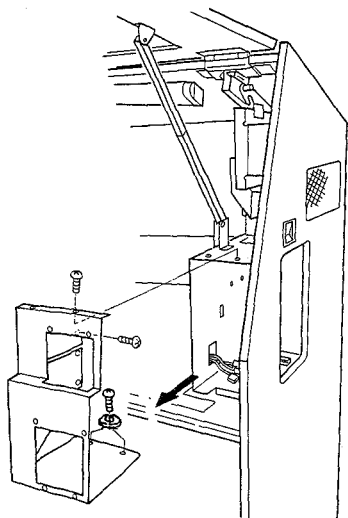

- ③ Attach the bill acceptor to the CD jukebox with the screws.  
Connect the connection cord (2).  
i) Attach the bill acceptor to the bill holder.  
ii) Fasten the bill holder with the two screws.  
iii) Close the menu door.  
iv) Adjust the bill acceptor horizontally and vertically (Press the bill acceptor against the panel side so that there is no gap, and the bill inlet is located at the center.), and fasten the lower part with the two screws ③.  
v) Tighten the screws ①, ② on both sides.

- ④ Reinstall the coin box.  
Insert it into the slot with the labeled side facing out.

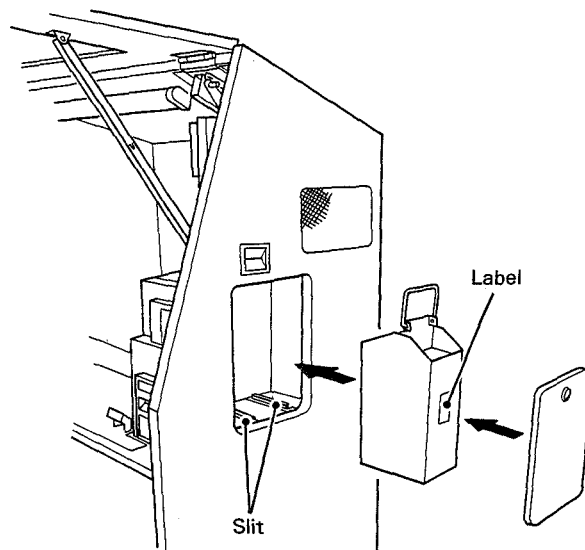
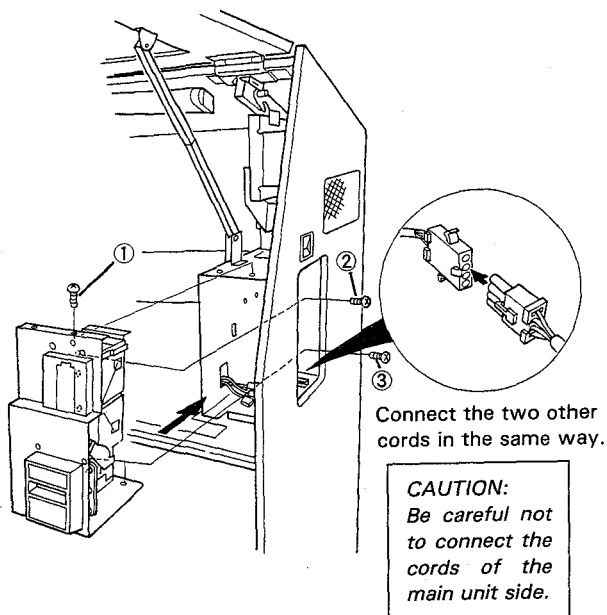

\* Use an NB-2JA-400 made by CONLUX USA for the bill acceptor.

# INSTALLING THE LOCK ON THE CHARGE STORAGE COVER

Install a retainer so that the cover can be locked.  
 Arrange the groove of the guarding metal so that the retainer can move.

A Cam FL 114, CamLock 8078 made by American Lock Co. for the lock of the charge storage cover is recommended.  
 Install a retainer so that the cover can be locked.

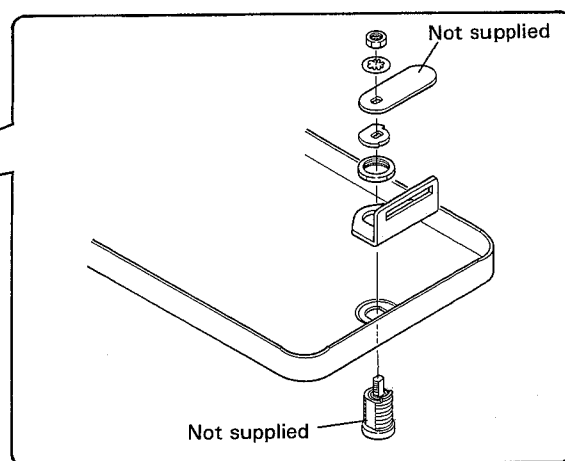
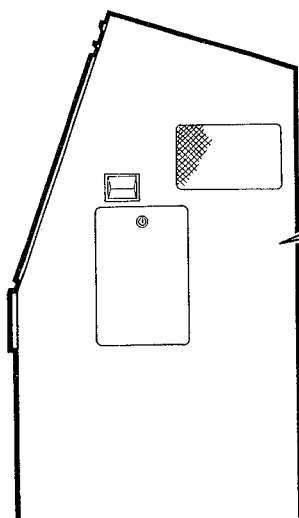
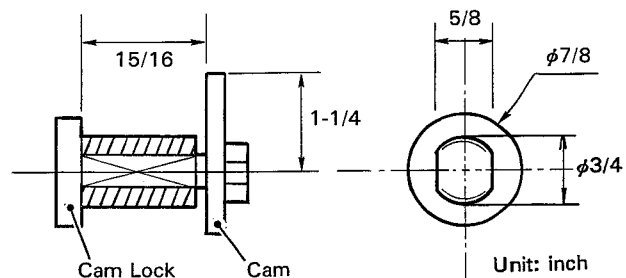

# INSTALLING DISCS TO THE MAGAZINES

Insert any discs which you may have into the magazine. Up to six discs may be inserted. The numbering of the discs begins with 1 at the topmost tray, and then increases in order from 2 to 6 for the lower trays.

② Position discs with the label side downward.

① Pull out only one disc tray.

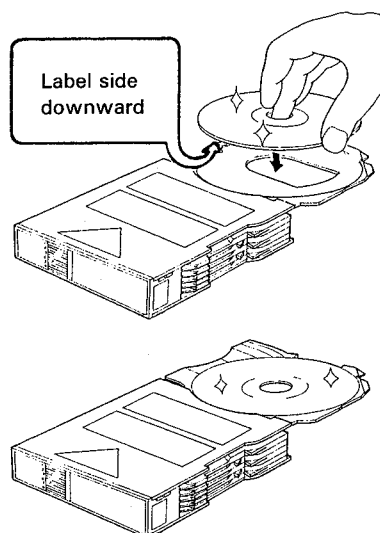
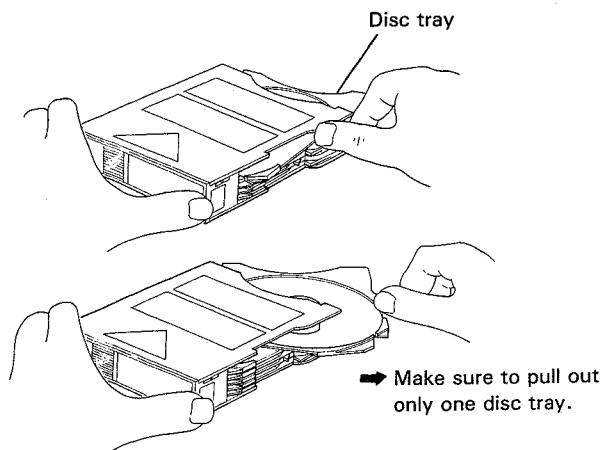

③ Push the disc tray back in.

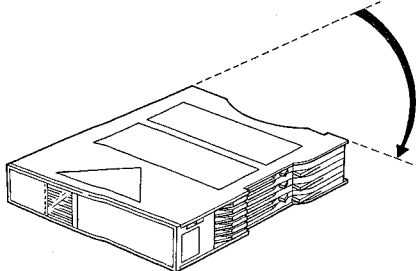

④ Insert other discs by repeating steps ① to ③.

**NOTE:**

- Please make sure to only pull out one disc tray at a time. (When a disc tray has been pulled out, do not pull out other disc trays.)
- If discs are inserted label side upward, it will not be possible for them to be played. Please make sure to insert them with the label side downward.
- Objects other than discs (song cards, explanations of disc contents, etc.), must never be inserted into the disc trays.
- Do not touch the playing surface of discs (the iridescent side) with hands or fingers.

⑤ Insert the magazine into the appropriate magazine insertion slot of the CD player until it clicks.

⑥ Insert the magazines into other magazine insertion slots by repeating step ① to ⑤.

**IMPORTANT**

Make sure to insert all three magazines into the three magazine insertion slots of the CD player. Otherwise, the CD player will not operate. Insert an empty magazine if no discs are required.

**CAUTIONS REGARDING HANDLING OF MAGAZINES**

- When inserting a magazine into the player, make sure that the direction of insertion is correct.
- After use, store in the case provided. Do not place in locations subjected to high temperatures or exposed to direct sunlight.
- Do not take magazines apart.
- Be careful not to drop or hit magazines against things. Also, do not apply strong force to trays which have been withdrawn.
- Application of benzene, thinner, insecticide or other volatile liquids to a magazine may damage the surface, so keep magazines away from such substances.

**CAUTION**

This magazine is for use with the CD JUKEBOX and, because of the wear which naturally occurs, should be replaced at 6 monthly intervals.

The 6 monthly interval is a rule of thumb. The real replacement interval depends on the frequency of use and the circumstances. The ball bearing becomes worn after the same tray has been used for play 5,000 – 8,000 times. Using the worn ball bearing increases the load to the mechanism, resulting in damage on the drive motor or other parts. Early replacement is therefore recommended.

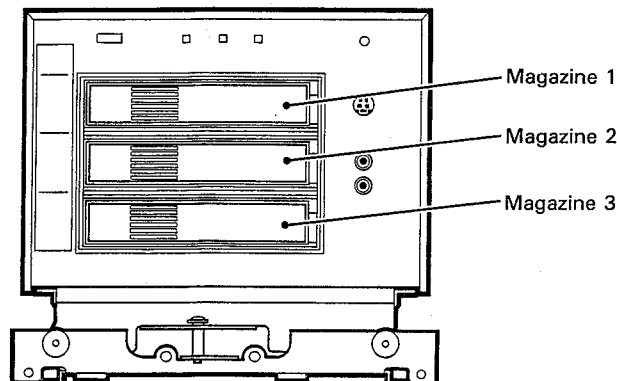

# ATTACHING THE MENU SHEET

- ① Affix the menu No. label corresponding to the same number as the disc number of the CD player.
- ② Insert the above portion of the menu sheet into the sheet guide.
- ③ Bend the sheet and insert the below portion into the sheet guide.

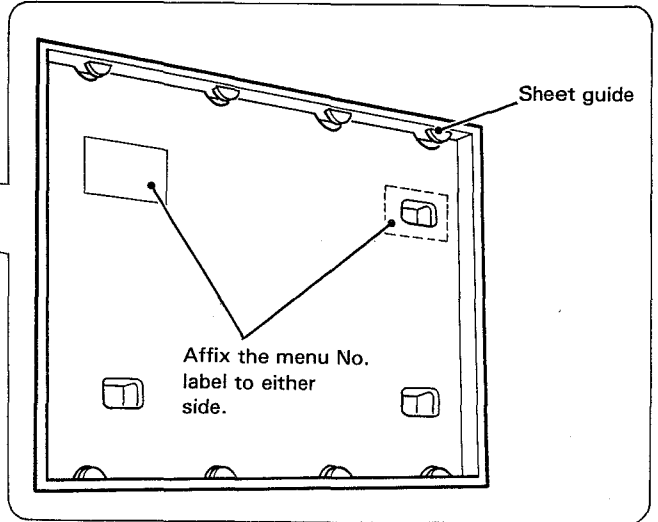
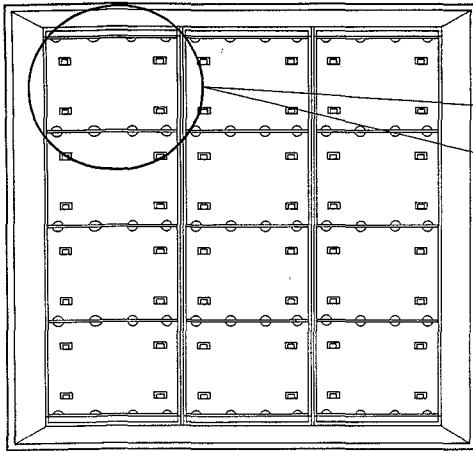

# INSTALLING THE LOCK TO THE MENU DOOR

Install the lock as shown in the figure so that the retainer can be moved by the key.  
Make sure, and turn the key when closing the door.

Use a CamLock 8068 made by American Lock Co. for the lock of the menu door.

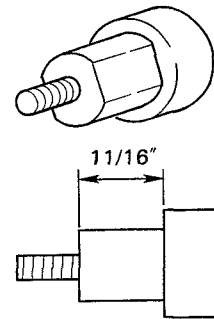
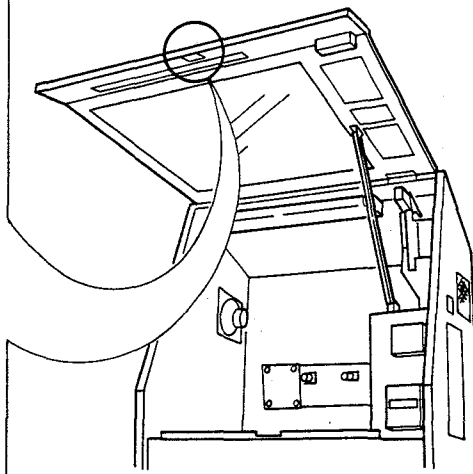
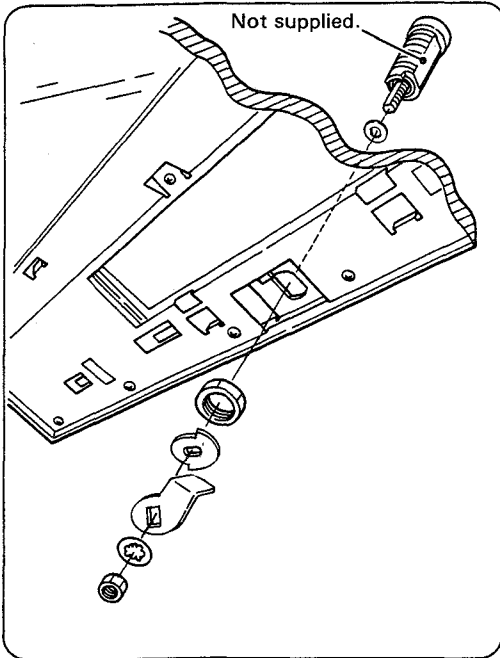

## CASTER LOCKING

The front casters are equipped with a locking mechanism. Make sure to lock the casters after installation as shown in the figure.

Open the main unit door before caster locking. (see page 5).

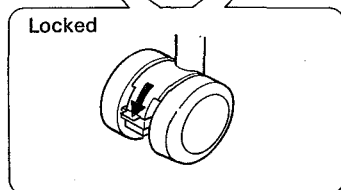
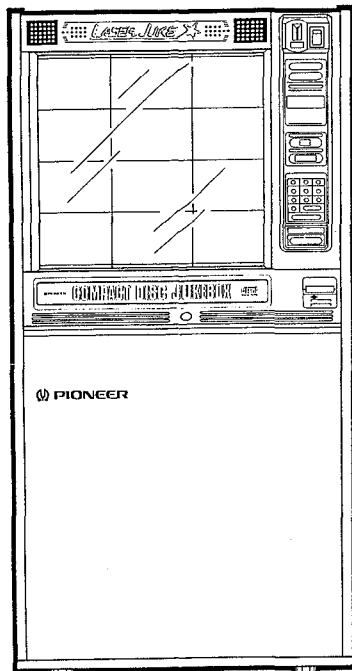

Lift the claw to unlock.

Lower the claw to lock. If locking is difficult, rotate the wheel a little.

## SETTING OF THE FUNCTION SWITCHES

(DIP switches for FUNCTION)

Function setting is effective only when the power is switched ON.

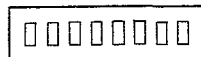

1 2 3 4 5 6 7 8

No.	Panel display	Up	Description
		Down	
1	FREE PLAY	No charge	Plays without charge.
		Charge	Plays only when coins/bills are put in.
2	—	—	—
3	—	—	—
4	—	—	—
5	BEST6-10/ RANDOM (Functions when AUTO PLAY 7 is ON.)	UP	Plays back the 6th to 10th BEST songs.
		DOWN	Plays back songs by random selection.
6	—	—	—
7	AUTO PLAY	ON	Selects songs at random and plays them as long as no song is being selected.
		OFF	Does not perform AUTO PLAY.
8	—	—	—

No function is assigned to the switches 2, 3, 4, 6 and 8.

# NAME AND FUNCTION OF EACH PART

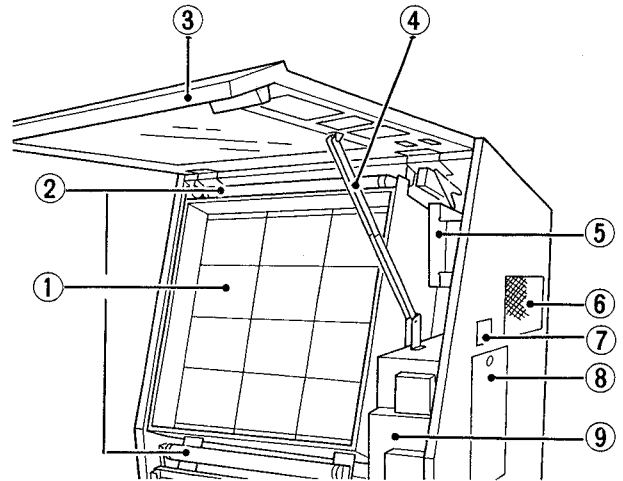
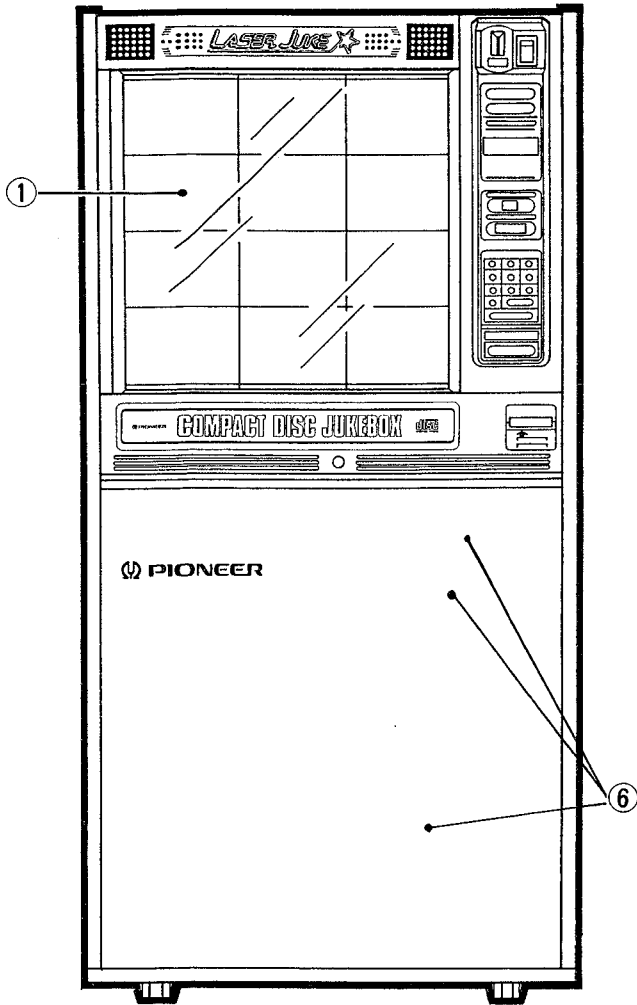

- ① Menu board
- ② Fluorescent lamp for menu illumination
- ③ Menu door
- ④ Arm
- ⑤ Coin acceptor
- ⑥ Speakers
- ⑦ Coin-return hole  
When a coin is inserted while the indication "DEPOSIT CASH" is off or unacceptable kinds of coins are inserted, they are returned via this hole.
- ⑧ CHARGE STORAGE COVER
- ⑨ Bill holder

(OPERATION SECTION)

⑩ Coin insertion hole

CAUTION:

Inserted coins will not be returned even though the coin-return lever is operated. Insert only the amount of coins needed.

⑪ Coin-return lever

Operate the coin-return lever when a deformed or steel imitation coin is caught. This will cause the coin to return via the coin-return hole.

⑫ Operation guide display

• DEPOSIT CASH.

When this indication is lit, you can insert cash.

• MAKE SELECTION.

This indication is lit when the system is ready for music selection.

⑬ SELECTIONS REMAINING indicator

This indication shows the number of music titles you can select using the inserted cash.

"FP" is displayed during free play.

⑭ YOUR SELECTION/NOW PLAYING indicator

This indication shows the number of credit entering by using numeric keys.

When no key input is being done, this indication shows the number of the music title currently being played.

"OPEN" is displayed while the menu door is open.

⑮ OPERATION key

• Numeric keys

Use these keys to enter the disc number and track number to be played.

• CLEAR key

The selection can be canceled by pressing the CLEAR key while the digits are flashing after entering the last digit.

• BEST HITS key

The most-popular piece of music on the location is automatically selected.

⑯ ROTATE MENU key

To rotate the menu board.

A maximum of 3 menu boards can be displayed.

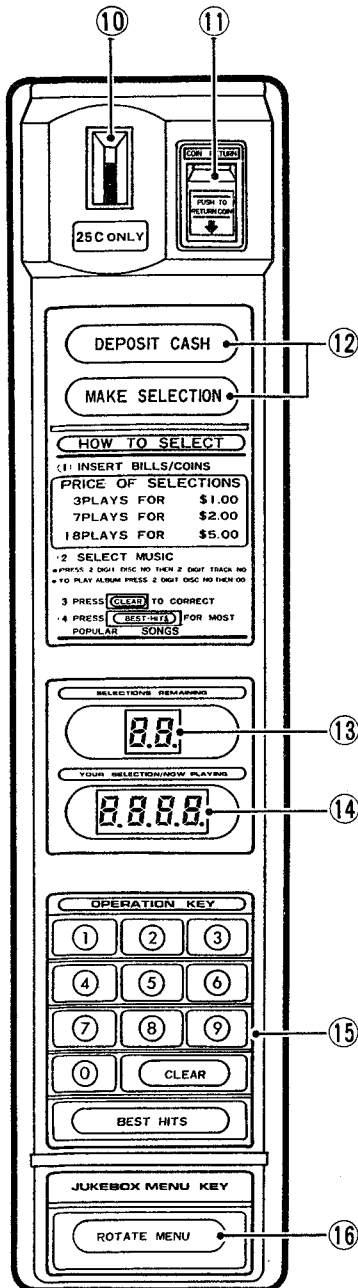



**NAME AND FUNCTION OF EACH PART**

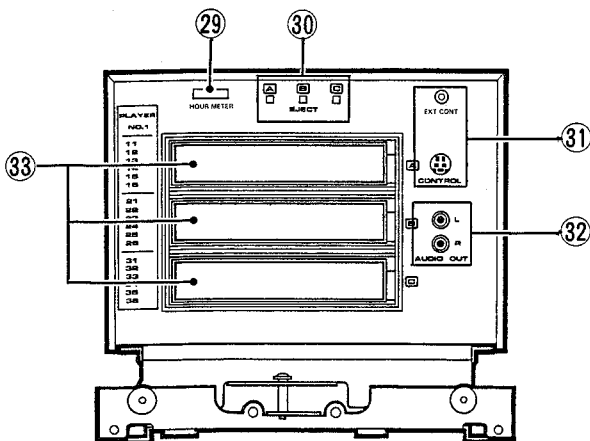
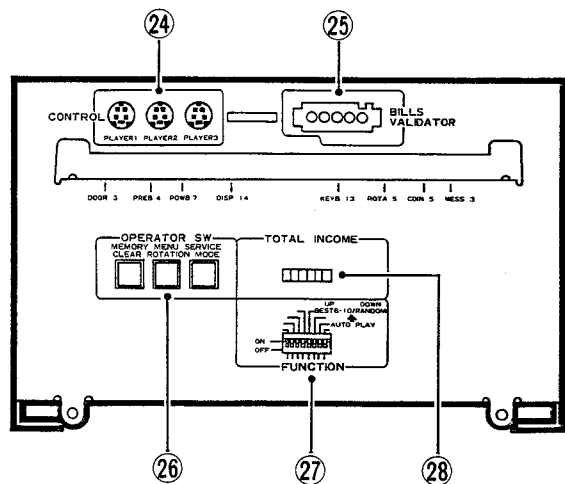
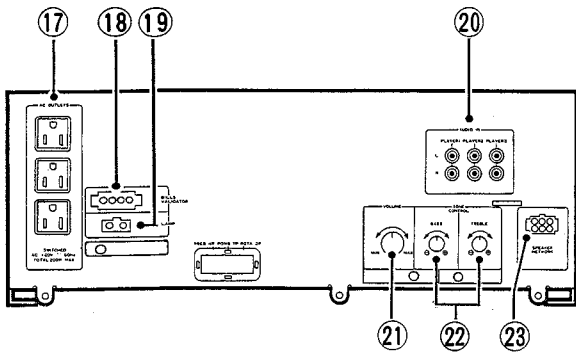

**(INSIDE OF THE MAIN UNIT DOOR)**

**■ Amplifier section**

\* Cords are connected to 18, 19 and 23 at shipping.

**17 AC OUTLETS (SWITCHED 200 W MAX)**

Connect the power cord of the CD player. Power supplied through these outlets is turned ON/OFF by the equipment's POWER switch. The total electrical power consumption of connected equipment should not exceed 200 W.

**NOTE:**

Do not connect appliances with high power consumption such as heaters, irons, or television sets to the AC OUTLETS in order to avoid overheating or fire risk. This can cause the equipment to malfunction.

**18 BILLS VALIDATOR terminal**

**19 LAMP terminal**

**20 AUDIO IN jacks**

Connect to the AUDIO OUT jacks of the CD player with the audio cord.

**21 VOLUME control knob**

**22 TONE CONTROL knob**

BASS ..... Adjusts the bass level.  
TREBLE ..... Adjusts the treble level.

**23 SPEAKER NETWORK terminal**

**■ Controller section**

**24 CONTROL jacks**

Connect to the CONTROL jack of the CD player with the designated control cord.

**25 BILLS VALIDATOR terminal**

A cord is connected to the terminal at shipping.

**26 OPERATOR SW (switches)**

**MEMORY CLEAR:**  
To clear the previous memory.  
**MENU ROTATION:**  
To rotate the menu board.  
**SERVICE MODE:**  
To set to service mode.

**27 FUNCTION switches**

See page 13.

**28 TOTAL INCOME counter**

Displays the amount of cash deposited. Reset impossible.

**■ Compact disc player section**

**29 HOUR METER**

Displays the duration of time the unit has been used.

**30 EJECT keys**

Press to eject the magazines.

**31 CONTROL jacks**

**CONTROL:**  
Connect to the specified CONTROL jacks (PLAYER 1) of the controller section.  
**EXT CONT.:**  
A terminal to externally control the CD player. Usually not used.

**32 AUDIO OUT jacks**

Connect to the specified AUDIO IN jack (PLAYER 1) of the amplifier section.

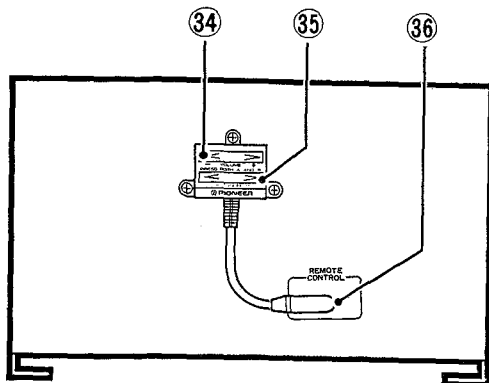

- 33 Magazine insertion slots**  
 Insert the 6-disc magazine.  
 Make sure to insert all three magazines into the three slots.  
 Otherwise, the CD player will not operate.  
 Insert an empty magazine if no disc is necessary.

**(REAR PANEL AND REMOTE CONTROL UNIT)**

- 34 VOLUME key**  
 +: Increases the volume level.  
 -: Decreases the volume level.
- 35 CANCEL key**  
 To cancel a selected song.  
 When both ends of the key A and B are pressed simultaneously, the song being played will be stopped and the next selected song will be played.
- 36 Remote control terminal**

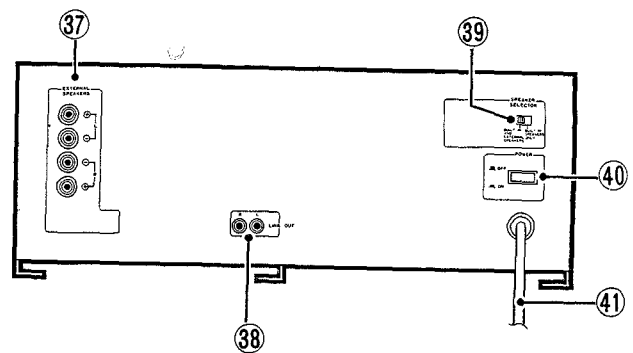

- 37 EXTERNAL SPEAKERS terminals**  
 L: Connect the left speaker system as seen from the listening position.  
 R: Connect the right speaker system as seen from the listening position.
- NOTE:**  
 Connect a speaker system having a nominal impedance ranging from 8Ω to 16Ω.
- 38 LINE OUT jacks**  
 CD audio is output.
- 39 SPEAKER SELECTOR switch**  
 Selects the speakers to be used for playback.  
 When using only the built-in speakers: Set the switch to the right.  
 When using both built-in and external speakers: Set the switch to the left.
- 40 POWER switch**  
 Press to turn the power of the unit ON/OFF.
- 41 POWER cord**

**OPERATION**

**HOW TO SELECT A SONG**

**Ordinary selection**

1. Rotate the menu by pressing the ROTATE MENU key, and select the desired song.
2. Insert bills or coins.
3. Select a song.
  - Type in a two-digit disc number and a track number.
  - To play an album, type in a two-digit disc number and "00".
  - The selection can be canceled by pressing the CLEAR key while the digits are flashing after entering the last digit.
  - A beep sound occurs when confirming the input. Keys which are not available for input are not lit. If the not-lit key is depressed, a beep sound occurs twice.

**One-touch selection**

1. Insert bills or coins.
2. Press BEST HITS key for the most popular songs.

**Playback sequence**

- Playback is made by arranging the reserved selection in a certain order.
- Multiple selections are played only once.

**Volume adjustment and song cancellation by the remote control unit**

Volume can be adjusted by the supplied remote control unit. The volume increases when the "+" side is pressed, and decreases when "-" side is pressed. To cancel the song being played, press both ends of the RESET key at the same time.

## REPLACING THE MENU AND DISC

To update the contents of the jukebox menu, replace the CD and corresponding menu sheet together.

- ① Open the menu door.
- ② Open the main unit door.
- ③ Replace the menu sheet corresponding to the replaced disc number.
- ④ Remove the magazine, which contains the disc to be replaced, from the CD player.
  1. Press the EJECT key (A/B/C) of the magazine to the removed.
  2. Remove the magazine.
  3. Pull out the disc tray and replace the disc.
  4. Return the disc tray.See page 10 for the installation of the disc to the magazine.
- ⑤ Insert the magazine into the slot of the CD player as before.
- ⑥ Close the main unit door and menu door, and lock them.

## ADDING A CD PLAYER

A maximum of two CD players can be added. (A total of three CD players can be used).

- ① Turn the power OFF.
- ② Open the menu door.
- ③ Remove the main unit door.
- ④ Remove the transport screws of the CD player.
  - See page 6.
- ⑤ Install the CD player.
  - Insert the CD player along the installation rail.
- ⑥ Connect the CD player's CONTROL jack to the controller's CONTROL jack using the designated control cord.

- ⑦ Connect the CD player's AUDIO OUT jack to the amplifier's INPUT jack using the audio cord.
- ⑧ Connect the CD player's power cord to the amplifier's AC OUTLET.

**NOTE:**

*When connecting the CD player to the amplifier and controller sections, connect the second CD player to PLAYER 2, and the third CD player to PLAYER 3.*

- ⑨ Reinstall the main unit door.
- ⑩ Close the menu door and lock it.

**Refer to the operating instructions of PD-MV55**

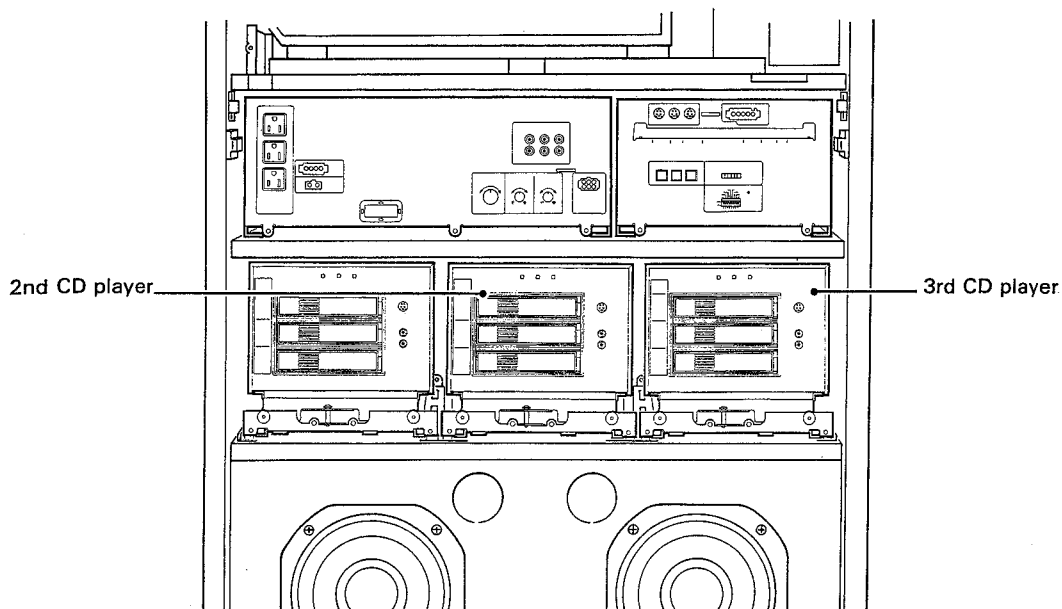

## REMOVING COINS/BILLS

### Taking out the coin box

- ① Open the charge storage cover, and take out the coin box by pulling the handle.
  - Where the coin box is equipped with an anti-burglar key, remove the key before taking the coin box out.
- ② Collect the coins/bills.
  - After collecting the coins, fix the coin box as it was before. Incline the lever towards you and push it. Holding from the label side place the box into the holder between the two alignment slits. Inclining the lever in the reverse direction makes the attachment of the coin box impossible. Where necessary, install an anti-burglar key.

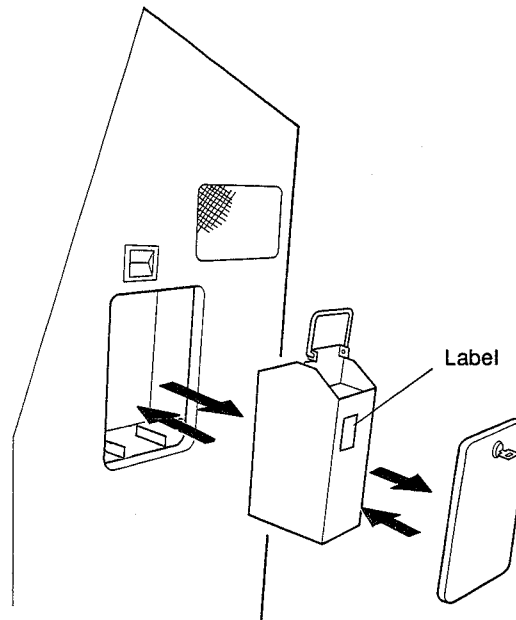

## MAINTENANCE

### CHANGING THE FLUORESCENT LAMPS

There are two fluorescent lamps located on the top and the bottom of the menu board.

- ① Turn the power OFF before changing the fluorescent lamps.
- ② Open the menu door.
- ③ Remove the colored cover of the fluorescent lamp.
- ④ Replace the fluorescent lamp (15 W).
- ⑤ Fasten the colored cover as before.

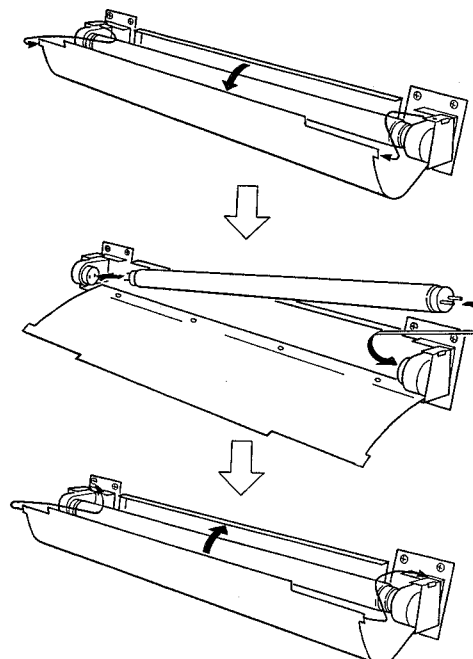

# CHANGING THE GLOW LAMP

To replace the glow lamp, remove the glow lamp cover on the rear.

- ① Turn the power OFF before changing the glow lamp.
- ② Open the glow lamp cover.
- ③ Replace the glow lamp.
  - The right glow lamp is for the lower fluorescent lamp, and the left glow lamp is for the upper fluorescent lamp.
  - Remove the burnt-out glow lamp by turning it to the left. Install a new glow lamp.
- ④ Install the glow lamp cover and tighten the screws.

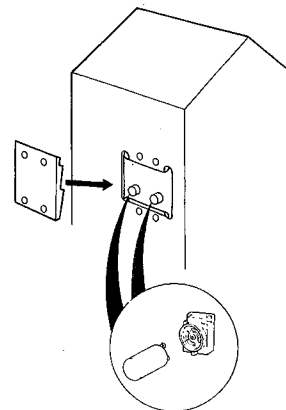

## SERVICE MODE

### HOW TO USE SERVICE MODE (Operation mode)

The CJ-V55 is provided with a service mode (operation mode) in which the following operations are available:

Submode		Function mode		Function mode and operation ( [A] [B]; A ... Function mode, B ... Operation)		
Reference mode	0	Audits	0	Playback audits (counting after previous reset)	00	Displays the number of songs selected for free-of-charge playback.
			01		01	Displays the number of songs selected for paid playback.
			02		02	Displays the number of songs selected in the normal mode.
			03		03	Displays the number of BEST HIT songs selected.
				04	Displays the number of albums selected.	
				05	Displays the number of times of actual playback.	
			1	Cash audits (counting after previous reset)	10	Displays total cash (25 cents = 1 unit)
					11	Displays total coins input.
					12	Displays total 1 \$ bills input.
					13	Displays total 5 \$ bills input.
				14	Generates the total and displays the bonus value.	
		2	Non-resettable playback audits (cannot be reset after shipping)	20	Displays the number of songs selected for free-of-charge playback.	
				21	Displays the number of songs selected for paid playback.	
				22	Displays the number of songs selected in the normal mode.	
				23	Displays the number of BEST HIT songs selected.	
				24	Displays the number of albums selected.	
				25	Displays the number of times of actual playback.	
		3	Non-resettable cash audits (cannot be reset after shipping)	30	Displays total cash.	
				31	Displays total coins input.	
				32	Displays total 1 \$ bills input.	
				33	Displays total 5 \$ bills input.	
				34	Generates the total and displays the bonus value.	
	1	Others	0	Most popular song*	00	Alternately displays the number of the song most frequently selected and the number of times of playback.
01					Alternately displays the number of the 2nd popular song and the number of times of playback.	
09					Alternately displays the number of the 10th popular song and the number of times of playback.	
			1	Most popular disc**	10	Alternately displays the number of the disc most frequently selected and the number of times of selection.
					11	Alternately displays the number of the 2nd popular disc and the number of times of selection.

		Submode	Function mode	Function mode and operation ( [A] [B]; A ... Function mode, B ... Operation)				
Reference mode					{ 19 Alternately displays the number of the 10th popular disc and the number of times of selection. }			
						2	Least popular disc**	20 Alternately displays the number of the disc least frequently selected and the number of times of selection. 21 Alternately displays the number of the disc which has been second least frequently selected and the number of selection. } 29 Alternately displays the number of the disc which has been tenth least frequently selected and the number of selection.
						3	Error history	30 Displays the most recent error code. 31 Displays the error code of the previous error. 32 Displays the error code of 2 steps before. 33 Displays the error code of 3 steps before. 34 Displays the error code of 4 steps before. 35 Displays the error code of 5 steps before. 36 Displays the error code of 6 steps before. 37 Displays the error code of 7 steps before. 38 Displays the error code of 8 steps before. 39 Displays the error code of 9 steps before.
						4	Number of times of cancellation by track skips	40 Alternately displays the number of the disc most frequently selected and the number of time of cancellation. 41 Alternately displays the number of the 2nd frequently cancelled and the number of time of cancellation. } 49 Alternately displays the number of disc 10th frequently cancelled and the number of time of cancellation.
						5	Display of ID No.	50 ) Displays location No. 51 ) Displays serial No. 52 ) 53 ) The ID No. consists of four sections, and each section will be displayed separately. **** - **** 50 51 52 53 Location No. Serial No.
						6	Display of microcomputer Ver.	6 Displays the version of the built-in microprocessor.
						Setting mode	2	Price & bonus
1	Number of songs per unit	1 Number of songs per unit (example: 4 = 3 songs)						
2	Bonus setting	20 Credit value for bonus 21 Bonus value for the credit of "21" 22 Credit value for bonus 23 Bonus value for the credit of "22" 24 Credit value for bonus 25 Bonus value for the credit of "24" 26 Credit value for bonus 27 Bonus value for the credit of "26" 28 Credit value for bonus 29 Bonus value for the credit of "28"						

		Submode	Function mode		Function mode and operation ( [A] [B]; A ... Function mode, B ... Operation)	
Setting mode	3	Others	0	Number of times of skip for cancellation	0	Sets the number of track skips allowed in one song.
			1	Auto-play interval input	1	Sets the interval time during auto-play in units of minutes.
			2	Pass word input	2	Sets a 4-digit number.
			3	ID No. input	30 31 32 33	) Location No. ) Serial No. The ID No. consists of four sections. Input it as follows:  <div style="text-align: center;">           * * * * * - * * * * *            30    31    32    33            Location No.    Serial No.         </div>
Delete mode	4	Delete	0	Deleting playback audits	0	The playback audits setting is cleared by pressing the CLEAR key.
			1	Deleting cash audits	1	The setting of cash audits is cleared by pressing the CLEAR key.
			2	Deleting most popular data	2	The data concerning a disc, which are stored in the memory, can be cleared by pressing the CLEAR key.
			3	Deleting error history	3	The data on error history is cleared by pressing the CLEAR key.
			4	Deleting credit	4	Credit is cleared by pressing the CLEAR key.
			5	Deleting song selection	5	The song selection is cleared by pressing the CLEAR key.
Aging mode	5	Aging	0	Number of time of aging	0	Number of times of aging.
			1	Aging (1)	1	All the songs are played in sequence starting with the uppermost disc (i.e., increase in the disc number). Every time one song has been completely played, the disc is returned to the magazine and the elevation mechanism is returned to the home position (the lowest position). The next song is then accessed. The system stops when all the songs have been completely played.
			2	Aging (2)	2	One song on each disc is played for 30 seconds in sequence, starting with the uppermost disc. The elevation mechanism is returned to the home position (the lowest position) after termination of playback. The next song (i.e., the next disc) is then accessed. The system stops when all the discs have been played.
			3	Aging (3)	3	The first and last songs on each disc are played for 30 seconds for each song in sequence starting with the uppermost disc. The elevation mechanism is returned to the home position (the lowest position) after termination of playback. The next song (i.e., the next disc) is then accessed. The system stops when all the discs have been played.
	6	Hard ware check	0	LED check	0	All LEDs light up.
			1	DIP switch setting display	1	DIP switch setting display.

- \* In case that there are more than one song with the same number of times of selection, the song that has been selected last is given priority.
- \*\* In case that there are more than one disc having the same number of times of selection, the disc with the smaller disc number is given priority.

**SERVICE MODE (OPERATION MODE) flowchart**

(During operation mode, the ROTATE MENU key functions as the shift key.)

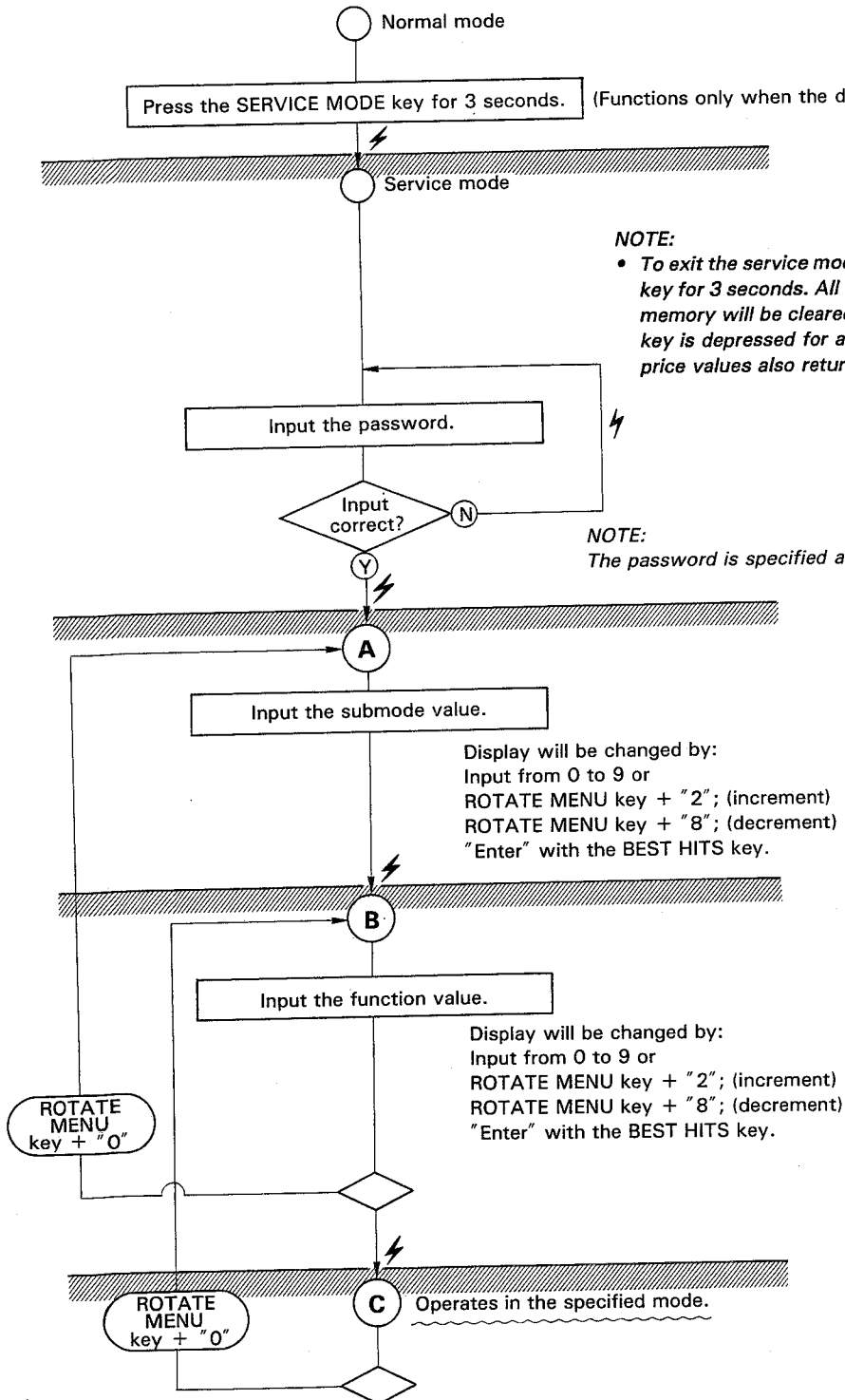



## HOW TO USE SERVICE MODE

### Shift key

During the service mode, the ROTATE MENU key functions as the shift key. When one of keys "0", "2", "4", "6" or "8" is pressed while depressing the ROTATE MENU key, the operation will be as follows:

ROTATE MENU	+	0	Reverses the progress of the service mode. Progress can be reversed as ③ → ② or ② → ① (see the SERVICE MODE flowchart).
		2	① Increases the numeric value during input of the value for submode or function mode. ② Increases the submode value during execution (step ③). ③ Increases the function mode value (upper digits) during execution (step ③).
		8	① Decreases the numeric value during input of the value for submode or function mode. ② Decreases the submode value during execution (step ③). ③ Decreases the function mode value (upper digits) during execution (step ③).
		6	Increases the function mode item (lower digits) during execution (step ③).
		4	Decreases the function mode item (lower digits) during execution (step ③).

(Example) During execution in the submode 0 and the function mode 12.

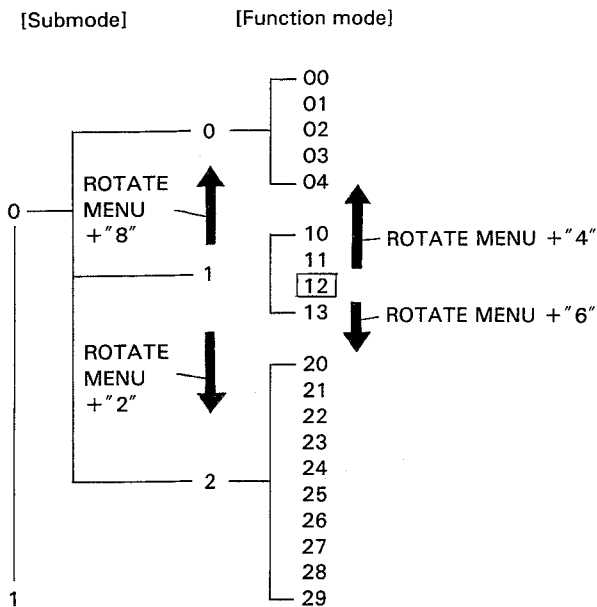

### Display and Usage

During the service mode, display is made with the indicators of SELECTION REMAINING and YOUR SELECTION/NOW PLAYING.

#### 1. Inputting the password



Displays "PS".

Input the password with the number keys.

(Example)

Upon correct input, "beep" will sound and it changes to submode input.

Upon incorrect input, "beep-beep" will sound. Input the password correctly.

#### 2. Inputting submode

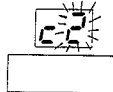

Displays "C".

Input the submode with the number keys.

(Example)

When the BEST HITS key is pressed, "beep" will sound and it changes to function mode input.

When a number not existing in the submode is input, "beep-beep" will sound. Input a correct number.

#### 3. Inputting function mode

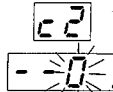

The "—" light up for the first two digits.  
 Input the value for the function mode (an upper digit or an upper and lower digit) with the number keys.

(Example)

When the BEST HITS key is pressed, "beep" will sound and changes to execution mode.

When number(s) not existing in the function mode are input, "beep-beep" will sound and it reverses to the previous display. Input correct number(s).

**4. During execution**

**(1) SELECTION REMAINING Indicator**



Alternately displays the submode (c2) and the function mode (20) for approximately once a second each.

If an upper digit is specified for the function mode value, a small "0" will be displayed for the lower digit.

(Example)

**(2) YOUR SELECTION/NOW PLAYING indicator**

**• Submode 0**

Up to 999,999 will be displayed.

The number will be displayed completely if the value is smaller-than-or-equal-to 9,999.

If the number is greater-than-or-equal-to 10,000, the first two digits and the remaining four digits will be displayed alternately.

(Example) Displaying 123,456:

(Displays periods and the first two digits.)

(Displays the remaining four digits.)

**• Submode 1**

**[Function mode 00 to 09]**

Displays the song number and the number of times of playback alternately.

(Example) Playback of track No. 1207 for 57 times:

(Displays the track No. with periods.)

(Number of times of playback)

**[Function mode 10 to 19, 20 to 29]**

Displays the disc number and the number of times as in the function mode 00 to 09. The disc number is displayed in the upper two digits, and the lower two digits are set to "00".

**[Function mode 30 to 39]**

Displays the 4-digit error codes.

(Example) Search in the lowest disc of the third CD player fails due to exceeding the time limit.

**[Function mode 50 to 53]**

The ID number is displayed in 3-digit, 3-digit, 2-digit and 3-digit numbers.

**[Function mode 6]**

Displays the version of the built-in microprocessor.

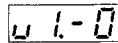

**• Submode 2**

**[Function mode 0 or 1]**

Displays a number up to two digits with periods.

(Example) When "04" is input:



When the BEST HITS key is pressed, "beep" will sound, and it changes to function mode 1 (from 0) or to 20 (from 1).

**[Function mode 20 to 29 (max. 99)]**

Five types of bonus rates can be set. Set the value of credit where the bonus applies in the function modes 20, 22, 24, 26 or 28, and the corresponding number of bonuses in the function modes 21, 23, 25, 27 or 29.

(Example) Setting credit 8 and bonus 1 to the function modes 20 and 21:

- Function mode 20



Displayed with blinking upper two digits.

- When the BEST HITS key is pressed, "beep" will sound and it changes to the function mode 21.
- Function mode 21

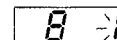

Displayed with blinking lower two digits.

- When the BEST HITS key is pressed, "beep" sound is output and changes to the function mode 22.

(Example of bonus rate setting)

Function mode		Function mode	
20	8	1	21
22	20	2	23
24	32	3	25
26	0	0	27
28	0	0	29

An identical credit value cannot be specified in the same setting. For example, when the bonus rate has been set as in the above table and credit value 20 is input to function mode 20, "beep-beep-beep" warning will sound and the credit value of the function mode 21 will change to 2, because the same value exists in the function mode 22. The credit values of function mode 24 and 25 will change to those of function modes 22 and 23.

Likewise, if credit value 8 is input to function mode 22, "beep-beep-beep" warning will sound and the function mode will change to 21, because the same value exists in the function mode 20. The credit values of function mode 24 and 25 will change to those of function modes 22 and 23.

## HOW TO USE SERVICE MODE

The bonus rate is stored in sequence from the smallest credit value. If the order has been changed during setting, the sequence will be reorganized according to the following conditions ("0" is treated as a maximum value):

- (1) Shift key function of either ROTATE MENU + "2" or ROTATE MENU + "0" is operated when one of the function modes 20 to 29 has been specified.
- (2) "0" is input in the function mode where the credit value is "0".
- (3) A value is input to the function mode 29 and the BEST HITS key is pressed.
- (4) To cancel the service mode.

- **Submode 3**

**[Function mode 0 to 1]**

Displays a number up to two digits with periods.  
 (Example) Inputting "24": (Inputting "4"=04)

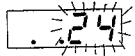

When the BEST HITS key is pressed, "beep" will sound and it changes to the next function mode.

**[Function mode 2]**

Displays a 4-digit number.  
 (Example) Inputting "5678":



When the BEST HITS key is pressed, "beep" will sound and it changes to function mode 30.

**[Function mode 30 to 33]**

The ID number is displayed in a 3-digit number for function modes 30, 31 and 33, and in a 2-digit number for function mode 32.

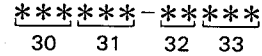

When the BEST HITS key is pressed, it changes to the next function mode. For function mode 33, however, the mode does not change.

- **Submode 4**

Displays "CL" and the function mode.  
 (Example) Function mode 2:

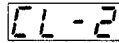

- **Submode 5**

The display is blinking during stand-by. This submode is activated when the BEST HITS key is pressed, and the display stops blinking and lights steady.

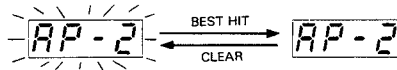

## ERROR CODE

Item	Error code	Option	Description
CASH	00	—	Trouble with coin acceptance*
	01	—	Trouble with \$1 bill acceptance*
	02	—	Trouble with \$5 bill acceptance*
	03	—	The bill stacker is full
PLAYER	20	Player number	Command break
	21	Disc number	Search timeout
	22	Disc number	Defocus
	23	Disc number	No disc
	24	Disc number	Trouble with setup
	25	Disc number	Impossible to return
	26	Disc number	Trouble with disc select
27	Disc number	The select mechanism cannot return	
COMMUNICATION with CDP	40	Player number	Disabled communication
	41	Player number	Unknown code returned from the player.
	42	Player number	The player did not recognize the command.
	13	—	Undefined DRT line
	60	—	Undefined DIP switch

\* Input time of (bill) signal is too long.

**Other**

- Error code 00 - 99 Up to 100 codes
- Option number
  - CD player number:
    - 01 for the first CD player
    - 02 for the second CD player
    - 03 for the third CD player
  - Disc number: the upper two digits when entered.
    - (Examples)
    - 96: the lowest disc in the third CD player
    - 11: the uppermost disc in the first CD player

## TROUBLESHOOTING

Incorrect operations are often mistaken for trouble and malfunctions. If you think that there is something wrong with this component, check the points below. Sometimes the trouble may lie in another component. Check the other components and electrical appliances being used. If the trouble cannot be rectified even after exercising the checks listed below, ask your nearest authorized PIONEER service center or your dealer to carry out repair work.

Symptom	Probable cause	Remedy
Cannot select songs.	<ul style="list-style-type: none"> <li>• No coins/bills are input.</li> <li>• Incorrect connection of the CD player.</li> </ul>	<ul style="list-style-type: none"> <li>• Input the specified charge.</li> <li>• Connect correctly.</li> </ul>
Magazine is not ejected when EJECT key is pressed.	<ul style="list-style-type: none"> <li>• Power plug is disconnected from outlet.</li> <li>• Power switch is OFF.</li> </ul>	<ul style="list-style-type: none"> <li>• Connect plug to AC OUTLET of the amplifier section.</li> <li>• Press POWER switch to ON.</li> </ul>
When playback is started, it stops immediately.	<ul style="list-style-type: none"> <li>• Disc is loaded upside down.</li> <li>• Smudges on the disc, etc.</li> </ul>	<ul style="list-style-type: none"> <li>• Load the disc correctly with the label side downward.</li> <li>• Clean the fog from the disc, and then play it again.</li> </ul>
No sound	<ul style="list-style-type: none"> <li>• Output cords are incorrectly or loosely connected.</li> <li>• Pin plugs and/or terminals are dirty.</li> </ul>	<ul style="list-style-type: none"> <li>• Connect properly.</li> <li>• Clean away dirt.</li> </ul>
Sound is distorted, and noise occurs.	<ul style="list-style-type: none"> <li>• Pin plugs and/or terminals are dirty.</li> </ul>	<ul style="list-style-type: none"> <li>• Clean away dirt.</li> </ul>
With certain discs, loud noise is produced, or play stops.	<ul style="list-style-type: none"> <li>• Disc has a bad scratch or warp.</li> <li>• Disc is extremely dirty.</li> </ul>	<ul style="list-style-type: none"> <li>• Replace the disc.</li> <li>• Clean disc.</li> </ul>

# SPECIFICATIONS

## Amplifier Section

**Continuously Average Power Output is 100 Watts \* per channel, min., at 8 ohms from 20 Hertz to 20,000 Hertz, with no more than 0.5 % total harmonic distortion.**

\* Measured pursuant to the Federal Trade Commission's Trade Regulation rules on Power Output Claims for Amplifier.

Frequency Response ..... 20 Hz to 20 kHz  $\pm$ 1.5 dB  
Tone Control

Bass (100 Hz) ..... Max. +10 dB, Min. -10 dB  
Treble (10 kHz) ..... Max. +10 dB, Min. -10 dB

## CD player section

Signal-to-Noise ratio ..... 94 dB or more

Dynamic Range ..... 85 dB or more

Wow and Flutter .....  $\pm$ 0.001 % or less

Frequency Response ..... 4 Hz to 20 kHz  $\pm$ 1.5 dB

Total Harmonic Distortion ..... 0.1 % or less

Output Voltage ..... 1.8 V

Number of channels ..... 2 channels (stereo)

Dimensions ..... 239 (W) x 463 (D) x 215 (H) mm

9-7/16 (W) x 18-1/4 (D) x 8-7/16 (H) in

Weight ..... 9 kg (19 lb 14 oz)

Power Requirements ..... AC120 V, 60 Hz

Power Consumption ..... 25 W

## Speaker Section

Enclosure ..... Bass-reflex type

Loudspeakers:

Woofer ..... 25 cm (10 in) x 2

Mid range ..... 10 cm (4 in) x 2

Tweeter ..... 6.6 cm (2-1/2 in) x 2

Expansion speaker ..... 10 cm (4 in) x 2

Nominal Impedance ..... 8  $\Omega$

Frequency Range ..... 30 Hz to 20 kHz

Sensitivity ..... 90 dB/W.m

Maximum Power ..... 100 W

## Miscellaneous

Power Requirements ..... AC120 V, 60 Hz

Power Consumption ..... 300 W

AC outlets

Switched (x3) ..... Total 200 W MAX.

Dimensions ..... 797 (W) x 618 (D) x 1640 (H) mm

31-3/8 (W) x 24-5/16 (D) x 64-9/16 (H) in

Weight ..... 146 kg (322 lb 5 oz)

Operating temperature ..... +5°C to +35°C

(+41°F to +95°F)

Operating humidity ..... 5 % to 85 %

## Audio output

Terminal ..... RCA pin-jack

EXT SP terminal ..... L,R x 1

Initialized time ..... 3 min. or less/CD player

Access time between playing ..... 15 sec. or less

## Others

Number of CD discs ..... 54 CD discs (18 discs with standard plus additional 36 with option)

Number of CD players ..... One CD player (additional two CD players with option)

Acceptance of \$1 and \$5 bills (option)

Acceptance of 25 cents coins (option)

Remote control unit (wired) ..... Volume up/down, cancellation

## Functions

- Song selection (up to 99 songs) ..... normal selection, cancellation of selection, best hit selection, album play

- Price per play

- Autoplay

- ID code

- Password

- Data output

- Income counter

- Selection memory clear

## Accessories

- Magazine x 3

- Coin / bill box x 1

- Remote control cord (30 m) x 1

- Charge storage cover x 1

- Stopper for the coin acceptance inlet x 1

- Menu number label x 1

- Rate seal x 1

- Bag for supplied components x 1

- Stiffening plate x 1

- Unlocking plate x 1

- Cord clasper x 2

- Screw A (M4 x 8) x 1

- Wooden screw x 4

- Washer x 2

- Follow-up card x 1

- Operating instructions x 1

- Screw B (tapping; M3 x 6) x 1

## NOTE:

Specifications and design subject to possible modification without notice, due to improvements.

The Magazine Type Multi-Play CD Players with  mark and the Magazines with the same mark are compatible for 5-inch (12cm) discs.

Published by Pioneer Electronic Corporation.  
Copyright © 1990 Pioneer Electronic Corporation.  
All rights reserved.

**PIONEER ELECTRONIC CORPORATION** 4-1, Meguro 1-Chome, Meguro-ku, Tokyo 153, Japan  
**PIONEER LASER ENTERTAINMENT, INC.** 22010 S.Wilmington Ave., Suite 201, Carson, CA. 90745 U.S.A.

<90A01YY0C01>

Printed in Japan <DRA1107-A>

2821

# Service Manual

**PIONEER**  
The future of sound and vision.

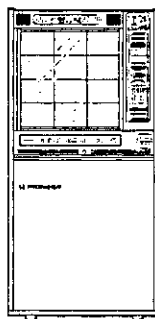

ORDER NO.  
ARP1913

COMPACT DISC JUKEBOX

# CJ-V55 PD-MV55

- Refer to the service manual (1) ARP1912, CJ-V55.
- This manual is applicable to the KUC type.
- PD-MV55/KUC type is a optional CD player of the CJ-V55/KUC type.
- PD-MV55/KUC type is the same as the built-in CD player of the CJ-V55/KUC type except packing and accessory parts.

## CONTENTS

1. SAFETY INFORMATION.....	2	6. ELECTRICAL PARTS LIST.....	84
2. EXPLODED VIEWS AND PARTS LIST.....	3	7. ADJUSTMENTS.....	91
3. PACKING.....	30	8. IC DESCRIPTION.....	102
4. SCHEMATIC DIAGRAMS AND P. C. BOARDS PATTERN.....	32	9. NOTES ON REPLACING THE LITHIUM CELL AND RAM (IC3 : TC5564APL-15).....	105
5. BLOCK DIAGRAM.....	82		

**PIONEER ELECTRONIC CORPORATION** 4-1, Meguro 1-Chome, Meguro-ku, Tokyo 153, Japan  
**PIONEER ELECTRONICS SERVICE INC.** P.O. Box 1760, Long Beach, California 90801 U.S.A.  
**PIONEER ELECTRONICS OF CANADA, INC.** 505 Cochrane Drive, Markham, Ontario L3R 8E3 Canada  
**PIONEER ELECTRONIC [EUROPE] N.V.** Keetberglaan 1, 2740 Beveren, Belgium  
**PIONEER ELECTRONICS AUSTRALIA PTY. LTD.** 178-184 Boundary Road, Braeside, Victoria 3195, Australia TEL: [03] 580-9911  
 © PIONEER ELECTRONIC CORPORATION 1990

IFI MAR. 1990 Printed in Japan

2821

This service manual is intended for qualified service technicians; it is not meant for the casual do-it-yourselfer. Qualified technicians have the necessary test equipment and tools, and have been trained to properly and safely repair complex products such as those covered by this manual.

Improperly performed repairs can adversely affect the safety and reliability of the product and may void the warranty. If you are not qualified to perform the repair of this product properly and safely, you should not risk trying to do so and refer the repair to a qualified service technician.

**WARNING**

Lead in solder used in this product is listed by the California Health and Welfare agency as a known reproductive toxicant which may cause birth defects or other reproductive harm (California Health & Safety Code, Section 25249.5).

When servicing or handling circuit boards and other components which contain lead in solder, avoid unprotected skin contact with the solder. Also, when soldering do not inhale any smoke or fumes produced.

# 1. SAFETY INFORMATION

(FOR USA MODEL ONLY)

## 1. SAFETY PRECAUTIONS

The following check should be performed for the continued protection of the customer and service technician.

### LEAKAGE CURRENT CHECK

Measure leakage current to a known earth ground (water pipe, conduit, etc.) by connecting a leakage current tester such as Simpson Model 229-2 or equivalent between the earth ground and all exposed metal parts of the appliance (input/output terminals, screwheads, metal overlays, control shaft, etc.). Plug the AC line cord of the appliance directly into a 120V AC 60Hz outlet and turn the AC power switch on. Any current measured must not exceed 0.5mA.

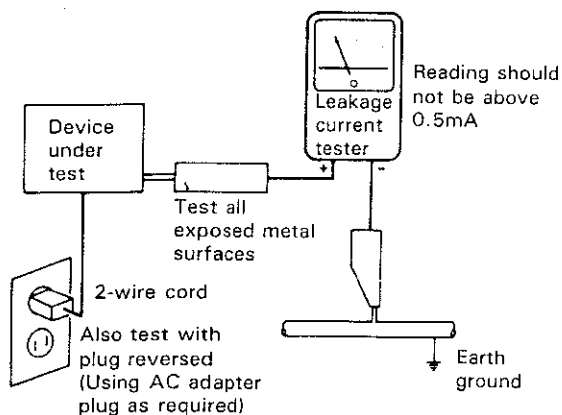

AC Leakage Test

ANY MEASUREMENTS NOT WITHIN THE LIMITS OUTLINED ABOVE ARE INDICATIVE OF A POTENTIAL SHOCK HAZARD AND MUST BE CORRECTED BEFORE RETURNING THE APPLIANCE TO THE CUSTOMER.

## 2. PRODUCT SAFETY NOTICE

Many electrical and mechanical parts in the appliance have special safety related characteristics. These are often not evident from visual inspection nor the protection afforded by them necessarily can be obtained by using replacement components rated for voltage, wattage, etc. Replacement parts which have these special safety characteristics are identified in this Service Manual.

Electrical components having such features are identified by marking with a  $\Delta$  on the schematics and on the parts list in this Service Manual.

The use of a substitute replacement component which does not have the same safety characteristics as the PIONEER recommended replacement one, shown in the parts list in this Service Manual, may create shock, fire, or other hazards.

Product Safety is continuously under review and new instructions are issued from time to time. For the latest information, always consult the current PIONEER Service Manual. A subscription to, or additional copies of, PIONEER Service Manual may be obtained at a nominal charge from PIONEER.

## 2. EXPLODED VIEWS AND PARTS LIST

### NOTES:

- Parts without part number cannot be supplied.
- The  $\Delta$  mark found on some component parts indicates the importance of the safety factor of the part. Therefore, when replacing, be sure to use parts of identical designation.
- Parts marked by "©" are not always kept in stock. Their delivery time may be longer than usual or they may be unavailable.

### 2.1 MAIN SECTION

#### 2.1.1 EXTERIOR (1)

#### Parts List

Mark No.	Part No.	Description	Mark No.	Part No.	Description
1	DAH1379	Sign board (upper)	40	SNH1018	Sash
2	DAH1380	Sign board (under)	41	SNH1017	Sash
3	DAH1183	Coin-return lever sheet A	42	SEB1072	Cushion
4	DAH1381	Operation guide display (A)	43	SEW1014	Safety belt
5	DAH1382	Operation guide display (B)	44	SEB1068	Packing
6	DAH1431	Key sheet	45	SDF1013	Earth lug assembly
7	DNK1236	Key knob A	101		DS holder assembly
8	DNK1214	Key knob B	102		• • • • •
9	DAH1432	Key sheet (B)	103		Shield packing (B)
10	DAH1393	Bill sheet	104		Coin guide (B)
11	SNB1035	Door stopper	105		Coin-return tray
12		• • • • •	106		Coin box assembly
13	SNB1037	Hook holder	107		Fluorescent lamp
14	SNX1034	Magnet catch	108		Reflection plate
15	DNK1618	Coin-return door	109		Socket holder (S)
16	DNK1616	Coin-return cover	110		Socket holder (L)
17	DNH1335	Cover of the money storage	111		Lamp bracket (L)
18	DNF1256	Reinforced plate	112		Lamp bracket (R)
19	10-757A	Speaker (Mid-range)	113		• • • • •
20	D66-AP45-52L	Speaker (Tweeter)	114		Nut
21	SMG1148	Grill	115		Cabinet
22	YE30FUC	E ring $\phi$ 3			
23	DEC1224	Illumination sheet			
24	DKK1006	Fluorescent lamp socket (upper)			
25	DEC1220	Bushing			
26	DEC-176	Plastic rivet			
27	PMH30P060FMC	Screw			
28	TNC35P140FZK	Screw			
29	SBA1061	Screw			
30	RWC35P160FZK	Screw			
31	IFZ30P080FMC	Screw			
32	BBZ30P060FMC	Screw			
33	DBA1007	Screw (3.5 x 12mm)			
34	PMB40F080FMC	Screw			
35	IFZ30P080FMC	Screw			
36	PMA60P100FMC	Screw			
37	SNB1039	Catch plate L			
38	SNB1040	Catch plate R			
39	SNB1041	Door hinge			

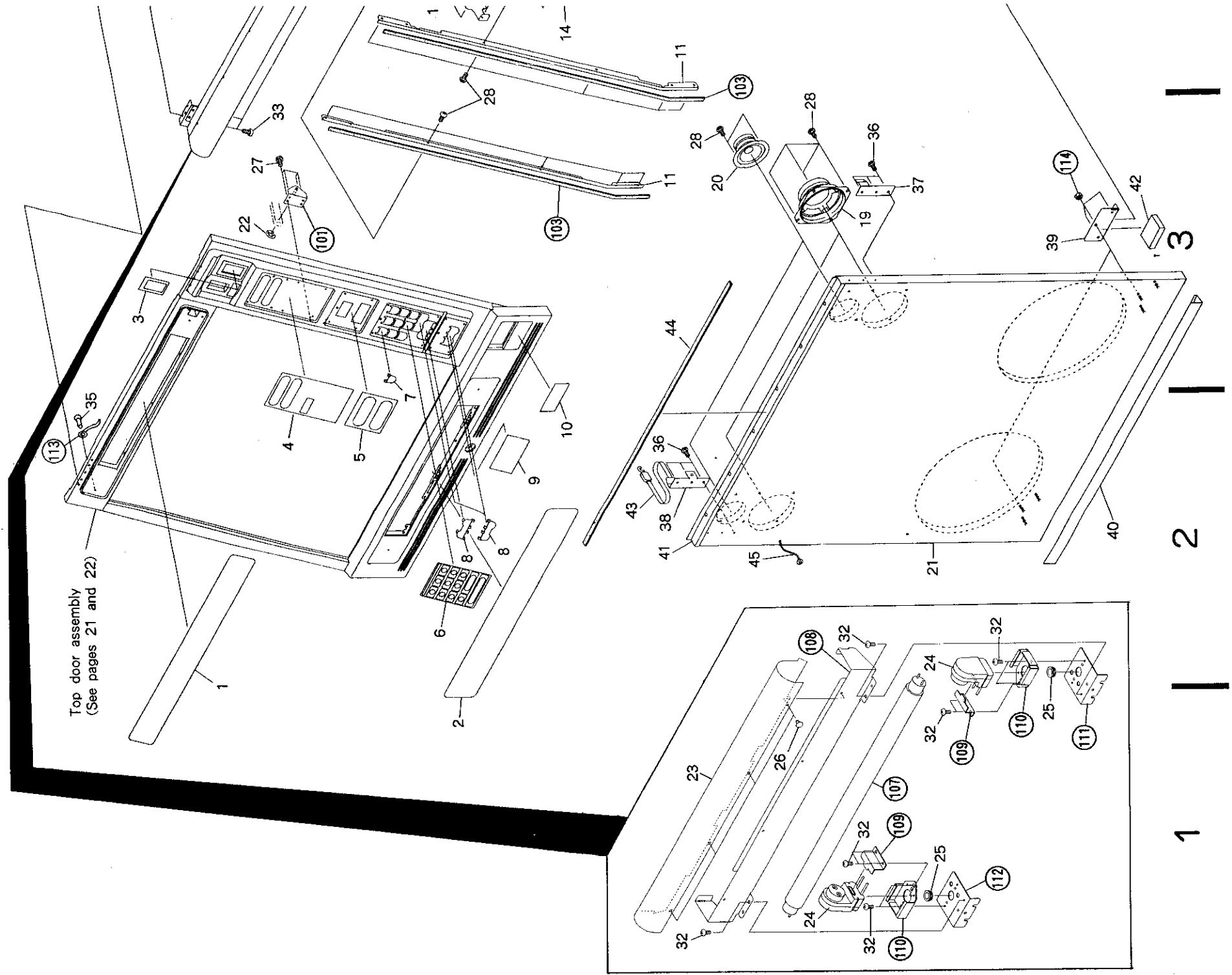



1 2 3 4 5 6

Therefore, when  
be unavailable. A

assembly  
assembly B

ing (B)  
B)  
tray

assembly  
lamp  
ate  
r (S)  
r (L)

st (L)  
st (R)

C

D

A

B

C

D

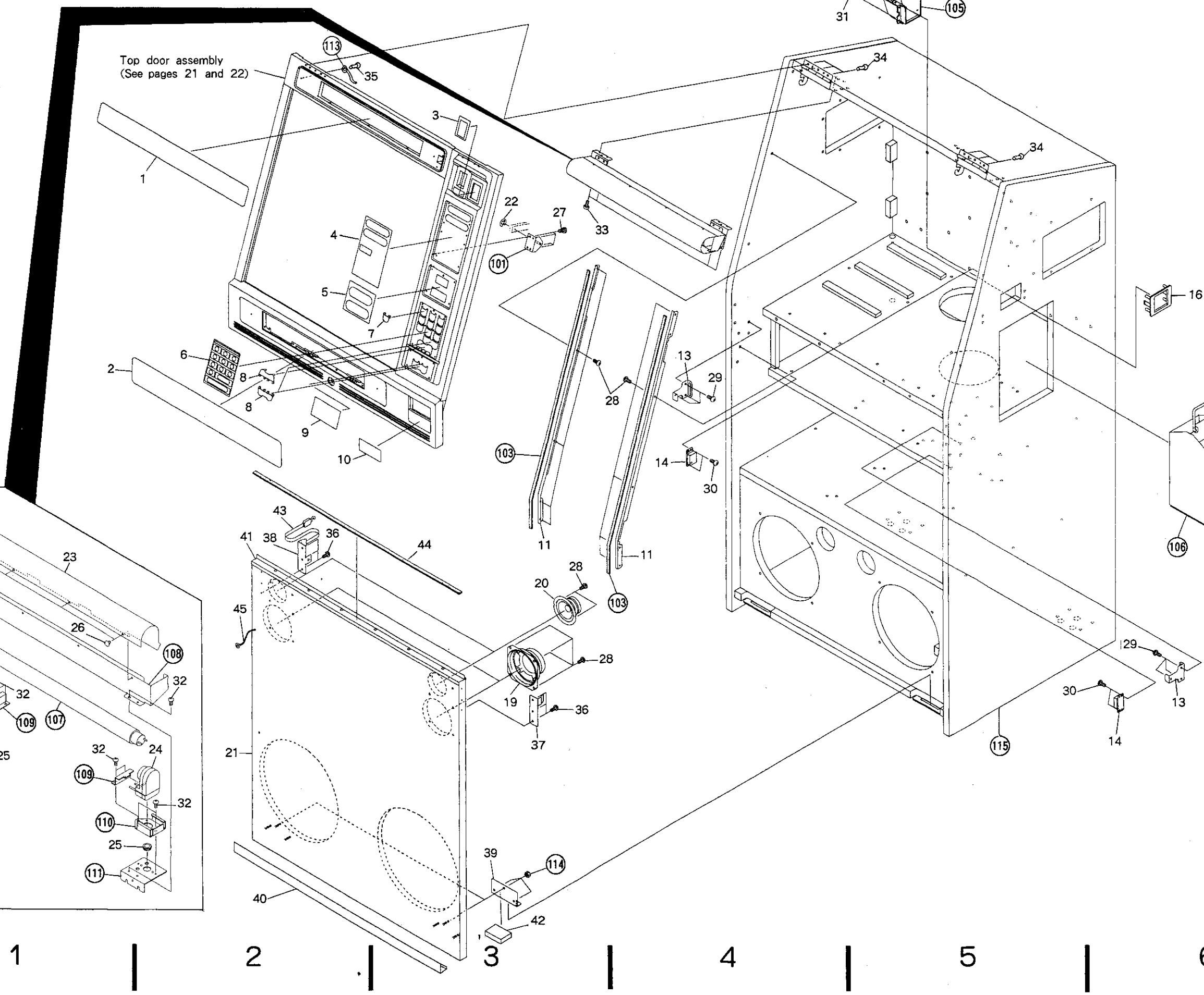

1 2 3 4 5 6

5

2.1.2 EXTERIOR (2)

Parts List

Mark	No.	Part No.	Description
	1	DNK1627	Plate
	2	SNA1219	Rail
	3	25-803A	Speaker (Woofer)
	4	DSF1001	Micro switch
	5	DBH1036	Door lock spring
	6	SNA1220	Reinforced plate
	7	DXB1022	Caster A
	8	DXB1023	Caster B
	9	YE20FUC	E ring $\phi 2$
	10	BBZ30P060FMC	Screw
	11	AMZ40P080FMC	Screw
	12	TNC35P140FZK	Screw
	13	PMH20P100FMC	Screw
	14	DBA1007	Screw (3.5 x 12mm)
	15	SBA1068	Screw
	16	PMB50P300FMC	Screw
	17	SBA-194	Screw
△	18	DDE1034	Connection cord
	19	PDE1065	Cord with pin plug
	20	DEC1184	Shell clip
	101		Top door stay
	102		MB fixing plate
	103		DRS guide
	104		Door switch holder
	105		Door lock shaft
	106		Cabinet
	107		Airway cover
	108		Earth lug assembly
	109		Cord clumper
	110		R pin
	111		Magazine assembly

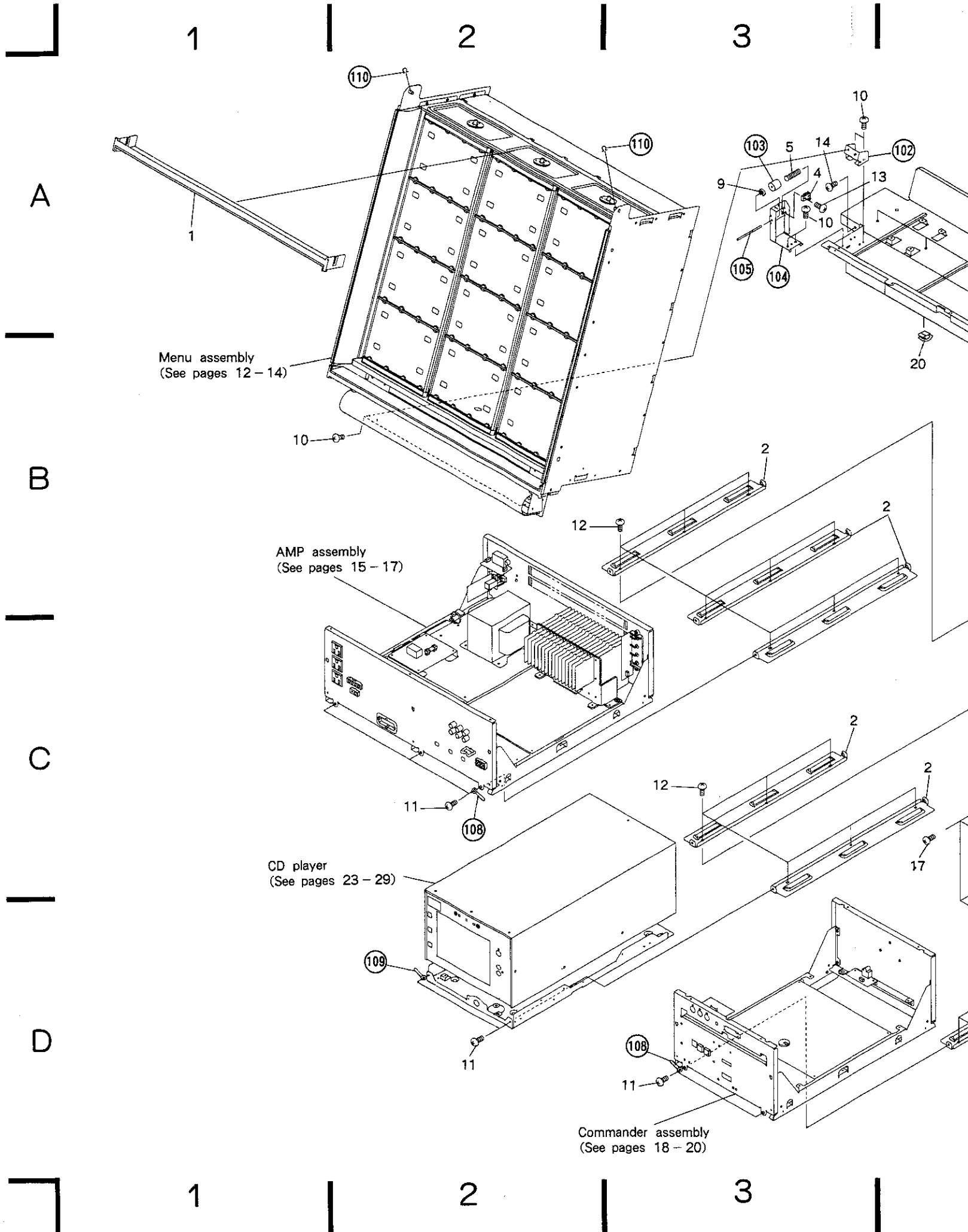

1 | 2 | 3 | 4 | 5 | 6

A

A

B

B

C

C

D

D

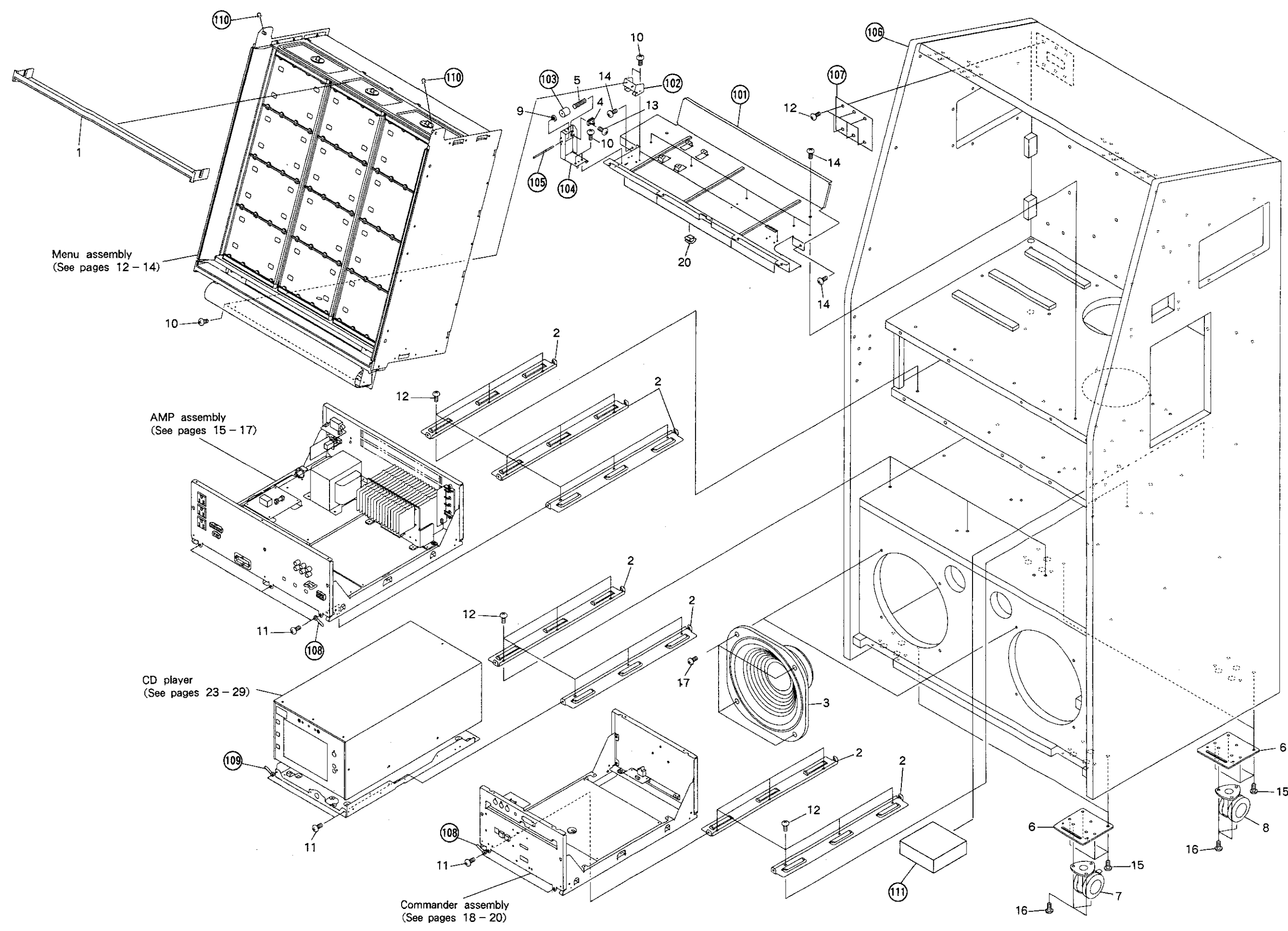

1 | 2 | 3 | 4 | 5 | 6

### 2.1.3 EXTERIOR (3)

#### Parts List

Mark	No.	Part No.	Description	Mark	No.	Part No.	Description
△	1	DTH1114	Ballast		101	LAMP	
△	2	DKK1009	Glow lamp socket		102	Stay A	
●	3	SWN1197	Network assembly		103	Glow lamp	
△	4	DEK1016	Fuse (2A, FU601)		104	CA holder A	
	5	10-757A	Speaker (Mid-range)		105	Hinge holder	
	6	SNB1038	Speaker holder		106	Rear plate	
	7	DXB1193	Hinge		107	.....	
	8		.....		108	Cord clamper	
	9	BBZ30P060FMC	Screw		109	Coin guide (A)	
	10	DBA1007	Screw (3.5 × 12mm)		110	Coin guide cover	
	11	TNC35P140FZK	Screw		111	Insertion guide A	
	12	AYC30P250FMC	Screw		112	CA holder B	
	13	AMZ30P060FZK	Screw		113	HL holder assembly	
	14	BSZ40P060FZK	Screw		114	CH lever assembly	
	15	BBZ40P080FMC	Screw		115	Bill holder (F)	
	16	BBZ30P080FMC	Screw		116	Bill holder (L)	
	17	DXB1207	Channel		117	Bill holder (RE)	
	18	DBH1035	CA spring		118	Bill holder (R)	
	19	YE30FUC	E ring φ 3		119	DS shaft A	
	20	BPZ30P080FCU	Screw		120	DS base	
	21	PMB40P080FMC	Screw		121	Door stay A	
	22	AMZ40P080FMC	Screw		122	Door stay B	
	23	SNC1078	Protection net		123	DS shaft B	
					124	Tape C	
					125	Tape D	
					126	UL tube	
					127	Ornament sash	
					128	Shield packing (A)	
					129	Cabinet	

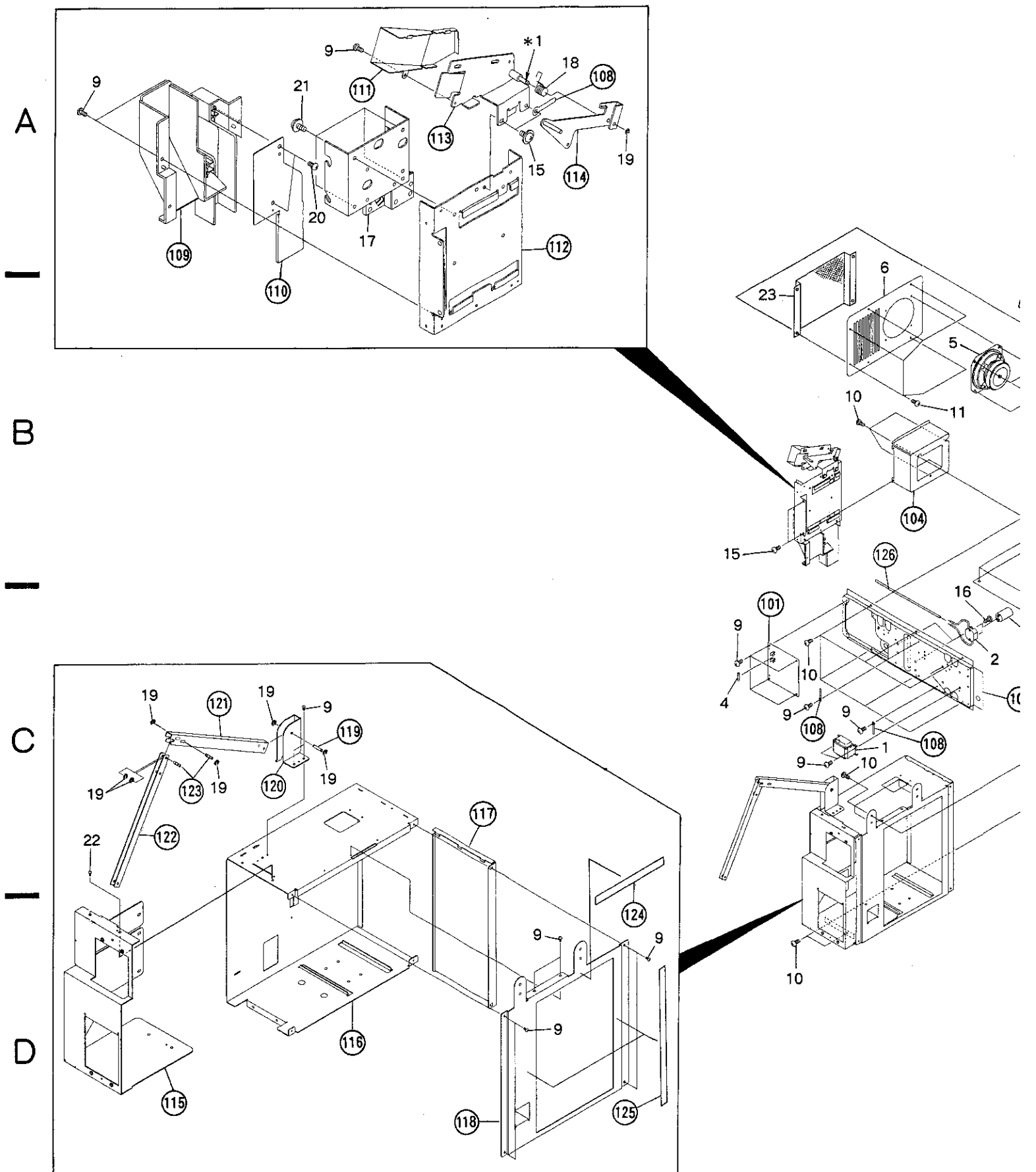

1 | 2 | 3 | 4 | 5 | 6

A

A

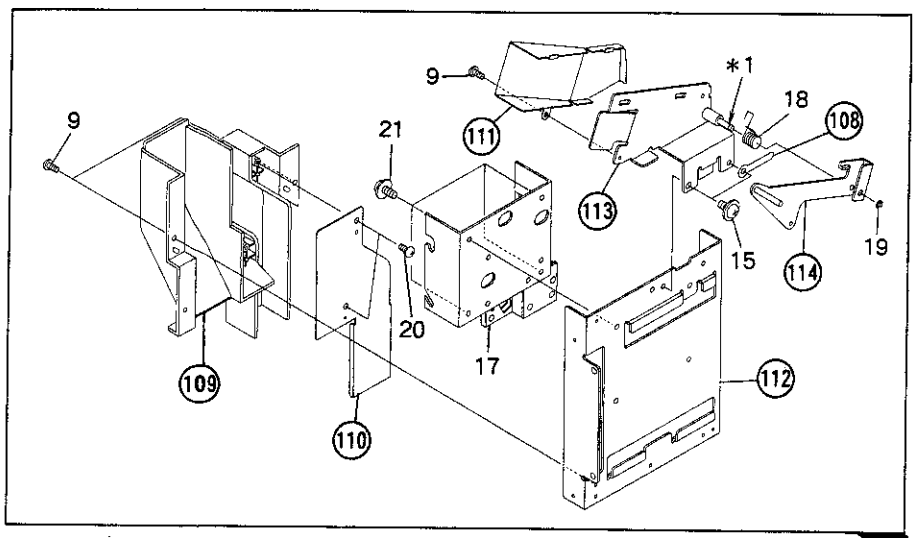

B

B

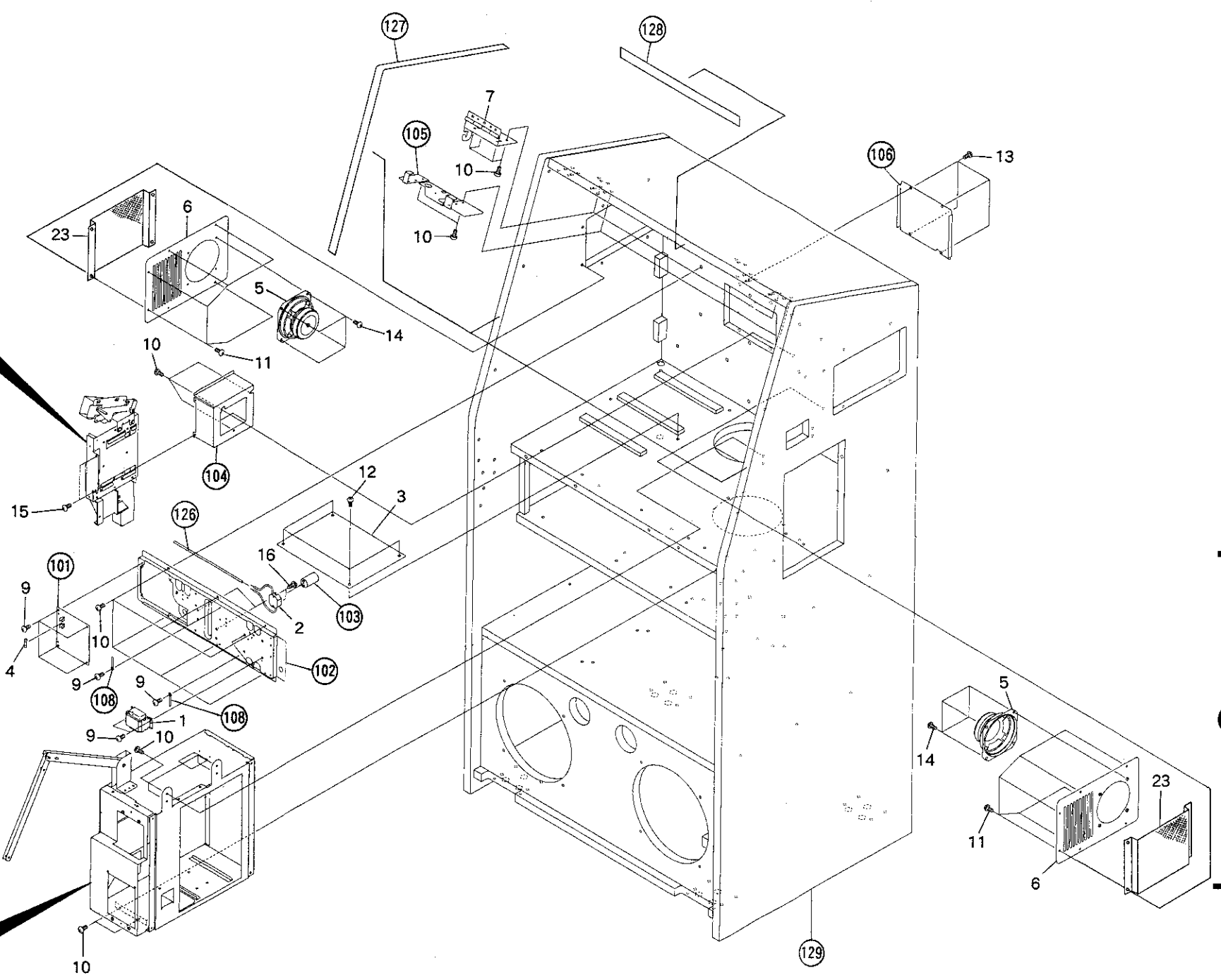

C

C

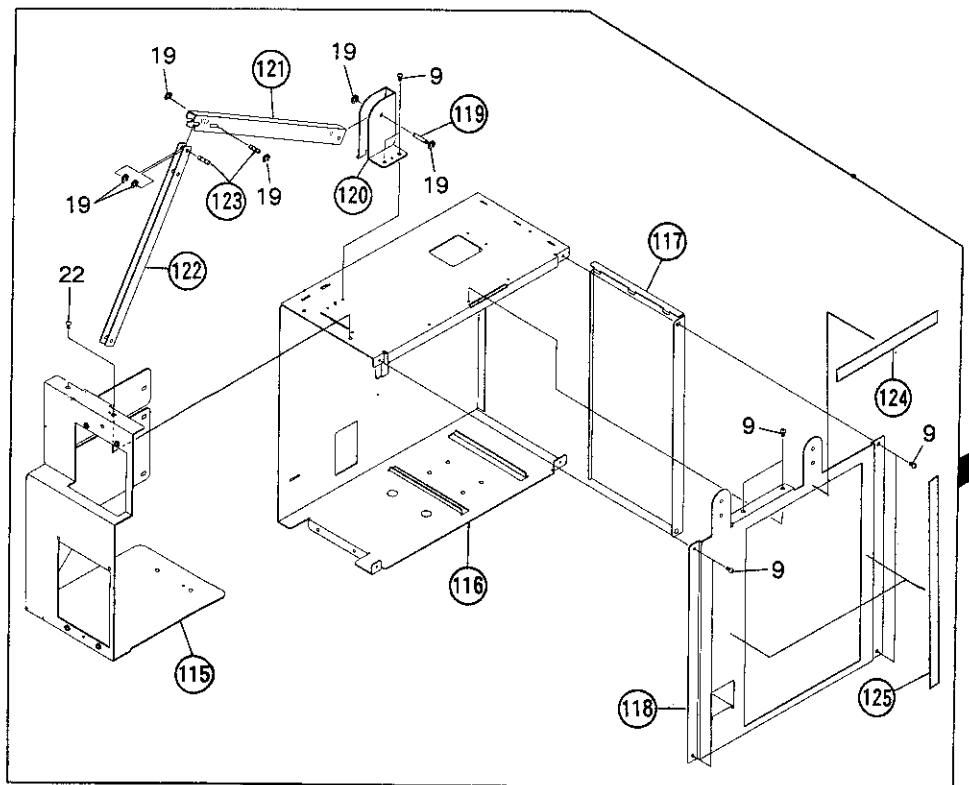

D

D

\*1 : Froil GYA-008

1 | 2 | 3 | 4 | 5 | 6 | 11

2.1.4 MENU BOARD SECTION

Parts List

Mark	No.	Part No.	Description	Mark	No.	Part No.	Description
1	DNK1633	Shaft holder	101	POSS			
2	DNF1257	Corner edge	102	ROTA			
3	DNK1629	Menu cap (L)	103	Top cover			
4	DNK1630	Menu cap (M)	104	Side frame (L)			
5	DEC1252	Menu sheet	105	Side frame (R)			
6	DNK1621	Worm wheel	106	Back frame			
7	DNK1626	Side ornament plate	107	Fluorescent lamp			
8	DEC1250	Side ornament plate sheet (L)	108	Reflection plate			
9	DEC1251	Side ornament plate sheet (R)	109	Socket holder (L)			
10	DNK1627	Ornament plate	110	Socket holder (S)			
11	DEC1224	Illumination sheet	111	Lamp plate (L)			
12	DKK1006	Fluorescent lamp socket (upper L)	112	Lamp plate (R)			
13	DKK1007	Fluorescent lamp socket (under R)	113	Tension plate (under)			
			114	Under frame			
			115	Adjustment plate			
14	DEC1220	Bushing	116	Cord clammer			
15	DXB-108	Bearing	117	Triangle frame (L)			
16	DBH1107	Tension spring (under)	118	Triangle frame (S)			
17	DMS1012	Synchro belt	119	CNTB			
18	DNK1622	Center pulley	120	Motor holder			
19	DNK1623	Synchro pulley	121	Sensor holder			
20	DBH1108	Adjustment spring	122	Motor pulley			
21	DEC-176	Plastic rivet					
22	VCN-002	Speed nut					
23	DNK1632	Menu cap (U)					
24	DNK1628	Menu					
25	DLA1300	Worm gear					
26	DNK1620	Pulley					
27	DNK1624	Worm shaft holder					
28	DMS1006	S2M timing belt					
29	DXB1160	Encoder disc assembly					
30	DXM1033	Motor					
31	DXX1368	Motor assembly					
32	CEANP010M50	C702,C704					
33	CGDYX104M25	C701,C703					
34	WA42D080D050	Washer					
35	BBZ30P080FZK	Screw					
36	BBZ40P080FMC	Screw					
37	ZMD40H080FBT	Screw					
38	SMZ30H120FBT	Screw					
39	BBZ30P060FMC	Screw					
40	PMH30P060FMC	Screw					
41	SMZ30H200FMC	Screw					
42	VBZ26P060FMC	Screw					
43	ZMD26H030FBT	Screw					
44	BBZ30P080FCU	Screw					
45	AMZ30P060FZK	Screw					

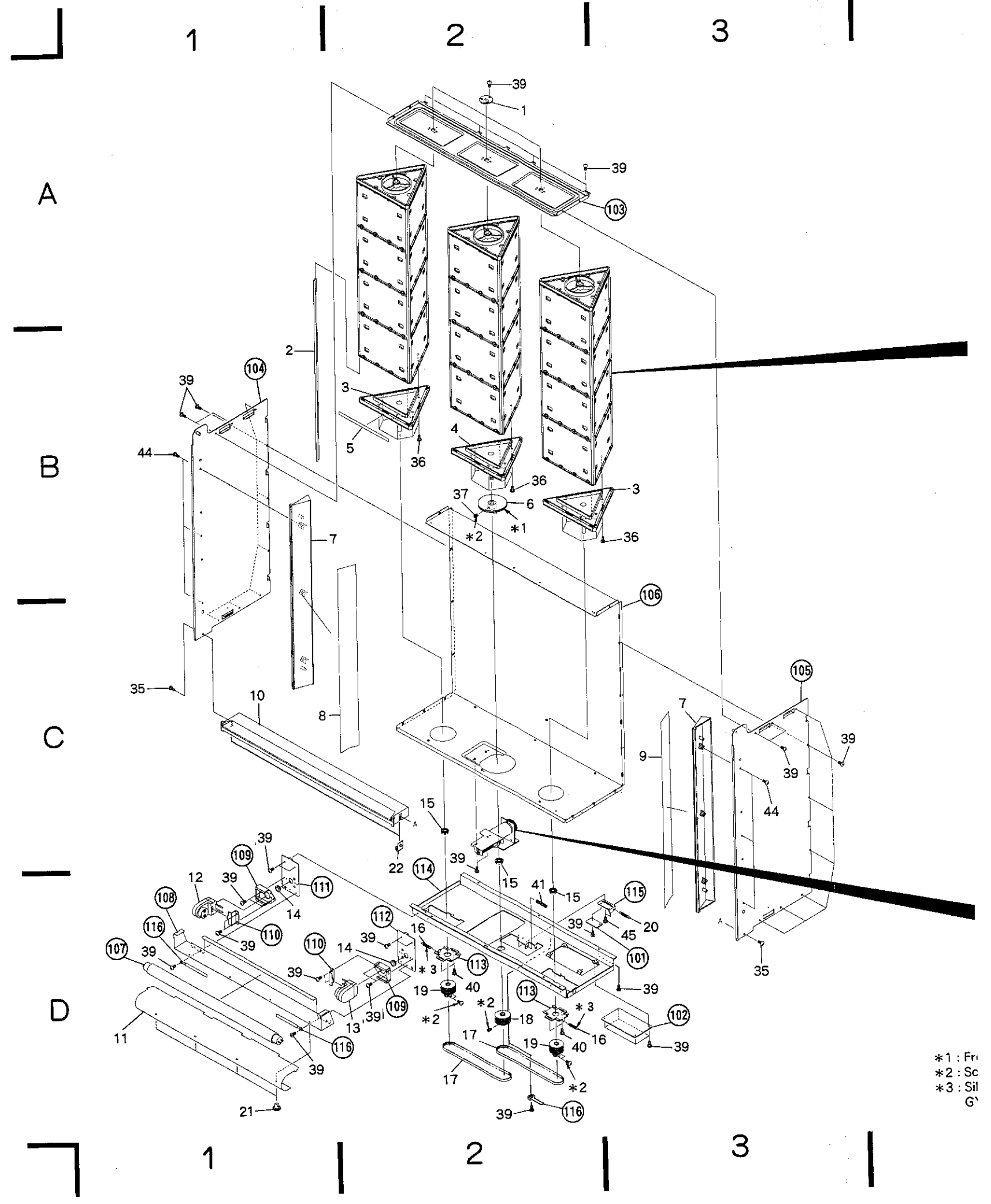

1

2

3

4

5

6

A

B

C

D

A

B

C

D

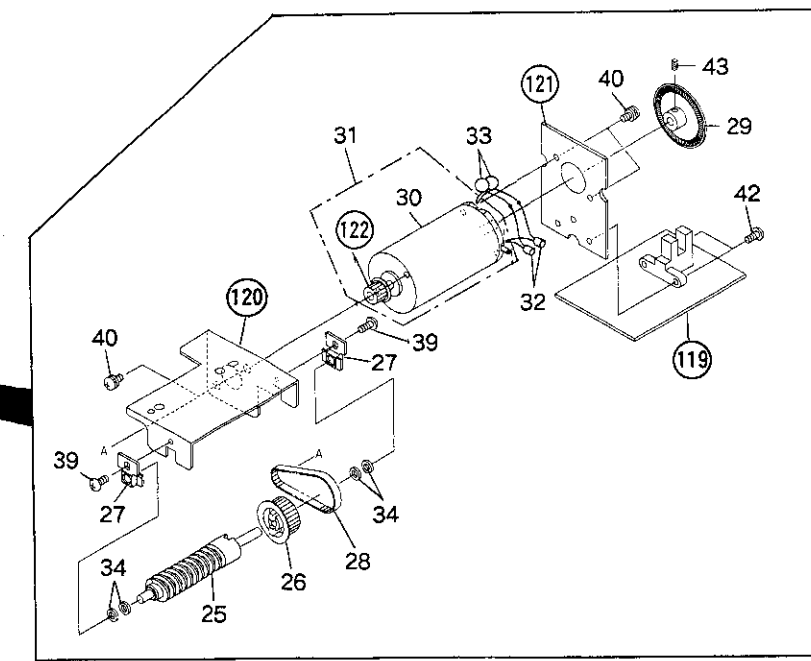
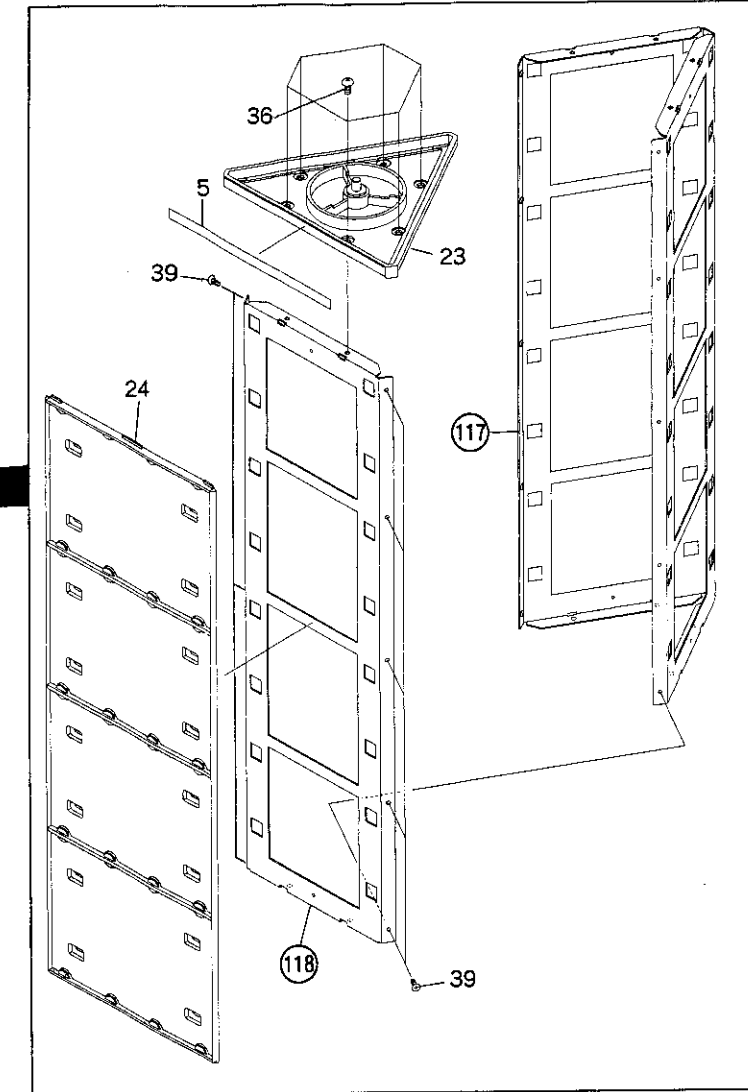
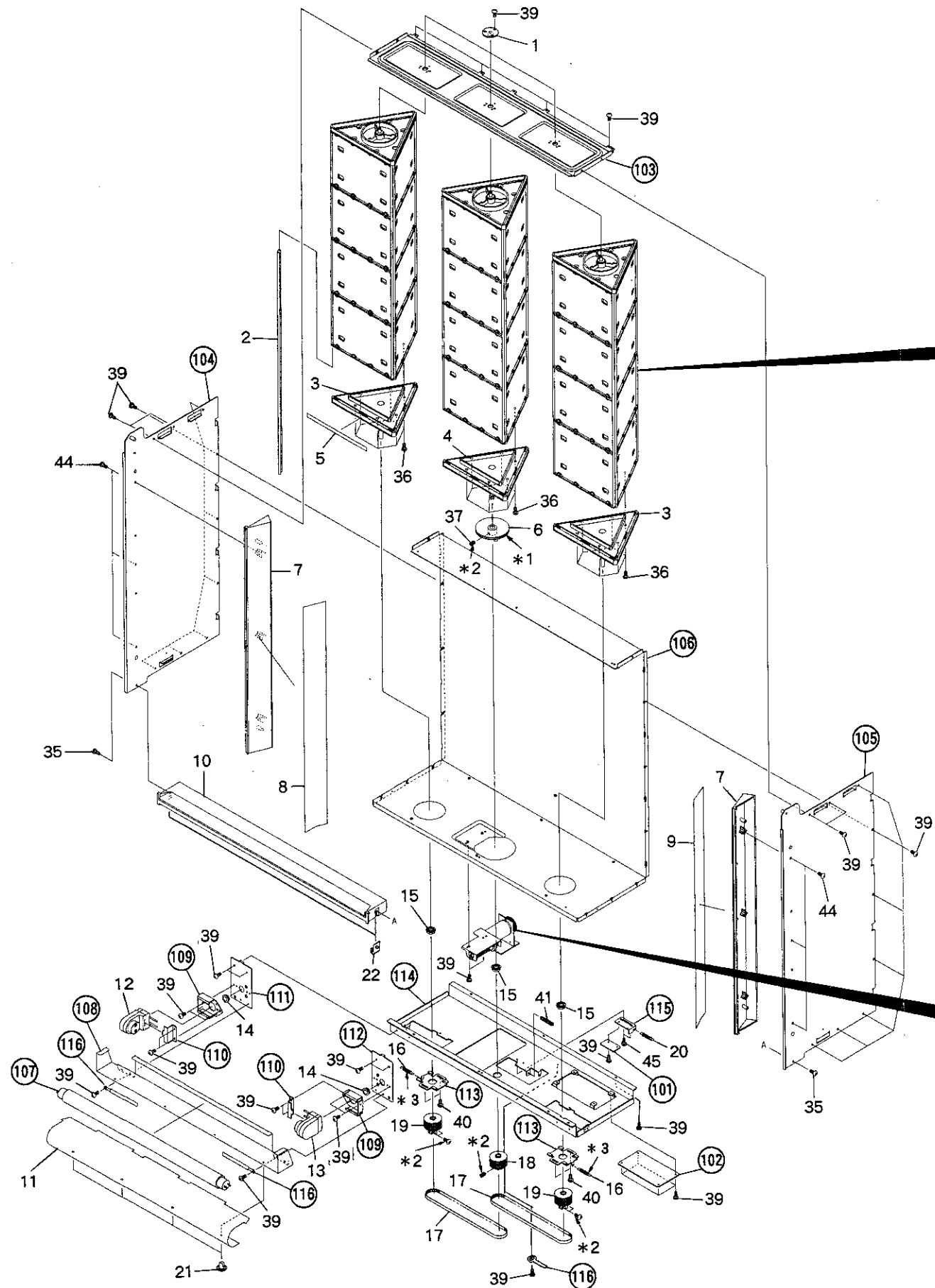

\*1 : Foil GYA-008  
 \*2 : Screw locking point  
 \*3 : Silicone grease  
 GYL1002 or GYA-009

1

2

3

4

5

6

## 2.1.5 AMP SECTION

### Parts List

Mark	No.	Part No.	Description	Mark	No.	Part No.	Description
●	1	DWR1056	POWB		101	ACIN	
	2	DWK1011	PREB		102	ASEL	
	3	DWH1007	PAMP		103	PSWB	
△	4	DEK1011	Fuse (1A, FU1)		104	LOJB	
△	5	DEK1015	Fuse (1.6A, FU2-FU4)		105	SPTB	
△	6	DEK1022	Fuse (6A, FU5)		106	CDJB	
△	7	DTT1039	Power transformer (120V)		107	Side frame L	
△	8	DKN-108	AC outlet		108	Side frame R	
△	9	DDG1025	AC power cord		109	Center frame	
△	10	VEC-201	Strain relief		110	Front panel A	
	11	RAC1210	VR knob A		111	Protector	
	12	RAC1211	VR knob B		112	Wire clip	
	13	DLA-177	Staddle		113	Transformer frame	
	14	DAC1107	Push knob		114	Cord clamber	
	15	BBZ30P060FMC	Screw		115	Rear panel A	
	16	BBZ30P080FZK	Screw		116	P.C.B. stopper	
	17	BBZ40P080FMC	Screw		117	Heat sink	
	18	BBZ30P140FMC	Screw		118	Connector assembly	
	19	PMB40P080FMC	Screw		119	Connector assembly	
	20	AMZ30P060FZK	Screw		120	Connector assembly	
					121	Earth terminal	

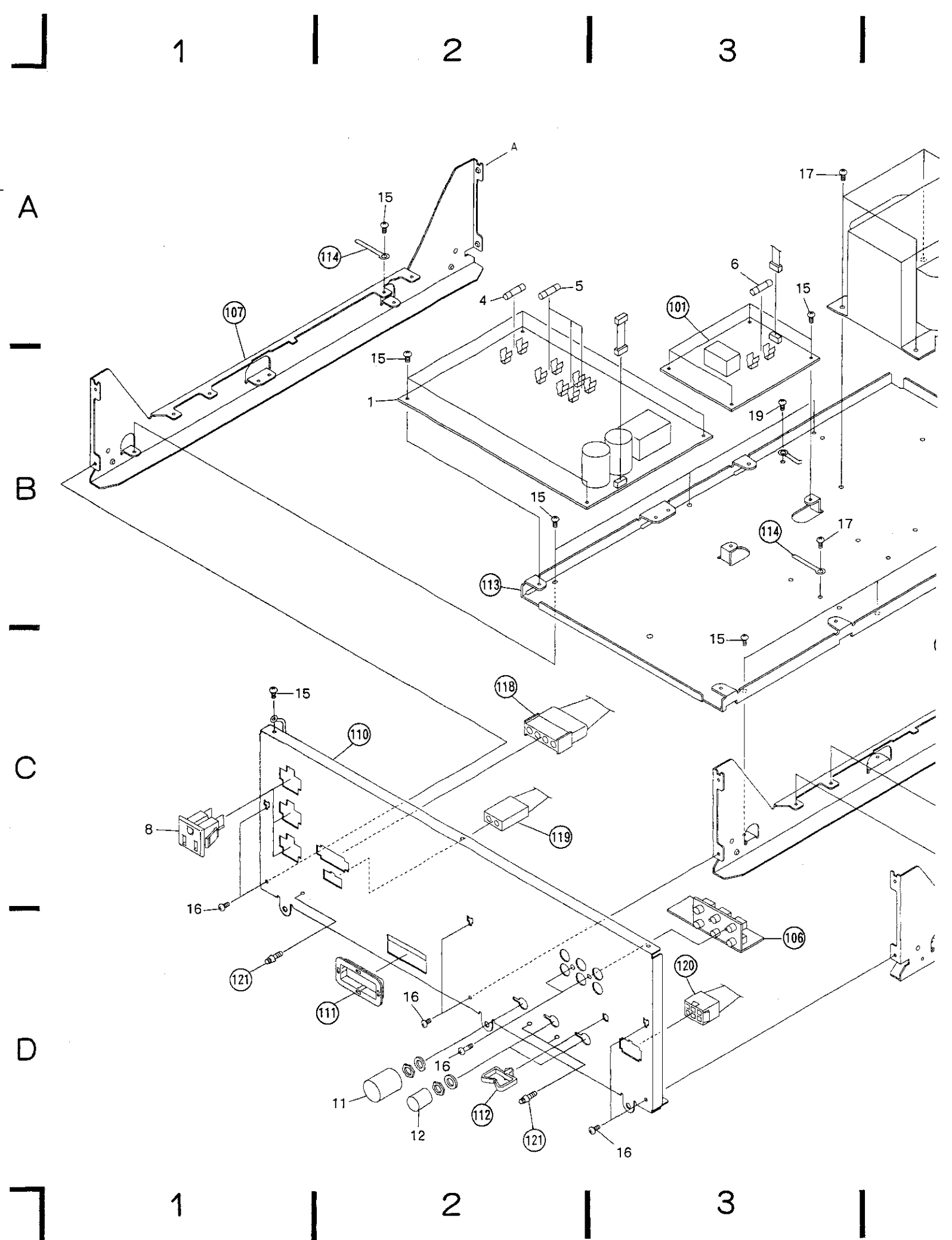



1

2

3

4

5

6

A

A

B

B

C

C

D

D

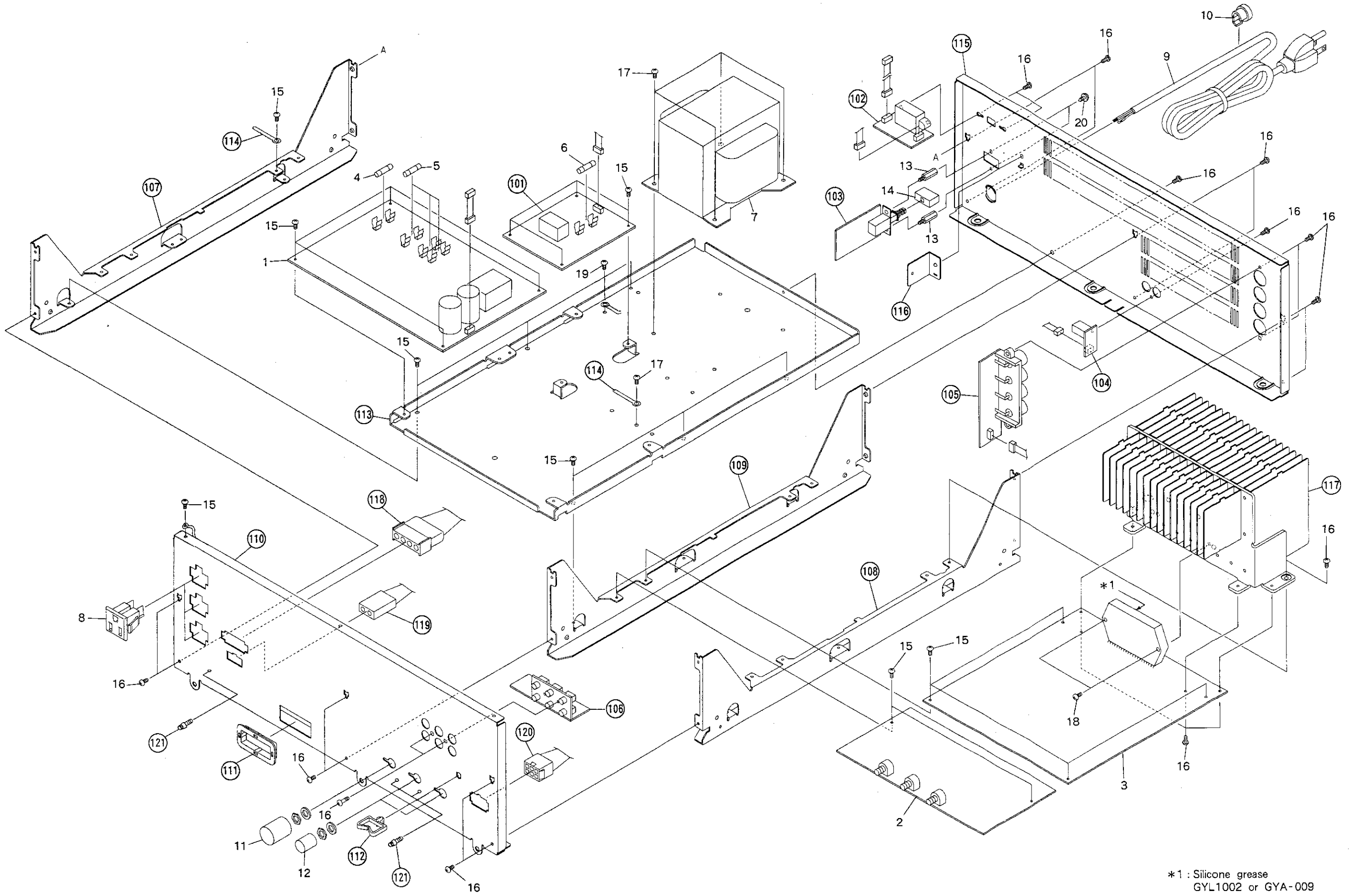

\*1 : Silicone grease  
 GYL1002 or GYA-009

1

2

3

4

5

6

17

2.1.6 COMMANDER SECTION

Parts List

Mark	No.	Part No.	Description
●	1	DWG1138	CONT
△	2	DEM1001	Lithium cell
	3	DAW1011	Electromagnetic counter
	4	DAC-116	Push button
	5	DXR1007	Remote control unit
	6	BBZ30P080FZK	Screw
	7	BBZ30P060FMC	Screw
	8	PMB30P050FCU	Screw
	101	CNNB	
	102	CRJB	
	103	OPER	
	104	DIPS	
	105	RMJB	
	106	Front panel B	
	107	Terminal holder	
	108	Counter holder	
	109	P.C.B. holder	
	110	Side frame L	
	111	Side frame R	
	112	Reinforced frame	
	113	Rear panel B	
	114	Connector assembly	

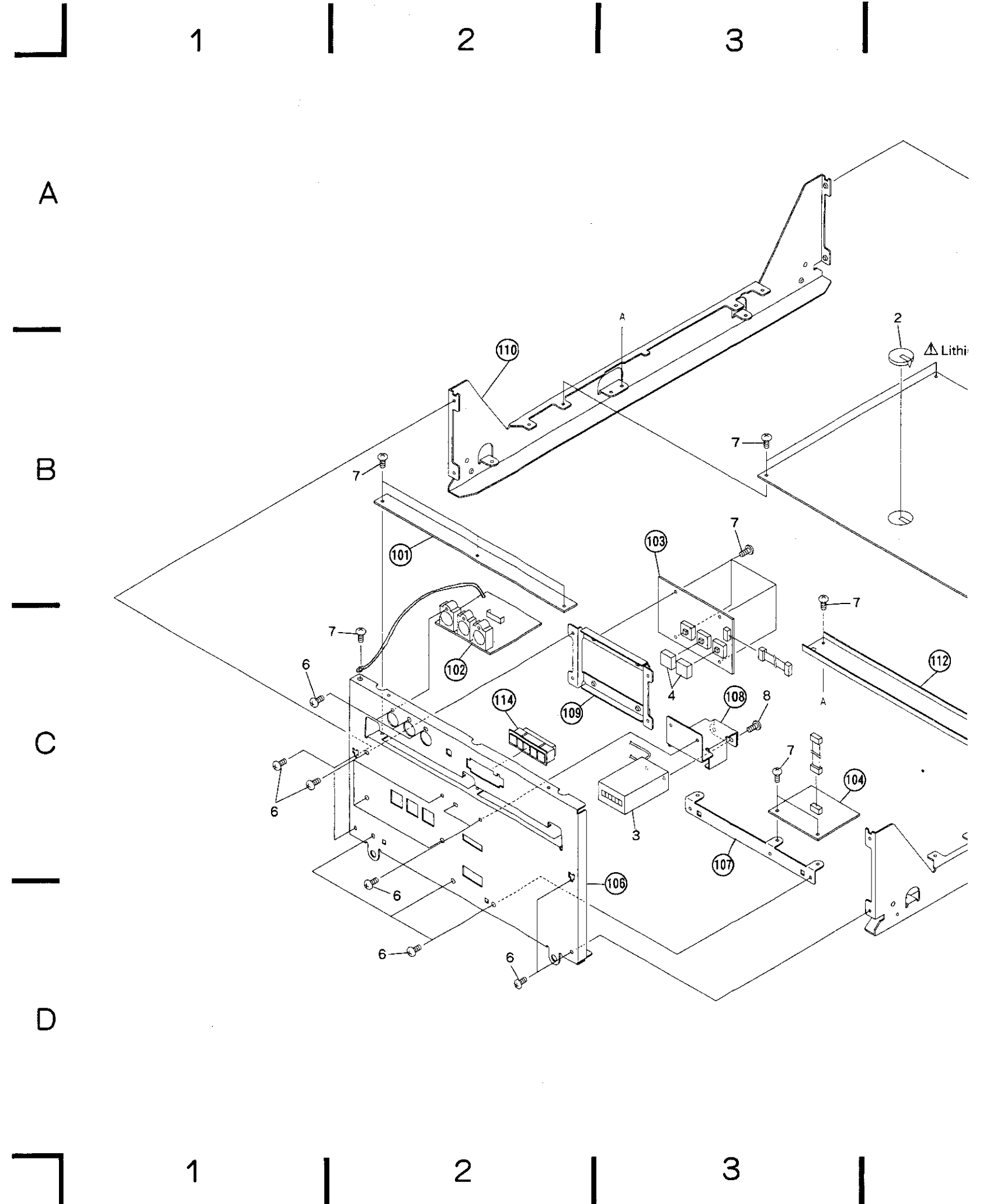

1

2

3

4

5

6

A

A

B

B

C

C

D

D

1

2

3

4

5

6

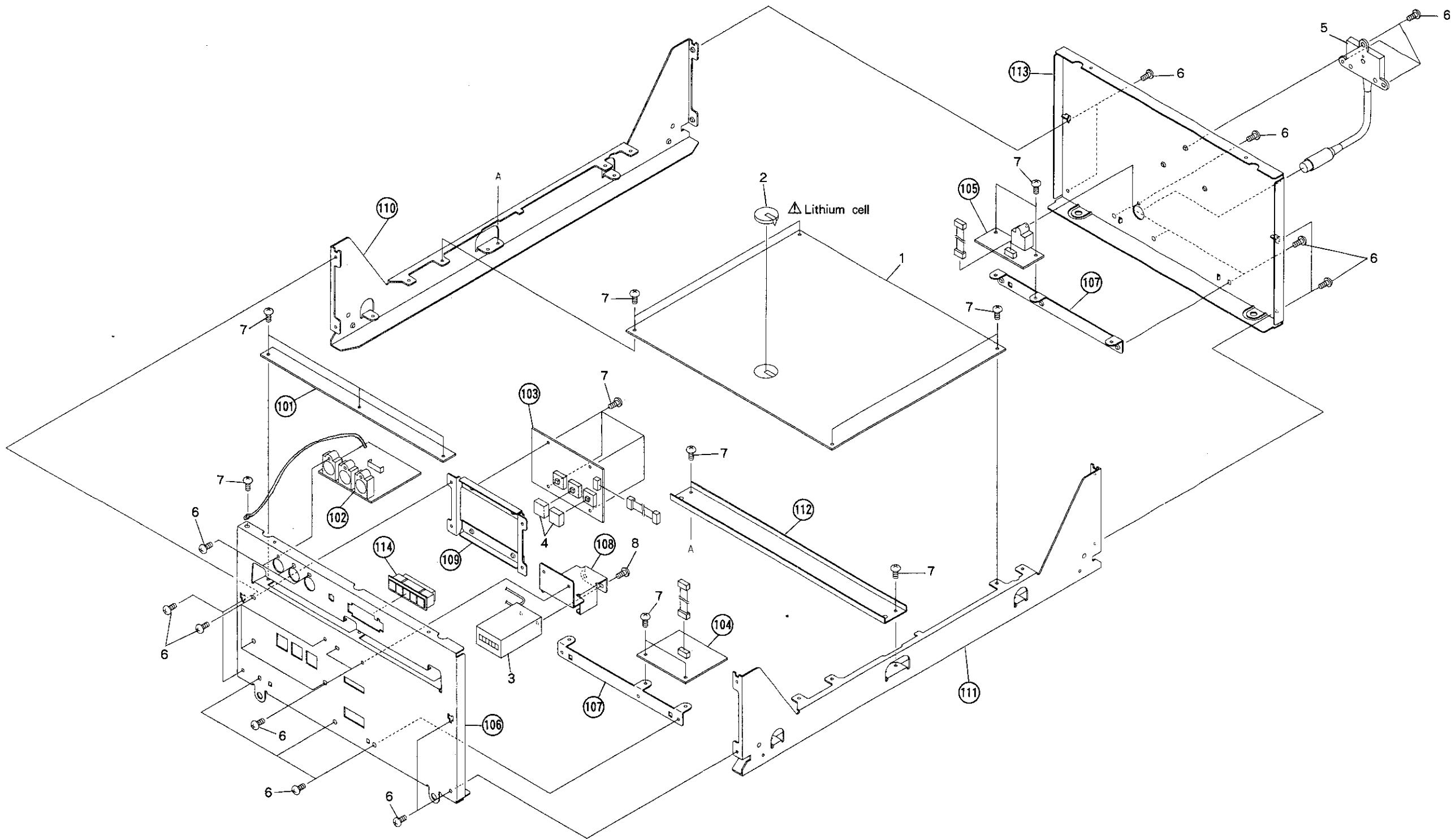

2.1.7 TOP DOOR SECTION

Parts List

Mark	No.	Part No.	Description	Mark	No.	Part No.	Description
●	1	DWG1128	MESS		101	BRAN	
●	2	DWG1129	DISP		102	Coin-return lever fixing plate	
●	3	DWS1101	KEYB		103	Coin spacer	
	4	DAH1184	Coin-return lever sheet B		104	Top door base	
	5	DAD1001	Coin-return lever		105	Top door lock plate	
	6	DBH1033	Coin-return lever spring		106	Lock plate stopper	
	7	DNS1044	Coin insertion hole		107	Cord clamber	
	8	DNH1332	Coin slit		108	Glass sash	
	9	DNK1609	Operation panel		109	Earth lug assembly	
	10	DNK1610	Top door panel (upper)				
	11	DNK1612	Top door panel (side)				
	12	DNK1611	Top door panel (under)				
	13	DBH1034	Lock spring				
	14	DEC1215	Transparent panel				
	15	DNS1084	Bill insertion hole				
	16	DNK1613	Bill insertion panel				
	17	DAN1010	Menu glass				
	18	BPZ30P080FCU	Screw				
	19	PMH30P120FMC	Screw				
	20	IPZ30P080FMC	Screw				
	21	BBZ30P060FMC	Screw				

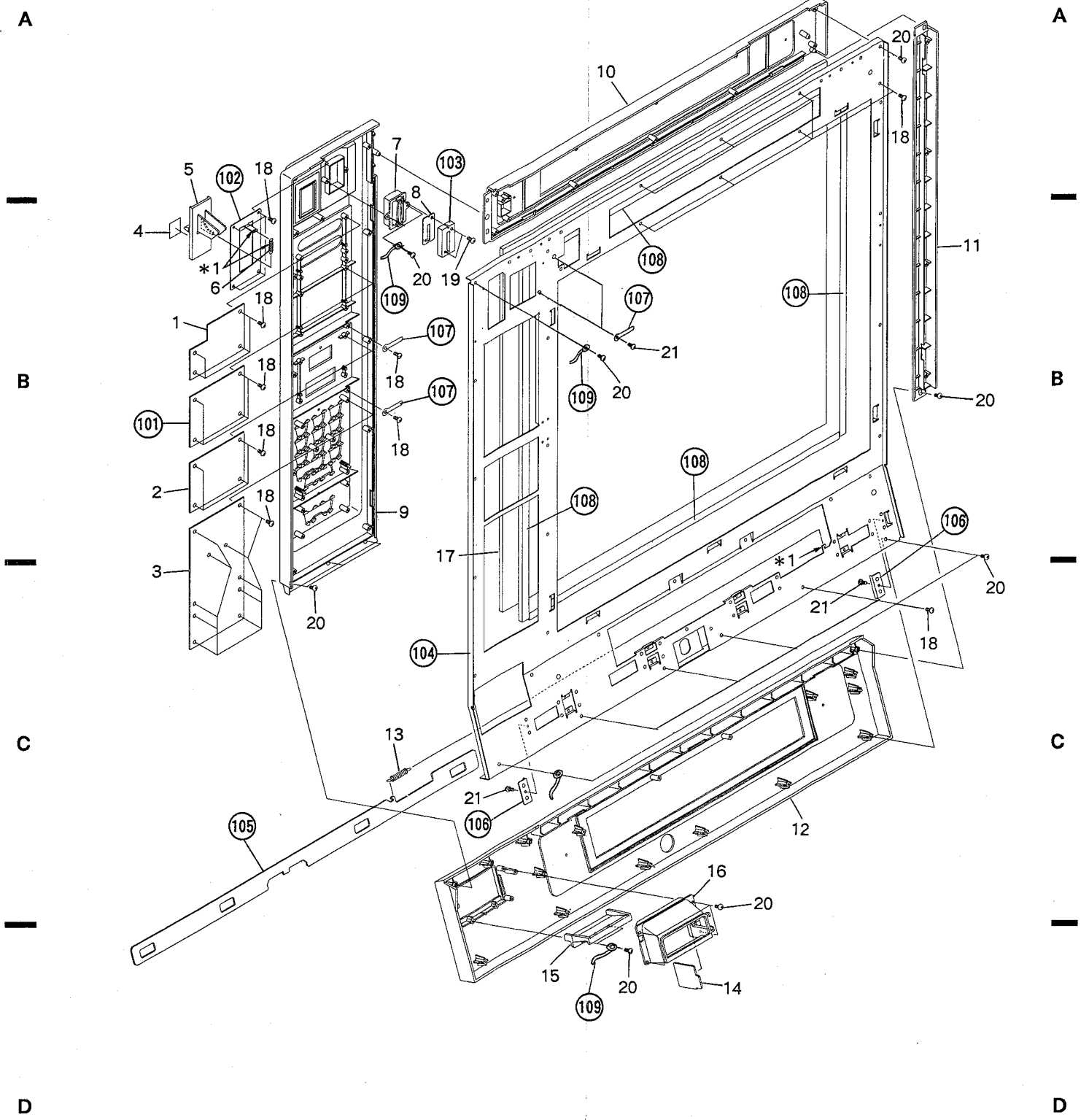

\*1: Silicone Adhesive GYL-014

2.2 CD SECTION  
2.2.1 EXTERIOR

A

B

C

D

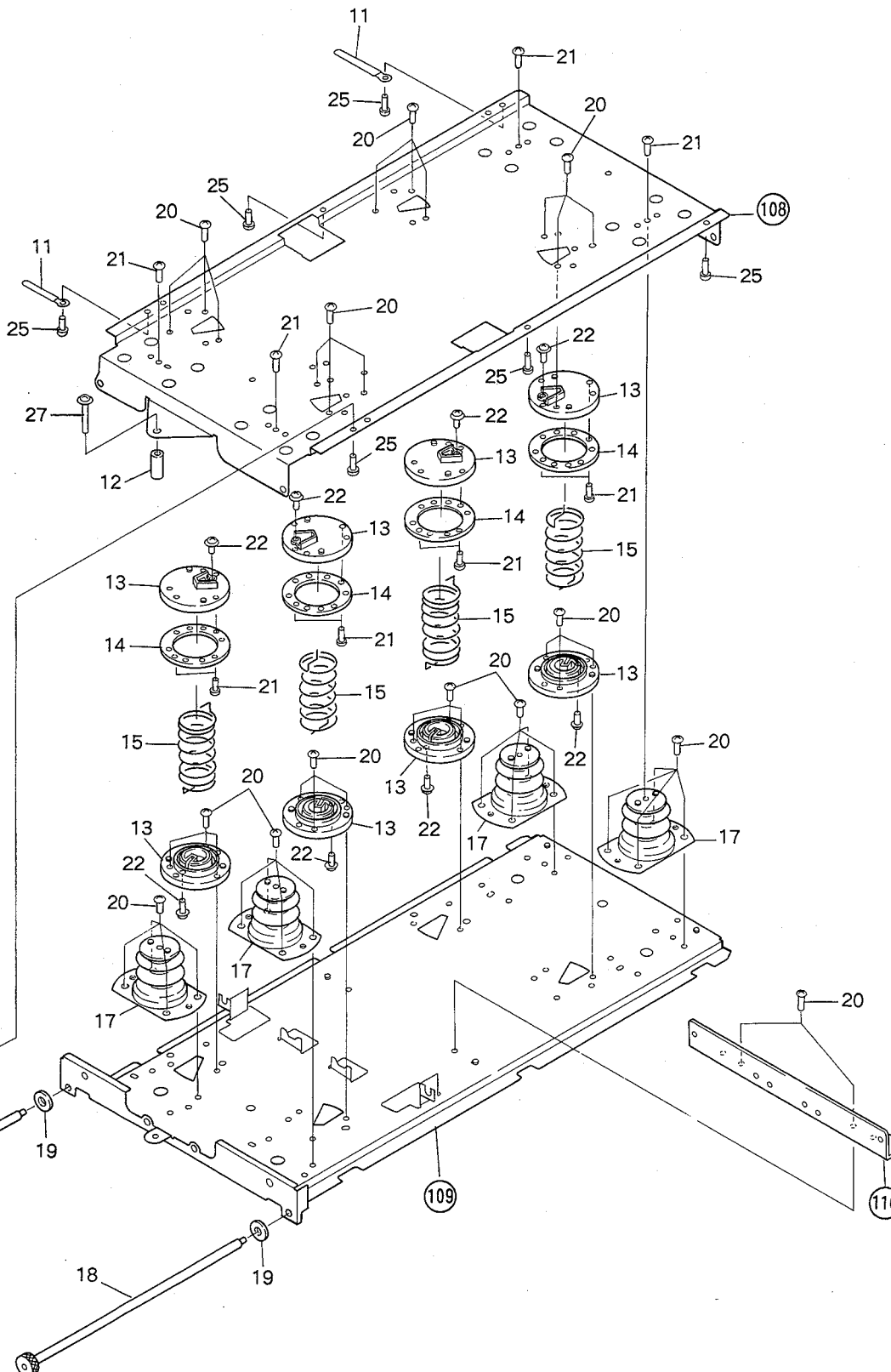
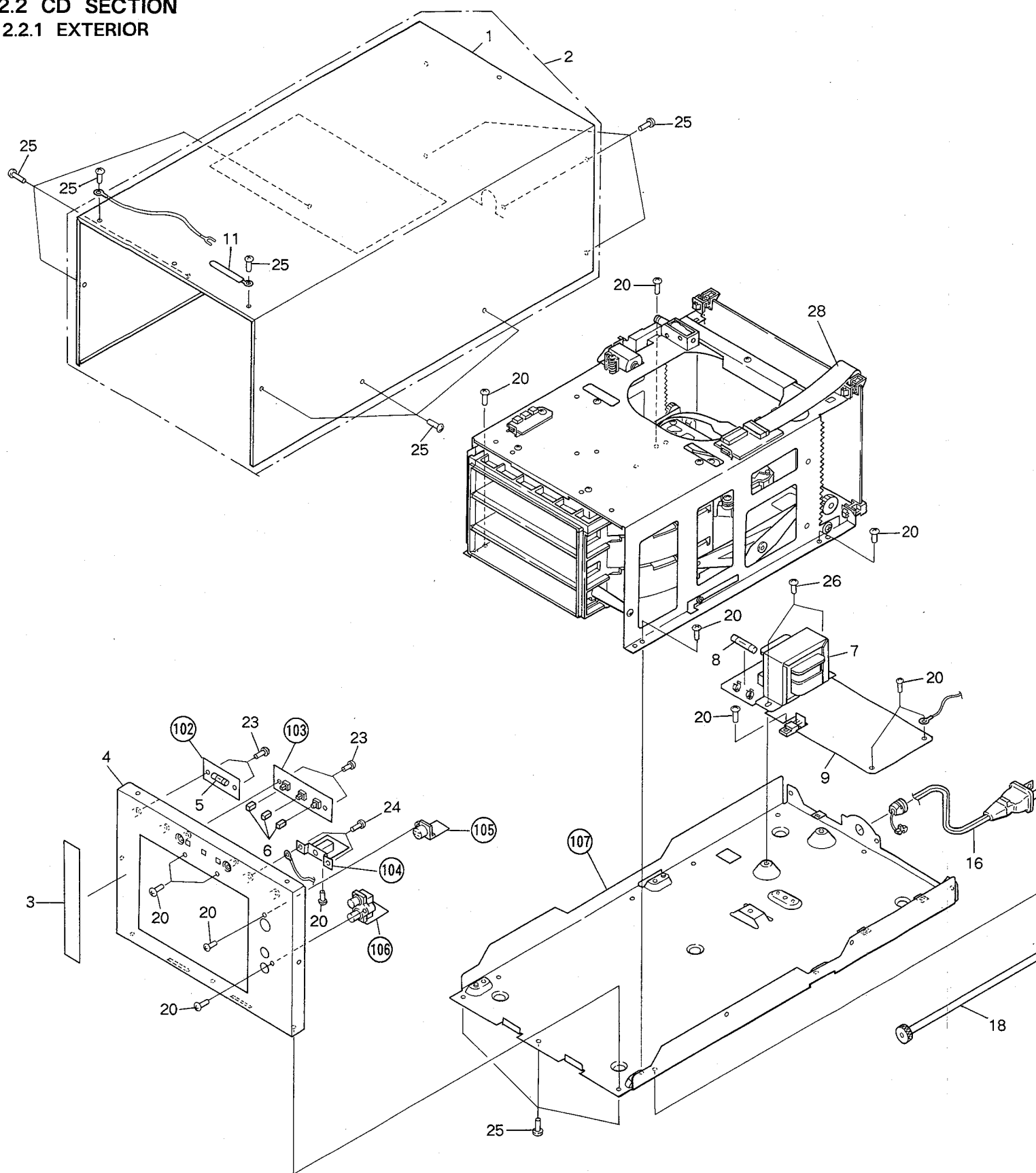

A

B

C

D

Parts List

Mark	No.	Part No.	Description	Mark	No.	Part No.	Description
	1	DNE1083	Bonnet		101		Insulation plate B
	2	DXX1357	Bonnet assembly		102		HRMB
	3	DRW1151	Label A		103		EKEY
	4	DNB1012	Front panel		104		RMJB
	5	VCX-006	Hour meter		105		DJAK
	6	DAC1196	Push button		106		PJAK
△	7	DTT1037	Power transformer (T201)		107		Chassis
△	8	REK-075	Fuse (FU201, 315mA)		108		Upper base
●	9	DWX1117	ANLG		109		Under base
	10	DEC-176	Plastic rivet		110		Sipping angle
	11	RNH-184	Cord clamper				
	12	DLA1336	Coller				
	13	DNK1179	SP holder				
	14	DNF1075	Plate B				
	15	DBH1105	Spring				
△	16	DDG1026	AC power cord				
	17	DEB1106	Air damper				
	18	DLA1337	Lock shaft				
	19	DEB1123	Rubber washer				
	20	BBZ30P080FMC	Screw				
	21	PMZ30P040FMC	Screw				
	22	IPZ30P060FMC	Screw				
	23	AMZ30P060FMC	Screw				
	24	PMZ30P060FMC	SCrew				
	25	PDZ30P050FMC	Screw				
	26	BBZ40P080FMC	Screw				
	27	AMZ40P250FMC	Screw				
	28	DDD1027	17P flexible cord				

**2.2.2 MECHANISM SECTION**

**Parts List**

Mark	No.	Part No.	Description	Mark	No.	Part No.	Description
	1	DNK1566	Lock lever		51	BMZ26P120FMC	Screw
	2	DXP1008	Plunger		52	PCZ30P050FZK	Screw
	3	DBH1101	Lock spring		53	DBA1023	Link screw
	4	PBH1015	SM spring		54	PBA1002	Floating screw
	5	DBK1028	Spring		55	PBA-125	Screw
	6	PXC-016	Damper assembly		56	WT26D047D050	Washer
	7	PBH-465	Eject spring		57	WT26D047D025	Washer
	8	DMS1011	Timing belt		58	WA31D054D050	Washer
	9	DNK1578	Timing pulley		59	WA31D054D025	Washer
	10	DNK1575	Gear E2		60	YE25FUC	E ring
	11	DSH1011	Slide switch		61	WT31D054D050	Washer
	12	PXM1002	Motor (SELECT, LOADING)		62	DXX1358	Select motor assembly
	13	DBH1100	Select spring		63	DXP1009	Plunger
	14	DNK1579	Select lever		64	BMZ26P030FMC	Screw
	15	DBH1102	Sensor spring		65	WT31D054D025	Washer
					66	ZMD26H040FBT	Screw
	16	RNH-184	Cord clamper				
	17	DWX1116	DEGT		101		MJSW
	18	DEC1237	Sheet		102		Side guide L
	19	PNW1110	Cam		103		SM select A
	20	PNW1111	Upper tray		104		Top guide
					105		Side guide R
	21	PED1001	Cushion A				
	22	DNK1581	Clamper holder B		106		Center guide
	23	DNS1080	Synchro gear		107		Eject lever
	24	DNK1577	Turn drive lever		108		SM select B
	25	DNK1574	Clamper cam		109		Bottom guide
					110		Guide bar
	26	PYY1025	Motor assembly				
	27	DNK1573	Clamper lever		111		Gear EF
	28	DSK1001	Lever switch		112		Gear angle
	29	DNK1569	Gear A		113		Motor base
	30	DNK1570	Gear B		114		Sensor holder
					115		REJC
	31	DEB1104	Belt				
	32	PNW1095	Gear pulley		116		Sensor plate
	33	PBH1016	Clamper spring T		117		Main chassis
	34	DBH1120	Clamper spring B		118		FREC
	35	DNK1572	Drive plate		119		Insulation plate A
					120		Card edge spacer
	36	DNK1571	Drive lever				
	37	PBP-001	Steel ball $\phi$ 4		121		Corner post
	38	DBH1103	Tension spring		122		SENS
	39	DNK1568	Main gear		123		Servo mechanism assembly
	40	PNW1107	Clamper holder T		124		Upper chassis
					125		Rubber tube
	41	PBP-009	Steel ball $\phi$ 3				
	42	PNW1448	Clamper		126		Synchro shaft
	43	DLA1286	Roller		127		Sub chassis
	44	PEB1014	Floating rubber		128		Hold plate
	45	DEC-176	Plastic rivet		129		Link plate
					130		Link L
	46	BPZ20P080FZK	Screw				
	47	BPZ30P100FMC	Screw		131		Link R
	48	BSZ26P040FMC	Screw		132		Motor pulley
	49	PMZ20P030FMC	Screw		133		Motor pulley
	50	PMZ20P080FMC	Screw				

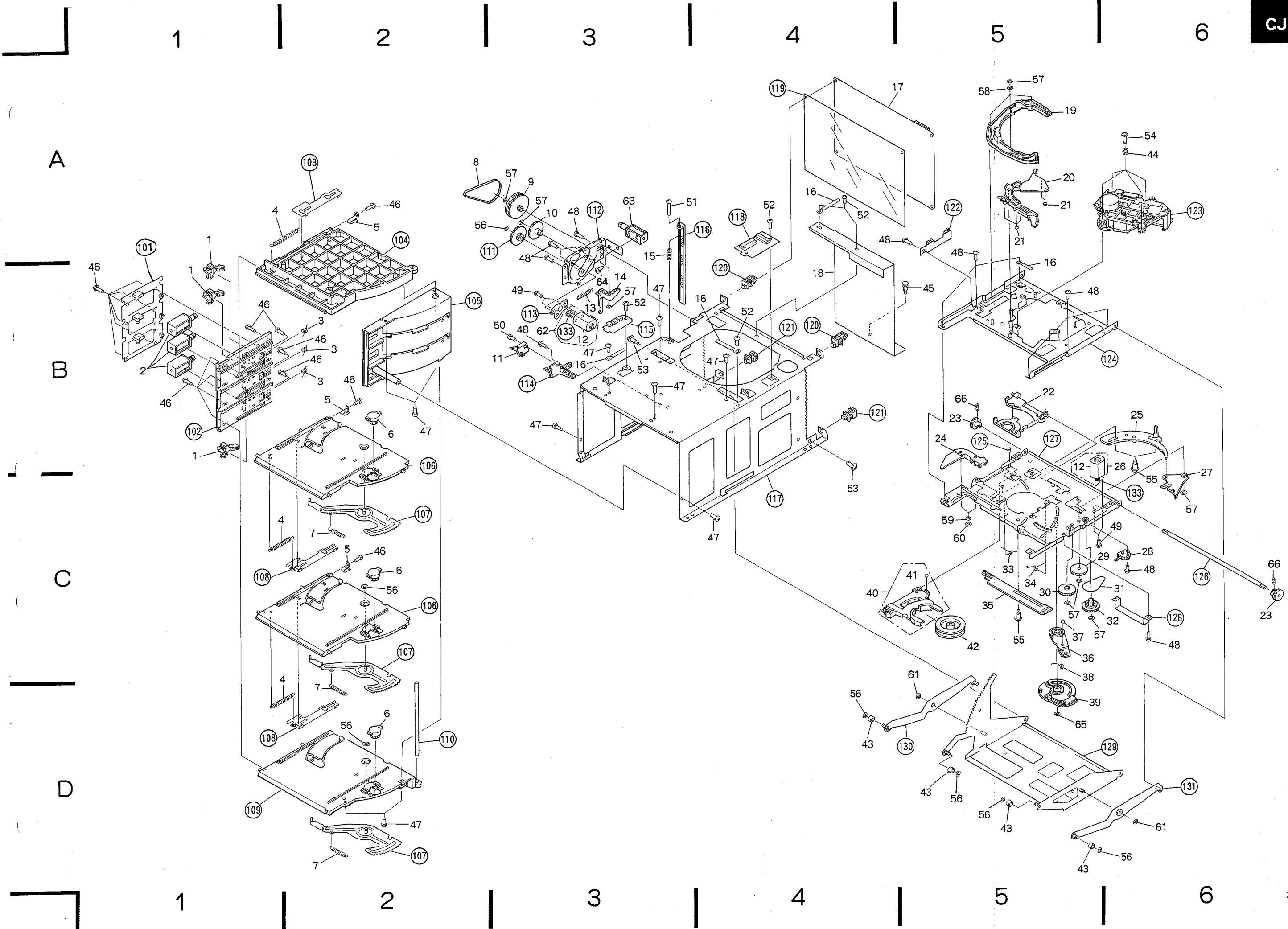



2.2.3 SERVO MECHANISM SECTION

Parts List

Mark	No.	Part No.	Description
	1	CGDYX104M25	Semiconductive ceramic capacitor
	2	PBH1008	Drive spring
	3	PLA1004	Guide bar
	4	PNW1063	Carriage plate
	5	PXM1002	Motor
	6	PWY1009	Pickup assembly
	7	PMZ20P030FMC	Screw
	8	DXX1361	Spindle motor assembly
	9	PYY1025	Motor assembly
101			Motor pulley
102			Carriage M-board

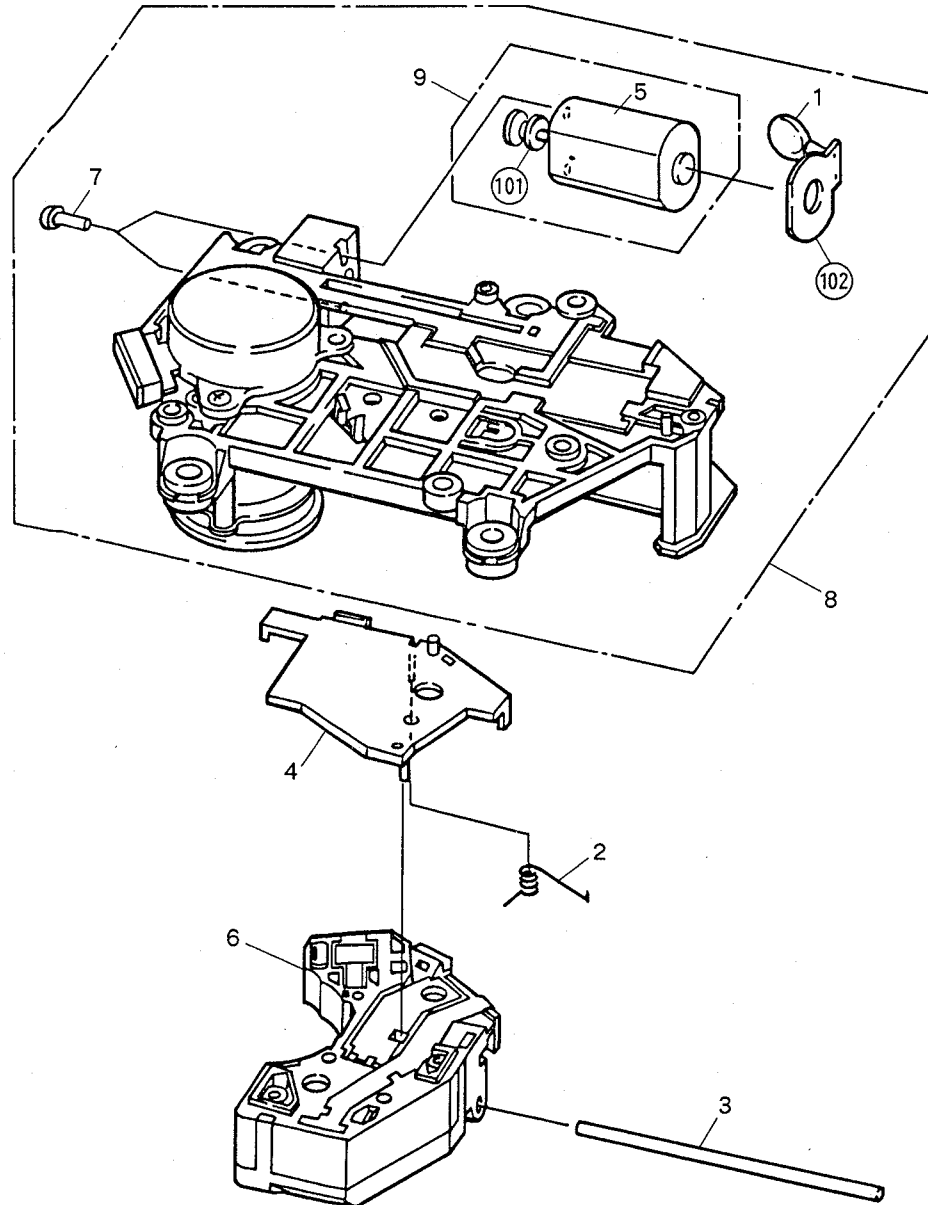

3. PACKING

3.1 MAIN SECTION

Parts List

Mark	No.	Part No.	Description
	1	DHG1162	Packing cap
	2	SGK1366	Reinforced plate
	3	SHA1370	Pad assembly B
	4	DHG1157	Packing case
	5	AHG-204	PP joint
	6	SHA1343	Pad assembly A
	7	DDE1036	Connection cable
	8	DRA1107	Operating instructions (English)
	9	DEC1236	Menu number label
	10	DAH1391	Rate seal A
	11	DNH1335	Cover of the money storage
	12	DNF1256	Reinforced plate
	13	DNK1671	Coin insertion cover
	14	DNH1126	Lock release plate
	15	AMZ40P080FMC	Screw
	16	BBZ30P060FMC	Screw
	17	DBA1007	Screw
	18	WA42F120M100	Wahser
101			Packing bag
102			Packing sheet
103			Vinyl bag
104			Vinyl bag
105			Vinyl bag
106			Blind plate
107			Cord clammer
108			Cord clammer

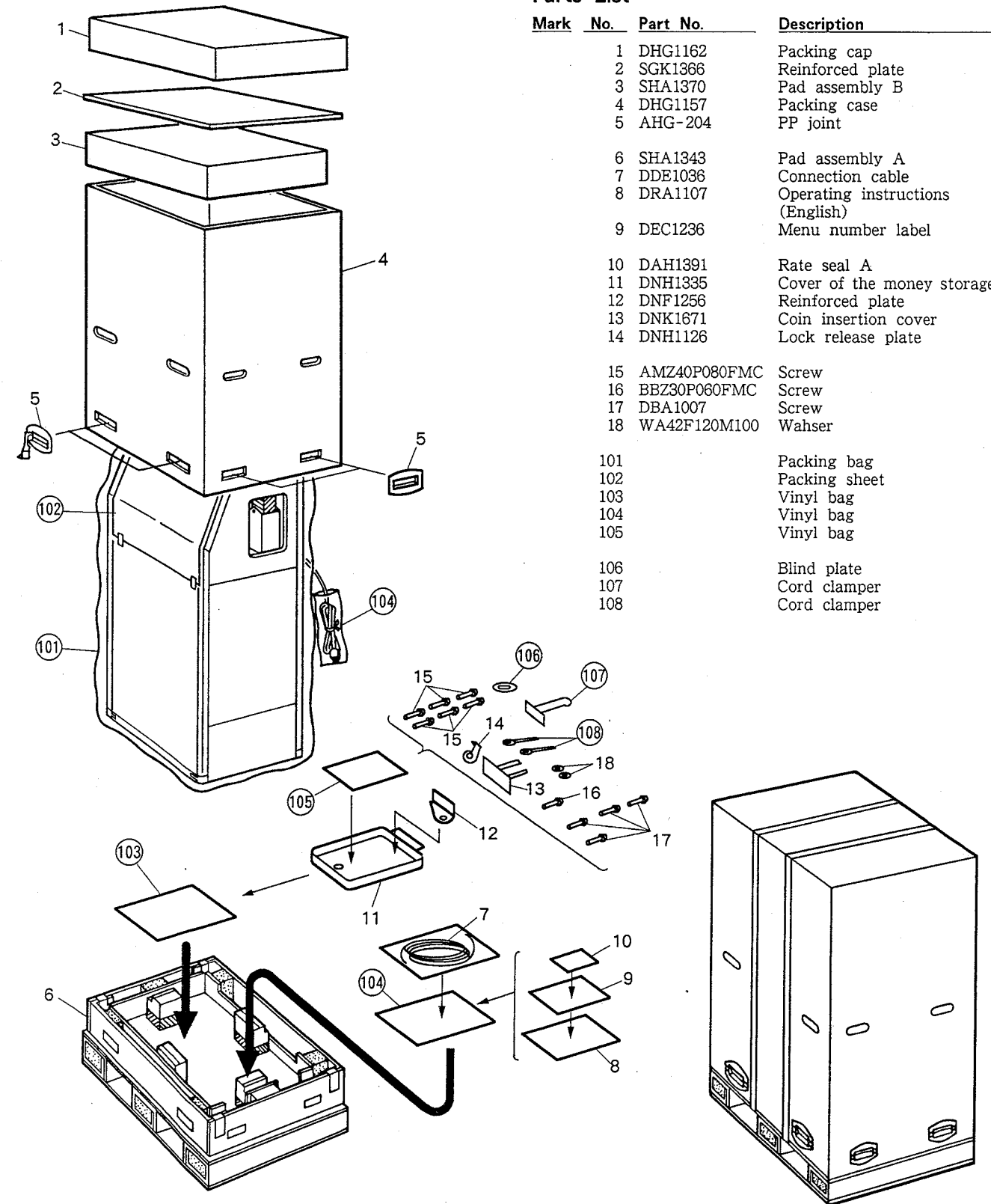

### 3.2 PACKING OF PD-MV55

#### Parts List

Mark	No.	Part No.	Description
	1	DHA1086	F pad
	2	DHA1087	R pad
	3	DHG1172	Packing case
	4	DDE1034	Connection cord
	5	PDE1065	Connection cord with pin plug
	6	AMZ40P080FMC	Screw
	7	DHG1164	Case
	8	DRW1156	Label B
	9	DRB1027	Operating instructions (English)
	10	DHC1015	Reinforcement plate
	101		Packing sheet
	102		Vinyl bag
	103		Vinyl bag
	104		Cord clumper
	105		Caution label
	106		Follow card bag
	107		Follow up card

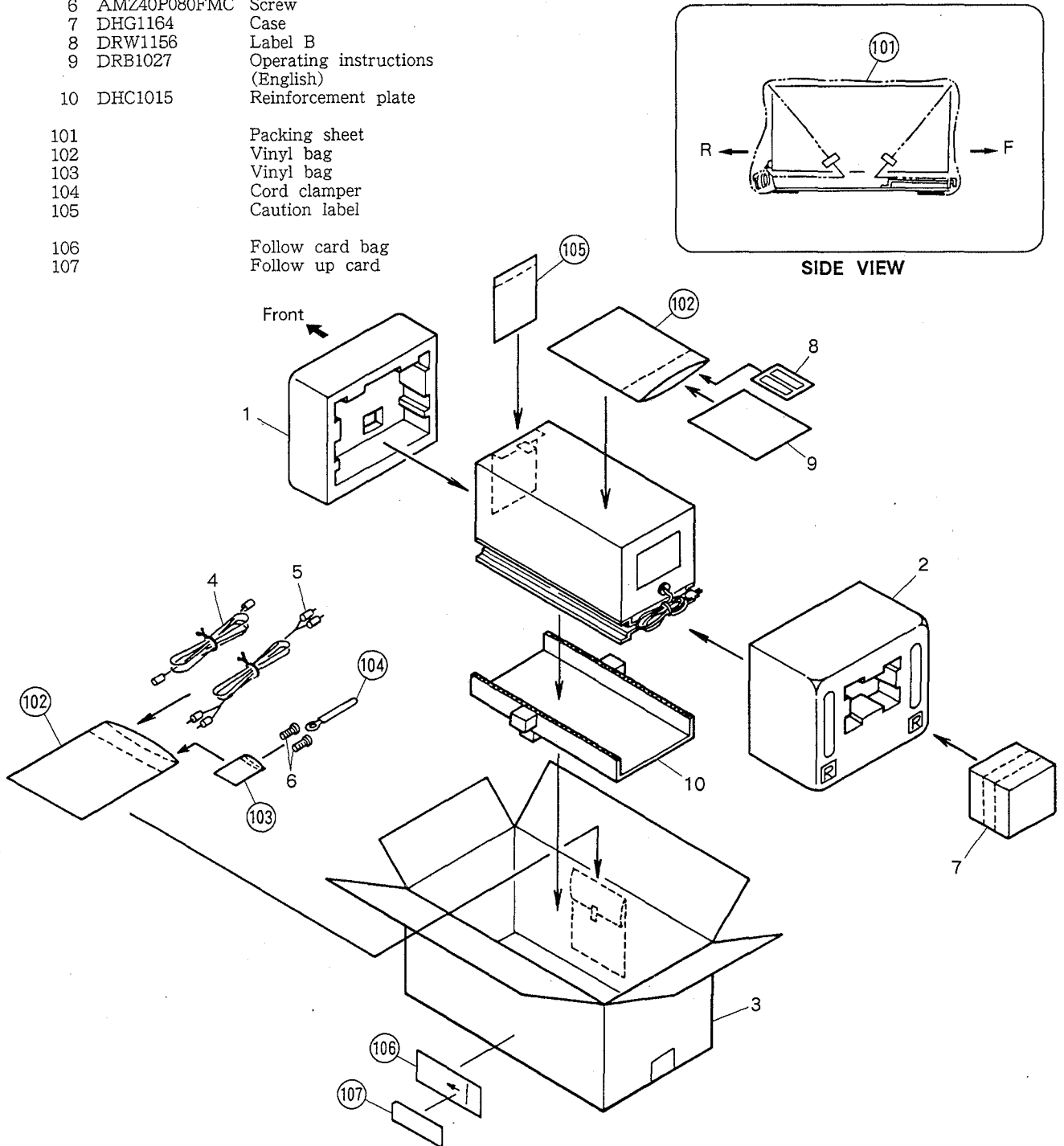

## 4. SCHEMATIC DIAGRAMS AND P. C. BOARDS PATTERN

### 1. RESISTORS :

Indicated in  $\Omega$ , 1/4W, 1/6W and 1/8W,  $\pm 5\%$  tolerance unless otherwise noted k ; k  $\Omega$ , M ; M  $\Omega$ , (F) ;  $\pm 1\%$ , (G) ;  $\pm 2\%$ , (K) ;  $\pm 10\%$ , (M) ;  $\pm 20\%$  tolerance.

### 2. CAPACITORS :

Indicated in capacity ( $\mu\text{F}$ ) / voltage (V) unless otherwise noted p ; pF. Indication without voltage is 50V except electrolytic capacitor.

### 3. VOLTAGE, CURRENT :

$\square$  ; DC voltage (V) at play state.  
 $\leftarrow$  mA ; DC current at play state.  
 Value in ( ) is DC current at stop state.

### 4. OTHERS :

$\rightarrow$  ; Signal route.  
 $\odot$  ; Adjusting point.  
 The  $\Delta$  mark found on some component parts indicates the importance of the safety factor of the part. Therefore, when replacing, be sure to use parts of identical designation.  
 \* marked capacitors and resistors have parts numbers.

This is the basic schematic diagram, but the actual circuit may vary due to improvements in design.

### 5. SWITCHES : (The underlined indicates the switch position)

MAIN SECTION	CD SECTION
OUTSIDE OF P.C.BOARDS	OUT SIDE OF P.C.BOARDS
DOOR SW	DOWN LIMIT TRAY SW
KEYB	CLAMP SW
S301 : 1	IN SIDE SW
S302 : 2	EKEY
S303 : 3	S301 : A
S304 : 4	S302 : B
S305 : 5	S303 : C
S306 : 6	] EJECT
S307 : 7	
S308 : 8	
S309 : 9	SENS
S310 : 0	S901 : UP LIMIT
S311 : ] CLEAR	MJSW
S312 : ]	S801 : 1
S313 : ] BEST HITS	S802 : 2
S314 : ]	S803 : 3
S315 : ] ROTATE MENU	S804 : 1
S316 : ]	S805 : 2
	S806 : 3
ASEL	] MJ LOCK
SPEAKER SELECTOR SW	
BUILT - IN AND BUILT - IN	
EXTERNAL — SPEAKERS	
SPEAKERS ONLY	
PSWB	
POWER SW ON — OFF	
OPER	
S301 : MEMORY CLEAR	
S302 : MENU ROTATION	
S303 : SERVICE MODE	
DIPS	
S1 : FUNCTION	

4.1 MAIN SECTION  
4.1.1 OVERALL CONNECTION DIAGRAM

A  
B  
C  
D  
E  
F

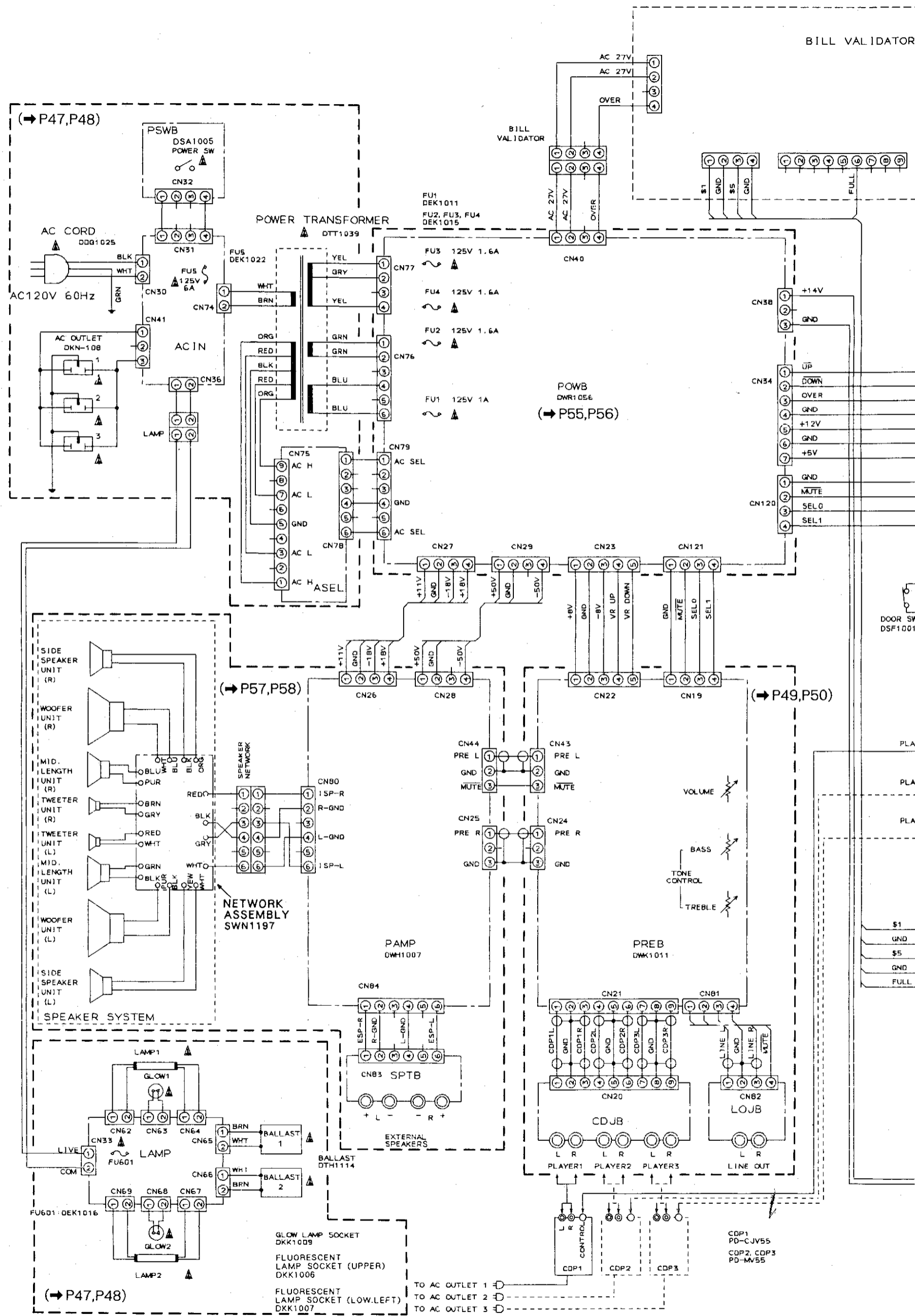

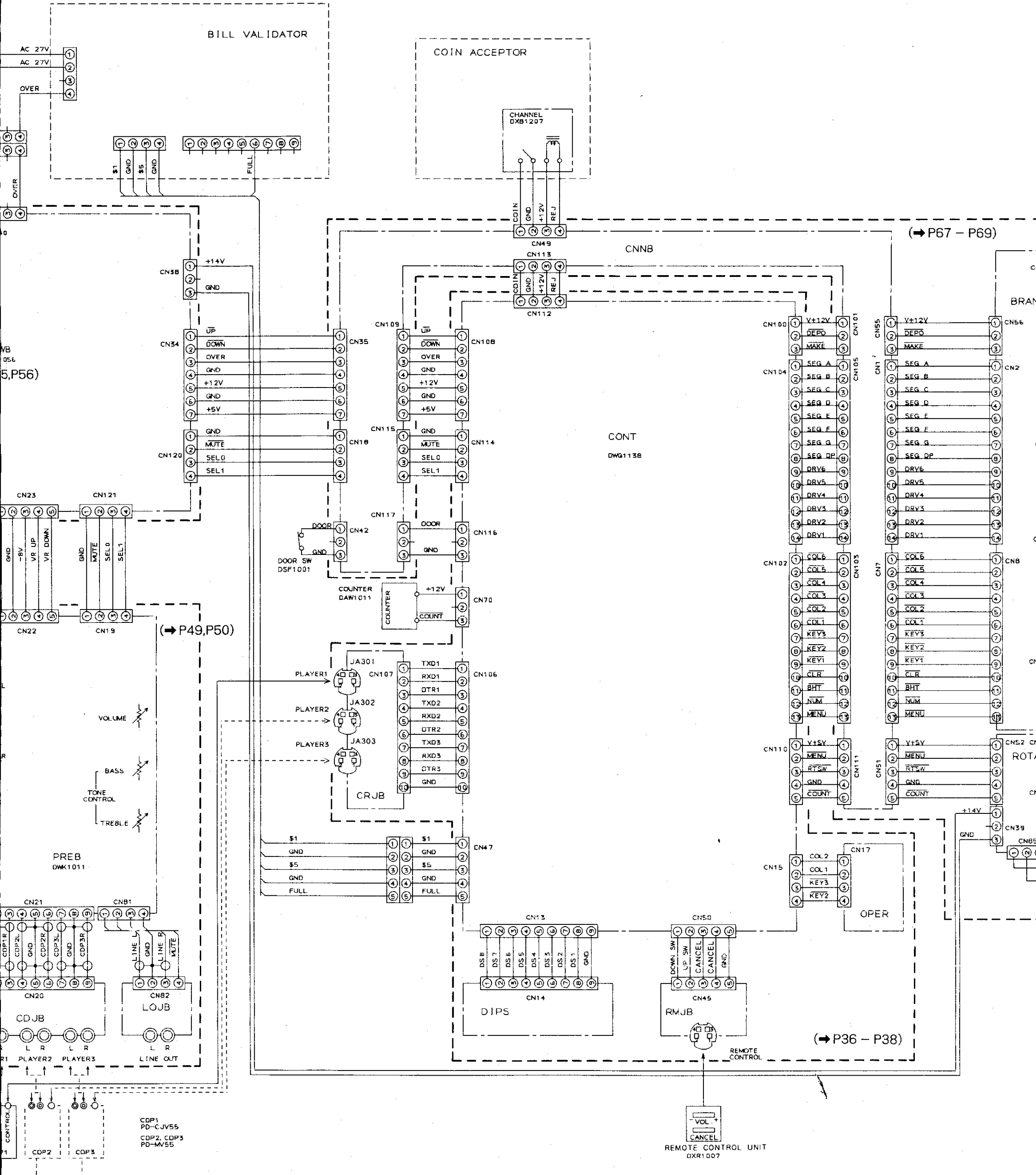

NOTE  
RESERVE : CN72 FOR RCU SENS

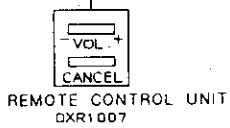
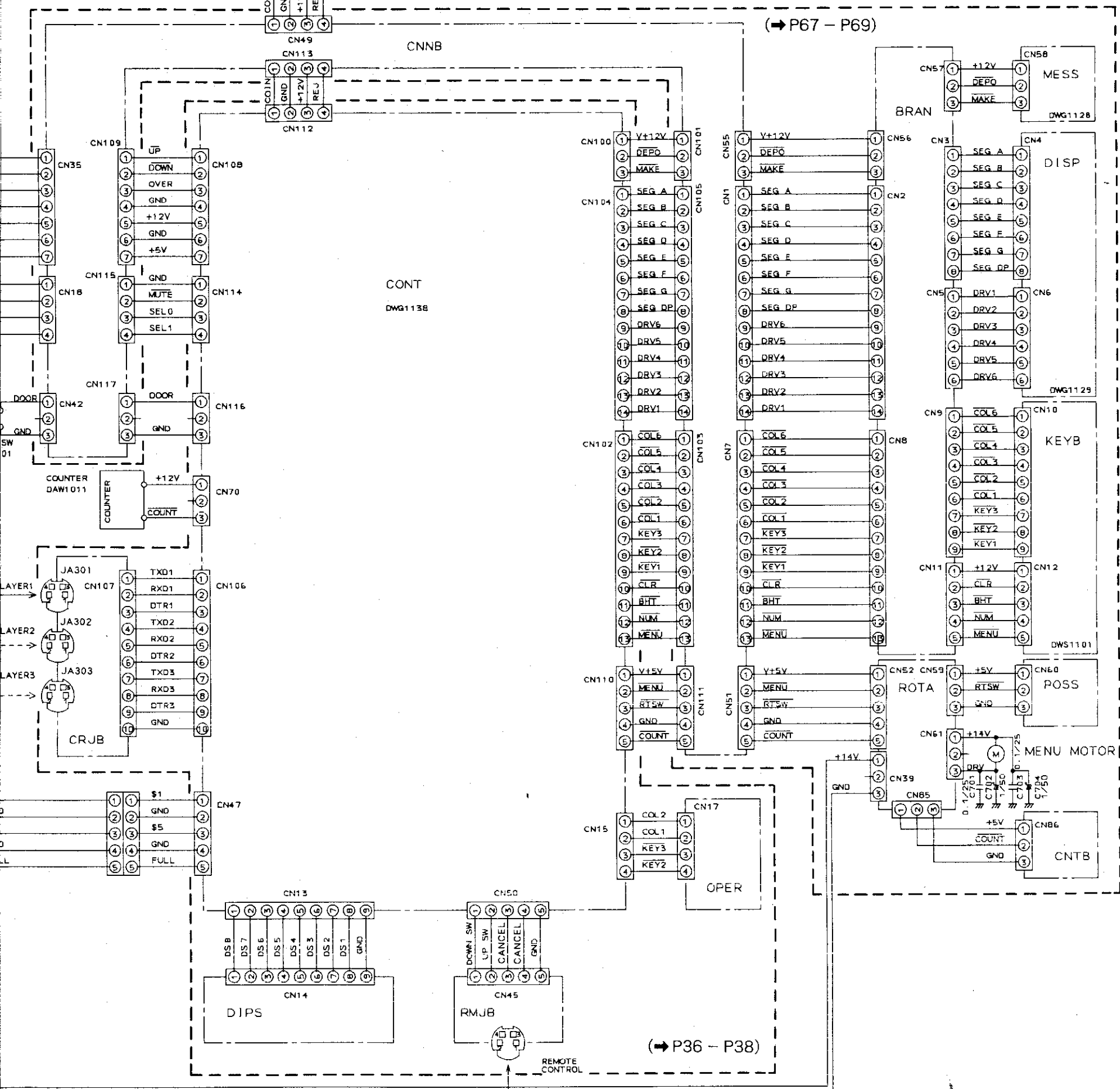
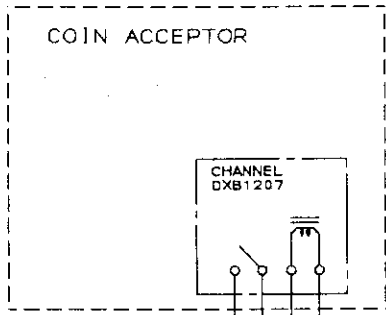

NOTE  
RESERVE : CN72 FOR RCU SENS

A  
B  
C  
D  
E  
F

4.1.2 DIPS, CRJB, CONT, RMJB AND OPER

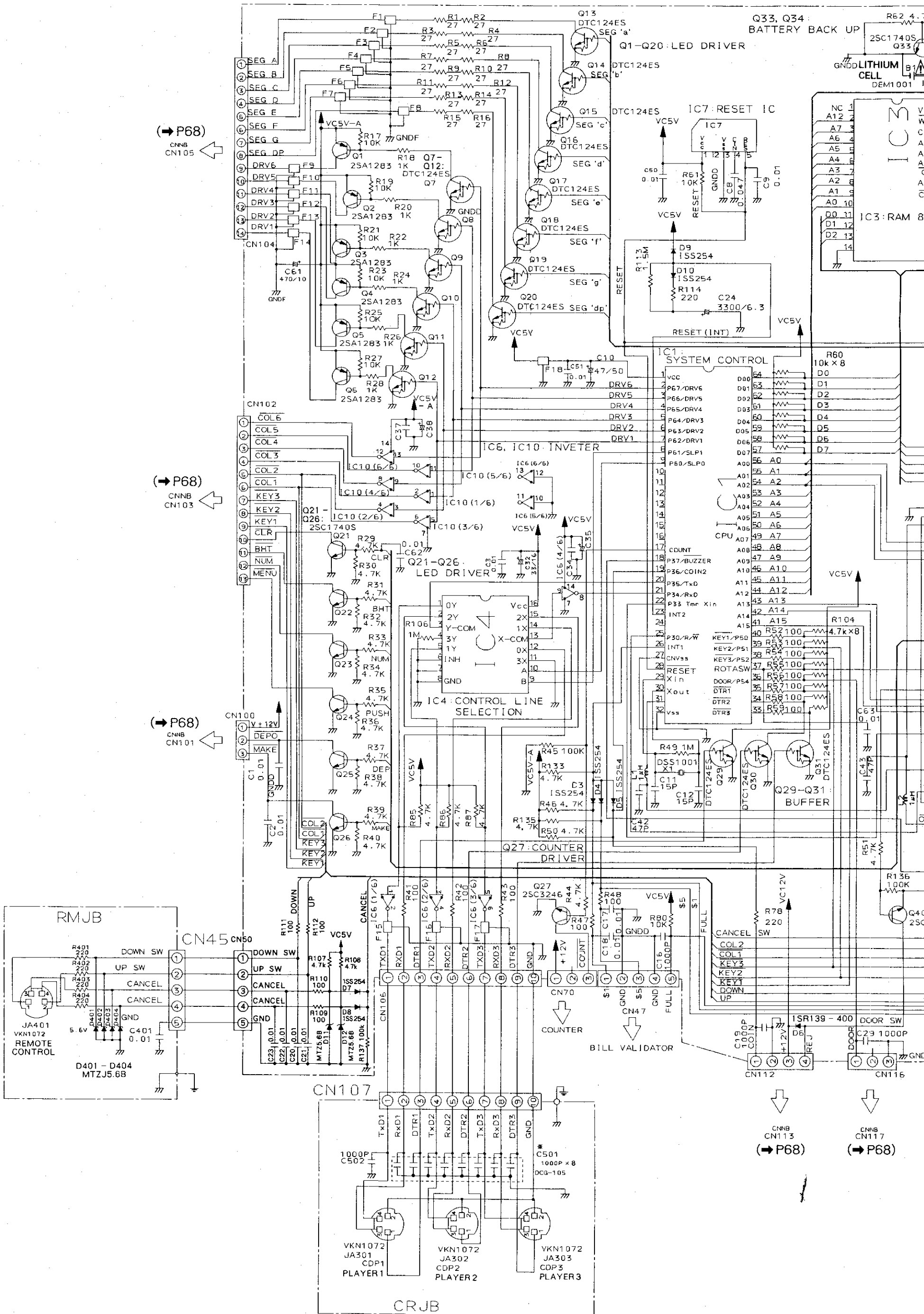

(→ P68)  
CNNB CN105

(→ P68)  
CNNB CN103

(→ P68)  
CNNB CN101

(→ P68)  
CNNB CN113

(→ P68)  
CNNB CN117

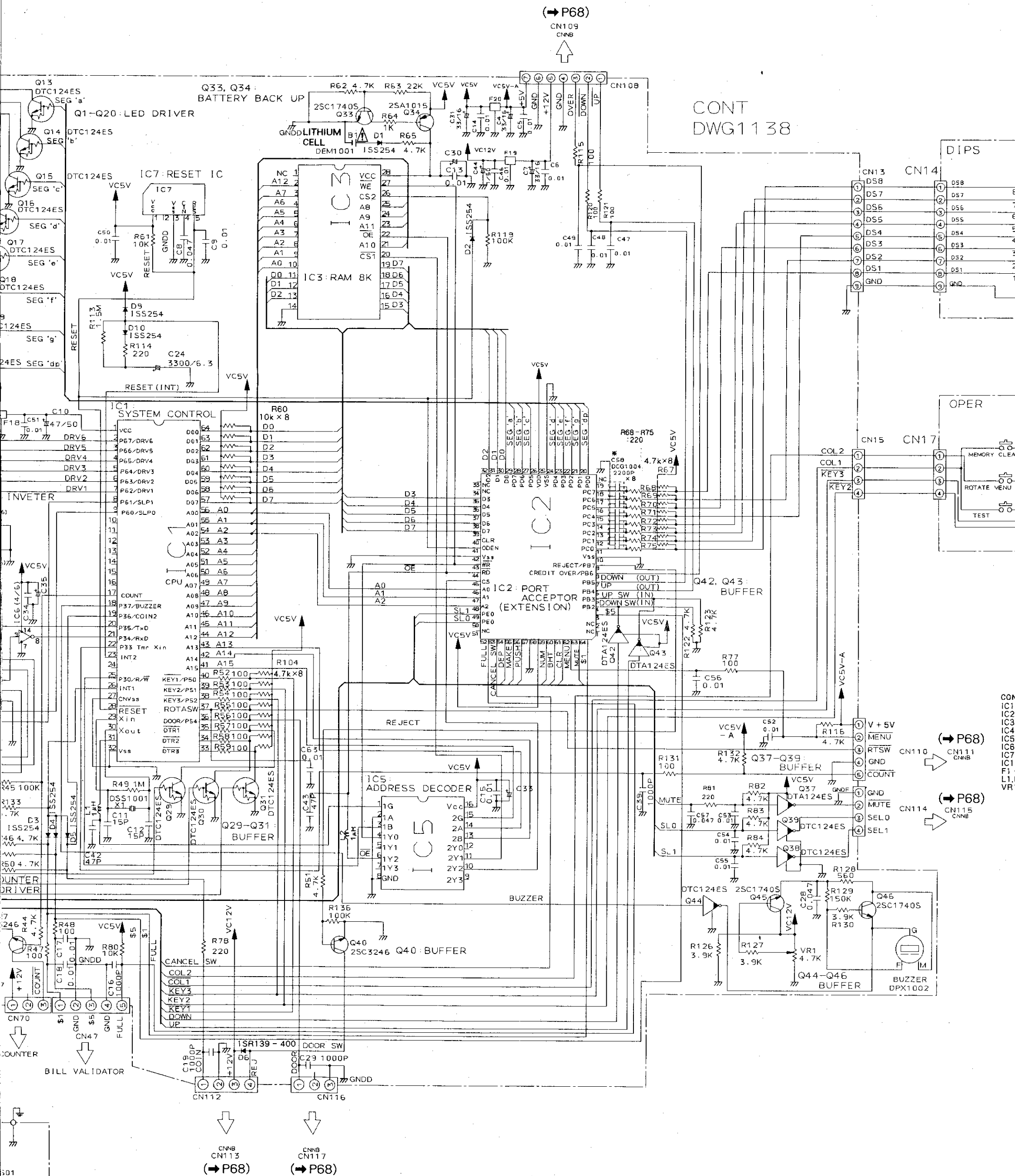

CONT  
DWG 1138

DIPS

OPER

(P68)

(P68)

(P68)

(P68)

KN1072  
JA303  
DP3  
LAYER3



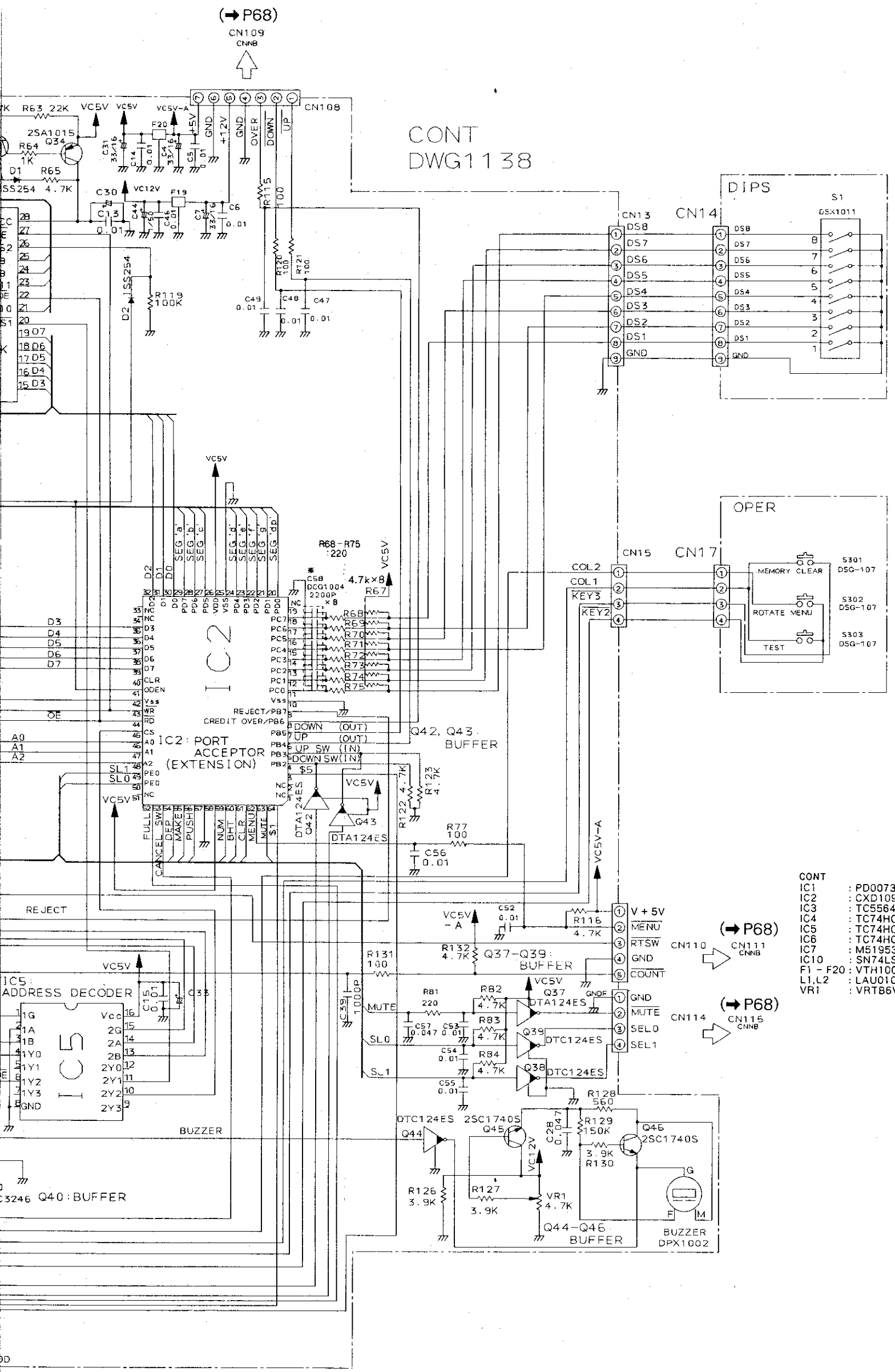

- CONT
- IC1 : PD0073
  - IC2 : CXD10950
  - IC3 : TC5564APL - 15
  - IC4 : TC74HC4052AP
  - IC5 : TC74HC139AP
  - IC6 : TC74HC04AP
  - IC7 : M51953BL
  - IC10 : SN74LS05N
  - F1 - F20 : VTH1001
  - L1, L2 : LAU010K
  - VR1 : VRTB6VS472

A

B

C

D

E

F

1 2 3 4 5 6

Q13—Q16 Q17—Q20  
 Q1 Q7  
 Q3 Q8  
 Q4 IC10 Q2 Q9 Q10  
 Q5 Q30 Q6 Q11 IC6  
 Q31 Q23 Q29 Q12 Q21  
 Q24 Q26 Q22 Q25 IC4 Q40 IC2 IC1 Q43 IC7 Q42 Q27 Q45 Q39  
 Q44 Q38 IC3 Q46  
 VR1

A

A

B

B

C

C

D

D

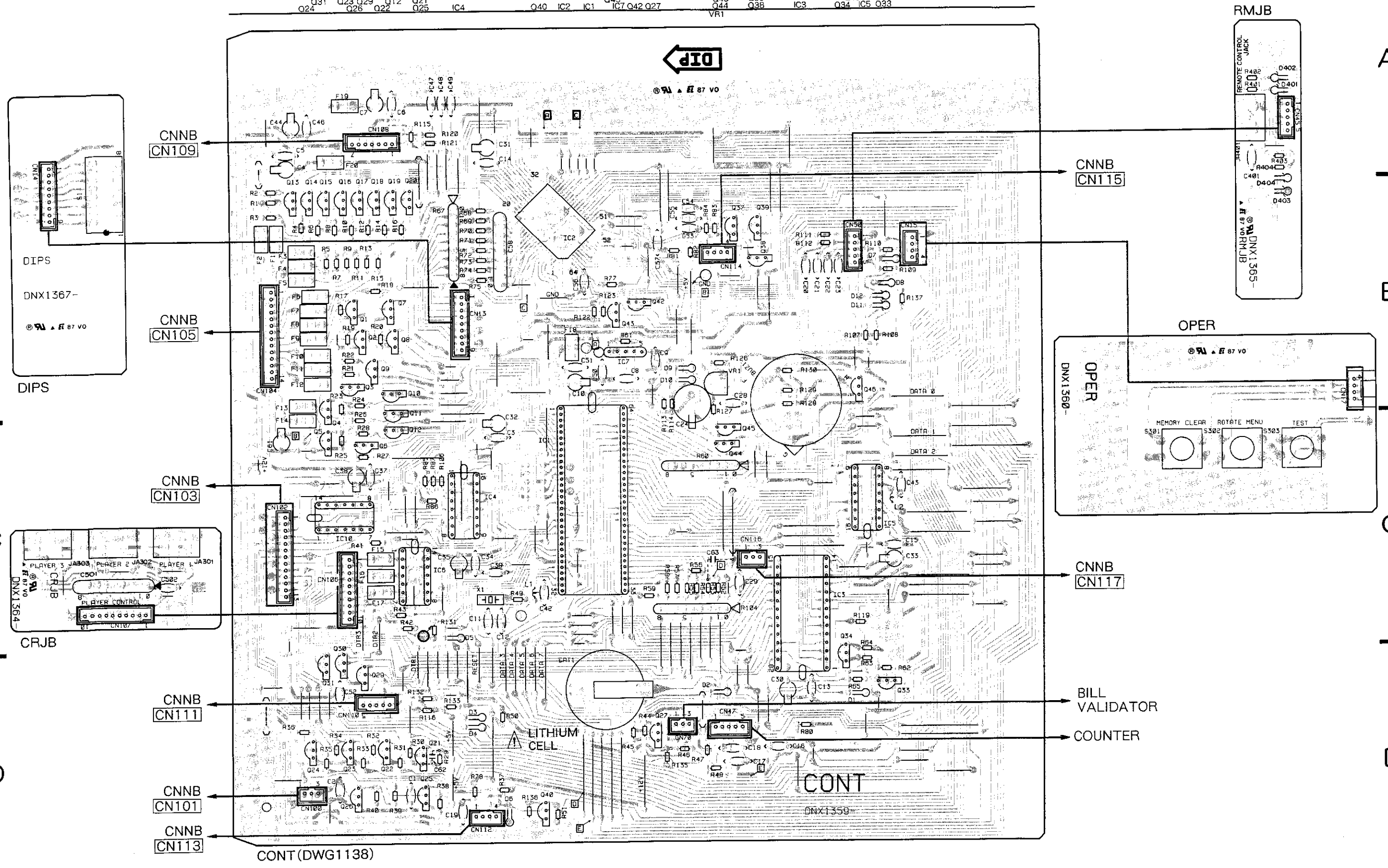

CONT (DWG1138)

1 2 3 4 5 6

054 052 053 051 050  
 034 033 032 031 030 029 028 027 026 025 024 023 022 021 020 019 018 017 016 015 014 013 012 011 010 009 008 007 006 005 004 003 002 001  
 031-016 017-050  
 031 030 029 028 027 026 025 024 023 022 021 020 019 018 017 016 015 014 013 012 011 010 009 008 007 006 005 004 003 002 001  
 031 030 029 028 027 026 025 024 023 022 021 020 019 018 017 016 015 014 013 012 011 010 009 008 007 006 005 004 003 002 001  
 031 030 029 028 027 026 025 024 023 022 021 020 019 018 017 016 015 014 013 012 011 010 009 008 007 006 005 004 003 002 001

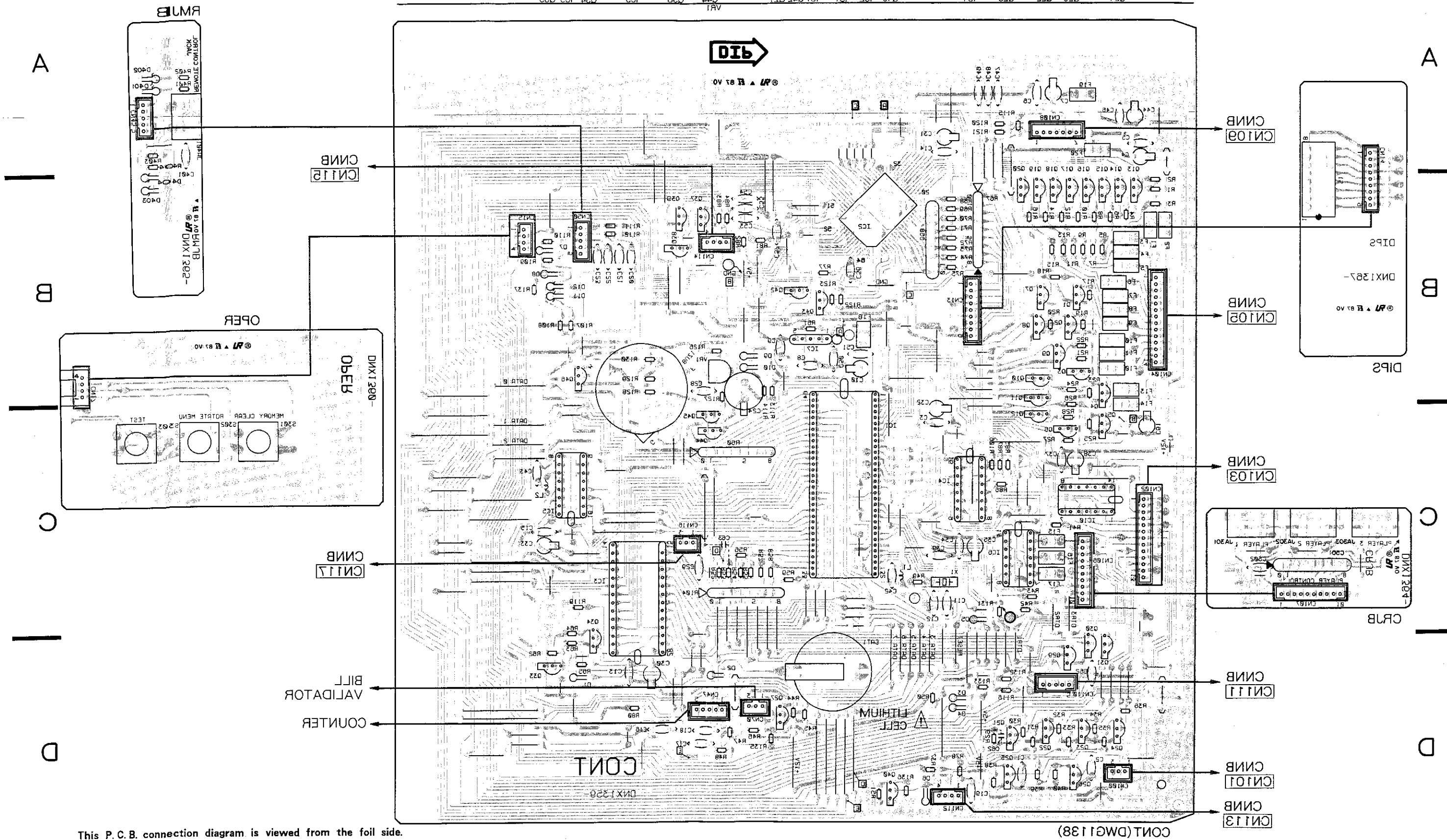

This P.C.B. connection diagram is viewed from the foil side.

CONT (DWG 138)

4.1.3 LAMP, P2WB, ACIN AND ASEL

This P.C.B. connection diagram is viewed from the foil side.

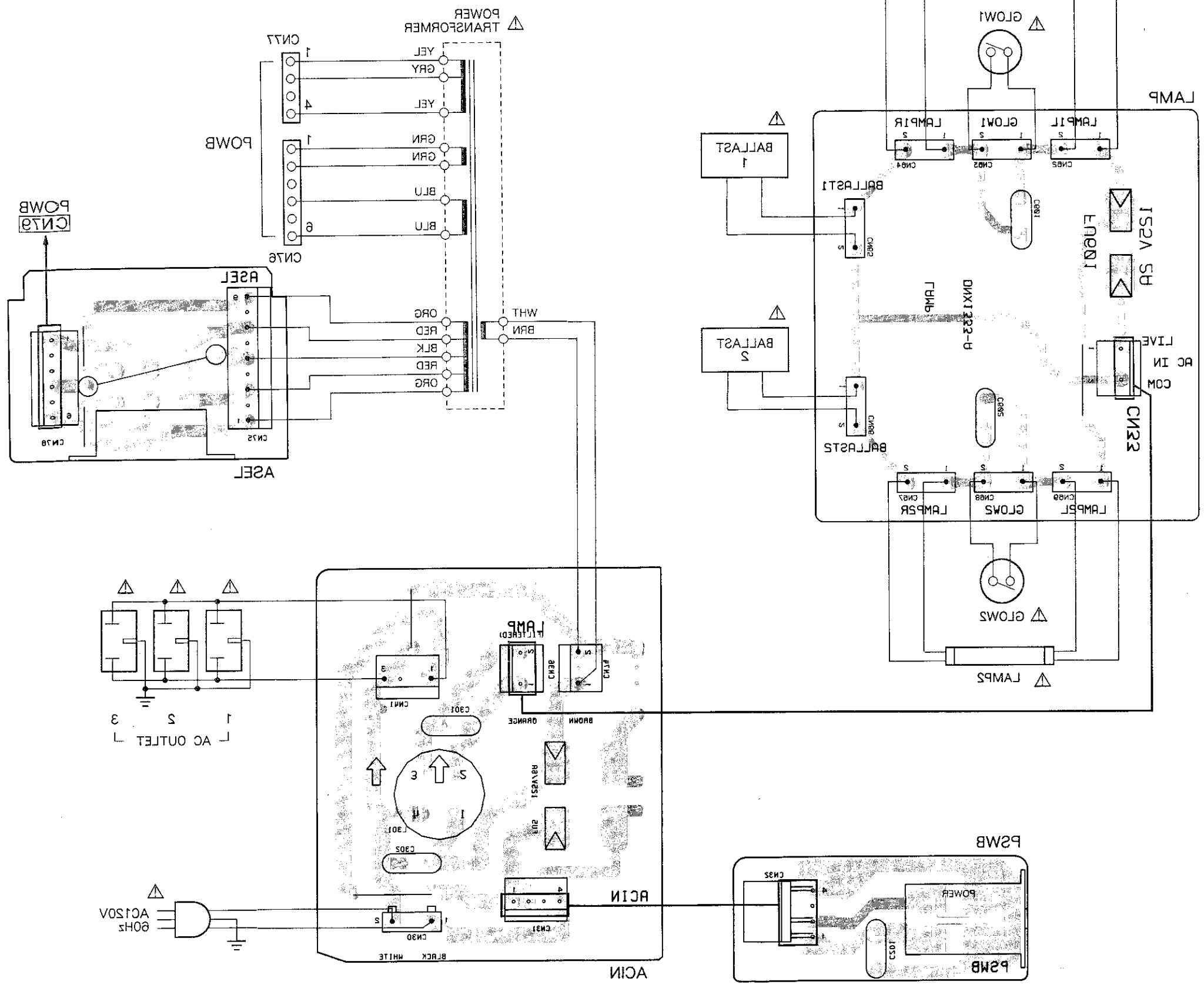

A

B

C

D

A

B

C

D

6

2

4

3

5

1

44

4.1.3 LAMP, PSWB, ACIN AND ASEL

P.C.B. pattern diagram indication	Corresponding part symbol	Part name
		Transistor
		FET
		Diode
		Zener diode
		LED
		Varactor
		Tact switch
		Inductor
		Coil
		Transformer
		Filter
		Ceramic capacitor
		Mylar capacitor
		Styrol capacitor
		Electrolytic capacitor (Non polarized)
		Electrolytic capacitor (Noiseless)
		Electrolytic capacitor (Polarized)
		Electrolytic capacitor (Polarized)
		Power capacitor
		Semi-fixed resistor
		Resistor array
		Resistor
		Resonator
		Thermistor

- This P.C.B. connection diagram is viewed from the parts mounted side.
- The parts which have been mounted on the board can be replaced with those shown with the corresponding wiring symbols listed in the above Table.
- The capacitor terminal marked with shows negative terminal.
- The diode marked with shows cathode side.
- The transistor terminal marked with shows emitter.

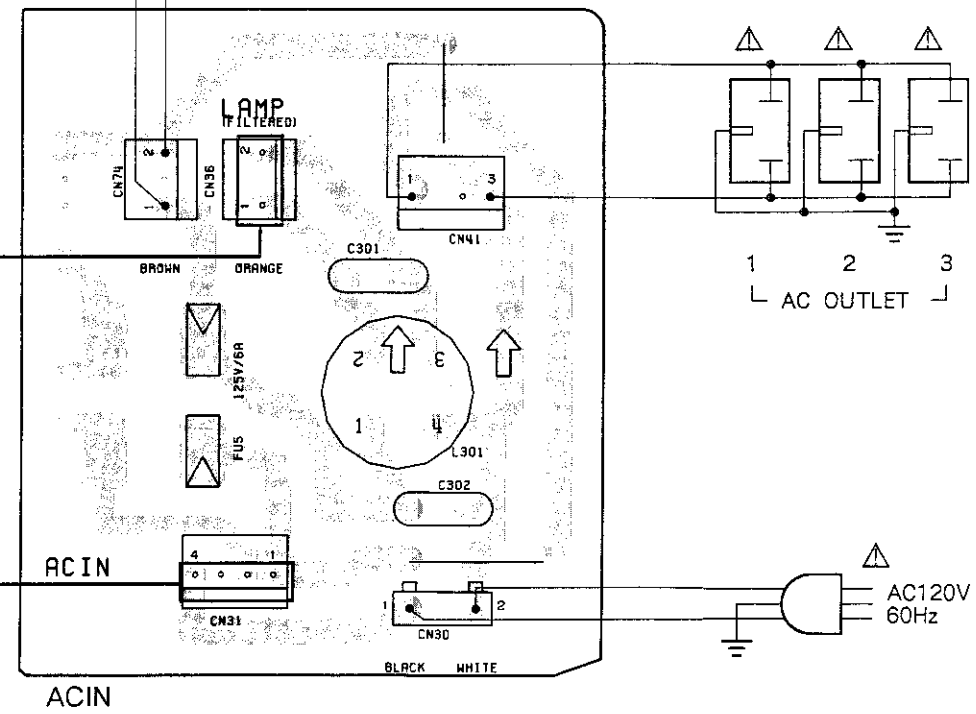
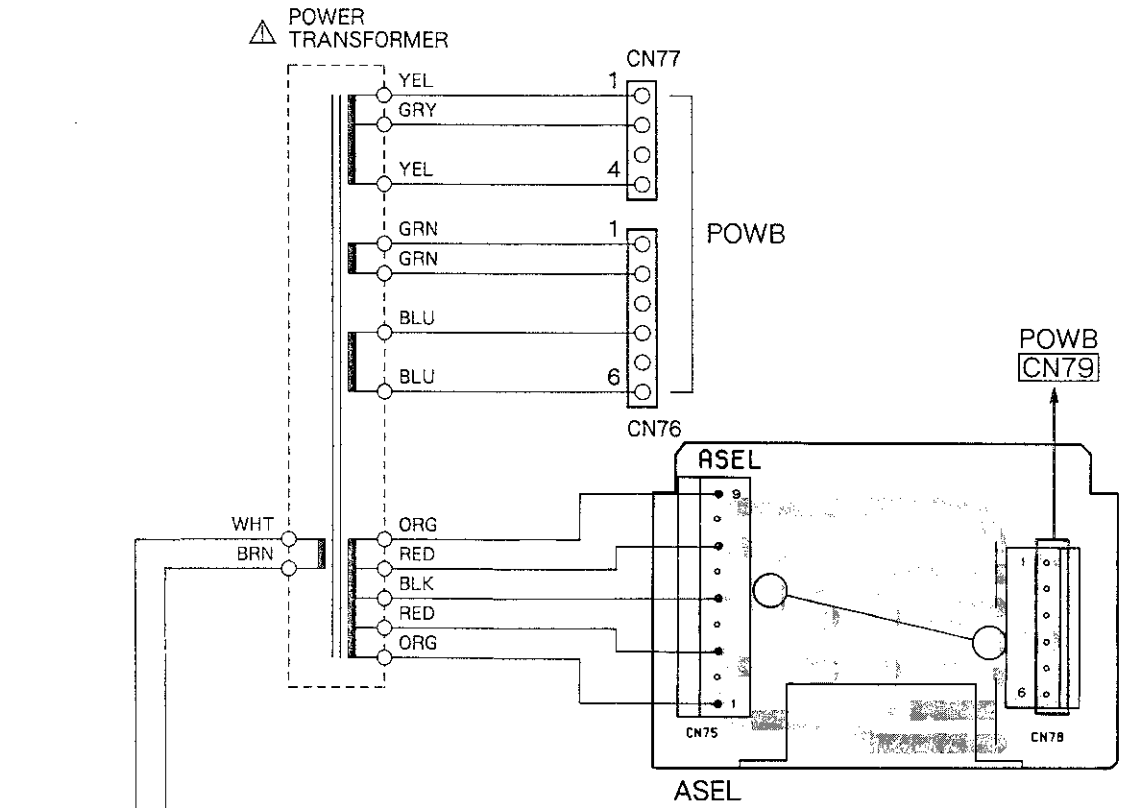
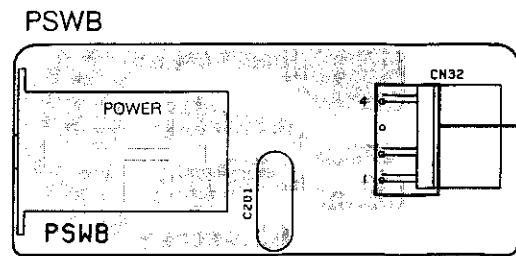
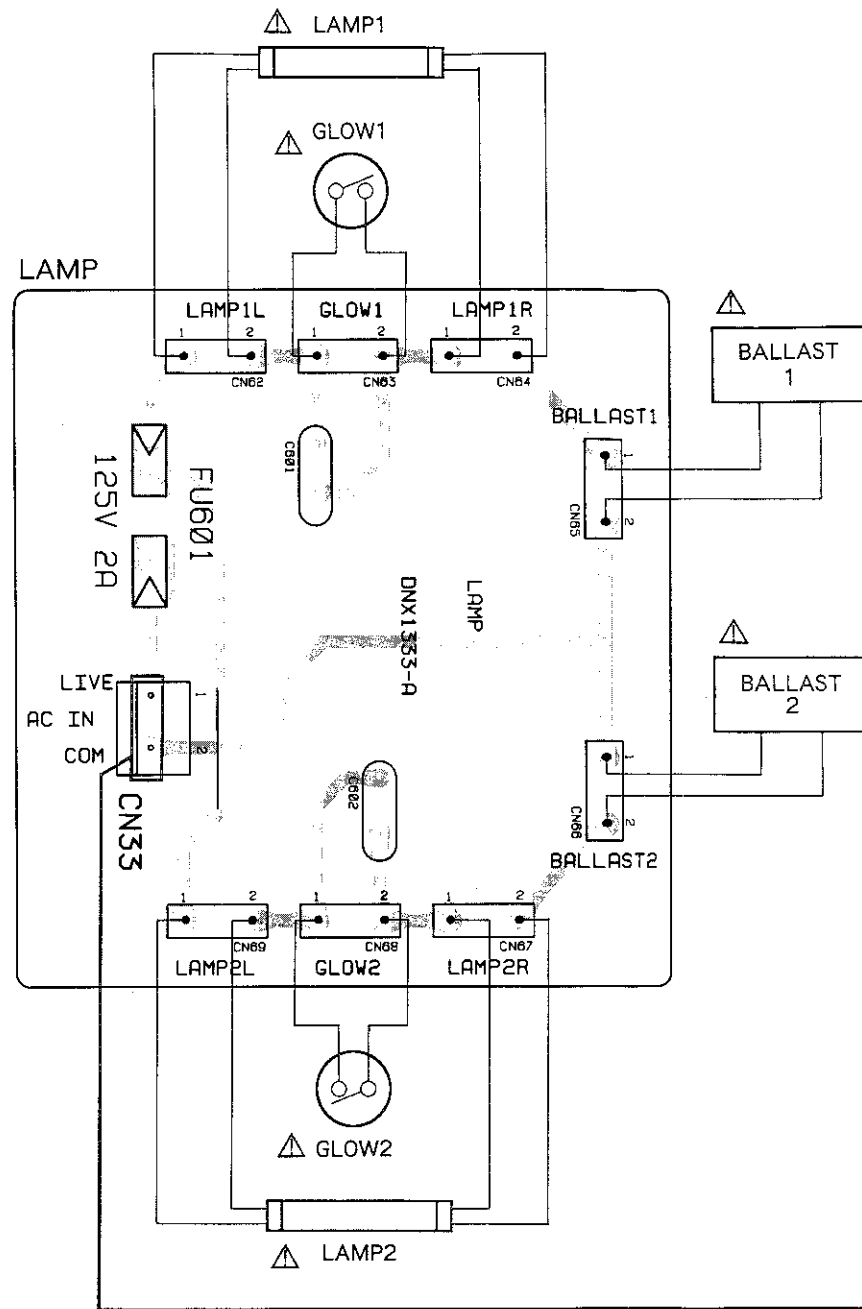

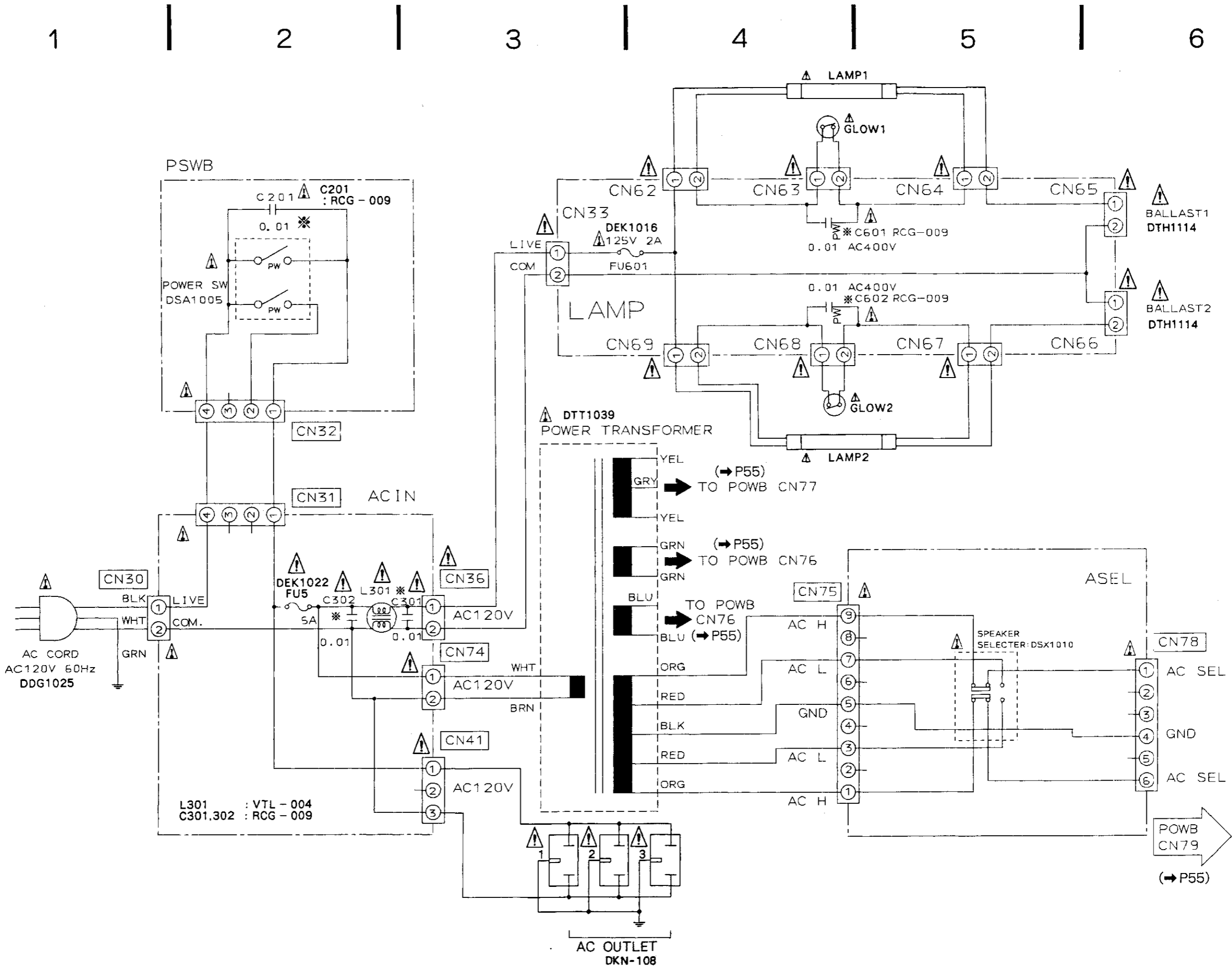

1

2

3

4

5

6

A

B

C

D

A

B

C

D

1

2

3

4

5

6

4.1.4 PREB, CDJB AND LOJB

PREB  
 Q1, 2: 2SC3311A  
 IC1: TC4052BP  
 IC2, 3: NJM4558S  
 VR1: DCS1013  
 VR2, 3: DCS1014

LOJB  
 Q50, Q51: 2SA1309A

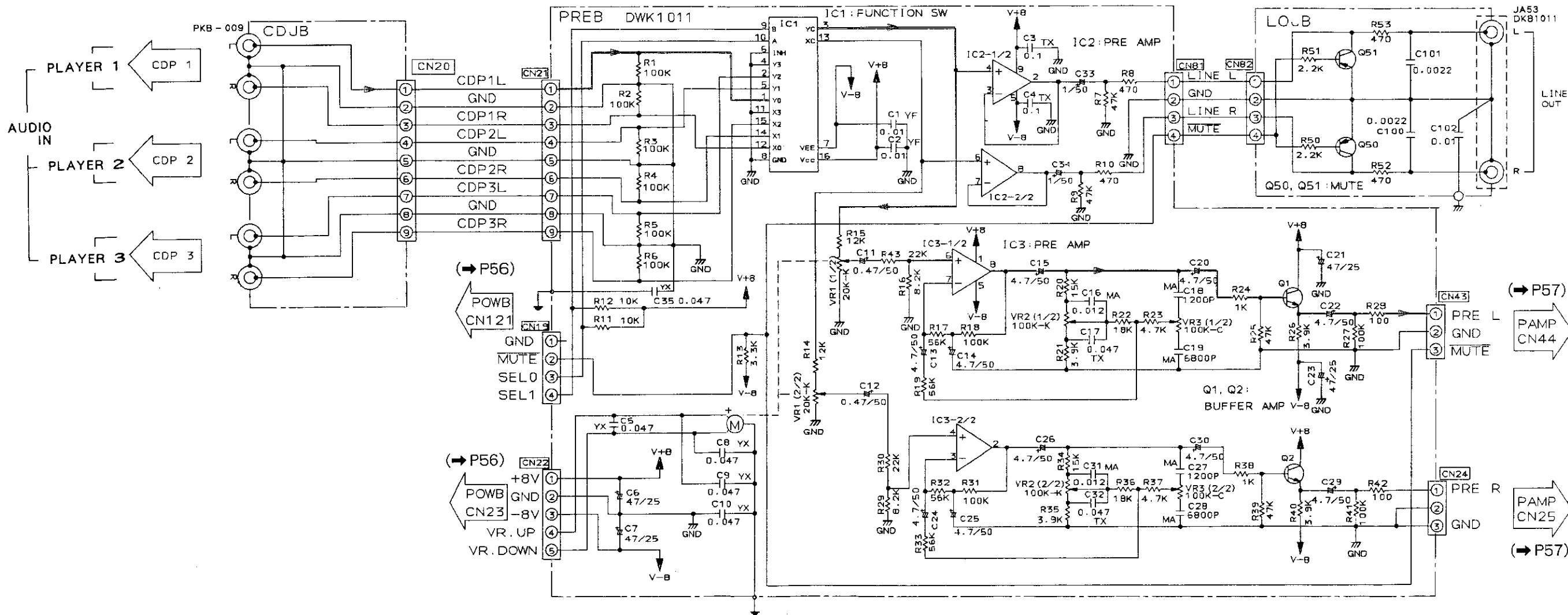

— : AUDIO Signal Line

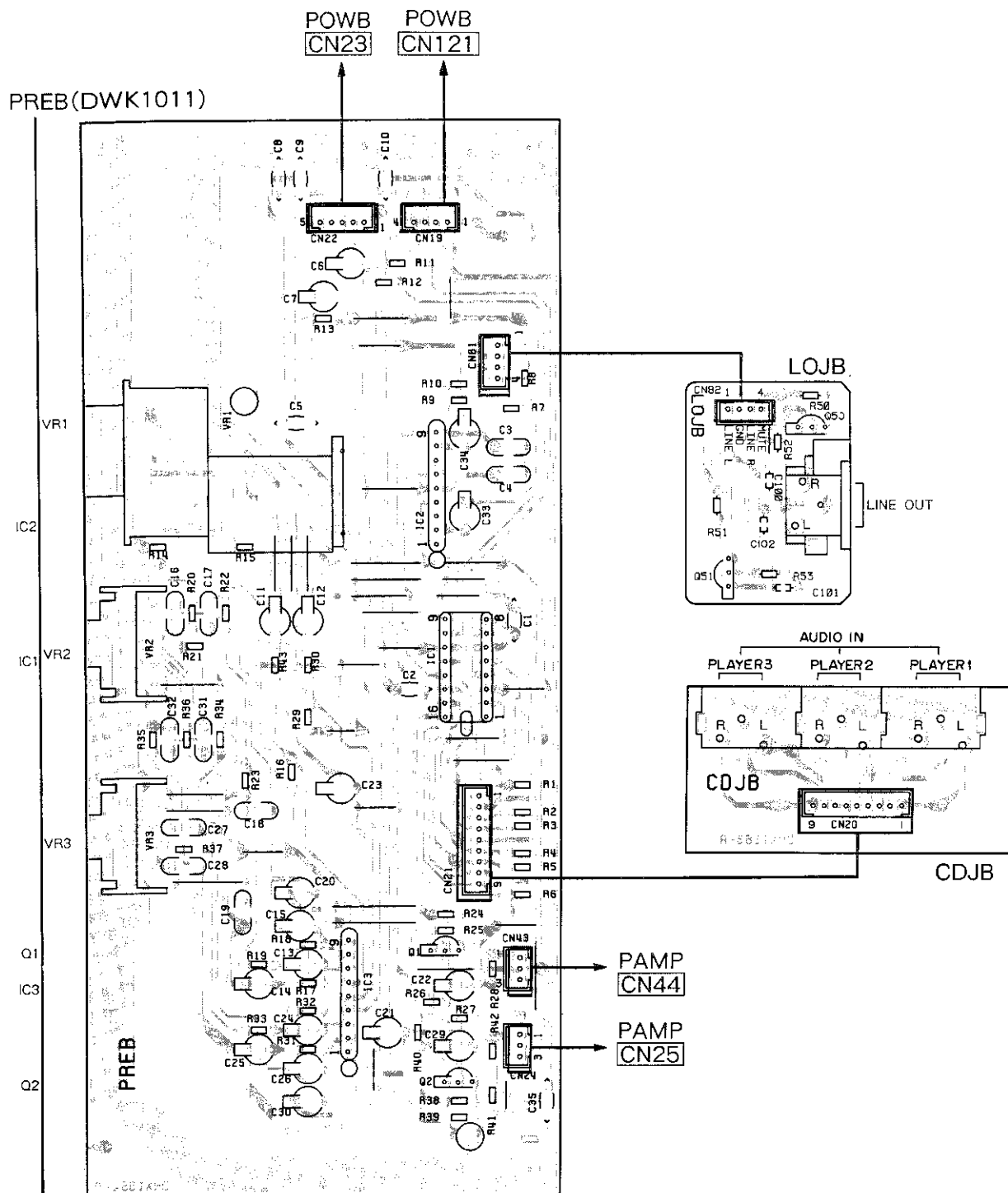



A

B

C

D

This P.C.B. connection diagram is viewed from the foil side.

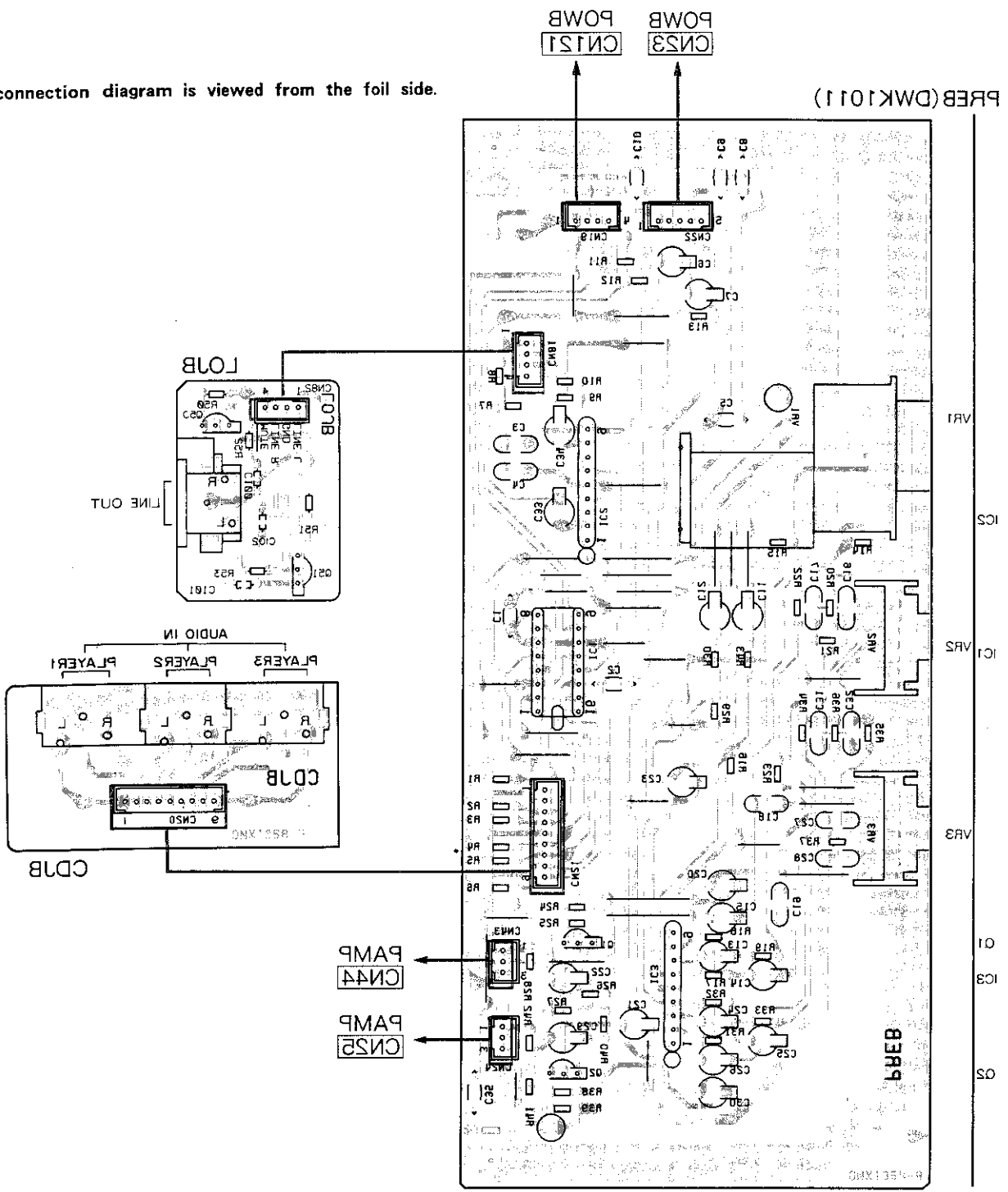



4.1.5 POWB  
OWER  
RANSFORMER

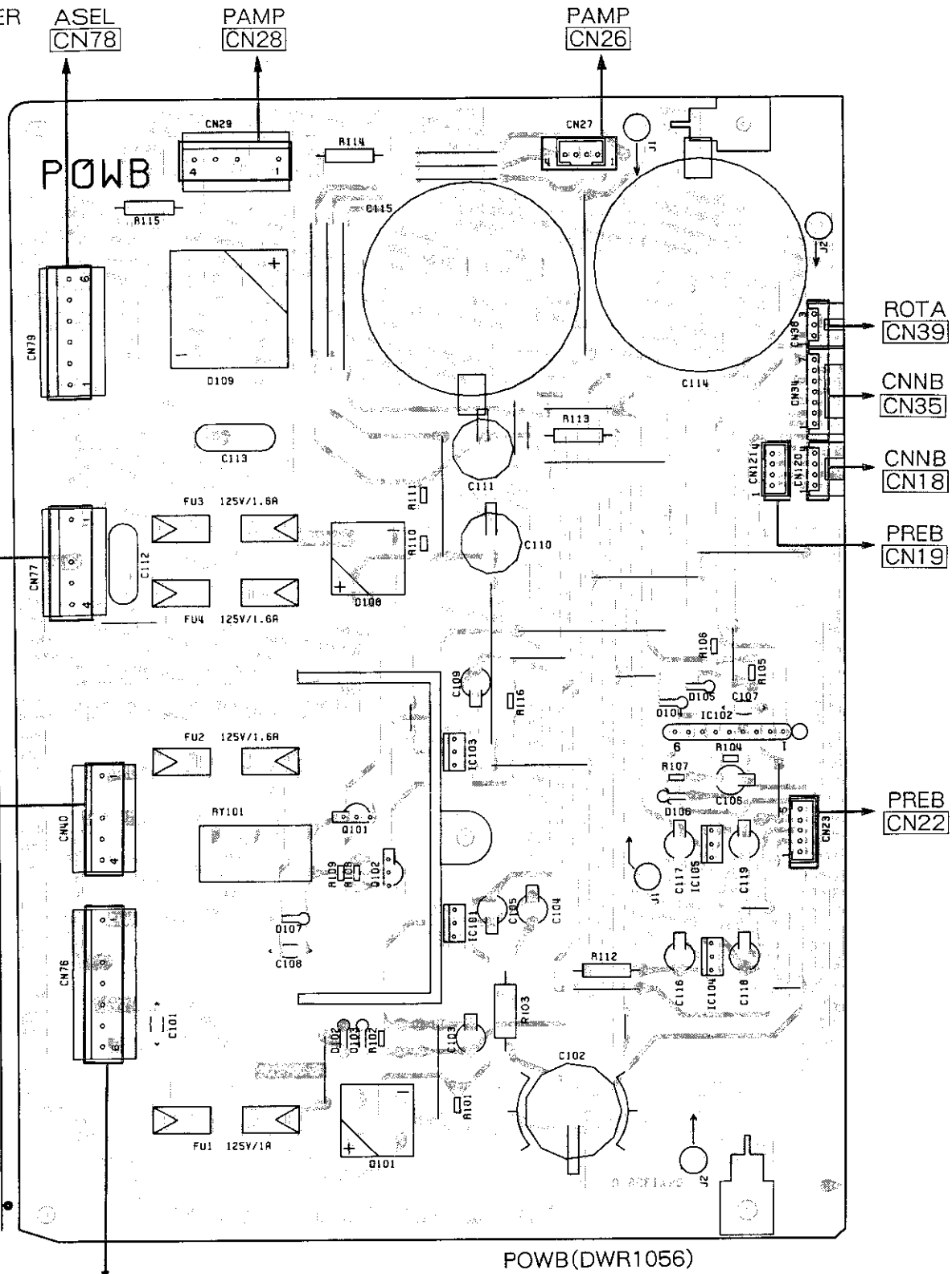

A

B

C

D

BILL  
VALIDATOR

POWER  
TRANSFORMER

POWB(DWR1056)

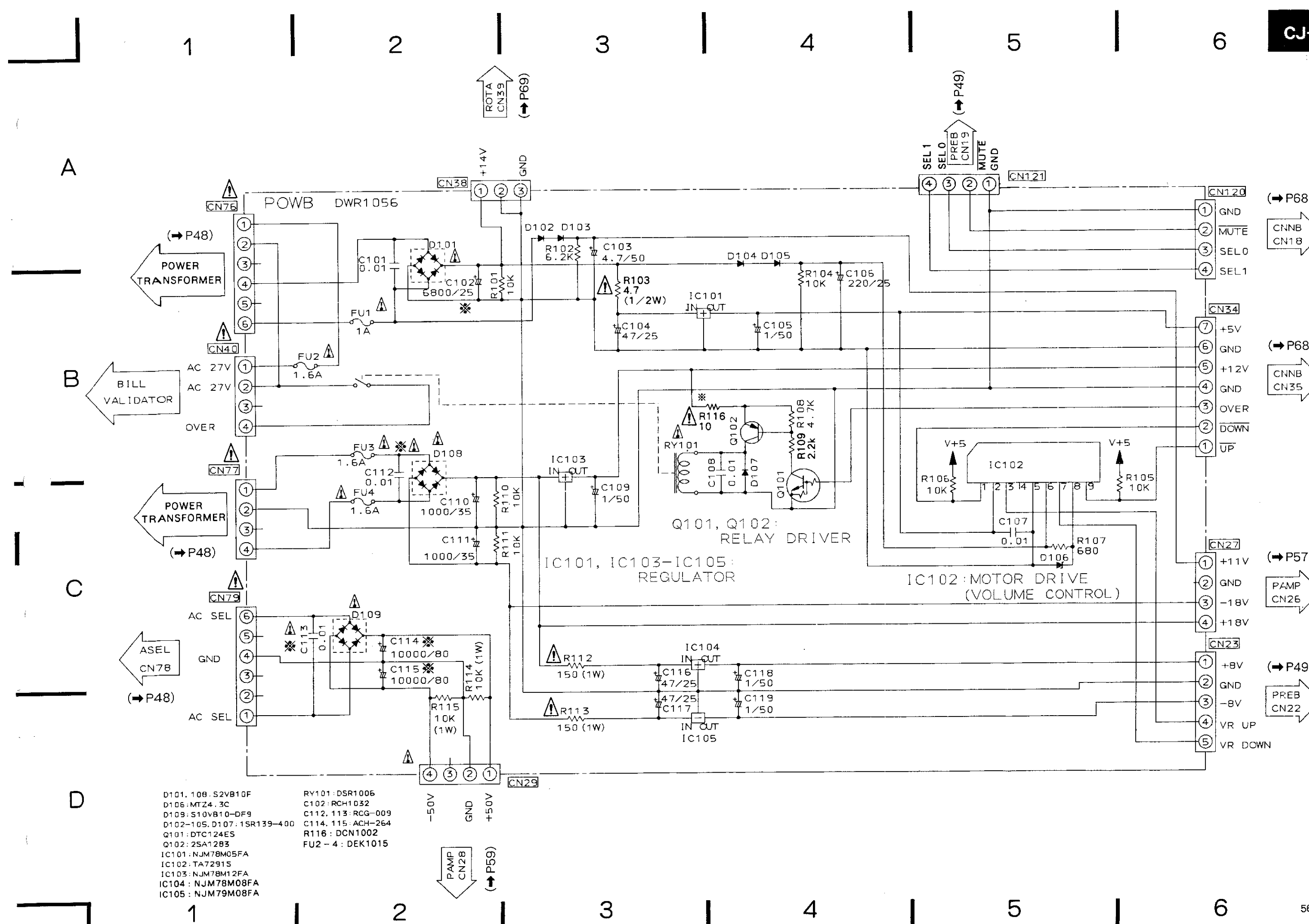

- D101, 108: S2VB10F
- D106: MT24.3C
- D109: S10VB10-DF9
- D102-105, D107: 1SR139-400
- Q101: DTC124ES
- Q102: 2SA1283
- IC101: NJM78M05FA
- IC102: TA7291S
- IC103: NJM78M12FA
- IC104: NJM78M08FA
- IC105: NJM79M08FA
- RY101: DSR1006
- C102: RCH1032
- C112, 113: RCG-009
- C114, 115: ACH-264
- R116: DCN1002
- FU2 - 4: DEK1015

**4.1.6 PAMP, SPTB AND NETWORK ASSEMBLY**

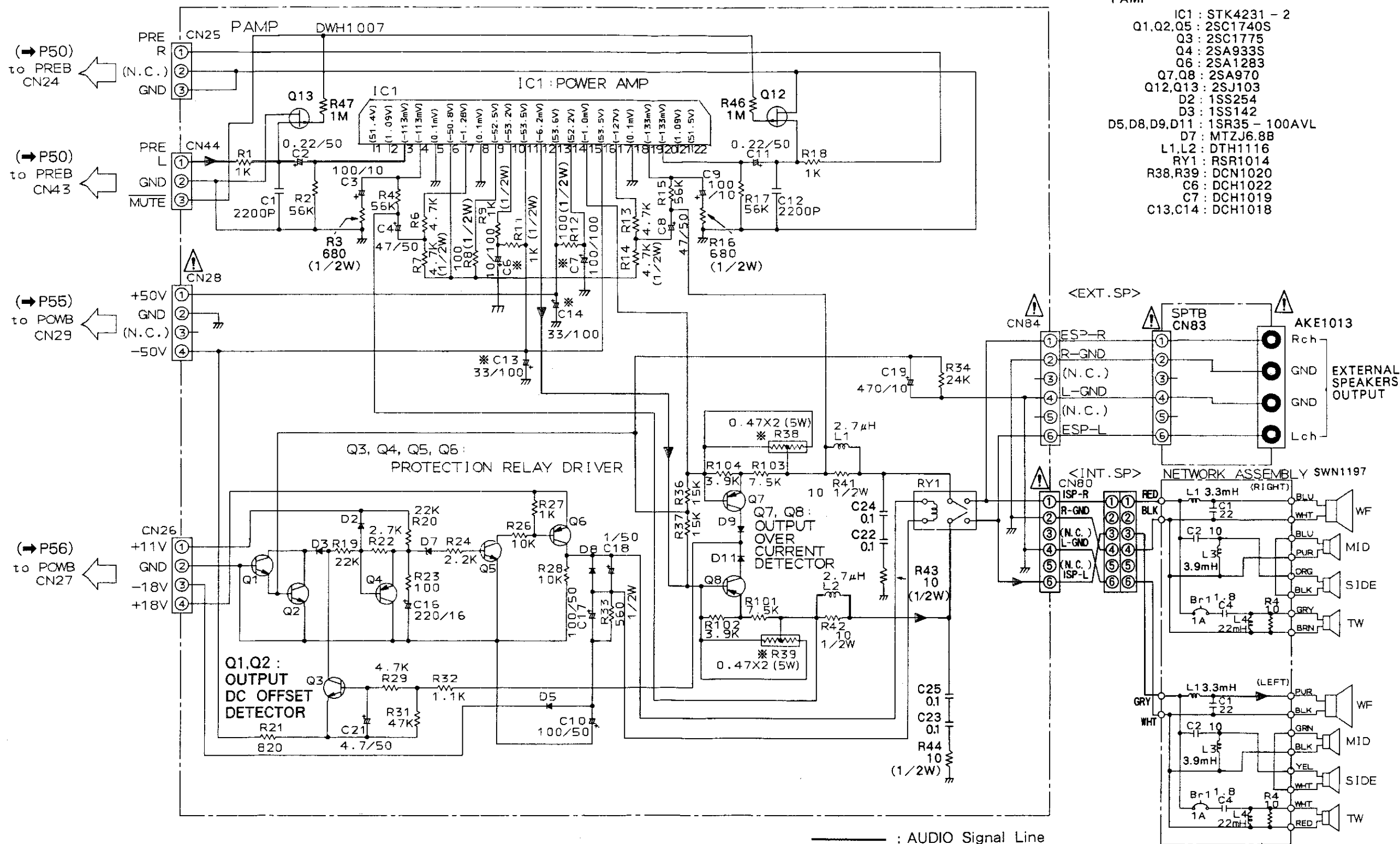

- PAMP**
- IC1 : STK4231 - 2
  - Q1,Q2,Q5 : 2SC1740S
  - Q3 : 2SC1775
  - Q4 : 2SA933S
  - Q6 : 2SA1283
  - Q7,Q8 : 2SA970
  - Q12,Q13 : 2SJ103
  - D2 : 1SS254
  - D3 : 1SS142
  - D5,D8,D9,D11 : 1SR35 - 100AVL
  - D7 : MTZJ6.8B
  - L1,L2 : DTH1116
  - RY1 : RSR1014
  - R38,R39 : DCN1020
  - C6 : DCH1022
  - C7 : DCH1019
  - C13,C14 : DCH1018

- NETWORK ASSEMBLY**
- L1 : STH1100
  - L3 : STH1021
  - L4 : STH - 327
  - Br1 : SSG - 004

— : AUDIO Signal Line

1 2 3 4 5 6

A

A

B

B

C

C

D

D

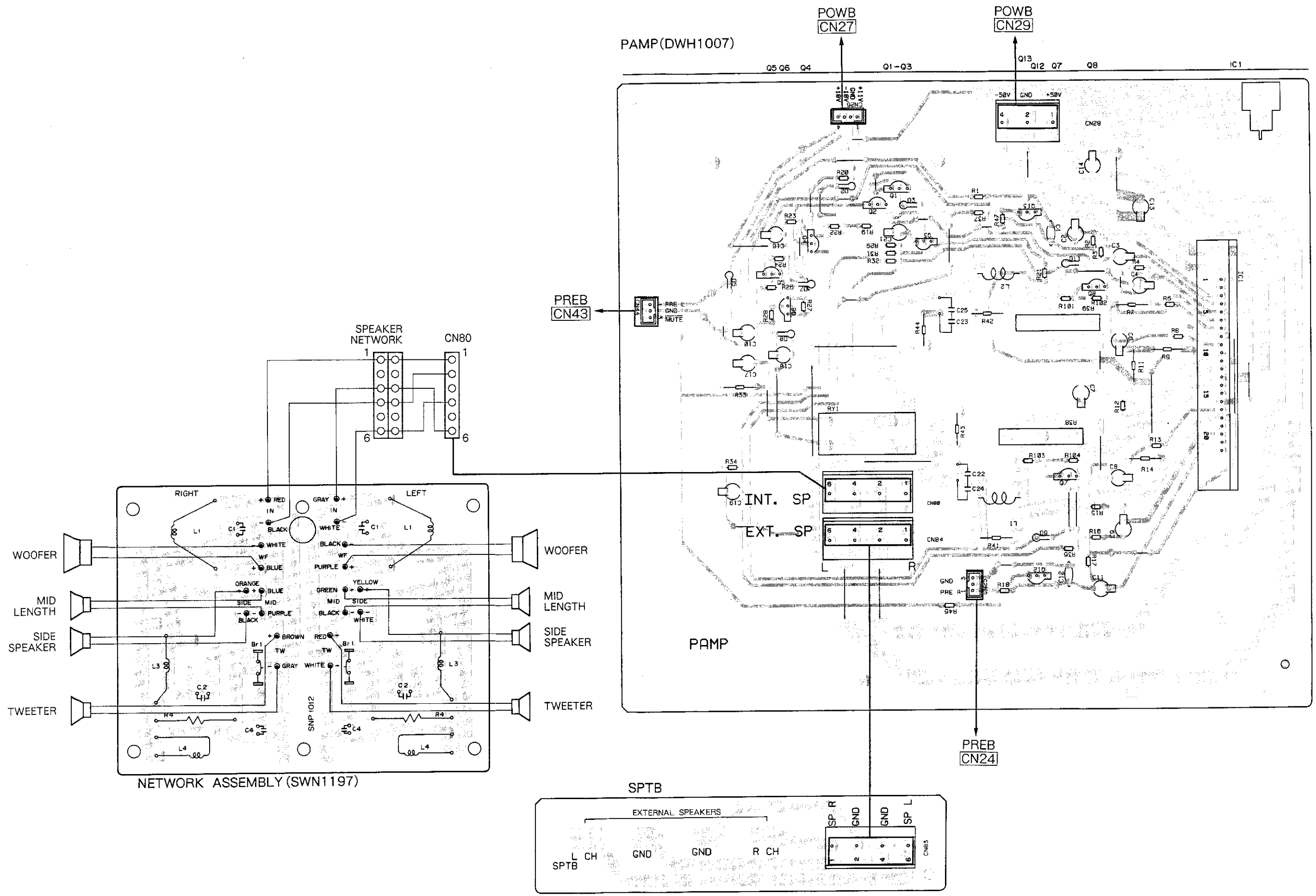

1 2 3 4 5 6



This P.C.B. connection diagram is viewed from the foil side.

A

B

C

D

A

B

C

D

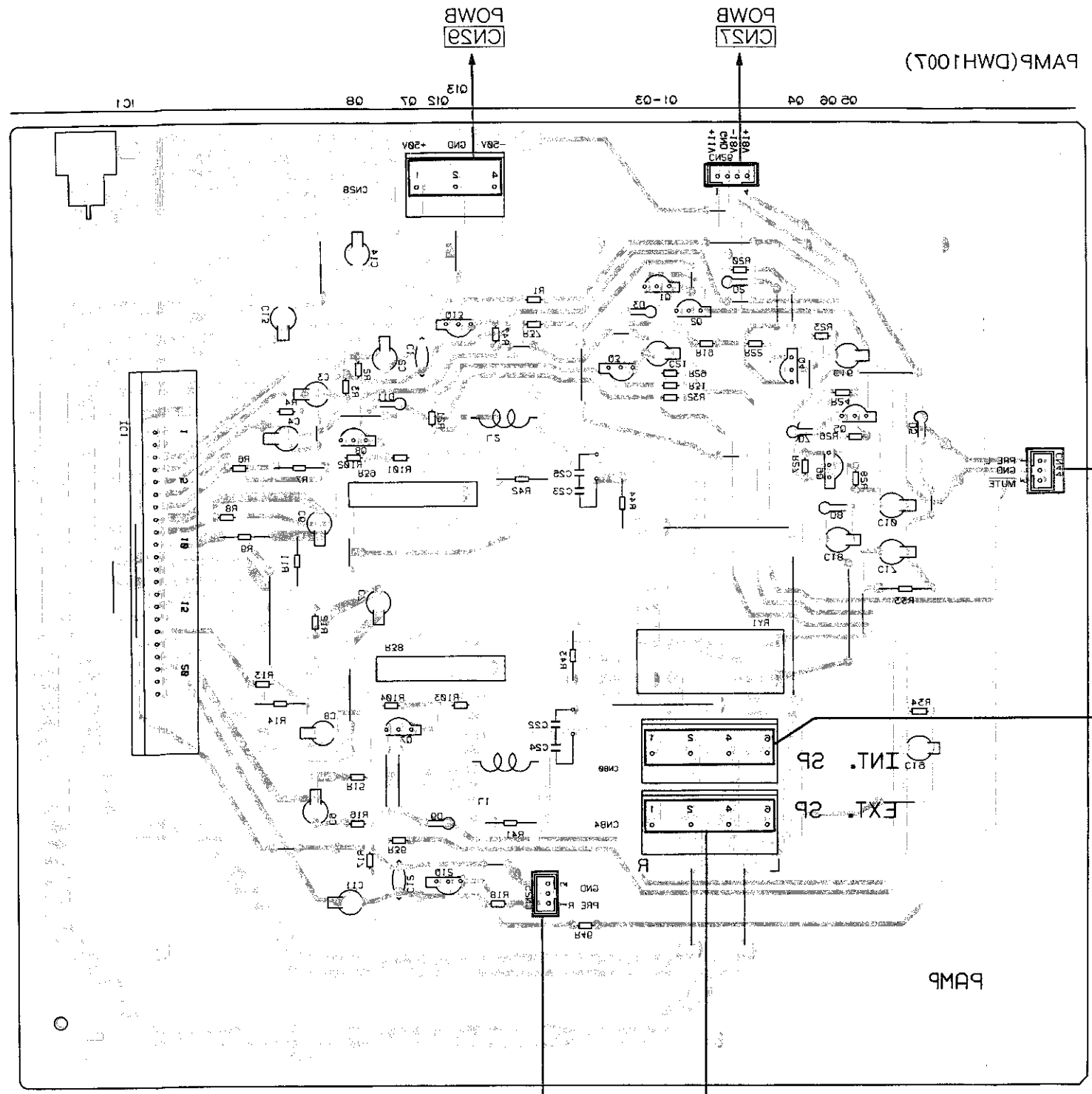

PREB  
CNS3

PREB  
CNS4

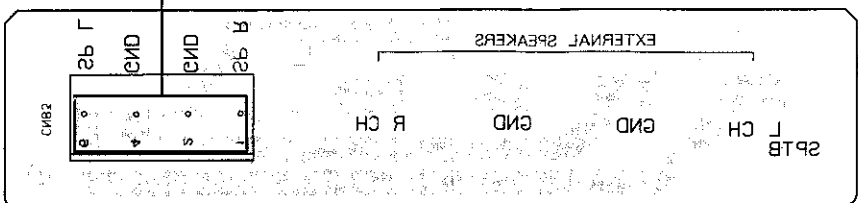

CNS80  
SPEAKER NETWORK

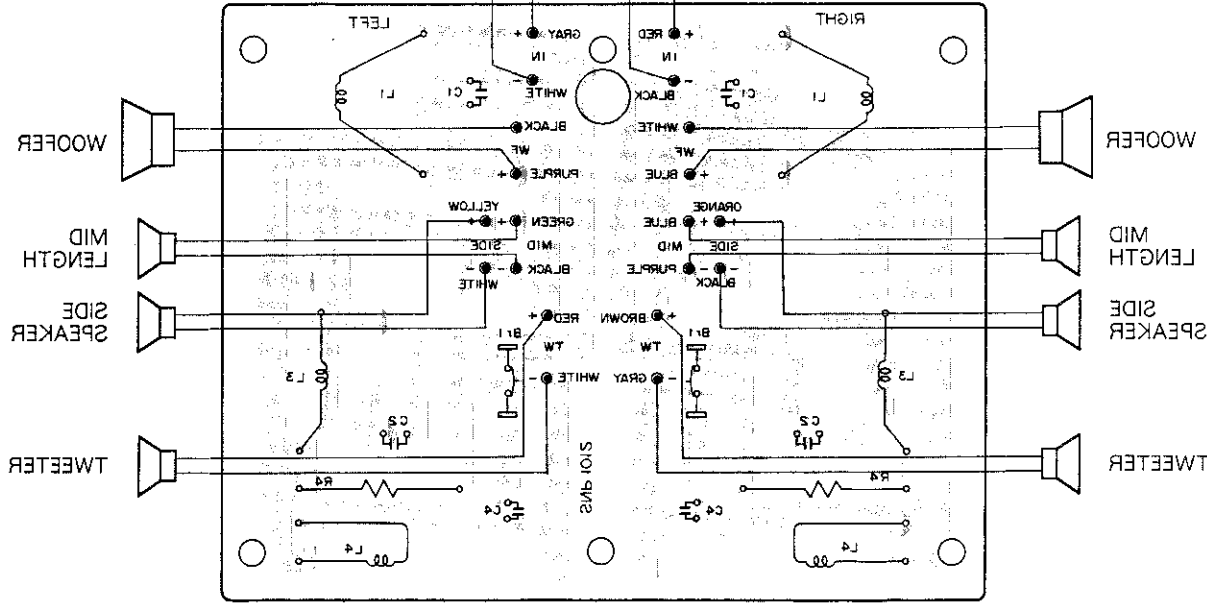

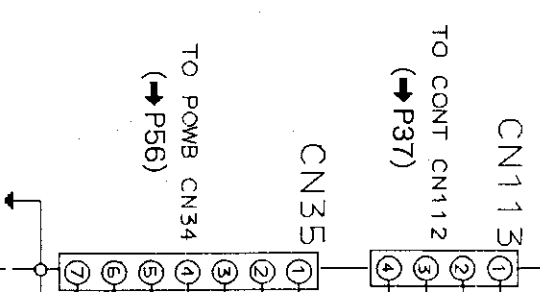
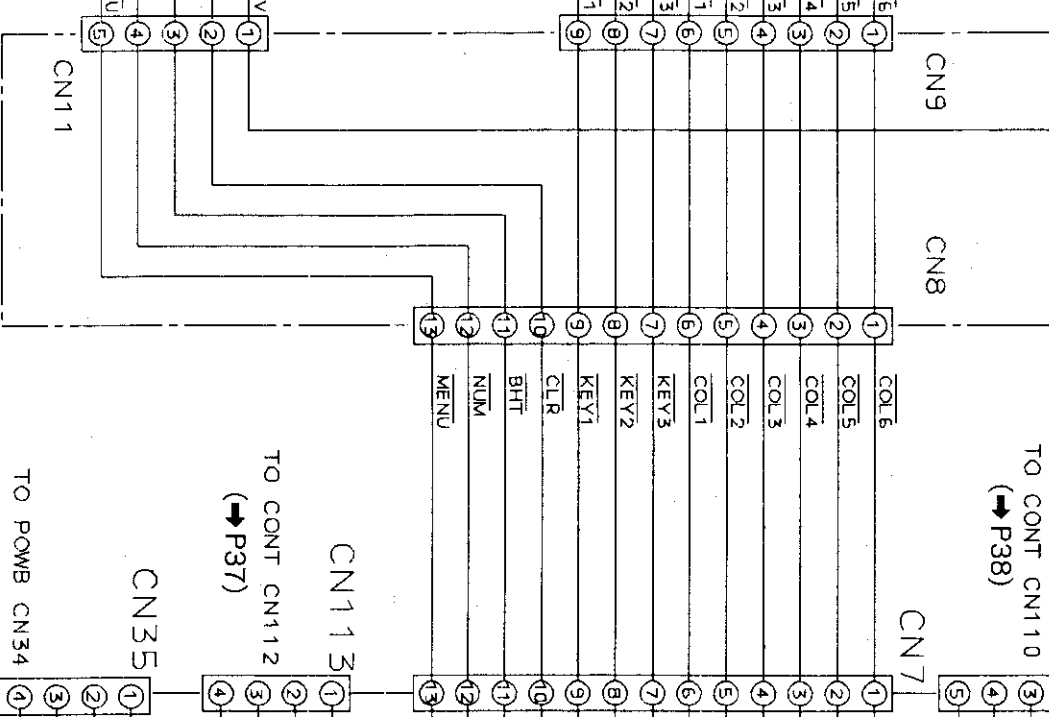
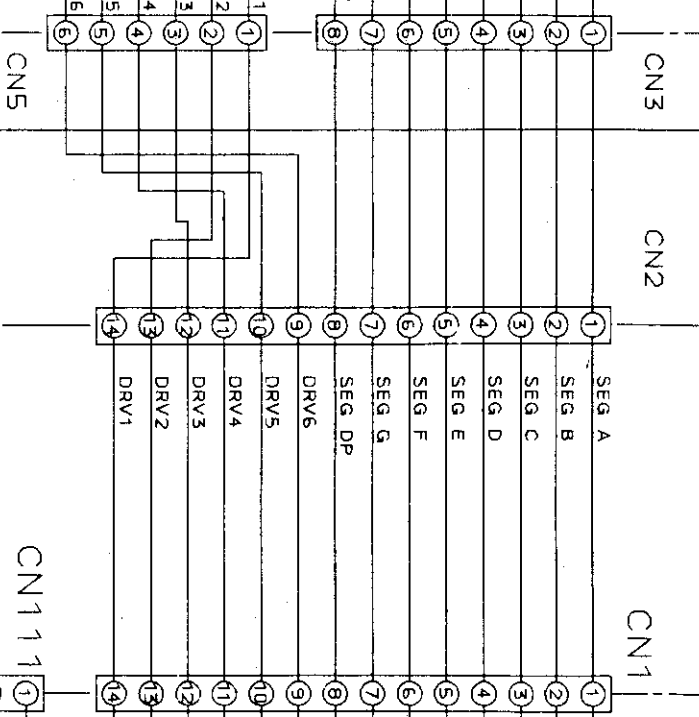
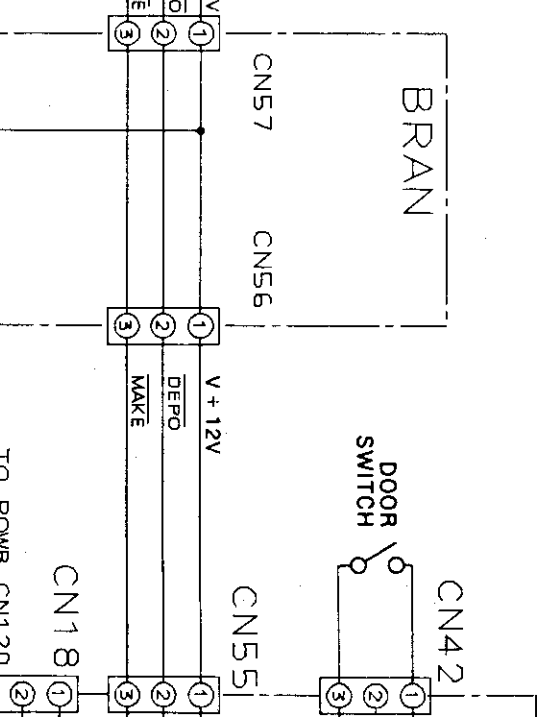
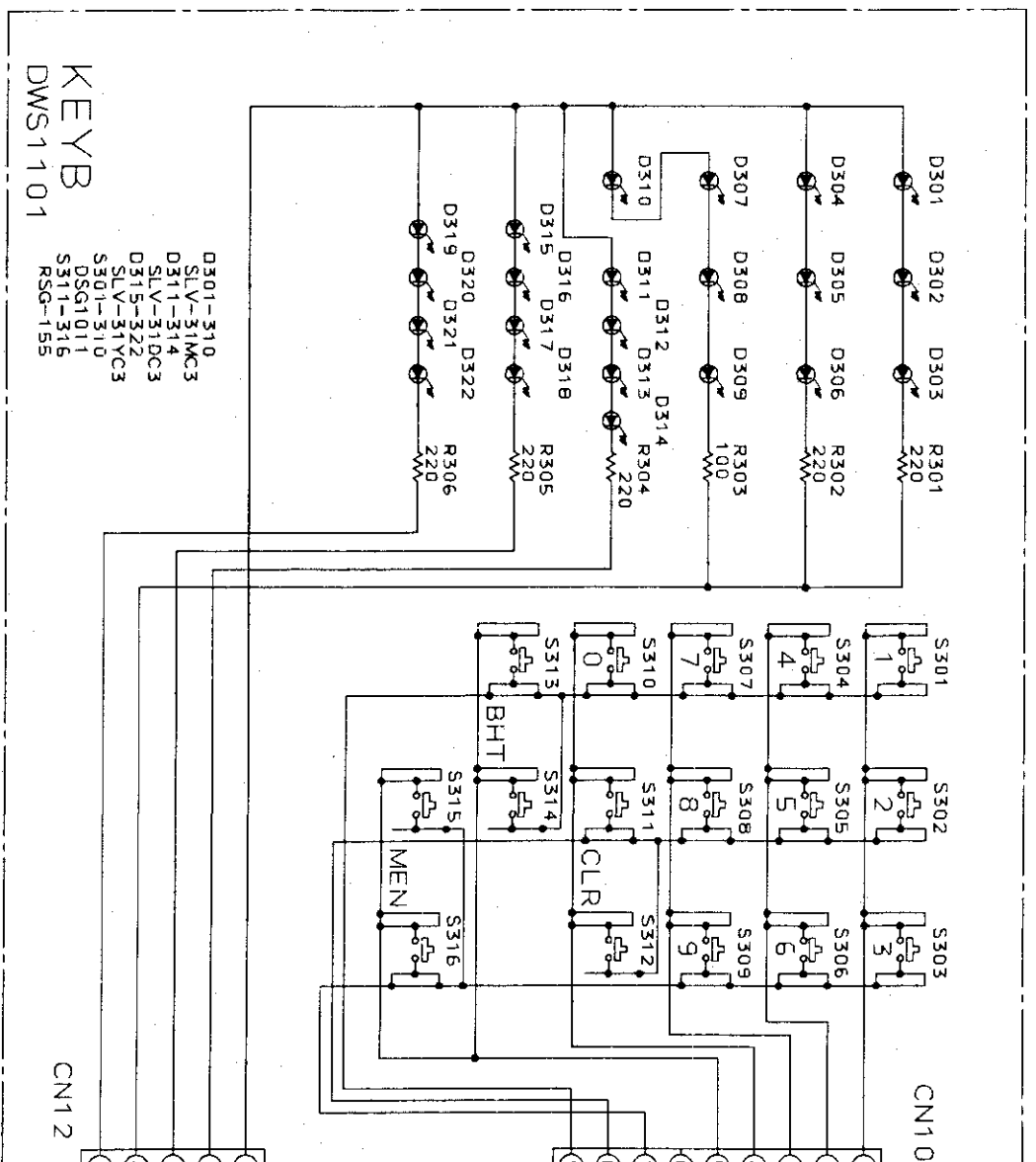
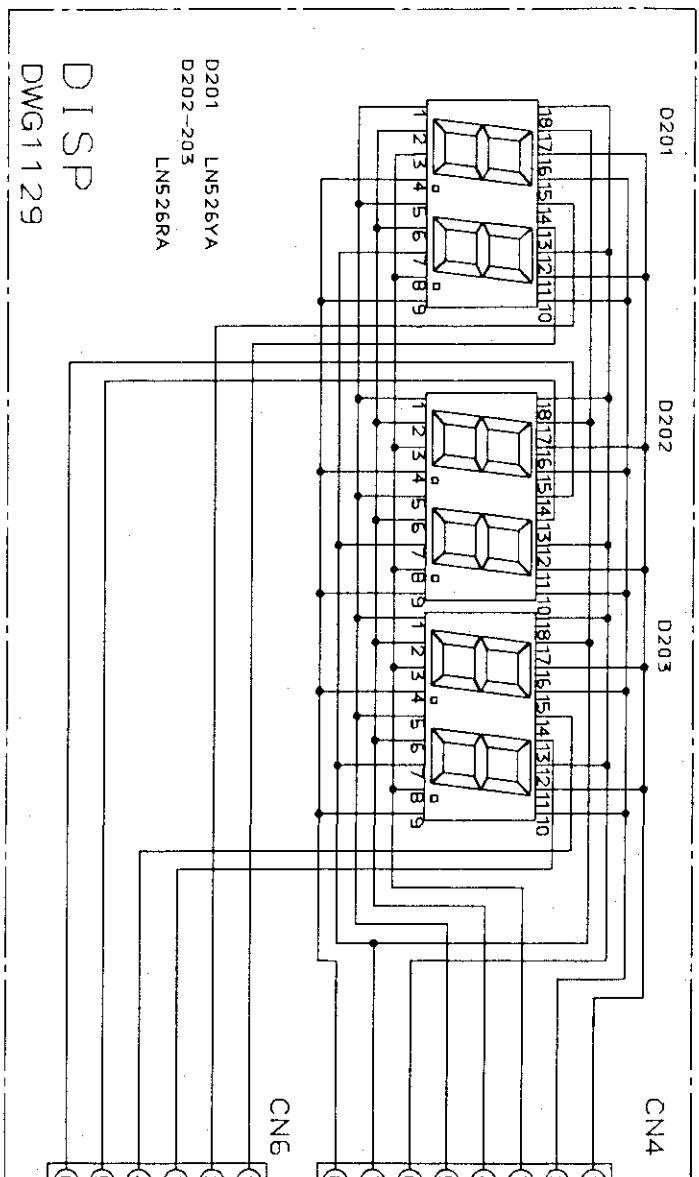
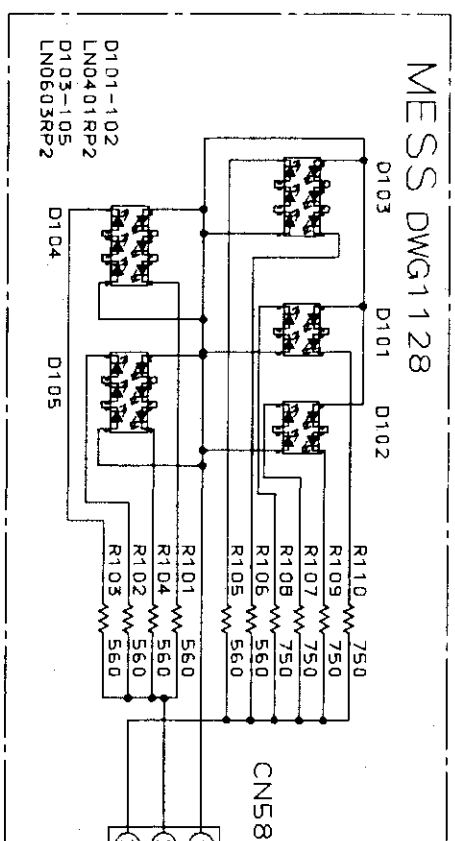



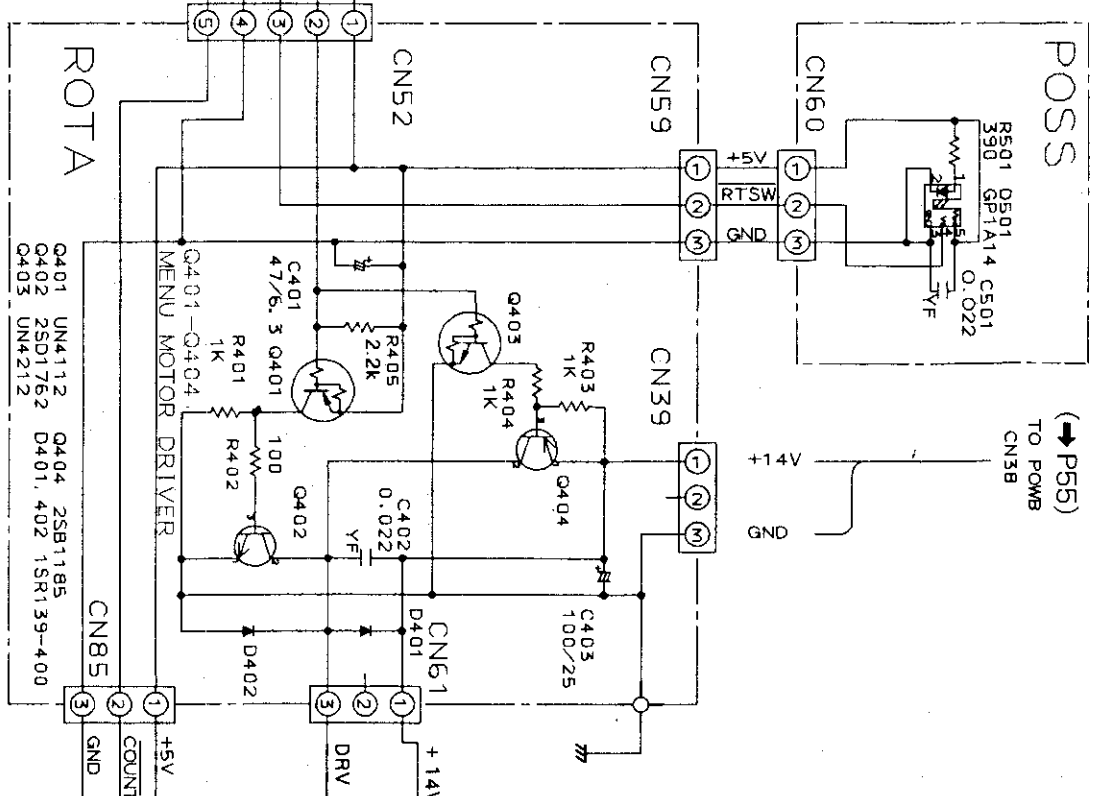
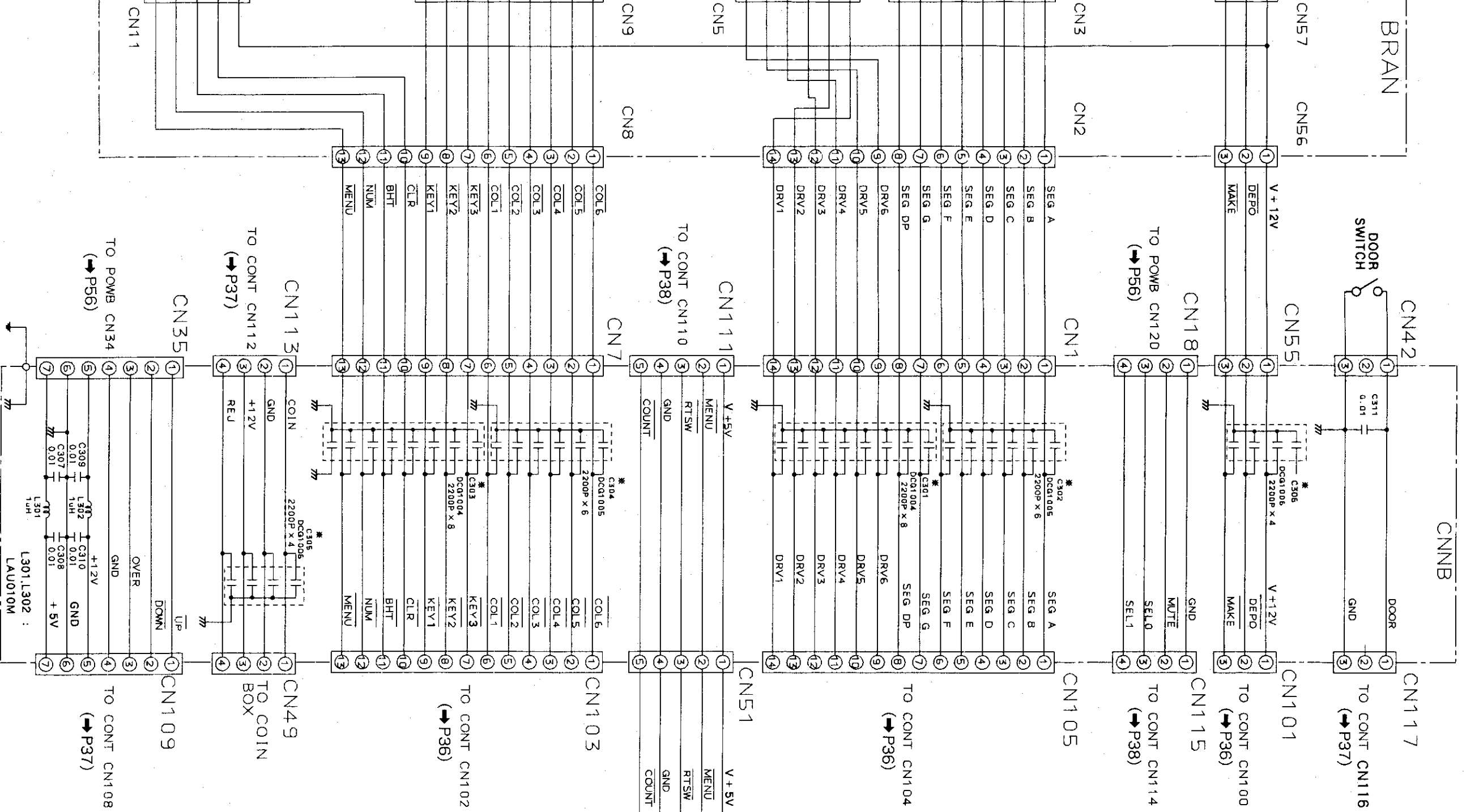

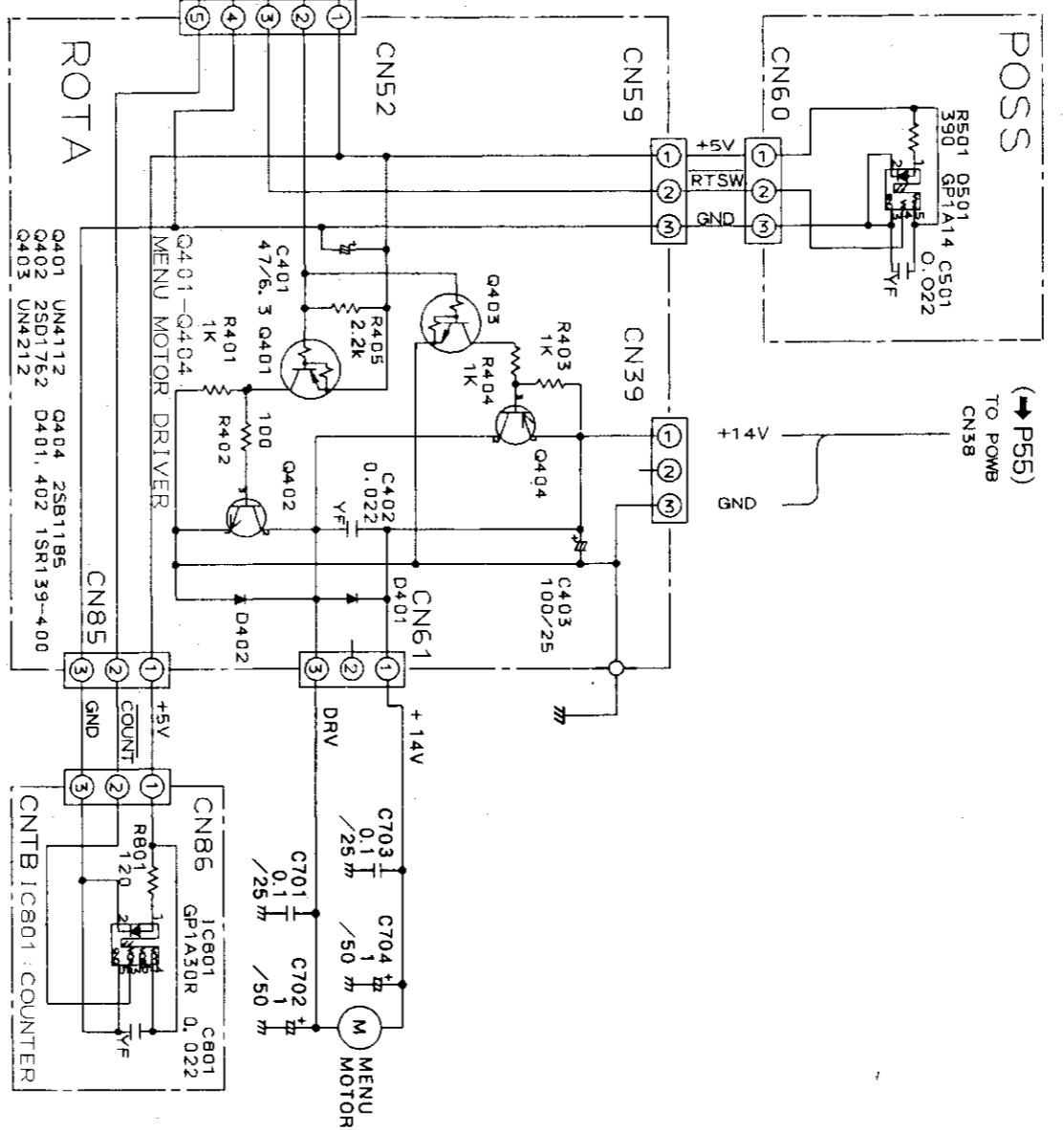
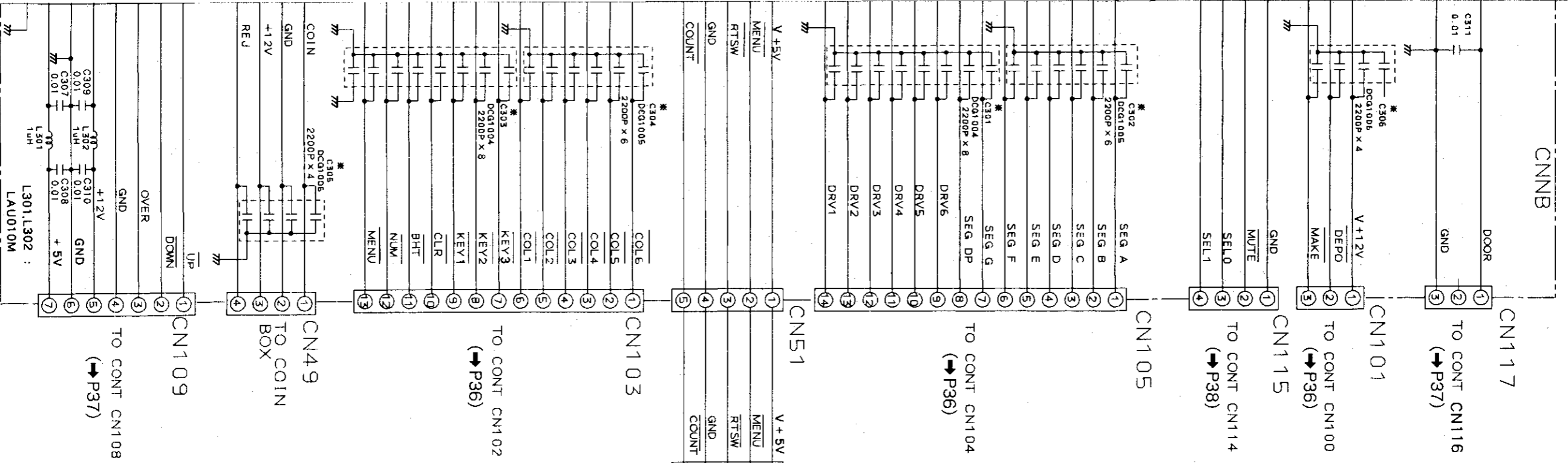

A B C D E F

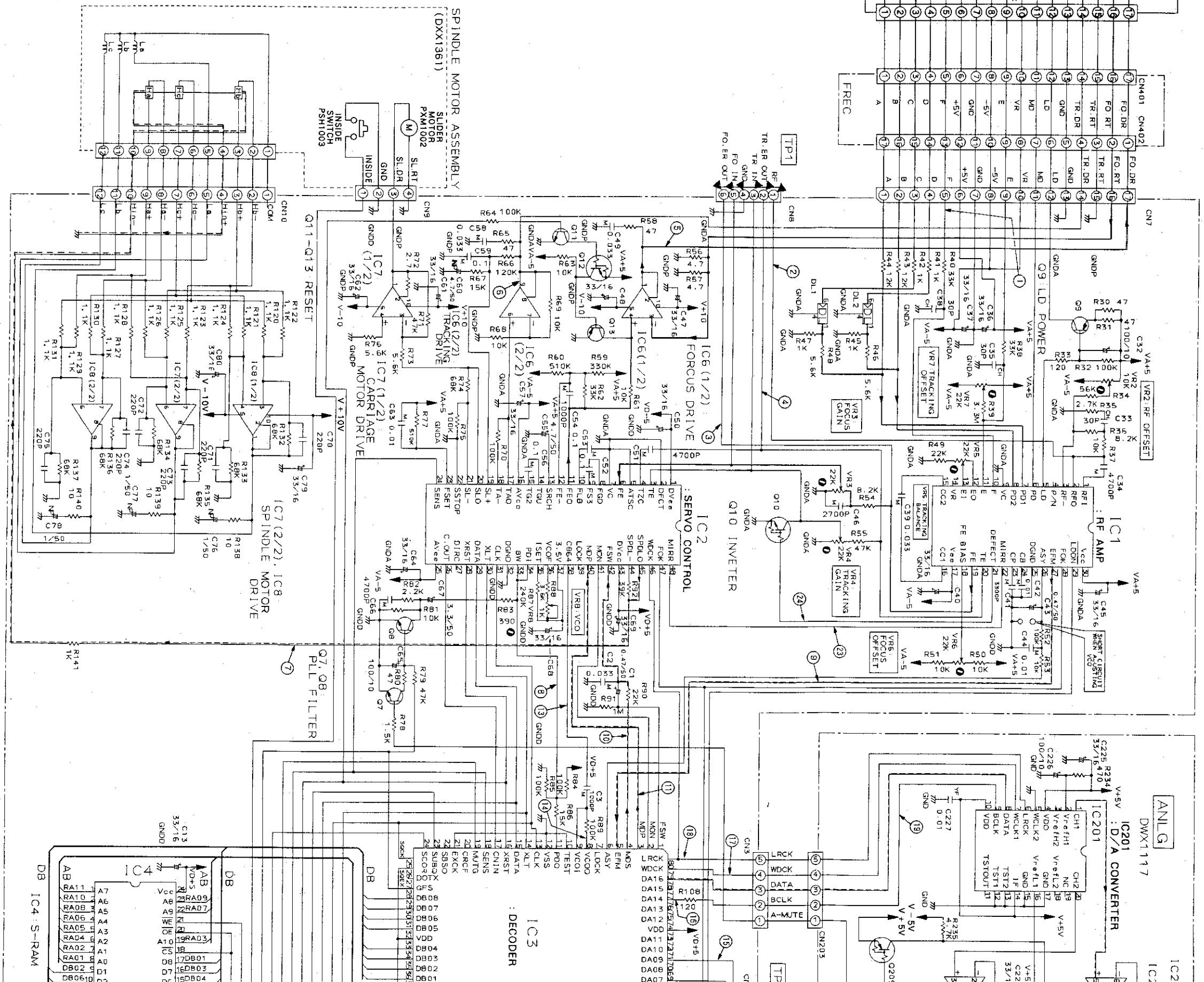
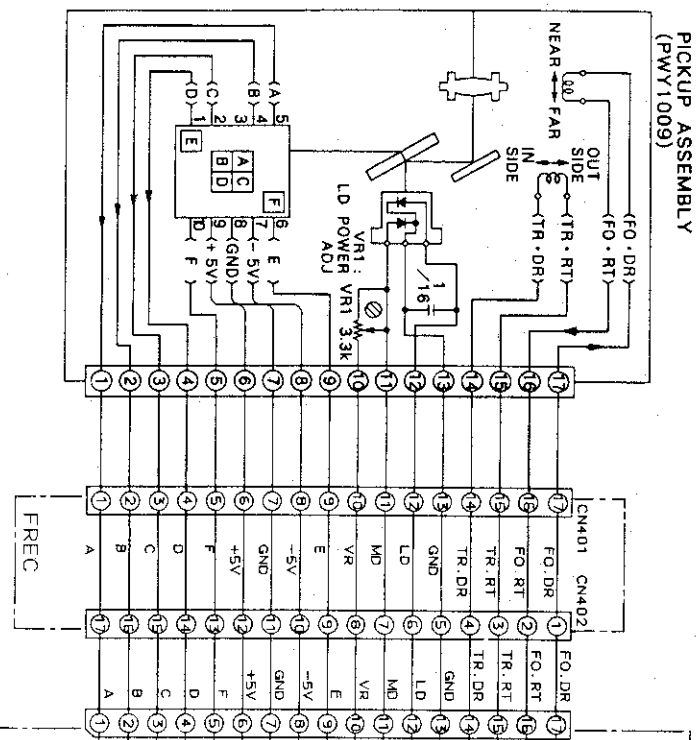

ANLG

IC201	: LCT78B1	Q201 Q202 Q204	: DTIC124ES	D201	: 2W02-5008
IC202	: NJM4558D	Q203 Q209	: DTAI24ES	C201 C202	: RCG-009
IC204	: NJM79L05A	Q205 Q206	: F202	: F204	: VTH1001
IC205	: NJM7805FA	Q207 Q208	: 2SC1740S	L201	: VTL-157

DEGT

IC1	: CXA1081S	Q1 Q3 Q5 Q12 Q14	: DTA124ES	DA-D7	: 1SS254
IC2	: CXA1082AS	Q2 Q4 Q6 Q15	: 2SC2497	VR2	: VRTBVS103
IC3	: CXD1135Q2	Q7 Q8 Q11	: 2SC1740S	VR3 - VR7	: VRTBVS223
IC4	: CXS816PN-12L	Q9	: 2SA1399	VR8	: VRTBVS102
IC5	: TD0068	Q10 Q16	: DTIC124ES	X1	: DSS1010
IC6	: TDU068	Q13	: 2SA933S	X2	: PSS-012
IC7	: IC81C10	Q13	: 2SA933S	DL1 DL2	: PTF1012
IC11	: M1535BL				

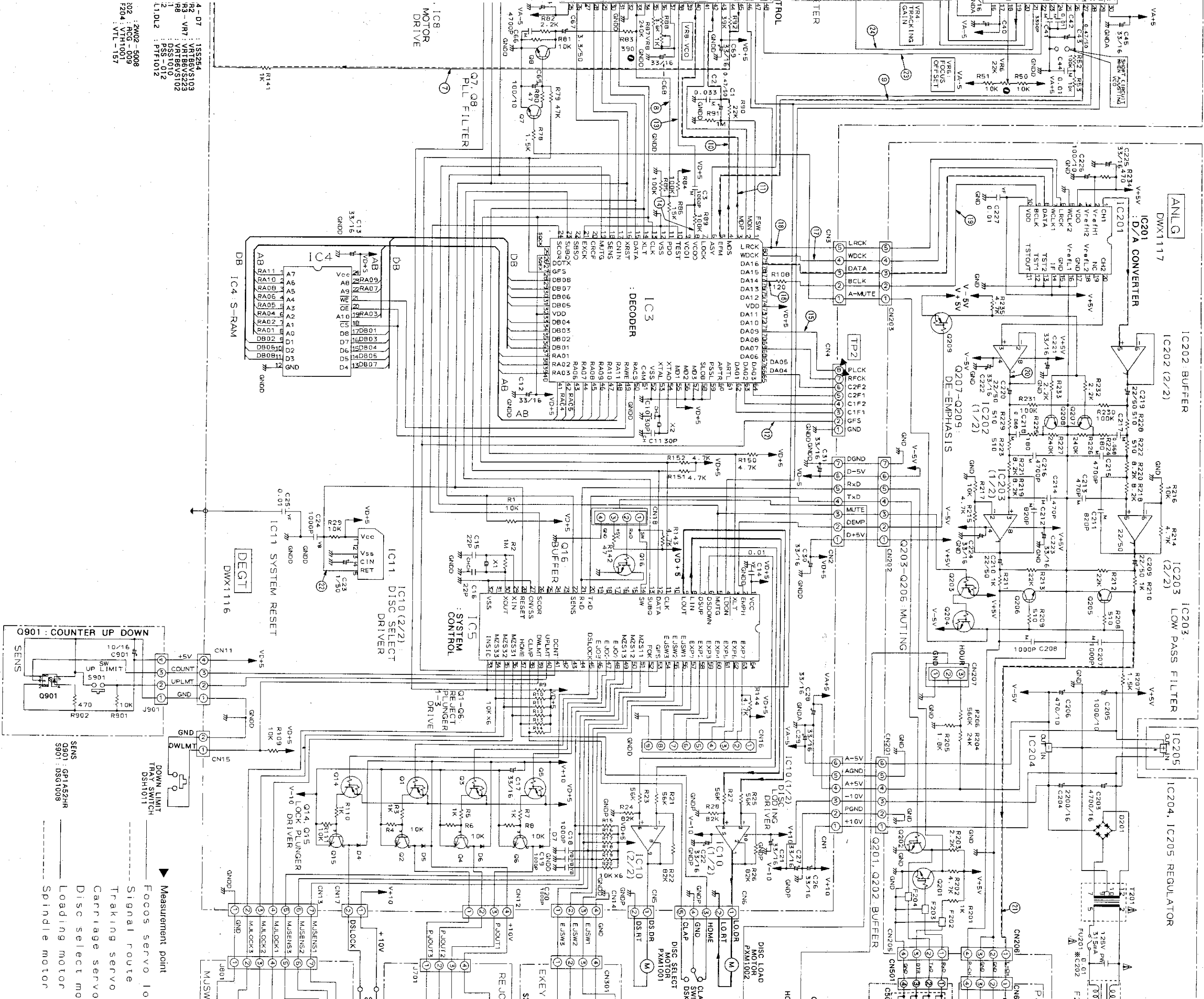

4 - 07 : 1SS254  
 R2 - VRT : VRT86VS103  
 R3 - VRT : VRT86VS223  
 R8 : VRT86VS102  
 DS1010 : DS1010  
 PSS - 012 : PSS-012  
 2 : L1DL2 : PTF1012  
 2A02 - 5008  
 202 : VRT - 009  
 F204 : VRT - 1001  
 VTL - 157

Measurement point  
 Focus servo lo  
 Signal route  
 Tracking servo  
 Carriage servo  
 Disc select mo  
 Loading motor  
 Spindle motor

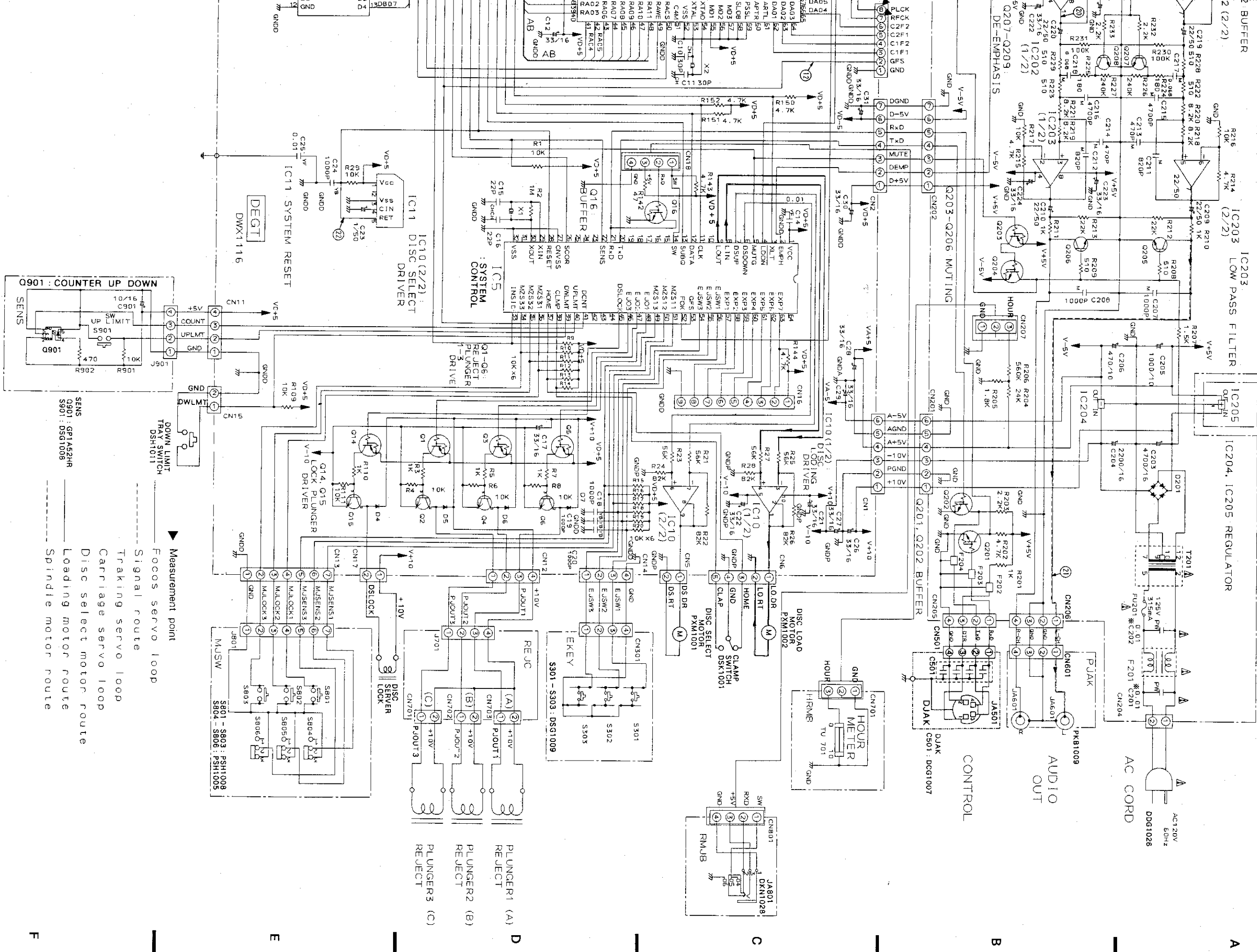

A

B

C

D

E

F

4.1.7 CNIB, KEYB, BRAN, DISP, MESS, POSS, CNTB AND ROTA

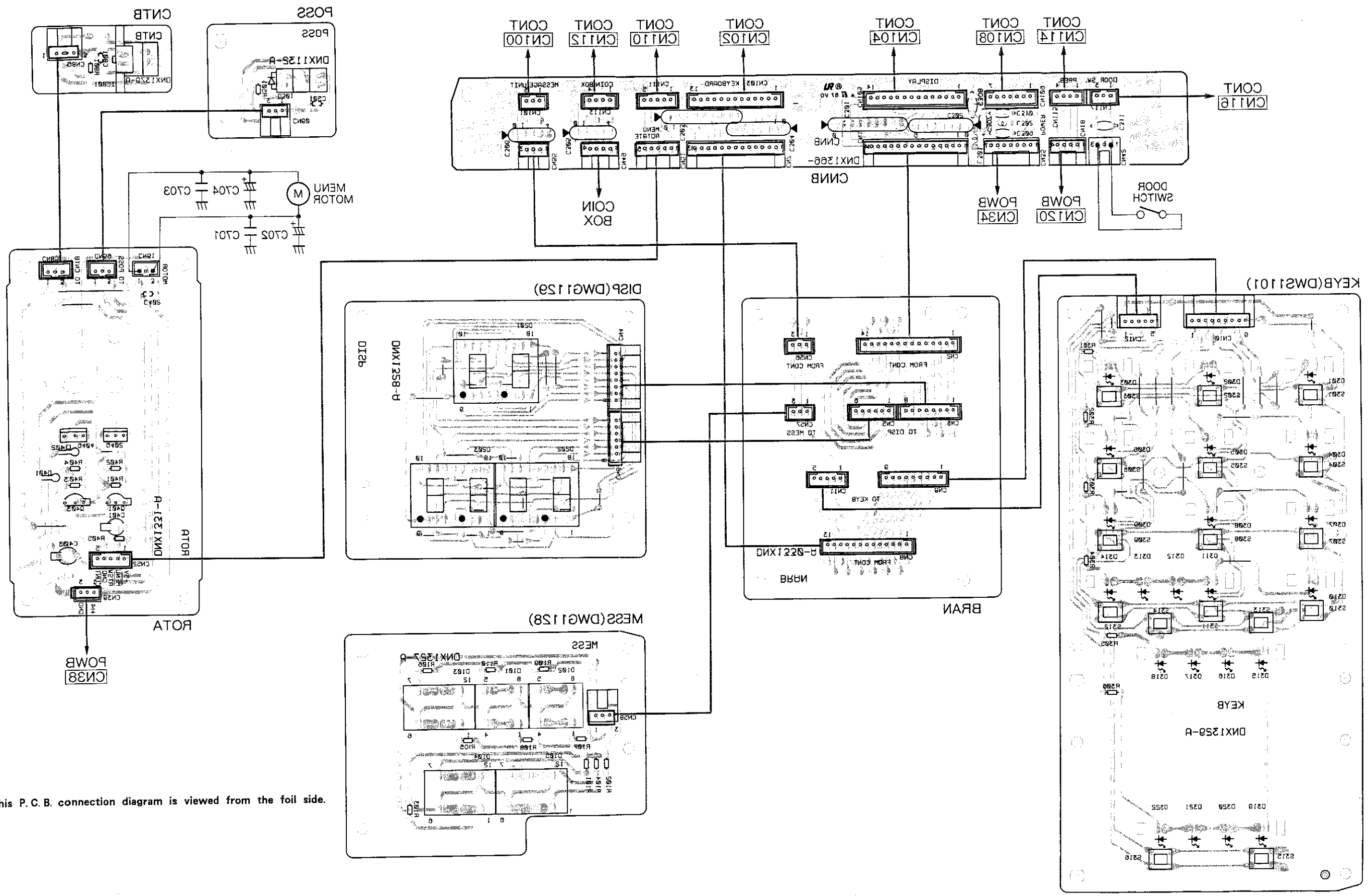

This P.C.B. connection diagram is viewed from the foil side.

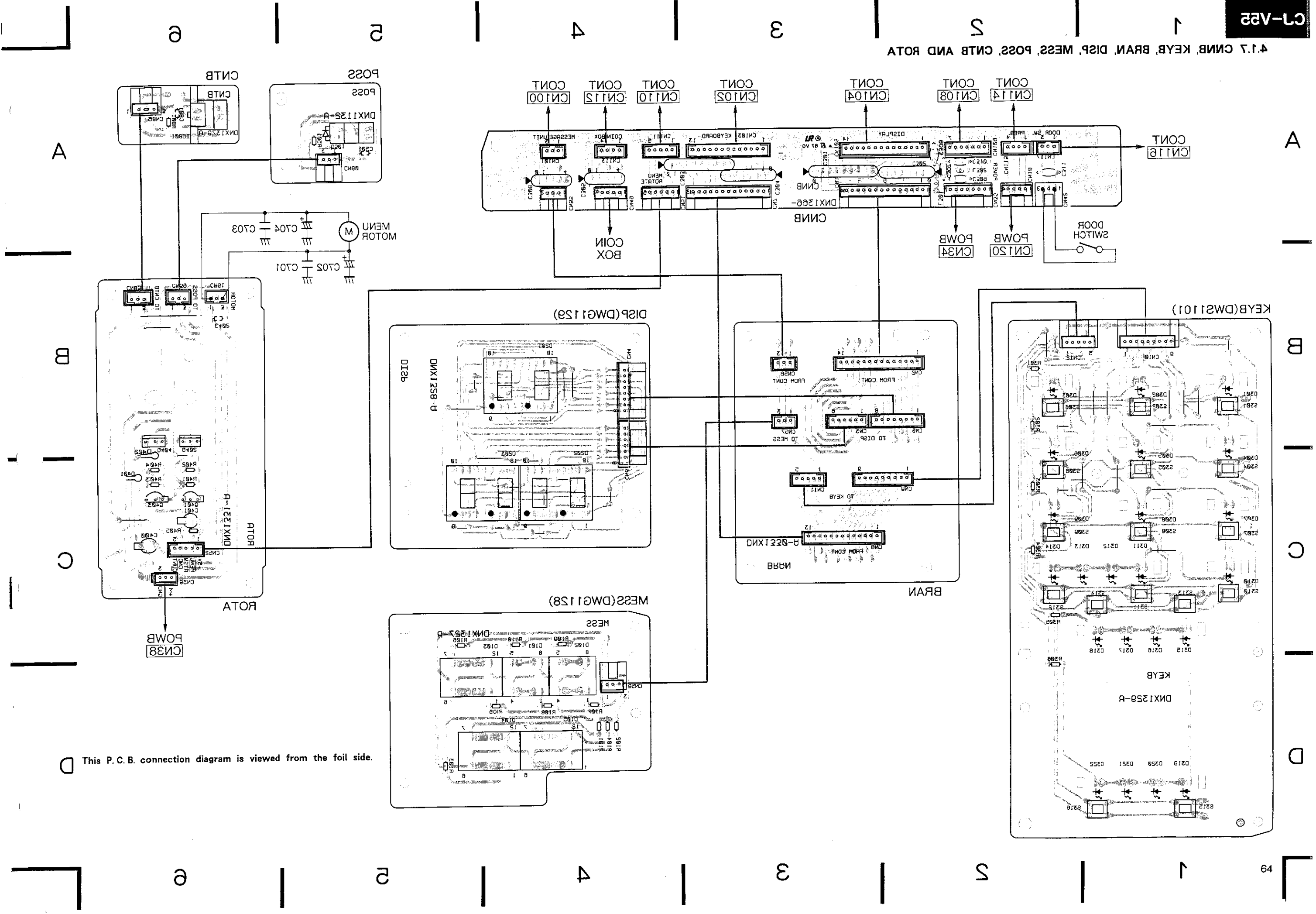

4.1.7 CNNB, KEYB, BRAN, DISP, MESS, POSS, CNTB AND ROTA

A

A

B

B

C

C

D

D

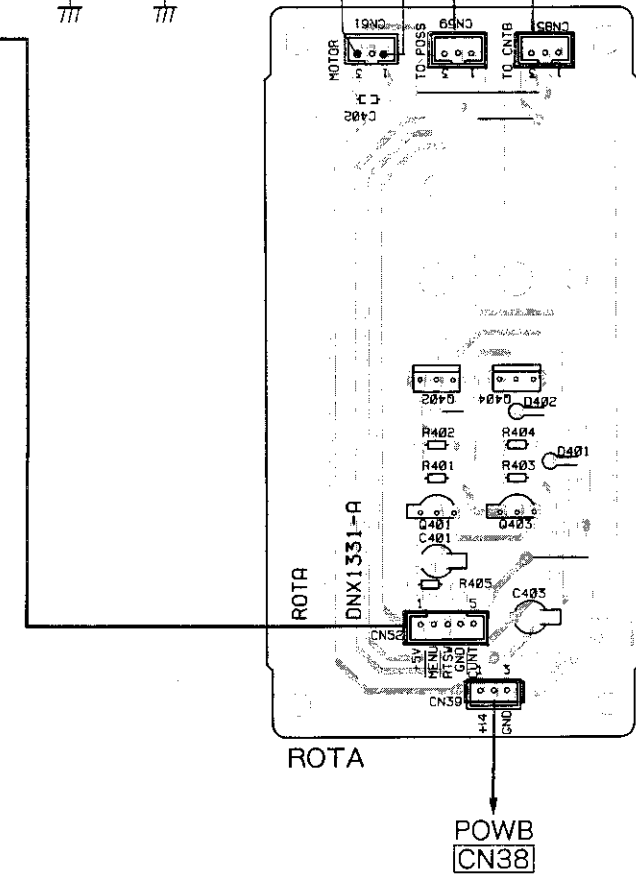
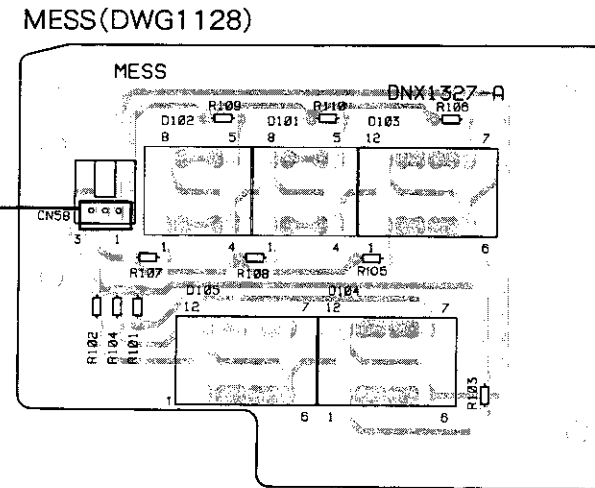
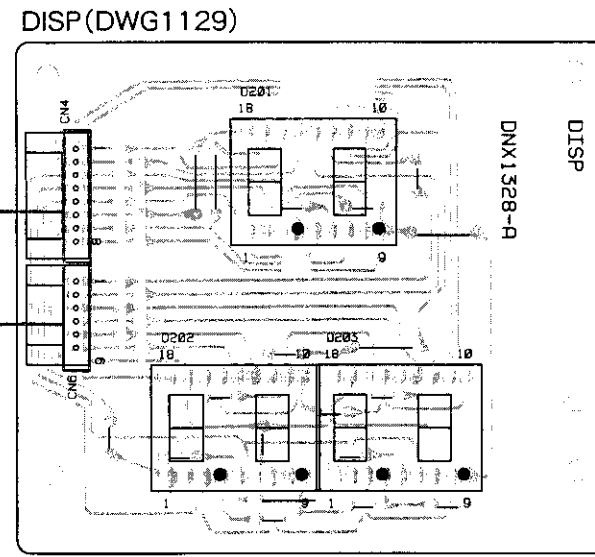
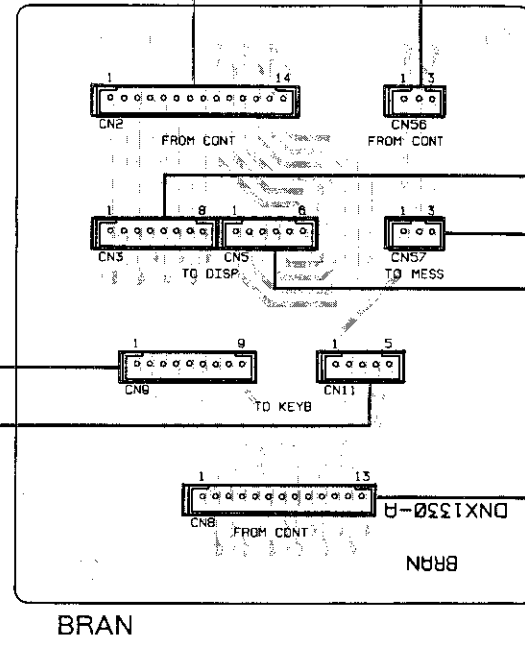
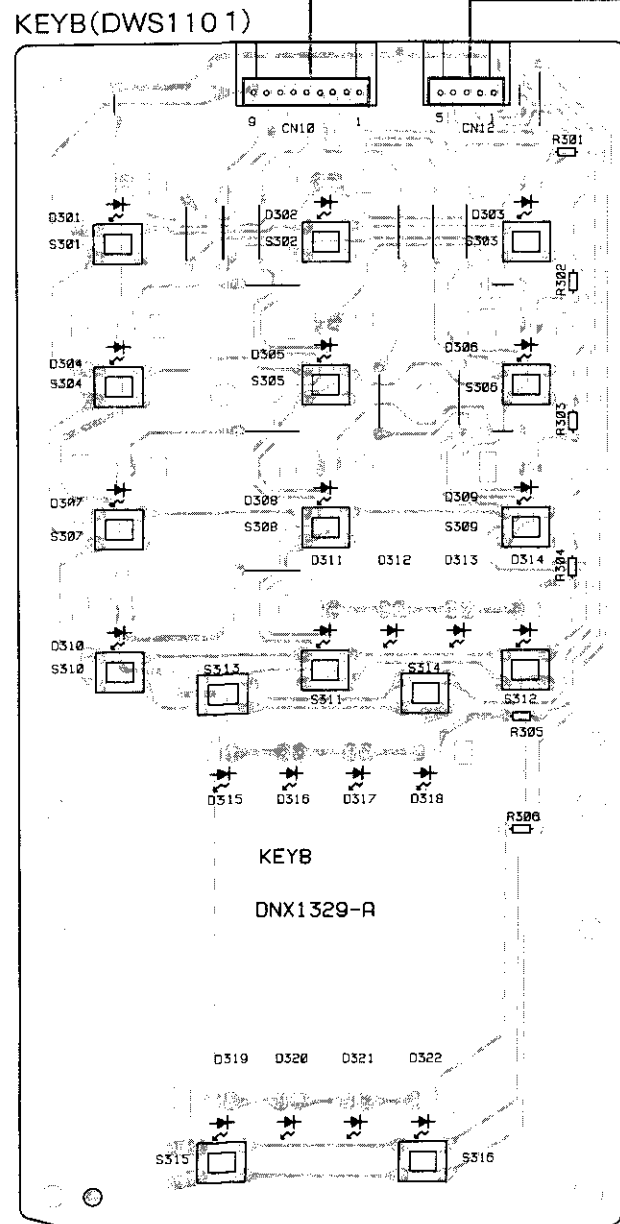
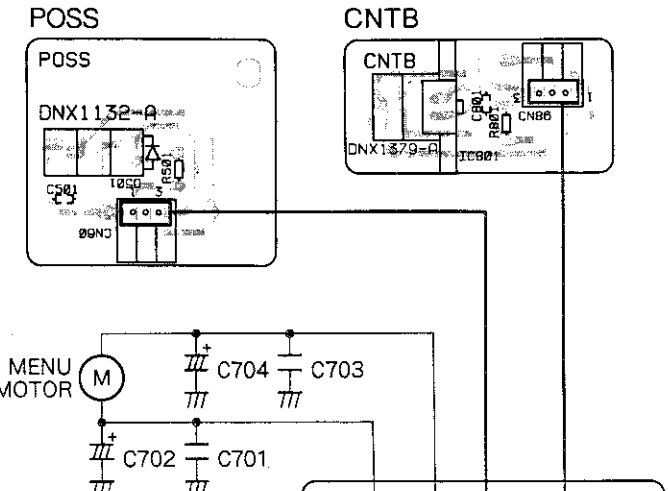
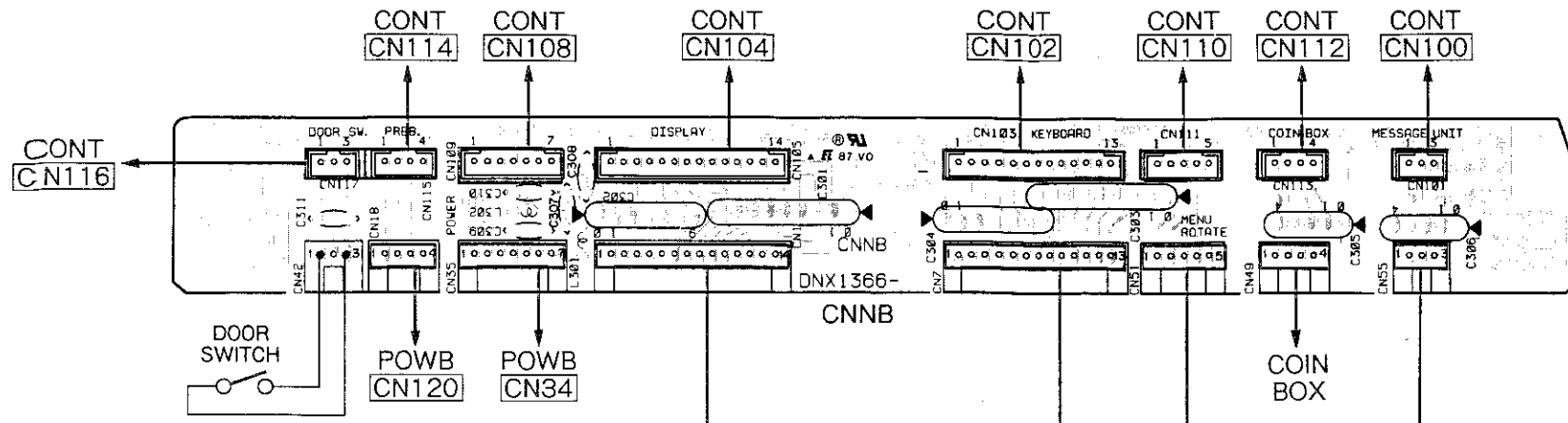

1

2

3

4

5

6

1

2

3

4

5

6

PICKUP ASSEMBLY (PWY1009)

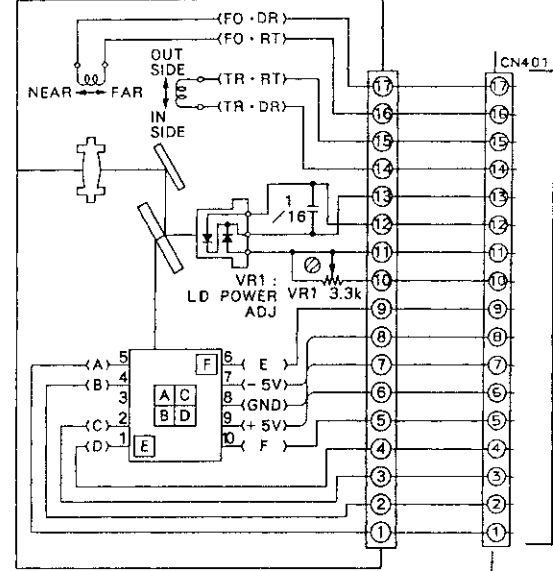

FREC

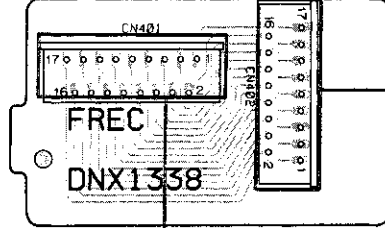

DEGT (DWX1116)

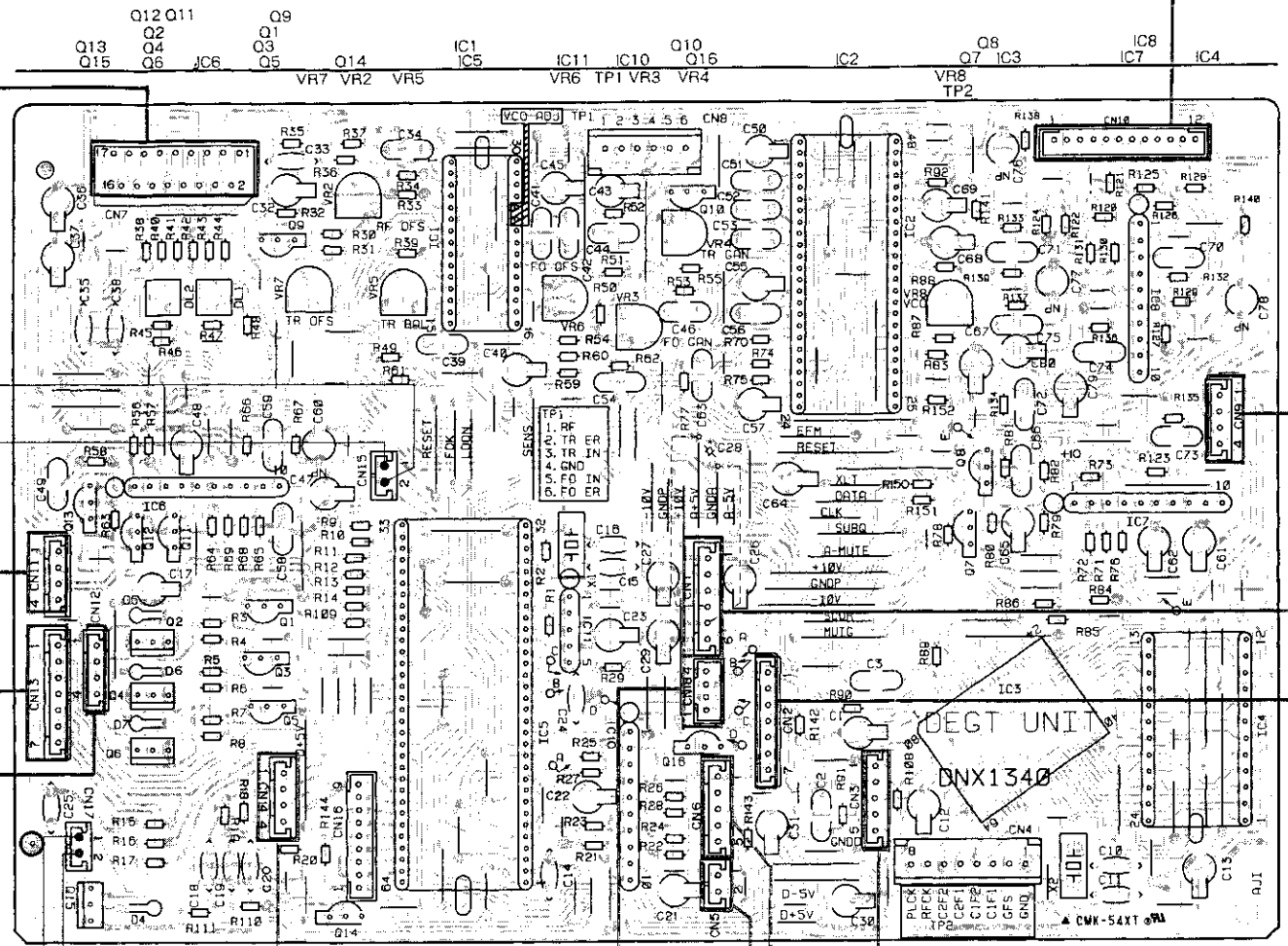

SENS

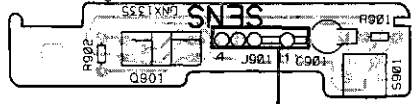

DOWN LIMIT TRAY SWITCH

DISC SERVER LOCK

DEGT UNIT  
DNX1340

A

B

MJSW

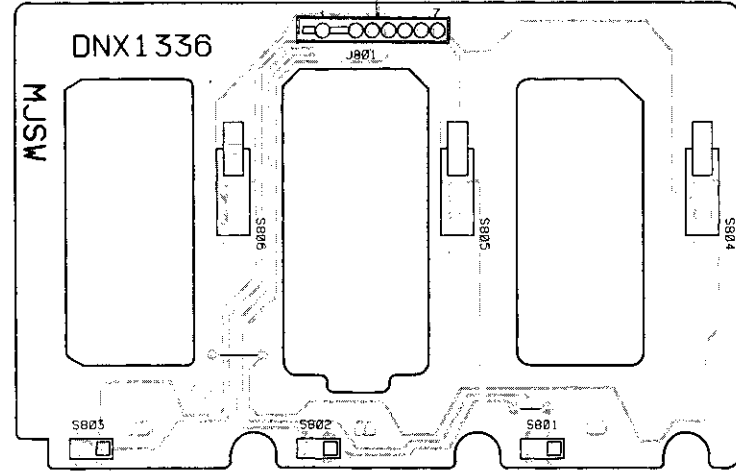

REJC

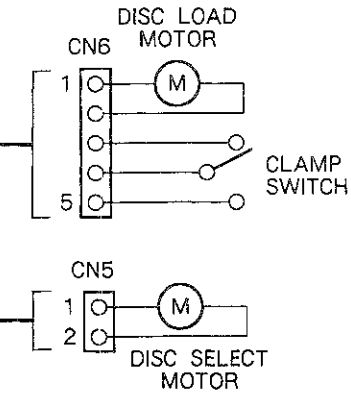
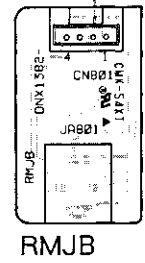
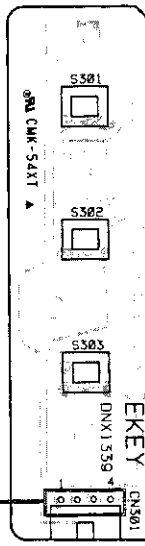
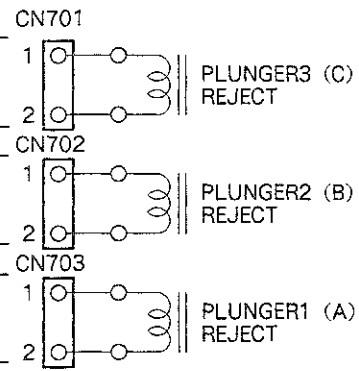
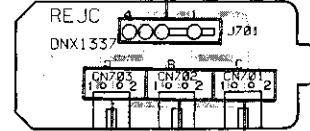

CLAMP SWITCH

C

D

PJAK

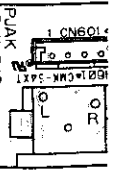

AUDIO OUT

1

2

3

4

5

6



4

5

6

7

8

9

DEGT (DWX1116)

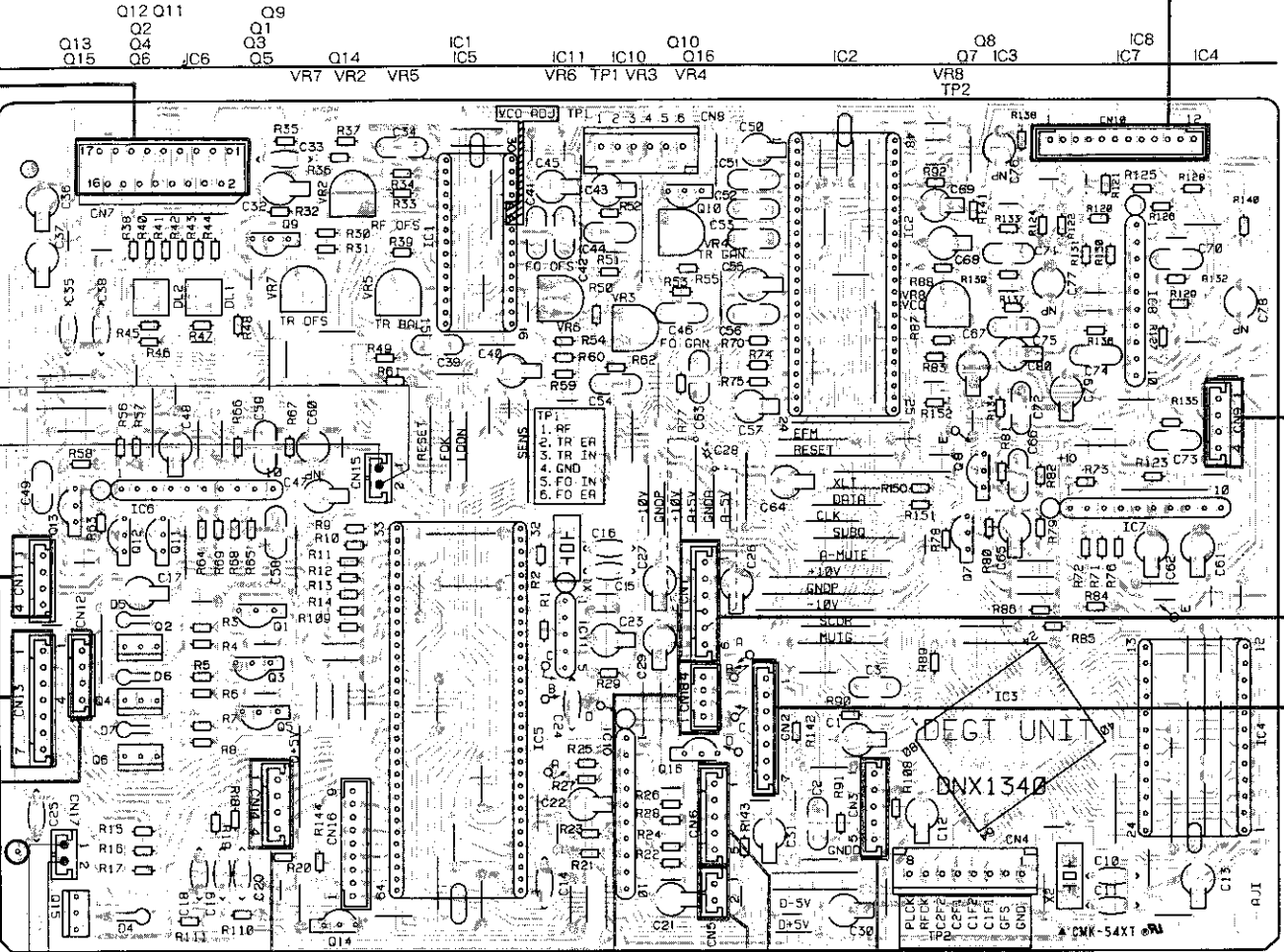

SPINDLE MOTOR ASSEMBLY (DXX1361)

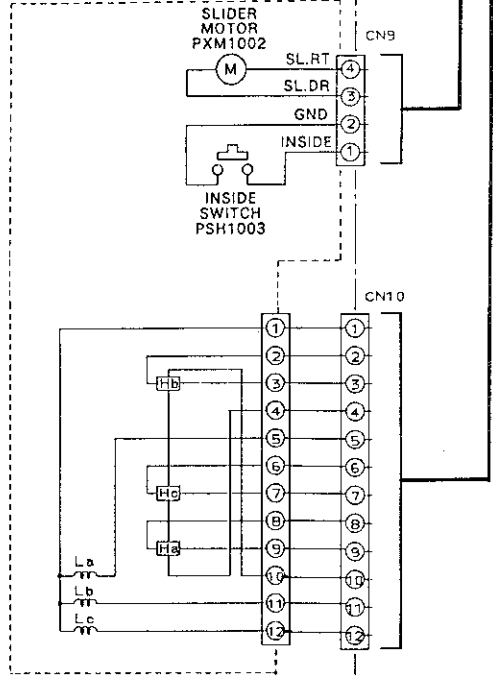

ANLG (DWX1117)

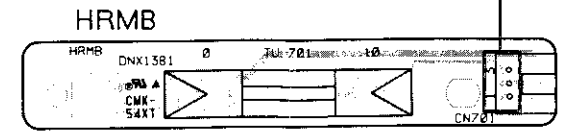
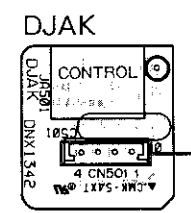
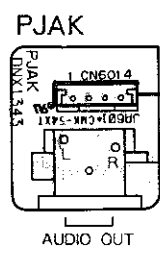
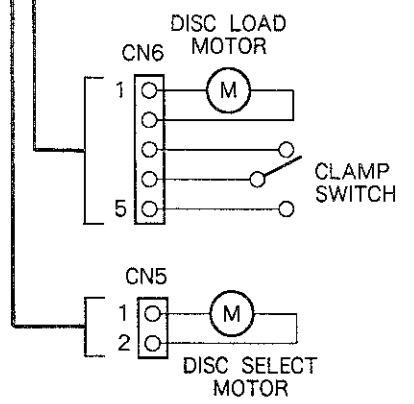
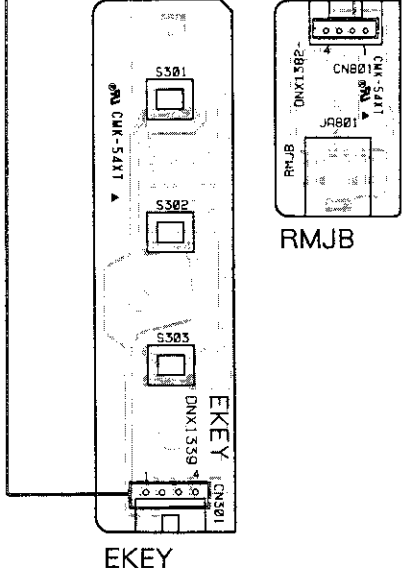
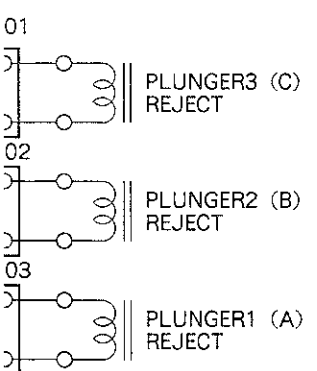
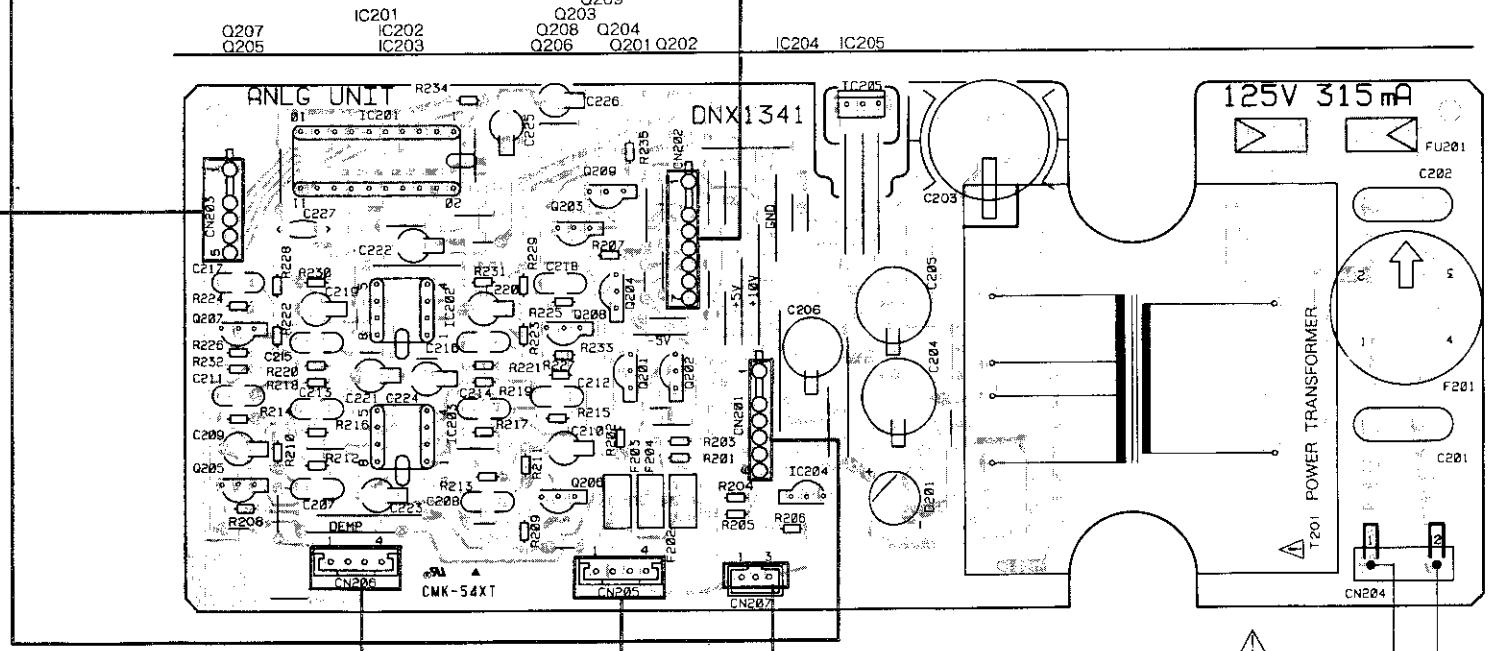

4

5

6

7

8

9

A

B

C

D

A

This P.C.B. connection diagram is viewed from the foil side.

B

C

D

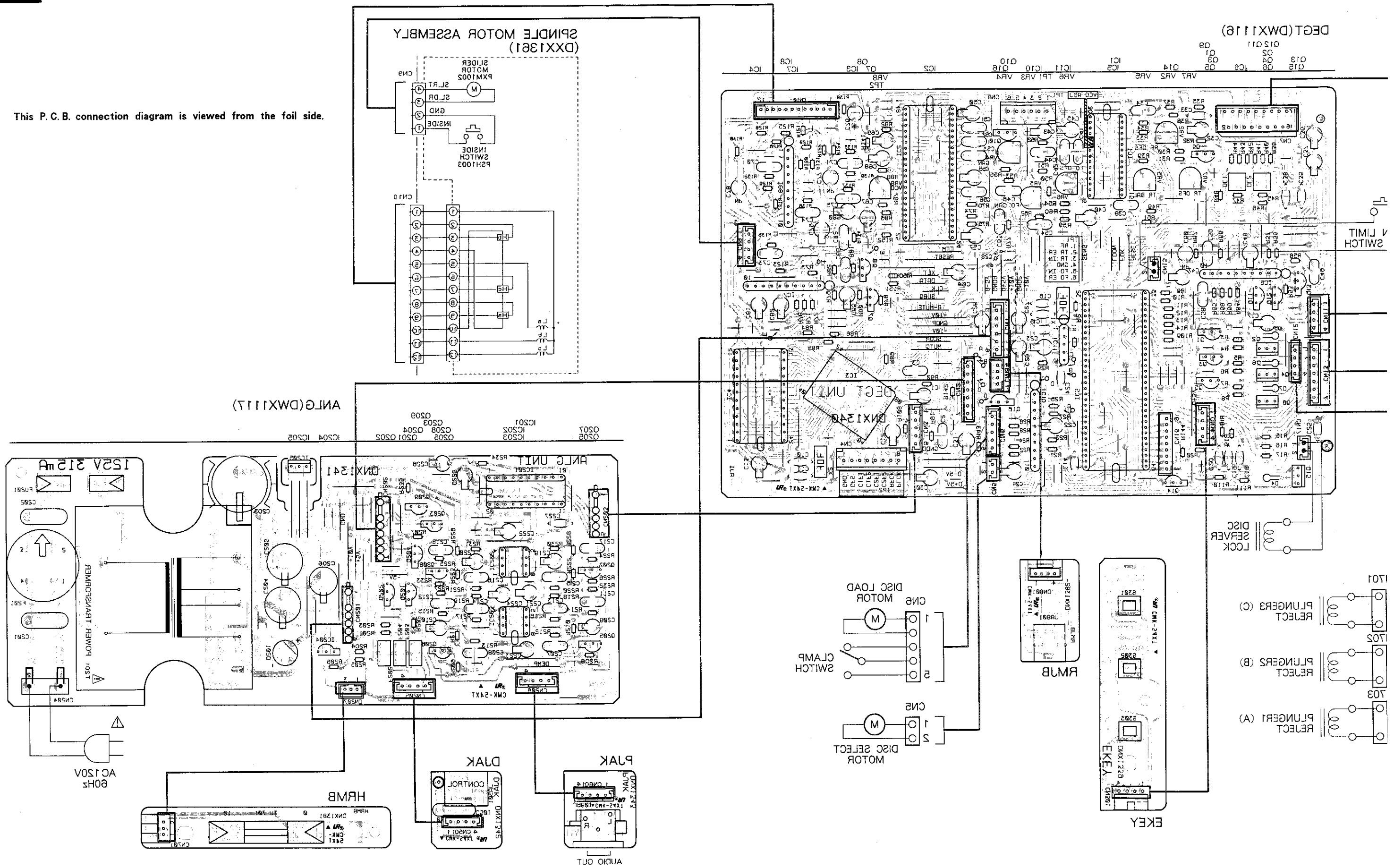

76

9

8

7

6

5

4

3

2

1

A

B

C

D

PICKUP ASSEMBLY(PWY1009)

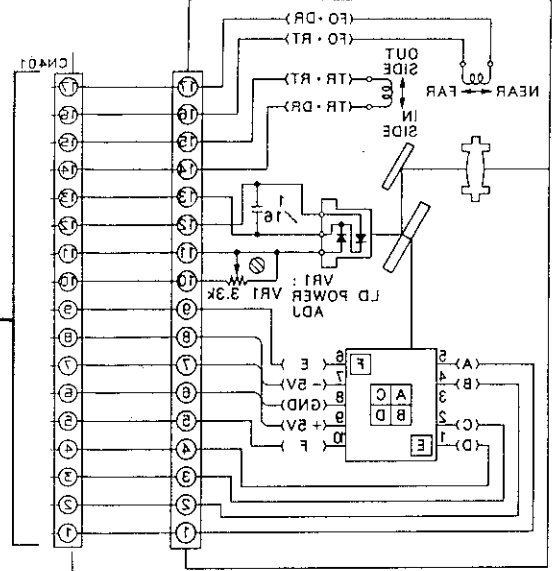

FREC

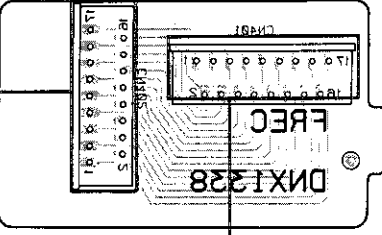

SENS

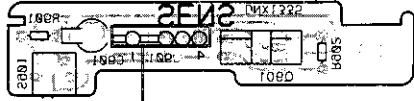

TRAY SWITCH  
DOWN LIMIT

REJC

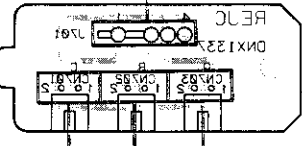

M72W

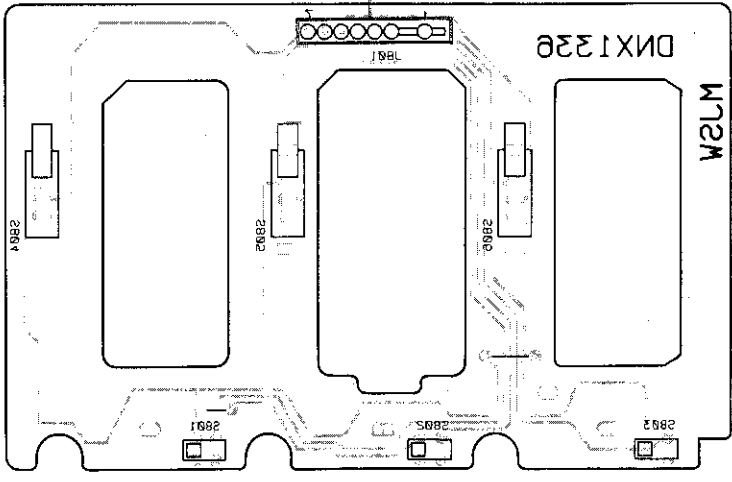

LOCK  
SERVER

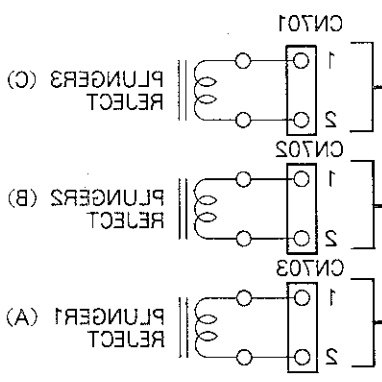

EKEY

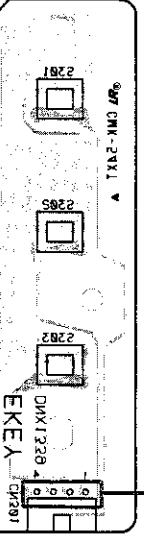

RM7B

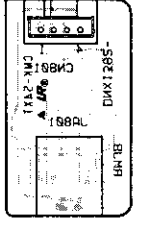

DISC SELECT  
MOTOR

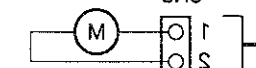

CLAMP  
SWITCH

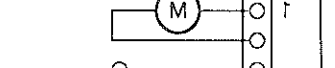

DISC LOAD  
MOTOR



DEGT(DWX116)

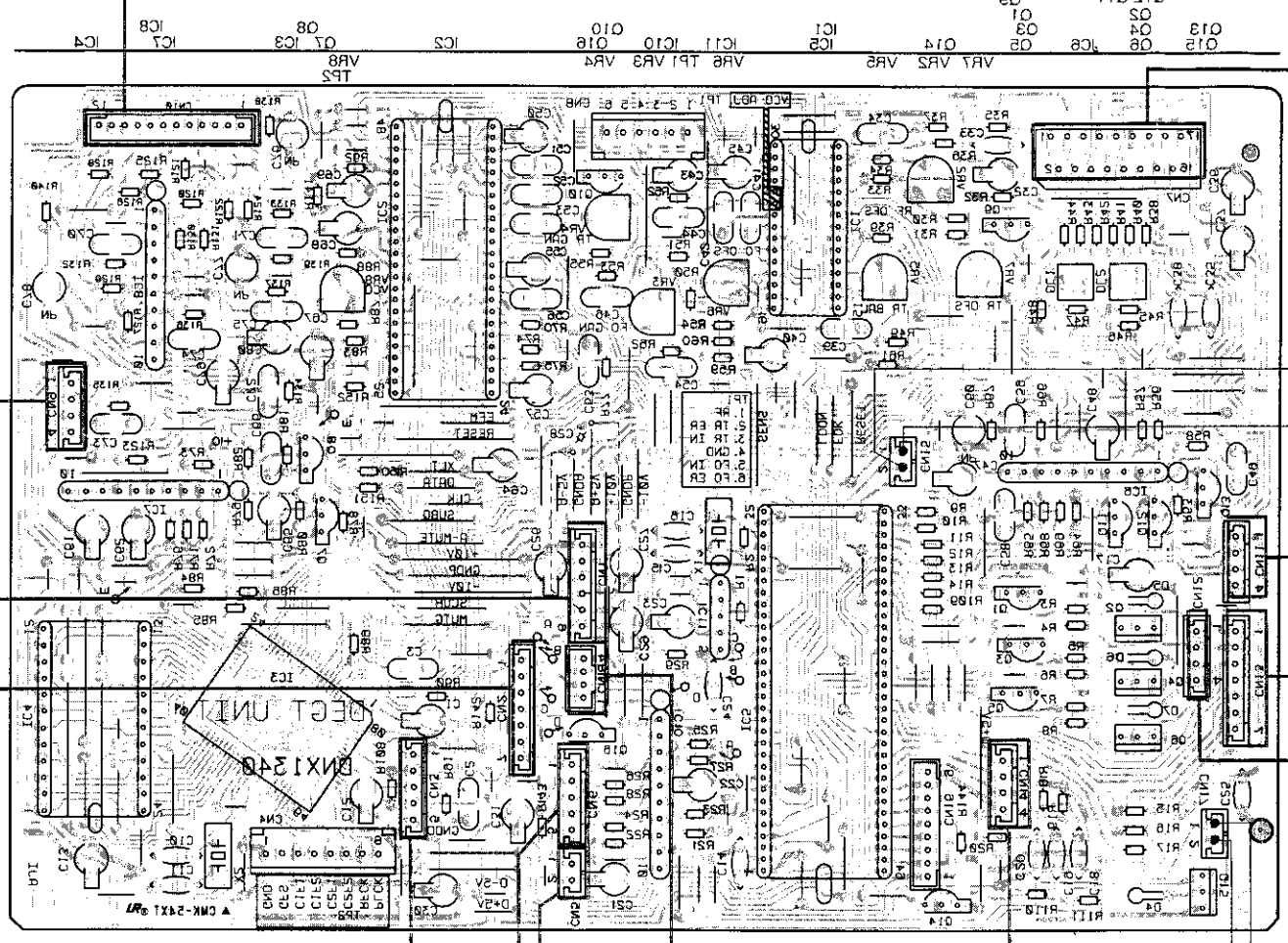

6

5

4

3

2

1

6

5

4

3

2

1

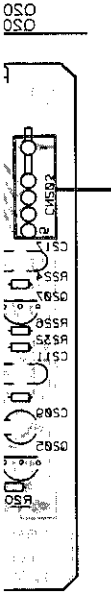

Wave Forms

NOTE: The encircled numbers denote measuring points in the schematic diagram.

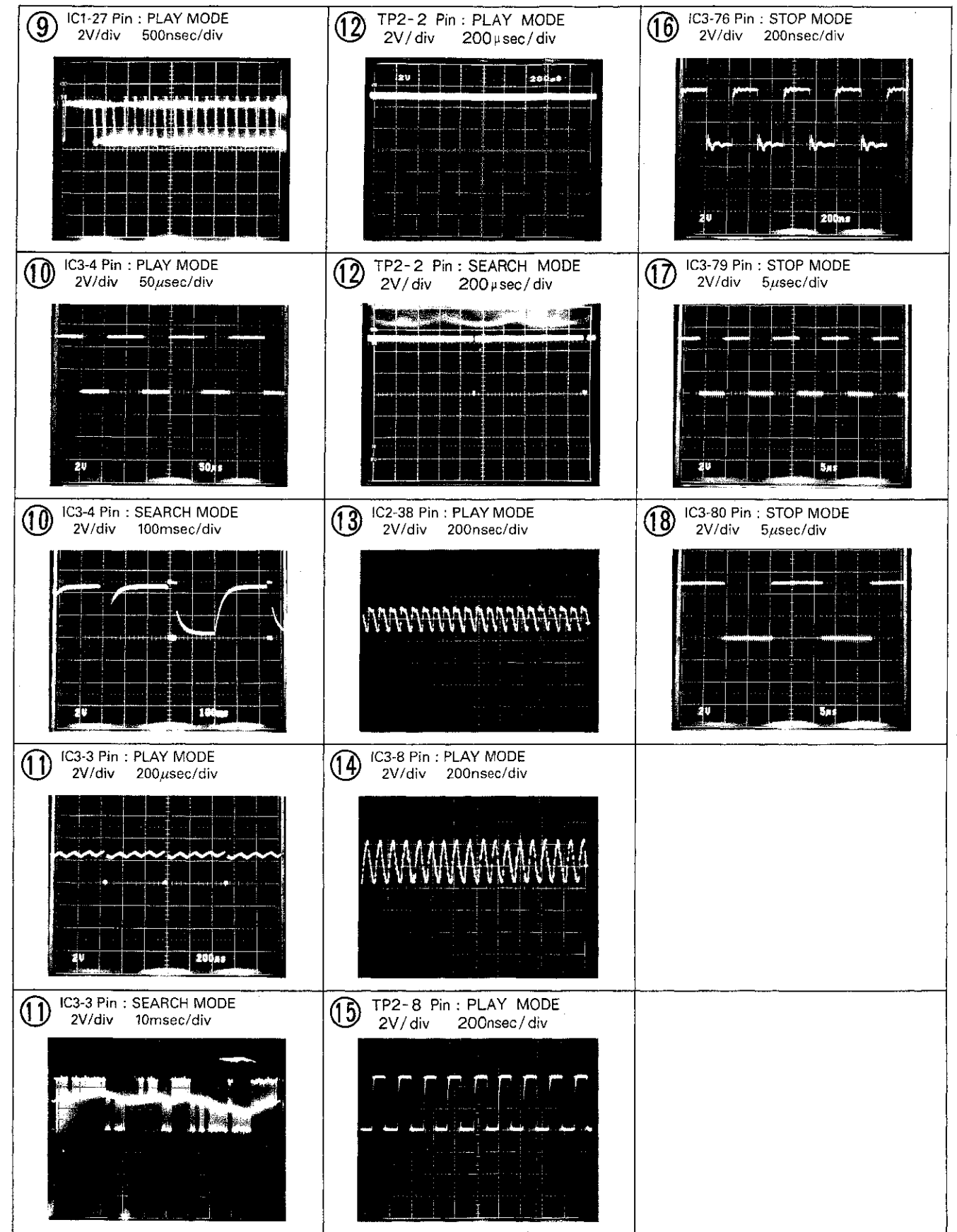
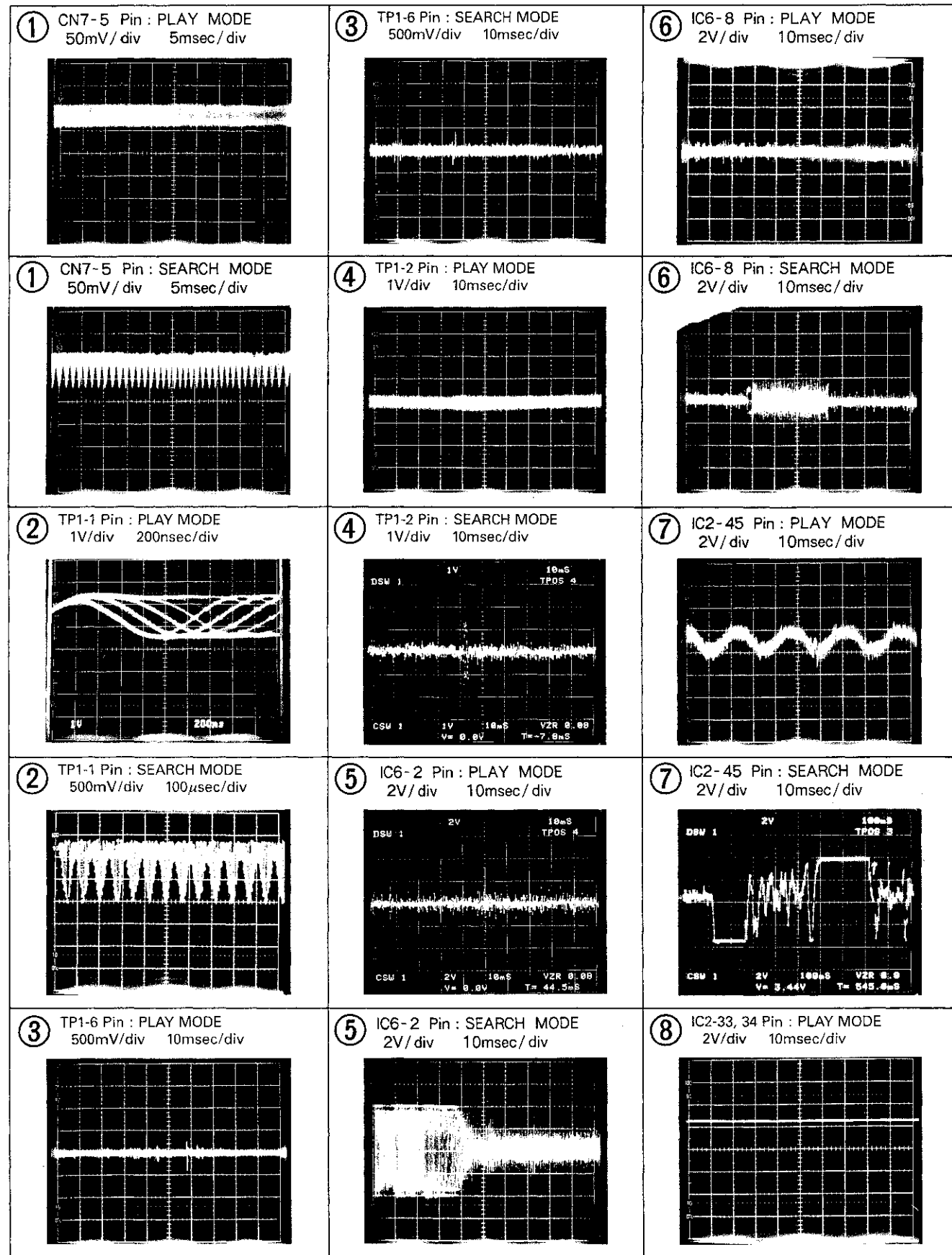

①

②

②

②

②

uring points in the

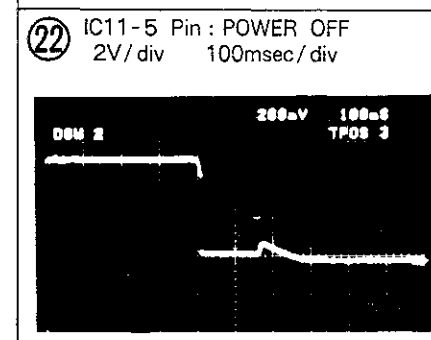
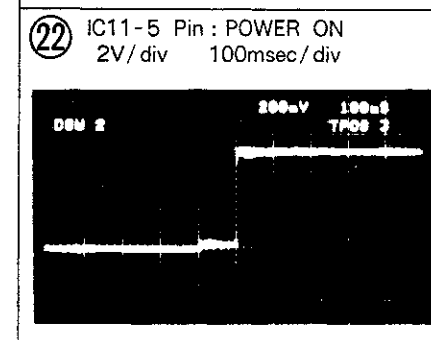
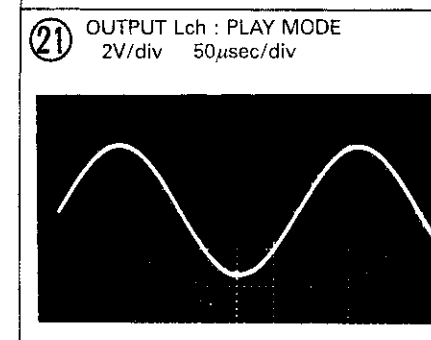
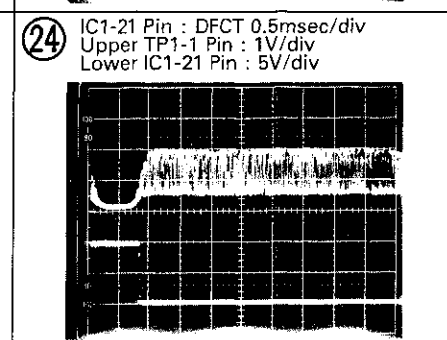
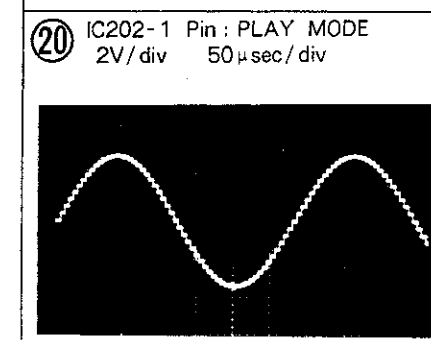
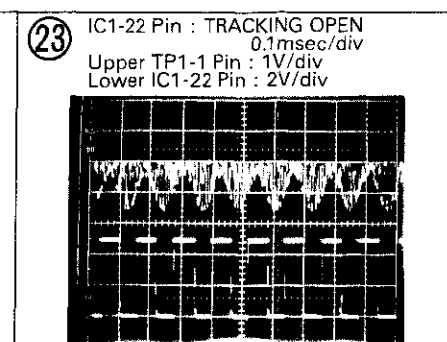
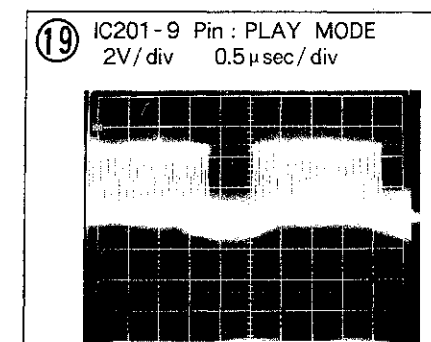
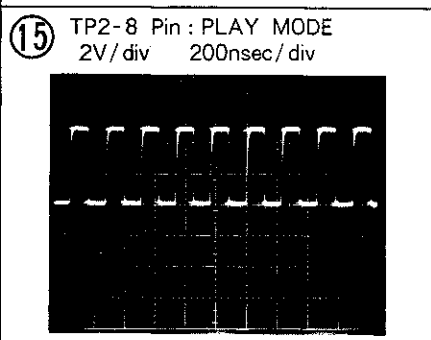
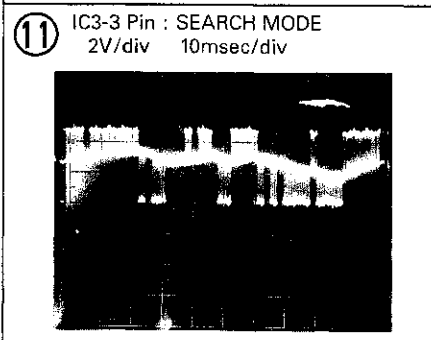
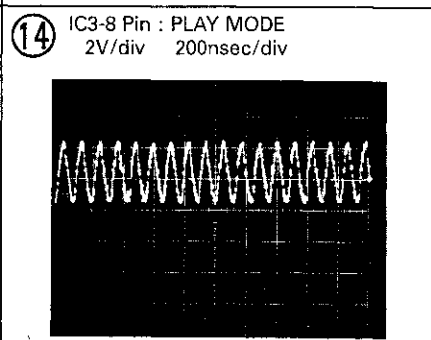
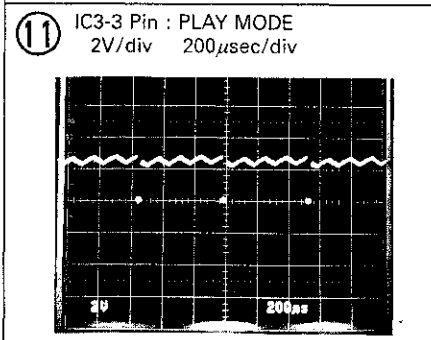
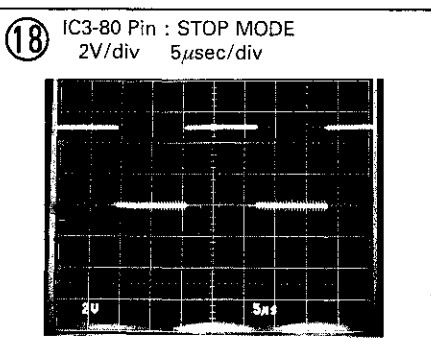
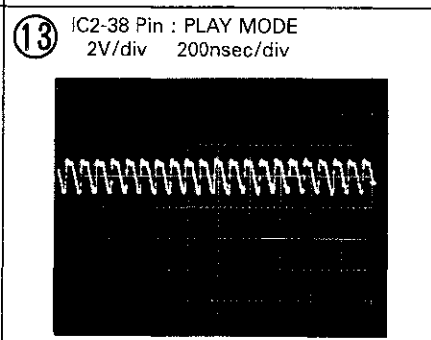
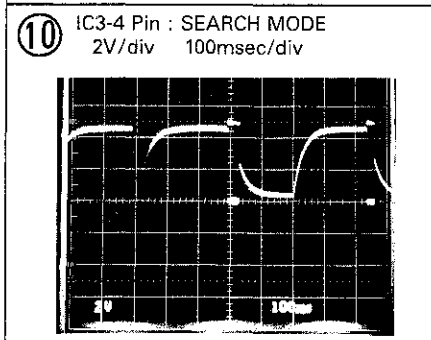
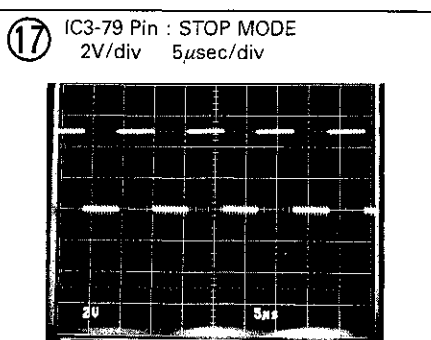
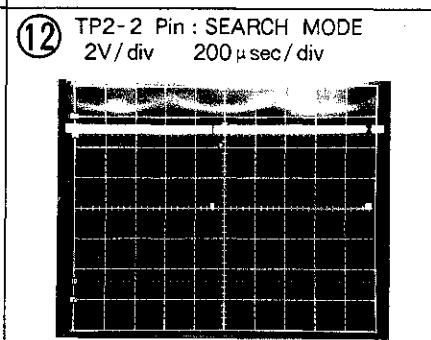
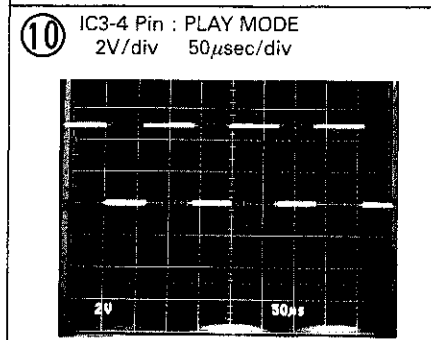
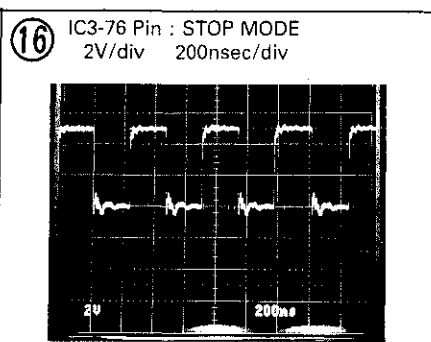
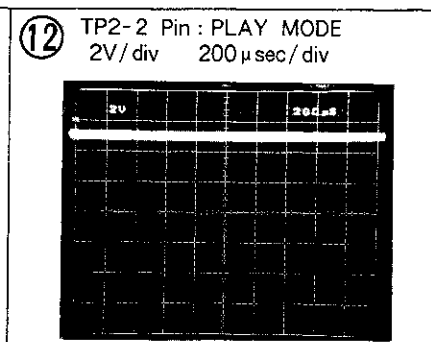
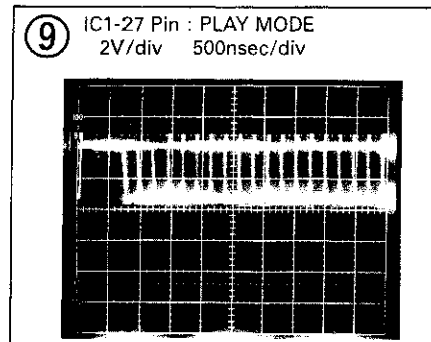
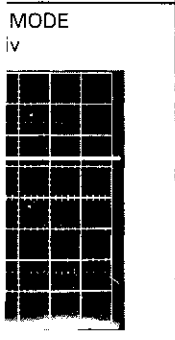
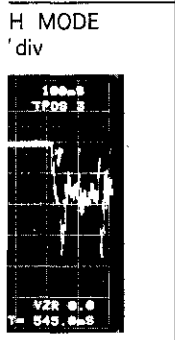
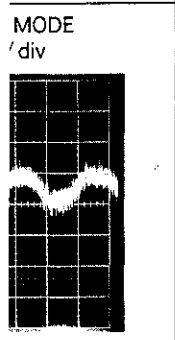
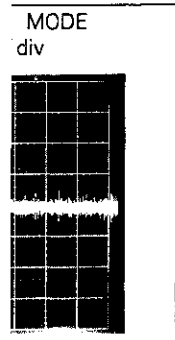
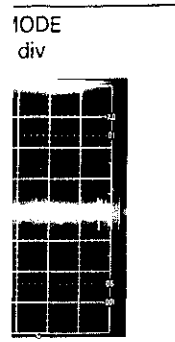

5. BLOCK DIAGRAM

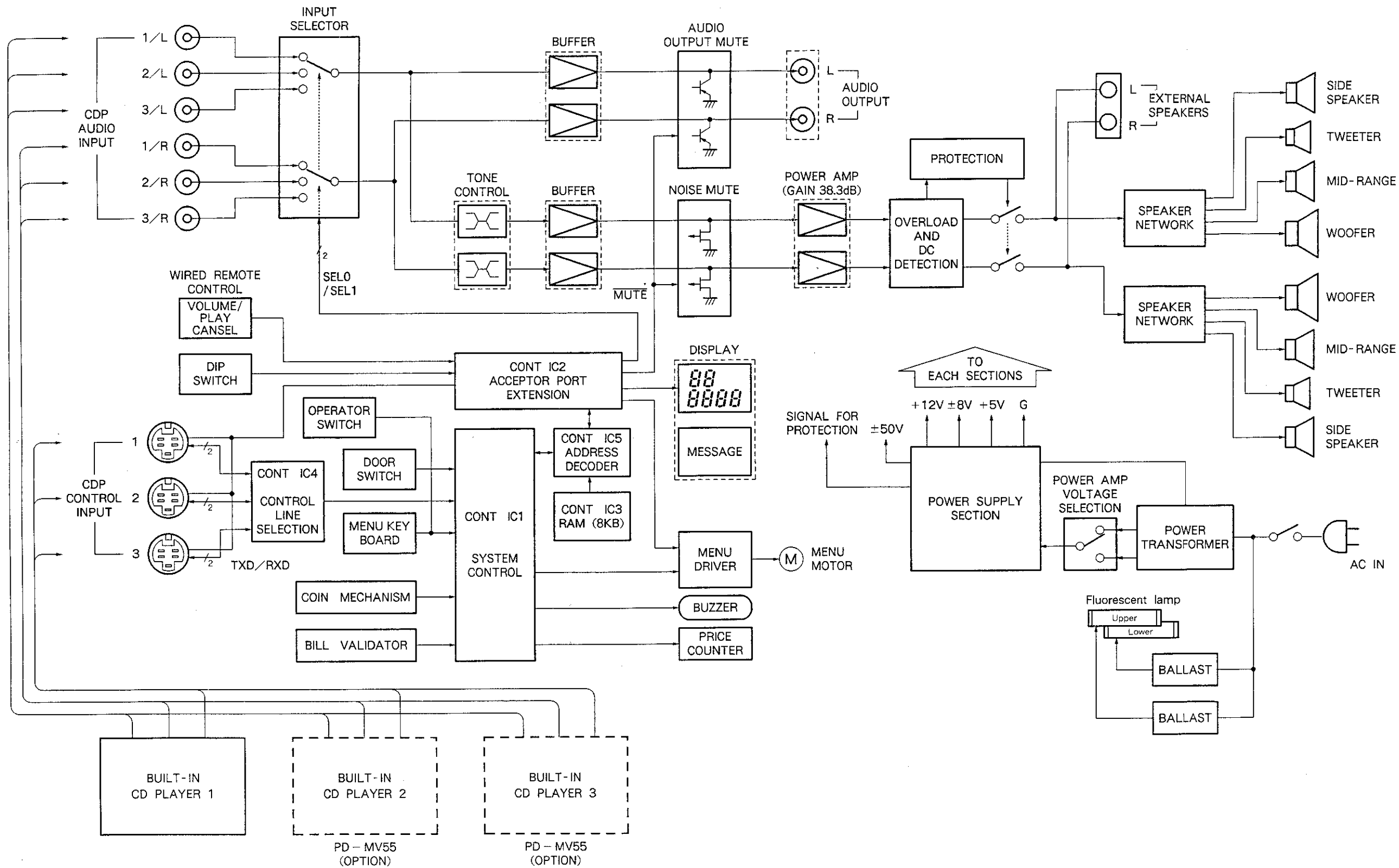

6. ELECT

6.1 MAIN :

NOTES :

- Parts without 1
- Parts marked b
- The  $\Delta$  mark for replacing, be st
- When ordering

Ex.1 When the  
 $J = 5\%$ ,  $\epsilon$   
 $560\ \Omega \rightarrow E$   
 $47k\ \Omega \rightarrow 4$   
 $0.5\ \Omega \rightarrow 0f$   
 $1\ \Omega \rightarrow 0r$

Ex.2 When the  
 $5.62k\ \Omega \rightarrow$

Miscellaneous

Mark	Symbol	Description
●	MESS	
●	DISP	
●	KEYB	
●	BRAN	
●	ROTA	
●	POSS	
●	LAMP	
●	CNTB	
●	PAMP	
●	SPTB	
●	LOJB	
●	PREB	
●	POWB	
●	ACIN	
●	ASEL	
●	PSWB	
●	CONP	
●	OPER	
●	CRJB	
●	RMJB	
●	CDJB	
●	DIPS	
●	CNNB	
●	Network	
$\Delta$	C702,C70	
$\Delta$	C701,C7C	
$\Delta$	FU1	
$\Delta$	FU2 - FU	
$\Delta$	FU5	
$\Delta$	FU601	
$\Delta$	Micro	
$\Delta$	Power	
$\Delta$	AC I	
$\Delta$	Elect	

## 6. ELECTRICAL PARTS LIST

### 6.1 MAIN SECTION

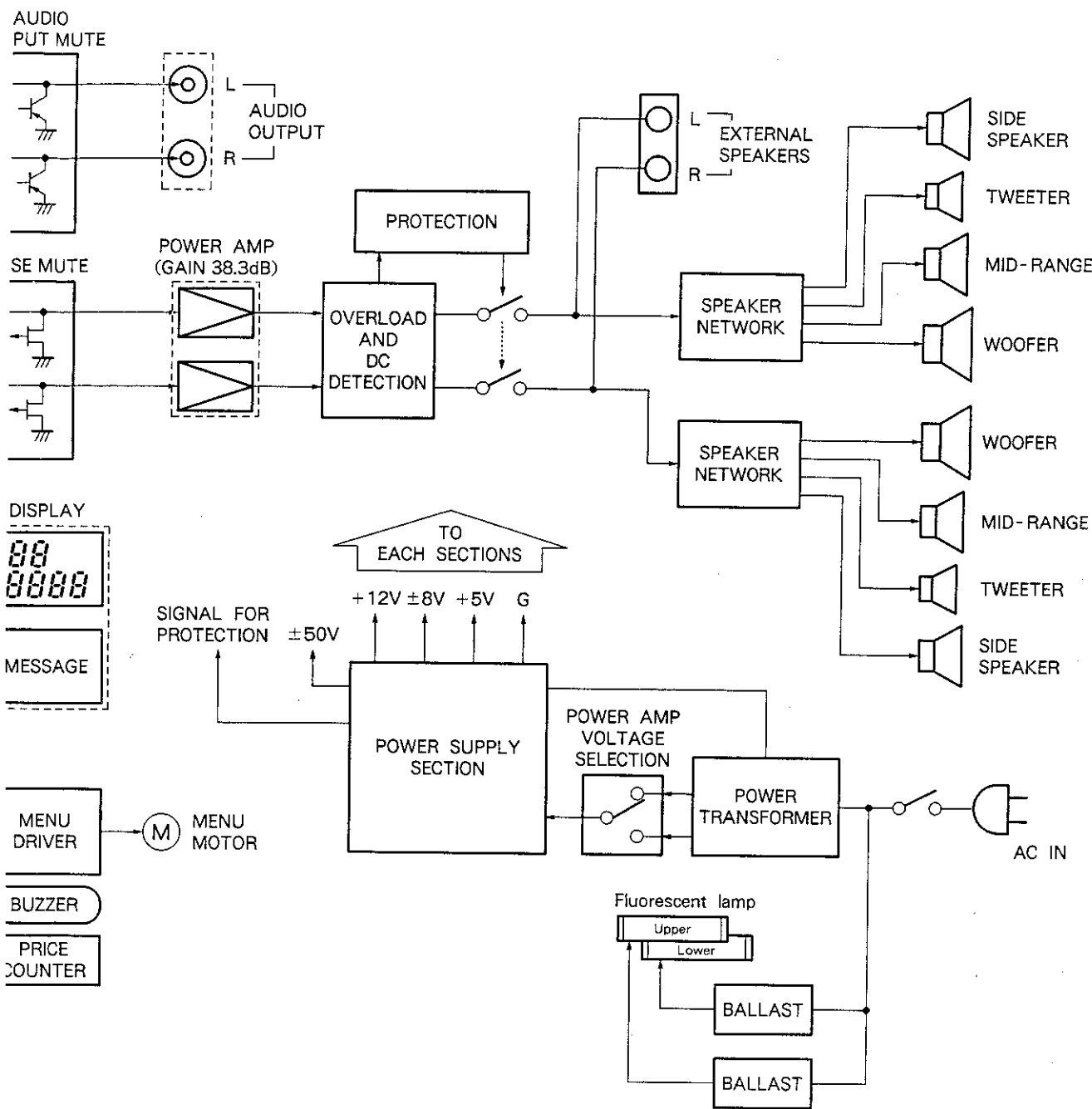

#### NOTES :

- Parts without part number cannot be supplied.
- Parts marked by "⊙" are not always kept in stock. Their delivery time may be longer than usual or they may be unavailable.
- The Δ mark found on some component parts indicates the importance of the safety factor of the part. Therefore, when replacing, be sure to use parts of identical designation.

● When ordering resistors, first convert resistance values into code form as shown in the following examples.

Ex.1 When there are 2 effective digits (any digit apart from 0), such as 560 ohm and 47k ohm (tolerance is shown by J = 5%, and K = 10%).

560 Ω → 56 × 10<sup>1</sup> → 561 ..... RD1/4PS 5 6 1 J

47k Ω → 47 × 10<sup>3</sup> → 473 ..... RD1/4PS 4 7 3 J

0.5 Ω → 0R5 ..... RN2H 0 R 5 K

1 Ω → 010 ..... RS1P 0 1 0 K

Ex.2 When there are 3 effective digits (such as in high precision metal film resistors).

5.62k Ω → 562 × 10<sup>1</sup> → 5621 ..... RN1/4SR 5 6 2 1 F

#### Miscellaneous Parts

Mark	Symbol & Description	Part No.	Mark	Symbol & Description	Part No.
⊙	MESS	DWG1128	Δ	AC outlet	DKN-108
⊙	DISP	DWG1129	Δ	Ballast	DTH1114
⊙	KEYB	DWS1101	Δ	Channel	DXB1107
	BRAN		Δ	Lithium cell	DEM1001
	ROTA		Δ	Strain relief	VEC-201
	POSS			Motor (Menu)	DXM1033
	LAMP			Motor assembly (Menu)	DXX1368
	CNTB			Remote control unit	DXR1007
⊙	PAMP	DWH1007	Δ	Connection cord	DDE1034
	SPTB		Δ	Fluorescent lamp socket (Upper)	DKK1006
	LOJB			Fluorescent lamp socket (Under L)	DKK1007
⊙	PREB	DWK1011	Δ	Fluorescent lamp socket (Under L)	DKK1007
⊙	POWB	DWR1056	Δ	Glow lamp socket	DKK1009
	ACIN		Δ	Cord with pin plug	PDE1065
	ASEL				
⊙	PSWB				
⊙	CONT	DWG1138			
	OPER				
	CRJB				
	RMJB				
	CDJB				
	DIPS				
	CNNB				
	Network assembly	SWN1197			
	C702,C704	CEANP010M50			
	C701,C703	CGDYX104M25			
Δ	FU1 Fuse (1A)	DEK1011			
Δ	FU2 - FU4 Fuse (1.6A)	DEK1015			
Δ	FU5 Fuse (6A)	DEK1022			
Δ	FU601 Fuse (2A)	DEK1016			
	Micro switch (DOOR)	DSF1001			
Δ	Power transformer	DTT1039			
Δ	AC Power cord	DDG1025			
	Electromagnetic counter	DAW1011			

#### ⊙ MESS (DWG1128)

#### SEMICONDUCTORS

Mark	Symbol & Description	Part No.
	D101,D102	LN0401RP2
	D103 - D105	LN0603RP2

#### RESISTORS

Mark	Symbol & Description	Part No.
	R101 - R110	RD1/6PM □ □ □ J

#### ⊙ DISP (DWG1129)

#### SEMICONDUCTORS

Mark	Symbol & Description	Part No.
	D202,D203	LN526RA (V)
	D201	LN526YA

◎KEYB (DWS1101)

**SEMICONDUCTORS**

Mark	Symbol & Description	Part No.
	D311 - D314	SLV-31DC3
	D301 - D310	SLV-31MC3
	D315 - D322	SLV-31YC3

**SWITCHES**

Mark	Symbol & Description	Part No.
	S301 - S310 Tact switch (1 - 10)	DSG1011
	S311 - S316 Tact switch (CLEAR, BEST HITS, ROTATE MENU)	RSG-155

**RESISTORS**

Mark	Symbol & Description	Part No.
	R301 - R306	RD1/6PM□□□J

**ROTA**

**SEMICONDUCTORS**

Mark	Symbol & Description	Part No.
	Q401	UN4112
	Q403	UN4212
	Q404	2SB1185
	Q402	2SD1762
	D401,D402	1SR139-400

**CAPACITORS**

Mark	Symbol & Description	Part No.
	C401	CEAL470M6R3
	C403	CEAS101M25
	C402	CKPUYF223Z25

**RESISTORS**

Mark	Symbol & Description	Part No.
	R401 - R405	RD1/6PM□□□J

**POSS**

**SEMICONDUCTOR**

Mark	Symbol & Description	Part No.
	D501	GP1A14

**CAPACITOR**

Mark	Symbol & Description	Part No.
	C501	CKPUYF223Z25

**RESISTOR**

Mark	Symbol & Description	Part No.
	R501	RD1/6PM391J

**BRAN**

There is not supplied in this unit.

**LAMP**

**CAPACITORS**

Mark	Symbol & Description	Part No.
△	C601,C602 (0.01 $\mu$ F)	RCG-009

**OTHERS**

Mark	Symbol & Description	Part No.
△	CN33 Connector	SD-5277-02A

**CNTB**

**SEMICONDUCTOR**

Mark	Symbol & Description	Part No.
	IC801	GP1A30R

**CAPACITOR**

Mark	Symbol & Description	Part No.
	C801	CKPUYF223Z25

**RESISTOR**

Mark	Symbol & Description	Part No.
	R801	RD1/6PM121J

**LOJB**

**SEMICONDUCTORS**

Mark	Symbol & Description	Part No.
	Q50,Q51	2SA1309A

**CAPACITORS**

Mark	Symbol & Description	Part No.
	C102	CKCYF103Z50
	C100,C101	CKPUYX222M16

**RESISTORS**

Mark	Symbol & Description	Part No.
	R50 - R53	RD1/6PM□□□J

**OTHERS**

Mark	Symbol & Description	Part No.
	JA53 2P pin jack	DKB1011



## SPTB

## OTHERS

Mark	Symbol & Description	Part No.
△	Speaker terminal	AKE1013

## ◎ PAMP (DWH1007)

## SEMICONDUCTORS

Mark	Symbol & Description	Part No.
	IC1	STK4231
	Q6	2SA1283
	Q4	2SA933S
	Q7,Q8	2SA970
	Q1,Q2,Q5	2SC1740S
	Q3	2SC1775
	Q12,Q13	2SJ103
	D7	MTZJ6.8B
	D5,D8,D9,D11	1SR35-100AVL
	D3	1SS142
	D2	1SS254

## RELAY

Mark	Symbol & Description	Part No.
	RY1 Relay	RSR1014

## COILS

Mark	Symbol & Description	Part No.
	L1,L2 AF choke coil	DTH1116

## CAPACITORS

Mark	Symbol & Description	Part No.
	C13,C14 (33/100)	DCH1018
	C7 (100/100)	DCH1019
	C6 (10/100)	DCH1022
	C2,C11	CEASR22M50
	C18	CEAS010M50
	C3,C9	CEAS101M10
	C10,C17	CEAS101M50
	C16	CEAS221M16
	C21	CEAS4R7M50
	C4,C8	CEAS470M50
	C19	CEAS471M10
	C1,C12	CKCYB222K50
	C22 - C25	CFTXA104J50

## RESISTORS

Mark	Symbol & Description	Part No.
	R38,R39 Wire wound resistor (0.47 × 2) (5W)	DCN1020
	R7 - R9,R11,R12,R14,R33, R41 - R44	RD1/2LF□□□J
	R3,R16	RD1/2PMF681J
	Other resistors	RD1/6PM□□□J

## ◎ PREB (DWK1011)

## SEMICONDUCTORS

Mark	Symbol & Description	Part No.
	IC2,IC3	NJM4558S
	IC1	TC4052BP
	Q1,Q2	2SC3311A

## CAPACITORS

Mark	Symbol & Description	Part No.
	C11,C12	CEASR47M50
	C33,C34	CEAS010M50
	C13 - C15,C20,C22,C24 - C26, C29,C30	CEAS4R7M50
	C6,C7,C21,C23	CEAS470M16
	C3,C4	CFTXA104J50
	C17,C32	CFTXA473J50
	C5,C8 - C10,C35	CGCYX473M25
	C1,C2	CKCYF103Z50
	C18,C27	CQMA122J50
	C16,C31	CQMA123J50
	C19,C28	CQMA682J50

## RESISTORS

Mark	Symbol & Description	Part No.
	VR1 Volume (20k)	DCS1013
	VR2,VR3 Volume (100k)	DCS1014
	Other resistors	RD1/6PM□□□J

## ACIN

## COIL

Mark	Symbol & Description	Part No.
△	L301 Line filter	VTL-004

## CAPACITORS

Mark	Symbol & Description	Part No.
△	C301,C302 (0.01 μF)	RCG-009

## OTHERS

Mark	Symbol & Description	Part No.
△	CN36,CN74 Connector	SD-5277-02A

## ASEL

## SWITCH

Mark	Symbol & Description	Part No.
△	Line voltage selector (SPEAKER SELECTOR)	DSX1010

## ◎ POWB (DWR1056)

## SEMICONDUCTORS

Mark	Symbol & Description	Part No.
	IC104	NJM78M08FA
	IC101	NJM78M05FA
	IC103	NJM78M12FA
	IC105	NJM79M08FA
	IC102	TA7291S
	Q101	DTC124ES
	Q102	2SA1283
	D106	MTZ4.3C
△	D109	S10VB10-DF9
△	D101,D108	S2VB10F
△	D102 - D105,D107	1SR139-400

## RELAY

Mark	Symbol & Description	Part No.
△	RY101 Relay	DSR1006

## CAPACITORS

Mark	Symbol & Description	Part No.
△	C114,C115 (10000/80)	ACH-264
	C112,C113 (0.01 $\mu$ F)	RCG-009
	C102 (6800/25)	RCH1032
	C105,C109,C118,C119	CEAS010M50
	C110,C111	CEAS102M35
	C106	CEAS221M25
	C103	CEAS4R7M50
	C104,C116,C117	CEAS470M25
	C101,C107,C108	CKCYF103Z50

## RESISTORS

Mark	Symbol & Description	Part No.
△	R116	DCN1002
	R114,R115	RS1LMF103J
△	R112,R113	RS1LMF151J
△	R103	RD1/2LF4R7J
	Other resistors	RD1/6PM□□□J

## PSWB

## SWITCH

Mark	Symbol & Description	Part No.
△	Power switch (POWER)	DSA1005

## CAPACITOR

Mark	Symbol & Description	Part No.
△	C201 (0.01 $\mu$ F)	RCG-009

## ◎ CONT (DWG1138)

## SEMICONDUCTORS

Mark	Symbol & Description	Part No.
	IC2	CXD1095Q
	IC7	M51953BL
	IC1	PD0073
	IC10	SN74LS05N
	IC3	TC5564APL-15
	IC6	TC74HC04AP
	IC5	TC74HC139AP
	IC4	TC74HC4052AP
	Q37,Q42,Q43	DTA124ES
	Q7-Q20,Q29 - Q31,Q38,Q39,Q44	DTC124ES
	Q34	2SA1015
	Q1 - Q6	2SA1283
	Q21 - Q26,Q33,Q45,Q46	2SC1740S
	Q27,Q40	2SC3246
	D11,D12	MTZ5.6B
	D6	1SR139-400
	D1 - D5,D7 - D10	1SS254

## COILS AND FILTERS

Mark	Symbol & Description	Part No.
	L1,L2	LAU010K
	F1 - F20 3 Terminal filter	VTH1001

## CAPACITORS

Mark	Symbol & Description	Part No.
	C58 Capacitor array (2200p × 8)	DCG1004
	C11,C12	CCCCH150J50
	C42,C43	CCCCH470J50
	C44	CEAS010M50
	C4,C7,C30 - C33,C35,C38	CEAS330M16
	C24	CEAS332M6R3
	C10	CEAS470M50
	C61	CEAS471M10
	C39	CKCYF102Z50
	C1 - C3,C5,C6,C9,C13 - C23, C29,C34,C37,C46 - C56	CKCYF103Z50
	C8,C28,C57	CKCYF473Z50
	C62,C63	CKCYF103Z50

## RESISTORS

Mark	Symbol & Description	Part No.
	VR1 Semi-fixed (4.7k)	VRTB6VS472
	R60,R67,R104 Resistor array	RA8S□□□J
	Other resistors	RD1/6PM□□□J

## OTHERS

Mark	Symbol & Description	Part No.
	X1 Crystal resonator	DSS1001
	Piezoelectric buzzer	DPX1002
	IC socket	VKH-029

**OPER**

**SWITCHES**

Mark	Symbol & Description	Part No.
	S301 - S303 Tact switch (MEMORY CLEAR, MENU ROTATION, SERVICE MODE)	DSG-107

**CRJB**

**CAPACITORS**

Mark	Symbol & Description	Part No.
	C501 Capacitor array (1000p × 8)	DCG-105
	C502	CKCYF102Z50

**OTHERS**

Mark	Symbol & Description	Part No.
	4P mini DIN socket	VKN1072

**RMJB**

**SEMICONDUCTORS**

Mark	Symbol & Description	Part No.
	D401 - D404	MTZJ5.6B

**CAPACITOR**

Mark	Symbol & Description	Part No.
	C401	CKCYF103Z50

**RESISTORS**

Mark	Symbol & Description	Part No.
	R401 - R404	RD1/6PM221J

**OTHERS**

Mark	Symbol & Description	Part No.
	4P mini DIN socket	VKN1072

**CDJB**

**OTHERS**

Mark	Symbol & Description	Part No.
	JA Pin jack (AUDIO IN)	PKB-009

**DIPS**

**SWITCH**

Mark	Symbol & Description	Part No.
	S1 8P DIP switch (FUNCTION)	DSX1011

**CNNB**

**COILS**

Mark	Symbol & Description	Part No.
	L301,L302	LAU010M

**CAPACITORS**

Mark	Symbol & Description	Part No.
	C301,C303 Capacitor array (2200p × 8)	DCG1004
	C302,C304 Capacitor array (2200p × 6)	DCG1005
	C305,C306 Capacitor array (2200p × 4)	DCG1006
	C307 - C311	CKCYF103Z50

**NETWORK ASSEMBLY (SWN1197)**

**COILS**

Mark	Symbol & Description	Part No.
	L1 (3.3mH)	STH1100
	L3 (3.9mH)	STH1021
	L4 (0.22mH)	STH-327

**CAPACITORS**

Mark	Symbol & Description	Part No.
	C1	CES4220KJ
	C2	CES4100KJ
	C4	CES4DX1R8KJ

**RESISTOR**

Mark	Symbol & Description	Part No.
	R4	RT10BAL100K

**OTHERS**

Mark	Symbol & Description	Part No.
	Br1 (1A)	SSG-004

## 6.2 CD SECTION

### NOTES :

- Parts without part number cannot be supplied.
- Parts marked by "⊙" are not always kept in stock. Their delivery time may be longer than usual or they may be unavailable.
- The Δ mark found on some component parts indicates the importance of the safety factor of the part. Therefore, when replacing, be sure to use parts of identical designation.

- When ordering resistors, first convert resistance values into code form as shown in the following examples.

Ex.1 When there are 2 effective digits (any digit apart from 0), such as 560 ohm and 47k ohm (tolerance is shown by J = 5 %, and K = 10 %).

560 Ω → 56 × 10<sup>1</sup> → 561 ..... RD1/4PS 561J

47k Ω → 47 × 10<sup>3</sup> → 473 ..... RD1/4PS 473J

0.5 Ω → 0R5 ..... RN2H 0R5K

1 Ω → 010 ..... RS1P 010K

Ex.2 When there are 3 effective digits (such as in high precision metal film resistors).

5.62k Ω → 562 × 10<sup>1</sup> → 5621 ..... RN1/4SR 5621F

### Miscellaneous Parts

Mark	Symbol & Description	Part No.
	EKEY	
	RMJB	
	SENS	
	PJAK	
	DJAK	
	FREQ	
⊙	ANLG	DWX1117
	DEGT	DWX1116
	MJSW	
	HRMB	
	REJC	
Δ	T201 Power transformer	DTT1037
Δ	FU201 Fuse (315mA)	REK-075
	Slide switch	DSH1011
	(DOWN LIMIT TRAY)	
	Lever switch (CLAMP)	DSK1001
	Slide switch (INSIDE)	PSH1003
	Pickup assembly	PWY1009
Δ	AC power cord	DDG1026
	Hour meter	VCX-006
	Select motor assembly	DXX1358
	Motor (SLIDER DISC LOAD, DISC SELECT)	PXM1002
	Motor assembly	PYY1025
	Spindle motor assembly	DXX1361
	Semiconductive ceramic capacitor	CGDYX104M25

### EKEY

### SWITCHES

Mark	Symbol & Description	Part No.
	S301 - S303 Tact switch (EJECT (A, B, C))	DSG1009

### RMJB

### OTHERS

Mark	Symbol & Description	Part No.
	3P mini jack	DKN1028

### SENS

### SEMICONDUCTOR

Mark	Symbol & Description	Part No.
	Q901	GP1A52HR

### SWITCH

Mark	Symbol & Description	Part No.
	S901 Switch (UP LIMIT)	DSG1008

### CAPACITOR

Mark	Symbol & Description	Part No.
	C901	CEJA100M16

### RESISTORS

Mark	Symbol & Description	Part No.
	R901,R902	RD1/6PM □□□J

### PJAK

### OTHERS

Mark	Symbol & Description	Part No.
	JA601 2P pin jack	PKB1009

### DJAK

### CAPACITORS

Mark	Symbol & Description	Part No.
	C501 Capacitor array	DCG1007

### OTHERS

Mark	Symbol & Description	Part No.
	4P mini DIN socket	VKN1072

### FREQ

### OTHERS

Mark	Symbol & Description	Part No.
	CN401,CN402 FPC connector	5597-17APB

© ANLG (DWX1117)

**SEMICONDUCTORS**

Mark	Symbol & Description	Part No.
	IC201	LC7881-C
	IC202,IC203	NJM4558D
	IC205	NJM7805FA
	IC204	NJM79L05A
	Q203,Q209	DTA124ES
	Q201,Q202,Q204	DTC124ES
	Q207,Q208	2SC1740S
	Q205,Q206	2SD1302
	D201	2W02-5008-L

**COIL AND FILTERS**

Mark	Symbol & Description	Part No.
	L201 Line filter	VTL-157
	F202 - F204 3 terminal filter	VTH1001

**CAPACITORS**

Mark	Symbol & Description	Part No.
	C201,C202 (0.01μF)	RCG-009
	C226	CEAS101M10
	C205	CEAS102M10
	C209,C210,C219,C220	CEAS220M50
	C204	CEAS222M16
	C221 - C225	CEAS330M16
	C206	CEAS471M10
	C203	CEAS472M16
	C227	CKCYF103Z50
	C207,C208	CQMA102J50
	C213,C214	CQMA471J50
	C215,C216	CQMA472J50
	C217,C218	CQMA683J50
	C211,C212	CQMA821J50

**RESISTORS**

Mark	Symbol & Description	Part No.
	All resistors	RD1/6PM□□□J

**DEGT (DWX1116)**

**SEMICONDUCTORS**

Mark	Symbol & Description	Part No.
	IC1	CXA1081S
	IC2	CXA1082AS
	IC3	CXD1135QZ
	IC4	CXK5816PN-12L
	IC11	M51953BL
	IC5	PD0068
	IC6 - IC8,IC10	TA7256P
	Q1,Q3,Q5,Q12,Q14	DTA124ES
	Q10,Q16	DTC124ES
	Q9	2SA1399
	Q13	2SA933S
	Q7,Q8,Q11	2SC1740S
	Q2,Q4,Q6,Q15	2SC2497
	D4-D7	1SS254

**CAPACITORS**

Mark	Symbol & Description	Part No.
	C15,C16	CCCCH220J50
	C70 - C75	CCCCH221J50
	C10,C11,C33,C35,C38	CCCCH300J50
	C76 - C78	CEANP010M50
	C60	CEANP4R7M50
	C1,C43	CEASR47M50
	C23	CEAS010M50
	C32,C65	CEAS101M10
	C67	CEAS3R3M50
	C12,C13,C17,C21,C22,C26 - C31,	CEAS330M16
	C36,C37,C40,C45,C47,C48,C50,C57,	
	C61,C62,C64,C68,C69,C79,C80	
	C55	CEAS4R7M50
	C18 - C20,C24	CKCYB102K50
	C14,C25	CKCYF103Z50
	C3,C54	CQMA102J50
	C42,C44,C63	CQMA103J50
	C52,C53,C56,C59	CQMA104J50
	C46	CQMA272J50
	C41	CQMA332J50
	C2,C39,C49,C58	CQMA333J50
	C34,C51,C66	CQMA472J50

**RESISTORS**

Mark	Symbol & Description	Part No.
	VR8 Semi-fixed (1k)	VRTB6VS102
	VR2 Semi-fixed (10k)	VRTB6VS103
	VR3 - VR7 Semi-fixed (22k)	VRTB6VS223
	Other resistors	RD1/6PM□□□J

**OTHERS**

Mark	Symbol & Description	Part No.
	X1 Crystal resonator	DSS1010
	X2 Crystal resonator	PSS-012
	DL1,DL2 Delay line	PTF1012
	CN8 6P Top post	B6P-SHF-1AA
	CN4 8P Top post (NH)	B8P-SHF-1AA
	CN7 FPC connector	5597-17APB
	IC socket	VKH-029

**MJSW**

**SWITCHES**

Mark	Symbol & Description	Part No.
	S804 - S806 Slide switch	PSH1005
	S801 - S803 Push switch	PSH1008

**HRMB**

There is not supplied parts in this unit.

**REJC**

There is not supplied parts in this unit.

## 7. ADJUSTMENTS

### 7.1 MECHANICAL ADJUSTMENTS

#### 7.1.1 MAIN SECTION

##### • Three sides of the menu synchronous adjustment (Fig. 7-1)

###### PREPARATIONS

- Adjust without installing the motor (menu).
  - Fix center pulley to menu shaft with the screws.
- (1) Apply synchro belt between synchro pulley and center pulley both on the right and left sides.
  - (2) While applying spring (tension) to under frame and tension plate, apply a tension to the synchro belt.
  - (3) Fix tension plate to under frame with screw ①.
  - (4) By placing a flat plate such as a ruler on them, align the three surfaces of the menu with each other on the same level.
  - (5) Fix the menu shaft to the synchro pulley using a hexagonal wrench.
  - (6) Remove the plate placed on the menu and check the following items while turning the menu by hand.
    1. Check that the three surfaces of the menu rotate smoothly.
    2. Check that all the three surfaces align with each other on the same level after turning the menu shaft once.

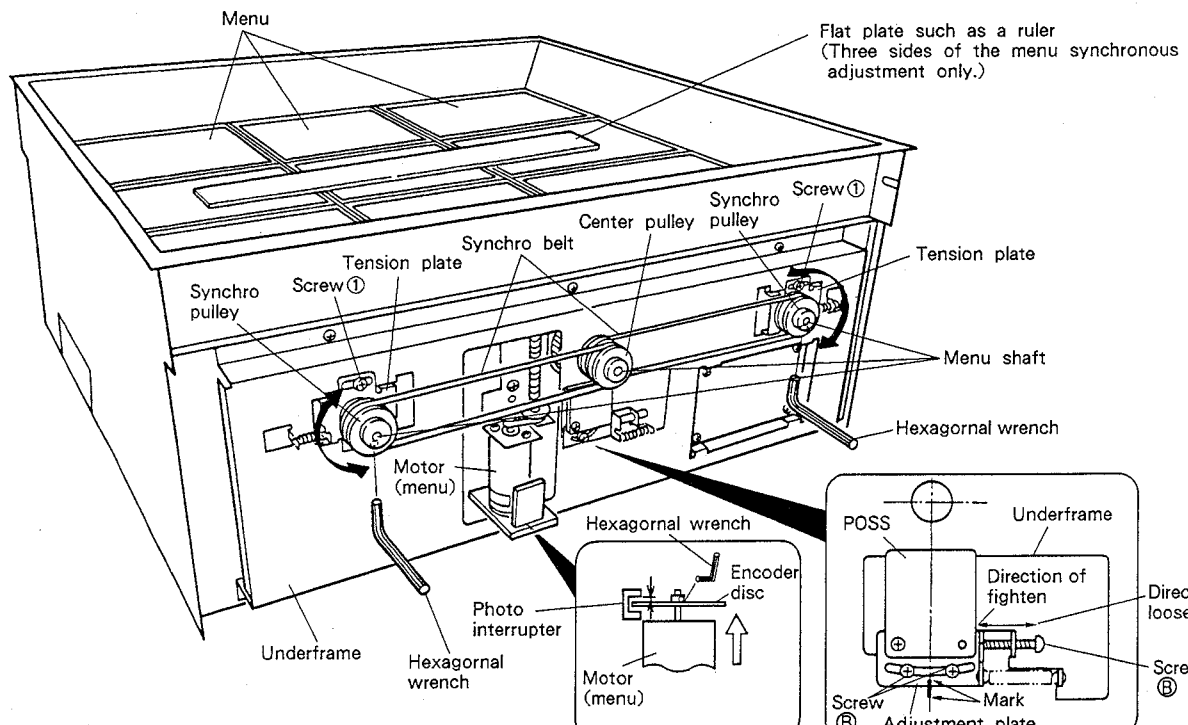

Fig. 7-1

##### • Adjustment of the stop position of menu rotation

###### PREPARATIONS

- Loosen the screw ② which holds the encoder disc using a hexagonal wrench.
  - Loosen screw ② which holds the adjustment plate.
  - Adjust with the motor (menu) attached.
- (1) Set the gap between the encoder disc and photo interrupter of the motor (menu) to  $1 \pm 0.5$  mm. (Fig. 7-2)
  - (2) Fix the screw of the encoder disc by tightening with a hex wrench.
  - (3) Turn screw ③ so that the carved mark on the adjustment plate align with the underframe. Then temporarily tighten screw ②.
  - (4) Push the ROTATE MENU key on the front panel of the main unit so that menu rotates. Then, perform the following adjustments depending on the condition. (Fig. 7-3)
    - When the menu stops after extending past the front ..... Loosen screw ②, then tighten screw ③ turning it clockwise.
    - When menu stops before reaching the front ..... Loosen screw ② and turn screw ③ counterclockwise to loosen it.
  - (5) Turn the menu again and firmly tighten screw ② when the menu stops directing its surfaces to the front. (Fig. 7-4 @)
  - (6) Finally, turn the menu and check that the menu stops directing all of its three surfaces to the front at every  $120^\circ$  rotation.

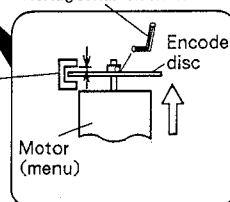

Fig. 7-2

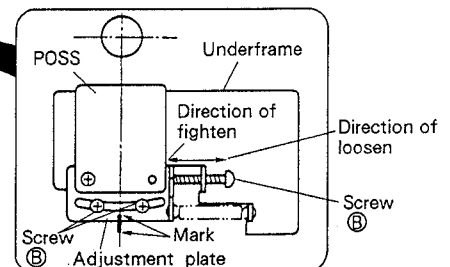

Fig. 7-3

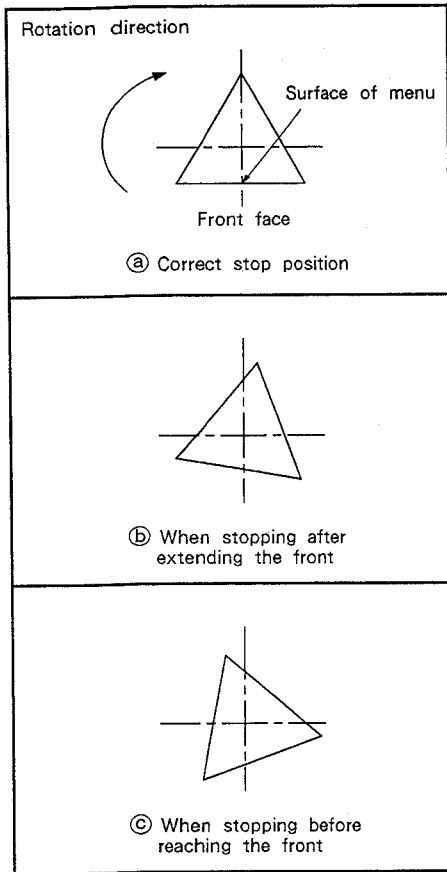

Fig. 7-4

### 7.1.2 CD SECTION

#### PREPARATIONS

- Set a magazine in the first and third modules of the CD main unit.
- Connect remote control unit (RU-V101) to the CD main unit.

#### 1. Rough adjustment of the select positon

(1) Align the distance from the upper side of the sensor plate to that of the main chassis to 7mm by turning screw Ⓐ.

#### 2. Adjustment of the select position

(1) First, proceed as follows.

① Press the 10keys in the sequence of **[1]+[8]+STILL/STEP** (DISC SELECT) key + **STILL/STEP** (DISC RETURN) key. When the operation is completed, check that the gap between the top of the rotation lever and the upper side of the sixth tray in the magazine is  $0.3^{+0.2}$ .

② If the distance is not within the specified range, turn screw Ⓐ to adjust the position of the sensor plate and press the 10keys again in the sequence of **[1]+[8]+STILL/STEP** (DISC SELECT) key + **STILL/STEP** (DISC RETURN) key until the distance comes within the specified range.

③ Push the 10keys in the sequence of **[6]+STILL/STEP** (DISC SELECT) key + **STILL/STEP** (DISC RETURN) key and check that the gap between the top of the rotation lever and the upper side of the sixth tray in the magazine is  $0.3\text{mm} \pm 0.1\text{mm}$ .

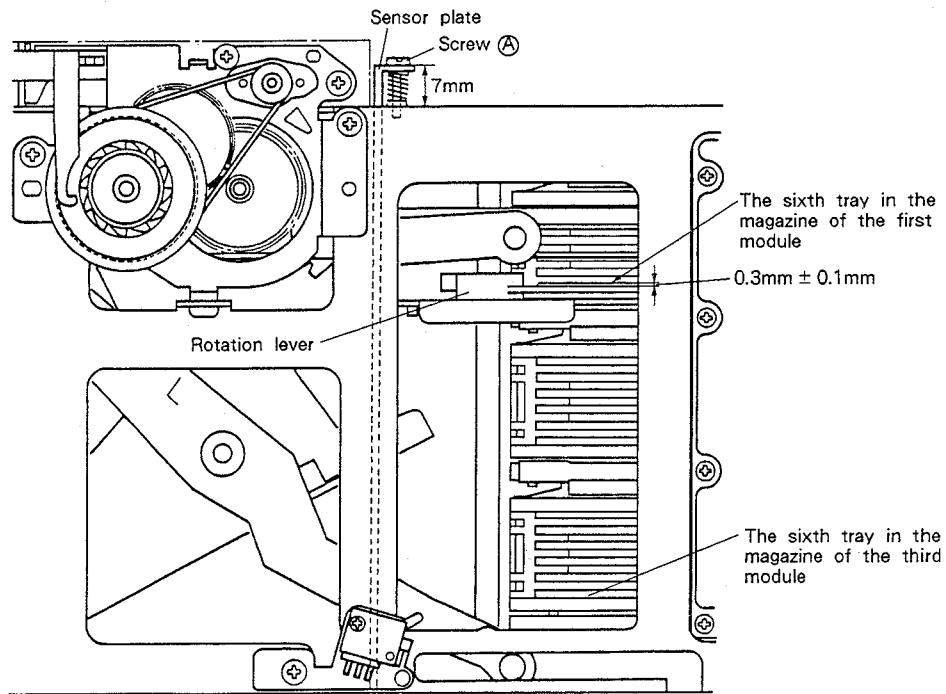

Fig. 7-5

## 7.2 ELECTRICAL ADJUSTMENTS

The adjustment items of this model should be performed in the order as shown below.

### • Adjustment and check Items

1. Tracking offset focus offset and RF offset adjustments
2. RF level adjustment
3. LD (Laser Diode) output power confirmation
4. Focus lock and spindle lock confirmation
5. Grating adjustment
6. Tracking balance adjustment
7. Tangential adjustment
8. Focus gain adjustment
9. Tracking gain adjustment
10. VCO free-run frequency adjustment
11. Method to confirm S character (FOCUS ERROR)

### • Measuring Equipment

1. Dual trace oscilloscope
2. Laser power meter
3. Test disc (YEDS-7)
4. Tracking balance adjustment filter
5. Loop gain adjustment filter
6. Signal generator
7. Frequency counter
8. Other general tools
9. Remote control unit (RU-V101)

### • Service Mode

The CD main unit can be operated independently when remote control unit (RU-V101) is connected to the unit.

For the operation, refer to Service manual (1) (ARP1912): Service Mode (page 14).

Note: Before operating the remote control unit (RU-V101), move the mechanism by using a 10keys + STILL/STEP▶▶ (DISC SELECT) key to the position where the test disc has been placed.

### • Adjustment VRs and their names

- VR1 : Laser power
- VR2 : RF offset (RF.OFS)
- VR3 : Focus gain (FCS.GAN)
- VR4 : Tracking gain (TRK.GAN)
- VR5 : Tracking balance (TRK.BAL)
- VR6 : Focus offset (FCS.OFS)
- VR7 : Tracking offset (TRK.OFS)
- VR8 : VCO adjustment (VCO.ADJ)

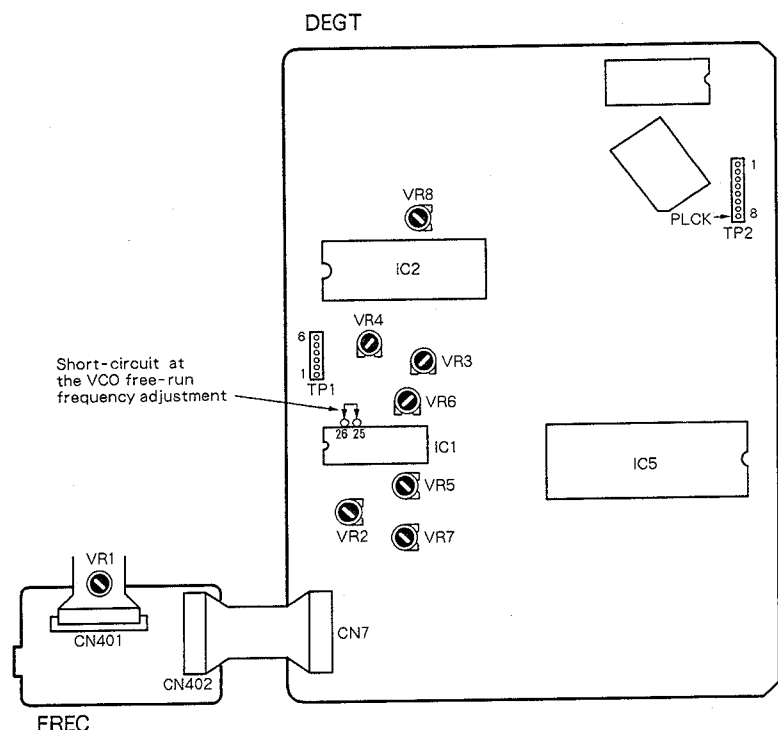
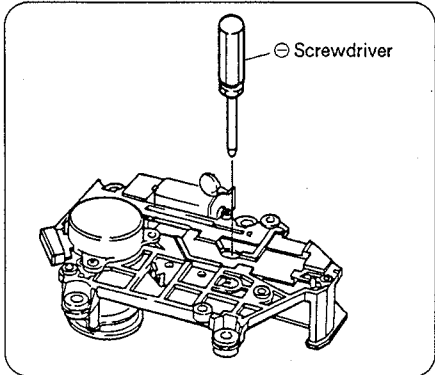
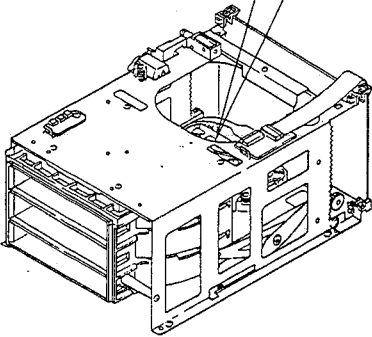
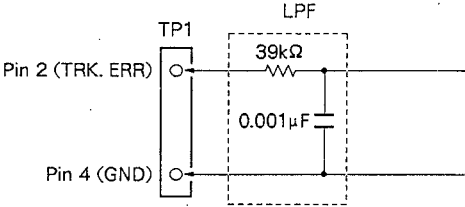

Fig. 7-6 Adjusting point



Step No.	Oscilloscope Setting		Test Points	Adjusting Points	Check items/ Adjustment specifications	Adjustment procedure
	V	H				
<b>1 TRACKING OFFSET, FOCUS OFFSET AND RF OFFSET ADJUSTMENT</b>						
			TP1 Pin 2 (TRK.ERR) TP1 Pin 6 (FCS.ERR) TP1 Pin 1 (RF OUTPUT)	VR5 (TRK.BAL) VR7 (TRK.OFS)  VR6 (FCS.OFS)  VR2 (RF.OFS)	Tracking offset 45° 0V ± 50mV  FOCUS offset 0V ± 50mV  RF offset 100mV ± 50mV	<ul style="list-style-type: none"> <li>● Set to Service mode.</li> <li>● Turn VR5 TRK.BAL (Tracking balance) volume clockwise 45° from the center.</li> <li>● Adjust with VR7 TRK.OFS (Tracking offset) volume so that the voltage of pin 2 TRK.ERR (Tracking error) of TP1 becomes 0V ± 50mV.</li> <li>● Adjust VR6 FCS.OFS (focus offset) so that the FCS.ERR (focus error) voltage at TP1 pin 6 becomes 0V ± 50mV.</li> <li>● Adjust VR2 RF.OFS (RF offset) so that the RF output voltage at TP1 pin 1 becomes 100mV ± 50mV.</li> </ul>
<b>2 RF LEVEL ADJUSTMENT</b>						
			TP1 Pin 1 (RF)	VR1 Laser power	1.5Vp-p <sup>+0.2V</sup> / <sub>-0V</sub>	<ul style="list-style-type: none"> <li>● Set to Service mode.</li> <li>● Play TEST disc and connect probe of an oscilloscope to pin 1 RF (RF output) of TP1 and measure the P-P voltage of RF waveform.</li> <li>● Adjust VR1 (Laser power) so that the value is within 1.5Vp-p <sup>+0.2V</sup>/<sub>-0V</sub>.</li> </ul>
<b>3 LD (LASER DIODE) OUTPUT POWER CONFIRMATION</b>						
					Confirmation : less than 0.13mW	<ul style="list-style-type: none"> <li>● Set to Service mode.</li> <li>● Press <b>[MULTI-SPEED+]</b> key + <b>[0]</b> and turn ON LD (laser diode).</li> <li>● Place sensor of the laser power meter immediately above the object lens and confirm that the output power of the LD is less than 0.13mW.</li> </ul>
<b>4 FOCUS LOCK AND SPINDLE LOCK CONFIRMATION</b>						
	0.5V/div	100msec / div	TP1 Pin 1 (RF output)		RF output exists  Normal rotation	<ul style="list-style-type: none"> <li>● Set TEST disc.</li> <li>● Set to Service mode.</li> <li>● Shift the pickup close to the center of the disc by pressing the <b>[MULTI-SPEED+]</b> key + <b>[4]</b>. * Note that this step must be performed.</li> <li>● Observe pin 1 RF (RF output) of TP1 with an oscilloscope and confirm that the RF signal is output after pressing the <b>[MULTI-SPEED+]</b> key + <b>[1]</b>.</li> <li>● Press <b>[MULTI-SPEED+]</b> key + <b>[2]</b> and be sure that the disc rotates in normal direction at almost the specified speed (as it is close to the center of the disc, the rotating speed is around 300 rpm) and not rotates abnormally or inversely.</li> </ul>

Step No.	Oscilloscope Setting		Test Points	Adjusting Points	Check items/ Adjustment specifications	Adjustment procedure
	V	H				
<b>5 GRATING ADJUSTMENT</b>						
						<ul style="list-style-type: none"> <li>● Set to Service mode.</li> <li>● Shift the pickup close to the center of the disc by pressing <b>[MULTI-SPEED+]</b> key + <b>[4]</b> so that the grating adjustment screw of the pickup can be seen through the oval hole of the upper side of the servo mechanism.</li> <li>● Insert the ⊖ screwdriver into the adjusting hole from the upper side of the mechanism as shown in Fig. 7-7, and confirm that the grating screw turns.</li> <li>● Press <b>[MULTI-SPEED+]</b> key + <b>[1]</b> and <b>[MULTI-SPEED+]</b> key + <b>[2]</b> sequentially and close the focus servo and spindle servo. (Do not close the tracking servo.)</li> <li>● Observe the waveform of pin 2 TRK. ERR (Tracking error) of TP1 with an oscilloscope. At this point, insert a 4kHz cutoff low-pass filter. (Fig. 7-8)</li> </ul>
						  <p style="text-align: center;">Fig. 7-7</p>
						 <p style="text-align: center;">Fig. 7-8</p>
	0.5V/div	5msec /div	TP1 Pin 2 (TRK. ERR)	Grating  Grating	Null point  Maximum amplitude	<ul style="list-style-type: none"> <li>● Turn the ⊖ screwdriver and find null point. (Photo. 7-1)</li> <li>● Then, turn slowly the ⊖ screwdriver counterclockwise from the null point and adjust at the point where the waveform (Tracking error signal) firstly becomes maximum amplitude. (See Photo. 7-2.)</li> </ul> <p>Note :</p> <p>If the ⊖ screwdriver is pressed strongly, the pickup moves toward disc center, accordingly adjustment becomes difficult.</p> <ul style="list-style-type: none"> <li>● Finally, be sure to confirm that the tracking error signal (at this time, 4kHz of cutoff low-pass filter is not inserted) when the pickup is moved toward the disc center and the P-P voltage of the tracking error signal at the outer circumference of the disc are not varied greatly. When the level is deviated over ±10%, adjust again by turning grating screw to the maximum error amplitude point.</li> </ul>

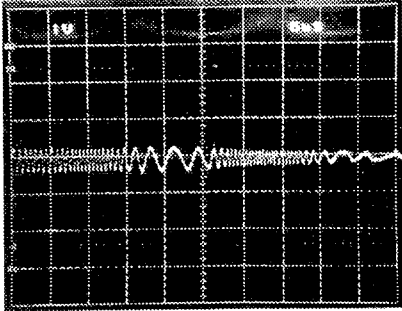

Photo. 7-1  
Null point

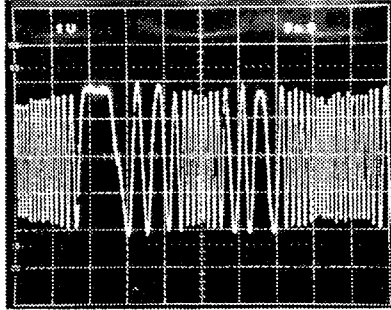

Photo. 7-2  
Maximum amplitude

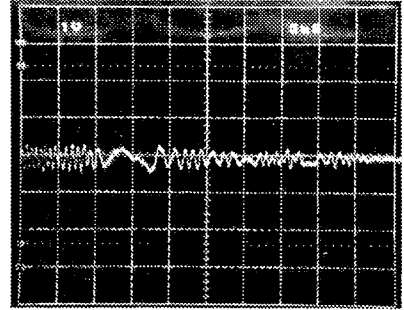

Photo. 7-3  
This is not the null-point waveform

Step No.	Oscilloscope Setting		Test Points	Adjusting Points	Check items/ Adjustment specifications	Adjustment procedure
	V	H				
<b>6 TRACKING BALANCE ADJUSTMENT</b>						
	0.5V/div	5msec /div	TP1 Pin 2 (TRK. ERR)	VR5 (TRK. BAL)	(TRK. ERR)	<ul style="list-style-type: none"> <li>● Set the TEST disc.</li> <li>● Set to Service mode.</li> <li>● Shift the carriage close to the center of the disc by pressing <b>[MULTI-SPEED+]</b> key + <b>[4]</b>.</li> <li>● Press <b>[MULTI-SPEED+]</b> key + <b>[1]</b> and <b>[MULTI-SPEED+]</b> key + <b>[2]</b> to start turning the disc.</li> <li>● Observe pin 2 TRK.ERR (Tracking error) of TP1 with an oscilloscope and adjust with VR5 TRK. BAL (Tracking balance) volume so that the DC component of the tracking error disappears.</li> </ul> <p>Note: Before proceeding with the above adjustments, be sure to adjust the tracking error offset.</p>
			<p>Photo. 7-4 DC elements mixed in signal</p>		<p>Photo. 7-5 DC elements eliminated</p>	

Step No.	Oscilloscope Setting		Test Points	Adjusting Points	Check items/ Adjustment specifications	Adjustment procedure
	V	H				
<b>7 TANGENTIAL ADJUSTMENT</b>						
		200nsec / div	TP1 Pin 1 (RF output)	Tangential adjustment screw	Best eye pattern	<ul style="list-style-type: none"> <li>● Set the TEST disc.</li> <li>● Set to Service mode.</li> <li>● Shift the pickup close to the center of the disc by pressing <b>[MULTI-SPEED+]</b> key + <b>[4]</b>.</li> <li>● Press <b>[MULTI-SPEED+]</b> key + <b>[1]</b>, <b>[MULTI-SPEED+]</b> key + <b>[2]</b> and <b>[MULTI-SPEED+]</b> key + <b>[3]</b> sequentially, and close all the servos. (Pause indicator lights up.)</li> <li>● Observe pin 1 RF (RF output) of TP1 with an oscilloscope and adjust with the tangential screw so that the eye pattern becomes clear. (Fig. 7-9 and 7-10)</li> <li>● The adjusting point is the middle point between the point where the eye pattern becomes deteriorate by turning the tangential screw clockwise and the point where the eye pattern becomes deteriorate by turning the tangential screw counterclockwise. As a criterion, observe that the overall waveform is clear and one of the diamond shapes within the eye pattern (Photo. 7-7), and adjust at as an optimum point where the diamond shape is seen relatively fine line.</li> </ul>

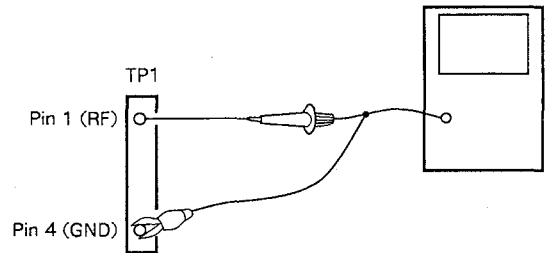
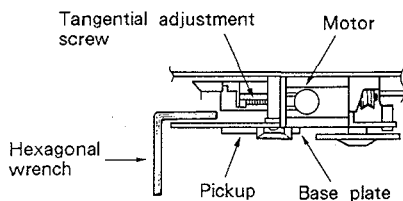

Fig. 7-9

Note : During the adjustment, hold hexagonal wrench to upward so as to keep the pickup body not goes down.



In the figure below, the top and bottom is opposite to that of the actual product.

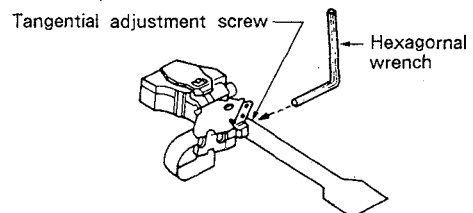

Fig. 7-10 Tangential adjustment

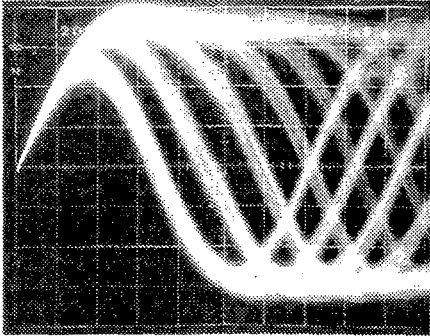

Photo. 7-6

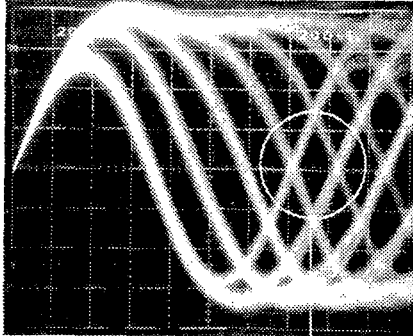

Photo. 7-7

Part to be observed

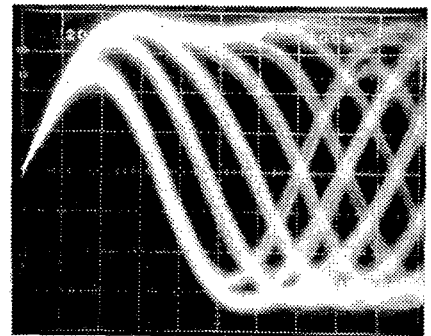
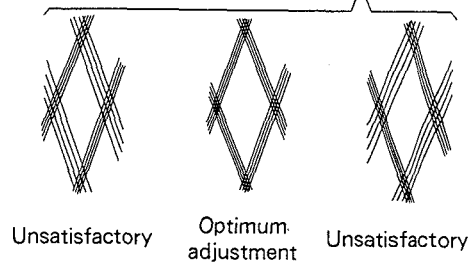

Photo. 7-8



Step No.	Oscilloscope Setting		Test Points	Adjusting Points	Check items / Adjustment specifications	Adjustment procedure
	V	H				
<b>8 FOCUS GAIN ADJUSTMENT</b>						
	20mV/div, 5mV/div. CH1 (X), CH2 (Y) (Probe 10 : 1)	X axis : TP1 Pin 5 (FCS. IN) Y axis : TP1 Pin 6 (FCS. ERR)	VR3 (FCS. GAN)	Phase difference 90°	<ul style="list-style-type: none"> <li>● In the POWER OFF state, connect an oscilloscope and oscillator as shown in Fig. 7-11.</li> <li>● Set the unit to the normal PLAY mode.</li> <li>● Turn the POWER of oscillator ON and output 1.2kHz 1Vp-p.</li> </ul> <p>Note : Depending upon oscillators, some of them output DC when their power turned ON. Therefore, it is desirable to connect oscillator after turning the power ON.</p> <ul style="list-style-type: none"> <li>● Adjust with VR3 FCS.GAN (Focus gain) volume so that the lissajous figure of the oscilloscope becomes horizontal circle (Phase difference 90°).</li> </ul>	

Fig. 7-11

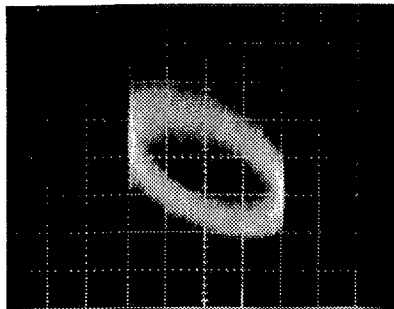

Photo. 7-9  
Gain overcompensated

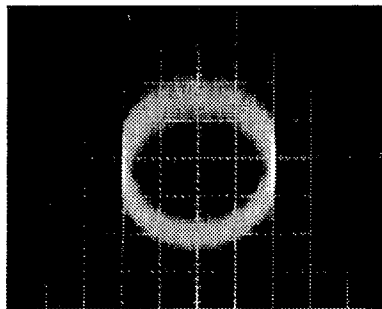

Photo. 7-10  
Gain optimum

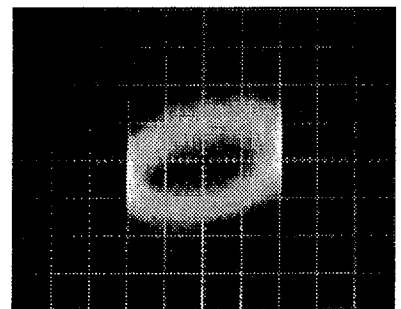

Photo. 7-11  
Gain undercompensated

Step No.	Oscilloscope Setting		Test Points	Adjusting Points	Check items/ Adjustment specifications	Adjustment procedure
	V	H				
<b>9</b>	<b>TRACKING GAIN ADJUSTMENT</b>					
	50mV/div, 5mV/div. CH1 (X), CH2 (Y) (Probe 10 : 1)	X axis : TP1 Pin 3 (TRK. IN) Y axis : TP1 Pin 2 (TRK. ERR)	VR4 (TRK. GAN)	Phase difference 90°	<ul style="list-style-type: none"> <li>● In the POWER OFF state, connect an oscilloscope and oscillator as shown in Fig. 7-12.</li> <li>● Set the unit to the normal PLAY mode.</li> <li>● Turn the POWER of oscillator ON and output 1.2kHz 2Vp-p.</li> </ul> <p>Note : Depending upon oscillators, some of them output DC when their power turned ON. Therefore, it is desirable to connect oscillator after turning the power ON.</p> <ul style="list-style-type: none"> <li>● Adjust with VR4 TRK. GAN (Tracking gain) volume so that the lissajous figure of the oscilloscope becomes horizontal circle (phase difference 90°).</li> </ul>	

Fig. 7-12

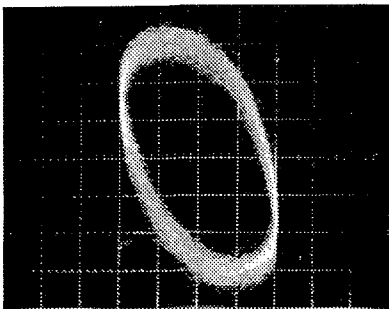

Photo. 7-12  
Gain overcompensated

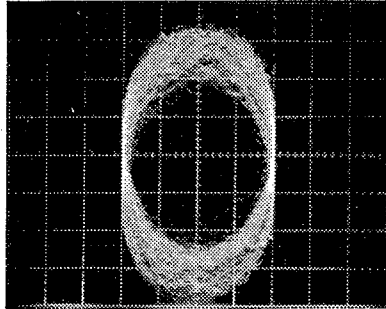

Photo. 7-13  
Gain optimum

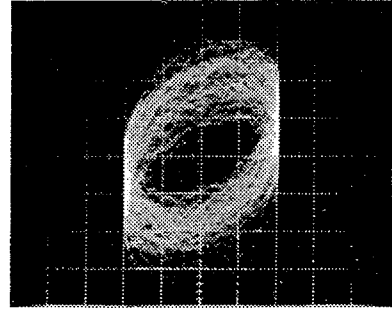
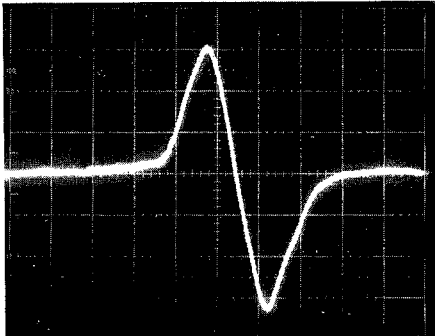

Photo. 7-14  
Gain undercompensated

Step No.	Oscilloscope Setting		Test Points	Adjusting Points	Check items/ Adjustment specifications	Adjustment procedure
	V	H				
<b>10</b>	<b>VCO FREE RUN FREQUENCY ADJUSTMENT</b>					
			TP2 Pin 8 (PLCK)	VR8 (VCO. ADJ)	4.275 ± 0.01MHz	<ul style="list-style-type: none"> <li>● Set to Service mode.</li> <li>● Short-circuit between pin 25 and pin 26 of IC1 in the DEGT assembly with ⊖ screwdriver, etc. (Fig. 7-6)</li> <li>● Connect frequency counter, which is measurable over 10MHz, to pin 8 of TP2 (PLCK).</li> <li>● Adjust with VR8 VCO. ADJ (VCO adjustment) volume so that the value of frequency counter becomes 4.275 ± 0.01MHz.</li> </ul>
<b>11</b>	<b>METHOD TO CONFIRM S CHARACTER (FOCUS ERROR)</b>					
			TP1 Pin 6 (FCS. ERR)			<ul style="list-style-type: none"> <li>● Set to Service mode.</li> <li>● Short-circuit between pin 5 FCS.IN (Focus in) of TP1 and GND.</li> <li>● Press <b>[MULTI-SPEED+]</b> key + <b>[I]</b> and observe the waveform of pin 6 FCS.ERR (Focus error) of TP1 at that time with an oscilloscope.</li> </ul>
						
<p>Photo. 7-16 Focus error</p>						



## 8. IC DESCRIPTION

### ■ PD0073

System control

#### ● Pin functions

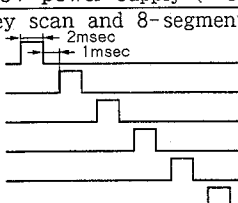
Pin	Pin name	I/O	Function	Pin	Pin name	I/O	Function																				
1	Vcc		+ 5V power supply ( $\pm 5\%$ )	25	R/W	O	Bus timing signal for access the ROM peripheral.																				
2	DRV6	O	Key scan and 8-segment LED drive. 	26	INT1	I	Interrupt signal by diode OR to the input signal of the coin and bill.																				
3	DRV5			27	CNVss			Connect to Vss																			
4	DRV4			28	RESET	I		Reset input																			
5	DRV3			29	Xin	I		Clock input																			
6	DRV2			30	Xout	O		Clock output																			
7	DRV1			31	$\phi$	O		Bus timing signal for access the ROM peripheral.																			
8	SLP1			O	CD player channel selector. Control the IC4. <table border="1" data-bbox="303 828 734 985"> <thead> <tr> <th>SLP0</th> <th>SLP1</th> <th>ON channel of IC4</th> <th>CD player</th> </tr> </thead> <tbody> <tr> <td>1</td> <td>1</td> <td>Y0, X0</td> <td>PL1</td> </tr> <tr> <td>1</td> <td>0</td> <td>Y1, X1</td> <td>PL2</td> </tr> <tr> <td>0</td> <td>1</td> <td>Y2, X2</td> <td>PL3</td> </tr> <tr> <td>0</td> <td>0</td> <td>Y3, X3</td> <td>N.C.</td> </tr> </tbody> </table>	SLP0	SLP1	ON channel of IC4	CD player	1	1	Y0, X0	PL1	1	0	Y1, X1	PL2	0	1	Y2, X2	PL3	0	0	Y3, X3	N.C.	32	Vss
SLP0	SLP1	ON channel of IC4	CD player																								
1	1	Y0, X0	PL1																								
1	0	Y1, X1	PL2																								
0	1	Y2, X2	PL3																								
0	0	Y3, X3	N.C.																								
9	SLP0	33	DTR3	I		Data terminal ready from the CD player 3. 0 at connecting the CD player.																					
10	N.C.	O	Non connection	34	DTR2	I	Data terminal ready from the CD player 2. 0 at connecting the CD player.																				
11	N.C.			35	DTR1	I		Data terminal ready from the CD player 1. 0 at connecting the CD player.																			
12	N.C.			36	DOOR	I		Door switch input. 0 at close.																			
13	N.C.			37	ROTASW	I		Rotation stop position signal of the menu board. 0 at stop position.																			
14	N.C.			38	KEY3	I		Key scan input.																			
15	N.C.			39	KEY2																						
16	N.C.			40	KEY1																						
17	COUNT	O	Mechanical counter drive output	41	A15	O	Address of IC3  Address bus for access the IC3 (RAM) and IC2 (I/O controller) peripheral. Address RAM : IN3 $2\phi\phi\phi - 3FFF$ Peripheral : IC2 $4\phi\phi\phi - 4\phi\phi7$																				
18	BUZZER	O	Buzzer drive output	42	A14																						
19	COIN	I	Money received signal from the coin acceptor (Normal : 1 Money received : 0 for about 45 through 50msec.	43	A13																						
20	TxD	O	Asynchronous serial Baud rate : 4800bps Data bit : 8bit Stop bit : 1bit Command transmission to the CD player.	44	A12																						
21	RxD	I	Asynchronous serial Baud rate : 4800bps Data bit : 8bit Stop bit : 1bit Status reception from the CD player.	45	A11																						
22	TmrXin	I	Pulse signal input for control the menu board rotation. Normal speed 1.6kHz.	46	A10																						
23	INT2	I/O	Generally, use for the port. Set to input at the rising up the power only, and estimate the OFF time of the power either discharge the capacitor or not. After the confirmation, output 1 and charge it. This function is for clearing the music selection and credit of the previous day.	47	A09																						
24	N.C.	O	Non connection	48	A08																						
				49	A07																						
				50	A06																						
				51	A05																						
				52	A04																						
				53	A03																						
				54	A02																						
				55	A01																						
				56	A00																						
				57	D07																						
				58	D06																						
				59	D05																						
				60	D04																						
				61	D03																						
				62	D02																						
				63	D01																						
				64	D00																						

■ STK4231-2

2 channel AF power amplifier

● Block diagram

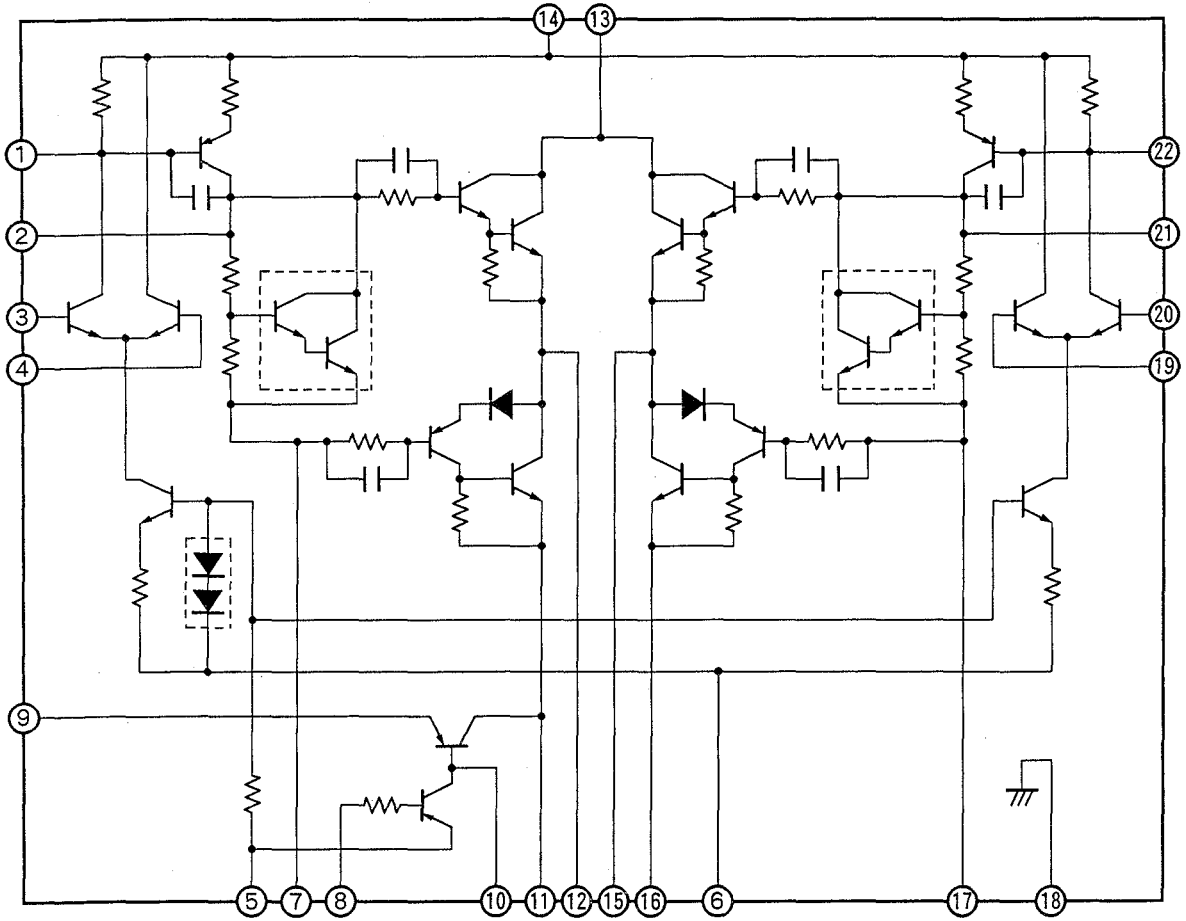

■ CXD1095Q

I/O controller

● Pin function

Pin	Pin name	I/O	Function	Pin	Pin name	I/O	Function		
1			Non connection	34			Non connection		
2			Non connection	35	D3	I/O	Data bus for access the RAM and microcomputer.		
3	\$ 5	I	Bill validator signal	36	D4				
4	UP SW	I	VR UP key input from the wired-remote control.	37	D5				
				38	D6				
5	DOWN SW	I	VR DOWN key input from the wired-remote control.	39	D7				
6	UP	O	Auto VR : Signal for increase the volume.	40	CLR	I	Non connection (pull up at the internal)		
7	DOWN	O	Auto VR : Signal for decrease the volume.	41	OPEN	I	Enable signal of the data transmission and reception with the microcomputer.		
8	OVER	O	Signal for bill box becomes full.	42	Vss		(GND)		
9	REJECT	O	Coin box reception prohibition signal.	43	WR	I	Timing signal for access the RAM and microcomputer.		
10	Vss		(GND)	44	RD (OE)				
11	PC0	I	Input port from the DIP switch.	45	CS				
12	PC1					46	A0	I	Address bus for access the RAM and microcomputer.
13	PC2					47	A1		
14	PC3					48	A2		
15	PC4					49	SL1	O	Selection control signal of CDP audio input.
16	PC5					50	SL0		
17	PC6					51			Non connection
18	PD7					52	FULL	I	Bill validator signal. (Not used)
19			Non connection	53	CANCEL SW	I	Cancel key input from the wired-remote control.		
20	SEG 'dp'	O	Segment drive signal of the 7-seg LED.	54	DEP	O	LED display output signal. "DEPOSIT CASH"		
21	SEG 'g'					55	MAKE	O	LED display output signal. "MAKE SELECTION"
22	SEG 'f'					56	PUSH	O	LED display output signal. "ROTATE MENU"
23	SEG 'e'					57			(GND)
24	SEG 'd'					58			(+ 5V)
25	Vss		(GND)	59	NUM	O	LED display output signal. Numeric keys.		
26	VDD		(+ 5V)	60	BHT	O	LED display output signal. "BEST HITS"		
27	SEG 'c'	O	Segment drive signal of the 7-seg LED.	61	CLR	O	LED display output signal. "CLEAR"		
28	SEG 'b'					62	MENU	O	Motor drive signal for rotate the menu board.
29	SEG 'a'					63	MUTE	O	Audio mute signal.
30	D0	I/O	Data bus for access the RAM and microcomputer.	64	\$ 1	I	Bill validator signal.		
31	D1								
32	D2								
33			Non connection						

## 9. NOTES ON REPLACING THE LITHIUM CELL AND RAM (IC3 : TC5564APL - 15)

- When replacing the Lithium cell (DEM1001) in the CONT unit of the commander block, clear RAM data in the following manner.

If the data is not cleared, a malfunction may occur.

### ● How to clear

1. Set the power switch to OFF and all the function switches of the commander block to ON.
2. While simultaneously pressing four keys, the volume + and - keys and the cancel A and B keys on the remote control unit, set the power switch to ON. A buzzer sounds in a few seconds, indicating that the clear operation is completed.

(Note : An error may occur if you set the power switch to OFF while pressing these four keys.)

When the data is cleared, the rate settings return to their default values (3 tunes/1\$, 18 tunes/5\$) and all other data become 0.

Be careful when performing this operation as it sets even the non-resettable data all to 0.