

Service Manual

 **PIONEER®**
The Art of Entertainment

ORDER NO.
ARP2270

CD CDV LD PLAYER

CLD-31_{KU}

CLD-1091_{KC}

- Refer to the service manual ARP2225, CLD-1090.
- This manual is applicable to the CLD-31/KU and CLD-1091/KC types.

1. CONTRAST OF MISCELLANEOUS PARTS

- NOTES:**
- Parts without part number cannot be supplied.
 - Parts marked by "⊙" are not always kept in stock. Their delivery time may be longer than usual or they may be unavailable.
 - The Δ mark found on some component parts indicates the importance of the safety factor of the part. Therefore, when replacing, be sure to use parts of identical designation.

The CLD-31/KU and CLD-1091/KC types are the same as the CLD-1090/KUC type with the exception of the following sections.

Mark	Symbol & Description	Part No.			Remarks
		CLD-1090/KUC type	CLD-31/KU type	CLD-1091/KC type	
⊙	MOTHER assembly	VWM1159	VWM1169	VWM1169	
	MAIN assembly	Non supply	Non supply	Non supply	
⊙	SYNR assembly	VWV1197	VWV1197	
	4P mini DIN cable	DDE1040	DDE1040	
	Front door assembly	VXA1572	VXA1633	VXA1572	
	Door assembly - S	VXX1633	VXX1654	VXX1633	
	Front panel assembly - S	VXX1645	VXX1652	VXX1646	
	Packing case	VHG1143	VHG1167	VHG1166	For packing

MAIN ASSEMBLY

The MAIN assembly of the CLD-31/KU and CLD-1091/KC types are the same as that of the CLD-1090/KUC type with the exception of the following parts.

Mark	Symbol & Description	Part No.			Remarks
		CLD-1090/KUC type	CLD-31/KU type	CLD-1091/KC type	
	IC101	PD0081C	PD0081B1	PD0081B1	
	IC205	NJM78L08A	NJM78M08FA	NJM78M08FA	
	IC206	NJM79L08A	NJM79M08FA	NJM79M08FA	
	IC211,IC213	NJM4580L	NJM5532SD	NJM5532SD	
	IC406	TA7302P	
	Q551,Q553,Q557,Q582,Q583	2SC1740S	
	Q552,Q556	2SA933S	
	Q554,Q581	2SA1037K	
	D203,D204	1SS254	
	F401	VTF1042	
	L222	VTH1013	
	L224,L231,L234	VTH1015	VTH1015	
	L232,L233	LAU180J	LAU180J	
	L354,L355	LAU101J	
	L551	LAU120J	
	L552	LAU470J	
	L553	LAU180J	
	C208,C257,C267	CEAS470M10	VCH1101	VCH1101	
	C216,C275	CEAS221M6R3	VCH1102	VCH1102	
	C241	CEAS221M50	VCH1098	VCH1098	
	C242,C244	CEAS221M10	VCH1099	VCH1099	
	C246,C261,C263	CEAS470M10	VCH1100	VCH1100	
	C251,C273	CEAS470M10	VCH1102	VCH1102	
	C252,C274	CKPUYF223Z25	
	C253,C255,C269,C271	CCCCH390J50	CCPUSL390J50	CCPUSL390J50	

Mark	Symbol & Description	Part No.			Remarks
		CLD-1090/KUC type	CLD-31/KU type	CLD-1091/KC type	
	C254,C256,C270,C272 C259,C265 C279,C329 C281,C283,C331,C333 C285,C335	CCCSL471J50 CEAS470M10 CQMA222J50 CEAS101M10 CEAS470M25	CFTXA471J50 VCH1103 CFTXA222J50 VCH1100 VCH1104	CFTXA471J50 VCH1103 CFTXA222J50 VCH1100 VCH1104	
	C296 C345 C437 C438 C551 CFTNA393J50 CCSQCH270J50 CCSQCH100D50 CEAS101M10	VCH1099 CCSQCH100D50 CCSQCH150J50	VCH1099 CCSQCH100D50 CCSQCH150J50	
	C552,C560,C561,C564,C584,C585 C553 C554,C563,C586 C555,C567,C581 C556	CKSQYF104Z25 CCSQCH181J50 CCSQCH101J50 CKSQYF473Z25 CEAS010M50	
	C557 C558,C559,C562 C582 C583 C859	CCSQCH150J50 CKSQYF103Z50 CEAS221M6R3 CEAS471M6R3 CEAS471M6R3 CEAS102M6R3 CEAS102M6R3	
	R299 R340,R344 R347,R348 R349 R551 RS1/10S123J RD1/6PM472J RS1/10S470J	RS1/10S823J VCNI029	RS1/10S823J VCNI029	
	R552 R553 R555 R556 R558	RD1/6PM102J RD1/6PM222J RS1/10S471J RD1/6PM821J RS1/10S152J	
	R559 R560 R561 R562 R563,R564	RS1/10S331J RS1/10S103J RS1/10S333J RS1/10S182J RD1/6PM332J	
	R565 R566 R567 R568 R569,R582	RS1/10S332J RS1/10S681J RS1/10S392J RD1/6PM331J RS1/10S122J	
	R570 R571 R572,R573 R581,R584 R583	RS1/10S680J RS1/10S472J RS1/10S101J RS1/10S561J RD1/6PM680J RD1/6PM680J	
	R585 JA4(AUDIO,VIDEO OUT) JA6(S VIDEO OUT) JA7(VHF ADAPTER OUTPUT)	RD1/6PM470J VKB1030 VKB1029 VKB1034 VKN1072 VKB1034 VKN1072	

© SYNRA Assembly (VWV1197)

SEMICONDUCTORS

Mark	Symbol & Description	Part No.
	IC3	CXA1413L
	IC1,IC2	CXL5504P
	IC4	TA7302P
	Q2-Q5,Q8,Q14,Q16,Q24,Q26,Q28, Q30	2SA933S
	Q1,Q6,Q7,Q9-Q13,Q15,Q17-Q23, Q25,Q27,Q29	2SC1740S

COILS

Mark	Symbol & Description	Part No.
	L1,L4,L6,L9,L10,L13-L16 L18,L19	LAU100J LAU150J
	L7,L20,L22	LAU180J
	L2,L3,L25	LAU220J
	L11,L12,L17	LAU4R7K
	L24	LAU470J
	L8,L21,L23	LAU680J

CAPACITORS

Mark	Symbol & Description	Part No.
	VC1 Ceramic trimmer (45p)	VCM1002
	C23,C57,C62	CCCCH050C50
	C24,C58,C61	CCCCH070D50
	C4,C20,C54,C63	CCCCH100D50
	C25,C28,C30,C31,C33,C35,C37	CCCCH121J50
	C71	CCCCH150J50
	C2,C47,C49	CCCCH151J50
	C29,C32,C36	CCCCH181J50
	C21,C55,C64	CCCCH330J50
	C48	CCCCH390J50
	C22,C56,C65	CCCCH560J50
	C50,C51	CCCCH680J50
	C5,C52	CCCCH820J50
	C11,C26,C43,C59	CEAS010M50
	C10,C16,C17,C18,C60,C66,C73, C75-C77,C79	CEAS101M10
	C8,C12,C19,C46,C53,C74	CEAS220M25
	C1,C3,C6,C7,C9,C13-C15,C27,C34, C38-C42,C44,C45,C68-C70,C72, C78	CKPUYY103N16

RESISTORS

Mark	Symbol & Description	Part No.
	VR3 Semi-fixed (1k Ω)	VRTB6VS102
	VR1,VR2,VR4 Semi-fixed(4.7k Ω)	VRTB6VS472
	Other resistors	RD1/6PM□□□J

OTHERS

Mark	Symbol & Description	Part No.
	X1 Crystal resonator	VSS1048

2. SCHEMATIC AND P.C. BOARDS DIAGRAM

2.1 OVERALL WIRING DIAGRAM

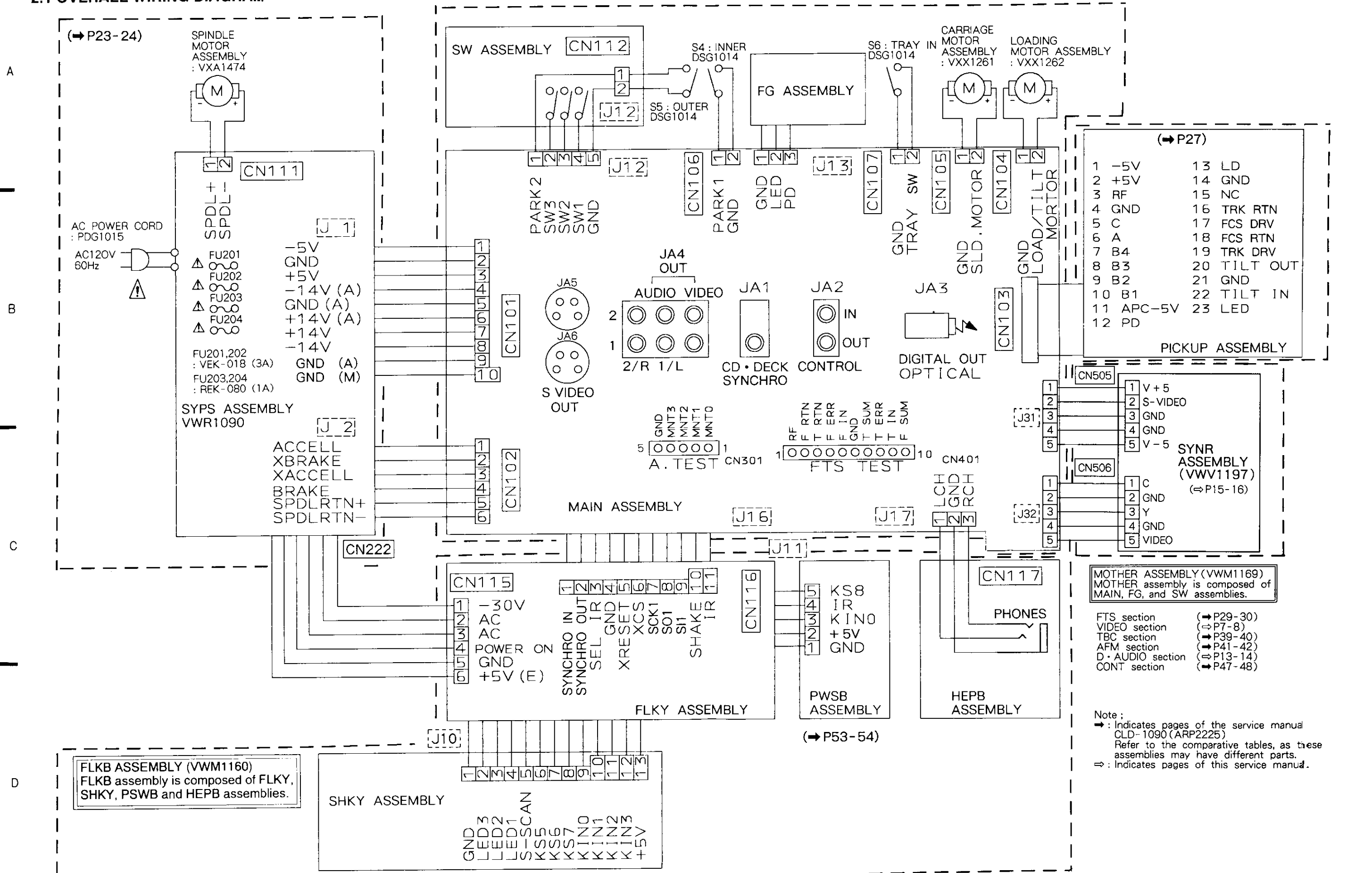

(⇒P27)

1	-5V	13	LD
2	+5V	14	GND
3	RF	15	NC
4	GND	16	TRK RTN
5	C	17	FCS DRV
6	A	18	FCS RTN
7	B4	19	TRK DRV
8	B3	20	TILT OUT
9	B2	21	GND
10	B1	22	TILT IN
11	APC-5V	23	LED
12	PD		

(⇒P15-16)

1	V + 5
2	S-VIDEO
3	GND
4	GND
5	V - 5

(⇒P29-30)

1	K S8
2	IR
3	K IN0
4	+5V
5	GND

(⇒P53-54)

1	SHAKE
2	IR
3	SHAKE
4	IR
5	SHAKE
6	IR
7	SHAKE
8	IR
9	SHAKE
10	IR
11	SHAKE
12	IR
13	SHAKE
14	IR
15	SHAKE
16	IR
17	SHAKE
18	IR
19	SHAKE
20	IR
21	SHAKE
22	IR
23	SHAKE
24	IR
25	SHAKE
26	IR
27	SHAKE
28	IR
29	SHAKE
30	IR
31	SHAKE
32	IR
33	SHAKE
34	IR
35	SHAKE
36	IR
37	SHAKE
38	IR
39	SHAKE
40	IR
41	SHAKE
42	IR
43	SHAKE
44	IR
45	SHAKE
46	IR
47	SHAKE
48	IR
49	SHAKE
50	IR
51	SHAKE
52	IR
53	SHAKE
54	IR
55	SHAKE
56	IR
57	SHAKE
58	IR
59	SHAKE
60	IR
61	SHAKE
62	IR
63	SHAKE
64	IR
65	SHAKE
66	IR
67	SHAKE
68	IR
69	SHAKE
70	IR
71	SHAKE
72	IR
73	SHAKE
74	IR
75	SHAKE
76	IR
77	SHAKE
78	IR
79	SHAKE
80	IR
81	SHAKE
82	IR
83	SHAKE
84	IR
85	SHAKE
86	IR
87	SHAKE
88	IR
89	SHAKE
90	IR
91	SHAKE
92	IR
93	SHAKE
94	IR
95	SHAKE
96	IR
97	SHAKE
98	IR
99	SHAKE
100	IR

2.2 MAIN ASSEMBLY(VIDEO SECTION)

MAIN ASSEMBLY (VIDEO SECTION)

1. RESISTORS:
Indicated in Ω, 1/4W, 1/8W and 1/8W, ±5% tolerance unless otherwise noted k(Ω), M(MΩ), (F): ±1%, (G): ±2%, (K): ±10%, (M): ±20% tolerance.
2. CAPACITORS:
Indicated in μF (voltage(V) unless otherwise noted p.p.F. Indication without voltage is 50V except electrolytic capacitor.
3. VOLTAGE, CURRENT:
□ :DC voltage (V) at no input signal.
Value in () is DC voltage at rated power.
mA :DC current at no input signal.
4. OTHERS:
→:Signal route.
⊗:Adjusting point.
The Δ mark found on some component parts indicates the importance of the safety factor of the part. Therefore, when replacing, be sure to use parts of identical designation.
※:marked capacitors and resistors have parts numbers.
This is the basic schematic diagram, but the actual circuit may vary due to improvements in design.

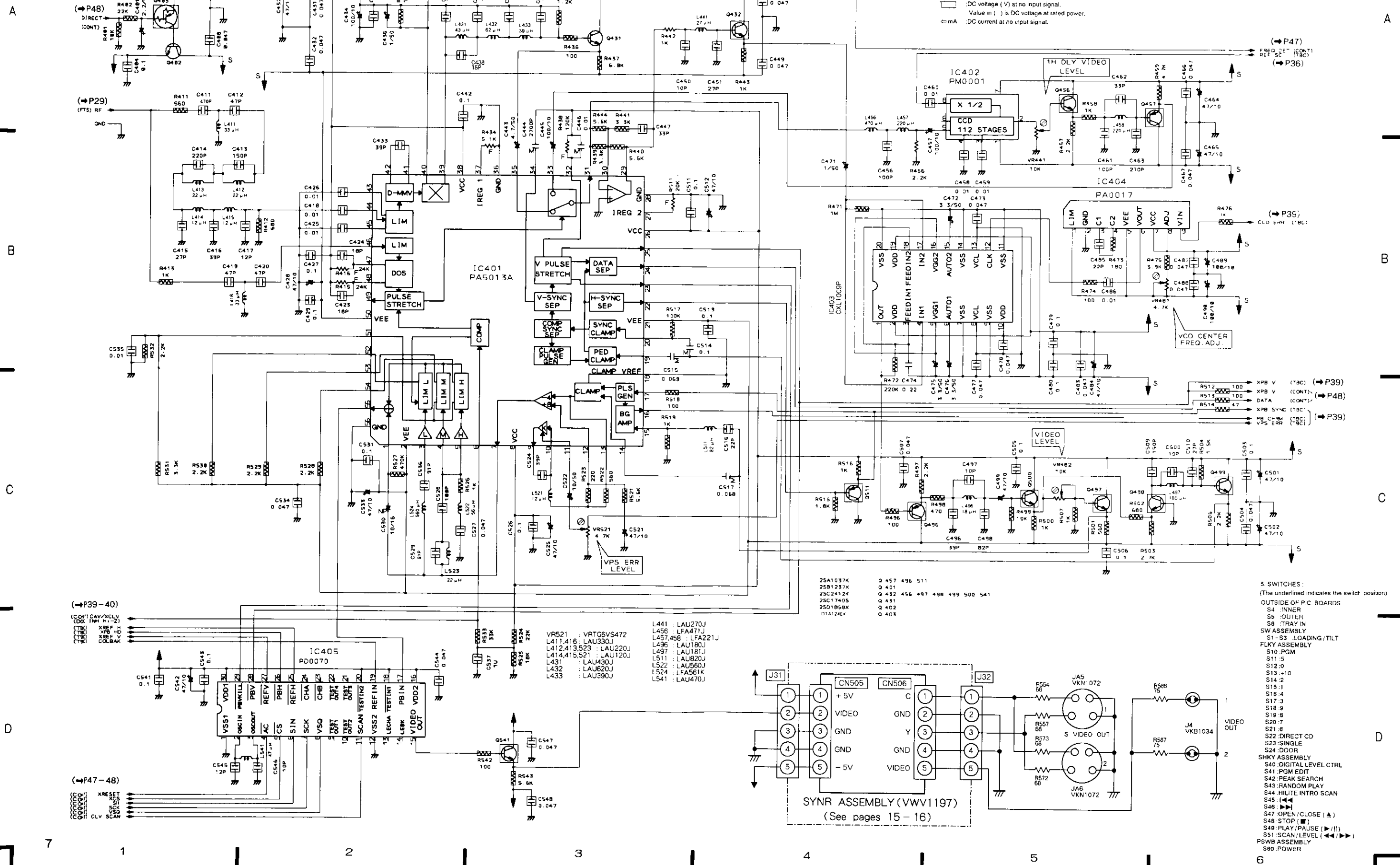

5. SWITCHES:
(The underlined indicates the switch position)
- OUTSIDE OF P.C. BOARDS
- S4 : INNER
 - S5 : OUTER
 - S6 : TRAY IN
- SW ASSEMBLY
- S1 : S3 : LOADING/TILT
- FLKY ASSEMBLY
- S10 : PGM
 - S11 : S
 - S12 : 0
 - S13 : 10
 - S14 : 2
 - S15 : 1
 - S16 : 4
 - S17 : 3
 - S18 : 8
 - S19 : 8
 - S20 : 7
 - S21 : 8
 - S22 : DIRECT CD
 - S23 : SINGLE
 - S24 : DOOR
- SHKY ASSEMBLY
- S40 : DIGITAL LEVEL CTRL
 - S41 : PGM EDIT
 - S42 : PEAK SEARCH
 - S43 : RANDOM PLAY
 - S44 : HILITE INTRO SCAN
 - S45 : [Left Arrow]
 - S46 : [Right Arrow]
 - S47 : OPEN/CLOSE (▲)
 - S48 : STOP (■)
 - S49 : PLAY/PAUSE (||)
 - S51 : SCAN/LEVEL (◀▶)
- PSWB ASSEMBLY
- S60 : POWER

MAIN ASSEMBLY

01S0 T0S0	IC215	IC204	VR605 VR603	1A20 0020 0040 IC405	0040
01S0 Q212 1S0 1S01	IC213 IC206 IC205	IC209 Q204 00S0	VR606 VR609	1100 1040 0040	1080 IC602 IC403 5140 0030 IC404 0080
01S0 01S0 Q209 1S0 00S0 IC351	IC211 Q352 Q351	0180 00S0	VR607 VR604 VR608	1240 0040	1080 0180 IC601 Q602 - Q605 0180
00S0 51S0 IC802 Q815 Q816	IC801	0580 IC201		0040 IC402	1010 0080 IC603 IC101
IC804 Q817 Q818 Q820 0S80 0180	S080 S180 - 1080			0S80 0S80 0080 - 0S80 0080	
TP901	VR601	VR602		VR521 VR482 VR441	TP101
					VR481 VC901

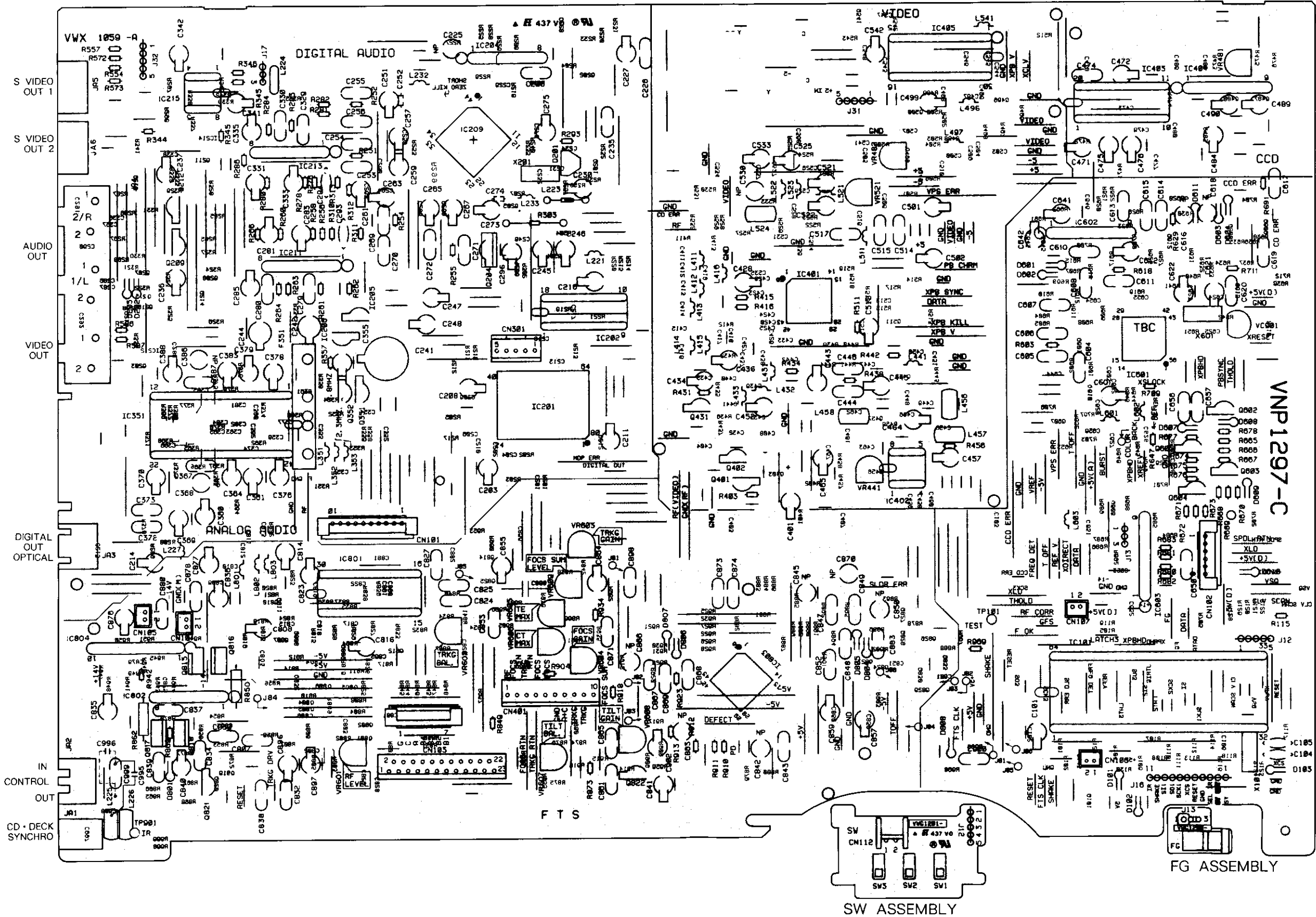

A

B

C

D

A

B

C

D

CLD-1091\KC
CLD-31\KN

MAIN ASSEMBLY

IC804	Q817	Q818	Q825	Q826	Q818	Q832	Q822	Q812	Q818	Q801	Q802	Q803	Q804	Q805	Q806	Q807	Q808	Q809	Q810	Q811	Q812	Q813	Q814	Q815	Q816	Q817	Q818	Q819	Q820	Q821	Q822	Q823	Q824	Q825	Q826	Q827	Q828	Q829	Q830	Q831	Q832	Q833	Q834	Q835	Q836	Q837	Q838	Q839	Q840	Q841	Q842	Q843	Q844	Q845	Q846	Q847	Q848	Q849	Q850	Q851	Q852	Q853	Q854	Q855	Q856	Q857	Q858	Q859	Q860	Q861	Q862	Q863	Q864	Q865	Q866	Q867	Q868	Q869	Q870	Q871	Q872	Q873	Q874	Q875	Q876	Q877	Q878	Q879	Q880	Q881	Q882	Q883	Q884	Q885	Q886	Q887	Q888	Q889	Q890	Q891	Q892	Q893	Q894	Q895	Q896	Q897	Q898	Q899	Q900	Q901	Q902	Q903	Q904	Q905	Q906	Q907	Q908	Q909	Q910	Q911	Q912	Q913	Q914	Q915	Q916	Q917	Q918	Q919	Q920	Q921	Q922	Q923	Q924	Q925	Q926	Q927	Q928	Q929	Q930	Q931	Q932	Q933	Q934	Q935	Q936	Q937	Q938	Q939	Q940	Q941	Q942	Q943	Q944	Q945	Q946	Q947	Q948	Q949	Q950	Q951	Q952	Q953	Q954	Q955	Q956	Q957	Q958	Q959	Q960	Q961	Q962	Q963	Q964	Q965	Q966	Q967	Q968	Q969	Q970	Q971	Q972	Q973	Q974	Q975	Q976	Q977	Q978	Q979	Q980	Q981	Q982	Q983	Q984	Q985	Q986	Q987	Q988	Q989	Q990	Q991	Q992	Q993	Q994	Q995	Q996	Q997	Q998	Q999	Q1000
-------	------	------	------	------	------	------	------	------	------	------	------	------	------	------	------	------	------	------	------	------	------	------	------	------	------	------	------	------	------	------	------	------	------	------	------	------	------	------	------	------	------	------	------	------	------	------	------	------	------	------	------	------	------	------	------	------	------	------	------	------	------	------	------	------	------	------	------	------	------	------	------	------	------	------	------	------	------	------	------	------	------	------	------	------	------	------	------	------	------	------	------	------	------	------	------	------	------	------	------	------	------	------	------	------	------	------	------	------	------	------	------	------	------	------	------	------	------	------	------	------	------	------	------	------	------	------	------	------	------	------	------	------	------	------	------	------	------	------	------	------	------	------	------	------	------	------	------	------	------	------	------	------	------	------	------	------	------	------	------	------	------	------	------	------	------	------	------	------	------	------	------	------	------	------	------	------	------	------	------	------	------	------	------	------	------	------	------	------	------	------	------	------	------	------	------	------	------	------	------	------	------	------	------	------	------	------	------	------	-------

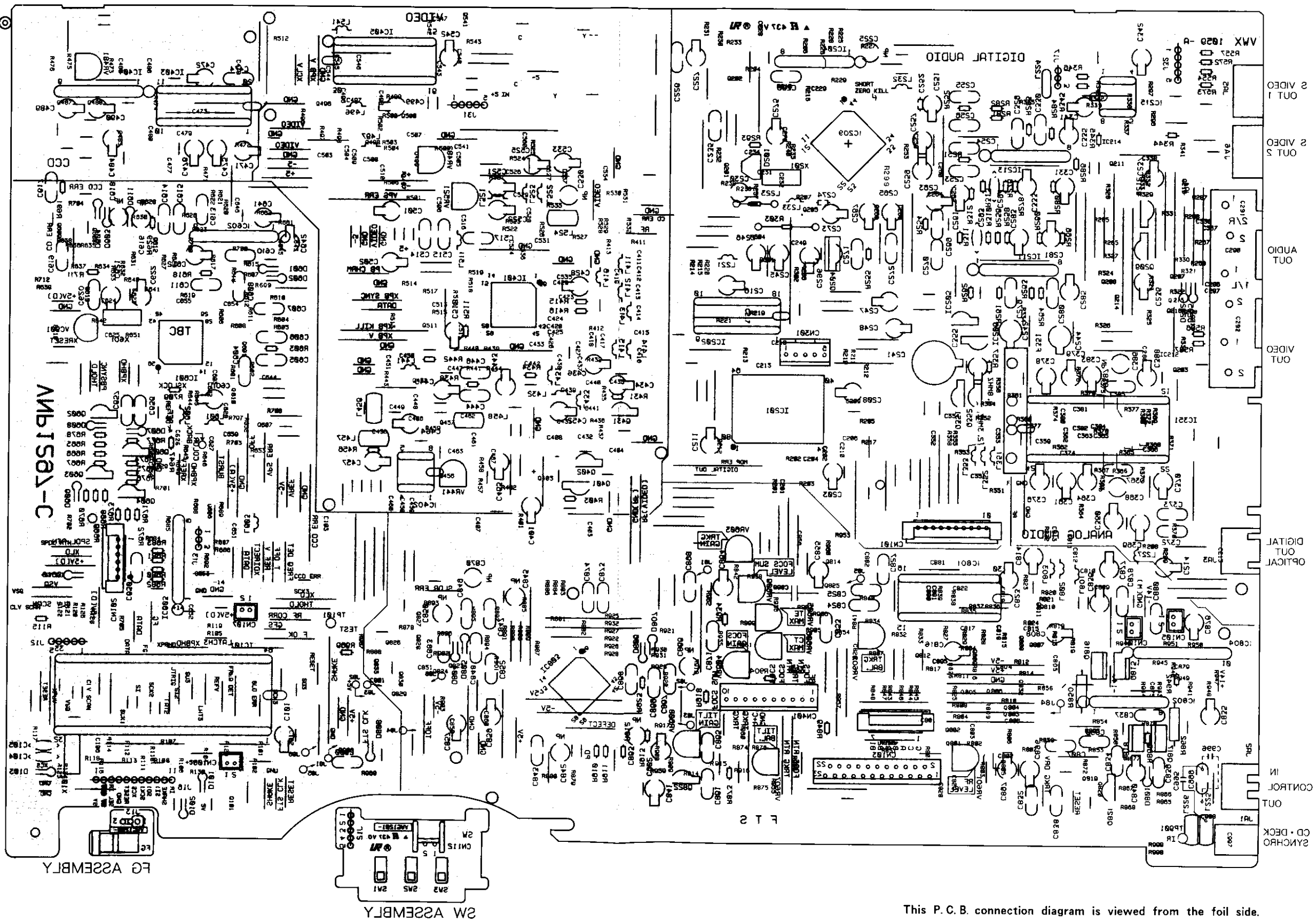

This P.C.B. connection diagram is viewed from the foil side.

2.3 MAIN ASSEMBLY(D·AUDIO SECTION)

MAIN ASSEMBLY (D · AUDIO SECTION)

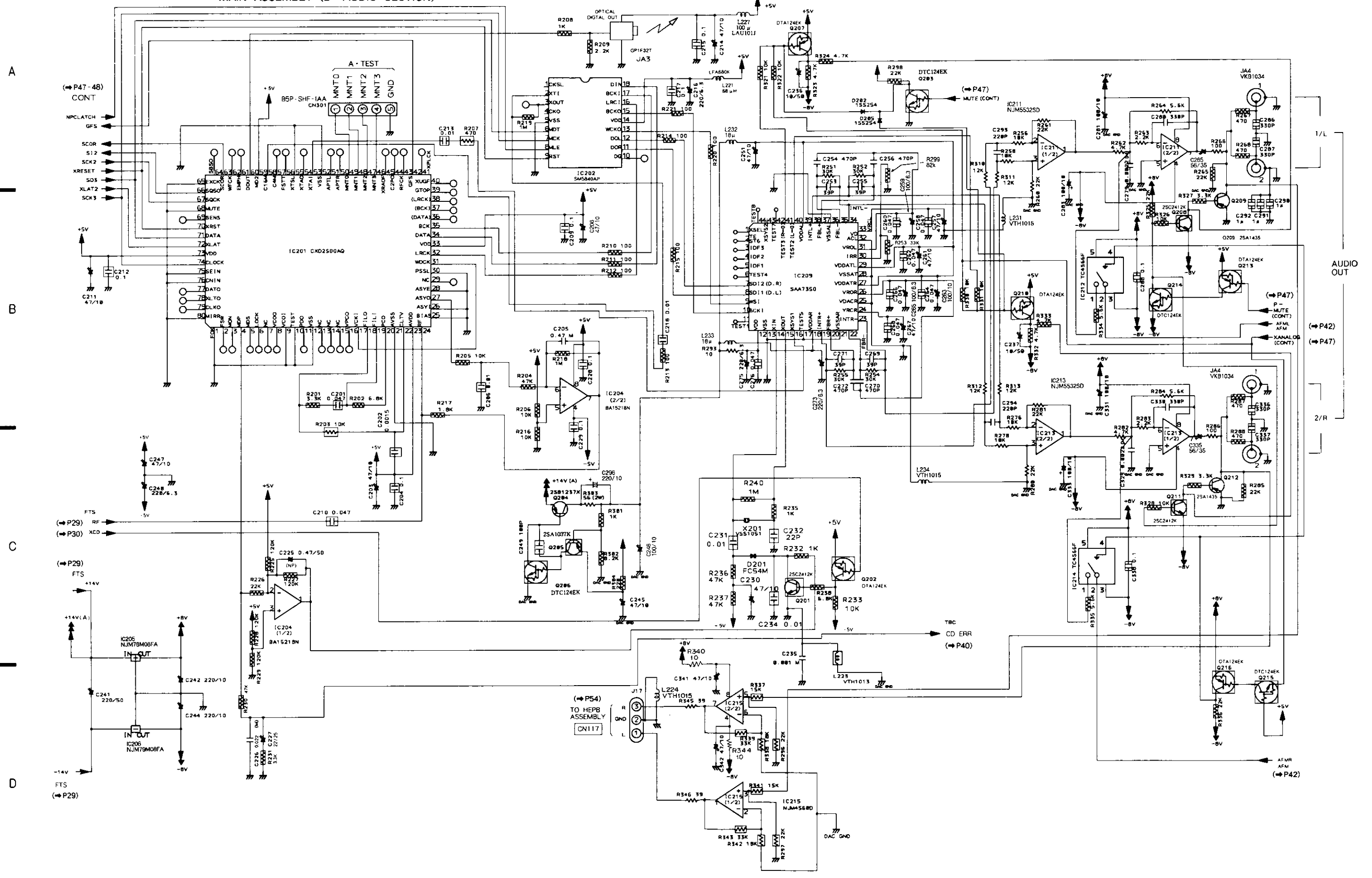

SYNR ASSEMBLY
(VWV1197)

VR1,2,4	: VRTB6VS472	L7,20,22	: LAU180J
VR3	: VRTB6VS102	L8,21,23	: LAU680J
VC1	: VCM1002	L11,12,17	: LAU47K
L1,4,6,9,10,13-16	: LAU100J	L18,19	: LAU150J
L2,3,25	: LAU220J	L24	: LAU470J

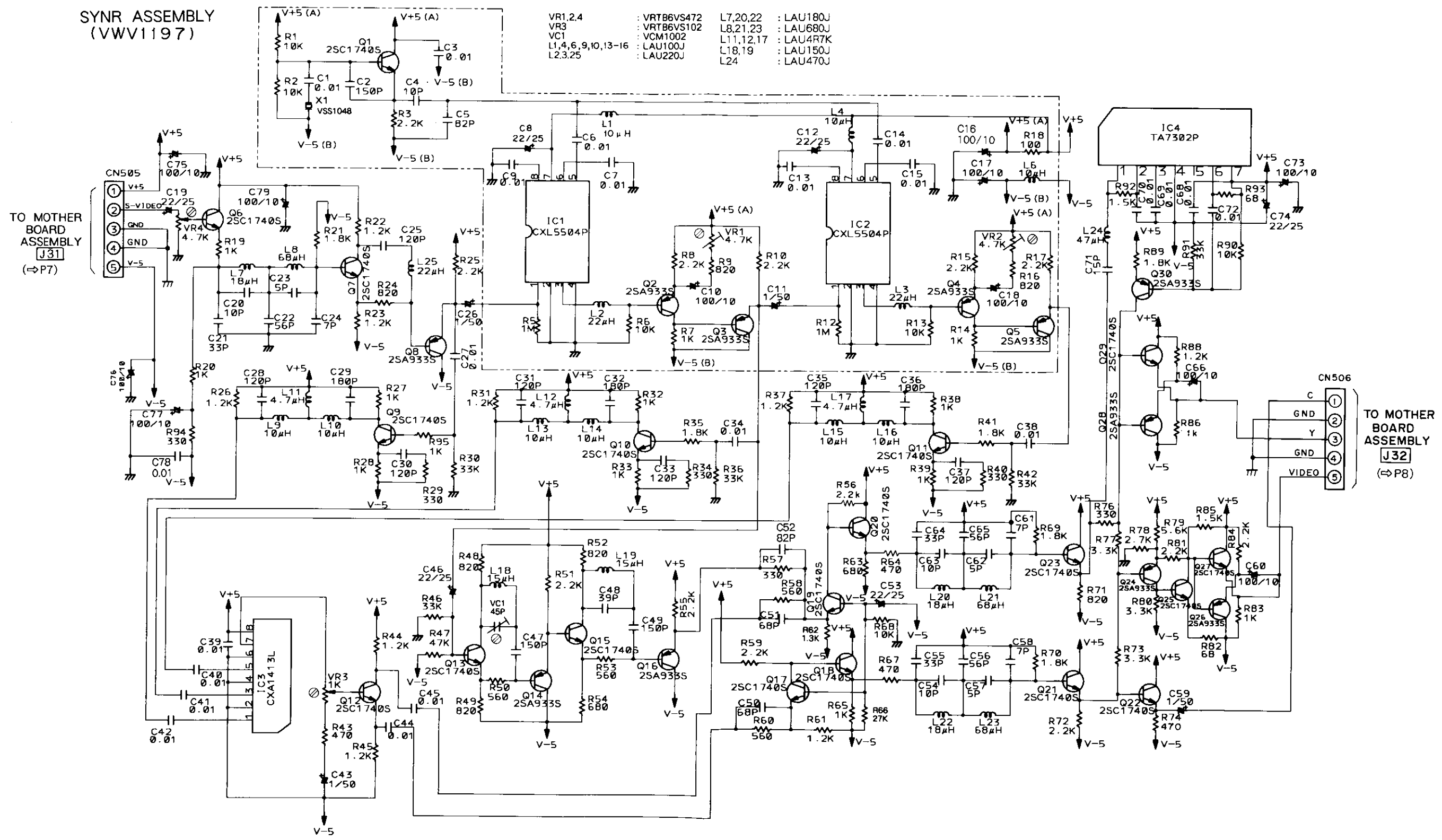

TO MOTHER BOARD ASSEMBLY
J31
(⇒P7)

TO MOTHER BOARD ASSEMBLY
J32
(⇒P8)

SYNR ASSEMBLY (VWV1197)

Q17-Q19 Q12 Q13-Q16 Q10 IC3 Q6 Q7 Q8 Q3 Q2 IC2 IC1 Q1
Q30 Q21 Q20 IC4 Q22-Q29 Q11 Q9 Q5 Q4
VR3 VC1 VR4 VR2 VR1

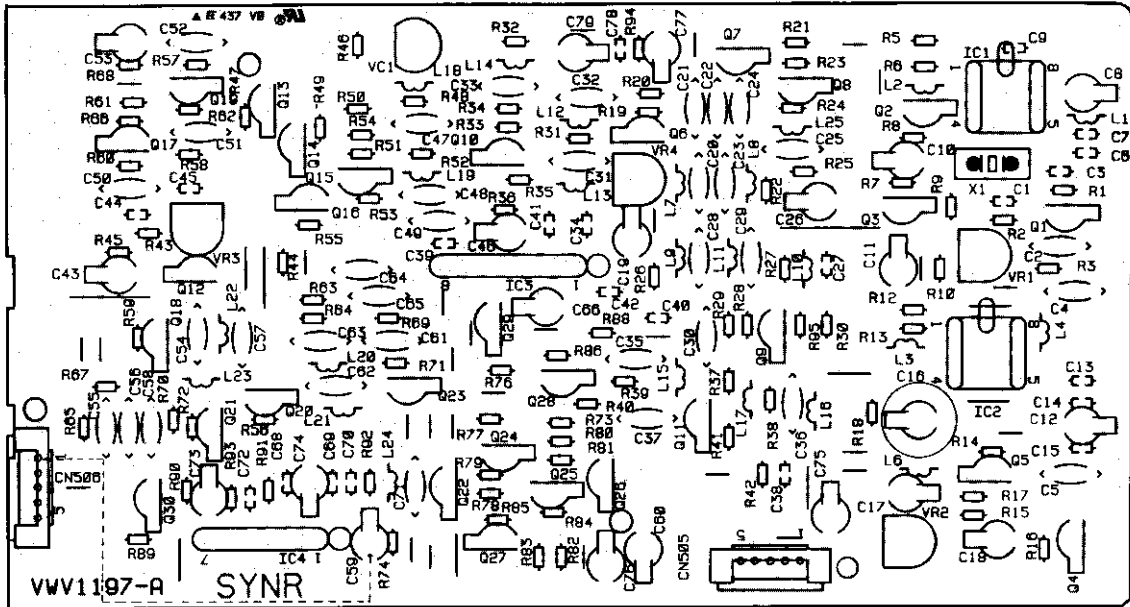

P.C.B. pattern diagram Indication	Corresponding part symbol	Part name	P.C.B. pattern diagram Indication	Corresponding part symbol	Part name
		Transistor			Ceramic capacitor
		FET			Mylar capacitor
		Diode			Styrofoam capacitor
		Zener diode			Electrolytic capacitor (Non polarized)
		LED			Electrolytic capacitor (Noiseless)
		Varactor			Electrolytic capacitor (Polarized)
		Tact switch			Electrolytic capacitor (Polarized)
		Inductor			Power capacitor
		Coll			Semi-fixed resistor
		Transformer			Resistor array
		Filter			Resistor

1. This P.C.B. connection diagram is viewed from the parts mounted side.
2. The parts which have been mounted on the board can be replaced with those shown with the corresponding wiring symbols listed in the above Table.
3. The capacitor terminal marked with shows negative terminal.
4. The diode marked with shows cathode side.
5. The transistor terminal marked with shows emitter.

SYNR ASSEMBLY (VWV1192)

- VR3 030 031 030 IC4 017-019 015 013-018
- VR4 033-034 010 IC3 08
- VR5 011 07 08
- VR6 03 05 03 IC5 IC1 01 04

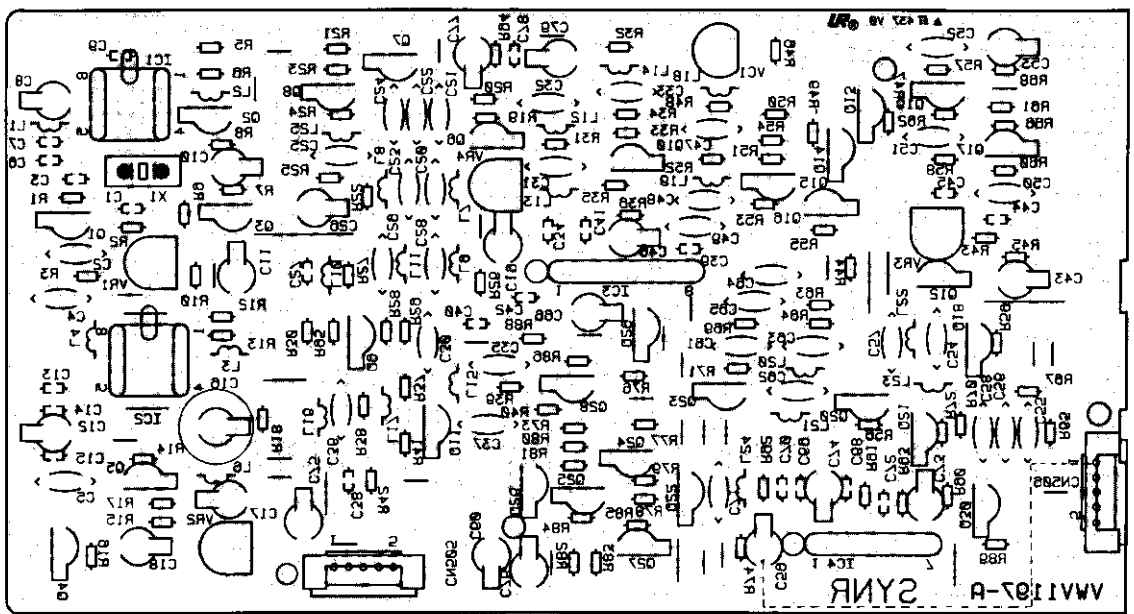

This P. C. B. connection diagram is viewed from the foil side.

A

B

C

D

Service Manual

PIONEER
The Art of Entertainment

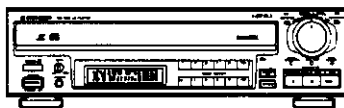

ORDER NO.
ARP2225

CD CDV LD PLAYER

CLD-1090

- This manual is applicable to the KUC type.

CONTENTS

1. SAFETY INFORMATION.....	2	7. DISASSEMBLY.....	60
2. EXPLODED VIEWS AND PARTS LIST.....	3	8. ADJUSTMENTS.....	68
3. PACKING	18	9. ABBREVIATIONS TABLE.....	92
4. P. C. BOARDS LOCATION	19	10. SPECIFICATIONS	93
5. SCHEMATIC AND P. C. BOARDS DIAGRAM ..	20	11. PANEL FACILITIES.....	95
6. ELECTRICAL PARTS LIST.....	55		

PIONEER ELECTRONIC CORPORATION 4-1, Meguro 1-Chome, Meguro-ku, Tokyo 153, Japan
PIONEER ELECTRONICS SERVICE INC. P.O. Box 1760, Long Beach, California 90801 U.S.A.
PIONEER ELECTRONICS OF CANADA, INC. 505 Cochrane Drive, Markham, Ontario L3R 8E3 Canada
PIONEER ELECTRONIC (EUROPE) N.V. Keetberglaan 1, 9120 Beveren, Belgium
PIONEER ELECTRONICS AUSTRALIA PTY. LTD. 178-184 Boundary Road, Braeside, Victoria 3195, Australia TEL: [03] 580-9911
© PIONEER ELECTRONIC CORPORATION 1991

IFJ APR. 1991 Printed in Japan

This service manual is intended for qualified service technicians; it is not meant for the casual do-it-yourselfer. Qualified technicians have the necessary test equipment and tools, and have been trained to properly and safely repair complex products such as those covered by this manual.

Improperly performed repairs can adversely affect the safety and reliability of the product and may void the warranty. If you are not qualified to perform the repair of this product properly and safely, you should not risk trying to do so and refer the repair to a qualified service technician.

WARNING

Lead in solder used in this product is listed by the California Health and Welfare agency as a known reproductive toxicant which may cause birth defects or other reproductive harm (California Health & Safety Code, Section 25249.5).

When servicing or handling circuit boards and other components which contain lead in solder, avoid unprotected skin contact with the solder. Also, when soldering do not inhale any smoke or fumes produced.

1. SAFETY INFORMATION

(FOR USA MODEL ONLY)

1. SAFETY PRECAUTIONS

The following check should be performed for the continued protection of the customer and service technician.

LEAKAGE CURRENT CHECK

Measure leakage current to a known earth ground (water pipe, conduit, etc.) by connecting a leakage current tester such as Simpson Model 229-2 or equivalent between the earth ground and all exposed metal parts of the appliance (input/output terminals, screw heads, metal overlays, control shaft, etc.). Plug the AC line cord of the appliance directly into a 120V AC 60Hz outlet and turn the AC power switch on. Any current measured must not exceed 0.5mA.

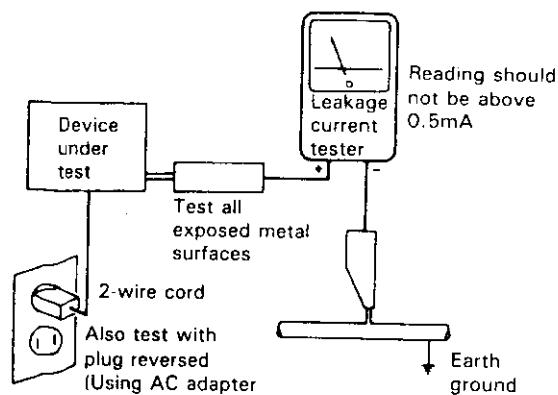

AC Leakage Test

ANY MEASUREMENTS NOT WITHIN THE LIMITS OUTLINED ABOVE ARE INDICATIVE OF A POTENTIAL SHOCK HAZARD AND MUST BE CORRECTED BEFORE RETURNING THE APPLIANCE TO THE CUSTOMER.

2. PRODUCT SAFETY NOTICE

Many electrical and mechanical parts in the appliance have special safety related characteristics. These are often not evident from visual inspection nor the protection afforded by them necessarily can be obtained by using replacement components rated for voltage, wattage, etc. Replacement parts which have these special safety characteristics are identified in this Service Manual.

Electrical components having such features are identified by marking with a Δ on the schematics and on the parts list in this Service Manual.

The use of a substitute replacement component which does not have the same safety characteristics as the PIONEER recommended replacement one, shown in the parts list in this Service Manual, may create shock, fire, or other hazards.

Product Safety is continuously under review and new instructions are issued from time to time. For the latest information, always consult the current PIONEER Service Manual. A subscription to, or additional copies of, PIONEER Service Manual may be obtained at a nominal charge from PIONEER.

2. EXPLODED VIEWS AND PARTS LIST

2.1 EXTERIOR SECTION

A

Parts List

Mark No.	Description	Part No.	Mark No.	Description	Part No.
1	Bonnet S	VXX1267	11	Screw	BBZ30P080FCC
2	Disc pad(L)	VEC1191	12	Screw	BCZ40P060FZK
3	Disc pad(S)	VEC1192	13	Screw	BBZ30P060FCC
4	Tray assembly	VXX1453			
5	Tray rubber	VEB1089	101	Center angle	
6	• • • • •		102	Cushion	
7	Screw	PCZ30P080FMC	103	Tray angle	
8	Screw	BPZ30P080FCU	104	Carry label	
9	Screw	CPZ30P100FMC	105	Tray reinforced plate	
10	Screw	BPZ30P140FMC	106	Tray	
			107	Side plate	

NOTES:

- Parts without part number cannot be supplied.
- The Δ mark found on some component parts indicates the importance of the safety factor of the part. Therefore, when replacing, be sure to use parts of identical designation.
- Parts marked by "⊙" are not always kept in stock. Their delivery time may be longer than usual or they may be unavailable.

B

C

D

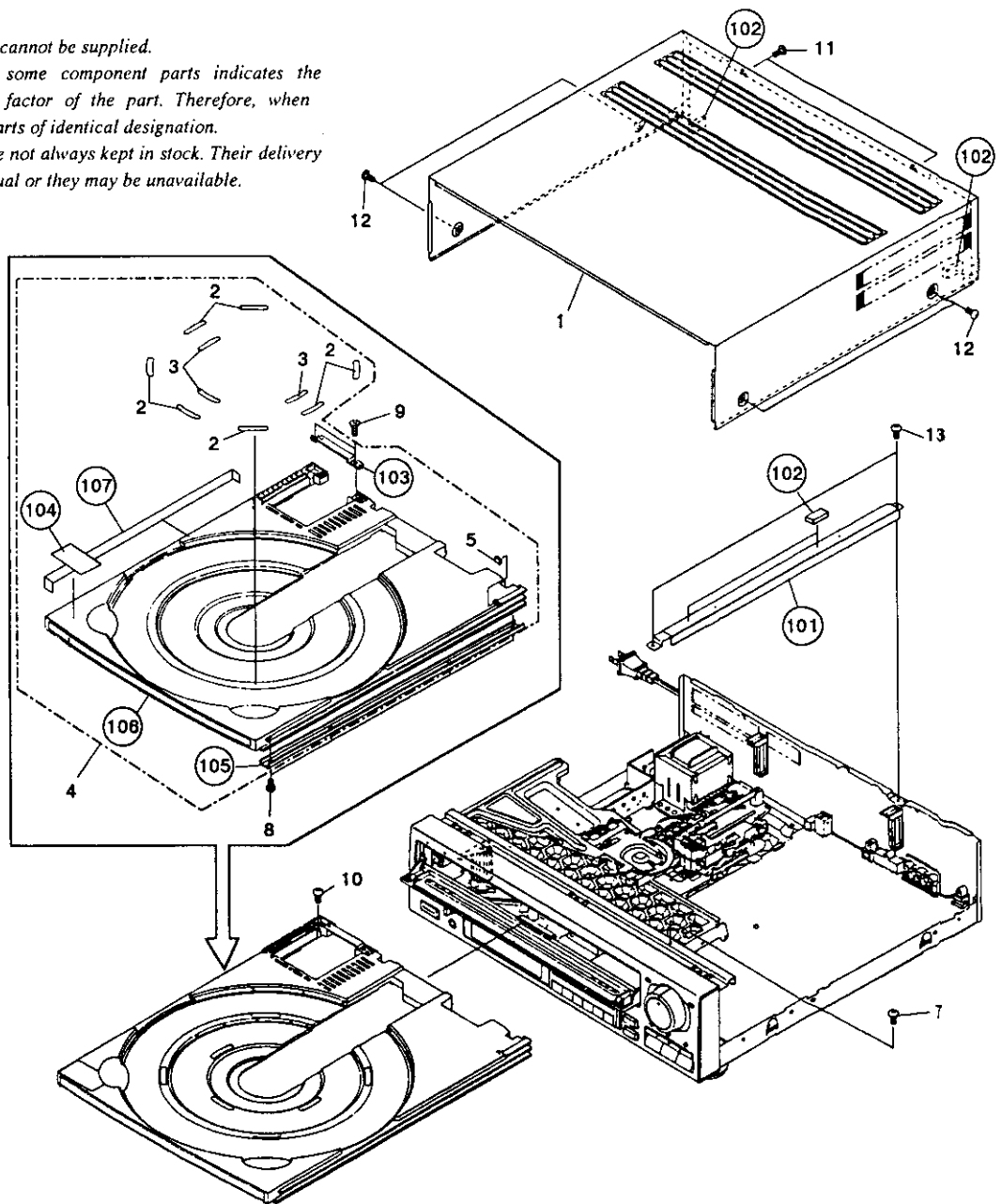

2.2 FRONT PANEL SECTION

Parts List

Mark	No.	Description	Part No.
	1	Front panel assembly S	VXX1549
	2	FL filter	VNK1659
	3	FL lens	VNK1660
	4	Volume knob	VNK1658
	5	Door assembly - S	VXX1548
	6	Front door assembly	VXA1572
	7	Door dump rubber	VEB1033
	8	Roller	VNL1042
	9	Door plate	VNE1482
	10	Door spring	VBH1136
	11	PW button	VNK1649
	12	Ten key	VNK1653
	13	Main key	VNK1654
	14	Sub key	VNK1655
	15	Sub panel	VNK1661
	16	Dumper assembly	VXA1053
	17	L key assembly	VXA1573
	18	Scan dial assembly	VXA1574
	19	Scan dial	VNK1656
	20	LED lens (S)	VNK1657
	21	Snap plate	VNE1102
	22	Screw	BPZ20P040FZK
	23	Screw	BBZ20P050FMC
	24	Screw	BPZ26P060FCU
	25	Screw	IPZ26P060FMC
	26	Screw	BPZ26P080FMC
	27	Screw	PMZ20P040FCU

Mark	No.	Description	Part No.
	101	Front panel assembly	
	102	Earth lug assembly	
	103	Dumper plate	
	104	Reinforced plate	
	105	Jack holder	
	106	SHKY assembly	
	107	FLKY assembly	
	108	PSWB assembly	
	109	HEPB assembly	
	110	Spacer	
	111	Dump rubber	

Note: 106 SHKY, 107 FLKY, 108 PSWB and 109 HEPB assemblies are supplied for service as the FLKB assembly (VWM1160).

A

B

C

D

A

B

C

D

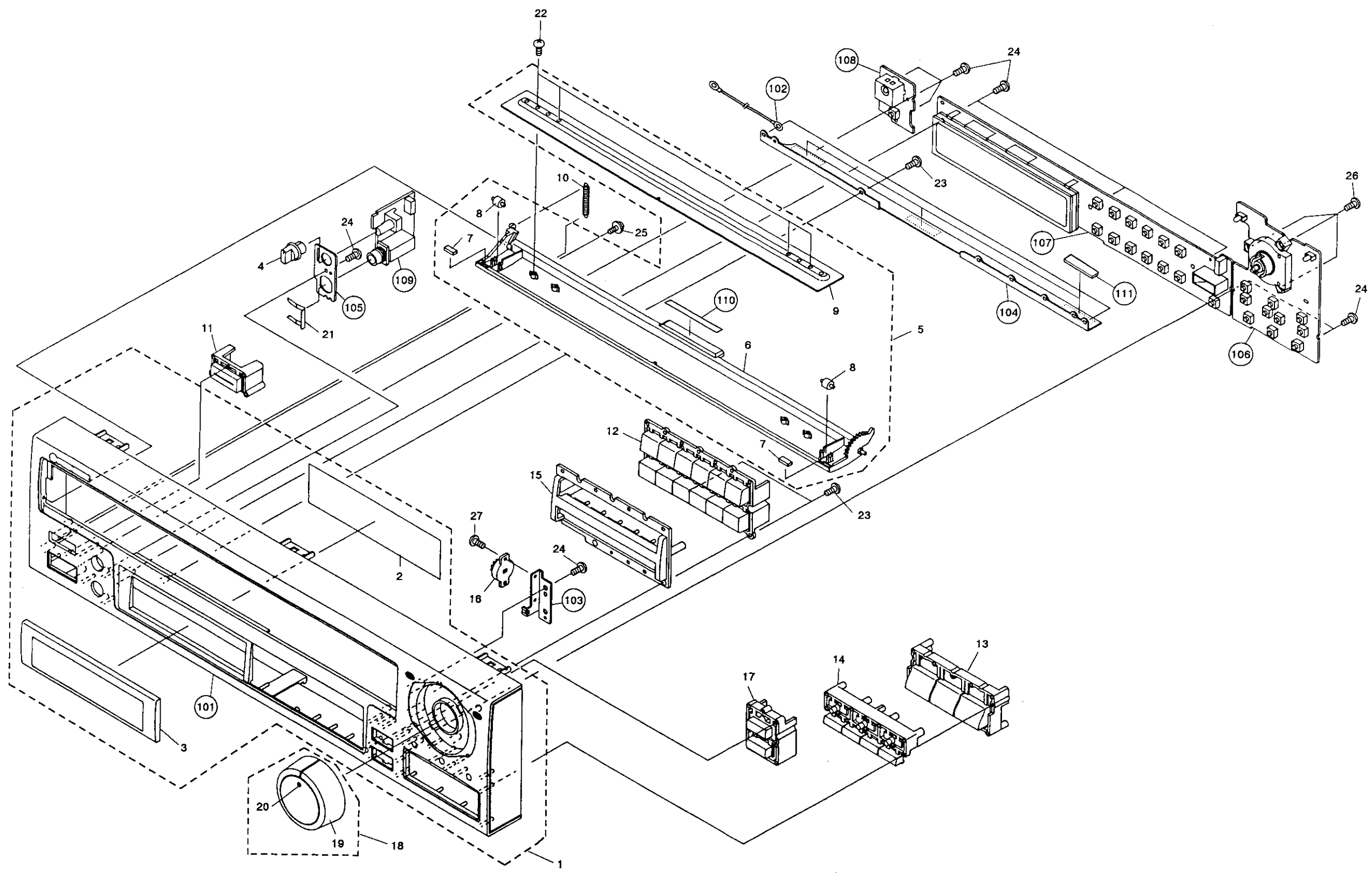

1

2

3

4

5

6

6

2.3 TOP VIEW SECTION

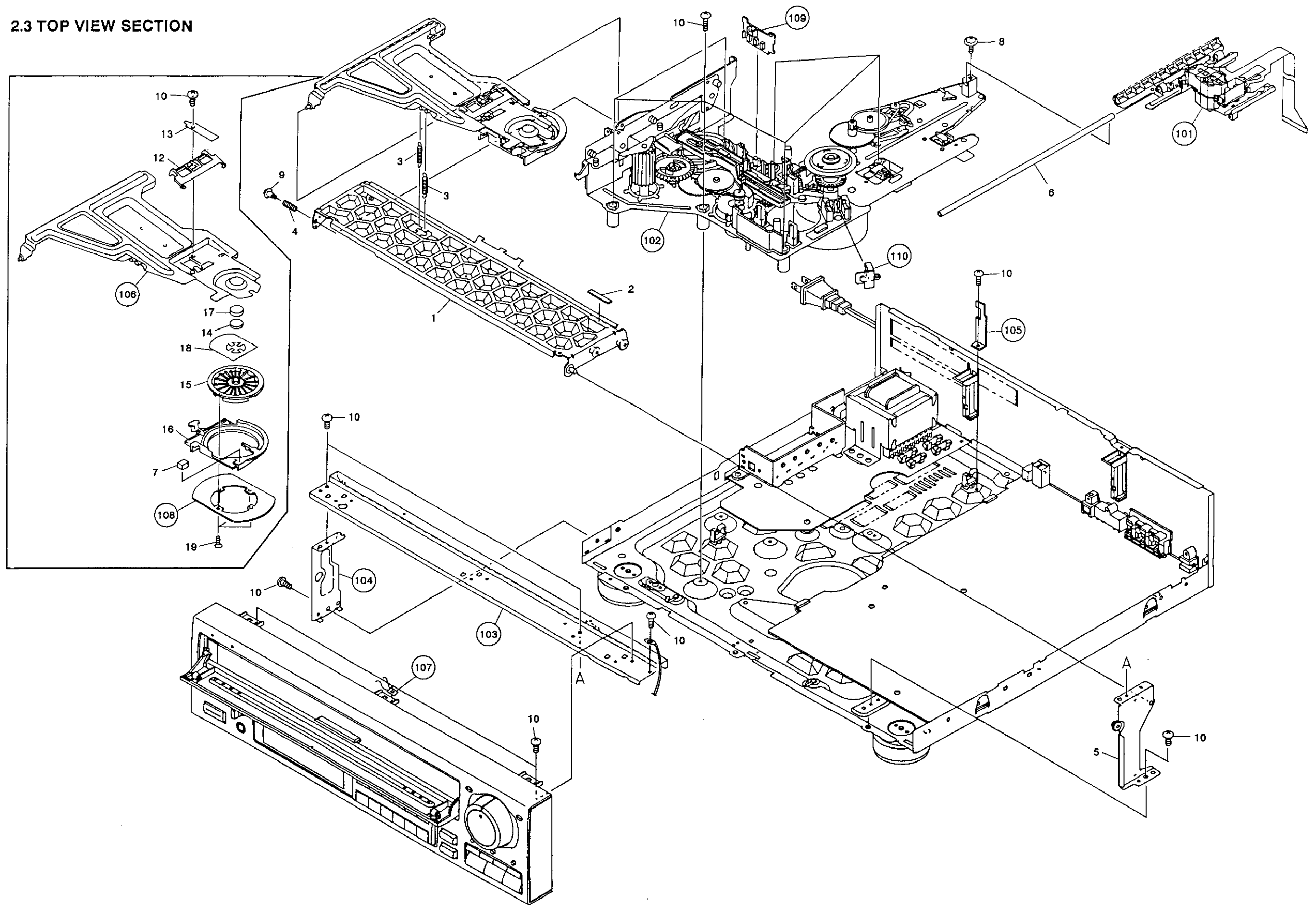

A
B
C
D

A
B
C
D

1

7

1

2

3

4

5

6

7

Parts List

Mark No.	Description	Part No.
1	Clamper arm (A) assembly	VXA1319
2	Rubber (A)	VEB1084
3	Clamper spring	VBH1094
4	Arm spring	VBH1093
5	Side stay (R) assembly	VXA1529
6	Carriage shaft	VLL1177
7	Clamper pad	VEC1264
8	Screw (B)	VBA1018
9	Screw (B)	VBA1008
10	Screw	BBZ30P060FCC
11	
12	Parallel link	VNL1254
13	Plate spring	VBK1014
14	Ball holder	VNL1289
15	Clamper S	VNL1248
16	Clamper holder	VNL1205
17	Rubber sheet	VEB1114
18	Thrust holder	VBK1018
19	Screw	CPZ20P050FMC

Mark No.	Description	Part No.
101	Rack assembly	
102	Mechanism assembly	
103	Front angle	
104	Side stay (L)	
105	SM head holder	
106	Clamper arm (B)	
107	Earth plate	
108	Stabilizer	
109	SW assembly	
110	FG assembly	

Note: 109 SW assembly and 110 FG assembly are supplied for service as the Mother assembly (VWM1159).

2.4 BASE SECTION

Parts List

Mark	No.	Description	Part No.
△	1	Power transformer	VTT1079
△	2	Strain relief	CM - 22C
△	3	AC power cord	PDG1015
△	4	Fuse (FU203, FU204) (1A)	REK - 080
△	5	Fuse (FU201, FU202) (3A)	VEK - 018
	6	Tray stopper	VNL1202
	7	Insulator assembly	VXA1289
	8	Insulator	VNK1095
	9	Insulator assembly	VXA1290
●	10	SYPS assembly	VWR1090
	11	Door dump rubber	VEB1033
	12	Screw	BBZ30P080FCC
	13	Screw	BBZ30P060FCC
	14	Screw	BCZ40P080FZK
	15	Screw	IPZ30P160FMC

Mark	No.	Description	Part No.
	101	P. C. B spacer	
	102	P plate holder	
	103	Wire crip (B)	
	104	Base chassis	
	105	Rear panel	
	106	Stopper	
	107	Insulator	
	108	MAIN assembly	
	109	Cord holder	

Note: 108 MAIN assembly is supplied for service as the Mother assembly (VWM1159).

1

2

A

B

C

D

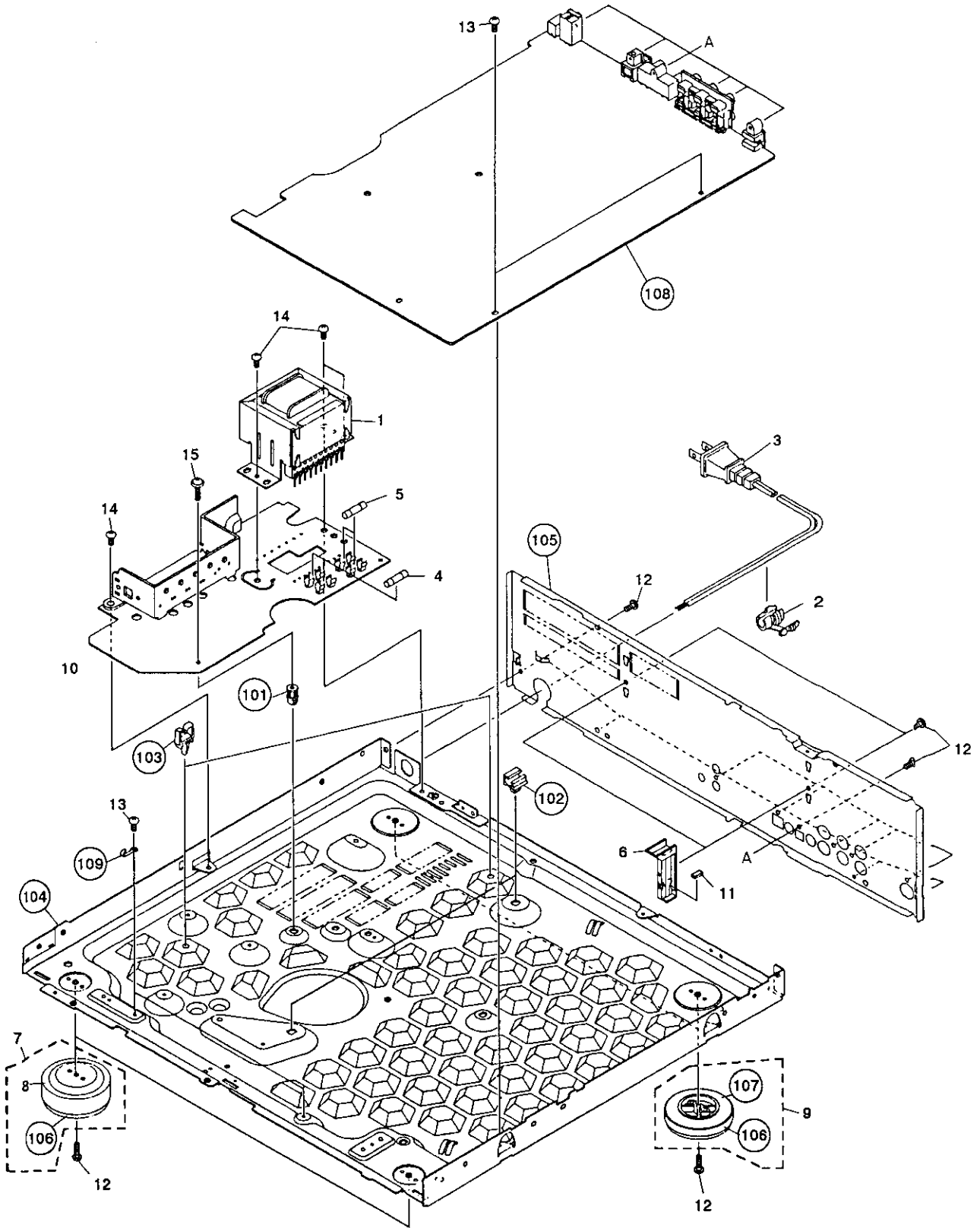

1

2

3

2.5 MECHANISM ASSEMBLY (1)

Parts List							
Mark	No.	Description	Part No.	Mark	No.	Description	Part No.
	1	Plate spring	VBK1013	6	• • • • •		
	2	Thrust spring	VBH1073	7	Screw		PMA30P050FMC
	3	Tilt shaft	VLL1175	8	Screw		ABZ26P050FMC
	4	Tilt pulling spring	VBH1074				
	5	Belt	PEB1013	101	Cam head stopper		

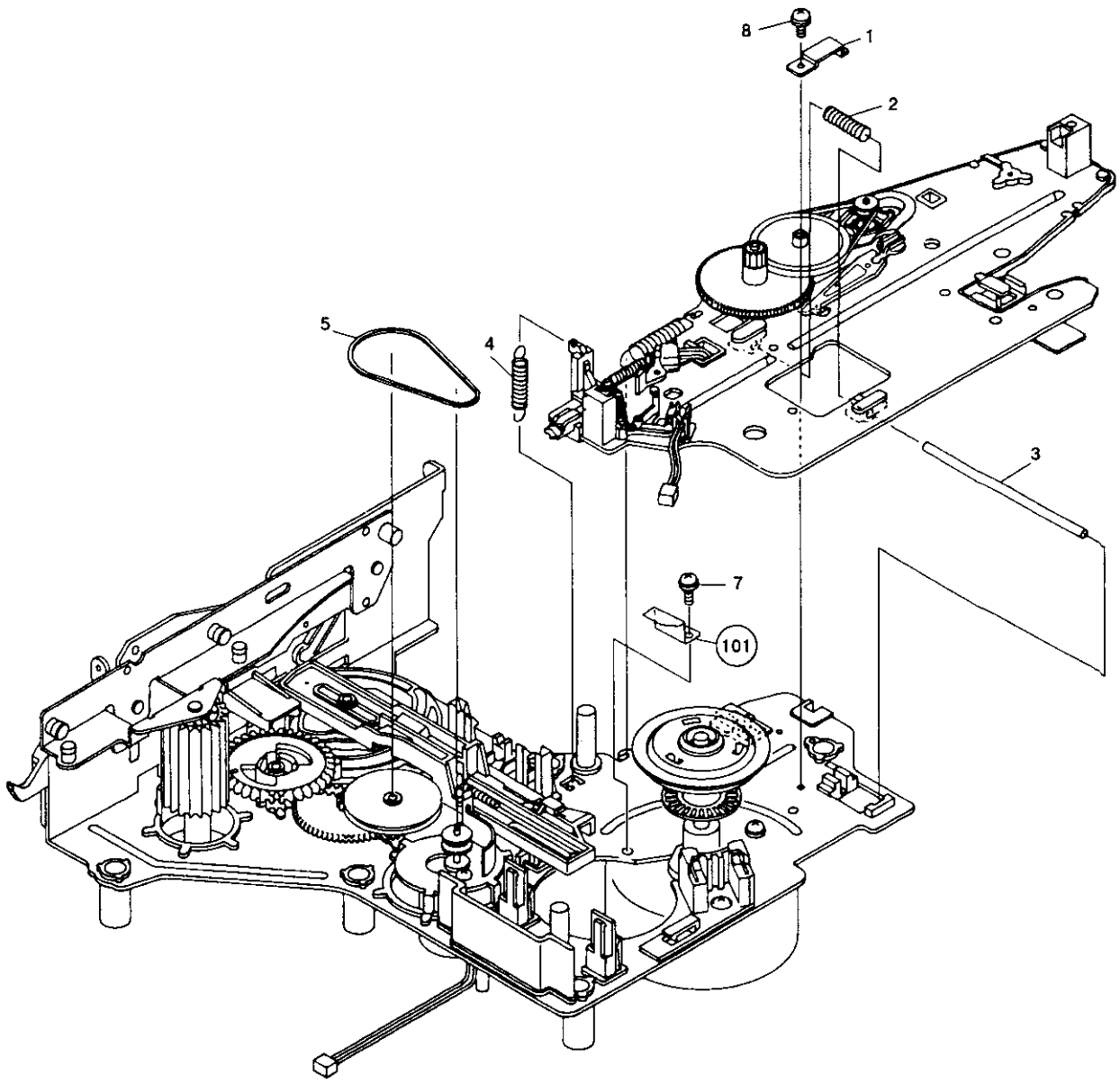

2.6 CHASSIS SECTION

Parts List			Parts List		
Mark No.	Description	Part No.	Mark No.	Description	Part No.
1	Spring slanting cam	VNL1191	101	Motor pulley	
2	Cam spring	VBH1082	102	Rubber sheet	
3	Belt	PEB1013	103	Turn table assembly	
4	Gear pulley	VNL1249	104	Oil stopped washer	
5	Follow gear	VNL1194	105	Spindle motor	
6	Roller plate assembly	VXA1531	106	Housing assembly	
7	Slide cam	VNL1188	107	Housing assembly	
8	•••••		108	Loading motor	
9	Loading motor assembly	VXX1262	109	Slider gear	
10	Spindle motor assembly	VXA1474	110	Housing assembly	
11	Centering hab	VNL1174			
12	Centering spring	VBH1083			
13	Door lever	VNL1407			
14	Washer	WT26D047D025			
15	Two stair gear	VNL1193			
16	Cam gear	VNL1340			
17	Screw (C)	VBA1015			
18	Screw (B)	VBA1008			
19	Nylon washer	WA32N080W020			
20	Screw	PMZ30P040FMC			
21	Screw	PMA30P050FMC			
22	Washer	WA32D060D025			
23	•••••				
24	Stop ring	VEB1091			
25	Chassis assembly	VXA1575			
26	E ring	YE23FUC			
27	Push switch	DSG1014			

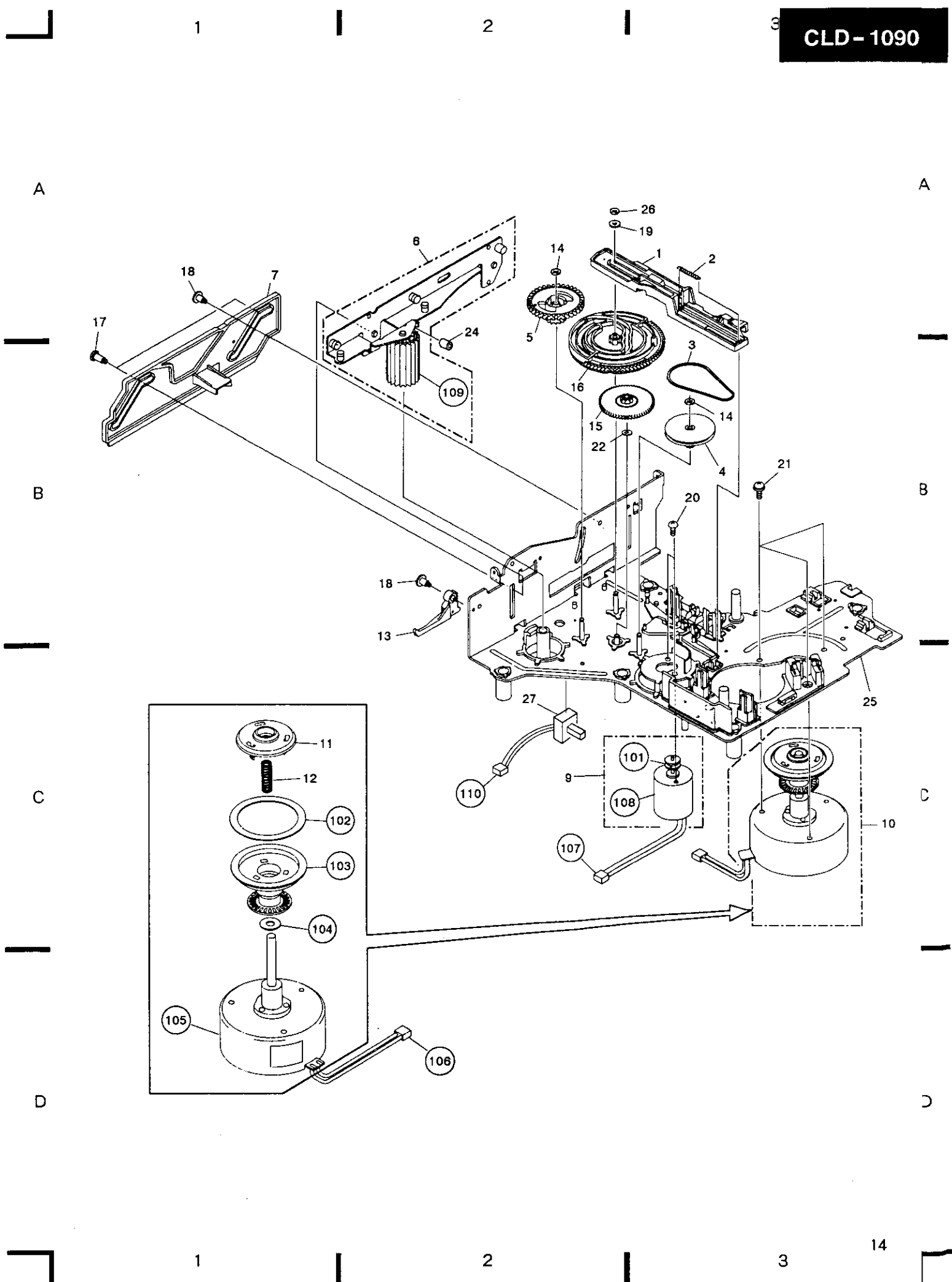

2.7 SERVO MECHANISM BASE SECTION

Parts List

Mark No.	Description	Part No.	Mark No.	Description	Part No.
1	CA gear(3)	VNL1196	13	Washer	WT26D047D025
2	Switch pulling spring	VBH1079	14	FLE base	VNL1341
3	TC pulling spring	VBH1080	15	Servo mechanism base assembly - S	VXA1583
4	Push switch (S5:OUTER)	DSG1014			
5	CA pulley (1)	VNL1197	101	Carriage motor	
6	Carriage motor assembly	VXX1261	102	Housing assembly	
7	Push switch (S4:INNER)	DSG1014	103	Housing assembly	
8	CA belt	VEB1077	104	Housing assembly	
9	CA pulley (2)	VNL1198	105	Holder (A)	
10	Screw	SMF30H080FBT	106	Holder (B)	
11	Screw	PMM26P040FMC			
12	Screw	BPZ26P050FMC			

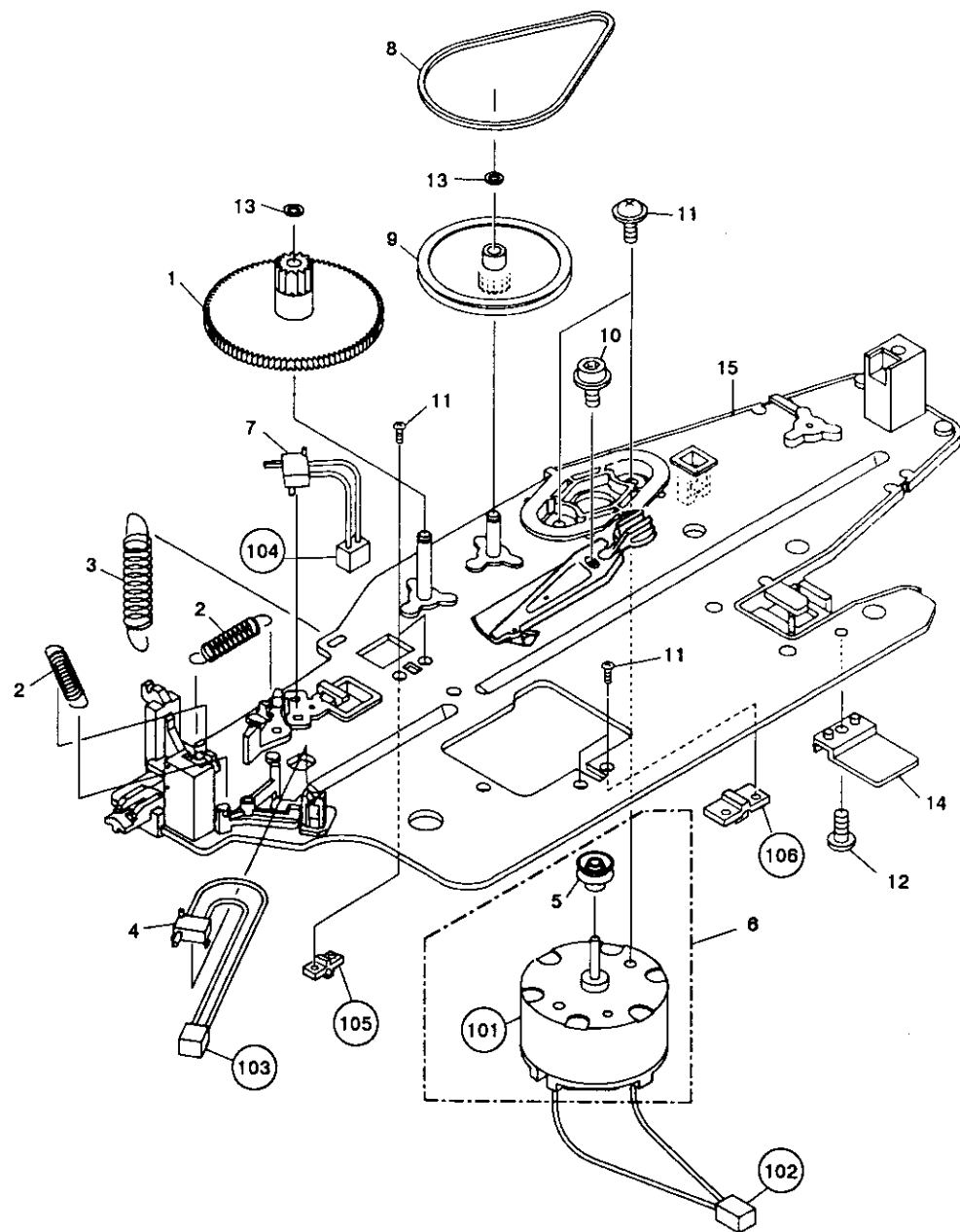

2.8 RACK SECTION

Parts List

Mark No.	Description	Part No.	Mark No.	Description	Part No.
1	PU base	VNL1209	11	TAN base	VNL1199
2	LP center spring	VBH1075	12	Screw	PMZ20P040FMC
3	PU pulling spring	VBH1089	13	Screw	PMA20P040FMC
4	L-2 spring	VBH1090	14	Screw	AMZ20P050FMC
5	Washer	WC30FMC	15	Slider assembly	VWT1060
6	Screw	VBA1007	16	PU mount base assembly	VXA1567
7	Screw (2.6 x 10)	VLL1192	17	Spacer (S)	VEC1284
8	Rack	VNL1186	18	TAN plate (1)	VNE1606
9	Screw	BMZ26P080FMC			
10	TAN spring	VBH1081	101	TAN plate (2)	
			102	Pickup assembly	

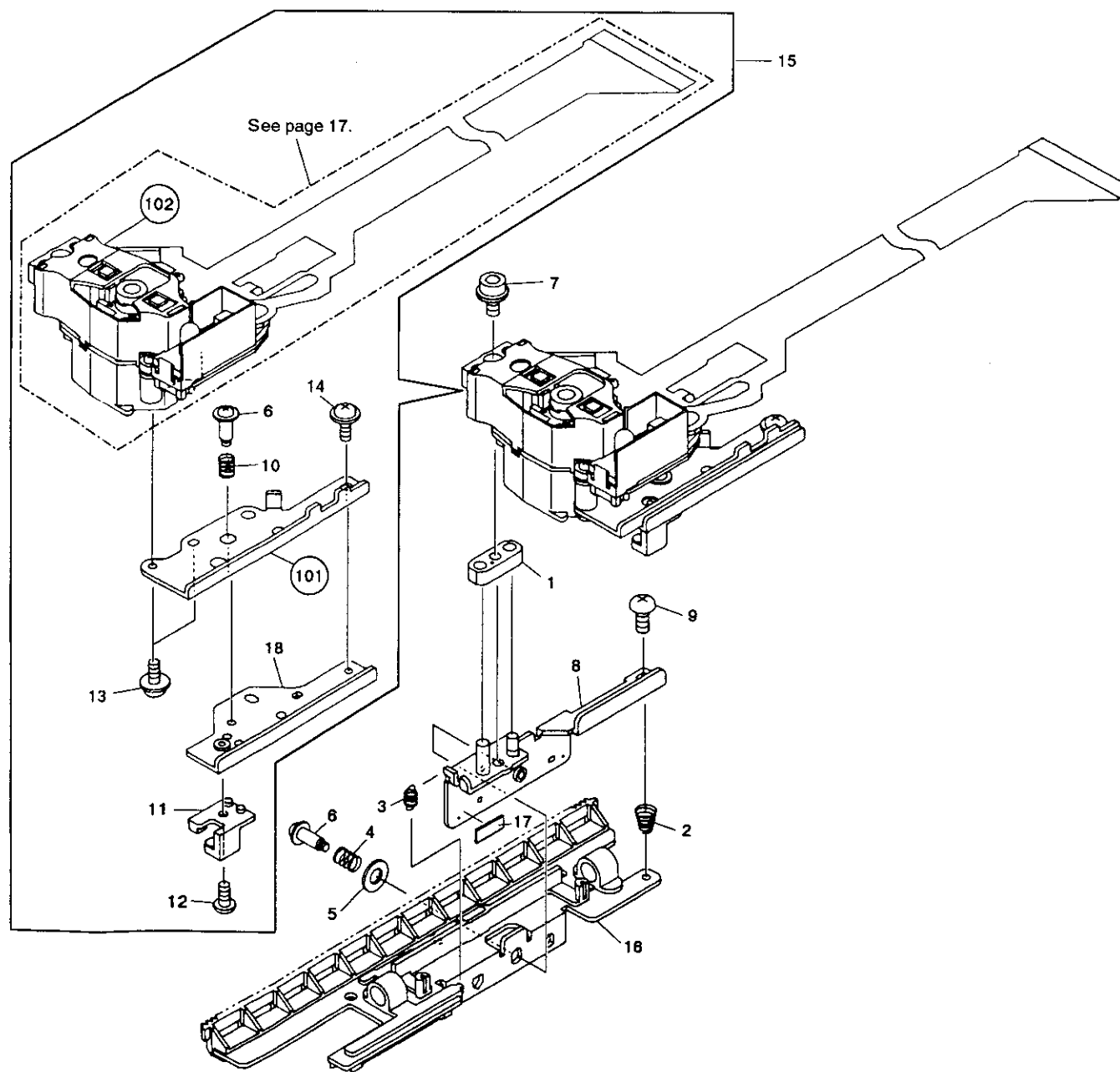

2.9 PICKUP ASSEMBLY

Parts List of Pickup assembly

Mark	No.	Description	Part No.
	1	Actuator assembly	VXX1551
	2	Sensor assembly	VEX1018
	3	Pre-pickup assembly	VXX1413
	4	Sensor stay	VNH1024
	5	Screw	PMA20P060FMC
	6	Screw	PMA20P080FMC
	7	Screw	PMA20P140FMC
	8	Screw	BMZ20P060FMC
	9	Sensor spring	VBH1087

A

B

C

D

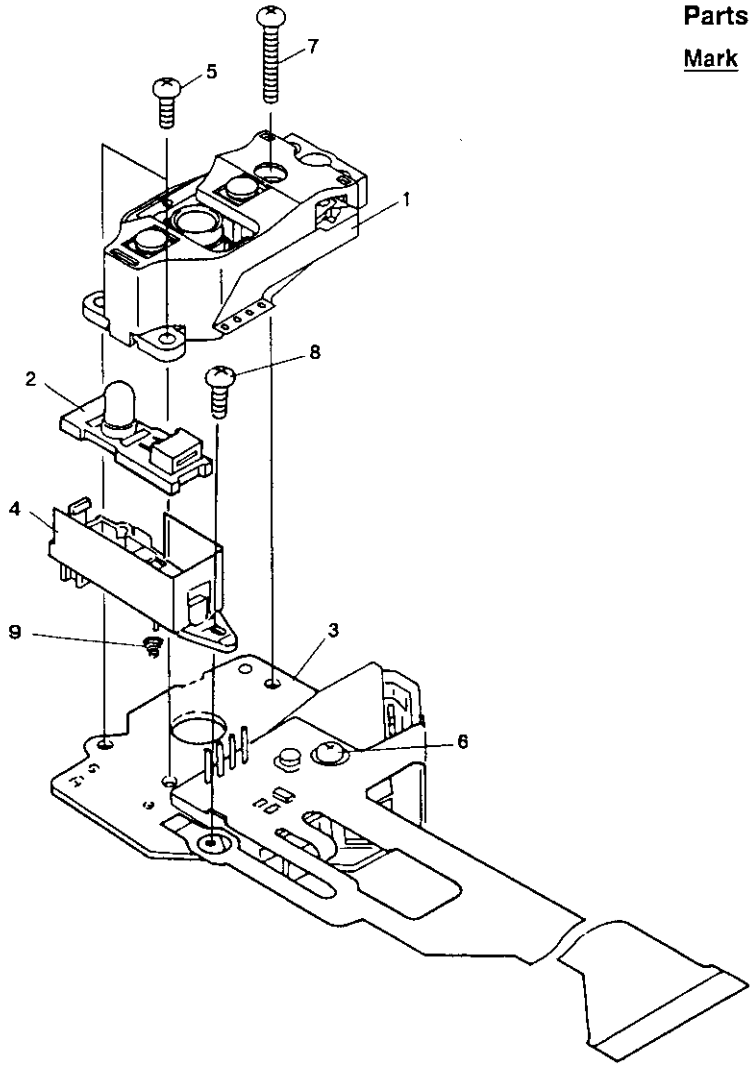

3. PACKING

Parts List

Mark No.	Description	Part No.	Mark No.	Description	Part No.
1	Connection cord	VDE-055	51	Dry cell battery (R03, AAA)	
2	Video cable	VDE-056	52	Polyethylene bag	
3	Operating instructions (English)	VRB1048	53	Caution card	
4	Remote control unit	VXX1530	54	Caution card (UC)	
5	Pad (F)	VHA1076			
6	Pad (R)	VHA1077			
7	Packing case	VHG1143			
8	Mirror mat	VHL1006			
9	Battery cover	VNK1806			

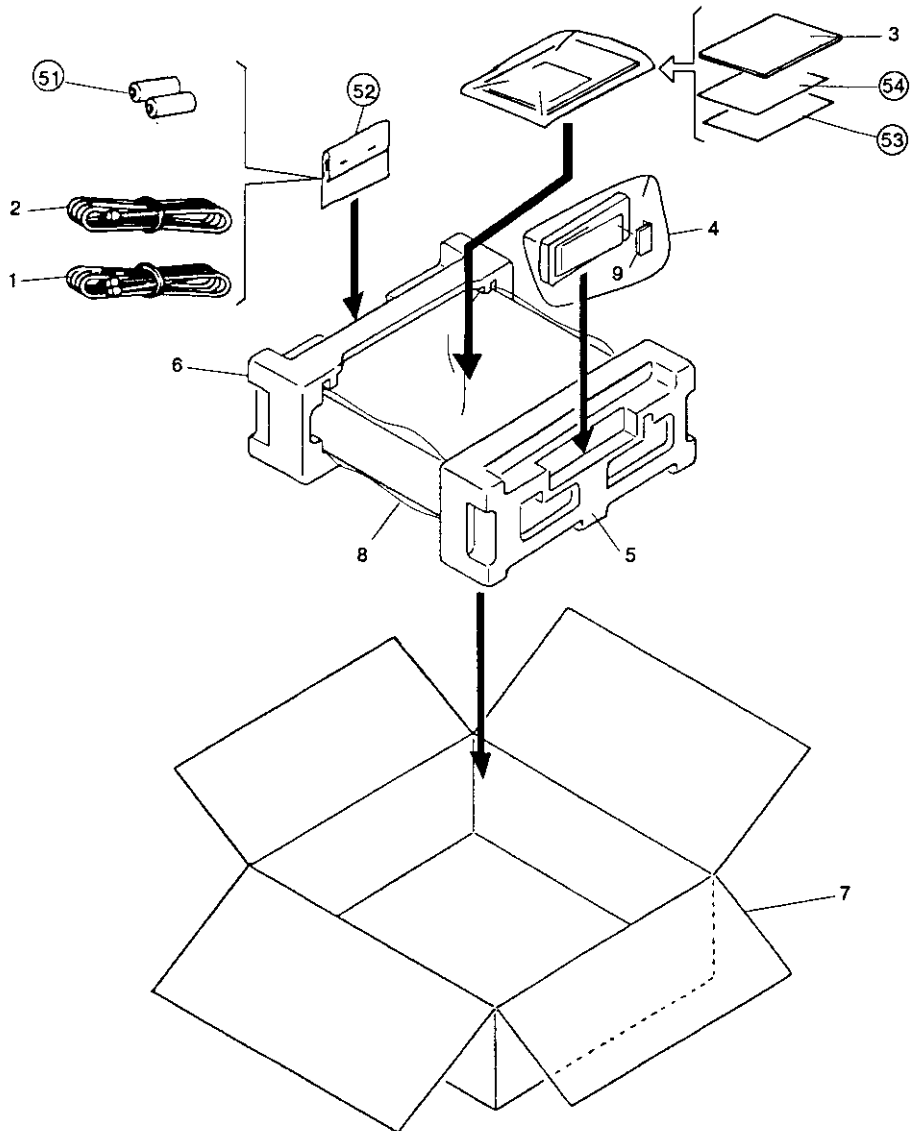

4. P. C. BOARDS LOCATION

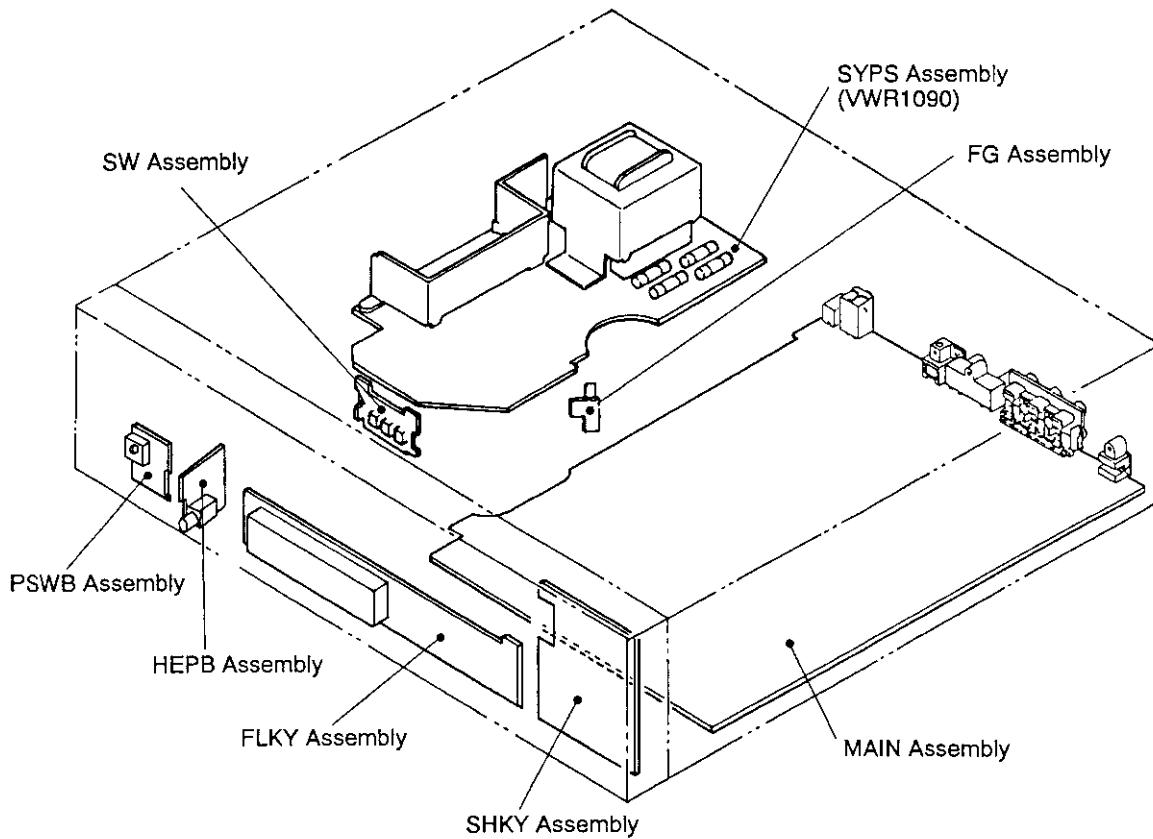

MOTHER ASSEMBLY (VWM1159)

MOTHER assembly is composed of MAIN, FG and SW assemblies.

FLKB ASSEMBLY (VWM1160)

FLKB assembly is composed of FLKY, SHKY, PSWB and HEPB assemblies.

MAIN : MAIN BOARD
FG : FG COUNTER BOARD
SW : SW BOARD
FLKY : FL TUBE AND KEY BOARD
SHKY : SHUTTLE AND KEY BOARD
PSWB : POWER SWITCH BOARD
HEPB : HEADPHONE BOARD
SYPS : SYSTEM POWER SUPPLY

5. SCHEMATIC AND P.C. BOARDS DIAGRAM

1. RESISTORS:

Indicated in Ω , 1/4W, 1/8W and 1/8W, $\pm 5\%$ tolerance unless otherwise noted k; k Ω , M; M Ω , (F); $\pm 1\%$, (G); $\pm 2\%$, (K); $\pm 10\%$, (M); $\pm 20\%$ tolerance.

2. CAPACITORS:

Indicated in capacity (μF) /voltage(V) unless otherwise noted p; pF. Indication without voltage is 50V except electrolytic capacitor.

3. VOLTAGE, CURRENT:

 :DC voltage (V) at no input signal.
Value in () is DC voltage at rated power.
 \leftarrow mA :DC current at no input signal.

4. OTHERS:

\rightarrow ;Signal route.
 \otimes ;Adjusting point.
The \triangle mark found on some component parts indicates the importance of the safety factor of the part. Therefore, when replacing, be sure to use parts of identical designation.
※ marked capacitors and resistors have parts numbers.

This is the basic schematic diagram, but the actual circuit may vary due to improvements in design.

5. SWITCHES : (The underlined indicates the switch position)

OUTSIDE OF P.C. BOARDS

S4 :INNER

S5 :OUTER

S6 :TRAY IN

SW ASSEMBLY

S1 - S3 :LOADING /TILT

FLKY ASSEMBLY

S10 :PGM

S11 :5

S12 :0

S13 :+10

S14 :2

S15 :1

S16 :4

S17 :3

S18 :9

S19 :8

S20 :7

S21 :6

S22 :DIRECT CD

S23 :SINGLE

S24 :DOOR

SHKY ASSEMBLY

S40 :DIGITAL LEVEL CTRL

S41 :PGM EDIT

S42 :PEAK SEARCH

S43 :RANDOM PLAY

S44 :HILITE INTRO SCAN

S45 : 

S46 : 

S47 :OPEN /CLOSE ()

S48 :STOP ()

S49 :PLAY /PAUSE ()

S51 :SCAN /LEVEL ()

PSWB ASSEMBLY

S60 :POWER

5.1 OVERALL WIRING DIAGRAM

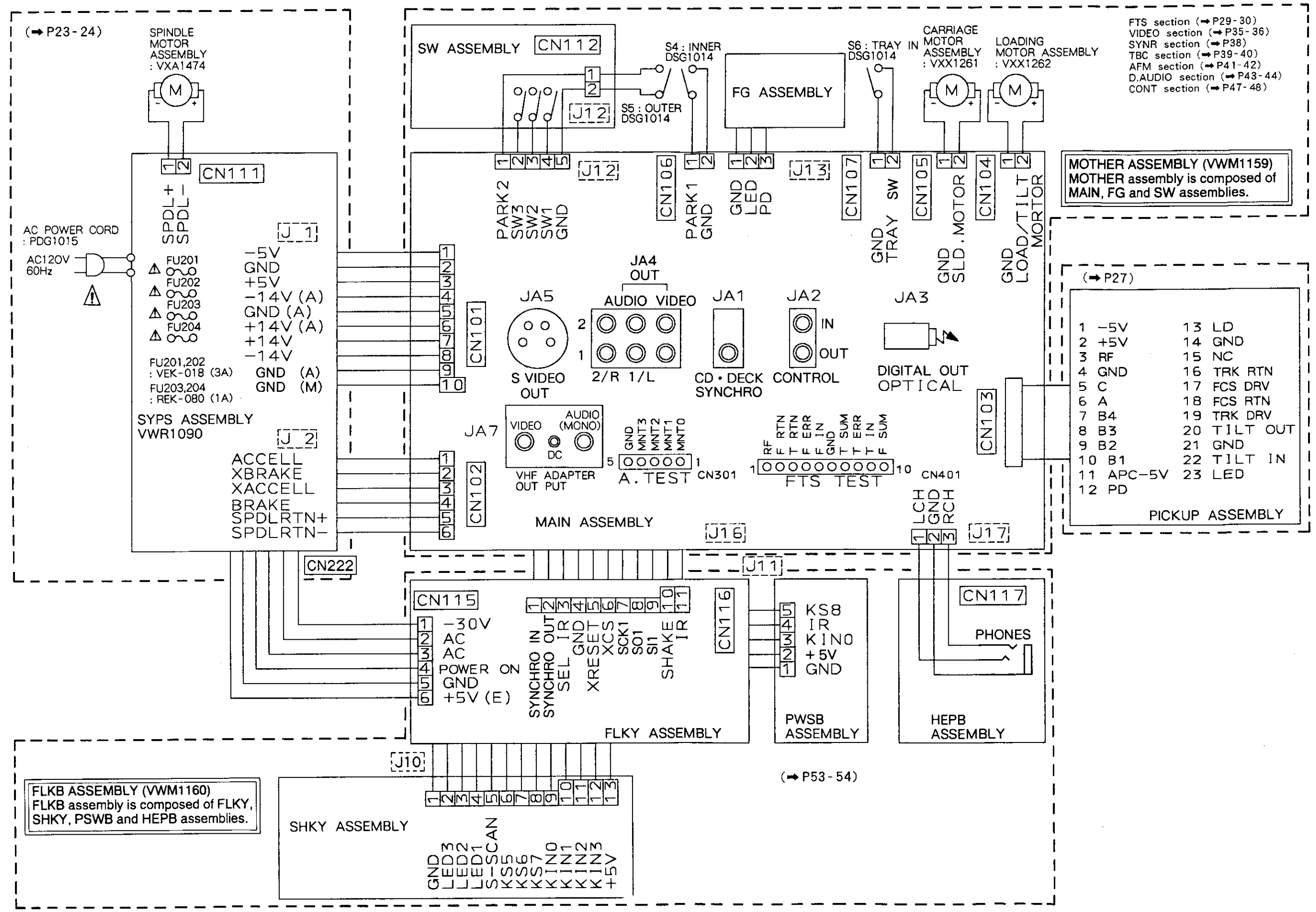

5.2 SYPS ASSEMBLY

- Q201, Q204, D101, 103 MTZJ5.6B
- Q206, 2SD1762 D102, 104 MTZJ5.1C
- Q202, Q203, D201, D202 52VB20
- Q205, 2SB1185 D208, D209,
- Q207, 2SB1238X D216, D217: 1SS252
- Q214, Q219: 2SA933S D213, D214,
- Q213: DTC114ES D222, D223: 1SR35-100AVL
- Q218: 2SC1740S D212, D215: 1DEL52
- Q217: DTA114ES D220: MTZJ22C
- IC201,202: ICP-N15 FU201,FU202 : VEK-018
- IC206: ICP-N25 FU203,FU204 : REK-080
- IC205: NJM78M05FA

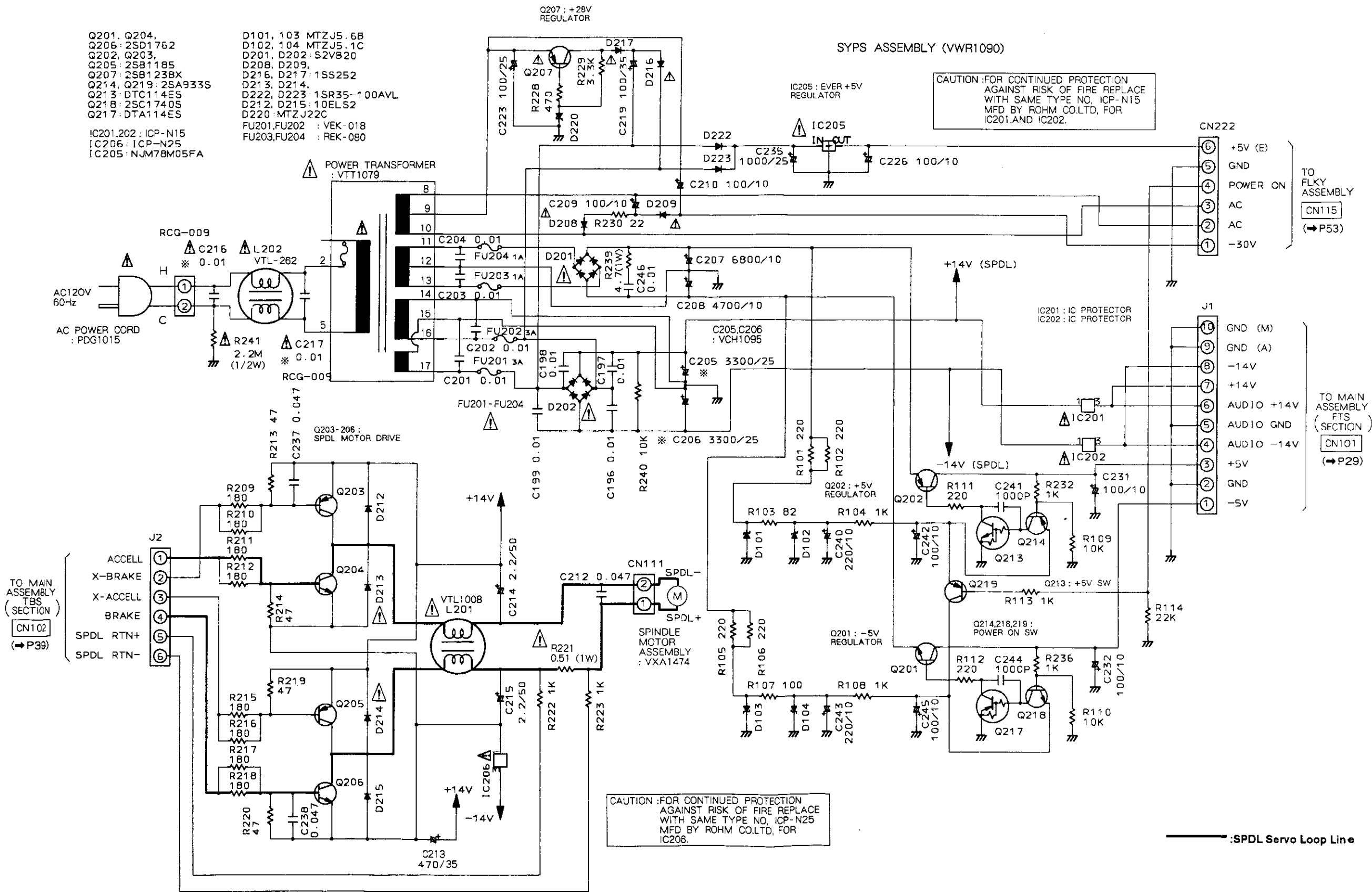

CAUTION: FOR CONTINUED PROTECTION AGAINST RISK OF FIRE REPLACE WITH SAME TYPE NO. ICP-N15 MFD BY ROHM CO.LTD. FOR IC201, AND IC202.

CAUTION: FOR CONTINUED PROTECTION AGAINST RISK OF FIRE REPLACE WITH SAME TYPE NO. ICP-N25 MFD BY ROHM CO.LTD. FOR IC206.

:SPDL Servo Loop Line

TO MAIN ASSEMBLY TBS (SECTION) CN102 (P39)

TO FLKY ASSEMBLY CN115 (P53)

TO MAIN ASSEMBLY (FTS SECTION) CN101 (P29)

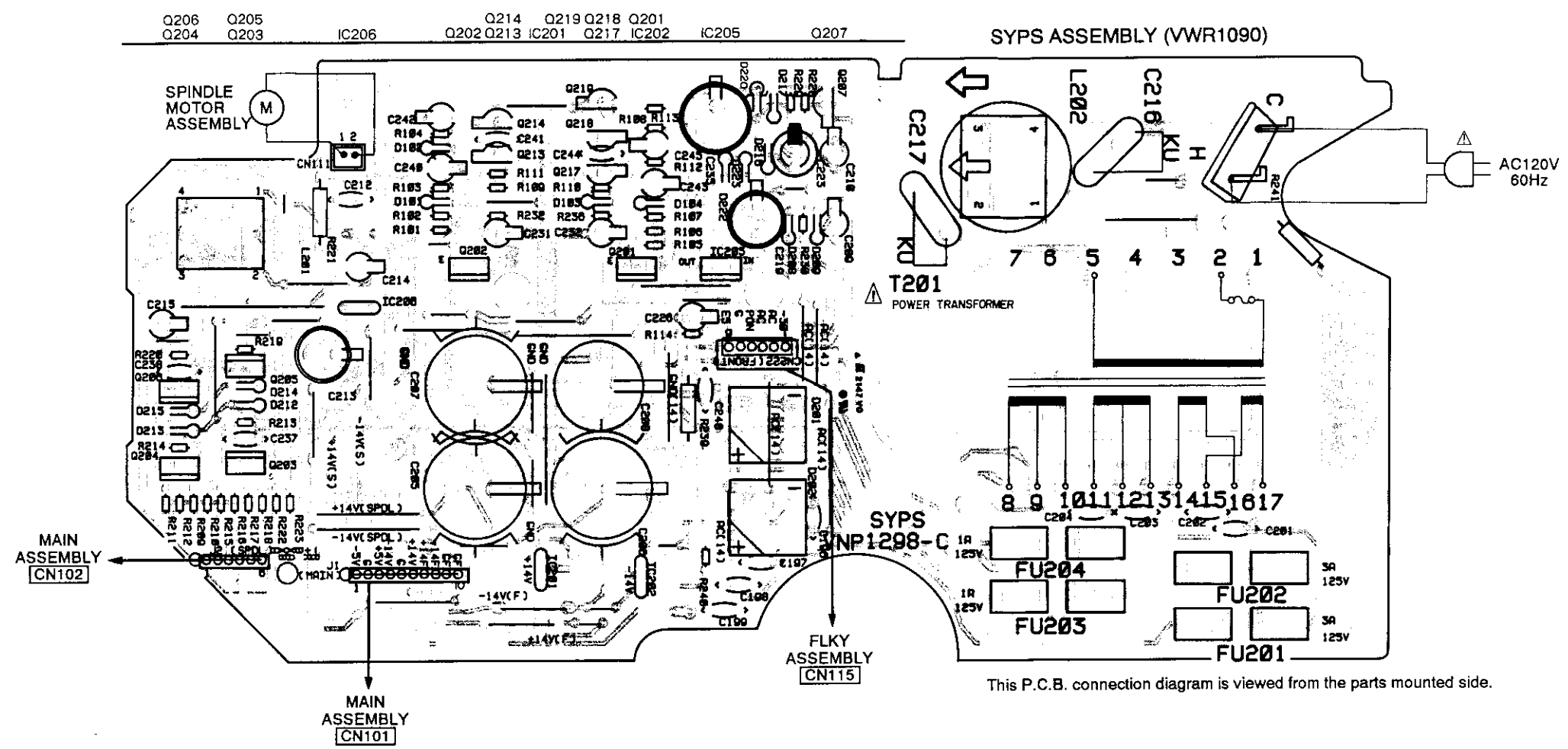

This P.C.B. connection diagram is viewed from the parts mounted side.

P.C.B. pattern diagram Indication	Corresponding part symbol	Part name
		Transistor
		FET
		Diode
		Zener diode
		LED
		Varactor
		Tact switch
		Inductor
		Coil
		Transformer
		Filter
		Ceramic capacitor
		Mylar capacitor
		Styroly capacitor
		Electrolytic capacitor (Non polarized)
		Electrolytic capacitor (Noiseless)
		Electrolytic capacitor (Polarized)
		Electrolytic capacitor (Polarized)
		Power capacitor
		Semi-fixed resistor
		Resistor array
		Resistor
		Resonator
		Thermistor

1. This P.C.B. connection diagram is viewed from the parts mounted side.
2. The parts which have been mounted on the board can be replaced with those shown with the corresponding wiring symbols listed in the above Table.
3. The capacitor terminal marked with shows negative terminal.
4. The diode marked with shows cathode side.
5. The transistor terminal marked with shows emitter.

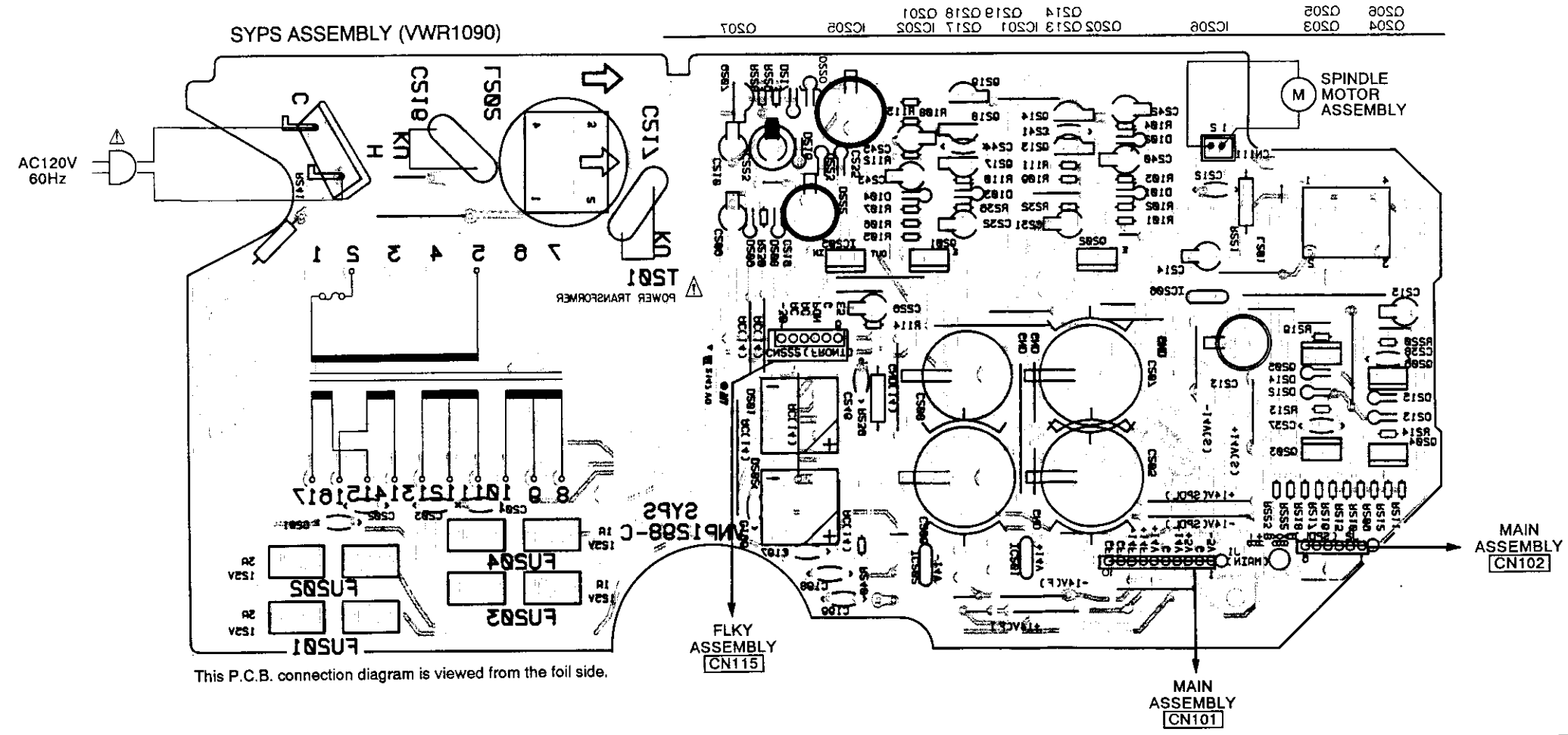

This P.C.B. connection diagram is viewed from the foil side.

5.3 PICKUP ASSEMBLY

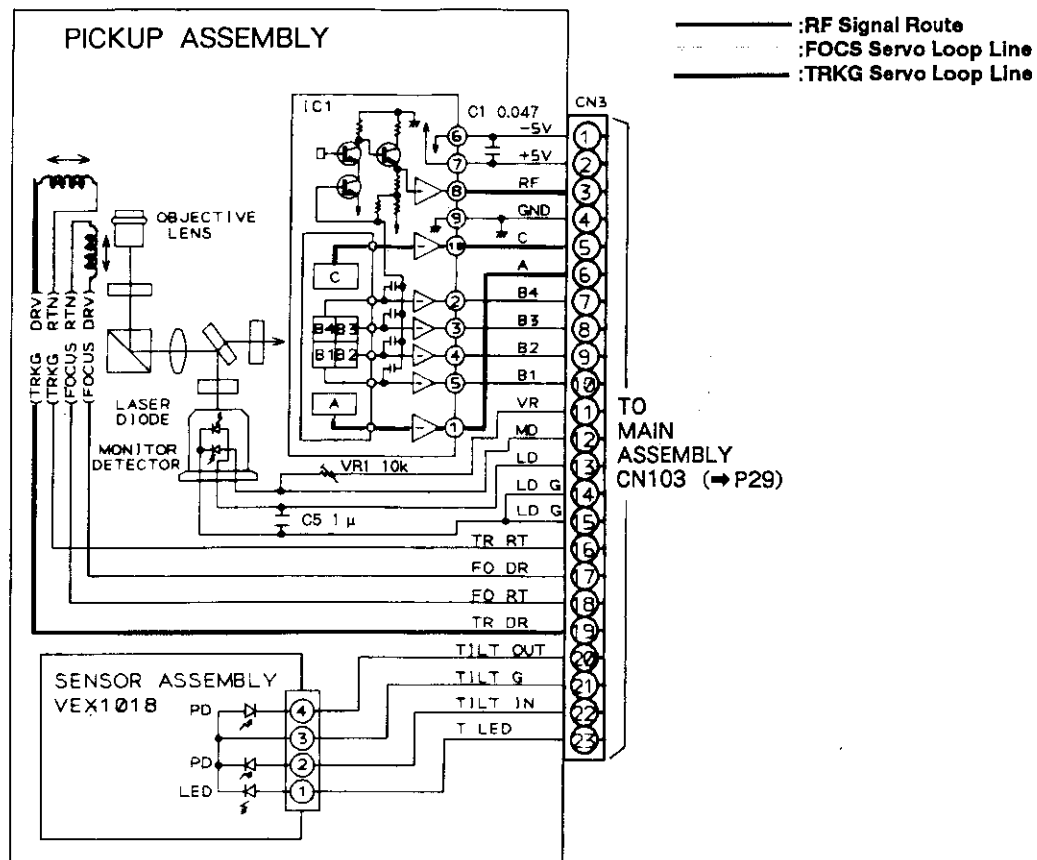

This P.C.B. connection diagram is viewed from the parts mounted side.

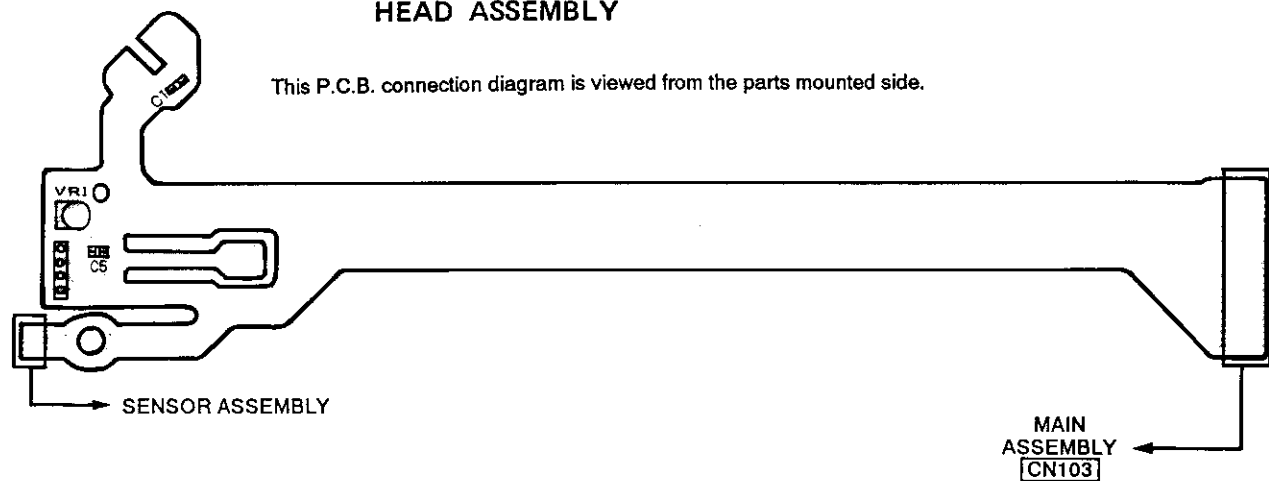

This P.C.B. connection diagram is viewed from the foil side.

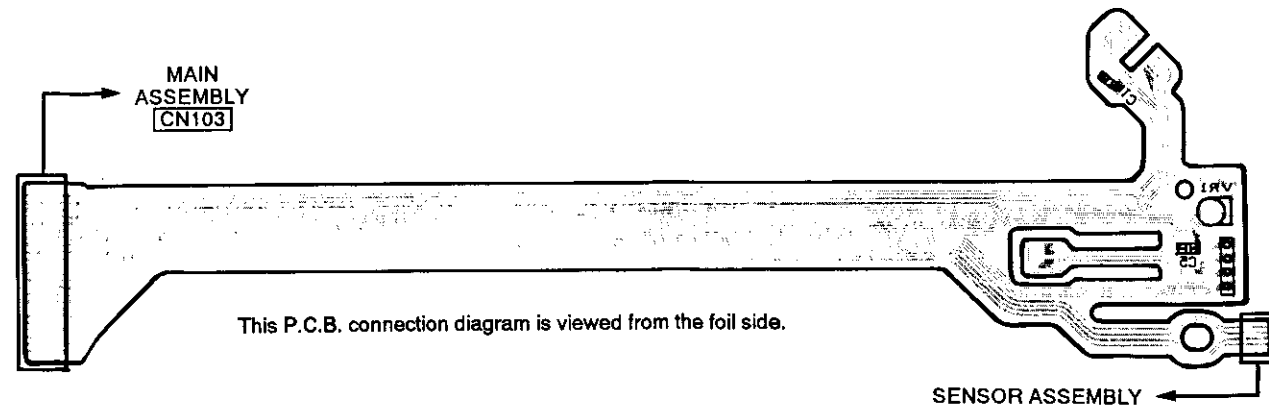

FTS SECTION

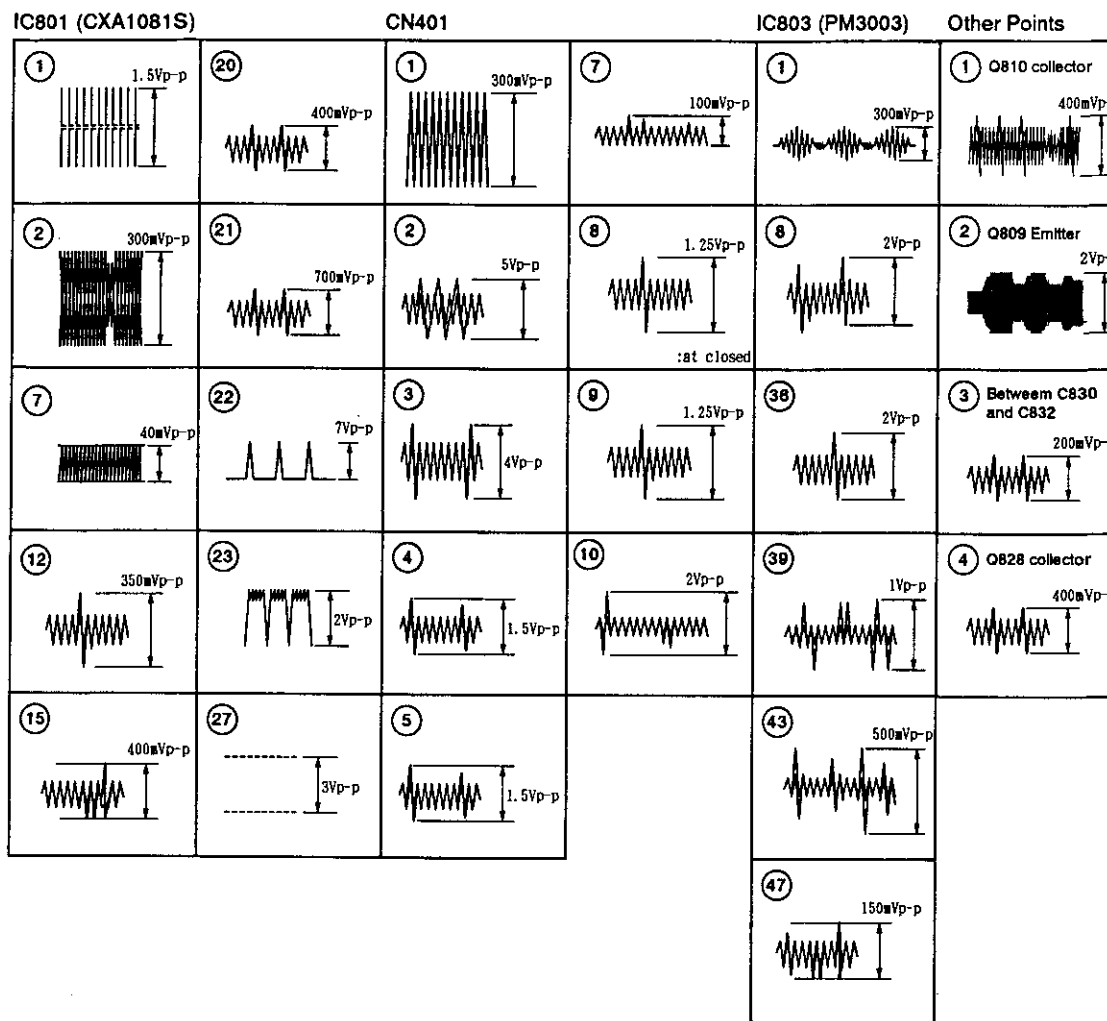

5.4 MAIN ASSEMBLY (FTS SECTION)

MAIN ASSEMBLY (FTS SECTION)

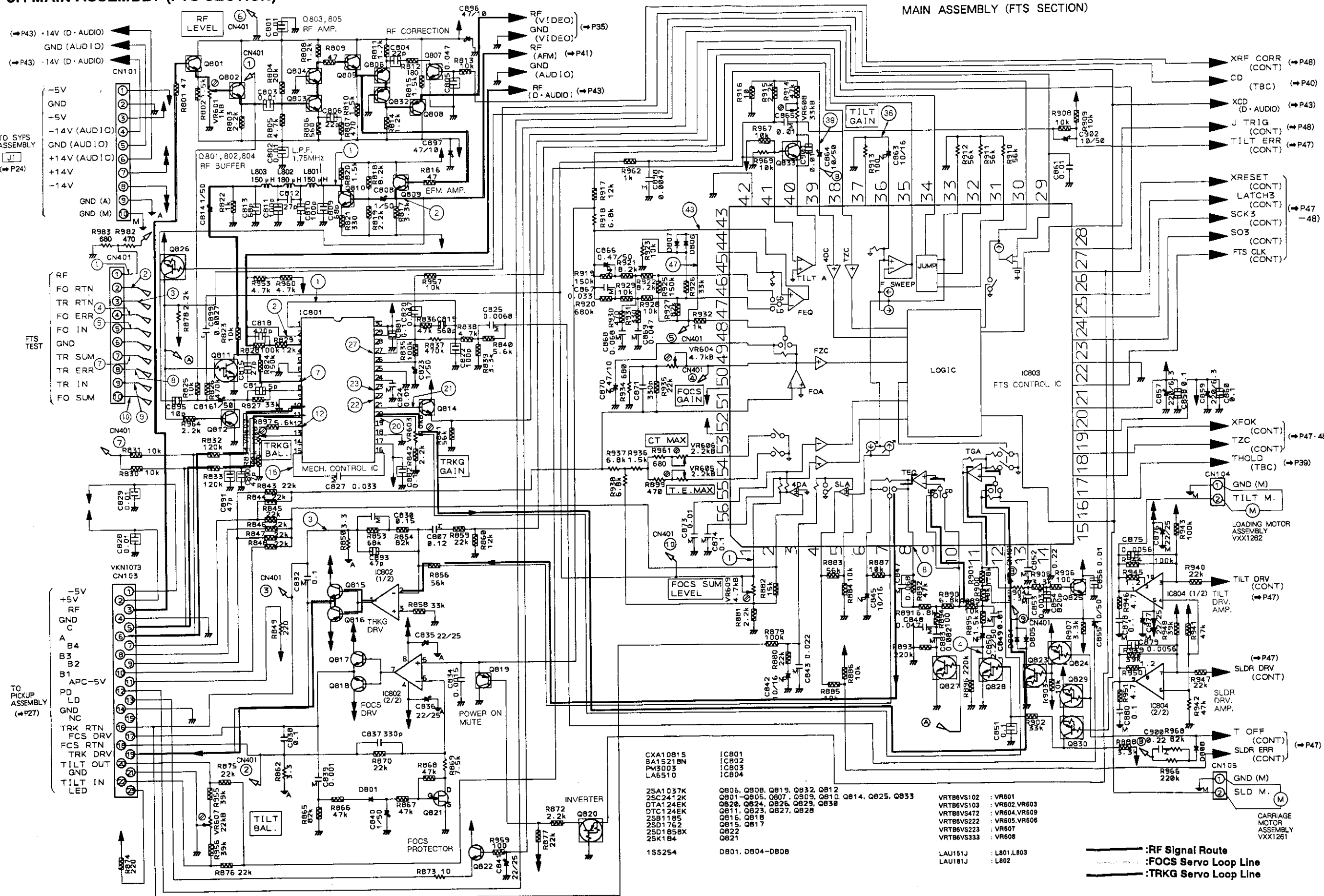

(P43) +14V (D-AUDIO)
GND (AUDIO)
(P43) -14V (D-AUDIO)

-5V
GND
+5V
-14V (AUDIO)
GND (AUDIO)
+14V (AUDIO)
+14V
-14V

GND (A)
GND (M)

RF
FO RTN
TR RTN
FO ERR
FO IN
TR SUM
TR ERR
FO SUM

FTS TEST

-5V
+5V
RF
GND
A
B4
B3
B2
B1
APC-5V
PD
LD
GND
NC

TRK RTN
FCS DRV
FCS RTN
TRK DRV
TILT OUT
GND
TILT IN
LED

TO PICKUP ASSEMBLY (P27)

RF (VIDEO) (P35)
GND (VIDEO)
RF (AFM) (P41)
GND (AUDIO)
RF (D-AUDIO) (P43)

XRF CORR (CONT) (P48)
CD (TBC) (P40)
XCD (D-AUDIO) (P43)
J TRIG (CONT) (P48)
TILT ERR (CONT) (P47)

XRESET (CONT) (P47)
LATCH3 (CONT) (P47)
SCK3 (CONT) (P47)
SO3 (CONT) (P47)
FTS CLK (CONT) (P47)

XFOK (CONT) (P47-48)
TZC (CONT) (P47-48)
THOLD (TBC) (P39)
GND (M)
TILT M.

LOADING MOTOR ASSEMBLY VXX1262

TILT DRV (CONT) (P47)
TILT DRV. AMP.

(P47)
SLDR DRV (CONT)
SLDR DRV. AMP.
T OFF (CONT) (P47)
SLDR ERR (CONT) (P47)
GND (M)
SLD M.

- | | |
|----------|-------|
| CXA10815 | IC801 |
| BA1521BN | IC802 |
| PM3003 | IC803 |
| LA6510 | IC804 |

- | | |
|----------|--|
| 2SA1037K | Q806, Q808, Q819, Q832, Q812 |
| 2SC2412K | Q801, Q805, Q807, Q809, Q810, Q814, Q825, Q833 |
| DTA124EK | Q820, Q824, Q826, Q829, Q838 |
| DTC124EK | Q811, Q823, Q827, Q828 |
| 2SB1195 | Q816, Q818 |
| 2SD1762 | Q815, Q817 |
| 2SD1858X | Q822 |
| 2SK184 | Q821 |

- | | |
|------------|--------------|
| VRT86VS102 | VR601 |
| VRT86VS103 | VR602, VR603 |
| VRT86VS472 | VR604, VR609 |
| VRT86VS222 | VR605, VR606 |
| VRT86VS233 | VR607 |
| | VR608 |

- | | |
|---------|------------|
| LAU151J | L801, L803 |
| LAU181J | L802 |

—:RF Signal Route
- - -:FOCUS Servo Loop Line
· · · ·:TRKG Servo Loop Line

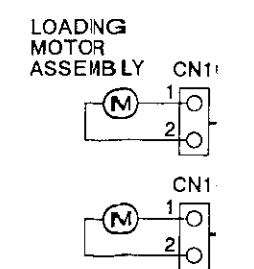
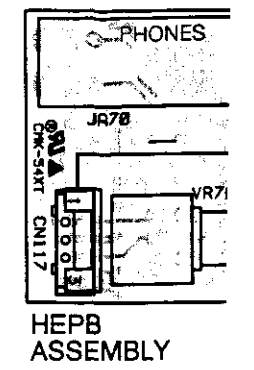

01SD T0SD 81SD 81SD 80SD 81SD IC804 Q817	IC215 Q212 TSD 81SD Q209 TSD 80SD IC802 Q815 Q816 Q818 Q82 DS80 8180	IC213 IC206 IC205 IC211 Q352 Q351 S880 S180 - T080	IC204 80SD IC209 Q204 80SD 8180 80SD 8S80 IC201	S0SD T0SD IC202 Q822	Q583 Q557 Q556 Q551 Q582 880 880 Q431 Q402 Q401 IC803	Q552 Q553 IC406 IC401 808D 8S80 8S80 Q580 - 8S80	1880 0080 8880 IC405 8880 1180 T880 8880 T880 S880 8880 IC402	1080 IC602 IC403 S180 8080 IC404 8080 T080 0180 IC601 Q602 - Q605 8180 T010 8080 IC603 IC101	VR601 VR602 VR605 VR603 VR606 VR609 VR607 VR604 VR608	VR521 VR482 VR441	TP101	VR481 VC901
---	--	--	--	----------------------------	--	---	--	--	---	----------------------	-------	----------------

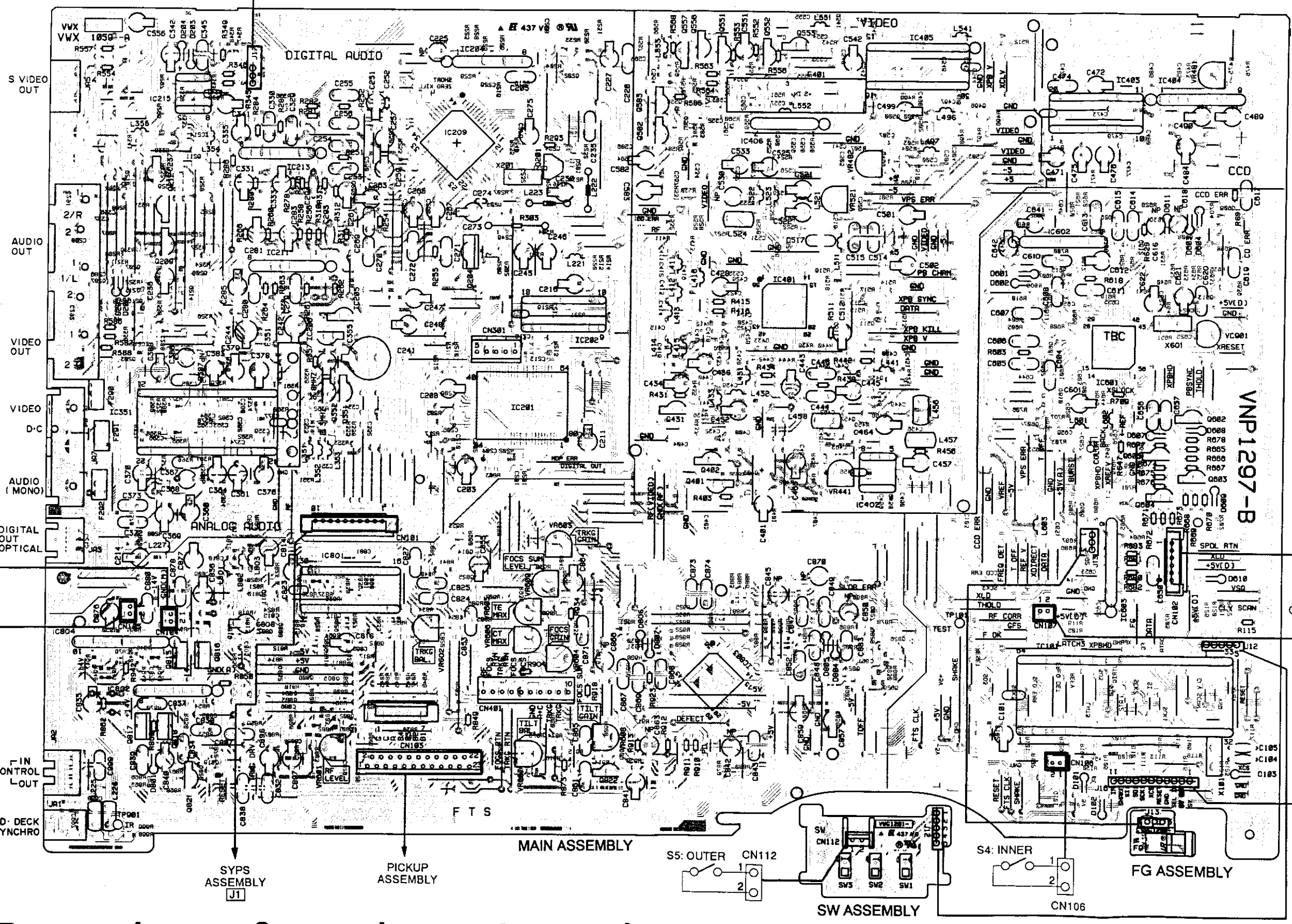
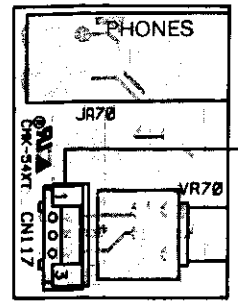

A
B
C
D

A

B

C

D

1 | 2 | 3 | 4 | 5 | 6

1 | 2 | 3 | 4 | 5 | 6

IC804 081 V 188 085 0280 180
IC801 180 085 0280 180
IC802 081 081 081
IC803 081 081 081
IC804 081 081 081
IC805 081 081 081
IC806 081 081 081
IC807 081 081 081
IC808 081 081 081
IC809 081 081 081
IC810 081 081 081
IC811 081 081 081
IC812 081 081 081
IC813 081 081 081
IC814 081 081 081
IC815 081 081 081
IC816 081 081 081
IC817 081 081 081
IC818 081 081 081
IC819 081 081 081
IC820 081 081 081
IC821 081 081 081
IC822 081 081 081
IC823 081 081 081
IC824 081 081 081
IC825 081 081 081
IC826 081 081 081
IC827 081 081 081
IC828 081 081 081
IC829 081 081 081
IC830 081 081 081
IC831 081 081 081
IC832 081 081 081
IC833 081 081 081
IC834 081 081 081
IC835 081 081 081
IC836 081 081 081
IC837 081 081 081
IC838 081 081 081
IC839 081 081 081
IC840 081 081 081
IC841 081 081 081
IC842 081 081 081
IC843 081 081 081
IC844 081 081 081
IC845 081 081 081
IC846 081 081 081
IC847 081 081 081
IC848 081 081 081
IC849 081 081 081
IC850 081 081 081
IC851 081 081 081
IC852 081 081 081
IC853 081 081 081
IC854 081 081 081
IC855 081 081 081
IC856 081 081 081
IC857 081 081 081
IC858 081 081 081
IC859 081 081 081
IC860 081 081 081
IC861 081 081 081
IC862 081 081 081
IC863 081 081 081
IC864 081 081 081
IC865 081 081 081
IC866 081 081 081
IC867 081 081 081
IC868 081 081 081
IC869 081 081 081
IC870 081 081 081
IC871 081 081 081
IC872 081 081 081
IC873 081 081 081
IC874 081 081 081
IC875 081 081 081
IC876 081 081 081
IC877 081 081 081
IC878 081 081 081
IC879 081 081 081
IC880 081 081 081
IC881 081 081 081
IC882 081 081 081
IC883 081 081 081
IC884 081 081 081
IC885 081 081 081
IC886 081 081 081
IC887 081 081 081
IC888 081 081 081
IC889 081 081 081
IC890 081 081 081
IC891 081 081 081
IC892 081 081 081
IC893 081 081 081
IC894 081 081 081
IC895 081 081 081
IC896 081 081 081
IC897 081 081 081
IC898 081 081 081
IC899 081 081 081
IC900 081 081 081

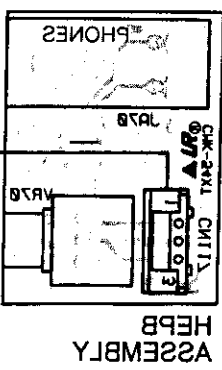
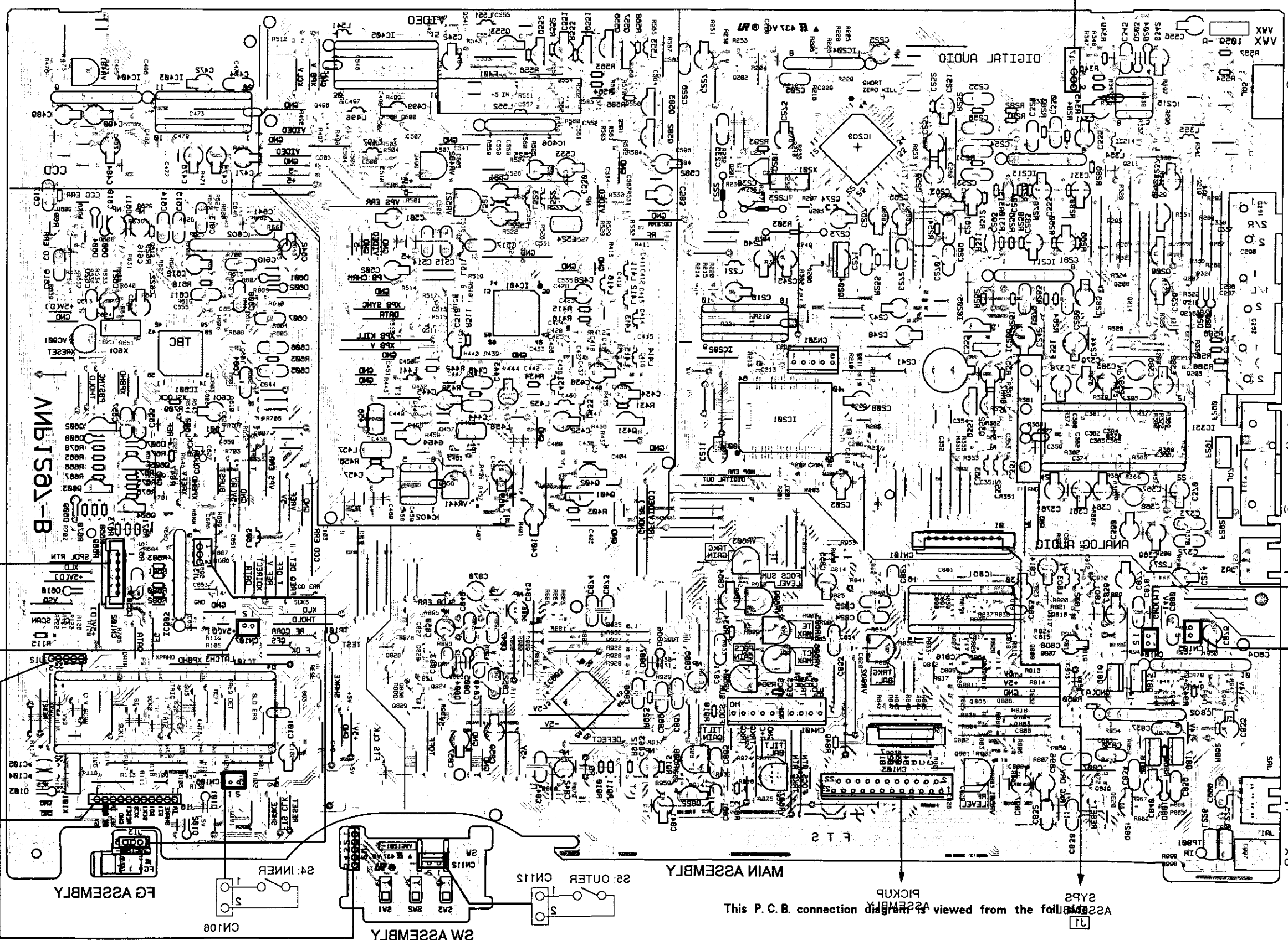

This P.C.B. connection diagram is viewed from the following...

5.5 MAIN ASSEMBLY (VIDEO SECTION)

MAIN ASSEMBLY (VIDEO SECTION)

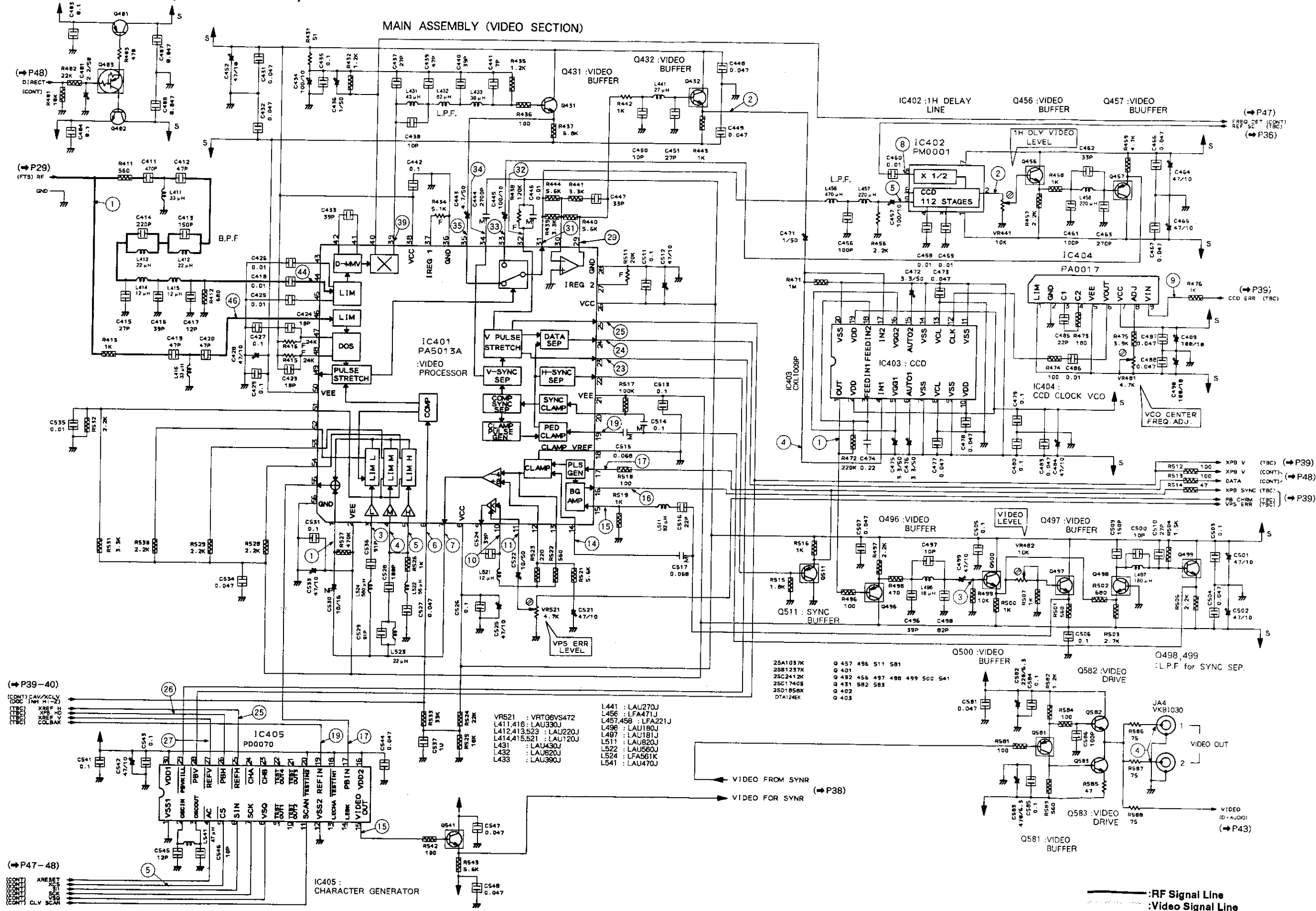

- L441 : LAU270J
- L456 : LFA471J
- L457,458 : LFA221J
- L496 : LAU180J
- L497 : LAU181J
- L511 : LAU820J
- L522 : LAU560J
- L524 : LFA561K
- L541 : LAU470J

- 25A1037K
- 25B1237K
- 25C2412K
- 25C1740S
- 25D1856X
- DTA124K

(P39-40)
 (CONT) CAVXCLY
 XREF
 XREF
 COLBAK

(P47-48)
 XRESET
 CLV
 SCK

:RF Signal Line
 :Video Signal Line

A

B

C

D

ASSEMBLY MOTOR
 ASSEMBLY MOTOR
 CARRIAGE MOTOR
 ASSEMBLY MOTOR
 LOADING MOTOR
 ASSEMBLY MOTOR

5.6 MAIN ASSEMBLY (SYNR SECTION)

WAVEFORMS OF THE VIDEO SECTION

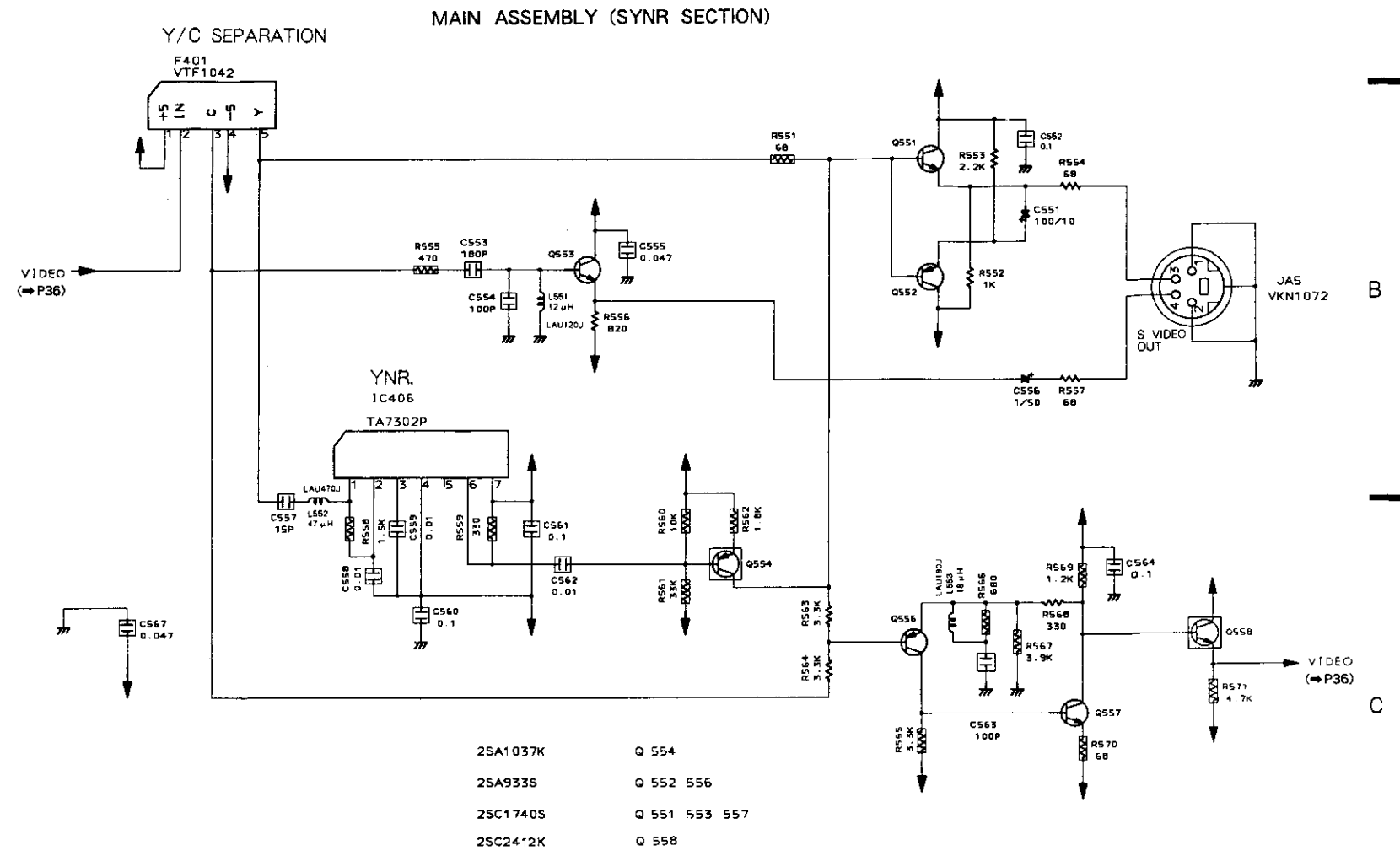
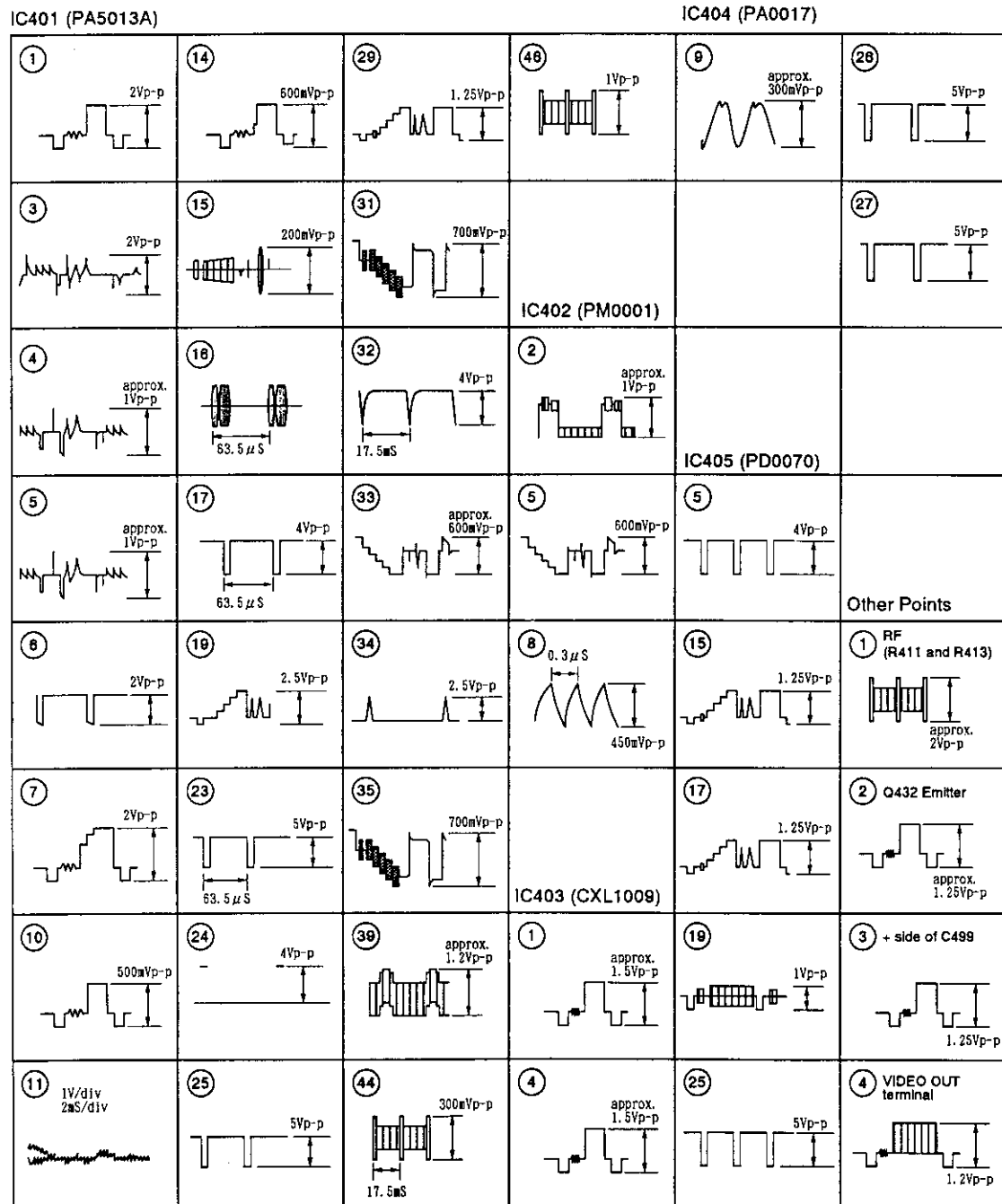

5.7 MAIN ASSEMBLY (TBC SECTION)

MAIN ASSEMBLY (TBC SECTION)

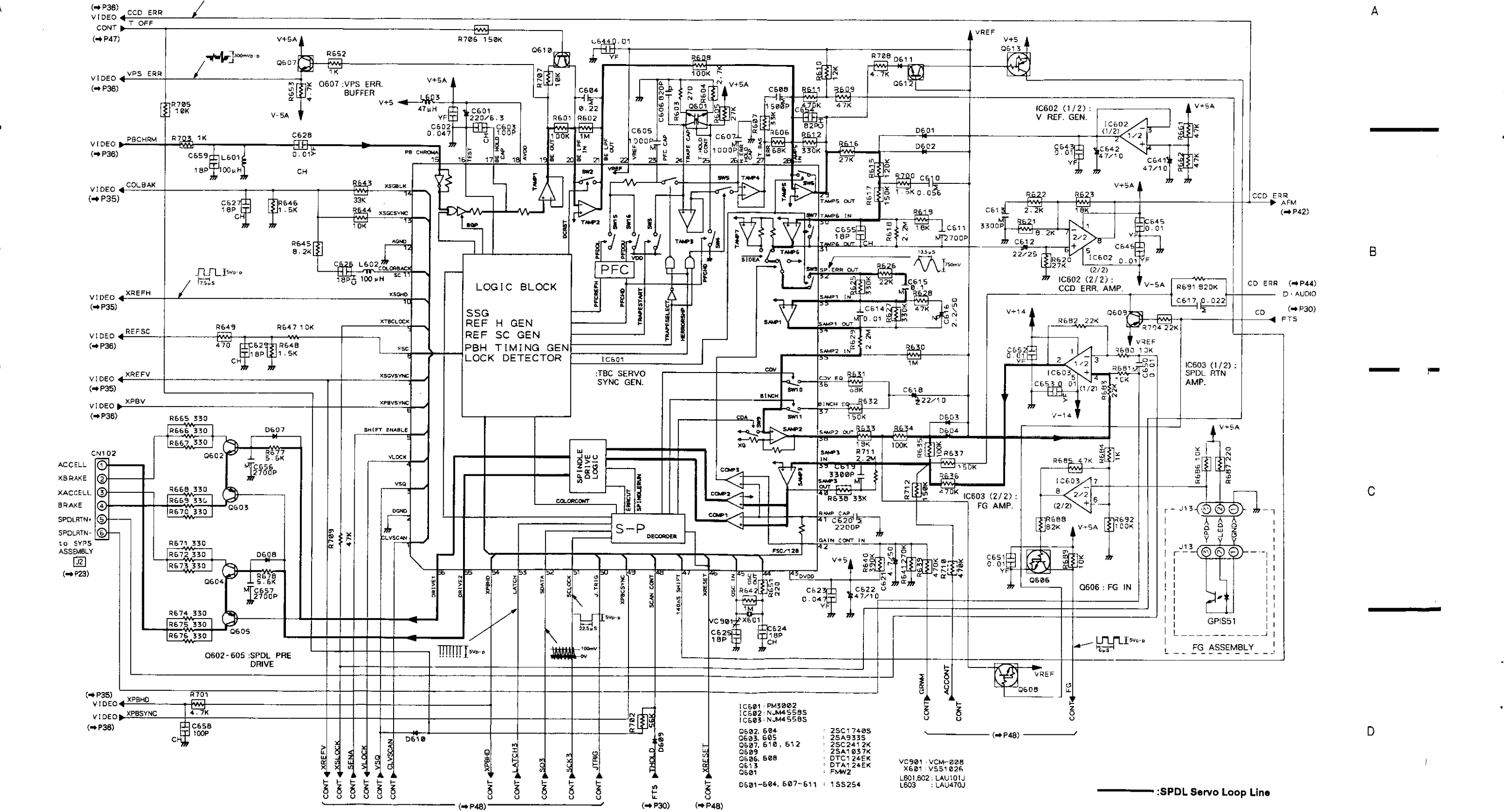

:SPDL Servo Loop Line

5.8 MAIN ASSEMBLY (AFM SECTION)

MAIN ASSEMBLY (AFM SECTION)

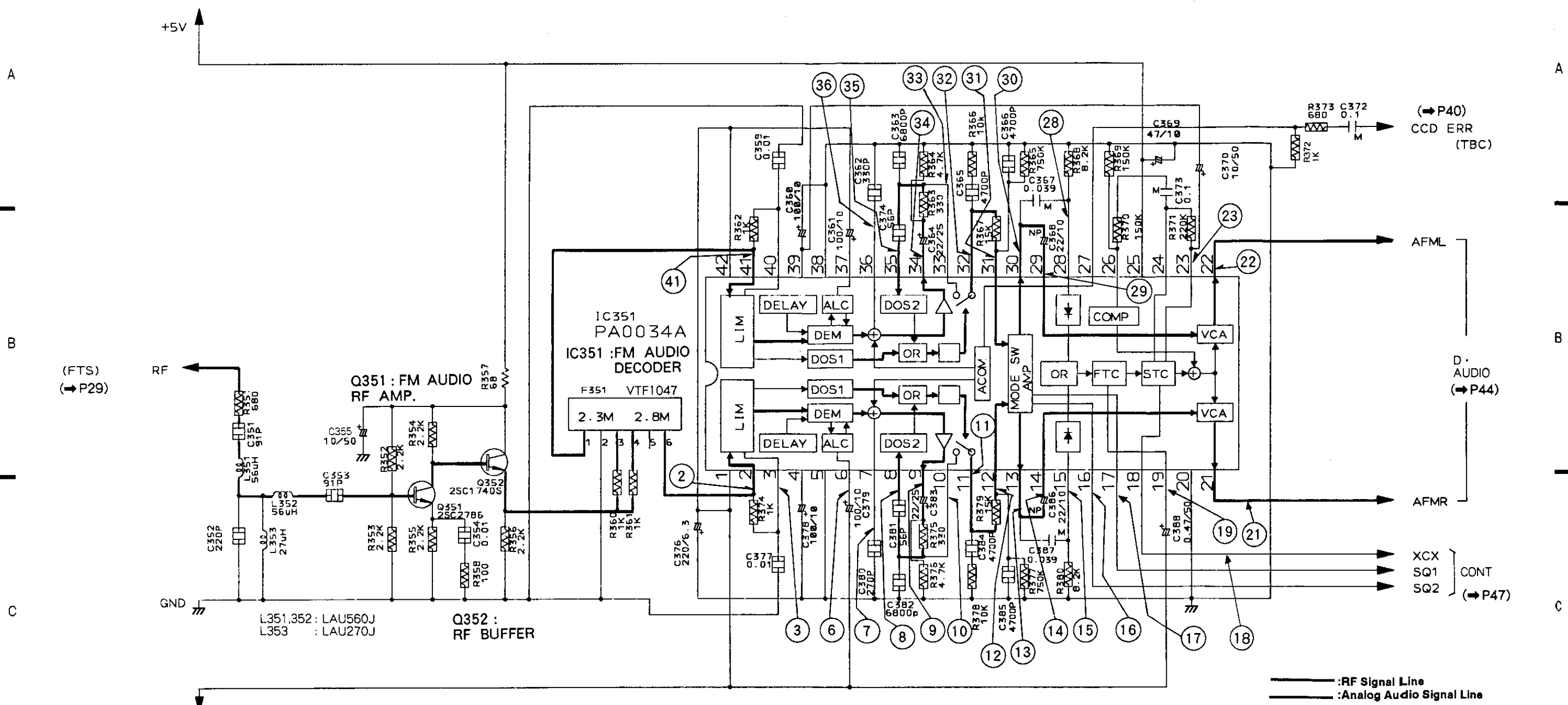

• IC351 (PA0034A)

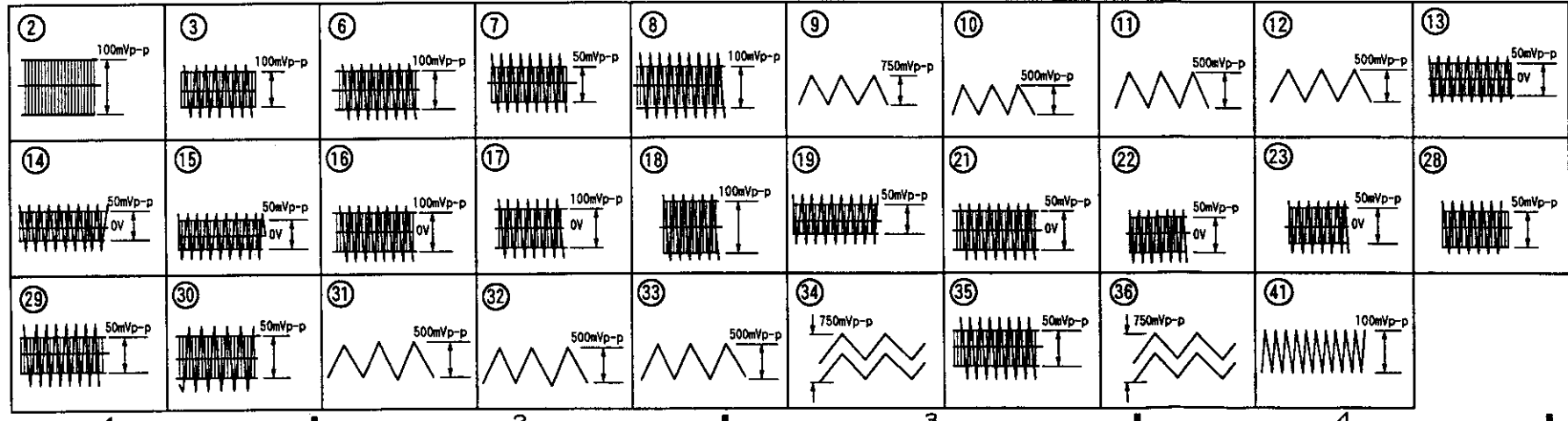

Note: Waveforms and voltages are at the PLAY state.
IC351 (PA0034A)

Pin No.	Voltage	Pin No.	Voltage	Pin No.	Voltage
1	-5V	15	*	29	*
2	*	16	*	30	*
3	*	17	*	31	*
4	*	18	*	32	*
5	*	19	*	33	*
6	*	20	0	34	*
7	*	21	*	35	*
8	*	22	*	36	*
9	*	23	*	37	*
10	*	24	0	38	*
11	*	25	5V	39	*
12	*	26	0	40	*
13	*	27	0	41	*
14	*	28	*	42	-5V

*: Refer to Waveforms

5.9 MAIN ASSEMBLY (D. AUDIO SECTION)

MAIN ASSEMBLY (D. AUDIO SECTION)

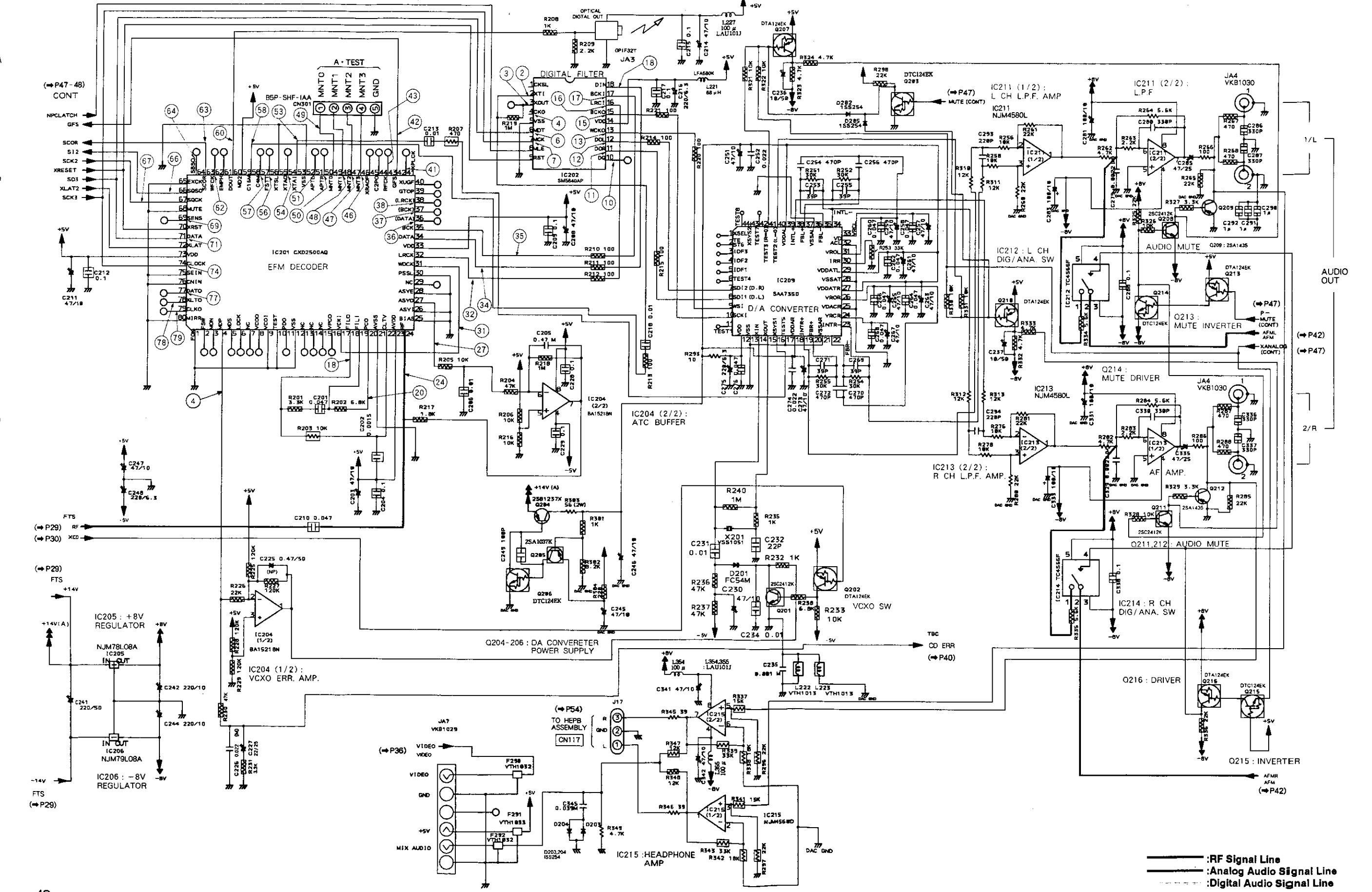

— :RF Signal Line
 - - - :Analog Audio Signal Line
 . . . :Digital Audio Signal Line

Note: Waveforms and voltages are at the PLAY

IC201 (CXD2500AQ)

Pin No.	Voltage	Pin No.	Voltage	Pin No.	Voltage	Pin No.	Voltage	Pin No.	Voltage	Pin No.	Voltage
1	0	15	0	29	0	43	*	57	*	71	*
2	0	18	4.8	30	0	44	0	58	*	72	5
3	0	17	0	31	*	45	4.8	59	5	73	5
4	*	18	*	32	*	46	*	60	*	74	*
5	0	19	2.4	33	4.8	47	*	61	5	75	0
6	4.8	20	*	34	*	48	*	62	*	76	0
7	0	21	0	35	*	49	*	63	*	77	*
8	4.8	22	2.3	36	*	50	*	64	*	78	*
9	0	23	4.8	37	*	51	*	65	0	79	*
10	0	24	*	38	*	52	0	66	*	80	0
11	0	25	0	39	0	53	*	67	*		
12	0	26	0	40	4.8	54	*	68	0		
13	0	27	*	41	*	55	0	69	*		
14	0	28	0	42	*	56	*	70	5		

IC202 (SM5840AP)

Pin No.	Voltage	Pin No.	Voltage
1	5	10	*
2	*	11	*
3	*	12	*
4	*	13	*
5	0	14	5
6	*	15	*
7	*	16	*
8	5	17	*
9	5	18	*

*: Refer to Waveforms

IC201 (CXD2500AQ)

IC202 (SM5840AP)

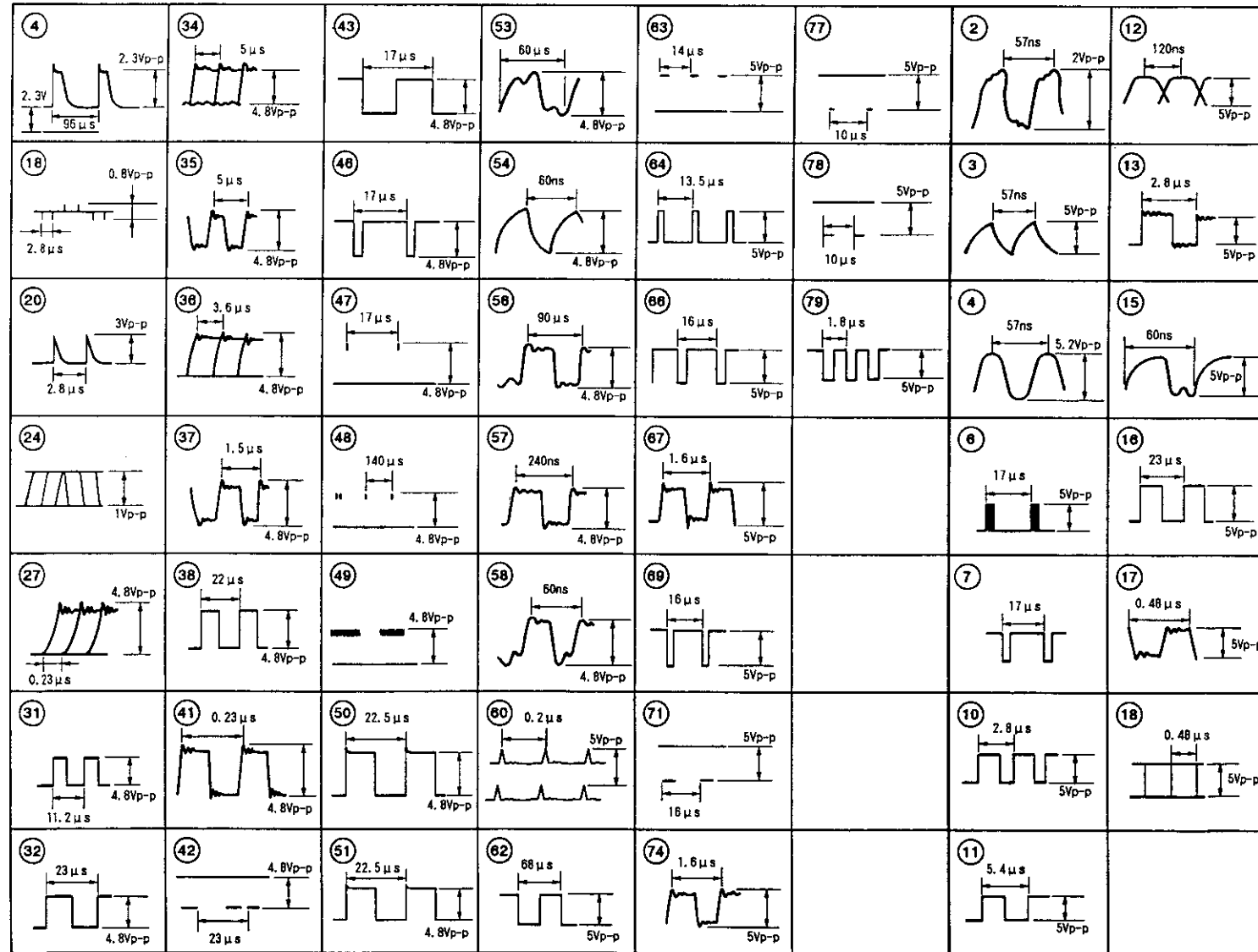

5.10 MAIN ASSEMBLY (CONT SECTION)

MAIN ASSEMBLY (CONT SECTION)

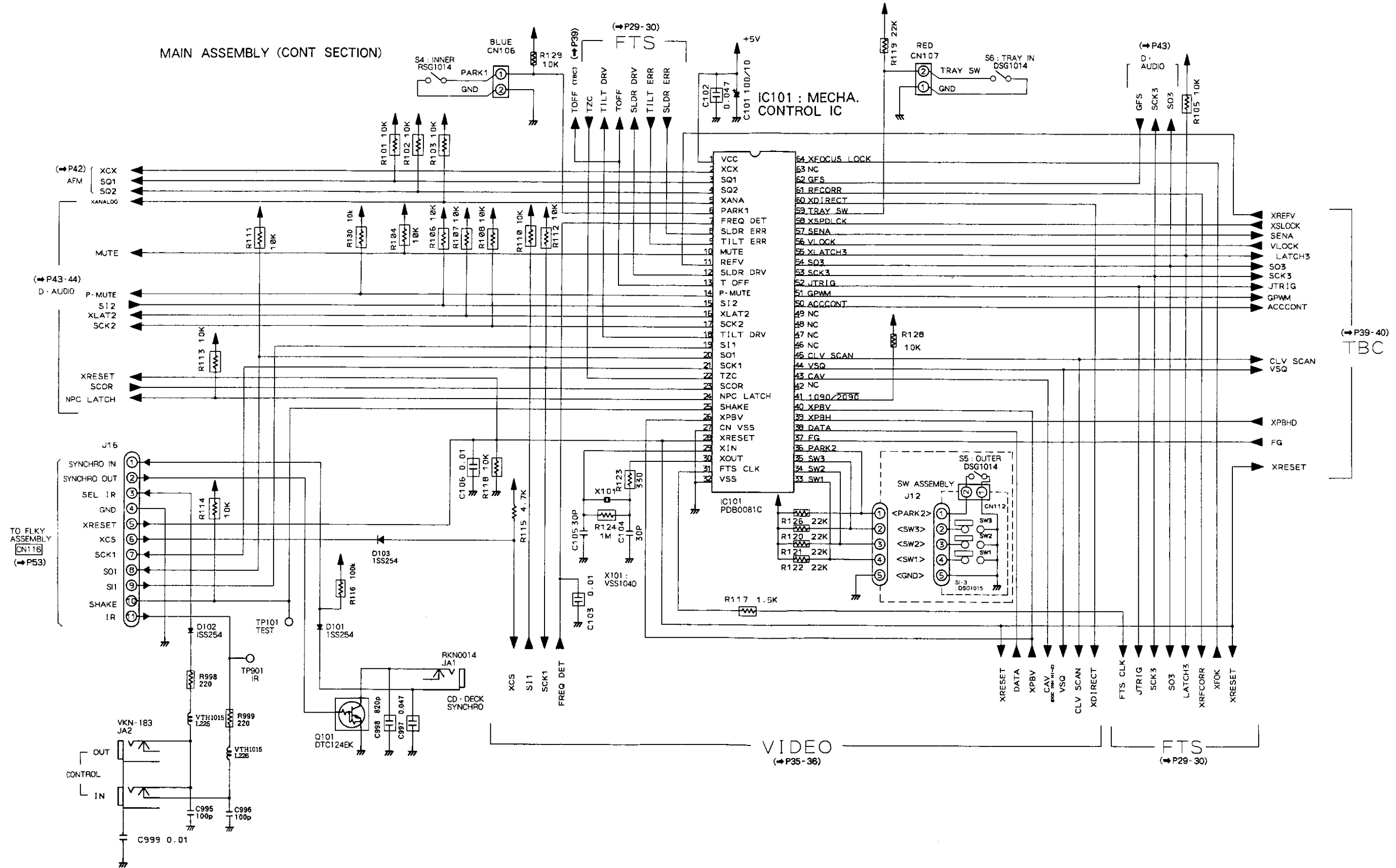

2.11 FLKY, PWSB AND SHKY ASSEMBLIES

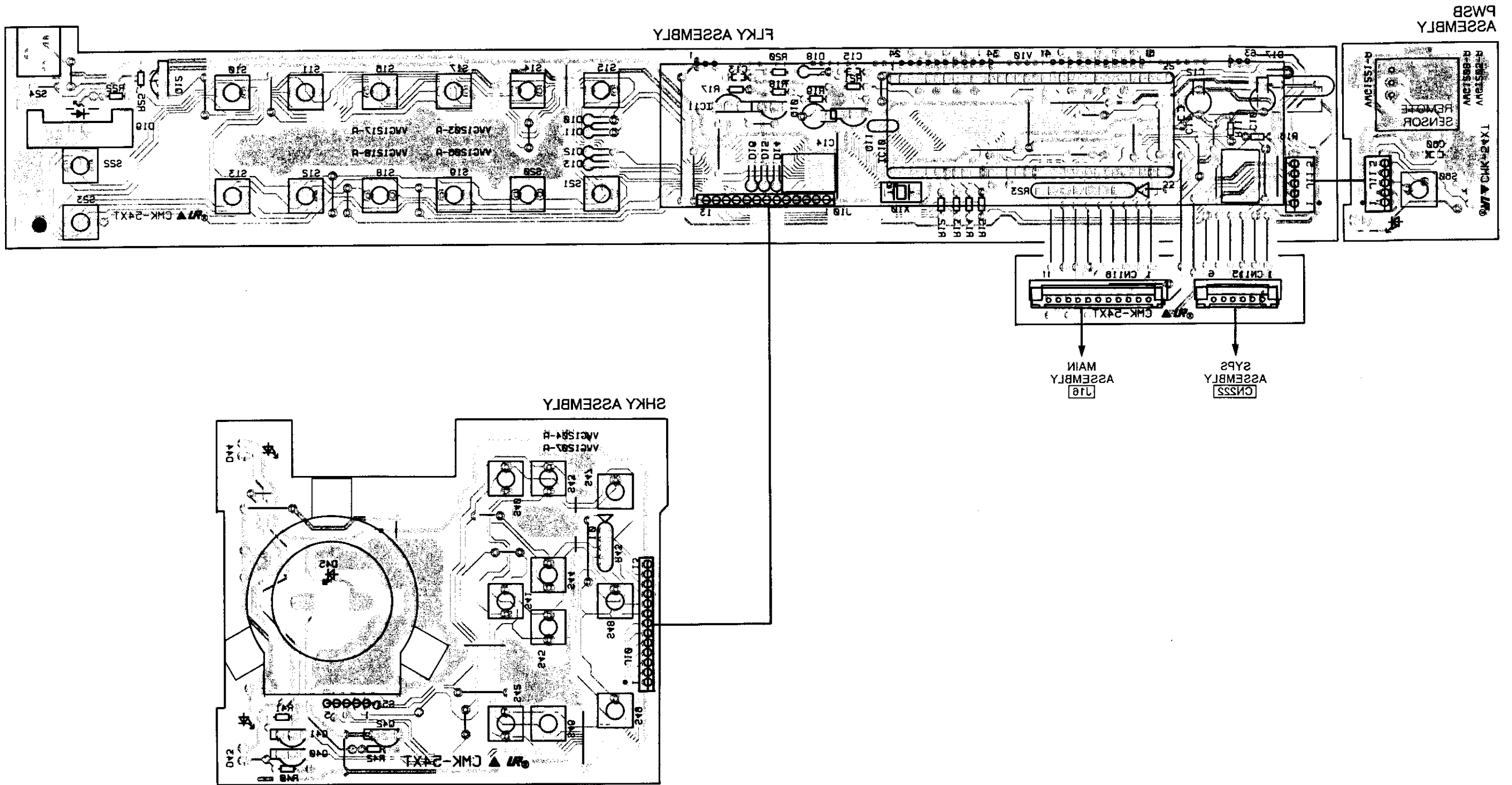

This P.C.B. connection diagram is viewed from the foil side.

5.11 FLKY, PWSB AND SHKY ASSEMBLIES

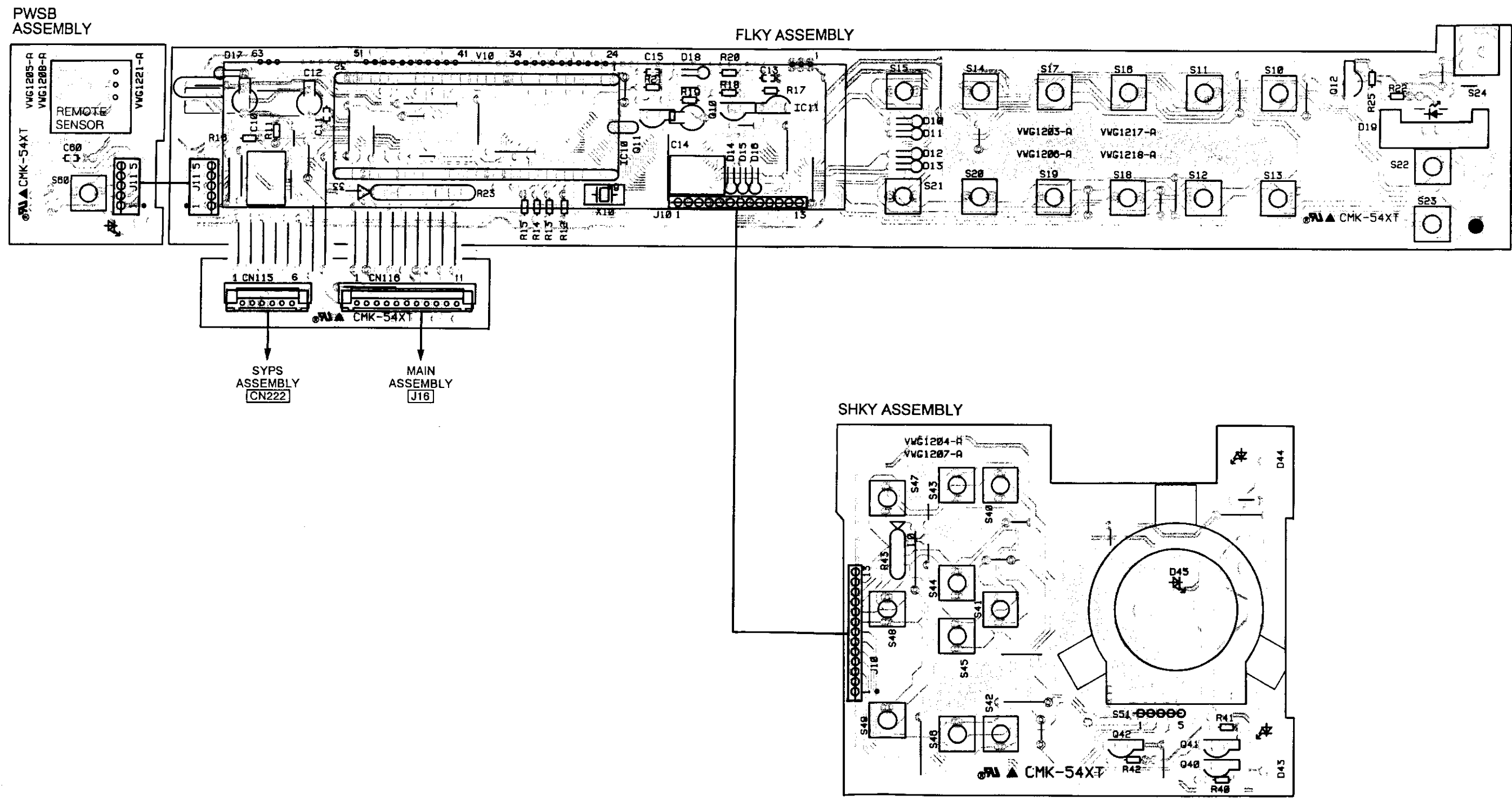

1 2 3 4 5 6

FLKY ASSEMBLY

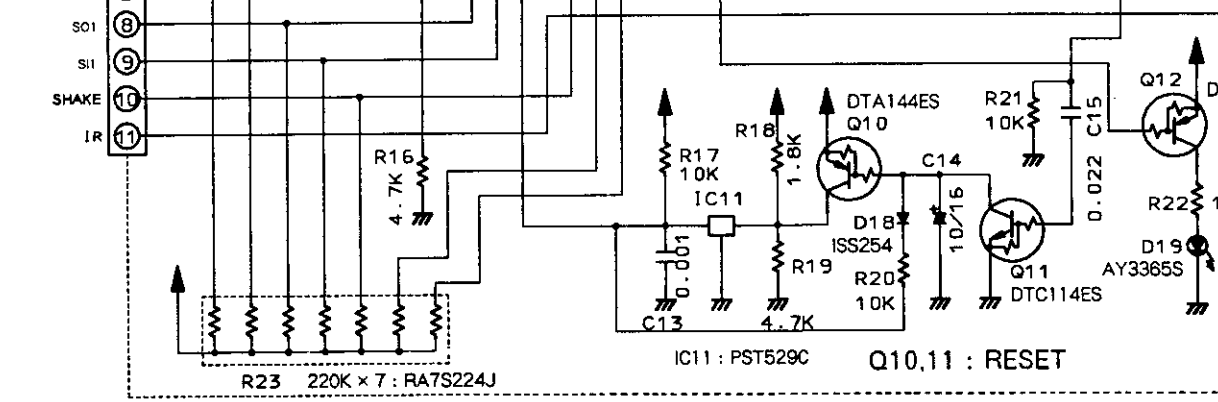
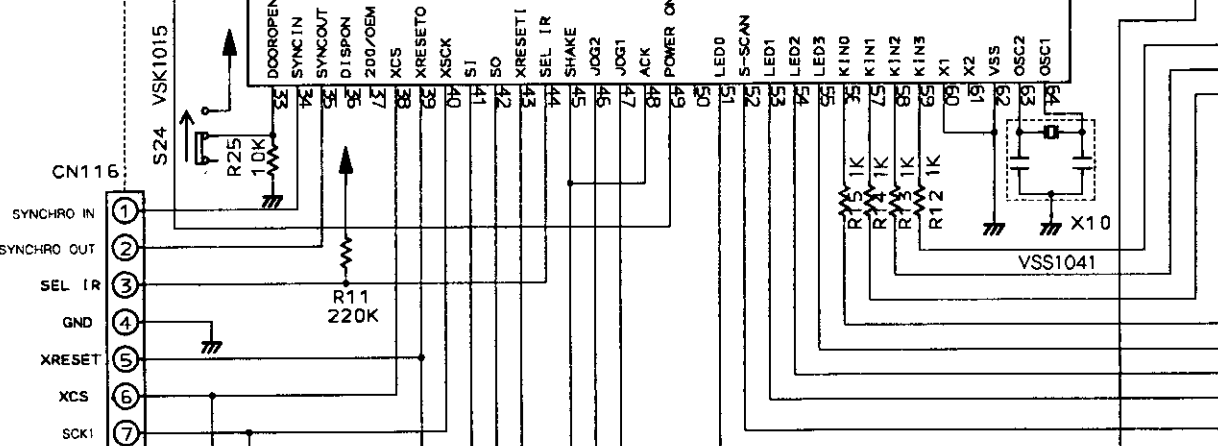
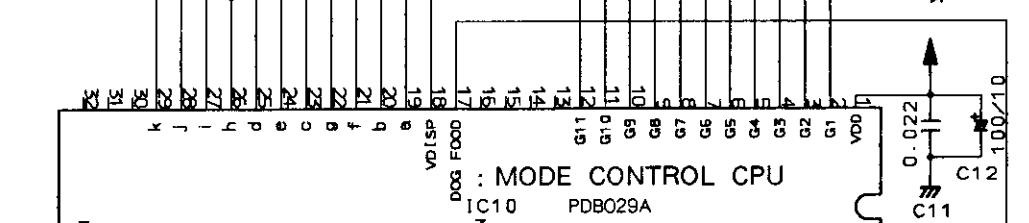
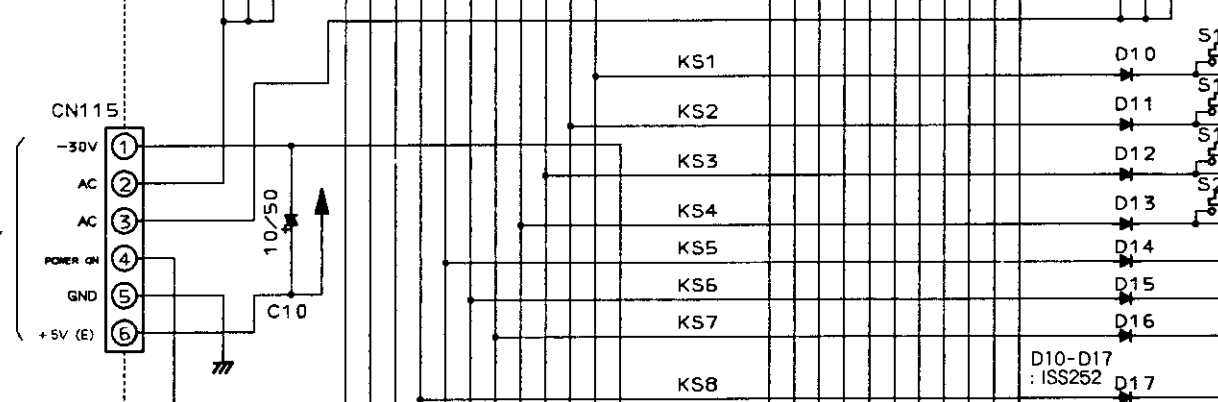
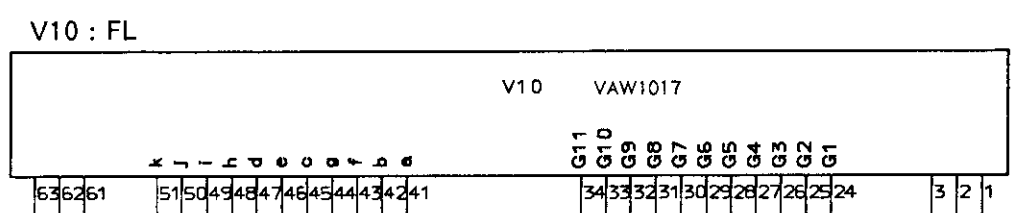

HEPB ASSEMBLY

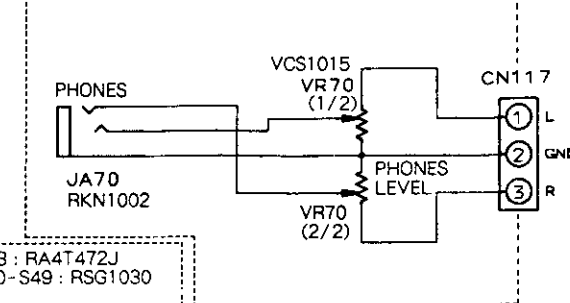

SHKY ASSEMBLY

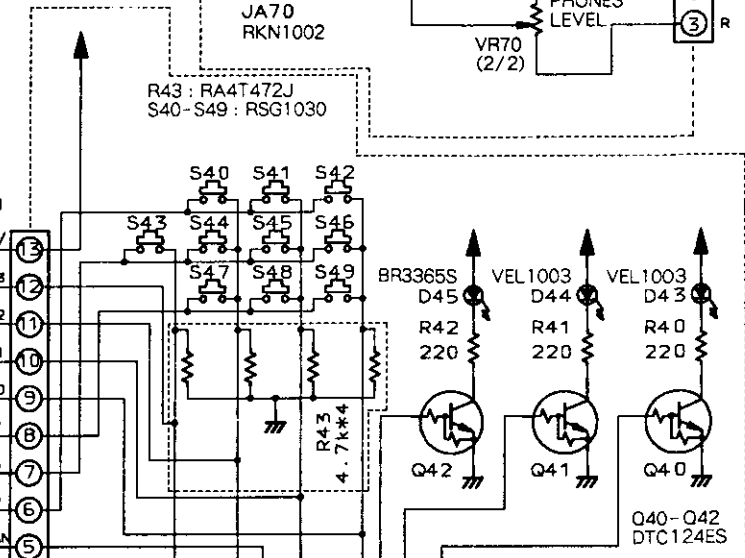

SCAN DIAL

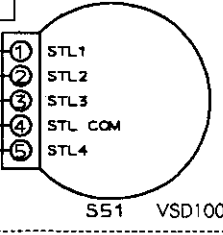

PSWB ASSEMBLY



TO SYPS ASSEMBLY
CN222
(P24)

TO MAIN ASSEMBLY
CONT
SECTION
J16
(P47)

TO MAIN ASSEMBLY
D-AUDIO
SECTION
J17
(P43)

1 2 3 4 5 6

6. ELECTRICAL PARTS LIST

- NOTES:**
- Parts without part number cannot be supplied.
 - Parts marked by "⊙" are not always kept in stock. Their delivery time may be longer than usual or they may be unavailable.
 - The Δ mark found on some component parts indicates the importance of the safety factor of the part. Therefore, when replacing, be sure to use parts of identical designation.
 - When ordering resistors, first convert resistance values into code form as shown in the following examples.

Ex.1 When there are 2 effective digits (any digit apart from 0), such as 560 ohm and 47k ohm (tolerance is shown by J=5%, and K=10%).

560 Ω → 56 × 10¹ → 561 RD1/4PS 561J
 47k Ω → 47 × 10³ → 473 RD1/4PS 473J
 0.5 Ω → 0R5 RN2H 0R5K
 1 Ω → 010 RS1P 010K

Ex.2 When there are 3 effective digits (such as in high precision metal film resistors).

5.62k Ω → 562 × 10¹ → 5621 RN1/4SR 5621F

Miscellaneous Parts

Mark	Symbol & Description	Part No.
⊙	MOTHER assembly	VWM1159
	├ MAIN assembly	
	├ FG assembly	
	└ SW assembly	
⊙	SYPS assembly	VWR1090
⊙	FLKB assembly	VWM1180
	├ FLKY assembly	
	├ SHKY assembly	
	├ PSWB assembly	
	└ HEPB assembly	
Δ	FU201,202 Fuse (3A)	VEK-018
Δ	FU203,204 Fuse (1A)	REK-080
Δ	Power transformer	VTT1079
Δ	Strain relief	CM-22C
Δ	AC power cord	PDG1015
	S4,S5 Push switch (INNER, OUTER)	DSG1014
	S6 Push switch (TRAY IN)	DSG1014
	Carriage motor assembly	VXX1261
	Loading motor assembly	VXX1262
	Spindle motor assembly	VXA1474
	Pre-pickup assembly	VXX1413
	Servo mechanism base assembly-S	VXX1583

⊙ MOTHER Assembly(VWM1159)

MOTHER assembly is composed of the MAIN, FG and SW assemblies.

MAIN Assembly

SEMICONDUCTORS

Mark	Symbol & Description	Part No.
	IC204,IC802	BA15218N
	IC801	CXA1081S
	IC201	CXD2500AQ
	IC403	CXL1009P
	IC804	LA6510
	IC602,IC603	NJM4558S
	IC215	NJM4560D
	IC211,IC213	NJM4580L
	IC205	NJM78L08A
	IC208	NJM78M05FA
	IC206	NJM79L08A
	IC404	PA0017
	IC351	PA0034A
	IC401	PA5013A
	IC405	PD0070
	IC101	PD0081C
	IC402	PM0001
	IC601	PM3002
	IC803	PM3003
	IC209	SAA7350
	IC202	SM5840AP
	IC406	TA7302P
	IC212,IC214	TC4S86F-TR
	Q202,Q207,Q210,Q213,Q216,Q403, Q813,Q820,Q824,Q826,Q829,Q830	DTA124EK
	Q101,Q203,Q208,Q214,Q215,Q606, Q608,Q811,Q823,Q827,Q828	DTC124EK
	Q601	FMW2-TR
	Q205,Q457,Q496,Q511,Q554,Q581, Q609,Q806,Q808,Q812,Q819,Q832	2SA1037K

Mark	Symbol & Description	Part No.
	Q209,Q212	2SA1435
	Q552,Q556,Q603,Q605	2SA933S
	Q816,Q818	2SB1185
	Q204,Q401	2SB1237X
	Q352,Q431,Q551,Q553,Q557, Q582,Q583,Q602,Q604	2SC1740S
	Q201,Q208,Q211,Q432,Q456, Q497-Q500,Q541,Q558,Q607, Q610,Q612,Q801-Q805,Q807, Q809,Q810,Q814,Q825,Q833 Q351	2SC2412K 2SC2786
	Q815,Q817	2SD1762
	Q402,Q822	2SD1858X
	Q821	2SK184
	D201	FC54M
	D101-D103,D202-D205, D601-D604,D607-D611,D801, D804-D808	1SS254

COILS AND FILTERS

Mark	Symbol & Description	Part No.
	L227,L354,L355,L601,L602 L414,L415,L521,L551 L801,L803 L496,L553 L497,L802	LAU101J LAU120J LAU151J LAU180J LAU181J
	L412,L413,L523 L353,L441 L411,L416 L433 L431	LAU220J LAU270J LAU330J LAU390J LAU430J
	L541,L552,L603 L351,L352,L522 L432 L511 L457,L458	LAU470J LAU560J LAU620J LAU820J LFA221J
	L456 L524 L221 L222,L223 Ferrite beads L225,L226	LFA471J LFA561K LFA680K VTH1013 VTH1015
	F401 Comb filter F351 BPF (2.30,02.81MHz) F290,F292 F291	VTF1042 VTF1047 VTH1032 VTH1033

CAPACITORS

Mark	Symbol & Description	Part No.
	VC901 Ceramic trimmer (20P)	VCM-008
	C985,C986	CCCCH101J50
	C104,C105	CCCCH300J50
	C253,C255,C269,C271	CCCCH390J50
	C837,C871	CCCSL331J50
	C293,C294	CKPUYB221K50

Mark	Symbol & Description	Part No.
	C254,C256,C270,C272 C441 C817 C438,C450,C497,C500,C546,C895 C249,C456,C461,C528,C554,C563, C586,C603,C658,C810,C811,C822	CCCSL471J50 CCSQCH070J50 CCSQCH050C50 CCSQCH100D50 CCSQCH101J50
	C417,C545 C557 C413,C509 C423,C424,C624-C627,C629, C655,C659	CCSQCH120J50 CCSQCH150J50 CCSQCH151J50 CCSQCH180J50
	C553 C232,C485,C516,C806 C352,C414 C415,C437,C451,C510,C812,C815 C380,C463	CCSQCH181J50 CCSQCH220J50 CCSQCH221J50 CCSQCH270J50 CCSQCH271J50
	C447,C462 C416,C433,C440,C496,C524,C804 C412,C419,C420,C439,C890,C891, C893 C374,C381	CCSQCH330J50 CCSQCH390J50 CCSQCH470J50 CCSQCH560J50
	C809,C813 C498,C654 C351,C353,C529,C536 C286,C287,C336,C337,C362 C411,C818	CCSQCH680J50 CCSQCH820J50 CCSQCH910J50 CCSQSL331J50 CCSQSL471J50
	C819 C401 C225,C866 C807,C838 C530,C842,C845,C863	CCSQSL561J50 CEAL2R2M50 CEANPR47M50 CEANP010M50 CEANP100M16
	C616,C850 C368,C386,C618 C870 C388 C436,C471,C556,C808,C814, C816,C823,C840	CEANP2R2M50 CEANP220M10 CEANP470M10 CEASR47M50 CEAS010M50
	C236,C237,C355,C370,C522,C855, C864,C902 C101,C281,C283,C331,C333,C360, C361,C378,C379,C434,C445,C457, C489,C490,551	CEAS100M50 CEAS101M10
	C227,C364,C383,C612,C835,C836, C841,C876,C877 C242,C244 C241 C216,C248,C275,C376,C582,C601, C857,C859	CEAS220M25 CEAS221M10 CEAS221M50 CEAS221M6R3
	C472,C475,C476 C443,C621 C208,C214,C230,C245-C247,C251, C257,C259,C261,C263,C265,C267, C273,C275,C341,C342,C369,C428, C452,C464,C465,C499,C501,C502, C512,C521,C525,C533,C542,C622, C641,C642,C896,C897	CEAS3R3M50 CEAS4R7M50 CEAS470M10

Mark	Symbol & Description	Part No.
C285, C335, C484 C583 C446, C614, C650, C824, C849, C861, C865, C873 C372, C373, C514, C615, C832, C838, C874, C878, C880	CEAS470M25 CEAS471M6R3 CFTNA103J50 CFTNA104J50	
C842, C845 C807 C226, C617, C843 C474, C604, C852, C900 C827, C867	CEJANP100M16 CFTNA124J50 CFTNA223J50 CFTNA224J50 CFTNA333J50	
C345, C367, C387 C203, C211 C848, C869 C205 C610	CFTNA393J50 CEJA470M10 CFTNA473J50 CFTNA474J50 CFTNA563J50	
C515, C517, C847, C868 C999 C830 C252, C274 C280, C330	CFTNA683J50 CKCYF103Z50 CFTNA154J50 CKPUYF223Z25 CKPUYB331K50	
C202 C365, C366, C384, C385 C875, C879 C363, C382 C883 C854, C998	CKSQYB152K50 CKSQYB472K50 CKSQYB562K50 CKSQYB682K50 CFTNA823J50 CKSQYB821K50	
C103, C106, C206, C213, C218, C231, C234, C354, C359, C377, C418, C425, C426, C458 - C460, C486, C535, C558, C559, C562, C628, C643 - C646, C651 - C653, C801 - C803, C828, C829, C856, C901	CKSQYF103Z50	
C204, C209, C212, C215, C217, C228, C229, C288, C338, C403, C404, C427, C429, C435, C442, C479, C480, C503, C505, C506, C511, C513, C528, C531, C541, C543, C552, C560, C561, C564, C584, C585, C851, C858, C860, C881, C882	CKSQYF104Z25	
C102, C201, C210, C258, C260, C262, C264, C266, C268, C276, C407, C408, C431, C432, C448, C449, C466, C467, C473, C477, C478, C483, C487, C488, C504, C507, C527, C534, C544, C547, C548, C555, C567, C581, C602, C623, C805, C820, C997	CKSQYF473Z25	
C290 - C292, C537 C235, C605, C607, C839 C808, C834 C279, C329, C620 C444, C811, C856, C657, C899	CKSYF105Z16 CQMA102J50 CQMA152J50 CQMA222J50 CQMA272J50	
C613, C619, C853 C898 C825 C606	CQMA332J50 CQMA472J50 CQMA682J50 CQPA821J100	

RESISTORS

Mark	Symbol & Description	Part No.
VR601 VR441, VR482, VR602, VR603 Semi-fixed (10k Ω) VR607 VR605, VR606	Semi-fixed (1k Ω) Semi-fixed (22k Ω) Semi-fixed (2.2k Ω)	VRTB6VS102 VRTB6VS103 VRTB6VS223 VRTB6VS222
VR608 VR481, VR604, VR609 VR521	Semi-fixed (33k Ω) Semi-fixed (4.7k Ω) Semi-fixed (4.7k Ω)	VRTB6VS333 VRTB6VS472 VRTG6VS472
R303 R415, R416, R434, R438, R511, R680 - R683		RS2LMF300J RN1/6PQ □□□□J
R115, R251, R252, R254 - R256, R258, R260 - R264, R266, R276, R278, R280 - R284, R286, R293, R310 - R313, R340, R344 - R346, R349, R357, R403, R431, R442, R456, R552 - R554, R556, R557, R563, R564, R568, R585 - R588, R603, R618, R629, R647, R665 - R678, R691, R709, R849, R850, R862, R869, R873, R904, R910 - R913, R918, R923, R934, R942		RD1/6PM □□□J
Other resistors		RS1/10S □□□J

OTHERS

Mark	Symbol & Description	Part No.
X601 X101 X201 CN301 CN103	Crystal resonator (14.318MHz) Ceramic resonator (9.00MHz) Crystal resonator (16MHz) 5P top post 23P top connector	VSS1025 VSS1049 VSS1051 B5P-SHF-1AA VKN1073
JA3 JA1 JA7	Optical digital module (DIGITAL OUT, OPTICAL) Mini jack (CD-DECK SYNCHRO) RF pin jack (VHF ADAPTER OUTPUT)	GP1F32F RKN1014 VKB1029
JA4 JA2	6P pin jack AUDIO, VIDEO OUT) 2P pin jack (CONTROL) 4P mini DIN socket (S VIDEO OUT)	VKB1039 VKN-183 VKN1072

FG Assembly

SEMICONDUCTORS

Mark	Symbol & Description	Part No.
	Photo interrupter	GP1S51

SW Assembly

SWITCHES

Mark	Symbol & Description	Part No.
S1 - S3	Push switch (LOADING/TILT)	DSG1015

⊙ FLKB Assembly (VWM1160)

FLKB assembly is composed of the FLKY, SHKY, PSWB and HEPB assemblies.

**FLKY Assembly
SEMICONDUCTORS**

Mark	Symbol & Description	Part No.
	IC10	PDB029A
	IC11	PST529C
	Q12	DTA124ES
	Q10	DTA144ES
	Q11	DTC114ES
	D19	AY3365S
	D10-D17	1SS252
	D18	1SS254

SWITCHES

Mark	Symbol & Description	Part No.
	S10-S23 Tact switch (PGM,DIRECT SEARCH (0-9,+10), DERECT CD,SINGLE)	RSG1030
	S24 Door switch	VSK1015

CAPACITORS

Mark	Symbol & Description	Part No.
	C10	CEAS100M50
	C12	CEAS101M10
	C14	CEJA100M16
	C13	CKPUYB102K50
	C11,C15	CKPUYF223Z25

RESISTORS

Mark	Symbol & Description	Part No.
	R23 Resistor array Other resistors	RA7S224J RD1/6PM□□□J

OTHERS

Mark	Symbol & Description	Part No.
	V10 Fluorescent indicator tube	VAW1017
	X10 Ceramic resonator (6.00MHz) FL spacer	VSS1041 VEB1125

SHKY Assembly

SEMICONDUCTORS

Mark	Symbol & Description	Part No.
	Q40-Q42	DTC124ES
	D45	BR3365S
	D43,D44	VEL1003

SWITCHES

Mark	Symbol & Description	Part No.
	S40-S49 Tact switch (DIGITAL LEVEL CTRL,PGM EDIT, PEAK SEARCH,RANDOM PLAY, HILITE INTRO SCAN,SKIP(◀◀, ▶▶), OPEN/CLOSE(▲), STOP(■), PLAY/PAUSE(▶/))	RSG1030
	S51 Rotary encoder	VSD1007

RESISTORS

Mark	Symbol & Description	Part No.
	R43 Resistor array R40-R42	RA4T472J RD1/6PM221J

PSWB Assembly

SWITCH

Mark	Symbol & Description	Part No.
	S60 Tact switch (POWER)	RSG1030

CAPACITOR

Mark	Symbol & Description	Part No.
	C60	CKPUYF223Z25

OTHERS

Mark	Symbol & Description	Part No.
	Remote control sensor unit	GP1U50X

HEPB Assembly

RESISTOR

Mark	Symbol & Description	Part No.
	VR70 Double rotary volume (LEVEL)	VCS1015

OTHER

Mark	Symbol & Description	Part No.
	JA70 Headphone jack	RKN1002

◎ SYPS Assembly (VWR1090)

SEMICONDUCTORS

Mark	Symbol & Description	Part No.
△	IC201	ICP - N15
	IC202	ICP - N15
	IC206	ICP - N25
△	IC205	NJM78M05FA
	Q217	DTA114ES
	Q213	DTC114ES
	Q214, Q219	2SA933S
	Q202, Q203, Q205	2SB1185
△	Q207	2SB1238X
	Q218	2SC1740S
	Q201, Q204, Q206	2SD1762
	D220	MTZJ22C
	D102, D104	MTZJ5.1C
	D101, D103	MTZJ5.6B
△	D201, D202	S2VB20 - F
△	D213, D214	1SR35 - 100AVL
	D222, D223	1SR35 - 100AVL
△	D208, D209	1SS252
△	D216, D217	1SS252
	D212, D215	10ELS2

COILS

Mark	Symbol & Description	Part No.
△	L202 Line filter	VTL - 262
△	L201 Coil (10mH)	VTL1008

CAPACITORS

Mark	Symbol & Description	Part No.
△	C205, C206 Aluminum (3300/25V)	VCH1095
	C216 Ceramic(10000p/AC400V)	RCG - 009
	C217 Ceramic(10000p/AC400V)	RCG - 009
	C209, C210, C226, C231, C232, C242, C245	CEAS101M10
	C213	CEAS471M35
	C223	CEAS101M25
	C219	CEAS101M35
	C235	CEAS102M25
	C214, C215	CEAS2R2M50
	C240, C243	CEAS221M10
	C208	CEAS472M10
	C207	CEAS682M10
	C212, C237, C238	CGCYX473M25
	C196 - C199, C246	CKCYF103Z50
	C241, C244	CKPUYB102K50
	C201 - C204	CKPUYF103Z25

RESISTORS

Mark	Symbol & Description	Part No.
△	R221	RS1LMFR51J
	R239	RS1LMF4R7J
	R241	RD1/2PM225J
	Other resistors	RD1/6PM □□□ J

HEAD Assembly

CAPACITORS

Mark	Symbol & Description	Part No.
	C1	CKSQYF473Z50
	C5	CKSYF105Z16

RESISTOR

Mark	Symbol & Description	Part No.
	VR1 Chip semi-fixed	VCP1040

7. DISASSEMBLY

7.1 REMOVING THE BONNET AND FRONT PANEL (Fig. 7-1, 2)

- ① Remove six screws (A) to remove the bonnet.
- ② To remove the front panel assembly, remove three screws (B) and lift the claws as shown in the figure and lower the front panel toward the front.

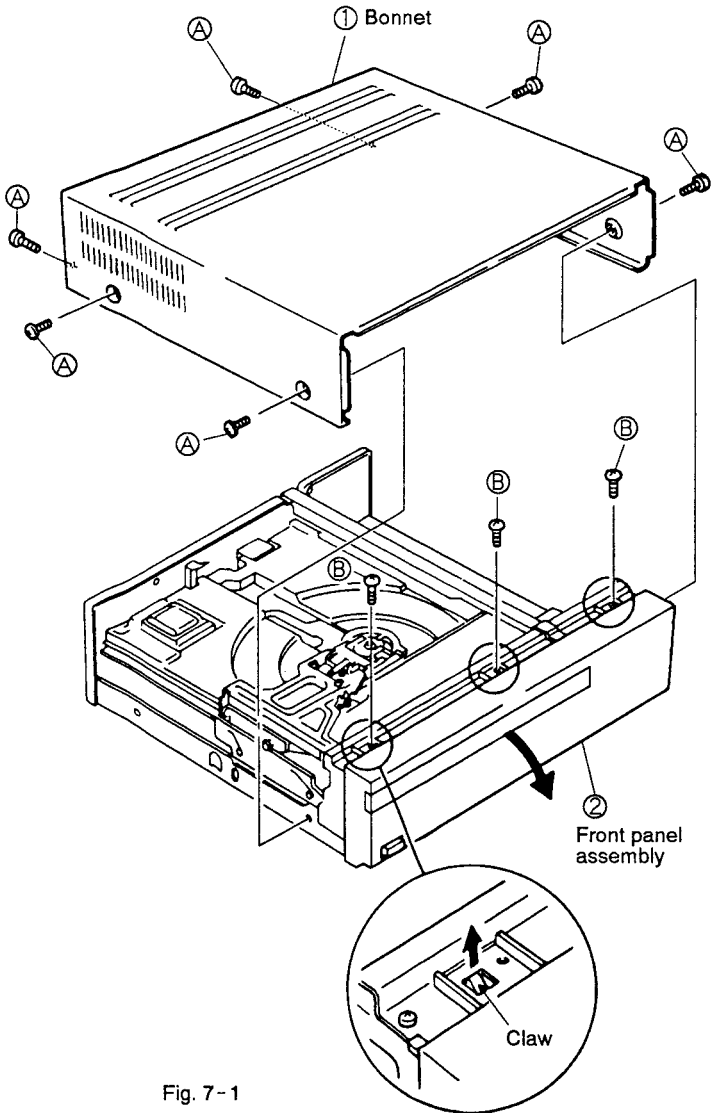

Fig. 7-1

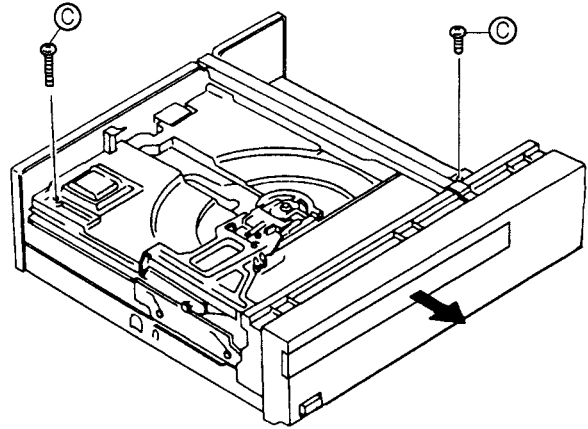

Fig. 7-2

7.2 REMOVING THE TRAY (Fig. 7-2, 3)

- ① Remove two stopper screws (C) shown in Fig. 7-2. When the power can be turned ON, press the OPEN (▲) button then pull the tray out from the player.
- ② When the power cannot be turned ON, remove the front panel (Fig. 7-1), and turn the gear pulley shown in Fig. 7-3 counterclockwise, and the tray will slide out toward the front.

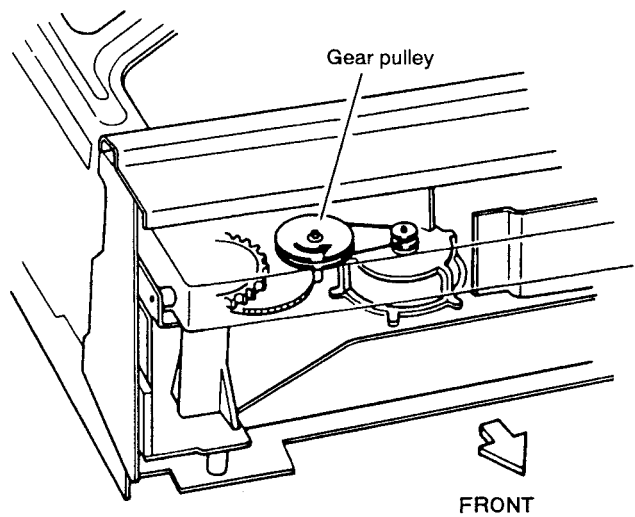

Fig. 7-3

7.3 REMOVING THE MAIN ASSEMBLY (Fig. 7-4)

- After removing the main binders, remove by the following procedure:
- ① Remove two screws (A) to remove the center angle.
- ② Remove two screws (B) holding the MAIN assembly, and remove seven screws (C) on the sides of the rear panel.
- ③ Remove the flexible cable from the connector.
- ④ Pull the MAIN assembly in the direction of the arrow.
- ⑤ While sliding the MAIN assembly to the right, lift it upward in the direction of the arrow.

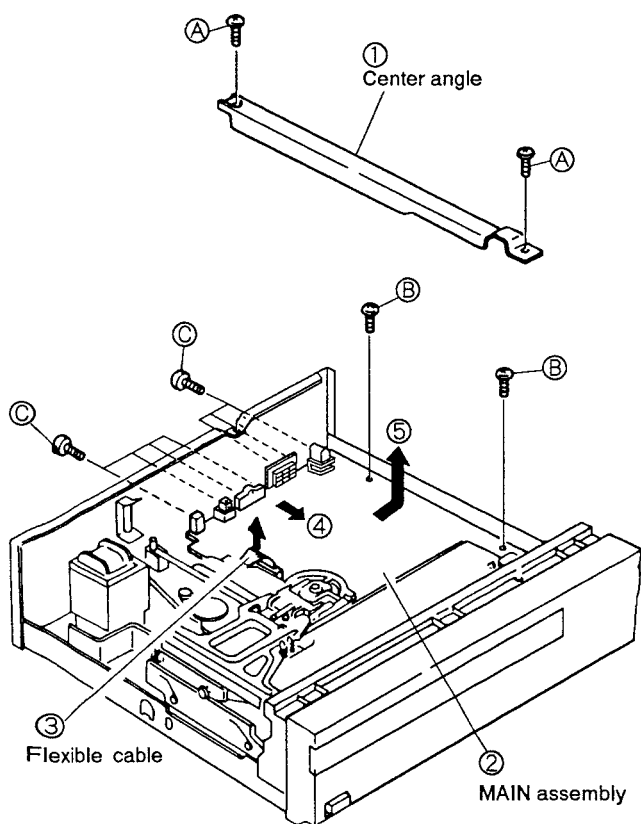

Fig. 7-4

● Diagnosis of the MAIN assembly

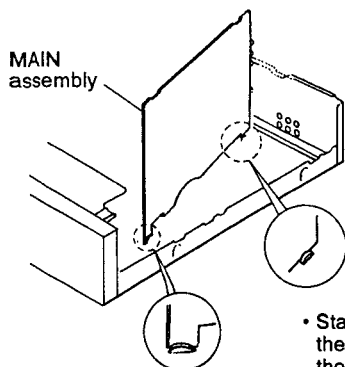

Fig. 7-5

- Stand the MAIN assembly in the chassis as illustrated, and the MAIN assembly is able to diagnose from the foil side.

7.4 REMOVING THE CLAMPER ARM (B) AND CLAMPER ARM (A) ASSEMBLY (Fig. 7-6)

Set the player with the tray moved up.

- ① Remove two clamber springs and raise clamper arm (B).
- ② Clamper arm (B) can be removed by pulling it in the direction of the arrow.
- ③ Remove a screw (A) with a arm spring holding the clamper arm (A) assembly.
- ④ Remove the clamper arm (A) assembly by pulling it in the direction of the arrow.

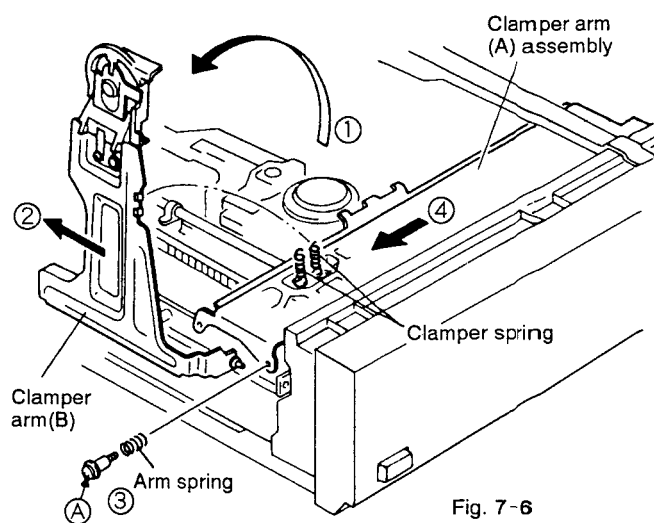

Fig. 7-6

7.5 REMOVING THE CLAMPER (Fig. 7-7)

- ① Remove the plate spring by unscrewing screw (A).
- ② Remove the parallel link by sliding it in the direction of the arrow. (Be careful not to damage the claw located on one side of the link.)
- ③ The clamber can be removed by sliding the clamber holder in the direction of the arrow.

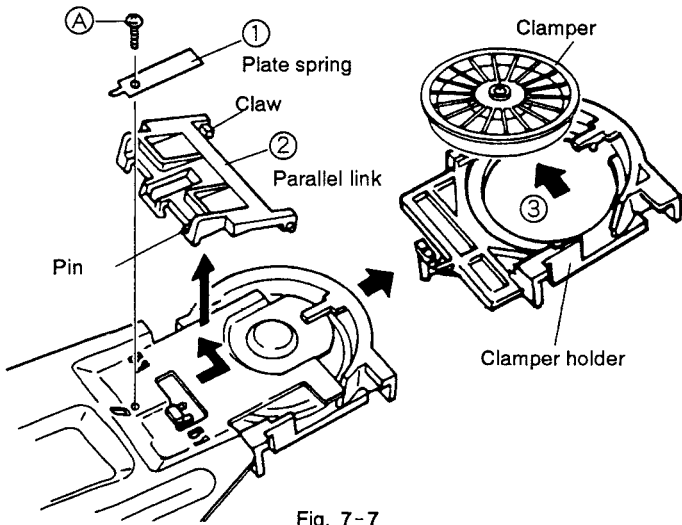

Fig. 7-7

7.6 REMOVING THE PICKUP ASSEMBLY (Fig. 7-8)

- ① Remove the flexible cable from the connector and also remove the flexible cable installed at section (a).
- ② Remove a screw (A) holding the carriage shaft.
- ③ Raise the shaft in the direction of the arrow to remove the rack assembly.
- ④ Remove a hexagonal screw (B) and lift up the pickup assembly slightly and turn the pickup assembly in the direction of arrow (5).
- ⑤ Remove two screws (C) on the back of the pickup assembly.

Note: Make sure that the rack assembly is not close to the turntable when it is removed.

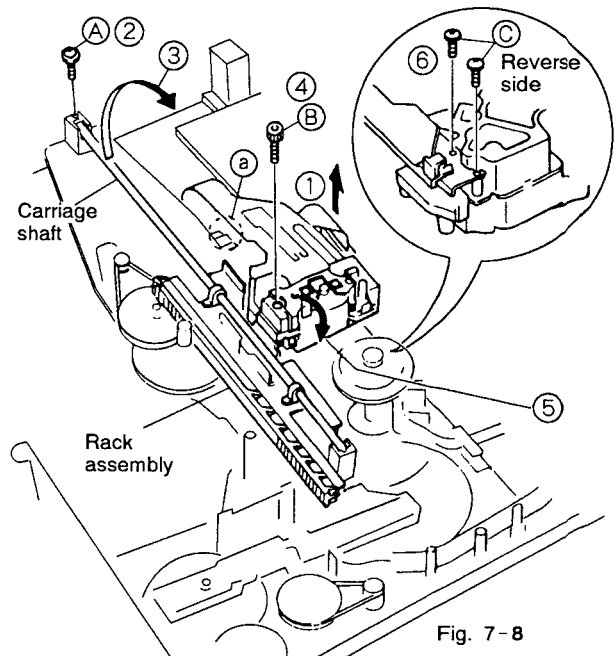

Fig. 7-8

7.7 REMOVING THE TILT SENSOR (Fig. 7-9)

- ① Remove the connector (arrow (A)) of the flexible cable and release the claw (arrow (B)) to remove the tilt sensor.

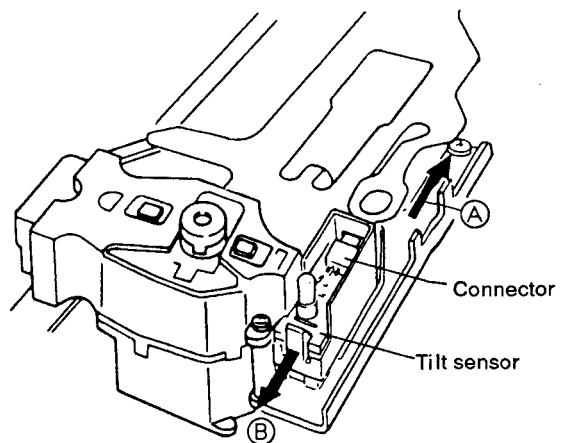

Fig. 7-9

7.8 REMOVING THE MECHANISM SECTION (Fig. 7-10)

Remove six screws (A), and the entire mechanism section can be removed.

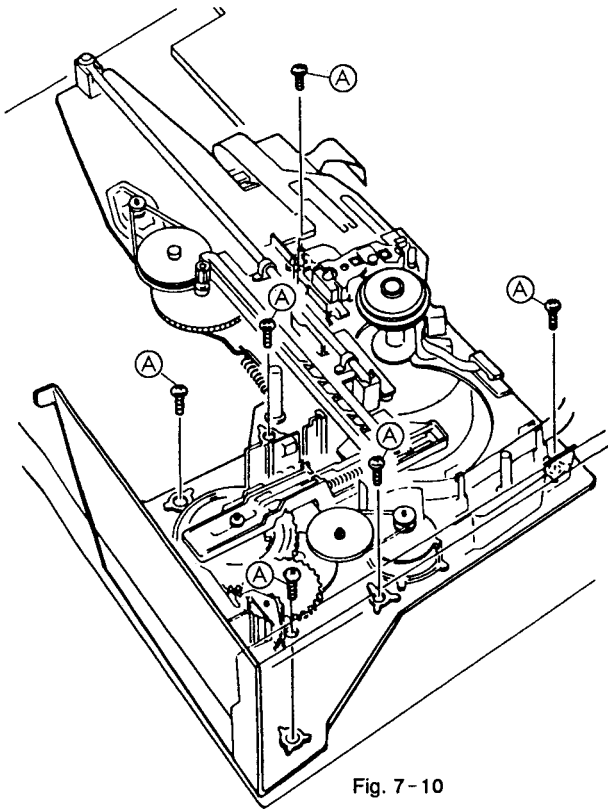

Fig. 7-10

7.9 REMOVING THE SLIDE CAM AND ROLLER PLATE ASSEMBLY (Fig. 7-11)

- ① Set the player with the tray down.
- ② Remove three screws (A) and slide the slide cam toward the rear to remove it.
- ③ Remove the clamber arm (A) assembly (see page 61) after removing slide cam to remove the roller plate assembly.

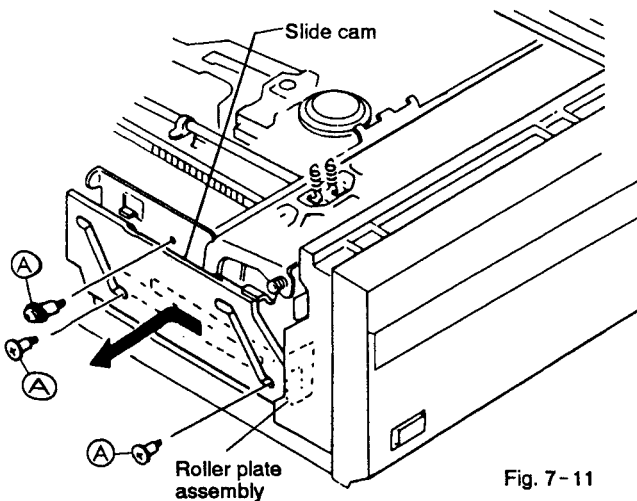

Fig. 7-11

7.10 ASSEMBLING THE MECHANISM SECTION

7.10.1. Positioning the gears

(Since the cam gears are used for the detection of all operation modes in this unit, the cam gears and the tray should be positioned correctly. Reassemble in the following procedure.)

- ① Position three switch levers so that they are nearly parallel (approx. 2mm), as shown in Fig. 7-12 (a).
- ② Insert the cam gear so that the end of the spiral groove on the upper surface of the cam gear comes to the position nearest to the shaft located at the front, as shown in Fig. 7-12 (b).

(In this case, the cam gear should be set in the position where the angle between the center line of the cam gear and the pin on the cam gear is 45°, by visual checking.)

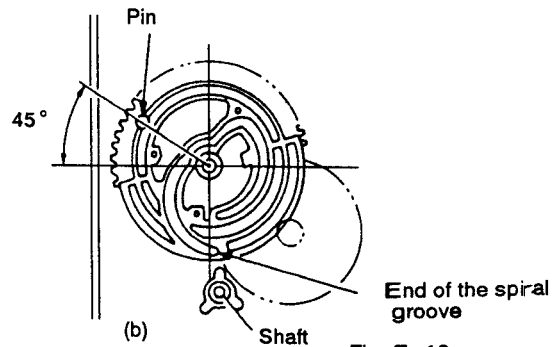
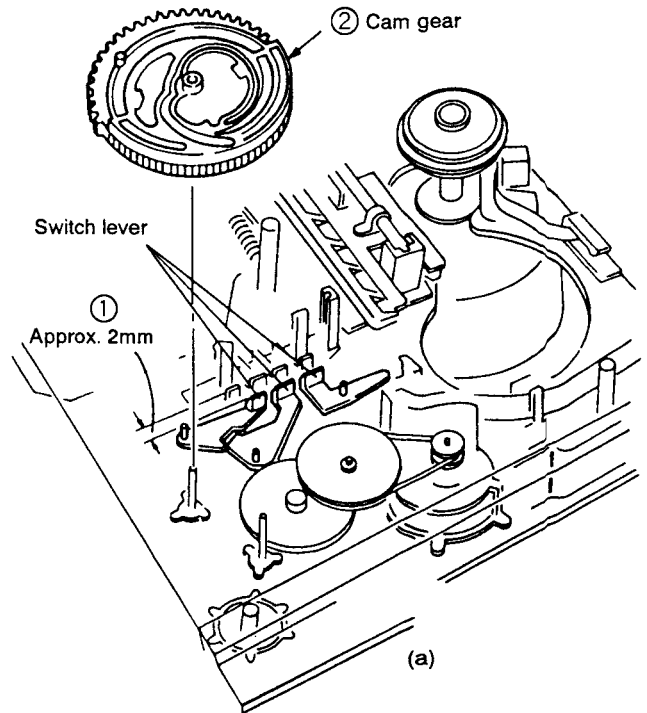

Fig. 7-12

- ③ Mount the spring slanting cam by raising the rack assembly in the direction of the arrow so that the tilt slide section comes under the rack assembly. Then, mount the cam spring. (Fig. 7-13 (a))
- ④ Insert the follow gear so that the "L"-shaped section of the follow gear comes to the end of the cam gear, as shown in Fig. 7-13 (b).

- ⑤ Mount the roller plate assembly in the position where the tooth with the triangle mark (▼) of the follow gear is engaged with the dip of the gear with the short rib on the roller plate gear, as shown in Fig. 7-14.

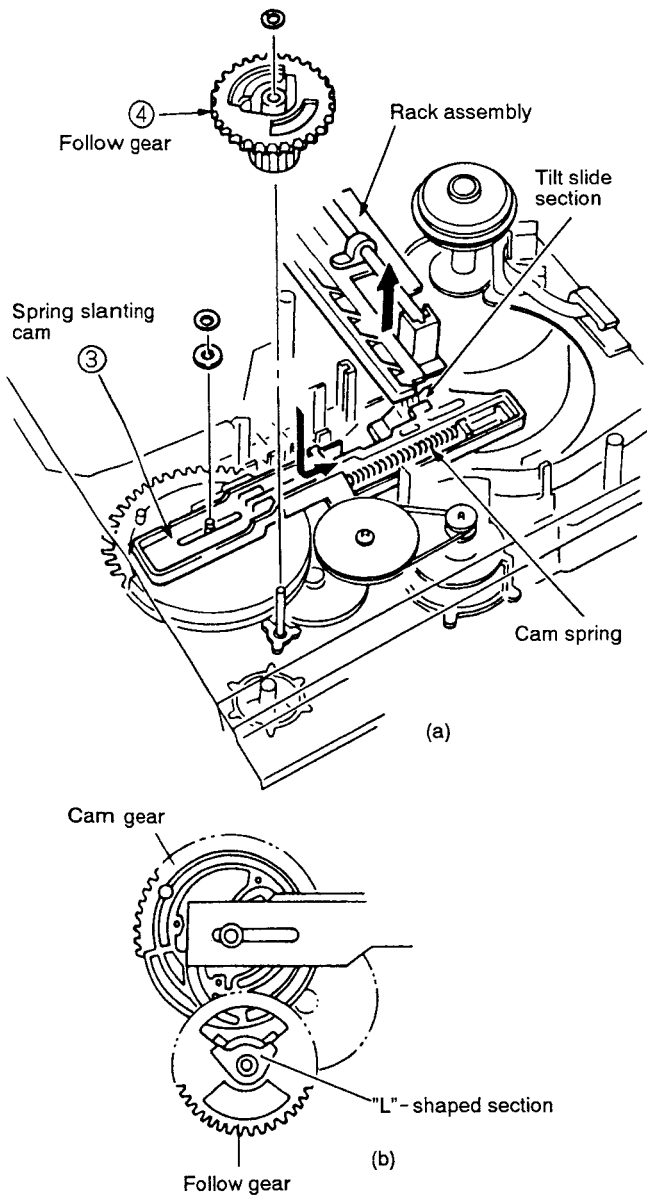

Fig. 7-13

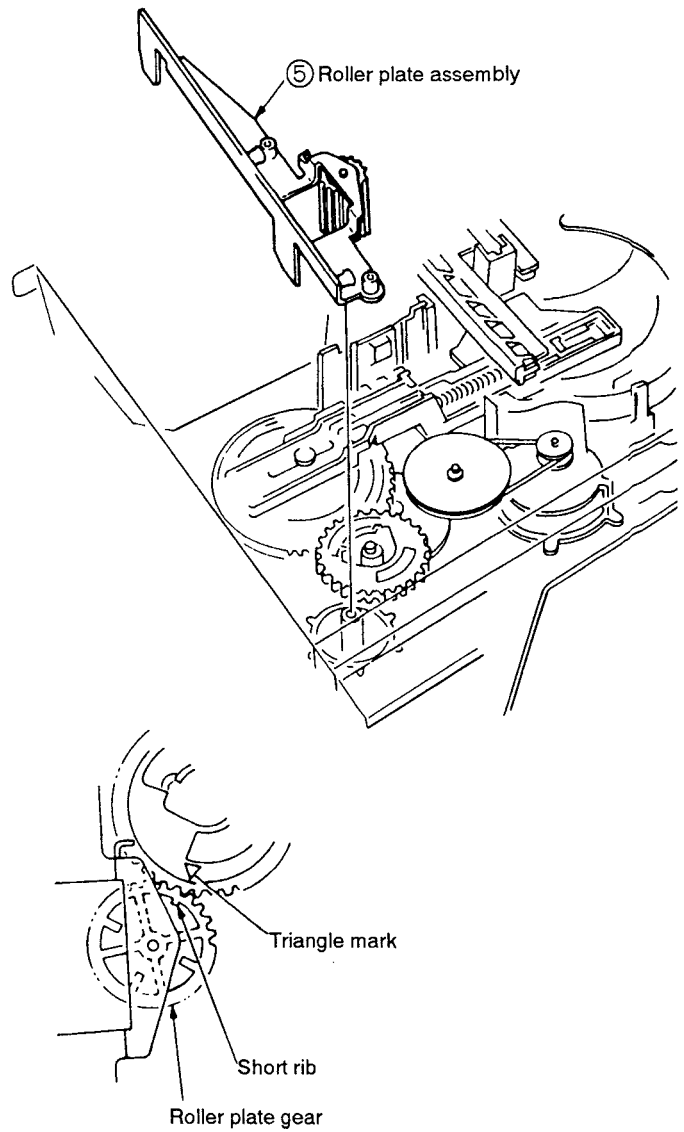

Fig. 7-14

7.10.2 Positioning the tray (Fig. 7-15)

- ① Set the player with the tray open.
- ② Set the roller plate gear so that the roller plate line intersects with the mid - point of missing tooth of the roller plate gear.
(At this time, adjust the position by the method shown in Fig. 7-15, or turn the power ON and use the SKIP (|◀, ▶|) buttons in the direction of OUT tilt it stops as shown in Fig. 7-15-1.)
- ③ Insert the tray.
At this time, the tray can be inserted only when the first missing tooth of the tray gear is engaged with the missing tooth section of the roller plate gear, as shown in the figure. (Fig.7-15-1)
Tray is easier to insert by pushing slightly upwards. (Fig.7-15-2)

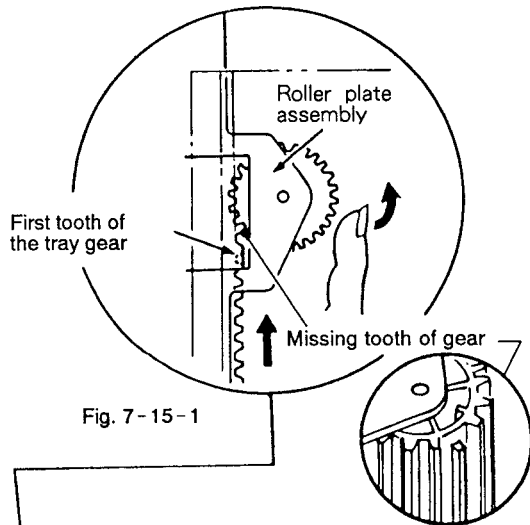

Fig. 7-15-1

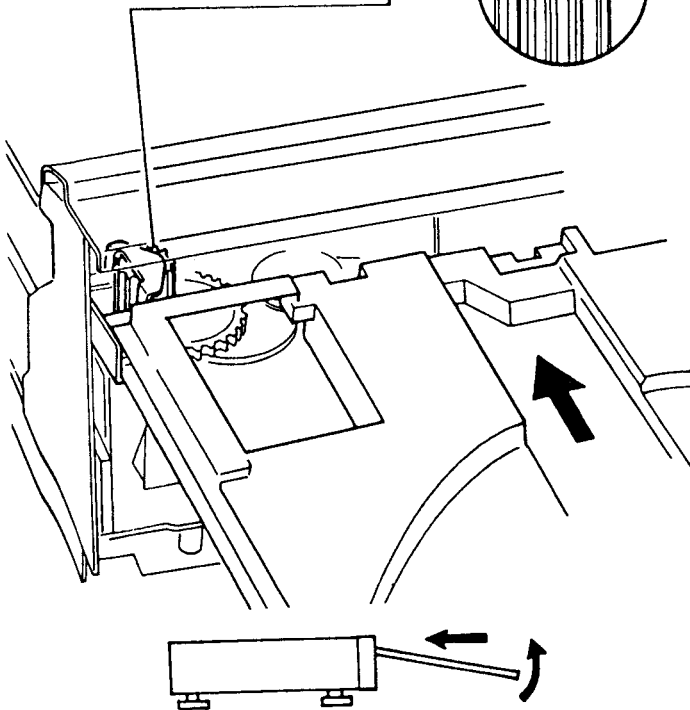

Fig. 7-15-2

7.10.3 Assembling the servo mechanism base assembly(Fig. 7-16)

When assembling the servo mechanism base assembly, pay special attention to the following points:

- After inserting the tilt shaft in the position shown in Fig. 7-16-1 of mechanism chassis assembly, mount the servo mechanism base assembly in the direction of the arrow so that the tilt shaft does not come over the shaft holder as shown in Fig. 7-16-2.
- The thrust spring should not come over the shaft holder.
- Check that the end of the plate spring is inserted under the base.

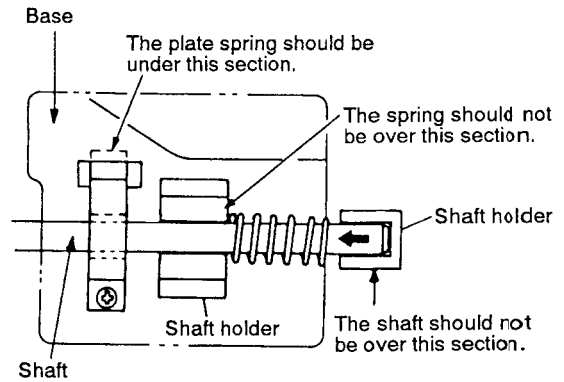

Fig 7-16-1

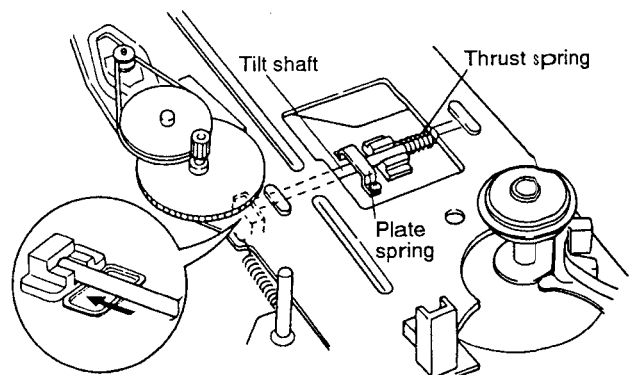

Fig. 7-16-2

7.10.4 Styling of the flexible cable (Fig. 7-17)

- ① Bend the flexible cable of the pickup assembly by about 45° at the ▲ mark.
- ② Insert the flexible cable into the connector.
- ③ Set the flexible cable under the protruding section.
- ④ Twist the flexible cable by a half turn.
- ⑤ Insert the triangular section.
- ⑥ Further insert the flexible cable under the protruding section.

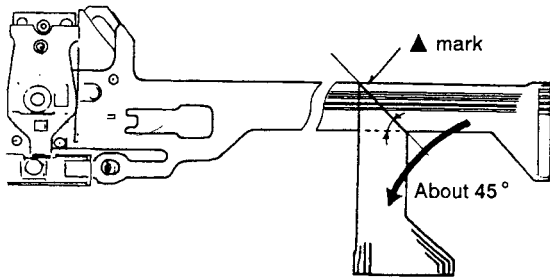

Fig. 7-17-1

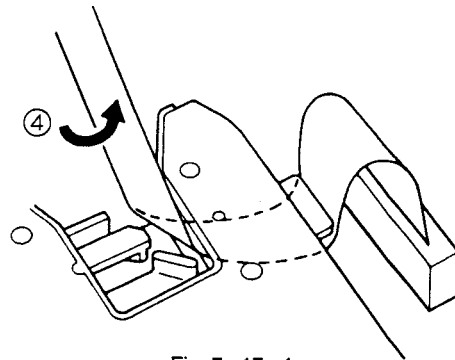

Fig. 7-17-4

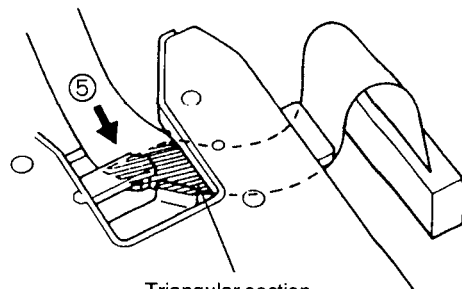

Fig. 7-17-5

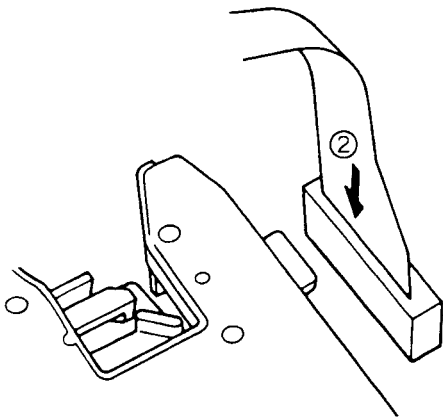

Fig. 7-17-2

Insert under this section

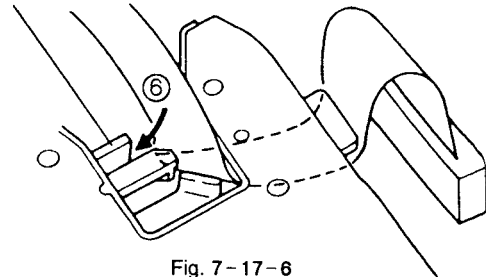

Fig. 7-17-6

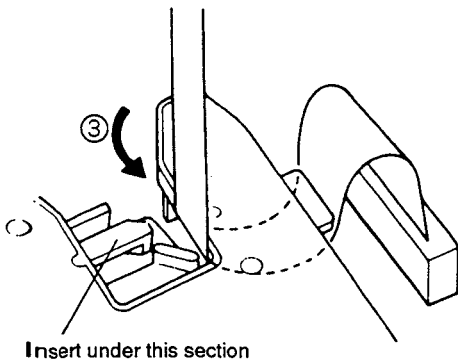
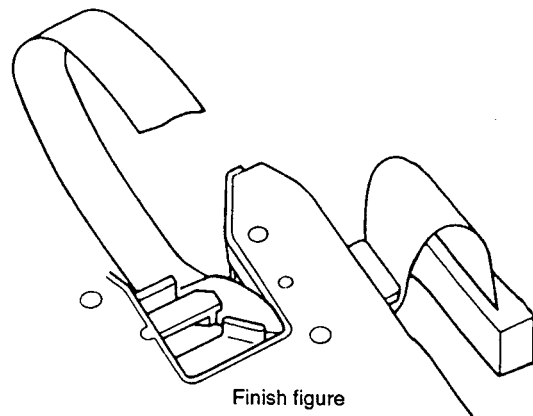

Fig. 7-17-3



Finish figure

Fig. 7-17-7

7.11 DIAGNOSING THE SYPS ASSEMBLY (Fig. 7-18)

Procedure-1

1. Remove the screw fixing the SYPS assembly and keep the SYPS assembly apart about 3cm from the base chassis (See Fig. 7-18-1).
2. Insert a soldering iron between the SYPS assembly and base chassis, alternately desolder the lapping pins of an AC power cord, and remove the lapping pins (See Fig. 7-18-1).
3. Solder the lapping pins through the foil side of the board with the SYPS assembly raised.
The SYPS assembly can be diagnosed for component replacement through the foil side.
(See Fig. 7-18-2).

Notes:

1. Interpose cloth for check so that the SYPS assembly does not touch the chassis.
2. Remove the rear panel when you are difficult to work.

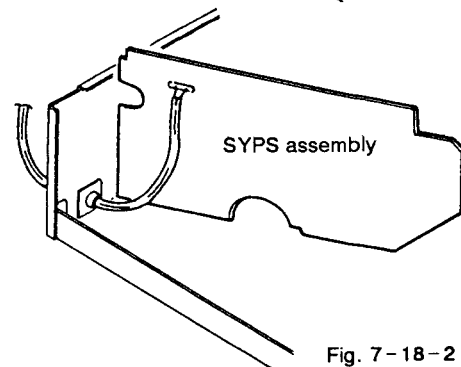
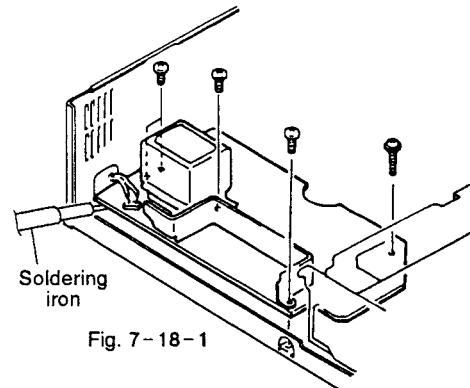

Procedure-2

1. Insert a screwdriver into the chassis hole near a strain relief through the back of the base chassis and remove the strain relief stop ring.
2. Remove the strain relief and pull the AC power cord toward the main unit to set up the SYPS assembly.

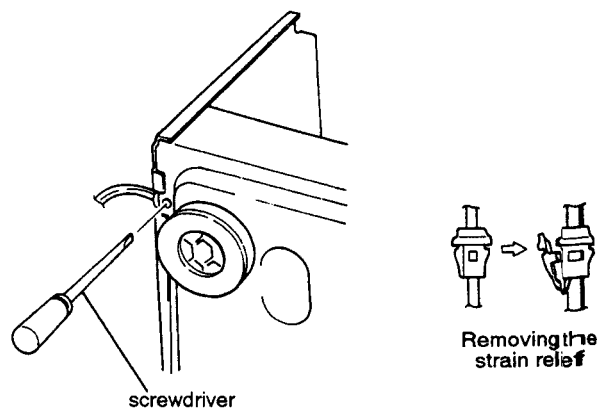

8. ADJUSTMENT

8.1 MAIN ASSEMBLY ADJUSTMENT SUMMARY

	ADJUSTMENT	P	Adjusting Point	Measurement equipment Connecting Point	Player Condition	Adjusting Specification
1	Tilt Servo Gain Adjustment	75	VR608	None	Power off	<ul style="list-style-type: none"> ● Making of Tilt GAIN VR position Red : Turn to Right Clear : Center Blue : Turn to Left
2	Coarse Adjustment of Grating and TRK Balance Adjustment	78	Grating/VR602	CN401-8 (TRK ERR)	<ul style="list-style-type: none"> ● Test mode #15,000 TRK servo loop open 	<ul style="list-style-type: none"> ● Null point → TRK error MAX ● Adjust VR602 so that the TRK error waveform amplitude's positive and negative level become equal.
3	Slider Shaft Horizontal Adjustment	77	Player SKIP key	CN401-2 (FCS RTN)	<ul style="list-style-type: none"> ● Test mode Tilt servo loop off TRK servo loop open #5.200 	<ul style="list-style-type: none"> ● Use the SKIP key to adjust to 0V ± 20mV.
4	Pickup Inclination Adjustment	78	Pickup Assembly TAN / TRK inclination adjustment screw	CN401-1 (RF)	<ul style="list-style-type: none"> ● Test mode #2,701 still TRK servo loop close /open Tilt servo loop open 	<ul style="list-style-type: none"> ● RF waveform's amplitude MAX (Pickup TAN / TRK adjustment screw) ● Minimized crosstalk.
5	TRKG Error Best / Crosstalk Best Adjustment	79	VR605 (TE BEST) VR606 (CT BEST)	CN401-8 (TRK ERR) CN401-1 (RF)	<ul style="list-style-type: none"> ● Test mode TRK servo close / open Tilt servo loop off 	<ul style="list-style-type: none"> ● RF MAX (VR606) TRK error MAX (VR605)
6	FOCS SUM Level Adjustment	80	VR609	CN401-10 (FCS SUM)	<ul style="list-style-type: none"> ● Play mode 	<ul style="list-style-type: none"> ● Adjust VR 609 so that the voltage becomes 1.5VDC.
7	Tilt Sensor Inclination / Tilt Balance Adjustment	81	Tilt sensor inclination adjustment screw VR607(TILT BAL)	TV monitor Test mode screen	<ul style="list-style-type: none"> ● Test mode #16,200 / #115 still TRK servo loop close Tilt servo loop off 	<ul style="list-style-type: none"> ● Set VR 607 to the center. ● Adjust the adjustment screw so that the tilt error display code is 6,7, or 8. ● Adjust VR607 so that the tilt error display becomes 7.
8	Verification and Adjustment of Spindle Motor Centering	82	Spindle motor centering adjustment screw.	CH1:CN401-8 (TRK ERR) CH2:CN401-7 (TRK SUM) (X-Y mode)	<ul style="list-style-type: none"> ● Test mode #25,000 / #1 TRK servo loop open Tilt servo loop on 	<ul style="list-style-type: none"> ● Adjust the centering adjustment screw so that the lissajous figures of #1 and #25,000 are the same.
9	Fine Adjustment of Grating and TRK Balance Adjustment	83	Grating / VR602	CH1:CN401-8 (TRK ERR) CH2:CN401-7 (TRK SUM) (X-Y mode)	<ul style="list-style-type: none"> ● Test mode TRK servo loop open Tilt servo loop on 	<ul style="list-style-type: none"> ● Minimize the Y direction of the lissajous figure. ● Level of the X direction of the lissajous figures are equal.
10	FCS Servo Loop Gain Adjustment	84	VR604	CH1:CN401-5 (FCS IN) CH2:CN401-4 (FCS ERR) (X-Y mode)	<ul style="list-style-type: none"> ● Test mode #15,000 still TRK servo loop close Tilt servo loop on 	<ul style="list-style-type: none"> ● Adjust VR604 so that the lissajous figure is symmetric with respect to the X and Y axes.
11	TRK Servo Loop Gain Adjustment	85	VR603	CH1:CN401-9 (TRK IN) CH2:CN401-8 (TRK ERR) (X-Y mode)	<ul style="list-style-type: none"> ● Test mode #15,000 still TRK servo loop close Tilt servo loop on 	<ul style="list-style-type: none"> ● Adjust VR603 so that the lissajous figure is symmetric with respect to the X and Y axes.
12	RF Gain Adjustment	86	VR601	CN401-1(RF)	<ul style="list-style-type: none"> ● #15,000 still 	<ul style="list-style-type: none"> ● Adjust VR601 so that the RF level becomes 300mV ± 50mV.
13	Ref. Sub Carrier Adjustment	87	VC901	IC402 pin 8	<ul style="list-style-type: none"> ● STOP 	<ul style="list-style-type: none"> ● Adjust VC901 so that the frequency becomes 3.579545 MHz.
14	VCO Center Frequency Adjustment	88	VR481	CH1:C471 + lead wire CH2:C499 + lead wire	<ul style="list-style-type: none"> ● #5,100 still 	<ul style="list-style-type: none"> ● The center of CH1's video signal jitter is delayed by 71 μS with CH2's video signal.
15	Output Video Level Adjustment	89	VR482	VIDEO OUT terminal	<ul style="list-style-type: none"> ● #19,900 still 	<ul style="list-style-type: none"> ● Adjust the VR482 so that the voltage between the sync tip and the white peak becomes 0.71V ± 5%.
16	1H Delay Video Level Adjustment	90	VR441	CH1:C443 - lead wire CH2:C445 - lead wire	<ul style="list-style-type: none"> ● #3,800 still 	<ul style="list-style-type: none"> ● The 1H delay video level becomes the same as the main line video level.
17	VPS Error Adjustment	91	VR521	TV monitor	<ul style="list-style-type: none"> ● #8,000 still 	<ul style="list-style-type: none"> ● Color irregularity on the magenta screen is minimized.

8.2 ADJUSTMENT POINTS OF THE MAIN ASSEMBLY

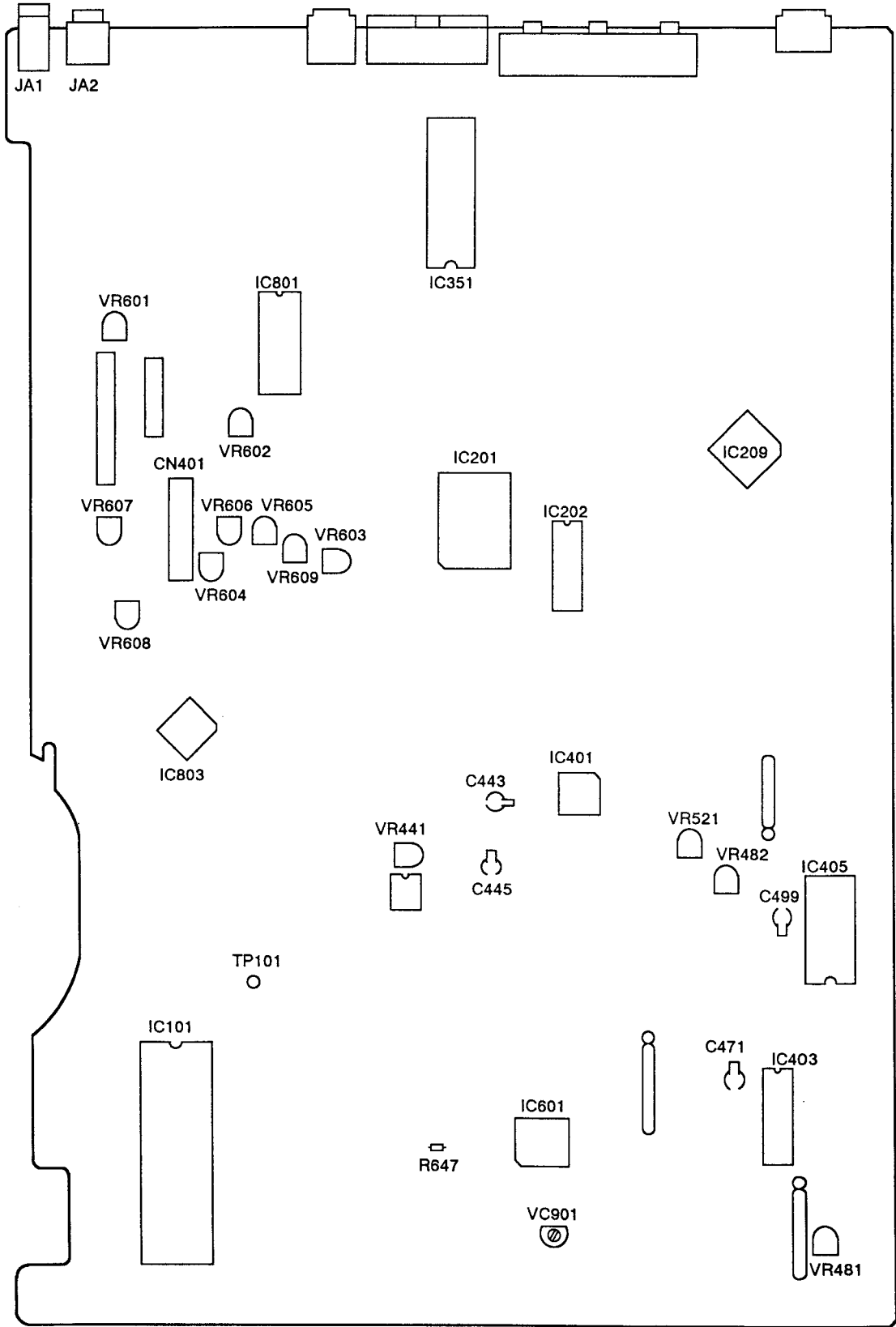

8.3 TEST MODE

8.3.1 TEST MODE

The player has a test mode function which allows the servicer to check the player's status on the TV screen by executing the respective key operation.

Also, since the TRK servo opens and closes easily, the test mode is especially useful for mechanical adjustments.

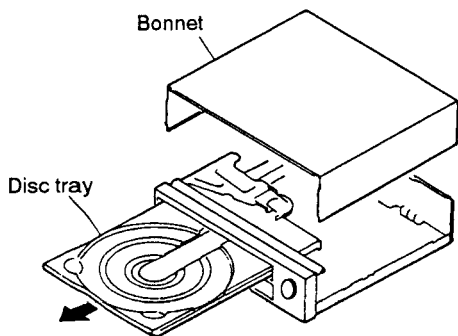

8.3.3 TEST MODE CANCELLATION

Turn off the power switch.

8.3.4 PLAYER OPERATION IN THE TEST MODE

Operate the player by selecting a test mode function with the keys on the player or on the remote control unit.

● CD PLAYBACK

① Place the CD disc on the turn table.
(Clamper is already lifted up.)

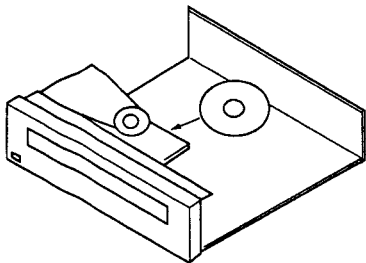

② Press the or key to appear "S-CD" on the TV screen display.

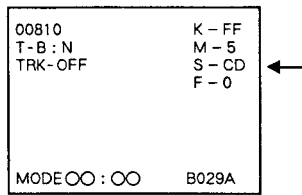

TV screen display

③ Clamp the disc by pressing the PLAY () key once. Then, press the PLAY () key twice, disc will be normal playbacked.

● LD PLAYBACK

① Place the LD disc on the turn table.
(Clamper is already lifted up.)

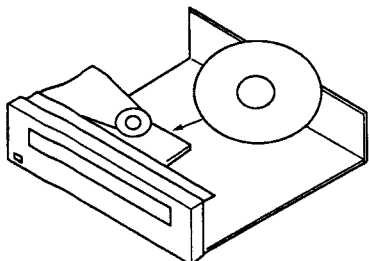

② Press the or key to appear "S-LD" on the TV screen display.

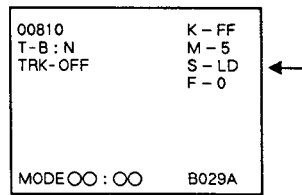

TV screen display

③ Clamp the disc by pressing the PLAY () key once. Then, press the PLAY () key twice, disc will be normal playbacked.

8.3.2 TEST MODE INITIATION

[Procedure]

Ⓐ When using the remote control unit (GGF1067) for the test mode.

● Press the **TEST** key after pressing the **ESC** key.

Ⓑ When not using the remote control unit (GGF1067) for the test mode.

1. Remove the bonnet and disc tray.
2. Connect the TP101 (TEST) in the MAIN assembly to GND.
3. Turn on the power switch.
4. Disconnect the TP101 from GND.

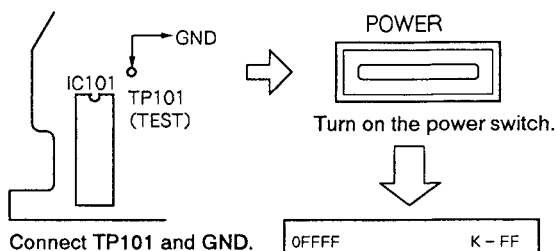

Connect TP101 and GND.

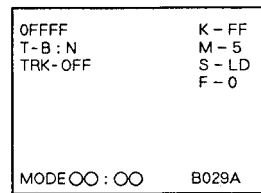

TV screen display

Table. Operation in the test mode by optional remote control unit (VXX1530).

Function	Player Status	Key Operation	Remarks
Open Tray	STOP mode	▲	
Close Tray	Tray open	▲	
Stop	PLAY mode	■	
Play	Disc placement and tray closed.	▶	<ul style="list-style-type: none"> • Start play with the TRK servo open. • Start play with tilt neutral. • The disc type (LD/CD/CDV) is determined when playback starts at the SLDR position during start play.
TRK Servo Open/Close	PLAY mode	▶	<ul style="list-style-type: none"> • Each time the PLAY button (▶) is pressed, the TRK servo will open or close alternately.
Still	PLAY mode TRK servo closed.	(Remote control unit key)	<ul style="list-style-type: none"> • Each time the STILL button () is pressed, the player will switch between the PLAY and STILL modes alternately.
SLDR REV SCAN	PLAY mode	SCAN DIAL	<ul style="list-style-type: none"> • Counterclockwise • With the TRK servo open, the pickup can be damaged if the SLD moves further inward than the lead-in area on the disc. Do not allow the SLD to move further inward than the lead-in area.
SLDR FWD SCAN	PLAY mode	SCAN DIAL	<ul style="list-style-type: none"> • Clockwise • With the TRK servo open, the pickup can be damaged if the SLD moves further outward than the lead-in area on the disc. Do not allow the SLD to move further outward than the lead-in area.
TILT Neutral	POWER switch ON	EDIT	
TILT Servo ON	PLAY mode	RANDOM PLAY	
TILT Minus TILT Servo OFF	PLAY mode	◀◀	<ul style="list-style-type: none"> • Press and hold down the keys.
TILT Plus TILT Servo OFF	PLAY mode	▶▶	<ul style="list-style-type: none"> • Press and hold down the keys.
Screen Display ON/OFF	POWER switch ON	PGM key	
Frame search	PLAY mode	+10 key ↓ 0-9 key ↓ ▶	<ul style="list-style-type: none"> • In the PLAY mode, press the +10 key. (The player will standby for the frame No. entry.) • Use the numeric keys(0 - 9) to enter the frame No.. Then press the player's PLAY key to search. • After the search is completed, the player will return to the previous mode before the search was performed.
Loading Motor Rotation Clockwise Counterclockwise	Tray open	▶▶ ◀◀	<ul style="list-style-type: none"> • FWD:Unloading • REV :Loading
FOCS OFFSET (CT BEST) VR806 Check	PLAY mode (TRK servo OPEN)	(Remote control unit) MULTI-SPEED FWD → F-1 REV → F-0 (Player) HILITE INTRO SCAN	<ul style="list-style-type: none"> • For checking VR604 F-0 : Normal mode <ul style="list-style-type: none"> •When closing the TRK servo, VR606 (CT BEST) is effectived. •When opening the TRK servo, VR605 (TE MAX) is effectived. F-1 : When opening the TRK servo, VR606 (CT BEST) is also effectived.

● Names of Front Panel

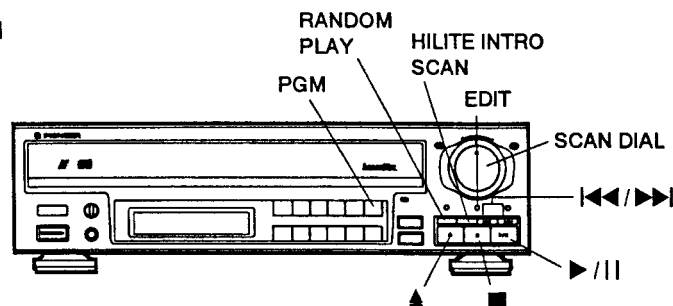

● Names of Remote Control Unit

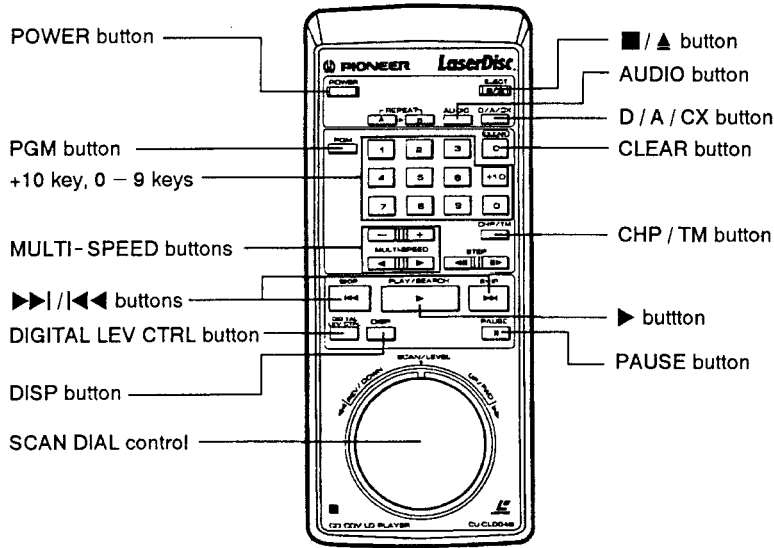

8.3.5 TV SCREEN AND LED DISPLAYS IN THE TEST MODE

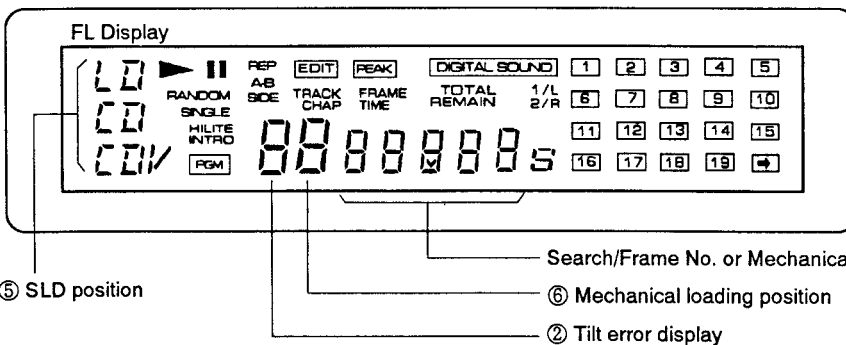
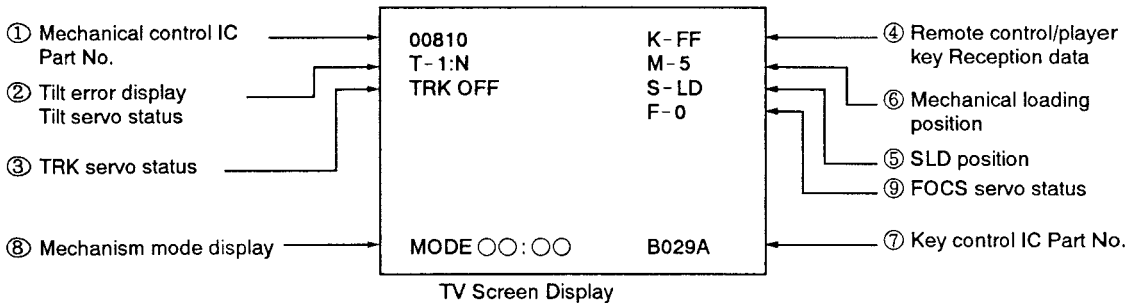

① The Mechanical Control IC (MAIN assembly) Part No. will be Displayed.
PDO081A1 → 00810

② Tilt Servo Status / Tilt Error Display
T-0:00
Tilt servo status : N...Tilt neutral
ON...Tilt servo ON
OFF...Tilt servo OFF
Tilt error display: 0 Tilt -
↓ Tilt neutral
F Tilt +

③ TRK Servo Status

TV screen display

TRK-○○○

↑ ON...TRK servo close
OFF...TRK servo open

④ Remote Control / Player Key Reception Data

TV screen display

K-○○

↑ See table below

Code	Function	Code	Function	Code	Function	Code	Function
00	0	20	F JOG0	40	(CHAP/TRK)	60	
01	1	21	F JOG1	41	(FRAM/TIM)	61	
02	2	22	F JOG2	42	(SEARCH)	62	
03	3	23	F JOG3	43	DISPLAY	63	
04	4	24	R JOG0	44	REPEAT B	64	
05	5	25	R JOG1	45	CLEAR	65	
06	6	26	R JOG2	46	SPEED -	66	
07	7	27	R JOG3	47	SPEED +	67	
08	8	28		48	REPEAT A	68	
09	9	29		49	(2/R)	69	
0A	VOLUME +	2A		4A	(STEREO)	6A	
0B	VOLUME -	2B		4B	(1/L)	6B	
0C	DGT/ANL	2C		4C	PROGRAM	6C	
0D		2D		4D		6D	PLAY/PAUSE
0E	CX ON/OFF	2E		4E		6E	STOP
0F	(TV/LDP)	2F		4F		6F	OPEN/CLOSE
10	(F-SCAN)	30		50	F-STEP	70	
11	(R-SCAN)	31		51		71	DIRECT CD
12		32		52	F-SKIP	72	PEAK
13	CHAP/FRME	33		53	R-SKIP	73	SINGLE
14		34		54	R-STEP	74	
15		35		55	R-MULT	75	
16	STOP/OPEN	36		56		76	
17	PLAY/SERCH	37	DGT LEVEL	57		77	
18	PAUSE	38		58	F-MULT	78	
19		39		59		79	
1A	(POW ON)	3A		5A	HILIT/INTR	7A	
1B	(POW OFF)	3B		5B		7B	
1C	POW ON/OFF	3C		5C		7C	
1D	EDIT	3D		5D		7D	
1E	AUDIO	3E		5E	RNDM (TEST)	7E	
1F	+10	3F		5F	(ESC)	7F	

⑤ SLD Position

TV screen display

S-○○○

↑ IN ... CD inside SW ON
CD ... CD active area
CDV ... CDV active area
LD ... LD active area

⑥ Mechanical Loading Position

TV screen display

M-○

↑ 0 ... Tray open
1 ... Loading
2 ... Standby
3 ... Clamped
5 ... Tilt minus
6 ... Tilt neutral (one side)
7 ... Tilt plus
8 ... Tilt limit
9 ... B side clamped (two sides)

⑦ Focus Offset VR Status

TV screen display

F-○

↑ 0 ... Normal mode
•When closing the TRK servo, VR606 (CT BEST) is effected.
•When opening the TRK servo, VR605 (TE MAX) is effected.
1 ... When opening the TRK servo, VR606 (CT BEST) is also effected.

8.4 ADJUSTMENTS

8.4.1 Required Instruments

- Small screwdriver (7 cm shaft)
- Small Phillips screwdriver (15 cm shaft)
- Low - pass filter (47k ohms+1 μ F / BP)
- Dual - trace oscilloscope (with delay)
- AF oscillator
- Frequency counter
- LD test disc (GGV1003)
- 8 - inch LDD disc
- CDV disc
- Short clip
- TV monitor
- Resistor (100k ohms, 330k ohms)
- Capacitor (0.01 μ F)
- Remote control unit
- 2mm hexagonal wrench

8.4.2 Adjustment Preparation and Notes

1. Player Preparation

Before perform the adjustment, remove the bonnet and the disc tray. Then place the player horizontally on a flat surface.

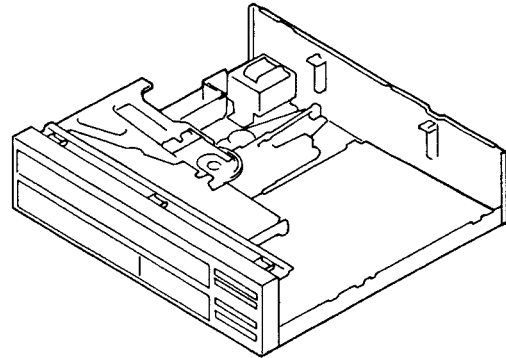

2. Disc Insertion

Insert the disc from the rear of the player. Place it securely on the turntable. When the PLAY key is pressed, the clamper will go down and secure the disc. Playback will then begin.

3. Use All the Oscilloscope's Probes at 10:1.

4. Only the MAIN Assembly Needs to be Adjusted.

Unless noted otherwise, all adjustment items and measuring instrument connections will be for the parts in the MAIN assembly.

5. Required adjustment after Replacement of major parts.

Adjustments	Replacements				
	Pickup	Actuator	Pre-pickup	Spindle motor	Tilt sensor
1. Tilt Sensor Adjustment	⊙				⊙
2. Coarse Grating Adjustment / TRK Balance Adjustment	⊙	⊙	⊙		
3. Slider Shaft Horizontal Adjustment	⊙	⊙	⊙	○	⊙
4. Pickup Inclination Adjustment	⊙	⊙	⊙	○	○
5. TRKG Error Best / Crosstalk Best Adjustment	⊙	⊙	⊙	○	○
6. FOCS SUM Level Adjustment	⊙	⊙	⊙	○	○
7. Tilt Sensor Inclination / Tilt Balance Adjustment	⊙	⊙	⊙	○	⊙
8. Spindle Motor Shaft Centering and Adjustment	⊙	⊙	⊙	⊙	
9. Fine Grating Adjustment / TRK Balance Adjustment	⊙	⊙	⊙		
10. FCS Servo Loop Gain Adjustment	⊙	⊙	⊙		
11. TRKG Servo Loop Gain Adjustment	⊙	⊙	⊙		
12. RF Gain Adjustment	⊙	⊙	⊙		

Note: Adjustments indicated by a ○ are made only when there is crosstalk.

8.4.3 MECHANICAL ADJUSTMENTS

1. TILT SERVO GAIN ADJUSTMENT

Mechanical Adjustment

- Purpose: Adjustment of the tilt servo's gain according to the tilt sensor's sensitivity rank.
- When not properly adjusted: Increased tilt servo hunting and increased crosstalk.

- Measuring instruments and jigs:
 - Measuring point:
 - Test disc and player mode
 - Positions to be adjusted
- Small screwdriver
 - VR608

Connection diagram

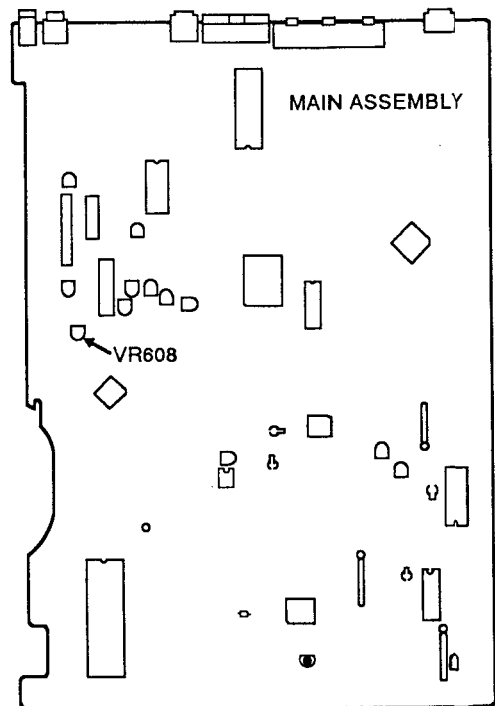
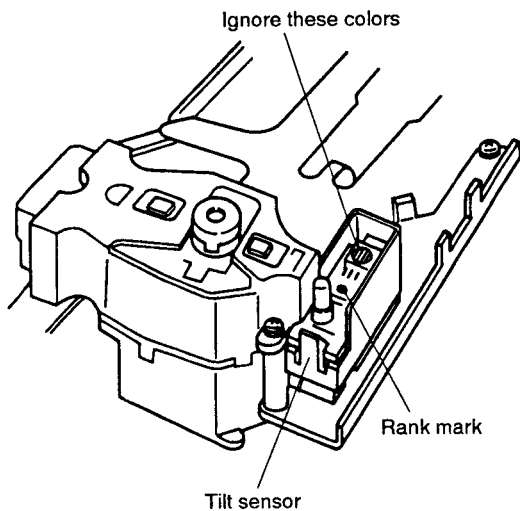

Adjustment Procedure

1. Use a screwdriver to adjust the angle of VR608 on the MAIN assembly according to the rank indicator's color.

Rank	Color	VR Angle
A	Red	Clockwise all the way
B	Clear	Mechanical center
C	Blue	Counterclockwise all the way

2. COARSE ADJUSTMENT OF GRATING AND TRK BALANCE

Mechanical Adjustment

- Purpose: Adjustment of the grating angle to enable disc playback and trick playback.
- When not properly adjusted: The disc cannot be played back. Track skipping occurs.

- | | |
|--|---|
| <ul style="list-style-type: none"> ● Measuring instruments and jigs: ● Measuring point: ● Test disc and player mode ● Positions to be adjusted | <ul style="list-style-type: none"> ● TV monitor ● Small screwdriver ● Oscilloscope ● CN401 - 8 (TRK ERR) and GND ● 8-inch LD test disc (GGV1003) ● Test Mode (Disc playback, TRK servo open, Tilt servo OFF) ● Pickup assembly grating ● VR602 (TRK BAL). |
|--|---|

Connection diagram

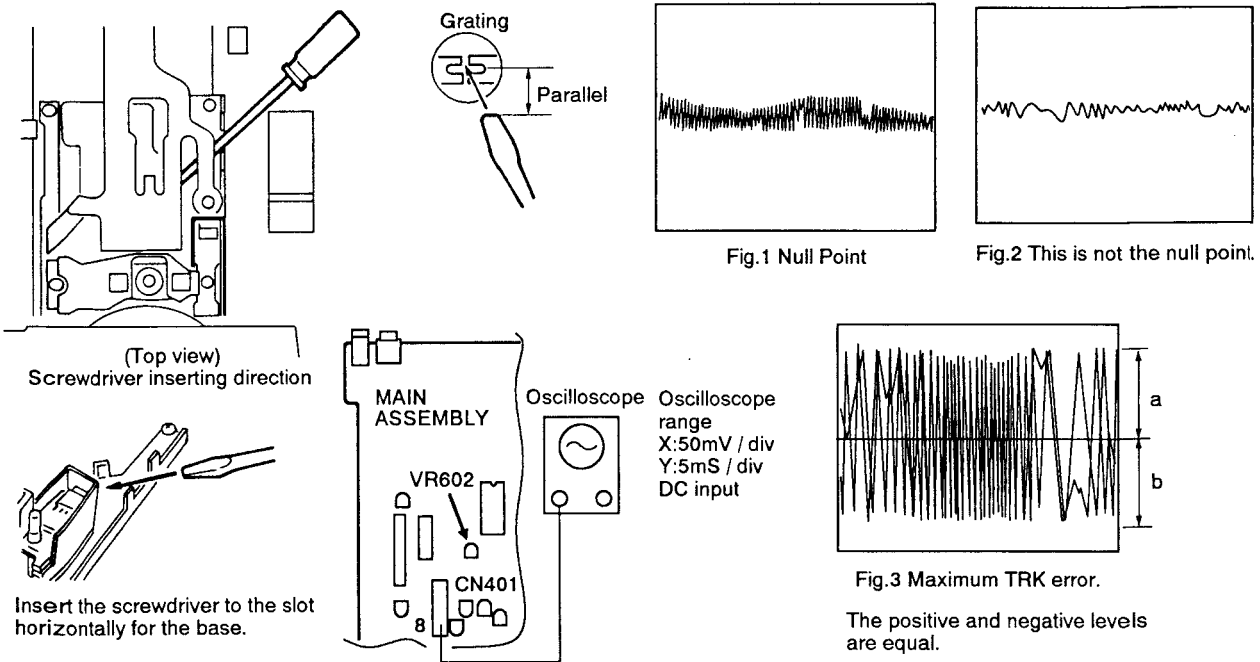

Adjustment Procedure

Coarse grating adjustment

1. Insert the test disc and press the PLAY key.
2. Search for frame #15,000 or thereabouts.
3. Open the TRK servo.
4. Connect CN401 - 8 to the oscilloscope and observe the waveform.
5. Slide the tip of a small screwdriver through the guide and insert it horizontally into the grating adjustment slit. Adjust grating angle so that the waveform becomes small as its envelope is smooth. (This point is called null point.) (See Fig. 1 and Fig. 2.)
6. Turn the screwdriver counterclockwise until the TRK waveform's amplitude reaches the first maximum from the null point. (See Fig. 3.)

TRK balance adjustment

1. Adjust VR602 so that the TRK error waveform amplitude's positive and negative level become equal. (See Fig. 3.)
2. Close the TRK servo and check if the image on the TV screen is normal.

3. SLIDER SHFT HORIZONTAL ADJUSTMENT

Mechanical Adjustment

- Purpose: Setting the slider shaft horizontally to enable the pickup to move over the disc horizontally.
- When not properly adjusted: With a warped disc, the FCS servo does not function at the inner or outer periphery.

- | | |
|--|---|
| <ul style="list-style-type: none"> ● Measuring instruments and jigs: ● Measuring point: ● Test disc and player mode ● Positions to be adjusted | <ul style="list-style-type: none"> ● Oscilloscope ● Low-pass filter (47k Ω + 1 μF) ● CN401 - 2 (FCS RTN) and GND ● 8 - inch LD test disc GGV1003 ● Test mode (#5,200 still, TRK servo open, Tilt servo OFF) ● Player SKIP key (In the test mode) |
|--|---|

Connection diagram

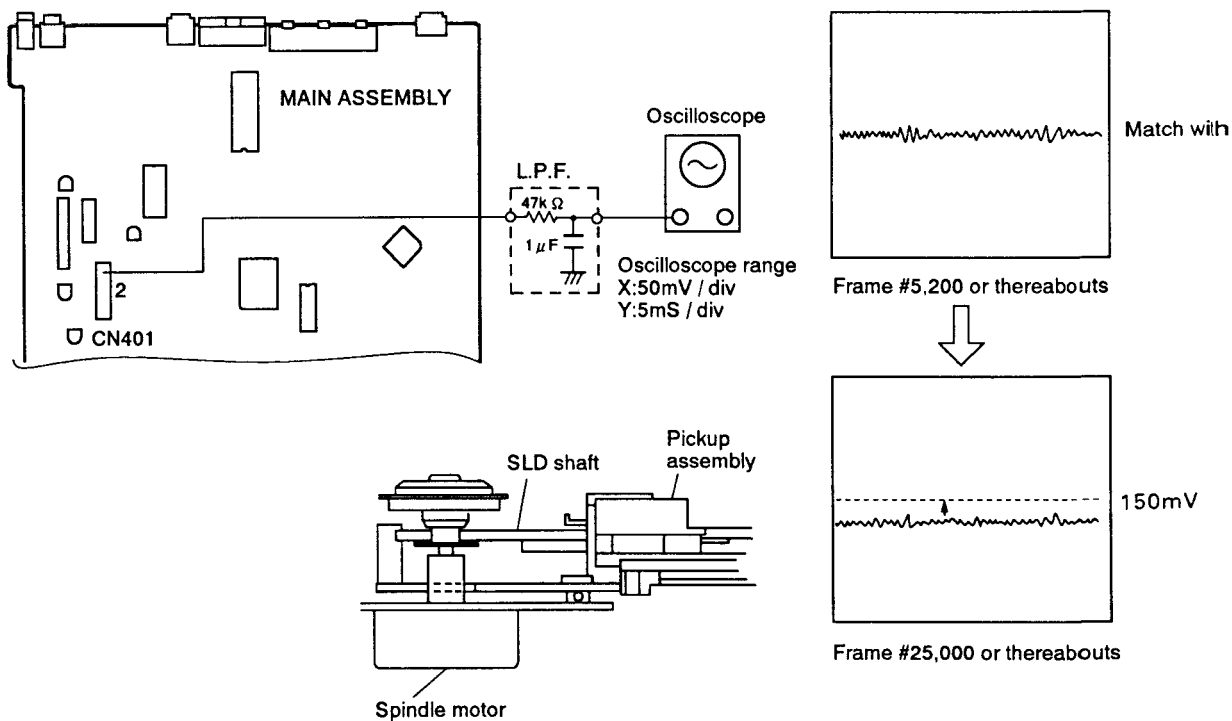

Adjustment Procedure

1. Use the SCAN key to send the slider to frame #5,200 or thereabouts (tilt fulcrum) on the test disc. Open the TRK servo.
2. Connect the oscilloscope to CN401 - 2 through L.P.F. and match the center of the waveform with the oscilloscope's GND.
3. Search for frame #25,000 and use the SKIP key to adjust the center of the waveform to 150mV \pm 20mV.

Note : This adjustment is critical in that it will affect the adjustments following.

Note : Regarding the test mode, see page 70.

4. PICKUP INCLINATION ADJUSTMENT

Mechanical Adjustment

- Purpose: Adjustment of the pickup inclination to direct the laser beam vertically with respect to the disc.
- When not properly adjusted: Crosstalk will be generated.

- Measuring instruments and jigs:
- Measuring point:
- Test disc and player mode
- Positions to be adjusted

- TV monitor ● Oscilloscope
- CN401-1 (RF)
- 8-inch LD test disc (GGV1003)
- Test Mode (#2,701 still (Black screen))
- Pickup assembly TRK / Tangential direction inclination adjustment screws

Connection diagram

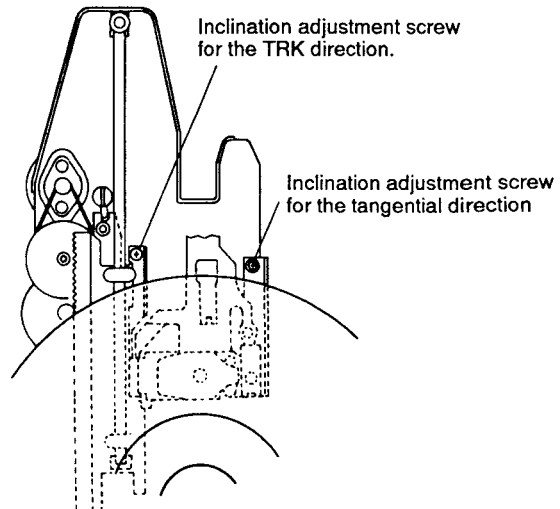
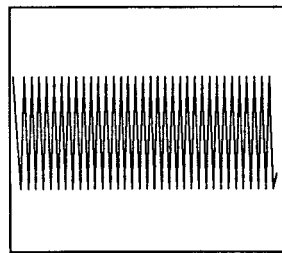
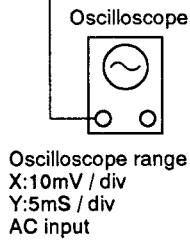
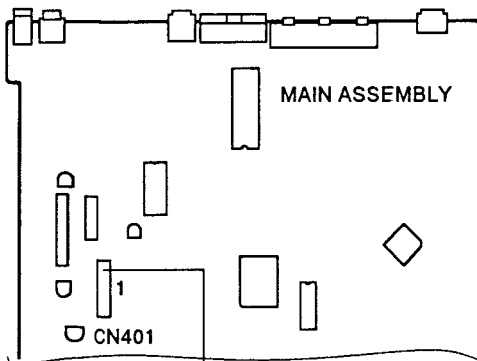

Adjustment Procedure

1. Connect the oscilloscope to CN401-1.
2. Search for #2,701 and observe the RF waveform.
3. Adjust the pickup's TRK / Tangential direction inclination adjustment screw to maximize the waveform's amplitude.
4. Look at the TV screen and make sure there is no crosstalk.

Note: If there is crosstalk on the TV screen even when the RF level is at the maximum, perform next steps.

5. TRKG ERROR MAX / CROSSTALK BEST ADJUSTMENT

Mechanical Adjustment

- Purpose: To set the FOCS servo to the optimum state when playing the normal playback and track jump (search).
- When not properly adjusted: Crosstalk will be generated.

- Measuring instruments and jigs:
- Measuring point:
- Test disc and player mode
- Positions to be adjusted

- TV monitor ● Oscilloscope
- CN401 - 1 (RF) ● CN401 - 8 (TRK ERR) ● Player's VIDEO OUT terminal
- 8-inch LD test disc (GGV1003)
- Test Mode (TRK servo close / open, Tilt servo OFF)
- VR605 (TE MAX) ● VR606 (CT BEST)

Connection diagram

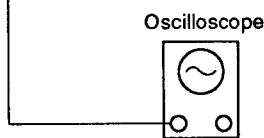
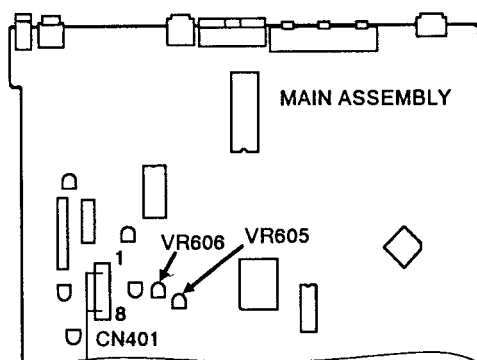

Oscilloscope range
 X: 10mV / div
 Y: 5mS / div
 AC input

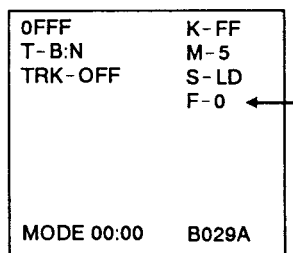

Screen display of test mode

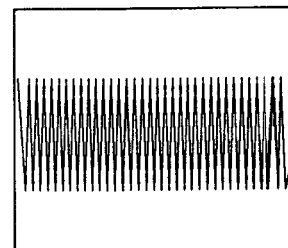

Set to maximum RF amplitude at frame #2,701.

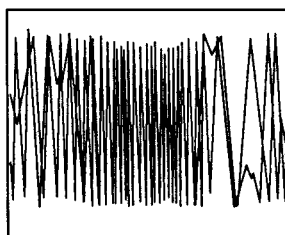

Maximize the TRKG error.

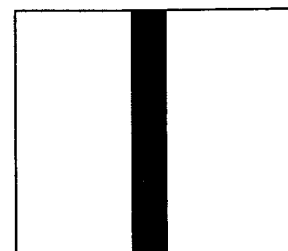

#115 crosstalk minimum

Adjustment Procedure

Note : Perform this adjustment when there is still noticeable crosstalk on the TV screen in section "4. Pickup Inclination Adjustment".

1. Connect the oscilloscope to CN401 - 8.
2. Open the TRK servo .
3. Confirm that the test mode screen display is F-0.
 If not, set the MULTI - SPEED REV button of the remote control unit to F-0.
4. Adjust VR605 so that the amplitude of the TRKG error waveform becomes maximum.
5. Close the TRKG servo.

6. Connect the oscilloscope to CN401 - 1 .
7. Press the MULTI - SPEED FWD button of the remote control unit to display "F-1" on the TV screen.
8. Search frame #2,701 and adjust VR606 so that the amplitude of the RF waveform becomes maximum.
9. Confirm that the crosstalk on the TV screen becomes minimum at frame #115.

Note : After adjustment is complete, be sure to perform "5. FOCS SUM Level Adjustment".

6. FOCS SUM LEVEL ADJUSTMENT

Mechanical Adjustment

- Purpose: To set the sum level (FOCS A+B) of B1 – B4 to the optimum value for activating the FOCS servo.
- When not properly adjusted: Crosstalk will be generated.

- | | |
|--|---|
| <ul style="list-style-type: none"> ● Measuring instruments and jigs: ● Measuring point: ● Test disc and player mode ● Positions to be adjusted | <ul style="list-style-type: none"> ● TV monitor ● Oscilloscope ● CN401-10 ● 8-inch LD test disc (GGV1003) ● Normal play mode ● VR609 |
|--|---|

Connection diagram

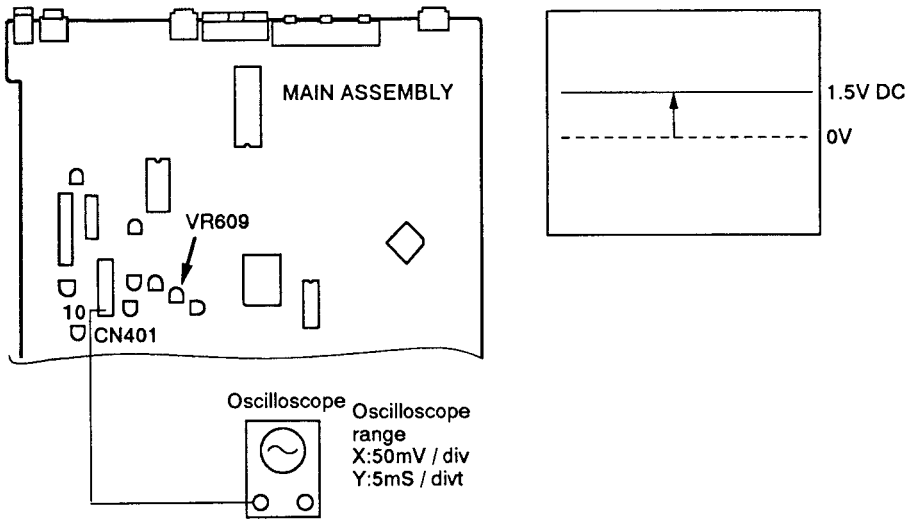

Adjustment Procedure

Note : Perform this adjustment after perform the "5. TRKG Error MAX / Crosstalk Best Adjustment".

1. Connect the oscilloscope to CN401-10.
2. Adjust VR609 so that the voltage becomes 1.5V DC.

7. TILT SENSOR INCLINATION / TILT BALANCE ADJUSTMENT

Mechanical Adjustment

- Purpose: Adjustment of the tilt sensor's inclination to direct the tilt sensor's LED vertically with respect to the disc. Also, compensation for the sensitivity difference between the two sensors.
- When not properly adjusted: Crosstalk will be generated.

- Measuring instruments and jigs:
- Measuring point:
- Test disc and player mode
- Positions to be adjusted

- TV monitor
- Small Phillips screwdriver
- Player's VIDEO OUT terminal
- 8-inch LD test disc (GGV1003)
- Test Mode (#16,200 still, TRK servo closed, Tilt servo OFF)
- Tilt sensor inclination adjustment screw
- VR607 (TILT BAL).

Connection diagram

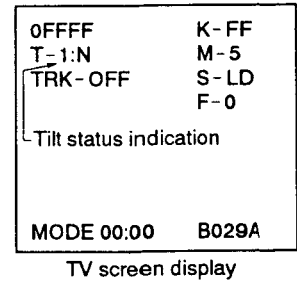
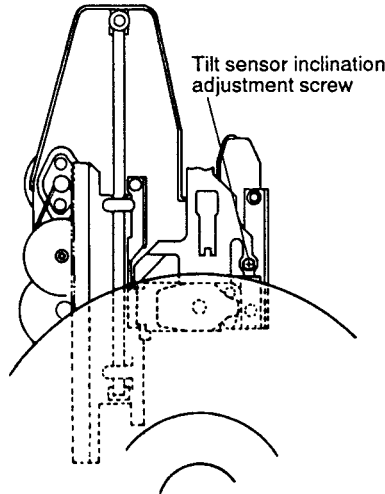
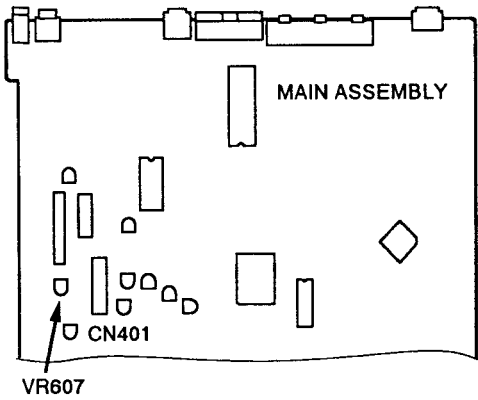

Note: This display indicates the tilt error display's location. Other displays may differ slightly from the actual.

Adjustment Procedure

1. Search for frame #16,200 on the test disc.
2. Set VR607 to the mechanical center.
3. Adjust the tilt sensor inclination adjustment screw so that the tilt status display code is 6, 7, or 8 on the TV monitor.
Note: Turn the tilt sensor inclination adjustment screw clockwise more than 1/4 turn to complete the adjustment.
4. Search for frame #115.
5. Adjust VR607 so that the tilt error display becomes 7.

8. VERIFICATION AND ADJUSTMENT OF SPINDLE MOTOR CENTERING

Mechanical Adjustment

- Purpose: Adjustment of the mechanical assembly position to set the spindle motor over the center of the laser beam path when the pickup assembly moves toward the inner or outer periphery of the disc.
- When not properly adjusted: There is track skipping and the search time is long.

- Measuring instruments and jigs:
- Measuring point:
- Test disc and player mode
- Positions to be adjusted

- Oscilloscope ● Small screwdriver ● L.P.F. (0.01 μ F + 1k Ω), (0.0027 μ F)
- 2mm Hexagonal wrench
- CH1 : CN401 - 8 (TRK ERR), CH2 : CN401 - 7 (TRK SUM)
- 8-inch LD test disc (GGV1003)
- Test Mode (#25,000 still, #1 still, TRK servo open, TILT servo ON)
- Spindle motor centering adjustment lever

Connection diagram

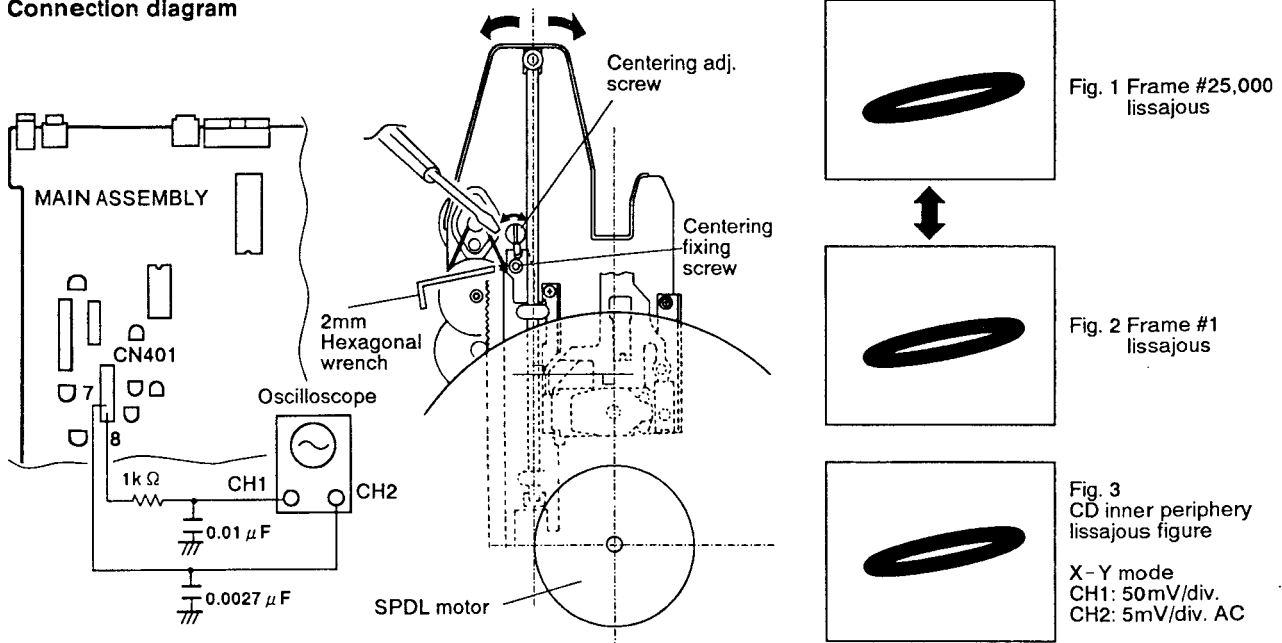

Adjustment Procedure

Note: Adjust the position of the slider shaft against the center line of the SPDL motor in this adjustment.

1. Set the oscilloscope to the X-Y mode and connect CH 1 (X input) and CH 2 (Y input) to CN401 - 8 and CN401 - 7 respectively.
2. Search for frame #25,000 on the test disc and look at the lissajous figure.
3. Search for frame #1 and check if the bulge of the lissajous figure is the same as that of frame #25,000's lissajous figure.
Note : If the bulge of the lissajous waveform in step 3 differs for the inner and outer peripheries, do steps 4 to 6 .
4. Search for frame #25,000 and #1 alternately. Loosen a centering fixing screw and adjust the spindle motor centering adjustment screw so that the bulge of the lissajous figures become identical.
5. Change to a compact disc and playback the inner periphery. Check if the lissajous figure is the same as the one shown in Fig. 3.
6. If the compact disc's inner periphery lissajous figure differs from the one shown in Fig. 3, repeat steps 4 to 5.
7. Fix the centering fixing screw.

9. FINE ADJUSTMENT OF GRATING AND TRK BALANCE ADJUSTMENT

Mechanical Adjustment

- Purpose: Fine adjustment of the grating to direct the two TRK servo laser beams at the disc at the optimum position over the track.
- When not properly adjusted: There is track skipping.

- | | |
|--|---|
| <ul style="list-style-type: none"> ● Measuring instruments and jigs: ● Measuring point: ● Test disc and player mode ● Positions to be adjusted | <ul style="list-style-type: none"> ● Oscilloscope ● Small screwdriver ● L.P.F. (0.01 μF + 1k Ω), (0.0027 μF) ● CH1 (X) : CN401-8 (TRK ERR), CH2 (Y) : CN401-7 (TRK SUM) ● 8-inch LD test disc (GGV1003) ● Test Mode (Play mode, TRK servo loop open, TILT servo ON) ● Grating slit in the pickup assembly ● VR602 |
|--|---|

Connection diagram

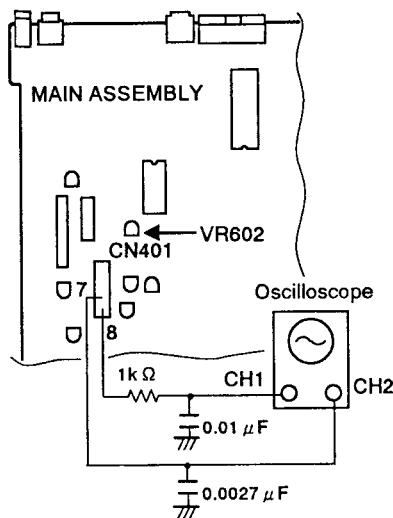

Set the probe to $\times 1$ only for Y.

- Oscilloscope range:
CH1 (X): 50mV/div.
CH2 (Y): 5mV/div. X-Y mode

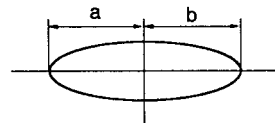

Frame #2,000
Lissajous figure
Y direction minimum, a=b.

Adjustment Procedure

1. Playback the test disc at frame #3,000 (inner periphery) or thereabouts.
2. Set the oscilloscope to the X-Y mode, and connect CN401-8 (TRK ERR) and CN401-7 (TRK SUM) to the X input and the Y input respectively. Then observe the lissajous figure.
3. Insert the small screwdriver tip into the grating adjustment slit. Fine adjust the grating to minimize the Y direction of the lissajous figure. (Refer to adjustment diagram on page 76.)
4. Check if "a" equals "b" for the lissajous figure. If "a" is not equal to "b", adjust VR602 (TRK BAL).
5. Close the TRK servo loop and check if the image on the TV screen is normal.

10. FCS SERVO LOOP GAIN ADJUSTMENT

Mechanical Adjustment

- Purpose: Setting the FCS servo's loop gain to the optimum setting.
- When not properly adjusted: Playability is poor.

- Measuring instruments and jigs:
- Measuring point:
- Test disc and player mode
- Positions to be adjusted

- Oscilloscope ● AF oscillator (1.7kHz / 10Vp-p) ● Resistor (47k Ω)
- CH1 (X) : CN401 - 5 (FCS IN), CH2 (Y) : CN401 - 4 (FCS ERR)
- 8 - inch LD test disc (GGV1003)
- Test Mode (Still mode, TRK servo loop close, TILT servo ON)
- VR604

Connection diagram

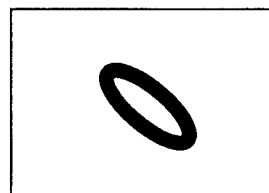
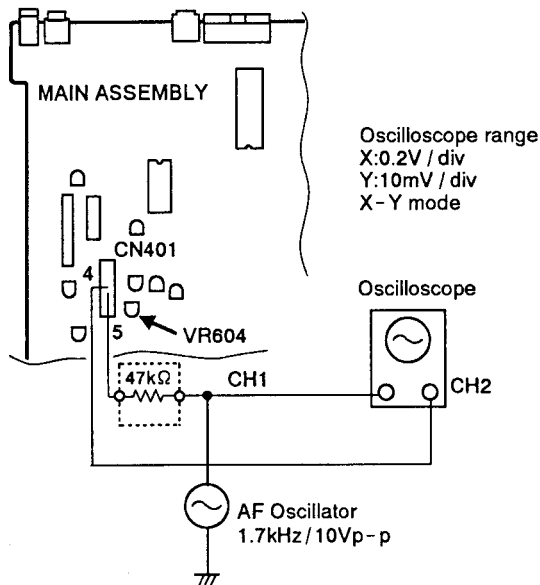

Fig. 1 Inadequate adjustment

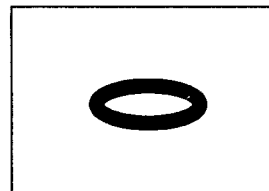

Fig. 2 After adjustment

Adjustment Procedure

1. Search for frame #15,000 on the test disc.
2. Connect the oscilloscope to CN401 - 4 and CN401 - 5 as shown above.
3. Set the oscilloscope to the X - Y mode and observe the lissajous figure.
4. Adjust VR604 so that the lissajous figure is symmetric with respect to the X and Y axes. (See Fig. 1 and 2.)

11. TRK SERVO LOOP ADJUSTMENT

Mechanical Adjustment

- Purpose: Optimum setting of the TRK servo's loop gain.
- When not properly adjusted: Playability is poor.

- Measuring instruments and jigs:
- Measuring point:
- Test disc and player mode
- Positions to be adjusted

- Oscilloscope ● AF oscillator (3.0kHz / 10Vp-p) ● Resistor (47k Ω)
- CH1 (X) : CN401 - 9 (TRK IN), CH2 (Y) : CN401 - 8 (TRK ERR)
- 8-inch LD test disc (GGV1003)
- Test Mode (Still mode at #15,000 (Black screen), TRK servo closed, TILT servo ON)
- VR603

Connection diagram

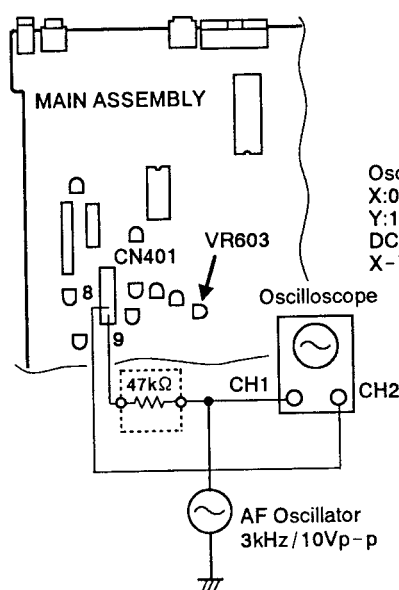

Oscilloscope range
 X:0.2V / div
 Y:10mV / div
 DC input
 X-Y mode



Fig. 1
Inadequate adjustment

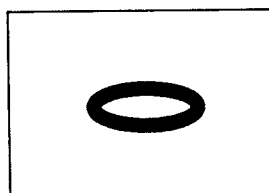

Fig. 2
After adjustment

Adjustment Procedure

1. Search for frame #15,000 on the test disc.
2. Connect the oscilloscope to CN401 - 9 (TRK IN) and CN401 - 8 (TRK ERR) as shown in the diagram below.
3. Set the oscilloscope to the X - Y mode and observe the lissajous figure.
4. Adjust VR603 to make the lissajous figure symmetrical with respect to the X and Y axes. (See Fig. 1 and 2.)

Note : If the waveform is not observable, either change the 47k Ω resistor to 33k Ω or increase the oscillator's output.

12. RF GAIN ADJUSTMENT

Mechanical Adjustment

- Purpose: Optimum of the RF signal's amplitude.
- When not properly adjusted: There is prominent dropout. Scan and search operations are unstable.

- | | |
|--|---|
| <ul style="list-style-type: none"> ● Measuring instruments and jigs: ● Measuring point: ● Test disc and player mode ● Positions to be adjusted | <ul style="list-style-type: none"> ● Oscilloscope ● CH1 : CN401 - 1 (RF) ● 8 - inch LD test disc (GGV1003) ● Test Mode (Still mode, TRK servo loop close, TILT servo ON) ● VR601 |
|--|---|

Connection diagram

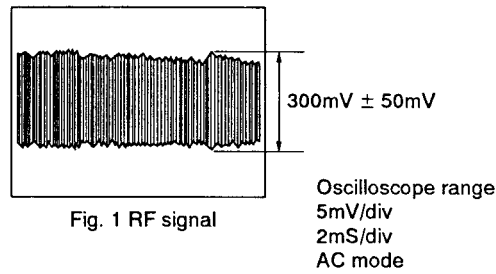
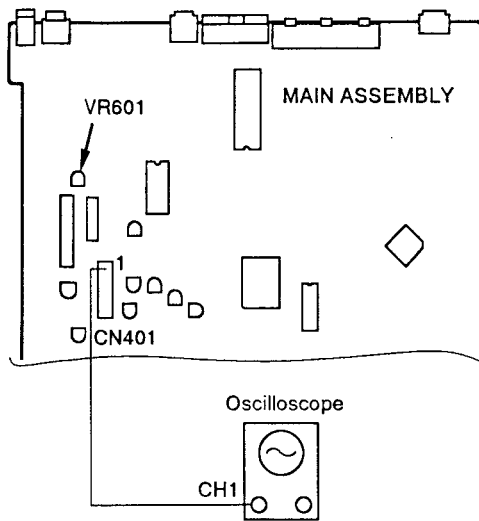

Adjustment Procedure

1. Search for frame #15,000 on the test disc.
2. Connect the oscilloscope to CN401 - 1 (RF) and observe the RF signal.
3. Adjust VR601 so that the RF signal's amplitude becomes $300\text{mV} \pm 50\text{mV}$. (See Fig. 1.)

8.4.5 ELECTRICAL ADJUSTMENT

13. Ref. SUB CARRIER ADJUSTMENT

Electrical Adjustment

- Purpose: Adjustment of the standard clock frequency.
- When not properly adjusted: Incorrect color tint, no TV color lock.

- | | |
|--|--|
| <ul style="list-style-type: none"> ● Measuring instruments and jigs: ● Measuring point: ● Test disc and player mode ● Positions to be adjusted | <ul style="list-style-type: none"> ● Frequency counter ● Oscilloscope 10:1 probe ● IC402 (PM0001) pin 8 ● Normal mode (Stop mode (Blueback screen)) ● VC901 |
|--|--|

Connection diagram

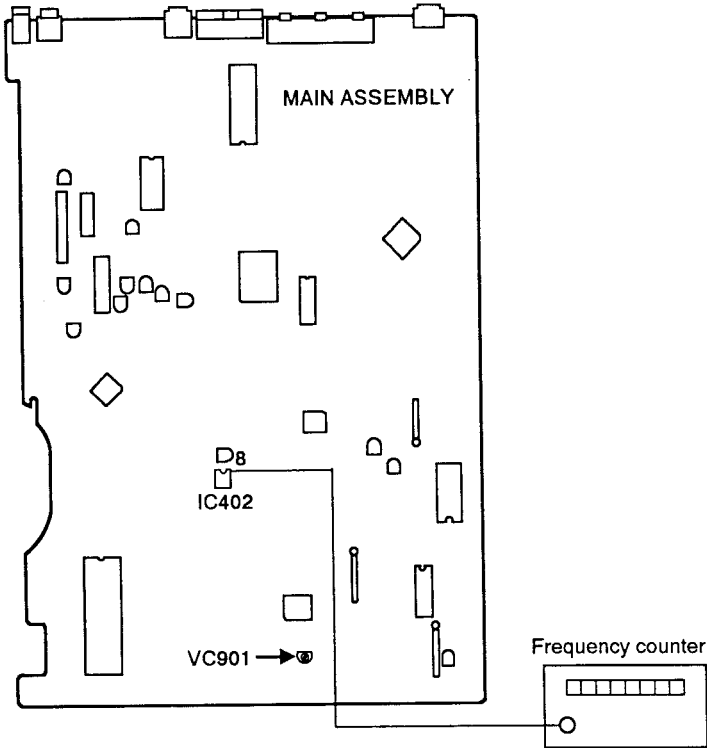

Adjustment Procedure

1. Adjust VC901 on the MAIN assembly so that the frequency of IC402 pin 8 becomes 3.579545MHz in the stop mode (blueback screen).

Note : The frequency counter probe should be an oscilloscope 10 : 1 probe.

14. VCO CENTER FREQUENCY ADJUSTMENT

Electrical Adjustment

- Purpose: Setting the optimum delay time for the time base error compensation CCD.
- When not properly adjusted: Difficult to color lock, there is color lock delay after a search, and flicker on the white screen.

- | | |
|--|---|
| <ul style="list-style-type: none"> ● Measuring instruments and jigs: ● Measuring point: ● Test disc and player mode ● Positions to be adjusted | <ul style="list-style-type: none"> ● Oscilloscope ● CH 1 : + side lead wire of C471. ● CH 2 : + side lead wire of C499. ● 8-inch LD test disc (GGV1003) ● Normal mode (Still mode) ● VR481 |
|--|---|

Connection diagram

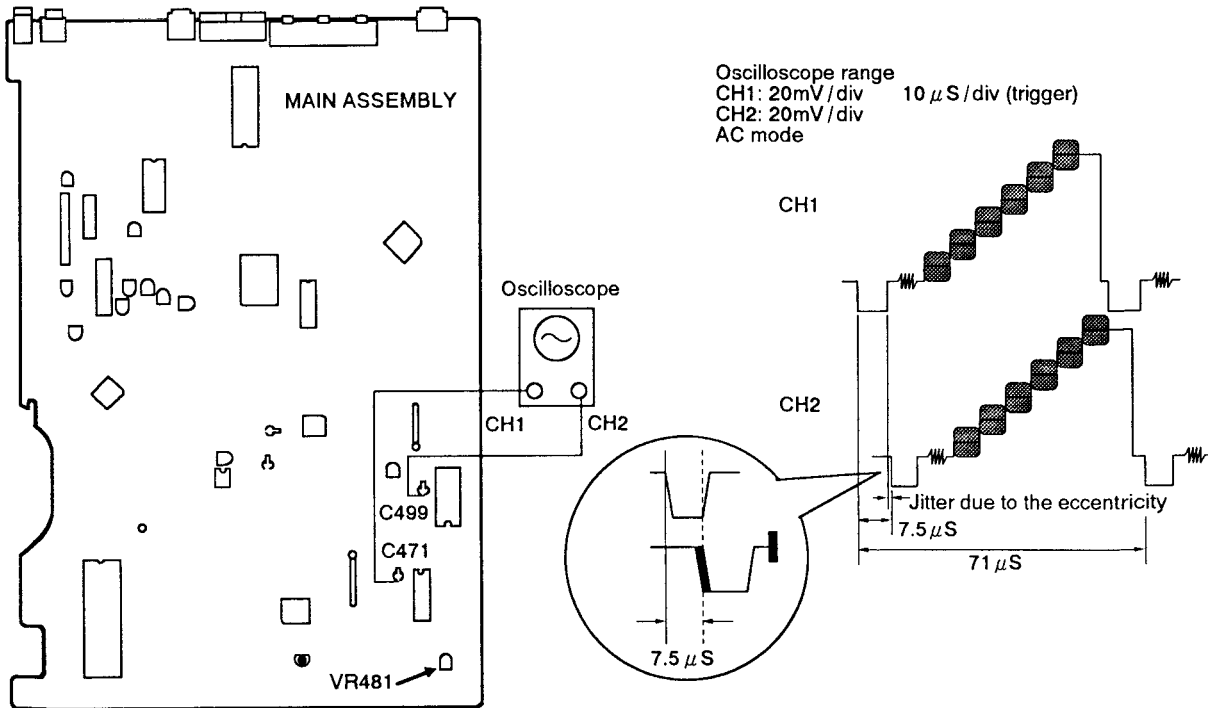

Adjustment Procedure

1. Connect the + side lead wire of C471 and the + side lead wire of C499 to CH 1 and CH 2 of the oscilloscope respectively.
 CH 1 : Video signal before time axis error compensation.
 CH 2 : Video signal after time base error compensation.
2. Search for frame #5,100 on the test disc. Adjust VR481 so that the center of CH 1's video signal jitter is delayed by 71 μs (1H + 7.5 μs) with respect to the CH 2's video signal.

Note : Do not confuse CH 1 and CH 2.

15. OUTPUT VIDEO LEVEL ADJUSTMENT

Electrical Adjustment

- Purpose: Setting the video signal level to 1Vp-p (75 Ω termination).
- When not properly adjusted: The player starts up midway without reading the data. The screen is too bright or too dark.

- | | |
|--|--|
| <ul style="list-style-type: none"> ● Measuring instruments and jigs: ● Measuring point: ● Test disc and player mode ● Positions to be adjusted | <ul style="list-style-type: none"> ● Oscilloscope ● Player's VIDEO OUT terminal ● 8-inch LD test disc (GGV1003) ● Normal mode (Still mode, #19,900) ● VR482 |
|--|--|

Connection diagram

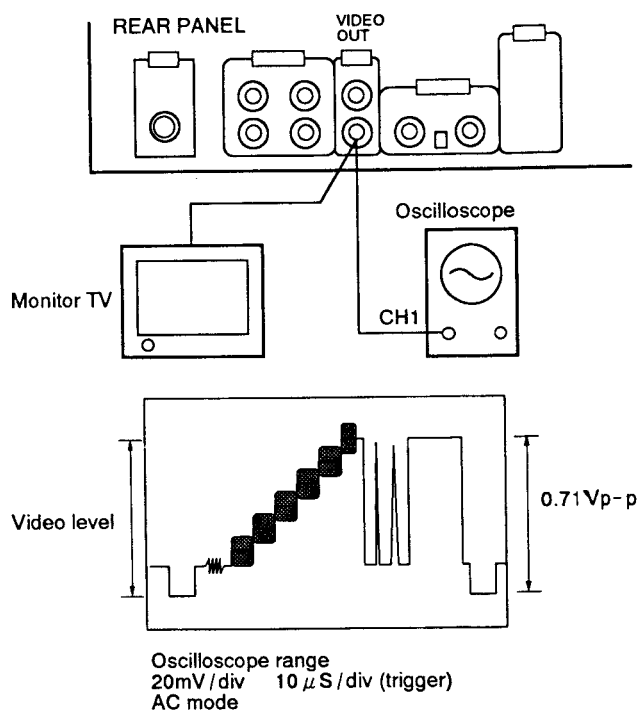
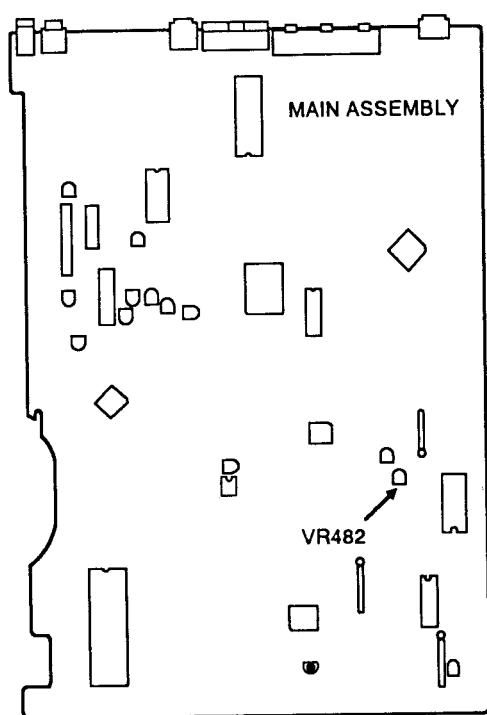

Adjustment Procedure

Note: Since the VIDEO OUT terminal is connected to a TV monitor, it is to have 75Ω termination. (If it is connected to a TV via VHF OUT, terminate the VIDEO OUT terminal with a 75Ω resistor).

1. Search for frame #19,900 on the test disc.
2. Adjust VR482 so that the white level becomes 0.71Vp-p ± 5% from the video signal's sync tip level.

16. 1H DELAY VIDEO LEVEL ADJUSTMENT

Electrical Adjustment

- Purpose: Equalization of the video levels of the 1H delay video signal and the main line video signal.
- When not properly adjusted: If the 1H delay video signal level is high, white dropout will be noticeable and there will be H shifting. (Horizontal stripes across the screen.)

- | | |
|--|--|
| <ul style="list-style-type: none"> ● Measuring instruments and jigs: ● Measuring point: ● Test disc and player mode ● Positions to be adjusted | <ul style="list-style-type: none"> ● Oscilloscope ● CH 1 : - side lead wire of C443 ● CH 2 : - side lead wire of C445 ● 8-inch LD test disc (GGV1003) ● Normal mode (Still mode) ● VR441 |
|--|--|

Connection diagram

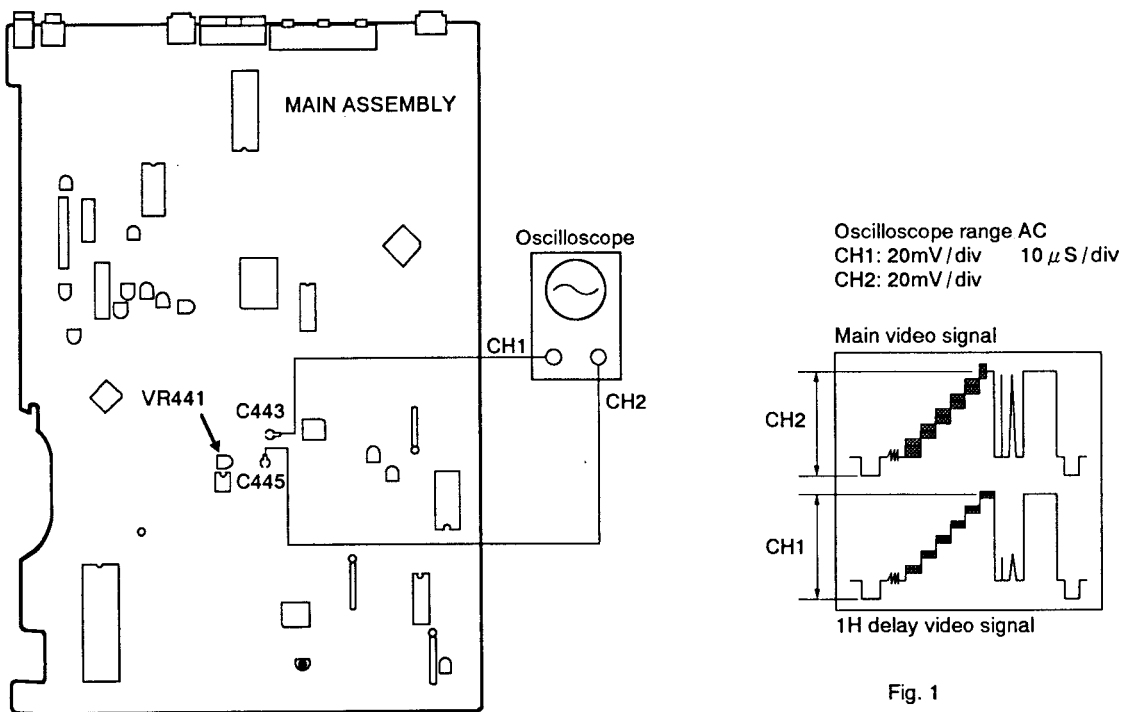

Fig. 1

Adjustment Procedure

1. Search for frame #3,800 on the test disc.
2. Connect - side lead wire of C443 to the oscilloscope's CH 1 and - side lead wire of C445 to the CH 2.
3. Adjust VR441 so that the 1H delay video level (CH 1) becomes the same as the main line video level (CH 2). (See Fig. 1)

Note : The video level is the level between the SYNC tip and the white peak.

17. VPS ERROR ADJUSTMENT

Electrical Adjustment

- Purpose: Optimization of the color tint compensation section's error signal level.
- When not properly adjusted: Substantial color irregularity. (especially on CDV.)

- | | |
|--|--|
| <ul style="list-style-type: none"> ● Measuring instruments and jigs: ● Measuring point: ● Test disc and player mode ● Positions to be adjusted | <ul style="list-style-type: none"> ● TV monitor ● 8-inch LD test disc (GGV1003) ● Normal mode (Still mode) ● VR521 |
|--|--|

Connection diagram

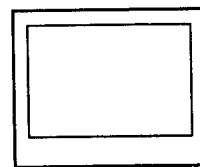
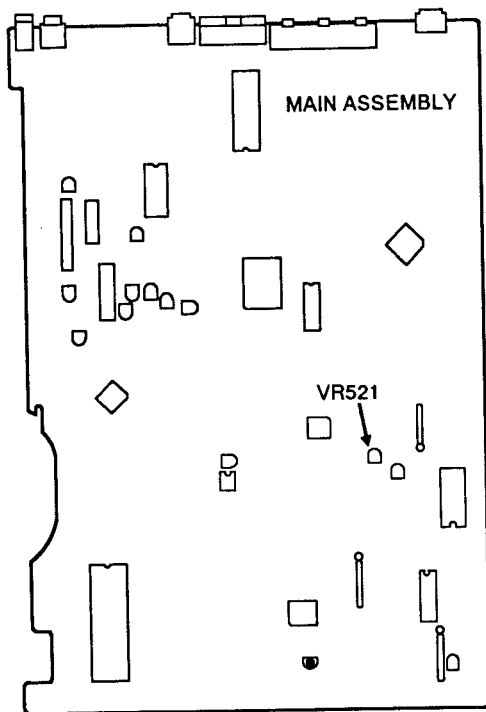

Color irregularity on the magenta screen is minimized.

Adjustment Procedure

1. Search for frame #8,000 on the test disc. (Magenta screen)
2. Adjust VR521 until the color irregularity on the magenta screen is minimized.

9. ABBREVIATIONS TABLE

A		M	
ACCEL	ACCELERATE	MTR	MOTOR
ACOM	AUDIO COMPENSATOR	μCOM	MICROCOMPUTER
AF	AUDIO FREQUENCY	P	
AFM	ANALOGUE FM AUDIO	PD	PHOTO DETECTOR
AGC	AUTOMATIC GAIN CONTROL	PB	PLAYBACK
ALC	AUTOMATIC LEVEL CONTROL	PLL	PHASE LOCKED LOOP
ANT	ANTENNA	P-ON	POWER ON
ATC	AUTOMATIC THRESHOLD CONTROL	R	
B		R-CH	RIGHT CHANNEL
BAL	BALANCE	RTN	RETURN
C		RFMD	RADIO FREQUENCY MODULATOR
CAV	CONSTANT ANGULAR VELOCITY	RST	RESET
CLV	CONSTANT LINEAR VELOCITY	REV	REVERSE
CCD	CHARGE COUPLED DEVICE	RF-CORR	RF CORRECTION
CD	COMPACT DISC	S	
CK	CLOCK	SPDL	SPINDLE
CONT	CONTROL	SLD	SLIDER
C-SYNC	COMPOSITE SYNCHRONIZATION	SO	SERIAL OUTPUT
CX	AFM NOISE REDUCTION	SI	SERIAL INPUT
D		SCK	SERIAL CLOCK
DEM	DEMODULATOR	SC	CHIP SELECT
DIG/ANA	DIGITAL/ANALOGUE	SYPS	SYSTEM POWER SUPPLY
DL	DELAY LINE	SW	SWITCH
DSP	DIGITAL SIGNAL PROCESSOR	S/H	SAMPLE & HOLD
DOS	DROP OUT SENSE	SENS	SENSITIVITY
DRV	DRIVER	SQ	SQUELCH
E		T	
EFM	EIGHT TO FOURTEEN MODULATION	TRK or TRKG	TRACKING
ERR	ERROR	TP	TEST POINT
EQ	EQUALIZER	TBC	TIME BASE CORRECTION
EXT	EXTERNAL	TGL	TOGGLE
F		U	
FCS or FOCS	FOCUS	UNREG	UNREGULATED
FG	FREQUENCY GENERATOR	V	
FL	FLUORESCENT LAMP	V-SYNC	VERTICAL SYNCHRONIZATION
FTS	FOCUS TRACKING SLIDER	VSQ	VIDEO SQUELCH
Fsc	CHROMINANCE SUBCARRIER FREQUENCY	VPS	VIDEO PHASE SHIFTER
FWD	FORWARD	VDEM	VIDEO DEMODULATOR
G		VHF	VERY HIGH FREQUENCY
GFS	GET FRAME SYNC LOCK	VCA	VOLTAGE CONTROLLED AMPLIFIER
GND	GROUND	VCO	VOLTAGE CONTROLLED OSCILLATOR
H		X	
HLD	HOLD	X...	ACTIVATED WHEN LOW VOLTAGE
H SYNC	HORIZONTAL SYNCHRONIZATION	I	
I		INT	INTERNAL
IR	INFRARED RAYS	L	
L		L-CH	LEFT CHANNEL
LAT	LATCH	LD	LASER DIODE
LD	LASER DIODE	LPF	LOW PASS FILTER
LPM	LOW PASS FILTER	LIM	LIMITER
LIM	LIMITER		

10. SPECIFICATIONS

1. General

System	LaserVision Disc system and Compact Disc digital audio system
Laser	Semiconductor laser wavelength 780 nm
Power requirements	
U.S. and Canadian models	AC 120V, 60 Hz
Multi voltage model	AC 110V/120-127V/220V/240V (Switchable), 50/60 Hz
Power consumption	
U.S. and Canadian models	39 W
Multi voltage model	43 W
Weight	7.6 kg (16 lbs 12 oz)
Dimensions	420 (W) x 418 (D) x 122 (H) mm
16-9/16 (W) x 16-7/16 (D) x 4-13/16 (H) in	
Operating temperature	+5°C ~ +35°C (41°F - 95°F)
Operating humidity	5% ~ 90%
(There should be no condensation of moisture.)	

2. Disc

LaserVision Discs

*Maximum playing times	
12-inch standard play disc	1 hour/both sides
12-inch extended play disc	2 hours/both sides
8-inch standard play disc	28 min/both sides
14 min/one side	
8-inch extended play disc	40 min/both sides
20 min/one side	
Spindle motor speed	
Standard play disc	1,800 rpm
Extended play disc	1,800 rpm (inner circumference) to 600 rpm (outer circumference)
(For a 12-inch disc)	

Compact Discs

DISC	Diameter: 5-inch, 3-inch, Thickness: 1.2 mm
Rotation direction (pickup side)	Counterclockwise
Liner speed	1.2 ~ 1.4m/sec
*Maximum playing time	

74 min. 5-inch discs
20 min. 3-inch discs
(For stereo playback)

Compact Discs with Video

Disc	Diameter: 5-inch, Thickness: 1.2 mm
Rotation direction (pickup side)	Counterclockwise
Linear speed	Audio portion: 1.2 ~ 1.4m/sec
Video portion: 11 ~ 12m/sec	
*Maximum playing time	Video portion: 5 min. (CLV)
Audio portion: 20 min. (Digital)	

* Actual playback time differs for each disc.

3. Video characteristics (two pairs)

Format	NTSC specifications
Video output	
Level	1 Vp-p nominal, sync. negative, terminated
Impedance	75Ω unbalanced
Jack	RCA jack

4. S-Video output

Y (luminance) - Output level	1 Vp-p (75 Ω)
C (color) - Output level	286 mVp-p (75 Ω)
Jack	S-VIDEO jack

5. Audio characteristics (two pairs)

Output level	
During analog audio output	200 mVrms (1 kHz, 40%)
During digital audio output	200 mVrms (1 kHz, -20 dB)
Jacks	Both RCA jacks
Number of channels	2

Digital Audio Characteristics

Frequency response	4 Hz - 20 kHz (±0.3 dB) (EIAJ)
SN ratio	112 dB (EIAJ)
Dynamic range	99 dB (EIAJ)
Channel separation	103 dB (EIAJ)
Total harmonic distortion	0.0019% (EIAJ)
Wow and flutter	Limit of measurement (EIAJ)

5. Other Terminals

Control input/output	Both miniature jacks
CD-DECK synchro	Miniature jack
VHF adapter output (Video/Audio)	Both RCA jacks with DC jack
Optical digital output	Optical digital jack

6. Accessories

Remote control unit (CU-CLD048)	1
Size "AAA" (IEC R03) dry cell batteries	2
Video cord	1
Audio cord	1
Operating instructions	1
Warranty card	1

7. Functions

Remote control unit operations (CU-CLD048)

	Function	Standard play Disc (CAV)	Extended play Disc (CLV)	Compact Disc with Video	Compact Disc
Basic Functions	Single-side play	YES	YES	YES	YES
	Pause	YES	YES	YES	YES
	Stop	YES	YES	YES	YES
Search	Fast forward (forward and reverse)	YES	YES	YES	YES
	Chapter/Track skip	YES	YES	YES	YES
	Direct chapter/Track number search	YES	YES	YES	YES
	Frame number search	YES	NO	NO	NO
	Time number search	NO	YES	YES	YES
	Absolute time search	NO	NO	NO	YES
Program	Chapter/Track program play	YES	YES	YES	YES
	Program correction	YES	YES	YES	YES
Repeat	Repeat between 2 points	YES	YES	YES	YES
	Memory repeat	YES	YES	YES	YES
	Chapter/Track repeat	YES	YES	YES	YES
	One-side repeat	YES	YES	YES	YES
	Program repeat	YES	YES	YES	YES
	Random repeat	YES* ¹	YES* ¹	YES	YES
	Program random repeat	YES	YES	YES	YES
Trick play	Still/Step	YES	NO	NO	NO
	Multi-speed (Forward/reverse 9-level variable)	YES	NO	NO	NO
Time display	Elapsed time display	NO	YES	YES	YES
	Absolute time display	YES* ¹	NO	NO	YES
	Remaining track time display	NO	NO	YES	YES
	Remaining total time display	YES* ¹	YES* ¹	YES	YES
	Total number of selections, total time display	YES* ¹	YES* ¹	YES	YES
Others	Single play	YES	YES	YES	YES
	Hi-Lite scan	NO	NO	YES* ⁴	YES
	Intro scan	YES	YES	YES* ⁵	NO
	Digital level control	YES* ³	YES* ³	YES	YES
	CX system ON/OFF	YES* ²	YES* ²	—	—
	AUTO DIGITAL/ANALOG switch	YES* ³	YES* ³	—	—
	Audio channel selection (Stereo, 1/L, 2/R)	YES	YES	YES	YES

*1 Only discs with TOC

*2 Valid for analog sound playing a disc with the  mark.

*3 Can only be used with discs with digital sound tracks.

*4 Audio part only

*5 Video part only

NOTE:

The specifications and design of this product are *subject to change without notice, due to improvement.*

PLAYER FUNCTIONS

- Display, Visual Calendar Display
- Intro Scan, Hi-Lite Scan, Direct CD, Singl Play, Digital Level Control, Peak Search, Random Playback, Program Random Playback and Compu Program/Auto Program Edit
- Digital Sound for LaserVision Discs
- Last Memory

11. PANEL FACILITIES

PHONES LEVEL control
Turn this control in the "MAX" direction to increase the output level from the PHONES jack. Turn this control in the "MIN" direction to decrease the output level from the PHONES jack.

REMOTE SENSOR

POWER STANBY/ON switch
Press to turn the power on and off.

PHONES jack

Display window

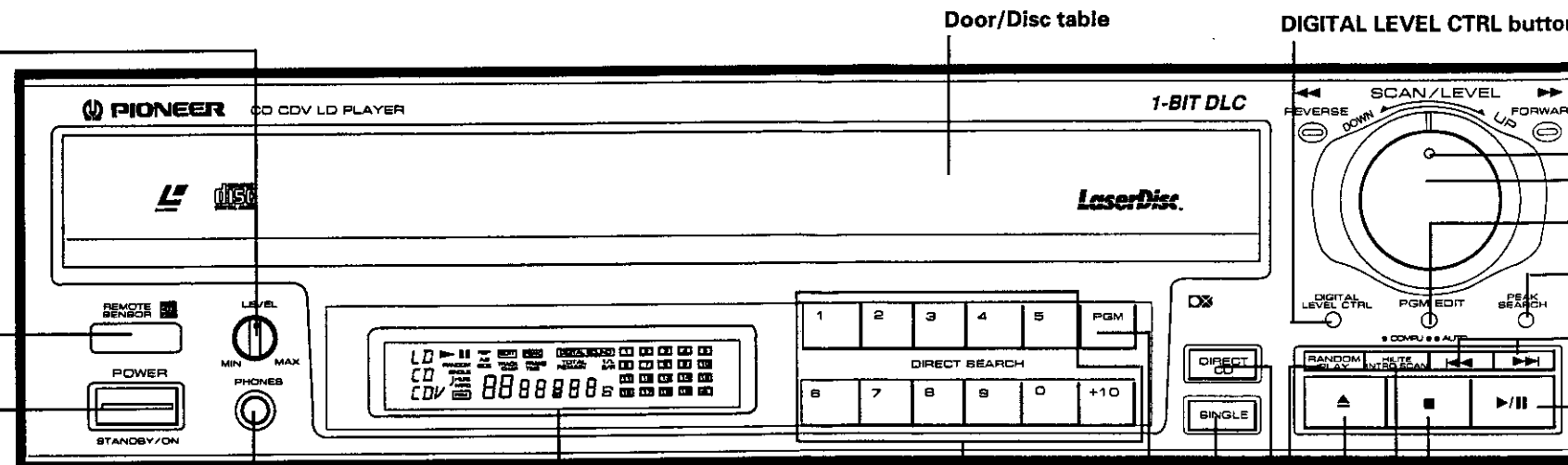

REP/A-B indicator
REP: Lights during repeat play.
A-B: Lights during A-B repeat play.
A: Lights during Memory repeat play.
SIDE: Lights during One side repeat play.

RANDOM indicator
Lights during random play.

PAUSE indicator
Lights when the player is in pause mode.

PLAY indicator
Lights during play. Blinks during search.

LD/CD/CDV indicator
Indicates the type of disc loaded in the player.

SINGLE indicator
Lights during Single play.

HILITE/INTRO indicator
Lights during Hi Lite Scan or Intro Scan mode.

DIGITAL SOUND indicator
Lights when the disc being played has a digital sound signal. With LD discs, this indicator lights when the digital sound signal is selected.

EDIT indicator
Lights when editing is performed.

PEAK indicator
Lights while searching for the peak level.

TRACK/CHAP. indicator
Indicates the TRACK number or CHAP (chapter) number.

PGM indicator
Lights during program play.

Visual calendar
When a disc is loaded, all of the chapter/track numbers recorded on the disc light up on the display. If the disc contains more than 19 chapters/tracks, the → indicator lights. During program play, only the programmed chapter/track numbers light. When a disc without a TOC section is played, only the selection number being played lights. When a CDV disc is loaded, the track numbers of the video part light followed by the track numbers of the audio part. After a chapter/track is finished playing, the corresponding number goes out.

REMAIN/TOTAL indicator
Indicates the REMAIN TIME (remaining play time) or TOTAL TIME (total play time).

FRAME/TIME indicator
Indicates the FRAME number or TIME.

1/L, 2/R indicator
Indicates the audio output channel.

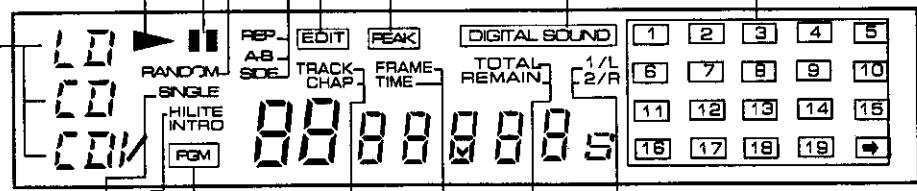

NAMES AND FUNCTIONS OF REMOTE CONTROL UNIT COMPONENTS

Remote control buttons with the same names or marks as buttons on the front panel of the player control the same operations as the corresponding front panel buttons.

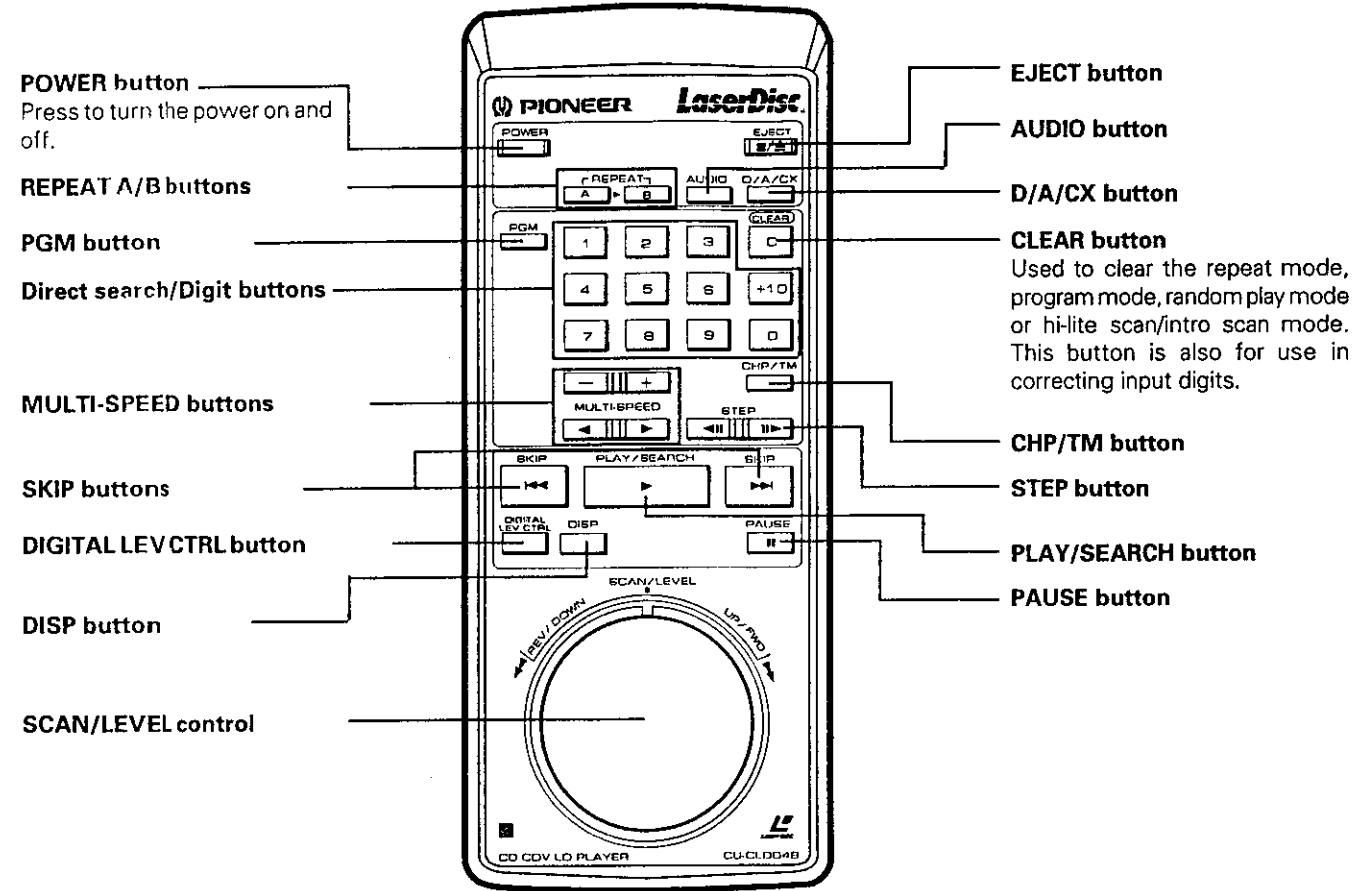

When operating the remote control unit, point the unit's infrared signal transmitter at the remote control receiver (REMOTE SENSOR) on the front panel of the player. The remote control unit can be used within a range of about 7 meters (23 feet) from the remote sensor, and within angles of up to about 30 degrees.

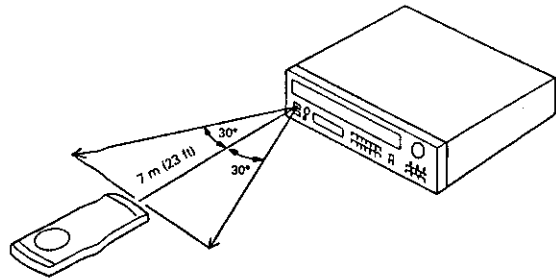

NOTE FOR USING THE REMOTE CONTROL UNIT

- If a plug is connected to the CONTROL IN terminal at the rear of the player, remote control operations cannot be done with the remote control unit aimed at the player's remote control sensor. Aim the remote control unit at the AV control center or the component display's sensor instead.

- If there is any obstacle between the remote control unit and the player, or if the unit is held at too large an angle relative to the front panel of the player, the signal from the remote control unit will fail to reach the remote sensor.
- If the player is operating in the vicinity of other appliances generating infrared rays, or if other remote control devices using infrared rays are used near the player, the player may operate improperly. Conversely, if the player's remote control unit is operated in the vicinity of other appliances which use an infrared remote control device, the other appliance may operate improperly. If this should happen, change the place of installation so that improper operation does not occur.
- If the range of operation of the remote control unit becomes too short, replace the batteries.
- When the unit is not to be used for a long period of time (more than one month), remove the batteries to prevent them from leaking inside the compartment. If leakage occurs, wipe up the liquid inside the compartment and replace the batteries with new ones.
- Do not place books or other objects on the remote control unit, since they might depress the keys and run down the batteries.