

Service Manual

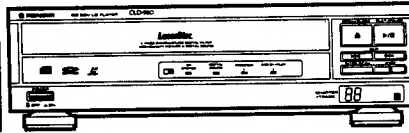

ORDER NO.
ARP2092

CD CDV LD PLAYER

CLD-980

MODEL CLD-980 HAS FOLLOWING VERSIONS :

Type	Power Requirement	Export Destination
KU/CA	AC120V only	U.S.A. and Canada
SD	AC110V, 120V-127V, 220V, 240V (Switchable)	Kingdom of Saudi Arabia and General market

- This manual is applicable to the CLD-980/KU/CA type.
- As to the other types, refer to additional service manuals.
- As to the adjusting methods that are not on this service manual, refer to "Adjustments for CLD players" on ARP2064.

CONTENTS

1. SAFETY INFORMATION.....	2
2. PACKING.....	3
3. EXPLODED VIEWS AND PARTS LIST.....	4
4. SCHEMATIC DIAGRAM AND P.C. BOARDS CONNECTION DIAGRAM.....	17
5. P.C.B's PARTS LIST.....	51
6. ADJUSTMENTS.....	58
7. PANEL FACILITIES.....	63
8. SPECIFICATIONS.....	66

This service manual is intended for qualified service technicians; it is not meant for the casual do-it-yourselfer. Qualified technicians have the necessary test equipment and tools, and have been trained to properly and safely repair complex products such as those covered by this manual.

Improperly performed repairs can adversely affect the safety and reliability of the product and may void the warranty. If you are not qualified to perform the repair of this product properly and safely, you should not risk trying to do so and refer the repair to a qualified service technician.

WARNING

Lead in solder used in this product is listed by the California Health and Welfare agency as a known reproductive toxicant which may cause birth defects or other reproductive harm (California Health & Safety Code, Section 25249.5).

When servicing or handling circuit boards and other components which contain lead in solder, avoid unprotected skin contact with the solder. Also, when soldering do not inhale any smoke or fumes produced.

1. SAFETY INFORMATION

(FOR USA MODEL ONLY)

1. SAFETY PRECAUTIONS

The following check should be performed for the continued protection of the customer and service technician.

LEAKAGE CURRENT CHECK

Measure leakage current to a known earth ground (water pipe, conduit, etc.) by connecting a leakage current tester such as Simpson Model 229-2 or equivalent between the earth ground and all exposed metal parts of the appliance (input/output terminals, screwheads, metal overlays, control shaft, etc.). Plug the AC line cord of the appliance directly into a 120V AC 60Hz outlet and turn the AC power switch on. Any current measured must not exceed 0.5mA.

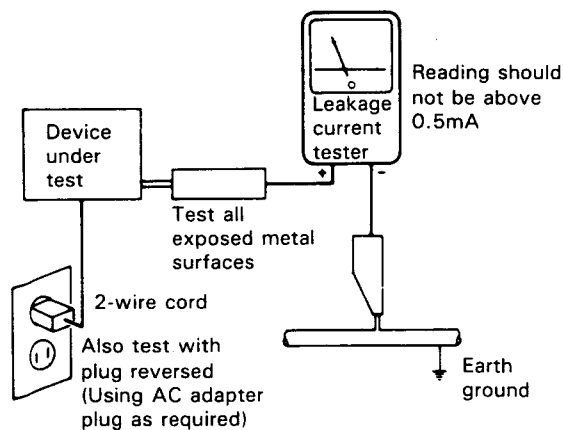

AC Leakage Test

ANY MEASUREMENTS NOT WITHIN THE LIMITS OUTLINED ABOVE ARE INDICATIVE OF A POTENTIAL SHOCK HAZARD AND MUST BE CORRECTED BEFORE RETURNING THE APPLIANCE TO THE CUSTOMER.

2. PRODUCT SAFETY NOTICE

Many electrical and mechanical parts in the appliance have special safety related characteristics. These are often not evident from visual inspection nor the protection afforded by them necessarily can be obtained by using replacement components rated for voltage, wattage, etc. Replacement parts which have these special safety characteristics are identified in this Service Manual.

Electrical components having such features are identified by marking with a Δ on the schematics and on the parts list in this Service Manual.

The use of a substitute replacement component which does not have the same safety characteristics as the PIONEER recommended replacement one, shown in the parts list in this Service Manual, may create shock, fire, or other hazards.

Product Safety is continuously under review and new instructions are issued from time to time. For the latest information, always consult the current PIONEER Service Manual. A subscription to, or additional copies of, PIONEER Service Manual may be obtained at a nominal charge from PIONEER.

(FOR EUROPEAN MODEL ONLY)

VARO!
 AVATTAESSA JA SUOJALUKITUS
 OHITETTAESSA OLET ALTTIINA
 NÄKYMÄTTÖMÄLLE LASERSÄTEILYLLE.
 ÄLÄ KATSO SÄTEESEEN.

ADVERSEL:
 USYNLIG LASERSTRÅLING VED ÅBNING
 NÅR SIKKERHEDSAFBRYDERE ER UDE AF
 FUNKTION UNDGÅ UDSÆTTELSE FOR
 STRÅLING.

VARNING!
 OSYNLIG LASERSTRÅLNING NÅR DENNA
 DEL ÄR ÖPPNAD OCH SPÄRREN
 ÄR URKOPPLAD. BETRAKTA EJ STRÅLEN.



LASER
 Kuva 1
 Lasersäteilyn
 varoitusmerkki

WARNING!
 DEVICE INCLUDES LASER DIODE WHICH
 EMITS INVISIBLE INFRARED RADIATION
 WHICH IS DANGEROUS TO EYES. THERE IS
 A WARNING SIGN ACCORDING TO PICTURE
 1 INSIDE THE DEVICE CLOSE TO THE LASER
 DIODE.



LASER
 Picture 1
 Warning sign for
 laser radiation

IMPORTANT
 THIS PIONEER APPARATUS CONTAINS
 LASER OF HIGHER CLASS THAN 1.
 SERVICING OPERATION OF THE APPARATUS
 SHOULD BE DONE BY A SPECIALLY
 INSTRUCTED PERSON.

LASER DIODE CHARACTERISTICS
 MAXIMUM OUTPUT POWER: 5 mw
 WAVELENGTH: 780-785 nm

2. PACKING

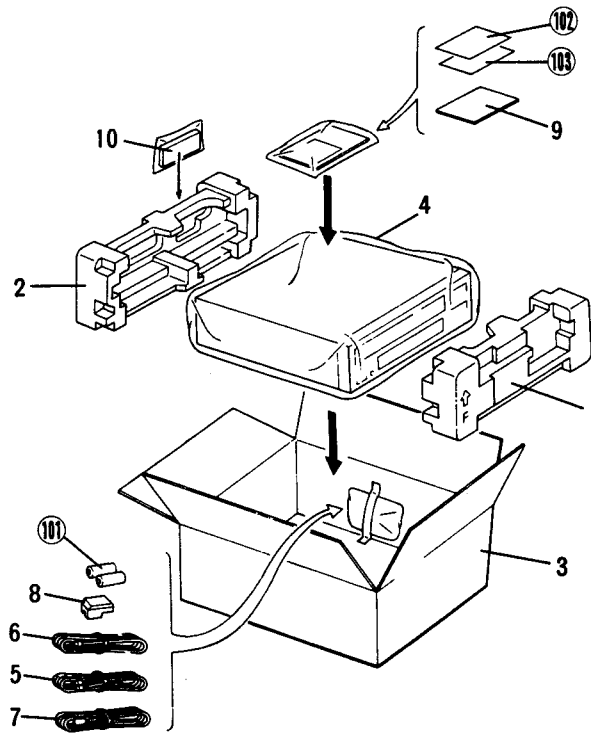

• Parts List of Packing

Mark	No.	Part No.	Description	Mark	No.	Part No.	Description
	1.	VHA1039	Pad (F)		101.		Battery UM-4
	2.	VHA1040	Pad (R)		102.		Caution card
	3.	VHG1112	Packing case		103.		Caution card (UC)
	4.	VHL1006	Packing mat				
	5.	VDE-055	Connection cord				
	6.	VDE-056	Video cable				
	7.	VDE1001	RF antenna cable				
	8.	VKX1003	Antenna adaptor				
	9.	VRB1037	Operating instructions				
	10.	VXX1442	Remote control unit				

3. EXPLODED VIEWS AND PARTS LIST

3.1 EXTERIOR SECTION

A

A

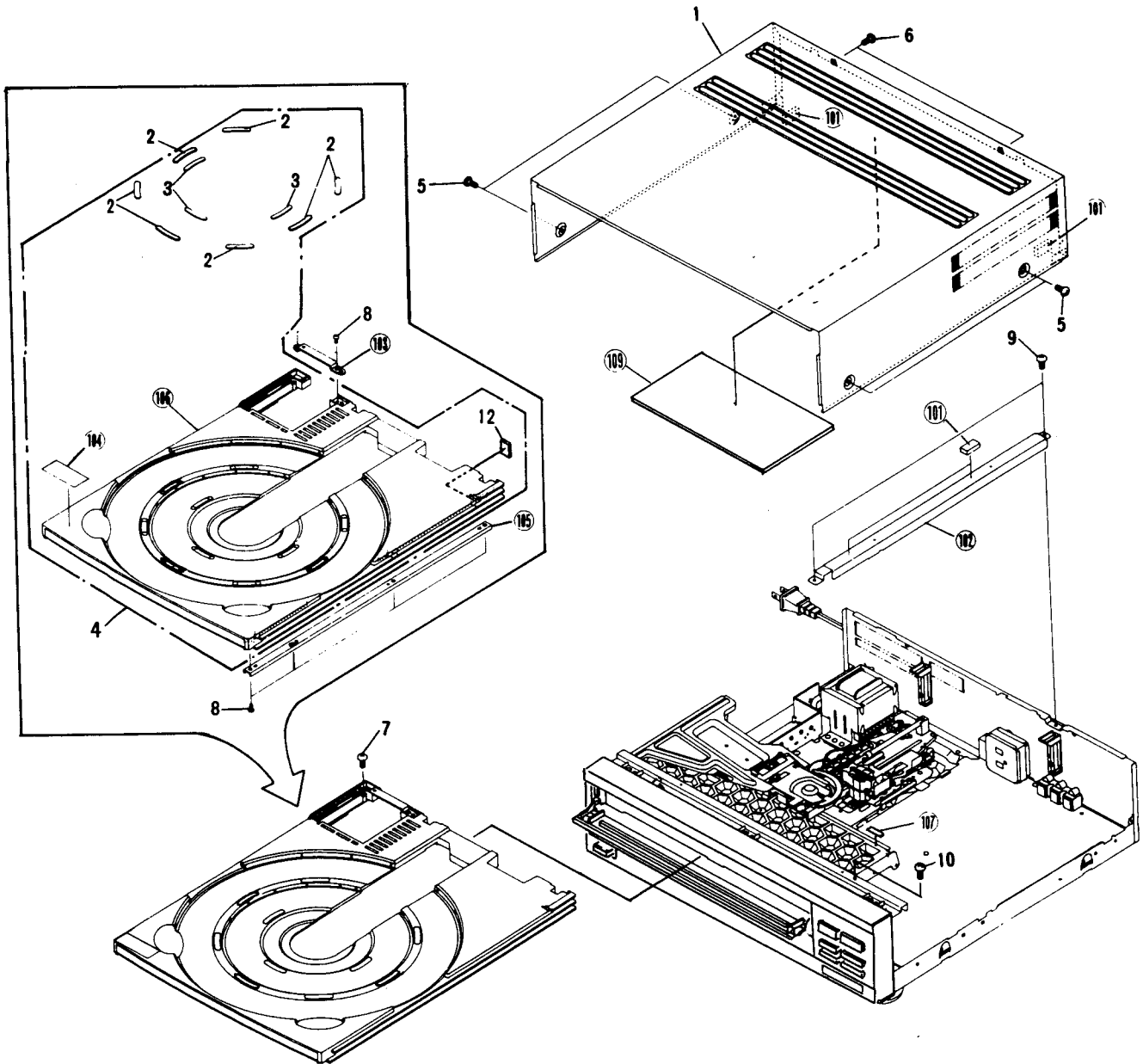

B

B

C

C

• Parts List of Exterior Section (1)

Mark	No.	Part No.	Description	Mark	No.	Part No.	Description
	1.	VXX1267	Bonnet S		101.		Insulator cushion
	2.	VEC1191	Disc pad (L)		102.		Center angle
	3.	VEC1192	Disc pad (S)		103.		Tray metal plate
	4.	VXX1454	Tray assembly S		104.		Carry label
	5.	BCZ40P080FZK	Screw		105.		Tray reinforced plate
	6.	BBZ30P080FCC	Screw		106.		Tray
	7.	BPZ30P140FMC	Screw		107.		Dump rubber
	8.	BPZ30P080FMC	Screw		108.	
	9.	BBZ30P060FCC	Screw		109.		Cushion
	10.	VCZ30P080FMC	Screw				
	11.					
	12.	VEB1089	Tray rubber				

D

D

3.2 FRONT PANEL SECTION

A

B

C

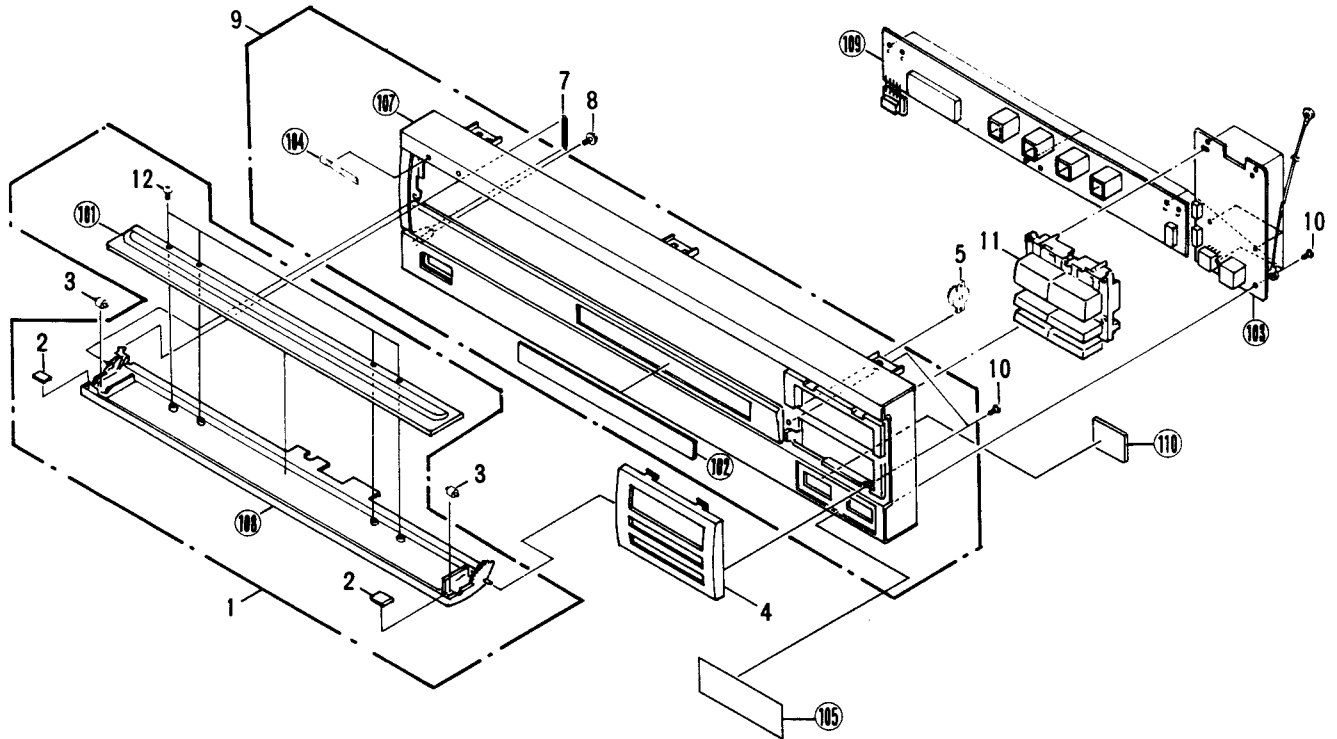

• Parts List of Front Panel Section

Mark	No.	Part No.	Description	Mark	No.	Part No.	Description
	1.	VXX1448	Door assemblyS		101.		Door plate
	2.	VEB1033	Door dump rubber		102.		Sub panel (L)
	3.	VNL1042	Roller		103.		KEYB assembly
	4.	VNK1526	Sub panel (R)		104.		Name plate
	5.	VXA1053	Dumper assembly		105.		7 Seg IR window
	6.			106.	
	7.	VBH1085	Door spring		107.		Front panel
	8.	IPZ26P060FMC	Screw		108.		Front door assembly
	9.	VXX1490	Front panel assemblyS		109.		LEDB assembly
	10.	BPZ26P080FZK	Screw		110.		Sheet
	11.	VNK1527	Function button				
	12.	BPZ20P040FZK	Screw				

D

3.3 LOADING SECTION

NOTES:

- Parts without part number cannot be supplied.
- The Δ mark found on some component parts indicates the importance of the safety factor of the part. Therefore, when replacing, be sure to use parts of identical designation.
- Parts marked by "◎" are not always kept in stock. Their delivery time may be longer than usual or they may be unavailable.

• Parts List of Exterior Section (2)

Mark	No.	Part No.	Description
	1.	VNK1318	Power knob
	2.
	3.	VXA1529	Side stay (R) assembly
	4.	VXA1319	Clamper arm (A) assembly
	5.	VBH1093	Arm spring
	6.	VBA1008	Screw
	7.	VBH1094	Clamper spring
	8.	VEB1084	Dump rubber (A)
	9.	VLL1177	Carriage shaft
	10.	BBZ30P060FCC	Screw
	11.	VBA1018	Screw
	12.	VNL1254	Parallel link
	13.	VBK1014	Plate spring
	14.	VNL1289	Ball holder
	15.	VNL1248	Clamper S
	16.	VNL1205	Clamper holder
	17.	VEB1114	Rubber sheet
	18.	BPZ30P140FMC	Screw
	19.	CPZ20P050FMC	Screw
	20.	VEC1264	Clamper pad
	21.	VBK1018	Thrust holder
	101.		Front angle
	102.		Mechanism assembly
	103.		SW board assembly
	104.		FG board assembly
	105.		SM head stopper
	106.		Clamper arm (B)
	107.		Side stay (L)
	108.	
	109.		Stabilizer

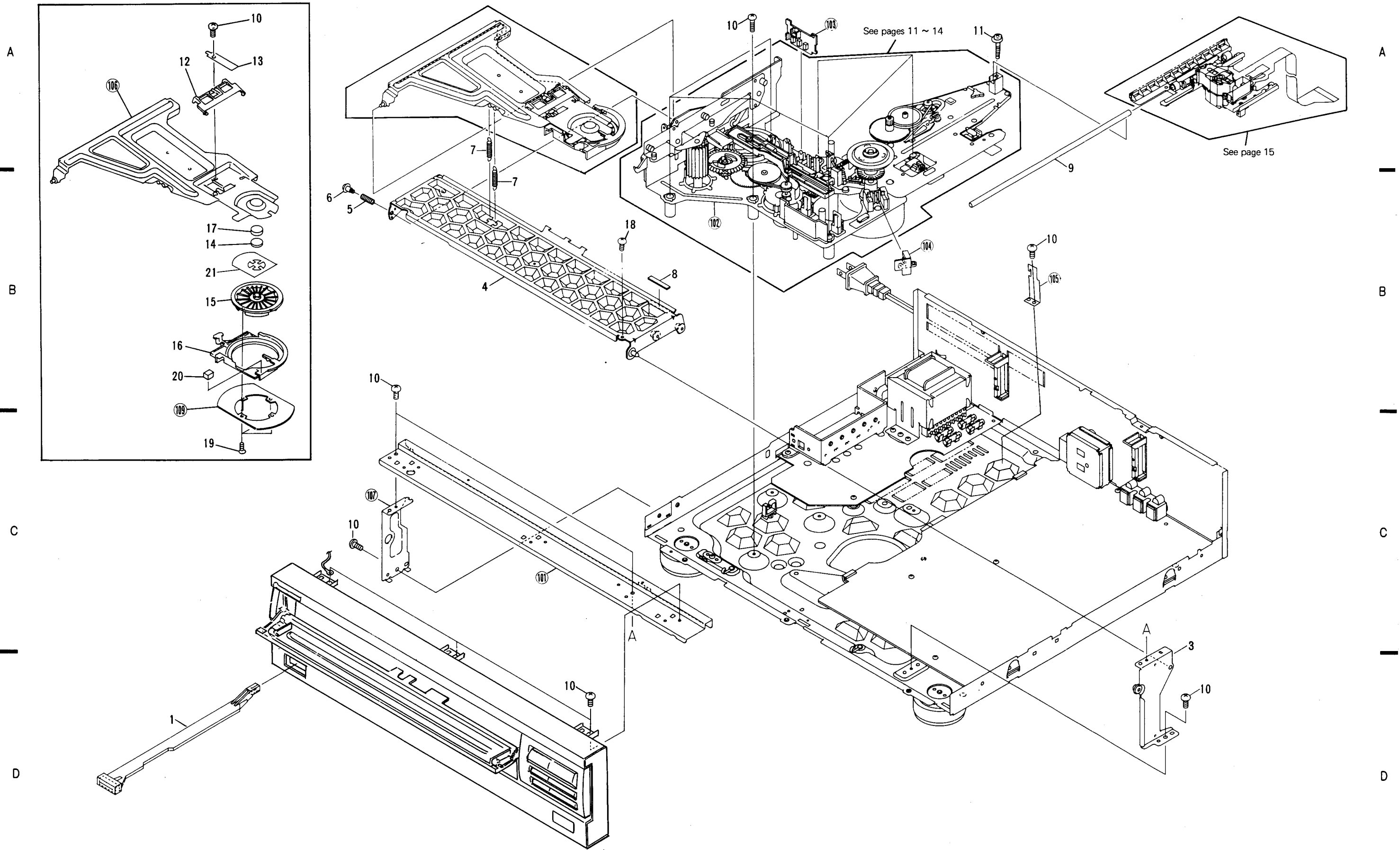

3.4 BASE SECTION

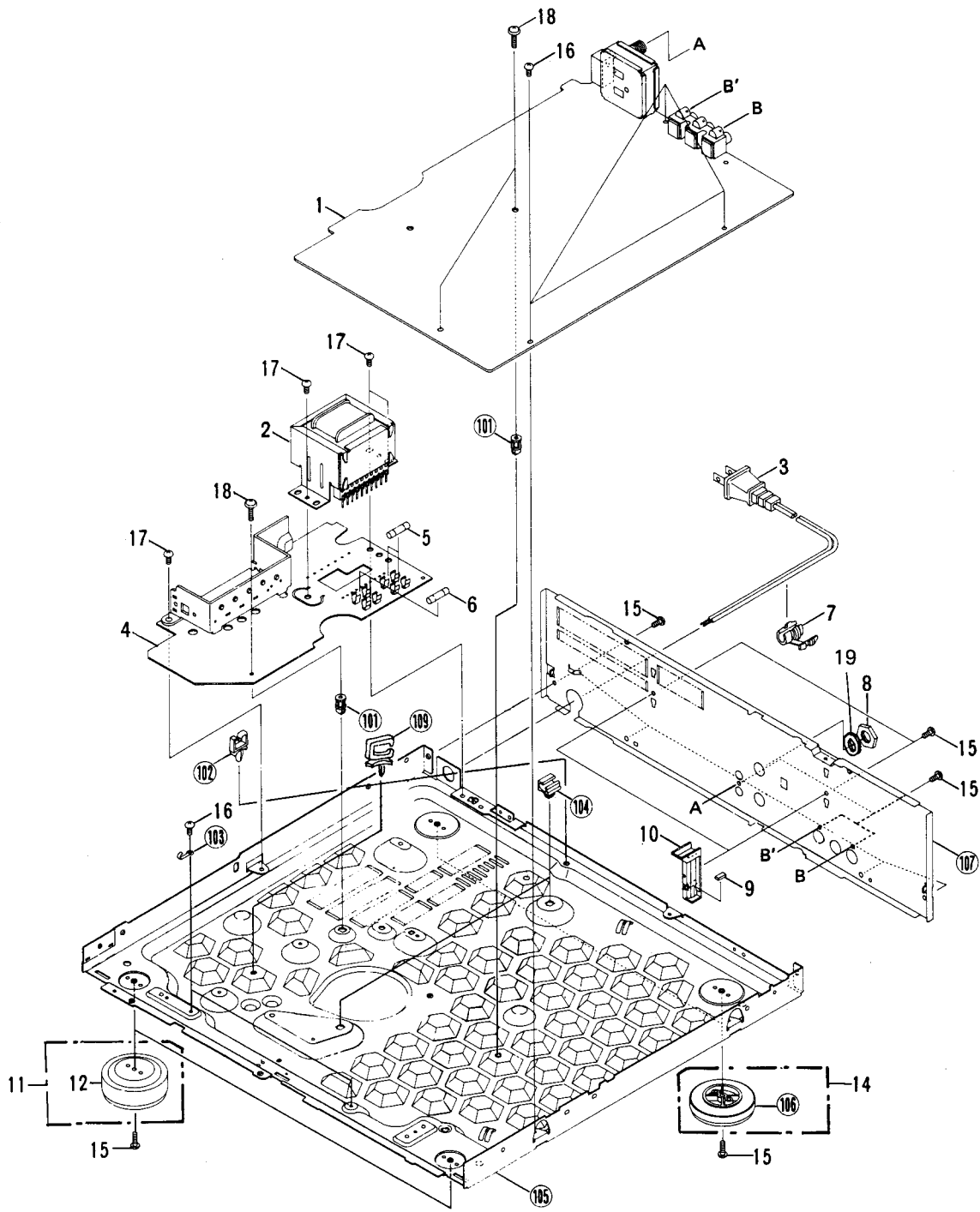

• Parts List of Base Section

Mark	No.	Part No.	Description
⊙	1.	VWX1039	MAIN assembly
△	2.	VTT1065	Power transformer (120V)
△	3.	PDG1002	AC power cord
⊙	4.	VWR1064	SYPS assembly
△	5.	VEK-018	Fuse (FU201, FU202) (3A)
△	6.	VEK-022	Fuse (FU203, FU204) (2A)
	7.	CM-22C	Strain relief
	8.	VLL-082	F-nut
	9.	VEB1033	Door dump rubber
	10.	VNL1202	Tray stopper
	11.	VXA1289	Insulator assembly (F)
	12.	VNK1095	Insulator (A)
	13.
	14.	VXA1290	Insulator assembly (B)
	15.	BBZ30P080FCC	Screw
	16.	BBZ30P060FCC	Screw
	17.	BCZ40P080FZK	Screw
	18.	IPZ30P160FMC	Screw
	19.	WA96F130N050	Washer
	101.		PCB spacer
	102.		Wire clip (B)
	103.		Cord holder
	104.		P board holder
	105.		Base chassis
	106.		Insulator (B)
	107.		Rear panel
	108.	
	109.		Wire clip

3.5 MECHANISM SECTION (1)

A
B
C
D

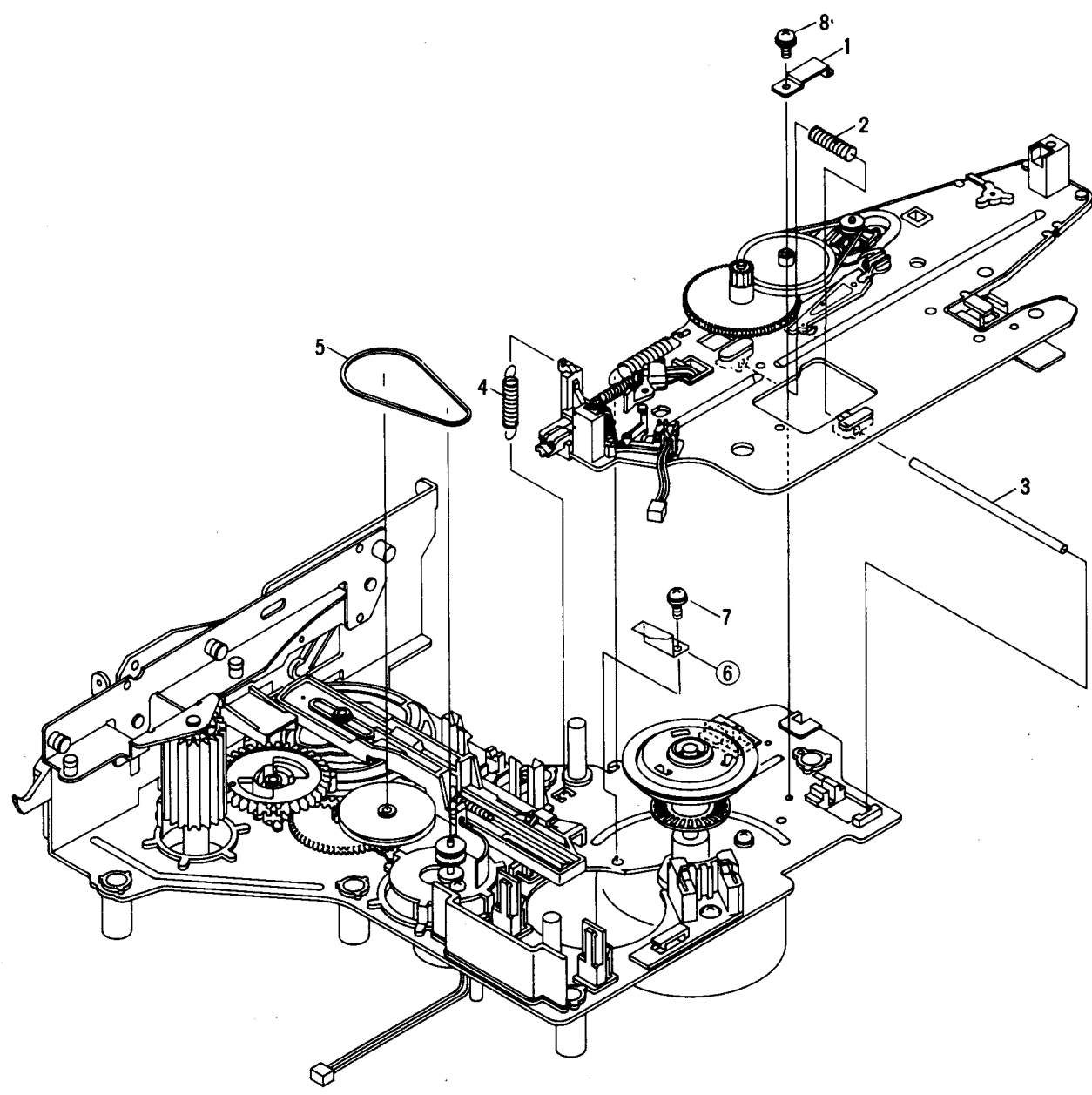

• Parts List of Mechanism Assembly (1)

Mark	No.	Part No.	Description
	1.	VBK1013	Plate spring
	2.	VBH1073	Thrust spring
	3.	VLL1175	Tilt shaft
	4.	VBH1074	Tilt pulling spring
	5.	PEB1013	Belt
	6.		Cam head stopper
	7.	PMA30P050FMC	Screw
	8.	ABZ26P050FMC	Screw

3.6 MECHANISM SECTION (2)

A
B
C
D

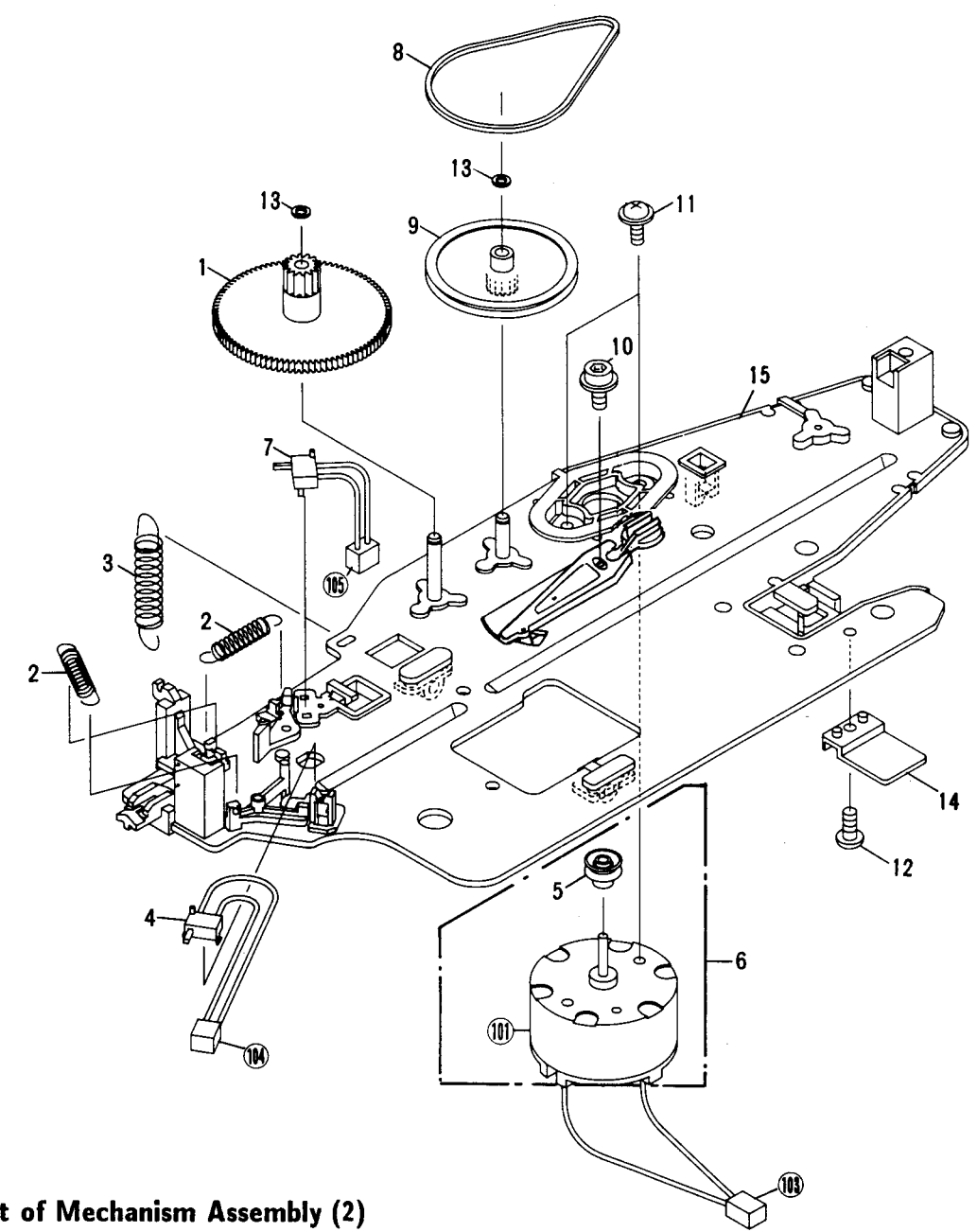

• Parts List of Mechanism Assembly (2)

Mark	No.	Part No.	Description	Mark	No.	Part No.	Description
	1.	VNL1196	CA gear (3)		101.		Carriage motor
	2.	VBH1079	Switch pulling spring		102.	
	3.	VBH1080	TC pulling spring		103.		Housing assembly
	4.	PSH1003	Slide switch(S5: LD/CD)		104.		Housing assembly
	5.	VNL1197	CA pulley (1)		105.		Housing assembly
	6.	VXX1261	Carriage motor assembly				
	7.	PSH1003	Slide switch (S4: CD/CDV)				
	8.	VEB1077	CA belt				
	9.	VNL1198	CA pulley (2)				
	10.	SMF30H080FBT	Screw				
	11.	PMA26P050FMC	Screw				
	12.	BPZ26P050FMC	Screw				
	13.	WT26D047D025	Washer				
	14.	VNL1210	FLE base				
⊙	15.	VXA1273	Servo Mechanism base assembly				

3.7 MECHANISM SECTION (3)

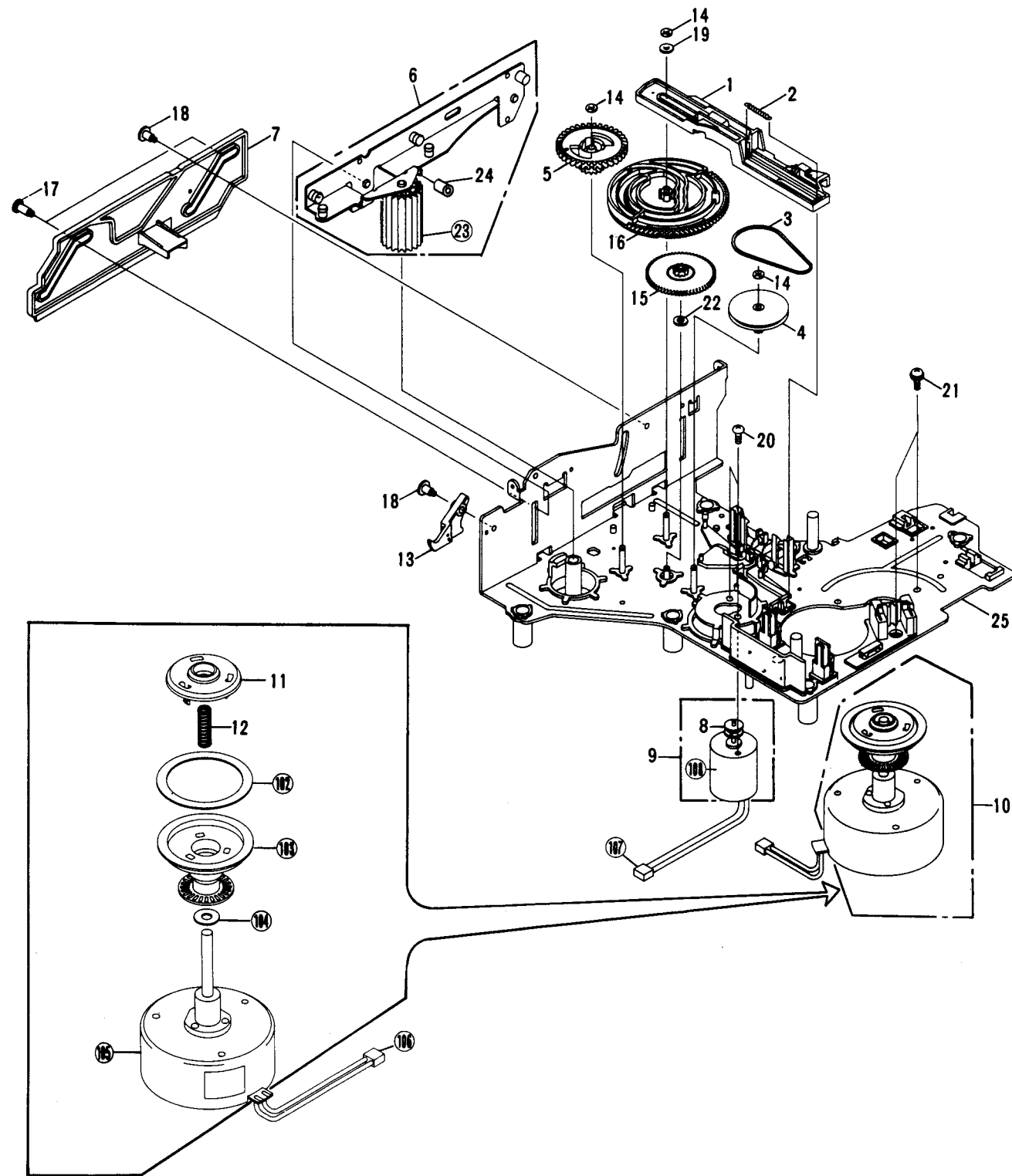

• Parts List of Mechanism Assembly (3)

Mark	No.	Part No.	Description	Mark	No.	Part No.	Description
	1.	VNL1191	Spring slanting cam		101.	
	2.	VBH1082	Cam spring		102.		Rubber sheet
	3.	PEB1013	Belt		103.		Turn-table assembly
	4.	VNL1249	Gear pulley		104.		Oil stopped washer
	5.	VNL1194	Follow gear		105.		Spindle motor
	6.	VXA1531	Roller plate assembly		106.		Housing assembly
	7.	VNL1188	Slide cam		107.		Housing assembly
	8.	VLL1176	Motor pulley		108.		Loading motor
	9.	VXX1262	Loading Motor assembly				
	10.	VXA1474	Spindle Motor assembly				
	11.	VNL1174	Centering hub				
	12.	VBH1083	Centering spring				
	13.	VNL1208	Door lever				
	14.	WT26D047D025	Washer				
	15.	VNL1193	Two stair gear				
	16.	VNL1190	Cam gear				
	17.	VBA1015	Screw (C)				
	18.	VBA1008	Screw (B)				
	19.	WA32N080V050	Nylon washer				
	20.	PMZ30P040FMC	Screw				
	21.	PMA30P050FMC	Screw				
	22.	WA32D060D025	Washer				
	23.		Slider gear				
	24.	VEB1091	Stopper ring				
⊙	25.	VXA1274	Chassis assembly				

3.8 RACK SECTION

A
B
C
D

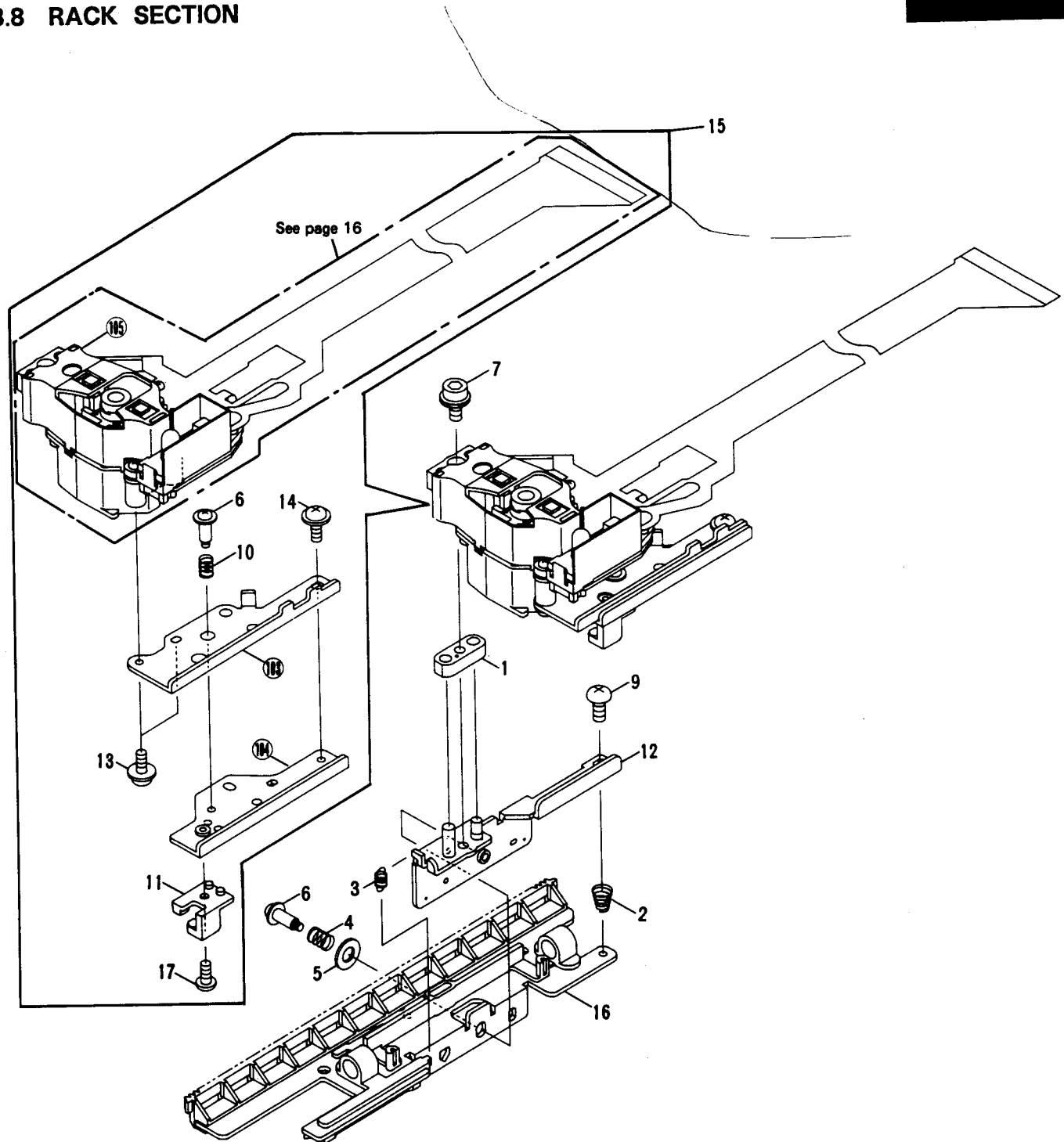

• Parts List of Rack Section

Mark	No.	Part No.	Description	Mark	No.	Part No.	Description
	1.	VNL1209	PU base		12.	VXA1276	PU mount base assembly
	2.	VBH1075	LP center spring		13.	PMA20P040FMC	Screw
	3.	VBH1089	PU pulling spring		14.	AMZ20P050FMC	Screw
	4.	VBH1090	L-2 spring		15.	VWT1060	Slider assembly
	5.	WA32F070M80	Washer		16.	VNL1186	Rack
	6.	VBA1007	Screw		17.	PMZ20P040FMC	Screw
	7.	VLL1192	Bolt 2.6×10		101.	
	8.			102.	
	9.	BMZ26P080FMC	Screw		103.		TAN plate (2)
	10.	VBH1081	TANspring		104.		TAN plate (1)
	11.	VNL1199	TAN base		105.		Pick-up assembly

3.9 PICK-UP ASSEMBLY

A

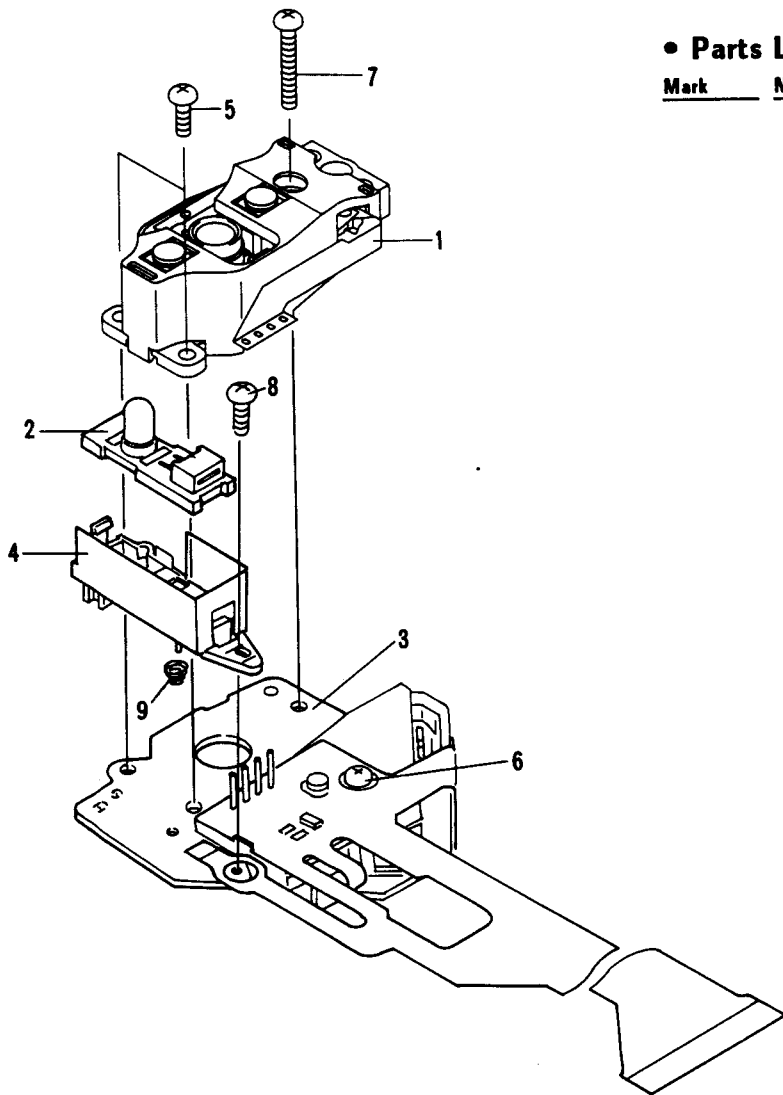

• Parts List of Pick-up Assembly

Mark	No.	Part No.	Description
	1.	VXX1266	Actuator assembly
	2.	VEX1018	Sensor assembly
	3.	VXX1413	Pre Pick-up assembly
	4.	VNH1024	Sensor stay
	5.	PMA20P060FMC	Screw
	6.	PMA20P080FMC	Screw
	7.	PMA20P140FMC	Screw
	8.	BMZ20P060FMC	Screw
	9.	VBH1087	Sensor spring

A

B

B

C

C

3.10 REMOTE CONTROL UNIT

D

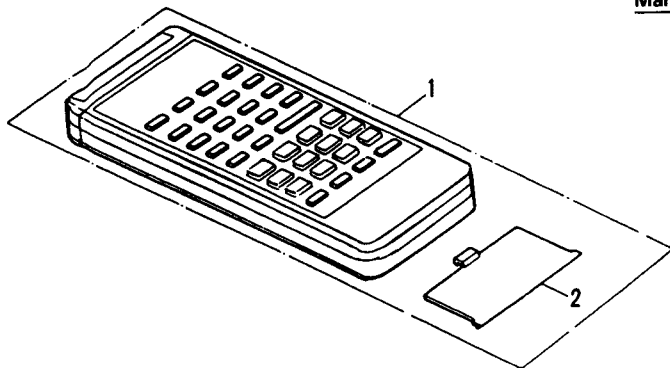

• Parts List of Remote Control Unit

Mark	No.	Part No.	Description
	1.	VXX1442	Remote control unit
	2.	VNK1293	Battery cover

D

4. SCHEMATIC DIAGRAM AND P.C. BOARDS CONNECTION DIAGRAM

4.1 OVERALL CONNECTION DIAGRAM

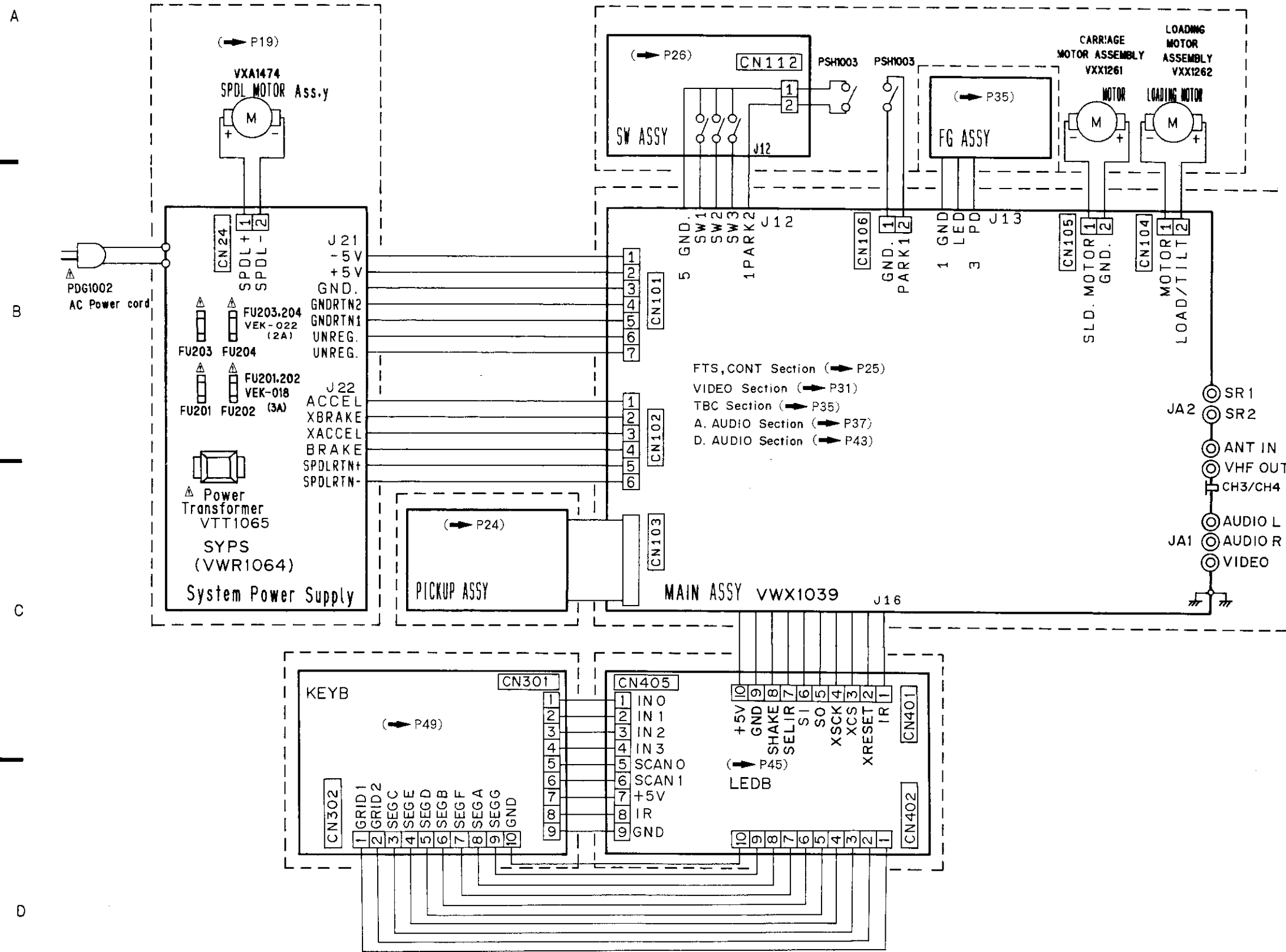

1. RESISTORS :
Indicated in Ω, 1/4W, 1/6W, 1/8W, ±5% tolerance unless otherwise noted k; kΩ, M; MΩ, (F); ±1%, (G); ±2%, (K); ±10%, (M); ±20% tolerance.
2. CAPACITORS :
Indicated in capacity (μF) /voltage (V) unless otherwise noted p; pF.
Indication without voltage is 50V except electrolytic capacitor.
3. VOLTAGE CURRENT :
⊖; DC voltage (V) at play state.
← mA; DC current at play state.
Value in () is DC current at stop state.
4. OTHERS :
→ : Signal route.
⊙ : Adjusting point.
The Δ mark found on some component parts indicates the importance of the safety factor of the part. Therefore, when replacing, be sure to use parts of identical designation.
※ marked capacitors and resistors have parts numbers.
5. SWITCHES (Underline indicates switch position)
SYPS ASSEMBLY
S201 : POWER ON/OFF
SW ASSEMBLY
S1-S3 :
KEYB ASSEMBLY
S301 : OPEN/CLOSE
S302 : CHAPTER SKIP
S303 : INTRO SCAN
S304 : PLAY/PAUSE
S305 : CHAPTER SKIP
S306 : STOP

4.2 SYPS ASSEMBLY

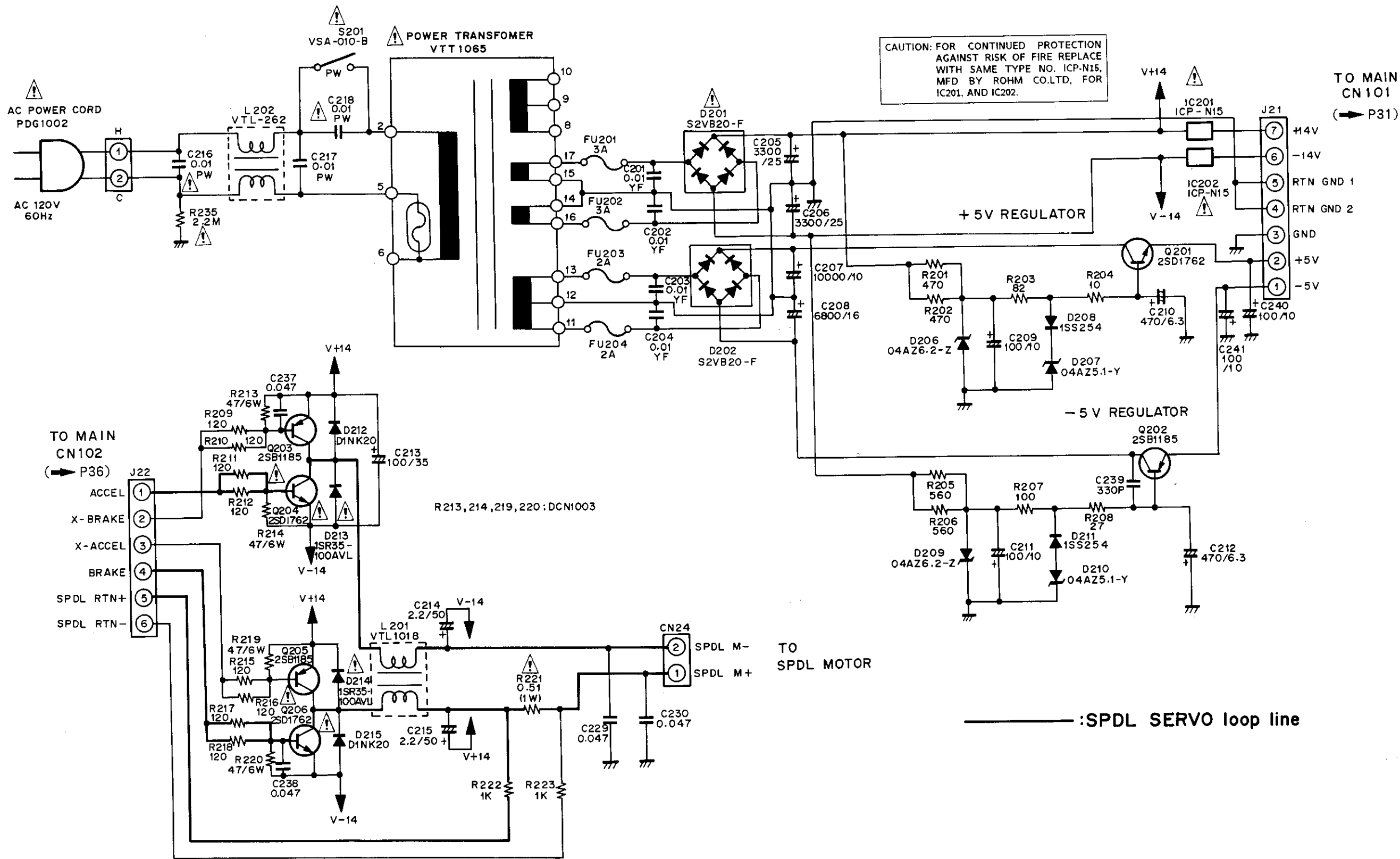

CAUTION: FOR CONTINUED PROTECTION AGAINST RISK OF FIRE REPLACE WITH SAME TYPE NO. ICP-N15, MFD BY ROHM CO.LTD. FOR IC201, AND IC202.

+ 5V REGULATOR

- 5V REGULATOR

:SPDL SERVO loop line

SYPS ASSEMBLY(VWR1064)

Q204 Q203 IC201 IC202 Q202
Q206 Q205 Q201

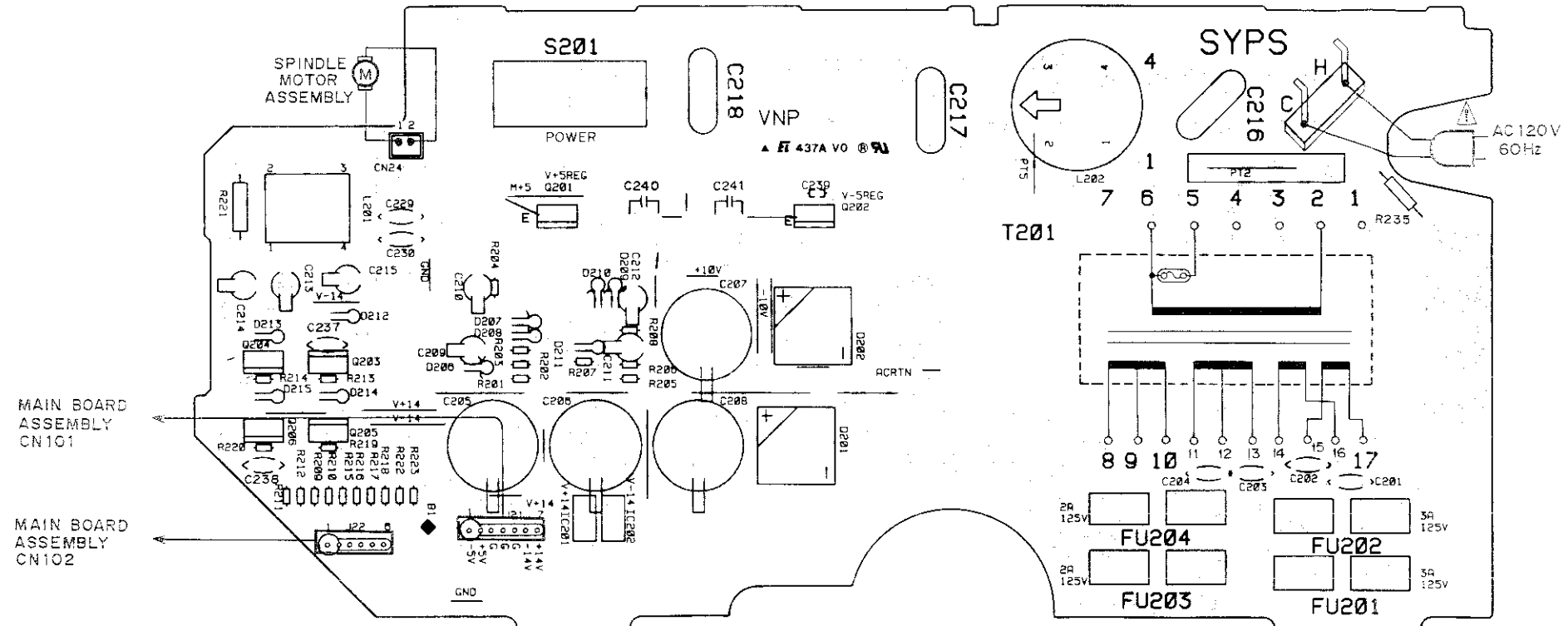

This P.C.B. connection diagram is viewed from the foil side.

SYPS ASSEMBLY(VWR1064)

Q506 Q505 Q504 Q503 IC501 IC502 Q501

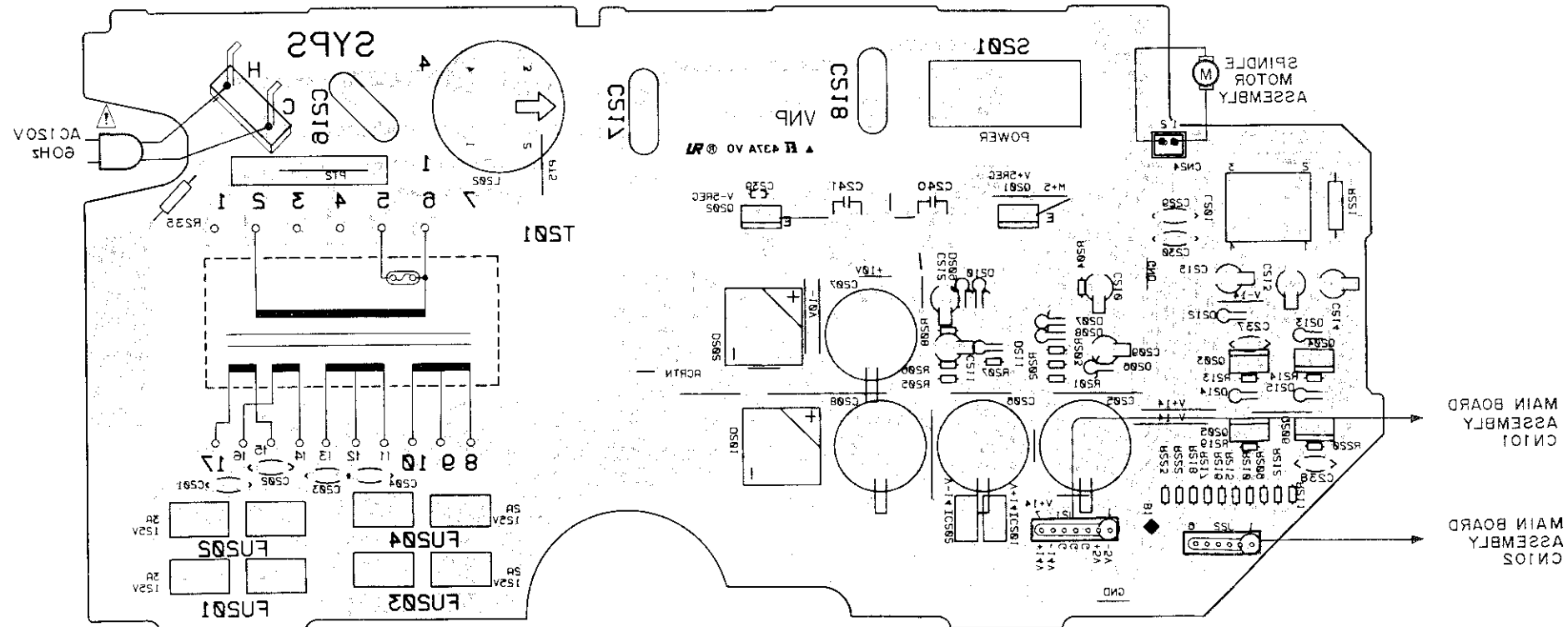

IC601 <K411S29NT>					IC602 <K7M4558S>		IC605 <1R3C02A>		IC801 <PDD0T1>						IC802 <TAB410AK>				
Pin No.	Voltage	Pin No.	Voltage	Pin No.	Voltage	Pin No.	Voltage	Pin No.	Voltage	Pin No.	Voltage	Pin No.	Voltage	Pin No.	Voltage				
1	-5	15	0	29	*	1	5	1	3	1	5	17	5	33	5	49	5	1	0
2	0	16	0	30	*	2	2.5	2	0	2	0	18	*	34	5	50	5	2	0.56
3	2	17	*	31	*	3	0	3	-3.5	3	0	19	*	35	0	51	5	3	0
4	0	18	*	32	*	4	0	4	-5	4	0	20	*	36	5	52	0	4	4
5	0	19	0	33	0	5	-5	5	5	5	0	21	*	37	*	53	2.5	5	5
6	0	20	*	34	-4	6	0	6	5	6	0	22	0	38	*	54	0	6	5
7	0	21	0	35	500 μ V	7	0	7	0	7	0	23	*	39	*	55	0	7	5
8	0	22	0	36	0	8	0	8	0	8	0	24	*	40	*	56	0	8	12
9	0	23	*	37	0	9	0	9	3.5	9	0	25	5	41	0	57	*	9	0
10	*	24	0	38	0	10	0	10	5	10	0	26	*	42	5	58	*	10	0.56
11	*	25	*	39	0	11	5	11	0	11	5	27	0	43	0	59	*		
12	*	26	*	40	0	12	2.5	12	0	12	2.5	28	5	44	5	60	NOISE		
13	0	27	*	41	0	13	*	13	0	13	*	29	*	45	5	61	NOISE		
14	0	28	*	42	5	14	0	14	0	14	5	30	*	46	0	62	0		
						15	0	15	0	15	0	31	0	47	0	63	0		
						16	5	16	0	16	5	32	0	48	0	64	0		

IC603 <B4152184>		IC606 <TAB410AK>	
Pin No.	Voltage	Pin No.	Voltage
1	*	1	*
2	0	2	*
3	0	3	0
4	5	4	0
5	0	5	-15
6	0	6	0
7	0	7	0
8	5	8	0
		9	0
		10	15

IC604 <L46500>	
Pin No.	Voltage
1	0
2	-15
3	15
4	0
5	0

Note: All waveforms and voltage tables are in normal play mode.

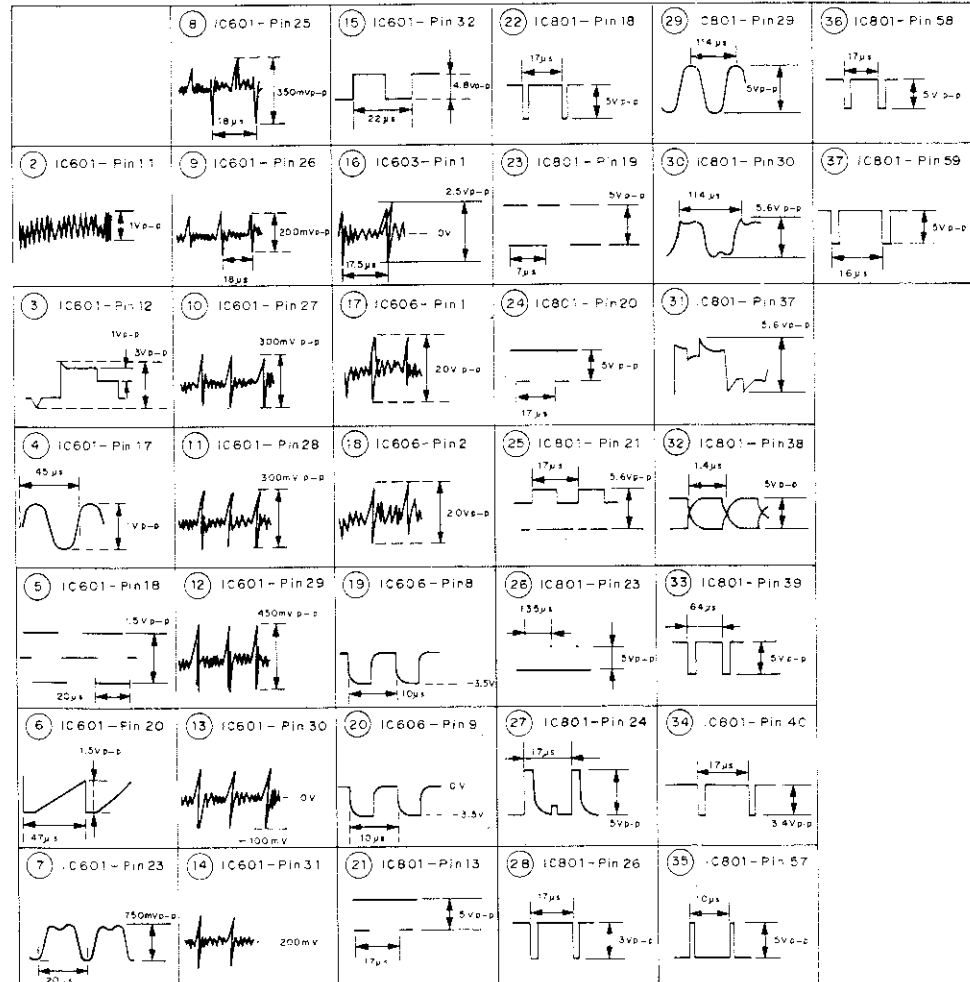

4.3 PICK-UP ASSEMBLY

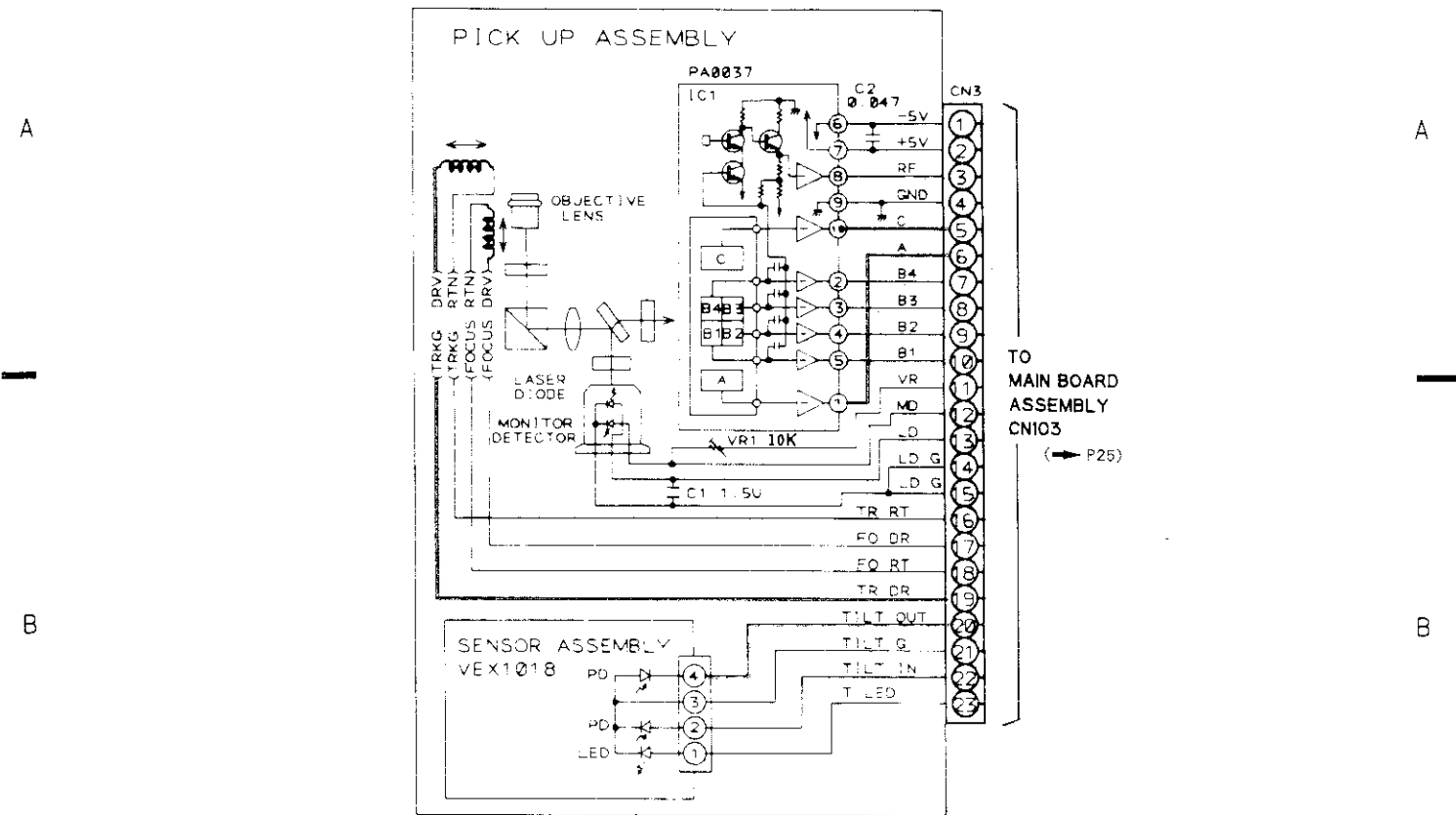

4.4 HEAD ASSEMBLY

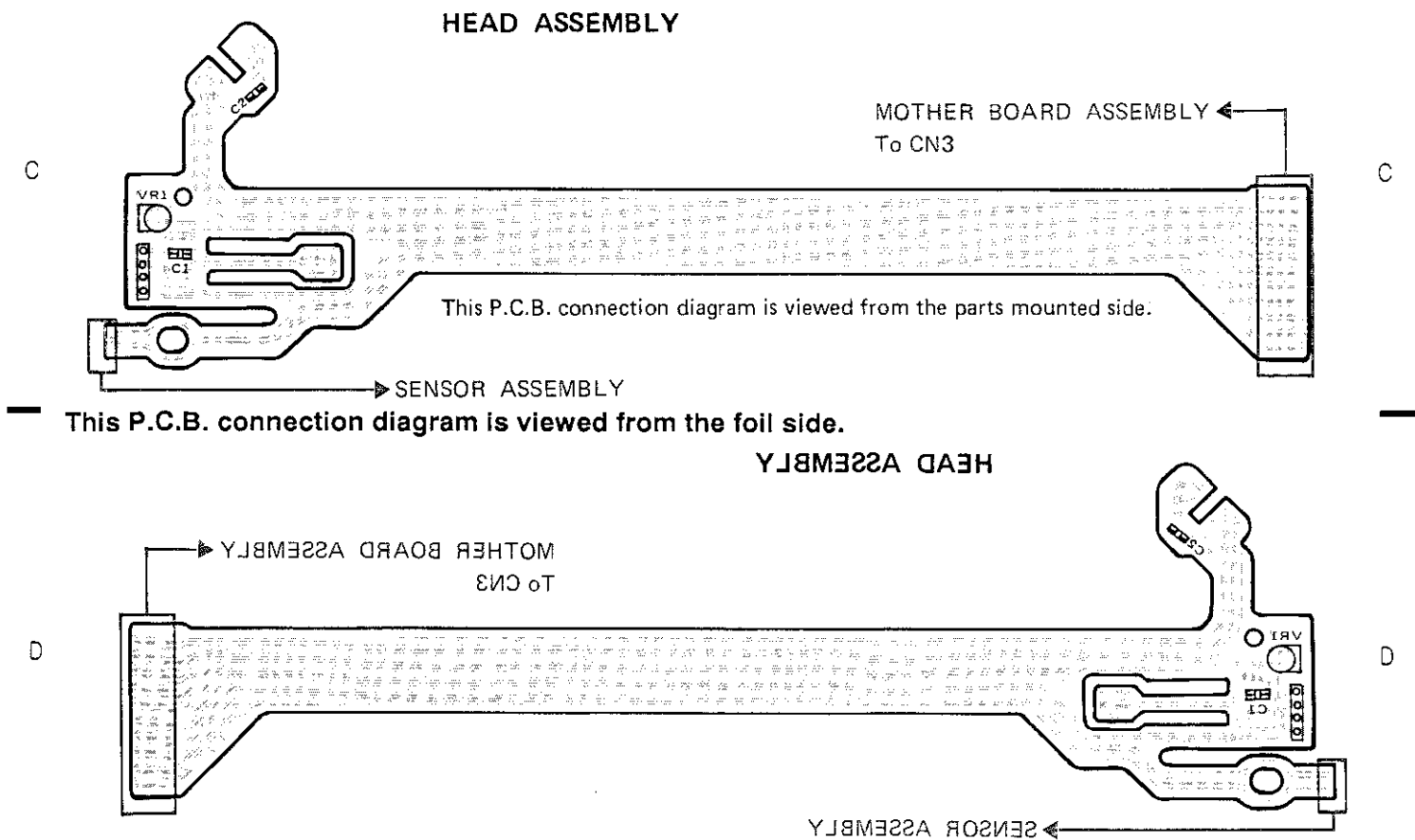

4.5 MAIN BOARD ASSEMBLY (FTS, CONT Section), SW BOARD ASSEMBLY

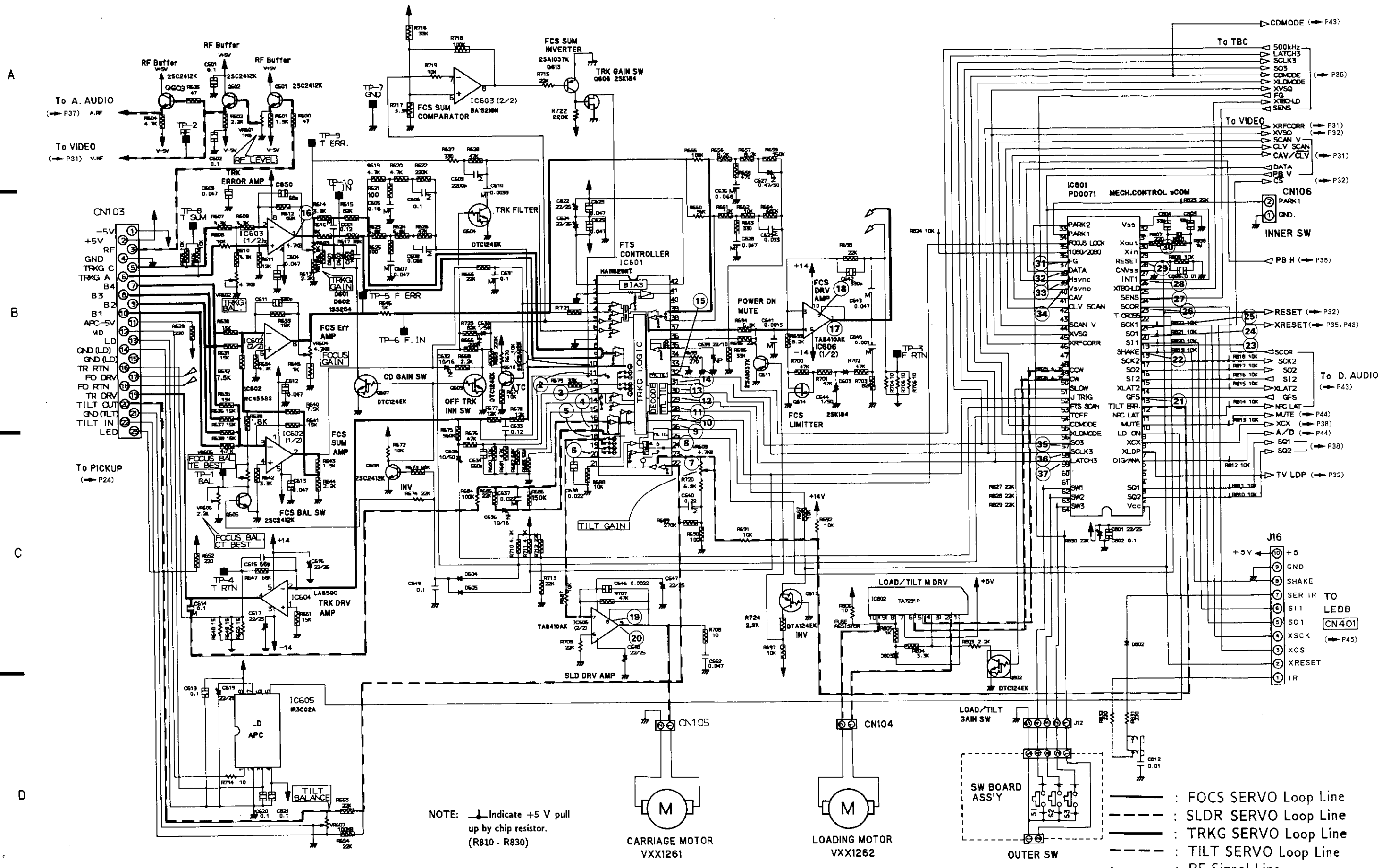

NOTE: \downarrow Indicate +5 V pull up by chip resistor. (R810 - R830)

CARRIAGE MOTOR VXX1261

LOADING MOTOR VXX1262

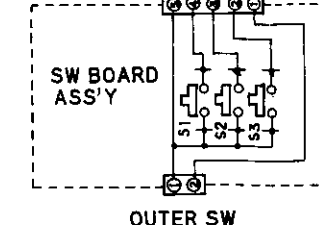

- : FOCUS SERVO Loop Line
- - - : SLDR SERVO Loop Line
- : TRKG SERVO Loop Line
- - - : TILT SERVO Loop Line
- - - : RF Signal Line

SY
BO
AS
J2

PIC
ASS

MAIN BOARD ASSEMBLY

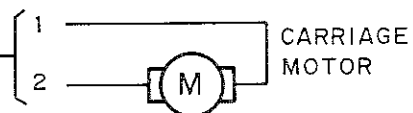
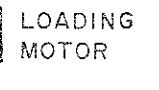
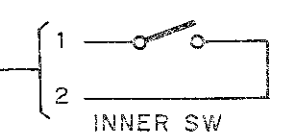
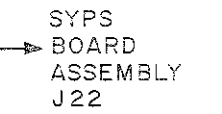
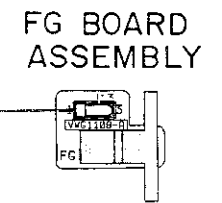
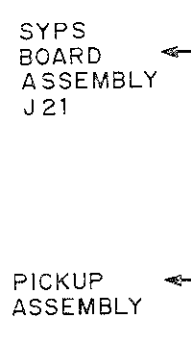
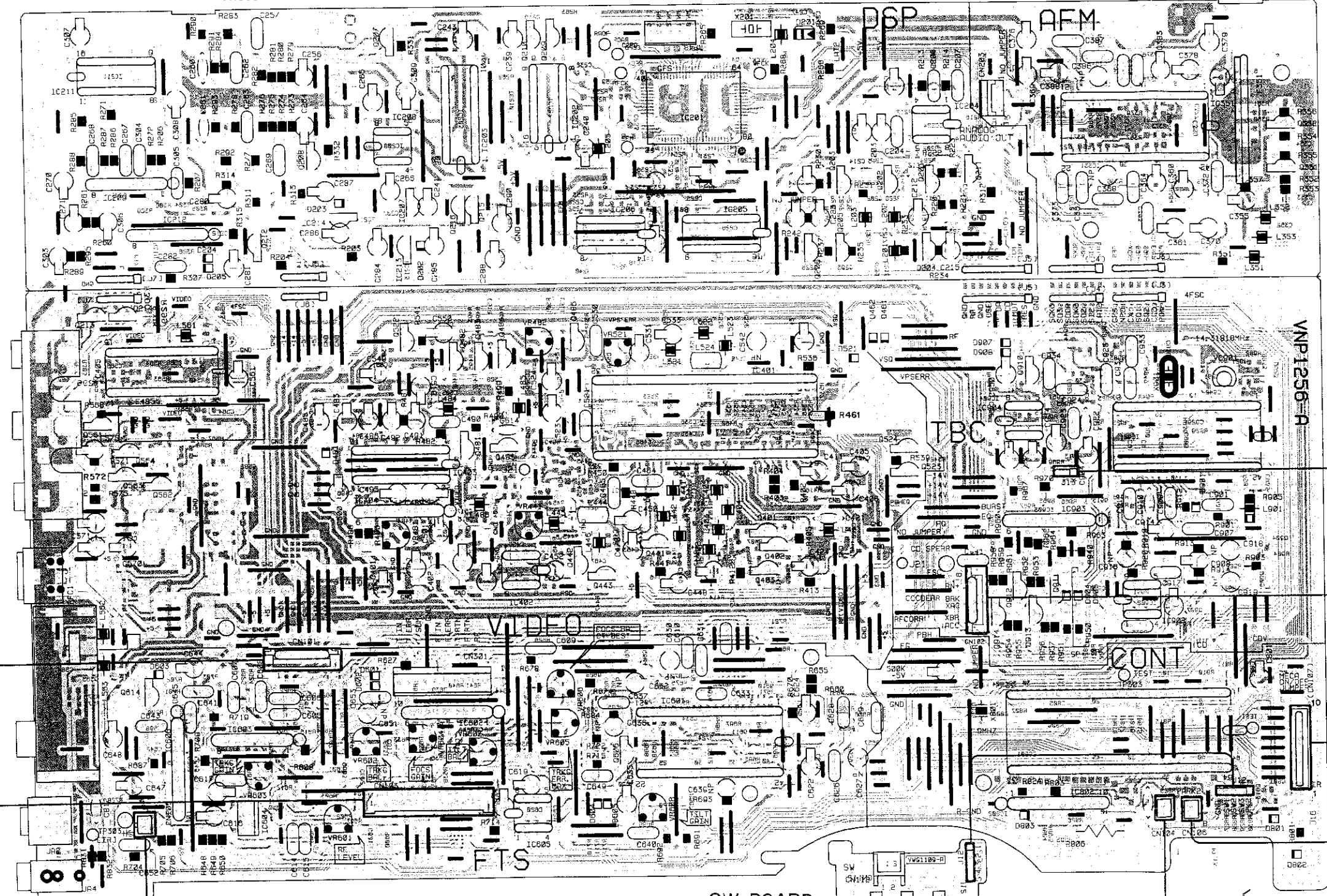
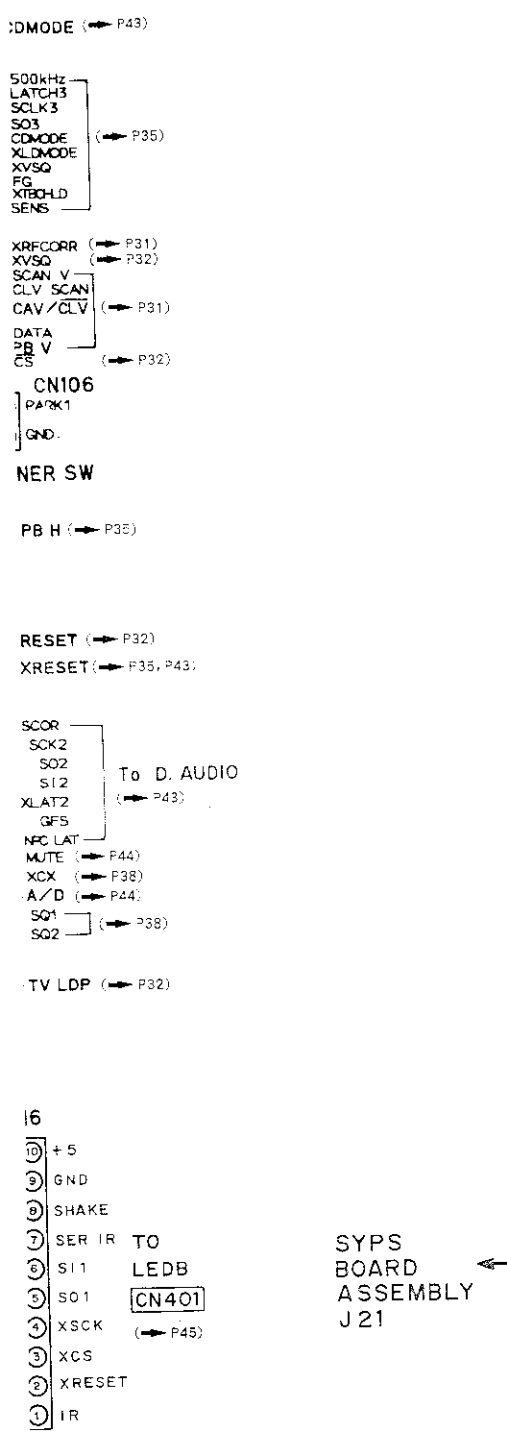
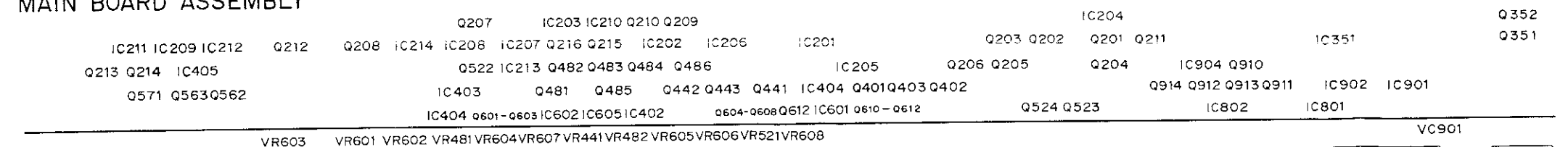

) Loop Line
) Loop Line
) Loop Line
 Loop Line
 e

4.6 MAIN BOARD ASSEMBLY (VIDEO Section)

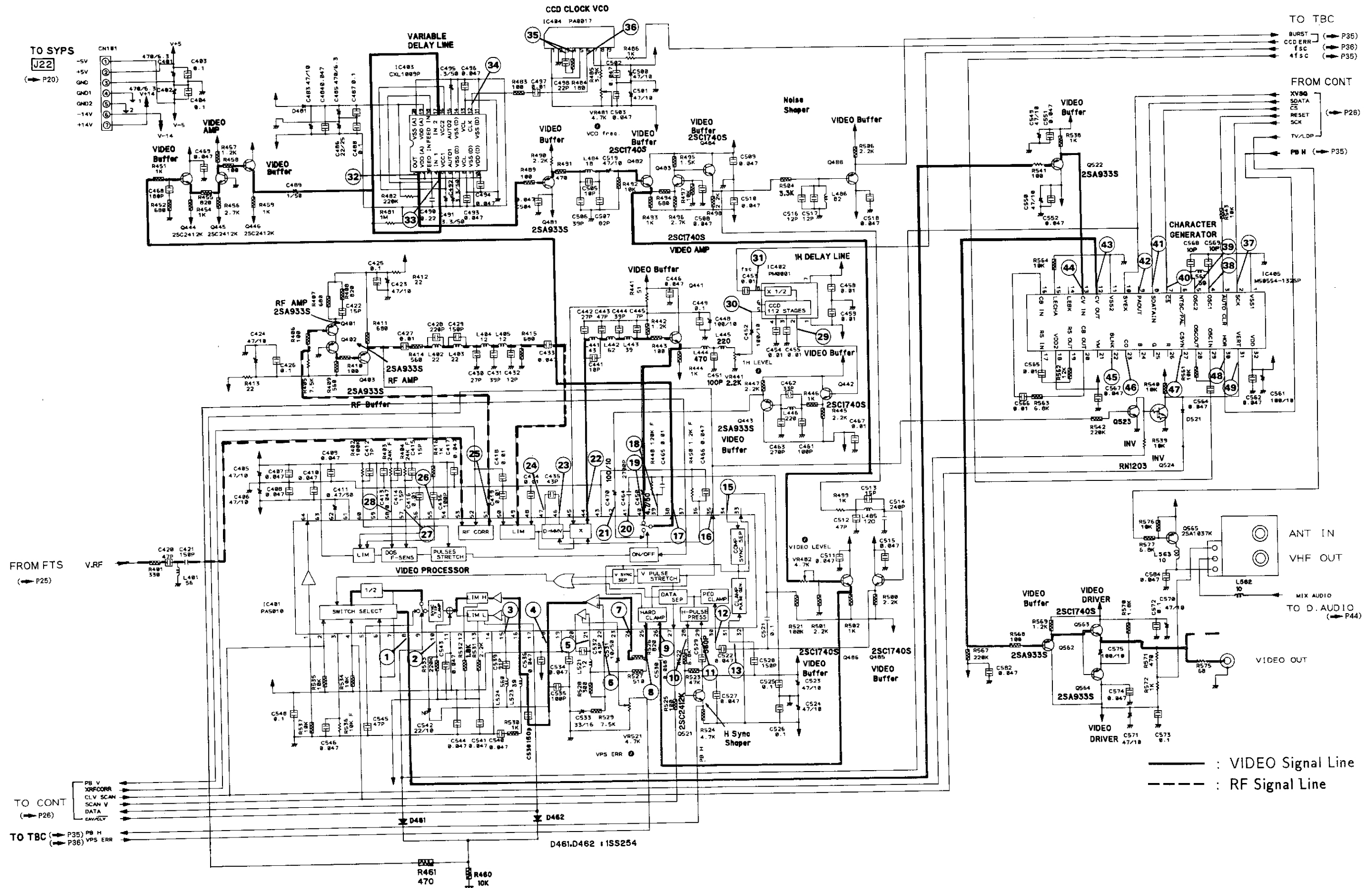

A
B
C
D

219 2A

Note: All waveforms and voltage tables are measured in the normal play mode.

IC401
<PA5010>

Pin No.	Voltage	Pin No.	Voltage	Pin No.	Voltage	Pin No.	Voltage
1	-1.2	17	0	33	•	49	-1.7
2	5	18	•	34	•	50	-1.7
3	-1	19	5	35	•	51	•
4	5	20	1	36	1	52	0
5	1	21	•	37	5	53	-2
6	5	22	•	38	•	54	5
7	5	23	-2.5	39	•	55	•
8	•	24	•	40	•	56	-2
9	5	25	•	41	•	57	•
10	•	26	•	42	•	58	•
11	5	27	0.5	43	0	59	5
12	-5	28	•	44	•	60	3.8
13	-5	29	•	45	5	61	-5
14	0	30	•	46	•	62	-3.2
15	•	31	•	47	•	63	5
16	-2	32	-5	48	-1.7	64	•

IC402
<PN0001>

Pin No.	Voltage
1	-5
2	•
3	-2
4	-2
5	•
6	0
7	5
8	•

IC403
<TAB410AX>

Pin No.	Voltage
1	•
2	4.2
3	-2
4	•
5	-3.5
6	1
7	-5
8	0
9	-5
10	4.2
11	-5
12	•
13	0
14	-5
15	0.3
16	-3.8
17	0.8
18	-2
19	4.2
20	-5

IC404
<PA0017>

Pin No.	Voltage
1	-5
2	0
3	•
4	•
5	-5
6	•
7	5
8	0.2

IC405
<H50554>

Pin No.	Voltage	Pin No.	Voltage
1	0	17	0.8
2	•	18	5
3	5	19	0
4	•	20	0
5	•	21	0
6	5	22	•
7	•	23	•
8	•	24	0
9	•	25	0
10	5	26	0
11	0	27	•
12	•	28	2
13	•	29	2
14	0.6	30	•
15	3.5	31	•
16	0.6	32	5

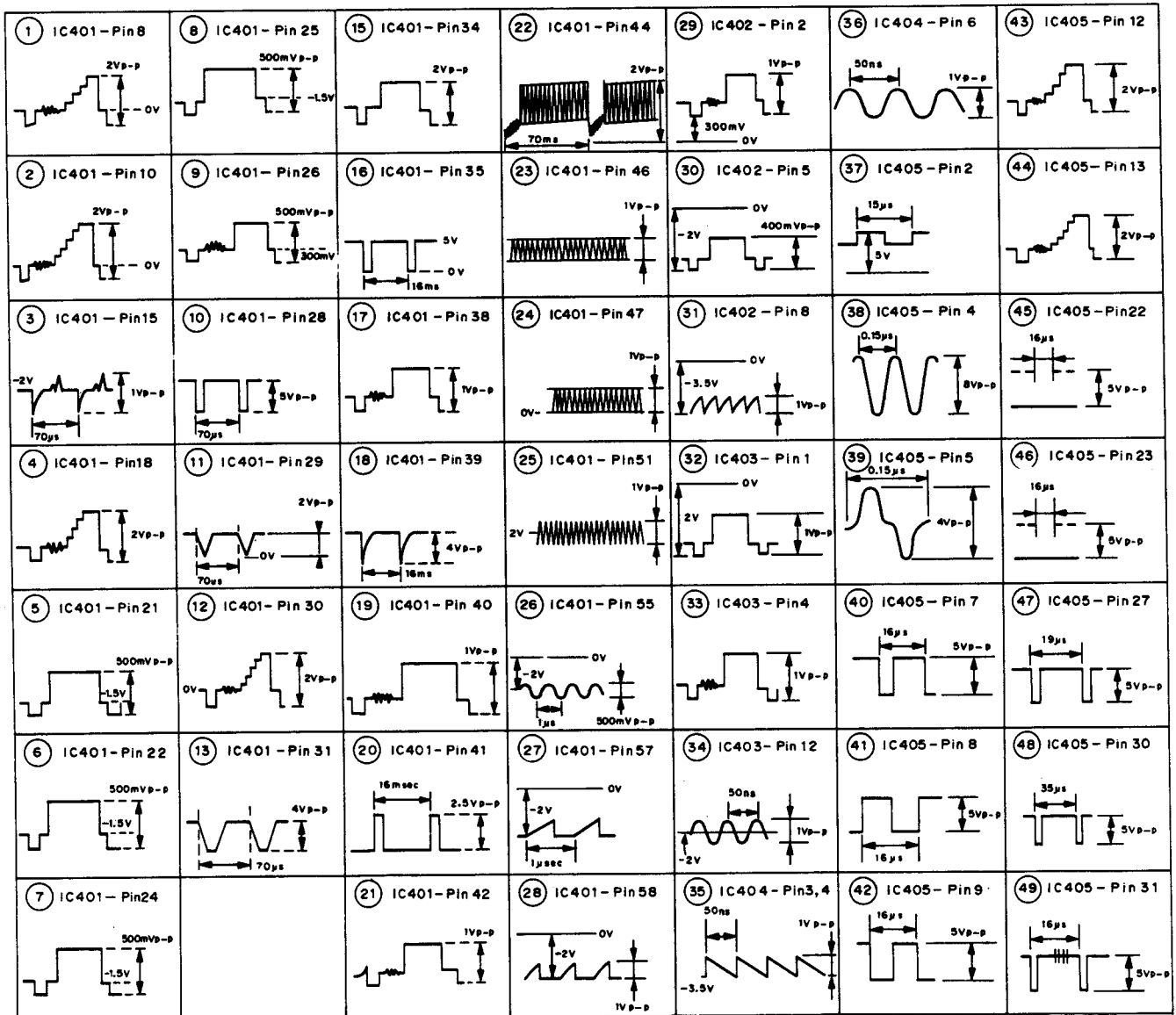

Note: All waveforms and voltage tables are measured in the normal play mode.

IC901
<BD49403NT>

Pin No.	Voltage	Pin No.	Voltage	Voltage	
1	*	15	*	*	
2	*	16	*	2.5	
3	*	17	*	2.5	
4	*	18	2.5	32	*
5	*	19	2.5	33	2.5
6	*	20	*	34	2.5
7	0	21	2.5	35	5
8	*	22	*	36	*
9	*	23	*	37	*
10	0	24	2.5	38	*
11	0	25	5	39	*
12	5	26	*	40	*
13	0	27	2.5	41	*
14	0	28	*	42	*

IC902
<NJM4558D>

Pin No.	Voltage
1	*
2	*
3	*
4	*
5	*
6	*
7	*
8	0

IC903
<NJM4558S>

Pin No.	Voltage
1	*
2	*
3	*
4	0
5	*
6	*
7	*
8	*

IC904
<NJM4558S>

Pin No.	Voltage
1	2.4
2	2.4
3	2.4
4	-2.4
5	0
6	0
7	0
8	0

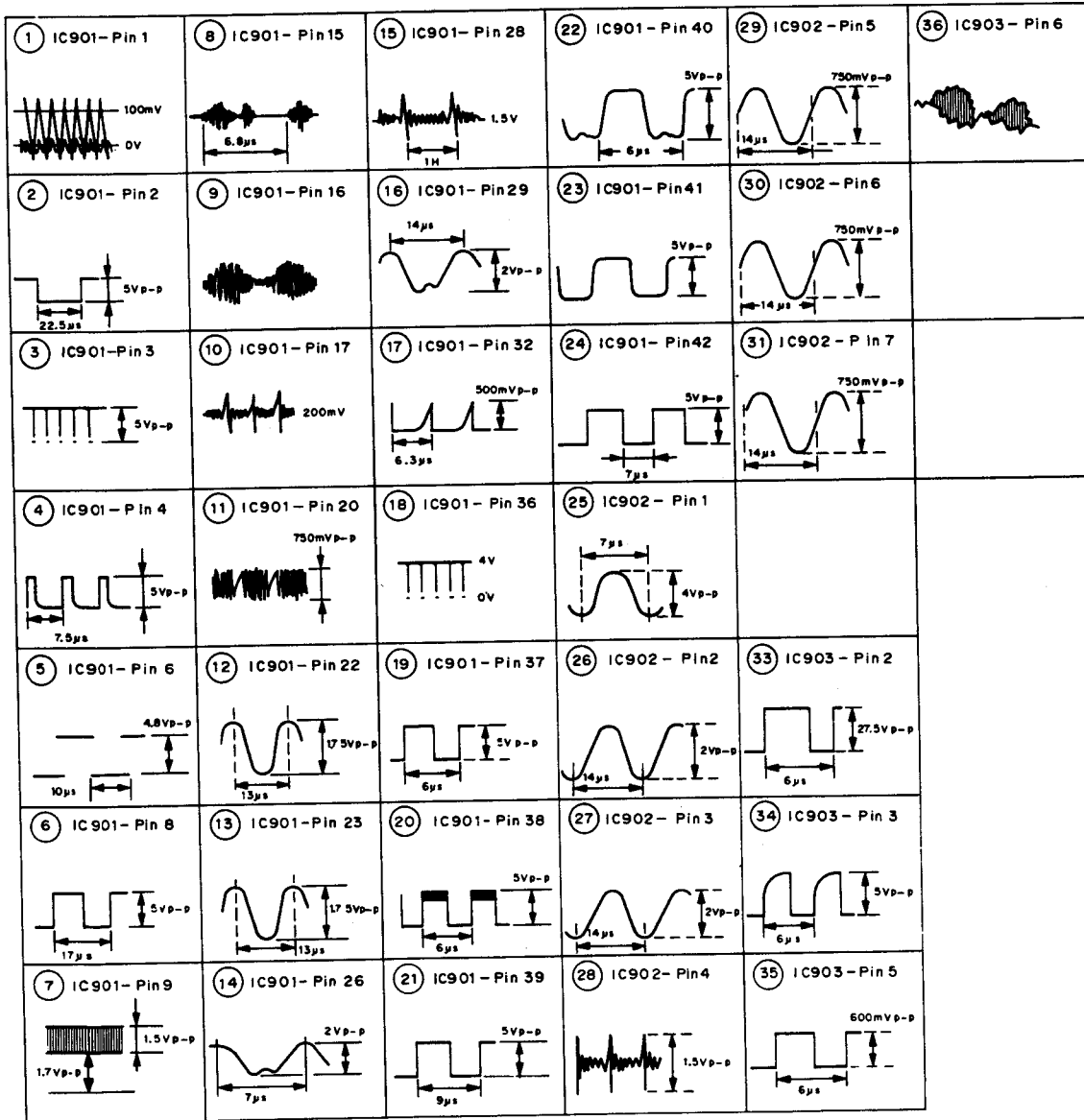

4.7 MAIN BOARD ASSEMBLY (TBC Section), FG BOARD ASSEMBLY

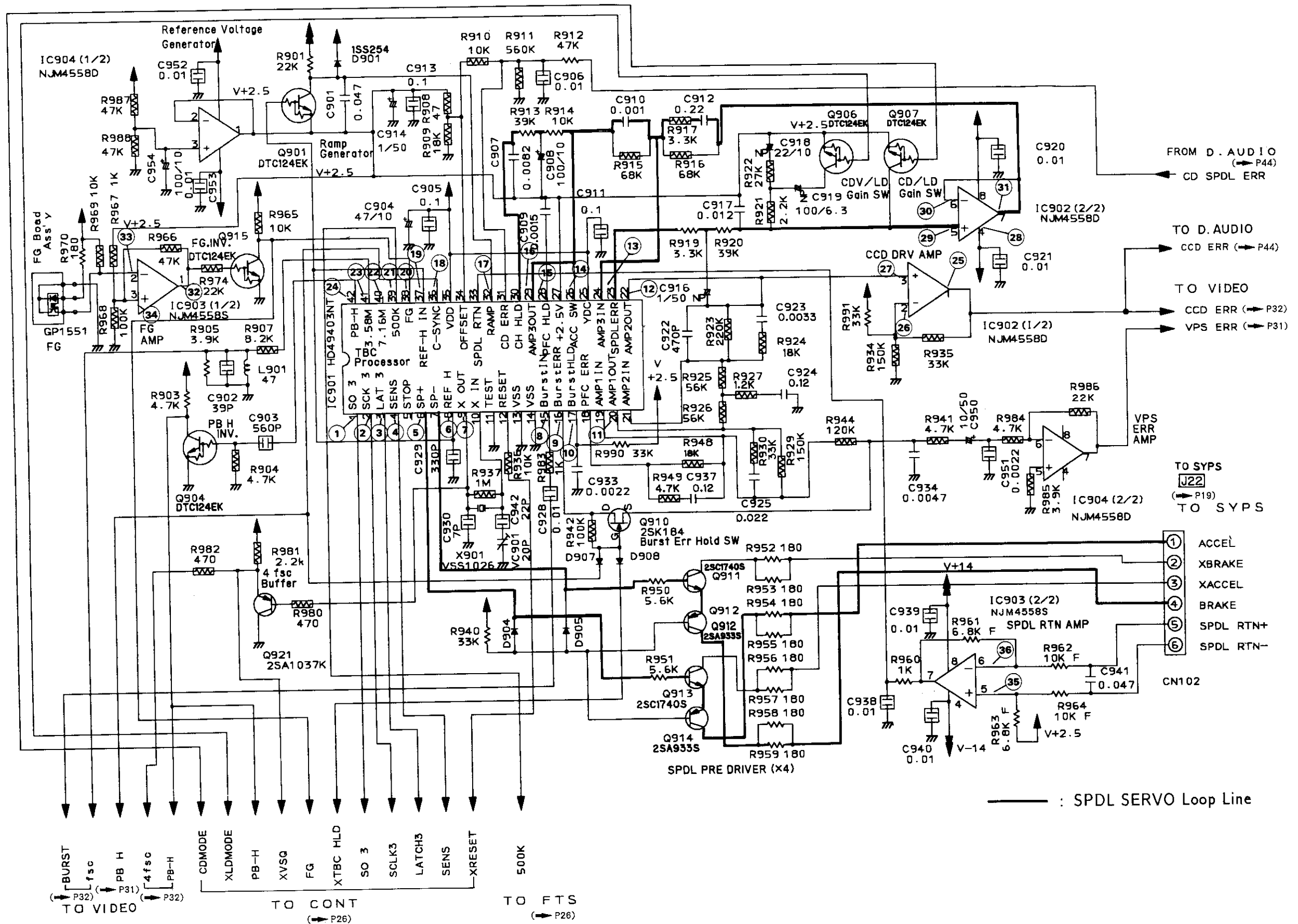

4.8 MAIN BOARD ASSEMBLY (ANALOG AUDIO Section)

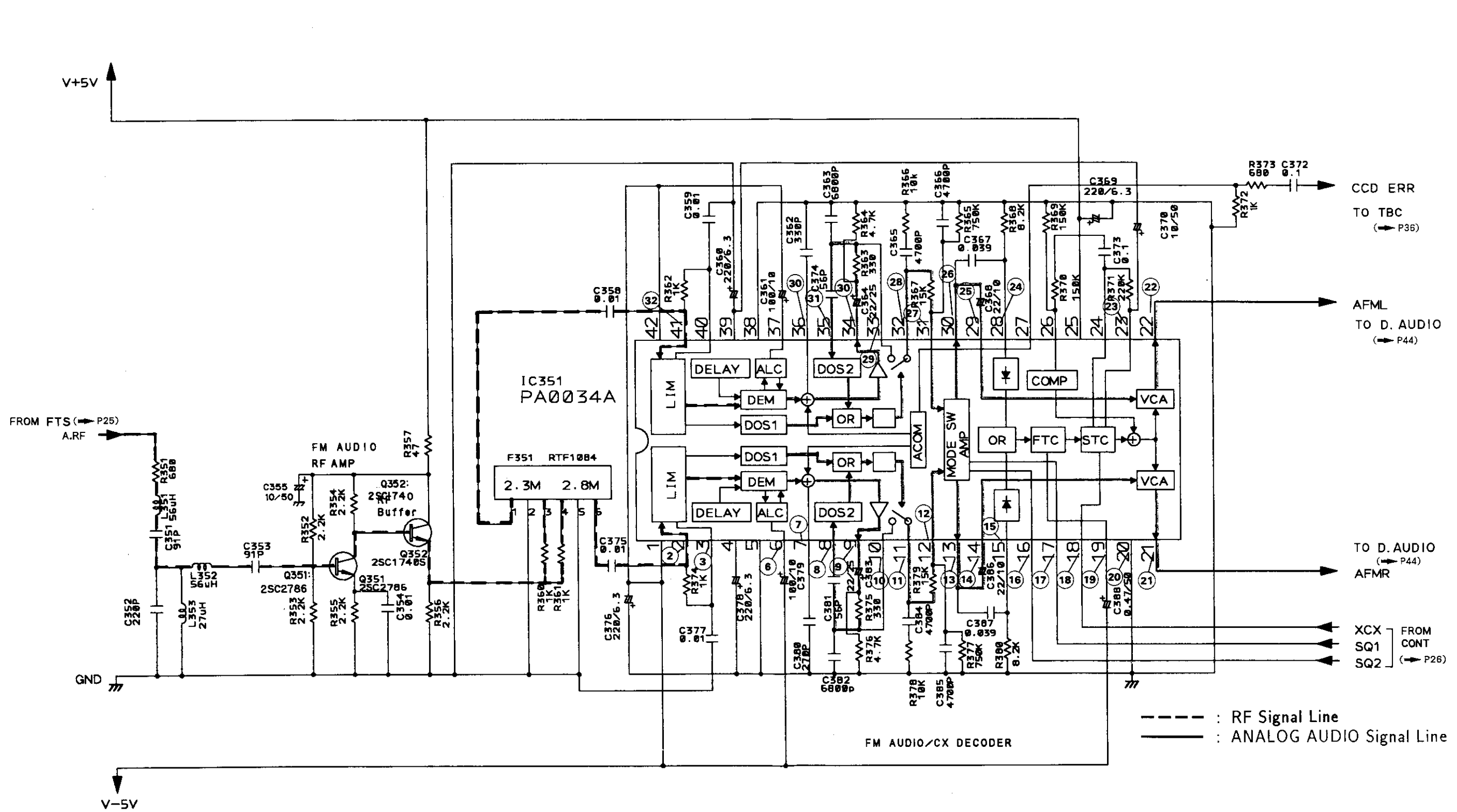

Note: All waveforms and voltage tables are measured in the normal play mode.

IC351
<PA0034A>

Pin No.	Voltage	Pin No.	Voltage	Pin No.	Voltage
1	*	15	*	29	*
2	*	16	*	30	*
3	*	17	*	31	*
4	*	18	*	32	*
5	*	19	*	33	*
6	*	20	*	34	*
7	*	21	*	35	*
8	*	22	*	36	*
9	*	23	*	37	*
10	*	24	0	38	*
11	*	25	0	39	*
12	*	26	0	40	*
13	*	27	0	41	*
14	*	28	*	42	*

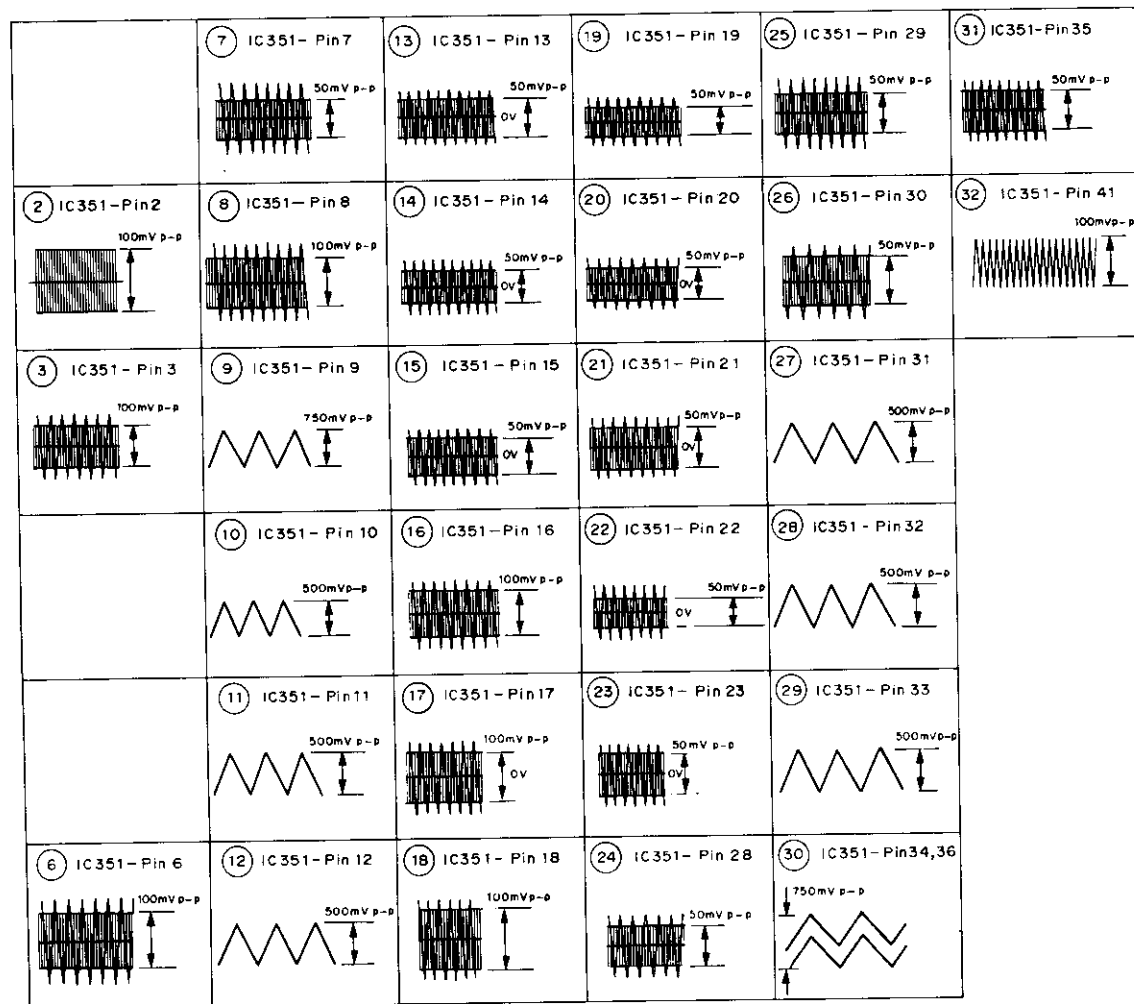

Note: All waveforms and voltage tables are measured in the normal play mode.

IC201 <C2025000>			
Pin No.	Voltage	Pin No.	Voltage
1	0	21	0
2	*	22	2.3
3	*	23	4.8
4	*	24	*
5	*	25	0
6	*	26	0
7	*	27	*
8	*	28	0
9	0	29	*
10	0	30	0
11	*	31	*
12	0	32	*
13	*	33	4.8
14	*	34	*
15	*	35	*
16	*	36	*
17	0	37	*
18	*	38	*
19	2.4	39	*
20	*	40	*
		41	*
		42	*
		43	*
		44	0
		45	4.8
		46	*
		47	*
		48	*
		49	*
		50	*
		51	*
		52	0
		53	*
		54	*
		55	0
		56	*
		57	*
		58	*
		59	5
		60	*
		61	5
		62	*
		63	*
		64	*
		65	0
		66	*
		67	*
		68	0
		69	*
		70	5
		71	*
		72	5
		73	5
		74	*
		75	0
		76	0
		77	*
		78	*
		79	*
		80	0

IC205 <BU40538>	
Pin No.	Voltage
1	0
2	3.6
3	0
4	-1.5
5	0
6	0
7	-5
8	0
9	0
10	0
11	0
12	*
13	*
14	*
15	*
16	5

IC206 <RU74IC004>	
Pin No.	Voltage
1	*
2	*
3	2.5
4	2.5
5	2.5
6	2.5
7	0
8	*
9	*
10	*
11	*
12	*
13	*
14	*
15	*
16	5

IC213 <N1W78L08>	
Pin No.	Voltage
1	8
2	0
3	11

IC214 <N1W79L08>	
Pin No.	Voltage
1	0
2	-11.5
3	-8

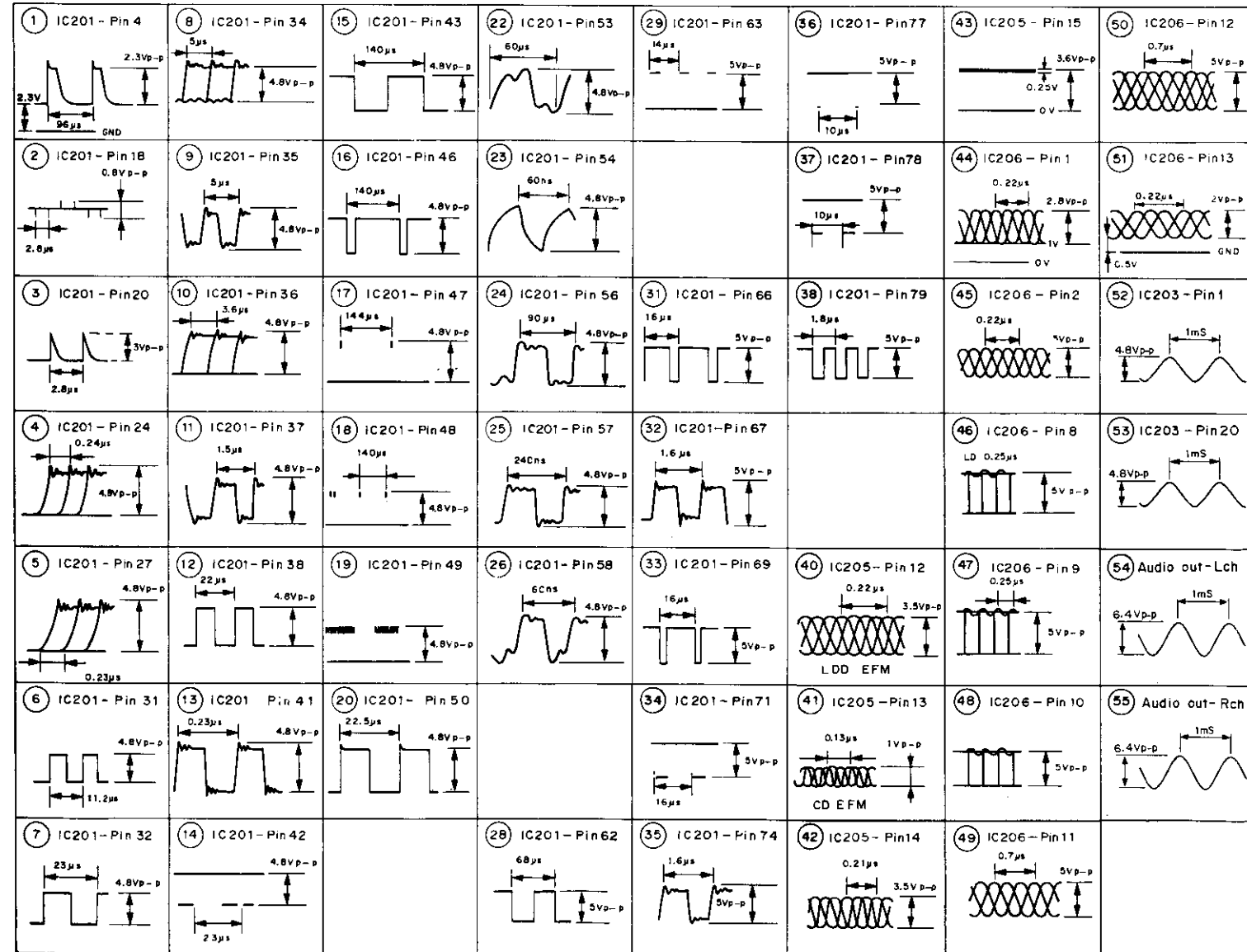

4.9 MAIN BOARD ASSEMBLY (DIGITAL AUDIO Section)

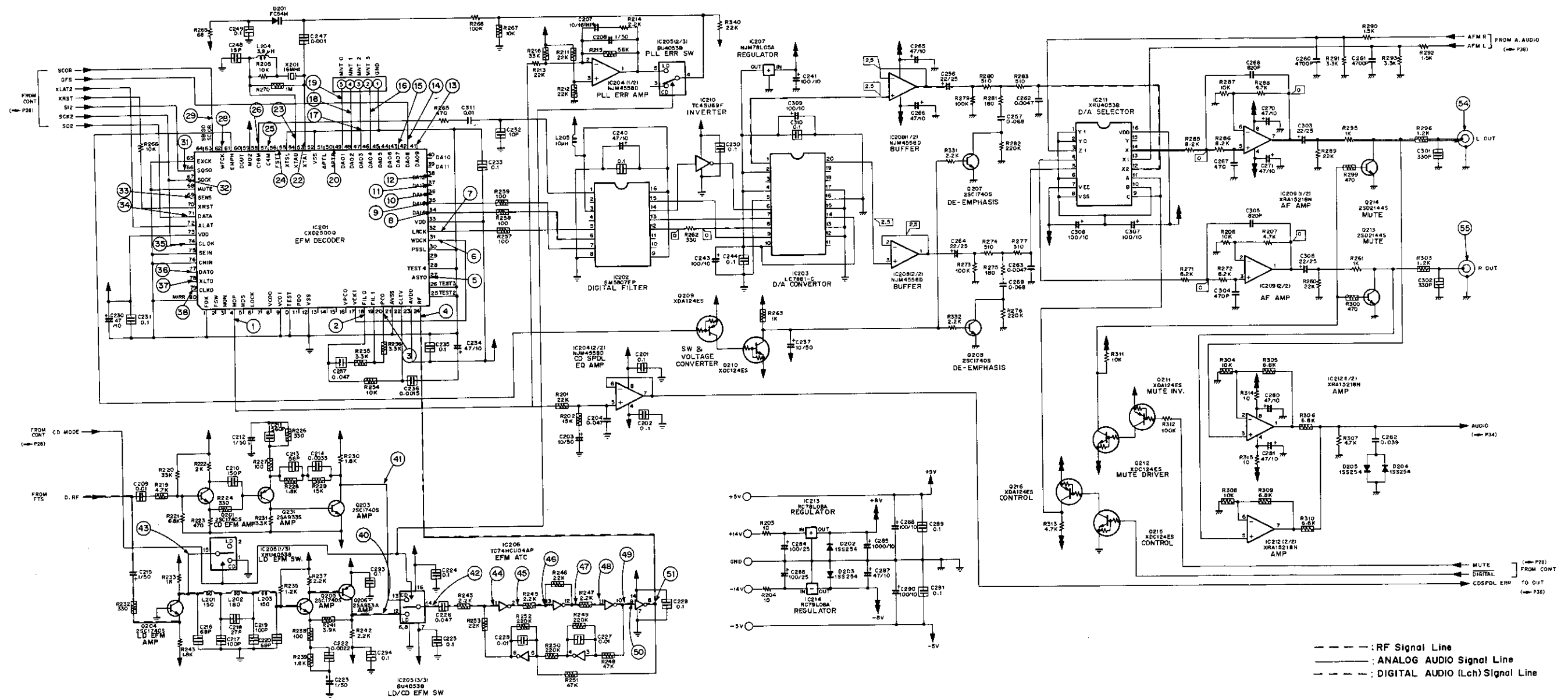

- - - - - : RF Signal Line
 _____ : ANALOG AUDIO Signal Line
 - . - . - : DIGITAL AUDIO (Lch) Signal Line

4.10 LEDB ASSEMBLY

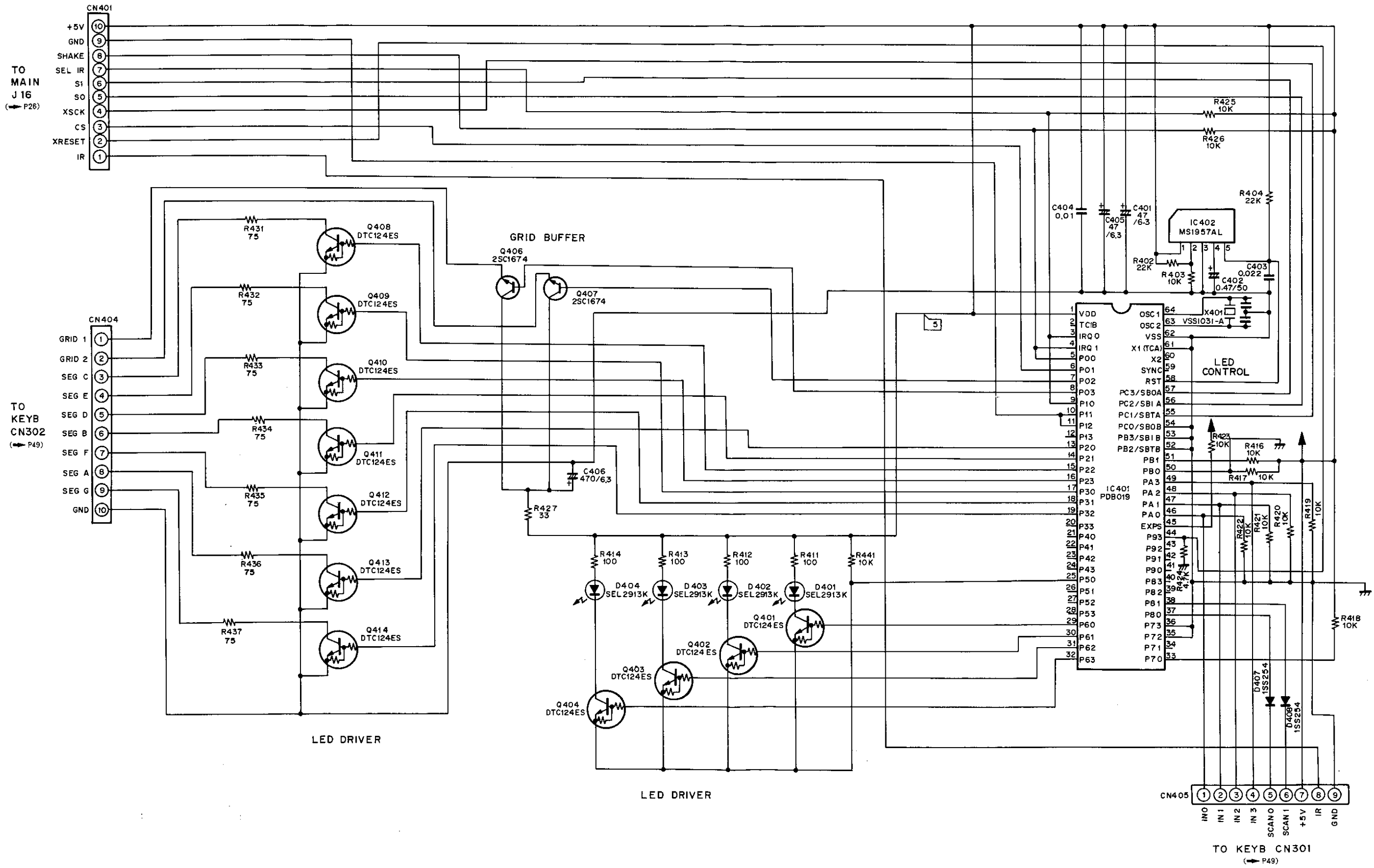

LEDB BOARD ASSEMBLY

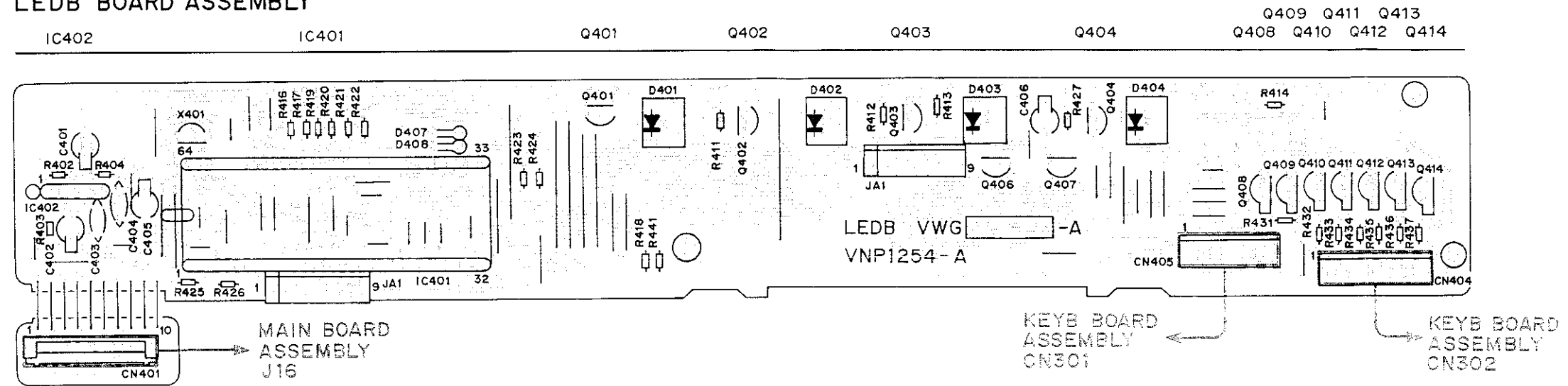

This P.C.B. connection diagram is viewed from the foil side.

LEDB BOARD ASSEMBLY

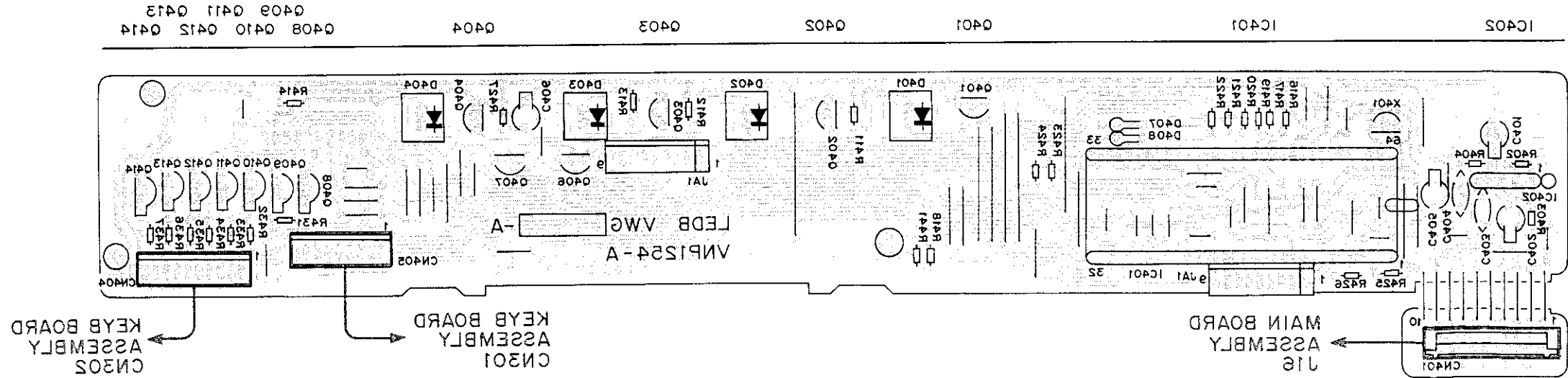

4.11 KEYB ASSEMBLY

A

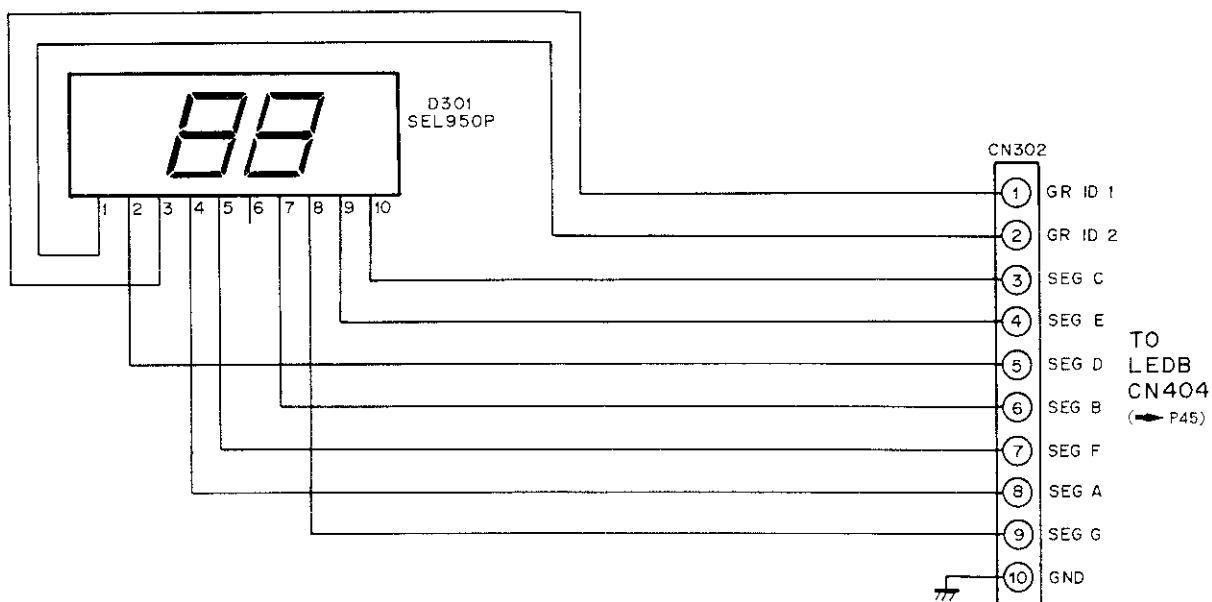

B

C

D

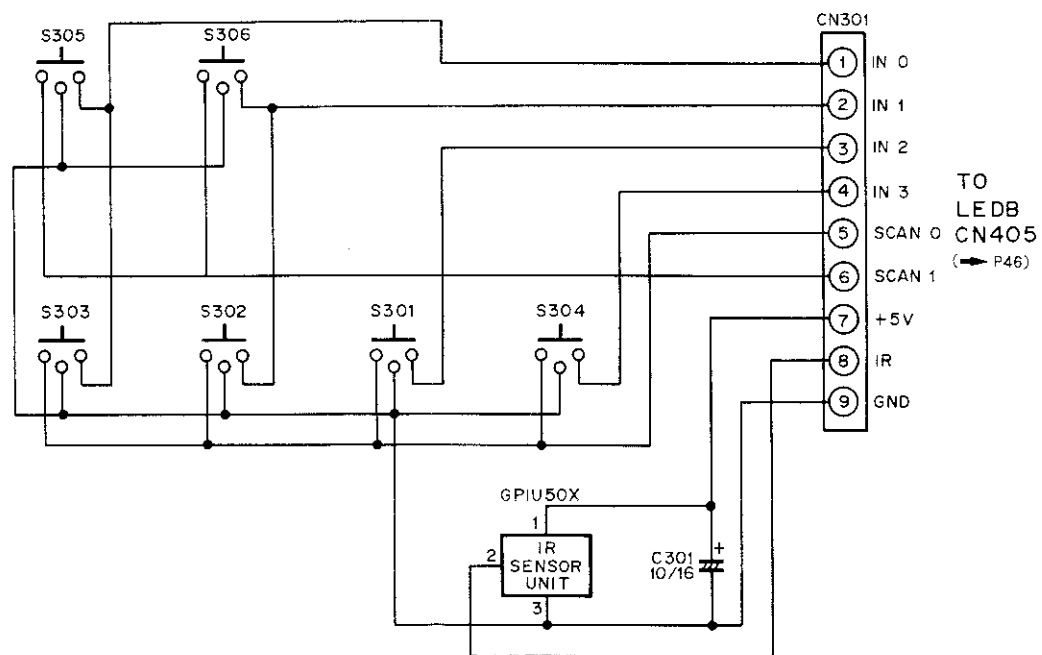

KEYB BOARD ASSEMBLY

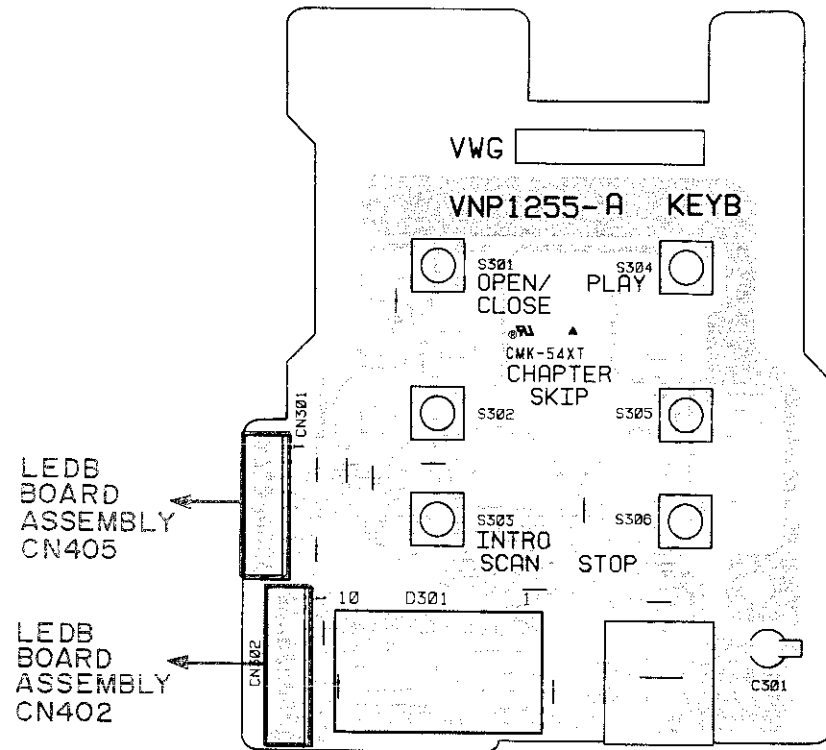

A

B

This P.C.B. connection diagram is viewed from the foil side.

KEYB BOARD ASSEMBLY

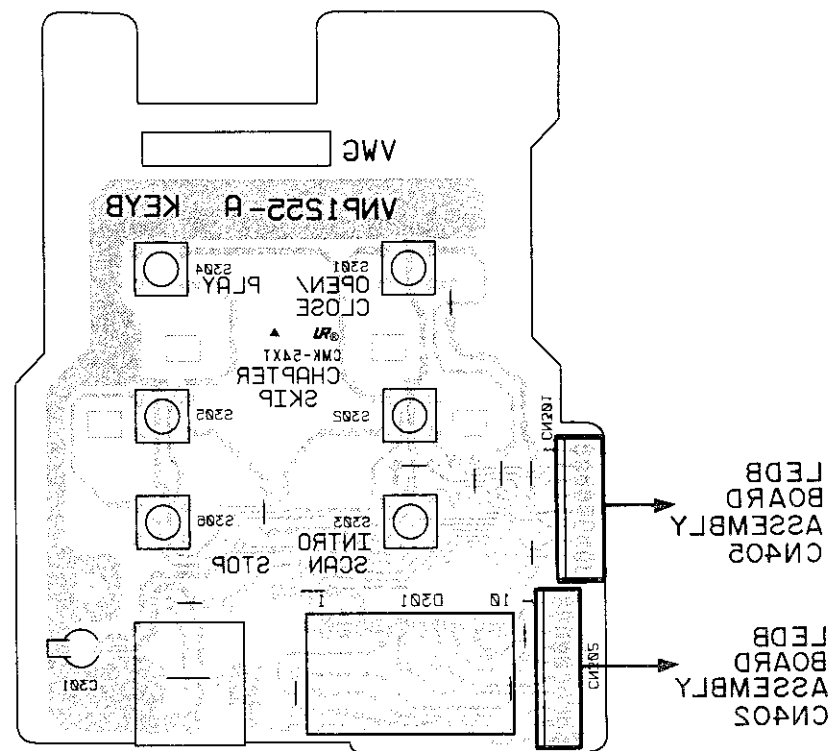

C

D

5. P.C.B's PARTS LIST

NOTES:

- Parts without part number cannot be supplied.
- Parts marked by "⊙" are not always kept in stock. Their delivery time may be longer than usual or they may be unavailable.
- The Δ mark found on some component parts indicates the importance of the safety factor of the part. Therefore, when replacing, be sure to use parts of identical designation.
- When ordering resistors, first convert resistance values into code form as shown in the following examples.

Ex.1 When there are 2 effective digits (any digit apart from 0), such as 560 ohm and 47k ohm (tolerance is shown by J=5%, and K=10%)

560 Ω → 56 × 10¹ → 561 RD1/4PS

5	6	1
---	---	---

 J
 47k Ω → 47 × 10³ → 473 RD1/4PS

4	7	3
---	---	---

 J
 0.5 Ω → 0R5 RN2H

0	R	5
---	---	---

 K
 1 Ω → 010 RS1P

0	1	0
---	---	---

 K

Ex.2 When there are 3 effective digits (such as in high precision metal film resistors).

5.62k Ω → 562 × 10¹ → 5621 RN1/4SR

5	6	2	1
---	---	---	---

 F

Mark No.	Symbol & Description	Part No.	Mark No.	Symbol & Description	Part No.
FG ASSEMBLY			KEYB ASSEMBLY		
OTHERS			SEMICONDUCTORS		
	PHOTO INTERRUPTER	GP1S51		D301	SEL950P
SW ASSEMBLY			SWITCHES		
				S301-306	RSG1010
SWITCHES			CAPACITORS		
	S1-3 PUSH SWITCH	PSH1008		C301	CEJA100M16
LEDB ASSEMBLY			OTHERS		
SEMICONDUCTORS				IR SENSOR UNIT	GP1U50X
	IC401	PDB019	⊙ MAIN ASSEMBLY(VWX1039)		
	IC402 SYSTEM RESET IC	M51957AL	(CONT Section)		
	Q401, 402 DIGITAL TRANSISTOR	DTC124ES	SEMICONDUCTORS		
	Q403, 404 DIGITAL TRANSISTOR	DTC124ES		IC801	PD0071
	Q406, 407	2SC1674		IC802	TA7291P
	Q408-414 DIGITAL TRANSISTOR	DTC124ES		Q801, 802	DTC124EK
	D401, 402	SEL2913K		D801, 802 DIODE	1SS254
	D403, 404	SEL2913K		D803	04AZ10
	D407, 408 DIODE	1SS254	CAPACITORS		
CAPACITORS				C801 ELECTR. CAPACITOR	CEAS220M25
	C401	CEAL470M6R3		C802 CERAMIC CAPACITOR	CKSQYF104Z25
	C402	CEALR47M50		C803 CHIP CAPACITOR	CCSQCH330J50
	C403	CKPUYF223Z25		C805 CHIP CAPACITOR	CKSQYF103Z50
	C404	CKPUYY103N16		C810, 811 CHIP CAPACITOR	CCSQCH101J50
	C405	CEAL470M6R3		C812 CERAMIC CAPACITOR	CKCYF103Z50
	C406 ELECTR. CAPACITOR	CEAS471M6R3		C813 CERAMIC CAPACITOR	CKSQYF473Z50
RESISTORS				C814 ELECTR. CAPACITOR	CEAS100M50
	R402-404 CARBONFILM RESISTOR	RD1/6PM□□□J	RESISTORS		
	R411-414 CARBONFILM RESISTOR	RD1/6PM□□□J		R801 CARBONFILM RESISTOR	RD1/6PM□□□J
	R416-427 CARBONFILM RESISTOR	RD1/6PM□□□J		R803 CARBONFILM RESISTOR	RD1/6PM□□□J
	R431-437 CARBONFILM RESISTOR	RD1/6PM□□□J		R804, 805	RS1/10S□□□J
	R441 CARBONFILM RESISTOR	RD1/6PM□□□J		R806 RESISTOR(10/2W)	VCN1023
OTHERS				R807-813	RS1/10S□□□J
	X401 CERAMIC RESONATOR	VSS1031			

Mark	No.	Symbol & Description	Part No.
	R815-823		RS1/10S□□□J
	R824	CARBONFILM RESISTOR	RD1/6PM□□□J
	R825-830		RS1/10S□□□J
	R831, 832	CARBONFILM RESISTOR	RD1/6PM□□□J

OTHERS

X801	CERAMIC RESONATOR	VSS1040
------	-------------------	---------

(FTS Section)

SEMICONDUCTORS

IC601		HA11529NT
IC602		RC4558S
IC603	IC	BA15218N
IC604		LA6500
IC605		IR3C02A
IC606		TA8410AK(V18)
Q601-603		2SC2412K
Q604		DTC124EK
Q605		2SC2412K
Q606	N-FET	2SK184
Q607		DTC124EK
Q608		2SC2412K
Q609		DTC124EK
Q610		2SC2412K
Q611		2SA1037K
Q612		DTA124EK
Q613		2SA1037K
Q614	N-FET	2SK184
D601-605	DIODE	1SS254

CAPACITORS

C601, 602	CERAMIC CAPACITOR	CKSQYF104Z25
C603, 604	CERAMIC CAPACITOR	CKSQYF473Z50
C605		CFTXA184J50
C606	AUDIO FILM CAPACITOR	CFTXA104J50
C607	AUDIO FILM CAPACITOR	CFTXA473J50
C608	AUDIO FILM CAPACITOR	CFTXA683J50
C609	MYLOR FILM CAPACITOR	CQMA222J50
C610	MYLOR FILM CAPACITOR	CQMA332J50
C611	CERAMIC CAPACITOR	CCSQL331J50
C612, 613	CERAMIC CAPACITOR	CKSQYF473Z50
C614	AUDIO FILM CAPACITOR	CFTXA104J50
C615	CERAMIC CAPACITOR	CCCCH560J50
C616, 617	ELECTR. CAPACITOR	CEAS220M25
C618	CERAMIC CAPACITOR	CKSQYF104Z25
C619	ELECTR. CAPACITOR	CEAS220M25
C620, 621	CERAMIC CAPACITOR	CKSQYF104Z25
C622	ELECTR. CAPACITOR	CEAS220M25
C623	CERAMIC CAPACITOR	CKSQYF473Z50
C624	ELECTR. CAPACITOR	CEAS220M25
C625	CERAMIC CAPACITOR	CKSQYF473Z50
C626	AUDIO FILM CAPACITOR	CFTXA683J50
C627	ELECTR. CAPACITOR	CEANPR47M50
C628	AUDIO FILM CAPACITOR	CFTXA473J50
C629	AUDIO FILM CAPACITOR	CFTXA333J50
C630	ELECTR. CAPACITOR	CEANP010M50

Mark	No.	Symbol & Description	Part No.
	C631	AUDIO FILM CAPACITOR	CFTXA104J50
	C632	ELECTR. CAPACITOR	CEANP100M16
	C633	AUDIO FILM CAPACITOR	CFTXA124J50
	C634	CHIP CAPACITOR	CCSQL561J50
	C635	ELECTR. CAPACITOR	CEAS100M50

C636	ELECTR. CAPACITOR	CEANP100M16
C637	AUDIO FILM CAPACITOR	CFTXA223J50
C638	CHIP CAPACITOR	CKSQYF223Z50
C639	ELECTR. CAPACITOR	CEANP220M10
C640	AUDIO FILM CAPACITOR	CFTXA224J50

C641		CFTXA152J50
C642	CERAMIC CAPACITOR	CCSQL331J50
C643	CERAMIC CAPACITOR	CGCYF473Z25
C644	ELECTR. CAPACITOR	CEAS010M50
C645		CFTXA102J50

C646	CHIP CAPACITOR	CKSQYB222K50
C647, 648	ELECTR. CAPACITOR	CEAS220M25
C649	AUDIO FILM CAPACITOR	CFTXA104J50
C650	CHIP CAPACITOR	CCSQCH680J50
C651	AUDIO FILM CAPACITOR	CFTXA124J50

C652	CERAMIC CAPACITOR	CGCYF473Z25
C653	MYLOR FILM CAPACITOR	CQMA102J50

RESISTORS

R600-607		RS1/10S□□□J
R608	CARBONFILM RESISTOR	RD1/6PM□□□J
R609-626		RS1/10S□□□J
R627	CARBONFILM RESISTOR	RD1/6PM□□□J
R628-647		RS1/10S□□□J

R648-650	CARBONFILM RESISTOR	RD1/6PM□□□J
R651-654		RS1/10S□□□J
R655	CARBONFILM RESISTOR	RD1/6PM□□□J
R656-659		RS1/10S□□□J
R660	CARBONFILM RESISTOR	RD1/6PM□□□J

R661-669		RS1/10S□□□J
R670	CARBONFILM RESISTOR	RD1/6PM□□□J
R671		RS1/10S□□□J
R672	CARBONFILM RESISTOR	RD1/6PM□□□J
R673		RS1/10S□□□J

R674	CARBONFILM RESISTOR	RD1/6PM□□□J
R675-683		RS1/10S□□□J
R684	CARBONFILM RESISTOR	RD1/6PM□□□J
R685, 686		RS1/10S□□□J
R687	CARBONFILM RESISTOR	RD1/6PM□□□J

R688-692		RS1/10S□□□J
R693	CARBONFILM RESISTOR	RD1/6PM□□□J
R694-703		RS1/10S□□□J
R704-706	CARBONFILM RESISTOR	RD1/6PM□□□J
R707, 708		RS1/10S□□□J

R709	CARBONFILM RESISTOR	RD1/6PM□□□J
R710-713		RS1/10S□□□J
R714, 715	CARBONFILM RESISTOR	RD1/6PM□□□J
R716-718		RS1/10S□□□J
R719	CARBONFILM RESISTOR	RD1/6PM□□□J

Mark	No.	Symbol & Description	Part No.	Mark	No.	Symbol & Description	Part No.
	R720, 721		RS1/10S□□□J		C923	MYLOR FILM CAPACITOR	CQMA332J50
	R722 CARBONFILM RESISTOR		RD1/6PM□□□J		C924	AUDIO FILM CAPACITOR	CFTXA124J50
	R723, 724		RS1/10S□□□J		C925	AUDIO FILM CAPACITOR	CFTXA223J50
	VR601 VR(1kΩ)		VRTB6VS102		C928	CHIP CAPACITOR	CKSQYF103Z50
	VR602-605 VR(4.7kΩ)		VRTB6VS472		C929	CERAMIC CAPACITOR	CCSQL331J50
	VR606 VR(2.2kΩ)		VRTB6VS222		C930	CERAMIC CAPACITOR	CCSQCH070D50
	VR607 VR(100kΩ)		VRTB6VS104		C933	MYLOR FILM CAPACITOR	CQMA222J50
	VR608 VR(4.7kΩ)		VRTB6VS472		C934	AUDIO FILM CAPACITOR	CFTXA472J50
OTHERS					C937	AUDIO FILM CAPACITOR	CFTXA124J50
CN103			YKN1073		C938-940	CHIP CAPACITOR	CKSQYF103Z50
(TBC Section)					C941	AUDIO FILM CAPACITOR	CFTXA473J50
SEMICONDUCTORS					C942	CERAMIC CAPACITOR	CCSQCH220J50
IC901			HD49403NT		C950	ELECTR. CAPACITOR	CEAS100M50
IC902			NJM4558D		C951	CHIP CAPACITOR	CKSQYB222K50
IC903			NJM4558S		C952, 953	CHIP CAPACITOR	CKSQYF103Z50
IC904			NJM4558D		C954	ELECTR. CAPACITOR	CEAS101M10
Q901			DTC124EK	RESISTORS			
Q904			DTC124EK	R901	CARBONFILM RESISTOR	RD1/6PM□□□J	
Q906, 907			DTC124EK	R903	CARBONFILM RESISTOR	RD1/6PM□□□J	
Q910 N-FET			2SK184	R904		RS1/10S□□□J	
Q911 TRANSISTOR			2SC1740S	R905	CARBONFILM RESISTOR	RD1/6PM□□□J	
Q912 TRANSISTOR			2SA933S	R907-911		RS1/10S□□□J	
Q913 TRANSISTOR			2SC1740S	R912-914	CARBONFILM RESISTOR	RD1/6PM□□□J	
Q914 TRANSISTOR			2SA933S	R915-917		RS1/10S□□□J	
Q915			DTC124EK	R919, 920	CARBONFILM RESISTOR	RD1/6PM□□□J	
Q921			2SA1037K	R921-927		RS1/10S□□□J	
D901 DIODE			1SS254	R929, 930		RS1/10S□□□J	
D904, 905 DIODE			1SS254	R934-937		RS1/10S□□□J	
D907, 908 DIODE			1SS254	R940	CARBONFILM RESISTOR	RD1/6PM□□□J	
COILS/TRANSFORMERS				R941, 942		RS1/10S□□□J	
L901 AXIAL INDUCTOR			LAU470J	R944		RS1/10S□□□J	
CAPACITORS				R948, 949		RS1/10S□□□J	
C901 AUDIO FILM CAPACITOR			CFTXA473J50	R950-960	CARBONFILM RESISTOR	RD1/6PM□□□J	
C902 CERAMIC CAPACITOR			CCSQCH390J50	R961-964		RN1/6PQ□□□□F	
C903 CHIP CAPACITOR			CCSQL561J50	R965-969		RS1/10S□□□J	
C904 ELECTR. CAPACITOR			CEAS470M10	R970	CARBONFILM RESISTOR	RD1/6PM□□□J	
C905 CERAMIC CAPACITOR			CKSQYF104Z25	R974		RS1/10S□□□J	
C906 CHIP CAPACITOR			CKSQYF103Z50	R980-988		RS1/10S□□□J	
C907 MYLOR FILM CAPACITOR			CQMA822J50	R990, 991		RS1/10S□□□J	
C908 ELECTR. CAPACITOR			CEAS101M10	OTHERS			
C909			CFTXA152J50	VC901	VARIABLE CAPACITOR	VCM-008	
C910 CERAMIC CAPACITOR			CKCYB102K50	X901	CRYSTAL RESONATOR	VSS1026	
C911 CERAMIC CAPACITOR			CKSQYF104Z25	(ANALOG AUDIO Section)			
C912 AUDIO FILM CAPACITOR			CFTXA224J50	SEMICONDUCTORS			
C913 CERAMIC CAPACITOR			CKSQYF104Z25	IC351		PA0034A	
C914 ELECTR. CAPACITOR			CEAS010M50	Q351	TRANSISTOR	2SC2786	
C916 ELECTR. CAPACITOR			CEANP010M50	Q352	TRANSISTOR	2SC1740S	
C917			CFTXA123J50	COILS/TRANSFORMERS			
C918 ELECTR. CAPACITOR			CEANP220M10	L351, 352	AXIAL INDUCTOR	LAU560J	
C919			CEANP101M6R3	L353	AXIAL INDUCTOR	LAU270J	
C920, 921	CHIP CAPACITOR		CKSQYF103Z50	F351	B. P. F	RTF1084	
C922	CERAMIC CAPACITOR		CCCSL471J50	CAPACITORS			
				C351			CCSQCH910J50

Mark	No.	Symbol & Description	Part No.
	C352	CERAMIC CAPACITOR	CCSQCH221J50
	C353		CCSQCH910J50
	C354	CHIP CAPACITOR	CKSQYF103Z50
	C355	ELECTR. CAPACITOR	CEAS100M50
	C358, 359	CHIP CAPACITOR	CKSQYF103Z50
	C360	ELECTR. CAPACITOR	CEAS221M6R3
	C361	ELECTR. CAPACITOR	CEAS101M10
	C362	CERAMIC CAPACITOR	CCSSQL331J50
	C363	CHIP CAPACITOR	CKSQYB682K50
	C364	ELECTR. CAPACITOR	CEAS220M25
	C365, 366	CERAMIC CAPACITOR	CKSQYB472K50
	C367	AUDIO FILM CAPACITOR	CFTXA393J50
	C368	ELECTR. CAPACITOR	CEANP220M10
	C369	ELECTR. CAPACITOR	CEAS221M6R3
	C370	ELECTR. CAPACITOR	CEAS100M50
	C372, 373	AUDIO FILM CAPACITOR	CFTXA104J50
	C374	CERAMIC CAPACITOR	CCSQCH560J50
	C375	CHIP CAPACITOR	CKSQYF103Z50
	C376	ELECTR. CAPACITOR	CEAS221M6R3
	C377	CHIP CAPACITOR	CKSQYF103Z50
	C378	ELECTR. CAPACITOR	CEAS221M6R3
	C379	ELECTR. CAPACITOR	CEAS101M10
	C380	CERAMIC CAPACITOR	CCSQCH271J50
	C381	CERAMIC CAPACITOR	CCSQCH560J50
	C382	CHIP CAPACITOR	CKSQYB682K50
	C383	ELECTR. CAPACITOR	CEAS220M25
	C384, 385	CERAMIC CAPACITOR	CKSQYB472K50
	C386	ELECTR. CAPACITOR	CEANP220M10
	C387	AUDIO FILM CAPACITOR	CFTXA393J50
	C388	ELECTR. CAPACITOR	CEASR47M50
RESISTORS			
	R351-357	CARBONFILM RESISTOR	RD1/6PM□□□J
	R360-380		RS1/10S□□□J
DIGITAL AUDIO Section			
SEMICONDUCTORS			
	IC201	EFM DEMODULATION IC	CXD2500Q
	IC202		SM5807EP
	IC203	D/A CONVERTER	LC7881-C
	IC204		NJM4558D
	IC205	LOGIC IC	BU4053B
	IC206		TC74HCU04AP
	IC207		NJM78L05A
	IC208		XRU4053B
	IC209	IC	XRA15218N
	IC210		TC4SU69F-TR
	IC211	LOGIC IC	XRU4053B
	IC212	IC	XRA15218N
	IC213		RC78L08A
	IC214		RC79L08A
	Q201	TRANSISTOR	2SC1740S
	Q202	TRANSISTOR	2SA933S
	Q203-205	TRANSISTOR	2SC1740S
	Q206	TRANSISTOR	2SA933S

Mark	No.	Symbol & Description	Part No.
	Q207, 208	TRANSISTOR	2SC1740S
	Q209	TRANSISTOR	XDA124ES
	Q210	TRANSISTOR	XDC124ES
	Q211	TRANSISTOR	XDA124ES
	Q212	TRANSISTOR	XDC124ES
	Q213, 214	TRANSISTOR	2SD2144S
	Q215	TRANSISTOR	XDC124ES
	Q216	TRANSISTOR	XDA124ES
	D201		FC54M
	D202-205	DIODE	1SS254
COILS/TRANSFORMERS			
	L201		LAU151K
	L202		LAU181J
	L203		LAU151K
	L204		LAU3R9J
	L205		LAU100J
CAPACITORS			
	C201, 202	CERAMIC CAPACITOR	CKSQYF104Z25
	C203	ELECTR. CAPACITOR	CEAS100M50
	C204	AUDIO FILM CAPACITOR	CFTXA473J50
	C207	ELECTR. CAPACITOR	CEANP100M16
	C208	ELECTR. CAPACITOR	CEANP010M50
	C209	CHIP CAPACITOR	CKSQYF103Z50
	C210	CERAMIC CAPACITOR	CCSQCH151J50
	C211	CHIP CAPACITOR	CCSSQL561J50
	C212	ELECTR. CAPACITOR	CEAS010M50
	C213	CERAMIC CAPACITOR	CCSQCH560J50
	C214	CERAMIC CAPACITOR	CKSQYB332K50
	C215	ELECTR. CAPACITOR	CEAS010M50
	C216	CHIP CAPACITOR	CCSQCH680J50
	C217	CHIP CAPACITOR	CCSQCH101J50
	C218	CERAMIC CAPACITOR	CCSQCH270J50
	C219	CHIP CAPACITOR	CCSQCH101J50
	C220	CHIP CAPACITOR	CCSQCH680J50
	C222	CHIP CAPACITOR	CKSQYB222K50
	C223	ELECTR. CAPACITOR	CEAS010M50
	C224, 225	CERAMIC CAPACITOR	CKSQYF104Z25
	C226	CERAMIC CAPACITOR	CKSQYF473Z50
	C227, 228	CHIP CAPACITOR	CKSQYF103Z50
	C229	CERAMIC CAPACITOR	CKSQYF104Z25
	C230	ELECTR. CAPACITOR	CEAS470M10
	C231	CERAMIC CAPACITOR	CKSQYF104Z25
	C232	CHIP CAPACITOR	CCSQCH100D50
	C233	CERAMIC CAPACITOR	CKSQYF104Z25
	C234	ELECTR. CAPACITOR	CEAS470M10
	C235	CERAMIC CAPACITOR	CKSQYF104Z25
	C236	CERAMIC CAPACITOR	CKSQYB152K50
	C237	CERAMIC CAPACITOR	CKSQYF473Z50
	C238	CERAMIC CAPACITOR	CKSQYF104Z25
	C239	ELECTR. CAPACITOR	CEAS100M50
	C240	ELECTR. CAPACITOR	CEAS470M10
	C241	ELECTR. CAPACITOR	CEAS101M10
	C243	ELECTR. CAPACITOR	CEAS101M10
	C244	CERAMIC CAPACITOR	CKSQYF104Z25

Mark	No.	Symbol & Description	Part No.	Mark	No.	Symbol & Description	Part No.
	L486	AXIAL INDUCTOR	LAU820J		C469	CERAMIC CAPACITOR	CKSQYF473Z50
	L521	AXIAL INDUCTOR	LAU120J		C470	ELECTR. CAPACITOR	CEAS101M10
	L523	AXIAL INDUCTOR	LAU390J		C483	ELECTR. CAPACITOR	CEAS470M10
	L524	AXIAL INDUCTOR	LRA561K				
	L561	AXIAL INDUCTOR	LAU390J		C484	CERAMIC CAPACITOR	CKSQYF473Z50
	L562, 563	AXIAL INDUCTOR	LAU100J		C485	ELECTR. CAPACITOR	CEAS471M6R3
					C486	ELECTR. CAPACITOR	CEAS220M25
					C487, 488	CERAMIC CAPACITOR	CKSQYF104Z25
					C489	ELECTR. CAPACITOR	CEAS010M50
CAPACITORS					C490	AUDIO FILM CAPACITOR	CFTXA224J50
	C401, 402	ELECTR. CAPACITOR	CEAS471M6R3		C491, 492	ELECTR. CAPACITOR	CEAS3R3M50
	C403, 404	CERAMIC CAPACITOR	CKSQYF104Z25		C493, 494	CERAMIC CAPACITOR	CKSQYF473Z50
	C405, 406	ELECTR. CAPACITOR	CEAS470M10		C495	ELECTR. CAPACITOR	CEAS3R3M50
	C407-410	CERAMIC CAPACITOR	CKSQYF473Z50		C496	CERAMIC CAPACITOR	CKSQYF473Z50
	C411	ELECTR. CAPACITOR	CEASR47M50				
	C412	CERAMIC CAPACITOR	CCSQCH070D50		C497	CHIP CAPACITOR	CKSQYF103Z50
	C413	CERAMIC CAPACITOR	CKSQYF473Z50		C498	CERAMIC CAPACITOR	CCSQCH220J50
	C414, 415	CERAMIC CAPACITOR	CCSQCH150J50		C500, 501	ELECTR. CAPACITOR	CEAS470M10
	C416	CHIP CAPACITOR	CKSQYF103Z50		C502-504	CERAMIC CAPACITOR	CKSQYF473Z50
	C417	CERAMIC CAPACITOR	CKSQYF473Z50		C505	CHIP CAPACITOR	CCSQCH100D50
	C418, 419	CHIP CAPACITOR	CKSQYF103Z50		C506	CERAMIC CAPACITOR	CCSQCH390J50
	C420	CERAMIC CAPACITOR	CCSQCH470J50		C507	CERAMIC CAPACITOR	CCSQCH820J50
	C421	CERAMIC CAPACITOR	CCCH151J50		C508-511	CERAMIC CAPACITOR	CKSQYF473Z50
	C422	CERAMIC CAPACITOR	CCSQCH150J50		C512	CERAMIC CAPACITOR	CCSQCH470J50
	C423, 424	ELECTR. CAPACITOR	CEAS470M10		C513	CERAMIC CAPACITOR	CCSQCH150J50
	C425, 426	CERAMIC CAPACITOR	CKSQYF104Z25		C514		CCCSL241J50
	C427	CHIP CAPACITOR	CKSQYF103Z50		C515	CERAMIC CAPACITOR	CKSQYF473Z50
	C428	CERAMIC CAPACITOR	CCSQCH221J50		C516, 517	CERAMIC CAPACITOR	CCSQCH120J50
	C429	CERAMIC CAPACITOR	CCSQCH151J50		C518	CERAMIC CAPACITOR	CKSQYF473Z50
	C430	CERAMIC CAPACITOR	CCSQCH270J50		C519	ELECTR. CAPACITOR	CEAS470M10
	C431	CERAMIC CAPACITOR	CCSQCH390J50		C521	AUDIO FILM CAPACITOR	CFTXA104J50
	C432	CERAMIC CAPACITOR	CCSQCH120J50		C522	CERAMIC CAPACITOR	CKSQYF473Z50
	C433	CERAMIC CAPACITOR	CKSQYF473Z50		C523, 524	ELECTR. CAPACITOR	CEAS470M10
	C434	CHIP CAPACITOR	CKSQYF103Z50		C525, 526	CERAMIC CAPACITOR	CKSQYF104Z25
	C435	CHIP CAPACITOR	CCSQCH430J50		C527	CERAMIC CAPACITOR	CKSQYF473Z50
	C436	CHIP CAPACITOR	CCSQCH101J50		C528	CERAMIC CAPACITOR	CCSQCH151J50
	C441	CHIP CAPACITOR	CCSQCH100D50		C529	CHIP CAPACITOR	CCSQSL561J50
	C442	CERAMIC CAPACITOR	CCSQCH270J50		C530	AUDIO FILM CAPACITOR	CFTXA683J50
	C443	CERAMIC CAPACITOR	CCSQCH470J50		C531	ELECTR. CAPACITOR	CEAS100M50
	C444	CERAMIC CAPACITOR	CCSQCH390J50		C532	CHIP CAPACITOR	CCSQCH430J50
	C445	CERAMIC CAPACITOR	CCSQCH070D50		C533	ELECTR. CAPACITOR	CEAS330M16
	C446	CERAMIC CAPACITOR	CKSQYF473Z50		C534	CERAMIC CAPACITOR	CKSQYF473Z50
	C448	ELECTR. CAPACITOR	CEAS101M10		C535	CHIP CAPACITOR	CCSQCH101J50
	C449	CERAMIC CAPACITOR	CKSQYF104Z25		C536	CERAMIC CAPACITOR	CKSQYF473Z50
	C450	ELECTR. CAPACITOR	CEAS4R7M50		C538	CERAMIC CAPACITOR	CCSQCH151J50
	C451	CHIP CAPACITOR	CCSQCH101J50		C539		CCSQCH910J50
	C452	ELECTR. CAPACITOR	CEAS101M10		C540, 541	CERAMIC CAPACITOR	CKSQYF473Z50
	C453-455	CHIP CAPACITOR	CKSQYF103Z50		C542	ELECTR. CAPACITOR	CEANP220M10
	C458, 459	CHIP CAPACITOR	CKSQYF103Z50		C543, 544	CERAMIC CAPACITOR	CKSQYF473Z50
	C461	CHIP CAPACITOR	CCSQCH101J50		C545	CERAMIC CAPACITOR	CCSQCH470J50
	C462	CHIP CAPACITOR	CCSQCH330J50		C546	CERAMIC CAPACITOR	CKSQYF473Z50
	C463	CERAMIC CAPACITOR	CCSQCH271J50		C548	CERAMIC CAPACITOR	CKSQYF104Z25
	C464	MYLOR FILM CAPACITOR	CQMA272J50		C549, 550	ELECTR. CAPACITOR	CEAS470M10
	C465	AUDIO FILM CAPACITOR	CFTXA103J50		C551, 552	CERAMIC CAPACITOR	CKSQYF473Z50
	C466	CERAMIC CAPACITOR	CKSQYF473Z50		C561	ELECTR. CAPACITOR	CEAS101M10
	C467	CHIP CAPACITOR	CKSQYF103Z50		C562	CERAMIC CAPACITOR	CKSQYF473Z50
	C468		CCSQCH181J50				

Mark No.	Symbol & Description	Part No.
C564	CERAMIC CAPACITOR	CKSQYF473Z50
C565	566 CHIP CAPACITOR	CKSQYF103Z50
C568	569 CHIP CAPACITOR	CCSQCH100D50
C570	571 ELECTR. CAPACITOR	CEAS470M10
C572	573 CERAMIC CAPACITOR	CKSQYF104Z25
C574	CERAMIC CAPACITOR	CKSQYF473Z50
C575	ELECTR. CAPACITOR	CEAS101M10
C582	CERAMIC CAPACITOR	CKSQYF473Z50
C584	CERAMIC CAPACITOR	CKSQYF473Z50
RESISTORS		
R401		RS1/10S□□□J
R402	CARBONFILM RESISTOR	RD1/6PM□□□J
R403	404	RN1/6PQ□□□□F
R405	CARBONFILM RESISTOR	RD1/6PM□□□J
R406-411		RS1/10S□□□J
R412	413 CARBONFILM RESISTOR	RD1/6PM□□□J
R414-416		RS1/10S□□□J
R441	CARBONFILM RESISTOR	RD1/6PM□□□J
R442-447		RS1/10S□□□J
R448		RN1/6PQ□□□□F
R450		RN1/6PQ□□□□F
R451	452	RS1/10S□□□J
R454-460		RS1/10S□□□J
R461	CARBONFILM RESISTOR	RD1/6PM□□□J
R481	482 CARBONFILM RESISTOR	RD1/6PM□□□J
R483	484	RS1/10S□□□J
R485	486 CARBONFILM RESISTOR	RD1/6PM□□□J
R489		RS1/10S□□□J
R490	CARBONFILM RESISTOR	RD1/6PM□□□J
R491-498		RS1/10S□□□J
R499	CARBONFILM RESISTOR	RD1/6PM□□□J
R500-502		RS1/10S□□□J
R504		RS1/10S□□□J
R506		RS1/10S□□□J
R521-535		RS1/10S□□□J
R536		RN1/6PQ□□□□F
R537	538	RS1/10S□□□J
R539	CARBONFILM RESISTOR	RD1/6PM□□□J
R540		RS1/10S□□□J
R541	CARBONFILM RESISTOR	RD1/6PM□□□J
R542	543	RS1/10S□□□J
R561-564		RS1/10S□□□J
R567-570		RS1/10S□□□J
R571	572 CARBONFILM RESISTOR	RD1/6PM□□□J
R575	CARBONFILM RESISTOR	RD1/6PM□□□J
R576	577	RS1/10S□□□J
VR441	VR	VRTB6VS222
VR481	482 VR	VRTB6VS472
VR521		VRTG6VS472

Mark No. Symbol & Description Part No.

◎ SYPS ASSEMBLY(VWR1064)

Mark No.	Symbol & Description	Part No.
SEMICONDUCTORS		
△	IC201, 202 IC PROTECTOR	ICP-N15
	Q201	2SD1762
	Q202, 203	2SB1185
△	Q204	2SD1762
△	Q205	2SB1185
△	Q206	2SD1762
△	D201, 202	S2VB20-F
	D206	04AZ6.2
	D207	04AZ5.1-Y
	D208 DIODE	1SS254
	D209	04AZ6.2
	D210	04AZ5.1
	D211 DIODE	1SS254
	D212	D1NK20
△	D213, 214 DIODE	1SR35-100AVL
	D215	D1NK20
SWITCHES		
△	S201 SWITCH	VSA-010
COILS/TRANSFORMERS		
	L201 COIL	VTL1018
	L202 FILTER	VTL-262
CAPACITORS		
	C201-204	CKPUYF103Z25
	C205, 206 ELECTR. CAPACITOR	CEAS332M25
	C207(10000/10)	VCH1051
	C208(6800/16)	VCH1053
	C209 ELECTR. CAPACITOR	CEAS101M10
	C210 ELECTR. CAPACITOR	CEAS471M6R3
	C211 ELECTR. CAPACITOR	CEAS101M10
	C212 ELECTR. CAPACITOR	CEAS471M6R3
	C213 ELECTR. CAPACITOR	CEAS101M35
	C214, 215 ELECTR. CAPACITOR	CEAS2R2M50
△	C216-218 CAPACITOR (0.01μF/AC400V)	RCG-009
	C229, 230 CERAMIC CAPACITOR	CGCYX473M25
	C237, 238 CERAMIC CAPACITOR	CGCYX473M25
	C239	CKPUYB331K50
	C240, 241 ELECTR. CAPACITOR	CEAS101M10
RESISTORS		
	R201-212 CARBONFILM RESISTOR	RD1/6PM□□□J
	R213, 214 RESISTOR(47/6W)	DCN1003
	R215-218 CARBONFILM RESISTOR	RD1/6PM□□□J
	R219, 220 RESISTOR(47/6W)	DCN1003
△	R221 METAL OXIDE RESISTOR	RS1PMFR51J
	R222, 223 CARBONFILM RESISTOR	RD1/6PM□□□J
△	R235 CARBONFILM RESISTOR	RD1/2PM225J

6. ADJUSTMENTS

As to the items that are not in this chapter, refer to "Adjustments for CLD players" on ARP2064.

6.1 TEST MODE

6.1.1 Test Mode

The player has a test mode function which allows the user to check the player's status on the TV screen by executing the respective key operation. Also, since the TRK servo opens and closes easily, the test mode is especially useful for mechanical adjustments.

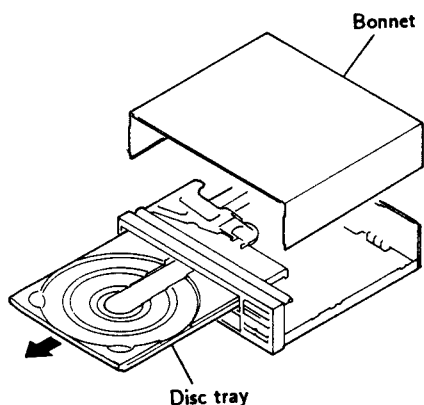

Remove the Bonnet and the Disc Tray

6.1.3 Test Mode Cancellation

Turn off the power switch.

6.1.4 Player Operation in the Test Mode

Operate the player by selecting a test mode function with the keys on the player or on the remote control unit.

[Sample Key Operation]

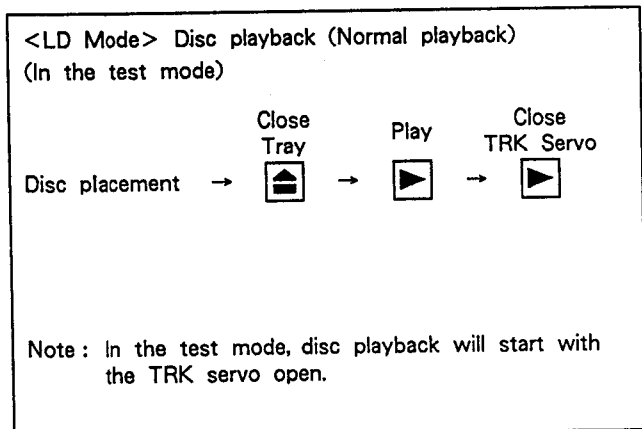

6.1.2 Test Mode Initiation

[Procedure]

1. Remove the bonnet and the disc tray.
2. Connect the TP303 mother board Ass'y to GND (ground).
3. Turn on the power switch.
4. Check if all the items on the FL tube are ON.
5. Disconnect the TEST TP.

• If power is turned on while tray is retracted into the main unit, and TEST MODE is selected without key operations, all LEDs turns on until any key operation is made.

7 segment LEDs indicate "88".

• The screen during TEST MODE is blue back with the exception of the following cases.

- ① While the video part of an LD or a CDV is being played.
- ② While a searching is being executed.

Apart from the audio area, the screen outputs the recorded screen during searching and does not become blue back.

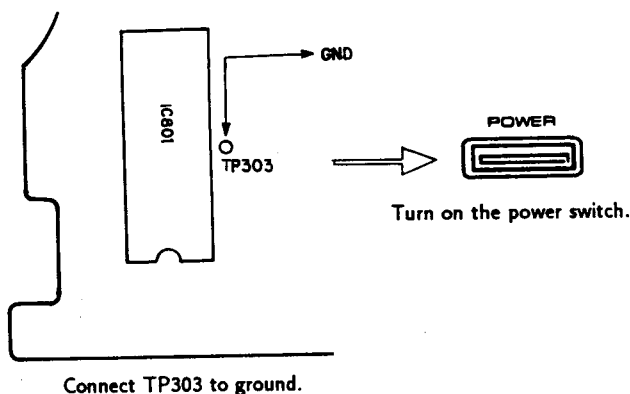

Connect TP303 to ground.

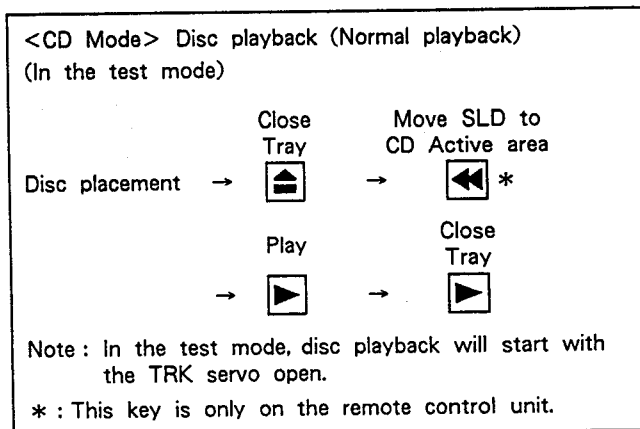

6.1.5 TV Screen and FL Tube Displays in the Tset Mode

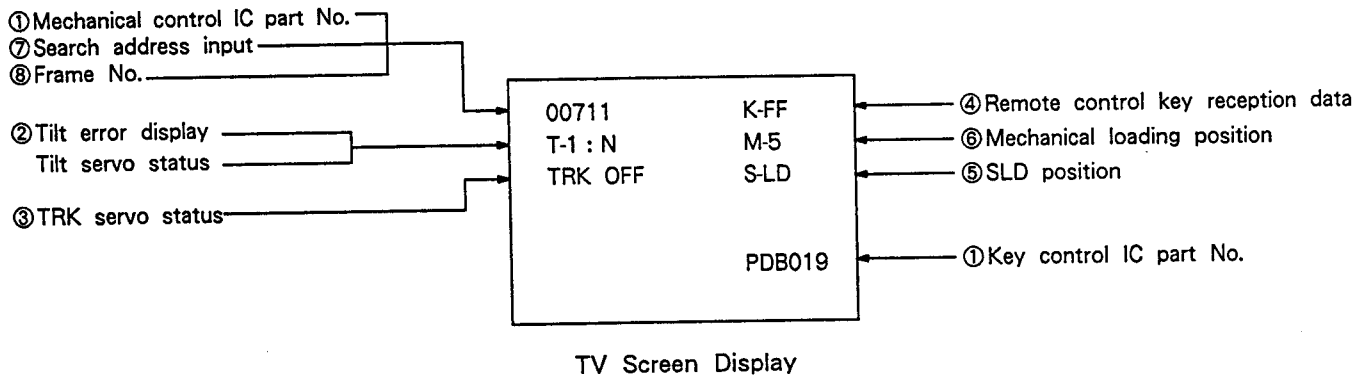

① The mechanical control IC (mother board ass'y IC801) part No. will be displayed
 PD0071A → 00711 (Mechanical control)
 PDB019 (Key control)

② Tilt servo status/Tilt error display

TV screen display

T-○ : ○○○

↑ Tilt servo status : N Tilt neutral
 ON..... Tilt servo ON
 OFF ... Tilt servo OFF

↑ Tilt error display : 0 Tilt -
 ↓ Tilt neutral
 F Tilt +

③ TRK Servo Status

TV screen display

TRK-○○○

↑ ON..... TRK servo closed
 OFF ... TRK servo open

Test Mode Operation (The remote control is used for all operations.)

Function	Player Status	Remote Control Unit Key Operation	Remarks
Open/Close Tray		Repeat B Key	
Stop		Repeat A Key	
Play		TV/LDP Key	<ul style="list-style-type: none"> Start up tracking while in open status. In the initial status, TILT is in neutral position. Disk type is determined by the slider position at start up. If the PLAY KEY is pressed while in open status, the tray is retracted and the unit becomes the stop mode.
	Stop mode	Play Key	
TRK Servo Open Close	Play mode	Step Forward Key	
	Play mode	Step Reverse Key	
Open/Close	Play mode	Play Key	<ul style="list-style-type: none"> In the PLAY mode, this key switches between OPEN/CLOSE each time pressed. (TOGGLE) In the STILL mode, STILL is only canceled.
Still	Play mode	CX Key	<ul style="list-style-type: none"> The key switches between PLAY/STILL each time pressed. (TOGGLE)
	TRK servo close	Pause Key	
SLDR REV SCAN		Scan Rev Key	
SLDR FWD SCAN		Scan Fwd Key	
TILT Neutral	Power SW ON	Speed Down Key	<ul style="list-style-type: none"> In the initial status, it is in neutral position.
TILT Servo ON		Speed Up Key	
TILT minus TILT Servo OFF	except Tray open	Skip Rev Key	
TILT Plus TILT Servo OFF	except Tray open	Skip Fwd Key	
Screen Display ON/OFF		Display Key	<ul style="list-style-type: none"> The key switches between ON/OFF each time pressed. (TOGGLE)
		Program Key	
Frame Search Address Input Entry		+10 Key	<ul style="list-style-type: none"> In the initial status, displays the last address searched. When SEARCH is executed in this status, it will search the same address previously searched.
	Address Input		
Search ON			Chapt/Frame Time Key
		Play Key or Search Key	
Search Break	Search	Clear Key	
LOAD Motor Loading Out Loading In	Tray open	Skip Fwd Key	
		Skip Rev Key	

Table. Operation in Test Mode

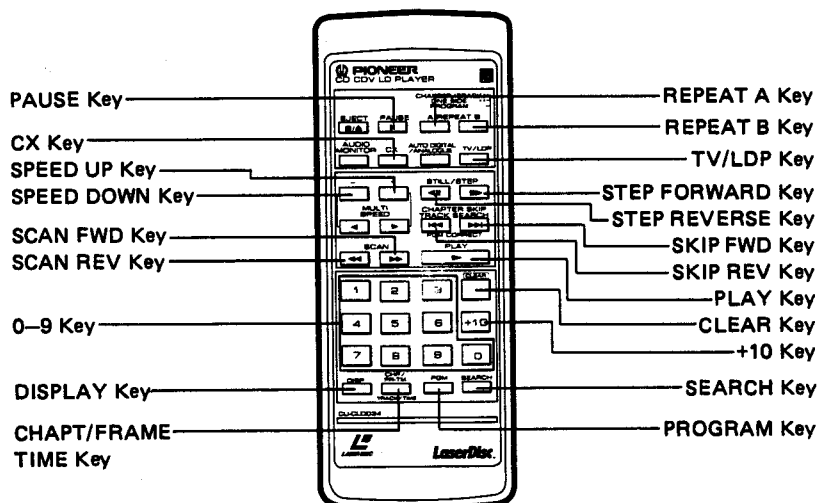

④ Remote Control/Player Key Reception Data

TV screen display

K-00

↑ See table below

- Basically, the main unit key data is converted into the remote control codes. However, keys that have no assigned remote control code are converted into unused remote control data.
- See below for data definitions.
- Codes in () can be accepted but are not normally originated from remote control/main unit keys.
- Blanks indicated unused code.
- FF is indicated when the remote control/main unit key data do not exist.

Code	Function	Code	Function	Code	Function	Code	Function	Code	Function	Code	Function
00	0	10	F-SCAN	20		30	(10)	40	(CHAPT)	50	R-STEP
01	1	11	R-SCAN	21		31	(11)	41	(FRAME)	51	
02	2	12		22		32	(12)	42	SEARCH	52	F-SKIP
03	3	13	CHP/FRM	23		33	(13)	43	DISPLAY	53	R-SKIP
04	4	14		24		34	(14)	44	REPT-B	54	F-STEP
05	5	15		25		35	(15)	45	CLEAR	55	R-MULTI
06	6	16	STP/OPN	26		36	OPN/CLS	46	SPEED-	56	
07	7	17	PLAY	27		37	STOP	47	SPEED+	57	
08	8	18	PAUSE	28		38	PLY/PAU	48	REPT-A	58	F-MULTI
09	9	19		29		39		49	(2/RCH)	59	
0A		1A		2A		3A	INTRO	4A	(STEREO)	5A	
0B		1B		2B		3B		4B	(1/LCH)	5B	
0C	DGT/ANL	1C		2C		3C		4C	PROGRAM	5C	
0D		1D		2D		3D		4D		5D	
0E	CX	1E	AUD.MON	2E		3E		4E		5E	(TEST)
0F	TV/LDP	1F	+10	2F		3F		4F		5F	(ECS)

⑤ SLD Position

TV screen display

S-0000

- ↑ IN (OFF) ... CD TOC area
 CD CD active area
 CDV CDV active area
 LD LD active area

⑦ Search Address Input

TV screen display

00000 (Flashing)

⑧ Frame No.

TV screen display

00000

- ↑ F ... Read in
 E ... Read out

⑥ Mechanical Loading Position

TV screen display

M-0

- ↑ 0 ... Tray open
 1 ... Loading
 2 ... Standing by
 3 ... Clamped
 4 ... Tilt minus
 5 ... Tilt neutral
 6 ... Tilt plus
 7 ... Tilt limit

6.2 ADJUSTMENT

The adjusting method of CLD-980 is different from CLD-1080 only in the position of VR605 and VR606 on the mother board assembly. As to other adjusting methods and points, refer to "Adjustments for CLD players" on ARP2064.

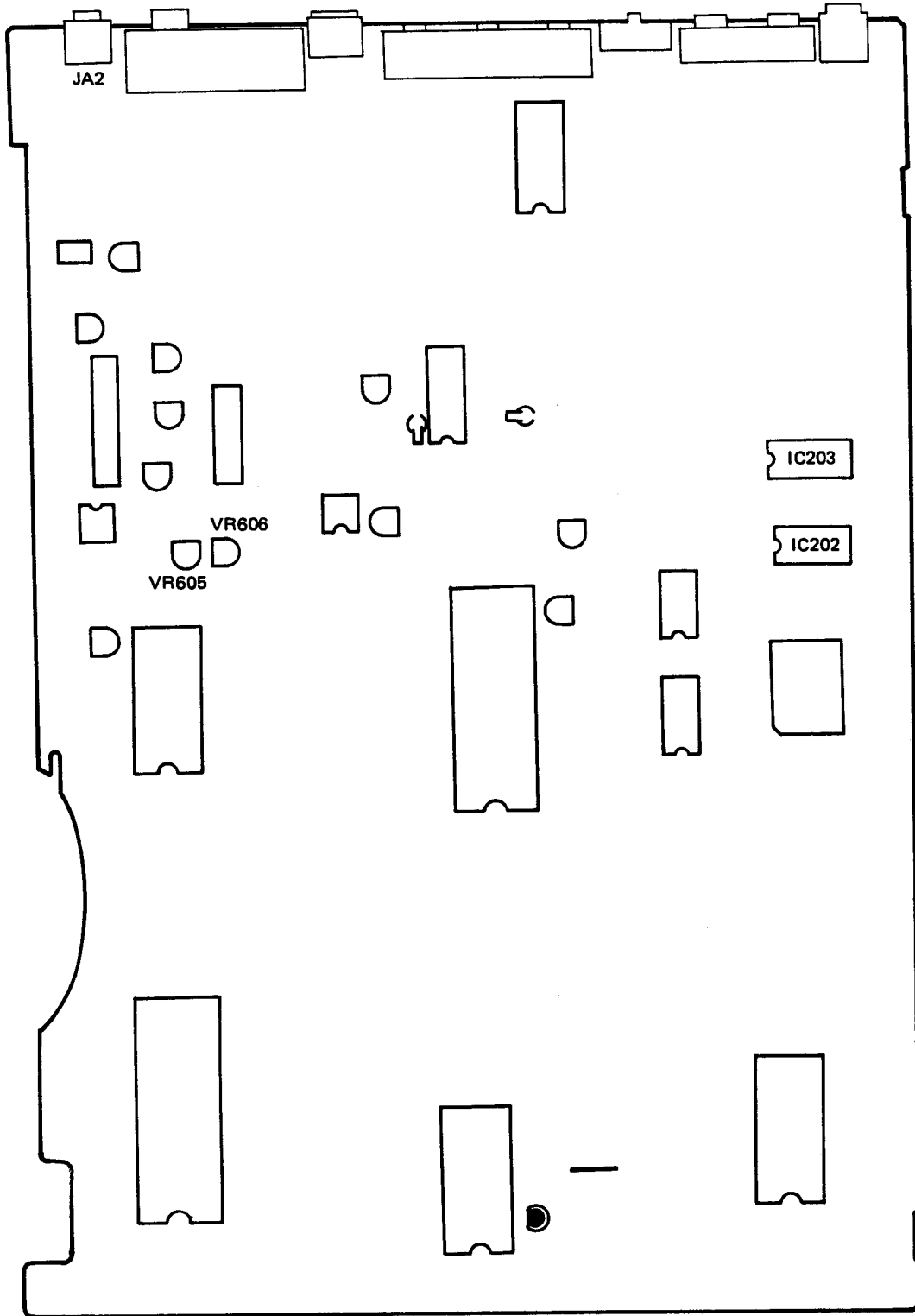

7. PANEL FACILITIES

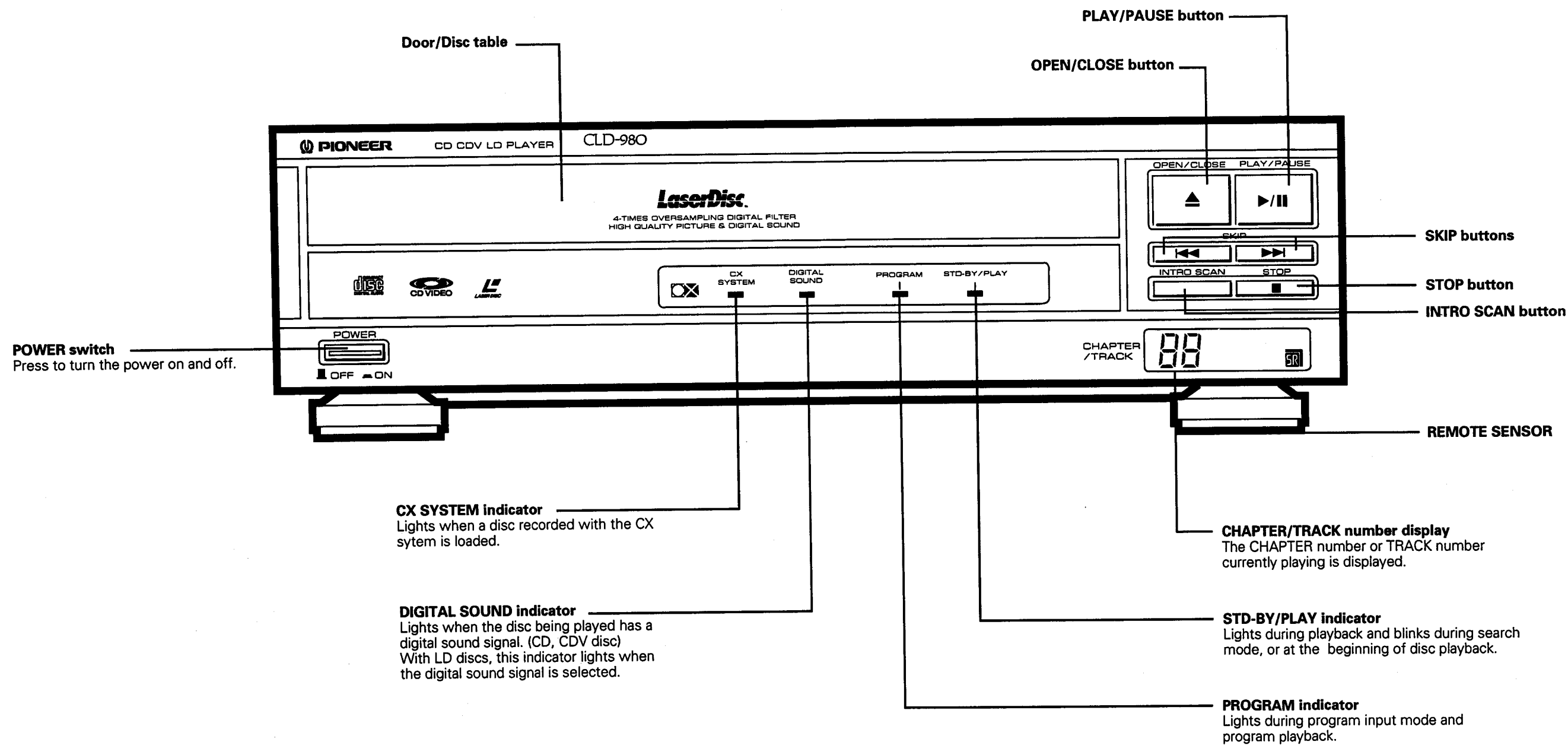

Remote control keys with the same names or marks as buttons on the front panel of the player control the same operations as the corresponding front panel buttons.

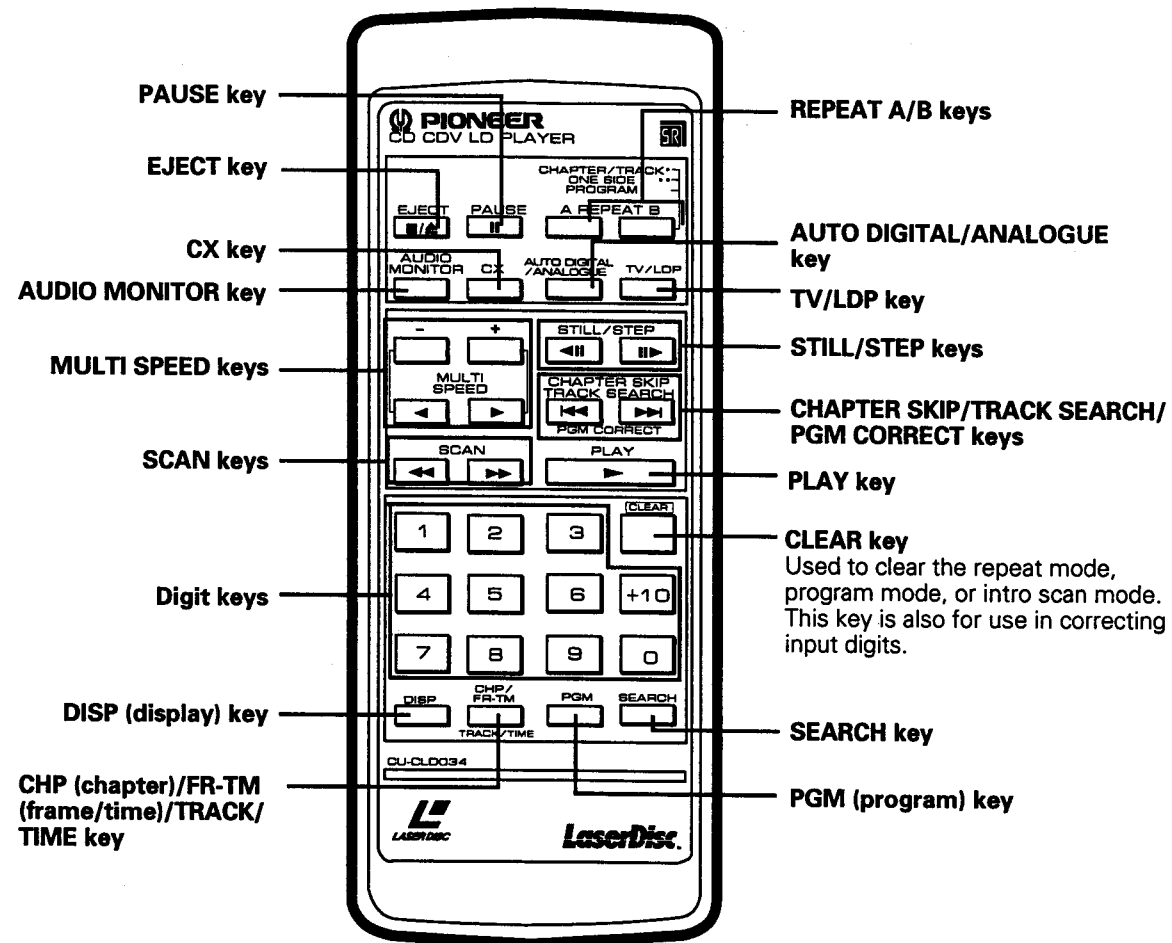

8. SPECIFICATIONS

1. General

System LaserVision Disc system and Compact Disc digital audio system
 Laser Semiconductor laser wavelength 780 nm
 Power requirements
 U.S. and Canadian models AC 120V, 60 Hz
 U.S. Military model AC 110V/120-127V/220V/240V or AC 110V/120V/220V/240V (Switchable), 50/60 Hz

Power consumption
 U.S. and Canadian models 37W
 U.S. Military model 37W
 Weight
 U.S. and Canadian models 7.6 kg (16 lbs 12 oz)
 U.S. Military model 7.6 kg (16 lbs 12 oz)
 Dimensions 420 (W) x 416 (D) x 122 (H) mm
 16-9/16 (W) x 16-3/8 (D) x 4-13/16 (H) in
 Operating temperature +5°C ~ +35°C (41°F - 95°F)
 Operating humidity 5% ~ 90% (There should be no condensation of moisture.)

2. Disc

LaserVision Discs

*Maximum playing times
 12-inch standard play disc 1 hour/both sides
 12-inch extended play disc 2 hours/both sides
 8-inch standard play disc 28 min/both sides
 14 min/one side
 8-inch extended play disc 40 min/both sides
 20 min/one side

Spindle motor speed
 Standard play disc 1,800 rpm
 Extended play disc 1,800 rpm (inner circumference) to 600 rpm (outer circumference) (For a 12-inch disc)

Compact Discs

DISC Diameter: 5-inch, 3-inch, Thickness: 1.2 mm
 Rotation direction (pickup side) Counterclockwise
 Liner speed 1.2 ~ 1.4m/sec
 *Maximum playing time
 74 min. 5-inch discs
 20 min. 3-inch discs
 (For stereo playback)

Compact Discs with Video

Disc Diameter: 5-inch, Thickness: 1.2 mm
 Rotation direction (pickup side) Counterclockwise
 Linear speed Audio portion: 1.2 ~ 1.4m/sec
 Video portion: 11 ~ 12m/sec
 Maximum playing time Video portion: 5 min. (CLV)
 Audio portion: 20 min. (Digital)

* Actual playback time differs for each disc.

3. Video characteristics

Format NTSC specifications
 Video output
 Level 1 Vp-p nominal, sync. negative, terminated
 Impedance 75Ω unbalanced
 Jack RCA jack
 VHF output
 Channel Channel 3 or 4 (switchable)
 Impedance 75Ω unbalanced
 Terminal F-type jack

4. Audio characteristics

Output level
 During analog audio output 200 mVrms (1 kHz, 40%)
 During digital audio output 200 mVrms (1 kHz, -20 dB)
 Jacks Both RCA jacks
 Number of channels 2

Digital Audio Characteristics

Frequency response	4 Hz - 20 kHz (±0.7 dB) (EIAJ)
SN ratio	105 dB (EIAJ)
Dynamic range	97 dB (EIAJ)
Channel separation	92 dB (EIAJ)
Wow and flutter	Limit of measurement (EIAJ)

5. Other Terminals

Control input/output Both miniature jacks

6. Accessories

Remote control unit (CU-CLD034) 1
 Size "AAA" (IEC R03) dry cell batteries 2
 RF antenna cable 1
 Video cord 1
 Audio cord 1
 Antenna adaptor (75Ω/300Ω → 75Ω F-type plug) 1
 F-type jack - IEC plug adaptor (U.S. Military model only) 1
 Operating instructions 1
 Warranty card 1

7. Functions

Remote control unit operations (CU-CLD034)

	Function	Standard play Disc (CAV)	Extended play Disc (CLV)	Compact Disc with Video	Compact Disc
Basic Functions	Single-side play	YES	YES	YES	YES
	Pause	YES	YES	YES	YES
	Stop	YES	YES	YES	YES
	Eject	YES	YES	YES	YES
Search	Manual search (forward and reverse)	YES	YES	YES	YES
	Chapter/Track skip	YES	YES	YES	YES
	Direct chapter/Track number search	YES	YES	YES	YES
	Frame number search	YES	NO	NO	NO
	Time number search	NO	YES	YES	YES
	Absolute time search	NO	NO	NO	YES
Program	Chapter/Track program play	YES	YES	YES	YES
	Program correction	YES	YES	YES	YES
Repeat	Repeat between 2 points	YES	YES	YES	YES
	Memory repeat	YES	YES	YES	YES
	Chapter/Track repeat	YES	YES	YES	YES
	One-side repeat	YES	YES	YES	YES
	Program repeat	YES	YES	YES	YES
Trick play	Still/Step	YES	NO	NO	NO
	Multi-speed (Forward/reverse 9-level variable)	YES	NO	NO	NO
Time display	Elapsed time display	NO	YES	YES	YES
	Absolute time display	YES*1	NO	NO	YES
	Remaining track time display	NO	NO	YES*4	YES
	Remaining total time display	YES*1	YES*1	YES	YES
	Total time display	YES*1	YES*1	YES	YES
Others	CX system ON/OFF	YES*2	YES*2	—	—
	AUTO DIGITAL/ANALOG switch	YES*3	YES*3	—	—
	Audio channel selection (Stereo, 1/L, 2/R)	YES	YES	YES	YES

*1 Only discs with TOC

*2 Valid for analog sound playing a disc with the  mark.

*3 Can only be used with discs with digital sound tracks.

*4 Audio part only

NOTE:

The specifications and design of this product are subject to change without notice, due to improvement.

PLAYER FUNCTIONS

- Intro Scan, Close disc table, Basic functions and chapter/track skip
- Digital Sound for LaserVision Discs

Service Manual

 **PIONEER**
The future of sound and vision.

282

ORDER NO.
ARP2064

ADJUSTMENTS FOR CLD PLAYERS

- This service manual explains CLD players adjustment methods.
- Typical model covered by this service manual is :
Model CLD-1080

- For details on items other than adjustment methods, see the service manual of each manual.

CONTENTS

1. MOTHER BOARD ASSEMBLY	
ADJUSTMENT ABSTRACT	2
2. TEST MODE	4
3. ADJUSTMENTS	8
3.1 Required Instruments	8
3.2 Adjustment Preparation and Notes	8
3.3 Mechanical Adjustments	10
3.4 Electrical Adjustments	20
4. ABBREVIATIONS TABLE	25

PIONEER ELECTRONIC CORPORATION 4-1, Meguro 1-Chome, Meguro-ku, Tokyo 153, Japan
PIONEER ELECTRONICS SERVICE INC. P.O. Box 1760, Long Beach, California 90801 U.S.A.
PIONEER ELECTRONICS OF CANADA, INC. 505 Cochrane Drive, Markham, Ontario L3R 8E3 Canada
PIONEER ELECTRONIC [EUROPE] N.V. Keetberglaan 1, 2740 Beveren, Belgium
PIONEER ELECTRONICS AUSTRALIA PTY. LTD. 178-184 Boundary Road, Braeside, Victoria 3195, Australia TEL: [03] 580-9911
© **PIONEER ELECTRONIC CORPORATION 1990**

FJ MAY. 1990 Printed in Japan 

1. MOTHER BOARD ASSEMBLY ADJUSTMENT ABSTRACT

	ADJUSTMENT	P	Adjusting points	Measurement equipment connecting points	Player condition	Adjusting Specification
1	Tilt Sensor Adjustment	10	VR608	None	Power off	Marking of Tilt sensor Red : Right Clear : Center Blue : left
2	Coarse Adjustment of Grating and TRK Balance Adjustment	11	Grating/VR602	CN301-9(TRK ERR)	• Test mode #15000 still TRK servo loop open	• Null point→TRK error MAX • Adjust VR602 so that the TRK error waveform amplitude's positive and negative level become equal
3	Slider Shaft Horizontal Adjustment	12	Player SKIP key	CN301-3(FCS RTN)	• Test mode Tilt servo loop off TRK servo loop open #5200 still	• Use the SKIP key to adjust to 0V
4	Pickup Inclination Adjustment / FCS Error Balance Adjustment	13	Pickup Ass'y TAN/TRK inclination adjustment screw VR605 VR606	CN301-2(RF) CN301-9(TRK ERR)	• Test mode #2701 still TRK servo loop close/ open Tilt servo loop off	• RF waveform's amplitude MAX (Pickup TAN / TRK adjustment screw) • TRK error MAX (VR605) RF MAX (VR606)
5	Tilt Sensor Inclination/ Tilt Balance Adjustment	14	Tilt sensor inclination adjustment screw VR607(TILT BAL)	TV monitor Test mode screen	• Test mode #16200/#115 still TRK servo loop close Tilt servo loop off	• Set VR607 to the center • Adjust the adjustment screw so that the tilt error display code is 6, 7, or 8 • Adjust VR607 so that the tilt error display becomes 7
6	Inspection and Adjustment of Spindle Motor Centering	15	Spindle motor centering adjustment lever	CH1 : CN301-9(TRK ERR) CH2 : CN301-8(TRK SUM)	• Test mode #25000/#1 still TRK servo loop open Tilt servo loop on	• Adjust the centering adjustment screw so that the resurge waveforms of #1 and #25000 are the same
7	Fine Adjustment of Grating and TRK Balance Adjustment	16	Grating/VR602	CH1 : CN301-9(TRK ERR) CH2 : CN301-8(TRK SUM)	• Test mode TRK servo loop open Tilt servo loop on	• Minimize the Y direction of the resurge waveform • Level of the X direction of the resurge waveforms are equal
8	FCS Servo Loop Gain Adjustment	17	VR604	CH1 : CN301-6(FCS IN) CH2 : CN301-5(FCS ERR)	• Test mode #15000 still TRK servo loop close Tilt servo loop on	• Adjust VR604 so that the resurge waveform is symmetric with respect to the X and Y axes
9	TRK Servo Loop Gain Adjustment	18	VR603	CH1 : CN301-10(TRK IN) CH2 : CN301-9(TRK ERR)	• Test mode #15000 still TRK servo loop close Tilt servo loop on	• Adjust VR603 so that the resurge waveform is symmetric with respect to the X and Y axes
10	RF Gain Adjustment	19	VR601	CH1 : CN301-2(RF)	#15000 still	• Adjust VR601 so that the RF level becomes $300 \pm 50mV$
11	14.31818MHz	20	VC901	JP(14.31818)	STOP	• Adjust VC901 so that the frequency becomes 14.31818 MHz
12	VCO Central Frequency Adjustment	21	VR481	CH1 : C489 lead wire CH2 : C519 lead wire	#5100 still	• The center of CH1's video signal jitter is delayed by 71μS with CH2's video signal
13	Output Video Level Adjustment	22	VR482	Video terminal	#19900 still	• Adjust the VR482 so that the voltage between the sync tip and the white peak becomes $1V \pm 5\%$
14	1H Delay Video Level Adjustment	23	VR441	IC401 pin 42 IC401 pin 40	#3800 still	• The 1H delay video level becomes the same as the main line video level.
15	Color Tint Error Signal Level Adjustment	24	VR521	TV monitor	#8000 still	• Color irregularity on the magenta screen is minimized

**MOTHER BOARD ASSEMBLY
ADJUSTMENT POINTS**

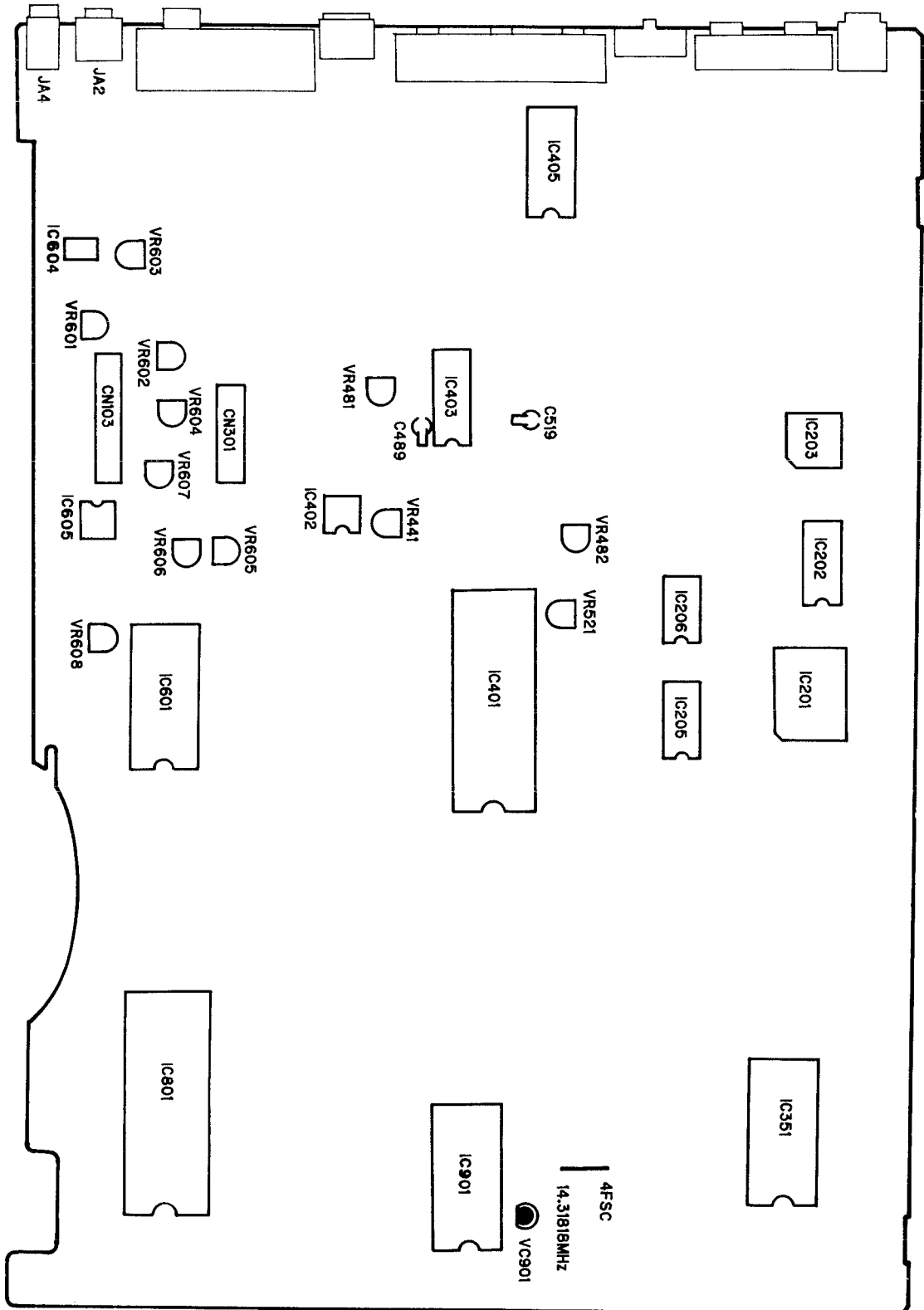

2. TEST MODE

2.1 Test Mode

The player has a test mode function which allows the user to check the player's status on the TV screen by executing the respective key operation.

Also, since the TRK servo opens and closes easily, the test mode is especially useful for mechanical adjustments.

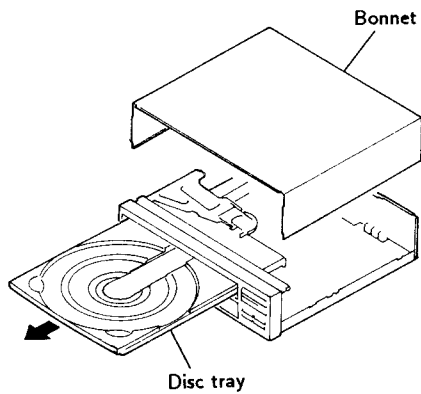

Remove the bonnet and the disc tray.

2.3 Test Mode Cancellation

Turn off the power switch.

2.4 Player Operation in the Test Mode

Operate the player by selecting a test mode function with the keys on the player or on the remote control unit.

[Sample Key Operation]

<LD Mode> Disc playback (Normal playback)
(In the test mode)

Disc placement → → →

Note: In the test mode, disc playback will start with the TRK servo open.

2.2 Test Mode Initiation

[Procedure]

1. Remove the bonnet and the disc tray.
2. Connect the TP303 mother board Ass'y to GND (ground).
3. Turn on the power switch.
4. Check if all the items on the FL tube are ON.
5. Disconnect the TEST TP.

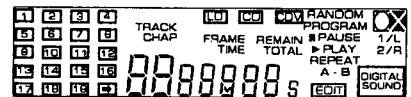
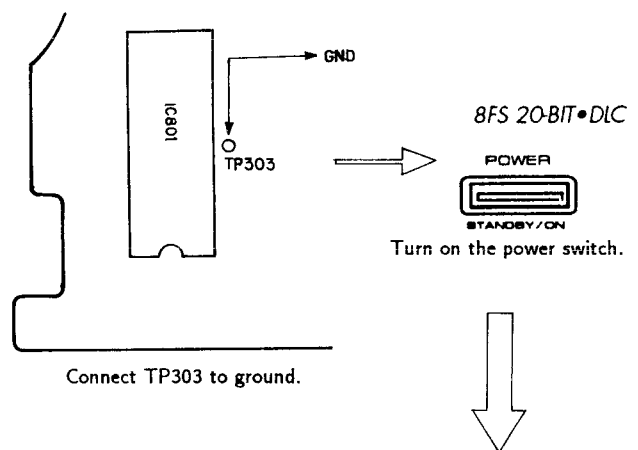

While in the test mode, all items on the FL tube will light.

<CD Mode> Disc playback (Normal playback)
(In the test mode)

Disc placement → → →

→ →

Note: In the test mode, disc playback will start with the TRK servo open.

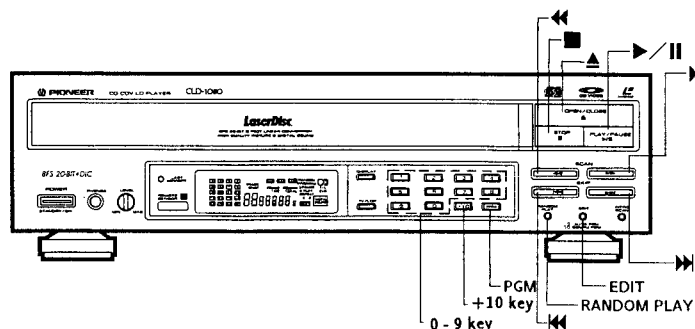

Function	Player Status	Key Operation	Remarks
Open Tray	Stop mode.	▲	
Close Tray	Tray open.	▲	
Stop	Play mode.	■	
Play	Disc placement and tray closed.	▶	<ul style="list-style-type: none"> Starts up with the TRK servo open. Starts up with tilt neutral. The disc type (LD/CD/CDV) is determined when playback starts at the SLDR position during startup.
TRK Servo Open/Close	Play mode.	▶	<ul style="list-style-type: none"> Each time the PLAY button (▶) is pressed, the TRK servo will open or close.
Still	Play mode. TRK servo closed.	 (Remote control unit key)	<ul style="list-style-type: none"> Each time the STILL button () is pressed, the player will switch between the PLAY and STILL modes.
SLDR REV SCAN	Play mode.	◀◀	<ul style="list-style-type: none"> Press and hold down the key. With the TRK servo open, the pickup can be damaged if the SLD moves further inward than the read-in area on the disc. Do not allow the SLD to move further inward than the read-in area.
SLDR FWD SCAN	Play mode.	▶▶	<ul style="list-style-type: none"> Press and hold down the key. With the TRK servo open, the pickup can be damaged if the SLD moves further outward than the read-out area on the disc. Do not allow the SLD to move further outward than the read-out area.
TILT Neutral	Power switch ON.	EDIT	
TILT Servo On	Play mode.	RANDOM PLAY	
TILT Minus TILT Servo OFF	Play mode.	◀◀	<ul style="list-style-type: none"> Press and hold down the key.
TILT Plus TILT Servo OFF	Play mode.	▶▶	<ul style="list-style-type: none"> Press and hold down the key.
Screen Display ON/OFF	Power switch ON.	PGM Key	
Frame Search	Play mode.	+10 Key ↓ 0 - 9 Key ↓ ▶	<ul style="list-style-type: none"> In the PLAY mode, press the +10 key. (The player will standby for the frame no. entry.) Use the numeric keys to enter the frame no. Then press the player's PLAY key to search. After the search is completed, the player will return to the operation mode before the search was performed.
LOAD Motor Rotation Clockwise Counterclockwise	Tray open.	◀◀ ▶▶	

Table. Operation in test mode.

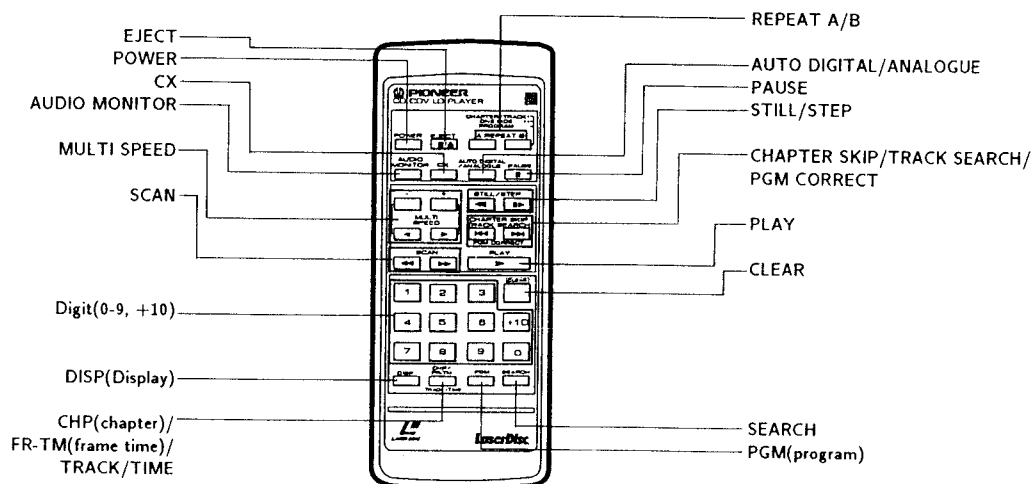

2. 5 TV Screen and FL Tube Displays in the Test Mode

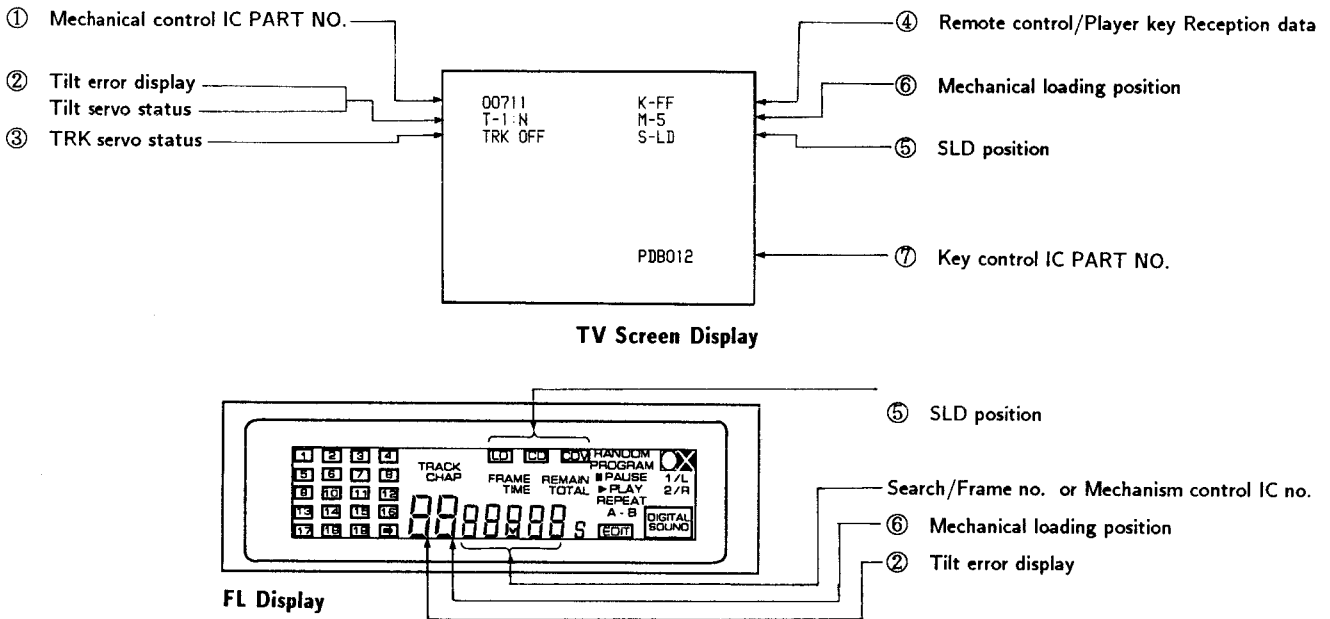

Note : The numbers in the figures above correspond to the numbered descriptions that follow.

- ① The mechanical control IC(mother board Ass'y IC801)part no.will be displayed.

PD0071A → 0071A

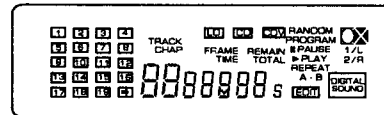

- ② Tilt servo status/Tilt error display

TV screen display

T-○:○○

Tilt servo status : N.....Tilt neutral
ON..... Tilt servo ON
OFF ... Tilt servo OFF

Tilt error display : 0 Tilt -
 ↑
 Tilt neutral
 ↓
 F Tilt +

- ③ TRK Servo Status

TV screen display

TRK-○○○

ON TRK servo closed
OFF ... TRK servo open

④ Remote Control/Player Key Reception Data

TV screen display

K-○○

↑ See table below

CODE	FUNCTION	CODE	FUNCTION	CODE	FUNCTION	CODE	FUNCTION	CODE	FUNCTION	CODE	FUNCTION
00	0	10	F-SCAN	20		30	(10)	40	(CHAPT)	50	R-STEP
01	1	11	R-SCAN	21		31	(11)	41	(FRAME)	51	
02	2	12		22		32	(12)	42	CHP/FRM	52	F-SKIP
03	3	13	CHP/FRM	23		33	(13)	43	SEARCH	53	R-SKIP
04	4	14		24		34	(14)	44	DISPLAY	54	F-STEP
05	5	15		25		35	(15)	45	CLEAR	55	R-MULTI
06	6	16	STP/OPN	26		36	OPN/CLS	46	SPEED -	56	
07	7	17	PLAY	27		37	STOP	47	SPEED +	57	
08	8	18	PAUSE	28		38	PLY/PAS	48	REP-A	58	F-MULTI
09	9	19		29		39	EDIT	49	(2/RCH)	59	
0A		1A	(POWON)	2A		3A	INTRO	4A	(STEREO)	5A	
0B		1B	(POWOFF)	2B		3B	RANDOM	4B	(1/LCH)	5B	
0C	DGT/ANL	1C	POWER	2C		3C		4C	PROGRAM	5C	
0D		1D		2D		3D		4D		5D	
0E	CX	1E	AUD.MON	2E		3E		4E		5E	(TEST)
0F	TV/LDP	1F	+10	2F		3F		4F		5F	(ESC)

⑤ SLD Position

TV screen display

S-○○○

- CD CD active area
- CDV ... CDV active area
- LD LD active area

FL Display

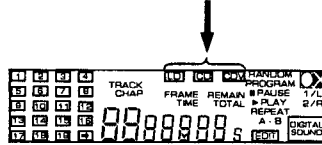

⑥ Mechanical Loading Position

TV screen display

M-○

- 0 ... Tray open
- 1 ... Loading
- 2 ... Standing by
- 3 ... Clamped
- 4 ... Tilt minus
- 5 ... Tilt neutral
- 6 ... Tilt plus
- 7 ... Tilt rimit

FL Display

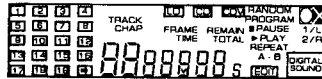

3. ADJUSTMENTS

3. 1 Required Instruments

- Small blade screwdriver (7-cm shaft)
- Small Phillips screwdriver (15-cm shaft)
- Low-pass filter (47 K + 1 μ F/BP)
- Dual trace oscilloscope (with delay)
- AF oscillator
- Frequency counter
- Test disc (GGV1003)
- 8-inch LDD disc
- CDV disc
- Short clip
- TV monitor
- Resistor (100 K, 330 K)
- Capacitor (0.01 μ F)
- Remote control unit

3. 2 Adjustment Preparation and Notes

1. Player preparation

Before doing the adjustment, remove the bonnet and the disc tray. Then place the player horizontally on a flat surface.

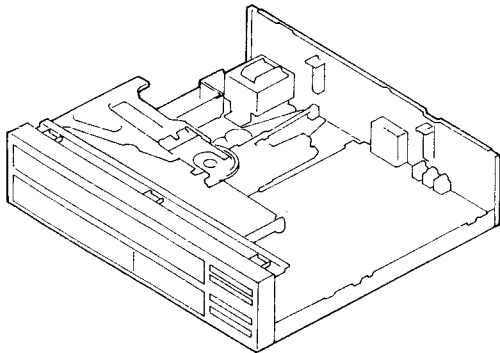

2. Disc Insertion

Insert the disc from the rear of the player. Place it securely on the turntable. When the PLAY key is pressed, the clamper will go down and secure the disc. Playback will then begin.

3. Use all the oscilloscope's probes at 10 : 1.

4. Only the mother board needs to be adjusted.

Unless noted otherwise, all adjustment items and measuring instrument connections will be for the parts in the mother board.

5. Required adjustment for replacement of major parts.

Adjustments	Replacements				
	Pickup	Actuator	Pre-pickup	Spindle motor	Tilt sensor
1. Tilt sensor adjustment	⊙				⊙
2. Coarse grating adjustment /TRK balance adjustment	⊙	⊙	⊙		
3. Slider shaft horizontal adjustment	⊙	⊙	⊙	○	⊙
4. Pickup inclination adjustment	⊙	⊙	⊙	○	○
5. Tilt sensor inclination/ Tilt balance adjustment	⊙	⊙	⊙	○	⊙
6. Spindle motor shaft centering and adjustment	⊙	⊙	⊙	⊙	
7. Fine grating adjustment/ TRK balance adjustment	⊙	⊙	⊙		
8. FCS servo loop gain adjustment	⊙	⊙	⊙		
9. TRKG servo loop gain adjustment	⊙	⊙	⊙		
10. RF gain adjustment	⊙	⊙	⊙		

Note : Adjustments indicated by a ○ are made only when there is crosstalk.

3. 3 MECHANICAL ADJUSTMENTS

1. TILT SENSOR ADJUSTMENT

[Mechanical Adjustment]

- Purpose : Adjustment of the tilt servo's gain according to the tilt sensor's sensitivity rank.
- Symptom when incorrectly adjusted : Increased tilt servo hunting and increased crosstalk.

Measurement equipment & jigs	Adjusting points
● Blade screwdriver	● VR608

Adjusting procedure

1. Use a blade screwdriver to adjust the angle of VR608 on the mother board Ass'y according to the rank indicator's color.

Rank	Color	VR Angle
A	Red	Clockwise all the way
B	Clear	Mechanical center
C	Blue	Counterclockwise all the way

Adjustment diagram

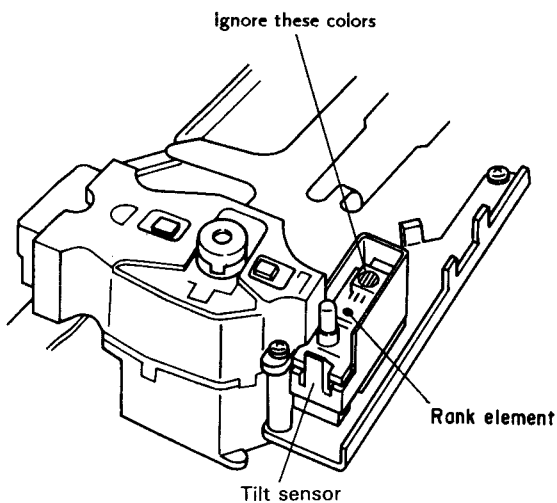

MOTHER BOARD ASSEMBLY

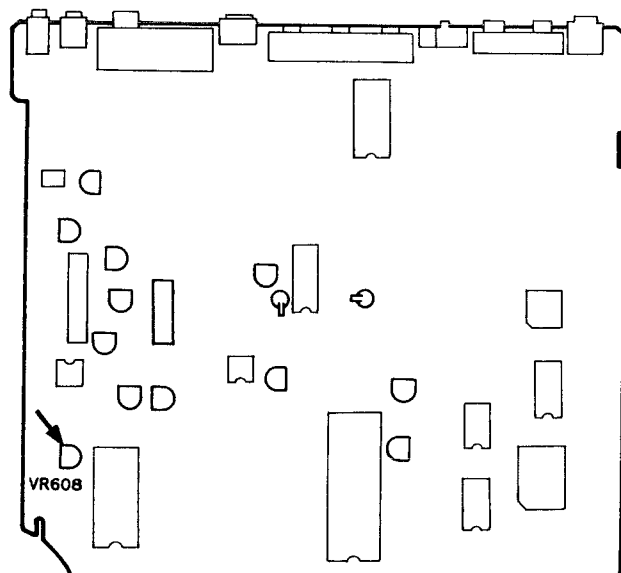

2. COARSE ADJUSTMENT OF GRATING AND TRK BALANCE ADJUSTMENT [Mechanical Adjustment]

- Purpose : Adjustment of the grating angle to enable disc playback and trick playback.
- Symptom when incorrectly adjusted : The disc cannot be played back. Track skipping occurs.

Measurement equipment & jigs	Measurement equipment connecting points	Player condition	Adjusting points
<ul style="list-style-type: none"> ● Blade screwdriver ● Oscilloscope ● Test disc (GGV1003) ● TV monitor 	<ul style="list-style-type: none"> ● Oscilloscope Between CN301-9 (TRK ERR) and GND. 	<ul style="list-style-type: none"> ● Test mode • Disc playback • TRK servo open • Tilt servo OFF 	<ul style="list-style-type: none"> ● Pickup Ass'y grating ● VR602 (TRK BAL)

Adjusting procedure

[Coarse grating adjustment]

1. Insert the test disc and press the PLAY key.
2. Search for frame #15000 or thereabouts.
3. Open the TRK servo.
4. Connect CN301-9 to the oscilloscope and observe the waveform.
5. Slide the tip of a small blade screwdriver through the guide and insert it horizontally into the grating adjustment hole. Look for the null point. (See Fig. 1 and Photo 1.)
6. Turn the screwdriver counterclockwise until the TRK waveform's amplitude reaches the first maximum from the null point. (See Photo 2.)

[TRK balance adjustment]

1. Adjust VR602 so that the TRK error waveform amplitude's positive and negative level become equal. (See Photo 3.)
2. Close the TRK servo and check if the image on the TV screen is normal.

Note : Set the oscilloscope's time axis range to the maximum and watch the TRK error waveform. The compressed waveform will then appear. This will make the adjustment easier.

Adjustment diagram

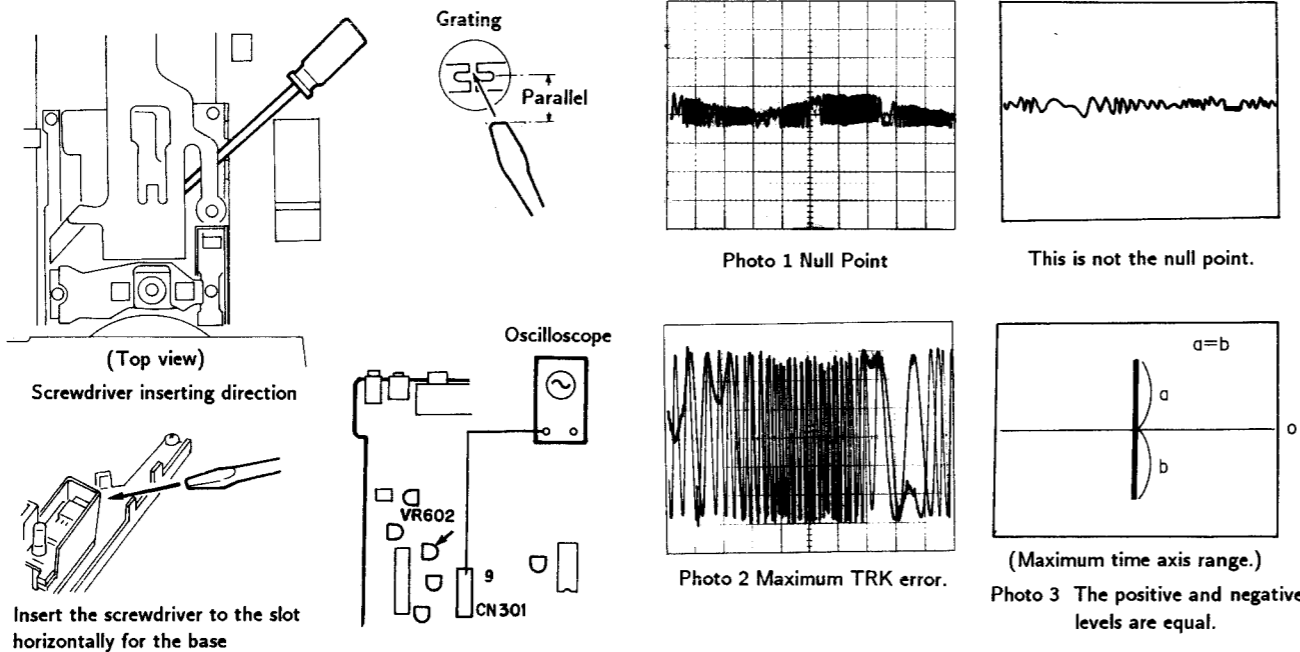

3. SLIDER SHAFT HORIZONTAL ADJUSTMENT [Mechanical Adjustment]

- Purpose : Setting the slider shaft horizontally to enable the pickup to move over the disc horizontally.
- Symptom when incorrectly adjusted : With a warped disc, the FCS servo does not function at the inner or outer periphery.

Measurement equipment & jigs	Measurement equipment connecting points	Player condition	Adjusting points
<ul style="list-style-type: none"> ● Oscilloscope ● Low-pass filter (47K 1μF) ● Test disc (GGV1003) 	<ul style="list-style-type: none"> ● Between CN301-3 (FCS RTN) and GND. 	<ul style="list-style-type: none"> ● Test mode • #5200 still • TRK servo open • Tilt servo OFF 	<ul style="list-style-type: none"> ● Player SKIP key (During test mode)

Adjusting procedure

1. Use the SCAN key to send the slider to frame #5200 or thereabouts (tilt fulcrum) on the test disc. Open the TRK servo.
2. Connect CN301-3 to the oscilloscope through L.P.F. and match the center of the waveform with the oscilloscope's GND.
3. Search for frame #25000 and use the SKIP key to adjust the center of the waveform to 0V.

Note : This adjustment is critical in that it will affect the adjustments following.

Note : Regarding the test mode, see page 6 .

Adjustment diagram

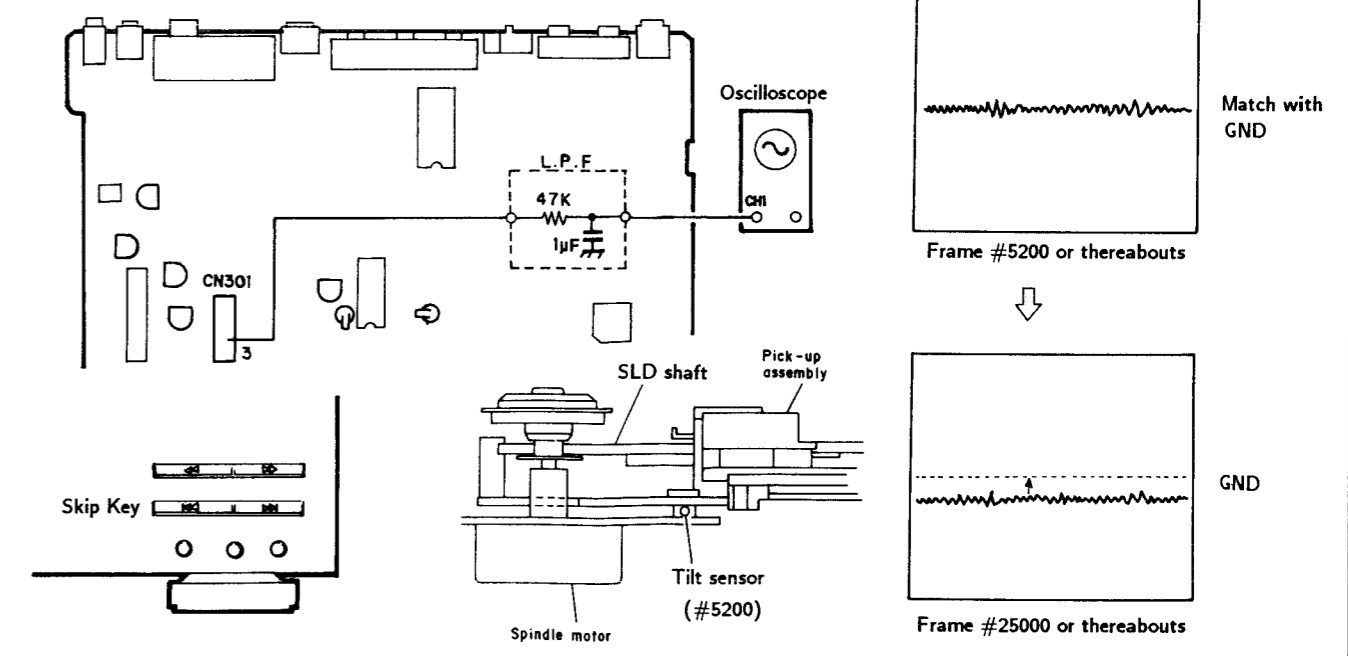

4. PICKUP INCLINATION ADJUSTMENT/FCS ERROR BALANCE ADJUSTMENT [Mechanical Adjustment]

- Purpose : Adjustment of the pickup inclination to direct the laser beam vertically with respect to the disc.
- Symptom when incorrectly adjusted : There is crosstalk.

Measurement equipment & jigs	Measurement equipment connecting points	Player condition	Adjusting points
<ul style="list-style-type: none"> ● Test disc (GGV1003) ● Oscilloscope ● TV monitor 	<ul style="list-style-type: none"> ● Oscilloscope CN301-2 (RF) ● TV monitor Player's video output terminal. 	<ul style="list-style-type: none"> ● Test mode <ul style="list-style-type: none"> · #2701 still (Black screen) · TRK servo closed · Tilt servo OFF 	<ul style="list-style-type: none"> ● Pickup Ass'y TRK/Tangential direction Inclination adjustment screw ● VR605 (TE BEST) ● VR606 (CT BEST)

Adjusting procedure

1. Connect CN301-2 to the oscilloscope.
2. Search for #2701 and look at the RF waveform.
3. Adjust the pickup's TRK/tangential direction inclination adjustment screw to maximize the waveform's amplitude.
4. Look at the TV screen and make sure there is no crosstalk.

Note: If there is crosstalk on the TV screen even when the RF level is at the maximum, do next steps as follows.

5. Connect CN301-9 to the oscilloscope.
6. Open the TRK servo loop and adjust VR605 to maximize the TRK waveform's amplitude.

Note: With the TRK servo closed, set it to still. Then adjust the jump pulse to the maximum level.

7. Close the TRK servo loop.
8. Connect CN301-2 to the oscilloscope.
9. Adjust VR606 to maximize the RF waveform's amplitude.
10. Watch #115 on the TV monitor and make sure there is no crosstalk.

Note: If there is noticeable crosstalk, watch #115 on the TV monitor and adjust VR606 until the crosstalk is eliminated.

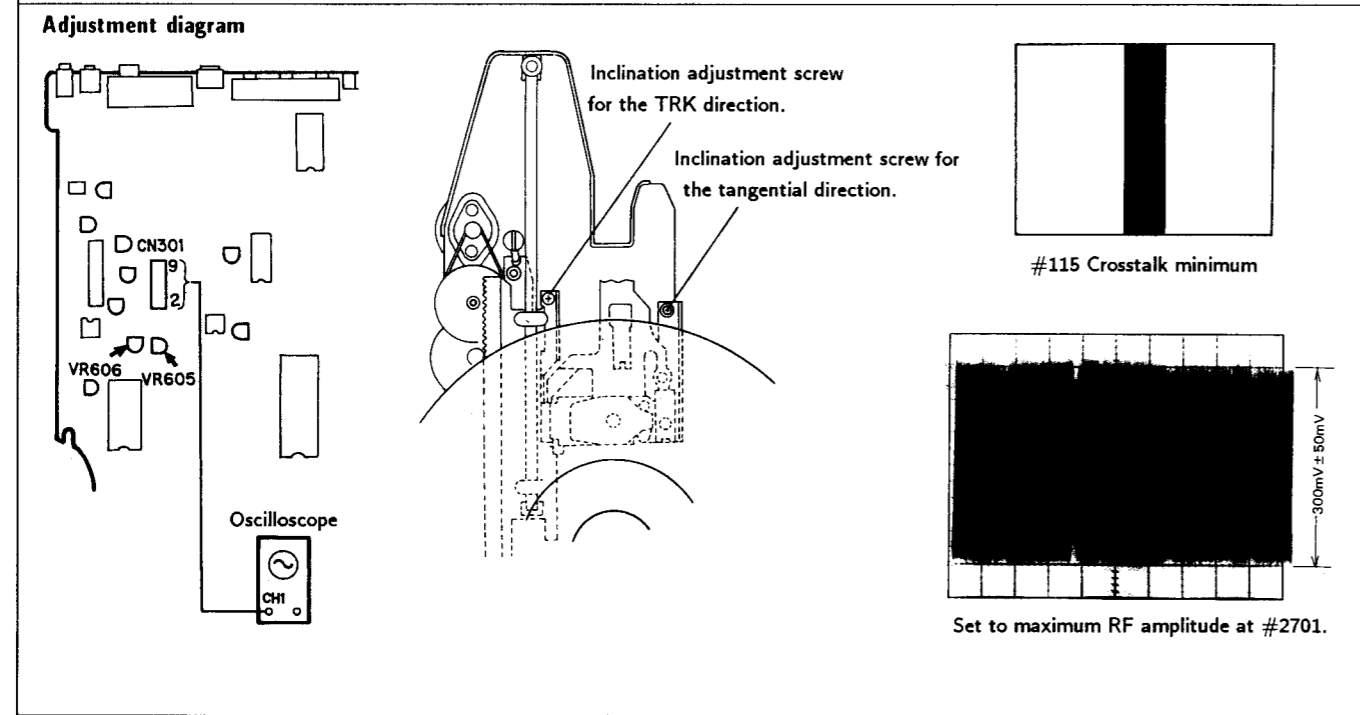

5. TILT SENSOR INCLINATION/TILT BALANCE ADJUSTMENT [Mechanical Adjustment]

- Purpose : Adjustment of the tilt sensor's inclination to direct the tilt sensor's LED vertically with respect to the disc. Also, compensation for the sensitivity difference between the two sensors.
- Symptom when incorrectly adjusted : There is crosstalk.

Measurement equipment & jigs	Measurement equipment connecting points	Player condition	Adjusting points
<ul style="list-style-type: none"> ● TV monitor ● Test disc (GGV1003) ● Small Phillips screwdriver 	<ul style="list-style-type: none"> ● TV monitor Player's video output terminal 	<ul style="list-style-type: none"> ● Test mode <ul style="list-style-type: none"> · #16200 still · TRK servo closed · Tilt servo OFF 	<ul style="list-style-type: none"> ● Tilt sensor inclination adjustment screw ● VR607 (TILT BAL)

Adjusting procedure

1. Search for frame #16200 on the test disc.
2. Set VR607 to the mechanical center.
3. Adjust the tilt sensor inclination adjustment screw so that the tilt error display code is 6, 7, or 8 on the TV monitor or FL tube.

Note: Turn the tilt sensor inclination adjustment screw clockwise more than 1/4 turn from the best point. Then turn the screw counterclockwise 1/4 turn to complete the adjustment.

4. Search for frame #115.
5. Adjust VR607 so that the tilt error display becomes 7.

Note: Regarding the test mode, see page 4.

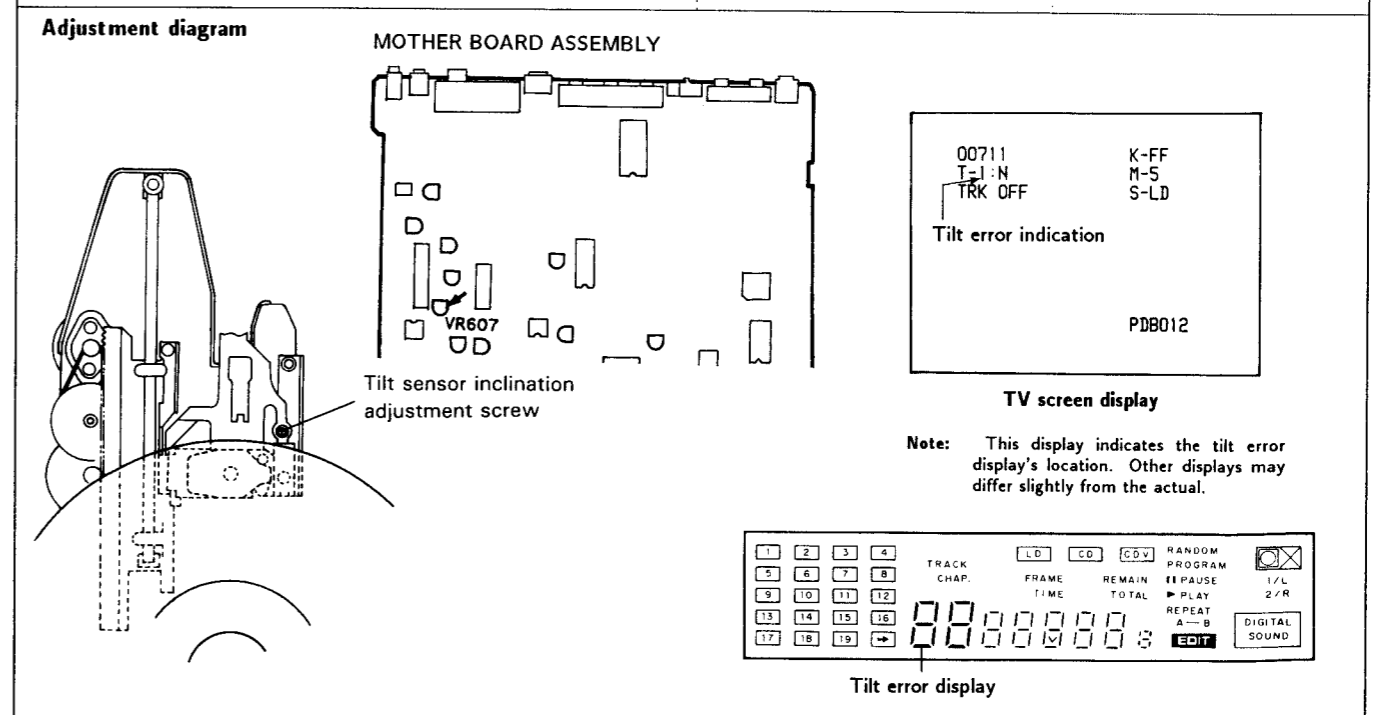

6. INSPECTION AND ADJUSTMENT OF SPINDLE MOTOR CENTERING

[Mechanical Adjustment]

- Purpose : Adjustment of the mechanical Ass'y position to set the spindle motor over the center of the laser beam path when the pickup Ass'y moves toward the inner or outer periphery of the disc.
- Symptom when incorrectly adjusted : There is track skipping and the search time is long.

Measurement equipment & jigs	Measurement equipment connecting points	Player condition	Adjusting points
<ul style="list-style-type: none"> ● Oscilloscope ● Test disc (GGV1003) ● Blade screwdriver ● L.P.F. (0.01μF, 1K) (0.027μF) 	<ul style="list-style-type: none"> ● Oscilloscope CH1 : CN301-9 (TRK ERR) CH2 : CN301-8 (TRK SUM) 	<ul style="list-style-type: none"> ● Test mode · #25000 still · #1 still · TRK servo open · TILT servo ON 	<ul style="list-style-type: none"> ● Spindle motor centering adjustment lever

Adjusting procedure

1. Set the oscilloscope to the X-Y mode and connect CN 301-9 and CN301-8 to CH 1 (X input) and CH 2 (Y input) respectively.
2. Search for frame #25000 on the test disc and look at the resurge waveform.
3. Search for frame #1 and check if the bulge of the resurge waveform is the same as that of frame #25000's resurge waveform.

Note : If the bulge of the resurge waveform in step 3 differs for the inner and outer peripheries, do steps 4 to 6 as follows.

4. Search for frames #25000 and #1 alternately. Adjust the spindle motor centering adjustment screw so that the resurge waveforms match.

5. Change to a compact disc and playback the inner periphery. Check if the resurge waveform is the same as the one shown in Photo 1.
6. If the compact disc's inner periphery resurge waveform differs from the one shown in Photo 3, repeat steps 4 to 5.

Adjustment diagram

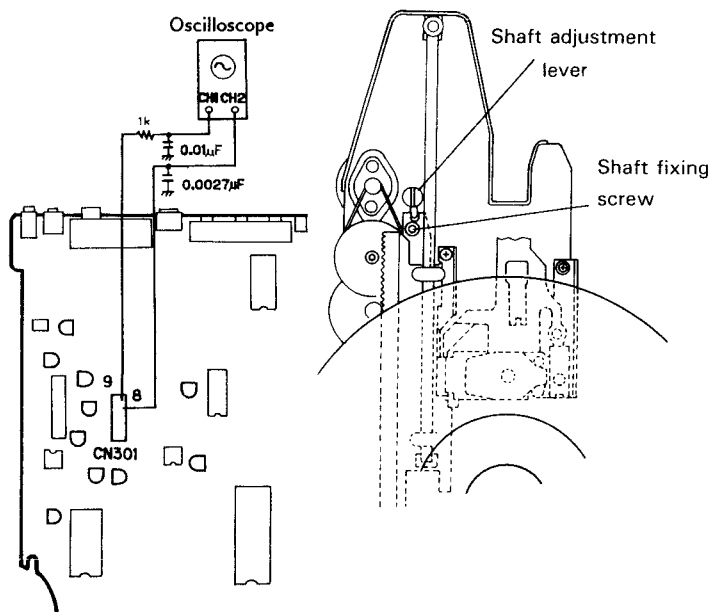

Photo 1 Frame #25000 resurge



Photo 2 Frame #1 resurge



Photo 3 CD inner periphery resurge waveform.

X-Y mode
CH1: 50mV/div
CH2: 5mV/div AC

7. FINE ADJUSTMENT OF GRATING AND TRK BALANCE ADJUSTMENT

[Mechanical Adjustment]

- Purpose: Fine adjustment of the grating to direct the two TRK servo laser beams at the disc at the optimum position over the track.
- Symptom when incorrectly adjusted: There is track skipping.

Measurement equipment & jigs	Measurement equipment connecting points	Player condition	Adjusting points
<ul style="list-style-type: none"> ● Oscilloscope ● Test disc (GGV1003) ● Blade screwdriver ● L.P.F. (0.01μF, 1K) (0.0027μF) 	<ul style="list-style-type: none"> ● Oscilloscope CH1 (X): Between TRK error (CN301-9) and GND. CH2 (Y): TRK sum (CN301-8) 	<ul style="list-style-type: none"> ● Test mode · PLAY mode · TRK servo loop open · TILT servo ON 	<ul style="list-style-type: none"> ● Grating screw on the mechanical Ass'y ● VR602

Adjusting procedure

1. Playback the disc at frame #3000 (inner periphery) or thereabouts.
2. Set the oscilloscope to the X-Y mode, and connect CN 301-9 (TRK error) and CN301-8 (TRK sum) to the X input and the Y input respectively. Then look at the resurge waveform.
3. Insert the blade screwdriver tip into the grating adjustment hole. Adjust the grating to minimize the Y direction of the resurge waveform. (Refer to adjustment diagram on page 11.)
4. Check if a equals b for the resurge waveform. If a is not equal to b, adjust VR602 (TRK balance).
5. Close the TRK servo loop and check if the image on the TV screen is normal.

Adjustment diagram

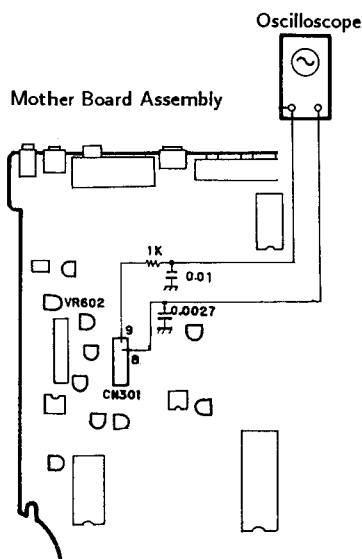

- Oscilloscope range:

CH1(X): 50mV/div

CH2(Y): 5mV/div

Set the probe to mu1 only for Y.

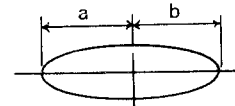

Frame #2000

Resurge waveform

Y direction minimum, a=b.

8. FCS SERVO LOOP GAIN ADJUSTMENT

[Mechanical Adjustment]

- Purpose : Setting the FCS servo's loop gain to the optimum setting.
- Symptom when incorrectly adjusted : Playability is poor.

Measurement equipment & jigs	Measurement equipment connecting points	Player condition	Adjusting points
<ul style="list-style-type: none"> ● Oscilloscope ● Test disc (GGV1003) ● AF oscillator (1.7 kHz/10 Vp-p) ● Resistor (47 k ohm) 	<ul style="list-style-type: none"> ● Oscilloscope CH 1(X) : Between FCS IN (CN301-6) and GND. CH 2(Y) : FCS error (CN301-5) 	<ul style="list-style-type: none"> ● Test mode · STILL mode · TRK servo loop close · TILT servo ON 	<ul style="list-style-type: none"> ● VR604

Adjusting procedure

1. Search for frame #15000 on the test disc.
2. Connect CN301-5 and CN301-6 as shown below.
3. Set the oscilloscope to the X-Y mode and look at the resurge waveform.
4. Adjust VR604 so that the resurge waveform is symmetric with respect to the X and Y axes. (See Photos 1 and 2.)

Adjustment diagram

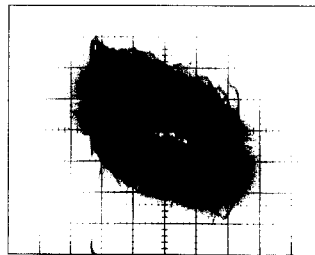

Photo 1 Inadequate adjustment.

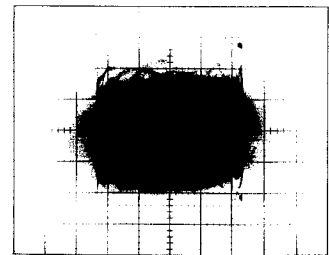
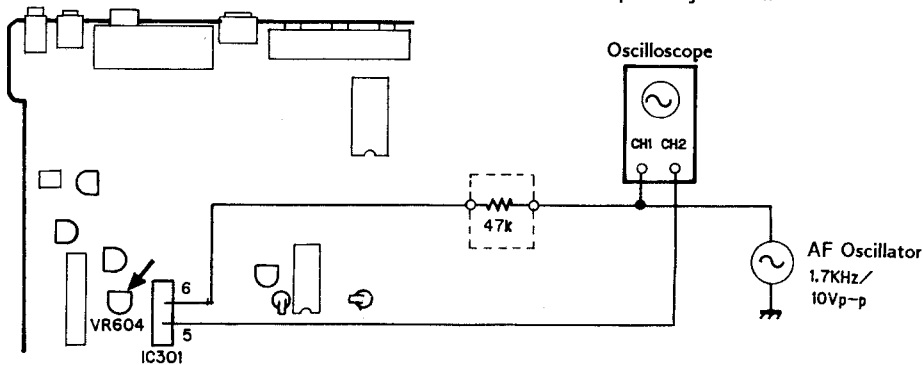

Photo 2 After adjustment.

Mother Board Assembly



9. TRK SERVO LOOP GAIN ADJUSTMENT

[Mechanical Adjustment]

- Purpose : Optimum setting of the TRK servo's loop gain.
- Symptom when incorrectly adjusted : Playability is poor.

Measurement equipment & jigs	Measurement equipment connecting points	Player condition	Adjusting points
<ul style="list-style-type: none"> ● Oscilloscope ● Test disc (GGV1003) ● AF oscillator (3.0kHz/10 V_{p-p}) ● Resistor(47kΩ) 	<ul style="list-style-type: none"> ● Oscilloscope CH 1(X) : CN301-10 (TRK IN) CH 2(Y) : CN301-9 (TRK ERR) 	<ul style="list-style-type: none"> ● Test mode · Still at frame #15000 (Black screen) · TRK servo closed. · Tilt servo ON 	<ul style="list-style-type: none"> ● VR603

Adjusting procedure

1. Search for frame #15000 on the test disc.
2. Connect CN301-10(TRK IN) and CN301-9(TRK ERR) as shown in the diagram below.
3. Set the oscilloscope to the X-Y mode and watch the resurge waveform.
4. Adjust VR603 to make the resurge waveform symmetrical with respect to the X and Y axes.(See Photos 1 and 2.)

Note : If the adjustment cannot be made, either set the 47kΩ resistor to 33kΩ or increase the oscillator's output.

Adjustment diagram

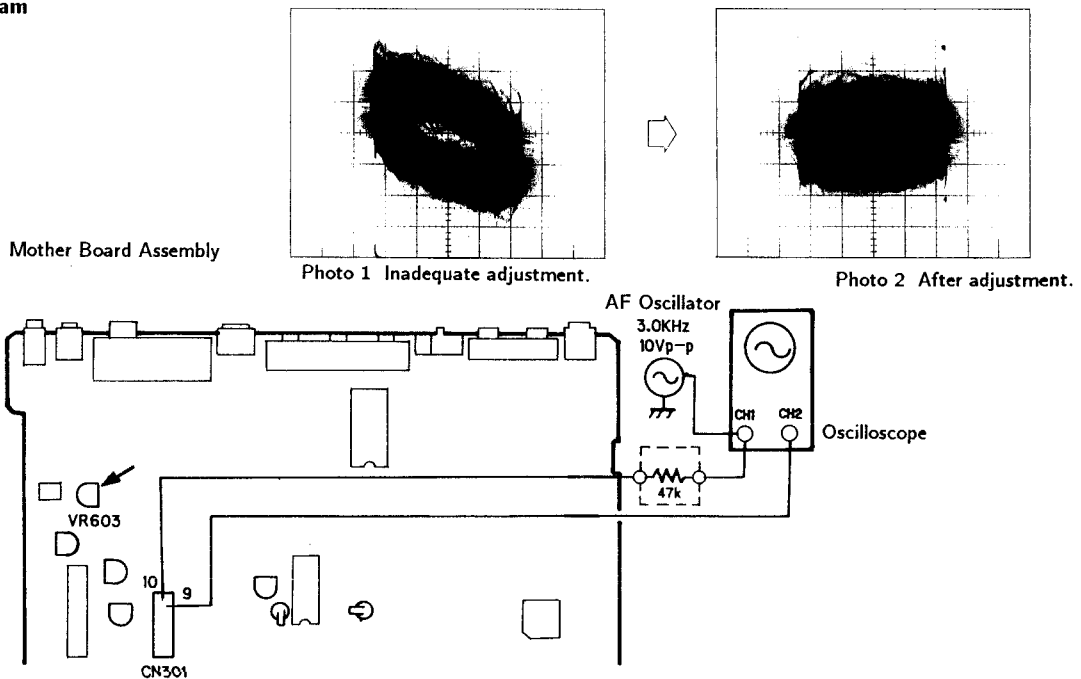

10. RF GAIN ADJUSTMENT

[Mechanical Adjustment]

- Purpose : Optimization of the RF signal's amplitude.
- Symptom when incorrectly adjusted : There is prominent dropout. Scan and search operations are unstable.

Measurement equipment & jigs	Measurement equipment connecting points	Player condition	Adjusting points
<ul style="list-style-type: none"> ● Oscilloscope ● Test disc (GGV1003) 	<ul style="list-style-type: none"> ● Oscilloscope CH 1 : Between RF (CN301-2) and GND. 	<ul style="list-style-type: none"> ● Test mode <ul style="list-style-type: none"> • STILL mode • TRK servo loop close • TILT servo ON 	<ul style="list-style-type: none"> ● VR601

Adjusting procedure

1. Search for frame #15000 on the test disc.
2. Connect CN301-2 (RF) to the oscilloscope and look at the RF signal.
3. Adjust VR601 so that the RF signal's amplitude becomes $300\text{mV} \pm 50\text{mV}$. (See Photo 1.)

Adjustment diagram

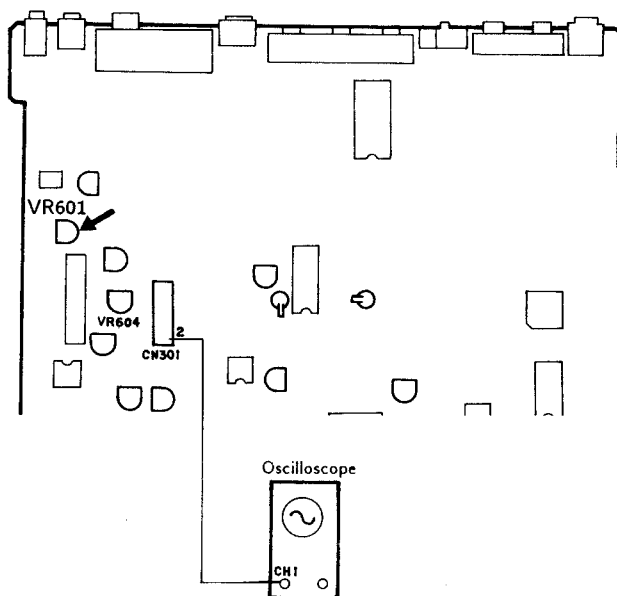

Oscilloscope range AC
5mV/div
2mS/div

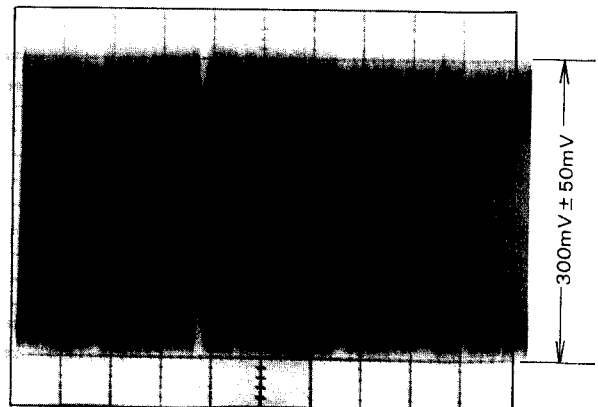

Photo 1

3. 4 ELECTRICAL ADJUSTMENTS

11. 14.31818 MHz

[Electrical Adjustment]

<ul style="list-style-type: none"> ● Purpose : Adjustment of the standard clock frequency. ● Symptom when incorrectly adjusted : Incorrect color tint, no TV color lock, and VCXO cannot be adjusted during LDD playback. 			
Measurement equipment & jigs	Measurement equipment connecting points	Player condition	Adjusting points
<ul style="list-style-type: none"> ● Frequency counter ● Oscilloscope 10 : 1 probe 	<ul style="list-style-type: none"> ● JP (14.31818) 	<ul style="list-style-type: none"> ● Normal mode • STOP mode (Blueback screen) 	<ul style="list-style-type: none"> ● VC901
Adjusting procedure			
<p>1. Adjust VC901 on the mother board Ass'y so that the frequency becomes 14.31818 MHz in the STOP mode (blueback screen).</p> <p><i>Note : The frequency counter probe should be an oscilloscope 10 : 1 probe.</i></p>			
Adjustment diagram			
<p>The diagram illustrates the connection for adjusting the clock frequency. A frequency counter is connected to the VC901 component on the motherboard. The counter's display shows 14.31818 MHz. A label '4f30' points to a specific location on the board, and another label '14.3181' points to the VC901 component. The counter is connected to the VC901 component via a probe.</p>			

12. VCO CENTERING FREQUENCY ADJUSTMENT

[Electrical Adjustment]

- Purpose : Setting the optimum delay time for the time axis error compensation CCD.
- Symptom when incorrectly adjusted : It is difficult to color lock, there is color lock delay after a search, and there is flicker on the white screen.

Measurement equipment & jigs	Measurement equipment connecting points	Player condition	Adjusting points
<ul style="list-style-type: none"> ● Oscilloscope ● Test disc (GGV1003) 	<ul style="list-style-type: none"> ● Oscilloscope CH 1 : C489 lead wire. CH 2 : C519 lead wire. (CCD OUT) 	<ul style="list-style-type: none"> ● Normal mode ● STILL mode 	<ul style="list-style-type: none"> ● VR481

Adjusting procedure

1. Connect the C489 lead wire and the C519 lead wire to CH 1 and CH 2 of the oscilloscope respectively.

CH 1 : Video signal *before* time axis error compensation.
 CH 2 : Video signal *after* time axis error compensation.

2. Search for frame #5100 on the test disc. Adjust VR481 so that the center of CH 1's video signal jitter is delayed by $71\mu\text{s}$ ($1\text{H} + 7.5\mu\text{s}$) with respect to the CH 2's video signal.

Note : Do not confuse CH 1 and CH 2.

Adjustment diagram

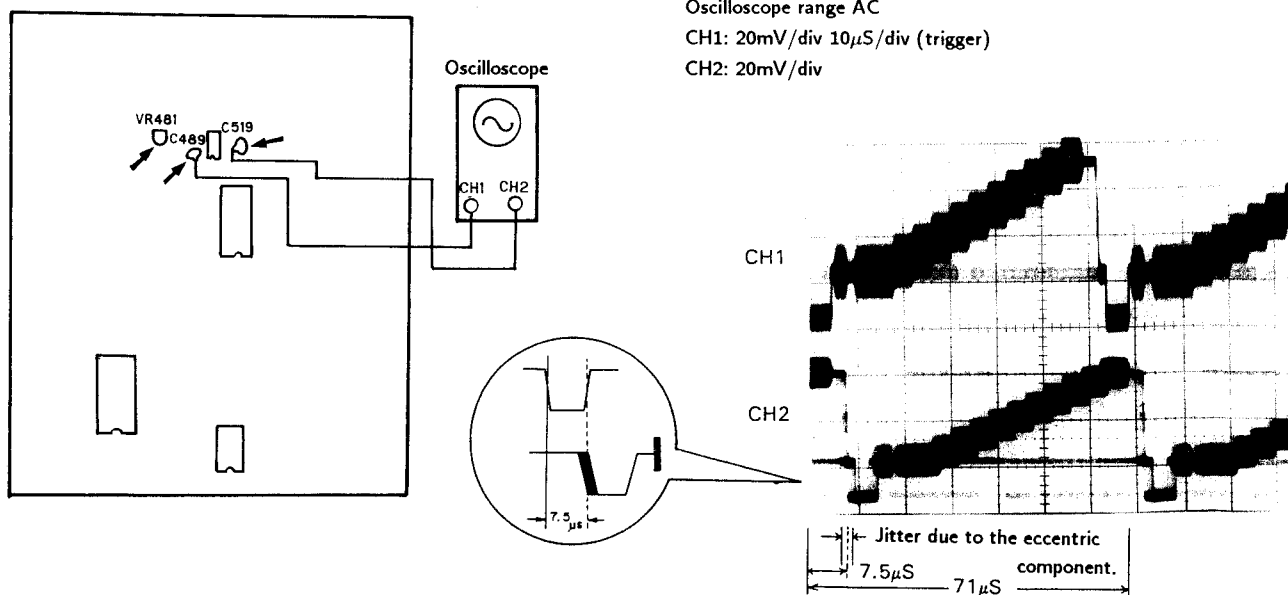

13. OUTPUT VIDEO LEVEL ADJUSTMENT

[Electrical Adjustment]

- Purpose : Setting the video signal level to 1Vp-p(75Ω termination).
- Symptom when incorrectly adjusted : The player starts up midway without reading the data. The screen is too bright or too dark.

Measurement equipment & jigs	Measurement equipment connecting points	Player condition	Adjusting points
<ul style="list-style-type: none"> ● Oscilloscope ● Test disc (GGV1003) 	<ul style="list-style-type: none"> ● Oscilloscope ● Player video output terminal 	<ul style="list-style-type: none"> ● Normal mode ● STILL mode ● #19900 	<ul style="list-style-type: none"> ● VR482

Adjusting procedure

Note : Since the video output terminal will be connected to a TV monitor, it is to have 75Ω termination. (If it is connected to a TV via VHF OUT, terminate the video output terminal with a resistance of 75Ω.)

1. Search for frame #19900 on the test disc.
2. Adjust VR482 so that the white level becomes $1V \pm 5\%$ from the video signal's sync tip level.

Adjustment diagram

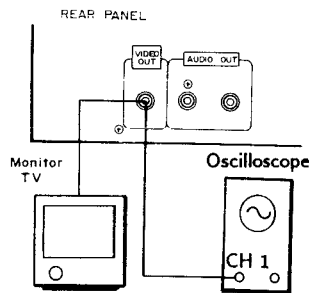

Oscilloscope range AC
CH1: 20mV/div 10μS/div (trigger)

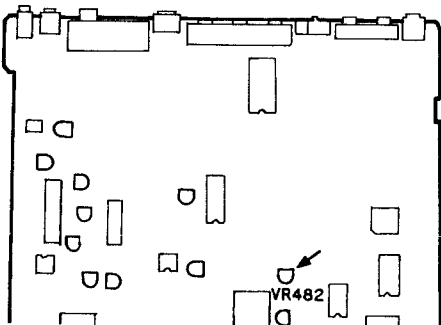
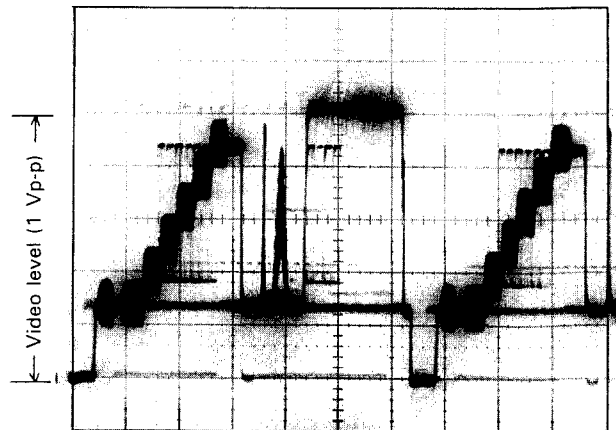

14. 1H Delay Video Level Adjustment

[Electrical Adjustment]

- Purpose : Equalization of the video levels of the 1 H delay video signal and the main line video signal.
- Symptom when incorrectly adjusted : If the 1 H delay video signal level is high, white dropout will be noticeable and there will be H shifting. (Horizontal stripes across the screen.)
If the 1 H delay video signal level is low, black dropout will be noticeable.

Measurement equipment & jigs	Measurement equipment connecting points	Player condition	Adjusting points
<ul style="list-style-type: none"> ● Oscilloscope ● Test disc (GGV1003) 	<ul style="list-style-type: none"> ● Oscilloscope CH 1 : Between IC401's pin 42 and GND. CH 2 : Pin 40 of IC401. 	<ul style="list-style-type: none"> ● Normal mode ● STILL mode 	<ul style="list-style-type: none"> ● VR441

Adjusting procedure

1. Search for frame #3800 on the test disc.
2. Adjust VR441 so that the 1 H delay video level (CH 1) becomes the same as the main line video level (CH 2). (See Photo 1.)

Note : The video level is the level between the SYNC tip and the white peak.

Adjustment diagram

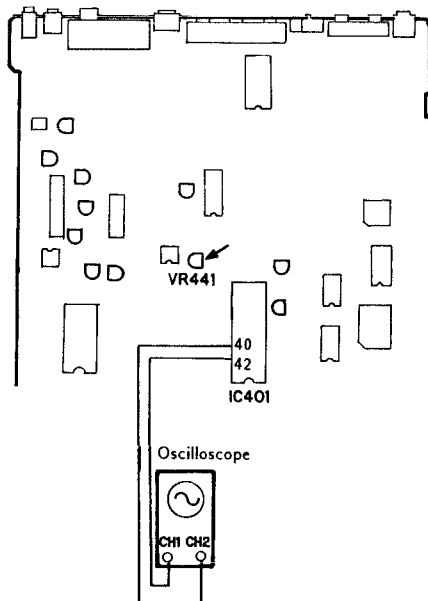

Oscilloscope range. AC
CH1: 20mV/div 10 μ S/div
CH2: 20mV/div

Main video signal

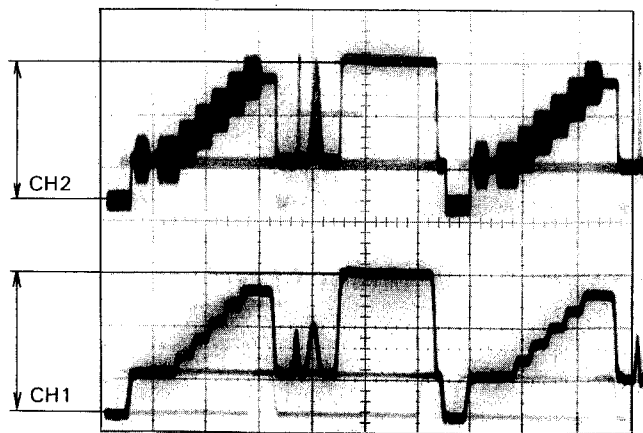

Photo 1

15. Color Tint Error Signal Level Adjustment

[Electrical Adjustment]

- Purpose : Optimization of the color tint compensation section's error signal level.
- Symptom when incorrectly adjusted : There is substantial color irregularity. (Especially for CDV.)

Measurement equipment & jigs	Measurement equipment connecting points	Player condition	Adjusting points
<ul style="list-style-type: none"> ● TV monitor ● Test disc (GGV1003) 	<ul style="list-style-type: none"> ● TV monitor 	<ul style="list-style-type: none"> ● Normal mode ● STILL mode 	<ul style="list-style-type: none"> ● VR521

Adjusting procedure

1. Search for frame #8000 on the test disc. (Magenta screen)
2. Adjust VR521 until the color irregularity on the magenta screen is minimized.

Adjustment diagram

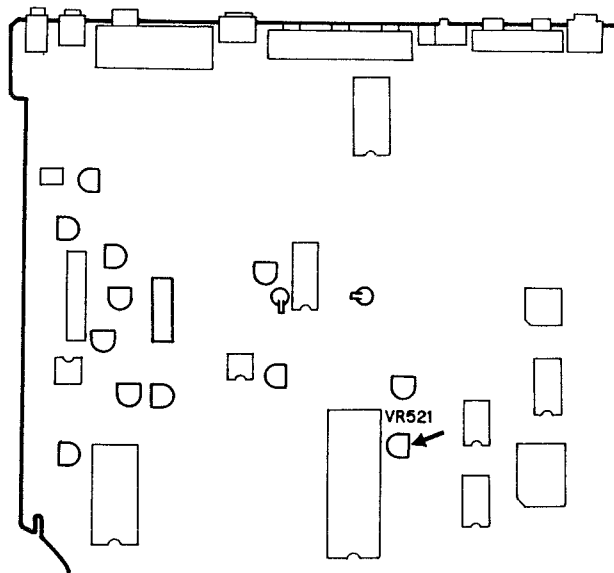

4. ABBREVIATIONS TABLE

A		M	
ACCEL	ACCELERATE	MTR	MOTOR
ACOM	AUDIO COMPENSATOR	μ COM	MICROCOMPUTER
AF	AUDIO FREQUENCY		
AFM	ANALOGUE FM AUDIO	P	
AGC	AUTOMATIC GAIN CONTROL	PD	PHOTO DETECTOR
ALC	AUTOMATIC LEVEL CONTROL	PB	PLAYBACK
ANT	ANTENNA	PLL	PHASE LOCKED LOOP
ATC	AUTOMATIC THRESHOLD CONTROL	P-ON	POWER ON
B		R	
BAL	BALANCE	R-CH	RIGHT CHANNEL
		RTN	RETURN
C		RFMD	RADIO FREQUENCY MODULATOR
CAV	CONSTANT ANGULAR VELOCITY	RST	RESET
CLV	CONSTANT LINEAR VELOCITY	REV	REVERSE
CCD	CHARGE COUPLED DEVICE	RF-CORR	RF CORRECTION
CD	COMPACT DISC		
CK	CLOCK	S	
CONT	CONTROL	SPDL	SPINDLE
C-SYNC	COMPOSITE SYNCHRONIZATION	SLD	SLIDER
CX	AFM NOISE REDUCTION	SO	SERIAL OUTPUT
		SI	SERIAL INPUT
D		SCK	SERIAL CLOCK
DEM	DEMODULATOR	SC	CHIP SELECT
DIG/ANA	DIGITAL/ANALOGUE	SYPS	SYSTEM POWER SUPPLY
DL	DELAY LINE	SW	SWITCH
DSP	DIGITAL SIGNAL PROCESSOR	S/H	SAMPLE & HOLD
DOS	DROP OUT SENSE	SENS	SENSITIVITY
DRV	DRIVER	SQ	SQUELCH
E		T	
EFM	EIGHT TO FOURTEEN MODULATION	TRK or TRKG	TRACKING
ERR	ERROR	TP	TEST POINT
EQ	EQUALIZER	TBC	TIME BASE CORRECTION
EXT	EXTERNAL	TGL	TOGGLE
F		U	
FCS or FOCS	FOCUS	UNREG	UNREGULATED
FG	FREQUENCY GENERATOR		
FL	FLUORESCENT LAMP	V	
FTS	FOCUS TRACKING SLIDER	V-SYNC	VERTICAL SYNCHRONIZATION
F _{sc}	CHROMINANCE SUBCARRIER FREQUENCY	VSQ	VIDEO SQUELCH
FWD	FORWARD	VPS	VIDEO PHASE SHIFTER
		VDEM	VIDEO DEMODULATOR
G		VHF	VERY HIGH FREQUENCY
GFS	GET FRAME SYNC LOCK	VCA	VOLTAGE CONTROLLED AMPLIFIER
GND	GROUND	VCO	VOLTAGE CONTROLLED OSCILLATOR
H		X	
HLD	HOLD	X...	ACTIVATED WHEN LOW VOLTAGE
H SYNC	HORIZONTAL SYNCHRONIZATION		
I			
INT	INTERNAL		
IR	INFRARED RAYS		
L			
L-CH	LEFT CHANNEL		
LAT	LATCH		
LD	LASER DIODE		
LPF	LOW PASS FILTER		
LIM	LIMITER		