

Service Manual

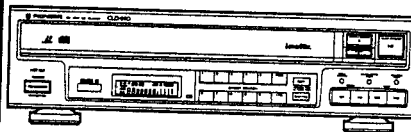

ORDER NO.
ARP2281

CD CDV LD PLAYER

CLD-990

- This manual is applicable to the CLD-990/KUC type.
- As to the circuit descriptions, refer to the CLD-1090 service guide (ARP2234).

CONTENTS

1. SAFETY INFORMATION	2
2. EXPLODED VIEWS AND PARTS LIST	3
3. PACKING	18
4. P.C. BOARD LOCATION	19
5. SCHEMATIC AND P.C. BOARDS DIAGRAM	20
6. P.C.B's PARTS LIST	55
7. DISASSEMBLY	61
8. ADJUSTMENTS	69
9. ABBREVIATIONS TABLE	93
10. PANEL FACILITIES	94
11. SPECIFICATIONS	96

PIONEER ELECTRONIC CORPORATION 4-1, Meguro 1-Chome, Meguro-ku, Tokyo 153, Japan
PIONEER ELECTRONICS SERVICE INC. P.O. Box 1760, Long Beach, California 90801 U.S.A.
PIONEER ELECTRONICS OF CANADA, INC. 505 Cochrane Drive, Markham, Ontario L3R 8E3 Canada
PIONEER ELECTRONIC [EUROPE] N.V. Keetberglaan 1, 9120 Beveren, Belgium
PIONEER ELECTRONICS AUSTRALIA PTY. LTD. 178-184 Boundary Road, Braeside, Victoria 3195, Australia TEL: [03] 580-9911

© PIONEER ELECTRONIC CORPORATION 1991

This service manual is intended for qualified service technicians; it is not meant for the casual do-it-yourselfer. Qualified technicians have the necessary test equipment and tools, and have been trained to properly and safely repair complex products such as those covered by this manual.

Improperly performed repairs can adversely affect the safety and reliability of the product and may void the warranty. If you are not qualified to perform the repair of this product properly and safely, you should not risk trying to do so and refer the repair to a qualified service technician.

WARNING

Lead in solder used in this product is listed by the California Health and Welfare agency as a known reproductive toxicant which may cause birth defects or other reproductive harm (California Health & Safety Code, Section 25249.5).

When servicing or handling circuit boards and other components which contain lead in solder, avoid unprotected skin contact with the solder. Also, when soldering do not inhale any smoke or fumes produced.

1. SAFETY INFORMATION

(FOR USA MODEL ONLY)

1. SAFETY PRECAUTIONS

The following check should be performed for the continued protection of the customer and service technician.

LEAKAGE CURRENT CHECK

Measure leakage current to a known earth ground (water pipe, conduit, etc.) by connecting a leakage current tester such as Simpson Model 229-2 or equivalent between the earth ground and all exposed metal parts of the appliance (input/output terminals, screwheads, metal overlays, control shaft, etc.). Plug the AC line cord of the appliance directly into a 120V AC 60Hz outlet and turn the AC power switch on. Any current measured must not exceed 0.5mA.

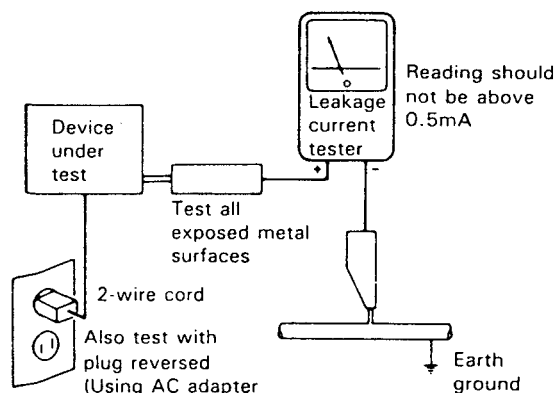

AC Leakage Test

ANY MEASUREMENTS NOT WITHIN THE LIMITS OUTLINED ABOVE ARE INDICATIVE OF A POTENTIAL SHOCK HAZARD AND MUST BE CORRECTED BEFORE RETURNING THE APPLIANCE TO THE CUSTOMER.

2. PRODUCT SAFETY NOTICE

Many electrical and mechanical parts in the appliance have special safety related characteristics. These are often not evident from visual inspection nor the protection afforded by them necessarily can be obtained by using replacement components rated for voltage, wattage, etc. Replacement parts which have these special safety characteristics are identified in this Service Manual.

Electrical components having such features are identified by marking with a Δ on the schematic and on the parts list in this Service Manual.

The use of a substitute replacement component which does not have the same safety characteristics as the PIONEER recommended replacement one, shown in the parts list in this Service Manual, may create shock, fire, or other hazards.

Product Safety is continuously under review and new instructions are issued from time to time. For the latest information, always consult the current PIONEER Service Manual. A subscription to, or additional copies of, PIONEER Service Manual may be obtained at a nominal charge from PIONEER.

2. EXPLODED VIEWS AND PARTS LIST

2.1 EXTERIOR SECTION

Parts List

Mark No.	Description	Part No.	Mark No.	Description	Part No.
1	Bonnet assembly - S	VXX1267	11	Screw	BBZ30P080FCC
2	Disc pad(L)	VEC1191	12	Screw	BCZ40P060FZK
3	Disc pad(S)	VEC1192	13	Screw	BBZ30P060FCC
4	Tray assembly - S	VXX1453	101	Center angle	
5	Tray rubber	VEB1089	102	Cushion	
6	• • • • •		103	Tray angle	
7	Screw	PCZ30P080FMC	104	Carry label	
8	Screw	BPZ30P080FCU	105	Tray reinforced plate	
9	Screw	CPZ30P100FMC	106	Tray	
10	Screw	BPZ30P140FMC	107	Side plate	

NOTES:

- Parts without part number cannot be supplied.
- The Δ mark found on some component parts indicates the importance of the safety factor of the part. Therefore, when replacing, be sure to use parts of identical designation.
- Parts marked by "⊙" are not always kept in stock. Their delivery time may be longer than usual or they may be unavailable.

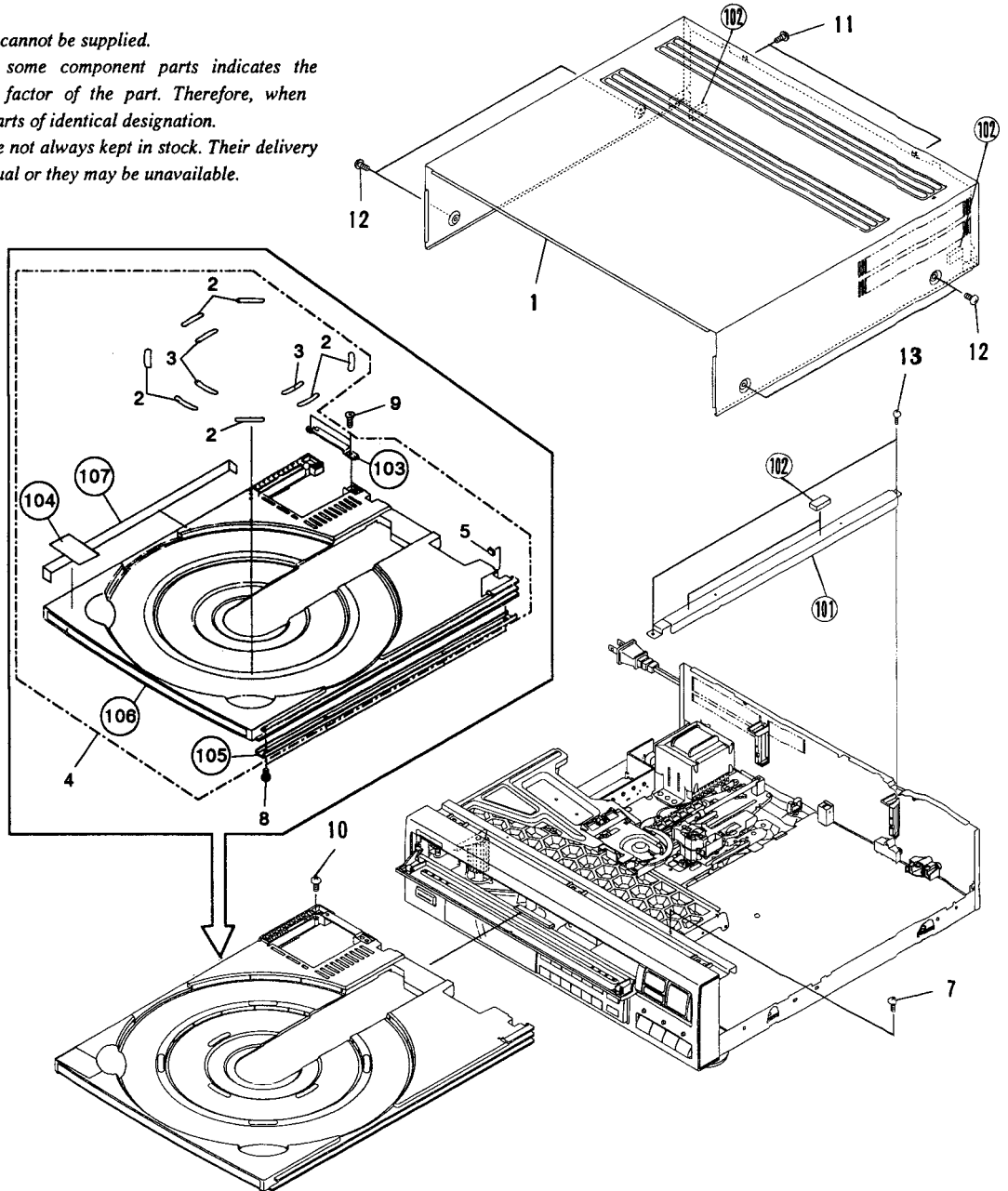

2.2 FRONT PANEL SECTION

Parts List

Mark	No.	Description	Part No.
	1	Front panel assembly - S	VXX1576
	2	
	3	
	4	Side panel	VNK1667
	5	Sub panel	VNK1669
	6	Ten key	VNK1670
	7	Door dump rubber	VEB1033
	8	Roller	VNL1042
	9	O/C key	VNK1666
	10	Main key	VNK1665
	11	Door assembly - S	VXX1548
	12	Power key	VNK1668
	13	Front door assembly	VXA1572
	14	Door plate	VNE1482
	15	Screw	BPZ20P040FZK
	16	Dumper assembly	VXA1053
	17	Screw	BBZ20P050FMC
	18	Screw	BPZ26P060FCU
	19	Door spring	VBH1144
	20	Screw	IPZ26P060FCC

Mark	No.	Description	Part No.
	101	Front panel	
	102	Name plate	
	103	PWSB	
	104	Reinforced plate	
	105	IRAB	
	106	FL filter	
	107	FLKY	
	108	Display panel	

Note : 103. PWSB, 105. IRAB and 107. FLKY are supplied as VWM1180 FLKB.

Front panel section

A

B

C

D

A

B

C

D

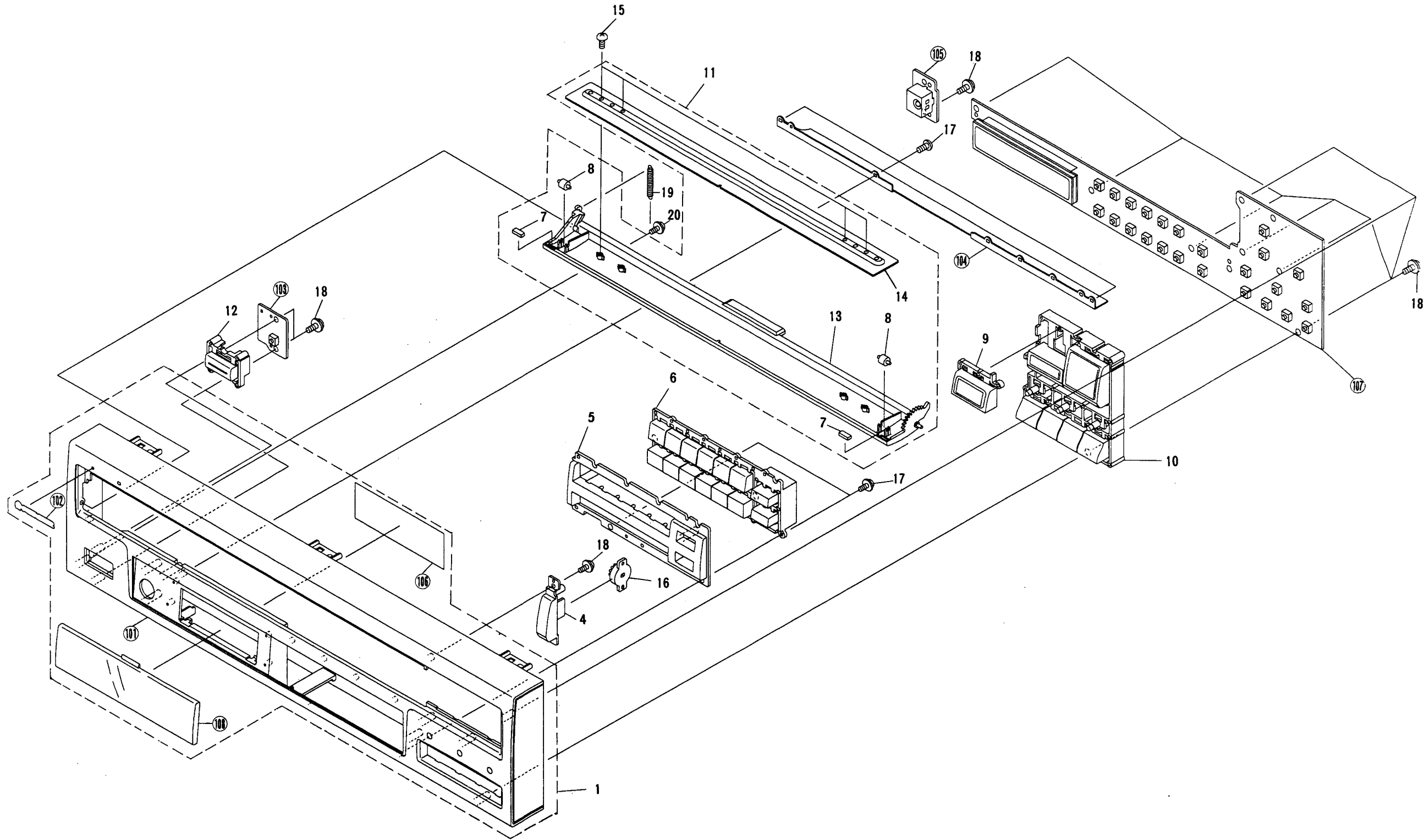

1

2

3

4

5

6

1

2

3

4

5

6

6

2.3 TOP VIEW SECTION

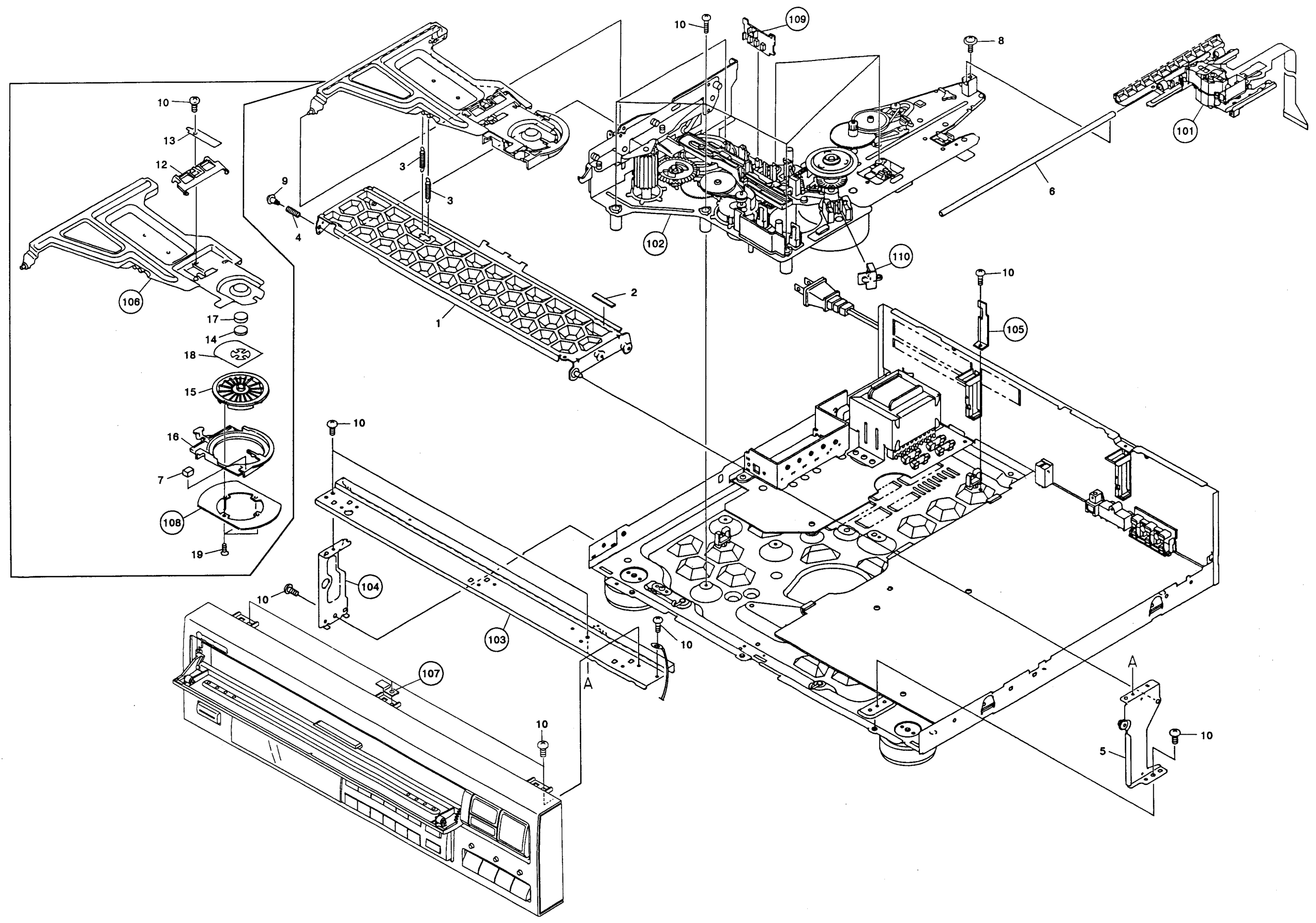

A
B
C
D

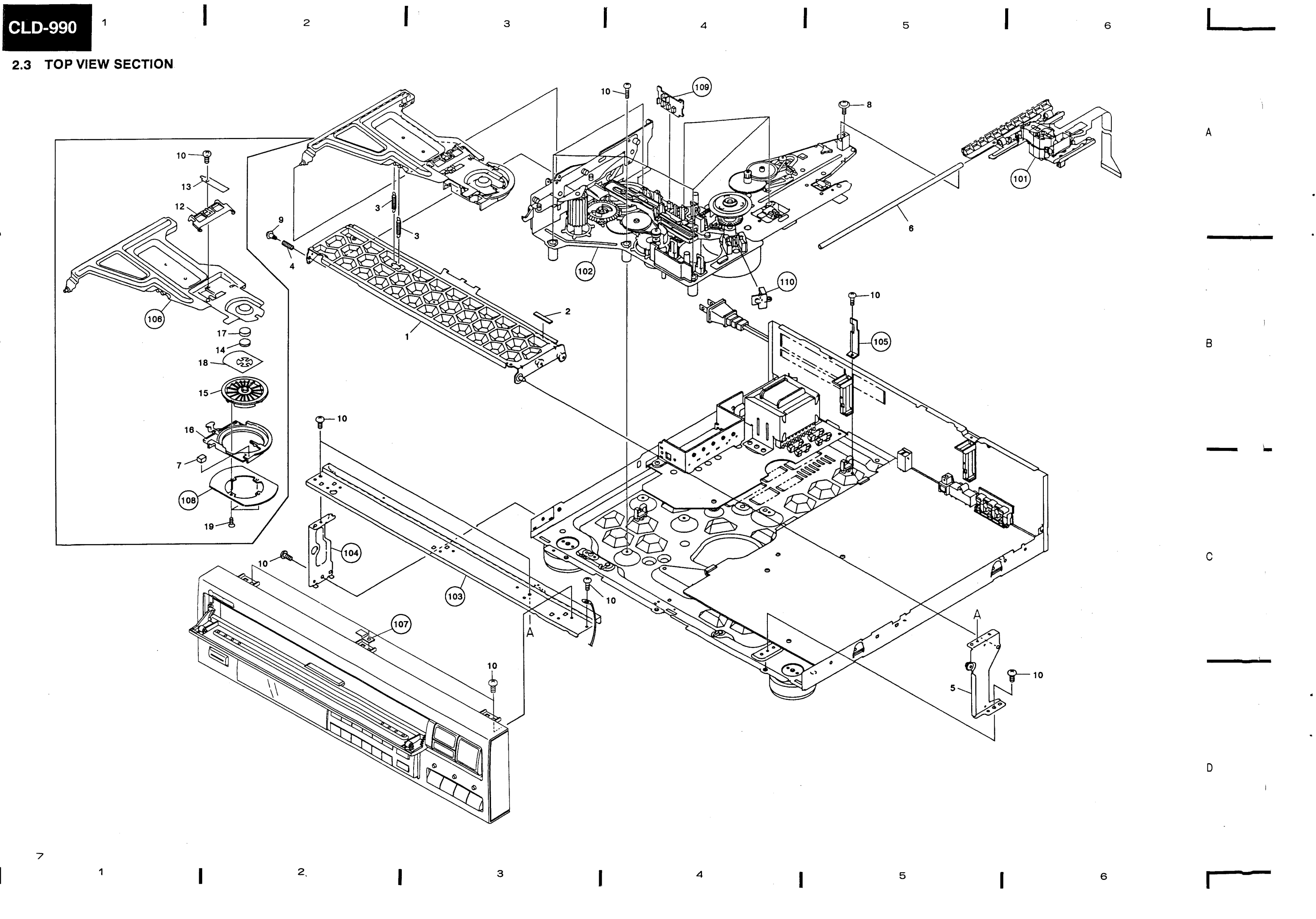

2.3 TOP VIEW SECTION

Parts List

<u>Mark</u>	<u>No.</u>	<u>Description</u>	<u>Part No.</u>	<u>Mark</u>	<u>No.</u>	<u>Description</u>	<u>Part No.</u>
	1	Clamper arm (A) assembly	VXA1319		101	Rack assembly	
	2	Rubber (A)	VEB1084		102	Mechanism assembly	
	3	Clamper spring	VBH1094		103	Front angle	
	4	Arm spring	VBH1093		104	Side stay (L)	
	5	Side stay (R) assembly	VXA1529		105	SM head holder	
	6	Carriage shaft	VLL1177		106	Clamper arm (B)	
	7	Clamper pad	VEC1264		107	Earth plate	
	8	Screw (B)	VBA1018		108	Stabilizer	
	9	Screw (B)	VBA1008		109	SW assembly	
	10	Screw	BBZ30P060FCC		110	FG assembly	
	11	• • • • •					
	12	Parallel link	VNL1254				
	13	Plate spring	VBK1014				
	14	Ball holder	VNL1289				
	15	Clamper S	VNL1248				
	16	Clamper holder	VNL1205				
	17	Rubber sheet	VEB1114				
	18	Thrust holder	VBK1018				
	19	Screw	CPZ20P050FMC				

Note : 109. SW assembly and 110. FG assembly are supplied as VWM1179 mother board assembly.

2.4 BASE SECTION

Parts List

Mark	No.	Description	Part No.	Mark	No.	Description	Part No.
	1	Power transformer	VTT1099		101	PCB spacer	
	2	Strain relief	CM - 22C		102	P plate holder	
	3	AC Power cord	PDG1015		103	Wire clip (B)	
	4			104	Base chassis	
	5	Fuse (3A)	VEK - 018		105	Rear panel	
	6	Tray stopper	VNL1202		106	Stopper	
	7	Insulator assembly	VXA1686		107	Insulator	
	8	Insulator	VNK1095		108	MAIN assembly	
	9	Insulator assembly	VXA1687		109	Cord holder	
	10	SYPS assembly	VWR1103				
	11	Door clump rubber	VEB1033				
	12	Screw	BBZ30P080FCC				
	13	Screw	BBZ30P060FCC				
	14	Screw	BCZ40P080FZK				
	15	Screw	IPZ30P160FMC				

Note : 108. MAIN assembly is supplied as VWM1179 mother board assembly.

Bottom view section

A

B

C

D

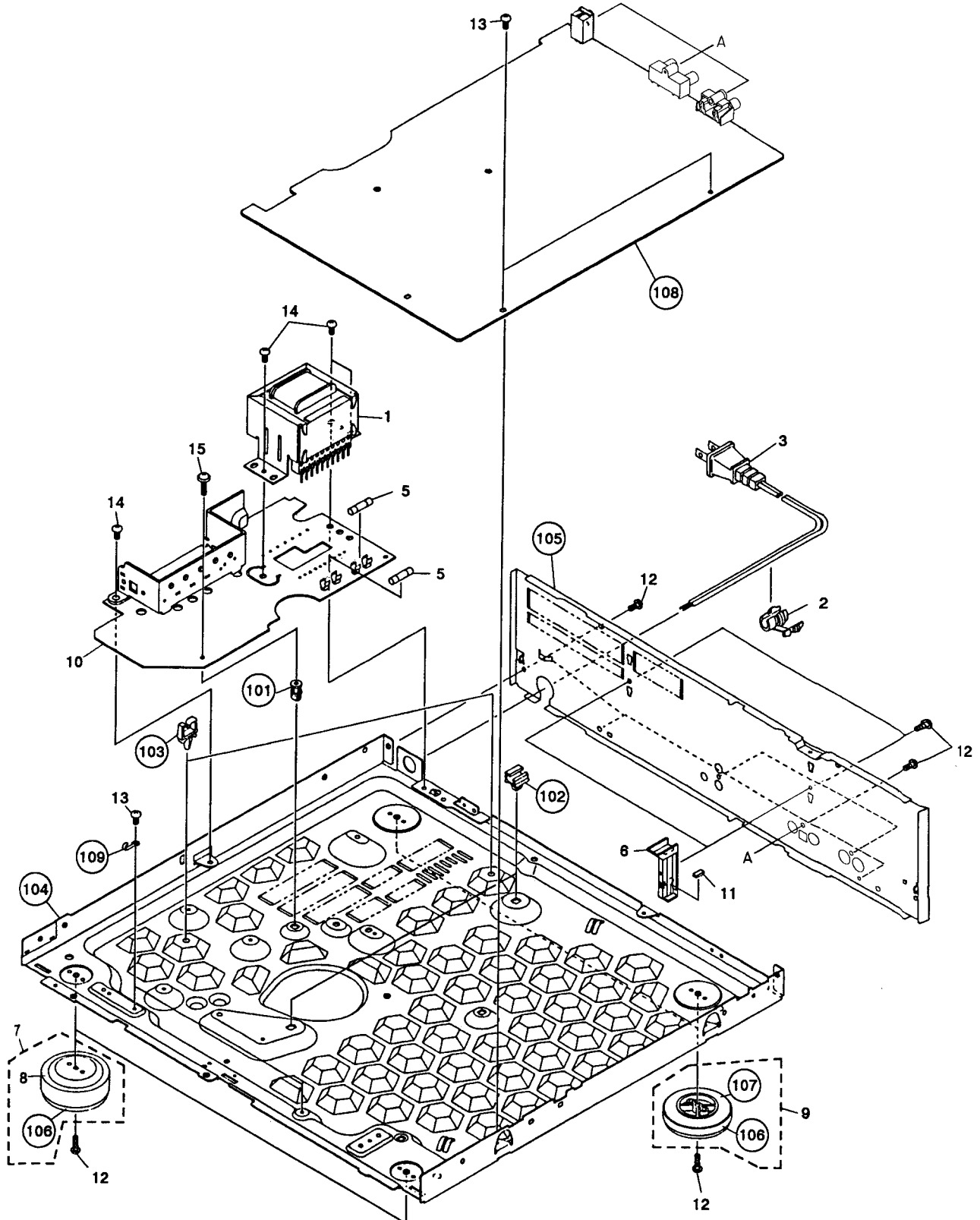

1

2

3

1

2

3

2.5 MECHANISM ASSEMBLY (1)

Parts List

Mark No.	Description	Part No.	Mark No.	Description	Part No.
1	Plate spring	VBK1013	6	• • • • •	
2	Thrust spring	VBH1073	7	Screw	PMA30P050FMC
3	Tilt shaft	VLL1175	8	Screw	ABZ26P050FMC
4	Tilt pulling spring	VBH1074			
5	Belt	PEB1013	101	Cam head stopper	

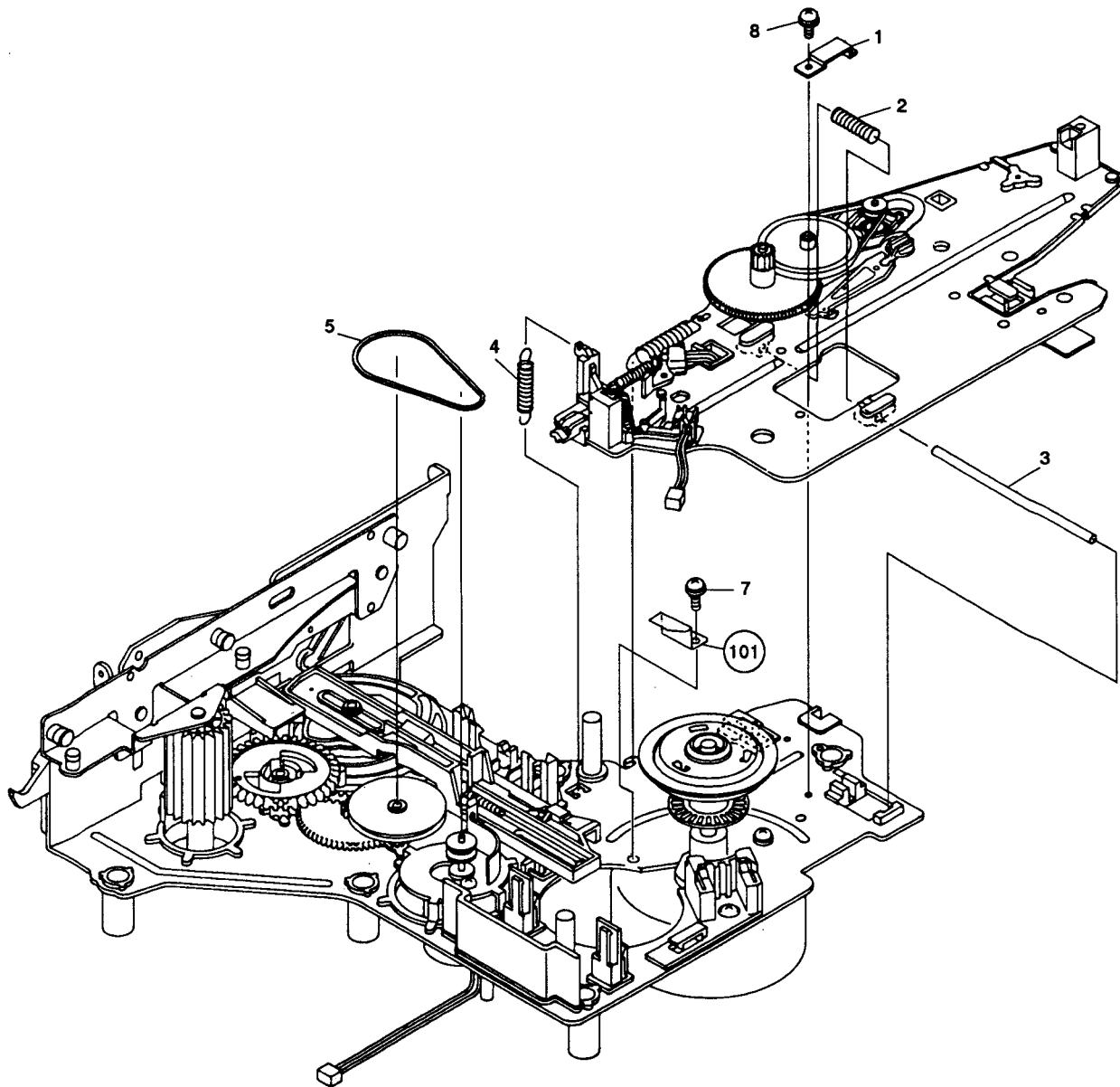

A

B

C

D

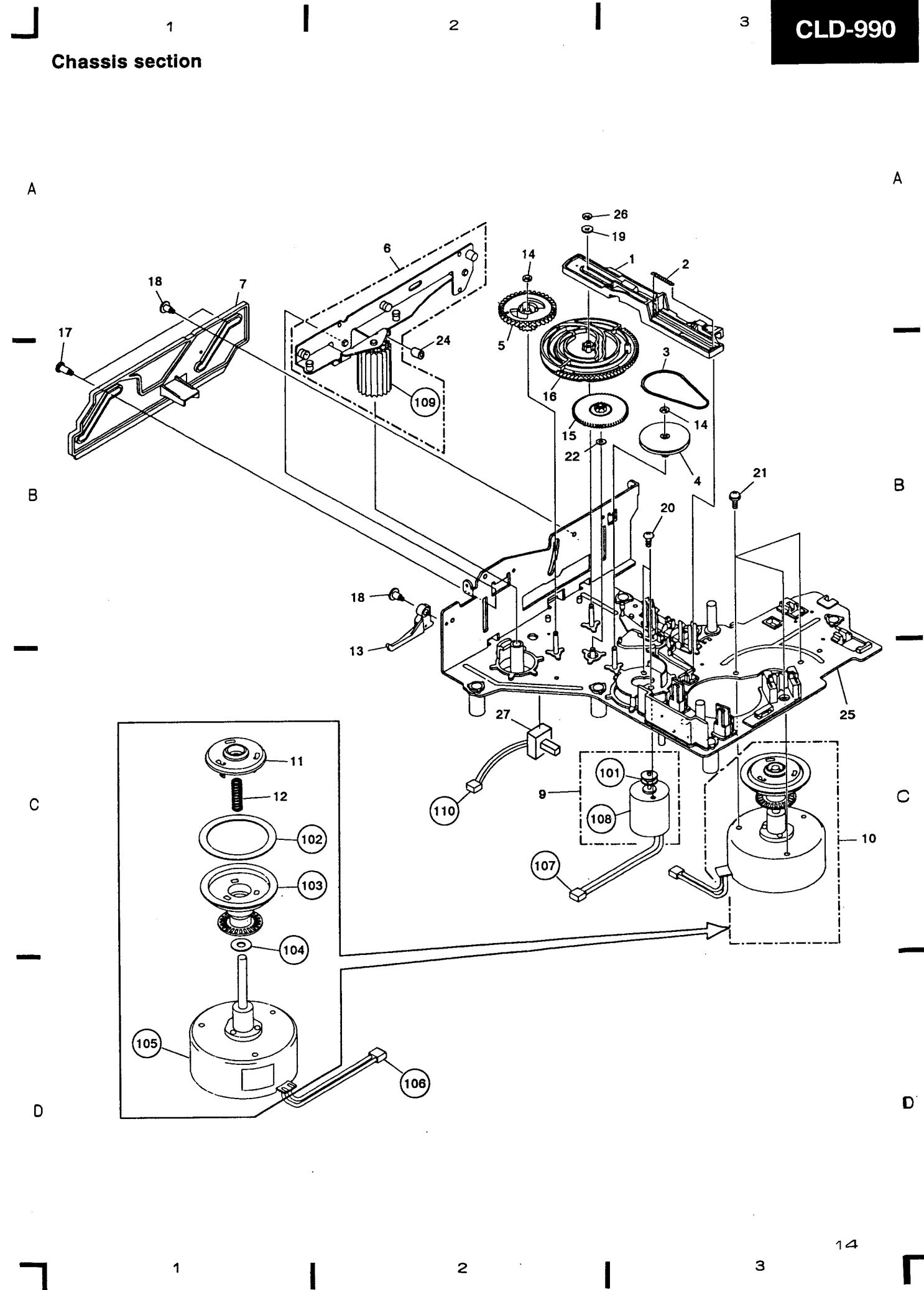

2.6 CHASSIS SECTION

Parts List			Parts List		
Mark No.	Description	Part No.	Mark No.	Description	Part No.
1	Spring slanting cam	VNL1191	101	Motor pulley	
2	Cam spring	VBH1082	102	Rubber sheet	
3	Belt	PEB1013	103	Turn table assembly	
4	Gear pulley	VNL1249	104	Oil stopped washer	
5	Follow gear	VNL1194	105	Spindle motor	
6	Roller plate assembly	VXA1531	106	Housing assembly	
7	Slide cam	VNL1188	107	Housing assembly	
8		108	Loading motor	
9	Loading motor assembly	VXX1262	109	Slider gear	
10	Spindle motor assembly	VXA1474	110	Housing assembly	
11	Centering hab	VNL1174			
12	Centering spring	VBH1083			
13	Door lever	VNL1407			
14	Washer	WT26D047D025			
15	Two stair gear	VNL1193			
16	Cam gear	VNL1190			
17	Screw (C)	VBA1015			
18	Screw (B)	VBA1008			
19	Nylon washer	WA32N080W020			
20	Screw	PMZ30P040FMC			
21	Screw	PMA30P050FMC			
22	Washer	WA32D060D025			
23				
24	Stop ring	VEB1091			
25	Chassis assembly	VXA1575			
26	E ring	YE23FUC			
27	Push switch	DSG1014			

2.7 SERVO MECHANISM BASE SECTION

Parts List

Mark No.	Description	Part No.
1	CA gear (3)	VNL1196
2	Switch pulling spring	VBH1079
3	TC pulling spring	VBH1080
4	Push switch (S5:OUTER)	DSG1014
5	CA pulley (1)	VNL1197
6	Carriage motor assembly	VXX1261
7	Push switch (S4:INNER)	DSG1014
8	CA belt	VEB1077
9	CA pulley (2)	VNL1198
10	Screw	SMF30H080FBT
11	Screw	PMM26P040FMC
12	Screw	BPZ26P050FMC

Mark No.	Description	Part No.
13	Washer	WT26D047D025
14	FLE base	VNL1341
15	Servo mechanism base assembly - S	VXA1583
101	Carriage motor	
102	Housing assembly	
103	Housing assembly	
104	Housing assembly	
105	Holder (A)	
106	Holder (B)	

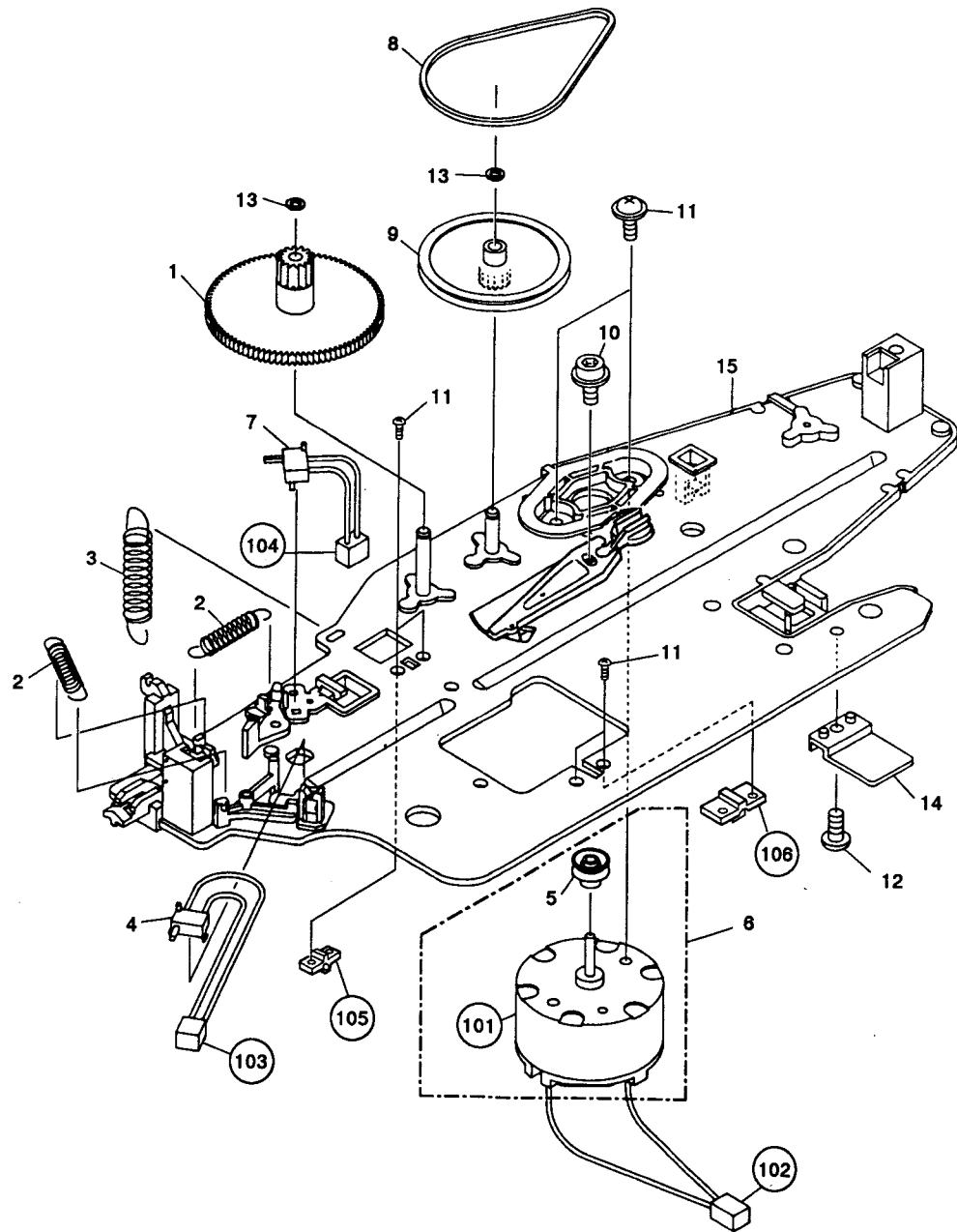

2.8 RACK SECTION

Parts List

Mark No.	Description	Part No.
1	PU base	VNL1209
2	LP center spring	VBH1075
3	PU pulling spring	VBH1089
4	L-2 spring	VBH1090
5	Washer	WA32F070M080
6	Screw	VBA1007
7	Screw (2.6 x 10)	VLL1192
8	Rack	VNL1186
9	Screw	BMZ26P080FMC
10	TAN spring	VBH1081

Mark No.	Description	Part No.
11	TAN base	VNL1199
12	Screw	PMZ20P040FMC
13	Screw	PMA20P040FMC
14	Screw	AMZ20P050FMC
15	Slider assembly	VWT1060
16	PU mount base assembly	VXA1567
17	Spacer (S)	VEC1284
18	TAN plate (1)	VNE1606
101	TAN plate (2)	
102	Pickup assembly	

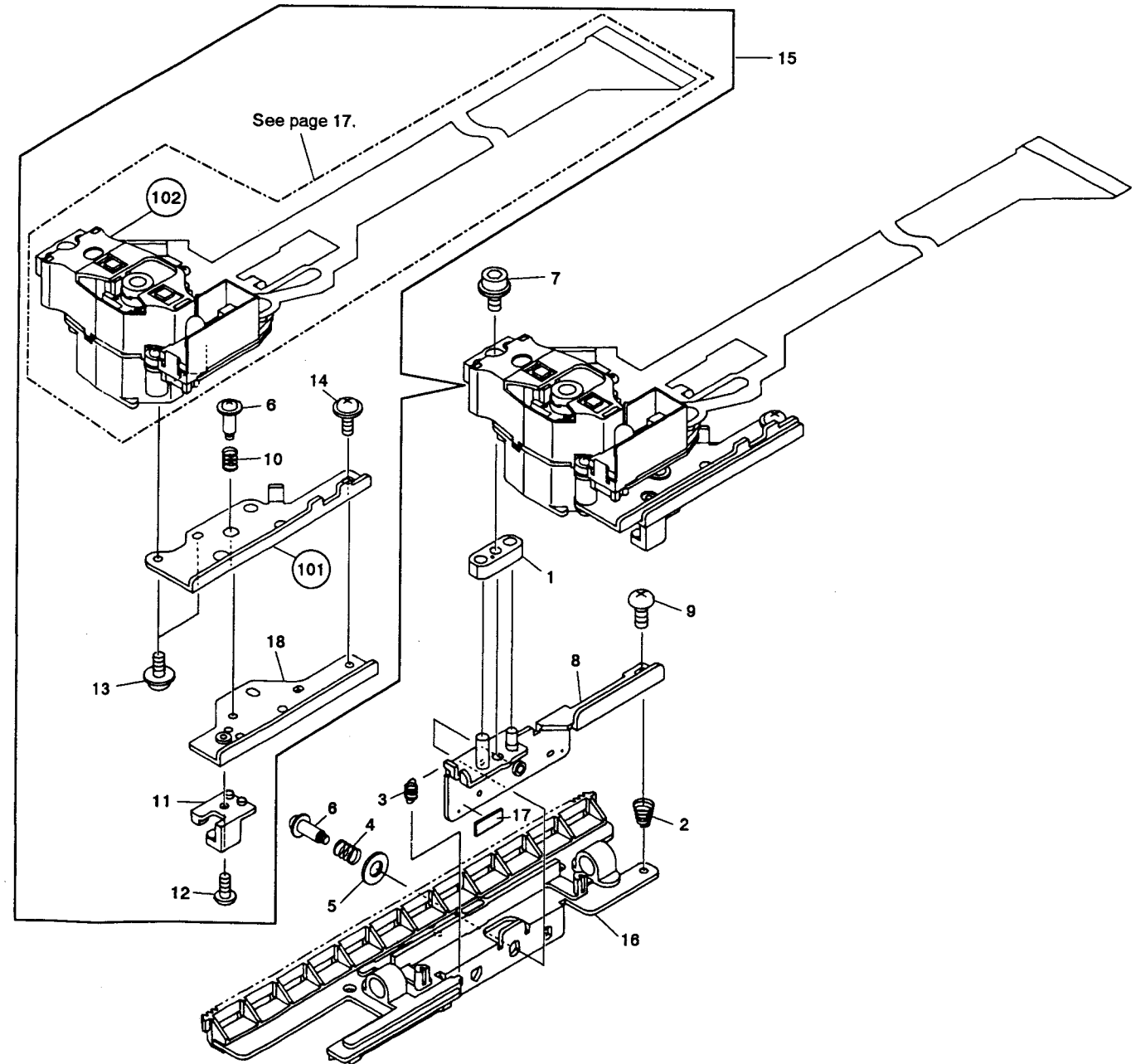

2.9 PICKUP ASSEMBLY

Parts List of Pickup assembly

Mark	No.	Description	Part No.
	1	Actuator assembly	VXX1551
	2	Sensor assembly	VEX1018
	3	Pre-pickup assembly	VXX1413
	4	Sensor stay	VNH1024
	5	Screw	PMA20P060FMC
	6	Screw	PMA20P080FMC
	7	Screw	PMA20P140FMC
	8	Screw	BMZ20P060FMC
	9	Sensor spring	VBH1087

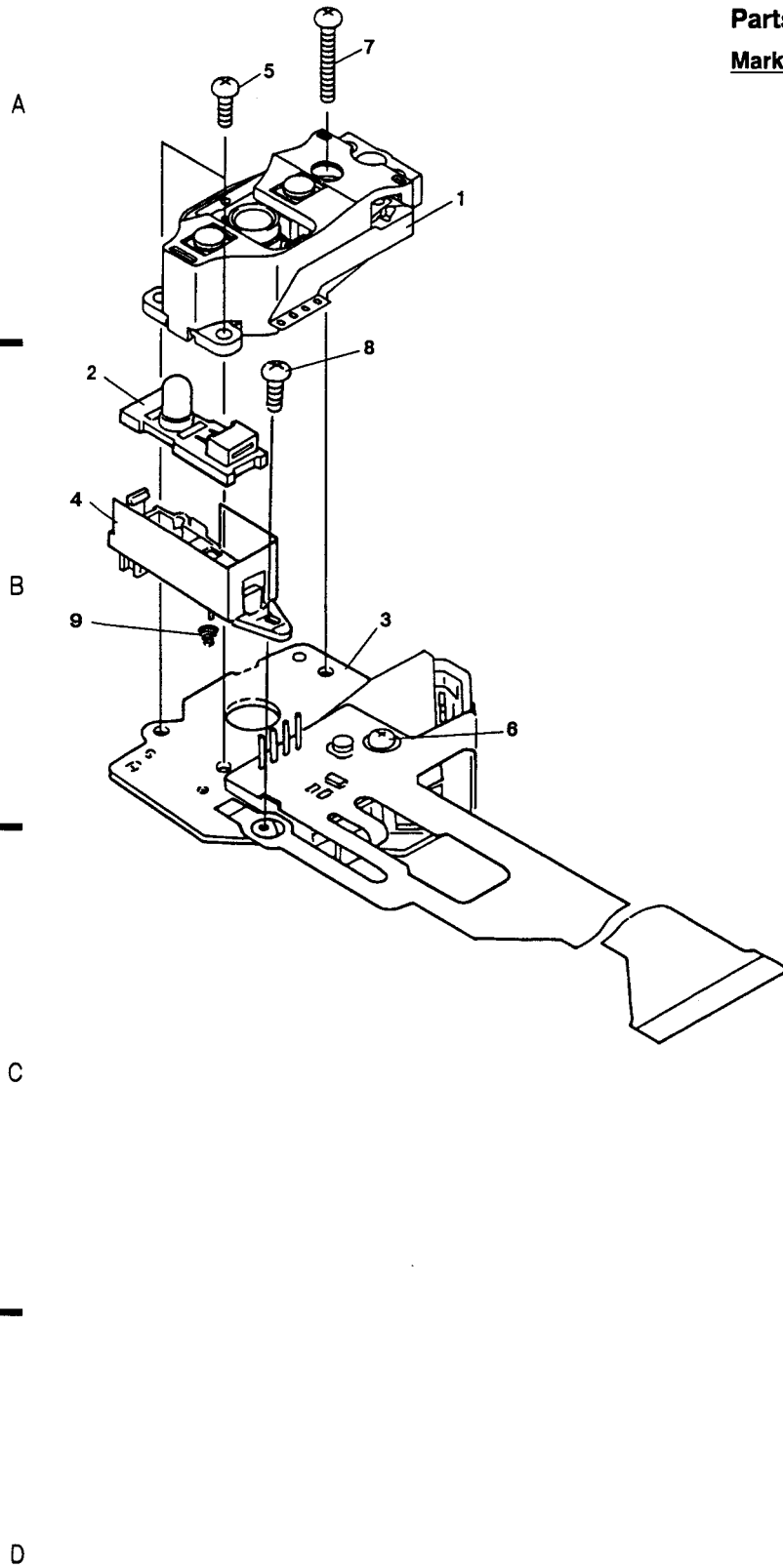

3. PACKING

Parts List

Mark No.	Description	Part No.	Mark No.	Description	Part No.
1	Connection cord	VDE - 055	51	Dry cell battery (R03, AAA)	
2	Video cable	VDE - 056	52	Polyethylene bag	
3	Operating instructions (English)	VRB1059	53	Caution card	
4	Remote control unit (CU - CLD040)	VXX1541	54	Caution card (UC)	
5	Pad (F)	VHA1076			
6	Pad (R)	VHA1077			
7	Packing case	VHG1144			
8	Mirror mat	VHL1006			
9	Battery cover	VNK1805			

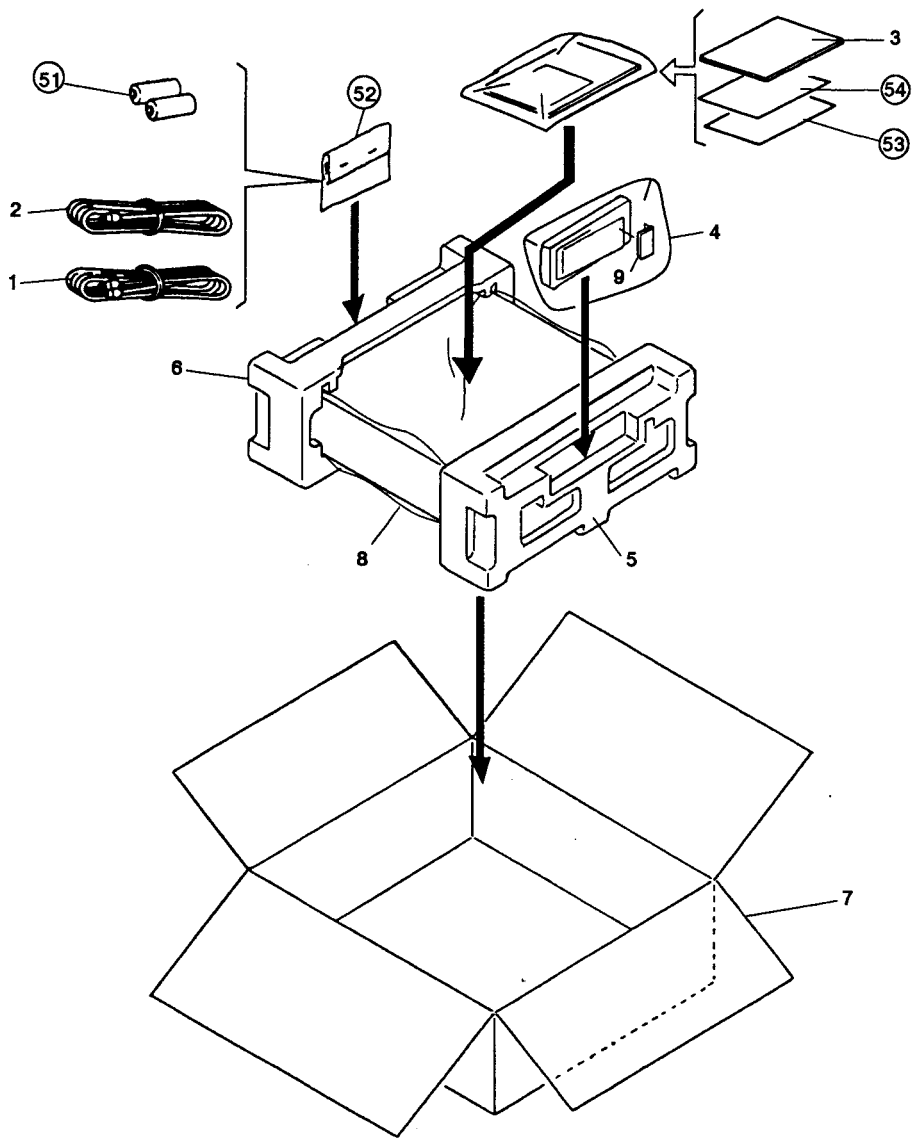

4. P. C. BOARDS LOCATION

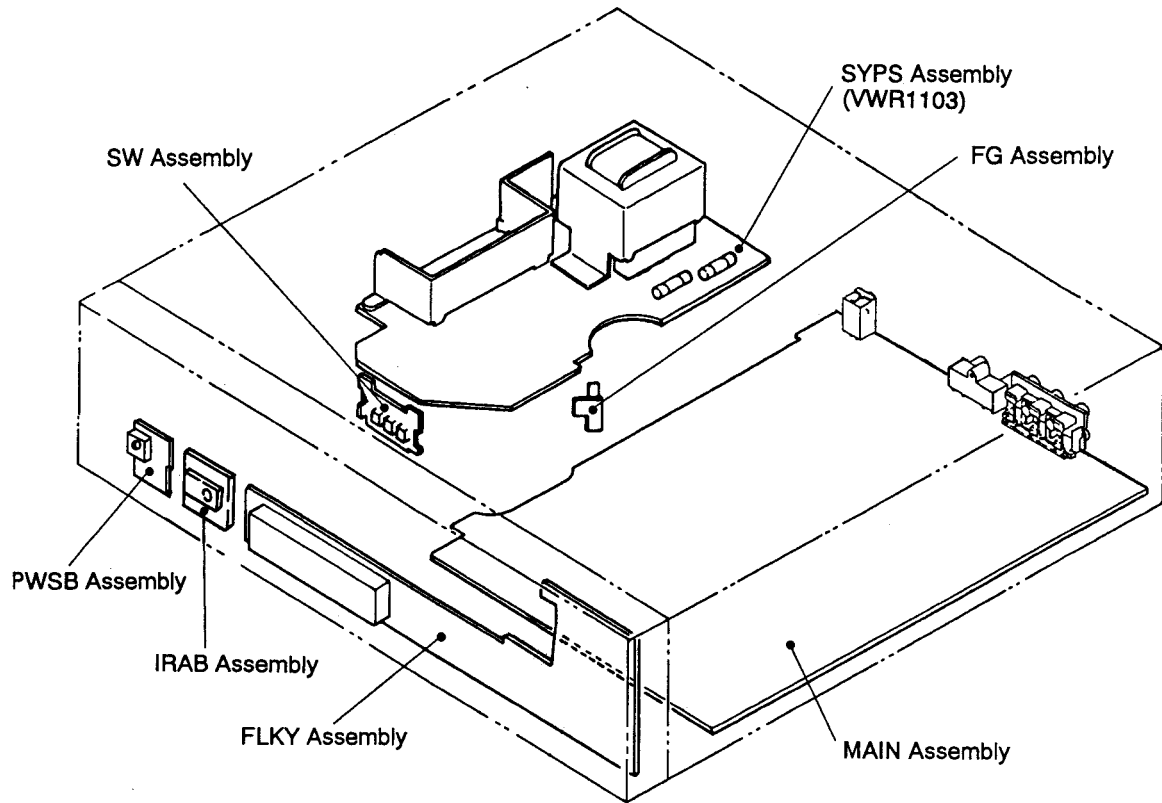

MOTHER ASSEMBLY (VWM1179)

MOTHER assembly is composed of MAIN, FG and SW assemblies.

FLKB ASSEMBLY (VWM1180)

FLKB assembly is composed of FLKY, PSWB and IRAB assemblies.

MAIN : MAIN BOARD
FG : FG COUNTER BOARD
SW : SW BOARD
FLKY : FL TUBE AND KEY BOARD
PSWB : POWER SWITCH BOARD
IRAB : INFRARED AMPLIFIER BOARD
SYPS : SYSTEM POWER SUPPLY

5. SCHEMATIC AND P.C. BOARDS DIAGRAM

1. RESISTORS:

Indicated in Ω , 1/4W, 1/8W and 1/8W, $\pm 5\%$ tolerance unless otherwise noted k;k Ω , M;M Ω , (F); $\pm 1\%$, (G); $\pm 2\%$, (K); $\pm 10\%$, (M); $\pm 20\%$ tolerance.

2. CAPACITORS:

Indicated in capacity (μF) /voltage(V) unless otherwise noted p;pF. Indication without voltage is 50V except electrolytic capacitor.

3. VOLTAGE, CURRENT:

 ;DC voltage (V) at no input signal.
Value in () is DC voltage at rated power.
 \Leftrightarrow mA ;DC current at no input signal.

4. OTHERS:

\rightarrow ;Signal route.
 \otimes ;Adjusting point.

The Δ mark found on some component parts indicates the importance of the safety factor of the part. Therefore, when replacing, be sure to use parts of identical designation.

※ marked capacitors and resistors have parts numbers.

This is the basic schematic diagram, but the actual circuit may vary due to improvements in design.

5.1 OVERALL CONNECTIONS

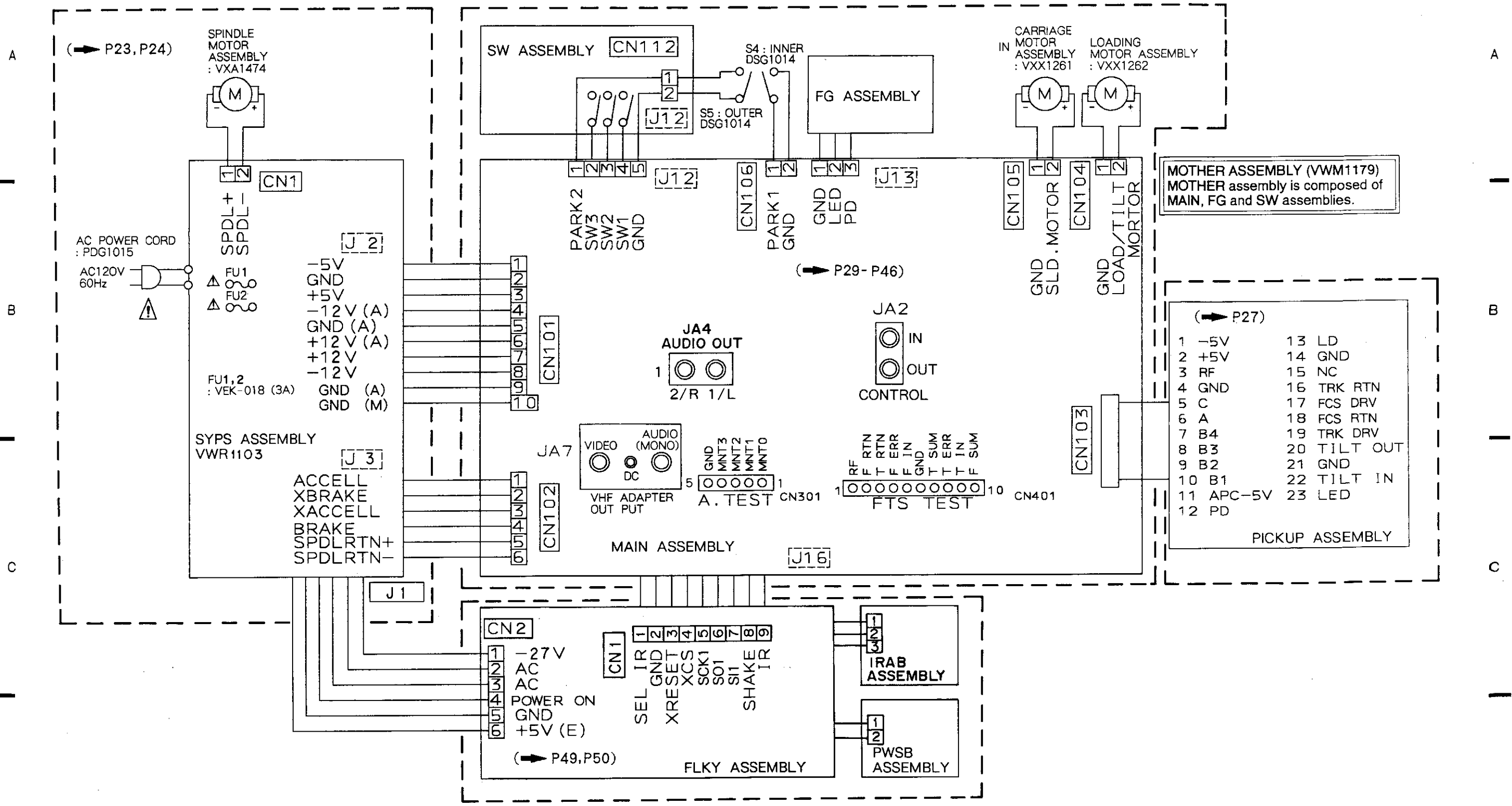

MOTHER ASSEMBLY (VWM1179)
MOTHER assembly is composed of
MAIN, FG and SW assemblies.

(P27)

1	-5V	13	LD
2	+5V	14	GND
3	RF	15	NC
4	GND	16	TRK RTN
5	C	17	FCS DRV
6	A	18	FCS RTN
7	B4	19	TRK DRV
8	B3	20	TILT OUT
9	B2	21	GND
10	B1	22	TILT IN
11	APC-5V	23	LED
12	PD		

PICKUP ASSEMBLY

FLKB ASSEMBLY (VWM1180)
FLKB assembly is composed of FLKY
and PWSB assemblies.

5.2 SYPS (VWR1103) ASSEMBLY

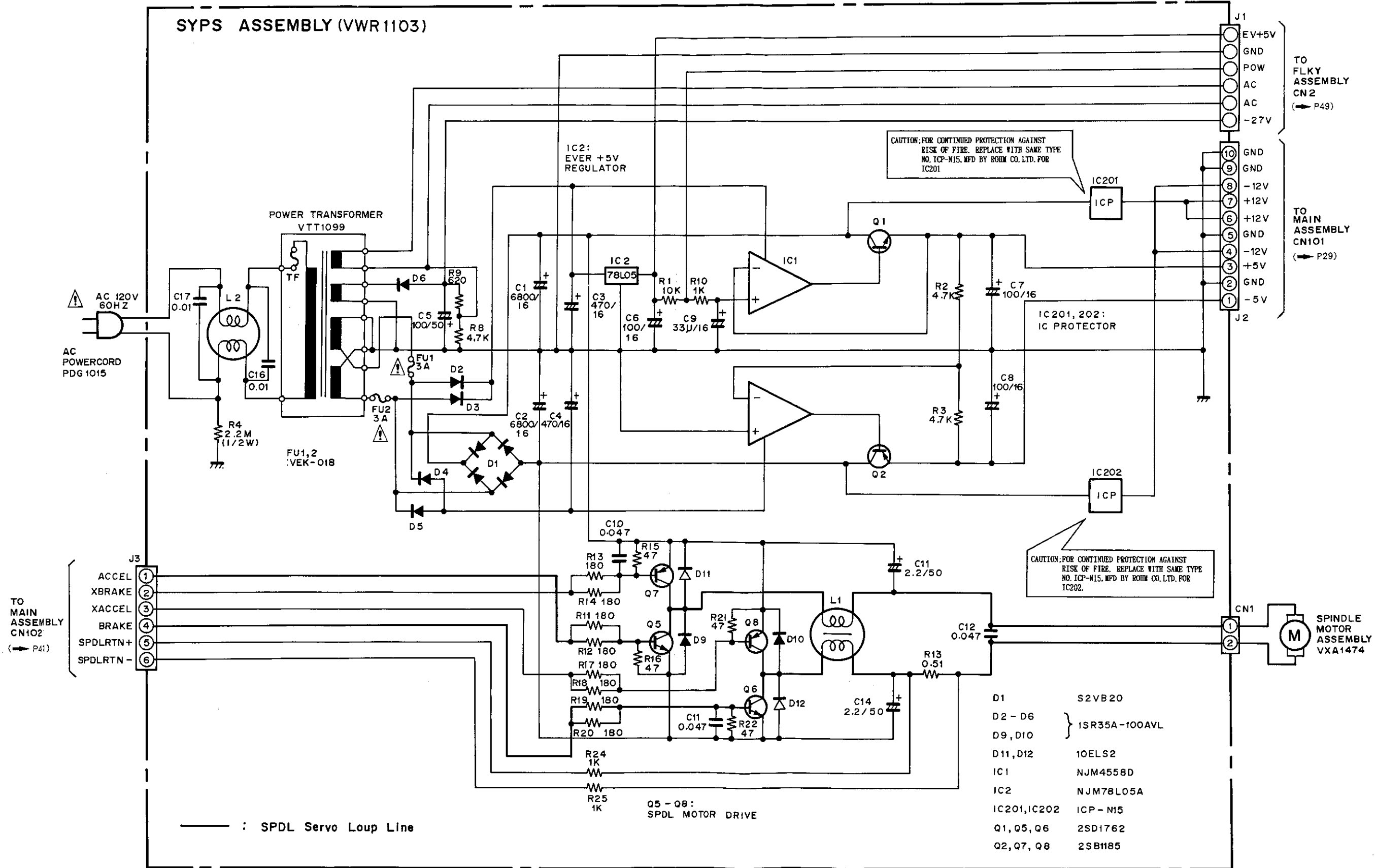

- D1 S2VB20
- D2 - D6 } 1SR35A-100AVL
- D9, D10 }
- D11, D12 10ELS2
- IC1 NJM4558D
- IC2 NJM78L05A
- IC201, IC202 ICP-N15
- Q1, Q5, Q6 2SD1762
- Q2, Q7, Q8 2SB1185

	IC206		IC2	
Q8	Q5	Q2	IC201	IC1
Q7	Q6	IC202		Q1

SYPS ASSEMBLY

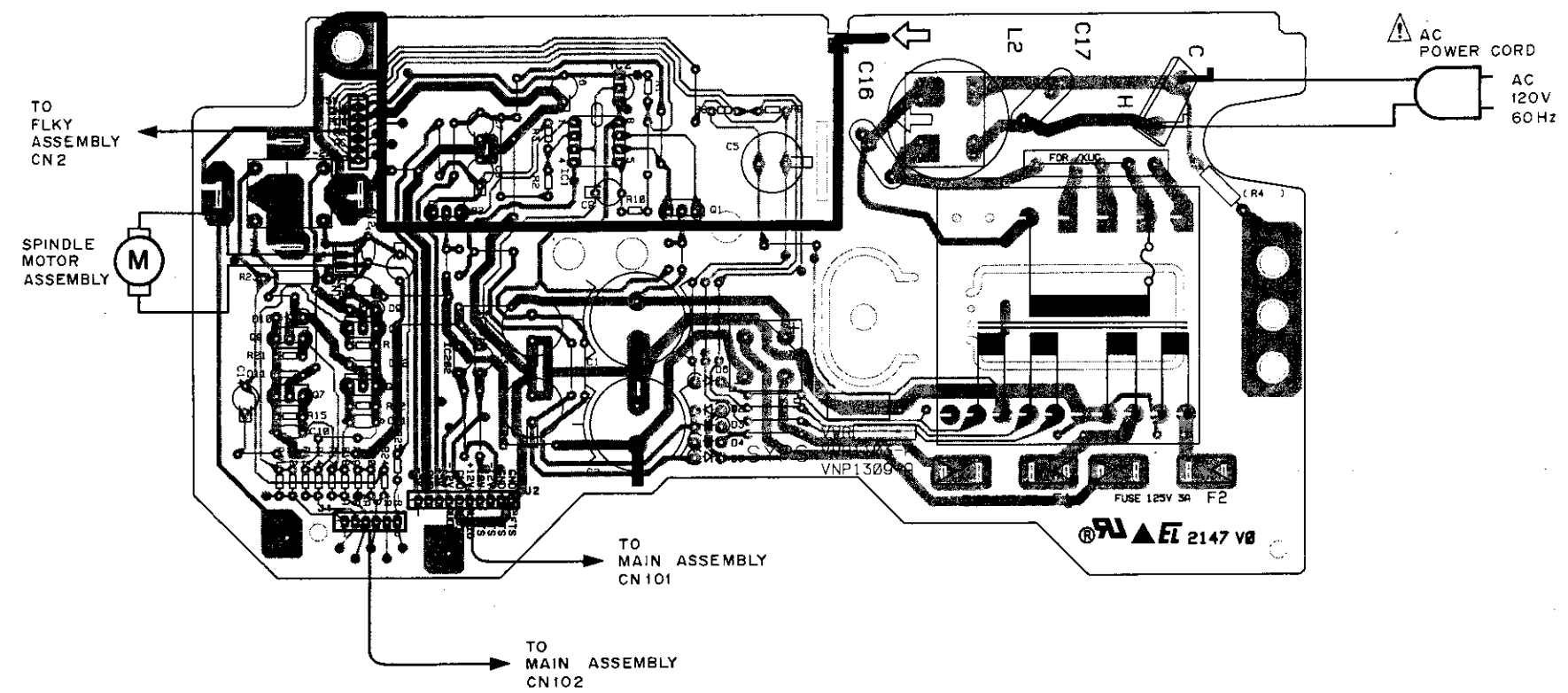

- View from component side
- View from soldering side

	IC3		IC508	
Q1	Q2	Q3	Q4	Q5
Q6	Q7	Q8	Q9	Q10

SYPS ASSEMBLY

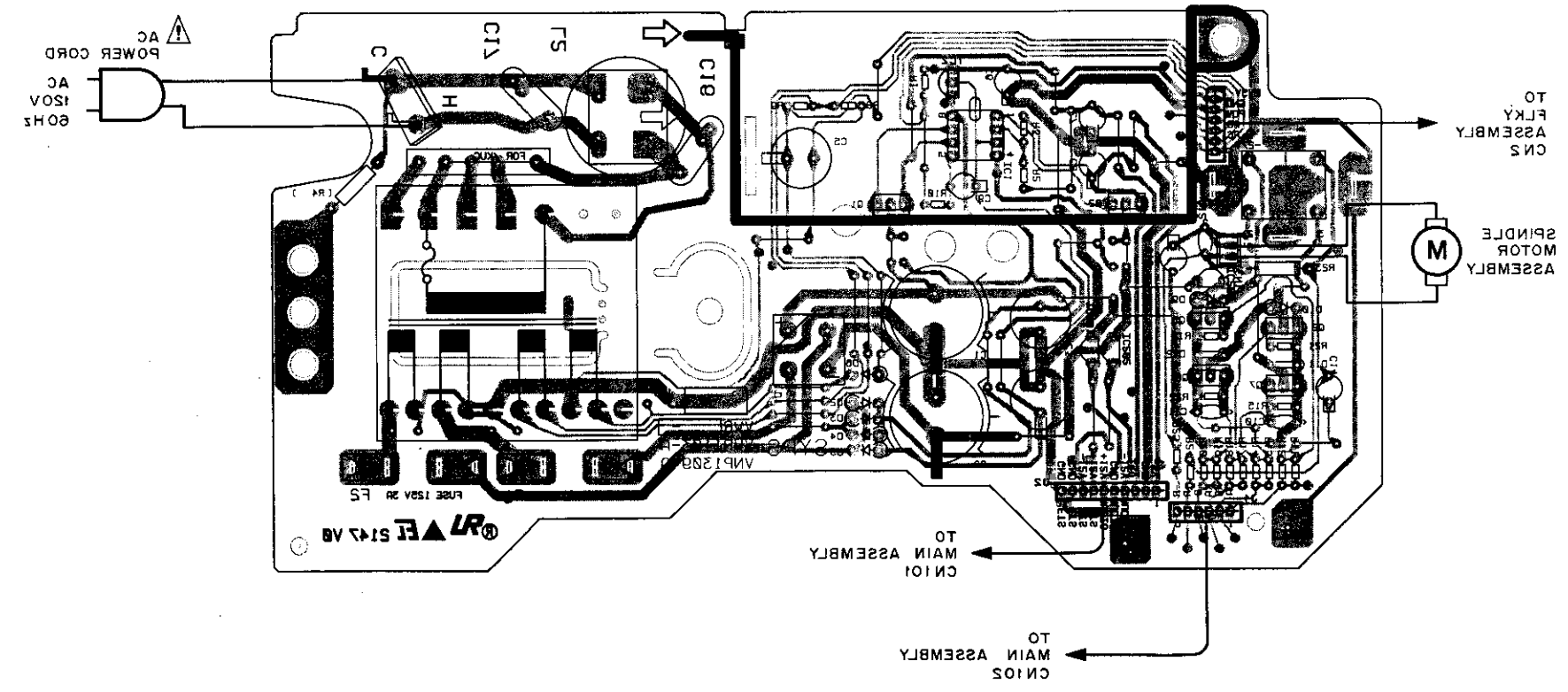

5.3 PICKUP ASSEMBLY

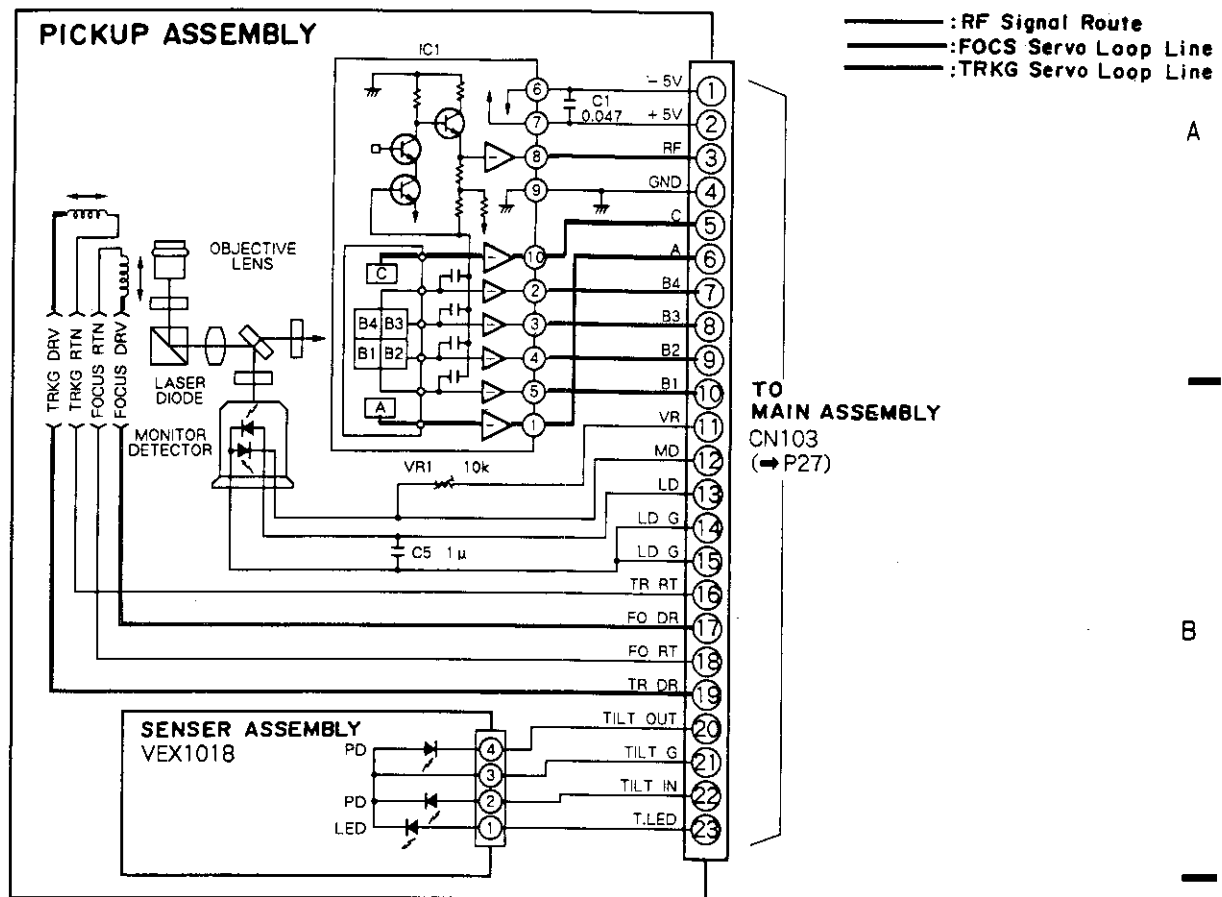

HEAD ASSEMBLY

• View from component side

• This P.C.B. connection diagram is viewed from the parts mounted side.

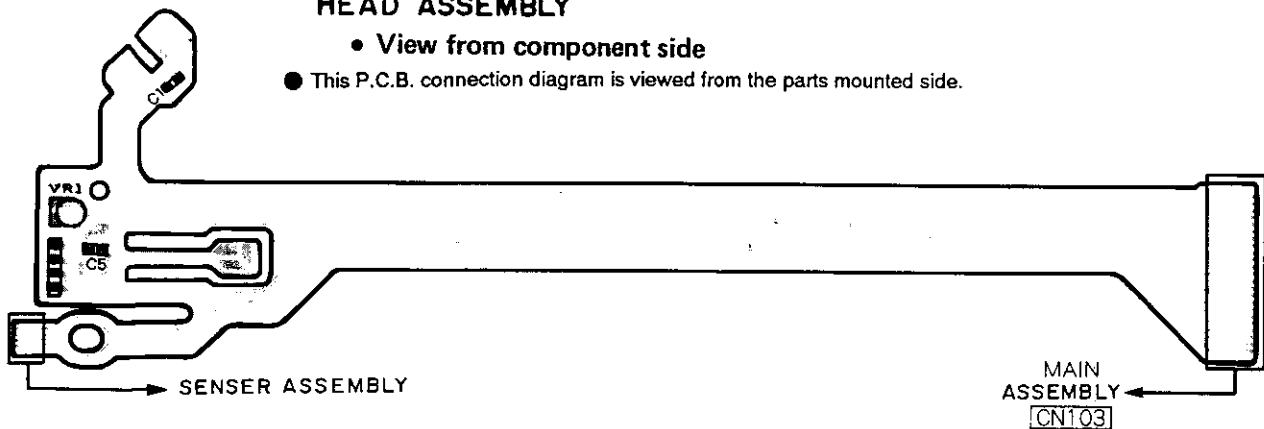

• View from soldering side

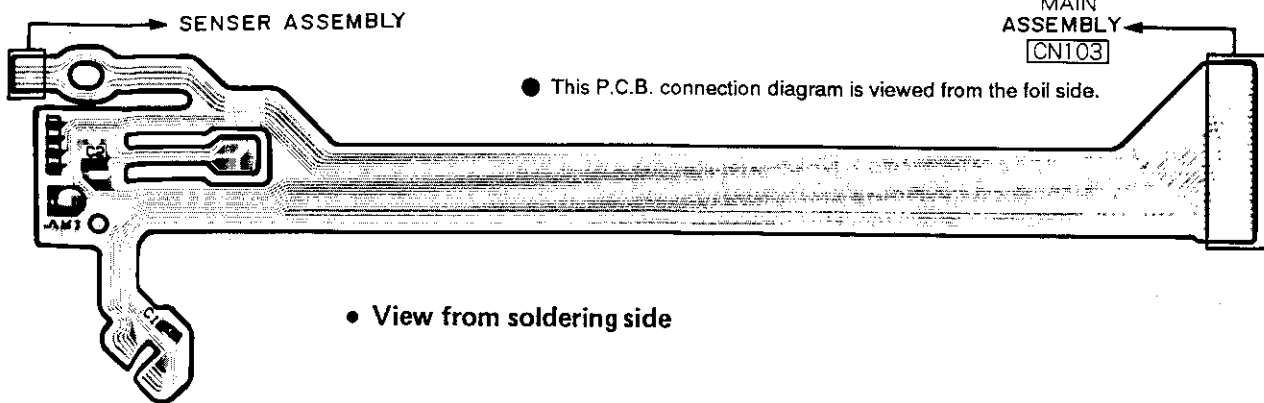

WAVEFORMS OF THE FTS SECTION

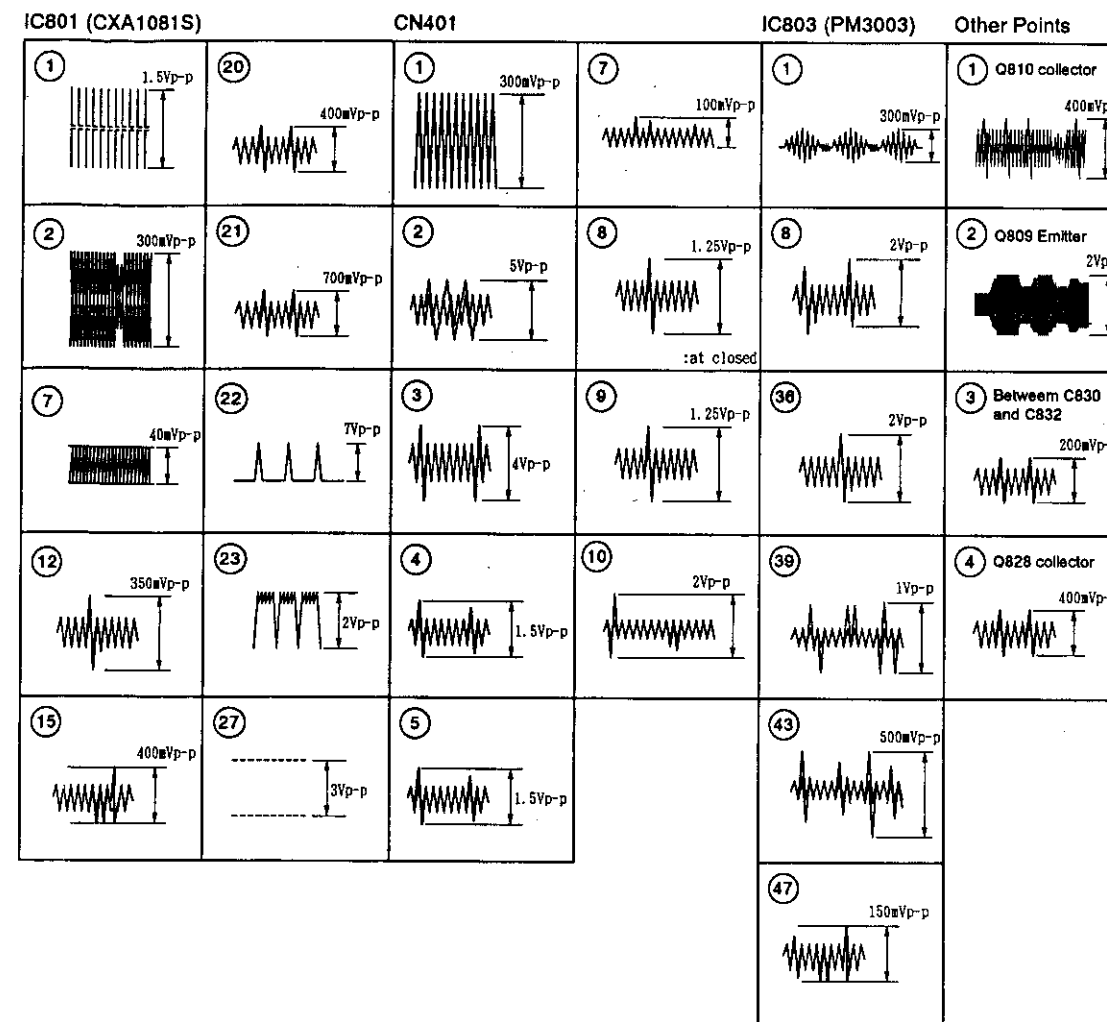

5.4 MAIN ASSEMBLY (FTS SECTION)

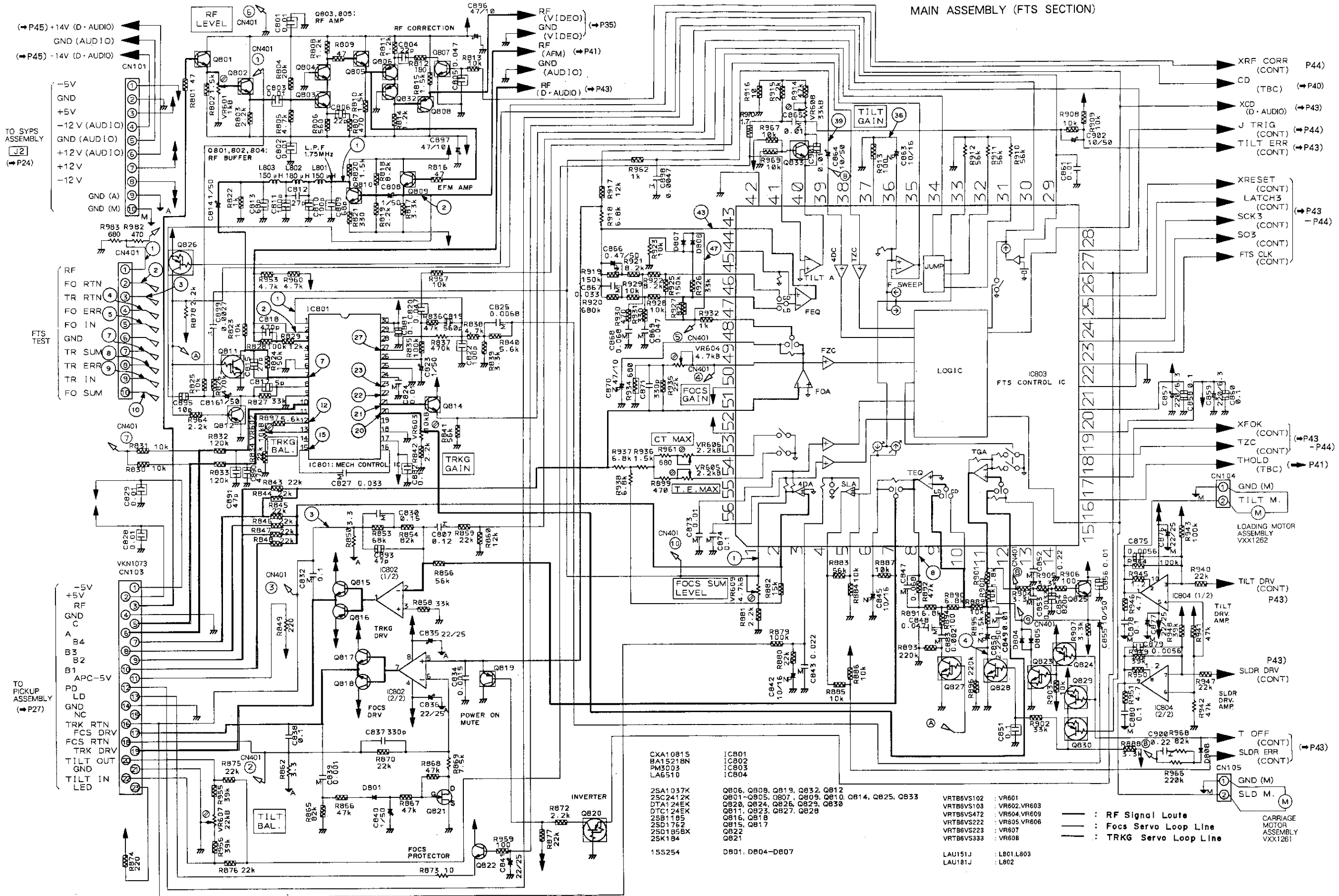

MAIN ASSEMBLY (FTS SECTION)

- 25A1037K
- 25C2412K
- D1A1244K
- DT1244K
- DT1244K
- 25B1185
- 25D1762
- 25D1858X
- 25K184

- IC801
- IC802
- IC803
- IC804

- Q805, Q809, Q819, Q832, Q812
- Q801-Q805, Q807, Q809, Q810, Q814, Q825, Q833
- Q828, Q824, Q826, Q829, Q838
- Q811, Q823, Q827, Q828
- Q816, Q817
- Q815, Q817
- Q822
- Q821

- 155254
- D801, D804-D807

- VRT8V5102 : VR601
- VRT8V5103 : VR602, VR603
- VRT8V5172 : VR604, VR609
- VRT8V5222 : VR605, VR606
- VRT8V5223 : VR607
- VRT8V5333 : VR608

- LAU151J : L801, L803
- LAU181J : L802

RF Signal Loute
 Focs Servo Loop Line
 TRKG Servo Loop Line

CARRIAGE MOTOR ASSEMBLY VXX1261

TO SYST J2

CARRIAGE MOTOR ASSEMBLY

LOADING MOTOR ASSEMBLY

CARRIAGE MOTOR ASSEMBLY VXX1261

View from component side

IC211 IC208 IC207 IC202 IC405 IC403 IC404
 Q205 IC210 IC206 Q431 IC401 Q605 Q602
 Q204 IC351 Q352 Q351 IC201 IC803 IC602 IC601 IC603 Q604 Q603
 IC804 Q815 Q816 IC801 Q822 VR521 VR482 VR481
 IC802 VC901
 Q817 Q818 Q821

MAIN ASSEMBLY

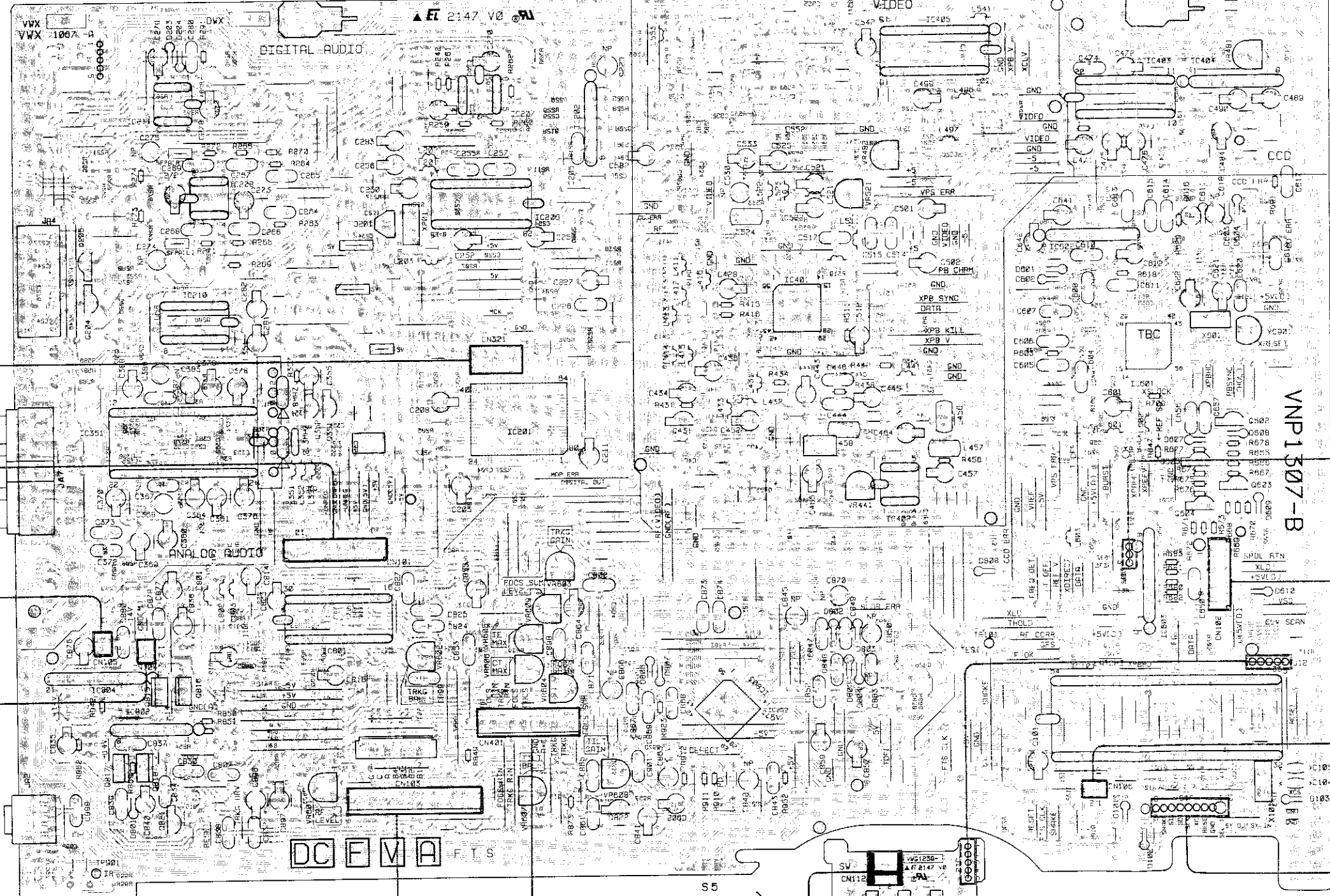

TO A TEST
 TO SYPS ASSEMBLY J2

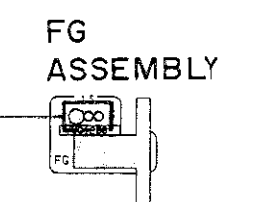
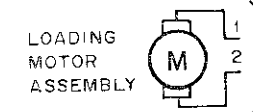
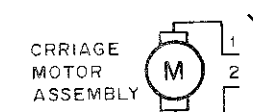

TO SYPS ASSEMBLY J1

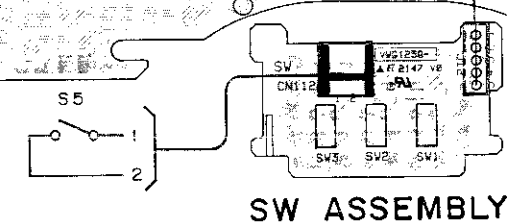

TO FLKY ASSEMBLY CN1

RF CORR (CONT) P44
 (-3C) (P40)
 (D-AUDIO) (P43)
 TRIG (CONT) (P44)
 ILT_ERR (CONT) (P43)
 RESET (CONT)
 LATCH-3 (CONT)
 CKS (CONT) (P43)
 CS (CONT)
 TS CLK (CONT)
 FOK (CONT) (P43)
 LC (CONT) (P44)
 HOLD (TBC) (P41)
 END (V)
 ILT M.
 CARRIAGE MOTOR ASSEMBLY VXX176
 SLDR DRV (CONT) P43
 OFF (CONT)
 SLDR_ERR (CONT)
 END (V)
 SLDR M.
 CARRIAGE MOTOR ASSEMBLY VXX176

A
 B
 C
 D

View from soldering side

0812 0818 0821
 IC805
 IC804 0812 0816
 IC801
 0325 0321
 IC501
 IC508
 IC507
 IC505
 0431
 IC401
 IC405
 VR551 VR485
 VR441
 VR481
 0855
 IC803
 IC802
 IC803
 IC804 0804 0803
 IC803 0804 0803
 IC805 0801
 IC804

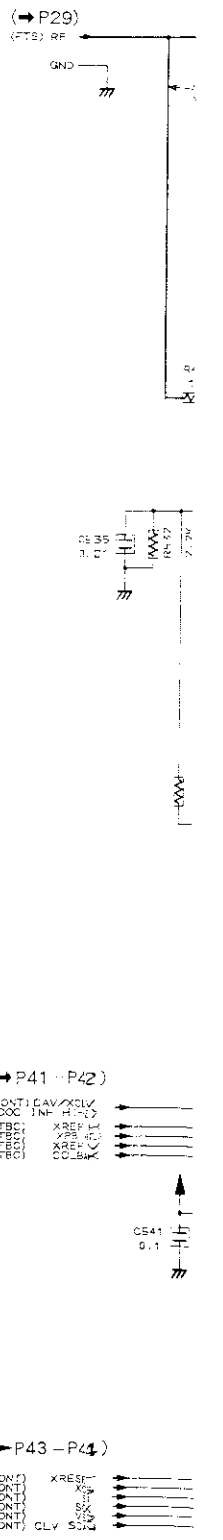
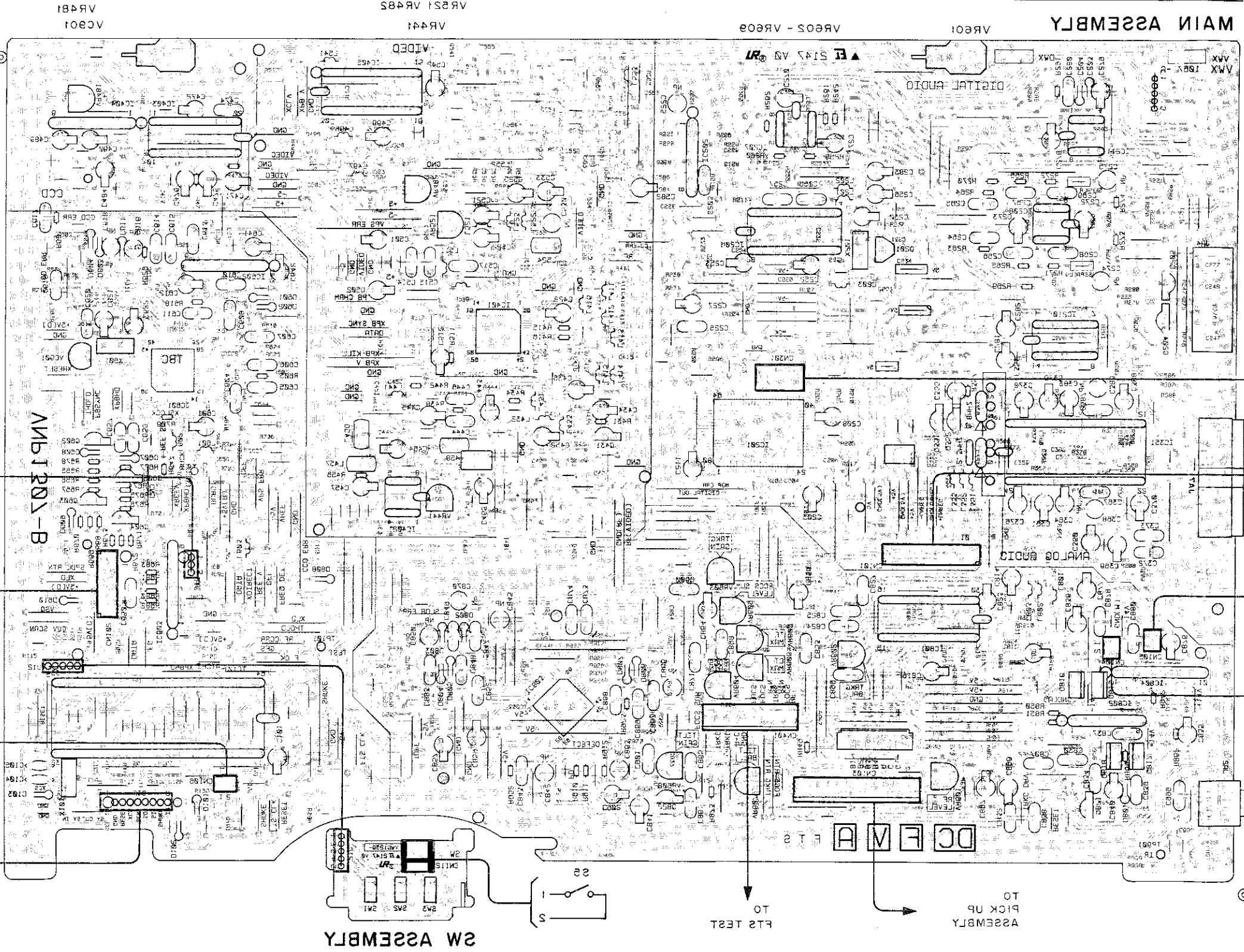

5.5 MAIN ASSEMBLY (VIDEO SECTION)

MAIN ASSEMBLY (VIDEO SECTION)

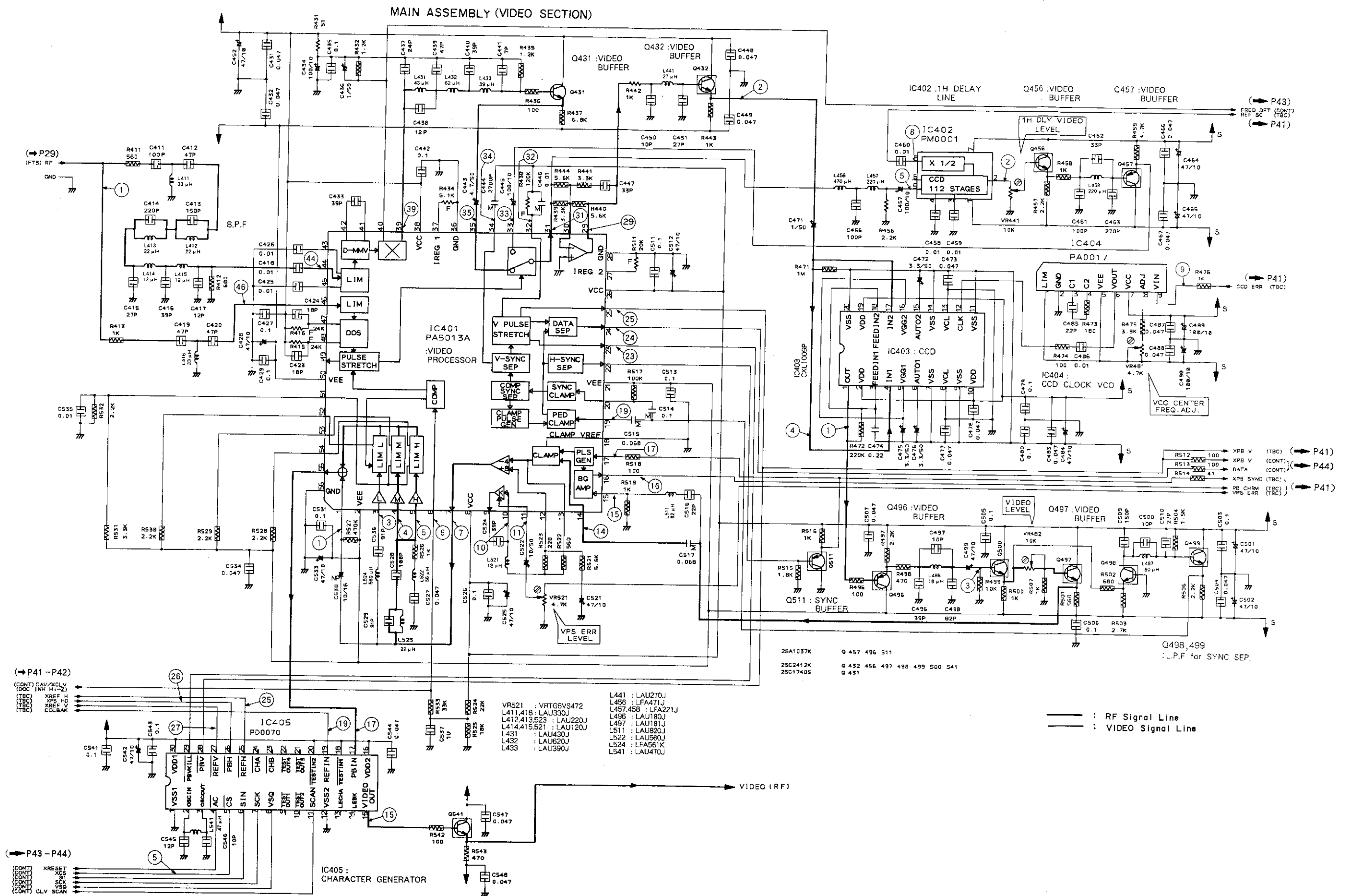

- 25A1037K Q 457 496 511
- 25C2412K Q 432 456 497 498 499 500 541
- 25C17405 Q 431

- VR521 : VRTGVS472
- L411,416 : LAU330J
- L412,413,523 : LAU220J
- L414,415,521 : LAU120J
- L431 : LAU430J
- L432 : LAU620J
- L433 : LAU390J
- L441 : LAU270J
- L456 : LFA471J
- L457,458 : LFA221J
- L496 : LAU180J
- L497 : LAU181J
- L511 : LAU820J
- L522 : LAU560J
- L524 : LFA561K
- L541 : LAU470J

RF Signal Line
VIDEO Signal Line

(P41-P42)
XREF V (TBC)
XREF H (CONT)
XREF Y (TBC)
XREF B (TBC)

(P43-P44)
XREF V (TBC)
XREF H (CONT)
XREF Y (TBC)
XREF B (TBC)

Q498,499 : L.P.F for SYNC SEP.

OT
ET. A
TO
SYP5 ASSEMBLY

CARRIAGE
MOTOR
ASSEMBLY

LOADING
MOTOR
ASSEMBLY

A
B
C
D

WAVEFORMS OF THE VIDEO SECTION

IC401 (PA5013A)

IC404 (PA0017)

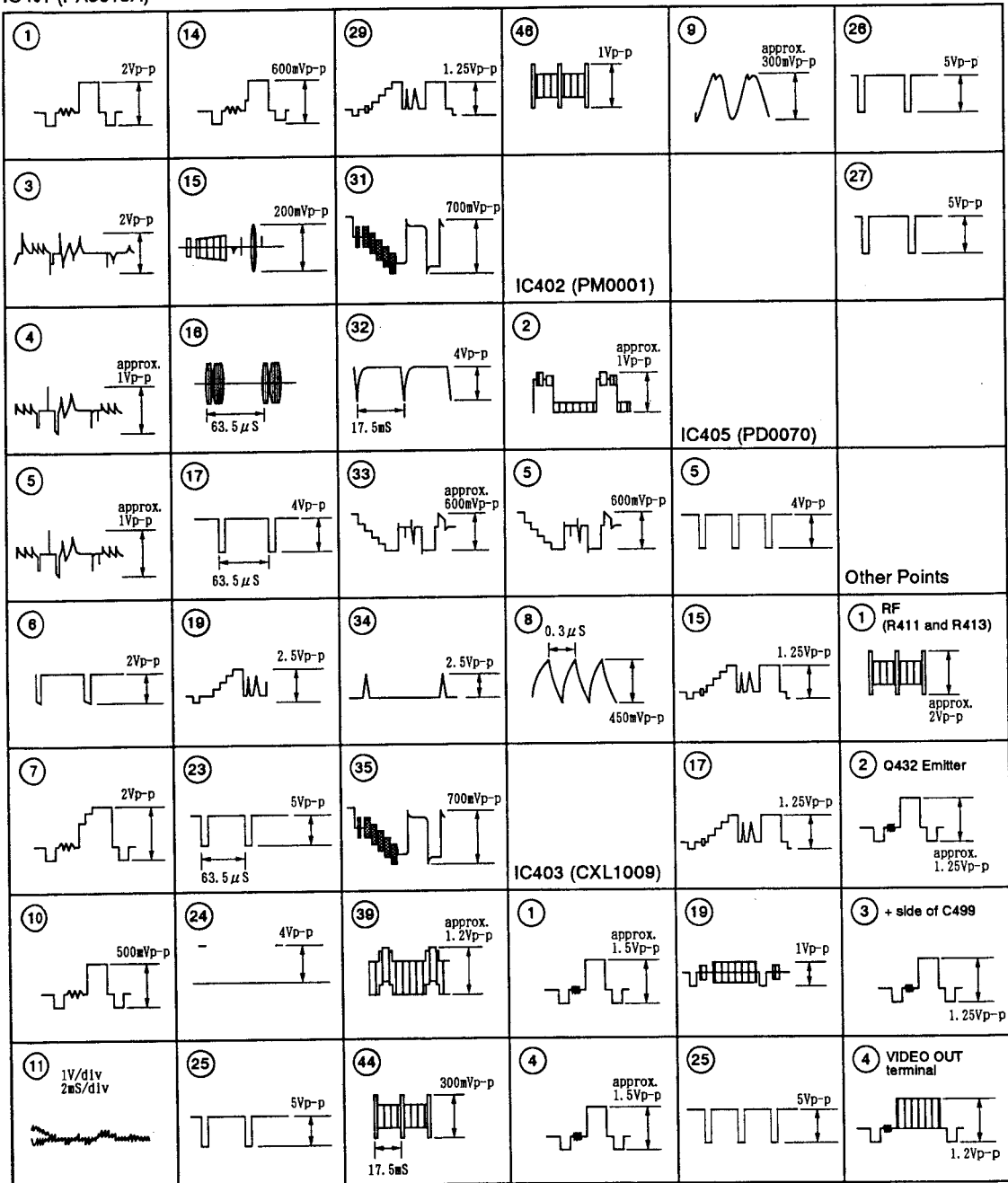

MAIN ASSEMBLY (AFM SECTION)

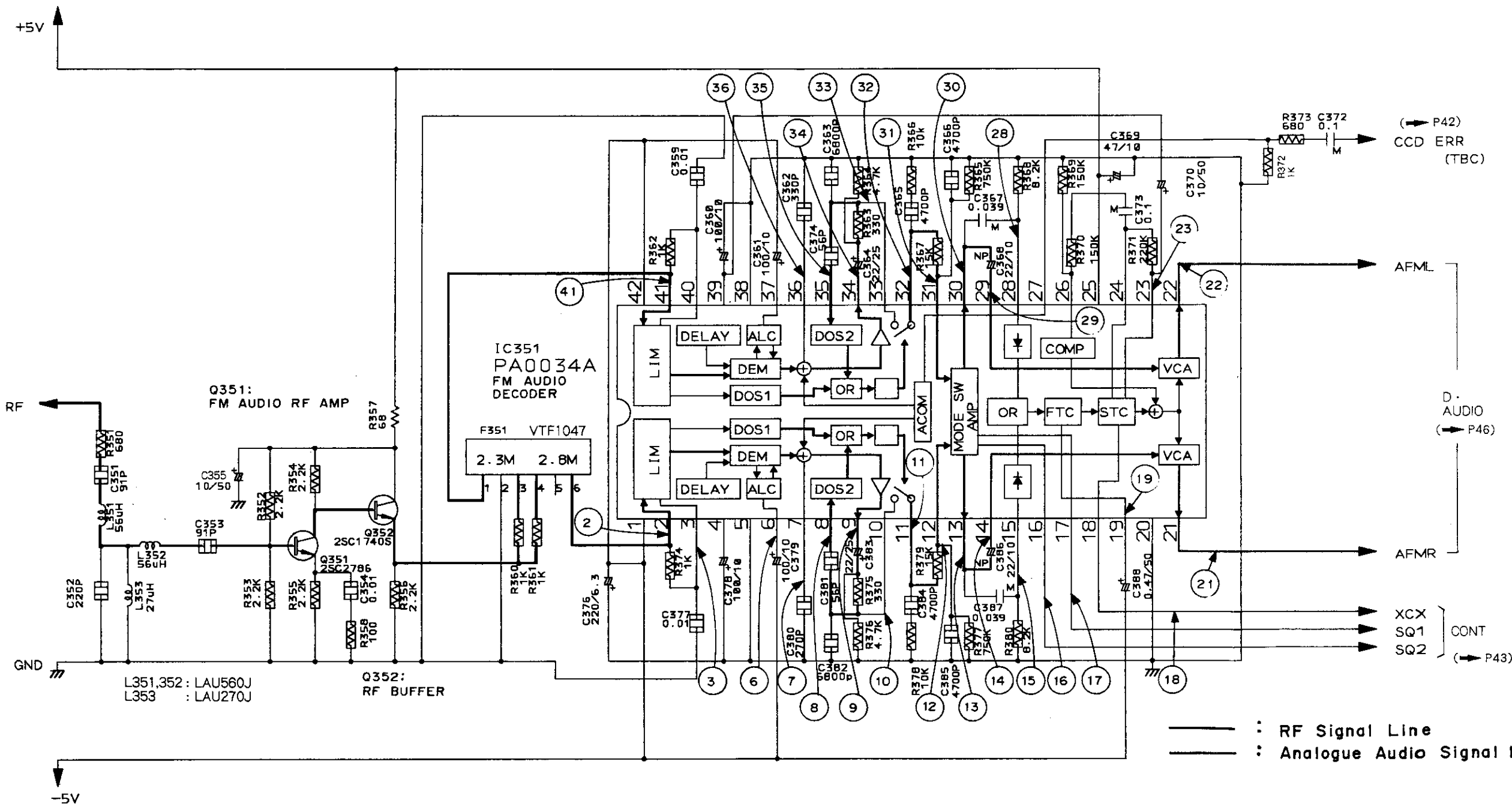

5.9 MAIN ASSEMBLY (D. AUDIO SECTION)

MAIN ASSEMBLY (D. AUDIO SECTION)

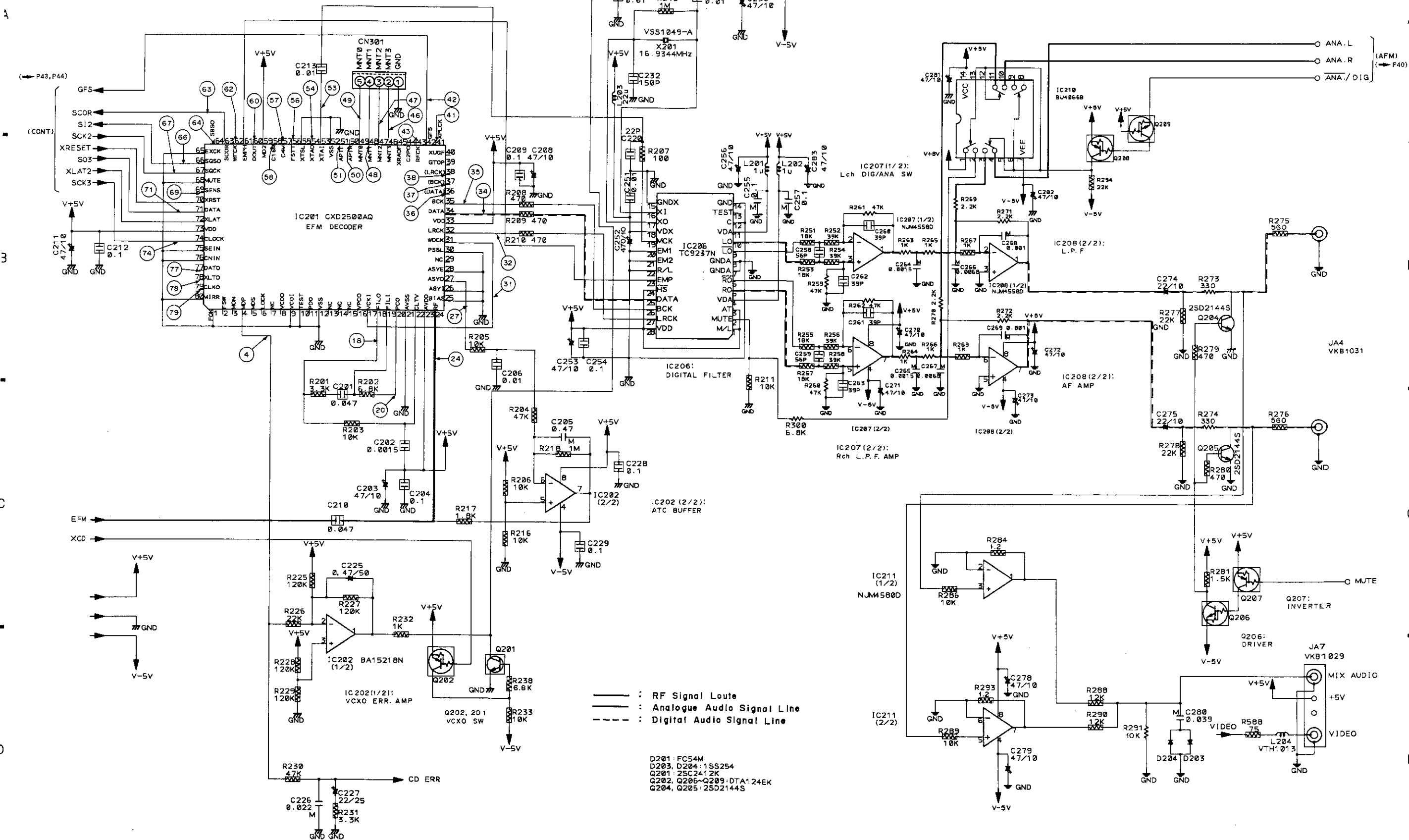

— : RF Signal Line
 - - - : Analogue Audio Signal Line
 - · - : Digital Audio Signal Line

D201: FC54M
 D203, D204: 1S5254
 Q201: 2SC2412K
 Q202, Q205-Q207: DTA124EK
 Q204, Q205: 2SD2144S

Note: Waveforms and voltages are at the PLAY
IC201 (CXD2500AQ)

Pin No.	Voltage	Pin No.	Voltage	Pin No.	Voltage	Pin No.	Voltage	Pin No.	Voltage	Pin No.	Voltage
1	0	15	0	29	0	43	*	57	*	71	*
2	0	16	4.8	30	0	44	0	58	*	72	5
3	0	17	0	31	*	45	4.8	59	5	73	5
4	*	18	*	32	*	46	*	60	*	74	*
5	0	19	2.4	33	4.8	47	*	61	5	75	0
6	4.8	20	*	34	*	48	*	62	*	76	0
7	0	21	0	35	*	49	*	63	*	77	*
8	4.8	22	2.3	36	*	50	*	64	*	78	*
9	0	23	4.8	37	*	51	*	65	0	79	*
10	0	24	*	38	*	52	0	66	*	80	0
11	0	25	0	39	0	53	*	67	*		
12	0	26	0	40	4.8	54	*	68	0		
13	0	27	*	41	*	55	0	69	*		
14	0	28	0	42	*	56	*	70	5		

*: Refer to Waveforms

IC201 (CXD2500AQ)

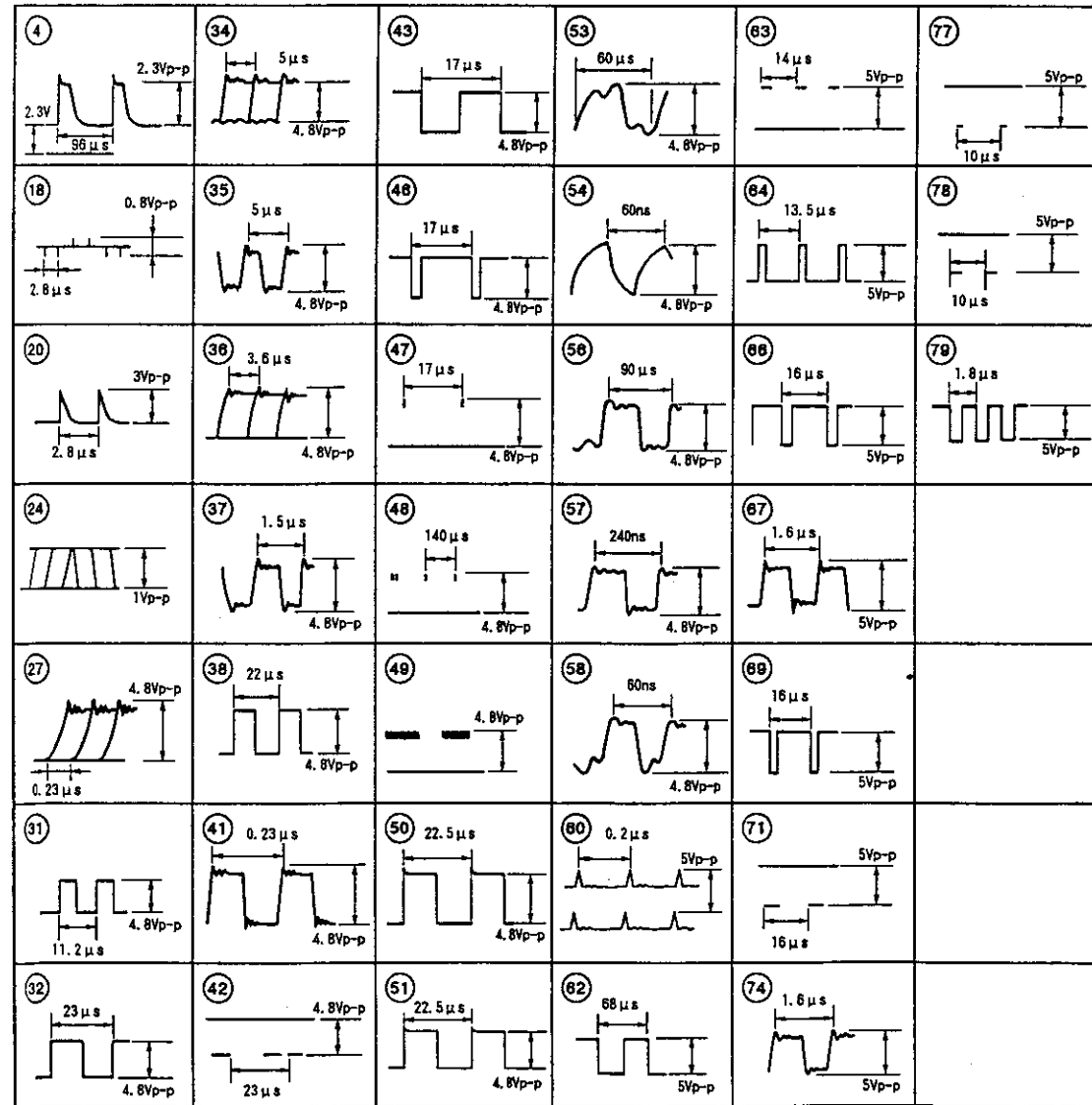

5.10 FLKY, PWSB AND IRAB ASSEMBLY

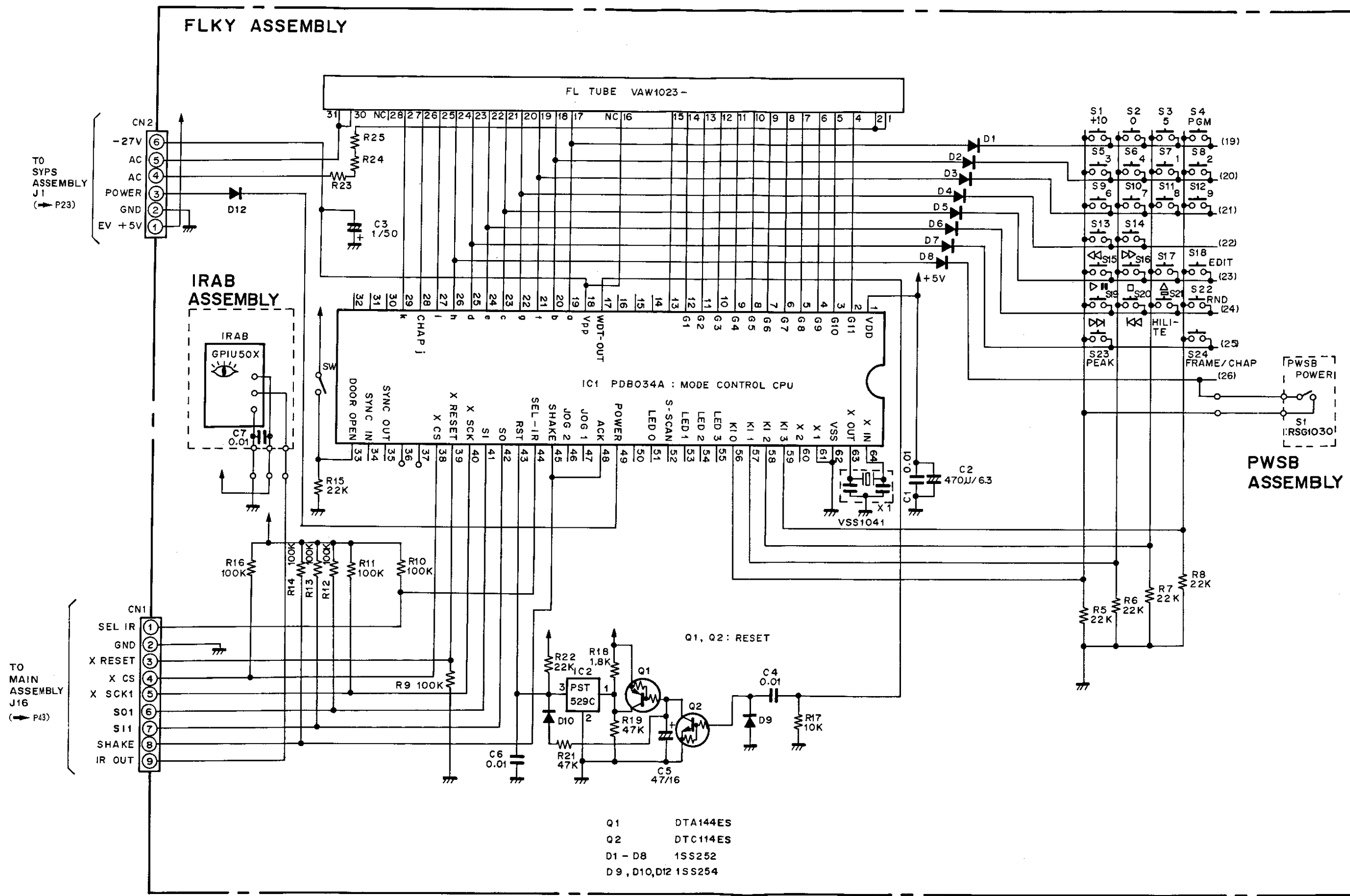

- Q1 DTA144ES
- Q2 DTC114ES
- D1 - D8 1SS252
- D9, D10, D12 1SS254

• View from component side

A

A

B

B

C

C

D

D

IRAB ASSEMBLY

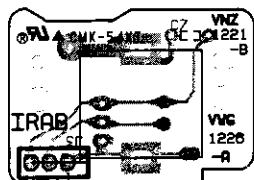

PWSB ASSEMBLY

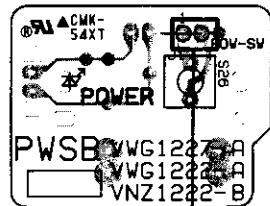

FLKY ASSEMBLY

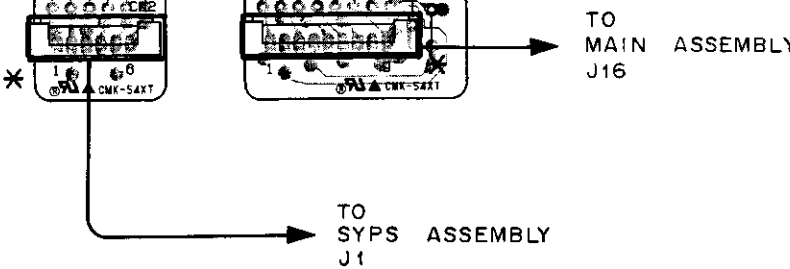
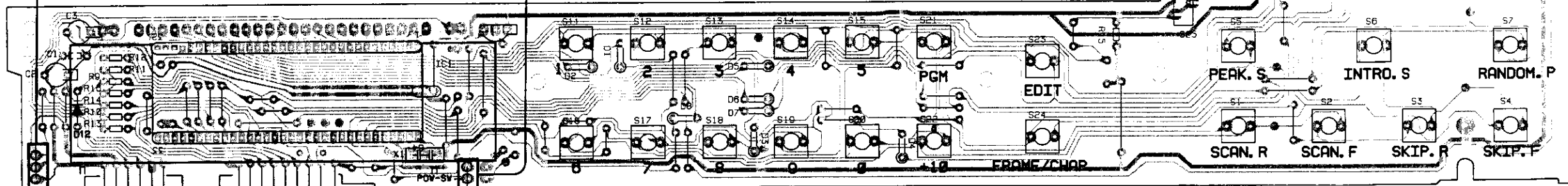
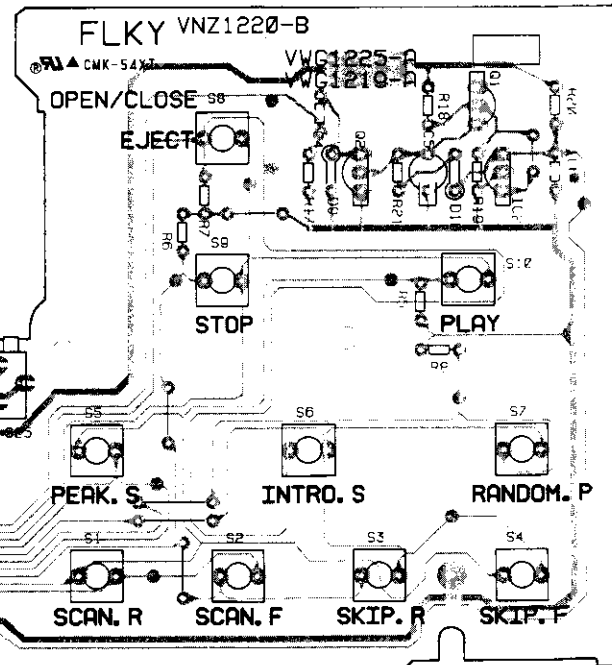

NOTE:
The marking line of the flat cable
Should be on the * Side.

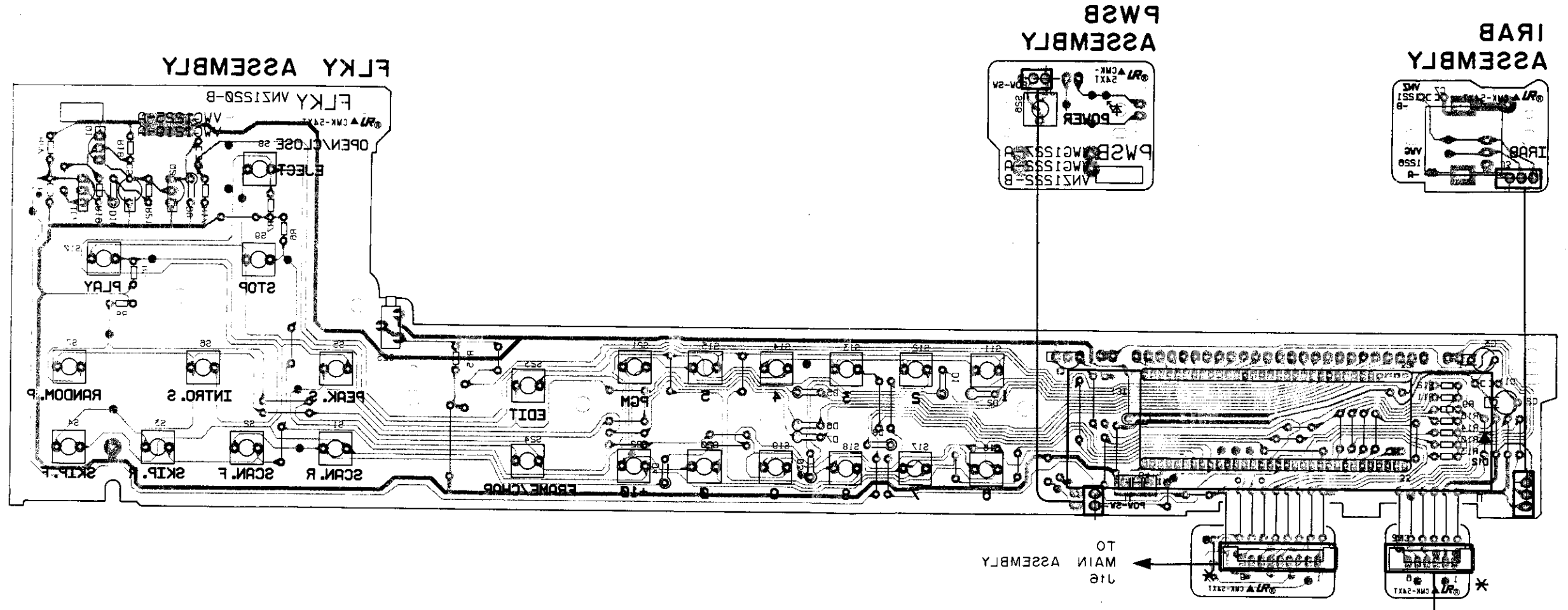

NOTE:
The marking line of the flat cable
Should be on the * side.

A
B
C
D

6. P.C.B's PARTS LIST

NOTES:

- Parts without part number cannot be supplied.
- Parts marked by "⊙" are not always kept in stock. Their delivery time may be longer than usual or they may be unavailable.
- The Δ mark found on some component parts indicates the importance of the safety factor of the part. Therefore, when replacing, be sure to use parts of identical designation.
- When ordering resistors, first convert resistance values into code form as shown in the following examples.

Ex.1 When there are 2 effective digits (any digit apart from 0), such as 560 ohm and 47k ohm (tolerance is shown by J=5%, and K=10%)

560 Ω → 56 × 10¹ → 561 RD1/4PS

5	6	1
---	---	---

 J
 47k Ω → 47 × 10³ → 473 RD1/4PS

4	7	3
---	---	---

 J
 0.5 Ω → 0R5 RN2H

0	R	5
---	---	---

 K
 1 Ω → 010 RSIP

0	1	0
---	---	---

 K

Ex.2 When there are 3 effective digits (such as in high precision metal film resistors).

5.62k Ω → 562 × 10¹ → 5621 RN1/4SR

5	6	2	1
---	---	---	---

 F

Mark	No.	Description	Part No.
FLKY ASSEMBLY			
SEMICONDUCTORS			
	IC1		PDB034A
	IC2 RESET IC		PST529C
	Q1 TRANSISTOR		DTA144ES
	Q2 TRANSISTOR		DTC114ES
	D1-8 DIODE		1SS252
	D9, 10 DIODE		1SS254
	D12 DIODE		1SS254
SWITCHES			
	S1-24 SWITCH		RSG1030
	S25 DOOR SWITCH		VSK1015
CAPACITORS			
	C1 CERAMIC CAPACITOR		CKPUYY103N16
	C2 ELECTR. CAPACITOR		CEAL100M16
	C3 ELECTR. CAPACITOR		CEAL010M50
	C4 CERAMIC CAPACITOR		CKPUYY103N16
	C5 ELECTR. CAPACITOR		CEAL470M6R3
	C6 CERAMIC CAPACITOR		CKPUYY103N16
RESISTORS			
	R5-21 CARBONFILM RESISTOR		RD1/6PM□□□J
OTHERS			
	FL SPACER		VEB1162
	V1 FL TUBE		VAW1023
	X1 CERAMIC RESONATOR		VSS1041

IRAB ASSEMBLY

CAPACITORS			
	C7 CERAMIC CAPACITOR		CKPUYY103N16
OTHERS			
	REMOTE SENSOR		GP1U50X

PWSB ASSEMBLY

SWITCHES			
	S26 SWITCH		RSG1030

Mark	No.	Description	Part No.
FG BOARD ASSEMBLY			
SEMICONDUCTORS			
	D1 OPT ISOLATOR		GP1S51
SW BOARD ASSEMBLY			
SWITCHES			
	S1-3 PUSH SWITCH		DSG1015
⊙ SYPS ASSEMBLY (VWR1103)			
SEMICONDUCTORS			
Δ	IC201, 202 IC PROTECTOR		ICP-N15
Δ	IC2 REGULATOR IC		NJM78M05FA
	IC1		NJM4558D
	Q1, 5, 6 TRANSISTOR		2SD1762
	Q2, 7, 8 TRANSISTOR		2SB1185
	D1		S2VB20-F
Δ	D2-6, 9, 10		1SR35-100AVL
Δ	D11, 12		10ELS2
COILS/TRANSFORMERS			
Δ	L1 FILTER		VTL1008
Δ	L2 FILTER		VTL-262
CAPACITORS			
	C1, 2 ELECTR. CAPACITOR(6800/10)		VCH1053
	C6-8 ELECTR. CAPACITOR		CEAS101M16
	C10-12 CERAMIC CAPACITOR		CGCYX473M25
	C3, 4 ELECTR. CAPACITOR		CEAS471M16
	C13, 14 ELECTR. CAPACITOR		CEAS2R2M50
Δ	C16, 17 CAPACITOR(0.01)		RCG-009
	C9 ELECTR. CAPACITOR		CEAS330M16
	C5 ELECTR. CAPACITOR		CEAS101M50
RESISTORS			
	R8-14 CARBONFILM RESISTOR		RD1/6PM□□□J
	R19, 20 CARBONFILM RESISTOR		RD1/6PM□□□J
	R4		RD1/2PM225J
Δ	R2, 3		RN16PQ4701F
Δ	R54		RS1PMFR51J

Mark No.	Description	Part No.
R15, 16, 21, 22(47Ω)		DCN1003
MAIN BOARD ASSEMBLY		
SEMICONDUCTORS		
IC101 MECHANISM CONT. MCU		PD0081C
IC201 EFM DEMODULATION IC		CXD2500AQ
IC202 IC		BA15218N
IC206		TC9237N
IC207, 208 OP-AMP IC		BA15218
IC210 ANALOG SWITCH		BU4066B
IC211 LINEAR IC		NJM4558D
IC351		PA0034A
IC401 VIDEO IC		PA5013A
IC402 CDD DELAY LINE		PM0001
IC403 IC		CXL1009P
IC404		PA0017
IC405 CHARACTER GENE IC		PD0070
IC601 TBC IC		PM3002
IC602, 603 OP-AMP IC		NJM4558S
IC801 PRE AMP IC		CXA1081S
IC802 IC		BA15218N
IC803 FTS IC		PM3003
IC804 POWER OP AMP		LA6510
Q201 CHIP TRANSISTOR		2SC2412K
Q202 DIGITAL TRANSISTOR		DTA124EK
Q204, 205 TRANSISTOR		2SD2144S
Q206		DTC124EK
Q207, 208 DIGITAL TRANSISTOR		DTA124EK
Q209		DTC124EK
Q351 TRANSISTOR		2SC2786
Q352 TRANSISTOR		2SC1740S
Q431 TRANSISTOR		2SC1740S
Q432 CHIP TRANSISTOR		2SC2412K
Q456 CHIP TRANSISTOR		2SC2412K
Q457 CHIP TRANSISTOR		2SA1037K
Q496 CHIP TRANSISTOR		2SA1037K
Q497-500 CHIP TRANSISTOR		2SC2412K
Q511 CHIP TRANSISTOR		2SA1037K
Q541 CHIP TRANSISTOR		2SC2412K
Q601		FMW2-TR
Q602 TRANSISTOR		2SC1740S
Q603 TRANSISTOR		2SA933S
Q604 TRANSISTOR		2SC1740S
Q605 TRANSISTOR		2SA933S
Q606		DTC124EK
Q607 CHIP TRANSISTOR		2SC2412K
Q608		DTC124EK
Q609 CHIP TRANSISTOR		2SA1037K
Q610 CHIP TRANSISTOR		2SC2412K
Q612 CHIP TRANSISTOR		2SC2412K
Q613 DIGITAL TRANSISTOR		DTA124EK
Q801-805 CHIP TRANSISTOR		2SC2412K
Q806 CHIP TRANSISTOR		2SA1037K
Q807 CHIP TRANSISTOR		2SC2412K

Mark No.	Description	Part No.
Q808 CHIP TRANSISTOR		2SA1037K
Q809, 810 CHIP TRANSISTOR		2SC2412K
Q811		DTC124EK
Q812 CHIP TRANSISTOR		2SA1037K
Q814 CHIP TRANSISTOR		2SC2412K
Q815 TRANSISTOR		2SD1762
Q816 TRANSISTOR		2SB1185
Q817 TRANSISTOR		2SD1762
Q818 TRANSISTOR		2SB1185
Q819 CHIP TRANSISTOR		2SA1037K
Q820 DIGITAL TRANSISTOR		DTA124EK
Q821 N-FET		2SK184
Q822 TRANSISTOR		2SD1858X
Q823		DTC124EK
Q824 DIGITAL TRANSISTOR		DTA124EK
Q825 CHIP TRANSISTOR		2SC2412K
Q826 DIGITAL TRANSISTOR		DTA124EK
Q827, 828		DTC124EK
Q829, 830 DIGITAL TRANSISTOR		DTA124EK
Q832 CHIP TRANSISTOR		2SA1037K
Q833 CHIP TRANSISTOR		2SC2412K
D102, 103 DIODE		1SS254
D201 VARI-CAP		FC54M
D203, 204 DIODE		1SS254
D601-604 DIODE		1SS254
D607-611 DIODE		1SS254
D801 DIODE		1SS254
D804-808 DIODE		1SS254
COILS/TRANSFORMERS		
L201, 202 AXIAL INDUCTOR		LAU010K
L203 AXIAL INDUCTOR		LAU220J
L204 FERRITE BEADS		VTH1013
L351, 352 AXIAL INDUCTOR		LAU560J
L353 AXIAL INDUCTOR		LAU270J
L411 AXIAL INDUCTOR		LAU330J
L412, 413 AXIAL INDUCTOR		LAU220J
L414, 415 AXIAL INDUCTOR		LAU120J
L416 AXIAL INDUCTOR		LAU430J
L431 AXIAL INDUCTOR		LAU430J
L432 AXIAL INDUCTOR		LAU620J
L433 AXIAL INDUCTOR		LAU390J
L441 AXIAL INDUCTOR		LAU270J
L456 RADIAL INDUCTOR		LFA471J
L457, 458 RADIAL INDUCTOR		LFA221J
L496 AXIAL INDUCTOR		LAU180J
L497 AXIAL INDUCTOR		LAU181J
L511 AXIAL INDUCTOR		LAU820J
L521 AXIAL INDUCTOR		LAU120J
L522 AXIAL INDUCTOR		LAU560J
L523 AXIAL INDUCTOR		LAU220J
L524 RADIAL INDUCTOR		LFA561K
L541 AXIAL INDUCTOR		LAU120J
L601, 602 AXIAL INDUCTOR		LAU101J
L603 AXIAL INDUCTOR		LAU470J

Mark	No.	Description	Part No.	Mark	No.	Description	Part No.
	L801	AXIAL INDUCTOR	LAU151J		C355	ELECTR. CAPACITOR	CEAS100M50
	L802	AXIAL INDUCTOR	LAU181J		C359	CHIP CAPACITOR	CKSQYF103Z50
	L803	AXIAL INDUCTOR	LAU151J		C360, 361	ELECTR. CAPACITOR	CEAS101M10
	F101	FILTER	VTH1033		C362	CERAMIC CAPACITOR	CCSSQL331J50
	F291	FILTER	VTH1033		C363	CHIP CAPACITOR	CKSQYB682K50
	F292	FILTER	VTH1032		C364	ELECTR. CAPACITOR	CEAS220M25
	F351		VTF1047		C365, 366	CERAMIC CAPACITOR	CKSQYB472K50
					C367	FILM CAPACITOR	CFTNA393J50
					C368	ELECTR. CAPACITOR	CEANP220M10
CAPACITORS							
	C101	ELECTR. CAPACITOR	CEAS101M10		C369	ELECTR. CAPACITOR	CEAS470M10
	C102	CERAMIC CAPACITOR	CKSQYF473Z25		C370	ELECTR. CAPACITOR	CEAS100M50
	C103	CHIP CAPACITOR	CKSQYF103Z50		C372, 373	FILM CAPACITOR	CFTNA104J50
	C104, 105	CERAMIC CAPACITOR	CCCCH300J50		C374	CERAMIC CAPACITOR	CCSQCH560J50
	C106	CHIP CAPACITOR	CKSQYF103Z50		C376	ELECTR. CAPACITOR	CEAS221M6R3
	C201	CERAMIC CAPACITOR	CKSQYF473Z25		C377	CHIP CAPACITOR	CKSQYF103Z50
	C202	CERAMIC CAPACITOR	CKSQYB152K50		C378, 379	ELECTR. CAPACITOR	CEAS101M10
	C203	ELECTR. CAPACITOR	CEJA470M10		C380	CHIP CERAMIC C.	CCSQCH271J50
	C204	CERAMIC CAPACITOR	CKSQYF104Z25		C381	CERAMIC CAPACITOR	CCSQCH560J50
	C205	FILM CAPACITOR	CFTNA474J50		C382	CHIP CAPACITOR	CKSQYB682K50
	C206	CHIP CAPACITOR	CKSQYF103Z50		C383	ELECTR. CAPACITOR	CEAS220M25
	C208	ELECTR. CAPACITOR	CEAS470M10		C384, 385	CERAMIC CAPACITOR	CKSQYB472K50
	C209	CERAMIC CAPACITOR	CKSQYF104Z25		C386	ELECTR. CAPACITOR	CEANP220M10
	C210	CERAMIC CAPACITOR	CKSQYF473Z25		C387	FILM CAPACITOR	CFTNA393J50
	C211	ELECTR. CAPACITOR	CEJA470M10		C388	ELECTR. CAPACITOR	CEASR47M50
	C212	CERAMIC CAPACITOR	CKSQYF104Z25		C407, 408	CERAMIC CAPACITOR	CKSQYF473Z25
	C213	CHIP CAPACITOR	CKSQYF103Z50		C411	CHIP CAPACITOR	CCSQCH101J50
	C220	CHIP CERAMIC C.	CCSQCH220J50		C412	CERAMIC CAPACITOR	CCSQCH470J50
	C225	ELECTR. CAPACITOR	CEANPR47M50		C413	CERAMIC CAPACITOR	CCSQCH151J50
	C226	FILM CAPACITOR	CFTNA223J50		C414	CHIP CERAMIC C.	CCSQCH221J50
	C227	ELECTR. CAPACITOR	CEAS220M25		C415	CERAMIC CAPACITOR	CCSQCH270J50
	C228, 229	CERAMIC CAPACITOR	CKSQYF104Z25		C416	CERAMIC CAPACITOR	CCSQCH390J50
	C230	ELECTR. CAPACITOR	CEAS470M10		C417, 418	CERAMIC CAPACITOR	CCSQCH120J50
	C231	CHIP CAPACITOR	CKSQYF103Z50		C419, 420	CERAMIC CAPACITOR	CCSQCH470J50
	C232	CERAMIC CAPACITOR	CCSQCH151J50		C423, 424	CHIP CAPACITOR	CCSQCH180J50
	C234	CHIP CAPACITOR	CKSQYF103Z50		C425, 426	CHIP CAPACITOR	CKSQYF103Z50
	C251	CHIP CAPACITOR	CKSQYF103Z50		C427	CERAMIC CAPACITOR	CKSQYF104Z25
	C252, 253	ELECTR. CAPACITOR	CEAS470M10		C428	ELECTR. CAPACITOR	CEAS470M10
	C254	CERAMIC CAPACITOR	CKSQYF104Z25		C429	CERAMIC CAPACITOR	CKSQYF104Z25
	C255	FILM CAPACITOR	CFTNA104J50		C431, 432	CERAMIC CAPACITOR	CKSQYF473Z25
	C256	ELECTR. CAPACITOR	CEAS470M10		C433	CERAMIC CAPACITOR	CCSQCH390J50
	C257	FILM CAPACITOR	CFTNA104J50		C434	ELECTR. CAPACITOR	CEAS101M10
	C258, 259	CERAMIC CAPACITOR	CCSQCH560J50		C435	CERAMIC CAPACITOR	CKSQYF104Z25
	C260-263	CERAMIC CAPACITOR	CCSQCH390J50		C436	ELECTR. CAPACITOR	CEAS010M50
	C264, 265	MYLOR FILM CAPACITOR	CQMA152J50		C437	CHIP CERAMIC C.	CCSQCH240J50
	C266, 267	MYLOR FILM CAPACITOR	CQMA682J50		C438	CERAMIC CAPACITOR	CCSQCH120J50
	C268, 269	MYLOR FILM CAPACITOR	CQMA102J50		C439	CERAMIC CAPACITOR	CCSQCH470J50
	C270-273	ELECTR. CAPACITOR	CEAS470M10		C440	CERAMIC CAPACITOR	CCSQCH390J50
	C274, 275	ELECTR. CAPACITOR	CEANP220M10		C441	CERAMIC CAPACITOR	CCSQCH070J50
	C278, 279	ELECTR. CAPACITOR	CEAS470M10		C442	CERAMIC CAPACITOR	CKSQYF104Z25
	C280	FILM CAPACITOR	CFTNA393J50		C443	ELECTR. CAPACITOR	CEAS4R7M50
	C281-283	ELECTR. CAPACITOR	CEAS470M10		C444	MYLOR FILM CAPACITOR	CQMA272J50
	C351	CHIP CAPACITOR	CCSQCH910J50		C445	ELECTR. CAPACITOR	CEAS101M10
	C352	CHIP CERAMIC C.	CCSQCH221J50		C446	FILM CAPACITOR	CFTNA103J50
	C353	CHIP CAPACITOR	CCSQCH910J50		C447	CHIP CAPACITOR	CCSQCH330J50
	C354	CHIP CAPACITOR	CKSQYF103Z50				

Mark	No.	Description	Part No.	Mark	No.	Description	Part No.
	C448, 449	CERAMIC CAPACITOR	CKSQYF473Z25		C534	CERAMIC CAPACITOR	CKSQYF473Z25
	C450	CHIP CAPACITOR	CCSQCH100D50		C535	CHIP CAPACITOR	CKSQYF103Z50
	C451	CERAMIC CAPACITOR	CCSQCH270J50		C536	CHIP CAPACITOR	CCSQCH910J50
	C452	ELECTR. CAPACITOR	CEAS470M10		C537	CAPACITOR(CERAMIC)	CKSYF105Z16
	C456	CHIP CAPACITOR	CCSQCH101J50		C541	CERAMIC CAPACITOR	CKSQYF104Z25
	C457	ELECTR. CAPACITOR	CEAS101M10		C542	ELECTR. CAPACITOR	CEAS470M10
	C458-460	CHIP CAPACITOR	CKSQYF103Z50		C543	CERAMIC CAPACITOR	CKSQYF104Z25
	C461	CHIP CAPACITOR	CCSQCH101J50		C544	CERAMIC CAPACITOR	CKSQYF473Z25
	C462	CHIP CAPACITOR	CCSQCH330J50		C545	CHIP CAPACITOR	CCSQCH680J50
	C463	CHIP CERAMIC C.	CCSQCH271J50		C546	CERAMIC CAPACITOR	CCSQCH470J50
	C464, 465	ELECTR. CAPACITOR	CEAS470M10		C547, 548	CERAMIC CAPACITOR	CKSQYF473Z25
	C466, 467	CERAMIC CAPACITOR	CKSQYF473Z25		C567	CERAMIC CAPACITOR	CKSQYF473Z25
	C471	ELECTR. CAPACITOR	CEAS010M50		C582	ELECTR. CAPACITOR	CEAS221M6R3
	C472	ELECTR. CAPACITOR	CEAS3R3M50		C601	ELECTR. CAPACITOR	CEAS221M6R3
	C473	CERAMIC CAPACITOR	CKSQYF473Z25		C602	CERAMIC CAPACITOR	CKSQYF473Z25
	C474	FILM CAPACITOR	CFTNA224J50		C603	CHIP CAPACITOR	CCSQCH101J50
	C475, 476	ELECTR. CAPACITOR	CEAS3R3M50		C604	FILM CAPACITOR	CFTNA224J50
	C477, 478	CERAMIC CAPACITOR	CKSQYF473Z25		C605	MYLOR FILM CAPACITOR	CQMA102J50
	C479, 480	CERAMIC CAPACITOR	CKSQYF104Z25		C606	CAPACITOR	CQPA821J100
	C483	CERAMIC CAPACITOR	CKSQYF473Z25		C607	MYLOR FILM CAPACITOR	CQMA102J50
	C484	ELECTR. CAPACITOR	CEAS470M25		C608	MYLOR FILM CAPACITOR	CQMA152J50
	C485	CHIP CERAMIC C.	CCSQCH220J50		C610	FILM CAPACITOR	CFTNA563J50
	C486	CHIP CAPACITOR	CKSQYF103Z50		C611	MYLOR FILM CAPACITOR	CQMA272J50
	C487, 488	CERAMIC CAPACITOR	CKSQYF473Z25		C612	ELECTR. CAPACITOR	CEAS220M25
	C489, 490	ELECTR. CAPACITOR	CEAS101M10		C613	MYLOR FILM CAPACITOR	CQMA332J50
	C496	CERAMIC CAPACITOR	CCSQCH390J50		C614	FILM CAPACITOR	CFTNA103J50
	C497	CHIP CAPACITOR	CCSQCH100D50		C615	FILM CAPACITOR	CFTNA563J50
	C498	CERAMIC CAPACITOR	CCSQCH820J50		C616	ELECTR. CAPACITOR	CEANP2R2M50
	C499	ELECTR. CAPACITOR	CEAS470M10		C617	FILM CAPACITOR	CFTNA223J50
	C500	CHIP CAPACITOR	CCSQCH100D50		C618	ELECTR. CAPACITOR	CEANP220M10
	C501, 502	ELECTR. CAPACITOR	CEAS470M10		C619	MYLOR FILM CAPACITOR	CQMA332J50
	C503	CERAMIC CAPACITOR	CKSQYF104Z25		C620	MYLOR FILM CAPACITOR	CQMA222J50
	C504	CERAMIC CAPACITOR	CKSQYF473Z25		C621	ELECTR. CAPACITOR	CEAS4R7M50
	C505, 506	CERAMIC CAPACITOR	CKSQYF104Z25		C622	ELECTR. CAPACITOR	CEAS470M10
	C507	CERAMIC CAPACITOR	CKSQYF473Z25		C623	CERAMIC CAPACITOR	CKSQYF473Z25
	C509	CERAMIC CAPACITOR	CCSQCH151J50		C624-627	CHIP CAPACITOR	CCSQCH180J50
	C510	CERAMIC CAPACITOR	CCSQCH270J50		C628	CHIP CAPACITOR	CKSQYF103Z50
	C511	CERAMIC CAPACITOR	CKSQYF104Z25		C629	CHIP CAPACITOR	CCSQCH180J50
	C512	ELECTR. CAPACITOR	CEAS470M10		C641, 642	ELECTR. CAPACITOR	CEAS470M10
	C513	CERAMIC CAPACITOR	CKSQYF104Z25		C643-646	CHIP CAPACITOR	CKSQYF103Z50
	C514	FILM CAPACITOR	CFTNA104J50		C650	FILM CAPACITOR	CFTNA103J50
	C515	FILM CAPACITOR	CFTNA683J50		C651-653	CHIP CAPACITOR	CKSQYF103Z50
	C516	CHIP CERAMIC C.	CCSQCH220J50		C654	CERAMIC CAPACITOR	CCSQCH820J50
	C517	FILM CAPACITOR	CFTNA683J50		C655	CHIP CAPACITOR	CCSQCH180J50
	C521	ELECTR. CAPACITOR	CEAS470M10		C656, 657	MYLOR FILM CAPACITOR	CQMA272J50
	C522	ELECTR. CAPACITOR	CEAS100M50		C658	CHIP CAPACITOR	CCSQCH101J50
	C524	CERAMIC CAPACITOR	CCSQCH390J50		C659	CHIP CAPACITOR	CCSQCH180J50
	C525	ELECTR. CAPACITOR	CEAS470M10		C801-803	CHIP CAPACITOR	CKSQYF103Z50
	C526	CERAMIC CAPACITOR	CKSQYF104Z25		C804	CERAMIC CAPACITOR	CCSQCH390J50
	C527	CERAMIC CAPACITOR	CKSQYF473Z25		C805	CERAMIC CAPACITOR	CKSQYF473Z25
	C528	CHIP CAPACITOR	CCSQCH101J50		C806	CHIP CERAMIC C.	CCSQCH220J50
	C529	CHIP CAPACITOR	CCSQCH910J50		C807	FILM CAPACITOR	CFTNA124J50
	C530	ELECTR. CAPACITOR	CEANP100M16		C808	ELECTR. CAPACITOR	CEAS010M50
	C531	CERAMIC CAPACITOR	CKSQYF104Z25		C809	CHIP CAPACITOR	CCSQCH680J50
	C533	ELECTR. CAPACITOR	CEAS470M10		C810, 811	CHIP CAPACITOR	CCSQCH101J50

Mark No.	Description	Part No.
R511	METALFILM RESISTOR	RN1/6PQ□□□□F
R512-519	CHIP RESISTOR	RS1/10S□□□□J
R521-533	CHIP RESISTOR	RS1/10S□□□□J
R542, 543	CHIP RESISTOR	RS1/10S□□□□J
R588		RS1/10S□□□□J
R601, 602	CHIP RESISTOR	RS1/10S□□□□J
R603	CARBONFILM RESISTOR	RD1/6PM□□□□J
R604-612		RS1/10S□□□□J
R615-617	CHIP RESISTOR	RS1/10S□□□□J
R618	CARBONFILM RESISTOR	RD1/6PM□□□□J
R619-623	CHIP RESISTOR	RS1/10S□□□□J
R625-628	CHIP RESISTOR	RS1/10S□□□□J
R629	CARBONFILM RESISTOR	RD1/6PM□□□□J
R630-646	CHIP RESISTOR	RS1/10S□□□□J
R647	CARBONFILM RESISTOR	RD1/6PM□□□□J
R648, 649	CHIP RESISTOR	RS1/10S□□□□J
R651-653	CHIP RESISTOR	RS1/10S□□□□J
R661, 662	CHIP RESISTOR	RS1/10S□□□□J
R665-678	CARBONFILM RESISTOR	RD1/6PM□□□□J
R680-683	METALFILM RESISTOR	RN1/6PQ□□□□F
R684-689	CHIP RESISTOR	RS1/10S□□□□J
R691	CARBONFILM RESISTOR	RD1/6PM□□□□J
R692	CHIP RESISTOR	RS1/10S□□□□J
R700-708	CHIP RESISTOR	RS1/10S□□□□J
R709	CARBONFILM RESISTOR	RD1/6PM□□□□J
R710	CHIP RESISTOR	RS1/10S□□□□J
R713		RS1/10S□□□□J
R801-848	CHIP RESISTOR	RS1/10S□□□□J
R849	CARBONFILM RESISTOR	RD1/6PM□□□□J
R850	METAL OXIDE RESISTOR	RS1LMF□□□□J
R853, 854	CHIP RESISTOR	RS1/10S□□□□J
R856		RS1/10S□□□□J
R858-860	CHIP RESISTOR	RS1/10S□□□□J
R862	METAL OXIDE RESISTOR	RS1LMF□□□□J
R865-868	CHIP RESISTOR	RS1/10S□□□□J
R869	CARBONFILM RESISTOR	RD1/6PM□□□□J
R870	CHIP RESISTOR	RS1/10S□□□□J
R872	CHIP RESISTOR	RS1/10S□□□□J
R873	CARBONFILM RESISTOR	RD1/6PM□□□□J
R874-897	CHIP RESISTOR	RS1/10S□□□□J
R899-909	CHIP RESISTOR	RS1/10S□□□□J
R910-912	CARBONFILM RESISTOR	RD1/6PM□□□□J
R913-922	CHIP RESISTOR	RS1/10S□□□□J
R923	CARBONFILM RESISTOR	RD1/6PM□□□□J
R925-932	CHIP RESISTOR	RS1/10S□□□□J
R934-938	CHIP RESISTOR	RS1/10S□□□□J
R940, 941	CHIP RESISTOR	RS1/10S□□□□J
R942	CARBONFILM RESISTOR	RD1/6PM□□□□J
R943-951		RS1/10S□□□□J
R953	CHIP RESISTOR	RS1/10S□□□□J
R955-957	CHIP RESISTOR	RS1/10S□□□□J
R959-962	CHIP RESISTOR	RS1/10S□□□□J
R964	CHIP RESISTOR	RS1/10S□□□□J
R966-970		RS1/10S□□□□J

Mark No.	Description	Part No.
R982, 983	CHIP RESISTOR	RS1/10S□□□□J
R998, 999	CHIP RESISTOR	RS1/10S□□□□J
R980	CHIP RESISTOR	RS1/10S□□□□J
VR441	SEMI-FIXED RESISTOR	VRTB6VS103
VR481	VR	VRTB6VS472
VR482	SEMI-FIXED RESISTOR	VRTB6VS103
VR521	VR	VRTG6VS472
VR601	VR	VRTB6VS102
VR602, 603	SEMI-FIXED RESISTOR	VRTB6VS103
VR604	VR	VRTB6VS472
VR605, 606	VR	VRTB6VS222
VR607	VR	VRTB6VS223
VR608	VARIABLE RESISTOR	VRTB6VS333
VR609	VR	VRTB6VS472

OTHERS

CN103	VKN1073
CN301	B5P-SHF-1AA
JA2 JACK	VKN-183
JA4 JACK	VKB1031
JA7 JACK	VKB1029
VC901 VARIABLE CAPACITOR	VCN-008
X101 CERAMIC RESONATOR	VSS1040
X201 CRYSTAL RESONATOR	VSS1049
X601 CRYSTAL RESONATOR	VSS1026

HEAD ASSEMBLY

CAPACITORS

C1	CKSQYF473Z50
C5	CKSYF105Z16

RESISTORS

VR1(10K)	VCP1040
----------	---------

7. DISASSEMBLY

7.1 REMOVING THE BONNET AND FRONT PANEL (Fig. 7-1, 2)

- ① Remove six screws (A) to remove the bonnet.
- ② To remove the front panel assembly, remove three screws (B) and lift the claws as shown in the figure and lower the front panel toward the front.

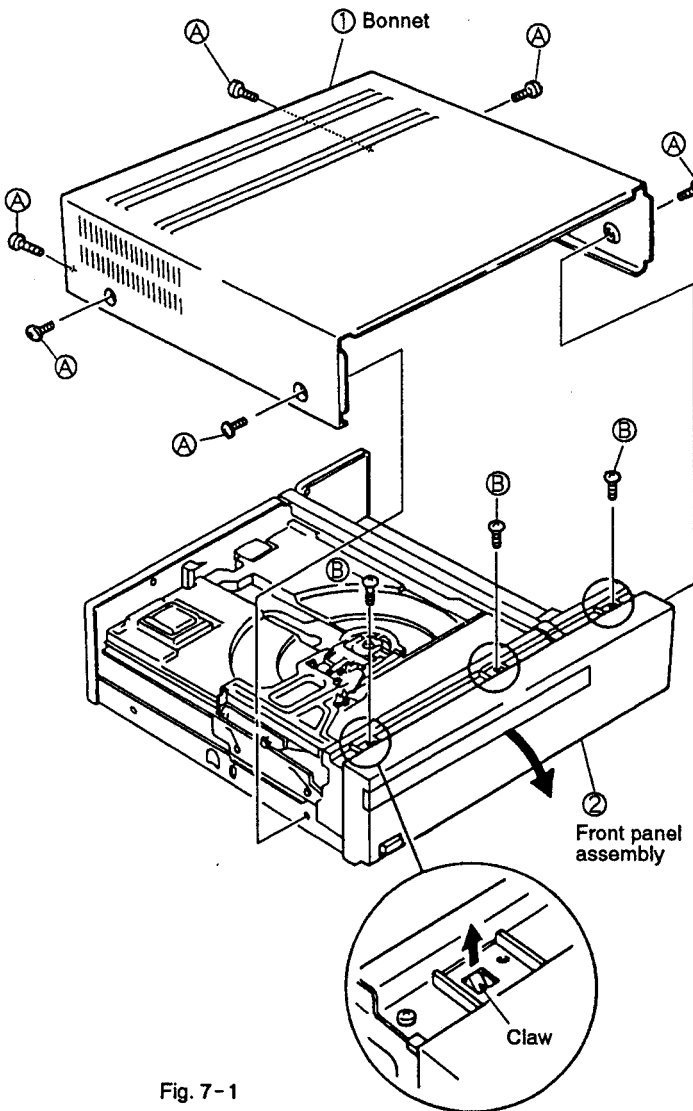

Fig. 7-1

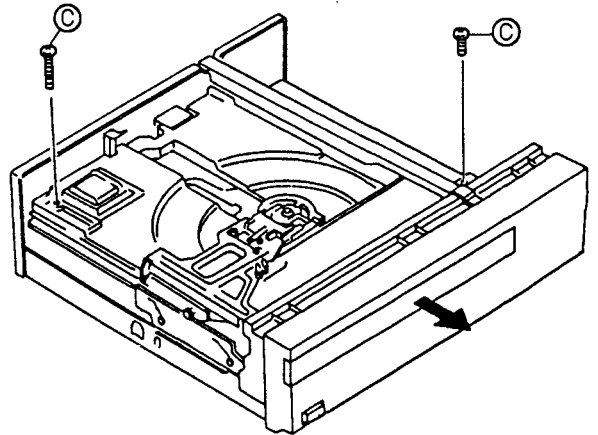

Fig. 7-2

7.2 REMOVING THE TRAY(Fig. 7-2, 3)

- ① Remove two stopper screws (C) shown in Fig. 7-2. When the power can be turned ON, press the OPEN (▲) button then pull the tray out from the player.
- ② When the power cannot be turned ON, remove the front panel (Fig. 7-1), and turn the gear pulley shown in Fig. 7-3 counterclockwise, and the tray will slide out toward the front.

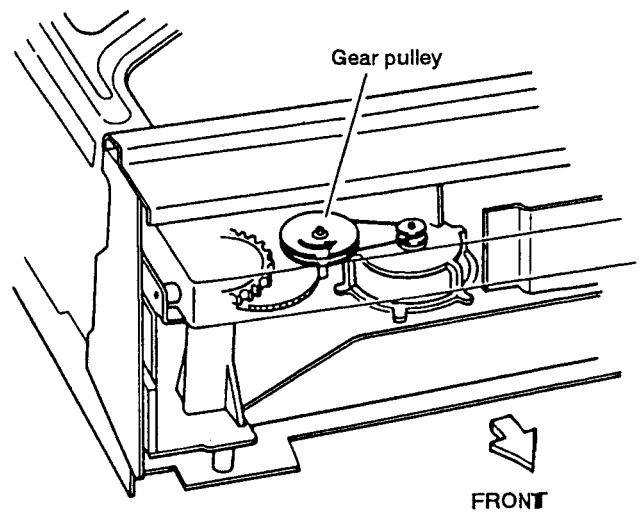

Fig. 7-3

**7.3 REMOVING THE MAIN ASSEMBLY
(Fig. 7-4)**

- After removing the main binders, remove by the following procedure:
- ① Remove two screws (A) to remove the center angle.
- ② Remove two screws (B) holding the MAIN assembly, and remove seven screws (C) on the sides of the rear panel.
- ③ Remove the flexible cable from the connector.
- ④ Pull the MAIN assembly in the direction of the arrow.
- ⑤ While sliding the MAIN assembly to the right, lift it upward in the direction of the arrow.

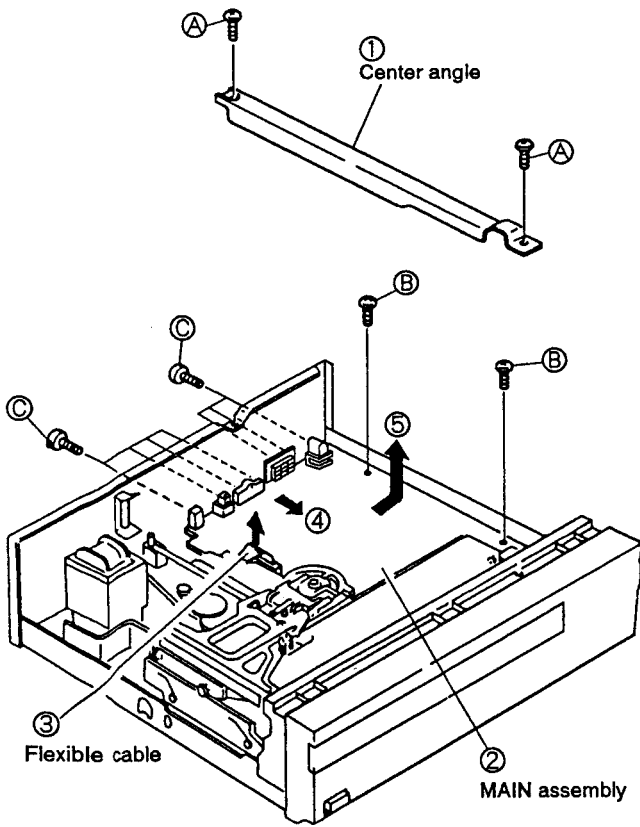

Fig. 7-4

● **Diagnosis of the MAIN assembly**

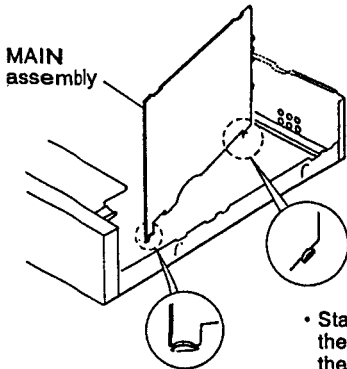

Fig. 7-5

- Stand the MAIN assembly in the chassis as illustrated, and the MAIN assembly is able to diagnose from the foil side.

**7.4 REMOVING THE CLAMPER ARM (B)
AND CLAMPER ARM (A) ASSEMBLY
(Fig. 7-6)**

Set the player with the tray moved up.

- ① Remove two clamber springs and raise clamber arm (B).
- ② Clamber arm (B) can be removed by pulling it in the direction of the arrow.
- ③ Remove a screw (A) with an arm spring holding the clamber arm (A) assembly.
- ④ Remove the clamber arm (A) assembly by pulling it in the direction of the arrow.

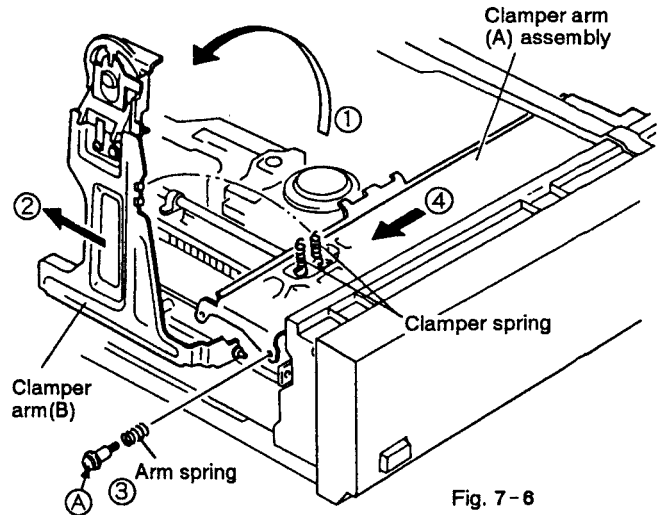

Fig. 7-6

7.5 REMOVING THE CLAMPER (Fig. 7-7)

- ① Remove the plate spring by unscrewing screw (A).
- ② Remove the parallel link by sliding it in the direction of the arrow. (Be careful not to damage the claw located on one side of the link.)
- ③ The clumper can be removed by sliding the clumper holder in the direction of the arrow.

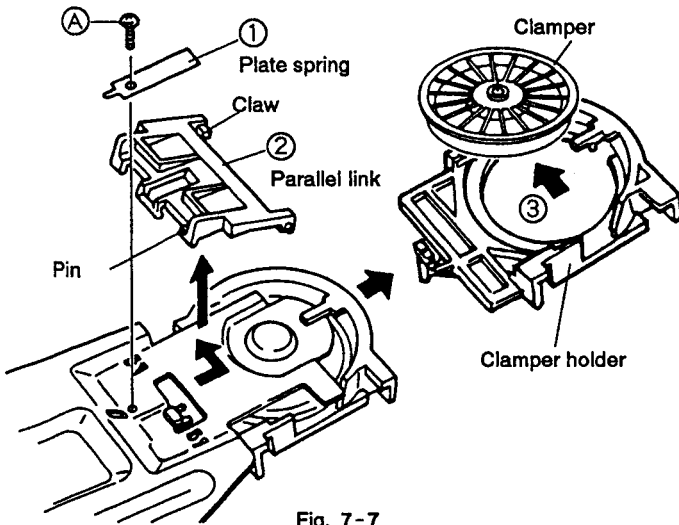

Fig. 7-7

7.6 REMOVING THE PICKUP ASSEMBLY (Fig. 7-8)

- ① Remove the flexible cable from the connector and also remove the flexible cable installed at section (a).
- ② Remove a screw (A) holding the carriage shaft.
- ③ Raise the shaft in the direction of the arrow to remove the rack assembly.
- ④ Remove a hexagonal screw (B) and lift up the pickup assembly slightly and turn the pickup assembly in the direction of arrow (5).
- ⑤ Remove two screws (C) on the back of the pickup assembly.

Note: Make sure that the rack assembly is not close to the turntable when it is removed.

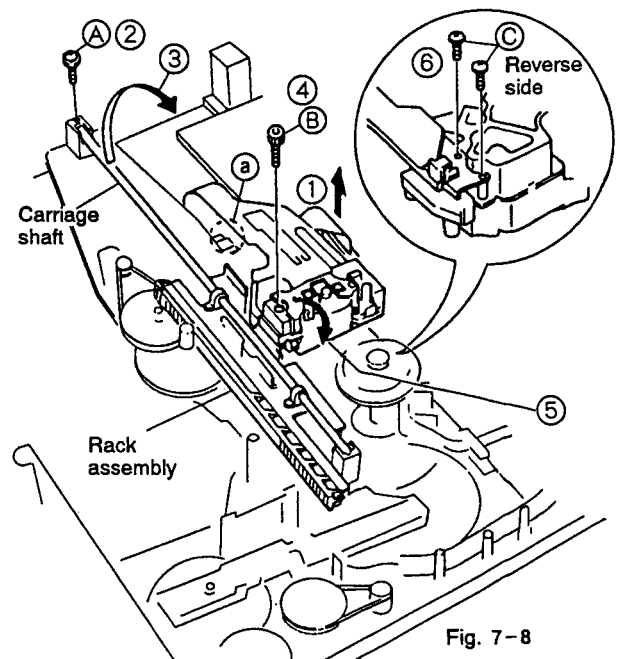

Fig. 7-8

7.7 REMOVING THE TILT SENSOR (Fig. 7-9)

- ① Remove the connector (arrow (A)) of the flexible cable and release the claw (arrow (B)) to remove the tilt sensor.

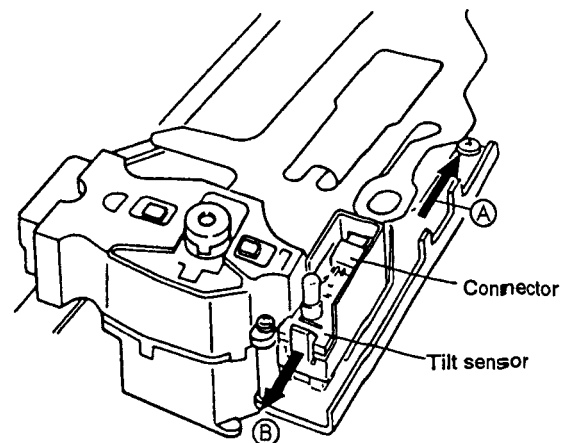

Fig. 7-9

7.8 REMOVING THE MECHANISM SECTION (Fig. 7-10)

Remove six screws (A), and the entire mechanism section can be removed.

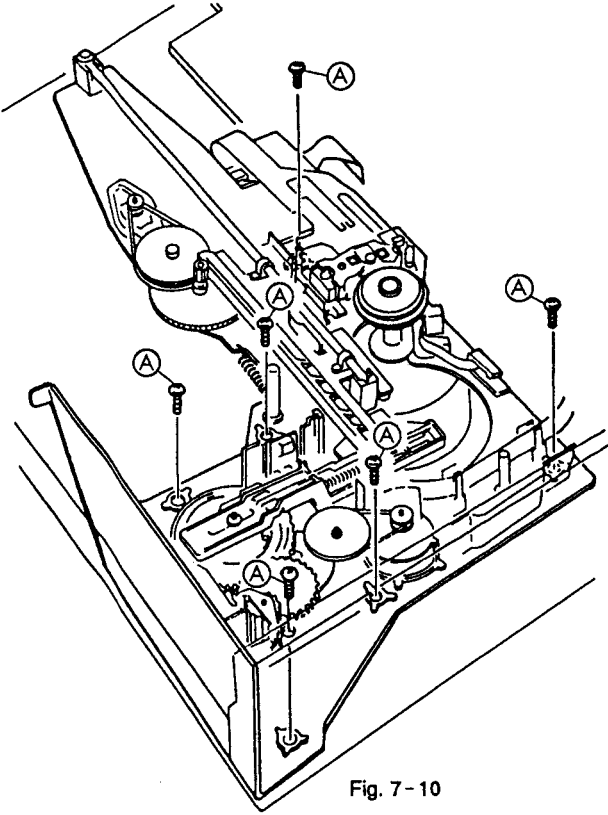

Fig. 7-10

7.9 REMOVING THE SLIDE CAM AND ROLLER PLATE ASSEMBLY (Fig. 7-11)

- ① Set the player with the tray down.
- ② Remove three screws (A) and slide the slide cam toward the rear to remove it.
- ③ Remove the clamber arm (A) assembly (see page 61) after removing slide cam to remove the roller plate assembly.

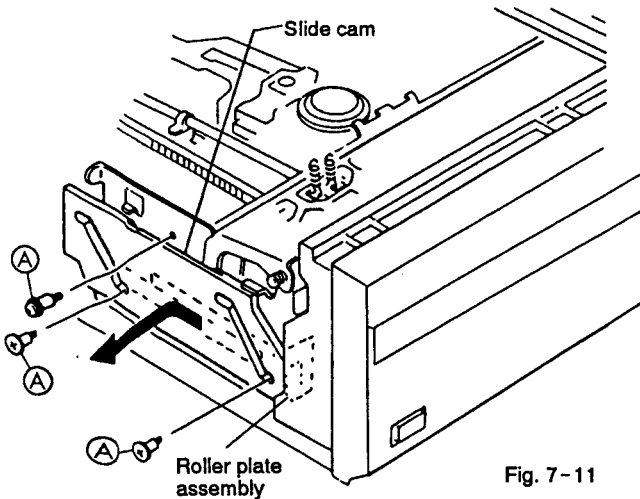

Fig. 7-11

7.10 ASSEMBLING THE MECHANISM SECTION

7.10.1. Positioning the gears

(Since the cam gears are used for the detection of all operation modes in this unit, the cam gears and the tray should be positioned correctly. Reassemble in the following procedure.)

- ① Position three switch levers so that they are nearly parallel (approx. 2mm), as shown in Fig. 7-12 (a).
- ② Insert the cam gear so that the end of the spiral groove on the upper surface of the cam gear comes to the position nearest to the shaft located at the front, as shown in Fig. 7-12 (b).

(In this case, the cam gear should be set in the position where the angle between the center line of the cam gear and the pin on the cam gear is 45°, by visual checking.)

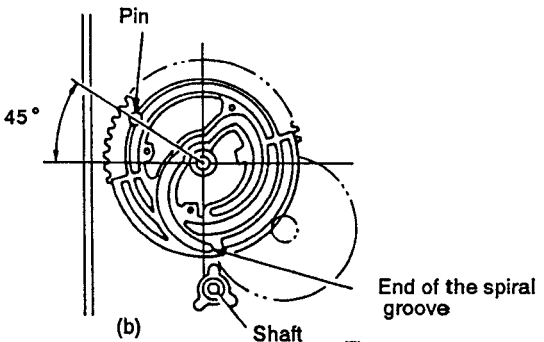
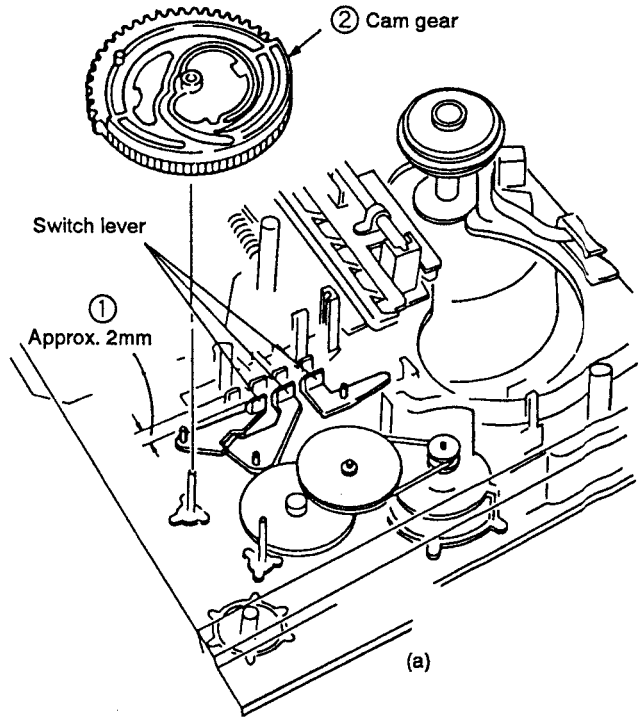

Fig. 7-12

- ③ Mount the spring slanting cam by raising the rack assembly in the direction of the arrow so that the tilt slide section comes under the rack assembly. Then, mount the cam spring. (Fig. 7-13 (a))
- ④ Insert the follow gear so that the "L"-shaped section of the follow gear comes to the end of the cam gear, as shown in Fig. 7-13 (b).

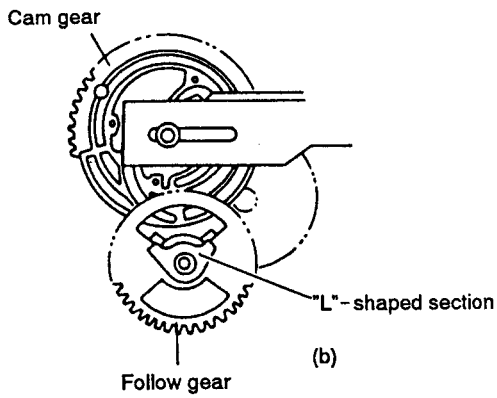
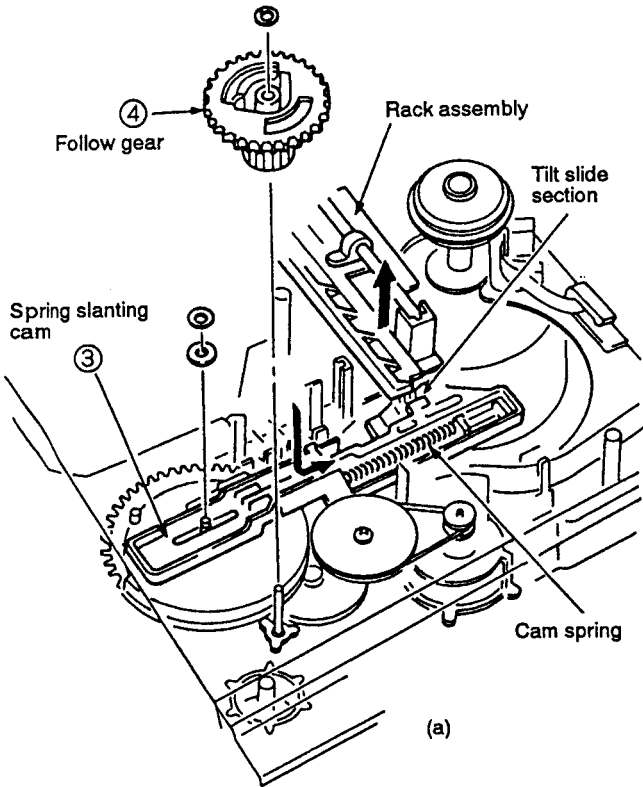

Fig. 7-13

- ⑤ Mount the roller plate assembly in the position where the tooth with the triangle mark (▼) of the follow gear is engaged with the dip of the gear with the short rib on the roller plate gear, as shown in Fig. 7-14.

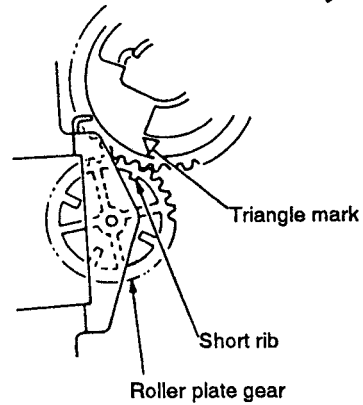
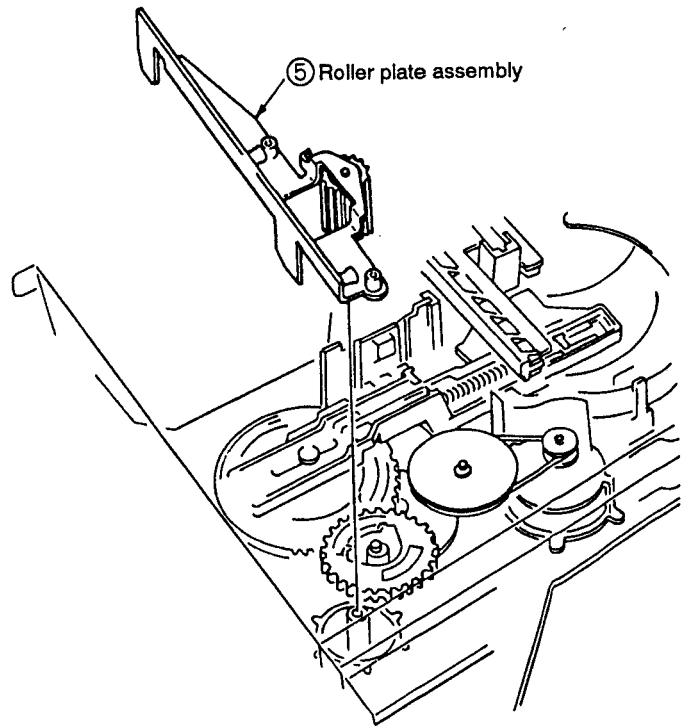

Fig. 7-14

7.10.2 Positioning the tray (Fig. 7-15)

- ① Set the player with the tray open.
- ② Set the roller plate gear so that the roller plate line intersects with the mid - point of missing tooth of the roller plate gear.
 (At this time, adjust the position by the method shown in Fig. 7-15, or turn the power ON and use the SKIP (←, →) buttons in the direction of OUT tilt it stops as shown in Fig. 7-15-1.)
- ③ Insert the tray.
 At this time, the tray can be inserted only when the first missing tooth of the tray gear is engaged with the missing tooth section of the roller plate gear, as shown in the figure. (Fig.7-15-1)
 Tray is easier to insert by pushing slightly upwards.
 (Fig.7-15-2)

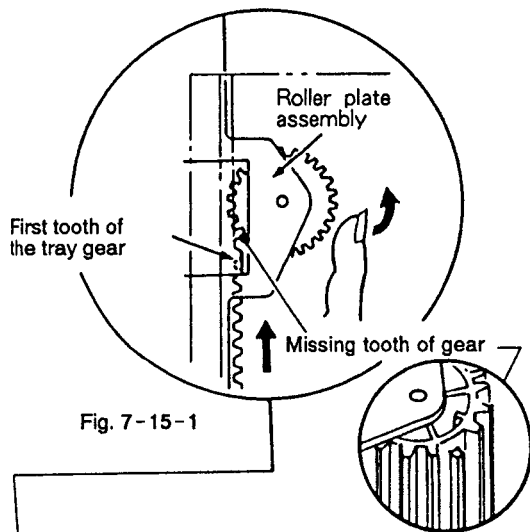

Fig. 7-15-1

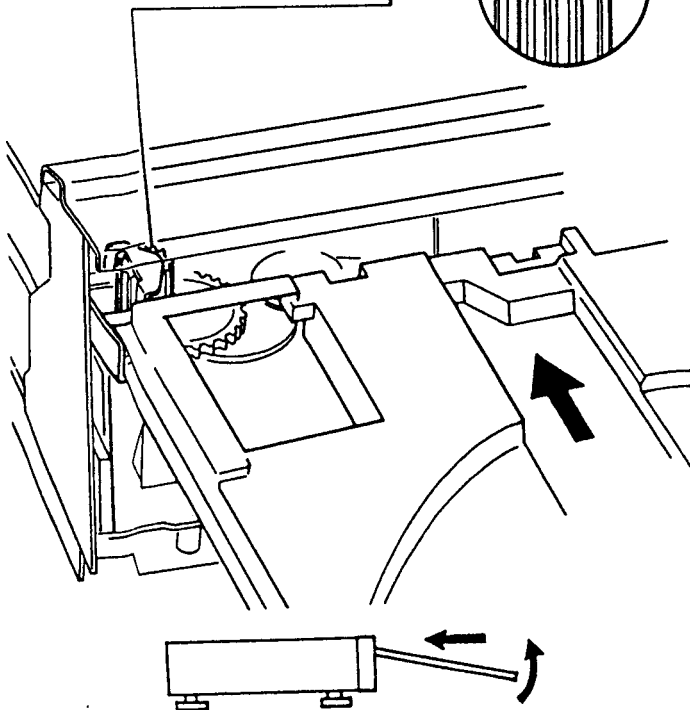

Fig. 7-15-2

7.10.3 Assembling the servo mechanism base assembly(Fig. 7-16)

When assembling the servo mechanism base assembly, pay special attention to the following points:

- After inserting the tilt shaft in the position shown in Fig. 7-16-1 of mechanism chassis assembly, mount the servo mechanism base assembly in the direction of the arrow so that the tilt shaft does not come over the shaft holder as shown in Fig. 7-16-2.
- The thrust spring should not come over the shaft holder.
- Check that the end of the plate spring is inserted under the base.

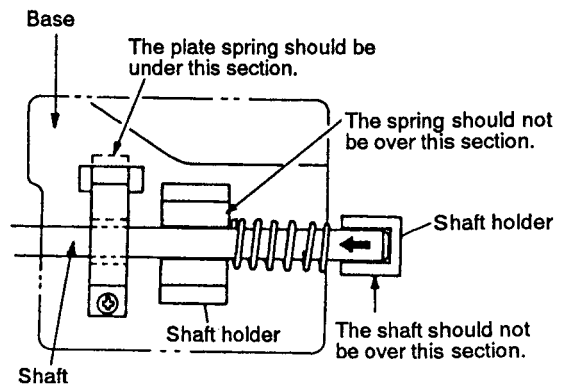

Fig 7-16-1

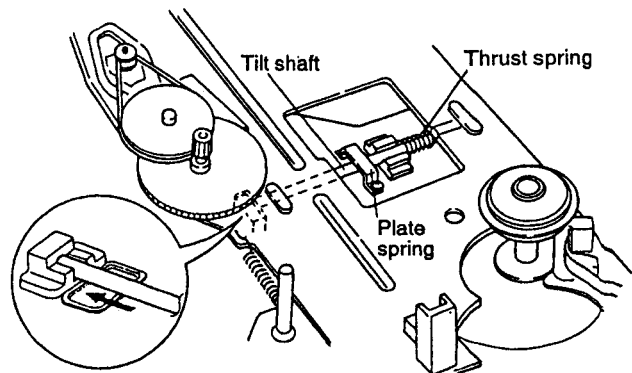

Fig. 7-16-2

7.10.4 Styling of the flexible cable (Fig. 7-17)

- ① Bend the flexible cable of the pickup assembly by about 45° at the ▲ mark.
- ② Insert the flexible cable into the connector.
- ③ Set the flexible cable under the protruding section.
- ④ Twist the flexible cable by a half turn.
- ⑤ Insert the triangular section.
- ⑥ Further insert the flexible cable under the protruding section.

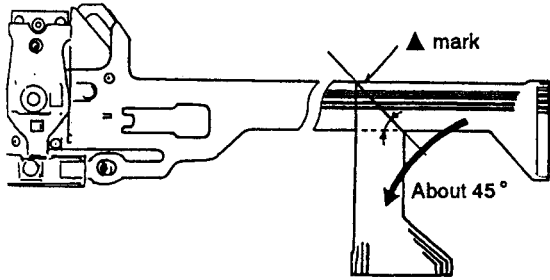

Fig. 7-17-1

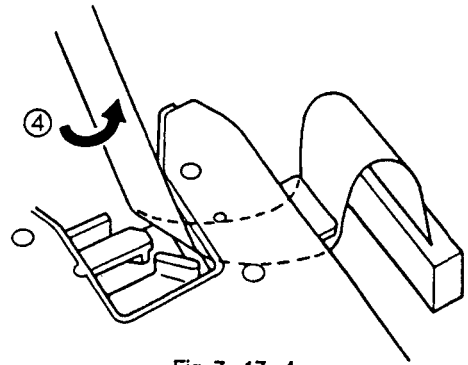
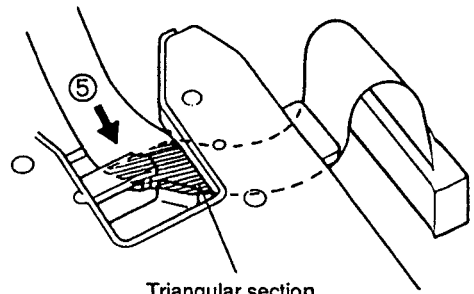

Fig. 7-17-4



Triangular section

Fig. 7-17-5

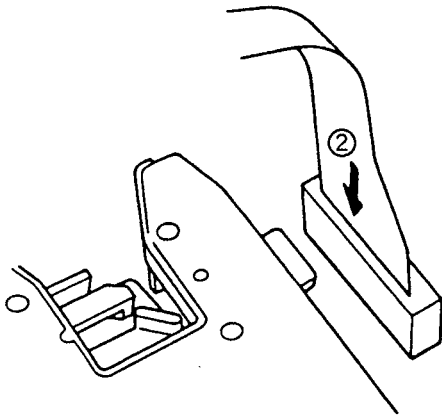

Fig. 7-17-2

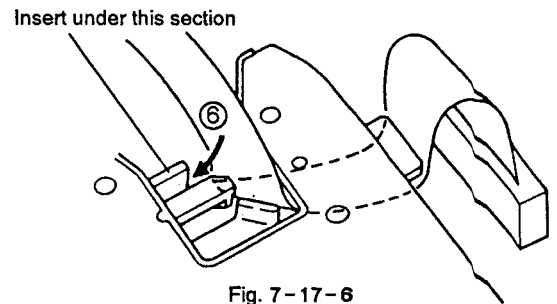
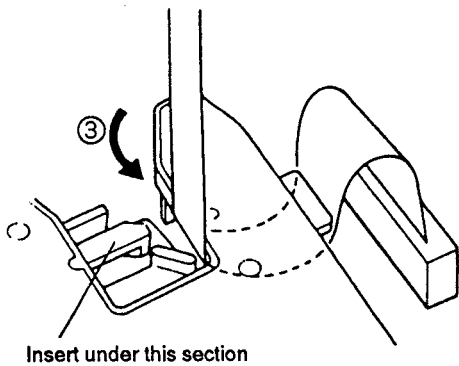
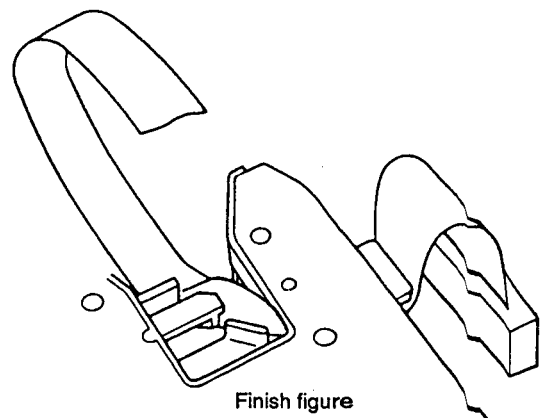

Fig. 7-17-6



Insert under this section

Fig. 7-17-3



Finish figure

Fig. 7-17-7

**7.11 DIAGNOSING THE SYPS ASSEMBLY
(Fig. 7-18)**

Procedure-1

1. Remove the screw fixing the SYPS assembly and keep the SYPS assembly apart about 3cm from the base chassis (See Fig. 7-18-1).
2. Insert a soldering iron between the SYPS assembly and base chassis, alternately desolder the lapping pins of an AC power cord, and remove the lapping pins (See Fig. 7-18-1).
3. Solder the lapping pins through the foil side of the board with the SYPS assembly raised.
The SYPS assembly can be diagnosed for component replacement through the foil side.
(See Fig. 7-18-2).

Notes:

1. Interpose cloth for check so that the SYPS assembly does not touch the chassis.
2. Remove the rear panel when you are difficult to work.

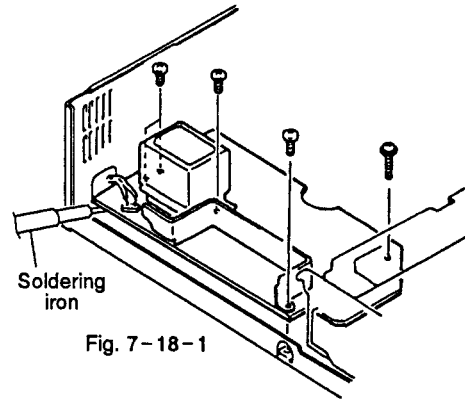

Fig. 7-18-1

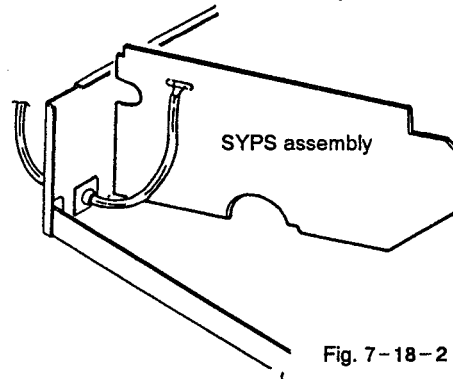

Fig. 7-18-2

Procedure-2

1. Insert a screwdriver into the chassis hole near a strain relief through the back of the base chassis and remove the strain relief stop ring.
2. Remove the strain relief and pull the AC power cord toward the main unit to set up the SYPS assembly.

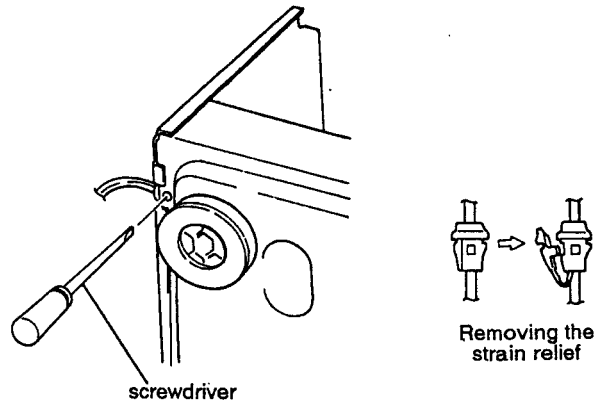

Fig. 7-19

8. ADJUSTMENT

8.1 MAIN ASSEMBLY ADJUSTMENT SUMMARY

	ADJUSTMENT	P	Adjusting Point	Measurement equipment Connecting Point	Player Condition	Adjusting Specification
1	Tilt Servo Gain Adjustment	75	VR808	None	Power off	<ul style="list-style-type: none"> • Making of Tilt GAIN VR position Red :Turn to Right Clear : Center Blue :Turn to Left
2	Coarse Adjustment of Grating and TRK Balance Adjustment	76	Grating/VR802	CN401-8 (TRK ERR)	<ul style="list-style-type: none"> • Test mode #15,000 TRK servo loop open 	<ul style="list-style-type: none"> • Null point → TRK error MAX • Adjust VR802 so that the TRK error waveform amplitude's positive and negative level become equal.
3	Slider Shaft Horizontal Adjustment	77	Player SKIP key	CN401-2 (FCS RTN)	<ul style="list-style-type: none"> • Test mode Tilt servo loop off TRK servo loop open #5,200 	<ul style="list-style-type: none"> • Use the SKIP key to adjust to $0V \pm 20mV$.
4	Pickup Inclination Adjustment	78	Pickup Assembly TAN / TRK inclination adjustment screw	CN401-1 (RF)	<ul style="list-style-type: none"> • Test mode #2,701 still TRK servo loop close / open Tilt servo loop open 	<ul style="list-style-type: none"> • RF waveform's amplitude MAX (Pickup TAN / TRK adjustment screw) • Minimized crosstalk.
5	TRKG Error Best / Crosstalk Best Adjustment	79	VR805 (TE BEST) VR806 (CT BEST)	CN401-8 (TRK ERR) CN401-1 (RF)	<ul style="list-style-type: none"> • Test mode TRK servo close / open Tilt servo loop off 	<ul style="list-style-type: none"> • RF MAX (VR806) • TRK error MAX (VR805)
6	FOCS SUM Level Adjustment	80	VR809	CN401-10 (FCS SUM)	<ul style="list-style-type: none"> • Play mode 	<ul style="list-style-type: none"> • Adjust VR 809 so that the voltage becomes 1.5VDC.
7	Tilt Sensor Inclination / Tilt Balance Adjustment	81	Tilt sensor inclination adjustment screw VR807 (TILT BAL)	TV monitor Test mode screen	<ul style="list-style-type: none"> • Test mode #18,200 / #115 still TRK servo loop close Tilt servo loop off 	<ul style="list-style-type: none"> • Set VR 807 to the center. • Adjust the adjustment screw so that the tilt error display code is 6,7, or 8. • Adjust VR807 so that the tilt error display becomes 7.
8	Verification and Adjustment of Spindle Motor Centering	82	Spindle motor centering adjustment screw.	CH1:CN401-8 (TRK ERR) CH2:CN401-7 (TRK SUM) (X-Y mode)	<ul style="list-style-type: none"> • Test mode #25,000 / #1 TRK servo loop open Tilt servo loop on 	<ul style="list-style-type: none"> • Adjust the centering adjustment screw so that the lissajous figures of #1 and #25,000 are the same.
9	Fine Adjustment of Grating and TRK Balance Adjustment	83	Grating / VR802	CH1:CN401-8 (TRK ERR) CH2:CN401-7 (TRK SUM) (X-Y mode)	<ul style="list-style-type: none"> • Test mode TRK servo loop open Tilt servo loop on 	<ul style="list-style-type: none"> • Minimize the Y direction of the lissajous figure. • Level of the X direction of the lissajous figures are equal.
10	FCS Servo Loop Gain Adjustment	84	VR804	CH1:CN401-5 (FCS IN) CH2:CN401-4 (FCS ERR) (X-Y mode)	<ul style="list-style-type: none"> • Test mode #15,000 still TRK servo loop close Tilt servo loop on 	<ul style="list-style-type: none"> • Adjust VR804 so that the lissajous figure is symmetric with respect to the X and Y axes.
11	TRK Servo Loop Gain Adjustment	85	VR803	CH1:CN401-9 (TRK IN) CH2:CN401-8 (TRK ERR) (X-Y mode)	<ul style="list-style-type: none"> • Test mode #15,000 still TRK servo loop close Tilt servo loop on 	<ul style="list-style-type: none"> • Adjust VR803 so that the lissajous figure is symmetric with respect to the X and Y axes.
12	RF Gain Adjustment	86	VR801	CN401-1 (RF)	<ul style="list-style-type: none"> • #15,000 still 	<ul style="list-style-type: none"> • Adjust VR801 so that the RF level becomes $300mV \pm 50mV$.
13	Ref. Sub Carrier Adjustment	87	VC801	IC402 pin 8	<ul style="list-style-type: none"> • STOP 	<ul style="list-style-type: none"> • Adjust VC801 so that the frequency becomes 3.579545 MHz.
14	VCO Center Frequency Adjustment	88	VR481	CH1:C471 + lead wire CH2:C499 + lead wire	<ul style="list-style-type: none"> • #5,100 still 	<ul style="list-style-type: none"> • The center of CH1's video signal jitter is delayed by $71 \mu S$ with CH2's video signal.
15	Output Video Level Adjustment	89	VR482	VIDEO OUT terminal	<ul style="list-style-type: none"> • #19,900 still 	<ul style="list-style-type: none"> • Adjust the VR482 so that the voltage between the sync tip and the white peak becomes $0.71V \pm 5\%$.
16	1H Delay Video Level Adjustment	90	VR441	CH1:C443 - lead wire CH2:C445 - lead wire	<ul style="list-style-type: none"> • #3,800 still 	<ul style="list-style-type: none"> • The 1H delay video level becomes the same as the main line video level.
17	VPS Error Adjustment	91	VR521	TV monitor	<ul style="list-style-type: none"> • #8,000 still 	<ul style="list-style-type: none"> • Color irregularity on the magenta screen is minimized.

8.2 ADJUSTMENT POINTS OF THE MAIN ASSEMBLY

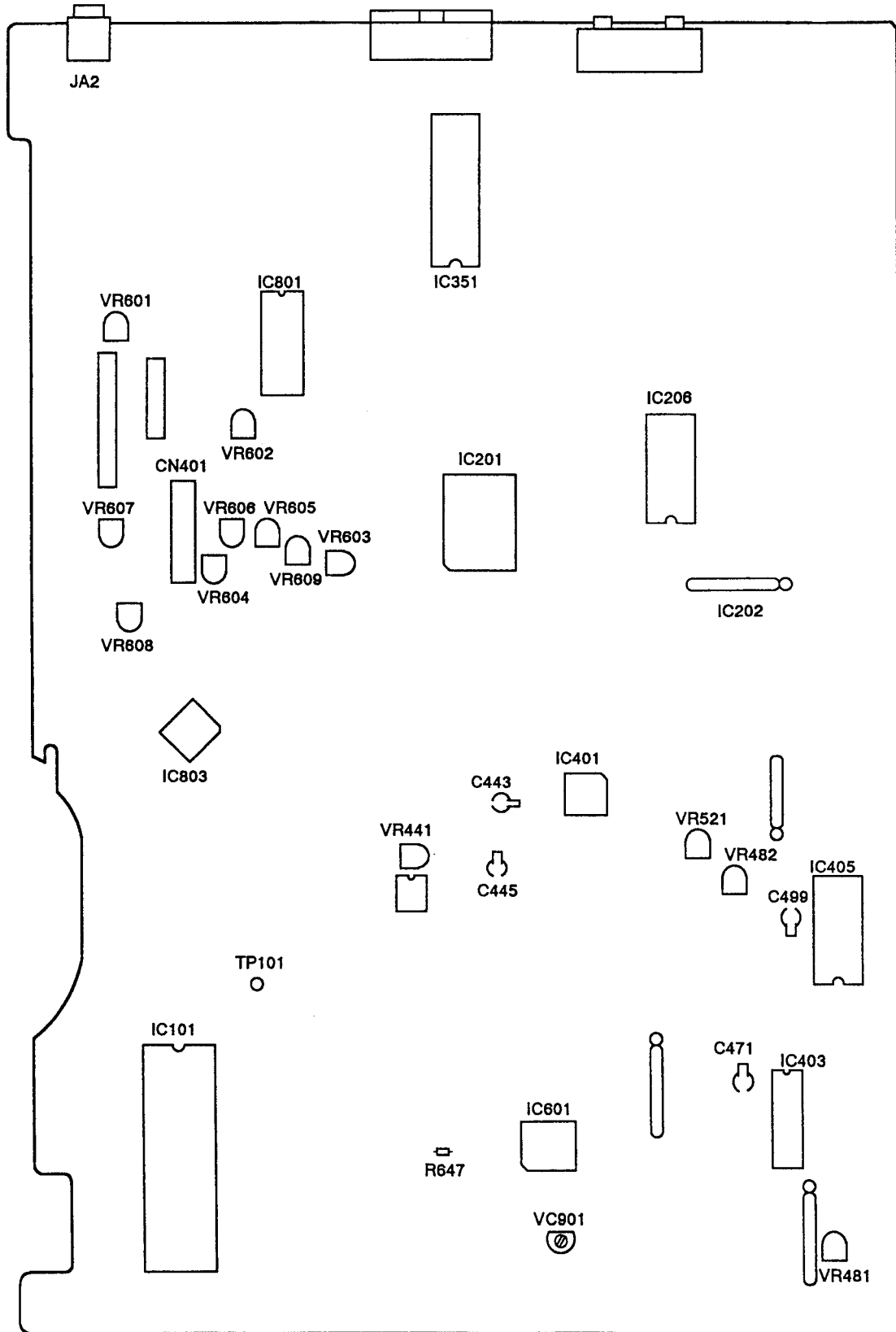

8.3 TEST MODE

8.3.1 TEST MODE

The player has a test mode function which allows the servicer to check the player's status on the TV screen by executing the respective key operation.

Also, since the TRK servo opens and closes easily, the test mode is especially useful for mechanical adjustments.

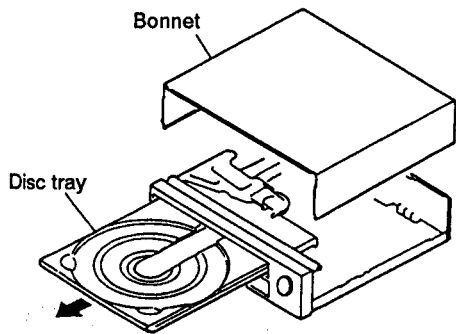

8.3.2 TEST MODE INITIATION

[Procedure]

1. Remove the bonnet and disc tray.
2. Connect the TP101 (TEST) in the MAIN assembly to GND.
3. Turn on the power switch.
4. Disconnect the TP101 from GND.

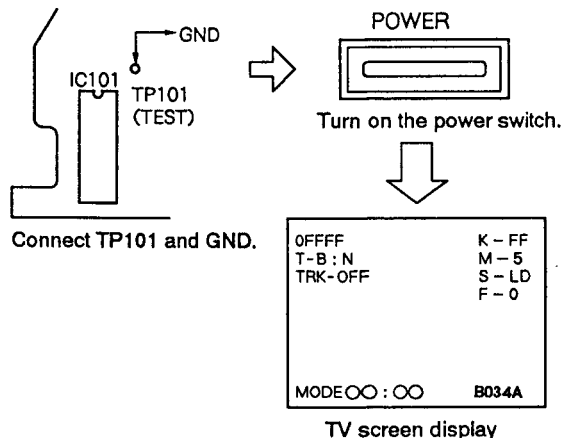

8.3.3 TEST MODE CANCELLATION

Turn off the power switch.

8.3.4 PLAYER OPERATION IN THE TEST MODE

Operate the player by selecting a test mode function with the keys on the player or on the remote control unit.

● **CD PLAYBACK**

- ① Place the CD disc on the turn table.
(Clamper is already lifted up.)

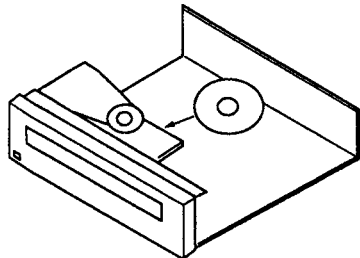

- ② Press the [REVERSE] or [FAST FORWARD] key to appear "S-CD" on the TV screen display.

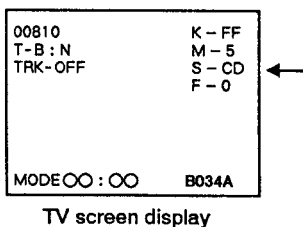

- ③ Clamp the disc by pressing the PLAY (▶) key once. Then, press the PLAY (▶) key twice, disc will be normal playbacked.

● **LD PLAYBACK**

- ① Place the LD disc on the turn table.
(Clamper is already lifted up.)

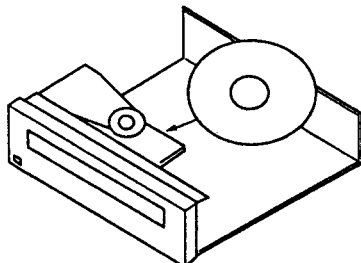

- ② Press the [REVERSE] or [FAST FORWARD] key to appear "S-LD" on the TV screen display.

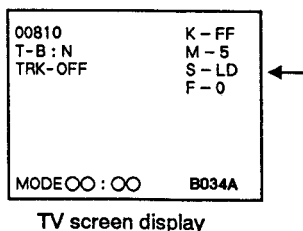

- ③ Clamp the disc by pressing the PLAY (▶) key once. Then, press the PLAY (▶) key twice, disc will be normal playbacked.

Table. Operation in the test mode by optional remote control unit.

Function	Player Status	Key Operation	Remarks
Open Tray	STOP mode	▲	
Close Tray	Tray open	▲	
Stop	PLAY mode	■	
Play	Disc placement and tray closed.	▶	<ul style="list-style-type: none"> • Start play with the TRK servo open. • Start play with tilt neutral. • The disc type (LD/CD/CDV) is determined when playback starts at the SLDR position during start play.
TRK Servo Open/Close	PLAY mode	▶	<ul style="list-style-type: none"> • Each time the PLAY button (▶) is pressed, the TRK servo will open or close alternately.
Still	PLAY mode TRK servo closed.	(Remote control unit key)	<ul style="list-style-type: none"> • Each time the STILL button () is pressed, the player will switch between the PLAY and STILL modes alternately.
TILT Neutral	POWER switch ON	EDIT	
TILT Servo ON	PLAY mode	RANDOM PLAY	
TILT Minus TILT Servo OFF	PLAY mode	◀◀	<ul style="list-style-type: none"> • Press and hold down the keys.
TILT Plus TILT Servo OFF	PLAY mode	▶▶	<ul style="list-style-type: none"> • Press and hold down the keys.
Screen Display ON/OFF	POWER switch ON	PGM key	
Frame search	PLAY mode	+10 key ↓ 0-9 key ↓ ▶	<ul style="list-style-type: none"> • In the PLAY mode, press the +10 key. (The player will standby for the frame No. entry.) • Use the numeric keys(0 - 9) to enter the frame No.. Then press the player's PLAY key to search. • After the search is completed, the player will return to the previous mode before the search was performed.
Loading Motor Rotation Clockwise Counterclockwise	Tray open	▶▶ ◀◀	<ul style="list-style-type: none"> • FWD:Unloading • REV :Loading
FOCS OFFSET (CT BEST) VR606 Check	PLAY mode (TRK servo OPEN)	(Remote control unit) MULTI-SPEED FWD → F-1 REV → F-0 (Player) HILITE INTRO SCAN	<ul style="list-style-type: none"> • For checking VR604 <p>F-0 : Normal mode •When closing the TRK servo, VR606 (CT BEST) becomes effective. •When opening the TRK servo, VR605 (TE MAX) is effectived. F-1 : When opening the TRK servo, VR606 (CT BEST) also becomes effective.</p>

● Names of Front Panel

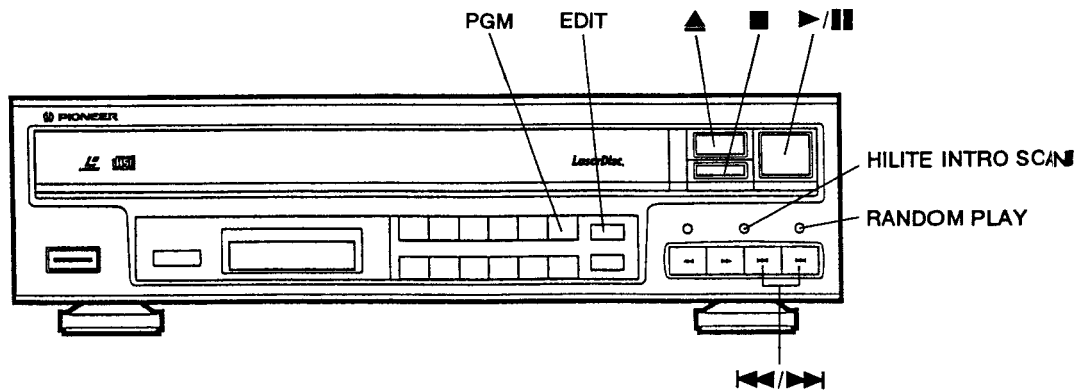

● Names of Remote Control Unit

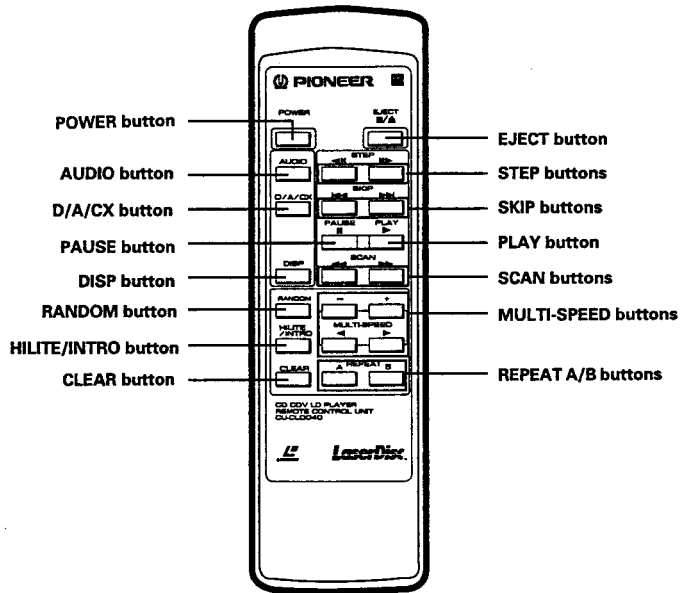

8.3.5 TV SCREEN AND LED DISPLAYS IN THE TEST MODE

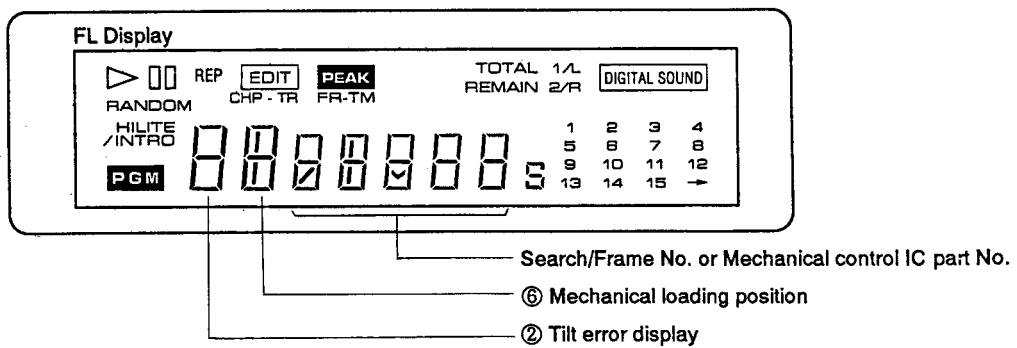
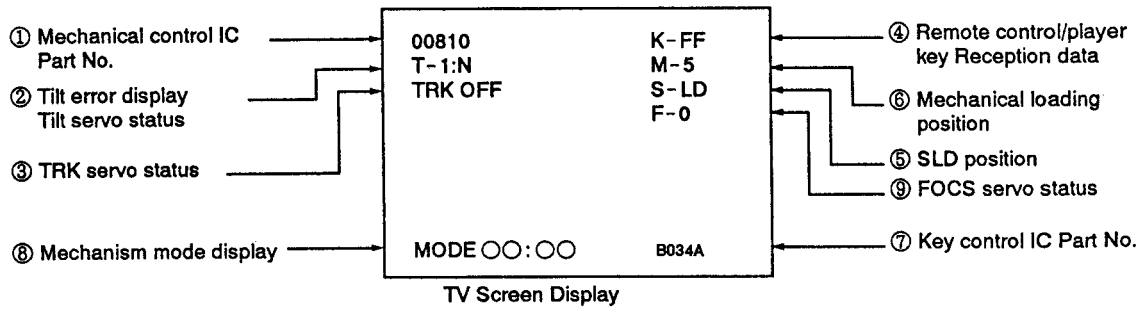

① The Mechanical Control IC (MAIN assembly) Part No. will be Displayed.
PD0081C → 00810

② Tilt Servo Status / Tilt Error Display
T-0:00
Tilt servo status : N...Tilt neutral
ON...Tilt servo ON
OFF...Tilt servo OFF
Tilt error display: 0 Tilt -
↓ Tilt neutral
F Tilt +

③ TRK Servo Status

TV screen display

TRK-○○○

ON...TRK servo close
OFF...TRK servo open

④ Remote Control / Player Key Reception Data

TV screen display

K-○○

See table below

Code	Function	Code	Function	Code	Function	Code	Function
00	0	20	F JOG0	40	(CHAP / TRK)	60	
01	1	21	F JOG1	41	(FRAM / TIM)	61	
02	2	22	F JOG2	42	(SEARCH)	62	
03	3	23	F JOG3	43	DISPLAY	63	
04	4	24	R JOG0	44	REPEAT B	64	
05	5	25	R JOG1	45	CLEAR	65	
06	6	26	R JOG2	46	SPEED -	66	
07	7	27	R JOG3	47	SPEED +	67	
08	8	28		48	REPEAT A	68	
09	9	29		49	(2 / R)	69	
0A	VOLUME +	2A		4A	(STEREO)	6A	
0B	VOLUME -	2B		4B	(1 / L)	6B	
0C	DGT / ANL	2C		4C	PROGRAM	6C	
0D		2D		4D		6D	PLAY / PAUSE
0E	CX ON/OFF	2E		4E		6E	STOP
0F	(TV / LDP)	2F		4F		6F	OPEN / CLOSE
10	(F-SCAN)	30		50	F-STEP	70	
11	(R-SCAN)	31		51		71	DIRECT CD
12		32		52	F-SKIP	72	PEAK
13	CHAP / FRME	33		53	R-SKIP	73	SINGLE
14		34		54	R-STEP	74	
15		35		55	R-MULT	75	
16	STOP / OPEN	36		56		76	
17	PLAY/SEARCH	37	DGT LEVEL	57		77	
18	PAUSE	38		58	F-MULT	78	
19		39		59		79	
1A	(POW ON)	3A		5A	HILIT / INTR	7A	
1B	(POW OFF)	3B		5B		7B	
1C	POW ON/OFF	3C		5C		7C	
1D	EDIT	3D		5D		7D	
1E	AUDIO	3E		5E	RNDM (TEST)	7E	
1F	+10	3F		5F	(ESC)	7F	

⑤ SLD Position

TV screen display

S-○○○

IN ... CD inside SW ON
CD ... CD active area
CDV ... CDV active area
LD ... LD active area

⑥ Mechanical Loading Position

TV screen display

M-○

0 ... Tray open
1 ... Loading
2 ... Standby
3 ... Clamped
5 ... Tilt minus
6 ... Tilt neutral (one side)
7 ... Tilt plus
8 ... Tilt limit
9 ... B side clamped (two sides)

⑦ Focus Offset VR Status

TV screen display

F-○

0 ... Normal mode
•When closing the TRK servo, VR606 (CT BEST) becomes effective.
•When opening the TRK servo, VR605 (TE MAX) becomes effective
1 ... When opening the TRK servo, VR606 (CT BEST) also becomes effective.

8.4 ADJUSTMENTS

8.4.1 Required Instruments

- Small screwdriver (7 cm shaft)
- Small Phillips screwdriver (15 cm shaft)
- Low - pass filter (47k ohms+1 μ F / BP)
- Dual - trace oscilloscope (with delay)
- AF oscillator
- Frequency counter
- LD test disc (GGV1003)
- 8 - inch LDD disc
- CDV disc
- Short clip
- TV monitor
- Resistor (100k ohms, 330k ohms)
- Capacitor (0.01 μ F)
- Remote control unit
- 2mm hexagonal wrench

8.4.2 Adjustment Preparation and Notes

1. Player Preparation

Before perform the adjustment, remove the bonnet and the disc tray. Then place the player horizontally on a flat surface.

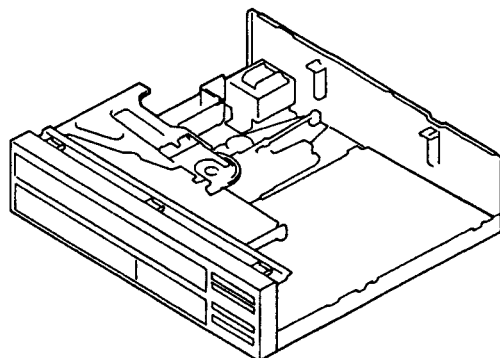

2. Disc Insertion

Insert the disc from the rear of the player. Place it securely on the turntable. When the PLAY key is pressed, the clamper will go down and secure the disc. Playback will then begin.

3. Use All the Oscilloscope's Probes at 10:1.

4. Only the MAIN Assembly Needs to be Adjusted.

Unless noted otherwise, all adjustment items and measuring instrument connections will be for the parts in the MAIN assembly.

5. Required adjustment after Replacement of major parts.

Adjustments	Replacements				
	Pickup	Actuator	Pre-pickup	Spindle motor	Tilt sensor
1. Tilt Sensor Adjustment	⊙				⊙
2. Coarse Grating Adjustment / TRK Balance Adjustment	⊙	⊙	⊙		
3. Slider Shaft Horizontal Adjustment	⊙	⊙	⊙	○	⊙
4. Pickup Inclination Adjustment	⊙	⊙	⊙	○	○
5. TRKG Error Best / Crosstalk Best Adjustment	⊙	⊙	⊙	○	○
6. FOCUS SUM Level Adjustment	⊙	⊙	⊙	○	○
7. Tilt Sensor Inclination / Tilt Balance Adjustment	⊙	⊙	⊙	○	⊙
8. Spindle Motor Shaft Centering and Adjustment	⊙	⊙	⊙	⊙	
9. Fine Grating Adjustment / TRK Balance Adjustment	⊙	⊙	⊙		
10. FCS Servo Loop Gain Adjustment	⊙	⊙	⊙		
11. TRKG Servo Loop Gain Adjustment	⊙	⊙	⊙		
12. RF Gain Adjustment	⊙	⊙	⊙		

Note: Adjustments Indicated by a ○ are made only when there is crosstalk.

8.4.3 MECHANICAL ADJUSTMENTS

1. TILT SERVO GAIN ADJUSTMENT

Mechanical Adjustment

- Purpose: Adjustment of the tilt servo's gain according to the tilt sensor's sensitivity rank.
- When not properly adjusted: Increased tilt servo hunting and increased crosstalk.

- Measuring instruments and jigs:
- Measuring point:
- Test disc and player mode
- Positions to be adjusted

- Small screwdriver
- VR608

Connection diagram

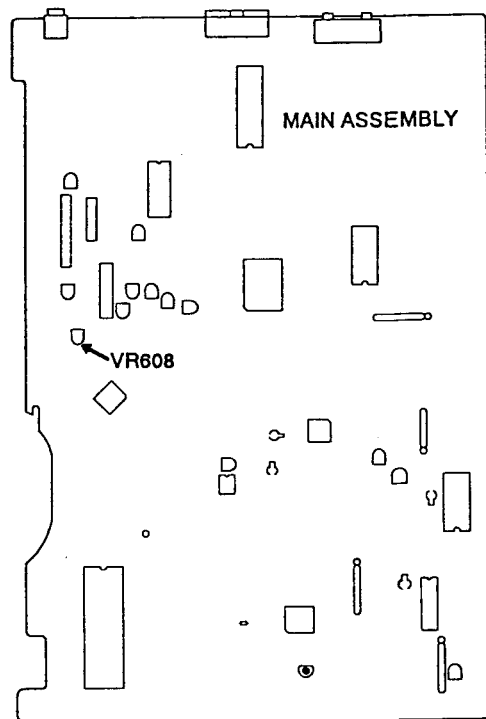
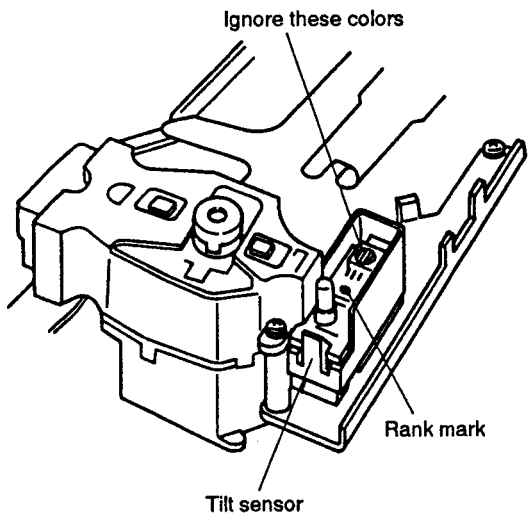

Adjustment Procedure

1. Use a screwdriver to adjust the angle of VR608 on the MAIN assembly according to the rank indicator's color.

Rank	Color	VR Angle
A	Red	Clockwise all the way
B	Clear	Mechanical center
C	Blue	Counterclockwise all the way

2. COARSE ADJUSTMENT OF GRATING AND TRK BALANCE

Mechanical Adjustment

- Purpose: Adjustment of the grating angle to enable disc playback and trick playback.
- When not properly adjusted: The disc cannot be played back. Track skipping occurs.

- | | |
|--|---|
| <ul style="list-style-type: none"> ● Measuring instruments and jigs: ● Measuring point: ● Test disc and player mode ● Positions to be adjusted | <ul style="list-style-type: none"> ● TV monitor ● Small screwdriver ● Oscilloscope ● CN401 - 8 (TRK ERR) and GND ● 8-inch LD test disc (GGV1003) ● Test Mode (Disc playback, TRK servo open, Tilt servo OFF) ● Pickup assembly grating ● VR602 (TRK BAL). |
|--|---|

Connection diagram

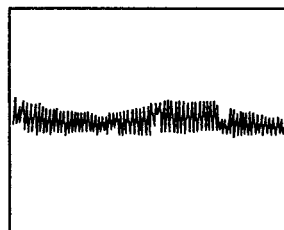
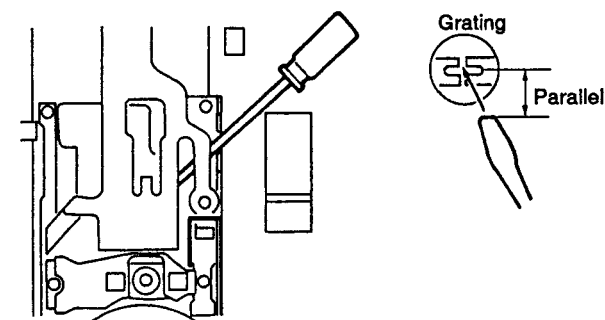

Fig.1 Null Point

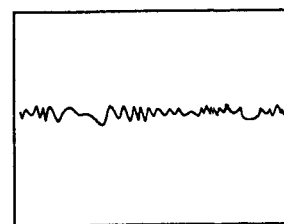
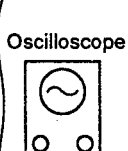
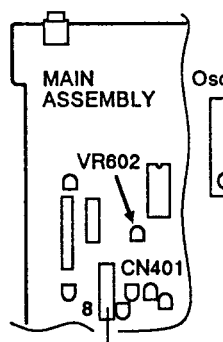
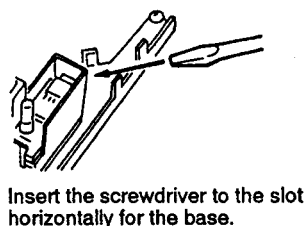

Fig.2 This is not the null point.

(Top view)
Screwdriver inserting direction



Oscilloscope range
X:50mV / div
Y:5mS / div
DC input

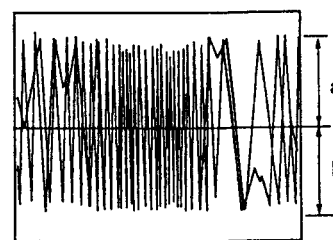

Fig.3 Maximum TRK error.

The positive and negative levels are equal.

Adjustment Procedure

Coarse grating adjustment

1. Insert the test disc and press the PLAY key.
2. Search for frame #15,000 or thereabouts.
3. Open the TRK servo.
4. Connect CN401 - 8 to the oscilloscope and observe the waveform.
5. Slide the tip of a small screwdriver through the guide and insert it horizontally into the grating adjustment slit. Adjust grating angle so that the waveform becomes small and its envelope is smooth. (This point is called null point.) (See Fig. 1 and Fig. 2.)
6. Turn the screwdriver counterclockwise until the TRK waveform's amplitude reaches the first maximum from the null point. (See Fig. 3.)

TRK balance adjustment

1. Adjust VR602 so that the TRK error waveform amplitude's positive and negative level become equal. (See Fig.3)
2. Close the TRK servo and check if the image on the TV screen is normal.

3. SLIDER SHAFT HORIZONTAL ADJUSTMENT

Mechanical Adjustment

- Purpose: Setting the slider shaft horizontally to enable the pickup to move over the disc horizontally.
- When not properly adjusted: With a warped disc, the FCS servo does not function at the inner or outer periphery.

- | | |
|--|---|
| <ul style="list-style-type: none"> ● Measuring instruments and jigs: ● Measuring point: ● Test disc and player mode ● Positions to be adjusted | <ul style="list-style-type: none"> ● Oscilloscope ● Low-pass filter (47k Ω + 1 μF) ● CN401 - 2 (FCS RTN) and GND ● 8-inch LD test disc GGV1003 ● Test mode (#5,200 still, TRK servo open, Tilt servo OFF) ● Player SKIP key (In the test mode) |
|--|---|

Connection diagram

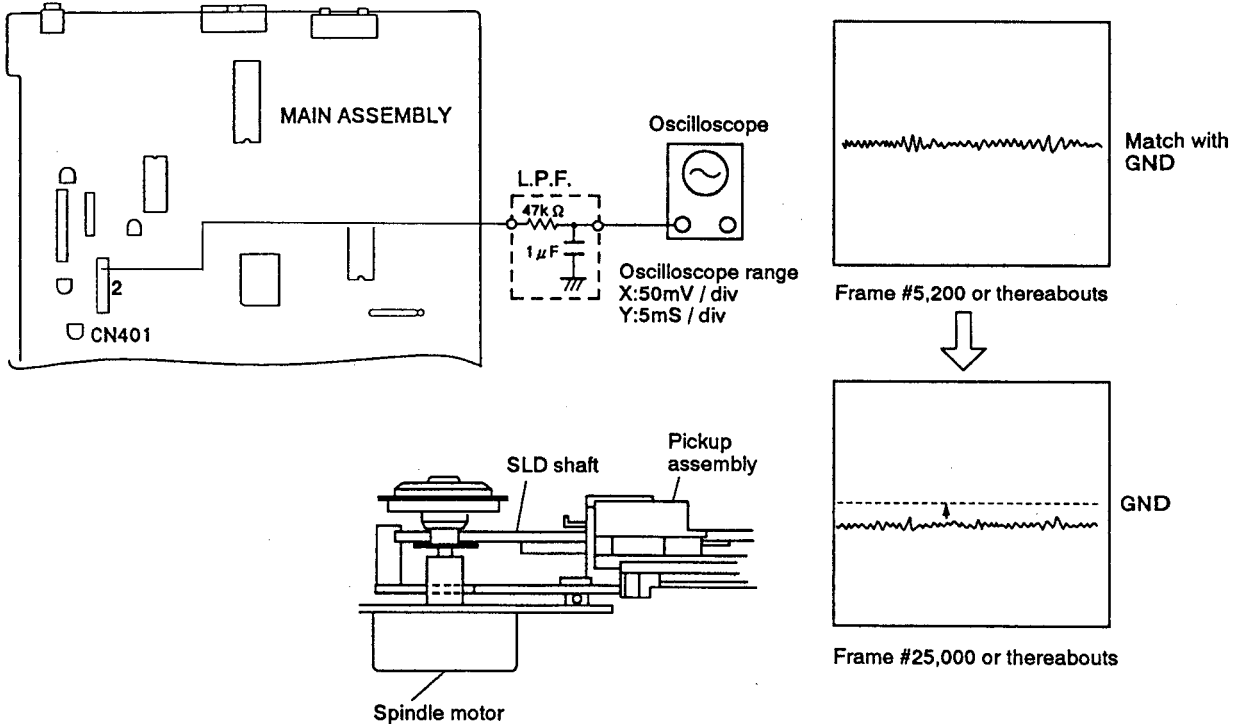

Adjustment Procedure

1. Use the SCAN key to send the slider to frame #5,200 or thereabouts (tilt fulcrum) on the test disc. Open the TRK servo.
2. Connect the oscilloscope to CN401 - 2 through L.P.F. and match the center of the waveform with the oscilloscope's GND.
3. Search for frame #25,000 and use the SKIP key to adjust the center of the waveform to $0V \pm 20mV$.

Note: This adjustment is critical in that it will affect the adjustments following.

Note: Regarding the test mode, see page 70.

4. PICKUP INCLINATION ADJUSTMENT

Mechanical Adjustment

- Purpose: Adjustment of the pickup inclination to direct the laser beam vertically with respect to the disc.
- When not properly adjusted: Crosstalk will be generated.

- | | |
|--|--|
| <ul style="list-style-type: none"> • Measuring instruments and jigs: • Measuring point: • Test disc and player mode • Positions to be adjusted | <ul style="list-style-type: none"> • TV monitor • Oscilloscope • CN401 - 1 (RF) • 8-inch LD test disc (GGV1003) • Test Mode (#2,701 still (Black screen)) • Pickup assembly TRK / Tangential direction inclination adjustment screws |
|--|--|

Connection diagram

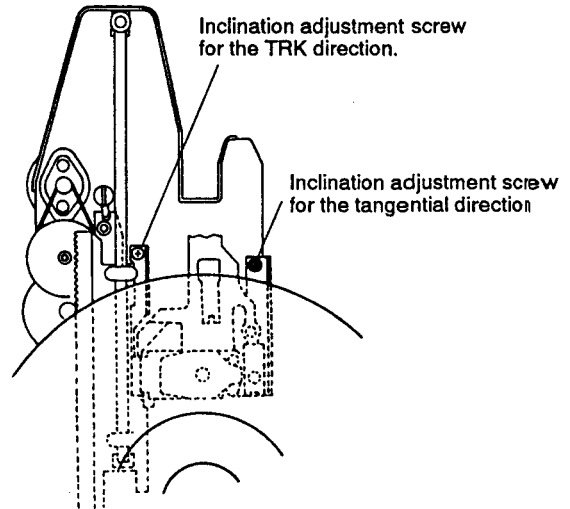
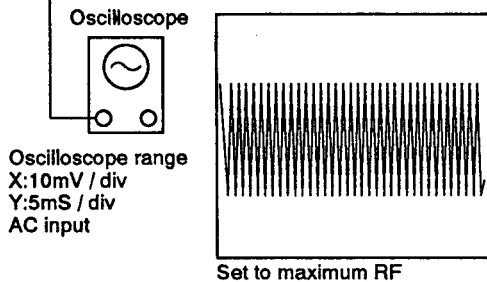
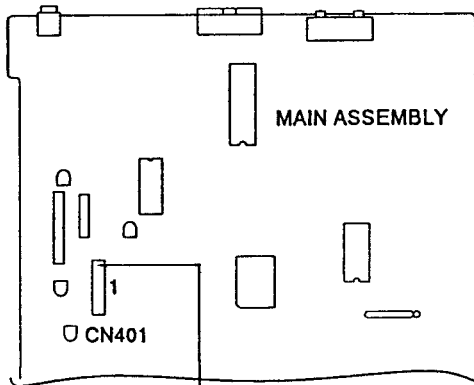

Adjustment Procedure

1. Connect the oscilloscope to CN401 - 1.
2. Search for #2,701 and observe the RF waveform.
3. Adjust the pickup's TRK / Tangential direction inclination adjustment screw to maximize the waveform's amplitude.
4. Look at the TV screen and make sure there is no crosstalk.

Note : If there is crosstalk on the TV screen even when the RF level is at the maximum, perform next steps .

5. TRKG ERROR MAX / CROSSTALK BEST ADJUSTMENT

Mechanical Adjustment

- Purpose: To set the FOCS servo to the optimum state when playing the normal playback and track jump (search).
- When not properly adjusted: Crosstalk will be generated.

- Measuring instruments and jigs:
- Measuring point:
- Test disc and player mode
- Positions to be adjusted

- TV monitor ● Oscilloscope
- CN401-1 (RF) ● CN401-8 (TRK ERR) ● Player's VIDEO OUT terminal
- 8-inch LD test disc (GGV1003)
- Test Mode (TRK servo close / open, Tilt servo OFF)
- VR605 (TE MAX) ● VR606 (CT BEST)

Connection diagram

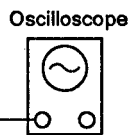
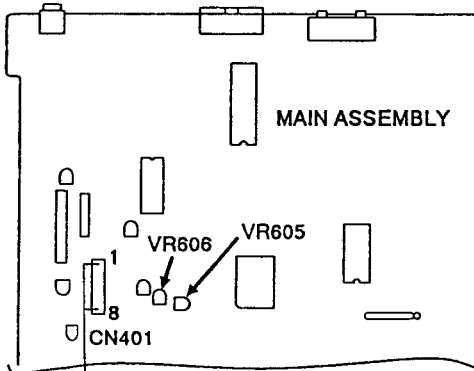

Oscilloscope range
X:10mV / div
Y:5mS / div
AC input

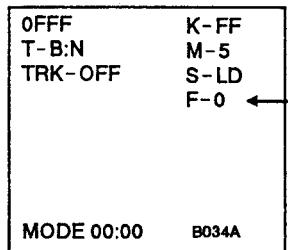

Screen display of test mode

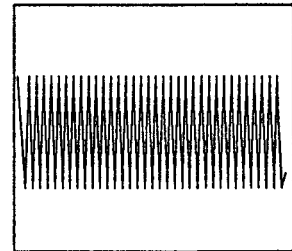

Set to maximum RF amplitude at frame #2,701.

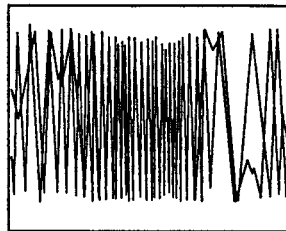

Maximize the TRKG error.

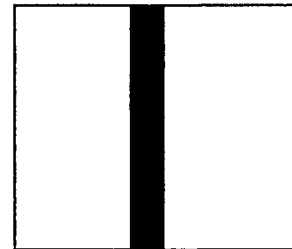

#115 crosstalk minimum

Adjustment Procedure

Note: Perform this adjustment when there is still noticeable crosstalk on the TV screen in section "4. Pickup Inclination Adjustment".

1. Connect the oscilloscope to CN401-8.
2. Open the TRK servo .
3. Confirm that the test mode screen display is F-0.
If not, set the MULTI- SPEED REV button of the remote control unit to F-0.
4. Adjust VR605 so that the amplitude of the TRKG error waveform becomes maximum.
5. Close the TRKG servo.

6. Connect the oscilloscope to CN401-1 .
7. Press the MULTI- SPEED FWD button of the remote control unit to display "F-1" on the TV screen.
8. Search frame #2,701 and adjust VR606 so that the amplitude of the RF waveform becomes maximum.
9. Confirm that the crosstalk on the TV screen becomes minimum at frame #115.

Note : After adjustment is complete, be sure to perform "6. FOC'S SUM Level Adjustment".

6. FOCS SUM LEVEL ADJUSTMENT

Mechanical Adjustment

- Purpose: To set the sum level (FOCS A+B) of B1 – B4 to the optimum value for activating the FOCS servo.
- When not properly adjusted: Crosstalk will be generated.

- | | |
|--|--|
| <ul style="list-style-type: none"> • Measuring instruments and jigs: • Measuring point: • Test disc and player mode • Positions to be adjusted | <ul style="list-style-type: none"> • TV monitor • Oscilloscope • CN401 - 10 • 8-inch LD test disc (GGV1003) • Normal play mode • VR609 |
|--|--|

Connection diagram

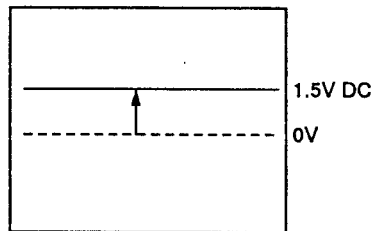
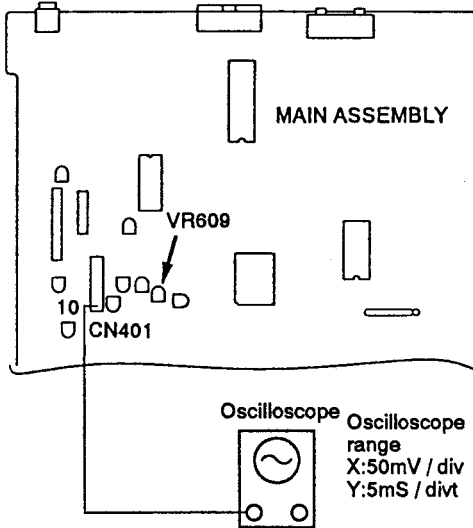

Adjustment Procedure

Note : Perform this adjustment after perform the "5. TRKG Error MAX / Crosstalk Best Adjustment".

1. Connect the oscilloscope to CN401 - 10.
2. Adjust VR609 so that the voltage becomes 1.5V DC.

7. TILT SENSOR INCLINATION / TILT BALANCE ADJUSTMENT

Mechanical Adjustment

- Purpose: Adjustment of the tilt sensor's inclination to direct the tilt sensor's LED vertically with respect to the disc. Also, compensation for the sensitivity difference between the two sensors.
- When not properly adjusted: Crosstalk will be generated.

- | | |
|--|---|
| <ul style="list-style-type: none"> ● Measuring instruments and jigs: ● Measuring point: ● Test disc and player mode ● Positions to be adjusted | <ul style="list-style-type: none"> ● TV monitor ● Small Phillips screwdriver ● Player's VIDEO OUT terminal ● 8-inch LD test disc (GGV1003) ● Test Mode (#16,200 still, TRK servo closed, Tilt servo OFF) ● Tilt sensor inclination adjustment screw ● VR607 (TILT BAL). |
|--|---|

Connection diagram

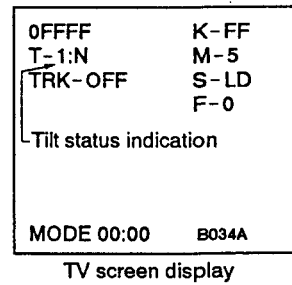
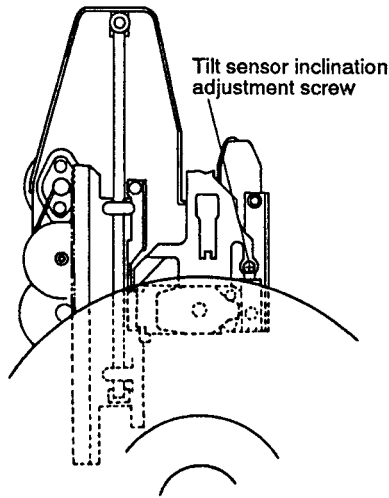
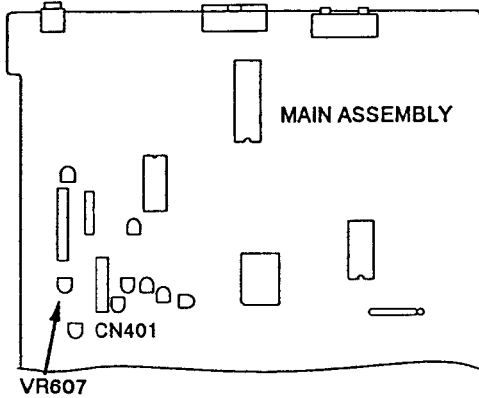

Note: This display indicates the tilt error display's location. Other displays may differ slightly from the actual.

Adjustment Procedure

1. Search for frame #16,200 on the test disc.
2. Set VR607 to the mechanical center.
3. Adjust the tilt sensor inclination adjustment screw so that the tilt status display code is 6, 7, or 8 on the TV monitor.
Note : Turn the tilt sensor inclination adjustment screw clockwise more than 1/4 turn to complete the adjustment.
4. Search for frame #115.
5. Adjust VR607 so that the tilt error display becomes 7.

8. VERIFICATION AND ADJUSTMENT OF SPINDLE MOTOR CENTERING

Mechanical Adjustment

- Purpose: Adjustment of the mechanical assembly position to set the spindle motor over the center of the laser beam path when the pickup assembly moves toward the inner or outer periphery of the disc.
- When not properly adjusted: There is track skipping and the search time is long.

- | | |
|--|--|
| <ul style="list-style-type: none"> ● Measuring instruments and jigs: ● Measuring point: ● Test disc and player mode ● Positions to be adjusted | <ul style="list-style-type: none"> ● Oscilloscope ● Small screwdriver ● L.P.F. (0.01 μF + 1k Ω), (0.0027 μF) ● 2mm Hexagonal wrench ● CH1 : CN401 - 8 (TRK ERR), CH2 : CN401 - 7 (TRK SUM) ● 8 - inch LD test disc (GGV1003) ● Test Mode (#25,000 still, #1 still, TRK servo open, TILT servo ON) ● Spindle motor centering adjustment lever |
|--|--|

Connection diagram

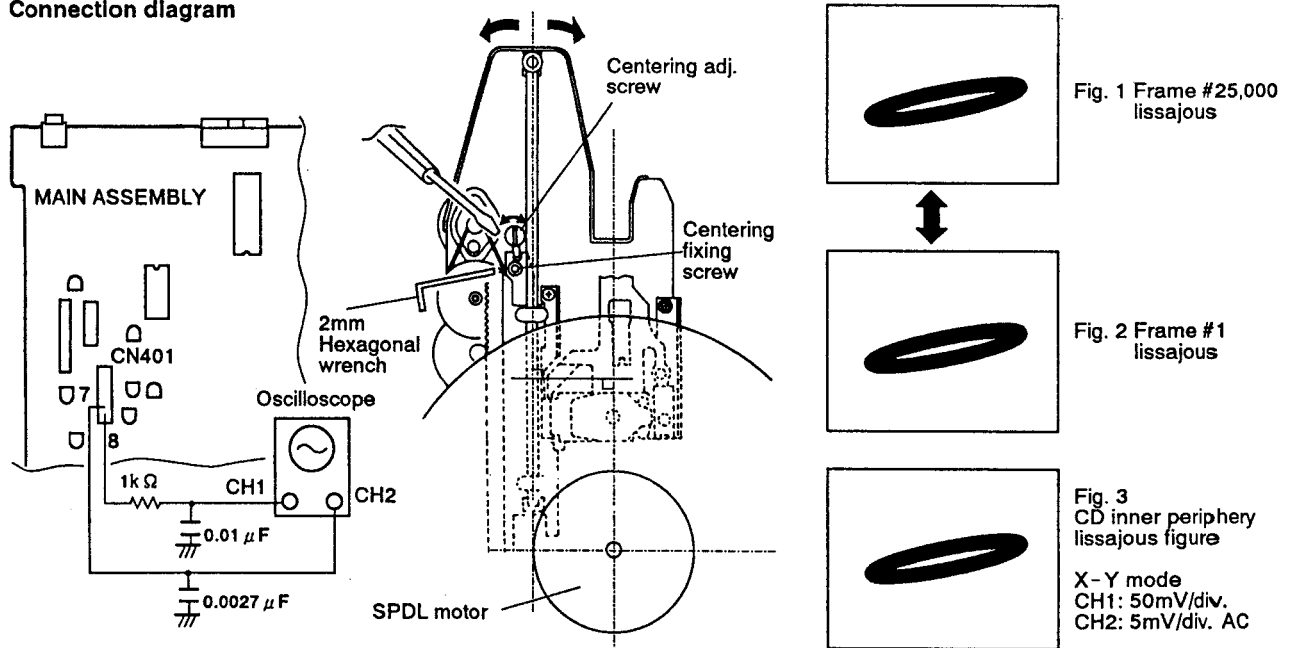

Adjustment Procedure

Note: Adjust the position of the slider shaft against the center line of the SPDL motor in this adjustment.

1. Set the oscilloscope to the X - Y mode and connect CH 1 (X input) and CH 2 (Y input) to CN401 - 8 and CN401 - 7 respectively.
2. Search for frame #25,000 on the test disc and look at the lissajous figure.
3. Search for frame #1 and check if the bulge of the lissajous figure is the same as that of frame #25,000's lissajous figure.
Note : If the bulge of the lissajous waveform in step 3 differs for the inner and outer peripheries, do steps 4 to 6 .
4. Search for frame #25,000 and #1 alternately. Loosen a centering fixing screw and adjust the spindle motor centering adjustment screw so that the bulge of the lissajous figures become identical.

5. Change to a compact disc and playback the inner periphery. Check if the lissajous figure is the same as the one shown in Fig. 3.
6. If the compact disc's inner periphery lissajous figure differs from the one shown in Fig. 3, repeat steps 4 to 5.
7. Fix the centering fixing screw.

9. FINE ADJUSTMENT OF GRATING AND TRK BALANCE ADJUSTMENT

Mechanical Adjustment

- Purpose: Fine adjustment of the grating to direct the two TRK servo laser beams at the disc at the optimum position over the track.
- When not properly adjusted: There is track skipping.

- Measuring instruments and jigs:
- Measuring point:
- Test disc and player mode
- Positions to be adjusted

- Oscilloscope ● Small screwdriver ● L.P.F. (0.01 μ F + 1k Ω), (0.0027 μ F)
- CH1 (X) : CN401-8 (TRK ERR), CH2 (Y) : CN401-7 (TRK SUM)
- 8-inch LD test disc (GGV1003)
- Test Mode (Play mode, TRK servo loop open, TILT servo ON)
- Grating slit in the pickup assembly
- VR602

Connection diagram

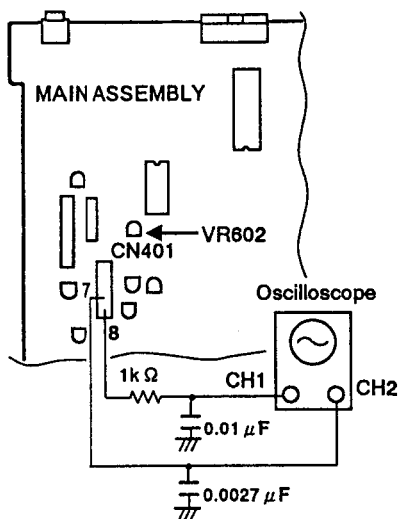

Set the probe to $\times 1$ only for Y.

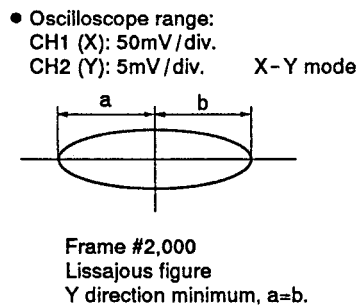

Adjustment Procedure

1. Playback the test disc at frame #3,000 (inner periphery) or thereabouts.
2. Set the oscilloscope to the X-Y mode, and connect CN401-8 (TRK ERR) and CN401-7 (TRK SUM) to the X input and the Y input respectively. Then observe the lissajous figure.
3. Insert the small screwdriver tip into the grating adjustment slit. Fine adjust the grating to minimize the Y direction of the lissajous figure. (Refer to adjustment diagram on page 76.)
4. Check if "a" equals "b" for the lissajous figure. If "a" is not equal to "b", adjust VR602 (TRK BAL).
5. Close the TRK servo loop and check if the image on the TV screen is normal.

10. FCS SERVO LOOP GAIN ADJUSTMENT

Mechanical Adjustment

- Purpose: Setting the FCS servo's loop gain to the optimum setting.
- When not properly adjusted: Playability is poor.

- | | |
|--|---|
| <ul style="list-style-type: none"> ● Measuring instruments and jigs: ● Measuring point: ● Test disc and player mode ● Positions to be adjusted | <ul style="list-style-type: none"> ● Oscilloscope ● AF oscillator (1.7kHz / 10Vp-p) ● Resistor (47k Ω) ● CH1 (X) : CN401 - 5 (FCS IN), CH2 (Y) : CN401 - 4 (FCS ERR) ● 8 - inch LD test disc (GGV1003) ● Test Mode (Still mode, TRK servo loop close, TILT servo ON) ● VR604 |
|--|---|

Connection diagram

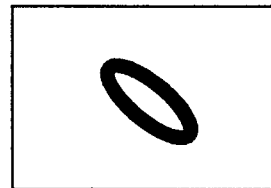
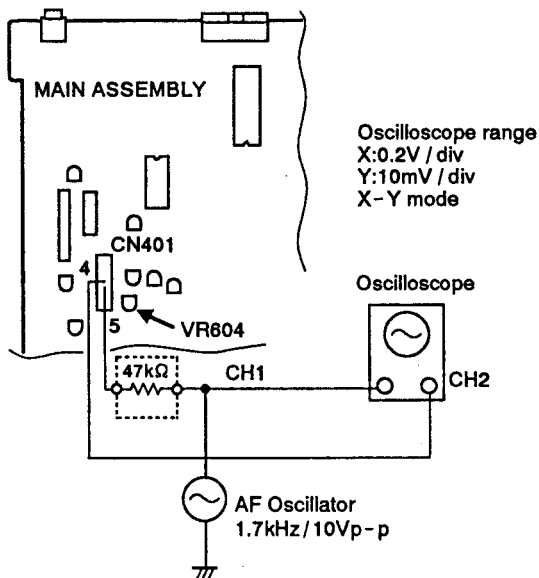

Fig. 1
Inadequate adjustment

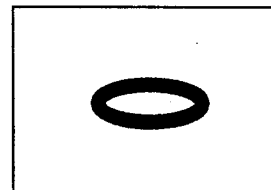

Fig. 2
After adjustment

Adjustment Procedure

1. Search for frame #15,000 on the test disc.
2. Connect the oscilloscope to CN401 - 4 and CN401 - 5 as shown above.
3. Set the oscilloscope to the X - Y mode and observe the lissajous figure.
4. Adjust VR604 so that the lissajous figure is symmetric with respect to the X and Y axes. (See Fig. 1 and 2.)

11. TRK SERVO LOOP ADJUSTMENT

Mechanical Adjustment

- Purpose: Optimum setting of the TRK servo's loop gain.
- When not properly adjusted: Playability is poor.

- Measuring instruments and jigs:
- Measuring point:
- Test disc and player mode
- Positions to be adjusted

- Oscilloscope
- AF oscillator (3.0kHz / 10Vp-p)
- Resistor (47k Ω)
- CH1 (X) : CN401-9 (TRK IN), CH2 (Y) : CN401-8 (TRK ERR)
- 8-inch LD test disc (GGV1003)
- Test Mode (Still mode at #15,000 (Black screen), TRK servo closed, TILT servo ON)
- VR603

Connection diagram

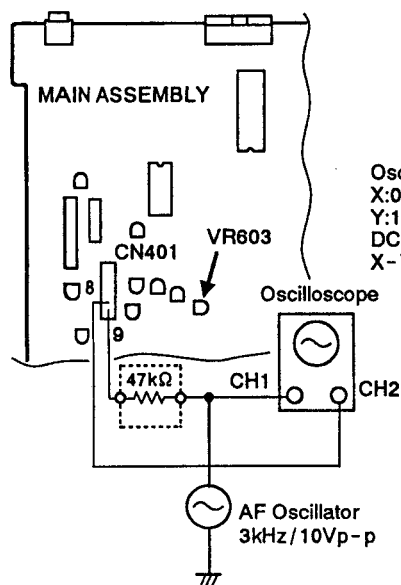

Oscilloscope range
 X:0.2V / div
 Y:10mV / div
 DC input
 X-Y mode



Fig. 1
 Inadequate adjustment

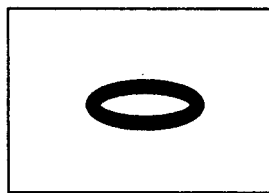

Fig. 2
 After adjustment

Adjustment Procedure

1. Search for frame #15,000 on the test disc.
2. Connect the oscilloscope to CN401-9 (TRK IN) and CN401-8 (TRK ERR) as shown in the diagram below.
3. Set the oscilloscope to the X-Y mode and observe the lissajous figure.
4. Adjust VR603 to make the lissajous figure symmetrical with respect to the X and Y axes. (See Fig. 1 and 2.)

Note : If the waveform is not observable, either change the 47k Ω resistor to 33k Ω or increase the oscillator's output.

12. RF GAIN ADJUSTMENT

Mechanical Adjustment

- Purpose: Optimum of the RF signal's amplitude.
- When not properly adjusted: There is prominent dropout. Scan and search operations are unstable.

- Measuring instruments and jigs:
- Measuring point:
- Test disc and player mode
- Positions to be adjusted

- Oscilloscope
- CH1 : CN401 - 1 (RF)
- 8 - inch LD test disc (GGV1003)
- Test Mode (Still mode, TRK servo loop close, TILT servo ON)
- VR601

Connection diagram

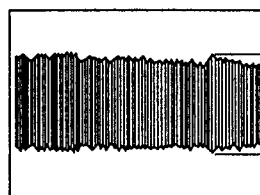
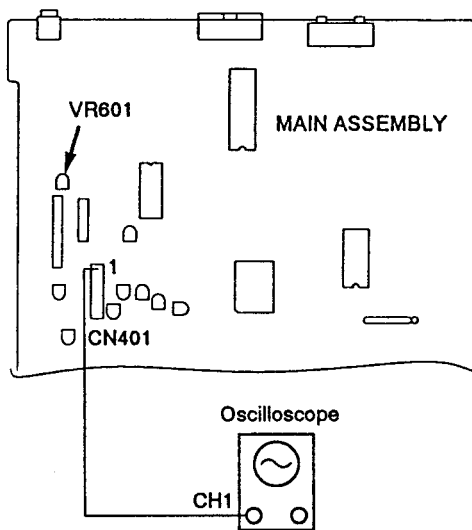

Fig. 1 RF signal

300mV ± 50mV

Oscilloscope range
5mV/div
2mS/div
AC mode

Adjustment Procedure

1. Search for frame #15,000 on the test disc.
2. Connect the oscilloscope to CN401 - 1 (RF) and observe the RF signal.
3. Adjust VR601 so that the RF signal's amplitude becomes 300mV ± 50mV. (See Fig. 1.)

8.4.5 ELECTRICAL ADJUSTMENT

13. Ref. SUB CARRIER ADJUSTMENT

Electrical Adjustment

- Purpose: Adjustment of the standard clock frequency.
- When not properly adjusted: Incorrect color tint, no TV color lock.

- | | |
|--|--|
| <ul style="list-style-type: none"> ● Measuring instruments and jigs: ● Measuring point: ● Test disc and player mode ● Positions to be adjusted | <ul style="list-style-type: none"> ● Frequency counter ● Oscilloscope 10:1 probe ● IC402 (PM0001) pin 8 ● Normal mode (Stop mode (Blueback screen)) ● VC901 |
|--|--|

Connection diagram

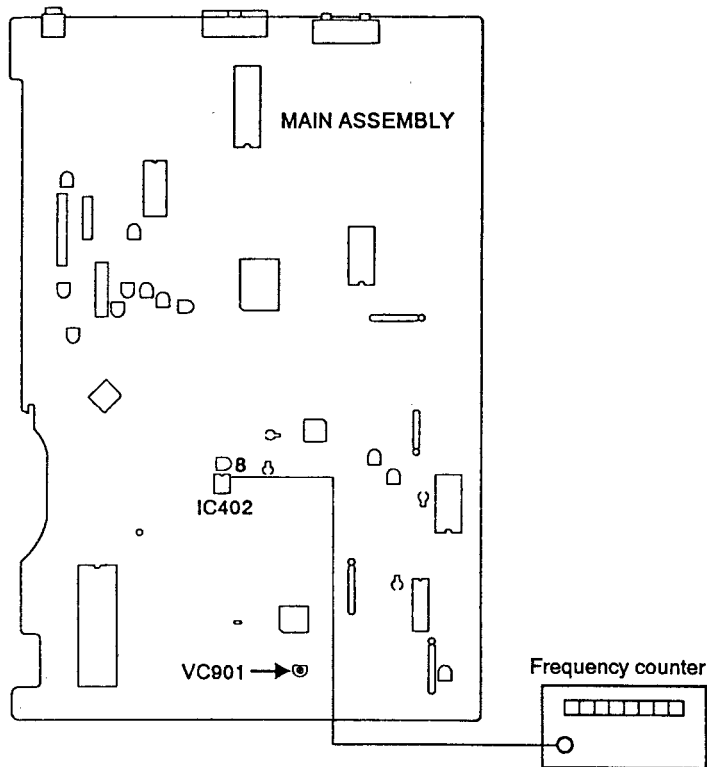

Adjustment Procedure

1. Adjust VC901 on the MAIN assembly so that the frequency of IC402 pin 8 becomes 3.579545MHz in the stop mode (blueback screen).

Note : The frequency counter probe should be an oscilloscope 10:1 probe.

14. VCO FREE RUN ADJUSTMENT

Electrical Adjustment

- Purpose: Setting the optimum delay time for the time base error compensation CCD.
- When not properly adjusted: Difficult to color lock, there is color lock delay after a search, and flicker on the white screen.

- | | |
|--|--|
| <ul style="list-style-type: none"> ● Measuring instruments and jigs: ● Measuring point: ● Test disc and player mode ● Positions to be adjusted | <ul style="list-style-type: none"> ● Oscilloscope ● CH 1 : + side lead wire of C471. ● CH 2 : + side lead wire of C499. ● 8-inch LD test disc (GGV1003) ● Normal mode (Still mode) ● VR481 |
|--|--|

Connection diagram

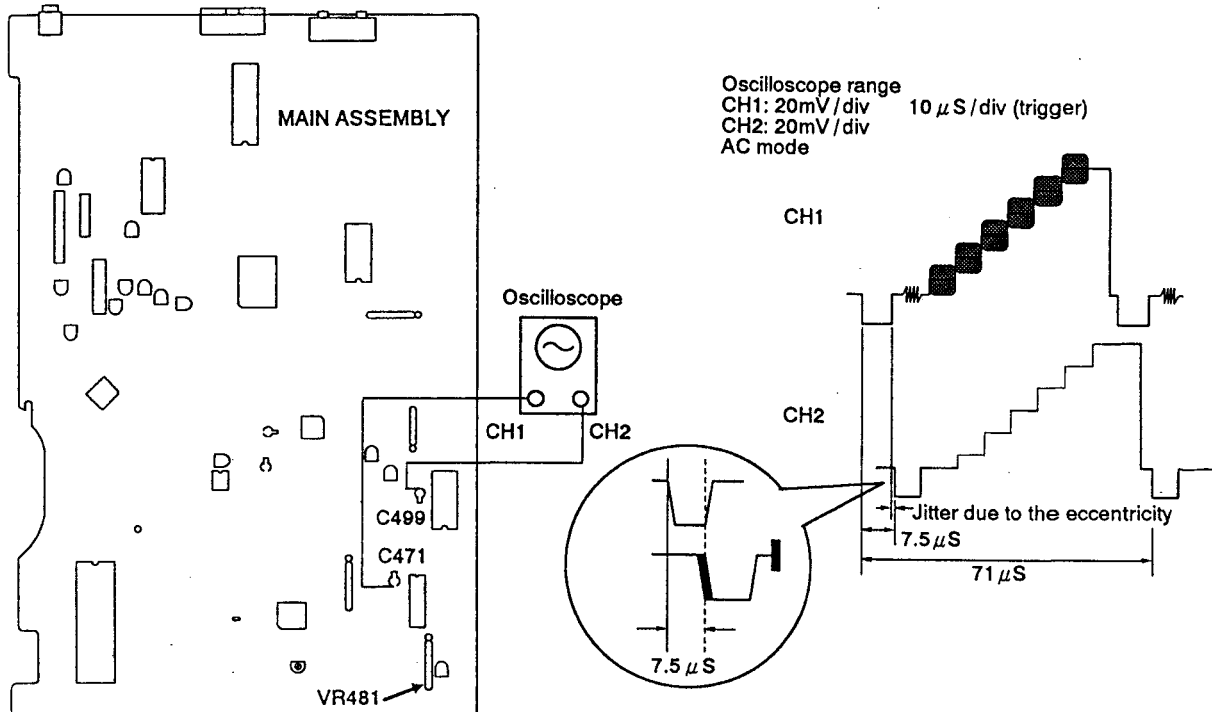

Adjustment Procedure

1. Connect the + side lead wire of C471 and the + side lead wire of C499 to CH 1 and CH 2 of the oscilloscope respectively.
 CH 1 : Video signal before time axis error compensation.
 CH 2 : Video signal after time base error compensation.
2. Search for frame #5,100 on the test disc. Adjust VR481 so that the center of CH 1's video signal jitter is delayed by 71 μs (1H + 7.5 μs) with respect to the CH 2's video signal.

Note : Do not confuse CH 1 and CH 2.

15. OUTPUT VIDEO LEVEL ADJUSTMENT

Electrical Adjustment

- Purpose: Setting the video signal level to 1Vp-p (75 Ω termination).
- When not properly adjusted: The player starts up midway without reading the data. The screen is too bright or too dark.

- | | |
|--|--|
| <ul style="list-style-type: none"> ● Measuring instruments and jigs: ● Measuring point: ● Test disc and player mode ● Positions to be adjusted | <ul style="list-style-type: none"> ● Oscilloscope ● Player's VIDEO OUT terminal ● 8-inch LD test disc (GGV1003) ● Normal mode (Still mode, #19,900) ● VR482 |
|--|--|

Connection diagram

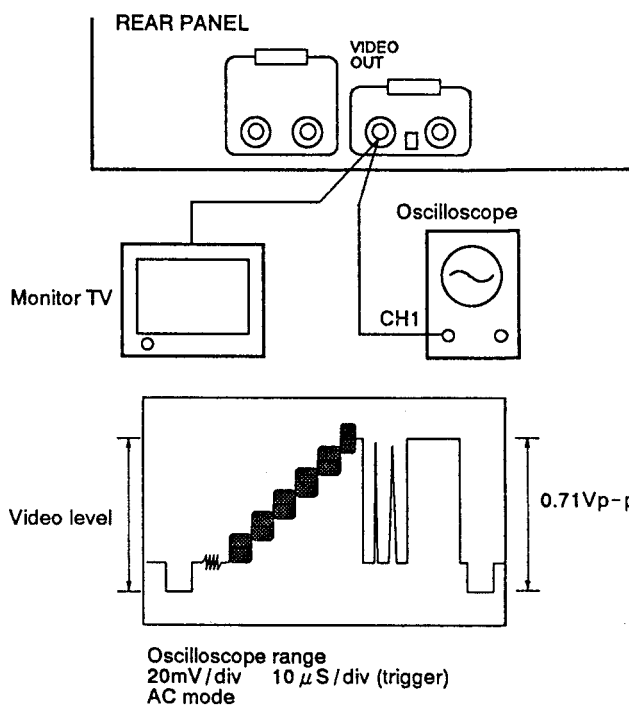
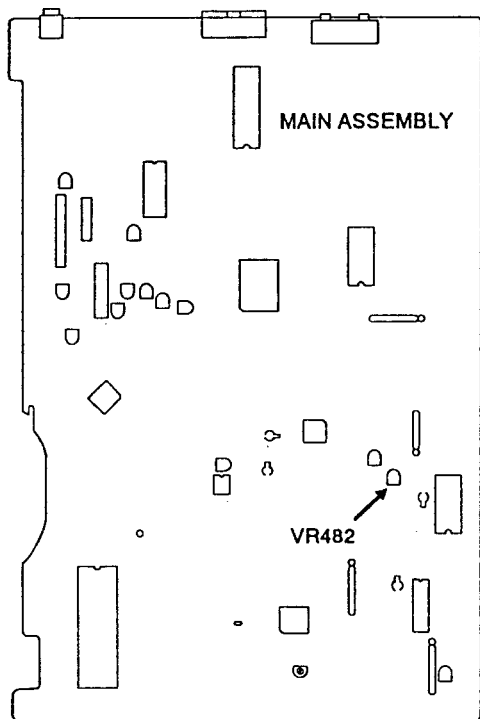

Adjustment Procedure

Note: Since the VIDEO OUT terminal is connected to a TV monitor, it is to have 75 Ω termination. (If it is connected to a TV via VHF OUT, terminate the VIDEO OUT terminal with a 75 Ω resistor).

1. Search for frame #19,900 on the test disc.
2. Adjust VR482 so that the white level becomes 0.71Vp-p ± 5% from the video signal's sync tip level.

16. 1H DELAY VIDEO LEVEL ADJUSTMENT

Electrical Adjustment

- Purpose: Equalization of the video levels of the 1H delay video signal and the main line video signal.
- When not properly adjusted: If the 1H delay video signal level is high, white dropout will be noticeable and there will be H shifting. (Horizontal stripes across the screen.)

- Measuring instruments and jigs:

- Measuring point:
- Test disc and player mode

- Positions to be adjusted

- Oscilloscope

- CH 1 : - side lead wire of C443
- CH 2 : - side lead wire of C445

- 8-inch LD test disc (GGV1003)

- Normal mode (Still mode)

- VR441

Connection diagram

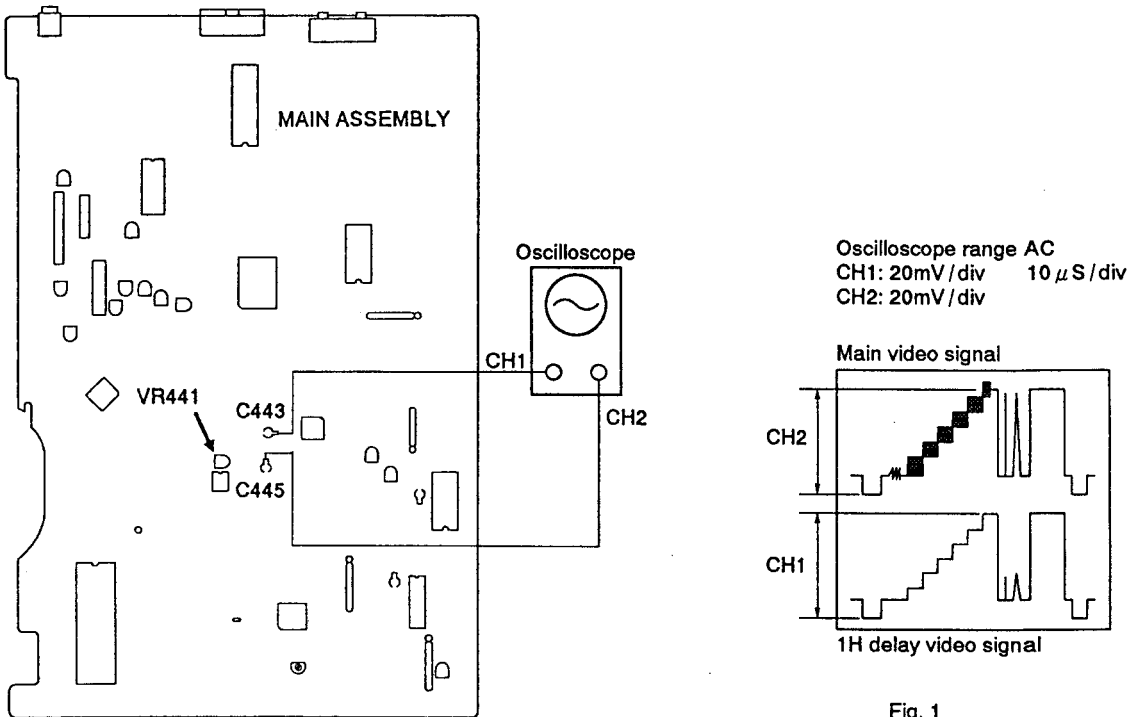

Adjustment Procedure

1. Search for frame #3,800 on the test disc.
2. Connect - side lead wire of C443 to the oscilloscope's CH 1 and - side lead wire of C445 to the CH 2.
3. Adjust VR441 so that the 1H delay video level (CH 1) becomes the same as the main line video level (CH 2). (See Fig. 1)

Note : The video level is the level between the SYNC tip and the white peak.

17. VPS ERROR ADJUSTMENT

Electrical Adjustment

- Purpose: Optimization of the color tint compensation section's error signal level.
- When not properly adjusted: Substantial color irregularity. (especially on CDV.)

- | | |
|--|--|
| <ul style="list-style-type: none"> ● Measuring instruments and jigs: ● Measuring point: ● Test disc and player mode ● Positions to be adjusted | <ul style="list-style-type: none"> ● TV monitor ● 8-inch LD test disc (GGV1003) ● Normal mode (Still mode) ● VR521 |
|--|--|

Connection diagram

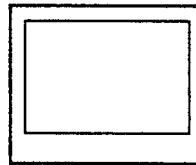
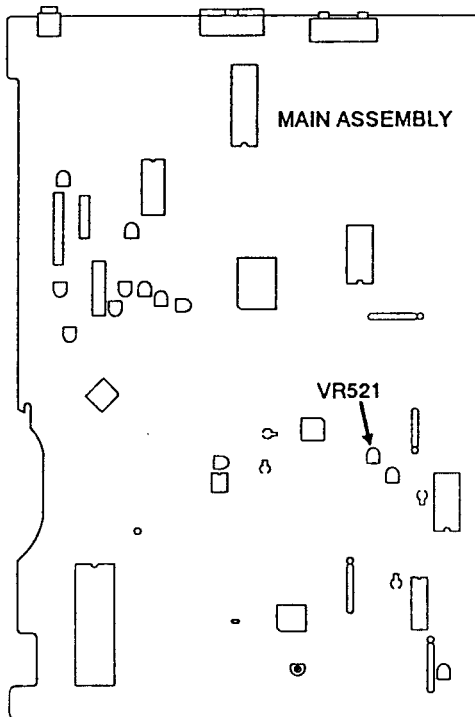

Color irregularity on the magenta screen is minimized.

Adjustment Procedure

1. Search for frame #8,000 on the test disc. (Magenta screen)
2. Adjust VR521 until the color irregularity on the magenta screen is minimized.

9. ABBREVIATIONS TABLE

A		M	
ACCEL	ACCELERATE	MTR	MOTOR
ACOM	AUDIO COMPENSATOR	μ COM	MICROCOMPUTER
AF	AUDIO FREQUENCY	P	
AFM	ANALOGUE FM AUDIO	PD	PHOTO DETECTOR
AGC	AUTOMATIC GAIN CONTROL	PB	PLAYBACK
ALC	AUTOMATIC LEVEL CONTROL	PLL	PHASE LOCKED LOOP
ANT	ANTENNA	P-ON	POWER ON
ATC	AUTOMATIC THRESHOLD CONTROL		
B		R	
BAL	BALANCE	R-CH	RIGHT CHANNEL
C		RTN	RETURN
CAV	CONSTANT ANGULAR VELOCITY	RFMD	RADIO FREQUENCY MODULATOR
CLV	CONSTANT LINEAR VELOCITY	RST	RESET
CCD	CHARGE COUPLED DEVICE	REV	REVERSE
CD	COMPACT DISC	RF-CORR	RF CORRECTION
CK	CLOCK	S	
CONT	CONTROL	SPDL	SPINDLE
C-SYNC	COMPOSITE SYNCHRONIZATION	SLD	SLIDER
CX	AFM NOISE REDUCTION	SO	SERIAL OUTPUT
D		SI	SERIAL INPUT
DEM	DEMODULATOR	SCK	SERIAL CLOCK
DIG/ANA	DIGITAL/ANALOGUE	SC	CHIP SELECT
DL	DELAY LINE	SYPS	SYSTEM POWER SUPPLY
DSP	DIGITAL SIGNAL PROCESSOR	SW	SWITCH
DOS	DROP OUT SENSE	S/H	SAMPLE & HOLD
DRV	DRIVER	SENS	SENSITIVITY
E		SQ	SQUELCH
EFM	EIGHT TO FOURTEEN MODULATION	T	
ERR	ERROR	TRK or TRKG	TRACKING
EQ	EQUALIZER	TP	TEST POINT
EXT	EXTERNAL	TBC	TIME BASE CORRECTION
F		TGL	TOGGLE
FCS or FOCS	FOCUS	U	
FG	FREQUENCY GENERATOR	UNREG	UNREGULATED
FL	FLUORESCENT LAMP	V	
FTS	FOCUS TRACKING SLIDER	V-SYNC	VERTICAL SYNCHRONIZATION
Fsc	CHROMINANCE SUBCARRIER FREQUENCY	VSQ	VIDEO SQUELCH
FWD	FORWARD	VPS	VIDEO PHASE SHIFTER
G		VDEM	VIDEO DEMODULATOR
GFS	GET FRAME SYNC LOCK	VHF	VERY HIGH FREQUENCY
GND	GROUND	VCA	VOLTAGE CONTROLLED AMPLIFIER
H		VCO	VOLTAGE CONTROLLED OSCILLATOR
HLD	HOLD	X	
H SYNC	HORIZONTAL SYNCHRONIZATION	X...	ACTIVATED WHEN LOW VOLTAGE
I			
INT	INTERNAL		
IR	INFRARED RAYS		
L			
L-CH	LEFT CHANNEL		
LAT	LATCH		
LD	LASER DIODE		
LPF	LOW PASS FILTER		
LIM	LIMITER		

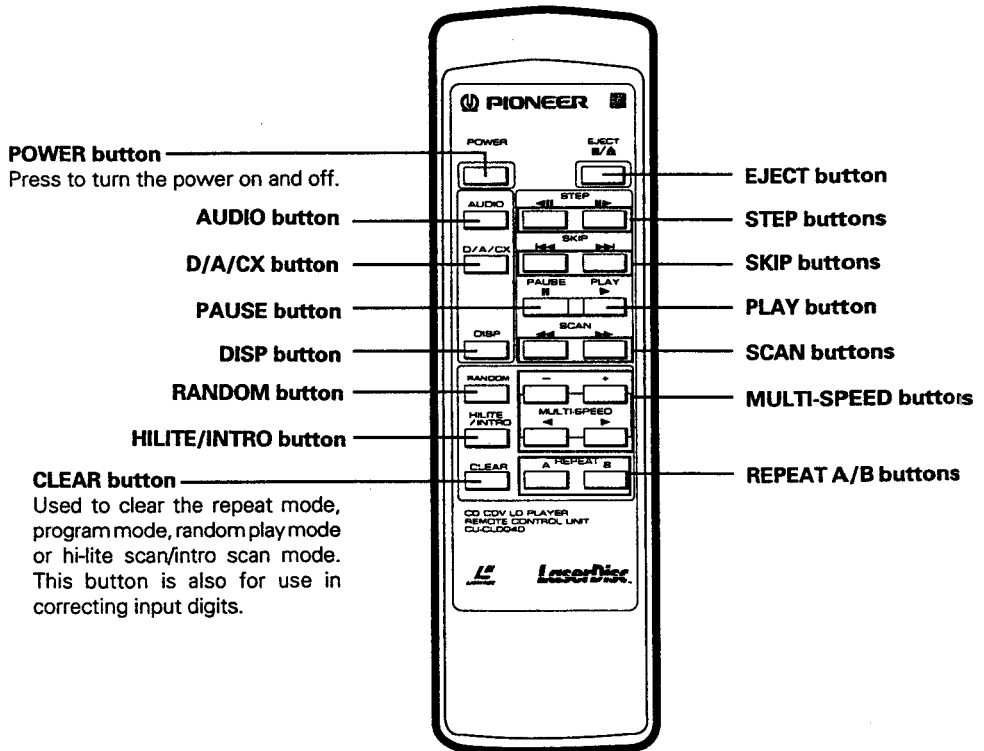
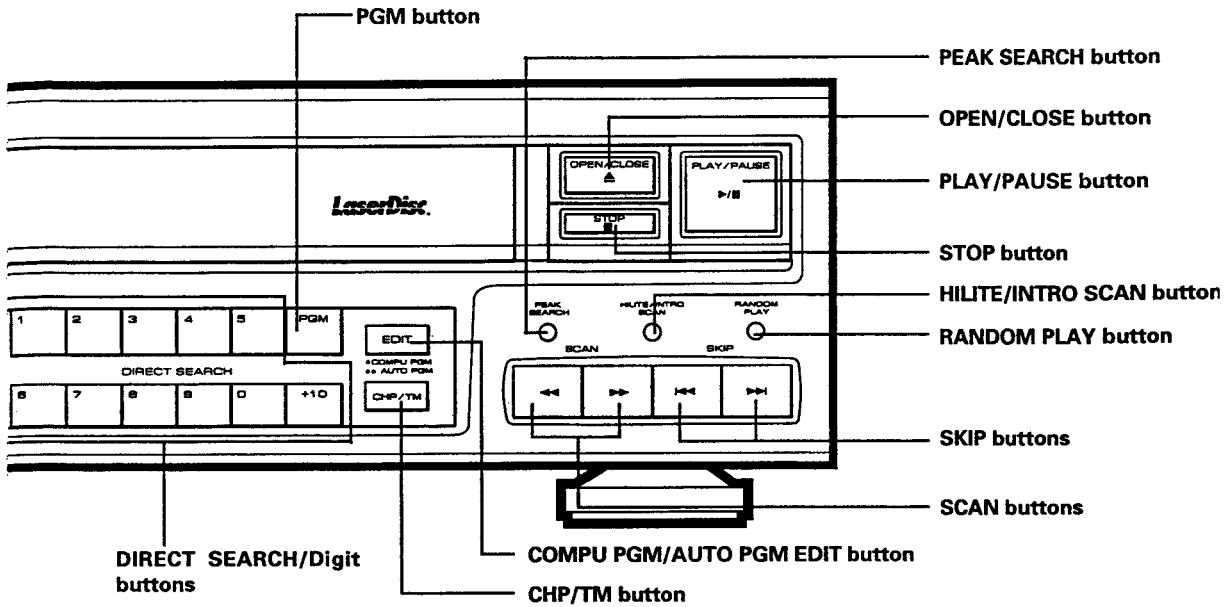

11. SPECIFICATIONS

1. General

System LaserVision Disc system and
Compact Disc digital audio system
Laser Semiconductor laser wavelength 780 nm
Power requirements AC 120V, 60 Hz
Power consumption 39 W
Weight 7.6 kg (16 lbs 12 oz)
Dimensions 420 (W) x 410 (D) x 122 (H) mm
16-9/16 (W) x 16-1/8 (D) x 4-13/16 (H) in
Operating temperature +5°C ~ +35°C
(41°F - 95°F)
Operating humidity 5% ~ 90%
(There should be no condensation of moisture.)

2. Disc

LaserVision Discs

*Maximum playing times
12-inch standard play disc 1 hour/both sides
12-inch extended play disc 2 hours/both sides
8-inch standard play disc 28 min/both sides
14 min/one side
8-inch extended play disc 40 min/both sides
20 min/one side
Spindle motor speed
Standard play disc 1,800 rpm
Extended play disc 1,800 rpm (inner circumference)
to 600 rpm (outer circumference)
(For a 12-inch disc)

Compact Discs

DISC Diameter: 5-inch, 3-inch, Thickness: 1.2 mm
Rotation direction (pickup side) Counterclockwise
Liner speed 1.2 ~ 1.4m/sec
*Maximum playing time
74 min. 5-inch discs
20 min. 3-inch discs
(For stereo playback)

Compact Discs with Video

Disc Diameter: 5-inch, Thickness: 1.2 mm
Rotation direction (pickup side) Counterclockwise
Liner speed Audio portion: 1.2 ~ 1.4m/sec
Video portion: 11 ~ 12m/sec
*Maximum playing time Video portion: 5 min. (CLV)
Audio portion: 20 min. (Digital)

* Actual playback time differs for each disc.

3. Video characteristics

Format NTSC specifications
Video output
Level 1 Vp-p nominal, sync. negative, terminated
Impedance 75 Ω unbalanced
Jack RCA jack

4. Audio characteristics

Output level
During analog audio output 200 mVrms
(1 kHz, 40%)
During digital audio output 200 mVrms
(1 kHz, -20 dB)
Jacks Both RCA jacks
Number of channels 2 (Stereo)

Digital Audio Characteristics

Frequency response	4 Hz - 20 kHz (±0.5 dB) (EIAJ)
SN ratio	100 dB (EIAJ)
Dynamic range	96 dB (EIAJ)
Channel separation	96 dB (EIAJ)
Total harmonic distortion	0.006% (EIAJ)
Wow and flutter	Limit of measurement (EIAJ)

5. Other Terminals

Control input/output Both miniature jacks
VHF adapter output
(Video:common to video
and audio/Audio) Both RCA jacks with DC jack

6. Accessories

Remote control unit (CU-CLD040) 1
Size "AAA" (IEC R03) dry cell batteries 2
Video cord 1
Audio cord 1
Operating instructions 1
Warranty card 1