

Service Manual

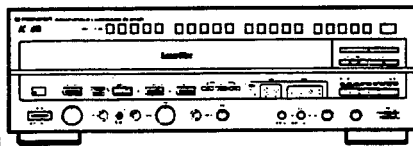

ORDER NO.
ARP2096

CD CDV LD PLAYER

CLD-1580K

- As to the circuit and mechanism descriptions, refer to the CLD-1080 service guide (ARP2063).
- As to the adjustments, refer to the adjustments for CLD Players Vol. 1 (ARP2064).
- This manual is applicable to the S type.

- The pre-pickup assembly (VXX1413) mounted on this player unit is not compatible with the pre-pickup assembly (VXX1274) used on the CLD-1070. Do not use the VXX1274 as a substitute for the VXX1413.

	①	②	Pre-pickup assembly	Slider assembly
CLD-1580K	Silver	I	VXX1413	VWT1060
CLD-1070	Brown	F	VXX1274	VWT1048

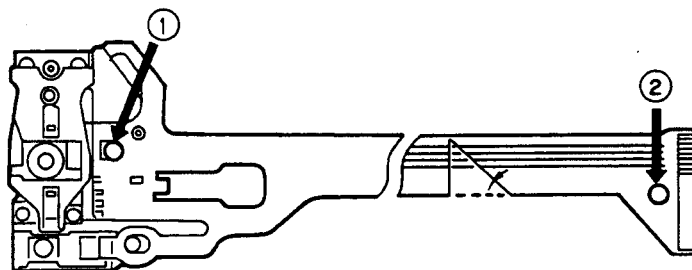

CONTENTS

1. SAFETY INFORMATION.....	2	7. DISASSEMBLY	73
2. PACKING	3	8. TEST MODE	81
3. EXPLODED VIEWS AND PARTS LIST	4	9. ADJUSTMENTS	85
4. P. C. BOARDS LOCATION	20	10. SPECIFICATIONS	86
5. SCHEMATIC AND P. C. BOARDS DIAGRAM	21	11. PANEL FACILITIES	88
6. ELECTRICAL PARTS LIST	65		

PIONEER ELECTRONIC CORPORATION 4-1, Meguro 1-Chome, Meguro-ku, Tokyo 153, Japan
PIONEER ELECTRONICS SERVICE INC. P.O. Box 1760, Long Beach, California 90801 U.S.A.
PIONEER ELECTRONICS OF CANADA, INC. 505 Cochrane Drive, Markham, Ontario L3R 8E3 Canada
PIONEER ELECTRONIC [EUROPE] N.V. Keelberglaan 1, 2740 Beveren, Belgium
PIONEER ELECTRONICS AUSTRALIA PTY. LTD. 178-184 Boundary Road, Braeside, Victoria 3195, Australia TEL: [03] 580-9911
 © PIONEER ELECTRONIC CORPORATION 1990

IFJ AUG.1990 Printed in Japan

This service manual is intended for qualified service technicians; it is not meant for the casual do-it-yourselfer. Qualified technicians have the necessary test equipment and tools, and have been trained to properly and safely repair complex products such as those covered by this manual.

Improperly performed repairs can adversely affect the safety and reliability of the product and may void the warranty. If you are not qualified to perform the repair of this product properly and safely, you should not risk trying to do so and refer the repair to a qualified service technician.

WARNING

Lead in solder used in this product is listed by the California Health and Welfare agency as a known reproductive toxicant which may cause birth defects or other reproductive harm (California Health & Safety Code, Section 25249.5).

When servicing or handling circuit boards and other components which contain lead in solder, avoid unprotected skin contact with the solder. Also, when soldering do not inhale any smoke or fumes produced.

1. SAFETY INFORMATION

(FOR USA MODEL ONLY)

1. SAFETY PRECAUTIONS

The following check should be performed for the continued protection of the customer and service technician.

LEAKAGE CURRENT CHECK

Measure leakage current to a known earth ground (water pipe, conduit, etc.) by connecting a leakage current tester such as Simpson Model 229-2 or equivalent between the earth ground and all exposed metal parts of the appliance (input/output terminals, screwheads, metal overlays, control shaft, etc.). Plug the AC line cord of the appliance directly into a 120V AC 60Hz outlet and turn the AC power switch on. Any current measured must not exceed 0.5mA.

ANY MEASUREMENTS NOT WITHIN THE LIMITS OUTLINED ABOVE ARE INDICATIVE OF A POTENTIAL SHOCK HAZARD AND MUST BE CORRECTED BEFORE RETURNING THE APPLIANCE TO THE CUSTOMER.

2. PRODUCT SAFETY NOTICE

Many electrical and mechanical parts in the appliance have special safety related characteristics. These are often not evident from visual inspection nor the protection afforded by them necessarily can be obtained by using replacement components rated for voltage, wattage, etc. Replacement parts which have these special safety characteristics are identified in this Service Manual.

Electrical components having such features are identified by marking with a Δ on the schematics and on the parts list in this Service Manual.

The use of a substitute replacement component which does not have the same safety characteristics as the PIONEER recommended replacement one, shown in the parts list in this Service Manual, may create shock, fire, or other hazards.

Product Safety is continuously under review and new instructions are issued from time to time. For the latest information, always consult the current PIONEER Service Manual. A subscription to, or additional copies of, PIONEER Service Manual may be obtained at a nominal charge from PIONEER.

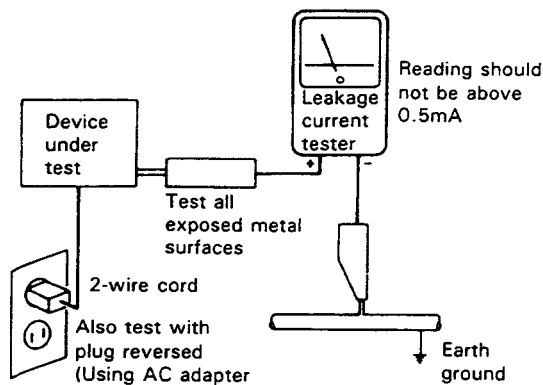

AC Leakage Test

2. PACKING

Parts List

Mark	No.	Part No.	Description	Mark	No.	Part No.	Description
	1	VHG1109	Packing case			101	Battery UM-4
	2	VHA1059	Pad (F)			102
	3	VHA1060	Pad (R)			103	Polyethelene bag
	4	VHL1012	Mirror mat			104	Caution card
	5				105	Caution card (UC)
	6	VXX1442	Remote control unit			106
	7				107
	8				108	Polyethelene bag
	9	VDE-055	Connection cord				
	10	VDE-056	Video cable				
	11	VDE1001	RF antenna cable				
	12					
	13	VKX1003	Antenna adaptor				
	14	VRB1039	Operating instructions (English)				
	15					
	16	VKX-017	F-IEC change plug				

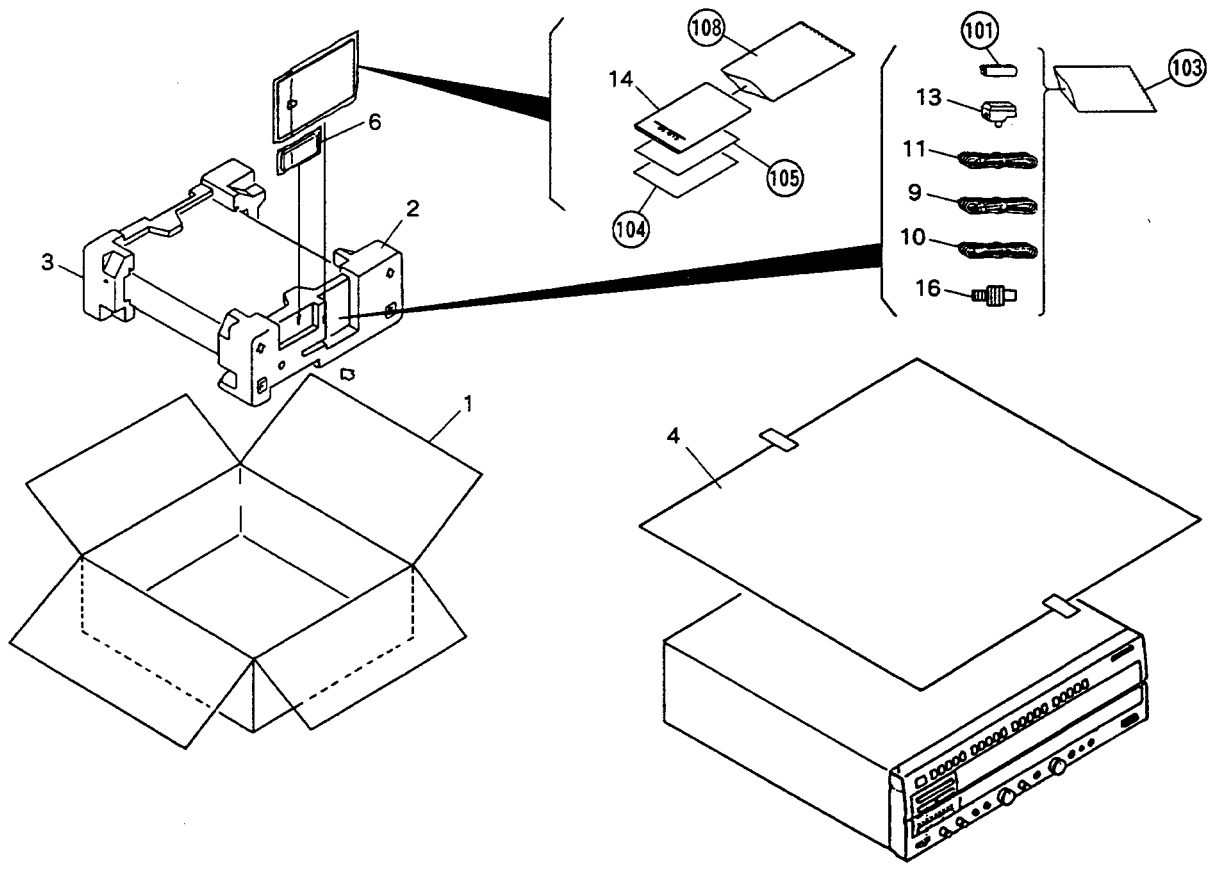

3. EXPLODED VIEWS AND PARTS LIST

NOTES :

- Parts without part number cannot be supplied.
- The Δ mark found on some component parts indicates the importance of the safety factor of the part. Therefore, when replacing, be sure to use parts of identical designation.
- Parts marked by "⊙" are not always kept in stock. Their delivery time may be longer than usual or they may be unavailable.

3.1 EXTERIOR SECTION

Parts List

<u>Mark</u>	<u>No.</u>	<u>Part No.</u>	<u>Description</u>
	1	VXX1458	Bonnet assembly S
	2	VEC1191	Disc pad (L)
	3	VEC1192	Disc pad (S)
	4	VXX1460	Tray assembly S
	5	BCZ40P060FZK	Screw
	6	BBZ30P080FZK	Screw
	7	BPZ30P140FMC	Screw
	8	BPZ30P080FMC	Screw
	9	BBZ30P060FMC	Screw
	10	PCZ30P080FMC	Screw
	11	VEB1089	Tray rubber
	12	VEC1252	CD pad
	13	VEC1177	Insulator pad
	14	
	15	CPZ30P100FMC	Screw
	101		Bonnet cushion
	102		Center angle
	103		Tray angle
	104		Carry label
	105		Tray reinforced plate
	106		Tray
	107		Side plate
	108		Rack reinforced plate
	109		Bridge cushion

1

2

A

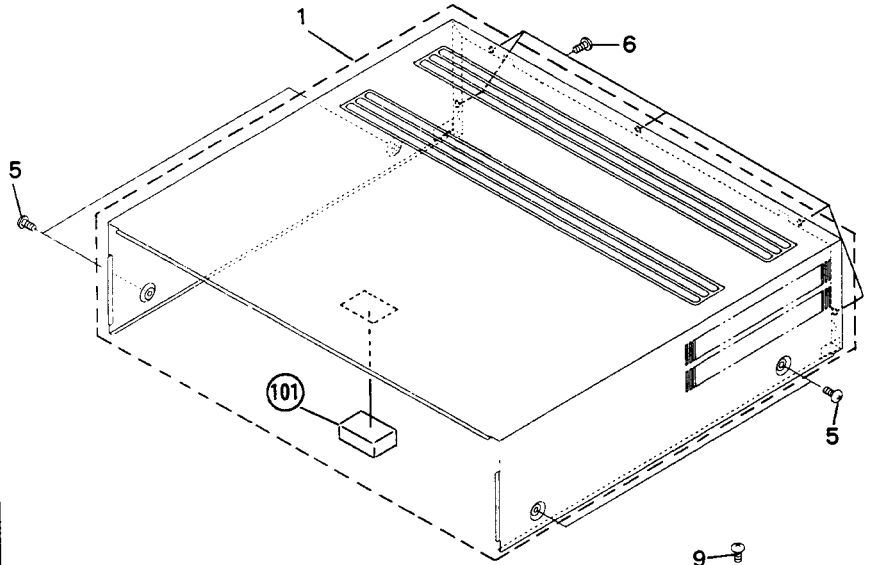

B

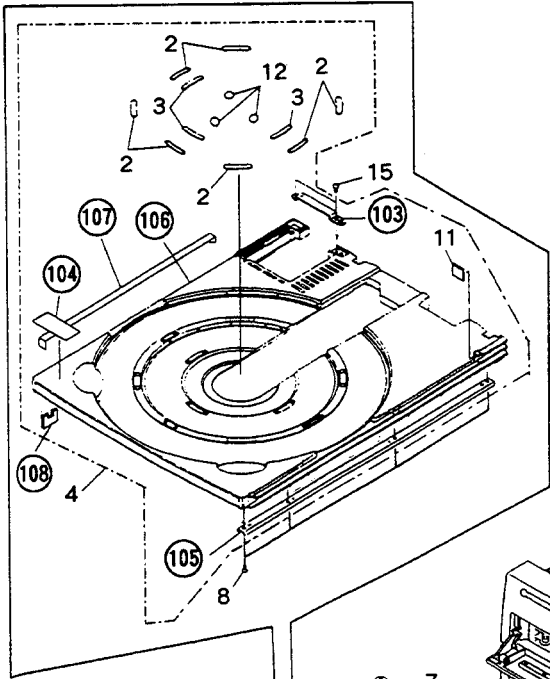

C

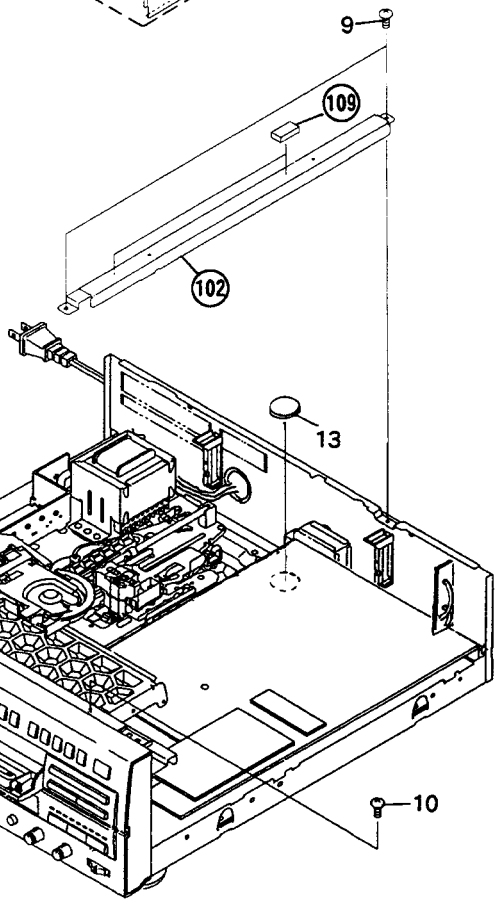

D

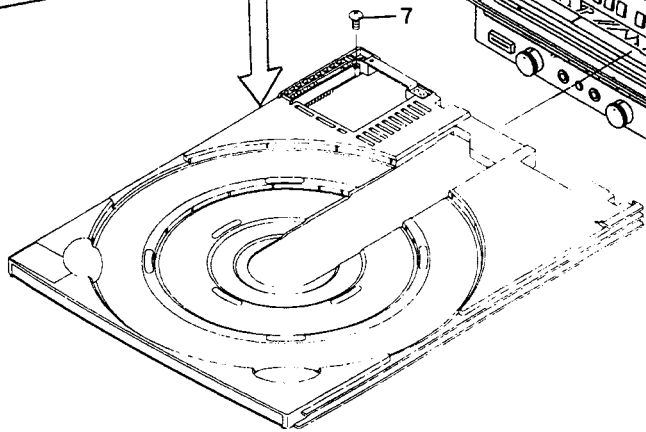

1

2

3

5

3.2 FRONT PANEL SECTION

Parts List

<u>Mark</u>	<u>No.</u>	<u>Part No.</u>	<u>Description</u>	<u>Mark</u>	<u>No.</u>	<u>Part No.</u>	<u>Description</u>
	1	VXX1477	Front panel assembly S			101	Front panel
	2	VNK1508	Acrylic display			102	Display sheet
	3	VNK1507	Sub panel			103	Name plate
	4	VNK1516	Volume knob (A)			104	Laser disc badge
	5	VNK1517	Volume knob (B)			105	Reinforced plate (FP)
	6				106	P. C. B holder
	7	VXA1453	Change key assembly			107	KEYB assembly
	8	VBH1096	Door spring			108	UCOM assembly
	9	VNL1042	Roller			109	INDB assembly
	10	VEB1033	Door dump rubber			110	MHVB assembly
	11	VXA1482	Door assembly			111	Black sheet
	12	VNK1515	Echo knob			112	DSPB assembly
	13	VNK1514	Slide knob			113	FP plate
	14	VNK1510	Function key				
	15	VNK1509	Key control button				
	16	VNK1512	Music select key (A)				
	17	VNK1513	Music select key (B)				
	18	VXA1053	Dumper assembly				
	19	BPZ20P040FZK	Screw				
	20	BPZ26P080FMC	Screw				
	21	IPZ26P060FMC	Screw				
	22	VNE1482	Door plate				

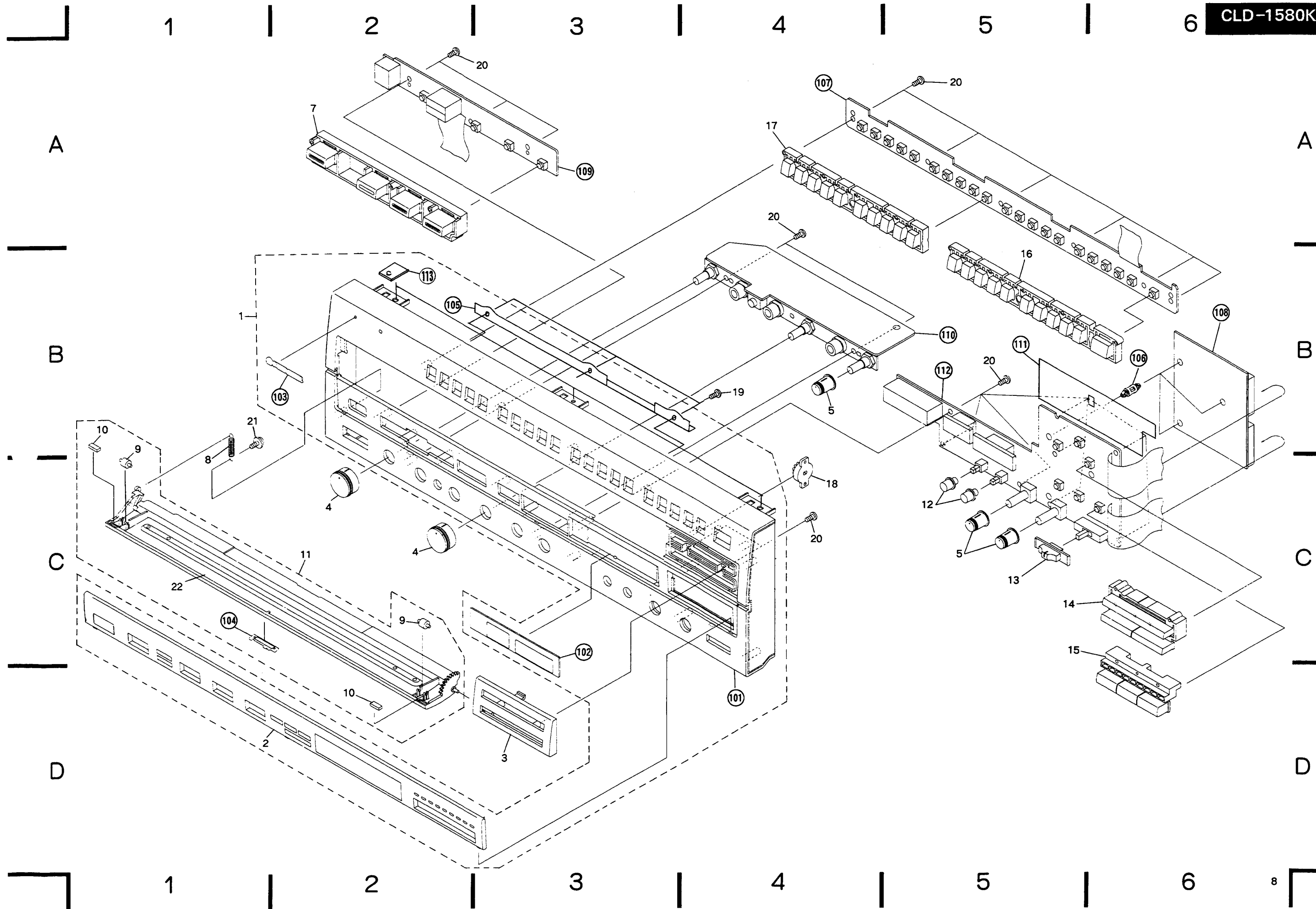

CLD-1580K

1

2

3

4

5

6

3.3 TOP VIEW SECTION

A

B

C

D

A

B

C

D

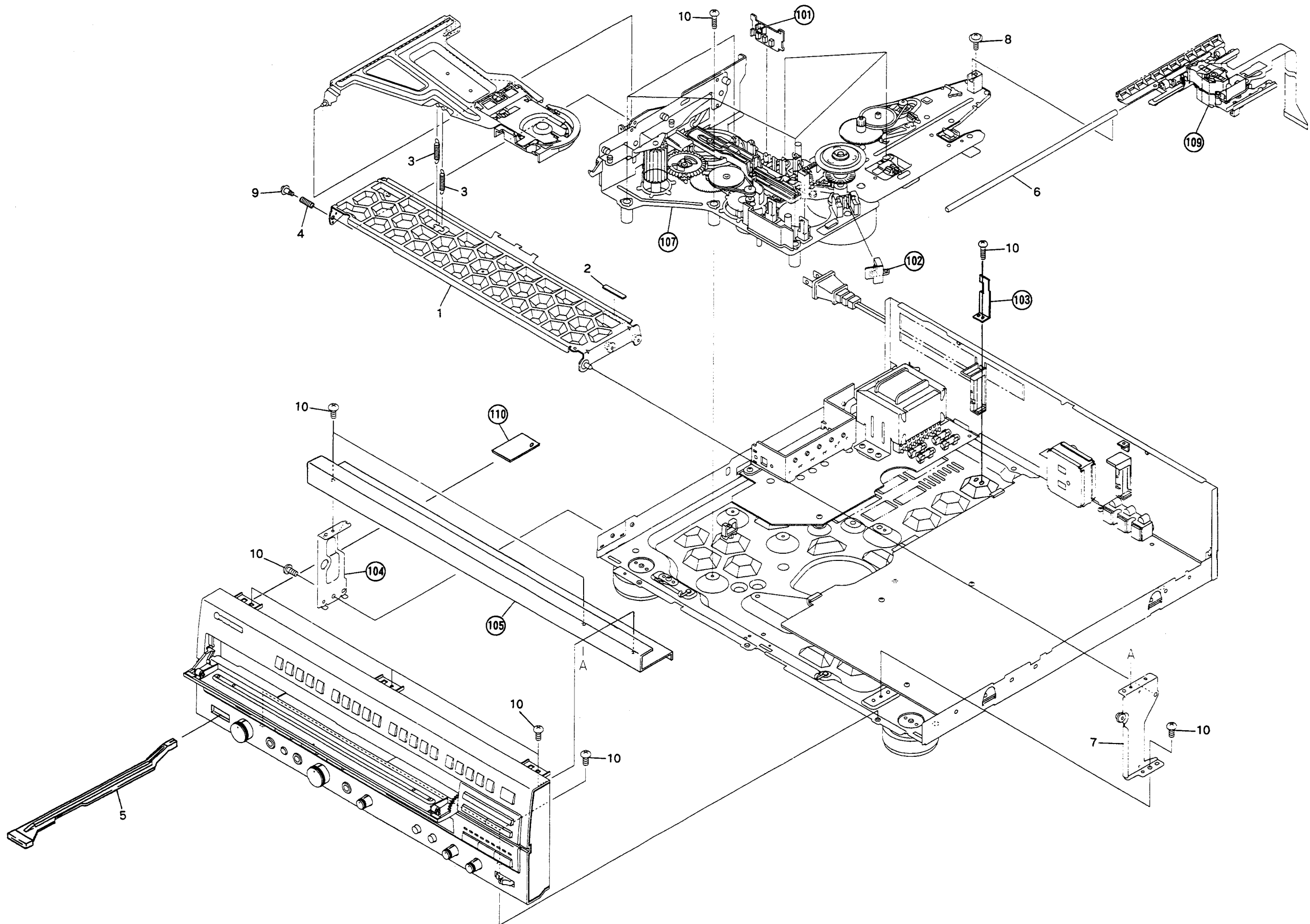

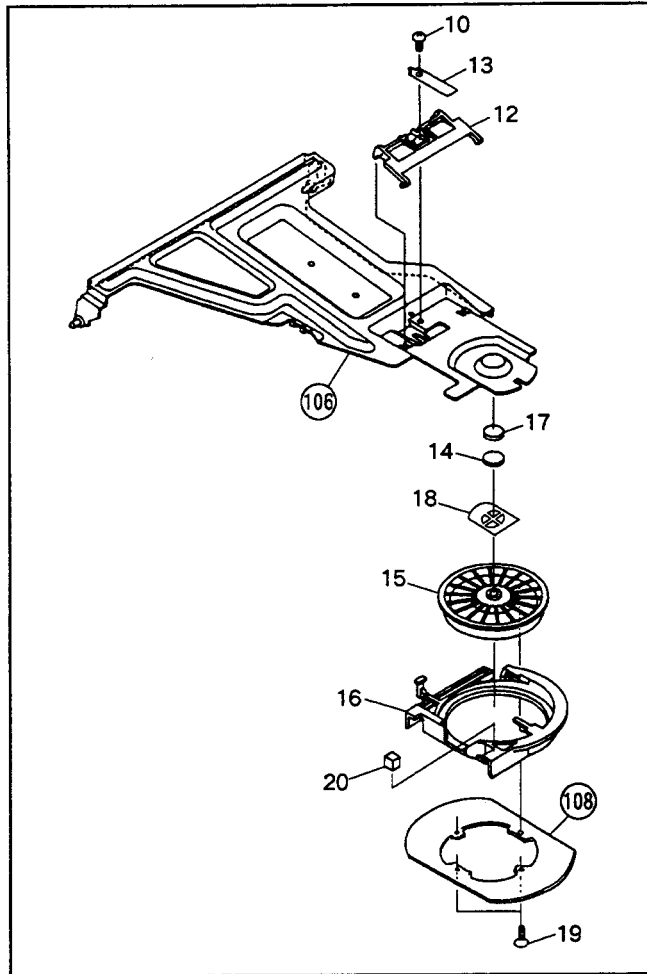

Parts List

Mark	No.	Part No.	Description	Mark	No.	Part No.	Description
	1	VXA1319	Clamper arm (A) assembly		16	VNL1205	Clamper holder
	2	VEB1084	Rubber (A)		17	VEB1114	Rubber sheet
	3	VBH1094	Clamper spring		18	VBK1018	Thrust holder
	4	VBH1093	Arm spring		19	CPZ20P050FMC	Screw
	5	VNK1511	Power knob		20	VEC1271	Clamper cushion
	6	VLL1177	Carriage shaft		101		SW assembly
	7	VXA1529	Side stay (R) assembly		102		FG assembly
	8	VBA1018	Screw		103		SM head stopper
	9	VBA1008	Screw (B)		104		Side stay (L)
	10	BBZ30P060FMC	Screw		105		Front angle
	11		• • • • •		106		Clamper arm (B)
	12	VNL1254	Parallel link		107		Mechanism assembly
	13	VBK1014	Plate spring		108		Stabilizer
	14	VNL1289	Ball holder		109		Rack assembly
	15	VNL1248	Clamper S		110		FP plate

3.4 BASE SECTION

Parts List

<u>Mark</u>	<u>No.</u>	<u>Part No.</u>	<u>Description</u>	<u>Mark</u>	<u>No.</u>	<u>Part No.</u>	<u>Description</u>
◎	1	VWX1046	MAIN assembly		101		P. C. B spacer
△	2	VTT1088	Power transformer		102		Wire crip (B)
△	3	VDG1034	AC power cord		103		Cord holder
◎	4	VWR1070	SYPS assembly		104		P plate holder
△	5	VEK-018	Fuse (FU201,FU202) (3A)		105		Base chassis
△	6	VEK-022	Fuse (FU203,FU204) (2A)		106		Insulator
△	7	CM-22	Strain relief		107		Rear panel
	8	VLL-082	F-nut		108		SURB assembly
	9	VEB1033	Door dump rubber		109		KCNB assembly
	10	VNL1202	Tray stopper		110		KFCB assembly
	11	VXA1455	Insulator assembly		111		PC support
	12			112		P. C. B hinge
	13	VNK1095	Insulator		113		PC support
	14	VXA1410	Insulator assembly		114		P. C. B holder (C)
	15	BBZ30P080FZK	Screw		115		Earth plate
	16	BBZ30P060FMC	Screw		116		Cushion
	17	BCZ40P080FZK	Screw		117		P. C. B holder (A)
	18	IPZ30P160FMC	Screw		118		Rear angle
	19	WA96F130N050	Washer		119		Angle
	20	IPZ30P160FMC	Screw		120		EXTB assembly
					121		Housing assembly
△	21	VSB-002	Voltage selector				
	22	VEC1265	Insulator sheet				
	23	BBZ30P080FMC	Screw				
	24	BCZ40P060FZK	Screw				

1

2

A

A

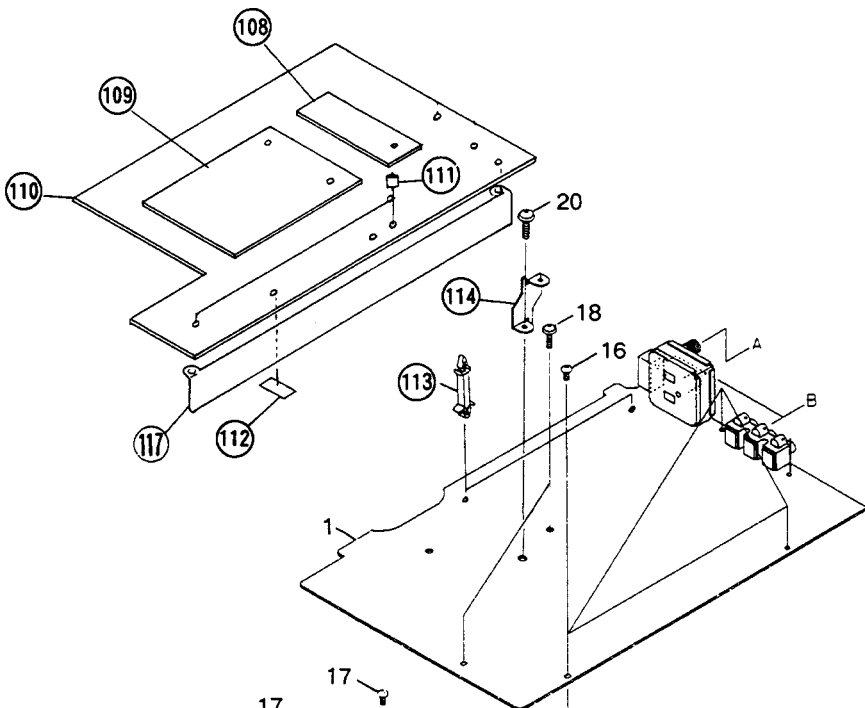

B

B

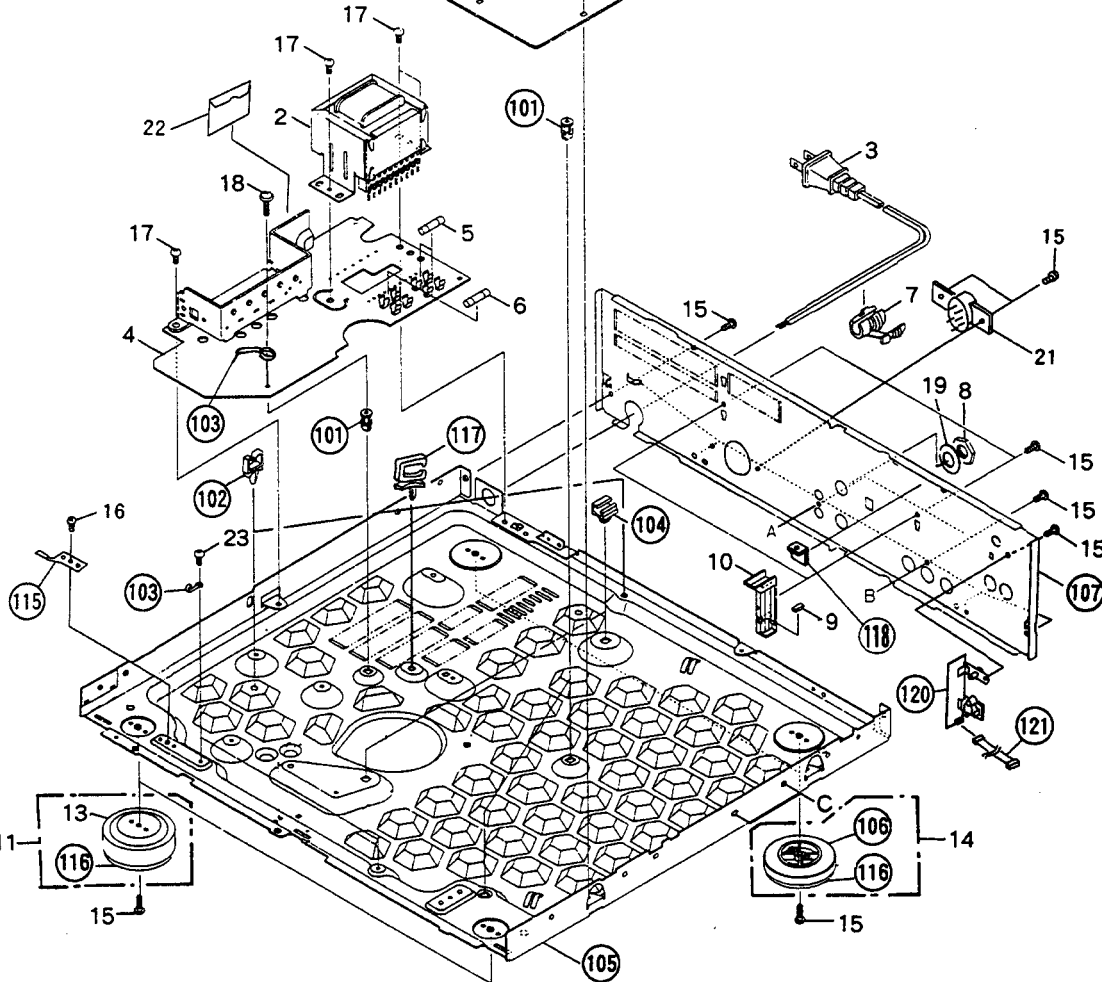

C

C

D

D

1

2

3

3.5 MECHANISM ASSEMBLY

A

B

C

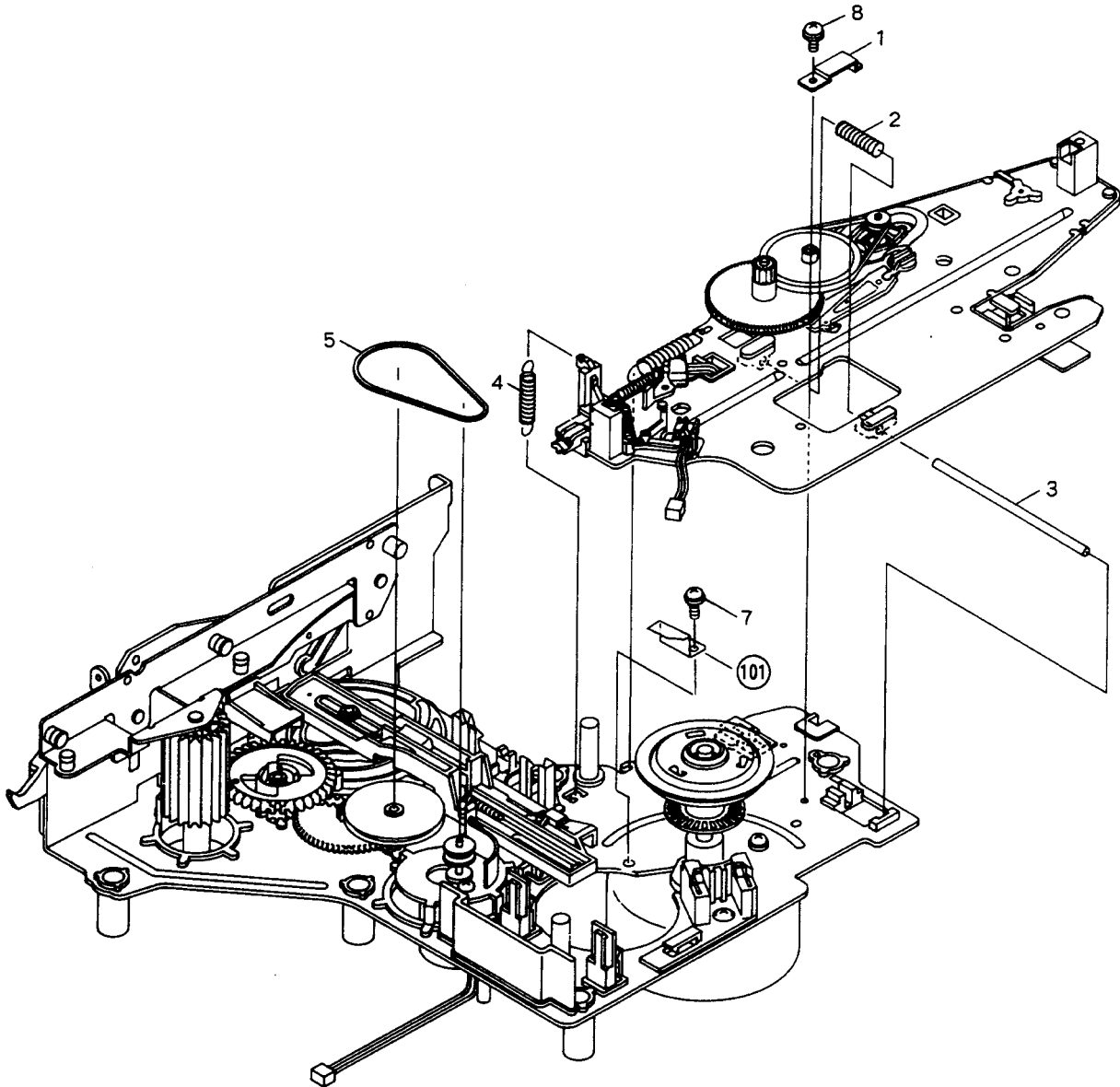

A

B

C

Parts List

Mark	No.	Part No.	Description
	1	VBK1013	Plate spring
	2	VBH1073	Thrust spring
	3	VLL1175	Tilt shaft
	4	VBH1074	Tilt pulling spring
	5	PEB1013	Belt
	6	
	7	PMA30P050FMC	Screw
	8	ABZ26P050FMC	Screw
	101		Cam head stopper

D

3.6 SERVO MECHANISM BASE SECTION

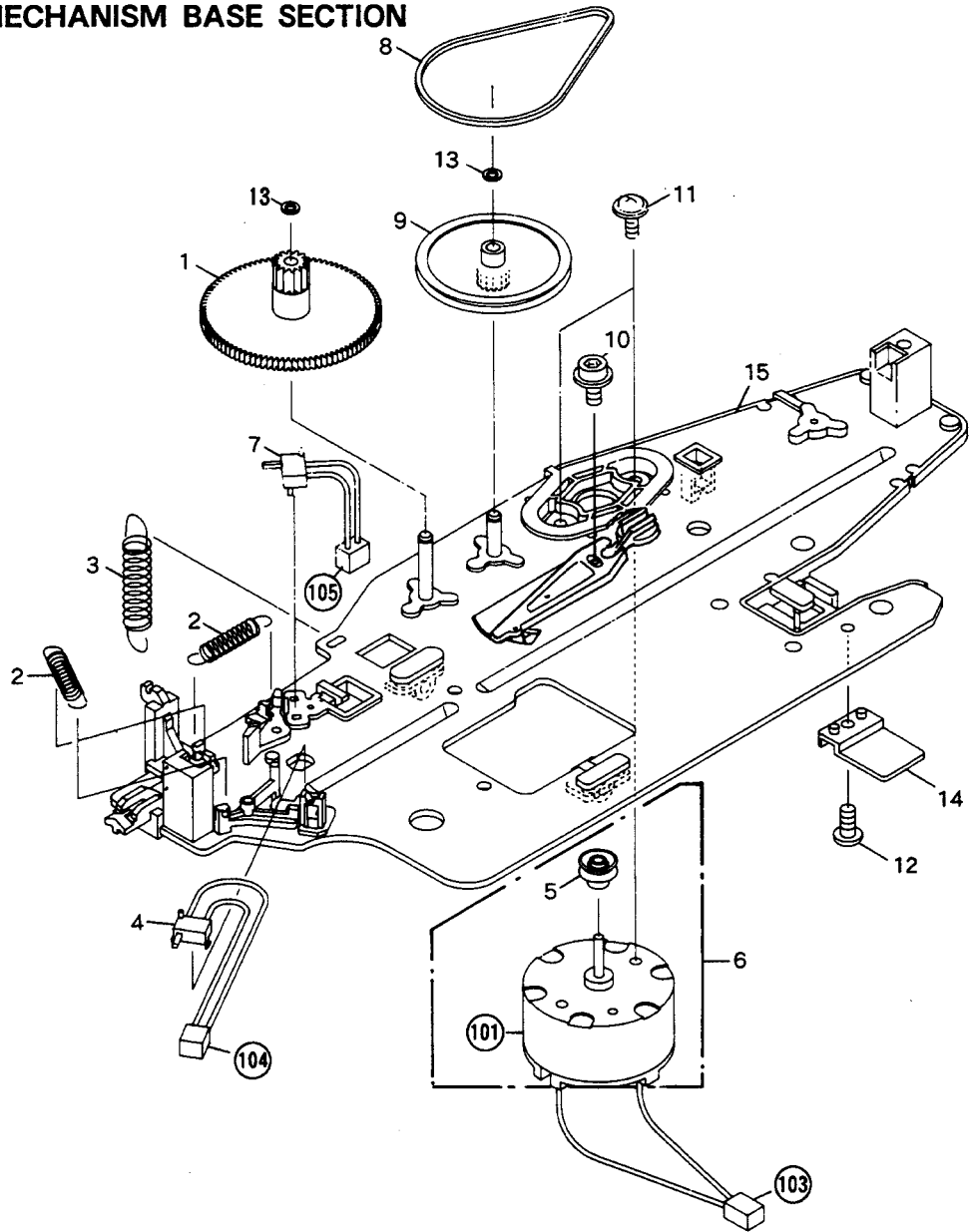

Parts List

Mark	No.	Part No.	Description	Mark	No.	Part No.	Description
	1	VNL1196	CA gear (3)	101			Carriage motor
	2	VBH1079	Switch pulling spring	102		
	3	VBH1080	TC pulling spring	103			Housing assembly
	4	PSH1003	Slide switch (S5)	104			Housing assembly
	5	VNL1197	CA pulley (1)	105			Housing assembly
	6	VXX1261	Carriage motor assembly				
	7	PSH1003	Slide switch (S4)				
	8	VEB1077	CA belt				
	9	VNL1198	CA pulley (2)				
	10	SMF30H080FBT	Screw				
	11	PMM26P040FMC	Screw				
	12	BPZ26P050FMC	Screw				
	13	WT26D047D025	Washer				
	14	VNL1210	FLE base				
⊙	15	VXA1273	Servo mechanism base				

3.7 CHASSIS SECTION

Parts List

<u>Mark</u>	<u>No.</u>	<u>Part No.</u>	<u>Description</u>	<u>Mark</u>	<u>No.</u>	<u>Part No.</u>	<u>Description</u>
	1	VNL1191	Spring slanting cam		101		Motor pulley
	2	VBH1082	Cam spring		102		Rubber sheet
	3	PEB1013	Belt		103		Turn table assembly
	4	VNL1249	Gear pulley		104		Oil stopped washer
	5	VNL1194	Follow gear		105		Spindle motor
	6	VXA1531	Roller plate assembly		106		Housing assembly
	7	VNL1188	Slide cam		107		Housing assembly
	8			108		Loading motor
	9	VXX1262	Loading motor assembly		109		Slider gear
	10	VXA1474	Spindle motor assembly				
	11	VNL1174	Centering hab				
	12	VBH1083	Centering spring				
	13	VNL1208	Door lever				
	14	WT26D047D025	Washer				
	15	VNL1193	Two stair gear				
	16	VNL1190	Cam gear				
	17	VBA1015	Screw (C)				
	18	VBA1008	Screw (B)				
	19	WA32N080W020	Nylon washer				
	20	PMZ30P040FMC	Screw				
	21	PMA30P050FMC	Screw				
	22	WA32D060D025	Washer				
	23					
	24	VEB1091	Stop ring				
◎	25	VXA1274	Chassis assembly				
	26	YE23FUC	E ring				

A

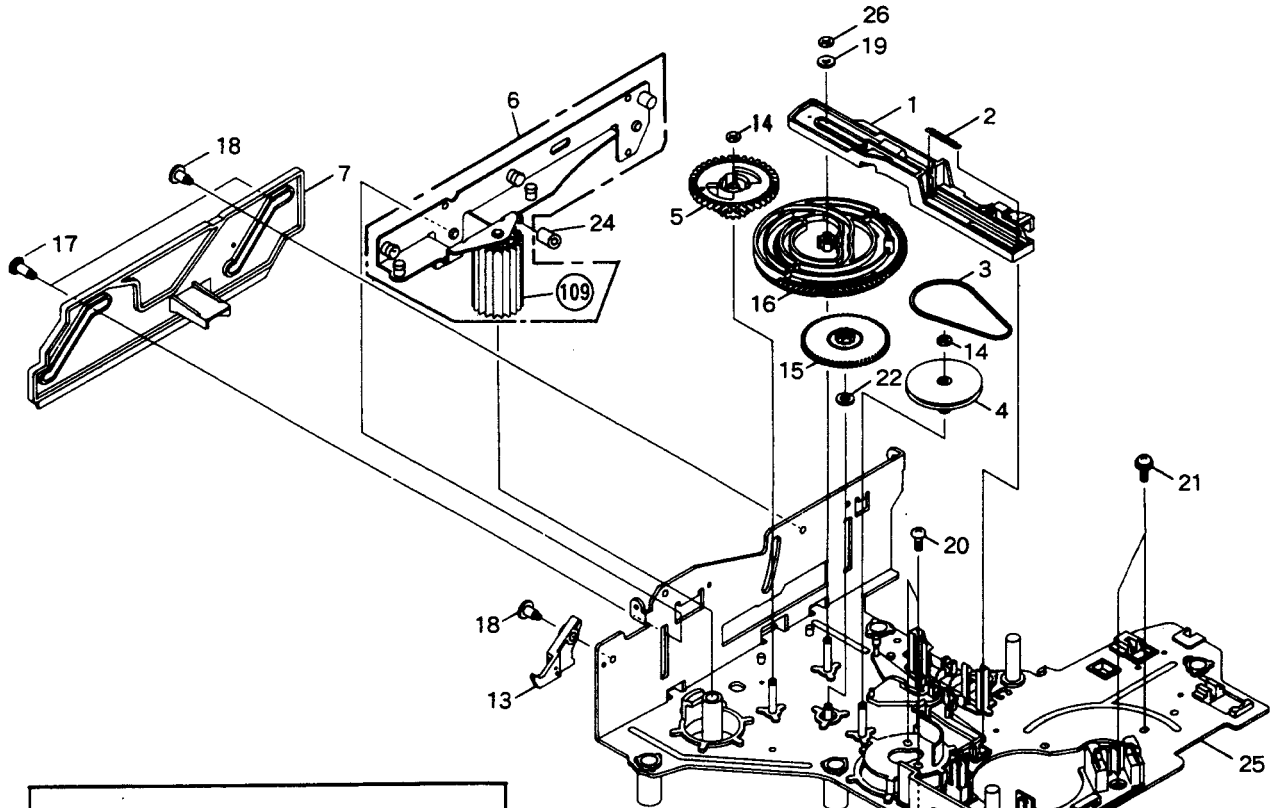

B

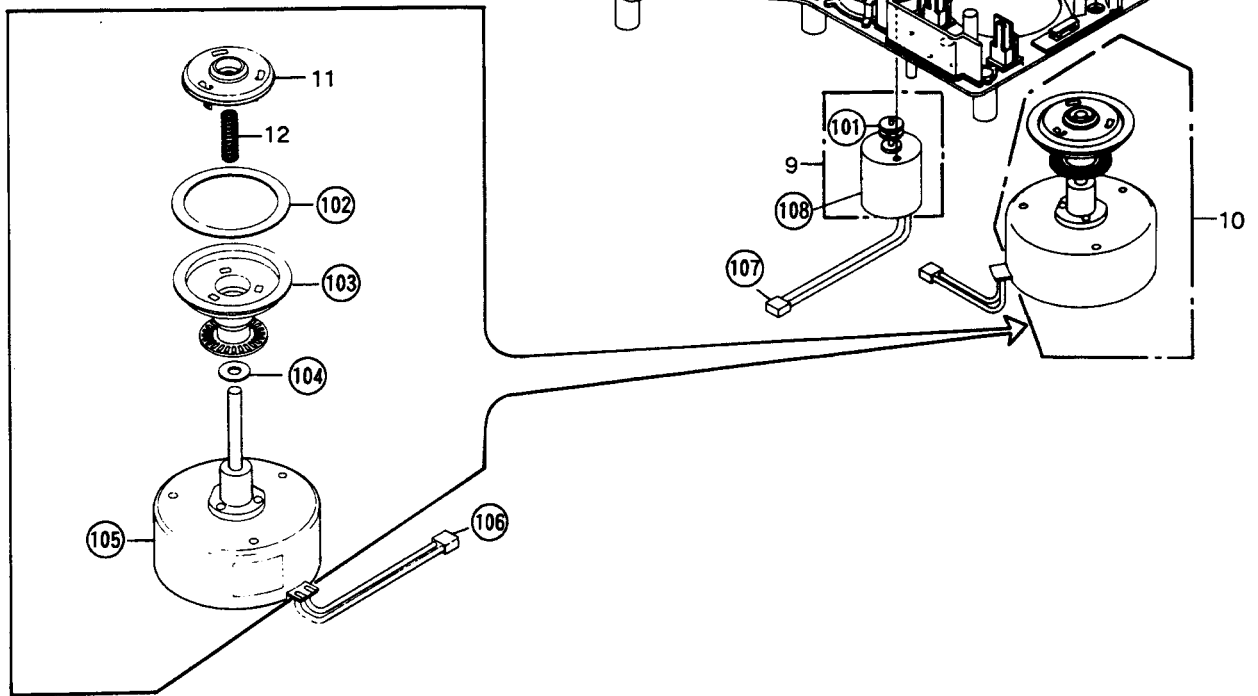

C

D

1

2

1

2

3

3.8 RACK SECTION

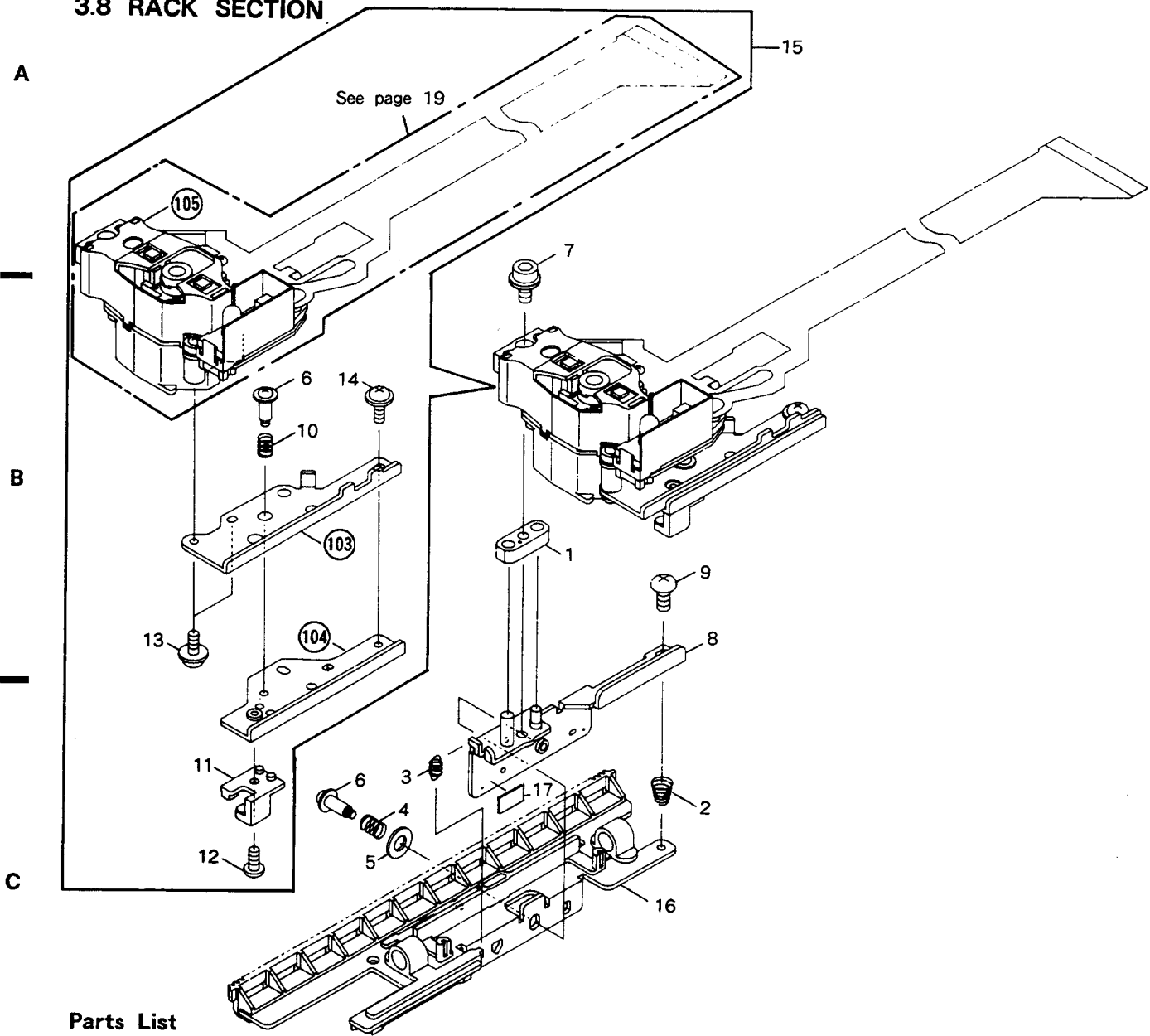

Parts List

Mark	No.	Part No.	Description	Mark	No.	Part No.	Description
	1	VNL1209	PU base		16	VXA1276	PU mount base assembly
	2	VBH1075	LP center spring		17	VEC1284	Spacer (S)
	3	VBH1089	PU pulling spring		101		• • • • •
	4	VBH1090	L-2 spring		102		• • • • •
	5	WC30FMC	Washer		103		TAN plate (2)
	6	VBA1007	Screw		104		TAN plate (1)
	7	VLL1192	Screw (2.6 × 10)		105		Pickup assembly
●	8	VNL1186	Rack				
	9	BMZ26P080FMC	Screw				
	10	VBH1081	TAN spring				
	11	VNL1199	TAN base				
	12	PMZ20P040FMC	Screw				
	13	PMA20P040FMC	Screw				
	14	AMZ20P050FMC	Screw				
	15	VWT1060	Slider assembly				

3.9 PICKUP ASSEMBLY

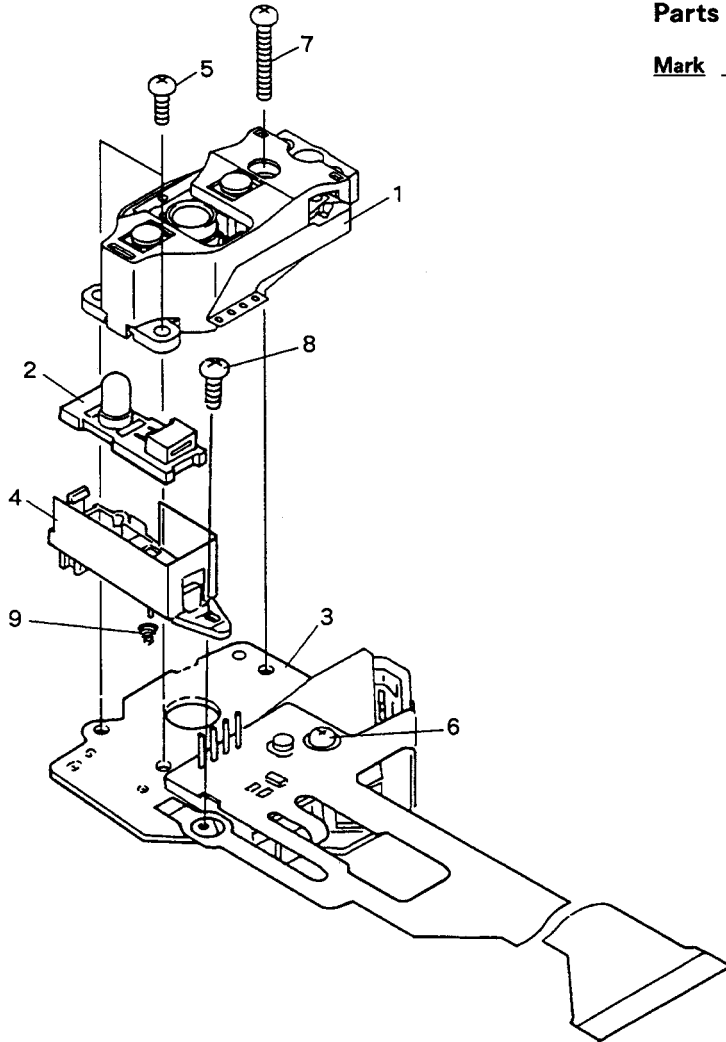

Parts List of Pickup assembly

Mark	No.	Part No.	Description
	1	VXX1266	Actuator assembly
	2	VEX1018	Sensor assembly
	3	VXX1413	Pre-pickup assembly
	4	VNH1024	Sensor stay
	5	PMA20P060FMC	Screw
	6	PMA20P080FMC	Screw
	7	PMA20P140FMC	Screw
	8	BMZ20P060FMC	Screw
	9	VBH1087	Sensor spring

3.10 REMOTE CONTROL UNIT

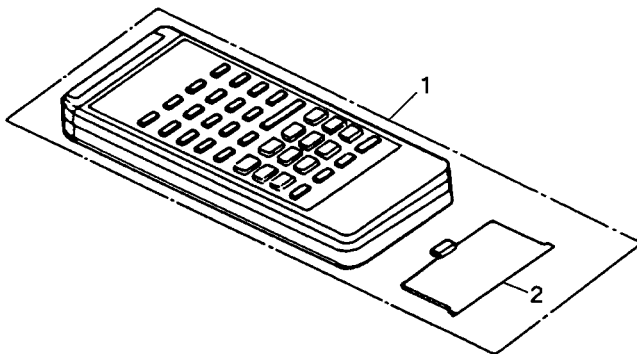

Parts List of Remote control unit

Mark	No.	Part No.	Description
	1	VXX1442	Remote control unuit
	2	VNK1293	Battery cover

4. P. C. BOARDS LOCATION

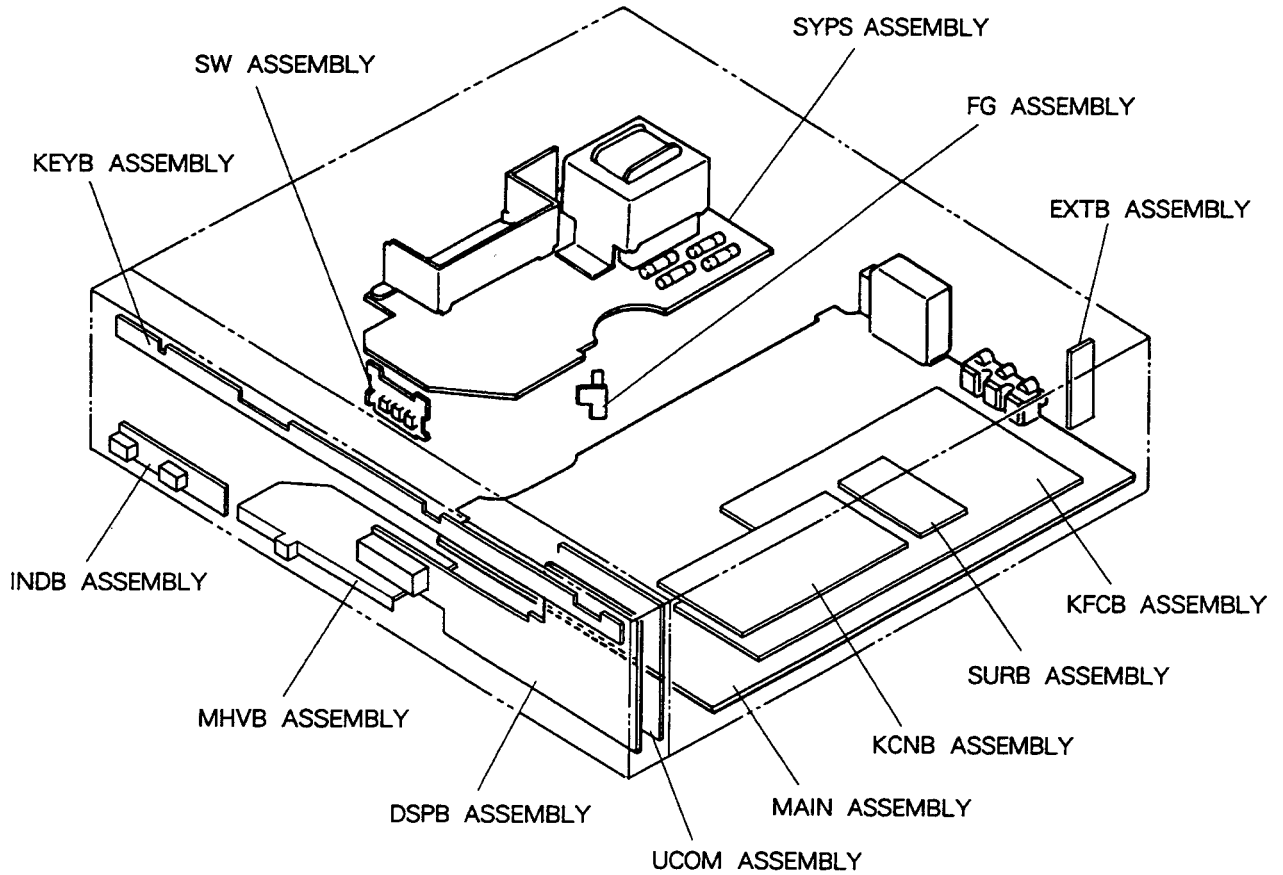

MAIN : MAIN BOARD
SYPS : SYSTEM POWER SUPPLY
FG : FG COUNTER BOARD
SW : SW BOARD
KEYB : KEY BOARD
EXTB : EXTERNAL BOARD
KFCB : KARAOKE FUNCTION BOARD
KCNB : KEY CONTROLLER BOARD
SURB : SURROUND BOARD
UCOM : U COMPUTER
INDB : INDICATOR BOARD
DSPB : DISPLAY BOARD
MHVB : MIC HEADPHONE VOLUME BOARD

5. SCHEMATIC AND P.C. BOARDS DIAGRAM
5.1 OVERALL WIRING DIAGRAM

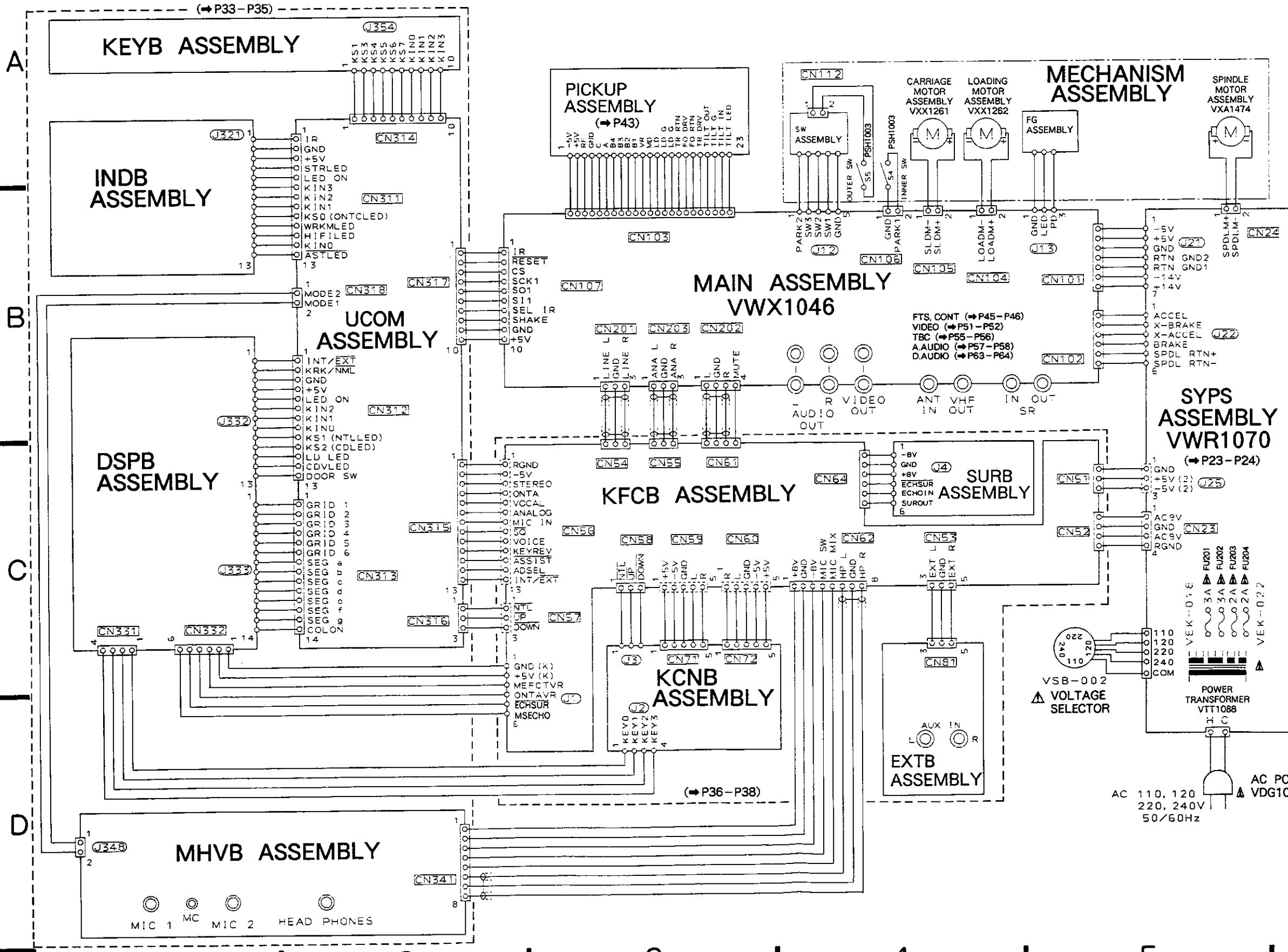

- RESISTORS:** Indicated in Ω , 1/4W, 1/6W and 1/8W, $\pm 5\%$ tolerance unless otherwise noted. k: k Ω , M: M Ω , (F): $\pm 1\%$, (G): $\pm 2\%$, (K): $\pm 10\%$, (M): $\pm 20\%$ tolerance.
- CAPACITORS:** Indicated in capacity (μ F)/voltage (V) unless otherwise noted. p: pF. Indication without voltage is 50V except electrolytic capacitor.
- VOLTAGE, CURRENT:** DC voltage (V) at no input signal. Value in () is DC voltage at rated power. mA: DC current at no input signal.
- OTHERS:** Signal route. Adjusting point. The Δ mark found on some component parts indicates the importance of the safety factor of the part. Therefore, when replacing, be sure to use parts of identical designation. * marked capacitors and resistors have parts numbers.

This is the basic schematic diagram, but the actual circuit may vary due to improvements in design.

5. SWITCHES: (The underlined indicates the switch position)

MAIN ASSEMBLY
S201: ATTENUATOR

SYPS ASSEMBLY
S201: POWER ON-OFF

INDB ASSEMBLY
S201: ONE TOUCH KARAOKE
S202: VOCAL ASSIST
S203: VOCAL PARTNER
S204: AUDIO MODE

DSPB ASSEMBLY
S301: OPEN/CLOSE
S302: PLAY/PAUSE
S303: STOP
S304: #
S305: #
S306: #

SW ASSEMBLY
S1-S3: LOADING/TILT

KEYB ASSEMBLY
S501: 1
S502: 2
S503: 3
S504: 4
S505: 5
S506: 6
S507: 7
S508: 8
S509: 9
S510: 10
S511: 11
S512: 12
S513: 13
S514: 14
S515: 15
S516: 16
S517: 17
S518: 18
S519: 19
S520: 20
S521: ONCE MORE

5.2 SYPS ASSEMBLY

SYPS ASSEMBLY (VWR1070)

A

B

C

D

A

B

C

D

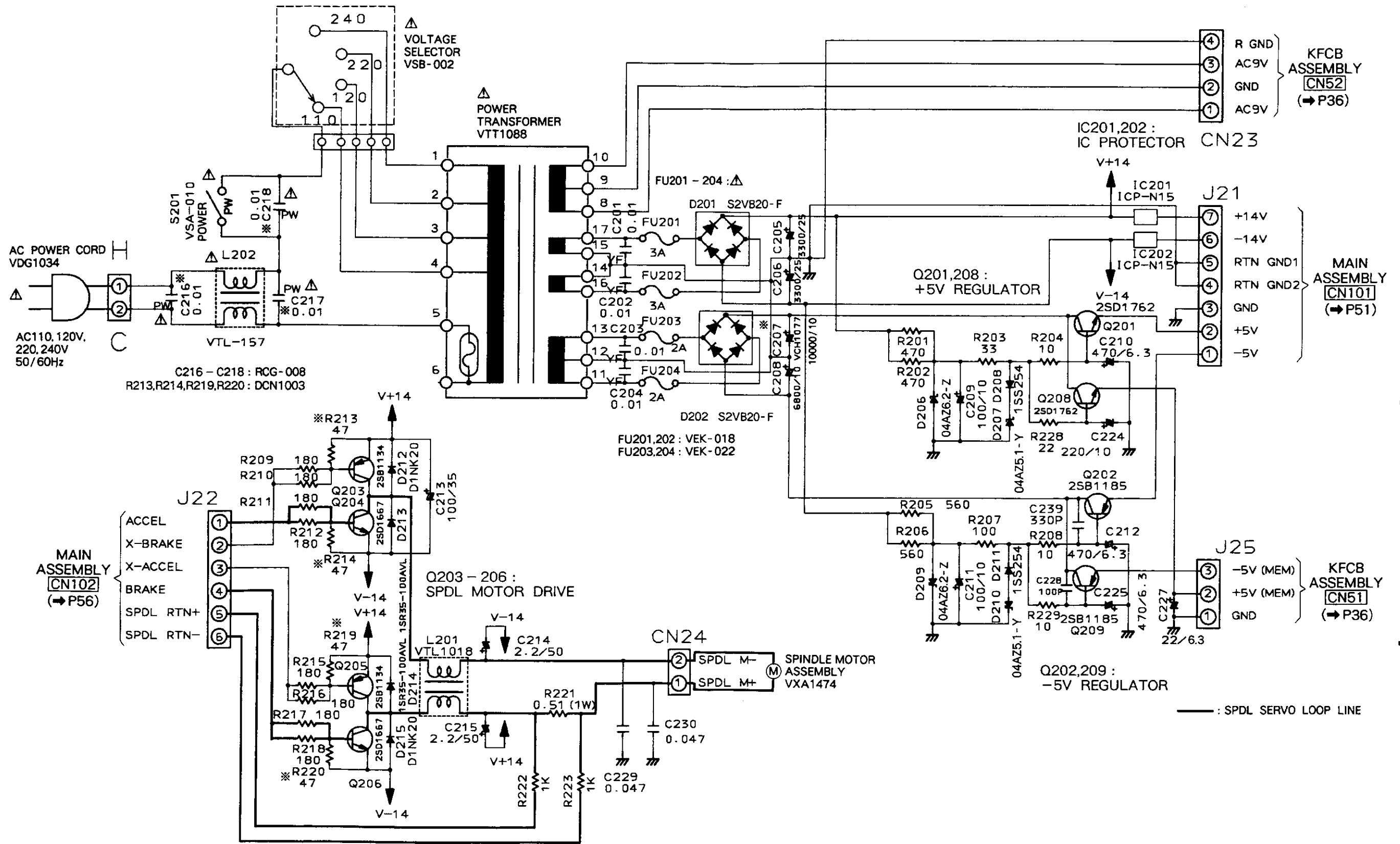

P.C.B. pattern diagram indication	Corresponding part symbol	Part name
		Transistor
		FET
		Diode
		Zener diode
		LED
		Varactor
		Tact switch
		Inductor
		Coil
		Transformer
		Filter
		Ceramic capacitor
		Mylar capacitor
		Styrol capacitor
		Electrolytic capacitor (Non polarized)
		Electrolytic capacitor (Nonpolarized)
		Electrolytic capacitor (Polarized)
		Power capacitor
		Semi-fixed resistor
		Resistor array
		Resistor
		Resonator
		Thermistor

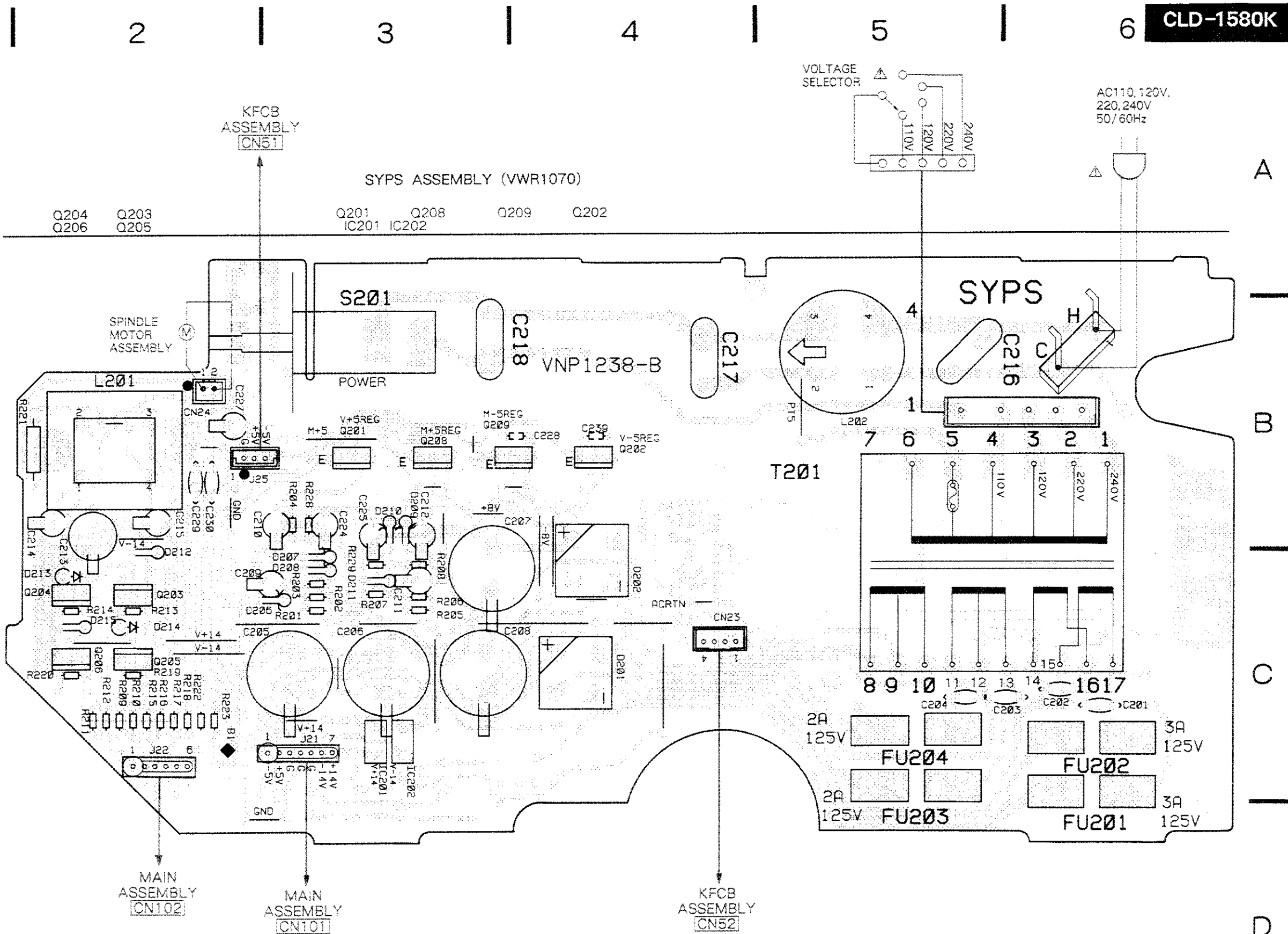

1. This P.C.B. connection diagram is viewed from the parts mounted side.
 2. The parts which have been mounted on the board can be replaced with those shown with the corresponding wiring symbols listed in the above Table.
 3. The capacitor terminal marked with shows negative terminal.
 4. The diode marked with shows cathode side.
 5. The transistor terminal marked with shows emitter.

1 | 2 | 3 | 4 | 5 | 6

A

B

C

D

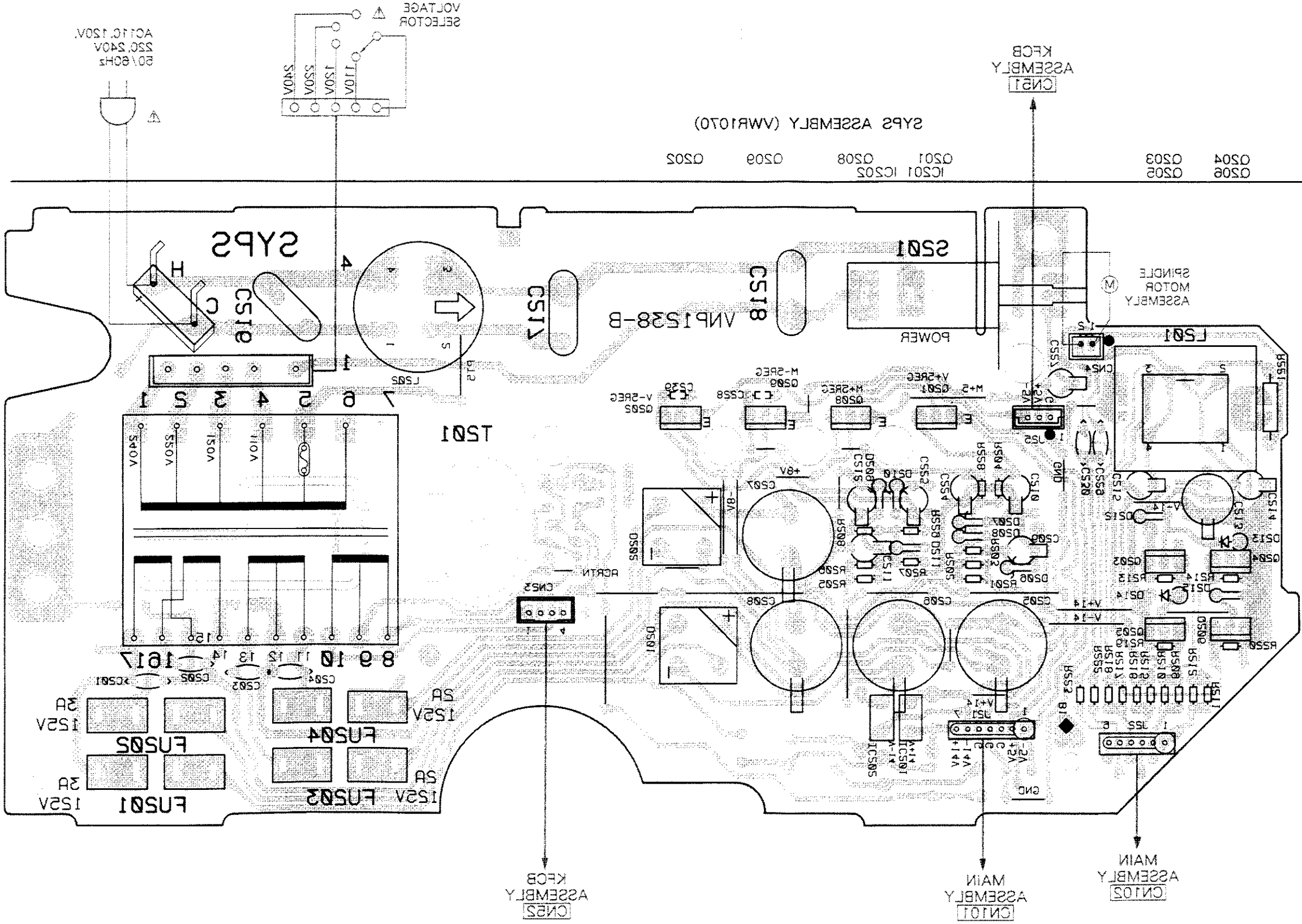

A

B

C

D

This P.C.B. connection diagram is viewed from the foil side.

1 | 2 | 3 | 4 | 5 | 6

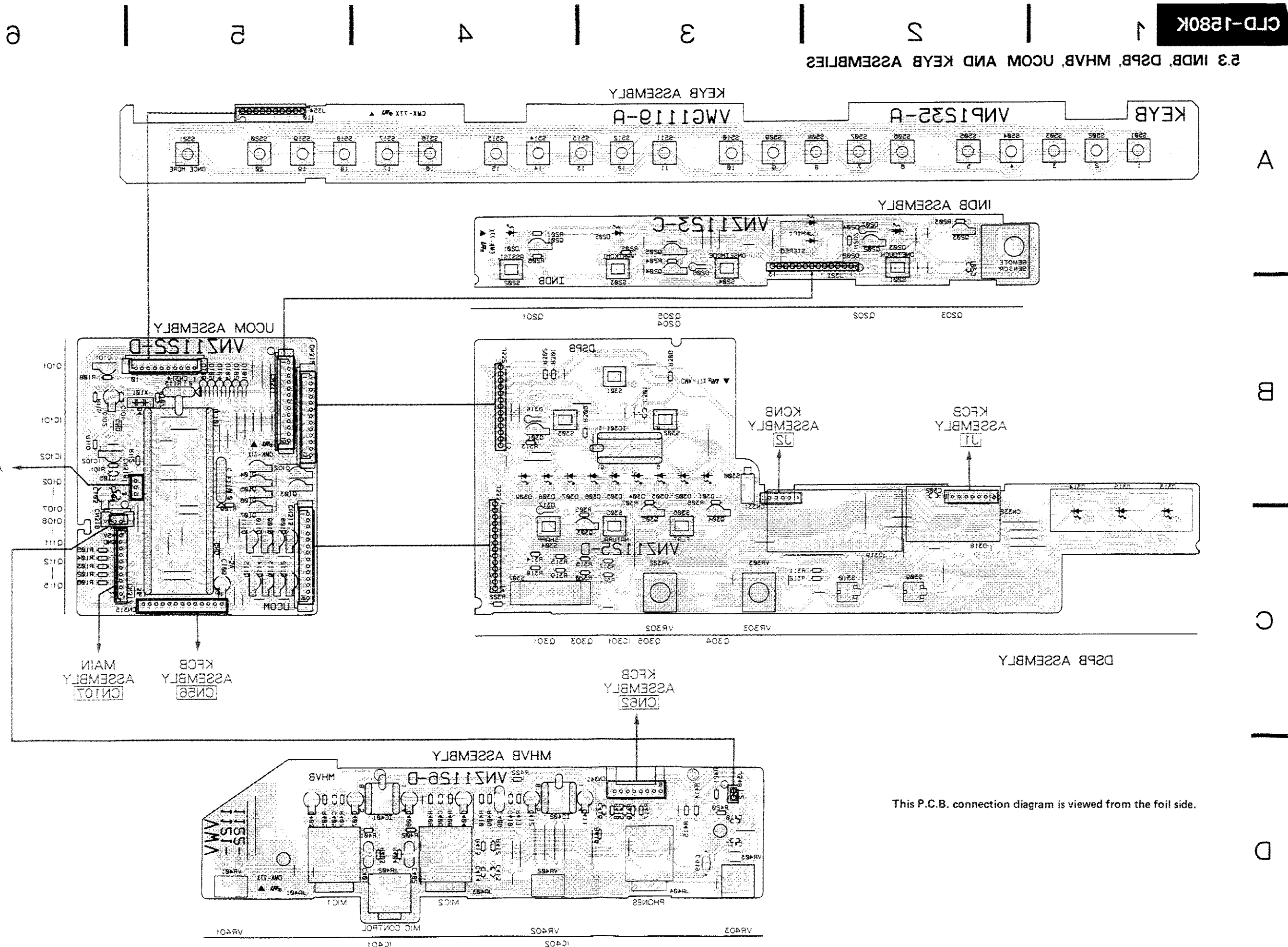

This P.C.B. connection diagram is viewed from the foil side.

5.3 INDB, DSPB, MHVB, UCOM AND KEYB ASSEMBLIES

A

A

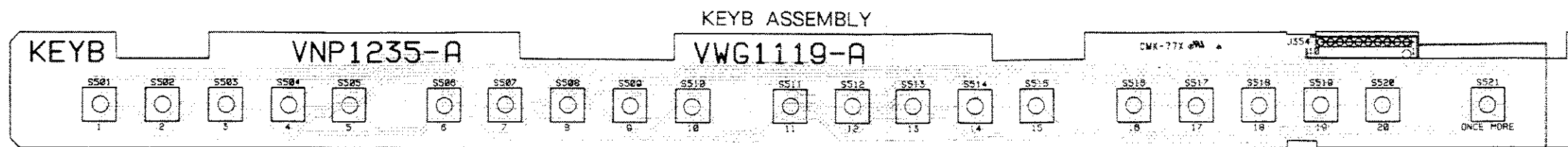

B

B

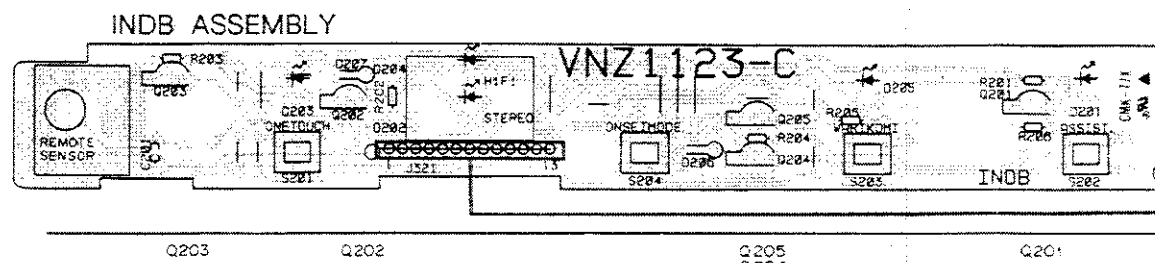

C

C

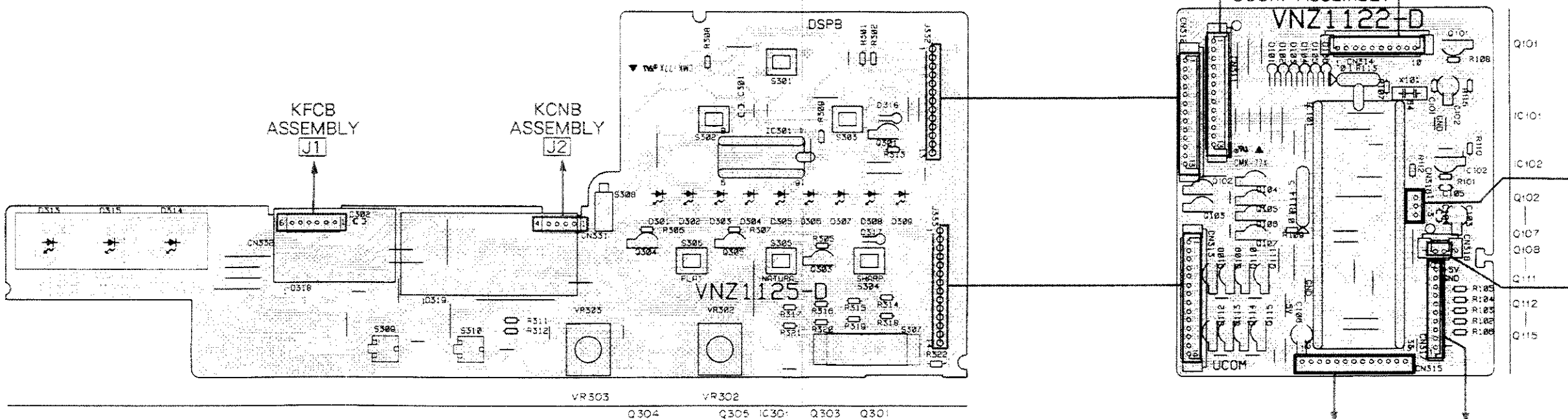

DSPB ASSEMBLY

D

D

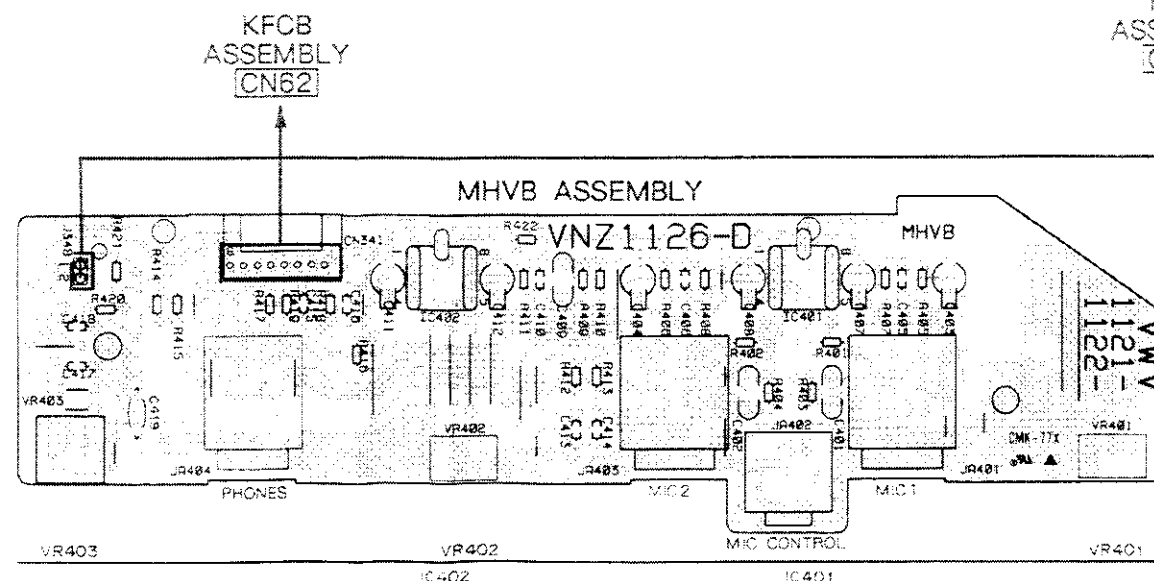

KFCB ASSEMBLY CN62

KFCB ASSEMBLY CN56

MAIN ASSEMBLY CN107

KFCB ASSEMBLY CN57

A

B

C

D

E

F

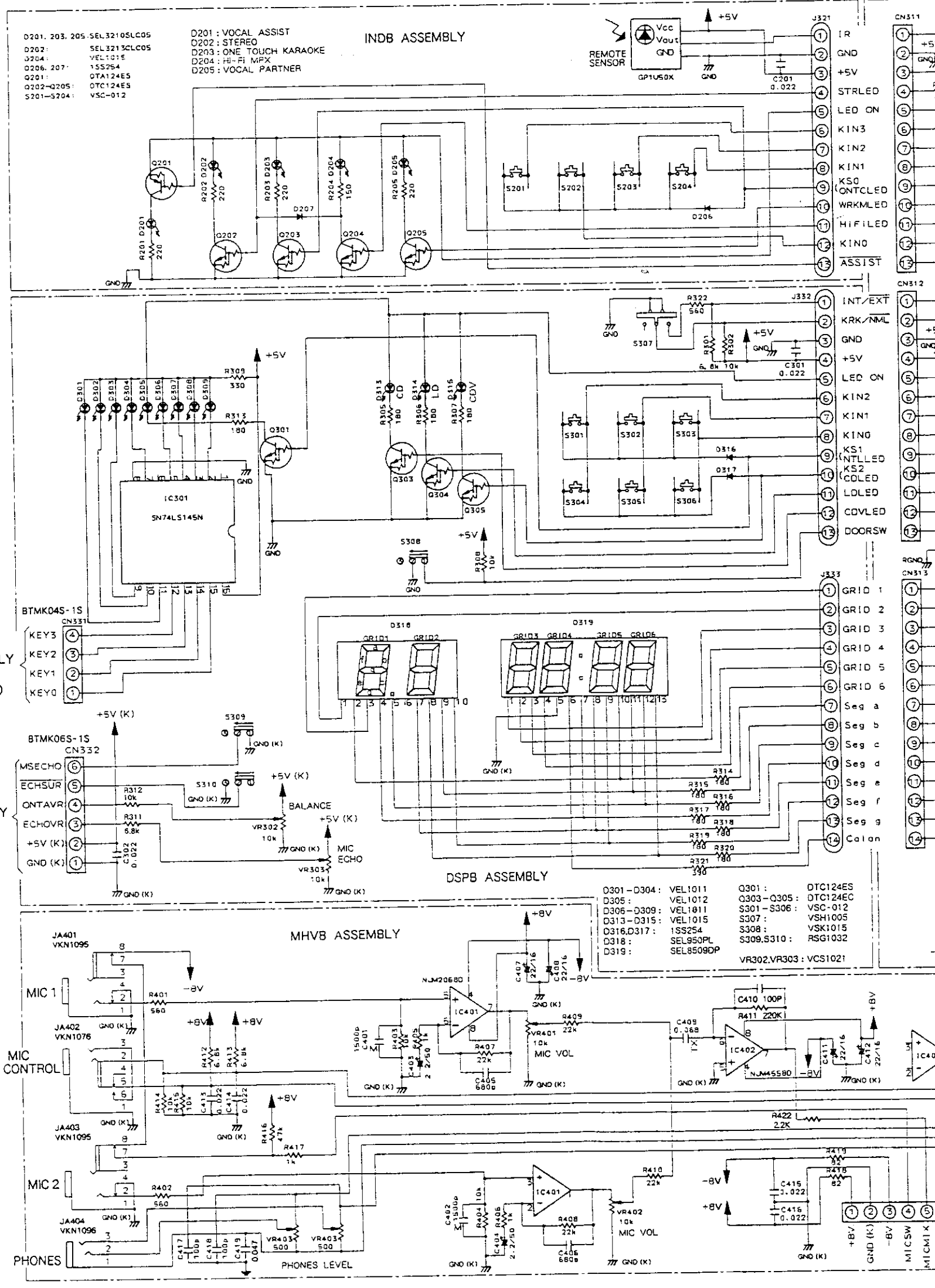

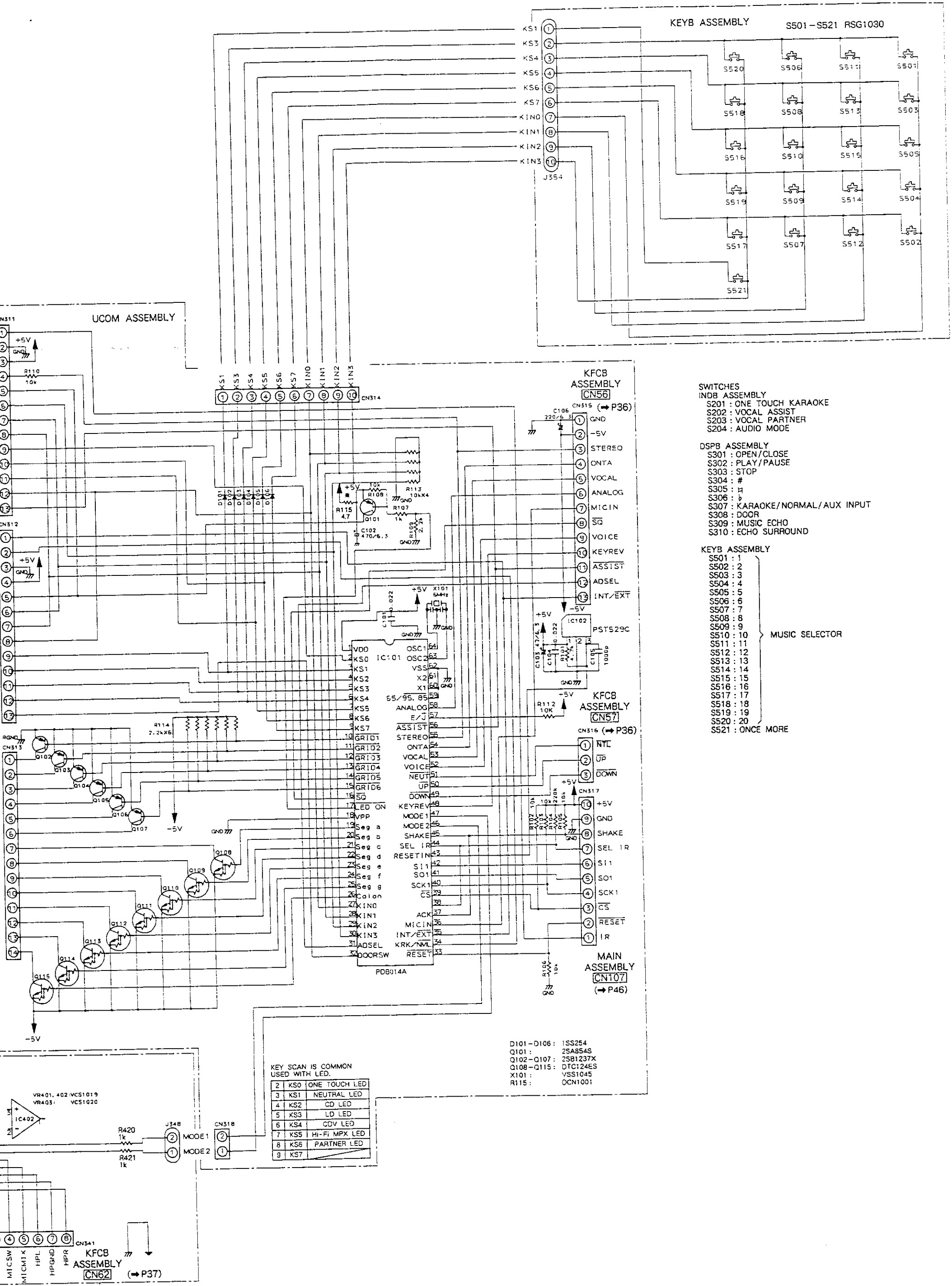

- SWITCHES**
- INDB ASSEMBLY**
 S201 : ONE TOUCH KARAOKE
 S202 : VOCAL ASSIST
 S203 : VOCAL PARTNER
 S204 : AUDIO MODE
- DSP8 ASSEMBLY**
 S301 : OPEN/CLOSE
 S302 : PLAY/PAUSE
 S303 : STOP
 S304 : #
 S305 : H
 S306 : J
 S307 : KARAOKE/NORMAL/AUX INPUT
 S308 : DOOR
 S309 : MUSIC ECHO
 S310 : ECHO SURROUND
- KEYB ASSEMBLY**
 S501 : 1
 S502 : 2
 S503 : 3
 S504 : 4
 S505 : 5
 S506 : 6
 S507 : 7
 S508 : 8
 S509 : 9
 S510 : 10
 S511 : 11
 S512 : 12
 S513 : 13
 S514 : 14
 S515 : 15
 S516 : 16
 S517 : 17
 S518 : 18
 S519 : 19
 S520 : 20
 S521 : ONCE MORE
- } MUSIC SELECTOR

KEY SCAN IS COMMON USED WITH LED.

2	KS0	ONE TOUCH LED
3	KS1	NEUTRAL LED
4	KS2	CD LED
5	KS3	LD LED
6	KS4	CDV LED
7	KS5	HI-FI MPX LED
8	KS6	PARTNER LED
9	KS7	

- D101-D106 : 1SS254
 Q101 : 2SA854S
 Q102-Q107 : 2SB1237X
 Q108-Q115 : DTC124ES
 X101 : VSS1045
 R115 : OCN1001

5.4 KFCB, EXTB, KCNB AND SURB ASSEMBLIES

A
B
C
D
E
F

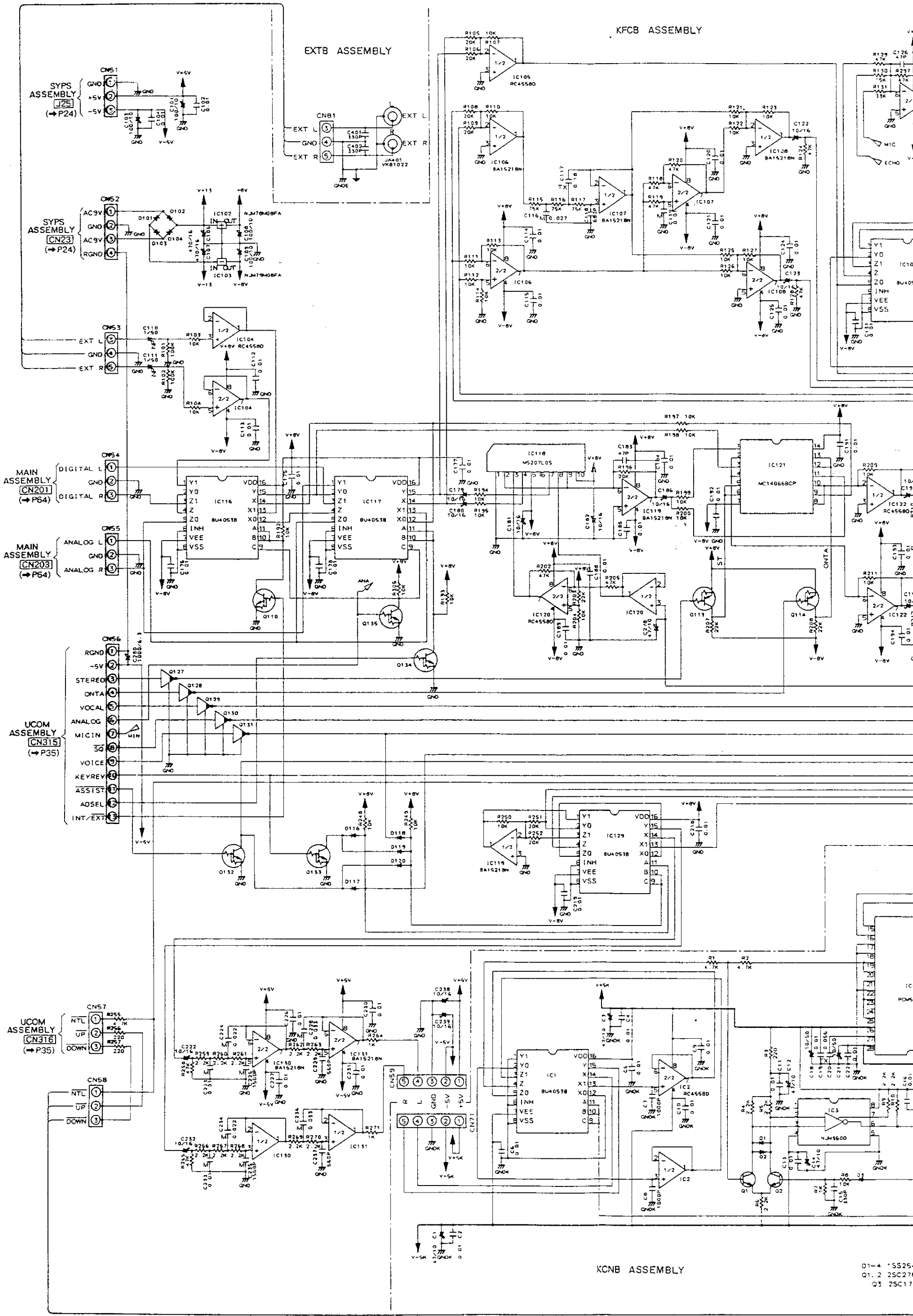

Q1-4 1SS254
Q1, 2 2SC2786
Q3 2SC174

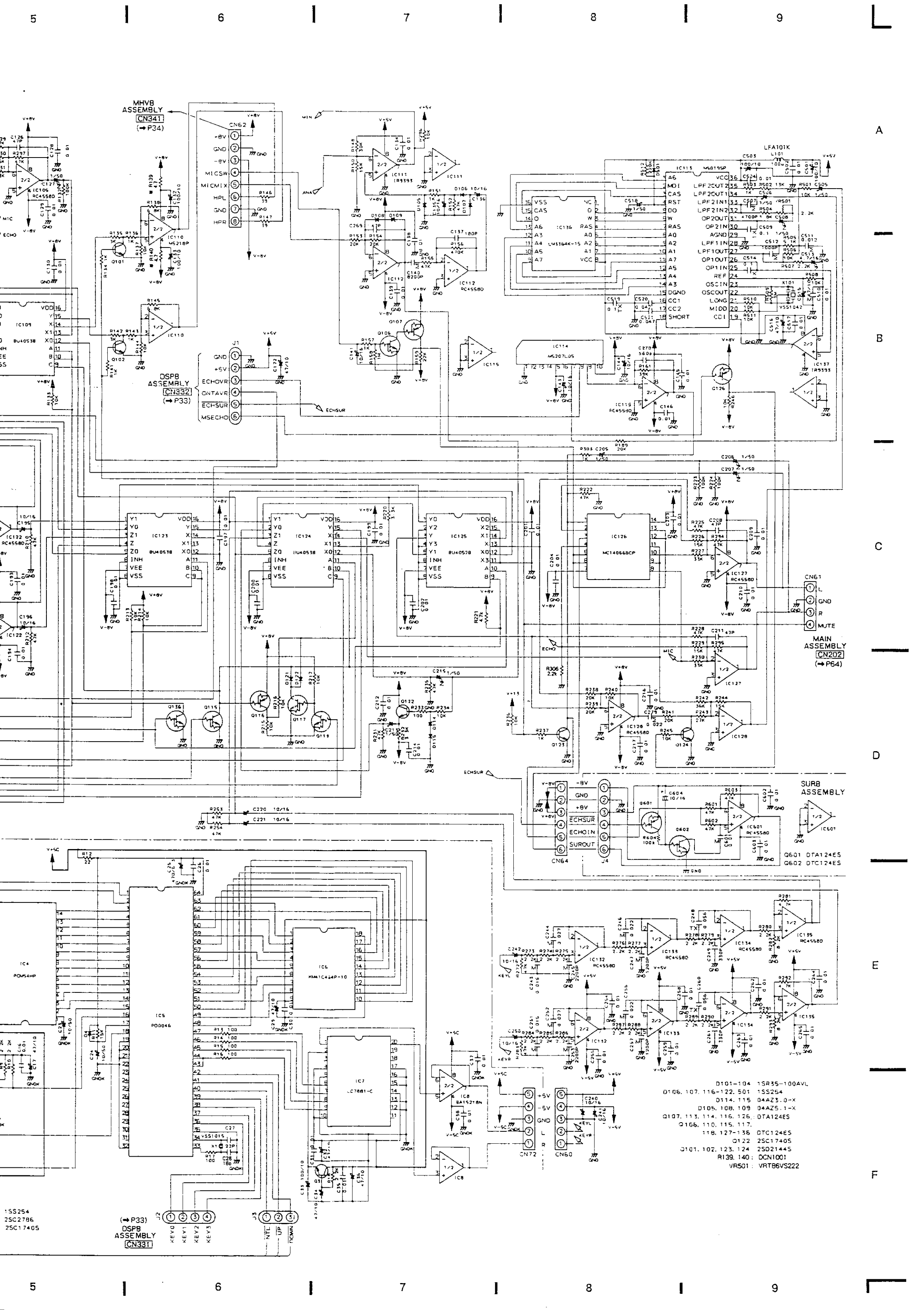

A

B

C

D

This P.C.B. connection diagram is viewed from the foil side.

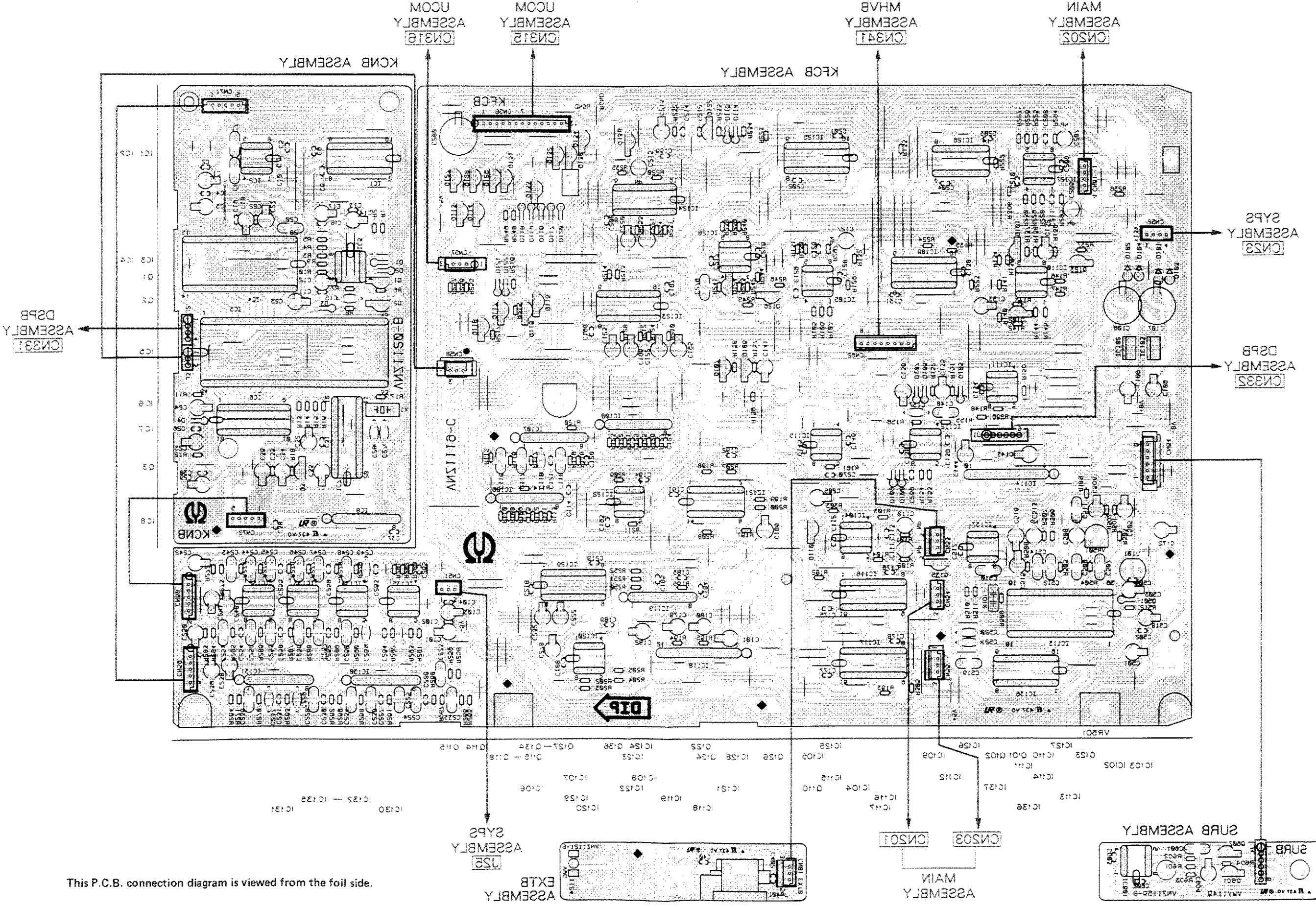

A

B

C

D

5.5 PICKUP ASSEMBLY

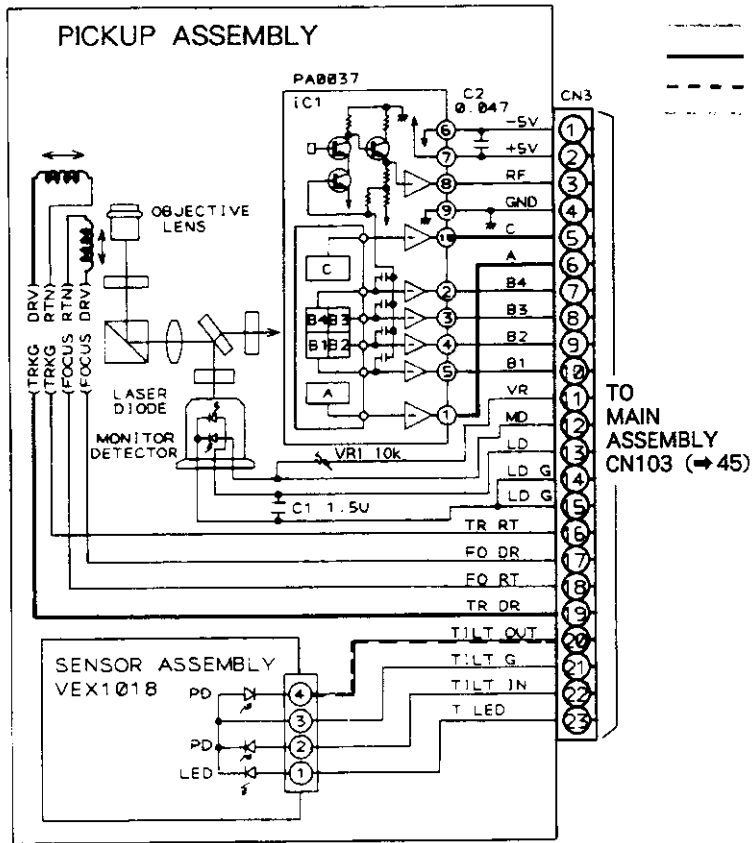

HEAD ASSEMBLY

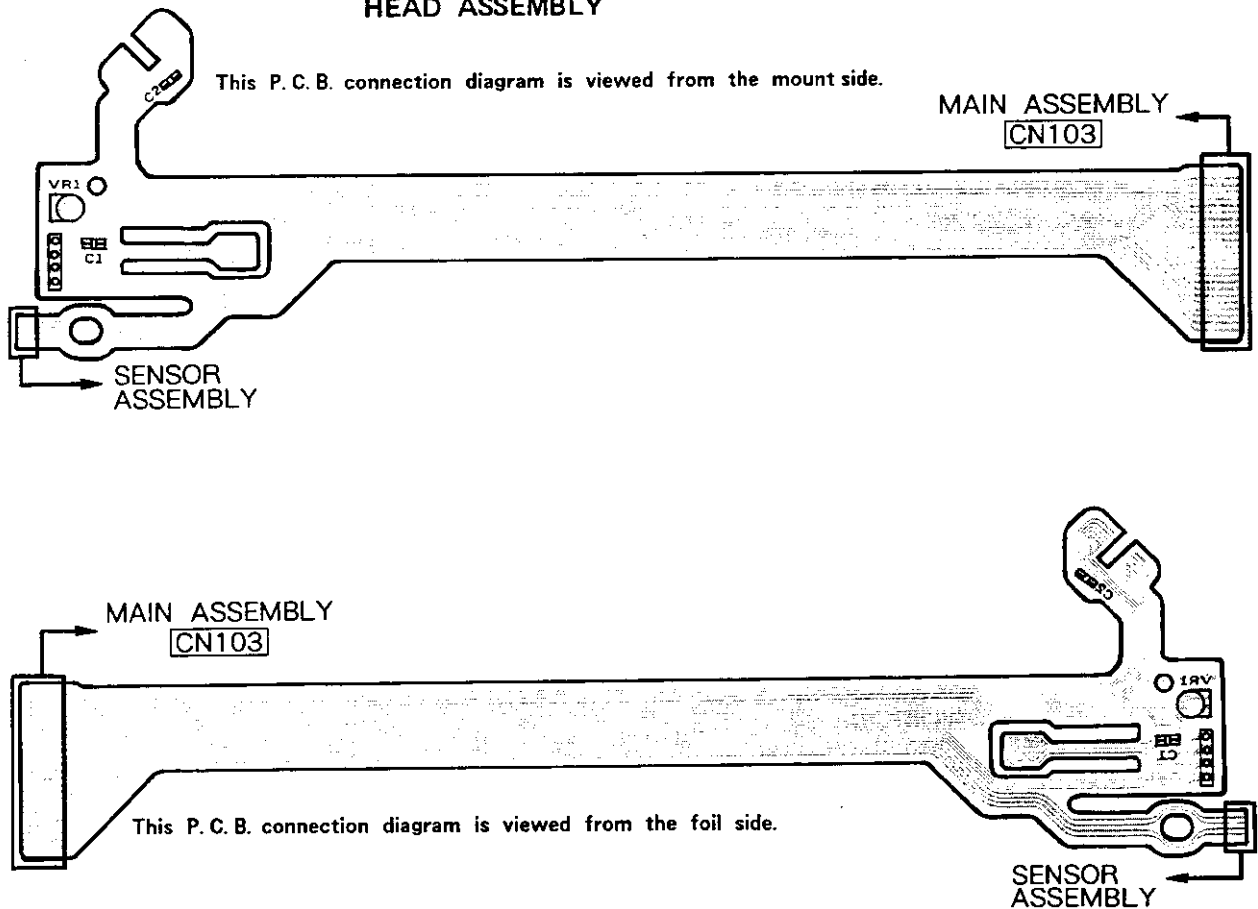

Note : Waveforms and voltages are at the PLAY state.

IC601
<KA11528NT>

Pin No.	Voltage	Pin No.	Voltage	Pin No.	Voltage
1	-5	15	0	29	*
2	0	16	0	30	*
3	2	17	*	31	*
4	0	18	*	32	*
5	0	19	0	33	0
6	0	20	*	34	-4
7	0	21	0	35	500mV
8	0	22	0	36	0
9	0	23	*	37	0
10	*	24	0	38	0
11	*	25	*	39	0
12	*	26	*	40	0
13	0	27	*	41	0
14	0	28	*	42	5

IC602
<NJM4558S>

Pin No.	Voltage
1	5
2	2.5
3	0
4	0
5	-5
6	0
7	0
8	0

IC605
<1R3C02>

Pin No.	Voltage
1	3
2	0
3	-3.5
4	-5
5	5
6	5
7	3.5
8	5

IC801
<PB0071>

Pin No.	Voltage	Pin No.	Voltage	Pin No.	Voltage	Pin No.	Voltage
1	5	17	5	33	5	49	5
2	0	18	*	34	5	50	5
3	0	19	*	35	0	51	5
4	0	20	*	36	5	52	0
5	0	21	*	37	*	53	2.5
6	0	22	0	38	*	54	0
7	5	23	*	39	*	55	0
8	5	24	*	40	*	56	0
9	5	25	5	41	0	57	*
10	0	26	*	42	5	58	*
11	5	27	0	43	0	59	*
12	2.5	28	5	44	5	60	NOISE
13	*	29	*	45	5	61	NOISE
14	5	30	*	46	0	62	0
15	0	31	0	47	0	63	0
16	5	32	0	48	0	64	0

IC802
<TA7291P>

Pin No.	Voltage
1	0
2	0.56
3	0
4	4
5	5
6	5
7	5
8	12
9	0
10	0.56

IC603
<BA15218N>

Pin No.	Voltage
1	*
2	0
3	0
4	-5
5	0
6	0
7	0
8	5

IC606
<TA8410AX>

Pin No.	Voltage
1	*
2	*
3	0
4	0
5	-15
6	0
7	0
8	0
9	0
10	15

IC604
<LJ6500>

Pin No.	Voltage
1	0
2	-15
3	15
4	0
5	0

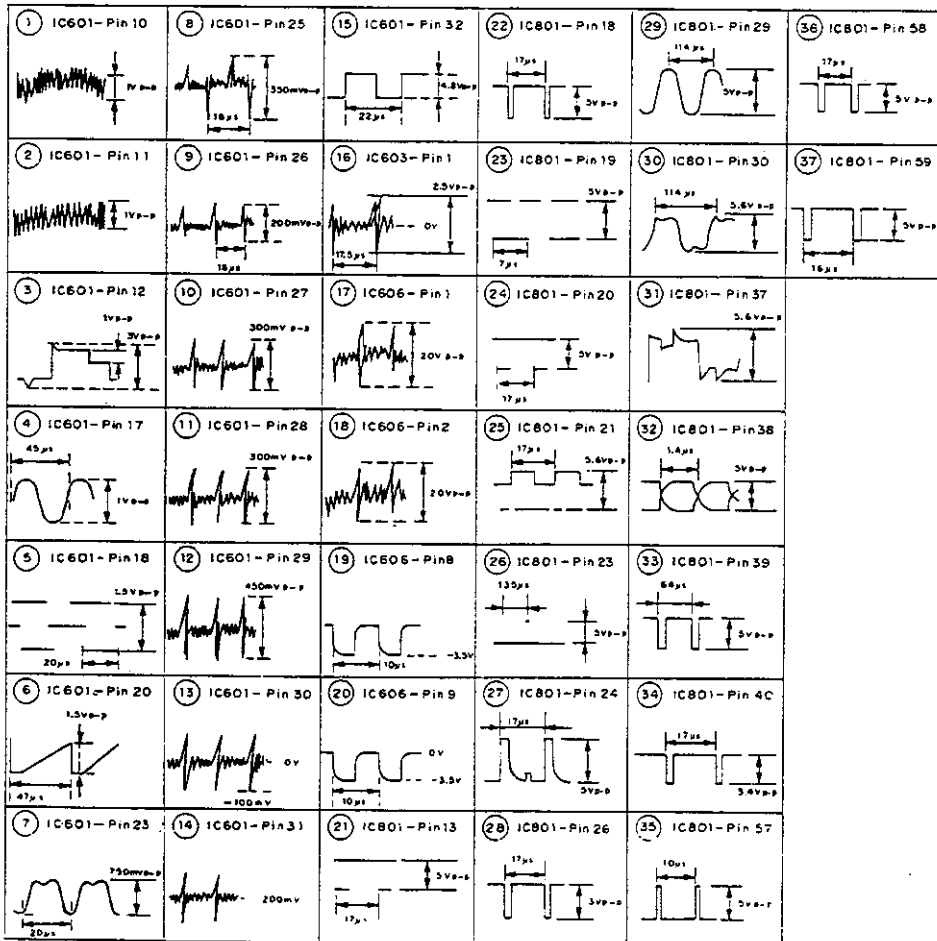

5.6 MAIN (CONT, FTS SECTION) AND SW ASSEMBLIES

MAIN ASSEMBLY (VWX1046)

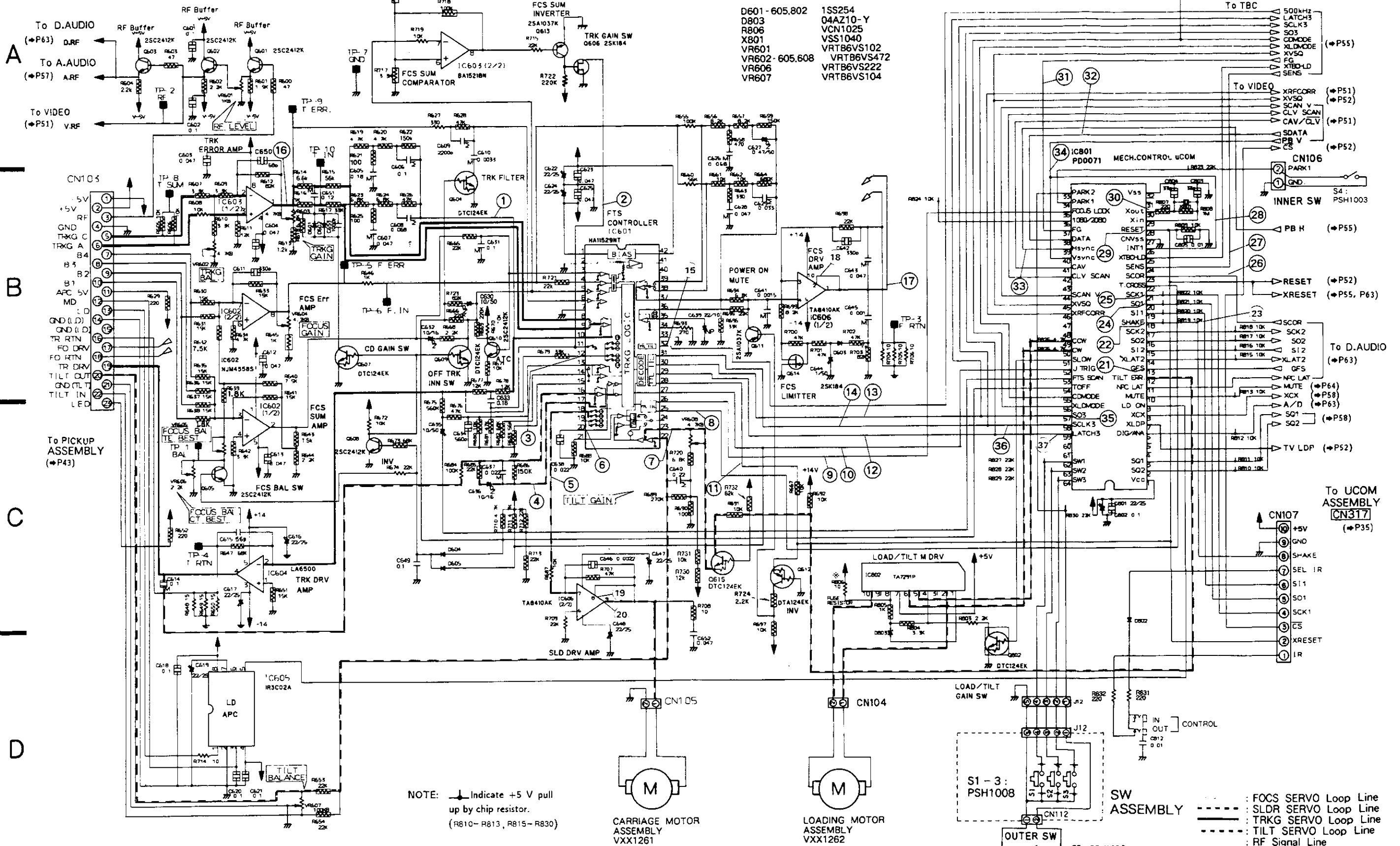

- D601 - 605.802
- D803
- R806
- X801
- VR601
- VR602 - 605.608
- VR606
- VR607
- 1SS254
- 04AZ10-Y
- VN1025
- VSS1040
- VRTB6VS102
- VRTB6VS472
- VRTB6VS222
- VRTB6VS104

NOTE: Indicate +5 V pull up by chip resistor. (R810- R813, R815- R830)

CARRIAGE MOTOR ASSEMBLY VXX1261

LOADING MOTOR ASSEMBLY VXX1262

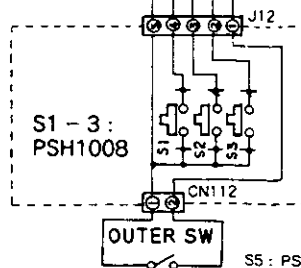

- - - FOCUS SERVO Loop Line
- - - SLDR SERVO Loop Line
- - - TRKG SERVO Loop Line
- - - TILT SERVO Loop Line
- - - RF Signal Line

IC:Q	Q213	Q212	Q214	Q563	Q562	Q614	IC606	IC603	IC209	IC208	IC214	IC213	IC403	IC404	IC602	IC601	IC207	Q482	Q483	Q484	Q485	Q442	IC206	IC401	Q441	IC601	IC205	Q403	Q401	Q402	IC204	Q202	Q201	Q204	Q211	IC903	Q910	IC904	Q911	Q912	Q913	IC351	IC901	IC902	Q352	Q351							
ADJ.									VR603	VR601	VR602	VR481	VR604	VR607	VR482	VR441	VR605	VR606	VR521	VR608																																	

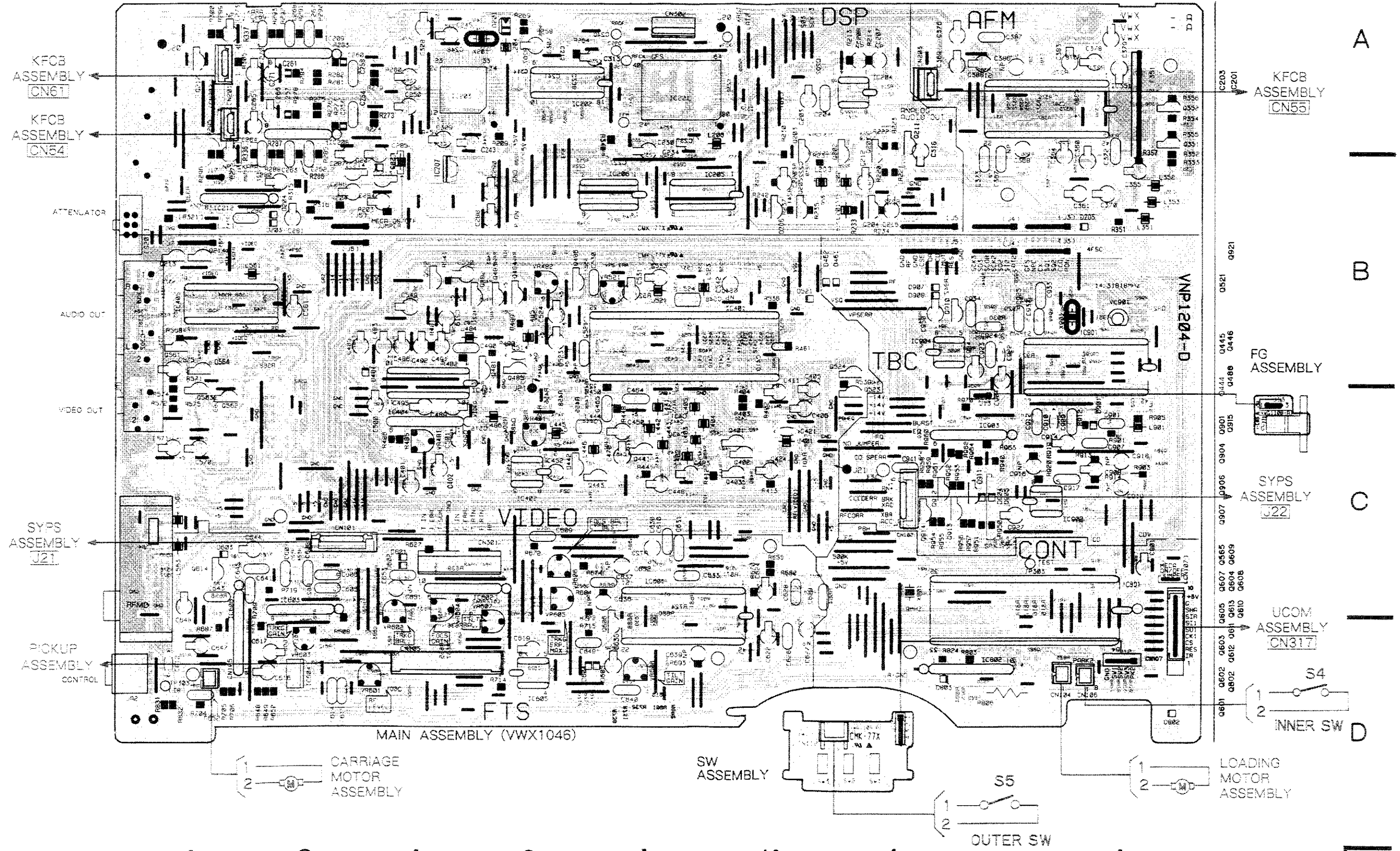

1 2 3 4 5 6

0221	0222	0223	0224	0225	0226	0227	0228	0229	0230	0231	0232	0233	0234	0235	0236	0237	0238	0239	0240	0241	0242	0243	0244	0245	0246	0247	0248	0249	0250	0251	0252	0253	0254	0255	0256	0257	0258	0259	0260	0261	0262	0263	0264	0265	0266	0267	0268	0269	0270	0271	0272	0273	0274	0275	0276	0277	0278	0279	0280	0281	0282	0283	0284	0285	0286	0287	0288	0289	0290	0291	0292	0293	0294	0295	0296	0297	0298	0299	0300	0301	0302	0303	0304	0305	0306	0307	0308	0309	0310	0311	0312	0313	0314	0315	0316	0317	0318	0319	0320	0321	0322	0323	0324	0325	0326	0327	0328	0329	0330	0331	0332	0333	0334	0335	0336	0337	0338	0339	0340	0341	0342	0343	0344	0345	0346	0347	0348	0349	0350	0351	0352	0353	0354	0355	0356	0357	0358	0359	0360	0361	0362	0363	0364	0365	0366	0367	0368	0369	0370	0371	0372	0373	0374	0375	0376	0377	0378	0379	0380	0381	0382	0383	0384	0385	0386	0387	0388	0389	0390	0391	0392	0393	0394	0395	0396	0397	0398	0399	0400	0401	0402	0403	0404	0405	0406	0407	0408	0409	0410	0411	0412	0413	0414	0415	0416	0417	0418	0419	0420	0421	0422	0423	0424	0425	0426	0427	0428	0429	0430	0431	0432	0433	0434	0435	0436	0437	0438	0439	0440	0441	0442	0443	0444	0445	0446	0447	0448	0449	0450	0451	0452	0453	0454	0455	0456	0457	0458	0459	0460	0461	0462	0463	0464	0465	0466	0467	0468	0469	0470	0471	0472	0473	0474	0475	0476	0477	0478	0479	0480	0481	0482	0483	0484	0485	0486	0487	0488	0489	0490	0491	0492	0493	0494	0495	0496	0497	0498	0499	0500
------	------	------	------	------	------	------	------	------	------	------	------	------	------	------	------	------	------	------	------	------	------	------	------	------	------	------	------	------	------	------	------	------	------	------	------	------	------	------	------	------	------	------	------	------	------	------	------	------	------	------	------	------	------	------	------	------	------	------	------	------	------	------	------	------	------	------	------	------	------	------	------	------	------	------	------	------	------	------	------	------	------	------	------	------	------	------	------	------	------	------	------	------	------	------	------	------	------	------	------	------	------	------	------	------	------	------	------	------	------	------	------	------	------	------	------	------	------	------	------	------	------	------	------	------	------	------	------	------	------	------	------	------	------	------	------	------	------	------	------	------	------	------	------	------	------	------	------	------	------	------	------	------	------	------	------	------	------	------	------	------	------	------	------	------	------	------	------	------	------	------	------	------	------	------	------	------	------	------	------	------	------	------	------	------	------	------	------	------	------	------	------	------	------	------	------	------	------	------	------	------	------	------	------	------	------	------	------	------	------	------	------	------	------	------	------	------	------	------	------	------	------	------	------	------	------	------	------	------	------	------	------	------	------	------	------	------	------	------	------	------	------	------	------	------	------	------	------	------	------	------	------	------	------	------	------	------	------	------	------	------	------	------	------	------	------	------	------	------	------	------	------	------	------	------	------	------	------	------	------

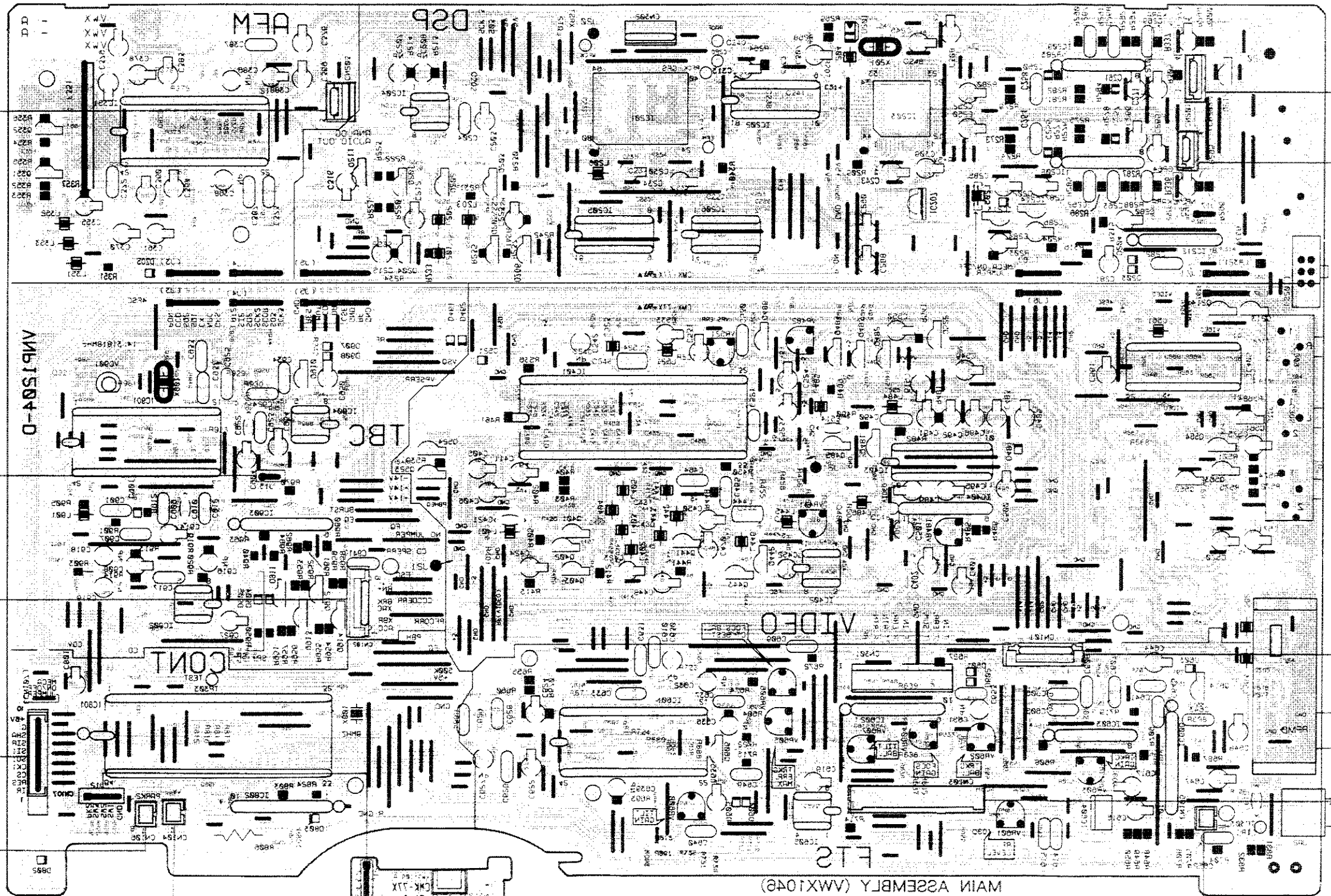

ASSEMBLY KFCB

ASSEMBLY KFCB

ASSEMBLY FG

ASSEMBLY KFCB

ASSEMBLY SPS

ASSEMBLY SPS

ASSEMBLY UCM

ASSEMBLY PICKUP

ASSEMBLY MOTOR

ASSEMBLY MOTOR

INNER SW

SW ASSEMBLY

OUTER SW

This P.C.B. connection diagram is viewed from the foil side.

1 2 3 4 5 6

5.7 MAIN ASSEMBLY (VIDEO SECTION)

MAIN ASSEMBLY (VWX1046)

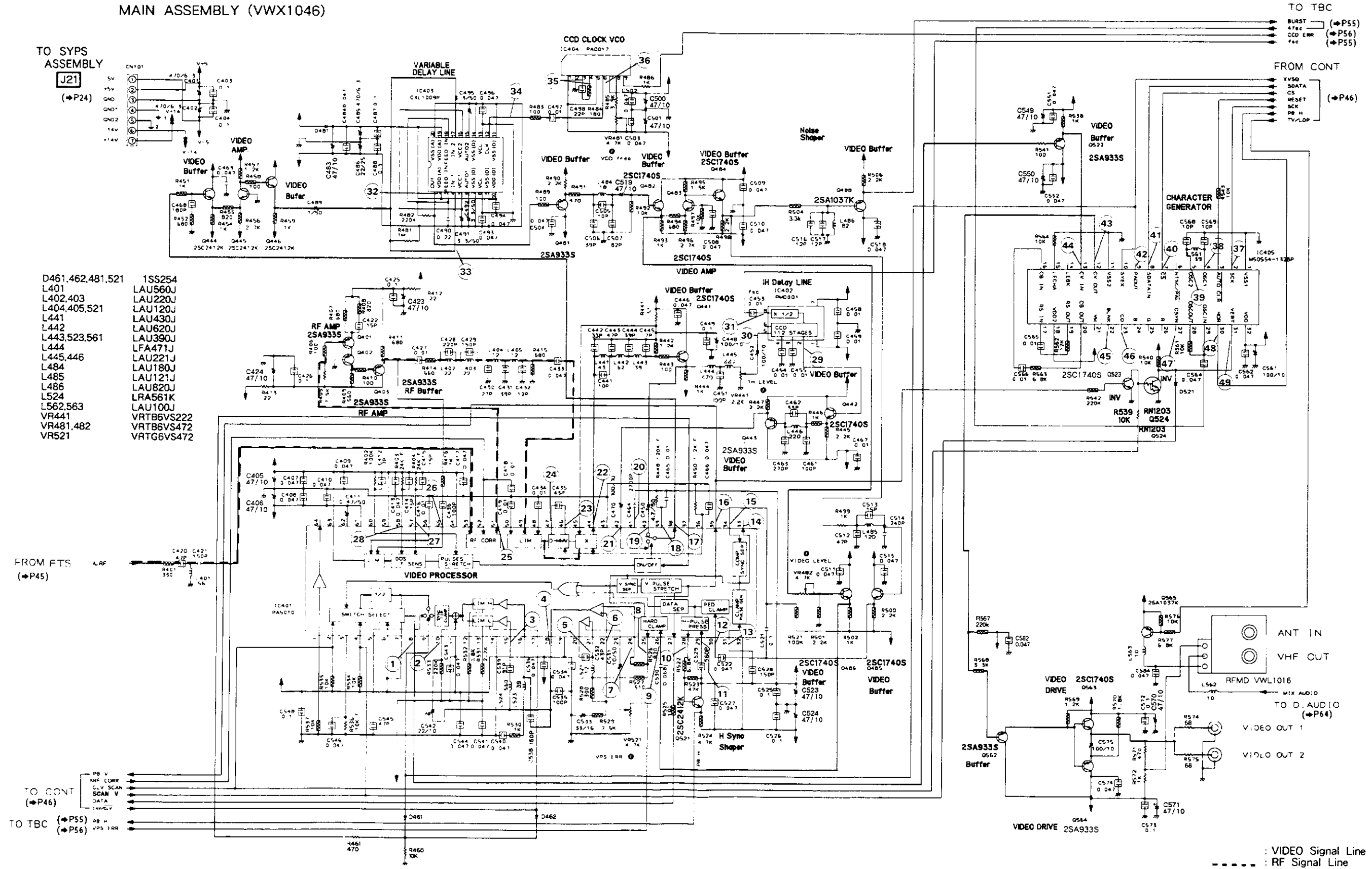

Note : Waveforms and voltages are at the PLAY state.

IC401
<PA5010>

Pin No.	Voltage	Pin No.	Voltage	Pin No.	Voltage	Pin No.	Voltage
1	-1.2	17	0	33	*	49	-1.7
2	5	18	*	34	*	50	-1.7
3	-1	19	5	35	*	51	*
4	5	20	1	36	1	52	0
5	1	21	*	37	5	53	-2
6	5	22	*	38	*	54	5
7	5	23	-2.5	39	*	55	*
8	*	24	*	40	*	56	-2
9	5	25	*	41	*	57	*
10	*	26	*	42	*	58	*
11	5	27	0.5	43	0	59	5
12	-5	28	*	44	*	60	3.8
13	-5	29	*	45	5	61	-5
14	0	30	*	46	*	62	-3.2
15	*	31	*	47	*	63	5
16	-2	32	-5	48	-1.7	64	0.2

IC402
<PH001>

Pin No.	Voltage
1	-5
2	*
3	-2
4	-2
5	*
6	0
7	5
8	*

IC403
<CXL1009P>

Pin No.	Voltage
1	*
2	4.2
3	-2
4	*
5	-3.5
6	1
7	-5
8	0
9	-5
10	4.2
11	-5
12	*
13	0
14	-5
15	0.3
16	-3.8
17	0.8
18	-2
19	4.2
20	-5

IC404
<PA0017>

Pin No.	Voltage
1	-5
2	0
3	*
4	*
5	-5
6	*
7	-5
8	0.2

IC405
<M50554-132SP>

Pin No.	Voltage	Pin No.	Voltage
1	0	17	0.8
2	*	18	5
3	5	19	0
4	*	20	0
5	*	21	0
6	5	22	*
7	*	23	*
8	*	24	0
9	*	25	0
10	5	26	0
11	0	27	*
12	*	28	2
13	*	29	2
14	0.6	30	*
15	3.5	31	*
16	0.6	32	5

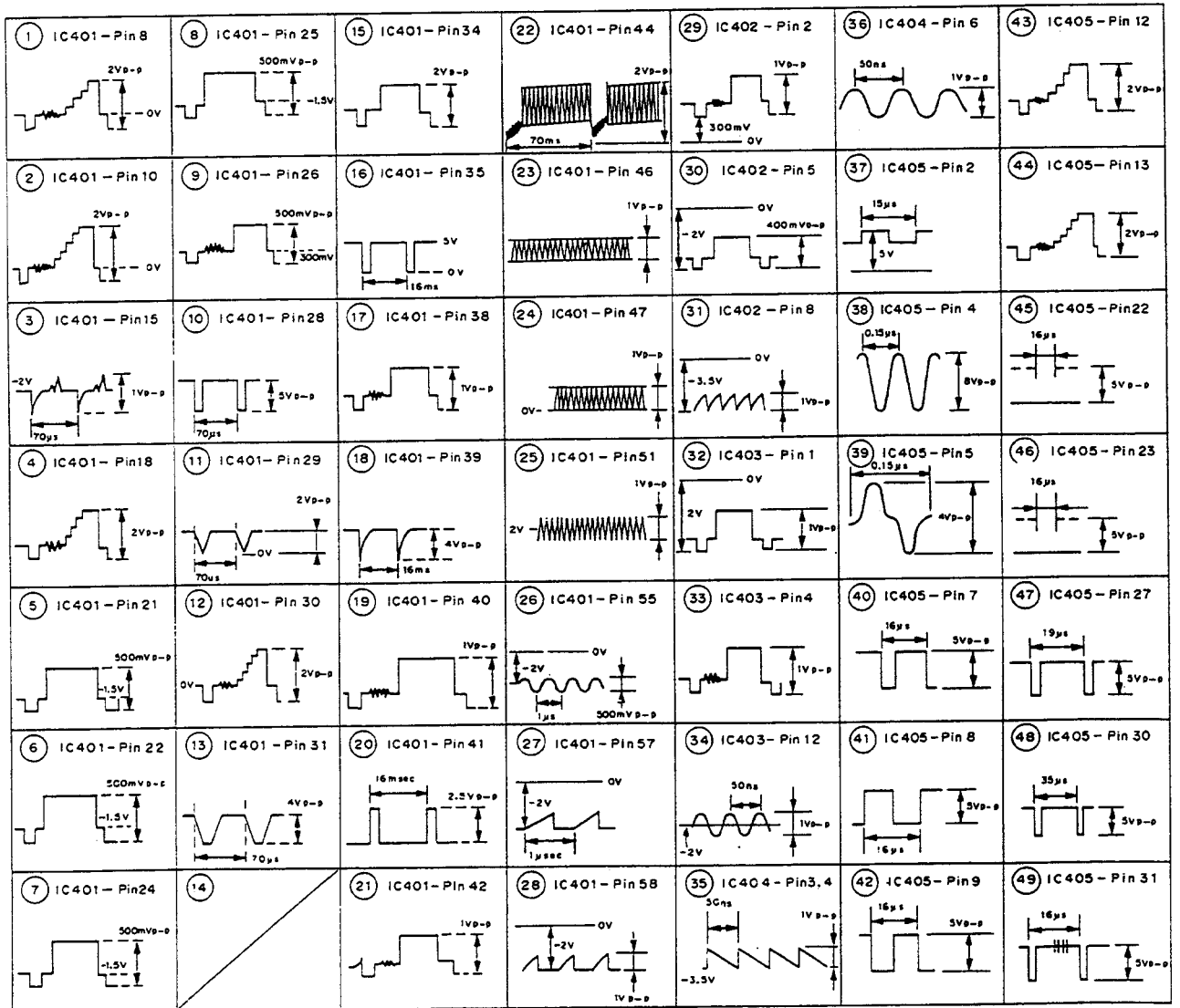

Note : Waveforms and voltages are at the PLAY state.

IC901
<HD49403HT>

Pin No.	Voltage	Pin No.	Voltage	Pin No.	Voltage
1	*	15	*	29	*
2	*	16	*	30	2.5
3	*	17	*	31	2.5
4	*	18	2.5	32	*
5	0	19	2.5	33	2.5
6	*	20	*	34	2.5
7	0	21	2.5	35	5
8	*	22	*	36	*
9	*	23	*	37	*
10	0	24	2.5	38	*
11	0	25	5	39	*
12	5	26	*	40	*
13	0	27	2.5	41	*
14	0	28	*	42	*

IC902
<NJM4558D>

Pin No.	Voltage
1	*
2	*
3	*
4	*
5	*
6	*
7	*
8	0

IC903
<RJH4558S>

Pin No.	Voltage
1	*
2	*
3	*
4	0
5	*
6	*
7	*
8	*

IC904
<NJM4558D>

Pin No.	Voltage
1	2.4
2	2.4
3	2.4
4	-2.4
5	0
6	0
7	0
8	0

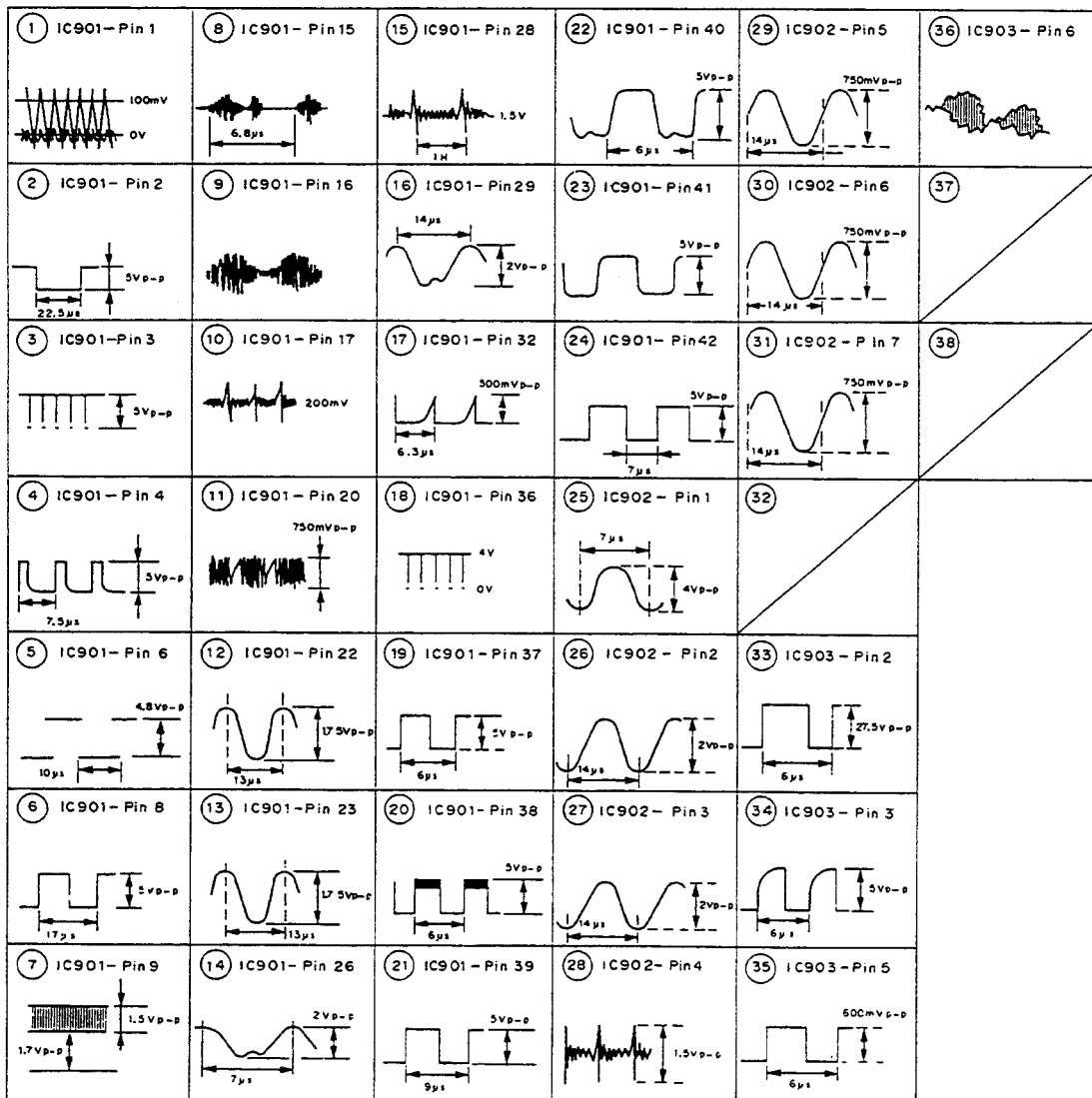

5.8 MAIN (TBC SECTION) AND FG ASSEMBLIES

MAIN ASSEMBLY (VWX1046)

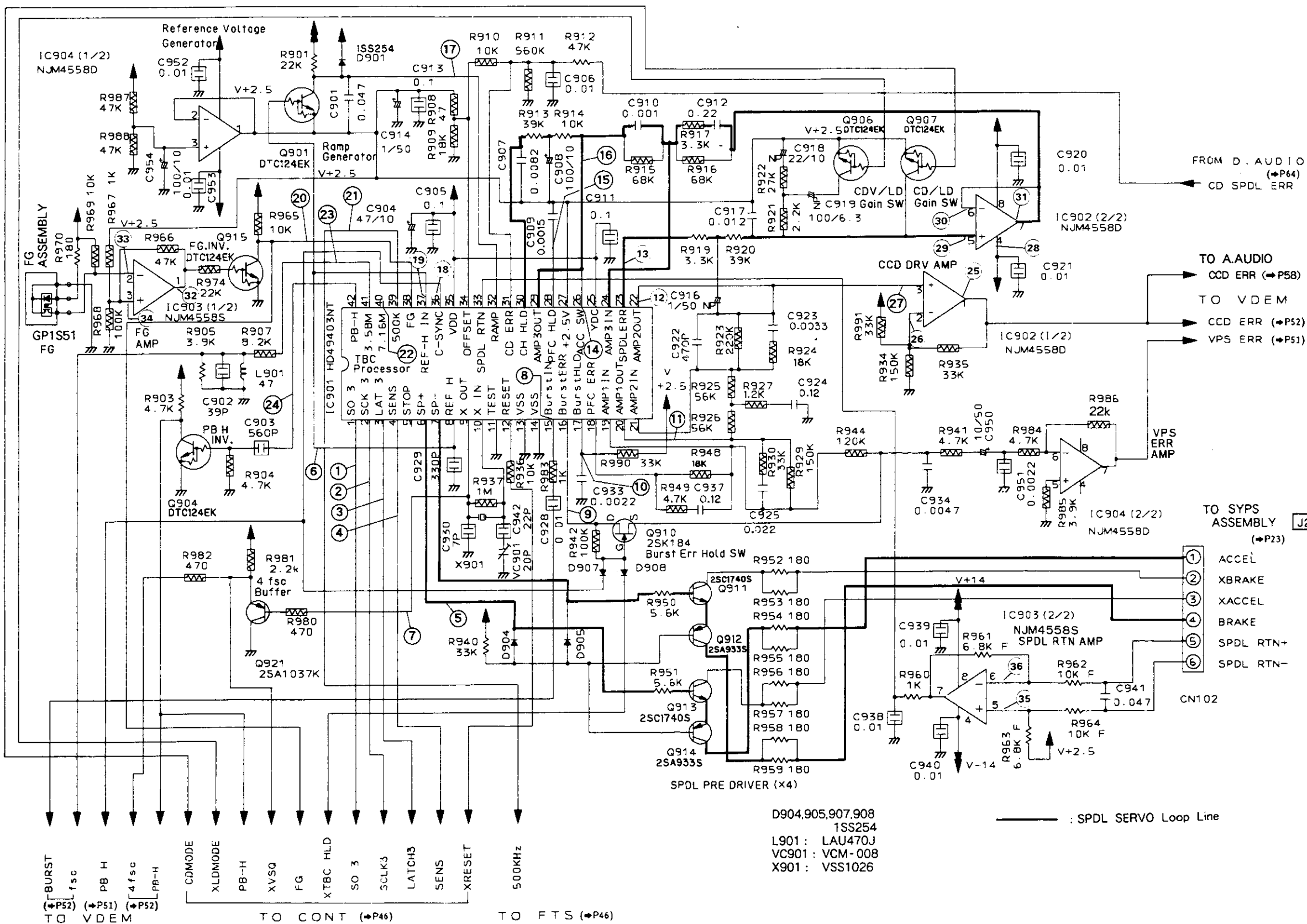

5.9 MAIN ASSEMBLY (A. AUDIO SECTION)

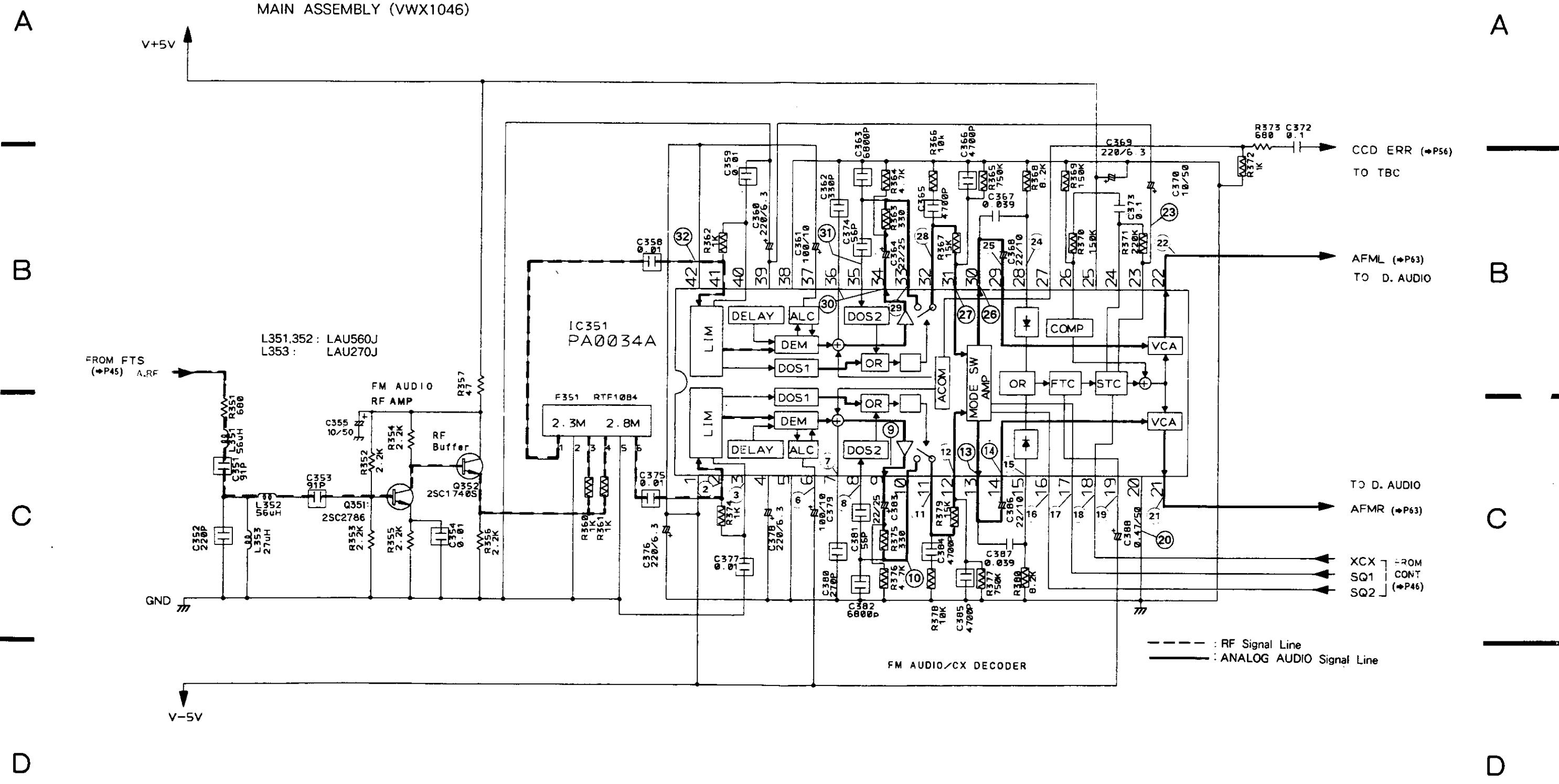

Note : Waveforms and voltages are at the PLAY state.

IC351
<PA0034A>

Pin No.	Voltage	Pin No.	Voltage	Pin No.	Voltage
1	*	15	*	29	*
2	*	16	*	30	*
3	*	17	*	31	*
4	*	18	*	32	*
5	*	19	*	33	*
6	*	20	*	34	*
7	*	21	*	35	*
8	*	22	*	36	*
9	*	23	*	37	*
10	*	24	0	38	*
11	*	25	0	39	*
12	*	26	0	40	*
13	*	27	0	41	*
14	*	28	*	42	*

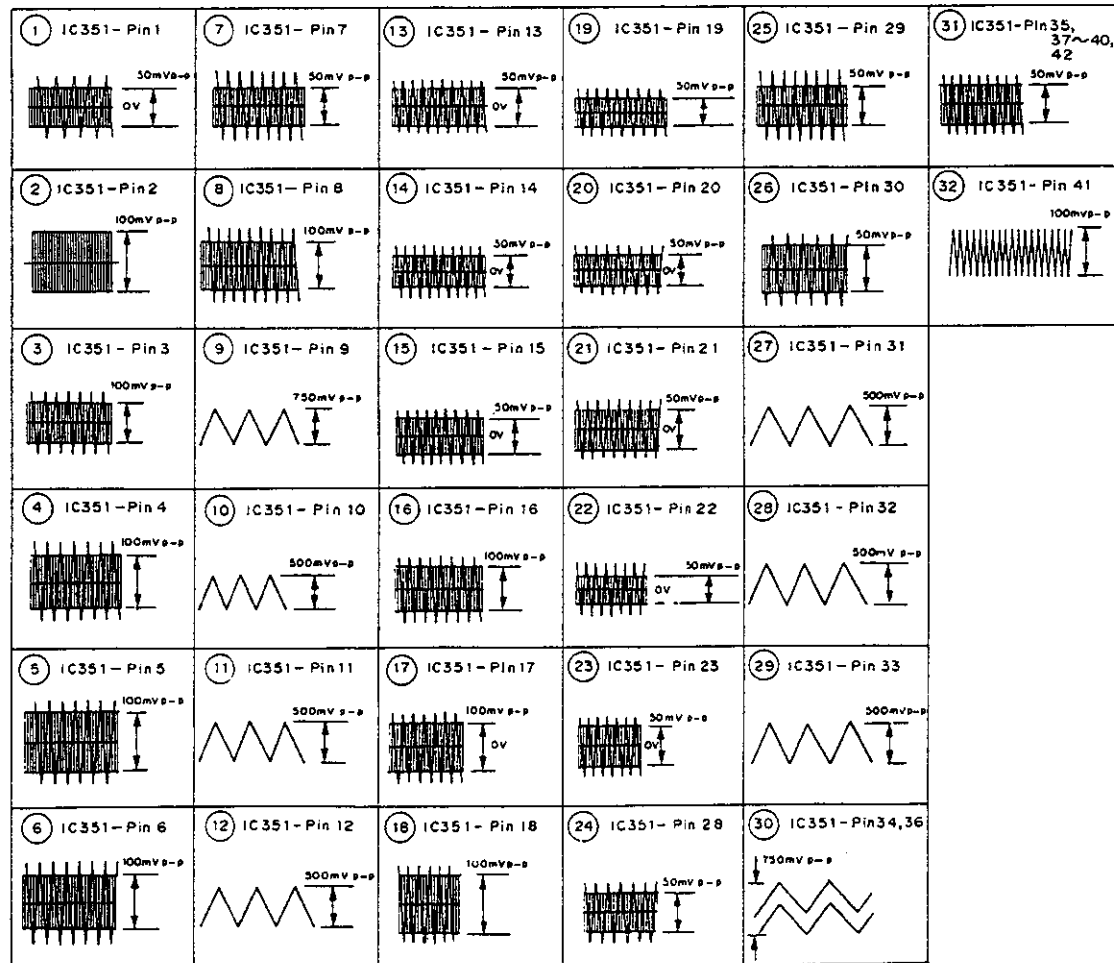

Note : Waveforms and voltages are at the PLAY state.

IC201 <C1D25902>				IC202 <SRS840AP>				IC203 <SRS860BF>				IC204 <M5218AP>		IC205 <BU4053F>		IC206 <TC74HCU04AP>		IC207 <NJM78L05A>		IC208 <NJM4580L>		IC209 <NJM4580L>		IC212 <85218L>		IC213 <NJM78L08A>		IC214 <NJM78L08A>	
Pin No.	Voltage	Pin No.	Voltage	Pin No.	Voltage	Pin No.	Voltage	Pin No.	Voltage	Pin No.	Voltage	Pin No.	Voltage	Pin No.	Voltage	Pin No.	Voltage	Pin No.	Voltage	Pin No.	Voltage	Pin No.	Voltage	Pin No.	Voltage	Pin No.	Voltage	Pin No.	Voltage
1	0	21	0	41	*	61	5	1	5	1	4.8	16	0	31	-	1	-	1	*	1	*	1	*	1	*	1	8	1	0
2	0	22	2.3	42	*	62	*	2	*	2	4.8	17	0	32	0	2	2.5	2	*	2	*	2	*	2	*	2	0	2	-11.5
3	0	23	4.8	43	*	63	*	3	*	3	4.8	18	*	33	0	3	2.5	3	*	3	*	3	*	3	*	3	11	3	-8
4	*	24	*	44	0	64	*	4	*	4	0	19	*	34	0	4	-5	4	-8	4	-8	4	-8	4	-8	4	-8	4	-8
5	0	25	0	45	4.8	65	0	5	0	5	0	20	4.8	35	4.8	5	2.7	5	0	5	0	5	0	5	0	5	0	5	0
6	4.8	26	0	46	*	66	*	6	*	6	4.8	21	4.8	36	0	6	0	6	0	6	0	6	0	6	0	6	0	6	0
7	0	27	*	47	*	67	*	7	*	7	4.8	22	*	37	0	7	2.8	7	*	7	*	7	*	7	*	7	*	7	*
8	4.8	28	0	48	*	68	0	8	5	8	*	23	0	38	*	8	0	8	*	8	*	8	*	8	*	8	*	8	*
9	0	29	0	49	*	69	*	9	5	9	0	24	0	39	4.8	9	0	9	*	9	*	9	*	9	*	9	*	9	*
10	0	30	0	50	*	70	5	10	*	10	0	25	*	40	*	10	0	10	*	10	*	10	*	10	*	10	*	10	*
11	0	31	*	51	*	71	*	11	*	11	*	26	4.8	41	*	11	0	11	*	11	*	11	*	11	*	11	*	11	*
12	0	32	*	52	0	72	5	12	*	12	*	27	4.8	42	*	12	*	12	*	12	*	12	*	12	*	12	*	12	*
13	0	33	4.8	53	*	73	5	13	*	13	*	28	0	43	*	13	*	13	*	13	*	13	*	13	*	13	*	13	*
14	0	34	*	54	*	74	*	14	5	14	*	29	0	44	4.8	14	*	14	*	14	*	14	*	14	*	14	*	14	*
15	0	35	*	55	0	75	0	15	*	15	*	30	*	45	*	15	*	15	*	15	*	15	*	15	*	15	*	15	*
16	4.8	36	*	56	*	76	0	16	*	16	*	*	*	46	*	16	*	16	*	16	*	16	*	16	*	16	*	16	*
17	0	37	*	57	*	77	*	17	*	17	*	*	*	47	*	17	*	17	*	17	*	17	*	17	*	17	*	17	*
18	*	38	*	58	*	78	*	18	*	18	*	*	*	48	*	18	*	18	*	18	*	18	*	18	*	18	*	18	*
19	2.4	39	0	59	5	79	*	19	*	19	*	*	*	49	*	19	*	19	*	19	*	19	*	19	*	19	*	19	*
20	*	40	4.8	60	*	80	0	20	*	20	*	*	*	50	*	20	*	20	*	20	*	20	*	20	*	20	*	20	*

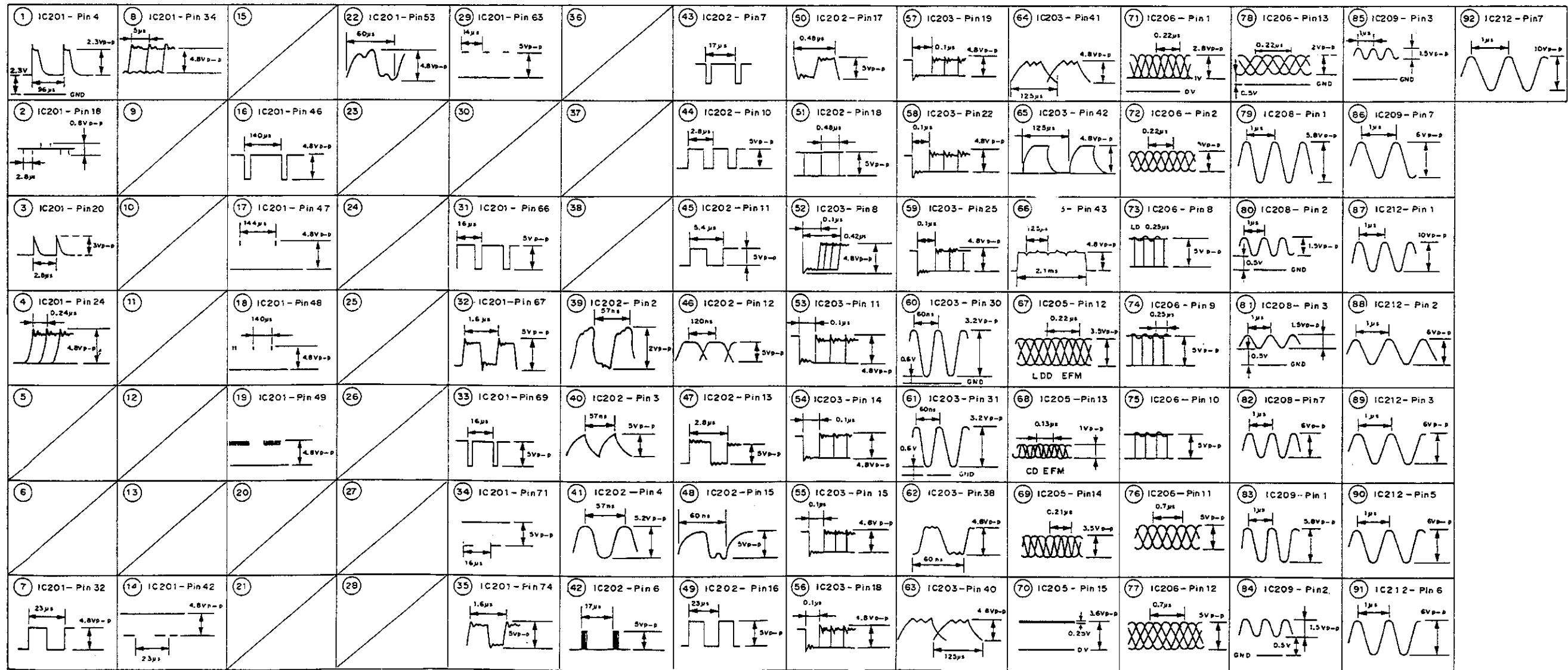

5.10 MAIN ASSEMBLY (D. AUDIO SECTION)

MAIN ASSEMBLY (VWX1046)

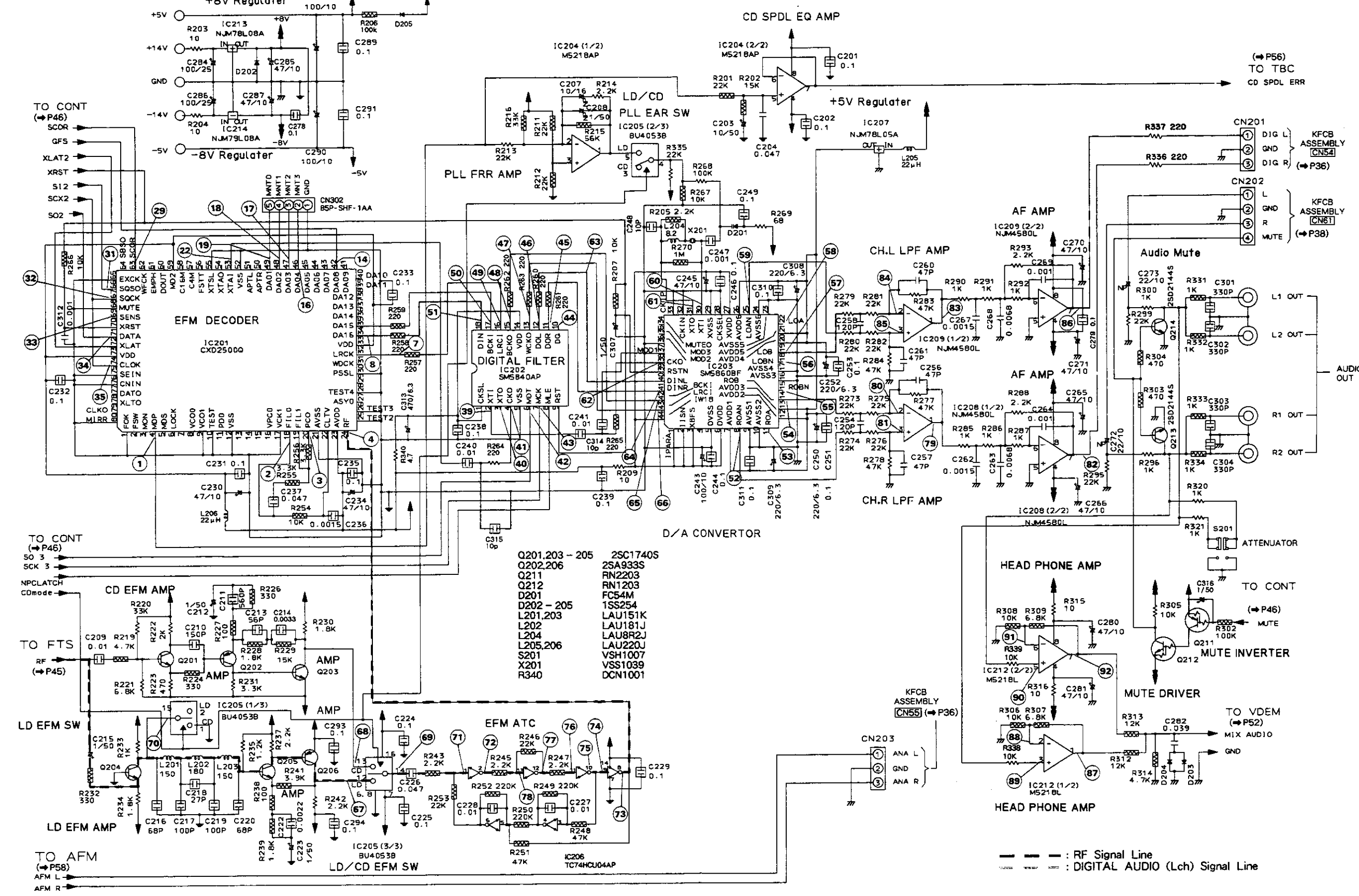

A

B

C

D

A

B

C

D

6. ELECTRICAL PARTS LIST

NOTES:

- Parts without part number cannot be supplied.
- Parts marked by "◎" are not always kept in stock. Their delivery time may be longer than usual or they may be unavailable.
- The △ mark found on some component parts indicates the importance of the safety factor of the part. Therefore, when replacing, be sure to use parts of identical designation.
- When ordering resistors, first convert resistance values into code form as shown in the following examples.
 Ex.1 When there are 2 effective digits (any digit apart from 0), such as 560 ohm and 47k ohm (tolerance is shown by J = 5%, and K = 10%).
 560 Ω → 56 × 10¹ → 561 RD1 / 4PS 561 J
 47k Ω → 47 × 10³ → 473 RD1 / 4PS 473 J
 0.5 Ω → 0R5 RN2H 0R5 K
 1 Ω → 010 RS1P 010 K
 Ex.2 When there are 3 effective digits (such as in high precision metal film resistors).
 5.62k Ω → 562 × 10¹ → 5621 RN1 / 4SR 5621 F

Miscellaneous Parts

Mark	Symbol & Description	Part No.
	KCNB assembly	
◎	MAIN assembly	VWX1046
	MHVB assembly	
	FG assembly	
◎	SYPS assembly	VWR1070
	EXTB assembly	
	DSPB assembly	
	HEAD assembly	
	KFCB assembly	
	SW assembly	
	SURB assembly	
	INDB assembly	
	UCOM assembly	
	KEYB assembly	
△	FU201, FU202 Fuse (3A)	VEK-018
△	FU203, FU204 Fuse (2A)	VEK-022
	S4, S5 Slide switch (INNER, OUTER)	PSH1003
△	Strain relief	CM-22
△	AC power cord	VDG1034
△	Power transformer	VTT1088
△	Voltage selector	VSF-002
	Spindle motor assembly	VXA1474
	Carriage motor assembly	VXX1261
	Loading motor assembly	VXX1262
	Pre-pickup assembly	VXX1413
	Remote control unit	VXX1442

KCNB Assembly

SEMICONDUCTORS

Mark	Symbol & Description	Part No.
	IC8	BA15218N
	IC1	BU4053B
	IC6	KM41C464P-10
	IC7	LC7881-C
	IC3	NJM360D
	IC4	PCM54HP
	IC5	PD0046
	IC2	RC4558D
	Q3	2SC1740S
	Q1, Q2	2SC2786
	D1 - D4	1SS254

CAPACITORS

Mark	Symbol & Description	Part No.
	C27	CCCCH220J50
	C28	CCCCH180J50
	C15	CCCSL331J50
	C33	CEAS101M10
	C1, C3, C12, C14, C17, C29, C32, C34, C36	CEAS470M10
	C25	CEAS471M6R3
	C18, C21, C23, C24	CEJA100M16
	C20	CFTXA563J50
	C2, C4 - C6, C9 - C11, C13, C16, C19, C22, C26, C30, C31, C35, C37, C38	CKPUYY103N16
	C7, C8	CQMA102J50

RESISTORS

Mark	Symbol & Description	Part No.
	All resistors	RD1 / 6PM □□□ J

OTHERS

Mark	Symbol & Description	Part No.
	X1 X'TAL	VSS1015

◎ MAIN Assembly (VWX1046)

VIDEO Section SEMICONDUCTORS

Mark	Symbol & Description	Part No.
	IC403	CXL1009P
	IC405	M50554-132SP
	IC404	PA0017
	IC401	PA5010
	IC402	PM0001
	Q524	RN1203
	Q488, Q565	2SA1037K
	Q401 - Q403, Q443, Q481, Q522, Q562, Q564	2SA933S
	Q441, Q442, Q482 - Q486, Q523, Q563	2SC1740S
	Q444 - Q446, Q521	2SC2412K
	D461, D462, D481, D521	1SS254

COILS

Mark	Symbol & Description	Part No.
	L562, L563	LAU100J
	L404, L405, L521	LAU120J
	L485	LAU121J
	L484	LAU180J
	L402, L403	LAU220J
	L445, L446	LAU221J
	L443, L523, L561	LAU390J
	L441	LAU430J
	L401	LAU560J
	L442	LAU620J
	L486	LAU820J
	L444	LFA471J
	L524	LRA561K

CAPACITORS

Mark	Symbol & Description	Part No.
	C421	CCCCH151J50
	C514	CCCSL241J50
	C412, C445	CCSQCH070D50
	C441, C505, C568, C569	CCSQCH100D50
	C436, C451, C461, C535	CCSQCH101J50
	C432, C516, C517	CCSQCH120J50
	C414, C415, C422, C513	CCSQCH150J50
	C429, C528, C538	CCSQCH151J50
	C468	CCSQCH181J50
	C498	CCSQCH220J50
	C428	CCSQCH221J50
	C430, C442	CCSQCH270J50
	C463	CCSQCH271J50
	C462	CCSQCH330J50
	C431, C444, C506	CCSQCH390J50

	C435, C532	CCSQCH430J50
	C420, C443, C512, C545	CCSQCH470J50
	C507	CCSQCH820J50
	C539	CCSQCH910J50
	C529	CCSQL561J50

Mark	Symbol & Description	Part No.
	C542	CEANP220M10
	C411	CEASR47M50
	C489	CEAS010M50
	C531	CEAS100M50
	C448, C452, C470, C561, C575	CEAS101M10
	C486	CEAS220M25
	C491, C492, C495	CEAS3R3M50
	C533	CEAS330M16
	C450	CEAS4R7M50
	C405, C406, C423, C424, C483, C500, C501, C519, C523, C524, C549, C550, C570, C571	CEAS470M10
	C401, C402, C485	CEAS471M6R3
	C465	CFTXA103J50
	C521	CFTXA104J50
	C490	CFTXA224J50
	C530	CFTXA683J50

	C416, C418, C419, C427, C434, C453 - C455, C458, C459, C467, C497, C565, C566	CKSQYF103Z50
	C403, C404, C425, C426, C449, C487, C488, C525, C526, C548, C572, C573	CKSQYF104Z25

	C407 - C410, C413, C417, C433, C446, C466, C469, C484, C493, C494, C496, C502 - C504, C508 - C511, C515, C518, C522, C527, C534, C536, C540, C541, C543, C544, C546, C551, C552, C562, C564, C574, C582, C584, C464	CKSQYF473Z50
		CQMA272J50

RESISTORS

Mark	Symbol & Description	Part No.
	VR441 Semi-fixed (2.2kΩ)	VRTB6VS222
	VR481, VR482	VRTB6VS472
	Semi-fixed (4.7kΩ)	
	VR521 Semi-fixed (4.7kΩ)	VRTG6VS472
	R402, R405, R412, R413, R441, R461, R481, R482, R485, R486, R490, R499, R539, R541, R571, R572, R574, R575	RD1 / 6PM □□□ J
	R403, R404, R448, R450, R536	RN1 / 6PQ □□□□ F
	Other resistors	RS1 / 10S □□□ J

OTHERS

Mark	Symbol & Description	Part No.
	RFMD	VWL1016

TBC Section

SEMICONDUCTORS

Mark	Symbol & Description	Part No.
	IC901	HD49403NT
	IC902,IC904	NJM4558D
	IC903	NJM4558S
	Q901,Q904,Q906,Q907,Q915	DTC124EK
	Q921	2SA1037K
	Q912,Q914	2SA933S
	Q911,Q913	2SC1740S
	Q910	2SK184
	D901,D904,D905,D907,D908	1SS254

COIL

Mark	Symbol & Description	Part No.
	L901	LAU470J

CAPACITORS

Mark	Symbol & Description	Part No.
	VC901 Ceramic trimmer (20p)	VCM-008
	C922	CCCSL471J50
	C930	CCSQCH070D50
	C942	CCSQCH220J50
	C902	CCSQCH390J50
	C929	CCSQSL331J50
	C903	CCSQSL561J50
	C916	CEANP010M50
	C919	CEANP101M6R3
	C918	CEANP220M10
	C914	CEAS010M50
	C950	CEAS100M50
	C908,C954	CEAS101M10
	C904	CEAS470M10
	C917	CFTXA123J50
	C924,C937	CFTXA124J50
	C909	CFTXA152J50
	C925	CFTXA223J50
	C912	CFTXA224J50
	C934	CFTXA472J50
	C901,C941	CFTXA473J50
	C910	CKCYB102K50
	C951	CKSQYB222K50
	C906,C920,C921,C928, C938 - C940,C952,C953	CKSQYF103Z50
	C905,C911,C913	CKSQYF104Z25
	C933	CQMA222J50
	C923	CQMA332J50
	C907	CQMA822J50

RESISTORS

Mark	Symbol & Description	Part No.
	R901,R903,R905,R912 - R914, R919,R920,R940,R950 - R960, R970	RD1/6PM□□□J
	R961 - R964	RN1/6PQ□□□□F
	Other resistors	RS1/10S□□□J

OTHERS

Mark	Symbol & Description	Part No.
	X901 Crystal resonator	VSS1026

CONT Section

SEMICONDUCTORS

Mark	Symbol & Description	Part No.
	IC801	PD0071
	IC802	TA7291P
	Q802	DTC124EK
	D803	04AZ10-Y
	D802	1SS254

CAPACITORS

Mark	Symbol & Description	Part No.
	C803,C804	CCSQCH330J50
	C801	CEAS220M25
	C812	CKCYF103Z50
	C805	CKSQYF103Z50
	C802	CKSQYF104Z25

RESISTORS

Mark	Symbol & Description	Part No.
	R806 Fusible resistor	VCN1025
	R803,R824,R831,R832	RD1/6PM□□□J
	Other resistors	RS1/10S□□□J

OTHERS

Mark	Symbol & Description	Part No.
	X801 Ceramic resonator	VSS1040

D. AUDIO Section

SEMICONDUCTORS

Mark	Symbol & Description	Part No.
	IC205	BU4053B
	IC201	CXD2500Q
	IC204	M5218AP
	IC212	M5218L
	IC208,IC209	NJM4580L
	IC207	NJM78L05A
	IC213	NJM78L08A
	IC214	NJM79L08A
	IC202	SM5840AP
	IC203	SM5860BF
	IC206	TC74HCU04AP
	Q212	RN1203
	Q211	RN2203
	Q202,Q206	2SA933S
	Q201,Q203 - Q205	2SC1740S
	Q213,Q214	2SD2144S
	D201	FC54M
	D202 - D205	1SS254

SWITCH

Mark	Symbol & Description	Part No.
	S201 Slide switch (ATTENUATOR)	VSH1007

COILS

Mark	Symbol & Description	Part No.
	L204	LAU8R2J
	L201,L203	LAU151K
	L202	LAU181J
	L205,L206	LAU220J

CAPACITORS

Mark	Symbol & Description	Part No.
	C254,C258	CCCCH121J50
	C256,C257,C260,C261	CCPUSL470J50
	C217,C219	CCSQCH101J50
	C248,C314,C315	CCSQCH100D50
	C210	CCSQCH151J50
	C218	CCSQCH270J50
	C213	CCSQCH560J50
	C216,C220	CCSQCH680J50
	C301 - C304	CCSSQL331J50
	C211	CCSSQL561J50
	C208	CEANP010M50
	C207	CEANP100M16
	C272,C273	CEANP220M10
	C212,C215,C223,C307,C316	CEAS010M50
	C203	CEAS100M50
	C243,C288,C290	CEAS101M10
	C284,C286	CEAS101M25
	C250,C252,C308,C309	CEAS221M6R3
	C230,C234,C245,C265,C266,C270,	CEAS470M10
	C271,C280,C281,C285,C287	
	C313	CEAS471M6R3
	C264,C269	CFTXA102J50
	C262,C267	CFTXA152J50
	C282	CFTXA393J50
	C204	CFTXA473J50
	C263,C268	CFTXA682J50
	C247,C312	CKSQYB102K50
	C236	CKSQYB152K50
	C222	CKSQYB222K50
	C214	CKSQYB332K50
	C209,C227,C228,C240,C241	CKSQYF103Z50
	C201,C202,C224,C225,C229,	CKSQYF104Z25
	C231 - C233,C235,C238,C239,	
	C244,C246,C249,C251,C253,C278,	
	C279,C289,C291,C293,C294,C310,	
	C311	
	C226,C237	CKSQYF473Z50

RESISTORS

Mark	Symbol & Description	Part No.
	R340 Fusible resistor (4.7Ω)	DCN1001
	R203,R204,R209,R213,R214,	RD1/6PM□□□J
	R220 - R223,R230,R231,	
	R233 - R235,R237,R242,R264,	
	R268,R269,R273 - R288,	
	R290 - R293,R295,R296,R299,	
	R300,R305,R315,R316,R320,R321,	
	R336,R337	
	Other resistors	RS1/10S□□□J

OTHERS

Mark	Symbol & Description	Part No.
	CN 5P Top post (NH)	B5P-SHF-1AA
	X201 Crystal resonator (16MHz)	VSS1039
	JA 6P Pin jack	VKB1020
	JA2 2P Mini jack	VKN-183

**FTS Section
SEMICONDUCTORS**

Mark	Symbol & Description	Part No.
	IC603	BA15218N
	IC601	HA11529NT
	IC605	IR3C02A
	IC604	LA6500
	IC602	NJM4558S
	IC606	TA8410AK
	Q612	DTA124EK
	Q604,Q607,Q609,Q615	DTC124EK
	Q611,Q613	2SA1037K
	Q601 - Q603,Q605,Q608,Q610	2SC2412K
	Q606,Q614	2SK184
	D601 - D605	1SS254

CAPACITORS

Mark	Symbol & Description	Part No.
	C615	CCCCH560J50
	C650	CCSQCH680J50
	C611,C642	CCSSQL331J50
	C634	CCSSQL561J50
	C627	CEANPR47M50
	C632,C636	CEANP100M16
	C639	CEANP220M10
	C644	CEAS010M50
	C630,C635	CEAS100M50
	C616,C617,C619,C622,C624,C647,	CEAS220M25
	C648	
	C645	CFTXA102J50
	C606,C614,C631,C649	CFTXA104J50
	C651	CFTXA124J50
	C641	CFTXA152J50
	C605,C633	CFTXA184J50
	C637	CFTXA223J50
	C640	CFTXA224J50
	C629	CFTXA333J50
	C607,C628	CFTXA473J50
	C608,C626	CFTXA683J50

Mark	Symbol & Description	Part No.
C643,C652		CGCYF473Z25
C646		CKSQYB222K50
C601,C602,C618,C620,C621		CKSQYF104Z25
C638		CKSQYF223Z50
C603,C604,C612,C613,C623,C625		CKSQYF473Z50
C653		CQMA102J50
C609		CQMA222J50
C610		CQMA332J50

RESISTORS

Mark	Symbol & Description	Part No.
VR601	Semi-fixed (1kΩ)	VRTB6VS102
VR607	Semi-fixed (100kΩ)	VRTB6VS104
VR606	Semi-fixed (2.2kΩ)	VRTB6VS222
VR602 - VR605,VR608	Semi-fixed (4.7kΩ)	VRTB6VS472
R608,R627,R648 - R650,R655, R660,R670,R672,R674,R684,R687, R693,R704 - R706,R709,R714, R715,R719,R722		RD1/6PM□□□J
Other resistors		RD1/10S□□□J

OTHERS

Mark	Symbol & Description	Part No.
CN103	23P Top connector	VKN1073

A. AUDIO Section

SEMICONDUCTORS

Mark	Symbol & Description	Part No.
IC351		PA0034A
Q352		2SC1740S
Q351		2SC2786

COILS AND FILTER

Mark	Symbol & Description	Part No.
L353		LAU270J
L351,L352		LAU560J
F351	BPF (2.30, 2.81MHz)	RTF1084

CAPACITORS

Mark	Symbol & Description	Part No.
C352		CCSQCH221J50
C380		CCSQCH271J50
C374,C381		CCSQCH560J50
C351,C353		CCSQCH910J50
C362		CCSQL331J50
C368,C386		CEANP220M10
C388		CEASR47M50
C355,C370		CEAS100M50
C361,C379		CEAS101M10
C364,C383		CEAS220M25

Mark	Symbol & Description	Part No.
C360,C369,C376,C378		CEAS221M6R3
C372,C373		CFTXA104J50
C367,C387		CFTXA393J50
C365,C366,C384,C385		CKSQYB472K50
C363,C382		CKSQYB682K50
C354,C358,C359,C375,C377		CKSQYF103Z50

RESISTORS

Mark	Symbol & Description	Part No.
R351 - R357		RD1/6PM□□□J
Other resistors		RS1/10S□□□J

MHVB Assembly

SEMICONDUCTORS

Mark	Symbol & Description	Part No.
IC401		NJM2068D
IC402		NJM4558D

CAPACITORS

Mark	Symbol & Description	Part No.
C403,C404		CEJA2R2M50
C407,C408,C411,C412		CEJA220M16
C409		CFTXA683J50
C419		CGCYX473K25
C410,C417,C418		CKPUYB101K50
C405,C406		CKPUYB681K50
C413 - C416		CKPUYF223Z25
C401,C402		CQMA152J50

RESISTORS

Mark	Symbol & Description	Part No.
VR401,VR402	Rotary volume (10kΩ) (MIC VOL)	VCS1019
VR403	Rotary volume (500Ω) (PHONES LEVEL)	VCS1020
Other resistors		RD1/6PM□□□J

OTHERS

Mark	Symbol & Description	Part No.
JA402	Stereo mini jack (MIC CONTROL)	VKN1076
JA401,JA403	Mic jack (MIC 1,2)	VKN1095
JA404	Stereo headphone jack (PHONES)	VKN1096

FG Assembly

SEMICONDUCTOR

Mark	Symbol & Description	Part No.
	Photo interrupter	GP1S51

◎ SYPS Assembly (VWR1070)

SEMICONDUCTORS

Mark	Symbol & Description	Part No.
	IC201,IC202	ICP-N15
	Q203,Q205	2SB1134
	Q202,Q209	2SB1185
	Q204,Q206	2SD1667
	Q201,Q208	2SD1762
	D212,D215	D1NK20
	D201,D202	S2VB20-F
	D207,D210	04AZ5.1-Y
	D206,D209	04AZ6.2-Z
	D213,D214	1SR35-100AVL
	D208,D211	1SS254

SWITCH

Mark	Symbol & Description	Part No.
△	S201 Power switch (POWER)	VSA-010

COILS

Mark	Symbol & Description	Part No.
△	L202 Line filter	VTL-157
	L201 Coil (10MH)	VTL1018

CAPACITORS

Mark	Symbol & Description	Part No.
	C209,C211	CEAS101M10
	C213	CEAS101M35
	C214,C215	CEAS2R2M50
	C227	CEJA220M6R3
	C224	CEAS221M10
	C205,C206	CEAS332M25
	C210,C212,C225	CEAS471M6R3
	C208	CEAS682M10
	C229,C230	CGCYX473M25
	C228	CKPUYB101K50
	C239	CKPUYB331K50
	C201 - C204	CKPUYF103Z25
△	C216 - C218 (0.01μ/AC250V)	RCG-008
	C207 (10000/10)	VCH1077

RESISTORS

Mark	Symbol & Description	Part No.
	R213,R214,R219,R220 (47Ω)	DCN1003
	R221	RS1PMFR51J
	Other resistors	RD1/6PM□□□J

EXTB Assembly

CAPACITORS

Mark	Symbol & Description	Part No.
	C401,C402	CKPUYB331K50

OTHERS

Mark	Symbol & Description	Part No.
	JA401 2P Pin jack	VKB1022

DSPB Assembly

SEMICONDUCTORS

Mark	Symbol & Description	Part No.
	IC301	SN74LS145N
	Q301,Q303 - Q305	DTC124ES
	D318	SEL950FL
	D319	SEL8509DP
	D301 - D304,D306 - D309	VEL1011
	D305	VEL1012
	D313 - D315	VEL1015
	D316,D317	1SS254

SWITCHES

Mark	Symbol & Description	Part No.
	S309,S310 Push switch (MUSIC ECHO, ECHO SURROUND)	RSG1032
	S301 - S306 Tact switch (OPEN/CLOSE, PLAY/PAUSE, STOP, #, ♪, ♫)	VSC-012
	S307 Slide switch (KARAOKE/NORMAL) (/AUX INPUT)	VSH1005
	S308 Push switch (DOOR)	VSK1015

CAPACITORS

Mark	Symbol & Description	Part No.
	C301,C302	CKPUYF223Z25

RESISTORS

Mark	Symbol & Description	Part No.
	VR302,VR303 Rotary volume (10kΩ) (BALANCE, MIC ECHO)	VCS1021
	Other resistors	RD1/6PM□□□J

OTHERS

Mark	Symbol & Description	Part No.
	CN331 2MM pitch bottom connector	BTMK04S-1S
	CN332 2MM pitch bottom connector	BTMK06S-1S
	FL spacer	VEB1080
	7 segment spacer	VEB1129

HEAD Assembly

CAPACITORS

Mark	Symbol & Description	Part No.
	C1	CKSQYF473Z50
	C5	CKSYF105Z16

RESISTORS

Mark	Symbol & Description	Part No.
	VR1 Semi-fixed (10kΩ)	VCP1010

KFCB Assembly

SEMICONDUCTORS

Mark	Symbol & Description	Part No.
	IC106 - IC108,IC119,IC130,IC131 IC125 IC109,IC116,IC117,IC123,IC124, IC129 IC111,IC137	BA15218N BU4052B BU4053B IR9393
	IC136 IC121,IC126 IC113 IC114,IC118 IC110	LM3364K - 15 MC14066BCP M50195P M5207L05 M5218P
	IC102 IC103 IC104,IC105,IC112,IC115,IC120, IC122,IC127,IC128,IC132 - IC135 Q107,Q113,Q114,Q116,Q126	NJM78M08FA NJM79M08FA RC4558D DTA124ES
	Q106,Q110,Q115, Q117,Q118,Q127 - Q136 Q122 Q101,Q102,Q123,Q124 D114,D115	DTC124ES 2SC1740S 2SD2144S 04AZ3.0 - X
	D105,D108,D109 D101 - D104 D106,D107,D116 - D122,D501	04AZ5.1 - X 1SR35 - 100AVL 1SS254

COIL

Mark	Symbol & Description	Part No.
	L101	LFA101K

CAPACITORS

Mark	Symbol & Description	Part No.
	C137 C249,C261 C229,C237 C118 C126,C183,C208,C211,C269	CCCSL181J50 CCCSL331J50 CCCSL561J50 CCCSL681J50 CCPUSL470J50
	C101,C103,C108,C109,C132, C133,C501,C503 C280 C172,C278,C515,C516	CEAS101M10 CEAS102M6R3 CEAS470M10
	C106,C107 C110,C111,C127,C206,C207,C215, C508 C513 C205,C213,C505,C506,C518	CEAS471M16 CEJANP010M50 CEJANP4R7M16 CEJA010M50
	C122,C123,C135,C136,C141,C143, C144,C179 - C182,C186,C195, C196,C220 - C222,C232, C238 - C242,C250 C509,C514,C519	CEJA100M16 CFTXA104J50

Mark	Symbol & Description	Part No.
	C117 C248,C260 C520,C521 C102,C104,C112 - C115,C120, C121,C124,C125,C128 - C131, C134,C138,C139,C145,C146, C175 - C178,C184,C185,C188, C189,C191 - C194,C197 - C204, C209,C210,C212,C214, C216 - C219,C226,C227,C230, C231,C254,C255,C258,C259, C262 - C265,C502,C504,C517	CFTXA184J50 CFTXA563J50 CGCYX473K25 CKPUYY103N16
	C270 C512 C119,C223,C233,C510 C247,C257 C511	CKPUYB561K50 CQMA102J50 CQMA103J50 CQMA122J50 CQMA123J50
	C225,C235 C243,C251 C245,C253 C224,C234,C246,C256,C279 C116,C244,C252	CQMA152J50 CQMA153J50 CQMA222J50 CQMA223J50 CQMA273J50
	C228,C236 C507 C140	CQMA333J50 CQMA472J50 CQMA822J50

RESISTORS

Mark	Symbol & Description	Part No.
	VR501 Semi-fixed (2.2k Ω) R139,R140 (4.7 Ω) Other resistors	VRTB6VS222 DCN1001 RD1/6PMM□□□J

OTHERS

Mark	Symbol & Description	Part No.
	X101 Ceramic resonator (3.00MHz)	VSS1042

SW Assembly

SWITCHES

Mark	Symbol & Description	Part No.
	S1 - S3 Push switch (LOADING/TILT)	PSH1008

SURB Assembly

SEMICONDUCTORS

Mark	Symbol & Description	Part No.
	IC601	RC4558D
	Q602	DTC124ES
	Q601	DTA124ES

CAPACITORS

Mark	Symbol & Description	Part No.
	C602,C603	CKPUYY103N16
	C601	CQMA103J50
	C604	CEJA100M16

RESISTORS

Mark	Symbol & Description	Part No.
	R601 - R604	RD1/6PM□□□J

INDB Assembly

SEMICONDUCTORS

Mark	Symbol & Description	Part No.
	Q201	DTA124ES
	Q202 - Q205	DTC124ES
	D201,D203,D205	SEL3210SLC05
	D202	SEL3213CLC05
	D204	VEL1015
	D206,D207	1SS254

SWITCHES

Mark	Symbol & Description	Part No.
	S201 - S204 Tact switch (ONE TOUCH KARAOKE, VOCAL ASSIST, VOCAL PARTNER, AUDIO MODE, STEREO, Hi-Fi MPX)	VSC-012

CAPACITOR

Mark	Symbol & Description	Part No.
	C201	CKPUYF223Z25

RESISTORS

Mark	Symbol & Description	Part No.
	All resistors	RD1/6PM□□□J

OTHERS

Mark	Symbol & Description	Part No.
	Remote control sensor	GP1U50X

UCOM Assembly

SEMICONDUCTORS

Mark	Symbol & Description	Part No.
	IC101	PDB014A
	IC102	PST529C
	Q108 - Q115	DTC124ES
	Q101	2SA854S
	Q102 - Q107	2SB1237X
	D101 - D106	1SS254

CAPACITORS

Mark	Symbol & Description	Part No.
	C106	CEAS221M6R3
	C102	CEAS471M6R3
	C103	CEJA470M6R3
	C105	CKPUYB102K50
	C101,C104	CKPUYF223Z25

RESISTORS

Mark	Symbol & Description	Part No.
	R115 Fusible resistor (4.7Ω)	DCN1001
	R113 Resistor array	RA4T103J
	R114 Resistor array	RA6T222J
	Other resistors	RD1/6PM□□□J

OTHERS

Mark	Symbol & Description	Part No.
	X101 Ceramic resonator	VSS1045

KEYB Assembly

SWITCHES

Mark	Symbol & Description	Part No.
	S501 - S521 Tact switch 5MM (1-20, ONCE MORE)	RSG1030

7. DISASSEMBLY

7.1 REMOVING THE BONNET AND FRONT PANEL (Fig. 7-1-3)

- ① Remove six screws (A) to remove the bonnet.
- ② To remove the front panel assembly, remove three screws (B) and lift the claws as shown in the figure and lower the front panel toward the front. Disconnect five connectors as shown in Fig. 7-2 and remove the front panel.
- ③ To remove the power knob, insert the flat-blade screwdriver into the slit on the side of the chassis as shown in Fig. 7-3, and push the protrusion of the knob. You can now remove the power knob easily. (Check that the power switch is in the OFF position before removal.)

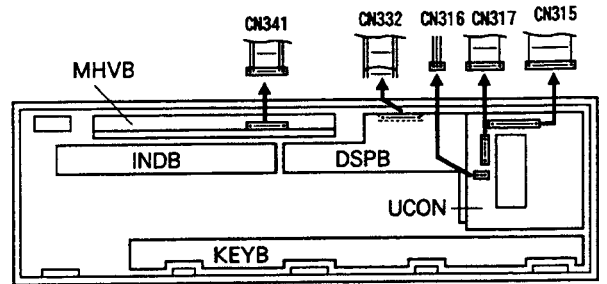

Fig. 7-2

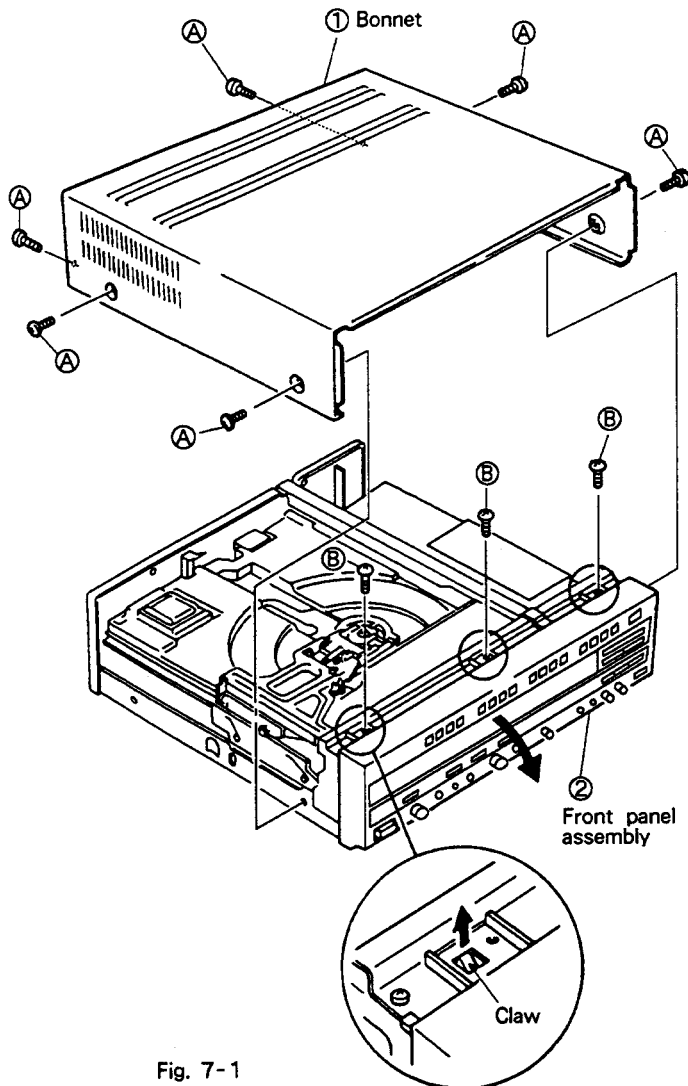

Fig. 7-1

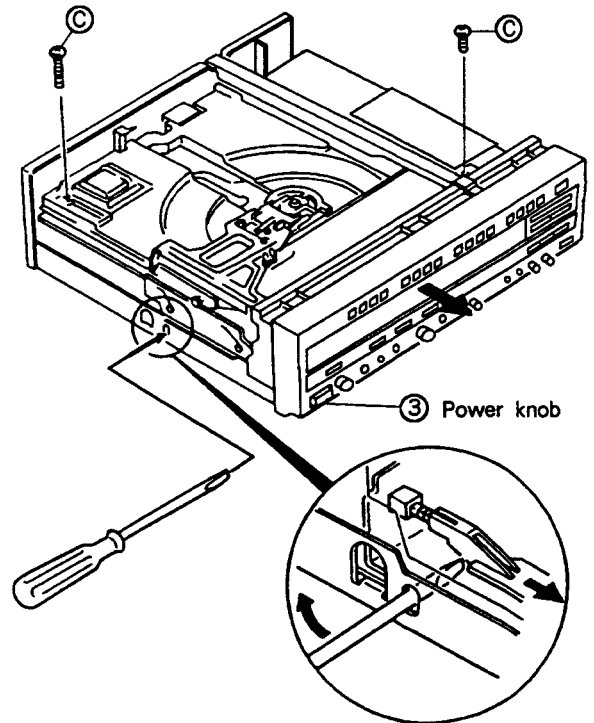

Fig. 7-3

7.2 REMOVING THE TRAY (Fig. 7-3, 4)

- ① Remove two stopper screws ③ shown in Fig. 7-3. When the power can be turned ON, press the OPEN button then pull the tray out from the player.
- ② When the power cannot be turned ON, remove the front panel (Fig. 7-1), and turn the gear pulley shown in Fig. 7-4 counterclockwise, and the tray will slide out toward the front.

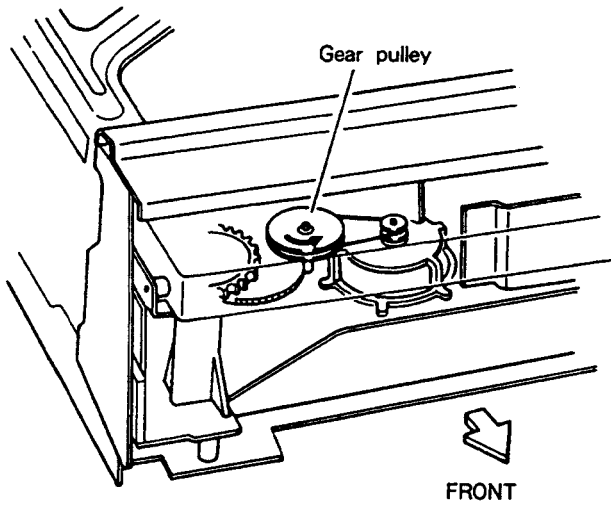

Fig. 7-4

7.3 REMOVING THE KCNB, KFCB AND MAIN ASSEMBLIES (Fig. 7-5, 6)

• After removing the center angle, remove by the following procedure.

7.3.1 REMOVING THE KCNB ASSEMBLY

- ① Remove three PCB holders and disconnect two connectors CN71 and CN72.

7.3.2 REMOVING THE KFCB ASSEMBLY

- ① Remove three screws ② and two PCB holders.

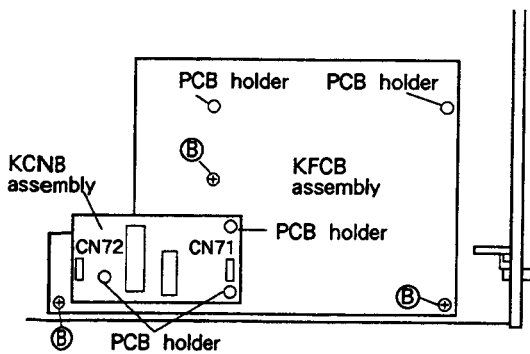

Fig. 7-5

7.3.3 REMOVING THE MAIN ASSEMBLY

• After removing the main binders, remove by the following procedure :

- ① Remove five screws ② holding the MAIN assembly, and remove two screws ③ on the sides of the rear panel with their nuts and washers.
- ② Remove the flexible board from the connector.
- ③ Remove the reinforced plate at the right side.
- ④ Pull the MAIN assembly in the direction of the arrow.
- ⑤ While sliding the MAIN assembly to the right, lift it upward in the direction of the arrow.

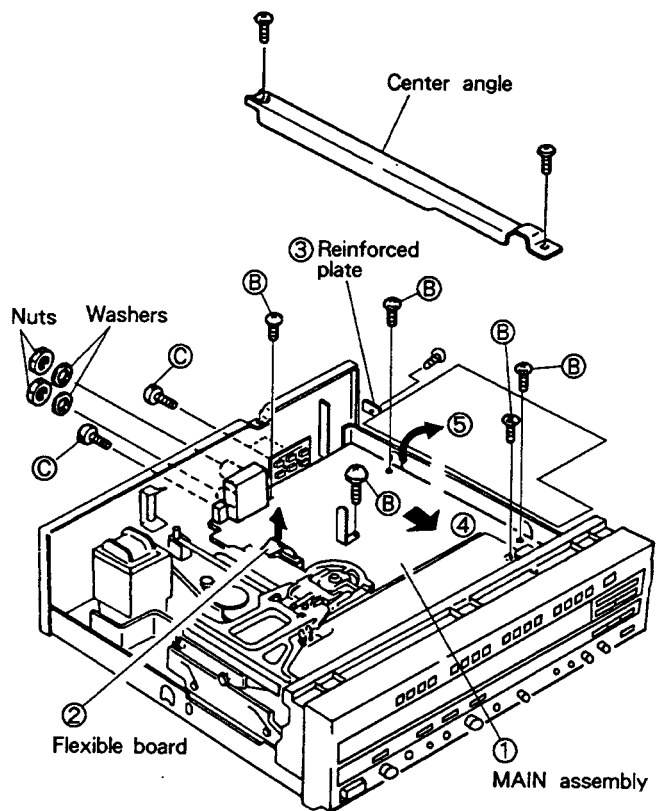

Fig. 7-6

● Diagnosis of the MAIN assembly

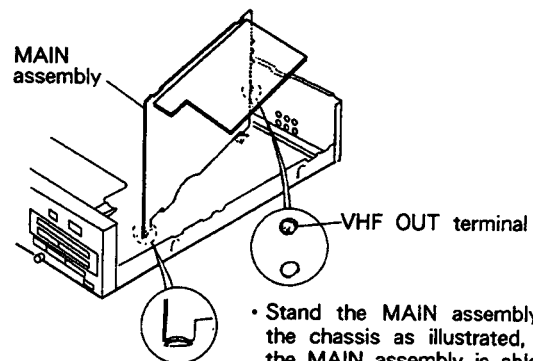

Fig. 7-7

• Stand the MAIN assembly in the chassis as illustrated, and the MAIN assembly is able to diagnose from the foil side.

7.4 REMOVING THE CLAMPER ARM (B) AND CLAMPER ARM (A) ASSEMBLY (Fig. 7-8)

Set the player with the tray moved up.

- ① Remove two clamber springs and raise clamber arm (B).
- ② Clamber arm (B) can be removed by pulling it in the direction of the arrow.
- ③ Remove a screw (A) with a arm spring holding the clamber arm (A) assembly.
- ④ Remove the clamber arm (A) assembly by pulling it in the direction of the arrow.

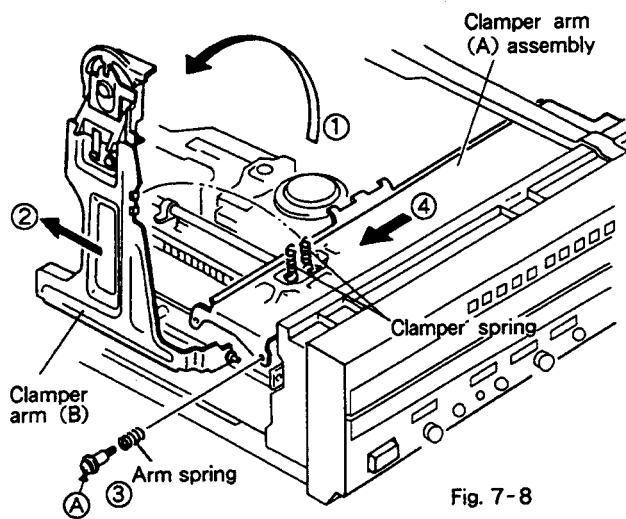

Fig. 7-8

7.5 REMOVING THE CLAMPER (Fig. 7-9)

- ① Remove the plate spring by unscrewing screw (A).
- ② Remove the parallel link by sliding it in the direction of the arrow. (Be careful not to damage the claw located on one side of the link.)
- ③ The clamber can be removed by sliding the clamber holder in the direction of the arrow.

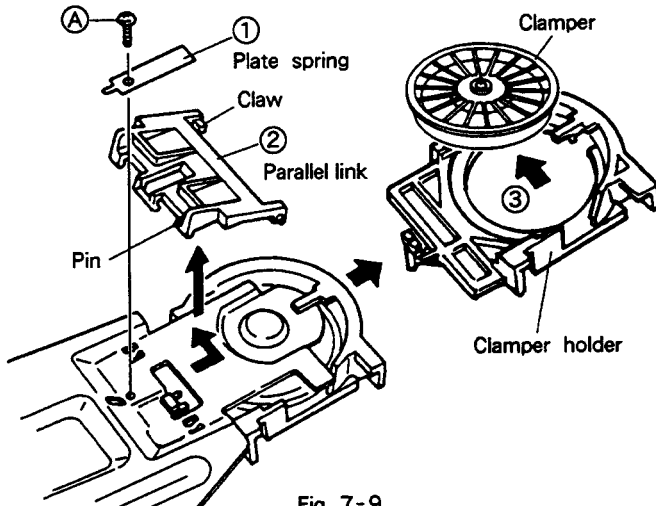

Fig. 7-9

7.6 REMOVING THE PICKUP ASSEMBLY (Fig. 7-10)

- ① Remove the flexible board from the connector and also remove the flexible board installed at section ③.
- ② Remove a screw (A) holding the carriage shaft.
- ③ Raise the shaft in the direction of the arrow to remove the rack assembly.
- ④ Remove a hexagonal screw (B) and lift up the pickup assembly slightly and turn the pickup assembly in the direction of arrow ⑤.
- ⑤ Remove two screws (C) on the back of the pickup assembly.

Note: Make sure that the rack assembly is not close to the turntable when it is removed.

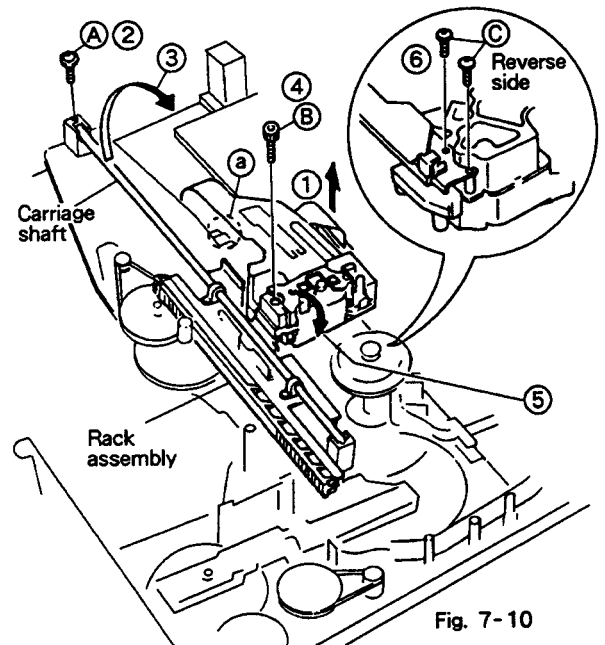

Fig. 7-10

7.7 REMOVING THE TILT SENSOR (Fig. 7-11)

- ① Remove the connector (arrow (A)) of the flexible board and release the claw (arrow (B)) to remove the tilt sensor.

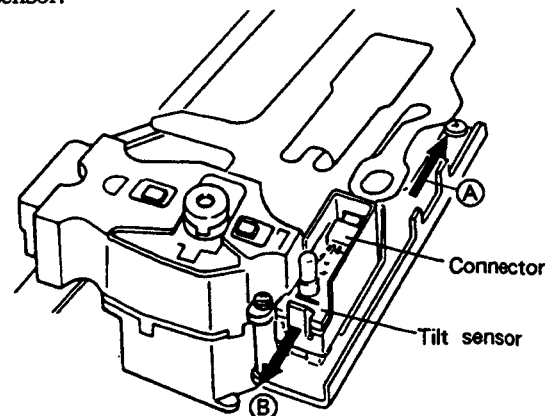

Fig. 7-11

7.8 REMOVING THE MECHANISM SECTION (Fig. 7-12)

Remove six screws (A), and the entire mechanism section can be removed.

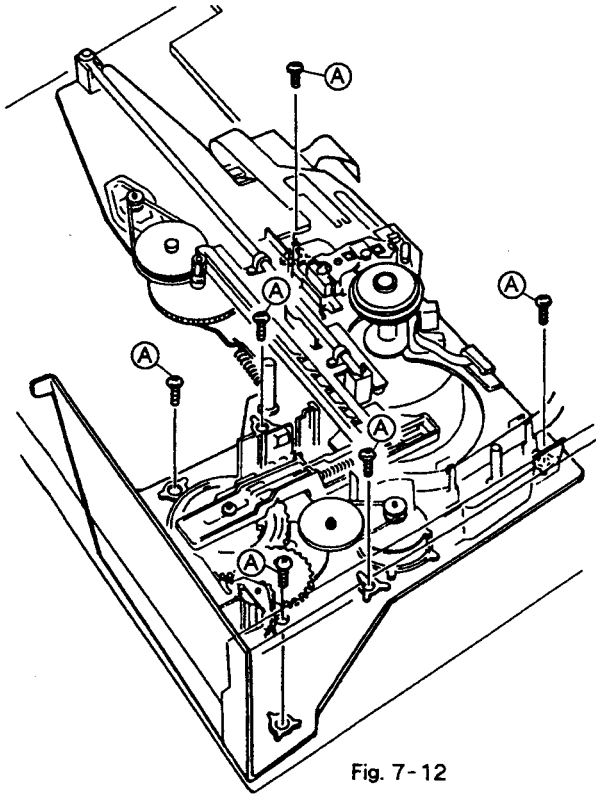

Fig. 7-12

7.9 REMOVING THE SLIDE CAM AND ROLLER PLATE ASSEMBLY (Fig. 7-13)

- ① Set the player with the tray down.
- ② Remove three screws (A) and slide the slide cam toward the rear to remove it.
- ③ Remove the clamber arm (A) assembly (see page 75) after removing slide cam to remove the roller plate assembly.

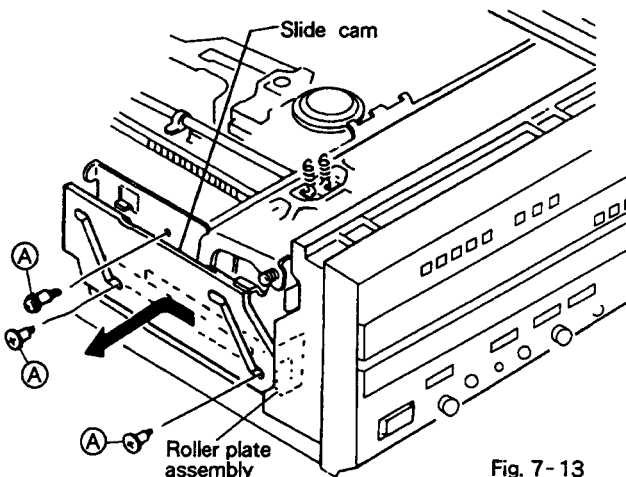

Fig. 7-13

7.10 ASSEMBLING THE MECHANISM SECTION

7.10.1. Positioning the gears

(Since the cam gears are used for the detection of all operation modes in this unit, the cam gears and the tray should be positioned correctly. Reassemble in the following procedure.)

- ① Position three switch levers so that they are nearly parallel (approx. 2mm), as shown in Fig. 7-14(a).
- ② Insert the cam gear so that the end of the spiral groove on the upper surface of the cam gear comes to the position nearest to the shaft located at the front, as shown in Fig. 7-14(b).

(In this case, the cam gear should be set in the position where the angle between the center line of the cam gear and the pin on the cam gear is 45°, by visual checking.)

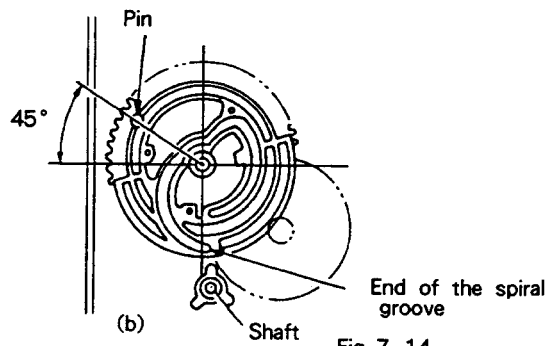
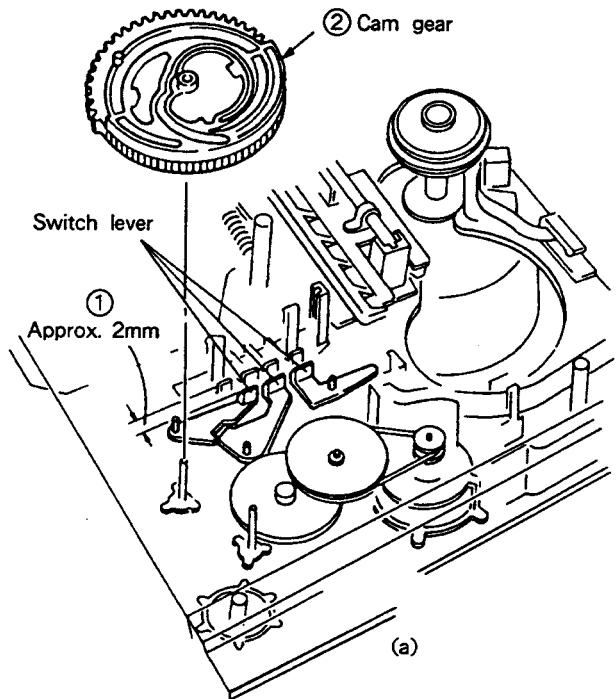

Fig. 7-14

- ③ Mount the spring slanting cam by raising the rack assembly in the direction of the arrow so that the tilt slide section comes under the rack assembly. Then, mount the cam spring. (Fig. 7-15(a))
- ④ Insert the follow gear so that the "L"-shaped section of the follow gear comes to the end of the cam gear, as shown in Fig. 7-15(b).

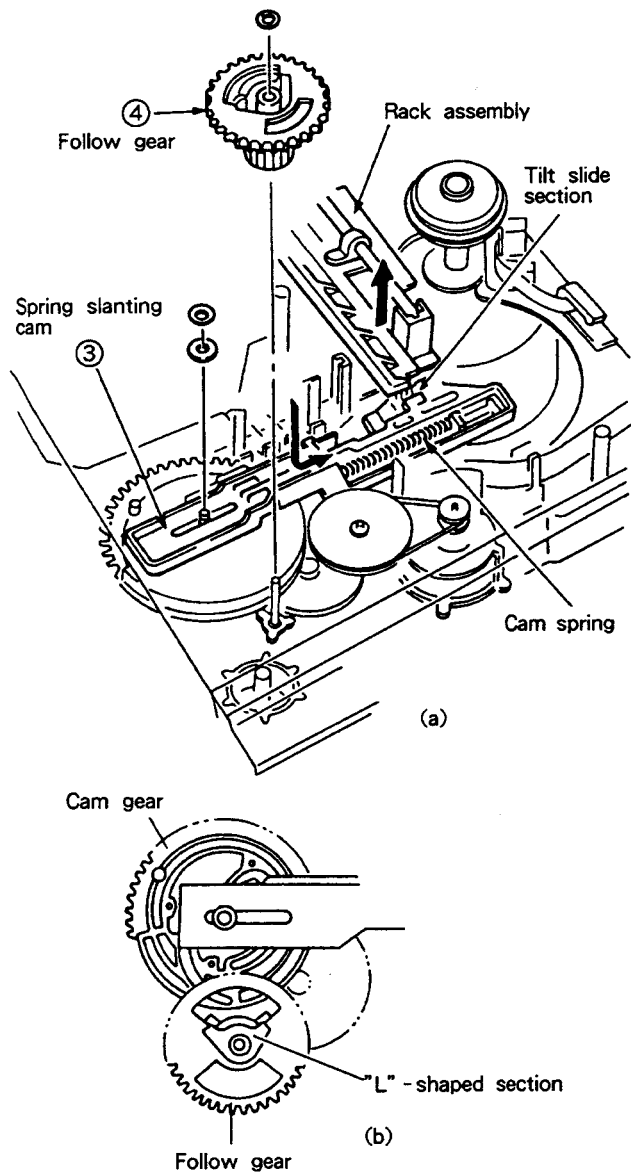

Fig. 7-15

- ⑤ Mount the roller plate assembly in the position where the tooth with the triangle mark (▼) of the follow gear is engaged with the dip of the gear with the short rib on the roller plate gear, as shown in Fig. 7-16.

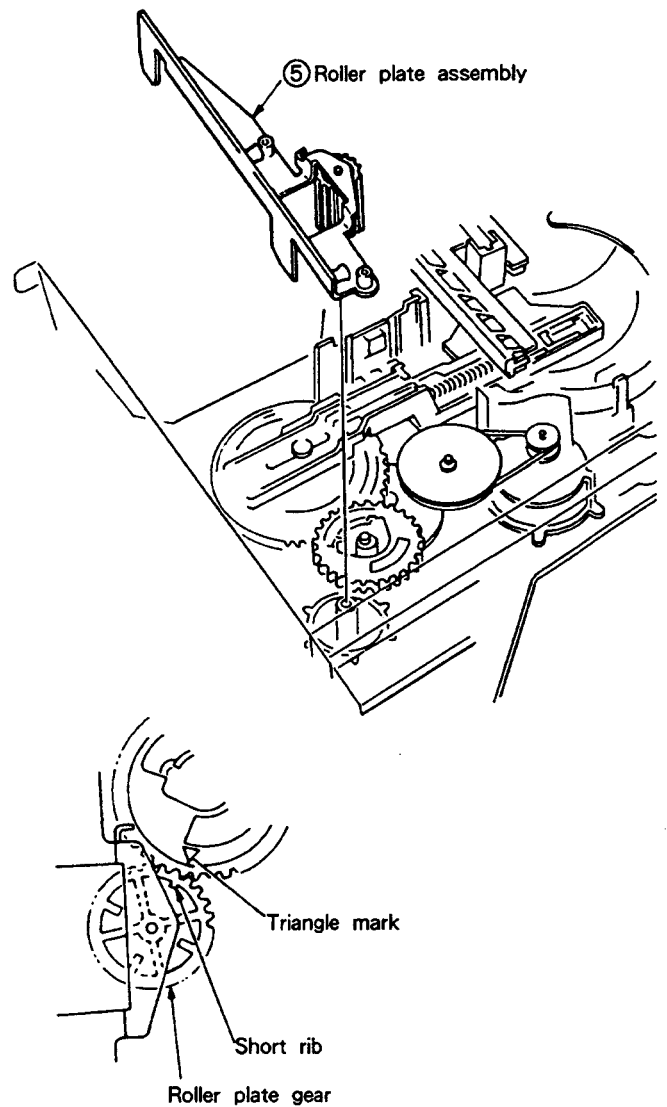

Fig. 7-16

7.10.2 Positioning the tray (Fig. 7-17)

- ① Set the player with the tray open.
- ② Set the roller plate gear so that the roller plate line intersects with the mid-point of missing tooth of the roller plate gear.

(At this time, adjust the position by the method shown in Fig. 7-17, or turn the power ON and use the SKIP (◀◀, ▶▶) buttons in the direction of OUT tilt it stops as shown in Fig. 7-17.)

- ③ Insert the tray.

At this time, the tray can be inserted only when the first missing tooth of the tray gear is engaged with the missing tooth section of the roller plate gear, as shown in the figure.

Tray is easier to insert by pushing upwards.

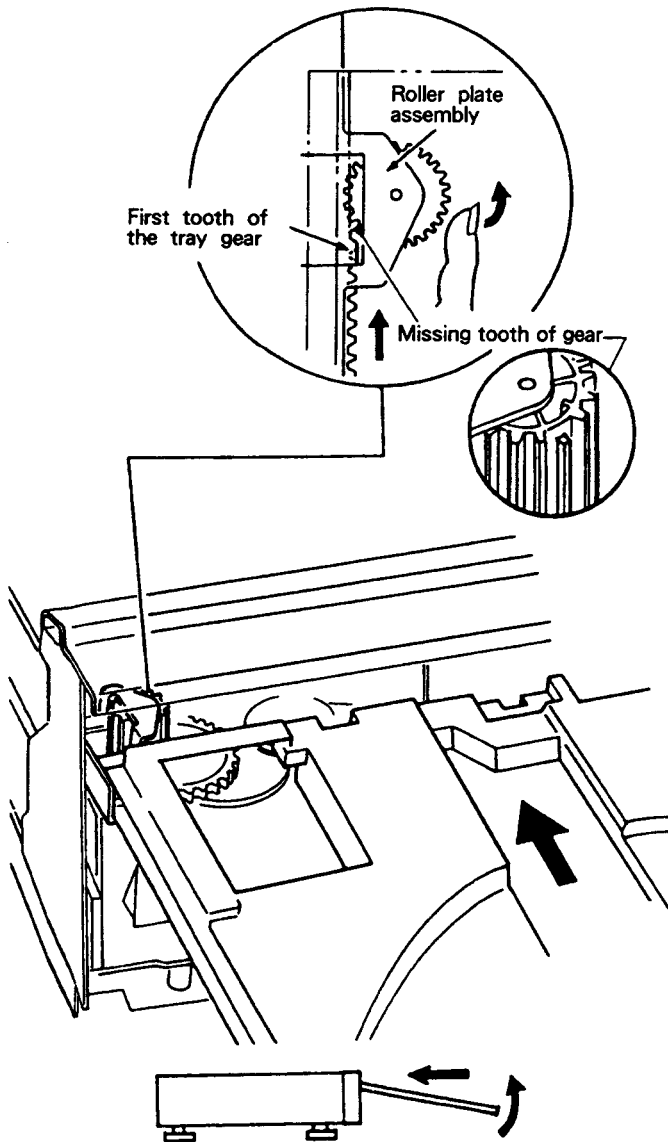

Fig. 7-17

7.10.3 Assembling the servo mechanism base assembly (Fig. 7-18)

When assembling the servo mechanism base assembly, pay special attention to the following points :

- After inserting the tilt shaft in the position shown in Fig. 7-18-1 of mechanism chassis assembly, mount the servo mechanism base assembly in the direction of the arrow so that the tilt shaft does not come over the shaft holder as shown in Fig. 7-18-2.
- The thrust spring should not come over the shaft holder.
- Check that the end of the plate spring is inserted under the base.

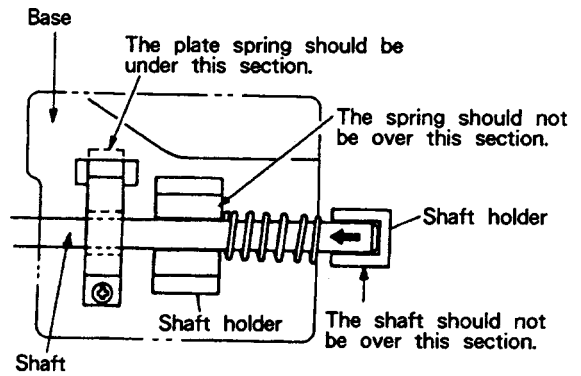

Fig 7-18-1

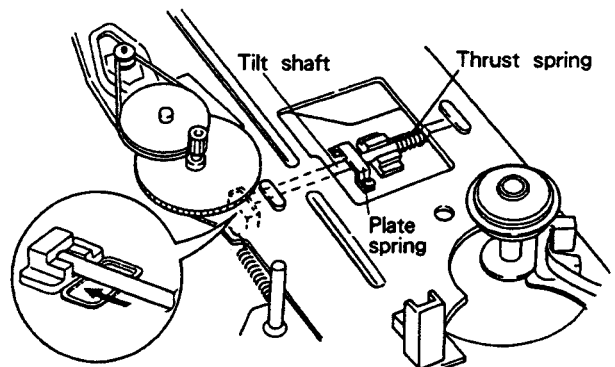

Fig. 7-18-2

7.10.4 Styling of the flexible board (Fig. 7-19)

- ① Bend the flexible board of the pickup assembly by about 45° at the ▲ mark.
- ② Insert the flexible board into the connector.
- ③ Set the flexible board under the protruding section.
- ④ Twist the flexible board by a half turn.
- ⑤ Insert the triangular section.
- ⑥ Further insert the flexible board under the protruding section.

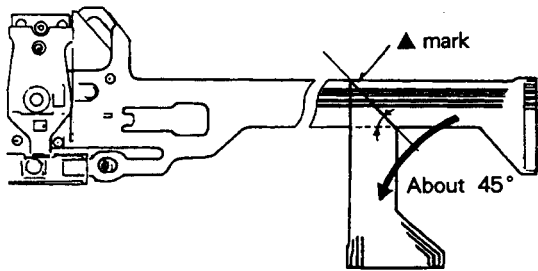

Fig. 7-19-1

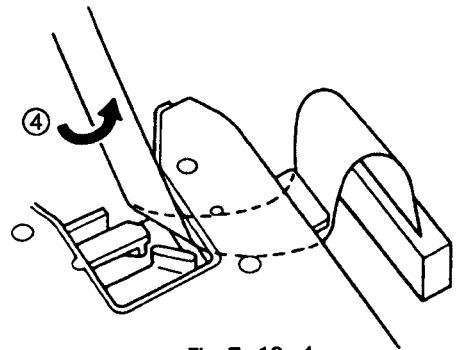

Fig. 7-19-4

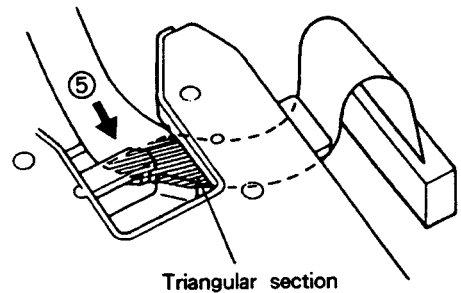

Fig. 7-19-5

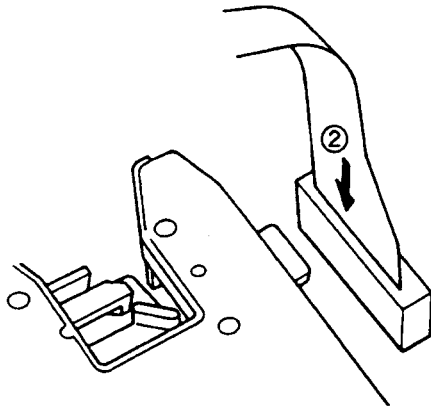

Fig. 7-19-2

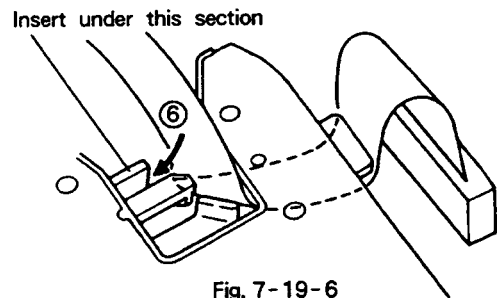

Fig. 7-19-6

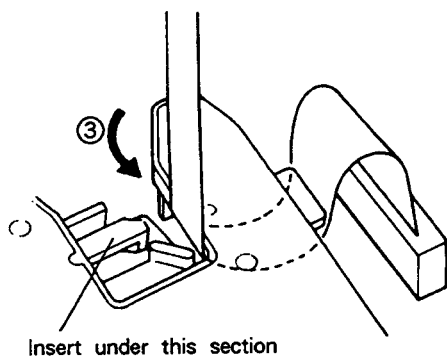

Fig. 7-19-3

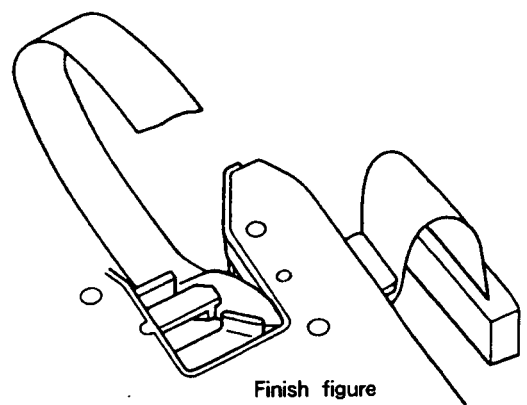

Fig. 6-19-7

7.11 DIAGNOSING THE SYPS ASSEMBLY (Fig. 7-20)

1. Remove the screw fixing the SYPS assembly and keep the SYPS assembly apart about 3cm from the base chassis (See Fig. 7-20-1).
2. Insert a soldering iron between the SYPS assembly and base chassis, alternately desolder the lapping pins of an AC power cord, and remove the lapping pins (See Fig. 7-20-1).
3. Solder the lapping pins through the foil side of the board with the SYPS assembly raised.
The SYPS assembly can be diagnosed for component replacement through the foil side.
(See Fig. 7-20-2).

Notes :

1. Interpose cloth for check so that the SYPS assembly does not touch the chassis.
2. Remove the rear panel when you are difficult to work.

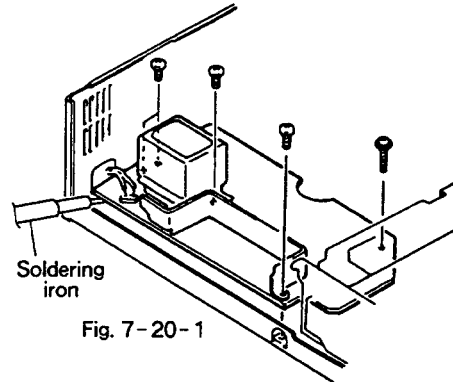

Fig. 7-20-1

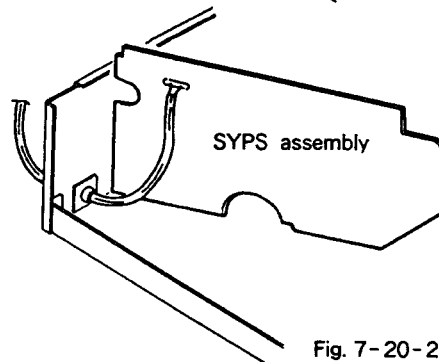

Fig. 7-20-2

8. TEST MODE

8.1 TEST MODE

The player has a test mode function which allows the user to check the player's status on the TV screen by executing the respective key operation.

Also, since the TRK servo opens and closes easily, the test mode is especially useful for mechanical adjustments.

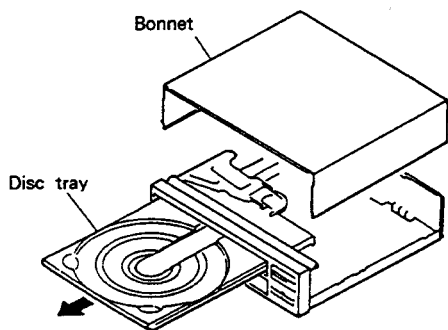

8.3 TEST MODE CANCELLATION

Turn off the power switch.

8.4 PLAYER OPERATION IN THE TEST MODE

Operate the player by selecting a test mode function with the keys on the player or on the remote control unit.

[Sample Key Operation]

< LD Mode >
Disc playback (Normal playback)

(In the Test Mode)

Disc placement → Close tray ▲ → Play ▶ → Close TRK Servo ▶

Note : In the test mode, disc playback will start with the TRK servo open.

8.2 TEST MODE INITIATION

[Procedure]

1. Remove the bonnet and disc tray.
2. Connect the TP303 in the MAIN assembly to GND.
3. Turn on the power switch.

Notes :

After the Test Mode is activated, LEDs light except the REMOTE SENSOR and STEREO LEDs until operating the key.

LED of 7-segment display the Chapter display section "88", and Time display section "88:88".

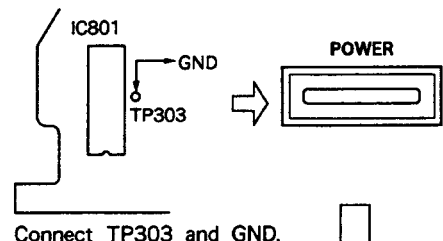

Connect TP303 and GND.

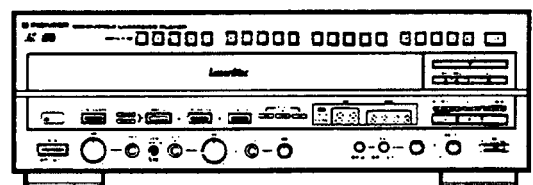

< CD Mode >
Disc playback (Normal playback)

(In the Test Mode)

Disc placement → Close tray ▲ → Move SLD to CD Active area. ◀◀ (Remote control key) → Close TRK Servo ▶

Play ▶

Note : In the test mode, disc playback will start with the TRK servo open.

Table. Operation in the test mode

Function	Player Status	Key Operation	Remarks
Open Tray	STOP mode	▲	
Close Tray	Tray open	▲	
Stop	PLAY mode	■	
Play	Disc placement and tray closed.	▶	<ul style="list-style-type: none"> • Raise up with the TRK servo open. • Raise up with tilt neutral. • The disc type (LD/CD/CDV) is determined when playback starts at the SLDR position during raise up.
TRK Servo Open/Close	PLAY mode	▶	• Each time the PLAY button (▶) is pressed, the TRK servo will open or close.
Still	PLAY mode TRK servo closed.		• Each time the STILL button () is pressed, the player will switch between the PLAY and STILL modes.
SLDR REV SCAN	PLAY mode	◀◀ (* 1)	<ul style="list-style-type: none"> • Press and hold the keys. • With the TRK servo open, the pickup can be damaged if the SLD moves further inward than the lead-in area on the disc. Do not allow the SLD to move further inward than the lead-in area.
SLDR FWD SCAN	PLAY mode	▶▶ (* 1)	<ul style="list-style-type: none"> • Press and hold down the keys. • With the TRK servo open, the pickup can be damaged if the SLD moves further outward than the lead-in area on the disc. Do not allow the SLD to move further outward than the lead-in area.
TILT Neutral	POWER switch ON	□	• Speed down key of the remote control unit.
TILT Servo ON	PLAY mode	□	• Speed up key of the remote control unit.
TILT Minus TIRT Servo OFF	PLAY mode	◀◀ (* 1)	• Press and hold down the keys.
TILT Plus TILT Servo OFF	PLAY mode	▶▶ (* 1)	• Press and hold down the keys.
Screen Display ON/OFF	POWER switch ON	PGM key (* 1)	
Frame search	PLAY mode	+ 10 key ↓ 0-9 key ↓ ▶ (* 1)	<ul style="list-style-type: none"> • In the PLAY mode, press the + 10 key. (The player will standby for the frame No. entry.) • Use the numeric keys (0-9) to enter the frame No.. Then press the player's PLAY key to search. • After the search is completed, the player will return to the operation mode before the search was performed.
LOAD Motor Rotation Clockwise Counterclockwise	Tray open	▶▶ ◀◀ (* 1)	

Note :

(* 1) : Remote control unit key

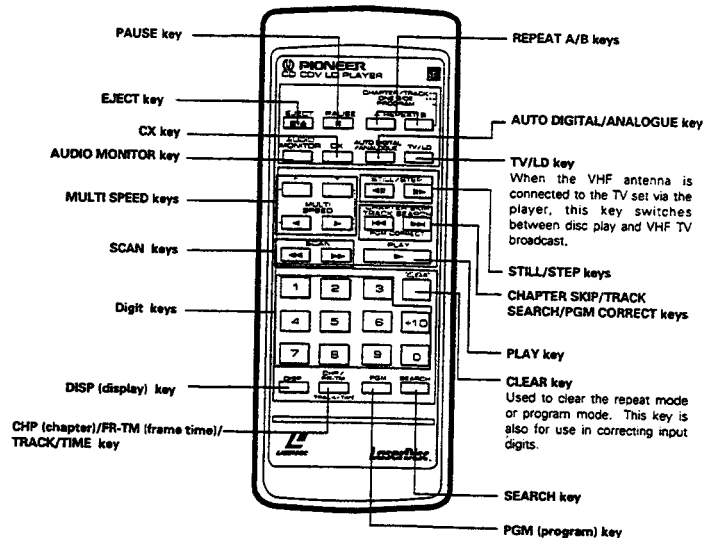

8.5 TV SCREEN AND LED DISPLAYS IN THE TEST MODE

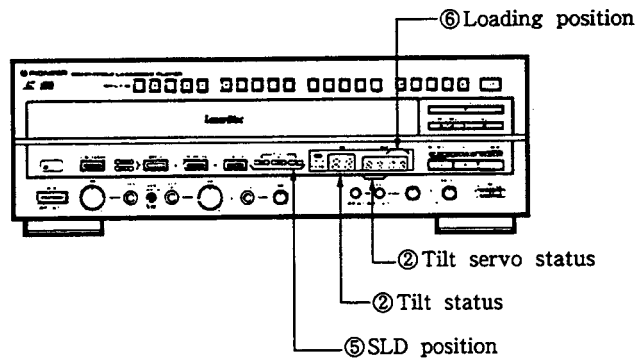
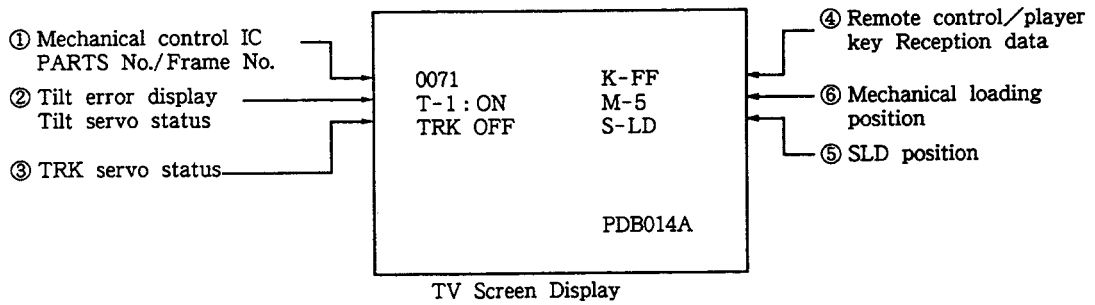

- ① The mechanical control IC (MAIN assembly) part No. will be displayed in the STOP status.
 Frame No. input
 Input frame No. except STOP status.
 F□□□□ : Lead-in
 E□□□□ : Lead-out

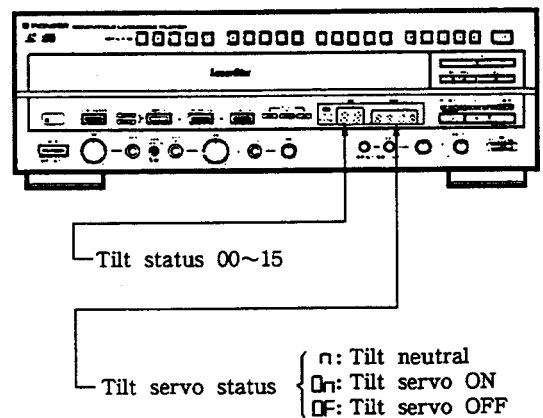

- ② Tilt servo status/Tilt error display
 T-○ : ○○
 Tilt servo status : N...Tilt neutral
 ON...Tilt servo ON
 OFF...Tilt servo OFF
 Tilt error display : 0 Tilt -
 ↓ Tilt neutral
 F Tilt +

- ③ TRK servo status
 TV screen display
 TRK-○○○
 ON...TRK servo close
 OFF...TRK servo open

④ Remote control/Player key reception data

K-○○

See table below

Code	Function	Code	Function	Code	Function	Code	Function	Code	Function	Code	Function	Code	Function
00	0	10	F-SCAN	20		30	10	40	(CHAPT)	50	R-STEP	60	OPN/CLS
01	1	11	R-SCAN	21		31	11	41	(FRAME)	51		61	VC.MUTE
02	2	12		22		32	12	42	SEARCH	52	F-SKIP	62	VC.CHG
03	3	13	CHP/FRM	23		33	13	43	DISPLAY	53	R-SKIP	63	KC #
04	4	14		24		34	14	44	REPT-B	54	F-STEP	64	KC b
05	5	15		25		35	15	45	CLEAR	55	R-MULTI	65	KC 4
06	6	16	STP/OPN	26		36	16	46	SPEED -	56		66	AUD.MOD
07	7	17	PLAY	27		37	17	47	SPEED +	57		67	V.ASIST
08	8	18	PAUSE	28		38	18	48	REPT-A	58		68	ONCEMO
09	9	19		29		39	19	49	(2/R)	59		69	PLY/PAUS
0A		1A		2A		3A	20	4A	(STEREO)	5A		6A	STOP
0B		1B		2B		3B		4B	(1/L)	5B		6B	
0C	DGT/ANL	1C		2C		3C		4C	PROGRAM	5C		6C	
0D		1D		2D		3D		4D		5D		6D	
0E	CX	1E	AUD.MON	2E		3E		4E		5E	TEST	6E	
0F	TV/LDP	1F	+10	2F		3F		4F		5F	ESC	6F	

⑤ SLD position

TV screen display

S-○○○

- CD ... CD active area
- CDV ... CDV active area
- LD ... LD active area
- IN ... CD TOC area

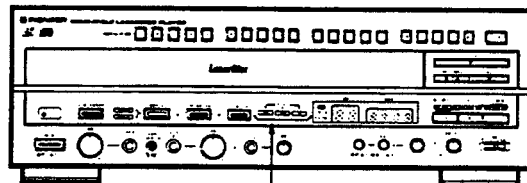

Three disc LEDs are not lighted : CD TOC area
 CD LED light : CD active area
 CDV LED light : CDV video area
 LD LED light : LD active area

⑥ Mechanical loading position

TV screen display

M-○

- 0 ... Tray open
- 1 ... Loading
- 2 ... Standby
- 3 ... Clamped
- 4 ... Tilt minus
- 5 ... Tilt neutral
- 6 ... Tilt plus
- 7 ... Tilt limit

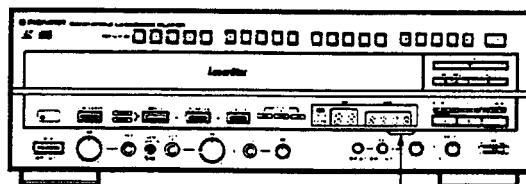

0~7

9. ADJUSTMENTS

9.1 KFCB ASSEMBLY ADJUSTMENT ECHO LEVEL ADJUSTMENT

Note :

As to the adjustments, refer to the ADJUSTMENTS FOR CLD PLAYERS (ORDER No. ARP2064) except adjustment procedure which this service manual is mentioned.

<ul style="list-style-type: none"> ● Purpose : Setting the optimum echo level. ● Symptom when incorrectly adjusted : Sound is interrupted or distorted when playing with echo effect. 			
Measurement equipment and jigs	Measurement equipment connecting point	Player condition	Adjusting points
<ul style="list-style-type: none"> ● Oscilloscope ● Test disc (GGV1002) 	<ul style="list-style-type: none"> ● KFCB assembly Lead wires of C505 and C506 (Minus side) 	<ul style="list-style-type: none"> ● Normal mode ● Play 	<ul style="list-style-type: none"> ● KFCB assembly VR501
Adjustment procedure			
<ol style="list-style-type: none"> 1. Turn the POWER switch OFF. 2. Connect the lead wire (IC113 side) of R510 and pin 8 (+5V) of IC137 in the KFCB assembly, pin 21 of IC113 will be pulled up to +5V. 3. Turn the POWER switch ON. 4. Set the MIC ECHO volume to maximum. 		<ol style="list-style-type: none"> 5. Play for chapter 1 through 3 on the test disc, Adjust VR501 so that the minus side level of C505 and the minus side level of C506 becomes equal. 	
Adjustment diagram			

10. SPECIFICATIONS

1. General

System	LaserVision Disc system and Compact Disc digital audio system
Laser	Semiconductor laser wavelength 780 nm
Power requirements	AC 110V/120V/220V/240V (Switchable), 50/60 Hz
Power consumption	39W
Weight	8.3 kg (18 lbs 5 oz)
Dimensions	420 (W) x 421 (D) x 136.5 (H) mm 16-9/16 (W) x 16-9/16 (D) x 5-3/8 (H) in
Operating temperature	+5°C ~ +35°C (41°F - 95°F)
Operating humidity	5% ~ 90% (There should be no condensation of moisture.)

2. Disc

LaserVision Discs

*Maximum playing times

12-inch standard play disc	1 hour/both sides
12-inch extended play disc	2 hours/both sides
8-inch standard play disc	28 min/both sides 14 min/one side
8-inch extended play disc	40 min/both sides 20 min/one side

Spindle motor speed

Standard play disc	1,800 rpm
Extended play disc	1,800 rpm (inner circumference) to 600 rpm (outer circumference) (For a 12-inch disc)

Compact Discs

DISC	Diameter: 5-inch, 3-inch, Thickness: 1.2 mm
Rotation direction (pickup side)	Counterclockwise
Liner speed	1.2 ~ 1.4m/sec

*Maximum playing time

74 min. 5-inch discs
20 min. 3-inch discs
(For stereo playback)

Compact Discs with Video

Disc	Diameter: 5-inch, Thickness: 1.2 mm
Rotation direction (pickup side)	Counterclockwise
Linear speed	Audio portion: 1.2 ~ 1.4m/sec Video portion: 11 ~ 12m/sec

*Maximum playing time	Video portion: 5 min. (CLV) Audio portion: 20 min. (Digital)
-----------------------------	---

¹* Actual playback time differs for each disc.

3. Video characteristics

Format	NTSC specifications
Video output	
Level	1 Vp-p nominal, sync. negative, terminated
Impedance	75Ω unbalanced
Jack	RCA jack (2 systems)
VHF output	
Channel	Channel 3 or 4 (switchable)
Impedance	75Ω unbalanced
Terminal	F-type jack

4. Audio characteristics

Output level	
During analog audio output	200 mVrms (1 kHz, 40%)
During digital audio output	200 mVrms (1 kHz, -20 dB)
Jacks	Both RCA jacks (2 systems)
Number of channels	2

5. Other Terminals

Control input/output	Both miniature jacks
AUX	RCA jacks
Number of channels	2

6. Accessories

Remote control unit (CU-CLD030)	1
Size "AAA" (IEC R03) dry cell batteries	2
RF antenna cable	1
Video cord	1
Audio cord	1
Antenna adaptor	
(75Ω/300Ω → 75Ω F-type plug)	1
F-type jack - IEC plug adaptor	1
Operating instructions	1

7. Functions

Remote control unit operations (CU-CLD030)

	Function	Standard play Disc (CAV)	Extended play Disc (CLV)	Compact Disc with Video	Compact Disc
Basic Functions	Single-side play	YES	YES	YES	YES
	Pause	YES	YES	YES	YES
	Stop	YES	YES	YES	YES
	Eject	YES	YES	YES	YES
Search	Fast forward (forward and reverse)	YES	YES	YES	YES
	Chapter/Track skip	YES	YES	YES	YES
	Direct chapter/Track number search	YES	YES	YES	YES
	Frame number search	YES	NO	NO	NO
	Time number search	NO	YES	YES	YES
Absolute time search	NO	NO	NO	YES	
Program	Chapter/Track program play	YES	YES	YES	YES
	Program correction	YES	YES	YES	YES
Repeat	Repeat between 2 points	YES	YES	YES	YES
	Memory repeat	YES	YES	YES	YES
	Chapter/Track repeat	YES	YES	YES	YES
	One-side repeat	YES	YES	YES	YES
	Program repeat	YES	YES	YES	YES
Trick play	Still/Step	YES	NO	NO	NO
	Multi-speed (Forward/reverse 9-level variable)	YES	NO	NO	NO
Time display	Elapsed time display	NO	YES	YES	YES
	Absolute time display	YES*1	NO	NO	YES
	Remaining track time display	NO	NO	YES*4	YES
	Remaining total time display	YES*1	YES*1	YES	YES
	Total number of selections, total time display	YES*1	YES*1	YES	YES
Others	CX system ON/OFF	YES*2	YES*2	—	—
	AUTO DIGITAL/ANALOG switch	YES*3	YES*3	—	—
	Audio channel selection (Stereo, 1/L, 2/R)*5	YES	YES	YES	YES

*1 Only discs with TOC

*2 Valid for analog sound playing a disc with the  mark.

*3 Can only be used with discs with digital sound tracks.

*4 Audio part only

*5 Except for KARAOKE mode

NOTE:

The specifications and design of this product are subject to change without notice, due to improvement.

11. PANEL FACILITIES

- Remote control keys with the same names or marks as buttons on the front panel of the player control the same operations as the corresponding front panel buttons.

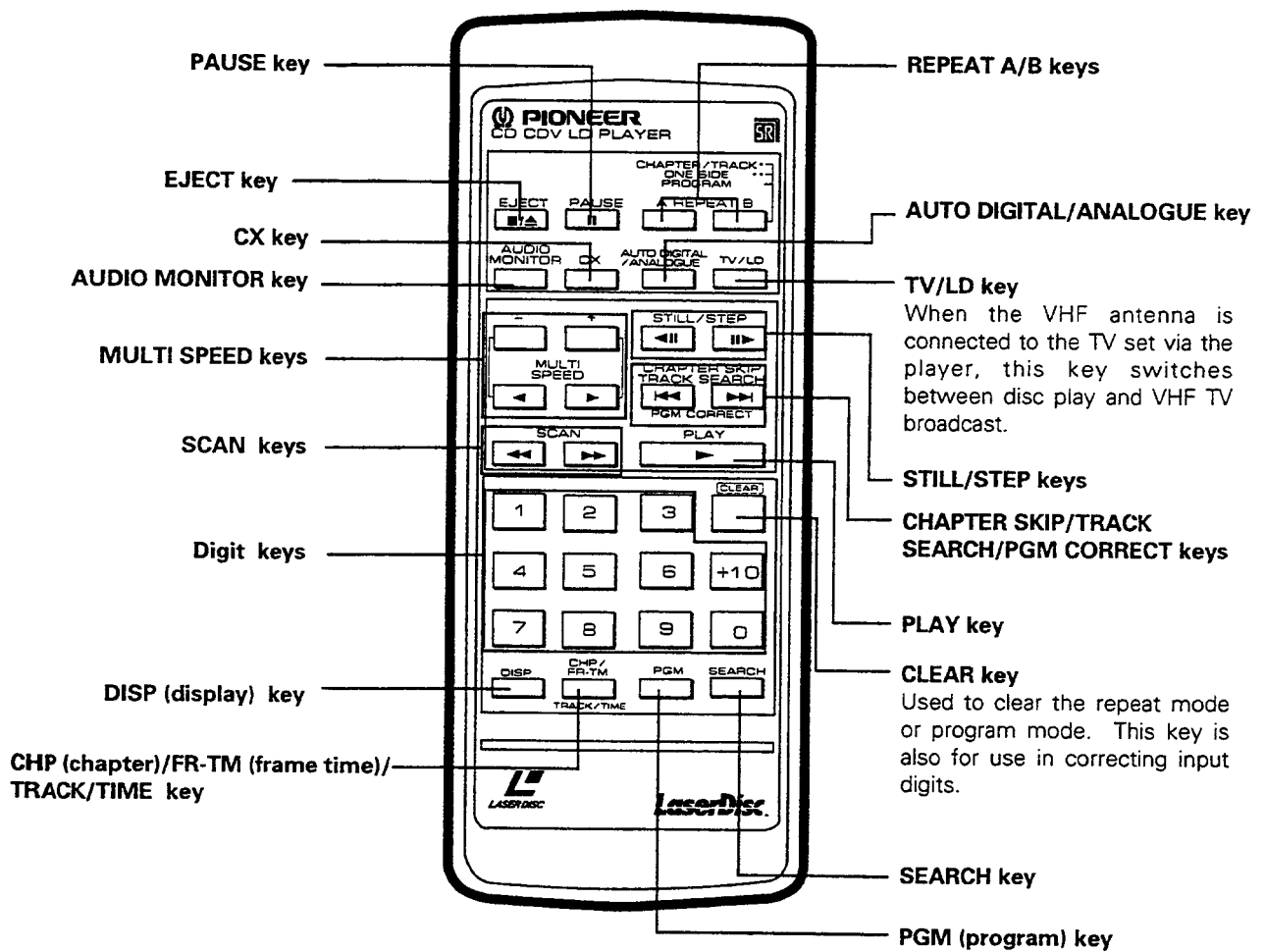

- Most of the buttons on the front panel are used for Karaoke play.

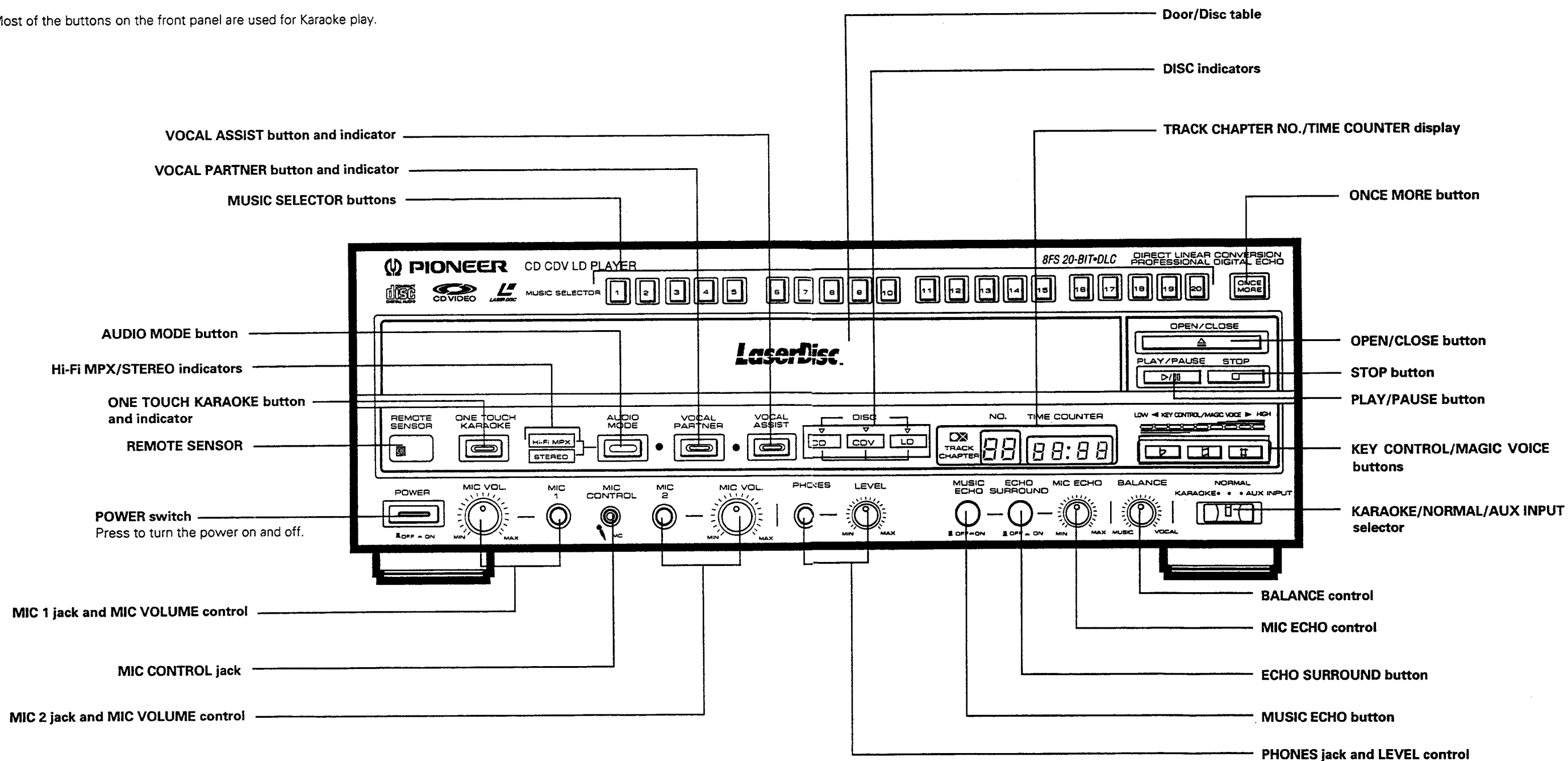

Service Manual

 **PIONEER**[®]
The future of sound and vision.

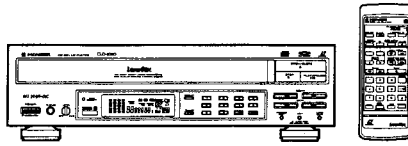

SERVICE GUIDE

ORDER NO.
ARP2063

CD CDV LD PLAYER

CLD-1080

CONTENTS

1. OVERALL BLOCK DIAGRAM	4
2. FOCUS(FOCS), TRACKING(TRKG), AND SLIDER(SLDR) SERVOS (Description of HA11529)	7
3. VIDEO SIGNAL DESCRIPTION	17
4. TBC (TIME BASE CORRECTOR) SECTION OUTLINE	23
5. AUDIO SIGNAL DESCRIPTION	29
6. CONTROL SYSTEM	38

PIONEER ELECTRONIC CORPORATION 4-1, Meguro 1-Chome, Meguro-ku, Tokyo 153, Japan

PIONEER ELECTRONICS SERVICE INC. P.O. Box 1760, Long Beach, California 90801 U.S.A.

PIONEER ELECTRONICS OF CANADA, INC. 505 Cochrane Drive, Markham, Ontario L3R 8E3 Canada

PIONEER ELECTRONIC [EUROPE] N.V. Keetberglaan 1, 2740 Beveren, Belgium

PIONEER ELECTRONICS AUSTRALIA PTY. LTD. 178-184 Boundary Road, Braeside, Victoria 3195, Australia TEL: [03] 580-9911

© **PIONEER ELECTRONIC CORPORATION 1990**

FJ MAY. 1990 Printed in Japan

1. OVERALL BLOCK DIAGRAM

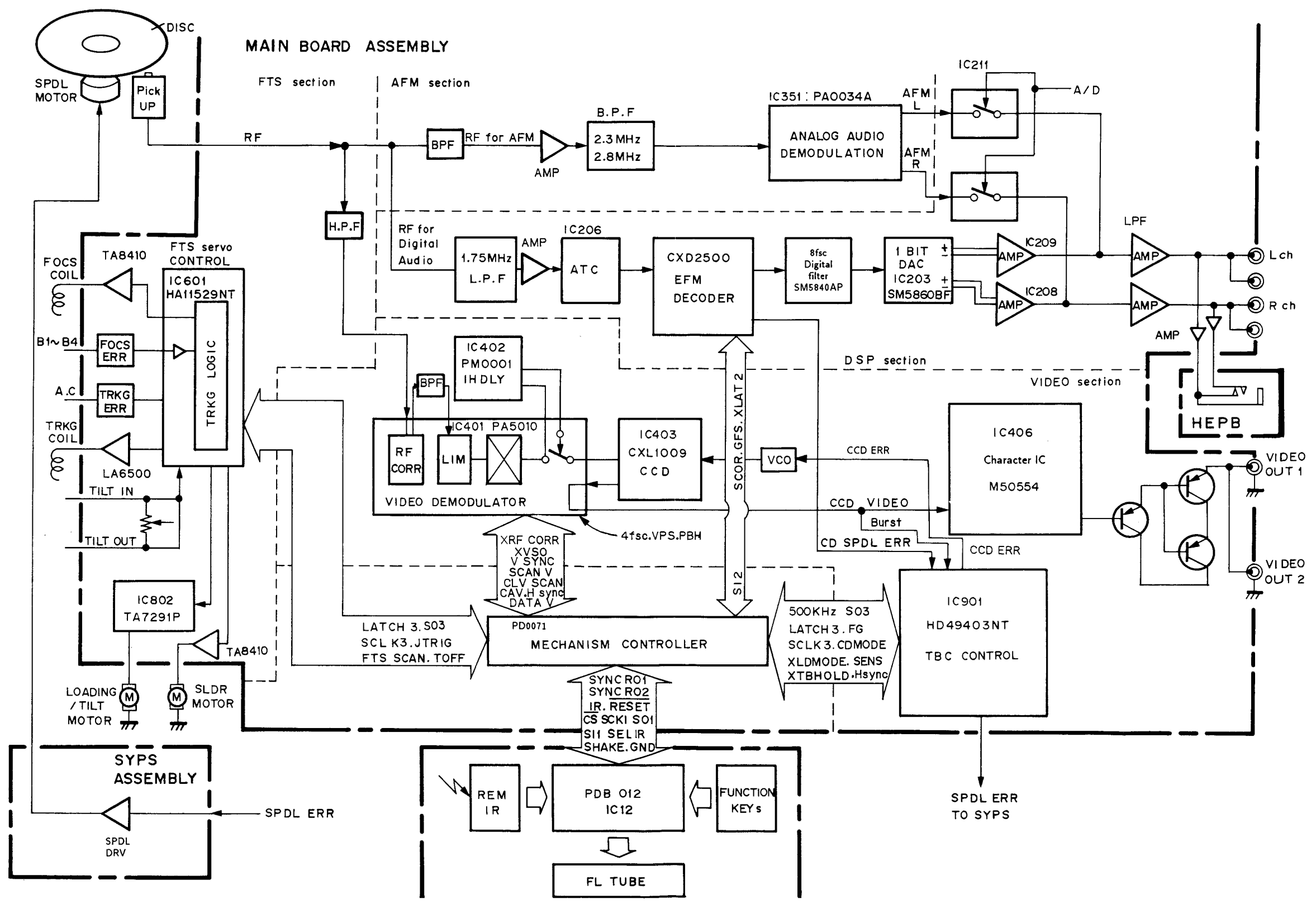

FTS BLOCK DIAGRAM (FCS, TRK, SLDR Servo)

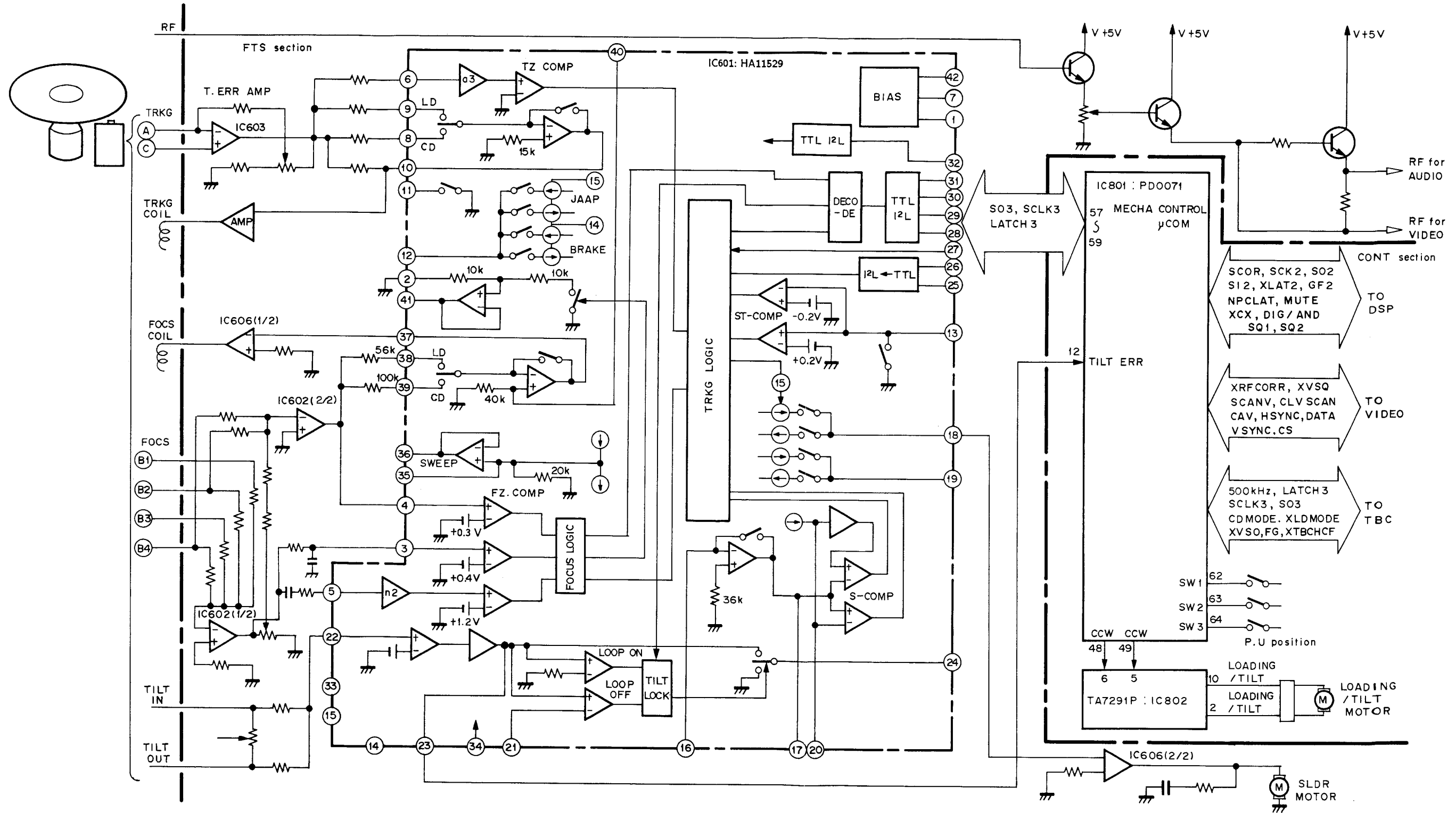

2. FOCUS (FCS), TRACKING (TRKG), AND SLIDER (SLDR) SERVOS (Description of HA11529)

(1) Outline

The HA11529 is an analog/digital bipolar IC. It is used by the FTS servos (FOCS, TRKG, and SLDR servos) and has the following functions :

1. FOCS servo control. (It controls the leading-in to the FOCS servo loop. Gain control.)
2. TRKG servo control (loop ON/OFF, track jumping, and brake control during SCAN).
3. SLDR servo control (loop ON/OFF, variable-speed playback, and motor PWM drive).
4. TILT servo control (loop ON/OFF).
5. CD/LD servo characteristic switching. (FOCS, TRKG)
6. The above functions are controlled by the 8-bit serial data which passes through the serial buses (DATA, CLK, LATCH).

The 8-bit serial data's commands are as follows.

MODE	ADDRESS				DATA			
	D7	D6	D5	D4	D3	D2	D1	D0
SCAN MODE CONT	1	0	0	0	SCAN SPEED 1	SCAN SPEED 2	SCAN SPEED 3	1:SCAN ON 0:SCAN OFF
SERVO MODE CONTROL 1	1	0	0	1	FOCS 1:ON 0:OFF	DIRECTION 1:FWD 0:RVS	TILT 1:ON 0:OFF	1: LD 0:CD
SERVO MODE CONTROL 2	1	0	1	0	TRKG Zero cross output 1:1/256 0:Through	TRKG 1:OFF 0:ON	TEST 1:TEST 0:NORMAL	

(2) HA11529 Terminal Functions

Pin No.	Pin Function
1	Vee: -5V
2	FOCS ERROR signal input: OP AMP input to which a SW is connected for gain control during SCAN operation.
3	FOCS SUM input: For DISC detection. Comparator input threshold is + 0.4V.
4	Comparator input threshold for the FOCS S-curve detection is +0.3V.
5	Comparator input threshold for MAIN BEAM ON/OFF track detection is +1.2V. FOCS SUM input.
6	TRKG ERROR input: Comparator input threshold for TRKG ERROR zero cross detection is 0V.
7	GND
8	TRKG ERROR AMP for CD input
9	TRKG ERROR AMP for LD input
10	TRKG ERROR AMP output. TRKG servo phase compensation is connected between this pin and pin 8.
11	Output for switching the TRKG servo loop characteristics during track jump. (Open or Close)
12	Outputs the actuator drive and brake pulse during track jump and the actuator brake pulse during SCAN.
13	Window comparator input to detect the amount of movement in the TRKG actuator during SCAN. Threshold voltage is 0.2V. Actually, an FTS SCAN signal is being input.
14	Current setting terminal for TRKG actuator brake.
15	Current setting terminal for pins other than pin 14.
16	TRKG RTN input : TRKG RTN input for SLDR servo.
17	SLDR servo amp output: During play, the SLDR motor is PWM driven and at that time this pin becomes the window comparator input.
18	SLDR drive signal output during play or when high speed slider is in operation.
19	SLDR drive signal output when SLDR is operating at low or mid speeds. (Not used.)
20	Capacitor connected pin for setting the slope of the reference triangular wave for the SLDR motor PWM drive during play.
21	Resistor connected to set comparator threshold for turning off the TILT servo drive.
22	TILT ERROR input: OP amp input.
23	A VR is connected for setting the TILT servo gain with the output of the OP amp from pin 22.
24	Output for TILT motor drive.
25	T-CROSS output : TRKG ERROR zero cross count output. Depending on the serial data command, output may be divided by 256.
26	F-LOCK output: "Low" when FOCS lock activated.
27	J-TRIG input: Triggered at startup. "Low" under normal operating conditions.
28	RESET input:
29	LATCH input: Serial interface bus to the system CPU.(pins 29,30,31) Data is latched on the trailing edge.
30	SDATA input: 8-bit serial command data input.
31	SCLK input: clock for serial data transmission.
32	500kHz input: internal logic clock input. About 450kHz.
33	TEST pin: Normal state is "Low". (Not used.)
34	Pin for setting the injection current used by internal I ² L logic.
35	Capacitor connected pin for setting the lens UP/DOWN cycle when FOCS ON is activated.
36	Drive voltage output for lens UP/DOWN.
37	FOCS ERROR amp output: FOCS servo phase compensation is connected between pins 38 and 39.
38	FOCS ERROR amp LD input.
39	FOCS ERROR amp CD input.
40	Pin with connected offset adjustment VR that uses the uninverted FOCS Error amp input.
41	Op amp output for FOCS gain control. (Not used.)
42	Vcc: +5V.

(3) Function Description

FOCS System

1. FOCS leading-in operation

The FOCS servo leading-in operation is executed when the objective lens is moved UP or DOWN and the DSUM (pin 3) and the FE (pin 4) inputs turn ON the FOCS loop when the FOCS lock conditions are met.

If defocusing occurs due to disc scratches, etc., a voltage of +0.6 V will be output to output pin 36 for about 0.5S when the FOCS servo loop is turned OFF. The lens will then switch to the UP operation again.

2. FOCS down and leading-in again

During playback, if the DSUM (pin 3) input falls to +0.4 V or less due to disc scratches, external vibration, etc., the abnormal condition will be detected and the FOCS servo loop will turn OFF. At the same time, the objective lens will go UP or DOWN automatically and turn ON the FOCS servo loop when the conditions described in "1." are met.

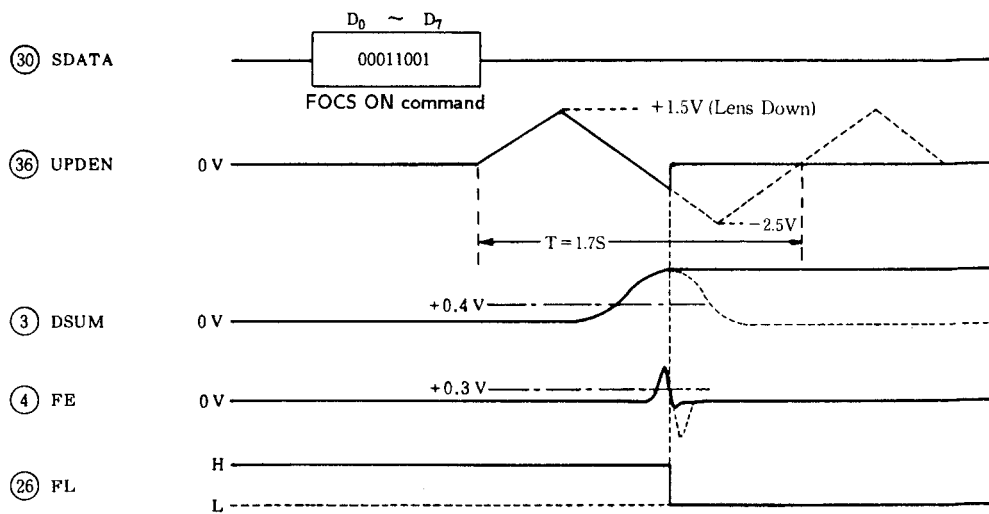

* The dotted line indicates the waveform when the FOCS servo loop is not ON.

Fig. FOCS servo pull in Timing Chart

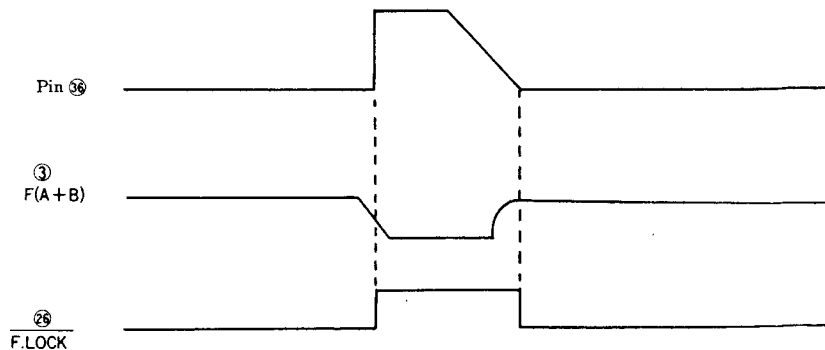
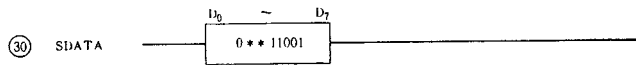

Fig. Defocus Timing Chart

3. CD/LD switching

The FOCS servo's loop gain and phase compensation characteristics are switched depending on the type of disc (CD or LD) being played back. The serial data bit for switching between CD and LD is in the same address as the FOCS ON command bit. Both can be set with a single transfer.

i) Focus ON command when the CD mode is set.



ii) FOCS ON command when the LD mode is set.

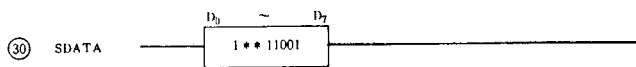

iii) When the CD/LD mode is switched during playback (CD mode → LD mode).

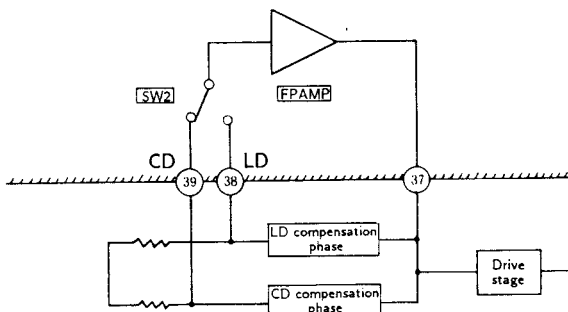
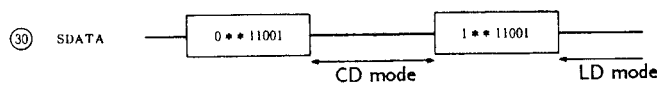

Fig. CD/LD switching

TRKG System

1. Track jump operation

The track jump starts when the jump trigger input's startup edge is received from JUMP (pin 27). The acceleration/deceleration pulse is switched by looking at the tracking error's zero cross. Also, SW12 and SW24 will operate in concert during the jump period. SW12 is used for switching the TRKG loop characteristic and SW24 is used for the TRKG error's zero cross phase adjustment.

The forward jump or reverse jump is switched by the serial data transfer.

The jump trigger signal controls the input signal to 6P so that it becomes advanced in phase.

i) Forward Jump

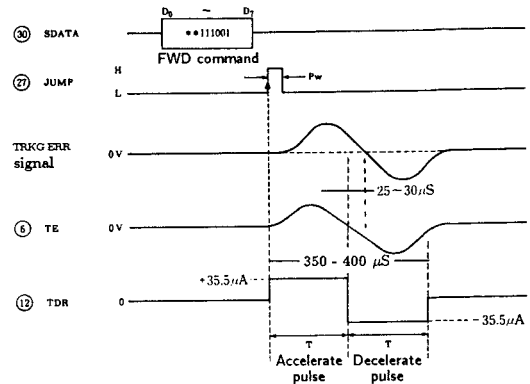
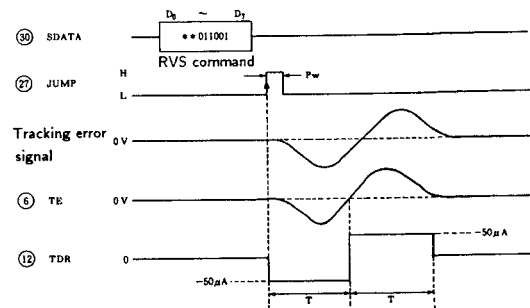

Fig. FWD JUMP Timing Chart

ii) Reverse Jump



Note: The jump trigger signal is normally LOW. The pulse width of Pw is set at 30µs.

Fig. Reverse jump Timing Chart

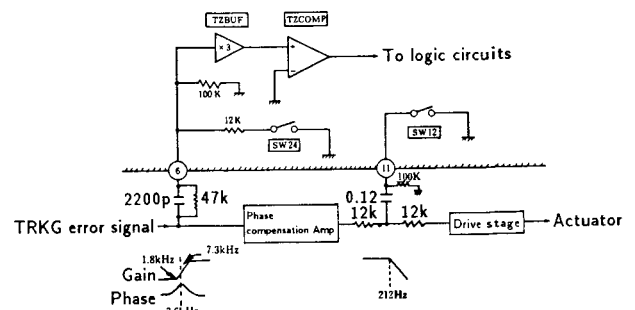

2. Scan operation

During low- to medium-speed scanning, the TKRG servo detects the actuator's displacement with the ST (pin 13) input. Then it turns OFF the loop and turns it ON again when TE's (pin 6) error signal falls below the stipulated frequency.

During the loop OFF period, the brake pulse will be output from TDR (pin 12) based on the timing chart below. The polarity of the timing pulse will be determined by the polarity of the signal that is input to ST (pin 13), rather than by the serial data transfer's direction setting. The brake pulse's duty is automatically set to five steps (50% - 100%) according to the actuator speed detected by TE (pin 6). Also, the adjustment of the brake current IB is enabled by BEST (pin 14).

In order for the system controller to determine the TRKG servo loop's open and closing timing during SCAN for 13P, the FTS SCAN signal below is input.

This signal is input to pin 12. Since its polarity is reverse that of the brake pulse, it improves the convergence during braking.

The FTS SCAN signal's cycle will be 128 mS.

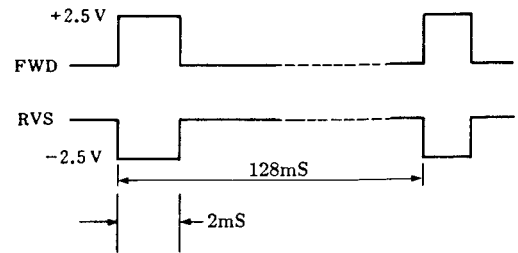

i) Forward scan

T.OFF changes FOCS BAL signal to optimize TRKG open/close during SCAN mode.

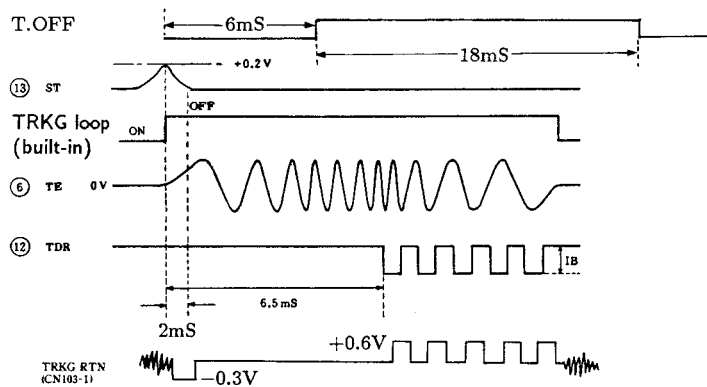

Fig. Forward Scan Timing Chart

ii) Reverse scan

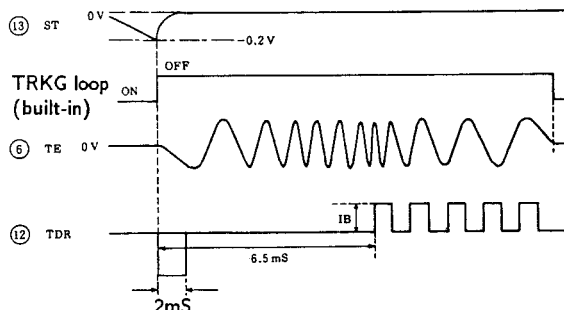
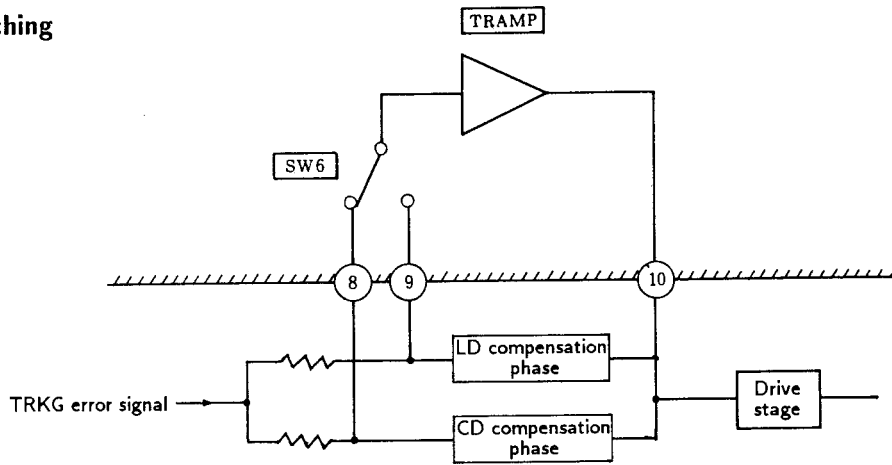

Fig. Reverse Scan Timing Chart

3. CD/LD switching

CD/LD switching can be done in the same way as for FOCS servo CD/LD switching.

CD/LD switching



4. TRKG loop ON/OFF control

The TRKG loop can be switched ON or OFF by the serial data transfer.

TRKG servo loop ON/OFF

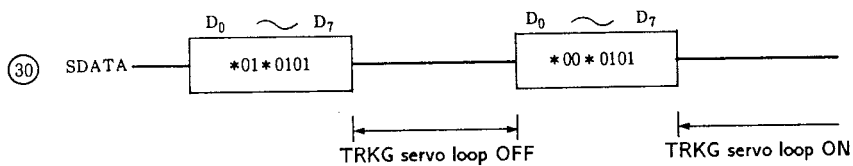

5. TRKG count

The track passing count during high-speed scanning which are counted by the FTS control IC are through output from TCNT(pin 25).

This signal is used for the misclamp detection when playback starts and the track count during CD search.

After playback starts, the misclamp detection sets the TRKG servo to an open loop. If there are 1,600 track passes (TRKG count, 5 passes: Approx. 1mm eccentricity) for one disc revolution (for FG24), it will be deemed normal. Any more track passes will be deemed as a misclamp and the disc will be ejected.

Slider System

1. Normal playback mode operation

During normal playback, the TRKG actuator drive current's DC component undergoes PWM modulation by SCOMP1 and SCOMP2. This PWM pulse turns ON SW16 and SW17 and outputs the drive signal.

The inclination of the standard triangular wave can be changed by the capacitor connected to SLP (pin 20).

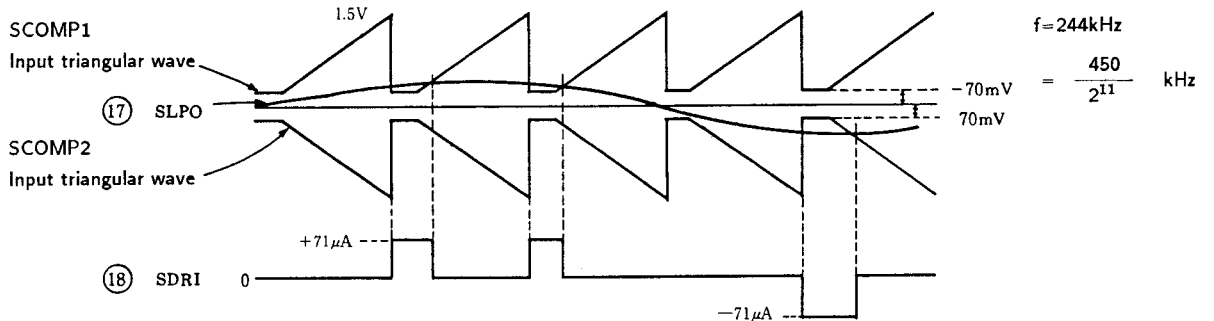

Fig. SLDR servo Operation

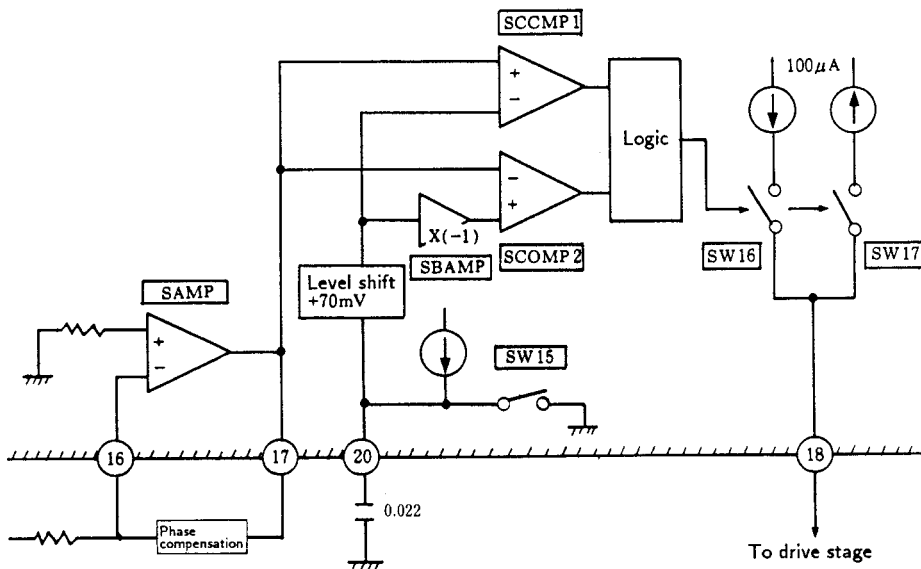

Fig. Serial Data transfer during Scan mode Operation

2. Scan mode operation

During a scan operation, the SLDR servo loop is turned OFF and the signal for the speed set by the serial data transfer is output from SDR1 (pin 18).

i) High-speed scanning

With the serial data transfer shown on the right, SW16 or SW17 can be turned ON. A $\pm 100\mu\text{A}$ drive signal is output from SDR1 (pin 18).

The direction will go according to the serial data transfer's direction setting.

With the pairing of the 10000001 high-speed scan command and the 10001110 SLDR servo loop OFF command, the SLDR's drive voltage is controlled and the scan speed is set.

ii) Low- to medium-speed scanning

The player doesn't use HA11529 pin 19, so the scan speed is set by duty ratio. The same as the high-speed scanning described above.

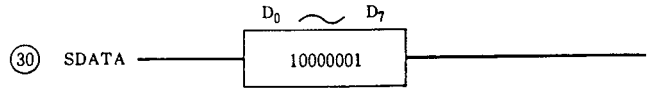

VIDEO SIGNAL BLOCK DIAGRAM

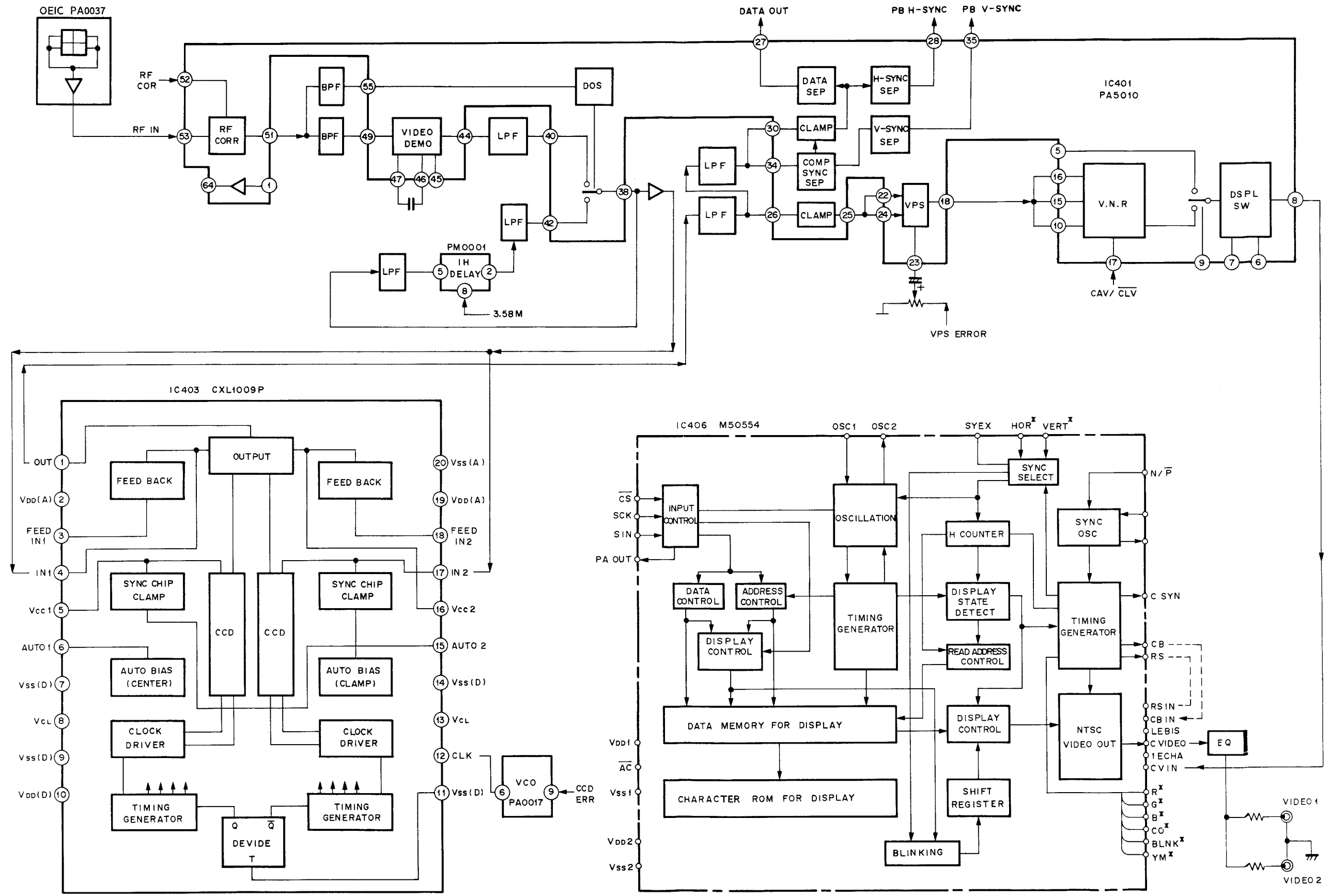

3 VIDEO SIGNAL DESCRIPTION

3.1 PA5010 Description

After the RF signal (output from PA0037 on the pickup Ass'y) undergoes gain adjustment, it is input to pin 53 of PA5010. The signal undergoes RF correction. Then its waveform is shaped by the internal limiter circuit and the signal is demodulated. The demodulated video signal passes through the 5MHz low-pass filter and the de-emphasis circuit. Then it is re-input from pin 40. At the same time, it undergoes dropout detection by DOS (dropout sense). If there is any dropout, the internal SW is switched so that the 1H delayed video signal is inserted.

PA5010 Internal Block Diagram

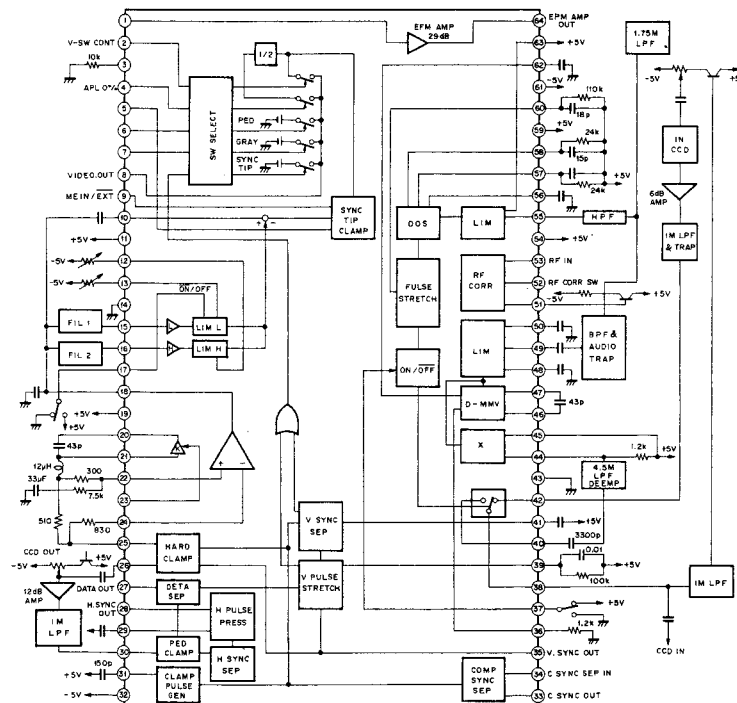

The video signal that is output from pin 38 of PA5010 is input to pins 4 and 17 of IC403 CXL1009. This is where the time base error's high-frequency component generated by the disc's eccentricity, etc., is removed.

The CCD video signal that is output from pin 1 of IC403 is input to pin 26 of IC401. The pedestal section is key clamped. Then after passing through the VPS (Video Phase Shifter) and VNR (Video Noise Reduction), the signal is output from pin 8. Also, the composite sync (PB-C sync), playback vertical synchronizing signal (PB-V Sync), playback horizontal synchronizing signal (PB-H Sync), and the V blanking period data (Philips code) are extracted from the video signal that is input from pin 34.

PA5010 External View

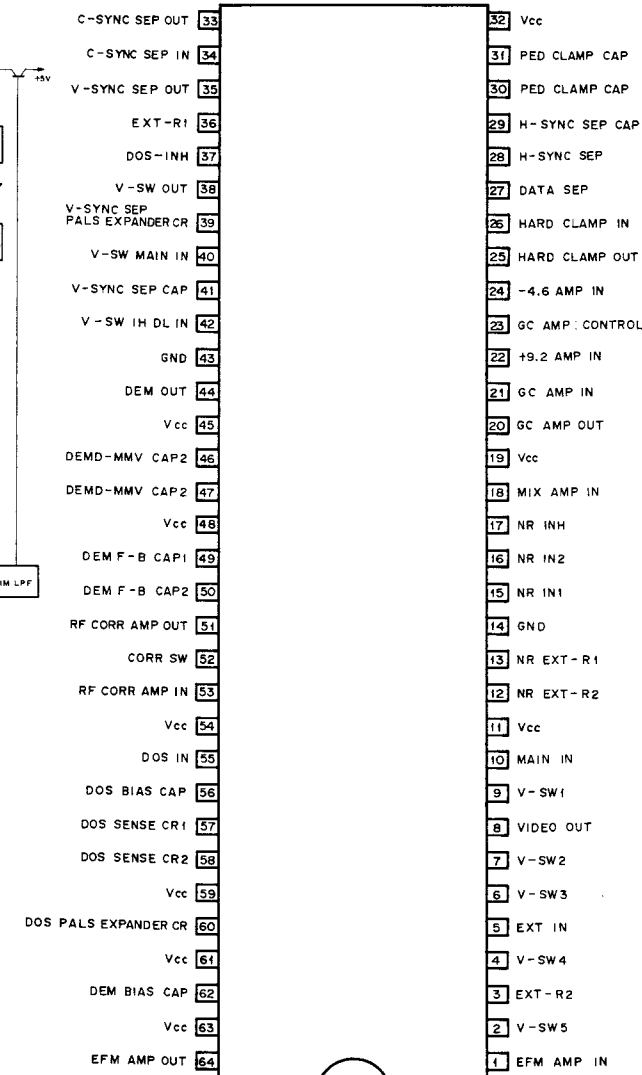

3.2 CXL1009 Description

PA5010 output pin 38's video signal is input to pins 4 and 17 of CXL1009. CXL1009 is a CMOS CCD-dedicated IC. The clock time is controlled by the error signal obtained by the phase comparison between the burst signal and the reference signal (3.58MHz). The CCD variable delay line's delay time is thereby changed.

CXL1009 Internal Block Diagram

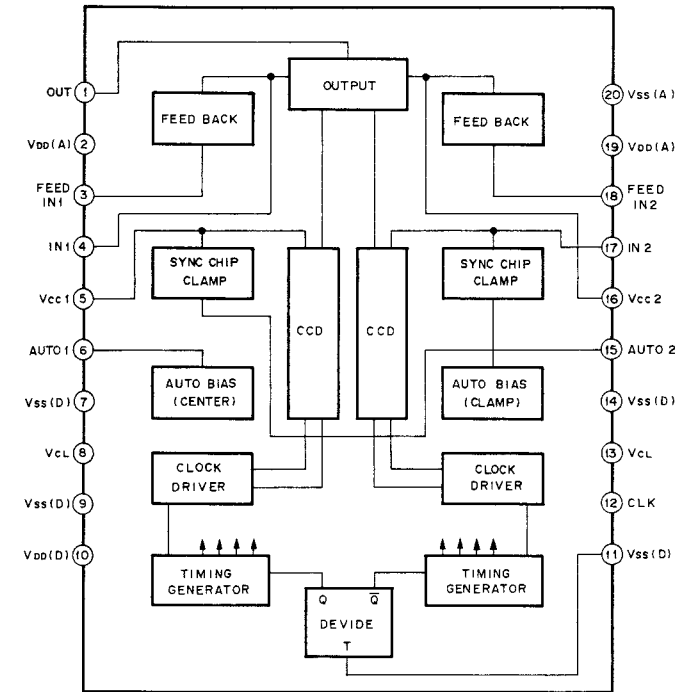

CXL1009 Pin Description

PIN No.	SYMBOL	I/O	PIN DESCRIPTION
1	OUT	O	OUTPUT
2	VDD (A)		Power supply input 1 (analog)
3	FEED IN1	I	Feedback input 1
4	IN1	I	Input 1
5	VCC1	I	Gate 1
6	AUTO1	O	Auto Bias 1
7	VSS(D)		GND (digital)
8	VCL		Power supply input 2(digital)
9	VSS(D)		GND (digital)
10	VDD(D)		Power supply input 1(digital)
12	CLK	I	Clock input
13	VCL		Power supply input 2(digital)
14	VSS(D)		GND(digital)
15	AUTO2	O	Auto Bias 2
16	VCC2	I	Gate 2
17	IN2	I	Input 2
18	FEED IN2	I	Feedback input 2
19	VDD(A)		Power supply input 1(analog)
20	VSS(A)		GND(analog)

3. 3 M50554 Description

M50554 is an IC which uses the silicon gate CMOS process and controls the TV screen character and pattern displays. The video signal demodulated by PA5010 is input to pin 13 (CVIN) of M50554. During superimposition, it overlays the character output.

The character data consists of 16 bits. The lower 11 bits contain the data, the next bit contains the parity code, and the data of the remaining upper 4 bits are all 0. The character data is input from pin 8 (SIN) in serial.

The address consists of 16 bits. The lower 8 bits are the effective address. The next 3 bits are 0. The next bit is the parity code and the data of the remaining upper 4 bits is all 0. After CS signal shutdown, SCK's 16 bits become the address. For the input data thereafter, the address is incremented for every 16 bits.

M50554 Data Configuration

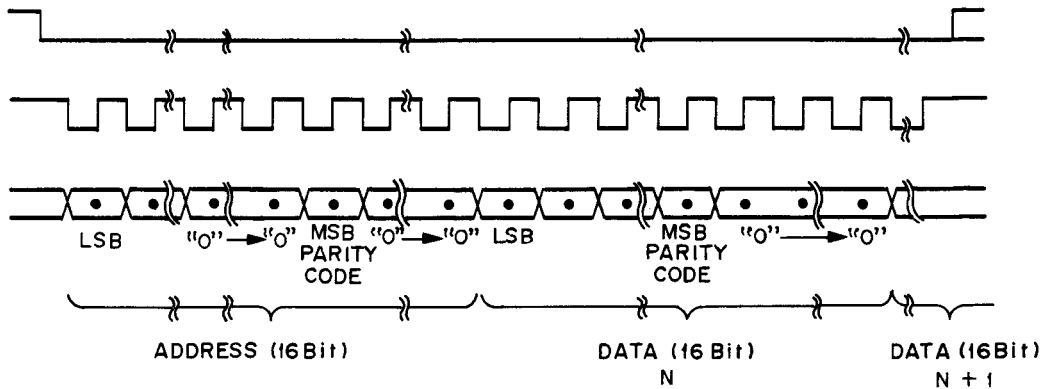

M50554 Internal Block Diagram

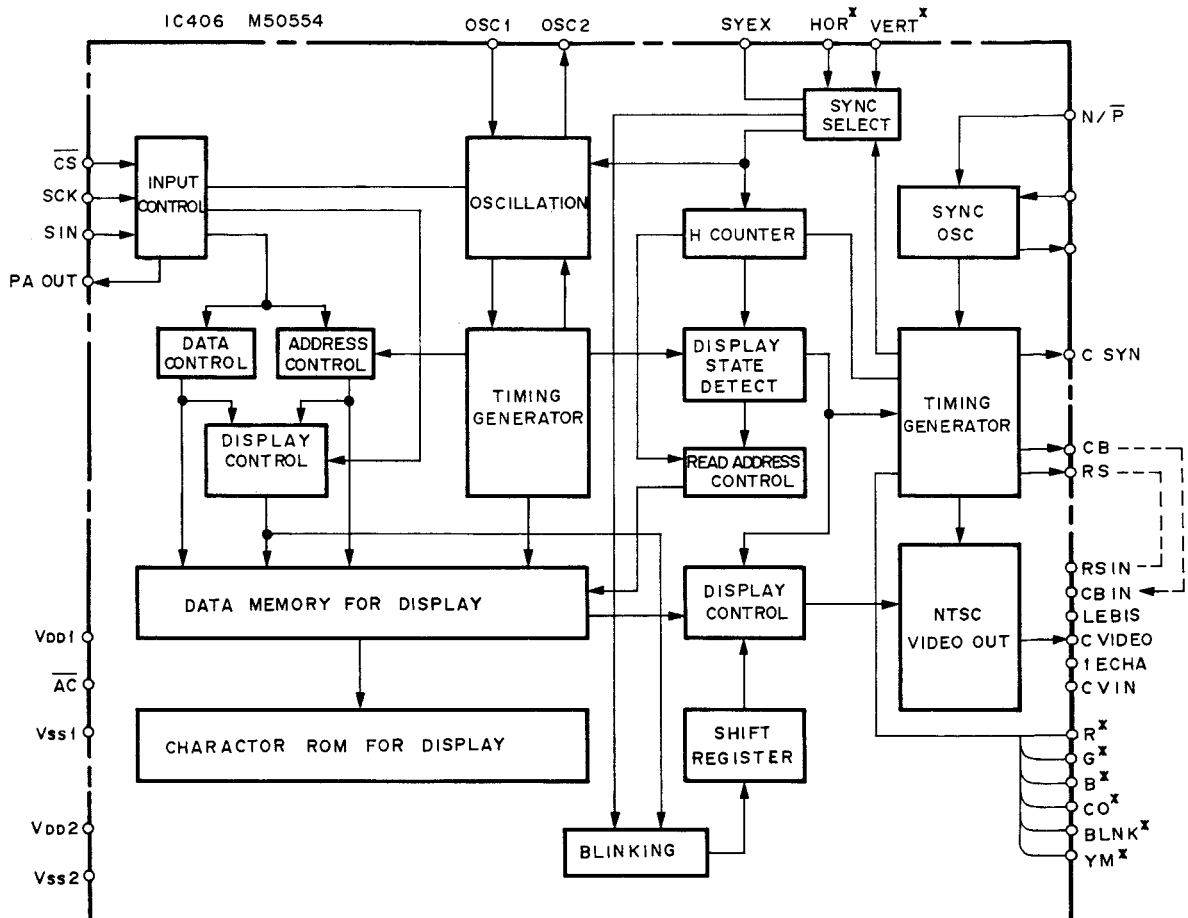

M50554 Pin Description

No.	SYMBOL	PIN NAME	DESCRIPTION
1	Vss1	Ground terminal	Connect to GND with the digital circuit's ground terminal.
2	SCK	Serial clock input	When the CS terminal is "Low", the SIN serial data will be taken when SCK starts up. Hysteresis input. Pull-up resistor is built-in.
3	AC	Auto clear input	When "Low", the IC's internal circuit is reset. Pull-up resistor is built-in. Hysteresis input.
4	OSC1	External oscillation circuit	These terminals are for an externally-attached oscillation circuit for the display. The standard oscillation frequency is about 7 MHz.
5	OSC2		This oscillation frequency determines the TV screen horizontal direction's display position and the character width.
6	N/P	NTSC/PAL switching input	This is a synchronizing signal generation switching terminal for NTSC or PAL. When "H", the NTSC synchronizing signal will be generated. And when it is "L", the PAL synchronizing signal will be generated. Pull-up resistor is built-in.
7	CS	Chip select input	This is the chip select terminal. It will be set to "L" for serial data transfers. Pull-up resistor is built-in.
8	SIN	Serial data input	The data and address of the display control register and the display data memory are input as serial. Pull-up resistor is built-in.
9	PAOUT	Parity output	This is an odd parity output which does 1 bit error detection on the SIN's 1 word.
10	SYEX	Synchronizing signal switching input	This is a switching terminal for the external synchronizing signal or the internal synchronizing signal. When "H," it will be set to the external synchronizing signal mode. And when "L," it will be set to the internal synchronizing signal mode. The SYEX consists of EX registers for addresses 2, 4, and 3 in the display control register, and the internal synchronizing priority's logical sum. Pull-up resistor is built-in.
11	Vss2	Ground terminal	Connect to GND with the analog circuit's ground terminal.
12	CVIDEO	Composite video output	This is the composite video signal's output terminal. It outputs a 2Vp-p composite video signal. During a superimposition, the signal is output after the character output, etc., is layered on the CVIN signal.
13	CVIN	Composite video input	This is the composite video signal's input terminal. During a superimposition, the character output, etc., is layered on the composite video signal.
14	LEBK	Blanking level	This is an input terminal which determines the video signal's blanking level.
15	LECHA	Character level input	This is an input terminal which determines the character output level in the video signal. The color of the characters will be white.
16	CBIN	Color burst signal input	The CB output is converted into the video signal's color burst signal level by the external circuit and then input.
17	RSIN	Character background carrier chrominance signal input	The RS output is converted into the video signal's carrier chrominance signal level by the external circuit and then input.
18	VDD2	Power terminal	Connect the analog circuit's power terminal to a +5 V power source.
19	RS	Character background carrier chrominance signal output	This is a carrier chrominance signal output for coloring the character background. It outputs a signal which has a phase angle with respect to the color burst signal CB. Amplitude is 5 V.
20	CB	Color burst signal output	A 3.58 kHz color burst signal is output for NTSC, and a 4.43 kHz color burst signal is output for PAL. Amplitude is 5 V.
21	YM	Luminance signal output	This is the luminance signal output. When the font ROM is determined, the polarity can be selected.
22	BLNK	Character background output	The character background signal is output. When the font ROM is determined, the polarity can be selected.
23	CO	Character output	The character signal is output. When the font ROM is determined, the polarity can be selected.
24	B	Blue output	This is the blue output terminal. When the font ROM is determined, the polarity can be selected.
25	G	Green output	This is the green output terminal. When the font ROM is determined, the polarity can be selected.
26	R	Red output	This is the red output terminal. When the font ROM is determined, the polarity can be selected.
27	CSYN	Composite synchronizing signal output	The NTSC or PAL composite synchronizing signal is output. The polarity is negative and the amplitude is 5 V.
28	OSCOUT	Synchronizing signal generation oscillation	These terminals are for the external synchronizing signal generation oscillation circuit.
29	OSCIN		It uses a 14.32 MHz oscillation frequency for NTSC and a 17.73 MHz oscillation frequency for PAL.
30	HOR	Horizontal synchronizing signal	The horizontal synchronizing signal is input. Hysteresis input. When the font ROM is determined, the polarity can be selected.
31	VERT	Vertical synchronizing signal	The vertical synchronizing signal is input. Hysteresis input. When the font ROM is determined, the polarity can be selected.
32	VDD1	Power supply input	Connect the digital circuit's power terminal to a +5 V power source.

TBC(Time Base Corrector) BLOCK DIAGRAM

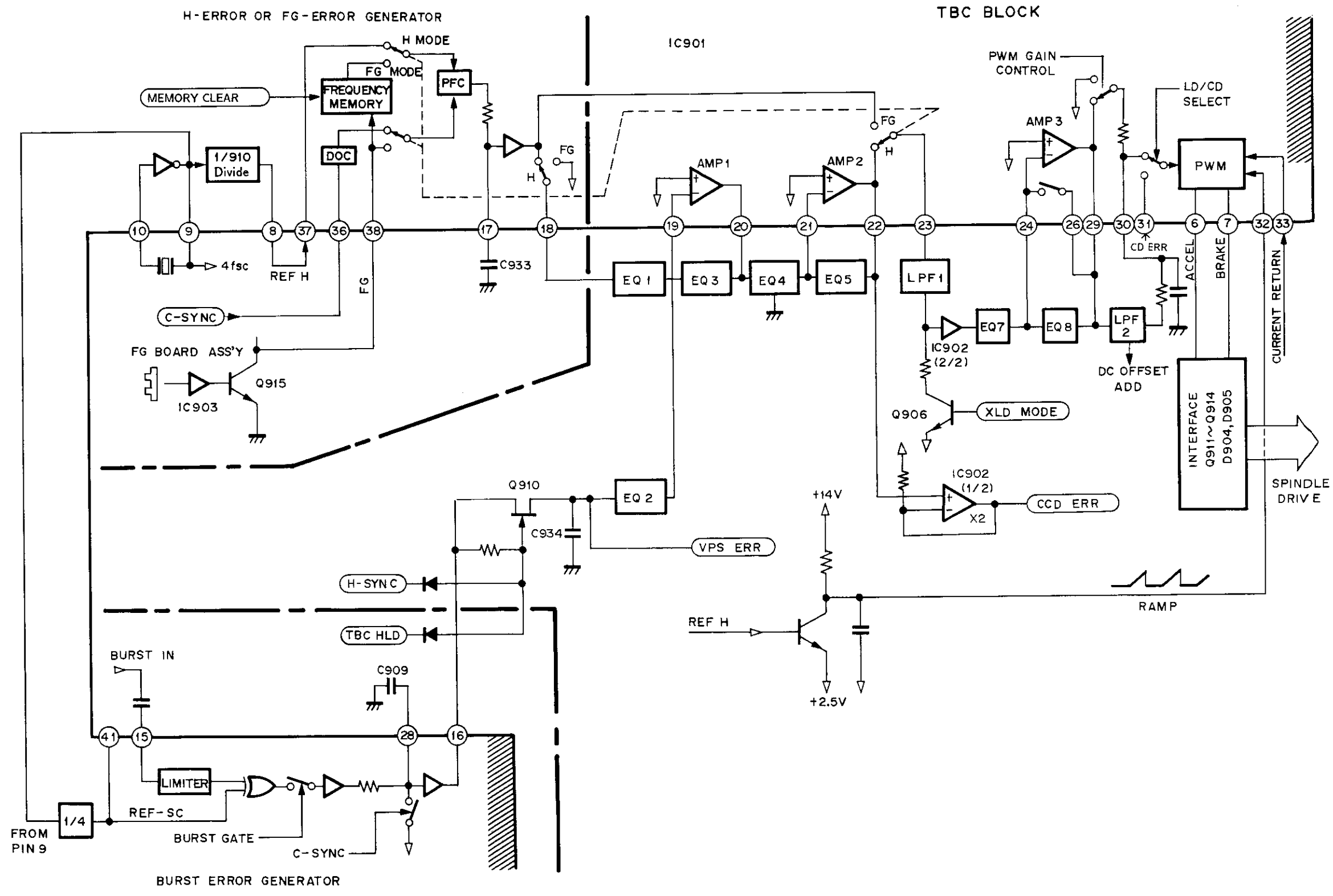

4 TBC SECTION OUTLINE

The player's time base corrector corrects the playback signal's comparative low-frequency error component with the spindle servo. Also, it corrects the high-frequency component (due to the disc's eccentricity) with the CCD servo, and it corrects the residual jitter component with the CPC error detection circuit.

4. 1 Spindle Servo

The player's spindle servo uses the PFC (same as TC5081) to produce the H error. Compared to the trapezoid, the PFC phase detection precision is low. Therefore, the loop mainly consists of the burst error. The loop is thus comprised of the addition of the burst error and the H error.

Multiple phase lock points are created where the direct current output of both phase comparators is balanced. The error signal that goes to the CCD passes through IC901 (1/2) and makes the direct current before the IC901(1/2) as the spindle servo's error. As a result, when the CCD loop is opened at the compulsory point, the spindle servo's gain setting is thrown off, disabling the locking of the spindle servo.

4. 2 Spindle Motor Runaway Detection System

The player's runaway detection system is very different from that of previous models. The player's runaway detection system relies largely on the FG (frequency generator) signal obtained by the FG sensor which is attached to the spindle motor. When the spindle motor starts up, it accelerates to about 1600 rpm. It then reaches 1800 rpm by the FG servo and enters the H loop. For CAV discs, if the spindle motor is unlocked, it will reach 1800 rpm by the FG servo and enter the H loop.

For a CLV disc, the rpm's FG frequency when the spindle motor is locked is stored in memory. When the lock is released, the rpm before the unlocking by the FG servo is taken from memory and input to the H servo.

4. 3 Spindle Motor Gain Control

The spindle motor's gain control is also different from that of previous player models. It is dependent on the FG. For a CLV disc, the FG is read and the spindle error undergoes PWM (Pulse Width Modulation) by the chopper to change the gain. This is to obtain the spindle gain that corresponds

to the rpm. The 8-inch disc's gain also switches the chopper according to the commands from the microcomputer.

Since IC901 is not compatible with the CDV disc's gain, an externally attached Q906 Tr switch is used for the switching. The switch between pins 29 and 30 of IC901 is the chopper switch. This chopper is attached to the spindle loop's last step. Therefore, since chopping is done up to the direct current error voltage (the voltage which rotates the spindle motor), the dynamic range at the outer periphery of the CLV disc will become inadequate. As a result, the direct current error voltage is bypassed by LPF2 to prevent offset.

4. 4 TBC Signal Flow

The TBC (Time Base Corrector) signal flow is described as follows. The quartz oscillator at pins 9 and 10 of IC901 produces a standard frequency of 14.31818 MHz. After 1/910 division, the REF-H is output to pin 8 and input to pin 37. The C-SYNC that is input to pin 36 undergoes dropout protection and becomes PB-H. Both signals are input to the PFC (Phase Frequency Comparator) and output from pin 17. Then they are smoothed by the C933 capacitor. After they pass through the buffer amplifier, the H error is output from pin 18. Meanwhile, the video signal whose chroma component had been removed by the BPF is input to pin 15 and undergoes waveform shaping by the limiter. Then the REF-SC (Reference Sub-carrier) which divided 14.31818 MHz into four undergoes phase comparison (EXOR circuit) and passes through the burst gate.

Next, the signal is smoothed by the C909 capacitor (IC901 pin 20) and it passes through the buffer amplifier. Then it is output from pin 16 as a burst error. The H error passes through EQ1 and the burst error passes through EQ2. Then they are mixed by AMP1. After passing through EQ3, EQ4, and EQ5, it passes through IC902(1/2) and drives the CCD. IC901 operates while centering on an operation point of 2.5V of the built-in OP AMP. Whereas IC902(1/2) operates while centering on 0V. The CCD loop consists of EQ1 to EQ5 above.

In the CCD loop, the direct current error for the spindle servo has more control. Therefore this direct current component controls the spindle motor's rpm. The FG loop or H loop is selected by the switch between pins 22 and 23 of IC901. Then it is input to LPF1. The LPF1 removes

the FG error's ripple. After passing through the IC902(2/2) buffer, it enters EQ7 and EQ8. Then it undergoes gain control by the chopper switch and it enters the PWM circuit. Pin 32 of IC902 is input with the RAMP signal that is produced by REF-H. The spindle error undergoes PWM(Pulse Width Modulation). Then it passes through the Q203 to Q206 switching drivers (in the power supply board assembly) and drives the spindle motor. The PWM circuit is built-in in IC901. The remaining jitter component which could not be removed by the TBC is suppressed by the VPS(in the video block) as with previous player models.

The player does not execute the 140 nS shift with TBC for every jump as previous models did. The reason is that since the loop relies on the burst error, it will be led into the 140 nS shifted phase for every jump in a short time. In order to make the lead-in smoother, the burst error is held by Q910 and C934 before and after the jump. Also, the ripple component of the burst error generated in IC901 may cause color irregularity. Therefore, with C-SYNC, Q910 does sample hold to suppress the ripple component.

These IC901 operations are controlled by the serial data from the microcomputer. From when the power is turned on to when the initial setting is completed by the microcomputer, D904 and D905 prevent the PWM circuit's output pins 6 and 7 from becoming high and also prevent all the spindle driver's (on the power supply board Ass'y) transistors from turning ON.

HD49403NT Internal Block Diagram

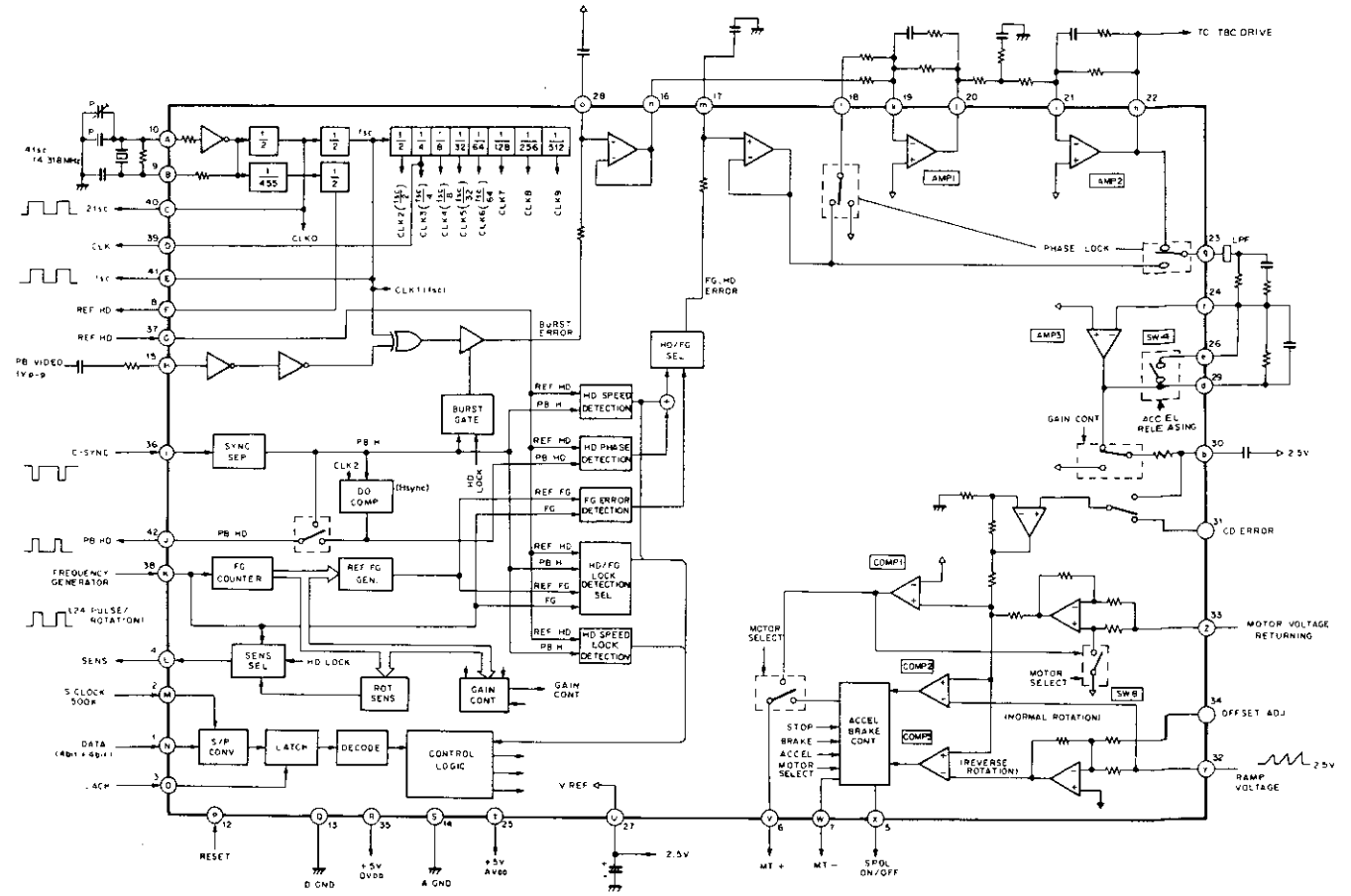

HD49403NT Pin Description

PIN No.	SYMBOL	I/O	DESCRIPTION
1	SDAT		Serial data input from CPU.
2	SCLK	I	Serial data clock input from CPU. Strobed at the negative edge.
3	LACH		Serial data latch pulse input from CPU.
4	SENS		IC internal state sense output. High-impedance when not selected.
5	STOP		Spindle motor ON signal output.
6	MTPL	O	Spindle motor accelerating signal output (brush motor). Torque generation direction signal output (3-phase).
7	MTMI		Spindle motor decelerating signal output (brush motor). Torque generation signal output (2-phase).
8	RHDO		Reference HD signal output.
9	OSCO		4 fsc reference signal output.
10	OSCI		4 fsc reference signal input.
11	TEST	I	Test pin (0V).
12	RSET		System reset signal input. "L" = reset.
13	DGND		GND for digital circuits (0V).
14	AGND		GND for analog circuits (0V).
15	PBVI	I	Burst signal input (AC-coupled).
16	AP1O		Op-amp 1 output (burst signal time-axis error output).
17	PFDO	O	LPF capacitor pin for HD/FG signal time-axis error smoothing.
18	AP2O		Op-amp 2 output (burst signal time-axis error output).
19	AP3I	I	Op-amp 3 invert input.
20	AP3O	O	Op-amp 3 invert output.
21	AP4I	I	Op-amp 4 invert input.
22	AP4O	O	Op-amp 4 output (for CCD circuit phase compensation).
23	SW3O		Analog switch 3 output (HD/FG control select).
24	AP5I	I	Op-amp 5 invert input
25	AVDD	-	Power supply for analog circuits (5V).
26	SW4I	I	Analog switch 4 (to discharge capacitor).
27	VREF	-	Reference power supply (Op-amp reference voltage: 2.5V).
28	BUER	O	LPF capacitor pin for burst signal time-axis error smoothing.
29	AP5O		Op-amp 5 output (for phase compensation of spindle motor circuits).
30	LPFC	-	LPF capacitor pin for gain control.
31	CDER		CD mode spindle motor control signal input.
32	VRMP	I	Lamp signal input for PWM.
33	VMOT		Spindle motor pin voltage feedback input
34	OFAD		Op-amp offset adjustment input.
35	DVDD	-	Power supply for digital circuits (5V).
36	SYNC		Composite sync signal input (digital signal).
37	RHDI	I	Reference HD signal input. Normally connected to RHDO (pin 8).
38	FG		FG input (digital signal).
39	CLK		Clock signal output for FTS. (447kHz)
40	2FSC	O	2 fsc clock signal output.
41	FSC		fsc clock signal output.
42	PBHD		Playback HD signal output (after dropout compensation).

AUDIO SIGNAL BLOCK DIAGRAM

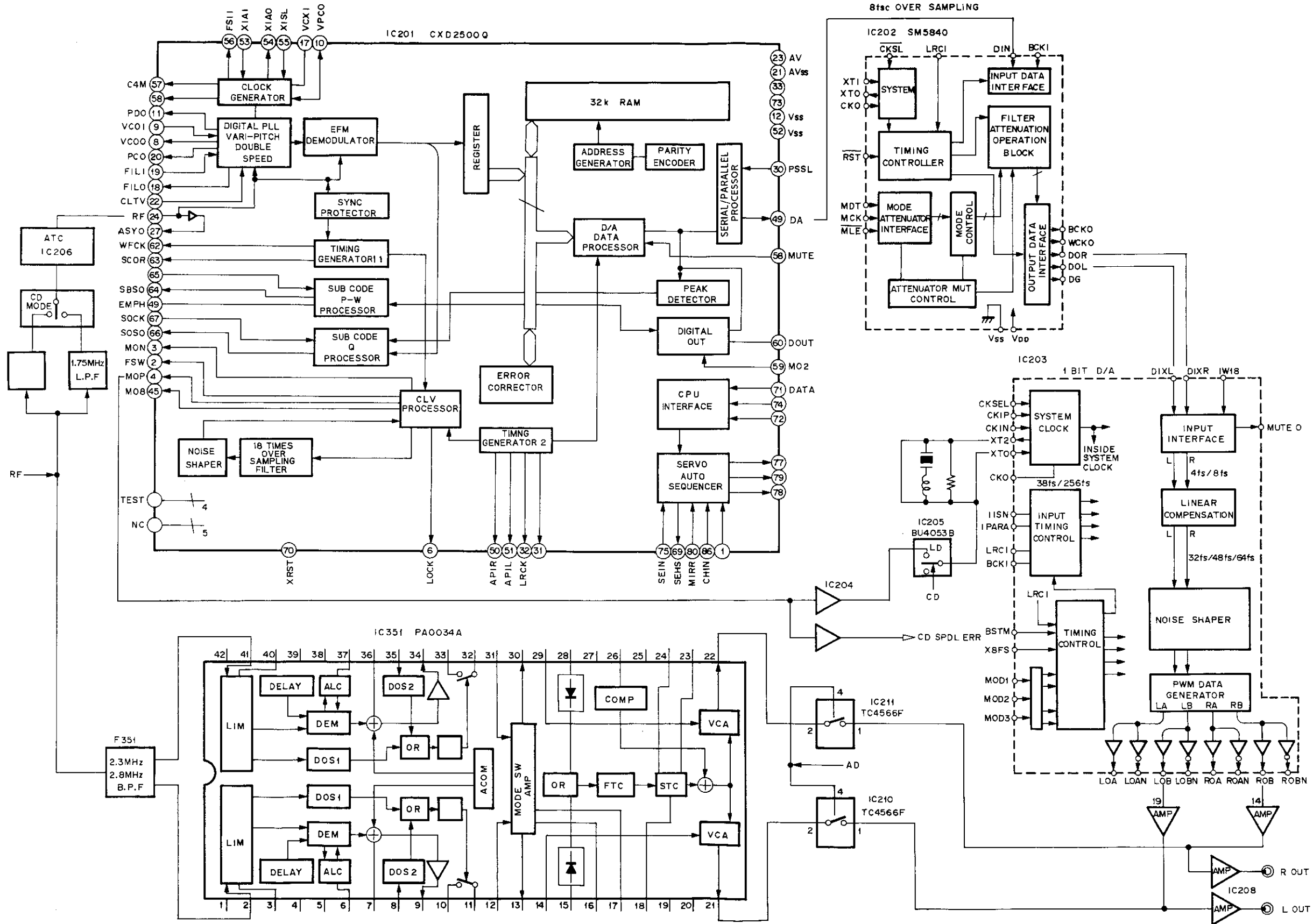

5. AUDIO SIGNAL DESCRIPTION

5.1 Analog Audio System Description (AFM section)

1) PA0034 Description

After the audio FM signal which was removed from the 2.3MHz (Lch) and the 2.8MHz (Rch) band-pass filters is demodulated, it will pass through the front hold circuit, the de-emphasis circuit, and the VCA (Voltage Control Amplifier). Then it is output as analog audio. Any dropout will be detected by the dropout detector. During the dropout detection, the front hold circuit will maintain the signal level at the level immediately before the dropout was produced. This is to prevent noise.

Also, the CX noise reduction system expands the audio circuit's dynamic range and improves the S/N ratio.

PA0034 is a single-chip IC dedicated to LD audio. It performs all of the signal processing above.

The analog audio L and R signals output from pins 22 and 21 are sent to the output terminals after digital or analog is selected by the IC210 and IC211 (TC4566F) switching ICs.

PA0034 Internal Block Diagram

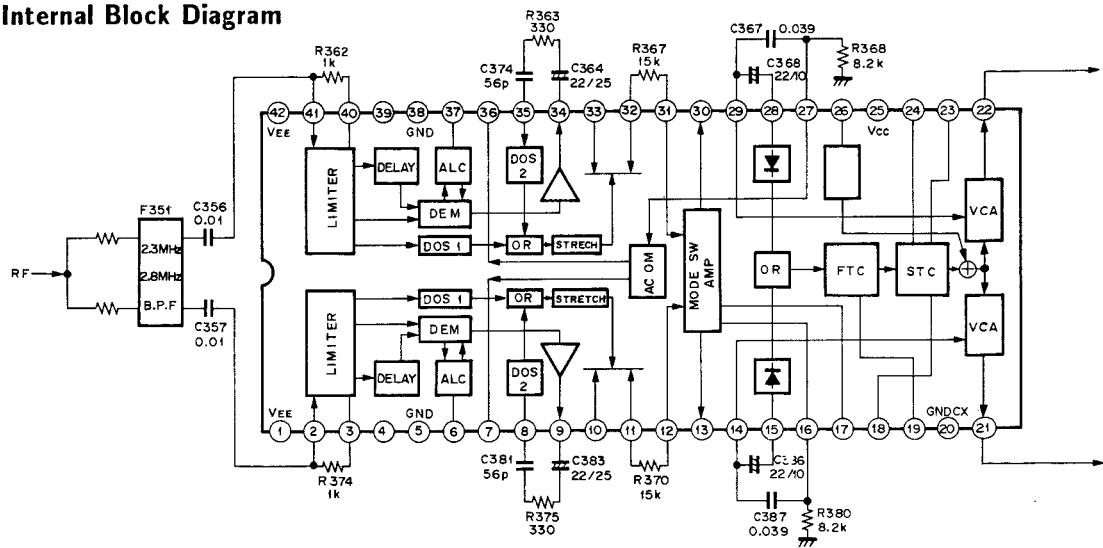

PA0034 Pin Description

PIN No.	SYMBOL	Terminal Function	PIN No.	SYMBOL	Terminal Function
1	VEER	Power supply input	22	LOUT	Lch output
2	VINR	FM signal input	23	STC2	STC terminal 2
3	BIASR	Input bias	24	STC1	STC terminal 1
4	VREFR	Internal reference power supply	25	VCC	Power supply input
5	GNDR	GND	26	COMP	Compensator terminal
6	ALCR	ALC capacitor	27	TBC	TBC error signal input
7	CSR	Carrier deletion	28	CINL	CX control signal input
8	DOS2R	DOS2 input	29	CXINL	CX input
9	DEMOR	Demodulator output	30	SWOL	Mode select amp output
10	SINR	Dropout correction switch input	31	SWINL	Mode select amp input
11	DOCR	Dropout correction switch output	32	DOCL	Dropout correction switch output
12	SWINR	Mode select amp input	33	SINL	Dropout correction switch input
13	SWOR	Mode select amp output	34	DEMOL	Demodulator output
14	CXINR	CX input	35	DOS2L	DOS2 input
15	CINR	CX control signal input	36	CSL	Carrier deletion
16	R	Mode select port R	37	ALCL	ALC capacitor
17	L	Mode select port L	38	GNDL	GND
18	CX	CX control	39	VREFL	Internal reference power supply
19	FTC	Capacitor connection for FTC	40	BIASL	Input bias
20	GNDLX	GND	41	VINL	FM signal input
21	ROUT	Rch output	42	VEEL	Power supply input

5. 2 Digital Audio Circuit Outline (DSP section)

1) Outline

The RF signal from the FTS section passes through the 1.75MHz low-pass filter. The low frequency of the separated EFM signal (which boosts during recording) is flattened by the de-emphasis circuit. Then the pulse is formed by the ATC (Automatic Threshold Control) of IC206(TC74HCU04 AP) and input to pin 24 of IC201 (CXD2500).

The address of the storage RAM is controlled by the frame synchronizing signal that is separated from data and the clock reproduced by the PLL from the EFM signal that was demodulated by CXD2500. The audio data stored in RAM must be read according to an accurate and stable clock. Otherwise the audio signal played back will have jitter or wow/flutter. Also, if the RAM is written to and read by an unrelated clock, the RAM will become full. The quartz oscillator's output, which is synchronized with the playback EFM signal's average frequency, is therefore used as the reading clock.

CXD2500 output pin 34's digital audio signal passes through the IC202(SM5840AP) 8fs oversampling digital filter. After undergoing digital/analog conversion by IC203

(SM5860BF), the signal is amplified by IC208 and IC209 and output.

2) CXD2500 Features

The CXD2500 has the following features :

1. Better frame sync protection

The sync protection window is produced by the X'tal circuit which has no bit slip. A protection window is also inserted before and after the sync protection window.

2. 4-layer correction

There is 4-layer correction for the error correction. The correction capacity for the burst error has been doubled to 16 frames.

3. Interleave error protection

This prevents noise for non-consecutive frames.

4. Built-in 32K RAM

5. Digital peak meter and level meter functions

6. Variable pitch playback

The PLL's output clock on the master side can be varied.

7. Auto zero cross mute

CXD2500Q Internal Block Diagram

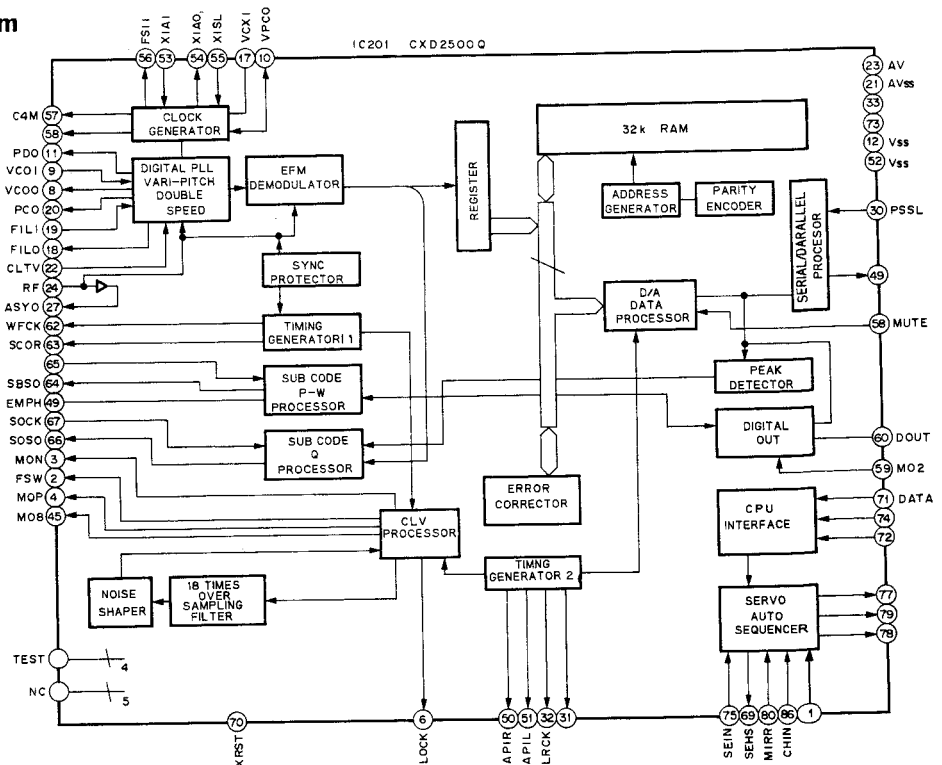

Interface Timing Chart

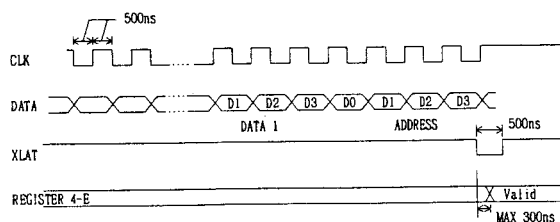

CXD2500Q Pin Description

PIN No.	SYMBOL	I/O	DESCRIPTION
1	FCOK		Focus OK input terminal. This is used for the SENS output and the servo auto sequencer.
2	FSW	O Z 0	Spindle motor's output filter switching output.
3	MON	O 1 0	Spindle motor's ON-OFF control output.
4	MDP	O Z 0	Spindle motor's servo control.
5	MDS	O Z 0	Spindle motor's servo control.
6	LOCK	O 1 0	H output when GFS undergoes sampling LH at 460 Hz. L output when there is L eight consecutive times.
7	NC		
8	VCOO	O 1 0	Oscillation circuit output for the analog EFM PLL.
9	VCOi		Oscillation circuit input $f_{\text{lock}} = 8.6436$ MHz for the analog EFM PLL
10	TEST		TEST pin. Normally GND.
11	PDO	O Z 0	Charge pump output for the analog EFM PLL.
12	Vss		GND
13			
14	NC		
15			
16	VPCO	O Z 0	PLL charge pump output for variable pitch.
17	VCKi		Clock input $f_{\text{center}} = 16.9344$ MHz from the variable pitch external VCO.
18	Filo	O A	Filter output (analog) for master PLL (slave = digital PLL).
19	FiLi		Filter input for the master PLL.
20	PCO	O Z 0	Charge pump output for the master PLL.
21	AVss		Analog GND.
22	CLTV		VCO control voltage input for the master PLL.
23	AVDD		Analog power supply (+5 V).
24	RF		EFM input after asymmetry correction.
25	TEST		To be GND.
26	TEST		To be GND.
27	ASYO	O 1 0	EFM full-swing output.
28	TEST		To be GND.
29	NC		
30	PSSL		Audio data output mode switching input. "L" serial output. Parallel output with "H".
31	WDCK	O 1 0	D/A interface for the 48-bit slot. Word clock $f = 2F_s$.
32	LRCK	O 1 0	D/A interface for the 48-bit slot. LR clock $f = F_s$.
33	VDD		Power supply (+5V)
34	DA16	O 1 0	DA16 (MSB) output when PSSL = 1. 48 slot serial data (2S'COMP) when PSSL = 0.
35	DA15	O 1 0	DA15 output when PSSL = 1. 48-bit slot bit clock when PSSL = 0.
36	DA14	O 1 0	DA14 output when PSSL = 1. 64-bit slot serial data 2S'COMP LSB first when PSSL = 0.
37	DA13	O 1 0	DA13 output when PSSL = 1. 64-bit slot bit clock when PSSL = 0.
38	DA12	O 1 0	DA12 output when PSSL = 1. 64-bit slot and LR clock when PSSL = 0.
39	DA11	O 1 0	DA11 output when PSSL = 1. GTO output when PSSL = 0.
40	DA10	O 1 0	DA10 output when PSSL = 1. XUGF output when PSSL = 0.

PIN No.	SYMBOL	I/O	DESCRIPTION
41	DA09	O $\begin{matrix} 1 \\ 0 \end{matrix}$	DA10 output when PSSL = 1. XPLCK output when PSSL = 0.
42	DA08	O $\begin{matrix} 1 \\ 0 \end{matrix}$	DA08 output when PSSL = 1. GFS output when PSSL = 0.
43	DA07	O $\begin{matrix} 1 \\ 0 \end{matrix}$	DA07 output when PSSL = 1. RFCK output when PSSL = 0.
44	DA06	O $\begin{matrix} 1 \\ 0 \end{matrix}$	DA06 output when PSSL = 1. C2PO output when PSSL = 0.
45	DA05	O $\begin{matrix} 1 \\ 0 \end{matrix}$	DA05 output when PSSL = 1. XRAOF output when PSSL = 0.
46	DA04	O $\begin{matrix} 1 \\ 0 \end{matrix}$	DA04 output when PSSL = 1. MNT3 output when PSSL = 0.
47	DA03	O $\begin{matrix} 1 \\ 0 \end{matrix}$	DA03 output when PSSL = 1. MNT2 output when PSSL = 0.
48	DA02	O $\begin{matrix} 1 \\ 0 \end{matrix}$	DA02 output when PSSL = 1. MNT1 output when PSSL = 0.
49	DA01	O $\begin{matrix} 1 \\ 0 \end{matrix}$	DA01 output when PSSL = 1. MNT0 output when PSSL = 0.
50	APTR	O $\begin{matrix} 1 \\ 0 \end{matrix}$	Aperture correction control output. "H" for the R ch.
51	APTL	O $\begin{matrix} 1 \\ 0 \end{matrix}$	Aperture correction control output. "H" for the L ch.
52	Vss		GND
53	XTAi	I	16.9344 MHz or 33.8688 MHz Xtal oscillation circuit input.
54	XTAO	O $\begin{matrix} 1 \\ 0 \end{matrix}$	16.9344 MHz or 33.8688 MHz Xtal oscillation circuit output.
55	XTSL	I	Xtal selection input terminal. "L" when it is 16.9344 MHz. "H" when it is 33.8688 MHz.
56	FSTT	O $\begin{matrix} 1 \\ 0 \end{matrix}$	2/3 divided output of the Xtal oscillation. Fixed during variable pitch.
57	C4M	O $\begin{matrix} 1 \\ 0 \end{matrix}$	4.2336 MHz output. Changes during variable pitch.
58	C16M	O $\begin{matrix} 1 \\ 0 \end{matrix}$	19.9344 MHz output. Changes during variable pitch.
59	MD2	I	Digital OUT ON/OFF control. ON when "H", and OFF when "L".
60	DOUT	O $\begin{matrix} 1 \\ 0 \end{matrix}$	Digital OUT output terminal.
61	EMPH	O $\begin{matrix} 1 \\ 0 \end{matrix}$	"H" output when the playback disc has emphasis. "L" output when it has no emphasis.
62	WFCK	O $\begin{matrix} 1 \\ 0 \end{matrix}$	Write frame clock output.
63	SCOR	O $\begin{matrix} 1 \\ 0 \end{matrix}$	"H" output when the subcode sync SO or SI is detected.
64	SBSO	O $\begin{matrix} 1 \\ 0 \end{matrix}$	Sub P - W code and serial output.
65	EXCK	I	For SBSO lead out. External clock input.
66	SQSO	O $\begin{matrix} 1 \\ 0 \end{matrix}$	SubQ 80-bit and PCM peak data 16-bit output.
67	SQCK	I	External clock input for SQSO lead out.
68	MUTE	I	Mute with "H", and cancel with "L".
69	SENS	O $\begin{matrix} 1 \\ 0 \end{matrix}$	SENS output. Sent to the CPU.
70	XRST	I	System reset. Reset when "L".
71	DATA	I	Serial data input from the CPU.
72	XLAT	I	Serial data from the CPU is latched with the latch input shutdown.
73	VDD		Power supply input (+5V).
74	CLK	I	From the CPU, serial data transfer clock input.
75	SEIN	I	From the SSP, SENSE input.
76	CNiN	I	Track jump count signal input.
77	DATO	O $\begin{matrix} 1 \\ 0 \end{matrix}$	Serial data output to the SSP.
78	XLTO	O $\begin{matrix} 1 \\ 0 \end{matrix}$	Serial data latch output to the SSP. Latched during shutdown.
79	CLKO	O $\begin{matrix} 1 \\ 0 \end{matrix}$	SP serial data transfer clock output.
80	MiRR	I	Mirror signal input. Used with the auto sequencer for jumps exceeding 128 tracks.

3) CXD2500 Command Code

As shown in the following table, the CXD2500 has 4-bit registers which have addresses from 4 to E. These registers are operated by being input externally with a total of 8 bits (address + data) of data.

CXD2500 Instruction and RESET Initialization

registers Name	Commands	Address				Data1				Data2				Data3				Data4			
		D3	D2	D1	D0	D3	D2	D1	D0	D3	D2	D1	D0	D3	D2	D1	D0	D3	D2	D1	D0
4	Auto Sequence	0	1	0	0	AS3	AS2	AS1	AS0	—	—	—	—	—	—	—	—	—	—	—	—
5	Blind(A,E), Overflow(C) Brake(A)	0	1	0	1	0.18ms 0.36ms	0.09ms 0.18ms	0.045ms 0.09ms	0.022ms 0.045ms	—	—	—	—	—	—	—	—	—	—	—	—
6	KICK(D)	0	1	1	0	11.6ms	5.8ms	2.9ms	1.45ms	—	—	—	—	—	—	—	—	—	—	—	—
7	Auto Sequencer(N) Track Jump	0	1	1	1	32,768	16,384	8,192	4,096	2,048	1,024	512	256	128	64	32	16	8	4	2	1
8	MODE	1	0	0	0	CDROM	0	D OUT MuTu-F	WSEL	—	—	—	—	—	—	—	—	—	—	—	—
9	Function	1	0	0	1	D CLV ON-OFF	DSPB ON-OFF	A SEQ ON-OFF	D PLL ON-OFF	Bili GL MAIN	Bili GL SUB	—	—	—	—	—	—	—	—	—	—
A	Audio CTRL	1	0	1	0	Vari UP	Vari Down	MUTE	ATT	PCT1	PCT2	—	—	—	—	—	—	—	—	—	—
B	Traverse Monitor Counter	1	0	1	1	32,768	16,384	8,192	4,096	2,048	1,024	512	256	128	64	32	16	8	4	2	1
C	Servo Factor	1	1	0	0	Gain MDPI	Gain MDPO	Gain MOSI	Gain MOSO	—	—	—	—	—	—	—	—	—	—	—	—
D	CLV CTRL	1	1	0	1	DCLV PWM MD	TB	TP	CLVS Gain	—	—	—	—	—	—	—	—	—	—	—	—
E	CLV MODE	1	1	1	0	CH3	CH2	CH1	CH0	—	—	—	—	—	—	—	—	—	—	—	—

4	Auto Sequence	0	1	0	0	0	0	0	0	—	—	—	—	—	—	—	—	—	—	—	—
5	Blind(A,E), Overflow(C) Brake(A)	0	1	0	1	0	1	0	1	—	—	—	—	—	—	—	—	—	—	—	—
6	KICK(D)	0	1	1	0	0	1	1	1	—	—	—	—	—	—	—	—	—	—	—	—
7	Auto Sequencer(N) Track Jump	0	1	1	1	0	0	0	0	0	0	0	1	0	0	0	0	0	0	0	0
8	MODE	1	0	0	0	0	0	0	0	—	—	—	—	—	—	—	—	—	—	—	—
9	Function	1	0	0	1	1	0	0	1	0	0	0	—	—	—	—	—	—	—	—	—
A	Audio CTRL	1	0	1	0	0	0	1	1	0	0	—	—	—	—	—	—	—	—	—	—
B	Traverse Monitor Counter	1	0	1	1	0	0	0	0	0	0	0	0	0	0	0	0	0	0	0	0
C	Servo Factor	1	1	0	0	0	1	1	0	—	—	—	—	—	—	—	—	—	—	—	—
D	CLV CTRL	1	1	0	1	0	0	0	0	—	—	—	—	—	—	—	—	—	—	—	—
E	CLV MODE	1	1	1	0	0	0	0	0	—	—	—	—	—	—	—	—	—	—	—	—

4) SM5840

DA01 to DA16, which are output from pin 49 of CXD2500, are input to pin 18 of SM5840. SM5840 is a multi-function digital filter for 8fs oversampling. Its functions include digital emphasis, digital attenuation, and soft muting.

SM5840 Internal Block Diagram

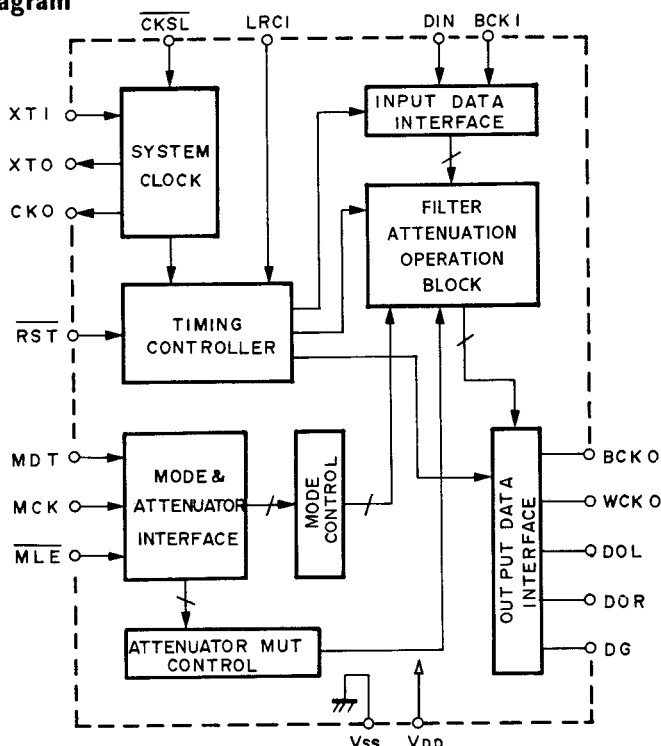

SM5840 Pin Description

“fs” means sampling frequency of input data.

PIN No.	SYMBOL	I/O	Description	
1	CKSL	IP	Select frequency of OSC and input (When CKSL=E, 384fs)	
2	XTI	I	OSC input (Frequency selected by CKSL)	
3	XTO	O	OSC output	
4	CKO	O	Clock of OSC output (Frequency is same as XTI)	
5	Vss		GND	
6	MDT	IP	Mode setting data	Setting the digital attenuator and the mode flag register.
7	MCK	IP	Mode setting clock	
8	MLE	IP	Mode setting latch enable	
9	RST	IP	System reset (Initialize)	
10	DG	O	When 8fsLR parallel output mode; Output De-giitch	
11	DOR	O	When 8fsLR parallel output mode; Output Rch data	
12	DOL	O	When 8fsLR parallel output mode; Output Lch data	
13	WCKO	O	Clock for output words	
14	VDD		Power supply input (5V)	
15	BCKO	O	Clock for output bits	
16	LRCI	IP	Clock for sampling rate (fs) of input data	
17	BCKI	IP	Clock for input bits	
18	DIN	IP	Data input	

SM5840 External View

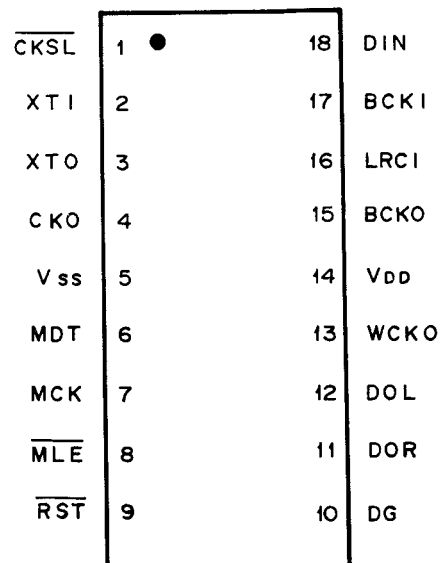

SM5840's basic computation block is shown on the right. The interpolation computation block consists of doubled interpolation filters connected in three steps. It outputs 8fs oversampling data for the signal that is input at the fs sample rate.

The output data is an 18 bit MSB first 2's complement. It is output from pins 11 and 12. With the 8fsc L and R parallel output mode, the L and R channel outputs are output simultaneously from two output terminals.

The input data is input from pin 18 in 16 bits, MSB first serial, and two's complement. All the serial data bits are read to the SIPO register (serial/parallel conversion register) with the bit clock BCKI's startup edge and are converted to parallel data. The SIPO's output is transferred to the respective L ch and R ch input registers with the LRCI clock's shutdown/startup edge.

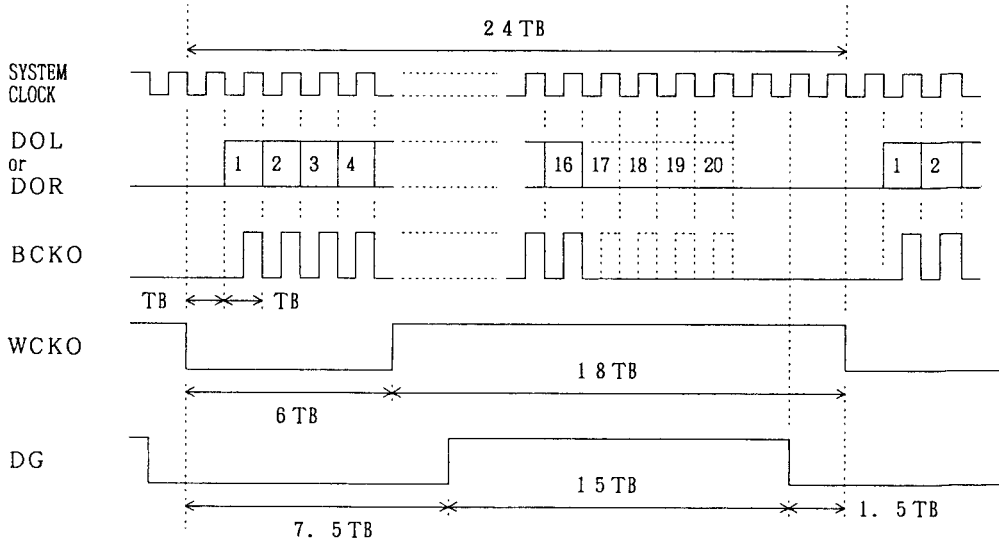
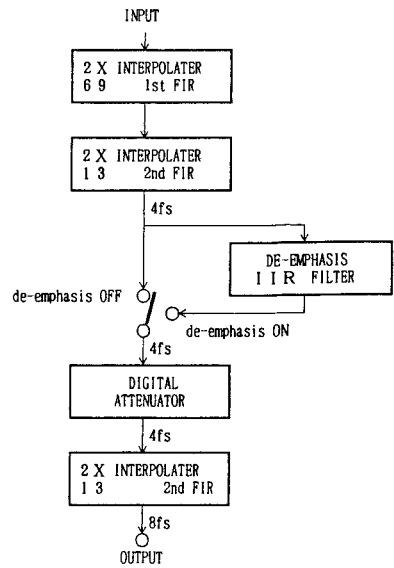

Fig. Data Output Timing Chart

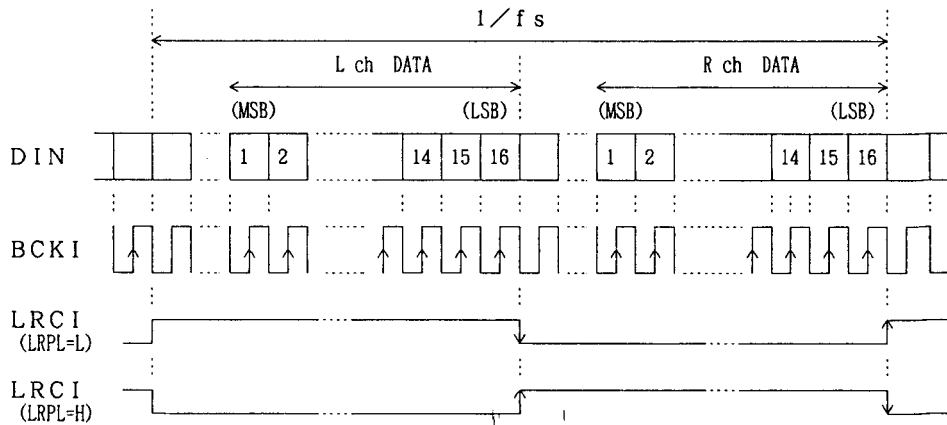
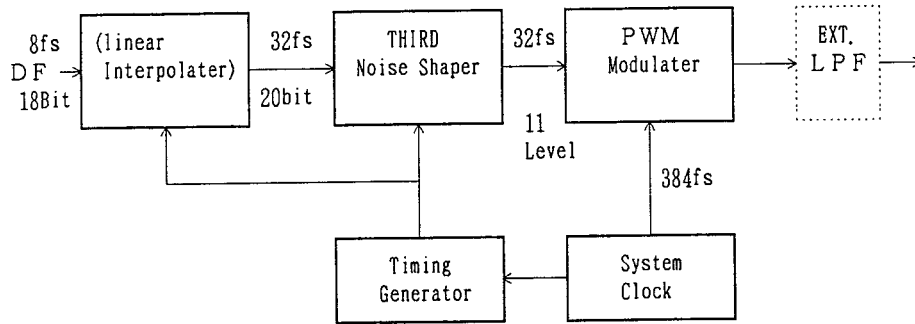

Fig. Data Input Timing Chart

5) SM5860

The data that is output from pins 11 and 12 of SM5840 is input to pins 40 and 41 of SM5860. SM5860 is a D/A converter for the 18-bit input. It has the following features :

- Built-in D/A converter for the LR2 channel.
- Built-in overflow limiter.
- Built-in quartz oscillation circuit.
- I/O TTL compatible.



SM5860 Internal Block Diagram

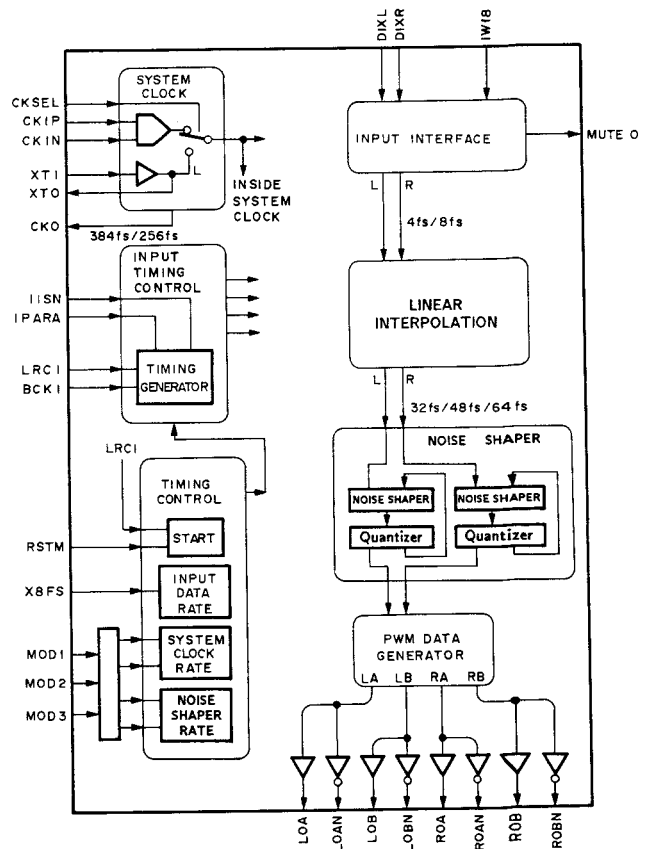

The SM5860's internal block is shown in the figure. The linear interpolator receives the data from SM5840. There is a 20-bit output resolution with the section of data which underwent higher order (32 fs) oversampling by the linear interpolation. With the linear interpolator, the next step's noise shaper shows the signal's (oversampled by the linear interpolator) 2^{20} line resolution signal with the level 11's signal. This method thereby pushes out the re-quantized noise from the audio band. To output the data that was dropped from the 20 bit to level 11 by the noise shaper, the PWM modulator is used. For the level number increase, the PWM modulation allows an increase of 1 system clock time toward only one side of the sample period center. A 1-bit D/A converter which uses low crystal oscillation is thereby realized.

SM5860 External View

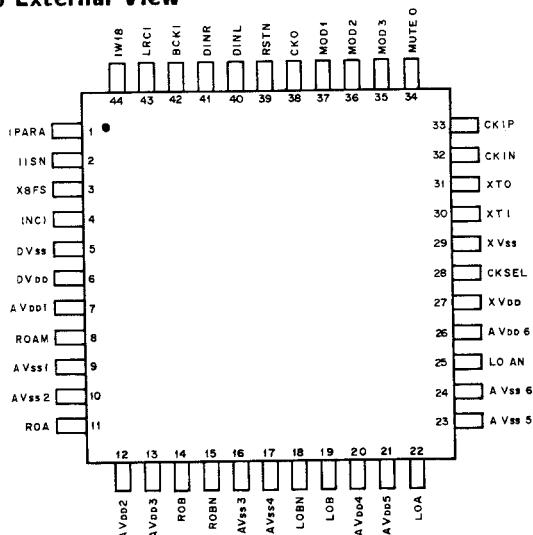

CONTROL SYSTEM BLOCK DIAGRAM

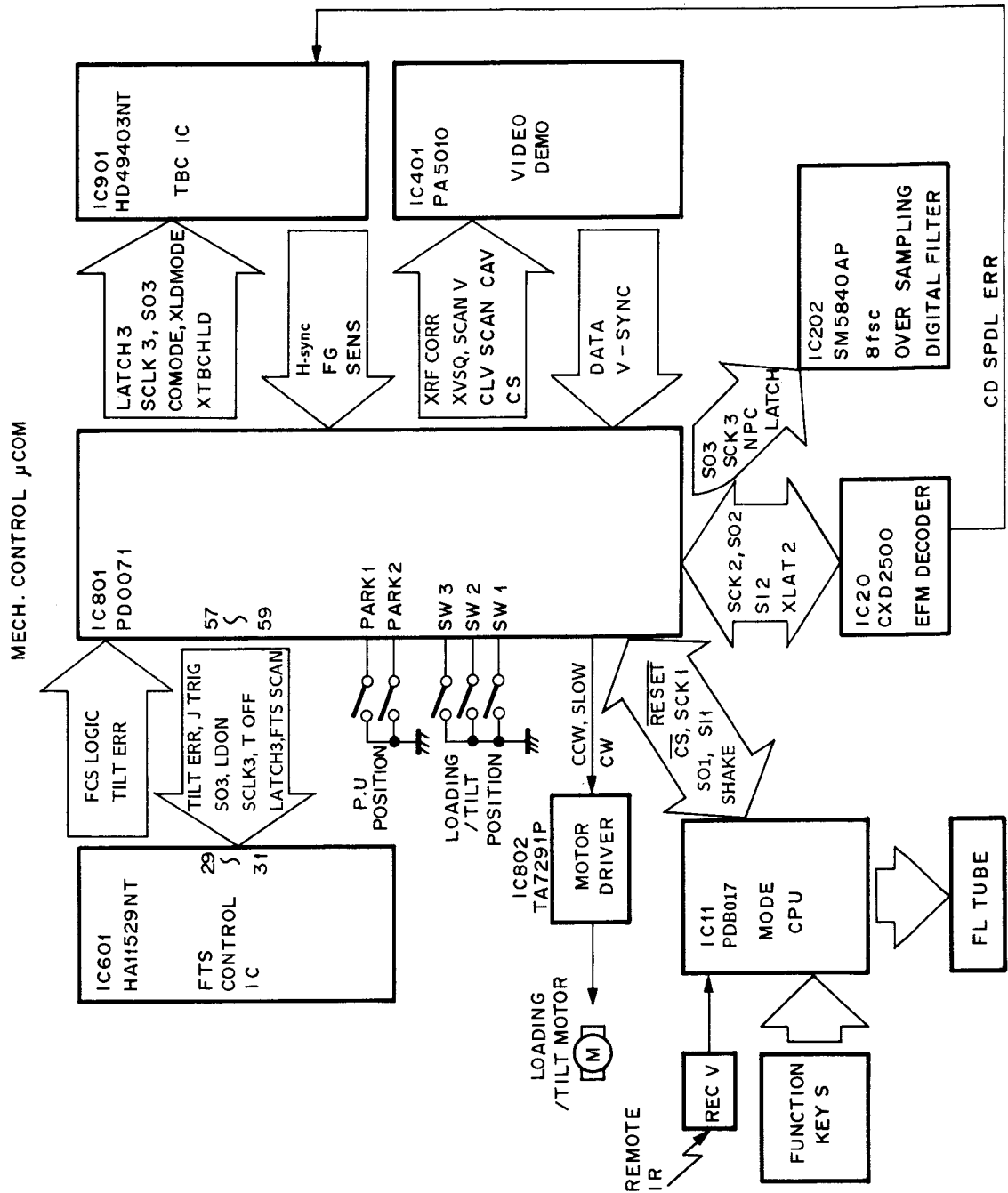

6 Control System

6.1 Microcomputer interfaces

The player's microcomputer consists of two chips : an 8-bit microcomputer (IC801: PD0071) which controls the mechanisms and a 4-bit microcomputer (IC11: PDB017) which controls the operation and display. These two microcomputers are connected via a serial interface. This transmission line is also used for controlling the character generator IC (IC405 : M50554-132SP).

● Timing Chart of Microcomputers' Communication

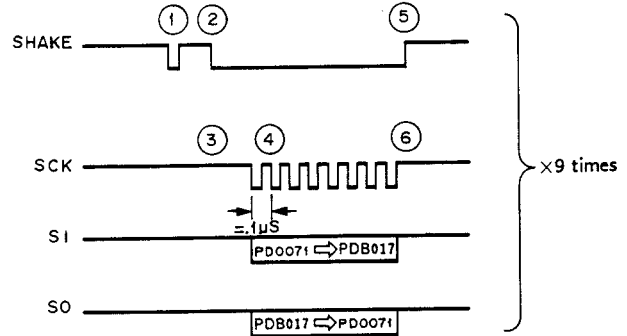

● Serial Data Transfer Connection

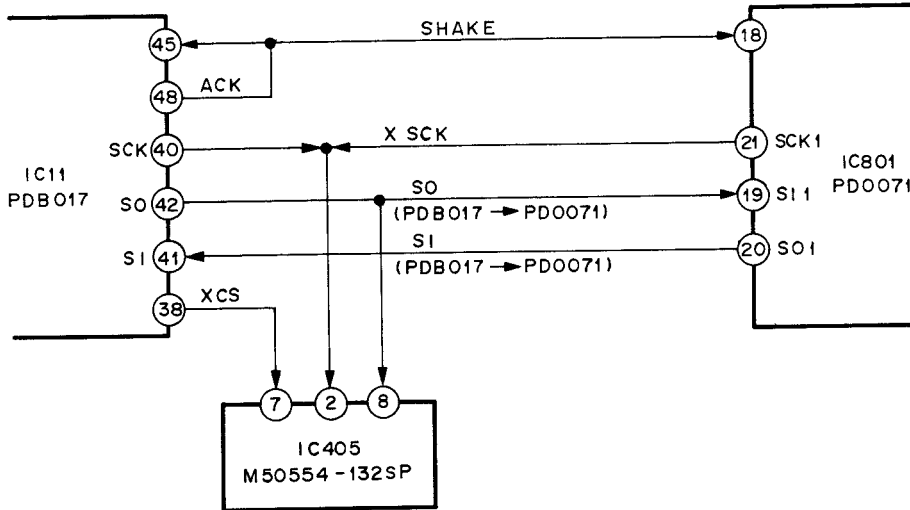

● Microcomputer communication sequence

1. PD0071 sets the SHAKE terminal (pin 18) to "L" for several μ S to request the start of a communication with PDB017.
2. When PDB017 receives the communication start request, it sets the ACK terminal (pin 48) to "L" and informs PD0071 that communication has been enabled.
3. PD0071 then sets SCK1 (pin 21), which had been used as an input port, to the output mode. PDB017 sets SCK (pin 40) to the input mode and connects the communication line between the microcomputers.
4. PD0071 sends the transfer clock (1MHz) in 8 bits. The data is then sent and received in synchronization with this clock.
5. When PDB017 receives 8-bit data, it sets the ACK terminal (pin 48) to "H" and reports that a single communication is completed.
6. PD0071 sets SCK1 (pin 21) to the input mode, and PDB017 sets SCK (pin 40) to the output mode. The communication line is thereby disconnected, and a single communication is completed.

- ★ The communication is takes place at a cycle between 10mS and 30mS. Nine bytes of data are transmitted at one time.
- ★ The handshake is done on a single line. Both PD0071 and PDB017 use a single port for both input and output. The output mode will be set only when the output is "L". Otherwise, it will be set to the input mode (high impedance). Also, before "L" is output, whether the SHAKE terminal is "H" is mutually checked. This is to prevent signal confusion between output signals.
- ★ The communication data is appended with a check code to prevent transfer errors. If sixteen consecutive transfer errors are detected, PDB017 will output the reset signal to PD0071 to reset it to the initial condition. This will also happen if the communication is not 300mS or longer.

6. 2 Mode Control Outline

Mode microcomputer (IC11 : PDB017)

The mode microcomputer performs the following :

1. Key data/remote control signal processing
The key switch and remote control signals are received and processed for the specified keys.
2. FL display operation
The FL tube display (VAW1010) is operated.
3. Screen display control
The character generator IC(IC405 : M50554-132SP) is controlled and characters are superimposed on the screen.
The blue back is also controlled.

4. Mechanism control micro computer control
When operational instructions are given to the mechanism control microcomputer(IC801 : PD0071), the time data is read at the same time.
5. System reset management
If there is any communication problems with the mechanism control microcomputer, the system reset will be activated to return the unit to the initial condition.

PIN No.	SYMBOL	I/O	DESCRIPTION	PIN No.	SYMBOL	I/O	DESCRIPTION
1	VDD	I	Power supply input (5V)	33	DOOR SW	I	Door switch input. "H": ON, "L": OFF
2			No connection	34	SYNC IN	I	Synchronized REC control input
3				35	SYNC OUT	O	Synchronized REC control output
4				36	POWER ON		Power ON/OFF "H": ON, "L": OFF
5				37	X RESET		PD0071 reset
6				38	X CS		M50554 select
7	G1			39			No connection
8	G2		O FL lighting timing output "H": ON, "L": OFF	40	X SCK	I/O	Serial data transfer clock
9	G3			41	SI	I	Serial data input
10	G4			42	SO	O	Serial data output
11	G5			43	RESET		Reset input
12	G6			44	SEL IR	I	Remote control unit input
13	G7			45	SHAKE		Serial communication start request input
14	G8			46			No connection
15	G9			47			
16	G10			48	ACK	O	Serial communication acceptance output
17	G11			49	KS0		O Key scan output "H": ON, "L": OFF
18	VDISP	I		FL display power supply input (-30V)	50	KS1	
19	l		O FL lighting segment output "H": ON, "L": OFF	51	KS2		
20	k			52	KS3		
21	j			53	KS4		
22	i			54	KS5		
23	h			55	KS6		
24	g			56	KIN0		I Key data input "H": ON, "L": OFF
25	f			57	KIN1		
26	e			58	KIN2		
27	d			59	KIN3		
28	c			60	X2		No connection
29	b		61	X1		GND (Not used.)	
30	a		62	Vss	-	GND	
31	LAST MEMORY		O LED lighting output. "H": ON, "L": OFF	63	OSC2	I	Oscillator (6.0MHz)
32	CD DIRECT			64	OSC1	O	

6. 3 Mechanism Control Outline

1 Processing during power ON

After the power is turned ON, the mechanism control microcomputer (IC801 : PD0071) will execute the initialization in the following sequence upon reset cancellation (pin 28 : H→L).

1. The internal RAM and port are initialized.
2. HA11529NT is initialized.
3. CXD2500 is initialized.
4. The tray position is detected.
5. HD49403 is initialized.
6. Communications with PDB017 is checked.
7. The pickup position is initialized.
8. The disc rotation stops.
9. The loading mode is initialized.

After all of the above initializations are completed, normal operation will begin.

2 Loading motor control

The loading motor drive is controlled by the signals output (via the motor driver IC[IC802]) from pins 49 to 51 of the CONT section's mechanism control IC (IC801). The voltage applied to the loading motor is switched by the control signal as follows.

SLOW	CW	CCW	LOAD M+	LOAD M-	Motor Operation
L	L	L
L	L	H	0V	5V	Low-speed CCW rotation
L	H	L	5V	0V	Low-speed CW rotation
L	H	H	0V	0V	Short brake mode
H	L	L	Open	Open	Motor both-ends open mode
H	L	H	0V	11V	High-speed CCW rotation
H	H	L	11V	0V	High-speed CW rotation
H	H	H

CW: Clockwise direction CCW: Counterclockwise direction

• Loading/Clamp operation

For the disc tray opening and closing, disc clamp operation, and stop operation, the motor is operated while the cam gear position is detected by the loading/tilt position detection switch which is connected to pins 62 to 64 of IC801.

The motor will operate in the high-speed mode. Even after the operation is completed, the loading/tilt position detection switch constantly monitors the cam gear position while the latter is in the standby position and in the tilt neutral position. If the cam gear position shifts, the motor will be operated in the low-speed mode.

• Tilt servo operation

When an LD disc or a CDV disc (video part) is played back, the loading motor will be used for the tilt servo. In this mode, the motor will be operated in the low-speed mode. The loading motor drive for the tilt servo will be PWM. There is two-stage duty (high-speed duty 50%, low-speed duty 8%). The tilt servo operates the loading motor so that the voltage of input pin 12 (TILT ERR) of IC801 becomes 2.5V. During normal playback, the tilt servo's operating range will be as follows :

- CAV disc (12-inch) : Frames 0 - 40999
(8-inch) : Frames 0 - 16999
- CLV disc (12-inch) : 0 min. - 44 min. 59 sec.
(8-inch) : 0 min. - 13 min. 59 sec.
- CDV disc(video part) : 0 min. 0 sec. - 0 min. 59 sec.
(Recording time > 3 min.)

If there is a problem with the disc or the tilt sensor circuit and the pickup inclination is $\pm 2\%$ or more and the TILT terminal's input voltage is still not within the set range, the status of the mechanical switch will be detected and the loading motor will be stopped.

• Slider motor control

The slider motor drive is controlled by the signal that is output from pin 18 of the FTS servo IC (IC601) via IC606.

The voltage applied to the slider motor is switched by the control signal from the mechanism control IC (IC801).

When the pickup position is moved compulsorily during disc recognition and startup, the motor is operated while the pickup position is detected by the park switch connected to pins 33 and 34 of IC801.

PD0071 Pin Description

Pin No.	SYMBOL	I/O	Description
1	Vcc	-	Power supply connection (+5V)
2	SQ2	O	Analog audio switching signal output terminal. Digital audio is controlled by IC201(CXD2500Q). (*1)
3	SQ1		
4	N.C.		
5	N.C.		Unused
6	X DIGITAL	O	Digital/analog audio switching signal output terminal. This signal switches the signal which is output to LINE OUT and HEADPHONE. When "H", analog audio. When "L", digital audio. (*1)
7	XLDP		RF modulator switching signal output terminal.
8	XCX		Analog audio CX noise reduction switching signal output terminal.
9	LDON		Laser diode ON/OFF control signal output terminal. When "H" Laser diode ON. When "L" Laser diode OFF.
10	MUTE		Audio system mute control signal output terminal. When "L", MUTE OFF. When "H", MUTE ON.
11	NPC LATCH		Digital filter IC (IC202: SM5840AP) control latch signal output terminal.
12	TILT ERR	I	Tilt sensor output signal input terminal. (Analog signal) The signal which amplified the tilt sensor output by 40dB to 50dB is input (0V - 5V). This signal undergoes A-D conversion and becomes the control input for the tilt servo. The loading motor is controlled so that the TILT input signal becomes 2.5V.
13	GFS		CD (EFM signal) frame lock signal input terminal. (IC201: Connected to pin 12 of CXD2500Q) When "H", OK. When "L", NG.
14	XLAT2	O	IC201 CXD2500Q control latch signal output terminal.
15	SI2	I	IC201 CXD2500Q subcode data input terminal
16	SO2	O	IC201 CXD2500Q control data output terminal.
17	SCK2		IC201 CXD2500Q control/subcode reading clock signal output terminal.
18	SHAKE	I/O	Mode Control IC (IC11: PDB017) data transmission handshake signal terminal. This terminal is a bidirectional data line. It transmits the timing for the data transfer after the respective microcomputer switches between the output or input mode. (*2)
19	SI1	I	Mode Control IC data transmission data I/O terminal. SCK1(pin 21) will be set to the input mode when there is no communications with the Mode Control IC.
20	SO1	O	
21	SCK1	I/O	
22	T.CROSS	O	Tracking error zero cross signal input terminal. This signal monitors the tracking error signal. During track count search, this signal is counted and the slider motor is controlled.
23	SCOR	I	Subcode sync signal input terminal. When this signal is "H", the subcode signal is input from IC201(CXD2500Q). The disc's playback status is also monitored through the existence or non-existence of the signal.
24	SENS		IC901(HD49403) SPDL servo status monitor signal input terminal.
25	XTBCHLD	O	During TBC servo jump, it is the correction signal output terminal. During a special playback of CAV disc, the signal becomes "L" when there is track jumping. After V sync and a fixed time period, it becomes "H".
26	V-Sync	I	Playback vertical synchronization signal input terminal for LD/CDV. The IC basically operates while in synchronization with this signal. (Trailing edge input) During a special playback mode for a CAV, the signal is the standard for producing the jump timing. It is "L" during vertical synchronization.
27	CNVss	-	GND.
28	XRESET	I	Reset signal input terminal. When "L", RESET. When "H", Normal operation.
29	XIN		9MHz clock oscillation input terminal.
30	XOUT	O	9MHz clock oscillation output terminal.
31	N.C.		Unused
32	Vss	-	GND.

Pin No.	SYMBOL	I/O	Description	
33	PARK2	I	The pickup position detection switch input terminals. Being a switch input for mechanism position detection, it detects the pickup's position. (*3)	
34	PARK1			
35	FOCUS LOCK		Focus servo lock signal input terminal. It is used for focus servo lock detection. When "L", OK. When "H", NG.	
36	1080/2080		Mechanism controller mode switching input terminal. When "H", CLD-1080.	
37	FG		Spindle motor FG signal switching input terminal.	
38	DATA		PHILIPS code decoder input terminal built-in in the mechanism controller.	
39	Hsync			
40	Vsync			
41	CAV	O		CAV/CLV switching signal output terminal. (IC201: Connected to pin 17 of PA5010, it is used as the video NR switching signal.)
42	CLVSCAN		CLV V sync scan mode signal output terminal. When CLVSCAN is "L", SCANV(pin 44) is inserted to the video signal.	
43	N.C.		Unused.	
44	SCANV	O	Pseudo V sync signal output terminal for the CLV V sync scan.	
45	XVSQ		Blue back switching signal output terminal for the video output. When "H", playback video. When "L", blue back.	
46	XRFCORR		RF correction switching signal output terminal. (Connected to IC201 PA5010 pin 52.) "H" at the outer periphery of the CAV.	
47	N.C.		Unused.	
48	N.C.			
49	CCW	O	Loading/tilt motor rotational direction control signal output terminal. The motor's rotational direction and brake mode are selected by pins 49 and 50. Pin 49: counterclockwise. Pin 50: clockwise. (*4)	
50	CW			
51	SLOW	O	Loading/tilt motor operation speed switching signal output terminal. When it is switched to the loading mode, high-speed operation will take effect. During tilt operation, low-speed operation will take effect. When, "L", low-speed. When "H", high-speed.	
52	J. TRIG			Track jump signal output terminal.
53	FTSSCAN	I/O	Signal output terminal for tracking servo stabilization. Normally, it will be HI-Z in the input mode.	
54	TOFF	O	Tracking servo operation control signal output terminal. This signal backs up the ON/OFF of the tracking servo operation. When "L", ON. When "H", OFF.	
55	CD MODE		Servo equalizer switching signal output terminal. This is switched according to the disc to be played. (*5)	
56	XLD MODE			
57	S03			Serial signal output terminal for the FTS servo IC(IC601: HA11529), the SPDL/TBC servo IC(IC901:HD49403), and the digital filter IC(IC202: SM5840AP). The serial signals of these three ICs are the same. They are distinguished by pin 11 (NPCLAT) and pin 59 (LATCH3).
58	SCLK3			
59	LATCH3			
60	N.C.	Unused.		
61	N.C.			
62	SW1	I	Loading/tilt position detection switch input terminals.	
63	SW2			
64	SW3			

*1

DIGITAL Pin 6	SQ1 Pin 3	SQ2 Pin 2	L-Ch Line Out	R-Ch Line Out
H	L	L	Analog L Channel	Analog R Channel
H	H	L	Analog L Channel	Analog L Channel
H	L	H	Analog R Channel	Analog R Channel
H	H	H	Mute	Mute
L	L	L	Digital L Channel	Digital R Channel
			Digital L Channel	Digital L Channel
			Digital R Channel	Digital R Channel
			Digital -12dB-L	Digital -12dB-R

CXD2500 switching the digital audio channel by commands from microcomputer.

*2

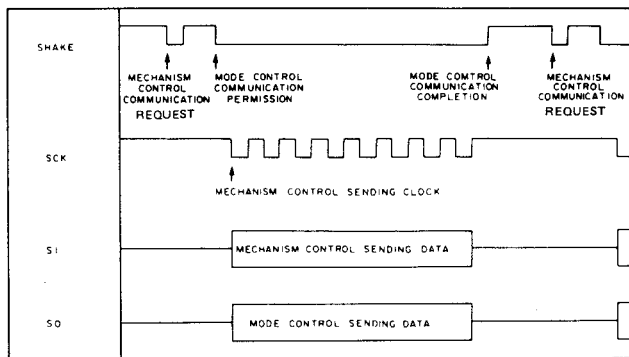

*3

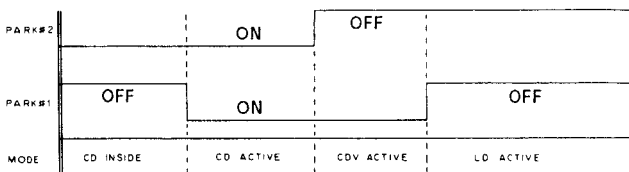

LD-inside position: Indicating the start of the active program area of an LD disc (R55 - R56.4)
 CDV-inside position: Indicating the start of the video part of a CDV disc. (R37 - R38.4)
 CD-inside position: Indicating the start of the active program of a CD disc. (R25 - R26.4)
 R: The distance from center of the spindle motor.

*4

CW	CCW	Loading/Tilt Motor Operation
L	L	Motor both-ends release (open mode)
L	H	Loading-out direction rotation
H	L	Loading-in direction rotation
H	H	Motor both-ends short-circuit (short-circuit mode)

*5

CDMODE	XLDMODE	Disc Mode
L	L	LD
L	H	CDV Video part
H	L	Not defined
H	H	CD/CDV Audio part

*6

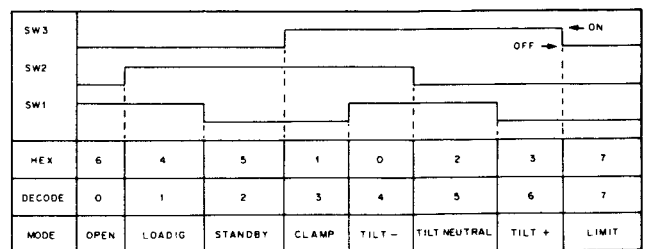

● Flowchart from tray open status to tray in operation

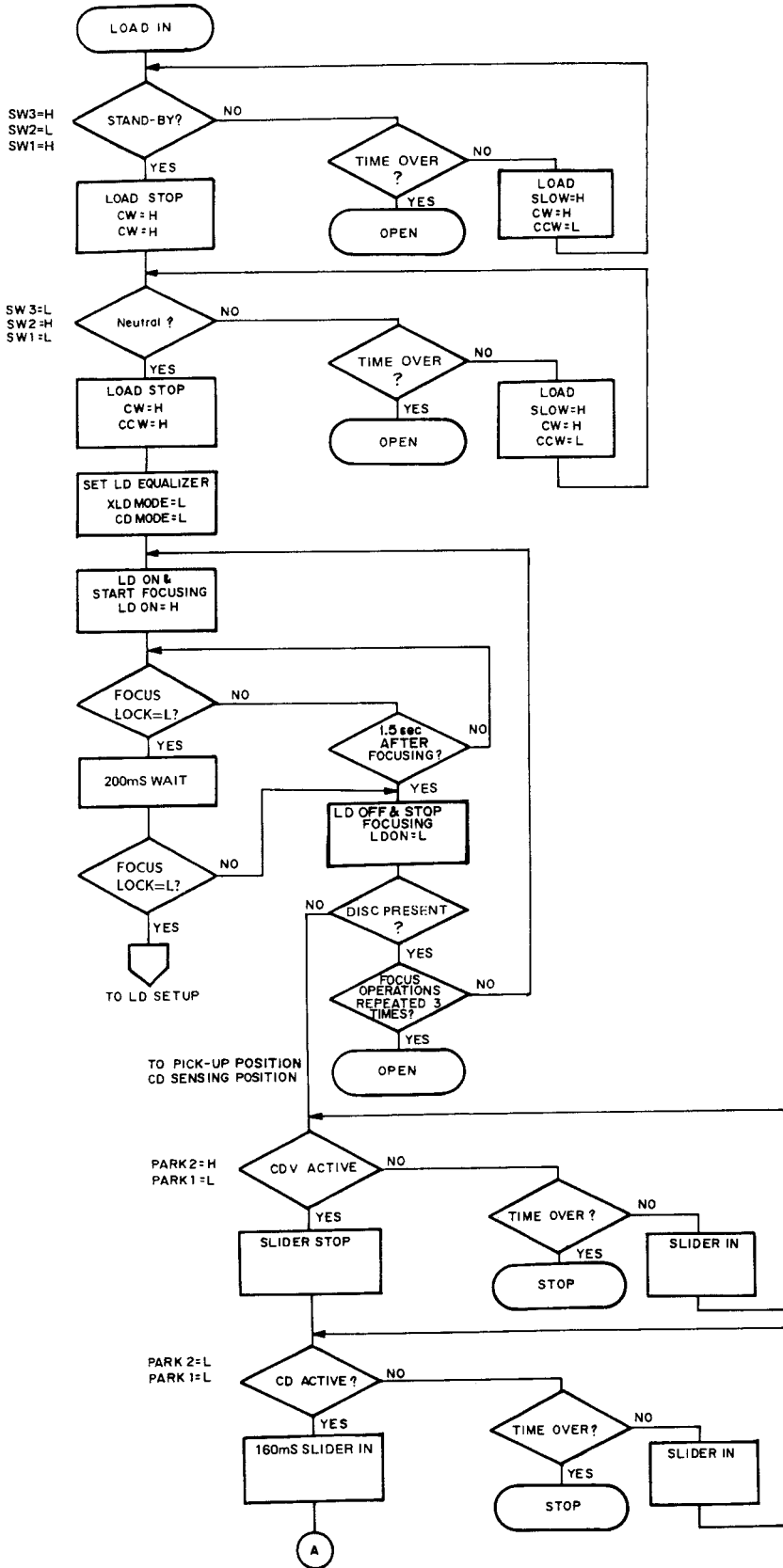

● From open status till tray-in operation is completed

● If the loading operation is not finished within 10 seconds, it is regarded as abnormal and the tray is opened again

● Clamping

● Pick-up position during LD focus operation: around R65
R: The distance from center of the spindle motor.

● During focus sweep operation, when FOCUS LOCK goes "L", it is regarded that a disc is present.

● With a disc present, if the focus lock is not obtained after sweeping the focus three times, it is regarded as abnormal and opens the tray.

● Slider operation limit timer: about 10 seconds

● If the slider operation is not finished within a fixed time, the player enters the stop mode and no key inputs other than OPEN key are accepted.

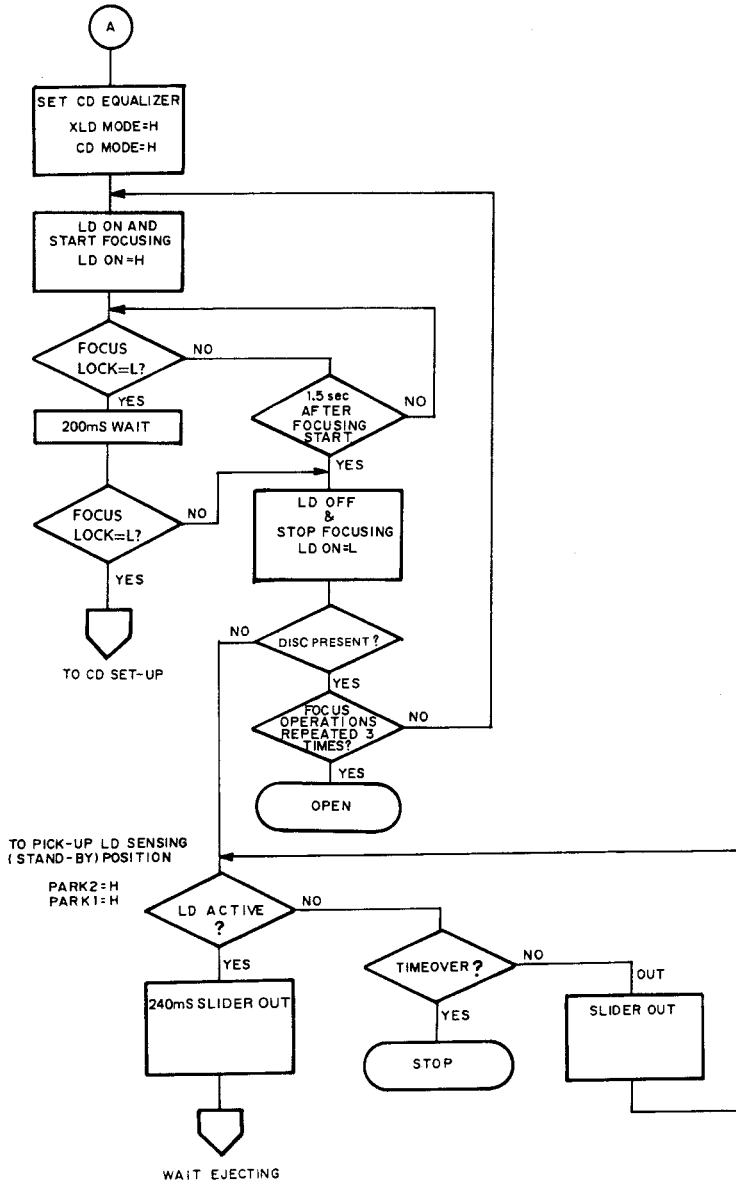

- Pick-up position during CD focus operation: around R30
- CD focus operation is performed in the same way as that for LDs.
- R: The distance from center of the spindle motor.

- LD sense position: around R65
- R: The distance from center of the spindle motor.
- Timer: about 10 seconds.
- Timer → The TIME OVER time mentioned on the left.

● Flowchart of LD Setup

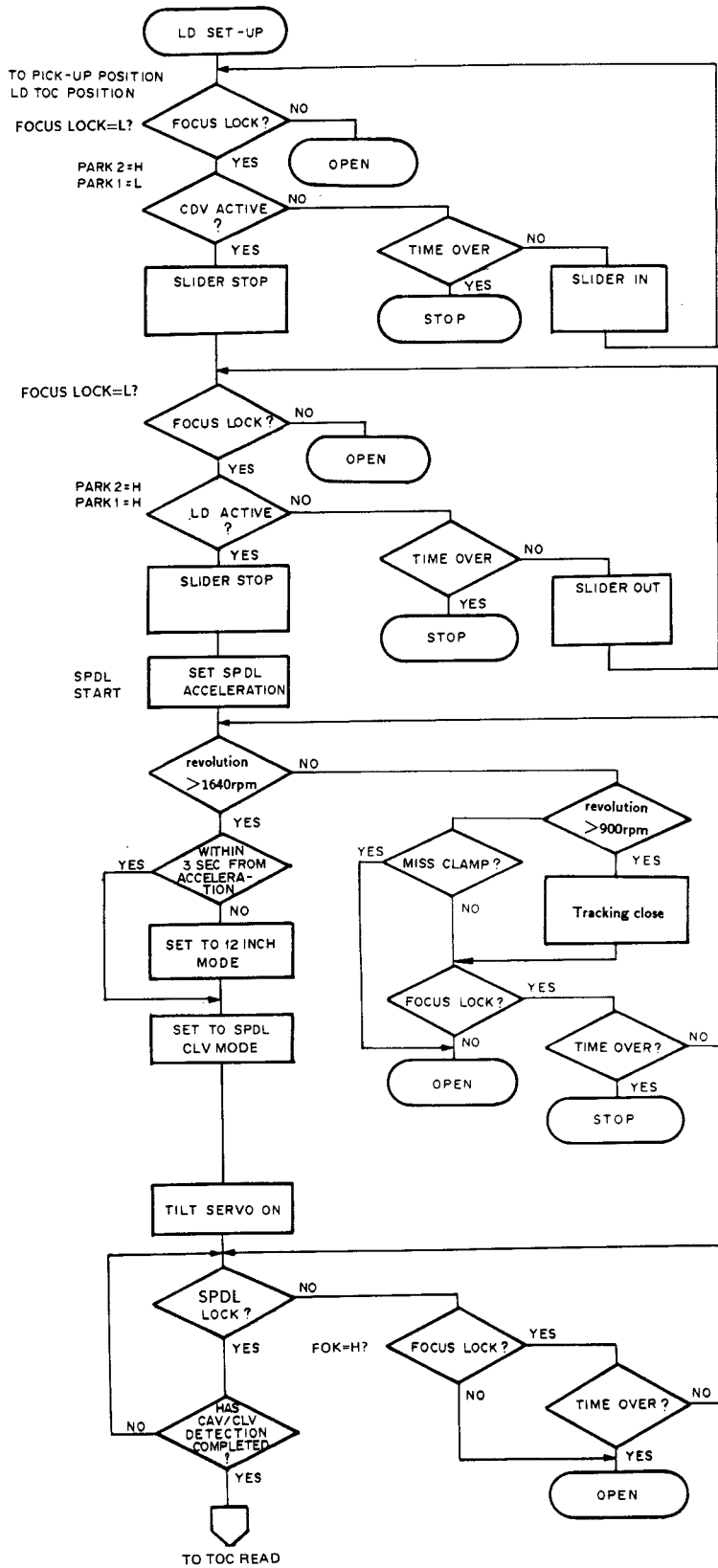

- When the focus is unlocked while the pick-up is moving to the spindle motor start position, it is judged that LD and CD discs have been loaded simultaneously and the tray is opened.

- Timer : about 10 seconds
Timer → The TIME OVER time mentioned on the left.

- Timer : about 10 seconds

- Until the disc rotation speed exceeds 900 rpm, the tracking servo is set to the open mode and spindle motor is forced acceleration.

- When the pick-up moves across more than 1600 rpm tracks in one revolution of the disc, it is judged as mis-clamping and the tray is opened.

- If the focus is unlocked during setup operation, it is judged that there is a scratch on the disc or that the unrecorded surface of the single-side disc is being played, and the tray is opened.

- When the disc rotation speed does not exceed 1640 rpm within 60 seconds after the spindle motor starts accelerating, the player enters the stop mode.

● Flowchart of CD Setup

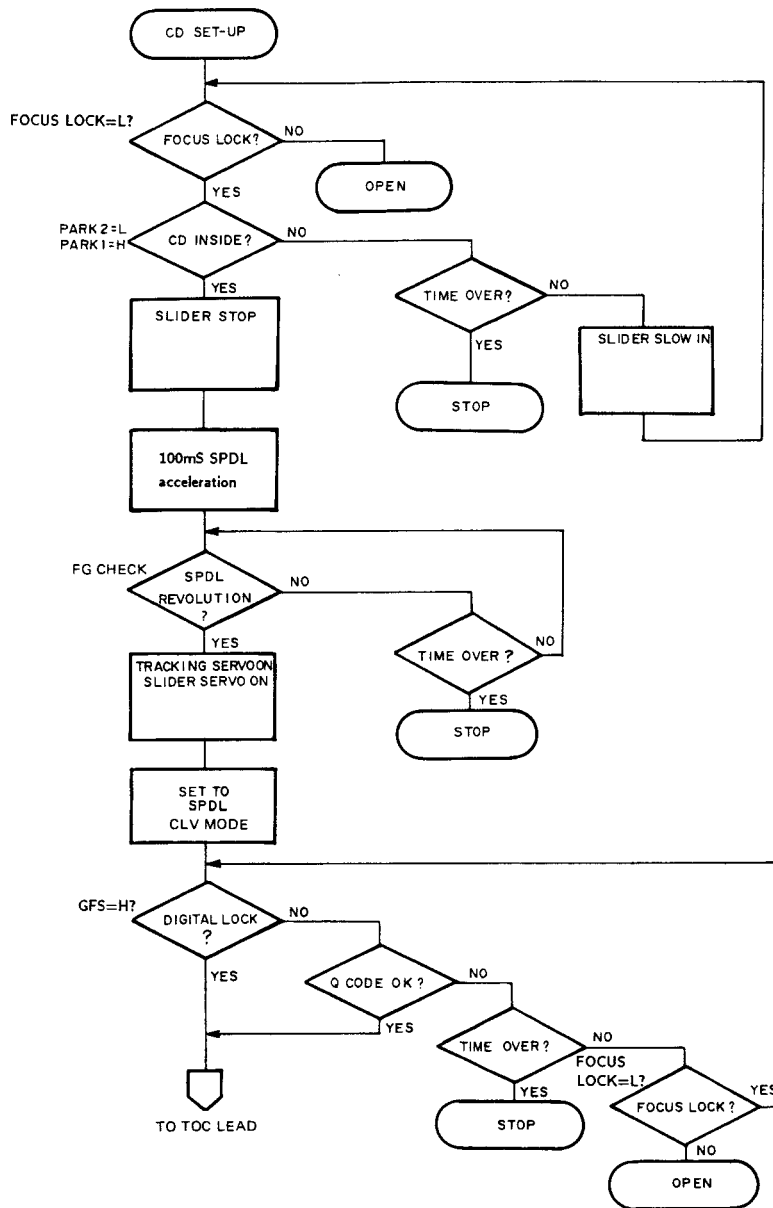

- When the pick-up is fed to the inside of the disc (CD), the disc speed is lowered by driving the slider motor in PWM drive.
- When a CD is loaded, the spindle motor is accelerated for 100 mS forcibly.

- When the FG input signal is not inverted 6 times within 2 seconds, the player enters the stop mode.

- When the digital lock or Q-code OK signal is not detected within 2 seconds after the tracking/ slider servo is closed, the player enters the stop mode.
- If the focus is unlocked during disc rotation, it is judged that the unrecorded surface of the disc has been placed on the tray, and the tray is opened.

● Flowchart of Frame Search Operation

SET TO THE LOW SPEED SCANNING MODE WHEN CODE READING IS NOT POSSIBLE (BACK UP)

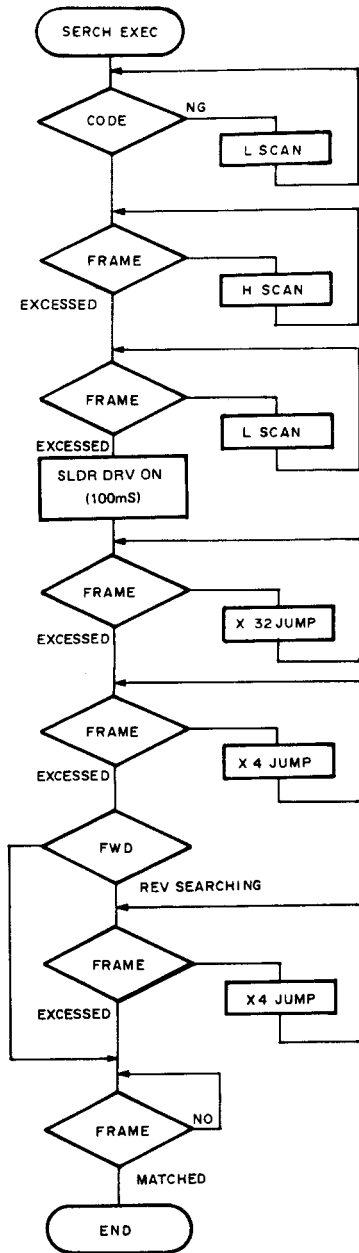

- Slider motor drive duty : 1/8
- Slider motor drive duty : 100%
- Slider motor drive duty : 1/8
- Waiting for 100 mS (tracking/ slider servo ON)
- 32-track jump
- 4-track jump
- 4-track jump (Reverse search only)

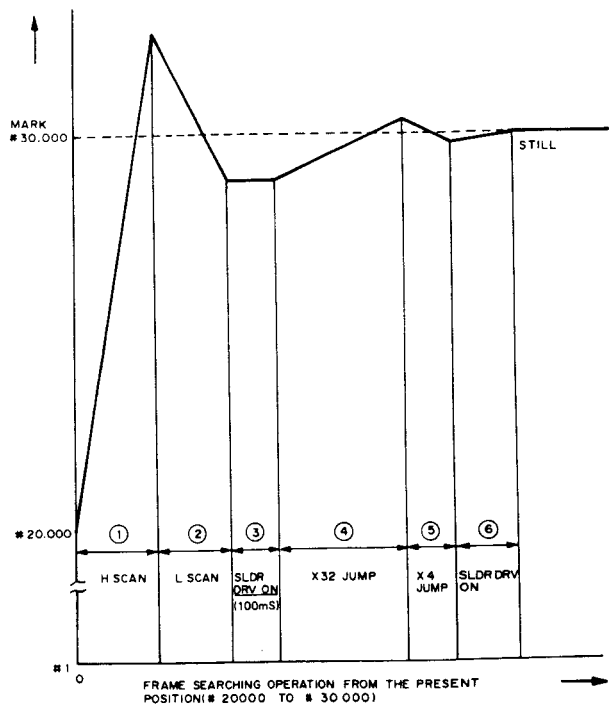

FRAME SEARCHING OPERATION FROM THE PRESENT POSITION(# 20000 TO # 30 000)

FRAME SEARCH OPERATION