

# Service Manual

 **PIONEER**  
The future of sound and vision.

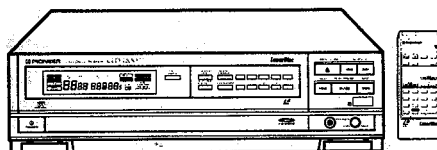

**ORDER NO.**  
**ARP 1633**

CD CDV LD PLAYER

# CLD-1200

- This service manual is applicable to the HEM and HB types.

## CONTENTS

1. SAFETY INFORMATION.....	2	6.5 2FSB AND SCRT ASSEMBLY .....	35
2. LABEL CHECK.....	3	6.6 HEPB, FLKY, IRKB AND CNNB ASSEMBLY .....	39
3. P.C. BOARDS LOCATIONS .....	4	7. ELECTRICAL PARTS LIST.....	43
4. EXPLODED VIEW AND PARTS LIST		8. PICK-UP ASSEMBLY REPLACEMENT PROCEDURE.....	50
4.1 EXTERIOR AND FRONT VIEW.....	5	9. ADJUSTMENTS.....	52
4.2 TOP VIEW .....	8	8. REMPLACEMENT DU SOUS-ENSEMBLE CAPTEUR .....	78
4.3 BOTTOM VEIW .....	10	9. REGLAGE .....	80
4.4 MECHANISM ASSEMBLY VIEW .....	12	8. PROCEDIMIENTOS PARA CAMBIAR EL CONJUNTO DEL FONOCAPTOR.....	106
4.5 PICK-UP ASSEMBLY VIEW .....	14	9. AJUSTE.....	108
4.6 REMOTE CONTROL UNIT .....	15	10. HB TYPE.....	134
4.7 PACKING.....	16	11. BLOCK DIAGRAM OF VSOP ASSEMBLY (TBC, CONT).....	135
5. CONNECTION DIAGRAM .....	17	12. SPECIFICATIONS .....	137
6. SCHEMATIC DIAGRAM AND P.C. BOARDS PATERNS		13. PANEL FACILITIES AND REMOTE CONTROL UNIT .....	138
6.1 LFSB AND SYPS ASSEMBLY .....	19		
6.2 BLDB, BLMB, FTSB, TNTR AND PICK-UP ASSEMBLY .....	23		
6.3 VSOP ASSEMBLY (VDEM, ADEM) .....	27		
6.4 VSOP ASSEMBLY (TBC, CONT) AND LMCB ASSEMBLY .....	31		

**PIONEER ELECTRONIC CORPORATION** 4-1, Meguro 1-Chome, Meguro-ku, Tokyo 153, Japan  
**PIONEER ELECTRONICS SERVICE INC.** P.O. Box 1760, Long Beach, California 90801 U.S.A.  
**PIONEER ELECTRONICS OF CANADA, INC.** 505 Cochrane Drive, Markham, Ontario L3R 8E3 Canada  
**PIONEER ELECTRONIC [EUROPE] N.V.** Keetberglaan 1, 2740 Beveren, Belgium  
**PIONEER ELECTRONICS AUSTRALIA PTY. LTD.** 178-184 Boundary Road, Braeside, Victoria 3195, Australia TEL: [03] 580-9911  
© PIONEER ELECTRONIC CORPORATION 1988

FJ AUG. 1988 Printed in Japan

# 1. SAFETY INFORMATION

-(FOR USA MODEL ONLY)-

## 1. SAFETY PRECAUTIONS

The following check should be performed for the continued protection of the customer and service technician.

### LEAKAGE CURRENT CHECK

Measure leakage current to a known earth ground (water pipe, conduit, etc.) by connecting a leakage current tester such as Simpson Model 229-2 or equivalent between the earth ground and all exposed metal parts of the appliance (input/output terminals, screwheads, metal overlays, control shaft, etc.). Plug the AC line cord of the appliance directly into a 120 V AC 60 Hz outlet and turn the AC power switch on. Any current measured must not exceed 0.5 mA.

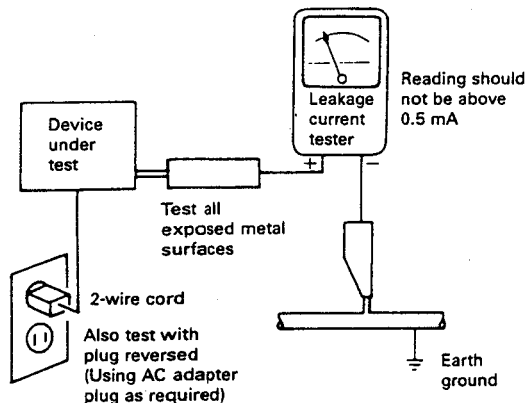

AC Leakage Test

ANY MEASUREMENTS NOT WITHIN THE LIMITS OUTLINED ABOVE ARE INDICATIVE OF A POTENTIAL SHOCK HAZARD AND MUST BE CORRECTED BEFORE RETURNING THE APPLIANCE TO THE CUSTOMER.

## 2. PRODUCT SAFETY NOTICE

Many electrical and mechanical parts in the appliance have special safety related characteristics. These are often not evident from visual inspection nor the protection afforded by them necessarily can be obtained by using replacement components rated for voltage, wattage, etc. Replacement parts which have these special safety characteristics are identified in this Service Manual.

Electrical components having such features are identified by marking with a  $\Delta$  on the schematics and on the parts list in this Service Manual.

The use of a substitute replacement component which does not have the same safety characteristics as the PIONEER recommended replacement one, shown in the parts list in this Service Manual, may create shock, fire, or other hazards.

Product Safety is continuously under review and new instructions are issued from time to time. For the latest information, always consult the current PIONEER Service Manual. A subscription to, or additional copies of, PIONEER Service Manual may be obtained at a nominal charge from PIONEER.

-(FOR EUROPEAN MODEL ONLY)-

**VAROITUS!**

LAITE SISÄLTÄÄ LASERDIODIN, JOKA LÄHETTÄÄ NÄKYMÄTÖNTÄ, SILMILLE VAARALLISTA INFRAPUNASATEILYÄ LAITTEEN SISÄLLÄ ON LASERDIODIN LÄHEISYYDESSÄ KUVAN 1. MUKAINEN VAROITUSMERKKI.



LASER  
Kuva 1  
Lasersäteilyn  
varoituserkki

**WARNING!**

DEVICE INCLUDES LASER DIODE WHICH EMITS INVISIBLE INFRARED RADIATION WHICH IS DANGEROUS TO EYES. THERE IS A WARNING SIGN ACCORDING TO PICTURE 1 INSIDE THE DEVICE CLOSE TO THE LASER DIODE.



LASER  
Picture 1  
Warning sign for  
laser radiation

**ADVERSEL:**

USYNLIG LASERSTRÅLING VED ÅBNING NÅR SIKKERHEDSAFBRYDERE ER UDE AF FUNKTION UDGÅ UDSAETTELSE FOR STRÅLING.

**VIKTIGT**

APARATEN INNEHÅLLER LASER AV HÖGRE KLASS ÄN 1. INGREPP I APPARATEN BÖR GÖRAS AV SPECIELLT UTBILDAD PERSONAL.

**IMPORTANT**

THIS PIONEER APPARATUS CONTAINS LASER OF HIGHER CLASS THAN 1. SERVICING OPERATION OF THE APPARATUS SHOULD BE DONE BY A SPECIALLY INSTRUCTED PERSON.

## 2. LABEL CHECK

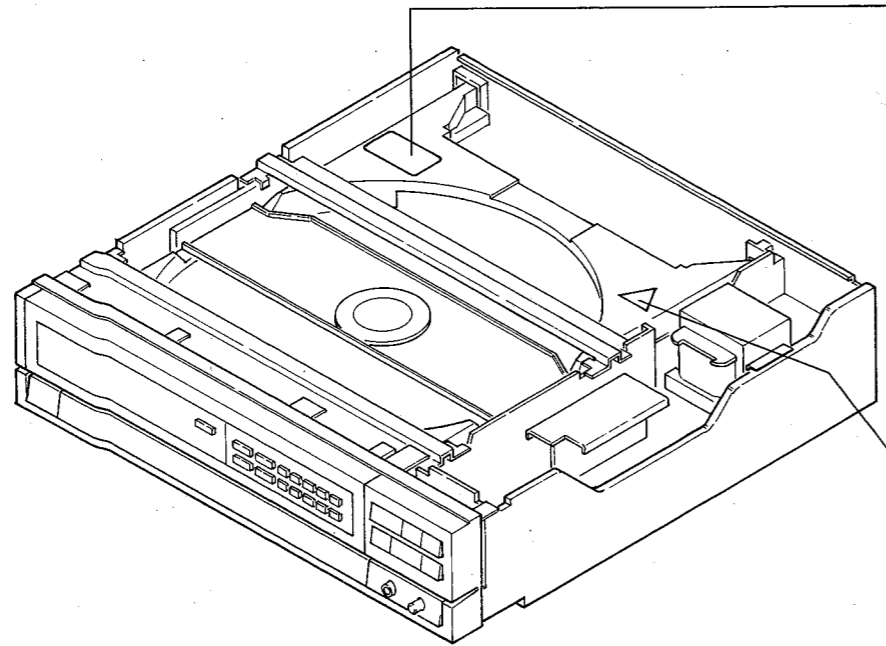

HB model

**CAUTION**  
**INVISIBLE LASER**  
**RADIATION WHEN OPEN,**  
**AVOID EXPOSURE**  
**TO BEAM** PRW1018

HEM model

LASER RADIATION  
 AVOID EXPOSURE TO BEAM, CLASS 3B LASER PRODUCT.  
 ADVARSEL  
 USYNLIG LASERSTRÅLING VED ÅBNING HAR SIKKERHED SAF  
 BRYDENE ER UDE AF FUNKTION  
 UNDGÅ UDSÆTTELSE FOR STRÅLING  
 UNSICHTBARE  
 LASERSTRÅLING NICHT DEM STRAHL AUSSETZEN LASER  
 KLASSE 3B. VRW-474

HB and HEM model

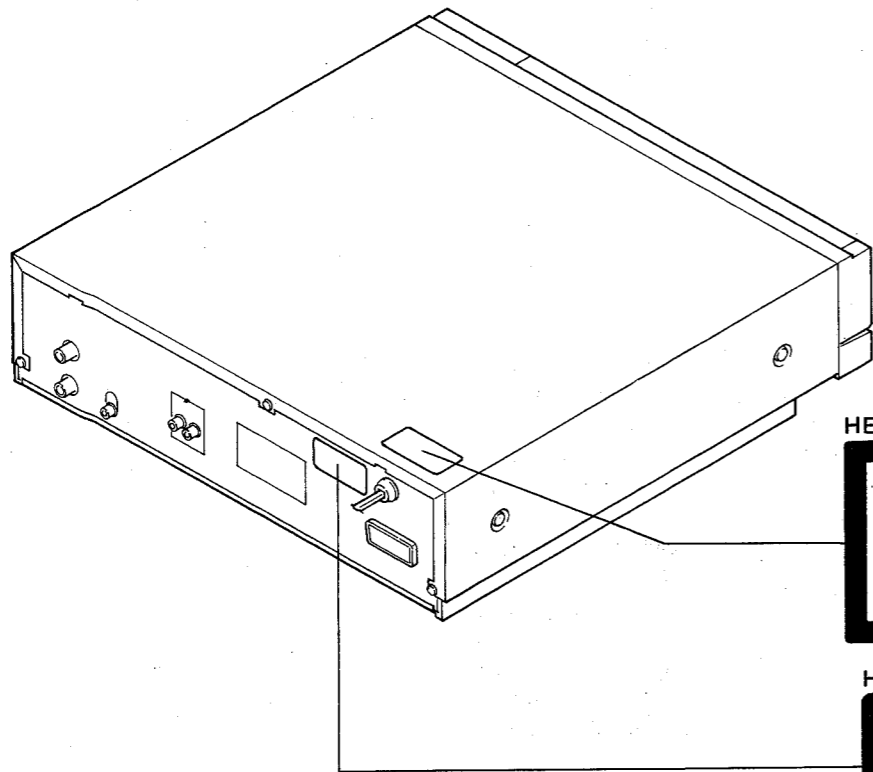

HB model

**CAUTION**  
**INVISIBLE LASER**  
**RADIATION WHEN OPEN,**  
**AVOID EXPOSURE**  
**TO BEAM** PRW1018

HEM model

**CAUTION**  
 LASER RADIATION WHEN OPEN, AVOID EXPOSURE TO BEAM.  
 ADVARSEL  
 FARE FOR USYNLIG LASERSTRÅLING VED ÅBNING AF DÆKSEL  
 UNDGÅ AT UDSÆTTE OJNENE FOR STRÅLING.  
 VORSICHT!  
 UNSICHTBARE LASERSTRÅLUNG TRIT AUS, WENN DECKEL  
 (ODER KLAPPE) GEÖFFNET IST NICHT DEM STRAHL AUSSE-  
 TZENI. VRW-475

HB and HEM model

**CLASS 1**  
**LASER PRODUCT**  
 VRW - 328

## 3. P.C. BOARDS LOCATIONS

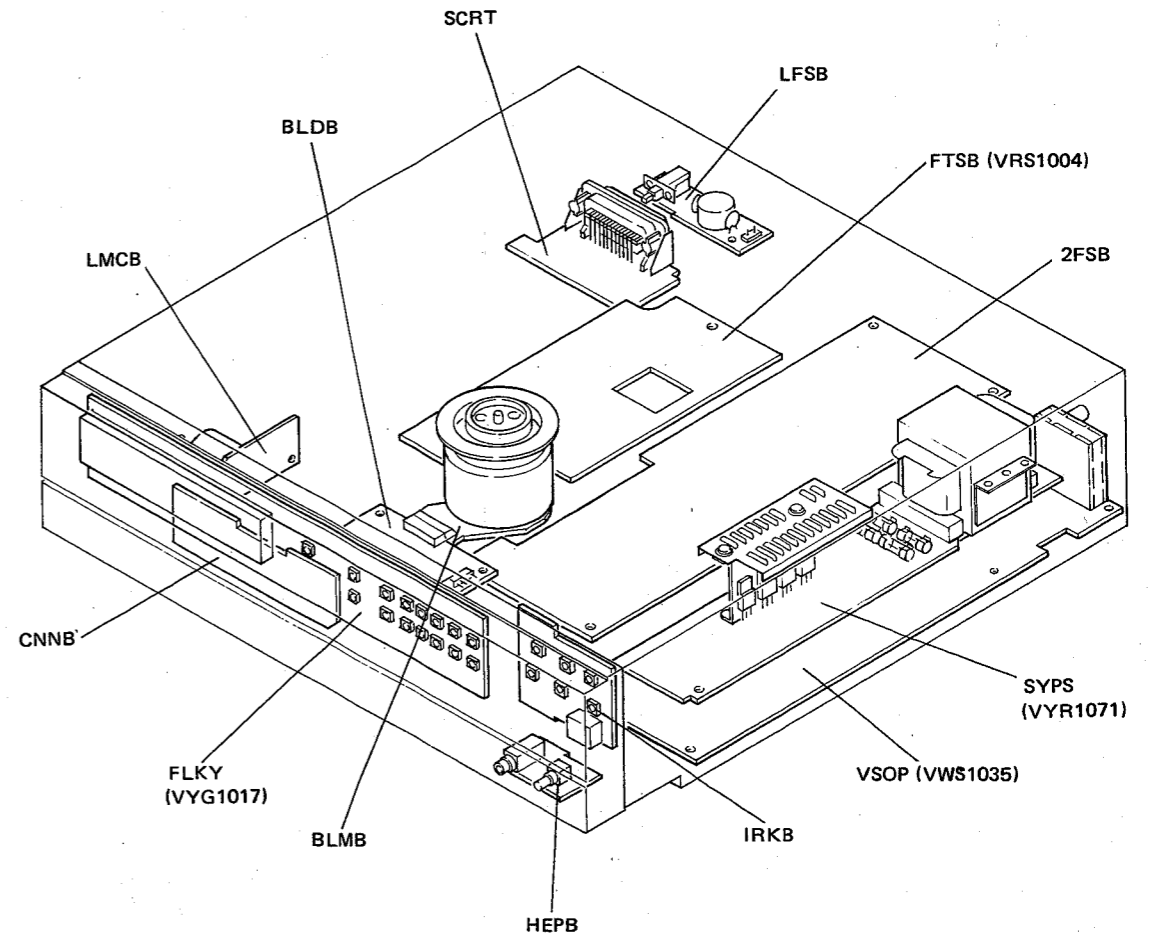

VSOP	VWS1035	Video Servo Organized Part
SYPS	VYR1071	System Power Supply Board
2FSB	VWV1047	2FS Board
FTSB	VYS1009	Focus Tracking and Slider Servo Board
LFSB		Line Filter and Power Switch
FLKY	VYG1017	Flourescent Display and Key Board
HEPB		Eead Phones Board
IRKB		Infrared Key Board
BLDB		Brushless Motor Drive Board
LMCB		Loading Motor Connecting Board
BLMB		Brushless Motor Board
CNNB		Connecting Board
SCRT		Senelec CRT Board

CLD-1200

# 4. EXPLODED VIEW AND PARTS LIST

## 4.1 EXTERIOR AND FRONT VIEW

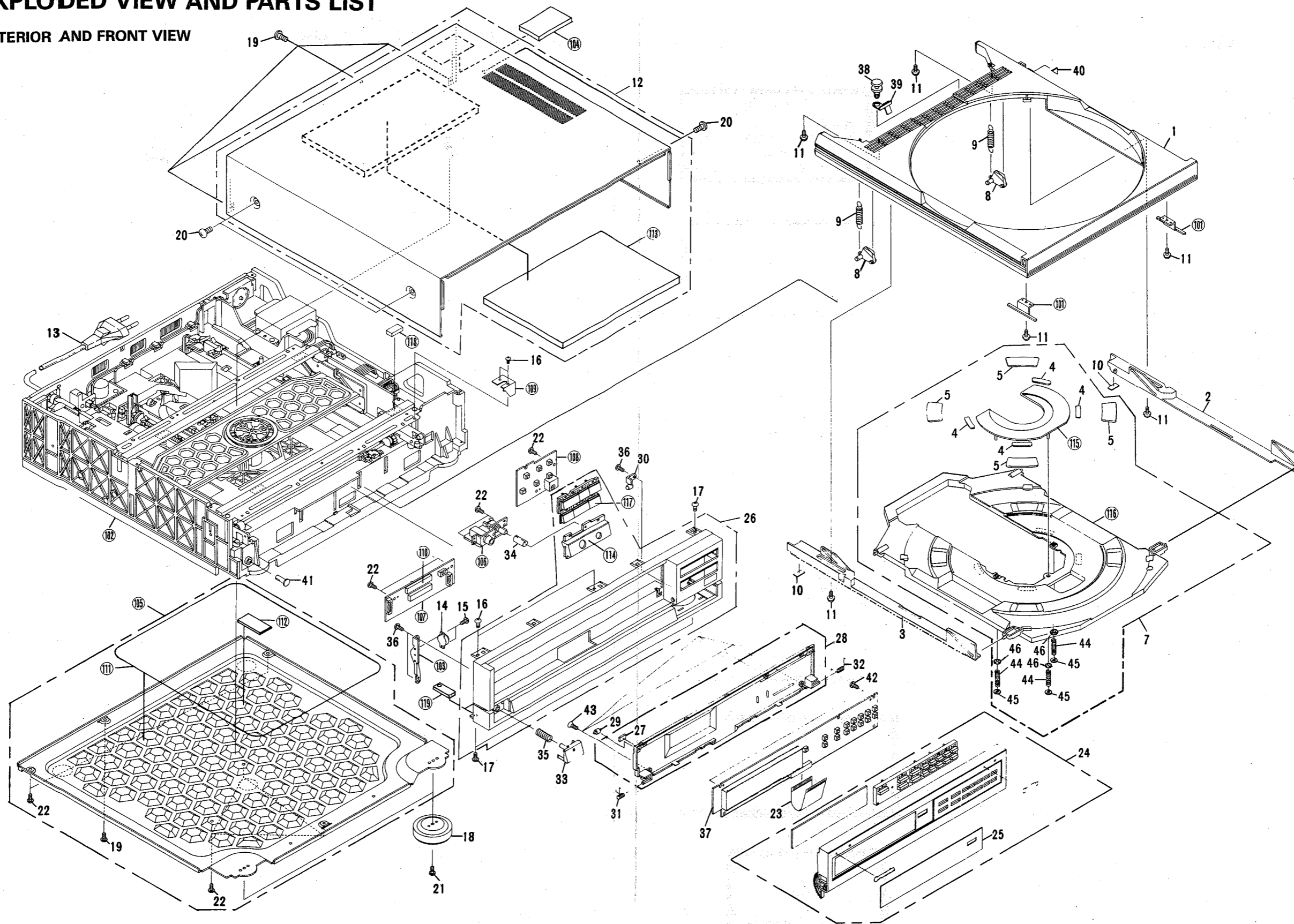

## NOTES:

- Parts without part number cannot be supplied.
- The  $\Delta$  mark found on some component parts indicates the importance of the safety factor of the part. Therefore, when replacing, be sure to use parts of identical designation.
- Parts marked by "●" are not always kept in stock. Their delivery time may be longer than usual or they may be unavailable.

## Parts List of Exterior and Front View

Mark	No.	Part No.	Description	Mark	No.	Part No.	Description
	1.	VNK1090	Caddy		41.	VNL1084	PSW cap
	2.	VNL1061	Rack gear (R)		42.	BPZ26P060FCU	Screw
	3.	VNL1060	Rack gear (L)		43.	CPZ26P100FZK	Screw
	4.	VEC1130	Disc pad (Z)		44.	VBH1047	Sub container spring
	5.	VEC1115	Disc pad		45.	WT16D060D025	Wsher
	6.	...	...		46.	WA22N050W020	Nylon washer
	7.	VXX1201	Container assembly-S		47.	...	...
	8.	VNL1062	Stopper		101.		Rack holder
	9.	VBH1021	Stopper spring		102.		Base assembly
	10.	VEB1041	Rack Dump rubber		103.		Dumper holder plate
	11.	IBZ30P080FCU	Screw		104.		Insulator cushion
	12.	VXX1125	Bonnet assembly-S		105.		Bottom plate assembly
	13.	VDG1014	AC Power cord		106.		HEPB assembly
	14.	REC1005	Dumper assembly		107.		CNNB assembly
	15.	PMZ20P040FCU	Screw		108.		IRKB assembly
	16.	BBZ30P050FCC	Screw		109.		Stop plate
	17.	APZ30P080FCU	Screw		110.		Cushion (A)
	18.	VXA1094	Insulator assembly		111.		Insulator sheet
	19.	BBT30P060FBR	Screw		112.		Spacer
	20.	BPZ40P100FBR	Screw		113.		Cushion (B)
	21.	APZ30P140FCU	Screw		114.		Jack panel
	22.	BPZ30P080FCU	Screw		115.		Sub container assembly
	23.	VDA1051	Fuji card		116.		Container (Z)
	24.	VXX1209	Front door assembly-S		117.		Function Button
	25.	VNK1125	FL panel (X)		118.		Cushion
	26.	VXX1091	Front panel assembly-S		119.		Front holder
	27.	VEB1033	Door dump rubber				
	28.	VXX1081	Door cover assembly-S				
	29.	VNL1042	Roller				
	30.	VXA1166	Hinge assembly				
	31.	VBH1048	Door spring (L)				
	32.	VBH1049	Door spring (R)				
	33.	VNK1105	Power button				
	34.	VNK1106	Volume knob				
	35.	VBH1019	Power spring				
	36.	BPZ30P080FCU	Screw				
	37.	VYG1017	FLKY assembly				
	38.	VEC1059	Plastic rivet				
	39.	VBK1009	Switch spring				
	40.	VEB1045	Stop dump rubber				

D-1200

4.2 TOP VIEW

1

2

3

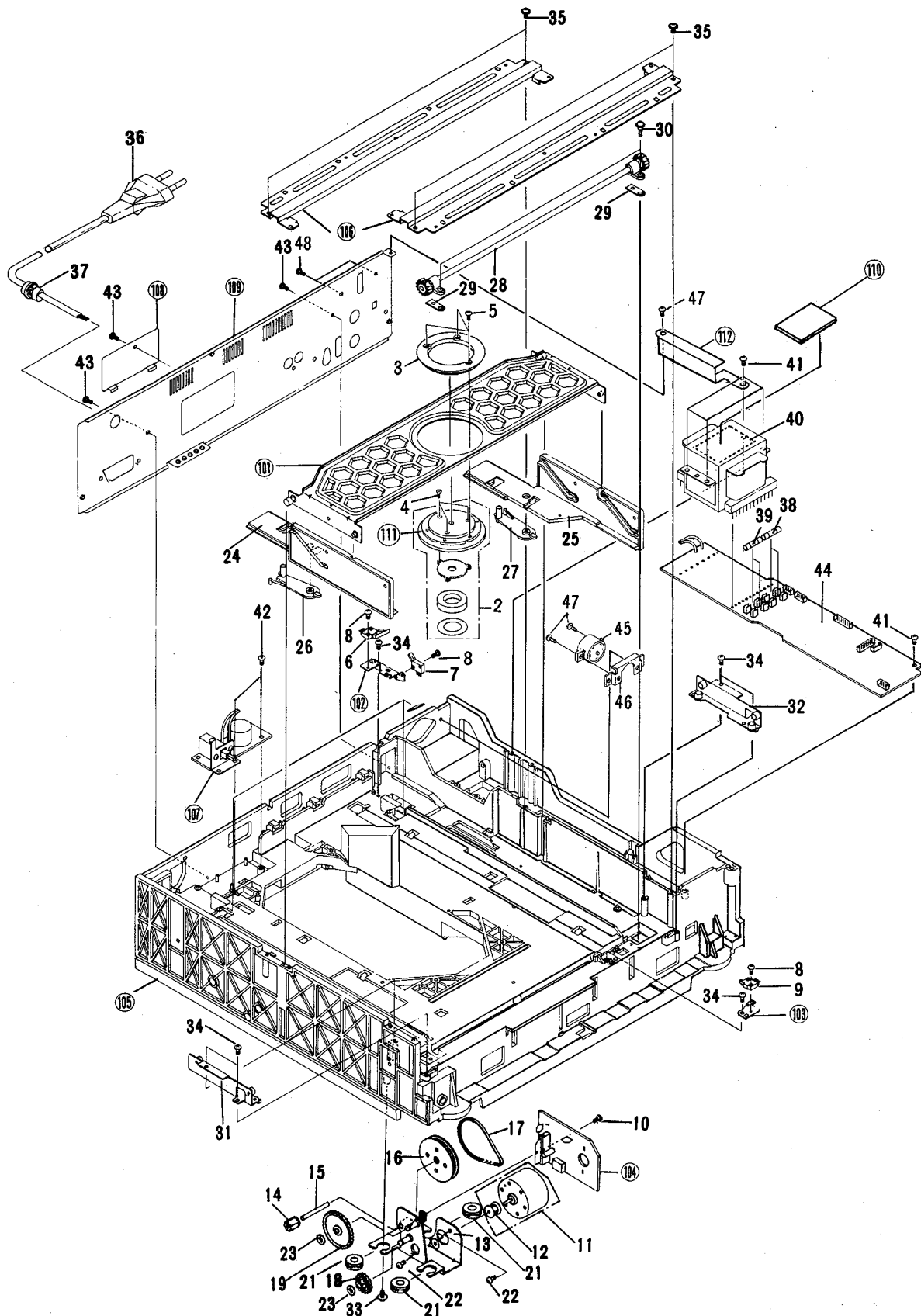

A

B

C

D

1

2

3

## Parts List of Top View

Mark	No.	Part No.	Description	Mark	No.	Part No.	Description
	1.	...	...		101.		Clamper holder assembly
	2.	VXX1156	Disc clamper assembly-S		102.		Switch holder (A)
	3.	VNL1130	Clamper head		103.		Switch holder (B)
	4.	CMZ20P050FCU	Screw		104.		LMCB assembly
	5.	BPZ26P060FCU	Screw		105.		Base
	6.	VSK-010	Slide switch (S2) (TABLE/IN)		106.		Bridge
	7.	VSK1003	Slide switch (S1) (TABLE/PARK)		107.		LFSB assembly
	8.	BMZ20P080FCU	Screw		108.		Rear cover
	9.	VSK-012	Slide switch (S3) (TABLE/OUT)		109.		Rear panel
	10.	VEC-143	Plastic rivet		110.		Transformer cushion
					111.		Disc clamper assembly
	11.	VXX1084	Loading motor assembly-S				
	12.	VNL1051	Motor pulley		112.		Earth plate
	13.	VXA1088	Motor base assembly				
	14.	VNL1020	Gear (A)				
	15.	VLL1037	Gear (A) shaft				
	16.	VXA-477	Pulley (L) assembly				
	17.	VEB-125	Synchronized belt L				
	18.	VNL1010	Gear (C)				
	19.	VNL1064	Gear (B)				
	20.	...	...				
	21.	VEB1025	Rubber bushing				
	22.	PMA26P040FCU	Screw				
	23.	WT32D060D050	Washer				
	24.	VNL1068	Clamper cam (L)				
	25.	VNL1069	Clamper cam (R)				
	26.	VNL1070	Rock lever (L)				
	27.	VNL1071	Rock lever (R)				
	28.	VXA1163	Synchronized gear assembly				
	29.	VEB1026	Dumper sheet				
	30.	VBA1002	Screw				
	31.	VXA1161	Roller plate (L) assembly				
	32.	VXA1162	Roller plate (R) assembly				
	33.	VBA1003	Screw				
	34.	BPZ30P080FCU	Screw				
	35.	APZ30P080FCU	Screw				
△	36.	VDG1014	AC Power cord				
	37.	CM-22B	Strain relief				
△	38.	REK-105	Fuse (3.15A) (FU1, FU2)				
△	39.	REK-103	Fuse (2A) (FU3, FU4)				
△	40.	VTT1038	Power transformer				
	41.	APZ30P080FCU	Screw				
	42.	BPZ30P080FCU	Screw				
	43.	BPZ30P080FBR	Screw				
	44.	VYR1071	SYPS assembly				
	45.	VSB-001	Line voltage selector (220V/240V)				
	46.	VNE1211	SW holder plate				
	47.	BBZ30P080FMC	Screw				
	48.	BBT30P100FZK	Screw				

D-1200

4.3 BOTTOM VIEW

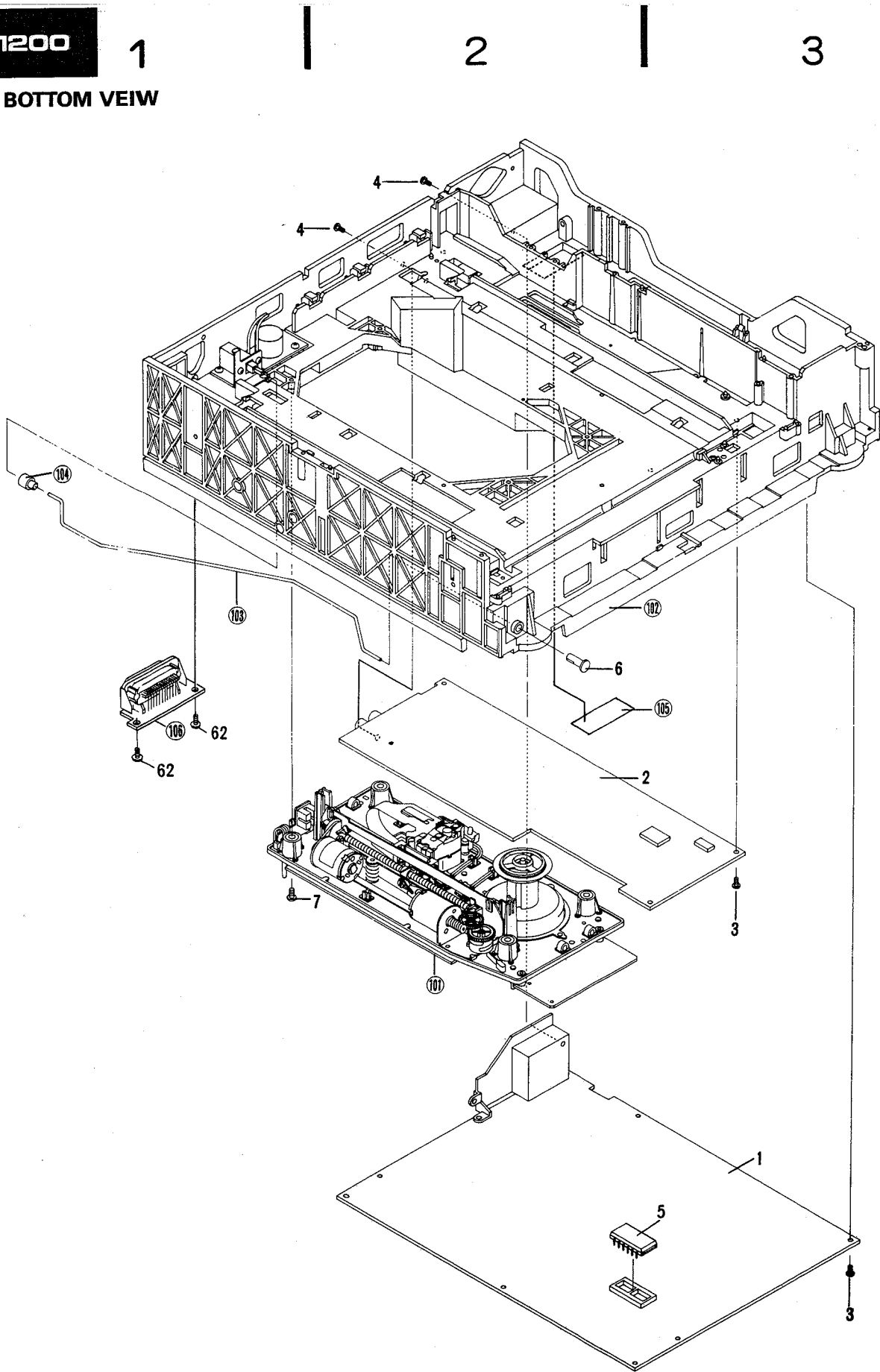

A

B

C

D

10

1

2

3



**Parts List of Bottom View**

<b>Mark</b>	<b>No.</b>	<b>Part No.</b>	<b>Description</b>
●	1.	VWS1035	VSOP assembly
●	2.	VWV1047	2FSB assembly
	3.	BPZ30P080FCU	Screw
	4.	BPZ30P080FBR	Screw
	5.	VYW1261	Program PROM (IC4)
	6.	VNL1084	PSW cap
	7.	VBA1004	Screw
	101.		Mechanism assembly
	102.		Base
	103.		PSW joint
	104.		Joint cap
	105.		Cover
	106.		SCRT assembly

D-1200

1

2

3

4.4 MECHANISM ASSEMBLY VIEW

A

A

3

B

C

C

D

D

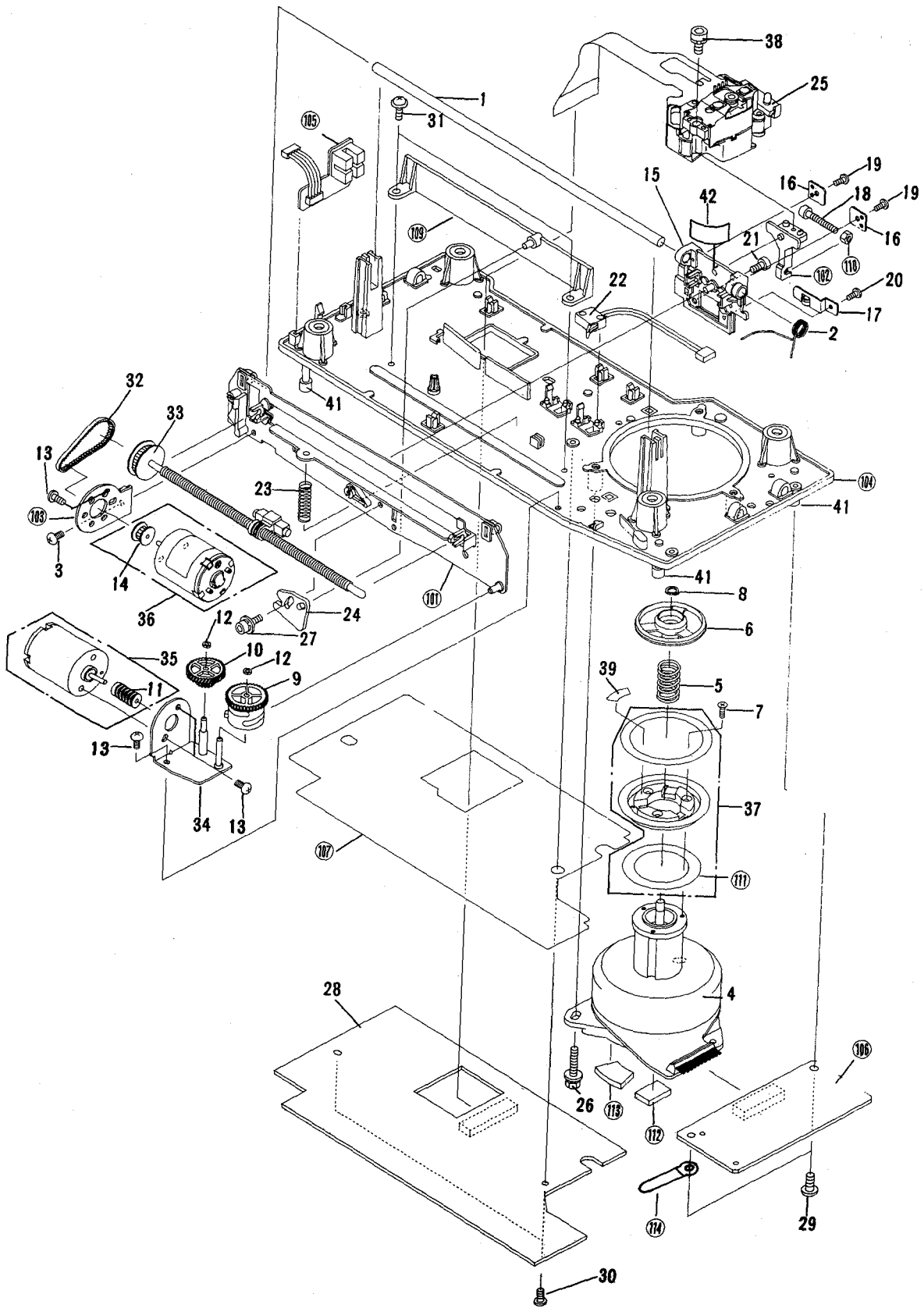

12

1

2

3

## Parts List of Mechanism Assembly

Mark	No.	Part No.	Description	Mark	No.	Part No.	Description
	1.	VLL1058	Carriage shaft		101.		Tilt base
	2.	VBH1040	Slider spring		102.		PU holder
	3.	PMA30P060FCU	Screw		103.		M holder
	4.	VXM1021	Spindle motor		104.		Mechanism base
	5.	VBH1024	Centering spring		105.		TNTR assembly
	6.	VNT1003	Centering hab		106.		BLDB assembly
	7.	CMZ20P080FCU	Screw		107.		FTS sheet
	8.	YC40FBT	Washer		108.		...
	9.	VNL1079	Cam gear		109.		Base plate
	10.	VNL1078	Gear		110.		Nut
	11.	VNL1085	Worm		111.		Insulator sheet
	12.	WT21D050D050	Washer		112.		Dump cushion
	13.	PMA30P040FCU	Screw		113.		Cushion E
	14.	VNL1051	Motor pulley		114.		Cord clamper
	15.	VNL1080	Slider				
	16.	VNE1100	Rock plate				
	17.	VXA1159	Roller assembly				
	18.	SMZ30H250FBT	Screw				
	19.	PPZ20P050FMC	Screw				
	20.	PMA20P040FCU	Screw				
	21.	SMZ30H080FBT	Screw				
	22.	VSK1003	Slide switch (SLIDER/PARK) (S4)				
	23.	VBH1022	Tilt spring				
	24.	VNL1077	Fulcrum cam				
	25.	VWY1011	Pick-up assembly				
	26.	VLL1065	Bolt 3 x 18				
	27.	VLL-378	Bolt 8				
	28.	VYS1009	FTSB assembly				
	29.	IPZ30P080FCU	Screw				
	30.	BPZ30P080FCU	Screw				
	31.	PMB30P060FCU	Screw				
	32.	VEB1029	Timing belt				
	33.	VXA1129	Screw nut assembly				
	34.	VXA1106	TL base assembly				
	35.	VXX1082	Tilt motor assembly-S				
	36.	VXX1155	Slider motor assembly-S				
	37.	VXX1154	Turntable assembly-S				
	38.	VLL1107	Bolt 2.6 x 6				
	39.	VEB1032	Sheet				
	40.	...	...				
	41.	VEB1017	Rubber tube				
	42.	VBK1010	SN spring				

4.5 PICK-UP ASSEMBLY VIEW

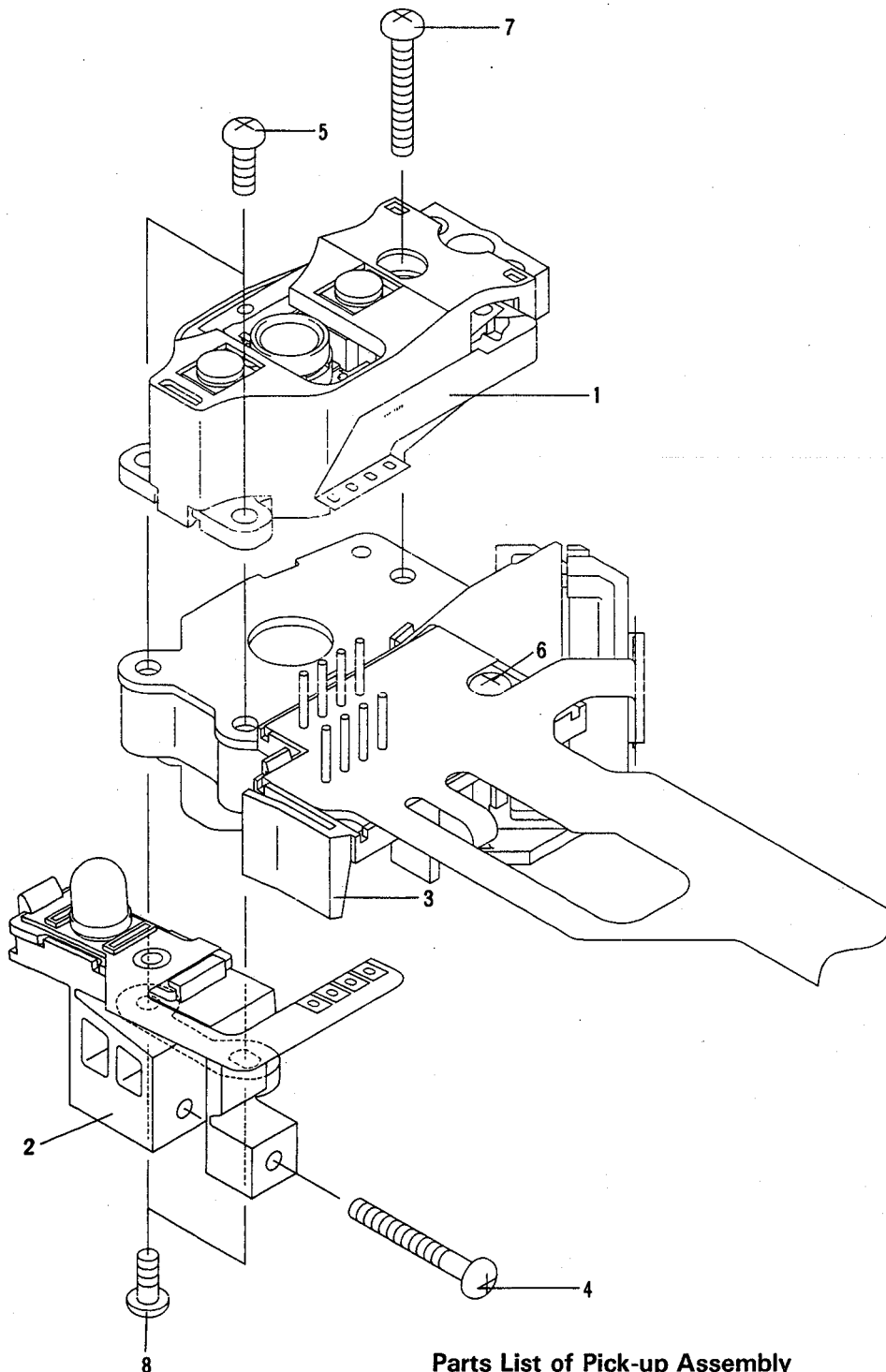

Parts List of Pick-up Assembly

Mark	No.	Part No.	Description
	1.	VXX1056	Actuator assembly
	2.	VXX1094	Sensor assembly-S
	3.	VXX1095	Pre pick-up assembly
	4.	PBZ20P160FMC	Screw
	5.	PMA20P060FMC	Screw
	6.	PMA20P080FMC	Screw
	7.	PMA20P140FMC	Screw
	8.	PMB20P050FMC	Screw

#### 4.6 REMOTE CONTROL UNIT

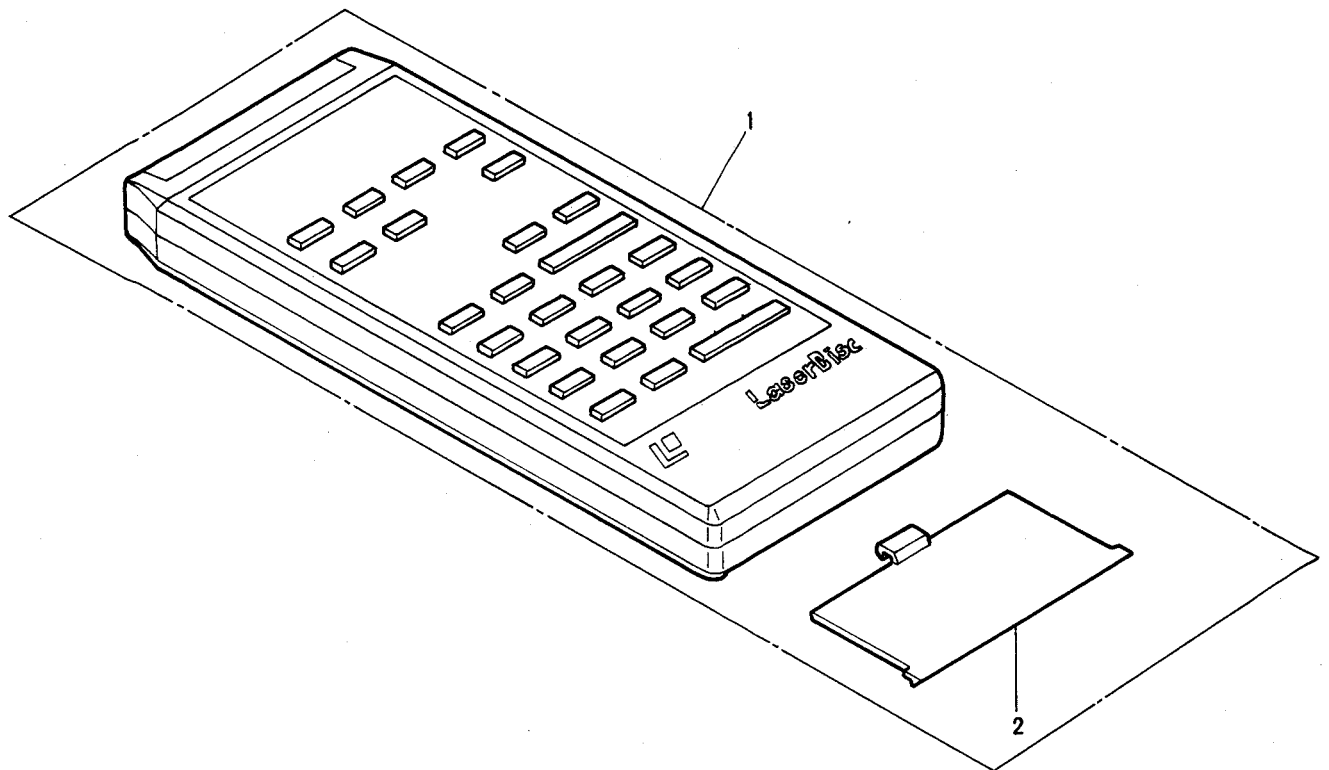

#### Parts List of Remote control unit

Mark	No.	Part No.	Description
	1.	VXX1208	Remote control unit
	2.	PNW1153	Battery cover

**4.7 PACKING**

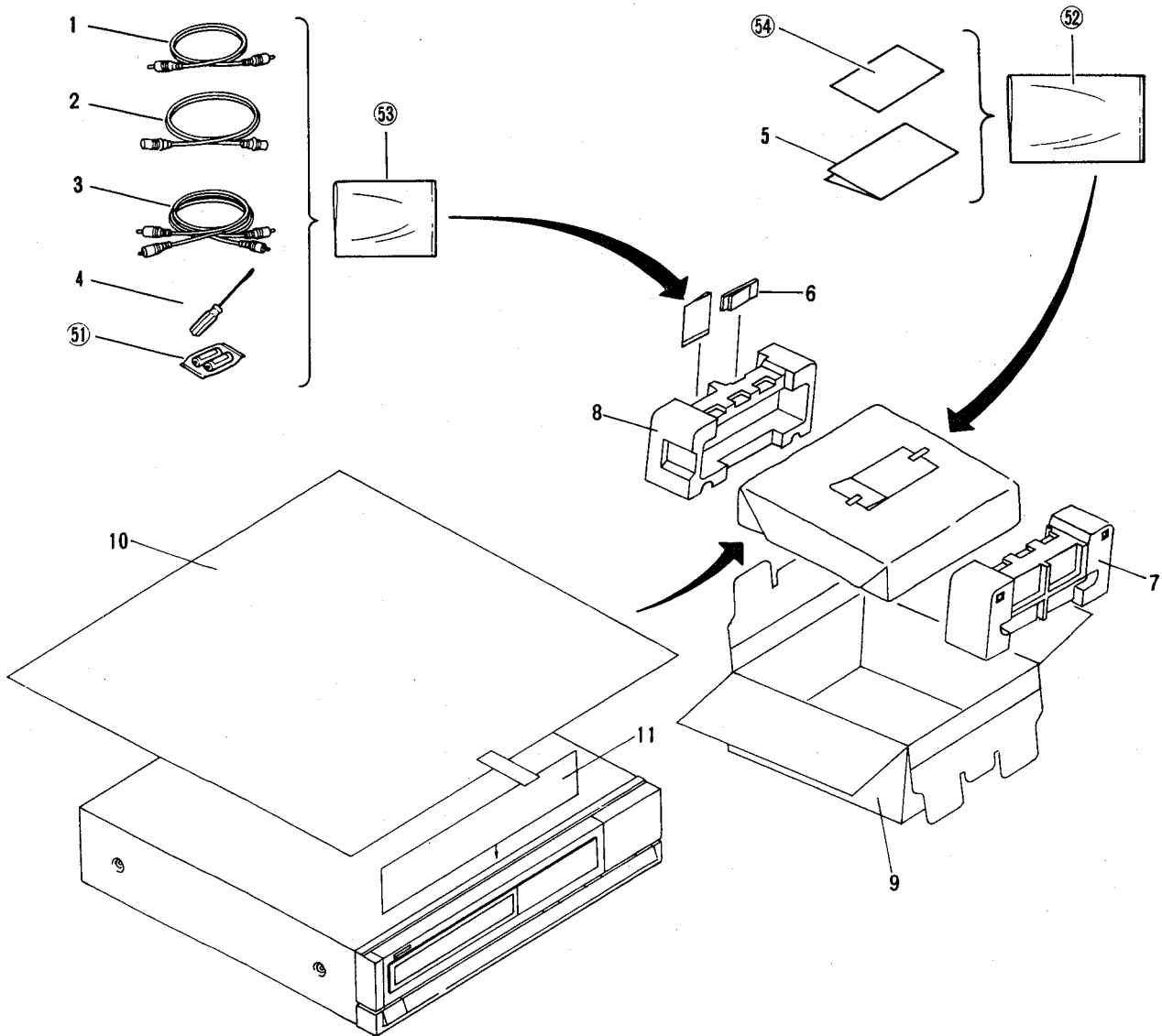

**Parts List of Packing**

Mark	No.	Part No.	Description	Mark	No.	Part No.	Description
	1.	VDE-056	Video cable		9.	VHG1041	Packing case
	2.	VDE-019	RF antenna cable		10.	VHL1006	Packing mat
	3.	VDE-055 (VDE1005)	Audio cable		11.	VHL1008	Packing sheet
	4.	VEX-006	Screwdriver (A)		51.		Battery UM-4
	5.	VRE1002	Operating instructions		52.		Polyethylene bag
	6.	VXX1208	Remote control unit		53.		Polyethylene bag
	7.	VHA1027	Pad (F)		54.		Caution card
	8.	VHA1028	Pad (R)		55.		Protection sheet

# 5. CONNECTION DIAGRAM

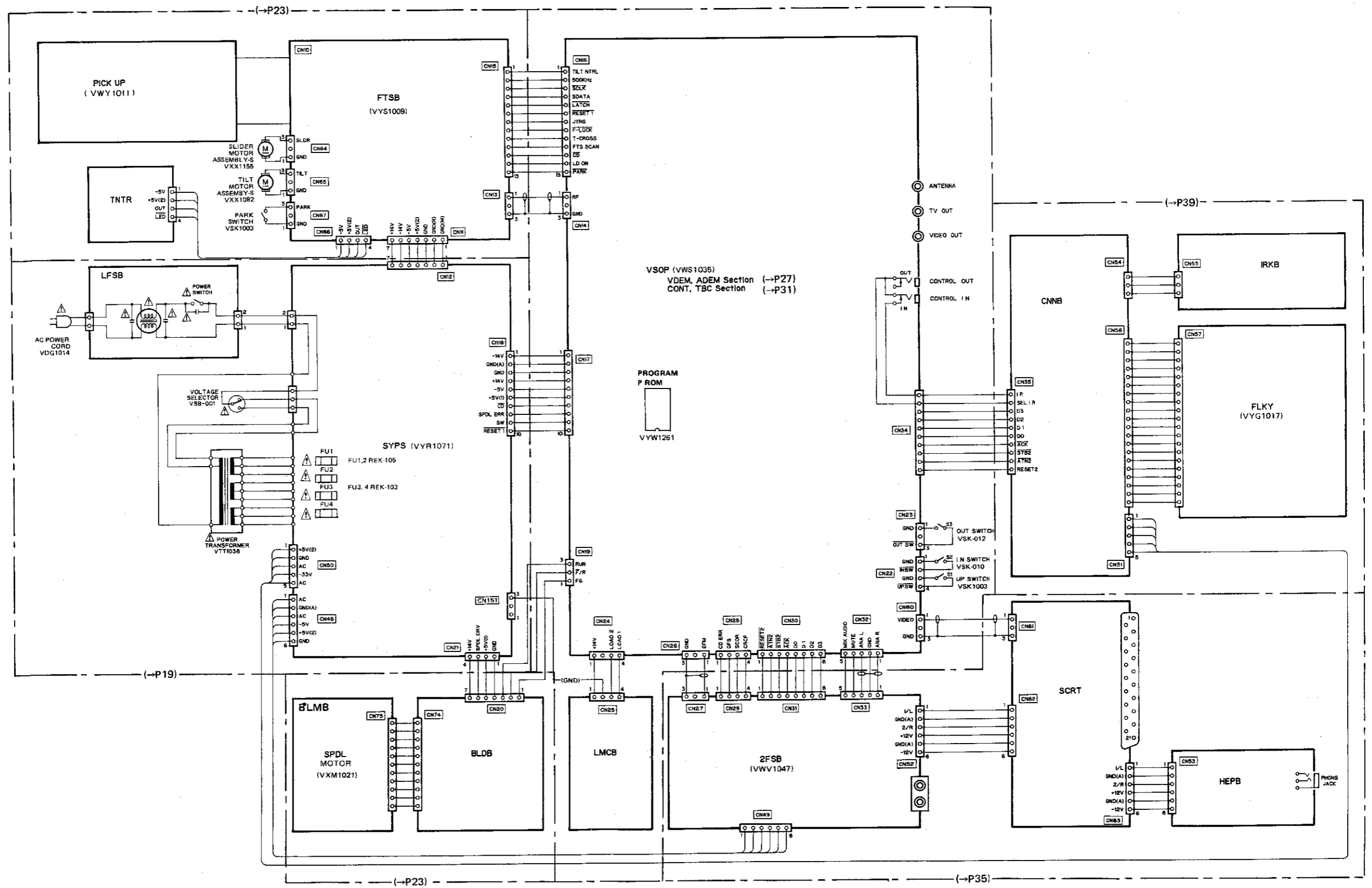

# 6. SCHEMATIC DIAGRAM AND P.C. BOARDS PATTERNS

## 6.1 LFSB AND SYPS ASSEMBLY

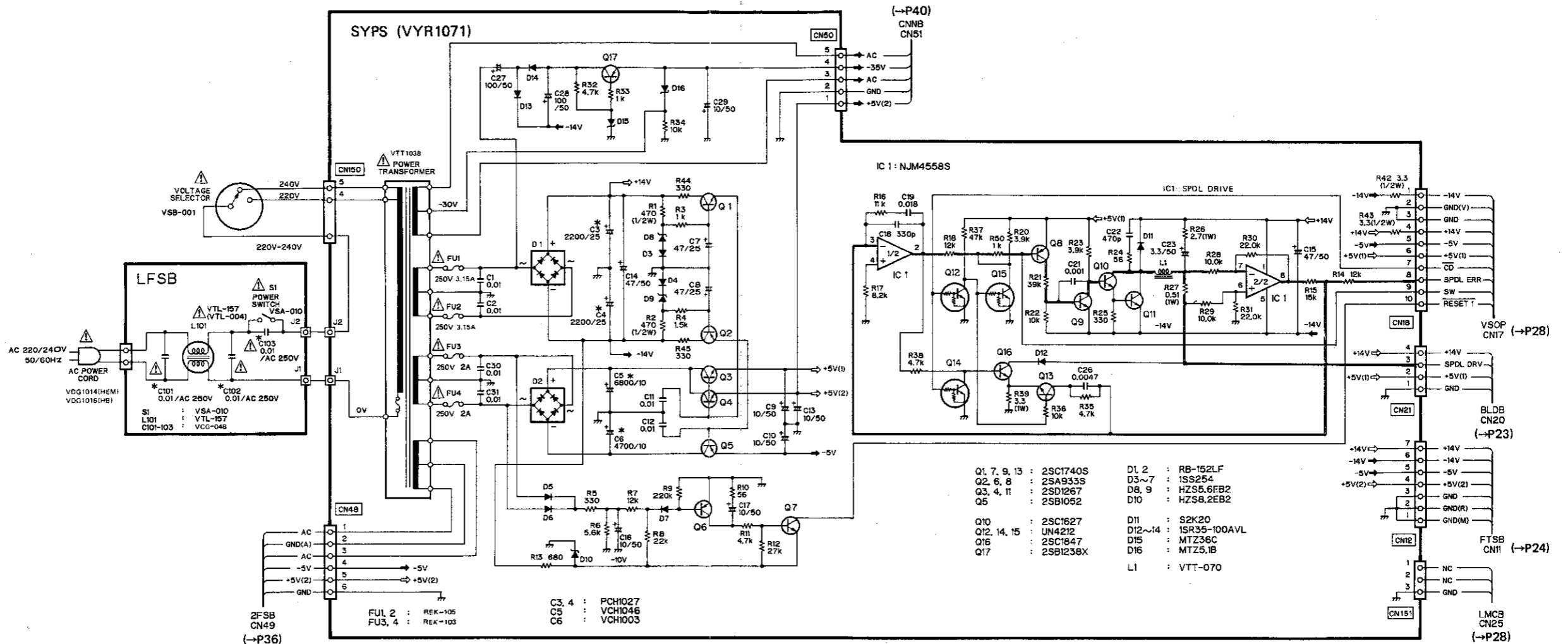

- RESISTORS:**  
Indicated in  $\Omega$ , 1/4W and 1/6W,  $\pm 5\%$  tolerance unless otherwise noted k: k $\Omega$ , M: M $\Omega$ , (F):  $\pm 1\%$ , (G):  $\pm 2\%$ , (K):  $\pm 10\%$ , (M):  $\pm 20\%$  tolerance.
- CAPACITORS:**  
Indicated in capacity ( $\mu F$ ) / voltage (V) unless otherwise noted p: pF. Indication without voltage is 50V except electrolytic capacitor.
- VOLTAGE, CURRENT:**  
□ : DC voltage (V) at no input signal.  
Value in ( ) is DC voltage at rated power.  
mA : DC current at no input signal.
- OTHERS:**  
→ : Signal route  
⊗ : Adjusting point.  
The  $\Delta$  mark found on some component parts indicates the importance of the safety factor of the part. Therefore, when replacing, be sure to use parts of identical designation.  
\* marked capacitors and resistors have parts numbers.

This is the basic schematic diagram, but the actual circuit may vary due to improvements in design.

— LD SPDL Signal Line



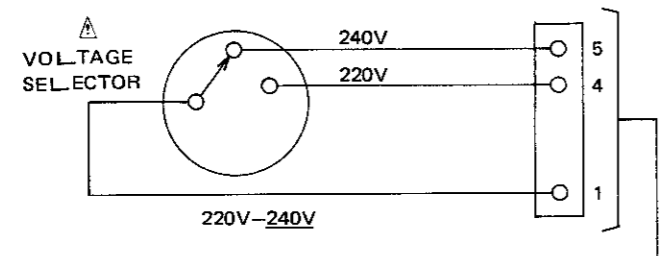

SYPS Assembly (VYR1071)

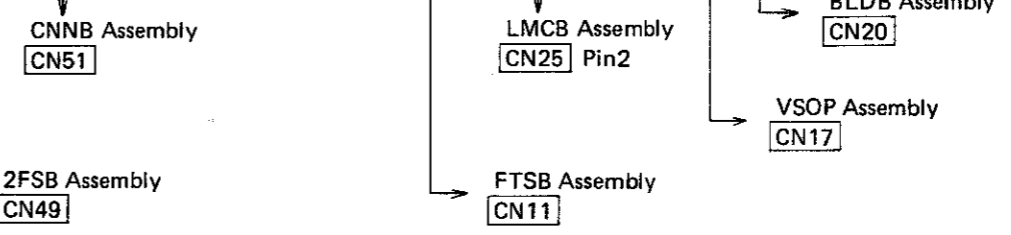
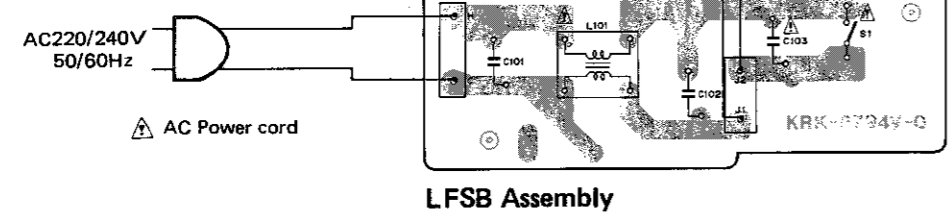
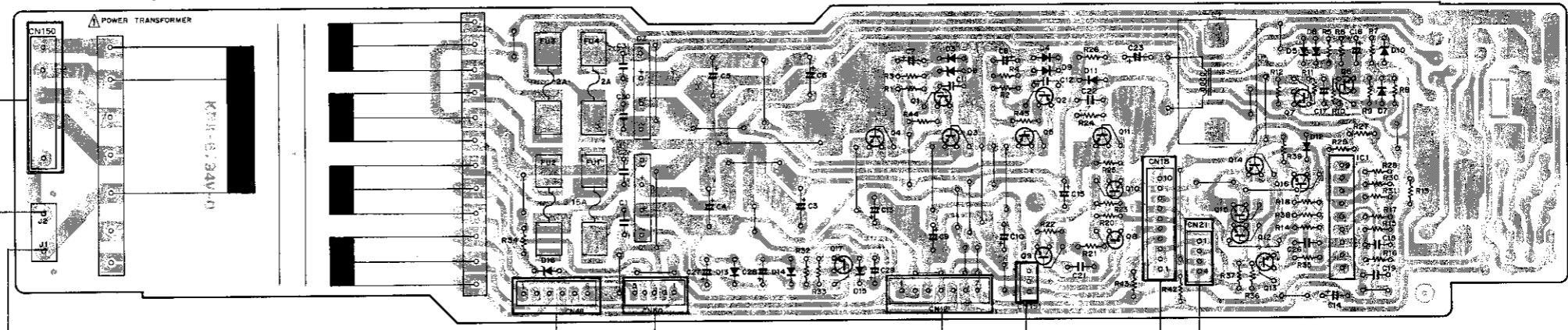

NJM4458S

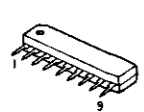

UN4212

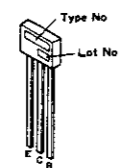

2SA993S  
2SC1740S

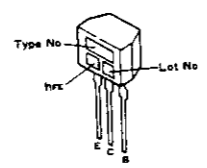

2SC1847

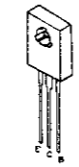

2SB1238X

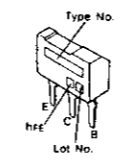

2SC1627

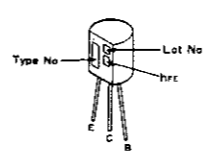

2SB1052  
2SD1267

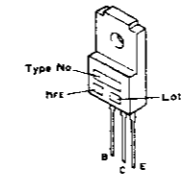



1

2

3

4

5

6

A

A

B

B

C

C

D

D

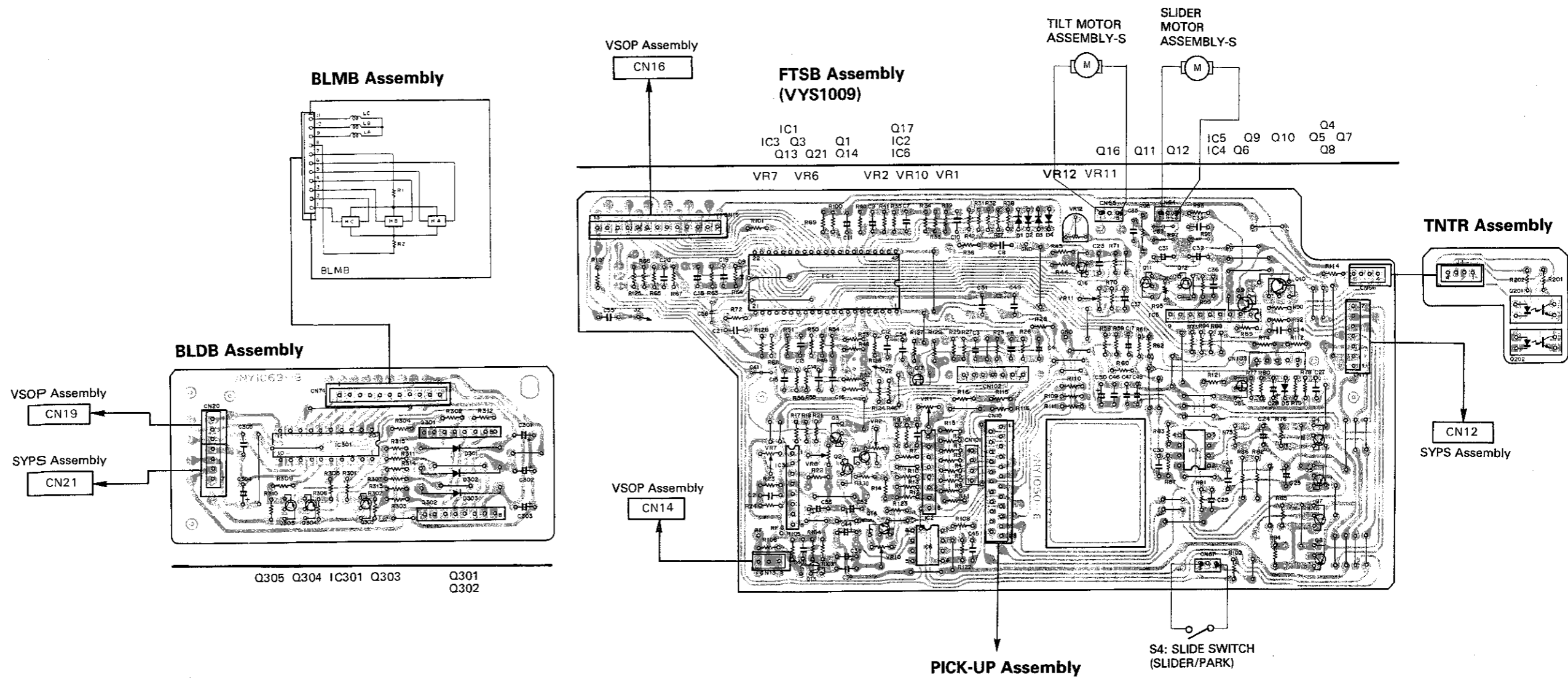

TA8413P

STA302A  
STA303A

2SA1048

BA15218N

HA11529

IR3C02A

NJM4556DE

NJM4556S

UN4112

2SB1185  
2SD1762

2SD1859X

2SK184

RPI-38

DTC363ES

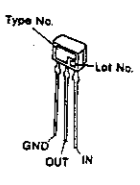
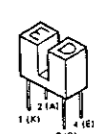
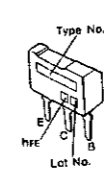
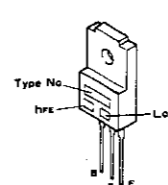
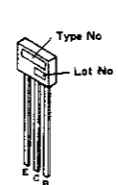
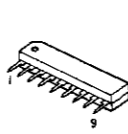
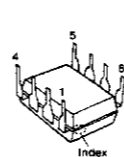
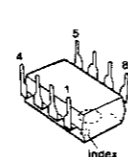
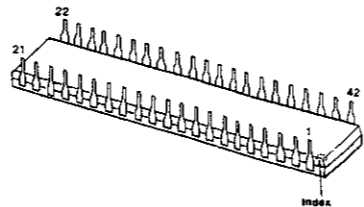
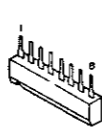
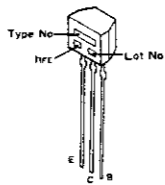
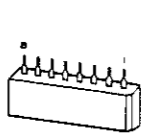
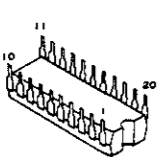

1

2

3

4

5

6

6.3 VSOP ASSEMBLY (TBC, CONT) AND LMCB ASSEMBLY

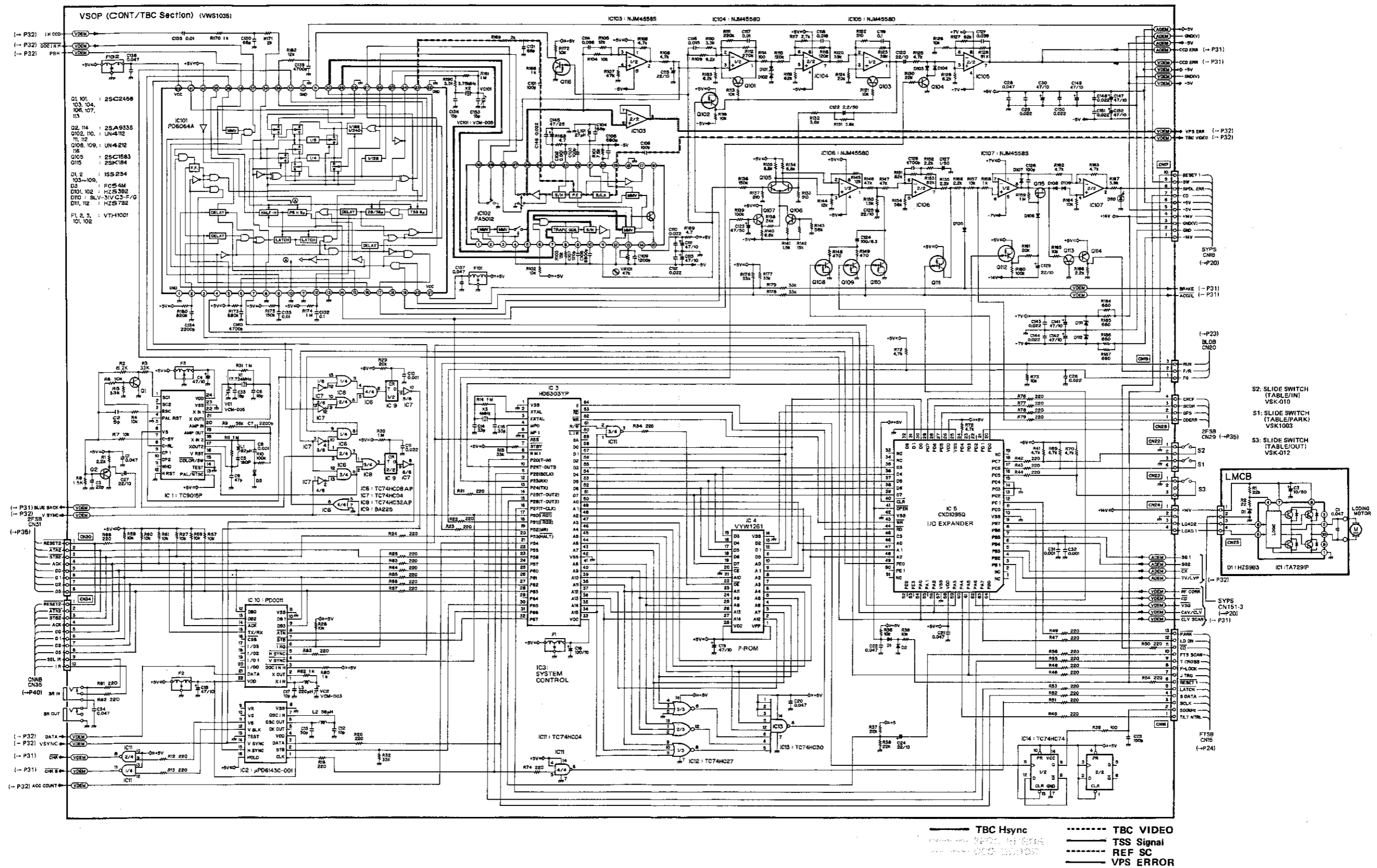

1 | 2 | 3 | 4 | 5 | 6

LMCB Assembly

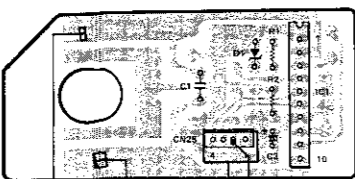

SYPS Assembly  
CN151  
PIN 2

SCRT Assembly  
CN81

FTSB Assembly  
CN13

2FSB Assembly  
CN27

2FSB Assembly  
CN33

VSOP Assembly (VWS1035)

Q422 IC407 Q424 Q423 Q401 Q404 Q406 Q402 Q602 Q430 IC301 IC403 IC401 Q409 Q408 Q410 Q411 Q407 Q419 Q403 Q101 Q104 Q604 Q103 Q413 Q105 Q414 IC102 IC106 Q11 Q16 Q10 Q13 Q12 Q14 Q108 Q12 IC12 IC13 IC11 IC101 IC3 IC2 IC4 IC9 IC5 IC8 IC10 IC14 IC6 IC7 Q1 Q2 Q3 Q4 Q5 Q6 Q7 Q8 Q9 Q10 Q11 Q12 Q13 Q14 Q15 Q16 Q17 Q18 Q19 Q20 Q21 Q22 Q23 Q24 Q25 Q26 Q27 Q28 Q29 Q30 Q31 Q32 Q33 Q34 Q35 Q36 Q37 Q38 Q39 Q40 Q41 Q42 Q43 Q44 Q45 Q46 Q47 Q48 Q49 Q50 Q51 Q52 Q53 Q54 Q55 Q56 Q57 Q58 Q59 Q60 Q61 Q62 Q63 Q64 Q65 Q66 Q67 Q68 Q69 Q70 Q71 Q72 Q73 Q74 Q75 Q76 Q77 Q78 Q79 Q80 Q81 Q82 Q83 Q84 Q85 Q86 Q87 Q88 Q89 Q90 Q91 Q92 Q93 Q94 Q95 Q96 Q97 Q98 Q99 Q100 Q101 Q102 Q103 Q104 Q105 Q106 Q107 Q108 Q109 Q110 Q111 Q112 Q113 Q114 Q115 Q116 Q117 Q118 Q119 Q120 Q121 Q122 Q123 Q124 Q125 Q126 Q127 Q128 Q129 Q130 Q131 Q132 Q133 Q134 Q135 Q136 Q137 Q138 Q139 Q140 Q141 Q142 Q143 Q144 Q145 Q146 Q147 Q148 Q149 Q150 Q151 Q152 Q153 Q154 Q155 Q156 Q157 Q158 Q159 Q160 Q161 Q162 Q163 Q164 Q165 Q166 Q167 Q168 Q169 Q170 Q171 Q172 Q173 Q174 Q175 Q176 Q177 Q178 Q179 Q180 Q181 Q182 Q183 Q184 Q185 Q186 Q187 Q188 Q189 Q190 Q191 Q192 Q193 Q194 Q195 Q196 Q197 Q198 Q199 Q200 Q201 Q202 Q203 Q204 Q205 Q206 Q207 Q208 Q209 Q210 Q211 Q212 Q213 Q214 Q215 Q216 Q217 Q218 Q219 Q220 Q221 Q222 Q223 Q224 Q225 Q226 Q227 Q228 Q229 Q230 Q231 Q232 Q233 Q234 Q235 Q236 Q237 Q238 Q239 Q240 Q241 Q242 Q243 Q244 Q245 Q246 Q247 Q248 Q249 Q250 Q251 Q252 Q253 Q254 Q255 Q256 Q257 Q258 Q259 Q260 Q261 Q262 Q263 Q264 Q265 Q266 Q267 Q268 Q269 Q270 Q271 Q272 Q273 Q274 Q275 Q276 Q277 Q278 Q279 Q280 Q281 Q282 Q283 Q284 Q285 Q286 Q287 Q288 Q289 Q290 Q291 Q292 Q293 Q294 Q295 Q296 Q297 Q298 Q299 Q300 Q301 Q302 Q303 Q304 Q305 Q306 Q307 Q308 Q309 Q310 Q311 Q312 Q313 Q314 Q315 Q316 Q317 Q318 Q319 Q320 Q321 Q322 Q323 Q324 Q325 Q326 Q327 Q328 Q329 Q330 Q331 Q332 Q333 Q334 Q335 Q336 Q337 Q338 Q339 Q340 Q341 Q342 Q343 Q344 Q345 Q346 Q347 Q348 Q349 Q350 Q351 Q352 Q353 Q354 Q355 Q356 Q357 Q358 Q359 Q360 Q361 Q362 Q363 Q364 Q365 Q366 Q367 Q368 Q369 Q370 Q371 Q372 Q373 Q374 Q375 Q376 Q377 Q378 Q379 Q380 Q381 Q382 Q383 Q384 Q385 Q386 Q387 Q388 Q389 Q390 Q391 Q392 Q393 Q394 Q395 Q396 Q397 Q398 Q399 Q400 Q401 Q402 Q403 Q404 Q405 Q406 Q407 Q408 Q409 Q410 Q411 Q412 Q413 Q414 Q415 Q416 Q417 Q418 Q419 Q420 Q421 Q422 Q423 Q424 Q425 Q426 Q427 Q428 Q429 Q430 Q431 Q432 Q433 Q434 Q435 Q436 Q437 Q438 Q439 Q440 Q441 Q442 Q443 Q444 Q445 Q446 Q447 Q448 Q449 Q450 Q451 Q452 Q453 Q454 Q455 Q456 Q457 Q458 Q459 Q460 Q461 Q462 Q463 Q464 Q465 Q466 Q467 Q468 Q469 Q470 Q471 Q472 Q473 Q474 Q475 Q476 Q477 Q478 Q479 Q480 Q481 Q482 Q483 Q484 Q485 Q486 Q487 Q488 Q489 Q490 Q491 Q492 Q493 Q494 Q495 Q496 Q497 Q498 Q499 Q500 Q501 Q502 Q503 Q504 Q505 Q506 Q507 Q508 Q509 Q510 Q511 Q512 Q513 Q514 Q515 Q516 Q517 Q518 Q519 Q520 Q521 Q522 Q523 Q524 Q525 Q526 Q527 Q528 Q529 Q530 Q531 Q532 Q533 Q534 Q535 Q536 Q537 Q538 Q539 Q540 Q541 Q542 Q543 Q544 Q545 Q546 Q547 Q548 Q549 Q550 Q551 Q552 Q553 Q554 Q555 Q556 Q557 Q558 Q559 Q560 Q561 Q562 Q563 Q564 Q565 Q566 Q567 Q568 Q569 Q570 Q571 Q572 Q573 Q574 Q575 Q576 Q577 Q578 Q579 Q580 Q581 Q582 Q583 Q584 Q585 Q586 Q587 Q588 Q589 Q590 Q591 Q592 Q593 Q594 Q595 Q596 Q597 Q598 Q599 Q600 Q601 Q602 Q603 Q604 Q605 Q606 Q607 Q608 Q609 Q610 Q611 Q612 Q613 Q614 Q615 Q616 Q617 Q618 Q619 Q620 Q621 Q622 Q623 Q624 Q625 Q626 Q627 Q628 Q629 Q630 Q631 Q632 Q633 Q634 Q635 Q636 Q637 Q638 Q639 Q640 Q641 Q642 Q643 Q644 Q645 Q646 Q647 Q648 Q649 Q650 Q651 Q652 Q653 Q654 Q655 Q656 Q657 Q658 Q659 Q660 Q661 Q662 Q663 Q664 Q665 Q666 Q667 Q668 Q669 Q670 Q671 Q672 Q673 Q674 Q675 Q676 Q677 Q678 Q679 Q680 Q681 Q682 Q683 Q684 Q685 Q686 Q687 Q688 Q689 Q690 Q691 Q692 Q693 Q694 Q695 Q696 Q697 Q698 Q699 Q700 Q701 Q702 Q703 Q704 Q705 Q706 Q707 Q708 Q709 Q710 Q711 Q712 Q713 Q714 Q715 Q716 Q717 Q718 Q719 Q720 Q721 Q722 Q723 Q724 Q725 Q726 Q727 Q728 Q729 Q730 Q731 Q732 Q733 Q734 Q735 Q736 Q737 Q738 Q739 Q740 Q741 Q742 Q743 Q744 Q745 Q746 Q747 Q748 Q749 Q750 Q751 Q752 Q753 Q754 Q755 Q756 Q757 Q758 Q759 Q760 Q761 Q762 Q763 Q764 Q765 Q766 Q767 Q768 Q769 Q770 Q771 Q772 Q773 Q774 Q775 Q776 Q777 Q778 Q779 Q780 Q781 Q782 Q783 Q784 Q785 Q786 Q787 Q788 Q789 Q790 Q791 Q792 Q793 Q794 Q795 Q796 Q797 Q798 Q799 Q800 Q801 Q802 Q803 Q804 Q805 Q806 Q807 Q808 Q809 Q810 Q811 Q812 Q813 Q814 Q815 Q816 Q817 Q818 Q819 Q820 Q821 Q822 Q823 Q824 Q825 Q826 Q827 Q828 Q829 Q830 Q831 Q832 Q833 Q834 Q835 Q836 Q837 Q838 Q839 Q840 Q841 Q842 Q843 Q844 Q845 Q846 Q847 Q848 Q849 Q850 Q851 Q852 Q853 Q854 Q855 Q856 Q857 Q858 Q859 Q860 Q861 Q862 Q863 Q864 Q865 Q866 Q867 Q868 Q869 Q870 Q871 Q872 Q873 Q874 Q875 Q876 Q877 Q878 Q879 Q880 Q881 Q882 Q883 Q884 Q885 Q886 Q887 Q888 Q889 Q890 Q891 Q892 Q893 Q894 Q895 Q896 Q897 Q898 Q899 Q900 Q901 Q902 Q903 Q904 Q905 Q906 Q907 Q908 Q909 Q910 Q911 Q912 Q913 Q914 Q915 Q916 Q917 Q918 Q919 Q920 Q921 Q922 Q923 Q924 Q925 Q926 Q927 Q928 Q929 Q930 Q931 Q932 Q933 Q934 Q935 Q936 Q937 Q938 Q939 Q940 Q941 Q942 Q943 Q944 Q945 Q946 Q947 Q948 Q949 Q950 Q951 Q952 Q953 Q954 Q955 Q956 Q957 Q958 Q959 Q960 Q961 Q962 Q963 Q964 Q965 Q966 Q967 Q968 Q969 Q970 Q971 Q972 Q973 Q974 Q975 Q976 Q977 Q978 Q979 Q980 Q981 Q982 Q983 Q984 Q985 Q986 Q987 Q988 Q989 Q990 Q991 Q992 Q993 Q994 Q995 Q996 Q997 Q998 Q999 Q1000

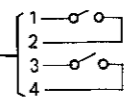
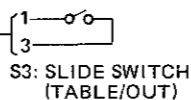

S2: SLIDE SWITCH  
(TABLE/IN)  
S1: SLIDE SWITCH  
(TABLE/PARK)

A

B

C

D

A

B

C

D

FTSB Assembly  
CN15

2FSB Assembly  
CN29

2FSB Assembly  
CN31

CNNB Assembly  
CN35

BLDB Assembly  
CN20

1 | 2 | 3 | 4 | 5 | 6

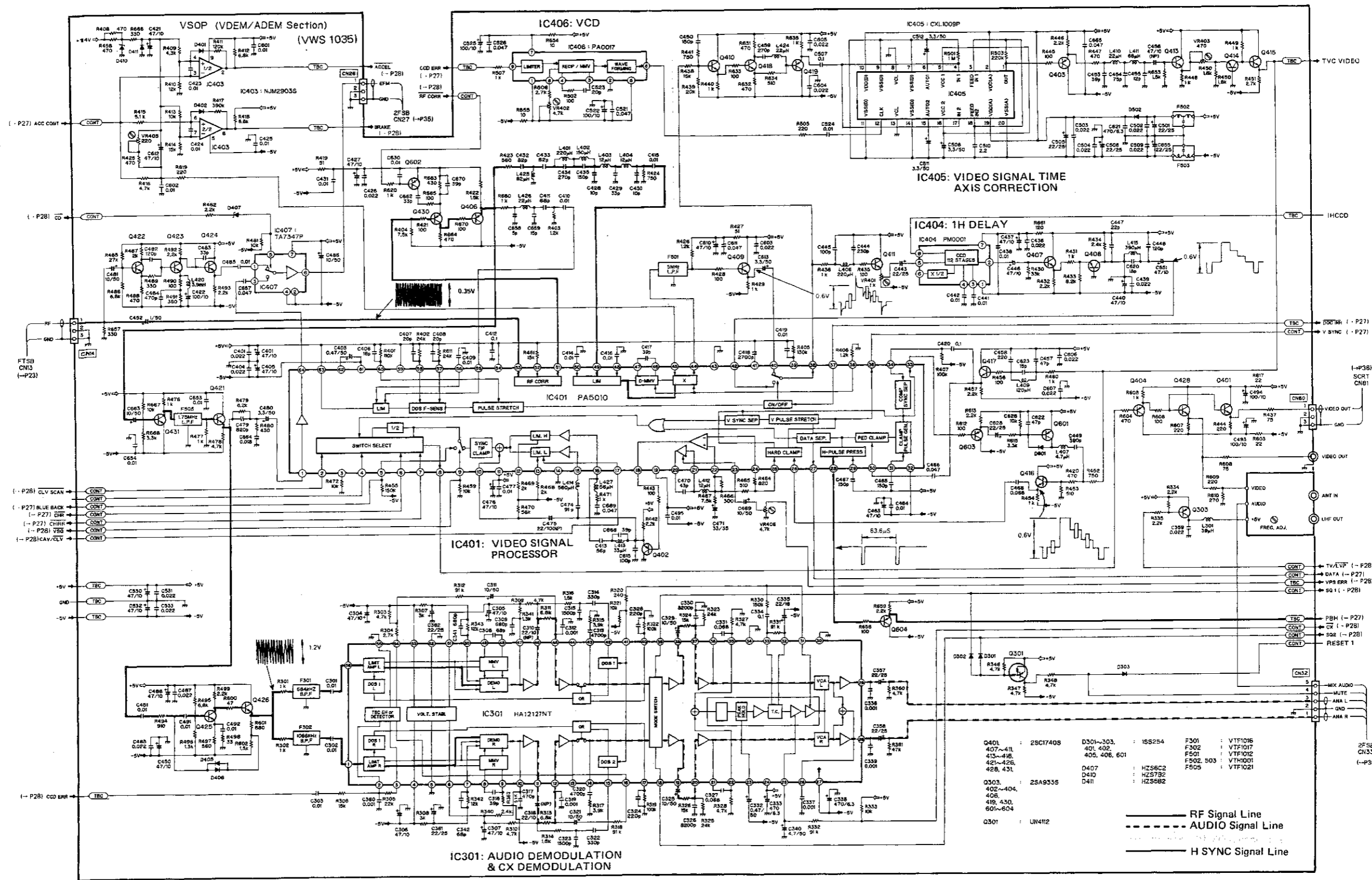

Q401	28C1740S	D301~303	1SS254	F301	VTF1016
407~411		401, 402		F302	VTF1017
415~418		405, 406, 601		F501	VTF1012
421~426				F502, 503	VTH1001
428, 431				F505	VTF1021
		D410	HZS6C2		
		D411	HZS7B2		
			HZS6B2		
Q303	2SA933S				
402~404					
406					
416, 430					
605~604					
Q301	UN4112				

RF Signal Line  
 AUDIO Signal Line  
 H SYNC Signal Line

LMCB Assembly

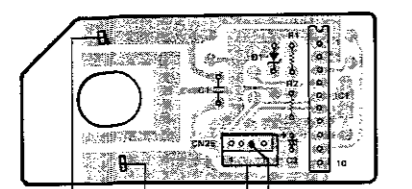

SYPS Assembly  
CN151  
PIN 2

SCRT Assembly  
CN81

FTSB Assembly  
CN13

2FSB Assembly  
CN27

2FSB Assembly  
CN33

VSOP Assembly (VWS1035)

Q422 IC407 Q424 Q423 Q431 Q404 Q408 Q402 Q603 IC404 Q419 Q417 Q418 IC405 Q413 Q415 Q107 Q108  
IC105 IC103 IC406 Q413 Q415 Q107 Q108 Q105 IC107 Q109 Q102 IC106 Q11 Q16 Q10 Q13 Q102 Q14 Q108 Q12 IC12 IC13 IC11 IC101  
ADJ. VR405 VR401 VR406 VR402 VR101 VR403 VC101 VC1 VC2

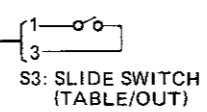

S3: SLIDE SWITCH  
(TABLE/OUT)

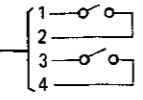

S2: SLIDE SWITCH  
(TABLE/IN)  
S1: SLIDE SWITCH  
(TABLE/PARK)

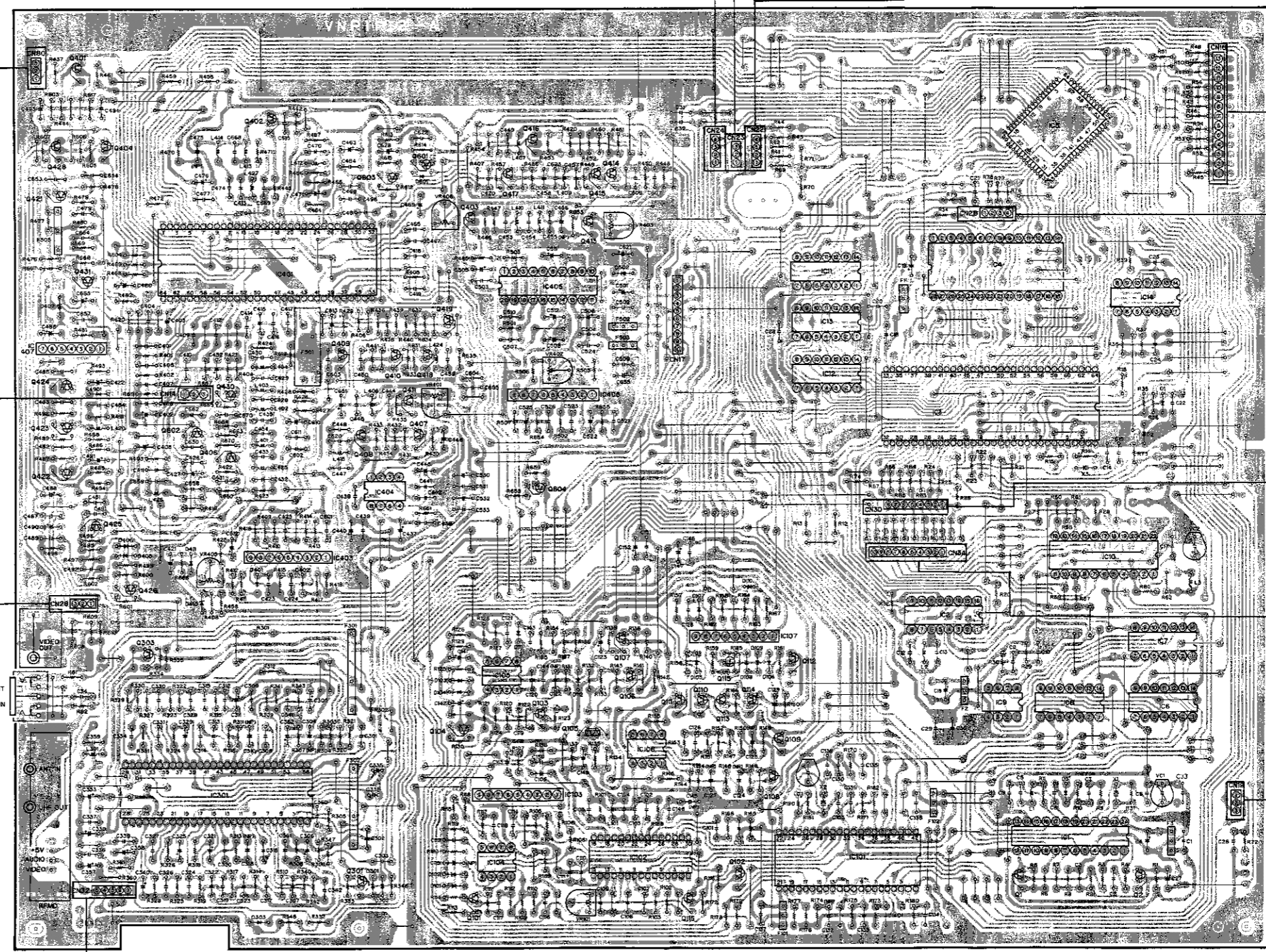

FTSB Assembly  
CN15

2FSB Assembly  
CN29

2FSB Assembly  
CN31

CNNB Assembly  
CN35

BLDB Assembly  
CN20

A

B

C

D

A

B

C

D

1

2

3

4

5

6

1

2

3

4

5

6

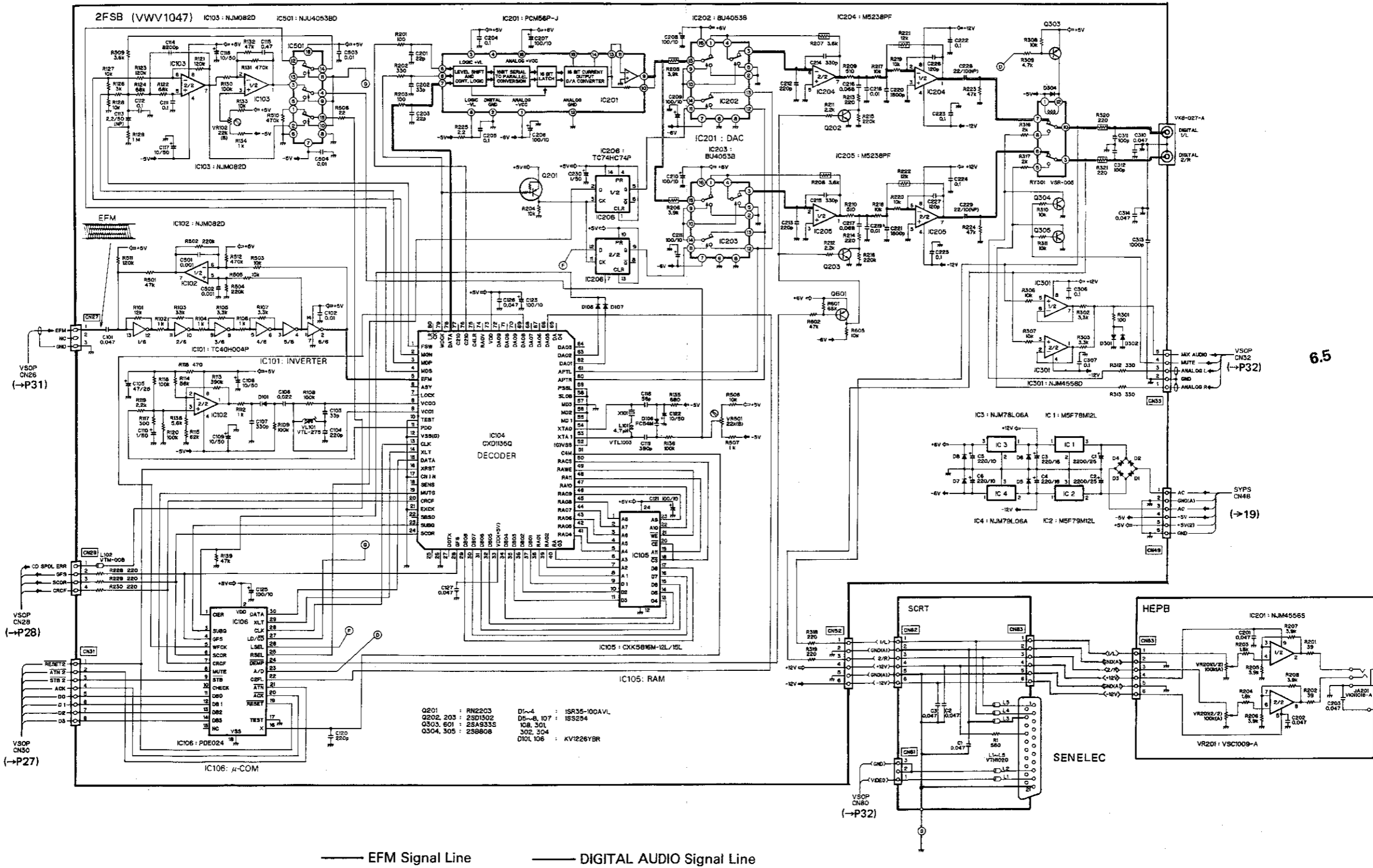



1 2 3 4 5 6

A

A

B

B

C

C

D

D

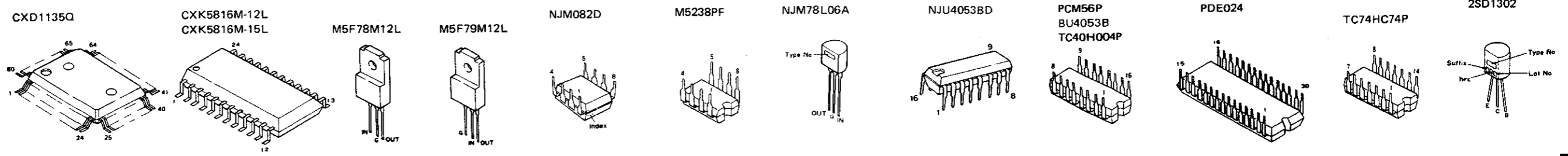
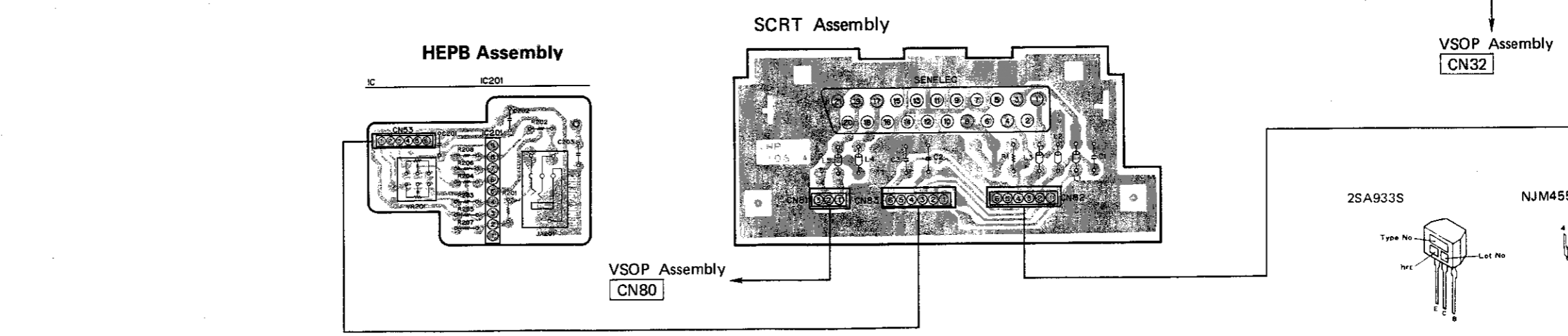
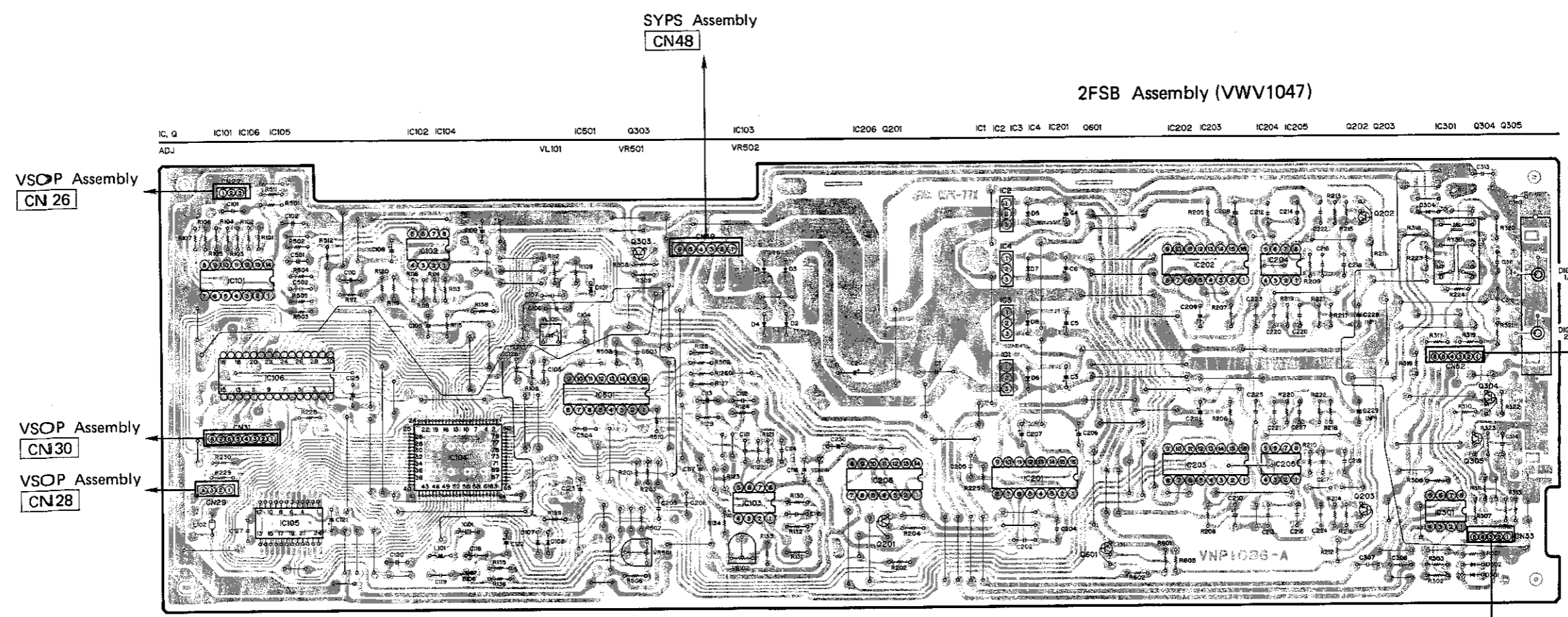

1 2 3 4 5 6

6.6 FLKY, IRKB AND CNNB ASSEMBLY

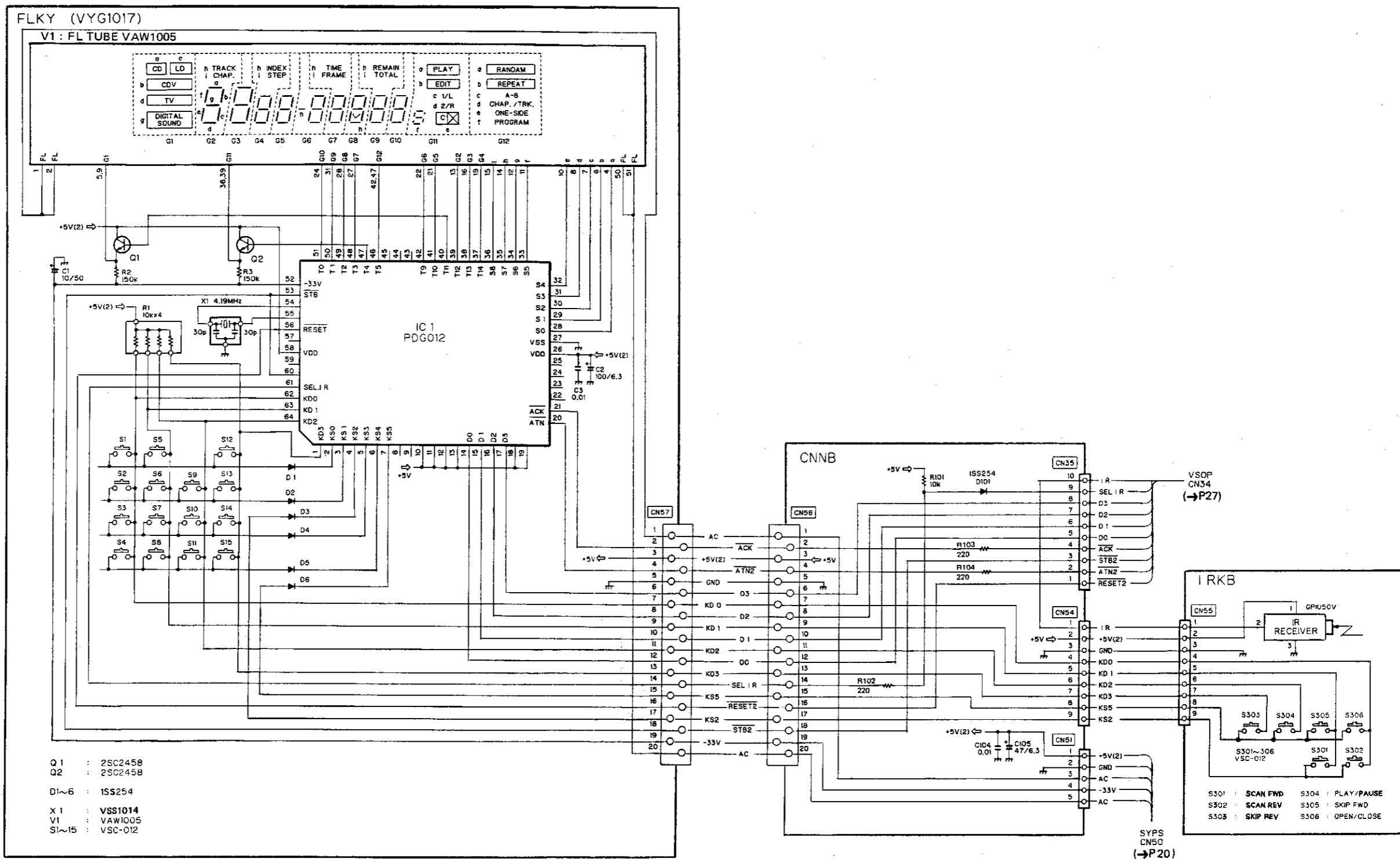



## 7. ELECTRICAL PARTS LIST

**NOTES:**

- Parts without part number cannot be supplied.
- Parts marked by "⊙" are not always kept in stock. Their delivery time may be longer than usual or they may be unavailable.
- The  $\Delta$  mark found on some component parts indicates the importance of the safety factor of the part. Therefore, when replacing, be sure to use parts of identical designation.
- When ordering resistors, first convert resistance values into code form as shown in the following examples.

Ex. 1 When there are 2 effective digits (any digit apart from 0), such as 560 ohm and 47k ohm (tolerance is shown by J = 5%, and K = 10%).

560Ω	56 × 10 <sup>1</sup>	561.....	RD1/4PS	Ⓜ	Ⓜ	Ⓜ	J
47kΩ	47 × 10 <sup>3</sup>	473.....	RD1/4PS	Ⓜ	Ⓜ	Ⓜ	J
0.5Ω	0R5.....		RN2H	Ⓜ	Ⓜ	Ⓜ	K
1Ω	010.....		RS1P	Ⓜ	Ⓜ	Ⓜ	K

Ex. 2 When there are 3 effective digits (such as in high precision metal film resistors).  
5.62kΩ 562 × 10<sup>1</sup> 5621..... RN1/4SR Ⓜ Ⓜ Ⓜ F

**Miscellaneous Parts**

**P.C. BOARD ASSEMBLIES**

Mark	Symbol & Description	Part No.
	VSOP assembly	VWS1035
	2FSB assembly	VWV1047
	TNTR assembly	
	BLDB assembly	
	FTSB assembly	VYS1009
	FLKY assembly	VYG1017
	CNNB assembly	
	IRKB assembly	
	HEPB assembly	
	LFSB assembly	
	SYPS assembly	VYR1071
	LMCB assembly	
	BLMB assembly	
	SCRT assembly	

**OTHERS**

Mark	Symbol & Description	Part No.
$\Delta$	Fuji card	VDA1051
	AC Power cord	VDG1014
	Strain relief	CM-22B
$\Delta$	FU1, FU2 Fuse (3.15A)	REK-105
$\Delta$	FU3, FU4 Fuse (2A)	REK-103
	S1 Slide switch (TABLE/PARK)	VSK1003
	S2 Slide switch (TABLE/IN)	VSK-010
	S3 Slide switch (TABLE/OUT)	VSK-012
	S4 Slide switch (TABLE/PARK)	VSK1003
	Loading motor assembly-S	VXX1084
	Spindle motor	VXM1021
	Pick-up assembly	VWY1011
	Tilt motor assembly-S	VXX1082
	Slider motor assembly-S	VXX1155
$\Delta$	IC4 Power transformer Program PROM-S Voltage selector	VTT1038 VYW1261 VSB-001

**VSOP Assembly (VWS1035)**

**SEMICONDUCTORS**

Mark	Symbol & Description	Part No.
	IC9	BA225
	IC5	CXD1095Q
	IC405	CXL1009P
	IC301	HA12127NT
	IC3	HD6303YP
	IC403	NJM2903S
	IC104 - IC106	NJM4558D
	IC103, IC107	NJM4558S
	IC406	PA0017
	IC401	PA5010
	IC102	PA5012
	IC10	PD0011
	IC101	PD6064A
	IC404	PM0001
	IC407	TA7347P
	IC11	TC74HC00P
	IC7	TC74HC04P
	IC6	TC74HC08AP
	IC12	TC74HC27P
	IC13	TC74HC30P
	IC8	TC74HC32AP
	IC14	TC74HC74P
	IC1	TC9015P
	IC2	μPD6143C-001
	Q102, Q110 - Q112, Q301	UN4112
	Q108, Q109, Q116	UN4212
	Q2, Q114, Q303, Q402 - Q404, Q406, Q419, Q430, Q601 - Q604, Q105	2SA933S
		2SC1583
	Q1, Q101, Q103, Q104, Q106, Q107, Q113, Q401, Q407 - Q411, Q413 - Q418, Q421 - Q426, Q428, Q431	2SC1740S
	Q115	2SK184

Mark	Symbol & Description	Part No.
	D3	FC54M
	D101, D102	HZS3B2
	D411	HZS5B2
	D407	HZS6C2
	D111, D112, D410	HZS7B2
	D110 LED	SLV-31VC3
	D502	SM-1XNO2
	D1, D2, D103 - D109, D301 - D303, D401, D402, D405, D406, D601	1SS254

**COILS AND FILTERS**

Mark	Symbol & Description	Part No.
	L403, L404, L412	LAU120J
	L409	LAU121J
	L402	LAU151K
	L410, L424, L426	LAU220J
	L3, L401, L406	LAU221J
	L101	LAU270J
	L413	LAU330J
	L407	LAU4R7K
	L2, L427	LAU560J
	L411	LAU680J
	L1, L425	LAU820J
	L301	LRA390K
	L415	LRA391K
	L414	LRA561K
	L420 Coil (3.9mH)	VTL-170
	F501 L.P.F (5.0MHz)	VTF1012
	F301 B.P.F (684kHz)	VTF1016
	F302 B.P.F (1066kHz)	VTF1017
	F505 L.P.F (1.75MHz)	VTF1021
	F1 - F3, F101, F102, F502, F503 3 terminal filter	VTH1001

**CAPACITORS**

Mark	Symbol & Description	Part No.
	C2	CCCCH050C50
	C101, C103, C106, C128, C445, C615	CCCCH101J50
	C448, C482	CCCCH121J50
	C23, C435, C450, C465, C467	CCCCH151J50
	C3, C447	CCCCH220J50
	C13	CCCCH300J50
	C14, C15, C429, C483, C662	CCCCH330J50
	C316, C417, C453, C668, C670	CCCCH390J50
	C470	CCCCH430J50
	C9, C457, C622	CCCCH470J50
	C413	CCCCH560J50
	C104, C130, C131, C308, C342, C411	CCCCH680J50
	C454	CCCCH750J50
	C432, C433	CCCCH820J50
	C474	CCCCH910J50

Mark	Symbol & Description	Part No.
	C5	CCCSL181J50
	C324, C328, C458	CCCSL221J50
	C434, C459	CCCSL271J50
	C314, C322, C444	CCCSL331J50
	C449	CCCSL391J50
	C12, C17, C428, C430	CCPUCH100J50
	C455	CCPUCH120J50
	C136, C153, C623, C658, C659	CCPUCH150J50
	C6, C33, C406, C620	CCPUCH180J50
	C407, C408, C523	CCPUCH200J50

Mark	Symbol & Description	Part No.
	C332	CEANLR47K50
	C335	CEANL220K16
	C127	CEANP010M50
	C124	CEANP101M6R3
	C122	CEANP2R2M50
	C115, C120, C125, C310, C318, C475	CEANP220M10
	C456	CEANP470M10
	C403	CEASR47M50
	C452	CEAS010M50
	C311, C321, C325, C329, C469, C481, C486, C663	CEAS100M50
	C16, C422, C493, C494, C522, C525	CEAS101M10
	C24, C27, C129, C357, C358, C361, C362, C443, C501, C505, C506, C628, C655	CEAS220M25
	C480, C508, C511, C512, C613	CEAS3R3M50
	C471	CEAS330M35
	C123, C340	CEAS4R7M50
	C4, C18, C19, C30, C111, C113, C141, C142, C145, C147, C149, C152, C304 - C307, C402, C405, C421, C427, C437, C440, C446, C463, C476, C488, C490, C530, C532, C610, C612, C651	CEAS470M10

Mark	Symbol & Description	Part No.
	C333, C338, C621	CEAS471M6R3
	C119, C132, C334, C412, C420, C507	CFTXA104J50
	C1, C20 - C22, C28, C34, C137, C138, C466, C521, C526, C611, C657, C669	CGCYX473M25
	C312,	CKCYB102K50
	C360, C31, C32, C319, C336, C337, C339	CKPUYB102K50
	C317	CKPUYB471K50
	C105, C309, C341	CKPUYB681K50
	C26, C29, C110, C112, C143, C144, C146, C148, C150, C151, C359, C401, C404, C426, C436, C439, C487, C489, C502 - C504, C509, C531, C533, C603 - C607	CKPUYF223Z25
	C135, C301, C302, C409, C410, C414 - C416, C423 - C425, C431, C438, C441, C442, C451, C464, C477, C485, C491, C492, C495, C524, C601, C602, C630, C653, C654	CKPUYY103N16
	C8, C10, C102	CQMA102J50
	C117, C133, C303, C419	CQMA103J50
	C109	CQMA122J50

Mark	Symbol & Description	Part No.
C315, C323 C116		CQMA152J50 CQMA153J50
C118, C664 C7, C11, C134 C510 C418 C121		CQMA183J50 CQMA222J50 CQMA224J50 CQMA272J50 CQMA393J50
C126, C139, C140, C313, C320 C114 C108 C327, C331, C468 C326, C330		CQMA472J50 CQMA563J50 CQMA682J50 CQMA683J50 CQMA822J50
C107 C484 C479		CQSA181J50 CQSA471J50 CQSA821J50
VC2 VC1, VC101	Ceramic trimmer Ceramic trimmer (30P)	VCM-003 VCM-005

**RESISTORS**

Mark	Symbol & Description	Part No.
VR401 VR405 VR403 VR402, VR406 VR101	Semi-fixed (1kΩ) Semi-fixed (220Ω) Semi-fixed (470Ω) Semi-fixed (4.7kΩ) Semi-fixed (47kΩ)	VRTB6VS102 VRTB6VS221 VRTB6VS471 VRTB6VS472 VRTB6VS473
R134, R135, R144, R145, R401, R402, R405, R410, R413, R414, R472, R479, R611		RN1/6PQ□□□□F
	Other resistors	RN1/6PM□□□□J

**OTHERS**

Mark	Symbol & Description	Part No.
X1 X2 X3	Crystal resonator (17.734MHz) Crystal resonator (3.750MHz) Ceramic resonator	VSS1019 VSS1018 KBR-4.0MS
	IC socket (28 Pin) Mini pin jack (2P) Video pin Jack RFMD (PAL)	VKH1001 VKN1034 VKB-014 VWL1010

**2FSB Assembly (VWV1047)**

**SEMICONDUCTORS**

Mark	Symbol & Description	Part No.
	IC202, IC203 IC104 IC105	BU4053B CXD1135Q CXK5816M-12L (CXK5816M-15L)
	IC1	M5F78M12L
	IC2 IC204, IC205 IC102, IC103 IC301 IC3	M5F79M12L M5238PF NJM082D NJM4558D NJM78L06A
	IC4 IC501 IC201 IC106 IC101 IC206	NJM79L06A NJU4053BD PCM56P-J PDE024 TC40H004P TC74HC74P
	Q201 Q303, Q601 Q304, Q305 Q202, Q203	RN2203 2SA933S 2SB808 2SD1302
	D106 D101 D1-D4 D5-D8, D107, D108, D301, D302, D304	FC54M KV1225YBR 1SR35-100AVL 1SS254

**RELAY**

Mark	Symbol & Description	Part No.
	RY301 Relay	VSR-005

**COILS**

Mark	Symbol & Description	Part No.
	VL101 Variable coil L101 Coil (4.7μH) L102	VTL-275 VTL1003 VTH-008

**CAPACITORS**

Mark	Symbol & Description	Part No.
	C201, C203 C118 C311, C312 C226, C227 C212, C213	CCCCH220J50 CCCCH560J50 CCCCL101J50 CCCCL121J50 CCCCL221J50

Mark	Symbol & Description	Part No.
	C107, C214, C215 C119 C104, C120 C103, C202 C113	CCCSL331J50 CCCSL391J50 CCCUJ221J50 CCCUJ330J50 CEANP2R2M50
	C228, C229 C110, C230 C108, C109, C116, C117, C122 C121, C123, C125, C206-C211 C5, C6	CEANP220M10 CEAS010M50 CEAS100M50 CEAS101M10 CEAS221M10
	C3, C4 C1, C2 C105 C112, C204, C205, C222-C225, C306, C307	CEAS221M25 CEAS222M25 CEAS470M25 CFTXA104J50
	C115 C216, C217 C101, C126, C127, C310, C314 C313 C102, C503, C504	CFTXA474J50 CFTXA683J50 CGCYX473M25 CKCYB102K50 CKCYF103Z50
	C501, C502 C111, C218, C219 C220, C221 C106 C114	CQMA102J50 CQMA103J50 CQMA182J50 CQMA223J50 CQMA822J50

**RESISTORS**

Mark	Symbol & Description	Part No.
	VR102, VR501 Semi-fixed (22kΩ)	VRTB6VS223
	R114, R115, R118, R120, R127, R128, R138	RN1/6PQ□□□□F
	Other resistors	RD1/6PM□□□J

**OTHERS**

Mark	Symbol & Description	Part No.
	X101 Crystal resonator (16MHz) Pin jack (2P)	VSS1004 VKB-027

**TNTR Assembly  
SEMICONDUCTORS**

Mark	Symbol & Description	Part No.
	Q201, Q202	RPI-38

**RESISTORS**

Mark	Symbol & Description	Part No.
	R201, R202	RD1/6PM472J

**BLDB Assembly  
SEMICONDUCTORS**

Mark	Symbol & Description	Part No.
	IC301	TA8413P
	Q301 Transistor array Q302 Transistor array Q303-Q305 D301-D303	STA302A STA303A 2SA1048 S2V10-4001

**CAPACITORS**

Mark	Symbol & Description	Part No.
	C301-C303 (33μF/50V) C304 C305	VCH1034 CEAS4R7M50 CKCYF103Z50

**RESISTORS**

Mark	Symbol & Description	Part No.
	All resistors	RD1/6PM□□□J

**FTSB Assembly (VYS 1009)  
SEMICONDUCTORS**

Mark	Symbol & Description	Part No.
	IC2, IC3 IC1 IC6 IC4 IC5	BA15218N HA11529 IR3C02A NJM4556DE NJM4556S
	Q1, Q3 Q2 Q16 Q5, Q8, Q10 Q12	DTC363ES UN4112 2SA933S 2SB1185 2SB1238X
	Q13, Q14 Q4, Q7, Q9 Q11 Q6, Q17	2SC1740S 2SD1762 2SD1859X 2SK184
	D1 - D5, D9	1SS254

**CAPACITORS**

Mark	Symbol & Description	Part No.
	C2 C38 C52, C53 C24, C25 C9, C37	CCPUSL680J50 CEAL010M50 CEAL220M6R3 CEAL330M25 CEJANPR47M50
	C3, C56, C57 C4, C18 C11 C28 C48, C50	CEJANP010M50 CEJANP100M10 CEJANP220M10 CEJA010M50 CEJA220M6R3
	C31, C32 C54 C5, C17, C19, C33, C35 C15, C16 C21	CEJA330M25 CFTXA103J50 CFTXA104J50 CFTXA184J50 CFTXA223J50

Mark	Symbol & Description	Part No.
	C7	CFTXA333J50
	C8, C14	CFTXA473J50
	C10, C13	CFTXA683J50
	C26	CKCYF103Z50
	C30	CKPUYB101K50

	C20, C23, C27, C34	CKPUYB102K50
	C1, C29	CKPUYB331K50
	C36, C39—C41, C45—C47, C49, C51	CKPUYF103Z25
	C12	CQMA272J50
	C55	CQMA472J50
	C44	CSZA220M10

**RESISTORS**

Mark	Symbol & Description	Part No.
	VR1—VR2, VR6, VR7, VR11 Semi-fixed (4.7kΩ)	VRTB6VS472
	VR10 Semi-fixed (2.2kΩ)	VRTB6VS222
	VR12	VRTB6VS103
	R128	RN1/6PQ5602F
	R82, R86, R93, R98 Other resistors	RD1/2PMF□□□J RD1/6PM□□□J

**OTHERS**

Mark	Symbol & Description	Part No.
	CN10 Side connector (23P)	VKN1013
	CN103	B5P-SHF-1AA

**FLKY Assembly (VYG1017)**

**SEMICONDUCTORS**

Mark	Symbol & Description	Part No.
	IC1	PDG012
	Q1, Q2	2SC2458
	D1—D6	1SS254

**SWITCHES**

Mark	Symbol & Description	Part No.
	S1—S15 Tact switch (SEARCH/MEMORY, RANDOM PLAY, TIME DISPLAY, PROGRAM, AUTO PGM EDITING, 10 KEY)	VSC-012

**CAPACITORS**

Mark	Symbol & Description	Part No.
	C1	CEJA100M50
	C2	CEJA101M6R3
	C3	CKPUYF103Z25

**RESISTORS**

Mark	Symbol & Description	Part No.
	R1 Resistors array (10kΩx4)	RA4S103J
	R2, R3	RD1/6PM154J

**OTHERS**

Mark	Symbol & Description	Part No.
	X1 Ceramic resonator	VSS1014
	V1 Fluorescent tube	VAW1005
	CN57 Connector (20P)	VKN1017

**CNNB Assembly  
SEMICONDUCTORS**

Mark	Symbol & Description	Part No.
	D101	1SS254

**CAPACITORS**

Mark	Symbol & Description	Part No.
	C105	CEJA470M6R3
	C104	CKPUYF103Z25

**RESISTORS**

Mark	Symbol & Description	Part No.
	R101	RD1/6PM103J
	R102—R104	RD1/4PM221J

**OTHERS**

Mark	Symbol & Description	Part No.
	CN56 Connector (20P)	VKN1020

**IRKB Assembly**

**SWITCHES**

Mark	Symbol & Description	Part No.
	S301—S306 Tact switch (OPEN/CLOSE, PLAY/PAUSE, SCAN, SKIP)	VSC-012

**OTHERS**

Mark	Symbol & Description	Part No.
	IR sensor unit	GP1U50V

**HEPB Assembly  
SEMICONDUCTORS**

Mark	Symbol & Description	Part No.
	IC201	NJM4556S

**CAPACITORS**

Mark	Symbol & Description	Part No.
	C201—C203	CGCYX473M25

**RESISTORS**

Mark	Symbol & Description	Part No.
	VR201 Variable resistor (2P)	VCS1009
	Other resistors	RD1/6PM□□□J

**OTHERS**

Mark	Symbol & Description	Part No.
	JA201 Headphone jack	VKN1018

**LFSB Assembly**

**SWITCH**

Mark	Symbol & Description	Part No.
△	S1 Power switch	VSA-010

**COIL**

Mark	Symbol & Description	Part No.
△	L101 Line filter	VTL-157

**CAPACITORS**

Mark	Symbol & Description	Part No.
△	C101-C103 Ceramic capacitor (0.01/AC125V)	VCG-048

**SYPS Assembly (VYR1071)  
SEMICONDUCTORS**

Mark	Symbol & Description	Part No.
	IC1	NJM4558S
	Q12, Q14, Q15	UN4212
	Q2, Q6, Q8	2SA933S
	Q5	2SB1052
	Q17	2SB1238X
	Q10	2SC1627
	Q1, Q7, Q9, Q13	2SC1740S
	Q16	2SC1847
	Q3, Q4, Q11	2SD1267
	D8, D9	HZS5.6EB2
	D10	HZS8.2EB2
	D15	MTZ36C
	D16	MTZ5.1B
	D1, D2	RB-152LF
	D11	S2K20
	D12-D14	1SR35-100AVL
	D3-D7	1SS254

**COIL**

Mark	Symbol & Description	Part No.
	L1 Coil	VTT-070

**CAPACITORS**

Mark	Symbol & Description	Part No.
	C18	CCCSL331J50
	C22	CCCSL471J50
	C9, C10, C13, C16, C17, C29	CEAS100M50
	C27, C28	CEAS101M50
	C23	CEAS3R3M50
	C7, C8	CEAS470M25
	C14, C15	CEAS470M50
	C21	CKCYB102K50
	C1, C2, C11, C12, C30, C31	CKCYF103Z50
	C19	CQMA183J50
	C26	CQMA472J50
	C3, C4 (2200μF/25V)	PCH1027
	C6 (4700μF/10V)	VCH1003
	C5 (6800μF/10V)	VCH1046

**RESISTORS**

Mark	Symbol & Description	Part No.
	R27	RS1PMFR51J
	R26	RS1PMF2R7J
	R39	RS1PMF3R3J
	R42, R43	RD1/2PMF3R3J
	R1, R2	RD1/2PM471J
	R28-R31	RN1/6PQ□□□□F
	Other resistors	RD1/6PM□□□□J

**LMCB Assembly  
SEMICONDUCTORS**

Mark	Symbol & Description	Part No.
	IC1	TA7291P
	D1	HZS9B3

**CAPACITORS**

Mark	Symbol & Description	Part No.
	C1	CGDYX473M25
	C3	CEAS100M50

**RESISTORS**

Mark	Symbol & Description	Part No.
	R1	RD1/4VM222J
	R2	RD1/4VM220J

**SCRT Assembly**

**COILS**

Mark	Symbol & Description	Part No.
	L1-L5	VTH1020

**CAPACITORS**

Mark	Symbol & Description	Part No.
	C1-C3	CKDYX473M25

**RESISTORS**

Mark	Symbol & Description	Part No.
	R1	RG1/4VM561

**OTHER**

Mark	Symbol & Description	Part No.
	RGB Connector	VKB1003





## 8. PICK-UP ASSEMBLY REPLACEMENT PROCEDURES

### 8.1 PICK-UP ASSEMBLY REPLACEMENT

1. Remove the bonnet and the bottom plate. (Fig.1)

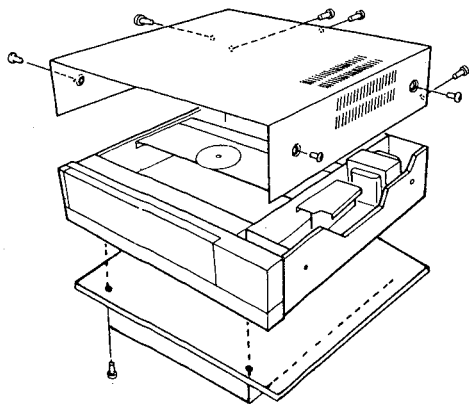

Fig.1

2. Switch the power on and press the OPEN/CLOSE key to eject the disc tray. Then switch the power off.
3. Shift the pick-up assembly to the position shown in Fig.2.

*Note: Rather than turning the slider motor by hand, the pick-up assembly can be readily moved by connecting a 1.5V battery across the slider motor terminals.*

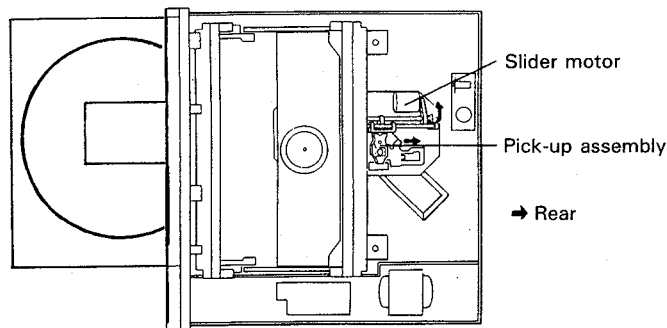

Fig.2

4. Stand the unit on its side with the power transformer at the bottom. Undo the four VSOP assembly screws and the two rear panel screws. Open the VSOP assembly and disconnect CN33 from the 2FSB assembly. (Fig.3)

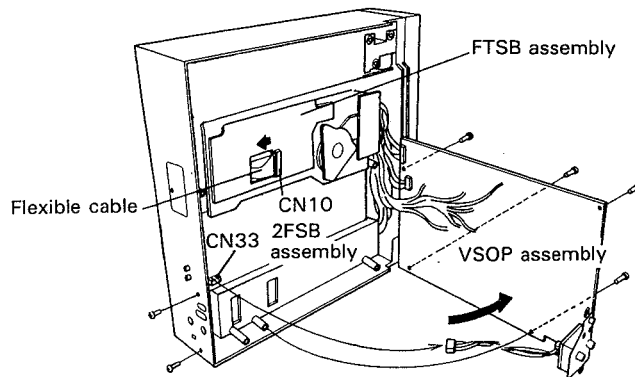

Fig.3

5. Disengage the CN10 lock in the FTSB assembly and carefully remove the flexible cable. In addition to protecting the cable from damage, also guard against electrostatic damage to the laser diode. For maximum protection, do not touch the conductor section of the cable under any circumstances.
6. Undo the pick-up securing screw from the top of the unit, and carefully remove the pick-up assembly. (Fig.4)

*Note: Do not touch soldered sections on the pick-up assembly.*

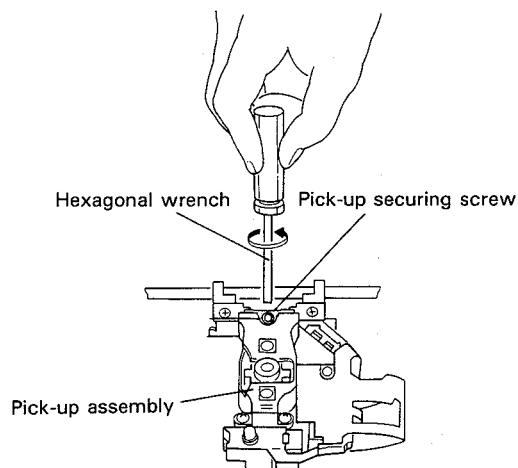

Fig.4

7. Mount a new pick-up assembly, tighten the securing screw, and carefully reconnect and lock the flexible cable to CN10 in the FTSB assembly. This completes replacement of the pick-up assembly.

*Note: After replacing the pick-up assembly, check the spindle motor centering. (Refer to Page 55)*

## 8.2 DISC TRAY REMOVAL

### 8.2.1 Disc Tray Removal Procedure

1. Remove the bonnet. (Fig.1)
2. Switch the power on and press the OPEN/CLOSE key to eject the disc tray. Then switch the power off and push the disc tray in by about 5cm.
3. Extract the rivet by pulling upwards, and remove the switch spring. (Fig.5)

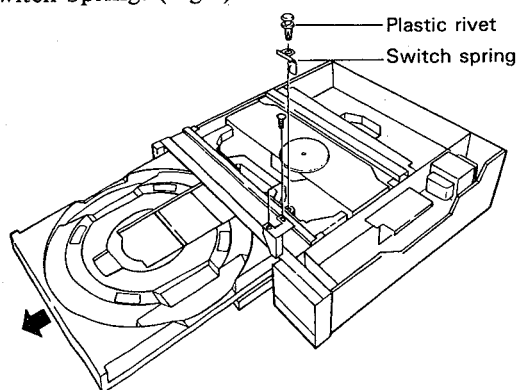

Fig.5

4. Undo a screw to remove the stopper plate. (Fig.5)
5. Remove the disc tray by gently pulling forward.

### 8.2.2 Method for Clamping Disc when Disc Tray is Removed

1. Insert disc from the rear and place it on the turntable.  
*Note: Take care not to let grease from the rails get on the disc surface.*
2. Pull the lock levers (L) and (R) toward the rear while being pushed outwards, the clamber is lowered to clamp the disc. Check that the disc has been properly clamped by turning the clamber by hand. (Fig.6)

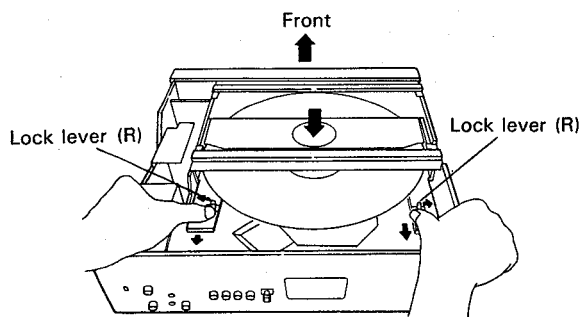

Fig.6

### 8.2.3 Play Procedure while Disc Tray is Removed

1. Switch the power on while pressing the slide switch, and then immediately press the play key. Release the slide switch after the disc starts to turn. (Fig.7)

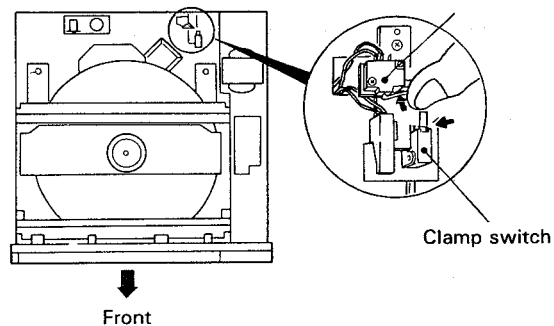

Fig.7

### 8.2.4 Disc Tray Insertion and Ejection

1. Insert the tray after aligning the disc tray tooth with the missing tooth section of the gear. (Fig.8)
2. Insert the rivet, switch spring, and stopper plate removed in steps 3 and 4 in procedure 7.2.1.

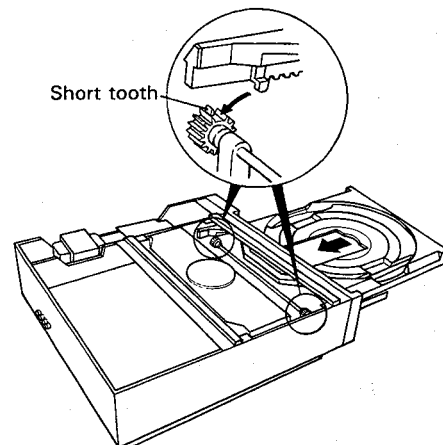

Fig.8

## 9. ADJUSTMENTS

### 9.1 JIGS AND INSTRUMENTS REQUIRED FOR ADJUSTMENTS

- Small screwdriver (about 7cm long axis)
- Small Philips head screwdriver (at least 15cm long axis)
- Hexagonal wrench (2.00mm and 2.5mm)
- L-shaped eccentric driver (GGV-129)
- 1.5V battery with lead wires
- Low-pass filter (100k  $\Omega$  + 1 $\mu$ F)
- Dual-trace oscilloscope (with delay)
- AF generator
- Frequency counter
- LD test disc J1
- LDD disc (local purchase)
- CD test disc (YEDS-7)
- Shorting clips
- Digital voltmeter

### 9.2 ADJUSTMENT PREPARATIONS AND PRECAUTIONS

#### 1. Player settings

For most adjustment procedures, the player should be stood on its side with the power transformer at the top and the VSOP assembly open. The 2FSB assembly CN33 connector may also be disconnected at this stage.

#### 2. Prevention of double clamping

When the disc tray is in position and a disc is clamped, the clamping action is actually performed twice. This is called "double clamping".

If double clamping is performed while the player is stood on its side for adjustment purposes, however, the disc will fall off the turntable. Therefore, short circuit pin 3 (white lead) to pin 4 (white lead) of CN22 in the VSOP assembly to prevent double clamping.

#### 3. Opening the tracking servo

The tracking servo can be opened and closed during test mode controlled by microcomputer.

##### — Switching to test mode —

- 1) Switch the power off.
- 2) See the patterned side of the VSOP assembly and find the 10k $\Omega$  resistor connecting pin 24 of IC5 (CXD1095Q) and +5V line. Connect the IC side of the resistor lead ground.

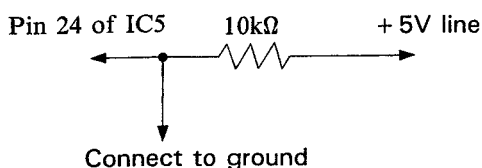

- 3) Switch the power on and check that the entire fluorescent tube display on the front panel comes on.

*Note 1. The player can still be used in the normal way during test mode.*

2. After switching to test mode, the ground connection described above in 2) can be disconnected without effecting test mode.
3. The disc is only stopped, not ejected, when the EJECT key is pressed in test mode.
4. Normal fluorescent tube display operation can be restored by pressing [CX] + [0] once. Pressing a second time turns the entire display back on.

##### — Opening and closing the tracking servo —

The tracking servo is opened by pressing [CX] + [3] on the remote control unit continuously. The servo is closed by pressing [CX] + [3] again. (The tracking servo is subsequently opened and closed alternately each time [CX] + [3] is pressed.)

##### — Cancellation of test mode —

Test mode can be canceled by switching the power off, or by pressing [CX] + [9] on the remote control unit.

**4. Grating adjustment**

Grating can be adjusted in two different ways.

— **Adjusting with player standing on its side** —  
 Stand the player on its side as shown in Fig.3. The grating can be adjusted by inserting a small screwdriver through the gap between the mechanical assembly and the 2FSB assembly. (Figs.9 and 10)

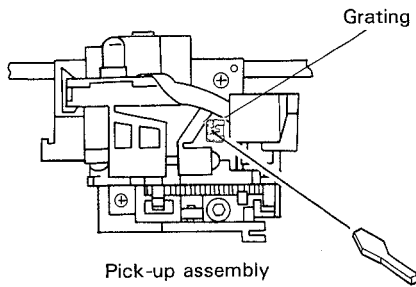

Grating position  
 Fig.9

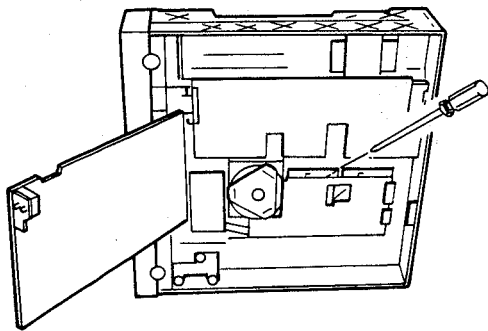

Screwdriver insertion position  
 Fig.10

— **Adjusting with player lying flat** —

Approaching from the direction shown in Fig.11, insert a small screwdriver along the edges of the two guides in the pick-up assembly as shown in Fig.12 and into the grating adjustment hole.

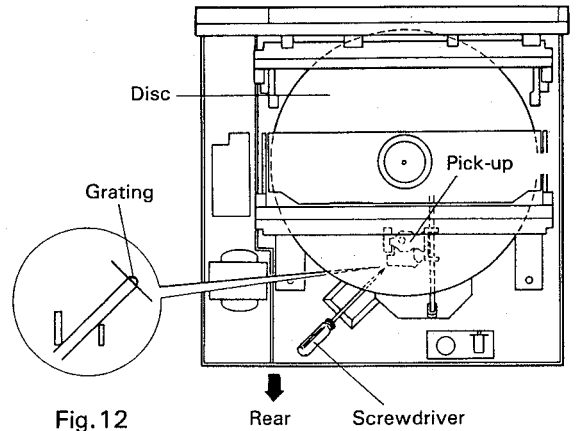

Fig.11

**5. Unless specified otherwise, all oscilloscope settings shown in the connection diagrams are values obtained by using a 10:1 probe.**

9.3 MECHANICAL ADJUSTMENTS

1. ROUGH GRATING AND TRACKING (TRKG) BALANCE ADJUSTMENTS 9.3 Mechanical Adjustments

- Purpose: Adjust the laser beam (divided into 3 beams by grating) to the optimum position on the playback tracks. Adjust TRKG servo offset voltage to 0V.
- Symptoms indicating need for adjustment: Improper tracking (Jumping, Skipping etc.)

- |  |  |
|--|--|
| <ul style="list-style-type: none"> <li>• Measuring instruments and jigs</li> <li>• Measuring position</li> <li>• Test disc and player mode</li> <li>• Adjustment position</li> </ul> | <ul style="list-style-type: none"> <li>• Small screwdriver • Oscilloscope</li> <li>• FTSB assembly CN102-3 (TRKG error)</li> <li>• LD test disc #17,000 • Test mode (TRKG servo open)</li> <li>• Grating • FTSB assembly VR6 (TRKG balance)</li> </ul> |
|--|--|

Connection diagrams

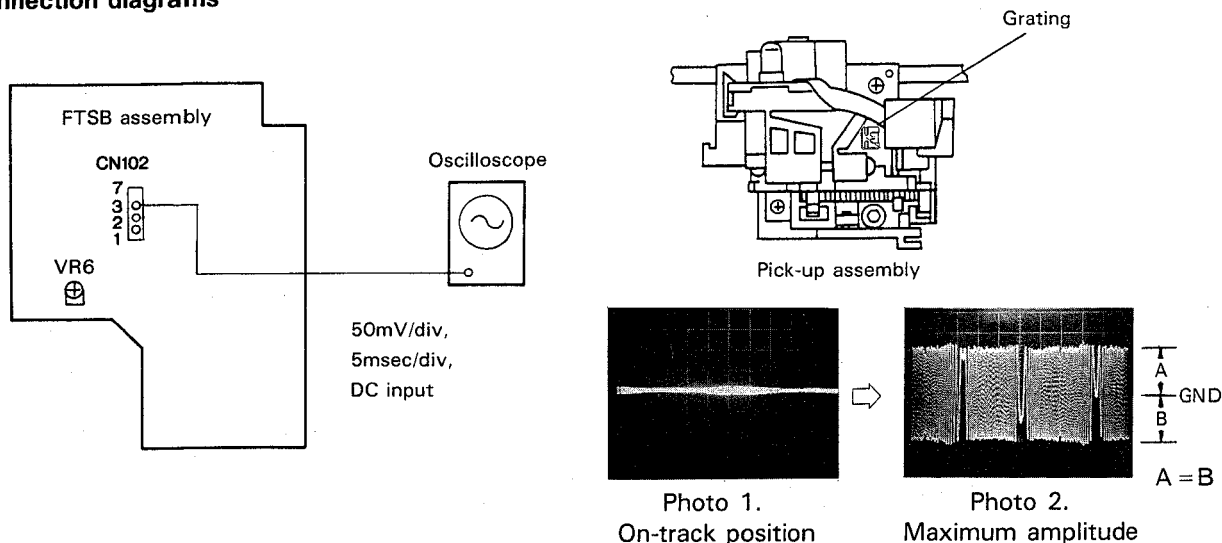

Adjustment Procedure

<Rough Grating Adjustment >

1. Play an LD test disc.
2. Press the DISPLAY key to display the frame # on the TV screen.
3. Move the pick-up to frame #17,000 by scanning or searching.
4. Open the TRKG servo. (See p.52.)
5. Connect the oscilloscope to CN102-3 of the FTSB assembly and observe the waveform.
6. Insert a small screwdriver into the grating adjustment hole (see p.53) and turn the grating so that the amplitude of the TRKG error signal varies large and small alternately. Find the position where the waveform amplitude reaches a minimum with a smooth waveform envelope. (See Photo 1.) (This condition indicates that the 3-way split laser beam is directed onto a single track. This is called the "on-track" position.)

7. Slowly turn the grating counterclockwise from the on-track position until the gradually increasing TRKG error waveform amplitude reaches a maximum. (See Photo 2.)

8. Close the TRKG servo and check that a normal picture is displayed on the TV screen.

<TRKG Balance Adjustment >

1. Align the oscilloscope GND with the center of the oscilloscope screen.
2. Adjust VR6 in the FTSB assembly to a position where the positive and negative halves of the TRKG error waveform are equal. (See Photo 2.)

## 2. SPINDLE MOTOR CENTERING CHECK

## 9.3 Mechanical Adjustments

- Purpose: Check that the spindle motor is centered on the locus traced by the laser beam.

- |  |  |
|--|--|
| <ul style="list-style-type: none"> <li>• Measuring instruments and jigs</li> <li>• Measuring position</li> <li>• Test disc and player mode</li> <li>• Adjustment position</li> </ul> | <ul style="list-style-type: none"> <li>• Oscilloscope</li> <li>• FTSB assembly CN102-3 (TRKG error) and CN102-7 (TRKG sum)</li> <li>• CD test disc • Test mode (TRKG servo: open)</li> <li>• Lissajous figure check</li> </ul> |
|--|--|

## Connection diagrams

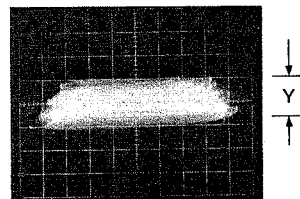
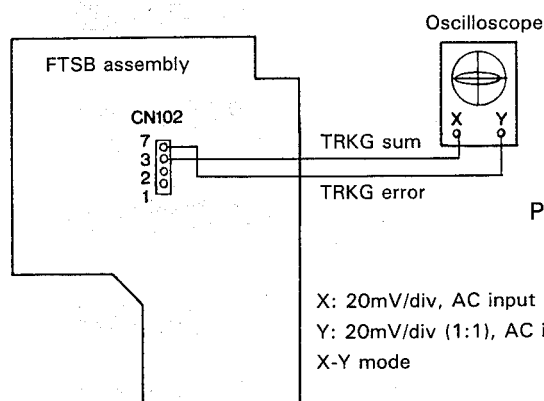

Photo 3 Lissajous figure at inner track of CD disc

Check that  $Y = Y'$ 

Photo 4 Lissajous figure at outer track of CD disc

## Check Procedure

1. Play a CD test disc.
2. Move the pick-up to the inner tracks of the disc by scanning or searching, and then open the TRKG servo.
3. Connect the oscilloscope X input (CH-1) to CN102-3 of the FTSB assembly, and the Y input (CH-2) to CN102-7. Switch the oscilloscope to X-Y mode and observe the Lissajous figures of the TRKG error and TRKG sum signals.
4. Record the amplitude of the Lissajous figures along the Y axis.
5. Close the TRKG servo, and move the pick-up to the outer tracks of the disc by scanning or searching. Open the TRKG servo again and observe the Lissajous figure.

Check that the amplitude of the Lissajous figures along the Y axis is the same as that recorded in step 4 above.

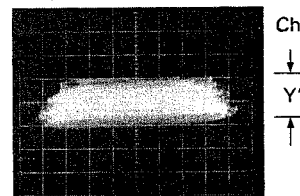
If it is not the same, proceed to the "Spindle Motor Centering Adjustment" procedure.

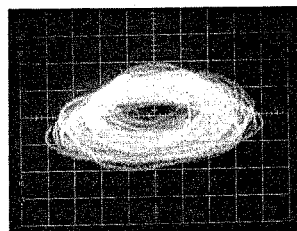

Lissajous figure indicating need for adjustment

Photo 5.

3. SPINDLE MOTOR CENTERING ADJUSTMENT

9.3 Mechanical Adjustments

- Purpose: Position the spindle motor center on the production of laser beam locus.
- Symptoms indicating need for adjustment: Track jumping. Long search times.

- |  |  |
|--|--|
| <ul style="list-style-type: none"> <li>● Measuring instruments and jigs</li> <li>● Measuring position</li> <li>● Test disc and player mode</li> <li>● Adjustment position</li> </ul> | <ul style="list-style-type: none"> <li>● L-shaped eccentric driver (GGV-129)</li> <li>● 2.5mm hexagonal wrench</li> <li>● Oscilloscope</li> <li>● FTSB assembly CN102-3 (TRKG error) and CN102-7 (TRKG sum)</li> <li>● CD test disc</li> <li>● Test mode (TRKG servo: open/close)</li> <li>● Spindle motor centering adjustment hole</li> <li>● Grating</li> </ul> |
|--|--|

Connection diagrams

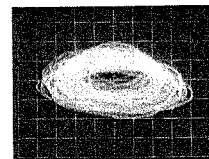
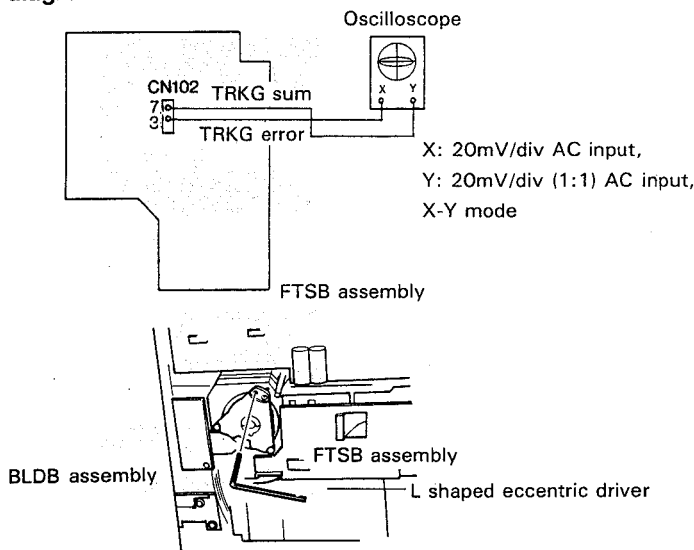

Photo 6

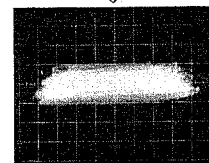

Photo 7

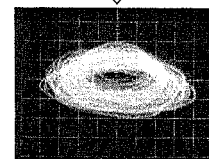

Photo 8

Adjustment Procedure

Note: This adjustment is necessary only when indicated by the Spindle Motor Centering Check.

1. Loosen the three spindle motor setscrews by turning each about half a turn.
2. Connect the oscilloscope X input (CH-1) to CN102-3 of the FTSC assembly, and the Y input (CH-2) to CN102-7.
3. Play a CD test disc, and move the pick-up to the outer tracks of the disc by scanning or searching.
4. Open the TRKG servo, and observe the Lissajous figures of the TRKG error and TRKG sum signals.
5. Fine adjust the grating until the amplitude of the Lissajous figures along the Y axis reaches a minimum. (See Photo 7.)
6. Close the TRKG servo, and move the pick-up to the inner tracks of the disc by scanning or searching.
7. Open the TRKG servo again and observe the Lissajous figures. Record the amplitude on the Y axis.
8. Insert the L-shaped eccentric screwdriver into the adjustment hole, and slowly turn in the direction which reduces the Lissajous figures amplitude on the Y axis. After reaching the minimum amplitude, continue turning the eccentric driver to the same direction until the same amplitude as that recorded in step 7 is reached. (See Photos 6 thru 8.)
9. Close the TRKG servo, and move the pick-up back to the outer tracks of the disc by scanning or searching.
10. Repeat steps 4, 5, and 6.
11. Open the TRKG servo again and observe the Lissajous figures. Check that the amplitude along the Y axis has reached a minimum. If the Lissajous figures are still inflated in the Y axis direction, repeat steps 8 thru 11.



## 4. PICK-UP TRACKING DIRECTION INCLINATION ADJUSTMENT

## 9. 3 Mechanical Adjustments

- Purpose: Adjustment of slider shaft inclination to ensure that the pick-up assembly moves parallel to the disc surface, and adjustment of the pick-up assembly tracking direction angle to ensure that the laser beam is beamed perpendicularly at the disc.
- Symptoms indicating need for adjustment: Crosstalk

- |  |   |
|--|---|
| <ul style="list-style-type: none"> <li>• Measuring instruments and jigs</li> <li>• Measuring position</li> <li>• Test disc and player mode</li> <li>• Adjustment position</li> </ul> | <ul style="list-style-type: none"> <li>• Oscilloscope</li> <li>• Battery with lead wires</li> <li>• Low-pass filter</li> <li>• 2.5mm hexagonal wrench</li> <li>• FTSB assembly CN103-5 (FOCS drive)</li> <li>• LD test disc #17,222, #98</li> <li>• Pick-up tracking direction angle adjustment screw</li> <li>• Adjust slider shaft angle with tilt motor</li> </ul> |
|--|---|

## Connection diagrams

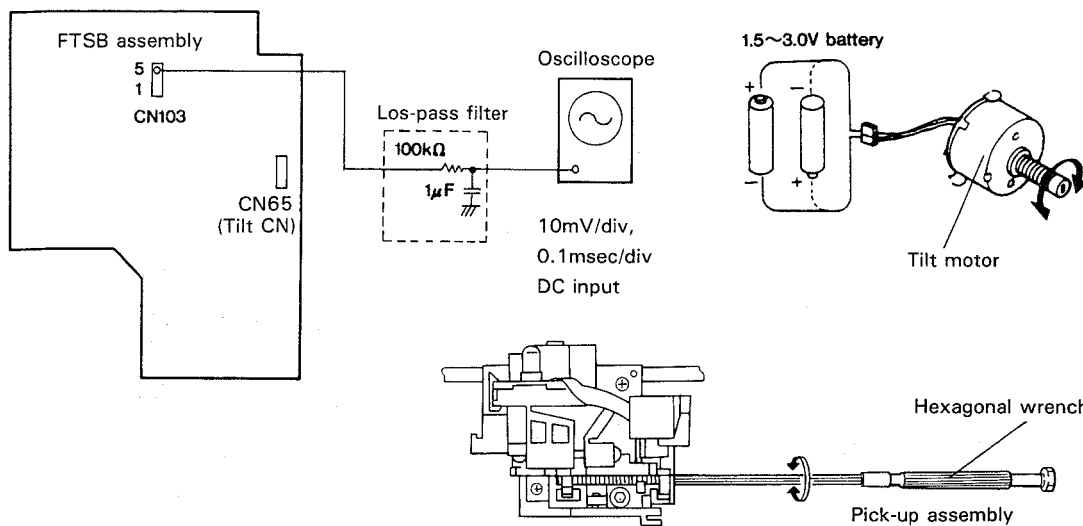

Fig. 1

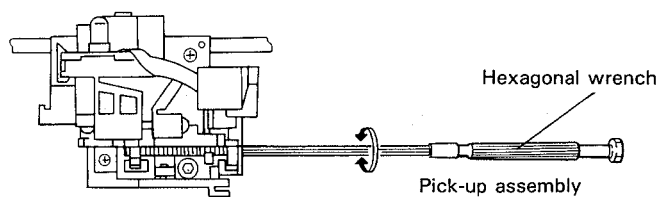

Fig. 2

## Adjustment Procedure

1. Disconnect the FTSB assembly CN65 (tilt motor) connector, and do not connect it again until the "Tilt Sensor Angle Adjustment" has been completed.
2. Play an LD test disc, and search to frame #98 where the tilt fulcrum is located.
3. Connect the oscilloscope to CN103-5 of the FTSB assembly via a low-pass filter, and observe the focus drive voltage. The oscilloscope GND level does not have to be aligned in the center of the screen at this stage.
4. Adjust the Y axis position adjustment knob on the oscilloscope to position the focus drive voltage waveform in the center of the oscilloscope screen.
5. If the focus drive voltage measured when searching for frame #17,222 differs from that obtained in step 4 above, connect a battery (1.5 to 3V) to the tilt motor connector, and turn the motor until the focus drive voltage is within  $\pm 50\text{mV}$  of the step 4 voltage.
6. Insert the hexagonal wrench into the adjustment hole in the rear panel, and adjust the pick-up tracking direction inclination adjustment screw to minimize the crosstalk on the left and right hand sides of the TV screen.
7. Search to frame #98 and check that crosstalk on the left and right hand sides of the TV screen has been minimized, and that it is about equal on both sides. If the level of crosstalk on the TV screen is still too high, repeat steps 6 and 7.

### 5. LD FOCS ERROR BALANCE ADJUSTMENT

### 9.3 Mechanical Adjustments

• Purpose: To ensure that the FOCS servo maintains the objective lens at the optimum distance from disc during LD playback.

• Symptoms indicating need for adjustment: Crosstalk

- Measuring instruments and jigs
- Measuring position
- Test disc and player mode
- Adjustment position

- TV monitor
- Player video output terminals
- LD test disc #98
- FTSB assembly VR2

#### Connection diagrams

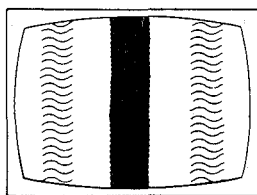
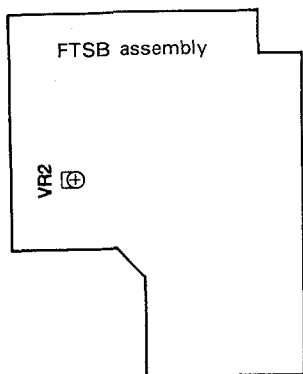

Screen showing generation of crosstalk

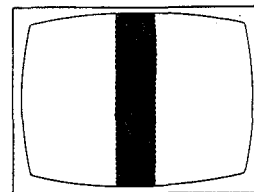

Minimum crosstalk

#### Adjustment Procedure

1. Play an LD test disc, and search to frame #98
2. Adjust VR2 on the FTSB assembly to minimize crosstalk in the left and right hand sides of the TV screen. If this adjustment fails to reduce crosstalk down to the allowable level, go to the "Pick-up Tangential Direction Angle Adjustment" procedure.

## 6. PICK-UP TANGENTIAL DIRECTION ANGLE ADJUSTMENT

## 9.3 Mechanical Adjustments

- Purpose: Adjustment of pick-up tangential direction inclination to minimize crosstalk.
- Symptoms indicating need for adjustment: Conspicuous crosstalk

- |  |   |
|--|---|
| <ul style="list-style-type: none"> <li>• Measuring instruments and jigs</li> <li>• Measuring position</li> <li>• Test disc and player mode</li> <li>• Adjustment position</li> </ul> | <ul style="list-style-type: none"> <li>• TV monitor</li> <li>• Crosstalk on the screen</li> <li>• LD test disc #17,222, #98</li> <li>• FTSB assembly CN102-3 (TRKG error)</li> <li>• Test mode (TRKG servo: open/close)</li> <li>• Pick-up tangential direction inclination adjustment screw</li> </ul> |
|--|---|

Connection diagrams (For the connection diagrams, refer to page 56.)

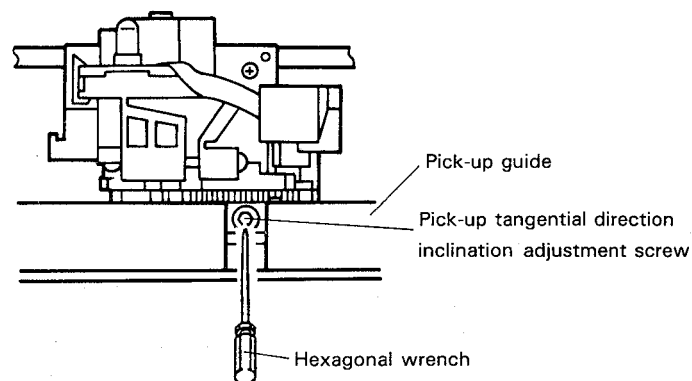
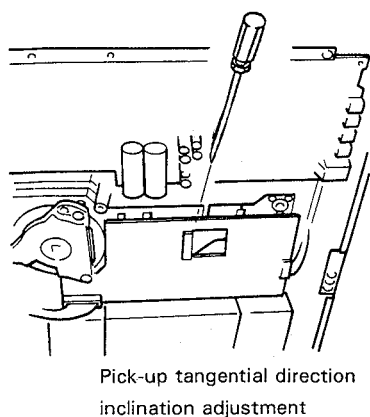
**Adjustment Procedure**

*Note: This adjustment is necessary only if crosstalk remains conspicuous after completing the "Pick-up Tracking Direction Inclination Adjustment" and "LD FOCUS Error Balance Adjustment" procedures.*

1. Play an LD test disc, search to frame #17,222, and open the TRKG servo.
2. Connect the oscilloscope to CN102-3 of the FTSB assembly and observe the TRKG error waveform.
3. Insert the hexagonal wrench through the gap between the 2FSB assembly and mechanical assembly to the pick-up tangential direction inclination adjustment screw.
4. Adjust this screw until the TRKG error waveform reaches maximum amplitude.
5. Remove the hexagonal wrench, then search to frame #98 and check that crosstalk on the left and right hand sides of the TV screen has been minimized,

and that it is about equal on both sides. Repeat steps 4 and 5 if considered necessary.

## 7. TILT SENSOR INCLINATION ADJUSTMENT

## 9.3 Mechanical Adjustments

- Purpose: Adjustment of the tilt servo offset voltage to 0V by adjustment of tilt sensor inclination.
- Symptoms indicating need for adjustment: Crosstalk

- |  |  |
|--|--|
| <ul style="list-style-type: none"> <li>• Measuring instruments and jigs</li> <li>• Measuring position</li> <li>• Test disc and player mode</li> <li>• Adjustment position</li> </ul> | <ul style="list-style-type: none"> <li>• Oscilloscope</li> <li>• Philips head screwdriver</li> <li>• FTSB assembly CN103-2 (tilt error)</li> <li>• LD test disc #17,222, #98 (TRKG servo: closed)</li> <li>• Tilt sensor inclination adjustment screw</li> <li>• FTSB assembly VR11 (tilt gain)</li> </ul> |
|--|--|

## Connection diagrams

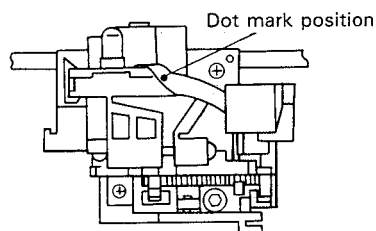
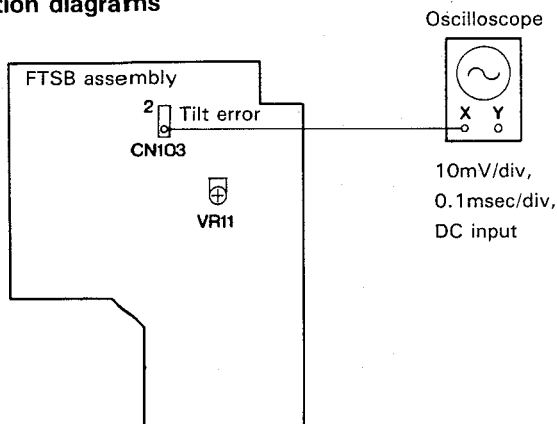

Fig. 1

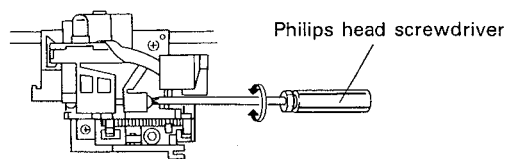

Fig. 2

## Adjustment Procedure

1. Check the color of the dot marked on the flexible cable next to the tilt sensor. (Fig.1)  
There are three types of dots. Adjust VR11 on the FTSB assembly accordingly.  
Red dot ... Turn VR11 fully clockwise.  
Blue dot ... Turn VR11 fully counter clockwise.  
No dot (no mark) ... Adjust VR11 to center position.
2. Play an LD test disc, and search to frame #17,222.
3. Connect the oscilloscope to CN103-2 of the FTSB assembly, and observe the tilt error DC voltage.
4. Insert a Philips head screwdriver with a long shaft through the rear panel and adjust the tilt sensor inclination adjustment screw until the tilt error DC voltage reads 0V. (See Fig.2.)  
During this step, it does not matter if the pick-up is displaced a little from the designated frame by the screwdriver.
5. Connect the tilt motor connector CN65 disconnected during the "Pick-up Tracking Direction Inclination Adjustment".
6. Search to frame #98 and check that crosstalk on the left and right hand sides of the TV screen has been minimized, and that it is about equal on both sides.

### 8. FINE GRATING ADJUSTMENT AND TRKG BALANCE ADJUSTMENT CHECK

### 9.3 Mechanical Adjustments

- Purpose:
  - Fine adjustment of the grating to ensure that the two beams for TRKG servo are directed to the optimum positions in the disc track.
  - Adjustment of TRKG servo loop offset voltage to 0V.
- Symptoms indicating need for adjustment: Improper Tracking (Skip. Jump etc)

- Measuring instruments and jigs
- Measuring position
- Test disc and player mode
- Adjustment position

- Oscilloscope
- Screwdriver
- FTSB assembly CN102-3 (TRKG error), CN102-7 (TRKG sum)
- LD test disc #17,000
- Test mode (TRKG servo: open)
- Grating
- FTSB assembly VR6

#### Connection diagrams

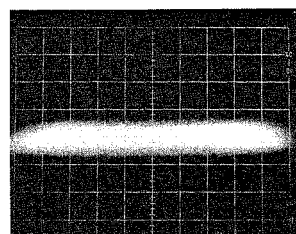
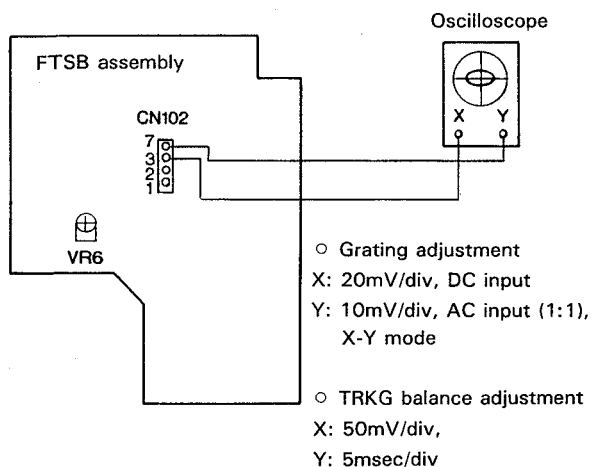

Photo 9. Fine grating adjustment

Minimum

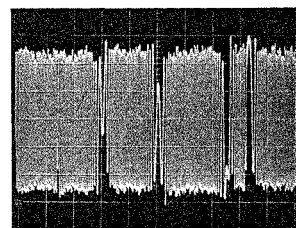

Photo 10. TRKG balance adjustment

A  
 B  
 GND  
 A=B

#### Adjustment procedure

1. Play an LD test disc, search to frame #17,000, and open the TRKG servo.
2. Connect the oscilloscope X input (CH-1) to CN102-3 of the FTSB assembly, and the Y input (CH-2) to CN102-7.  
 Switch the oscilloscope to X-Y mode, and observe the Lissajous figures for the TRKG error and TRKG sum signals.
3. Insert a small screwdriver into the grating adjustment hole (see p.53), and fine adjust the grating until the amplitude of the Lissajous figures along the Y axis reaches a minimum. (Photo 9.)  
 If the grating is turned too far and the optimum position can no longer be found, repeat the "Rough Grating Adjustment".
4. Using the X input (CH-1) of the oscilloscope, check that the positive and negative amplitudes of the TRKG error signal are equal. (Photo 10.) If they are not

5. Close the TRKG servo, and check that a normal picture is shown on the TV screen.

**9.4 FTSB ASSEMBLY ADJUSTMENTS**

**9.4 FTSB Assembly Adjustments**

**1. RF GAIN ADJUSTMENT**

- Purpose: Adjustment of RF signal amplitude to the optimum value.
- Symptoms indicating need for adjustment: Frequent drop-out

- |  |  |
|--|--|
| <ul style="list-style-type: none"> <li>• Measuring instruments and jigs</li> <li>• Measuring position</li> <li>• Test disc and player mode</li> <li>• Adjustment position</li> </ul> | <ul style="list-style-type: none"> <li>• Oscilloscope</li> <li>• Lead of R106 on FTSB assembly (RF signal)</li> <li>• LD test disc #17,000 (TRKG servo: closed)</li> <li>• FTSB assembly VR10 (RF gain)</li> </ul> |
|--|--|

**Connection diagrams**

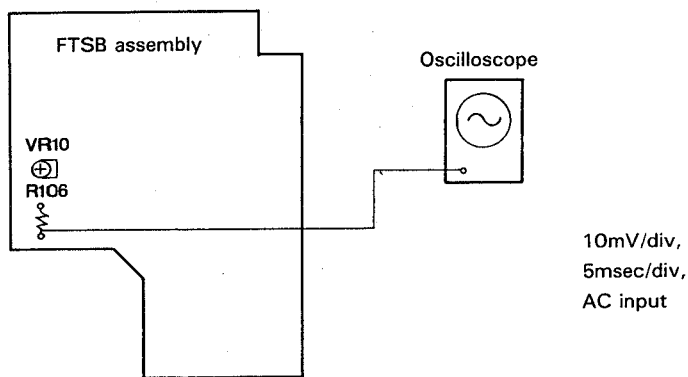

**Adjustment procedure**

1. Play an LD test disc and search to frame #17,000.
2. Connect the oscilloscope to the lead of R106 on the FTSB assembly and observe the RF signal.
3. Adjust VR10 on the FTSB assembly to obtain an RF signal amplitude of  $300\text{mV} \pm 50\text{mV}$ . (Photo 11.)

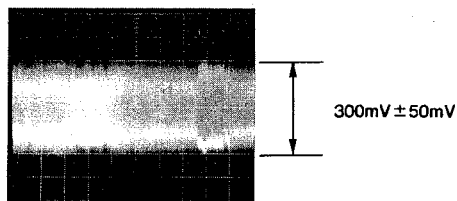

RF signal

Photo 11

2. TRKG SERVO LOOP GAIN ADJUSTMENT

9.4 FTSB Assembly Adjustments

- Purpose: Adjustment of TRKG servo loop gain to the optimum value.
- Symptoms indicating need for adjustment: Improper tracking (Skip, Jump, etc)

- |  |  |
|--|--|
| <ul style="list-style-type: none"> <li>• Measuring instruments and jigs</li> <li>• Measuring position</li> <li>• Test disc and player mode</li> <li>• Adjustment position</li> </ul> | <ul style="list-style-type: none"> <li>• Oscilloscope</li> <li>• Resistor (100kΩ)</li> <li>• AF generator</li> <li>• FTSB assembly CN102-1 (TRKG error), CN102-3 (TRKG gain)</li> <li>• LD test disc #17,000 (TRKG servo: close)</li> <li>• FTSB assembly VR7</li> </ul> |
|--|--|

Connection diagrams

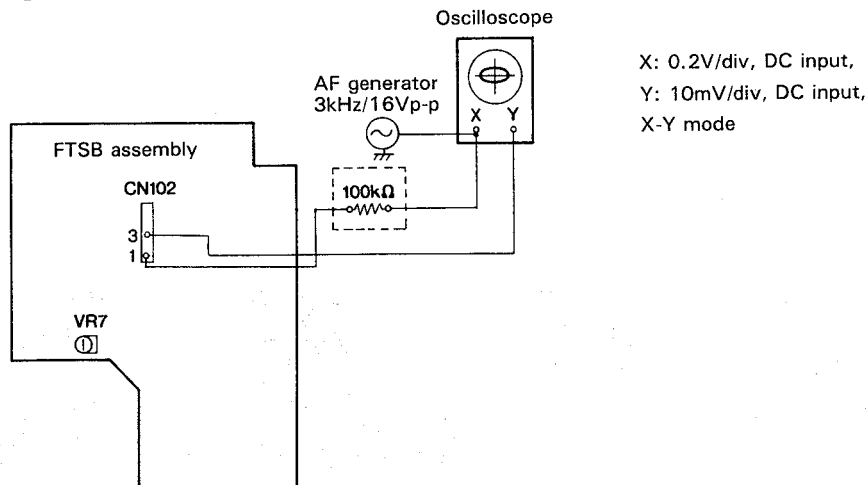

Adjustment procedure

1. Play an LD test disc and search to frame #17,000.
2. Connect the resistor, AF generator, and oscilloscope to CN102 on the FTSB assembly as shown in the diagram.
3. Set the AF generator output to 3kHz/16Vp-p.
4. Put the oscilloscope into X-Y mode, and observe the Lissajous figures.
5. Adjust VR7 on the FTSB assembly until the Lissajous figures become symmetrical along the respective X and Y axes of the oscilloscope. (Photo 12.)

*Note: If the AF generator output does not exceed 16Vp-p, decrease the value of the above resistor (100kΩ) until the Lissajous figures become easy to observe. (33kΩ limit.)*

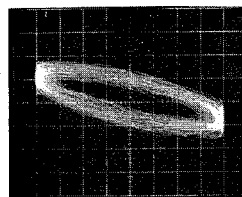

Out of adjustment

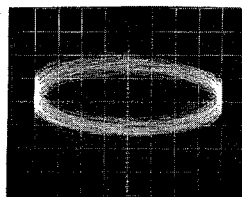

After adjustment Photo 12

Photo 12

## 3. FOCS SERVO LOOP GAIN ADJUSTMENT

## 9.4 FTSB Assembly Adjustments

- Purpose: Adjustment of FOCS servo loop gain to the optimum value.
- Symptoms indicating need for adjustment: Poor playback performance  
Improper focusing. (No initial focusing, intermittent play etc)

- |  |  |
|--|--|
| <ul style="list-style-type: none"> <li>• Measuring instruments and jigs</li> <li>• Measuring position</li> <li>• Test disc and player mode</li> <li>• Adjustment position</li> </ul> | <ul style="list-style-type: none"> <li>• Oscilloscope • Resistor (100k<math>\Omega</math>) • AF generator</li> <li>• FTSB assembly CN102-5 (FOCS error), CN102-4 (FOCS gain)</li> <li>• Suspend FOCS motor protector circuit function.</li> <li>• LD test disc #17,000</li> <li>• FTSB assembly VR1</li> </ul> |
|--|--|

## Connection diagrams

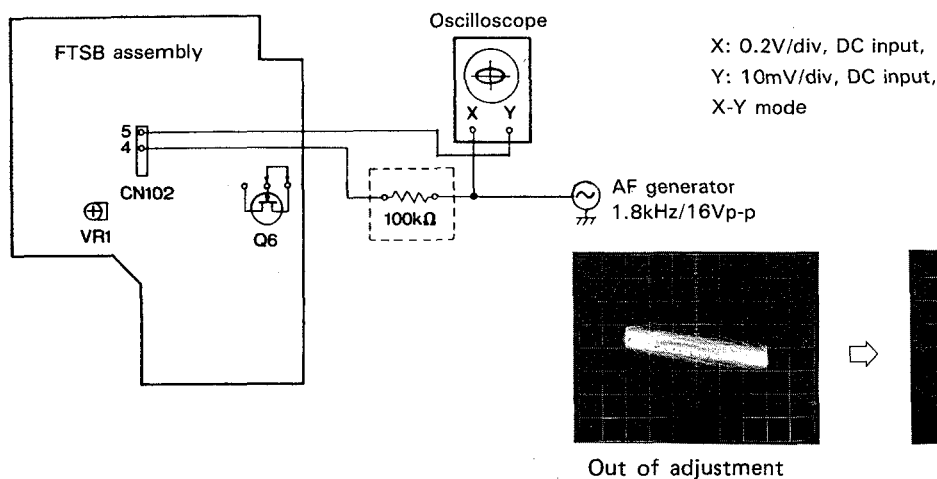

Photo 13

## Adjustment procedure

1. Connect the gate of FTSB assembly Q6 (2SK184) to ground to suspend the focus motor protector circuit function.
2. Connect the resistor, AF generator, and oscilloscope to CN102 on the FTSB assembly as shown in the diagram.
3. Set the AF generator output to 1.8kHz/16Vp-p.
4. Put the oscilloscope into X-Y mode, and observe the Lissajous figures.
5. Adjust VR1 on the FTSB assembly until the Lissajous figures become symmetrical along the respective X and Y axes of the oscilloscope. (Photo 13.)
6. Disconnect the gate of FTSB assembly Q6 from ground.

*Note: If the AF generator output does not exceed 16Vp-p, decrease the value of the above resistor (100k $\Omega$ ) until the Lissajous figures become easy to observe. (33k $\Omega$  limit.)*



4. CD FOCS ERROR BALANCE ADJUSTMENT

9.4 FTSB Assembly Adjustments

- Purpose: To ensure that the FOCS maintains the objective lens at the optimum distance from the disc during CD playback.
- Symptoms indicating need for adjustment: Noise in CD playback sound

- |  |  |
|--|--|
| <ul style="list-style-type: none"> <li>• Measuring instruments and jigs</li> <li>• Measuring position</li> <li>• Test disc and player mode</li> <li>• Adjustment position</li> </ul> | <ul style="list-style-type: none"> <li>• Oscilloscope</li> <li>• VSOP assembly CN26-1 (EFM OUT)</li> <li>• CD test disc (YEDS-7)</li> <li>• FTSB assembly VR3</li> </ul> |
|--|--|

Connection diagrams

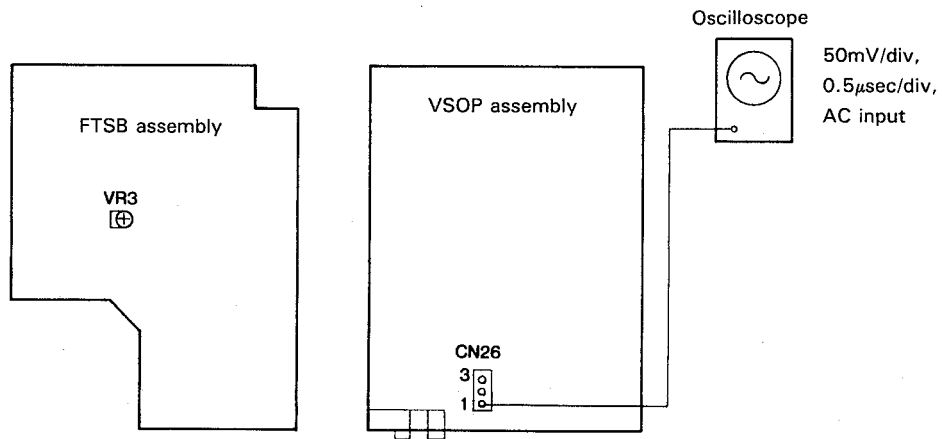

Adjustment Procedure

1. Play a CD test disc.
2. Connect the oscilloscope to CN26-1 (EFM OUT) on the VSOP assembly, and observe the EFM signal (eye pattern).
3. Adjust VR3 on the FTSB assembly until the EFM signal reaches maximum amplitude. (Photo 14.)

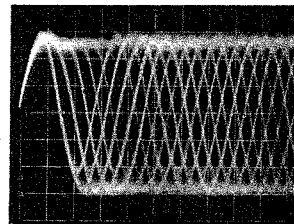

Photo 14. EFM signal

9.5 VSOP ASSEMBLY ADJUSTMENT

9.5 VSOP (TBC, CONT) Assembly Adjustments

1. BURST GATE POSITION ADJUSTMENT

- Purpose: Adjustment of the burst gate position.
- Symptoms indicating need for adjustment: Playback commenced from intermediate position (not from start of disc), missing or irregular color, fine stripes

- |  |  |
|--|--|
| <ul style="list-style-type: none"> <li>• Measuring instruments and jigs</li> <li>• Measuring position</li> <li>• Test disc and player mode</li> <li>• Adjustment position</li> </ul> | <ul style="list-style-type: none"> <li>• Oscilloscope</li> <li>• VSOP assembly Q415 (emitter), IC102 (PA5012) pin 20</li> <li>• LD test disc, PLAY</li> <li>• VSOP assembly VR101</li> </ul> |
|--|--|

Connection diagrams

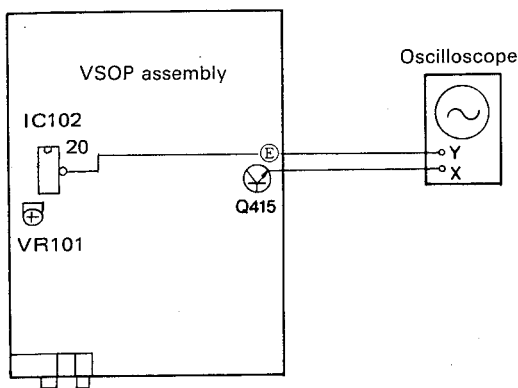

Adjustment Procedure

1. Play an LD test disc.
2. Connect the oscilloscope X input (CH-1) to the emitter of Q415 on the VSOP assembly, and the Y input (CH-2) to pin 20 of IC102 (PA5012).
3. Adjust VR101 on the VSOP assembly until the trailing edge of the MMV output is delayed by about 1.5μsec in respect to the trailing edge of the H-sync of the video-signal. (Photo 17.)  
MMV: Monostable Multi-Vibrator

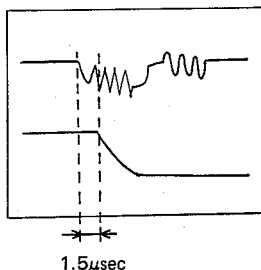

Top: Q415 emitter (TBC VIDEO)  
Bottom: IC102 pin 20

Photo 17

## 2. REF. 17.734475 MHz ADJUSTMENT

## 9.5 VSOP (TBC, CONT) Assembly Adjustments

- Purpose: Reference clock frequency adjustment
- Symptoms indicating need for adjustment: Color aberration, spindle servo lock failure

- |  |  |
|--|--|
| <ul style="list-style-type: none"> <li>• Measuring instruments and jigs</li> <li>• Measuring position</li> <li>• Test disc and player mode</li> <li>• Adjustment position</li> </ul> | <ul style="list-style-type: none"> <li>• Frequency counter</li> <li>• VSOP assembly the foot of R3 (or IC1, pin 21)</li> <li>• Switch power on without playing disc.</li> <li>• VSOP assembly VC1</li> </ul> |
|--|--|

## Connection diagrams

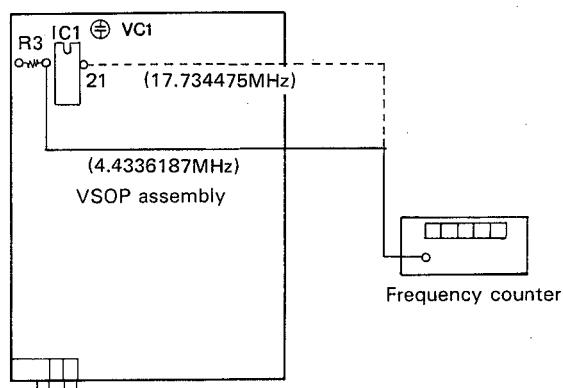
**Adjustment Procedure**

1. Switch the power on, and connect the frequency counter to the foot of R3 on the VSOP assembly.
2. Adjust VC1 on the VSOP assembly until the reference clock frequency reads 4.4336187MHz.

*Note: If this frequency is difficult to adjust, play an LD test disc, and adjust the VSOP assembly VC1 to obtain a frequency of 17.734475MHz at pin 21 of IC1 (TC9015P) during playback.*

### 3. STARTING OSCILLATION FREQUENCY ADJUSTMENT 9.5 VSOP (TBC-CONT) Assembly Adjustments

- Purpose: Adjustment the reference clock frequency to 3.75MHz.

- |   |   |
|---|---|
| <ul style="list-style-type: none"><li>• Measuring instruments and jigs</li><li>• Measuring position</li><li>• Test disc and player mode</li><li>• Adjustment position</li></ul> | <ul style="list-style-type: none"><li>• Frequency counter</li><li>• VSOP assembly IC101 (PD6064A) pin 29</li><li>• Switch power ON without playing the disc</li><li>• VSOP assembly VC101</li></ul> |
|---|---|

#### Connection diagrams

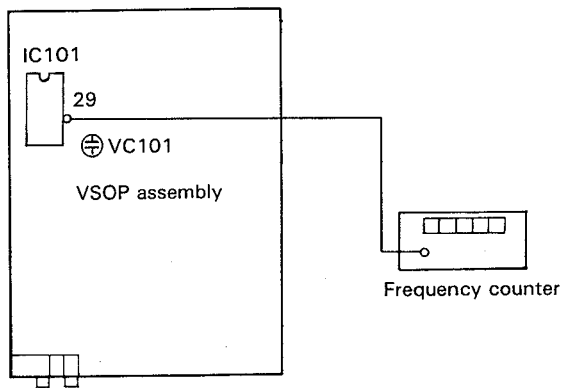

#### Adjustment Procedure

1. Turn power ON.
2. Connect the frequency counter to pin 29 (TSSO) of IC101 (PD6064A) in the VSOP assembly. Adjust to 15.6250kHz  $\pm$  0.1Hz with VC101.

4. 1H DELAYED VIDEO LEVEL ADJUSTMENT

9.5 VSOP (VDEM, ADEM) Assembly Adjustments

- Purpose: Adjustment of the amplitude of the 1H delayed video signal to the same amplitude as the main video signal.
- Symptoms indicating need for adjustment: Considerable white drop-out and H displacement (horizontal lines on the screen) when 1H level is large, and considerable black drop-out when 1H level is small.

- |  |  |
|--|--|
| <ul style="list-style-type: none"> <li>• Measuring instruments and jigs</li> <li>• Measuring position</li> <li>• Test disc and player mode</li> <li>• Adjustment position</li> </ul> | <ul style="list-style-type: none"> <li>• Dual-trace oscilloscope</li> <li>• VSOP assembly • IC401 (PA5010) pin 42 and pin 40</li> <li>• LD test disc Chap. #11</li> <li>• VSOP assembly VR401</li> </ul> |
|--|--|

Connection diagrams

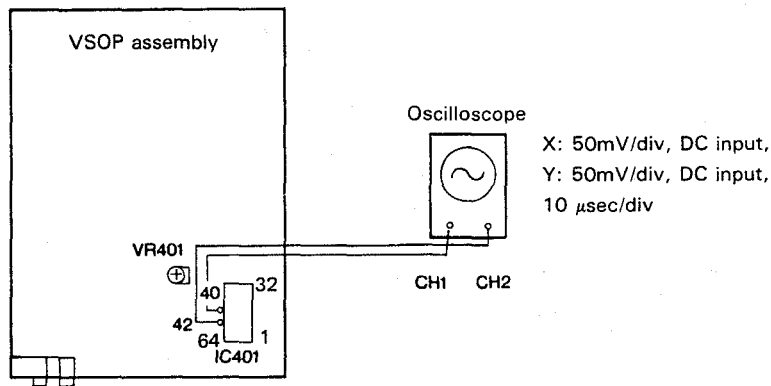

Adjustment Procedure

1. Play an LD test disc, and search Chap. #11.
2. Connect the oscilloscope X input (CH-1) to pin 40 of IC401 (PA5010) on the VSOP assembly, and the Y input (CH-2) to pin 42. Observe the main video signal and the 1H delayed video signal waveforms simultaneously.
3. Adjust VR401 on the VSOP assembly until the amplitude from the synk tip to the white level in the 1H delayed video signal (CH-2) is the same as the amplitude of the main video signal (CH-1). (Photo 18.)

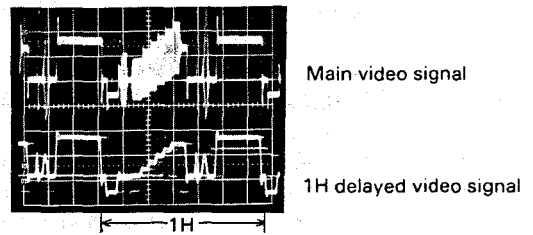

Photo 18

5. VCO CENTER FREQUENCY ADJUSTMENT

9.5 VSOP (VDEM, ADEM) Assembly Adjustments

- Purpose: Optimization of the CCD delay time for time base error compensation purposes.
- Symptoms indicating need for adjustment: Color lock failure. Slow color lock after a search.

- |  |   |
|--|---|
| <ul style="list-style-type: none"> <li>• Measuring instruments and jigs</li> <li>• Measuring position</li> <li>• Test disc and player mode</li> <li>• Adjustment position</li> </ul> | <ul style="list-style-type: none"> <li>• Dual-trace oscilloscope</li> <li>• VSOP assembly Q412 emitter and Q413 emitter</li> <li>• LD test disc Chap. #11</li> <li>• VSOP assembly VR402</li> </ul> |
|--|---|

Connection diagrams

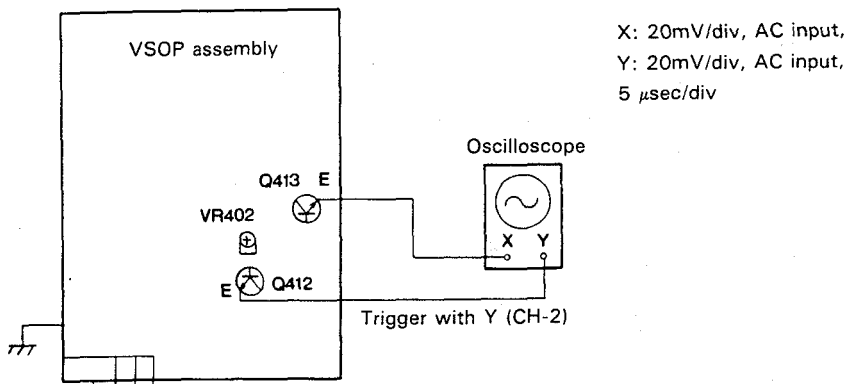

Adjustment Procedure

1. Play an LD test disc, and search to Chap. #11
2. Connect the oscilloscope X input (CH-1) to the emitter of Q413 on the VSOP assembly, and the Y input (CH-2) to the emitter of Q412. Trigger with CH-2, and observe the video signal waveforms before and after time base error compensation simultaneously.
3. The video signal of following time base error compensation in CH-1 contains jitter. Adjust VR402 on the VSOP assembly to delay the center of that jitter by 68 μsec (1H + 4 μsec) from the trailing edge of the horizontal synchronizing signal (H-sync) in the video signal prior to time base error compensation at CH-2. (Photo 19.)

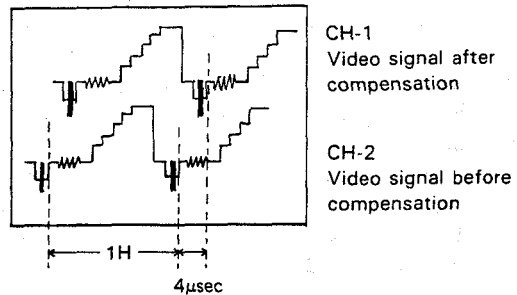

Photo 19

6. DECODER CLOCK ADJUSTMENT

9.5 VSOP (TBC-CONT) Assembly Adjustments

- Purpose: Adjustment the standard clock frequency.

- |  |   |
|--|---|
| <ul style="list-style-type: none"> <li>• Measuring instruments and jigs</li> <li>• Measuring position</li> <li>• Test disc and player mode</li> <li>• Adjustment position</li> </ul> | <ul style="list-style-type: none"> <li>• Frequency counter</li> <li>• VSOP assembly IC10 (PD0011) pin 3</li> <li>• Switch power ON. • Set to test mode.</li> <li>• VSOP assembly VC2</li> </ul> |
|--|---|

Connection diagrams

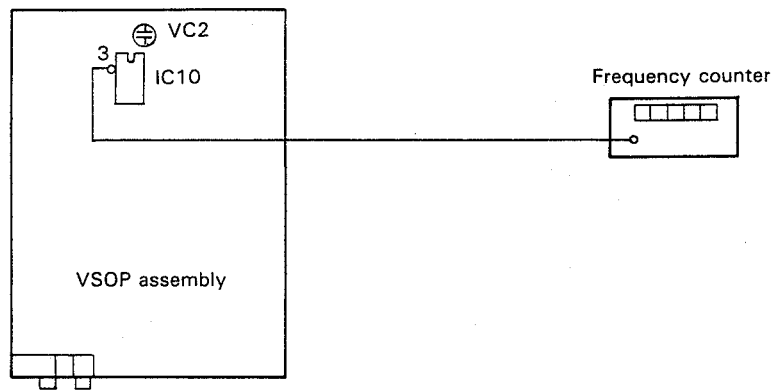

Adjustment Procedure

1. Turn power ON.
2. Connect the frequency counter to pin 3 of IC10.
3. After switching to test mode, press the following keys on the remote control: **CX** + **4**.  
+
- \* This causes a continuous DOC INH signal to be generated.
4. Adjust so that the frequency of the signal from pin 3 of IC10 is 3.0MHz ±50kHz with VC2.

7. OUTPUT VIDEO LEVEL ADJUSTMENT

9.5 VSOP (VDEM, ADEM) Assembly Adjustments

- Purpose: Adjustment of the amplitude of the output video signal (pedestal ↔ 100% white) to 0.71Vp-p.
- Symptoms indicating need for adjustment: Replay started from intermediate position due to misreading data. Screen too bright or too dark.

- |  |   |
|--|---|
| <ul style="list-style-type: none"> <li>• Measuring instruments and jigs</li> <li>• Measuring position</li> <li>• Test disc and player mode</li> <li>• Adjustment position</li> </ul> | <ul style="list-style-type: none"> <li>• Oscilloscope</li> <li>• Video output terminals</li> <li>• LD test disc Chap. #11</li> <li>• VSOP assembly VR403</li> </ul> |
|--|---|

Connection diagrams

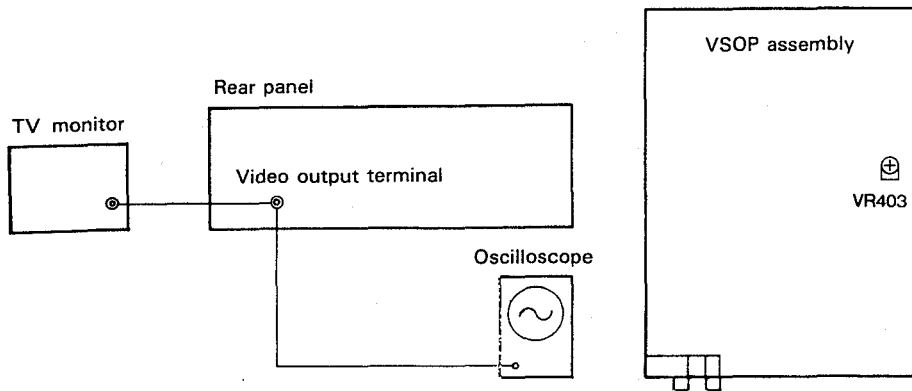

Adjustment Procedure

*Note: Connect the player video output terminal to a video monitor, and terminate the monitor internally with 75 ohms. If using a TV set with no video input terminal, terminate the player video output terminal with 75 ohms.*

1. Play an LD test disc and search to Chap. #11
2. Connect the oscilloscope to the player video output terminal, and observe the playback video signal waveform.
3. Adjust VR403 on the VSOP assembly until the amplitude from the pedestal level to the white level of the playback video signal waveform reaches  $0.71V \pm 5\%$ . (Photo 20.)

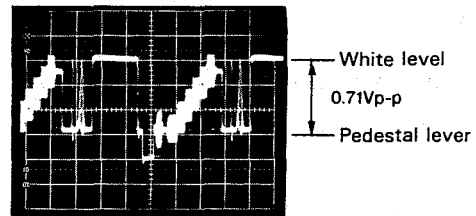



**8.COLOR PHASE ERROR SIGNAL LEVEL ADJUSTMENT 9.5 VSOP (VDEM, ADEM) Assembly Adjustments**

- Purpose: Optimization of the amount of color phase error signal to be applied to the color phase compensation stage.
- Symptoms indicating need for adjustment: Conspicuous color irregularities

- |  |   |
|--|---|
| <ul style="list-style-type: none"> <li>• Measuring instruments and jigs</li> <li>• Measuring position</li> <li>• Test disc and player mode</li> <li>• Adjustment position</li> </ul> | <ul style="list-style-type: none"> <li>• TV monitor</li> <li>• Adjust while watching the monitor screen.</li> <li>• LD test disc Chap. # 14</li> <li>• VSOP assembly VR406</li> </ul> |
|--|---|

**Connection diagrams**

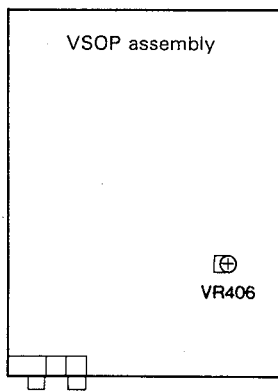

**Adjustment Procedure**

1. Play an LD test disc and search to Chap. # 14
2. Adjust VR406 on the VSOP assembly to minimize magenta screen color irregularities.

## 9. DETECTOR LEVEL ADJUSTMENT

## 9.5 VSOP (VDEM, ADEM) Assembly Adjustments

- Purpose: Optimization of the input voltage applied to the spindle motor speed detector comparator.
- Symptoms indicating need for adjustment: Spindle servo lock failure. Picture aberration.

- |  |  |
|--|--|
| <ul style="list-style-type: none"> <li>• Measuring instruments and jigs</li> <li>• Measuring position</li> <li>• Test disc and player mode</li> <li>• Adjustment position</li> </ul> | <ul style="list-style-type: none"> <li>• Digital voltmeter</li> <li>• VSOP assembly IC403 (NJM2903S) pins 6 and 7</li> <li>• Test disc #3,001</li> <li>• VSOP assembly (VDEM, ADEM) VR405</li> </ul> |
|--|--|

## Connection diagrams

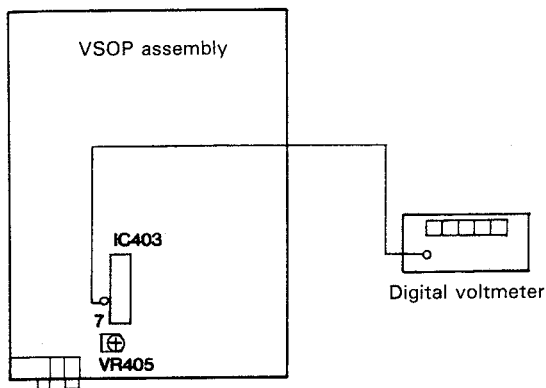

## Adjustment Procedure

1. Play an LD test disc and search to frame #3,001.
2. Connect the digital voltmeter to pin 7 of IC403 (NJM2903S) on the VSOP assembly. Measure and record the reference voltage of the spindle motor speed detector comparator.
3. Also connect the digital voltmeter to pin 6 of the same IC and measure the speed detector output voltage. Adjust VR405 on the VSOP assembly to obtain a voltage  $+260\text{mV} \pm 20\text{mV}$  higher at pin 6 than at pin 7.

9.6 2FSB ASSEMBLY ADJUSTMENTS

1. VCXO FREE-RUN FREQUENCY ADJUSTMENT

9.6 2FSB Assembly Adjustments

- Purpose: Adjustment of the frequency of the crystal generator used in the EFM decoder to the optimum value

- |   |   |
|---|---|
| <ul style="list-style-type: none"> <li>• Measuring instruments and jigs:</li> <li>• Measuring position</li> <li>• Test disc and player mode</li> <li>• Adjustment position</li> </ul> | <ul style="list-style-type: none"> <li>• Frequency counter</li> <li>• 2FSB assembly R137 lead wire</li> <li>• CD test disc — play any track</li> <li>• 2FSB assembly VR501</li> </ul> |
|---|---|

Connection diagrams

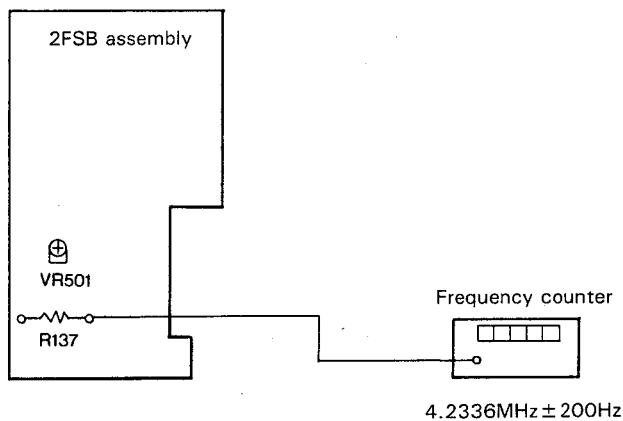

Adjustment procedure

1. Play any track of the CD test disc.
2. Connect the frequency counter to the lead wire of R137 on the 2FSB assembly and observe the VCXO free-run frequency.
3. Set the frequency to  $4.2336\text{MHz} \pm 200\text{Hz}$  by adjusting VR501 on the 2FSB assembly.

## 2. PLL FREE-RUN FREQUENCY ADJUSTMENT

## 9.6 2FSB Assembly Adjustments

- Purpose: Adjustment of the free-run frequency of the PLL VCO used in the EFM decoder to the optimum value
- Symptoms indicating need for adjustment: No digital sound, or intermittent digital sound

- |   |  |
|---|--|
| <ul style="list-style-type: none"> <li>• Measuring instruments and jigs:</li> <li>• Measuring position</li> <li>• Test disc and player mode</li> <li>• Adjustment position</li> </ul> | <ul style="list-style-type: none"> <li>• Digital voltmeter</li> <li>• 2FSB assembly IC102 (NJM082D) pin 1</li> <li>• LaserVision disc with digital sound (LDD) disc hereafter — play any frame</li> <li>• 2FSB assembly VL101</li> </ul> |
|---|--|

## Connection diagrams

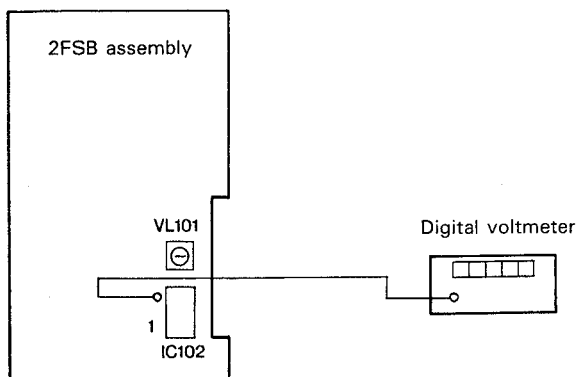

## Adjustment procedure

1. Play any frame of the LDD disc.
2. Connect the digital voltmeter to pin 1 of IC102 on the 2FSB assembly and measure the DC voltage of the VCO control signal.
3. Set the DC voltage of the VCO controller signal to  $150\text{mV} \pm 100\text{mV}$  by adjusting VL101 on the 2FSB assembly.

3. VCXO OFFSET ADJUSTMENT

9.6 2FSB Assembly Adjustments

- Purpose: Minimize the VCXO PLL phase error offset voltage
- Symptoms indicating need for adjustment: Intermittent output of digital sound during LDD playback (output of synchronous noise)

- |   |  |
|---|--|
| <ul style="list-style-type: none"> <li>• Measuring instruments and jigs:</li> <li>• Measuring position</li> <li>• Test disc and player mode</li> <li>• Adjustment position</li> </ul> | <ul style="list-style-type: none"> <li>• Oscilloscope</li> <li>• 2FSB assembly J170 (MDP)</li> <li>• LDD disc — play any frame</li> <li>• 2FSB assembly VR102</li> </ul> |
|---|--|

Connection diagrams

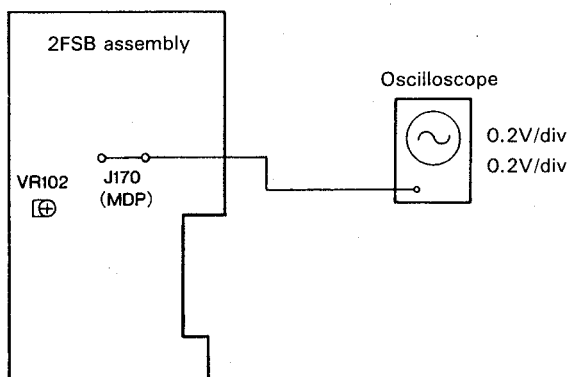

Adjustment procedure

1. Play any frame of the LDD disc.
2. Connect the oscilloscope to jumper lead J170 (MDP) on the 2FSB assembly and observe the VCXO PLL phase error output signal.
3. Adjust VR102 on the 2FSB assembly to minimize the pulse width on the positive or negative side and obtain a continuous waveform. (Center waveform in Photo 23.)

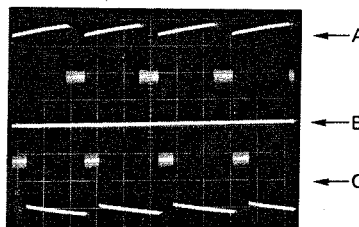

Photo 23

- A Waveform obtained when VR102 is turned clockwise from the position of optimum adjustment.
- B Optimum adjustment
- C Waveform obtained when VR102 is turned counter clockwise from the position of optimum adjustment.

## 8. REMPLACEMENT DU SOUS-ENSEMBLE CAPTEUR

### 8.1 REMPLACEMENT DU SOUS-ENSEMBLE CAPTEUR

1. Déposer le coffret et la plaque de fond. (Fig. 1)

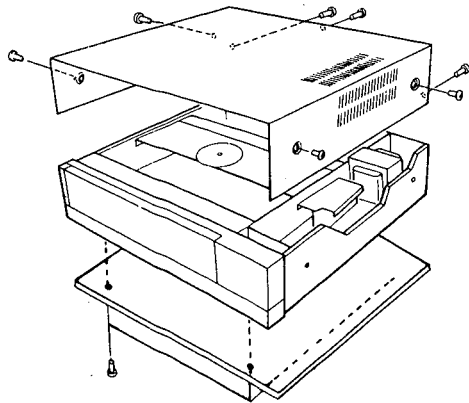

Fig. 1

2. Mettre l'appareil sous tension et appuyer sur la touche OPEN/CLOSE pour éjecter le plateau porte-disque. Mettre l'appareil hors tension.

3. Amener le sous-ensemble capteur dans la position illustrée par la figure 2.

*Note: Plutôt que de manoeuvrer le moteur de déplacement à la main, il est préférable de brancher une pile de 1,5 V aux bornes de ce moteur.*

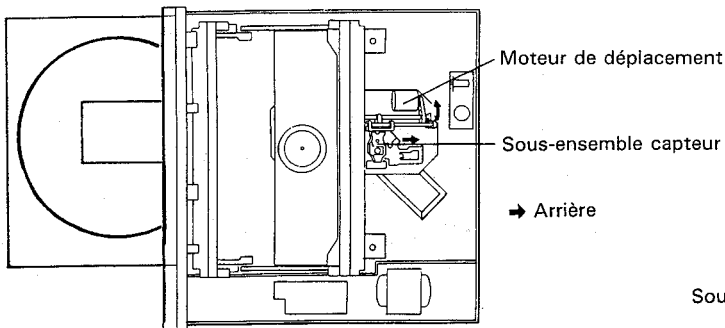

Fig. 2

4. Placer l'appareil sur le côté, le transformateur d'alimentation étant à la partie inférieure. Retirer les quatre vis du sous-ensemble VSOP et les deux vis du panneau arrière.

Ouvrir le sous-ensemble VSOP et débrancher CN33 du sous-ensemble 2FSB. (Fig. 3)

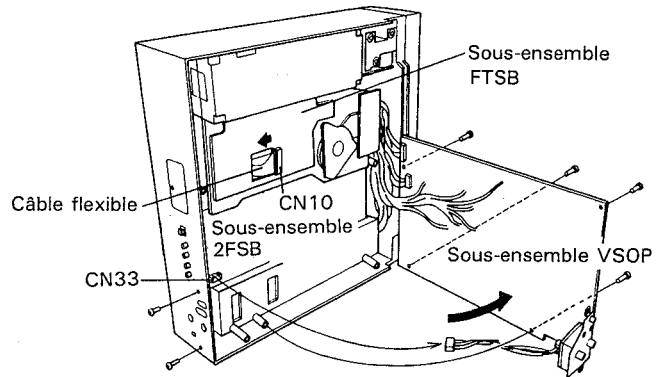

Fig. 3

5. Libérer le verrouillage de CN10, sur le sous-ensemble FTSB et retirer avec précaution le câble flexible. Eviter d'endommager le câble et d'appliquer une charge électrostatique sur la diode laser. Ne toucher, sous aucun prétexte, aux conducteurs du câble.

6. Retirer la vis qui maintient le capteur en procédant par le dessus et déposer avec précaution le sous-ensemble capteur. (Fig. 4)

*Note: Ne pas toucher les points de soudure qui se trouvent sur le sous-ensemble capteur.*

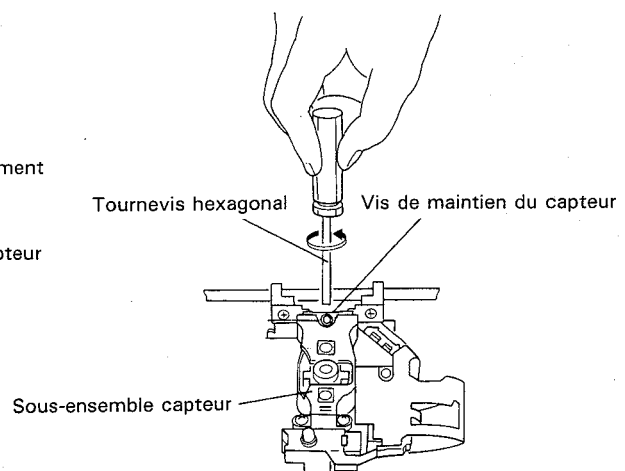

Fig. 4

7. Mettre en place un nouveau sous-ensemble capteur, serrer la vis de maintien, rebrancher soigneusement le câble sur CN10 et assurer son verrouillage. Cela constitue la dernière opération du remplacement du sous-ensemble capteur.

*Note: Après avoir remplacé le sous-ensemble capteur, vérifier le centrage du moteur de rotation. (Se reporter page 83.)*

## 8.2 DÉPOSE DU PLATEAU PORTE-DISQUE

### 8.2.1 Procédure de dépose

1. Déposer le coffret. (Fig. 1)
2. Mettre l'appareil sous tension et appuyer sur la touche OPEN/CLOSE pour éjecter le plateau porte-disque. Mettre l'appareil hors tension et repousser le plateau porte-disque d'environ 5 cm.
3. Extraire le rivet en le tirant vers le haut et retirer le ressort interrupteur. (Fig. 5)

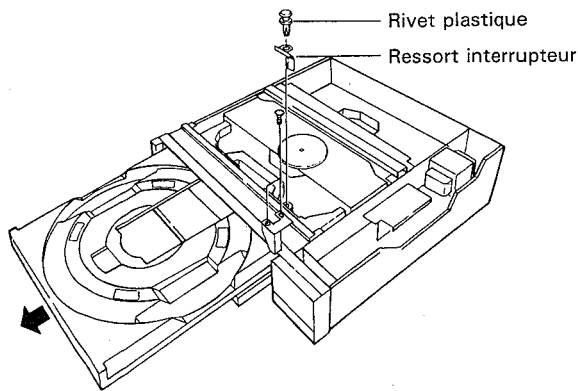

Fig.5

4. Retirer la vis pour déposer la plaquette d'arrêt. (Fig. 5)
5. Déposer le plateau porte-disque en le tirant doucement vers l'avant.

### 8.2.2 Méthode pour saisir un disque lorsque le plateau est déposé

1. Introduire un disque par l'arrière et le placer sur la platine tourne-disque.

*Note: Veiller à ce que la graisse qui se trouve sur les rails ne souille pas la surface du disque.*

2. Tirer les leviers de blocage (G) et (D) vers l'arrière et l'extérieur; le verrou s'abaisse et saisit le disque. S'assurer que le disque est correctement maintenu en tournant le verrou à la main. (Fig. 6)

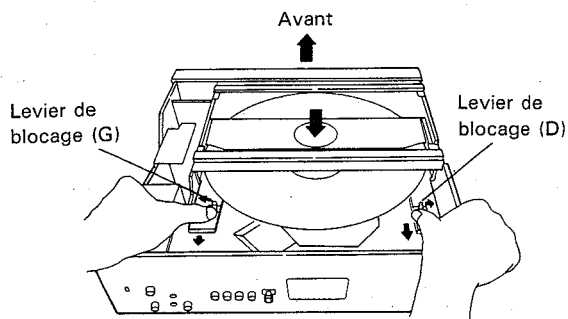

Fig.6

### 8.2.3 Méthode pour lire un disque lorsque le plateau est déposé

1. Mettre l'appareil sous tension tout en appuyant sur l'interrupteur du moteur de déplacement puis immédiatement après cela, appuyer sur la touche de lecture. Relâcher l'interrupteur du moteur de déplacement dès que le disque commence à tourner. (Fig. 7)

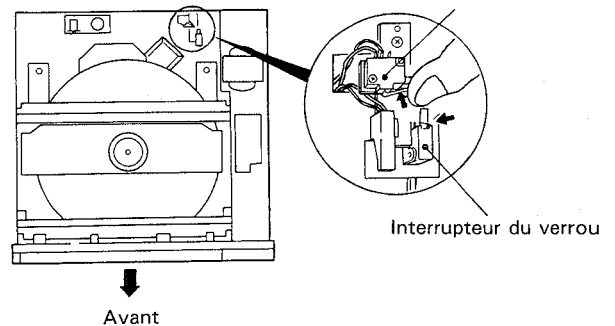

Fig.7

### 8.2.4 Déplacement du plateau porte-disque

1. Introduire le plateau porte-disque après avoir engagé la première dent de sa crémaillère dans l'encoche pratiquée sur l'engrenage. (Fig. 8)
2. Poser le rivet, le ressort d'interrupteur et la plaquette d'arrêt qui ont été déposés en 8.2.1

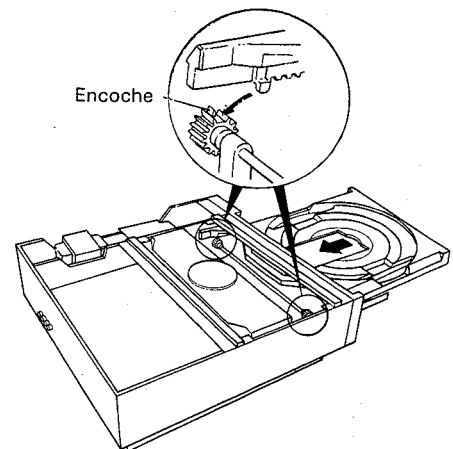

Fig.8

## 9. REGLAGES

### 9.1 OUTILLAGE ET INSTRUMENTS REQUIS POUR LES RÉGLAGES

- Un petit tournevis (longueur: environ 7 cm)
- Un petit tournevis cruciforme (longueur: au moins 15 cm)
- Deux tournevis hexagonaux (2,00 mm et 2,5 mm)
- Une clé en L (GGV-129)
- Une pile de 1,5 V et deux conducteurs
- Un filtre passe-bas (100Ωk + 1μF)
- Un oscilloscope double trace (avec ligne à retard)
- Un générateur basse fréquence
- Un fréquencemètre
- Un disque d'essai LD J1
- Un disque LDD (approvisionné localement)
- Un disque d'essai CD (YEDS-7)
- Des pinces pour court-circuit
- Un voltmètre digital

### 9.2 PRÉPARATION DES RÉGLAGES ET PRÉCAUTIONS

#### 1. Etat du lecteur

Pour la plupart des réglages, le lecteur est placé sur un côté, le transformateur d'alimentation étant à la partie supérieure et le sous-ensemble VSOP est ouvert. Le connecteur CN33 du sous-ensemble 2FSB peut également être débranché.

#### 2. Pour empêcher que le disque ne soit saisi deux fois

Lorsque le plateau porte-disque est en place, le disque est saisi deux fois.

Si cela est réalisé alors que le lecteur est posé sur le côté pour permettre les réglages, le disque s'échappe de la platine tourne-disque. En conséquence, relier la borne 3 (isolant blanc) et la borne 4 (isolant blanc) de CN22 du sous-ensemble VSOP de manière que le disque ne soit saisi qu'une seule fois.

#### 3. Ouverture de la boucle d'asservissement de poursuite

La boucle d'asservissement de poursuite peut être ouverte et fermée pendant le mode d'essai commandé par le microcalculateur.

##### — Accès au mode d'essai —

- 1) Mettre l'appareil hors tension.
- 2) Rechercher la résistance de 10 k qui relie la borne 24 de IC5 (CDX1095Q) et la ligne + 5V sur le sous-ensemble VSOP. Relier le conducteur de la résistance qui se trouve du côté de IC5 à la masse.

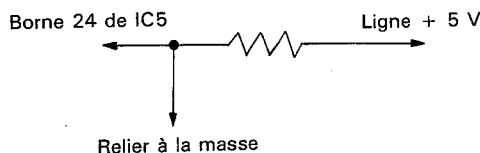

- 3) Mettre l'appareil sous tension et s'assurer que la totalité du tube fluorescent de l'affichage s'éclaire.

*Notes: 1. Le lecteur peut être employé comme à l'accoutumée lorsqu'il est en mode d'essai.*

2. *Après être passé en mode d'essai, la mise à la masse dont il a été question en 2) peut être supprimée sans que cela ait un effet sur le mode de fonctionnement.*
3. *Dans le mode d'essai, la rotation du disque est arrêtée mais le disque n'est pas éjecté lorsque l'on appuie sur la touche EJECT.*
4. *Le fonctionnement normal du tube fluorescent peut être restauré en appuyant une fois sur [CX] + [0]. Une seconde pression met la totalité l'affichage en service.*

##### — Ouverture et fermeture de la boucle d'asservissement de poursuite —

La boucle d'asservissement de poursuite est ouverte en appuyant continuellement sur [CX] + [3] sur la télécommande. La boucle est fermée en appuyant une nouvelle fois sur [CX] + [3]. (La boucle est ouverte et fermée à chaque pression sur [CX] + [3]).

##### — Pour quitter le mode d'essai —

Il est possible de quitter le mode d'essai en mettant l'appareil hors tension ou en appuyant sur [CX] + [9] sur la télécommande.



#### 4. Réglage du réseau optique

Le réseau optique peut être réglé de deux manières différentes.

— **Réglage tandis que le lecteur est posé sur le côté** —  
Poser le lecteur sur le côté comme le montre la figure 3. Le réseau optique peut être réglé en introduisant un petit tournevis dans l'espace entre le sous-ensemble mécanique et le sous-ensemble 2FSB. (Fig. 9 et 10)

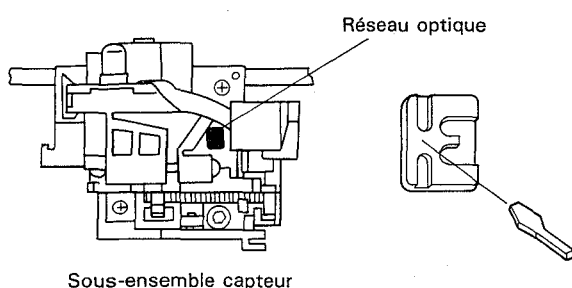

Emplacement du réseau optique

Fig.9

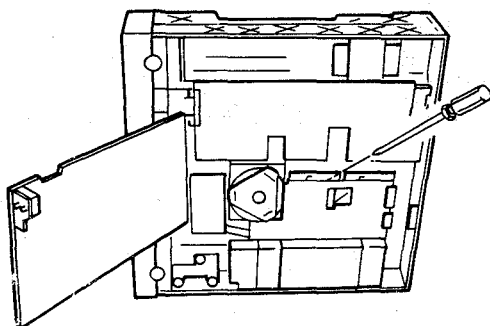

Emplacement où doit être introduit le tournevis

Fig.10

— **Réglage tandis que le lecteur est posé à plat** —  
Introduire, comme le montre la figure 11, un petit tournevis dans le trou de réglage du réseau optique en le glissant entre les deux guides du sous-ensemble capteur (Fig. 12).

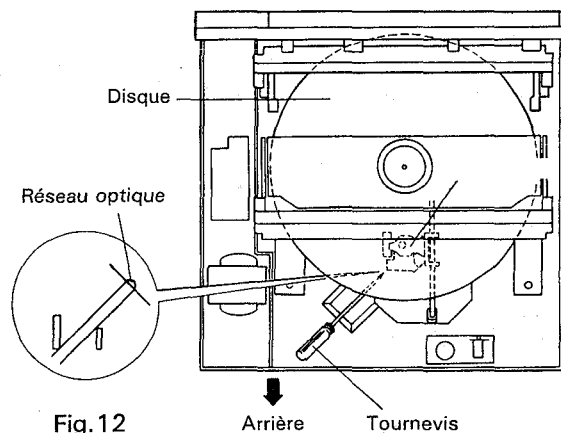

Fig.11

5. Sauf indication contraire, les valeurs lues sur l'oscilloscope sont obtenues avec une sonde 10:1.

### 9.3 RÉGLAGES MÉCANIQUES

#### 1. RÉGLAGE GROSSIER DU RÉSEAU OPTIQUE

#### 9.3 Réglages mécaniques

- Buts: régler le réseau optique pour que les trois faisceaux laser soient positionnés au mieux. Régler la tension d'erreur de l'asservissement de poursuite (TRKG) à la valeur 0 V.
- Symptômes d'un défaut de réglage: les disques ne peuvent pas être lus et le capteur saute les plages.

- |   |  |
|---|--|
| <ul style="list-style-type: none"> <li>• Appareils de mesures et outillage</li> <li>• Point de mesure</li> <li>• Disque d'essai et mode de fonctionnement du lecteur</li> <li>• Point de réglage</li> </ul> | <ul style="list-style-type: none"> <li>• Tournevis • Oscilloscope</li> <li>• Borne CN102-3 (erreur de poursuite) sur le sous-ensemble FTSB</li> <li>• Disque LD d'essai, image numéro 17.000 • Mode d'essai (asservissement de poursuite ouvert)</li> <li>• Réseau optique * VR6 du sous-ensemble FTSB (équilibrage de poursuite)</li> </ul> |
|---|--|

#### Schéma de raccordement

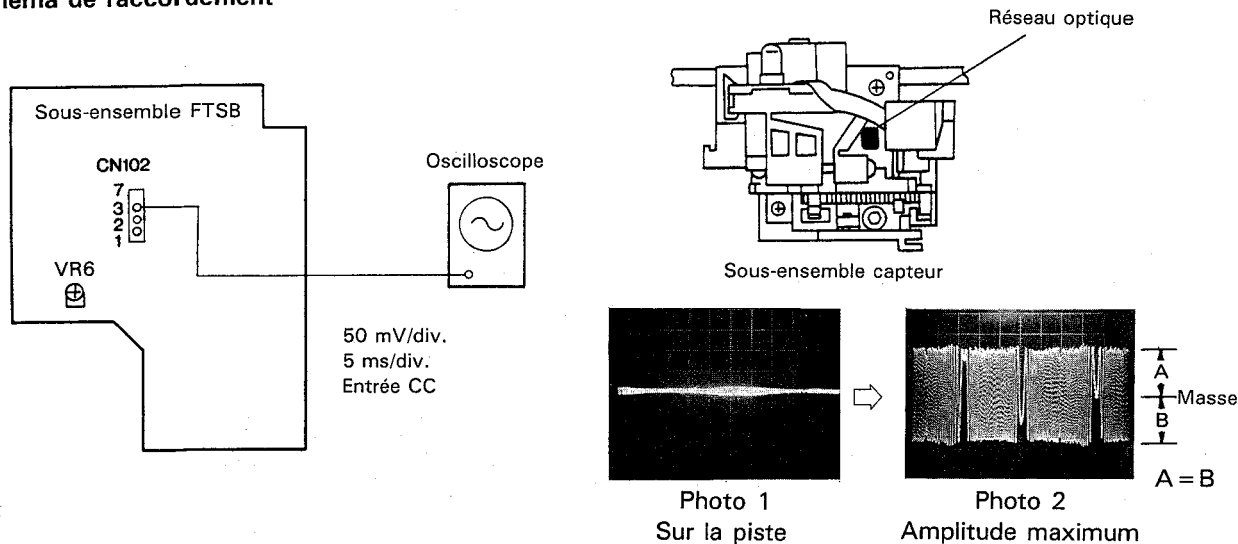

#### Pcédure de réglage

<Réglage grossier du réseau >

1. Lire le disque LD d'essai.
2. Appuyer sur la touche DISPLAY pour afficher le numéro de l'image sur le téléviseur.
3. Déplacer, par balayage ou recherche, le capteur jusqu'à l'image numéro 17.000.
4. Ouvrir la boucle d'asservissement de poursuite (voir page 80).
5. Brancher l'oscilloscope sur CN102-3 du sous-ensemble FTSB et observer l'allure de la trace.
6. Introduire un petit tournevis dans le trou de réglage du réseau (voir page 81) et manoeuvrer le tournevis de sorte que l'amplitude du signal d'erreur de poursuite augmente puis diminue alternativement. Rechercher la position pour laquelle l'amplitude est minimum et son enveloppe régulière (voir la photo 1). (Dans ces conditions, les trois faisceaux laser sont dirigés sur une seule piste. C'est la position "sur la piste".)

7. Tourner doucement le réseau optique dans le sens contraire des aiguilles d'une montre à partir de la position "sur la piste" jusqu'à ce que l'amplitude de l'erreur de poursuite devienne maximum (voir photo 2).
  8. Fermer la boucle d'asservissement de poursuite et s'assurer que l'image fournie par le téléviseur est normale.
- <Réglage de l'équilibrage de poursuite >
1. Amener la trace de la masse de l'oscilloscope au centre de l'écran.
  2. Régler VR6 du sous-ensemble FTSB de manière que les alternances positives et négatives de l'erreur de poursuite soient égales (voir photo 2).

2. VÉRIFICATION DU CENTRAGE DU MOTEUR DE ROTATION

9.3 Réglages mécaniques

- But: vérifier que le moteur est centré par rapport au lieu des points balayés par le faisceau laser.

- |   |  |
|---|--|
| <ul style="list-style-type: none"> <li>• Appareils de mesures et outillage</li> <li>• Point de mesure</li> <li>• Disque d'essai et mode de fonctionnement du lecteur</li> <li>• Point de réglage</li> </ul> | <ul style="list-style-type: none"> <li>• Oscilloscope</li> <li>• CN102-3 (erreur de poursuite) et CN102-7 (somme de poursuite) du sous-ensemble FTSB</li> <li>• Disque CD d'essai • Mode d'essai (asservissement de poursuite ouvert)</li> <li>• Vérification de la figure de Lissajous</li> </ul> |
|---|--|

Schéma de raccordement

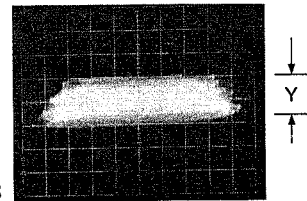
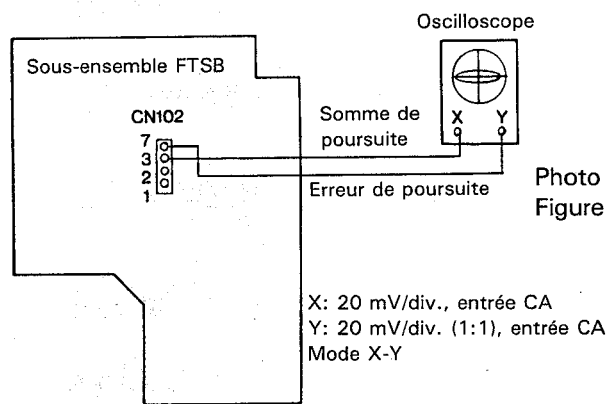

Photo 3  
Figure de Lissajous sur la piste intérieure du disque

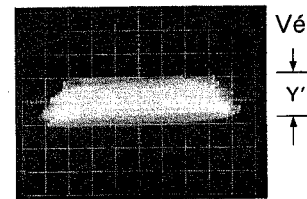

Photo 4  
Figure de Lissajous sur la piste extérieure du disque

Procédure de réglage

1. Lire le disque CD d'essai.
2. Déplacer, par balayage ou recherche, le capteur jusqu'à une piste proche du centre puis ouvrir la boucle d'asservissement de poursuite.
3. Brancher l'entrée X (CH-1) de l'oscilloscope sur CN102-3 du sous-ensemble FTSB et l'entrée Y (CH-2) sur CN102-7 de ce même sous-ensemble. Régler l'oscilloscope en mode X-Y et observer les figures de Lissajous fournies par les signaux d'erreur et de somme de poursuite.
4. Noter l'amplitude des figures de Lissajous sur l'axe des Y.
5. Fermer la boucle d'asservissement de poursuite et déplacer, par balayage ou recherche, le capteur jusqu'à une piste proche du bord extérieur.

S'assurer que l'amplitude des figures de Lissajous sur l'axe des Y est la même que celle notée en 4. Dans le cas contraire, procéder au centrage du moteur de rotation.

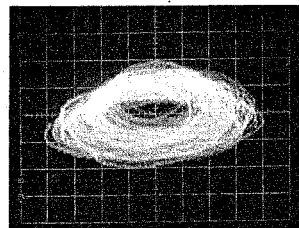

Figure de Lissajous indiquant qu'un réglage est nécessaire

Photo 5

## 3. CENTRAGE DU MOTEUR DE ROTATION

## 9.3 Réglages mécaniques

- But: placer le moteur au centre du lieu des points balayés par le faisceau laser.
- Symptômes d'un défaut de réglage: saut de piste et recherche anormalement longue.

- |   |   |
|---|---|
| <ul style="list-style-type: none"> <li>• Appareils de mesures et outillage</li> <li>• Point de mesure</li> <li>• Disque d'essai et mode de fonctionnement du lecteur</li> <li>• Point de réglage</li> </ul> | <ul style="list-style-type: none"> <li>• Clé en L (GGV-129) • Tournevis hexagonal de 2,5 mm • Oscilloscope</li> <li>• CN102-3 (erreur de poursuite) et CN102-7 (somme de poursuite) du sous-ensemble FTSB</li> <li>• Disque CD d'essai • Mode d'essai (asservissement de poursuite ouvert/fermé)</li> <li>• Trou de réglage du centre du moteur de rotation • Réseau optique</li> </ul> |
|---|---|

## Schéma de raccordement

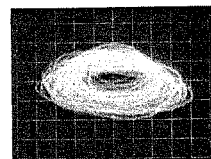
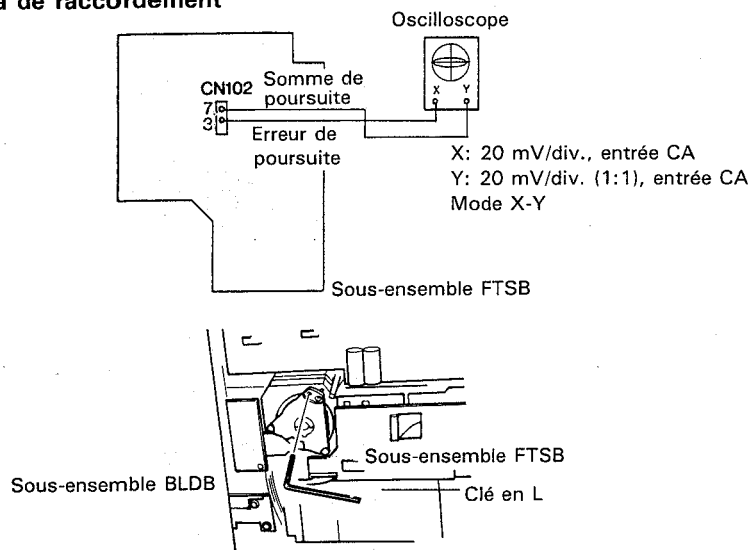

Photo 6

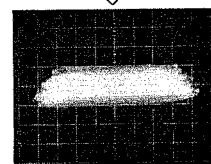

Photo 7

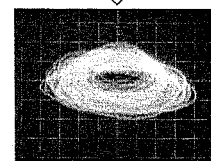

Photo 8

## Procédure de réglage

*Note: Ce réglage ne sera entrepris que s'il apparaît nécessaire à la suite de la vérification du centrage du moteur de rotation.*

- Desserrer les trois vis de fixation du moteur en tournant chacune d'un demitour.
- Brancher l'entrée X (CH-1) de l'oscilloscope sur CN102-3 du sous-ensemble FTSB et l'entrée Y (CH-2) sur CN102-7 de ce même sous-ensemble.
- Lire le disque CD d'essai. Déplacer, par balayage ou recherche, le capteur jusqu'à une piste proche du bord extérieur.
- Ouvrir la boucle d'asservissement de poursuite et observer les figures de Lissajous fournies par les signaux d'erreur et de somme de poursuite.
- Régler doucement le réseau optique de sorte que l'amplitude de ces figures sur l'axe des Y soit maximum (voir photo 7).
- Fermer la boucle d'asservissement de poursuite et déplacer, par balayage ou recherche, le capteur jusqu'à une piste proche du centre.
- Ouvrir la boucle d'asservissement de poursuite et observer les figures de Lissajous. Noter leur amplitude sur l'axe des Y.
- Introduire la clé en L dans le trou de réglage et la tourner lentement dans la direction telle que l'amplitude des figures de Lissajous sur l'axe des Y diminue. Le minimum étant atteint, tourner la clé en L dans le même sens pour obtenir à nouveau une amplitude égale à celle notée en 7 (voir photos 6 à 8).
- Fermer la boucle d'asservissement de poursuite et déplacer à nouveau le capteur jusqu'à une piste proche du bord extérieur.
- Répéter les opérations 4, 5 et 6.
- Ouvrir la boucle d'asservissement de poursuite et observer les figures de Lissajous. Vérifier que l'amplitude le long de l'axe des Y est minimum. Dans le cas contraire, répéter les opérations 8 à 11.

## 4. Réglage de l'inclinaison du capteur

## 9.3 Réglages mécaniques

- But: régler l'inclinaison de l'axe de déplacement de manière que le sous-ensemble capteur se déplace parallèlement à la surface du disque et régler l'inclinaison du sous-ensemble capteur de façon que le faisceau laser soit perpendiculaire à la surface du disque.

- Symptômes d'un défaut de réglage: diaphonie.

- Appareils de mesures et outillage
- Point de mesure
- Disque d'essai et mode de fonctionnement du lecteur
- Point de réglage

- Oscilloscope
- Pile avec conducteurs
- Filtre passe-bas (FPB)
- Tournevis hexagonal de 2,5 mm
- Borne CN103-5 du sous-ensemble FTSB (mise au point)
- Disque LD d'essai, images numéro 17.222 et 98
- Vis de réglage de l'inclinaison du capteur
- Réglage de l'axe de déplacement par le moteur d'inclinaison

## Schéma de raccordement

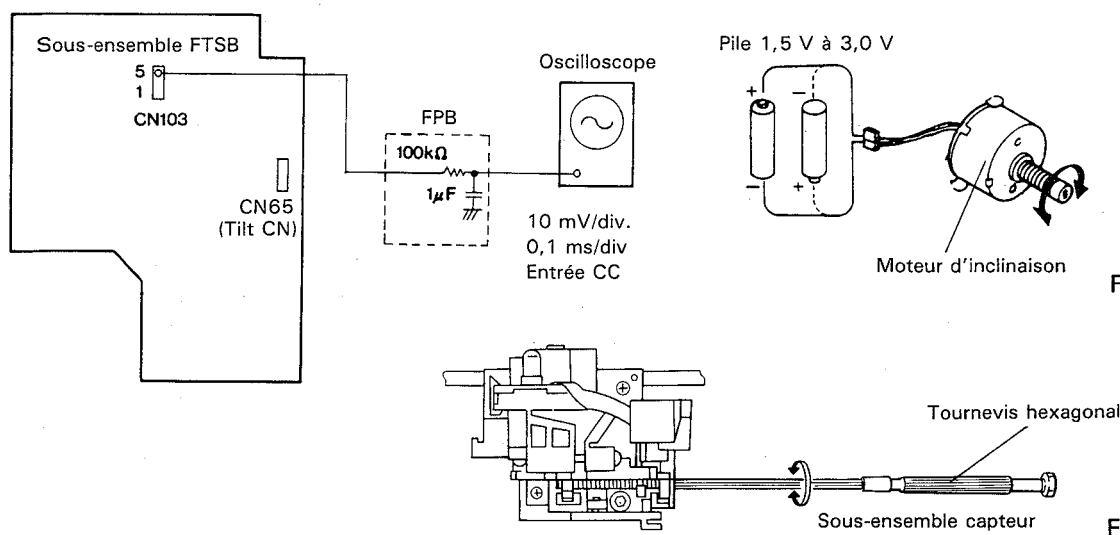

## Procédure de réglage

1. Débrancher le connecteur CN65 (moteur d'inclinaison) du sous-ensemble FTSB et ne pas le rebrancher tant que le réglage de l'angle du capteur d'inclinaison n'est pas terminé.
2. Lire le disque LD d'essai et rechercher l'image numéro 98 qui correspond au pivotement du moteur d'inclinaison.
3. Brancher l'oscilloscope sur la borne CN103-5 du sous-ensemble FTSB à travers un filtre passe-bas et observer la tension de mise au point. Il n'est pas nécessaire d'amener la trace de la masse de l'oscilloscope au centre de l'écran.
4. Tourner le bouton de réglage de la trace sur l'axe des Y de manière à amener la trace de la tension de mise au point au centre de l'écran.
5. Si la tension de mise au point mesurée en 4, diffère de celle mesurée pour l'image numéro 17.222, relier une pile (1,5 V à 3 V) aux bornes du connecteur du moteur et entraîner le moteur jusqu'à ce que la tension de mise au point pour cette image soit égale à celle mesurée en 4 à  $\pm 50$  mV près.
6. Introduire le tournevis hexagonal dans le trou de réglage pratiqué dans le panneau arrière et tourner la vis d'inclinaison du capteur de sorte que la diaphonie sur les bords de l'écran soit minimum.
7. Rechercher l'image numéro 98 et vérifier que la diaphonie est également minimum et à peu près égale sur chaque bord. Si le niveau de diaphonie sur l'écran est trop important, répéter les opérations 6 et 7.

## 5. Réglage de l'équilibrage de l'erreur de mise au point LD

## 9.3 Réglages mécaniques

- But: s'assurer que l'asservissement de mise au point maintient l'objectif à la distance optimum pendant la lecture d'un disque LD.
- Symptômes d'un défaut de réglage: diaphonie.

- |   |   |
|---|---|
| <ul style="list-style-type: none"> <li>• Appareils de mesures et outillage</li> <li>• Point de mesure</li> <li>• Disque d'essai et mode de fonctionnement du lecteur</li> <li>• Point de réglage</li> </ul> | <ul style="list-style-type: none"> <li>• Moniteur</li> <li>• Bornes de sortie vidéo</li> <li>• Disque LD d'essai, image numéro 98</li> <li>• VR2 sur le sous-ensemble FTSB</li> </ul> |
|---|---|

## Schéma de raccordement

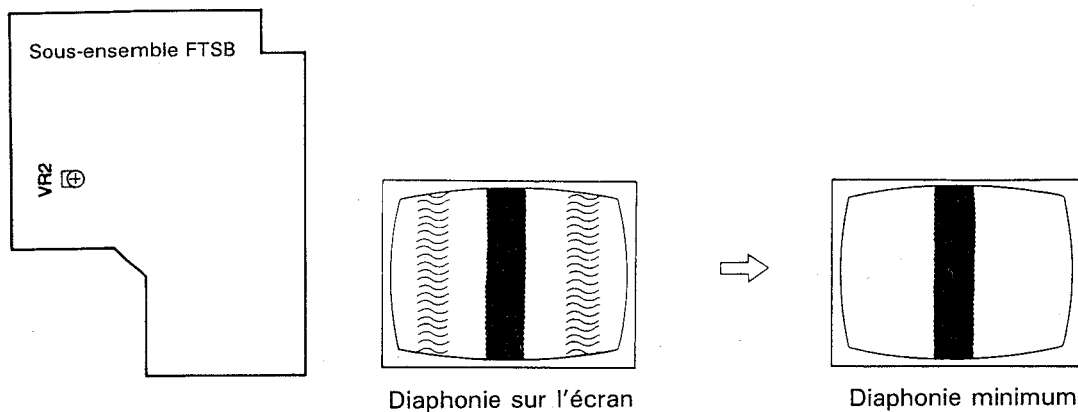

## Procédure de réglage

1. Lire le disque LD d'essai et rechercher l'image 98.
2. Régler VR2 du sous-ensemble FTSB de sorte que la diaphonie sur les bords de l'écran soit minimum. Si ce réglage ne permet pas de réduire à diaphonie à un niveau acceptable, procéder comme il est dit au paragraphe "Réglage de l'angle du capteur dans la direction tangentielle".

## 6. RÉGLAGE DE L'ANGLE DU CAPTEUR DANS LA DIRECTION TANGENTIELLE 9.3 Réglages mécaniques

- But: réglage de l'inclinaison du capteur dans la direction tangentielle de sorte que la diaphonie soit minimum.
- Symptômes d'un défaut de réglage: diaphonie manifeste.

- |   |   |
|---|---|
| <ul style="list-style-type: none"> <li>• Appareils de mesures et outillage</li> <li>• Point de mesure</li> <li>• Disque d'essai et mode de fonctionnement du lecteur</li> <li>• Point de réglage</li> </ul> | <ul style="list-style-type: none"> <li>• Moniteur</li> <li>• Diaphonie sur l'écran</li> <li>• Borne CN102-3 (erreur de poursuite) du sous-ensemble FTSB</li> <li>• Disque LD d'essai, images numéro 17.222 et 98</li> <li>• Mode d'essai (asservissement de poursuite ouvert)</li> <li>• Vis de réglage de l'inclinaison du capteur dans la direction tangentielle</li> </ul> |
|---|---|

Schéma de raccordement (Voir page 82.)

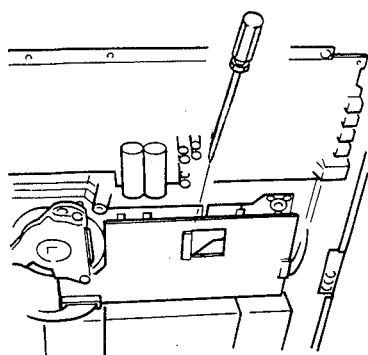

Réglage de l'inclinaison du capteur dans la direction tangentielle

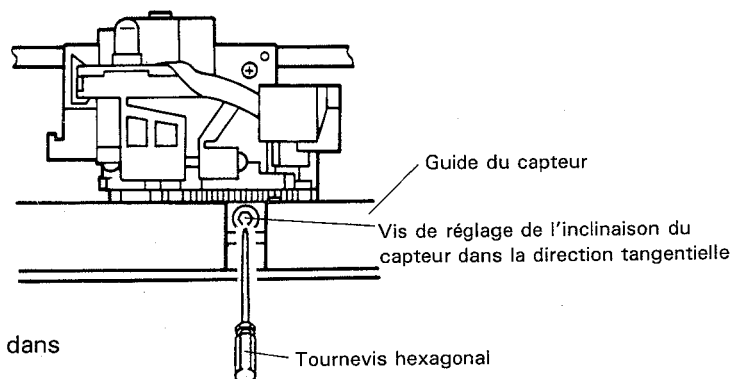

### Procédure de réglage

*Note: Ce réglage ne sera entrepris que s'il apparaît nécessaire à la suite du réglage de l'inclinaison du capteur et du réglage de l'équilibrage de l'erreur de mise au point LD.*

1. Lire le disque LD d'essai, rechercher l'image 17.222 et ouvrir la boucle d'asservissement de poursuite.
2. Brancher l'oscilloscope sur la borne CN102-3 du sous-ensemble FTSB et observer la trace de l'erreur de poursuite.
3. Introduire un tournevis hexagonal entre le sous-ensemble 2FSB et le sous-ensemble mécanique pour atteindre la vis de réglage.
4. Tourner la vis jusqu'à ce que l'amplitude de l'erreur de poursuite soit maximum.
5. Retirer le tournevis hexagonal, rechercher l'image numéro 98 et vérifier que la diaphonie sur les bords de l'écran est minimum et à peu près égale sur chaque bord. Le cas échéant, répéter les opérations 4 et 5.

## 7. RÉGLAGE DU CAPTEUR D'INCLINAISON

## 9.3 Réglages mécaniques

- But: régler la tension d'erreur de l'asservissement d'inclinaison à la valeur de 0 V par le réglage du capteur d'inclinaison
- Symptômes d'un défaut de réglage: diaphonie.

- |   |   |
|---|---|
| <ul style="list-style-type: none"> <li>• Appareils de mesures et outillage</li> <li>• Point de mesure</li> <li>• Disque d'essai et mode de fonctionnement du lecteur</li> <li>• Point de réglage</li> </ul> | <ul style="list-style-type: none"> <li>• Oscilloscope • Tournevis cruciforme</li> <li>• CN103-2 (erreur d'inclinaison) du sous-ensemble FTSB</li> <li>• Disque LD d'essai, images numéro 17.222 et 98 (asservissement de poursuite ouvert)</li> <li>• Vis de réglage du capteur d'inclinaison • VR11 (gain de la boucle d'inclinaison) du sous-ensemble FTSB</li> </ul> |
|---|---|

## Schéma de raccordement

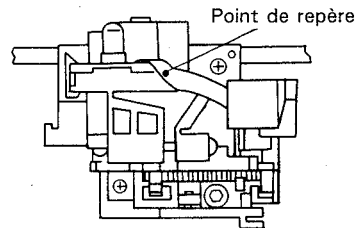
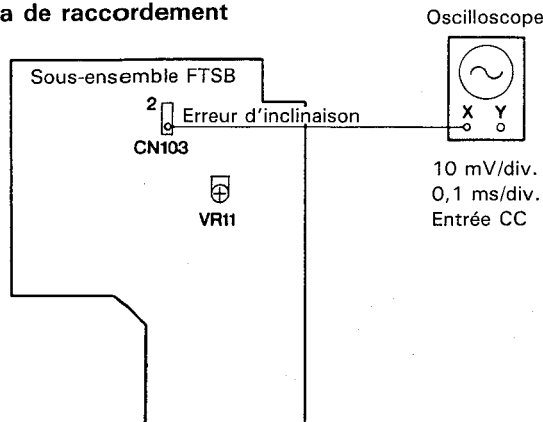
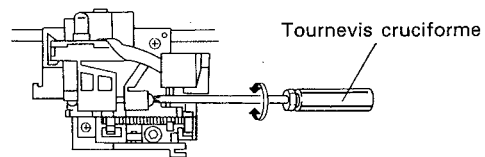

Fig. 1



Réglage du capteur d'inclinaison

Fig. 2

## Procédure de réglage

1. Prendre connaissance de la couleur du point de repère, s'il existe, placé sur le câble flexible, près du capteur d'inclinaison (voir figure 1).

Ce point de repère peut avoir deux couleurs; régler VR11 du sous-ensemble FTSB en fonction des couleurs ou de l'absence de point de repère.

Couleur rouge ... tourner VR11 à fond dans le sens des aiguilles d'une montre.

Couleur bleue ... tourner VR11 à fond dans le sens contraire des aiguilles d'une montre.

Pas de repère ... placer VR11 au centre.

2. Lire le disque LD d'essai et rechercher l'image 17.222.
3. Brancher l'oscilloscope sur CN103-2 du sous-ensemble FTSB et observer la tension d'erreur d'inclinaison.
4. Introduire un tournevis cruciforme muni d'un long axe à travers le panneau arrière et régler la vis du capteur d'inclinaison de sorte que la tension d'erreur (tension

continue) soit nulle (voir figure 2).

Au cours de cette étape, le capteur peut être légèrement déplacé et ne plus se trouver sur l'image indiquée mais cela est sans importance.

5. Brancher le connecteur CN65 du moteur d'inclinaison (ce connecteur a été débranché au cours du réglage de l'inclinaison du capteur).
6. Rechercher l'image numéro 98 et vérifier que la diaphonie sur les bords de l'écran est minimum et à peu près égale sur chaque bord.



## 8. RÉGLAGE FIN DU RÉSEAU OPTIQUE ET VÉRIFICATION DE L'ÉQUILIBRAGE DE POURSUITE

### 9.3 Réglages mécaniques

- Buts: réglage fin du réseau optique afin de s'assurer que les deux faisceaux de l'asservissement de poursuite sont dirigés au mieux vers la piste. Régler la tension d'erreur de la boucle d'asservissement de poursuite à une valeur égale à 0 V.
- Symptômes d'un défaut de réglage: défaut de lecture.

- |   |   |
|---|---|
| <ul style="list-style-type: none"> <li>• Appareils de mesures et outillage</li> <li>• Point de mesure</li> <li>• Disque d'essai et mode de fonctionnement du lecteur</li> <li>• Point de réglage</li> </ul> | <ul style="list-style-type: none"> <li>• Oscilloscope • Tournevis</li> <li>• Borne CN102-3 (erreur de poursuite) et CN102-7 (somme de poursuite) du sous-ensemble FTSB</li> <li>• Disque LD d'essai, image numéro 17.000 Mode d'essai (asservissement de poursuite ouvert)</li> <li>• Réseau optique • VR6 du sous-ensemble FTSB</li> </ul> |
|---|---|

#### Schéma de raccordement

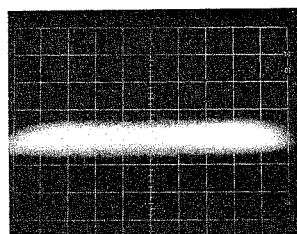
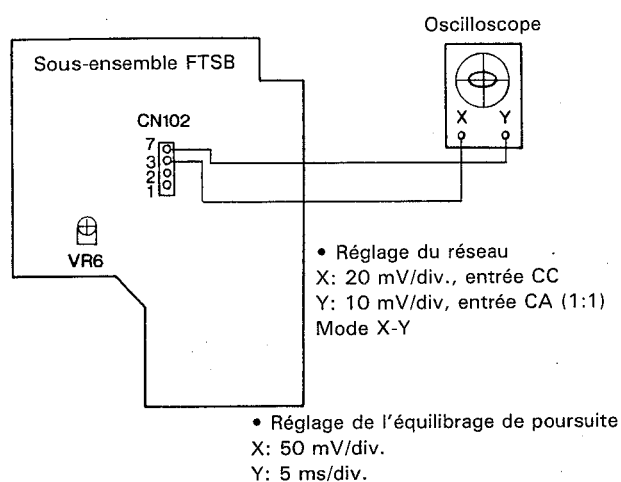

Photo 9  
Réglage fin du réseau optique

Minimum

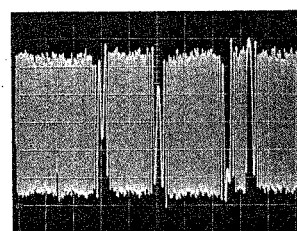

Photo 10  
Réglage de l'équilibrage de poursuite

A  
Masse  
B  
A = B

#### Procédure de réglage

1. Lire le disque LD d'essai, rechercher l'image numéro 17.000 et ouvrir la boucle d'asservissement de poursuite.
2. Brancher l'entrée X (CH-1) de l'oscilloscope sur CN102-3 du sous-ensemble FTSB et l'entrée Y (CH-2) sur CN102-7 de ce même sous-ensemble. Régler l'oscilloscope en mode X-Y et observer les figures de Lissajous fournies par les signaux d'erreur et de somme de poursuite.
3. Introduire un petit tournevis dans le trou de réglage du réseau optique (voir page 81) et régler le réseau de manière à rendre minimum l'amplitude des figures de Lissajous sur l'axe des Y (photo 9).  
Si le réseau est dérégulé au cours de cette opération au point qu'il est impossible de trouver la position optimum, reprendre le réglage grossier du réseau optique.
4. A l'aide de l'entrée X (CH-1) de l'oscilloscope, vérifier que les amplitudes positive et négative du signal

d'erreur de poursuite sont égales (photo 10). Si ce n'est pas le cas, reprendre le réglage de l'équilibrage de poursuite.

5. Fermer la boucle d'asservissement de poursuite et s'assurer que l'image fournie par l'écran est normale.

## 9.4 RÉGLAGES DU SOUS-ENSEMBLE FTSB

## 1. Réglage du gain radiofréquence

## 9.4 Réglages du sous-ensemble FTSB

- But: régler l'amplitude du signal radiofréquence à la valeur optimale.
- Symptômes d'un défaut de réglage: nombreuses pertes de signal.

- Appareils de mesures et outillage
- Point de mesure
- Disque d'essai et mode de fonctionnement du lecteur
- Point de réglage

- Oscilloscope
- Extrémité de R106 du sous-ensemble FTSB (signal radiofréquence)
- Disque LD d'essai, image 17.000 (asservissement de poursuite fermé)
- VR10 du sous-ensemble FTSB (gain radiofréquence)

## Schéma de raccordement

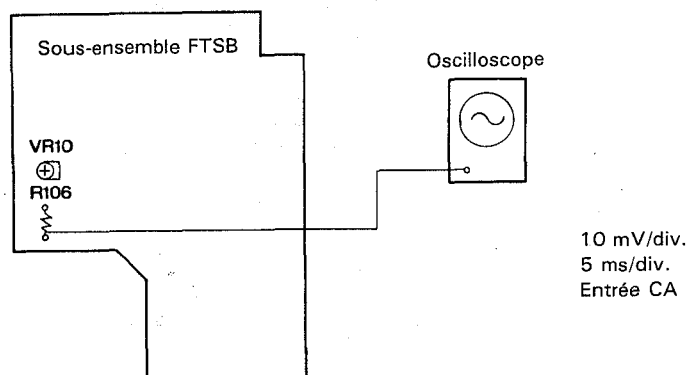

## Procédure de réglage

1. Lire le disque LD d'essai et rechercher l'image numéro 17.000.
2. Brancher l'oscilloscope sur R106 du sous-ensemble FTSB et observer le signal radiofréquence.
3. Régler VR10 du sous-ensemble FTSB de sorte que l'amplitude du signal radiofréquence soit égale à  $300 \text{ mV} \pm 50 \text{ mV}$  (photo 11).

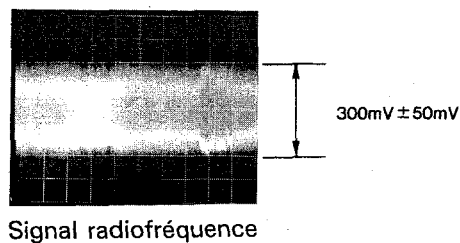

## 2. Réglage du gain de la boucle d'asservissement de poursuite 9.4 Réglages du sous-ensemble FTSB

- But: régler le gain de la boucle d'asservissement de poursuite à la valeur optimale.
- Symptômes d'un défaut de réglage: défaut de lecture.

- |   |  |
|---|--|
| <ul style="list-style-type: none"> <li>• Appareils de mesures et outillage</li> <li>• Point de mesure</li> <li>• Disque d'essai et mode de fonctionnement du lecteur</li> <li>• Point de réglage</li> </ul> | <ul style="list-style-type: none"> <li>• Oscilloscope</li> <li>• Résistance (100k<math>\Omega</math>)</li> <li>• Générateur basse fréquence</li> <li>• Borne CN102-1 (erreur de poursuite et borne CN102-3 (gain de poursuite) du sous-ensemble FTSB</li> <li>• Disque LD d'essai, image numéro 17.000 (asservissement de poursuite fermé)</li> <li>• VR7 du sous-ensemble FTSB</li> </ul> |
|---|--|

### Schéma de raccordement

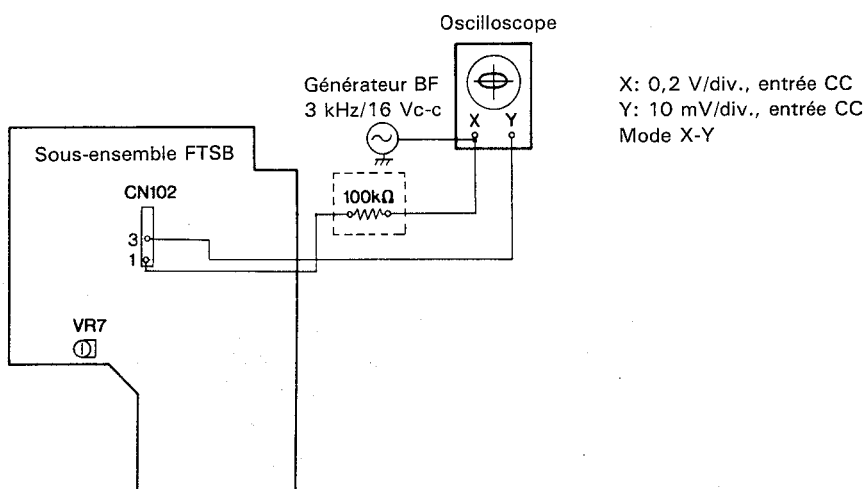

### Procédure de réglage

1. Lire le disque LD d'essai et rechercher l'image numéro 17.000.
2. Brancher le générateur basse fréquence, la résistance et l'oscilloscope sur CN102 du sous-ensemble FTSB comme le montre le schéma.
3. Régler la sortie du générateur sur 3 kHz/16 Vc-c.
4. Régler l'oscilloscope en mode X-Y et observer les figures de Lissajous.
5. Régler VR7 du sous-ensemble FTSB de sorte que les figures de Lissajous soient symétriques par rapport à l'axe des X et à l'axe des Y (photo 12).

*Note: Si le générateur basse fréquence ne permet pas d'obtenir une tension de 16 Vc-c, diminuer la résistance (100k $\Omega$ ) de manière que les figures de Lissajous soient facilement observables (limite inférieure de la résistance: 33k $\Omega$ ).*

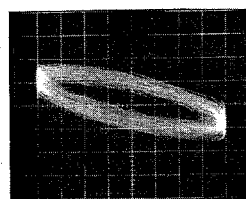

Réglage incorrect

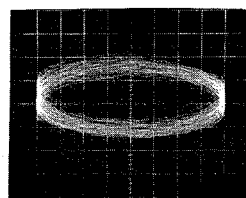

Réglage correct

Photo 12

### 3. RÉGLAGE DU GAIN DE LA BOUCLE D'ASSERVISSEMENT DE MISE AU POINT

#### 9.4 Réglages du sous-ensemble FTSB

- But: régler le gain de la boucle d'asservissement de mise au point à la valeur optimale.
- Symptômes d'un défaut de réglage: lecture de qualité médiocre, défaut de mise au point, lecture intermittente, etc.

- |   |  |
|---|--|
| <ul style="list-style-type: none"> <li>• Appareils de mesures et outillage</li> <li>• Point de mesure</li> <li>• Disque d'essai et mode de fonctionnement du lecteur</li> <li>• Point de réglage</li> </ul> | <ul style="list-style-type: none"> <li>• Oscilloscope • Résistance (100k<math>\Omega</math>) • Générateur basse fréquence</li> <li>• Borne CN102-5 (erreur de mise au point) et borne CN102-4 (gain de mise au point) du sous-ensemble FTSB</li> <li>• Inhiber le circuit de protection du moteur de mise au point.</li> <li>• Disque LD d'essai, image numéro 17.000 • VR1 du sous-ensemble FTSB</li> </ul> |
|---|--|

#### Schéma de raccordement

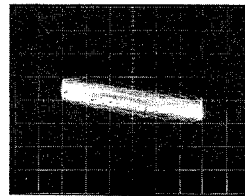
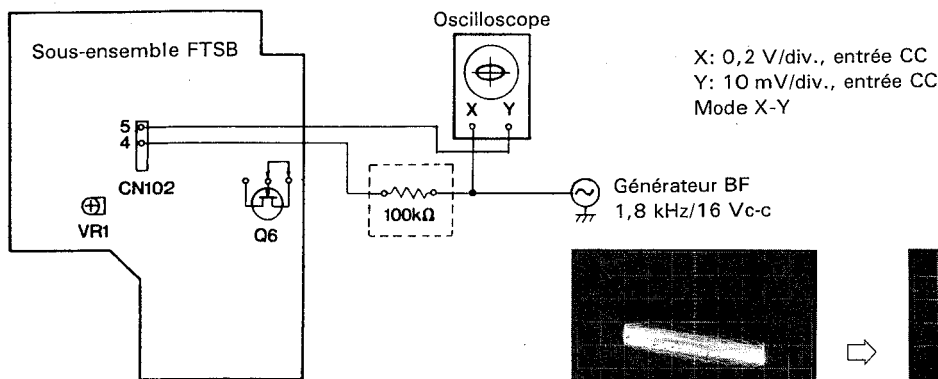

Réglage incorrect

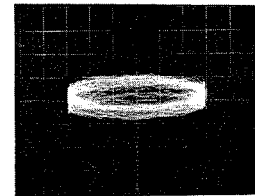

Réglage correct

Photo 13

#### Procédure de réglage

1. Relier la base de Q6 (2SK184) du sous-ensemble FTSB à la masse de manière à inhiber le circuit de protection du moteur de mise au point.
2. Brancher le générateur basse fréquence, la résistance et l'oscilloscope sur CN102 du sous-ensemble FTSB comme le montre le schéma.
3. Régler la sortie du générateur sur 1,8 kHz/16 Vc-c.
4. Régler l'oscilloscope en mode X-Y et observer les figures de Lissajous.
5. Régler VR1 du sous-ensemble FTSB de sorte que les figures de Lissajous soient symétriques par rapport à l'axe des X et à l'axe des Y (photo 13).

*Note: Si le générateur basse fréquence ne permet pas d'obtenir une tension de 16 Vc-c, diminuer la résistance (100k $\Omega$ ) de manière que les figures de Lissajous soient facilement observables (limite inférieure de la résistance: 33k $\Omega$ ).*

#### 4. RÉGLAGE DE L'ÉQUILIBRAGE DE L'ERREUR DE MISE AU POINT CD

#### 9.4 Réglages du sous-ensemble FTSB

- But: s'assurer que l'asservissement de mise au point maintient l'objectif à la distance optimum pendant la lecture d'un CD
- Symptômes d'un défaut de réglage: bruit pendant la lecture d'un CD

- |   |   |
|---|---|
| <ul style="list-style-type: none"> <li>• Appareils de mesures et outillage</li> <li>• Point de mesure</li> <li>• Disque d'essai et mode de fonctionnement du lecteur</li> <li>• Point de réglage</li> </ul> | <ul style="list-style-type: none"> <li>• Oscilloscope</li> <li>• Borne CN26-1 (EFM OUT) du sous-ensemble VSOP</li> <li>• Disque CD s'essai (YEDS-7)</li> <li>• VR3 du sous-ensemble FTSB</li> </ul> |
|---|---|

#### Schéma de raccordement

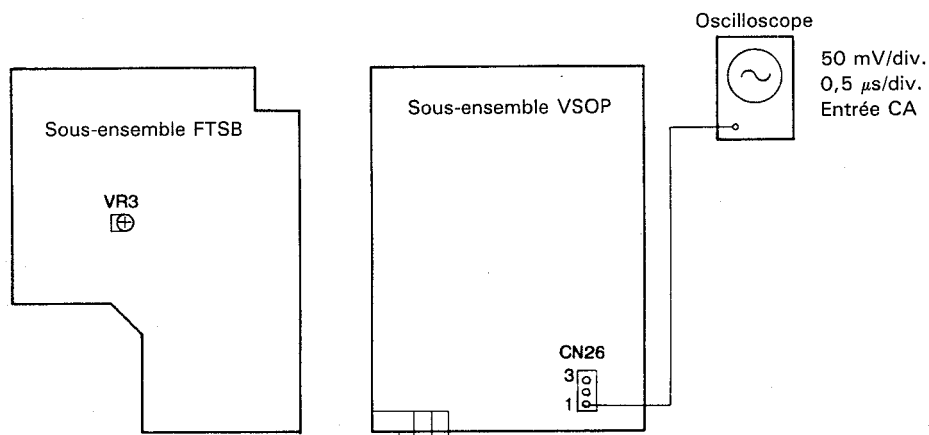

#### Procédure de réglage

1. Lire le disque CD d'essai.
2. Brancher l'oscilloscope sur la borne CN26-1 (EFM OUT) du sous-ensemble VSOP et observer le signal EFM.
3. Régler VR3 du sous-ensemble FTSB de sorte que l'amplitude du signal EFM soit maximale (photo 14)

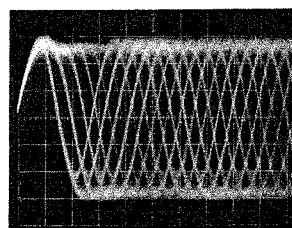

Signal EFM

Photo 14

9.5 RÉGLAGE DU SOUS-ENSEMBLE VSOP

1. RÉGLAGE DU DÉCLENCHEMENT DES PAQUETS

9.5 Réglages du sous-ensemble VSOP (TBC, CONT)

- But: réglage du déclenchement des paquets.
- Symptômes d'un défaut de réglage: la lecture commence d'une position intermédiaire et non pas du début du disque, les couleurs sont irrégulières ou absentes, de fines rayures apparaissent.

- |   |  |
|---|--|
| <ul style="list-style-type: none"> <li>• Appareils de mesures et outillage</li> <li>• Point de mesure</li> <li>• Disque d'essai et mode de fonctionnement du lecteur</li> <li>• Point de réglage</li> </ul> | <ul style="list-style-type: none"> <li>• Oscilloscope</li> <li>• Emetteur de Q415 du sous-ensemble VSOP, borne 20 de IC102 (PA5012)</li> <li>• Disque LD d'essai, mode lecture</li> <li>• VR101 du sous-ensemble VSOP</li> </ul> |
|---|--|

Schéma de raccordement

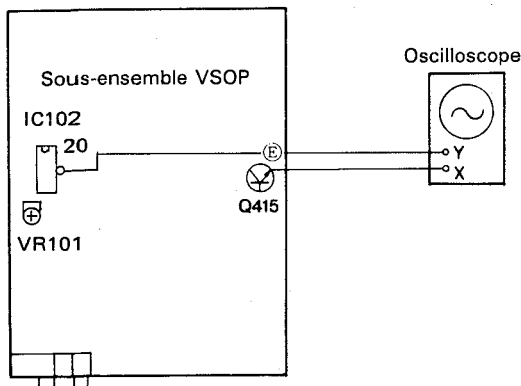

Procédure de réglage

1. Lire le disque LD d'essai.
2. Brancher l'entrée X (CH-1) de l'oscilloscope sur l'émetteur de Q415 du sous-ensemble VSOP et l'entrée Y (CH-2) sur la borne 20 de IC102 (PA5012).
3. Régler VR101 du sous-ensemble VSOP de sorte que le flanc arrière de la sortie du multivibrateur monostable soit en retard de  $1,5\mu s$  par rapport au flanc arrière de la synchro verticale du signal vidéo (photo 17).

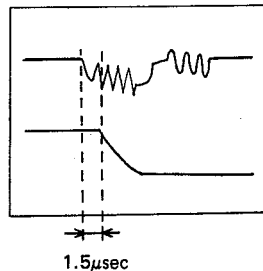

En haut : émetteur de Q415 (TBC VIDEO)

En bas: borne 20 de IC102

Photo 17

2. RÉGLAGE DE L'HORLOGE 17,734475 MHz

9.5 Réglages du sous-ensemble VSOP (TBC, CONT)

- But: réglage de l'horloge de référence.
- Symptômes d'un défaut de réglage: aberration des couleurs, défaut de verrouillage du moteur de rotation.

- |   |  |
|---|--|
| <ul style="list-style-type: none"> <li>• Appareils de mesures et outillage</li> <li>• Point de mesure</li> <li>• Disque d'essai et mode de fonctionnement du lecteur</li> <li>• Point de réglage</li> </ul> | <ul style="list-style-type: none"> <li>• Fréquence-mètre</li> <li>• R3 (ou borne 21 de IC1) du sous-ensemble VSOP</li> <li>• L'appareil est sous tension mais non en lecture</li> <li>• VC1 du sous-ensemble VSOP</li> </ul> |
|---|--|

Schéma de raccordement

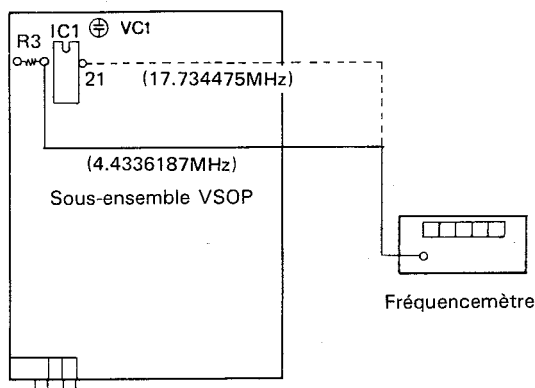

Procédure de réglage

1. Mettre l'appareil sous tension et brancher le fréquence-mètre sur R3 du sous-ensemble VSOP.
2. Régler VC1 du sous-ensemble VSOP de sorte que la fréquence lue soit égale à 4,4336187 MHz.

*Note: Si le réglage est difficile à obtenir, lire le disque LD d'essai et régler VC1 du sous-ensemble VSOP de manière à obtenir une fréquence égale à 17,734475 MHz sur la borne 21 de IC1 (TC9015P).*

## 3. RÉGLAGE DE LA FRÉQUENCE D'OSCILLATION DE BASE 9.5 Réglages du sous-ensemble VSOP (TBC, CONT)

- But: régler la fréquence de l'horloge à 3,75 MHz.

- |   |   |
|---|---|
| <ul style="list-style-type: none"> <li>• Appareils de mesures et outillage</li> <li>• Point de mesure</li> <li>• Disque d'essai et mode de fonctionnement du lecteur</li> <li>• Point de réglage</li> </ul> | <ul style="list-style-type: none"> <li>• Fréquencemètre</li> <li>• Borne 29 de IC101 (PD6064A) du sous-ensemble VSOP</li> <li>• L'appareil est sous tension mais non en lecture</li> <li>• VC101 du sous-ensemble VSOP</li> </ul> |
|---|---|

## Schéma de raccordement

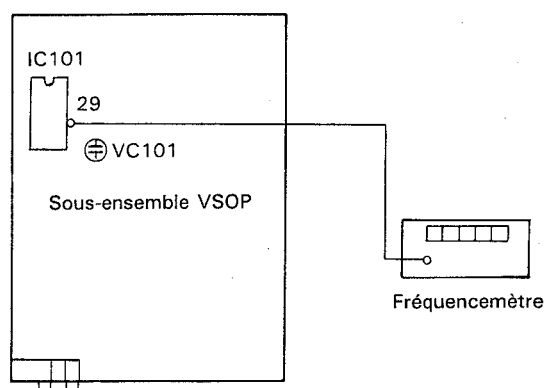

## Procédure de réglage

1. Mettre l'appareil sous tension.
2. Brancher le fréquencemètre sur la borne 29 (TSSO) de IC101 (PD6064A) du sous-ensemble VSOP. Régler VC101 pour obtenir 15,6250 kHz  $\pm$  0,1 Hz.



#### 4. RÉGLAGE DU NIVEAU DE LA VIDÉO RETARDÉE 1H 9.5 Réglages du sous-ensemble VSOP (VDEM, ADEM)

- But: régler l'amplitude du signal de la vidéo retardée 1 H au même niveau que celui du signal principal.
- Symptômes d'un défaut de réglage: nombreuses pertes de blanc et lignes horizontales sur l'écran lorsque 1H est très grand et nombreuses pertes de noir lorsque 1H est très petit.

- |   |   |
|---|---|
| <ul style="list-style-type: none"> <li>● Appareils de mesures et outillage</li> <li>● Point de mesure</li> <li>● Disque d'essai et mode de fonctionnement du lecteur</li> <li>● Point de réglage</li> </ul> | <ul style="list-style-type: none"> <li>● Oscilloscope double trace</li> <li>● Sous-ensemble VSOP Bornes 40 et 42 de IC401 (PA5010)</li> <li>● Disque LD d'essai, chapitre numéro 11</li> <li>● VR401 du sous-ensemble VSOP</li> </ul> |
|---|---|

##### Schéma de raccordement

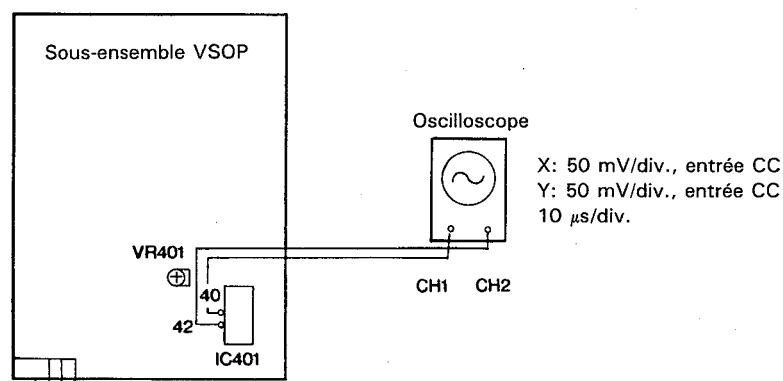

##### Procédure de réglage

1. Lire le disque LD d'essai et rechercher le chapitre numéro 11.
2. Brancher l'entrée X (CH-1) de l'oscilloscope sur la borne 40 de IC401 (PA5010) du sous-ensemble VSOP et l'entrée Y (CH-2) sur la borne 42 (CH-2). Observer en même temps l'allure des signaux vidéo principal et retardé.
3. Régler VR401 sur le sous-ensemble VSOP de sorte que l'amplitude entre la pointe de synchro et le niveau de blanc du signal retardé 1H (CH-2) soit la même que l'amplitude du signal vidéo principal (CH-1) (photo 18).

- a. Signal vidéo principal
- b. Signal vidéo retardé 1H

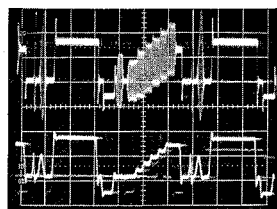

Photo 18

## 5. RÉGLAGE DE LA FRÉQUENCE CENTRALE DU VCO 9.5 Réglages du sous-ensemble VSOP (VDEM, ADEM)

- But: optimiser le retard du dispositif à couplage de charge (CCD) afin de compenser les erreurs de base de temps.
- Symptômes d'un défaut de réglage: défaut de verrouillage de l'horloge. Verrouillage lent des couleurs après une recherche.

- |   |   |
|---|---|
| <ul style="list-style-type: none"> <li>• Appareils de mesures et outillage</li> <li>• Point de mesure</li> <li>• Disque d'essai et mode de fonctionnement du lecteur</li> <li>• Point de réglage</li> </ul> | <ul style="list-style-type: none"> <li>• Oscilloscope double trace</li> <li>• Emetteur de Q412 et émetteur de Q413 du sous-ensemble VSOP</li> <li>• Disque LD d'essai, chapitre numéro 11</li> <li>• VR402 du sous-ensemble VSOP</li> </ul> |
|---|---|

### Schéma de raccordement

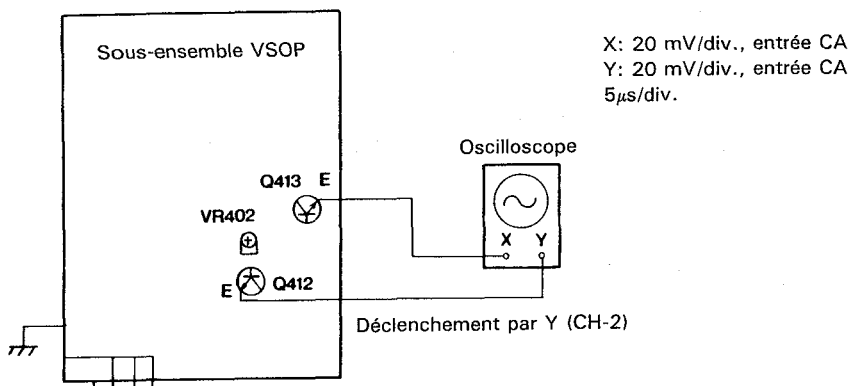

### Procédure de réglage

1. Lire le disque LD s'essai et rechercher le chapitre numéro 11.
2. Brancher l'entrée X (CH-1) de l'oscilloscope sur l'émetteur de Q413 du sous-ensemble VSOP et l'entrée Y (CH-2) sur l'émetteur de Q412. Déclencher par la trace CH-2. Observer l'allure des signaux vidéo avant et après la compensation de l'erreur de la base de temps.
3. Le signal vidéo appliqué sur CH-1 après compensation de l'erreur de base de temps contient un certain niveau de gigue. Régler VR402 du sous-ensemble VSOP de manière à retarder le centre de cette gigue de 68  $\mu$ s (1H + 4 $\mu$ s) par rapport au flanc arrière du signal de synchronisation horizontale (H-sync), appliqué en CH-2, du signal vidéo avant compensation de l'erreur de base de temps (photo 19).

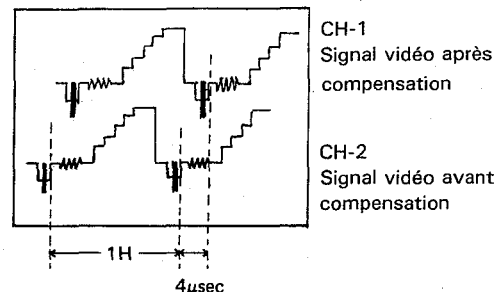

Photo 19

## 6. RÉGLAGE DE L'HORLOGE DE DÉCODAGE

## 9.5 Réglages du sous-ensemble VSOP (TBC, CONT)

- But: régler la fréquence de l'horloge.

- Appareils de mesures et outillage
- Point de mesure
- Disque d'essai et mode de fonctionnement du lecteur
- Point de réglage

- Fréquencemètre
- Borne 3 de IC10 (PD0011) du sous-ensemble VSOP
- L'appareil est sous tension • Mode d'essai
- VC2 du sous-ensemble VSOP

## Schéma de raccordement

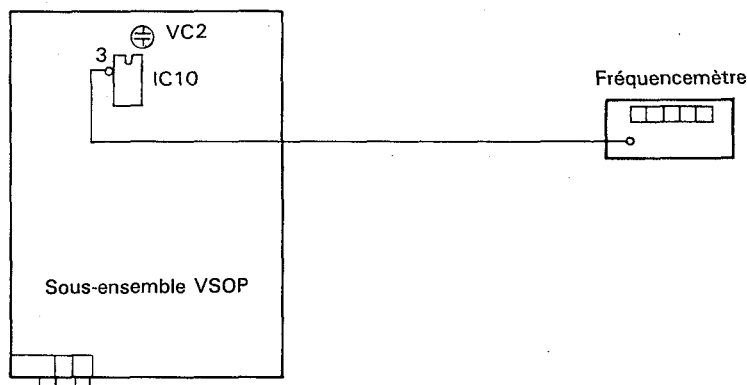

## Procédure de réglage

1. Mettre l'appareil sous tension.
2. Brancher le fréquencemètre sur la borne 3 de IC10.
3. Régler l'appareil en mode d'essai puis appuyer sur les touches suivantes de la télécommande **CX** + **4**.

\* Cela entraîne la génération d'un signal DOC INH continu.

4. Régler VC2 de sorte que la fréquence du signal présent sur la borne 3 de IC10 soit égale à  $3,0 \text{ MHz} \pm 50 \text{ kHz}$ .

**7. RÉGLAGE DU NIVEAU DE SORTIE VIDÉO**

**9.5 Réglages du sous-ensemble VSOP (VDEM, ADEM)**

- But: réglage de l'amplitude du signal vidéo (décollement du niveau du noir ↔ 100% blanc) à 0,7 Vc-c
- Symptômes d'un défaut de réglage: la relecture commence d'une position intermédiaire en raison d'une erreur de compréhension des données. l'écran est trop brillant ou trop sombre.

- |   |   |
|---|---|
| <ul style="list-style-type: none"> <li>• Appareils de mesures et outillage</li> <li>• Point de mesure</li> <li>• Disque d'essai et mode de fonctionnement du lecteur</li> <li>• Point de réglage</li> </ul> | <ul style="list-style-type: none"> <li>• Oscilloscope</li> <li>• Prise de sortie vidéo</li> <li>• Disque LD d'essai, chapitre numéro 11</li> <li>• VR403 du sous-ensemble VSOP</li> </ul> |
|---|---|

**Schéma de raccordement**

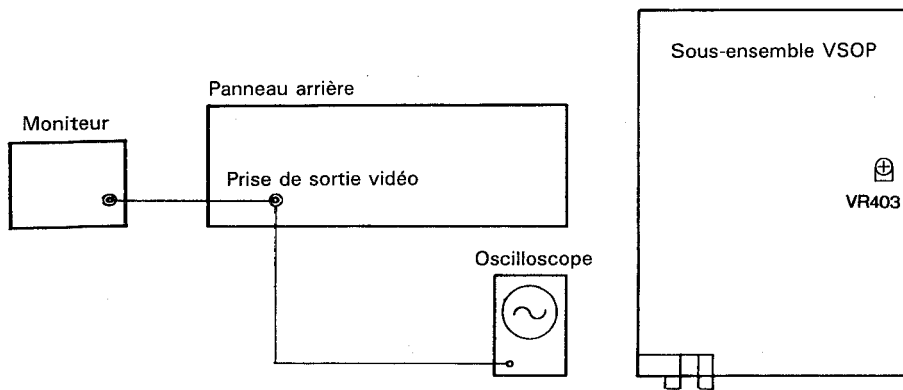

**Procédure de réglage**

*Note: Brancher la sortie vidéo du lecteur sur un moniteur et une résistance de 75 Ohms sur la prise d'entrée de celui-ci. Si l'on emploie un téléviseur sans prise vidéo, brancher une résistance de 75 Ohms sur la prise du lecteur.*

1. Lire le disque LD d'essai et rechercher le chapitre numéro 11.
2. Brancher l'oscilloscope sur la sortie du lecteur et observer l'allure du signal vidéo.
3. Régler VR403 du sous-ensemble VSOP de sorte que la différence entre le niveau de décollement du noir et le niveau de blanc soit égale à 0,7 Vc-c ± 5% (photo 20).

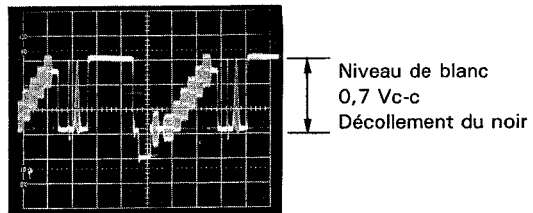

## 8. RÉGLAGE DU NIVEAU DE SIGNAL D'ERREUR DE PHASE COULEUR

### 9.5 Réglages du sous-ensemble VSOP (VDEM, ADEM)

- But: optimisation de la quantité de signal d'erreur de phase couleur à appliquer à l'étage de compensation de phase couleur.
- Symptômes d'un défaut de réglage: couleurs irrégulières évidentes.

- |   |  |
|---|--|
| <ul style="list-style-type: none"> <li>• Appareils de mesures et outillage</li> <li>• Point de mesure</li> <li>• Disque d'essai et mode de fonctionnement du lecteur</li> <li>• Point de réglage</li> </ul> | <ul style="list-style-type: none"> <li>• Moniteur</li> <li>• Régler tout en observant l'écran</li> <li>• Disque LD d'essai, chapitre numéro 14</li> <li>• VR406 du sous-ensemble VSOP</li> </ul> |
|---|--|

#### Schéma de raccordement

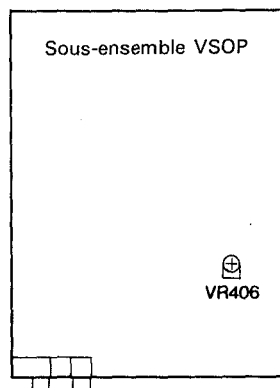

#### Procédure de réglage

1. Lire le disque LD d'essai et rechercher le chapitre numéro 14.
2. Régler VR406 du sous-ensemble VSOP pour minimiser les irrégularités du magenta.

## 9. RÉGLAGE DU NIVEAU DE COMPAREUR DE VITESSE

### 9.5 Réglages du sous-ensemble VSOP (VDEM, ADEM)

- But: optimiser la tension d'entrée appliquée au comparateur de vitesse du moteur de rotation
- Symptômes d'un défaut de réglage: défaut de verrouillage du moteur de rotation. Aberration des images.

- |   |  |
|---|--|
| <ul style="list-style-type: none"> <li>• Appareils de mesures et outillage</li> <li>• Point de mesure</li> <li>• Disque d'essai et mode de fonctionnement du lecteur</li> <li>• Point de réglage</li> </ul> | <ul style="list-style-type: none"> <li>• Voltmètre digital</li> <li>• Bornes 6 et 7 de IC403 (NJM2903S) du sous-ensemble VSOP</li> <li>• Disque d'essai, image numéro 3.001</li> <li>• VR405 du sous-ensemble VSOP (VDEM, ADEM)</li> </ul> |
|---|--|

#### Schéma de raccordement

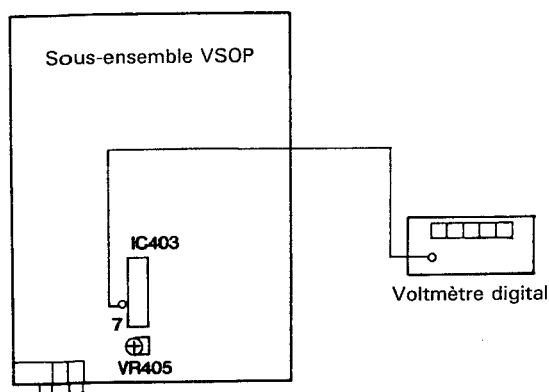

#### Procédure de réglage

1. Lire le disque LD d'essai et rechercher l'image numéro 3.001.
2. Brancher le voltmètre digital sur la borne 7 de IC403 (NJM2903S) du sous-ensemble VSOP. Mesurer et noter la tension de référence du comparateur de vitesse du moteur de rotation.
3. Brancher le voltmètre digital sur la borne 6 du même CI et mesurer la sortie du détecteur de vitesse. Régler VR405 du sous-ensemble VSOP pour que la tension sur la borne 6 soit supérieure de  $+ 260 \text{ mV} \pm 20 \text{ mV}$  à la tension sur la borne 7.

## 9.6 RÉGLAGES DU SOUS-ENSEMBLE 2FSB

### 1. RÉGLAGE DE LA FRÉQUENCE D'OSCILLATION LIBRE DU VCXO 9.6 Réglages du sous-ensemble 2FSB

- But: régler la fréquence de l'oscillateur employé par le décodeur EFM à la valeur optimale.

- |   |  |
|---|--|
| <ul style="list-style-type: none"> <li>• Appareils de mesures et outillage</li> <li>• Point de mesure</li> <li>• Disque d'essai et mode de fonctionnement du lecteur</li> <li>• Point de réglage</li> </ul> | <ul style="list-style-type: none"> <li>• Fréquencemètre</li> <li>• R137 du sous-ensemble 2FSB</li> <li>• Disque CD d'essai, lecture d'une piste quelconque</li> <li>• VR501 du sous-ensemble 2FSB</li> </ul> |
|---|--|

#### Schéma de raccordement

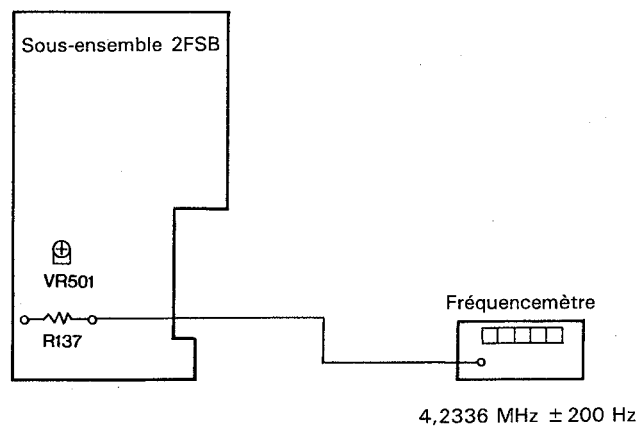

#### Procédure de réglage

1. Lire une piste quelconque du disque CD d'essai.
2. Brancher le fréquencemètre sur R137 du sous-ensemble 2FSB et noter la fréquence du VCXO.
3. Régler VR501 du sous-ensemble 2FSB de sorte que la fréquence soit égale à 4,2336 MHz.

## 2. RÉGLAGE DE LA FRÉQUENCE D'OSCILLATION LIBRE DU VCO PLL 9.6 Réglages du sous-ensemble 2FSB

- But: régler la fréquence d'oscillation libre du VCO PLL employé dans le décodeur EFM à la valeur optimale.
- Symptômes d'un défaut de réglage: absence de son digital ou son digital intermittent.

- |   |  |
|---|--|
| <ul style="list-style-type: none"> <li>• Appareils de mesures et outillage</li> <li>• Point de mesure</li> <li>• Disque d'essai et mode de fonctionnement du lecteur</li> <li>• Point de réglage</li> </ul> | <ul style="list-style-type: none"> <li>• Voltmètre digital</li> <li>• Borne 1 de IC102 du sous-ensemble 2FSB</li> <li>• Disque LaserDisc avec son digital (LDD), lecture d'une piste quelconque.</li> <li>• VL101 du sous-ensemble 2FSB</li> </ul> |
|---|--|

### Schéma de raccordement

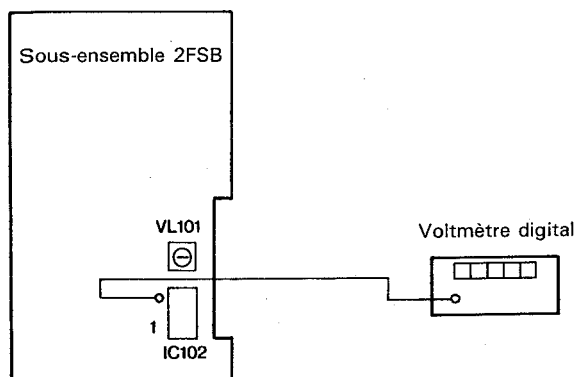

### Procédure de réglage

1. Lire une image quelconque du disque LDD.
2. Brancher le voltmètre digital sur la borne 1 de IC102 du sous-ensemble 2FSB et mesurer la tension continue du signal de commande du VCO.
3. Régler VL101 du sous-ensemble 2FSB de sorte que la tension continue de commande du VCO soit égale à  $150 \text{ mV} \pm 100 \text{ mV}$ .



## 3. RÉGLAGE DE L'ERREUR DE VCXO

## 9.6 Réglages du sous-ensemble 2FSB

- But: minimiser la tension d'erreur de phase du VCXO PLL
- Symptômes d'un défaut de réglage: sortie intermittente du son digital pendant la lecture d'un LDD (sortie de bruit synchronisé)

- |   |   |
|---|---|
| <ul style="list-style-type: none"> <li>• Appareils de mesures et outillage</li> <li>• Point de mesure</li> <li>• Disque d'essai et mode de fonctionnement du lecteur</li> <li>• Point de réglage</li> </ul> | <ul style="list-style-type: none"> <li>• Oscilloscope</li> <li>• J170 (MDP) du sous-ensemble 2FSB</li> <li>• Disque LDD, lecture d'une image quelconque</li> <li>• VR102 du sous-ensemble 2FSB</li> </ul> |
|---|---|

## Schéma de raccordement

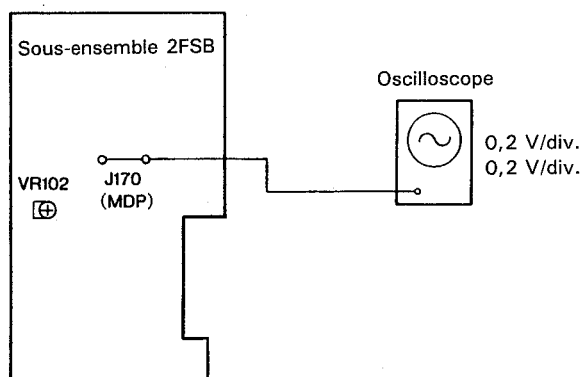

## Procédure de réglage

1. Lire une image quelconque du disque LDD.
2. Brancher l'oscilloscope sur la jarretière J170 (MDP) du sous-ensemble 2FSB et observer le signal d'erreur de phase du VCXO PLL.
3. Régler VR102 pour minimiser la largeur des impulsions positives ou négatives et obtenir une trace continue (la trace au centre de la photo 23.)

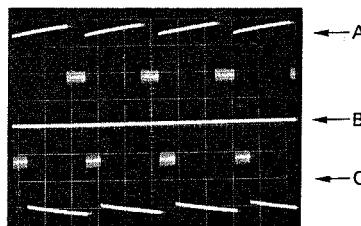

Photo 23

- A Allure des signaux lorsque VR102 est tournée dans le sens des aiguilles d'une montre à partir de la position optimale.
- B Position optimale
- C Allure des signaux lorsque VR102 est tournée dans le sens contraire des aiguilles d'une montre à partir de la position optimale.

## 8. PROCEDIMIENTOS PARA CAMBIAR EL CONJUNTO DEL FONOCAPTOR

### 8.1 CAMBIO DEL CONJUNTO DEL FONOCAPTOR

1. Saque la cubierta superior y la placa inferior. (Fig. 1)

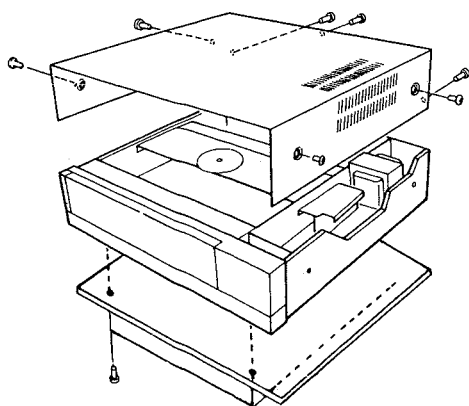

Fig. 1

2. Conecte la alimentación y presione la tecla OPEN/CLOSE para que salga la bandeja de discos. Luego desconecte la alimentación.

3. Mueva el conjunto del fonocaptor a la posición que se indica en la Fig. 2.

*Nota: En lugar de girar el motor deslizante con la mano, es preferible hacer mover el fonocaptor mediante la conexión de una batería de 1,5 V en los terminales del motor deslizante.*

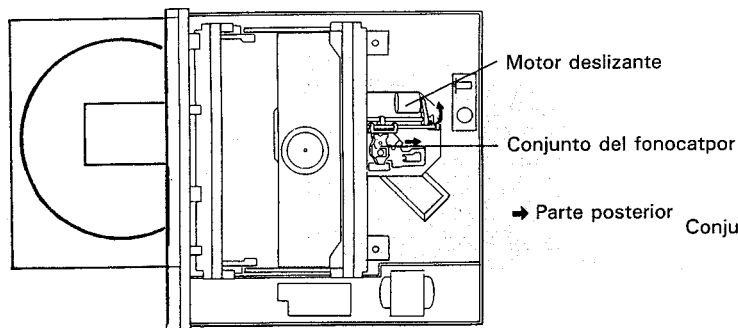

Fig. 2

4. Coloque la unidad de lado con el transformador en la parte inferior. Afloje los cuatro tornillos del conjunto VSOP y los dos tornillos del panel posterior. Abra el conjunto VSOP y desconecte CN33 del conjunto 2FSB. (Fig. 3)

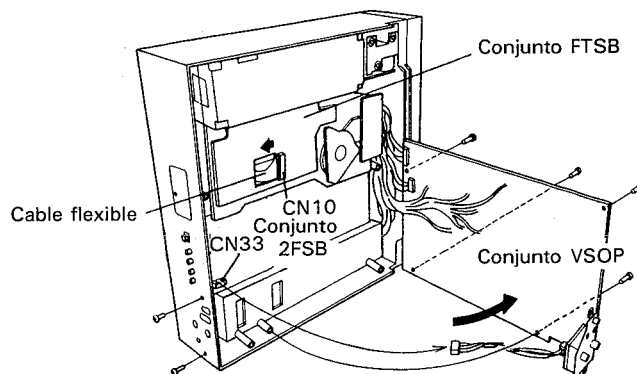

Fig. 3

5. Desenganche el fiador CN10 del conjunto FTSB y saque con cuidado el cable flexible. Evite dañar el cable flexible, y proteja el diodo láser de la electricidad estática. Para una mayor protección, no toque bajo ninguna circunstancia la sección del conductor del cable.

6. Afloje el tornillo de fijación del fonocaptor de la parte superior de la unidad, y saque con cuidado el onjunto del fonocaptor. (Fig. 4)

*Nota: No toque las partes soldadas del conjunto del fonocaptor.*

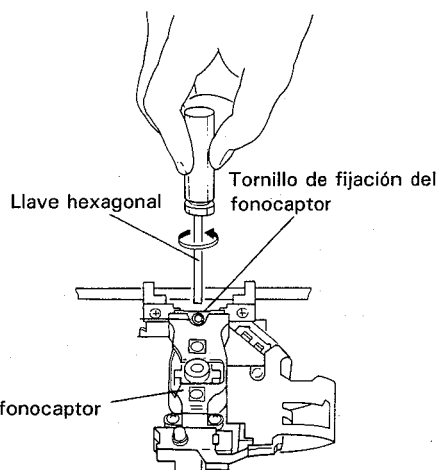

Fig. 4

7. Instale un conjunto de fonocaptor nuevo, apriete el tornillo de fijación, y conecte y fije con cuidado el cable flexible con el CN10 del conjunto FTSB. De este modo se completa el cambio del conjunto del fonocaptor.

*Nota: Después de cambiar el conjunto del fonocaptor, compruebe el centramiento del motor del eje. (Refiérase a la página 112)*

## 8.2 DESMONTAJE DE LA BANDEJA DE DISCOS

### 8.2.1 Procedimientos para el desmontaje de la bandeja de discos

1. Saque la cubierta superior. (Fig. 1)
2. Conecte la alimentación y presione la tecla OPEN/CLOSE para que salga la bandeja de discos. Luego desconecte la alimentación, y presione la bandeja de discos unos 5cm hacia dentro.
3. Saque el remache tirándolo hacia arriba, y quite el muelle del interruptor. (Fig. 5)

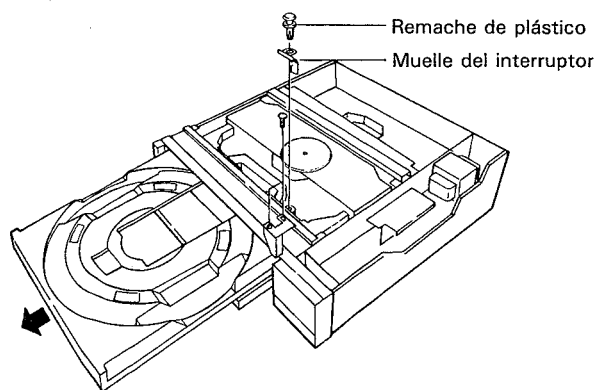

Fig. 5

4. Afloje el tornillo para sacar la placa de tope. (Fig. 5)
5. Saque la bandeja de discos tirando suavemente hacia delante.

### 8.2.2 Método para fijar un disco cuando se ha sacado la bandeja de discos

1. Inserte un disco por la parte posterior y colóquelo en el plato giradiscos.

*Nota: Evite que la grasa de los rieles ensucie la superficie del disco.*

2. Tire de las palancas de fijación (I) y (D) hacia atrás a la vez que las presiona hacia afuera, y la abrazadera bajará para fijar el disco. Compruebe que el disco haya quedado bien fijado girando la abrazadera con la mano. (Fig. 6)

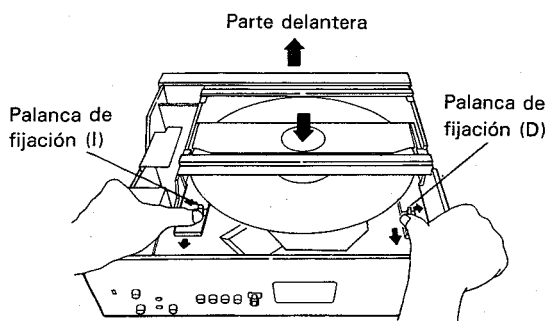

Fig. 6

### 8.2.2 Procedimientos para la reproducción cuando se ha sacado la bandeja de discos

1. Conecte la alimentación presionado a la vez el interruptor deslizante, y luego presione inmediatamente la tecla de reproducción. Suelte el interruptor deslizante después que el disco empiece a girar. (Fig. 7)

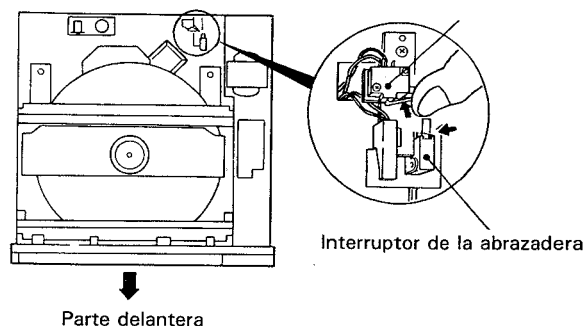

Fig. 7

### 8.2.4 Inserción y eyección de la bandeja de discos

1. Inserte la bandeja después de alinear los dientes de la bandeja de discos con la sección no dentada del engranaje. (Fig. 8)
2. Inserte el remache, el muelle del interruptor, y la placa de tope que se sacaron en los pasos e y 4 del apartado 8.2.1.

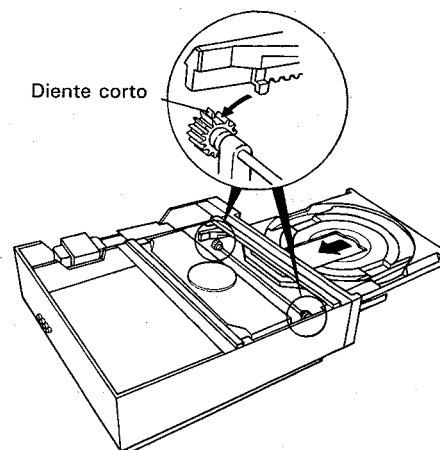

Fig. 8

## 9. AJUSTES

### 9.1 INSTRUMENTOS Y PORTAPIEZAS NECESARIOS PARA LOS AJUSTES

- Destornillador pequeño (eje de unos 7cm de longitud)
- Destornillador pequeño de cabeza Philips (eje de al menos 15cm de longitud)
- Llave hexagonal (2,00mm y 2,5mm)
- Llave acodada en forma de L (GGV-129)
- Batería de 1,5V con hilos conductores
- Filtro de paso bajo ( $100k\Omega + 1\mu F$ )
- Osciloscopio de seguimiento doble (con retardo)
- Generador de AF
- Frecuencímetro
- Disco de pruebas LD J1
- Disco LDD (de adquisición local)
- Disco de pruebas CD (YEDS-7)
- Pinzas de cortocircuito
- Voltímetro digital

### 9.2 PREPARACIONES PARA EL AJUSTE Y PRECAUCIONES

#### 1. Ajustes del tocadiscos

Para la mayoría de los procedimientos de ajuste, el tocadiscos debe colocarse de lado con el transformador en la parte superior y el conjunto VSOP abierto. El conector CN33 del conjunto 2FSB puede también dejarse desconectado.

#### 2. Prevención de doble fijación

Cuando la bandeja de discos está en posición normal con un disco fijado, la acción de fijación se realiza en realidad dos veces. Esto se llama "doble fijación". Sin embargo, si la doble fijación se realiza mientras el tocadiscos está de lado para realizar los ajustes, el disco caerá del plato giradiscos. Por lo tanto, cortocircuite el alfiler 3 (conductor blanco) con el alfiler 4 (conductor blanco) del CN22 del conjunto VSOP para evitar la doble fijación.

#### 3. Abertura del servoseguimiento

El servoseguimiento puede abrirse y cerrarse durante el modo de pruebas controlado por un microprocesador.

— Para conmutar al modo de pruebas —

- 1) Desconecte la alimentación.
- 2) Vea el lado de la configuración del conjunto VSOP y encuentre el resistor de 10k de conexión con el alfiler 24 del CI5 (CXD1095Q) y la línea de +5V. Conecte el lado del CI del conductor de masa del resistor.

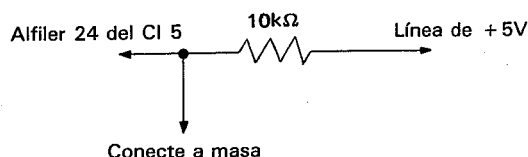

- 3) Conecte la alimentación y compruebe que se encienda el conjunto de la indicación de tubo fluorescente del panel delantero.

- Nota 1. El tocadisco puede aún utilizarse en el modo normal durante el modo de pruebas.*
2. Después de conmutar al modo de pruebas, la conexión a masa descrita en el paso 2) anterior puede desconectarse sin afectar el modo de pruebas.
  3. El disco sólo se para, y no sale eyectado, cuando se presiona la tecla EJECT en el modo de pruebas.
  4. La función normal de indicación de tubo fluorescente puede reestablecerse presionando **CX** + **0** una vez. Si presiona una segunda vez, se reestablece toda la indicación.

— Abertura y cierre del servoseguimiento —

El servoseguimiento puede abrirse presionando continuamente **CX** + **3** en la unidad de control a distancia. El servo puede cerrarse presionando **CX** + **3** otra vez. (El servoseguimiento puede abrirse y cerrarse alternativamente cada vez que se presiona **CX** + **3**.)

— Cancelación del modo de pruebas —

El modo de pruebas puede cancelarse desconectando la alimentación, o presionando **CX** + **9** en la unidad de control a distancia.

#### 4. Ajuste de rejilla

La rejilla puede ajustarse de dos modos diferentes.

##### — Ajuste con el tocadiscos colocado de lado —

Coloque el tocadiscos de lado tal como se muestra en la Fig. 3. La rejilla puede ajustarse insertando un destornillador pequeño por el espacio entre el conjunto mecánico y el conjunto 2FSB. (Figs. 9 y 10)

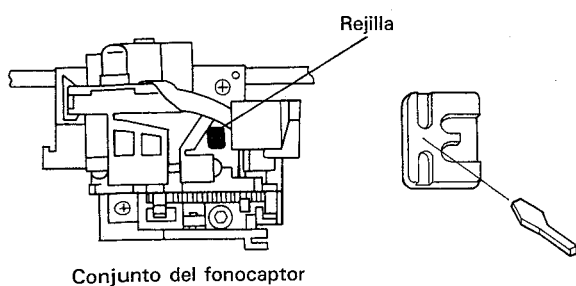

Posición de la rejilla

Fig. 9

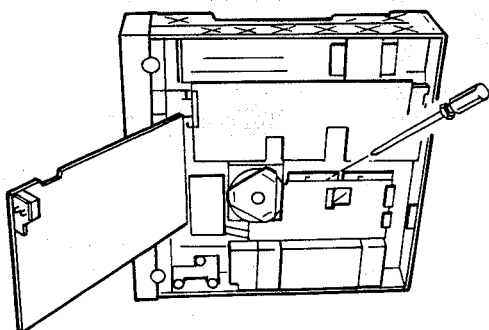

Posición de inserción del destornillador

Fig. 10

##### — Ajuste con el tocadiscos en posición plana —

En la dirección que se indica en la Fig. 11, inserte un destornillador pequeño por los bordes de las dos guías del conjunto del fonocaptor (tal como se muestra en la Fig. 12) y en el orificio de ajuste de rejilla.

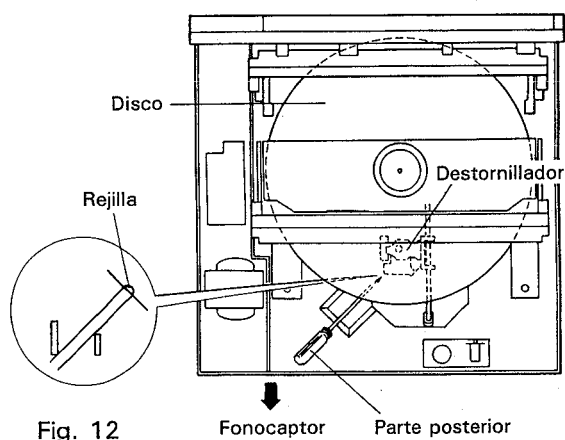

Fig. 12

Fig. 11

5. Si no se especifica lo contrario, todos los ajustes del osciloscopio que se muestran en los diagramas de conexión son valores obtenidos con una sonda de 10:1.

9.3 AJUSTES MECANICOS

1. AJUSTES APROXIMADOS DE REJILLA Y DE BALANCE DE SEGUIMIENTO (TRKG) 9.3 Ajustes mecánicos

- Objetivo: Ajustar el haz de láser (dividido en 3 haces por la rejilla) en la posición óptima de las pistas de reproducción. Ajustar la contratensión del servo TRKG a 0V.
- Síntomas que indican la necesidad del ajuste: Seguimiento incorrecto (saltos, omisiones, etc.)

- Instrumentos y portapiezas de medición
- Posición de medición
- Disco de pruebas y modo del tocadiscos
- Posición de ajuste
- Destornillador pequeño
- Osciloscopio
- CN102-3 del conjunto de FTBS (error de TRKG)
- Disco de pruebas LD n. # 17.000
- Modo de pruebas (servo TRKG abierto)
- Rejilla
- VR6 del conjunto FTBS (balance de TRKG)

Diagramas de conexión

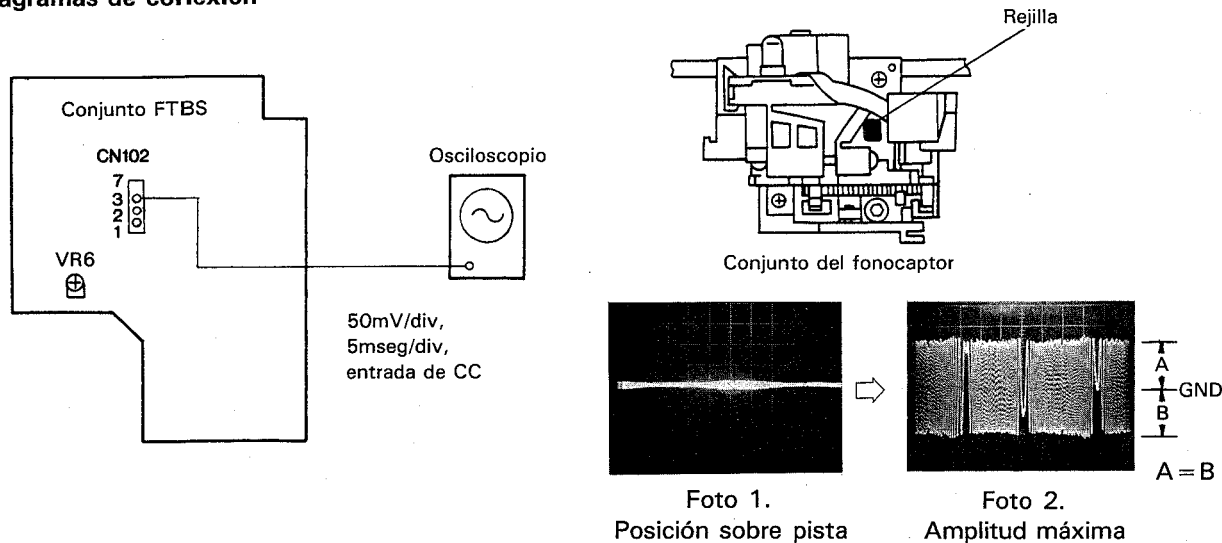

Procedimientos para el ajuste

<Ajuste aproximado de rejilla>

1. Reproduzca un disco de pruebas LD.
2. Presione la tecla DISPLAY para indicar el n. # de cuadro de la pantalla de TV.
3. Mueva el fonocaptor al cuadro n. # 17.000 mediante la función de exploración o búsqueda.
4. Abra el servo de TRKG. (Vea la pág. 108.)
5. Conecte el osciloscopio en CN102-3 del conjunto FTBS y observe la forma de onda.
6. Inserte un destornillador pequeño en el orificio de ajuste de rejilla (vea la pág. 109) y gire la rejilla de manera que la amplitud de la señal de error de TRKG varíe mucho y poco alternativamente. Localice la posición donde la amplitud de la forma de onda alcanza un mínimo con una curva de contorno suave. (Vea la Foto 1.) (Este estado indica que el haz de láser dividido en 3 está dirigido sobre una única pista. Esto se ha denominado posición "sobre pista".)

7. Gire lentamente la rejilla hacia la izquierda a partir de la posición sobre pista hasta que la amplitud de la forma de onda de error de TRKG que sube gradualmente alcance un máximo. (Vea la Foto 2.)
8. Cierre el servo de TRKG y compruebe que aparezca una imagen normal en la pantalla de TV.

<Ajuste del balance de TRKG>

1. Alinee la posición GND del osciloscopio con el centro de la pantalla del osciloscopio.
2. Ajuste VR6 del conjunto FTBS a una posición donde las mitades positiva y negativa de la forma de onda de error de TRKG sean iguales. (Vea la Foto 2.)

2. COMPROBACION DEL CENTRAMIENTO DEL MOTOR DEL EJE

9.3 Ajustes mecánicos

- Objetivo: Comprobar que el motor del eje en lugar trazado por el haz de láser

- |  |  |
|--|--|
| <ul style="list-style-type: none"> <li>• Instrumentos y portapiezas de medición</li> <li>• Posición de medición</li> <li>• Disco de pruebas y modo del tocadiscos</li> <li>• Posición de ajuste</li> </ul> | <ul style="list-style-type: none"> <li>• Osciloscopio</li> <li>• CN102-3 del conjunto FTSB (error de TRKG) y CN102-7 (suma de TRKG)</li> <li>• Disco de pruebas CD • Modo de pruebas (Servo de TRKG: abierto)</li> <li>• Comprobación de la figura de Lissajous</li> </ul> |
|--|--|

Diagramas de conexión



Foto 3  
Figura de Lissajous en la pista interior del disco CD



Foto 4  
Figura de Lissajous en la pista exterior del disco CD

Procedimientos de comprobación

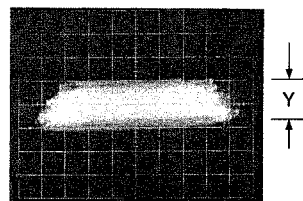
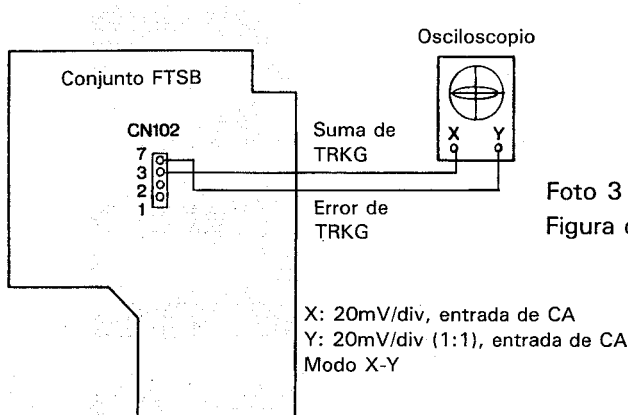
1. Reproduzca un disco de pruebas CD.
2. Mueva el fonocaptor a las pistas interiores del disco mediante las funciones de exploración o búsqueda, y luego abra el servo de TRKG.
3. Conecte la entrada X del osciloscopio (CH-1) en CN102-3 del conjunto FTSB, y la entrada Y (CH-2) en CN102-7. Conmute el osciloscopio al modo X-Y y observe las figuras de Lissajous de las señales de error de TRKG y de suma de TRKG.
4. Registre la amplitud de las figuras de Lissajous en el eje Y.
5. Cierre el servo de TRKG, y mueva el fonocaptor a las pistas exteriores del disco mediante las funciones de exploración o búsqueda. Abra el servo de TRKG otra vez y observe las figuras de Lissajous. Compruebe que la amplitud de las figuras de Lissajous en el eje Y sea la misma que la registrada en el paso 4 anterior. Si no fuera la misma, realice los pro-

cedimientos de "Ajuste del centramiento del motor del eje"

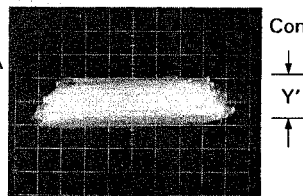

Figura de Lissajous que indica la necesidad de ajuste

Foto 5.

## 3. AJUSTE DEL CENTRAMIENTO DEL MOTOR DEL EJE

## 9.3 Ajustes mecánicos

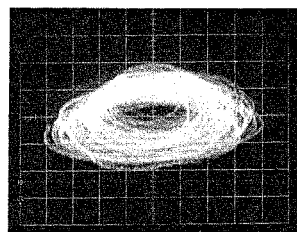
- Objetivo: Colocar el motor del eje en el centro del lugar trazado por el haz de láser.
- Síntomas que indican la necesidad del ajuste: Salto de pistas. Tiempos de búsqueda largos.

- |  |   |
|--|---|
| <ul style="list-style-type: none"> <li>• Instrumentos y portapiezas de medición</li> <li>• Posición de medición</li> <li>• Disco de pruebas y modo del tocadiscos</li> <li>• Posición de ajuste</li> </ul> | <ul style="list-style-type: none"> <li>• Llave acodada en forma de L (GGV-129)</li> <li>• Llave hexagona de 2,5mm</li> <li>• Osciloscopio</li> <li>• CN102-3 del conjunto FTSB (error de TRKG) y CN102-7 (suma de TRKG)</li> <li>• Disco de pruebas CD</li> <li>• Modo de pruebas (Servo de TRKG: abierto/cerrado)</li> <li>• Orificio de ajuste del centramiento del motor del eje</li> <li>• Rejilla</li> </ul> |
|--|---|

## Diagramas de conexión



Foto 6



Foto 7

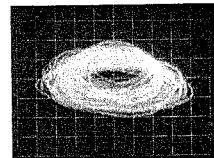
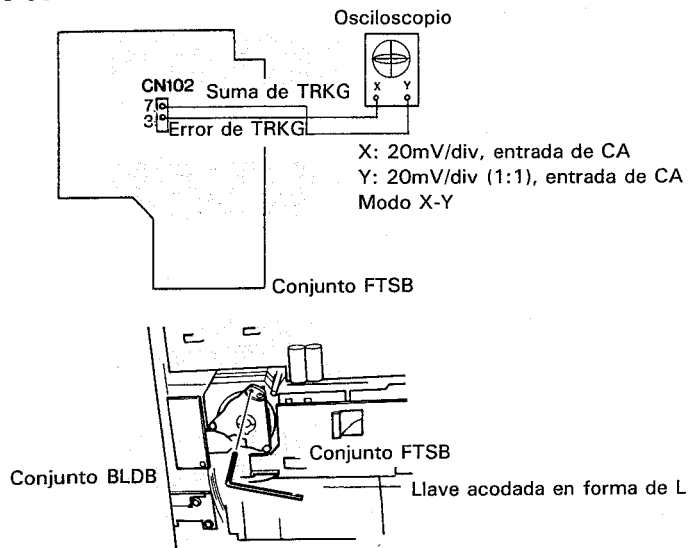

Foto 8

## Procedimientos para el ajuste

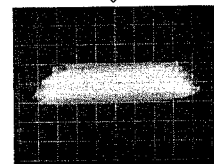
*Nota: Este ajuste solamente será necesario cuando así lo indique la Comprobación del centramiento de motor del eje.*

1. Afloje los tres tornillos del motor del eje girando cada uno media vuelta.
2. Conecte la entrada X del osciloscopio (CH-1) en CN102-3 del conjunto FTSB, y la entrada Y (CH-2) en CN102-7.
3. Reproduzca un disco de pruebas, y mueva el fonocaptor a los surcos exteriores del disco mediante las funciones de exploración o búsqueda.
4. Abra el servo de TRKG y observe las figuras de Lissajous de las señales de error de TRKG y de suma de TRKG.
5. Ajuste la rejilla hasta que la amplitud de las figuras de Lissajous en el eje Y alcancen un mínimo. (Vea la Foto 7.)
6. Cierre el servo de TRKG y mueva el fonocaptor a las pistas interiores del disco mediante las funciones de exploración o búsqueda.
7. Abra el servo de TRKG otra vez y observe las figuras de Lissajous. Registre la amplitud en el eje Y.
8. Inserte la llave acodada en forma de L en el orificio de ajuste, y gire lentamente en la dirección que reduzca la amplitud de la figura de Lissajous en el eje Y. Después de alcanzar la amplitud mínima, continúe girando la llave acodada en la misma dirección hasta que se alcance la misma amplitud que se registró en el paso 7. (Vea las Fotos 6, 7 y 8.)
9. Cierre el servo de TRKG otra vez y mueva otra vez el fonocaptor a las pistas exteriores del disco mediante las funciones de exploración o búsqueda.
10. Repita los pasos 4, 5, y 6.
11. Abra otra vez el servo de TRKG y observe las figuras de Lissajous. Compruebe que la amplitud en el eje Y haya alcanzado un mínimo. Si las figuras de Lissajous están todavía infladas en la dirección del eje Y, repita los pasos del 8 al 11.

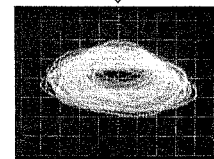

**4. AJUSTE DE LA INCLINACION DE LA DIRECCION DE SEGUIMIENTO DEL FONOCAPTOR**

**9.3 Ajustes mecánicos**

- **Objetivo:** Ajuste de la inclinación del eje deslizante para asegurar que el conjunto del fonocaptor se mueva en paralelo a la superficie del disco, y ajuste del ángulo de dirección de seguimiento del conjunto del fonocaptor para asegurar que el haz de láser sea enfocado perpendicularmente al disco.
- **Síntomas que indican la necesidad del ajuste:** Diafonía

- |  |  |
|--|--|
| <ul style="list-style-type: none"> <li>● Instrumentos y portapiezas de medición</li> <li>● Posición de medición</li> <li>● Disco de pruebas y modo del tocadiscos</li> <li>● Posición de ajuste</li> </ul> | <ul style="list-style-type: none"> <li>● Osciloscopio</li> <li>● Batería con hilos conductores</li> <li>● Filtro de paso bajo</li> <li>● Llave hexagonal de 2,5mm</li> <li>● CN103-5 del conjunto FTSB (excitador FOCS)</li> <li>● Disco de pruebas LD n. # 17.222, n. # 98</li> <li>● Tornillo de ajuste del ángulo de dirección de seguimiento del fonocaptor</li> <li>● Ajuste del ángulo del eje deslizante con el motor de inclinación</li> </ul> |
|--|--|

**Diagramas de conexión**

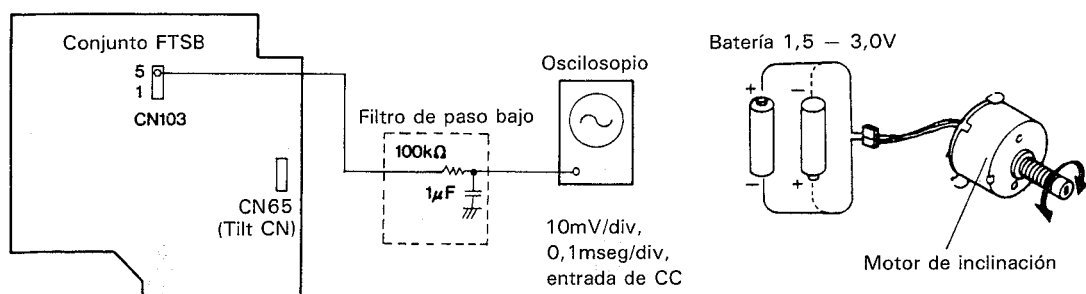

Fig.1

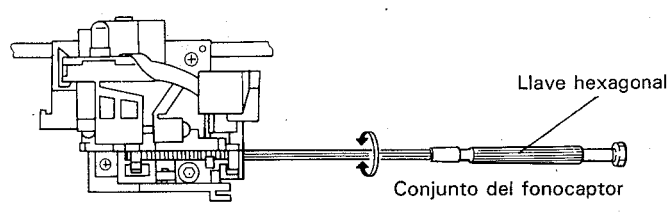

Fig.2

**Procedimientos para el ajuste**

1. Desconecte el conector CN65 (motor de inclinación) del conjunto FTSB, y no lo conecte otra vez hasta que haya completado el "Ajuste de ángulo del sensor de inclinación".
2. Reproduzca un disco de pruebas LD, y localice el cuadro n. # 98 donde se encuentra el fulcro de inclinación.
3. Conecte el osciloscopio a CN103-5 del conjunto FTSB a través del filtro de paso bajo, y observe la tensión de excitación de foco. El nivel GND del osciloscopio no tiene que estar alineado en el centro de la pantalla en esta fase.
4. Ajuste el mando de ajuste de posición del eje Y del osciloscopio para poner la forma de onda de la tensión de excitación de foco en el centro de la pantalla del osciloscopio.
5. Si la tensión de excitación de foco medida durante la búsqueda del cuadro n.\* 17.222 difiere de la obtenida en el paso 4 anterior, conecte un batería (1,5 a 3V) en el conector del motor de inclinación, y gire el motor hasta que la tensión de excitación de foco sea  $\pm 50mV$  de la tensión del paso 4.
6. Inserte la llave hexagonal en el orificio de ajuste del panel posterior, y ajuste el tornillo de ajuste de la dirección de seguimiento del fonocaptor para reducir la diafonía en los lados derecho e izquierdo de la pantalla de TV.
7. Localice el cuadro n. # 98 y compruebe que se haya reducido la diafonía en los lados derecho e izquierdo del pantalla de TV, y que sea aproximadamente igual en ambos lados. Si el nivel de diafonía en la pantalla de TV es todavía demasiado alto, repita los pasos 6 y 7.

**5. AJUSTE DEL BALANCE DE ERROR DE LD FOCS**

**9.3 Ajustes mecánicos**

- Objetivo: Asegurar que el servo de FOCS mantiene las lentes a una distancia óptima del disco durante la reproducción de LD.
- Síntomas que indican la necesidad del ajuste: Diafonía

- |  |   |
|--|---|
| <ul style="list-style-type: none"> <li>• Instrumentos y portapiezas de medición</li> <li>• Posición de medición</li> <li>• Disco de pruebas y modo del tocadiscos</li> <li>• Posición de ajuste</li> </ul> | <ul style="list-style-type: none"> <li>• Monitor de TV</li> <li>• Terminales de salida de vídeo del tocadiscos</li> <li>• Disco de pruebas LD n. # 98</li> <li>• VR2 del conjunto FTSB</li> </ul> |
|--|---|

**Diagramas de conexión**

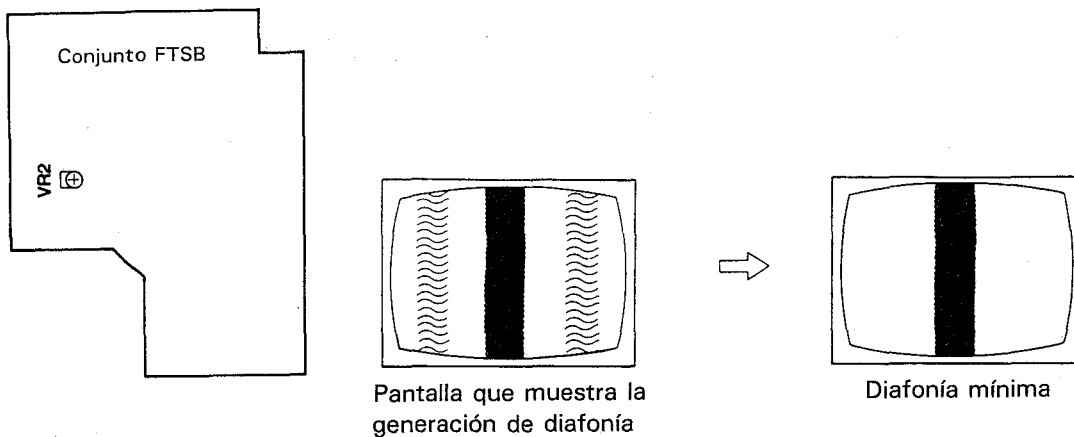

**Procedimientos para el ajuste**

1. Reproduzca un disco de pruebas LD, y localice el cuadro n. # 98.
2. Ajuste VR2 del conjunto FTSB para reducir la diafonía en los lados derecho e izquierdo de la pantalla de TV. Si con este ajuste no se logra reducir la diafonía al nivel permisible, pase a los procedimientos de "Ajuste del ángulo de dirección tangencial del fonocaptor".

6. AJUSTE DEL ANGULO DE DIRECCION TANGENCIAL DEL FONOCAPTOR

9.3 Ajustes mecánicos

- Objetivo: Ajuste de la inclinación de la dirección tangencial del fonocaptor para reducir la diafonía.
- Síntomas que indican la necesidad del ajuste: Diafonía notable

- |  |  |
|--|--|
| <ul style="list-style-type: none"> <li>• Instrumentos y portapiezas de medición</li> <li>• Posición de medición</li> <li>• Disco de pruebas y modo del tocadiscos</li> <li>• Posición de ajuste</li> </ul> | <ul style="list-style-type: none"> <li>• Monitor de TV</li> <li>• Diafonía en la pantalla • CN102-3 del conjunto FTSB (error de TRKG)</li> <li>• Disco de pruebas LD n. # 17.222, n. # 98 • Modo de pruebas (servo de TRKG: abierto/cerrado)</li> <li>• Tornillo de ajuste de la inclinación de dirección tangencial del fonocaptor</li> </ul> |
|--|--|

Diagramas de conexión (Para los diagramas de conexión, refiérase a la página 110.)

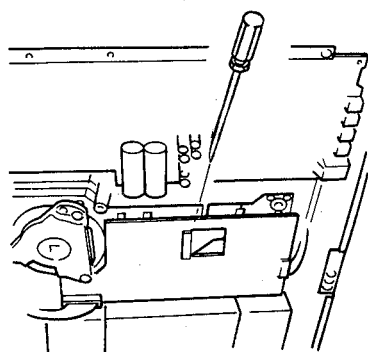

Ajuste de la inclinación de dirección tangencial del fonocaptor

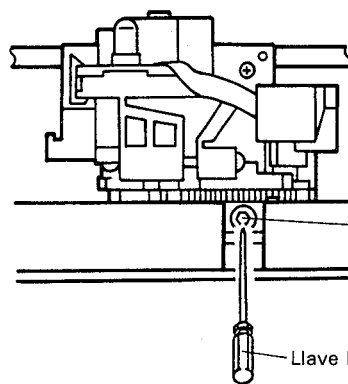

Guía del fonocaptor

Tornillo de ajuste de la inclinación de dirección tangencial del fonocaptor

Llave hexagonal

**Procedimientos para el ajuste**

*Nota: Este ajuste sólo será necesario si la diafonía es todavía notable después de completar los procedimientos de "Ajuste de la inclinación de la dirección de seguimiento del fonocaptor" y de "Ajuste de balance de error de LD FOCS".*

1. Reproduzca un disco de pruebas LD, localice el cuadro n. # 17.222, y abra el servo de TRKG.
2. Conecte el osciloscopio en CN102-3 del conjunto FTSB y observe la forma de onda del error de TRKG.
3. Inserte la llave hexagonal por el espacio entre el conjunto 2FSB y el conjunto mecánico en el tornillo de ajuste de la inclinación de dirección tangencial del fonocaptor.
4. Ajuste este tornillo hasta que la forma de onda del error de TRKG alcance la amplitud máxima.
5. Saque la llave hexagonal, luego localice el cuadro n. # 98 y compruebe que la diafonía en los lados derecho e izquierdo de la pantalla de TV se haya reducido, y

que sea aproximadamente igual en ambos lados. Repita los pasos 4 y 5 si fuera necesario.

7. AJUSTE DE LA INCLINACION DEL SENSOR DE INCLINACION

9.3 Ajustes mecánicos

- Objetivo: Ajuste de la contratensión del servo de inclinación a 0V mediante el ajuste de la inclinación del servo de inclinación.
- Síntomas que indican la necesidad del ajuste: Diafonía

- |  |   |
|--|---|
| <ul style="list-style-type: none"> <li>• Instrumentos y portapiezas de medición</li> <li>• Posición de medición</li> <li>• Disco de pruebas y modo del tocadiscos</li> <li>• Posición de ajuste</li> </ul> | <ul style="list-style-type: none"> <li>• Osciloscopio • Destornillador de cabeza Philips</li> <li>• CN102-3 del conjunto FTSB (error de inclinación)</li> <li>• Disco de pruebas LD n. # 17.222, n. # 98 (servo de TRKG: cerrado)</li> <li>• Tornillo de ajuste de la inclinación del sensor de inclinación • VR11 del conjunto FTSB (ganancia de inclinación)</li> </ul> |
|--|---|

Diagramas de conexión

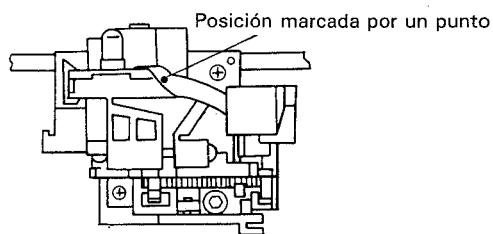
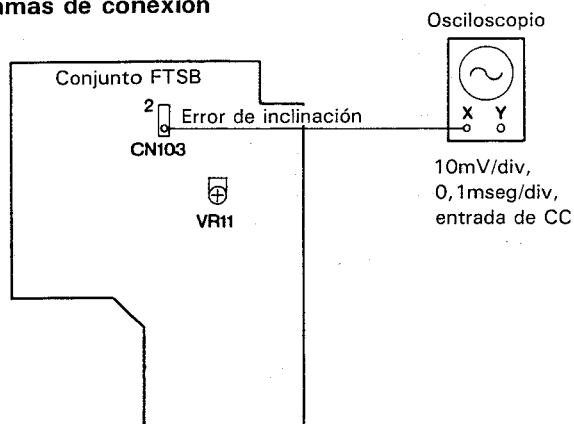
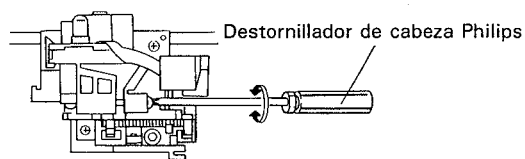

Fig. 1



Ajuste de la inclinación del sensor de inclinación

Fig. 2

Procedimientos para el ajuste

1. Compruebe el color del punto marcado en el cable flexible del lado del sensor de inclinación. (Fig. 1) Hay tres tipos de puntos. Ajuste VR11 del conjunto FTSB consecuentemente.
  - Punto rojo ... Gire VR11 completamente hacia la derecha.
  - Punto azul ... Gire VR11 completamente hacia la izquierda.
  - Sin punto (sin marca) ... Ajuste VR11 a la posición central.
2. eproduzcaun disco de pruebas LD, y localice el n. # de cuadro 17.222.
3. Conecte el osciloscopio en CN102-3 del conjunto FTSB, y observe la tensión de CC de error de inclinación.
4. Inserte un destornillador de cabeza Philips de eje largo por el panel posterior y ajuste el tornillo de ajuste de la inclinación del sensor de inclinación hasta que

- la tensión de CC de error de inclinación sea de 0V. (Vea la Fig. 2.) Durante este paso, no importa que el fonocaptor sea ligeramente desplazado del cuadro designado por el destornillador.
5. Conecte el conector CN65 del motor de inclinación desconectado durante el "Ajuste de la inclinación de la dirección de seguimiento del fonocaptor".
  6. Localice el cuadro n. # 98 y compruebe que la diafonía en los lados derecho e izquierdo de la pantalla de TV se haya reducido, y que sea aproximadamente igual en ambos lados.

**8. AJUSTE PRECISO DE REJILLA Y COMPROBACION DEL AJUSTE DE BALANCE DE TRKG**

**9.3 Ajustes mecánicos**

- **Objetivo:**
  - Ajuste preciso de la rejilla para asegurar que los dos haces para el servo de TRKG sean dirigidos en las posiciones óptimas de las pistas del disco.
  - Ajuste de la contratensión del servobucle de TRKG a 0V.
- **Síntomas que indican la necesidad del ajuste:** Seguimiento incorrecto (omisiones, saltos, etc.)

- |  |  |
|--|--|
| <ul style="list-style-type: none"> <li>• Instrumentos y portapiezas de medición</li> <li>• Posición de medición</li> <li>• Disco de pruebas y modo del tocadiscos</li> <li>• Posición de ajuste</li> </ul> | <ul style="list-style-type: none"> <li>• Osciloscopio • Destornillador</li> <li>• CN102-3 del conjunto FTSB (error de TRKG), CN102-7 (suma de TRKG)</li> <li>• Disco de pruebas n. # 17.000 # Modo de pruebas (Servo de TRKG: abierto)</li> <li>• Rejilla • VR6 del conjunto FTSB</li> </ul> |
|--|--|

**Diagramas de conexión**



Foto 9. Ajuste preciso de rejilla



Foto 10. Ajuste de balance de TRKG

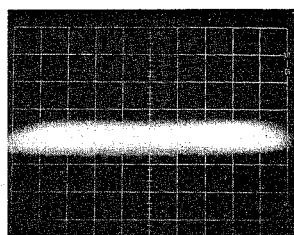
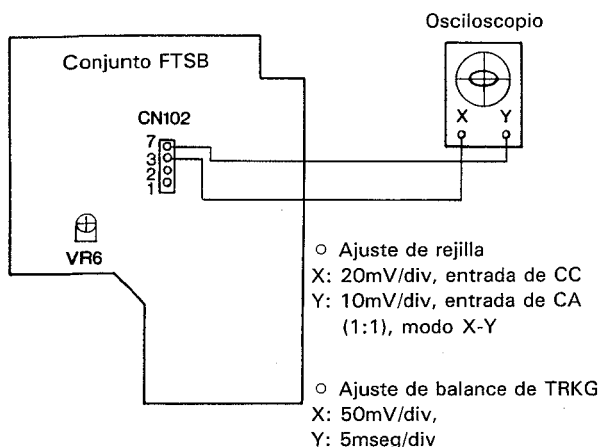

**Procedimientos para el ajuste**

1. Reproduzca un disco de pruebas LD, localice el cuadro n. # 17.000, y abra el servo de TRKG.
2. Conecte la entrada X del osciloscopio (CH-1) en CN102-3 del conjunto FTSB, y la entrada Y (CH-2) en CN102-7.  
Conmute el osciloscopio en el modo X-Y, y observe las figuras de Lissajous de las señales de error de TRKG y de suma de TRKG.
3. Inserte un destornillador pequeño en el orificio de ajuste de la rejilla (vea la pág. 109), y ajuste la rejilla hasta que la amplitud de las figuras de Lissajous en el eje Y alcancen un mínimo. (Foto 9.)  
Si se gira demasiado la rejilla y no se puede localizar la posición Óptima, repita los procedimientos del "Ajuste aproximado de rejilla".
4. Utilizando la entrada X (CH-1) del osciloscopio, compruebe que las amplitudes positiva y negativa de la señal de error de TRKG sean iguales. (Foto 10.). Si

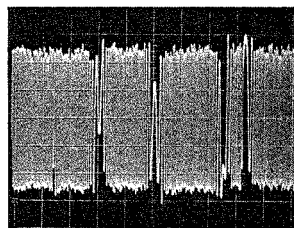
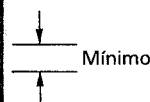
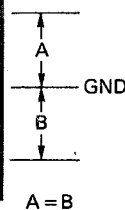
no lo fueran, repita los procedimientos de "Ajuste de balance de seguimiento".

5. Cierre el servo de TRKG, y compruebe que la imagen que sale por la pantalla de TV sea normal.

9.4 AJUSTES DEL CONJUNTO FTSB

1. AJUSTE DE GANANCIA DE RF

9.4 Ajustes del conjunto FTSB

- Objetivo: Ajuste de la amplitud de la señal de RF al valor óptimo
- Síntomas que indican la necesidad del ajuste: Caídas frecuentes

- |  |  |
|--|--|
| <ul style="list-style-type: none"> <li>• Instrumentos y portapiezas de medición</li> <li>• Posición de medición</li> <li>• Disco de pruebas y modo del tocadiscos</li> <li>• Posición de ajuste</li> </ul> | <ul style="list-style-type: none"> <li>• Osciloscopio</li> <li>• Conductor de R106 del conjunto FTSB (señal de RF)</li> <li>• Disco de pruebas LD n. # 17.000 (Servo de TRKG: cerrado)</li> <li>• VR10 del conjunto FTSB (ganancia de RF)</li> </ul> |
|--|--|

Diagramas de conexión

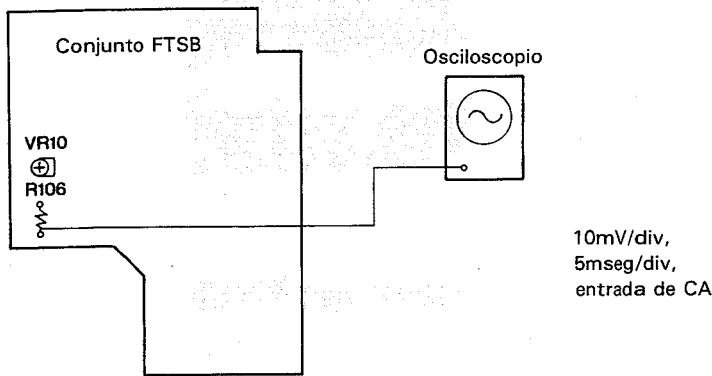

Procedimientos para el ajuste

1. Reproduzca un disco de pruebas LD y localice el cuadro n. # 17.000.
2. Conecte el osciloscopio con el conductor de R106 del conjunto FTSB y observe la señal de RF.
3. Ajuste VR10 del conjunto FTSB para obtener una amplitud de señal de RF de  $300\text{mV} \pm 50\text{mV}$ . (Foto 11.)

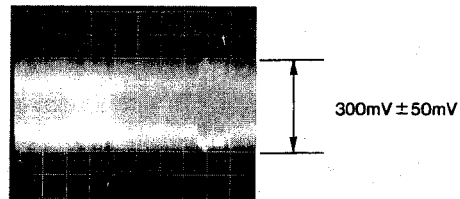

Señal de RF

Foto 11

## 2. AJUSTE DE LA GANANCIA DEL SERVOBUCLE DE TRKG

## 9.4 Ajustes del conjunto FTSB

- Objetivo: Ajuste de la ganancia del servobucle de TRKG al valor óptimo.
- Síntomas que indican la necesidad del ajuste: Seguimiento incorrecto (omisiones, saltos, etc.)

- |  |   |
|--|---|
| <ul style="list-style-type: none"> <li>• Instrumentos y portapiezas de medición</li> <li>• Posición de medición</li> <li>• Disco de pruebas y modo del tocadiscos</li> <li>• Posición de ajuste</li> </ul> | <ul style="list-style-type: none"> <li>• Osciloscopio • Resistor (<math>100k\Omega</math>) • Generador de AF</li> <li>• CN102-1 del conjunto FTSB (error de TRKG), CN102-3 (ganancia de TRKG)</li> <li>• Disco de pruebas LD n. # 17.000 (Servo de TRKG: cerrado)</li> <li>• VR7 del conjunto FTSB</li> </ul> |
|--|---|

## Diagramas de conexión

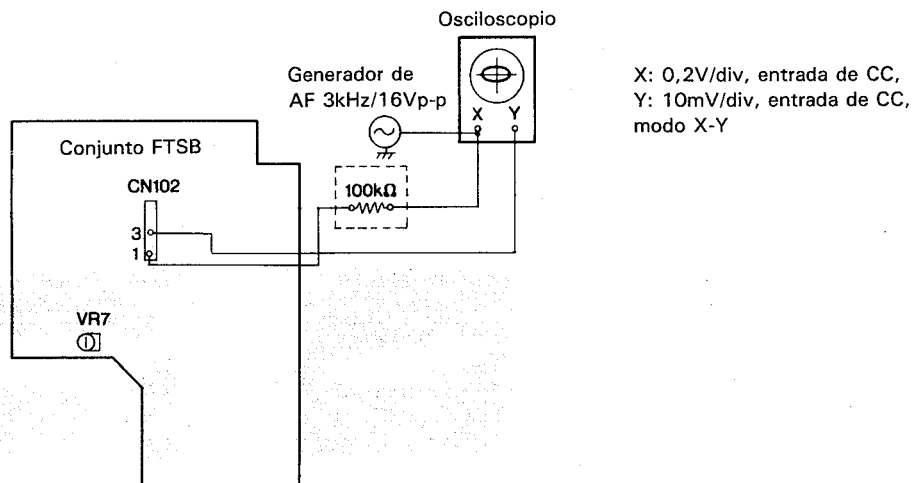

## Procedimientos para el ajuste

1. Reproduzca un disco de pruebas LD y localice el cuadro n. # 17.000.
2. Conecte el resistor, el generador de AF, y el osciloscopio con CN102 del conjunto FTSB tal como se muestra en el diagrama.
3. Ajuste la salida del generador de AF a 3kHz/16Vp-p.
4. Ponga el osciloscopio en el modo X-Y, y observe las figuras de Lissajous.
5. Ajuste VR7 del conjunto FTSB hasta que las figuras de Lissajous sean simétricas en los ejes respectivos X y Y del osciloscopio. (Foto 12.)

*Nota: Si la salida del generador de AF no excede los 16Vp-p, disminuya el valor del resistor anterior ( $100k\Omega$ ) hasta que las figuras de Lissajous sean fáciles de observar. (Límite a  $33k\Omega$ .)*

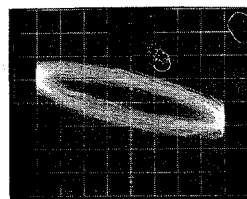

Desajustado

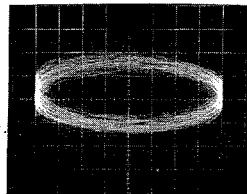

Después del ajuste Foto 12

## 3. AJUSTE DE LA GANANCIA DEL SERVOBUCLE DE FOCS

## 9.4 Ajustes del conjunto FTSB

- Objetivo: Ajuste de la ganancia del servobucle de FOCS al valor óptimo.
- Síntomas que indican la necesidad del ajuste: Mala reproducción Enfoque incorrecto. (Falta de enfoque inicial, reproducción intermitente, etc.)

- |  |   |
|--|---|
| <ul style="list-style-type: none"> <li>• Instrumentos y portapiezas de medición</li> <li>• Posición de medición</li> <li>• Disco de pruebas y modo del tocadiscos</li> <li>• Posición de ajuste</li> </ul> | <ul style="list-style-type: none"> <li>• Osciloscopio</li> <li>• Resistor (<math>100k\Omega</math>)</li> <li>• Generador de AF</li> <li>• CN102-5 del conjunto FTSB (error de FOCS), CN102-4 (ganancia de FOCS)</li> <li>• Función suspendida del circuito protector del motor FOCS.</li> <li>• Disco de pruebas LD n. # 17.000</li> <li>• VR1 del conjunto FTSB</li> </ul> |
|--|---|

## Diagramas de conexión



Foto 13

## Procedimientos para el ajuste

1. Conecta la compuerta de Q6 (2SK184) del conjunto FTSB a masa para suspender la función del circuito protector del motor de foco.
2. Conecte el resistor, el generador de AF, y el osciloscopio con CN102 del conjunto FTSB tal como se muestra en el diagrama.
3. Ajuste la salida del generador de AF a 1,8kHz/16Vp-p.
4. Ponga el osciloscopio en el modo X-Y, y observe las figuras de Lissajous.
5. Ajuste VR1 del conjunto FTSB hasta que las figuras de Lissajous sean simétricas en los ejes respectivos X y Y del osciloscopio. (Foto 13.)
6. Desconecte la compuerta Q6 del conjunto FTSB de masa.

*Nota: Si la salida del generador de AF no excede los 16Vp-p, disminuya el valor del resistor anterior ( $100k\Omega$ ) hasta que las figuras de Lissa-*

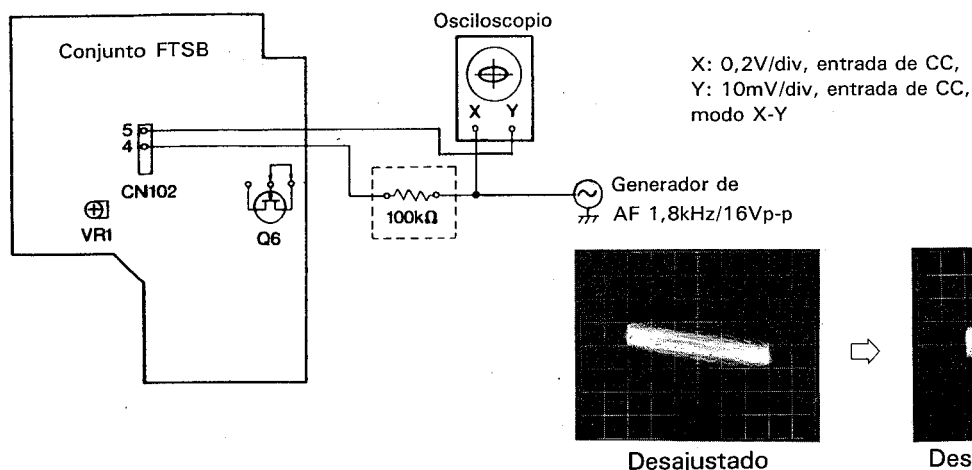
*jous sean fáciles de observar. (Limite a  $33k\Omega$ .)*



## 4. AJUSTE DEL BALANCE DE ERROR DE CD FOCS

## 9.4 Ajustes del conjunto FTSB

- **Objetivo:** Asegurar que FOCS mantenga las lentes a una distancia óptima del disco durante la reproducción de discos compactos.
- **Síntomas que indican la necesidad del ajuste:** Ruido durante la reproducción de discos compactos

- |  |   |
|--|---|
| <ul style="list-style-type: none"> <li>• Instrumentos y portapiezas de medición</li> <li>• Posición de medición</li> <li>• Disco de pruebas y modo del tocadiscos</li> <li>• Posición de ajuste</li> </ul> | <ul style="list-style-type: none"> <li>• Osciloscopio</li> <li>• CN26-1 del conjunto VSOP (EFM OUT)</li> <li>• Disco de pruebas CD (YEDS-7)</li> <li>• VR3 del conjunto FTSB</li> </ul> |
|--|---|

## Diagramas de conexión

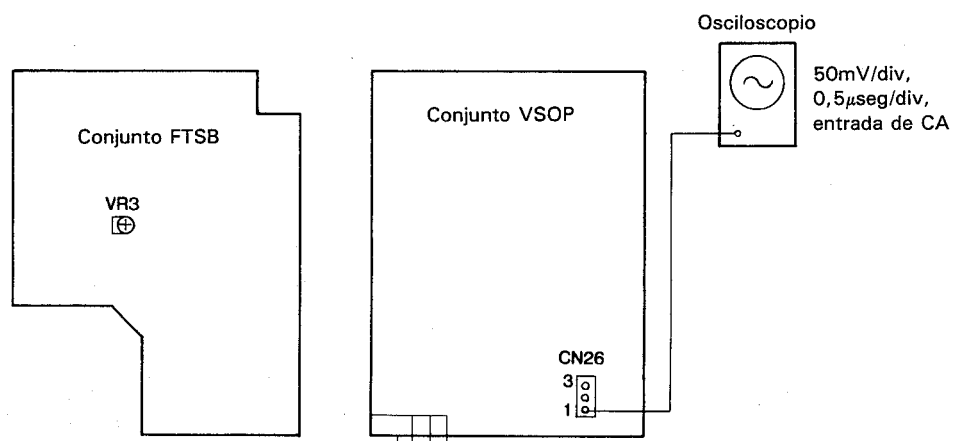

## Procedimientos para el ajuste

1. Reproduzca un disco de pruebas CD.
2. Conecte el osciloscopio con CN26-1 (EFM-OUT) del conjunto VSOP, y observe la señal EFM (configuración visual).
3. Ajuste VR3 del conjunto FTSB hasta que la señal EFM alcance la amplitud máxima. (Foto 14.)



Foto 14. Señal EFM

9.5 AJUSTE DEL CONJUNTO VSOP

1. AJUSTE DE LA POSICIÓN DE LA COMPUERTA DE SINCRONIZACIÓN CROMÁTICA

9.5 Ajustes del conjunto VSOP (TBC, CONT)

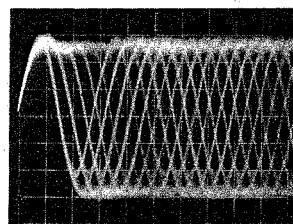
- Objetivo: Ajuste de la posición de la compuerta de sincronización cromática.
- Síntomas que indican la necesidad del ajuste: Reproducción iniciada a partir de la mitad (no desde el principio del disco), falta de color o color irregular, bandas finas

- |  |   |
|--|---|
| <ul style="list-style-type: none"> <li>● Instrumentos y portapiezas de medición</li> <li>● Posición de medición</li> <li>● Disco de pruebas y modo del tocadiscos</li> <li>● Posición de ajuste</li> </ul> | <ul style="list-style-type: none"> <li>● Osciloscopio</li> <li>● Q415 (emisor) del conjunto VSOP, alfiler 20 de CI102 (PA5012)</li> <li>● Disco de pruebas LD, PLAY</li> <li>● VR101 del conjunto VSOP</li> </ul> |
|--|---|

Diagramas de conexión

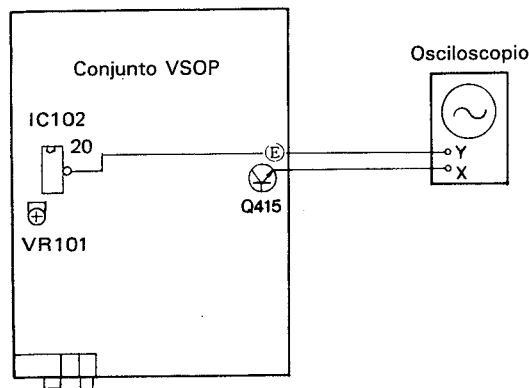

Procedimientos para el ajuste

1. Reproduzca un disco de pruebas LD.
  2. Conecte la entrada X (CH-1) del osciloscopio con el emisor de Q415 del conjunto VSOP, y la entrada Y (CH-2) con el alfiler 20 del CI102 (PA5012).
  3. Ajuste VR101 del conjunto VSOP hasta que el flanco posterior de la salida de MMV se retrase aproximadamente  $1,5\mu$  seg con relación al flanco posterior de sincronización H de la videoseñal. (Foto 17.)
- MMV: Multivibrador monoestable

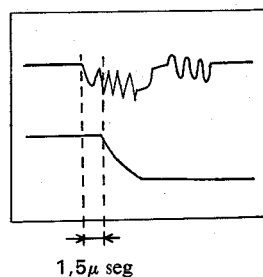

Parte superior: Emisor Q415 (TBC VIDEO)  
 Parte inferior: Alfiler 20 del CI102

Foto 17

## 2. AJUSTE DE 17,734475 MHz DE REF.

## 9.5 Ajustes del conjunto VSOP (TBC, CONT)

- Objetivo: Ajuste de frecuencia del reloj de referencia
- Sintomas que indican la necesidad del ajuste: Aberración cromática, fallo en la fijación del servo de eje

- |  |  |
|--|--|
| <ul style="list-style-type: none"> <li>● Instrumentos y portapiezas de medición</li> <li>● Posición de medición</li> <li>● Disco de pruebas y modo del tocadiscos</li> <li>● Posición de ajuste</li> </ul> | <ul style="list-style-type: none"> <li>● Frecuencímetro</li> <li>● Base de R3 del conjunto VSOP (o CI1, alfiler 21)</li> <li>● Alimentación conectada sin reproducir ningún disco.</li> <li>● VC1 del conjunto VSOP</li> </ul> |
|--|--|

## Diagramas de conexión

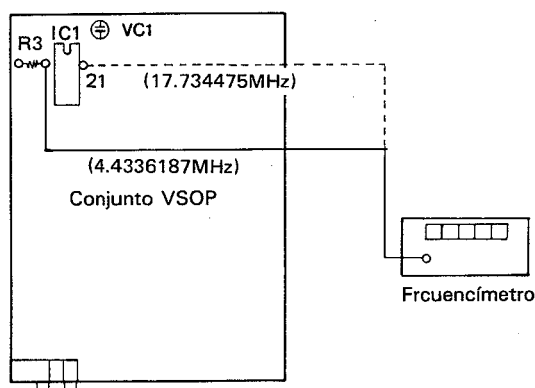

## Procedimientos para el ajuste

1. Conecte la alimentación, y conecte el frecuencímetro a la base de R3 del conjunto VSOP.
2. Ajuste VC1 del conjunto VSOP hasta que la frecuencia del reloj de referencia sea de 4,4336187MHz.

*Nota: Si esta frecuencia fuera difícil de ajustar, reproduzca un disco de pruebas LD, y ajuste VC1 del conjunto VSOP para obtener una frecuencia de 17,734475MHz en el alfiler 21 del CI1 (TC9015P) durante la reproducción.*

### 3. AJUSTE DE LA FRECUENCIA DE OSCILACION INICIAL 9.5 Ajustes del conjunto VSOP (TBC, CONT)

- Objetivo: Ajuste de la frecuencia del reloj de referencia a 3,75MHz.

- |  |  |
|--|--|
| <ul style="list-style-type: none"> <li>• Instrumentos y portapiezas de medición</li> <li>• Posición de medición</li> <li>• Disco de pruebas y modo del tocadiscos</li> <li>• Posición de ajuste</li> </ul> | <ul style="list-style-type: none"> <li>• Frecuencímetro</li> <li>• Alfiler 29 de CI101 (PD6064A) del conjunto VSOP</li> <li>• Alimentación conectada sin reproducir ningún disco</li> <li>• VC101 del conjunto VSOP</li> </ul> |
|--|--|

#### Diagramas de conexión

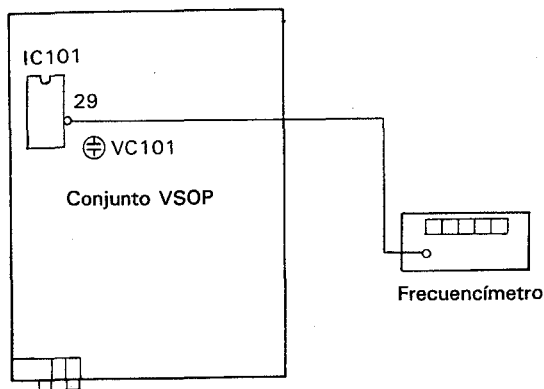

#### Procedimientos para el ajuste

1. Conecte la alimentación
2. Conecte el frecuencímetro con el alfiler 29 (TSSO) del CI101 (PD6064A) del conjunto VSOP. Ajuste a 15,6250kHz  $\pm$  0,1Hz con VC101.

**4. AJUSTE DEL NIVEL DE VIDEO RETARDADO 1H 9.5 Ajustes del conjunto VSOP (VDEM, ADEM)**

- **Objetivo:** Ajuste de la amplitud de la señal de vídeo retardada 1H a la misma amplitud de la señal de vídeo principal.
- **Síntomas que indican la necesidad del ajuste:** Considerable caída al blanco y desplazamiento de H (líneas horizontales de la pantalla) cuando el nivel 1H es grande, y considerable caída al negro cuando el nivel 1H es pequeño.

- |  |   |
|--|---|
| <ul style="list-style-type: none"> <li>● Instrumentos y portapiezas de medición</li> <li>● Posición de medición</li> <li>● Disco de pruebas y modo del tocadiscos</li> <li>● Posición de ajuste</li> </ul> | <ul style="list-style-type: none"> <li>● Osciloscopio de seguimiento doble</li> <li>● Conjunto VSOP • Alfiler 40 y alfiler 42 del CI401 (PA5010)</li> <li>● Disco de pruebas cap. n. # 11</li> <li>● VR401 del conjunto VSOP</li> </ul> |
|--|---|

**Diagramas de conexión**

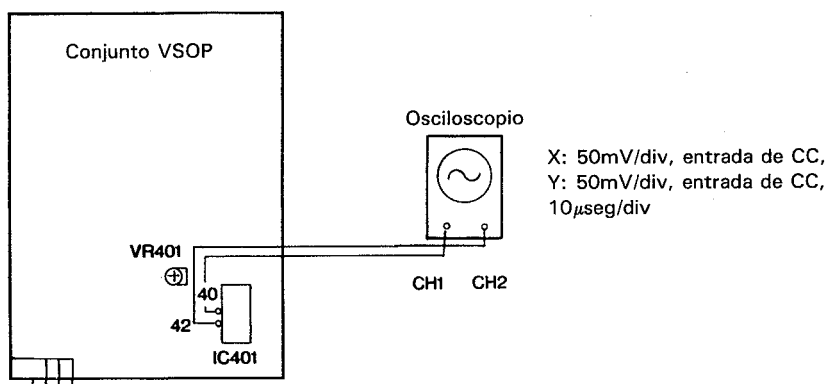

**Procedimientos para el ajuste**

1. Reproduzca un disco de pruebas LD, y localice el cap. n. # 11.
2. Conecte la entrada X (CH-1) del osciloscopio con el alfiler 40 del CI401 (PA5010) del conjunto VSOP, y la entrada Y (CH-2) con el alfiler 42. Observe simultáneamente las formas de onda de la señal de vídeo principal y la señal de vídeo retardada H1.
3. Ajuste VR401 del conjunto VSOP hasta que la amplitud desde la punta de sincronización hasta el nivel de blanco de la señal de vídeo retardada 1H (CH-2) sea la misma que la amplitud de la señal de vídeo principal (CH-1). (Foto 18.)

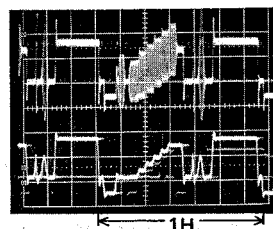

Señal de vídeo principal

Señal de vídeo retardada 1H

Foto 18

5. AJUSTE DE LA FRECUENCIA CENTRAL VCO

9.5 Ajustes del conjunto VSOP (VDEM, ADEM)

- Objetivo: Mejoramiento del tiempo de retardo de CCD para compensación del error de base de tiempo.
- Síntomas que indican la necesidad del ajuste: Fallo en la fijación de color. Fijación lenta del color después de una operación de búsqueda.

- |  |   |
|--|---|
| <ul style="list-style-type: none"> <li>• Instrumentos y portapiezas de medición</li> <li>• Posición de medición</li> <li>• Disco de pruebas y modo del tocadiscos</li> <li>• Posición de ajuste</li> </ul> | <ul style="list-style-type: none"> <li>• Osciloscopio de seguimiento doble</li> <li>• Emisor Q412 y emisor Q413 del conjunto VSOP</li> <li>• Disco de pruebas LD cap. n. # 11</li> <li>• VR402 del conjunto VSOP</li> </ul> |
|--|---|

Diagramas de conexión

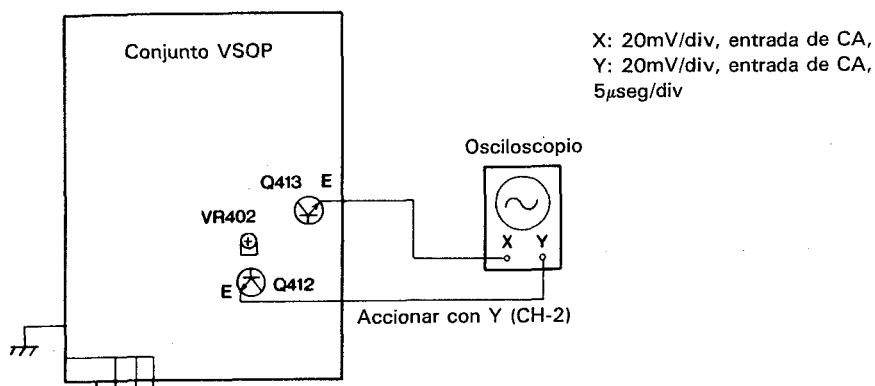

Procedimientos para el ajuste

1. Reproduzca un disco de pruebas LD, y localice el cap. n. # 11.
2. Conecte la entrada X (CH-1) del osciloscopio con el emisor de Q413 del conjunto VSOP, y la entrada Y (CH-2) con el emisor de Q412. Accionar con CH-2, y observar simultáneamente las formas de onda de la señal de vídeo antes y después de la compensación del error de base de tiempo.
3. La señal de vídeo de la siguiente compensación de error de base de tiempo del CH-1 contiene vibraciones. Ajuste VR402 del conjunto VSOP para retardar la parte central de la vibración en  $68\mu\text{seg}$  ( $1H + 4\mu\text{seg}$ ) desde el flanco posterior de la señal de sincronización horizontal (H-sync) de la señal de vídeo antes de compensación de error de base de tiempo en CH-2. (Foto 19.)



Foto 19

6. AJUSTE DEL RELOJ DECORD

9.5 Ajustes del conjunto VSOP (TBC, CONT)

- Objetivo: Ajuste de la frecuencia normal del reloj.

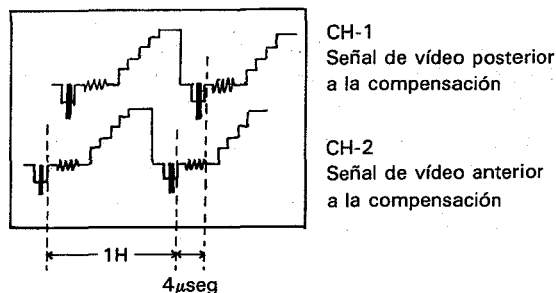
- |  |   |
|--|---|
| <ul style="list-style-type: none"> <li>• Instrumentos y portapiezas de medición</li> <li>• Posición de medición</li> <li>• Disco de pruebas y modo del tocadiscos</li> <li>• Posición de ajuste</li> </ul> | <ul style="list-style-type: none"> <li>• Frecuencímetro</li> <li>• Alfiler 3 del CI10 (PA0011) del conjunto VSOP</li> <li>• Alimentación conectada • Ajustado al modo de pruebas.</li> <li>• VC2 del conjunto VSOP</li> </ul> |
|--|---|

Diagramas e conexión

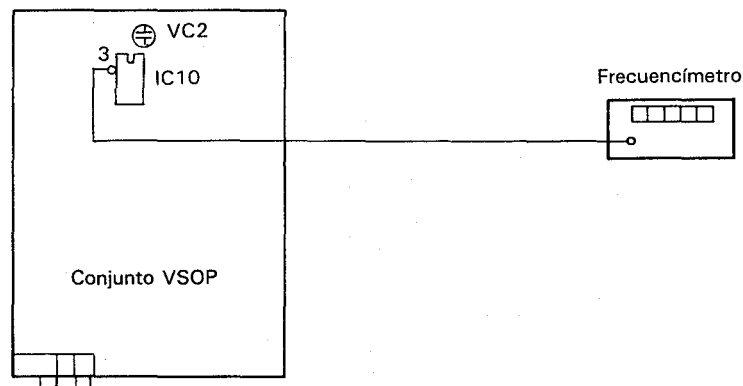

Procedimientos para el ajuste

1. Conecte la alimentación.
  2. Conecte el frecuencímetro con el alfiler 3 del CI10.
  3. Después de conmutar al modo de pruebas, presione las siguientes teclas del mando de control a distancia: **CX** + **4**.
- \* De este modo se consigue la generación continua de una señal DOC INH.
4. Ajuste de manera que la frecuencia de la señal del alfiler 3 del CI10 sea de 3MHz ± 50kHz con VC2.

## 7. AJUSTE DEL NIVEL DE SALIDA DE VIDEO

## 9.5 Ajustes del conjunto VSOP (VDEM, ADEM)

- Objetivo: Ajuste de la amplitud de la señal de vídeo de salida (pedestal ↔ 100% blanco) a 0,7Vp-p.
- Síntomas que indican la necesidad del ajuste: Reproducción iniciada a partir de la mitad debido a una lectura incorrecta de los datos. Pantalla demasiado brillante o demasiado oscura.

- |  |  |
|--|--|
| <ul style="list-style-type: none"> <li>• Instrumentos y portapiezas de medición</li> <li>• Posición de medición</li> <li>• Disco de pruebas y modo del tocadiscos</li> <li>• Posición de ajuste</li> </ul> | <ul style="list-style-type: none"> <li>• Osciloscopio</li> <li>• Terminales de salida de vídeo</li> <li>• Disco de pruebas LD cap. n. # 11</li> <li>• VR403 del conjunto VSOP</li> </ul> |
|--|--|

## Diagramas de conexión

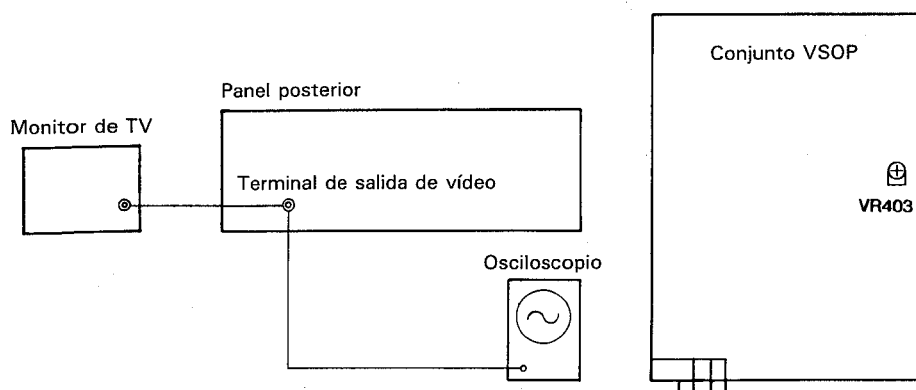

## Procedimientos para el ajuste

*Nota: Conecte el terminal de salida de vídeo del tocadiscos con un monitor e vídeo, y terminar el monitor internamente con 75 ohmios. Si utiliza un televisor sin terminal de entrada de vídeo, terminar el terminal de salida de vídeo del tocadiscos con 75 ohmios.*

1. Reproduzca un disco de pruebas y localice el cap. n. # 11.
2. Conecte el osciloscopio con el terminal de salida de vídeo del tocadiscos, y observe la forma de onda de la señal de vídeo de la reproducción.
3. Ajuste VR403 del conjunto VSOP hasta que la amplitud del nivel de pedestal al nivel de blanco de la forma de onda de la señal de vídeo de la reproducción alcance  $0,7V \pm 5\%$ . (Foto 20.)

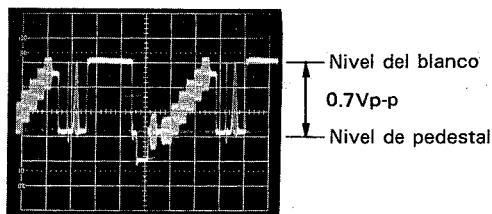



**8. AJUSTE EL NIVEL DE SEAL DE ERROR DE FASE DE COLOR 9.5 Ajustes del conjunto VSOP (VDEM, ADEM)**

- **Objetivo:** Mejoramiento de la cantidad de señal de error de fase de color que debe aplicarse en la etapa de compensación de fase de color.
- **Síntomas que indican la necesidad del ajuste:** Irregularidades notables de color

- |  |   |
|--|---|
| <ul style="list-style-type: none"> <li>● Instrumentos y portapiezas de medición</li> <li>● Posición de medición</li> <li>● Disco de pruebas y modo del tocadiscos</li> <li>● Posición de ajuste</li> </ul> | <ul style="list-style-type: none"> <li>● Monitor de TV</li> <li>● Ajuste mientras se observa la pantalla del monitor.</li> <li>● Disco de pruebas LD cap. n. # 14</li> <li>● VR406 del conjunto VSOP</li> </ul> |
|--|---|

**Diagramas de conexión**

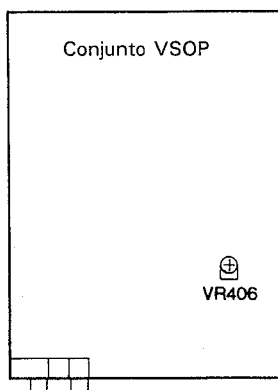

**Procedimientos para el ajuste**

1. Reproduzca un disco de pruebas LD y localice el cap. n. # 14
2. Ajuste VR406 del conjunto VSOP para reducir las irregularidades de color magenta de la pantalla.

9. AJUSTE DEL NIVEL DETECTOR

9.5 Ajustes del conjunto VSOP (VDEM, ADEM)

- Objetivo: Mejoramiento de la tensión de entrada aplicada al comparador del detector de velocidad del motor del eje.
- Síntomas que indican la necesidad del ajuste: Fallo en la fijación del servo del eje. Aberración de la imagen.

- |  |   |
|--|---|
| <ul style="list-style-type: none"> <li>● Instrumentos y portapiezas de medición</li> <li>● Posición de medición</li> <li>● Disco de pruebas y modo del tocadiscos</li> <li>● Posición de ajuste</li> </ul> | <ul style="list-style-type: none"> <li>● Voltímetro digital</li> <li>● Alfileres 6 y 7 del CI403 (NJM2903S) del conjunto VSOP</li> <li>● Disco de pruebas n. # 3.001</li> <li>● VR405 del conjunto VSOP (VDEM, ADEM)</li> </ul> |
|--|---|

Diagramas de conexión

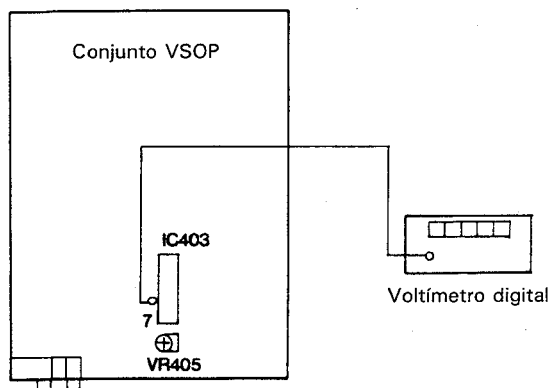

Procedimientos para el ajuste

1. Reproduzca un disco de pruebas y localice el cuadro n. # 3.001.
2. Conecte el voltímetro digital con el alfiler 7 del CI403 (NJM2903S) del conjunto VSOP. Mida y registre la tensión de referencia del comparador del detector de velocidad del motor del eje.
3. Conecte también el voltímetro digital con el alfiler 6 del mismo CI y mida la tensión de salida del detector de velocidad. Ajuste VR403 del conjunto VSOP para obtener una tensión de  $+260\text{mV} \pm 20\text{mV}$  mayor en el alfiler 6 que en el 7.

## 9.6 AJUSTES DEL CONJUNTO 2FSB

## 1. AJUSTE DE LA FRECUENCIA PROPIA DE VCOX

## 9.6 Ajustes del conjunto 2FSB

- Objetivo: Ajuste de la frecuencia del generador de cristal utilizado en el descodificador de EFM al valor óptimo.

- Instrumentos y portapiezas de medición
- Posición de medición
- Disco de pruebas y modo del tocadiscos
- Posición de ajuste

- Frecuencímetro
- Hilo conductor R137 del conjunto 2FSB
- Disco de pruebas CD — reproducción de cualquier pista
- VR501 del conjunto 2FSB

## Diagramas de conexión

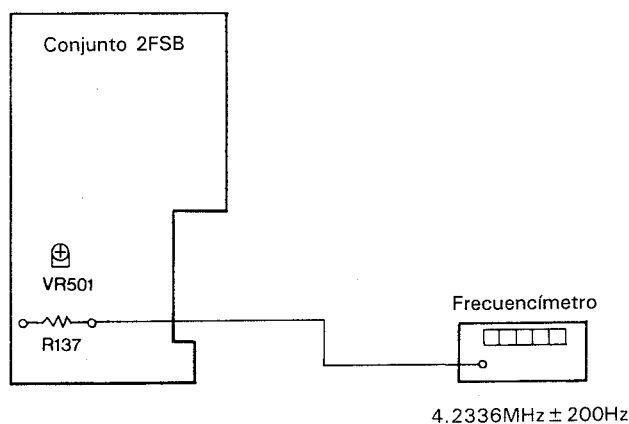

## Procedimientos para el ajuste

1. Reproduzca una pista cualquiera del disco de pruebas CD.
2. Conecte el frecuencímetro con el hilo conductor de R137 del conjunto 2FSB y observe la frecuencia propia de VCOX.
3. Ajuste la frecuencia a  $4,2336\text{MHz} \pm 200\text{Hz}$  ajustando VR501 del conjunto 2FSB.

## 2. AJUSTE DE LA FRECUENCIA PROPIA DE PLL

## 9.6 Ajustes del conjunto 2FSB

- Objetivo: Ajuste de la frecuencia propia de PLL VCO utilizado en el descodificador de EFM al valor óptimo.
- Síntomas que indican la necesidad del ajuste: No hay sonido digital, o sonido digital intermitente.

- |  |  |
|--|--|
| <ul style="list-style-type: none"> <li>• Instrumentos y portapiezas de medición</li> <li>• Posición de medición</li> <li>• Disco de pruebas y modo del tocadiscos</li> <li>• Posición de ajuste</li> </ul> | <ul style="list-style-type: none"> <li>• Voltímetro digital</li> <li>• Alfiler 1 del CI102 (NJM082D) del conjunto 2FSB</li> <li>• Disco LaserVision con disco de sonido digital (LDD) — reproducción de cualquier cuadro</li> <li>• VL101 del conjunto 2FSB</li> </ul> |
|--|--|

## Diagramas de conexión

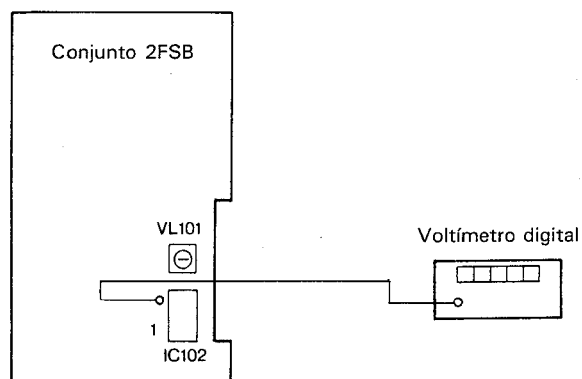

## Procedimientos para el ajuste

1. Reproduzca cualquier cuadro del disco LDD.
2. Conecte el voltímetro digital con el alfiler 1 del CI102 del conjunto 2FSB y mida la tensión de CC de la señal de control de VCO.
3. Ajustela tensión de CC de la señal de control de VCO a  $150\text{mV} \pm 100\text{mV}$  ajustando VL101 del conjunto 2FSB.

3. AJUSTE DE LA DESVIACION DE VCXO

9.6 Ajustes del conjunto 2FSB

- Objetivo: Reducir la contratensión de error de fase de VCXO PLL
- Síntomas que indican la necesidad del ajuste: Salida intermitente de sonido digital durante la reproducción de LDD (salida de ruido sincrónico)

- |  |   |
|--|---|
| <ul style="list-style-type: none"> <li>• Instrumentos y portapiezas de medición</li> <li>• Posición de medición</li> <li>• Disco de pruebas y modo del tocadiscos</li> <li>• Posición de ajuste</li> </ul> | <ul style="list-style-type: none"> <li>• Osciloscopio</li> <li>• J170 del conjunto 2FSB (MDP)</li> <li>• Disco LDD — reproducción de cualquier cuadro</li> <li>• VR102 del conjunto 2FSB</li> </ul> |
|--|---|

Diagramas de conexión

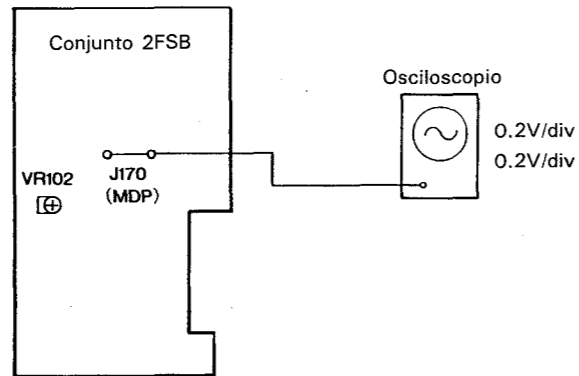

Procedimientos para el ajuste

1. Reproduzca cualquier cuadro del disco LDD.
2. Conecte el osciloscopio al conductor de puente J170 (MDP) del conjunto 2FSB y observe la señal de salida de error de fase de VCXO PLL.
3. Ajuste VE102 del conjunto 2FSB para reducir la anchura de los impulsos del lado positivo o negativo y poder obtener una forma de onda continua. (Forma de onda central en la Foto 23.)



Foto 23

- A Forma de onda obtenida cuando VR102 se gira hacia la derecha a partir del punto de ajuste óptimo.
- B Ajuste óptimo
- C Forma de onda obtenida cuando VR102 se gira hacia la izquierda a partir del punto de ajuste óptimo.

10. HB TYPE

The CLD-1200/HB type is the same as the CLD-1200/HEM type with the exception of the following sections.

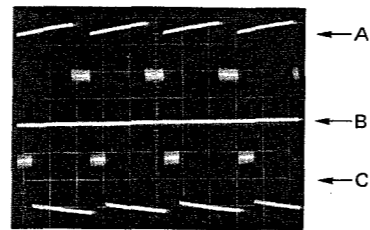
Mark	Symbol & Description	Part No.		Remarks
		HEM type	HB type	
	* VSOP assembly (RFMD)	VWS1035 (VWL1010)	VWS1040 (VWL1012)	
	AC power cord	VDG1014	VDG1016	
	Operating instructions (English)	...	VRB1014	
	Operating instructions (English/Dutch/French/Italian)	VRE1002	...	

\* The difference of the VSOP assembly between VWS1035 (for HEM type) and VWS1040 (for HB type) is the RFMD.

### 11. BLOCK DIAGRAM OF VSOP ASSEMBLY (TBC, CONT)

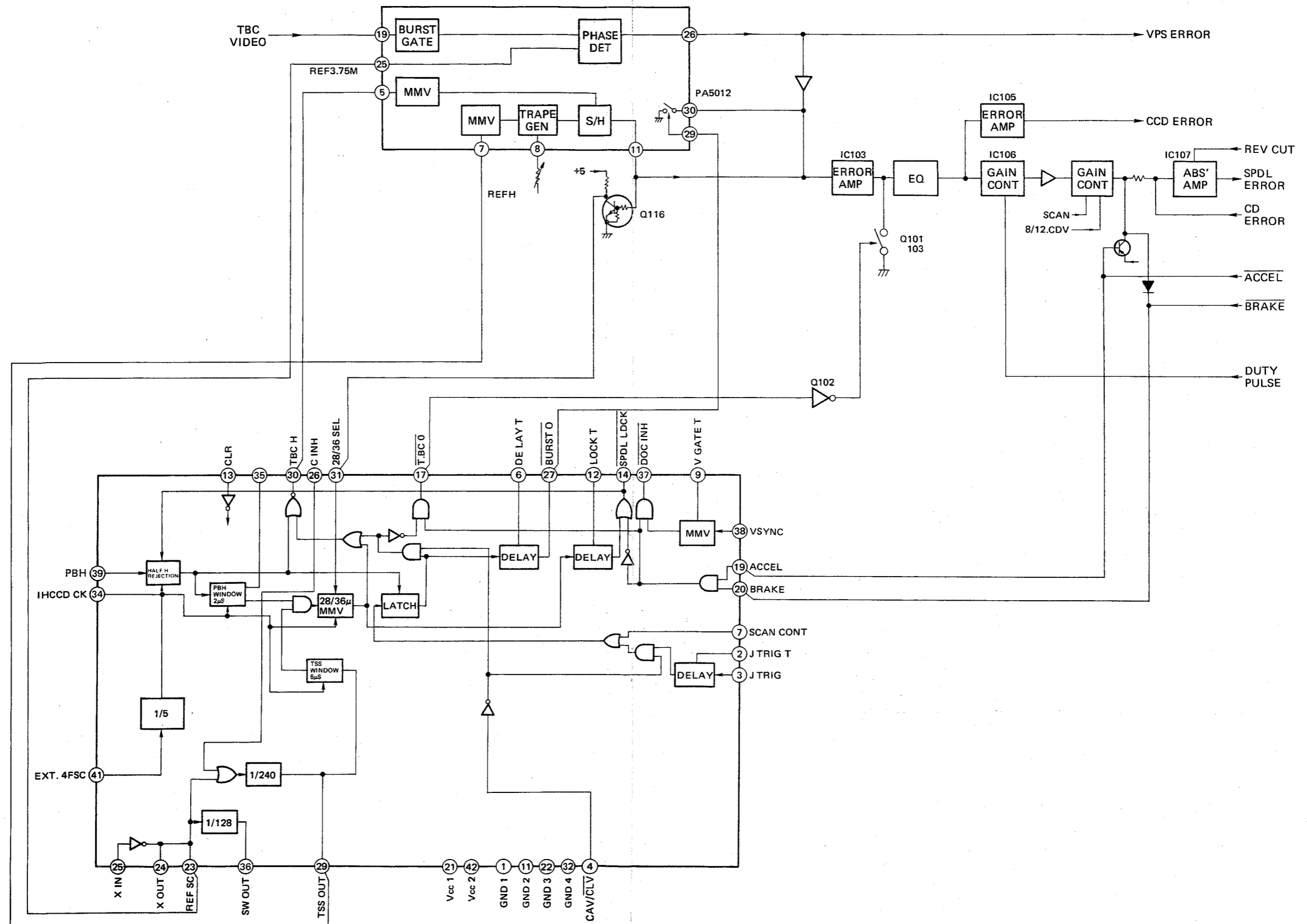

## 12. SPECIFICATIONS

### 1. General

System .....	LaserVision Disc system and Compact Disc digital audio system
Laser .....	Semiconductor laser wavelength 780 nm
Power requirements .....	AC 220/240 V (Switchable) 50/60 Hz
Power consumption .....	33 W
Weight .....	9.2 kg
Dimensions .....	420(W) x 438(D) x 110(H) mm
Operating temperature .....	+5°C — +35°C
Operating humidity .....	5% — 90%
(There should be no condensation of moisture.)	

### 2. Disc

CDV .....	12 cm, 20 cm, 30 cm
LaserVision .....	30 cm
CD .....	12 cm, 8 cm

### 3. Video characteristics

Format .....	PAL specifications
Video output	
Level .....	1 Vp-p nominal, sync. negative, terminated
Impedance .....	75Ω unbalanced
Terminal .....	RCA jack
TV output (PAL-G)	
Channel .....	UHF CH.32 — CH.40 (adjustable)
Impedance .....	75Ω unbalanced
Terminal .....	IEC jack

### 4. Audio characteristics

Output level	
During analog audio output .....	200 mVrms (1kHz, 40%)
During digital audio output .....	200 mVrms (1kHz, -20dB)
Terminal .....	RCA jacks
Number of channels .....	2

#### Digital Audio Characteristics

Frequency response	4 Hz - 20 kHz ( $\pm 0.5$ dB / $-1.0$ dB)
S/N ratio	98 dB
Dynamic range	95 dB
Channel separation	92 dB
Total harmonic distortion	0.005%
Wow and flutter	Limit of measurement ( $\pm 0.001\%$ W.PEAK) or less

### 5. Other Terminals

Control input/output .....	Both miniature jacks
Headphones .....	Standard stereo jack

### 6. Accessories

Remote control unit (CU-CLD011) .....	1
Size "AAA" (IEC R03) dry cell battery .....	2
RF aerial cable .....	1
Audio connecting cord .....	1
Video connecting cord .....	1
Operating instructions .....	1
Adjustment screwdriver .....	1

## 13. PANEL AND REMOTE CONTROL UNIT FACILITIES

### [PLAYER FRONT PANEL]

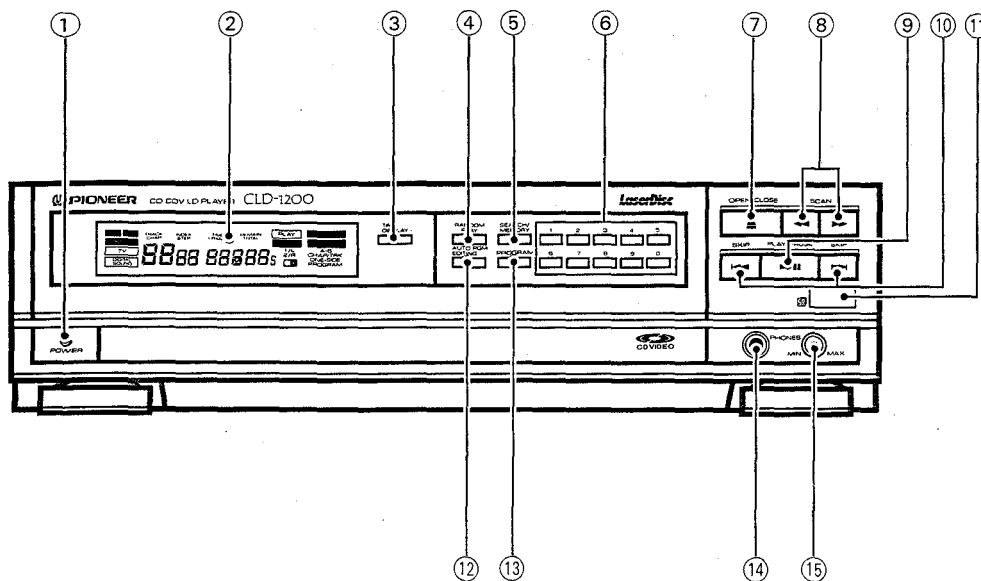

#### ① POWER button

#### ② Door/indicators

When power is switched on, and OPEN/CLOSE button is pressed, the door opens downward, and at the same time, the disc table is expelled outward. (Refer to the "INDICATORS".)

#### ③ TIME DISPLAY button

This is used to change the indication, the on-screen display and the indicator display. With discs which do not feature a table of contents (TOC), this serves as the ON/OFF button for the monitor display. (Refer to the "INDICATORS".)

#### ④ RANDOM PLAY button

This function is limited to Compact Discs and the audio portion of 12 cm CDV Discs. Press the button to start random playback.

#### ⑤ SEARCH/MEMORY button

Search button function:

- Execution of search operation.
- For memory repeat operation.

Memory button function:

This button is also used to input programs for programmed play.

#### ⑥ DIGIT button (0 — 9)

- This is used for search, track selection and program input.
- Use the DIGIT button during editing to designate the time in minutes. (This function is limited to Compact Discs and the audio portion of 12 cm CDV Discs.)

#### ⑦ OPEN/CLOSE (▲) button

This button is used to open and close the disc table. Setting a disc on the disc table then pressing this button retracts the disc table in to the player and begins play of the disc. Pressing this button during play stops play and extends the table from the player.

#### ⑧ SCAN (◀▶) buttons

After play has begun, the disc is fast forwarded as long as the ▶▶ button is held down or fast backwarded as long as the ◀◀ button is held down. There are two speeds. The first two seconds that a button is held down the scanning is at low speed, then it changes to high speed.

#### ⑨ PLAY/PAUSE (▶/||) button

- Setting a disc on the disc table then pressing this button retracts the disc table into the player and begins play of the disc.
- Pressing this button while the disc is stopped begins play of the disc.
- Pressing this button during play pauses the play. Pressing this button again restarts the play from the point at which it was paused.
- Press this button to begin chapter programming.



## PANEL AND REMOTE CONTROL UNIT FACILITIES

## ⑩ SKIP (◀, ▶) buttons

- This is used to move to the head of the chapter for LaserVision Discs, or to the head of the track for Compact Discs or 12 cm CDV Disc.
- During program input of programmed playback, by using the chapter skip ◀ or ▶ key (also used as PGM CORRECT key), the contents of a program already input can be altered.

## ⑪ Remote sensor window

## ⑫ AUTO PGM EDITING (Auto Program Editing) button

This function is limited to the Compact Discs and the audio portion of 12 cm CDV Discs.

Press the AUTO PGM EDITING button to program selections which can be played within the designated time.

## ⑬ PROGRAM button

This button is used for programmed playback, which is playback in which the order of chapters or the order of tracks.

## ⑭ PHONES (headphones) jack

When you wish to use headphones, insert the plug for the headphones into the headphone jack.

## ⑮ PHONES level control knob

Use to adjust the level of sound when using headphones. Turning the knob to the right increases the sound level.

## INDICATORS:

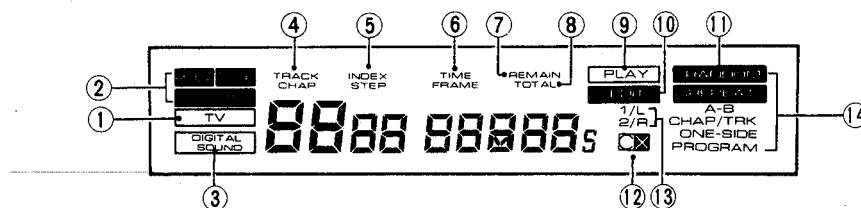

- |   |  |   |  |
|---|--|---|--|
| <p>① TV</p> <p>Turned off</p> <p>Turned on</p>                        | <p>: Lights when the television connected to the TV output terminal on the back of the player is receiving a TV program.</p> <p>: When a disc is being played back.</p> <p>: While TV broadcasting is being received. When the power is turned on initially, the indicator is not lit.</p> | <p>6 TIME FRAME</p>                       | <p>: Indicates the elapsed playing time or frame number for active play discs (CAV).</p>   |
| <p>② CD, CDV, LD</p> <p>CD</p> <p>CDV</p> <p>LD</p> <p>LD and CDV</p> | <p>: Lights while the Compact Disc is being played back.</p> <p>: Lights while the 12 cm CDV Disc is being played back.</p> <p>: Lights while the LaserVision Disc is being played back.</p> <p>: Lights while the 20 cm or 30 cm CDV Disc is being played back.</p>                       | <p>7 REMAIN</p>                           | <p>: Indicates the time remaining from the present playing position to the end of play for CDs or the audio portion of 12 cm CDVs.</p>   |
| <p>③ DIGITAL SOUND</p>  | <p>: Lights while the CDV or CD Disc is being played back.</p>   | <p>8 TOTAL</p>                            | <p>: Indicates total number of selections and total playback time (TRACK/CHAP) on the playback side of the disc. Also when playing the LD Discs, TOTAL is not displayed.</p>   |
| <p>④ TRACK CHAP</p>   | <p>: Indicates the track no. or chapter no.</p>  | <p>9 PLAY</p>                             | <p>: Lights during playback. Flashes when proceeding to playback and during search.</p>  |
| <p>⑤ INDEX STEP</p>   | <p>: Indicates the index no. for the signals indexed in a music program or the program step number when a program is being played back.</p>  | <p>10 EDIT</p> <p>11 RANDOM</p>           | <p>: Lights while editing is being performed.</p> <p>: Lights along with the REPEAT indicator during random play.</p>  |
|   |  | <p>12 CX ( <input type="checkbox"/> )</p> | <p>: Lights up when the CX noise reduction system is operating. CX is a trademark of CBS Inc. This player meets the CX EXPANDING SPECIFICATION.</p> <p>● CX is used only when LaserVision Disc is being played back.</p>                     |
|   |  | <p>13 1/L, 2/R</p>                        | <p>: Indicates the audio output channel. 1/L indicates the 1st audio channel or left channel; 2/R indicates the 2nd audio channel or the right channel.</p> <p>When the power is turned on, both 1/L and 2/R light (in the STEREO mode).</p> |

## PANEL AND REMOTE CONTROL UNIT FACILITIES

- ⑭ REPEAT : Indicates the type of repeat play during playback. REPEAT play is selected with the A or B keys of the remote control unit.
- A — B : Indicates when the repeat play of an interval between two points A and B is selected.
- CHAP/TRK : Indicates chapter repeat with LaserVision Discs or 20 cm or 30 cm CDV Discs; indicates the track (selection number) which is set for repeat playback with Compact Discs and 12 cm CDV Discs.
- ONE-SIDE : Indicates that one side repeat play has been selected.
- PROGRAM : Indicates that program repeat play has been selected.

## TIME (FRAME)/REMAIN/TOTAL

Changes when the TIME DISPLAY button or remote control unit DISPLAY key is pressed.

\*1 In the case of the video portion of CDV Discs:

→ TIME (FRAME) → TIME (FRAME) → TOTAL

In the case of CDs and the audio portion of 12 cm CDVs:

→ TIME → TIME → REMAIN → TOTAL

\*1 : The INDEX is a prerecorded signal which indicates different points within a selection or between selections. For discs which have an INDEX signal recorded on them, an INDEX indication is provided in the instructions.

## [REMOTE CONTROL UNIT]

- \* Refer to fig. ② on page 2 for inserting batteries in the remote control unit.

Keys for which no special instructions are given correspond to the same functions as the buttons of the player. (Refer to the section [PLAYER FRONT PANEL].)

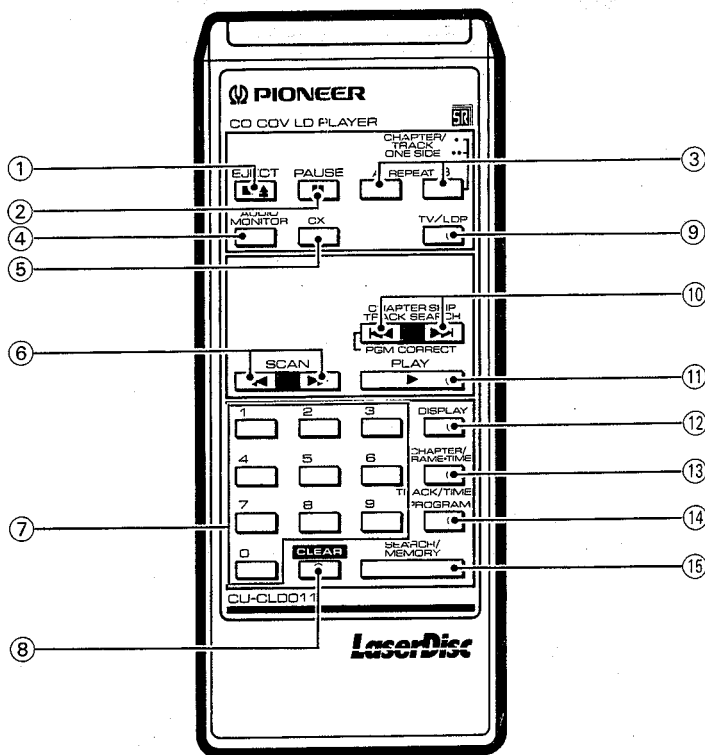

## ① EJECT (■ / ▲) key

This key is used to stop playback and remove the disc. The first time this key is pressed stops the rotation of the disc. The second time this key is pressed extends the disc table from the player. If there is no disc on the disc table, the disc table is extended out from the player the first time this key is pressed.

## ② PAUSE (||) key

When this is pressed, the playback is temporarily interrupted. To release the pause mode, press the PAUSE key again.

## ③ REPEAT (A, B) keys

These are used for repeat playback.

## PANEL AND REMOTE CONTROL UNIT FACILITIES

### ④ AUDIO MONITOR key

Switches the audio channel. When the player is first turned on, the audio is stereo and the 1/L and 2/R indicators are both lit up. Each time this key is pressed, the audio channel moves one step through the sequence: 1/L → 2/R → 1/L and 2/R (Stereo) → 1/L ... (See page 25 "AUDIO REPRODUCTION PLAYBACK".)

### ⑤ CX key

This is the on/off key for the CX noise reduction system.

### ⑥ SCAN (◀◀, ▶▶) keys

This is used for fast forward and fast reverse playback.

### ⑦ DIGIT (0 — 9) keys

### ⑧ CLEAR key

The Clear key is used in the following cases:

- To stop repeat playback, to interrupt a search, or to correct input made with the DIGIT keys.
- To erase the last step of the program.
- To end program playback.
- To end random playback.

### ⑨ TV/LDP key

When the aerial is connected to the TV set via the player, this key switches between disc playback and UHF TV broadcast reception.

### ⑩ CHAPTER SKIP/TRACK SEARCH, PGM CORRECT (◀◀, ▶▶) keys

This key has the same functions as the SKIP button on the front of the player.

### ⑪ PLAY (▶) key

- Setting a disc on the disc table then pressing this key retracts the disc table into the player and begins play of the disc.
- Pressing this key when the disc is stopped starts playback.
- Pressing this key when player is paused restarts normal playback.
- Pressing this key after chapter programming starts play for that chapter program.  
(See page 33 "PROGRAM PLAYBACK".)

### ⑫ DISPLAY key

This has the same function as TIME DISPLAY button on the front of the player.

### ⑬ CHAPTER/FRAME-TIME, TRACK/TIME key

This key is used to call up the part of the disc that you wish to see or listen to (search).  
(See page 26 and 29.)

### ⑭ PROGRAM key

This key has the same functions as the PROGRAM button on the front of the player.

### ⑮ SEARCH/MEMORY key

This key has the same functions as the SEARCH/MEMORY button on the front of the player.