

 **PIONEER**
The Art of Entertainment

Service Manual

ORDER NO.
ARP2722

CD CDV LD PLAYER

CLD-1800

CLD-800

CLD-1800 AND CLD-800 HAVE THE FOLLOWING :

Type	Model		Power Requirement	Remarks
	CLD-1800	CLD-800		
HEZ	○	○	AC220-230V, 240V (switchable) *	
HB	-	○	AC220-230V, 240V (switchable) *	

*Change the connection of the power transformer's primary wiring.

- Refer to the service manual ARP2543 for CLD-1700 and CLD-700.
- This manual is applicable to the following : CLD-1800/HEZ; CLD-800/HEZ and HB.

PIONEER ELECTRONIC CORPORATION 4-1, Meguro 1-Chome, Meguro-ku, Tokyo 153, Japan
PIONEER ELECTRONICS SERVICE INC. P.O. Box 1760, Long Beach, California 90801 U.S.A.
PIONEER ELECTRONICS OF CANADA, INC. 300 Allstate Parkway Markham, Ontario L3R 0P2 Canada
PIONEER ELECTRONIC [EUROPE] N.V. Haven 1087 Keetberglaan 1, 9120 Melsele, Belgium
PIONEER ELECTRONICS AUSTRALIA PTY. LTD. 178-184 Boundary Road, Braeside, Victoria 3195, Australia TEL: [03] 580-9911
 © PIONEER ELECTRONIC CORPORATION 1993

IFO MAR. 1993 Printed in Japan

1. CONTRAST OF MISCELLANEOUS PARTS

NOTES:

- Parts marked by "NSP" are generally unavailable because they are not in our Master Spare Parts List.
- The Δ mark found on some component parts indicates the importance of the safety factor of the part. Therefore, when replacing, be sure to use parts of identical designation.
- Parts marked by "⊙" are not always kept in stock. Their delivery time may be longer than usual or they may be unavailable.

CLD-1800/HEZ, CLD-800/HEZ, HB and CLD-1700/HEZ have the same construction except for the following:

Mark	Symbol & Description	Part No.				Remarks
		CLD-1700 / HEZ	CLD-1800 / HEZ	CLD-800 / HEZ	CLD-800 / HB	
⊙	MOTHER assembly	VWM1276	VWM1396	VWM1397	VWM1397	
NSP	MAIN assembly	VWX1123	VWX1182	VWX1183	VWX1183	
NSP	AUDIO assembly	VWX1124	VWX1124	VWX1117	VWX1117	
⊙	FLKB assembly	VWM1278	VWM1278	VWM1277	VWM1277	
NSP	FLKY assembly	VWG1336	VWG1336	VWG1335	VWG1335	
NSP	HEPB assembly	VWV1254	VWV1254	
⊙	SYPS assembly	VWR1146	VWR1146	VWR1146	VWR1147	
⊙	SCRB assembly	VWV1248	VWV1248	VWV1255	VWV1255	
	Rack assembly	VWT1080	VWT1099	VWT1099	VWT1099	*1
Δ	AC power cord	VDG1028	PDG1003	PDG1003	VDG1051	
	Cord stopper	CM-22B	CM-22B	CM-22B	
	Euro scart cable (21P)	VDE1027	VDE1027	
	Cord with plug	VDE-056	VDE-056	
	Packing case	VHG1260	VHG1267	VHG1268	VHG1269	
NSP	Rear panel	VNA1278	VNA1323	VNA1324	VNA1325	
	Snap plate	VNE1102	VNE1102	
	Jack holder	VNE1811	VNE1811	
	Volume knob	VNK2003	VNK2003	
	Operating instructions (English / French / German / Italian)	VRE1010	VRE1013	VRE1014	VRE1014	
	Operating instructions (Dutch / Swedish / Spanish / Portuguese)	VRF1017	VRF1020	VRF1021	
NSP	Front panel assembly	VXA1867	VXA1955	VXA1956	VXA1956	
	CD door	VNK2033	VNK2244	VNK2244	VNK2244	
	CD door assembly-S	VXX1728	VXX1848	VXX1848	VXX1848	
	Pin cap	VEC1616	No. 1 (*)
	Pad (R)	VHA1106	VHA1106	VHA1106	VHA1123	
	Remote control unit (CU-CLD077)	VXX1758	VXX1758	
	Remote control unit (CU-CLD072)	VXX1751	VXX1751	
	Battery cover	VNK1293	VNK1293	PZN1010	PZN1010	
NSP	Caution card (UC)	VRM1026	
NSP	Caution card (EW)	VRM1027	VRM1027	VRM1027	
NSP	Caution label	PRW1018	

*1 : The rack assembly VWT1080 is not compatible with VWT1099.

(*) : Refer to the exploded view.

MAIN, AUDIO, FLKY, SYPS AND SCRIB ASSEMBLIES

VWX1116, VWX1117, VWG1335, VWR1147 and VWV1255 are the same as those of CLD-700/HB which is shown in the service manual ARP2543 for CLD-1700 and CLD-700.

● Exploded View for CLD-800/HB

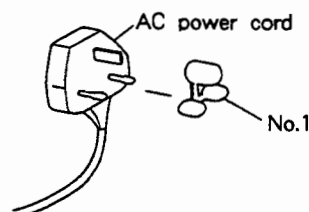

MAIN ASSEMBLY (For CLD-1800)

VWX1182 and VWX1123 have the same construction except for the following :

Mark	Symbol & Description	Part No.		Remarks
		VWX1123	VWX1182	
	R852,R853 R868 R871	RS1/10S823J RS1/10S222J RS1/10S223J	RS1/10S563J RS1/10S182J RS1/10S203J	

MAIN ASSEMBLY (For CLD-800)

VWX1183 and VWX1116 have the same construction except for the following :

Mark	Symbol & Description	Part No.		Remarks
		VWX1116	VWX1183	
	R852,R853 R868 R871	RS1/10S823J RS1/10S222J RS1/10S223J	RS1/10S563J RS1/10S182J RS1/10S203J	

• **ADJUSTMENT**

Frequency of AF oscillator in step 9 TRK Servo loop gain adjustment is changed as follows:

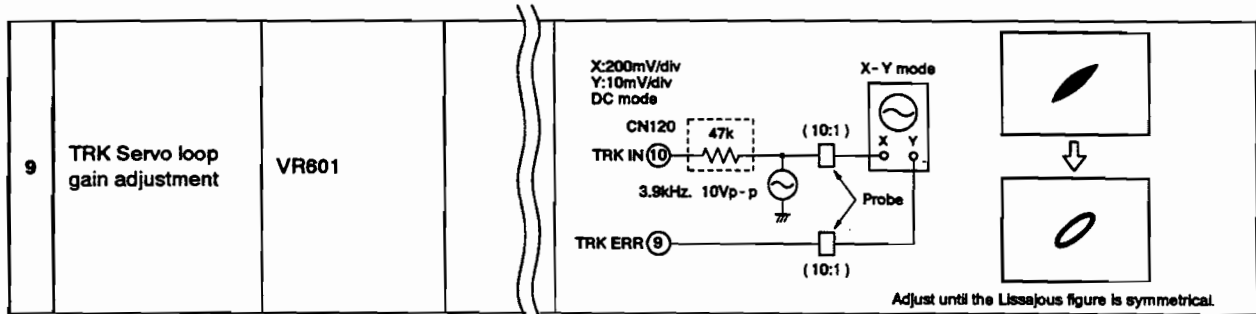

Service Manual

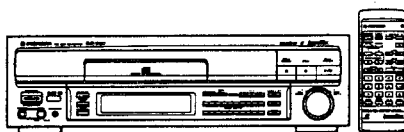

ORDER NO.
ARP2543

CD CDV LD PLAYER

CLD-1700

CLD-700

CLD-1700 AND CLD-700 HAVE THE FOLLOWING :

Type	Model		Power Requirement	Remarks
	CLD-1700	CLD-700		
HEZ	○	○	AC220-230V, 240V (switchable) *	
HB	--	○	AC220-230V, 240V (switchable) *	

*Change the connection of the power transformer's primary wiring.

- This manual is applicable to the following : CLD-1700/HEZ; CLD-700/HEZ and HB.
- For CLD-700/HEZ and HB, refer to page 82.
- Ce manuel pour le service comprend les explications de réglage en français.
- Este manual de servicio trata del método ajuste escrito en español.

CONTENTS

1. SAFETY INFORMATION.....	2	5. ADJUSTMENTS	50
2. EXPLODED VIEWS, PACKING AND PARTS LIST.....	3	REGLAGES.....	59
3. SCHEMATIC AND PCB CONNECTIONS DIAGRAMS.....	16	AJUSTES.....	68
4. PCB PARTS LIST.....	43	6. IC INFORMATION	77
		7. FOR CLD-700/HEZ AND HB.....	82
		8. CONNECTIONS	85
		9. PANEL FACILITIES	87
		10. SPECIFICATIONS	90

1. SAFETY INFORMATION

(FOR EUROPEAN MODEL ONLY)

VARO!

AVATTAESSA JA SUOJALUKITUS OHITETTAESSA OLET ALTTIINA NÄKYMÄTTÖMÄLLE LASERSÄTEILYLLE. ÄLÄ KATSO SÄTEESEEN.



LASER
Kuva 1
Lasersäteilyn
varoituserkki

WARNING!

DEVICE INCLUDES LASER DIODE WHICH EMITS INVISIBLE INFRARED RADIATION WHICH IS DANGEROUS TO EYES. THERE IS A WARNING SIGN ACCORDING TO PICTURE 1 INSIDE THE DEVICE CLOSE TO THE LASER DIODE.



LASER
Picture 1
Warning sign for
laser radiation

ADVERSEL:

USYNLIG LASERSTRÅLING VED ÅBNING NÅR SIKKERHEDSAFBRYDERE ER UDE AF FUNKTION UNDGÅ UDSÆTTELSE FOR STRÅLING.

VARNING!

OSYNLIG LASERSTRÅLING NÅR DENNA DEL ÄR ÖPPNAD OCH SPÄRREN ÄR URKOPPLAD. BETRAKTA EJ STRÅLEN.

IMPORTANT

THIS PIONEER APPARATUS CONTAINS LASER OF CLASS 1. SERVICING OPERATION OF THE APPARATUS SHOULD BE DONE BY A SPECIALLY INSTRUCTED PERSON.

LASER DIODE CHARACTERISTICS

MAXIMUM OUTPUT POWER: 5 mw
WAVELENGTH: 780-785 nm

LABEL CHECK

HB model



HEZ model

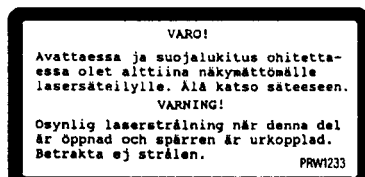

HEZ and HB model



HEZ model

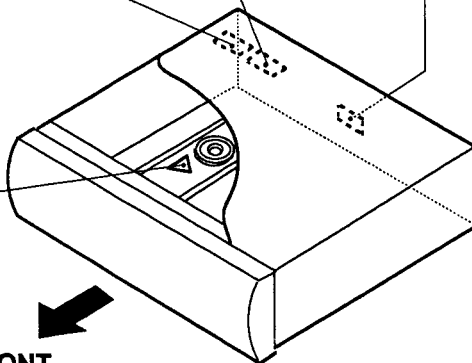
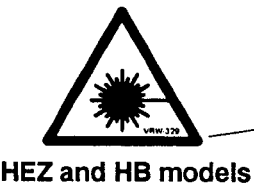
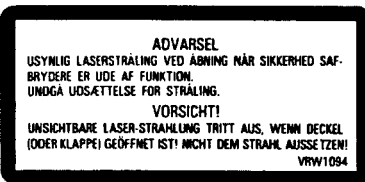

Additional Laser Caution

1. The ON/OFF statuses of the slider - position detection switches (PARK INNER, PARK OUTER on the PKSB assembly), loading - status detection switches (SW 1, 2 and 3 on PKSB assembly) are detected by the microprocessor (IC101 in the MAIN assembly). To permit the laser diode to oscillate, it is required to set the slider - position detection switch for the LD ACTIVE status (PARK INNER: OFF, PARK OUTER: OFF), and to set the loading - status detection switch for clamped state (SW1: OFF, SW2: ON, SW3: ON). As long as these requirements are not satisfied, the laser diode will not oscillate. When the requirements are met in any way, the laser diode can oscillate. The laser diode oscillation will continue if pin 29 of IC801 is shorted to GND or the emitter and collector of Q809 are shorted each other (fault condition) in MAIN assembly. In test mode (see page 51), the laser diode oscillates when microprocessor detects a PLAY signal or when the PLAY key is pressed (S223: ON in the FLKY assembly), with the above requirements satisfied.
2. When the cover is open, close viewing through the objective lens with the naked eye will cause exposure to a Class 1 laser beam.

2. EXPLODED VIEWS, PACKING AND PARTS LIST

NOTES:

- Parts marked by "NSP" are generally unavailable because they are not in our Master Spare Parts List.
- The Δ mark found on some component parts indicates the importance of the safety factor of the part. Therefore, when replacing, be sure to use parts of identical designation.
- Parts marked by "⊙" are not always kept in stock. Their delivery time may be longer than usual or they may be unavailable.

(1) EXTERIOR SECTION

Parts List

Mark	No.	Description	Part No.	Mark	No.	Description	Part No.
	1	Guide plate (L)	VNE1805		16	Tray panel	VNK2032
	2	Guide plate (R)	VNE1806		17	Door holder	VNE1812
	3	Lock plate spring	VBH1188		18	Door shaft	VLL1441
	4	Lock plate	VNL1513		19	•••••	
	5	CD tray	VNK1992	NSP	20	Spacer	VEC1585
	6	Tray assembly - S	VXX1729	NSP	21	Damp cushion	VEC1110
NSP	7	LD tray	VNK1991	NSP	22	PCB holder	VNE1830
	8	Disc pad	VEC1191		23	Screw	BPZ30P060FCU
	9	Disc pad (C)	VEC1380		24	Screw	IPZ26P060FMC
NSP	10	Label	VRW1289		25	Screw	BBZ30P080FCC
	11	Bonnet S	VXX1726		26	Screw	BCZ40P060FZK
	12	Door spring	VBH1202		27	Screw	IPZ20P050FMC
	13	CD door assembly - S	VXX1728		28	Screw	VBA1032
	14	Cushion	VEC1578		29	Tray rubber	VEB1091
NSP	15	CD door	VNK2033				

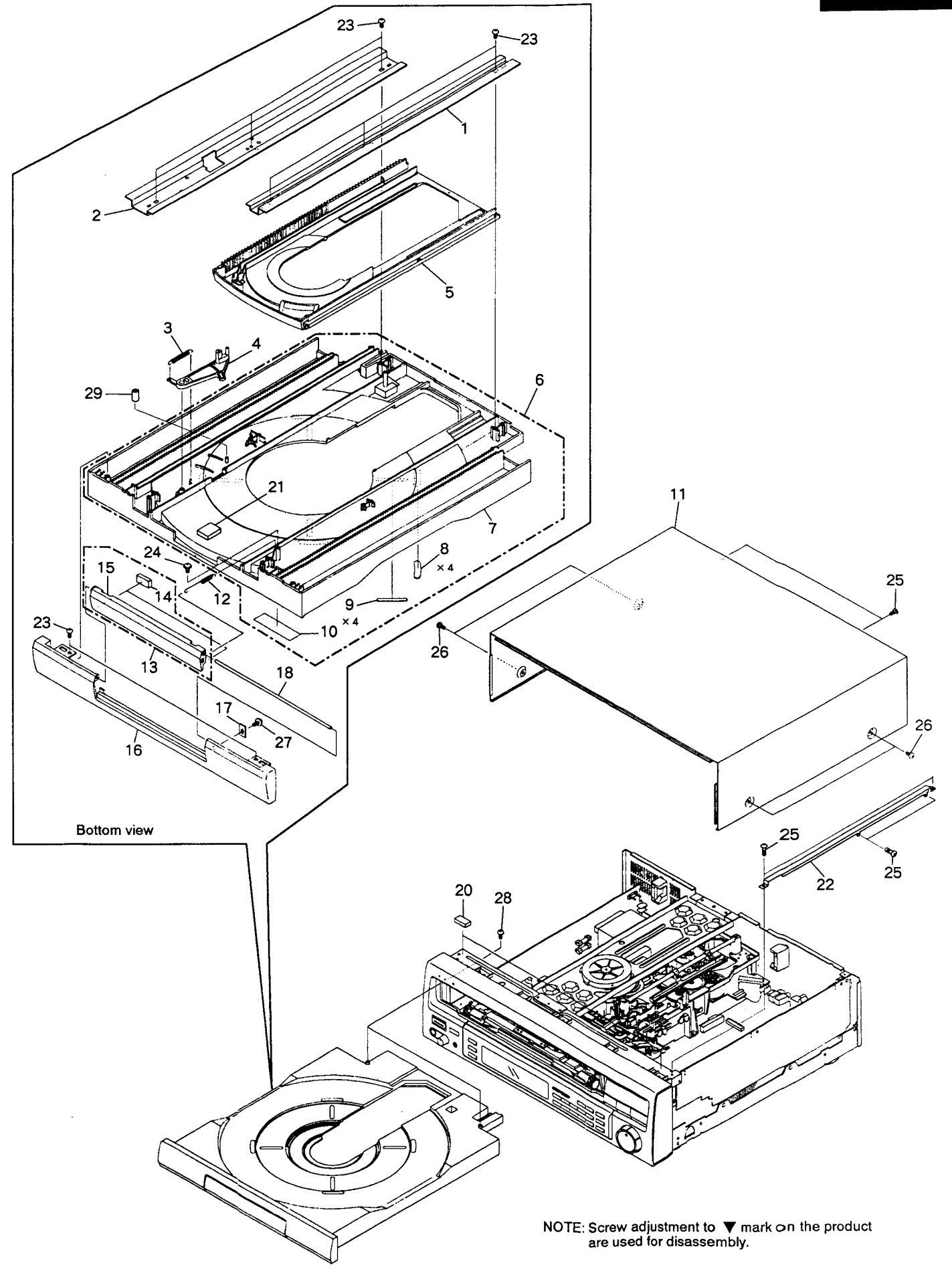

NOTE: Screw adjustment to ▼ mark on the product are used for disassembly.

(2) TOP VIEW SECTION

Parts List

Mark	No.	Description	Part No.
	1	Clamper holder	VNL1514
	2	Rubber sheet	VEB1114
	3	Thrust holder	VNL1289
	4	Clamper head	VNL1516
	5	Clamper	VNL1515
	6	Clamper spring	VBH1192
	7	Clamper arm	VNE1804
	8	Stabilizer	VNE1807
	9	Rack assembly	VWT1080
	10	Carriage shaft	VLL1434
NSP	11	Side stay (R)	VNE1810
NSP	12	Front angle	VNE1808
	13	Screw	CPZ20P050FMC
	14	Screw	BBZ30P080FCC
	15	Screw	IBZ30P060FCC
B	16	Screw	IPZ30P060FMC
	17	Screw	PCZ30P060FMC
	18	Earth plate	VNE1518

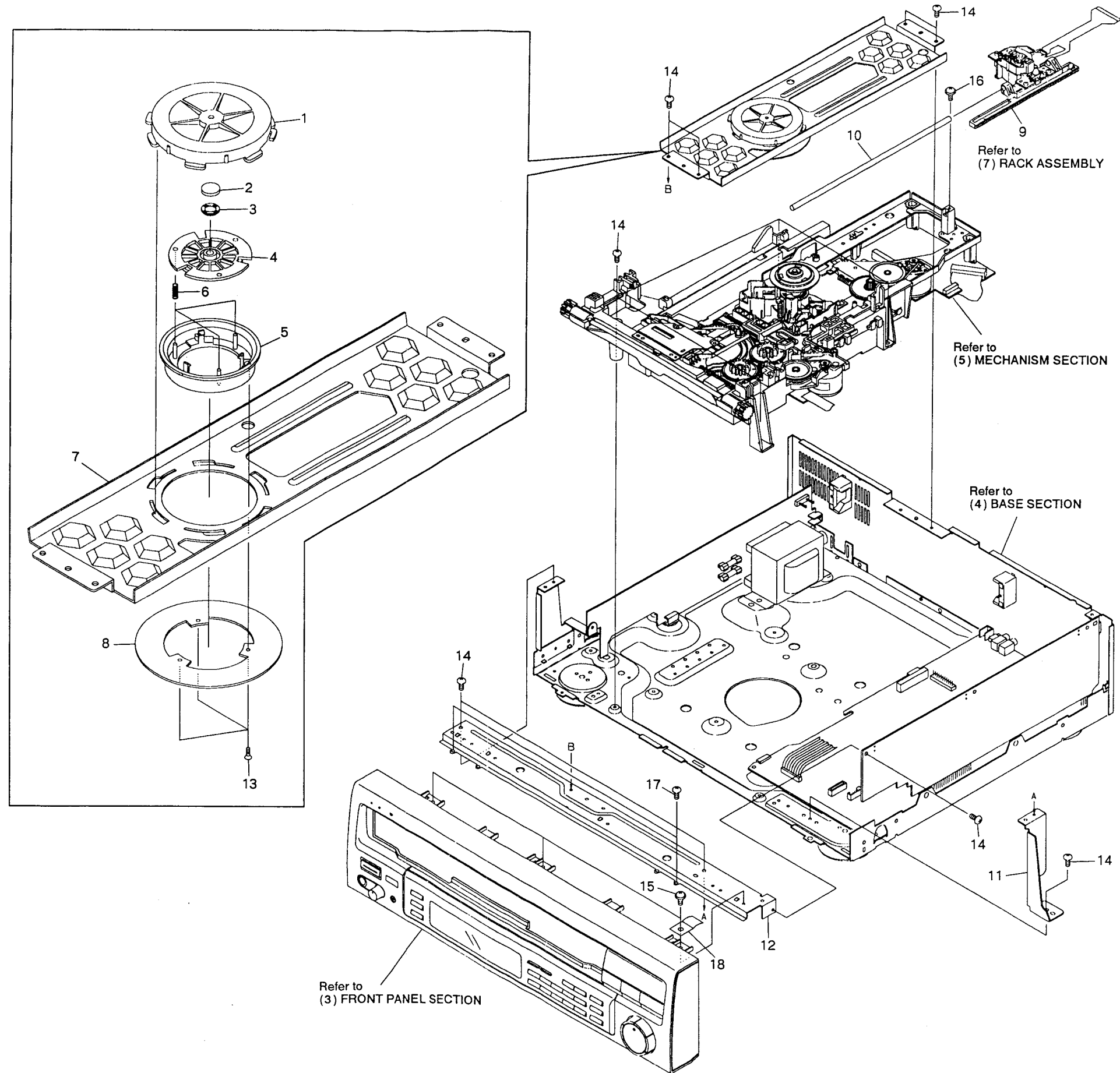

(3) FRONT PANEL SECTION

Parts List

Mark	No.	Description	Part No.	Mark	No.	Description	Part No.
NSP	1	PSWB assembly	VWG1315	NSP	11	Center panel	VNK2085
	2	PW button	VNK2002		12	FL lens	VEC1568
	3	Mode key	VNK2037		13	FL filter	VNK1694
NSP	4	FLKY assembly	VWG1336		14	Center panel assembly - S	VXX1757
	5	CD button	VNK2038		15	Screw	BPZ26P060FCU
	6	Ten key	VNK2036	NSP	16	HEPB assembly	VWV1254
	7	Main key	VNK2035		17	Jack holder	VNE1811
	8	Front panel assembly	VXA1867		18	Snap plate	VNE1102
	9	Shuttle knob	VNK2039		19	Volume knob	VNK2003
	10	Sub panel	VNK2034				

B

E

C

D

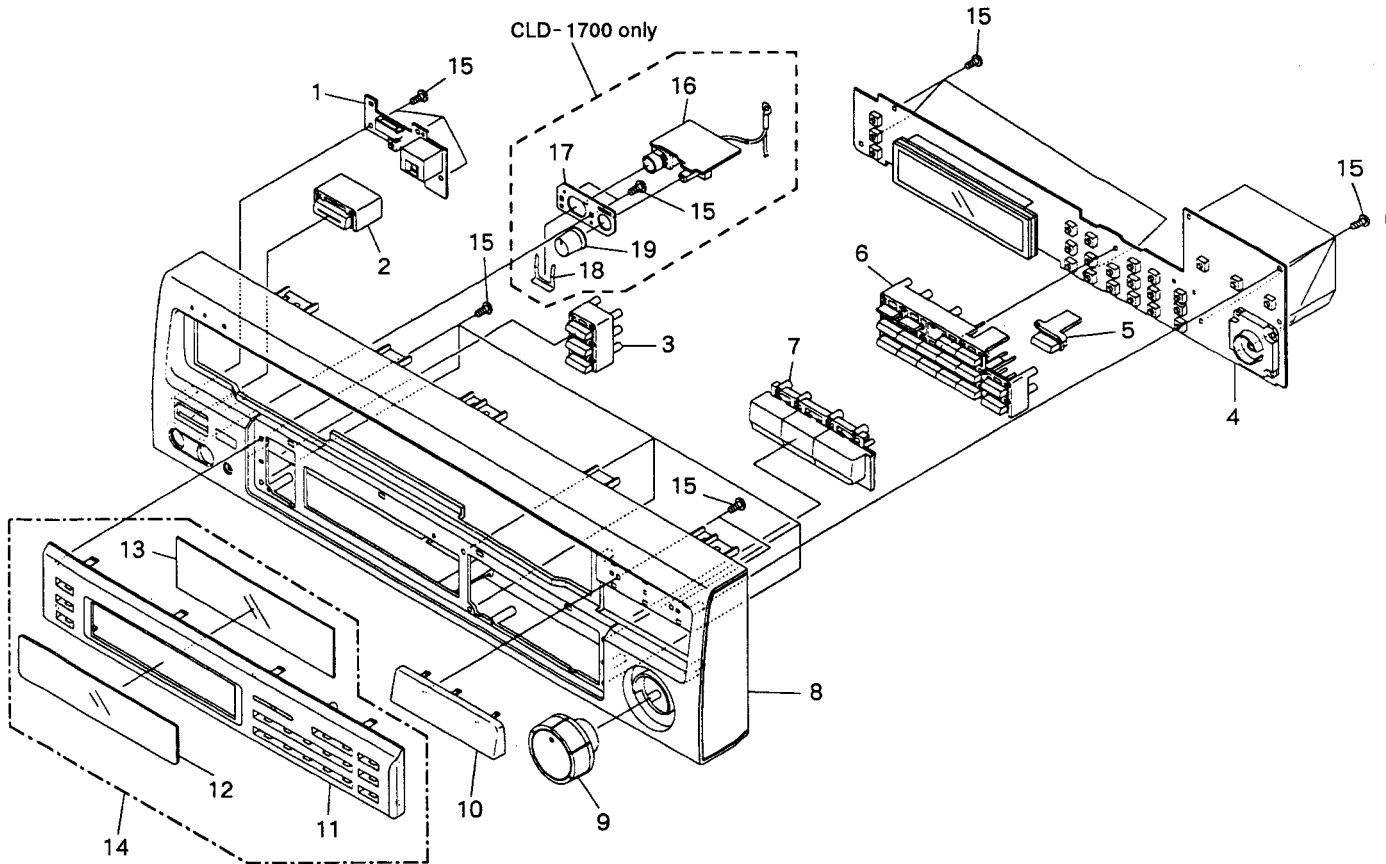

(4) BASE SECTION

Parts List

Mark	No.	Description	Part No.
NSP	1	MAIN assembly	VWX1123
NSP	2	AUDIO assembly	VWX1124
●	3	SYPS assembly	VWR1146
	4	Tray stopper	VNL1519
△	5	AC power cord	VDG1028
	6	Cord stopper	CM-22B
NSP	7	Rear panel	VNA1278
	8	PCB cushion	VEC1573
NSP	9	Cord clamber	VNF-005
NSP	10	PCB hinge	VEC1174

Mark	No.	Description	Part No.
△	11	Power transformer	VTT1115
△	12	Fuse (FU1, FU2) (3.15A)	REK-105
NSP	13	P. plate holder	PNY-405
NSP	14	Side stay (L)	VNE1809
	15	Cord clamber	VNF-069
	16	Insulator	PNW1912
NSP	17	Base chassis	VNA1255
	18	Insulator assembly	VXA1881
	19	Screw	BBZ30P080FCC
	20	Screw	BBZ30P040FMC
	21	Screw	BCZ40P060FZK
	22	Screw	BCZ30P080FCC
●	23	SCRB assembly	VWV1248
NSP	24	Support cushion	VEC1601
NSP	25	PC suport	VEC1584
NSP	26	Plate	VNE1854
	27	Binder	VEC-067

A

B

C

D

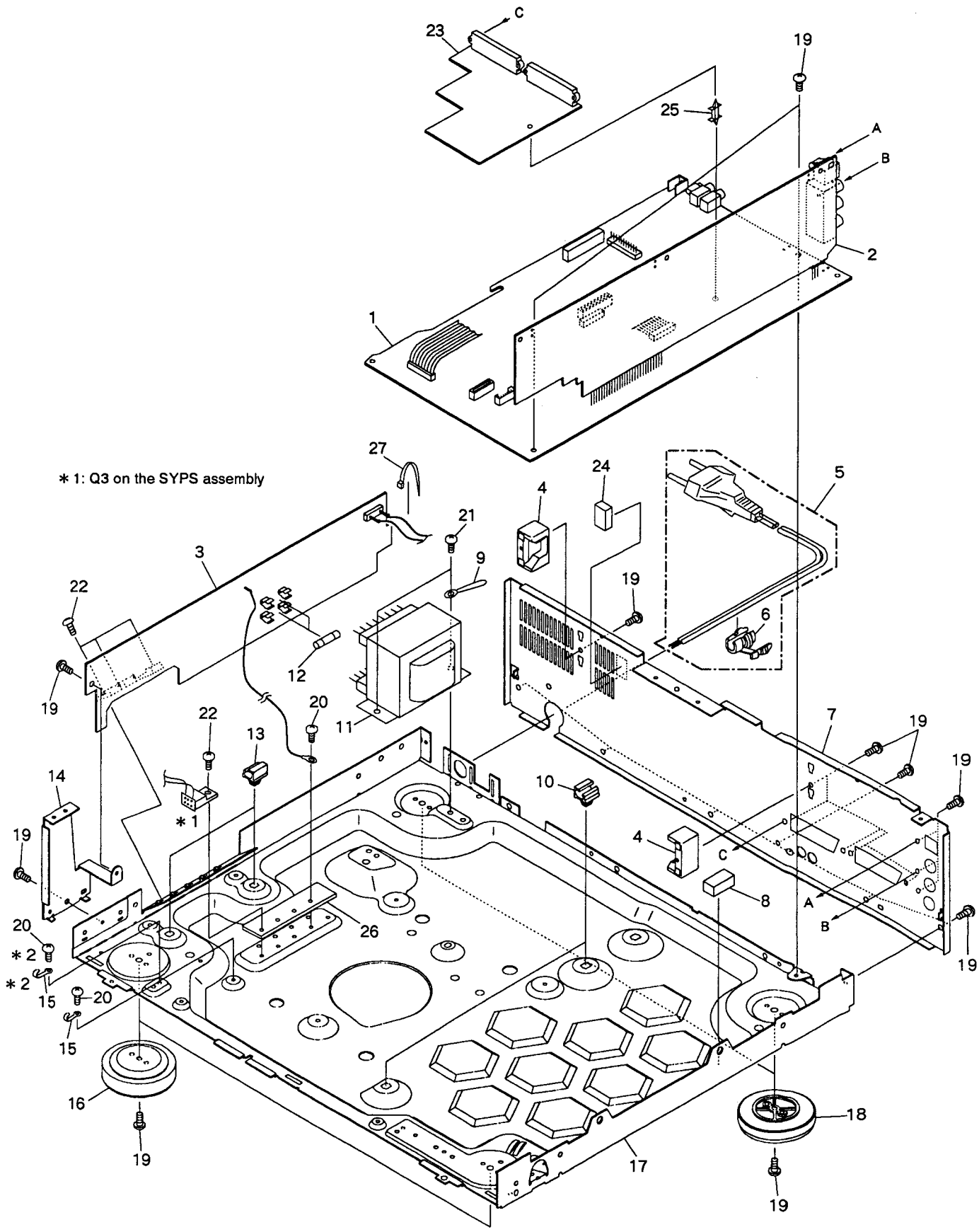

* 1: Q3 on the SYPS assembly

* 2: CLD-1700 only

(5) MECHANISM SECTION

Parts List

<u>Mark</u>	<u>No.</u>	<u>Description</u>	<u>Part No.</u>	<u>Mark</u>	<u>No.</u>	<u>Description</u>	<u>Part No.</u>
	1	Mechanism base	VNK1990		14	L-SW lever	VNL1504
	2	Flexible cable	VDA1409		15	C-SW lever	VNL1505
	3	Clamp cam	VNL1500		16	R-SW lever	VNL1506
	4	Shaft holder	VNE1817		17	LOSB ASS'Y	VWG1307
	5	Cam plate	VNL1511	NSP	18	Synchro gear ASS'Y	VXA1822
	6	CAS spring	VBH1190		19	Roller	VNL1042
	7	Cam gear	VNL1507	NSP	20	LOMB ASS'Y	VWG1308
	8	CD plate	VNL1512		21	Loading motor ASS'Y	VXX1712
	9	CDP spring	VBH1191		22	Slider motor	VXM1033
	10	Rubber belt	VEB1184	NSP	23	Motor pulley	PNW1643
	11	Gear pulley	VNL1510		24	Screw	Z39-019
	12	Twin gear	VNL1508		25	Screw	BMZ26P040FMC
	13	Center gear	VNL1509				

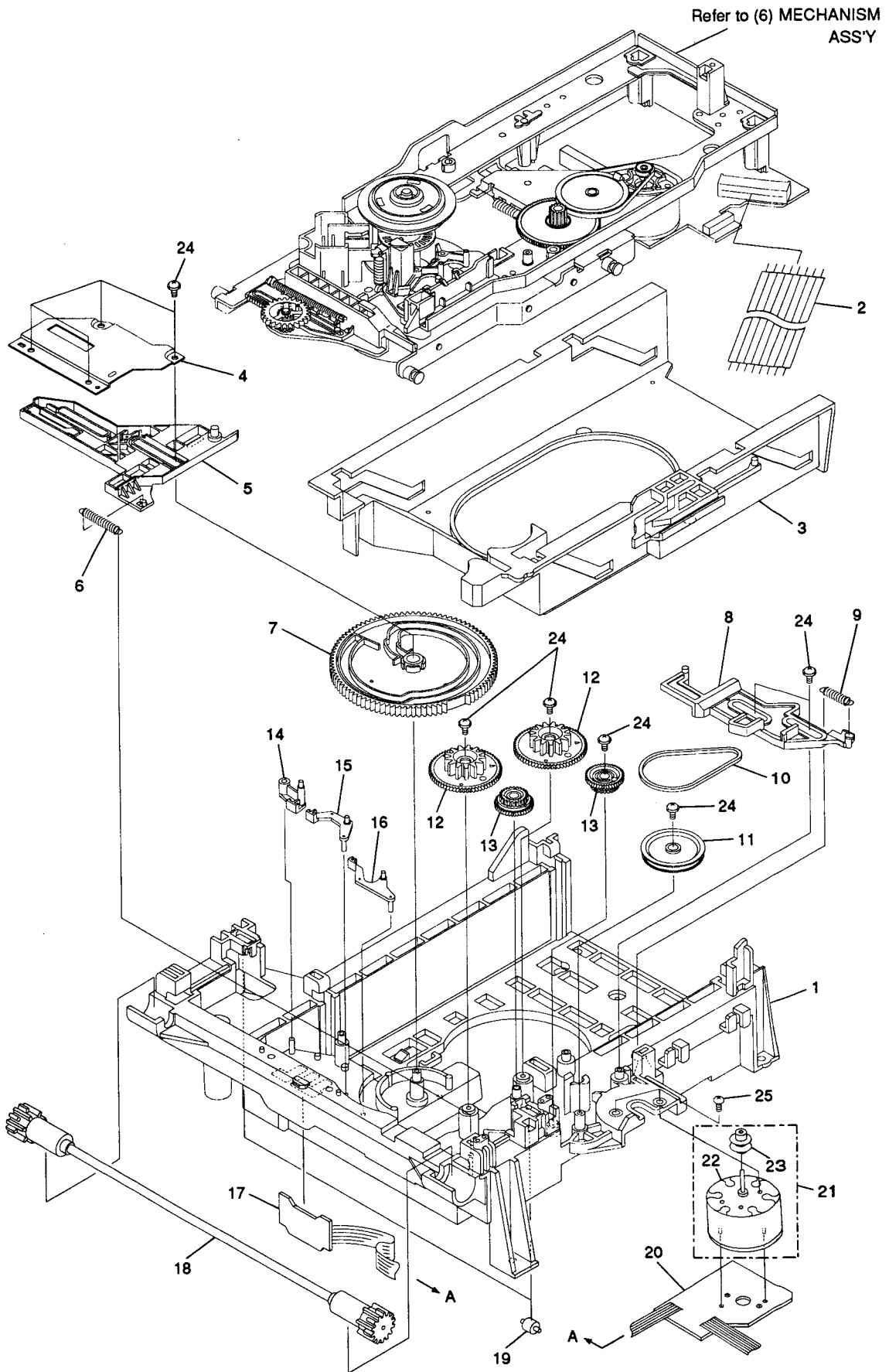

(6) MECHANISM ASS'Y

Parts List

<u>Mark</u>	<u>No.</u>	<u>Description</u>	<u>Part No.</u>	<u>Mark</u>	<u>No.</u>	<u>Description</u>	<u>Part No.</u>
	1	CA belt	VEB1077		16	Y gear	VNL1501
	2	CA pulley	VNL1496		17	Tilt cam spring	VBH1189
	3	CA gear	VNL1497		18	Tilt cam	VNL1502
	4	Tilt base	VNL1499		19	Spindle motor ASS'Y	VXA1825
	5	CA-SW lever	VNL1498		20	Centering hab	VNL1174
NSP	6	CAMB ASS'Y	VWG1306		21	Centering spring	VBH1083
	7	CRG motor ASS'Y	VXX1261	NSP	22	Rubber sheet	VEB1103
NSP	8	Slider motor	VXM1033	NSP	23	Turn table ASS'Y	VXA1283
	9	CA pulley (1)	VNL1197	NSP	24	Oil stopper	VBF1002
NSP	10	PKSB ASS'Y	VWG1305	NSP	25	Spindle motor	VXM1050
	11	Radial spring	VBH1201		26	Motor base	VNE1803
	12	Thrust spring	VBH1200		27	Screw	BMZ26P040FMC
	13	Tilt tension	VBH1187		28	Screw	ABZ30P300FMC
NSP	14	FG ASS'Y	VWG1304		29	Screw	PMA30P050FMC
	15	FG base	VNL1503		30	Washer	WT26D060D025

B

C

D

E

F

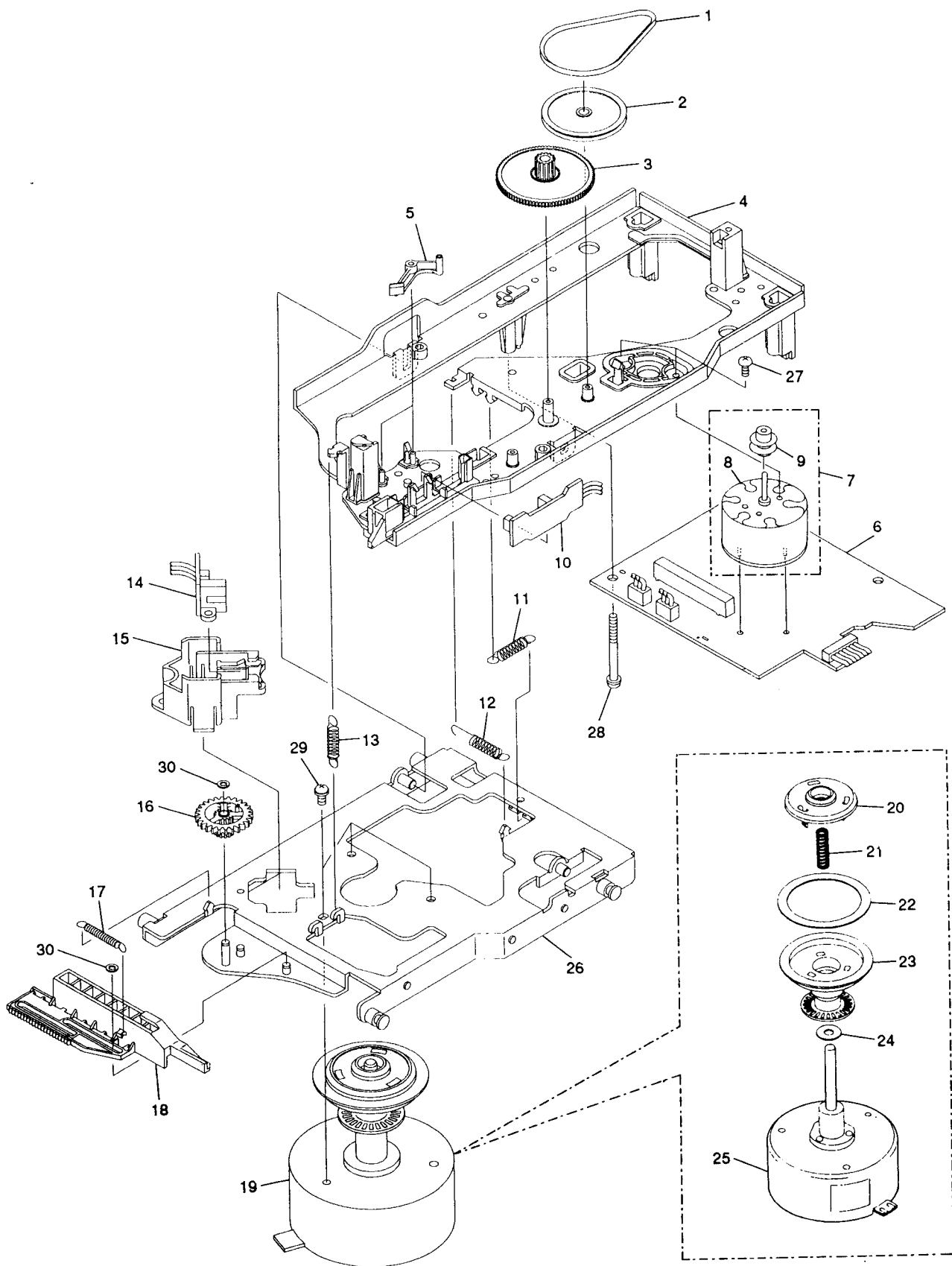

(7) RACK ASS'Y

Parts List

Mark	No.	Description	Part No.
NSP	1	Sensor stay	VBK1036
NSP	2	Tilt sensor	SG-302
NSP	3	Pick up ASS'Y	VWY1030
	4	Rack	VNL1495
	5	Tan. base	VNL1494
	6	Screw	PBB26P080FMC
	7	Screw	PMA20P060FMC
	8	Screw	PMA20P080FMC
	9	Screw	PMH20P040FMC
	10	Screw	SMZ20H120FZK

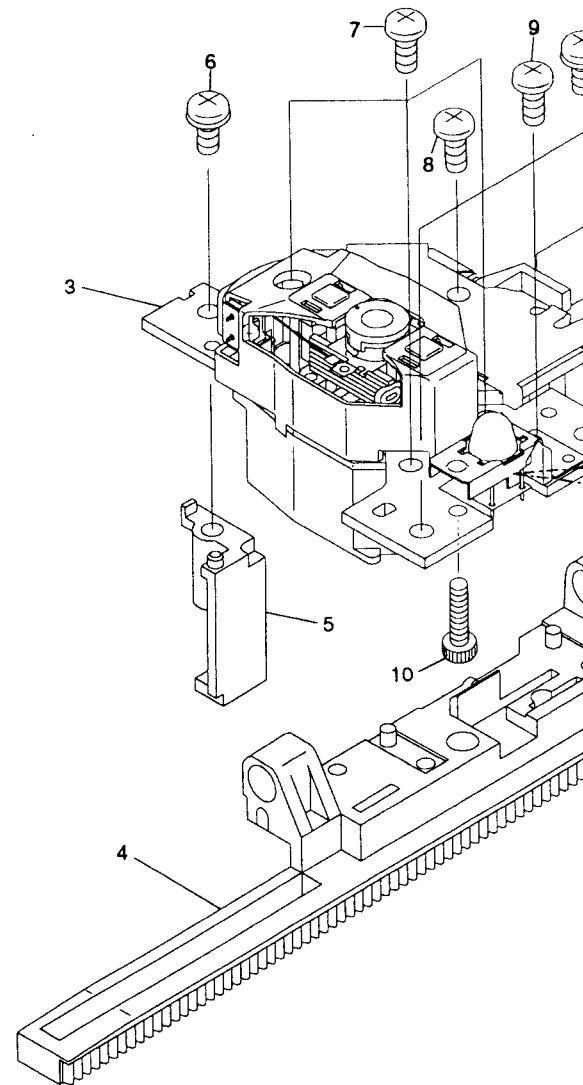

(8) PACKING

Parts List

Mark No.	Description	Part No.	Mark No.	Description	Part No.
NSP 1	Warranty card	ARW-088	NSP 9	Caution card (UC)	VRM1039
2	Connection cord	VDE-055	NSP 10	Caution card	VRR1009
3	Euro scart cable (21P)	VDE1027	11	Remote control unit (CU-CLD077)	VXX1758
NSP 4	Battery (R03, AAA)	VEM-022	12	Battery cover	VNK1293
NSP 5	Polyethylene bag	VHL-014	NSP 13	Polyethylene bag	Z21-029
6	Operating instructions (English/French/German/Italian)	VRE1010	14	Pad (F)	VHA1105
7	Operating instructions (Dutch/Swedish/Spanish/Portuguese)	VRF1017	15	Pad (R)	VHA1106
NSP 8	Caution card (EW)	VRM1027	16	Packing case	VHG1228
			17	Mirror mat	VHL1006

MC
FMC
FMC
FMC
FZK

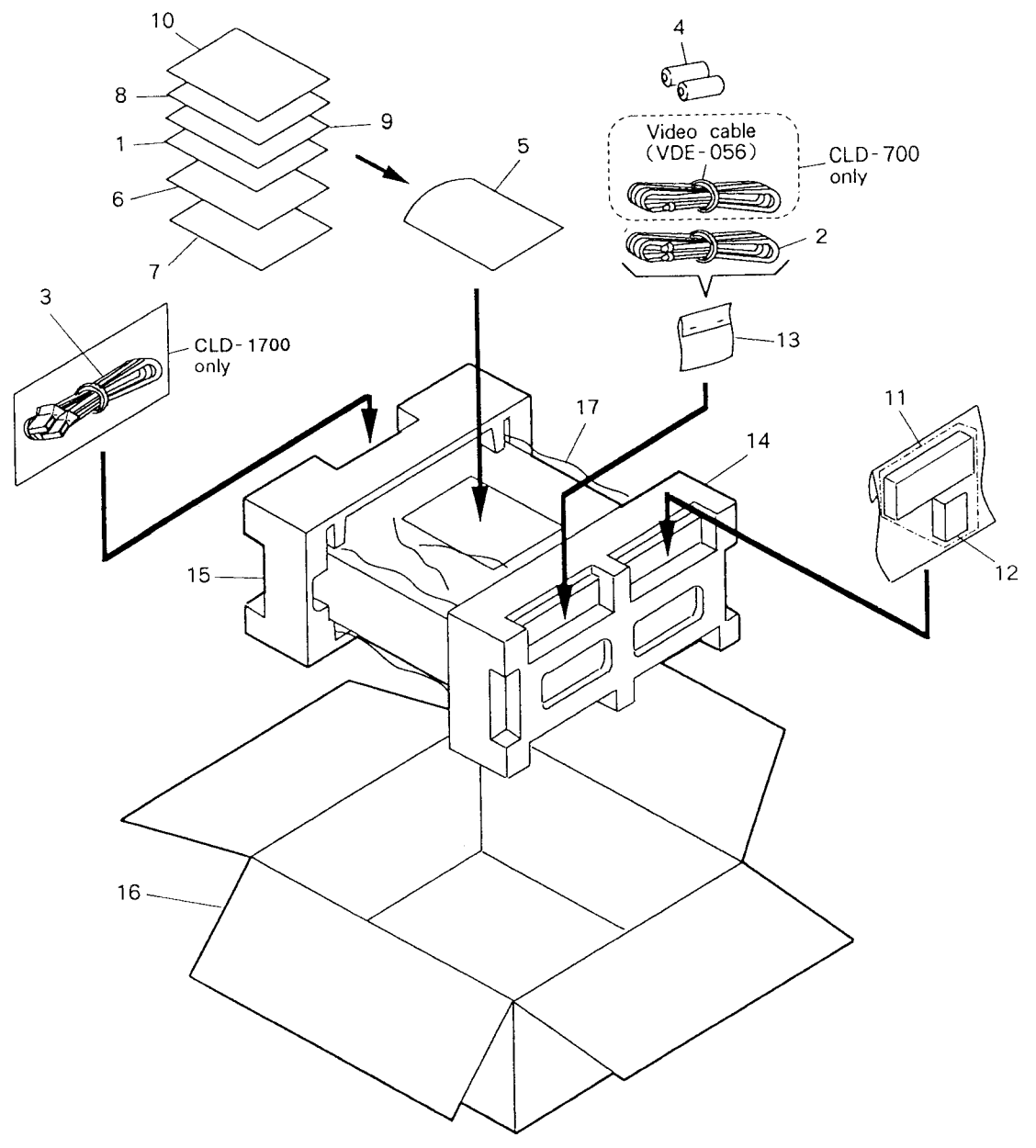
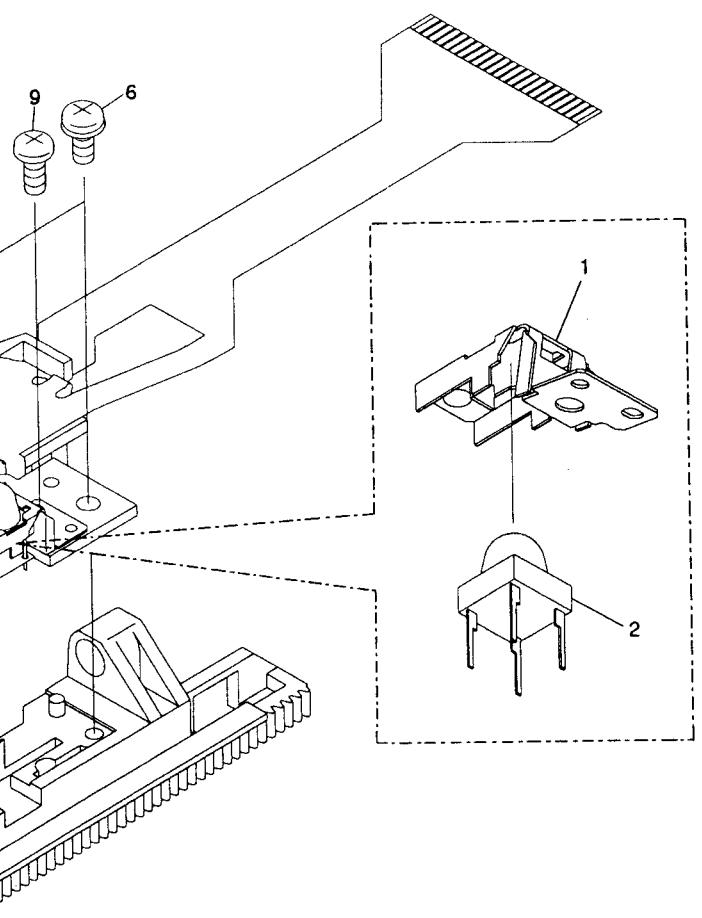

A

B

C

D

E

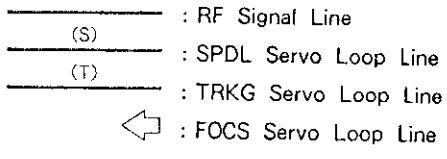

- Note:** (Type 4)
- When ordering service parts, be sure to refer to "PARTS LIST of EXPLODED VIEWS" or "PCB PARTS LIST".
 - Since these are basic circuits, some parts of them or the values of some components may be changed for improvement.
 - RESISTORS:**
Unit: k Ω , M Ω , or Ω unless otherwise noted.
Rated power: 1/4W, 1/6W, 1/8W, 1/10W unless otherwise noted.
Tolerance: (F): $\pm 1\%$, (G): $\pm 2\%$, (K): $\pm 10\%$, (M): $\pm 20\%$ or $\pm 5\%$ unless otherwise noted.
 - CAPACITORS:**
Unit: p μ F or μ F unless otherwise noted.
Ratings: capacitor (μ F) / voltage (V) unless otherwise noted.
Rated voltage: 50V except for electrolytic capacitors.
 - COILS:**
Unit: m μ H or μ H unless otherwise noted.
 - VOLTAGE AND CURRENT:**
□ : DC voltage (V) in PLAY mode unless otherwise noted.
◁ mA or ▷ mA: DC current in PLAY mode unless otherwise noted.
Value in () is DC current in STOP mode.
 - OTHERS**
• → : Signal route.
⊙ : Adjustment point.
⊕ (Red) : Measurement point.
• The Δ mark found on some component parts indicates the importance of the safety factor of the parts. Therefore, when replacing, be sure to use parts of identical designation.
 - SWITCHES** (Underline indicates switch position):
PKSB ASSEMBLY
S224 : POWER (STANDBY/ON)

PKSB ASSEMBLY
S4 : PARK OUT
S5 : PARK IN

LOSB ASSEMBLY
S1 : TILT LOADING 1
S2 : TILT LOADING 2
S3 : TILT LOADING 3

FLKY ASSEMBLY
S201 : LANGUAGE
S202 : RANDOM PLAY
S203 : HILITE/INTRO SCAN
S204 : CHP/TIME
S205 : PGM EDIT
S206 : SKIP (◀) (▶)
S207 : SKIP (▶) (▶) (▶)
S208 : 1
S209 : 2
S210 : 3
S211 : 4
S212 : 6
S213 : 7
S214 : 8
S215 : 9
S216 : 0
S217 : 5
S218 : PGM
S219 : +10
S220 : DIRECT CD (CD)
S221 : OPEN/CLOSE (▲)
S222 : STOP (■)
S223 : PLAY/PAUSE (▶/||)
S225 : ROTARY ENCODER

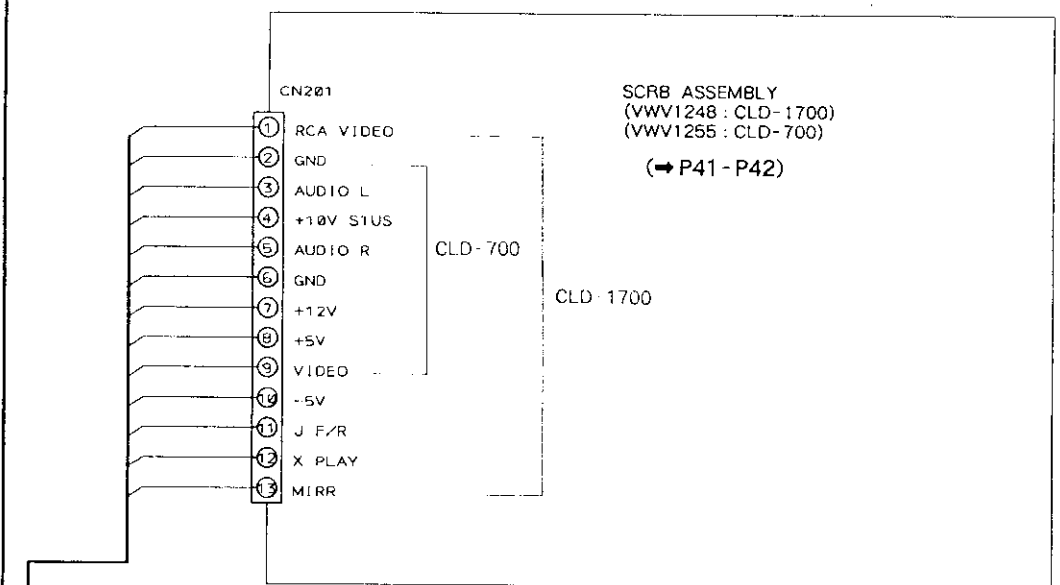
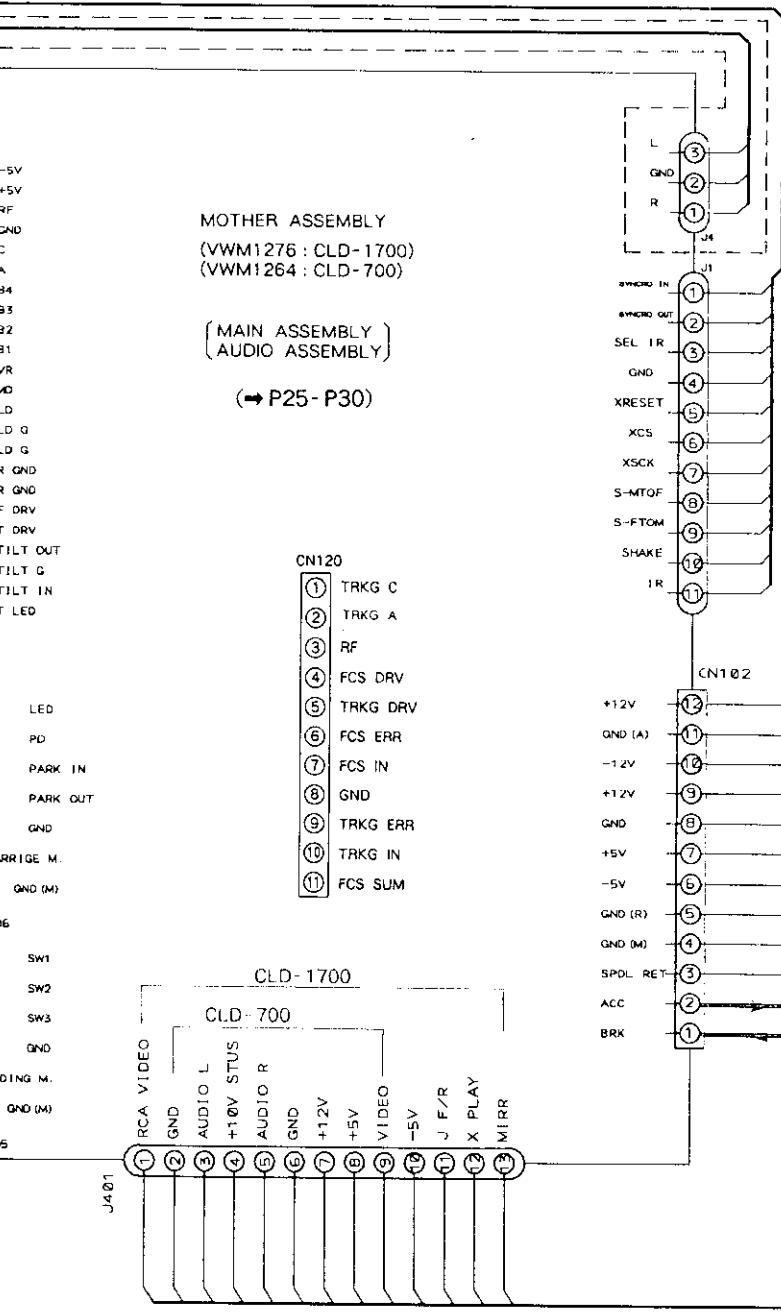
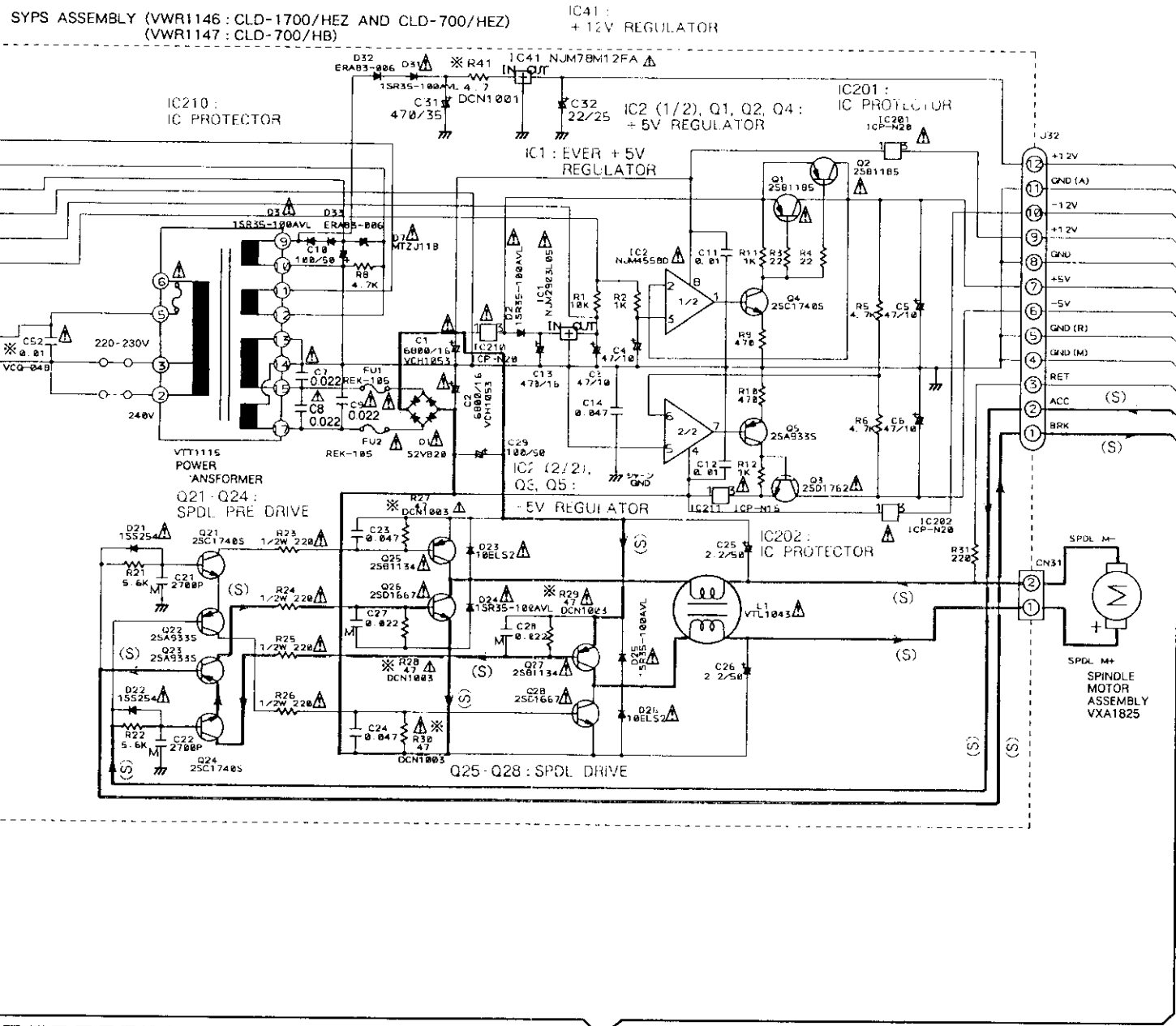

FL Display (V201: VAW 1026)

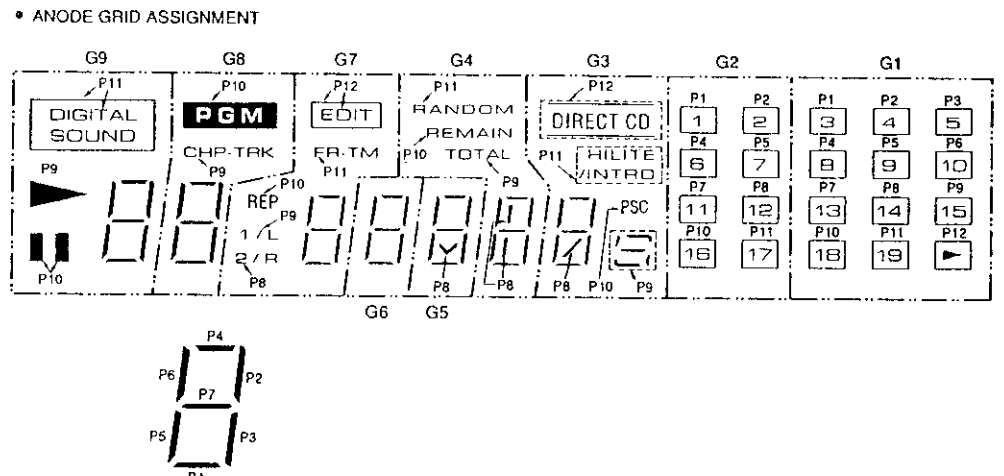

P.C.B. pattern diagram Indication	Corresponding part symbol	Part name	P.C.B. pattern diagram Indication	Corresponding part symbol	Part name
		Transistor			Ceramic capacitor
		FET			Mylar capacitor
		Diode			Styrol capacitor
		Zener diode			Electrolytic capacitor (Non polarized)
		LED			Electrolytic capacitor (Noneless)
		Varactor			Electrolytic capacitor (Polarized)
		Tact switch			Power capacitor
		Inductor			Resistor array
		Coil			Resistor
		Transformer			Resonator
		Filter			Thermistor

1. This P.C.B. connection diagram is viewed from the parts mounted side.
2. The parts which have been mounted on the board can be replaced with those shown with the corresponding wiring symbols listed in the above Table.
3. The capacitor terminal marked with shows negative terminal.
4. The diode marked with shows cathode side.
5. The transistor terminal marked with shows emitter.

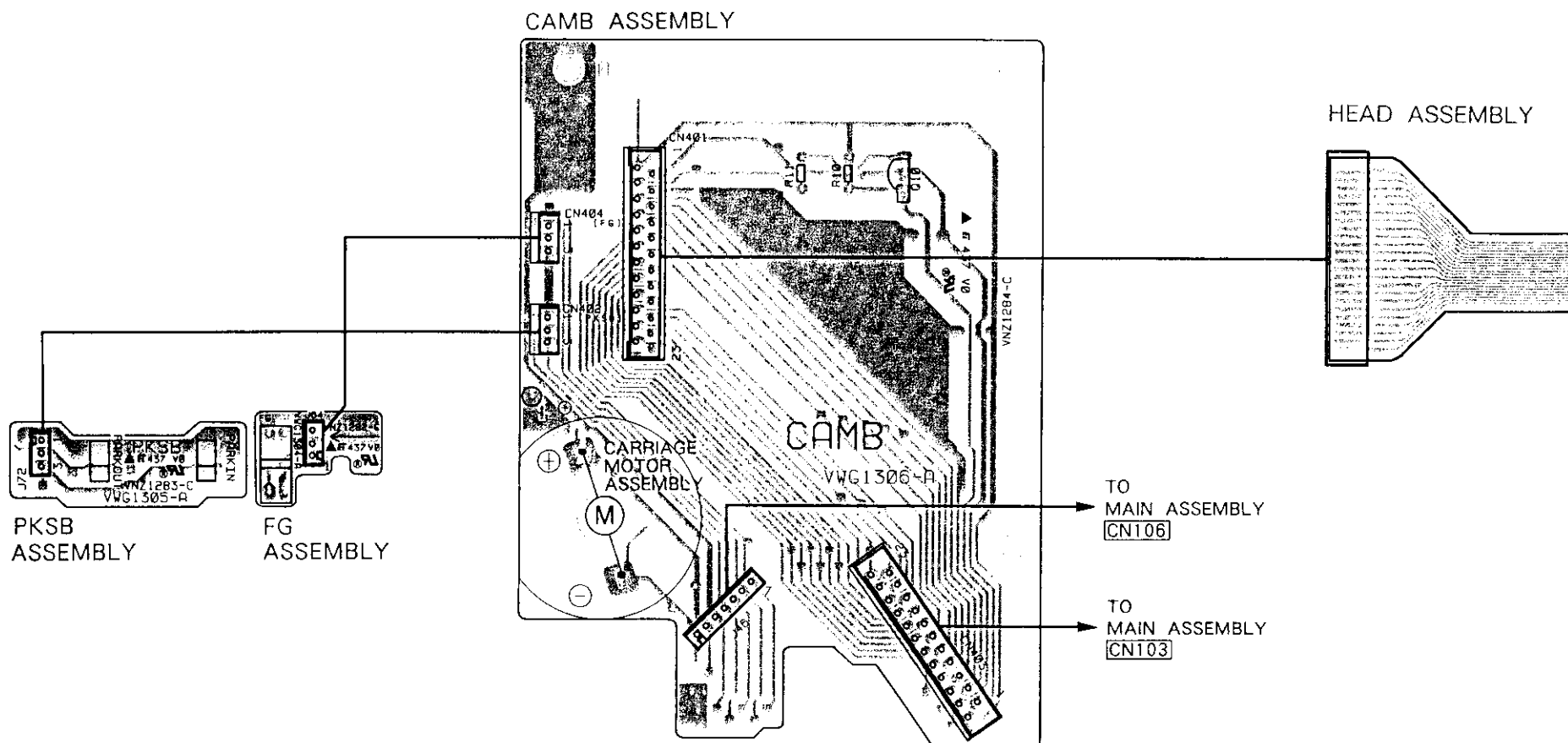
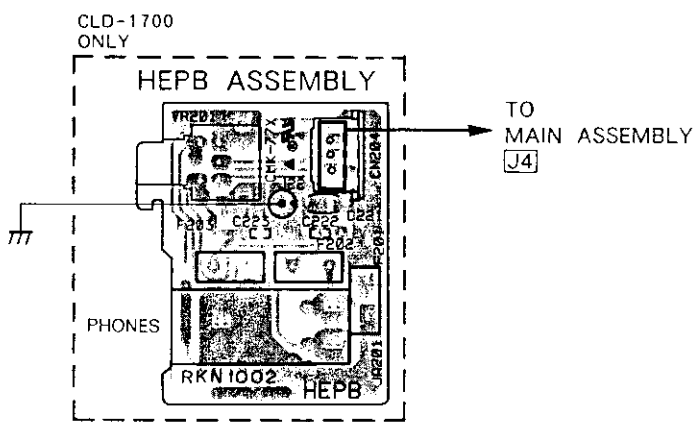
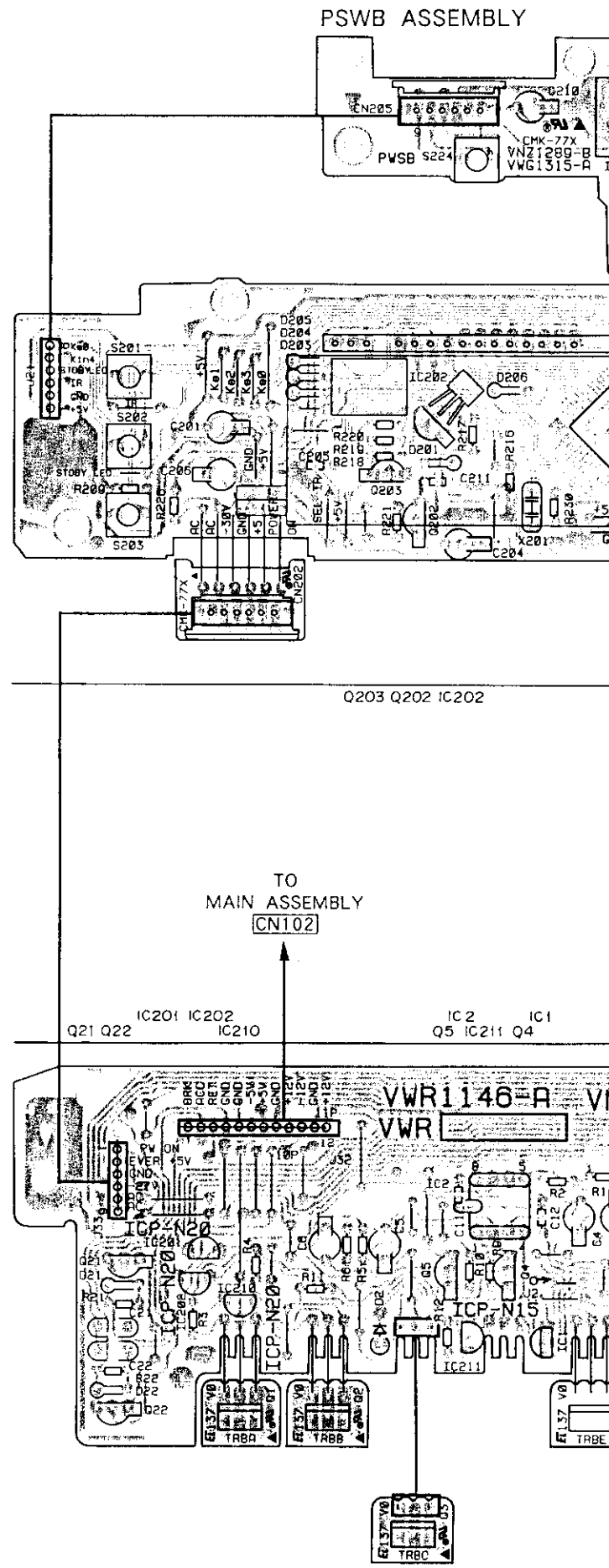

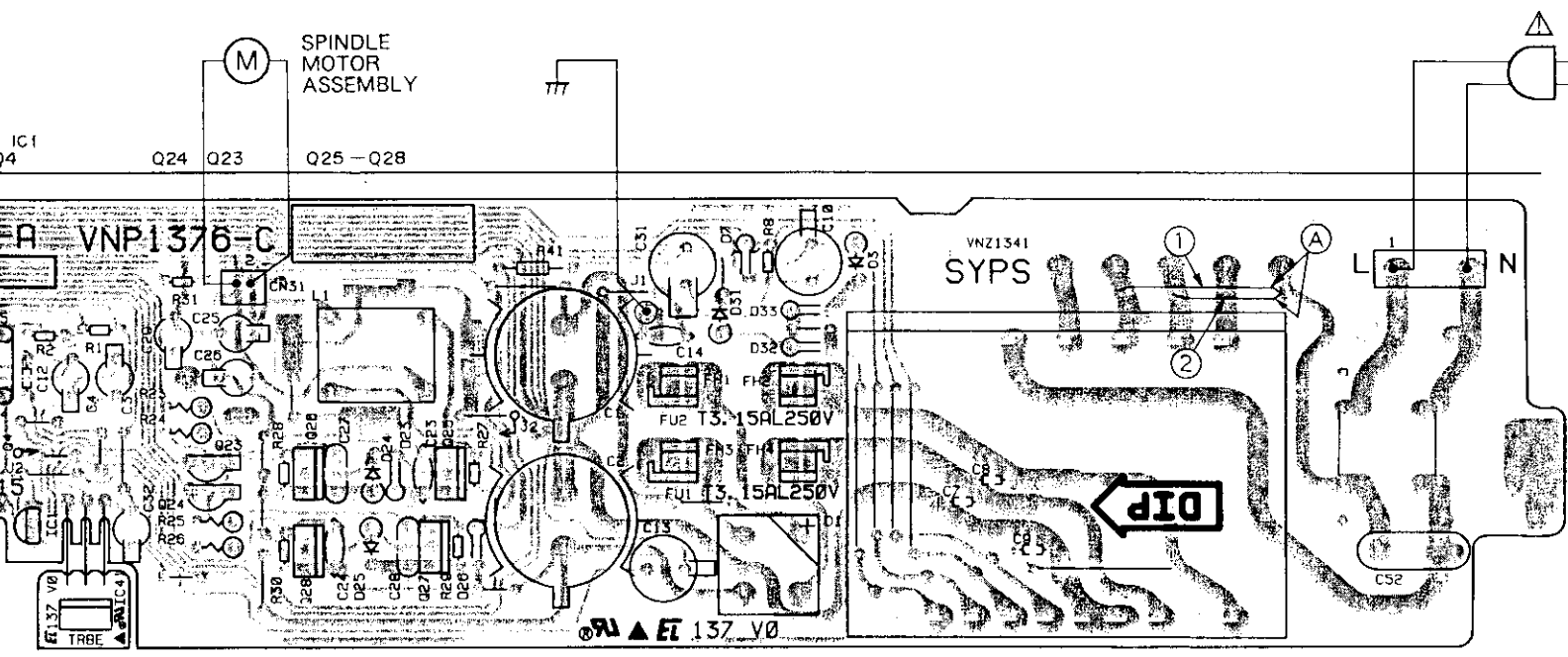
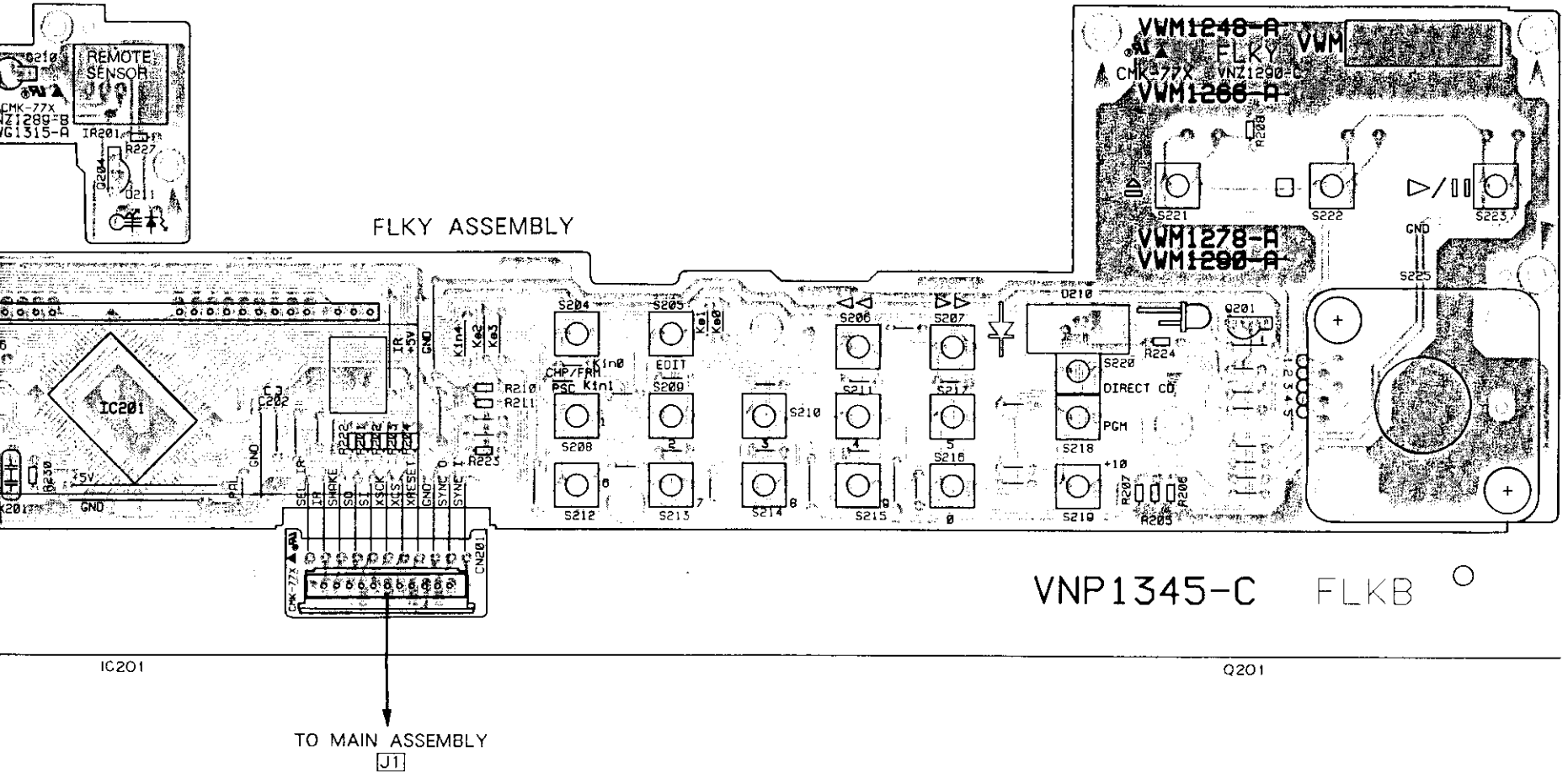

Line voltage selection

- Line voltage can be changed as follows:
1. Disconnect the AC power cord.
 2. Remove the cover.
 3. Change the position of the jumper wire (A) as follows.

Voltage	jumper wire (A) position
220V - 230V	①
240V	②

4. Stick the line voltage label on the rear panel.

Part No.	Description
AAx-193	220V label
AAx-192	240V label

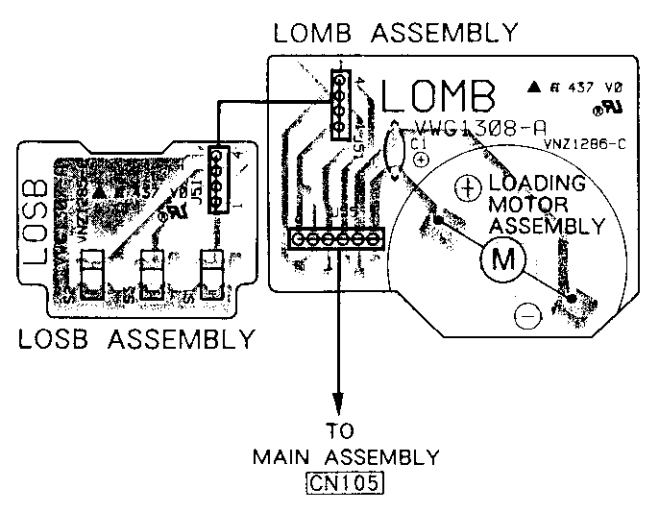
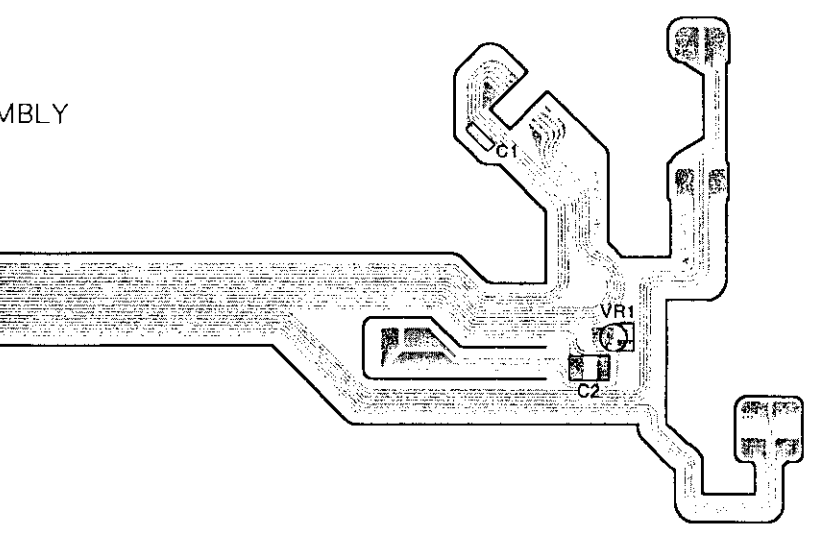

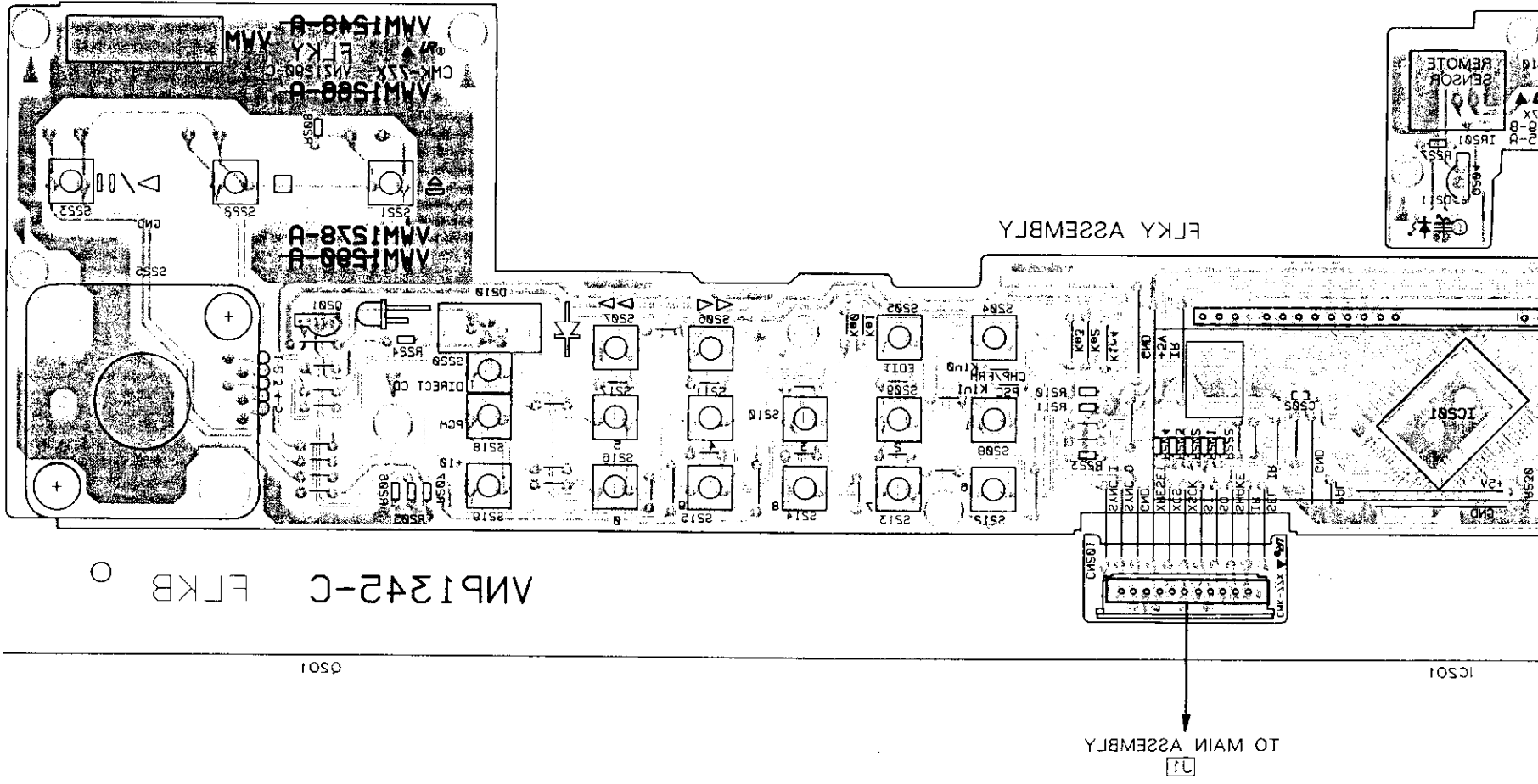

Line voltage selection
 Line voltage can be changed as follows:
 1. Disconnect the AC power cord.
 2. Remove the cover.
 3. Change the position of the jumper wire as follows.
 (A) as follows.

Voltage	Jumper wire (A) position
240V	①
220V-230V	②

4. Stick the line voltage label on the rear panel.

Part No.	Description
AAX-193	220V label
AAX-192	240V label

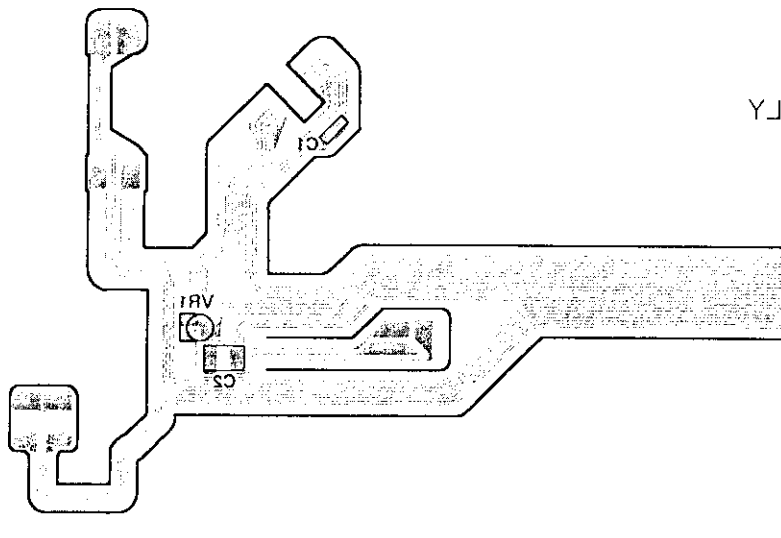
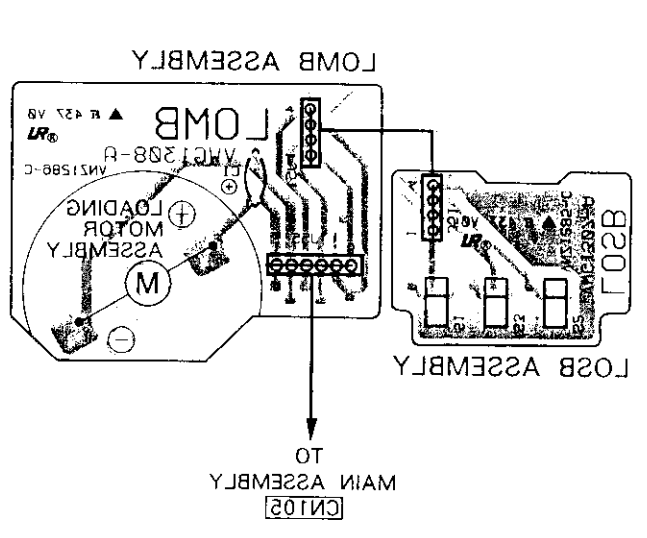
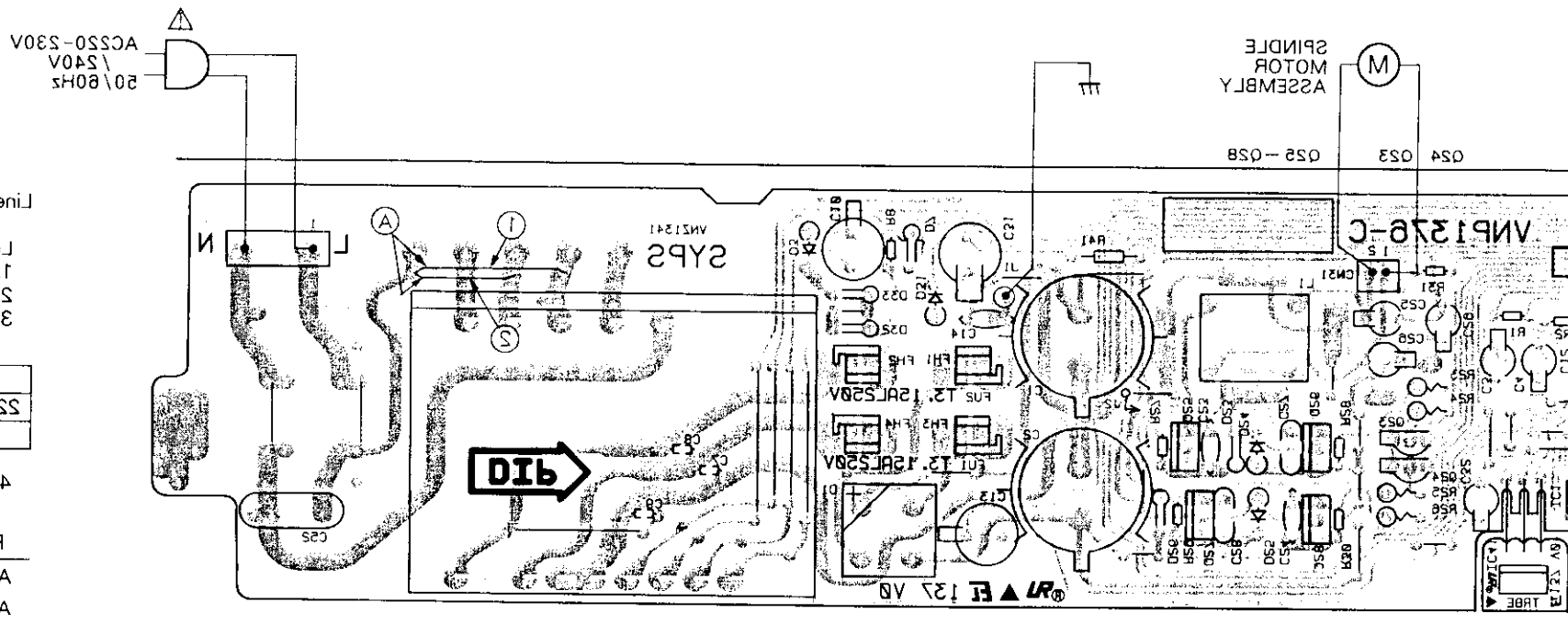

This P.C.B. connection diagram is viewed from the foil side.

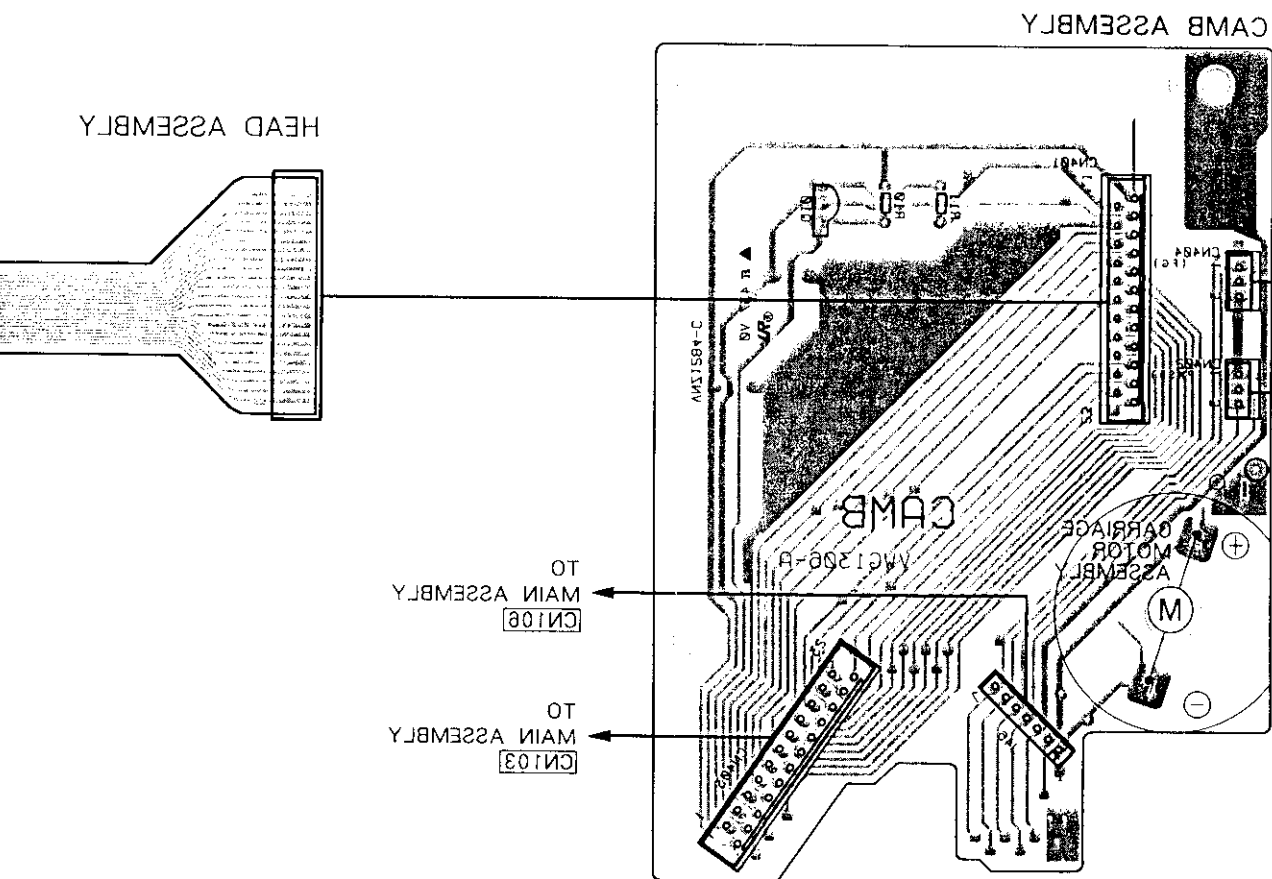
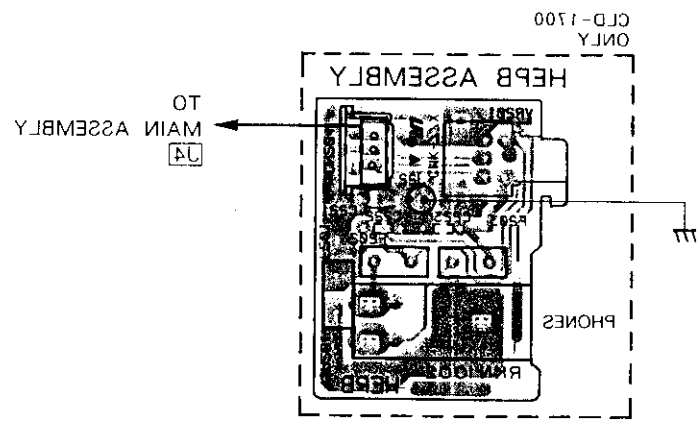
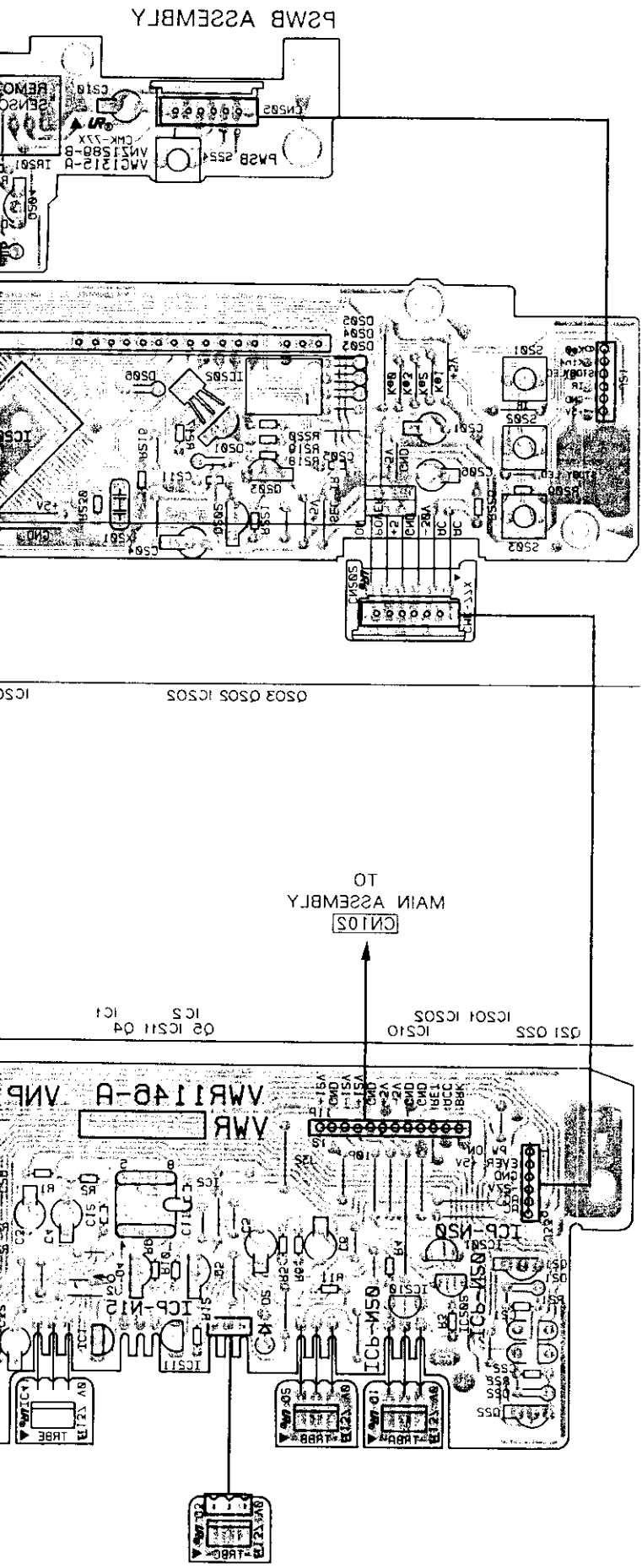

B
C
D
E
F

3.2 MAIN ASSEMBLY (1/2)

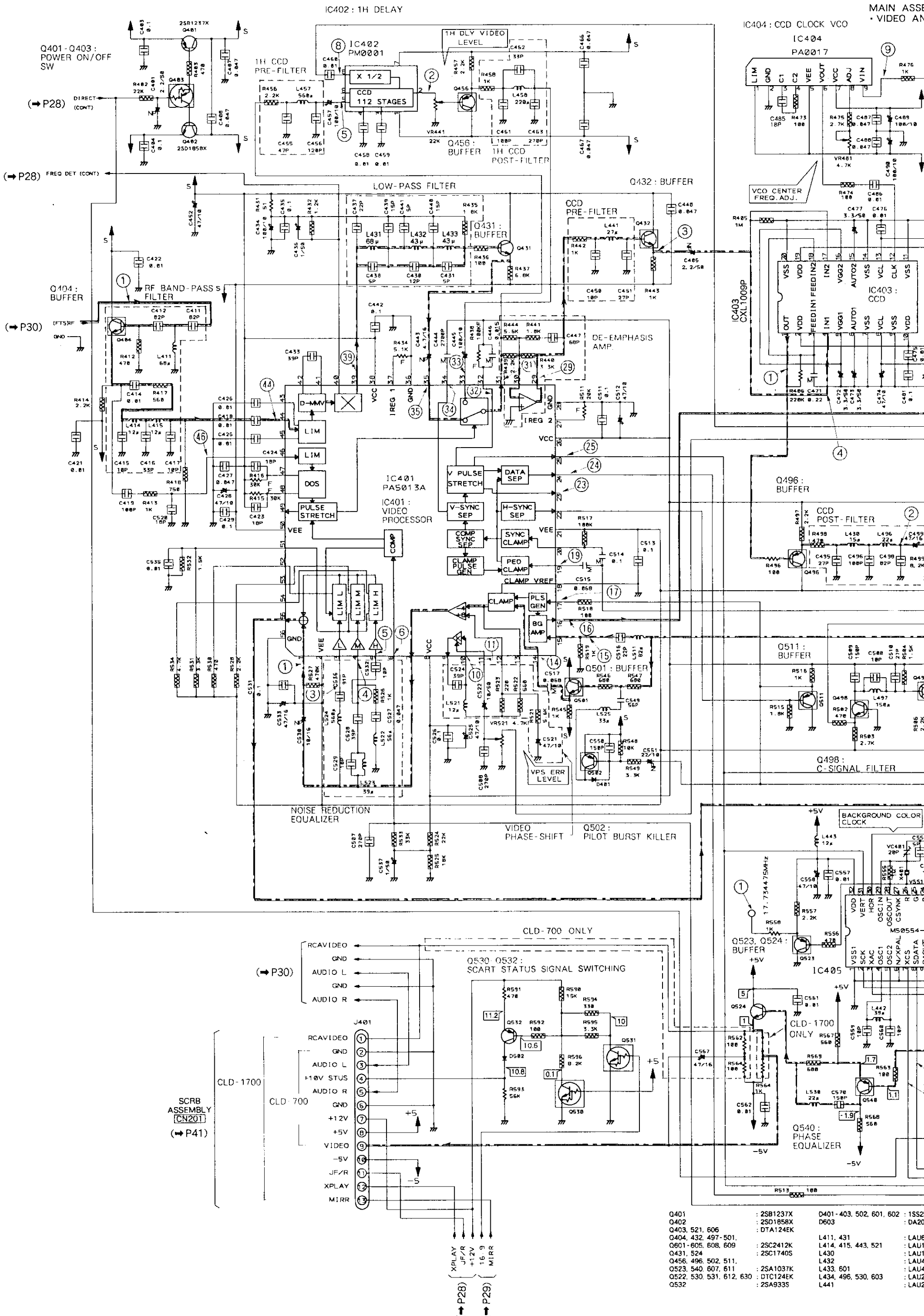

- | | | | |
|--------------------------|------------|-------------------------|---------|
| Q401 | : 25R1237X | Q401-403, 502, 601, 602 | : 1SS22 |
| Q402 | : 25D1858X | D603 | : DA20 |
| Q403, 521, 606 | : DTA124EK | | |
| Q404, 432, 497-501, | | L411, 431 | : LAU6 |
| Q601-605, 608, 609 | : 25C2412K | L414, 415, 443, 521 | : LAU1 |
| Q431, 524 | : 25C1740S | L430 | : LAU1 |
| Q456, 496, 502, 511, | | L432 | : LAU4 |
| Q523, 540, 607, 611 | : 25A1037K | L433, 601 | : LAU4 |
| Q522, 530, 531, 612, 630 | : DTC124EK | L434, 496, 530, 603 | : LAU2 |
| Q532 | : 25A933S | L441 | : LAU2 |

VIDEO AND TBC SECTION

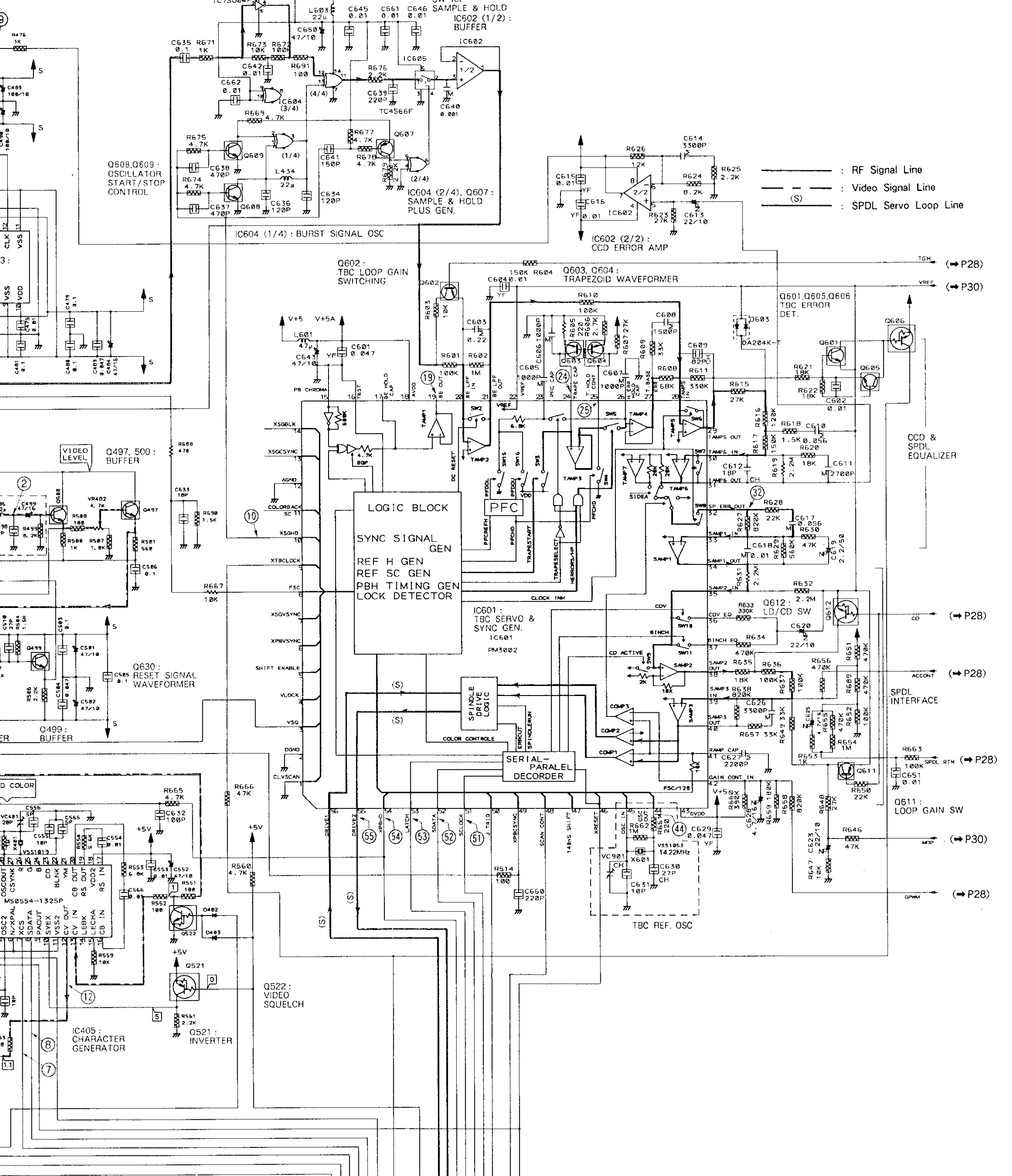

- 602 : 1SS254
- 603 : DA204K
- 604 : LAU680J
- 605 : LAU120J
- 606 : LAU150J
- 607 : LAU430J
- 608 : LAU470J
- 609 : LAU220J
- 610 : LAU270J
- 611 : L442, 523
- 612 : L457, 524
- 613 : L458
- 614 : L497
- 615 : L511
- 616 : L522
- 617 : L525
- 618 : VC401, 901
- 619 : VR441
- 620 : VR481, 482, 521
- 621 : LAU390J
- 622 : LFA561J
- 623 : LFA221J
- 624 : LAU151J
- 625 : LAU820J
- 626 : LAU560J
- 627 : LAU330J
- 628 : VCM-008
- 629 : VRT86VS223
- 630 : VRT86VS472

3.3 MAIN ASSEMBLY (2/2) AND AUDIO ASSEMBLY

MAIN ASSEMBLY (2/2) - FTS SECTION

AUDIO ASSEMBLY

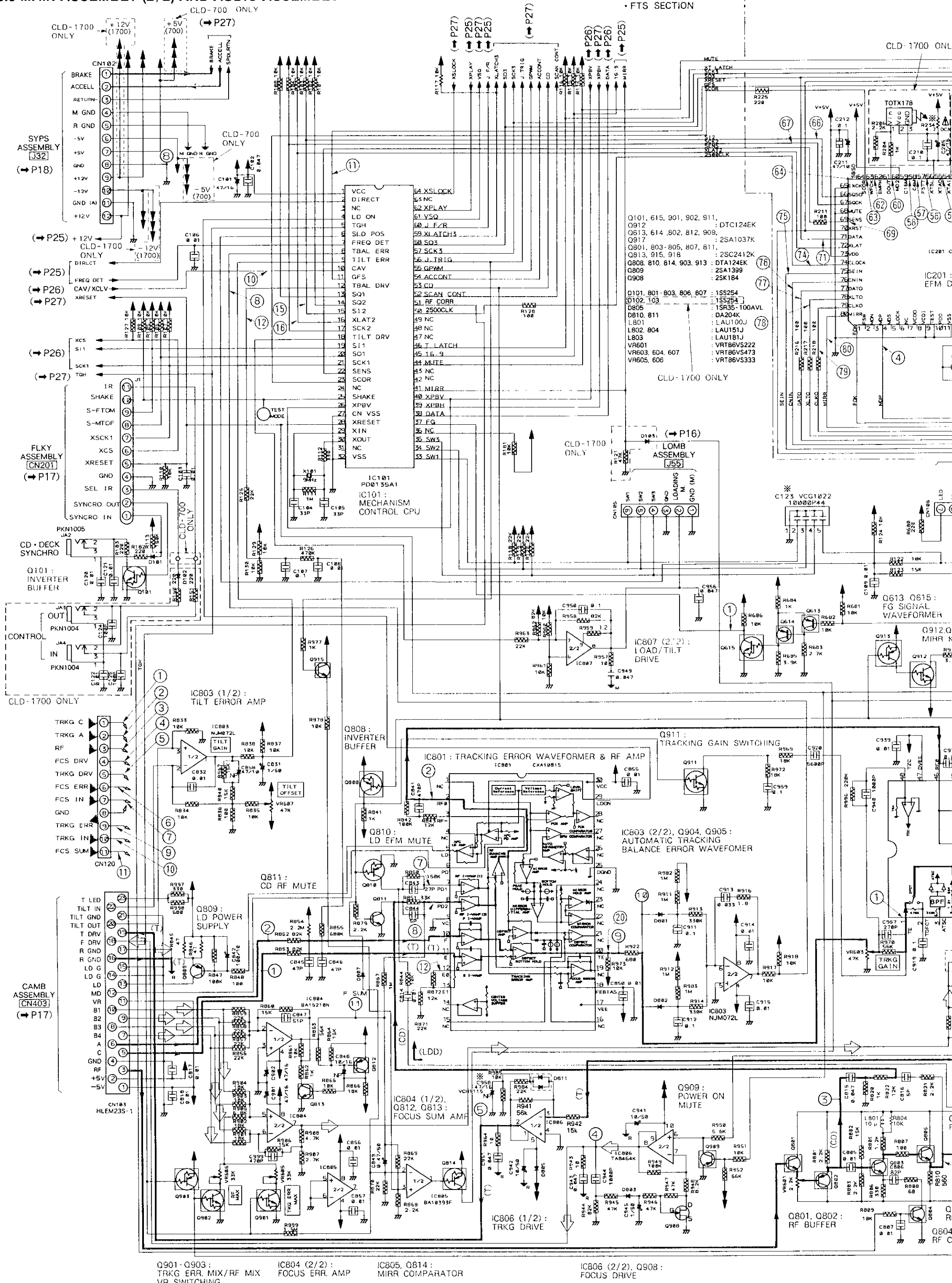

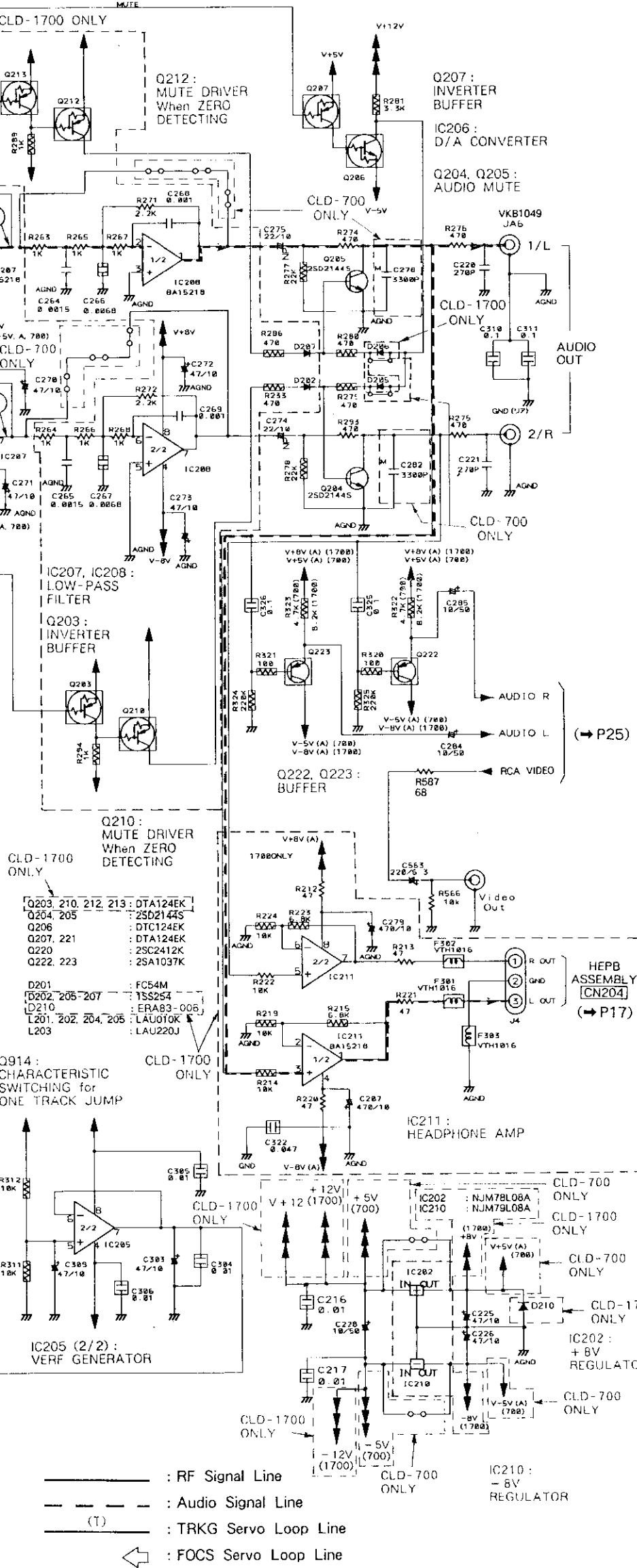
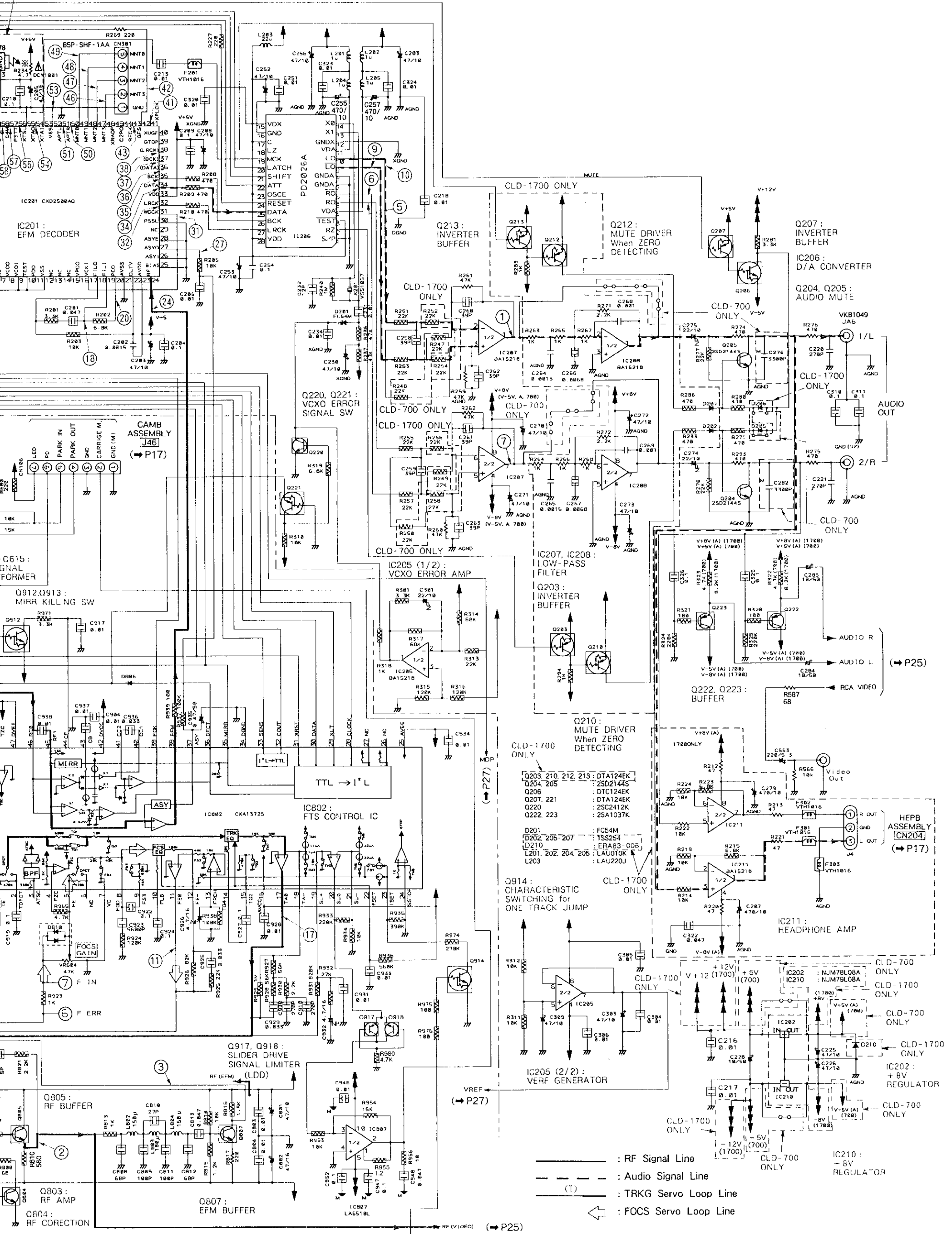

Q203, 210, 212, 213: 0TA124EK
 Q204, 205: 2SD2144S
 Q206: DTA124EK
 Q207, 221: DTA124EK
 Q220: 2SC2412K
 Q222, 223: 2SA1037K

D201: FC54M
 D202, 205-207: 1SS254
 D210: ERA83-008
 L201, 202, 204, 205: LAU010K
 L203: LAU220J

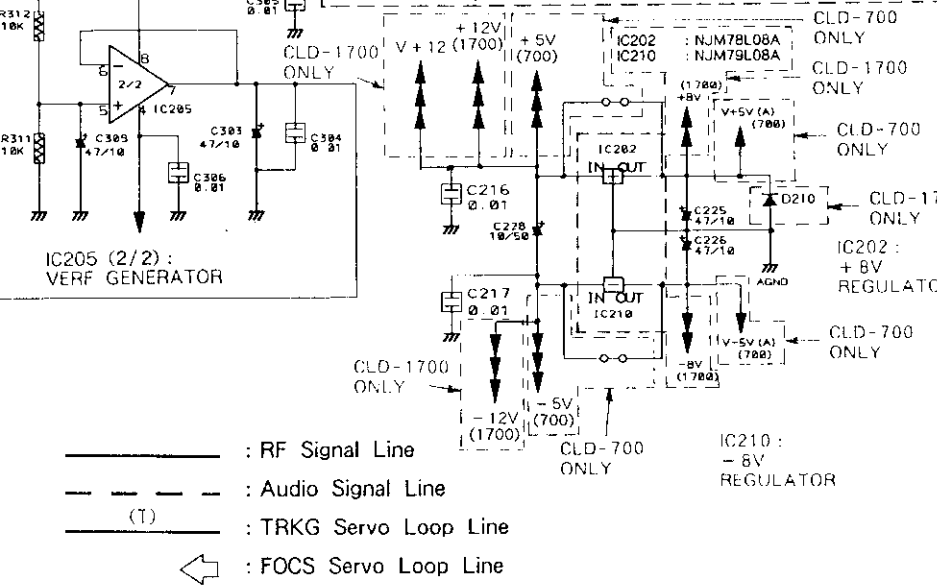

- : RF Signal Line
- - - : Audio Signal Line
- (T) : TRKG Servo Loop Line
- ← : FOCS Servo Loop Line

B
C
D
E
F

**WAVEFORMS AND VOLTAGES
VIDEO AND TBC SECTION**

Note: (No.) in the table correspond to the pin number.

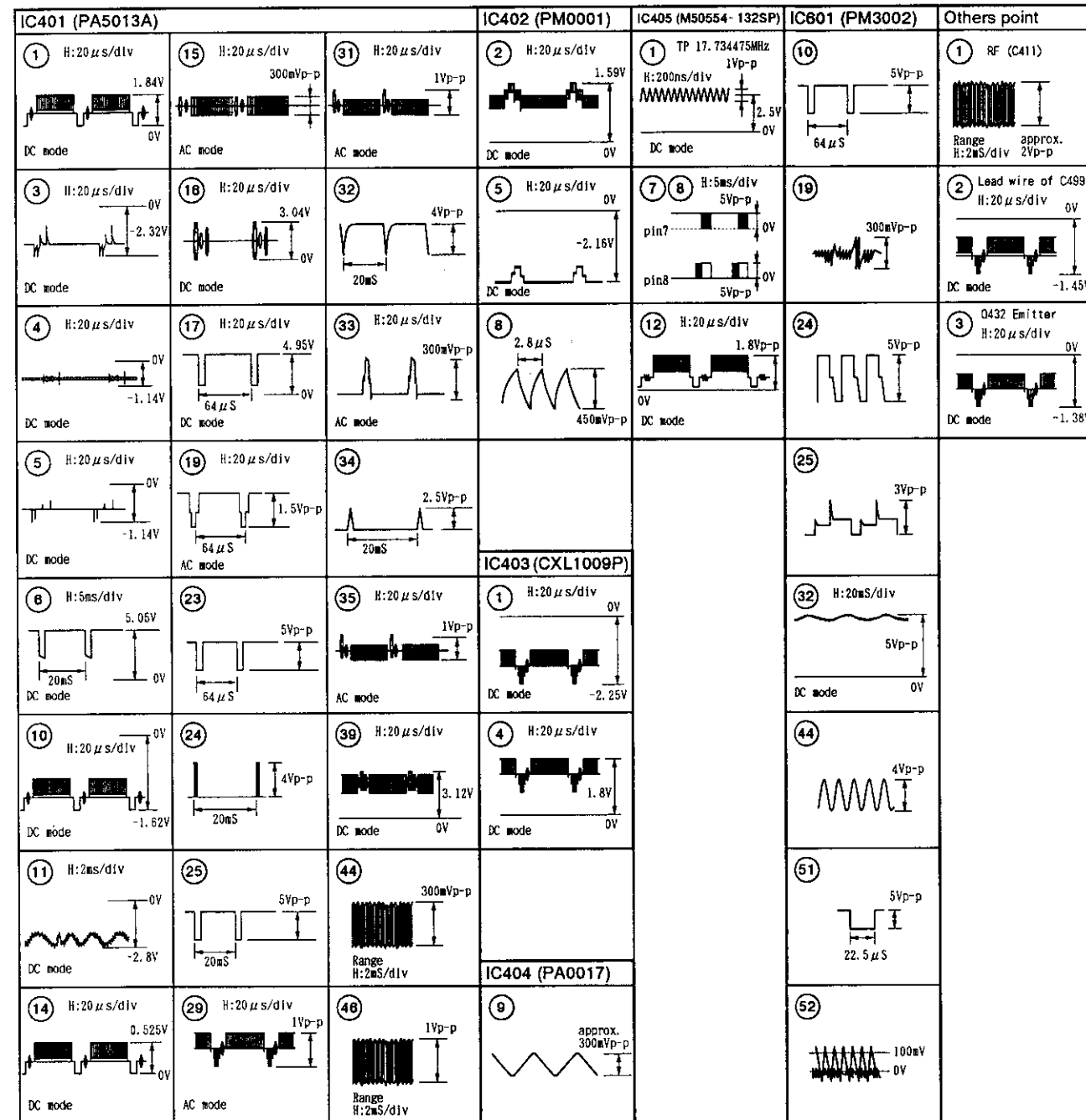

Note : Waveforms and voltages are at the PLAY mode.

IC405 (M50554-132SP)

Pin No.	Voltage	Pin No.	Voltage	Pin No.	Voltage	Pin No.	Voltage
1	0	9	-	17	0.8	25	-
2	5	10	5	18	-	26	-
3	5	11	0	19	0	27	-
4	2.4	12	1.1	20	0	28	2.3
5	2.4	13	1.1	21	-	29	2.3
6	0	14	-	22	-	30	-
7	5	15	1.8	23	-	31	4.8
8	0.4	16	0.6	24	-	32	-

FTS AND AUDIO SECTION

Note: (No.) in the table correspond to the pin number.

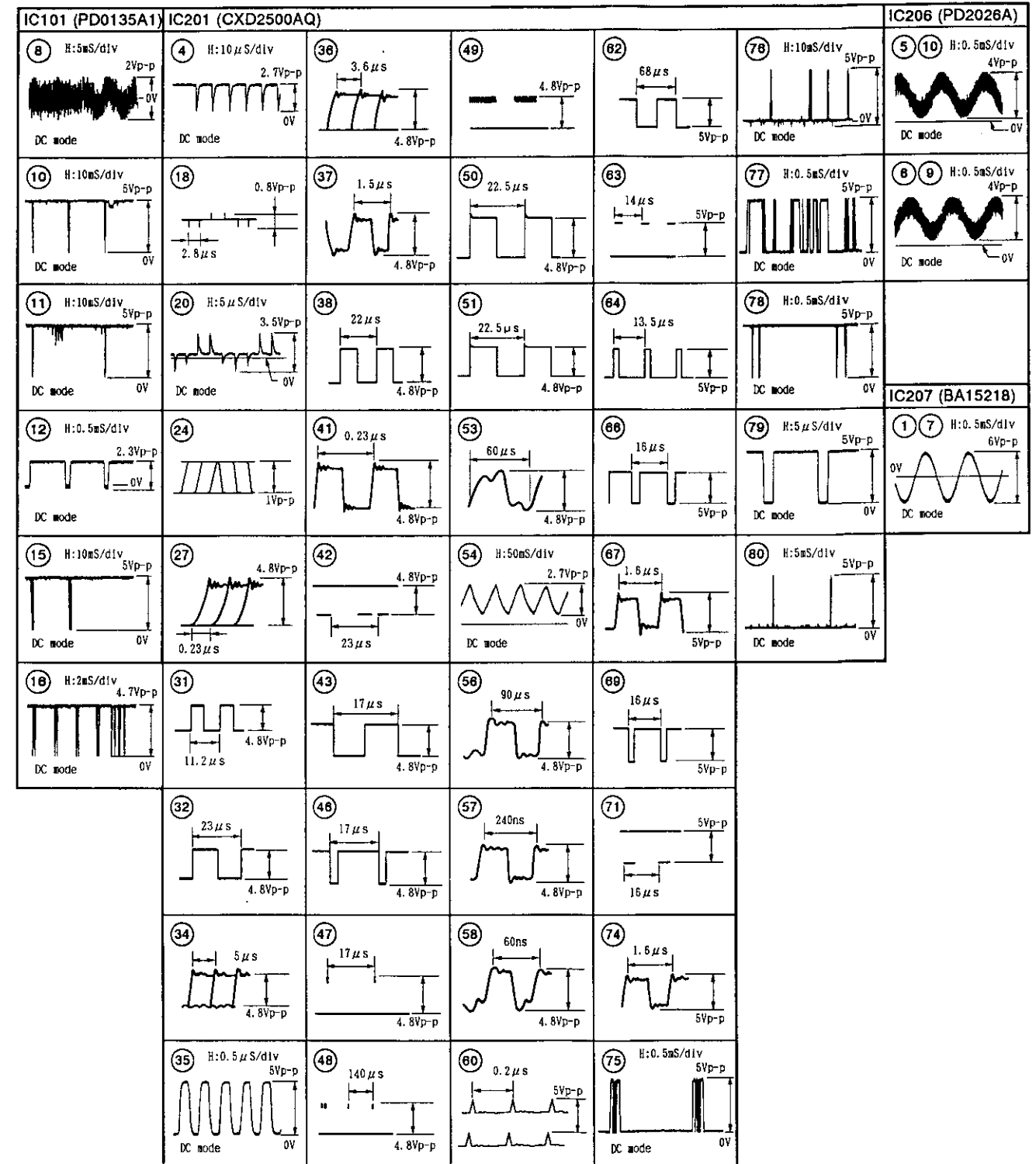

Note: (No.) in the table correspond to the pin number.

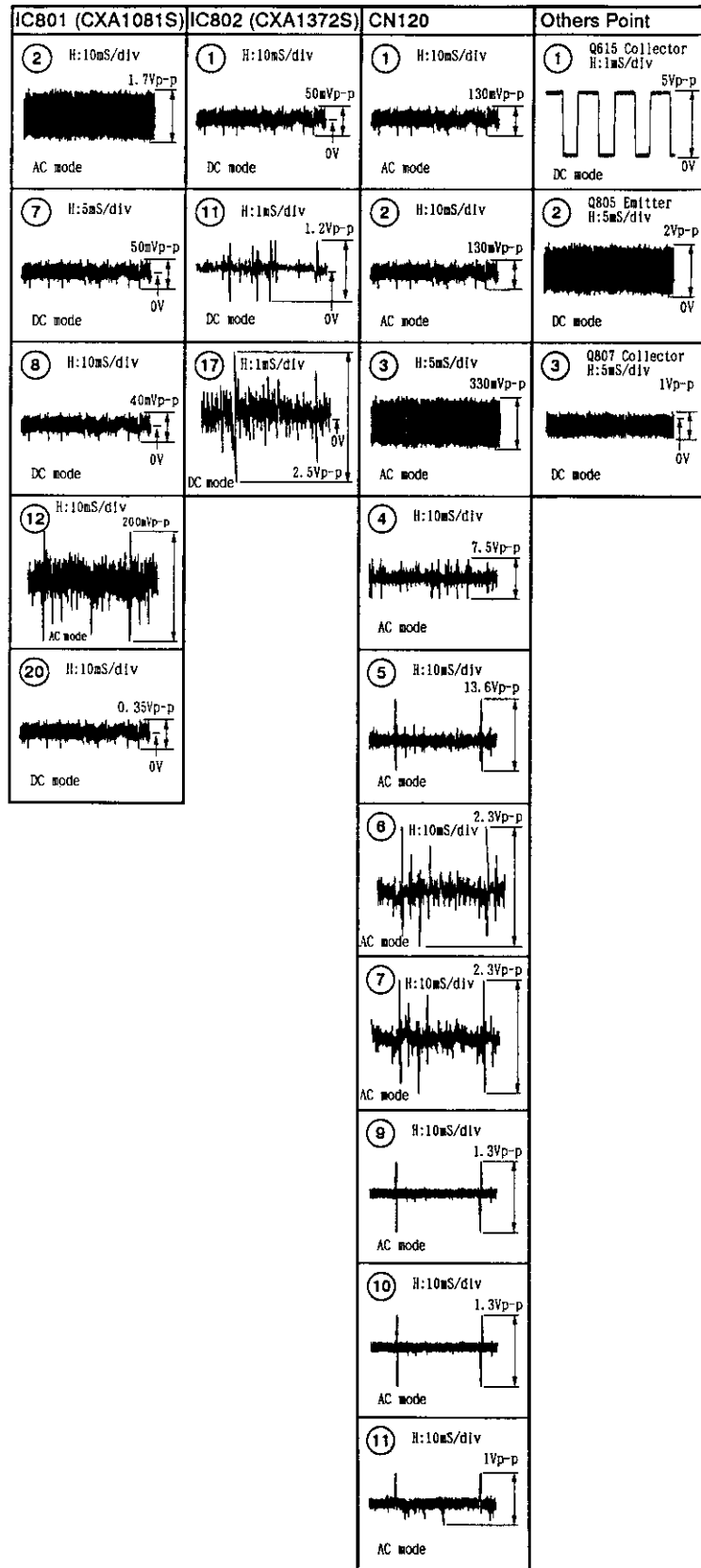

Note: Waveforms and voltages are at the PLAY mode.

IC201 (CXD2500AQ)

Pin No.	Voltage	Pin No.	Voltage	Pin No.	Voltage	Pin No.	Voltage	Pin No.	Voltage
1	4.8	17	0	33	4.8	49	*	65	0
2	0	18	*	34	*	50	*	66	*
3	0	19	2.4	35	*	51	*	67	*
4	*	20	*	36	*	52	0	68	0
5	0	21	0	37	*	53	*	69	*
6	4.8	22	2.3	38	*	54	*	70	5
7	-	23	4.8	39	0	55	0	71	*
8	4.8	24	*	40	4.8	56	*	72	5
9	0	25	0	41	*	57	*	73	5
10	0	26	0	42	*	58	*	74	*
11	0	27	*	43	*	59	5	75	*
12	0	28	0	44	0	60	*	76	*
13	0	29	0	45	4.8	61	5	77	*
14	0	30	0	46	*	62	*	78	*
15	0	31	*	47	*	63	*	79	*
16	4.8	32	*	48	*	64	*	80	*

*: Refer to waveform

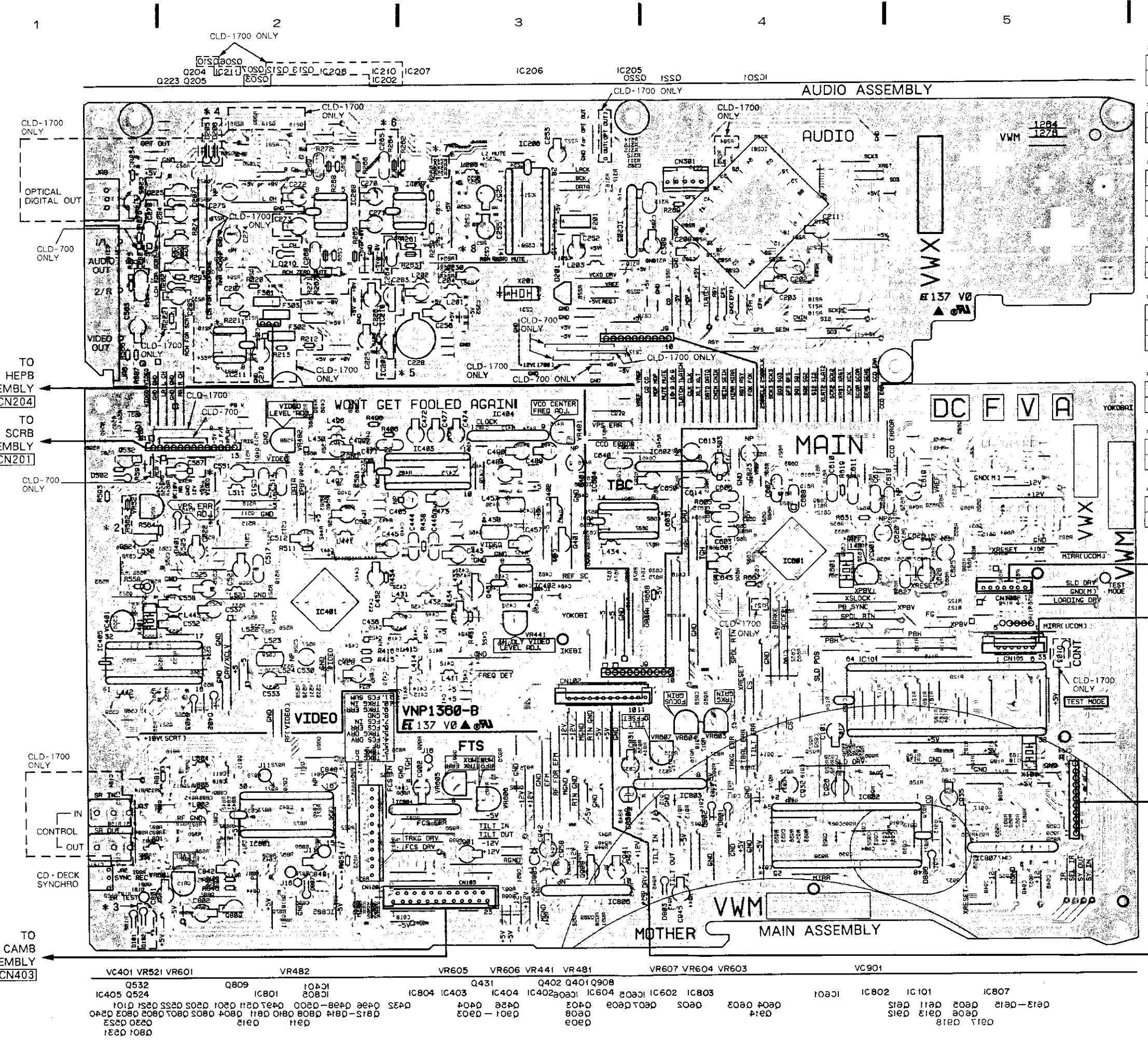

* 1

CLD-1700	C567
CLD-700	JUMPER

* 2

CLD-1700	JUMPER
CLD-700	R562

* 3

	D102	JUMPER
CLD-1700	USED	OPEN
CLD-700	OPEN	USED

* 4

CLD-1700	D205, 206
CLD-700	JUMPER

* 5

	IC202, 210	JUMPER
CLD-1700	USED	OPEN
CLD-700	OPEN	USED

* 6

CLD-1700	R263-266, 271, 272	OTHER PARTS
CLD-700	JUMPER	OPEN

* 7

CLD-1700	R256, 258	OPEN
CLD-700	OPEN	R248, 250

* 8

CLD-1700	R252, 254	OPEN
CLD-700	OPEN	R247, 248

TO HEPB ASSEMBLY [CN204]

TO SCRB ASSEMBLY [CN201]

CLD-700 ONLY

CLD-1700 ONLY

IN CONTROL

CD DECK SYNCHRO

TO CAMB ASSEMBLY [CN403]

TO SYPS ASSEMBLY [J32]

TO CAMB ASSEMBLY [J46]

TO LOMB ASSEMBLY [J55]

TO FLKY ASSEMBLY [CN201]

TO SYPS ASSEMBLY [J32]

VC401	VR521	VR601	VR482	VR605	VR606	VR441	VR481	VR607	VR604	VR603	VC901				
Q532	Q809	IC405	IC524	IC801	IC801	IC804	IC403	IC404	IC402	IC604	IC602	IC803	IC807	IC101	IC807
Q430	Q431	Q402	Q401	Q908	Q430	Q431	Q402	Q401	Q908	Q430	Q431	Q402	Q401	Q908	Q430
Q430	Q431	Q402	Q401	Q908	Q430	Q431	Q402	Q401	Q908	Q430	Q431	Q402	Q401	Q908	Q430
Q430	Q431	Q402	Q401	Q908	Q430	Q431	Q402	Q401	Q908	Q430	Q431	Q402	Q401	Q908	Q430
Q430	Q431	Q402	Q401	Q908	Q430	Q431	Q402	Q401	Q908	Q430	Q431	Q402	Q401	Q908	Q430

3.4 SCRB ASSEMBLY

This P.C.B. connection diagram is viewed from the foil side.

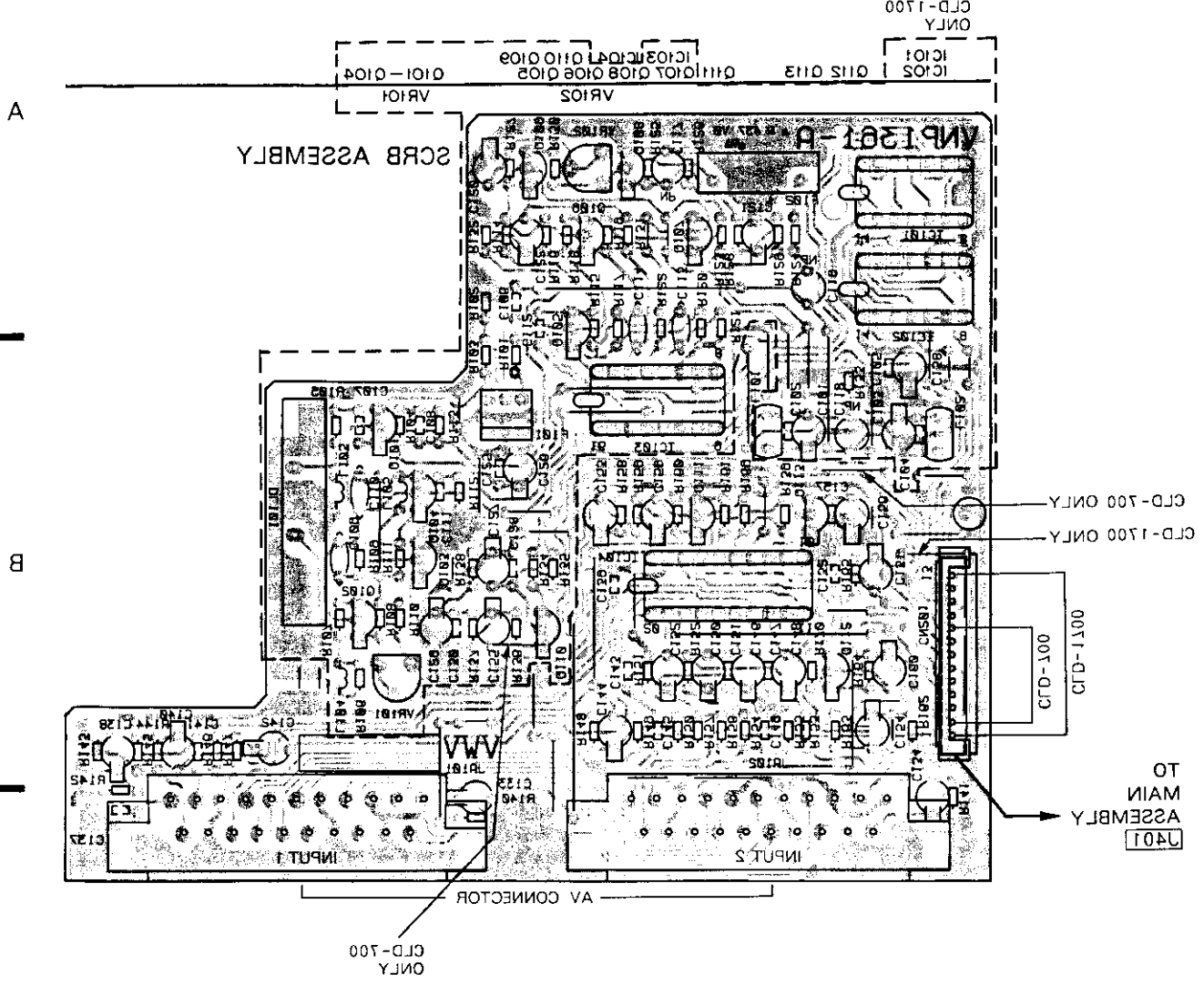

SCRB ASSEMBLY

Note: (No.) in the table correspond to the pin number.

IC103 (BU4023B)		Others Point	
<p>DC mode 380Vp-p</p> <p>pin2</p> <p>pin3</p> <p>pin13</p> <p>pin15</p> <p>pin16</p> <p>pin17</p> <p>pin18</p> <p>pin19</p> <p>pin20</p> <p>pin21</p> <p>pin22</p> <p>pin23</p> <p>pin24</p> <p>pin25</p> <p>pin26</p> <p>pin27</p> <p>pin28</p> <p>pin29</p> <p>pin30</p> <p>pin31</p> <p>pin32</p> <p>pin33</p> <p>pin34</p> <p>pin35</p> <p>pin36</p> <p>pin37</p> <p>pin38</p> <p>pin39</p> <p>pin40</p> <p>pin41</p> <p>pin42</p> <p>pin43</p> <p>pin44</p> <p>pin45</p> <p>pin46</p> <p>pin47</p> <p>pin48</p> <p>pin49</p> <p>pin50</p> <p>pin51</p> <p>pin52</p> <p>pin53</p> <p>pin54</p> <p>pin55</p> <p>pin56</p> <p>pin57</p> <p>pin58</p> <p>pin59</p> <p>pin60</p> <p>pin61</p> <p>pin62</p> <p>pin63</p> <p>pin64</p> <p>pin65</p> <p>pin66</p> <p>pin67</p> <p>pin68</p> <p>pin69</p> <p>pin70</p> <p>pin71</p> <p>pin72</p> <p>pin73</p> <p>pin74</p> <p>pin75</p> <p>pin76</p> <p>pin77</p> <p>pin78</p> <p>pin79</p> <p>pin80</p> <p>pin81</p> <p>pin82</p> <p>pin83</p> <p>pin84</p> <p>pin85</p> <p>pin86</p> <p>pin87</p> <p>pin88</p> <p>pin89</p> <p>pin90</p> <p>pin91</p> <p>pin92</p> <p>pin93</p> <p>pin94</p> <p>pin95</p> <p>pin96</p> <p>pin97</p> <p>pin98</p> <p>pin99</p> <p>pin100</p>	<p>DC mode 420Vp-p</p> <p>pin13</p> <p>pin15</p> <p>pin16</p> <p>pin17</p> <p>pin18</p> <p>pin19</p> <p>pin20</p> <p>pin21</p> <p>pin22</p> <p>pin23</p> <p>pin24</p> <p>pin25</p> <p>pin26</p> <p>pin27</p> <p>pin28</p> <p>pin29</p> <p>pin30</p> <p>pin31</p> <p>pin32</p> <p>pin33</p> <p>pin34</p> <p>pin35</p> <p>pin36</p> <p>pin37</p> <p>pin38</p> <p>pin39</p> <p>pin40</p> <p>pin41</p> <p>pin42</p> <p>pin43</p> <p>pin44</p> <p>pin45</p> <p>pin46</p> <p>pin47</p> <p>pin48</p> <p>pin49</p> <p>pin50</p> <p>pin51</p> <p>pin52</p> <p>pin53</p> <p>pin54</p> <p>pin55</p> <p>pin56</p> <p>pin57</p> <p>pin58</p> <p>pin59</p> <p>pin60</p> <p>pin61</p> <p>pin62</p> <p>pin63</p> <p>pin64</p> <p>pin65</p> <p>pin66</p> <p>pin67</p> <p>pin68</p> <p>pin69</p> <p>pin70</p> <p>pin71</p> <p>pin72</p> <p>pin73</p> <p>pin74</p> <p>pin75</p> <p>pin76</p> <p>pin77</p> <p>pin78</p> <p>pin79</p> <p>pin80</p> <p>pin81</p> <p>pin82</p> <p>pin83</p> <p>pin84</p> <p>pin85</p> <p>pin86</p> <p>pin87</p> <p>pin88</p> <p>pin89</p> <p>pin90</p> <p>pin91</p> <p>pin92</p> <p>pin93</p> <p>pin94</p> <p>pin95</p> <p>pin96</p> <p>pin97</p> <p>pin98</p> <p>pin99</p> <p>pin100</p>	<p>DC mode H:30Vp-p</p> <p>pin13</p> <p>pin15</p> <p>pin16</p> <p>pin17</p> <p>pin18</p> <p>pin19</p> <p>pin20</p> <p>pin21</p> <p>pin22</p> <p>pin23</p> <p>pin24</p> <p>pin25</p> <p>pin26</p> <p>pin27</p> <p>pin28</p> <p>pin29</p> <p>pin30</p> <p>pin31</p> <p>pin32</p> <p>pin33</p> <p>pin34</p> <p>pin35</p> <p>pin36</p> <p>pin37</p> <p>pin38</p> <p>pin39</p> <p>pin40</p> <p>pin41</p> <p>pin42</p> <p>pin43</p> <p>pin44</p> <p>pin45</p> <p>pin46</p> <p>pin47</p> <p>pin48</p> <p>pin49</p> <p>pin50</p> <p>pin51</p> <p>pin52</p> <p>pin53</p> <p>pin54</p> <p>pin55</p> <p>pin56</p> <p>pin57</p> <p>pin58</p> <p>pin59</p> <p>pin60</p> <p>pin61</p> <p>pin62</p> <p>pin63</p> <p>pin64</p> <p>pin65</p> <p>pin66</p> <p>pin67</p> <p>pin68</p> <p>pin69</p> <p>pin70</p> <p>pin71</p> <p>pin72</p> <p>pin73</p> <p>pin74</p> <p>pin75</p> <p>pin76</p> <p>pin77</p> <p>pin78</p> <p>pin79</p> <p>pin80</p> <p>pin81</p> <p>pin82</p> <p>pin83</p> <p>pin84</p> <p>pin85</p> <p>pin86</p> <p>pin87</p> <p>pin88</p> <p>pin89</p> <p>pin90</p> <p>pin91</p> <p>pin92</p> <p>pin93</p> <p>pin94</p> <p>pin95</p> <p>pin96</p> <p>pin97</p> <p>pin98</p> <p>pin99</p> <p>pin100</p>	<p>DC mode H:30Vp-p</p> <p>pin13</p> <p>pin15</p> <p>pin16</p> <p>pin17</p> <p>pin18</p> <p>pin19</p> <p>pin20</p> <p>pin21</p> <p>pin22</p> <p>pin23</p> <p>pin24</p> <p>pin25</p> <p>pin26</p> <p>pin27</p> <p>pin28</p> <p>pin29</p> <p>pin30</p> <p>pin31</p> <p>pin32</p> <p>pin33</p> <p>pin34</p> <p>pin35</p> <p>pin36</p> <p>pin37</p> <p>pin38</p> <p>pin39</p> <p>pin40</p> <p>pin41</p> <p>pin42</p> <p>pin43</p> <p>pin44</p> <p>pin45</p> <p>pin46</p> <p>pin47</p> <p>pin48</p> <p>pin49</p> <p>pin50</p> <p>pin51</p> <p>pin52</p> <p>pin53</p> <p>pin54</p> <p>pin55</p> <p>pin56</p> <p>pin57</p> <p>pin58</p> <p>pin59</p> <p>pin60</p> <p>pin61</p> <p>pin62</p> <p>pin63</p> <p>pin64</p> <p>pin65</p> <p>pin66</p> <p>pin67</p> <p>pin68</p> <p>pin69</p> <p>pin70</p> <p>pin71</p> <p>pin72</p> <p>pin73</p> <p>pin74</p> <p>pin75</p> <p>pin76</p> <p>pin77</p> <p>pin78</p> <p>pin79</p> <p>pin80</p> <p>pin81</p> <p>pin82</p> <p>pin83</p> <p>pin84</p> <p>pin85</p> <p>pin86</p> <p>pin87</p> <p>pin88</p> <p>pin89</p> <p>pin90</p> <p>pin91</p> <p>pin92</p> <p>pin93</p> <p>pin94</p> <p>pin95</p> <p>pin96</p> <p>pin97</p> <p>pin98</p> <p>pin99</p> <p>pin100</p>

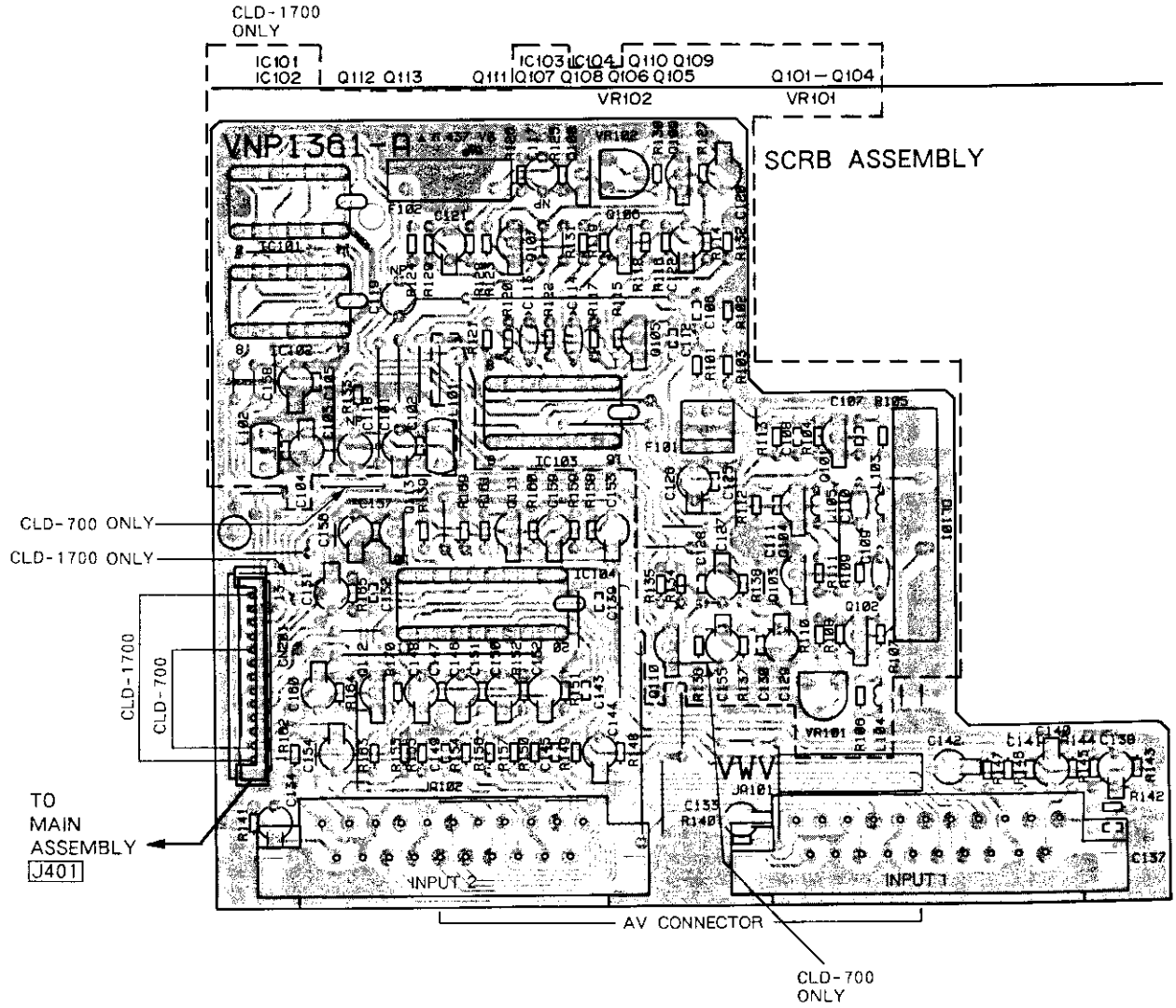

SCRIB ASSEMBLY

Note: (No.) in the table correspond to the pin number.

IC103 (BU4053B)		Others Point	
<p>(3) (5)</p> <p>H: 5mS/div 320mVp-p</p> <p>pin3 0V</p> <p>pin5 0V</p> <p>DC mode 280mVp-p</p>	<p>(12) (13)</p> <p>H: 5mS/div 280mVp-p</p> <p>pin12 0V</p> <p>pin13 0V</p> <p>DC mode 450mVp-p</p>	<p>(6) Q109 Emitter 1.4Vp-p</p> <p> 0V</p> <p>DC mode H: 20 μS/div</p>	<p>(7) Q101 Emitter H: 20 μS/div</p> <p> 0V</p> <p>280Vp-p</p> <p>DC mode</p>

SCRB ASSEMBLY (VWV1248 : CLD-1700)
(VWV1255 : CLD-700)

IC104
• Truth table

CONTROL 1 PIN4	CONTROL 2 PIN8	MUTE IN PIN10	VIDEO OUT		AUDIO OUT	
			1	2	1	2
L	L	L	IN1	IN1	IN1	IN1
L	H	L	IN1	IN3	IN1	IN3
H	L	L	IN2	IN2	IN2	IN2
H	H	L	IN2	IN3	IN2	IN3
L	L	H	IN1	IN1	IN1	
L	H	H	IN1	IN3	IN1	
H	L	H	IN2	IN2	IN2	
H	H	H	IN2	IN3	IN2	

(L, R)

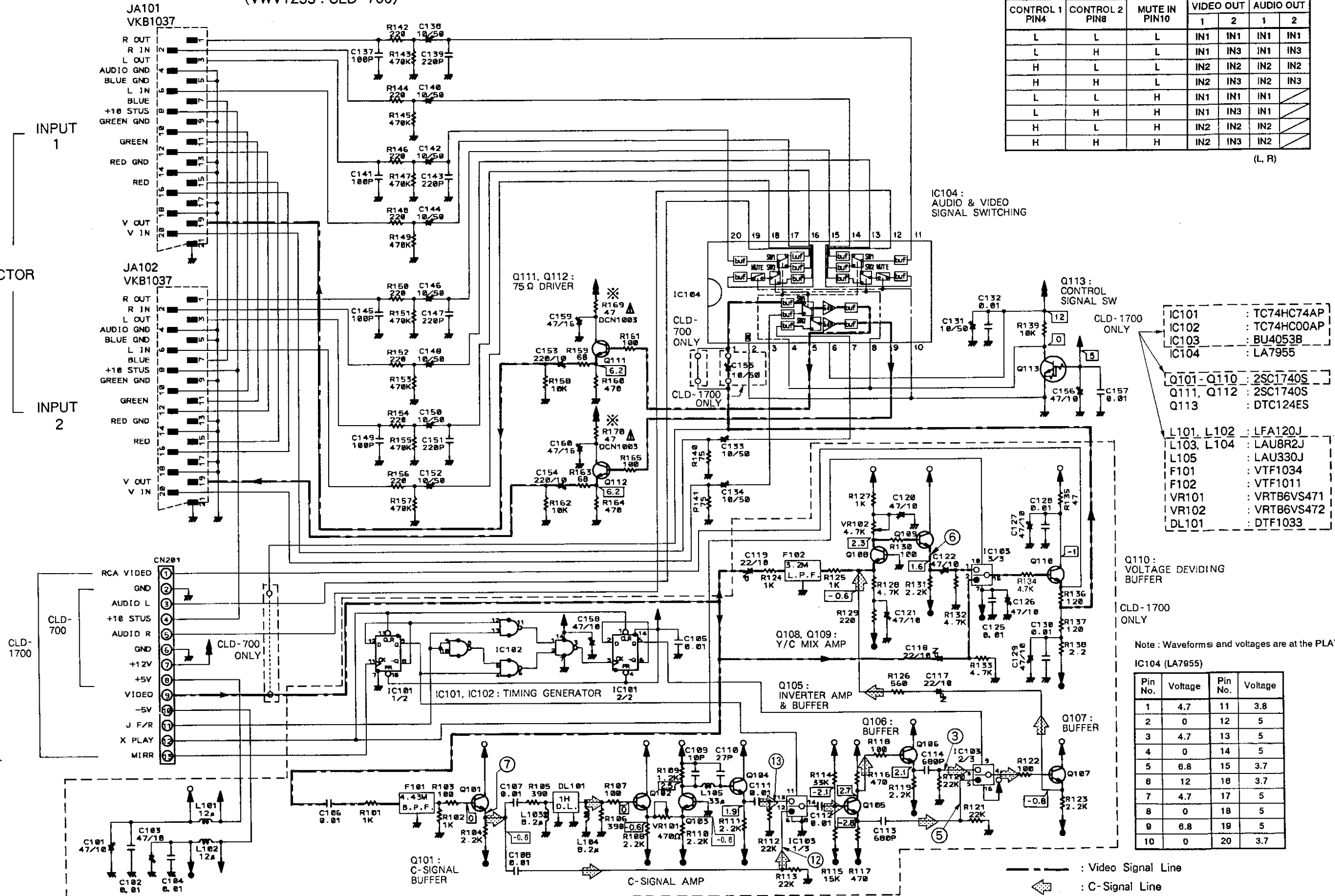

- IC101 : TC74HC74AP
- IC102 : TC74HC00AP
- IC103 : BU4053B
- IC104 : LA7955

- Q101 - Q110 : 2SC1740S
- Q111, Q112 : 2SC1740S
- Q113 : DTC124ES

- L101, L102 : LFA120J
- L103, L104 : LAU8R2J
- L105 : LAU330J
- F101 : VTF1034
- F102 : VTF1011
- VR101 : VRTB6VS471
- VR102 : VRTB6VS472
- DL101 : DTF1033

Q110 :
VOLTAGE DIVIDING
BUFFER

CLD-1700
ONLY

Note : Waveforms and voltages are at the PLAY

IC104 (LA7955)

Pin No.	Voltage	Pin No.	Voltage
1	4.7	11	3.8
2	0	12	5
3	4.7	13	5
4	0	14	5
5	6.8	15	3.7
6	12	16	3.7
7	4.7	17	5
8	0	18	5
9	6.8	19	5
10	0	20	3.7

— : Video Signal Line
— : C-Signal Line

4. PCB PARTS LIST

NOTES:

- Parts marked by "NSP" are generally unavailable because they are not in our Master Spare Parts List.
- The Δ mark found on some component parts indicates the importance of the safety factor of the part. Therefore, when replacing, be sure to use parts of identical designation.
- Parts marked by "⊙" are not always kept in stock. Their delivery time may be longer than usual or they may be unavailable.
- When ordering resistors, first convert resistance values into code form as shown in the following examples.

Ex.1 When there are 2 effective digits (any digit apart from 0), such as 560 ohm and 47k ohm (tolerance is shown by J=5%, and K=10%).

560 Ω \rightarrow 56 \times 10¹ \rightarrow 561..... RD1/8PM 5|6|1|J

47k Ω \rightarrow 47 \times 10³ \rightarrow 473..... RD1/4PS 4|7|3|J

0.5 Ω \rightarrow 0RS..... RN2H 0|R|5|K

1 Ω \rightarrow 010..... RSIP 0|1|0|K

Ex.2 When there are 3 effective digits (such as in high precision metal film resistors).

5.62k Ω \rightarrow 562 \times 10¹ \rightarrow 5621..... RN1/4PC 5|6|2|1|F

Mark	No.	Description	Part No.	Mark	No.	Description	Part No.
------	-----	-------------	----------	------	-----	-------------	----------

LIST OF ASSEMBLIES

⊙	MOTHER ASSEMBLY	VWM1276
NSP	└ MAIN ASSEMBLY	VWX1123
NSP	└ AUDIO ASSEMBLY	VWX1124
⊙	FLKB ASSEMBLY	VWM1278
NSP	└ PSWB ASSEMBLY	VWG1315
NSP	└ FLKY ASSEMBLY	VWG1336
NSP	└ HEPB ASSEMBLY	VWV1254
⊙	SYPS ASSEMBLY	VWR1146
⊙	SCRB ASSEMBLY	VWV1248
⊙	MACB ASSEMBLY	VWM1250
NSP	└ FG ASSEMBLY	VWG1304
NSP	└ PKSB ASSEMBLY	VWG1305
NSP	└ CAMB ASSEMBLY	VWG1306
NSP	└ LOSB ASSEMBLY	VWG1307
NSP	└ LOMB ASSEMBLY	VWG1308

FG ASSEMBLY

SEMICONDUCTOR		
D1		GP1S51

PKSB ASSEMBLY

SWITCHES		
S4, 5	PUSH SWITCH	DSG1015

LOSB ASSEMBLY

SWITCHES		
S1-3	PUSH SWITCH	DSG1015

CAMB ASSEMBLY

SEMICONDUCTORS		
Q10	TRANSISTOR	2SC1740S
RESISTORS		
R10	CARBON FILM RESISTOR	RD1/6PM182J
R11	CARBON FILM RESISTOR	RD1/6PM470J
OTHERS		
CN401	CONNECTOR (23P)	VKN1073
CN403	CONNECTOR (23P)	HLEM23R-1

LOMB ASSEMBLY

CAPACITOR		
C1	CERAMIC CAPACITOR	CGCYX473M25

PSWB ASSEMBLY

SEMICONDUCTORS		
Q204	TRANSISTOR	DTC124ES
D211	LED	SLH34VCF04
SWITCH		
S224	SWITCH	RSG1030
CAPACITOR		
C210	ELECT. CAPACITOR	CEAS100M16
RESISTOR		
R227	CARBON FILM RESISTOR	RD1/6PM151J
OTHERS		
	REMOTE CONTROL SENSOR UNIT	GP1U58X

Mark	No.	Description	Part No.
------	-----	-------------	----------

FLKY ASSEMBLY

SEMICONDUCTORS		
IC201	MODE CONTROL MCU	PD3214A
IC202	RESET IC	PST529C
Q201	TRANSISTOR	DTC124ES
Q202	TRANSISTOR	DTC114EL
Q203	TRANSISTOR	DTA144EL

D201, 203	DIODE	1SS252
D204-206	DIODE	1SS252
D210	LED	PG3361X

SWITCHES

S201-223	SWITCH	RSG1030
S225	ROTARY ENCODER	VSD1008

CAPACITORS

C201	ELECTR. CAPACITOR	CEAL101M6R3
C202	CERAMIC CAPACITOR	CKPUYF223225
C204	ELECTR. CAPACITOR	CEAL100M16
C205	CERAMIC CAPACITOR	CKPUYF103225
C206	ELECTR. CAPACITOR	CEAL2R2M50
C211	CERAMIC CAPACITOR	CKPUYF223225

RESISTORS

ALL RESISTORS		RD1/6PM□□□J
---------------	--	-------------

OTHERS

	FL SPACER	VEB1125
	LED HOLDER	VNL1522
Y201	FL TUBE	VAW1026
X201	CERAMIC RESONATOR	EFOGC8004T4

SYPS ASSEMBLY

SEMICONDUCTORS		
Δ IC1	REGULATOR IC	NJM2930L05
Δ IC2	LINEAR IC	NJM4558D
Δ IC201, 202	IC PROTECTOR	ICP-N20
Δ IC210	IC PROTECTOR	ICP-N20
Δ IC211	IC PROTECTOR	ICP-N15

Δ IC41	REGULATOR IC	NJM78M12FA
Δ Q1, 2	TRANSISTOR	2SB1185
Q21	TRANSISTOR	2SC1740S
Q22, 23	TRANSISTOR	2SA933S
Q24	TRANSISTOR	2SC1740S

Δ Q25	TRANSISTOR	2SB1134
Δ Q26	TRANSISTOR	2SD1667
Δ Q27	TRANSISTOR	2SB1134
Δ Q28	TRANSISTOR	2SD1667
Δ Q3	TRANSISTOR	2SD1762

Q4	TRANSISTOR	2SC1740S
Q5	TRANSISTOR	2SA933S
Δ D1		S2VB20-F1
Δ D2	DIODE	1SR35-100AVL
Δ D21, 22	DIODE	1SS254

Mark	No.	Description	Part No.
------	-----	-------------	----------

Δ D23	DIODE	10ELS2
Δ D24, 25	DIODE	1SR35-100AVL
Δ D26	DIODE	10ELS2
Δ D3, 31	DIODE	1SR35-100AVL
Δ D32, 33	SCHOTTKY DIODE	ERA83-006
Δ D7	ZENER DIODE	MTZJ11B

COIL

Δ L1	SPDL CHORK COIL	VTL1043
-------------	-----------------	---------

CAPACITORS

Δ C1	ELECTR. CAPACITOR (6800/16)	VCH1053
C10	ELECT. CAPACITOR	CEAS101M50
C11, 12	CERAMIC CAPACITOR	CKPUYF103Z25
C13	ELECT. CAPACITOR	CEAS471M16
C14	CERAMIC CAPACITOR	CGCYX473M25
Δ C2	ELECTR. CAPACITOR (6800/16)	VCH1053
C21, 22	MYLAR FILM CAPACITOR	CQMA272J50
C23, 24	CERAMIC CAPACITOR	CGCYX473M25
C25, 26	ELECT. CAPACITOR	CEAS2R2M50
C27, 28	MYLAR FILM CAPACITOR	CQMA223J50
C29	ELECT. CAPACITOR	CEAS101M50
C3	ELECT. CAPACITOR	CEAS470M10
C31	ELECT. CAPACITOR	CEAS471M35
C32	ELECT. CAPACITOR	CEAS220M25
C4, 5	ELECT. CAPACITOR	CEAS470M10
Δ C52	CAPACITOR (CERAMIC) (0.01)	VCG-048
C6	ELECT. CAPACITOR	CEAS470M10
Δ C7-9	CERAMIC CAPACITOR	CKPUYF223225

RESISTORS

Δ R23-26	CARBON FILM RESISTOR	RD1/2VM221J
Δ R27-30	RESISTOR (27 Ω)	DCN1003
R41	RESISTOR (4.7 Ω)	DCN1001
OTHER RESISTORS		RD1/6PM□□□J

SCRB ASSEMBLY

SEMICONDUCTORS		
IC101	LOGIC IC	TC74HC74AP
IC102	LOGIC IC	TC74HC00AP
IC103	LOGIC IC	BU4053B
IC104	IC	LA7955
Q101-112	TRANSISTOR	2SC1740S
Q113	TRANSISTOR	DTC124ES

COILS AND FILTERS

L101, 102	RADIAL INDUCTOR	LFA120K
L103, 104	AXIAL INDUCTOR	LAU8R2J
L105	AXIAL INDUCTOR	LAU330J
F101	FILTER (4.43MHz)	VTF1034
F102	FILTER (3.2MHz)	VTF1011

CAPACITORS

C101	ELECT. CAPACITOR	CEAS470M10
C102	CERAMIC CAPACITOR	CKPUYY103N16
C103	ELECT. CAPACITOR	CEAS470M10
C104-108	CERAMIC CAPACITOR	CKPUYY103N16
C109	CERAMIC CAPACITOR	CCCCH100D50

Mark	No.	Description	Part No.
	C110	CERAMIC CAPACITOR	CCCCH270J50
	C111, 112	CERAMIC CAPACITOR	CKPUYY103N16
	C113, 114	CERAMIC CAPACITOR	CKCYB681K50
	C117-119	ELECT. CAPACITOR	CEANP220M10
	C120-122	ELECT. CAPACITOR	CEAS470M10
	C125	CERAMIC CAPACITOR	CKPUYY103N16
	C126, 127	ELECT. CAPACITOR	CEAS470M10
	C128	CERAMIC CAPACITOR	CKPUYY103N16
	C129	ELECT. CAPACITOR	CEAS470M10
	C130	CERAMIC CAPACITOR	CKPUYY103N16
	C131	ELECT. CAPACITOR	CEAS100M50
	C132	CERAMIC CAPACITOR	CKPUYY103N16
	C133, 134	ELECT. CAPACITOR	CEAS100M50
	C137	AXIAL CAPACITOR	CKPUYB101K50
	C138	ELECT. CAPACITOR	CEAS100M50
	C139	AXIAL CAPACITOR	CKPUYB221K50
	C140	ELECT. CAPACITOR	CEAS100M50
	C141	AXIAL CAPACITOR	CKPUYB101K50
	C142	ELECT. CAPACITOR	CEAS100M50
	C143	AXIAL CAPACITOR	CKPUYB221K50
	C144	ELECT. CAPACITOR	CEAS100M50
	C145	AXIAL CAPACITOR	CKPUYB101K50
	C146	ELECT. CAPACITOR	CEAS100M50
	C147	AXIAL CAPACITOR	CKPUYB221K50
	C148	ELECT. CAPACITOR	CEAS100M50
	C149	AXIAL CAPACITOR	CKPUYB101K50
	C150	ELECT. CAPACITOR	CEAS100M50
	C151	AXIAL CAPACITOR	CKPUYB221K50
	C152	ELECT. CAPACITOR	CEAS100M50
	C153, 154	ELECT. CAPACITOR	CEAS221M10
	C155	ELECT. CAPACITOR	CEAS100M50
	C156	ELECT. CAPACITOR	CEAS470M10
	C157	CERAMIC CAPACITOR	CKPUYY103N16
	C158	ELECT. CAPACITOR	CEAS470M10
	C159, 160	ELECT. CAPACITOR	CEAS470M16

RESISTORS

	VR101	SEMI-FIXED VR (470Ω)	VRTB6VS471
	VR102	SEMI-FIXED VR (4.7kΩ)	VRTB6VS472
Δ	R169, 170	RESISTOR (27Ω)	DCN1003
	OTHER RESISTORS		RD1/6PM□□□J

OTHERS

	DL101	DELAY LINE	DTF1033
	JA101, 102	CONNECTOR	VKB1037

HEPB ASSEMBLY

FILTERS

	F201-203	COIL	VTH1016
--	----------	------	---------

CAPACITORS

	C221	CERAMIC CAPACITOR	CGCYF473Z25
	C222, 223	AXIAL CAPACITOR	CKPUYB101K50

RESISTOR

	VR201	VR	VCS1015
--	-------	----	---------

Mark	No.	Description	Part No.
OTHERS			
	JA201	JACK (PHONES)	RKN1002

MAIN ASSEMBLY

SEMICONDUCTORS

	IC101	MECHANISM CONT. MCU	PD0135A1
	IC401	VIDEO IC	PA5013A
	IC402	CDD DELAY LINE	PM0001
	IC403	IC	CXL1009P
	IC404	IC	PA0017
	IC405	CHARACTER IC	M50554-132SP
	IC601	TBC IC	PM3002
	IC602	IC	BA15218N
	IC604	LOGIC IC	TC74HC86AP
	IC605	LOGIC IC	TC4S66F
	IC606	LOGIC IC	TC7SU04F
	IC801	PRE AMP IC	CXA1081S
	IC802	SERVO IC	CXA1372S
	IC803	OP-AMP IC	NJM072L
	IC804	IC	BA15218N
	IC805	COMPARATOR	BA10393F
	IC806	OP AMP	TA8464K
	IC807	POWER OP AMP	LA6510L
	Q101	DIGITAL TRANSISTOR	DTC124EK
	Q401	TRANSISTOR	2SB1237X
	Q402	TRANSISTOR	2SD1858X
	Q403	DIGITAL TRANSISTOR	DTA124EK
	Q404	CHIP TRANSISTOR	2SC2412K
	Q431	TRANSISTOR	2SC1740S
	Q432	CHIP TRANSISTOR	2SC2412K
	Q456, 496	CHIP TRANSISTOR	2SA1037K
	Q497-501	CHIP TRANSISTOR	2SC2412K
	Q502, 511	CHIP TRANSISTOR	2SA1037K
	Q521	DIGITAL TRANSISTOR	DTA124EK
	Q522	DIGITAL TRANSISTOR	DTC124EK
	Q523	CHIP TRANSISTOR	2SA1037K
	Q524	TRANSISTOR	2SC1740S
	Q530, 531	DIGITAL TRANSISTOR	DTC124EK
	Q532	TRANSISTOR	2SA933S
	Q540	CHIP TRANSISTOR	2SA1037K
	Q601-605	CHIP TRANSISTOR	2SC2412K
	Q606	DIGITAL TRANSISTOR	DTA124EK
	Q607	CHIP TRANSISTOR	2SA1037K
	Q608, 609	CHIP TRANSISTOR	2SC2412K
	Q611	CHIP TRANSISTOR	2SA1037K
	Q612	DIGITAL TRANSISTOR	DTC124EK
	Q613, 614	CHIP TRANSISTOR	2SA1037K
	Q615	DIGITAL TRANSISTOR	DTC124EK
	Q801	CHIP TRANSISTOR	2SC2412K
	Q802	CHIP TRANSISTOR	2SA1037K
	Q803-805	CHIP TRANSISTOR	2SC2412K
	Q807	CHIP TRANSISTOR	2SC2412K
	Q808	DIGITAL TRANSISTOR	DTA124EK
	Q809	TRANSISTOR	2SA1399
	Q810	DIGITAL TRANSISTOR	DTA124EK

Mark	No.	Description	Part No.	Mark	No.	Description	Part No.
Q811		CHIP TRANSISTOR	2SC2412K	C106		CHIP CAPACITOR	CKSQYF103Z50
Q812		CHIP TRANSISTOR	2SA1037K	C107		CERAMIC CAPACITOR	CKSQYF104Z25
Q813		CHIP TRANSISTOR	2SC2412K	C108, 109		CHIP CAPACITOR	CKSQYF103Z50
Q814		DIGITAL TRANSISTOR	DTA124EK	C120-122		CHIP CAPACITOR	CKSQYF103Z50
Q901, 902		DIGITAL TRANSISTOR	DTC124EK	C123		CAPACITOR ARRAY (100P×4)	VCG1022
Q903		DIGITAL TRANSISTOR	DTA124EK	C124, 125		CHIP CAPACITOR	CCSQCH101J50
Q908		N-FET	2SK184	C401		ELECT. CAPACITOR	CEANP2R2M50
Q909		CHIP TRANSISTOR	2SA1037K	C403, 404		CERAMIC CAPACITOR	CKSQYF104Z25
Q911, 912		DIGITAL TRANSISTOR	DTC124EK	C405		ELECT. CAPACITOR	CEANP2R2M50
Q913		DIGITAL TRANSISTOR	DTA124EK	C407, 408		CERAMIC CAPACITOR	CKSQYF473Z25
Q914		DIGITAL TRANSISTOR	DTC124EK	C411, 412		CHIP CAPACITOR	CCSQCH820J50
Q915		CHIP TRANSISTOR	2SC2412K	C414		CHIP CAPACITOR	CKSQYF103Z50
Q917		CHIP TRANSISTOR	2SA1037K	C415		CHIP CAPACITOR	CCSQCH100D50
Q918		CHIP TRANSISTOR	2SC2412K	C416		CHIP CAPACITOR	CCSQCH330J50
D101-103		DIODE	1SS254	C417		CHIP CAPACITOR	CCSQCH100D50
D401-403		DIODE	1SS254	C418		CHIP CAPACITOR	CKSQYF103Z50
D502		DIODE	1SS254	C419		CHIP CAPACITOR	CCSQCH101J50
D603		DIODE	DA204K	C421, 422		CHIP CAPACITOR	CKSQYF103Z50
D801-803		DIODE	1SS254	C423, 424		CHIP CAPACITOR	CCSQCH180J50
D805		DIODE	1SR35-100AVL	C425, 426		CHIP CAPACITOR	CKSQYF103Z50
D806, 807		DIODE	1SS254	C427		CERAMIC CAPACITOR	CKSQYF473Z25
D810, 811		DIODE	DA204K	C428		ELECT. CAPACITOR	CEAS470M10
				C429		CERAMIC CAPACITOR	CKSQYF104Z25
				C430		CHIP CAPACITOR	CCSQCH120J50
				C431		CHIP CAPACITOR	CCSQCH050C50
				C433		CHIP CAPACITOR	CCSQCH390J50
				C434		ELECT. CAPACITOR	CEAS101M10
				C435		CERAMIC CAPACITOR	CKSQYF104Z25
				C436		ELECT. CAPACITOR	CEAS010M50
				C437		CHIP CERAMIC C.	CCSQCH220J50
				C438		CHIP CAPACITOR	CCSQCH050C50
				C439, 440		CHIP CERAMIC C.	CCSQCH150J50
				C441		CHIP CAPACITOR	CCSQCH050C50
				C442		CERAMIC CAPACITOR	CKSQYF104Z25
				C443		ELECT. CAPACITOR	CEJANP4R7M16
				C444		MYLAR FILM CAPACITOR	CQMA272J50
				C445		ELECT. CAPACITOR	CEAS101M10
				C446		MYLAR FILM CAPACITOR	CQMA153J50
				C447		CHIP CAPACITOR	CCSQCH680J50
				C448		CERAMIC CAPACITOR	CKSQYF473Z25
				C450		CHIP CAPACITOR	CCSQCH100D50
				C451		CHIP CAPACITOR	CCSQCH270J50
				C452		ELECT. CAPACITOR	CEAS470M10
				C455		CHIP CAPACITOR	CCSQCH470J50
				C456		CHIP CAPACITOR	CCSQCH121J50
				C457		ELECT. CAPACITOR	CEAS101M10
				C458-460		CHIP CAPACITOR	CKSQYF103Z50
				C461		CHIP CAPACITOR	CCSQCH101J50
				C462		CHIP CAPACITOR	CCSQCH330J50
				C463		CHIP CERAMIC C.	CCSQCH271J50
				C466, 467		CERAMIC CAPACITOR	CKSQYF473Z25
				C471		AUDIO FILM CAPACITOR	CFTXA224J50
				C472, 473		ELECT. CAPACITOR	CEAS3R3M50
				C474		ELECT. CAPACITOR	CEAS470M10
				C475, 476		CHIP CAPACITOR	CKSQYF103Z50
COILS							
L411		AXIAL INDUCTOR	LAU680J				
L414, 415		AXIAL INDUCTOR	LAU120J				
L430		AXIAL INDUCTOR	LAU150J				
L431		AXIAL INDUCTOR	LAU680J				
L432		AXIAL INDUCTOR	LAU430J				
L433		AXIAL INDUCTOR	LAU470J				
L434		AXIAL INDUCTOR	LAU220J				
L441		AXIAL INDUCTOR	LAU270J				
L442		AXIAL INDUCTOR	LAU390J				
L443		AXIAL INDUCTOR	LAU120J				
L457		RADIAL INDUCTOR	LFA561J				
L458		RADIAL INDUCTOR	LFA221J				
L496		AXIAL INDUCTOR	LAU220J				
L497		AXIAL INDUCTOR	LAU151J				
L511		AXIAL INDUCTOR	LAU820J				
L521		AXIAL INDUCTOR	LAU120J				
L522		AXIAL INDUCTOR	LAU560J				
L523		AXIAL INDUCTOR	LAU390J				
L524		RADIAL INDUCTOR	LFA561J				
L525		AXIAL INDUCTOR	LAU330J				
L530		AXIAL INDUCTOR	LAU220J				
L601		AXIAL INDUCTOR	LAU470J				
L603		AXIAL INDUCTOR	LAU220J				
L801		AXIAL INDUCTOR	LAU100J				
L802		AXIAL INDUCTOR	LAU151J				
L803		AXIAL INDUCTOR	LAU181J				
L804		AXIAL INDUCTOR	LAU151J				
CAPACITORS							
VC401, 901		VARIABLE CAPACITOR(20P)	VCM-008				
C101		ELECT. CAPACITOR	CEAS470M16				
C102		CERAMIC CAPACITOR	CKSQYF473Z25				
C103		CHIP CAPACITOR	CKSQYF103Z50				
C104, 105		CHIP CAPACITOR	CCSQCH330J50				

Mark	No.	Description	Part No.	Mark	No.	Description	Part No.
	C477	ELECT. CAPACITOR	CEAS3R3M50		C566	CHIP CAPACITOR	CKSQYF103Z50
	C479-481	CERAMIC CAPACITOR	CKSQYF104Z25		C570	CHIP CAPACITOR	CCSQCH151J50
	C483	CERAMIC CAPACITOR	CKSQYF473Z25		C601	CERAMIC CAPACITOR	CKSQYF473Z25
	C484	ELECT. CAPACITOR	CEAS470M16		C602	CHIP CAPACITOR	CKSQYF103Z50
	C485	CHIP CERAMIC C.	CCSQCH180J50		C603	AUDIO FILM CAPACITOR	CFTXA224J50
	C486	CHIP CAPACITOR	CKSQYF103Z50		C604	CHIP CAPACITOR	CKSQYF103Z50
	C487, 488	CERAMIC CAPACITOR	CKSQYF473Z25		C605-607	AUDIO FILM CAPACITOR	CFTXA102J50
	C489, 490	ELECT. CAPACITOR	CEAS101M10		C608	AUDIO FILM CAPACITOR	CFTXA152J50
	C495	CHIP CAPACITOR	CCSQCH270J50		C609	CHIP CAPACITOR	CCSQCH820J50
	C496	CHIP CAPACITOR	CCSQCH101J50		C610	AUDIO FILM CAPACITOR	CFTXA563J50
	C498	CHIP CAPACITOR	CCSQCH820J50		C611	MYLAR FILM CAPACITOR	CQMA272J50
	C499	ELECT. CAPACITOR	CEAS470M16		C612	CHIP CAPACITOR	CCSQCH180J50
	C500	CHIP CAPACITOR	CCSQCH100D50		C613	ELECT. CAPACITOR	CEANP220M10
	C501, 502	ELECT. CAPACITOR	CEAS470M10		C614	AUDIO FILM CAPACITOR	CFTXA332J50
	C503	CERAMIC CAPACITOR	CKSQYF104Z25		C615, 616	CHIP CAPACITOR	CKSQYF103Z50
	C504	CERAMIC CAPACITOR	CKSQYF473Z25		C617	AUDIO FILM CAPACITOR	CFTXA563J50
	C505, 506	CERAMIC CAPACITOR	CKSQYF104Z25		C618	MYLAR FILM CAPACITOR	CQMA103J50
	C507, 508	CHIP CERAMIC C.	CCSQCH271J50		C619	ELECT. CAPACITOR	CEANP2R2M50
	C509	CHIP CAPACITOR	CCSQCH151J50		C620, 623	ELECT. CAPACITOR	CEANP220M10
	C510	CHIP CAPACITOR	CCSQCH270J50		C625	ELECT. CAPACITOR	CEJANP4R7M16
	C511	CERAMIC CAPACITOR	CKSQYF104Z25		C626	AUDIO FILM CAPACITOR	CFTXA332J50
	C512	ELECT. CAPACITOR	CEAS470M10		C627	MYLAR FILM CAPACITOR	CQMA222J50
	C513	CERAMIC CAPACITOR	CKSQYF104Z25		C628	ELECT. CAPACITOR	CEJANP4R7M16
	C514	AUDIO FILM CAPACITOR	CFTXA104J50		C629	CERAMIC CAPACITOR	CKSQYF473Z25
	C515	AUDIO FILM CAPACITOR	CFTXA683J50		C630	CHIP CAPACITOR	CCSQCH270J50
	C516	CHIP CERAMIC C.	CCSQCH220J50		C631	CHIP CAPACITOR	CCSQCH100D50
	C517	AUDIO FILM CAPACITOR	CFTXA683J50		C632	CHIP CAPACITOR	CCSQCH101J50
	C520	CHIP CAPACITOR	CCSQCH180J50		C633	CHIP CAPACITOR	CCSQCH180J50
	C521	ELECT. CAPACITOR	CEAS470M10		C634	CHIP CAPACITOR	CCSQCH121J50
	C522	ELECT. CAPACITOR	CEAS100M50		C635	CERAMIC CAPACITOR	CKSQYF104Z25
	C524	CHIP CAPACITOR	CCSQCH390J50		C636	CHIP CAPACITOR	CCSQCH121J50
	C525	ELECT. CAPACITOR	CEAS470M10		C637, 638	CHIP CAPACITOR	CCSQL471J50
	C526	CERAMIC CAPACITOR	CKSQYF104Z25		C639	CHIP CERAMIC C.	CCSQCH221J50
	C527	CERAMIC CAPACITOR	CKSQYF473Z25		C640	AUDIO FILM CAPACITOR	CFTXA102J50
	C528	CHIP CAPACITOR	CCSQCH390J50		C641	CHIP CAPACITOR	CCSQCH151J50
	C529	CHIP CAPACITOR	CCSQCH180J50		C642	CHIP CAPACITOR	CKSQYF103Z50
	C530	ELECT. CAPACITOR	CEANP100M16		C643	ELECT. CAPACITOR	CEAS470M10
	C531	CERAMIC CAPACITOR	CKSQYF104Z25		C645, 646	CHIP CAPACITOR	CKSQYF103Z50
	C532	CHIP CAPACITOR	CCSQCH100D50		C650	ELECT. CAPACITOR	CEAS470M10
	C533	ELECT. CAPACITOR	CEAS470M16		C651	CHIP CAPACITOR	CKSQYF103Z50
	C535	CHIP CAPACITOR	CKSQYF103Z50		C660	CHIP CERAMIC C.	CCSQCH221J50
	C536	CHIP CAPACITOR	CCSQCH910J50		C661, 662	CHIP CAPACITOR	CKSQYF103Z50
	C537	ELECT. CAPACITOR	CEAS010M50		C801	ELECT. CAPACITOR	CEAS470M10
	C549	CERAMIC CAPACITOR	CCSQCH560J50		C802	ELECT. CAPACITOR	CEAS470M16
	C550	CHIP CAPACITOR	CCSQCH151J50		C803-805	CHIP CAPACITOR	CKSQYF103Z50
	C551	ELECT. CAPACITOR	CEANP220M10		C806	CHIP CAPACITOR	CCSQCH820J50
	C552	ELECT. CAPACITOR	CEAS470M10		C807	CHIP CAPACITOR	CKSQYF103Z50
	C553, 554	CHIP CAPACITOR	CKSQYF103Z50		C808	CHIP CAPACITOR	CCSQCH680J50
	C555	CHIP CAPACITOR	CCSQCH100D50		C809	CHIP CAPACITOR	CCSQCH101J50
	C556	CHIP CAPACITOR	CCSQCH050C50		C810	CHIP CAPACITOR	CCSQCH270J50
	C557	CHIP CAPACITOR	CKSQYF103Z50		C811	CHIP CAPACITOR	CCSQCH101J50
	C558	ELECT. CAPACITOR	CEAS470M10		C812	CHIP CAPACITOR	CCSQCH680J50
	C559, 560	CHIP CAPACITOR	CCSQCH100D50		C813	CERAMIC CAPACITOR	CKSQYF473Z25
	C561, 562	CHIP CAPACITOR	CKSQYF103Z50		C814	CHIP CAPACITOR	CKSQYF103Z50
	C565	CHIP CAPACITOR	CCSQCH050C50		C815	CERAMIC CAPACITOR	CKSQYF473Z25

Mark	No.	Description	Part No.
	C816	CHIP CAPACITOR	CCSQCH050C50
	C817, 818	CHIP CAPACITOR	CKSQYF103Z50
	C831	ELECT. CAPACITOR	CEAS010M50
	C832	CHIP CAPACITOR	CKSQYF103Z50
	C841	CHIP CERAMIC C.	CCSQCH471J50
	C842	ELECT. CAPACITOR	CEAS101M10
	C843	CHIP CAPACITOR	CCSQCH270J50
	C844	CHIP CAPACITOR	CCSQCH050C50
	C845, 846	CHIP CAPACITOR	CCSQCH470J50
	C847	CERAMIC CAPACITOR	CCSQCH510J50
	C848	ELECT. CAPACITOR	CEANP100M16
	C849	ELECT. CAPACITOR	CEJAR47M50
	C850, 855	CHIP CAPACITOR	CKSQYF103Z50
	C856, 857	CHIP CAPACITOR	CKSQYF103Z50
	C858	ELECT. CAPACITOR	CEANP470M10
	C901, 902	ELECT. CAPACITOR	CEAS470M16
	C904	CHIP CAPACITOR	CKSQYF103Z50
	C911, 912	CERAMIC CAPACITOR	CKSQYF104Z25
	C913	CERAMIC CAPACITOR	CKSQYB333K25
	C914, 915	CHIP CAPACITOR	CKSQYF103Z50
	C917	CHIP CAPACITOR	CKSQYF103Z50
	C918	CHIP CERAMIC C.	CCSQCH271J50
	C919	CERAMIC CAPACITOR	CKSQYF104Z25
	C920	CERAMIC CAPACITOR	CKSQYB562K50
	C922	CERAMIC CAPACITOR	CKSQYF104Z25
	C923	CERAMIC CAPACITOR	CKSQYB562K50
	C924	CERAMIC CAPACITOR	CKSQYF104Z25
	C925	CERAMIC CAPACITOR	CKSQYB333K25
	C926	ELECT. CAPACITOR	CEJANP4R7M16
	C927	CERAMIC CAPACITOR	CKSQYF104Z25
	C928	CHIP CAPACITOR	CKSQYF103Z50
	C929	CERAMIC CAPACITOR	CKSQYB333K25
	C930	CHIP CERAMIC C.	CCSQCH271J50
	C931	CHIP CAPACITOR	CKSQYF103Z50
	C932	ELECT. CAPACITOR	CEJANP4R7M16
	C933, 934	CHIP CAPACITOR	CKSQYF103Z50
	C935	ELECT. CAPACITOR	CEJAR47M50
	C936	CERAMIC CAPACITOR	CKSQYB333K25
	C937-939	CHIP CAPACITOR	CKSQYF103Z50
	C940	CHIP CAPACITOR	CKSQYB102K50
	C941, 942	ELECT. CAPACITOR	CEHAQ100M50
	C943	CERAMIC CAPACITOR	CKSQYF473Z25
	C944	CHIP CAPACITOR	CKSQYB102K50
	C945	ELECT. CAPACITOR	CEAS010M50
	C946	CHIP CAPACITOR	CKSQYF103Z50
	C947	CERAMIC CAPACITOR	CKSQYF104Z25
	C948, 949	CERAMIC CAPACITOR	CKSQYF473Z25
	C950	CERAMIC CAPACITOR	CKSQYF104Z25
	C951	CERAMIC CAPACITOR	CKSQYF473Z25
	C952	CERAMIC CAPACITOR	CKSQYF104Z25
	C956	CERAMIC CAPACITOR	CKSQYF473Z25
	C957	CHIP CERAMIC C.	CCSQCH271J50
	C958	CAPACITOR (ALUMINUM) (47 μ /16V)	VCH1115
	C959	CERAMIC CAPACITOR	CKSQYF104Z25
	C999	CHIP CERAMIC C.	CCSQCH471J50

Mark	No.	Description	Part No.
RESISTORS			
	VR441	SEMI-FIXED VR(22k Ω)	VRTB6VS223
	VR481, 482	SEMI-FIXED VR(4.7k Ω)	VRTB6VS472
	VR521	SEMI-FIXED VR(4.7k Ω)	VRTB6VS472
	VR601	SEMI-FIXED VR(2.2k Ω)	VRTB6VS222
	VR603, 604	SEMI-FIXED VR(47k Ω)	VRTB6VS473
	VR605, 606	SEMI-FIXED VR(33k Ω)	VRTB6VS333
	VR607	SEMI-FIXED VR(47k Ω)	VRTB6VS473
	R406	CARBON FILM RESISTOR	RD1/6PM224J
	R415, 416	METALFILM RESISTOR	RN1/6PQ3002F
	R431	CARBON FILM RESISTOR	RD1/6PM510J
	R434, 438	METALFILM RESISTOR	RN1/6PQ□□□□F
	R496	CARBON FILM RESISTOR	RD1/6PM101J
	R511	METALFILM RESISTOR	RN1/6PQ2002F
	R558, 564	CARBON FILM RESISTOR	RD1/6PM102J
	R591, 593	CARBON FILM RESISTOR	RD1/6PM□□□J
	R605, 619	CARBON FILM RESISTOR	RD1/6PM□□□J
	R631, 667	CARBON FILM RESISTOR	RD1/6PM□□□J
	R668, 817	CARBON FILM RESISTOR	RD1/6PM□□□J
	R845, 846	CARBON FILM RESISTOR	RD1/6PM470J
	R854	CARBON FILM RESISTOR	RD1/6PM225J
	OTHER RESISTORS		RS1/10S□□□J

OTHERS

	TERMINAL	VNE1841
	CN103 CONNECTOR (23P)	HLEM23S-1
	JA2 JACK	PKN1005
	JA3, 4 JACK/12V	PKN1004
	X101 CERAMIC RESONATOR (9MHz)	VSS1040
	X401 CRYSTAL RESONATOR (17.734MHz)	VSS1019
	X601 CRYSTAL RESONATOR (14.22MHz)	VSS1053

AUDIO ASSEMBLY

SEMICONDUCTORS

	IC201	EFM DEMODULATION IC	CXD2500AQ
	IC202	REGULATOR IC	NJM78L08A
	IC205	IC	BA15218N
	IC206	D/A CONVERTER IC	PD2026A
	IC207, 208	OP-AMP IC	BA15218
	IC210	REGULATOR IC	NJM79L08A
	IC211	OP-AMP IC	BA15218
	Q203	DIGITAL TRANSISTOR	DTA124EK
	Q204, 205	TRANSISTOR	2SD2144S
	Q206	DIGITAL TRANSISTOR	DTC124EK
	Q207, 210	DIGITAL TRANSISTOR	DTA124EK
	Q212, 213	DIGITAL TRANSISTOR	DTA124EK
	Q220	CHIP TRANSISTOR	2SC2412K
	Q221	DIGITAL TRANSISTOR	DTA124EK
	Q222, 223	CHIP TRANSISTOR	2SA1037K
	D201	VARI-CAP	FC54M
	D202, 205	DIODE	1SS254
	D206, 207	DIODE	1SS254
	D210	SCHOTTKY DIODE	ERA83-006

Mark No.	Description	Part No.
COILS AND FILTERS		
L201, 202	AXIAL INDUCTOR	LAU010K
L203	AXIAL INDUCTOR	LAU220J
L204, 205	AXIAL INDUCTOR	LAU010K
F201, 301	COIL	VTH1016
F302, 303	COIL	VTH1016

CAPACITORS

C201	CERAMIC CAPACITOR	CKSQYF473Z25
C202	AUDIO FILM CAPACITOR	CFTXA152J50
C203	ELECT. CAPACITOR	CEAS470M10
C204	CERAMIC CAPACITOR	CKSQYF104Z25
C205	ELECT. CAPACITOR	CEAS470M16
C206	CHIP CAPACITOR	CKSQYF103Z50
C207	ELECT. CAPACITOR	CEAS471M10
C208	ELECT. CAPACITOR	CEAS470M10
C209, 210	CERAMIC CAPACITOR	CKSQYF104Z25
C211	ELECT. CAPACITOR	CEAS470M10
C212	CERAMIC CAPACITOR	CKSQYF104Z25
C213, 216	CHIP CAPACITOR	CKSQYF103Z50
C217, 218	CHIP CAPACITOR	CKSQYF103Z50
C219	CERAMIC CAPACITOR	CKSQYF104Z25
C220, 221	CHIP CERAMIC C.	CCSQCH271J50
C225, 226	ELECT. CAPACITOR	CEAS470M10
C228	ELECT. CAPACITOR	CEAS100M50
C230	ELECT. CAPACITOR	CEAS470M10
C231	CHIP CAPACITOR	CKSQYF103Z50
C232	CHIP CAPACITOR	CCSQCH120J50
C234, 251	CHIP CAPACITOR	CKSQYF103Z50
C252, 253	ELECT. CAPACITOR	CEAS470M10
C254	CERAMIC CAPACITOR	CKSQYF104Z25
C255	ELECT. CAPACITOR	CEAS471M10
C256	ELECT. CAPACITOR	CEAS470M10
C257	ELECT. CAPACITOR	CEAS471M10
C258-263	CHIP CAPACITOR	CCSQCH390J50
C264, 265	AUDIO FILM CAPACITOR	CFTXA152J50
C266, 267	CHIP CAPACITOR	CKSQYB682K50
C268, 269	AUDIO FILM CAPACITOR	CFTXA102J50
C270-273	ELECT. CAPACITOR	CEAS470M10
C274, 275	ELECT. CAPACITOR	CEANP220M10
C279	ELECT. CAPACITOR	CEAS471M10
C283	ELECT. CAPACITOR	CEAS470M10
C284, 285	ELECT. CAPACITOR	CEAS100M50
C301	ELECT. CAPACITOR	CEANP220M10
C303	ELECT. CAPACITOR	CEAS470M10
C304-306	CHIP CAPACITOR	CKSQYF103Z50
C309	ELECT. CAPACITOR	CEAS470M10
C310, 311	CERAMIC CAPACITOR	CKSQYF104Z25
C320	CHIP CAPACITOR	CKSQYF103Z50
C322	CERAMIC CAPACITOR	CKSQYF473Z25
C323, 324	CHIP CAPACITOR	CKSQYF103Z50
C325, 326	CERAMIC CAPACITOR	CKSQYF104Z25
C563	ELECT. CAPACITOR	CEAS221M6R3

Mark No.	Description	Part No.
RESISTORS		
R212, 213	CARBON FILM RESISTOR	RD1/6PM470J
R220-222	CARBON FILM RESISTOR	RD1/6PM□□□J
△ R234	RESISTOR (4.7Ω)	DCN1001
R259-269	CARBON FILM RESISTOR	RD1/6PM□□□J
R271, 272	CARBON FILM RESISTOR	RD1/6PM222J

R274-276	CARBON FILM RESISTOR	RD1/6PM471J
R293	CARBON FILM RESISTOR	RD1/6PM471J
R566, 587	CARBON FILM RESISTOR	RD1/6PM□□□J

OTHERS

TERMINAL		VNE1841
CN301	5P TOP POST (NH)	B5P-SHF-1AA
JA6	JACK (3P)	VKB1049
JA8	OPTICAL OUTPUT JACK	TOTX178
X201	CRYSTAL RESONATOR(16MHz)	VSS1057

5. ADJUSTMENTS

5.1 PRELIMINARIES

• Jigs for Adjustment

- CD test disc (STD - 901 or STD - 902)
- LD test disc (GGV1003 and GGV1007)
- (-) screwdriver (medium)
- (-) screwdriver (small)
- Hexagonal wrench driver (straight type, size: 3mm)
- Resistors (10kΩ × 2, 47kΩ)
- Dual - trace oscilloscope (with delay)
- AF oscillator
- Frequency counter
- TV monitor
- Low-pass filter

Use the low-pass filters below in the coarse centering adjustment 2. and fine centering adjustment 6. when the S/N of the waveform is hard to observe.

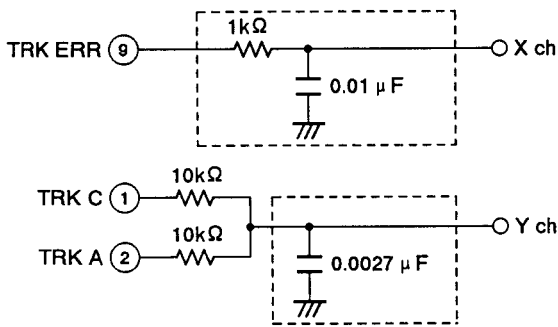

• Rack Assembly During Centering Adjustment

The S - IN position (without hitting the mechanism stopper) of the rack assembly during centering adjustment is indicated below.

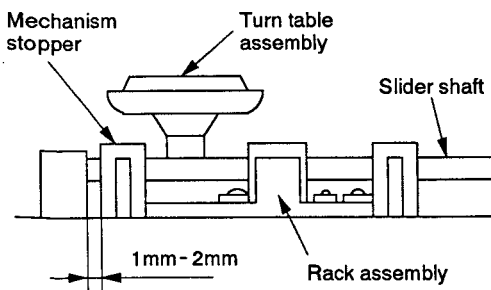

Fig. 1 Right side view

• Adjustment Locations

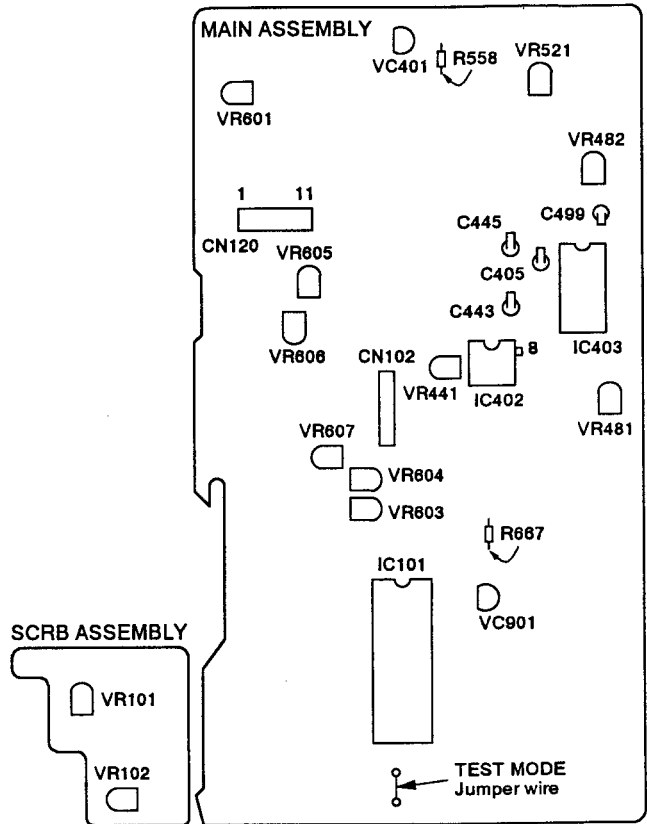
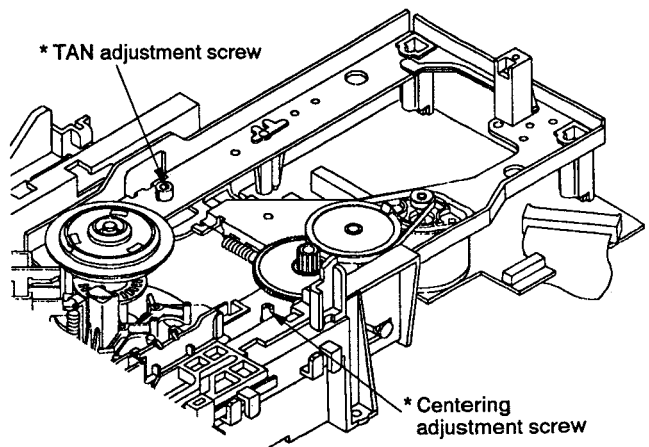

Fig. 2 MAIN and SCRB assemblies section



* : As the adjustment range of both the TAN and centering adjustment screws is only ± 90° from the center, do not turn the screws beyond this range.

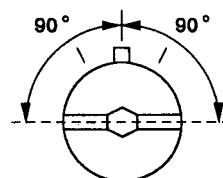

Fig. 3 TILT base section

● Test Mode

1) Activating the Test Mode

1. While power is ON, connect the Test mode jumper wire (Fig. 2) to the GND for about one second.
2. After checking whether the FL display device is fully lit, disconnect the Test mode jumper wire from GND.

2) Canceling the Test Mode

1. Turn the power OFF.

● Key operation in the Test mode

Player Status	Key Operation	Function	Remarks
Tray Open	◀◀/▶▶ SKIP (Refer to Note 1)	◀◀: Shifts the tray in the closed direction and also raises the turn table while it is held down. ▶▶: Shifts the tray in the open direction and also lowers the turn table while it is held down.	
Tray Open	▶ Play	Clamps	
Clamp	▶ Play	Turns the disc through TRK Servo Open	TRK - OFF
TRK Servo Open	▶ Play	TRK Servo Close	TRK - ON
TILT Neutral	+MULTI - SPEED	TILT Servo Close	T-□:ON
TILT ON	- MULTI - SPEED	TILT Neutral	T-□:N
TILT Neutral or ON	◀◀/▶▶ SKIP	Setting TILT Servo to OFF, can force TILT to move.	T- 1 to T- E
Clamp	◀◀/▶▶ SCAN	Can force the slider to move	S - LD S - CDV S - CD S - IN
Play	PAUSE	Still	
Play	■ STOP	Stop	
Stop	▲ OPEN	Open	
Play	<div style="text-align: center;"> +10 ↓ 0 to 9 ↓ ▶ PLAY </div>	Set to SEARCH lead address input mode. Designates the SEARCH lead address through keys 0 to 9. Press the CLEAR C key if the designated address is incorrect. Searches the designated address upon pressing the PLAY key.	

Note 1: Press SKIP (|◀◀/▶▶|) keys after the tray is set to open state by pressing OPEN (▲) key.
In tray open state, pressing PLAY (▶) key causes is to TILT control state and SKIP keys cannot function properly.

● Player Operation in the Test Mode

Operate the player by selecting a test mode function with the keys on the player or on the remote control unit.

• CD PLAYBACK

- ① Place the CD disc on the turn table.

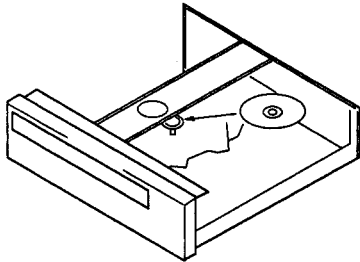

- ② Press the PLAY (▶) key once. (Twin gear starts to move.)
- ③ Push the cam plate (Fig. 4) in the direction of the arrow and wait until the CD disc is clamped.

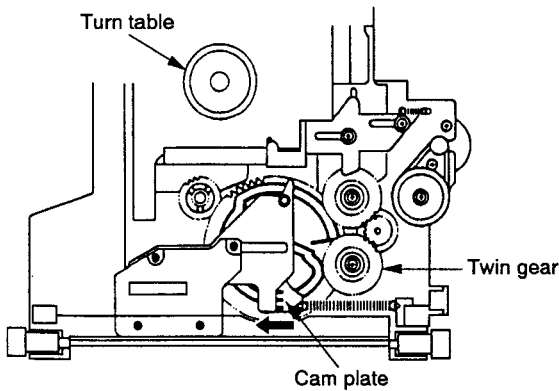
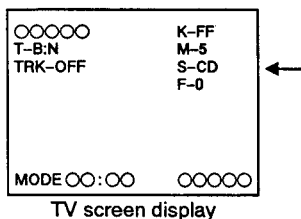

Fig. 4

- ④ Press the ◀◀ or ▶▶ keys to appear "S - CD" on the TV screen display.



- ⑤ Press the PLAY (▶) key twice, disc will be normally playbacked.

• LD PLAYBACK

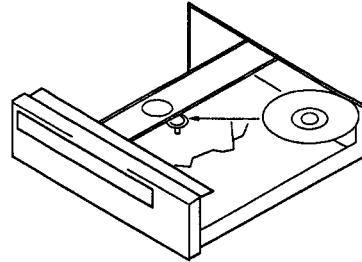

- ① Place the LD disc on the turn table.

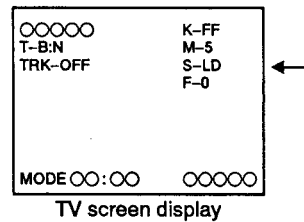

- ② Press the PLAY (▶) key once. (Twin gear starts to move.)
- ③ Press the SKIP REV (◀◀) key to raise the turn table (spindle motor section) while pressing the cam plate (Fig. 4) in the direction of the arrow. Raise it to the position where the LD disc can be easily placed on the turn table. If the turn table is raised too high, lower it with the SKIP FWD (▶▶) key.
- ④ Place the LD disc on the turn table and press the PLAY (▶) key once to clamp the disc.
- ⑤ Press the ◀◀ or ▶▶ keys to appear "S - LD" on the TV screen display.

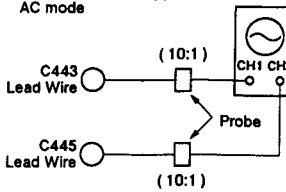
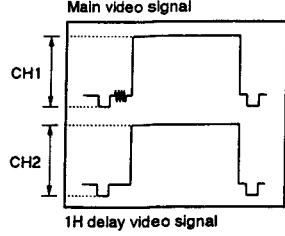

- ⑥ Press the PLAY (▶) key twice, disc will be normally playbacked.

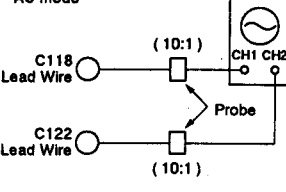
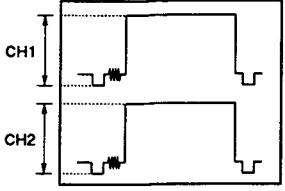
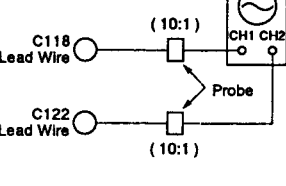
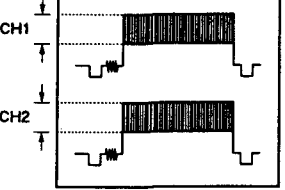
	Adjustment name	Adjustment point	Measuring equipment and jigs	Measurement point	Player condition	Adjustment procedure	Waveform and connection diagram
15	1H DLY video level adjustment	VR441	<ul style="list-style-type: none"> Oscilloscope GGV1007 	CH1: C443 lead wire CH2: C445 lead wire	<ul style="list-style-type: none"> Normal mode GGV1007 #5,300 STILL 	Adjust until the sync tip to 100% white level at the white (100%) signal is the same as in CH1 and CH2.	<p>V:20mV/div (CH1) 20mV/div (CH2) H:10 μsec/div (Trigger) AC mode</p>  
16	VPS error level adjustment	VR521	<ul style="list-style-type: none"> TV monitor GGV1007 	TV monitor	<ul style="list-style-type: none"> Normal mode GGV1007 #6,001 to #6,750 PLAY (Magenta screen) 	Adjust until the color irregularity on the magenta screen is minimized.	
17	MOD video level adjustment	VR102	<ul style="list-style-type: none"> Oscilloscope GGV1007 	CH1: C118 lead wire CH2: C122 lead wire	<ul style="list-style-type: none"> Normal mode GGV1007 #5,300 STILL 	Adjust until the sync tip to 100% white level at the white (100%) signal is the same as in CH1 and CH2.	<p>V:20mV/div (CH1) 20mV/div (CH2) H:10 μsec/div AC mode</p>  
18	1H delay sub carrier adjustment	VR101	<ul style="list-style-type: none"> Oscilloscope GGV1007 	CH1: C118 lead wire CH2: C122 lead wire	<ul style="list-style-type: none"> Normal mode GGV1007 #5,100 STILL 	Adjust until the chroma signal level at the magenta signal is the same as in CH1 and CH2.	<p>V:20mV/div (CH1) 20mV/div (CH2) H:10 μsec/div (Trigger) AC mode</p>  

5. REGLAGES

5.1 PREPARATIFS

● Instruments Pour Reglage

- Disque d'essai pour CD (STD - 901 ou STD - 902)
- Disque d'essai pour LD (GGV1003 ou GGV1007)
- (-) Tournevis à tête plate (taille moyenne)
- (-) Tournevis à tête plate (petit)
- Clé hexagonale (type droit, taille: 3mm)
- Résistances (10kΩ × 2, 47 kΩ)
- Oscilloscope à double traces (avec retard)
- Oscillateur audiofréquence (AF)
- Compteur de fréquence
- Moniteur TV
- Filtre passe-bas

Utiliser les filtres passe-bas ci - dessous pour le réglage approximatif de centrage 2 et le réglage fin de centrage 6 si la forme d'onde du S/B est difficile à observer.

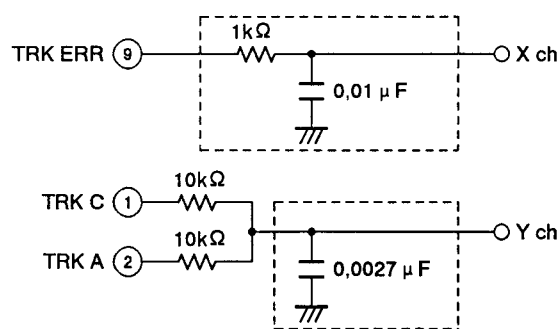

● Ensemble de Rack Pour le Reglage de Centrage

La position S - IN (la position où la butée de mécanisme n'est pas cognée) du rack pour le réglage de centrage est indiquée ci - dessous.

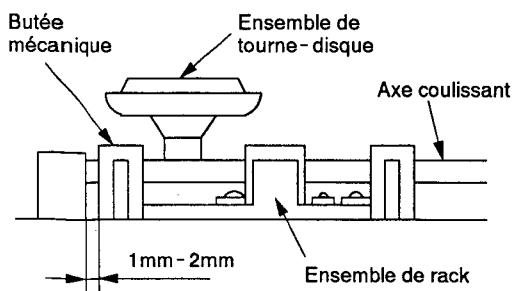

Fig. 1 Vue de la côté droite

● Points de Regrave

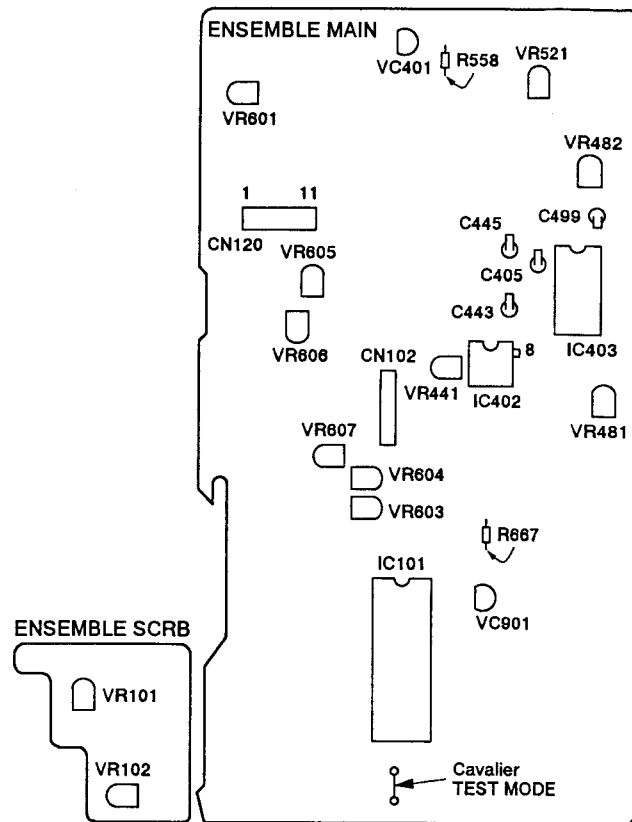
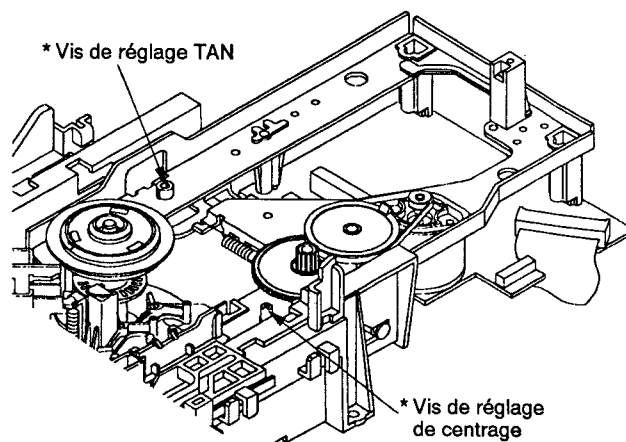

Fig. 2 Ensembles MAIN et SCRB



* : Ne pas tourner les vis de réglage TAN et de centrage au - delà de la gamme de réglage, c'est - à - dire, ± 90° du centre.

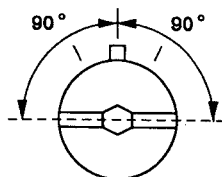

Fig. 3 Base TILT

● Mode D'essai

1) Lancement du mode d'essai

1. Après la mise en marche de l'appareil, connecter le cavalier du mode d'essai (Fig. 2) à GND pendant environ une seconde.
2. Après avoir confirmé que l'affichage FL est allumé à fond, débrancher le cavalier du mode d'essai de GND.

2) Annulation du mode d'essai

1. Mettre l'appareil hors tension.

● Fonction des touches en mode d'essai

Etat de lecteur	Touche à déclencher	Fonction	Remarques
Plateau ouvert	⏮ / ⏭ SKIP (Se reporter à la Remarque 1.)	⏮ : Déplace le plateau à la direction de fermeture et élève le tourne - disque pendant que la touche est enfoncée. ⏭ : Déplace le plateau à la direction de ouverture et baisse le tourne - disque pendant que la touche est enfoncée.	
Plateau ouvert	▶ Play	Verrouille.	
Verrouillé	▶ Play	Tourner le disque par la commande TRK SERVO OPEN.	TRK - OFF
Asservissement TRK ouvert	▶ Play	Asservissement TRK fermé.	TRK - ON
TILT en neutre	+MULTI - SPEED	Asservissement TILT fermé.	T - □ : ON
TILT ON	- MULTI - SPEED	TILT en neutre	T - □ : N
TILT en neutre ou ON	⏮ / ⏭ SKIP	En plaçant l'asservissement TILT sur OFF, il est possible de mouvoir TILT.	T - 1 à T - E
Verrouillé	⏮ / ⏭ SCAN	Il est possible de faire le coulisseau déplacer.	S - LD S - CDV S - CD S - IN
Lecture	PAUSE	Arrêt sur image	
Lecture	■ STOP	Arrête	
Arrêt	▲ OPEN	Ouvrir	
Lecture	+10 ↓ 0 à 9 ↓ ▶ PLAY	Placer sur le mode entrée de recherche d'adresse d'amorçage. Designier l'adresse d'amorçage à rechercher avec les touches 0 à 9. Appuyer sur la touche CLEAR [C] si l'adresse désignée est incorrecte. L'appareil commence à rechercher l'adresse désignée quand la touche PLAY est appuyée.	

Remarque 1: Appuyer sur les touche SKIP (⏮ / ⏭) après que le plateau est placé en mode ouverture par la touche OPEN (▲).
En état ouverture de plateau, une poussée sur la touche PLAY (▶) rend l'appareil en état d'inclinaison et les touches SKIP ne fonctionnent pas correctement.

5.2 ADJUSTMENT TABLE

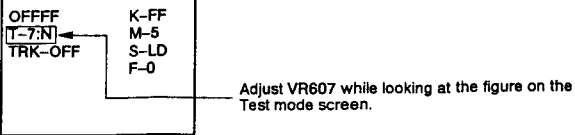
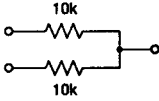
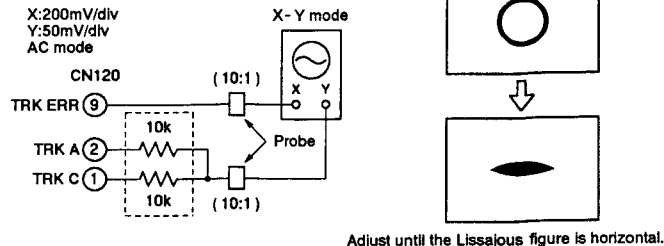
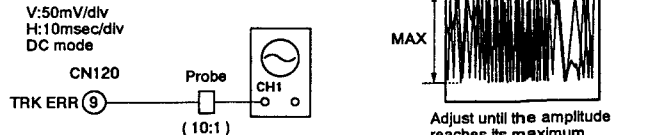
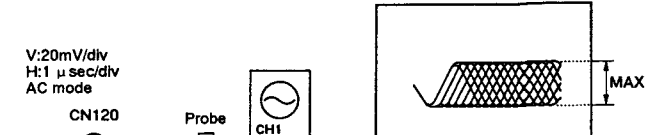
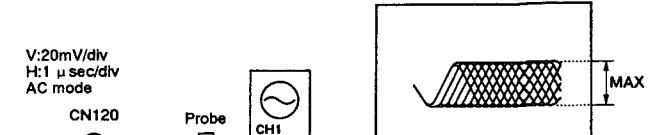
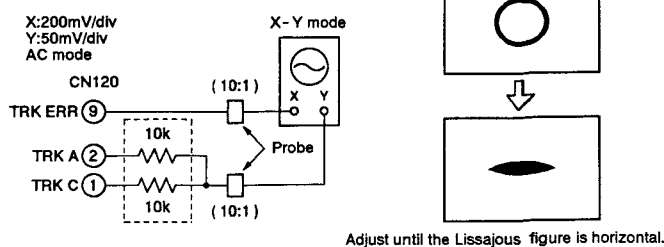
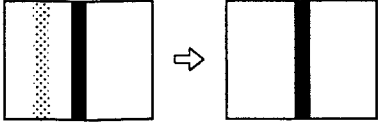
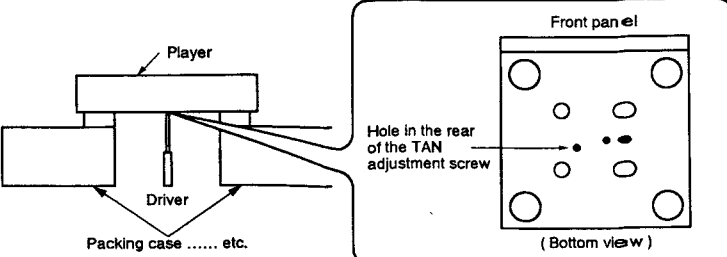
	Adjustment name	Adjustment point	Measuring equipment and jigs	Measurement point	Player condition	Adjustment procedure	Waveform and connection diagram
1	Tilt Offset Check and Adjustment	VR607	• TV monitor	Tilt indication on Test mode screen	• Power ON • Test mode • Disc not installed	1. Check if the tilt indication on the Test mode screen is at T-6 to T-8. 2. If the tilt indication is not at T-6 to T-8, adjust VR607 until the tilt indication reaches T-6 to T-8.	
2	Coarse centering adjustment	Tilt base centering adjustment screw	• Oscilloscope • STD-901 or STD-902 • MIX resistor 	CN120 X: ③ Pin (TRK ERR) Y: ①+② Pin (TRK SUM)	• Test mode TRK Servo Open Tilt Servo ON • Innermost track of STD-901 or STD-902 which does not come in contact with the mechanical stopper.	1. Move the slider until it does not come in contact with the mechanical stopper at the slider position indication S-IN. 2. Observe TRK ERR (Xch) and TRK SUM (Ych) at the X-Y mode during TRK Servo Open. 3. Turn the centering adjustment screw until the Lissajous figure is horizontal.	
3	FCS balance adjustment (1) TRK ERR MAX	VR605	• Oscilloscope • STD-901 or STD-902	CN120 ③ Pin (TRK ERR)	• Test mode TRK Servo Open Tilt Servo ON • Inner track of STD-901 or STD-902	1. Observe TRK ERR at CH1 of the oscilloscope during TRK Servo Open. 2. Adjust VR605 until the amplitude of the waveform reaches its maximum.	
4	FCS balance adjustment (2) RF MAX	VR606	• Oscilloscope • STD-901 or STD-902	CN120 ③ Pin (RF)	• Test mode TRK Servo Close Tilt Servo ON • Inner track of STD-901 or STD-902	1. Close the TRK Servo and observe RF at CH1 of the oscilloscope. 2. Adjust VR606 until the amplitude of the waveform reaches its maximum and the envelope is very clear.	
5	Tangential direction angle adjustment	Tilt base TAN adjustment screw	• Oscilloscope • STD-901 or STD-902	CN120 ③ Pin (RF)	• Test mode TRK Servo Close Tilt Servo ON • Inner track of STD-901 or STD-902	1. Observe RF at CH1 of the oscilloscope during TRK Servo Close. 2. Adjust the TAN adjustment screw until the amplitude of the waveform reaches its maximum and the envelope is very clear.	
6	Fine centering adjustment	Tilt base Centering adjustment screw	• Oscilloscope • STD-901 or STD-902	CN120 X: ③ Pin (TRK ERR) Y: ①+② Pin (TRK SUM)	• Test mode TRK Servo Open Tilt Servo ON • Innermost track of STD-901 or STD-902 which does not come in contact with the mechanical stopper.	Perform fine centering adjustment by following the same procedure as in "(2) Coarse centering adjustment".	
7	Crosstalk check and Tilt offset adjustment	VR607	• TV monitor • GGV1003	Crosstalk check screen	• Test mode TRK Servo Close Tilt Servo ON • GGV1003 #115 STILL	1. Search for address 115 of GGV1003 and still the address. 2. Check the crosstalk . If the crosstalk is pronounced, adjust VR607 until the crosstalk is not noticeable.	
	When the crosstalk is still noticeable in spite of the adjustment in (7), use a hexagonal wrench driver (straight type, size: 3 mm) to adjust the TAN adjustment screw on the bottom side of the player through the GGV1003 #115 STILL screen. Afterwards, perform the adjustment procedures from (6).						

Adjustment name	Adjustment point	Measuring equipment and jigs	Measurement point	Player condition	Adjustment procedure	Waveform and connection diagram
8 FCS Servo loop gain adjustment	VR604	<ul style="list-style-type: none"> Oscilloscope GGV1003 AF Oscillator Resistor (47kΩ) 	CN120 X: ⑦ Pin (FCS IN) Y: ⑥ Pin (FCS ERR)	<ul style="list-style-type: none"> Test mode TRK Servo Close Tilt Servo ON GGV1003 #15,000 STILL 	<ol style="list-style-type: none"> Search for address 15,000 of GGV1003 and still the address. Xch: Connect the resistor (47kΩ) to the channel and connect to FCS IN. Ych: Connect to FCS ERR. Connect the AF oscillator between Xch and the 47kΩ resistor, and adjust VR604 until the Lissajous figure is symmetrical. 	<p>Adjust until the Lissajous figure is symmetrical.</p>
9 TRK Servo loop gain adjustment	VR601	<ul style="list-style-type: none"> Oscilloscope GGV1003 AF Oscillator Resistor (47kΩ) 	CN120 X: ⑩ Pin (TRK IN) Y: ⑨ Pin (TRK ERR)	<ul style="list-style-type: none"> Test mode Stop mode or TRK Servo Close Tilt Servo ON GGV1003 #15,000 STILL 	<ol style="list-style-type: none"> Xch: Connect the 47kΩ resistor to channel and connect to TRK IN. Ych: Connect to TRK ERR. Connect the AF oscillator between Xch and the 47kΩ resistor and note the tilt angle against the horizon with the disc in the stopped state. Search for address 15,000 of GGV1003 and still the address. Set the disc PLAY mode (TRK servo closed, TILT on). Adjust VR603 so that the tilt angle of the waveform will be the same as the tilt angle noted in step 3. 	<p>Adjust until the Lissajous figure is symmetrical.</p>
10 RF level adjustment	VR601	<ul style="list-style-type: none"> Oscilloscope GGV1003 	CN120 ③ Pin (RF)	<ul style="list-style-type: none"> Test mode TRK Servo Close Tilt Servo ON GGV1003 #15,000 STILL 	<ol style="list-style-type: none"> Search for address 15,000 of GGV1003 and still the address. Observe RF at CH1 of the oscilloscope. Adjust VR601 until the RF amplitude is 300mV ± 50mVp-p. 	
11 Synchronizing signal generator clock adjustment	VC401	<ul style="list-style-type: none"> Frequency counter 	R558 lead wire (No connection side)	<ul style="list-style-type: none"> Power ON Stop mode 	Adjust clock frequency (17.734475MHz) ± 100Hz.	
12 REF-H adjustment	VC901	<ul style="list-style-type: none"> Frequency counter 	R667 lead wire (IC601 (PM3002) ③ Pin side)	<ul style="list-style-type: none"> Power ON Stop mode 	Adjust FCS (3.5546875 MHz) ± 25Hz.	
13 VCO center frequency adjustment	VR481	<ul style="list-style-type: none"> Oscilloscope GGV1007 	CH1: C405 lead wire CH2: C499 lead wire	<ul style="list-style-type: none"> Normal mode GGV1007 #15,000 STILL 	Place a trigger in CH1 and adjust until the center of the CH2 video signal jitter is 75 μsec (1H + 11 μsec) ± 2 μsec compared to the CH1 video signal.	
14 Video level adjustment	VR482	<ul style="list-style-type: none"> TV monitor Oscilloscope GGV1007 	Video output terminal	<ul style="list-style-type: none"> Normal mode GGV1007 #5,251 to #6,000 PLAY 	Connect a 75Ω resistor to the VIDEO output terminal (possibly by connecting to the monitor) and adjust until the sync tip to 100% white level is 1Vp-p ± 5% at the white (100%) signal.	

● **Fonctionnement du Lecteur en Mode D'essai**

Manipuler le lecteur en choisissant le mode d'essai avec les touches du lecteur ou celles de la télécommande.

● **LECTURE DE CD**

- ① Placer le disque CD sur le tourne - disque.

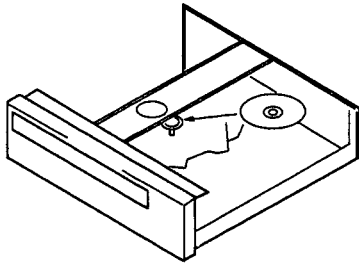

- ② Appuyer une fois sur la touche PLAY (▶).
- (Une paire d'engrenage commence à mouvoir.)
- ③ Enfoncer la came à plaque (Fig. 4) dans la direction de la flèche, et attendre que le disque CD soit verrouillé.

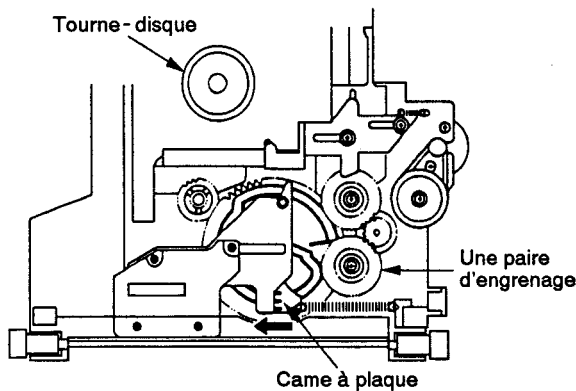
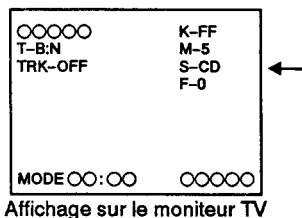

Fig. 4

- ④ Appuyer sur la touche ◀◀ ou ▶▶ pour faire apparaître "S - CD" sur l'écran du moniteur TV.



- ⑤ Appuyer deux fois sur la touche PLAY (▶). Le disque sera reproduit normalement.

● **LECTURE DE LD**

- ① Placer le disque LD sur le tourne - disque.

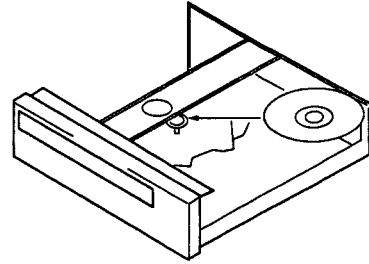

- ② Appuyer une fois sur la touche PLAY (▶).
- (Une paire d'engrenage commence à mouvoir.)
- ③ Appuyer sur la touche SKIP REV (◀◀) tout en appuyant sur la came à plaque (Fig. 4) dans la direction de la flèche pour faire élever le tourne - disque (section moteur de broche). Elever le tourne - disque de sorte que le disque LD peut être placé facilement sur le tourne - disque. Si le tourne - disque est trop élevé, l'abaisser avec la touche SKP FWD (▶▶).
- ④ Placer le disque LD sur le tourne - disque et appuyer une fois sur la touche PLAY (▶) pour verrouiller le disque.
- ⑤ Appuyer sur la touche ◀◀ ou ▶▶ pour faire apparaître "S - LD" sur l'écran du moniteur TV.

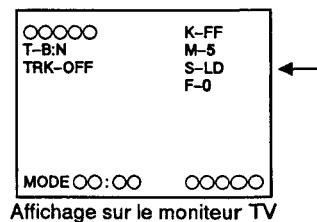

- ⑥ Appuyer deux fois sur la touche PLAY (▶). Le disque sera reproduit normalement.

5.2 SOMMAIRE DES REGLAGE

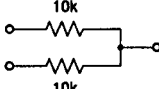
	Réglage	Point de réglage	Equipement de mesure et calibre	Point de mesure	Etat du lecteur
1	Vérification et réglage de correction d'inclinaison	VR607	<ul style="list-style-type: none"> • Moniteur TV 	Indication d'inclinaison sur l'écran du mode d'essai	<ul style="list-style-type: none"> • Alimentation sur ON • Mode d'essai • Pas de disque installé
2	Réglage approximatif de centrage	Vis de réglage de centrage sur la base d'inclinaison	<ul style="list-style-type: none"> • Oscilloscope • STD-901 ou STD-902 • Resistance MIX 	CN120 X: Broche ⑨ (TRK ERR) Y: Broche ① + ② (TRK SUM)	<ul style="list-style-type: none"> • Mode d'essai Asservissement d'alignement ouvert Asservissement d'inclinaison ON • La piste la plus intérieure de STD-901 ou STD-902, qui n'est pas en contacte avec la butée mécanique.
3	Réglage de balance de mise au point (1) TRK ERR MAX	VR605	<ul style="list-style-type: none"> • Oscilloscope • STD-901 ou STD-902 	CN120 Broche ⑨ (TRK ERR)	<ul style="list-style-type: none"> • Mode d'essai Asservissement d'alignement ouvert Asservissement d'inclinaison ON • La piste intérieure de STD-901 ou STD-902
4	Réglage de balance de mise au point (2) RF MAX	VR606	<ul style="list-style-type: none"> • Oscilloscope • STD-901 ou STD-902 	CN120 Broche ③ (RF)	<ul style="list-style-type: none"> • Mode d'essai Asservissement d'alignement fermé Asservissement d'inclinaison ON • La piste intérieure de STD-901 ou STD-902
5	Réglage d'angle de direction tangentielle	Vis de réglage TAN sur la base d'inclinaison	<ul style="list-style-type: none"> • Oscilloscope • STD-901 ou STD-902 	CN120 Broche ③ (RF)	<ul style="list-style-type: none"> • Mode d'essai Asservissement d'alignement fermé Asservissement d'inclinaison ON • La piste intérieure de STD-901 ou STD-902
6	Réglage fin de centrage	Vis de réglage de centrage sur la base d'inclinaison	<ul style="list-style-type: none"> • Oscilloscope • STD-901 ou STD-902 	CN120 X: Broche ⑨ (TRK ERR) Y: Broche ① + ② (TRK SUM)	<ul style="list-style-type: none"> • Mode d'essai Asservissement d'alignement ouvert Asservissement d'inclinaison ON • La piste la plus intérieure de STD-901 ou STD-902, qui n'est pas en contacte avec la butée mécanique.
7	Vérification de diaphonie et réglage de correction d'inclinaison	VR607	<ul style="list-style-type: none"> • Moniteur TV • GGV1003 	Ecran de vérification de diaphonie	<ul style="list-style-type: none"> • Mode d'essai Asservissement d'alignement fermé Asservissement d'inclinaison ON • GGV1003 #115 STILL
	<p>Si la diaphonie est encore apparente après le réglage indiqué dans (7), régler la vis de réglage TAN situé sur le fond de la lecteur à l'aide de la clé hexagonale (type droit, taille: 3 mm) en observant l'arrêt sur image du GGV1003#115 sur l'écran. Ensuite, procéder au réglage dans (6).</p>				

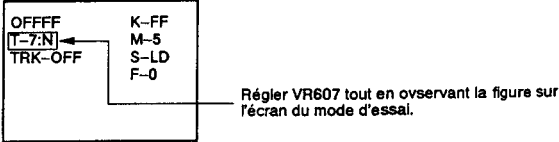
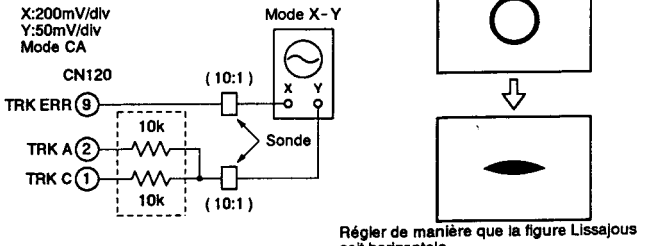
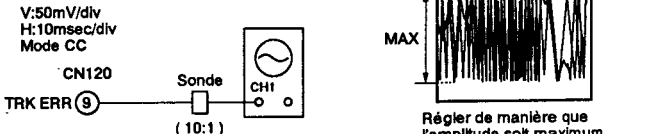
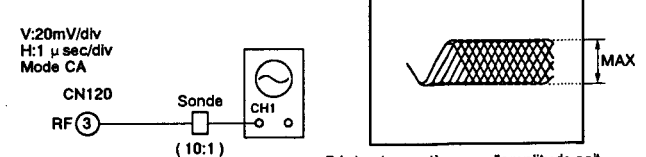
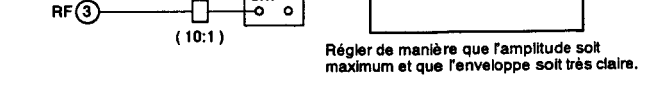
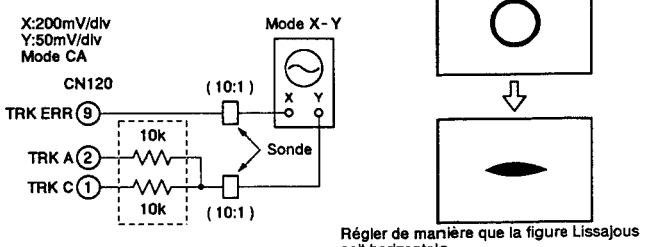
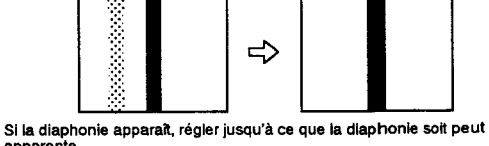
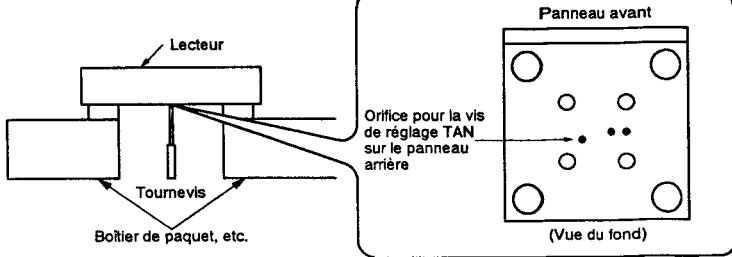
Procédure de réglage	Forme d'onde et schéma de connexion
<ol style="list-style-type: none"> Vérifier que l'indication d'inclinaison sur l'écran du mode d'essai est entre T-6 et T-8. Si l'indication d'inclinaison n'est pas entre T-6 et T-8, Régler VR607 jusqu'à ce que l'indication soit entre T-6 et T-8. 	
<ol style="list-style-type: none"> Faire glisser le coulisseau pour qu'il n'est pas en contact avec la butée mécanique située sur la position de l'indication S-IN pour le cliiseau. Observer TRK ERR (Xch) et TRK SUM (Ych) en mode X-Y avec l'asservissement TRK ouvert. Tourner la vis de réglage de centrage jusqu'à ce que la figure de Lissajous soit horizontale. 	
<ol style="list-style-type: none"> Observer TRK ERR du CH1 sur l'oscilloscope avec l'asservissement TRK ouvert. Régler VR605 jusqu'à ce que l'amplitude de la forme d'onde soit maximum. 	
<ol style="list-style-type: none"> Fermer l'asservissement TRK et observer RF du CH1 sur l'oscilloscope. Régler VR606 jusqu'à ce que l'amplitude de la forme d'onde soit maximum et que l'enveloppe soit très claire. 	
<ol style="list-style-type: none"> Observer RF du CH1 sur l'oscilloscope avec l'asservissement TRK fermé. Régler la vis de réglage TAN jusqu'à ce que l'amplitude de la forme d'onde soit maximum et que l'enveloppe soit très claire. 	
<p>Effectuer les réglage fin de centrage en suivant la même procédure que dans "(2) Réglage approximatif de centrage".</p>	
<ol style="list-style-type: none"> Rechercher l'adresse 115 de GGV1003 et geler l'image. Vérifier la diaphonie. Si la diaphonie apparaît, régler VR607 jusqu'à ce que la diaphonie soit peut apparent. 	
	

	Réglage	Point de réglage	Equipement de mesure et calibre	Point de mesure	Etat du lecteur
8	Réglage de gain de boucle d'asservissement de mise au point	VR604	<ul style="list-style-type: none"> • Oscilloscope • GGV1003 • Oscillateur AF • Resistance (47kΩ) 	CN120 X: Broche ⑦ (FCS IN) Y: Broche ⑥ (FCS ERR)	<ul style="list-style-type: none"> • Mode d'essai Asservissement TRK fermé Asservissement d'inclinaison ON • GGV1003 #15,000 STILL
9	Réglage de gain de boucle d'asservissement d'alignement	VR601	<ul style="list-style-type: none"> • Oscilloscope • GGV1003 • Oscillateur AF • Resistance (47kΩ) 	CN120 X: Broche ⑩ (TRK IN) Y: Broche ⑨ (TRK ERR)	<ul style="list-style-type: none"> • Mode d'essai Mode arrêt ou l'asservissement TRK fermé Asservissement d'inclinaison ON • GGV1003 #15,000 STILL
10	Réglage de niveau RF	VR601	<ul style="list-style-type: none"> • Oscilloscope • GGV1003 	CN120 Broche ③ (RF)	<ul style="list-style-type: none"> • Mode d'essai Asservissement TRK fermé Asservissement d'inclinaison ON • GGV1003 #15,000 STILL
11	Réglage de rythmeur de générateur synchronisation	VC401	<ul style="list-style-type: none"> • Compteur de fréquence 	Câble R558 (Pas de côté de connexion)	<ul style="list-style-type: none"> • Alimentation ON • Mode arrêt
12	Réglage de REF-H	VC901	<ul style="list-style-type: none"> • Compteur de fréquence 	Câble R667 (IC601 (PM3002), côté de la broche ⑧)	<ul style="list-style-type: none"> • Alimentation ON • Mode arrêt
13	Réglage de fréquence central VCO	VR481	<ul style="list-style-type: none"> • Oscilloscope • GGV1007 	CH1: Câble C405 CH2: Câble C499	<ul style="list-style-type: none"> • Mode normal • GGV1007 #15,000 STILL
14	Réglage de niveau vidéo	VR482	<ul style="list-style-type: none"> • Moniteur TV • Oscilloscope • GGV1007 	Borne de sortie vidéo	<ul style="list-style-type: none"> • Mode normal • GGV1007 #5,251 à #6,000 PLAY

Procédure de réglage	Forme d'onde et schéma de connexion
<ol style="list-style-type: none"> 1. Rechercher l'adresse 15,000 de GGV1003 et geler l'image. 2. Xch: Connecter la résistance (47 kΩ) au canal et FCS IN. Ych: Connecter à FCS ERR. 3. Connecter l'oscillateur AF entre Xch et la résistance de 47 kΩ, et régler VR604 pour que la figure Lissajous soit symétrique. 	<p>X:200mV/div Y:20mV/div Mode CC</p> <p>Régler de façon que la figure Lissajous soit symétrique.</p>
<ol style="list-style-type: none"> 1. Xch: Connecter la résistance de 47 kΩ au canal et TRK IN. Ych: Connecter à TRK ERR. 2. Connecter l'oscillateur AF entre Xch et la résistance de 47 kΩ. Noter l'angle d'inclinaison par rapport à la ligne horizontale avec le disque en mode arrêt. 3. Rechercher l'adresse 15,000 de GGV1003 et geler l'image. 4. Placer en mode de lecture (avec l'asservissement TRK fermé, l'inclinaison ON). Régler VR603 de façon que l'angle d'inclinaison de la forme d'onde soit la même que l'angle notée à l'étape 3. 	<p>X:200mV/div Y:10mV/div Mode CC</p> <p>Régler de façon que la figure Lissajous soit symétrique.</p>
<ol style="list-style-type: none"> 1. Rechercher l'adresse 15,000 de GGV1003 et geler l'image. Observer RF du CH1 sur l'oscilloscope. 2. Régler VR601 pour que l'amplitude RF soit 300mV ± 50mVc-c. 	<p>V:10mV/div H:2msec/div Mode CA</p>
<p>Régler la fréquence de l'horloge (17,734475 MHz) ± 100Hz.</p>	<p>Compteur de fréquence</p>
<p>Régler la mise au point sur 3,5546875 MHz ± 25Hz.</p>	<p>Compteur de fréquence</p>
<p>Placer la détente dans le CH1 et régler de façon que le centre d'instabilité (jitter) de signal vidéo du CH2 soit 75 μsec (1H + 11 μsec) ± 2 μsec par rapport au signal vidéo du CH2.</p>	<p>V:20mV/div (CH1) 20mV/div (CH2) H:10 μsec/div (Défente) Mode CA</p> <p>Instabilité causée par l'excentricité 11 μS 75 μS</p>
<p>Connecter la résistance de 75Ω à la borne de sortie vidéo (peut-être en connectant au moniteur) et régler de façon que la pointe de synchronisation du niveau du signal blanc de 100% soit 1Vc-c ± 5%.</p>	<p>Sortie vidéo</p> <p>Niveau vidéo</p> <p>1,0Vp-p ± 5%</p> <p>Gamme de l'oscilloscope V:20mV/div 10 μsec/div (Défente) Mode CA</p> <p>Moniteur TV Oscilloscope</p>

	Réglage	Point de réglage	Equipement de mesure et calibre	Point de mesure	Etat du lecteur
15	Réglage du niveau vidéo avec retard 1H	VR441	<ul style="list-style-type: none"> • Oscilloscope • GGV1007 	CH1: Câble C443 CH2: Câble C445	<ul style="list-style-type: none"> • Mode normal • GGV1007 • #5,300 STILL
16	Réglage du niveau d'erreur VPS	VR521	<ul style="list-style-type: none"> • Moniteur TV • GGV1007 	Moniteur TV	<ul style="list-style-type: none"> • Mode normal • GGV1007 • #6,100 à #6,750 PLAY (Ecran magenta)
17	Réglage du niveau vidéo MOD	VR102	<ul style="list-style-type: none"> • Oscilloscope • GGV1007 	CH1: Câble C118 CH2: Câble C122	<ul style="list-style-type: none"> • Mode normal • GGV1007 • #5,300 STILL
18	Réglage du sous-porteuse avec retard 1H	VR101	<ul style="list-style-type: none"> • Oscilloscope • GGV1007 	CH1: Câble C118 CH2: Câble C122	<ul style="list-style-type: none"> • Mode normal • GGV1007 • #5,100 STILL

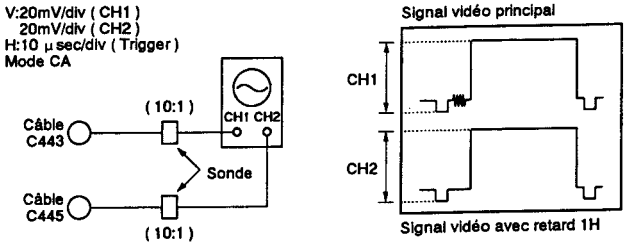
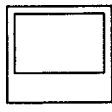
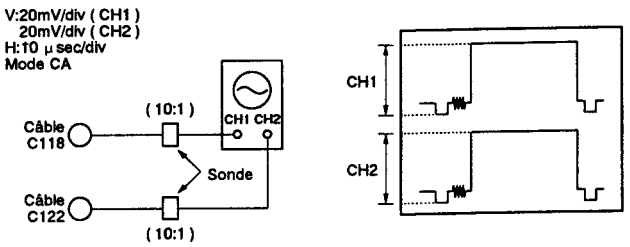
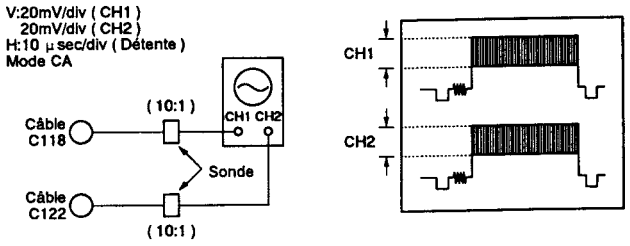
Procédure de réglage	Forme d'onde et schéma de connexion
<p>Régler de façon que les niveaux de la pointe de synchronisation du niveau du signal blanc (100%) pour les CH1 et CH2 soient les mêmes.</p>	<p>V:20mV/div (CH1) 20mV/div (CH2) H:10 µsec/div (Trigger) Mode CA</p> 
<p>Régler de façon que l'irrégularité sur l'écran magenta soit minimisée.</p>	 <p>L'irrégularité sur l'écran magenta est minimisée.</p>
<p>Régler de façon que les niveaux de la pointe de synchronisation du signal de blanc (100%) pour les CH1 et CH2 soient les mêmes.</p>	<p>V:20mV/div (CH1) 20mV/div (CH2) H:10 µsec/div Mode CA</p> 
<p>Régler de façon que les niveaux du signal chroma du signal magenta pour les CH1 et CH2 soient les mêmes.</p>	<p>V:20mV/div (CH1) 20mV/div (CH2) H:10 µsec/div (Défente) Mode CA</p> 

5. AJUSTES

5.1 PRELIMINARIOS

● Instrumentos de Los Ajustes

- Disco de prueba de CD (STD - 901 o STD - 902)
- Disco de prueba de LD (GGV1003 o GGV1007)
- Destornillador con la cabeza de (-) (medio)
- Destornillador con la cabeza de (-) (pequeño)
- Llave inglesa hexagonal (tipo recto, tamaño: 3mm)
- Resistores ($10k\Omega \times 2$, $47k\Omega$)
- Osciloscopio de traza doble (con retraso)
- Oscilador de AF
- Contador de frecuencia
- Monitor de TV
- Filtro de paso bajo

Use los filtros de paso bajo como se ven abajo en el procedimiento de ajuste aproximado del centrado 2., y en el procedimiento de ajuste fino del centrado 6., cuando es difícil observar la forma de onda del señal y ruido.

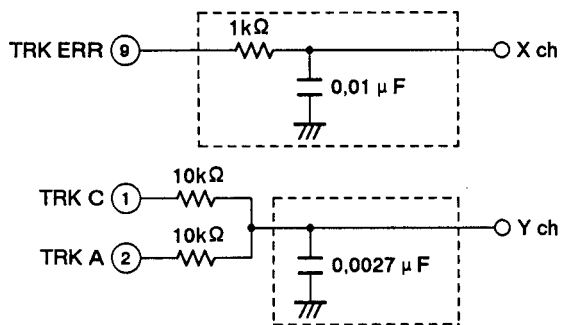

● Montaje de Armario Durante el Ajuste del Centrado

La posición de S - IN (sin golpear el taponador) del montaje de armario durante el ajuste del centrado se ilustra abajo.

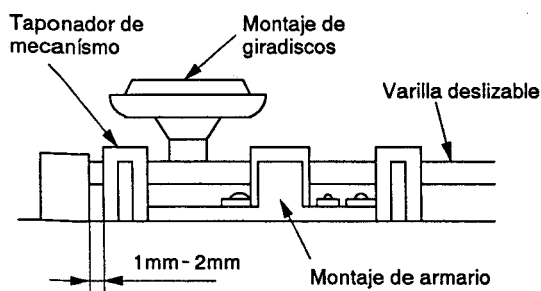

Fig. 1 Vista desde el lado derecho

● Puntos de Ajuste

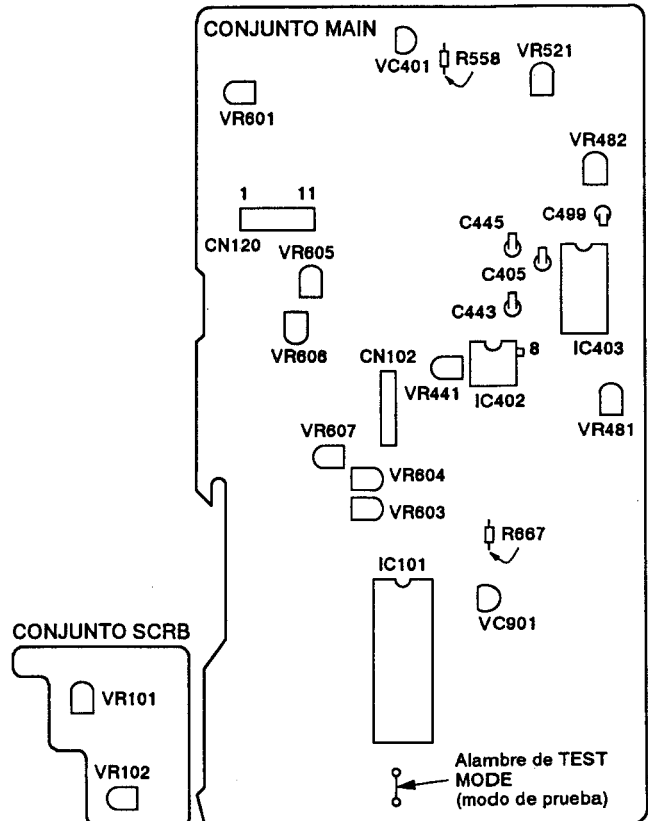
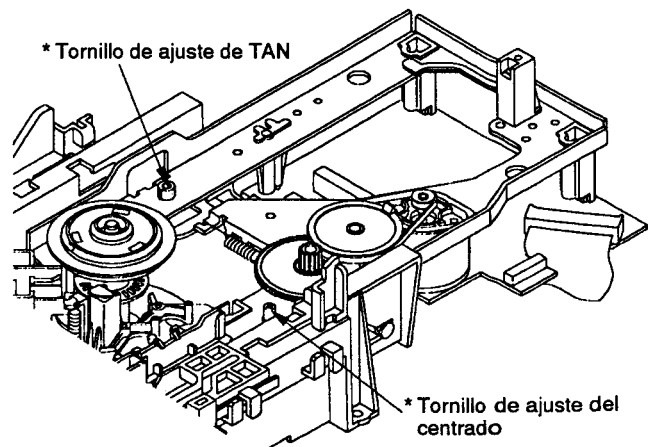

Fig. 2 Sección de los conjuntos MAIN y SCRB



* : Porque la gama de ajuste de los tornillos de TAN y del centrado es solamente ± 90 grados. No haga girar los tornillos más allá de esta gama desde el centro.

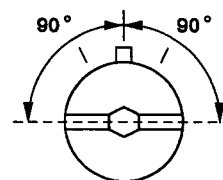

Fig. 3 Sección de la base de inclinación

● Modo de Prueba

- 1) Para activar el modo de prueba
 1. Mientras que se alimenta, conecte el alambre (Figura 2) a GND por aproximadamente 1 segundo.
 2. Después de comprobar que la pantalla está completamente encendida, desconecte el alambre desde GND.
- 2) Para cancelar el modo de prueba
 1. Desconecte la alimentación.

● Operaciones de las teclas en el modo de prueba

Condición del reproductor	Operación de las teclas	Funcionamiento	Notas
La bandeja abierta	◀◀/▶▶ SKIP (Refiérase a nota 1.)	◀◀: Mueve la bandeja en la dirección cerrada y levanta el giradiscos cuando está bajado. ▶▶: Mueve la bandeja en la dirección abierta y baja el giradisco cuando está bajado.	
La bandeja abierta	▶ Avance	Sujetador	
Sujetador	▶ Avance	Haga girar el disco a través del servo TRK Abierto	TRK - OFF
El servo de TRK abierto	▶ Avance	Servo TRK Cerrado	TRK - ON
La inclinación neutral	+MULTI - SPEED	Servo TILT Cerrado	T-□:ON
TILT ON	- MULTI - SPEED	Neutral TILT	T-□:N
TILT Neutral u ON	◀◀/▶▶ SKIP	Ponga el servo TILT en OFF, y se moverá TILT.	T-1 a T-E
Sujetador	◀◀/▶▶ SCAN	Puede enforzar el sujetador a mover.	S - LD S - CDV S - CD S - IN
Avance	PAUSE	Pausa	
Avance	■ STOP	Parada	
Parada	▲ OPEN	Abierto	
Avance	<div style="text-align: center;"> <div style="border: 1px solid black; padding: 2px; display: inline-block;">+10</div> ↓ <div style="border: 1px solid black; padding: 2px; display: inline-block;">0 a 9</div> ↓ <div style="border: 1px solid black; padding: 2px; display: inline-block;">▶ PLAY</div> </div>	Ponga en el modo de entrada de domicilio de SEARCH. Indique el alambre de domicilio de SEARCH con las teclas 0 a 9. Presione la tecla [C] CLEAR si es incorrecto el domicilio designado. Busca el domicilio designado al presionar la tecla PLAY.	

Nota 1: Presione las teclas SKIP (|◀◀/▶▶|) después de que la bandeja esté en el estado abierto por presionando la tecla OPEN (▲). En el estado abierto de la bandeja, si se presiona la tecla PLAY (▶) se cambia en el estado del control de TILT y las teclas SKIP no funcionan correctamente.

● Operación del Reproductor en el Modo de Prueba

Después de seleccionar el modo de prueba, maneje las teclas sobre el reproductor o sobre la unidad de control remoto.

• REPRODUCCION DE UN DISCO COMPACTO

- ① Ponga un disco compacto sobre el giradiscos.

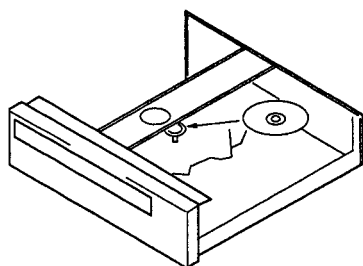

- ② Presione la tecla PLAY (▶) una vez.
(El piñon gemelo se pone en marcha.)
③ Empuje el plato de leva en la dirección de la flecha y espere hasta que se enganche el disco compacto.

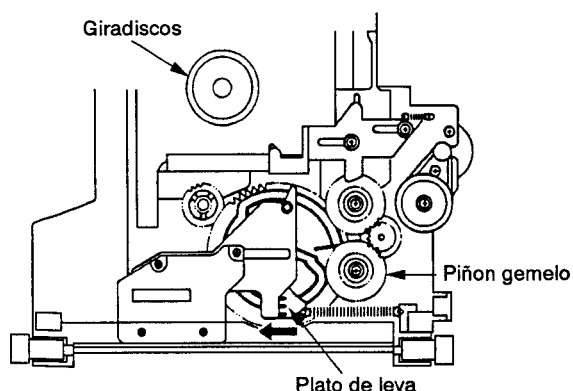
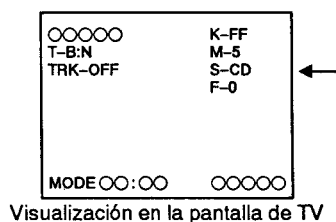

Fig. 4

- ④ Presione la tecla ◀◀ o ▶▶ hasta que se muestre la visualización "S - CD" en la pantalla.
⑤ Presione la tecla PLAY (▶) y el disco se reproducirá normalmente.



Visualización en la pantalla de TV

• REPRODUCCION DE UN DISCO LASERICO

- ① Ponga un disco láserico sobre el giradiscos.

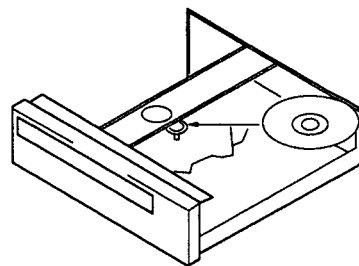

- ② Presione la tecla PLAY (▶) una vez.
(El piñon gemelo se pone en marcha.)
③ Presione la tecla SKIP REV (◀◀) para levantar el giradiscos (sección del motor de eje) mientras que presiona el plato de leva (Fig. 4) en la dirección de la flecha. Levántelo en la posición en la que se pone el disco fácilmente sobre el giradiscos.
Si se pone el giradiscos demasiado arriba, rebájelo con la tecla SKIP FWD (▶▶).
④ Ponga el disco láserico sobre el giradiscos y presione la tecla PLAY (▶) una vez para enganchar el disco.
⑤ Presione la tecla ◀◀ o ▶▶ hasta que la visualización "S - LD" se muestre en la pantalla.

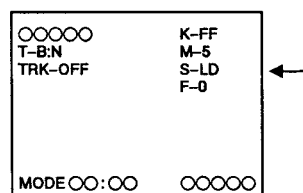

Visualización en la pantalla de TV

- ⑥ Presione la tecla PLAY (▶) dos veces, y el disco se reproducirá normalmente.

5.2 TABLA DE LOS AJUSTES

	Nombre de ajuste	Punto de ajuste	Equipo y instrumento de medida	Punto de medida	Estado del giradiscos	Procedimiento de ajuste	Forma de onda y diagrama de conexión
1	Comprobación y ajuste de desviación de inclinación	VR607	• Monitor de TV	Indicación de inclinación en la pantalla del modo de prueba	• Alimentación ON • Modo de prueba • No se instala el disco.	1. Compruebe que la indicación sobre la pantalla del modo de prueba está en T-6 a T-8. 2. Si la indicación no se quede en T-6 a T-8, ajuste VR607 hasta que la indicación de inclinación alcance a T-6 a T-8.	
2	Ajuste aproximado del centrado	Tornillo de ajuste del centrado de base de inclinación	• Osciloscopio • STD-901 o STD-902 • Resistor de MIX 	CN120 X: ③ Clavija (TRK ERR) Y: ①+② Clavija (TRK SUM)	• Modo de comprobación Servo de TRK: Abierto Servo de inclinación: ON • Pista más interior de STD-901 o STD-902 que no se toca al taponador	1. Mueva el deslizador hasta que no toque al taponador mecánico en la posición indicada como S-IN. 2. Observe TRK ERR (canal X) y TRK SUM (canal Y) en el modo de X-Y mientras que está abierto el servo de TRK. 3. Haga girar el tornillo para el ajuste del centrado hasta que la figura de Lissajous esté horizontal.	
3	Ajuste de equilibrio de foco (1) TRK ERR MAX	VR605	• Osciloscopio • STD-901 o STD-902	CN120 ③ Clavija (TRK ERR)	• Modo de prueba Servo de TRK: Abierto Servo de inclinación: ON • Pista más interior de STD-901 o STD-902	1. Observe TRK ERR en CH1 del osciloscopio mientras que está abierto el servo de TRK. 2. Ajuste VR605 hasta que la forma de onda de la amplitud alcance a su máxima.	
4	Ajuste de equilibrio de foco (2) RF MAX	VR606	• Osciloscopio • STD-901 o STD-902	CN120 ③ Clavija (RF)	• Modo de prueba Servo de TRK: Cerrado Servo de inclinación: ON • Pista más interior de STD-901 o STD-902	1. Cierre el servo de TRK y observe RF en CH1 del osciloscopio. 2. Ajuste VR606 hasta que la forma de onda de la amplitud alcance a su máxima y se quede muy clara la cubierta.	
5	Ajuste del ángulo del sentido tangencial	Tornillo de ajuste de TAN de la base de inclinación	• Osciloscopio • STD-901 o STD-902	CN120 ③ Clavija (RF)	• Modo de prueba Servo de TRK: Cerrado Servo de inclinación: ON • Pista más interior de STD-901 o STD-902	1. Observe RF en CH1 del osciloscopio mientras que está cerrado el servo de TRK. 2. Ajuste el tornillo para el ajuste de TAN hasta que la forma de onda de la amplitud alcance a su máxima y se quede muy clara la cubierta.	
6	Ajuste fino del centrado	Tornillo de ajuste del centrado de base de inclinación	• Osciloscopio • STD-901 o STD-902	CN120 X: ③ Clavija (TRK ERR) Y: ①+② Clavija (TRK SUM)	• Modo de prueba Servo de TRK: Abierto Servo de inclinación: ON • Pista más interior de STD-901 o STD-902 que no toca al taponador	Haga el ajuste fino del centrado siguiendo el procedimiento mismo que se explica en la sección "(2) Ajuste aproximado del centrado".	
7	Comprobación de diafonía y ajuste de desviación de inclinación	VR607	• Monitor de TV • GGV1003	Pantalla de comprobación de diafonía	• Modo de prueba Servo de TRK: Cerrado Servo de inclinación: ON • GGV1003 Número 115 STILL	1. Busque el domicilio 115 de GGV1003 y establézcalo. 2. Compruebe la diafonía. Si la diafonía está pronunciada, ajuste VR607 hasta que la diafonía no esté notable.	
7	Cuando la diafonía todavía está notable aun después del ajuste en (7), use una llave inglesa hexagonal (tipo recto, tamaño: 3mm) para ajustar el tornillo para el ajuste de TAN situado en el fondo del reproductor observando la pantalla de GGV1003 número 115 STILL. Después, haga los procedimientos desde (6).						

	Nombre de ajuste	Punto de ajuste	Equipo y instrumento de medida	Punto de medida	Estado del giradiscos	Procedimiento de ajuste	Forma de onda y diagrama de conexión
8	Ajuste de la ganancia del bucle de servo de foco	VR604	<ul style="list-style-type: none"> Osciloscopio GGV1003 Oscilador de AF Resistor (47kΩ) 	CN120 X: ⑦ Clavija (FCS IN) Y: ⑥ Clavija (FCS ERR)	<ul style="list-style-type: none"> Modo de prueba Servo de TRK: Cerrado Servo de inclinación: ON GGV1003 Número 15000 STILL 	<ol style="list-style-type: none"> Busque el domicilio 15000 de GGV1003 y establézcalo. Canal X: Conecte el resistor (47 kΩ) al canal y a FCS IN. Canal Y: Conecte a FCS ERR. Conecte el oscilador AF entre el canal X y el resistor de 47 kΩ, y ajuste VR604 hasta que la figura de Lissajous esté simétrica. 	<p>X:200mV/div Y:20mV/div Modo de CC</p> <p>Modo de X-Y</p> <p>Ajuste hasta que la figura de Lissajous esté simétrica.</p>
9	Ajuste de la ganancia del bucle de servo de seguimiento	VR601	<ul style="list-style-type: none"> Osciloscopio GGV1003 Oscilador de AF Resistor (47kΩ) 	CN120 X: ⑩ Clavija (TRK IN) Y: ⑨ Clavija (TRK ERR)	<ul style="list-style-type: none"> Modo de prueba Modo de parada o Servo de TRK: Cerrado Servo de inclinación: ON GGV1003 Número 15000 STILL 	<ol style="list-style-type: none"> Canal X: Conecte el resistor de 47 kΩ y a TRK IN. Canal Y: Conecte a TRK ERR. Conecte el oscilador de AF entre el canal X y el resistor de 47 kΩ y anote el ángulo de inclinación hasta la línea horizontal en el estado de parada. Busque el domicilio 15000 de GGV1003 y establézcalo. Ponga en el modo de PLAY (Servo de TRK cerrado, y TILT ON.) Ajuste VR603 para que el ángulo de inclinación de la forma de onda esté mismo que el ángulo de inclinación anotado en el procedimiento 3. 	<p>X:200mV/div Y:10mV/div Modo de CC</p> <p>Modo de X-Y</p> <p>Ajuste hasta que la figura de Lissajous esté simétrica.</p>
10	Ajuste del nivel de RF	VR601	<ul style="list-style-type: none"> Osciloscopio GGV1003 	CN120 ③ Clavija (RF)	<ul style="list-style-type: none"> Modo de prueba Servo de TRK: Cerrado Servo de inclinación: ON GGV1003 Número 15000 STILL 	<ol style="list-style-type: none"> Busque el domicilio 15000 de GGV1003 y establézcalo. Observe RF en CH1 del osciloscopio. Ajuste VR601 hasta que la amplitud de RF esté 300 mV ± 50mVp-p. 	<p>V:10mV/div H:2msec/div Modo de CA</p> <p>300mVp-p ± 50mV</p>
11	Ajuste del reloj degenerador para la señal sincrónica	VC401	<ul style="list-style-type: none"> Contador de frecuencia 	R558 Alambre de conducción (No el lado de conexión)	<ul style="list-style-type: none"> Alimentación ON Modo de parada 	Ajuste la frecuencia del reloj (17.734475MHz) ± 100Hz.	<p>Contador de frecuencia</p>
12	Ajuste de REF-H	VC901	<ul style="list-style-type: none"> Contador de frecuencia 	R667 Alambre de conducción (IC601 (PM3002) ⑧ Lado de clavija)	<ul style="list-style-type: none"> Alimentación ON Modo de parada 	Ajuste FCS (3,5546875 MHz) ± 25 Hz.	<p>Contador de frecuencia</p>
13	Ajuste de frecuencia central de VCO	VR481	<ul style="list-style-type: none"> Osciloscopio GGV1007 	CH1: C405 Alambre de conducción CH2: C499 Alambre de conducción	<ul style="list-style-type: none"> Modo normal GGV1007 Número 15000 STILL 	Ponga un gatillo en el canal 1 y ajuste hasta que el centro de la fluctuación de la señal del canal 2 esté 75 μ segundo (1H + 11 ± segundo) ± 2 μ segundo comparado con la señal de video del canal 1.	<p>V:20mV/div (CH1) 20mV/div (CH2) H:10 μ sec/div (Gatillo) Modo de CA</p> <p>CH1 CH2</p> <p>"Jitter" causado por excentricidad 11 μ S 75 μ S</p>
14	Ajuste del nivel de video	VR482	<ul style="list-style-type: none"> Monitor de TV Osciloscopio GGV1007 	Terminal de la salida de video	<ul style="list-style-type: none"> Modo normal GGV1007 Números 5251 a 6000 PLAY 	Conecte un resistor de 75Ω al terminal de salida de VIDEO (posible por conectando al monitor) y ajuste hasta que la microplaqueta sincrónica al nivel blanco de 100 % esté 1 Vp-p 5 % a la señal blanca (100 %).	<p>Salida de video</p> <p>Nivel de video</p> <p>Osciloscopio</p> <p>CH1</p> <p>1.0Vp-p ± 5%</p> <p>Gama de osciloscopio V:20mV/div 10 μ sec/div (Gatillo) Modo CA</p> <p>Visualización en la pantalla de TV</p>

	Nombre de ajuste	Punto de ajuste	Equipo y instrumento de medida	Punto de medida	Estado del giradiscos	Procedimiento de ajuste	Forma de onda y diagrama de conexión
15	Ajuste del nivel de video 1H DLY	VR441	<ul style="list-style-type: none"> Osciloscopio GGV1007 	CH1: C443 Alambre de conducción CH2: C445 Alambre de conducción	<ul style="list-style-type: none"> Modo normal GGV1007 Número 5300 STILL 	Ajuste hasta que la microplaqueta sincrónica al nivel blanco de 100 % en la señal blanca (100%) esté la misma que en CH1 y CH2.	<p>V:20mV/div (CH1) 20mV/div (CH2) H:10 μsec/div (Gatillo) Modo de CA</p>
16	Ajuste del nivel de error de VPS	VR521	<ul style="list-style-type: none"> Monitor de TV GGV1007 	Monitor de TV	<ul style="list-style-type: none"> Modo normal GGV1007 Números 6001 a 6750 PLAY (Pantalla majenta) 	Ajuste hasta que la irregularidad en color en la pantalla majenta se disminuya.	<p>La irregularidad en color se disminuya.</p>
17	Ajuste del nivel de video de MOD	VR102	<ul style="list-style-type: none"> Osciloscopio GGV1007 	CH1: C118 Alambre de conducción CH2: C122 Alambre de conducción	<ul style="list-style-type: none"> Modo normal GGV1007 Número 5300 STILL 	Ajuste hasta que la microplaqueta sincrónica al nivel blanco de 100% en la señal blanca (100%) esté la misma que en CH1 y CH2.	<p>V:20mV/div (CH1) 20mV/div (CH2) H:10 μsec/div (Gatillo) Modo de CA</p>
18	Ajuste de sub portador con retraso de 1H (hora)	VR101	<ul style="list-style-type: none"> Osciloscopio GGV1007 	CH1: C118 Alambre de conducción CH2: C122 Alambre de conducción	<ul style="list-style-type: none"> Modo normal GGV1007 Número 5100 STILL 	Ajuste hasta que la señal de croma en la señal majenta esté misma en CH1 y CH2.	<p>V:20mV/div (CH1) 20mV/div (CH2) H:10 μsec/div (Gatillo) Modo de CA</p>

6. IC INFORMATION

- The information shown in the list is basic information and may not correspond exactly to that shown in the schematic diagrams.

6.1 PD0135A1 (IC101)

• Mechanism control IC

● Pin Function

No.	Pin Name	I/O	Function
1	VCC	-	Power supply connection pin. Set to 5V ± 10%.
2	DIRECT	O	CD DIRECT video system power OFF signal output pin "H"=video system power OFF, "L"=ON
3	N.C.	-	Not used.
4	LD ON	O	Laser video ON/OFF switching signal output H: ON, L: OFF
5	TGH	O	Tracking operation control signal output pin The control signal supports ON/OFF of the tracking servo-mechanism operation. "H"=OFF, "L"=ON
6	SLDR POS	I	Pickup position detection switch input pin (analog signal) Divides the resistance among the switches, reads the value of the A/D input, and detects the position.
7	FREQ DET	I	RF detection signal input pin (analog signal) Inputs the A/D conversion of the RF detection output and is used in the spindle luff servo-mechanism. Voltage and frequency are proportional.
8	TBAL ERR	I	Tracking balance error signal input pin (analog signal) Signal is A/D converted and is input as the tracking offset control.
9	TILT ERR	I	Tilt sensor output signal input pin (analog signal) Inputs (0 to 5V) the tilt sensor output amplified to a 40 to 50dB signal. The signal is A/D converted and is input as the tilt sensor control. Controls the tilt motor until the signal is 2.5V.
10	CAV	O	CAV/CLV switching signal output pin "H"=CAV, "L"=CLV Connected to pin 6 of PA5013A and used as a VIDEO NR switching signal.
11	GFS	I	CD (EFM signal) frame lock signal input pin Connected to pin 12 of the EFM decoder IC: CXD2500AQ. "H"=Lock, "L"=Unlock GFS is an abbreviation for Good Frame Sync.
12	TBAL DRV	O	Tracking offset control signal output pin Outputs the tracking offset after PWM and is used in auto tracking offset. Cycle: 910 μ sec; 3-value control H, L, Z.
13	SQ2	O	Analog audio switching signal output pin 2/R Squelch: H
14	SQ1	O	Analog audio switching signal output pin 1/L Squelch: H When in digital audio mode, the signal is output through the control of the EFM decoder IC: CXD2500AQ.
15	SI2	I	EFM decoder IC: CXD2500AQ subcode input pin Reads the subcodes of SCK2 and the signal.
16	XLAT2	O	EFM decoder IC: CXD2500AQ control latch signal output pin Sends the control command using SO3 and 2500CLK.
17	SCK2	O	EFM decoder IC: CXD2500AQ subcode read clock signal output pin Sets the clock to 96 and reads the subcode.
18	TILT DRV	O	Tilt control signal output pin Outputs the tilt drive after PWM and is used in tilt servo-mechanism.
19	S-FTOM	I	Input pin of data from the mode control IC Serial Used with the data signal to the carriage generating IC.
20	S-MTOM	O	Serial data output to the mode control IC Serial

No.	Pin Name	I/O	Function
21	SCK1	I/O	Clock for serial communication with the mode control IC In the input mode except during serial communication with the mode control IC Used with the clock signal to the carriage generating IC
22	SENS	I	SENS signal input pin All of the following signals from 2500 are switched and are output to the signal: SEIN, FZC, A.S, TZC, XBUSY, FOK, GFS, COMP, COUT and OV64.
23	SCOR	I	Subcode SYNC signal input pin Inputs the subcode signal from the EFM decoder IC: CXD2500AQ when the signal is "H". Supervises the disc playback depending on the presence of the signal.
24	N.C.	-	Not used.
25	SHAKE	I/O	Pin of hand shake signal for data communication with the mode control IC This pin is a bi-directional data path which sends the data transfer timing through the I/O mode switching of the respective microcomputers.
26	XPBV	I	LD/CDV playback V-SYNC signal input pin IC basically operates in sync hronization (rising and leading edges) with the signal. Setting the signal as standard in the special CAV playback mode, generates jump timing. "L"=V-SYNC ongoing
27	CN VSS	-	GND for A/D conversion
28	XRESET	I	Reset signal input pin "L"=Reset, "H"=Cancel reset
29	XTAL IN	I	9MHz clock generation input pin
30	XTAL OUT	O	9MHz clock generation output pin
31	FTS CLK	O	φ external clock output pin Outputs a clock which is one-fourth of the master clock (9MHz) used in the FTS IC: PM3003. 2.25MHz Does not output when using an FTS IC other than PM3003
32	VSS	-	GND
33	SW1	I	Loading/tilt position detection switch input pin
34	SW2	I	Loading/tilt position detection switch input pin
35	SW3	I	Loading/tilt position detection switch input pin
36	N.C.	I	Not used Processing needed when used for input
37	FG	I	Spindle motor-FG signal input pin 24 pulses per signal Divided into thirds and used inside the microcomputer.
38	DATA	I	Input pin for Phillips code decoder in the mechanism controller
39	XPBH	I	Playback H-SYNC input for Phillips code decoder
40	XPBV	I	Playback V-SYNC input for Phillips code decoder
41	GI. MIRR	O	False MIRR signal output pin to jump 1 track for LD.
42	N.C.	-	Not used
43	N.C.	-	Not used
44	MUTE	O	Audio system audio mute control output pin "H"=MUTE ON, "L"=MUTE OFF
45	16:9	O	16:9 switching signal output pin 16:9 "H", 4.3 (Nomal) "L"
46	T LATCH	O	DAC & Digital PD2026 serial control latch signal output pin
47	N.C.	-	Not used
48	N.C.	-	Not used
49	N.C.	-	Not used
50	2500CLK	O	2500 command clock signal output pin The commands for 2500 are the following: 2500CLK; SO3 and XLAT2.
51	RFCORR	O	RF correction switching signal output pin "H"=gain up. Increases gain (# 8000 to # 8100) within the CAV.

No.	Pin Name	I/O	Function
52	SCAN CONT	O	TBC control signal output pin H: multi-track jump ongoing, L: others
53	CD	O	CD/LD switching signal output pin H: CD, CDV-A, L: LD, CDV-V
54	ACC CONT	O	Spindle acceleration signal output pin H=acceleration, L=deceleration, Z=CD, stop and play
55	GPWM	O	Spindle gain switching duty pulse signal output pin CLV inner circumference: L, outer circumference: H, CAV: L, CDV: H
56	J. TRIG	O	Track jump signal output pin Used for single track jump H: start of track, L: others, Width of "H": approx. 20 μ sec
57	SCK3	O	Serial 3 clock signal output pin Reads the leading edge "H"=within 2 μ sec, "L"=within 20 μ sec
58	SO3	O	Serial 3 data signal output pin With the serial signal as the common signal, divides the signals into three types of latch signals (XLAT3, XLAT2 and T LATCH). LSB first
59	XLATCH3	O	Spindle servo-mechanism IC latch signal output pin
60	J F/R	O	CLV V-SYNC scan mode signal output pin
61	VSQ	O	Video output switching signal output pin "H"=squelch, "L"=playback video
62	XPLAY	I	Usually, held "L" in PLAY mode.
63	N.C.	-	Not used.
64	XSPLOCK	I	Spindle lock signal input pin L: lock, H: unlock

6.2 PD3214A (IC201)

• Mode control IC

● Pin Function

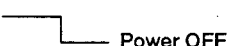
No.	Pin Name	Signal name	I/O	Function
1	PO4/AN4	N.C.	I	Not used
2	PO5/AN5	N.C.	I	Not used
3	PO6/AN6	N.C.	I	Not used
4	PO7/AN7	N.C.	I	Not used
5	AVss	AVss	—	Connected to standard power supply (Vss) for A/D conversion
6	TEST	TEST	I	Test pin Connected to Vss
7	X2	X2	O	Subclock Release
8	X1	X1	I	Subclock Connected to Vcc
9	Vss	Vss	—	Ground
10	OSC1	OSC1	I	System clock Connects 8MHz ceramic lock
11	OSC2	OSC2	I	System clock Connects 8MHz ceramic lock
12	RESET	RESET	I	Reset
13	P10/IRQ0	SHAKE	I/O	Communication timing clock with mechanism control
14	P11/IRP1	SEL IR	I	Remote control signal (including SR)
15	P12/IRQ2	W.D.F	O	For watchdog timer pulse output 
16	P13/IRQ3	POWER On	O	Power ON  Power OFF
17	P14/IRQ4	N.C.	O	Not used
18	P15/IRQ5	N.C.	O	Not used
19	P16/EVENT	N.C.	I	Not used
20	P33/FS27	N.C.	O	Not used
21	P32/FS26	N.C.	O	Not used
22	P31/FS25	N.C.	O	Not used
23	P30/FS24	STANDBY LED	O	Standby LED drive output
24	P47/FS23	N.C.	O	Not used
25	P46/FS22	N.C.	O	Not used
26	P45/FS21	N.C.	O	Not used
27	P44/FS20	N.C.	O	Not used
28	P43/FS19	seg l/KS3	O	FL segment l output and key scan 3 output
29	P42/FS18	seg k/KS2	O	FL segment k output and key scan 2 output
30	P41/FS17	seg j/KS1	O	FL segment j output and key scan 1 output
31	P40/FS16	seg i/KS0	O	FL segment i output and key scan 0 output
32	P50/FS15	seg h	O	FL segment h output
33	P51/FS14	seg g	O	FL segment g output
34	P52/FS13	seg f	O	FL segment f output
35	P53/FS12	seg e	O	FL segment e output

No.	Pin Name	Signal name	I/O	Function
36	P54/FS11	seg d	O	FL segment d output
37	P55/FS10	seg c	O	FL segment c output
38	P56/FS9	seg b	O	FL segment b output
39	P57/FS8	seg a	O	FL segment a output
40	P17/Vdisp	- 30V	-	FL drive power supply
41	P60/FD0/FS7	G9	O	FL grid 9 output
42	P61/FD1/FS6	G8	O	FL grid 8 output
43	P62/FD2/FS5	G7	O	FL grid 7 output
44	P63/FD3/FS4	G6	O	FL grid 6 output
45	P64/FD4/FS3	G5	O	FL grid 5 output
46	P65/FD5/FS2	G4	O	FL grid 4 output
47	P66/FD6/FS1	G3	O	FL grid 3 output
48	P67/FD7/FS0	G2	O	FL grid 2 output
49	P70/FD8	G1	O	FL grid 1 output
50	P71/FD9	N.C.	O	Not used
51	P72/FD10	N.C.	O	Not used
52	P73/FD11	N.C.	O	Not used
53	P74/FD12	N.C.	O	Not used
54	P75/FD13	D.CD LED	O	DIRECT CD LED drive output
55	P76/FD14	S-SCAN	I/O	SHUTTER SCAN output
56	P77/FS15	N.C.	O	Not used
57	Vcc	Vcc	-	Power supply
58	P80	KIN0	I	Key input 0
59	P81	KIN1	I	Key input 1
60	P82	KIN2	I	Key input 2
61	P83	KIN3	I	Key input 3
62	P84	KIN4	I	Key input 4
63	P85	KIN5	I	Key input 5
64	P86	KIN6	I	Key input 6
65	P87	N.C.	-	Not used
66	P90/PWM	SYNCHRO OUT	O	SYNCHRO REC output
67	P91/SCK1	XSCK	I/O	Communication clock with mechanism control/OSD
68	P92/SI1	SI	I	Receive data from mechanism control
69	P93/SO1	SO	O	Send data to mechanism control/OSD
70	P94/SCK2	XRESET	O	RESET output from other than mechanism control/OSD
71	P95/S12/CS	XSC	O	OSD chip select
72	P96/SO2	SYNCHRO IN	I	SYNCHRO REC input
73	P97/UD	1700/700	I	Switching input for 1700/700 H: 1700, L: 700
74	PA0	N.C.	O	Not used
75	PA1	N.C.	O	Not used
76	AVcc	AVcc	-	Connection to Vcc of standard power supply for A/D conversion
77	P00/AN0	N.C.	O	Not used
78	P01/AN1	N.C.	O	Not used
79	P02/AN2	N.C.	O	Not used
80	P03/AN3	N.C.	O	Not used

7. FOR CLD- 700 / HEZ AND HB

NOTES:

- Parts marked by "NSP" are generally unavailable because they are not in our Master Spare Parts List.
- The Δ mark found on some component parts indicates the importance of the safety factor of the part. Therefore, when replacing, be sure to use parts of identical designation.
- Parts marked by "⊙" are not always kept in stock. Their delivery time may be longer than usual or they may be unavailable.

CONTRAST OF MISCELLANEOUS PARTS

CLD - 700 / HEZ, HB and CLD - 1700 / HEZ have the same construction except for the following:

Mark	Symbol & Description	Part No.			Remarks
		CLD-1700 / HEZ	CLD-700 / HEZ	CLD-700 / HB	
⊙	MOTHER assembly	VWM1276	VWM1264	VWM1264	
NSP	MAIN assembly	VWX1123	VWX1116	VWX1116	
NSP	AUDIO assembly	VWX1124	VWX1117	VWX1117	
⊙	FLKB assembly	VWM1278	VWM1277	VWM1277	
NSP	FLKY assembly	VWG1336	VWG1335	VWG1335	
NSP	HEPB assembly	VWV1254	
⊙	SYPS assembly	VWR1146	VWR1146	VWR1147	
⊙	SCRB assembly	VWV1248	VWV1255	VWV1255	
Δ	AC power cord	VDG1028	VDG1028	VDG1029	
	Euro scart cable	VDE1027	
	Video cable	VDE-056	VDE-056	
NSP	Packing case	VHG1228	VHG1226	VHG1226	
	Rear panel	VNA1278	VNA1276	VNA1277	
	Snap plate	VNE1102	
	Jack holder	VNE1811	
	Volume knob	VNK2003	
	Operating instructions (English / French / German / Italian)	VRE1010	VRE1011	
	Operating instructions (Dutch / Swedish / Spanish / Portuguese)	VRF1017	VRF1018	
	Operating instructions (English)	VRB1071	
	Front panel assembly	VXA1867	VXA1866	VXA1866	
	Remote control unit (CU-CLD077)	VXX1758	
	Remote control unit (CU-CLD072)	VXX1751	VXX1751	
	Battery cover	VNK1293	PZN1010	PZN1010	
NSP	Caution card (UC)	VRM1026	
NSP	Caution card (EW)	VRM1027	VRM1027	

LIST OF ASSEMBLIES (FOR CLD- 700/HEZ AND HB)

- FLKB assembly
 - └ PSWB assembly
 - └ FLKY assembly

SCRB assembly

VW1255 and VWV1248 have the same construction except for the following:

Mark	Symbol & Description	Part No.		Remarks
		VWV1248	VWV1255	
	IC101	TC74HC74AP	•••••	
	IC102	TC74HC00AP	•••••	
	IC103	BU4053B	•••••	
	Q101-Q110	2SC1740S	•••••	
	L101, L102	LFA120K	•••••	
	L103, L104	LAU8R2J	•••••	
	L105	LAU330J	•••••	
	F101	VTF1034	•••••	
	F102	VTF1011	•••••	
	C101, C103, C120-C123, C126, C127, C129, C158	CEAS470M10	•••••	
	C102, C104-C108, C111, C112, C125, C128, C130	CKPUYY103N16	•••••	
	C109	CCCCH100D50	•••••	
	C110	CCCCH270J50	•••••	
	C113, C114	CKCYB681K50	•••••	
	C117-C119	CEANP220M10	•••••	
	C155	CEAS100M50	•••••	
	VR101	VRTB6VS471	•••••	
	VR102	VRTB6VS472	•••••	
	R101, R102, R124, R125, R127	RD1/6PM102J	•••••	
	R103, R107, R118, R122, R130	RD1/6PM101J	•••••	
	R104, R108, R110, R111, R119, R123, R131	RD1/6PM222J	•••••	
	R105, R106	RD1/6PM391J	•••••	
	R109	RD1/6PM122J	•••••	
	R112, R113, R120, R121	RD1/6PM223J	•••••	
	R114	RD1/6PM333J	•••••	
	R115	RD1/6PM153J	•••••	
	R116, R117	RD1/6PM471J	•••••	
	R126	RD1/6PM561J	•••••	
	R128, R132-R134	RD1/6PM472J	•••••	
	R129	RD1/6PM221J	•••••	
	R135	RD1/6PM470J	•••••	
	R136, R137	RD1/6PM121J	•••••	
	R138	RD1/6PM2R2J	•••••	
	DL101	DTF1033	•••••	

FLKY assembly

Although VWG1335 and VWG1336 are different in part number, they consist of the same components.

SYPS assembly

Although VWR1147 and VWR1146 are different in part number, they consist of the same components.

8. CONNECTIONS

USING TELEVISION WITH AUDIO AND VIDEO JACKS

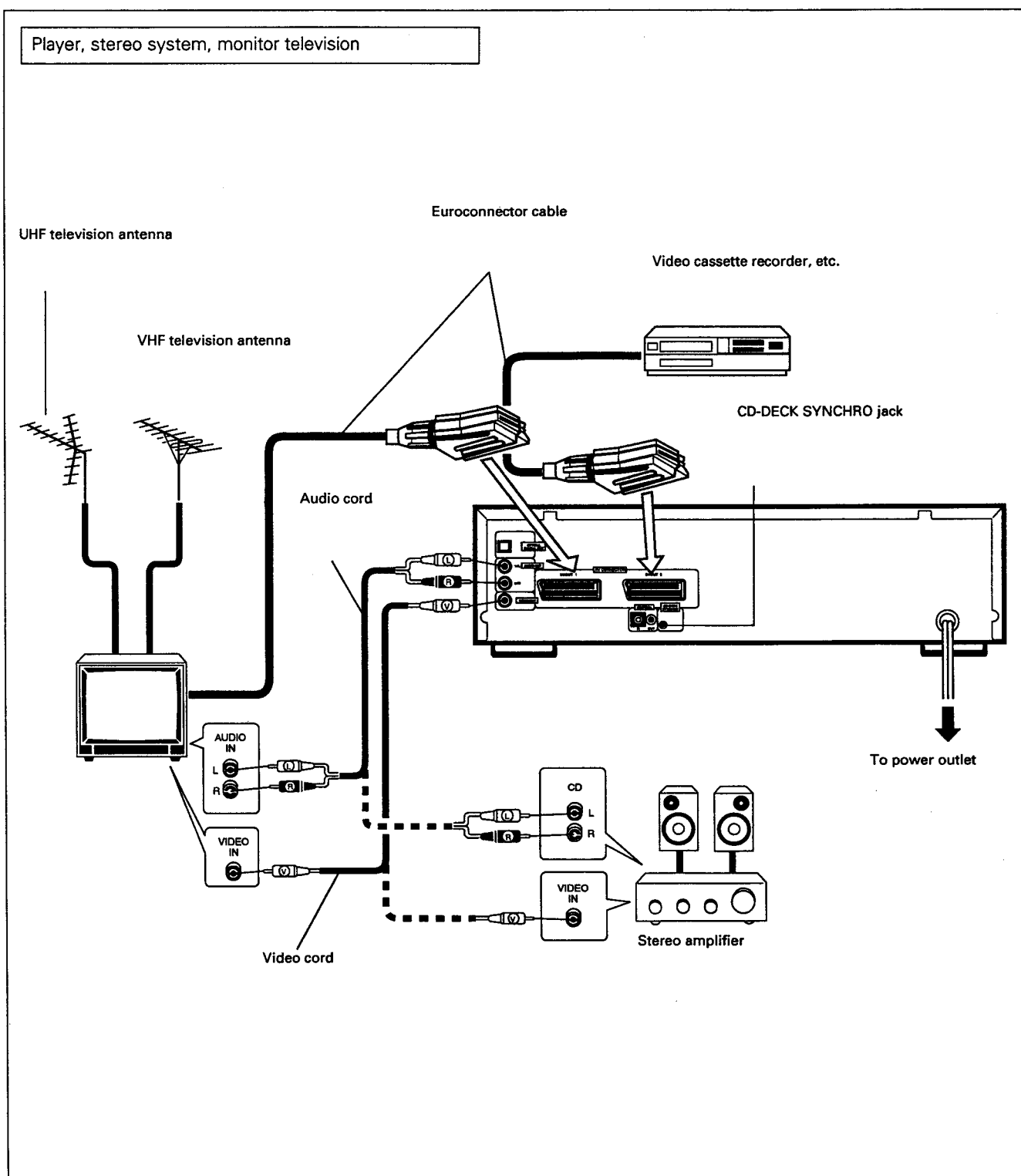

- Connect the VIDEO OUT jack of the player to the video input jack of the monitor television.
- Connect the AUDIO OUT jacks to the stereo amplifier AUX, CD, LD, VDP or other jacks, except the PHONO input jacks. The television speakers can also be used by connecting the television audio input jacks and the player AUDIO OUT jacks, however connection to a stereo amplifier is recommended to obtain superior audio playback quality for Compact Discs and LaserVision Discs. Do not change the television antenna connections.
- When using a video TV monitor (or TV) with AV CONNECTOR terminal, connect the AV CONNECTOR terminal to the AV CONNECTOR IN/OUT terminal of the player. Use supplied Euroconnector cable.
- Connect the power cord to an AC wall outlet.
- Combined system control is possible when a Pioneer television and audio/video stereo receiver are connected. Refer to page 28 for an explanation of the connection procedure.
- When making connections to stereo amplifier equipped with a built-in D/A converter and an optical digital jack, refer to the connection instructions
- When using a video cassette recorder with AV CONNECTOR terminal, connect the AV CONNECTOR terminal to the AV CONNECTOR IN/OUT terminal of the player. When a TV has been connected to the player using the AV CONNECTOR terminal and the power cord is plugged to an AC outlet, signals from the video cassette recorder are fed to the TV set via the player while the player is turned off.
- When using wide aspect type TV (16:9), be sure to connect the AV CONNECTOR terminal to the AV CONNECTOR IN/OUT terminal of the player.

9. PANEL FACILITIES

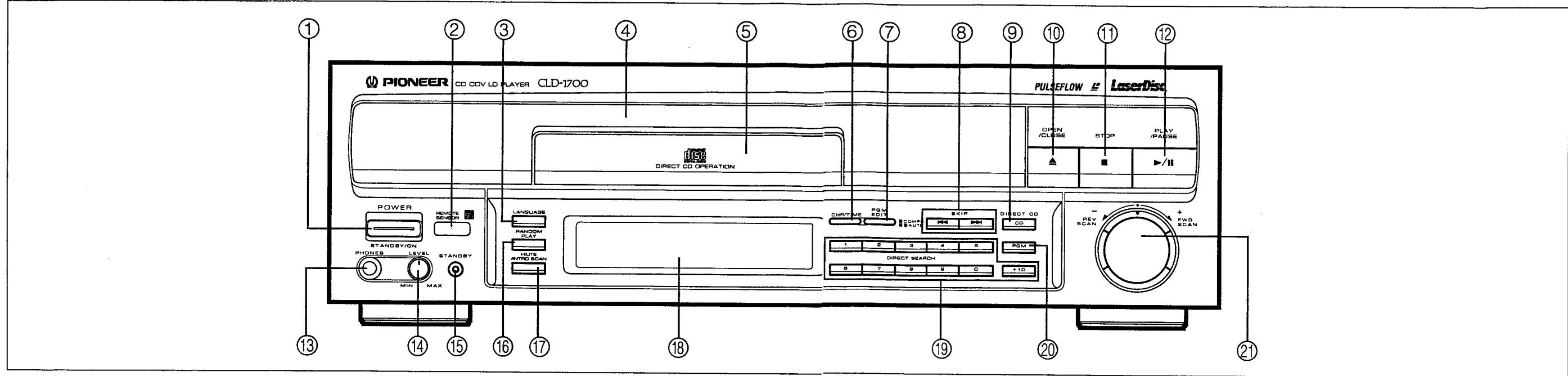

- ① **POWER STANDBY/ON switch**
Press to turn the power on and off.
- ② **REMOTE SENSOR**
- ③ **LANGUAGE button**
- ④ **Disc table**
- ⑤ **CD disc table**
- ⑥ **CHP/TIME button**
- ⑦ **PGM EDIT button**
- ⑧ **SKIP buttons**
- ⑨ **DIRECT CD button**
- ⑩ **OPEN/CLOSE button**
- ⑪ **STOP button**
- ⑫ **PLAY/PAUSE button**
- ⑬ **PHONES jack**
- ⑭ **PHONES LEVEL control**
Turn this control in the "MAX" direction to increase the output level from the PHONES jack. Turn this control in the "MIN" direction to decrease the output level from the PHONES jack.
- ⑮ **STANDBY indicator**
- ⑯ **RANDOM PLAY button**
- ⑰ **HILITE/INTRO SCAN button**
- ⑱ **Display window**
- ⑲ **DIRECT SEARCH/Digit buttons**
- ⑳ **PGM (program) button**
- ㉑ **SCAN control**

Display window

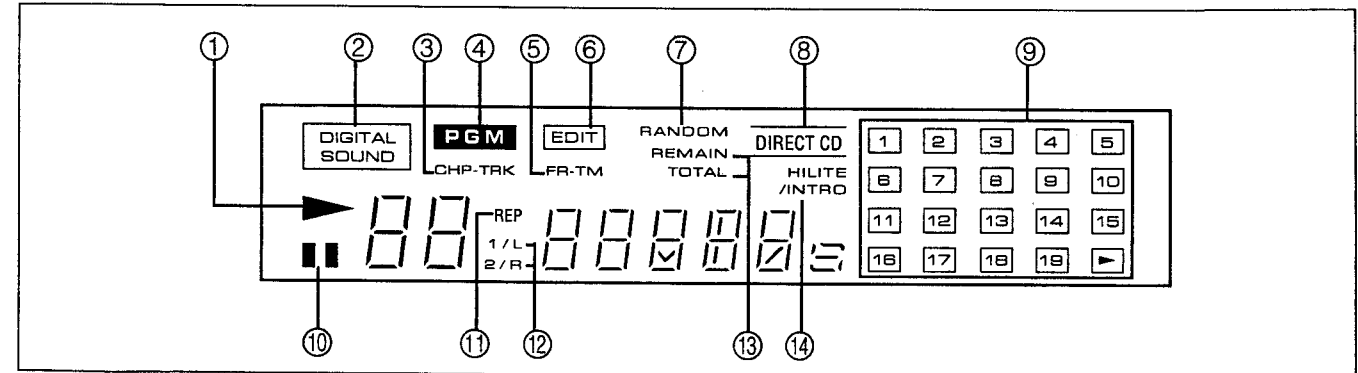

- ① **▶ play indicator**
Lights during play. Blinks during search.
- ② **DIGITAL SOUND indicator**
Lights when the power is turned on. When an analog audio disc is played back, the indicator goes out.
- ③ **CHP-TRK indicator**
Indicates the CHP (chapter) number or TRK (track) number.
- ④ **PGM indicator**
Lights during program play and programming.
- ⑤ **FR-TM indicator**
Indicates the FR (frame) number or TM (time).
- ⑥ **EDIT indicator**
Lights when editing is performed.
- ⑦ **RANDOM indicator**
Lights during random play.
- ⑧ **DIRECT CD indicator**
- ⑨ **Visual calendar**
When a disc is loaded, all of the chapter/track numbers recorded on the disc light up on the display. If the disc contains more than 19 chapters/tracks, the ▶ indicator lights.
During program play, only the programmed chapter/track numbers light. When a disc without a TOC section is played, only the selection number being played lights.
When a CDV disc is loaded, the track numbers of the video part light followed by the track numbers of the audio part. After a chapter/track is finished playing, the corresponding number goes out.
- ⑩ **|| pause indicator**
Lights when the player is in pause mode.
- ⑪ **REP indicator**
Lights during repeat play.
- ⑫ **1/L, 2/R indicator**
Indicates the audio output channel.
- ⑬ **REMAIN/TOTAL indicator**
Indicates the REMAIN TIME (remaining play time) or TOTAL TIME (total play time).
- ⑭ **HILITE/INTRO indicator**
Lights during Hi-Lite Scan or Intro Scan mode.

Remote control buttons with the same names or marks as buttons on the front panel of the player control the same operations as the corresponding front panel buttons.

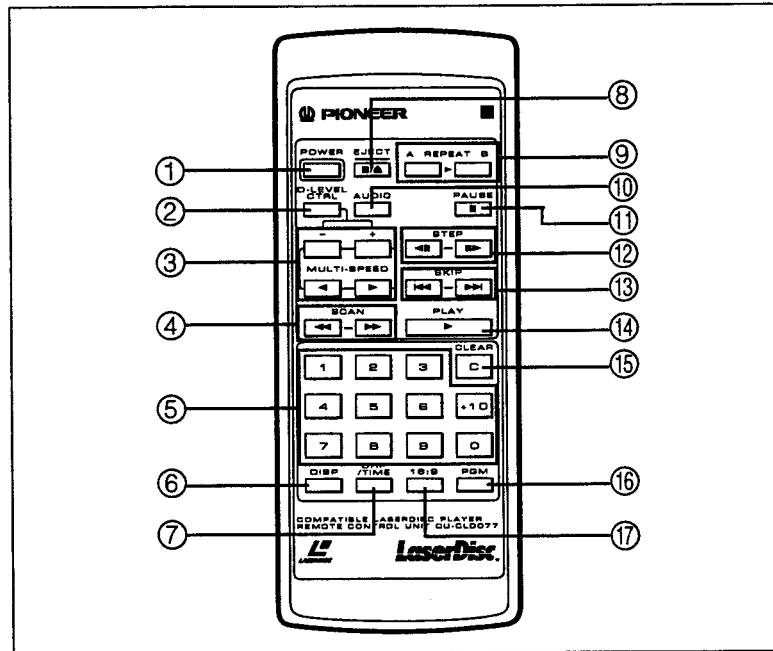

- ① **POWER button**
Press to turn the power on and off.
- ② **D-LEVEL CTRL button**
- ③ **MULTI-SPEED buttons**
- ④ **SCAN buttons**
- ⑤ **Direct search/Digit buttons**
- ⑥ **DISP button**
- ⑦ **CHP/TIME button**
- ⑧ **EJECT button**
- ⑨ **REPEAT A/B buttons**
- ⑩ **AUDIO button**
- ⑪ **PAUSE button**
- ⑫ **STEP buttons**
- ⑬ **SKIP buttons**
- ⑭ **PLAY button**
- ⑮ **CLEAR button**
Used to clear the repeat mode, program mode, random play mode or hi-lite scan/intro scan mode. This button is also for use in correcting input digits.
- ⑯ **PGM (program) button**
- ⑰ **16:9 button**

10. SPECIFICATIONS

1. General

System LaserVision Disc system and Compact Disc digital audio system
 Laser Semiconductor laser wavelength 780 nm
 Power requirements AC 220 - 230 V, 50/60 Hz
 Power consumption 42 W
 Weight 7.4 kg
 Dimensions 420 (W) x 390 (D) x 122 (H) mm
 Operating temperature +5°C ~ +35°C (41°F - 95°F)
 Operating humidity 5% ~ 90%
 (There should be no condensation of moisture.)

2. Disc

LaserVision Discs

PAL disc

*Maximum playing times
 30 cm active play disc 72 min/both sides
 30 cm long play disc 2 hours/both sides
 20 cm active play disc 28 min/both sides
 14 min/one side
 20 cm long play disc 40 min/both sides
 20 min/one side

Spindle motor speed

Active play disc 1,500 rpm
 Long play disc 1,500 rpm (inner circumference)
 to 570 rpm (outer circumference)
 (For a 30 cm disc)

Compact Discs

DISC Diameter: 12 cm, 8 cm, Thickness: 1.2 mm
 Rotation direction (pickup side)
 Counterclockwise
 Linear speed 1.2 ~ 1.4m/sec
 * Maximum playing time 74 min. 12 cm discs
 20 min. 8 cm discs
 (For stereo playback)

Compact Discs with Video

Disc Diameter: 12 cm, Thickness: 1.2 mm
 Rotation direction (pickup side)
 Counterclockwise
 Linear speed Audio portion: 1.2 ~ 1.4m/sec
 Video portion: 11 ~ 12m/sec
 * Maximum playing time Video portion: 5 min. (CLV)
 Audio portion: 20 min. (Digital)

* Actual playback time differs for each disc.

3. Video characteristics

Format PAL specifications
 Video output
 Level 1 Vp-p nominal, sync. negative, terminated
 Impedance 75 Ω unbalanced
 Jack RCA jack

4. Audio characteristics

Output level 200 mVrms (1 kHz, -20 dB)
 Jacks Both RCA jacks
 Number of channels 2

Digital Audio Characteristics

Frequency response	4 Hz - 20 kHz
SN ratio	105 dB (EIAJ)
Dynamic range	97 dB (EIAJ)
Total harmonic distortion	0.003% (EIAJ)
Wow and flutter	Limit of measurement (±0.001 % W.PEAK) (EIAJ)

5. Other Terminals

Control input/output Both miniature jacks
 CD-DECK synchro Miniature jack
 Optical digital output Optical digital jack
 AV connector input/output 21-pin connector
 This connector provides the video and audio signals for connection to a colour video TV monitor (or TV set) which has a "AV CONNECTOR" terminal.

PIN assignment

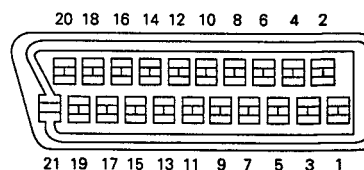

PIN no.	1 Audio 2/R out	17 GND
	3 Audio 1/L out	19 Video out
	4 GND	21 GND
	8 Status	

6. Accessories

Remote control unit (CU-CLD077) 1
 Size "AAA" (IEC R03) dry cell batteries 2
 Euroconnector cable 1
 Audio cord 1
 Operating instructions 1
 Warranty card 1

7. Functions

Remote control unit operations (CU-CLD077)

	Function	Active play Disc (CAV)	Long play Disc (CLV)	Compact Disc with Video	Compact Disc
Basic Functions	Single-side play Pause Stop	YES YES YES	YES YES YES	YES YES YES	YES YES YES
Search	Fast forward (forward and reverse) Chapter/Track skip Direct chapter/Track number search Frame number search Time number search Absolute time search	YES YES YES YES NO NO	YES YES YES NO YES NO	YES YES YES NO YES NO	YES YES YES NO. YES YES
Program	Chapter/Track program play Program correction	YES YES	YES YES	YES YES	YES YES
Repeat	Repeat between 2 points Memory repeat Chapter/Track repeat One-side repeat Program repeat Random repeat Program random repeat	YES YES YES YES YES YES*1 YES	YES YES YES YES YES YES*1 YES	YES YES YES YES YES YES YES	YES YES YES YES YES YES YES
Trick play	Still/Step Multi-speed (Forward/reverse 9-level variable)	YES YES	NO NO	NO NO	NO NO
Time display	Elapsed time display Absolute time display Remaining track time display Remaining total time display Total number of selections, total time display	NO YES*1 NO YES*1 YES*1	YES NO NO YES*1 YES*1	YES NO YES YES YES	YES YES YES YES YES
Others	Compu program/Auto program edit Hi-Lite scan Intro scan Digital level control Audio channel selection (Stereo, 1/L, 2/R)	YES*1 NO YES YES*2 YES	YES*1 NO YES YES*2 YES	YES YES*3 YES*4 YES YES	YES YES NO YES YES

*1 Only discs with TOC

*2 Can only be used with discs with digital audio signal tracks.

*3 Audio part only

*4 Video part only

NOTE:

The specifications and design of this product are subject to change without notice, due to improvement.

PLAYER FUNCTIONS

- Display, Visual Calendar Display
- Intro Scan, Hi-Lite Scan, Direct CD, Digital Level Control, Random Playback, Program Random Playback and Compu Program/Auto Program Edit
- Digital Audio Signal for LaserVision Discs
- Last Memory