

Service Manual

ORDER NO.
RRV1378

CD CDV LD PLAYER

CLD-160K

CLD-1850K

- Refer to the service manual RRV1160 for CLD-160K/HB.

THIS MANUAL IS APPLICABLE TO THE FOLLOWING MODEL(S) AND TYPE(S).

Type	Model		Power Requirement	The voltage can be converted by the following method.
	CLD-160K	CLD-1850K		
HB8	○	—	AC220 – 230V	AC240V, *
HEZ8	○	—	AC220 – 230V	AC240V, *
N	—	○	AC220V	AC240V, *

* : Alter the wiring of the Power-supply block at the primary winding of Power-transformer referring to the "Line Voltage Selection" described in Service Manual.

1. CONTRAST OF MISCELLANEOUS PARTS

NOTES:

- Parts marked by "NSP" are generally unavailable because they are not in our Master Spare Parts List.
- The Δ mark found on some component parts indicates the importance of the safety factor of the part. Therefore, when replacing, be sure to use parts of identical designation.
- Parts marked by "●" are not always kept in stock. Their delivery time may be longer than usual or they may be unavailable.

CLD-160K/HB8, CLD-160K/HEZ8, CLD-1850K/N and CLD-160K/HB have the same construction except for the following:

Mark	Symbol & Description	Part No.				Remarks
		CLD-160K/HB	CLD-160K/HB8	CLD-160K/HEZ8	CLD-1850K/N	
NSP	Warranty card	ARW-088	ARW-088	ARW-088	ARW1020	
Δ	Cord stopper	CM-22B	CM-22B	CM-22B	CM-22	
Δ	Power cord	PDG1055	PDG1055	PDG1003	PDG1013	
Δ	Fuse(TSA)	PEK1003	PEK1003	Not used	Not used	
	Caution label	PRW1018	PRW1018	Not used	Not used	
NSP	CE label	Not used	RRW1222	RRW1222	Not used	
NSP	Getter	Not used	Not used	Not used	VAX1003	
	FL panel	VEC1718	VEC1718	VEC1718	VEC1853	
	Pad(R)	VHA1123	VHA1123	VHA1106	VHA1106	
	Packing case	VHG1387	VHG1387	VHG1386	VHG1533	
	Rear panel	VNA1476	VNA1436	VNA1436	VNA1678	
	Ten key(L)	VNK2663	VNK2663	VNK2663	VNK3589	
	Ten key(R)	VNK2665	VNK2665	VNK2665	VNK3588	
NSP	Tray panel	VNK2836	VNK2836	VNK2836	VNK3561	
NSP	Front panel	VNK3003	VNK3003	VNK3003	VNK2719	
	Operating instructions (English/French/German/Italian)	VRE1030	VRE1030	VRE1030	Not used	
	Operating instructions (Dutch/Swedish/Spanish/Portuguese)	Not used	Not used	VRF1032	Not used	
	Operating instructions (English/Chinese)	Not used	Not used	Not used	VRD1047	
NSP	Caution(EW)	Not used	Not used	VRM1027	VRM1027	
NSP	Caution	Not used	Not used	VRR1009	VRR1009	
NSP	Caution label(F)	VRW-328	VRW-328	VRW-328	Not used	
	Caution label(G)	VRW-329	VRW-329	VRW-329	Not used	
	Caution label	Not used	Not used	VRW1094	Not used	
NSP	Caution label(HE)	Not used	Not used	VRW1297	Not used	
	FLKB ASSY	VWG1567	VWG1719	VWG1719	VWG1719	*
	SYPS ASSY	VWR1220	VWR1219	VWR1219	VWR1219	
NSP	JACB ASSY	VWV1396	VWV1465	VWV1465	VWV1465	
	Remote control unit	VXX2071	VXX2071	VXX2071	VXX1603	
	Tray panel ASSY - S	VXX2128	VXX2128	VXX2128	VXX2392	
	Front panel ASSY - S	VXX2192	VXX2192	VXX2192	VXX2393	

Note *: Although VWR1220 and VWR1219 are different in part number, they have the same service parts.

● CONTRAST OF PCB ASSEMBLIES

FLKB ASSY

VWG1719 and VWG1567 have the same construction except for the following:

Mark	Symbol & Description	Part No.		Remarks
		VWG1567	VWG1719	
	C116, C118 X101	Not used VSS1031	CKPUYF223Z25 EFOEC8004A4	* 8.00MHz

Note *: Refer to 2.SCHEMATIC AND PCB DIAGRAMS.

JACB ASSY

VWV1465 and VWV1396 have the same construction except for the following:

Mark	Symbol & Description	Part No.		Remarks
		VWV1396	VWV1465	
	C611, C612 Earth plate	CKPUYB101K50 Not used	Not used VNF1092	

Note : Δ mark is added to F602 - F609 in JACB ASSY VWV1465.

2. SCHEMATIC AND PCB DIAGRAMS

● FLKB ASSY, JACB ASSY

Note : For FLKB assy, only the differences between VWG1719 and VWG1567 are shown.

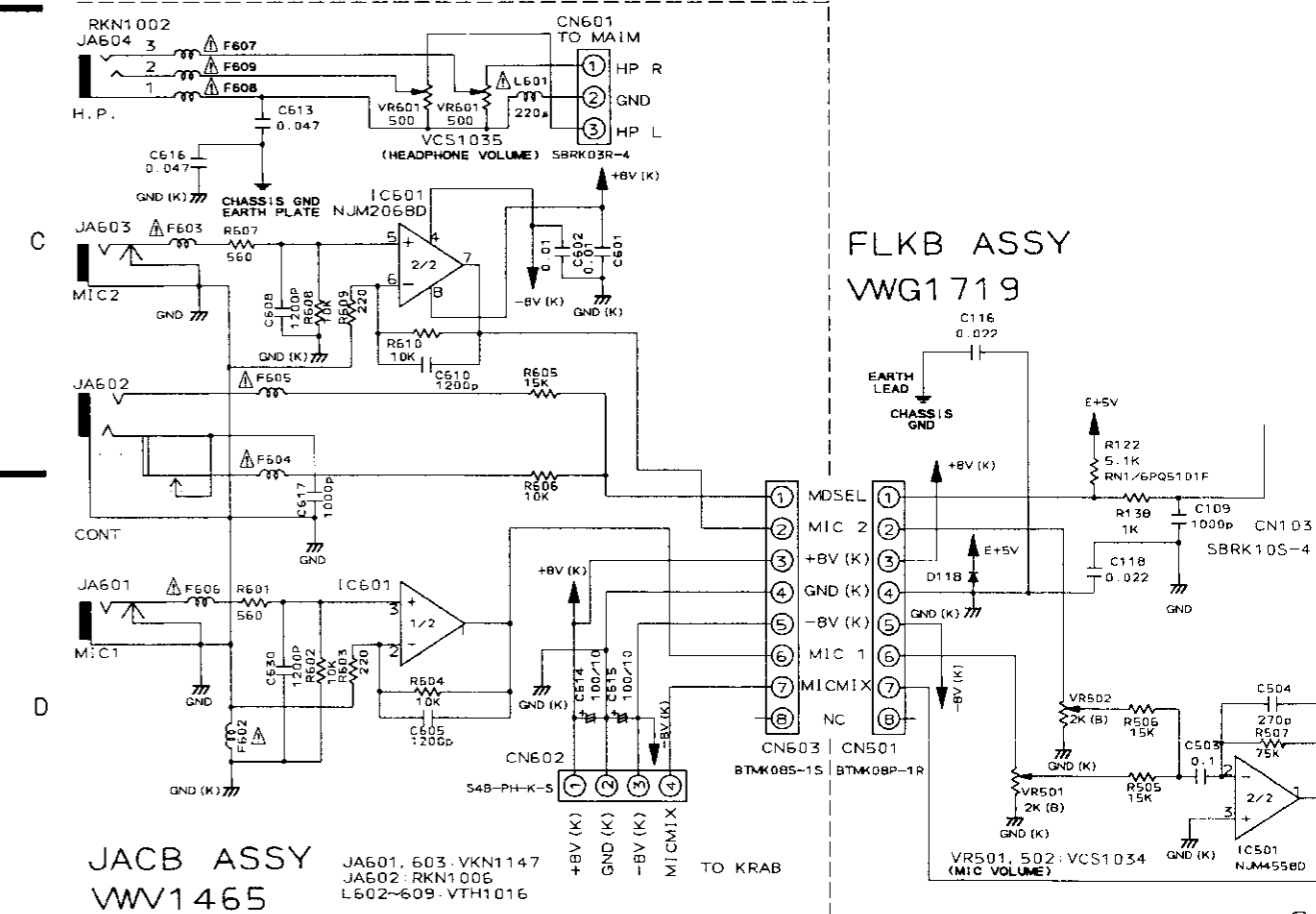

● This diagram is viewed from the mounted parts side.

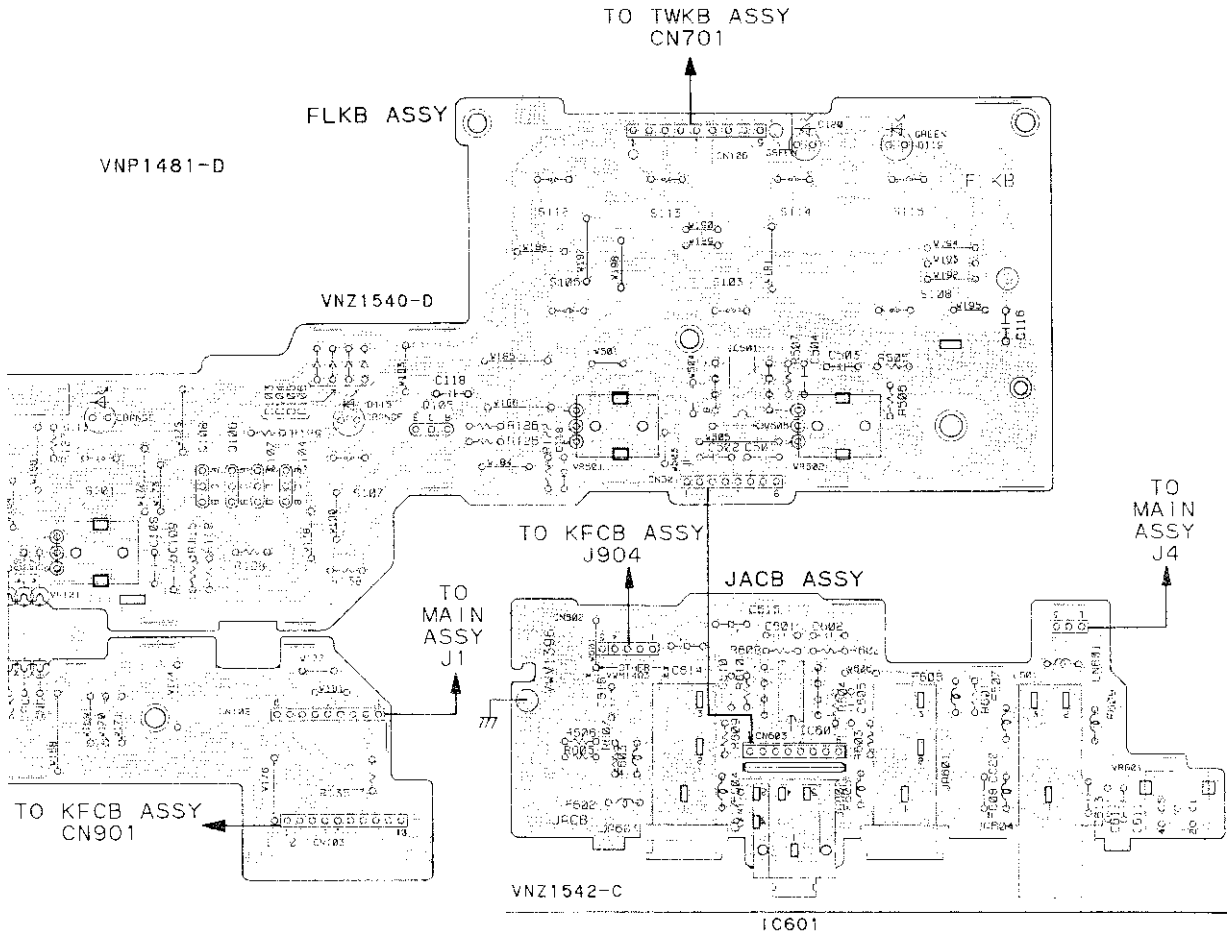

NOTE FOR PCB DIAGRAMS:

1. Part numbers in PCB diagrams match those in the schematic diagrams.
2. A comparison between the main parts of PCB and schematic diagrams is shown below.

Symbol in PCB Diagrams	Symbol in Schematic Diagrams	Part Name
		Transistor
		Transistor with resistor
		Field effect transistor
		Resistor array
		3-terminal regulator

3. The parts mounted on this PCB include all necessary parts for several destinations.
For further information for respective destinations, be sure to check with the schematic diagram.

4246



Service Manual

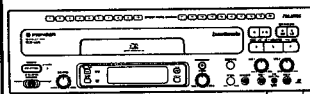

ORDER NO.
RRV1160

The chapter 1 of this Service Manual will not be reprinted. On your additional orders, we may supply only the chapter 2. For the chapter 1, please make copies and attach to the chapter 2 at your side if necessary.

CD CDV LD PLAYER

CLD-160K

THIS MANUAL IS APPLICABLE TO THE FOLLOWING MODEL(S) AND TYPE(S).

Type	Model	Power Requirement	The voltage can be converted by the following method.
	CLD-160K		
HB	○	AC240V	AC220—230V, *
HEZ	○	AC220—230V	AC240V, *

* : Alter the wiring of the Power-supply block at the primary winding of Power-transformer referring to the "Line Voltage Selection" described in Service Manual.

CONTENTS

CHAPTER 1

- 1.1 SAFETY INFORMATION 1-2
- 1.2 SPECIFICATIONS 1-3
- 1.3 PANEL FACILITIES..... 1-4
- 1.4 IC INFORMATION 1-6
- 1.5 FL INFORMATION 1-9
- 1.6 ADJUSTMENTS..... 1-10
- 1.7 PARTS LIST FOR PACKING AND EXPLODED VIEWS 1-23
- 1.8 PCB PARTS LIST 1-27

CHAPTER 2

- 2.1 PACKING AND EXPLODED VIEWS ... 2-3
- 2.2 SCHEMATIC AND PCB CONNECTION DIAGRAMS..... 2-12

PIONEER ELECTRONIC CORPORATION 4-1, Meguro 1-Chome, Meguro-ku, Tokyo 153, Japan
PIONEER ELECTRONICS SERVICE INC. P.O. Box 1760, Long Beach, California 90801 U.S.A.
PIONEER ELECTRONICS OF CANADA, INC. 300 Allstate Parkway Markham, Ontario L3R 0P2 Canada
PIONEER ELECTRONIC [EUROPE] N.V. Haven 1087 Keetberglaan 1, 9120 Melsele, Belgium
PIONEER ELECTRONICS AUSTRALIA PTY. LTD. 178-184 Boundary Road, Braeside, Victoria 3195, Australia TEL: [03] 580-9911
 © **PIONEER ELECTRONIC CORPORATION 1994**

T-FFM AUG. 1994 Printed in Japan

4246

CHAPTER 1

1.1 SAFETY INFORMATION

(FOR EUROPEAN MODEL ONLY)

VARO!
AVATTAESSA JA SUOJALUKITUS OHITETTAESSA OLET ALTIINA NÄKYMÄTTÖMÄLLE LASERSÄTEILYLLE. ÄLÄ KATSO SÄTEESEEN.



LASER
Kuva 1
Lasersäteilyn varoitusmerkki

WARNING!
DEVICE INCLUDES LASER DIODE WHICH EMITS INVISIBLE INFRARED RADIATION WHICH IS DANGEROUS TO EYES. THERE IS A WARNING SIGN ACCORDING TO PICTURE 1 INSIDE THE DEVICE CLOSE TO THE LASER DIODE.



LASER
Picture 1
Warning sign for laser radiation

ADVARSEL:
USYNLIG LASERSTRÅLING VED ÅBNING NÅR SIKKERHEDSAFBRYDERE ER UDE AF FUNKTION. UNDGÅ UDSÆTTELSE FOR STRÅLING.

VARNING!
OSYNLIG LASERSTRÅLING NÅR DENNA DEL ÄR ÖPPNAD OCH SPÄRREN ÄR URKOPPLAD. BETRakta EJ STRÅLEN.

IMPORTANT
THIS PIONEER APPARATUS CONTAINS LASER OF CLASS 1. SERVICING OPERATION OF THE APPARATUS SHOULD BE DONE BY A SPECIALLY INSTRUCTED PERSON.

LASER DIODE CHARACTERISTICS
MAXIMUM OUTPUT POWER: 5 mw
WAVELENGTH: 780-785 nm

LABEL CHECK

HB model

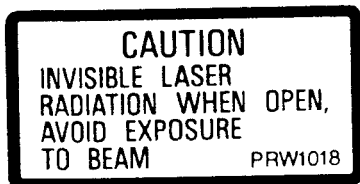

HEZ model

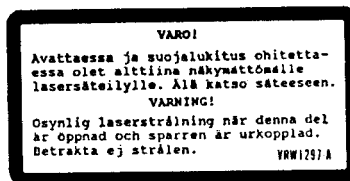

HEZ and HB models



HEZ model

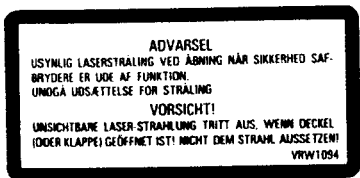

HEZ and HB models

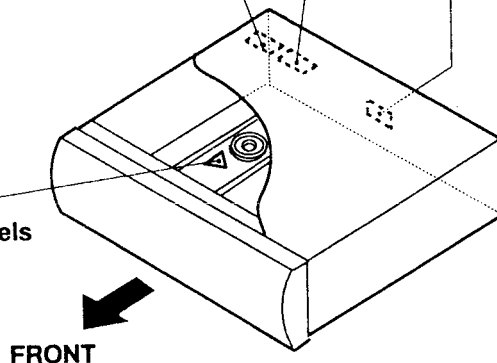

Additional Laser Caution

- The ON/OFF statuses of the slider - position detection switches (PARK INNER, PARK OUTER on the PASB assembly), loading - status detection switches (SW 1,2 and 3 on LOSB assembly) are detected by the microprocessor (IC101 in the MAIN ASSY). To permit the laser diode to oscillate, it is required to set the slider - position detection switch for the LD ACTIVE status (PARK INNER: OFF, PARK OUTER: OFF), and to set the loading - status detection switch for tilt neutral state (SW1: ON, SW2: OFF, SW3: ON). As long as these requirements are not satisfied, the laser diode will not oscillate. When the requirements are met in any way, the laser diode can oscillate. The laser diode oscillation will continue if pin 13 of IC801 is shorted to GND or the emitter and collector of Q834 are shorted each other (fault condition) in MAIN ASSY. In the test mode*, the laser diode oscillates when microprocessor detects a PLAY signal, or when the PLAY key is pressed (S207 ON in the FLKY assembly), with the above requirements satisfied.
- When the cover is open, close viewing through the objective lens with the naked eye will cause exposure to a Class 1 laser beam.

* Refer to page 1-10.

1.2 SPECIFICATIONS

General

System	LaserVision Disc system and Compact Disc digital audio system
Laser	Semiconductor laser wavelength 780 nm
Power requirements	
European model	AC 220 - 230 V, 50/60 Hz
U.K. model	AC 240 V, 50/60 Hz
Power consumption	43 W
Weight	
European model	7.5 kg
U.K. model	7.6 kg
Dimensions	420 (W) x 385 (D) x 122 (H) mm
Operating temperature	+5 °C ~ +35 °C
Operating humidity	5 % ~ 85 %
(There should be no condensation of moisture.)	

Video characteristics

Format	NTSC/PAL specifications
Video output	
Level	1 Vp-p nominal, sync. negative, terminated
Impedance	75 Ω unbalanced
Jack	RCA jack

Audio characteristics

Output level	
During analog audio output	200 mVrms (1 kHz, 40 %)
During digital audio output	200 mVrms (1 kHz, -20 dB)
Jacks	Both RCA jacks
Number of channels	2 (Stereo)

Other terminals

Control input/output	Both miniature jacks
AUX	RCA jacks
Microphone input	2
MIC control input	miniature jack
Headphone input	1
AV connector output	21-pin connector
This connector provides the video and audio signals for connection to a colour video TV monitor (or TV set) which has a "AV CONNECTOR" terminal.	

21-pin connector assignment

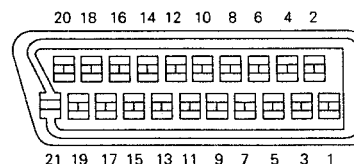

PIN no.	1 Audio 2/R out	17 GND
	3 Audio 1/L out	19 Video out
	4 GND	21 GND
	8 Status	

Accessories

Remote control unit	1
Size "AAA" (IEC R03) dry cell batteries	2
Audio cord	1
Video cord	1
Operating instructions	1
Warranty card	1

NOTE:

The specifications and design of this product are subject to change without notice, due to improvement.

1.3 PANEL FACILITIES

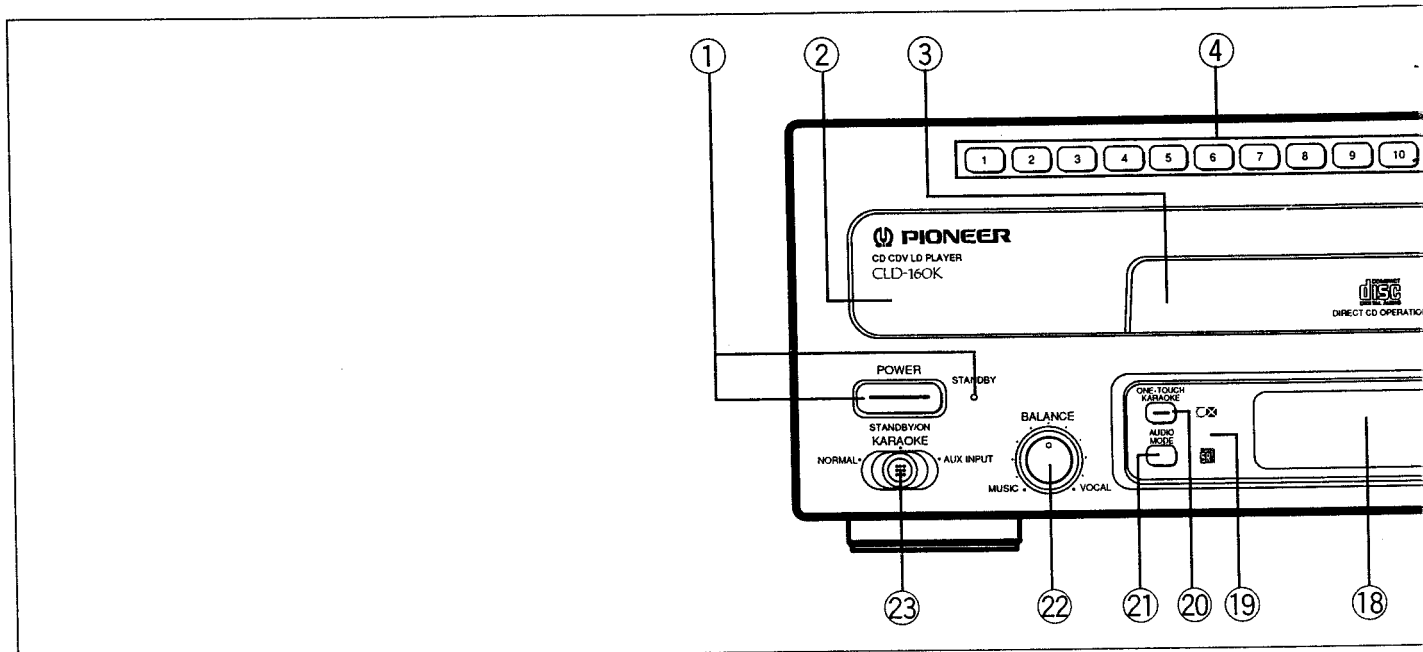

- ① **POWER STANDBY/ON switch and STANDBY indicator**
Press to turn the power on and off.
- ② **Disc table**
- ③ **CD Disc table**
- ④ **DIRECT MUSIC SEARCH buttons**
- ⑤ **Stop (■) button**
- ⑥ **Play/Pause (▶/⏸) button**
- ⑦ **OPEN/CLOSE (CD ▲/LD ▲) buttons**
- ⑧ **KEY CONTROL buttons**
- ⑨ **MIC 1 jack and MIC 1 level control**
- ⑩ **MIC 2 jack and MIC 2 level control**
- ⑪ **MIC CONTROL jack**

- ⑫ **PHONES jack and LEVEL control**
- ⑬ **SCORING button/indicator**
- ⑭ **ECHO level control**
- ⑮ **SURROUND button/indicator**
- ⑯ **SYSTEM button**
- ⑰ **16:9 button**
- ⑱ **Display window**
- ⑲ **Remote sensor**
- ⑳ **ONE-TOUCH KARAOKE button/indicator**
- ㉑ **AUDIO MODE button**
- ㉒ **BALANCE control**
- ㉓ **NORMAL/KARAOKE/AUX INPUT selector**

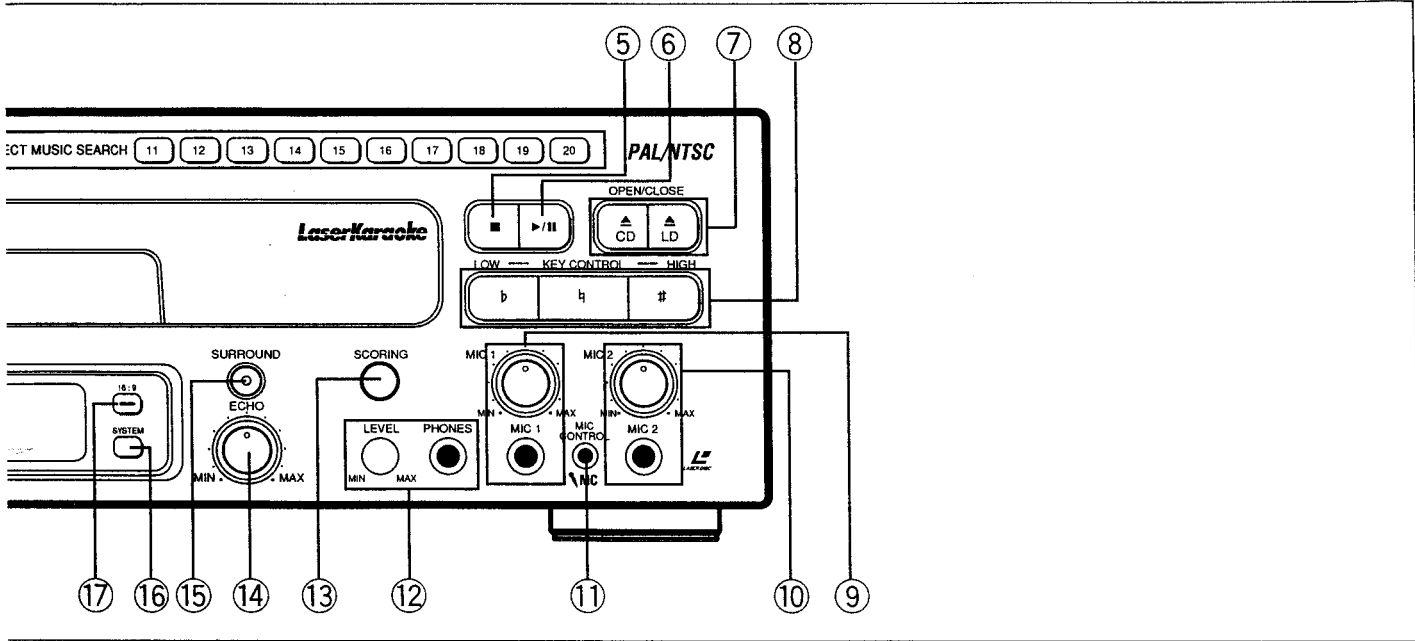

1.4 IC INFORMATION

■ PD3286B (FLKB ASSY IC101)

● Mode control IC

● Pin function

No.	Symbol	Pin name	I/O	Function
1	AN4	xREQ	I	Request for DSP L: Request
2	AN5	MICSENS	I	Microphone detection H: Installed L: Not installed
3	AN6	MODESW	I	Audio mode (A/D) Karaoke/Normal/AUX input
4	AN7	Not Used	I	GND
5	AVSS	Not Used	I	
6	TEST	Not Used	I	
7	X2	---	O	Not connected (Open)
8	X1	---	I	GND
9	VSS	GND	I	
10	OSC1	---	I	Main system clock oscillation (8 MHz)
11	OSC2	---	O	
12	xRST	RESET	I	CPU Reset (L: Reset)
13	IRQ0	SHAKE	I	Mechanism controller serial communication request
14	IRQ1	SEL IR	I	Remote control input
15	P12	DOGFOOD	O	Pulse output for watchdog timer
16	P13	POWERON	O	Switching output for mother board power supply
17	P14	THRU	O	Through output for DSP H: Through L: DSP ON
18	P15	EXTXINT	O	External/Internal H: External L: Internal
19	P16	XPOWKEY	I	Power-key input L: Key ON H: OFF
20	P33	Not Used	I	GND
21	P32	Not Used	I	
22	P31	Not Used	I	
23	P30	Not Used	O	Not connected (Open)
24	P47	xMICON	O	Microphone input ON/OFF H: Disable microphone input L: Enable
25	P46	LEDWKV	O	LED for the VOCAL PARTNER
26	P45	LEDONT	O	LED for the one-touch karaoke
27	P44	STDBYL	O	LED for standby
28	P43	Not Used	O	Not connected (Open)
29	P42	SEG k	O	
30	P41	SEG j	O	
31	P40	SEG i	O	
32	P50	KSCAN0/SEG h	O	Key scan output/ Display segment output
33	P51	KSCAN1/SEG g	O	
34	P52	KSCAN2/SEG f	O	
35	P53	KSCAN3/SEG e	O	
36	P54	KSCAN4/SEG d	O	
37	P55	KSCAN5/SEG c	O	
38	P56	SEG b	O	
39	P57	SEG a	O	
40	VDISP	---	I	-27V (FL bias)

- The information shown in the list is basic information and may not correspond exactly to that shown in the schematic diagrams.

No.	Symbol	Pin name	I/O	Function
41	P60	G1	O	Display grid output
42	P61	G2	O	
43	P62	G3	O	
44	P63	G4	O	
45	P64	G5	O	
46	P65	G6	O	
47	P66	G7	O	
48	P67	G8	O	
49	P70	G9	O	
50	P71	G10	O	
51	P72	LEDSCR	O	LED output for the scoring mode
52	P73	LEDSRD	O	LED output for the DSP surround
53	P74	LEDWID	O	LED output for the 16:9 H: 16:9
54	P75	LEDLDO	O	LED output for the CD tray control
55	P76	LEDCDO	O	LED output for the LD tray control
56	P77	Not Used	O	Not connected (Open)
57	VCC	---	I	+5V
58	P80	KIN0	I	Key data input
59	P81	KIN1	I	
60	P82	KIN2	I	
61	P83	KIN3	I	
62	P84	KIN4	I	
63	P85	KIN5	I	Not connected (Open)
64	P86	Not Used	I	
65	P87	Not Used	I	
66	P90	Not Used	I	
67	xSCK1	XSCK	I/O	Serial communication clock for the mechanism controller and the character generator DSP.
68	SI1	S-MTOF	I	Serial communication data input from the mechanism controller
69	SO1	S-FTOM	O	Serial communication data output for the mechanism controller and the character generator DSP.
70	P94	XRESET	O	Reset output for the mother board
71	P95	XCSDSD	O	Chip select of the character generator DSP L: Active
72	P96	Not Used	O	Not connected (Open)
73	P97	Not Used	I	
74	PA0	XCSDSP	O	Chip select of DSP L: Active
75	PA1	A/D	O	For DSP H: Address L: Data
76	AVCC	---	I	+5V
77	AN0	ECHVOL	I	Echo volume (A/D)
78	AN1	MPXBAL	I	Multiplex onta balance (A/D)
79	AN2	MICSW	I	Microphone status input (A/D)
80	AN3	XD_RDY	I	READY input for DSP H: Busy L: Ready

■ PD0193A (MAIN ASSY IC101)

● Mechanism control IC

● Pin function

No.	Pin name	I/O	Function
1	VCC	I	Power connection pin Impresses 5V±10%.
2	XCD	O	LD/CD switching signal output pin. "L" = CD "H" = LD
3	RFCORR	O	RF collection switch signal output pin. "H" = gain up CD,CDV-A:Low Raise the gain with the CAV inner circuit, otherwise High.
4	GPWM	O	Duty pulse signal output terminal for spindle gain switching. CLV inner circuit : L Outer circuit : H
5	FBAL	O	Focus balance control H: TEMAX L: RFMAX
6	SLDERR	I A/D	Carries out A/D conversion of this signal and controlled input of the slider servo. Control the slider motor so that this signal becomes 2.5V.
7	SLDPOS	I A/D	Pick up position detection switch input pin. Divides the resistance of each switch and detects the reading position of the A/D input value.
8	TBALERR	I A/D	Tracking balance error signal input pin. Carries out A/D conversion of this signal and controlled input of the tracking offset.
9	TILTERR	I A/D	Carries out A/D conversion of this signal and controlled input of the tilt servo. Control the tilt motor so that this signal becomes 2.5V.
10	XFOK	I	Focus servo lock signal input pin. "L" = lock "H" = unlock Used for detecting focus servo locking.
11	FSEQ	I	Sub-code sync conformity detection signal input pin. "L" = Others "H" = Conformity
12	TBALDRV	O PWM	Carries out PWM output of the tracking offset, and is used for auto tracking offset. 910µsec cycles, 3 value control H, L, Z.
13	TLATCH	O	DAC & digital filter PD2026 serial control latch signal output terminal. Startup is latched.
14	TILTDRV	I/O	Load/tilt control output pin. 0, 5V-tray IN, OUT/tilt DOWN, UP 2.5V-STOP Carries out PWM output of the tilt drive, and is used for the tilt servo.
15	SQOUT	I	DSP reading command data input pin. SUBQ is read out.
16	COIN	O	DSP writing command data output pin.
17	CQCK	O	DSP reading/writing command clock output pin. Start-up reading.
18	SLD DRV	O PWM	Slider control signal output pin. 5V = FWD, 0V = REV, 2.5V = STOP 910µsec cycles, 3 value control H, L, Z.
19	SI1	I	Input pin for data from mode control IC.
20	SO1	O	Serial data output to mode control IC.
21	SCK1	I/O	Clock for serial communication with mode control IC. Is set to input mode at all times when not used for communication with the mode control IC.
22	TZC	I INT	Tracking error zero cross signal input pin. At the time of miss clamp detection, this signal is monitored during track count search.
23	WRQ	I	Sub-code Q reading OK signal input pin. "L" = NG "H" = OK This terminal becomes H when the sub-code Q data passes the CRC check.
24	RWC	O	DSP reading/writing command signal output pin. "L" = READ "H" = WRITE
25	SHAKE	I/O	Handshake signal pin for data communication with mode control IC. This terminal is used as a data line for both directions, and each microcomputer carries out input/output control.
26	XPBV	I	LD/CDV play vertical synchronous signal input pin. "L" = vertical synchronous
27	CNVss	I	GND grounding for A/D conversion.
28	XRESET	I	Reset signal input pin. "L" = reset "H" = reset cancel Controlled by mode control IC.
29	XIN	I	9MHz clock oscillation input pin.
30	XOUT	O	9MHz clock oscillation output pin.
31	N. C.	O	Not used. Since it is for only ϕ output, it cannot be used for anything else.
32	GND	I	GND grounding.
33	SW1	I	Switch input pin for loading/tilt position detection.

No.	Pin name	I/O	Function
34	SW2	I	Switch input pin for loading/tilt position detection.
35	SW3	I	Switch input pin for loading/tilt position detection.
36	XSLOCK	I	Spindle lock signal input pin. "H" = unlock "L" = lock
37	FG	I	Spindle motor FG signal input pin 24 outputs per rotation. Used after dividing by 3 in microcomputer.
38	DATA	I	Input pin for Phillips code decoder with built in mechanism controller.
39	PBH	I	Play H—SYNC input for Phillips code decoder.
40	XPBV	I	Play V—SYNC input for Phillips code decoder.
41	16:9	O	16:9 switching signal output pin. 16:9 "H" 4:3 (normal) "L"
42	VLOCK	I	Vertical synchronous lock detection signal input pin. "L" = phase is not correct "H" = phase is correct.
43	N. C.	O	Not used
44	N. C.	O	Not used
45	XPAL	O	PAL/NTSC signal output pin. L : PAL, H : NTSC
46	XPLAY	O	PLAY signal output terminal for PAL. L : PLAY H : NOT PLAY
47	JF/R	I/O	JUMP FWD signal output terminal for PAL. FWD jump : H REV jump : L Others : Z
48	SCK3	O	Serial 3 clock signal output pin.
49	XLATCH3	O	Serial 3 latch signal output pin TBC.
50	SO3	O	Serial 3 data signal output pin. The serial signal is a common one, and the signals are distinguished with latch signals (XLAT3, TLAT).
51	DIRECT	O	CD direct video line power off signal output pin. Video PWOFF: H normal: L
52	XCLV	O	CAV/CLV switching signal output pin. "H" = CAV, "L" = CLV
53	VSQ	O	Switching signal output terminal for the video signal. H : squelch ON L : squelch OFF
54	SENA	O	Shift enable signal output terminal. H : H is picked and REFV is made closer to PBV. L : Normal
55	CLRSCN	O	Clear scan signal output terminal. H : During clear scanning. L : Others
56	T HOLD	I	Track jump accelerating/decelerating signal input pin. "H" = accelerating/decelerating "L" = Others
57	HQON	O	High quality circuit control signal output terminal. H : HQ circuit ON. L : HQ circuit OFF.
58	AMPDET	I	Spindle overcurrent detection signal input pin. "L" = overcurrent "H" = normal
59	SQ1	O	Analog sound switching signal output pin. 1/L "L" = squelch OFF "H" = squelch ON
60	SQ2	O	Analog sound switching signal output pin. 2/R "L" = squelch OFF "H" = squelch ON
61	XCX	O	Analog sound CX noise reduction switching signal output pin. "L" = CX ON "H" = CX OFF
62	MUTE	O	Audio line sound mute control signal output pin. "H" = MUTE "L" = MUTE CANCEL
63	ACCONT	I/O	Output terminal for signal increasing/reducing the spindle speed. H : Accelerator L : Brake Z : Others
64	XANA	O	Digital/analog audio switch signal output pin. "H" = digital "L" = analog

1.5 FL INFORMATION

● VAW1034 (FLKB ASSY : V101)

ANODE GRID ASSIGNMENT

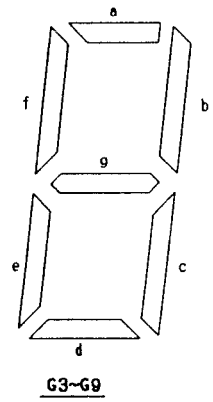
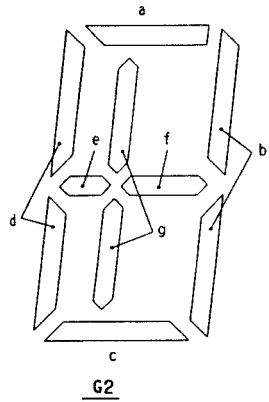
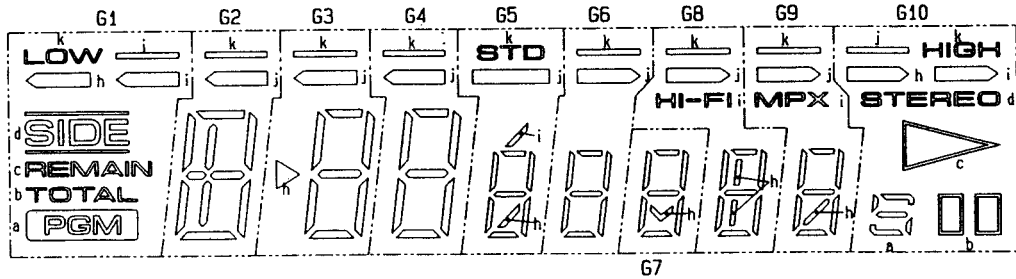

	G1	G2	G3	G4	G5	G6	G7	G8	G9	G10
P1	PGM	a	a	a	a	a	a	a	a	S
P2	TOTAL	b	b	b	b	b	b	b	b	□□
P3	REMAIN	c	c	c	c	c	c	c	c	△
P4	SIDE	d	d	d	d	d	d	d	d	STEREO
P5	/	e	e	e	e	e	e	e	e	/
P6	/	f	f	f	f	f	f	f	f	/
P7	/	g	g	g	g	g	g	g	g	/
P8	◀ (L)	/	▶	/	▄ (Lower)	/	▾	▄	▄	◀ (L)
P9	◀ (R)	/	/	/	▄ (Upper)	/	/	HI-FI	MPX	◀ (R)
P10	—	◀	◀	◀	◀	◀	/	◀	◀	—
P11	LOW	—	—	—	STD	—	/	—	—	HIGH

PIN ASSIGNMENT

Pin No.	1	2	3	4	5	6	7	8	9	10	11	12	13	14	15	16	17
Assignment	F	F	NP	NL	NL	NL	NL	P11	P10	P9	P8	P7	P6	P5	P4	P3	P2

Pin No.	18	19	20	21	22	23	24	25	26	27	28	29	30	31	32	33	34
Assignment	P1	NL	G1	G2	G3	G4	G5	G6	G7	G8	G9	G10	NL	NL	NP	F	F

F:Filament G1-G10:Grid P1-P11:Anode NP:No pin NL:No lead

1.6 ADJUSTMENTS

1.6.1 TEST MODE

1) How to start test mode

With the MAIN ASSY test mode TP (W407) dropped to GND, the test mode is started by putting the power switch ON. (Fig. 1)

After confirming that all FL indicators are lit, remove test mode jumper wire and GND connection. Or, with power switch ON, press test mode remote control (GGF1067) ESC key and TEST key in order.

- When entering the test mode, the FL display and the LED will light until an operation is carried out with a key.
- When entering the test mode, the TV system will become that of NTSC.
- During the test mode, the background will be blue if an LD or a CDV is not playing (When NTSC and PAL), or black (in the case of quasi-PAL).
- The TV system is unconditionally toggled between the 3 systems of PAL → NTSC → quasi-PAL.

2) How to cancel test mode

Turn power switch OFF. Or, press test mode remote control ESC key.

3) Functions and key control when in test mode

Note: For keys not on player or on accompanying remote control, use test mode remote control (GGF1067)

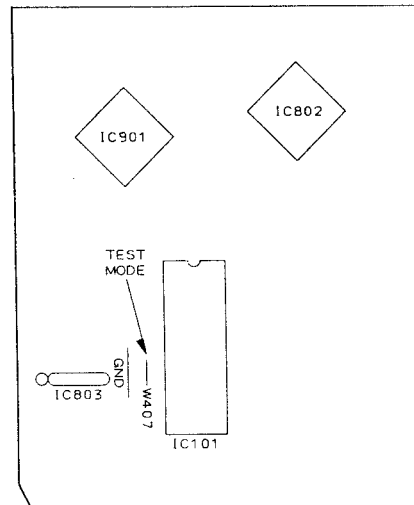

MAIN ASSY

Fig. 1

• Key operation in the Test mode

Player Status	Key Operation	Function	Remarks
Tray Open	⏮/⏭ SKIP (Refer to Note 1)	⏮: Shifts the tray in the closed direction and also raises the turn table while pressing the key. ⏭: Shifts the tray in the open direction and also lowers the turn table while pressing the key.	
Tray Open	▶ PLAY	Clamps	
Clamp	▶ PLAY	Turns the disc through TRK. Servo OFF	TRK-OFF
TRK Servo OFF	▶ PLAY	TRK Servo ON	TRK-ON
TRK Servo ON	▶ PLAY	TRK Servo OFF	TRK-OFF
TRK Servo ON	◀ / ▶ (STEP)	FOCS balance select	F-0/F-1
TILT Neutral	+ MULTI-SPEED	TILT Servo ON	T-□: ON
TILT ON	- MULTI-SPEED	TILT Neutral	T-□: N
TILT Neutral or ON	⏮/⏭ SKIP	Setting TILT Servo to OFF, can force TILT to move.	T-1 to T-E
Clamp	◀/▶ SCAN	Can force the slider to move	S-LD S-CDV S-CD S-IN
Play	⏸ PAUSE	Still	
Play	■ STOP	Stop	
Stop	▲ OPEN	Open	
Play	<div style="text-align: center;"> +10 ↓ 0 to 9 ↓ ▶ PLAY </div>	Sets to SEARCH Lead Address Input mode. Designates the SEARCH lead address through keys 0 to 9. Press the CLEAR [C] key if the designated address is incorrect. Searches the designated address upon pressing the PLAY key.	

Note 1: Press SKIP (⏮/⏭) Keys after the tray is set to open state by pressing Open (▲) key. Because, in tray open state, pressing PLAY (▶) key causes it to set to clamp state and SKIP (⏮/⏭) keys can not function properly.

Table 1

● PLAYER OPERATION IN THE TEST MODE

Operate the player by selecting a test mode function with the keys on the player or on the remote control unit.

• CD PLAYBACK

- ① Place the CD disc on the turn table.

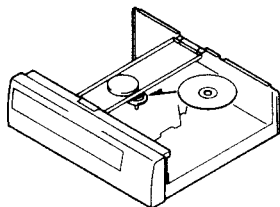

- ② Press the PLAY (▶) key once. (Twin gear starts to move.)
- ③ Push the cam plate (Fig. 4) in the direction of the arrow and wait until the CD disc is clamped.

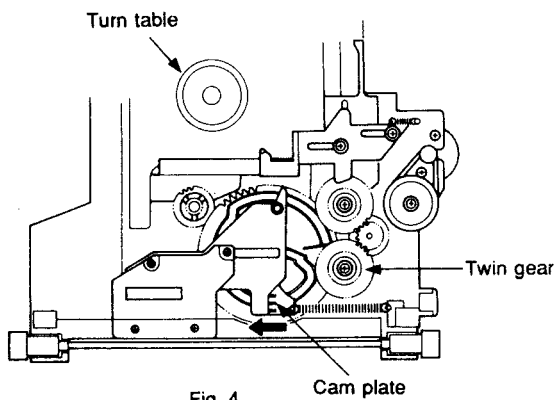

- ④ Press the ◀◀ or ▶▶ keys to appear "S-CD" on the TV screen display.

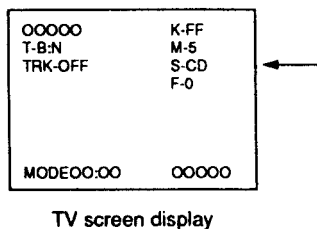

- ⑤ Press the PLAY (▶) key twice, disc will be normally playbacked.

• LD PLAYBACK

- ① Press the PLAY (▶) key once. (Twin gear starts to move.)
- ② Press the SKIP REV (⏮) key to raise the turn table (spindle motor section) while pressing the cam plate (Fig. 4) in the direction of the arrow. Raise it to the position where the LD disc can be easily placed on the turn table. If the turn table is raised too high, lower it with the SKIP FWD (⏭) key.
- ③ Place the LD disc on the turn table and press the PLAY (▶) key once to clamp the disc.
- ④ Press the ◀◀ or ▶▶ keys to appear "S-LD" on the TV screen display.

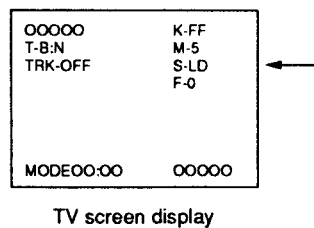

- ⑤ Press the PLAY (▶) key twice, disc will be normally playbacked.

1.6.2 ADJUSTMENT PRECAUTIONS

● JIGS FOR ADJUSTMENT

- CD test disc (STD-901 or STD-902)
- LD test disc (GGV1003 and GGV1007)
- (-) Screwdriver (medium)
- (-) Screwdriver (small)
- Hexagonal wrench driver (straight type, size : 3mm)
- Resistor (10kΩ × 2, 47kΩ)
- Dual-trace oscilloscope (with delay)
- AF oscillator
- Frequency counter
- Digital voltmeter
- TV monitor
- Low-pass filter

Use the low-pass filters below in the coarse centering adjustment 2. and fine centering adjustment (L.P.F.1 and L.P.F.2) 6. and PLL OFFSET adjustment (L.P.F.3) 1. when the S/N of the waveform is hard to observe.

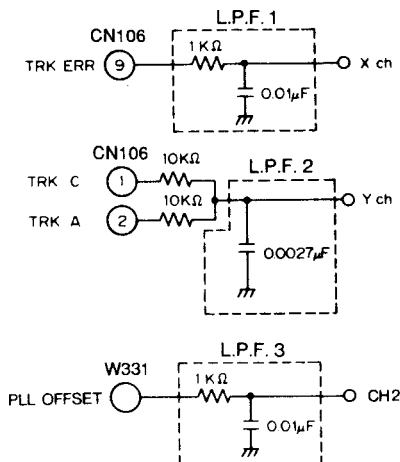

● RACK ASSEMBLY DURING CENTERING ADJUSTMENT

The S-IN position (without hitting the mechanism stopper) of the rack assembly during centering adjustment is indicated below.

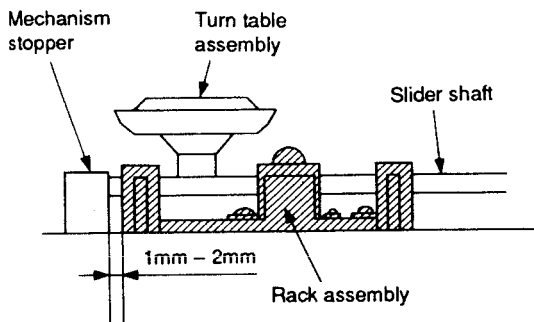
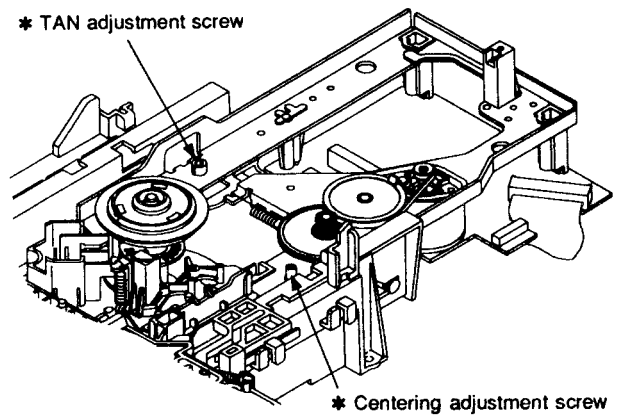

Fig. 1 Right side view



* : As the adjustment range of both the TAN and centering adjustment screws is only ±90° from the center, do not turn the screws beyond this range.

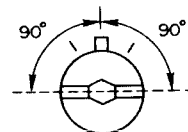
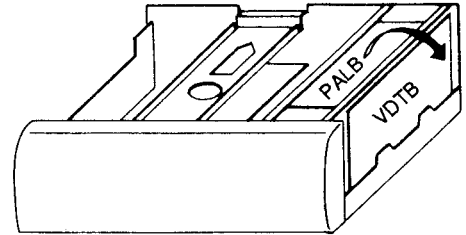

Fig. 2 TILT base section

● **DISASSEMBLY ORDER**
(When diagnosing the MAIN ASSY)

① Remove the tray, open PALB assy, and fix it to the holder.



② Removes SCRB, KFCB and EXTB assy.

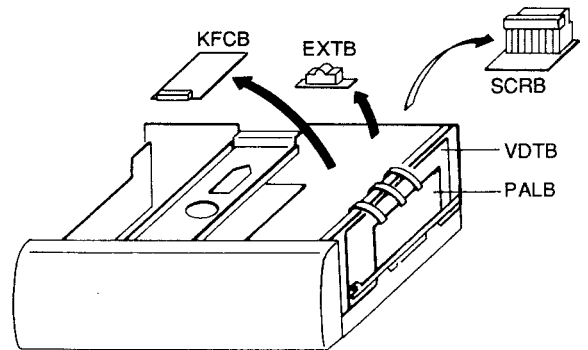

③ Remove VDTB and MAIN assy, and stand MAIN assy up.
 Put isolating material on top of the clamper, and then place the VDTB and PALB assy on top.

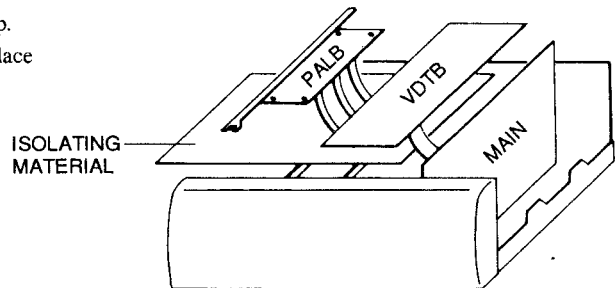

1.6.3 MAIN ASSY, VDTB ASSY AND PALB ASSY ADJUSTMENT LOCATION

● MAIN ASSY

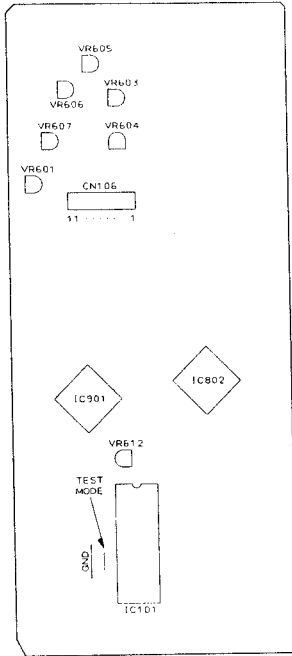

- VR607 : Tilt offset adjustment
- VR605 : FCS Balance adjustment (TRK error max)
- VR606 : FCS Balance adjustment (RF level max)
- VR604 : FCS Servo loop gain adjustment
- VR603 : TRK Servo loop gain adjustment
- VR601 : RF level adjustment
- VR612 : PLL offset adjustment
(Order in adjustment)

Fig. 1 Adjustment diagram of MAIN ASSY

● VDTB ASSY AND PALB ASSY

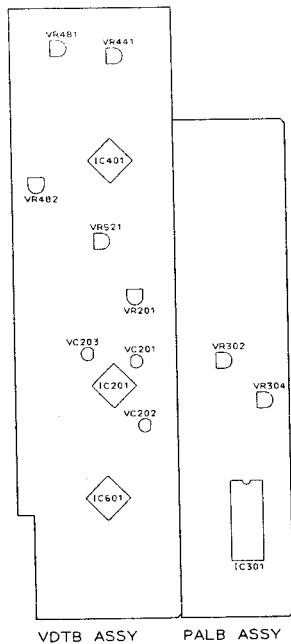

- VC202 : NTSC Reference clock adjustment
- VC201 : PAL Reference clock 910fH adjustment
- VC203 : PAL Reference clock adjustment
- VR481 : VCO Center frequency adjustment
- VR482 : Output video level adjustment
- VR441 : 1H Delay video level adjustment
- VR521 : VPS Error adjustment
- VR304 : MOD Y - Signal level adjustment
- VR302 : MOD C - Signal level adjustment
- VR201 : PAL Inverting SC phase adjustment
(Order in adjustment)

Fig. 2 Adjustment diagram of VDTB ASSY AND PALB ASSY

1.6.4 MECHANICAL ADJUSTMENT

NOTE : All VRs and CNs (connectors) in the tables are parts of MAIN ASSY.

Adjustment name	Adjustment point	Measuring equipment and jigs	Measurement point	Player condition	Adjustment procedure	Waveform and connection diagram
1 Tilt offset Check and adjustment	VR607	• TV monitor	Tilt indication on Test mode screen	• Power ON • Test mode • Disc not installed	1. Check if the tilt indication on the test mode screen is at T-6 to T-8. 2. If the tilt indication is not at T-6 to T-8, adjust VR607 until the tilt indication reaches T-6 to T-8.	
2 Coarse centering adjustment	Mechanism assembly Centering adjustment screw	• ⊖ Screwdriver (Large) • Oscilloscope • STD-901 or STD-902 • MIX resistor 	CN106 X : ⑨ pin (TRK ERR) Y : ①+② pin (TRK SUM)	• Test mode TRK servo OFF Tilt servo ON • Innermost track of STD-901 or STD-902 which does not come in contact with the mechanical stopper.	Note : Be careful not to turn the centering adjustment screw past its limit. 1. Move the slider until it does not come in contact with the mechanical stopper at the slider position indication S-IN. 2. Observe TRK ERR (Xch) and TRK SUM (Ych) at the X-Y mode during TRK Servo OFF. 3. Adjust centering adjustment screw until the Lissajous' figure is horizontal.	
3 FCS balance adjustment (1) TRK ERR MAX	VR605	• Oscilloscope • STD-901 or STD-902	CN106 ⑨ pin (TRK ERR)	• Test mode TRK servo OFF Tilt servo ON • Inner track of STD-901 or STD-902	1. Observe TRK ERR at CH1 of the oscilloscope during TRK Servo OFF. 2. Adjust VR605 until the amplitude of the waveform reaches its maximum and the envelope is very clear.	
4 FCS balance adjustment (2) RF LEVEL MAX	VR606	• Oscilloscope • STD-901 or STD-902	CN106 ③ pin (RF)	• Test mode TRK servo ON Tilt servo ON • Inner track of STD-901 or STD-902	1. Observe RF at CH1 of the oscilloscope at TRK Servo ON. 2. Adjust VR606 until the amplitude of the waveform reaches its maximum and the envelope is very clear.	
5 Tangential direction angle adjustment	Carriage assembly TAN adjustment screw	• Oscilloscope • STD-901 or STD-902 • ⊕ Screwdriver (Medium)	CN106 ③ pin (RF)	• Test mode TRK servo ON Tilt servo ON • Outermost track of STD-901 or STD-902 (position where TAN screw can be seen)	Note : Be careful not to turn the TAN adjustment screw past its limit. 1. Observe RF at CH1 of the oscilloscope at TRK Servo Close. 2. Turn TAN adjustment screw until the amplitude of the waveform reaches its maximum and the envelope is very clear. After adjustment, stabilize the screw with an adhesive.	
6 Fine centering adjustment	Mechanism assembly Centering adjustment screw	• Oscilloscope • STD-901 or STD-902 • MIX resistor 	CN106 X : ⑨ pin (TRK ERR) Y : ①+② pin (TRK SUM)	• Test mode TRK servo OFF Tilt servo ON • Innermost track of STD-901 or STD-902 which does not come in contact with the mechanical stopper.	Note : Be careful not to turn the centering adjustment screw past its limit. Perform fine centering adjustment again by following the same procedure as in "Coarse centering adjustment" (2). After adjustment, stabilize the screw with an adhesive.	
7 Crosstalk check and tilt offset adjustment.	VR607	• TV monitor • GGV1003	Crosstalk check screen	• Test mode TRK servo ON Tilt servo ON • GGV1003still #115	1. Search for address #115 of GGV1003 and still the address 2. Check the crosstalk. If the crosstalk is pronounced, adjust VR607 until the crosstalk is not noticeable.	
When the crosstalk is still noticeable in spite of the adjustment in (7), after carrying out the adjustment in (1) and bringing the tilt indication to T-6 to T-8, use a hexagonal wrench driver (straight type, size : 3mm) to adjust the TAN adjustment screw on the bottom side of the player through the GGV1003 # 115 STILL screen. Afterwards, perform the adjustment procedures from (6).						

Adjustment name	Adjustment point	Measuring equipment and jigs	Measurement point	Player condition	Adjustment procedure	Waveform and connection diagram
8 FCS Servo loop gain adjustment	A VR604	<ul style="list-style-type: none"> Oscilloscope GGV1003 AF Oscillator Resistor (47kΩ) 	CN106 X : ⑦ pin FCS IN Y : ⑥ pin FCS ERR	<ul style="list-style-type: none"> Test mode TRK servo ON Tilt servo ON GGV1003 # 15,000still 	1. Xch : Connect to ⑦ pin with 47kΩ Ych : Connect to ⑥ pin 2. Search #15,000 of GGV1003 and still the address. 3. Connect AF oscillator between Xch and 47kΩ and adjust VR604 until Lissajous' figure is a circle.	
	B VR604	<ul style="list-style-type: none"> Oscilloscope GGV1003 Clip etc. (Short GND—⑦ pin) 	CN106 X : — Y : ⑥ pin FCS ERR ⑦ pin GND (⑦, ⑥ pin Short)	<ul style="list-style-type: none"> Test mode Stop mode F-1 	1. Ych : connect to ⑥ pin. Drop ⑦ pin to GND. 2. Put in GGV1003, press reverse side of skip key and bring F-0 to F-1. 3. Press brake and adjust VR604 until the waveform level is 2.6 Vp-p±0.1 V.	
9 TRK Servo loop gain adjustment	A VR603	<ul style="list-style-type: none"> Oscilloscope GGV1003 AF Oscillator Resistor (47kΩ) 	CN106 X : ⑩ pin TRK IN Y : ⑨ pin TRK ERR	<ul style="list-style-type: none"> Test mode TRK servo ON Tilt servo ON GGV1003 # 15,000still 	1. Xch : Connect to ⑩ pin with 47kΩ Ych : Connect to ⑨ pin 2. Search #15,000 of GGV1003 and still the address. 3. Connect AF oscillator between Xch and 47kΩ and adjust VR603 until Lissajous' figure is a circle.	
	B VR603	<ul style="list-style-type: none"> Oscilloscope GGV1003 	CN106 X : — Y : ⑨ pin TRK ERR	<ul style="list-style-type: none"> Test mode TRK servo ON Tilt servo ON F-1 GGV1003 # 15,000still 	1. Ych : connect to ⑨ pin. 2. Search #15,000 of GGV1003 and still the address. 3. Adjust VR603 until the waveform level is 1.6 Vp-p±0.1 V.	
10 RF level adjustment	VR601	<ul style="list-style-type: none"> Oscilloscope GGV1003 	CN106 ③ pin (RF)	<ul style="list-style-type: none"> Test mode TRK servo ON Tilt servo ON GGV1003 # 15,000still 	1. Search for address #15,000 of GGV1003, still the address, and observe RF at CH1. 2. Adjust VR601 until RF amplitude is 300mVp-p±50mV.	

1.6.5 ELECTRICAL ADJUSTMENT

ADJUSTMENT TABLE OF MAIN ASSY, VDTB ASSY, PALB ASSY AND YCNR ASSY

Adjustment name	Adjustment point	Measuring equipment and jigs	Measurement point	Player condition	Adjustment procedure	Waveform and connection diagram
1 PLL offset adjustment	VR612 (MAIN ASSY)	<ul style="list-style-type: none"> Oscilloscope DC Volt meter STD-901 or STD-902 (or LDD disc) 	Digital sound terminal W331	<ul style="list-style-type: none"> Test mode Tilt servo ON TRK servo ON/OFF Digital sound play 	<p>With TRK Servo OFF, play digital sound and coarsely adjust VR612 so that sound is produced.</p> <p>Connect W331 and DC voltmeter and while playing digital sound, turn TRK Servo on and off. Adjust VR612 so that DC voltage difference between ON and OFF conditions is $0 \pm 0.1V$.</p>	
2 NTSC Reference clock adjustment	VC202 (VDTB ASSY)	<ul style="list-style-type: none"> Frequency counter GGV1003 	IC201-33(TBC CLK)	<ul style="list-style-type: none"> NTSC PLAY mode. Play the NTSC disc. or Select the NTSC mode with the SYSTEM button of the front panel. (Note1) 	Adjust VC202 so that the 4fsc frequency becomes $14.31818MHz \pm 0.1kHz$.	
3 PAL Reference clock 910fH adjustment	VC201 (VDTB ASSY)	<ul style="list-style-type: none"> Frequency counter GGV1007 	IC201-33(TBC CLK)	<ul style="list-style-type: none"> PAL PLAY mode. Play the PAL disc. or Select the PAL mode with the SYSTEM button of the front panel. (Note1) 	Adjust VC201 so that the 910fH frequency becomes $14.21875MHz \pm 0.1kHz$.	
4 PAL Reference clock adjustment	VC203 (VDTB ASSY)	<ul style="list-style-type: none"> Frequency counter GGV1007 	IC201-24(OSD CLK)	<ul style="list-style-type: none"> PAL PAUSE mode. Play the PAL disc and set to pause state. or Select the PAL mode with the SYSTEM button of the front panel. (Note1) 	Adjust VC203 so that the 4fsc frequency becomes $17.734475MHz \pm 0.1kHz$.	
5 PAL VCXO ERR Offset check	VC201 (VDTB ASSY)	<ul style="list-style-type: none"> Oscilloscope GGV1007 	IC203-1	<ul style="list-style-type: none"> Play the PAL disc. 	<p>Play the PAL disc and check that the voltage of VCXO ERR at IC203-1pin is $0V \pm 100mV$. If the specified voltage is not obtained, adjust VC201 so that the voltage becomes $0V \pm 100mV$.</p> <p>Note : The adjustment of VC201 in this step should have priority over that in step 2.</p>	
6 VCO Center frequency adjustment	VR481 (VDTB ASSY)	<ul style="list-style-type: none"> Oscilloscope GGV1007 	CH1 : C405 lead wire CH2 : C499 + lead wire	<ul style="list-style-type: none"> Normal mode GGV1007 #4,000 still 	Adjust VR481 so that the center position of jitter of CH2 video signal is delayed to $75\mu S(1H + 11 \mu S) \pm 1.4\mu S$ as compared with CH1 video signal.	
7 Output video level adjustment	VR482 (VDTB ASSY)	<ul style="list-style-type: none"> Oscilloscope TV monitor GGV1003 	Video output terminal (75Ω termination or TV monitor connection)	<ul style="list-style-type: none"> Normal mode GGV1003 #19,900 still HQ circuit OFF 	Adjust VR482 so that the voltage between the sync tip and the white peak becomes $1.0Vp-p \pm 5\%$.	

Note1 : → PAL mode → NTSC mode → MOD PAL mode (Cyclic change)

Adjustment name	Adjustment point	Measuring equipment and jigs	Measurement point	Player condition	Adjustment procedure	Waveform and connection diagram
8 1H Delay video level adjustment	VR441 (VDTB ASSY)	• Oscilloscope • GGV1003	CH1 : C443—(minus) lead wire CH2 : C445—(minus) lead wire	• Normal mode • GGV1003 #19,900 still	Adjust VR441 so that the level of the 1H delay video signal becomes the same as that of the main video signal.	<p>Oscilloscope range CH1: 20mV/div 10 μs/div CH2: 20mV/div AC mode</p> <p>Main video signal CH1 CH2 1H delay video signal</p>
9 VPS Error adjustment	VR521 (VDTB ASSY)	• TV monitor • GGV1003	Video output terminal (TV monitor)	• Normal mode • GGV1003 #8,000 still	Color irregularity on the magenta screen is minimized.	<p>Rear panel Video output TV monitor</p>
10 MOD Y— Signal level adjustment	VR304 (PALB ASSY)	• Oscilloscope • GGV1003	CH1 : IC303—2 (REFERENCE) CH2 : IC303—1	• Normal mode • GGV1003 #19,900 still • HQ circuit ON	Adjust VR304 so that the level of Y signal at IC303—1 pin between the sync tip and the white 100% becomes the same as that of the Y signal at IC303—2 pin.	<p>IC303 ② IC303 ①</p> <p>CH1 CH2</p>
11 MOD C—Signal level adjustment	VR302 (PALB ASSY)	• Oscilloscope • GGV1003	CH1 : IC303—2 (REFERENCE) CH2 : IC303—1	• Normal mode • GGV1003 #8,000 still	Adjust VR302 so that the level of C signal at IC303—1 pin becomes the same as that of the C signal at IC303—2 pin.	<p>IC303 ② IC303 ①</p> <p>CH1 CH2</p>
12 PAL Inverting SC phase adjustment	VR201 (VDTB ASSY)	• TV monitor • GGV1007	Video output terminal (TV monitor)	• Normal mode GGV1007 test disc #6,500 still	Adjust VR201 so that the color irregularity on the magenta screen is minimized at still.	<p>Rear panel Video output TV monitor</p>

Note2 : It is possible to terminate video output terminal with 75Ω by connecting TV monitor.

1.7 PARTS LIST FOR PACKING AND EXPLODED VIEWS

NOTES:

- Parts marked by "NSP" are generally unavailable because they are not in our Master Spare Parts List.
- The Δ mark found on some component parts indicates the importance of the safety factor of the part. Therefore, when replacing, be sure to use parts of identical designation.
- Parts marked by "☉" are not always kept in stock. Their delivery time may be longer than usual or they may be unavailable.
- Parts list without notice are common for CLD - 160K/HB and CLD - 160K/HEZ.

1.7.1 PACKING

(1) CONTRAST OF CLD - 160K/HB AND CLD - 160K/HEZ.

CLD - 160K/HB and CLD - 160K/HEZ have the same construction except for the following :

Mark	No.	Symbol & Description	Part No.	
			CLD - 160K/HB	CLD - 160K/HEZ
	1	Pad (R)	VHA1123	VHA1106
	3	Packing case	VHG1387	VHG1386
	15	Operating instructions (Dutch/Swedish/Spanish/Portuguese)	Not used	VRF1032
	16	Caution(UC)	VRR1020	Not used
NSP	16	Caution(EW)	Not used	VRM1027
NSP	17	Caution	Not used	VRR1009

(2) FOR CLD - 160K/HB

Mark	No.	Description	Parts No.
	1	Pad (R)	VHA1123
	2	Pad (F)	VHA1149
	3	Packing case	VHG1387
	4	
	5	
	6	Battery cover	PZN1012
	7	Remote control unit	VXX2071
	8	Mirror mat sheet	VHL1006
	9	Audio cord	VDE1033
	10	Video cord	VDE1034
NSP	11	Battery (R03, AAA)	VEM-022
NSP	12	Polyethylene bag	Z21-029
NSP	13	Warranty card	ARW-088
	14	Operating instructions (English/French/German/Italian)	VRE1030
	15	
	16	Caution (UC)	VRR1020
	17	
NSP	18	Polyethylene bag	VHL-014

1.7.2 EXTERIOR SECTION

(1) CONTRAST OF CLD - 160K/HB AND CLD - 160K/HEZ.

CLD - 160K/HB and CLD - 160K/HEZ have the same construction except for the following :

Mark	No.	Symbol & Description	Part No.	
			CLD - 160K/HB	CLD - 160K/HEZ
	32	Caution label	PRW1018	VRW1094
	33	Caution label(HE)	Not used	VRW1297

(2) FOR CLD - 160K/HB

Mark	No.	Description	Parts No.	Mark	No.	Description	Parts No.
	1	Guide plate (L)	VNE1805	NSP	21	Damp cushion	VEC1110
	2	Guide plate (R)	VNE1806		22	
	3	Lock plate spring	VBH1188		23	Screw	BPZ30P060FCU
	4	Lock plate	VNL1513		24	Screw	BPZ30P080FCU
	5	CD tray	VNK1992		25	Screw	BBZ30P080FCC
	6	Tray ASSY -- S	VXX2066		26	Screw	BCZ40P060FZK
NSP	7	LD tray	VNK2550		27	Screw	BPZ20P040FZK
	8	Disc pad (L)	VEC1657		28	Screw	VBA1032
	9	Disc pad (C)	VEC1658		29	Tray rubber	VEB1091
NSP	10	Carry label	VRW1289	NSP	30	Cushion	VEC1618
	11	Bonnet case S	VXX1898		31	Caution label(G)	VRW - 329
	12	Door spring	VBH1223		32	Caution label	PRW1018
NSP	13	KARAOKE badge	VAM1034		33	
	14	Tray panel ASSY - S	VXX2128				
	15	CD door	VNK2716				
NSP	16	Tray panel	VNK2836				
	17	Door holder	VNE1905				
	18	Door shaft	VLL1441				
	19	Name plate	VAM1032				
	20	Damper ASSY	VXA2112				

1.7.3 TOP VIEW SECTION

Mark	No.	Description	Parts No.	Mark	No.	Description	Parts No.
	1	Clamper holder	VNL1514		19	Flexible cable (22P)	VDA1448
	2	Rubber sheet	VEB1114		20	Screw	BBZ30P060FMC
	3	Thrust holder	VNL1289	NSP	21	Mechanism ASSY	VWT1108
	4	Clamper head	VNL1615	NSP	22	Caution label (F)	VRW - 328
	5	Clamper	VNL1515	NSP	23	PALB ASSY	VWV1383
	6	Clamp spring	VBH1192		24	
	7	Clamper arm	VNE1804	NSP	25	SCRB ASSY	VWV1384
	8	Stabilizer	VNE1807		26	
	9	Rack ASSY	VWT1099	NSP	27	PCB holder(A)	VNE1875
	10	Carriage shaft	VLL1434	NSP	28	PCB holder(B)	VNE1880
NSP	11	Side stay (R)	VNE1810	NSP	29	P plate holder	PNY - 405
NSP	12	Front angle	VNE1808	NSP	30	Wire clamp (A)	VEC1217
	13	Screw	CPZ20P050FMC		31	Housing ASSY (2P)	VKP2048
	14	Screw	BBZ30P080FCC		32	Flexible cable (28P)	VDA1461
	15	Screw	IBZ30P060FCC		33	Connector ASSY	PF06PP - C20
	16	Screw	IPZ30P060FMC		34	Connector ASSY	PF03PP2C22
NSP	17	Earth plate	VNE1518				
	18	Screw	PCZ30P060FMC				

1.7.4 FRONT PANEL SECTION

Mark No.	Description	Parts No.	Mark No.	Description	Parts No.
NSP 1	Front panel	VNK3003	14	Headphones knob	PAC1707
2	FL panel(4)	VEC1718	NSP 15	TWKB ASSY	VWG1551
3	LED lens	PNW2019	16	Volume holder	VNE1933
4	PW button	VNK2668	17	Cushion	VEC1497
5	L key (L)	VNK2761	18	VR knob (L)	VNK2674
6	L key (R)	VNK2670	19	VR knob (S)	VNK2671
7	Main key	VNK2667	20	Front panel ASSY - S	VXX2192
8	Ten key (R)	VNK2665	21	Screw	BPZ26P080FMC
9	Ten key (L)	VNK2663	22	Plastic rivet	VEC1298
10	FLKB ASSY	VWG1567	NSP 23	NRPB (PC board)	VNZ1546
NSP 11	PONB ASSY	VWG1552	NSP 24	Rubber spacer	VEB1219
12	Slide knob	VNK2675	25	Cushion	VEC1717
NSP 13	JACB ASSY	VWV1396			

1.7.5 BASE SECTION

(1) CONTRAST OF CLD - 160K/HB AND CLD - 160K/HEZ.

CLD - 160K/HB and CLD - 160K/HEZ have the same construction except for the following :

Mark	No.	Symbol & Description	Part No.	
			CLD - 160K/HB	CLD - 160K/HEZ
△	3	SYPS ASSY	VWR1220	VWR1219
	5	Power cord with plug	PDG1055	PDG1003
△	7	Rear panel	VNA1476	VNA1436
	28	Fuse(T5A)	PEK1003	Not used

(2) FOR CLD - 160K/HB

Mark No.	Description	Parts No.	Mark No.	Description	Parts No.
NSP 1	MAIN ASSY	VWX1211	19	Screw	BBZ30P080FCC
△ 2	Cord stopper	CM-22B	20	Screw	BBZ30P040FMC
3	SYPS ASSY	VWR1220	21	Screw	BCZ40P060FZK
4	Tray stopper	VNL1519	22	Screw	BCZ30P080FMC
△ 5	Power cord with plug	PDG1055	23	Screw	BPZ30P140FMC
6	PCB spacer	PNY-404	NSP 24	Heat sink	VNE1854
7	Rear panel	VNA1476	25	PCB holder	VEC1624
△ 8	Fuse (T500mA) (FU3)	REK-097	26	Screw	BCZ30P060FCC
NSP 9	Cord clasper	Z09-060	NSP 27	VDTB ASSY	VWS1141
NSP 10	PCB hinge	VEC1174	△ 28	Fuse(T5A)	PEK1003
△ 11	Power transformer	VTI1138	NSP 29	Rear angle	VNE1844
△ 12	Fuse (T3.15A) (FU1, FU2)	REK.-105	NSP 30	Damp cushion	VEC1110
NSP 13	P. plate holder	PNY-405	NSP 31	EXTB ASSY	VWG1559
NSP 14	Side stay (L)	VNE1809	32	KFCB ASSY	VWV1403
NSP 15	Cord clasper	Z09-061	33	Flat cable (10P)	D20PDY1035B
16	Insulator	PNW1912	34	Flat cable (6P)	D20PDY0610G
NSP 17	Base chassis	VNA1255			
18	Insulator ASSY	VXA1881			

1.7.6 MECHANISM SECTION

Mark No.	Description	Parts No.	Mark No.	Description	Parts No.
1	Mechanism base	VNK1990	16	R-SW lever	VNL1506
2		NSP 17	LOSB ASSY	VWG1419
3	Clamp cam	VNL1621	18	Synchro gear ASSY	VXA1822
4	Shaft holder	VNE1817	19	Roller	VNL1042
5	Cam plate	VNL1511	NSP 20	LOMB ASSY	VWG1420
6	CAS spring	VBH1190	21	Loading motor ASSY	VXX1712
7	Cam gear	VNL1507	NSP 22	Slider motor	VXM1033
8	CD plate	VNL1512	23	Motor pulley	PNW1643
9	CDP spring	VBH1191	24	Screw	Z39-019
10	Rubber belt	VEB1184	25	Screw	BMZ26P040FMC
11	Gear pulley	VNL1510			
12	Twin gear	VNL1508			
13	Center gear	VNL1509			
14	L-SW lever	VNL1504			
15	C-SW lever	VNL1505			

1.7.7 MECHANISM ASSY

Mark No.	Description	Parts No.	Mark No.	Description	Parts No.
1	CA belt	VEB1077	16	Y gear	VNL1501
2	CA pulley (2)	VNL1496	17	Tilt cam spring	VBH1189
3	CA gear (3)	VNL1497	18	Tilt cam	VNL1502
4	Tilt base	VNL1499	19	Spindle motor ASSY	VXA2108
5	CA-SW lever	VNL1498	20	Centering hab	VNL1174
NSP 6	CAMB ASSY	VWG1418	21	Centering spring	VBH1083
7	Carriage motor ASSY	VXX1261	NSP 22	Rubber sheet	VEB1103
NSP 8	Carriage motor	VXM1033	NSP 23	Turn table ASSY	VXA1283
9	CA pulley (1)	VNL1197	NSP 24	Oil stopper	VBFI002
NSP 10	PASB ASSY	VWG1417	NSP 25	Spindle motor	VXM1053
11	Radial spring	VBH1201	26	Motor base	VNE1803
12	Thrust spring	VBH1200	27	Screw	BMZ26P040FMC
13	Tilt tension spring	VBH1187	28	Screw	ABZ30P300FMC
NSP 14	FG ASSY	VWG1416	29	Screw	PMA30P050FMC
15	FG. base	VNL1503	30	Washer	WT26D060D025
			31	Housing ASSY	VKP2020

1.7.8 RACK ASSY

Mark No.	Description	Parts No.
NSP 1	Sensor stay	VBK1036
NSP 2	Tilt sensor	SG-302
NSP 3	Pickup ASSY	VWY1036
4	Rack	VNL1495
5	Tan. base	VNL1494
6	Screw	PBB26P080FMC
7	Screw	PMA20P060FMC
8	Screw	PMA20P080FMC
9	Screw	PMH20P040FMC
10	Screw	SMZ20H120FZK

1.8 PCB PARTS LIST

NOTES:

- Parts marked by "NSP" are generally unavailable because they are not in our Master Spare Parts List.
- The Δ mark found on some component parts indicates the importance of the safety factor of the part. Therefore, when replacing, be sure to use parts of identical designation.
- Parts marked by "⊙" are not always kept in stock. Their delivery time may be longer than usual or they may be unavailable.
- When ordering resistors, first convert resistance values into code form as shown in the following examples.

Ex.1 When there are 2 effective digits (any digit apart from 0), such as 560 ohm and 47k ohm (tolerance is shown by J = 5%, and K = 10%).

560Ω	→	56 × 10 ¹	→	561	RD1/8PM	5 6 1 J
47kΩ	→	47 × 10 ³	→	473	RD1/4PS	4 7 3 J
0.5Ω	→	0R5			RN2H	0 R 5 K
1Ω	→	010			RS1P	0 1 0 K

Ex.2 When there are 3 effective digits (such as in high precision metal film resistors).

5.62kΩ	→	562 × 10 ¹	→	5621	RN1/4PC	5 6 2 1 F
--------	---	-----------------------	---	------	-------	---------	---

Mark No.	Description	Parts No.	Mark No.	Description	Parts No.
----------	-------------	-----------	----------	-------------	-----------

LIST OF ASSEMBLIES

NSP	MACBS ASSY	VWM1358
NSP	└─ FG ASSY	VWG1416
NSP	└─ PASB ASSY	VWG1417
NSP	└─ CAMB ASSY	VWG1418
NSP	└─ LOSB ASSY	VWG1419
NSP	└─ LOMB ASSY	VWG1420
	SYPS ASSY(HB TYPE)	VWR1220
	SYPS ASSY(HEZ TYPE)	VWR1219

Note : Although VWR1220 and VWR1219 are different in part number, they have the same service parts.

NSP	FRPB ASSY	VWM1521
	└─ FLKB ASSY	VWG1567
NSP	└─ TWKB ASSY	VWG1551
NSP	└─ PONB ASSY	VWG1552
NSP	└─ JACB ASSY	VWV1396
	MOTHER ASSY	VWM1499
NSP	└─ MAIN ASSY	VWX1211
	VTPB ASSY	VWM1501
NSP	└─ VDTB ASSY	VWS1141
NSP	└─ PALB ASSY	VWV1383
NSP	└─ SCRb ASSY	VWV1384
NSP	KRAB ASSY	VWM1512
NSP	└─ EXTb ASSY	VWG1559
	└─ KFCB ASSY	VWV1403

MACBS ASSY

OTHERS	PCB(MACBS)	VNP1396
---------------	------------	---------

FG ASSY

SEMICONDUCTORS	D1 Photo interruptor	GP1S51V
-----------------------	----------------------	---------

OTHERS	HOUSING ASS'Y	VKP1950
---------------	---------------	---------

PASB ASSY

SWITCHES AND RELAYS	S4, S5	DSG1015
----------------------------	--------	---------

OTHERS	HOUSING ASS'Y	VKP1951
---------------	---------------	---------

CAMB ASSY

SEMICONDUCTORS	Q10	2SC1740S
-----------------------	-----	----------

RESISTORS

R10	RD1/4VM182J
R11	RD1/4VM470J

Other Resistors	RD1/6PM□□□J
-----------------	-------------

OTHERS

CN403	22P Connector	52045-2245
CN404	Connector post	B3B-PH-K-S
CN402	KR Connector	B3B-PH-K-R
CN401	23P FFC Connector(Top)	SLEM23S-2
	HOUSING ASS'Y	VKP2009

LOSb ASSY

SWITCHES AND RELAYS	S1-S3	DSG1015
----------------------------	-------	---------

LOMB ASSY

CAPACITORS	C1	CGCYX473M25
-------------------	----	-------------

OTHERS	4P Cable holder	51048-0400
	J55 2mm Pitch flat cable(6P)	D20PWY0615G

SYPS ASSY

SEMICONDUCTORS	Δ IC205	ICP-N10
	Δ IC204	ICP-N15
	Δ IC201-IC203	ICP-N20
	Δ IC2	NJM4558D
	Δ IC1	NJM78L05A

Mark	No.	Description	Parts No.	Mark	No.	Description	Parts No.
△	IC41		NJM78M12FA	FLKB ASSY			
	Q22,Q23,Q29,Q5		2SA933S	SEMICONDUCTORS			
△	Q60,Q61		2SB1185	IC501		NJM4558D	
	Q31		2SB1240	IC101		PD3286B	
△	Q25,Q27		2SB1566	IC102		S-806D	
	Q21,Q24,Q4		2SC1740S	Q102		DTA144ES	
△	Q3		2SD1762	Q101,Q104-Q109		DTC114ES	
△	Q26,Q28		2SD2395				
	Q32		DTC114TS	D101-D107,D118		1SS252	
	Q30		DTC124ES	D114,D119,D120		SEL6410E-TS	
				D113,D115,D116		SEL6910A-TS	
△	D23,D26		10ELS2	SWITCHES AND RELAYS			
△	D3,D41,D42		11ES2	S101-S108,S110,S112-S115		RSG1030	
△	D2,D24,D25		1SR35-100AVL	CAPACITORS			
△	D21,D22		1SS254	C114,C117		CCPUSL330J50	
△	D7		MTZJ12B	C105		CEAL100M16	
				C101		CEAL100M50	
△	D1		S4VB20F	C103,C113		CEAL101M6R3	
				C503		CFTYA104J50	
COILS AND FILTERS							
△	L51		VTL-004	C106,C109		CKPUYB102K50	
△	L1		VTL1043	C504		CKPUYB271K50	
				C104		CKPUYF223Z25	
				C102,C107,C108,C112		CKPUYY103N16	
				C501,C502		CKPUYY103N16	
				RESISTORS			
				R122		RN1/6PQ5101F	
				VR101,VR501,VR502 (2K · B)		VCS1034	
				Other Resistors		RD1/6PM□□□J	
				OTHERS			
				CN105	FJ Connector(8P)	08R-FJ	
				CN101	6P Jumper connector	52147-0610	
				CN102	9P Jumper connector	52147-0910	
				CN106	Board to board connector(9P)	9133S-09A	
				CN501	2mm Pitch bottom connector plug	BTMK08P-1R	
					Remote sensor	GPIU58X	
				V101	FL Tube	VAW1034	
					Spacer	VEC1599	
					PCB Binder	VEF1008	
					FL Holder	VNF1085	
				X101	Ceramic resonator	VSS1031	
				TWKB ASSY			
				SWITCHES AND RELAYS			
				S701-S720		RSG1030	
				OTHERS			
				CN701	2.5mm Pitch pin header	1068-09C-PP	
				PONB ASSY			
				SEMICONDUCTORS			
				Q201		DTC114ES	
				D201		SEL6C10S-TS	
				SWITCHES AND RELAYS			
				S202		RSG1030	
				S201		VSH1005	
				FRPB ASSY			
				OTHERS			
				PCB(FRPB)		VNP1481	

Mark No.	Description	Parts No.	Mark No.	Description	Parts No.
CAPACITORS			Q103,Q206,Q217,Q502,Q503	DTC124EK	
C201		CKPUYY103N16	D202	11EQS06	
RESISTORS			D102,D502,D520,D905	1SS254	
VR201	(2K · B)	VCS1034	D963,D964	1SS254	
	Other Resistors	RD1/6PM□□□J	D201	FC54M	
OTHERS			COILS AND FILTERS		
CN201	FJ Connector(8P)	08P--FJ	L802-L804	LAU121J	
JACB ASSY			L351	LAU181J	
SEMICONDUCTORS			L201-L205,L352,L800,L801	LAU220J	
IC601		NJM2068D	F201,F206--F208	VTH1016	
COILS AND FILTERS			SWITCHES AND RELAYS		
L601		LFA221J	S201	VSH1009	
F602-F609		VTH1016	CAPACITORS		
CAPACITORS			C159,C809,C811	CCSQCHI00D50	
C614,C615		CEJA101M10	C108,C109,C258,C259,C370	CCSQCHI01J50	
C613,C616		CKCYF473Z50	C814,C846,C848	CCSQCHI21J50	
C611,C612		CKPUYB101K50	C232	CCSQCHI50J50	
C617		CKPUYB102K50	C161,C353,C810	CCSQCHI51J50	
C605,C608,C610,C630		CKPUYX122M16	C352	CCSQCHI80J50	
C601,C602		CKPUYY103N16	C812	CCSQCH221J50	
RESISTORS			C371	CCSQCH270J50	
VR601	(0.5KB)	VCS1035	C208,C209	CCSQCH271J50	
	Other Resistors	RD1/6PM□□□J	C106,C107,C354,C813	CCSQCH330J50	
OTHERS			C351,C931	CCSQCH390J50	
CN603	2mm Pitch bottom connector	BTMK08S-1S	C260-C263,C963	CCSQCH470J50	
JA604	Headphone jack	RKN1002	C375,C806	CCSQCH680J50	
JA602	Headphone jack	RKN1006	C374	CCSQCH820J50	
CN602	KR Connector	S4B-PH-K-S	C902	CEAL2R2M50	
JA601,JA603	Mic jack	VKN1147	C893,C933	CEAL470M6R3	
	Snap plate	VNE1102	C871	CEALNP100M16	
	Jack holder(FE)	VNE1932	C522	CEANP100M16	
MAIN ASSY			C926	CEANP2R2M50	
SEMICONDUCTORS			C838	CEANP470M6R3	
IC202,IC205,IC903		BA4560F	C904	CEAS010M50	
IC351		CA0002AM	C228,C367,C845	CEAS100M50	
IC803		LA6510L	C225,C226,C256,C364	CEAS101M10	
IC802		LC78681E	C274,C275	CEAS220M10	
IC206		NJM78L08A	C227,C281	CEAS2R2M50	
IC207		NJM79L08A	C101,C230,C252,C253,C363	CEAS470M10	
IC801		PAC002A	C369,C801,C803,C833,C836	CEAS470M10	
IC901		PAC003A	C842,C844,C927,C974,C975	CEAS470M10	
IC101		PD0193A	C207,C255,C257,C270,C271	CEAS471M10	
IC201		PD2026B(L)	C279	CEAS471M10	
IC902		TA8464K	C368,C913	CEASR47M50	
Q102,Q154,Q802,Q963		2SA1037K	C970	CEHAQ010M50	
Q501		2SA933S	C967,C968	CEHAQ100M50	
Q834		2SB1237X	C987	CEHAQ220M50	
Q201,Q202,Q801,Q805		2SC2412K	C278,C282	CFTXA152J50	
Q903-Q905,Q907,Q913		2SC2412K	C365,C908,C910	CFTYA104J50	
Q152,Q803,Q804		2SC3802K	C359,C360,C905	CFTYA224J50	
Q204,Q205,Q214		2SD2144S	C521	CFTYA563J50	
Q962		2SK184	C891,C914,C936,C969	CKSQYB102K50	
Q207,Q208,Q216		DTA124EK	C110,C888,C907	CKSQYB222K50	
			C361,C362	CKSQYB392K50	
			C355-C358	CKSQYB472K50	
			C105,C122,C160,C213,C231	CKSQYF103Z50	
			C234,C251,C286,C288,C376	CKSQYF103Z50	
			C523,C807,C834,C835,C843	CKSQYF103Z50	

Mark No.	Description	Parts No.	Mark No.	Description	Parts No.
C410,C437		CCSQCH220J50	RESISTORS		
C204,C208,C416,C495,C510		CCSQCH270J50	R496		RD1/6PM101J
C775,C779		CCSQCH270J50	R406		RD1/6PM224J
C402,C463,C507,C508		CCSQCH271J50	R403		RD1/6PM271J
C206,C240,C462		CCSQCH330J50	R431		RD1/6PM510J
			R512		RD1/6PM680J
C211,C433,C524,C528		CCSQCH390J50			
C406		CCSQCH391J50	R612,R613		RN1/10SE103D
C205,C239,C455		CCSQCH470J50	R771		RN1/10SE202D
C549,C778		CCSQCH560J50	R475,R521		RN1/10SE562D
C411,C412,C498,C609		CCSQCH820J50	R438		RN1/6PQ1803F
			R511		RN1/6PQ2002F
C536		CCSQCH910J50			
C651		CCSQSL102J50	R415,R416		RN1/6PQ3002F
C530		CEANP100M25	R434		RN1/6PQ5101F
C551,C613,C620		CEANP220M10	VR201		VRTB6VS222
C537		CEAS010M50	VR441		VRTB6VS223
			VR481,VR482,VR521		VRTB6VS472
C472,C477		CEAS3R3M50		Other Resistors	RS1/10S□□□J
C484,C522		CEJA100M16	OTHERS		
C473		CEJA3R3M50		5P Cable holder	51048-0500
C201,C213,C220-C222,C227		CEJA470M6R3		7P Cable holder	51048-0700
C428,C434,C445,C452,C457		CEJA470M6R3		12P Cable holder	51048-1200
			CN603	1.0mm Pitch FFC Connector	SLW28S-1C7
C474,C489,C490,C499		CEJA470M6R3		PCB Binder	VEF1040
C501,C502,C512,C521,C525		CEJA470M6R3			
C533,C622,C624,C643,C647		CEJA470M6R3			
C675,C676		CEJA470M6R3	JA14	1P Pin jack	VKB1063
C401,C405,C619		CEJANP2R2M50		Screw terminal	VNE1841
			X202	Crystal resonator(14.32MHz)	VSS1029
C443,C625,C628		CEJANP4R7M16	X203	Crystal resonator(17.734MHz)	VSS1059
C223		CEJANPR47M50	X201	Crystal resonator(14.22MHz)	VSS1060
C446,C618		CFTYA103J50	PALB ASSY		
C514		CFTYA104J50	SEMICONDUCTORS		
C224		CFTYA223J50	IC303		BU4053BCF
			IC301		M50552-132SP
C471,C603		CFTYA224J50	IC302		TA7320P
C610,C617		CFTYA563J50	Q303,Q310,Q363,Q951		2SA1037K
C515,C517		CFTYA683J50	Q361,Q365		2SC1740S
C202,C209,C214-C217		CKSQYF103Z50			
C225,C226,C230,C232,C233		CKSQYF103Z50	Q308,Q309,Q311,Q352,Q353		2SC2412K
			Q355,Q356,Q359,Q360		2SC2412K
C242,C414,C418,C421,C422		CKSQYF103Z50	Q952,Q953		2SC2412K
C425,C426,C458-C460		CKSQYF103Z50	Q304,Q307,Q317,Q351		DTA124EK
C475,C476,C486,C535,C602		CKSQYF103Z50	Q305,Q306,Q318		DTC124EK
C604,C615,C616,C621,C644		CKSQYF103Z50			
C776,C777,C780,C781,C783		CKSQYF103Z50	D302		DAP202K
			COILS AND FILTERS		
C403,C404,C427,C429,C435		CKSQYF104Z25	L302,L303,L355,L951,L952		LAU120J
C442,C479-C481,C483		CKSQYF104Z25	L304		LAU220J
C503-C506,C511,C513,C526		CKSQYF104Z25	F951		VTF1011
C531		CKSQYF104Z25	F303		VTF1034
C407,C408,C466,C467		CKSQYF473Z25	F952		VTF1064
			CAPACITORS		
C487,C488,C527,C601,C629		CKSQYF473Z25	C356,C364,C392,C958		CCSQCH101J50
C219,C605-C607,C626		CQMA102J50	C327,C959		CCSQCH151J50
C608		CQMA152J50	C957		CCSQCH221J50
C627		CQMA222J50	C325		CCSQCH330J50
C444,C611		CQMA272J50	C326		CCSQCH390J50
C614		CQMA332J50			
C218		CQMA472J50			
VC201		PCM1001			
VC202		VCM-008			
VC203		VCM1005			

Mark No.	Description	Parts No.	Mark No.	Description	Parts No.
C960		CCSQCH820J50	OTHERS		
C352		CCSQSL391J50		4P Cable holder	51048-0400
C383		CEALNP470M6R3	J401	2mm Pitch flat cable(4P)	D20PDY0410B
C384		CEANP220M10	JA401	2P Pin jack	VKB1031
C951,C952		CEANP470M10		PCB Holder(S)	VNE1952
C953,C955		CEAS470M16	KFCB ASSY		
C319,C323,C336,C354,C358		CEJA470M6R3	SEMICONDUCTORS		
C360,C362,C373,C375		CEJA470M6R3	IC101,IC102,IC105,IC106		BA4560F
C380-C382,C386,C388,C390		CEJA470M6R3	IC103		BU4053BCF
C318,C320-C322,C324		CKSQYF103Z50	IC107		MB81464-12P
C328,C329,C335,C351,C353		CKSQYF103Z50	IC104		PM0005A
C355,C357,C359,C361,C363		CKSQYF103Z50	Q102		2SD2144S
C369,C374,C376,C385,C954		CKSQYF103Z50			
C956		CKSQYF103Z50	Q101		DTC124EK
C389,C391		CKSQYF104Z25	D103-D105		DA204K
RESISTORS			COILS AND FILTERS		
R387		RD1/6PM101J	L102		LFA100K
R355,R361		RD1/6PM470J	L103		LFA3R9J
R316		RN1/10SE562D	L104		LFA102J
VR304		VRTB6VS222	CAPACITORS		
VR302		VRTB6VS471	C135-C139		CCSQCH100D50
Other Resistors		RS1/10S□□□J	C120,C152-C154		CCSQCH101J50
OTHERS			C133		CCSQCH181J50
7P Cable holder		51048-0700	C111,C115		CCSQCH680J50
12P Cable holder		51048-1200	C101,C102		CEALNP010M50
CN302 KR Connector		B3B-PH-K-R	C105,C106		CEALNP100M16
CN303 KR Connector		B6B-PH-K-S	C141		CEAS102M6R3
CN301 3P Side post		B53P-SHF-1AA	C125,C127,C134		CEJA100M16
C330,C331 Chip capacitor		CCSQSL102J50	C148,C149		CEJA101M10
			C147		CEJA101M6R3
SCRB ASSY			C126		CEJA330M16
SEMICONDUCTORS			C112,C118		CEJA470M6R3
Q181		2SC1740S	C128		CFTYA104J50
CAPACITORS			C110,C114,C132		CFTYA223J50
C183,C184		CCSQCH271J50	C119		CFTYA473J50
C181,C182		CEAS470M16	C109,C113		CKSQYB332K50
C186		CEAS471M10	C131		CKSQYB472K50
C187,C188		CKSQYB103K50	C103,C104,C108,C116,C117		CKSQYF103Z50
C185		CKSQYF104Z25	C123,C124,C129,C130,C140		CKSQYF103Z50
RESISTORS			C142-C146,C150,C151		CKSQYF103Z50
△ R185 (47,1/6W)		DCN1003	RESISTORS		
R189		RD1/6PM103J	All Resistors		RS1/10S□□□J
R184		RD1/6PM391J	OTHERS		
R186		RD1/6PM750J	CN106	2mm Pitch bottom connector	52084-1010
Other Resistors		RS1/10S□□□J	CN105	6P Jumper connector	52147-0610
OTHERS			J904	Connector	PF04PG-D37
JA181 Connector		VKB1037		PCB Binder	VEF1040
KRAB ASSY					
OTHERS					
PCB(KRAB)		VNP1480			
EXTB ASSY					
CAPACITORS					
C401,C402		CCSQCH331J50			

Service Manual

ORDER NO.
RRZ1160

The chapter 1 of this Service Manual will not be reprinted. On your additional orders, we may supply only the chapter 2. For the chapter 1, please make copies and attach to the chapter 2 at your side if necessary.

CD CDV LD PLAYER

CLD-160K

CHAPTER 2

CONTENTS

CHAPTER 2

2.1 PACKING AND EXPLODED VIEWS ...	2-3
2.2 SCHEMATIC AND PCB CONNECTION DIAGRAMS	2-12

PIONEER ELECTRONIC CORPORATION 4-1, Meguro 1-Chome, Meguro-ku, Tokyo 153, Japan

PIONEER ELECTRONICS SERVICE INC. P.O. Box 1760, Long Beach, California 90801 U.S.A.

PIONEER ELECTRONICS OF CANADA, INC. 300 Allstate Parkway Markham, Ontario L3R 0P2 Canada

PIONEER ELECTRONIC [EUROPE] N.V. Haven 1087 Keetberglaan 1, 9120 Melsele, Belgium

PIONEER ELECTRONICS AUSTRALIA PTY. LTD. 178-184 Boundary Road, Braeside, Victoria 3195, Australia TEL: [03] 580-9911

© **PIONEER ELECTRONIC CORPORATION 1994**

T-FFM AUG. 1994 Printed in Japan

2.1 PACKING AND EXPLODED VIEWS

2.1.1 PACKING

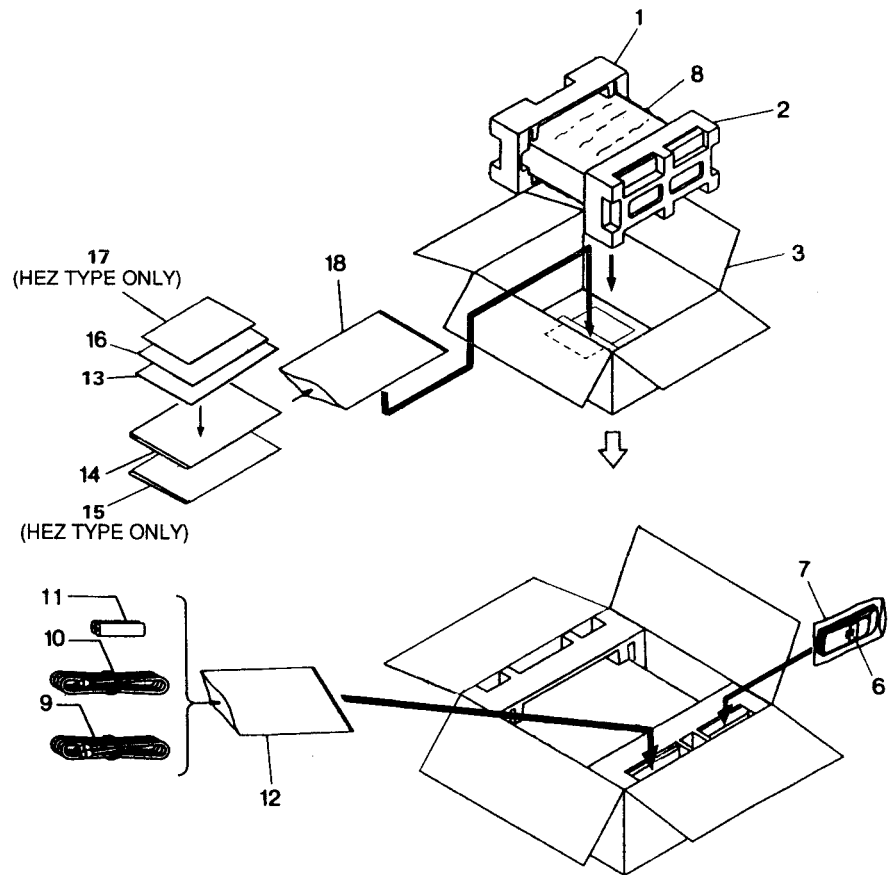

2.1.2 EXTERIOR SECTION

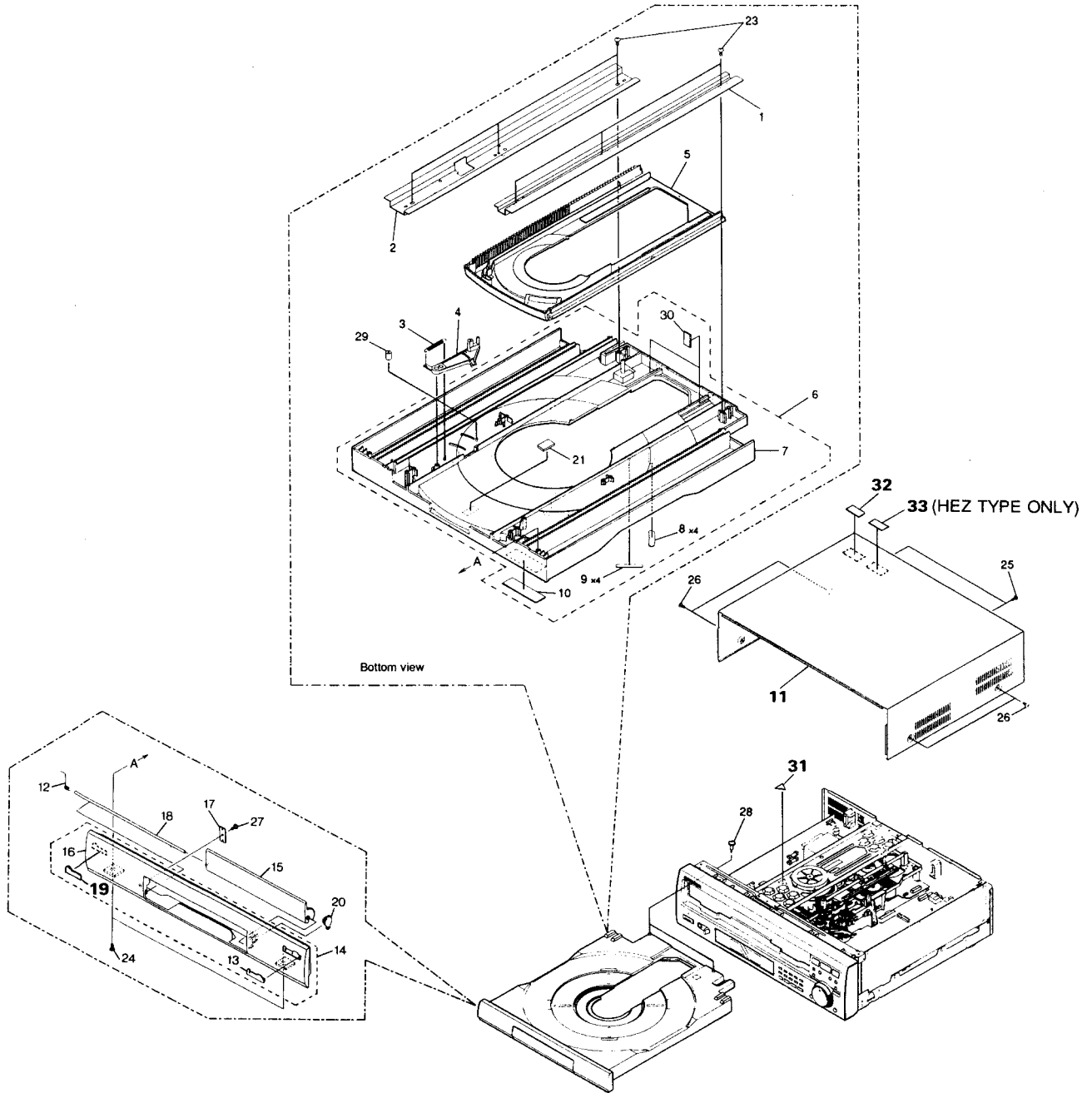

NOTE : Screws adjacent to ▼ mark on product are used for disassembly.

2.1.3 TOP VIEW SECTION

A

B

C

D

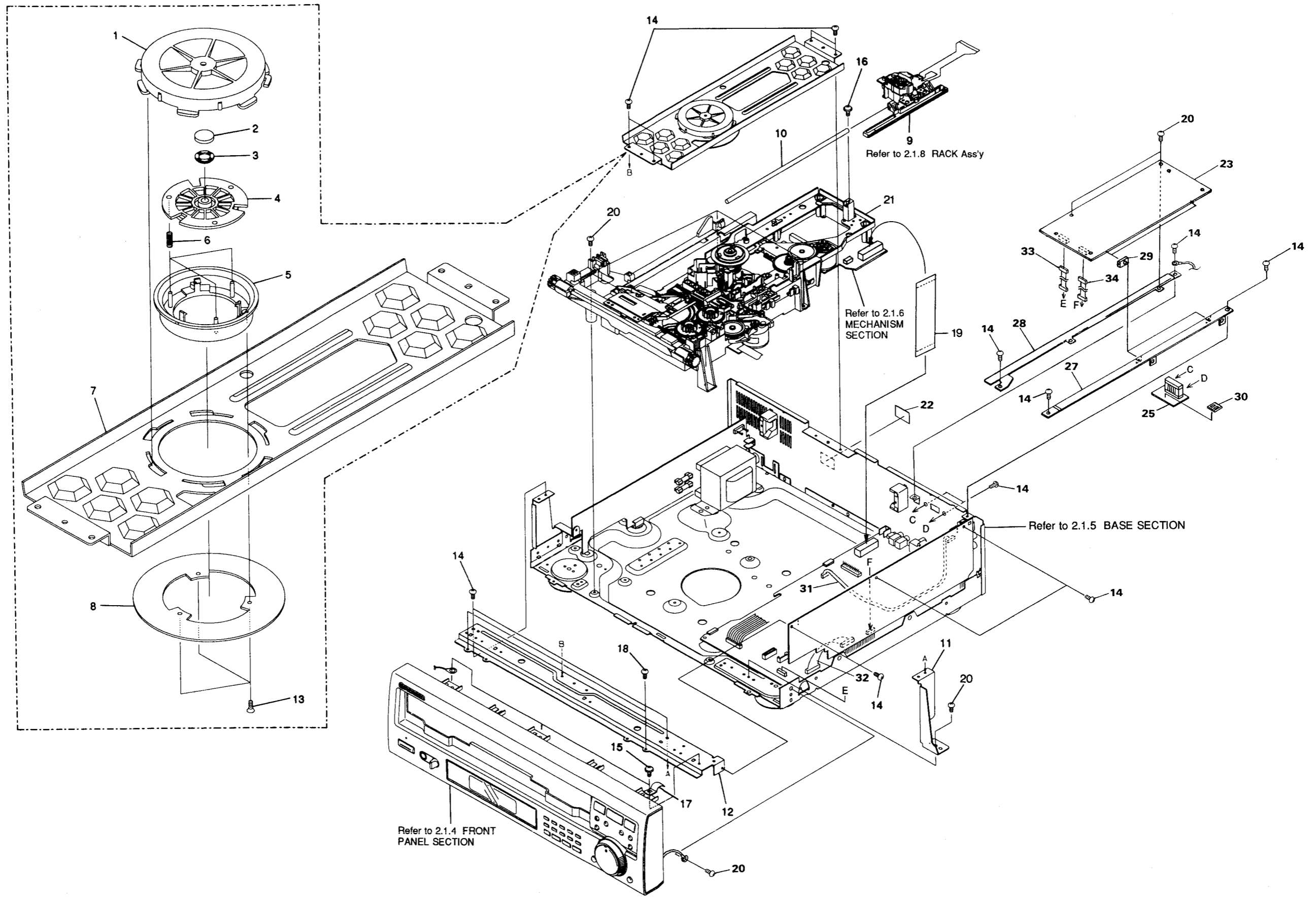

2.1.4 FRONT PANEL SECTION

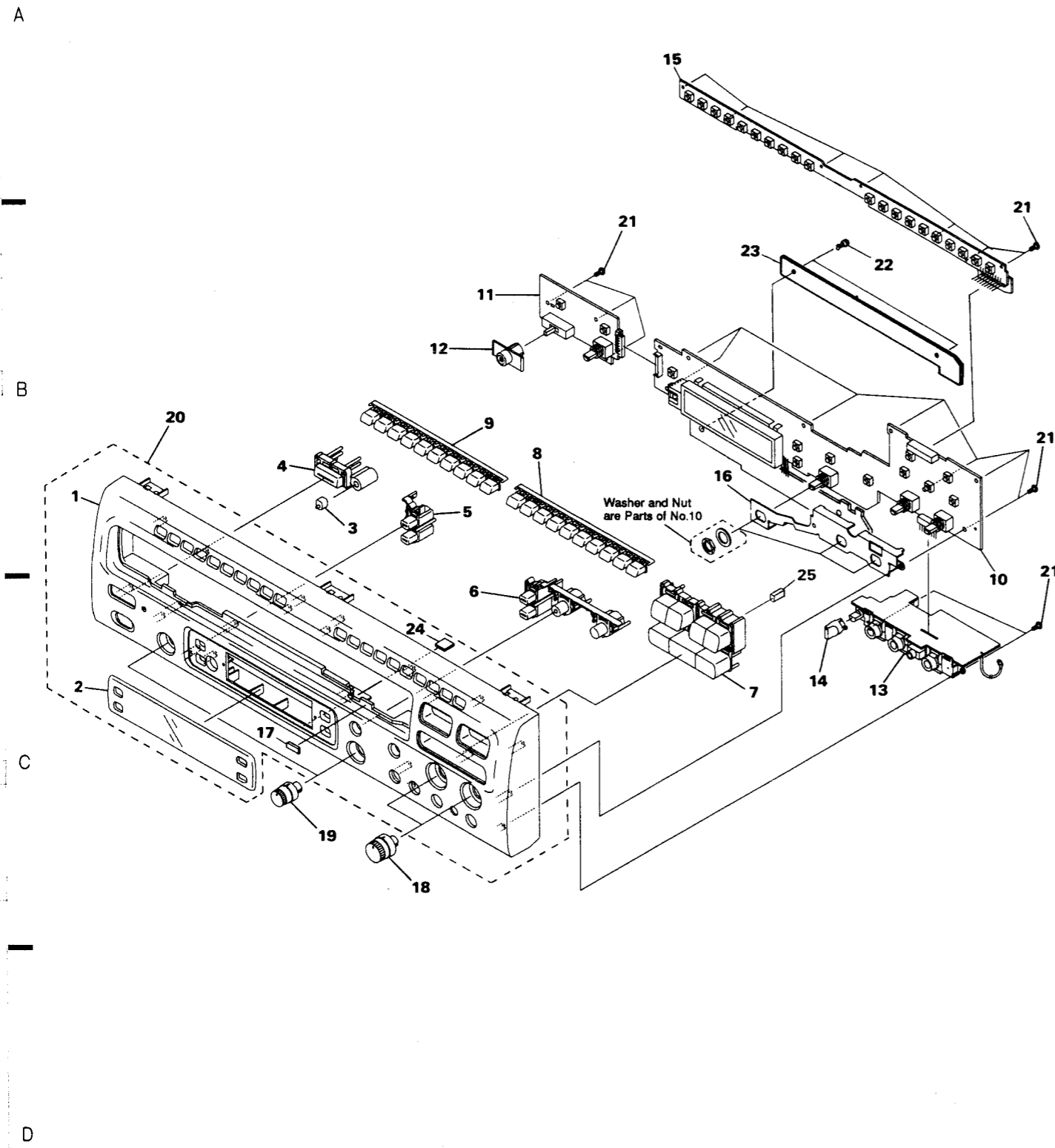

2.1.5 BASE SECTION

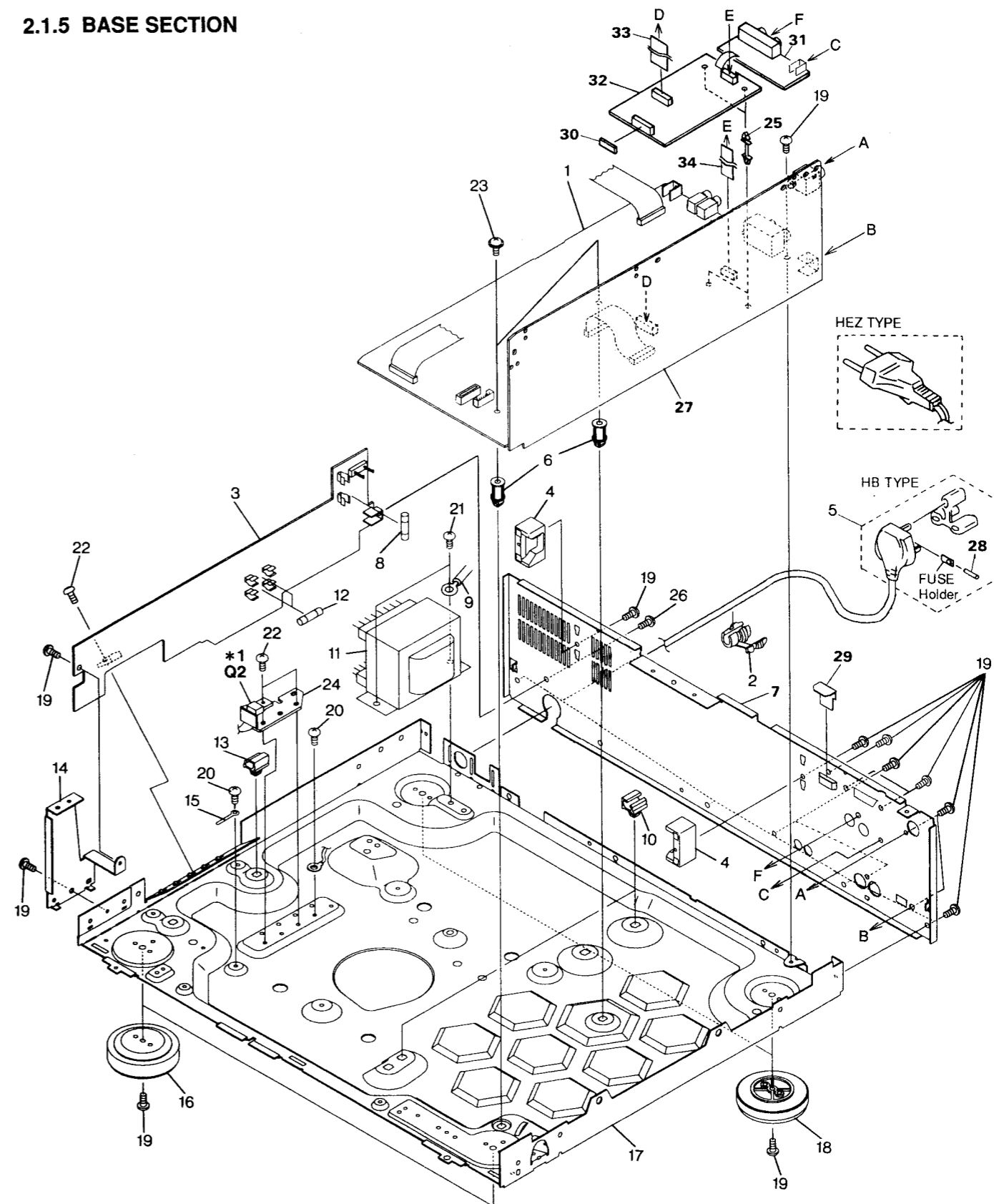

Note :
 * 1 : Q2 is component of the SYPS Ass'y.

2.1.6 MECHANISM SECTION

Refer to 2.1.7 MECHANISM Ass'y

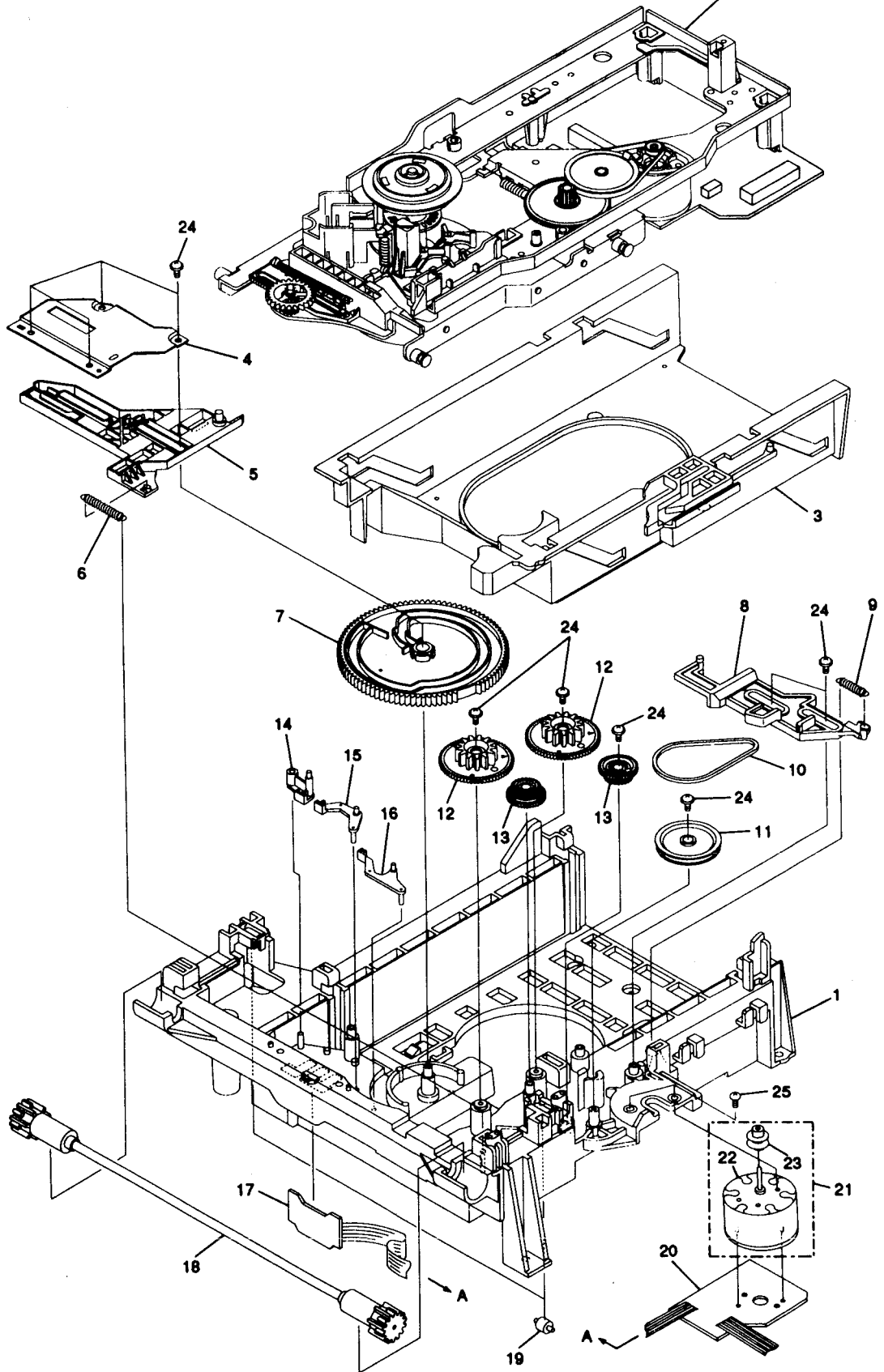

2.1.7 MECHANISM ASSY

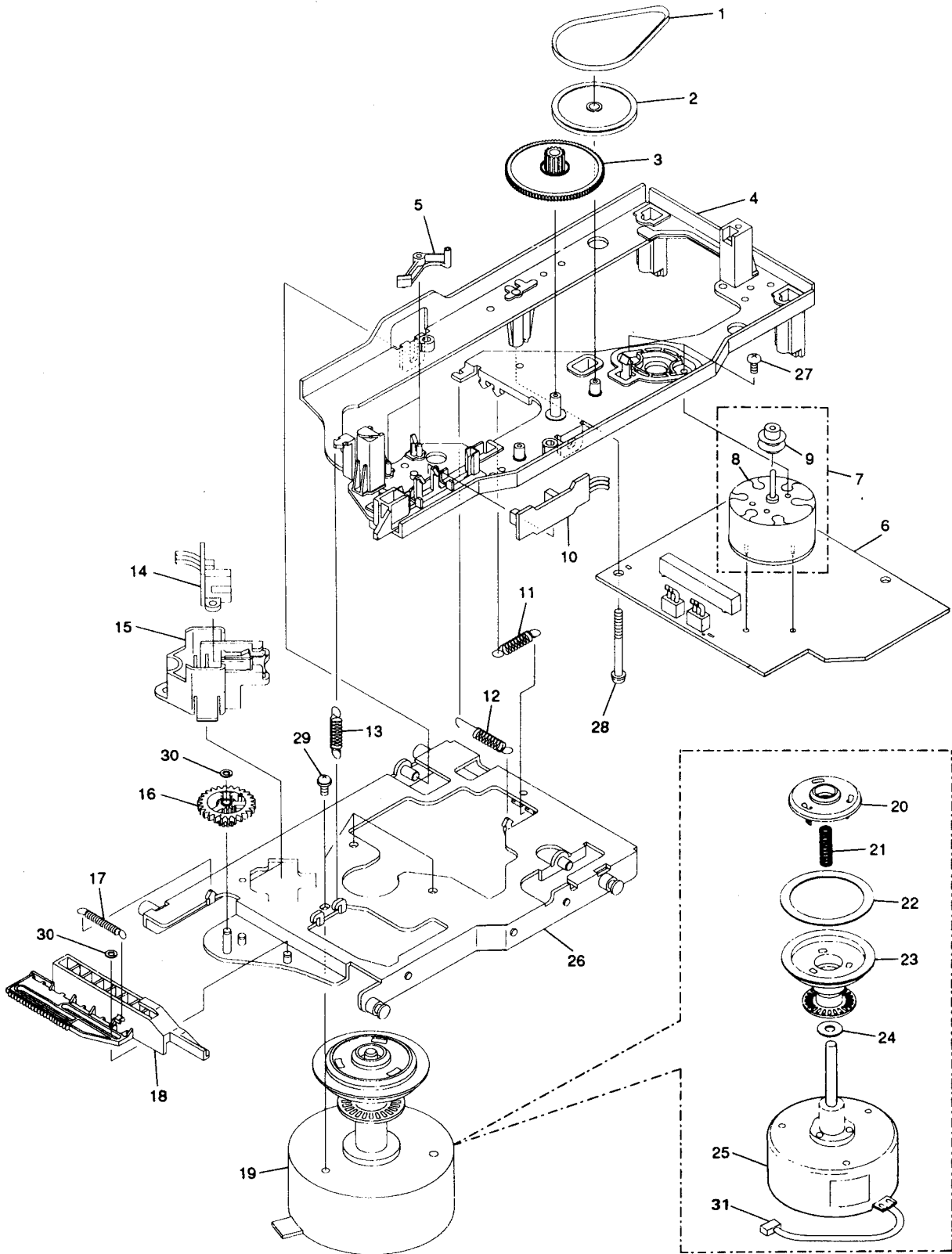

2.1.8 RACK ASSY

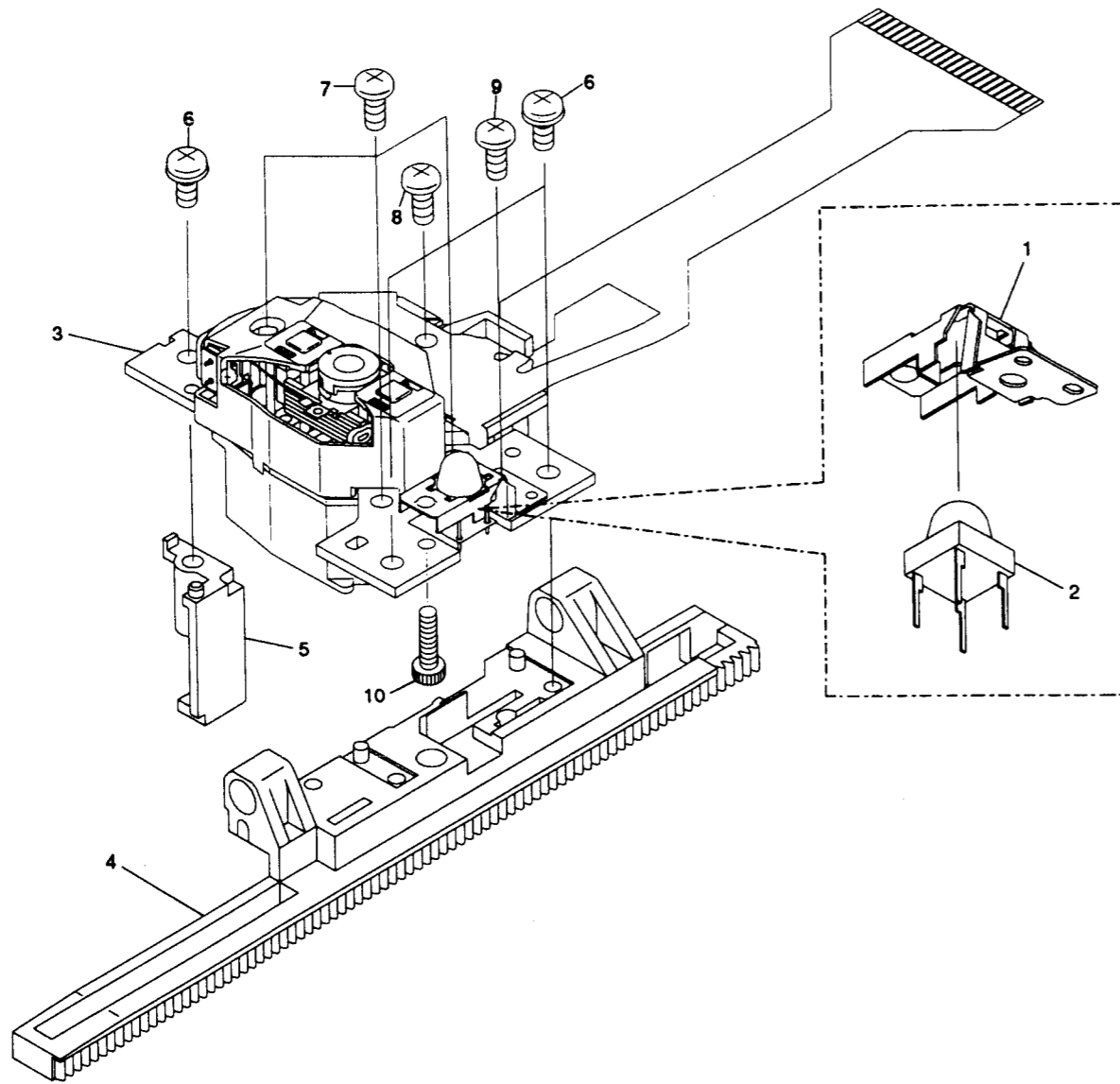

2.2 SCHEMATIC AND PCB CONNECTION DIAGRAMS

NOTE FOR SCHEMATIC DIAGRAMS (Type 4A)

1. When ordering service parts, be sure to refer to "PARTS LIST of EXPLODED VIEWS" or "PCB PARTS LIST".

2. Since these are basic circuits, some parts of them or the values of some components may be changed for improvement.

3. RESISTORS:
Unit: k:kΩ, M:MΩ, or Ω unless otherwise noted.
Rated power: 1/4W, 1/6W, 1/8W, 1/10W unless otherwise noted.
Tolerance: (F): ±1%, (G): ±2%, (K): ±10%, (M): ±20% or ±5% unless otherwise noted.

4. CAPACITORS:
Unit: p:pF or μF unless otherwise noted.
Ratings: capacitor (μF)/ voltage (V) unless otherwise noted.
Rated voltage: 50V except for electrolytic capacitors.

5. COILS:
Unit: m:mH or μH unless otherwise noted.

6. VOLTAGE AND CURRENT:
□ or - V : DC voltage (V) in PLAY mode unless otherwise noted.
↔ mA or - mA : DC current in PLAY mode unless otherwise noted.
Value in () is DC current in STOP mode.

7. OTHERS:
• ⊙ or ○ : Adjusting point.
• ◀ : Measurement point.
• The Δ mark found on some component parts indicates the importance of the safety factor of the parts. Therefore, when replacing, be sure to use parts of identical designation.

8. SCH-□ ON THE SCHEMATIC DIAGRAM:
• SCH-□ indicates the drawing number of the schematic diagram. (SCH stands for schematic diagram.)

9. SWITCHES (Underline indicates switch position):

FLKB ASSY	TWKB ASSY
S101 : SURROUND	S701 : 1
S102 : SYSTEM	S702 : 2
S103 : 4	S703 : 3
S104 : ONE-TOUCH KARAOKE	S704 : 4
S105 : 16 : 9	S705 : 5
S106 : b	S706 : 6
S107 : SCORING	S707 : 7
S108 : #	S708 : 8
S110 : AUDIO MODE	S709 : 9
S112 : ■	S710 : 10
S113 : ▶/	S711 : 11
S114 : ▲CD (OPEN/CLOSE)	S712 : 12
S115 : ▲LD (OPEN/CLOSE)	S713 : 13
	S714 : 14
PONB ASSY	S715 : 15
S201 : NORMAL/KARAOKE/AUX INPUT	S716 : 16
S202 : POWER (STANDBY/ON)	S717 : 17
	S718 : 18
	S719 : 19
	S720 : 20

NOTE FOR PCB DIAGRAMS:

1. Part numbers in PCB diagrams match those in the schematic diagrams.
2. A comparison between the main parts of PCB and schematic diagrams is shown below.

Symbol in PCB Diagrams	Symbol in Schematic Diagrams	Part Name
		Transistor
		Transistor with resistor
		Field effect transistor
		Resistor array
		3-terminal regulator

2.2.1 OVERALL CONNECTIONS, SYPS, FG, PASB, CAMB, LOSB, LOMB AND PICKUP ASSEMBLIES

● This diagram is viewed from the mounted parts side.

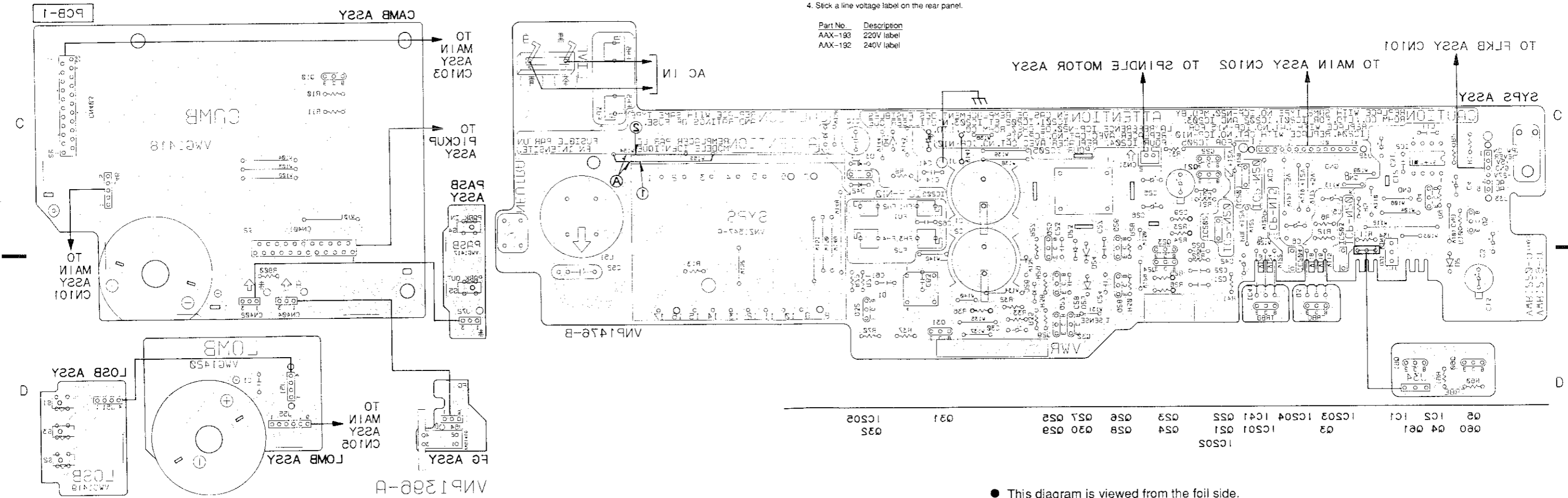
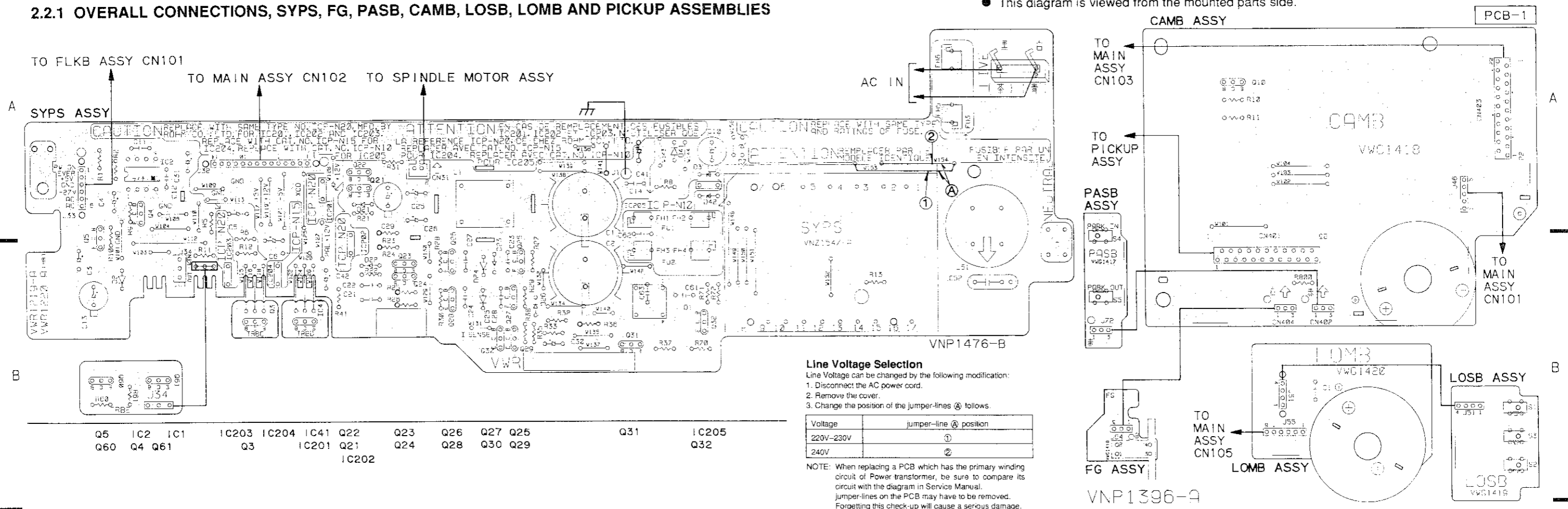

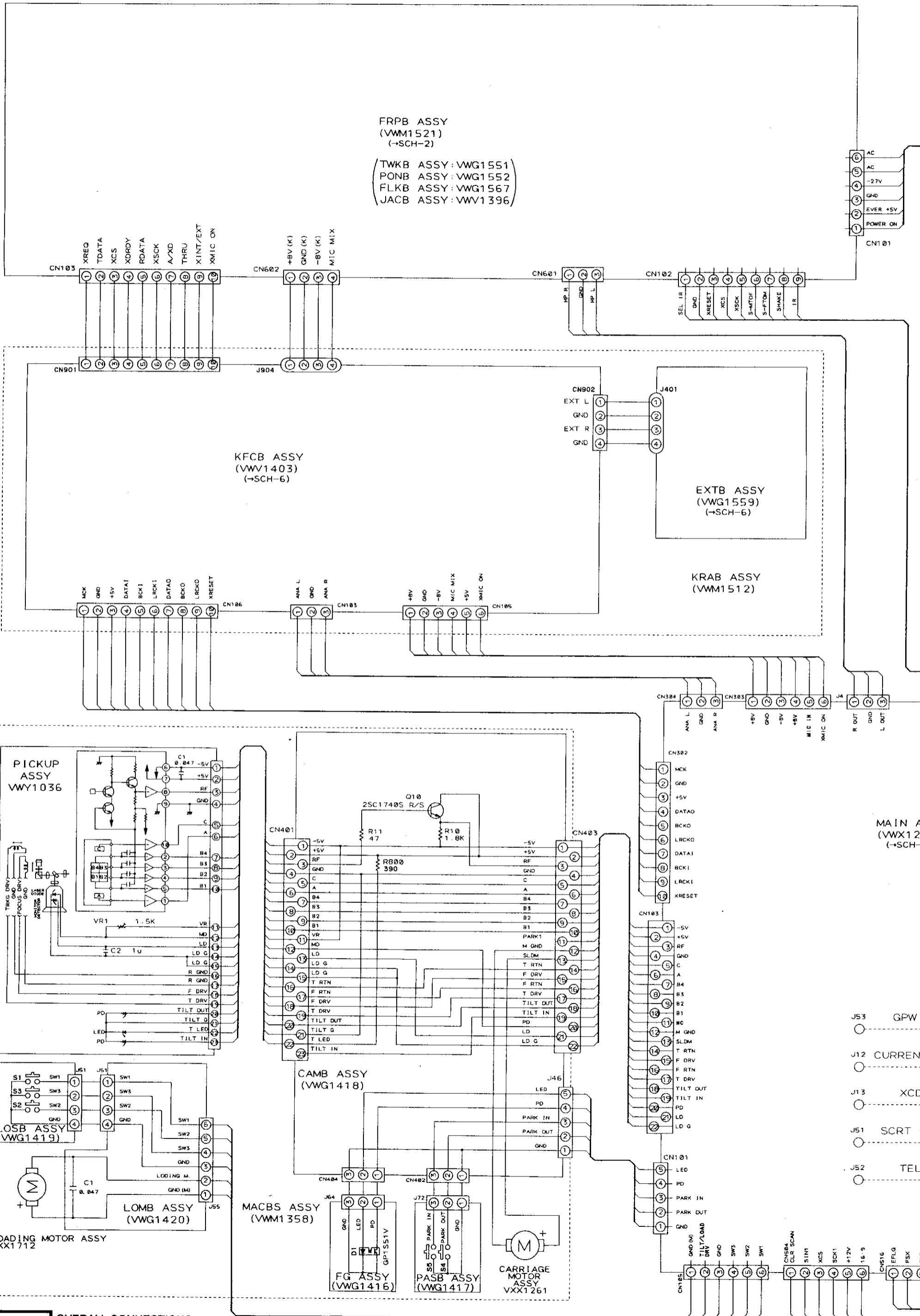

SCH-1

OVERALL CONNECTIONS, SYPS ASSY, FG ASSY, PASB ASSY, CAMB ASSY, LOB ASSY, LOMB ASSY, PICKUP ASSY

CAUTION: FOR CONTINUED PROTECTION AGAINST RISK OF FIRE, REPLACE WITH SAME TYPE NO. ICP-N10, MFD BY ROHM CO., LTD. FOR IC205.

CAUTION: FOR CONTINUED PROTECTION AGAINST RISK OF FIRE, REPLACE WITH SAME TYPE NO. ICP-N20, MFD BY ROHM CO., LTD. FOR IC201-IC203.

CAUTION: FOR CONTINUED PROTECTION AGAINST RISK OF FIRE, REPLACE WITH SAME TYPE NO. ICP-N15, MFD BY ROHM CO., LTD. FOR IC204.

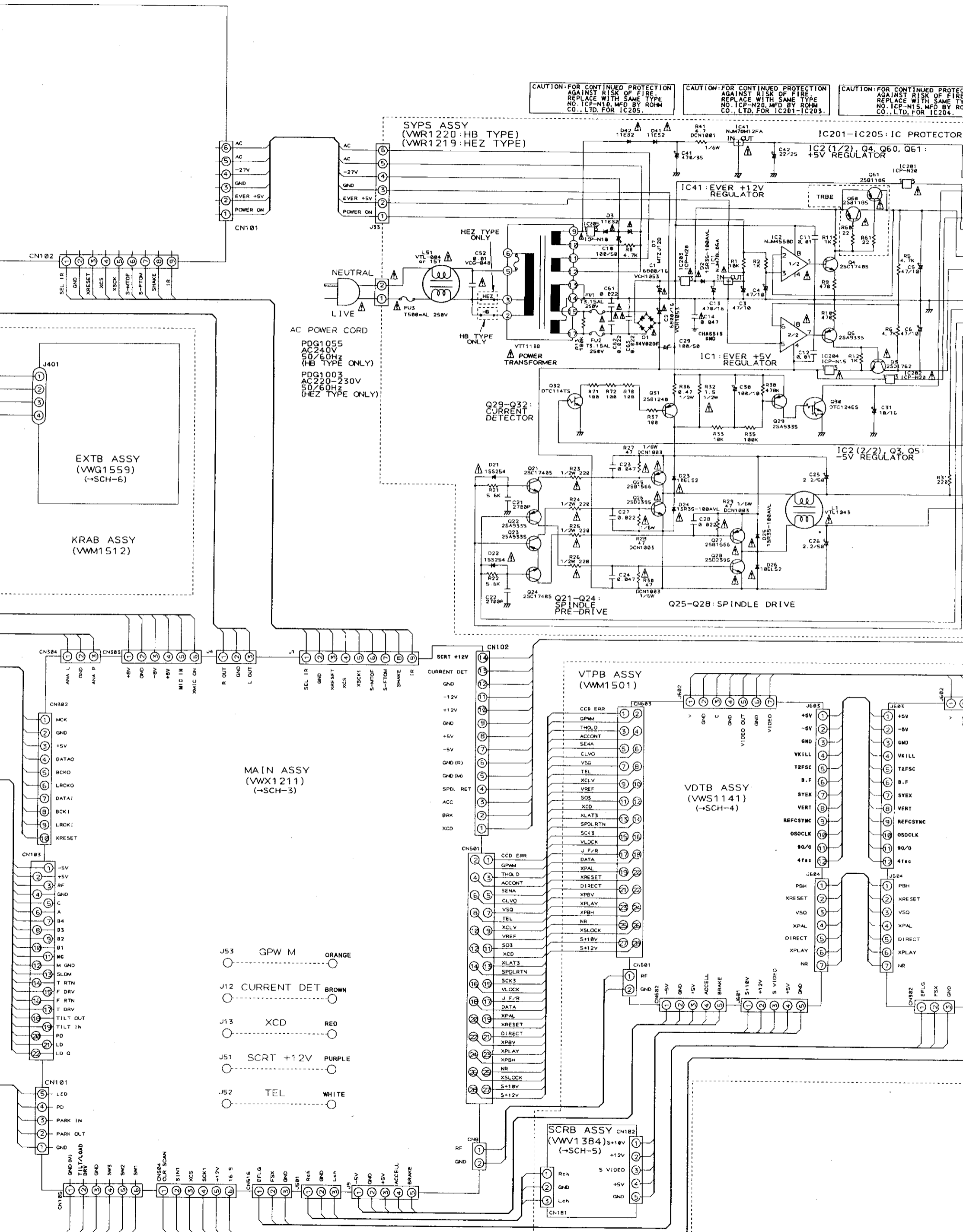

OVERALL CONNECTIONS
 SYPS ASSY, FG ASSY, PASB ASSY
 CAMB ASSY, LOSB ASSY
 LOMB ASSY, PICKUP ASSY

SCH-1

CAUTION: FOR CONTINUED PROTECTION AGAINST RISK OF FIRE REPLACE WITH SAME TYPE NO. ICP-N10, MFD BY ROHM CO., LTD. FOR IC205.

CAUTION: FOR CONTINUED PROTECTION AGAINST RISK OF FIRE REPLACE WITH SAME TYPE NO. ICP-N20, MFD BY ROHM CO., LTD. FOR IC201-IC203.

CAUTION: FOR CONTINUED PROTECTION AGAINST RISK OF FIRE REPLACE WITH SAME TYPE NO. ICP-N15, MFD BY ROHM CO., LTD. FOR IC204.

SYPS ASSY (VWR1220:HB TYPE) (VWR1219:HEZ TYPE)

IC201-IC205: IC PROTECTOR

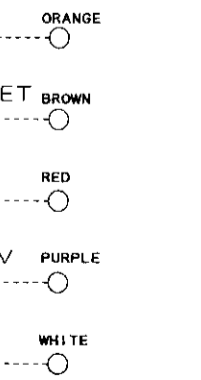
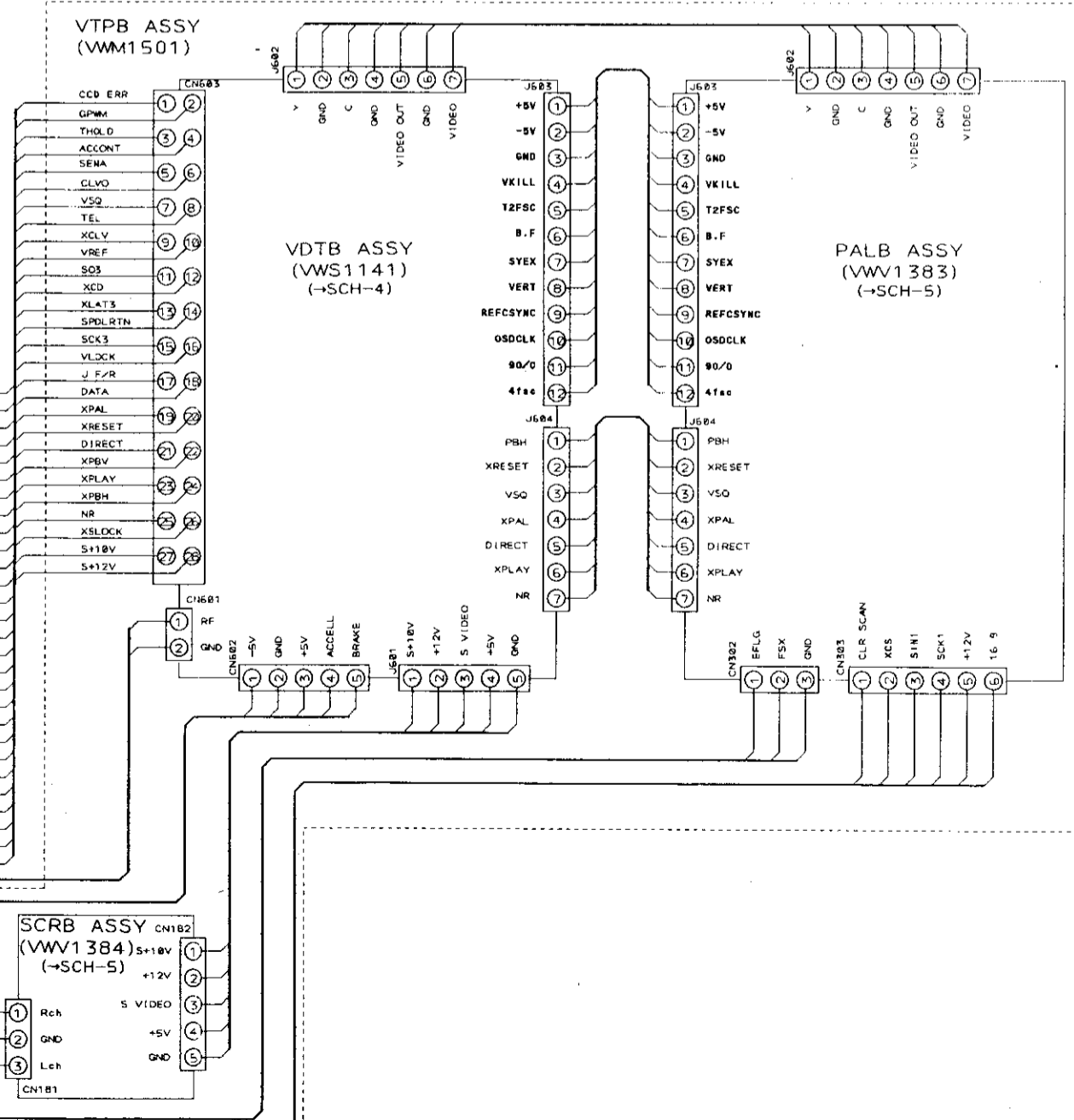
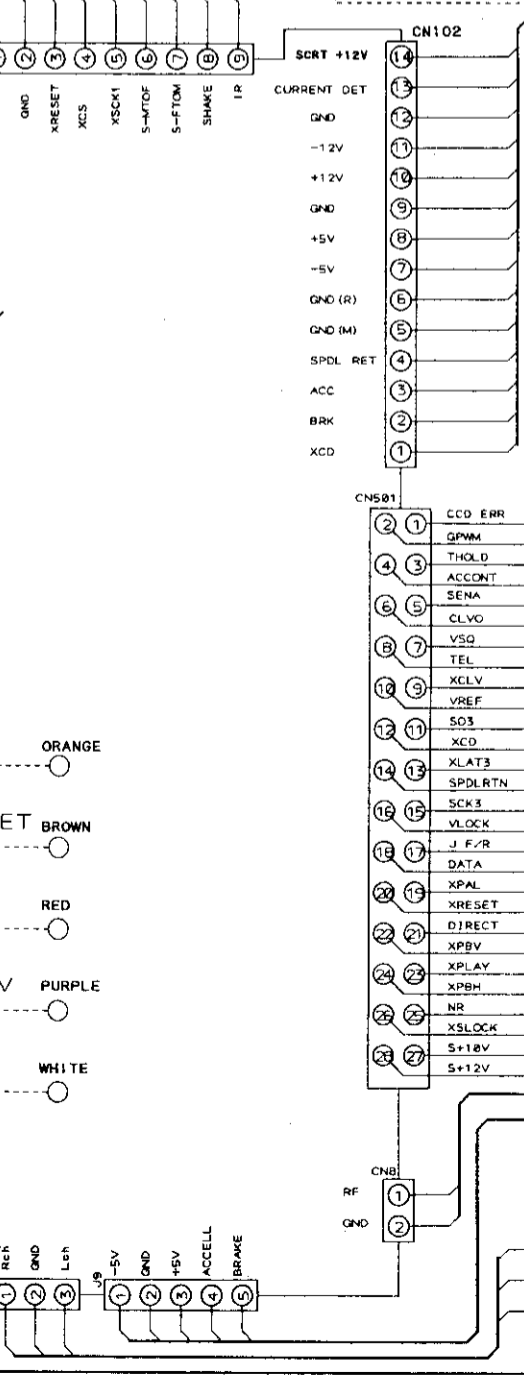
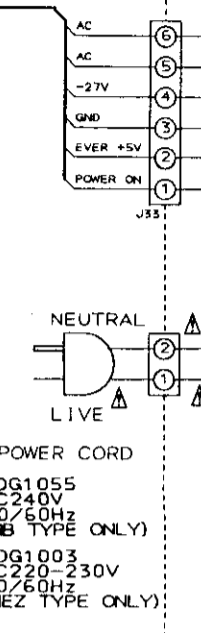
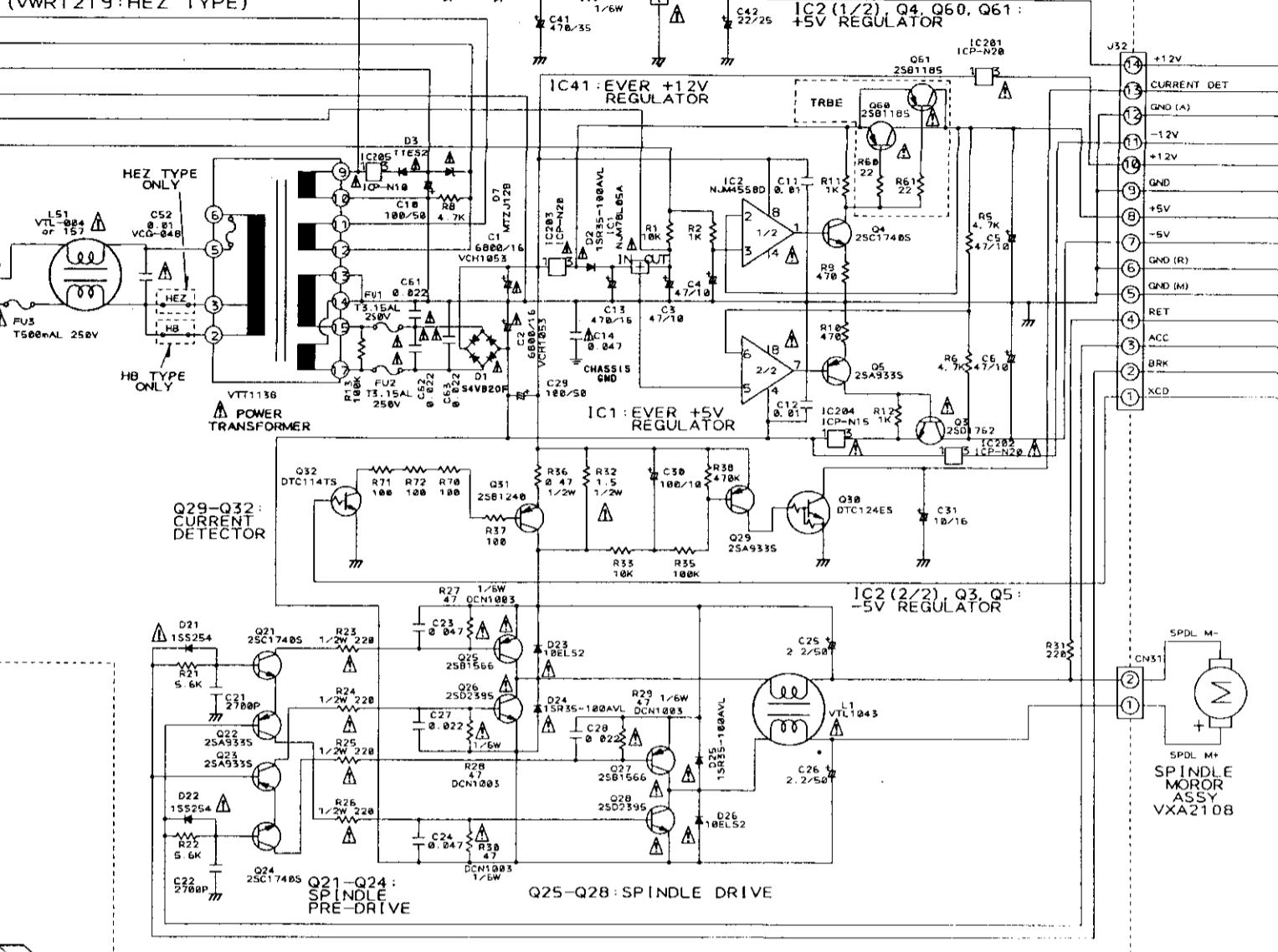

OVERALL CONNECTIONS, SYPS ASSY, FG ASSY, PASB ASSY, CAMB ASSY, LOSB ASSY, LOMB ASSY, PICKUP ASSY

SCH-1

A
B
C
D
E
F

2.2.2 FLKB, JACB, TWKB AND PONB ASSEMBLIES

A

B

C

D

E

F

FLKB ASSY
VWG1567

106B-09C-PP CN701
9133S-09A CN106

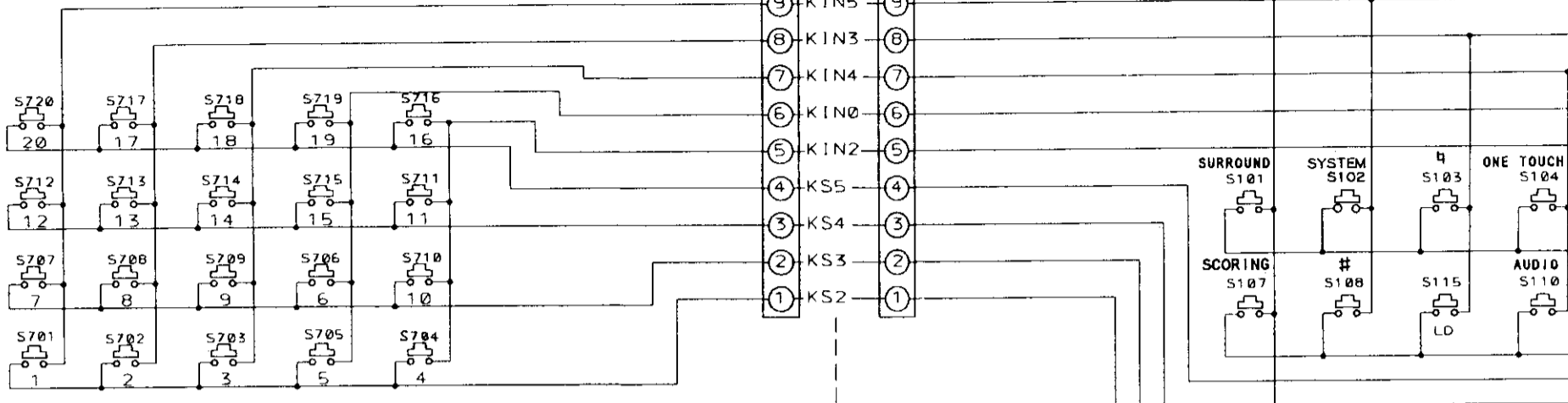

TWKB ASSY
VWG1551

	KIN0	KIN1	KIN2	KIN3	KIN4	KIN5
KS0		SCORING	CD	LD	AUDIO	#
KS1	16/19	SURROUND	b	h	ONE-TOUCH KARAOKE	SYSTEM
KS2	5	PLAY/PAUSE	4	2	3	1
KS3	6	STOP	10	8	9	7
KS4	15		11	13	14	12
KS5	19		16	17	18	20

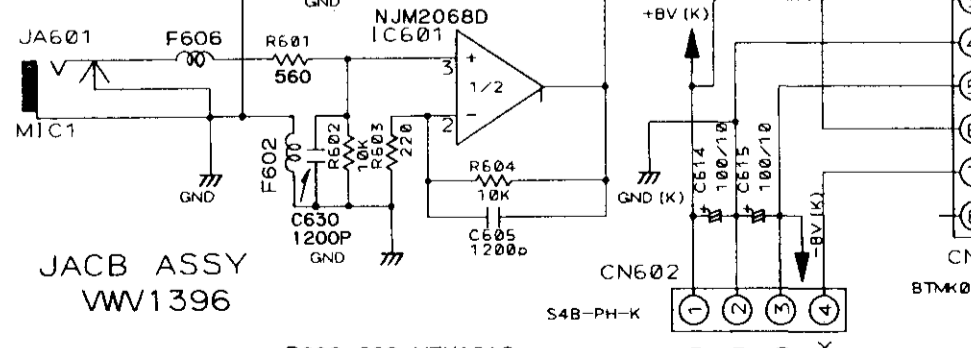
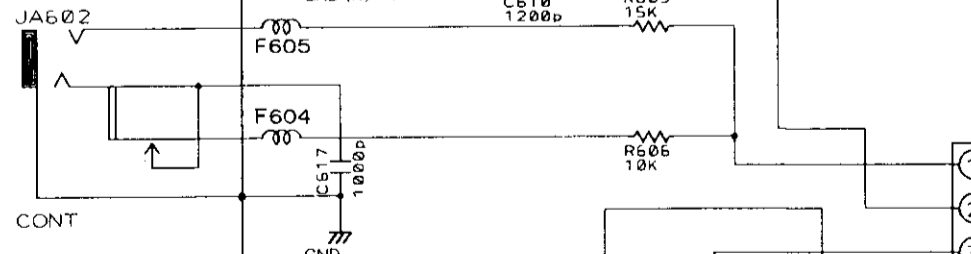
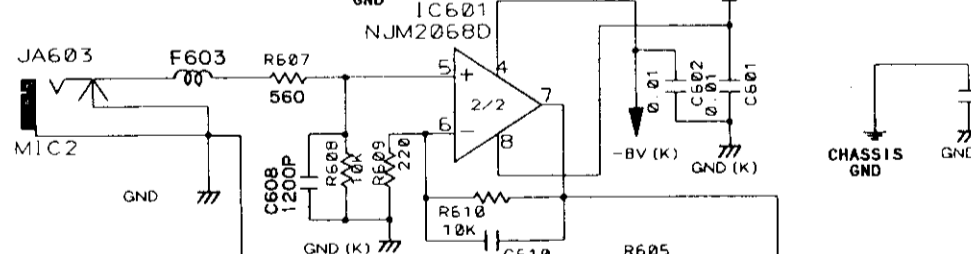
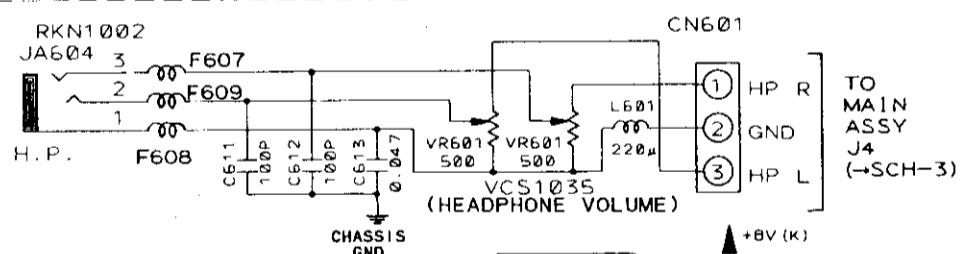
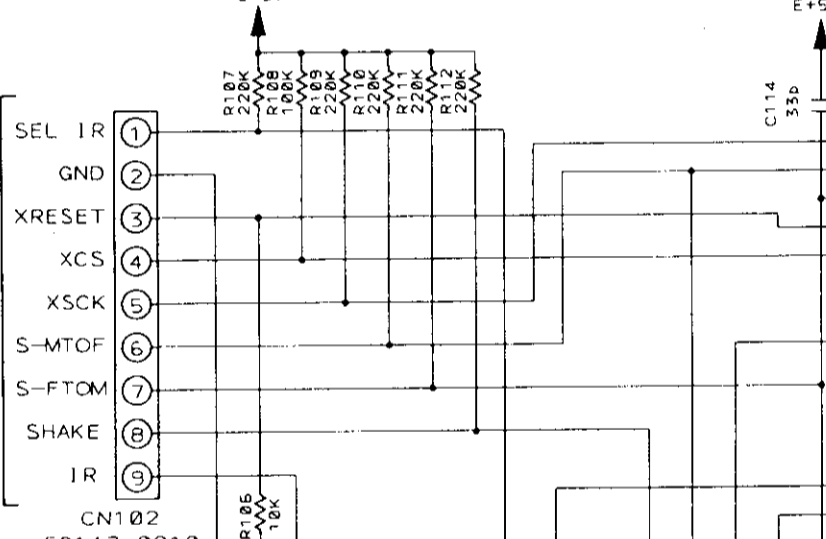
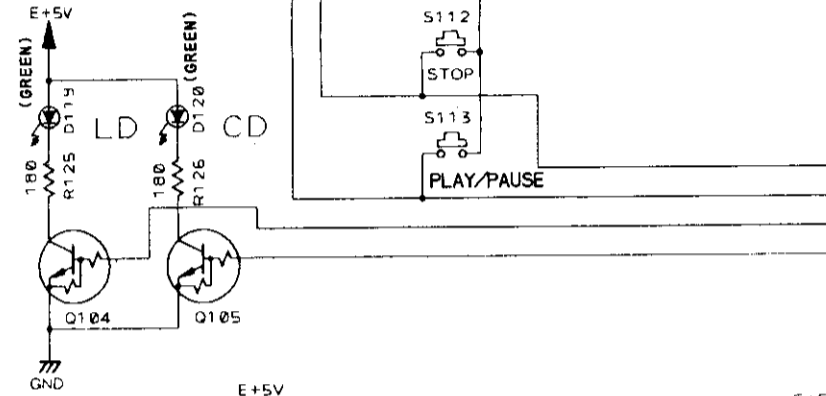

JACB ASSY
VW1396

F602-609:VTH1016
JA601, 603:VKN1147
JA602:RKN1006

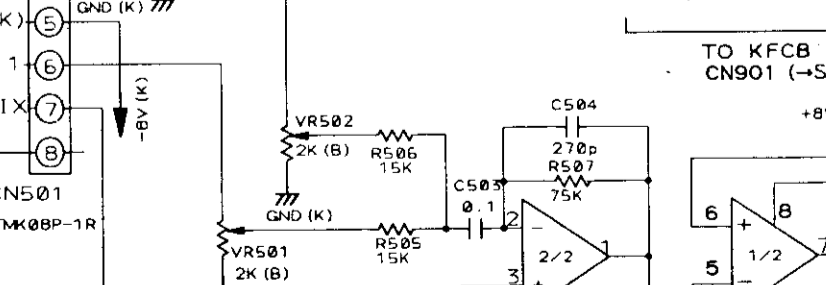
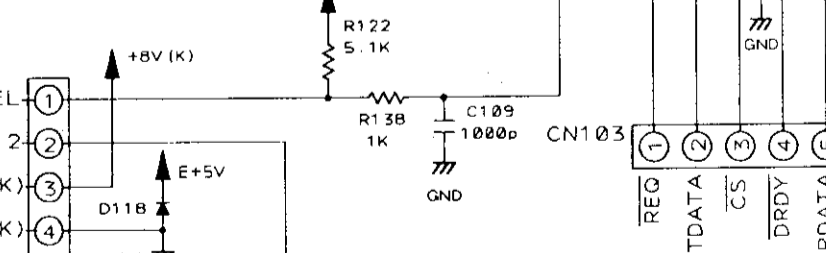
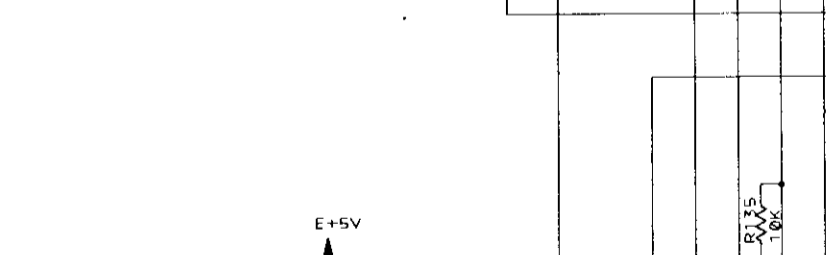
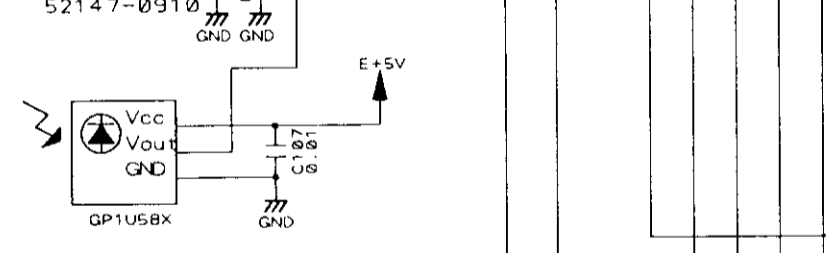

VR501, 502:VCS1034 (MIC VOLUME)

SCH-2

FLKB ASSY, JACB ASSY,
TWKB ASSY, PONB ASSY

TO KFCB ASSY J904 (-SCH-6)

FLKB ASSY
VWG1567

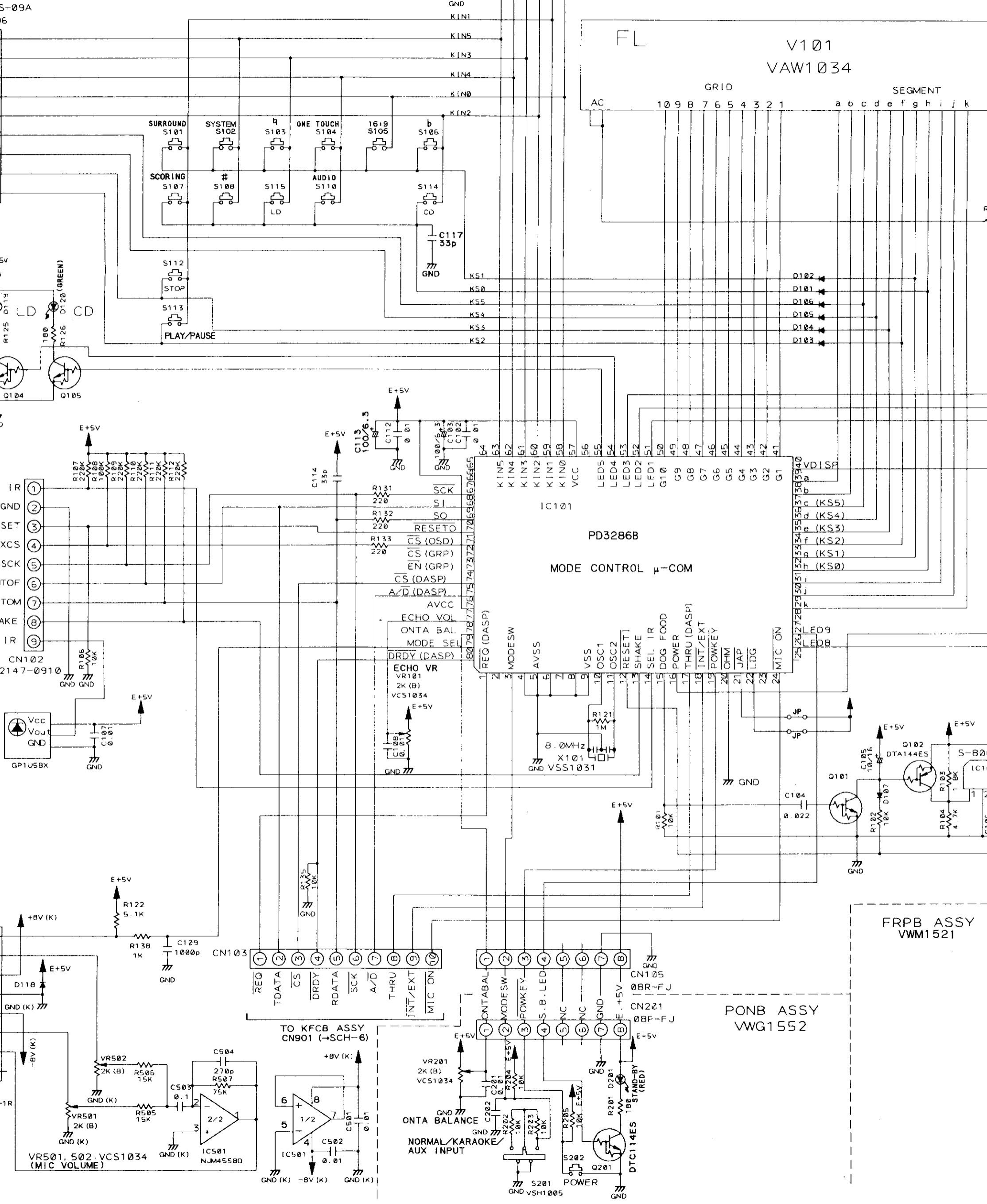

FRPB ASSY
VWM1521

PONB ASSY
VWG1552

TO KFCB ASSY
CN901 (-SCH-6)

SCH-2

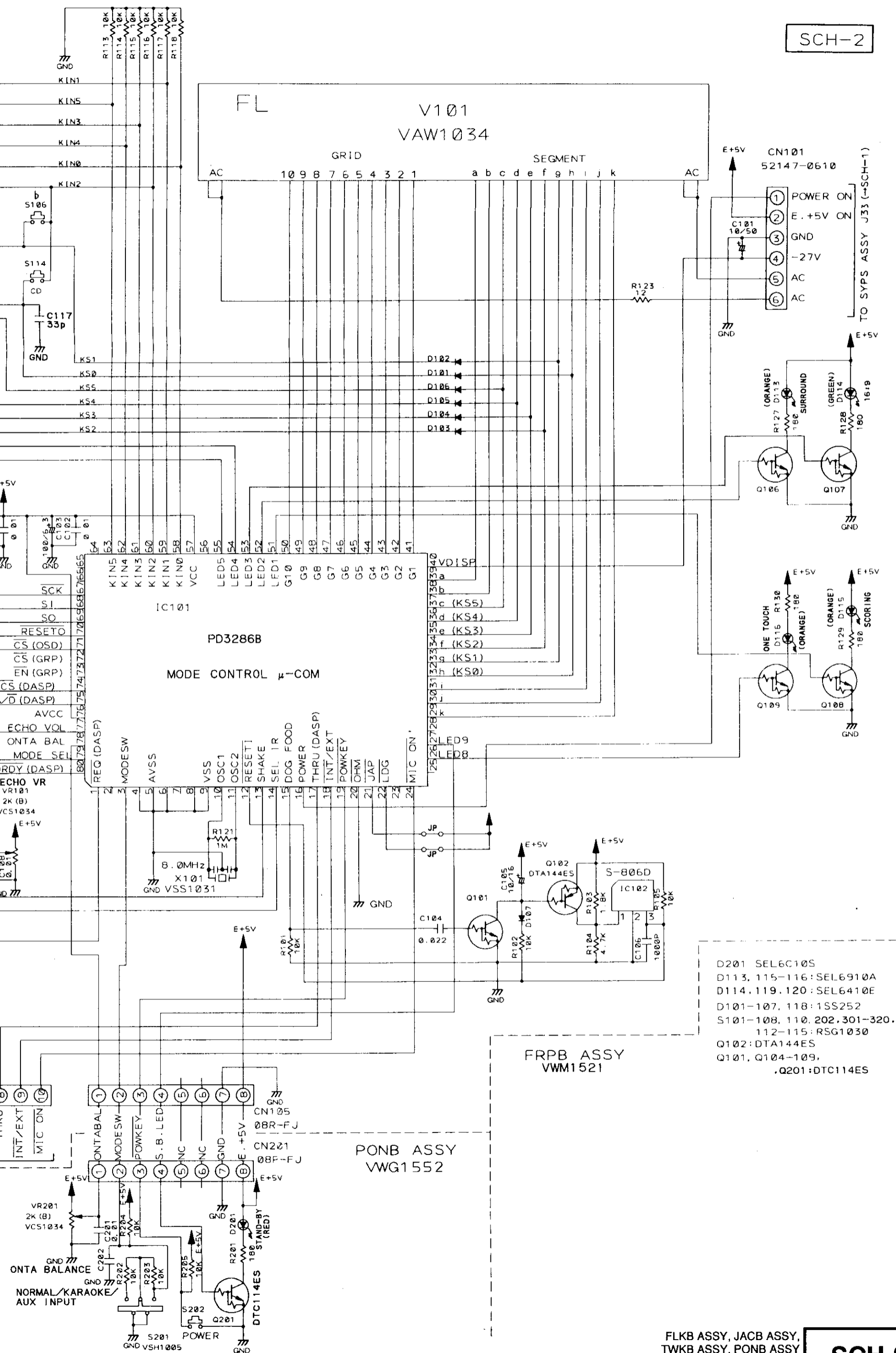

- D201 SEL6C10S
- D113, 115-116: SEL6910A
- D114, 119, 120: SEL6410E
- D101-107, 118: 1SS252
- S101-108, 110, 202, 301-320, 112-115: RSG1030
- Q102: DTA144ES
- Q101, Q104-109, Q201: DTC114ES

SCH-2

• This d

A

B

C

D

E

F

TWKB ASSY

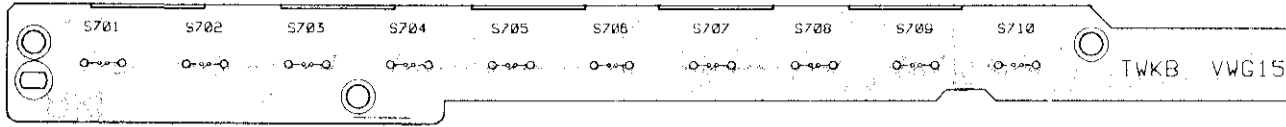

PONB ASSY

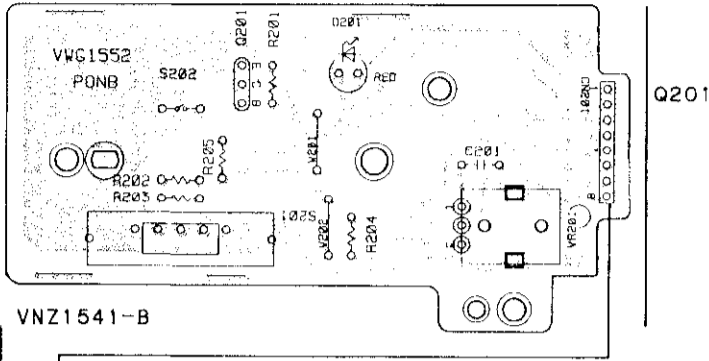

VNZ1541-B

- IC501
- Q109
- Q105
- Q104
- Q102
- Q106
- IC102
- Q108
- Q101
- IC101

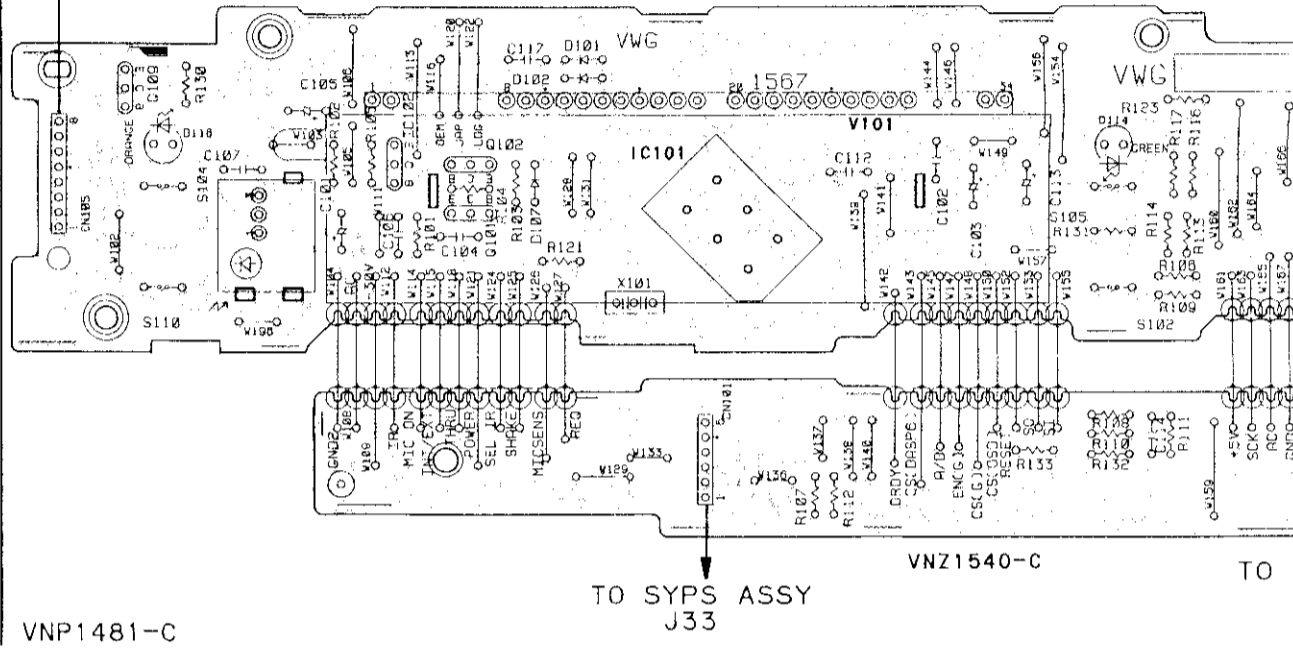

VNP1481-C

• This d

PCB-S

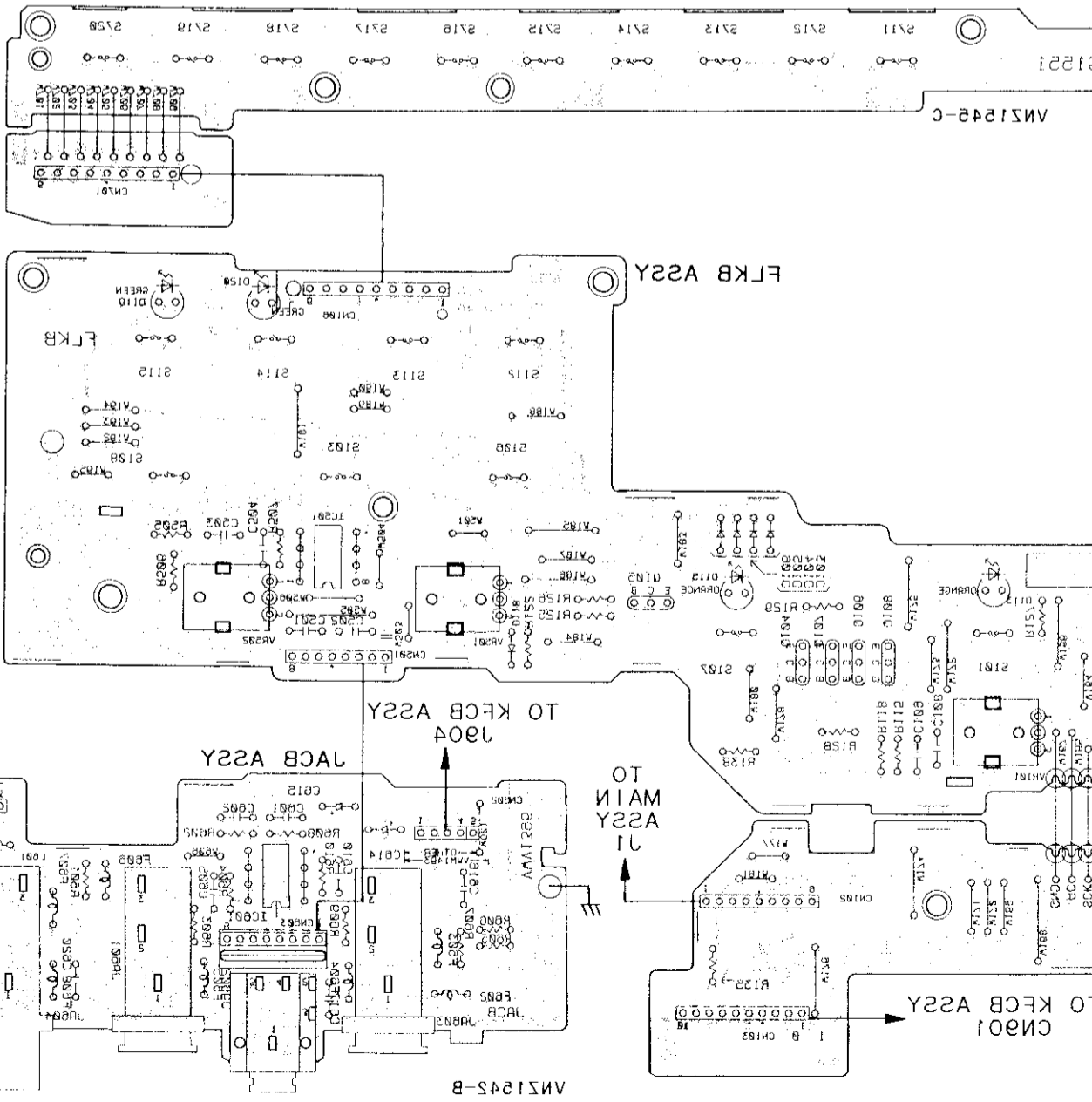

IC901

● This diagram is viewed from the mounted parts side.

PCB-2

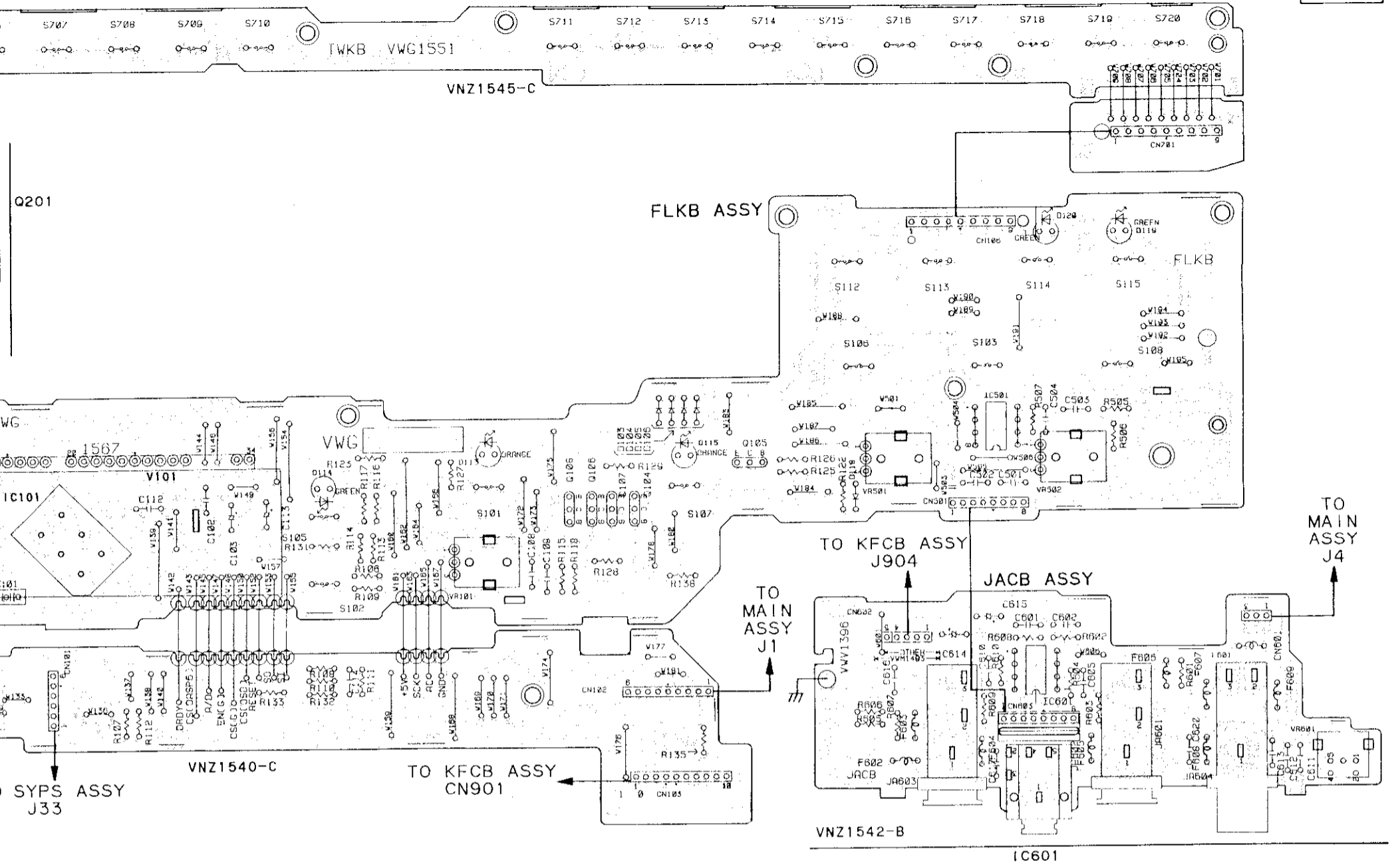

● This diagram is viewed from the foil side.

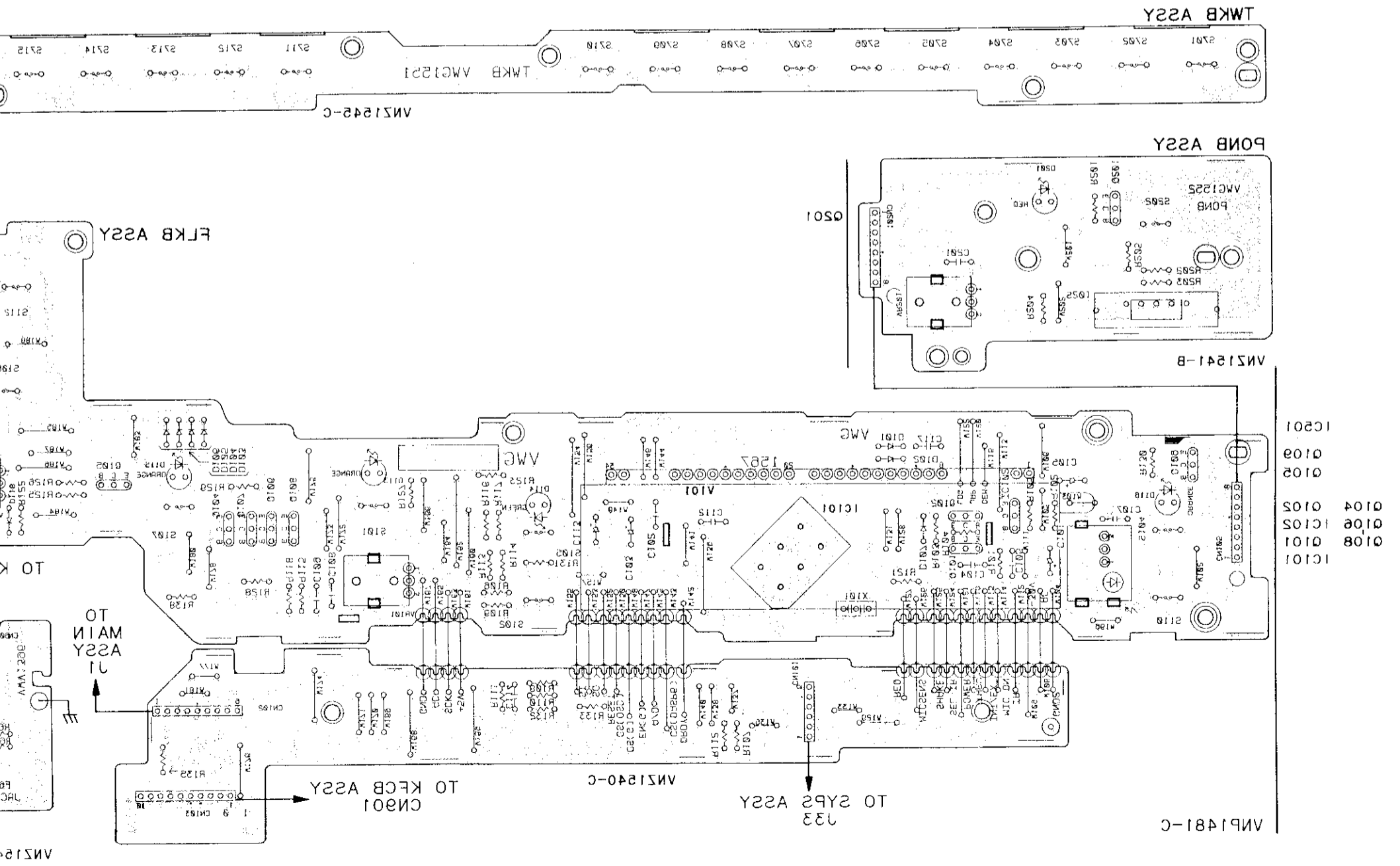

2.2.3 MAIN ASSEMBLY

A
B
C
D
E
F

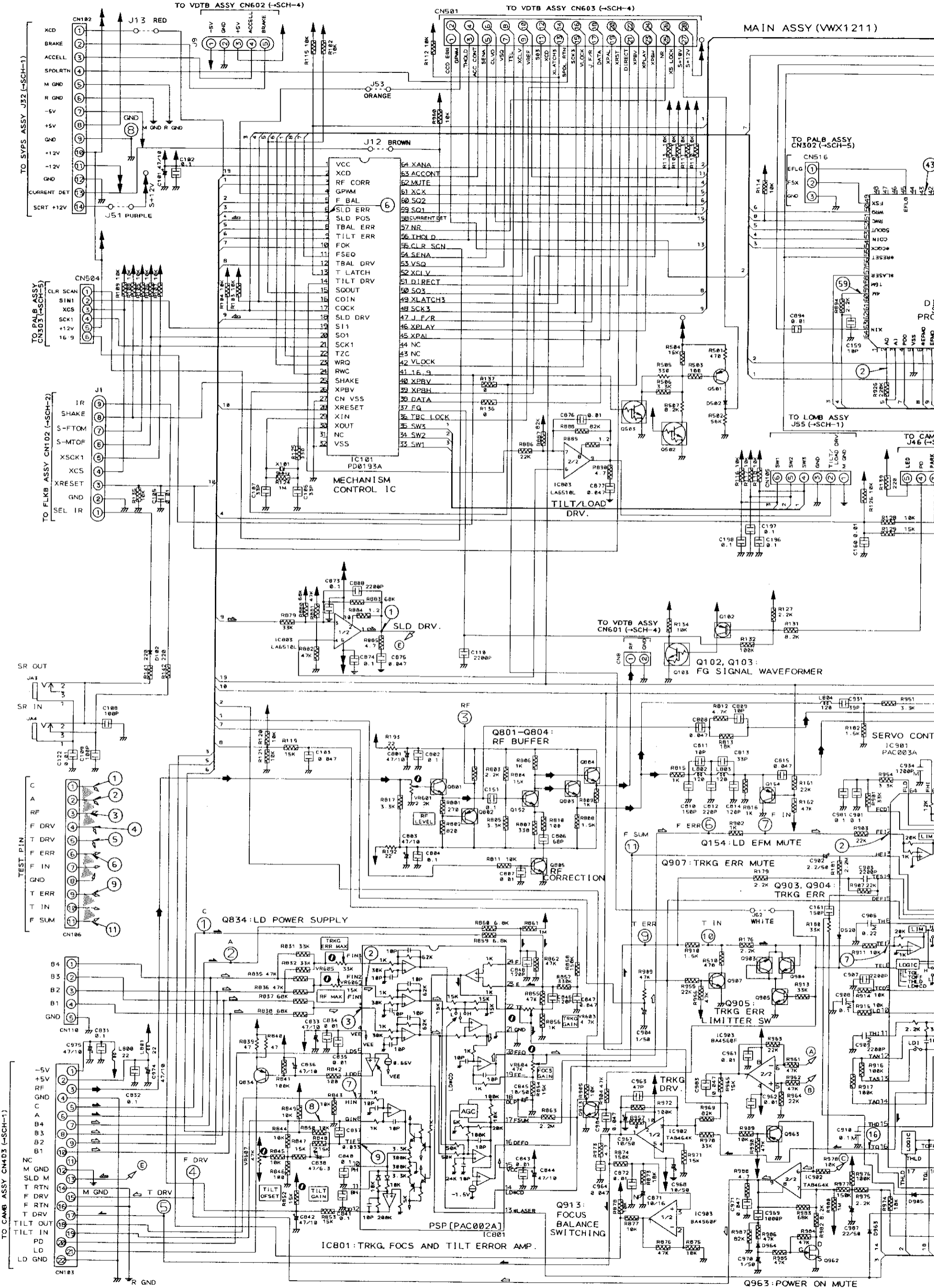

SCH-3

MAIN ASSY

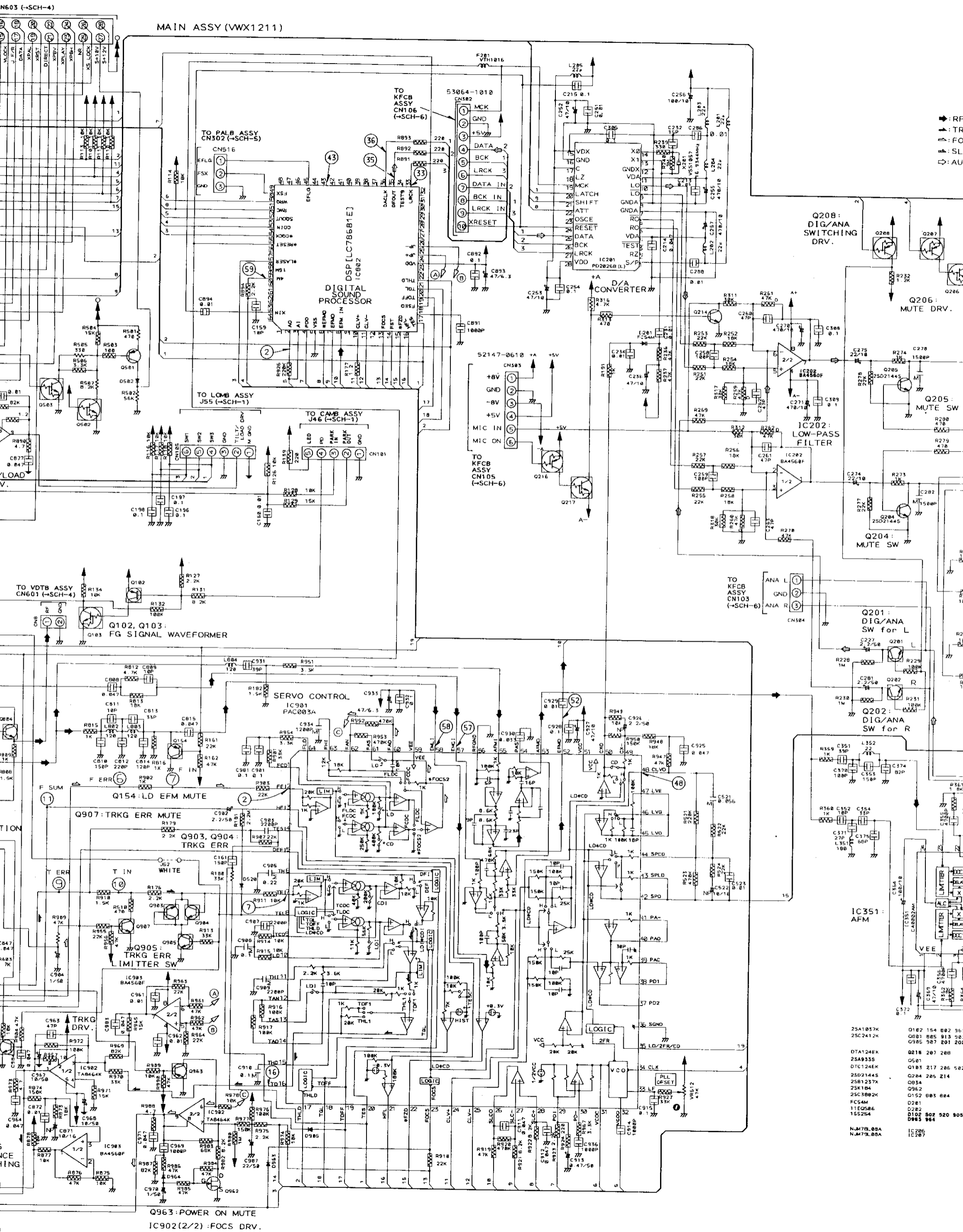

MAIN ASSY (VWX1211)

DSP [LC78681E]
DIGITAL SOUND PROCESSOR

53064-1010
MCK
GND
+5V
DATA
BCK
LRCK
DATA IN
BCK IN
LRCK IN
XRESET

D/A CONVERTER
IC201 PD2826B (L)

LOW-PASS FILTER
IC202 BA4560F

Q208: DIG/ANA SWITCHING DRV.

Q206: MUTE DRV.

Q205: MUTE SW

Q204: MUTE SW

Q201: DIG/ANA SW for L

Q202: DIG/ANA SW for R

IC351: AFM

Q963: POWER ON MUTE
IC902(2/2): FOCUS DRV.

- 25A1037K
- 25C2412K
- DTA124EK
- 25A935S
- DTG124EK
- 25D2144S
- 25B1237K
- 25K184
- 25C3802K
- FC54M
- 11E0586
- 15S254
- NJM78L08A
- NJM79L08A
- O182 154 602 96
- O81 885 913 98
- O95 987 201 202
- Q218 207 208
- O51
- O183 217 206 502
- Q284 285 214
- Q362
- O152 683 684
- O21
- O282
- O102 502 520 305
- D883 964
- IC286
- IC287

SCH-3

A

B

C

D

E

F

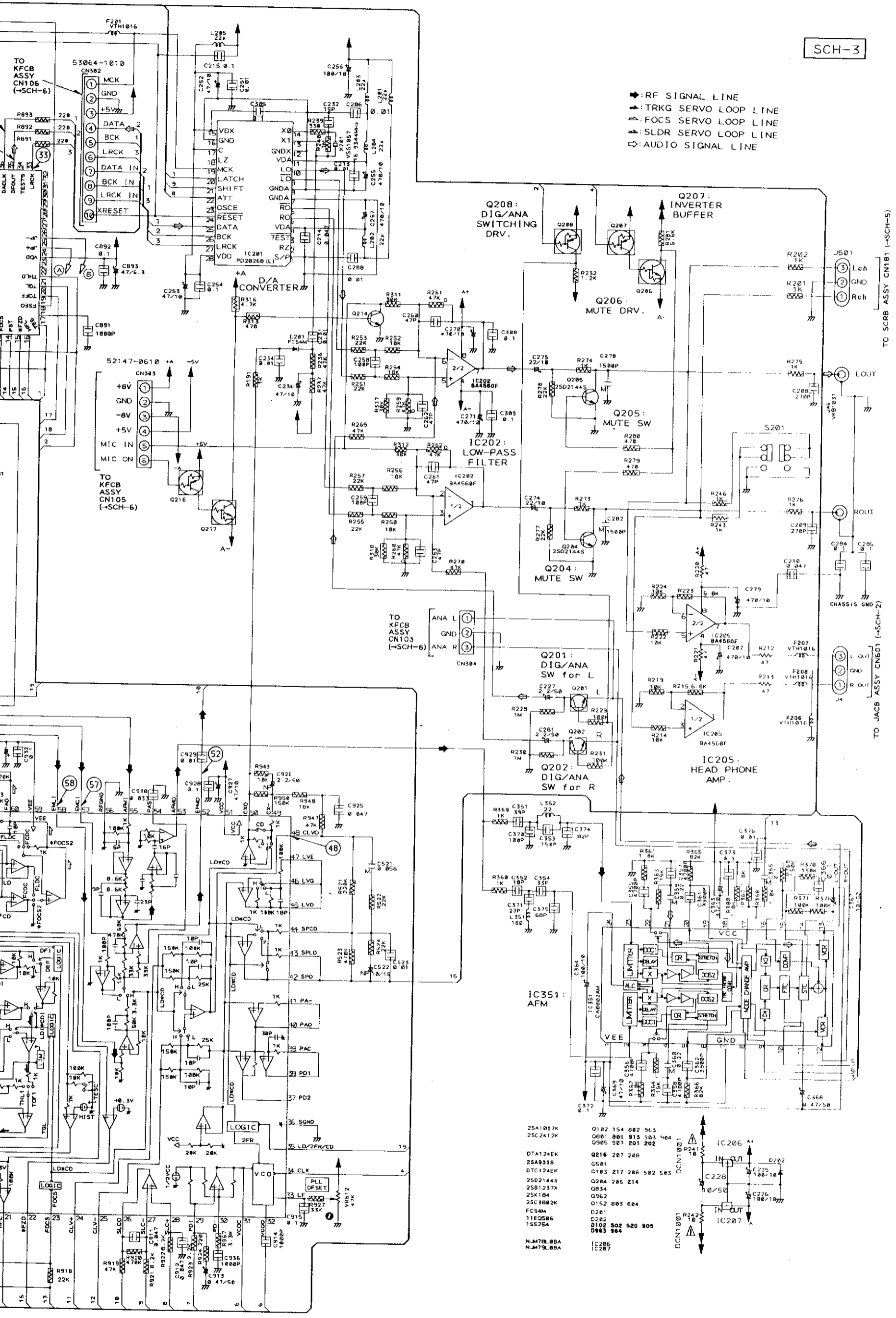

- ◆ RF SIGNAL LINE
- ▲ TRKG SERVO LOOP LINE
- ▷ FOCSS SERVO LOOP LINE
- ◁ SLDR SERVO LOOP LINE
- ◁ AUDIO SIGNAL LINE

25A1037K	0102 154 002 963
25C2412K	0001 005 915 503 404
	0905 007 201 202
DTA124EK	Q216 207 208
25A933S	C501
DT124EK	0103 217 206 502 503
25D2144S	Q204 205 214
25B1237K	Q834
25K184	Q962
25C3002K	0152 005 604
FC504K	D201
11E0506	C202
15S254	D102 502 520 905
	D003 004
N.M70L.00A	IC206
N.M75L.00A	IC207

MAIN ASSY

SCH-3

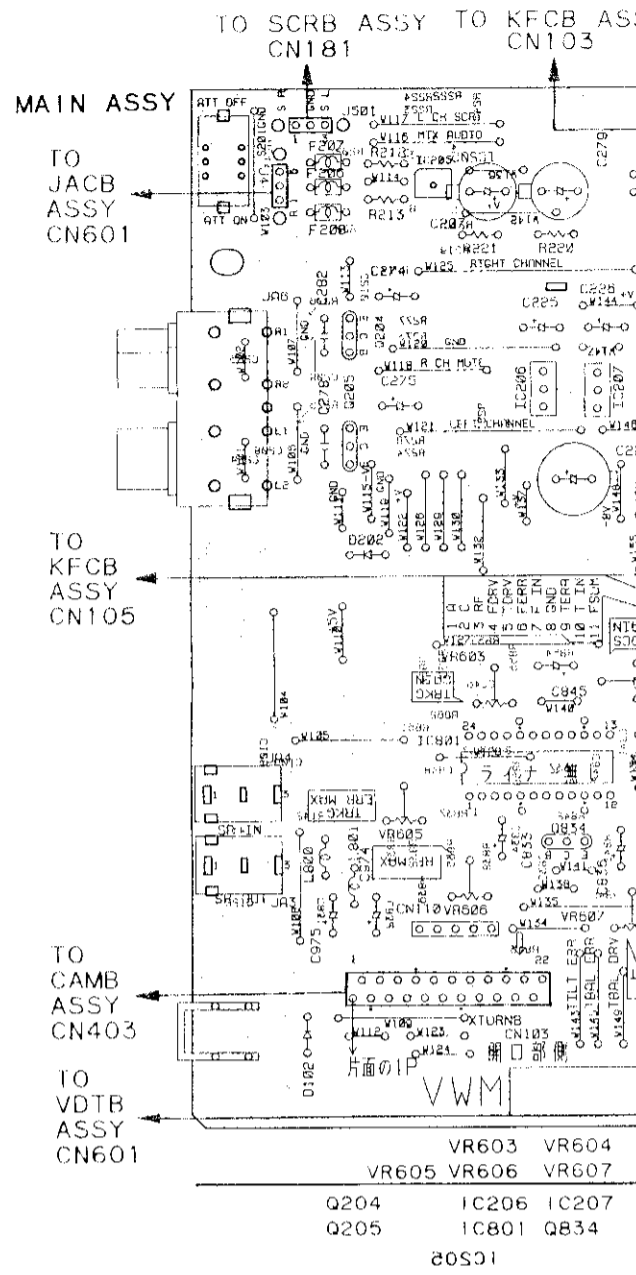

MAIN ASSEMBLY

Note: (No.) in the table correspond to the pin number.

Measurement condition: In case when (D.audio) is written, at time when disc that has digital audio recording is played.

IC801(PAC002A)	IC802(LC78681E)	IC803(LA6510L)	IC901(PAC003A)	CN106	IC101 (PD0193A)
②, ③ 1mS/Div. 16mVp-p AC mode	② 0.1μS/Div. 4.3Vp-p AC mode(D.audio)	① 2mS/Div. 18Vp-p DC mode	② 0.2mS/Div. 74mVp-p DC mode	①, ② 5mS/Div. 65mVp-p DC mode	⑥ 1V/Div 5mS/Div approx. 1.8V DC mode (Slidr err)
⑦, ⑧ 1mS/Div. 67mVp-p DC mode	③③ 10μS/Div. 4.2Vp-p AC mode(D.audio)		⑦ 0.2mS/Div. 74mVp-p DC mode	③ 0.5mS/Div. 300mVp-p AC mode	
⑨ 5mS/Div. 0.1Vp-p DC mode	③⑤ 0.2μS/Div. 4.4Vp-p AC mode(D.audio)		①⑥ 0.2mS/Div. 0.61Vp-p DC mode	④ 5mS/Div. 15Vp-p DC mode	
	③⑥ 0.2μS/Div. 4.5Vp-p AC mode(D.audio)		④⑧ 50μS/Div. 6.2Vp-p DC mode	⑤ 5mS/Div. 5.8Vp-p DC mode	
	④③ 0.1μS/Div. 4.5Vp-p AC mode(D.audio)		⑤② 0.2μS/Div. 2.1Vp-p AC mode	⑥ 5mS/Div. 3.5Vp-p DC mode	
	⑤⑨ 0.1μS/Div. 2Vp-p AC mode(D.audio)		⑤⑦ 1mS/Div. 0.53Vp-p DC mode	⑨ 5mS/Div. 1.25Vp-p DC mode	
			⑤⑧ 0.2mS/Div. 0.32Vp-p DC mode	①① 10mS/Div. 1.7Vp-p DC mode	

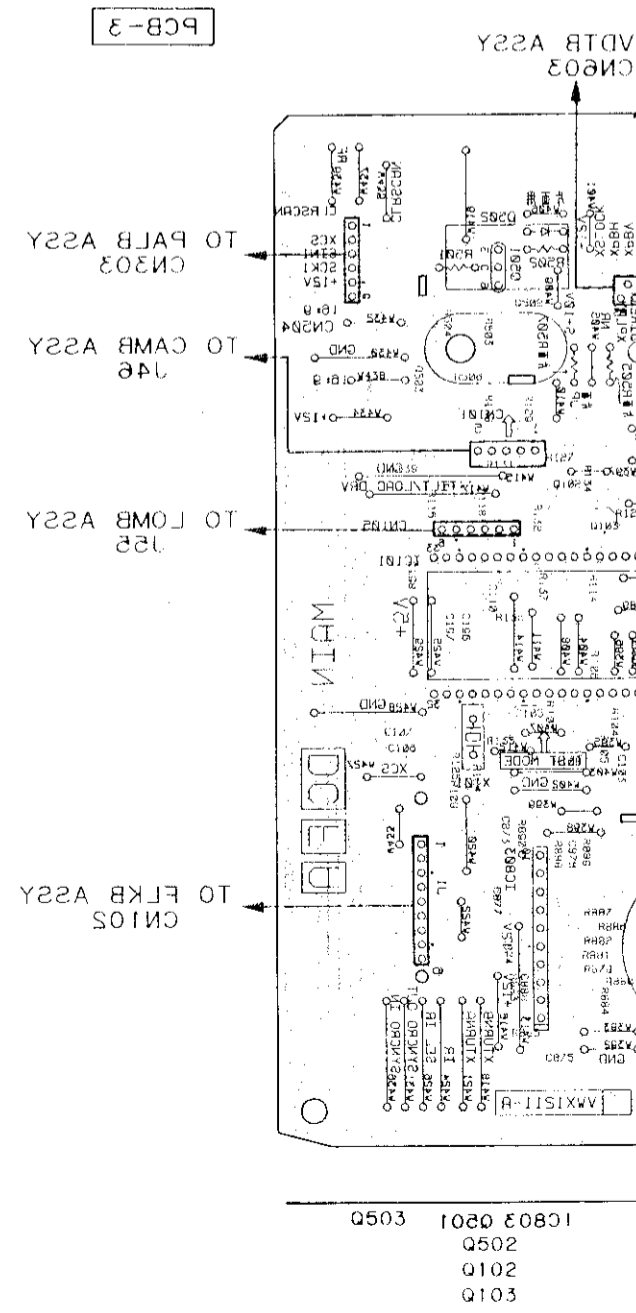

● This diagram is viewed from the mounted parts

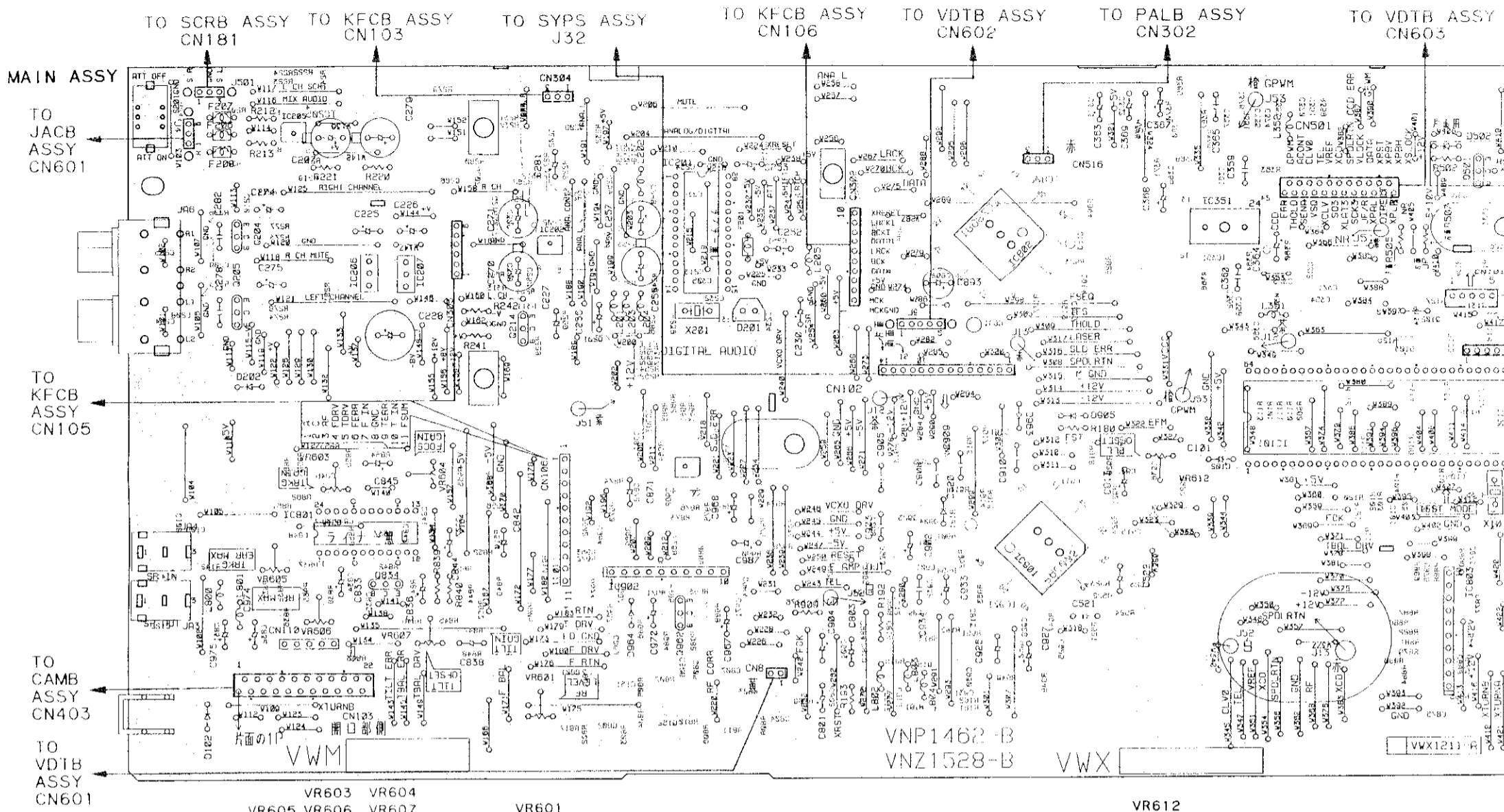

VR603	VR604	VR605	VR606	VR607	VR601	VR612
Q204	IC206	IC207	Q805	Q214	IC902	IC201
Q205	IC801	Q834	Q807	Q808	Q809	Q803
	IC802		Q804	Q806	Q804	Q804
			Q806	Q805	Q804	Q803
			Q806	Q805	Q804	Q803
			Q806	Q805	Q804	Q803
			Q806	Q805	Q804	Q803

● This diagram is viewed from the foil side.

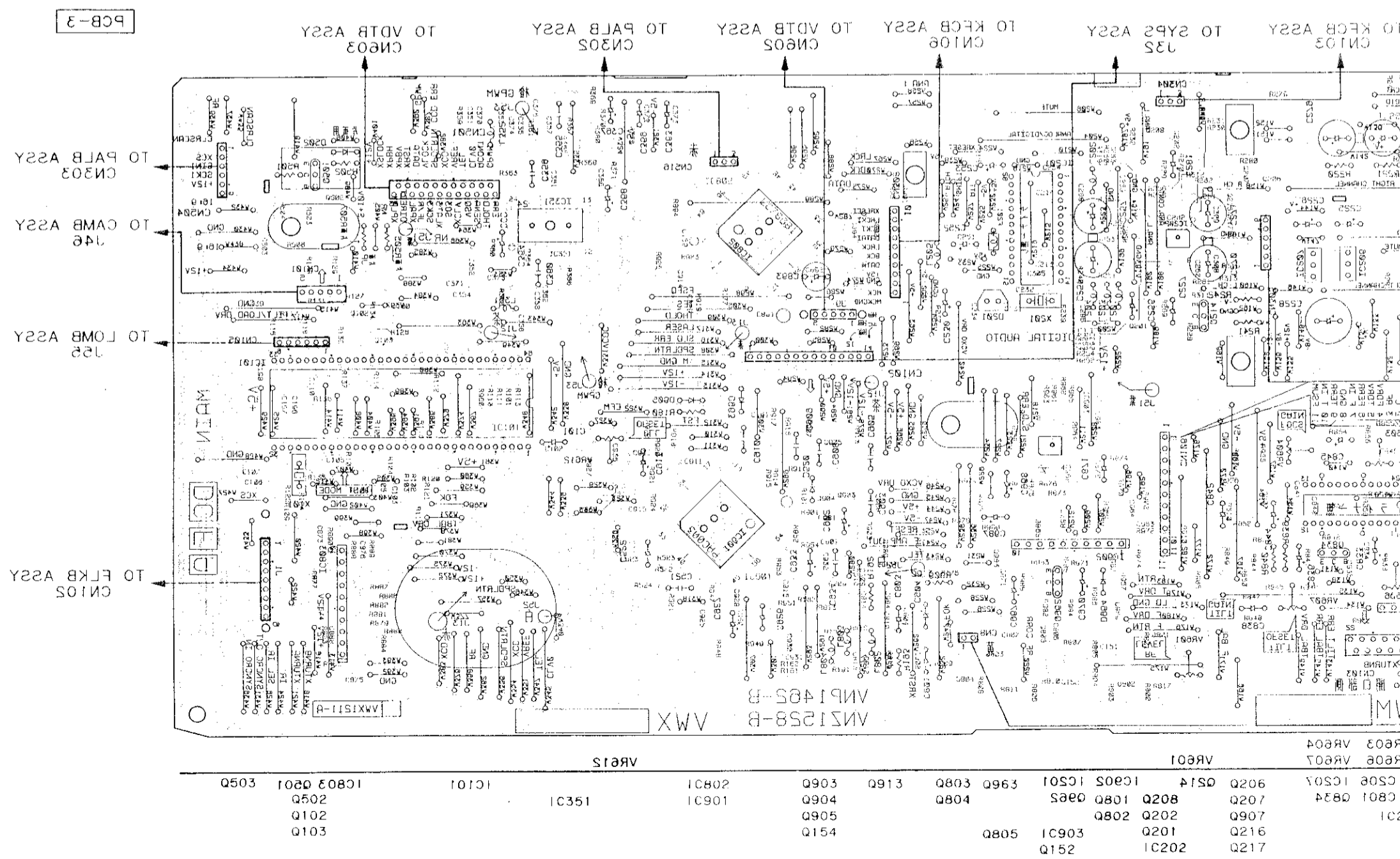

VR603	VR604	VR605	VR606	VR607	VR601	VR612
Q503	IC083	IC082	IC081	IC080	IC079	IC078
Q502	Q502	Q502	Q502	Q502	Q502	Q502
Q102	Q102	Q102	Q102	Q102	Q102	Q102
Q103	Q103	Q103	Q103	Q103	Q103	Q103

A
B
C
D
E
F

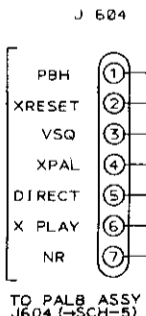
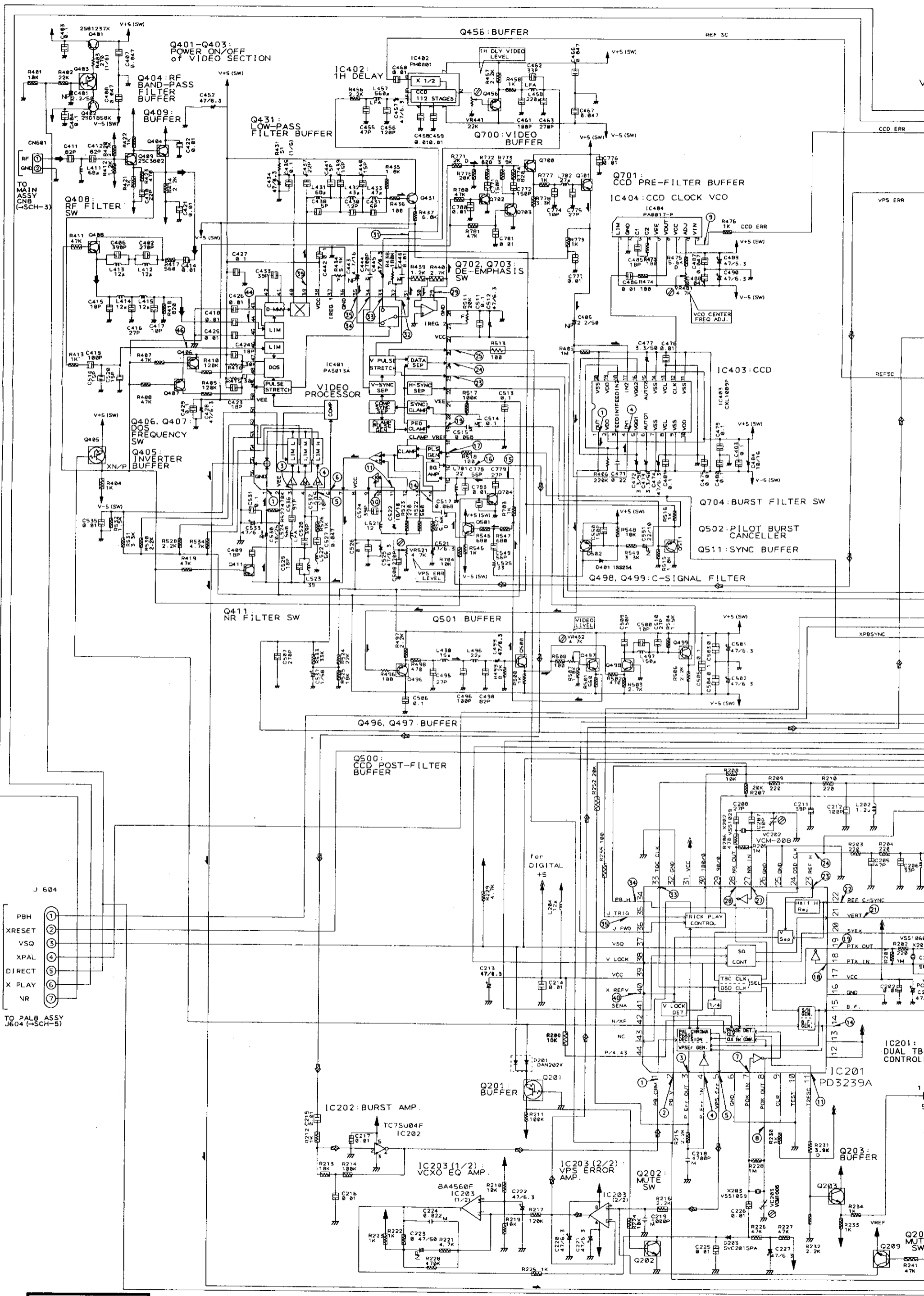

SCH-4

VDTB ASSY

VDTB ASSY (VWS1141)

DTA124EK	Q201	403	405	606	609	621	622	623			
25C2412K	Q202	213	205	206	209	404	408	497	498		
Q499	510	501	601	602	603	604	605	608	701	702	
25A1037K	Q204	207	406	407	411	456	496	502	511	703	704
25B1237K	Q401										
25D1858K	Q402										
25C3602K	Q403										
25C11740S	Q431										
DTC124EK	Q607	610	612	613	624	625					

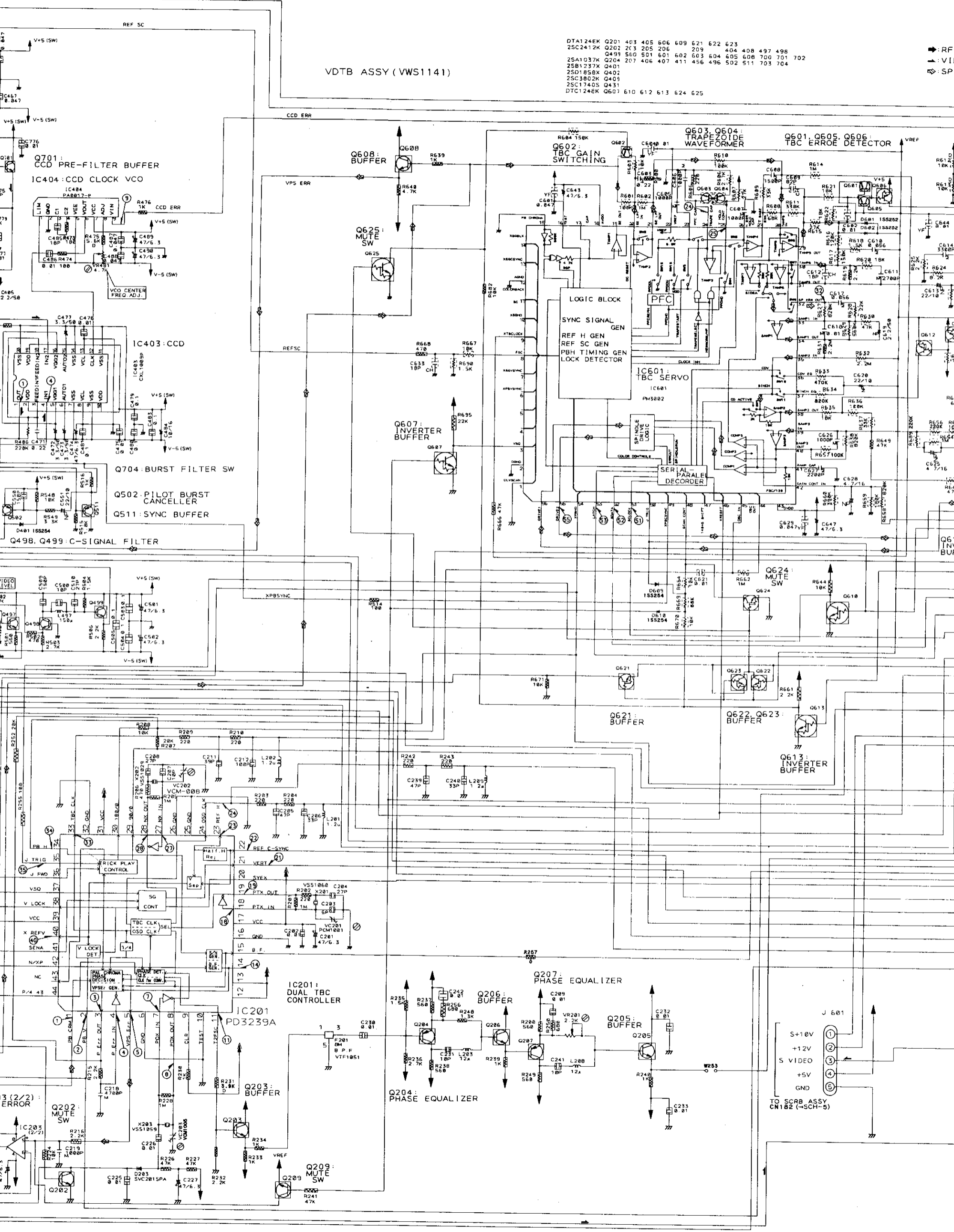

SCH-4

ASSY (VWS1141)

DTA124EK	Q201	403	405	606	609	621	622	623
25C2412K	Q202	203	205	206		209	404	408
Q499	500	501	601	602	603	604	605	606
25A1037K	Q204	207	406	407	411	456	496	502
25B1237X	Q401							
25D1858K	Q402							
25C3802K	Q403							
25C1740S	Q431							
DTC124EK	Q607	610	612	613	624	625		

- ◆ RF SIGNAL LINE
- ▲ VIDEO SIGNAL LINE
- ◇ SPINDLE SERVO LOOP LINE

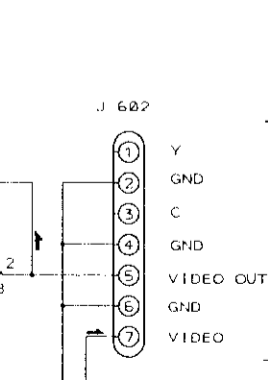
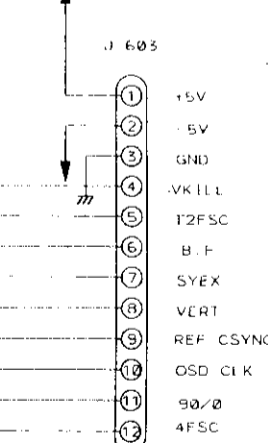
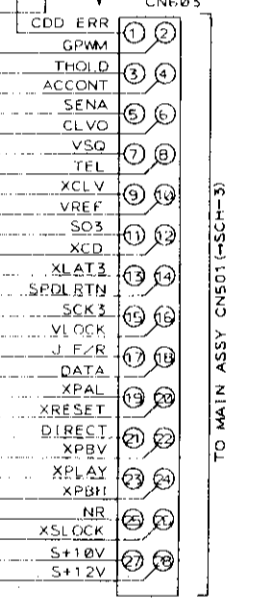
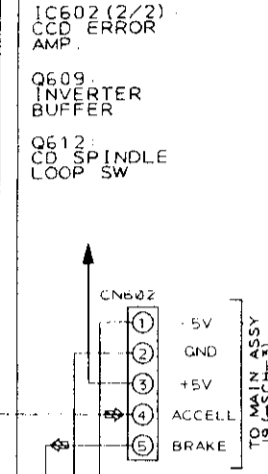
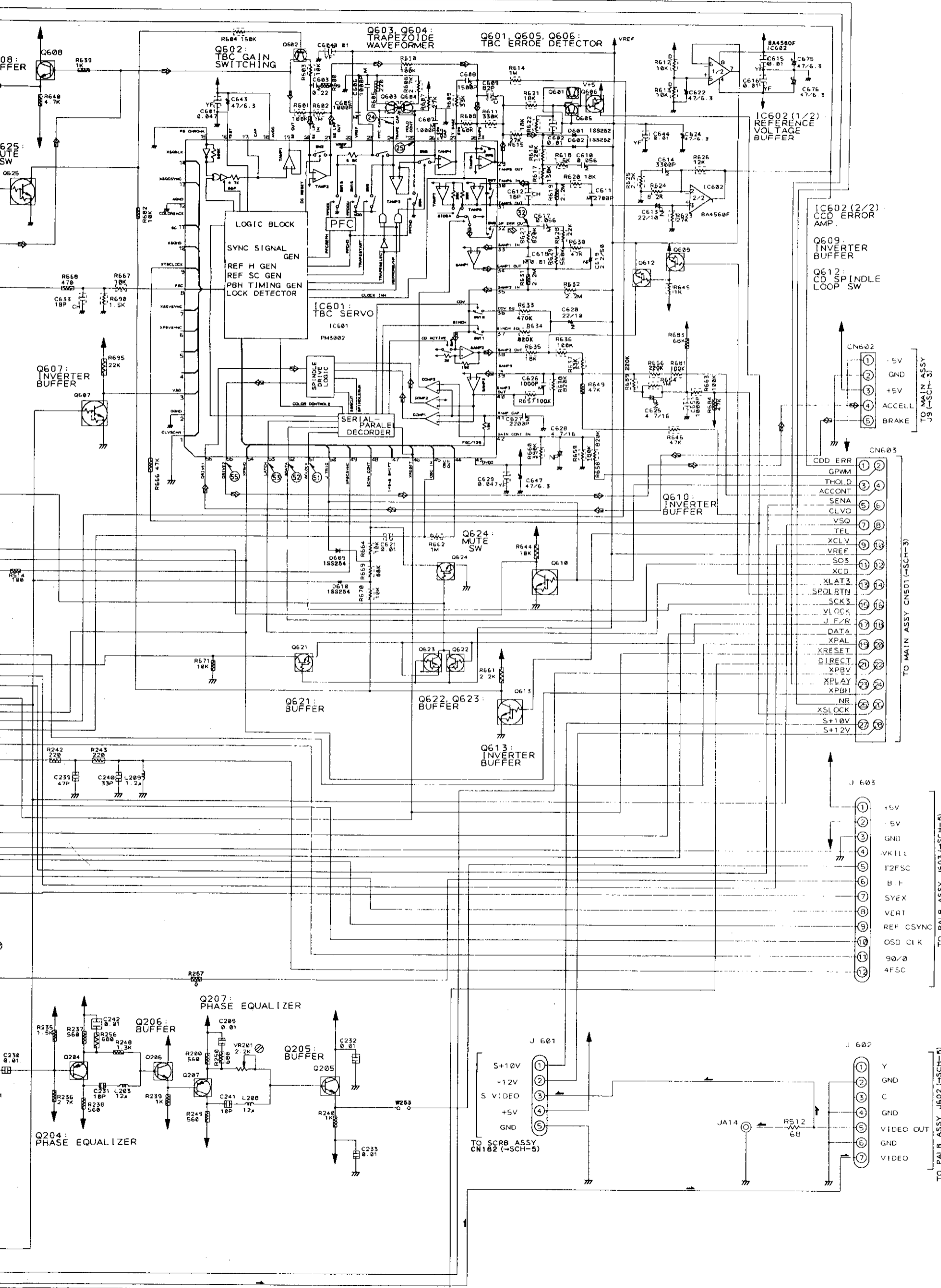

VDTB ASSY

SCH-4

VDTB ASSEMBLY

Note: (No.) in the table correspond to the pin number.

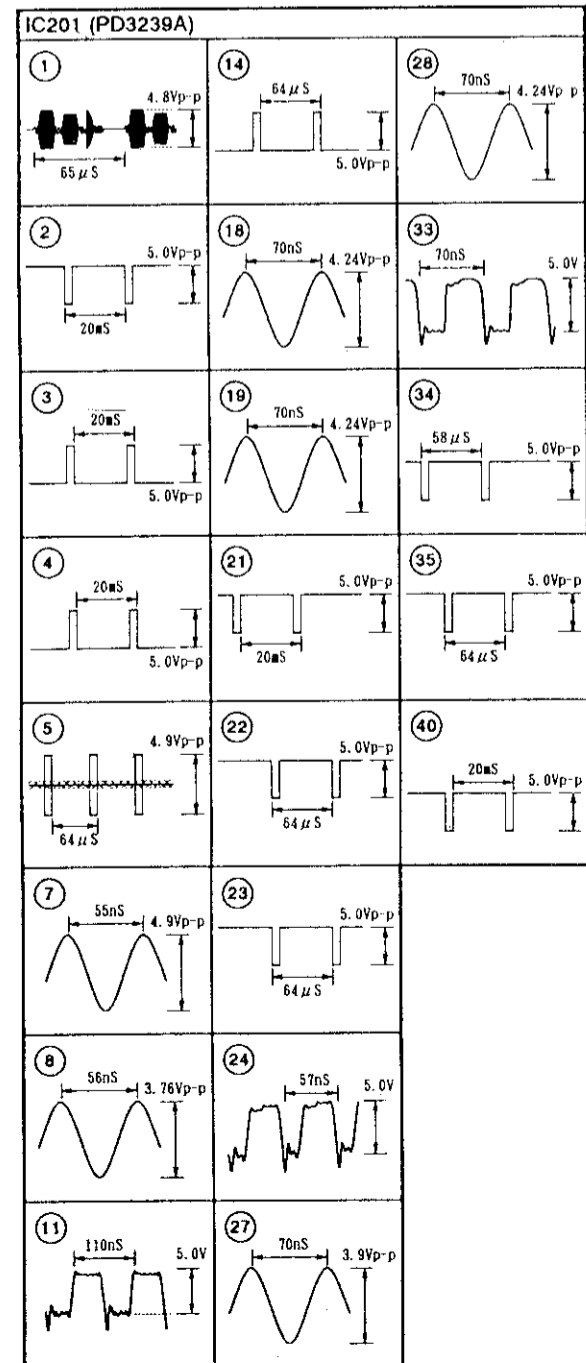
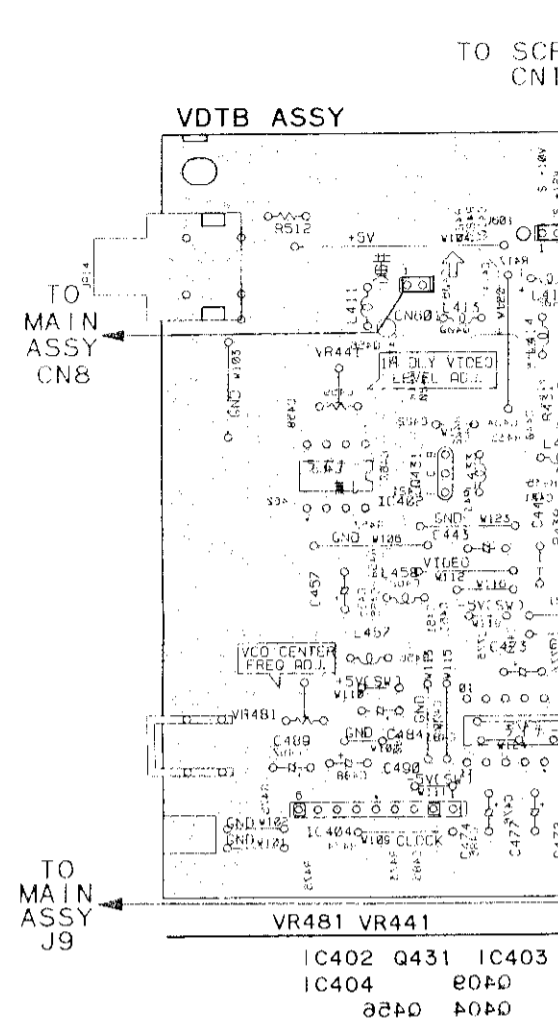
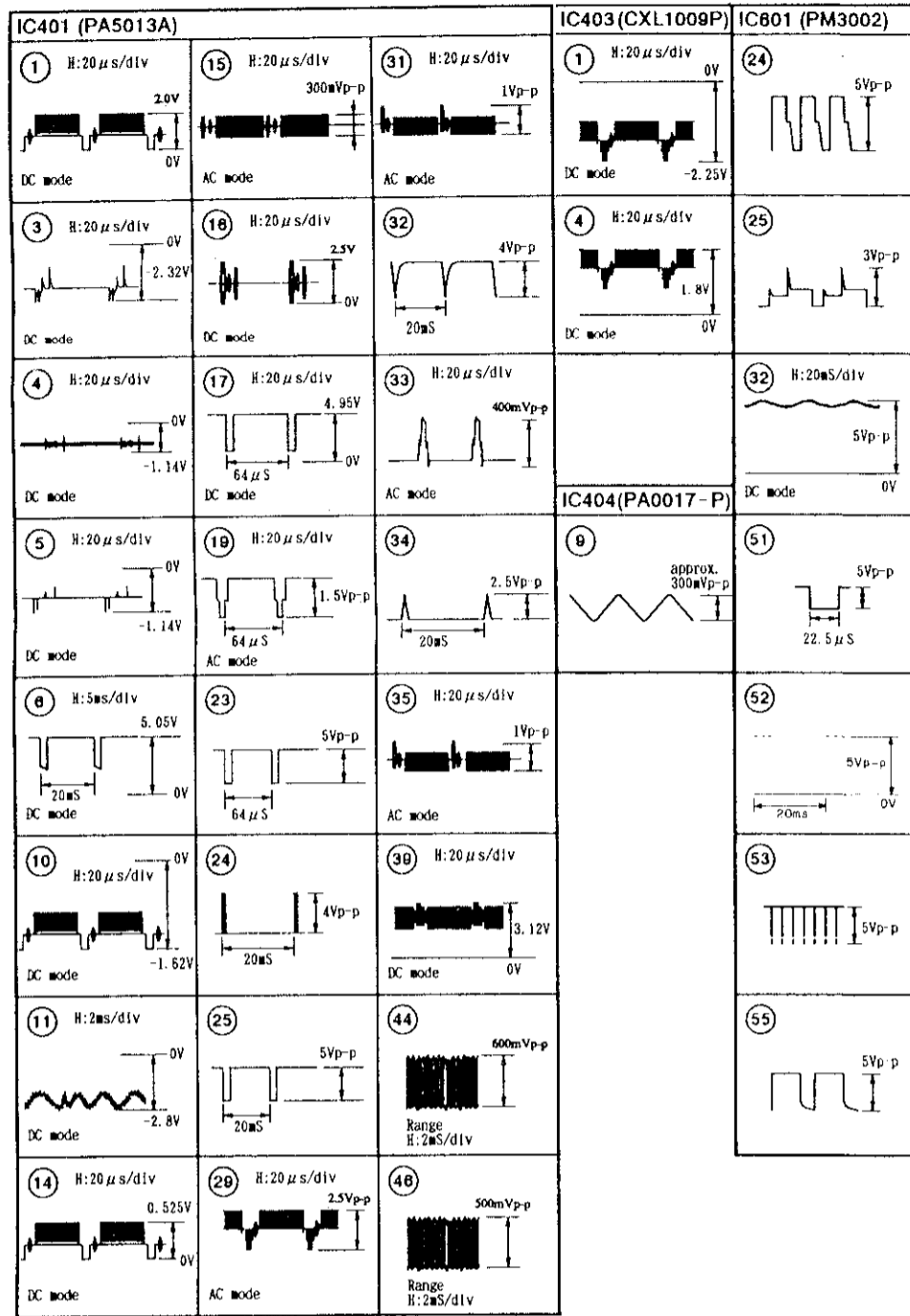

Note: These waveforms and voltage are in the PAL DISC playback.

● IC201 (PD3239A)

Pin No.	Voltage (V)	Pin No.	Voltage (V)	Pin No.	Voltage (V)	Pin No.	Voltage (V)
1	*	12	5.0	23	*	34	*
2	*	13	5.0	24	*	35	*
3	*	14	*	25	0	36	5.0
4	*	15	5.0	26	0	37	5.0
5	*	16	0	27	*	38	5.0
6	0	17	5.0	28	*	39	5.0
7	*	18	*	29	5.0	40	*
8	*	19	*	30	5.0	41	0
9	5.0	20	5.0	31	5.0	42	0
10	0	21	*	32	0	43	5.0
11	*	22	*	33	*	44	5.0

*: Refer to waveforms

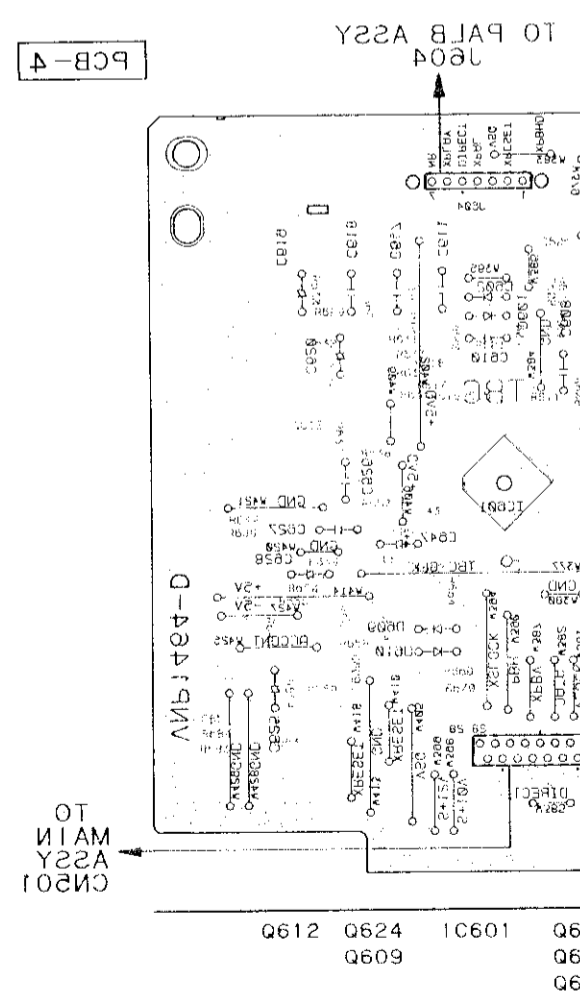

● This diagram is viewed from the mounted p

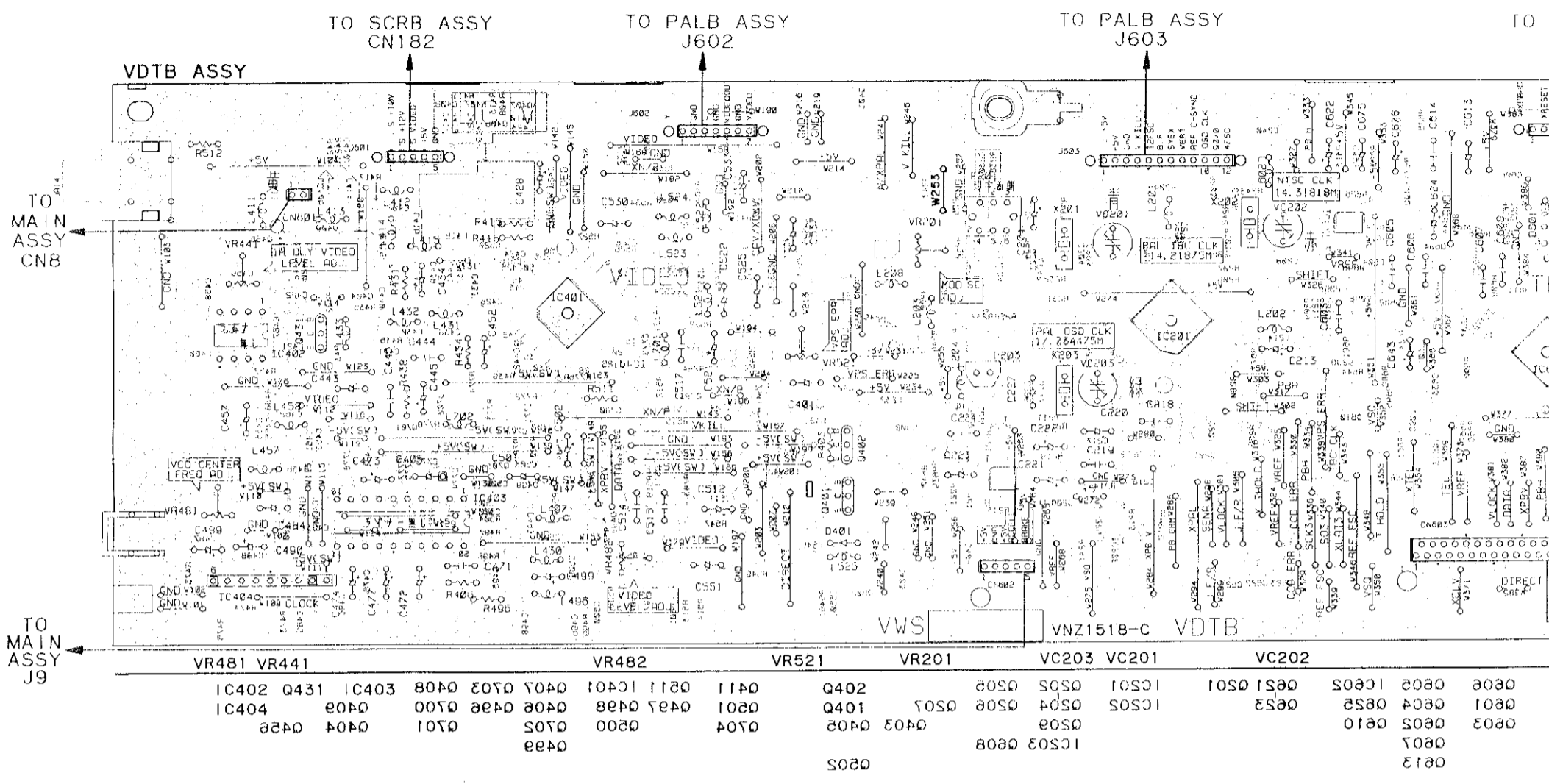

● This diagram is viewed from the foil side.

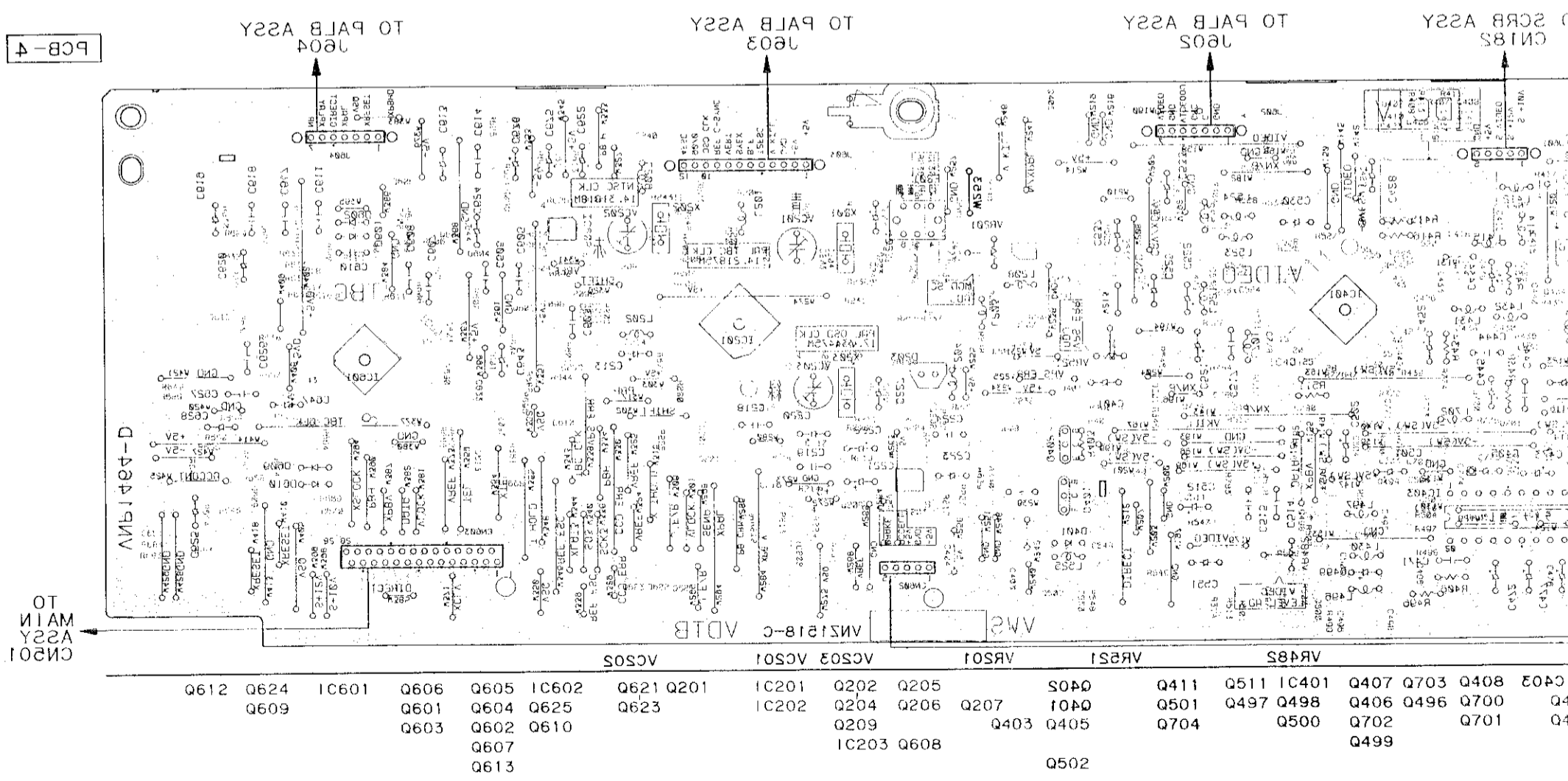

• This diagram is viewed from the mounted parts side.

A

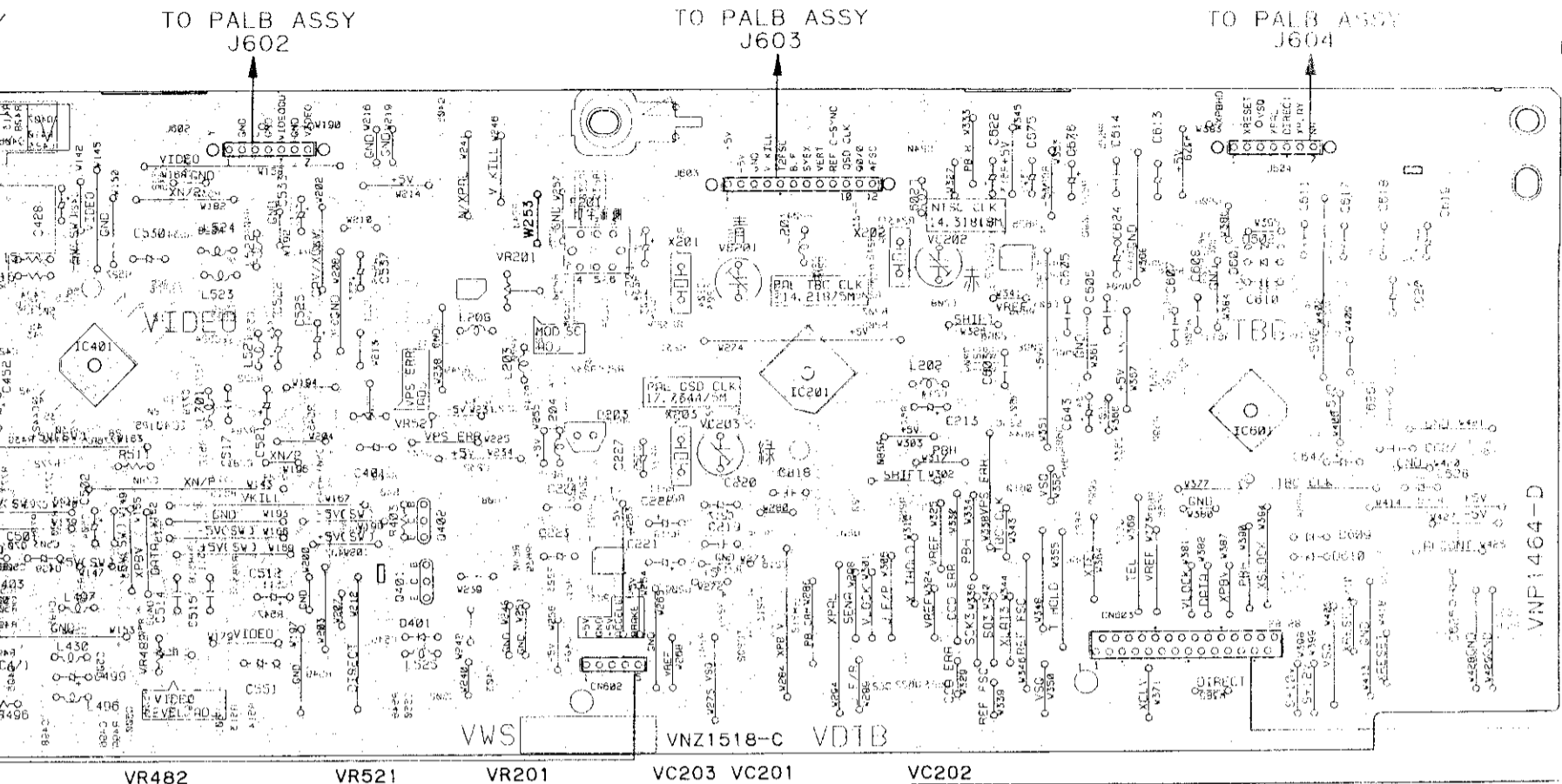

PCB-4

VR482	VR521	VR201	VC203	VC201	VC202	VR481	VR441	VR442	VR443	VR444	VR445	VR446	VR447	VR448	VR449	VR450	VR451	VR452	VR453	VR454	VR455	VR456	VR457	VR458	VR459	VR460	VR461	VR462	VR463	VR464	VR465	VR466	VR467	VR468	VR469	VR470	VR471	VR472	VR473	VR474	VR475	VR476	VR477	VR478	VR479	VR480	VR481	VR482	VR483	VR484	VR485	VR486	VR487	VR488	VR489	VR490	VR491	VR492	VR493	VR494	VR495	VR496	VR497	VR498	VR499	VR500																																	
Q401	Q402	Q403	Q404	Q405	Q406	Q407	Q408	Q409	Q410	Q411	Q412	Q413	Q414	Q415	Q416	Q417	Q418	Q419	Q420	Q421	Q422	Q423	Q424	Q425	Q426	Q427	Q428	Q429	Q430	Q431	Q432	Q433	Q434	Q435	Q436	Q437	Q438	Q439	Q440	Q441	Q442	Q443	Q444	Q445	Q446	Q447	Q448	Q449	Q450	Q451	Q452	Q453	Q454	Q455	Q456	Q457	Q458	Q459	Q460	Q461	Q462	Q463	Q464	Q465	Q466	Q467	Q468	Q469	Q470	Q471	Q472	Q473	Q474	Q475	Q476	Q477	Q478	Q479	Q480	Q481	Q482	Q483	Q484	Q485	Q486	Q487	Q488	Q489	Q490	Q491	Q492	Q493	Q494	Q495	Q496	Q497	Q498	Q499	Q500

• This diagram is viewed from the foil side.

D

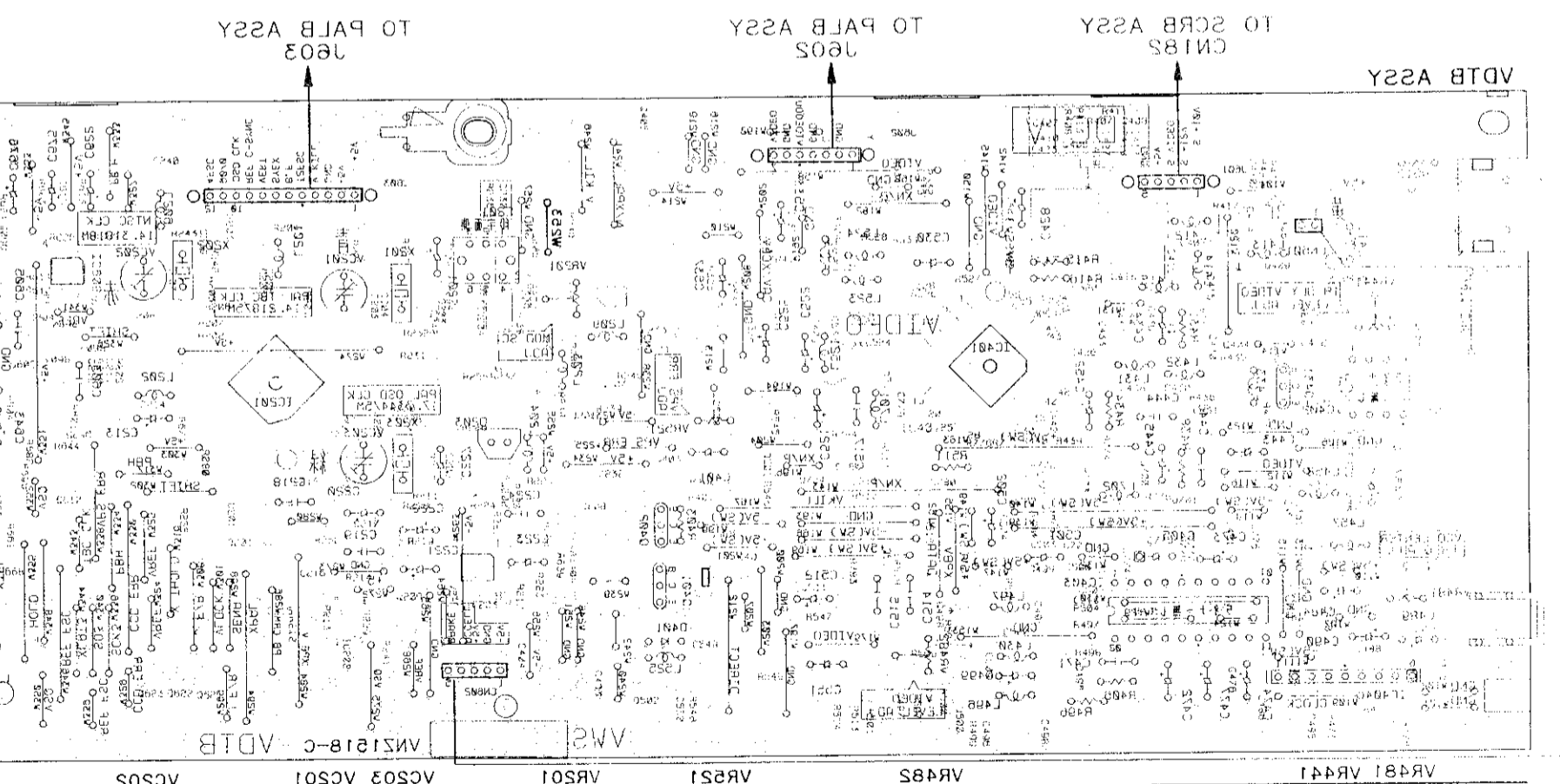

VR481	VR441	VR482	VR442	VR483	VR443	VR484	VR444	VR485	VR445	VR486	VR446	VR487	VR447	VR488	VR448	VR489	VR449	VR490	VR440	VR491	VR441	VR492	VR442	VR493	VR443	VR494	VR444	VR495	VR445	VR496	VR446	VR497	VR447	VR498	VR448	VR499	VR449	VR500	VR450	VR451	VR452	VR453	VR454	VR455	VR456	VR457	VR458	VR459	VR460	VR461	VR462	VR463	VR464	VR465	VR466	VR467	VR468	VR469	VR470	VR471	VR472	VR473	VR474	VR475	VR476	VR477	VR478	VR479	VR480	VR481	VR482	VR483	VR484	VR485	VR486	VR487	VR488	VR489	VR490	VR491	VR492	VR493	VR494	VR495	VR496	VR497	VR498	VR499	VR500										
Q401	Q402	Q403	Q404	Q405	Q406	Q407	Q408	Q409	Q410	Q411	Q412	Q413	Q414	Q415	Q416	Q417	Q418	Q419	Q420	Q421	Q422	Q423	Q424	Q425	Q426	Q427	Q428	Q429	Q430	Q431	Q432	Q433	Q434	Q435	Q436	Q437	Q438	Q439	Q440	Q441	Q442	Q443	Q444	Q445	Q446	Q447	Q448	Q449	Q450	Q451	Q452	Q453	Q454	Q455	Q456	Q457	Q458	Q459	Q460	Q461	Q462	Q463	Q464	Q465	Q466	Q467	Q468	Q469	Q470	Q471	Q472	Q473	Q474	Q475	Q476	Q477	Q478	Q479	Q480	Q481	Q482	Q483	Q484	Q485	Q486	Q487	Q488	Q489	Q490	Q491	Q492	Q493	Q494	Q495	Q496	Q497	Q498	Q499	Q500

F

2.2.5 PALB AND SCRIB ASSEMBLIES

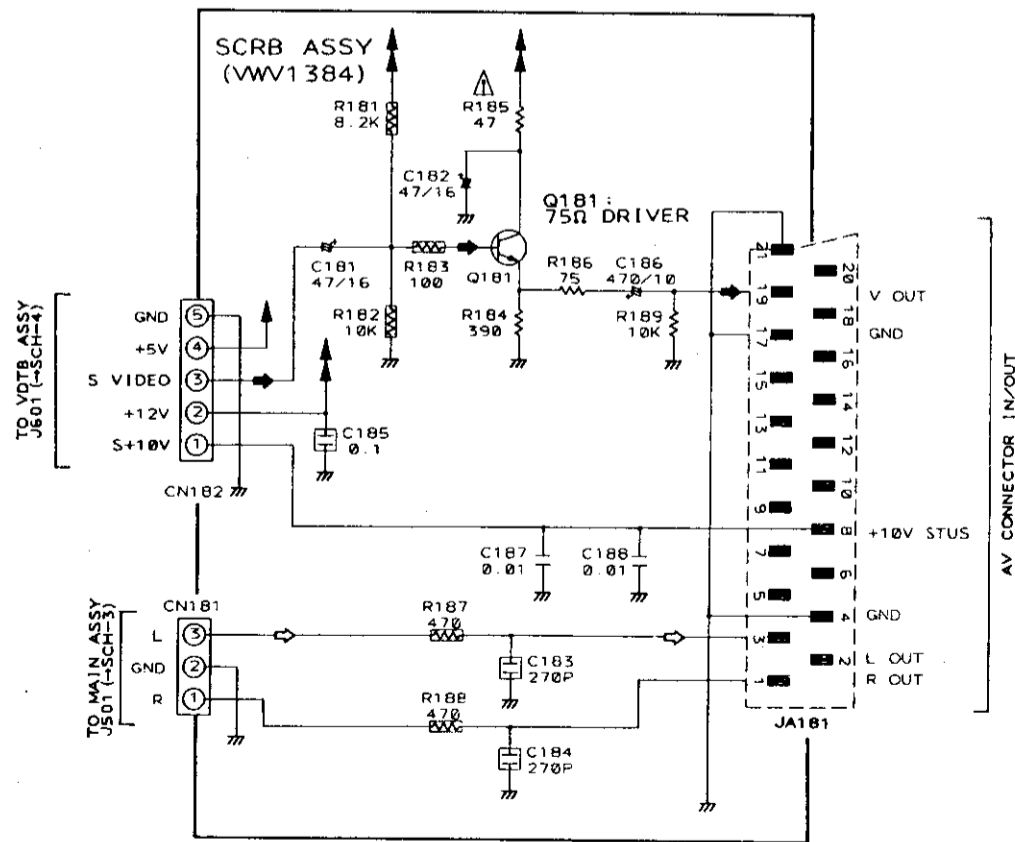
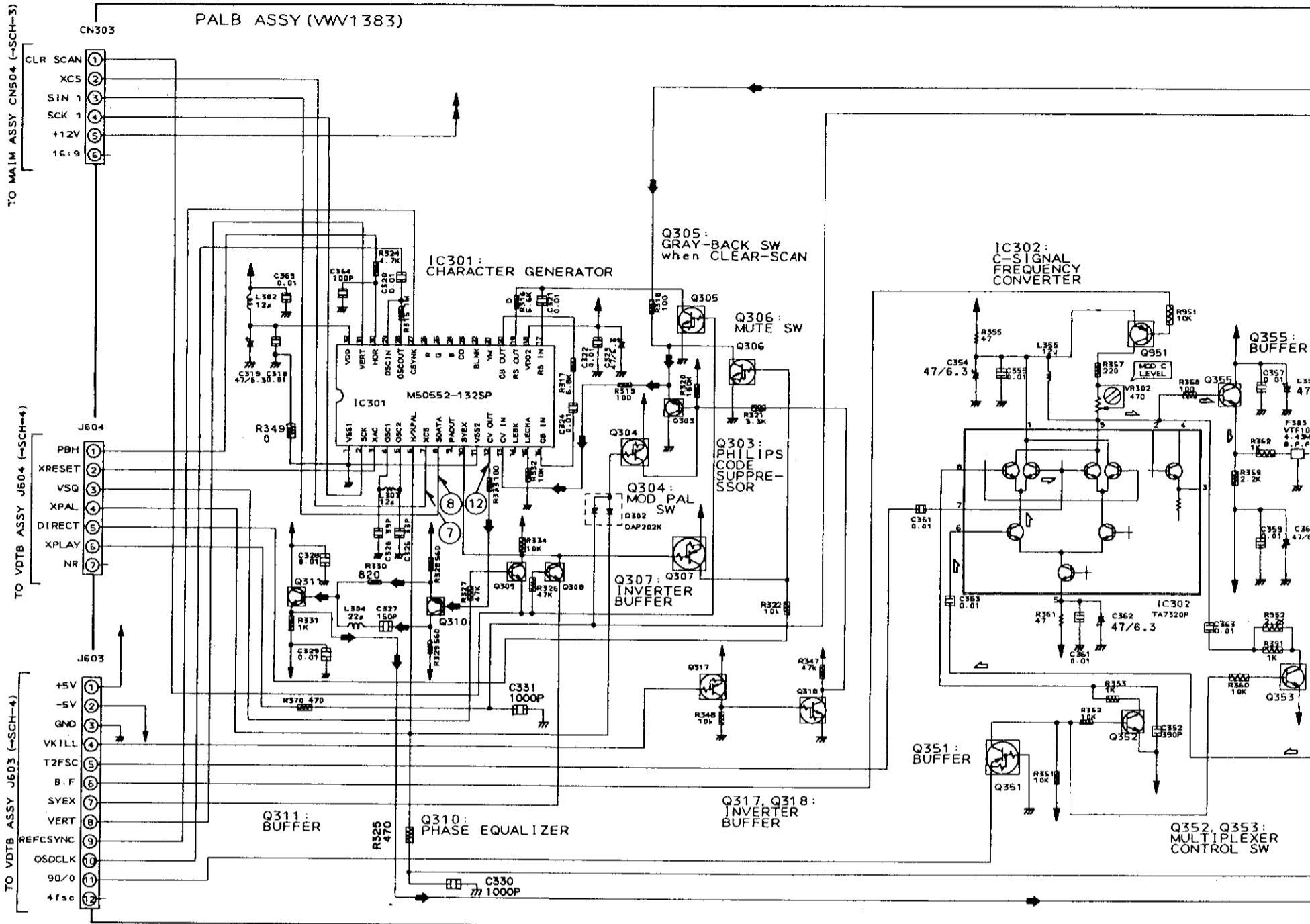

SCH-5

PALB ASSY, SCRIB ASSY

- ▶ : VIDEO
- ▶ : Y-SIGNAL
- ▶ : C-SIGNAL
- ◁ : AUDIO

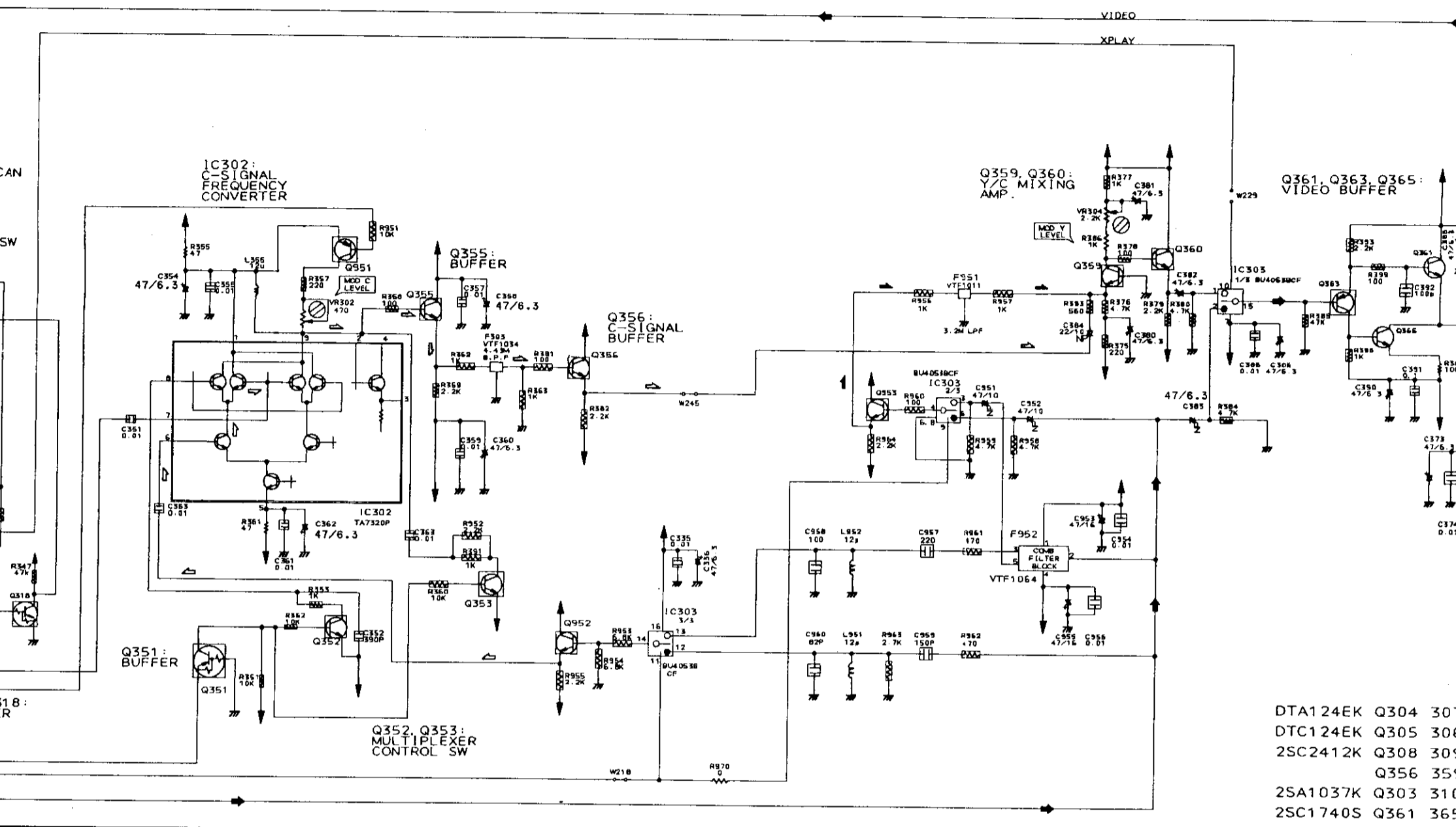

- DTA124EK Q304 30
- DTC124EK Q305 30
- 2SC2412K Q308 30
- Q356 35
- 2SA1037K Q303 31
- 2SC1740S Q361 36

PALB ASSEMBLY

Note: (No.) in the table correspond to the pin number.

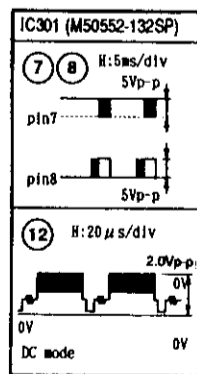

(PALB ASS)
Note: These

• IC301 (M

Pin No.	Voltage (V)
1	0
2	5
3	5
4	2.4
5	2.4
6	-
7	5
8	0.4

AV CONNECTOR IN/OUT

A
B
C
D
E
F

SCH-5

- ◆ : VIDEO SIGNAL LINE
- ▲ : Y-SIGNAL LINE
- △ : C-SIGNAL LINE
- ◇ : AUDIO SIGNAL LINE

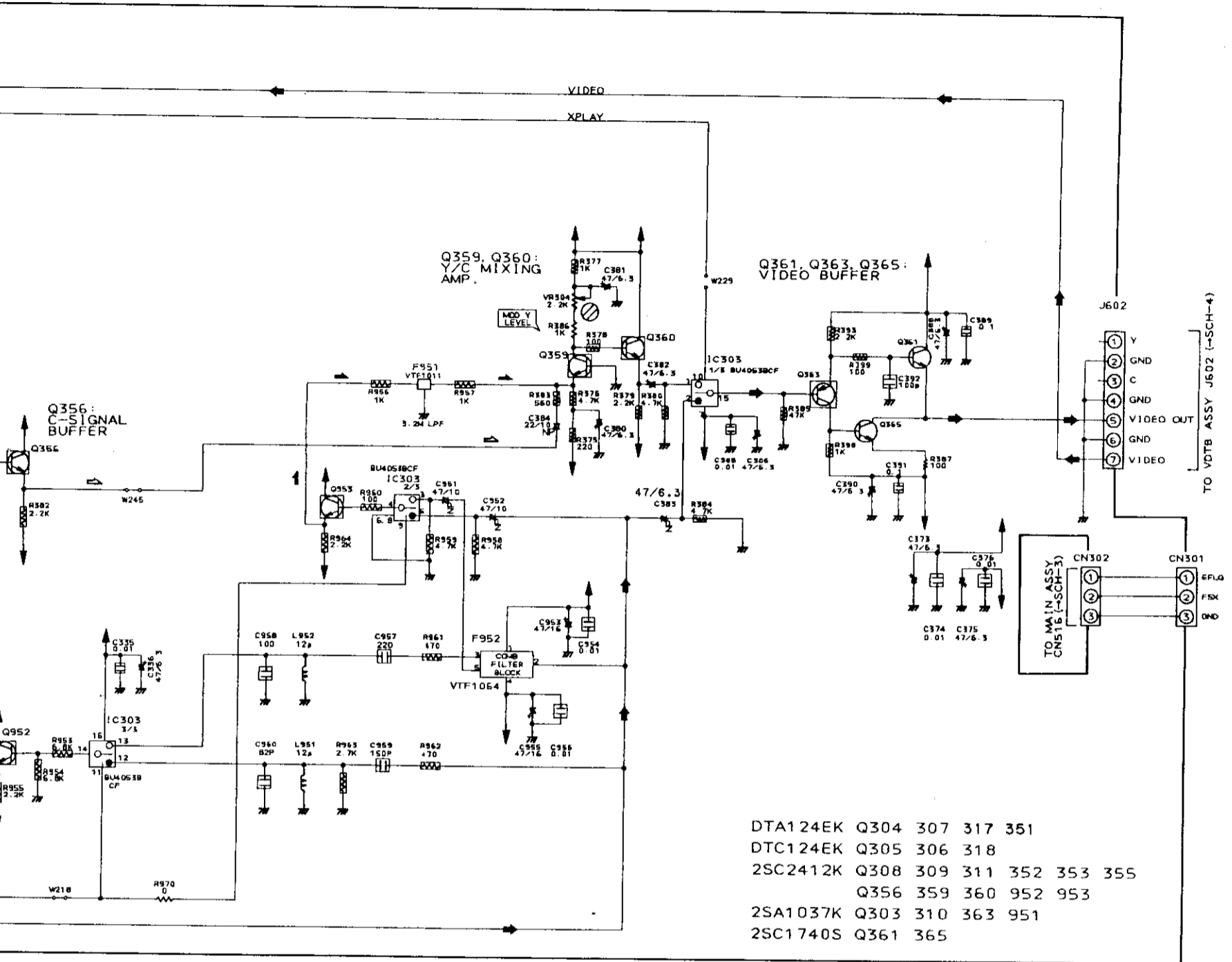

- DTA124EK Q304 307 317 351
- DTC124EK Q305 306 318
- 2SC2412K Q308 309 311 352 353 355
- Q356 359 360 952 953
- 2SA1037K Q303 310 363 951
- 2SC1740S Q361 365

PALB ASSEMBLY

Note: (No.) in the table correspond to the pin number.

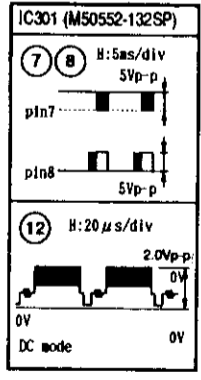

[PALB ASSY]

Note: These waveforms and voltage are in the play mode.

● IC301 (M50552-132SP)

Pin No.	Voltage (V)	Pin No.	Voltage (V)	Pin No.	Voltage (V)	Pin No.	Voltage (V)
1	0	9	-	17	0.8	25	-
2	5	10	5	18	-	26	-
3	5	11	0	19	0	27	-
4	2.4	12	1.1	20	0	28	2.3
5	2.4	13	1.1	21	-	29	2.3
6	-	14	-	22	-	30	-
7	5	15	1.8	23	-	31	-
8	0.4	16	0.6	24	-	32	-

SCH-5

This diagram is viewed from the foil side.

This diagram is viewed from the mounted parts side.

PALB ASSY

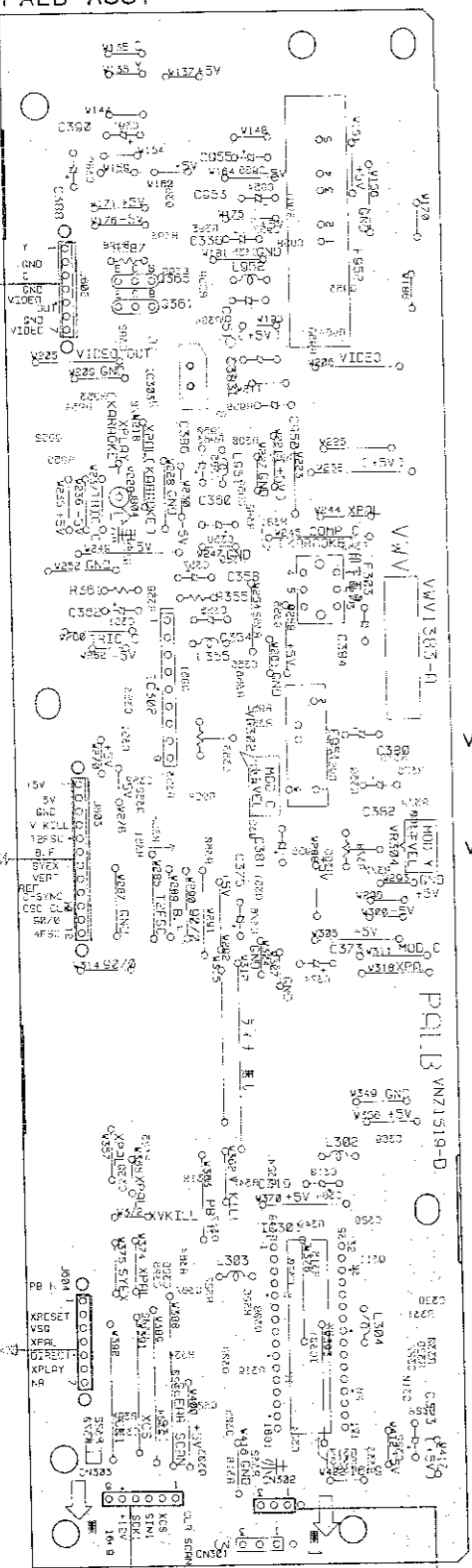

TO VDTB ASSY J602

TO VDTB ASSY J603

TO VDTB ASSY J604

TO MAIN ASSY CN504

TO MAIN ASSY CN516

VR302

VR304

PALB VNT1519-D

PCB-5

SCRB ASSY

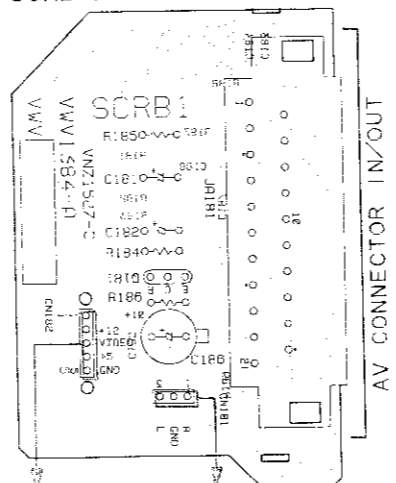

TO VDTB ASSY TO MAIN ASSY J501 J501

Q181

VNP1464-D

PCB-2

2SCRB ASSY

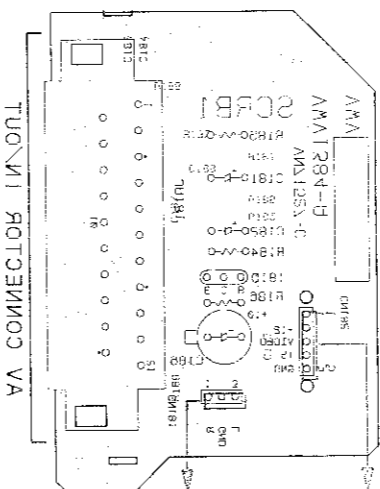

TO VDTB ASSY TO MAIN ASSY J501 J501

Q181

VNP1464-D

PALB ASSY

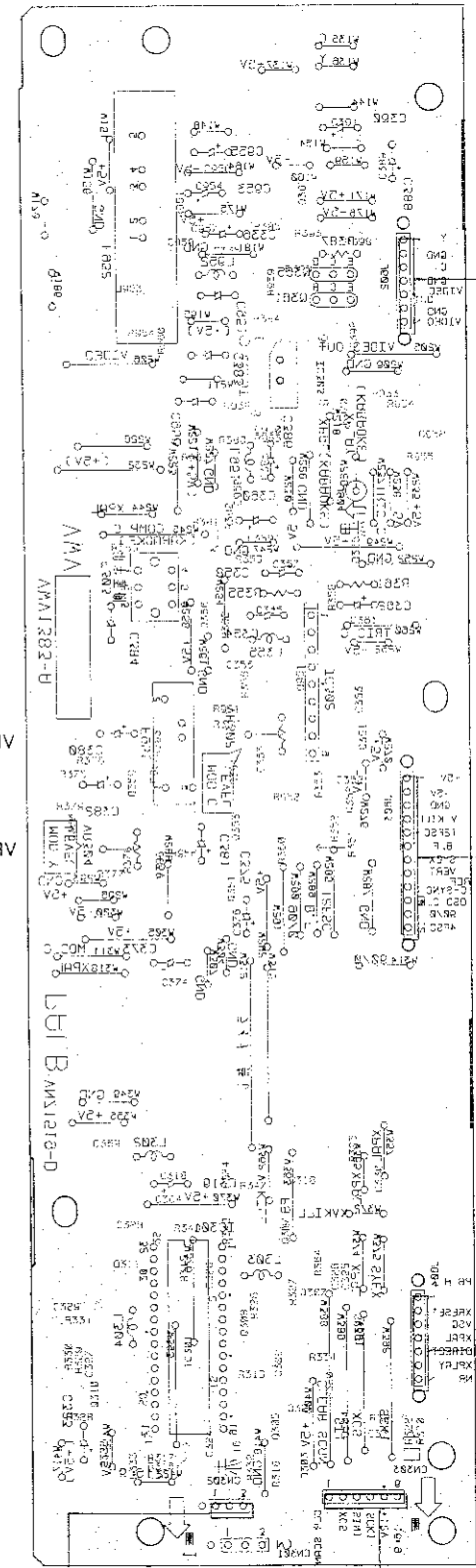

TO VDTB ASSY J602

TO VDTB ASSY J603

TO VDTB ASSY J604

TO MAIN ASSY CN519

TO MAIN ASSY CN520

VR305

VR304

PALB VNT1519-D

TO VDTB ASSY J602

TO VDTB ASSY J603

TO VDTB ASSY J604

TO MAIN ASSY CN519

TO MAIN ASSY CN520

2.2.6 KFCB AND EXTB ASSEMBLIES

NOTE: Measuring condition of voltages and waveforms in the schematic diagram is follows:
Karaoke mode
Playing the disc contains analog and digital audio signals.

(MIC-E) : AUDIO SIGNAL LINE for ECHO
(MIC-D) : AUDIO SIGNAL LINE(MIC)
◇ : AUDIO SIGNAL LINE(Digital)
▽ : AUDIO SIGNAL LINE(Lch)

SCH-6

A

B

C

D

A

B

C

D

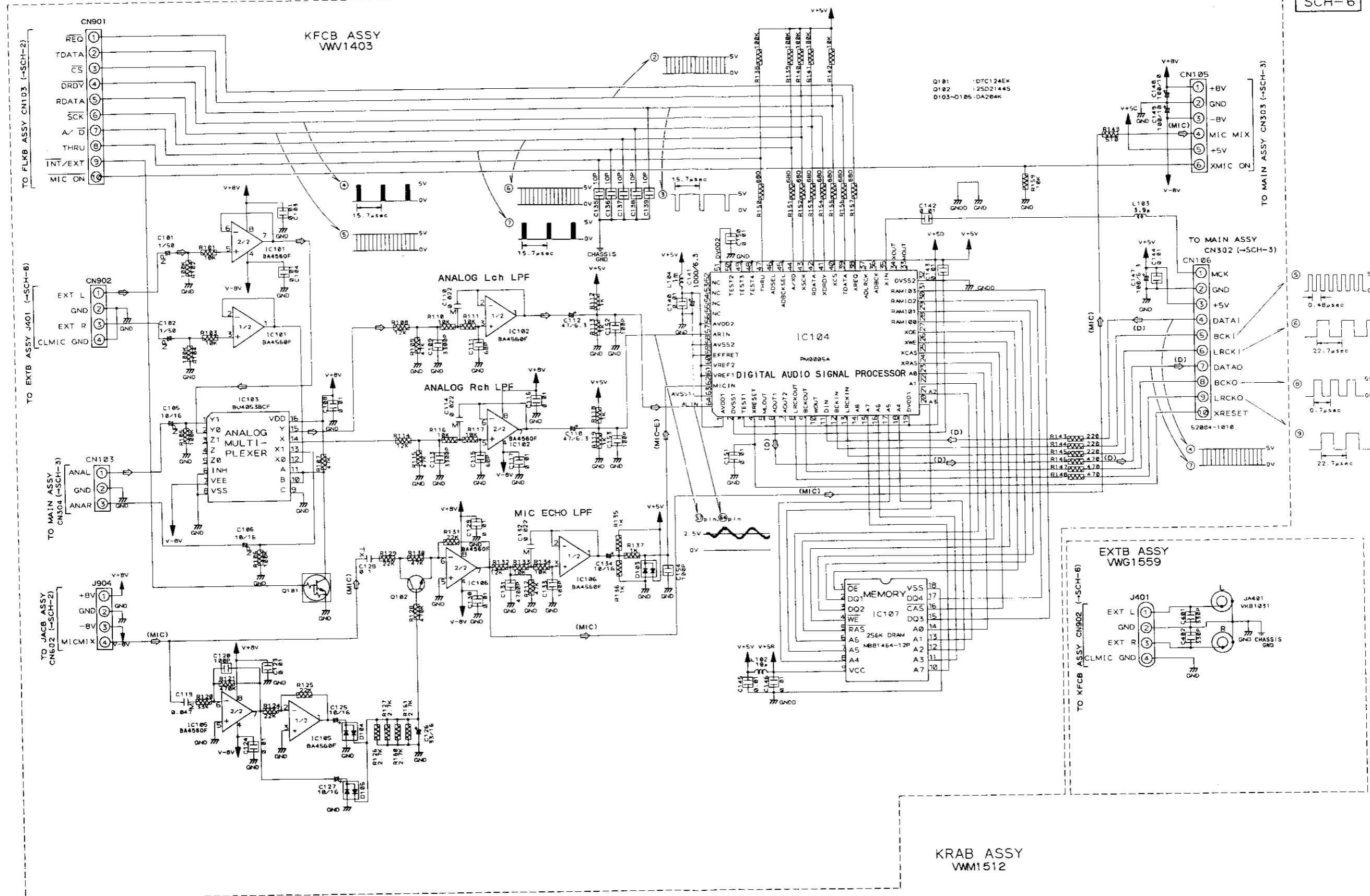

KFCB ASSY, EXTB ASSY
SCH-6

KFCB ASSY, EXTB ASSY
SCH-6

KRAB ASSY
VMM1512

• This diagram is viewed from the mounted parts side.

PCB-6

A

B

C

D

IC107
IC104
S0101
S0101
S0101
Q102
S0101
S0101

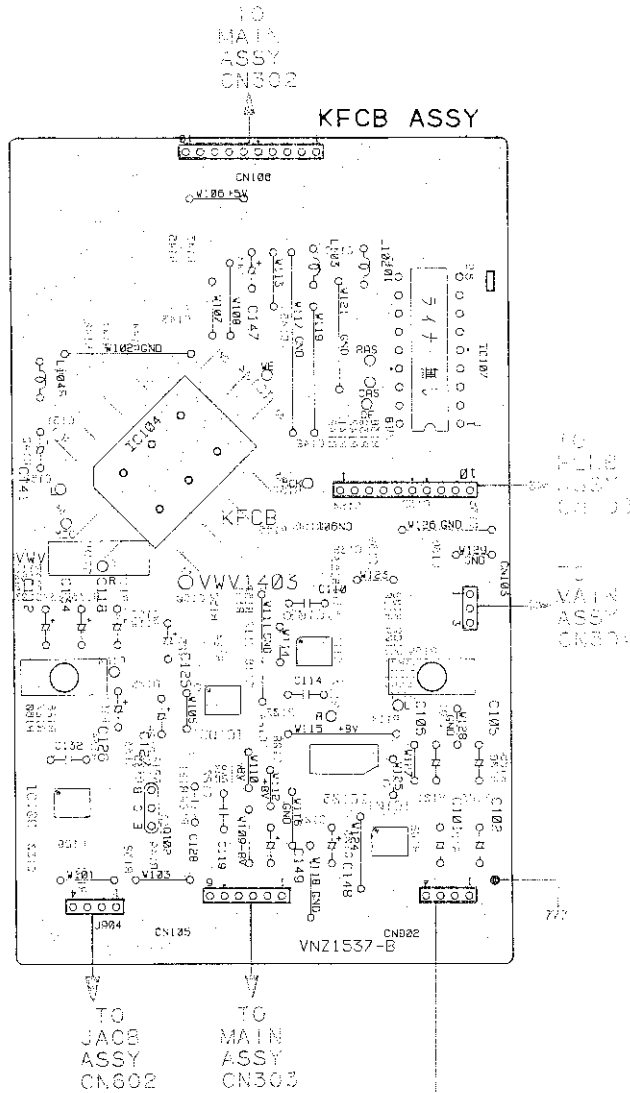

EXTB ASSY

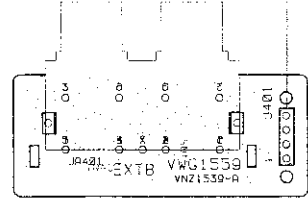

VNP1482-B

● This diagram is viewed from the foil side.

PCB-8

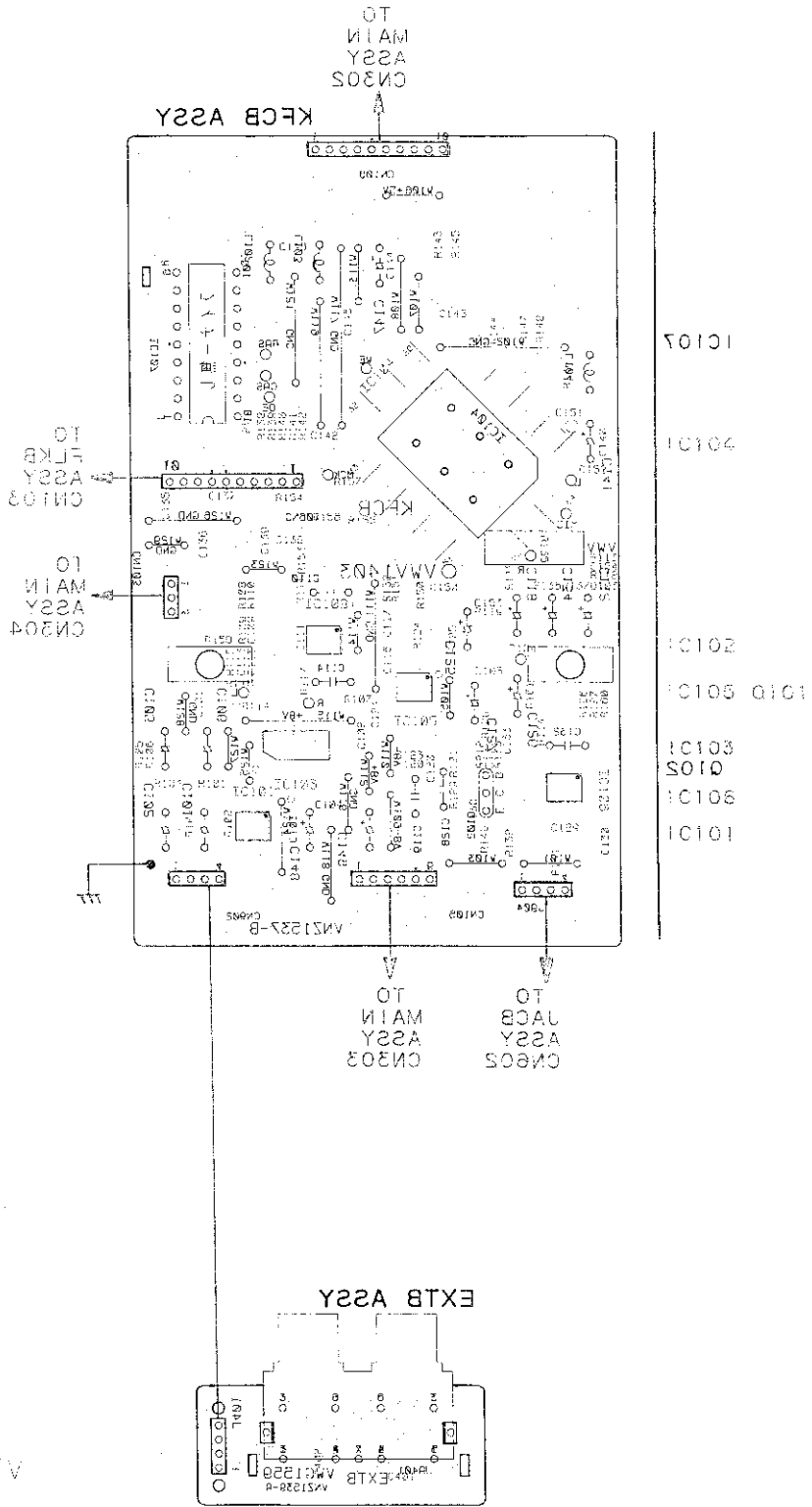

A
B
C
D

AN51480-B