

Service Manual

PIONEER
The Art of Entertainment

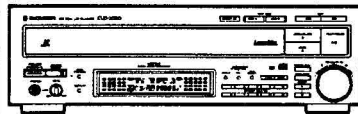

ORDER NO.
ARP2241

CD CDV LD PLAYER

CLD-2090

- This manual is applicable to the KU/CA type.

CONTENTS

1. SAFETY INFORMATION	2	7. DISASSEMBLY	62
2. EXPLODED VIEWS AND PARTS LIST	3	8. ADJUSTMENTS	67
3. PACKING	19	9. ABBREVIATIONS TABLE	94
4. P. C. BOARDS LOCATION	20	10. SPECIFICATIONS	95
5. SCHEMATIC AND P. C. BOARDS DIAGRAM ..	21	11. PANEL FACILITIES	97
6. ELECTRICAL PARTS LIST	57		

PIONEER ELECTRONIC CORPORATION 4-1, Meguro 1-Chome, Meguro-ku, Tokyo 153, Japan
PIONEER ELECTRONICS SERVICE INC. P.O. Box 1760, Long Beach, California 90801 U.S.A.
PIONEER ELECTRONICS OF CANADA, INC. 505 Cochrane Drive, Markham, Ontario L3R 8E3 Canada
PIONEER ELECTRONIC [EUROPE] N.V. Keetberglaan 1, 9120 Beveren, Belgium
PIONEER ELECTRONICS AUSTRALIA PTY. LTD. 178-184 Boundary Road, Braeside, Victoria 3195, Australia TEL: [03] 580-9911
© PIONEER ELECTRONIC CORPORATION 1991

IFJ APR. 1991 Printed in Japan

This service manual is intended for qualified service technicians; it is not meant for the casual do-it-yourselfer. Qualified technicians have the necessary test equipment and tools, and have been trained to properly and safely repair complex products such as those covered by this manual.

Improperly performed repairs can adversely affect the safety and reliability of the product and may void the warranty. If you are not qualified to perform the repair of this product properly and safely, you should not risk trying to do so and refer the repair to a qualified service technician.

WARNING

Lead in solder used in this product is listed by the California Health and Welfare agency as a known reproductive toxicant which may cause birth defects or other reproductive harm (California Health & Safety Code, Section 25249.5).

When servicing or handling circuit boards and other components which contain lead in solder, avoid unprotected skin contact with the solder. Also, when soldering do not inhale any smoke or fumes produced.

1. SAFETY INFORMATION

(FOR USA MODEL ONLY)

1. SAFETY PRECAUTIONS

The following check should be performed for the continued protection of the customer and service technician.

LEAKAGE CURRENT CHECK

Measure leakage current to a known earth ground (water pipe, conduit, etc.) by connecting a leakage current tester such as Simpson Model 229-2 or equivalent between the earth ground and all exposed metal parts of the appliance (input/output terminals, screwheads, metal overlays, control shaft, etc.). Plug the AC line cord of the appliance directly into a 120V AC 60Hz outlet and turn the AC power switch on. Any current measured must not exceed 0.5mA.

ANY MEASUREMENTS NOT WITHIN THE LIMITS OUTLINED ABOVE ARE INDICATIVE OF A POTENTIAL SHOCK HAZARD AND MUST BE CORRECTED BEFORE RETURNING THE APPLIANCE TO THE CUSTOMER.

2. PRODUCT SAFETY NOTICE

Many electrical and mechanical parts in the appliance have special safety related characteristics. These are often not evident from visual inspection nor the protection afforded by them necessarily can be obtained by using replacement components rated for voltage, wattage, etc. Replacement parts which have these special safety characteristics are identified in this Service Manual.

Electrical components having such features are identified by marking with a Δ on the schematics and on the parts list in this Service Manual.

The use of a substitute replacement component which does not have the same safety characteristics as the PIONEER recommended replacement one, shown in the parts list in this Service Manual, may create shock, fire, or other hazards.

Product Safety is continuously under review and new instructions are issued from time to time. For the latest information, always consult the current PIONEER Service Manual. A subscription to, or additional copies of, PIONEER Service Manual may be obtained at a nominal charge from PIONEER.

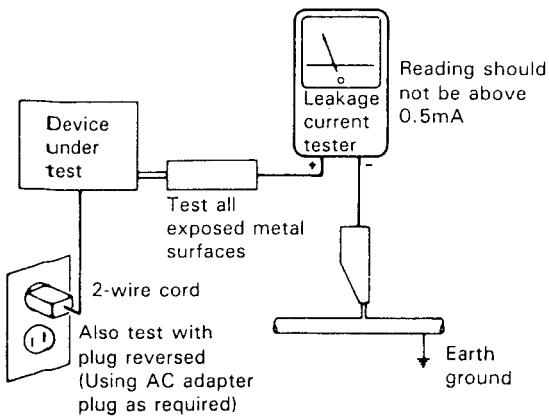

AC Leakage Test

2. EXPLODED VIEWS AND PARTS LIST

2.1 EXTERIOR SECTION

A Parts List

Mark No.	Description	Part No.	Mark No.	Description	Part No.
1	Bonnet - S	VXX1535	101	Tray	
2	Tray assembly - S	VXX1534	102	Carry label	
3	Tray rubber	VEB1089	103	Cushion	
4	Disc pad (L)	VEC1191	104	Cushion	
5	Disc pad (B)	VEC1379	105	Cushion	
6	Disc pad (C)	VEC1380	106	Reinforced plate angle	
7	Screw	VCZ30P100FMC			
8	Screw	BBT30P060FCC			
9	Screw	BCZ40P060FZK			
10	Screw	IBZ30P060FCC			

NOTES:

- Parts without part number cannot be supplied.
- The Δ mark found on some component parts indicates the importance of the safety factor of the part. Therefore, when replacing, be sure to use parts of identical designation.
- Parts marked by "●" are not always kept in stock. Their delivery time may be longer than usual or they may be unavailable.

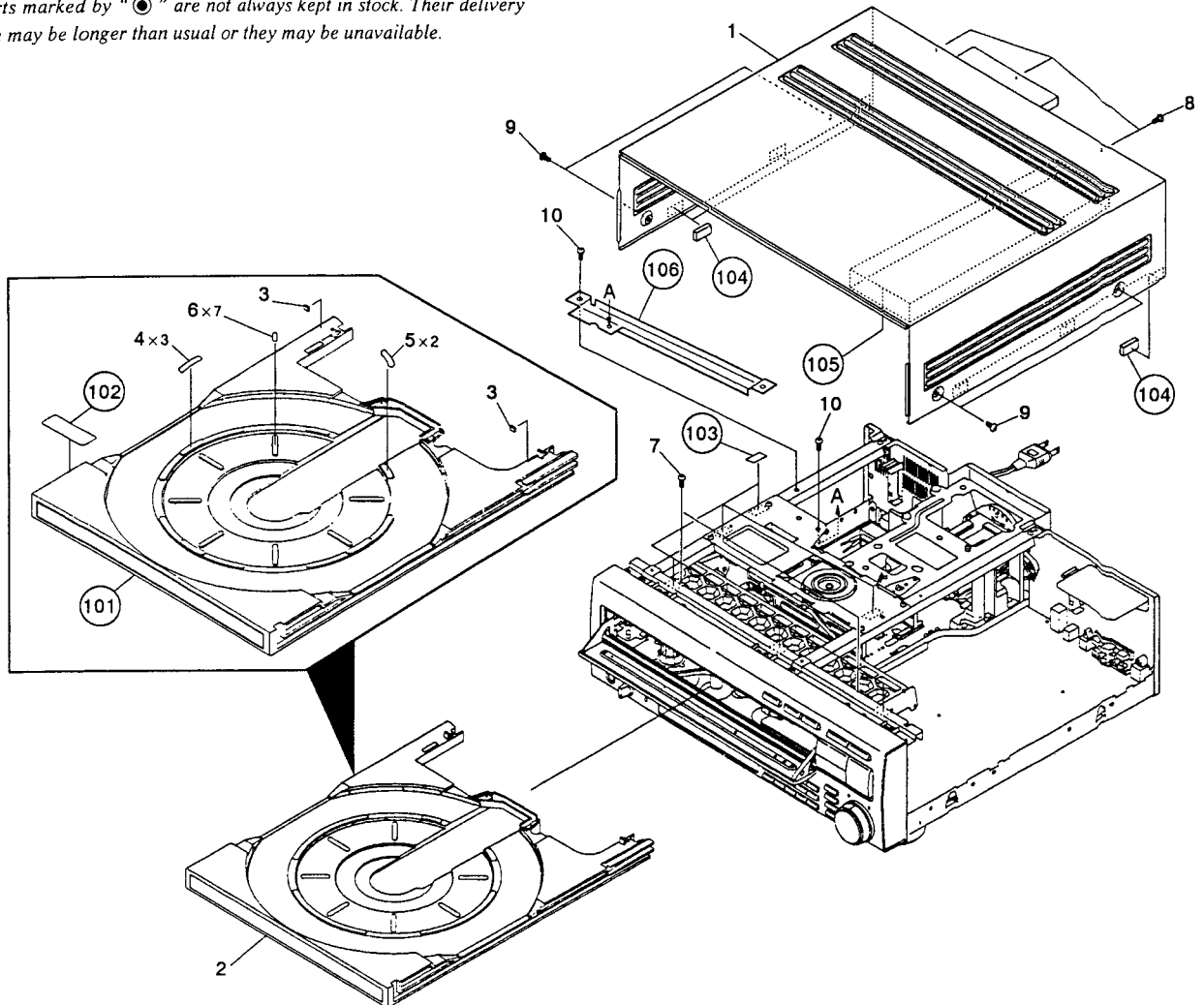

2.2 FRONT PANEL SECTION

Parts List							
Mark	No.	Description	Part No.	Mark	No.	Description	Part No.
	1	Front panel assembly - S	VXX1533	101		Front panel assembly	
	2	Door dump rubber	VEB1141	102		Jack holder	
	3	FL lens	VNK1540	103		FLKY assembly	
	4	FL filter	VNK1677	104		PWSB assembly	
	5	Scan escutcheon	VNK1589	105		HEPB assembly	
	6	Main key	VNK1676				
	7	Sub key	VNK1555				
	8	Ten key	VNK1542				
	9	L key assembly	VXA1519				
	10	Gold button (A)	VNK1547				
	11	Gold button (B)	VNK1559				
	12	PW button	VNK1536				
	13	•••••					
	14	Front door assembly	VXA1588				
	15	Hinge plate assembly	VXA1518				
	16	Dumper assembly	VXA1053				
	17	Dumper plate assembly	VXA1517				
	18	Button spring	VBH1137				
	19	Door spring	VBH1167				
	20	Volume knob	VNK1539				
	21	O/C button	VNK1675				
	22	Stop button	VNK1678				
	23	Scan dial (L)	VNK1588				
	24	Snap plate	VNE1102				
	25	Screw	BPZ26P060FCU				
	26	Screw	BPZ26P080FMC				
	27	Screw	IPZ26P060FMC				
	28	Screw	PMZ20P040FCU				
	29	Fiber washer	VEC1254				
	30	Stopper rubber	VEB1149				

1

2

3

4

5

6

A

A

B

B

C

C

D

D

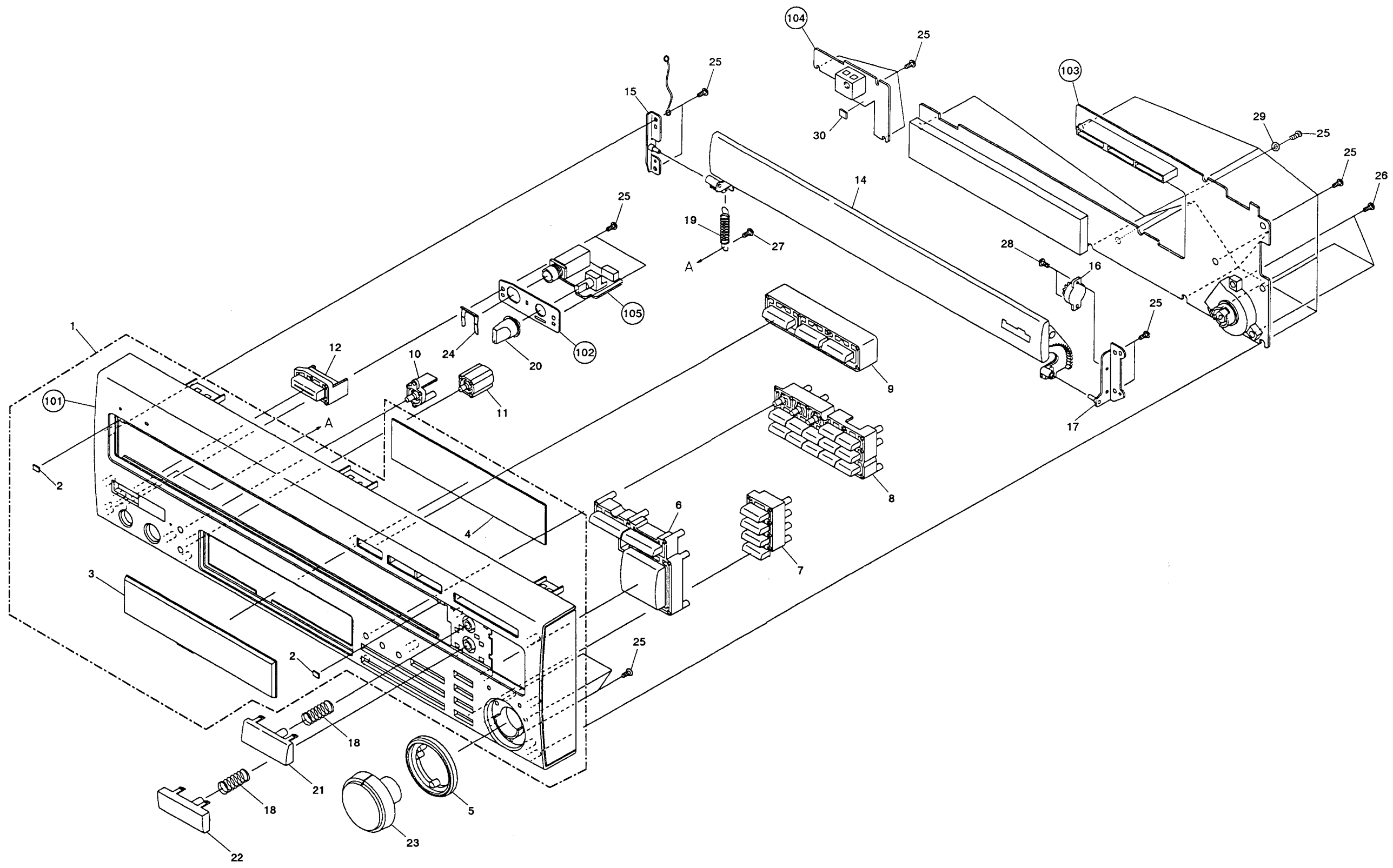

1

2

3

4

5

6

6

2.3 TOP VIEW SECTION

Parts List			Parts List		
Mark No.	Description	Part No.	Mark No.	Description	Part No.
1	Screw (B)	VBA1008	101	Front angle	
2	Arm spring	VBH1093	102	Center angle	
3	Tray guide assembly	VXA1576	103	Side stay (L)	
4	Screw	BBZ30P060FCC			
5	Screw	IBZ30P060FCC			
6	Door lever	VNL1330			

2.4 CLAMPER SECTION

Parts List			Parts List		
Mark No.	Description	Part No.	Mark No.	Description	Part No.
1	Pivot screw	VBA1022	101	Center plate assembly	
2	Clamp cam	VNL1306	102	Lever (B) assembly	
3	Limiter spring	VBH1168	103	Lever (A) assembly	
4	Clamper holder	VNL1305	104	Clamp shaft	
5	Washer	WT26D060D050	105	Limiter plate	
6	E ring	YE40FUC	106	Slide plate	
7	Screw	IPZ30P060FMC	107	Lever (C) assembly	
8	Screw	IPZ30P080FCC	108	Clamper head	
			109	Spacer	

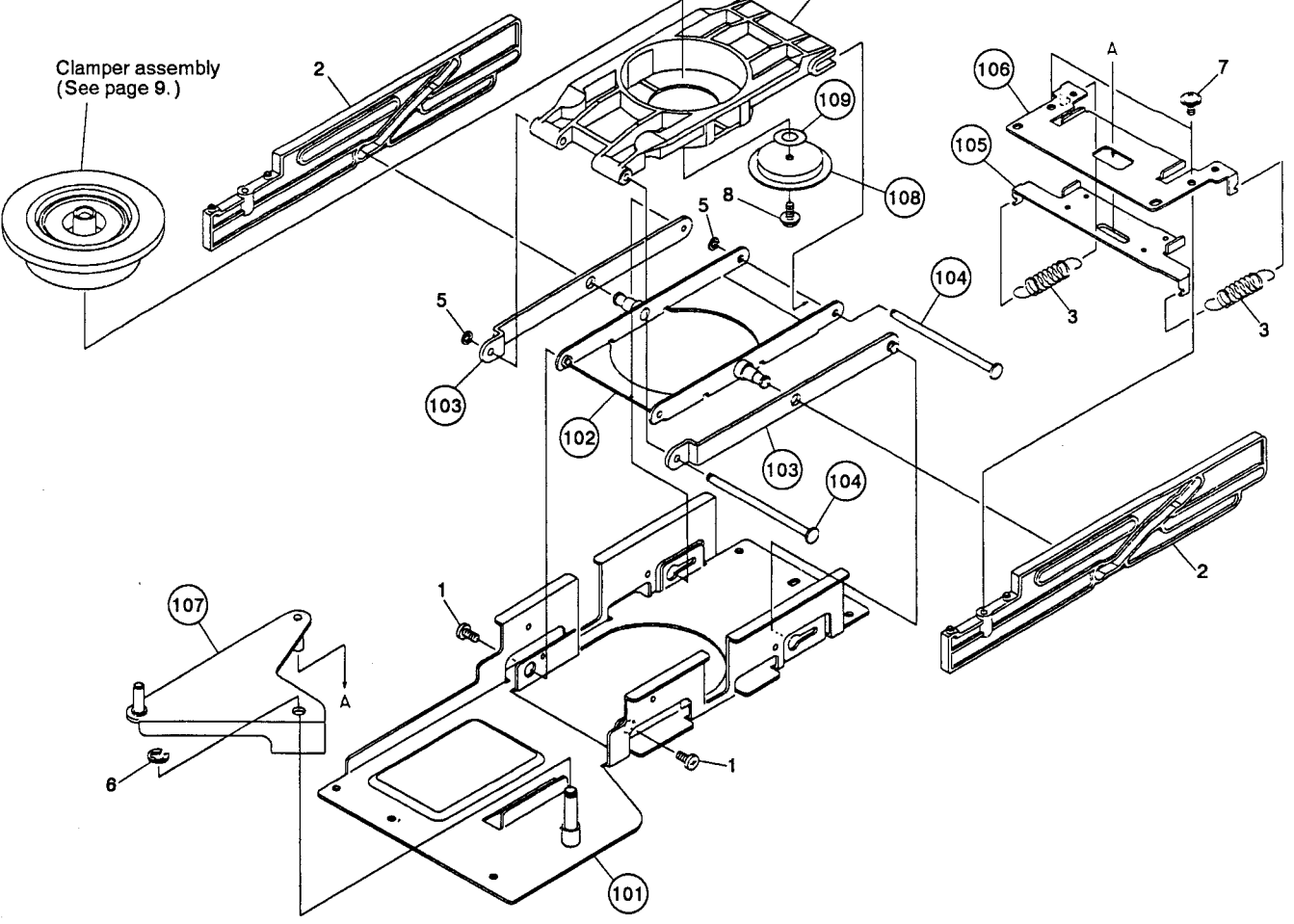
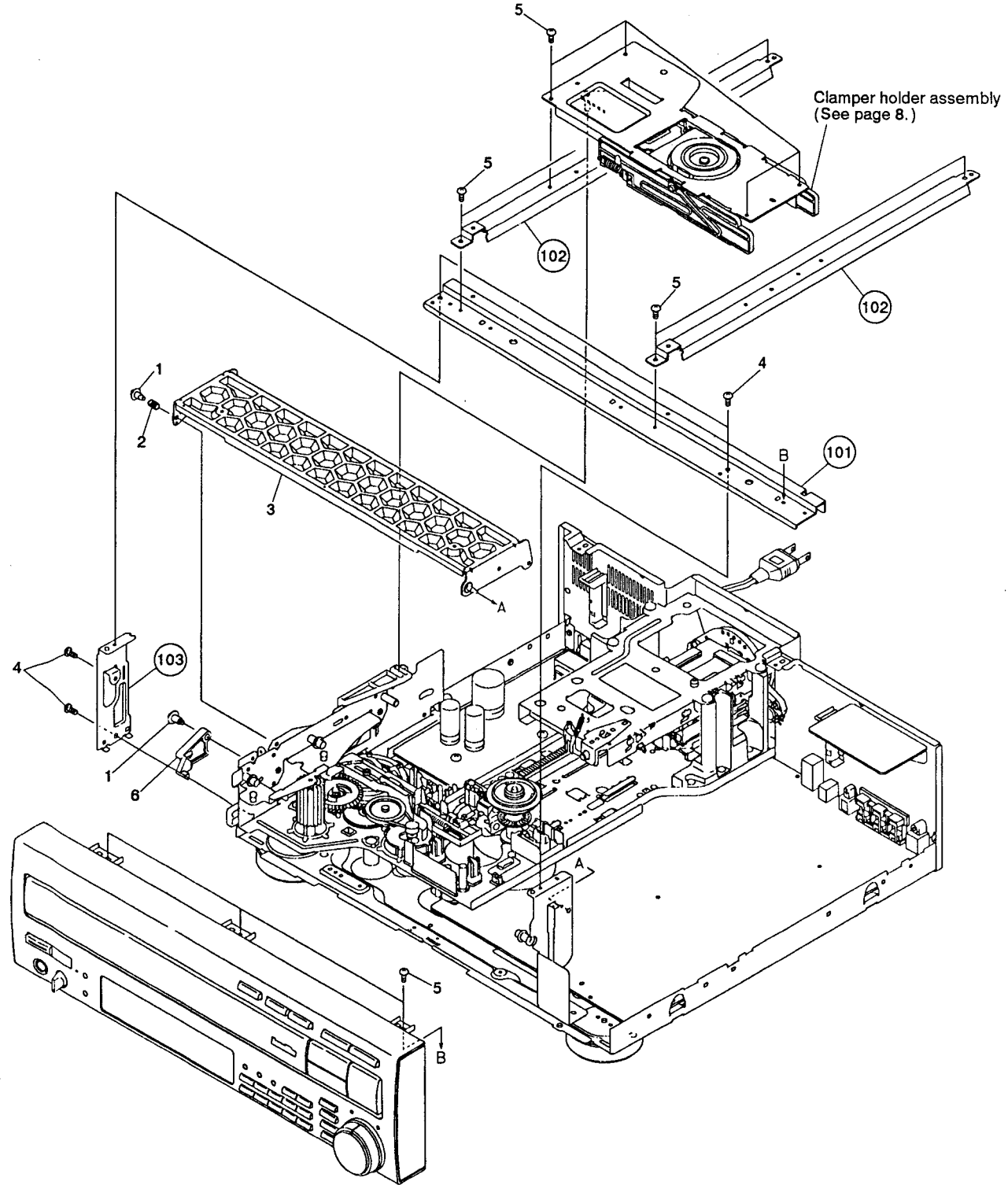

2.5 CLAMPER ASSEMBLY

Parts List			Parts List		
Mark No.	Description	Part No.	Mark No.	Description	Part No.
1	Magnet assembly - S	VXX1475	101	Magnet	
2	Disc clamber	VNL1362	102	Gap sheet	
3	Clamber spring	VBH1153	103	Clamber plate	
4	Clamber base	VNL1364	104	Absorber rubber(A)	
5	Centering hab (B)	VNL1297			
6	Steel ball	VNX1006			
7	Centering spring (B)	VBH1130			
8	Clamber cover	VNL1363			
9	Screw	AMZ20P040FMC			

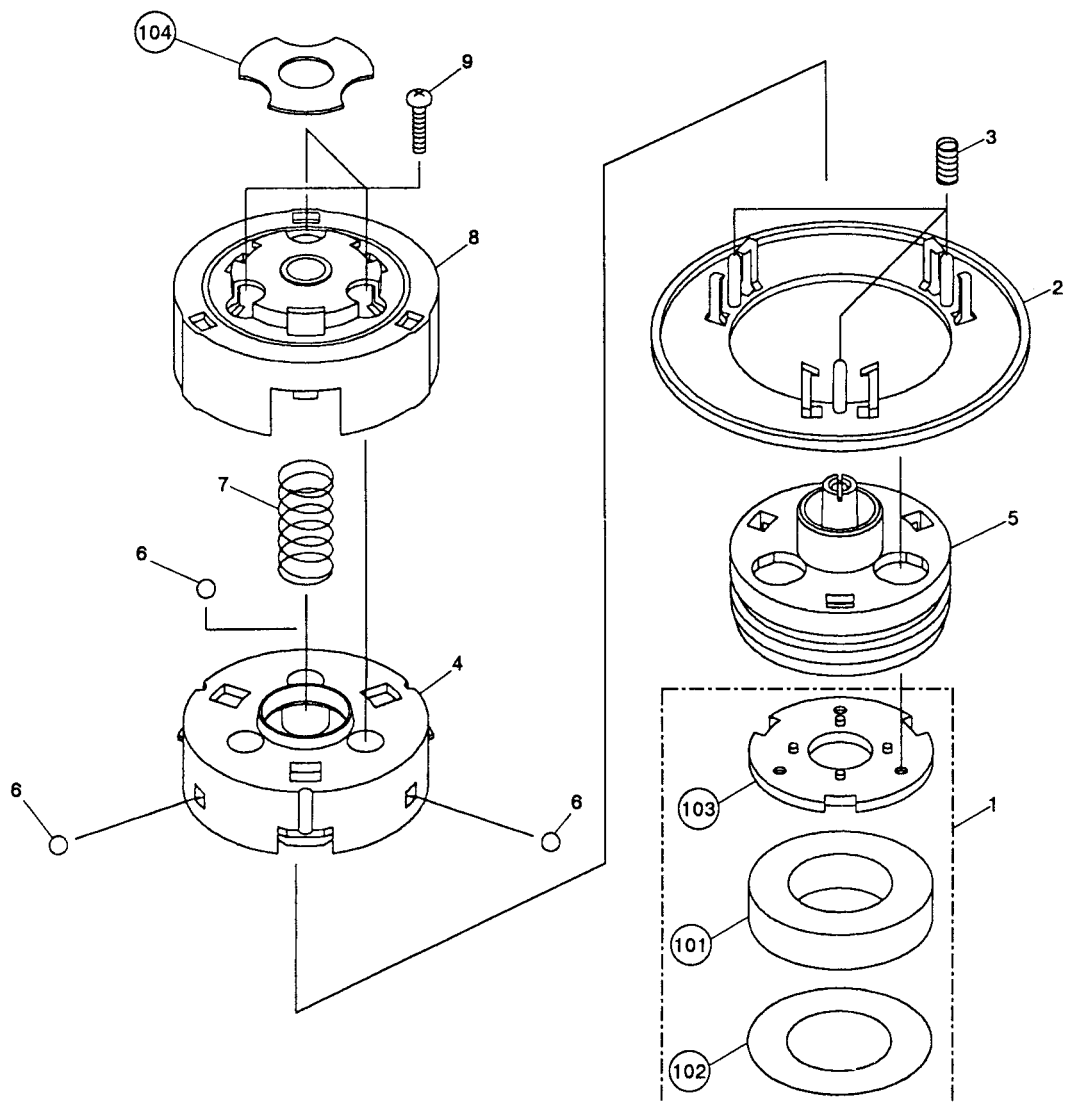

2.6 BASE SECTION (1)

Parts List

Mark No.	Description	Part No.	Mark No.	Description	Part No.
1	Tray stopper	VNL1202	101	FG board assembly	
2	Door dump rubber	VEB1033	102	Switch board assembly	
3	Side stay (R) assembly	VXA1492	103	Rear panel	
4	Base spring	VBH1145	104	Mechanism assembly	
5	DRVB assembly	VWS1087	105	Label (A)	
6	Screw	BBT30P060FCC	106	TB holder	
7	Screw	BPZ30P080FCU	107	6P earth plate	
8	Screw	BBZ30P060FCC			
9	Screw (B)	VBA1023			

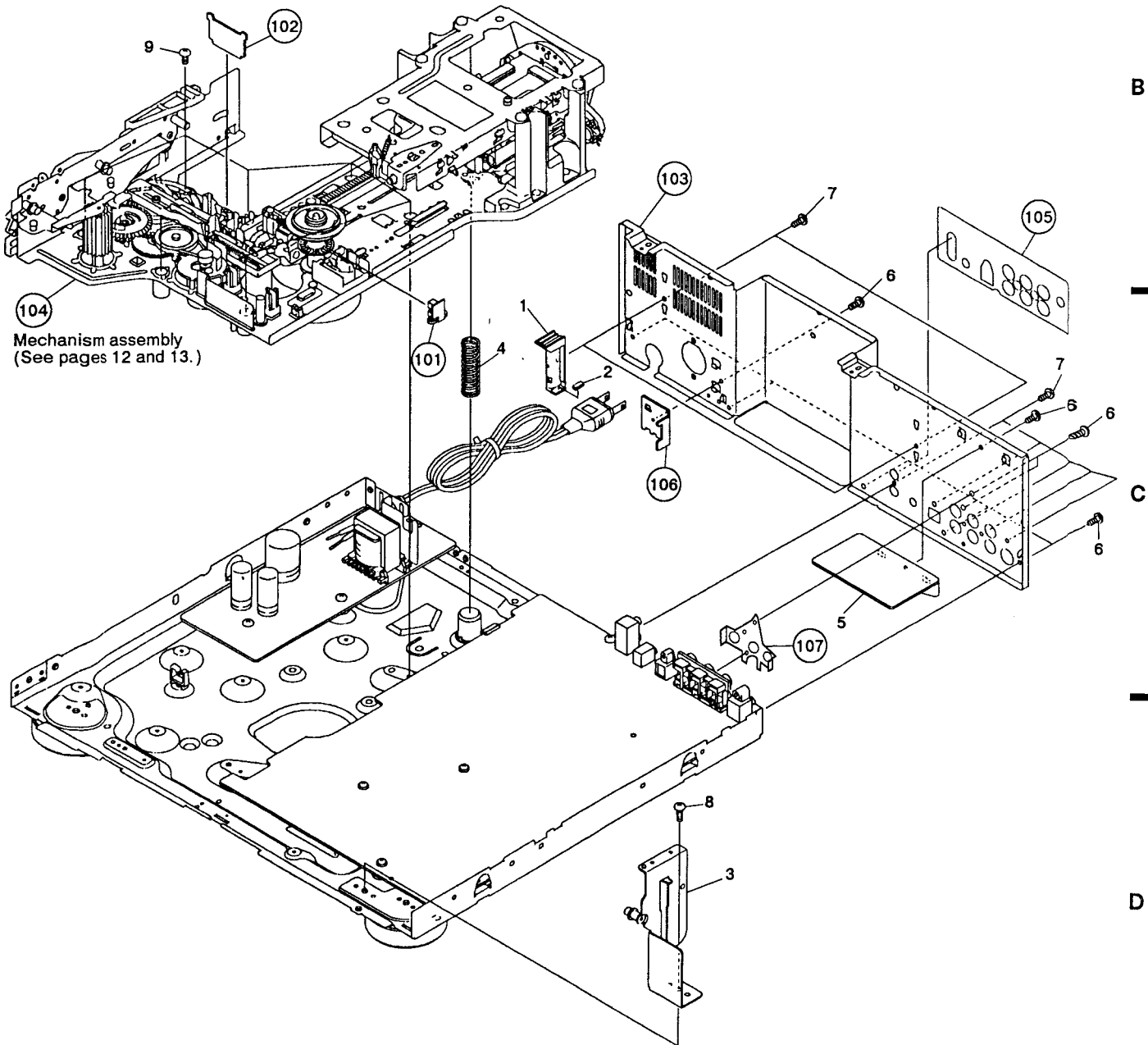

A

B

C

D

2.7 BASE SECTION (2)

Parts List

Mark	No.	Description	Part No.	Mark	No.	Description	Part No.
△	1	AC power cord	PDG1015	104		P plate holder	
△	2	Strain relief	CM-22C	105		Wire crip	
	3	Power supply board assembly	VWR1098	106		Base chassis	
	4	Insulator assembly	VXA1289	107		Spring guide	
	5	Insulator assembly	VXA1290	108		PCB spacer	
	6	Insulator	VNK1095	109		Cord holder	
	7	Screw	BBZ30P060FCC	110		Earth lug assembly	
	8	Screw	BBZ30P080FCC				
	9	Screw	IBZ30P060FCC				
	10	Screw	IBZ30P160FMC				
	101	MOTHER board assembly					
	102	Stopper 3					
	103	Insulator					

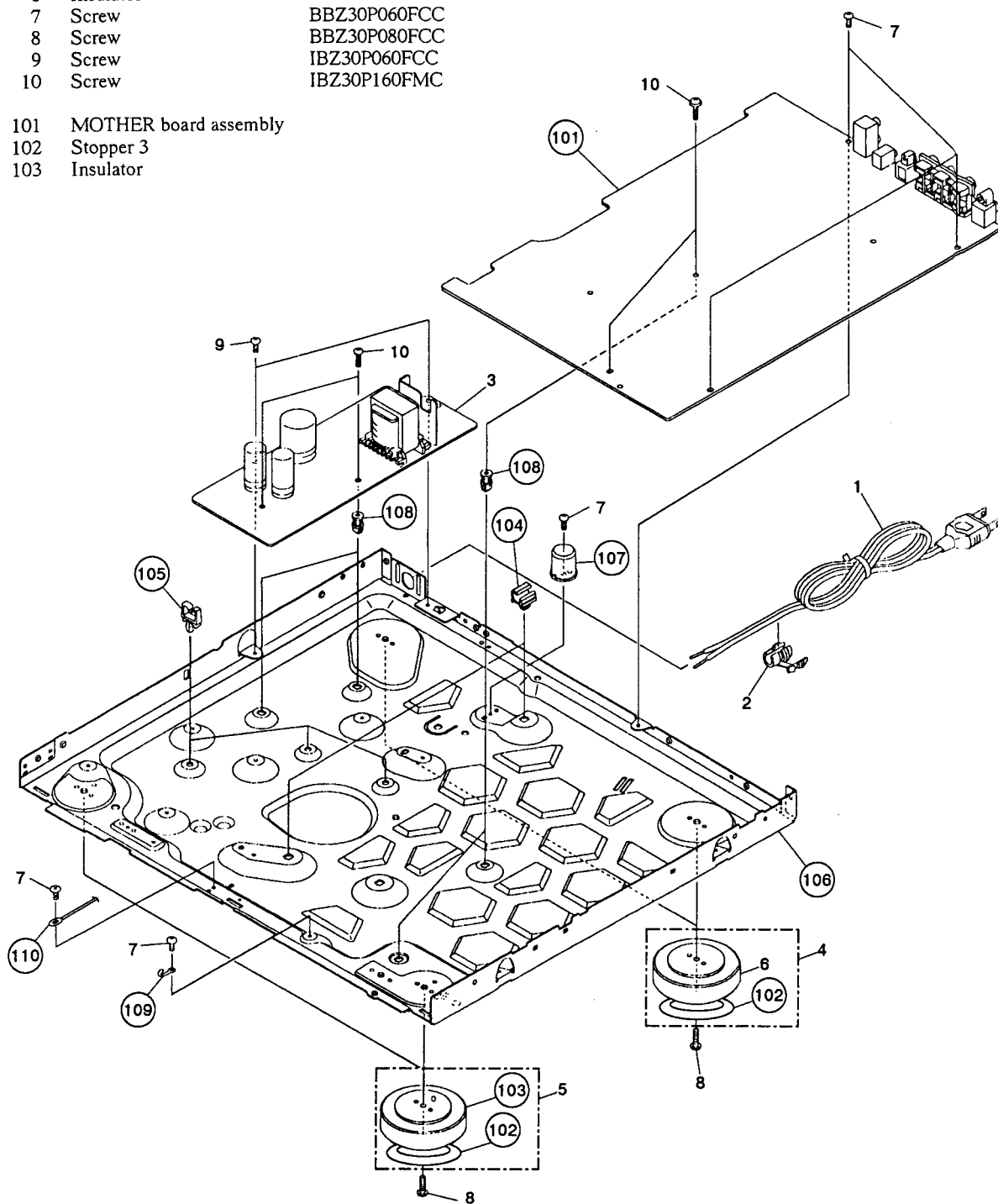

2.8 MECHANISM ASSEMBLY

Parts List

<u>Mark</u>	<u>No.</u>	<u>Description</u>	<u>Part No.</u>	<u>Mark</u>	<u>No.</u>	<u>Description</u>	<u>Part No.</u>
	1	Tilt shaft	VLL1326		11	Screw	ABZ26P050FMC
	2	Plate spring	VBK1013		12	Screw	IBZ30P100FMC
	3	Tilt spring	VBH1146		13	Screw	IPZ30P100FCU
	4	Thrust spring	VBH1163				
	5	Post (L)	VNL1347				
	6	Post (R)	VNL1348		101	Housing assembly (3P)	
⊙	7	Carriage assembly	VWT1068				
	8	Flexible cable (22P)	VDA1329				
	9	Belt	PEB1013				
	10	Lever switch (TURN SW)	DSK1003				

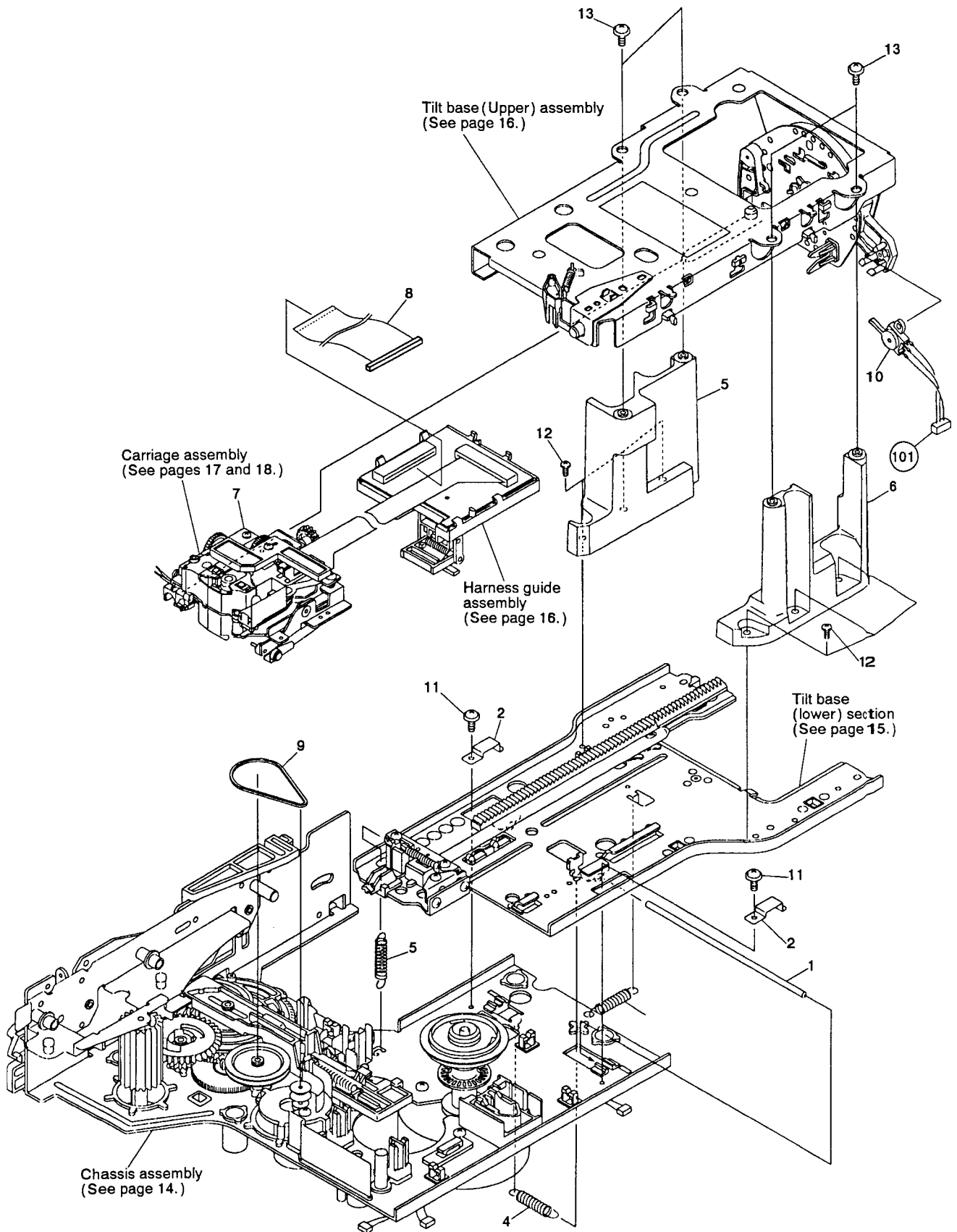

2.9 MECHANISM CHASSIS SECTION

Parts List

Mark No.	Description	Part No.	Mark No.	Description	Part No.
1	Chassis assembly	VXA1577	21	Nylon washer	WA32N080W020
2	Rubber bushing	VEB1138	22	Washer	WT26D047D025
3	Loading motor assembly	VXX1262	23	Screw	PMZ30P040FCU
4	Spindle motor assembly	VXA1679	24	Screw	PMA30P050FCU
5	Centering spring	VBH1024	25	E ring 2,3	YE23FUC
6	Sheet	VEC1486	26	Push switch (TRAY SW)	DSG1014
7	Yoke plate A	VNE1360	27	Door lever	VNL1330
8	Centering hab (A)	VNL1296			
9	Two stair gear	VNL1326	101	Loading motor	
10	Gear pulley	VNL1249	102	Motor pulley	
11	Cam gear	VNL1350	103	Oil stopped washer	
12	Follow gear	VNL1317	104	Rubber sheet	
13	Spring slanting cam	VNL1316	105	Housing assembly	
14	Cam spring	VBH1082	106	Turn table assembly	
15	Radial spring	VBH1164	107	Spindle motor	
16	Roller plate assembly	VXA1493	108	Housing assembly	
17	Slide cam	VNL1304			
18	Screw (B)	VBA1008			
19	Screw (C)	VBA1015			
20	Return spring	VBH1129			

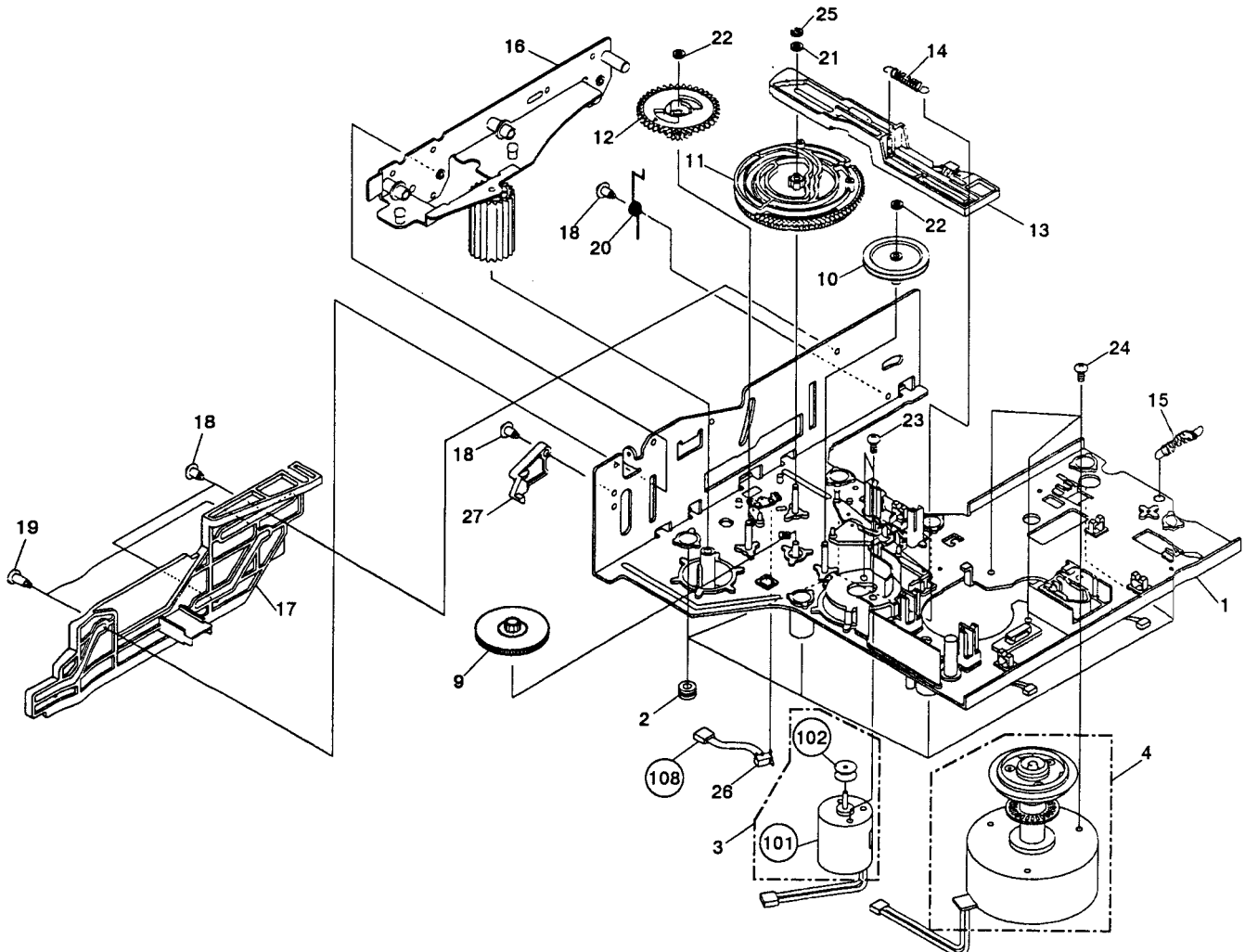

A

B

C

D

2.10 TILT BASE (LOWER) SECTION

Parts List

A	Mark No.	Description	Part No.	Mark No.	Description	Part No.	A
⊙	1	Tilt base (Lower) assembly	VXA1578	11	Screw	IPZ26P060FMC	
	2	Slide switch (LD,CDV INSIDE)	OSH1001	12	Screw	BMZ26P100FMC	
	3	Rack spring	VBH1133	13	Screw	PMZ20P060FMC	
	4	Rack gear (lower)	VNL1346	14	Screw	PMZ20P030FMC	
	5	Carriage shaft (lower)	VLL1325	101	SW holder		
	6	Shaft plate (lower) assembly	VXA1626	102	Housing assembly		
	7	S plate spring	VBH1149	103	Roller shaft holder		
	8	S plate holder	VNE1621				
	9	Screw	BBZ30P060FCC				
	10	Screw	PPZ20P120FMC				

B

C

D

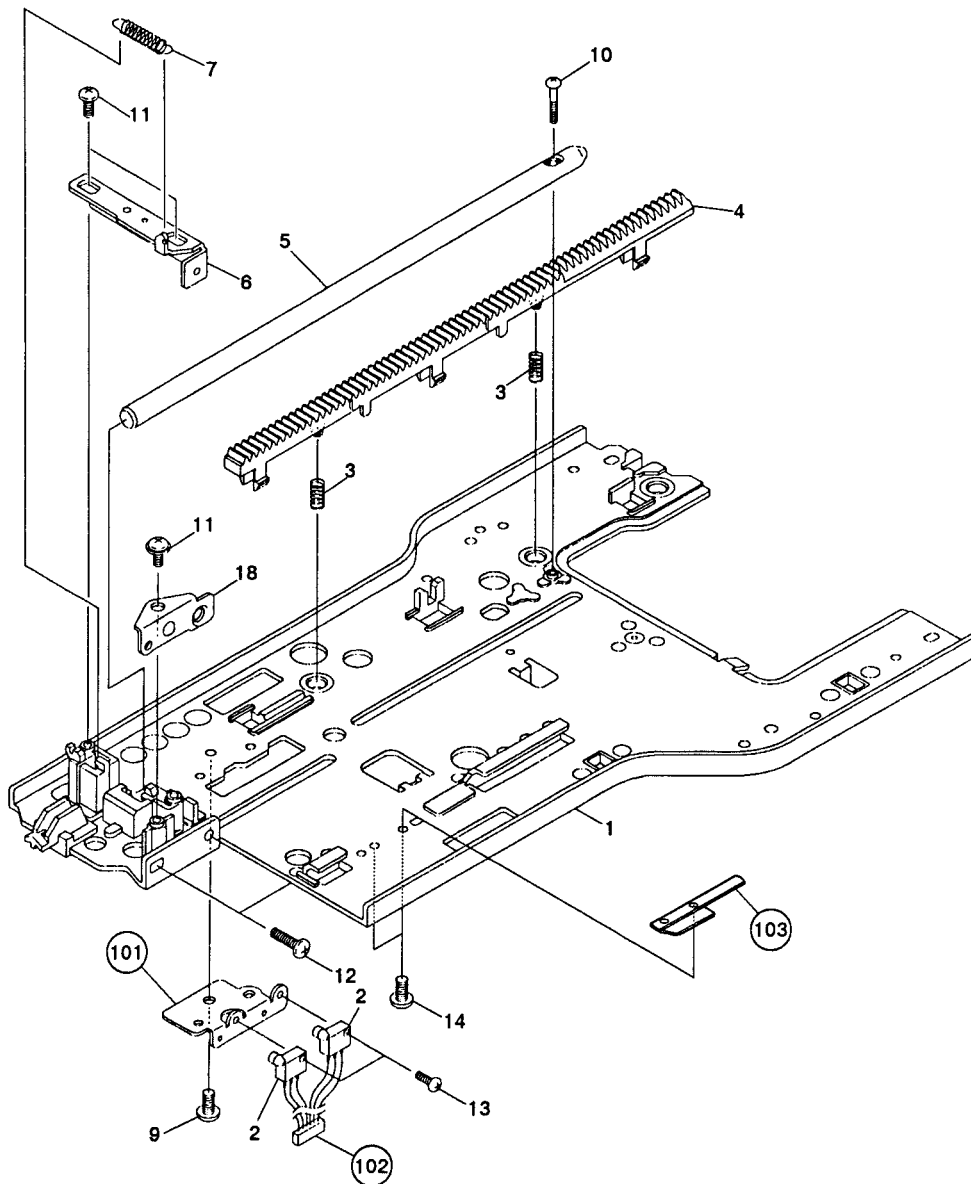

2.11 TILT BASE (UPPER) SECTION

Parts List

Mark No.	Description	Part No.	Mark No.	Description	Part No.
1	Tilt base (upper) assembly	VXA1580	11	Guide spring (B)	VBH1155
2	SW lever	VNL1359	12	Harness guide (B)	VNL1408
3	SW lever spring	VBH1150	13	Guide spring (A)	VBH1166
4	Carriage shaft (upper)	VLL1324	14	Harness guide (A)	VNL1349
5	Rack gear (upper)	VNL1345	15	Washer	WT16D032D025
6	Internal gear assembly	VXA1491	16	Washer	WT36D072D050
7	R plate assembly	VXA1579	17	Screw	PMZ20P120FMC
8	Lock lever	VNL1351	18	Screw	BBZ26P050FCC
9	Lever spring	VBH1127	19	Carriage assembly	VWT1068
10	Harness guide (C)	VNL1361	20	Rock plate	VBK1026
			21	Screw	IBZ20P040FCC
			101	CNNB assembly	

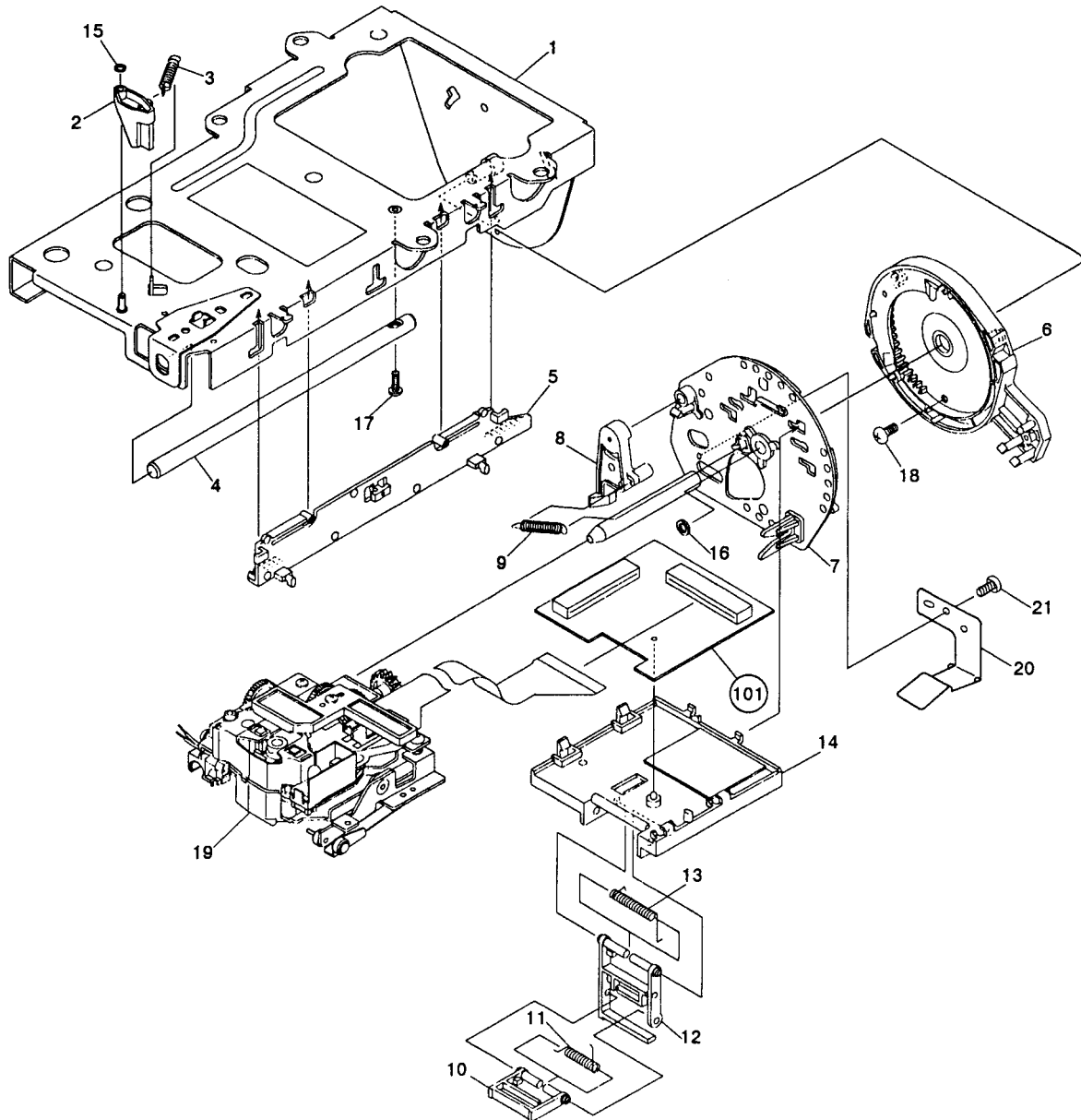

A

B

C

D

2.12 CARRIAGE ASSEMBLY

Mark No.	Description	Part No.
1	Flexible holder	VNL1358
2	PU base	VNT1037
3	Housing assembly (1.5MP2P)	VKP1852
4	Bolt 2.6X10	VLL1192
5	TAN base assembly	VXA1678
6	TAN spring	VBH1151
7	Slide switch (CD,B INSIDE)	VSK1008
8	TRKG spring	VBH1152
9	SL shaft (B)	VLL1334
10	Gear (F)	VNL1356
11	Carriage shaft holder	VNT1036
12	Gear (E)	VNL1355
13	PU plate assembly	VXA1583
14	Screw 4	VLL-183
15	Spring washer φ4	VEF-027
16	Pickup assembly-S	VXX1553
17	Carriage motor assembly-S	VXX1537
18	SL gear (A)	VNL1250
19	SL Shaft (C)	VLL1289
20	Gear (G)	VNL1365
21	Motor holder assembly	VXA1585
22	Gear (H)	VNL1357
23	Gear (C)	VNL1353
24	SL Shaft (A)	VLL1333
25	Gear (B)	VNL1352
26	Gear (D)	VNL1354
27	E ring	YE12FUC
28	Washer	WT17D034D050
29	Screw	JGZ20P022FMC
30	Screw	PMZ26P100FMC
31	Screw	BMZ26P080FMC
32	Screw	PMA20P040FMC
33	Screw	PBZ26P040FMC
34	Screw	PBZ20P070FCC
35	Screw	BBZ26P050FMC
36	Actuator assembly	VXX1551
37	Sensor assembly	VEX1018
38	Pre-pickup assembly	VXX1554
39	Sensor assembly	VNH1024
40	Screw	PMA20P060FMC
41	Screw	PMA20P080FMC
42	Screw	PMA20P140FMC
43	Screw	BMZ20P060FMC
44	Sensor spring	VBH1087
101	Slider motor	
102	SLMB assembly	

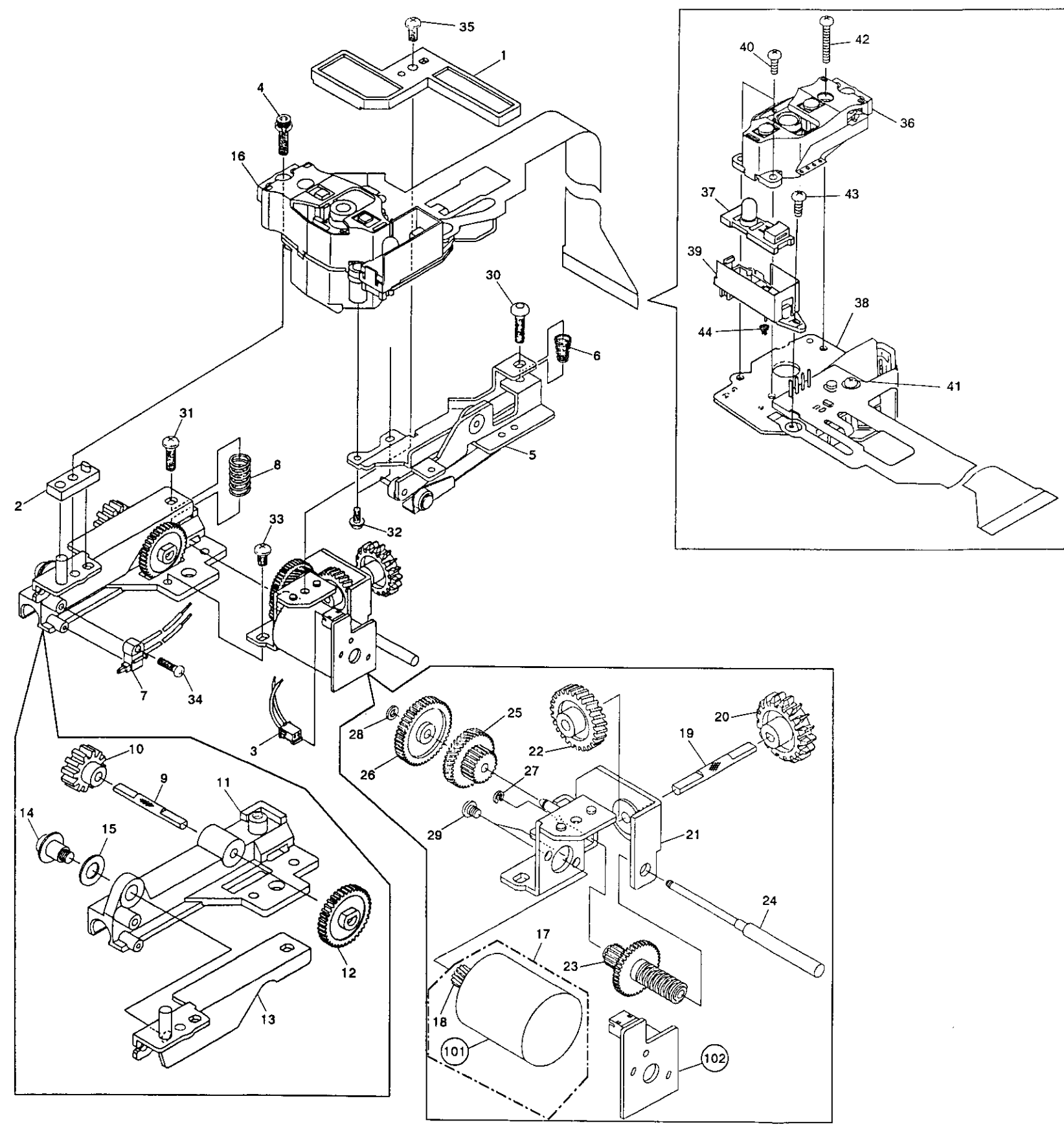

1 | 2 | 3 | 4 | 5 | 6

1 | 2 | 3 | 4 | 5 | 6 | 18

3. PACKING

Parts List

Mark No.	Description	Part No.	Mark No.	Description	Part No.
1	Connection cord	VDE-055	51	Dry cell battery (R03, AAA)	
2	Video cable	VDE-056	52	Polyethylene bag	
3		53	Caution card	
4	Operating instructions (English)	VRB1046	54	
5	Remote control unit	VXX1536	55	Caution card (UC)	
6	Pad (F)	VHA1070	56	Polyethylene bag	
7	Pad (R)	VHA1071			
8				
9	Packing case	VHG1145			
10	Mirror mat	VHL1006			
11	Battery cover	VNK1806			

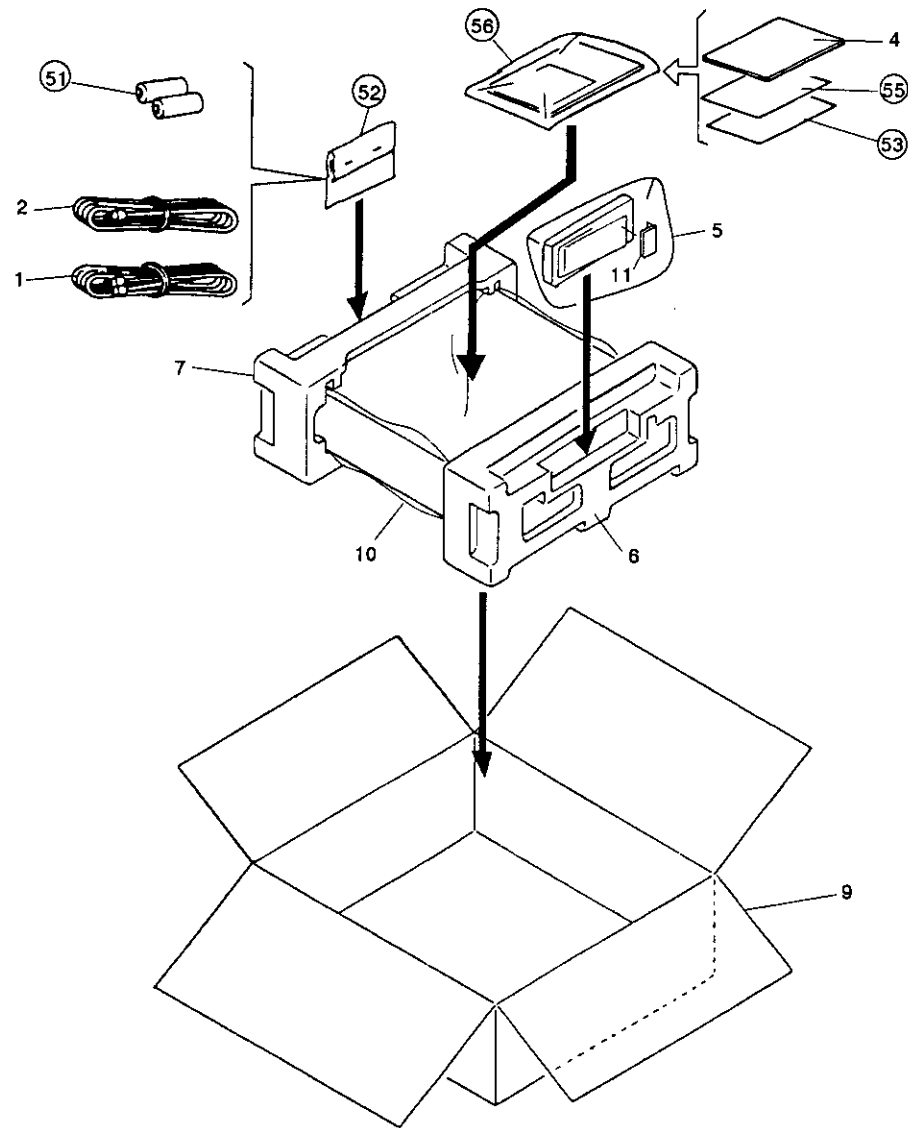

4. P. C. BOARDS LOCATION

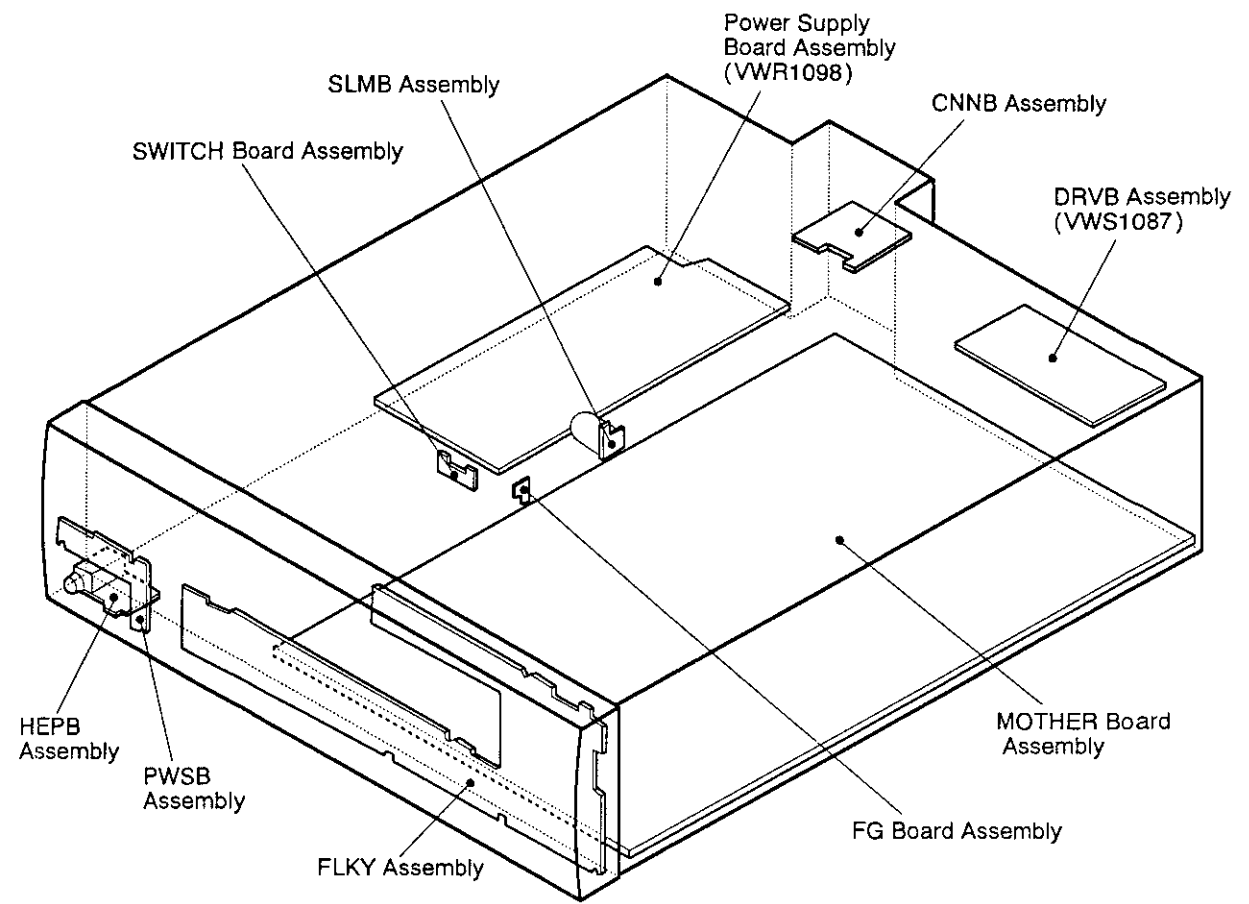

MAIN BOARD ASSEMBLY (VWM1155)

MAIN board assembly is composed of MOTHER, FG and SWITCH board assemblies.

FLKB ASSEMBLY (VWM1114)

FLKB assembly is composed of FLKY, PWSB and HEPB assemblies.

5. SCHEMATIC AND P.C. BOARDS DIAGRAM

5.1 OVERALL WIRING DIAGRAM

A
B
C
D

A
B
C
D

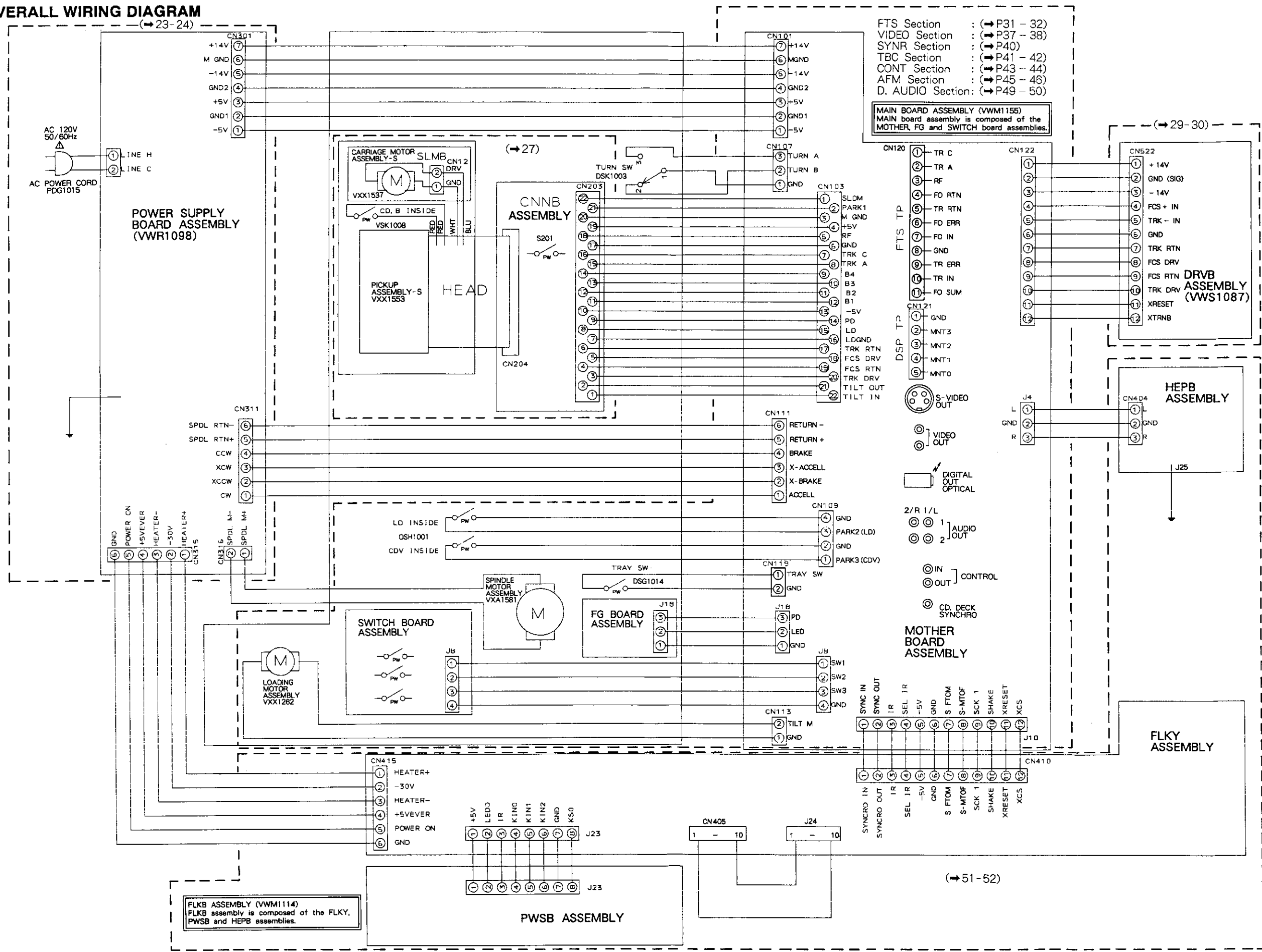

FLKB ASSEMBLY (VWM1114)
FLKB assembly is composed of the FLKY, PWSB and HEPB assemblies.

(→ 51-52)

5.2 POWER SUPPLY BOARD ASSEMBLY

POWER SUPPLY BOARD ASSEMBLY (VWR1098)

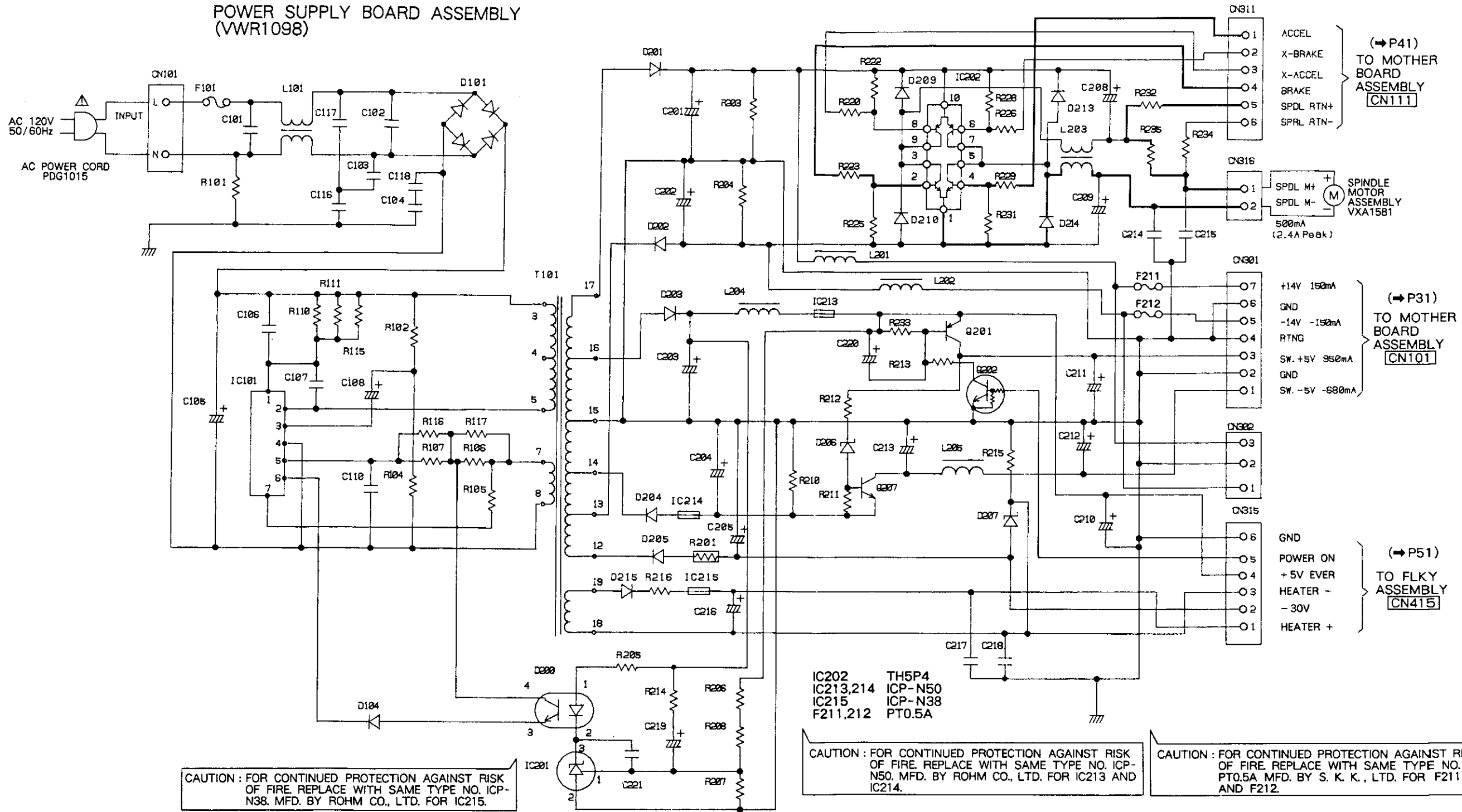

1. RESISTORS:
Indicated in Ω, 1/4W, 1/8W and 1/8W, ± 5% tolerance unless otherwise noted k; kΩ, M; MΩ, (F); ± 1%, (G); ± 2%, (K); ± 10%, (M); ± 20% tolerance.

4. OTHERS:
→: Signal route.
⊗: Adjusting point.
The Δ mark found on some component parts indicates the importance of the safety factor of the part. Therefore, when replacing, be sure to use parts of identical designation.
※ marked capacitors and resistors have parts numbers.

2. CAPACITORS:
Indicated in capacity (μF) / voltage(V) unless otherwise noted p; pF. Indication without voltage is 50V except electrolytic capacitor.

3. VOLTAGE, CURRENT:
□: DC voltage (V) at no input signal.
Value in () is DC voltage at rated power.
← mA: DC current at no input signal.

5. SWITCHES (The underlined indicates the switch position)
OUTSIDE OF P.C. BOARDS
Push switch : TRAY SW
Lever switch : TURN SW
Slide switch : LD, CDV INSIDE
Slide switch : CD, B INSIDE
SWITCH BOARD ASSEMBLY
S101 - S103 :

FLKY ASSEMBLY
S101 : DOOR
S102 : SINGLE
S103 : EDIT
S104 : PEAK SEARCH
S105 : +10
S106 : PGM
S107 : 1

S108 : 2
S109 : 3
S110 : 4
S111 : 5
S112 : 6
S113 : 7
S114 : 8
S115 : 9
S116 : 0
S117 : DIRECT CD
S118 : SIDE A
S119 : SIDE B
S120 : SKIP |◀◀
S121 : SKIP ▶▶|
S122 : OPEN / CLOSE
S123 : STOP
S124 : PLAY / PAUSE

S125 : RANDOM PLAY
S126 : INTRO SCAN
S127 : REPEAT A
S128 : REPEAT B
S129 : SCAN

PWSB ASSEMBLY
S301 : SOFT PICTURE
S302 : DISPLAY
S303 : POWER

CNNB ASSEMBLY
S201 :

—: SPDL Servo Loop Line

POWER SUPPLY BOARD ASSEMBLY (VWR1098)

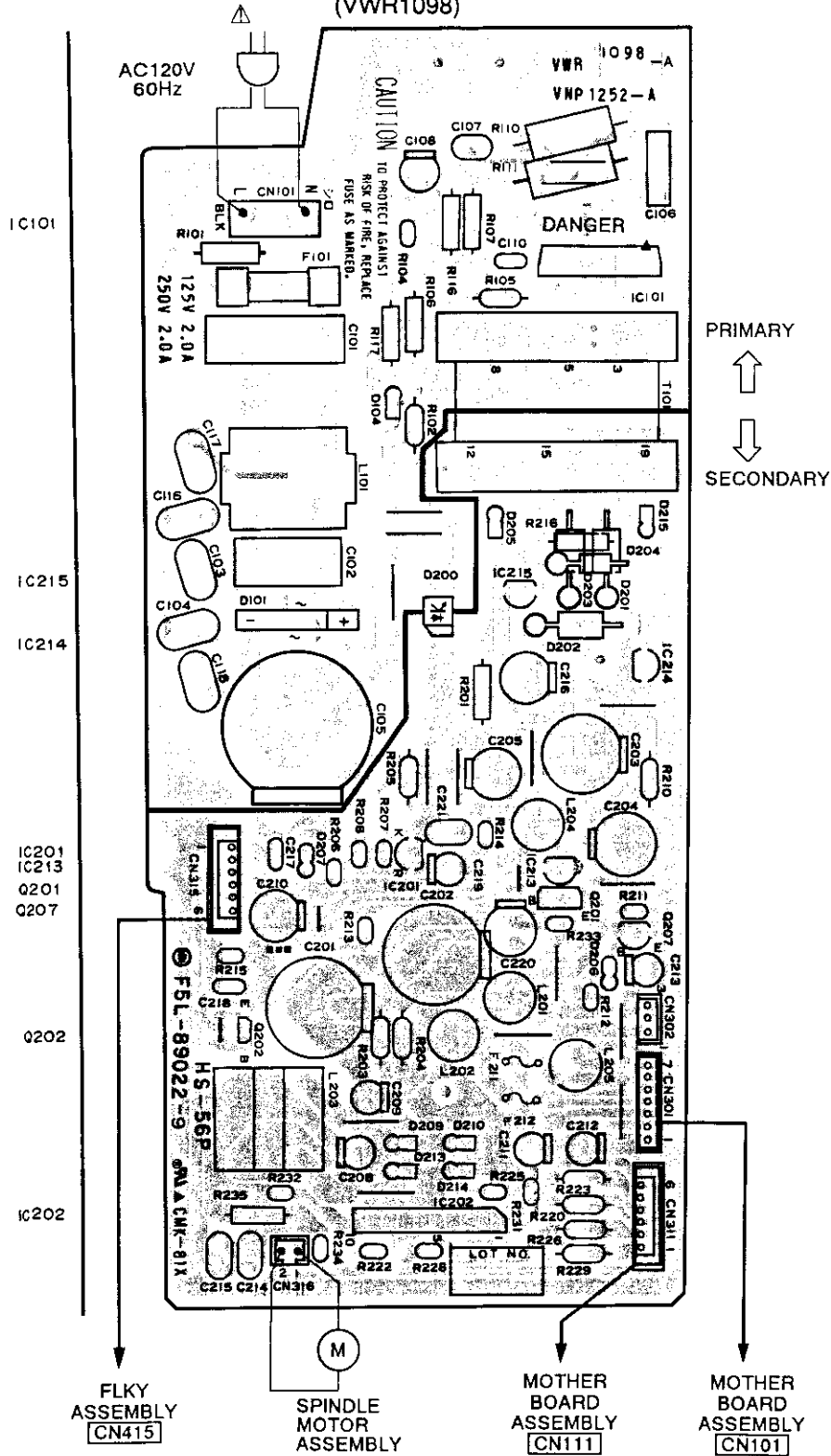

P.C.B. pattern diagram indication	Corresponding part symbol	Part name
		Transistor
		FET
		Diode
		Zener diode
		LED
		Varactor
		Tact switch
		Inductor
		Coil
		Transformer
		Filter
		Ceramic capacitor
		Mylar capacitor
		Styroly capacitor
		Electrolytic capacitor (Non polarized)
		Electrolytic capacitor (Noiseless)
		Electrolytic capacitor (Polarized)
		Power capacitor
		Semi-fixed resistor
		Resistor array
		Resistor
		Resonator
		Thermistor

1. This P.C.B. connection diagram is viewed from the parts mounted side.
2. The parts which have been mounted on this board can be replaced with those shown with the corresponding wiring symbols listed in the above Table.
3. The capacitor terminal marked with shows negative terminal.
4. The diode marked with shows cathode side.
5. The transistor terminal marked with shows emitter.

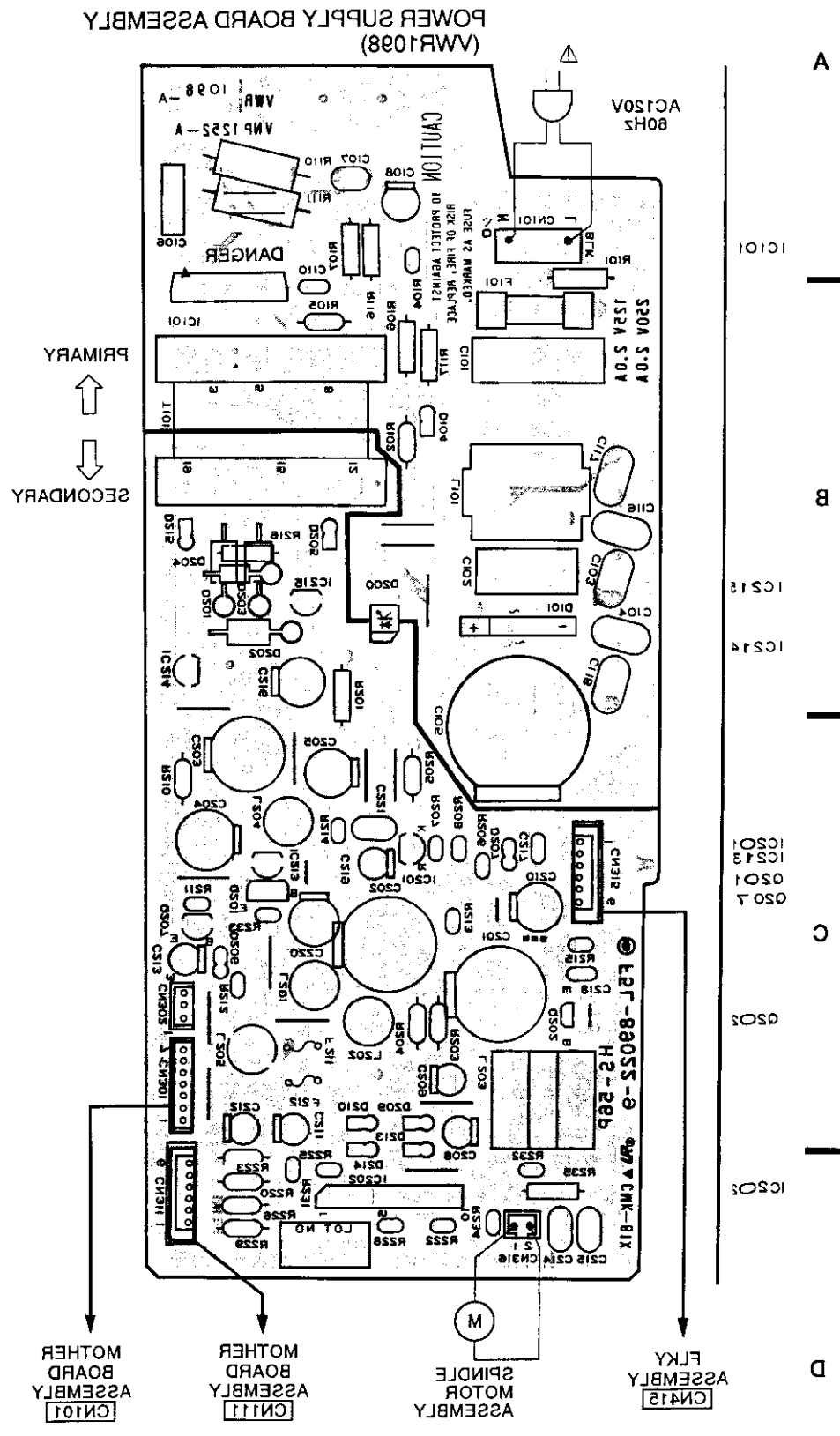

This P. C. B. connection diagram is viewed from the foil side.

5.3 PICKUP AND CNNB ASSEMBLY

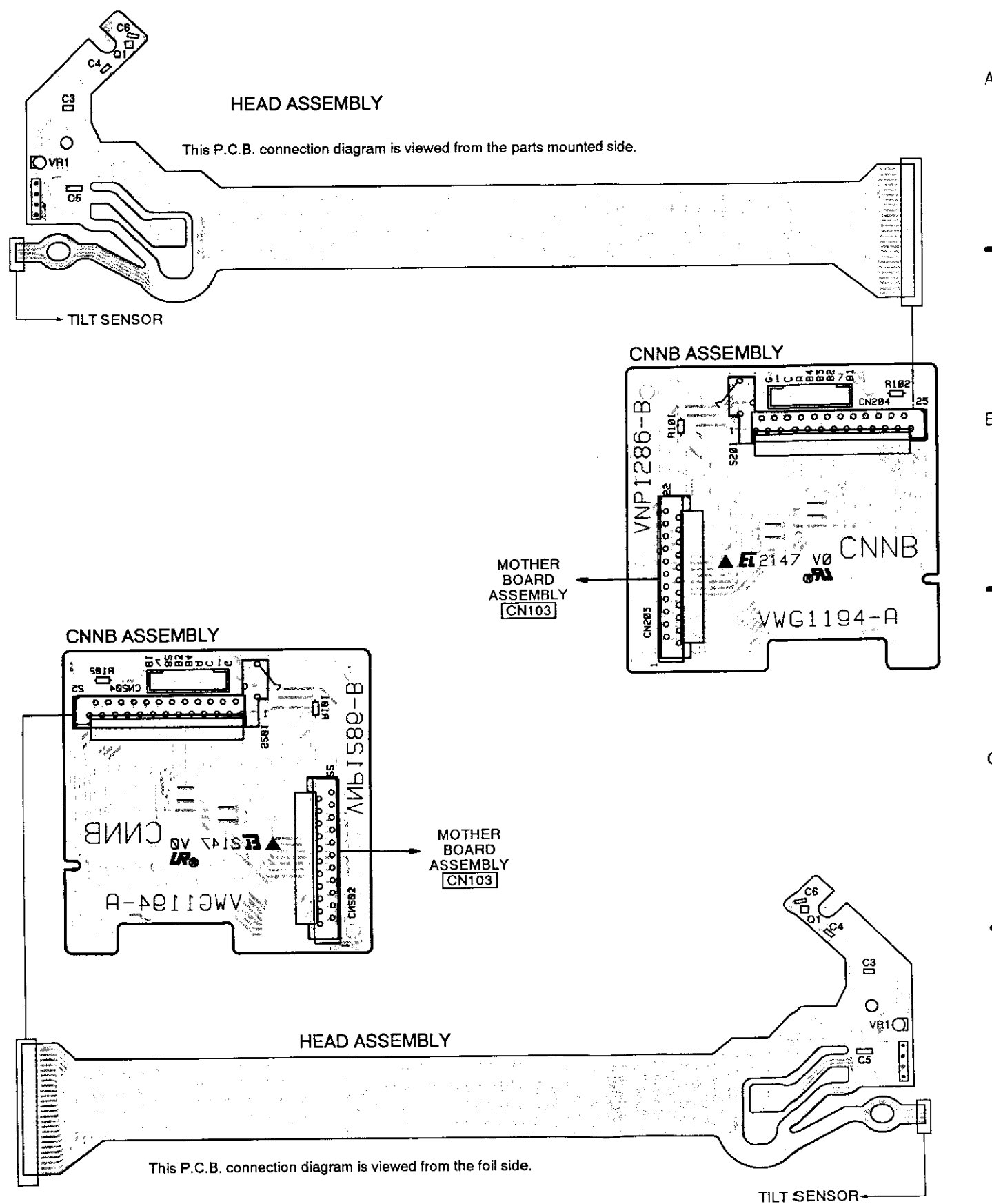
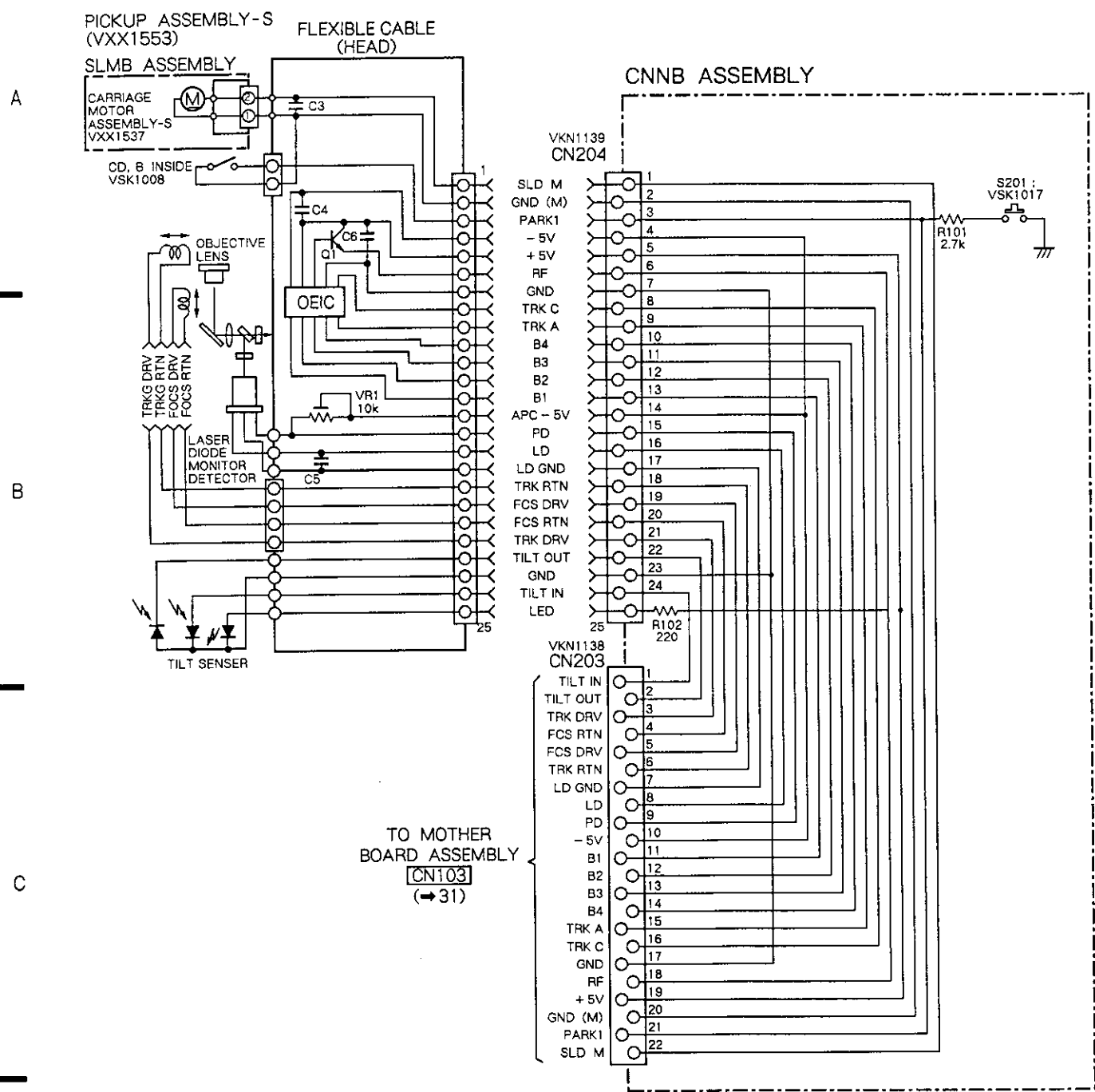

5.4 DRVB ASSEMBLY

DRVB ASSEMBLY (VWS1087)

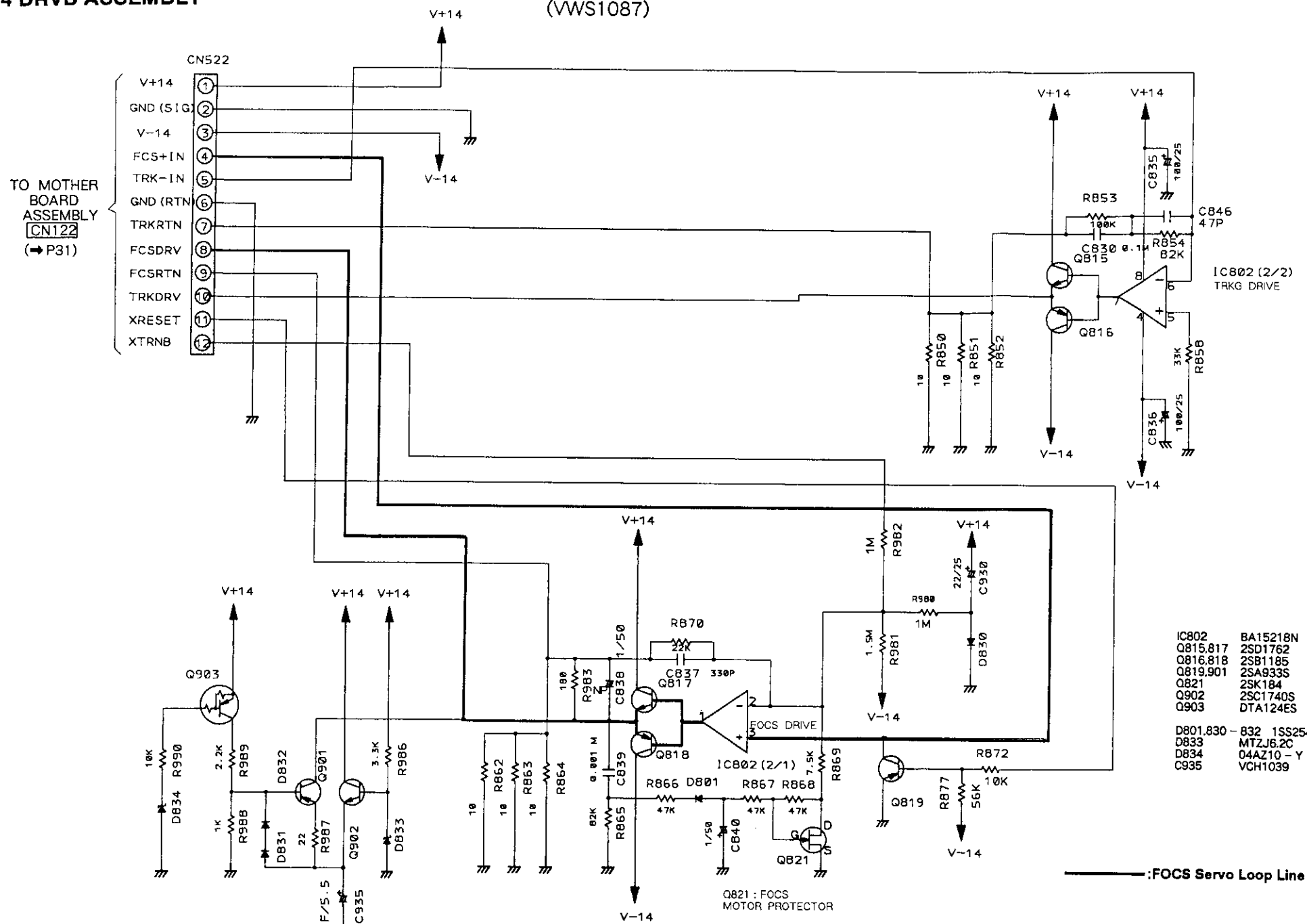

DRVB ASSEMBLY

DRVB ASSEMBLY

- Q902
- Q903
- Q901
- Q815
- Q816
- Q817
- Q818
- IC802
- Q821
- Q819

- Q818
- Q819
- Q820
- Q821
- Q822
- Q823
- Q824
- Q825
- Q826
- Q827
- Q828
- Q829
- Q830
- Q831
- Q832
- Q833
- Q834
- Q835
- Q836
- Q837
- Q838
- Q839
- Q840
- Q841
- Q842
- Q843
- Q844
- Q845
- Q846
- Q847
- Q848
- Q849
- Q850
- Q851
- Q852
- Q853
- Q854
- Q855
- Q856
- Q857
- Q858
- Q859
- Q860
- Q861
- Q862
- Q863
- Q864
- Q865
- Q866
- Q867
- Q868
- Q869
- Q870
- Q871
- Q872
- Q873
- Q874
- Q875
- Q876
- Q877
- Q878
- Q879
- Q880
- Q881
- Q882
- Q883
- Q884
- Q885
- Q886
- Q887
- Q888
- Q889
- Q890
- Q891
- Q892
- Q893
- Q894
- Q895
- Q896
- Q897
- Q898
- Q899
- Q900
- Q901
- Q902
- Q903
- Q904
- Q905
- Q906
- Q907
- Q908
- Q909
- Q910
- Q911
- Q912
- Q913
- Q914
- Q915
- Q916
- Q917
- Q918
- Q919
- Q920
- Q921
- Q922
- Q923
- Q924
- Q925
- Q926
- Q927
- Q928
- Q929
- Q930
- Q931
- Q932
- Q933
- Q934
- Q935
- Q936
- Q937
- Q938
- Q939
- Q940
- Q941
- Q942
- Q943
- Q944
- Q945
- Q946
- Q947
- Q948
- Q949
- Q950
- Q951
- Q952
- Q953
- Q954
- Q955
- Q956
- Q957
- Q958
- Q959
- Q960
- Q961
- Q962
- Q963
- Q964
- Q965
- Q966
- Q967
- Q968
- Q969
- Q970
- Q971
- Q972
- Q973
- Q974
- Q975
- Q976
- Q977
- Q978
- Q979
- Q980
- Q981
- Q982
- Q983
- Q984
- Q985
- Q986
- Q987
- Q988
- Q989
- Q990
- Q991
- Q992
- Q993
- Q994
- Q995
- Q996
- Q997
- Q998
- Q999
- Q1000

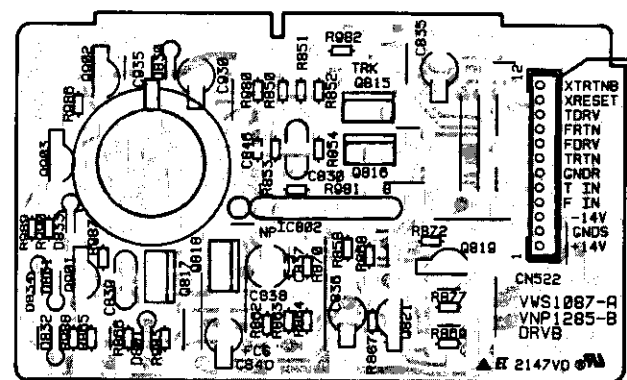

MOTHER BOARD ASSEMBLY (CN122)

MOTHER BOARD ASSEMBLY (CN122)

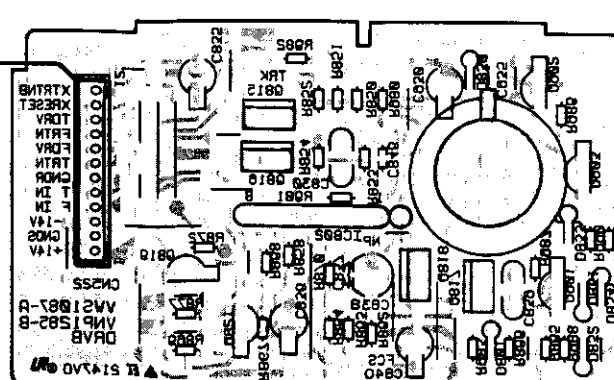

This P.C.B. connection diagram is viewed from the foil side.

WAVEFORMS OF THE FTS SECTION

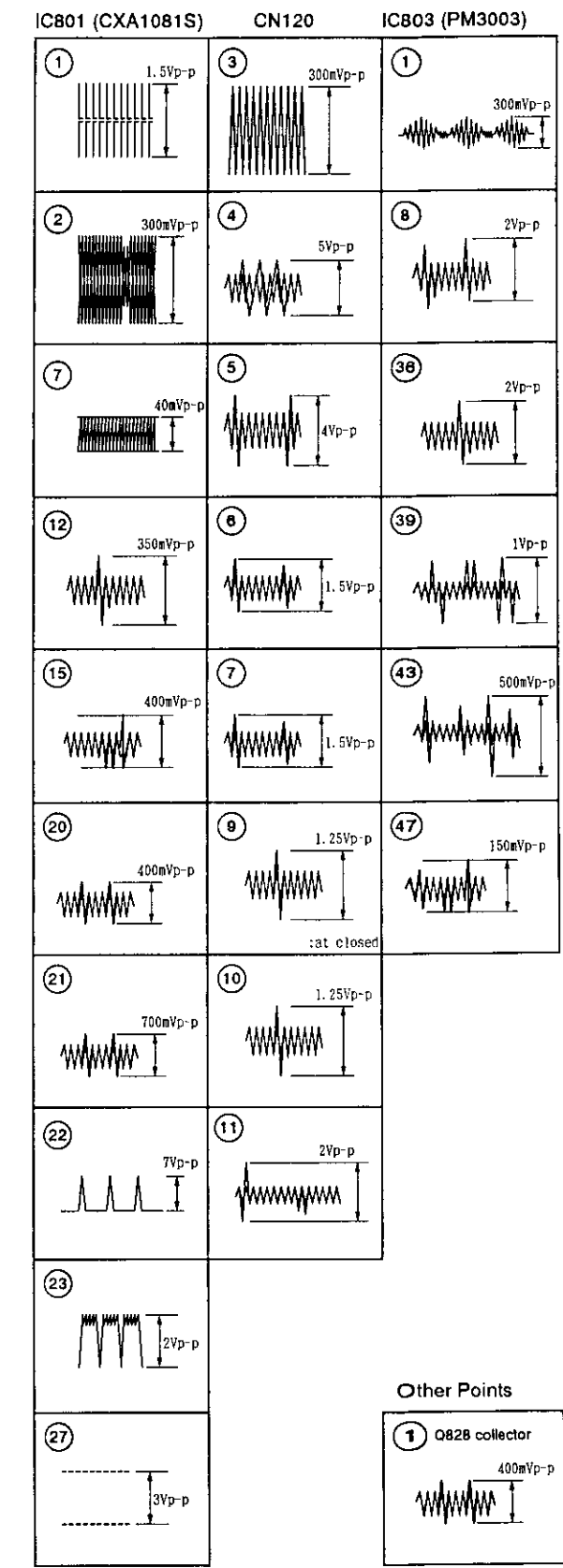

A
B
C
D

This P.C.B. connection diagram is viewed from the parts mounted side.

5.5 MOTHER BOARD ASSEMBLY (FTS SECTION)

MOTHER BOARD ASSEMBLY (FTS SECTION)

HEPB ASSEMBLY

A

B

C

D

(P24)
TO POWER SUPPLY BOARD ASSEMBLY (CN301)

TRK C
TRK A
RF
FO RTN
TR RTN
FO ERR
FO IN
GND
TR ERR
TR IN
FO SUM

(P27)
TO CNNB ASSEMBLY (CN203)

SLD M
PARK1
M GND
+5V
RF
GND
TRK C
TRK A
B4
B3
B2
B1
-5V
PD
LD
GND (LD)
TRK RTN
FCS DRV
FCS RTN
TRK DRV
TILT OUT
TILT IN

TO DRV B ASSEMBLY (P29) (CN522)

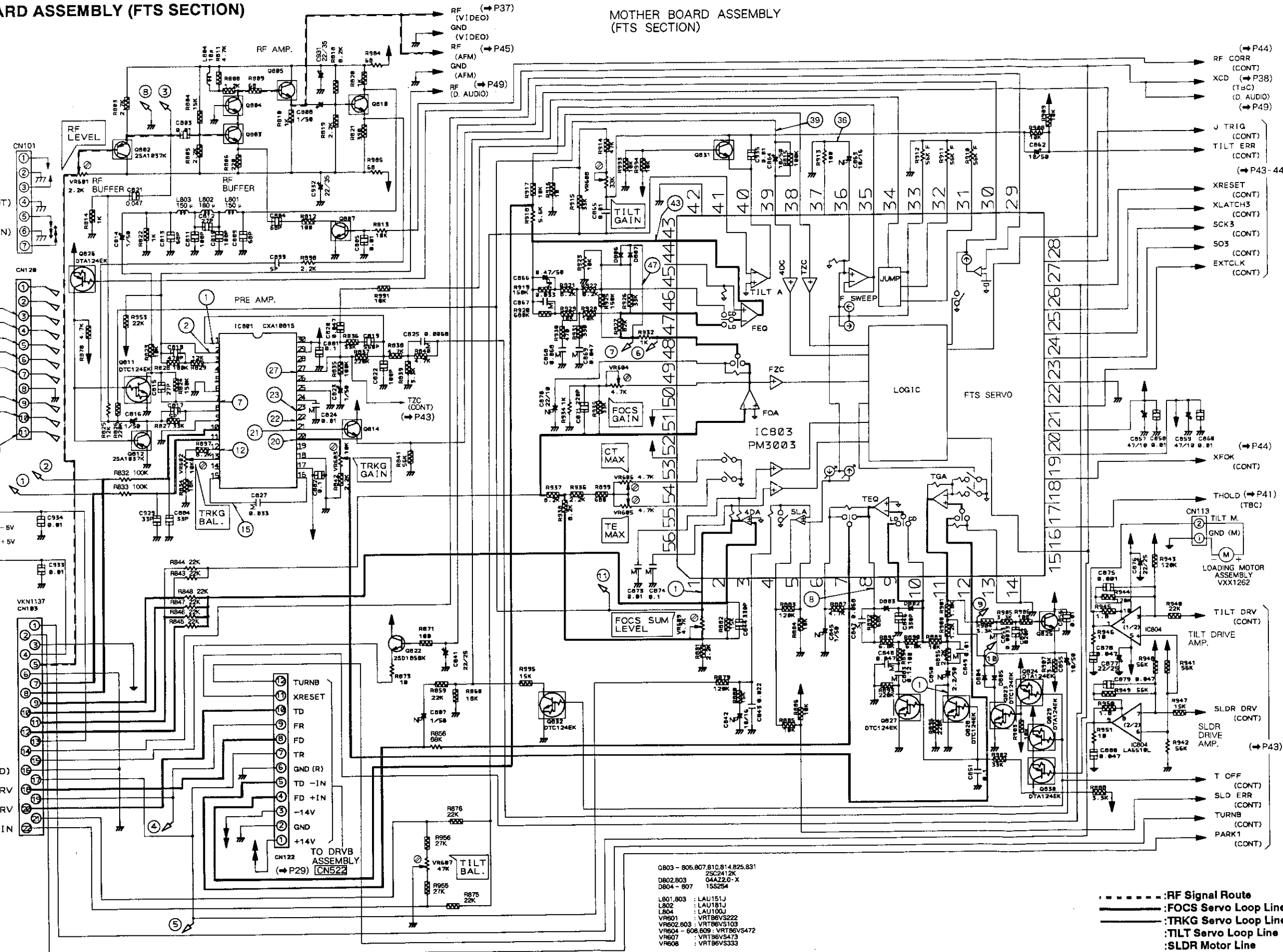

(P44)
RF CORR (CONT)
XCD (P38) (TBC)
D. AUDIO (P49)
J TRIG (CONT)
TILT ERR (CONT)
(P43-44)
XRESET (CONT)
XLATCH3 (CONT)
SCK3 (CONT)
S03 (CONT)
EXTCLK (CONT)

(P44)
XFOK (CONT)

(P41)
THOLD (TBC)

(P44)
TILT M. (CONT)
LOADING MOTOR ASSEMBLY VXX1262

(P44)
TILT DRV (CONT)
TILT DRIVE AMP.

(P44)
SLDR DRV (CONT)
SLDR DRIVE AMP.

(P43)
T OFF (CONT)
SLD ERR (CONT)
TURNB (CONT)
PARK1 (CONT)

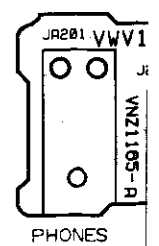

Q803 - 805,807,810,814,825,831
D802,803 : 2SC2412K
L802 : 044220-X
D804 - 807 : 1SS254
L801,803 : LAU151-J
L802 : LAU181-J
L804 : LAU100J
VR601 : VRTB6VS222
VR602,803 : VRTB6VS103
VR604 - 806,809 : VRTB6VS472
VR607 : VRTB6VS473
VR608 : VRTB6VS333

--- : RF Signal Route
— : FOCUS Servo Loop Line
— : TRKG Servo Loop Line
— : TILT Servo Loop Line
— : SLDR Motor Line

7

8

9

10

11

12

HEPB ASSEMBLY

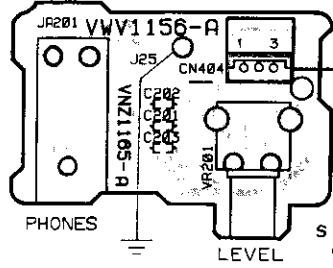

- (P44) CORR (CONT)
- (P38) (TBC)
- (D. AUDIO) (P49)
- RIG (CONT)
- T. ERR (CONT)
- (P43-44) SET (CONT)
- TC#3 (CONT)
- 3 (CONT)
- (CONT) CLK (CONT)

- (P44) (CONT)
- (P41) (TBC)
- MOTOR MBL 262
- DRV (CONT)
- DRV (CONT)
- (P43) (CONT)
- ERR (CONT)
- (CONT)
- (CONT)

Loop Line

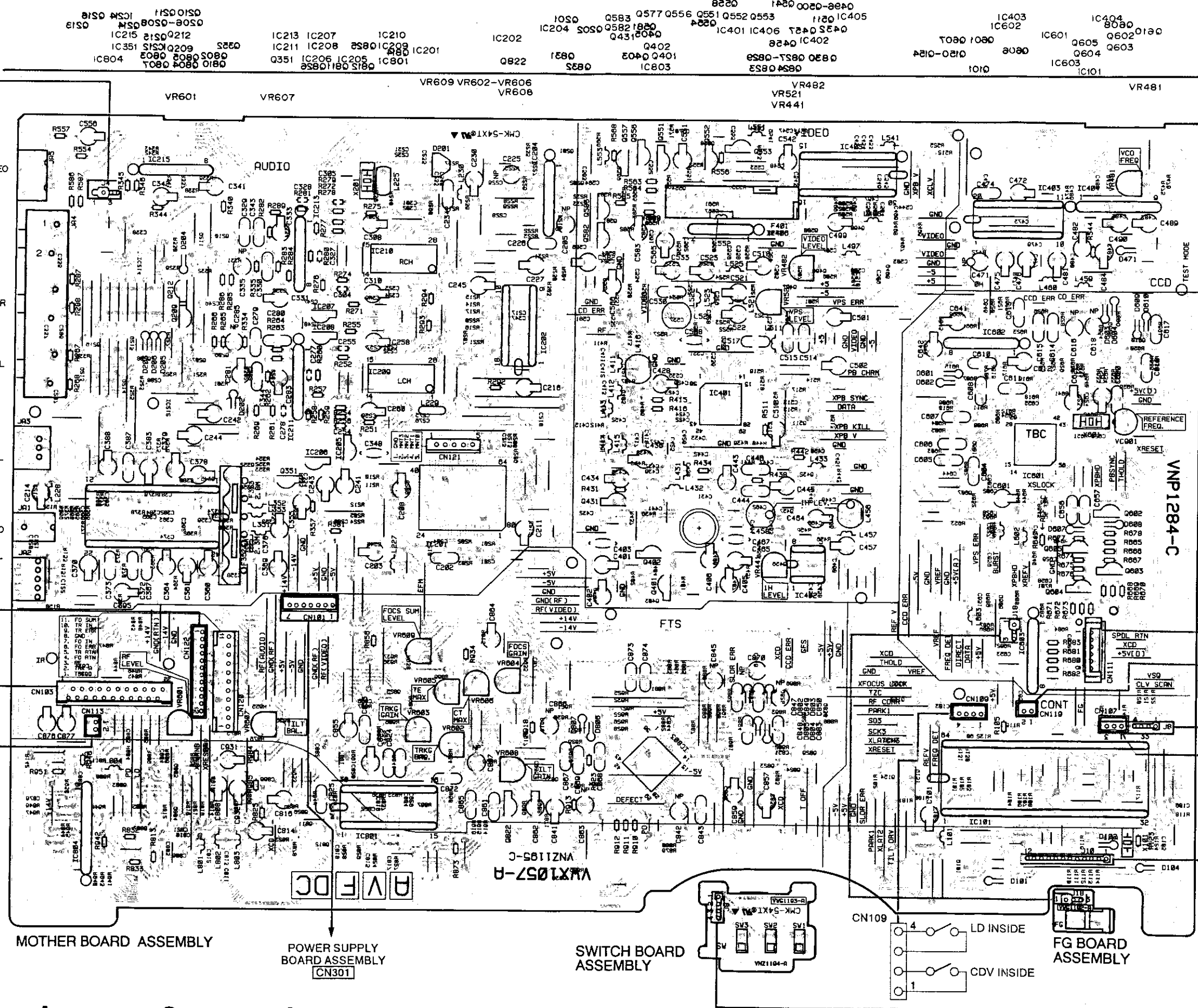

A

B

C

D

7

8

9

10

11

12

MOTHER BOARD ASSEMBLY

POWER SUPPLY BOARD ASSEMBLY CN301

SWITCH BOARD ASSEMBLY

FG BOARD ASSEMBLY

FLKY ASSEMBLY CN410

POWER SUPPLY BOARD ASSEMBLY CN311

VNP1284-C

VN1107-A

VN1104-A

DRV B ASSEMBLY CN522

CNNB ASSEMBLY CN203

LOADING MOTOR ASSEMBLY

CN119 TRAY SW

CN107

TURN SW

CN109 LD INSIDE CDV INSIDE

1 | 2 | 3 | 4 | 5 | 6

A

B

C

D

P44

P31

P4

P43

P4

IC804 IC805 IC806 IC807 IC808 IC809 IC810 IC811 IC812 IC813 IC814 IC815 IC816 IC817 IC818 IC819 IC820 IC821 IC822 IC823 IC824 IC825 IC826 IC827 IC828 IC829 IC830 IC831 IC832 IC833 IC834 IC835 IC836 IC837 IC838 IC839 IC840 IC841 IC842 IC843 IC844 IC845 IC846 IC847 IC848 IC849 IC850 IC851 IC852 IC853 IC854 IC855 IC856 IC857 IC858 IC859 IC860 IC861 IC862 IC863 IC864 IC865 IC866 IC867 IC868 IC869 IC870 IC871 IC872 IC873 IC874 IC875 IC876 IC877 IC878 IC879 IC880 IC881 IC882 IC883 IC884 IC885 IC886 IC887 IC888 IC889 IC890 IC891 IC892 IC893 IC894 IC895 IC896 IC897 IC898 IC899 IC900

This P.C.B. connection diagram is viewed from the foil side.

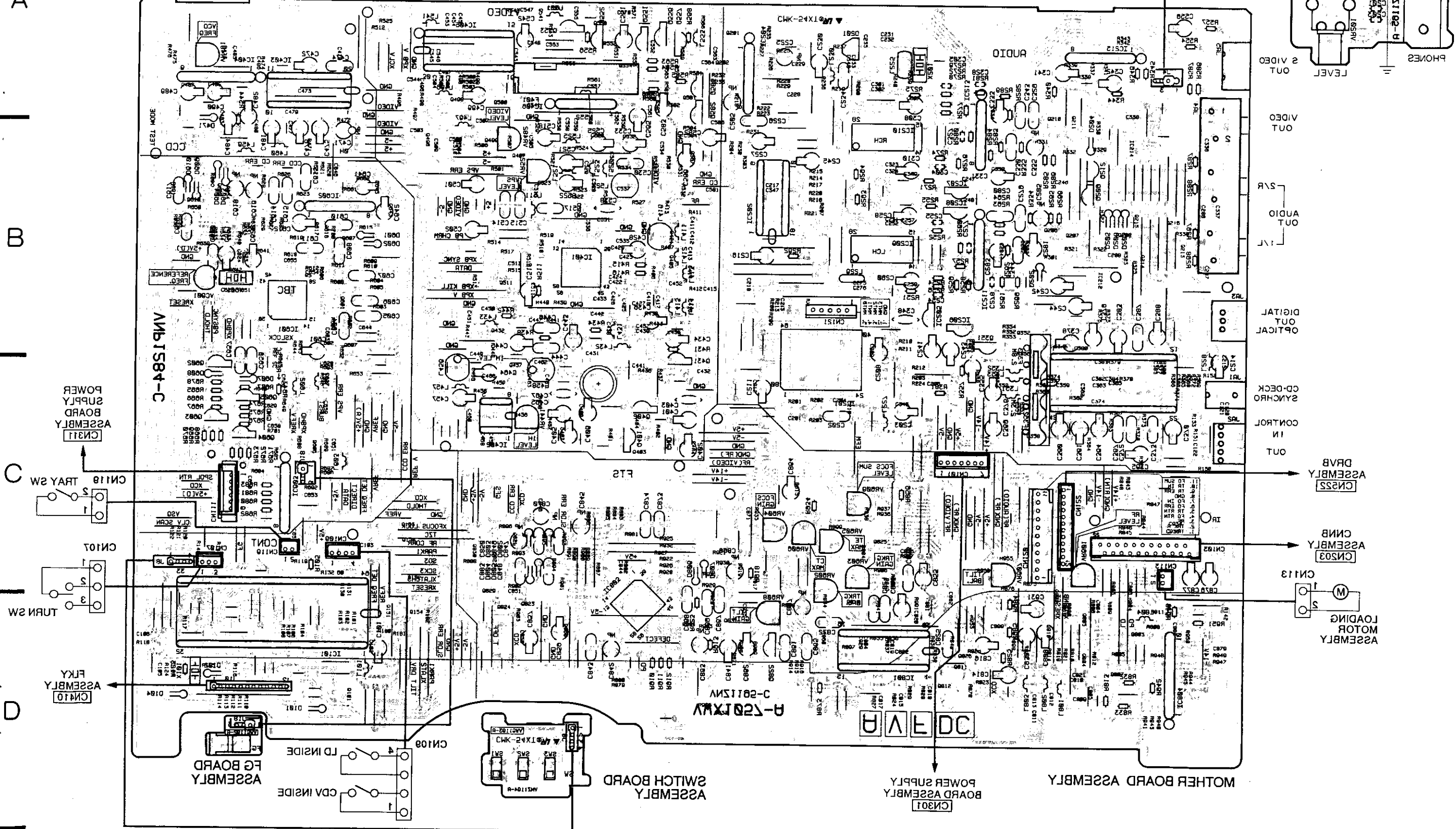

1 | 2 | 3 | 4 | 5 | 6

5.6 MOTHER BOARD ASSEMBLY (VIDEO SECTION)

MOTHER BOARD ASSEMBLY (VIDEO SECTION)

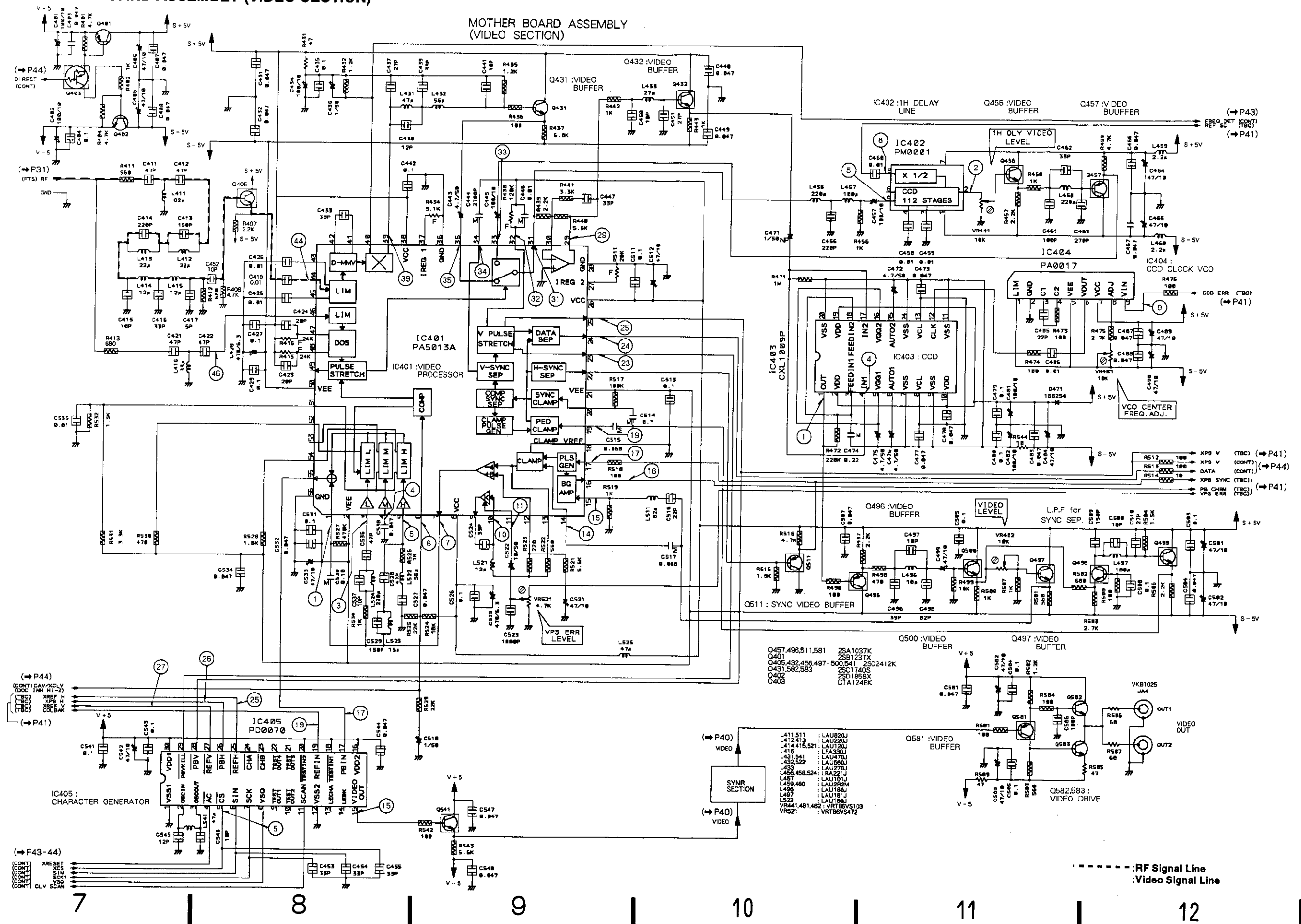

- Q457,496,511,581 2SA1037K
- Q401 2S81237X
- Q405,432,456,497-500,541 2SC2412K
- Q43 2SD1740S
- Q402 2SD1868X
- Q403 DTA124EK

- L411,511 : LAUR20U
- L412,413 : LAU250U
- L414,415,521 : LAU120U
- L416 : LA330U
- L431,541 : LAU470U
- L432,522 : LAU560U
- L433 : LAU970U
- L456,458,524 : LRA221U
- L457 : LAU101U
- L458,460 : LAUR204U
- L496 : LAU180U
- L497 : LAU181U
- L523 : LAU182U
- VR441,481,482 : VRT86VS103
- VR521 : VRT86VS472

---:RF Signal Line
 ---:Video Signal Line

5.7 MOTHER BOARD ASSEMBLY (SYNR SECTION)

WAVEFORMS OF THE VIDEO SECTION

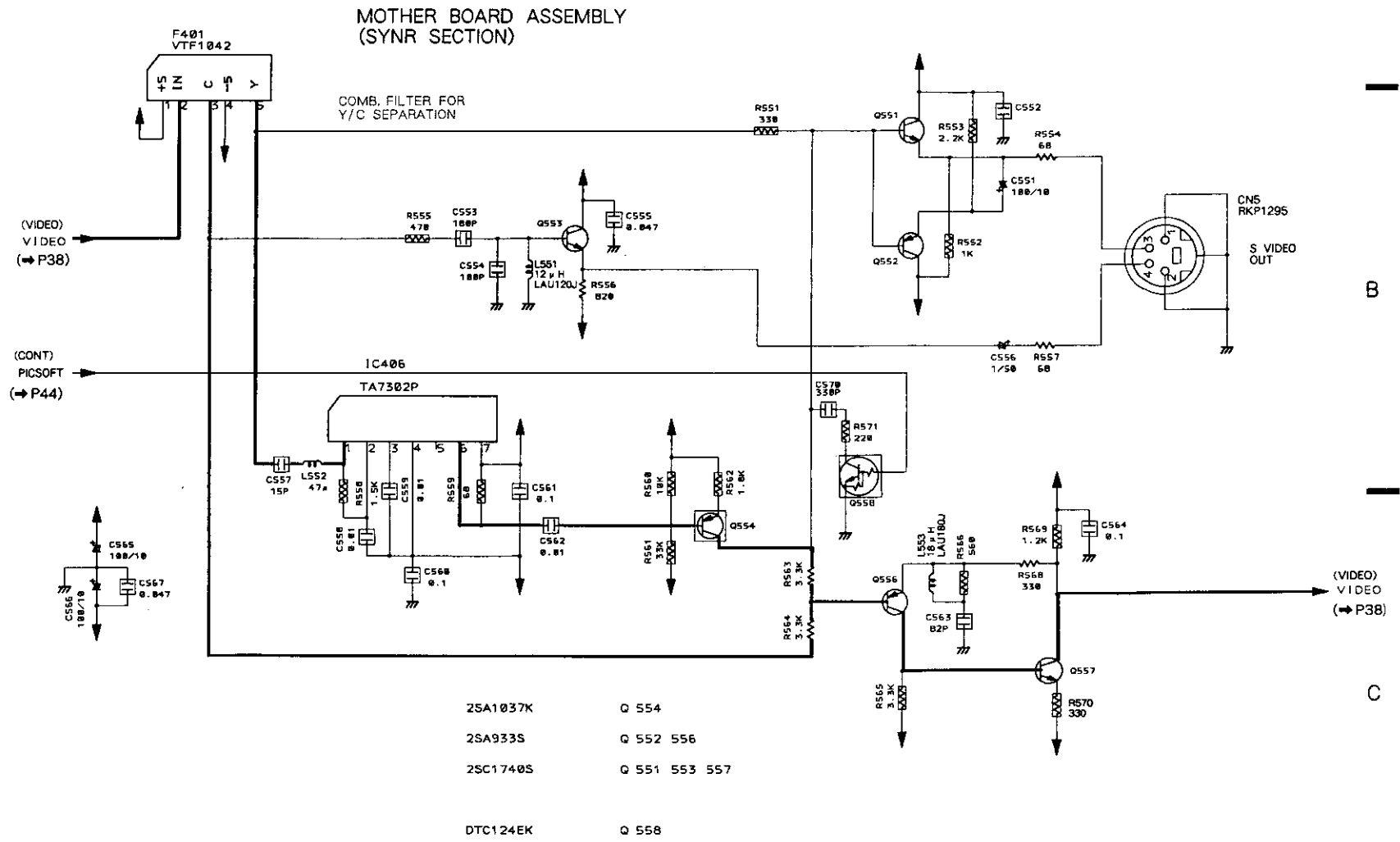
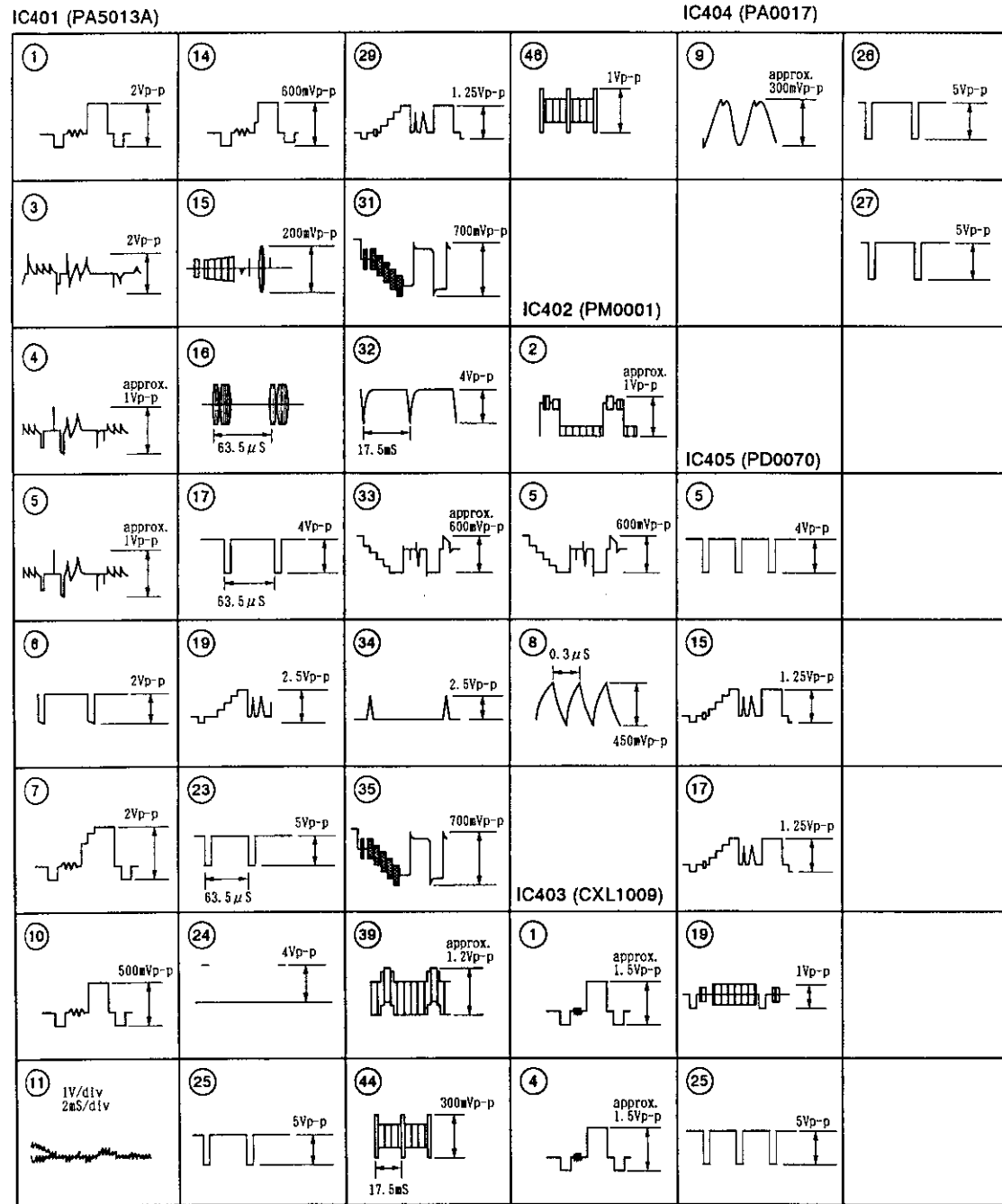

- 2SA1037K Q 554
- 2SA933S Q 552 556
- 2SC1740S Q 551 553 557
- DTC124EK Q 558

:Video Signal Line

5.8 MOTHER BOARD ASSEMBLY (TBC SECTION) AND FG BOARD ASSEMBLY

MOTHER BOARD ASSEMBLY (TBC SECTION)

- IC601: PM3802
- IC602: BA15218N
- IC603: BA15218N
- Q601: FMW2
- Q602, 604: 2SC1740S
- Q603, 605: 2SA933S
- Q606: DTC124EK
- Q607, 618: 2SC2412K
- Q608: DTAT24EK
- D601-604, 607-610: 1SS254
- VC901: VCM-008
- X601: VSS1026
- L601, 602: LAU101J
- L603: LAU470J

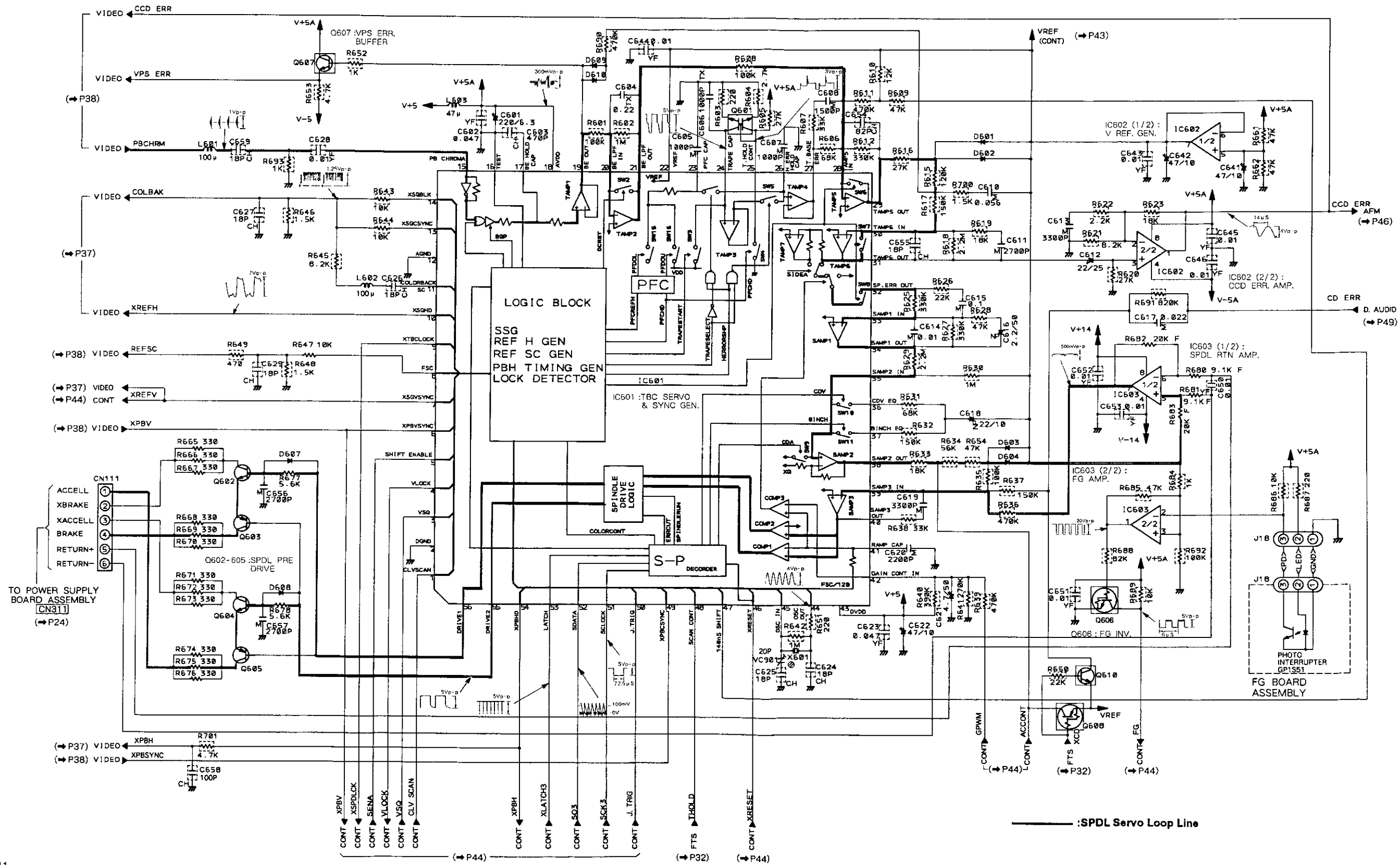

— :SPDL Servo Loop Line

5.9 MOTHER BOARD ASSEMBLY (CONT SECTION)
AND SWITCH BOARD ASSEMBLY

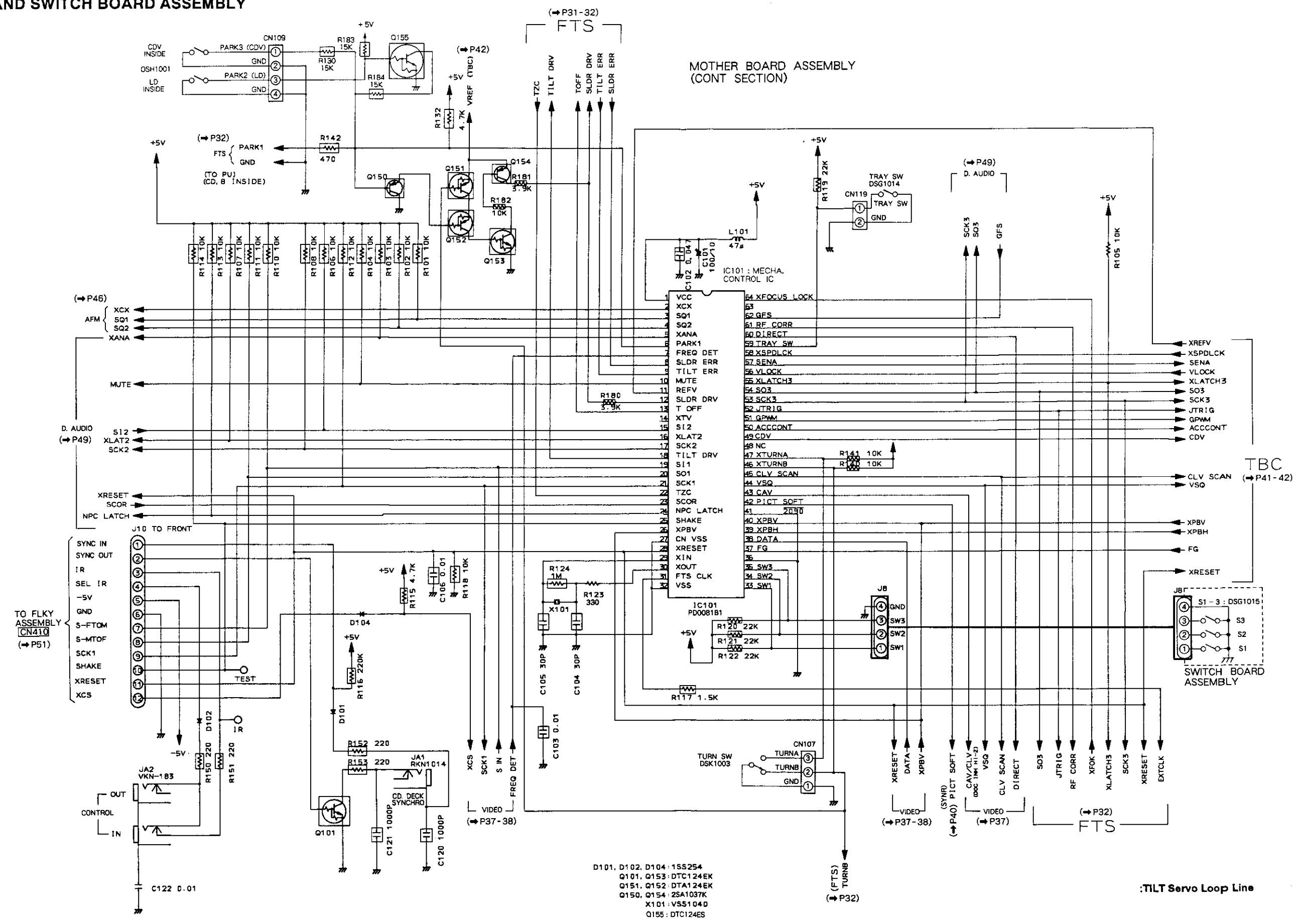

- D101, D102, D104: 1SS254
- Q101, Q153: DTC124EK
- Q151, Q152: DTA124EK
- Q150, Q154: 2SA1037K
- X101: VSS104D
- Q155: DTC124ES

:TILT Servo Loop Line

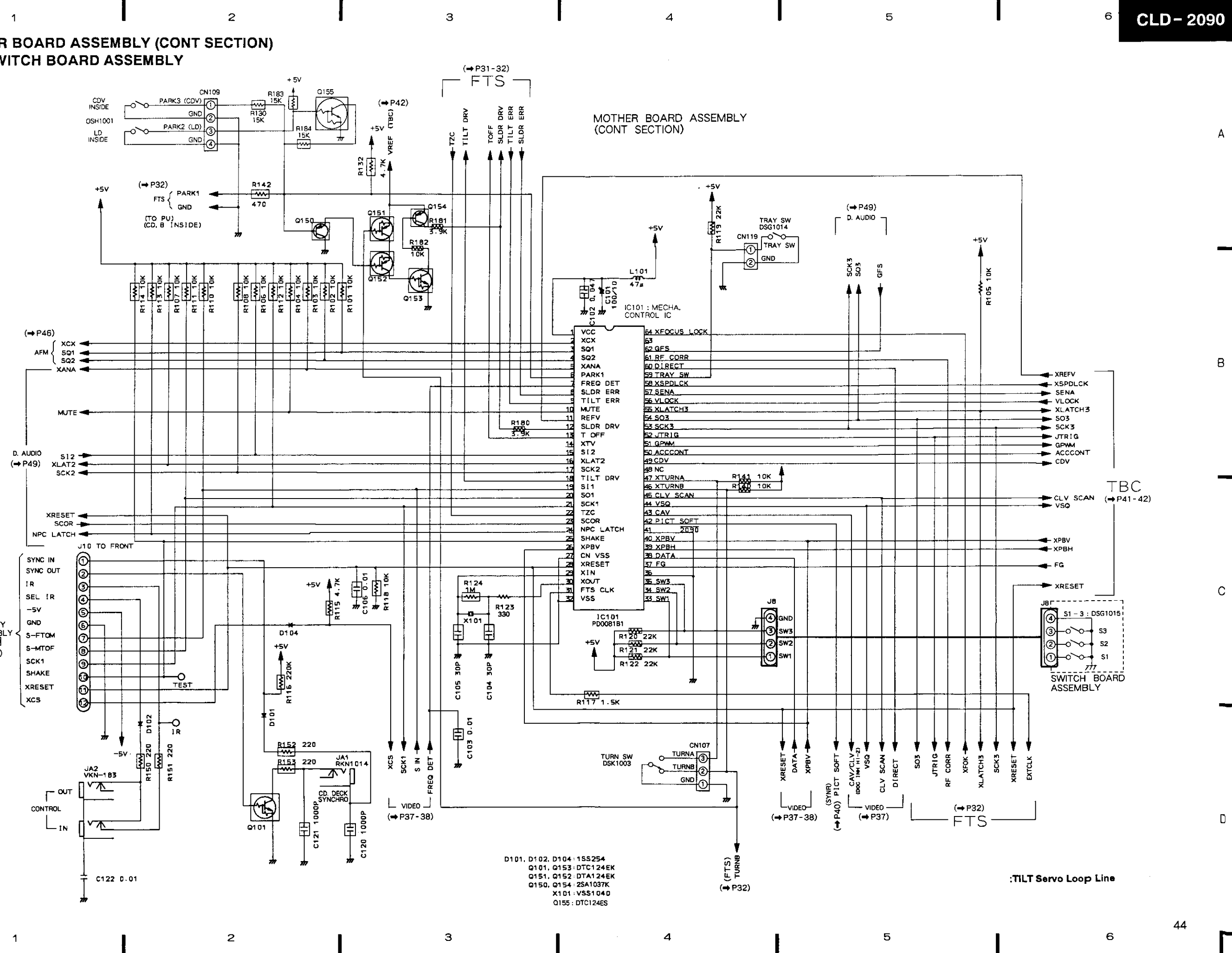

5.10 MOTHER BOARD ASSEMBLY (AFM SECTION)

MOTHER BOARD ASSEMBLY (AFM SECTION)

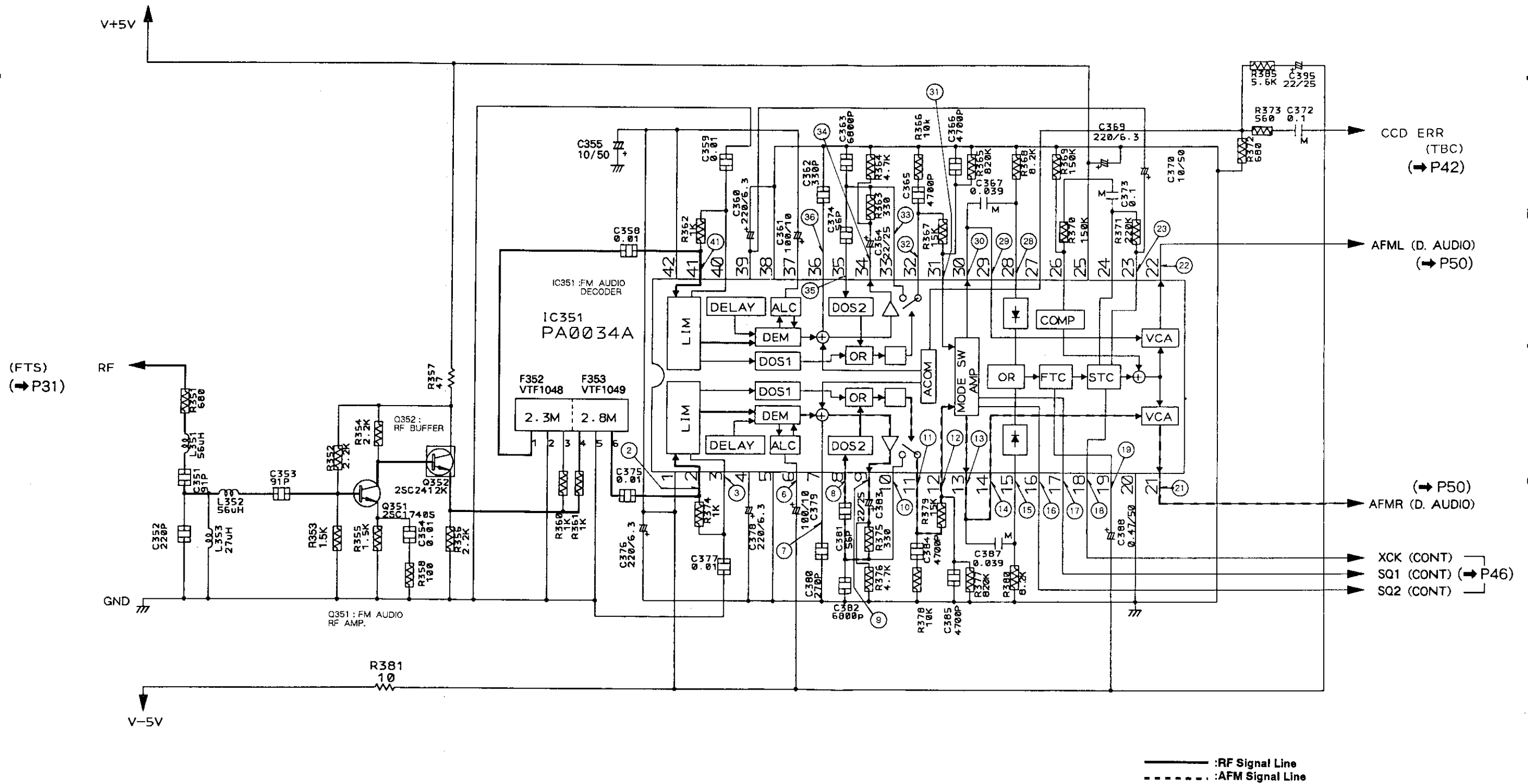

(FTS) (→ P31)

CCD ERR (TBC) (→ P42)

AFML (D. AUDIO) (→ P50)

AFMR (D. AUDIO) (→ P50)

XCK (CONT) SQ1 (CONT) (→ P46) SQ2 (CONT)

— :RF Signal Line
- - - :AFM Signal Line

Note: Waveforms and voltages are at the PLAY state.

IC351 (PA0034A)

Pin No.	Voltage	Pin No.	Voltage	Pin No.	Voltage
1	-5V	15	*	29	*
2	*	18	*	30	*
3	*	17	*	31	*
4	—	18	*	32	*
5	—	19	*	33	*
6	*	20	0	34	*
7	*	21	*	35	*
8	*	22	*	36	*
9	*	23	*	37	—
10	*	24	0	38	—
11	*	25	5V	39	—
12	*	28	0	40	—
13	*	27	0	41	*
14	*	28	*	42	-5V

*: Refer to Waveforms

● IC351 (PA0034A)

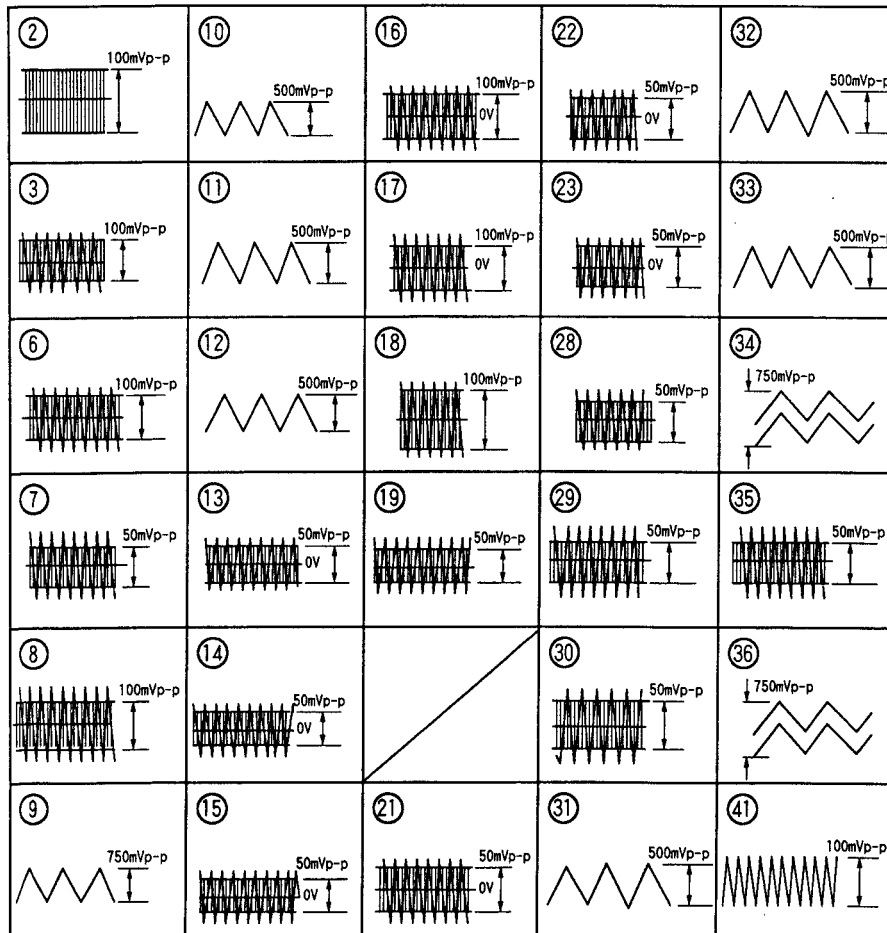

Note: Waveforms and voltages are at the PLAY

IC201 (CXD2500AQ)

Pin No.	Voltage	Pin No.	Voltage	Pin No.	Voltage	Pin No.	Voltage	Pin No.	Voltage	Pin No.	Voltage
1	0	15	0	29	0	43	*	57	*	71	*
2	0	16	4.8	30	0	44	0	58	*	72	5
3	0	17	0	31	*	45	4.8	59	5	73	5
4	*	18	*	32	*	46	*	60	*	74	*
5	0	19	2.4	33	4.8	47	*	61	5	75	0
6	4.8	20	*	34	*	48	*	62	*	76	0
7	0	21	0	35	*	49	*	63	*	77	*
8	4.8	22	2.3	36	*	50	*	64	*	78	*
9	0	23	4.8	37	*	51	*	65	0	79	*
10	0	24	*	38	*	52	0	66	*	80	0
11	0	25	0	39	0	53	*	67	*		
12	0	26	0	40	4.8	54	*	68	0		
13	0	27	*	41	*	55	0	69	*		
14	0	28	0	42	*	56	*	70	5		

*: Refer to Waveforms

IC202 (SM5840AP)

Pin No.	Voltage	Pin No.	Voltage
1	5	10	*
2	*	11	*
3	*	12	*
4	*	13	*
5	0	14	5
6	*	15	*
7	*	16	*
8	5	17	*
9	5	18	*

IC201 (CXD2500AQ)

IC202 (SM5840AP)

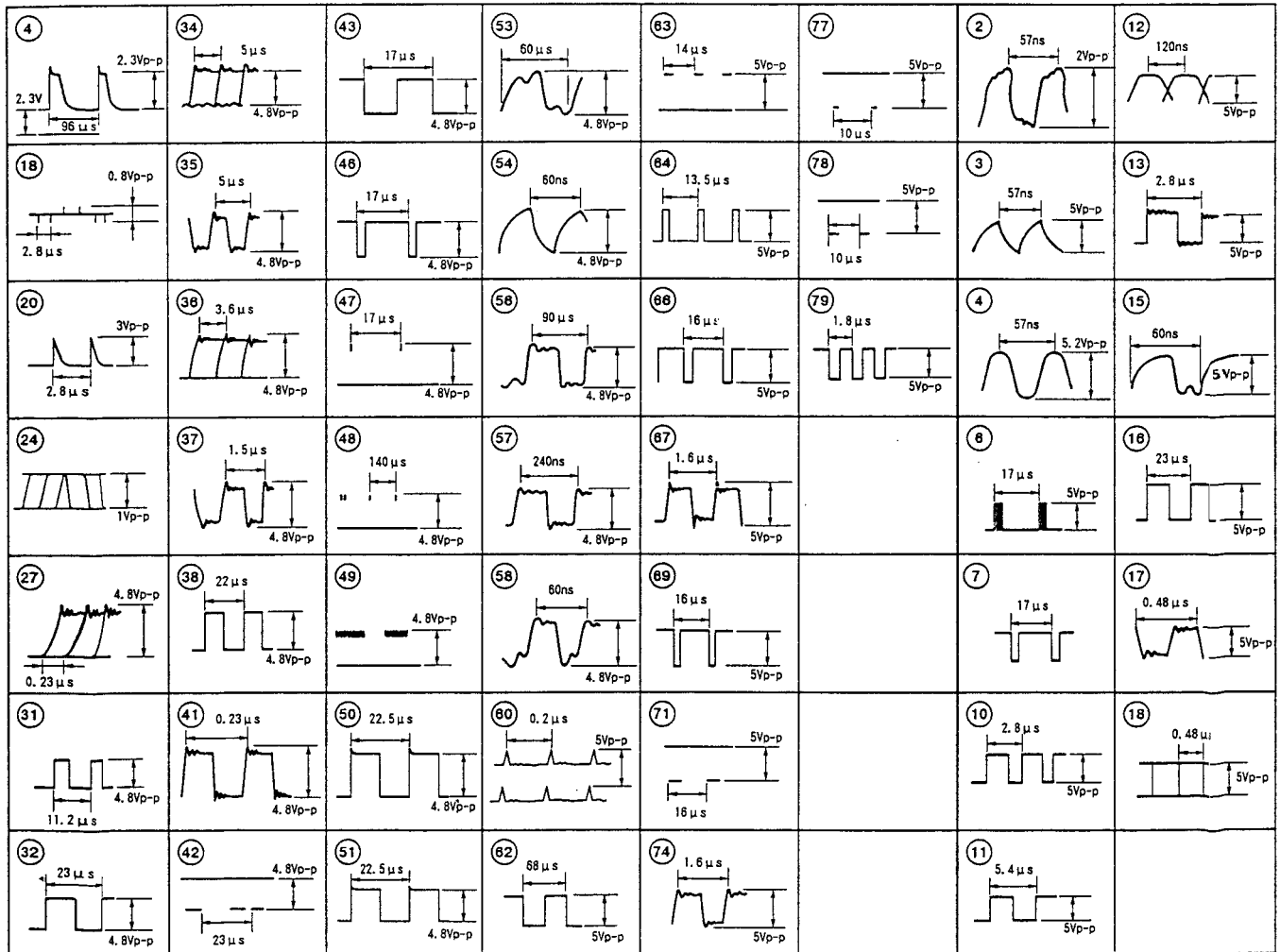

5.11 MOTHER BOARD ASSEMBLY (D.AUDIO SECTION)

MOTHER BOARD ASSEMBLY (D. AUDIO SECTION)

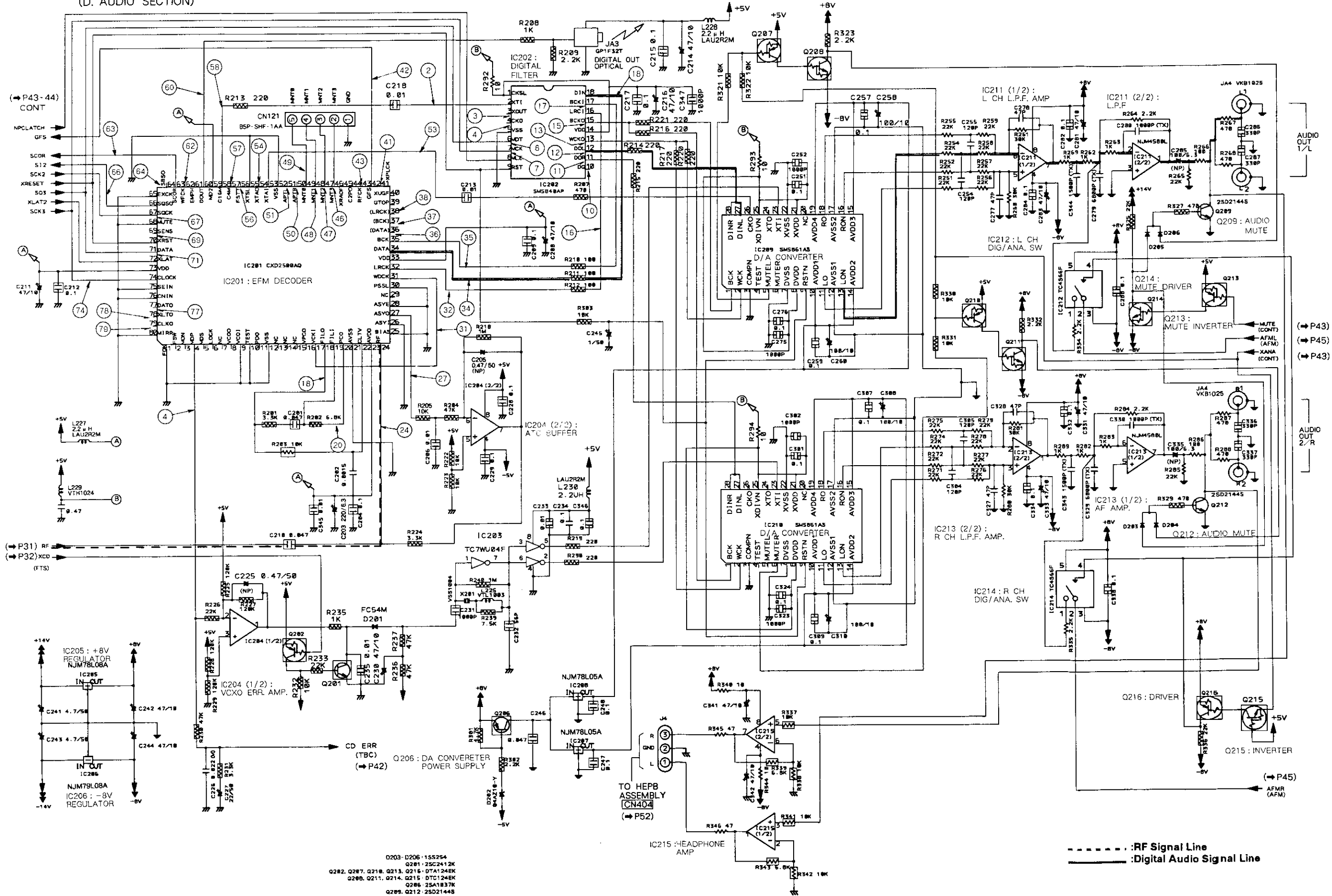

- D203-D206: 15S254
- Q201: 25C2412K
- Q202, Q207, Q210, Q213, Q215: 07A1248K
- Q208, Q211, Q214, Q215: 07C1248K
- Q206: 25A1837K
- Q209, Q212: 25D21445

--- :RF Signal Line
 --- :Digital Audio Signal Line

5.12 FLKY, HEPB AND PWSB ASSEMBLIES

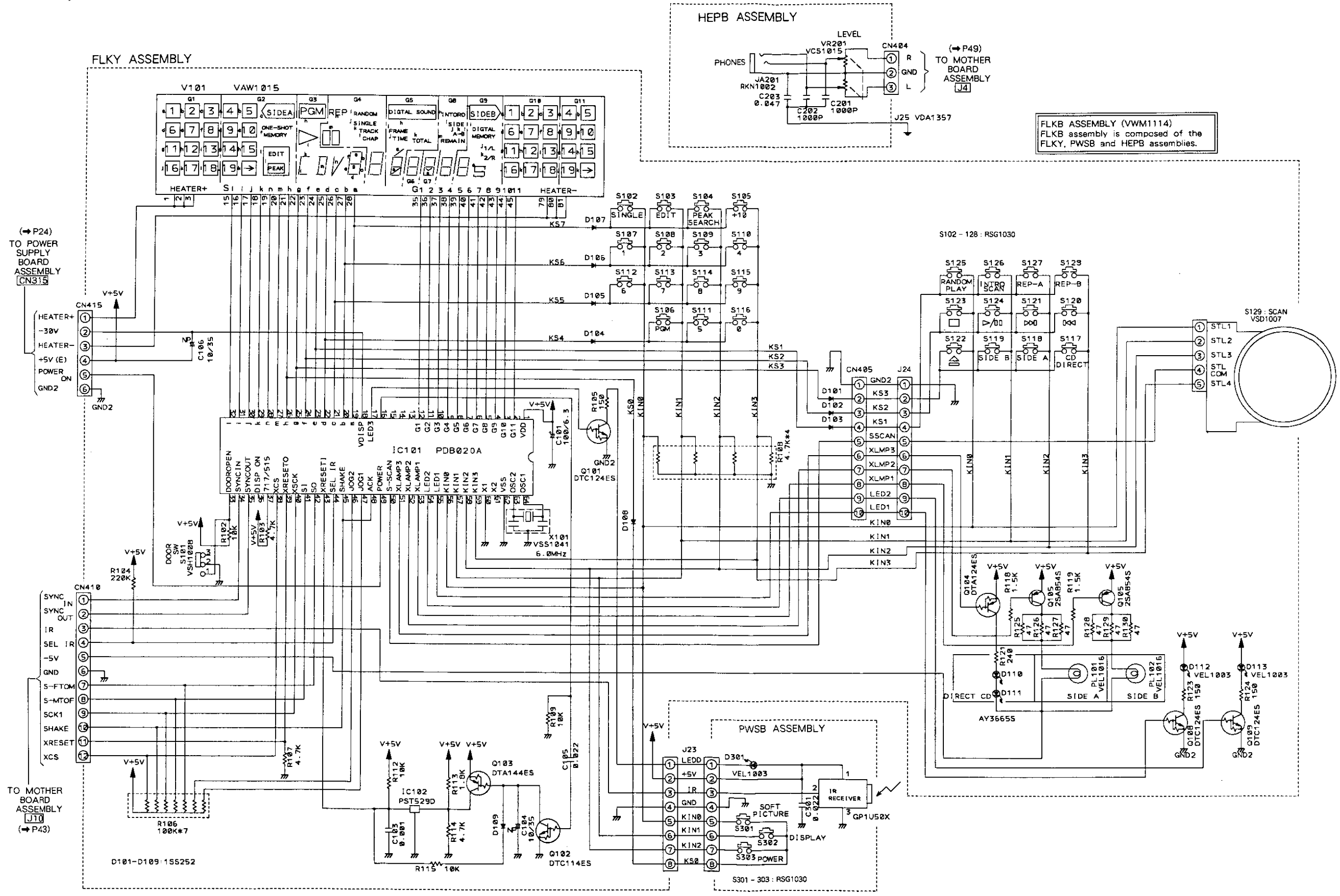

1

2

3

4

5

6

A

A

FLKY ASSEMBLY

PWSB ASSEMBLY

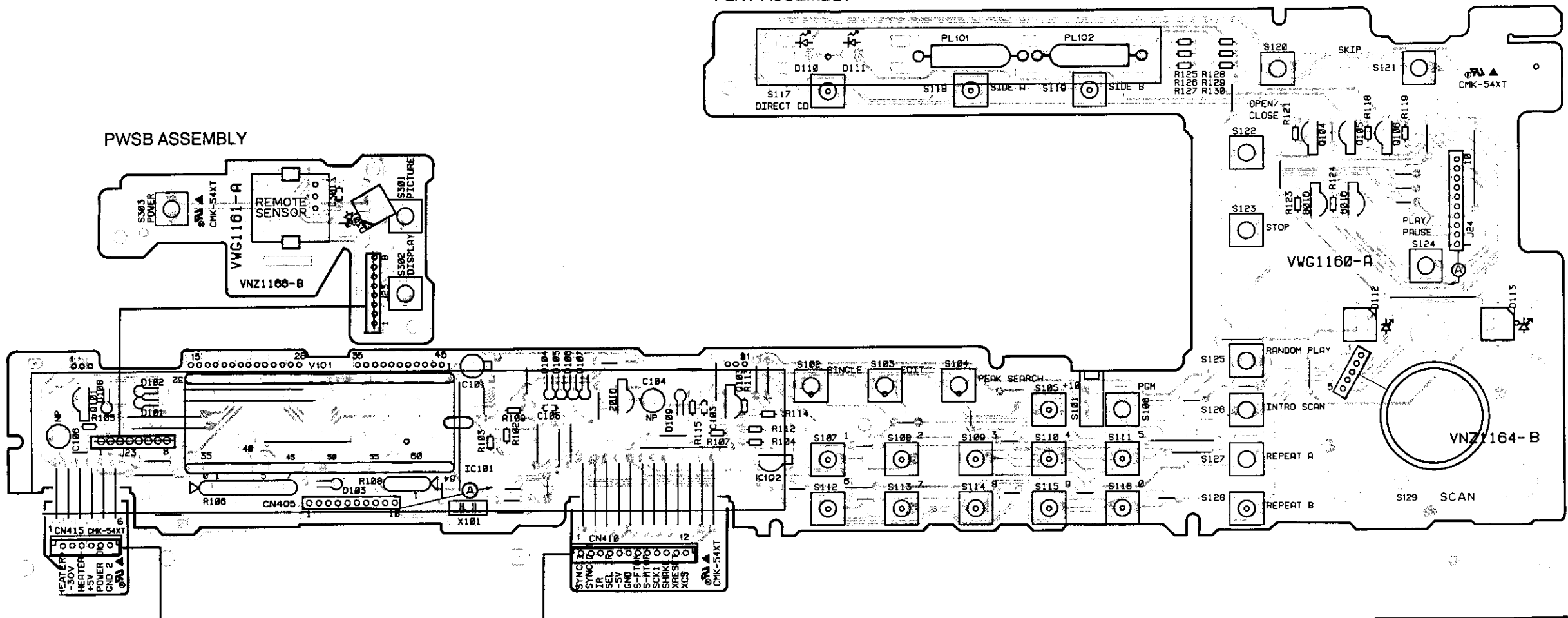

B

B

C

C

POWER SUPPLY BOARD ASSEMBLY
CN315

MOTHER BOARD ASSEMBLY
J10

1

2

3

4

5

6

D

D

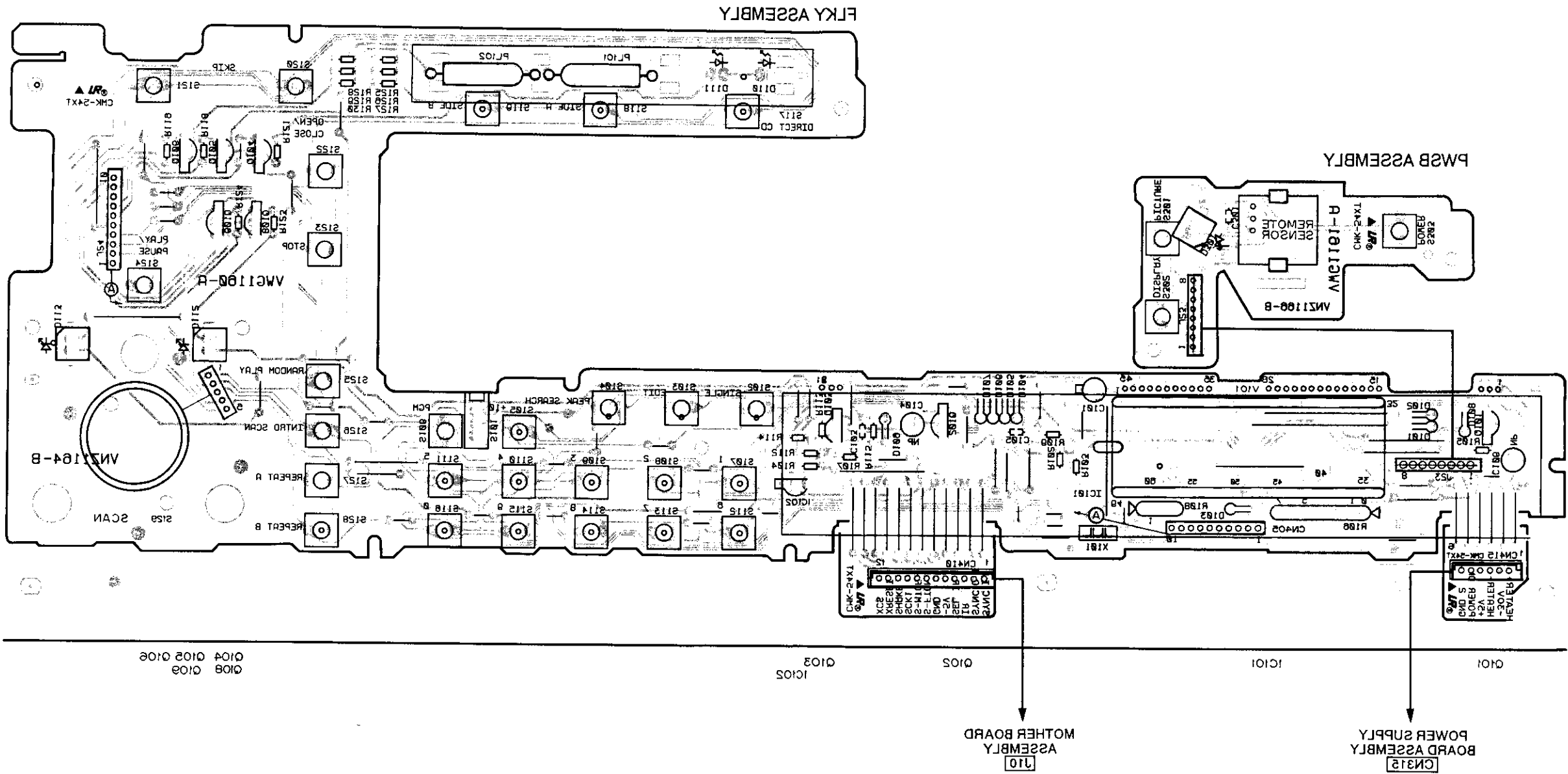

This P.C.B. connection diagram is viewed from the foil side.

6. ELECTRICAL PARTS LIST

NOTES:

- Parts without part number cannot be supplied.
- Parts marked by "⊙" are not always kept in stock. Their delivery time may be longer than usual or they may be unavailable.
- The Δ mark found on some component parts indicates the importance of the safety factor of the part. Therefore, when replacing, be sure to use parts of identical designation.
- When ordering resistors, first convert resistance values into code form as shown in the following examples.

Ex.1 When there are 2 effective digits(any digit apart from 0), such as 560 ohm and 47k ohm(tolerance is shown by J=5%, and K=10%).

560 Ω → 56 × 10¹ → 561 RD1/4PS 561J
 47k Ω → 47 × 10³ → 473 RD1/4PS 473J
 0.5 Ω → 0R5 RN2H 0R5K
 1 Ω → 010 RS1P 010K

Ex.2 When there are 3 effective digits(such as in high precision metal film resistors).

5.62k Ω → 562 × 10¹ → 5621 RN1/4SR 5621F

Miscellaneous Parts

Mark	Symbol & Description	Part No.
⊙	MAIN board assembly MOTHER board assembly SWITCH board assembly FG board assembly	VWM1155
⊙	FLKB assembly FLKY assembly PWSB assembly HEPB assembly	VWM1114
⊙	DRVB assembly	VWS1087
	CNNB assembly	VWR1098
	Power supply board assembly	VWR1098
Δ	Strain relief	CM-22C
Δ	AC power cord	PDG1015
	Push switch (TRAY SW)	DSG1014
	Lever switch (TURN SW)	DSK1003
	Slide switch (LD,CDV INSIDE)	OSH1001
	Slide switch (CD,B INSIDE)	VSK1008
	Spindle motor assembly	VXA1581
	Loading motor assembly	VXX1262
	Carriage motor assembly - S	VXX1537
	Pickup assembly - S	VXX1553

Power Supply Board Assembly (VWR1098)

SEMICONDUCTORS

Mark	Symbol & Description	Part No.
	IC215	ICP-N38
	IC213,IC214	ICP-N50
	IC202	TH5P4
	F211,F212	PT0.5A
	Other parts are not supplied.	

⊙ MAIN Board Assembly (VWM1155)

MAIN board assembly is composed of the MOTHER, FG and SWITCH board assemblies.

MOTHER Board Assembly

SEMICONDUCTORS

Mark	Symbol & Description	Part No.
	IC204,IC602,IC603	BA15218N
	IC801	CXA1081S
	IC201	CXD2500AQ
	IC403	CXL1009P
	IC804	LA6510L
	IC211,IC213,IC215	NJM4580L
	IC207,IC208	NJM78L05A
	IC205	NJM78L08A
	IC206	NJM79L08A
	IC404	PA0017
	IC351	PA0034A
	IC401	PA5013A
	IC405	PD0070
	IC101	PD0081B1
	IC402	PM0001
	IC601	PM3002
	IC803	PM3003
	IC202	SM580AP
	IC209,IC210	SM5851AS
	IC406	TA7302P
	IC212,IC214	TC4S06F
	IC203	TC7WJ04F
	Q151,Q152,Q202,Q207,Q210,Q213, Q216,Q403,Q608,Q824,Q826,Q829, Q830	DTA124EK
	Q101,Q153,Q208,Q211,Q214,Q215, Q558,Q606,Q811,Q823,Q827,Q828, Q832	DTC124EK
	Q601	FMW2
	Q150,Q154,Q206,Q457,Q496,Q511, Q554,Q581,Q802,Q812	2SA1237K
	Q155	DTC124ES

Mark	Symbol & Description	Part No.
	Q552, Q556, Q603, Q605	2SA933S
	Q401	2SB1237X
	Q351, Q431, Q551, Q553, Q557, Q582, Q583, Q602, Q604	2SC1740S
	Q201, Q352, Q405, Q432, Q456, Q497 - Q500, Q541, Q607, Q610, Q803 - Q805, Q807, Q810, Q814, Q825, Q831	2SC2412K
	Q402, Q822	2SD1858X
	Q209, Q212	2SD2144S
	D201 (Variable capacitor)	FC54M
	D202	04AZ10
	D101, D102, D104, D203 - D206, D471, D601 - D604, D607 - D610, D804 - D807	1SS254
	D802, D803	04AZ2.0

COILS AND FILTERS

Mark	Symbol & Description	Part No.
	L804	LAU100J
	L457, L601, L602	LAU101J
	L414, L415, L521, L551	LAU120J
	L523	LAU150J
	L801, L803	LAU151J
	L496, L553	LAU180J
	L497, L802	LAU181J
	L227, L228, L230, L459, L460	LAU2R2M
	L412, L413	LAU220J
	L353, L433	LAU270J
	L101, L431, L525, L541, L552, L603	LAU470J
	L351, L352, L432, L522	LAU560J
	L411, L511	LAU820J
	L456, L458, L524	LRA221J
	L229 (Ferrite bead)	VTH1024
	L416	LFA330J
	L225 (4.7 μH)	VTL1003
	F401	VTF1042
	F352 SIF (2.30MHz)	VTF1048
	F353 SIF (2.80MHz)	VTF1049

CAPACITORS

Mark	Symbol & Description	Part No.
	VC901 Ceramic trimmer(20p)	VCM - 008
	C277, C278, C327, C328	CCPUSL470J50
	C417, C817, C899	CCSQCH050C50
	C415, C441, C450, C452, C497, C500, C537, C545, C546	CCSQCH100D50
	C461, C554, C586, C658, C810, C811, C822	CCSQCH101J50
	C557	CCSQCH150J50
	C413, C509, C529	CCSQCH151J50
	C624 - C627, C629, C655, C659	CCSQCH180J50
	C553	CCSQCH181J50
	C485, C516	CCSQCH220J50

Mark	Symbol & Description	Part No.
	C352, C414, C456, C871	CCSQCH221J50
	C437, C451, C510, C812, C815	CCSQCH270J50
	C380, C463	CCSQCH271J50
	C438	CCSQCH120J50
	C423, C424	CCSQCH200J50
	C104, C105	CCSQCH300J50
	C416, C439, C447, C453 - C455, C462, C884, C929	CCSQCH330J50
	C433, C496, C524	CCSQCH390J50
	C411, C412, C421, C422, C528, C536	CCSQCH470J50
	C232, C374, C381	CCSQCH560J50
	C804, C809, C813	CCSQCH680J50
	C498, C563, C654	CCSQCH820J50
	C351, C353	CCSQCH910J50
	C286, C287, C336, C337, C362, C570, C844, C846	CCSQSL331J50
	C603, C818	CCSQSL471J50
	C819	CCSQSL561J50
	C808, C814, C816	CEAL010M50
	C931, C932	CEAL220M35
	C205, C225, C866	CEANPR47M50
	C471, C807, C845	CEANP010M50
	C842, C863	CEANP100M16
	C285, C335	CEANP101M6R3
	C616, C850	CEANP2R2M50
	C618, C870	CEANP220M10
	C388	CEASR47M50
	C245, C436, C518, C556, C823	CEAS010M50
	C355, C370, C522, C855, C862, C864	CEAS100M50
	C101, C258, C260, C308, C310, C361, C379, C401, C402, C434, C445, C457, C481, C482, C551, C565, C566	CEAS101M10
	C227, C364, C383, C395, C612, C841, C876, C877	CEAS220M25
	C203, C360, C369, C376, C378, C601	CEAS221M6R3
	C241, C243, C443, C472, C475, C476, C621	CEAS4R7M50
	C208, C211, C214, C216, C230, C242, C244, C281, C283, C331, C333, C341, C342, C405, C406, C464, C465, C484, C489, C490, C499, C501, C502, C512, C521, C533, C542, C582, C583, C622, C641, C642, C857, C859	CEAS470M10
	C428, C525	CEAS471M6R3
	C446, C614, C824, C849, C861, C865, C873	CFTNA103J50
	C234, C372, C373, C514, C615, C874	CFTNA104J50
	C226, C617, C843	CFTNA223J50
	C827, C867	CFTNA333J50
	C367, C387	CFTNA393J50
	C848, C869	CFTNA473J50
	C610	CFTNA563J50
	C515, C517, C847, C868	CFTNA683J50

Mark	Symbol & Description	Part No.
	C280, C330, C605, C606, C607, C883	CFTXA102J50
	C202, C343, C344, C608	CFTXA124J50
	C530	CFTXA184J50
	C474, C604	CFTXA224J50
	C279, C329, C825	CFTXA682J50
	C348, C403, C467, C538	CGCYX473K25
	C254, C255, C304, C305	CKPUYB121K50
	C120, C121, C231, C252, C275, C302, C323, C347, C523, C875	CKSQYB102K50
	C365, C366, C384, C385	CKSQYB472K50
	C363, C382	CKSQYB682K50
	C854	CKSQYB821K50
	C103, C106, C122, C206, C213, C218, C233, C235, C345, C354, C358, C359, C375, C377, C425, C426, C458 - C460, C486, C535, C558, C559, C562, C628, C643 - C646, C650 - C653, C803, C805, C821, C856, C858, C860, C933 - C935, C418	CKSQYF103Z50
	C204, C209, C212, C215, C217, C228, C229, C247, C248, C251, C257, C259, C276, C282, C284, C288, C301, C307, C309, C324, C332, C334, C338, C346, C404, C427, C429, C435, C442, C479, C480, C503, C505, C506, C508, C511, C513, C526, C531, C541, C543, C552, C560, C561, C564, C584, C585, C851, C881, C882	CKSQYF104Z25
	C102, C201, C210, C246, C407, C408, C431, C432, C448, C449, C466, C473, C477, C478, C483, C487, C488, C504, C507, C527, C532, C534, C544, C547, C548, C555, C567, C581, C602, C623, C820, C878 - C880	CKSQYF473Z25
	C620	CQMA222J50
	C444, C611, C656, C657	CQMA272J50
	C613, C619, C853	CQMA332J50

RESISTORS

Mark	Symbol & Description	Part No.
	VR441, VR481, VR482, VR602, VR603	VRTB6VS103
	Semi-fixed(10kΩ)	
	VR601	VRTB6VS222
	Semi-fixed(2.2kΩ)	
	VR521, VR604 - VR606, VR609	VRTB6VS472
	Semi-fixed(4.7kΩ)	
	VR608	VRTB6VS333
	Semi-fixed(33kΩ)	
	VR607	VRTB6VS473
	Semi-fixed(47kΩ)	
	R415, R416, R434, R438, R511, R680 - R683	RN1/6PQ □□□□F

Mark	Symbol & Description	Part No.
	R105, R123, R180, R183, R184, R251, R252, R254 - R269, R271, R272, R274 - R289, R292 - R294, R334, R335, R340, R344 - R346, R357, R381, R431, R442, R544, R554, R556, R557, R563, R564, R568, R585 - R587, R589, R647, R665 - R678, R690, R813, R825, R832, R833, R856, R873, R910 - R913, R918, R923, R934, R942, R946, R951, R984, R985, R999	RD1/6PM □□□J
	Other resistors	RS1/10S □□□J

OTHERS

Mark	Symbol & Description	Part No.
	X201 Crystal resonator (16MHz)	VSS1004
	X601 Crystal resonator (14.318MHz)	VSS1026
	X101 Ceramic resonator (9.00MHz)	VSS1040
	CN121 5P top post	B5P-SHF-1AA
	CN5 S terminal connector	RKP1295
	CN103 22P top connector	VKN1137
	JA3 Optical digital module	GP1F32T
	JA1 Mini jack	RKN1014
	JA4 6P pin jack	VKB1025
	JA2 2P mini jack	VKN-183

FG Board Assembly

OTHERS

Mark	Symbol & Description	Part No.
	Photo interrupter	GP1S51

SWITCH Board Assembly

SWITCHES

Mark	Symbol & Description	Part No.
	S101 - S103 Push switch (LD, CD, CDV DETECT)	DSG□O15

◎ FLKB Assembly (VWM1114)

FLKB assembly is composed of the FLKY, PWSB and HEPB assemblies.

FLKY Assembly

SEMICONDUCTORS

Mark	Symbol & Description	Part No.
	IC101	PDB020A
	IC102	PST529D
	Q104	DTA124ES
	Q103	DTA144ES
	Q102	DTC114ES
	Q101, Q108, Q109	DTC124ES
	Q105, Q106	2SA854S
	D110, D111 (LED, YELLOW)	AY3665S
	D112, D113 (LED, YELLOW)	VEL1003
	D101 - D109	1SS252

SWITCHES

Mark	Symbol & Description	Part No.
	S102 - S128 Tact switch SINGLE, EDIT, PEAK SERCH, +10, PGM, 1 - 9, 0, DIRECT CD, DISC SIDE (SIDE A, SIDE B), SKIP (⏪, ⏩), OPEN/CLOSE (⏏), STOP (⏏), PLAY/PAUSE (⏮ / ⏭), RANDOM PLAY, INTRO SCAN, REPEAT (A, B)	RSG1030
	S129 Rotary encoder (Scan (⏪ / ⏩))	VSD1007
	S101 Detector switch (Door sw)	VSH1008

CAPACITORS

Mark	Symbol & Description	Part No.
	C104, C106	CEALNP100M35
	C101	CEAL101M6R3
	C103	CKPUYB102K50
	C105	CKPUYF223Z25

RESISTORS

Mark	Symbol & Description	Part No.
	R108 Resistor array	RA4T472J
	R106 Resistor array	RA7S104J
	Other resistors	RD1/6PM □□□J

OTHERS

Mark	Symbol & Description	Part No.
	X101 Ceramic resonator	VSS1041
	V101 Fluorescent indicator tube	VAW1015
	PL101, PL102 Lamp	VEL1016
	FL spacer	VEB1140

PWSB Assembly

SEMICONDUCTOR

Mark	Symbol & Description	Part No.
	D301 (LED, YELLOW)	VEL1003

SWITCHES

Mark	Symbol & Description	Part No.
	S301 - S303 Tact switch (SOFT PICTURE, DISPLAY, POWER)	RSG1030

CAPACITOR

Mark	Symbol & Description	Part No.
	C301	CKPUYF223Z25

OTHERS

Mark	Symbol & Description	Part No.
	Remote control sensor unit	GP1U50X

HEPB Assembly

CAPACITOR

Mark	Symbol & Description	Part No.
	C201, C202	CKPUYB102K50
	C203	CGCY473K25

RESISTOR

Mark	Symbol & Description	Part No.
	VR201 Double rotary volume (LEVEL)	VCS1015

OTHERS

Mark	Symbol & Description	Part No.
	JA201 Headphone jack (PHONES)	RKN1002

◎ DRVB Assembly (VWS1087)

SEMICONDUCTORS

Mark	Symbol & Description	Part No.
	IC802	BA15218N
	Q903	DTA124ES
	Q819, Q901	2SA933S
	Q816, 818	2SB1185
	Q902	2SC1740S
	Q815, Q817	2SD1762
	Q821	2SK184
	D833	MTZJ6.2C
	D834	04AZ10 - Y
	D801, D830 - D832	1SS254

CAPACITORS

<u>Mark</u>	<u>Symbol & Description</u>	<u>Part No.</u>
	C935 (1F/5.5V)	VCH1039
	C846	CCPUSL470J50
	C838	CEANP010M50
	C840	CEAS010M50
	C930	CEAS220M25
	C835, C836	CEAS101M25
	C837	CKPUYB331K50
	C839	CQMA102J50
	C830	CQMA104J50

RESISTORS

<u>Mark</u>	<u>Symbol & Description</u>	<u>Part No.</u>
	All resistors	RD1/6PM□□□J

CNNB Assembly

SWITCH

<u>Mark</u>	<u>Symbol & Description</u>	<u>Part No.</u>
	S201 Lever switch	VSK1017

RESISTORS

<u>Mark</u>	<u>Symbol & Description</u>	<u>Part No.</u>
	R102	RD1/6PM221J
	R101	RD1/6PM272J

OTHERS

<u>Mark</u>	<u>Symbol & Description</u>	<u>Part No.</u>
	CN203 22P Side connector	VKN1138
	CN204 25P Side connector	VKN1139

7. DISASSEMBLY

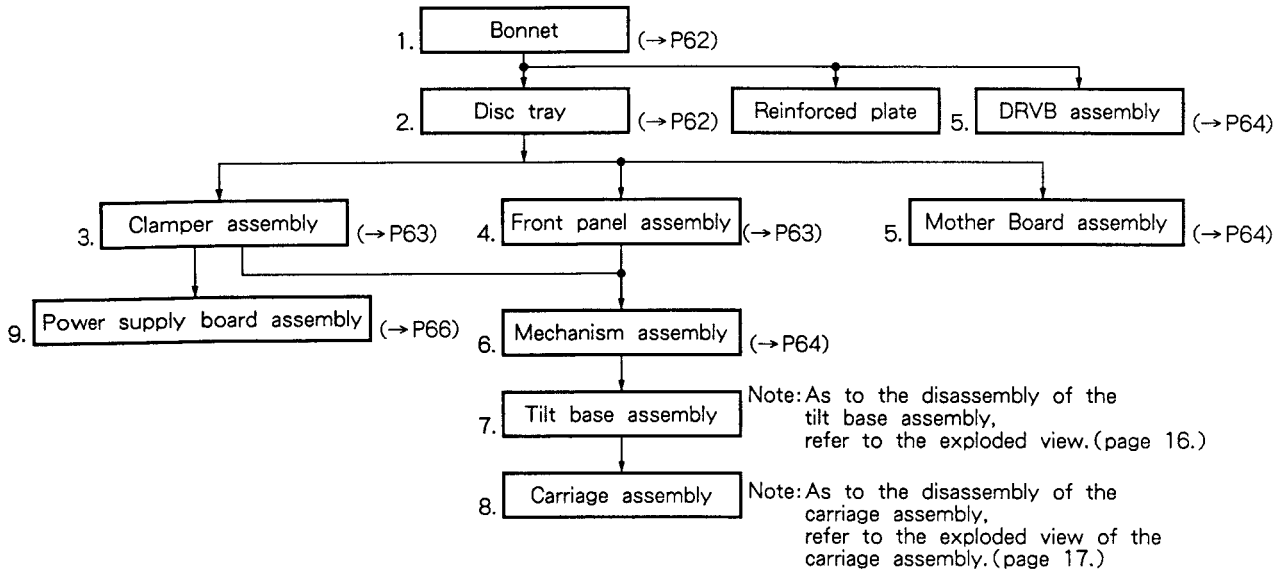

1. Bonnet

- ① Remove four screws **A** from the both sides of bonnet and remove three screws **B** from the rear of the bonnet.

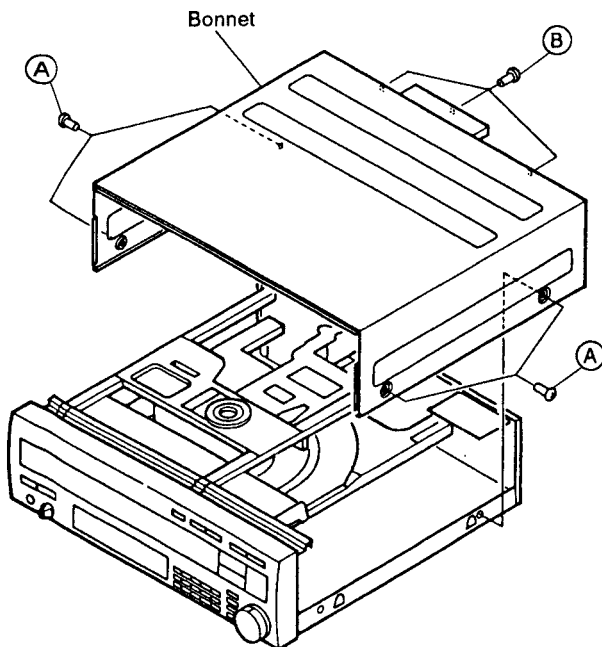

Fig. 7-1

2. Disc Tray

- ① Turn the power switch on and press the EJECT button then pull the tray out from the player.
- ② Remove two tray stopper screws **A**.
- ③ Pull out the tray toward the front.

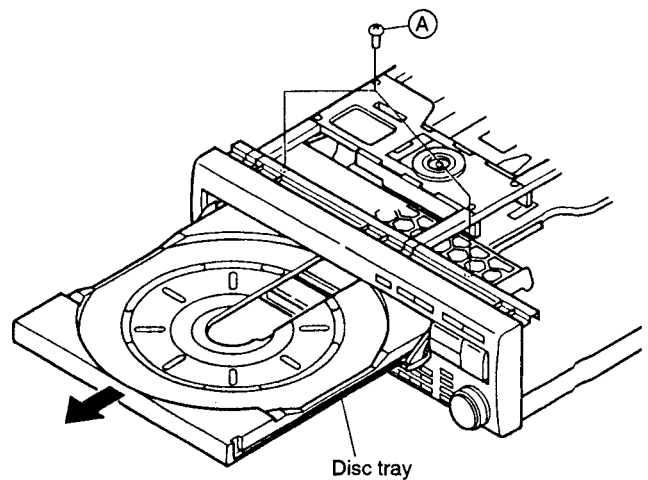

Fig. 7-2

3. Clamper Assembly

- ① Remove four screws **A** to remove the clamper assembly.
- ② Remove a screw **B** to remove the clamper.

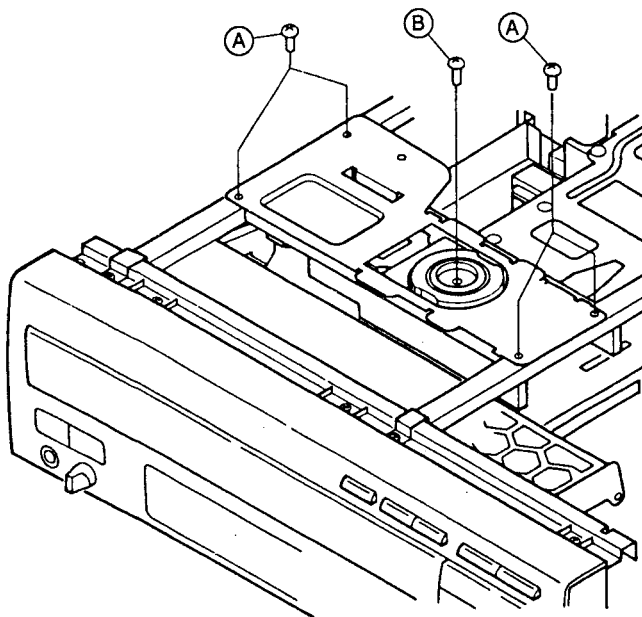

Fig. 7-3

- ③ Remove two screws **C**.
- ④ Remove two springs **D**. (Be careful of the one side of spring is fixed with bond adhesive.)

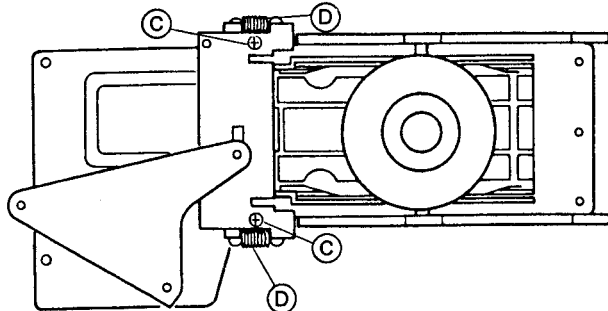

Fig. 7-4 Rear side of the clamper assembly

- ⑤ Set the roller pin to lowermost point of the clamp cam for clamper. Then remove the clamp cam by sliding it.

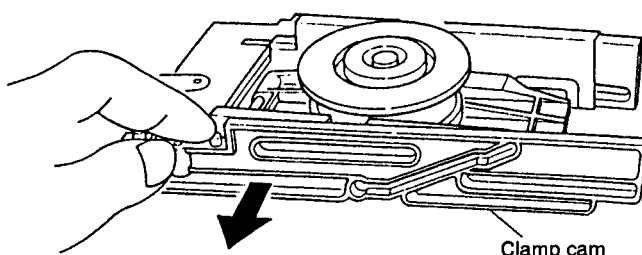

Fig. 7-5

4. Front Panel

- ① Remove three screws **A** by opening the front door (tray is out).

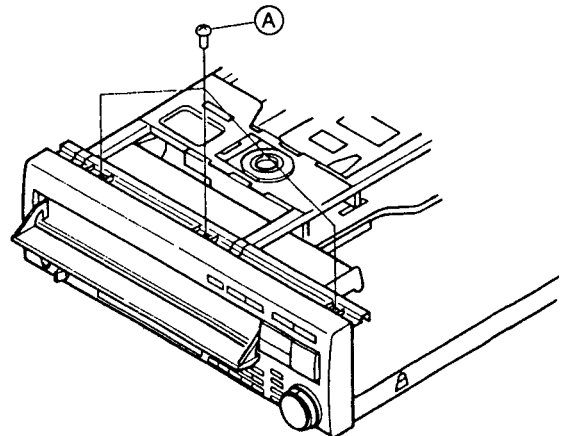
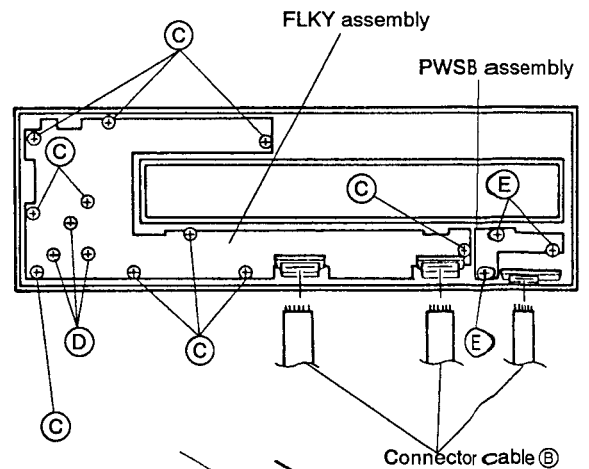

Fig. 7-6

- ② Disconnect three connector cables **B**.
- ③ Remove ten screws **C** to remove the FLKY assembly and three screws **D** to remove the jog dial.
- ④ Pull out the jog dial.
- ⑤ Remove three screws **E** to remove the PWSB assembly.



Connector cable **B**

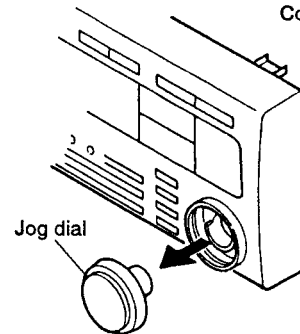

Fig. 7-7

5. MOTHER Board Assembly and DRVB Assembly

- ① Disconnect the flexible cable. (Be careful of the static electricity.)
- ② Remove four screws (A) from the MOTHER board assembly.
- ③ Remove five screws (B) from the rear panel.
- ④ Disconnect all connectors from the MOTHER board assembly.

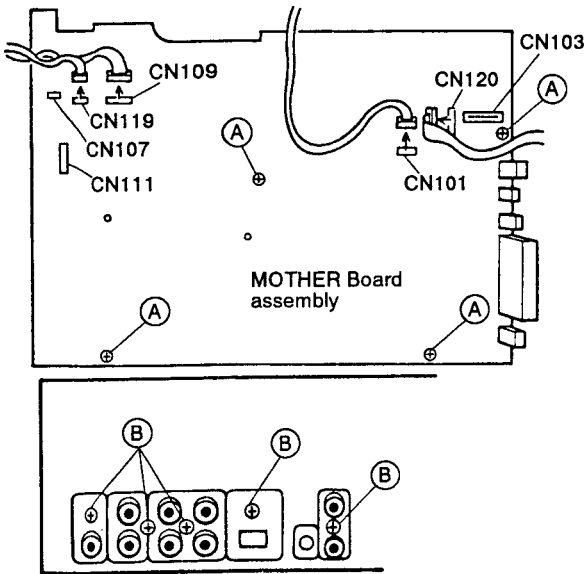

Fig. 7-8

- Diagnosis of the MOTHER board assembly -

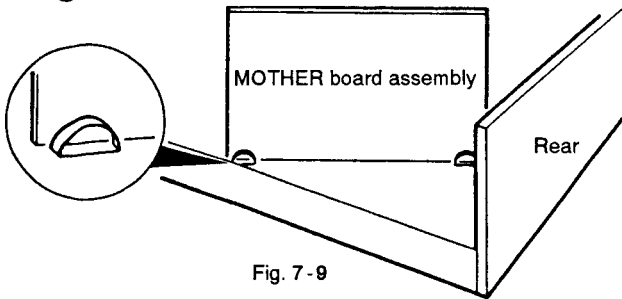

Fig. 7-9

- DRVB assembly -

- ① Remove a screw (A) from the rear panel.
- ② Remove the DRVB assembly by sliding the DRVB assembly as shown in arrow.

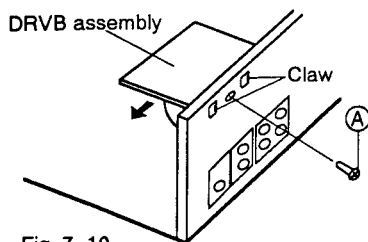

Fig. 7-10

6. Mechanism Assembly and Tilt Base (Upper) Assembly

- ① Remove three screws (A) from the left side of the slide cam.
- ② Remove two screws (B) from the side stay (L).

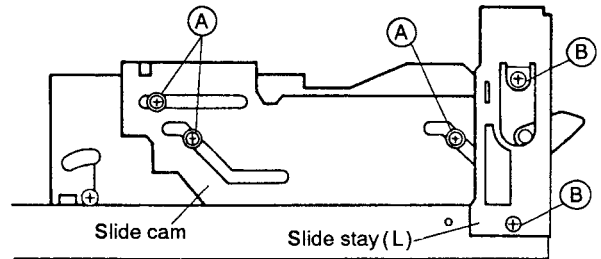

Fig. 7-11

- ③ Remove seven screws (C) from the mechanism chassis to remove the mechanism assembly.
- ④ Remove four screws (D) to remove the tilt base (upper) assembly.

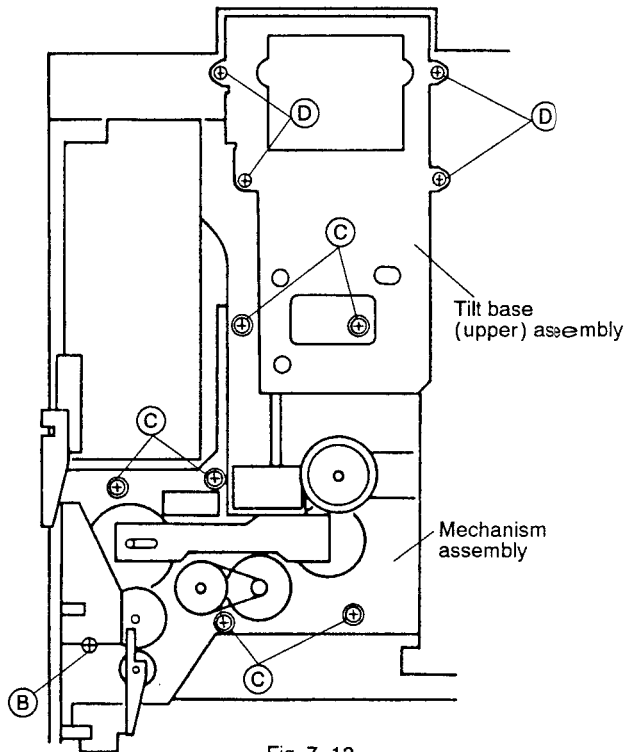

Fig. 7-12

-Positioning the gears and the grease apply points-

1. Apply a grease to the spring bus cam.

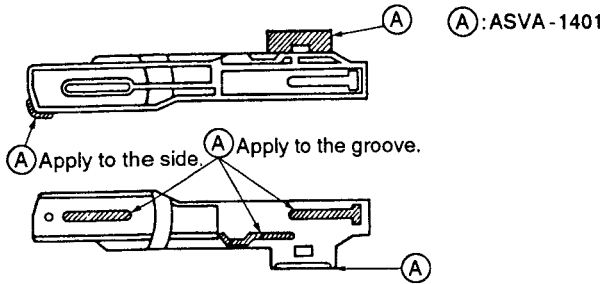

Fig. 7-13

2. Apply a grease to the cam gear.

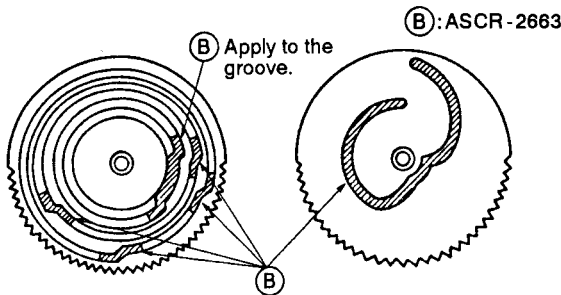

Fig. 7-14

3. Positioning the roller plate assembly (slide gear).

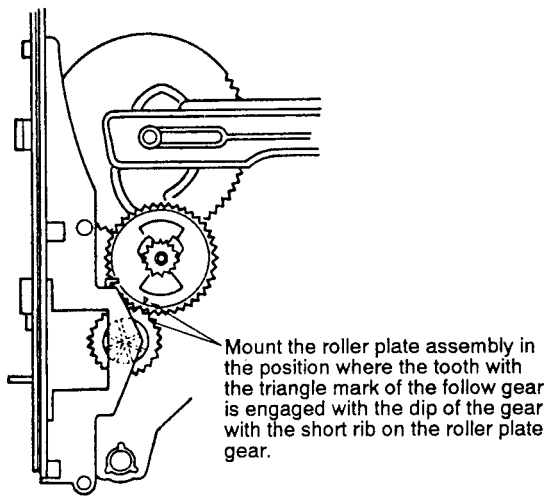

Fig. 7-15

4. Positioning the cam gear.

- ① Move two cams in the direction of arrow.
- ② Move this cam in the direction of arrow.
- ③ Insert the cam gear so that the end of the cam gear comes to the position nearest to the shaft.
- ④ Confirm that two cams are moved when turning the came gear to the shaft in the direction of arrow.
- ⑤ Confirm that the cam is turned when pressing the direct SW.

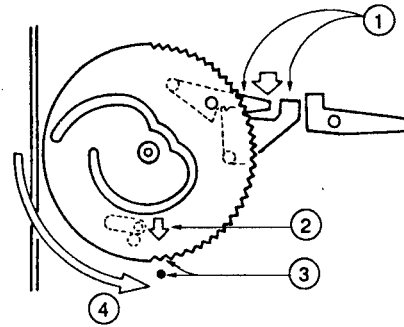

Fig. 7-16

5. Apply a grease to the follow gear.

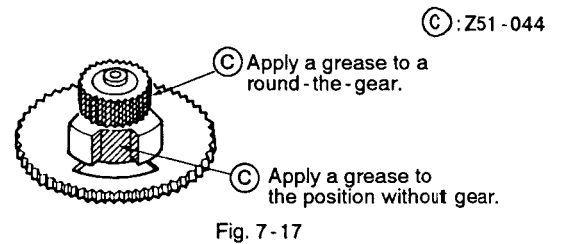

Fig. 7-17

6. Caution of installing the stop ring

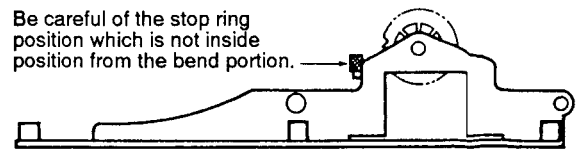

Fig. 7-18

8. Carriage Assembly

- ① Slide the carriage assembly to the shaft of the turn plate by hand.

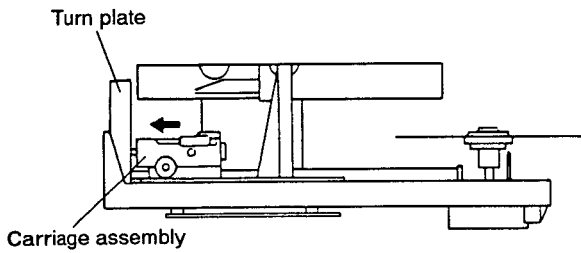

Fig. 7-19

- ② Disconnect two connectors (B) and (C) from the CNNB assembly to remove the flexible cable.
- ③ Remove six screws (A) from the post (L) and (R) to remove the tilt base.
- ④ Pull out the carriage assembly by setting the tilt base (upper) toward the upper.

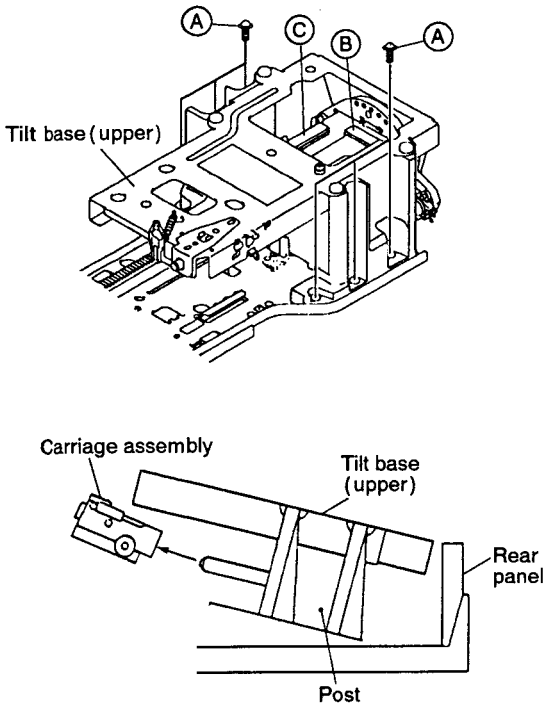

Fig. 7-20

9. Power Supply Board Assembly

- ① Insert a screwdriver into the chassis hole near a strain relief through the back of the base chassis and remove the strain relief stop ring.

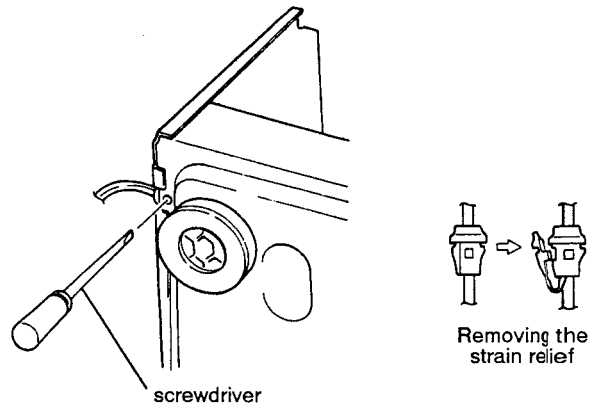

Fig. 7-21

- ② Remove four screws (A) and raise the power supply board assembly. Then the power supply board assembly can be diagnosed for component replacement through the foil side.

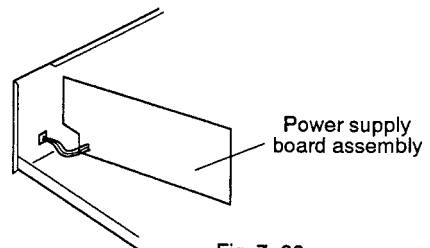
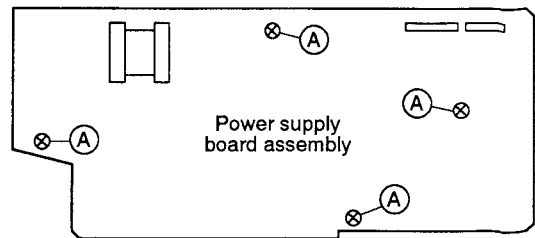
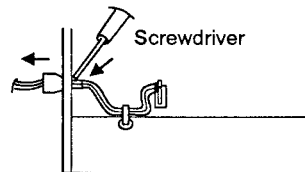

Fig. 7-22

8. ADJUSTMENT

8.1 MOTHER BOARD ASSEMBLY ADJUSTMENT ABSTRACT

	ADJUSTMENT	P	Adjusting Point	Measurement equipment Connecting Point	Player Condition	Adjusting Specification
1	Coarse Grating and Tracking Balance Adjustment	75	Grating / VR602	CN120-9 (TRKG ERR)	<ul style="list-style-type: none"> Test mode #6,500 still TRKG servo open 	<ul style="list-style-type: none"> Null point → TRK error MAX Adjust VR602 so that the TRK error waveform amplitude's positive and negative level become equal.
2	FOCS RTN Calibration Adjustment	76	Player SKIP key	CN120-4 (FOCS RTN)	<ul style="list-style-type: none"> #9,800 still #25,600 still TRKG servo open 	<ul style="list-style-type: none"> Adjust that the FOCS RTN voltage becomes $0 \pm 20\text{mV}$.
3	Pickup Tangential Direction Angle Adjustment and Tilt Servo Balance Adjustment	77	VR608 (TILT GAIN) VR607 (TILT BAL)	CN120-3 (RF)	<ul style="list-style-type: none"> Test mode #2,701 (black screen) still TRKG servo open/close 	<ul style="list-style-type: none"> Adjust TILT BALANCE (VR607) RF waveform's amplitude MAX (VR608 : TILT GAIN, and Pickup tangential direction angle adjustment screw)
4	TRKG Error Best / Crosstalk Best Adjustment	78	VR605 (TE BEST) VR606 (CT BEST)	CN120-3 (RF) CN120-9 (TRKG ERR)	<ul style="list-style-type: none"> Test mode TRKG servo close / open Tilt servo OFF 	<ul style="list-style-type: none"> TRK error MAX (VR605) RF MAX (VR606)
5	FOCS SUM Level Adjustment	79	VR609	CN120-11 (FOCS SUM)	<ul style="list-style-type: none"> Play mode 	<ul style="list-style-type: none"> Adjust VR609 so that the voltage becomes 2V DC.
6	Spindle Motor Centering Check	80	Check the lissajous figure.	CH1:CN120-9 (TRKG ERR) CH2:CN120-1, 2 (TRKG A+C)	<ul style="list-style-type: none"> Test mode #100 and #22,000 TRKG servo open 	<ul style="list-style-type: none"> Check that the amplitude of the lissajous figure of the frame #100 is the same as that of the frame #22,000.
7	Spindle Motor Centering Adjustment	81	Spindle motor centering adjustment screw.	CH1:CN120-9 (TRKG ERR) CH2:CN120-1, 2 (TRKG A+C)	<ul style="list-style-type: none"> Test mode #100 and #22,000 TRKG servo open / close 	<ul style="list-style-type: none"> Adjust the centering adjustment screw so that the lissajous figures of #100 and #22,000 are the same.
8	Fine Grating Adjustment	82	Grating	CH1:CN120-9 (TRKG ERR) CH2:CN120-1, 2 (TRK A+C)	<ul style="list-style-type: none"> Test mode #6,500 still TRKG servo open 	<ul style="list-style-type: none"> Minimize the Y direction of the lissajous figure. Level of the X direction of the lissajous figure are equal.
9	RF Gain Adjustment	83	VR601	CH1:CN120-3 (RF)	<ul style="list-style-type: none"> Test mode #15,000 still TRKG servo close 	<ul style="list-style-type: none"> Adjust VR601 so that the RF level becomes $300\text{mV} \pm 50\text{mV}$.
10	FOCS Servo Loop Gain Adjustment	84	VR604	CH1:CN120-6 (FOCS ERR) CH2:CN120-7 (FOCS IN)	<ul style="list-style-type: none"> Test mode #15,000 still TRKG servo close 	<ul style="list-style-type: none"> Adjust VR604 so that the lissajous figure is symmetrical with respect to the X and Y axes.
11	TRKG Servo Loop Gain Adjustment	85	VR603	CH1:CN120-9 (TRKG ERR) CH2:CN120-1, 2 (TRKG A+C)	<ul style="list-style-type: none"> Test mode #15,000 still TRKG servo close 	<ul style="list-style-type: none"> Adjust VR603 so that the lissajous figure is symmetrical with respect to the X and Y axes.
12	Position Check at the Start Play and Centering Adjustment for Side B Play	86	Centering adjustment hole for side B.	CH1:CN120-9 (TRKG ERR) CH2:CN120-1, 2 (TRKG A+C)	<ul style="list-style-type: none"> Test mode #100 play TRKG servo open / close 	<ul style="list-style-type: none"> Adjust that the X-axis amplitude of the lissajous figure becomes maximum.
13	Pickup Tangential Direction Angle Adjustment for Side B Play	87	Pickup tangential direction angle adjustment screw.	TV monitor	<ul style="list-style-type: none"> Test mode #115 still 	<ul style="list-style-type: none"> Adjust that the crosstalk is minimized.
14	Fine Centering Adjustment for Side B Play	88	Centering adjustment hole for side B	CH1:CN120-9 (TRKG ERR) CH2:CN120-1, 2 (TRKG A+C)	<ul style="list-style-type: none"> Test mode #100 play TRKG servo open 	<ul style="list-style-type: none"> Adjust that the X-axis amplitude of the lissajous figure becomes maximum.
15	Reference Frequency Adjustment	89	VC901	R647 lead wire	<ul style="list-style-type: none"> Stop mode (blueback screen) 	<ul style="list-style-type: none"> Adjust VC901 so that the frequency becomes 3.579545 MHz.
16	VCO Centering Frequency Adjustment	90	VR481	CH1:C471 lead wire CH2:C499 lead wire	<ul style="list-style-type: none"> #5,100 still 	<ul style="list-style-type: none"> The center of CH1's video signal jitter is delayed by $71 \mu\text{S}$ with CH2's video signal.
17	Output Video Level Adjustment	91	VR482	VIDEO OUT terminal	<ul style="list-style-type: none"> #19,900 still 	<ul style="list-style-type: none"> Adjust VR482 so that the voltage between the sync tip and the white peak becomes $0.71\text{V} \pm 5\%$.
18	1H Delay Video Level Adjustment	92	VR441	CH1:L458 lead wire CH2:L456 lead wire	<ul style="list-style-type: none"> #3,800 still 	<ul style="list-style-type: none"> The 1H delay video level becomes the same as the main line video level.
19	Color Tint Error Signal Level Adjustment	93	VR521	TV monitor	<ul style="list-style-type: none"> #8,000 still 	<ul style="list-style-type: none"> Color irregularity on the magnetron screen is minimized.

8.2 ADJUSTMENT POINTS OF THE MOTHER BOARD ASSEMBLY

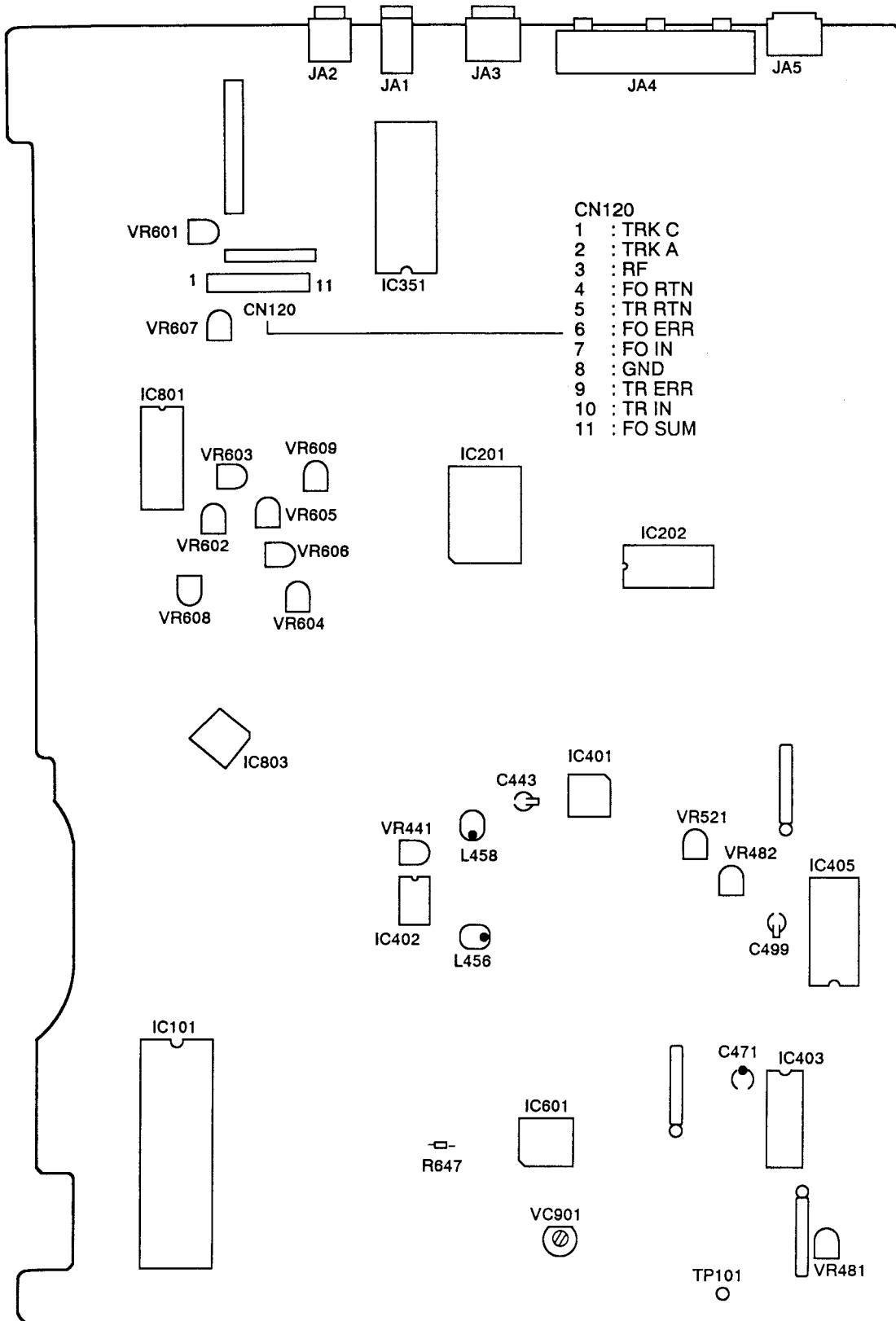

8.3 TEST MODE

8.3.1 TEST MODE

The player has a test mode function which allows the servicer to check the player's status on the TV screen by executing the respective key operation.

Also, since the TRK servo opens and closes easily, the test mode is especially useful for mechanical adjustments.

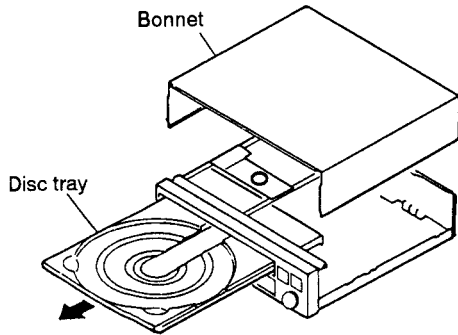

8.3.2 TEST MODE INITIATION

[Procedure]

Ⓐ When using the remote control unit (GGF1067) for the test mode.

- Press the **TEST** key after pressing the **ESC** key.

Ⓑ When not using the remote control unit (GGF1067) for the test mode.

1. Remove the bonnet and disc tray.
2. Connect the TEST (TP) in the Mother board assembly to GND.
3. Turn on the power switch.
4. Disconnect the TEST (TP) from GND.

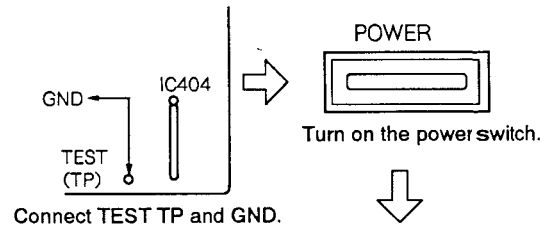

Connect TEST TP and GND.

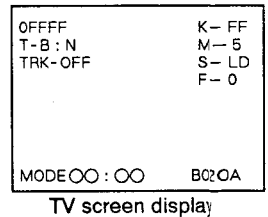

8.3.3 TEST MODE CANCELLATION

Turn off the power switch.

8.3.4 PLAYER OPERATION IN THE TEST MODE

Operate the player by selecting a test mode function with the keys on the player or on the remote control unit.

● CD PLAYBACK

- ① Place the CD disc on the turn table. (Clamper is already lifted up.)

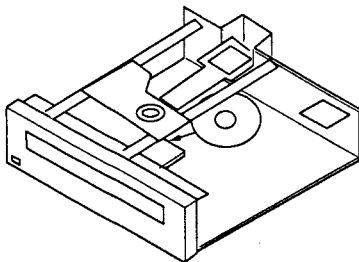

- ② Press the **◀** or **▶** keys to appear "S - CD" on the TV screen display.

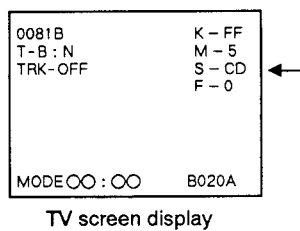

- ③ Clamp the disc by pressing the **PLAY (▶)** key once. Then, press the **PLAY (▶)** key twice, disc will be normal playbacked.

● LD PLAYBACK

- ① Place the LD disc on the turn table. (Clamper is already lifted up.)

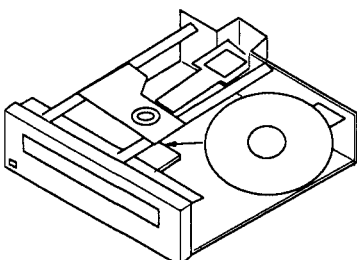

- ② Press the **◀** or **▶** keys to appear "S - LD" on the TV screen display.

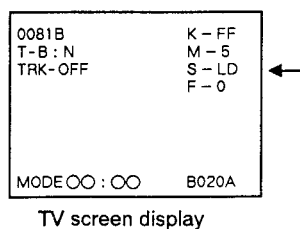

- ③ Clamp the disc by pressing the **PLAY (▶)** key once. Then, press the **PLAY (▶)** key twice, disc will be normal playbacked.

Table. Operation in the test mode by optional remote control unit (VXX1530).

Function	Player Status	Key Operation	Remarks
Open Tray	STOP mode	▲	
Close Tray	Tray open	▲	
Stop	PLAY mode	■	
Play	Disc placement and tray closed.	▶	<ul style="list-style-type: none"> • Start play with the TRK servo open. • Raise up with tilt neutral. • The disc type (LD/CD/CDV) is determined when playback starts at the SLDR position during start play.
TRK Servo Open/Close	PLAY mode	▶	<ul style="list-style-type: none"> • Each time the PLAY button (▶) is pressed, the TRK servo will open or close alternately.
Still	PLAY mode TRK servo closed.	▢ (Remote control unit key)	<ul style="list-style-type: none"> • Each time the STILL button (▢) is pressed, the player will switch between the PLAY and STILL modes alternately.
SLDR REV SCAN	PLAY mode	SCAN DIAL	<ul style="list-style-type: none"> • Counterclockwise • With the TRK servo open, the pickup can be damaged if the SLD moves further inward than the lead-in area on the disc. Do not allow the SLD to move further inward than the lead-in area.
SLDR FWD SCAN	PLAY mode	SCAN DIAL	<ul style="list-style-type: none"> • Clockwise • With the TRK servo open, the pickup can be damaged if the SLD moves further outward than the lead-in area on the disc. Do not allow the SLD to move further outward than the lead-in area.
TILT Neutral	POWER switch ON	EDIT	
TILT Servo ON	PLAY mode	RANDOM PLAY	
TILT Minus TILT Servo OFF	PLAY mode	◀◀	<ul style="list-style-type: none"> • Press and hold down the keys.
TILT Plus TILT Servo OFF	PLAY mode	▶▶	<ul style="list-style-type: none"> • Press and hold down the keys.
Screen Display ON / OFF	POWER switch ON	PGM key	
Frame search	PLAY mode	+10 key ↓ 0-9 key ↓ ▶	<ul style="list-style-type: none"> • In the PLAY mode, press the +10 key. (The player will standby for the frame No. entry.) • Use the numeric keys(0 - 9) to enter the frame No.. Then press the player's PLAY key to search. • After the search is completed, the player will return to the operation mode before the search was performed.
Loading Motor Rotation Clockwise Counterclockwise	Tray open	▶▶ ◀◀	<ul style="list-style-type: none"> • FWD:Unloading • REV:Loading
Focus Offset (CT MAX) for Checking VR606	PLAY mode TRKG servo open	Remote control unit key •MULTI-SPEED FWD→F-1 REV→F-0 Player key •INTRO SCAN (toggle)	VR606 and VR605 : For chek F - 0 : Normal state ----- TRKG close : VR606 (CT BEST) TRKG open : VR605 (TE MAX) F - 1 : VR606 is effected when opening the TRKG.

● Names of Front Panel

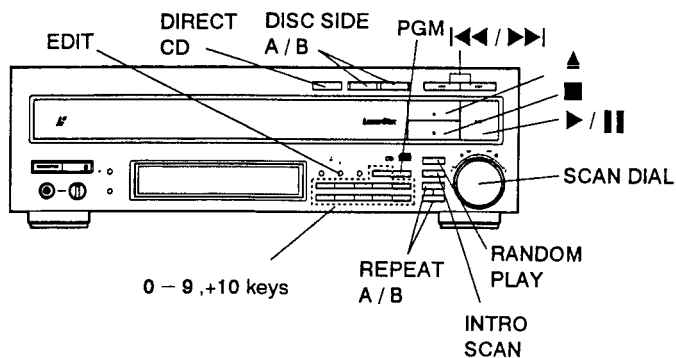

● Names of Remote Control Unit

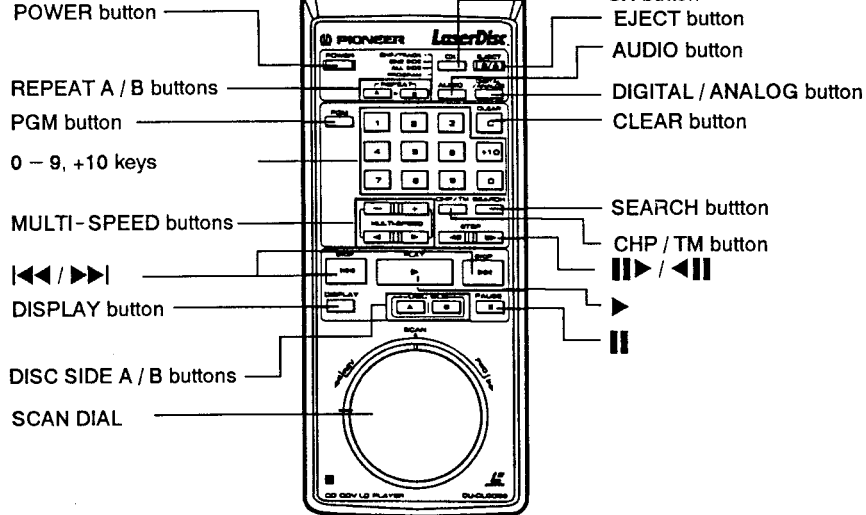

8.3.5 TV SCREEN AND LED DISPLAYS IN THE TEST MODE

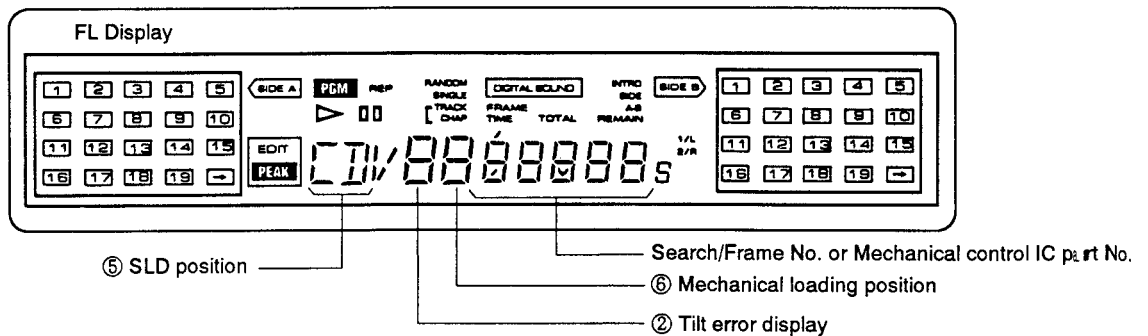
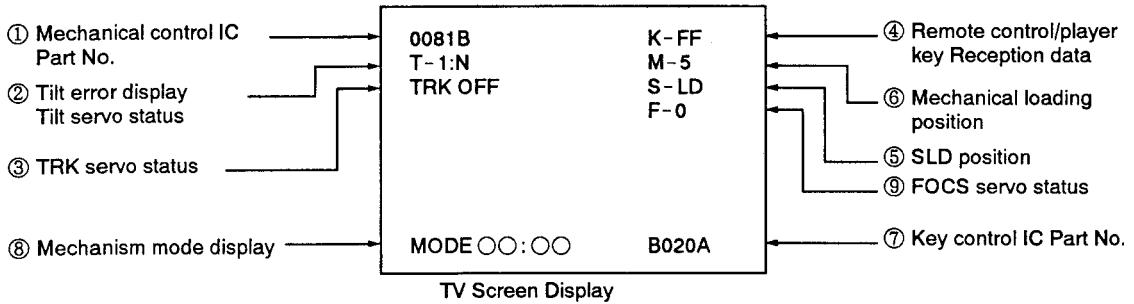

① The Mechanical Control IC (MAIN assembly) Part No. will be Displayed.
PD0081B1 → 0081B

② Tilt Servo Status / Tilt Error Display
T-0:00
Tilt servo status : N...Tilt neutral
ON...Tilt servo ON
OFF...Tilt servo OFF
Tilt error display: 0 Tilt -
↑ Tilt neutral
F Tilt +

③ TRK Servo Status

TV screen display

TRK-○○○

- └ ON...TRK servo close
- └ OFF...TRK servo open

⑤ SLD Position

TV screen display

S-○○○

- └ IN ... CD inside SW ON
- └ CD ... CD active area
- └ CDV ... CDV active area
- └ LD ... LD active area
- └ B IN ... LD B inside SW ON

④ Remote Control / Player Key Reception Data

TV screen display

K-○○

└ See table below

Code	Function	Code	Function	Code	Function	Code	Function
00	0	20	F JOG0	40	(CHAP / TRK)	60	
01	1	21	F JOG1	41	(FRAM / TIM)	61	
02	2	22	F JOG2	42	(SEARCH)	62	
03	3	23	F JOG3	43	DISPLAY	63	
04	4	24	R JOG0	44	REPEAT B	64	
05	5	25	R JOG1	45	CLEAR	65	
06	6	26	R JOG2	46	SPEED -	66	
07	7	27	R JOG3	47	SPEED +	67	
08	8	28		48	REPEAT A	68	
09	9	29		49	(2 / R)	69	
0A	VOLUME +	2A		4A	(STEREO)	6A	
0B	VOLUME -	2B		4B	(1 / L)	6B	
0C	DGT / ANL	2C		4C	PROGRAM	6C	
0D		2D		4D		6D	PLAY / PAUSE
0E	CX ON/OFF	2E		4E		6E	STOP
0F	(TV / LDP)	2F		4F		6F	OPEN / CLOSE
10	(F-SCAN)	30		50	F-STEP	70	
11	(R-SCAN)	31		51		71	DIRECT CD
12		32		52	F-SKIP	72	PEAK
13	CHAP / FRME	33		53	R-SKIP	73	SINGLE
14		34		54	R-STEP	74	
15		35		55	R-MULT	75	
16	STOP / OPEN	36		56		76	
17	PLAY/SERCH	37	DGT LEVEL	57		77	
18	PAUSE	38		58	F-MULT	78	
19		39		59		79	
1A	(POW ON)	3A		5A	HILIT / INTR	7A	
1B	(POW OFF)	3B		5B		7B	
1C	POW ON/OFF	3C		5C		7C	
1D	EDIT	3D		5D		7D	
1E	AUDIO	3E		5E	RNDM (TEST)	7E	
1F	+10	3F		5F	(ESC)	7F	

⑥ Mechanical Loading Position

TV screen display

M-○

- └ 0 ... Tray open
- └ 1 ... Loading
- └ 2 ... Standby
- └ 3 ... Clamped
- └ 5 ... Tilt minus
- └ 7 ... Tilt plus
- └ 8 ... Tilt limit
- └ 9 ... B side clamped (two sides)

⑦ Focus offset VR Status

TV screen display

F-○

- └ 0 ... Normal state
- └ TRKG close : VR606(CT MAX)
- └ TRKG open : VR605(TE MAX)
- └ 1 ... VR606 is effected when opening the TRKG.

⑧ As to the mode indication, refer to the CLD-2090 service guide.

8.4 ADJUSTMENT

8.4.1 JIGS AND INSTRUMENTS REQUIRED FOR ADJUSTMENT

- Small screwdriver (about 10cm long)
- Small Phillips screwdriver
- Hexagonal wrenches (2.0mm and 2.5mm)
- Dual-trace oscilloscope (with delay)
- AF oscillator
- Frequency counter
- LD test disc (GGV1003)
- LDD disc (buy locally)
- CD test disc (YEDS-7)
- Shorting clip
- L-shaped eccentric screwdriver (GGV-129)
- Phillips head screwdriver
- Resistor ($47k\Omega$, $10k\Omega \times 2$)
- Low-pass filter ($47k\Omega + 1\mu F$)

8.4.2 PREPARATIONS FOR ADJUSTMENT AND PRECAUTIONS

1) When replacing the pickup assembly, adjust in the following way:

–Carriage assembly in forward state–

1. Coarse grating adjustment, tracking balance adjustment
2. FOCS RTN calibration adjustment
3. Crosstalk adjustment
 - 1) Adjustment of inclination of the pickup in the tangential direction and tilt servo balance adjustment
 - 2) TRKG error best / crosstalk best adjustment
4. FOCS SUM level adjustment
5. 1) Spindle motor centering check
2) Spindle motor centering adjustment
6. Fine grating adjustment
7. RF gain adjustment
8. FOCS servo loop gain adjustment
9. TRKG servo loop gain adjustment

–Carriage assembly in reverse state–

10. Centering adjustment for side B play
11. Pickup tangential direction angle adjustment for side B play
12. Fine centering adjustment for side B play

Note: The forward status of carriage assembly is when the carriage assembly is in the position to play side A of the disc. The reverse status is when it is in the position to play side B of the disc.

2) Adjust the height of the turntable when the spindle motor is replaced.

Carriage assembly forward state

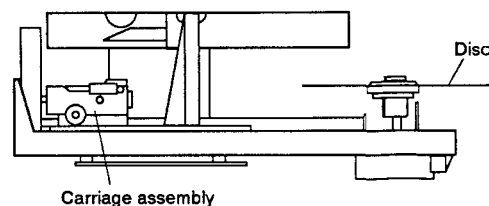

Carriage assembly reverse state

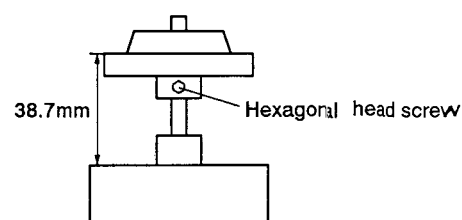
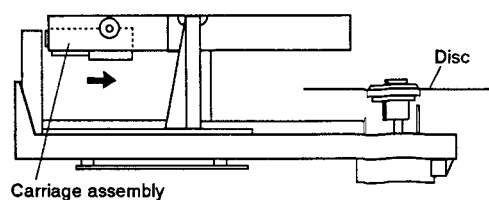

Loosen the hexagonal head screw and measure the height with a caliper. Then retighten the screw.

Turntable height adjustment

3) Side B play

Direct side B play is possible by pressing the SIDE B key of the front panel.

4) Where to insert the screwdriver when adjusting the pickup assembly

– Carriage assembly in forward state –

Pickup tangential direction angle adjustment for side B (small phillips screwdriver)

Eccentricity adjustment for side B (L-shaped eccentric screwdriver)

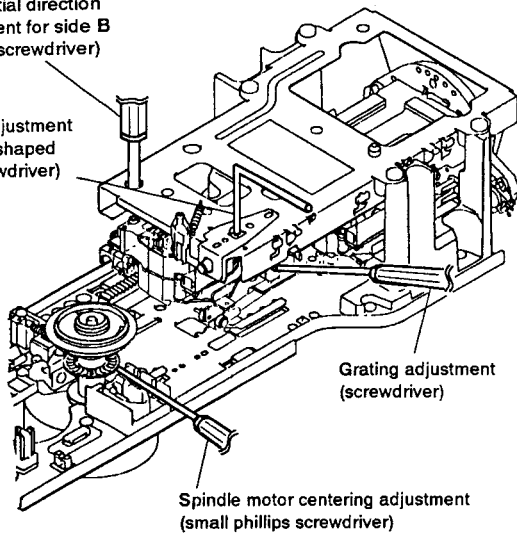

5) Test disc

The LD test disc used for mechanical adjustment and MOTHER board assembly adjustment may either be the GGV1003. The frame numbers given in the text are for the GGV1003.

The LD test disc used for electrical adjustments can be either N series.

6) Numbers given in connection diagram correspond to those in the text covering the adjustment procedure.

7) Frame numbers are not displayed on the monitor TV, please read the FL display.

8) Perform all adjustment by setting the tilt serve to ON.

8.4.3 MECHANICAL ADJUSTMENT

1. COARSE GRATING AND TRACKING (TRKG) BALANCE ADJUSTMENT

Mechanical Adjustment

- Purpose: To adjust the laser beam which is divided into three by the grating to the optimum position on the track. Set the TRKG servo offset voltage to 0 V.
- When not properly adjusted: Disc playback will be impossible. During play, tracks may be skipped.

- Measuring instruments and jigs:
- Measuring point:
- Test disc and player mode
- Positions to be adjusted

- Small screwdriver ● Oscilloscope
- CN120-9 (TRKG ERR)
- 8-inch LD test disc GGV1003...#6,500 ● Still mode
- Test Mode (TRKG servo:Open)
- The carriage assembly should be in the forward state.
- Grating ● VR602 (TRKG balance)

Connection diagram

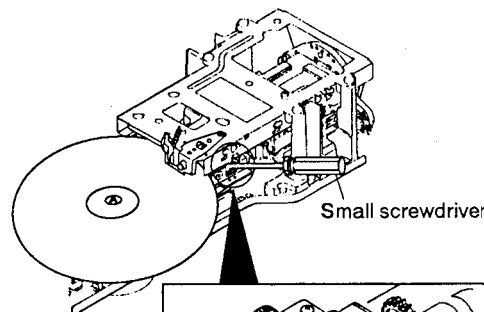
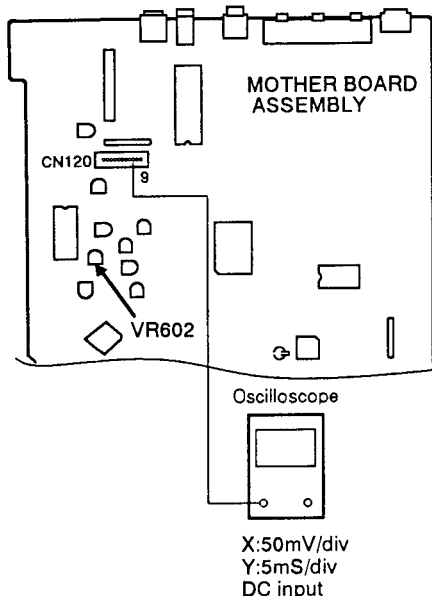

4. Connect an oscilloscope to CN120-9 in the MOTHER board assembly.
5. Insert the small screwdriver into the grating adjustment hole.

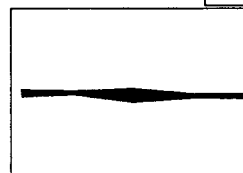
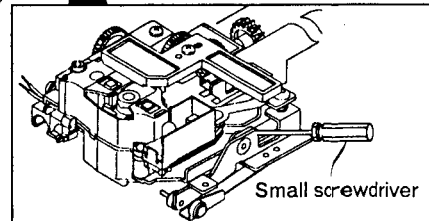

Fig. 1 On-track position



Fig. 2 Maximum amplitude A=B

Adjustment Procedure

<Coarse Grating Adjustment>

1. Play the LD test disc.
2. Search around for frame #6,500.
3. Open the TRKG servo. (See page 70.)
4. Connect an oscilloscope to CN120-9 and observe the waveform.
5. Insert the small screwdriver into the grating adjustment hole. Turning the grating will allow you to vary the amplitude of the TRKG error waveform. Find the position where the waveform amplitude becomes minimum with a smooth envelope. (Fig. 1) (This indicates that the 3-way split laser beams are directed onto the track. This is called the "on-track" position.)
6. Slowly turn the grating counterclockwise from the on track position until the waveform amplitude becomes maximum. (Fig. 2)

7. Close the TRKG servo and check that a normal picture is displayed on the TV screen.

<TRKG Balance Adjustment>

1. Align the oscilloscope GND so that it comes to the center of the oscilloscope screen.
2. Adjust VR602 so that the positive and negative amplitude of the TRKG error waveform become equal. (Fig. 2)

Note: If adjustment of VR602 fails to disturb the tracking, perform the adjustment after set VR607 to the mechanical center.

2. FOCS RTN CALIBRATION ADJUSTMENT

Mechanical Adjustment

- Purpose: Setting the slider shaft horizontally to enable the pickup to move over the disc horizontal.
- When not properly adjusted: With a warped disc, the FOCS servo does not function at the inner or outer periphery.

- | | |
|--|---|
| <ul style="list-style-type: none"> ● Measuring instruments and jigs: ● Measuring point: ● Test disc and player mode | <ul style="list-style-type: none"> ● Digital voltmeter ● Low-pass filter (47kΩ + 1 μF) ● CN120 - 4 (FOCS RTN) and GND. ● 8 - inch LD test disc GGV1003 ● Test Mode (#9,800 / #25,600, TRKG servo:Open, Tilt servo OFF) |
| <ul style="list-style-type: none"> ● Positions to be adjusted | <ul style="list-style-type: none"> ● Player SKIP key (During test mode) |

Connection diagram

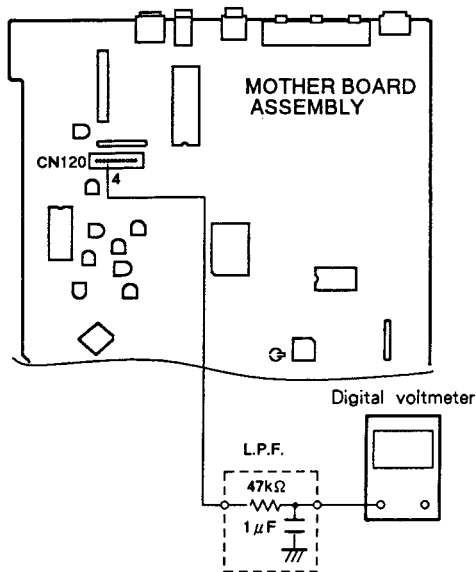

Adjustment Procedure

1. Connect a digital voltmeter to CN120- 4 through L. P. F.
2. Open the TRKG servo, and search around for frame #9,800.
3. Check the voltage.
3. Search around for frame #25,600 and check that the voltage is same as the frame #9,800. If not, adjust the SKIP key so that the voltage is same as the frame #9,800.

3. CROSSTALK ADJUSTMENT

Pickup Tangential Direction Angle Adjustment and Tilt Servo Balance Adjustment (Pickup TRKG Direction Angle Adjustment)

Mechanical Adjustment

- Purpose: To adjust the pickup tangential direction angle so as to minimize crosstalk.
- When not properly adjusted: Noticeable crosstalk will appear.

- Measuring instruments and jigs:
- Measuring point:
- Test disc and player mode
- Positions to be adjusted

- TV monitor
- Phillips screwdriver
- Oscilloscope
- Crosstalk on the screen
- CN120-3(RF)
- 8-inch LD test disc GGV1003...#115, #2,701 (black screen)
- Still mode
- Test Mode (TRKG servo: Open/Close)
- The carriage assembly should be in the forward state.
- Pickup tangential direction angle adjustment screw
- VR608 (TILT GAIN) and VR607 (TILT BAL.).

Connection diagram

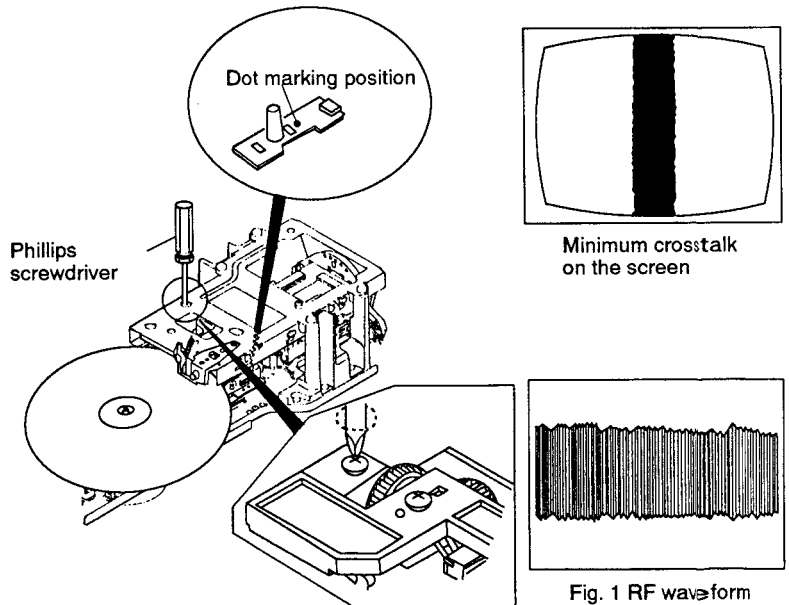
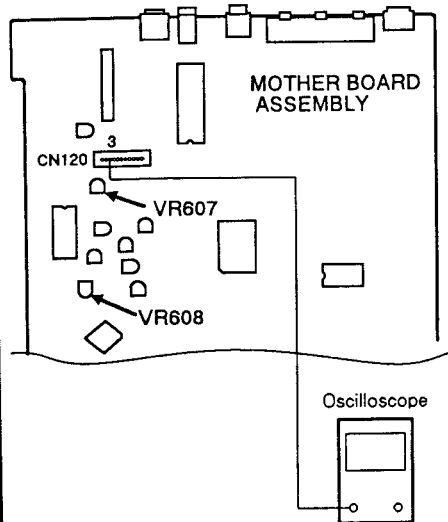

Adjustment Procedure

1. Check the color of the dot marked on the top of the tilt sensor as shown above.
Some players have red and blue dots. According to the color of the dot, adjust VR608 as follows:
Red dot: Turn VR608 fully counterclockwise.
Blue dot: Turn VR608 fully clockwise.
No dot: Set VR608 to the center position.
- Tilt Servo Balance Adjustment-
(Pickup TRKG Direction Angle Adjustment)
2. Confirm that the tilt servo is ON. Set VR607 (TILT BAL.) to the mechanical center.
3. Connect an oscilloscope to CN120-3.
4. Search for frame #2,701 and observe the RF waveform. (Fig. 1)
5. Adjust VR607 (turn to slowly) so that the amplitude of waveform becomes maximum.
(Turn VR607 to alter the tilt of the pickup assembly TRKG direction.)

6. Search for frame #115 and confirm that the crosstalk on the TV screen becomes minimum.
7. If there is still noticeable crosstalk on the TV screen, perform tangential adjustment as follows.

-Pickup Tangential Direction Angle Adjustment-

8. Search frame #2,701 and observe the RF waveform (Fig. 1).
9. Insert the phillips screwdriver into the adjustment hole of the side B play mechanism, and adjust the pickup tangential direction angle adjustment screw so that the RF waveform becomes maximum.
10. Search for frame #115 and confirm that the crosstalk on the TV screen becomes minimum.
11. After adjustment is complete, tighten the locking screw and adhere it.

Note: When the pickup tangential angle is changed in the side A play mode, be sure to perform "6. Spindle Motor Centering Check", "12. Centering Adjustment for Side B Play" and "13. Pickup Tangential Direction Angle Adjustment for Side B Play".

4. TRKG ERROR BEST/ CROSSTALK BEST ADJUSTMENT

Mechanical Adjustment

- Purpose: To set the FOCS servo to the optimum state when playing the normal playback and track jump (search).
- When not properly adjusted: Crosstalk will be generated.

- Measuring instruments and jigs:
- Measuring point:
- Test disc and player mode

- TV monitor ● Oscilloscope
- CN120-3(RF) ● CN120-9(TRKG ERR) ● Player's VIDEO OUT terminal
- 8-inch LD test disc (GGV1003)
- Test Mode (TRK servo close / open, Tilt servo OFF)

- Positions to be adjusted

- VR605 (TE BEST) ● VR606 (CT BEST)

Connection diagram

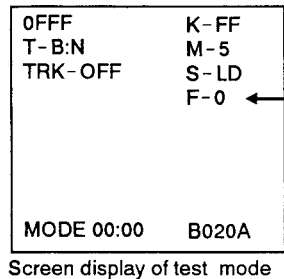
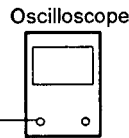
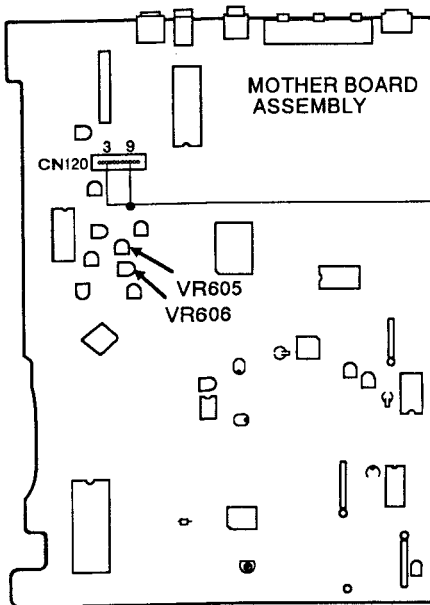

Screen display of test mode

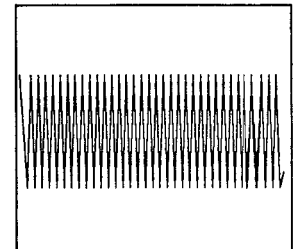

Set to maximum RF amplitude at frame #2,701.

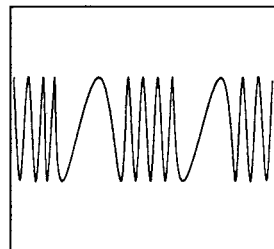

Maximize the TRKG error.

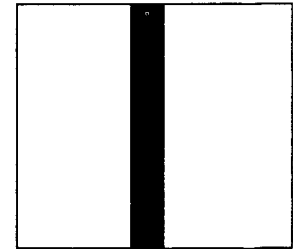

#115 crosstalk minimum

Adjustment Procedure

Note: Perform this adjustment when there is still noticeable crosstalk on the TV screen in section "3. Pickup Tangential Direction Angle Adjustment".

1. Connect the oscilloscope to CN120-9.
2. Open the TRK servo.
3. Confirm that the test mode screen display is F-0.
If not, set the MULTI - SPEED REV button of the remote control unit to F-0.
4. Adjust VR605 so that the amplitude of the TRKG error waveform becomes maximum.
5. Close the TRKG servo.

6. Connect the oscilloscope to CN120-3.
7. Press the MULTI - SPEED FWD button of the remote control unit to display "F-1" on the TV screen.
8. Search frame #2,701 and adjust VR606 so that the amplitude of the RF waveform becomes maximum.
9. Confirm that the crosstalk on the TV screen becomes minimum at frame #115.

Note: After adjustment is complete, be sure to perform "5. FOCS SUM Level Adjustment".

5. FOCS SUM LEVEL ADJUSTMENT

Mechanical Adjustment

- Purpose: To set the sum level (FOCS A+B) of B1 – B4 to the optimum value for activating the FOCS servo.
- When not properly adjusted: Crosstalk will be generated.

- Measuring instruments and jigs:
- Measuring point:
- Test disc and player mode
- Positions to be adjusted

- TV monitor ● Oscilloscope
- CN120-11 (FOCS SUM)
- 8-inch LD test disc GGV1003...#15,000 ● Still mode
- Test mode (TRKG servo : Close) ● Tilt servo : Neutral
- VR609

Connection diagram

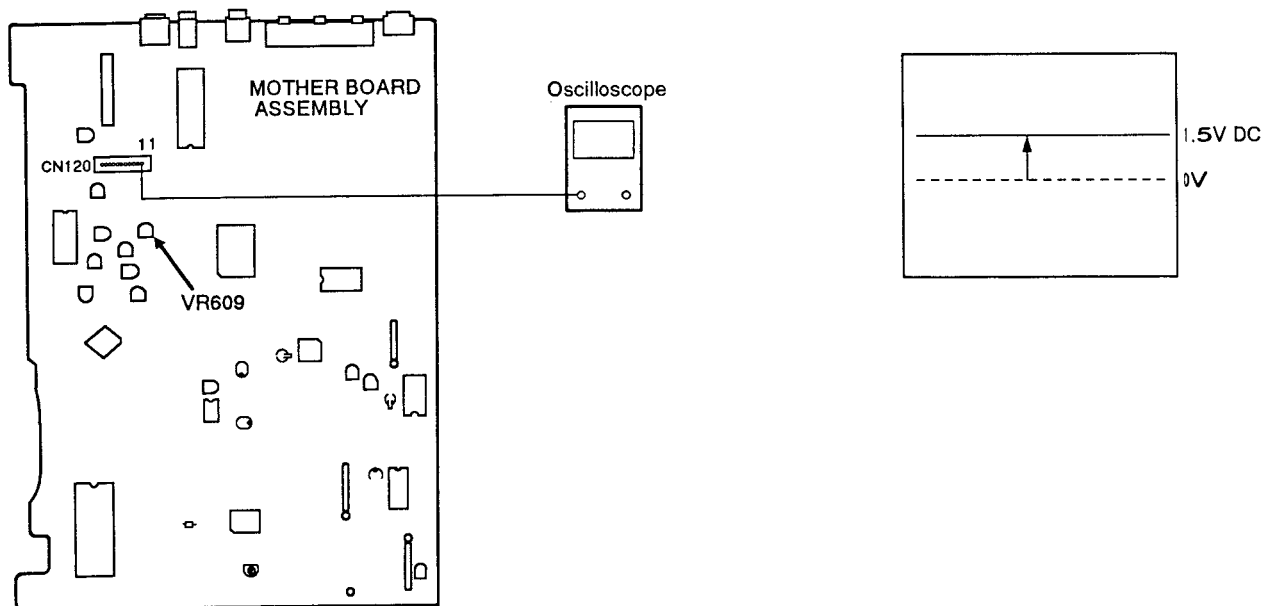

Adjustment Procedure

Note : Perform this adjustment after perform the "4. TRKG Error Best / Crosstalk Best Adjustment".

1. Connect the oscilloscope to CN120-11.
2. Adjust VR609 so that the voltage becomes 1.5V DC.

6. SPINDLE MOTOR CENTERING CHECK

Mechanical Adjustment

- Purpose: To check that the center of the spindle motor is on the orbit of the laser beam.

- Measuring instruments and jigs:
- Measuring point:
- Test disc and player mode
- Positions to be adjusted

- Oscilloscope ● Resistor(10kΩ × 2)
- CN120-9(TRKG ERR), CN120-1(TRKG C) and CN120-2(TRKG A)
- 8-inch LD test disc GGV1003...#100 and #22,000 (#100 and #22,000 with a commercially available "karaoke" LD disc)
- Play mode ● CD test disc (YEDS-7) ● Test Mode (TRKG servo:Open)
- The carriage assembly should be in the forward state.
- Check the Lissajous figure

Connection diagram

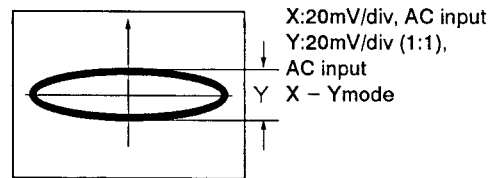
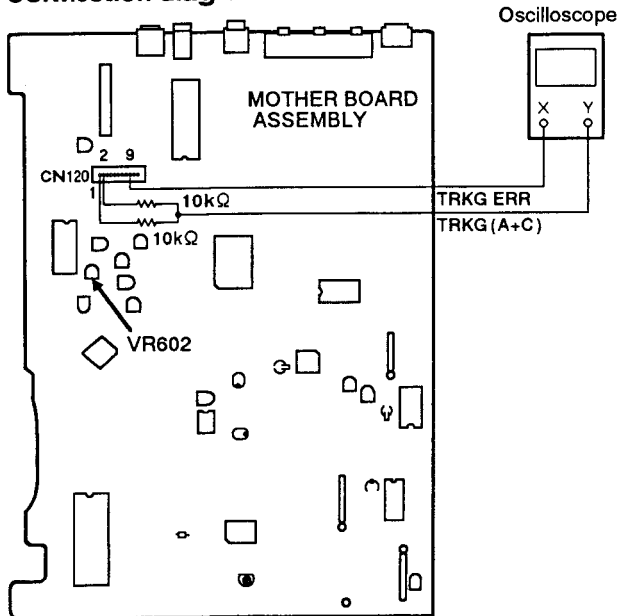

Fig. 1 Lissajous figure of the inner track of the disc (CD)

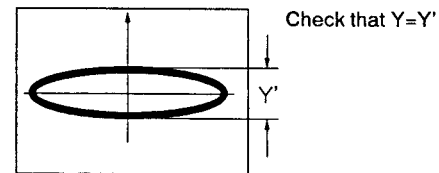

Fig. 2 Lissajous figure of the outer track of the disc (CD)

5. The Y-axis of the Lissajous figure should be the same for the inner and the outer tracks.

Note : LD test disc F2 is not suitable for this adjustment because the recorded portion with a track pitch of 1.52μm is present only around inner tracks #1 to #500.

Checking Procedure

1. Play the 8-inch LD test disc.
2. Move the pickup to frame #22,000 by scanning or searching, then open the TRKG servo.
3. Connect the X-input (CH-1) of the oscilloscope to CN120-9 and the Y-input (CH-2) to CN120-1 and 2. Set the oscilloscope to the X-Y mode and observe the Lissajous figures of the TRKG error signal and the TRKG (A+C) signal.
4. Write down the Y-axis amplitudes of the Lissajous figures. (Fig. 1)
5. Close the TRKG servo and search frame #100, then open the TRKG servo again to observe the Lissajous figure. At this time, check that the Y-axis amplitude of the Lissajous

figure is the same as that noted in step 4. (Fig. 2)

6. Remove the 8-inch LD test disc from the player, then load the CD test disc and repeat the checking procedures steps 1 to 5. However, it is not necessary to specify the inner or outer track positions of the disc. If the Y-axis amplitude of the Lissajous figure is different for the inner and outer tracks, perform "7. Spindle Motor Centering Adjustment".

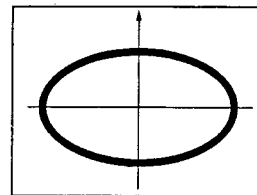

Fig. 3 Lissajous figure when not properly adjusted

7. SPINDLE MOTOR CENTERING ADJUSTMENT

Mechanical Adjustment

- Purpose: To adjust so that the center of the spindle motor is on the orbit of the laser beam.
- When not properly adjusted: Track skips, or searching takes too long.

- | | |
|--|---|
| <ul style="list-style-type: none"> ● Measuring instruments and jigs: ● Measuring point: ● Test disc and player mode ● Positions to be adjusted | <ul style="list-style-type: none"> ● Small phillips screwdriver ● Oscilloscope ● Resistor(10kΩ × 2) ● CN120-9(TRKG ERR), CN120-1 (TRKG C) and CN120-2(TRKG A) ● 8-inch LD test disc GGV1003...#100 and #22,000 (Or a commercially available "karaoke" LD disc) ● Play mode ● Test Mode (TRKG servo:Open/Close) ● CD test disc (YEDS-7) ● The carriage assembly should be in the forward state. ● Spindle motor centering adjustment screw |
|--|---|

Connection diagram

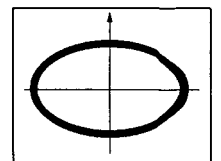
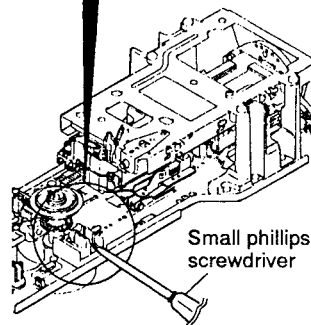
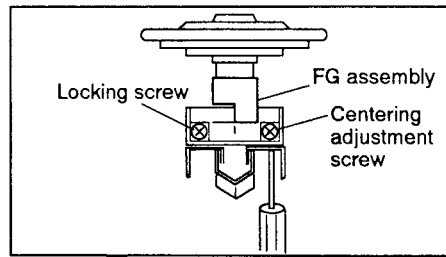
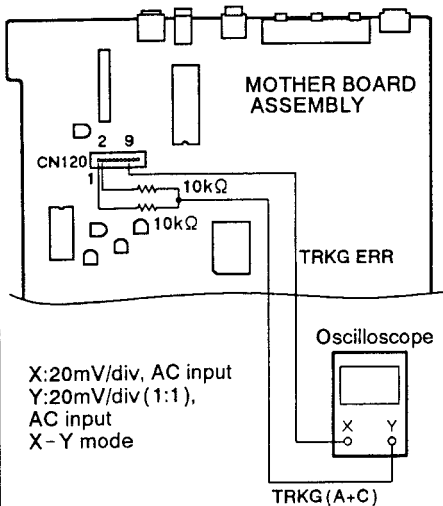

Fig. 1

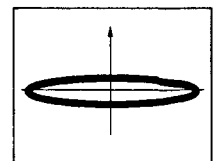

Fig. 2

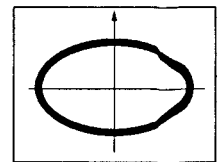

Fig. 3

7. Lissajous figure.

7. Adjust the centering adjustment screw.

Adjustment Procedure

Note: For the same reasons given in the "Note" in section 6., the LD test disc F2 is not suitable for this adjustment.

1. Connect the X-input (CH-1) of the oscilloscope to CN120-9 and the Y-input (CH-2) to CN120-1 and 2.
2. Play the 8-inch LD test disc and search frame #22,000.
3. Open the TRKG servo and observe the Lissajous figures of the TRKG error signal and the TRKG sum signal.
4. Fine-adjust the grating so that the Y-axis amplitude of the Lissajous figure is minimized. (Fig. 2)
5. Close the TRKG servo and search frame #100.
6. Open the TRKG servo again and observe the Lissajous figure and write the values down. (Fig. 1)
7. Loosen a locking screw and insert the small phillips head screwdriver from the adjusting hole, and turn the centering adjustment screw slowly so that the Y-axis amplitude of the Lissajous figure is reduced. After the Y-axis amplitude of the Lissajous figure is minimized, turn the adjusting screw further until the amplitude becomes the same shape as the observed in procedure 6. (Fig. 1-3)
8. Close the TRKG servo, and move the pickup assembly to the outer track of the disc (#22,000), then perform the adjustments in steps 4 to 6 again.
9. Re-open the TRKG servo and observe the Lissajous figure to check that the Y-axis amplitude is minimum. (Fig. 2) If the Y-axis amplitude of the Lissajous figure is larger than specified, repeat the adjustment procedures from steps 5 to 8.
10. After adjustment is complete, perform the adjustment in "6. Spindle Motor Centering Check" item 6.
11. Tighten the locking screw.

8. FINE GRATING ADJUSTMENT

Mechanical Adjustment

- Purpose: To fine adjust the grating so that the two tracking beams for the TRKG servo are projected in the optimum positions on the tracks being played. Set the TRKG servo loop offset voltage to 0V.
- When not properly adjusted: During play, tracks may be skipped.

- Measuring instruments and jigs:
- Measuring point:
- Test disc and player mode
- Positions to be adjusted

- Oscilloscope ● Small screwdriver ● Resistor(10kΩ × 2)
- CN120-9(TRKG ERR), CN120-1 (TRKG C)and CN120-2(TRKG A)
- 8 - inch LD test disc GGV1003...#6,500 ● Still mode ● Test Mode (TRKG servo:Open)
- The carriage assembly should be in the forward state.
- Grating

Connection diagram

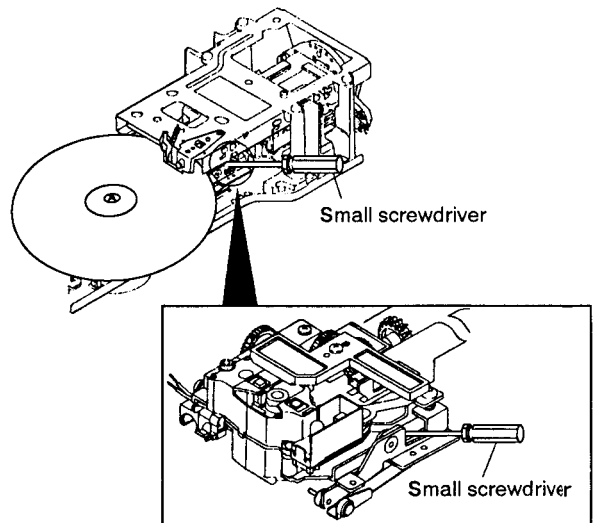
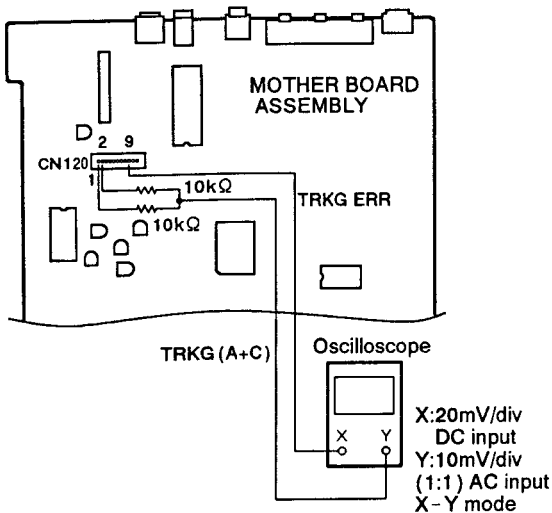

3. Insert the small screwdriver into the grating adjustment hole to fine adjust it.

Adjustment Procedure

1. Play the LD test disc and search frame #6,500, then open the TRKG servo.
2. Connect the X - input(CH-1)of the oscilloscope to CN120-9 and the Y - input(CH2) to CN120-1 and 2 . Set the oscilloscope to the X-Y mode and observe the Lissajous figures of the TRKG error signal and the TRKG sum signal.
3. Insert the small screwdriver into the grating adjustment hole, and fine - adjust the grating so that the Y - axis amplitude of the Lissajous figures is minimized. (Fig. 1)
If the grating is turned too much and the optimum position can no longer be found, repeat the "1. Coarse Grating Adjustment".
4. Select the oscilloscope's X - input(CH-1) and check that the positive and negative amplitudes of the TRKG error signal are equal. (Fig. 2)
If they are not, repeat the "1. Tracking Balance Adjustment".

5. Close the TRKG servo and check that the picture(image) on the TV screen is normal.

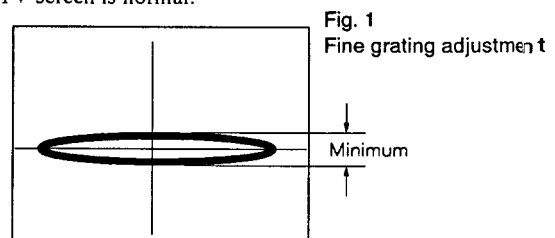

3. Y - axis amplitude of Lissajous figure becomes minimum.

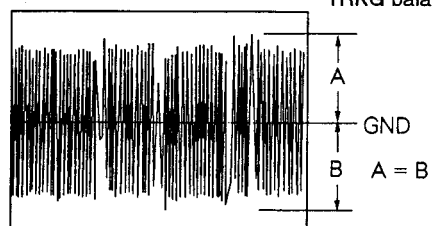

9. RF GAIN ADJUSTMENT

Mechanical Adjustment

- Purpose: To adjust the RF signal amplitude to the optimum value.
- When not properly adjusted: Dropout occurs frequently.

- | | |
|--|--|
| <ul style="list-style-type: none"> ● Measuring instruments and jigs: ● Measuring point: ● Test disc and player mode ● Positions to be adjusted | <ul style="list-style-type: none"> ● Oscilloscope ● CN120-3(RF signal) ● 8-inch LD test disc GGV1003...#15,000 ● Still mode ● Test Mode(TRKG servo:Close) ● Tilt servo : Neutral ● The carriage assembly should be in the forward state. ● VR601(RF LEVEL) |
|--|--|

Connection diagram

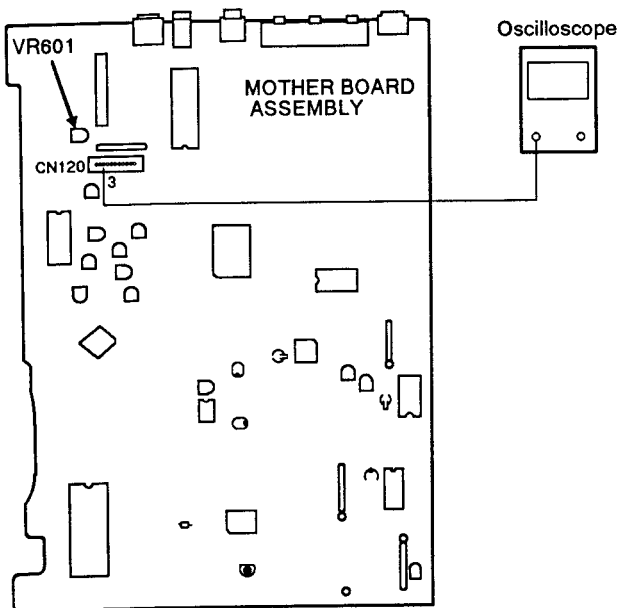

Adjustment Procedure

1. Play the LD test disc and search frame #15,000.
2. Connect an oscilloscope to CN120-3(RF signal) and observe the RF signal.
3. Adjust VR601 so that the amplitude of the RF signal becomes $300\text{mV} \pm 50\text{mV}$. (Fig. 1)

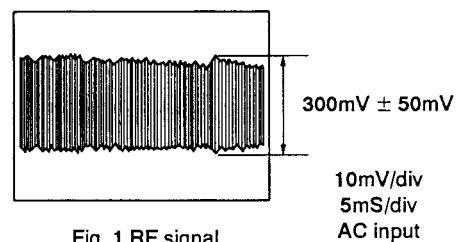

Fig. 1 RF signal

10. FOCUS SERVO LOOP GAIN ADJUSTMENT

Mechanical Adjustment

- Purpose: To set the loop gain of the FOCS servo to the optimum value.
- When not properly adjusted: Performance deteriorates.

- | | |
|--|--|
| <ul style="list-style-type: none"> ● Measuring instruments and jigs: ● Measuring point: ● Test disc and player mode ● Positions to be adjusted | <ul style="list-style-type: none"> ● Oscilloscope ● AF oscillator ● Resistor(47kΩ) ● CN120-6(FOCS ERR) and CN120-7(FOCS IN) ● 8-inch LD test disc GGV1003...#15,000 ● Still mode ● Test mode (TRKG servo:Close) ● Tilt servo : Neutral ● The carriage assembly should be in the forward state. ● VR604 |
|--|--|

Connection diagram

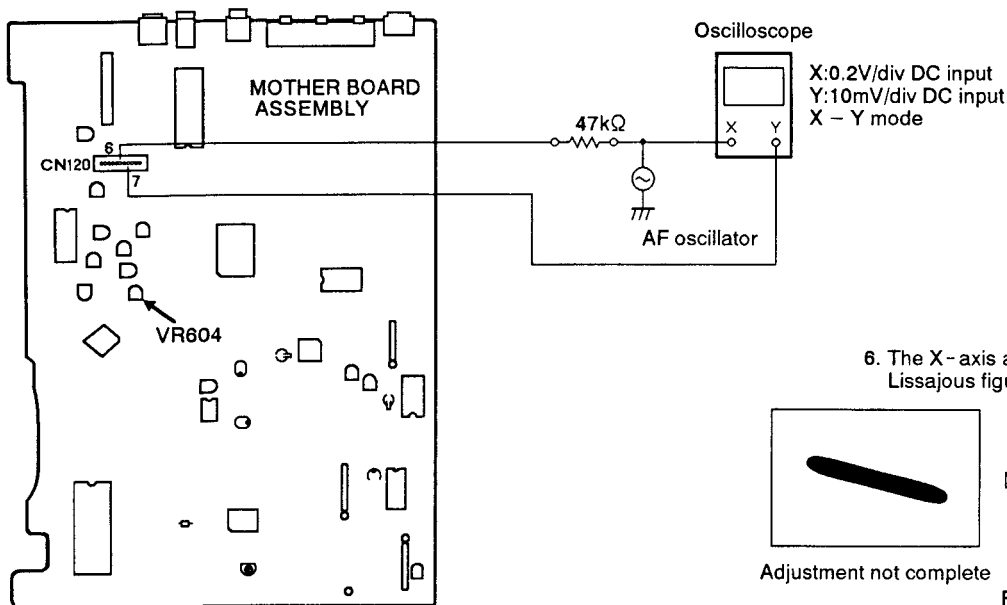

6. The X-axis and Y-axis of the Lissajous figure are symmetrical

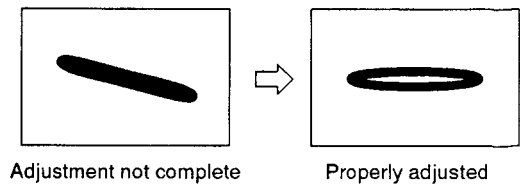

Fig. 1

Adjustment Procedure

1. Connect the oscilloscope's X-input(CH-1) via the resistor and AF oscillator to CN120-6, and the Y-input (CH-2) to CN120-7, as shown in the above diagram.
2. Set the AF oscillator output to 1.7kHz/6Vp-p for GGV1003, according to the test disc used.
3. Play the 8-inch LD test disc and search frame #15,000.
4. Set the oscilloscope to the X-Y mode and observe the Lissajous figure.
5. Adjust VR604 so that the Lissajous figure is symmetrical on both the X-axis and Y-axis of the oscilloscope. (Fig. 1)

Note : If the AF oscillator output does not exceed 6Vp-p, reduce the value of the resistor (47kΩ) in the above diagram, for easier observation of the Lissajous figure. (not below 33kΩ)

11. TRKG SERVO LOOP GAIN ADJUSTMENT

Mechanical Adjustment

- Purpose: To set the loop gain of the TRKG servo to the optimum value.
- When not properly adjusted: Performance deteriorates

- Measuring instruments and jigs:
- Measuring point:
- Test disc and player mode
- Positions to be adjusted

- Oscilloscope ● Resistor(47kΩ) ● AF oscillator
- CN120-9(TRKG ERR), CN120-10(TRKG IN)
- 8-inch LD test disc GGV1003...#15,000 ● Still mode ● Tilt servo : Neutral
- Test mode (TRKG servo:Close) ● The carriage assembly should be in the forward state.
- VR603

Connection diagram

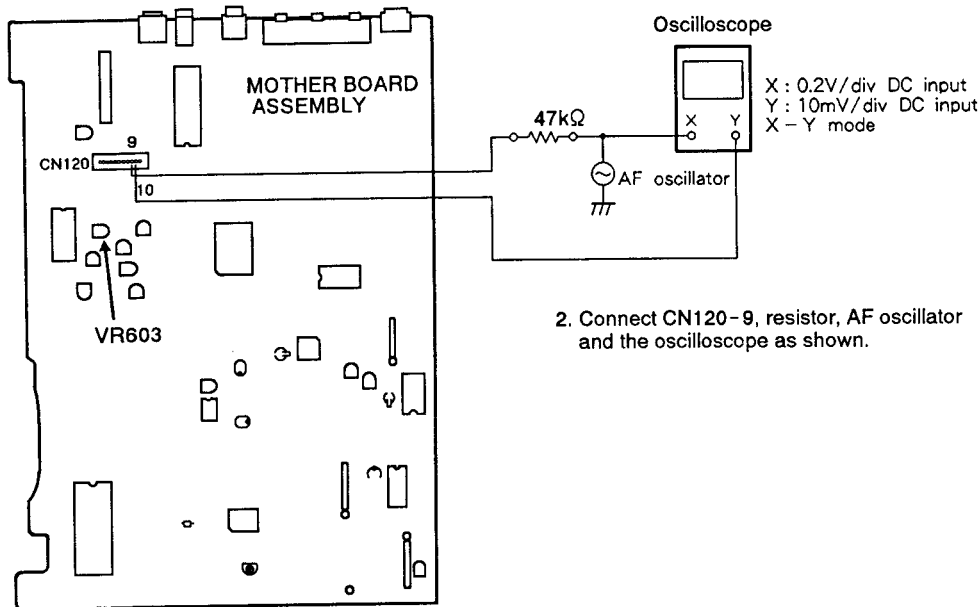

Adjustment Procedure

1. Play the LD test disc and search frame #15,000.
2. Connect the oscilloscope's X-input(CH-1) via the resistor and AF oscillator to CN120-9, and the Y-input (CH-2) to CN120-10, as shown in the above diagram.
3. Set the AF oscillator output to 3.0kHz/6Vp-p for GGV1003, according to the test disc used.
4. Set the oscilloscope to the X-Y mode and observe the Lissajous figure.
5. Adjust VR603 so that the Lissajous figure is symmetrical on both the X-axis and Y-axis of the oscilloscope. (Fig. 1)

Note : If the AF oscillator output does not exceed 6Vp-p, reduce the value of the resistor (47kΩ) in the above diagram, for easier observation of the Lissajous figure. (not below 33kΩ)



Adjustment not complete

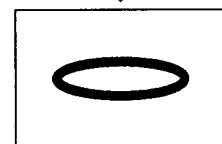

Properly adjusted

Fig. 1

5. The X-axis and Y-axis of the Lissajous figure are symmetrical.

12. POSITION CHECK AT THE START PLAY AND CENTERING ADJUSTMENT FOR SIDE B PLAY

Mechanical Adjustment

- Purpose: To check that the position check at the start play and to set the center of the spindle motor on the path of the laser beam when playing the side B of the disc.
- When not properly adjusted: Tracks skipped, longer searching time or searching is impossible when playing side B of the disc.

- Measuring instruments and jigs:
- Measuring point:
- Test disc and player mode
- Positions to be adjusted

- L-shaped eccentric screwdriver (GGV-129)
- Oscilloscope
- Resistor (10kΩ)
- CN120-9 (TRKG ERR), CN120-1 (TRKG C) and CN120-2 (TRKG A)
- 8-inch LD test disc GGV1003...#100
- Play mode
- The carriage assembly should be in the reverse state.
- Test mode (TRKG servo: Open / Close)
- Centering adjustment hole for side B

Connection diagram

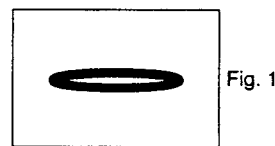
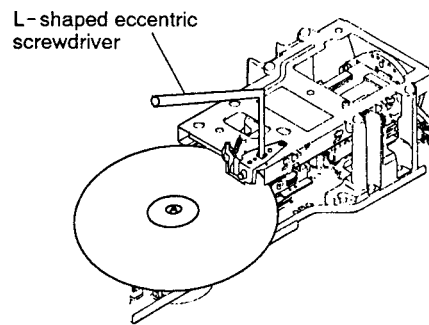
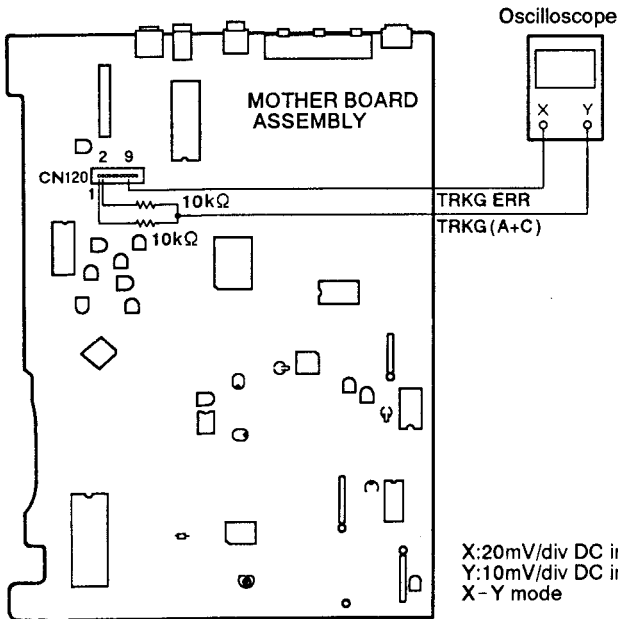

4. Centering adjustment for side B play.

4. Properly adjusted (X: maximum).

Adjustment Procedure

1. Turn the LD test disc upside-down (change from side A to side B). The start play position from side A to B should be within frame #3,500.
2. Set the oscilloscope to the X-Y mode, and connect the oscilloscope's X-input (CH-1) to CN120-9 (TRKG ERR) and the Y-input (CH-2) to CN120-1 and 2 (TRKG A+C).
3. Play the LD test disc and search frame #100, then open the tracking servo.

Note: If the center is too eccentric on side B of the disc, since searching will be impossible on side B, open the TRKG servo when the carriage assembly moves to the side B play position and searches around frame #100.

4. While observing the Lissajous figure on the oscilloscope, insert the eccentric screwdriver into the centering adjustment hole for side B and adjust it so that the X-axis amplitude of the Lissajous figure is minimized (on-track position). Then turn the eccentric screwdriver clockwise until the X-axis amplitude of the Lissajous figure becomes maximum. (Fig. 1)

Note: When "3. Tangential Direction Angle Adjustment" is performed with the pickup in the forward state, perform "13. Pickup Tangential Direction Angle Adjustment for Side B Play" and "14. Fine Centering Adjustment for Side B play".

13. PICKUP TANGENTIAL DIRECTION ANGLE ADJUSTMENT FOR SIDE B PLAY Mechanical Adjustment

- Purpose: To adjust the crosstalk to become minimum in the tangential direction angle of the pickup assembly when playing side B of the disc.
- When not properly adjusted: Crosstalk is significant.

● Measuring instruments and jigs:

● Measuring point:

● Test disc and player mode

● Positions to be adjusted

● TV monitor ● Small Phillips screwdriver

● Monitor screen

● 8-inch LD test disc GGV1003...#115 ● Still mode

● The carriage assembly should be in the reverse state.

● Pickup tangential direction angle adjustment screw

Connection diagram

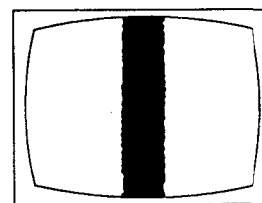
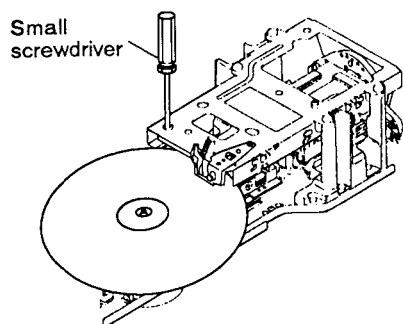

2. Minimum crosstalk

Adjustment Procedure

1. Play the LD test disc and search frame #115.
2. Check if crosstalk appears on the screen of the TV monitor, and adjust the pickup tangential direction angle adjustment screw so that the crosstalk is minimized.
3. After steps 1 and 2 have been completed, perform "12. Centering Adjustment for Side B Play" again.

Note: When the pickup tangential direction angle for side B play is varied by this adjustment, the center of the disc for side B may be shifted slightly. As a countermeasure, perform the centering adjustment again.

14. FINE CENTERING ADJUSTMENT FOR SIDE B PLAY

Mechanical Adjustment

- Purpose: To set the center of the spindle motor on the track of the laser beam when playing the side B of the disc.
- When not properly adjusted: Tracks skipped when playing side B of the disc.

- Measuring instruments and jigs:
- Measuring point:
- Test disc and player mode
- Positions to be adjusted

- Oscilloscope ● L-Shaped eccentric screwdriver(GGV - 129) ● Resistor (10kΩ × 2)
- CN120-9(TRKG ERR), CN120-1 (TRKG C) and CN120-2(TRKG A)
- 8-inch LD test disc GGV1003...#100 ● Test mode (TRKG servo: Open)
- Play mode ● The carriage assembly should be in the reverse state.
- Centering adjustment hole for side B

Connection diagram

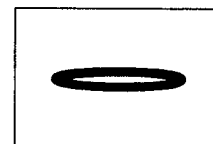
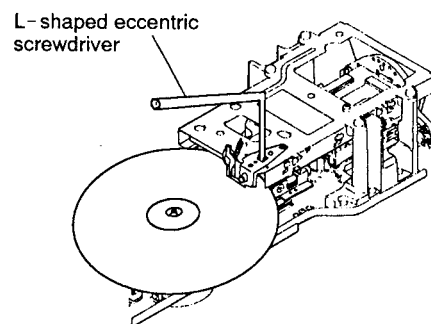
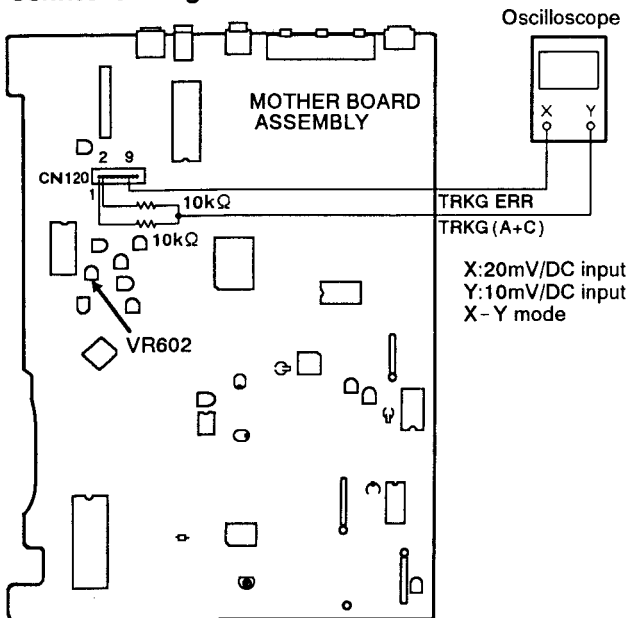

Fig. 1

4. X-axis of Lissajous figure maximum.

Adjustment Procedure

1. Set the oscilloscope to the X-Y mode, and connect the oscilloscope's X-input (CH-1) to CN120-9 (TRKG ERR) and the Y-input (CH-2) to CN120-1 and 2 (TRKG A+C).
2. Play the LD test disc and search frame #100.
3. Open the TRKG servo.
4. While observing the Lissajous figure on the oscilloscope, insert the eccentric screwdriver into the centering adjustment hole for side B and adjust it so that the X-axis amplitude of the Lissajous figure becomes maximum. (Fig. 1)
5. Turn the power OFF.
6. Fixing and locking the screws as follows;
 - Grating screw
 - Spindle motor centering adjustment screw
 - Pickup tangential direction angle adjustment screw
 - Centering adjustment hole for side B
 - Tilt sensor screw
 - Shaft plate (upper)

8.4.4 ELECTRICAL ADJUSTMENT

15. REFERENCE FREQUENCY ADJUSTMENT

Electrical Adjustment

- Purpose: Adjustment of the standard clock frequency.
- When not properly adjusted: Incorrect color tint, no TV color lock, and VCXO cannot be adjusted during LDD playback.

- | | |
|--|---|
| <ul style="list-style-type: none"> ● Measuring instruments and jigs: ● Measuring point: ● Test disc and player mode ● Positions to be adjusted | <ul style="list-style-type: none"> ● Frequency counter ● Oscilloscope 10:1 probe ● lead wire of R647 ● Normal mode (Stop mode (Blueback screen)) ● VC901 |
|--|---|

Connection diagram

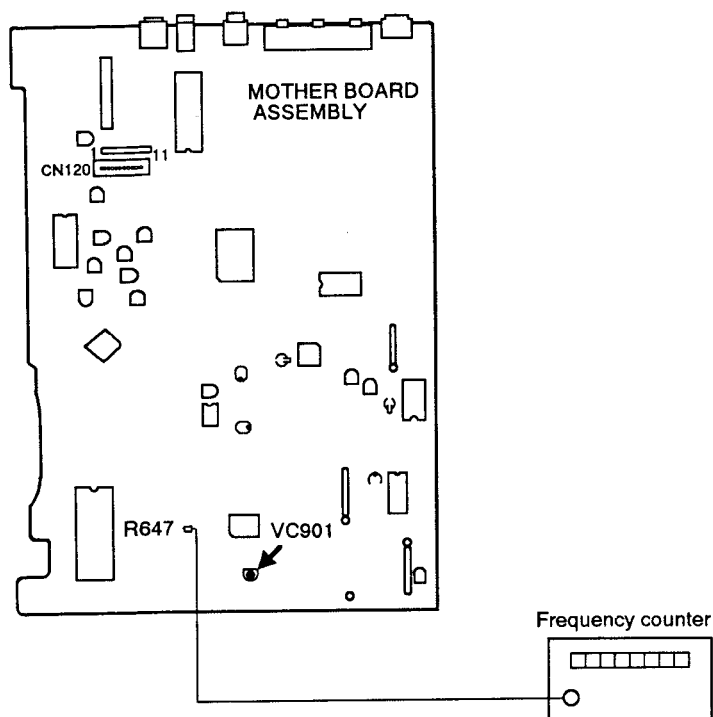

Adjustment Procedure

1. Adjust VC901 so that the frequency of the lead wire of R647 becomes 3.579545MHz in the stop mode (blueback screen).

Note : The frequency counter probe should be an oscilloscope 10 : 1 probe.

16. VCO CENTERING FREQUENCY ADJUSTMENT

Electrical Adjustment

- Purpose: Setting the optimum delay time for the time axis error copensation CCD.
- When not properly adjusted: It is difficult to color lock, there is color lock delay after a search, and there is flicker on the white screen.

- | | |
|--|---|
| <ul style="list-style-type: none"> ● Measuring instruments and jigs: ● Measuring point: ● Test disc and player mode | <ul style="list-style-type: none"> ● Oscilloscope ● CH 1 : lead wire of C471. ● CH 2 : + side lead wire of C499. ● 8 - inch LD test disc (GGV1003) ● Normal mode (Still mode, #5,100) |
| <ul style="list-style-type: none"> ● Positions to be adjusted | <ul style="list-style-type: none"> ● VR481 |

Connection diagram

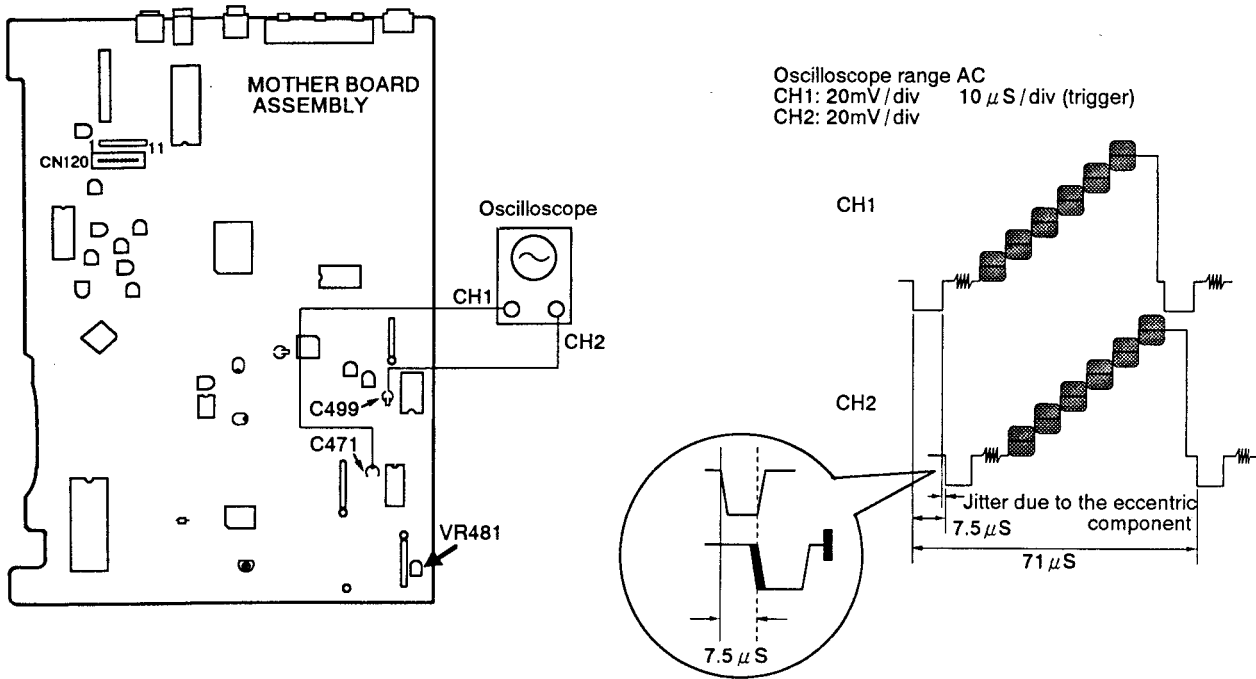

Adjustment Procedure

1. Connect the lead wire of C471 and the + side lead wire of C499 to CH 1 and CH 2 of the oscilloscope respectively.
 CH 1 : Video signal before time axis error compensation.
 CH 2 : Video signal after time axis error compensation.
2. Search for frame #5,100 on the test disc. Adjust VR481 so that the center of CH 1's video signal jitter is delayed by 71 μs (1H + 7.5 μs) with respect to the CH 2's video signal.

Note : Do not confuse CH 1 and CH 2.

17. OUTPUT VIDEO LEVEL ADJUSTMENT

Electrical Adjustment

- Purpose: Setting the video signal level to 1Vp-p (75 Ω termination).
- When not properly adjusted: The player starts up midway without reading the data. The screen is too bright or too dark.

- | | |
|--|---|
| <ul style="list-style-type: none"> ● Measuring instruments and jigs: ● Measuring point: ● Test disc and player mode | <ul style="list-style-type: none"> ● Oscilloscope ● Player's VIDEO OUT terminal ● 8 - inch LD test disc (GGV1003) ● Normal mode (Still mode, #19,900) |
| <ul style="list-style-type: none"> ● Positions to be adjusted | <ul style="list-style-type: none"> ● VR482 |

Connection diagram

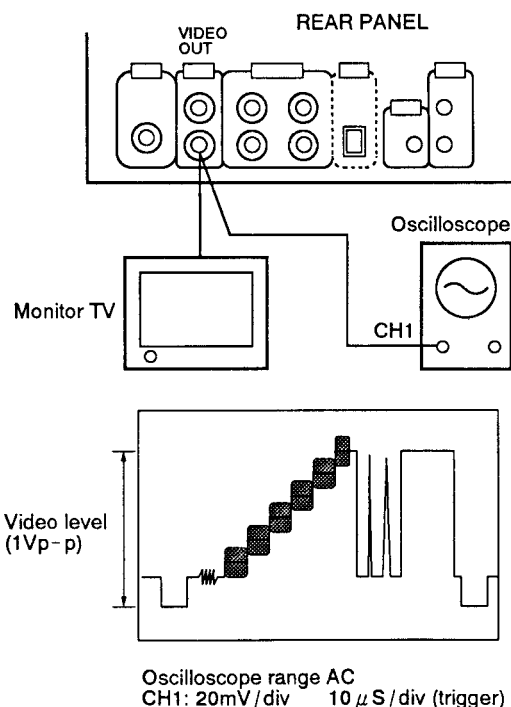
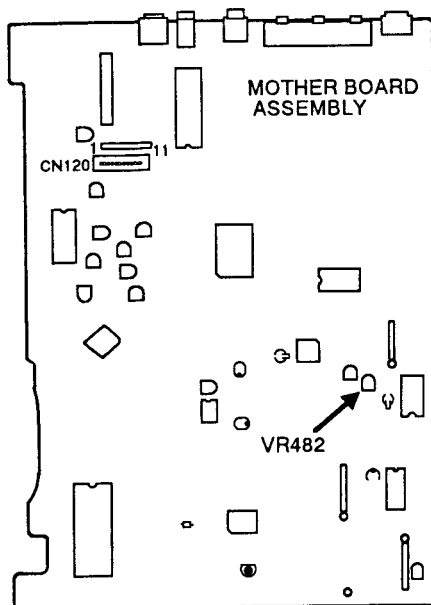

Adjustment Procedure

Note : Since the VIDEO OUT terminal will be connected to a TV monitor, it is to have 75Ω termination. (If it is connected to a TV via VHF OUT, terminate the VIDEO OUT terminal with a 75Ω resistor).

1. Search for frame #19,900 on the test disc.
2. Adjust VR482 so that the white level becomes 0.71Vp-p ± 5% from the video signal's sync tip level.

18. 1H DELAY VIDEO LEVEL ADJUSTMENT

Electrical Adjustment

- Purpose: Equalization of the video levels of the 1H delay video signal and the main line video signal.
- When not properly adjusted: If the 1H delay video signal level is high, white dropout will be noticeable and there will be H shifting. (Horizontal stripes across the screen.)

- | | |
|--|---|
| <ul style="list-style-type: none"> ● Measuring instruments and jigs: ● Measuring point: ● Test disc and player mode ● Positions to be adjusted | <ul style="list-style-type: none"> ● Oscilloscope ● CH 1 : lead wire of L458 ● CH 2 : lead wire of L456 ● 8-inch LD test disc (GGV1003) ● Normal mode (Still mode, #3,800) ● VR441 |
|--|---|

Connection diagram

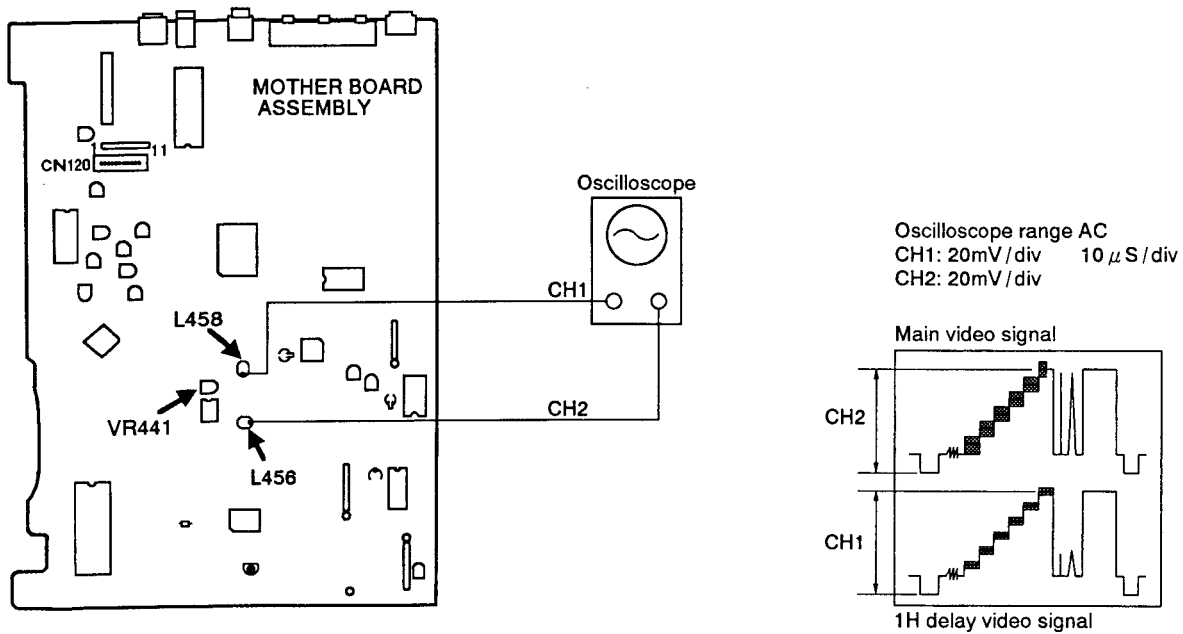

Fig. 1

Adjustment Procedure

1. Search for frame #3,800 on the test disc.
2. Connect lead wire of L458 to the oscilloscope's CH 1 and lead wire of L456 to the CH 2.
3. Adjust VR441 so that the 1H delay video level (CH 1) becomes the same as the main line video level (CH 2). (See Fig. 1)

Note : The video level is the level between the SYNC tip and the white peak.

19. COLOR TINT ERROR SIGNAL LEVEL ADJUSTMENT

Electrical Adjustment

- Purpose: Optimization of the color tint compensation section's error signal level.
- When not properly adjusted: There is substantial color irregularity. (especially for CDV.)

- Measuring instruments and jigs:
- Measuring point:
- Test disc and player mode

- Positions to be adjusted

- TV monitor

- 8-inch LD test disc (GGV1003)
- Normal mode (Still mode, #8,000)

- VR521

Connection diagram

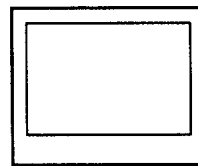
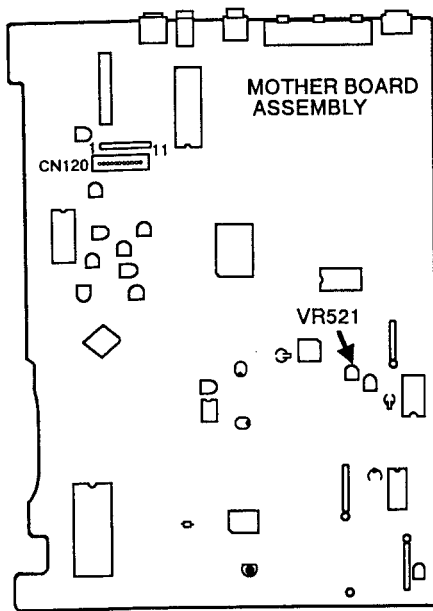

Color irregularity on the magenta screen is minimized.

Adjustment Procedure

1. Search for frame #8,000 on the test disc. (Magenta screen)
2. Adjust VR521 until the color irregularity on the magenta screen is minimized.

9. ABBREVIATIONS TABLE

A		M	
ACCEL	ACCELERATE	MTR	MOTOR
ACOM	AUDIO COMPENSATOR	μCOM	MICROCOMPUTER
AF	AUDIO FREQUENCY	P	
AFM	ANALOGUE FM AUDIO	PD	PHOTO DETECTOR
AGC	AUTOMATIC GAIN CONTROL	PB	PLAYBACK
ALC	AUTOMATIC LEVEL CONTROL	PLL	PHASE LOCKED LOOP
ANT	ANTENNA	P-ON	POWER ON
ATC	AUTOMATIC THRESHOLD CONTROL	R	
B		R-CH	RIGHT CHANNEL
BAL	BALANCE	RTN	RETURN
C		RFMD	RADIO FREQUENCY MODULATOR
CAV	CONSTANT ANGULAR VELOCITY	RST	RESET
CLV	CONSTANT LINEAR VELOCITY	REV	REVERSE
CCD	CHARGE COUPLED DEVICE	RF-CORR	RF CORRECTION
CD	COMPACT DISC	S	
CK	CLOCK	SPDL	SPINDLE
CONT	CONTROL	SLD	SLIDER
C-SYNC	COMPOSITE SYNCHRONIZATION	SO	SERIAL OUTPUT
CX	AFM NOISE REDUCTION	SI	SERIAL INPUT
D		SCK	SERIAL CLOCK
DEM	DEMODULATOR	SC	CHIP SELECT
DIG/ANA	DIGITAL/ANALOGUE	SYPS	SYSTEM POWER SUPPLY
DL	DELAY LINE	SW	SWITCH
DSP	DIGITAL SIGNAL PROCESSOR	S/H	SAMPLE & HOLD
DOS	DROP OUT SENSE	SENS	SENSITIVITY
DRV	DRIVER	SQ	SQUELCH
E		T	
EFM	EIGHT TO FOURTEEN MODULATION	TRK or TRKG	TRACKING
ERR	ERROR	TP	TEST POINT
EQ	EQUALIZER	TBC	TIME BASE CORRECTION
EXT	EXTERNAL	TGL	TOGGLE
F		U	
FCS or FOCS	FOCUS	UNREG	UNREGULATED
FG	FREQUENCY GENERATOR	V	
FL	FLUORESCENT LAMP	V-SYNC	VERTICAL SYNCHRONIZATION
FTS	FOCUS TRACKING SLIDER	VSQ	VIDEO SQUELCH
Fsc	CHROMINANCE SUBCARRIER FREQUENCY	VPS	VIDEO PHASE SHIFTER
FWD	FORWARD	VDEM	VIDEO DEMODULATOR
G		VHF	VERY HIGH FREQUENCY
GFS	GET FRAME SYNC LOCK	VCA	VOLTAGE CONTROLLED AMPLIFIER
GND	GROUND	VCO	VOLTAGE CONTROLLED OSCILLATOR
H		X	
HLD	HOLD	X...	ACTIVATED WHEN LOW VOLTAGE
H SYNC	HORIZONTAL SYNCHRONIZATION	I	
I		INT	INTERNAL
IR	INFRARED RAYS	L	
L		L-CH	LEFT CHANNEL
LAT	LATCH	LD	LASER DIODE
LD	LASER DIODE	LPF	LOW PASS FILTER
LPF	LOW PASS FILTER	LIM	LIMITER
LIM	LIMITER		

10. SPECIFICATIONS

1. General

System	LaserVision Disc system and Compact Disc digital audio system
Laser	Semiconductor laser wavelength 780 nm
Power requirements	
U.S. and Canadian models	AC 120 V, 60 Hz
Multi voltage model	AC 110 - 127 V/220 - 240 V (Switchable), 50/60 Hz
Power consumption	
U.S. and Canadian models	43 W
Multi voltage model	43 W
Weight	8.4 kg (18 lbs 8 oz)
Dimensions	420 (W) x 438 (D) x 135 (H) mm 16-9/16 (W) x 17-1/4 (D) x 5-5/16 (H) in
Operating temperature	+5°C ~ +35°C (41°F - 95°F)
Operating humidity	5% ~ 90% (There should be no condensation of moisture.)

2. Disc

LaserVision Discs

*Maximum playing times	
12-inch standard play disc	1 hour/both sides
12-inch extended play disc	2 hours/both sides
8-inch standard play disc	28 min/both sides 14 min/one side
8-inch extended play disc	40 min/both sides 20 min/one side
Spindle motor speed	
Standard play disc	1,800 rpm
Extended play disc	1,800 rpm (inner circumference) to 600 rpm (outer circumference) (For a 12-inch disc)

Compact Discs

DISC	Diameter: 5-inch, 3-inch, Thickness: 1.2 mm
Rotation direction (pickup side)	Counterclockwise
Liner speed	1.2 ~ 1.4m/sec
*Maximum playing time	

	74 min. 5-inch discs
	20 min. 3-inch discs
	(For stereo playback)

Compact Discs with Video

Disc	Diameter: 5-inch, Thickness: 1.2 mm
Rotation direction (pickup side)	Counterclockwise
Linear speed	Audio portion: 1.2 ~ 1.4m/sec Video portion: 11 ~ 12m/sec
Maximum playing time	Video portion: 5 min. (CLV) Audio portion: 20 min. (Digital)

* Actual playback time differs for each disc.

3. Video characteristics

Format	NTSC specifications
Video output	
Level	1 Vp-p nominal, sync. negative, terminated
Impedance	75 Ω unbalanced
Jacks	Both RCA jacks
Number of channels	2

4. S-Video output

Y (luminance) - Output level	1 Vp-p (75 Ω)
C (color) - Output level	286 mVp-p (75 Ω)
Jack	S-VIDEO jack

5. Audio characteristics

Output level	
During analog audio output	200 mVrms (1 kHz, 40%)
During digital audio output	200 mVrms (1 kHz, -20 dB)
Jacks	Both RCA jacks
Number of channels	2

Digital Audio Characteristics

Frequency response	4 Hz - 20 kHz (±0.2 dB) (EIAJ)
SN ratio	114 dB (EIAJ)
Dynamic range	99 dB (EIAJ)
Channel separation	104 dB (EIAJ)
Total harmonic distortion	0.0018 % (EIAJ)
Wow and flutter	Limit of measurement (EIAJ)

5. Other Terminals

Control input/output	Both miniature jacks
CD-DECK synchro	Miniature jack
Optical digital output	Optical digital jack

6. Accessories

Remote control unit (CU-CLD039)	1
Size "AAA" (IEC R03) dry cell batteries	2
Video cord	1
Audio cord	1
Operating instructions	1
Warranty card	1

7. Functions

Remote control unit operations (CU-CLD039)

	Function	Standard play Disc (CAV)	Extended play Disc (CLV)	Compact Disc with Video	Compact Disc
Basic Functions	Two-side play Single-side play Pause Stop	YES YES YES YES	YES YES YES YES	NO YES YES YES	NO YES YES YES
Search	Fast forward (forward and reverse) Chapter/Track skip Direct chapter/Track number search Frame number search Time number search Absolute time search	YES YES YES YES NO NO	YES YES YES NO YES NO	YES YES YES NO YES NO	YES YES YES NO YES YES
Program	Chapter/Track program play Program correction	YES YES	YES YES	YES YES	YES YES
Repeat	Repeat between 2 points Memory repeat Chapter/Track repeat One-side repeat Two-side repeat Program repeat Random repeat Program random repeat	YES YES YES YES YES YES YES*1 YES	YES YES YES YES YES YES YES*1 YES	YES YES YES YES NO YES YES YES	YES YES YES YES NO YES YES YES
Trick play	Still/Step Multi-speed (Forward/reverse 9-level variable)	YES YES	NO NO	NO NO	NO NO
Time display	Elapsed time display Absolute time display Remaining track time display Remaining total time display Total number of selections, total time display	NO YES*1 NO YES*1 YES*1	YES NO NO YES*1 YES*1	YES NO YES YES YES	YES YES YES YES YES
Others	Single play CX system ON/OFF AUTO DIGITAL/ANALOG switch Audio channel selection (Stereo, 1/L, 2/R)	YES YES*2 YES*3 YES	YES YES*2 YES*3 YES	YES NO NO YES	YES NO NO YES

*1 Only discs with TOC

*2 Valid for analog sound playing a disc with the  mark.

*3 Can only be used with discs with digital sound tracks.

NOTE:

The specifications and design of this product are subject to change without notice, due to improvement.

PLAYER FUNCTIONS

- Display, Visual Calendar Display
- Intro Scan, Direct CD, Single Play, Peak Search, Random Playback, Program Random Playback and Compu Program/Auto Program Edit
- Digital Sound for LaserVision Discs
- Last Memory

11. PANEL FACILITIES

• FRONT PANEL

A detailed description is provided on the indicated page(s).

SOFT PICTURE button/indicator

Press to turn the soft picture function on and off. When the soft picture function is ON, SOFT PICTURE indicator lights and picture will be softened.

REMOTE SENSOR

Press to turn the power on and off.

PHONES jack

PHONES LEVEL control

Turn this control in the "MAX" direction to increase the output level from the PHONES jack. Turn this control in the "MIN" direction to decrease the output level from the PHONES jack.

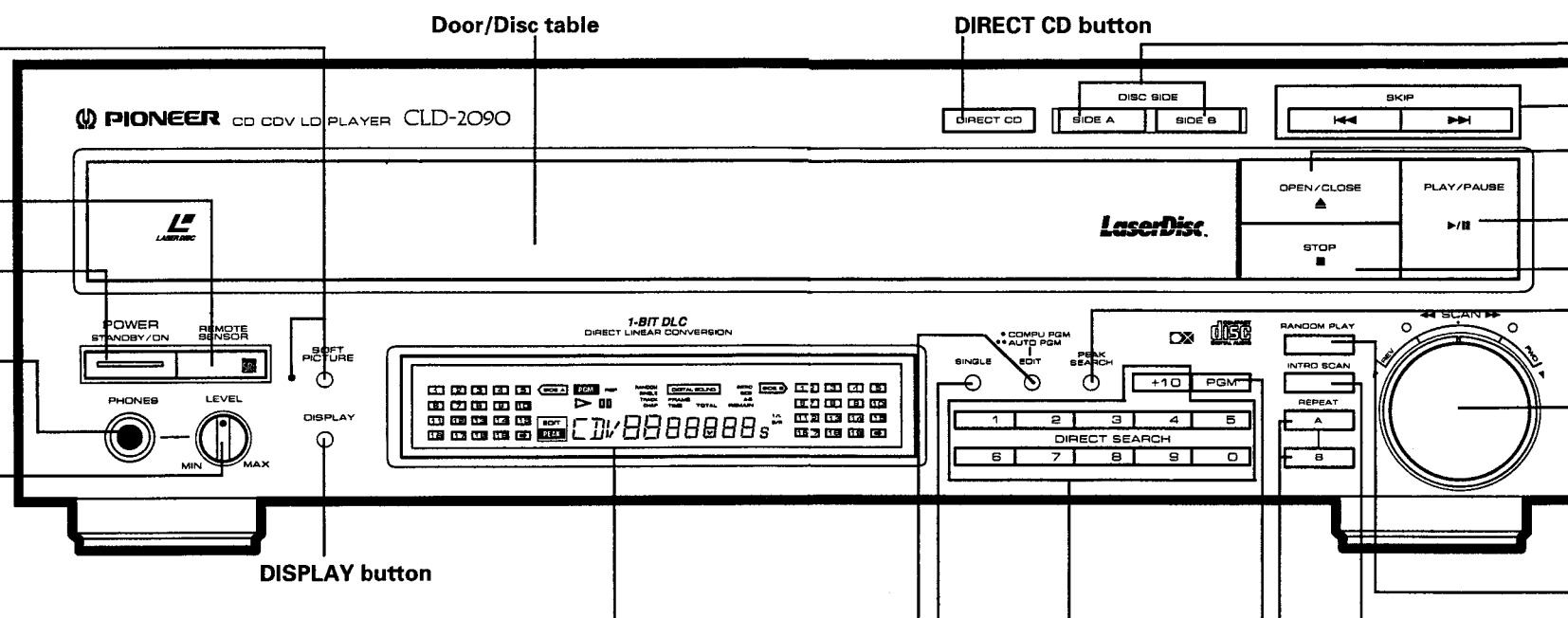

DISC SIDE A/B buttons

SKIP buttons

OPEN/CLOSE ▲ button

PLAY/PAUSE ►/II button

STOP ■ button

PEAK SEARCH button

SCAN control

RANDOM PLAY button

INTRO SCAN button

REPEAT A/B buttons

PGM button

DIRECT SEARCH/Digit buttons

SINGLE button

EDIT button
(■ COMPU PGM/■ AUTO PGM)

Display window

TRACK/CHAP. indicator

Indicates the TRACK number or CHAP (chapter) number.

REP indicator

Lights during repeat play.

II PAUSE indicator

Lights when the player is in pause mode.

PGM indicator

Lights during program play.

▶ PLAY indicator

Lights during play. Blinks during search.

SIDE A indicator

SINGLE indicator

Lights during Single play.

RANDOM indicator

Lights during random play.

FRAME/TIME indicator

Indicates the FRAME number or TIME.

DIGITAL SOUND indicator

Lights when the disc being played has a digital sound signal. With LD discs, this indicator lights when the digital sound signal is selected.

INTRO indicator

Lights during Intro Scan mode.

SIDE B indicator

LD side A/CD/CDV visual calendar

When a disc is loaded, all of the chapter/track numbers recorded on the disc light up on the display. If the disc contains more than 19 chapters/tracks, the → indicator lights. During program play, only the programmed chapter/track numbers light. When a disc without a TOC section is played, only the selection number being played lights. When a CDV disc is loaded, the track numbers of the video part light followed by the track numbers of the audio part. After a chapter/track is finished playing, the corresponding number goes out.

LD/CD/CDV indicator

Indicates the type of disc loaded in the player.

EDIT indicator

Lights when editing is performed.

PEAK indicator

Lights while searching for the peak level.

REMAIN/TOTAL indicator

Indicates the REMAIN TIME (remaining play time) or TOTAL TIME (total play time).

LD side B visual calendar

A visual calendar for the B side of two-sided LDs. Numbers light in the same way as on the side A visual calendar.

1/L, 2/R indicator

Indicates the audio output channel.

• REMOTE CONTROL UNIT

A detailed description is provided on the indicated page(s).

Remote control buttons with the same names or marks as buttons on the front panel of the player control the same operations as the corresponding front panel buttons.

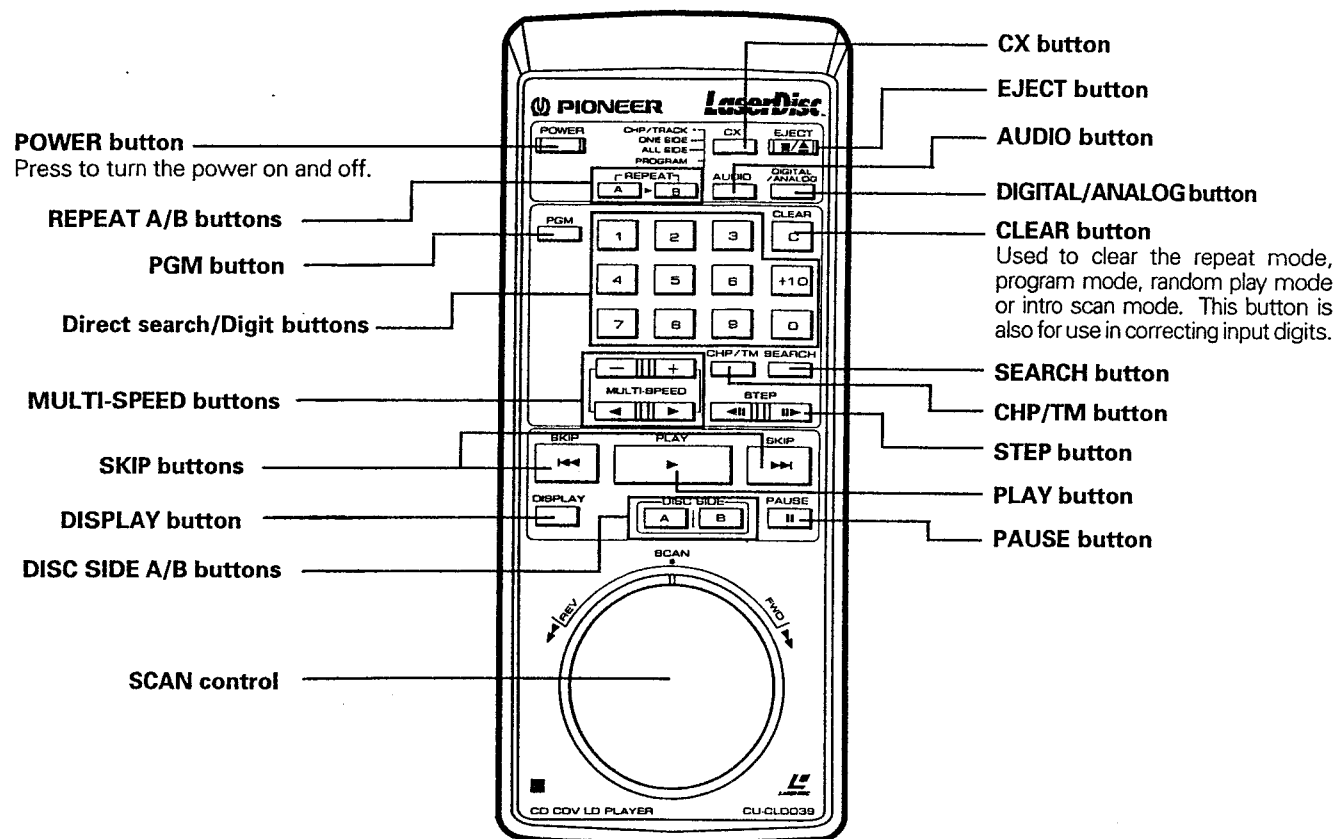

When operating the remote control unit, point the unit's infrared signal transmitter at the remote control receiver (REMOTE SENSOR) on the front panel of the player. The remote control unit can be used within a range of about 5 meters (16 feet) from the remote sensor, and within angles of up to about 30 degrees.

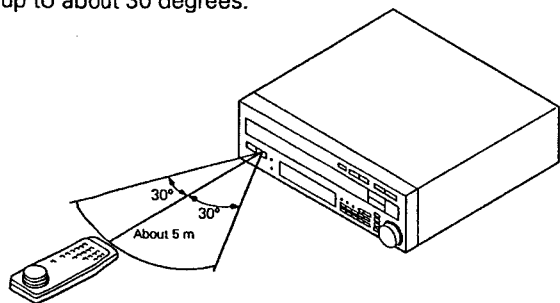

NOTE FOR USING THE REMOTE CONTROL UNIT

• If a plug is connected to the CONTROL IN terminal at the rear of the player, remote control operations cannot be done with the remote control unit aimed at the player's remote control sensor. Aim the remote control unit at the AV control center or the component display's sensor instead.

- If there is any obstacle between the remote control unit and the player, or if the unit is held at too large an angle relative to the front panel of the player, the signal from the remote control unit will fail to reach the remote sensor.
- If the player is operating in the vicinity of other appliances generating infrared rays, or if other remote control devices using infrared rays are used near the player, the player may operate improperly. Conversely, if the player's remote control unit is operated in the vicinity of other appliances which use an infrared remote control device, the other appliance may operate improperly. If this should happen, change the place of installation so that improper operation does not occur.
- If the range of operation of the remote control unit becomes too short, replace the batteries.
- When the unit is not to be used for a long period of time (more than one month), remove the batteries to prevent them from leaking inside the compartment. If leakage occurs, wipe up the liquid inside the compartment and replace the batteries with new ones.
- Do not place books or other objects on the remote control unit, since they might depress the buttons and run down the batteries.
- If the remote control sensor window is in a position where it receives strong light such as sunlight or fluorescent light, control may not be possible.