

Service Manual

PIONEER
The Art of Entertainment

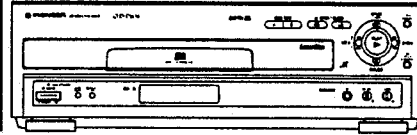

• CLD-D504

ORDER NO.
RRV1251

CD CDV LD PLAYER

CLD-D504

CLD-D580

THIS MANUAL IS APPLICABLE TO THE FOLLOWING MODEL(S) AND TYPE(S).

Type	Model		Power Requirement	Remarks
	CLD-D504	CLD-D580		
KU	○	-	AC120V	
KC	○	-	AC120V	
RD	-	○	AC110-240V	Automatic select

CONTENTS

1. SAFETY INFORMATION	2	5. SELF-DIAGNOSTIC FUNCTIONS	43
2. EXPLODED VIEWS, PACKING AND PARTS LIST	3	6. ADJUSTMENTS	45
3. SCHEMATIC AND PCB CONNECTION DIAGRAMS	17	7. IC INFORMATION	55
4. PCB PARTS LIST	37	8. FL INFORMATION	62
		9. BLOCK DIAGRAM	63
		10. PANEL FACILITIES	65
		11. SPECIFICATIONS	66

PIONEER ELECTRONIC CORPORATION 4-1, Meguro 1-Chome, Meguro-ku, Tokyo 153, Japan
PIONEER ELECTRONICS SERVICE INC. P.O. Box 1760, Long Beach, California 90801 U.S.A.
PIONEER ELECTRONICS OF CANADA, INC. 300 Allstate Parkway Markham, Ontario L3R 0P2 Canada
PIONEER ELECTRONIC [EUROPE] N.V. Haven 1087 Keetberglaan 1, 9120 Melsele, Belgium
PIONEER ELECTRONICS AUSTRALIA PTY. LTD. 178-184 Boundary Road, Braeside, Victoria 3195, Australia TEL: [03] 580-9911
 © PIONEER ELECTRONIC CORPORATION 1995

1. SAFETY INFORMATION



This service manual is intended for qualified service technicians; it is not meant for the casual do-it-yourselfer. Qualified technicians have the necessary test equipment and tools, and have been trained to properly and safely repair complex products such as those covered by this manual. Improperly performed repairs can adversely affect the safety and reliability of the product and may void the warranty. If you are not qualified to perform the repair of this product properly and safely, you should not risk trying to do so and refer the repair to a qualified service technician.

WARNING

Lead in solder used in this product is listed by the California Health and Welfare agency as a known reproductive toxicant which may cause birth defects or other reproductive harm (California Health & Safety Code, Section 25249.5). When servicing or handling circuit boards and other components which contain lead in solder, avoid unprotected skin contact with the solder. Also, when soldering do not inhale any smoke or fumes produced.



NOTICE

(FOR CANADIAN MODEL ONLY)

Fuse symbols  (fast operating fuse) and/or  (slow operating fuse) on PCB indicate that replacement parts must be of identical designation.

REMARQUE

(POUR MODÈLE CANADIEN SEULEMENT)

Les symboles de fusible  (fusible de type rapide) et/ou  (fusible de type lent) sur CCI indiquent que les pièces de remplacement doivent avoir la même désignation.

(FOR USA MODEL ONLY)

1. SAFETY PRECAUTIONS

The following check should be performed for the continued protection of the customer and service technician.

LEAKAGE CURRENT CHECK

Measure leakage current to a known earth ground (water pipe, conduit, etc.) by connecting a leakage current tester such as Simpson Model 229-2 or equivalent between the earth ground and all exposed metal parts of the appliance (input/output terminals, screwheads, metal overlays, control shaft, etc.). Plug the AC line cord of the appliance directly into a 120V AC 60Hz outlet and turn the AC power switch on. Any current measured must not exceed 0.5mA.

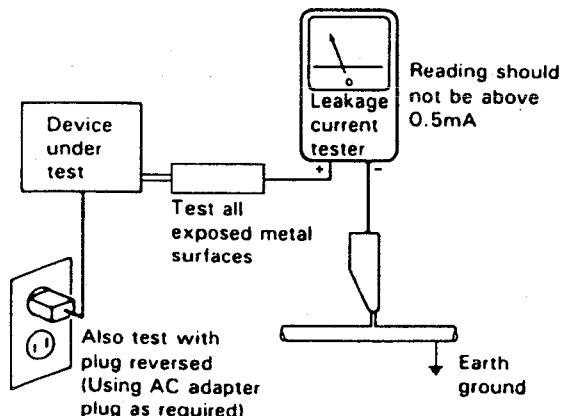

AC Leakage Test

ANY MEASUREMENTS NOT WITHIN THE LIMITS OUTLINED ABOVE ARE INDICATIVE OF A POTENTIAL SHOCK HAZARD AND MUST BE CORRECTED BEFORE RETURNING THE APPLIANCE TO THE CUSTOMER.

2. PRODUCT SAFETY NOTICE

Many electrical and mechanical parts in the appliance have special safety related characteristics. These are often not evident from visual inspection nor the protection afforded by them necessarily can be obtained by using replacement components rated for voltage, wattage, etc. Replacement parts which have these special safety characteristics are identified in this Service Manual.

Electrical components having such features are identified by marking with a Δ on the schematics and on the parts list in this Service Manual.

The use of a substitute replacement component which does not have the same safety characteristics as the PIONEER recommended replacement one, shown in the parts list in this Service Manual, may create shock, fire, or other hazards.

Product Safety is continuously under review and new instructions are issued from time to time. For the latest information, always consult the current PIONEER Service Manual. A subscription to, or additional copies of, PIONEER Service Manual may be obtained at a nominal charge from PIONEER.

2. EXPLODED VIEWS, PACKING AND PARTS LIST

NOTES:

- Parts marked by "NSP" are generally unavailable because they are not in our Master Spare Parts List.
- The Δ mark found on some component parts indicates the importance of the safety factor of the part. Therefore, when replacing, be sure to use parts of identical designation.
- Parts marked by "⊙" are not always kept in stock. Their delivery time may be longer than usual or they may be unavailable.
- Parts list without notice are common for CLD-D504/KU, CLD-D504/KC and CLD-D580/RD.

2.1 EXTERIOR AND DISC TRAY SECTION

(1) CONTRAST OF CLD-D504/KU, CLD-D504/KC AND CLD-D580/RD.

CLD-D504/KU, CLD-D504/KC and CLD-D580/RD have the same construction except for the following:

Mark	No.	Symbol & Description	Part No.			Remarks
			CLD-D504/KU	CLD-D504/KC	CLD-D580/RD	
	4 21	Rear cover 65 label	VNK3129 ORW1069	VNK3129 Not used	VNK3131 Not used	

(2) PARTS LIST FOR CLD-D504/KU

Mark	No.	Description	Part No.	Mark	No.	Description	Part No.
	1	Bonnet S	VXX2252		11	Cushion	VEC1682
	2	Screw	BBZ30P080FMC		12	Damp Cushion	VEC1683
	3	Screw	BCZ40P060FZK	NSP	13	Label	VRW1289
	4	Rear cover	VNK3129		14	LD tray assy	VXA2173
	5	Guide plate (R)	VNE1939		15	CD door assy	VXA2190
	6	Guide plate (L)	VNE1938		16	Door spring	VBH1248
	7	CD tray	VNK3007		17	Door holder	VNE1967
	8	Lock plate	VNL1635		18	Damper assy	VXA1999
	9	Lock plate spring	VBH1188		19	Tray panel	VNK2993
	10	Tray assy-S	VXX2307		20	Laser disc badge	VAM1029
					21	65 label	ORW1069
					22	Tray panel assy-S	VXX2286

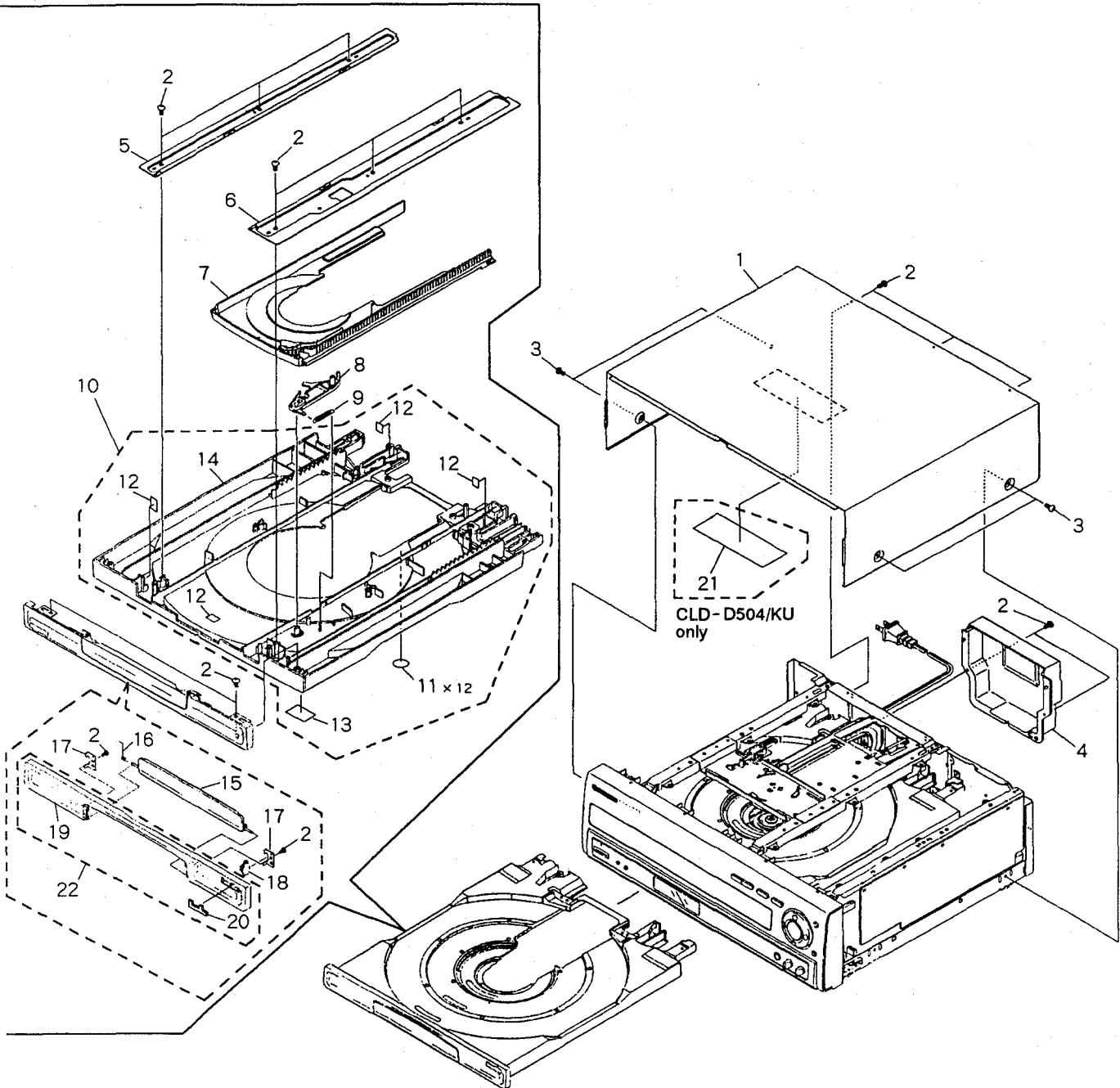

A

B

C

D

NOTE: Screws adjacent to ▼ mark on the product are used for disassembly.

2.2 TOP VIEW SECTION

(1) CONTRAST OF CLD - D504/KU, CLD - D504/KC AND CLD - D580/RD.

CLD - D504/KU, CLD - D504/KC and CLD - D580/RD have the same construction except for the following:

A A

Mark	No.	Symbol & Description	Part No.			Remarks
			CLD - D504/KU	CLD - D504/KC	CLD - D580/RD	
	21	Flexible cable (7P)	VDA1468	VDA1468	Not used	

(2) PARTS LIST FOR CLD - D504/KU

B B

Mark	No.	Description	Part No.	Mark	No.	Description	Part No.
	1	Screw	PBZ20P060FMC		16	Center angle	VNE1965
	2	D lever assy	VXA2205	NSP	17	PCB holder	VNE1964
	3	Clamper holder	VNE1971		18	GYCB assy	VWV1397
	4	Rubber mat	VEB1114		19	Screw	IBZ30P080FMC
	5	Thrust holder	VNL1663		20	Screw	BBZ30P080FMC
	6	Clamper head	VNL1603		21	Flexible cable (7P)	VDA1468
	7	LD spring	VBH1240	NSP	22	Damp cushion	VEC1602
	8	Cover spring	VBH1234				
	9	Ball cover	VNL1602				
	10	LD hab	VNT1047				
	11	Ball	VNX1013				
	12	Ball guide	VNL1616				
	13	Clamp spring	VBH1239				
	14	Clamper	VNL1604				
	15	Clamper holder	VNL1680				

C C

D D

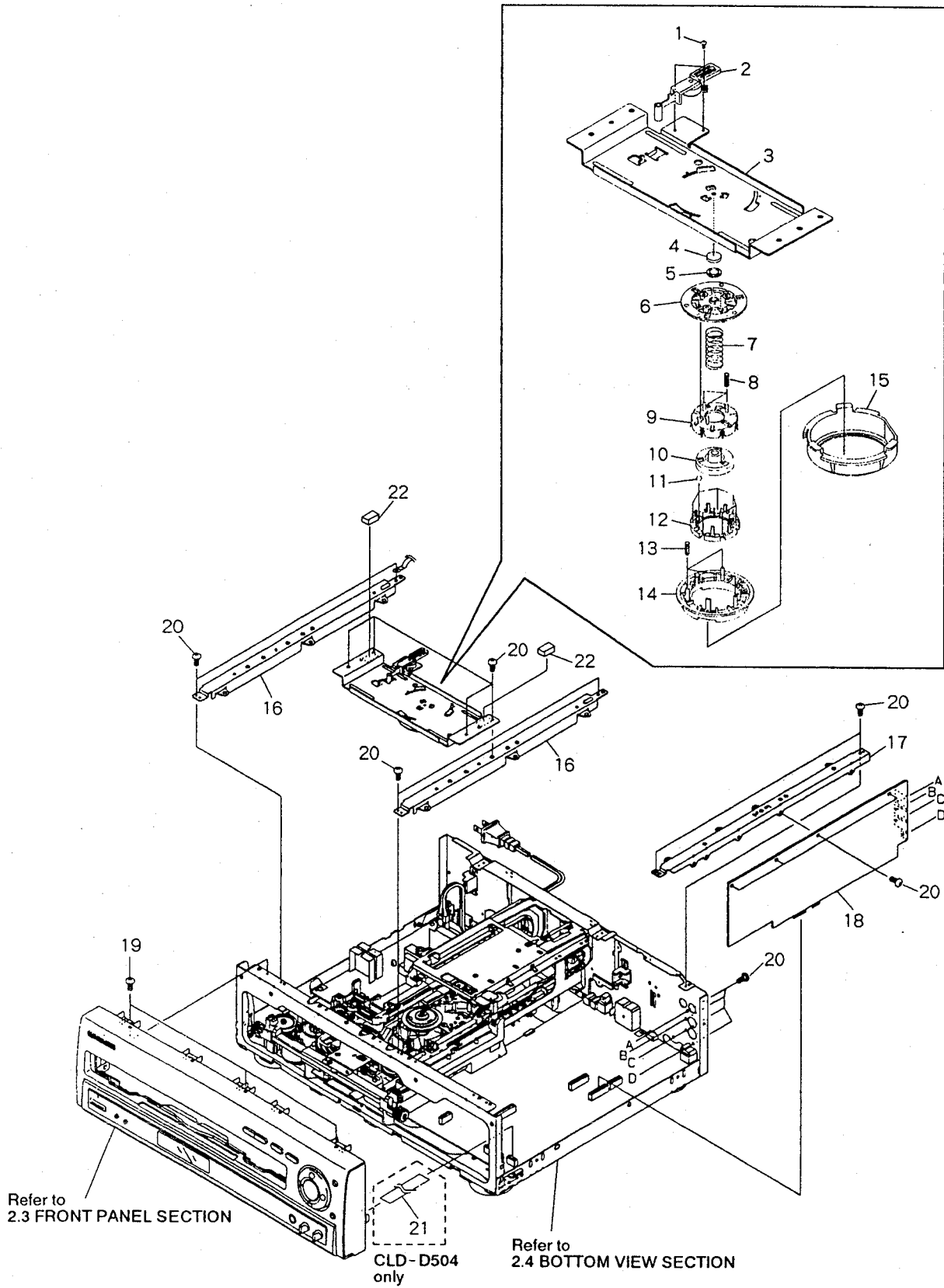

2.3 FRONT PANEL SECTION

(1) CONTRAST OF CLD-D504/KU, CLD-D504/KC AND CLD-D580/RD.

CLD-D504/KU, CLD-D504/KC and CLD-D580/RD have the same construction except for the following:

Mark	No.	Symbol & Description	Part No.			Remarks
			CLD-D504/KU	CLD-D504/KC	CLD-D580/RD	
NSP	1	Front panel assy - S	VXX2284	VXX2284	VXX2312	
	2	Front panel	VNK3242	VNK3242	VNK3067	
NSP	5	FL lens	VEC1758	VEC1758	VEC1782	
	13	FLKY assy	VWG1607	VWG1607	VWG1608	
	15	Double locking spacer	VEC1742	VEC1742	Not used	
	16	ECOB assy	VWV1405	VWV1405	Not used	
	17	MJBA assy	VWV1410	VWV1410	Not used	
NSP	18	Snap plate	VNE1102	VNE1102	Not used	
	19	Jack holder	VNE1966	VNE1966	Not used	
	20	Knob	PAC1707	PAC1707	Not used	
	21	Mini clamp	VEC1312	VEC1312	Not used	

(2) PARTS LIST FOR CLD-D504/KU

Mark	No.	Description	Part No.	Mark	No.	Description	Part No.
NSP	1	Front panel assy - S	VXX2284	NSP	16	ECOB assy	VWV1405
	2	Front panel	VNK3242		17	MJBA assy	VWV1410
NSP	3	Pioneer badge	PAM1608	NSP	18	Snap plate	VNE1102
	4	Sub panel	VNK3071		19	Jack holder	VNE1966
NSP	5	FL lens	VEC1758	20	Knob	PAC1707	
	6	Key A	VNK2793	21	Mini clamp	VEC1312	
	7	LED lens	PNW2019	22	Flexible cable 13P	VDA1496	
	8	Power button	VNK2329	23		
	9	L key C	VNK3070	24	Screw	BPZ30P080FCC	
NSP	10	L key	VNK2987				
	11	Main key	VNK2995				
NSP	12	Screw	BBZ30P080FMC				
	13	FLKY assy	VWG1607				
NSP	14	KEYB assy	VWG1598				
NSP	15	Double locking spacer	VEC1742				

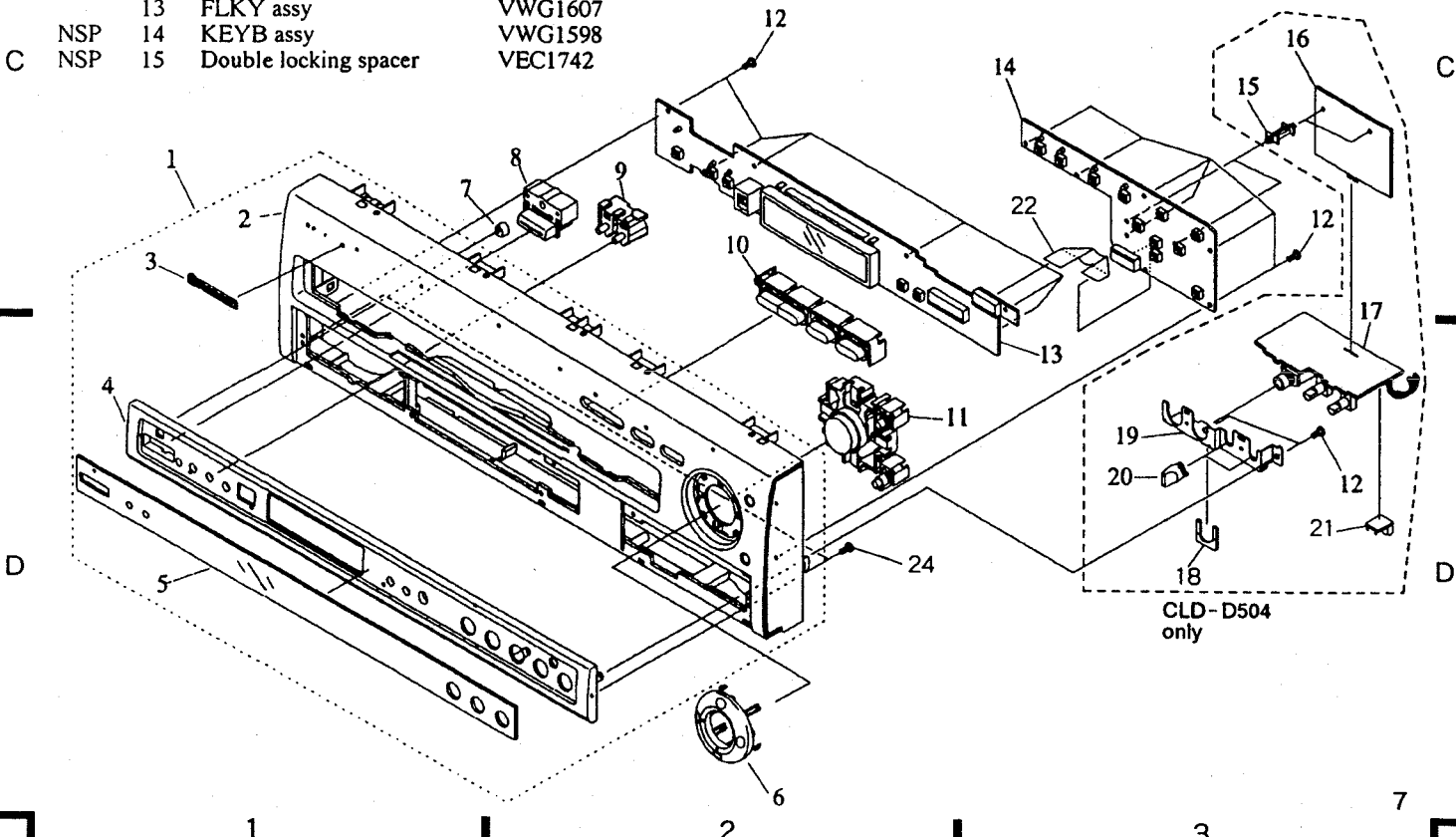

2.4 BOTTOM VIEW SECTION

(1) CONTRAST OF CLD - D504/KU, CLD - D504/KC AND CLD - D580/RD.

CLD - D504/KU, CLD - D504/KC and CLD - D580/RD have the same construction except for the following:

Mark	No.	Symbol & Description	Part No.			Remarks
			CLD - D504/KU	CLD - D504/KC	CLD - D580/RD	
△	1	MOTHER assy	VWS1169	VWS1169	VWS1170	
	3	SYPS assy	VWR1246	VWR1246	VWR1247	
	4	AC power cord	VDG1057	VDG1057	Not used	
	5	AC code stopper	CM - 22C	CM - 22C	Not used	
	7	Rear panel (R)	VNA1532	VNA1532	VNA1606	
NSP	14	Chassis	VNA1461	VNA1461	VNA1564	
	15	Rear panel (L)	VNA1533	VNA1533	VNA1557	
	18	Flexible cable (18P)	VDA1489	VDA1489	Not used	
NSP	18	Flexible cable (16P)	Not used	Not used	VDA1488	
	22	Fuse caution label	VRW - 548	VRW - 548	Not used	
△	23	F. ICP caution label	VRW1525	VRW1525	Not used	
	24	AC inlet assy	Not used	Not used	VKP2116	

(2) PARTS LIST FOR CLD - D504/KU

Mark	No.	Description	Part No.	Mark	No.	Description	Part No.
	1	MOTHER assy	VWS1169	NSP	14	Chassis	VNA1461
	2	Screw	BBZ30P080FMC		15	Rear panel (L)	VNA1533
△	3	SYPS assy	VWR1246	NSP	16	Spacer	REB1171
△	4	AC power cord	VDG1057		17	Flexible cable (21P)	VDA1465
△	5	AC code stopper	CM - 22C		18	Flexible cable (18P)	VDA1489
	6	Tray stopper	VNL1657	NSP	19	Panel holder	VNA1507
	7	Rear panel (R)	VNA1532		20	Screw	BBZ30P100FMC
NSP	8	P plate holder	PNY - 405	NSP	21	Mechanism assy	VWT1123
NSP	9	PC support	VEC - 269	NSP	22	Fuse caution label	VRW - 548
NSP	10	PCB hinge	VEC1174		23	F. ICP caution label	VRW1525
NSP	11	Wire clip (H)	VEC1181		24	• • • • •	
	12	Inshulater	PNW1912	NSP	25	Rubber spacer	VEB1252
	13	Card spacer	VEC1708				

1

2

A

A

B

B

C

C

D

D

Refer to
2.5 SERVO MECHANISM SECTION

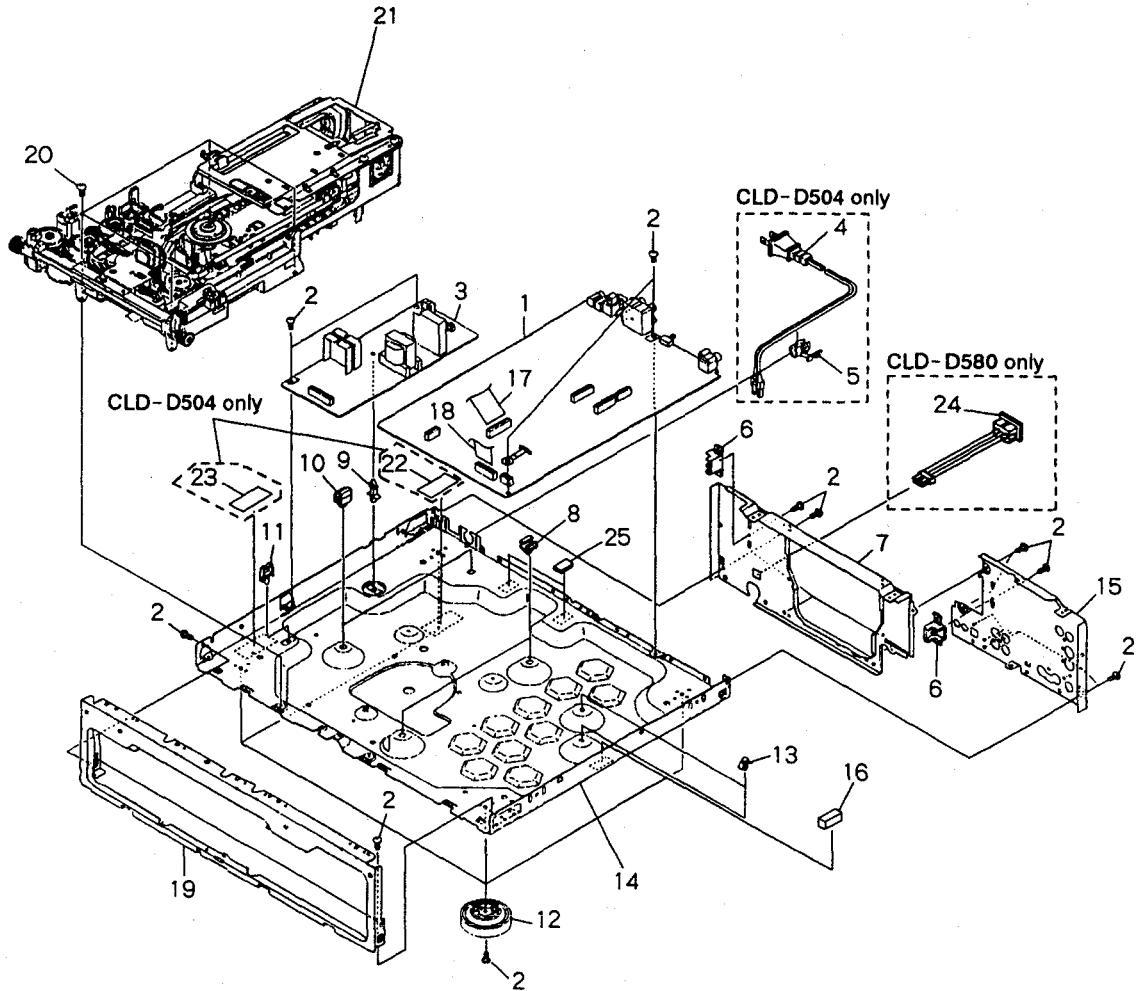

1

2

3

9

2.5 SERVO MECHANISM SECTION

Parts List

Mark	No.	Description	Part No.	Mark	No.	Description	Part No.	
NSP	1	Tilt base (upper)	VNE1969	NSP	31	Housing assy (3P, yellow)	VKP2046	
	2	BISB assy	VWG1558		32	FG assy	VWG1556	
	3	Screw	BBZ30P060FMC		33	FG base	VNL1645	
	4	A horn	VNL1689		34	Tilt cam	VNL1643	
	5	Rack (upper)	VNL1679		35	Tilt cam spring	VBH1243	
	6	Shaft stay	VNL1671		36	Screw	PMA30P070FMC	
	7	Carriage shaft (upper)	VLL1457		37	Screw	IBZ26P120FMC	
	8	B cam	VNL1673		38	Motor base	VNE1975	
	9	Shaft support	VNL1672		39	Motor spacer	VNE2007	
	10	Support spring	VBH1265		40	Spindle motor assy	VXA2208	
	11	SW lever (B)	VNL1678		41	PRC hub	VNL1684	
	12	Large hill	VNL1682		42	Centering spring	VBH1269	
	13	Flexible cable (23P)	VDA1490		NSP	43	R turn table assy	VXA2225
	14	Turn guide	VNL1676		NSP	44	Oil stopper	VPF1002
	15	FFC style shaft	VLL1474		NSP	45	Spindle motor	VXM1061
NSP	16	Guide	VNL1674	NSP	46	Housing assy (12P)	VKP2099	
	17	Lever spring	VBH1266		47	TS spacer	VEC1802	
	18	Turn gear	VNL1696		48	Screw	IBZ26P060FMC	
	19	SW lever (T)	VNL1695		49	Screw	BPZ20P040FZK	
	20	TNSB assy	VWG1557		50	Housing assy	VKP2060	
	21	Housing assy (3P, black)	VKP2059		NSP	51	Earth lead unit	VDA1494
	22	Tilt base (under)	VNL1670			52	Carriage shaft (under)	VLL1458
	23	TAN guide	VNE1973			53	Body guard	VNL1681
	24	CA rack	VNL1647			54	FFC holder	VNL1656
	25	FFC style spring	VBH1270			55	CA guide	VNL1668
NSP	26	Thrust spring	VBH1245	56	TAN spring (B)	VBH1264		
	27	CA - SW lever	VNL1644	57	TAN lever (B)	VNL1669		
	28	PKSB assy	VWG1555	58	Screw	PMZ20P060FZK		
	29	Housing assy (3P, blue)	VKP2045	59	Carriage assy	VWT1110		
	30	Tilt spring	VBH1263	NSP	60	Cord binder	ZCB-069Z	
				61	Screw	BBZ30P080FMC		

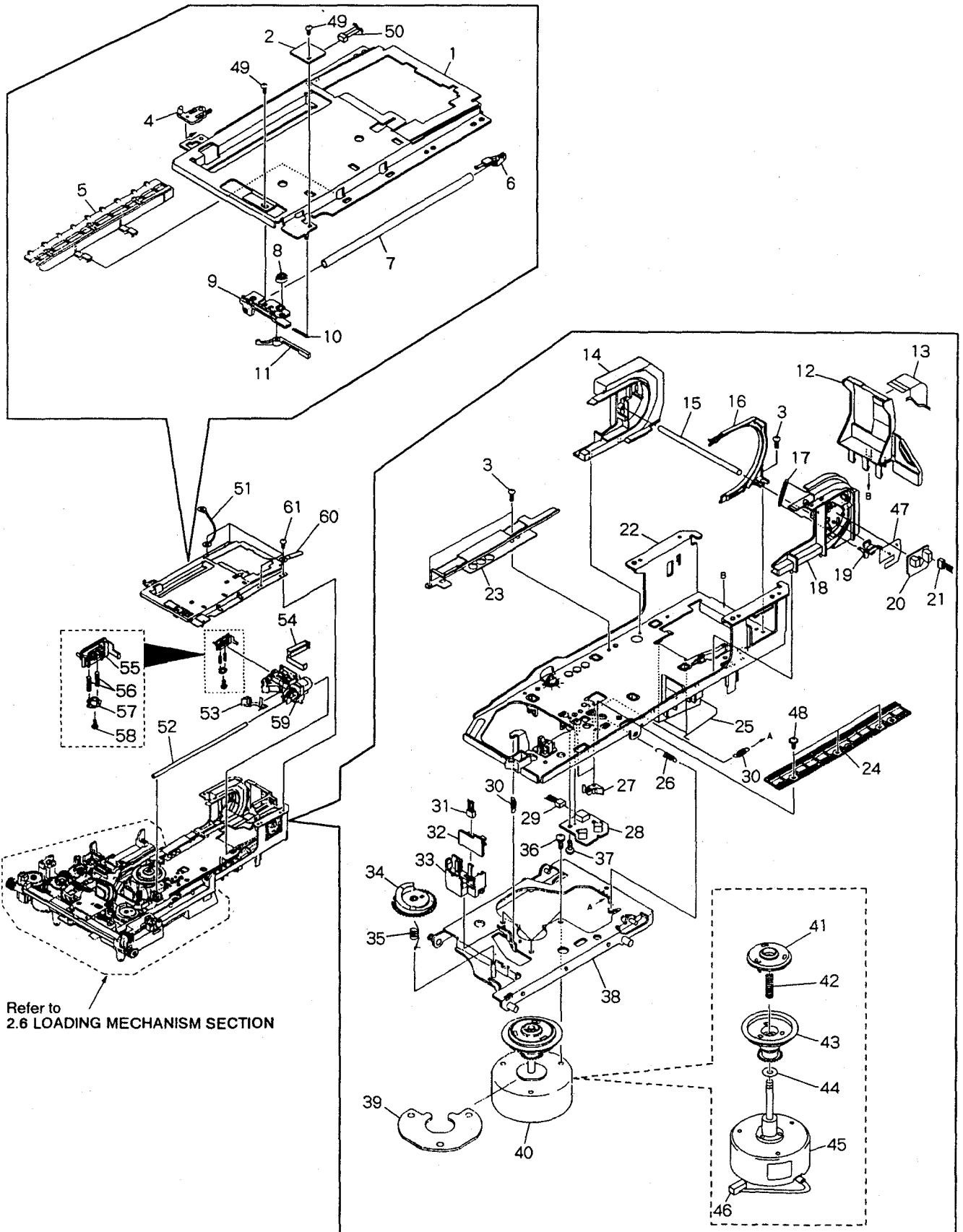

Refer to
2.6 LOADING MECHANISM SECTION

2.6 LOADING MECHANISM SECTION

Parts List

Mark	No.	Description	Part No.
	1	Clamp cam	VNL1633
	2	CDP spring	VBH1191
	3	Screw	Z39-019
	4	CD plate	VNL1685
	5	Rubber belt	VEB1184
	6	Gear pulley	VNL1662
	7	Twin gear	VNL1626
	8	Center gear	VNL1660
	9	Mechanism base	VNK3239
	10	Screw	BMZ26P040FMC
	11	Roller	VNL1042
NSP	12	Motor pulley	VNL1630
	13	Synchro gear assy	VXA2105
NSP	14	LMSB assy	VWG1612
	15	Cam holder	VNE2032
NSP	16	Carriage motor	VXM1033
	17	Shaft holder	VNE1942
	18	CAS spring	VBH1190
	19	Cam plate	VNL1631
	20	Cam gear	VNL1625
	21	Loading motor assy	VXX2045
	22	MB-SW lever	VNL1664
	23	Slider (R)	VNL1666
	24	Slider (L)	VNL1665
	25	Double gear	VNL1661
	26	Flexible cable (12P)	VDA1485

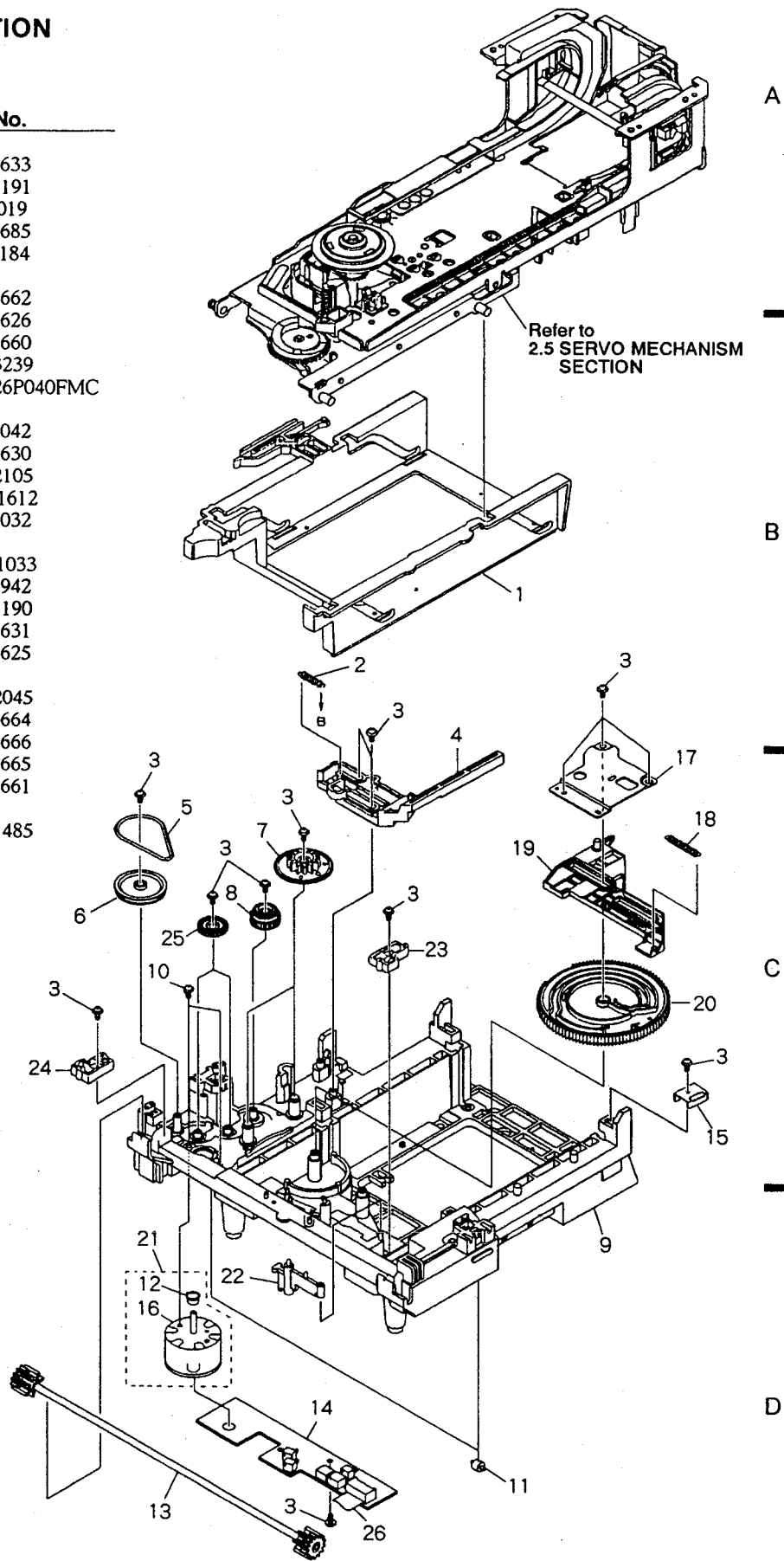

2.7 CARRIAGE ASSY

Parts List

Mark	No.	Description	Part No.
	1	CA gear (A)	VNL1638
	2	CA gear (B)	VNL1639
	3	Slider motor assy	VXX2082
	4	M holder	VNL1637
	5	Screw	PBZ20P050FMC
	6	Screw	PMZ20P030FMC

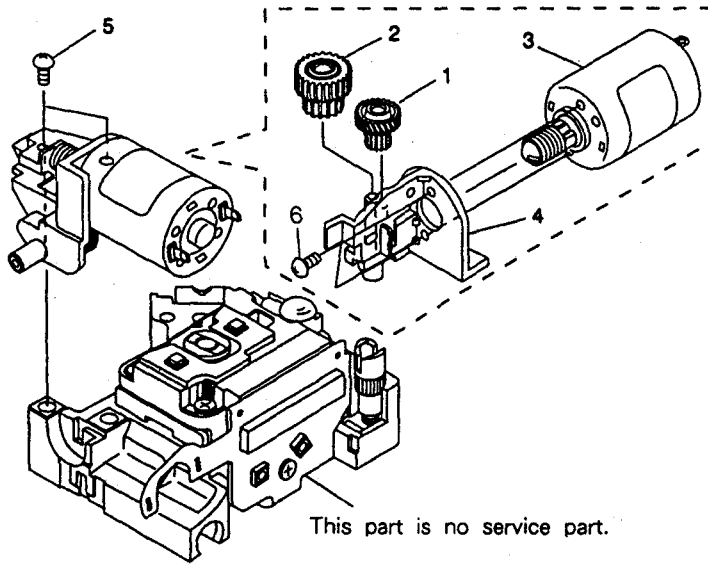

B

C

D

2.8 PACKING

(1) CONTRAST OF CLD-D504/KU, CLD-D504/KC AND CLD-D580/RD.

CLD-D504/KU, CLD-D504/KC and CLD-D580/RD have the same construction except for the following:

Mark	No.	Symbol & Description	Part No.			Remarks
			CLD-D504/KU	CLD-D504/KC	CLD-D580/RD	
NSP	5	Warranty card	ARY1044	ARY1039	ARW1020	
NSP	6	Soft catalogue	VRY1051	Not used	Not used	
	7	Operating instructions (English)	VRB1147	VRB1147	Not used	
	7	Operating instructions (English/Chinese/Spanish)	Not used	Not used	VRE1037	
	9	Remote control unit	VXX2244	VXX2244	VXX2246	
	10	Battery cover	VNK2431	VNK2431	VNK2805	
	11	Upper cover	Not used	Not used	VNK2828	
	15	Packing case	VHG1467	VHG1467	VHG1481	
NSP	16	Sample disc	KS-01	Not used	Not used	
NSP	17	Microphone	VPM1007	VPM1007	Not used	
	20	Mirror mat	Z23-004	Z23-004	Not used	
	21	Operating instructions (French)	Not used	VRC1043	Not used	
	23	KC label	Not used	VRW1402	Not used	
△	24	AC power cord	Not used	Not used	ADG1109	
NSP	25	Caution	VRN1008	VRN1008	Not used	

(2) PARTS LIST FOR CLD-D504/KU

Mark	No.	Description	Part No.	Mark	No.	Description	Part No.
NSP	1	Battery (R03, AAA)	VEM-022		14	Mirror mat	VHL1027
	2	Video cord	DDE1090		15	Packing case	VHG1467
	3	Audio cord	DDE1089	NSP	16	Sample disc	KS-01
NSP	4	Polyethylene bag (205*315*0.05)	Z21-029	NSP	17	Microphone	VPM1007
					18	Protector	VHB1010
NSP	5	Warranty card	ARY1044		19	Protector B	VHB1022
NSP	6	Soft catalogue	VRY1051		20	Mirror mat	Z23-004
	7	Operating instructions (English)	VRB1147		21	
NSP	8	Polyethylene bag	VHL-014		22	Caution label	VRM1044
					23	
	9	Remote control unit	VXX2244		24	
	10	Battery cover	VNK2431	NSP	25	Caution	VRN1008
	11					
	12					
	13					

A

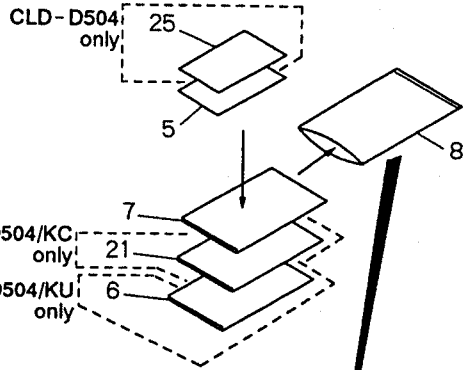

B

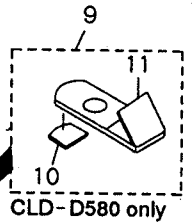
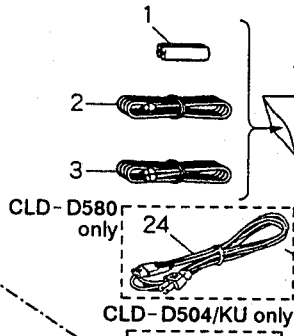

C

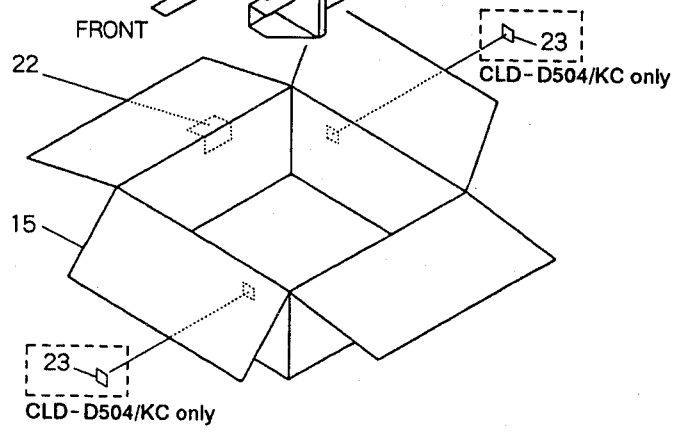
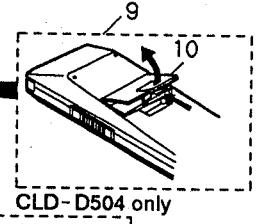
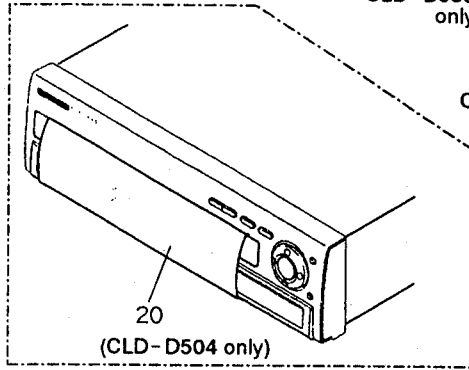

D



A



B



C



D



3. SCHEMATIC AND PCB CONNECTION DIAGRAMS

3.1 OVERALL CONNECTIONS, KEYB, FLKY, ECOB, MJBA, SYPS, PKSB, FG, TNSB, BISB AND LMSB ASSEMBLIES

NOTE FOR SCHEMATIC DIAGRAMS

1. When ordering service parts, be sure to refer to "PARTS LIST of EXPLODED VIEWS" or "PCB PARTS LIST".

2. Since these are basic circuits, some parts of them or the values of some components may be changed for improvement.

3. RESISTORS:
Unit: k Ω , M Ω , or Ω unless otherwise noted.
Rated power: 1/4W, 1/8W, 1/8W, 1/10W unless otherwise noted.
Tolerance: (F): $\pm 1\%$, (G): $\pm 2\%$, (K): $\pm 10\%$, (M): $\pm 20\%$ or $\pm 5\%$ unless otherwise noted.

4. CAPACITORS:
Unit: pF or μF unless otherwise noted.
Ratings: capacitor (μF) / voltage (V) unless otherwise noted.
Rated voltage: 50V except for electrolytic capacitors.

5. COILS:
Unit: mH or μH unless otherwise noted.

6. VOLTAGE AND CURRENT:
or $\leftarrow V$:
DC voltage (V) in PLAY mode unless otherwise noted.
mA or $\leftarrow mA$:
DC current in PLAY mode unless otherwise noted.
Value () is DC current in STOP mode.

7. OTHERS:
● or ○ : Adjusting point.
◀ : Measurement point.
The Δ mark found on some component parts indicates the importance of the safety factor of the parts. Therefore, when replacing, be sure to use parts of identical designation.

8. SCH - □ ON THE SCHEMATIC DIAGRAM:
● SCH-□ indicates the drawing number of the schematic diagram. (SCH stands for schematic diagram.)

9. SWITCHES (Underline indicates switch position):

FLKY ASSY
S101 : POWER ON/STANDBY
S102 : QUICK TURN
S103 : DISPLAY OFF

KEYB ASSY
S201 : A
S202 : B
S203 : CD
S204 : LD
S205 : \blacksquare
S206 : LAST MEMORY
S207 : \lll / \lll
S208 : \lll / \lll
S209 : \blacktriangleright
S210 : \lll
S211 : ONE TOUCH KARAOKE

LMSB ASSY
S101 : SW1
S102 : SW2
S103 : SW3

PKSB ASSY
S104 : OUTER
S105 : INNER

TNSB ASSY
S111 : TURN

BISB ASSY
S112 : B INSIDE

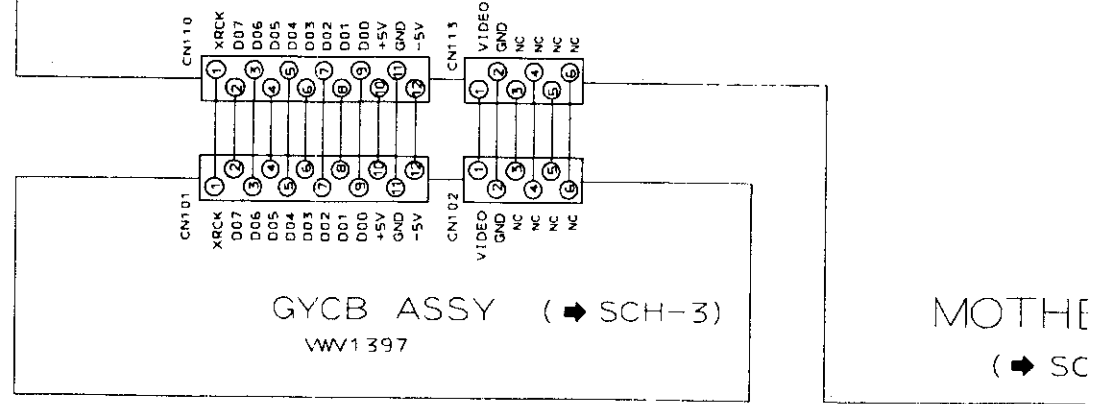
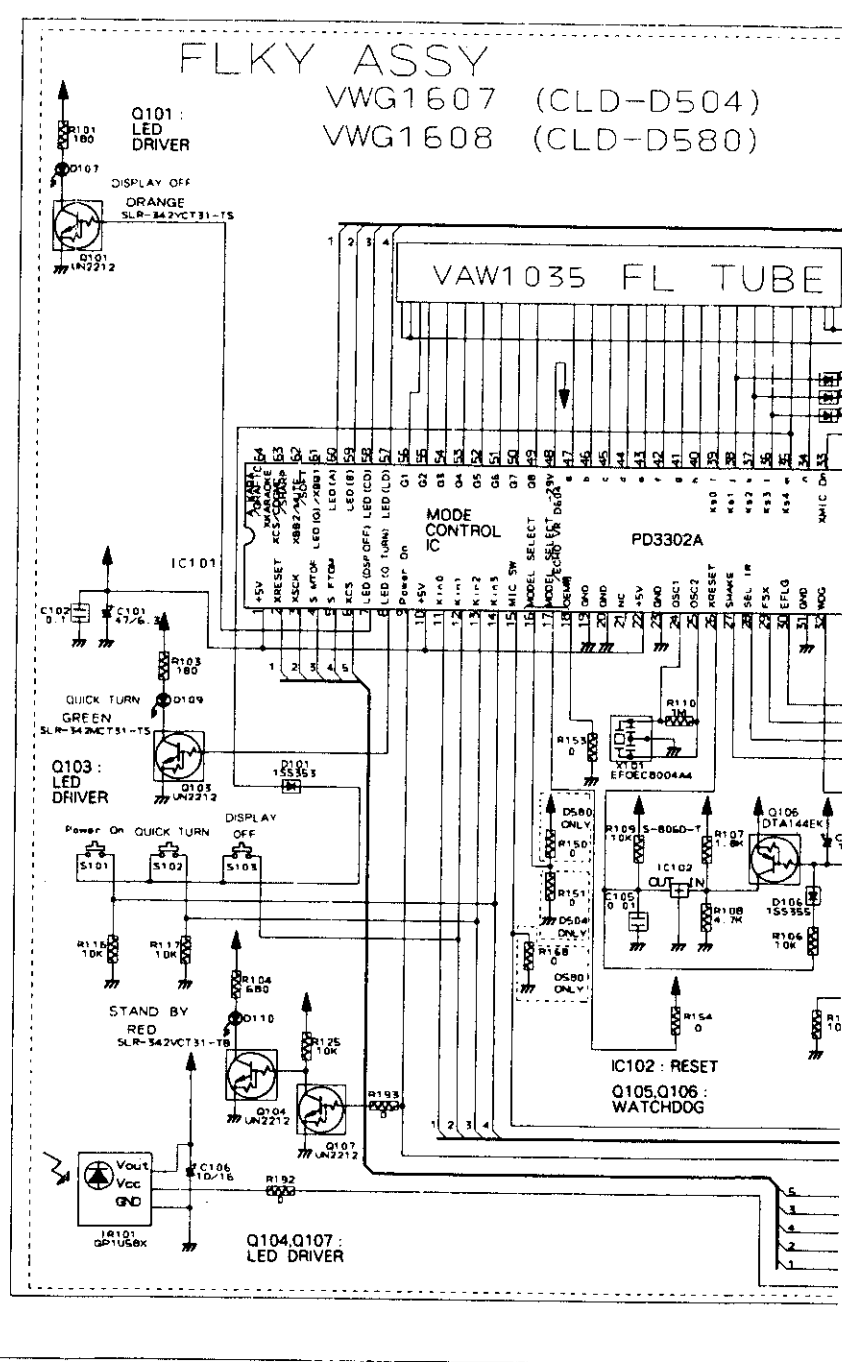
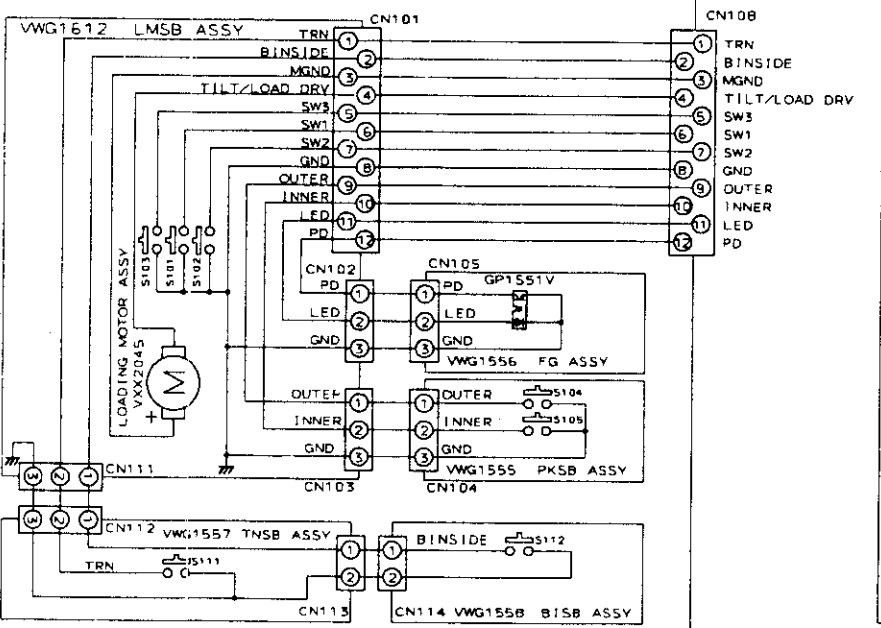
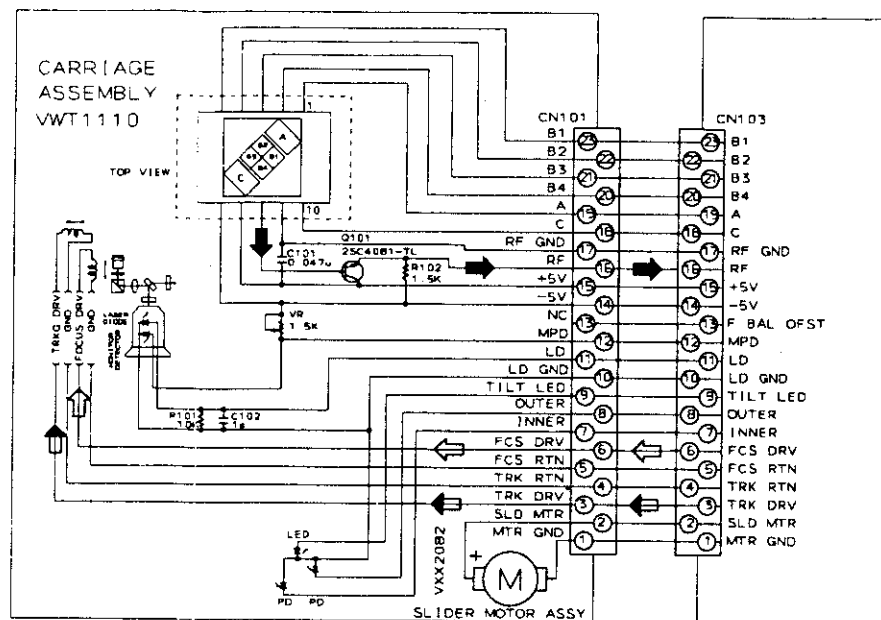

SCH-1 OVERALL CONNECTIONS, KEYB ASSY, FLKY ASSY, ECOB ASSY, MJBA ASSY, SYPS ASSY, PKSB ASSY, FG ASSY, TNSB ASSY, BISB ASSY, LMSB ASSY

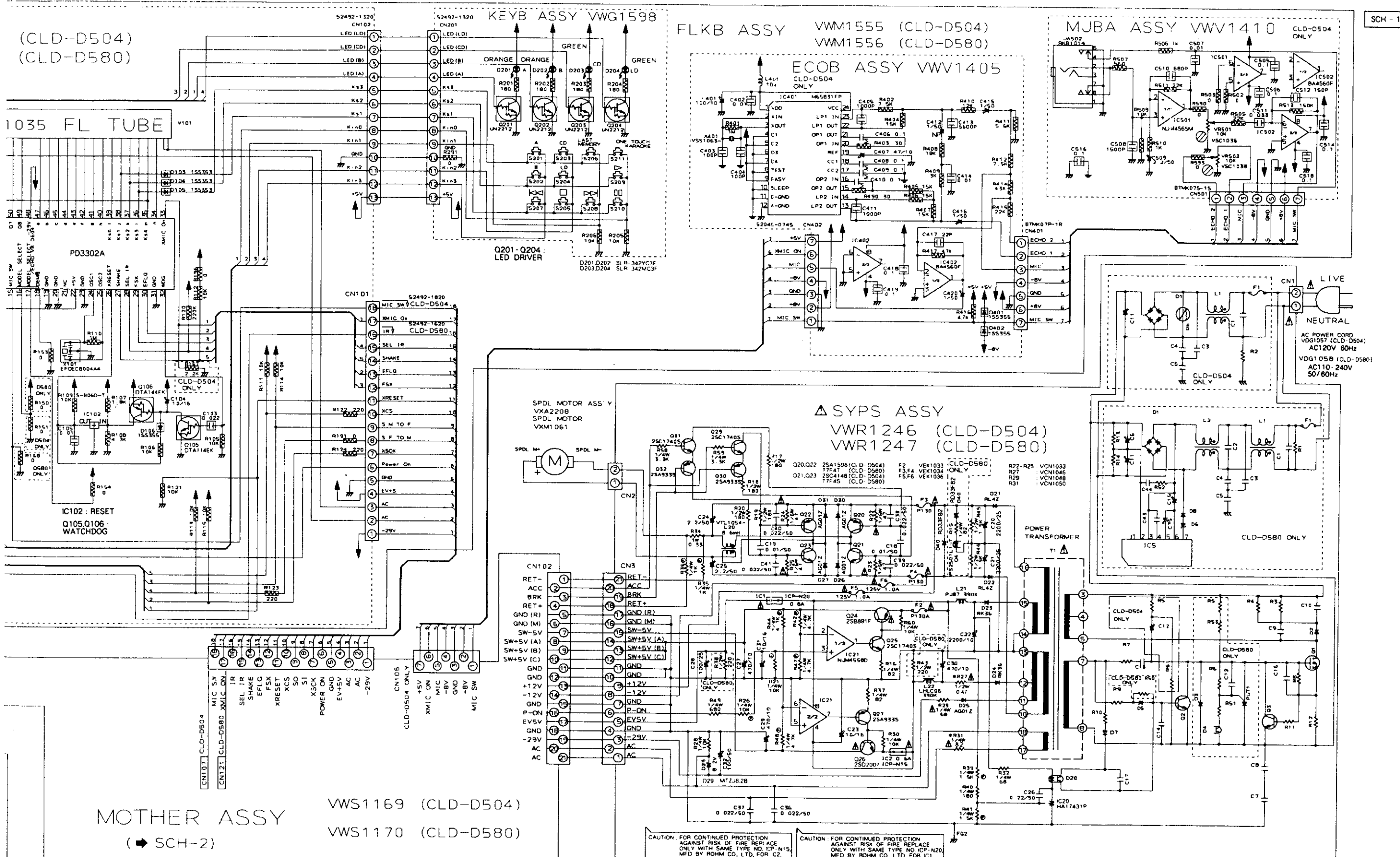

SCH-1

A

B

C

D

NOTE FOR FUSE REPLACEMENT
CAUTION — FOR CONTINUED PROTECTION AGAINST RISK OF FIRE, REPLACE ONLY WITH SAME TYPE AND RATINGS ONLY.

OVERALL CONNECTIONS, KEYB ASSY, FLKY ASSY, ECOB ASSY, MJBA ASSY, SYPS ASSY, PKSB ASSY, FG ASSY, TNSB ASSY, BISB ASSY, LMSB ASSY

SCH-1

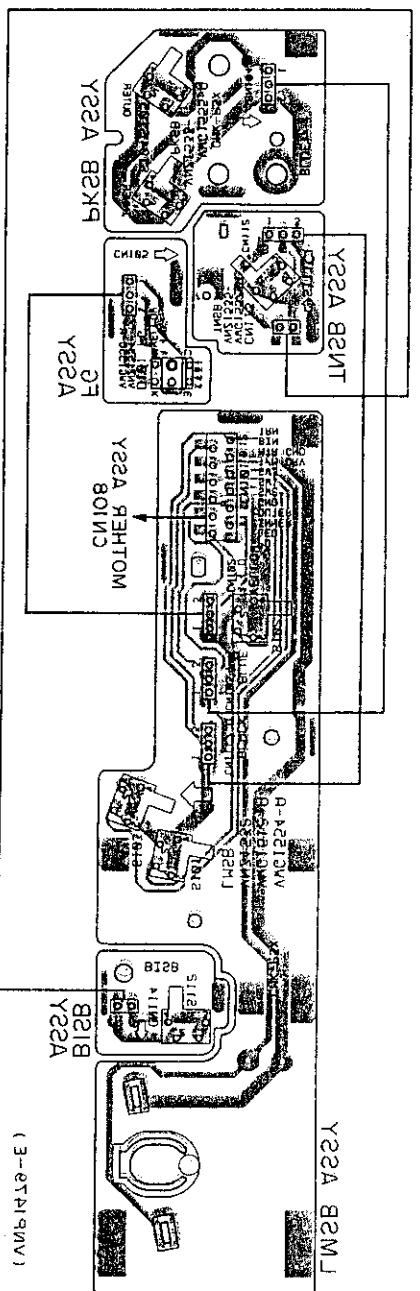

• This diagram is viewed from the

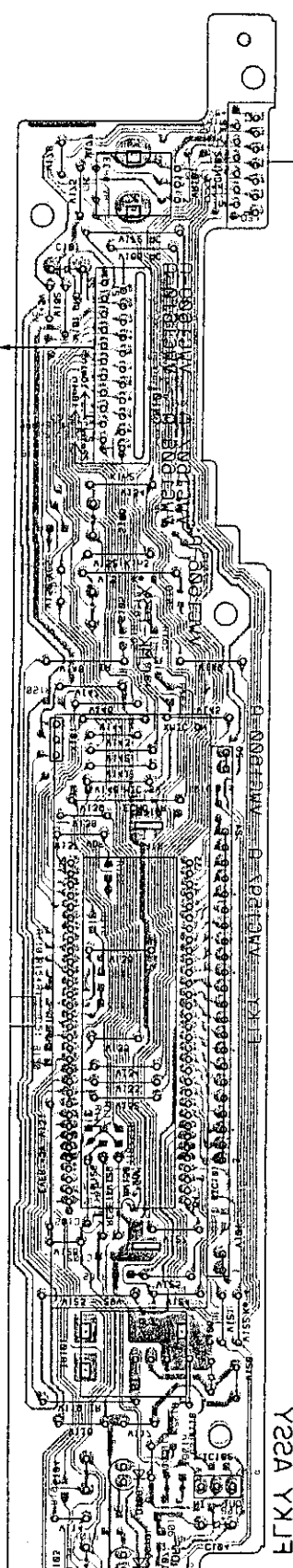
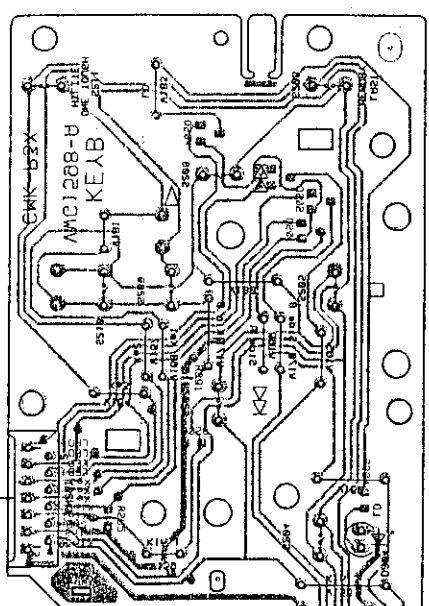
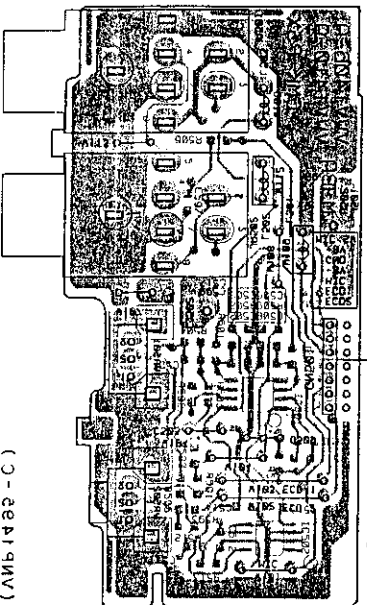
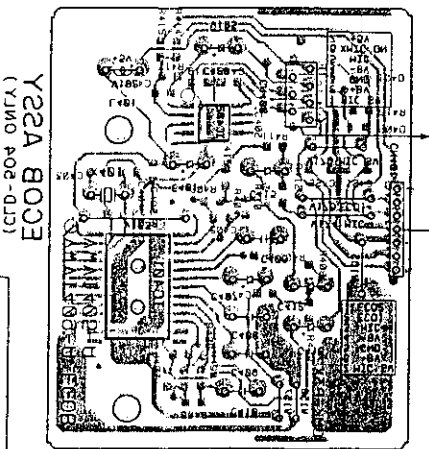

SQ11
Q105 Q106

NOTE FOR PCB DIAG
1. Part numbers in PCB di
2. Diagrams in PCB di
3. Comparison between
4. Part numbers in PCB
diagram & schematic diagram.

Symbol in PCB Diagram	S	B	B	B	B	B
	□	○	○	○	○	○
	□	○	○	○	○	○
	□	○	○	○	○	○
	□	○	○	○	○	○

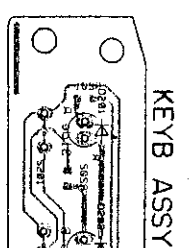

• The parts mounted on this PCB include all necessary destinations. For further information for respective destination with the schematic diagram.

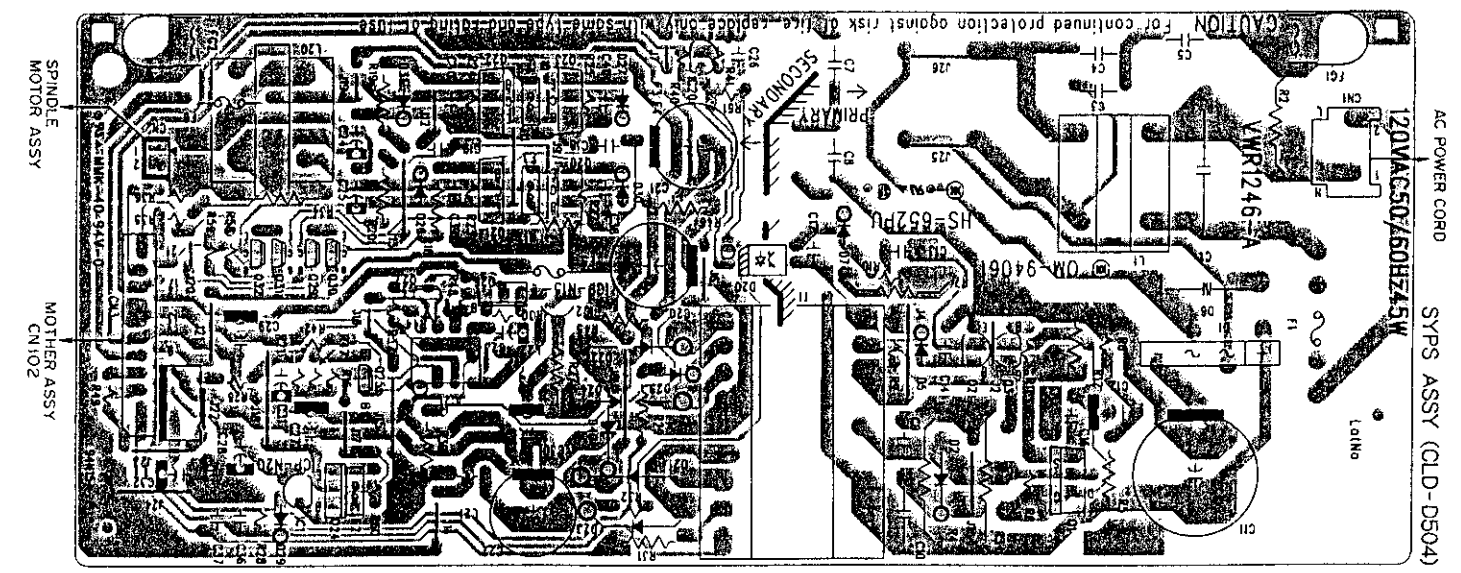
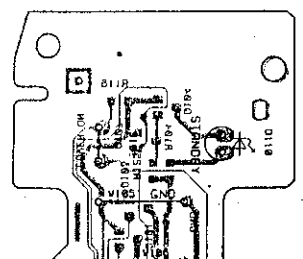

- IC20
- Q1
- Q2
- Q3
- Q23
- Q22
- IC2
- Q26
- Q22
- Q21
- IC21
- Q27
- Q25
- Q30
- Q29
- IC1
- Q31
- Q32

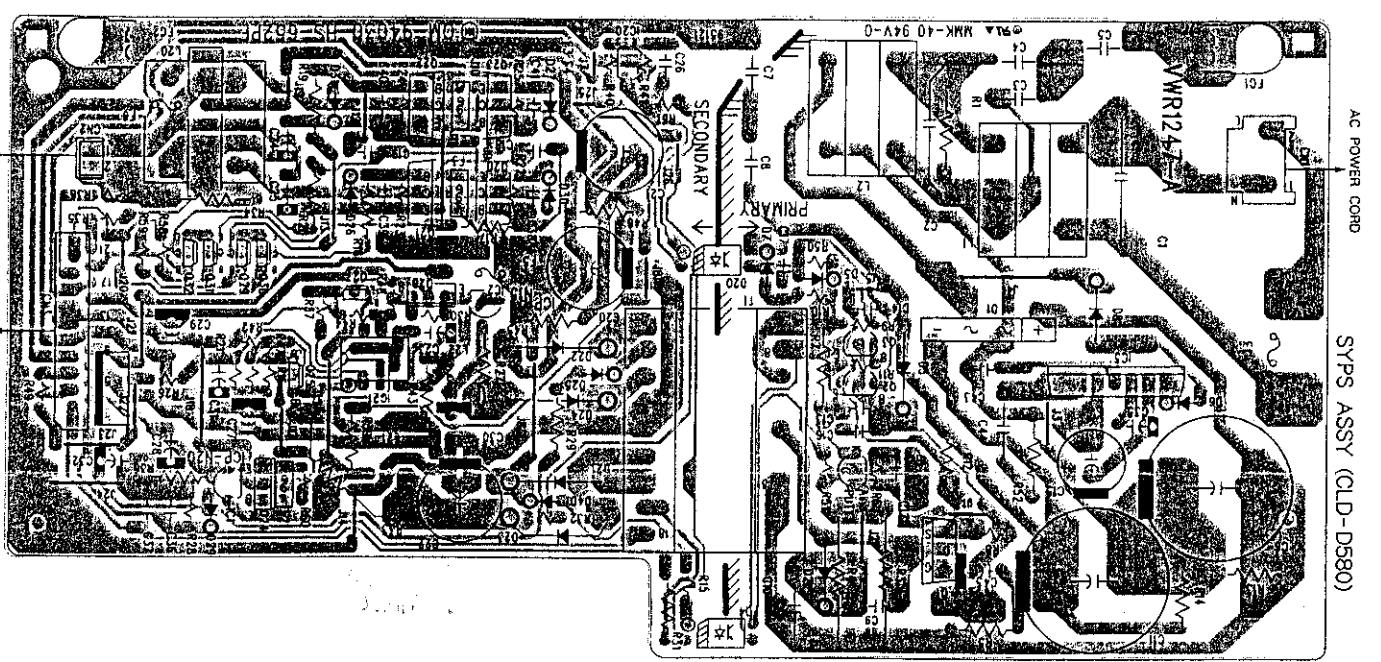

- IC20
- Q1
- Q2
- Q26
- Q22
- Q21
- IC21
- Q27
- Q25
- Q24
- Q30
- Q29
- IC1
- Q31
- Q32

• This diagram is viewed from the

is viewed from the foil side.

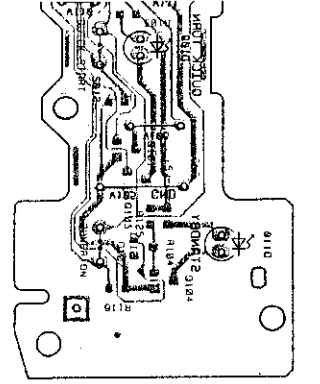
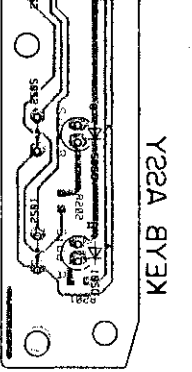

NOTE FOR PCB DIAGRAMS:
 0101 0103 0107 0104

1. Part numbers in PCB diagrams match those in the schematic diagrams.
2. A comparison between the main parts of PCB and schematic diagrams is shown below.

Symbol in PCB Diagrams	Symbol in Schematic Diagrams	Part Name
		Transistor
		Transistor with resistor
		Field effect transistor
		Resistor array
		3-terminal regulator

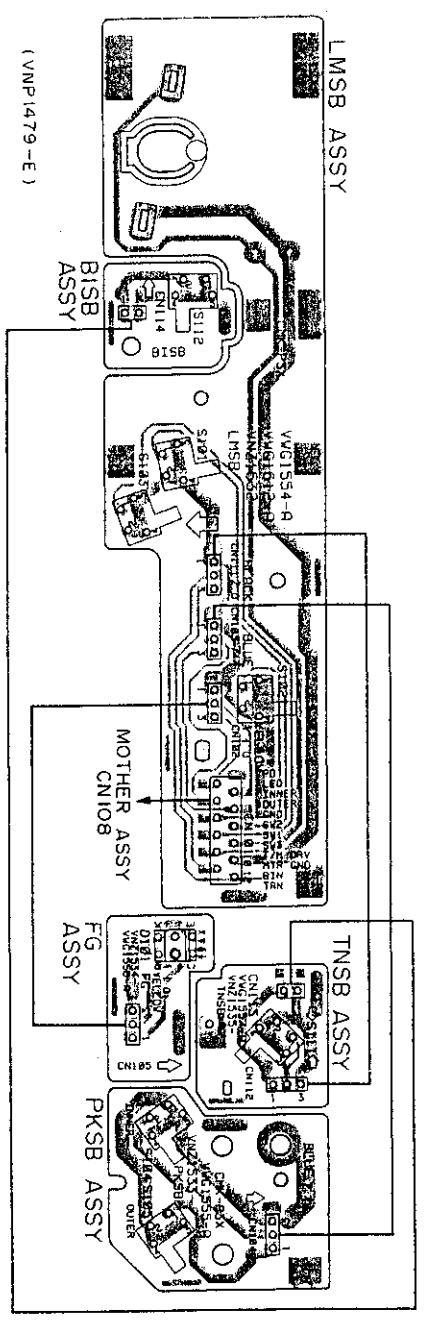
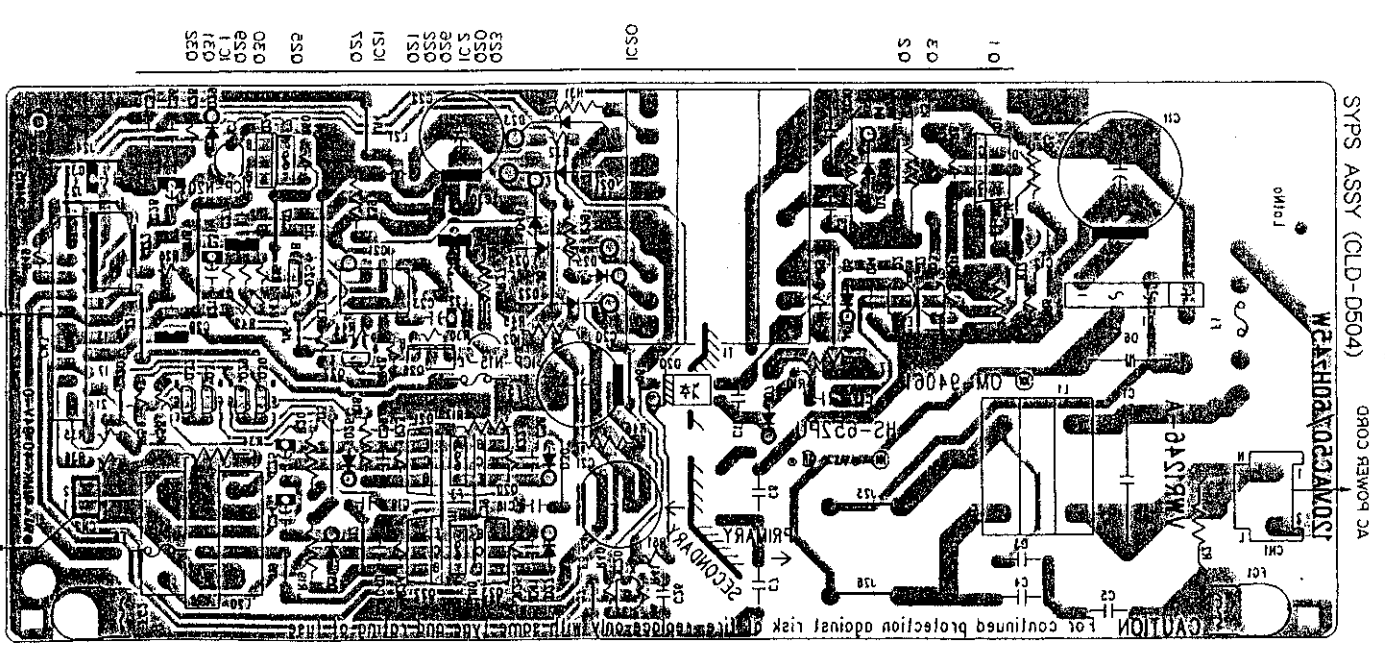
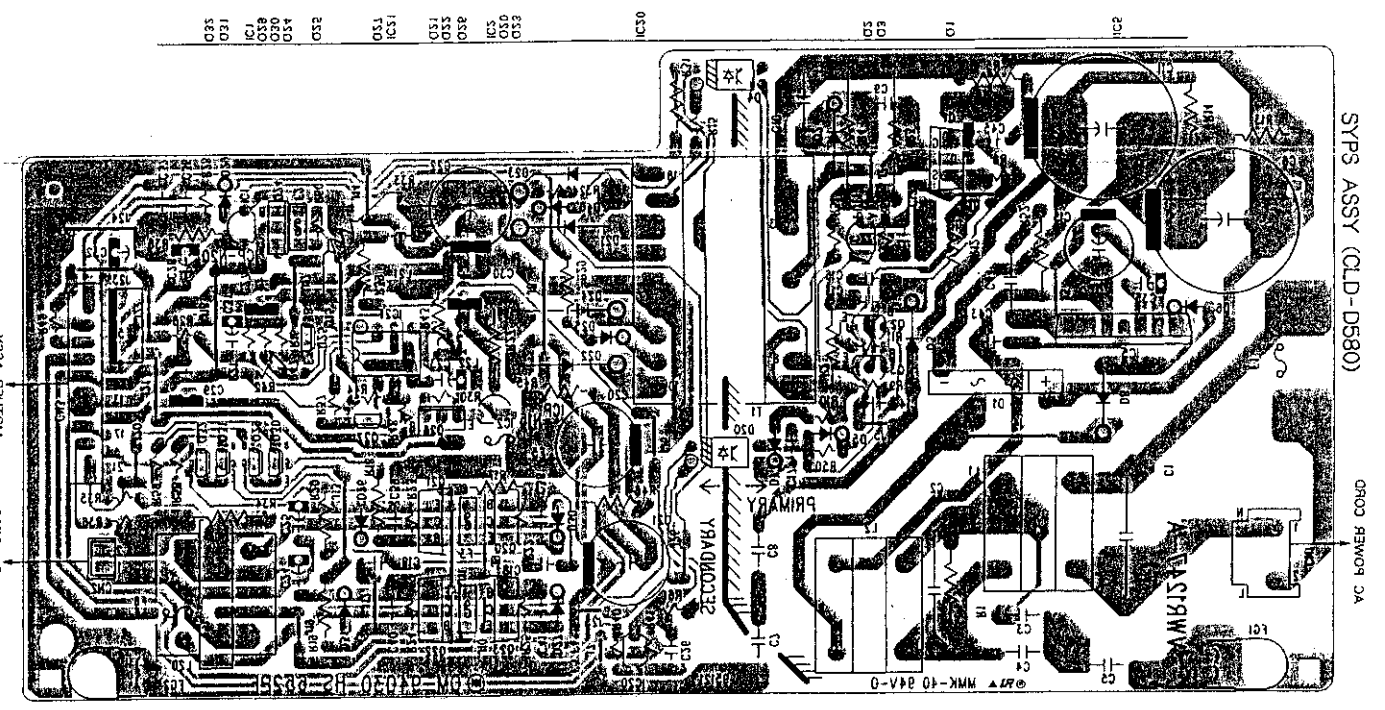

KEYB ASSY

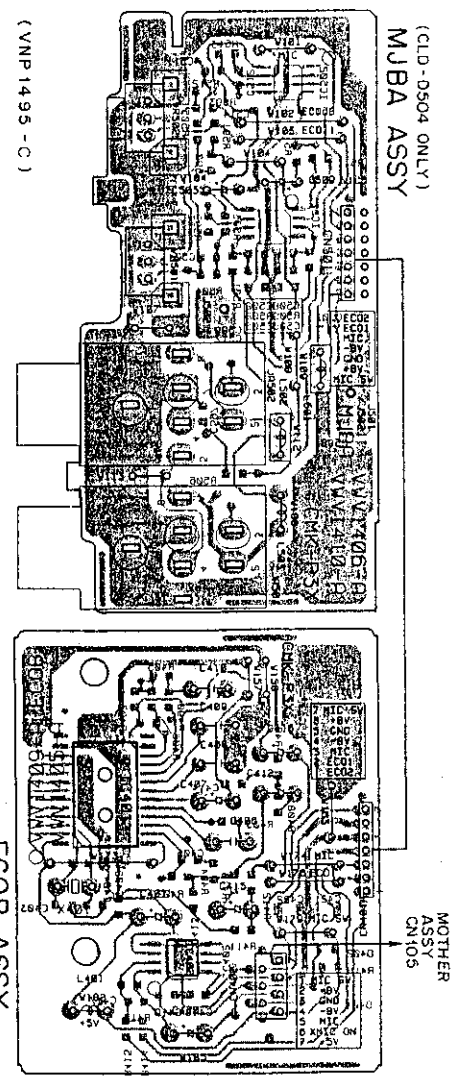
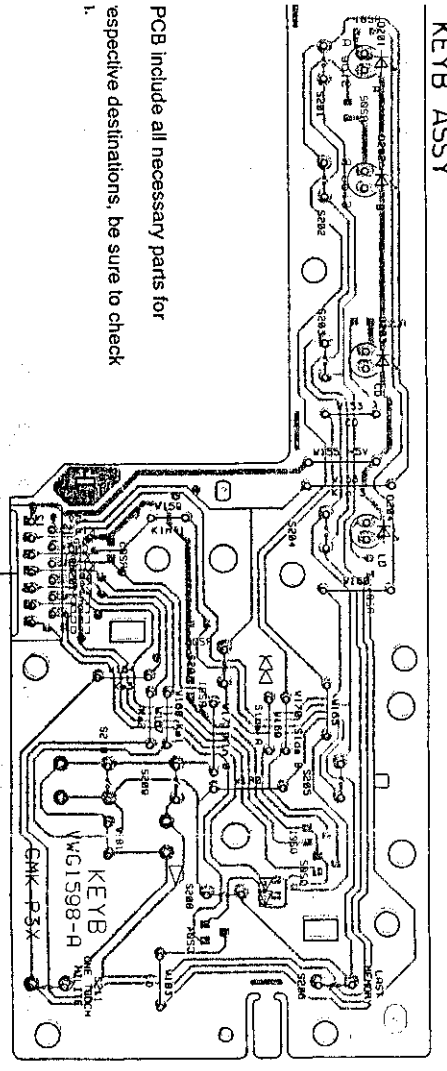

PCB include all necessary parts for respective destinations. be sure to check

FLKY ASSY

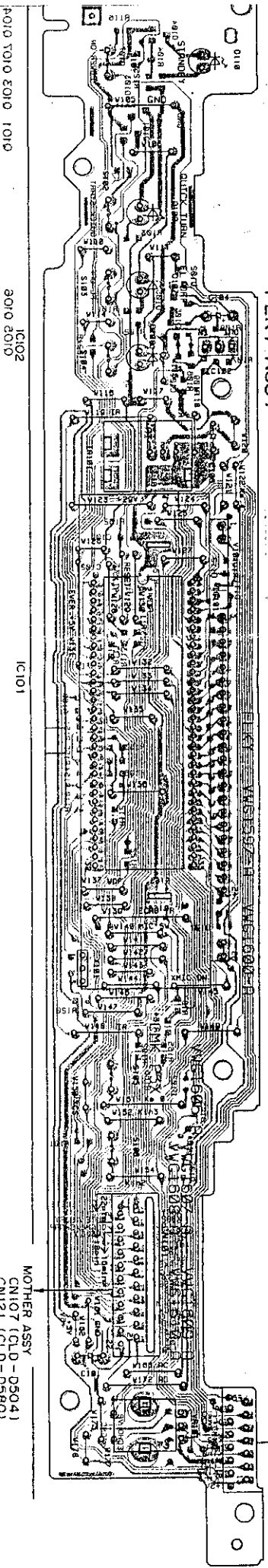

PCB is viewed from the mounted parts side.

MOTHER ASSY (WMS1169) (CLD-D504)
(WMS1170) (CLD-D580)

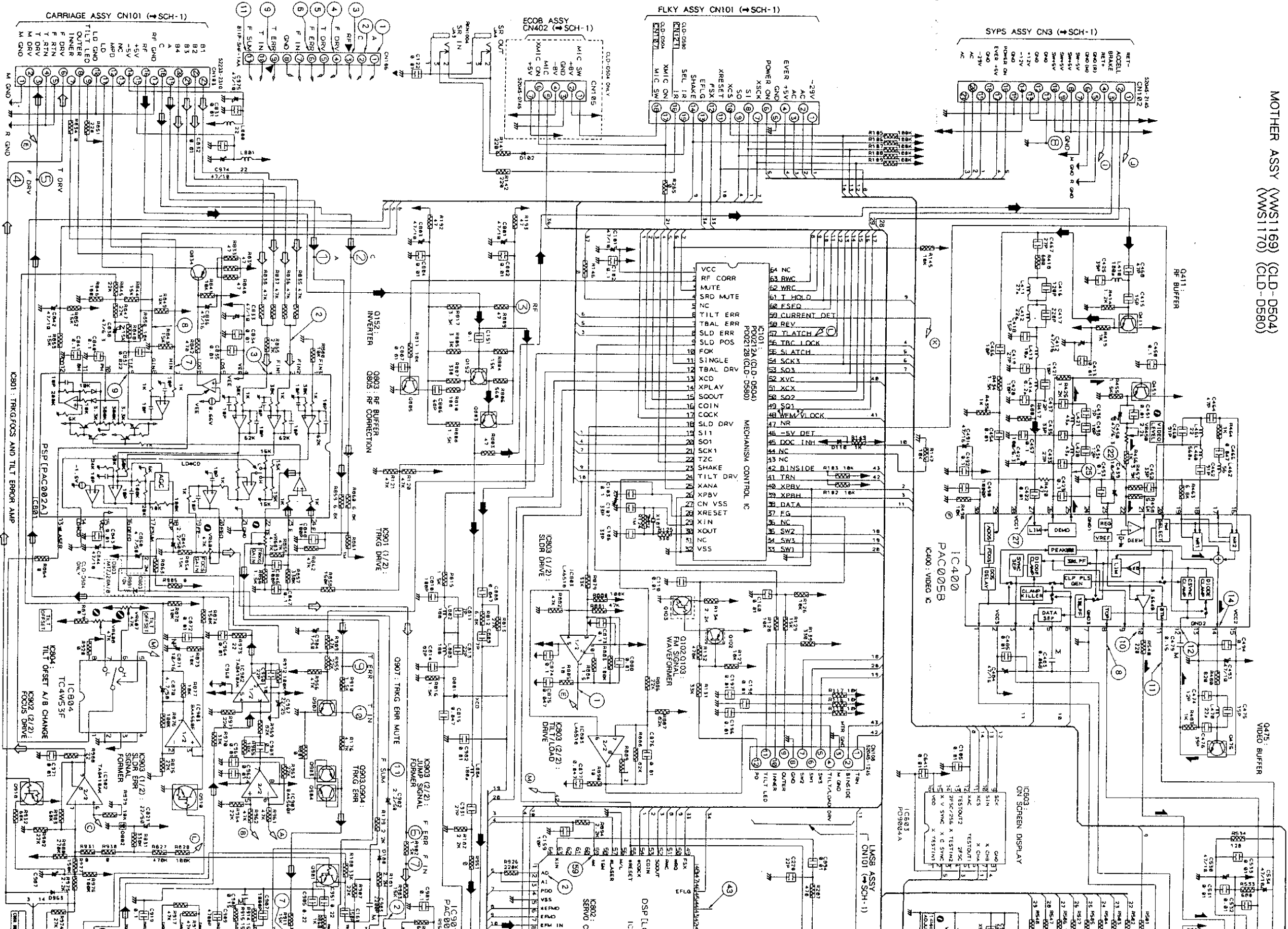

SCH-2

MOTHER ASSY

- RF SIGNAL ROUTE
- VIDEO SIGNAL ROUTE
- FOCUS SERVO LOOP LINE
- TRACKING SERVO LOOP LINE
- AUDIO SIGNAL ROUTE (DIGITAL)
- AUDIO SIGNAL ROUTE (ANALOG)

K206: +8V REGULATOR

K207: -8V REGULATOR

SCH-2

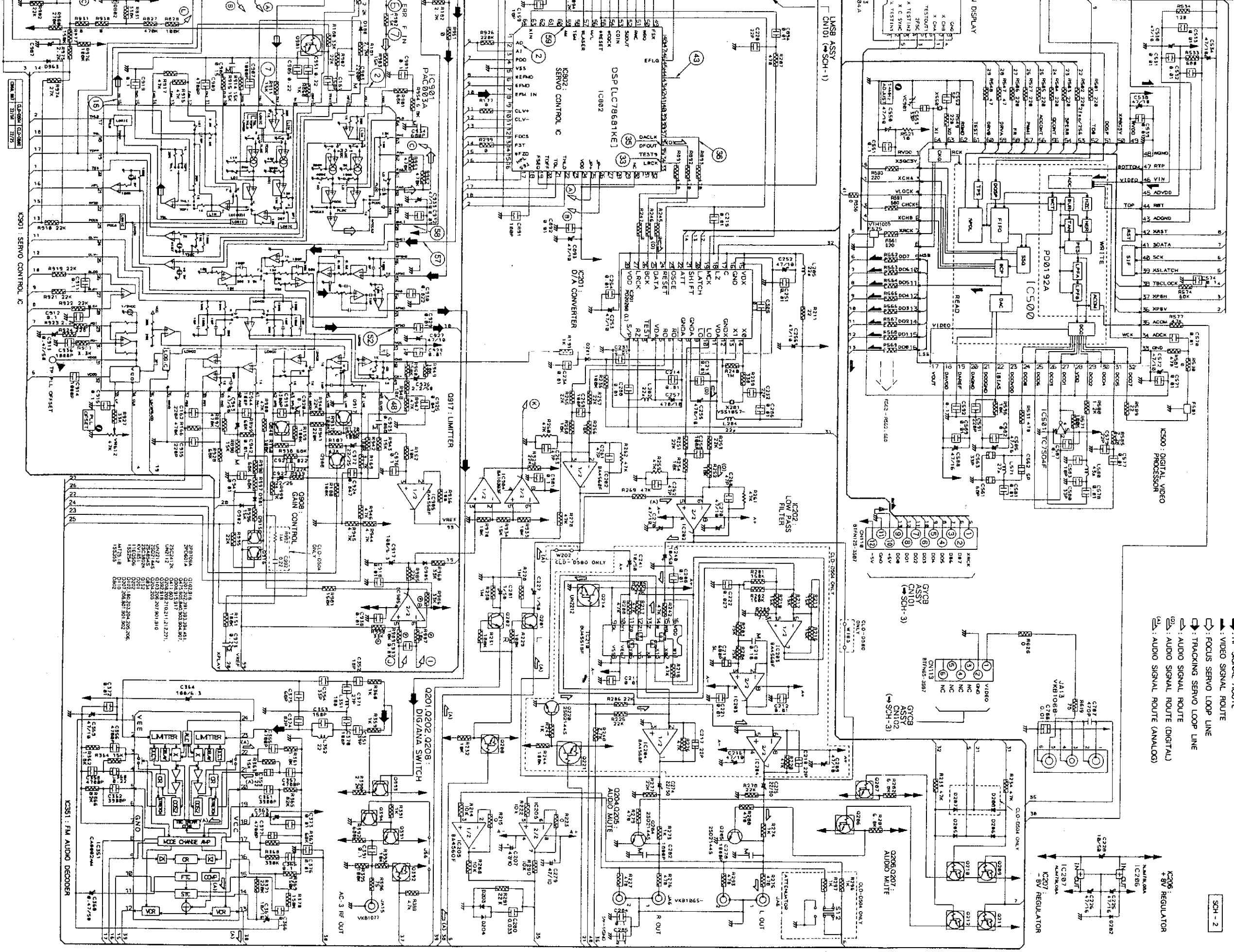

MOTHER ASSY

SCH-2

WAVEFORMS AND VOLTAGE MOTHER ASSY

Note : (No) in the table correspond to the pin number.

Measurement condition : In case when (D. audio) is written, at time when disc that has digital audio recording is played.

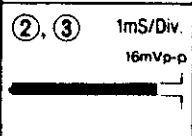
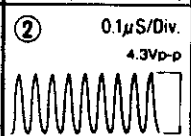
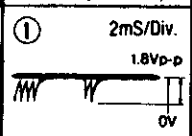
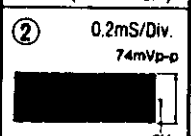
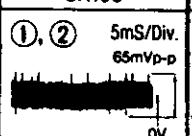
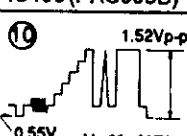
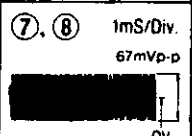
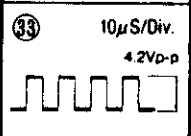
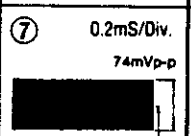
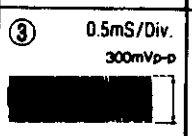
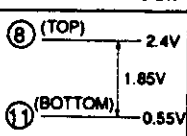
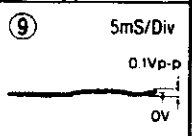
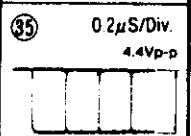
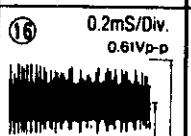
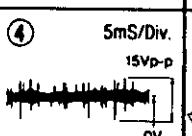
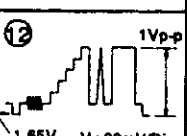
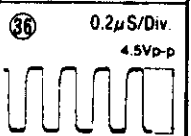
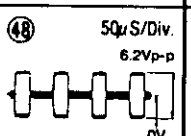
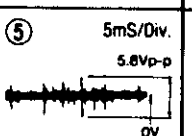
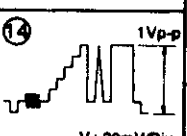
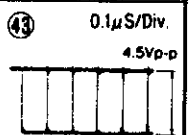
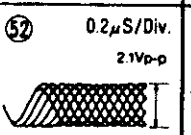
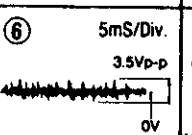
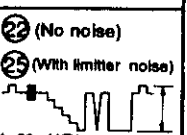
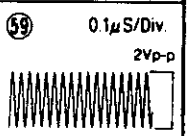
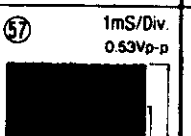
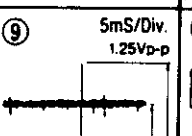
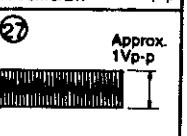
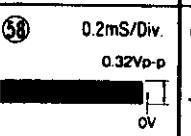
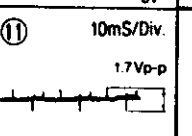
IC801(PAC002A)	IC802(LC78681KE)	IC803(LA6510)	IC901(PAC003A)	CN106	IC400(PAC005B)
(2), (3) 1mS/Div. 16mVp-p  AC mode	(2) 0.1μS/Div. 4.3Vp-p  AC mode(D.audio)	(1) 2mS/Div. 1.8Vp-p  DC mode	(2) 0.2mS/Div. 74mVp-p  DC mode	(1), (2) 5mS/Div. 65mVp-p  DC mode	(10) 1.52Vp-p  V : 20mV/Div H : 10mS/Div
(7), (8) 1mS/Div. 67mVp-p  DC mode	(33) 10μS/Div. 4.2Vp-p  AC mode(D.audio)		(7) 0.2mS/Div. 74mVp-p  DC mode	(3) 0.5mS/Div. 300mVp-p  AC mode	(8) (TOP) 2.4V (11) (BOTTOM) 0.55V  V : 20mV/Div H : 10mS/Div
(9) 5mS/Div. 0.1Vp-p  DC mode	(35) 0.2μS/Div. 4.4Vp-p  AC mode(D.audio)		(16) 0.2mS/Div. 0.61Vp-p  DC mode	(4) 5mS/Div. 15Vp-p  DC mode	(12) 1Vp-p  V : 20mV/Div H : 10mS/Div
	(36) 0.2μS/Div. 4.5Vp-p  AC mode(D.audio)		(48) 50μS/Div. 6.2Vp-p  DC mode	(5) 5mS/Div. 5.8Vp-p  DC mode	(14) 1Vp-p  V : 20mV/Div H : 10mS/Div
	(43) 0.1μS/Div. 4.5Vp-p  AC mode(D.audio)		(52) 0.2μS/Div. 2.1Vp-p  AC mode	(6) 5mS/Div. 3.5Vp-p  DC mode	(22) (No noise) (25) (With limiter noise)  V : 20mV/Div H : 10mS/Div Approx. 330mVp-p
	(59) 0.1μS/Div. 2Vp-p  AC mode(D.audio)		(57) 1mS/Div. 0.53Vp-p  DC mode	(9) 5mS/Div. 1.25Vp-p  DC mode	(27) Approx. 1Vp-p  0.5mS/Div
		(58) 0.2mS/Div. 0.32Vp-p  DC mode	(11) 10mS/Div. 1.7Vp-p  DC mode		

● The inside block diagram of IC901 (PAC003A)

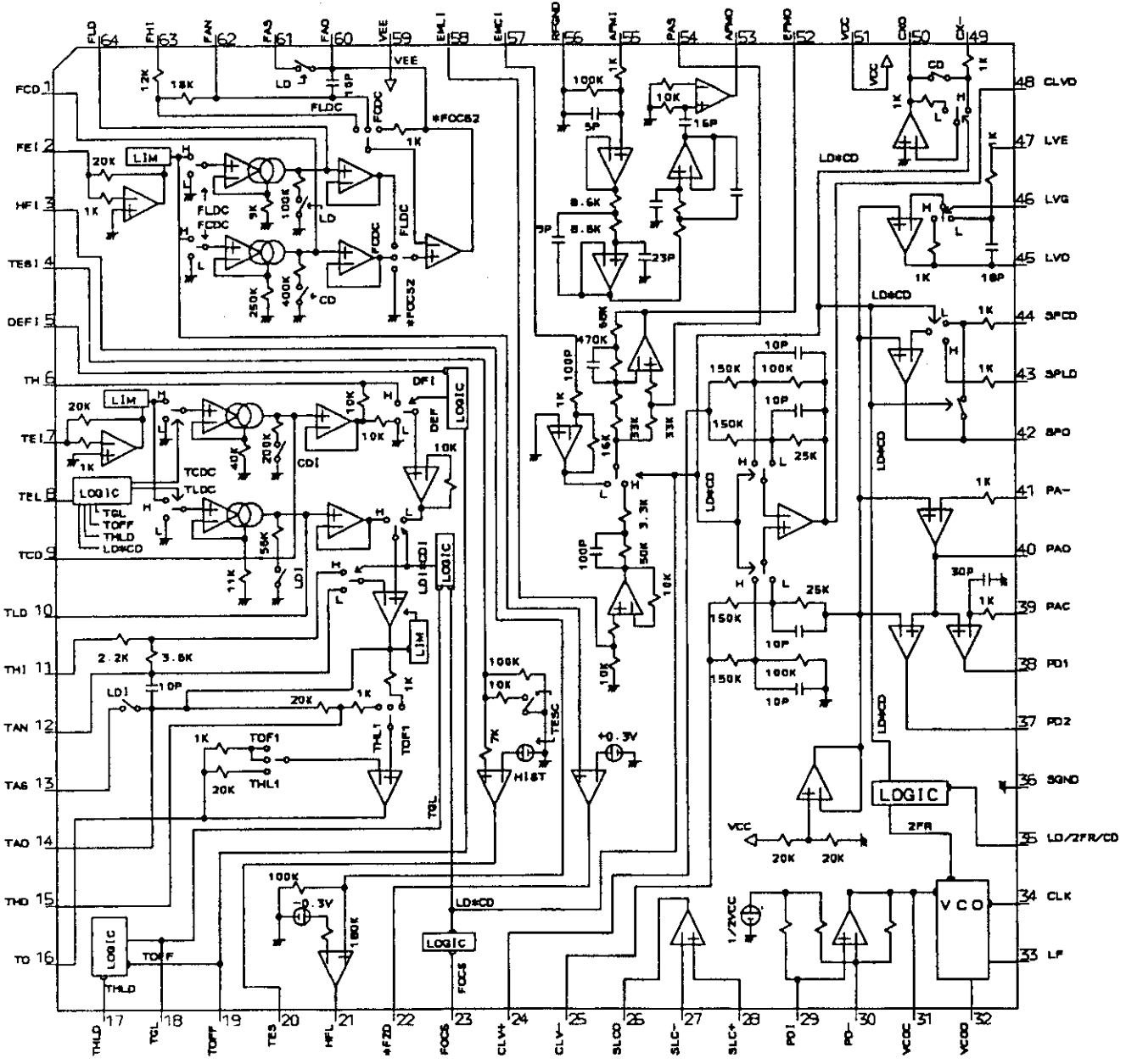

MOTHER ASSY

A

B

C

D

A

B

C

D

GYCB ASSY
CN 102

GYCB ASSY
CN 101

ECOB ASSY
CN 402

FLKY
ASSY
CN 101

SYPS
ASSY
CN 3

LMSB
ASSY
CN 101

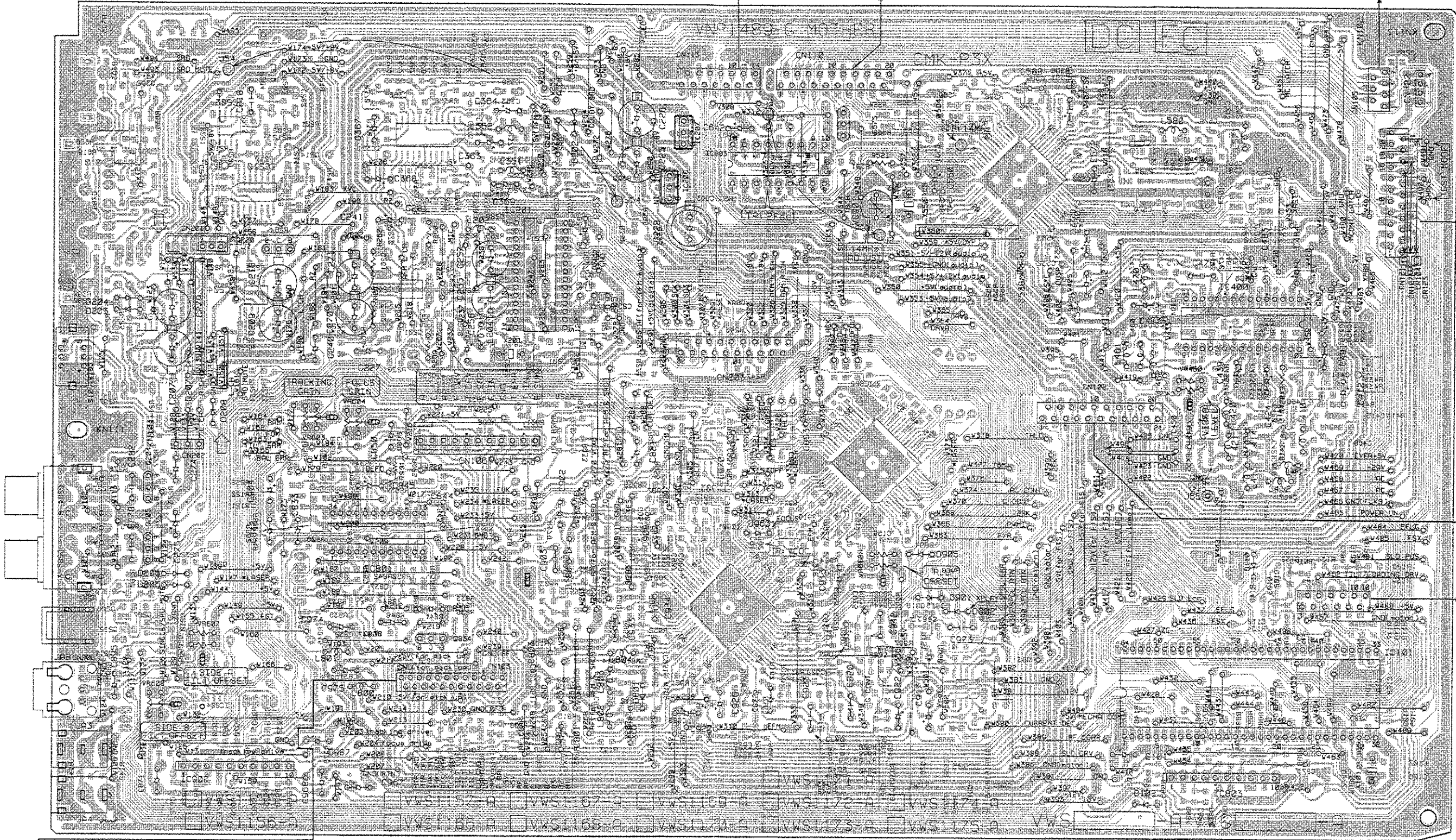

CARRIAGE ASSY CN101	VR608 VR607	VR603 VR604	IC801	IC834	IC201	IC206	IC207	IC603	VC901	VR612	VR450	IC400	IC803	IC101	IC110
	Q205 Q204 IC902 Q220		Q501 Q502	Q183 Q181	Q381 Q382	Q383 Q384	Q385 Q386	Q387 Q388	Q389 Q390	Q391 Q392	Q393 Q394	Q395 Q396	Q397 Q398	Q399 Q400	Q401 Q402
	S150 S151 S152 S153	S154 S155 S156 S157	S158 S159 S160 S161	S162 S163 S164 S165	S166 S167 S168 S169	S170 S171 S172 S173	S174 S175 S176 S177	S178 S179 S180 S181	S182 S183 S184 S185	S186 S187 S188 S189	S190 S191 S192 S193	S194 S195 S196 S197	S198 S199 S200 S201	S202 S203 S204 S205	S206 S207 S208 S209
	S210 S211 S212 S213	S214 S215 S216 S217	S218 S219 S220 S221	S222 S223 S224 S225	S226 S227 S228 S229	S230 S231 S232 S233	S234 S235 S236 S237	S238 S239 S240 S241	S242 S243 S244 S245	S246 S247 S248 S249	S250 S251 S252 S253	S254 S255 S256 S257	S258 S259 S260 S261	S262 S263 S264 S265	S266 S267 S268 S269

• This diagram is viewed from the mounted parts side.

• The parts mounted on this PCB include all necessary parts for several destinations. For further information for respective destinations, be sure to check with the schematic diagram.

MOTHER ASSY

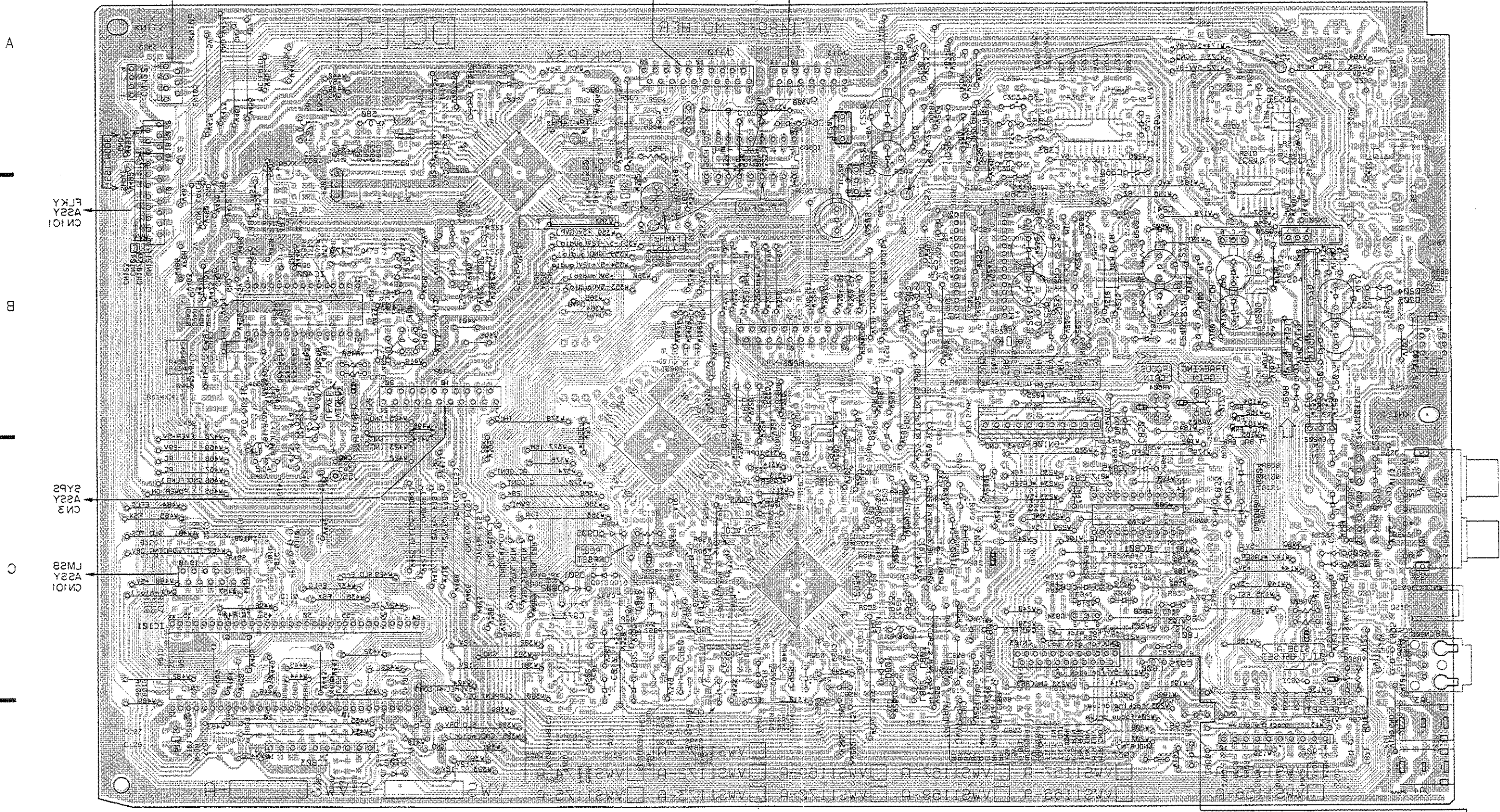

A

B

C

D

A

B

C

D

• The parts mounted on this PCB include all necessary parts for several destinations. For further information for respective destinations, be sure to check with the schematic diagram.

• This diagram is viewed from the foil side.

Q141	Q103	Q102	Q101	IC400	IC803	IC101	VR450
Q191	Q190	Q189	Q188	Q187	Q186	Q185	Q184
Q183	Q182	Q181	Q180	Q179	Q178	Q177	Q176
Q175	Q174	Q173	Q172	Q171	Q170	Q169	Q168
Q167	Q166	Q165	Q164	Q163	Q162	Q161	Q160
Q159	Q158	Q157	Q156	Q155	Q154	Q153	Q152
Q151	Q150	Q149	Q148	Q147	Q146	Q145	Q144
Q143	Q142	Q141	Q140	Q139	Q138	Q137	Q136
Q135	Q134	Q133	Q132	Q131	Q130	Q129	Q128
Q127	Q126	Q125	Q124	Q123	Q122	Q121	Q120
Q119	Q118	Q117	Q116	Q115	Q114	Q113	Q112
Q111	Q110	Q109	Q108	Q107	Q106	Q105	Q104
Q103	Q102	Q101	Q100	Q99	Q98	Q97	Q96
Q95	Q94	Q93	Q92	Q91	Q90	Q89	Q88
Q87	Q86	Q85	Q84	Q83	Q82	Q81	Q80
Q79	Q78	Q77	Q76	Q75	Q74	Q73	Q72
Q71	Q70	Q69	Q68	Q67	Q66	Q65	Q64
Q63	Q62	Q61	Q60	Q59	Q58	Q57	Q56
Q55	Q54	Q53	Q52	Q51	Q50	Q49	Q48
Q47	Q46	Q45	Q44	Q43	Q42	Q41	Q40
Q39	Q38	Q37	Q36	Q35	Q34	Q33	Q32
Q31	Q30	Q29	Q28	Q27	Q26	Q25	Q24
Q23	Q22	Q21	Q20	Q19	Q18	Q17	Q16
Q15	Q14	Q13	Q12	Q11	Q10	Q9	Q8
Q7	Q6	Q5	Q4	Q3	Q2	Q1	Q0

PCB-2

3.3 GYCB ASSY

GYCB ASSY

IC105
4010
IC106
Q118
1110
Q155

IC101
1010
3010
2010

MOTHER ASSY CN113

MOTHER ASSY CN110

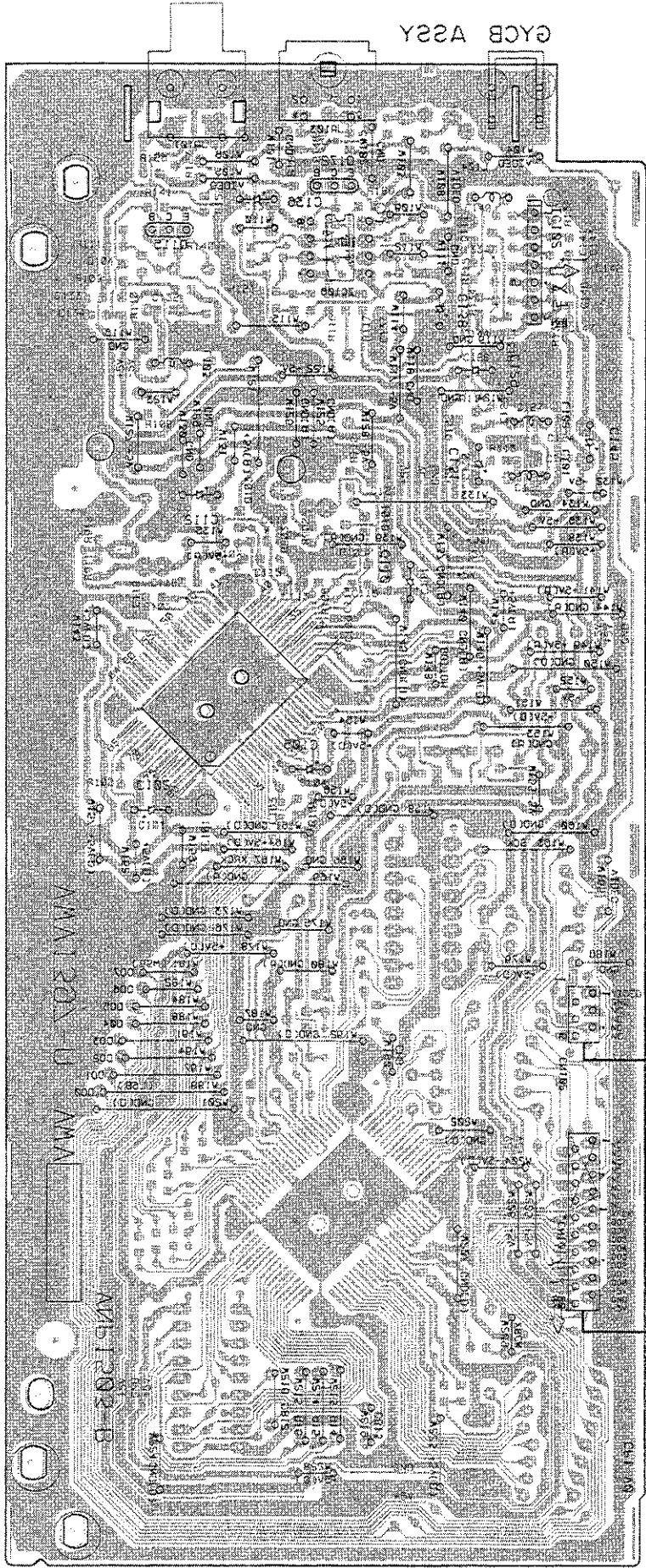

◆ This diagram is viewed from the foil side.

3.3 GYCB ASSY

GYCB ASSY

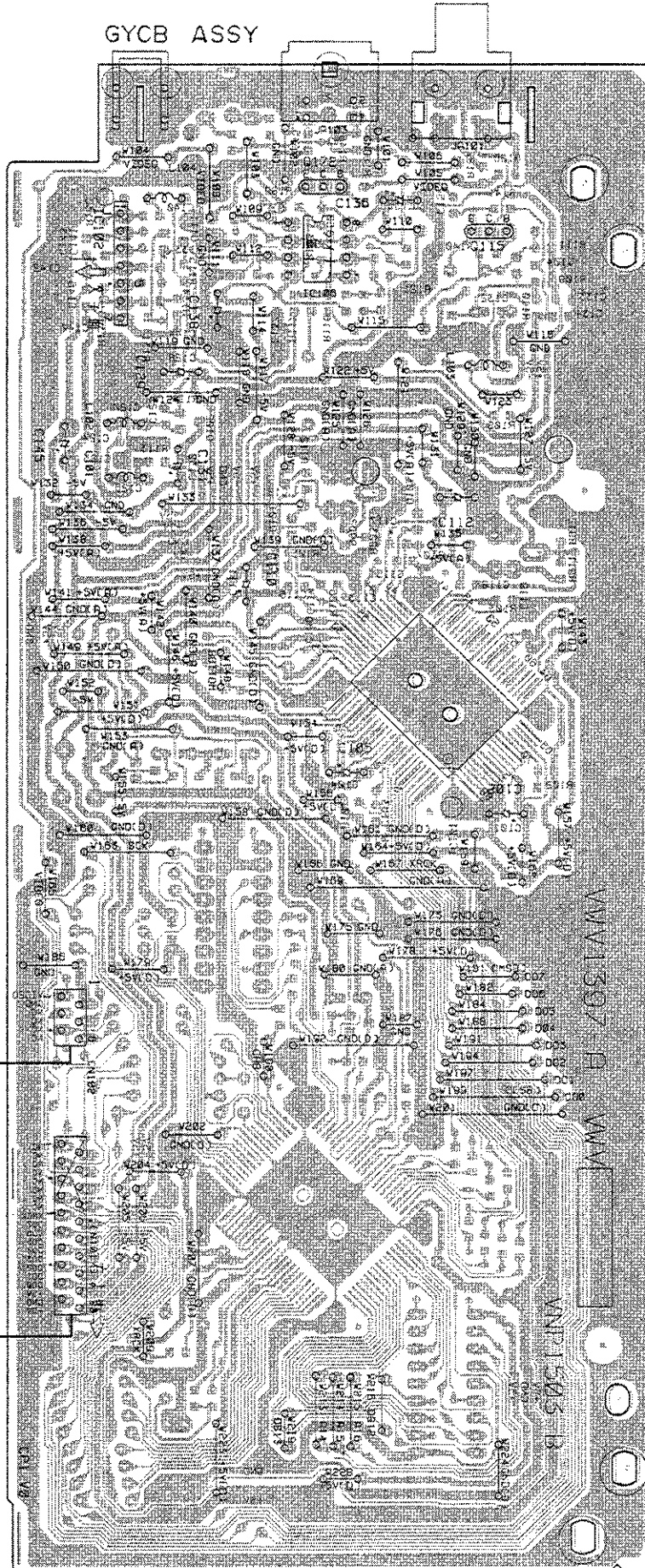

- A
- Q172
- I110
- IC115
- IC105
- P010
- IC102
- SO10
- EO10
- IO10
- B
- IO10
- C
- D

MOTHER ASSY
CN113

MOTHER ASSY
CN110

• This diagram is viewed from the mounted parts side.

GYCB ASSY (VWV1397)

(Y) : Y Signal Route
 (C) : C Signal Route
 (V) : Video Signal Route
 SCH - 3

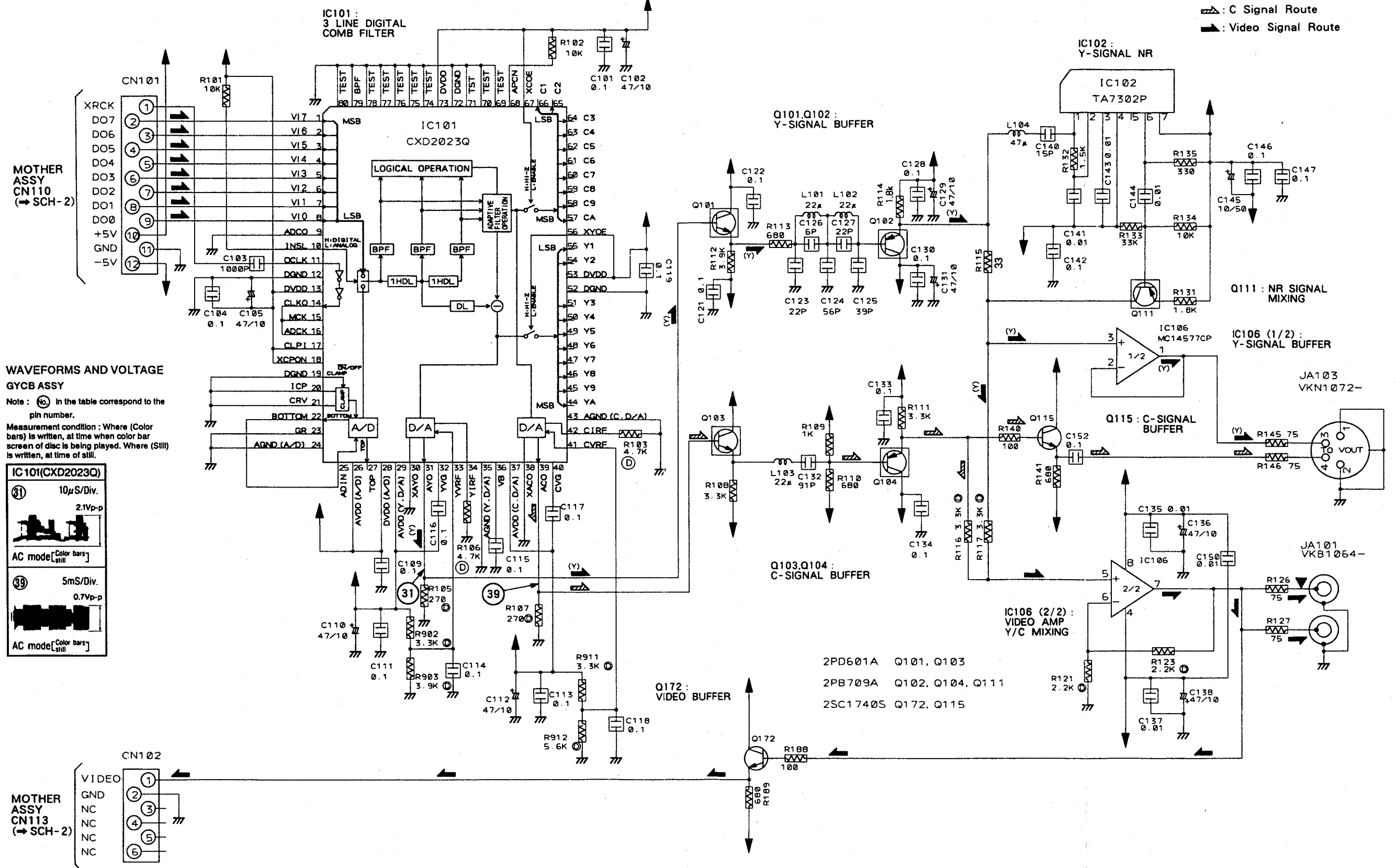

WAVEFORMS AND VOLTAGE
 GYCB ASSY

Note: (C) in the table correspond to the pin number.
 Measurement condition: Where (Color bars) is written, at time when color bar screen of disc is being played. Where (Still) is written, at time of still.

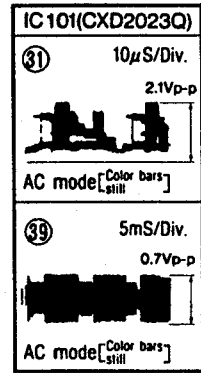

SCH-3

SCH-3

4. PCB PARTS LIST

NOTES:

- Parts marked by "NSP" are generally unavailable because they are not in our Master Spare Parts List.
- The Δ mark found on some component parts indicates the importance of the safety factor of the part. Therefore, when replacing, be sure to use parts of identical designation.
- Parts marked by "⊙" are not always kept in stock. Their delivery time may be longer than usual or they may be unavailable.
- When ordering resistors, first convert resistance values into code form as shown in the following examples.

Ex.1 When there are 2 effective digits(any digit apart from 0), such as 560 ohm and 47k ohm(tolerance is shown by J=5%, and K=10%).

560 Ω \rightarrow 56 \times 10¹ \rightarrow 561..... RD1/8PM $\boxed{561}J$

47k Ω \rightarrow 47 \times 10³ \rightarrow 473..... RD1/4PS $\boxed{473}J$

0.5 Ω \rightarrow 0R5 RN2H $\boxed{0R5}K$

1 Ω \rightarrow 010..... RSIP $\boxed{010}K$

Ex.2 When there are 3 effective digits(such as in high precision metal film resistors).

5.62k Ω \rightarrow 562 \times 10¹ \rightarrow 5621 RN1/4PC $\boxed{5621}F$

Mark	No.	Description	Part No.
LIST OF ASSEMBLIES			
NSP		MACB ASSY	YWM1535
NSP		PKSB ASSY	VWG1555
NSP		FG ASSY	VWG1556
NSP		TNSB ASSY	VWG1557
NSP		BISB ASSY	VWG1558
NSP		LMSB ASSY	VWG1612
Δ		SYPS ASSY (For CLD-D504)	VWR1246
Δ		SYPS ASSY (For CLD-D580)	VWR1247
NSP		FLKB ASSY (For CLD-D504)	VWM1555
NSP		FLKB ASSY (For CLD-D580)	VWM1556
NSP		KEYB ASSY	VWG1598
		FLKY ASSY (For CLD-D504)	VWG1607
		FLKY ASSY (For CLD-D580)	VWG1608
		ECOB ASSY (CLD-D504 only)	VWV1405
		MJBA ASSY (CLD-D504 only)	VWV1410
		MOTHER ASSY (For CLD-D504)	VWS1169
		MOTHER ASSY (For CLD-D580)	VWS1170
		GYCB ASSY	VWV1397

MACB ASSY

OTHERS

PCB (MACB) VNP1479

PKSB ASSY

SWITCHES

S104, S105 DSG1017

FG ASSY

SEMICONDUCTOR

D101 GPIS24

Mark	No.	Description	Part No.
TNSB ASSY			
SWITCH			
		S111	DSG1017
BISB ASSY			
SWITCH			
		S112	DSG1017
LMSB ASSY			
SWITCHES			
		S101-S103	DSG1017
OTHERS			
		CN101 12P FFC CONNECTOR	52044-1245

SYPS ASSY (For CLD- D504)

SEMICONDUCTORS

	IC20	HA17431P
Δ	IC2	ICP-N15
Δ	IC1	ICP-N20
	IC21	NJM4558D
	Q20, Q22	2SA1598
	Q27, Q30, Q32	2SA933S
Δ	Q24	2SB891F
	Q25, Q29, Q31	2SC1740S
	Q21, Q23	2SC4148
Δ	Q26	2SD2007
	D25-D27, D30, D31	AG01Z-V0
	D29	MTZJ8. 2B
	D40	RD33FB2
	D23, D24	RK36
	D21, D22	RL4Z

Mark	No.	Description	Part No.
------	-----	-------------	----------

RESISTORS

△	R22-R25	(47Ω, 1/6W)	VCN1033
△	R27	(0.47Ω, 1/2W)	VCN1046
△	R29	(68Ω, 1/4W)	VCN1048
△	R31	(8.2Ω, 1/4W)	VCN1050

OTHERS

△	F2	FUSE	VEK1033
△	F3, F4	FUSE	VEK1034
△	F5, F6	FUSE(1.0A/125V)	VEK1036

SYPS ASSY (For CLD- D580)

SEMICONDUCTORS

	IC20		HA17431P
△	IC2		ICP-N15
△	IC1		ICP-N20
	IC21		NJM4558D
	Q27, Q30, Q32		2SA933S
△	Q24		2SB891F
	Q25, Q29, Q31		2SC1740S
△	Q26		2SD2007
	Q21, Q23		T7F4S
	Q20, Q22		T7F4T
	D25-D27, D30, D31		AG01Z-V0
	D29		MTZJ8. 2B
	D40		RD33FB2
	D23, D24		RK36
	D21, D22		RL4Z

RESISTORS

△	R22-R25	(47Ω, 1/6W)	VCN1033
△	R27	(0.47Ω, 1/2W)	VCN1046
△	R29	(68Ω, 1/4W)	VCN1048
△	R31	(8.2Ω, 1/4W)	VCN1050

OTHERS

△	F2	FUSE	VEK1033
△	F3, F4	FUSE	VEK1034
△	F5, F6	FUSE(1.0A/125V)	VEK1036

FLKB ASSY

OTHERS

	PCB(FLKB)		VNP1495
--	-----------	--	---------

KEYB ASSY

SEMICONDUCTORS

	Q201-Q204		UN2212
	D203, D204		SLR-342MC3F
	D201, D202		SLR-342YC3F

SWITCHES

	S201-S211		RSG1030
--	-----------	--	---------

RESISTORS

	All Resistors		RS1/10S□□□J
--	---------------	--	-------------

Mark	No.	Description	Part No.
------	-----	-------------	----------

OTHERS

	CN201	FFC BOTTOM CONNECTOR 13P	52492-1320
		PCB BINDER	VEF1040

FLKY ASSY (For CLD- D504)

SEMICONDUCTORS

	IC101		PD3302A
	IC102		S-806D
	Q106		DTA144EK
	Q105		DTC114EK
	Q101, Q103, Q104, Q107		UN2212
	D101, D103-D105		ISS353
	D106		ISS355
	D109		SLR-342MCT31-TS
	D110		SLR-342VCT31-TS
	D107		SLR-342YCT31-TS

SWITCHES

	S101-S103		RSG1030
--	-----------	--	---------

CAPACITORS

	C104, C106		CEAL100M16
	C101		CEAL470M6R3
	C105		CKSQYF103Z50
	C102		CKSQYF104Z25
	C103		CKSQYF223Z50

RESISTORS

	All Resistors		RS1/10S□□□J
--	---------------	--	-------------

OTHERS

	CN102	FFC BOTTOM CONNECTOR 13P	52492-1320
	CN101	FFC BOTTOM CONNECTOR 18P	52492-1820
	X101	CERAMIC RESONATOR	EFOEC8004A4
		REMOTE SENSOR	GPIU58X
	V101	FL TUBE	VAW1035
		SPACER	VEC1599
		FL HOLDER	VNF1087

FLKY ASSY (For CLD- D580)

SEMICONDUCTORS

	IC101		PD3302A
	IC102		S-806D
	Q106		DTA144EK
	Q105		DTC114EK
	Q101, Q103, Q104, Q107		UN2212
	D101, D103-D105		ISS353
	D106		ISS355
	D109		SLR-342MCT31-TS
	D110		SLR-342VCT31-TS
	D107		SLR-342YCT31-TS

SWITCHES

	S101-S103		RSG1030
--	-----------	--	---------

Mark No.	Description	Part No.
CAPACITORS		
C104, C106		CEAL100M16
C101		CEAL470M6R3
C105		CKSQYF103Z50
C102		CKSQYF104Z25
C103		CKSQYF223Z50

RESISTORS		
All Resistors		RS1/10S□□□J

OTHERS		
CN102	FFC BOTTOM CONNECTOR 13P	52492-1320
CN101	FFC BOTTOM CONNECTOR 16P	52492-1620
X101	CERAMIC RESONATOR	EFOEC8004A4
	REMOTE SENSOR	GP1U58X
V101	FL TUBE	VAW1035
	SPACER	VEC1599
	FL HOLDER	VNF1087

ECOB ASSY

SEMICONDUCTORS

IC402	BA4560F
IC401	M65831FP
D401, D402	ISS355

COIL

L401	LFA100J
------	---------

CAPACITORS

C403, C404	CCSQCH101J50
C417	CCSQCH220J50
C412	CEANP010M50
C415, C416, C420	CEAS010M50
C401	CEAS101M10
C407	CEAS470M10
C406, C408-C410	CFTXA104J50
C405, C411	CKSQYB102K50
C413	CKSQYB562K50
C402, C414	CKSQYF103Z50
C418, C419	CKSQYF104Z25

RESISTORS

All Resistors	RS1/10S□□□J
---------------	-------------

OTHERS

CN402	7P FFC CONNECTOR	52045-0745
CN401	2mm PITCH BOTTOM CONNECTOR	BTMK07P-1R
X401	CERAMIC RESONATOR(2.00MHz)	VSS1063

MJBA ASSY

SEMICONDUCTORS

IC502	BA4560F
IC501	NJM4565M

CAPACITORS

C512	CCSQCH151J50
C509	CEJA2R2M50
C508	CKSQYB152K50
C511	CKSQYB333K25
C510	CKSQYB681K50

Mark No.	Description	Part No.
C507		CKSQYF103Z50
C505, C506, C514, C515		CKSQYF104Z25
C516		CKSYF105Z16

RESISTORS

VR501, VR502(10kΩ)	VCS1036
Other Resistors	RS1/10S□□□J

OTHERS

CN501	2mm PITCH BOTTOM CONNECTOR	BTMK07S-1S
JA502	HEADPHONE JACK	RKB1014

MOTHER ASSY (For CLD - D504)

SEMICONDUCTORS

IC904	BA10393F
IC202-IC205, IC903, IC905	BA4560F
IC210	BU4551BF
IC351	CA0002AM
IC803	LA6510
IC802	LC78681KE
IC206	NJM78L08A
IC207	NJM79L08A
IC801	PAC002A
IC901	PAC003A
IC400	PAC005B
IC500	PD0192A
IC101	PD0212A
IC201	PD2026B(L)
IC603	PD9004A
IC902	TA8410AK
IC804	TC4W53F
IC501	TC7S04F
Q102, Q916	2PB709A
Q201, Q202, Q391, Q393, Q394	2PD601A
Q451, Q475, Q805, Q840	2PD601A
Q903, Q904, Q907, Q908, Q915	2PD601A
Q917	2PD601A
Q834	2SA854S
Q411, Q803	2SC2412K
Q152	2SC3802K
Q204, Q205, Q220	2SD2144S
Q208-Q212, Q221, Q392, Q918	UN2112
Q103, Q206, Q207, Q214, Q901	UN2212
Q910	UN2212
D202	11EQS06
D102, D180, D203-D208, D801	1SS254
D901, D902, D905, D963	1SS254
D802	1SS355
D201	KV1851
D803	MTZJ2.0A/B
D110	MTZJ5.1B

COILS AND FILTERS

L413	LAU100J
L410	LAU101J
L351, L802-L804	LAU181J
L202, L204, L205, L352, L412	LAU220J
L461, L470, L800, L801	LAU220J

Mark	No.	Description	Part No.
	L411, L571		LAU270J
	L420, L421, L580		LAU430J
	L462		LAU560J
	L414		LAU8R2J
	L460		LFA561J
	F501		VTF1055
	F575		VTH1005

SWITCH

S12	VSH1009
-----	---------

CAPACITORS

C562	CCSQCH050C50
C436, C809, C811	CCSQCH070D50
C159, C420, C421, C438, C466	CCSQCH100D50
C583	CCSQCH100D50
C258, C259, C370, C810, C846	CCSQCH101J50
C848, C891, C944	CCSQCH101J50
C434, C437, C474	CCSQCH120J50
C416	CCSQCH121J50
C415, C418, C475	CCSQCH150J50
C161, C353, C812	CCSQCH151J50
C352, C552	CCSQCH180J50
C210, C217, C220, C232, C579	CCSQCH220J50
C813, C950	CCSQCH220J50
C162, C417, C591, C935	CCSQCH221J50
C371, C419, C433, C467, C931	CCSQCH270J50
C106, C107, C354, C435, C452	CCSQCH330J50
C553, C563, C580	CCSQCH330J50
C351, C425, C476	CCSQCH390J50
C260-C263, C464, C468	CCSQCH470J50
C787	CCSQCH471J50
C375, C561, C806	CCSQCH680J50
C374, C814	CCSQCH820J50
C460, C462	CCSQCH910J50
C219	CCSQSL681J50
C367, C439	CEAL100M16
C225, C226, C412, C484, C491	CEAL470M16
C585, C588, C836, C844	CEAL470M16
C850, C870	CEAL4R7M50
C450, C838	CEALNP470M6R3
C972	CEANP220M10
C227, C281, C904	CEAS010M50
C228, C240, C241	CEAS100M50
C364, C424	CEAS101M10
C274, C275, C821, C922, C967	CEAS220M25
C845, C902, C926	CEAS2R2M50
C101, C207, C209, C216	CEAS470M10
C252, C253, C256, C270, C271	CEAS470M10
C279, C363, C369, C493, C530	CEAS470M10
C534, C538, C550, C572, C801	CEAS470M10
C803, C833, C842, C893, C927	CEAS470M10
C933, C974, C975	CEAS470M10
C255, C257	CEAS471M10
C368, C913, C943	CEASR47M50
C968, C987	CEHAQ220M50
C917	CEJA101M6R3

Mark	No.	Description	Part No.
	C218		CFTYA184J50
	C490, C907, C914, C936		CKSQYB102K50
	C222		CKSQYB273K50
	C919		CKSQYB332K50
	C361, C362		CKSQYB392K50
	C355-C358, C377, C909		CKSQYB472K50
	C105, C110, C122, C160		CKSQYF103Z50
	C196-C198, C208, C211-C215		CKSQYF103Z50
	C221, C231, C234, C251, C254		CKSQYF103Z50
	C286, C288, C372, C373, C376		CKSQYF103Z50

C413, C451, C454, C485	CKSQYF103Z50
C531-C533, C539, C570, C571	CKSQYF103Z50
C577, C578, C581, C589, C641	CKSQYF103Z50
C788, C802, C804, C807	CKSQYF103Z50
C831, C832, C834, C835, C843	CKSQYF103Z50

C872, C876, C888, C892, C894	CKSQYF103Z50
C918, C928, C929, C932	CKSQYF103Z50
C937, C938, C941, C961, C962	CKSQYF103Z50
C964, C971, C982	CKSQYF103Z50
C102, C103, C151, C284, C285	CKSQYF104Z25

C305, C365, C366, C391	CKSQYF104Z25
C422, C423, C453, C457, C458	CKSQYF104Z25
C492, C494, C551, C574, C582	CKSQYF104Z25
C587, C592, C840, C841, C847	CKSQYF104Z25
C873, C874, C901, C910-C912	CKSQYF104Z25

C915, C976, C981, C983	CKSQYF104Z25
C837, C921, C930	CKSQYF223Z50
C359, C360, C905, C951	CKSQYF224Z25
C280	CKSQYF333Z25
C465, C808, C815, C875, C877	CKSQYF473Z25

C924, C925	CKSQYF473Z25
C942	CQMA103J50
C920	CQMA104J50
C479, C908	CQMA154J50
C278, C282	CQMA182J50

C903	CQMA222J50
C973, C992	CQMA224J50
C934	CQMA681J50
C483, C923	CQMA683J50
C871	VCH1152

VC901 (20P)	VCM-008
-------------	---------

RESISTORS

R521	RD1/6PM010J
R991	RD1/6PM103J
R992	RD1/6PM105J
R420	RD1/6PM470J
R259-R262	RD1/6PM473J

R490, R987, R989	RN1/10SE103D
R880, R883	RN1/10SE104D
R879, R986, R990	RN1/10SE333D
R881, R882	RN1/10SE473D
VR450 (2.2kΩ)	PCP1025

VR603 (4.7kΩ)	PCP1028
VR604, VR607, VR608, VR612 (47kΩ)	PCP1031
Other Resistors	RS1/10S□□□□

Mark No.	Description	Part No.
OTHERS		
CN105	7P FFC CONNECTOR	52045-0745
CN108	12P FFC CONNECTOR	52045-1245
CN107	18P FFC CONNECTOR	52045-1845
CN102	21P FFC CONNECTOR	52045-2145
CN103	23P FFC CONNECTOR	52233-2310
CN106	11P TOP POST	B11P-SHF-1AA
CN110	B TO B CONNECTOR 12P	BTFN12S-3SB7
CN113	B TO B CONNECTOR 6P	BTFN6S-3SB7
JA3, JA4	REMOTE CONTROL JACK PCB BINDER	RKN1004 VEF1040
JA6	4P PIN JACK	VKB1065
JA13	RF PIN JACK	VKB1068
JA15	1P PIN JACK	VKB1077
	64P IC SOCKET	VKH1004
	SCREW TERMINAL	VNE1948
KN101, KN102	EARTH PLATE	VNF1084
X101	CERAMIC RESONATOR (9.00MHz)	VSS1040
X201	CERAMIC RESONATOR (16MHz)	VSS1057
X550	CRYSTAL RESONATOR (14.318MHz)	VSS1073

MOTHER ASSY (For CLD- D580)

SEMICONDUCTORS

IC904	BA10393F
IC202, IC205, IC903, IC905	BA4560F
IC351	CA0002AM
IC803	LA6510
IC802	LC78681KE
IC206	NJM78L08A
IC207	NJM79L08A
IC801	PAC002A
IC901	PAC003A
IC400	PAC005B
IC500	PD0192A
IC101	PD0212A
IC201	PD2026B(L)
IC603	PD9004A
IC902	TA8410AK
IC804	TC4W53F
IC501	TC7S04F
Q102, Q916	2PB709A
Q201, Q202, Q391, Q393, Q394	2PD601A
Q451, Q475, Q805, Q840	2PD601A
Q903, Q904, Q907, Q908, Q915	2PD601A
Q917	2PD601A
Q834	2SA854S
Q411, Q803	2SC2412K
Q152	2SC3802K
Q204, Q205	2SD2144S
Q208-Q212, Q392, Q918	UN2112
Q103, Q206, Q207, Q901, Q910	UN2212
D202	11EQS06
D102, D180, D203-D206, D801	1SS254
D901, D902, D905, D963	1SS254
D802	1SS355
D201	KV1851
D110	MTZJ5. 1B

Mark No.	Description	Part No.
COILS AND FILTERS		
	L413	LAU100J
	L410	LAU101J
	L351, L802-L804	LAU181J
	L202, L204, L205, L352, L412	LAU220J
	L461, L470, L800, L801	LAU220J
	L411, L571	LAU270J
	L420, L421, L580	LAU430J
	L462	LAU560J
	L414	LAU8R2J
	L460	LFA561J
	F501	VTF1055
	F575	VTH1005

CAPACITORS

C562	CCSQCH050C50
C436, C809, C811	CCSQCH070D50
C159, C420, C421, C438, C466	CCSQCH100D50
C583	CCSQCH100D50
C258, C259, C370, C810, C846	CCSQCH101J50
C848, C891, C944	CCSQCH101J50
C434, C437, C474	CCSQCH120J50
C416	CCSQCH121J50
C415, C418, C475	CCSQCH150J50
C161, C353, C812	CCSQCH151J50
C352, C552	CCSQCH180J50
C220, C232, C579, C813, C950	CCSQCH220J50
C162, C417, C591, C935	CCSQCH221J50
C371, C419, C433, C467, C931	CCSQCH270J50
C106, C107, C354, C435, C452	CCSQCH330J50
C553, C563, C580	CCSQCH330J50
C351, C425, C476	CCSQCH390J50
C260-C263, C464, C468	CCSQCH470J50
C787	CCSQCH471J50
C375, C561, C806	CCSQCH680J50
C374, C814	CCSQCH820J50
C460, C462	CCSQCH910J50
C367, C439	CEAL100M16
C225, C226, C412, C484, C491	CEAL470M16
C585, C588, C836, C844	CEAL470M16
C850, C870	CEAL4R7M50
C450, C838	CEALNP470M6R3
C972	CEANP220M10
C227, C281, C904	CEAS010M50
C228	CEAS100M50
C364, C424	CEAS101M10
C274, C275, C821, C922	CEAS220M25
C967	CEAS220M25
C845, C902, C926	CEAS2R2M50
C101, C207, C252, C253, C256	CEAS470M10
C270, C271, C279, C363, C369	CEAS470M10
C493, C530, C534, C538, C550	CEAS470M10
C572, C801, C803, C833, C842	CEAS470M10
C893, C927, C933, C974, C975	CEAS470M10
C255, C257	CEAS471M10
C368, C913, C943	CEASR47M50
C968, C987	CEHAQ220M50
C917	CEJA101M6R3
C490, C907, C914, C936	CKSQYB102K50
C919	CKSQYB332K50

Mark	No.	Description	Part No.
	C361, C362		CKSQYB392K50
	C355-C358, C377, C909		CKSQYB472K50
	C105, C110, C122, C160		CKSQYF103Z50
	C196-C198, C213-C215, C231		CKSQYF103Z50
	C234, C251, C254, C286, C288		CKSQYF103Z50
	C372, C373, C376, C413, C451		CKSQYF103Z50
	C454, C485, C531-C533, C539		CKSQYF103Z50
	C570, C571, C577, C578, C581		CKSQYF103Z50
	C589, C641, C788, C802, C804		CKSQYF103Z50
	C807, C831, C832, C834, C835		CKSQYF103Z50
	C843, C872, C876, C888, C892		CKSQYF103Z50
	C894, C918, C928, C929, C932		CKSQYF103Z50
	C937, C938, C941, C961, C962		CKSQYF103Z50
	C964, C971, C982		CKSQYF103Z50
	C102, C103, C151, C284, C285		CKSQYF104Z25
	C305, C365, C366, C391		CKSQYF104Z25
	C422, C423, C453, C457, C458		CKSQYF104Z25
	C492, C494, C551, C574, C582		CKSQYF104Z25
	C587, C592, C840, C841, C847		CKSQYF104Z25
	C873, C874, C901, C910-C912		CKSQYF104Z25
	C915, C976, C981, C983		CKSQYF104Z25
	C837, C921, C930		CKSQYF223Z50
	C359, C360, C905, C951		CKSQYF224Z25
	C280		CKSQYF333Z25
	C465, C808, C815, C875, C877		CKSQYF473Z25
	C924, C925		CKSQYF473Z25
	C942		CQMA103J50
	C920		CQMA104J50
	C479, C908		CQMA154J50
	C278, C282		CQMA182J50
	C903		CQMA222J50
	C973		CQMA224J50
	C934		CQMA681J50
	C483, C923		CQMA683J50
	C871		VCH1152
	VC901(20P)		VCM-008

RESISTORS

R521	RD1/6PM010J
R420	RD1/6PM470J
R259-R262	RD1/6PM473J
R490, R987, R989	RN1/10SE103D
R880, R883	RN1/10SE104D
R879, R986, R990	RN1/10SE333D
R881, R882	RN1/10SE473D
VR450(2.2kΩ)	PCP1025
VR603(4.7kΩ)	PCP1028
VR604, VR607, VR608, VR612(47kΩ)	PCP1031
Other Resistors	RS1/10S□□□J

OTHERS

CN108	12P FFC CONNECTOR	52045-1245
CN121	16P FFC CONNECTOR	52045-1645
CN102	21P FFC CONNECTOR	52045-2145
CN103	23P FFC CONNECTOR	52233-2310
CN106	11P TOP POST	B11P-SHF-1AA
CN110	B TO B CONNECTOR 12P	BTFN12S-3SB7
CN113	B TO B CONNECTOR 6P	BTFN6S-3SB7
JA3, JA4	REMOTE CONTROL JACK	RKN1004
	PCB BINDER	VEF1040
JA6	4P PIN JACK	VKB1065

Mark	No.	Description	Part No.
	JA13	RF PIN JACK	VKB1068
	JA15	1P PIN JACK	VKB1077
		64P IC SOCKET	VKH1004
		SCREW TERMINAL	VNE1948
	KN101, KN102	EARTH PLATE	VNF1084
	X101	CERAMIC RESONATOR(9.00MHz)	VSS1040
	X201	CERAMIC RESONATOR(16MHz)	VSS1057
	X550	CRYSTAL RESONATOR(14.318MHz)	VSS1073

GYCB ASSY

SEMICONDUCTORS

IC101	CXD2023Q
IC106	MC14577CP
IC102	TA7302P
Q102, Q104, Q111	2PB709A
Q101, Q103	2PD601A
Q115, Q172	2SC1740S

COILS

L101-L103	LFA220J
L104	LFA470J

CAPACITORS

C126	CCSQCH060D50
C140	CCSQCH150J50
C123, C127	CCSQCH220J50
C125	CCSQCH390J50
C124	CCSQCH560J50
C132	CCSQCH910J50
C145	CEAS100M50
C102, C105, C110, C112, C129	CEAS470M10
C131, C136, C138	CEAS470M10
C103	CKSQYB102K50
C135, C137, C141, C143, C144	CKSQYF103Z50
C150	CKSQYF103Z50
C101, C104, C109, C111	CKSQYF104Z25
C113-C119, C121, C122, C128	CKSQYF104Z25
C130, C133, C134, C142	CKSQYF104Z25
C146, C147, C152	CKSQYF104Z25

RESISTORS

R121, R123	RN1/10SE222D
R105, R107	RN1/10SE271D
R116, R117, R902, R911	RN1/10SE332D
R903	RN1/10SE392D
R103, R106	RN1/10SE472D
R912	RN1/10SE562D
Other Resistors	RS1/10S□□□J

OTHERS

CN101	B TO B CONNECTOR 12P	BTFN12P
CN102	B TO B CONNECTOR 6P	BTFN6P-3RD7
JA101	2P PIN JACK	DKB1028
JA103	4P MINI DIN SOCKET	VKN1072
	PIN JACK PLATE	VNE2021

5.SELF-DIAGNOSTIC FUNCTIONS

5.1 SELF-DIAGNOSTIC FUNCTIONS

The self-diagnostic functions automatically display an error code on the TV screen and front panel fluorescent display section when there is an error. The customer checks the error code and conveys it to the service personnel to make repairs more efficient.

After an error occurs, even if the error code goes off, you can display the error code again by holding down the **CLEAR** key for 10 seconds (except a loading error **L *** display). At that time, partial error is displayed with the mechanism switch information. However, if the power cord is unplugged, the error code information is lost.

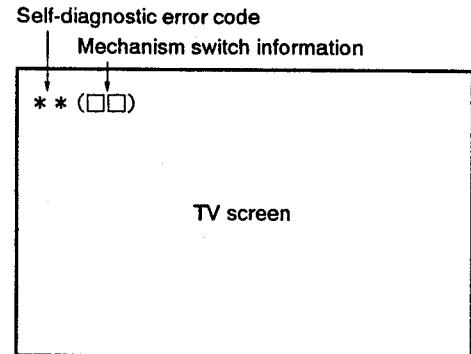

Fig. 1 TV screen display

This table explains the information for analyzing the cause when an error occurs with the CLD player.

Self-diagnostic error code	Contents	Conditions	Probable cause
H0	Spindle overcurrent detection error.	In the play state, overcurrent was detected in the spindle motor. Monitoring starts 5 seconds after the start of play or special playback mode, this error is detected if the overcurrent port is "L" for 4 seconds.	<ul style="list-style-type: none"> • Motor NG • Clamper rubbing
U0	FG abnormality error	<ol style="list-style-type: none"> ① At LD startup, the rate of rotation calculated from the FG was less than 15 rpm for 5 consecutive seconds from the spindle run command. ② At CD startup, there was less than 1/8th rotation even after 5 seconds had passed since the end of acceleration. ③ During play search, CD : subcodes are being read/LD : Phillips codes are being read and the spindle is locked, but a state in which the rate of rotation calculated from the FG was less than 15 rpm continued for 5 seconds or more. In the above case, it is judged that an abnormality has occurred in the FG sensor and that accurate rotation rate calculation has become impossible. 	<ul style="list-style-type: none"> • FG sensor abnormality, FG signal not coming to mechanism controller • FG sensor clogged • Rubbing between FG sensor and slit • Turntable dropped • FG slit deposition NG
H1	Partial short error	<ol style="list-style-type: none"> ① At LD startup, the speed did not reach 1200 rpm within a certain time (12 seconds) after the spindle run command. ② At CD startup, a certain speed (313 rpm) was not reached within 6 seconds from the end of spindle acceleration. 	<ul style="list-style-type: none"> • Spindle motor NG • Commutator NG • Bearing too tight • Power supply NG
H2 A0	Power supply abnormality error	<p>– 5V power supply abnormality detected.</p> <p>The power supply abnormality port is constantly monitored and if its signal stays high for about 1 second consecutively, the power supply is judged to be abnormal.</p>	<ul style="list-style-type: none"> • – 5V not fed from SYPS assy • Parts shorted
L *	Loading error	<ol style="list-style-type: none"> ① When loading operation goes over time (approx. 10 sec.). ② When assist at disc sense entry ends and is not tilt neutral. ③ When assist at set up entry ends and is not tilt neutral. 	<ul style="list-style-type: none"> • Tilt switch 1, 2, 3 abnormal, so tilt/loading state not read in correctly • Tilt/loading mechanism mechanically locked • Drive IC NG • Power supply NG
E *	Slider error	During slider movement, a time over-run occurred (track count search 20 seconds, mandatory movement 10 seconds)	<ul style="list-style-type: none"> • Slider ceased being able to run • The slider mechanism is mechanically locked and can no longer move to its target. • Slider position switch NG • Flexible cable pulled out • Drive IC NG • Power supply abnormal
U1	Miss clamp error	<ol style="list-style-type: none"> ① During LD setup, after 1/8th rotation, the track count during 1/8 rotation exceeded 511. ② During start-up, the focus was lost once and refocusing was attempted, but the focus could not be locked. ③ Two FG pulses did not come within 800 ms from from the start of LD start-up. ④ The disc clamp operation did not end within 5 seconds. 	<ul style="list-style-type: none"> • Disc sandwiched • Disc shifted • Spindle motor NG • Disc scratched or dirty defocused during start up • Two discs loaded • PU actuator NG • Tilt sensor NG • Tilt neutral NG (tilt base NG)

Self-diagnostic error code	Contents	Conditions	Probable cause
P *	Spindle error	① During TOC reading with an LD, the spindle servo was not locked within 60 seconds from the start of the spindle run. ② When CAV/CLV determination is not finished within 60 seconds from spindle servo lock. ③ The codes could not be read for 10 - 15 seconds consecutively for an LD or 7 - 10 seconds for a CD/CDV and the spindle servo was not locked. ④ The speed exceeded 2100 rpm during LD start up.	P0: •PH code, SUB-Q code can not be read •VCO, PLL offset out of adjustment •Disc defect P5: •PAL disc, mirror disc, etc. PLAY •No RF P6: •Spindle servo does not lock •Spindle motor NG
F *	Focus error	① "In the "no disc" state, a setup command was received from the mode controller. ② When LD is out of focus when slider is moved to starting position during set up. In case of CD/CDV is NG even after three focus tries. ③ During start-up, the maximum slider servo duty continued for 3 loops or more.	F5: •CD, LD on top of each other •LD scratched or dirty defocused during slider movement •Disc NG •Slider position switch NG F6: •Inner edge of disc scratched or dirty •Slider ran into inner edge mechanical stopper

* Besides the above errors, there is the "U2" communications error (the mode controller could not communicate normally with the mechanism controller)
 The probable cause is a defective mechanism controller, disconnected cable, etc..

- * Mechanism mode contents (meaning of * for L * etc.)
- | | | |
|----------------|----------------------------|---------------------|
| 0 : Play | 5 : Setup (rotation start) | 9 : Side A → Side B |
| 1 : Open | 6 : TOC read | A : Side B → Side A |
| 2 : Standby | 7 : Play | |
| 3 : Clamp | 8 : Search | |
| 4 : Disc sense | | |

5.2 FORMAT OF THE MECHANISM SWITCH INFORMATION WHICH IS TRANSMITTED TO THE MODE CONTROL IN THE ERROR OCCURRENCE

• Mechanism switch information (1 7)

Mechanism control → Mode control
 Communication byte address 5 (COMBUF5)
 (Mode control displays this value as it is.)

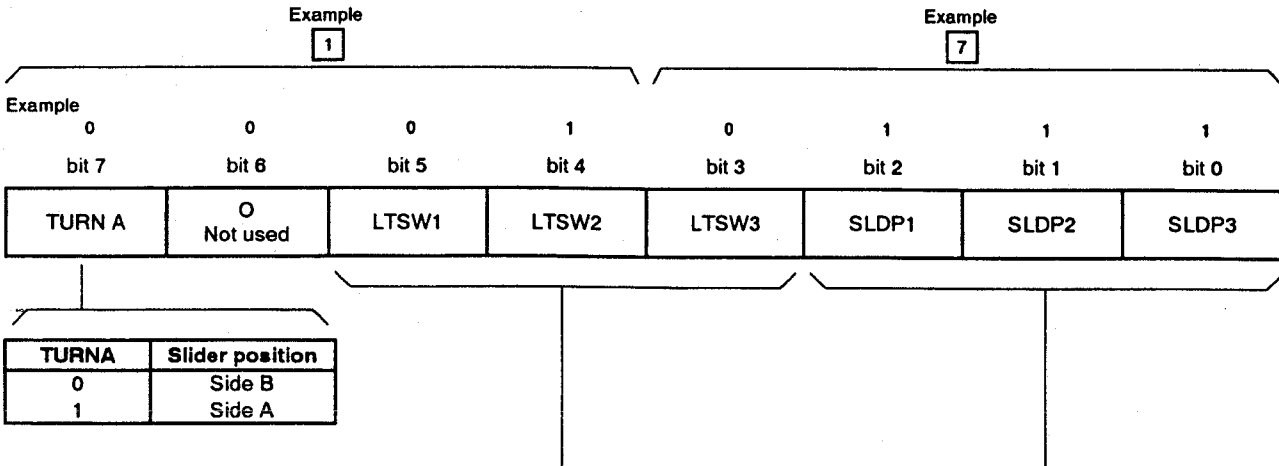

Example of 1 7 is indicated as follows.

(Slider : Side B
 Tilt : Tilt +
 Position : B-INSIDE)

LTSW			Loading/tilt position
1	2	3	
0	1	1	Open (Tray open state)
0	0	1	Loading (During move the tray horizontally)
1	0	1	Standby (Tray close & spindle down state)
1	0	0	Clamp (Durring spindle up or down)
0	0	0	Tilt - (Clamp state)
0	1	0	Tilt + (Clamp state)
1	1	0	Tilt limit (Clamp state)

SLDP			Slider position
1	2	3	
1	0	0	CD active position
1	0	1	CDV active position
1	1	0	LD active position
0	1	1	CD inside position
1	1	1	Side B inside position

6.2 ADJUSTMENT PRECAUTIONS

• Equipment and jigs needed for adjustment

- CD test disc (YEDS - 7)
- LD test disc (GGV1012)
- Medium-sized blade screwdriver
- Small blade screwdriver
- Large Phillips screwdriver
- Medium-sized Phillips screwdriver
- Two-channel oscilloscope (with delay)
- Frequency counter
- TV monitor

• Preparation for Adjustment

1. Disc tray removal

1. Remove the seven screws (A) fastening the bonnet and remove the bonnet.
2. With the power supply on, press the OPEN/CLOSE (LD) button and put the disc tray in the open position.
3. While pushing the hooks (B) on both sides of the rear of the disc tray inwards, pull out the disc tray.

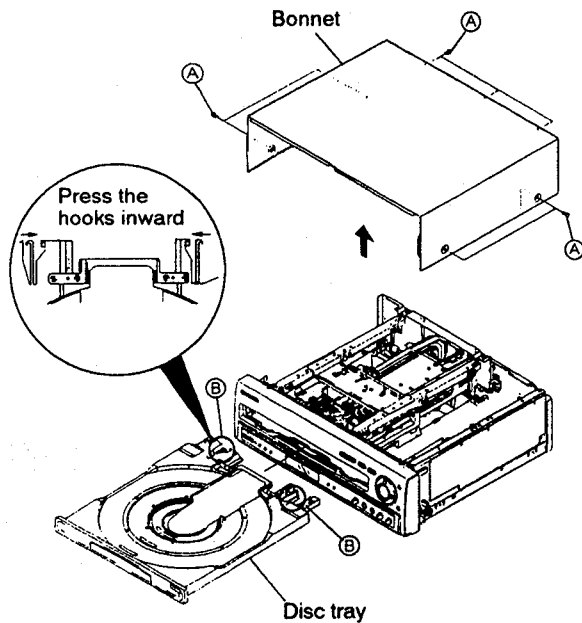

Fig. 7

Note: The adjustments other than "Electrical Adjustments 3. PLL OFFSET Adjustment" can be carried out with the disc tray mounted.

2. Diagnostic method of MOTHER assy

1. Remove the four screws (C) fastening the rear panel (L). (Fig. 8)

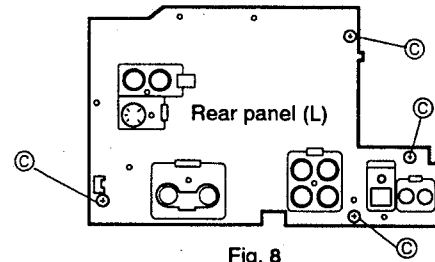

Fig. 8

2. Remove a screw (D) fastening the front side of PCB holder. (Fig. 9)
3. Remove the two screws (E) fastening the MOTHER assy. (Fig. 9)

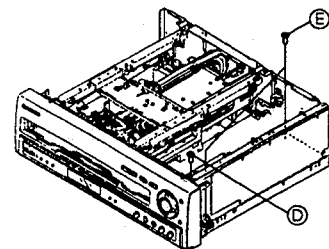

Fig. 9

4. Loosen the binder for fixing flat cable in the MOTHER assy.
5. While pulling up the rear panel (L) toward the rear, MOTHER assy will be removed with the rear panel (L). Then MOTHER assy can be diagnosed by standing it as shown in Fig. 10.

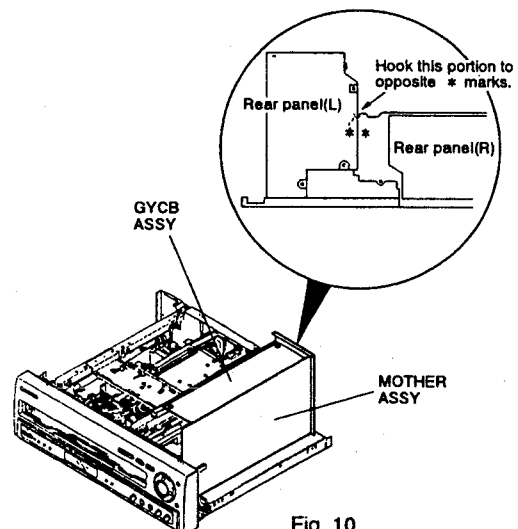

Fig. 10

Note 1: The MOTHER assy can be diagnosed with the disc tray mounted.

Note 1: When inserting the disc tray, please hold down the flat cable without hanging to the tray.

- Before adjusting mechanism system
- Centering adjustment screw and TAN adjustment screw

Note: Be careful not to turn centering adjustment screw and TAN adjustment screw past their adjustment range.

After the adjustments, apply the lock-tight to centering and TAN adjustment screws.

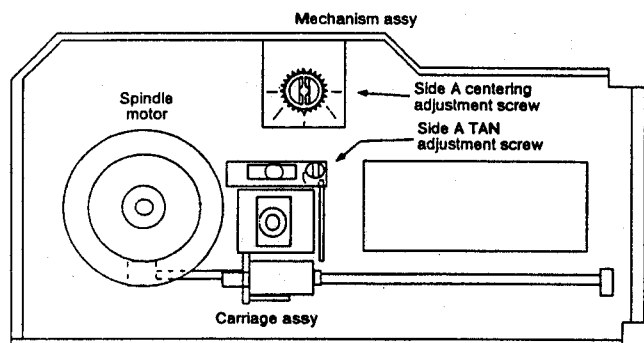

80° ±0.75mm 80° ±0.75mm

Do not turn the centering and TAN adjustment screws past their ranges, which are ± 0.75mm and ± 80° from center. Apply the lock-tight after the adjustment.

Fig. 11 Mechanism assy adjustment (side A)

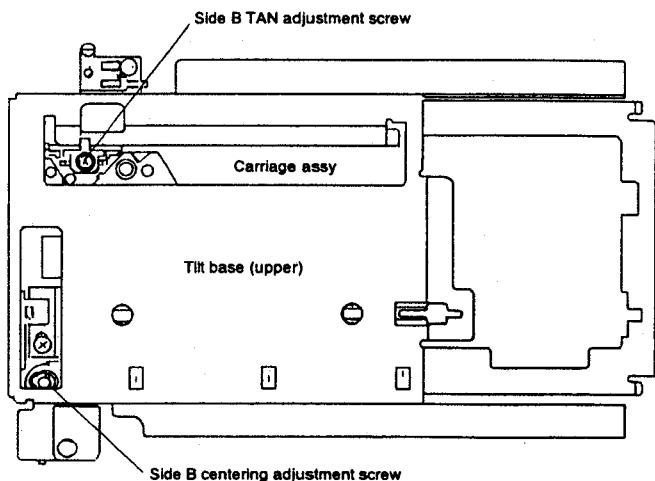

Centering adjustment range ± 90°
TAN adjustment range ± two turns

Fig. 12 Mechanism assy adjustment (side B)

- The mechanical adjustments can all be carried out with disc tray mounted.

- Notes when adjusting centering

If waveform S/N is bad and difficult to observe in "3 and 8. SPDL motor centering adjustment" use the low pass filter in diagram. (Fig. 13)

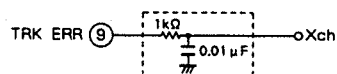

Fig. 13 Low pass filter

- Carriage assy position when adjusting centering

When moving slider to inner position to adjust the innermost track of disc during centering adjustment, be careful not to keep the mechanism stopper and carriage assy from bumping each other. (Fig. 14)

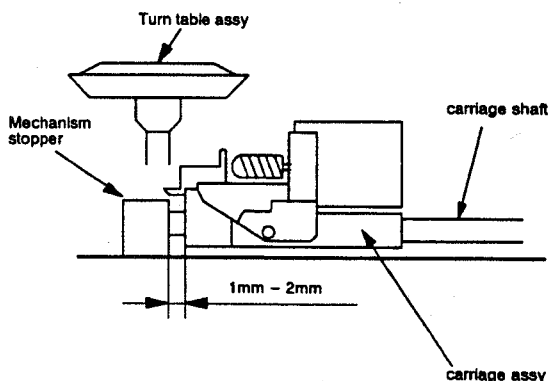

Fig. 14

- Notes when adjusting pickup assy

Please clean lens first when readjusting the pickup assy that is on this product. Also, when changing pickup assy, change whole carriage assy (VWT1100).

6.3 HOW TO REPLACE THE FLEXIBLE CABLE

① Bend the flexible cable as shown below.

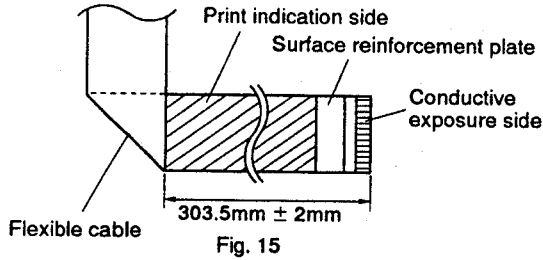

② Put the bended portion to hook ① of the large hill.
 ③ Bend the flexible cable along the wall of large hill.

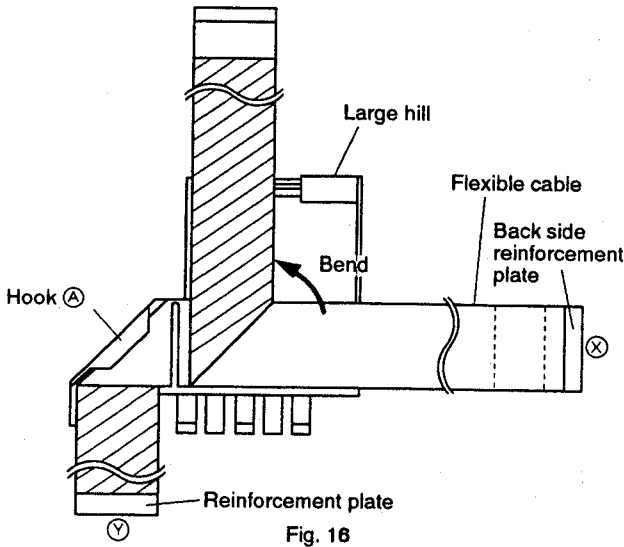

④ Pull the flexible cable not to slackened after passing the ① edge side of flexible cable through the large hill as shown in Fig. 17.

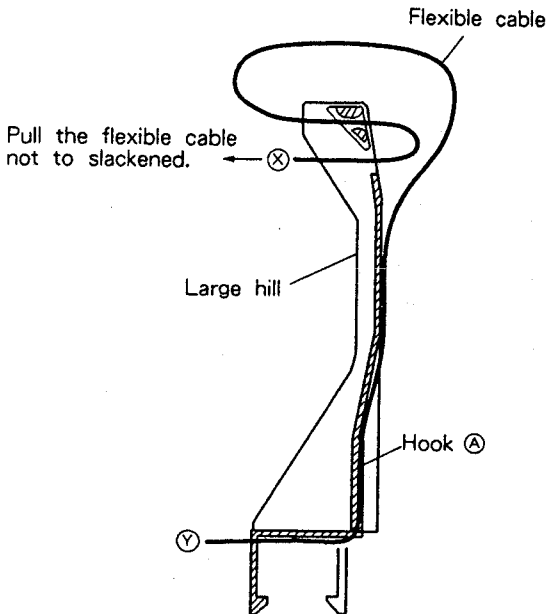

Fig. 17 Sectional plan

⑤ Put the flexible cable to hook ② after the ② edge side of flexible cable is bended along the hook ② position of the tilt base (lower), then insert to connector CN103 of the MOTHER assy.

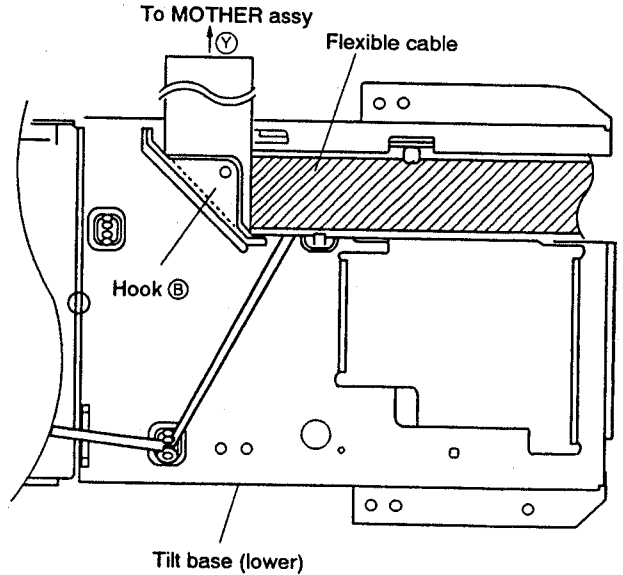

Fig. 18

⑥ Insert the ① edge side of flexible cable to connector of the carriage assy after passing through the FFC holder.
 ⑦ Move the FFC holder to touch the connector, lock the FFC holder to turn up the flexible cable to lower side.

Caution: Be sure to insert the MOTHER assy first of all for prevent the static electricity.

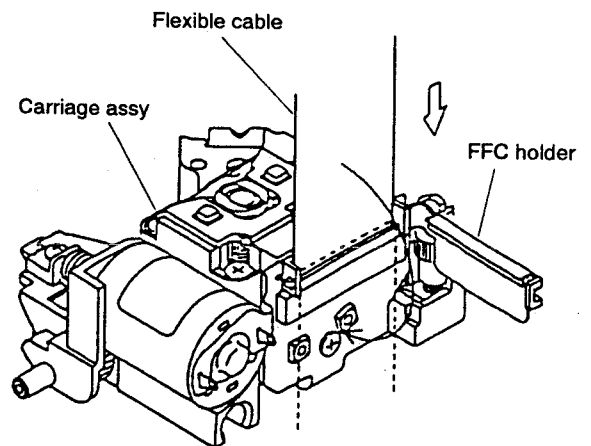
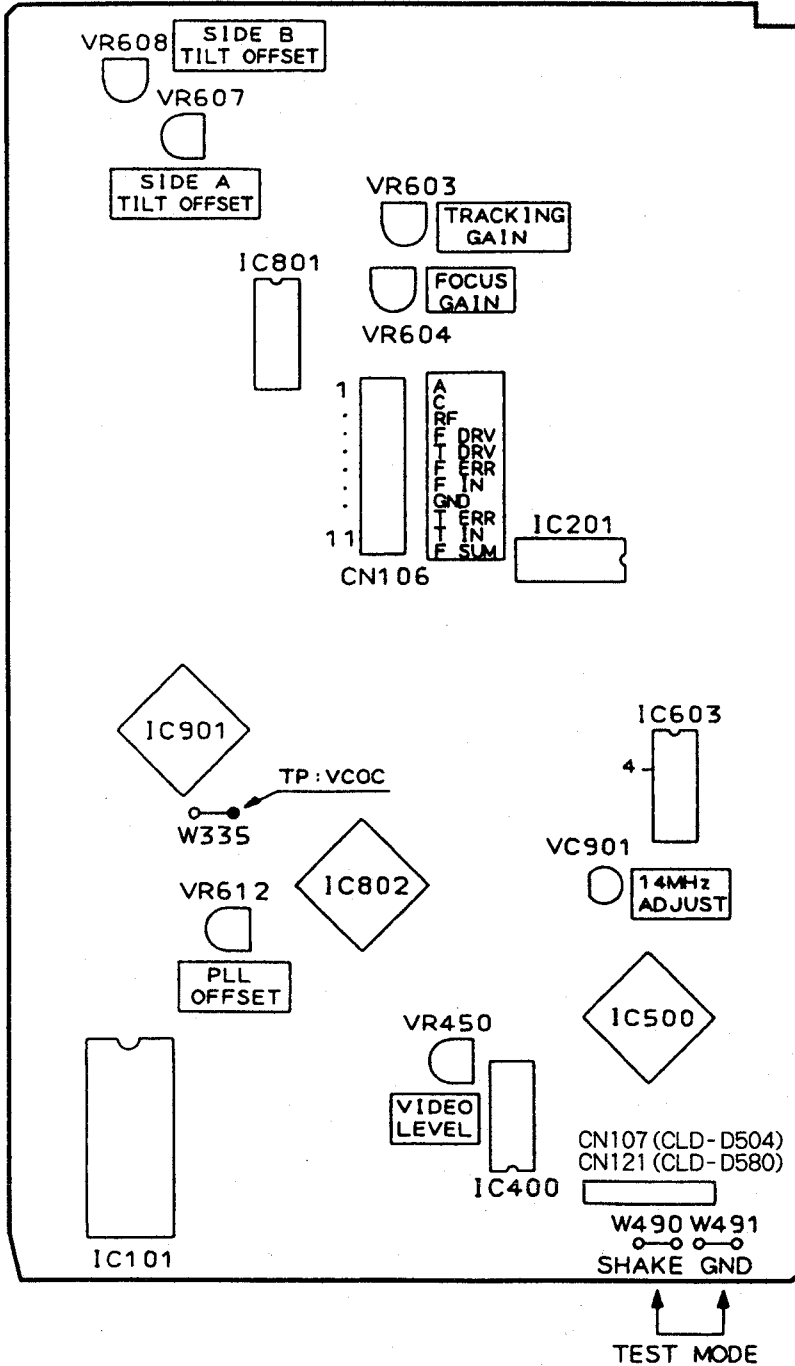

Fig. 19

6.4 ADJUSTMENT LOCATION

• MOTHER assy adjustment location



- VR607: Side A tilt offset adjustment
- VR608: Side B tilt offset adjustment
- VR604: Focus servo loop gain adjustment
- VR603: Tracking servo loop gain adjustment
- VC901: Master clock adjustment
- VR450: Output video level adjustment
- VR612: PLL offset adjustment (Orderin adjustment)

Fig. 20 Adjustment diagram of MOTHER assy

6.5 ADJUSTMENT METHOD

• Mechanical adjustment

Step	Adjustment name	Adjustment point	Measuring point and measuring mode	Player condition	Adjustment procedure	Waveform and connection diagram
1	Tilt offset adjustment	MOTHER assy VR607, VR608 (TILT OFFSET)		Test mode Disc not installed	Check the positions of VR607 and VR608 to the mechanical center with eyes. If there positions are shifted, set to the center.	Set to the mechanical center
2	Tangential direction angle adjustment (side A)	Carriage assy TAN adjustment screw (side A)	CN106-3 (RF)	CD test disc outer track play (See position for TAN adjustment screw) TRKG- ON, TILT- ON	Adjust so that the amplitude of the RF waveform reaches its maximum and the envelope is very clear. Apply the lock-tight after the adjustment.	V:20mV/div H:1 μsec/div AC mode
3	Spindle motor centering adjustment (side A)	Mechanism assy Centering adjustment screw (side A)	CN106-9 (TRKG error)	CD test disc inner track play (CD inside position in the program area) TRKG- OFF, TILT- ON	Adjust so that the amplitude of the tracking error waveform reaches its maximum and the envelope is very clear. Apply the lock-tight after the adjustment.	V:50mV/div H:10msec/div DC mode
4	Crosstalk check and tilt offset re-adjustment (side A)	MOTHER assy VR607 (side A) (TILT OFFSET)	TV monitor Crosstalk monitor check	LD test disc #115 still TRKG- ON, TILT- ON	If the crosstalk is pronounced, adjust VR607 until the crosstalk is not noticeable.	
5	Focus servo loop gain adjustment	MOTHER assy VR604 (FOCUS GAIN)	CN106-6 (FOCUS error) CH2 "X-Y mode"	LD test disc (PLAY STANDBY) Short CN106-7 (F IN) and 8 (GND), then press the PLAY key (disc not turn)	Adjust VR604 until the waveform level is $4.8 \pm 0.5V$.	Y: 50mV/div DC mode X-Y mode
6	Tracking servo loop gain adjustment	MOTHER assy VR603 (TRACKING GAIN)	CN106-9 (TRKG error) CH2 "X-Y mode"	LD test disc #115 still TRKG- ON, TILT- ON	Adjust VR603 until the waveform level is $1.8 \pm 0.2V$.	Y: 50mV/div DC mode X-Y mode
7	Tangential direction angle adjustment (side B)	Carriage assy TAN adjustment screw (side B)	CN106-3 (RF)	LD test disc #115 still TRKG- ON, TILT- ON	Adjust so that the amplitude of the RF waveform reaches its maximum and the envelope is very clear. Apply the lock-tight after the adjustment.	V:20mV/div H:1 μsec/div AC mode
8	Spindle motor centering adjustment (side B)	Mechanism assy Centering adjustment screw (side B)	CN106-9 (TRKG error)	LD test disc #115 still TRKG- OFF, TILT- ON	Adjust so that the amplitude of the tracking error waveform reaches its maximum and the envelope is very clear. Apply the lock-tight after the adjustment.	V:50mV/div H:10msec/div DC mode
9	Crosstalk check and tilt offset re-adjustment (side B)	MOTHER assy VR607 (side B) (TILT OFFSET)	TV monitor Crosstalk monitor check	LD test disc #115 still TRKG- ON, TILT- ON	If the crosstalk is pronounced, adjust VR607 until the crosstalk is not noticeable.	

(NOTE) • This adjustment can be thought to be about the same adjustment as on the manufacturing line with differing adjustment tools. Follow the adjustment procedures even for checking the adjustments.
 • When you open the tray in test mode, the screen displays goes out. To display the screen again, press the **DISPLAY** key.
 • The mechanical adjustment can be all carried out with disc tray mounted.

• Electrical adjustment

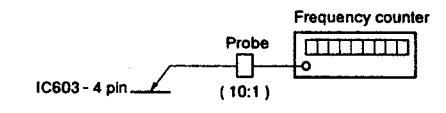
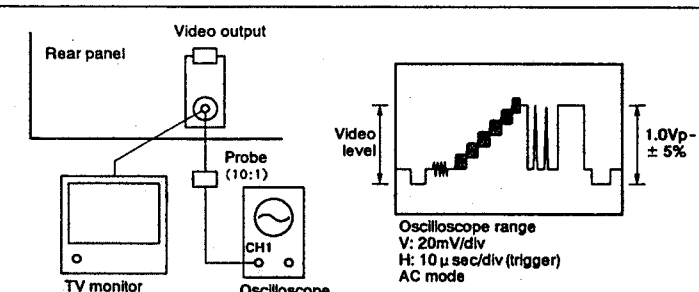
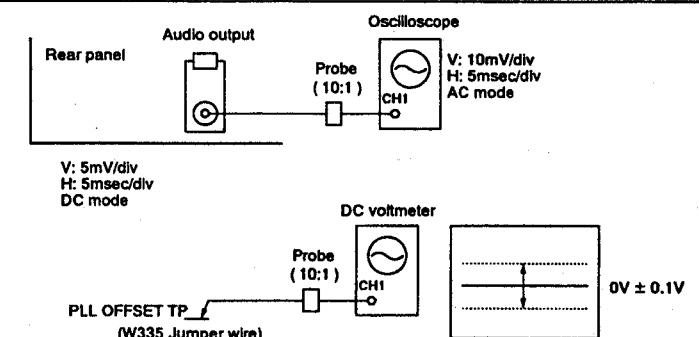
Step	Adjustment name	Adjustment point	Measurement point	Player condition	Adjustment procedure	Waveform and connection diagram
1	Master clock adjustment	MOTHER assy VC901	IC603-4 (2 fsc)	Power ON	Adjust VC901 so that frequency with power on is $7.159090\text{MHz} \pm 20\text{Hz}$. Connect video output terminal and oscilloscope. (Video output terminal is terminated with 75Ω)	
2	Output video level adjustment	MOTHER assy VR450 (VIDEO LEVEL)	Video output terminal	Normal mode LD test disc #19,900 still	Adjust VR450 so that level from video signal sync tip to 100% white becomes $1\text{Vp-p} \pm 5\%$. (It's possible to terminate video output terminal with 75Ω by connecting TV monitor)	
3	PLL OFFSET adjustment	MOTHER assy VR612 (PLL OFFSET)	W335 (PLL OFFSET TP)	Test mode CD test disc play TRKG servo OFF/ON	Note: Before adjusting remove disc tray. With the tracking servo off, playback digital audio and roughly adjust VR612 so that the sound is audible. Connect W335 and a DC voltmeter and while playing back digital audio, switch the tracking servo on and off and adjust VR612 so that the difference between the DC voltage when the tracking servo is on and when it is off is no greater than $0 \pm 0.1\text{V}$.	

7. IC INFORMATION

- The information shown in the list is basic information and may not correspond exactly to that shown in the schematic diagrams.

■ PD3302A (FLKY ASSY IC101)

• MODE CONTROL IC

• Pin Function

No.	Mark	Pin Name	I/O	Function	No.	Mark	Pin Name	I/O	Function
1	VCC	———	I	+5V	33	P48	XMIC ON	O	MIC MIX L : ON, H : OFF
2	P90	xRESET OUT	O	Mother board reset output.	34	P45	SEG N	O	Display segment output.
3	SCKI	xS - CLOCK	I/O	Serial communication clock. (Mech. control and character generator)	35	P44	KSCAN4/SEG M	O	Key scan output / Display segment output.
4	SI1	S - MTOF	I	Serial communication data input. (Mech. control)	36	P43	KSCAN3/SEG L	O	
5	SO1	S - FTOM	O	Serial communication data output. (Mech. control and character generator)	37	P42	KSCAN2/SEG K	O	
6	P94	xCS	O	Character generator (PD0108A) CS output. (L : enable)	38	P41	KSCAN1/SEG J	O	
7	P95	LED(D1SP0FF)	O	LED output : Display OFF indication.	39	P40	KSCAN0/SEG I	O	Display segment output.
8	P96	LED(Q TURN)	O	LED output : Quick turn indication.	40	P50	SEG H	O	
9	P97	POWCTL	O	Mother board power supply SW output.	41	P51	SEG G	O	
10	AVCC	———	I	+5V	42	P52	SEG F	O	
11	P00	KIN0	I	Key data input.	43	P53	SEG E	O	
12	P01	KIN1	I		44	P54	SEG D	O	
13	P02	KIN2	I		45	P55	SEG C	O	
14	P03	KIN3	I		46	P56	SEG B	O	
15	P04	KARXNOR	I	MIC SW L : OFF normal mode H : ON karaoke mode	47	P57	SEG A	O	- 27V
16	P05	XB KARA	I	B karaoke selection port L : B karaoke present H : absent	48	VDISP	———	I	
17	P06	ENGXJAP	I	Japanese/English selection port L : Japanese H : English	49	P60	G8	O	Display grid output.
18	P07	OEMSEL	I	OEM selection port L : PIONNER M : YAMAHA H : RCA	50	P61	G7	O	
					51	P62	G6	O	
19	AVSS	———	I	GND	53	P64	G4	O	
20	TEST	Not used	I	GND	54	P65	G3	O	
21	X2	Not used	O	NC (OPEN)	55	P68	G2	O	
22	X1	Not used	I	+5V	56	P67	G1	O	
23	VSS	GND	I	GND	57	P70	LED(LD)	O	LED output : LD indication
24	OSC1	———	I	Main system clock oscillation (8MHz)	58	P71	LED(CD)	O	LED output : CD indication
25	OSC2	———	O		59	P72	LED(SIDE B)	O	LED output : Side B indication
26	xRST	xRESET IN	I		CPU reset (L : reset)	60	P73	LED(SIDE A)	O
27	IRQ0	SHAKE	I/O	Mech. control serial communication requirement.	61	P74	Not used	O	N.C. (OPEN)
28	IRQ1	SEL IR	I	Remote control input.	62	P75	Not used	O	N.C. (OPEN)
29	P14	FSX	I	For measuring the error rate.					
30	P15	EFLG	I	For measuring the error rate.	63	P76	Not used	O	N.C. (OPEN)
31	P16	Not used	I	GND					
32	P47	DOGFOOD	O	Pulse output for watch dog.	64	P77	Not used	O	N.C. (OPEN)

■ PD9004A (MOTHER ASSY IC603)
-OSD IC

● Block Diagram

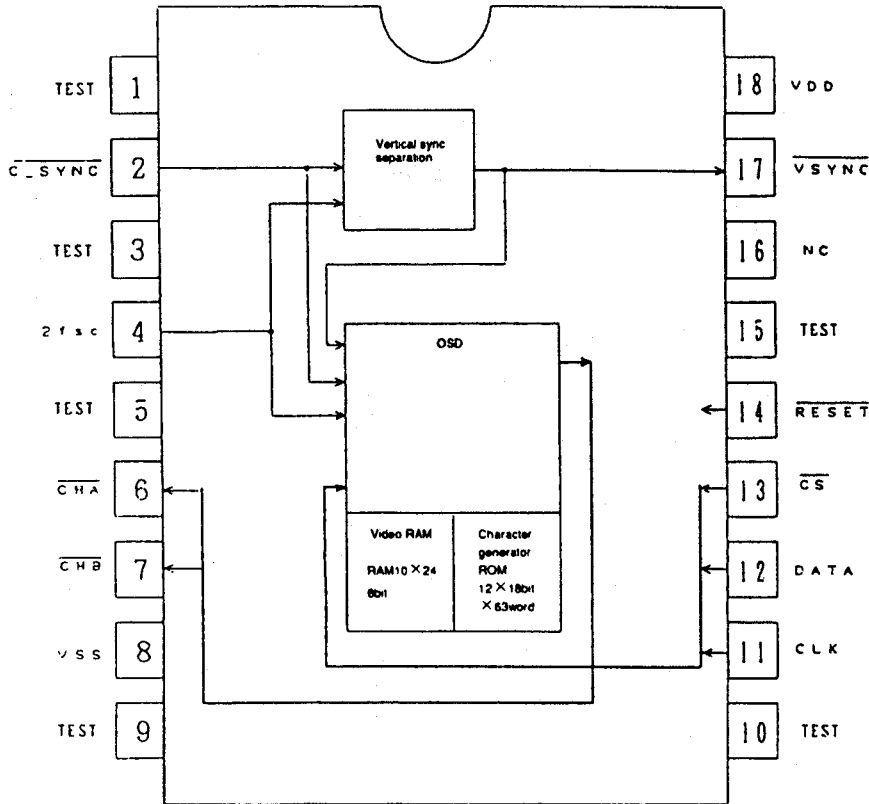

● Pin Function

Pin No	Code	I/O	Logic	Function
1	TEST	—	—	Do not connect any external components.
2	CSYNC	I	Negative	Composite sync signal input
3	TEST	—	—	Do not connect any external components.
4	2fsc	I	—	Color subcarrier frequency 2× clock input (NTSC about 7.14 MHz PAL about 8.8 MHz)
5	TEST	—	—	Do not connect any external components.
6	CHA	O	Negative	Character timing output
7	CHB	O	Negative	Blanking timing output
8	VSS	—	—	Connected to system ground
9	TEST	—	—	Do not connect any external components.
10	TEST	—	—	Do not connect any external components.
11	CLK	I	↑	Data read-in clock input pin; the data applied to the Data pin is read-in at the rising edge of the clock.
12	DATA	I	Positive	Control data input pin; the data is read-in synchronized with the clock applied to the CLK pin.
13	CS	I	Negative	Low for serial communications
14	RESET	I	Negative	Hardware reset with pull-up resistance
15	TEST	—	—	Do not connect any external components.
16	NC	—	—	Not connected
17	VSYNC	O	Negative	Signal with V sync separated from C sync
18	VDD	—	—	Power supply (+5V) pin

**■ PAC005B (MOTHER ASSY IC400)
-VIDEO IC**

● Block Diagram

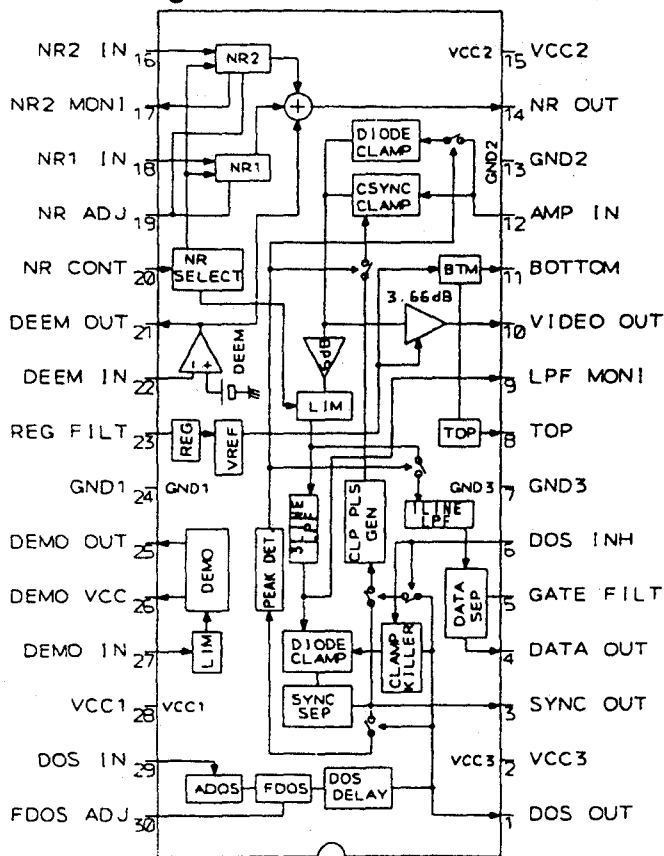

● Pin Function

No.	Pin Name	Function
1	.DOS OUT	Drop out pulse output.
2	VCC3	VCC for SYNC SEP section.
3	SYNC OUT	Composite sync output.
4	DATA OUT	Data pulse output.
5	GATE FILT	Connect a capacitor for Gate - Gate.
6	DOS INH	Clamp pulse and clamp killer control.
7	GND3	GND for SYNC SEP section.
8	TOP	Reference DC (TOP) for A/D.
9	LPF MONI	Monitor the LPF for SYNC SEP.
10	VIDEO OUT	Signal output for A/D.
11	BOTTOM	Reference DC (BOTTOM) for A/D.
12	AMP IN	Sync chip clamp input.
13	GND2	GND for VIDEO.
14	NR OUT	Noise reduction output.
15	VCC2	VCC for VIDEO section.
16	NR2 IN	Signal input (2) for noise reduction.
17	NR2 MONI	Limiter output for noise reduction.
18	NR1 IN	Signal input (1) for noise reduction.
19	NR ADJ	Limiter level adjusting pin for noise reduction.
20	NR CONT	Noise reduction (1, 2) select and limiter control.
21	DEEM OUT	De-emphasis output.
22	DEEM IN	De-emphasis input.
23	REG FILT	Connect a capacitor for regulator.
24	GND1	GND for RF section.
25	DEMO OUT	Demodulation output of RF signal.
26	DEMO VCC	VCC for FM demodulation output.
27	DEMO IN	RF input for FM demodulation.
28	VCC1	VCC for RF section.
29	DOS IN	RF input for DOS.
30	FDOS ADJ	FDOS sensitivity adjustment.

■ PD0192A (MOTHER ASSY IC500)
• DIGITAL VIDEO PROCESSOR

● Block Diagram

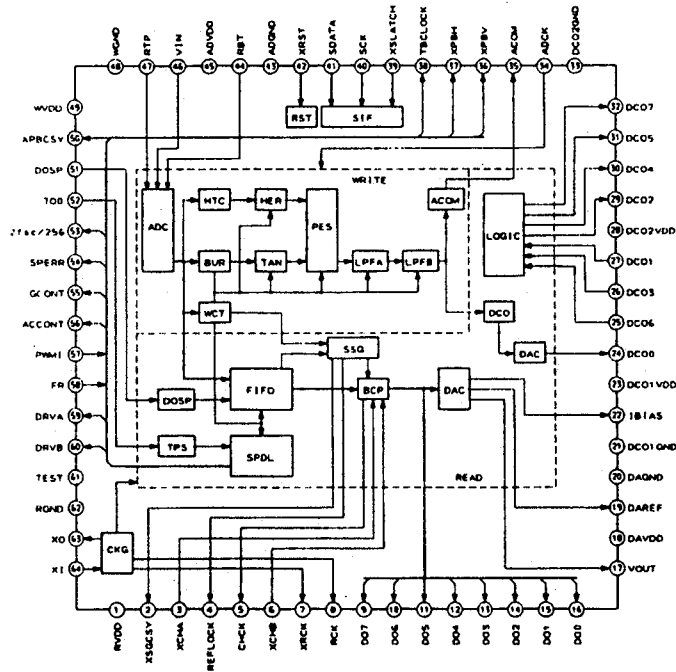

● Pin Function

No.	Pin Name	Function
1	RVDD	Power pin for reference system. Connect to +5V.
2	XSGCSY	Reference composite sync. is output at negative logic. Delay can be controlled by serial command.
3	WFM	MEMSYS : 1 Field monitor output for write system. Outputs "H" when in odd field.
	XCHA	MEMSYS : 0 Character input pin. Inputs "L" during character insertion.
4	XTBCH	MEMSYS : 1 TBC H sync. output. Outputs time base-corrected (TBC) H sync. at negative logic.
	REFLOCK	MEMSYS : 0 SSG phase detection signal output. Outputs "H" when phase difference of H, V sync. between Playbacksystem (after TBC) and SSG system is small enough.
5	XTBCV	MEMSYS : 1 TBC V sync. output. Outputs time base-corrected V sync. at negative logic.
	GHCK	MEMSYS : 0 Clock output for character generator. Output 2fsc.
6	FCH	MEMSYS : 1 Field change input. Switches field of SSG when "H".
	XCHB	MEMSYS : 0 Character frame input pin. Inputs "L" when character frame is inserted.
7	XRCK	Reference CLK is reversed and output.
8	RCK	Reference CLK output.
9	DO7	Data output 7
10	DO6	Data output 6
11	DO5	Data output 5
12	DO4	Data output 4
13	DO3	Data output 3
14	DO2	Data output 2
15	DO1	Data output 1
16	DO0	Data output 0
17	VOUT	DAC output of TBC video signal.
18	DAVDD	Power pin for D/A converter. Connect to +5V.
19	DAREF	D/A converter reference for video. Normally connect to DAGND via 0.1 μF of laminated ceramic capacitor.
20	DAGND	Ground pin for D/A converter. Connect to GND.
21	DCO1GND	Ground pin for DCO. Connect to GND.
22	IBIAS	Current setting pin of bias circuit. Normally connect to DAGND via external resistor (10k Ω).
23	DCO1VDD	Power pin for DCO. Connect to +5V.

No.	Pin Name	Function
24	DCO0	DCO output pin. ADCK is generated by multiplying this signal by 4.
25	DCO6	Waveform shaping input pin 6. Inputs signal of DCO5 output signal that is delayed 35 ns (self-biased).
26	DCO3	Waveform shaping input pin 3. Inputs signal of DCO2 output signal that is delayed 70 ns (self-biased).
27	DCO1	Waveform shaping input pin 1. Inputs DCO0 signal via band-pass filter of fsc (self-biased).
28	DCO2VDD	Power supply pin for multiplied by 4 section. Connect to +5V.
29	DCO2	Waveform shaping output pin 2. Outputs signal of waveform of DCO1 signal that is shaped.
30	DCO4	Waveform shaping output pin 4. Outputs signal of waveform of DCO3 signal that is shaped.
31	DCO5	Waveform shaping output pin 5. Outputs signal multiplied by 2.
32	DCO7	Waveform shaping output pin 7. Outputs signal multiplied by 4.
33	DCO2GND	Ground pin for multiplied by 4 section. Connect to GND.
34	ADCK	CLK input pin for write system. Inputs signal of DCO7 output signal that is filtered through 4 fsc ceramic filter. (self-biased)
35	ACOM	Jitter correction signal output for analog audio. Used to cancel the jitter of analog audio.
36	XPBV	V sync. output for playback system. Outputs signal that has V sync. separated from pin 50 (XPBCSY) signal at negative logic.
37	XPBH	H sync. output for playback system. Outputs signal that has H sync. separated from pin 50 (XPBCSY) signal at negative logic.
38	TBCLOCK	PLL LOCK detection signal output. Outputs "H" when spindle servo loop and TBC servo loop are locked.
39	XSLATCH	Serial interface latch signal input. Generates timing to latch data that was input to serial interface. (latched at L, Schmitt trigger input)
40	SCK	Serial interface CLK input. CLK input for serial interface. SDATA value is read at rising edge. (Schmitt trigger input)
41	SDATA	Serial interface data input. Inputs data to serial interface. (Schmitt trigger input)
42	XRST	System reset input. Initializes internal registers of IC at negative logic. (Schmitt trigger input)
43	ADGND	Ground pin for A/D converter. Connect to GND.
44	RBT	A/D converter bottom reference input. Inputs bottom reference voltage of A/D converter.
45	ADVDD	Power supply pin for A/D converter. Connect to +5V.
46	VIN	A/D converter input. Inputs composite video signal.
47	RTP	A/D converter top reference input. Inputs top reference voltage of A/D converter.
48	WGND	Ground pin for write system. Connect to GND.
49	WVDD	Power pin for write system. Connect to +5V.
50	XPBCSY	Composite sync. input for playback system. Inputs composite sync. for playback system at negative logic. (Schmitt trigger input)
51	DOSP	Drop out pulse input. Inputs drop out detection pulse at positive logic. (Schmitt trigger input)
52	TO0	Tracking open pulse input. Inputs tracking open pulse at positive logic. (Schmitt trigger input)
53	XI/512	Master clock 512 division output. Outputs clock of master clock (4fsc) that is divided by 512.
54	SPERR	Spindle error PFD error output. Outputs result after performing PFD on PBH and RefH at tri-state.
55	GCONT	Spindle gain control output. Outputs PWM signal according to set value (GD0 - GD3), using serial instructions.
56	ACCNT	Accelerated control output. Outputs acceleration/deceleration signal by forced acceleration/deceleration and PBH sync. frequency detection at tri-state.
57	PWMI	Spindle error PWM input. Inputs signals that have voltage compared between spindle errors that passed through a loop filter and chopping waves. (Schmitt trigger input)
58	FR	Spindle error direction component input. Inputs signals that have voltage compared between spindle errors that passed through a loop filter and target voltage. (Schmitt trigger input)
59	DRVA	Transistor control signal output pin for spindle motor drive. This setting is performed by the interface corresponding to the brush motor and brushless motor.
60	DRVB	Transistor control signal output pin for spindle motor drive. This setting is performed by the interface corresponding to the brush motor and brushless motor.
61	TEST	Input pin for IC test. Fixed to "L".
62	RGND	Ground pin for reference system. Connect to GND.
63	XO	Oscillation output. Connect the X'tal (4 fsc) for oscillation.
64	XI	Oscillation input. Connect the X'tal (4 fsc) for oscillation.

■ PD0212A (MOTHER ASSY IC101)
 • MECHANISM CONTROL IC

• Pin Function

No.	Pin Name	I/O	Function
1	VCC	I	Power supply pin. Apply 5V ± 10%.
2	RFCORR	O	RF correction switch signal output. "H" = gain UP CD, CDV - A: Low, CAV inner circuit gain up, others are High.
3	MUTE	O	Audio mute control signal output of audio system. L : Release MUTE , H : MUTE
4	SRDMUTE	O	Mute control signal output for AC3. Release MUTE during playback.. L : Release MUTE, H : MUTE
5	TILT ON	O	(For debugging)Tilt operation information. H : during operation for checking tilt operation.
6	TILTERR	I A/D	This signal is A/D converted as the tilt servo control input. Control the tilt motor so that this signal becomes 2.5V.
7	TBALERR	I A/D	Tracking error balance signal input. This signal is A/D converted as the tracking offset control input.
8	SLDERR	I A/D	This signal is A/D converted as the slider servo control input. Control the tilt motor so that this signal becomes 2.5V.
9	SLDPOS	I A/D	Pickup position detection switch input. Detect the position by reading A/D input value which each switches are resistance divided.
10	XFOK	I	Focus servo lock signal input. L : Lock , H : Unlock Use for lock detection of focus servo.
11	SINGLE	I	ATT - SW of rear panel use for the single mode. This information transmit to mode control by communication. L : Single H : Normal
12	TBALDRV	O PWM	Output the tracking offset signal to PWM output, then use for auto tracking offset. 910 μsec period, tri-state control H, L, Z
13	XCD	O	LD/CD switch signal output pin. L : CD H : LD
14	XPLAY	O	Signal output during spindle servo. L : during servo H : during acceleration, brake and stop
15	SQOUT	I	Command data input from DSP. Read out SUBQ.
16	COIN	O	Command data output to DSP.
17	CQCK	O	DSP reading/writing command clock output pin. read at rising edge.
18	SLDDR	O PWM	Slider control signal output pin. 5V=FWD, 0V=REV, 2.5V=STOP 910 μsec period, tri-state control H, L, Z
19	SI1	I	Data input from the mode control IC.
20	SO1	O	Serial data output to the mode control IC.
21	SCK1	I/O	Clock for serial communication with the mode control IC. Becomes input mode without communicate with the mode control IC.
22	TZC	I INT	Tracking error zero cross signal input pin. Monitor this signal when searching track count in the miss clamp detection.
23	SHAKE	I/O	Hand shake signal for data communication with the mode control IC. Each microcomputer controls input/output by bilateral data line.
24	TILTDRV	I/O	LOAD/TILT control output pin. 0.5V - tray IN, OUT/tilt DOWN, UP 2.5V - STOP Use for tilt servo that tilt drive is PWM output.
25	XANA	O	Digital/Analog audio switch signal output. L : Analog H : Digital
26	XPBV	I	Playback vertical sync. signal input of LD/CDV. L : during vertical sync.
27	CNVss	I	Ground pin for A/D conversion.
28	XRESET	I	Reset signal input. L : Reset H : Release reset Mode control is controlled.
29	XIN	I	9MHz clock oscillation input pin.
30	XOUT	O	9MHz clock oscillation output pin.
31	N.C.	O	Not used.
32	GND	I	Ground.
33	SW1	I	Switch input for Loading/Tilt position detection
34	SW3	I	
35	SW2	I	

No.	Pin Name	I/O	Function
36	N.C.	I	Not used.
37	FG	I	Spindle motor FG signal input. 16 outputs per rotation. Used after dividing by 2 in microcomputer.
38	DATA	I	Input pin for Phillips code decoder with built in mechanism controller.
39	XPBH	I	Playback H - SYNC input for Phillips code decoder.
40	XPBV	I	Playback V - SYNC input for Phillips code decoder.
41	TURNA	I	Turn switch input. H : side A L : side B
42	BINSIDE	I	Side B inside switch input. L : Side B inside H : others
43	MEMLAT	O	Serial control latch output of memory control IC (PD4510A). Latches at falling edge.
44	MEMORY	I	Memory yes/no determination input pin. H :memory yes L : memory no
45	DOCINH	O	Control the clamp pulse and clamp killer by tri-state values.
46	DETPOW	I	Use for power abnormal signal input port. L : Normal H : Abnormal
47	NROFF	O	Control output of the noise reduction by VDEM. L : Normal H : Not NR
48	WFM	I	Field determination signal from DVP. L : EVEN H : ODD
49	SQ1	O	Analog audio switch signal output 1/L. L : squelch OFF H : squelch ON
50	SQ2	O	Analog audio switch signal output 2/R. L : squelch OFF H : squelch ON
51	XCX	O	Analog audio CX noise reduction switch signal output. L : CX ON H : CX OFF
52	XVCECAN	O	Voice cancel output. L : CANCEL ON , H : OFF
53	SO3	O	Serial 3 data signal output. Serial signal is commoned, signal distinguish by latch signal (DVPLAT, TLAT).
54	SCK3	O	Serial 3 clock signal output.
55	DVPLAT	O	PD0192A serial latch signal output pin. Latches at falling edge.
56	TBCLOCK	I	Spindle lock signal input pin. L : Unlock , H : Lock
57	TLATCH	O	DAC & digital filter PD2026B serial control latch signal output pin. Latches at falling edge.
58	XREV	O	Side A/side B switch pin. H : side A , L : side B
59	DETAMP	I	Spindle over-current detection signal input pin. L : over current , H : Normal
60	FSEQ	I	Subcode sync. conformity detection signal input pin. L : Not conformity , H : Conformity
61	THOLD	I	Track jump accelerating/decelerating signal input pin. L : other H : accelerating/decelerating
62	WRQ	I	Subcode Q reading OK signal input pin. L : NG , H : OK This pin will be H when Subcode Q data passed by CRC check.
63	RWC	O	DSP read/write command signal output pin. L : READ H : WRITE
64	RWC2	I	Set to input port without influence when this pin short-circuit to pin 63.

8. FL INFORMATION

■ VAW1035 (FLKY ASSY V101)
FL TUBE

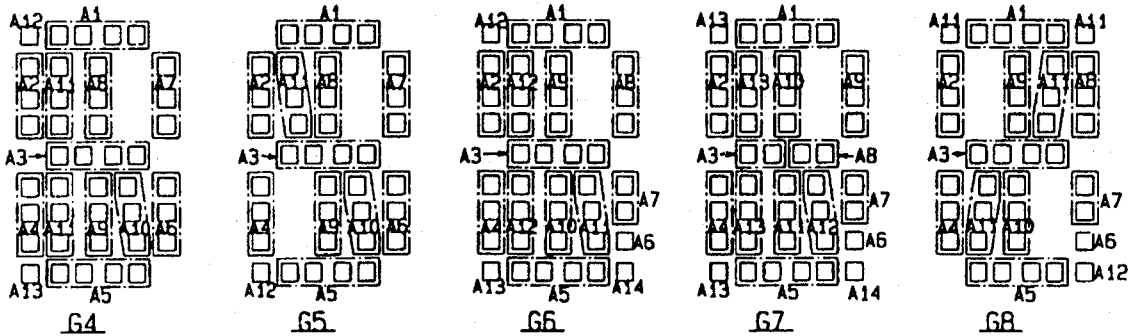
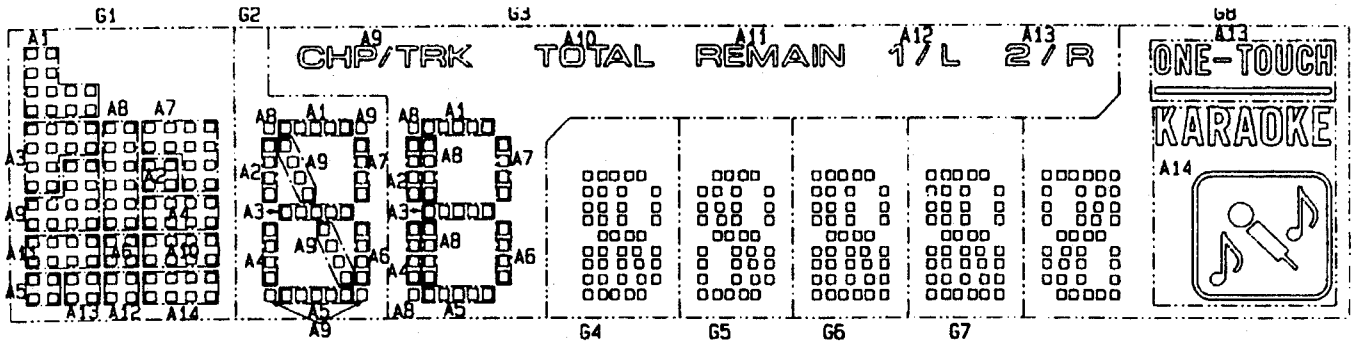

ANODE GRID ASSIGNMENT & PIN ASSIGNMENT

	G1	G2	G3	G4	G5	G6	G7	G8
P1	A1	A1	A1	A1	A1	A1	A1	A1
P2	A2	A2	A2	A2	A2	A2	A2	A2
P3	A3	A3	A3	A3	A3	A3	A3	A3
P4	A4	A4	A4	A4	A4	A4	A4	A4
P5	A5	A5	A5	A5	A5	A5	A5	A5
P6	A6	A6	A6	A6	A6	A6	A6	A6
P7	A7	A7	A7	A7	A7	A7	A7	A7
P8	A8	A8	A8	A8	A8	A8	A8	A8
P9	A9	A9	CHP/TRK	A9	A9	A9	A9	A9
P10	A10		TOTAL	A10	A10	A10	A10	A10
P11	A11		REMAIN	A11	A11	A11	A11	A11
P12	A12		1/L	A12	A12	A12	A12	A12
P13	A13		2/R	A13		A13	A13	ONE-TOUCH
P14	A14					A14	A14	KARAOKE

PIN ASSIGNMENT

Pin No.	1	2	3	4	5	6	7	8	9	10	11	12	13	14	15	16	17
Assignment	F	F	NP	NL	NL	NL	NL	G1	G2	G3	G4	G5	G6	G7	G8	P1	P2

Pin No.	18	19	20	21	22	23	24	25	26	27	28	29	30	31	32	33	34
Assignment	P3	P4	P5	P6	P7	P8	P9	P10	P11	P12	P13	P14	NL	NL	NP	F	F

F:Filament G1-G8:Grid P1-P14:Anode NP:No pin NL:No Lead

9. BLOCK DIAGRAM

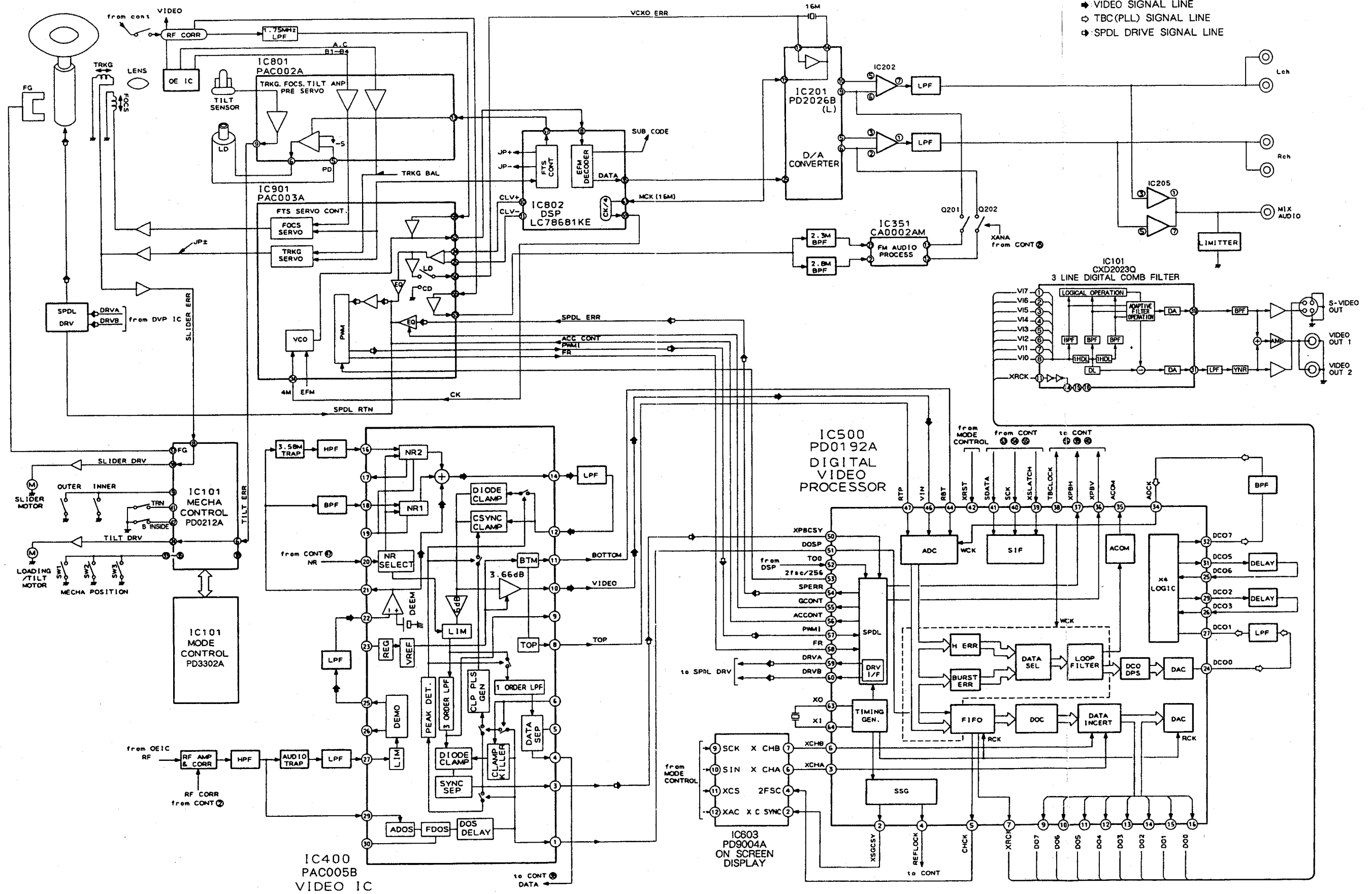

10. PANEL FACILITIES

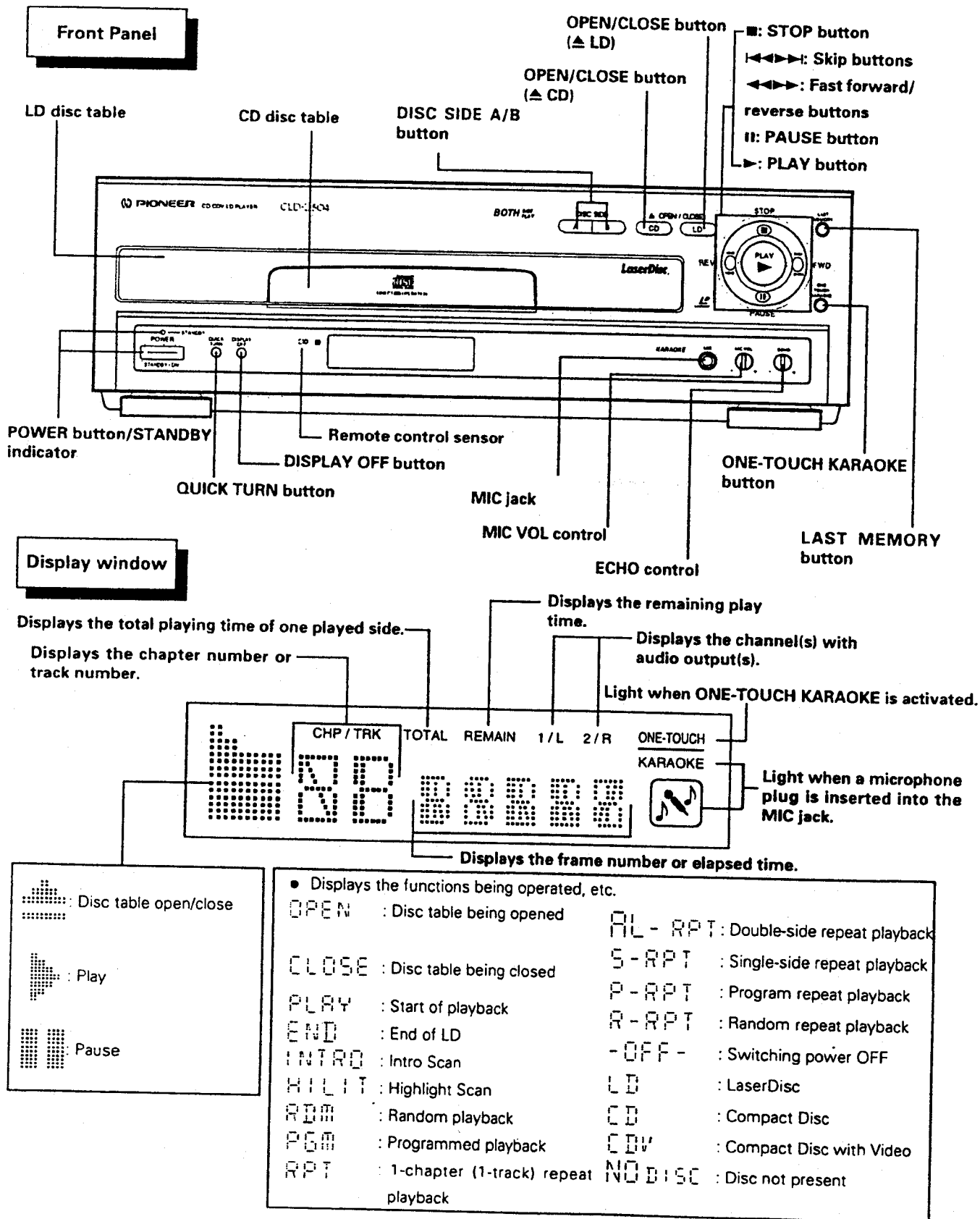

11. SPECIFICATIONS

• For CLD - D504

General

System LaserVision Disc system and
Compact Disc digital audio system
Laser Semiconductor laser wavelength 780 nm
Power requirement AC 120 V, 60 Hz
Power consumption 34 W
Weight 6.7 kg (14.8 lbs)
Dimensions 420 (W) x 404 (D) x 132 (H) mm
16-9/16 (W) x 15-15/16 (D) x 5-3/16 (H) in
Operating temperature +5°C ~ +35°C
(41°F ~ 95°F)
Operating humidity 5% ~ 85%
(There should be no condensation of moisture.)

Video characteristics (2 pairs)

Format NTSC specifications
Video output
Level 1 Vp-p nominal, sync. negative, terminated
Impedance 75 Ω unbalanced
Jacks RCA jacks

S VIDEO output

Y output level 1 Vp-p (75 Ω)
C output level 286 mVp-p (75 Ω)
Jacks S VIDEO jacks

Audio characteristics (2 pairs)

Output level
During analog audio output 200 mVrms
(1 kHz, 40%)
During digital audio output 200 mVrms
(1 kHz, -20 dB)
Jacks Both RCA jacks
Number of channels 2 (Stereo)

Digital Audio Characteristics

Frequency characteristics	4 Hz - 20 kHz
SN ratio	115 dB (EIAJ)
Dynamic range	96 dB (EIAJ)
Total harmonic distortion	Below 0.0035%
Wow and flutter	Below measurable limit (± 0.001% W.PEAK) (EIAJ)

LD is in compliance with EIAJ.

Other terminals

Control input/output Both miniature jacks
VHF adapter output (Video/Audio) Both RCA jacks
with CD jack
AC-3 RF OUT RCA jack

Accessories

Remote control unit 1
Size "AAA" (IEC R03) dry cell batteries 2
Microphone 1
Video cord 1
Audio cord 1
Operating instructions 1
Warranty card 1

NOTE :

The specifications and design of this product are subject to change without notice, due to improvement.

• For CLD - D580

General

System LaserVision Disc system and
Compact Disc digital audio system
Laser Semiconductor laser wavelength 780 nm
Power requirement AC 110-240 V, 50/60 Hz
(automatic select)
Power consumption 34 W
Weight 6.6 kg (14.5 lbs)
Dimensions 420 (W) x 404 (D) x 132 (H) mm
16-9/16 (W) x 15-15/16 (D) x 5-3/16 (H) in
Operating temperature +5°C ~ +35°C
(41°F ~ 95°F)
Operating humidity 5% ~ 85%
(There should be no condensation of moisture.)

Video characteristics (2 pairs)

Format NTSC specifications
Video output
Level 1 Vp-p nominal, sync. negative, terminated
Impedance 75 Ω unbalanced
Jacks RCA jack

S VIDEO output

Y output level 1 Vp-p (75 Ω)
C output level 286 mVp-p (75 Ω)
Jacks S VIDEO jack

Audio characteristics (2 pairs)

Output level
During analog audio output 200 mVrms
(1 kHz, 40%)
During digital audio output 200 mVrms
(1 kHz, -20 dB)
Jacks Both RCA jacks
Number of channels 2 (Stereo)

Digital Audio Characteristics

Frequency characteristics	4 Hz - 20 kHz
SN ratio	115 dB (EIAJ)
Dynamic range	96 dB (EIAJ)
Total harmonic distortion	Below 0.0035%
Wow and flutter	Below measurable limit (± 0.001% W.PEAK) (EIAJ)

LD is in compliance with EIAJ.

Other terminals

Control input/output Both miniature jacks
VHF adapter output (Video/Audio) Both RCA jacks with CD jack
AC-3 RF OUT RCA jack

Accessories

Remote control unit 1
Size "AAA" (IEC R03) dry cell batteries 2
Video cord 1
Audio cord 1
Power cord 1
Operating instructions 1
Warranty card 1

NOTE :

The specifications and design of this product are subject to change without notice, due to improvement.