

Service Manual

PIONEER
The Art of Entertainment

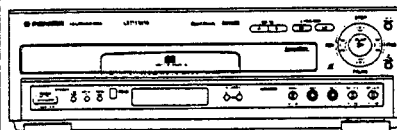

• CLD-D604

ORDER NO.
RRV1252

CD CDV LD PLAYER

CLD-D604

CLD-D780

THIS MANUAL IS APPLICABLE TO THE FOLLOWING MODEL(S) AND TYPE(S).

Type	Model		Power Requirement	Remarks
	CLD-D604	CLD-D780		
KU	○	—	AC120V	
KC	○	—	AC120V	
RD	—	○	AC110-240V	Automatic select

CONTENTS

1. SAFETY INFORMATION	2	5. SELF-DIAGNOSTIC FUNCTIONS	49
2. EXPLODED VIEWS, PACKING AND PARTS LIST	3	6. ADJUSTMENTS	51
3. SCHEMATIC AND PCB CONNECTION DIAGRAMS	17	7. IC INFORMATION	61
4. PCB PARTS LIST	42	8. FL INFORMATION	72
		9. BLOCK DIAGRAM	73
		10. PANEL FACILITIES	75
		11. SPECIFICATIONS	76

PIONEER ELECTRONIC CORPORATION 4-1, Meguro 1-Chome, Meguro-ku, Tokyo 153, Japan
PIONEER ELECTRONICS SERVICE INC. P.O. Box 1760, Long Beach, California 90801 U.S.A.
PIONEER ELECTRONICS OF CANADA, INC. 300 Allstate Parkway Markham, Ontario L3R 0P2 Canada
PIONEER ELECTRONIC [EUROPE] N.V. Haven 1087 Keetberglaan 1, 9120 Melsele, Belgium
PIONEER ELECTRONICS AUSTRALIA PTY. LTD. 178-184 Boundary Road, Braeside, Victoria 3195, Australia TEL: [03] 580-9911
 © PIONEER ELECTRONIC CORPORATION 1995

T-IFM FEB. 1995 Printed in Japan

1. SAFETY INFORMATION



This service manual is intended for qualified service technicians; it is not meant for the casual do-it-yourselfer. Qualified technicians have the necessary test equipment and tools, and have been trained to properly and safely repair complex products such as those covered by this manual. Improperly performed repairs can adversely affect the safety and reliability of the product and may void the warranty. If you are not qualified to perform the repair of this product properly and safely, you should not risk trying to do so and refer the repair to a qualified service technician.

WARNING

Lead in solder used in this product is listed by the California Health and Welfare agency as a known reproductive toxicant which may cause birth defects or other reproductive harm (California Health & Safety Code, Section 25249.5). When servicing or handling circuit boards and other components which contain lead in solder, avoid unprotected skin contact with the solder. Also, when soldering do not inhale any smoke or fumes produced.



NOTICE

(FOR CANADIAN MODEL ONLY)

Fuse symbols  (fast operating fuse) and/or  (slow operating fuse) on PCB indicate that replacement parts must be of identical designation.

REMARQUE

(POUR MODÈLE CANADIEN SEULEMENT)

Les symboles de fusible  (fusible de type rapide) et/ou  (fusible de type lent) sur CCI indiquent que les pièces de remplacement doivent avoir la même désignation.

(FOR USA MODEL ONLY)

1. SAFETY PRECAUTIONS

The following check should be performed for the continued protection of the customer and service technician.

LEAKAGE CURRENT CHECK

Measure leakage current to a known earth ground (water pipe, conduit, etc.) by connecting a leakage current tester such as Simpson Model 229-2 or equivalent between the earth ground and all exposed metal parts of the appliance (input/output terminals, screwheads, metal overlays, control shaft, etc.). Plug the AC line cord of the appliance directly into a 120V AC 60Hz outlet and turn the AC power switch on. Any current measured must not exceed 0.5mA.

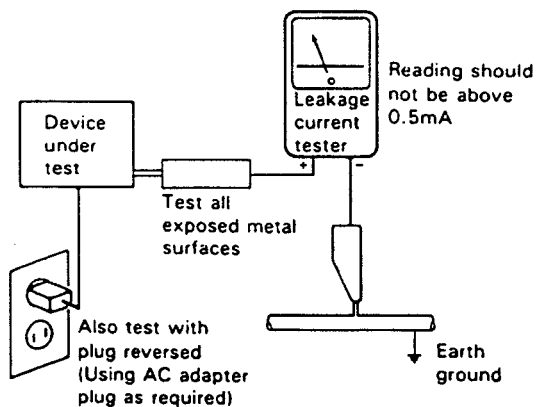

AC Leakage Test

ANY MEASUREMENTS NOT WITHIN THE LIMITS OUTLINED ABOVE ARE INDICATIVE OF A POTENTIAL SHOCK HAZARD AND MUST BE CORRECTED BEFORE RETURNING THE APPLIANCE TO THE CUSTOMER.

2. PRODUCT SAFETY NOTICE

Many electrical and mechanical parts in the appliance have special safety related characteristics. These are often not evident from visual inspection nor the protection afforded by them necessarily can be obtained by using replacement components rated for voltage, wattage, etc. Replacement parts which have these special safety characteristics are identified in this Service Manual.

Electrical components having such features are identified by marking with a Δ on the schematics and on the parts list in this Service Manual.

The use of a substitute replacement component which does not have the same safety characteristics as the PIONEER recommended replacement one, shown in the parts list in this Service Manual, may create shock, fire, or other hazards.

Product Safety is continuously under review and new instructions are issued from time to time. For the latest information, always consult the current PIONEER Service Manual. A subscription to, or additional copies of, PIONEER Service Manual may be obtained at a nominal charge from PIONEER.

2. EXPLODED VIEWS, PACKING AND PARTS LIST

NOTES:

- Parts marked by "NSP" are generally unavailable because they are not in our Master Spare Parts List.
- The Δ mark found on some component parts indicates the importance of the safety factor of the part. Therefore, when replacing, be sure to use parts of identical designation.
- Parts marked by "☉" are not always kept in stock. Their delivery time may be longer than usual or they may be unavailable.
- Parts list without notice are common for CLD-D604/KU, CLD-D604/KC and CLD-D780/RD.

2.1 EXTERIOR AND DISC TRAY SECTION

(1) CONTRAST OF CLD - D604/KU, CLD - D604/KC AND CLD - D780/RD.

CLD - D604/KU, CLD - D604/KC and CLD - D780/RD have the same construction except for the following:

Mark	No.	Symbol & Description	Part No.			Remarks
			CLD - D604/KU	CLD - D604/KC	CLD - D780/RD	
	4	Rear cover	VNK3128	VNK3128	VNK3303	
	21	65 label	ORW1069	Not used	Not used	

(2) PARTS LIST FOR CLD - D604/KU

Mark	No.	Description	Part No.	Mark	No.	Description	Part No.
	1	Bonnet S	VXX2252		11	Cushion	VEC1682
	2	Screw	BBZ30P080FMC		12	Damp Cushion	VEC1683
	3	Screw	BCZ40P060FZK	NSP	13	Label	VRW1289
	4	Rear cover	VNK3128		14	LD tray assy	VXA2173
	5	Guide plate (R)	VNE1939		15	CD door assy	VXA2190
	6	Guide plate (L)	VNE1938		16	Door spring	VBH1248
	7	CD tray	VNK3007		17	Door holder	VNE1967
	8	Lock plate	VNL1635		18	Damper assy	VXA1999
	9	Lock plate spring	VBH1188		19	Tray panel	VNK2993
	10	Tray assy - S	VXX2307		20	Laser disc badge	VAM1029
					21	65 label	ORW1069
					22	Tray panel assy - S	VXX2286

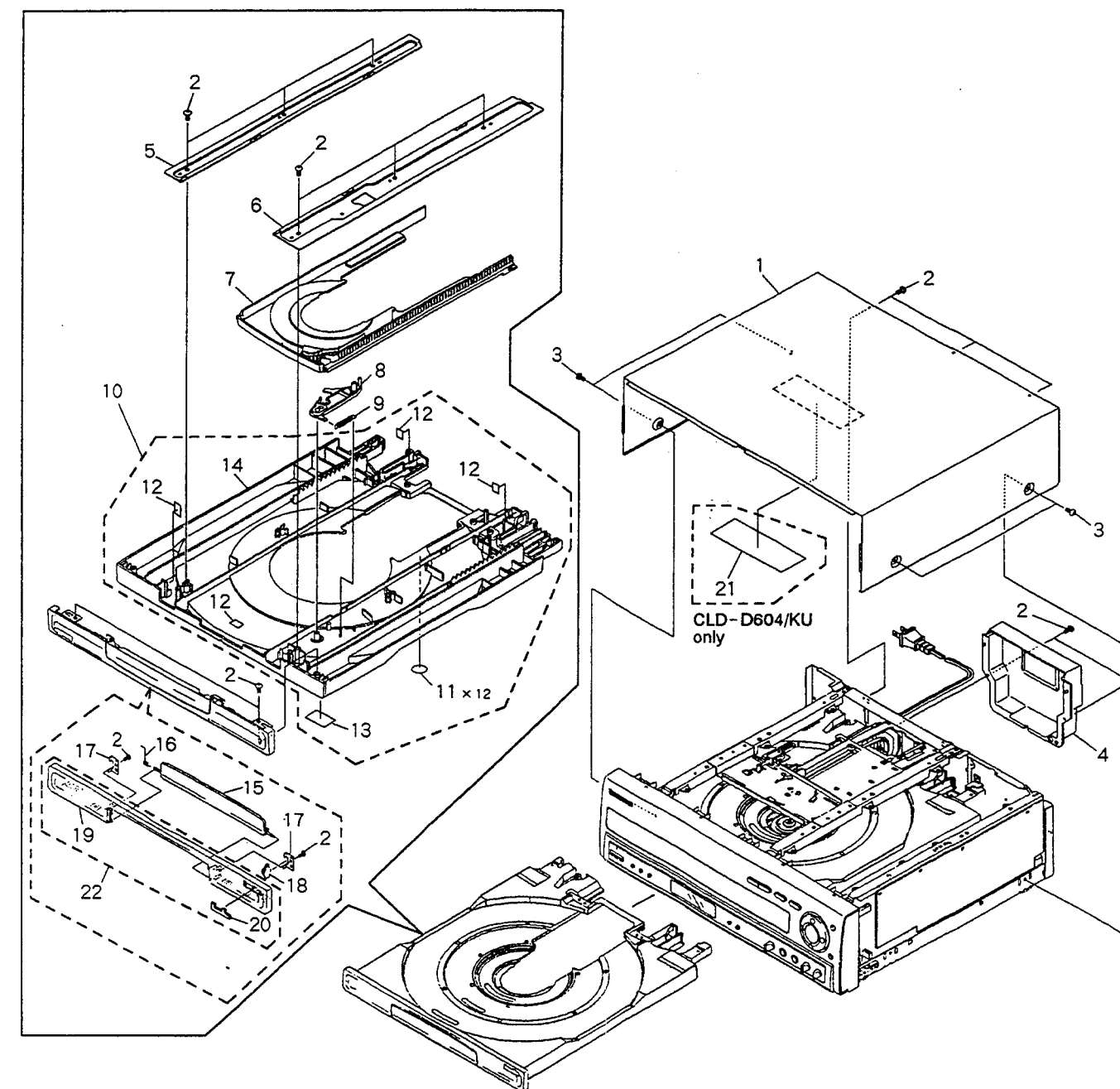

NOTE: Screws adjacent to ▼ mark on the product are used for disassembly.

2.2 TOP VIEW SECTION

(1) CONTRAST OF CLD - D604/KU, CLD - D604/KC AND CLD - D780/RD.

CLD - D604/KU, CLD - D604/KC and CLD - D780/RD have the same construction except for the following:

Mark	No.	Symbol & Description	Part No.			Remarks
			CLD - D604/KU	CLD - D604/KC	CLD - D780/RD	
NSP	21	BBKB assy	VWG1605	VWG1605	Not used	
	22	Flat cable (4P)	D20PDY0430E	D20PDY0430E	Not used	
	23	Connector	PF02PP - C15	PF02PP - C15	Not used	
	24	Connector	PF03EE - C10	PF03EE - C10	Not used	
	25	Connector	PF03PP6C10	PF03PP6C10	Not used	
NSP	28	KQTB assy	VWG1674	Not used	Not used	
	29	Rubber stopper	PEB1257	Not used	Not used	

(2) PARTS LIST FOR CLD - D604/KU

Mark	No.	Description	Part No.	Mark	No.	Description	Part No.
B	1	Screw	PBZ20P060FMC	NSP	16	Center angle	VNE1965
	2	D lever assy	VXA2205		17	PCB holder	VNE1964
	3	Clamper holder	VNE1971		18	MYCB assy	VWV1412
	4	Rubber mat	VEB1114		19	Screw	IBZ30P080FMC
	5	Thrust holder	VNL1663		20	Screw	BBZ30P080FMC
	6	Clamper head	VNL1603	NSP	21	BBKB assy	VWG1605
	7	LD spring	VBH1240		22	Flat cable (4P)	D20PDY0430E
	8	Cover spring	VBH1234		23	Connector	PF02PP - C15
	9	Ball cover	VNL1602		24	Connector	PF03EE - C10
	10	LD hab	VNT1047		25	Connector	PF03PP6C10
	11	Ball	VNX1013	NSP	26	Flexible cable (7P)	VDA1468
	12	Ball guide	VNL1616		27	Damp cushion	VEC1602
	13	Clamp spring	VBH1239		28	KQTB assy	VWG1674
	14	Clamper	VNL1604		29	Rubber stopper	PEB1257
	15	Clamper holder	VNL1680				

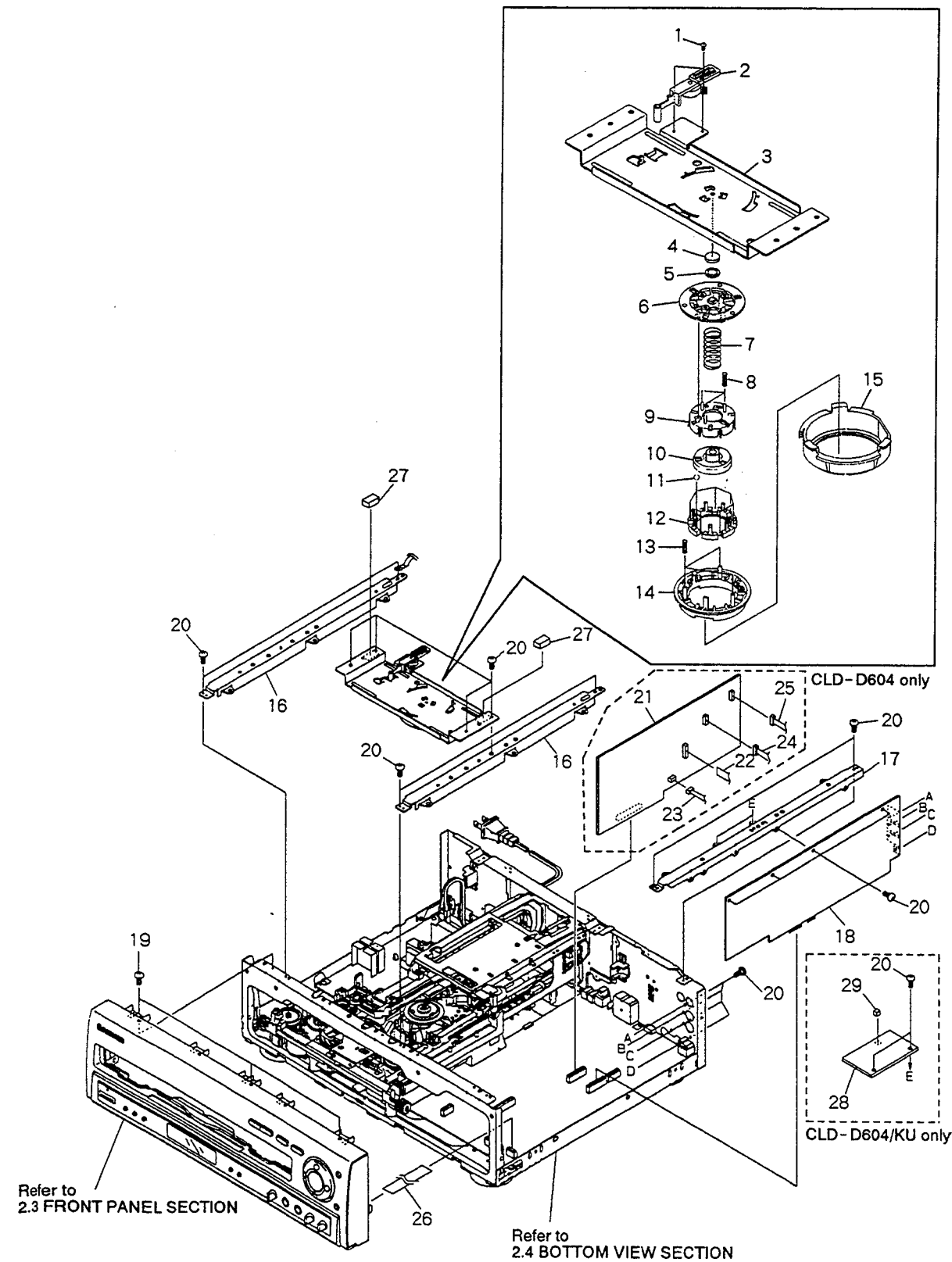

2.3 FRONT PANEL SECTION

(1) CONTRAST OF CLD- D604/KU, CLD- D604/KC AND CLD- D780/RD.

CLD- D604/KU, CLD- D604/KC and CLD- D780/RD have the same construction except for the following:

Mark	No.	Symbol & Description	Part No.			Remarks
			CLD- D604/KU	CLD- D604/KC	CLD- D780/RD	
NSP	1	Front panel assy - S	VXX2285	VXX2285	VXX2308	
	2	Front panel	VNK2991	VNK2991	VNK3065	
	5	FL lens	VEC1756	VEC1756	VEC1821	
	9	L key B	VNK3008	VNK3008	Not used	
	9	L key C	Not used	Not used	VNK3070	
NSP	13	FLKY assy	VWG1600	VWG1600	VWG1609	
	16	ECOB assy	VWV1409	VWV1409	Not used	
	16	ECOB assy	Not used	Not used	VWV1405	
	17	MJBA assy	VWV1406	VWV1406	VWV1410	
	23	Key K	VNK2998	VNK2998	Not used	

(2) PARTS LIST FOR CLD- D604/KU

Mark	No.	Description	Part No.	Mark	No.	Description	Part No.
NSP	1	Front panel assy - S	VXX2285	NSP	16	ECOB assy	VWV1409
	2	Front panel	VNK2991		17	MJBA assy	VWV1406
	3	Name plate	VAM1032		18	Snap plate	VNE1102
NSP	4	Sub panel	VNK3071	19	Jack holder	VNE1966	
	5	FL lens	VEC1756	20	Knob	PAC1707	
NSP	6	Key A	VNK2793	NSP	21	Mini clamp	VEC1312
	7	LED lens	PNW2019		22	Flexible cable 13P	VDA1496
	8	Power button	VNK2329		23	Key K	VNK2998
	9	L key B	VNK3008		24	Screw	BPZ30P080FCC
	10	L key	VNK2987				
	11	Main key	VNK2995				
	12	Screw	BBZ30P080FMC				
	13	FLKY assy	VWG1600				
	14	KEYB assy	VWG1598				
	15	Double locking spacer	VEC1742				

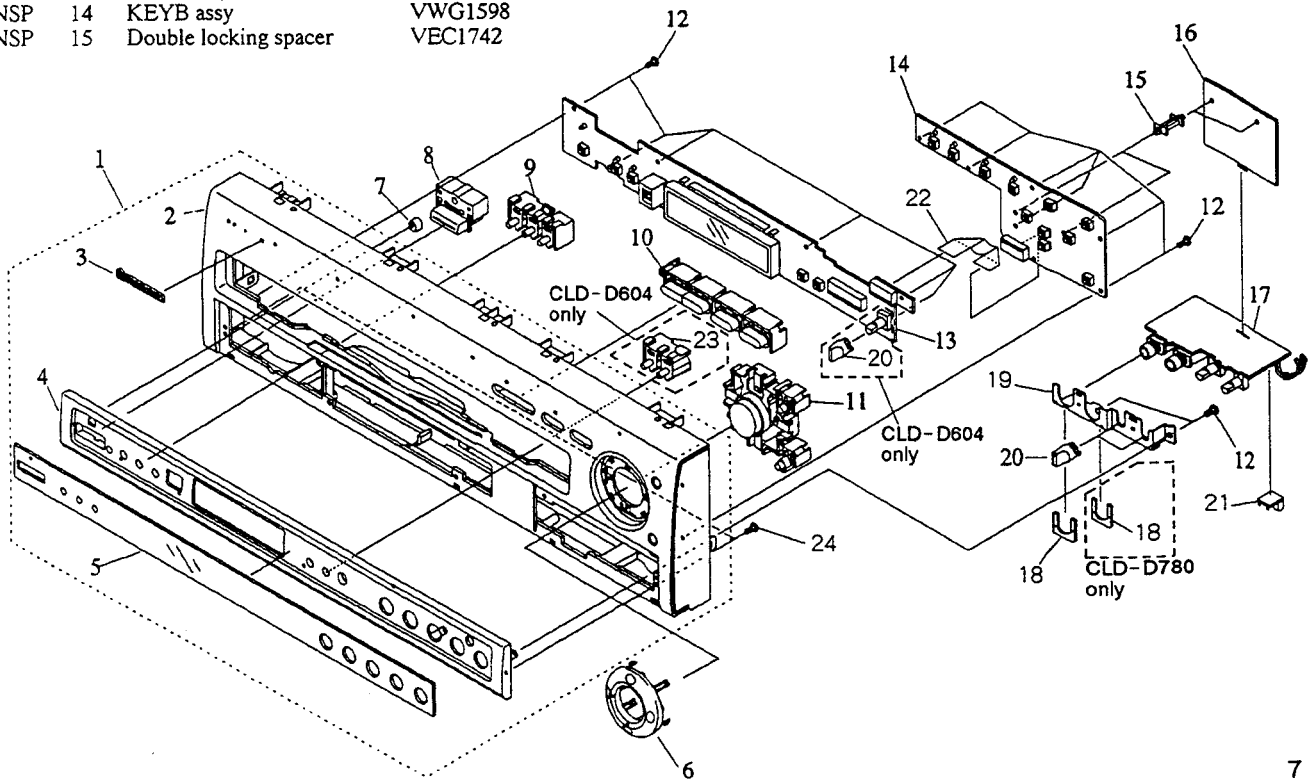

2.4 BOTTOM VIEW SECTION

(1) CONTRAST OF CLD - D604/KU, CLD - D604/KC AND CLD - D780/RD.

CLD - D604/KU, CLD - D604/KC and CLD - D780/RD have the same construction except for the following:

Mark	No.	Symbol & Description	Part No.			Remarks
			CLD - D604/KU	CLD - D604/KC	CLD - D780/RD	
△	1	MOTHER assy	VWS1171	VWS1171	VWS1172	
	3	SYPS assy	VWR1256	VWR1256	VWR1247	
	4	AC power cord	VDG1057	VDG1057	Not used	
	5	AC code stopper	CM - 22C	CM - 22C	Not used	
NSP	7	Rear panel (R)	VNA1532	VNA1532	VNA1606	
	14	Chassis	VNA1461	VNA1461	VNA1564	
	15	Rear panel (L)	VNA1531	VNA1531	VNA1605	
NSP	18	Flexible cable (22P)	VDA1486	VDA1486	Not used	
	18	Flexible cable (18P)	Not used	Not used	VDA1489	
	22	Fuse caution label	VRW - 548	VRW - 548	Not used	
	23	F. ICP caution label	VRW1525	VRW1525	Not used	
	24	AC inlet assy	Not used	Not used	VKP2116	

(2) PARTS LIST FOR CLD - D604/KU

Mark	No.	Description	Part No.	Mark	No.	Description	Part No.
	1	MOTHER assy	VWS1171	NSP	14	Chassis	VNA1461
	2	Screw	BBZ30P080FMC		15	Rear panel (L)	VNA1531
△	3	SYPS assy	VWR1256	NSP	16	Spacer	REB1171
△	4	AC power cord	VDG1057		17	Flexible cable (21P)	VDA1465
△	5	AC code stopper	CM - 22C		18	Flexible cable (22P)	VDA1486
	6	Tray stopper	VNL1657	NSP	19	Panel holder	VNA1507
	7	Rear panel (R)	VNA1532		20	Screw	BBZ30P100FMC
NSP	8	P plate holder	PNY - 405	NSP	21	Mechanism assy	VWT1123
NSP	9	PC support	VEC - 269	NSP	22	Fuse caution label	VRW - 548
NSP	10	PCB hinge	VEC1174		23	F. ICP caution label	VRW1525
					24	•••••	
NSP	11	Wire clip (H)	VEC1181				
	12	Inshulater	PNW1912	NSP	25	Rubber spacer	VEB1252
	13	Card spacer	VEC1708				

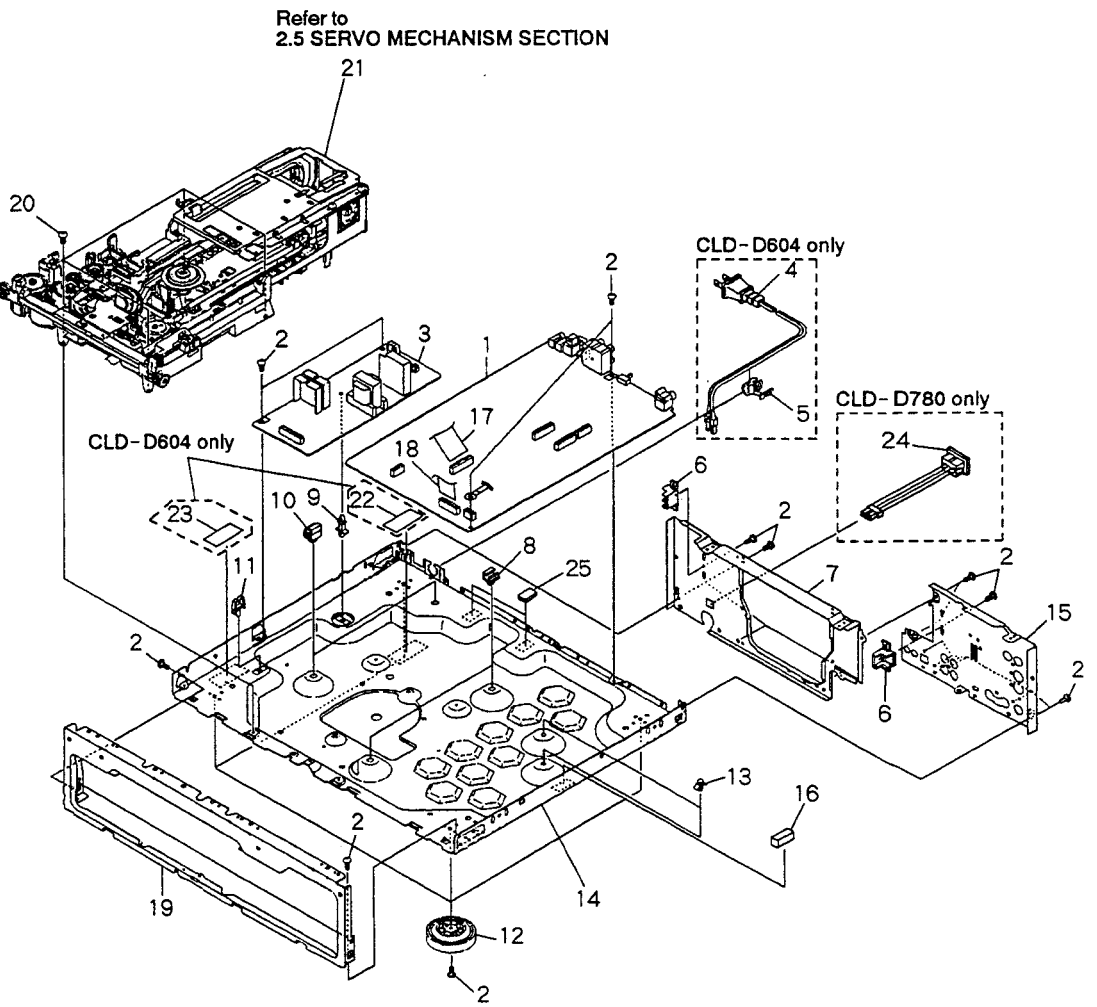

A

B

C

D

A

B

C

D

2.5 SERVO MECHANISM SECTION

Parts List

Mark	No.	Description	Part No.	Mark	No.	Description	Part No.	
NSP	1	Tilt base (upper)	VNE1969	NSP	31	Housing assy (3P, yellow)	VKP2046	
	2	BISB assy	VWG1558		32	FG assy	VWG1556	
	3	Screw	BBZ30P060FMC		33	FG base	VNL1645	
	4	A horn	VNL1689		34	Tilt cam	VNL1643	
	5	Rack (upper)	VNL1679		35	Tilt cam spring	VBH1243	
	6	Shaft stay	VNL1671		36	Screw	PMA30P070FMC	
	7	Carriage shaft (upper)	VLL1457		37	Screw	IBZ26P120FMC	
	8	B cam	VNL1673		38	Motor base	VNE1975	
	9	Shaft support	VNL1672		39	Motor spacer	VNE2007	
	10	Support spring	VBH1265		40	Spindle motor assy	VXA2208	
	11	SW lever (B)	VNL1678		41	PRC hub	VNL1684	
	12	Large hill	VNL1682		42	Centering spring	VBH1269	
	13	Flexible cable (23P)	VDA1490		NSP	43	R turn table assy	VXA2225
	14	Turn guide	VNL1696		NSP	44	Oil stopper	VBF1002
	15	FFC style shaft	VLL1474		NSP	45	Spindle motor	VXM1061
NSP	16	Guide	VNL1674	NSP	46	Housing assy (12P)	VKP2099	
	17	Lever spring	VBH1266		47	TS spacer	VEC1802	
	18	Turn gear	VNL1675		48	Screw	IBZ26P060FMC	
	19	SW lever (T)	VNL1695		49	Screw	BPZ20P040FZK	
	20	TNSB assy	VWG1557		50	Housing assy	VKP2060	
	21	Housing assy (3P, black)	VKP2059		NSP	51	Earth lead unit	VDA1494
	22	Tilt base (under)	VNL1670		52	Carriage shaft (under)	VLL1458	
	23	TAN guide	VNE1973		53	Body guard	VNL1681	
	24	CA rack	VNL1647		54	FFC holder	VNL1656	
	25	FFC style spring	VBH1270		55	CA guide	VNL1668	
NSP	26	Thrust spring	VBH1245	56	TAN spring (B)	VBH1264		
	27	CA - SW lever	VNL1644	57	TAN lever (B)	VNL1669		
	28	PKSB assy	VWG1555	58	Screw	PMZ20P060FZK		
	29	Housing assy (3P, blue)	VKP2045	59	Carriage assy	VWT1110		
	30	Tilt spring	VBH1263	NSP	60	Cord binder	ZCB - 069Z	
				61	Screw	BBZ30P080FMC		

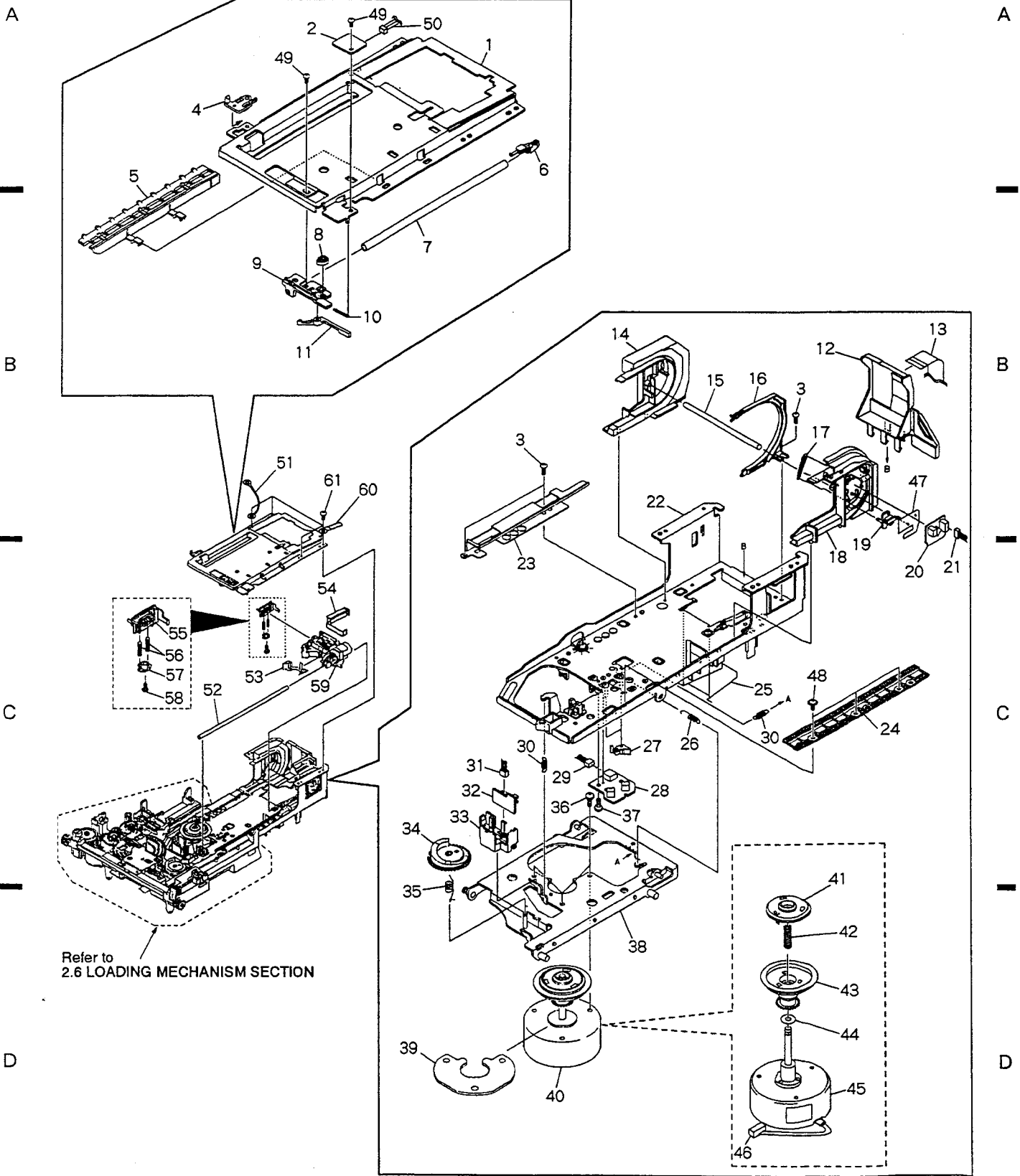

2.6 LOADING MECHANISM SECTION

Parts List

Mark	No.	Description	Part No.
	1	Clamp cam	VNL1633
	2	CDP spring	VBH1191
	3	Screw	Z39-019
	4	CD plate	VNL1685
	5	Rubber belt	VEB1184
	6	Gear pulley	VNL1662
	7	Twin gear	VNL1626
	8	Center gear	VNL1660
	9	Mechanism base	VNK3239
	10	Screw	BMZ26P040FMC
	11	Roller	VNL1042
NSP	12	Motor pulley	VNL1630
	13	Synchro gear assy	VXA2105
NSP	14	LMSB assy	VWG1612
	15	Cam holder	VNE2032
NSP	16	Carriage motor	VXM1033
	17	Shaft holder	VNE1942
	18	CAS spring	VBH1190
	19	Cam plate	VNL1631
	20	Cam gear	VNL1625
	21	Loading motor assy	VXX2045
	22	MB-SW lever	VNL1664
	23	Slider (R)	VNL1666
	24	Slider (L)	VNL1665
	25	Double gear	VNL1661
	26	Flexible cable (12P)	VDA1485

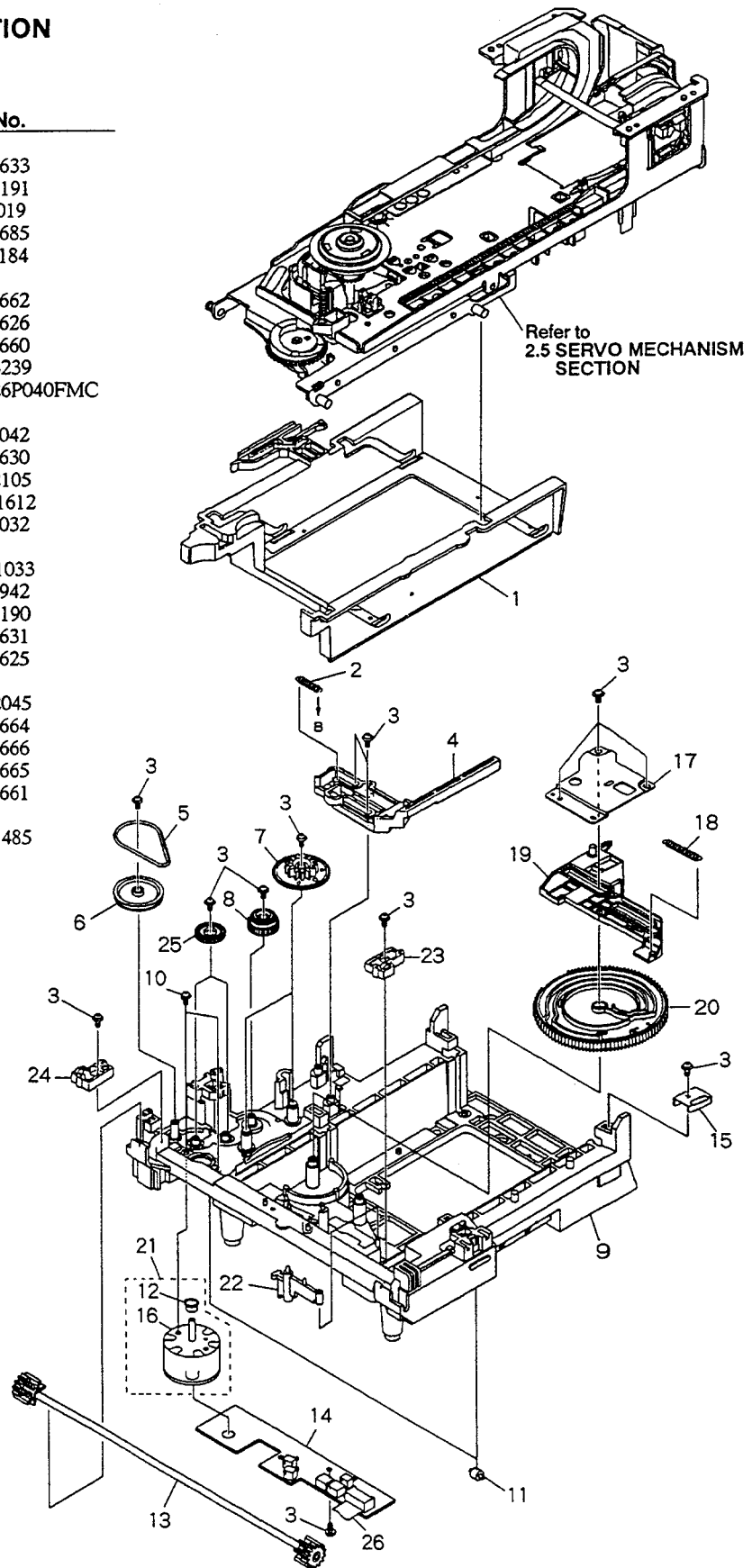

2.7 CARRIAGE ASSY

Parts List

Mark	No.	Description	Part No.
	1	CA gear (A)	VNL1638
	2	CA gear (B)	VNL1639
	3	Slider motor assy	VXX2082
	4	M holder	VNL1637
	5	Screw	PBZ20P050FMC
	6	Screw	PMZ20P030FMC

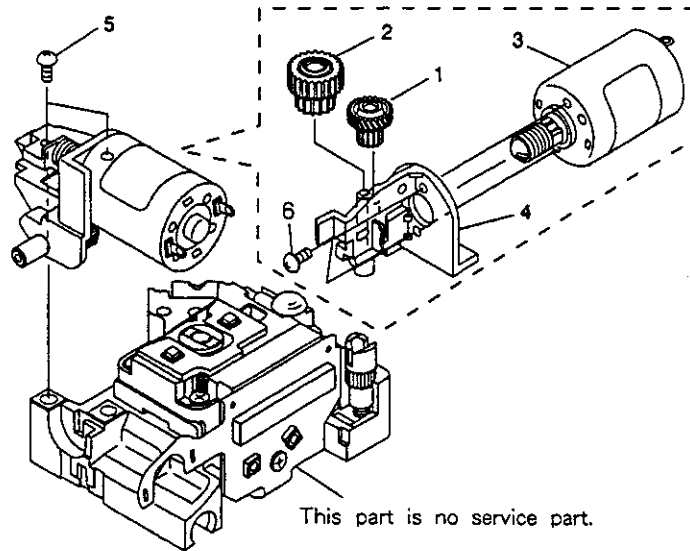

2.8 PACKING

(1) CONTRAST OF CLD-D604/KU, CLD-D604/KC AND CLD-D780/RD.

CLD-D604/KU, CLD-D604/KC and CLD-D780/RD have the same construction except for the following:

Mark	No.	Symbol & Description	Part No.			Remarks
			CLD-D604/KU	CLD-D604/KC	CLD-D780/RD	
NSP	5	Warranty card	ARY1044	ARY1039	ARW1020	
NSP	6	Soft catalogue	VRY1051	Not used	Not used	
	7	Operating instructions (English)	VRB1148	VRB1148	Not used	
	7	Operating instructions (English/Chinese/Spanish)	Not used	Not used	VRE1038	
	9	Remote control unit	VXX2241	VXX2241	VXX2242	
	13	Case (upper)	VNK3133	VNK3133	VNK3134	
	15	Packing case	VHG1468	VHG1468	VHG1476	
NSP	16	Sample disc	KS-01	Not used	Not used	
NSP	17	Microphone	VPM1007	VPM1007	Not used	
	20	Mirror mat	Z23-004	Z23-004	Not used	
	21	Operating instructions (French)	Not used	VRC1044	Not used	
△	24	AC power cord	Not used	Not used	ADG1109	
NSP	25	Caution	VRN1008	Not used	Not used	

(2) PARTS LIST FOR CLD-D604/KU

Mark	No.	Description	Part No.	Mark	No.	Description	Part No.
NSP	1	Battery (R03, AAA)	VEM-022		14	Mirror mat	VHL1027
	2	Video cord	DDE1090		15	Packing case	VHG1468
	3	Audio cord	DDE1089	NSP	16	Sample disc	KS-01
NSP	4	Polyethylene bag (205*315*0.05)	Z21-029	NSP	17	Microphone	VPM1007
					18	Protector	VHB1010
NSP	5	Warranty card	ARY1044		19	Protector B	VHB1022
NSP	6	Soft catalogue	VRY1051		20	Mirror mat	Z23-004
	7	Operating instructions (English)	VRB1148		21	
NSP	8	Polyethylene bag	VHL-014		22	Caution label	VRM1044
					23	KC label	VRW1402
	9	Remote control unit	VXX2241		24	
	10	Battery cover	DNK2286	NSP	25	Caution	VRN1008
	11	Case (below)	VNK2062				
	12	Filter	VNK2063				
	13	Case (upper)	VNK3133				

Remarks

Part No.
 IL1027
 IG1468
 J-01
 M1007
 B1010
 B1022
 3-004
 M1044
 W1402
 N1008

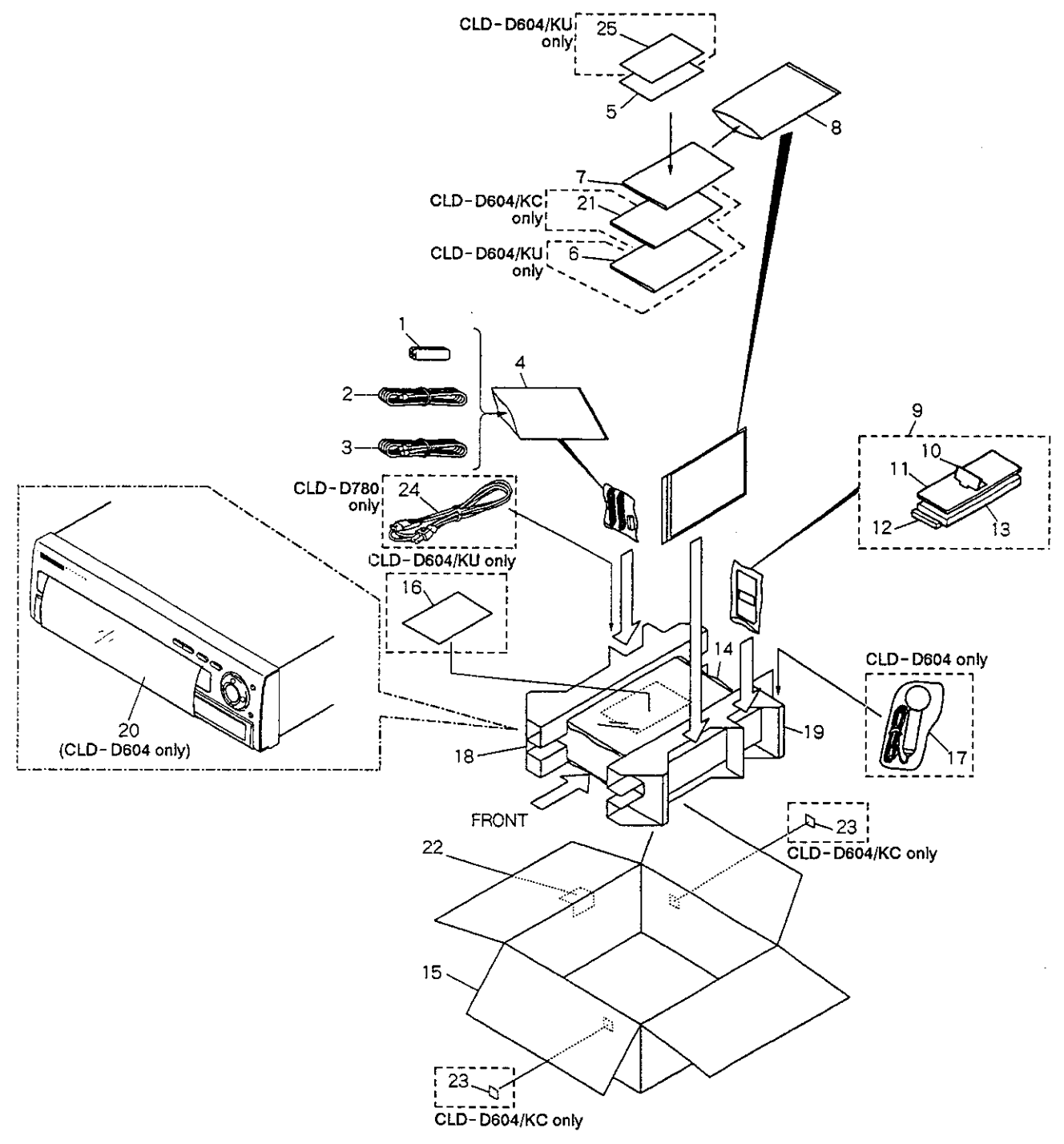

3. SCHEMATIC AND PCB CONNECTION DIAGRAMS

3.1 OVERALL CONNECTIONS, KEYB, FLKY, ECOB, MJBA, SYPS, PKSB, FG, TNSB, BISB AND LMSB ASSEMBLIES

NOTE FOR SCHEMATIC DIAGRAMS

- (Type 4A)
- When ordering service parts, be sure to refer to "PARTS LIST of EXPLODED VIEWS" or "PCB PARTS LIST".
 - Since these are basic circuits, some parts of them or the values of some components may be changed for improvement.
 - RESISTORS:**
Unit: k:kΩ, M:MΩ, or Ω unless otherwise noted.
Rated power: 1/4W, 1/8W, 1/8W, 1/10W unless otherwise noted.
Tolerance: (F): ±1%, (G): ±2%, (K): ±10%, (M): ±20% or ±5% unless otherwise noted.
 - CAPACITORS:**
Unit : p:pF or μ:F unless otherwise noted.
Ratings : capacitor (μF) /voltage (V) unless otherwise noted.
Rated voltage : 50V except for electrolytic capacitors.
 - COILS:**
Unit : m:mH or μ:H unless otherwise noted.
 - VOLTAGE AND CURRENT:**
□ or ← V : DC voltage (V) in PLAY mode unless otherwise noted.
← mA or ← mA : DC current in PLAY mode unless otherwise noted.
Value in () is DC current in STOP mode.
 - OTHERS:**
⊙ or ⊙ : Adjusting point.
◀ : Measurement point.
• The Δ mark found on some component parts indicates the importance of the safety factor of the parts. Therefore, when replacing, be sure to use parts of identical designation.
 - SCH - □ ON THE SCHEMATIC DIAGRAM:**
• SCH - □ indicates the drawing number of the schematic diagram. (SCH stands for schematic diagram.)
 - SWITCHES** (Underline indicates switch position):

- FLKY ASSY
S101 : POWER ON/STANDBY
S102 : QUICK TURN
S103 : DISPLAY OFF
S104 : THEATER BASS
S104 : #
S105 : b

- KEYB ASSY
S201 : A
S202 : B
S203 : CD
S204 : LD
S205 : ■
S206 : LAST MEMORY
S207 : ■
S208 : ■
S209 : ▼
S210 : ■
S211 : ONE TOUCH KARAOKE

- LMSB ASSY
S101 : SW1
S102 : SW2
S103 : SW3

- PKSB ASSY
S104 : OUTER
S105 : INNER

- TNSB ASSY
S111 : TURN

- BISB ASSY
S112 : B INSIDE

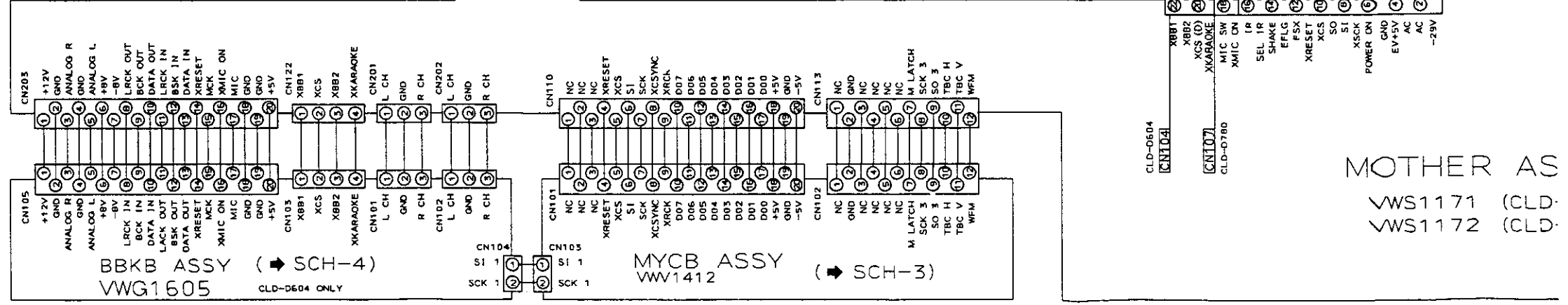
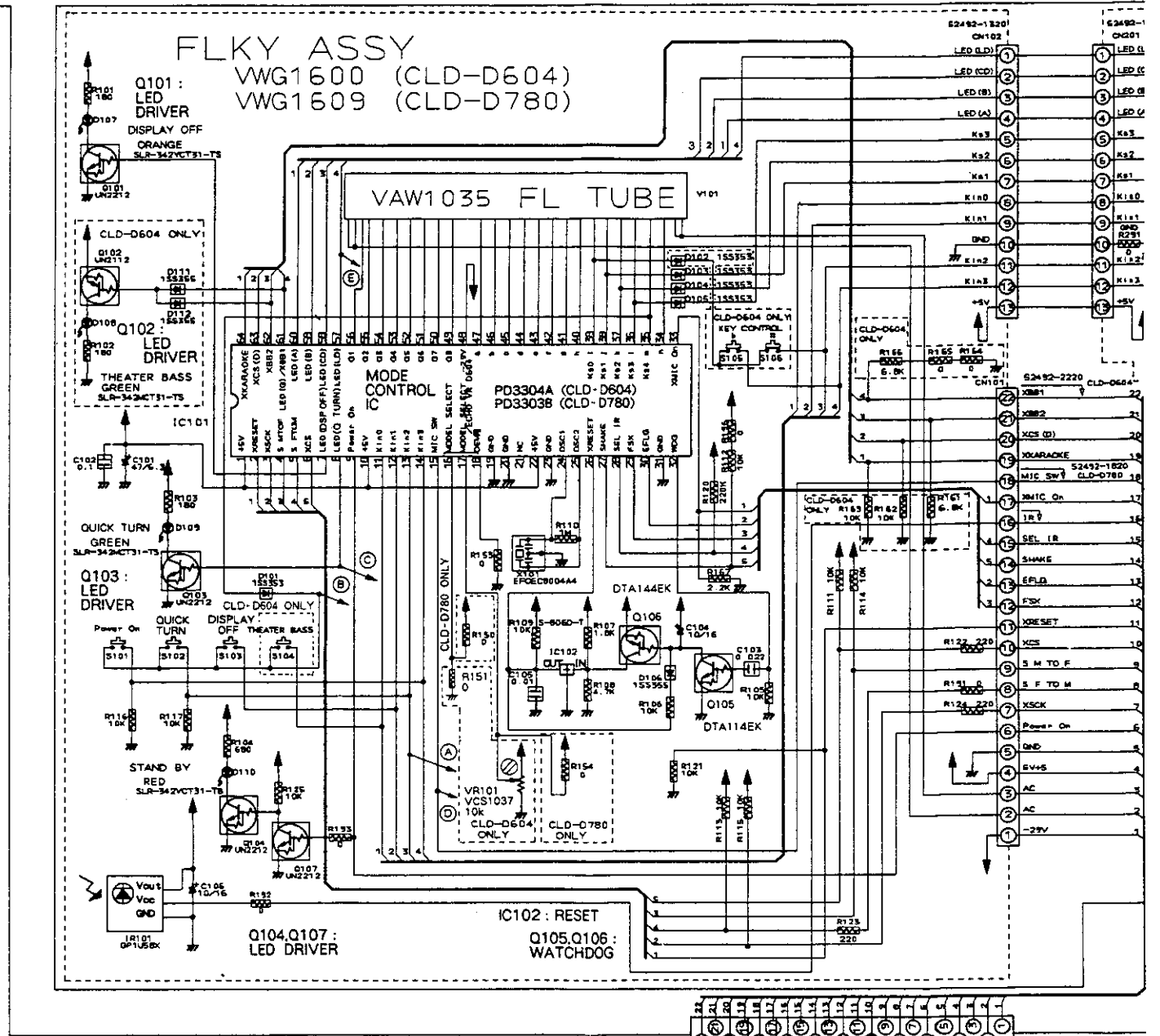
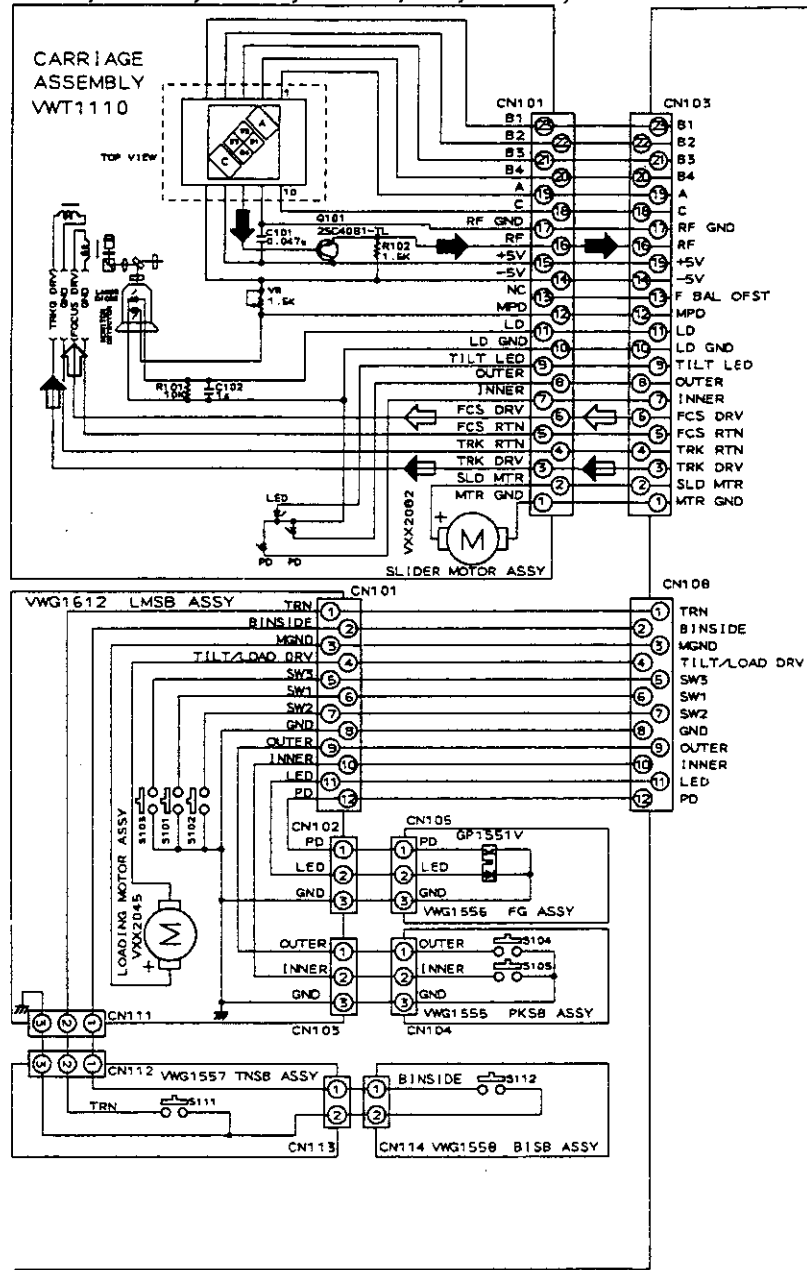

OVERALL CONNECTIONS, KEYB ASSY, FLKY ASSY, ECOB ASSY, MJBA ASSY, SYPS ASSY, PKSB ASSY, FG ASSY, TNSB ASSY, BISB ASSY, LMSB ASSY

SCH-1

MOTHER AS
WVS1171 (CLD-D604)
WVS1172 (CLD-D780)

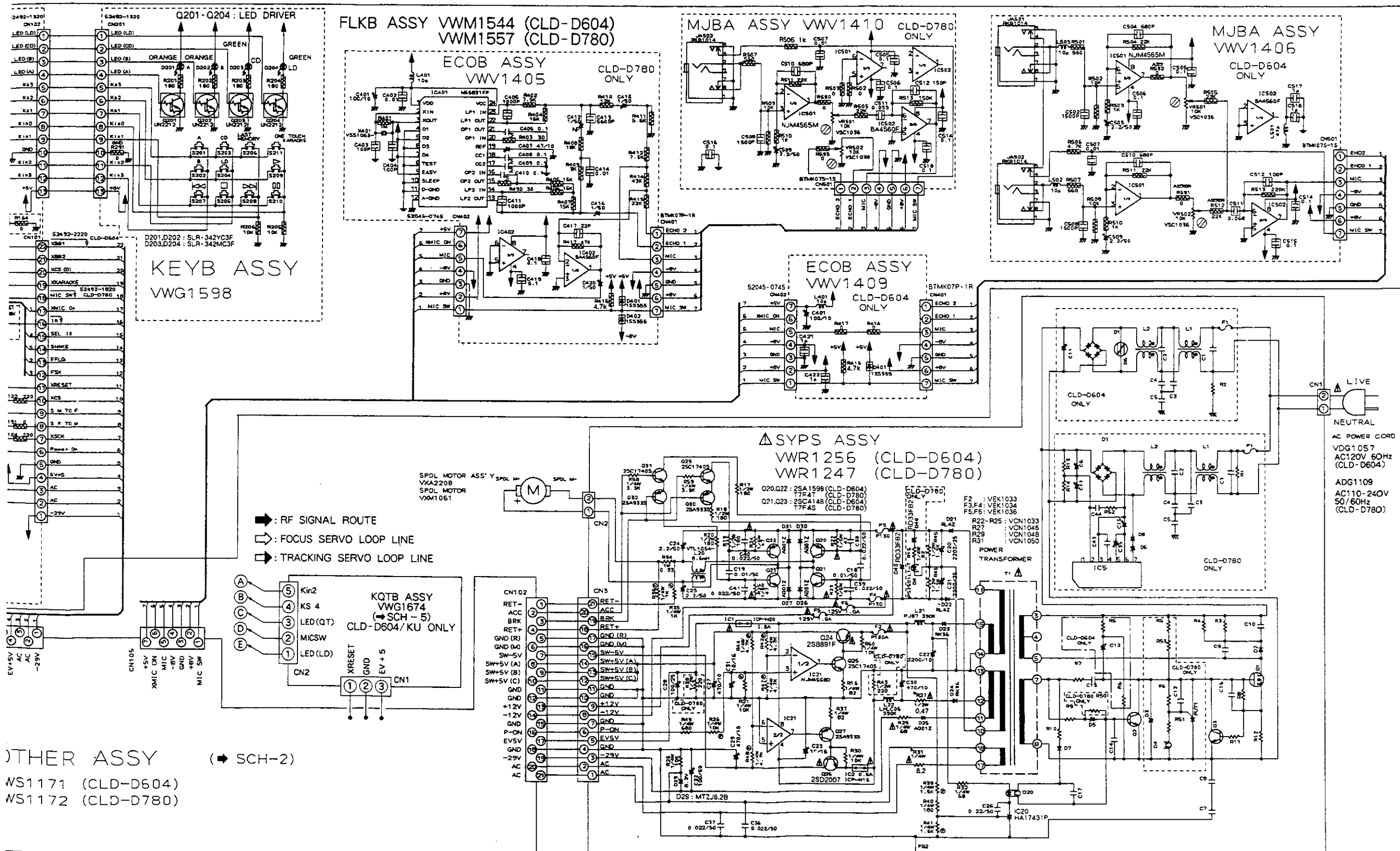

OVERALL CONNECTIONS, KEYB ASSY,
 FLKY ASSY, ECOC ASSY, MJBA ASSY,
 SYPS ASSY, PKSB ASSY, FG ASSY,
 TNSB ASSY, BISB ASSY, LMSB ASSY

SCH-1

CAUTION: FOR CONTINUED PROTECTION AGAINST RISK OF FIRE REPLACE ONLY WITH SAME TYPE NO. OF N15, MFD BY ROHM CO., LTD. FOR IC2.

CAUTION: FOR CONTINUED PROTECTION AGAINST RISK OF FIRE REPLACE ONLY WITH SAME TYPE NO. ICP-N20, MFD BY ROHM CO., LTD. FOR IC1.

NOTE FOR FUSE REPLACEMENT
 CAUTION - FOR CONTINUED PROTECTION AGAINST RISK OF FIRE, REPLACE ONLY WITH SAME TYPE AND RATINGS ONLY.

A

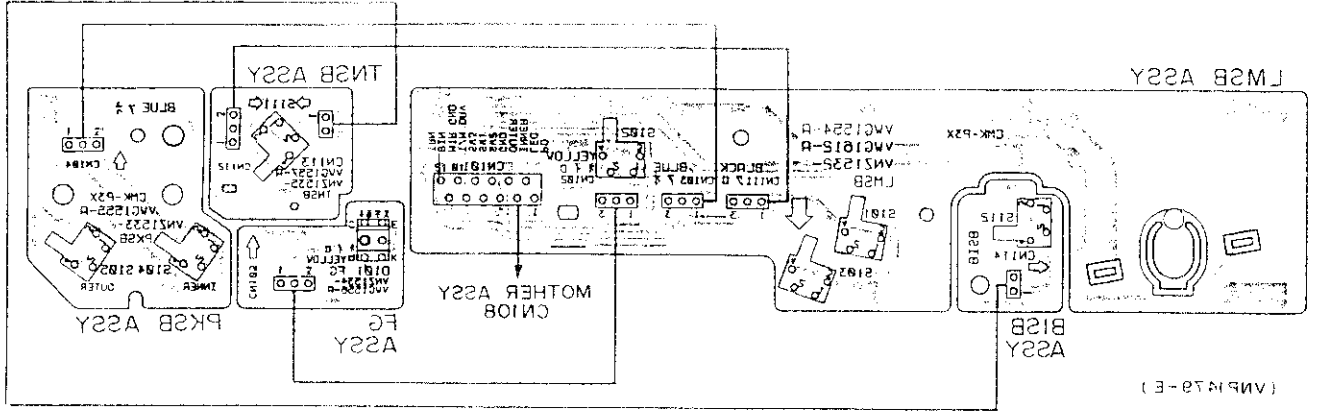

B

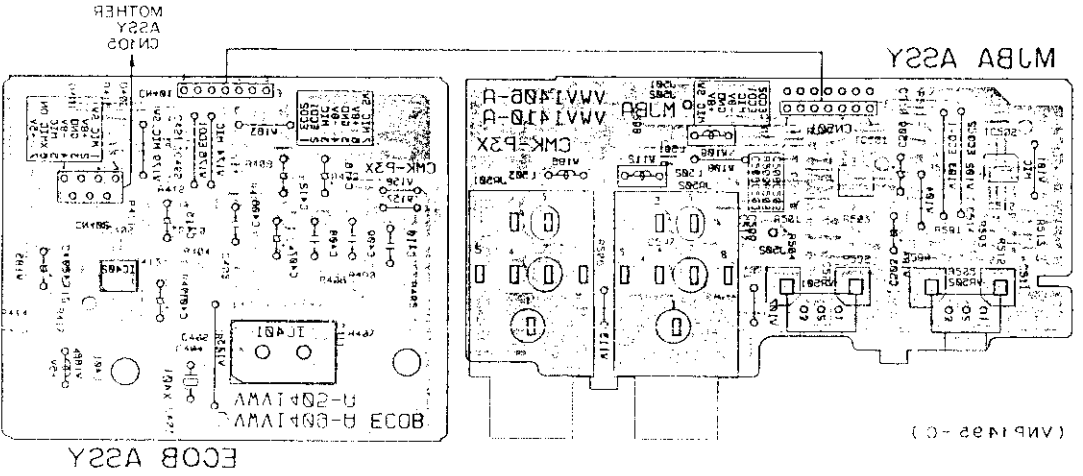

C

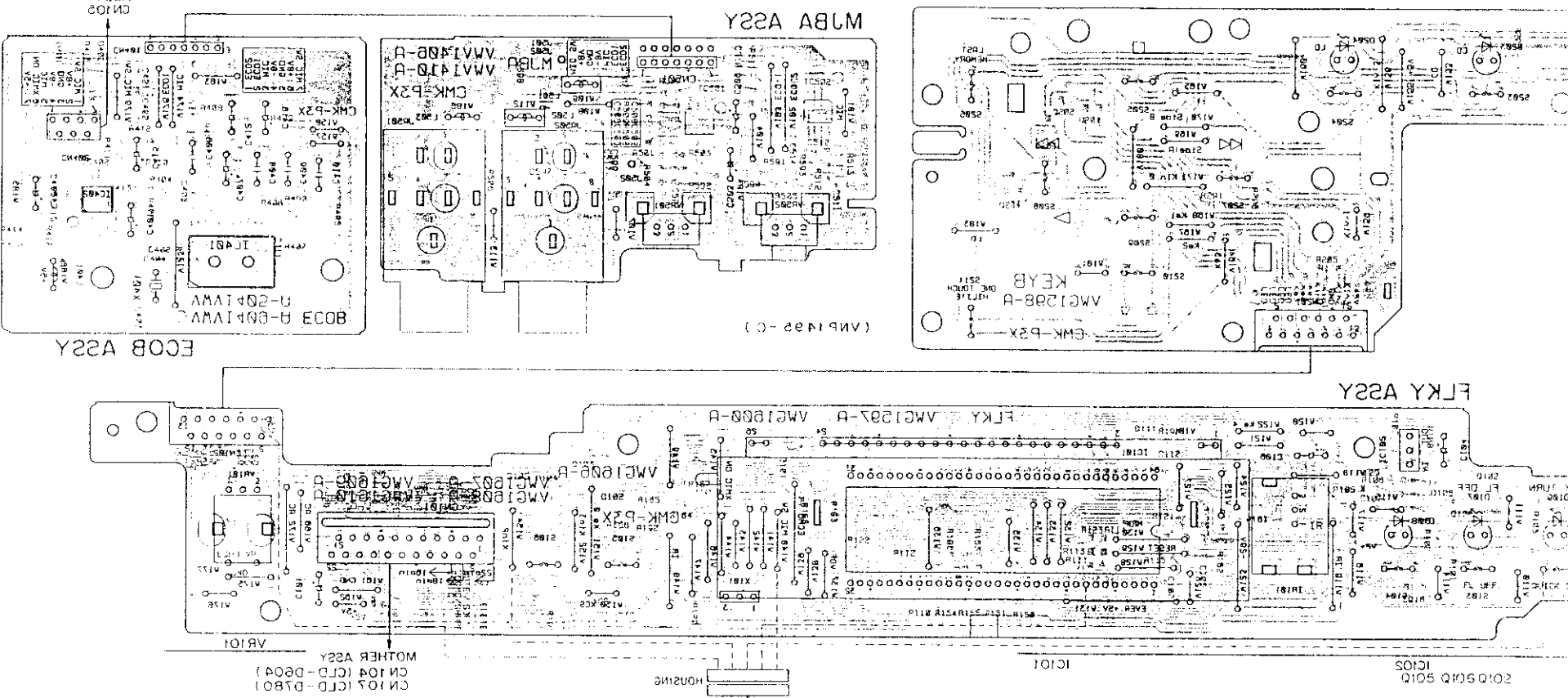

D

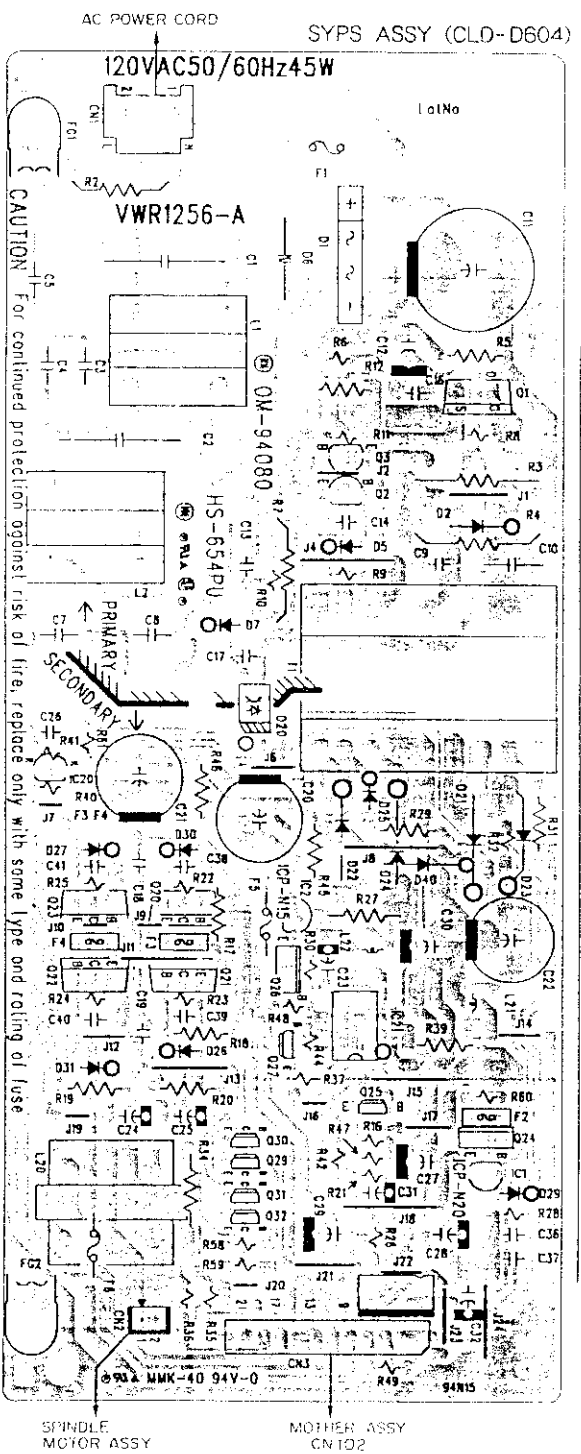

U

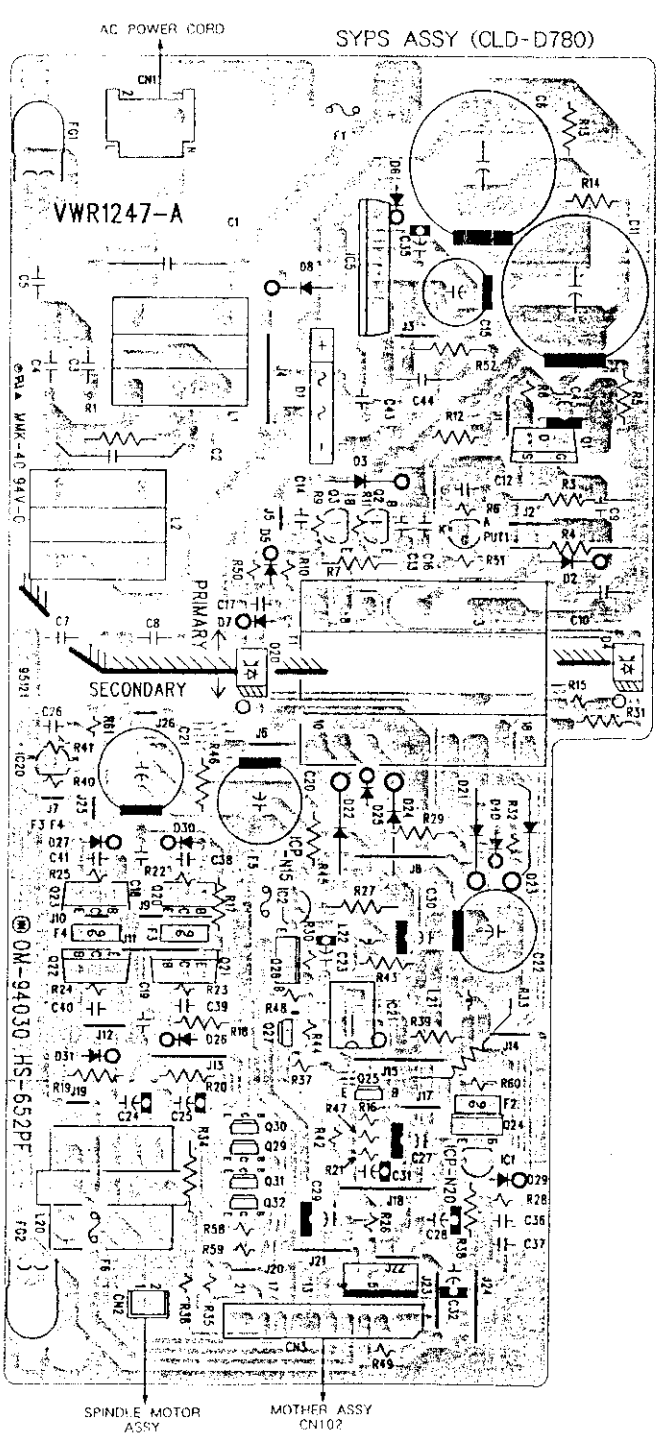

T

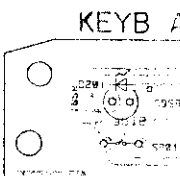

The parts mounted on this PCB include several destinations. For further information for respective with the schematic diagram.



This diagram is viewed from the mounted parts side

This diagram is viewed from the foil side.

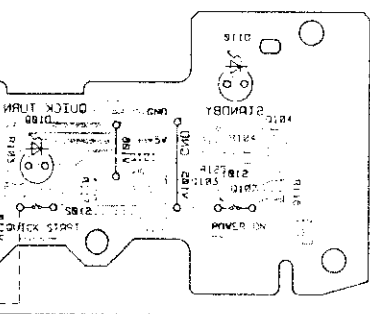
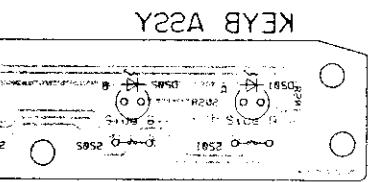

Q101 Q103 Q107 Q104

NOTE FOR PCB DIAGRAMS:

1. Part numbers in PCB diagrams match those in the schematic diagrams.
2. A comparison between the main parts of PCB and schematic diagrams is shown below.

Symbol in PCB Diagrams	Symbol in Schematic Diagrams	Part Name
		Transistor
		Transistor with resistor
		Field effect transistor
		Resistor array
		3-terminal regulator

B ASSY

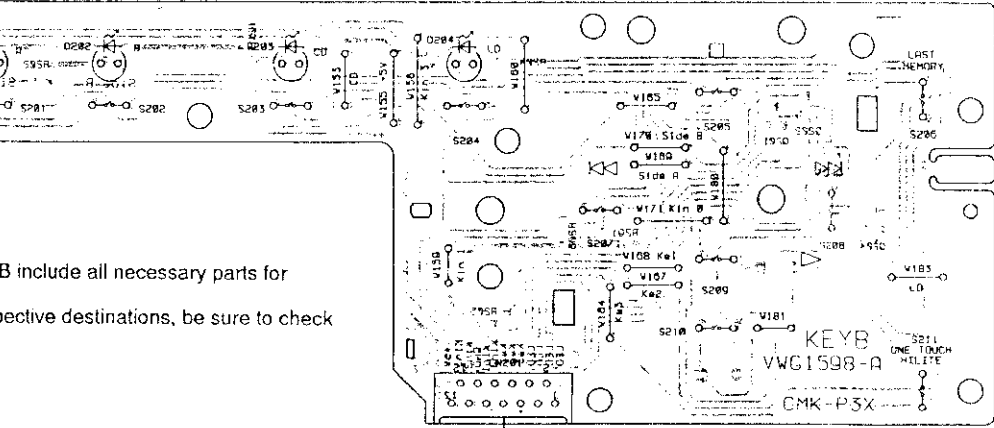

Include all necessary parts for respective destinations, be sure to check

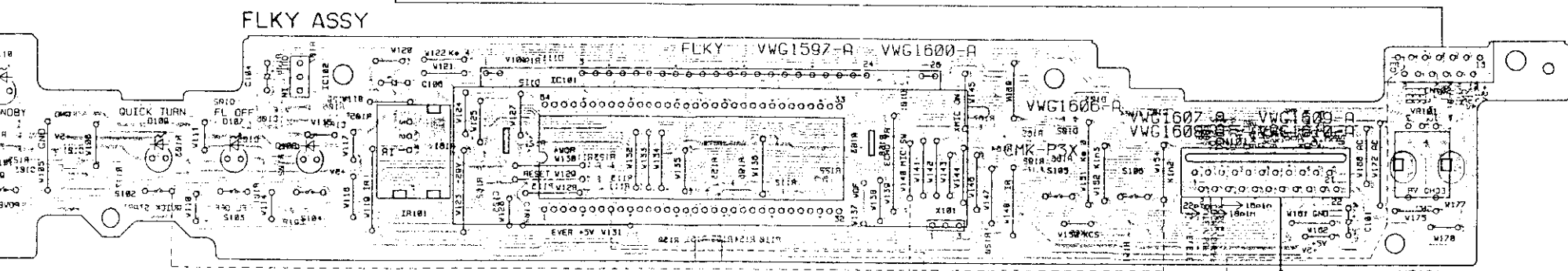

IC102 IC101

parts side.

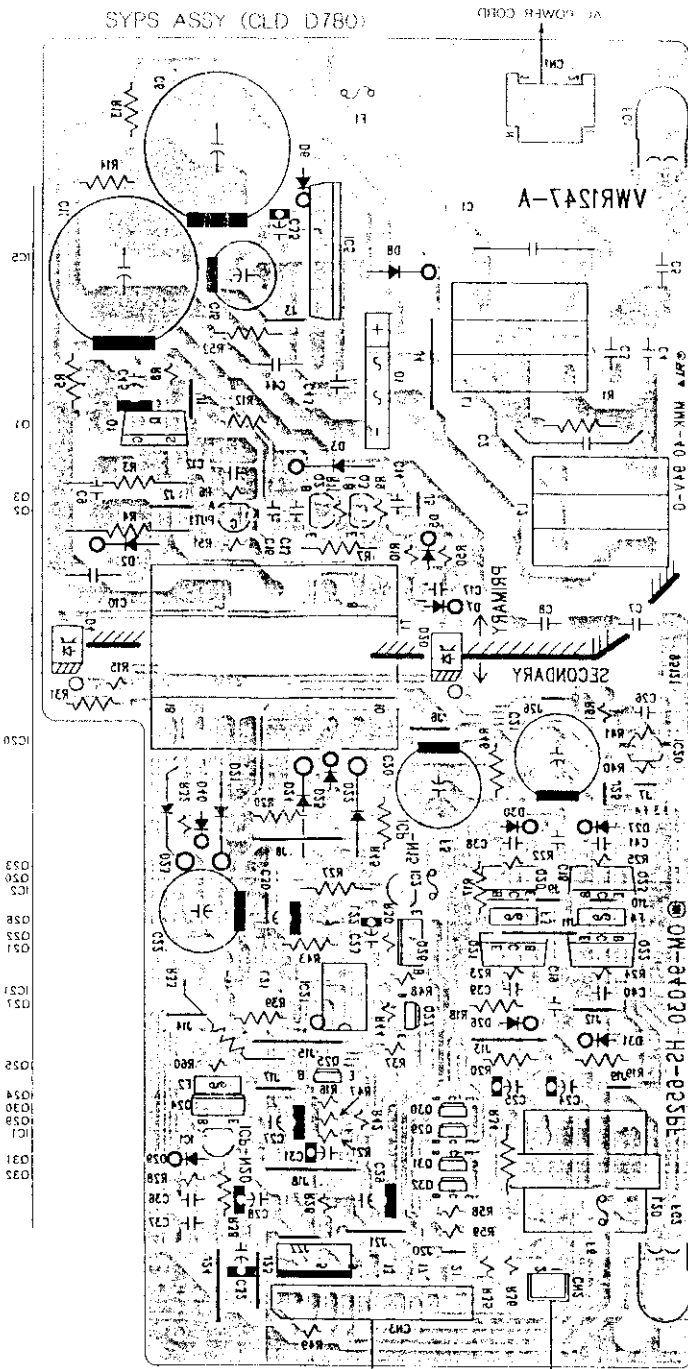

MOTHER ASSY SPINDLE MOTOR ASSY

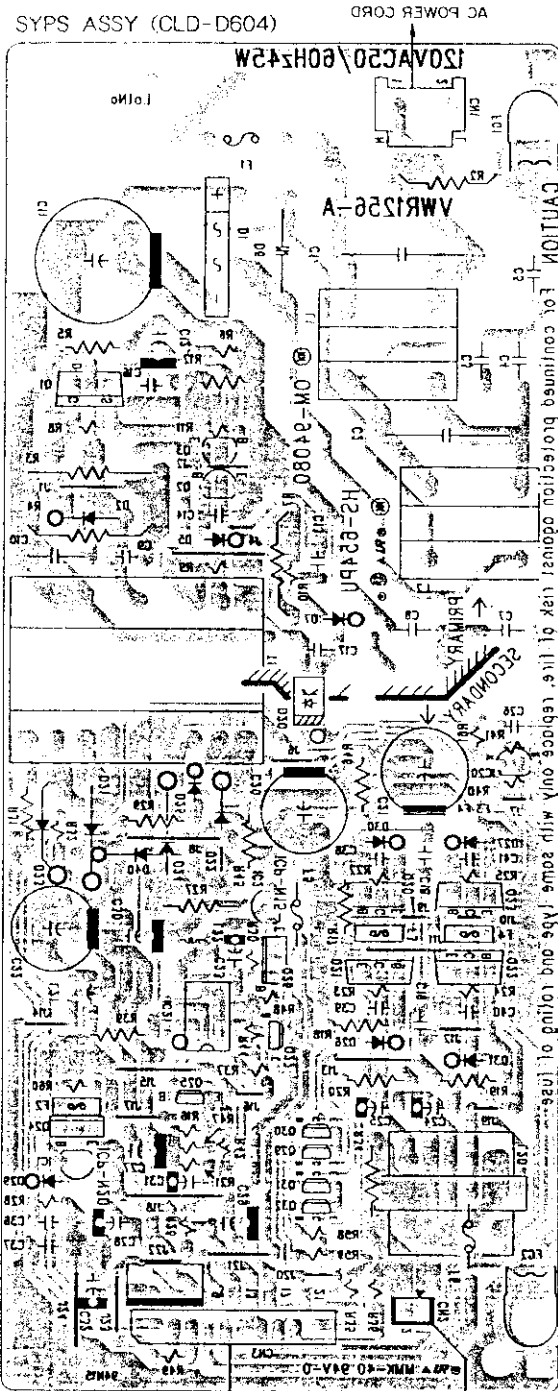

MOTHER ASSY SPINDLE MOTOR ASSY

PCB - 1

LMSB ASSY

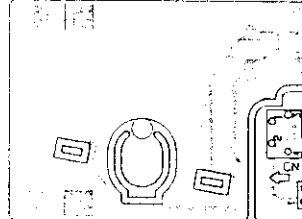

(VNP1479-E)

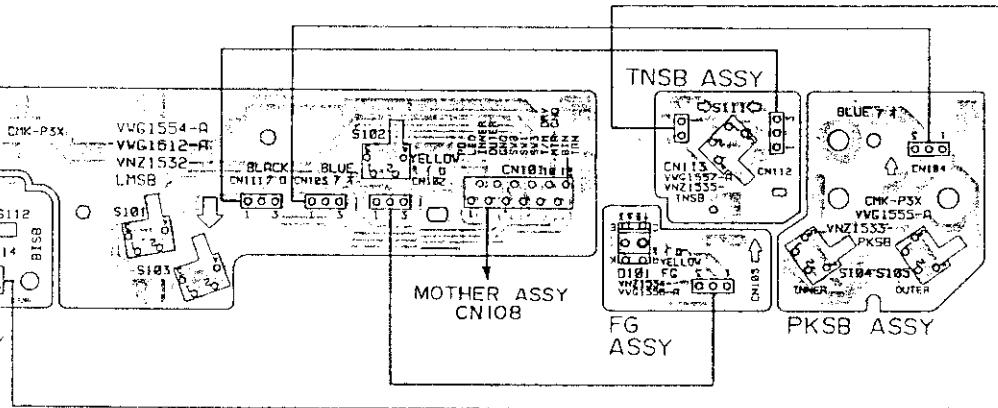

MJBA ASSY

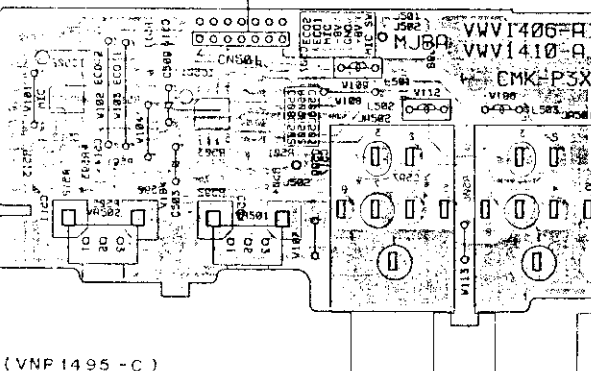

(VNP1495-C)

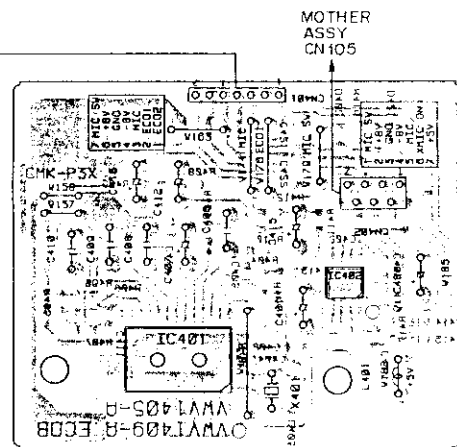

ECOB ASSY

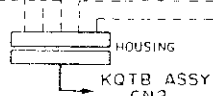

MOTHER ASSY CN104 (CLD-D604) CN107 (CLD-D780)

3.2 MOTHER ASSY

MOTHER ASSY (VWS1171) (CLD-D604)
(VWS1172) (CLD-D780)

A

B

C

D

E

F

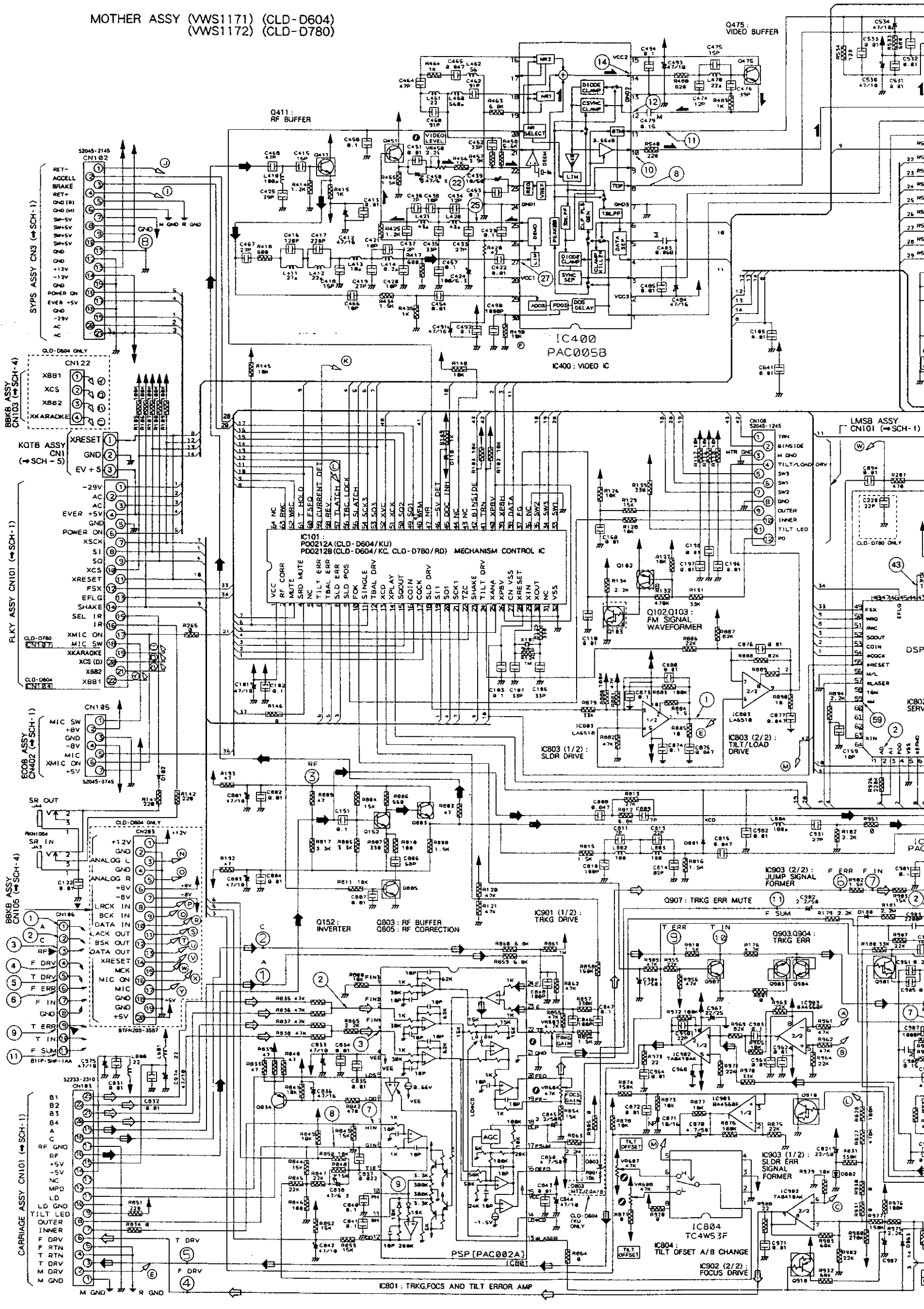

SCH-2

MOTHER ASSY

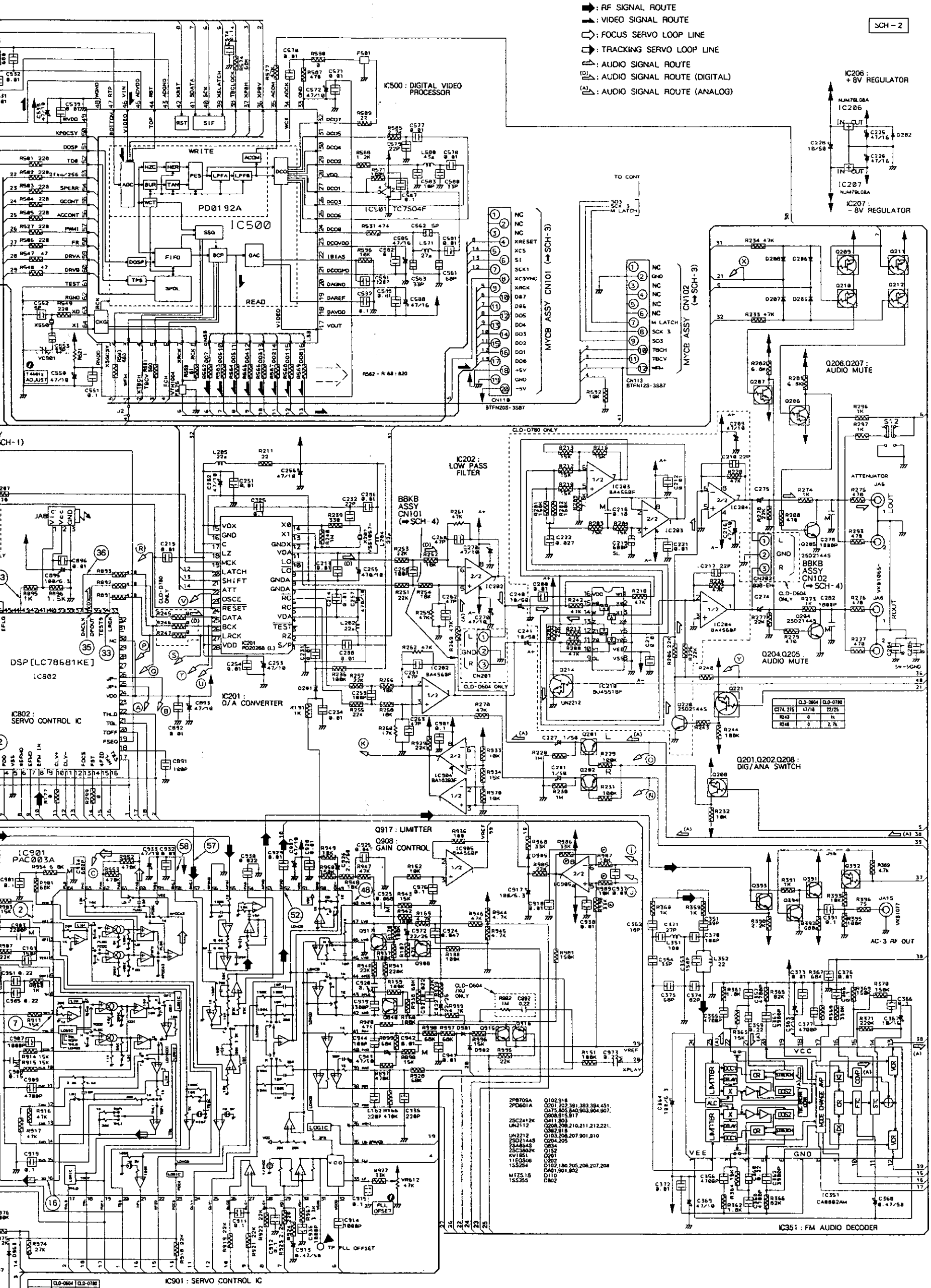

- : RF SIGNAL ROUTE
- - -: VIDEO SIGNAL ROUTE
- ⋯: FOCUS SERVO LOOP LINE
- : TRACKING SERVO LOOP LINE
- : AUDIO SIGNAL ROUTE
- (A)—: AUDIO SIGNAL ROUTE (DIGITAL)
- (A)—: AUDIO SIGNAL ROUTE (ANALOG)

SCH-2

A
B
C
D
E
F

MOTHER ASSY

SCH-2

**WAVEFORMS AND VOLTAGE
MOTHER ASSY**

Note : (No) in the table correspond to the pin number.

Measurement condition : In case when (D. audio) is written, at time when disc that has digital audio recording is played.

IC801(PAC002A)	IC802(LC78681KE)	IC803(LA6510)	IC901(PAC003A)	CN106	IC400 (PAC005B)
<p>②, ③ 1mS/Div. 16mVp-p</p> <p>AC mode</p>	<p>② 0.1μS/Div. 4.3Vp-p</p> <p>AC mode(D.audio)</p>	<p>① 2mS/Div. 1.8Vp-p</p> <p>DC mode</p>	<p>② 0.2mS/Div. 74mVp-p</p> <p>DC mode</p>	<p>①, ② 5mS/Div. 65mVp-p</p> <p>DC mode</p>	<p>⑩ 1.52Vp-p</p> <p>V : 20mV/Div H : 10mS/Div</p>
<p>⑦, ⑧ 1mS/Div. 67mVp-p</p> <p>DC mode</p>	<p>③③ 10μS/Div. 4.2Vp-p</p> <p>AC mode(D.audio)</p>		<p>⑦ 0.2mS/Div. 74mVp-p</p> <p>DC mode</p>	<p>③ 0.5mS/Div. 300mVp-p</p> <p>AC mode</p>	<p>⑧ (TOP) 2.4V</p> <p>⑪ (BOTTOM) 0.55V</p>
<p>⑨ 5mS/Div. 0.1Vp-p</p> <p>DC mode</p>	<p>③⑤ 0.2μS/Div. 4.4Vp-p</p> <p>AC mode(D.audio)</p>		<p>⑩ 0.2mS/Div. 0.61Vp-p</p> <p>DC mode</p>	<p>④ 5mS/Div. 15Vp-p</p> <p>DC mode</p>	<p>⑫ 1Vp-p</p> <p>V : 20mV/Div H : 10mS/Div</p>
	<p>③⑥ 0.2μS/Div. 4.5Vp-p</p> <p>AC mode(D.audio)</p>		<p>④⑧ 50μS/Div. 6.2Vp-p</p> <p>DC mode</p>	<p>⑤ 5mS/Div. 5.8Vp-p</p> <p>DC mode</p>	<p>⑭ 1Vp-p</p> <p>V : 20mV/Div H : 10mS/Div</p>
	<p>④③ 0.1μS/Div. 4.5Vp-p</p> <p>AC mode(D.audio)</p>		<p>⑤② 0.2μS/Div. 2.1Vp-p</p> <p>AC mode</p>	<p>⑥ 5mS/Div. 3.5Vp-p</p> <p>DC mode</p>	<p>⑲ (No noise)</p> <p>⑳ (With limiter noise)</p> <p>V : 20mV/Div H : 10mS/Div Approx. 330mVp-p</p>
	<p>⑤⑨ 0.1μS/Div. 2Vp-p</p> <p>AC mode(D.audio)</p>		<p>⑤⑦ 1mS/Div. 0.53Vp-p</p> <p>DC mode</p>	<p>⑨ 5mS/Div. 1.25Vp-p</p> <p>DC mode</p>	<p>⑳ (No noise)</p> <p>㉑ (With limiter noise)</p> <p>V : 20mV/Div H : 10mS/Div Approx. 1.25Vp-p</p>
			<p>⑤⑧ 0.2mS/Div. 0.32Vp-p</p> <p>DC mode</p>	<p>⑪ 10mS/Div. 1.7Vp-p</p> <p>DC mode</p>	

• The inside block diagram of IC901 (PAC003A)

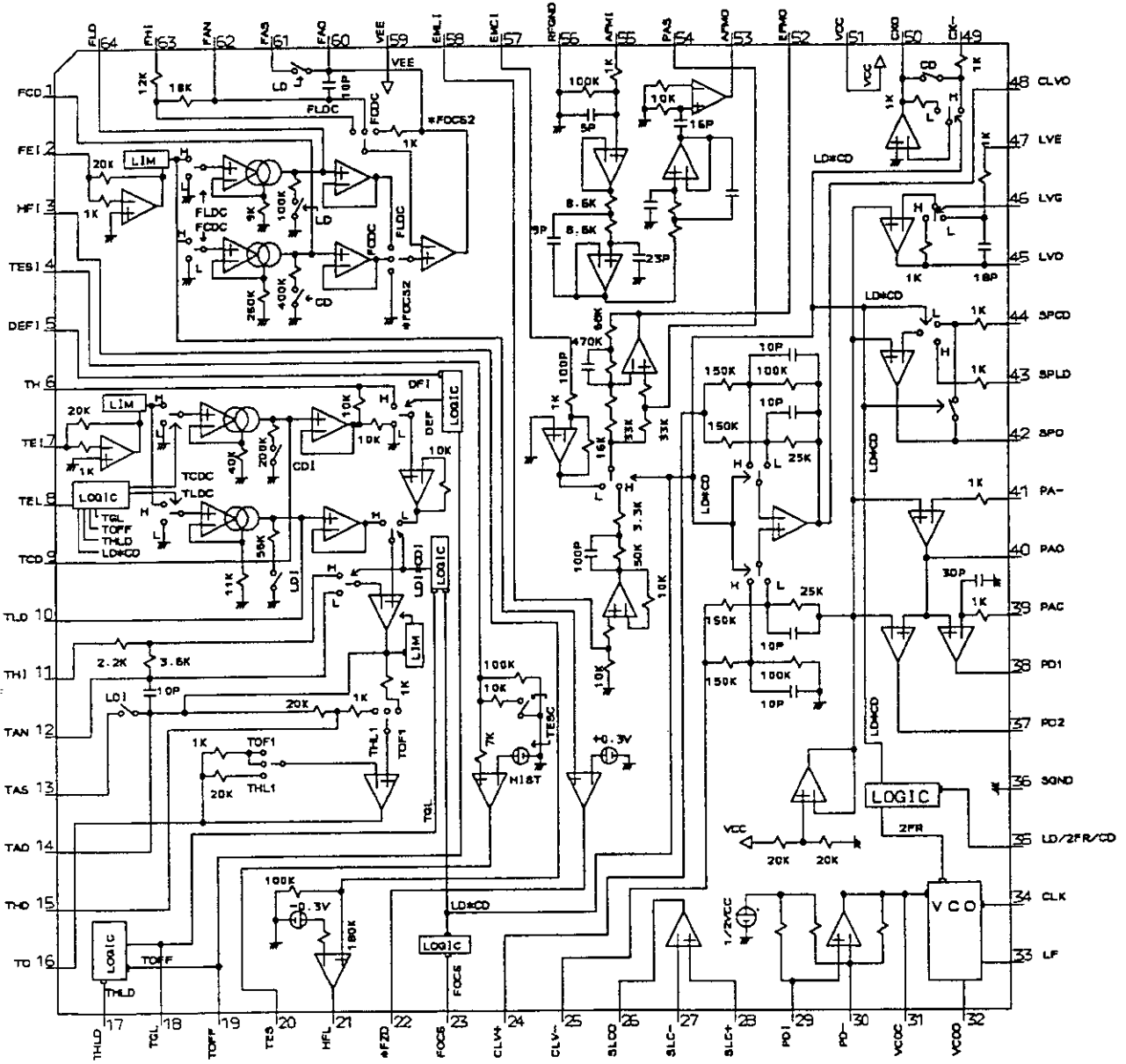

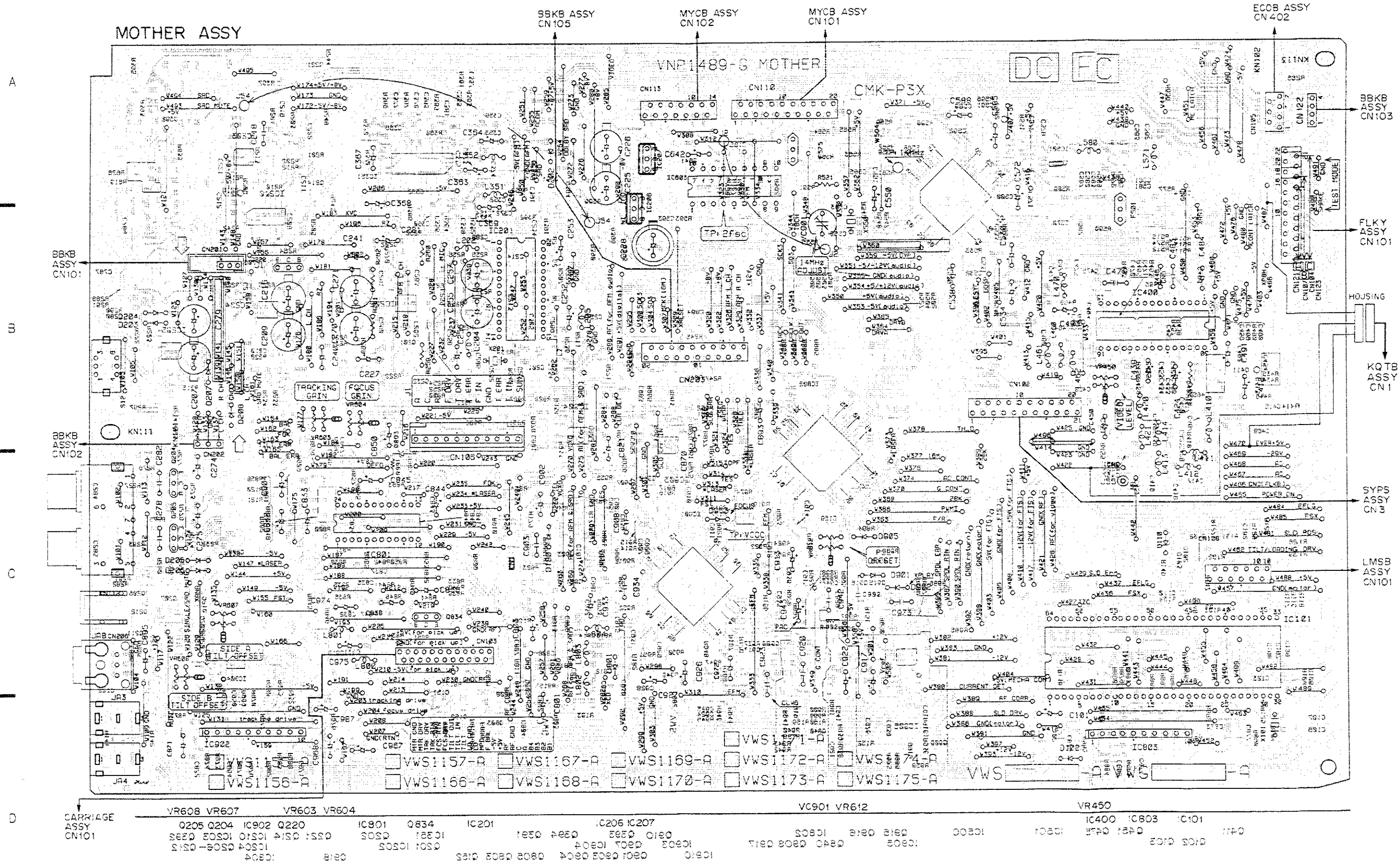

• This diagram is viewed from the mounted parts side.

• The parts mounted on this PCB include all necessary parts for several destinations. For further information for respective destinations, be sure to check with the schematic diagram.

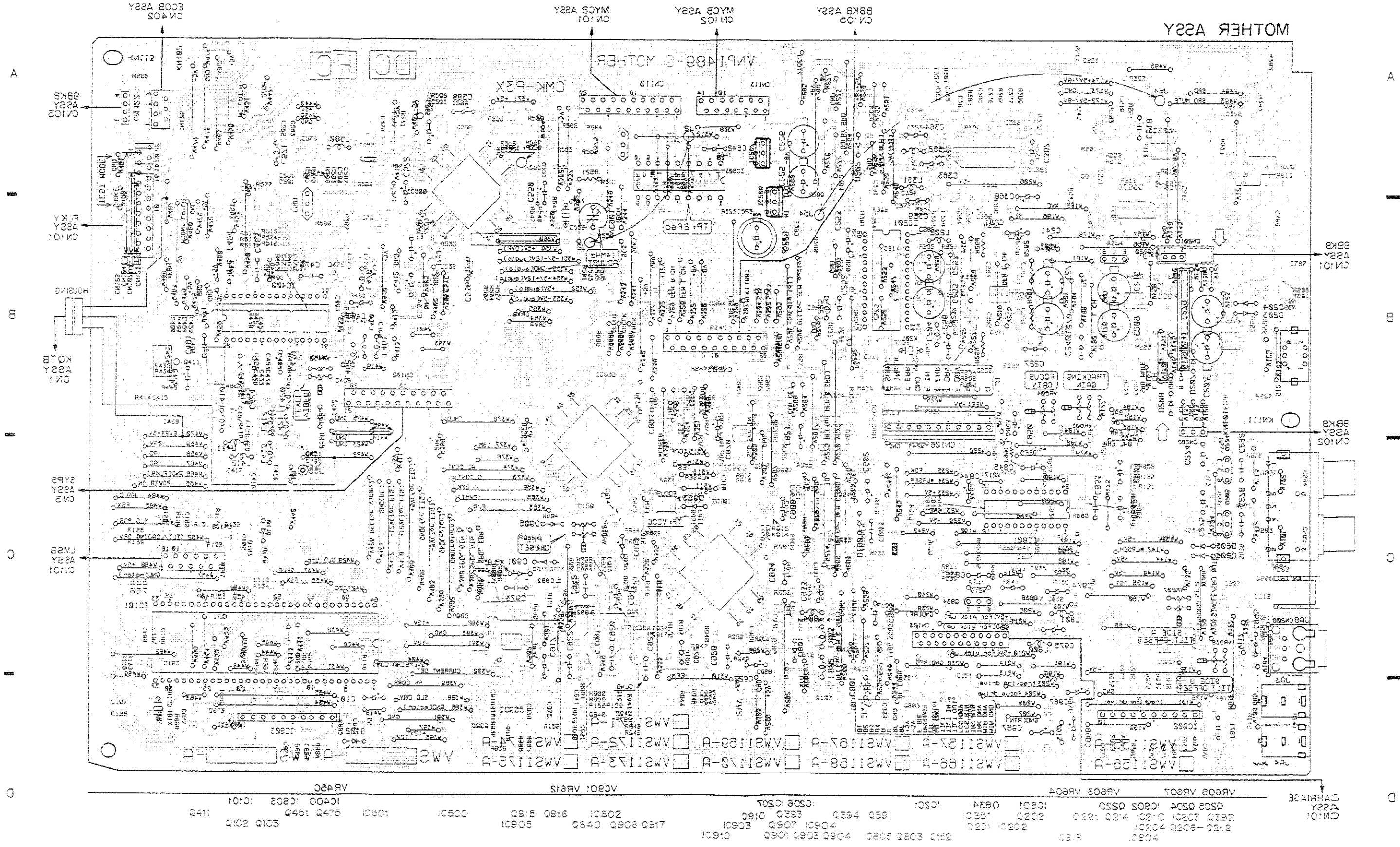

This diagram is viewed from the foil side.

3.3 MYCB ASSY

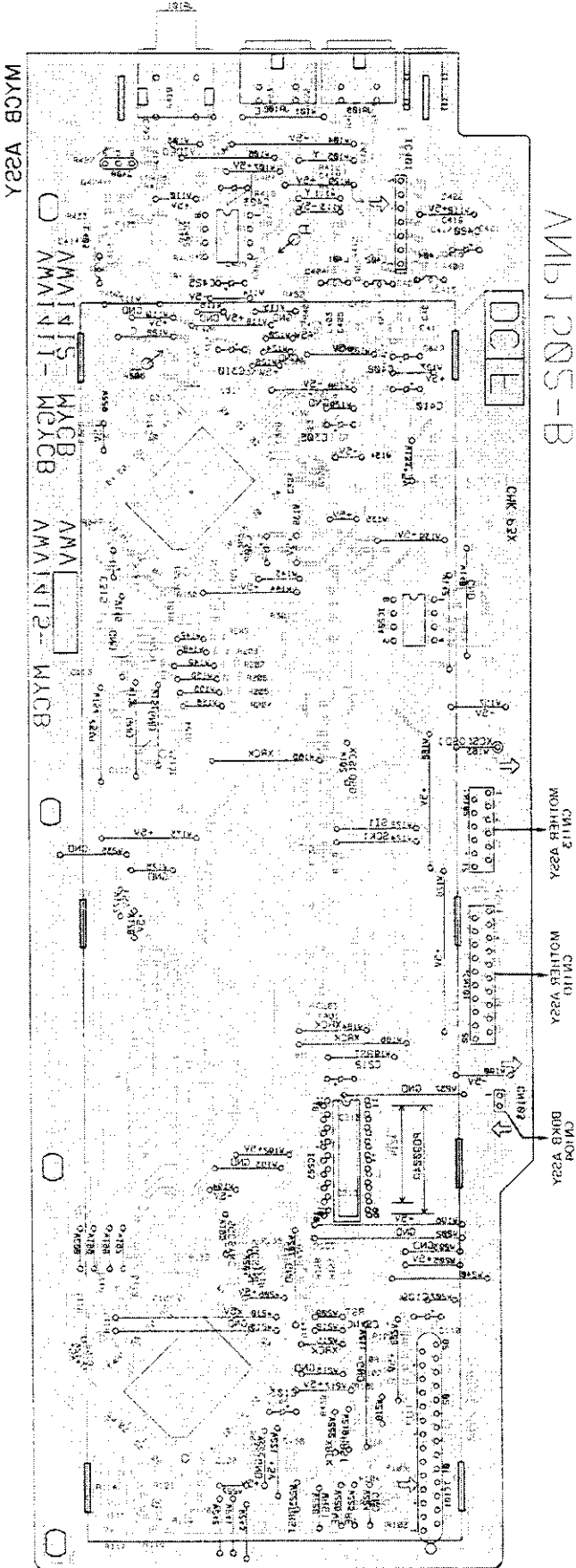

• This diagram is viewed from the foil side.

PCB - 3

A

B

C

D

3

2

3

2

3.3 MYCB ASSY

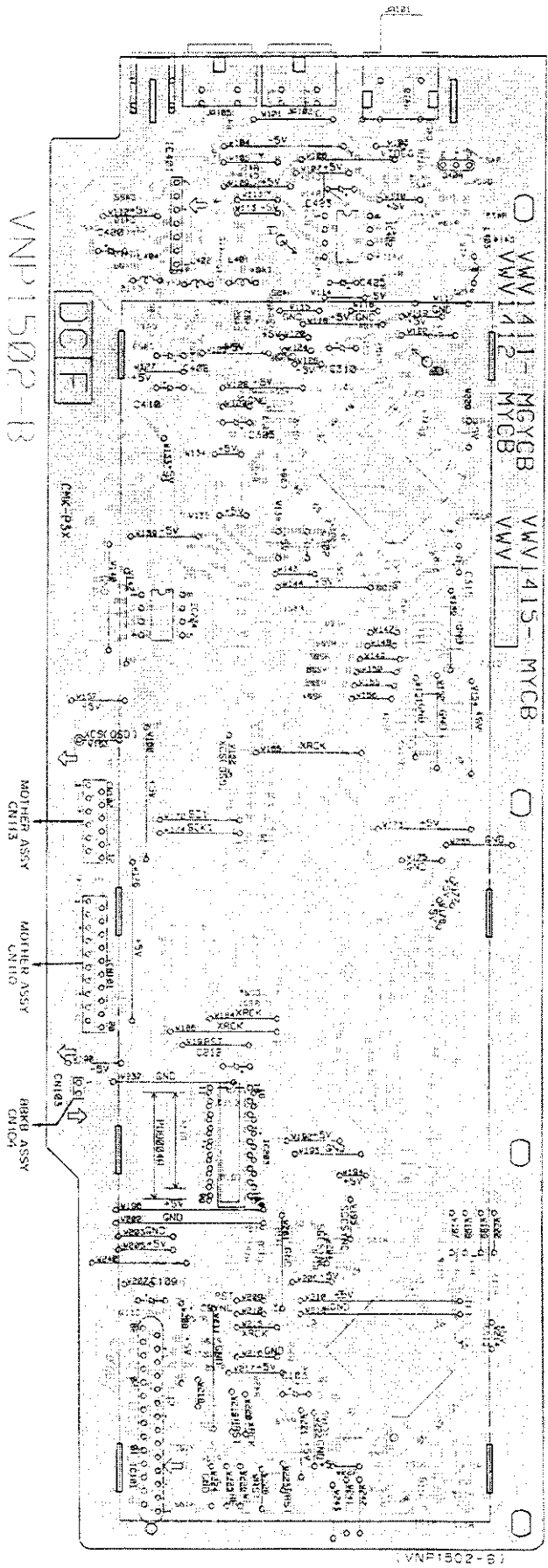

MYCB ASSY

Q408 PARTS
K402 (330) 5041 (100) 104D 107 H 1-211. 241 H

IC203

501 H IC101

VNP1502-B3

• This diagram is viewed from the mounted parts side.

WAVEFORMS AND VOLTAGE
MYCB ASSY

A Note: (No.) in the table correspond to the pin number.
Measurement condition: Where (Color bars) is written, at time when color bar screen of disc is being played. Where (Still) is written, at time of still.

IC102 (PD4510A)

(8) V:2V/div., H:5mS/div.

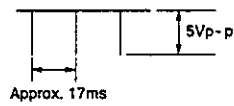

AC mode (Color bars, still)

(9) V:2V/div., H:20 μS/div.

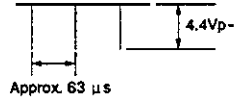

AC mode (Color bars, still)

(11) V:2V/div., H:50 μS/div.

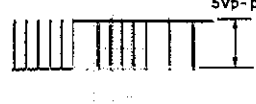

AC mode (Color bars, still)

(53) V:2V/div., H:50 μS/div.

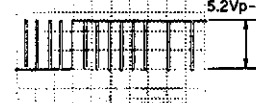

AC mode (Color bars, still)

IC301 (CXD2023Q)

(31) 10 μS/Div.



AC mode [Color bars]

(39) 5mS/Div.



AC mode [Color bars]

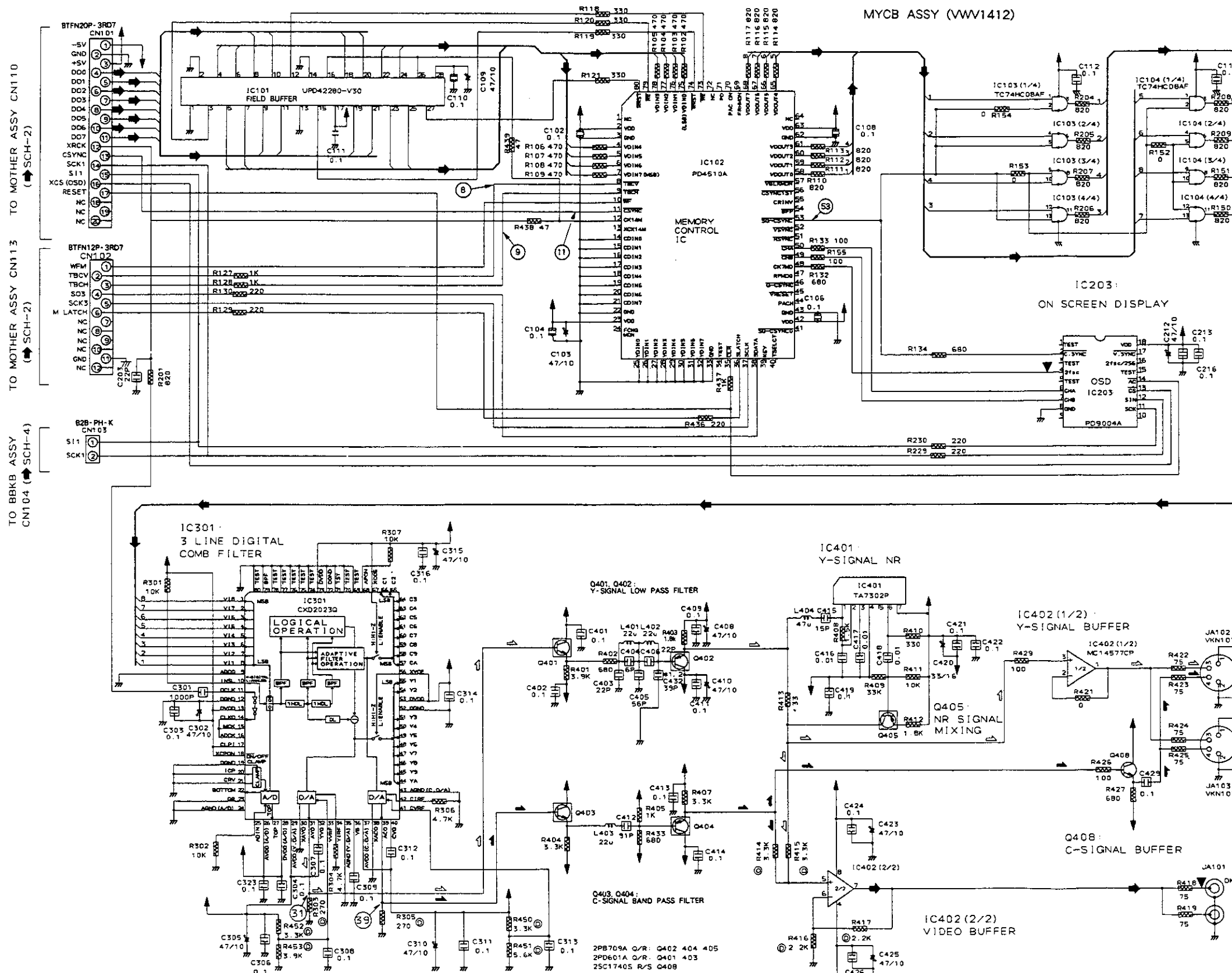

▶ VIDEO SIGNAL LINE
◀ Y SIGNAL LINE
▶ C SIGNAL LINE

SCH-3 MYCB ASSY

MYCB ASSY SCH-3

3.4 BBKB ASSY

BBKB ASSY (VWG1605)

SCH-4

- 155355 D101 102 106
- DT25 68/C D103 104
- DA204K D105
- DT24 78/C D107 D108 D109 D110

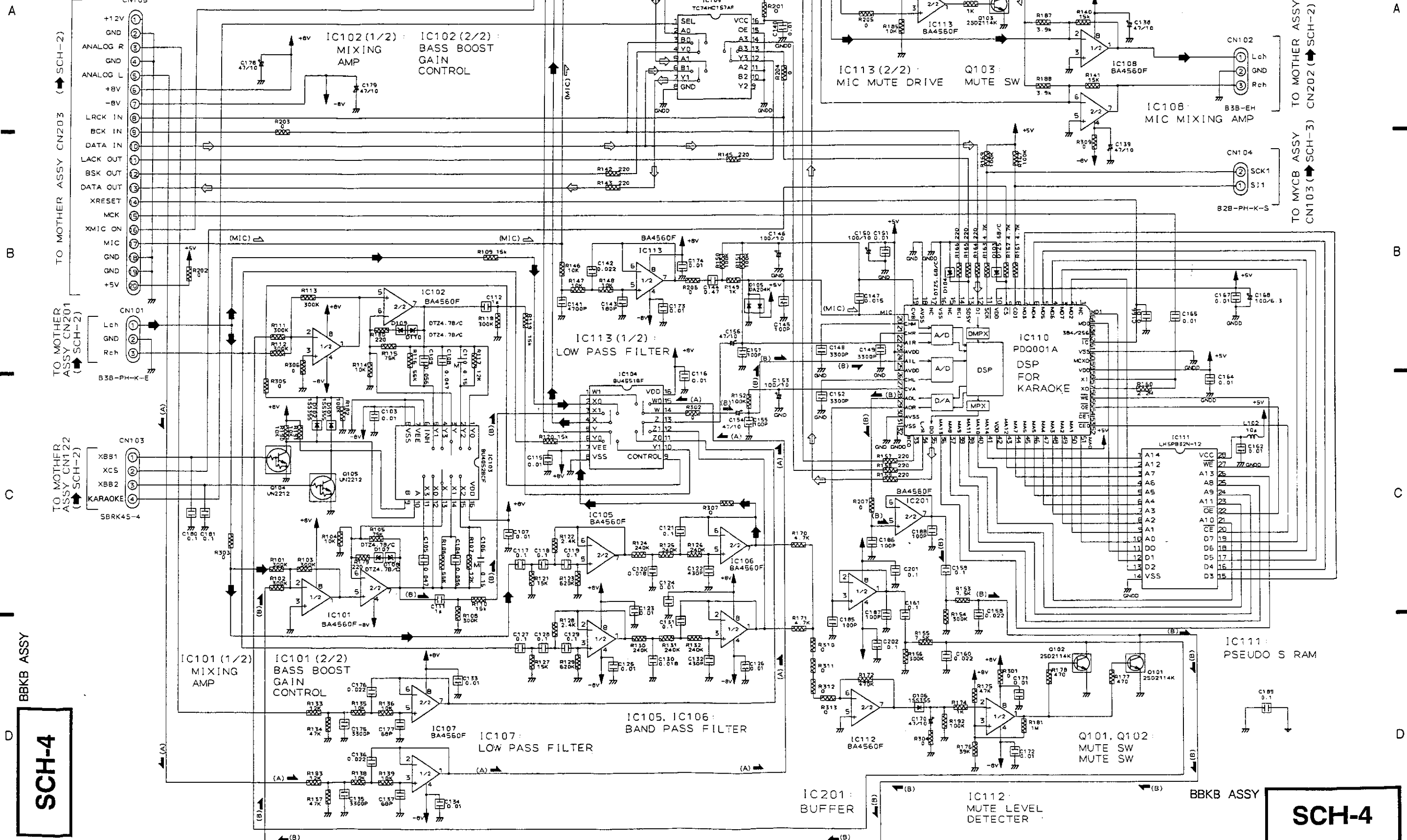

SCH-4

SCH-4

PCB - 4

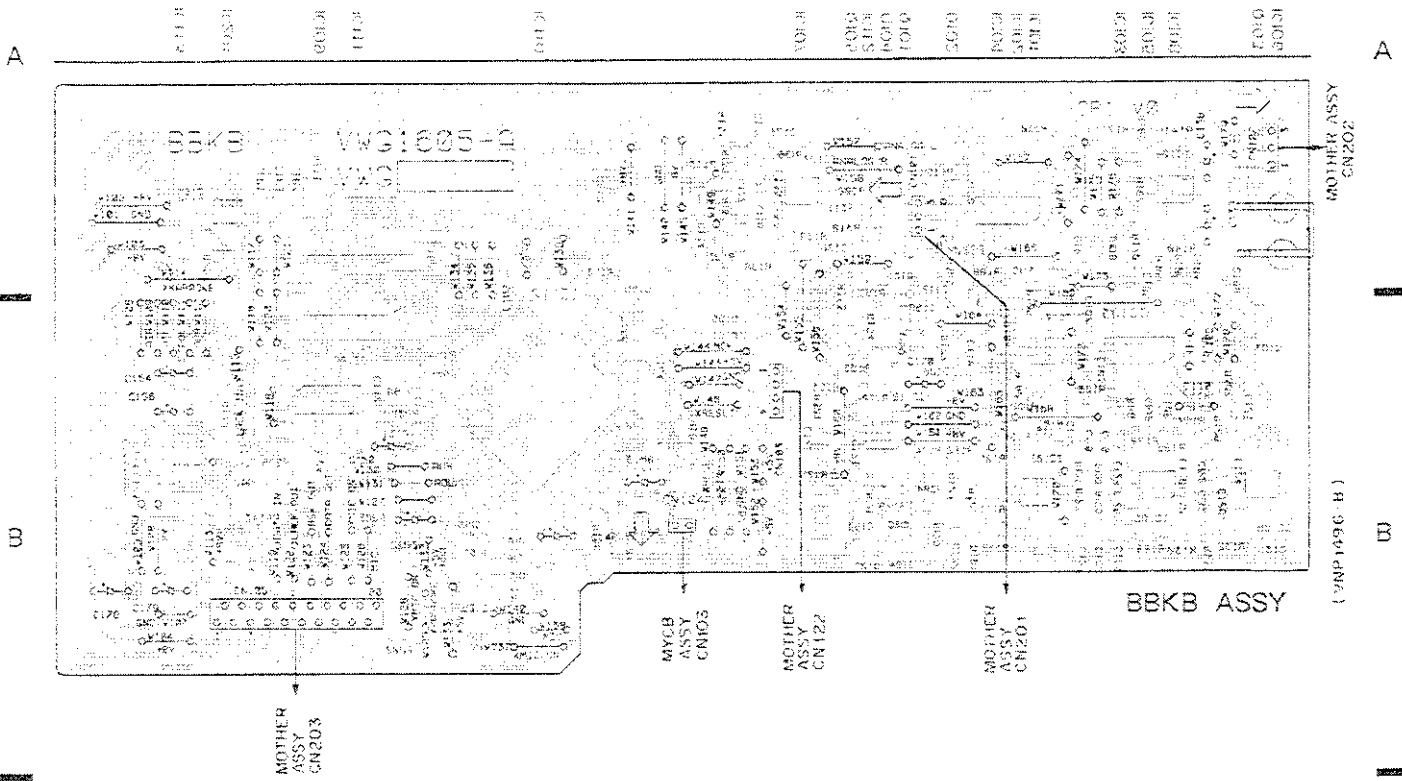

• This diagram is viewed from the mounted parts side.

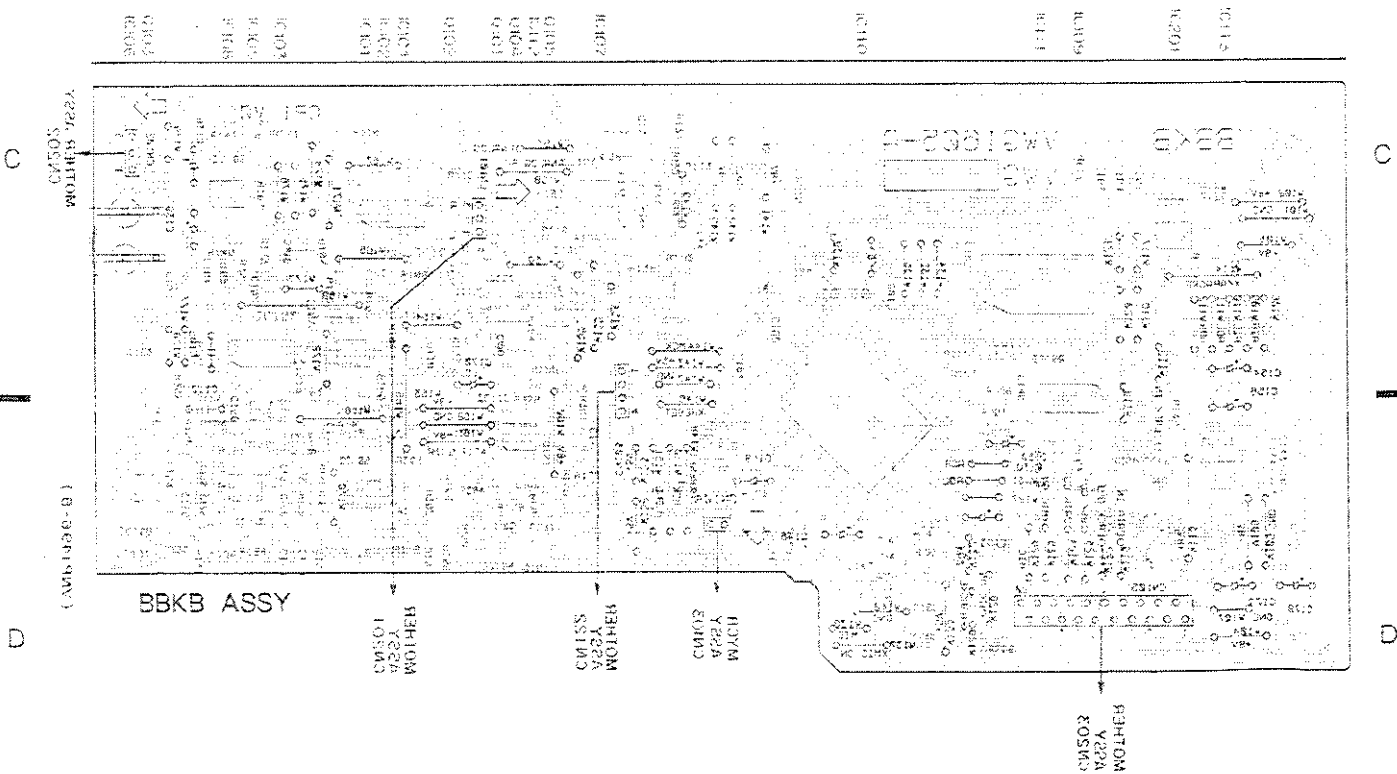

• This diagram is viewed from the foil side.

3.5 KQTB ASSY

A

SCH-5

A

KQTB ASSY (VWG1674)

DTC124ES-T Q1, 3, 5, 6
DTA124ES-T Q2, 4

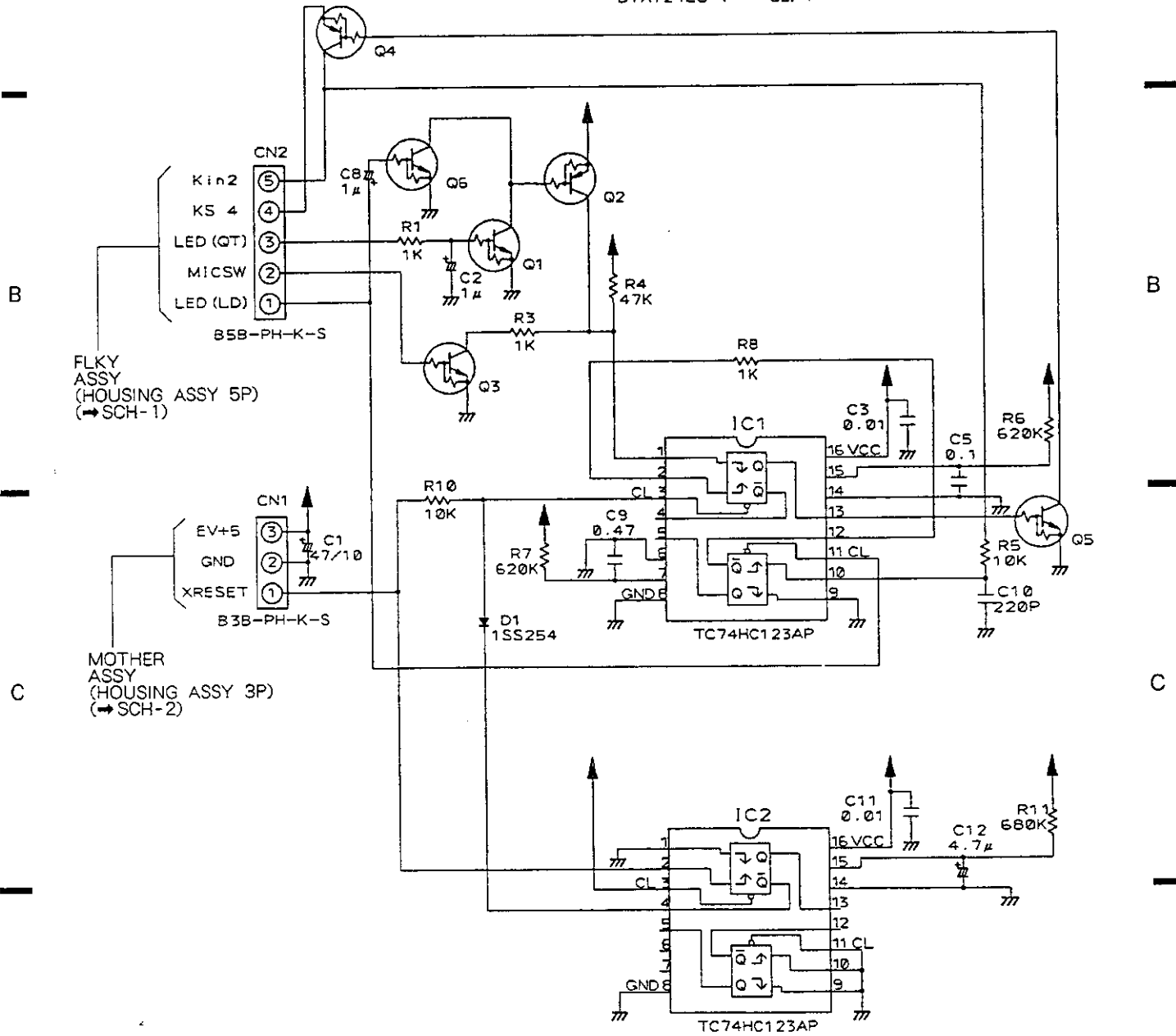

B

B

C

C

D

D

SCH-5

KQTB ASSY

FCB - 5

KQTB ASSY

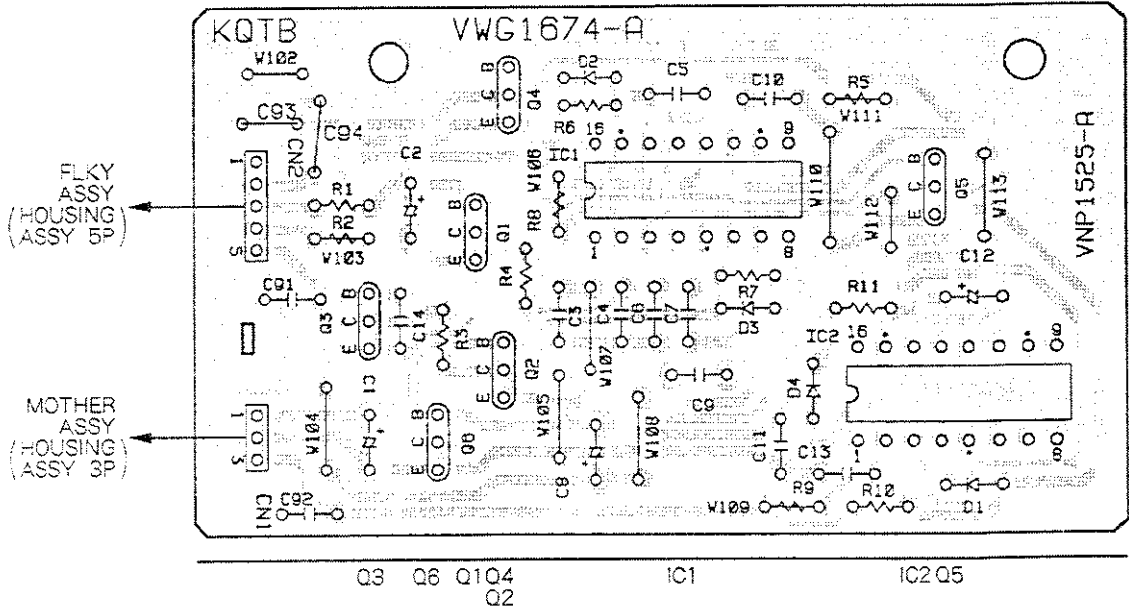

- This diagram is viewed from the mounted parts side.
- The parts mounted on this PCB include all necessary parts for several destinations. For further information for respective destinations, be sure to check with the schematic diagram.

KQTB ASSY

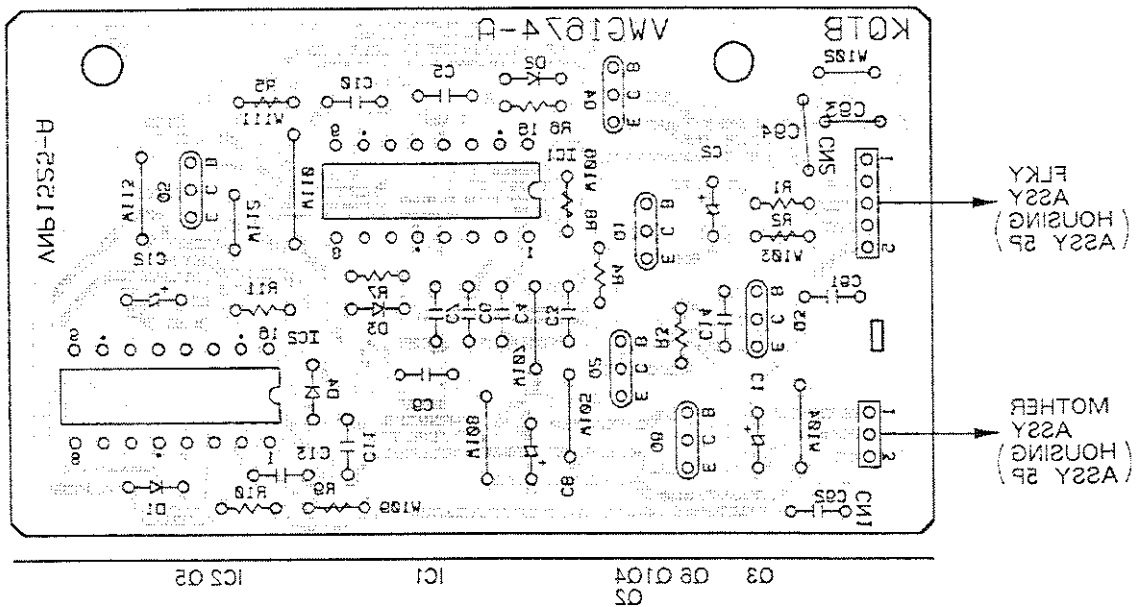

- This diagram is viewed from the foil side.

4. PCB PARTS LIST

NOTES:

- Parts marked by "NSP" are generally unavailable because they are not in our Master Spare Parts List.
- The Δ mark found on some component parts indicates the importance of the safety factor of the part. Therefore, when replacing, be sure to use parts of identical designation.
- Parts marked by "⊙" are not always kept in stock. Their delivery time may be longer than usual or they may be unavailable.
- When ordering resistors, first convert resistance values into code form as shown in the following examples.

Ex.1 When there are 2 effective digits (any digit apart from 0), such as 560 ohm and 47k ohm (tolerance is shown by J=5%, and K=10%).

560 Ω \rightarrow 56 \times 10¹ \rightarrow 561 RD1/8PM $\boxed{5}\boxed{6}\boxed{1}\boxed{J}$
 47k Ω \rightarrow 47 \times 10³ \rightarrow 473 RD1/APS $\boxed{4}\boxed{7}\boxed{3}\boxed{J}$
 0.5 Ω \rightarrow 0R5 RN2H $\boxed{0}\boxed{R}\boxed{5}\boxed{K}$
 1 Ω \rightarrow 010 RSIP $\boxed{0}\boxed{1}\boxed{0}\boxed{K}$

Ex.2 When there are 3 effective digits (such as in high precision metal film resistors).

5.62k Ω \rightarrow 562 \times 10¹ \rightarrow 5621 RN1/4PC $\boxed{5}\boxed{6}\boxed{2}\boxed{1}\boxed{F}$

Mark	No.	Description	Part No.	Mark	No.	Description	Part No.
------	-----	-------------	----------	------	-----	-------------	----------

LIST OF ASSEMBLIES

NSP	MACB ASSY	VWM1535
NSP	PKSB ASSY	VWG1555
NSP	FG ASSY	VWG1556
NSP	TNSB ASSY	VWG1557
NSP	BISB ASSY	VWG1558
NSP	LMSB ASSY	VWG1612
Δ	SYPS ASSY (For CLD-D604)	VWR1256
Δ	SYPS ASSY (For CLD-D780)	VWR1247
NSP	FLKB ASSY (For CLD-D604)	VWM1544
NSP	FLKB ASSY (For CLD-D780)	VWM1557
NSP	KEYB ASSY	VWG1598
NSP	FLKY ASSY (For CLD-D604)	VWG1600
	FLKY ASSY (For CLD-D780)	VWG1609
	ECOB ASSY (For CLD-D604)	VWV1409
	ECOB ASSY (For CLD-D780)	VWV1405
	MJBA ASSY (For CLD-D604)	VWV1406
	MJBA ASSY (For CLD-D780)	VWV1410
	MOTHER ASSY (For CLD-D604)	VWS1171
	MOTHER ASSY (For CLD-D780)	VWS1172
	MYCB ASSY	VWV1412
	BBKB ASSY (CLD-D604 only)	VWG1605
	KQTB ASSY (CLD-D604/KU only)	VWG1674

MACB ASSY

OTHERS

PCB (MACB)	VNP1479
------------	---------

PKSB ASSY

SWITCHES

S104, S105	DSG1017
------------	---------

FG ASSY

SEMICONDUCTOR

D101	GP1S24
------	--------

TNSB ASSY

SWITCH

S111	DSG1017
------	---------

BISB ASSY

SWITCH

S112	DSG1017
------	---------

LMSB ASSY

SWITCHES

S101-S103	DSG1017
-----------	---------

OTHERS

CN101 12P FFC CONNECTOR	52044-1245
-------------------------	------------

SYPS ASSY (For CLD- D604)

SEMICONDUCTORS

	IC20	HA17431P
Δ	IC2	ICP-N15
Δ	IC1	ICP-N20
	IC21	NJM4558D
	Q20, Q22	2SA1598
	Q27, Q30, Q32	2SA933S
Δ	Q24	2SB891F
	Q25, Q29, Q31	2SC1740S
	Q21, Q23	2SC4148
Δ	Q26	2SD2007
	D25-D27, D30, D31	AG01Z-V0
	D29	MTZJ8. 2B
	D40	RD33FB2
	D23, D24	RK36
	D21, D22	RL4Z

Mark No. Description Part No.

RESISTORS

△ R22-R25 (47Ω, 1/6W) VCN1033
 △ R27 (0.47Ω, 1/2W) VCN1046
 △ R29 (68Ω, 1/4W) VCN1048
 △ R31 (8.2Ω, 1/4W) VCN1050

OTHERS

△ F2 FUSE VEK1033
 △ F3, F4 FUSE VEK1034
 △ F5, F6 FUA6 (1.0A/125V) VEK1036

SYPS ASSY (For CLD- D780)

SEMICONDUCTORS

IC20 HA17431P
 △ IC2 ICP-N15
 △ IC1 ICP-N20
 IC21 NJM4558D
 Q27, Q30, Q32 2SA933S
 △ Q24 2SB891F
 Q25, Q29, Q31 2SC1740S
 △ Q26 2SD2007
 Q21, Q23 T7F4S
 Q20, Q22 T7F4T
 D25-D27, D30, D31 AG01Z-V0
 D29 MTZJ8. 2B
 D40 RD33FB2
 D23, D24 RK36
 D21, D22 RL4Z

RESISTORS

△ R22-R25 (47Ω, 1/6W) VCN1033
 △ R27 (0.47Ω, 1/2W) VCN1046
 △ R29 (68Ω, 1/4W) VCN1048
 △ R31 (8.2Ω, 1/4W) VCN1050

OTHERS

△ F2 FUSE VEK1033
 △ F3, F4 FUSE VEK1034
 △ F5, F6 FUSE (1.0A/125V) VEK1036

FLKB ASSY

OTHERS

PCB (FLKB) VNP1495

KEYB ASSY

SEMICONDUCTORS

Q201-Q204 UN2212
 D203, D204 SLR-342MC3F
 D201, D202 SLR-342YC3F

SWITCHES

S201-S211 RSG1030

RESISTORS

All Resistors RS1/10S□□□J

Mark No. Description Part No.

OTHERS

CN201 FFC BOTTOM CONNECTOR 13P 52492-1320
 PCB BINDER VEF1040

FLKY ASSY (For CLD- D604)

SEMICONDUCTORS

IC101 PD3304A
 IC102 S-806D
 Q106 DTA144EK
 Q105 DTC114EK
 Q102 UN2112
 Q101, Q103, Q104, Q107 UN2212
 D101-D105 1SS353
 D106, D111, D112 1SS355
 D108, D109 SLR-342MCT31-TS
 D110 SLR-342VCT31-TS
 D107 SLR-342YCT31-TS

SWITCHES

S101-S106 RSG1030

CAPACITORS

C104, C106 CEAL100M16
 C101 CEAL470M6R3
 C105 CKSQYF103Z50
 C102 CKSQYF104Z25
 C103 CKSQYF223Z50

RESISTORS

VR101 (10kΩ) VCS1037
 Other Resistors RS1/10S□□□J

OTHERS

CN102 FFC BOTTOM CONNECTOR 13P 52492-1320
 CN101 FFC BOTTOM CONNECTOR 22P 52492-2220
 X101 CERAMIC RESONATOR EFOEC8004A4
 REMOTE SENSOR GP1U58X
 V101 FL TUBE VAW1035
 SPACER VEC1599
 HOUSING ASSY VKP2118
 FL HOLDER VNF1087

FLKY ASSY (For CLD- D780)

SEMICONDUCTORS

IC101 PD3303B
 IC102 S-806D
 Q106 DTA144EK
 Q105 DTC114EK
 Q101, Q103, Q104, Q107 UN2212
 D101, D103-D105 1SS353
 D106 1SS355
 D109 SLR-342MCT31-TS
 D110 SLR-342VCT31-TS
 D107 SLR-342YCT31-TS

SWITCHES

S101-S103 RSG1030

CLD - D604, CLD - D780

Mark No.	Description	Part No.
CAPACITORS		
C104, C106		CEAL100M16
C101		CEAL470M6R3
C105		CKSQYF103Z50
C102		CKSQYF104Z25
C103		CKSQYF223Z50

RESISTORS		
All Resistors		RS1/10S□□□J

OTHERS		
CN102	FFC BOTTOM CONNECTOR 13P	52492-1320
CN101	FFC BOTTOM CONNECTOR 18P	52492-1820
X101	CERAMIC RESONATOR	EF0EC8004A4
	REMOTE SENSOR	GP1U58X
V101	FL TUBE	VAW1035
	SPACER	VEC1599
	FL HOLDER	VNF1087

ECOB ASSY (For CLD- D604)

SEMICONDUCTOR		
D401		1SS355

COIL		
L401		LFA100J

CAPACITORS		
C401		CEAS101M10
C421, C422		CKSYF105Z16

RESISTORS		
All Resistors		RS1/10S□□□J

OTHERS		
CN402	7P FFC CONNECTOR	52045-0745
CN401	2mm PITCH BOTTOM CONNECTOR	BTMK07P-1R

ECOB ASSY (For CLD- D780)

SEMICONDUCTORS		
IC402		BA4560F
IC401		W65831FP
D401, D402		1SS355

COIL		
L401		LFA100J

CAPACITORS		
C403, C404		CCSQCH101J50
C417		CCSQCH220J50
C412		CEANP010M50
C415, C416, C420		CEAS010M50
C401		CEAS101M10
C407		CEAS470M10
C406, C408-C410		CFTXA104J50
C405, C411		CKSQYB102K50
C413		CKSQYB562K50
C402, C414		CKSQYF103Z50
C418, C419		CKSQYF104Z25

Mark No.	Description	Part No.
RESISTORS		
All Resistors		RS1/10S□□□J

OTHERS		
CN402	7P FFC CONNECTOR	52045-0745
CN401	2mm PITCH BOTTOM CONNECTOR	BTMK07P-1R
X401	CERAMIC RESONATOR (2.00MHz)	VSS1063

MJBA ASSY (For CLD- D604)

SEMICONDUCTORS		
IC502		BA4560F
IC501		NJM4565M

COILS		
L502, L503		LFA100J
L501		LFA470J

CAPACITORS		
C512		CCSQCH101J50
C503, C509		CEJA2R2M50
C502, C508		CKSQYB152K50
C504, C510		CKSQYB681K50
C511		CKSQYB683K25

C507		CKSQYF103Z50
C505, C506, C514, C515		CKSQYF104Z25
C516, C517		CKSYF105Z16

RESISTORS		
VR501, VR502 (10kΩ)		VCS1036
Other Resistors		RS1/10S□□□J

OTHERS		
CN501	2mm PITCH BOTTOM CONNECTOR	BTMK07S-1S
JA501, JA502	HEADPHONE JACK	RKB1014

MJBA ASSY (For CLD- D780)

SEMICONDUCTORS		
IC502		BA4560F
IC501		NJM4565M

CAPACITORS		
C512		CCSQCH151J50
C509		CEJA2R2M50
C508		CKSQYB152K50
C511		CKSQYB333K25
C510		CKSQYB681K50

C507		CKSQYF103Z50
C505, C506, C514, C515		CKSQYF104Z25
C516		CKSYF105Z16

RESISTORS		
VR501, VR502 (10kΩ)		VCS1036
Other Resistors		RS1/10S□□□J

OTHERS		
CN501	2mm PITCH BOTTOM CONNECTOR	BTMK07S-1S
JA502	HEADPHONE JACK	RKB1014

Mark No.	Description	Part No.	Mark No.	Description	Part No.
MOTHER ASSY (For CLD - D604)			C848, C891, C944		CCSQCH101J50
SEMICONDUCTORS			C434, C437, C474		CCSQCH120J50
IC904		BA10393F	C416		CCSQCH121J50
IC202, IC903, IC905		BA4560F	C415, C418, C475		CCSQCH150J50
IC351		CA0002AM	C161, C353, C812		CCSQCH151J50
IC803		LA6510	C352, C552		CCSQCH180J50
IC802		LC78681KE	C232, C579, C813, C950		CCSQCH220J50
IC206		NJM78L08A	C162, C417, C591, C935		CCSQCH221J50
IC207		NJM79L08A	C371, C419, C433, C467, C931		CCSQCH270J50
IC801		PAC002A	C106, C107, C354, C435, C452		CCSQCH330J50
IC901		PAC003A	C553, C563, C580		CCSQCH330J50
IC400		PAC005B	C351, C425, C476		CCSQCH390J50
IC500		PD0192A	C260-C263, C464, C468		CCSQCH470J50
IC101		PD0212A	C375, C561, C806		CCSQCH680J50
IC201		PD2026B(L)	C374, C814		CCSQCH820J50
IC902		TA8410AK	C460, C462		CCSQCH910J50
IC804		TC4W53F	C367, C439		CEAL100M16
IC501		TC7S04F	C225, C226, C274, C275, C412		CEAL470M16
Q102, Q916		2PB709A	C484, C491, C585, C588, C836		CEAL470M16
Q201, Q202, Q391, Q393, Q394		2PD601A	C844		CEAL470M16
Q451, Q475, Q805, Q840		2PD601A	C850, C870		CEAL47M50
Q903, Q904, Q907, Q908, Q915		2PD601A	C450, C838		CEALNP470M6R3
Q917		2PD601A	C972		CEANP220M10
Q834		2SA854S	C227, C281, C904		CEAS010M50
Q411, Q803		2SC2412K	C228, C240, C241		CEAS100M50
Q152		2SC3802K	C364, C424		CEAS101M10
Q204, Q205		2SD2144S	C821, C922, C967		CEAS220M25
Q208-Q212, Q221, Q392, Q918		UN2112	C845, C902, C926		CEAS2R2M50
Q103, Q206, Q207, Q901, Q910		UN2212	C101, C252, C253, C256		CEAS470M10
D202		11BQS06	C270, C271, C363, C369, C493		CEAS470M10
D102, D180, D205-D208, D801		1SS254	C530, C534, C538, C550, C572		CEAS470M10
D901, D902, D905, D963		1SS254	C801, C803, C833, C842, C893		CEAS470M10
D802		1SS355	C927, C933, C974, C975		CEAS470M10
D201		KV1851	C255, C257		CEAS471M10
D803		MTZJ2. 0A/B	C368, C913, C943		CEASR47M50
D110		MTZJ5. 1B	C968, C987		CEHAQ220M50
COILS AND FILTERS			C895, C917		CEJA101M6R3
L413		LAU100J	C490, C907, C914, C936		CKSQYB102K50
L410		LAU101J	C919		CKSQYB332K50
L351, L802-L804		LAU181J	C361, C362		CKSQYB392K50
L202, L204, L205, L352, L412		LAU220J	C355-C358, C377, C909		CKSQYB472K50
L461, L470, L800, L801		LAU220J	C105, C110, C122, C160		CKSQYF103Z50
L411, L571		LAU270J	C196-C198, C213-C215, C231		CKSQYF103Z50
L420, L421, L580		LAU430J	C234, C251, C254, C286, C288		CKSQYF103Z50
L462		LAU560J	C372, C373, C376, C413, C451		CKSQYF103Z50
L414		LAU8R2J	C454, C485, C531-C533, C539		CKSQYF103Z50
L460		LFA561J	C570, C571, C577, C578, C581		CKSQYF103Z50
F501		VTF1055	C589, C641, C802, C804, C807		CKSQYF103Z50
F575		VTH1005	C831, C832, C834, C835, C843		CKSQYF103Z50
SWITCH			C872, C876, C888, C892, C894		CKSQYF103Z50
S12		VSH1009	C896, C918, C928, C929, C932		CKSQYF103Z50
CAPACITORS			C937, C938, C941, C961, C962		CKSQYF103Z50
C562		CCSQCH050C50	C964, C971, C982		CKSQYF103Z50
C436, C809, C811		CCSQCH070D50	C102, C103, C151, C284, C285		CKSQYF104Z25
C159, C420, C421, C438, C466		CCSQCH100D50	C305, C365, C366, C391		CKSQYF104Z25
C583		CCSQCH100D50	C422, C423, C453, C457, C458		CKSQYF104Z25
C258, C259, C370, C810, C846		CCSQCH101J50	C492, C494, C551, C574, C582		CKSQYF104Z25
			C587, C592, C840, C841, C847		CKSQYF104Z25
			C873, C874, C901, C910-C912		CKSQYF104Z25

Mark No.	Description	Part No.
C915, C976, C981, C983		CKSQYF104Z25
C837, C921, C930		CKSQYF223Z50
C359, C360, C905, C951		CKSQYF224Z25
C465, C808, C815, C875, C877		CKSQYF473Z25
C924, C925		CKSQYF473Z25
C942		CQMA103J50
C920		CQMA104J50
C479, C908		CQMA154J50
C278, C282		CQMA182J50
C903		CQMA222J50
C973		CQMA224J50
C934		CQMA681J50
C483, C923		CQMA683J50
C871		VCH1152
VC901 (20P)		VCM-008

RESISTORS

R521	RD1/6PM010J
R991	RD1/6PM103J
R992	RD1/6PM105J
R420	RD1/6PM470J
R259-R262	RD1/6PM473J
R490, R987, R989	RN1/10SE103D
R880, R883	RN1/10SE104D
R879, R986, R990	RN1/10SE333D
R881, R882	RN1/10SE473D
VR450 (2.2kΩ)	PCP1025
VR603 (4.7kΩ)	PCP1028
VR604, VR607, VR608, VR612 (47kΩ)	PCP1031
Other Resistors	RS1/10S□□□J

OTHERS

CN105	7P FFC CONNECTOR	52045-0745
CN108	12P FFC CONNECTOR	52045-1245
CN102	21P FFC CONNECTOR	52045-2145
CN104	22P FFC CONNECTOR	52045-2245
CN103	23P FFC CONNECTOR	52233-2310
CN106	11P TOP POST	B11P-SHF-1AA
CN202	3P TOP POST	B3B-EH
CN201	KR CONNECTOR 3P	B3B-PH-K-E
CN113	B TO B CONNECTOR 12P	BTFN12S-3SB7
CN110, CN203	B TO B CONNECTOR 20P	BTFN20S-3SB7
JA8	OPTICAL OUTPUT MODULE	GP1F32T
J1	CONNECTOR ASSY	PF02NN-C07
JA3, JA4	REMOTE CONTROL JACK	RKN1004
PCB BINDER		VEF1040
JA6	4P PIN JACK	VKB1065
JA15	1P PIN JACK	VKB1077
64P IC SOCKET		VKH1004
HOUSING ASSY		VKP2117
SCREW TERMINAL		VNE1948
KN101, KN102	EARTH PLATE	VNF1084
X101	CERAMIC RESONATOR (9.00MHz)	VSS1040
X201	CRYSTAL RESONATOR (16MHz)	VSS1057
X550	CRYSTAL RESONATOR (14.318MHz)	VSS1073

MOTHER ASSY (For CLD - D780)

SEMICONDUCTORS

IC904	BA10393F
IC202-IC204, IC903, IC905	BA4560F
IC210	BU4551BF
IC351	CA0002AM
IC803	LA6510
IC802	LC78681KE
IC206	NJM78L08A
IC207	NJM79L08A
IC801	PAC002A
IC901	PAC003A
IC400	PAC005B
IC500	PD0192A
IC101	PD0212A
IC201	PD2026B(L)
IC902	TA8410AK
IC804	TC4W53F
IC501	TC7S04F
Q102, Q916	2PB709A
Q201, Q202, Q391, Q393, Q394	2PD601A
Q451, Q475, Q805, Q840	2PD601A
Q903, Q904, Q907, Q908, Q915	2PD601A
Q917	2PD601A
Q834	2SA854S
Q411, Q803	2SC2412K
Q152	2SC3802K
Q204, Q205, Q220	2SD2144S
Q208-Q212, Q221, Q392, Q918	UN2112
Q103, Q206, Q207, Q214, Q901, Q910	UN2212
D202	11EQS06
D102, D180, D205-D208, D801	1SS254
D901, D902, D905, D963	1SS254
D802	1SS355
D201	KV1851
D110	MTZJ5.1B

COILS AND FILTERS

L413	LAU100J
L410	LAU101J
L351, L802-L804	LAU181J
L202, L204, L205, L352, L412	LAU220J
L461, L470, L800, L801	LAU220J
L411, L571	LAU270J
L420, L421, L580	LAU430J
L462	LAU560J
L414	LAU8R2J
L460	LFA561J
F501	VTF1055
F575	VIH1005

SWITCH

S12	VSH1009
-----	---------

CAPACITORS

C562	CCSQCH050C50
C436, C809, C811	CCSQCH070D50
C159, C420, C421, C438, C466	CCSQCH100D50
C583	CCSQCH100D50

Mark	No.	Description	Part No.	Mark	No.	Description	Part No.
	C258, C259, C370, C810, C846		CCSQCH101J50		C305, C365, C366, C391		CKSQYF104Z25
	C848, C891, C944		CCSQCH101J50		C422, C423, C453, C457, C458		CKSQYF104Z25
	C434, C437, C474		CCSQCH120J50		C492, C494, C551, C574, C582		CKSQYF104Z25
	C416		CCSQCH121J50		C587, C592, C840, C841, C847		CKSQYF104Z25
	C415, C418, C475		CCSQCH150J50		C873, C874, C901, C910-C912		CKSQYF104Z25
	C161, C353, C812		CCSQCH151J50		C915, C976, C981, C983		CKSQYF104Z25
	C352, C552		CCSQCH180J50		C837, C921, C930		CKSQYF223Z50
	C210, C217, C220, C232, C579		CCSQCH220J50		C359, C360, C905, C951		CKSQYF224Z25
	C813, C950		CCSQCH220J50		C465, C808, C815, C875, C877		CKSQYF473Z25
	C162, C417, C591, C935		CCSQCH221J50		C924, C925		CKSQYF473Z25
	C371, C419, C433, C467, C931		CCSQCH270J50		C942		QOMA103J50
	C106, C107, C354, C435, C452		CCSQCH330J50		C920		QOMA104J50
	C553, C563, C580		CCSQCH330J50		C479, C908		QOMA154J50
	C351, C425, C476		CCSQCH390J50		C278, C282		QOMA182J50
	C260-C263, C464, C468		CCSQCH470J50		C903		QOMA222J50
	C375, C561, C806		CCSQCH680J50		C973		QOMA224J50
	C374, C814		CCSQCH820J50		C934		QOMA681J50
	C460, C462		CCSQCH910J50		C483, C923		QOMA683J50
	C219		CCSQSL681J50		C871		VCH1152
	C367, C439		CEAL100M16		VC901 (20P)		VCM-008
	C225, C226, C412		CEAL470M16	RESISTORS			
	C484, C491, C585, C588, C836		CEAL470M16		R521		RD1/6PM010J
	C844		CEAL470M16		R420		RD1/6PM470J
	C850, C870		CEAL4R7M50		R259-R262		RD1/6PM473J
	C450, C838		CEALNP470M6R3		R490, R987, R989		RN1/10SE103D
	C972		CEANP220M10		R880, R883		RN1/10SE104D
	C227, C281, C904		CEAS010M50		R879, R986, R990		RN1/10SE333D
	C228, C240, C241		CEAS100M50		R881, R882		RN1/10SE473D
	C364, C424		CEAS101M10		VR450 (2.2kΩ)		PCP1025
	C274, C275, C821, C922, C967		CEAS220M25		VR603 (4.7kΩ)		PCP1028
	C968, C987		CEAS220M25		VR604, VR607, VR608, VR612 (47kΩ)		PCP1031
	C845, C902, C926		CEAS2R2M50		Other Resistors		RS1/10S□□□□J
	C101, C209, C216, C252, C253		CEAS470M10	OTHERS			
	C256, C270, C271, C363, C369		CEAS470M10		CN105 7P FFC CONNECTOR		52045-0745
	C493, C530, C534, C538, C550		CEAS470M10		CN108 12P FFC CONNECTOR		52045-1245
	C572, C801, C803, C833, C842		CEAS470M10		CN107 18P FFC CONNECTOR		52045-1845
	C893, C927, C933, C974, C975		CEAS470M10		CN102 21P FFC CONNECTOR		52045-2145
	C255, C257		CEAS471M10		CN103 23P FFC CONNECTOR		52233-2310
	C368, C913, C943		CEASR47M50		CN106 11P TOP POST		B11P-SHF-1AA
	C895, C917		CEJA101M6R3		CN113 B TO B CONNECTOR 12P		BTFN12S-3SB7
	C218		CFTYA184J50		CN110 B TO B CONNECTOR 20P		BTFN20S-3SB7
	C490, C907, C914, C936		CKSQYB102K50		JA8 OPTICAL OUTPUT MODULE		GP1F32T
	C222		CKSQYB273K50		JA3, JA4 REMOTE CONTROL JACK		RKN1004
	C919		CKSQYB332K50		PCB BINDER		YEF1040
	C361, C362		CKSQYB392K50		JA6 4P PIN JACK		VKB1065
	C355-C358, C377, C909		CKSQYB472K50		JA15 1P PIN JACK		VKB1077
	C105, C110, C122, C160		CKSQYF103Z50		64P IC SOCKET		VKH1004
	C196-C198, C208		CKSQYF103Z50		SCREW TERMINAL		VNE1948
	C211-C215, C221, C231		CKSQYF103Z50		KN101, KN102 EARTH PLATE		VNF1084
	C234, C251, C254, C286, C288		CKSQYF103Z50		X101 CERAMIC RESONATOR (9.00MHz)		VSS1040
	C372, C373, C376, C413, C451		CKSQYF103Z50		X201 CRYSTAL RESONATOR (16MHz)		VSS1057
	C454, C485, C531-C533, C539		CKSQYF103Z50		X550 CRYSTAL RESONATOR (14.318MHz)		VSS1073
	C570, C571, C577, C578, C581		CKSQYF103Z50	MYCB ASSY			
	C589, C641, C802, C804, C807		CKSQYF103Z50	SEMICONDUCTORS			
	C831, C832, C834, C835, C843		CKSQYF103Z50		IC301		CXD2023Q
	C872, C876, C888, C892, C894		CKSQYF103Z50		IC402		MC14577CP
	C896, C918, C928, C929, C932		CKSQYF103Z50		IC102		PD4510A
	C937, C938, C941, C961, C962		CKSQYF103Z50		IC203		PD9004A
	C964, C971, C982		CKSQYF103Z50		IC401		TA7302P
	C102, C103, C151, C284, C285		CKSQYF104Z25				

CLD - D604, CLD - D780

Mark	No.	Description	Part No.
	IC103, IC104		TC74HC08AF
	IC101		UPD42280V-30
	Q402, Q404, Q405		2PB709A
	Q401, Q403		2PD601A
	Q408		2SC1740S
COILS			
	L401-L403		LFA220J
	L404		LFA470J
CAPACITORS			
	C404		CCSQCH060D50
	C415		CCSQCH150J50
	C203, C403, C406		CCSQCH220J50
	C432		CCSQCH390J50
	C405		CCSQCH560J50
	C412		CCSQCH910J50
	C420		CEAS330M16
	C103, C109, C212, C302, C305		CEAS470M10
	C310, C315, C408, C410, C423		CEAS470M10
	C425		CEAS470M10
	C301		CKSQYB102K50
	C416-C418		CKSQYF103Z50
	C102, C104, C106, C108		CKSQYF104Z25
	C110-C113, C213, C216		CKSQYF104Z25
	C303, C304, C306-C309		CKSQYF104Z25
	C311-C314, C316, C323		CKSQYF104Z25
	C401, C402, C409, C411		CKSQYF104Z25
	C413, C414, C419, C421, C422		CKSQYF104Z25
	C424, C426, C429		CKSQYF104Z25
RESISTORS			
	R416, R417		RN1/10SE222D
	R303, R305		RN1/10SE271D
	R414, R415, R450, R452		RN1/10SE332D
	R453		RN1/10SE392D
	R304, R306		RN1/10SE472D
	R451		RN1/10SE562D
	Other Resistors		RS1/10S□□□J
OTHERS			
	CN103 KR CONNECTOR 2P		B2B-PH-K
	CN102 B TO B CONNECTOR 12P		BTFN12P-3RD7
	CN101 B TO B CONNECTOR 20P		BTFN20P-3RD7
	JA101 2P PIN JACK		DKB1028
	JA102, JA103 4P MINI DIN SOCKET		VKN1072
	SCREW TERMINAL		VNE2021
BBKB ASSY			
SEMICONDUCTORS			
	IC101, IC102, IC105-IC108		BA4560F
	IC112, IC113, IC201		BA4560F
	IC103		BU4052BCF
	IC104		BU4551BF
	IC111		LH5P832N-12
	IC110		PDQ001A
	IC109		TC74HC157AF
	Q101-Q103		2SD2114K
	Q104, Q105		UN2212
	D101, D102, D106		1SS355
	D105		DA204K
	D107-D110		DTZ4. 7B/C
	D103, D104		DTZ5. 6B/C

Mark	No.	Description	Part No.
COIL			
	L102		LFA100J
CAPACITORS			
	C185-C188		CCSQCH101J50
	C143		CCSQCH181J50
	C122, C132		CCSQCH431J50
	C137, C177		CCSQCH680J50
	C145, C155, C157		CCSQSL101J50
	C168		CEAL101M6R3
	C138, C139		CEAL470M10
	C146, C150, C153		CEAS101M10
	C154, C156, C170, C178, C179		CEAS470M10
	C106, C110		CFTXA154J50
	C165, C166		CKSQYB103K50
	C117-C119, C121, C127-C129		CKSQYB104K25
	C131, C159, C161		CKSQYB104K25
	C147		CKSQYB153K50
	C120, C130		CKSQYB183K50
	C136, C142, C158, C160, C176		CKSQYB223K50
	C135, C148, C149, C152, C175		CKSQYB332K50
	C141		CKSQYB472K50
	C105, C108		CKSQYB473K25
	C104, C109		CKSQYB563K25
	C103, C107, C115, C116		CKSQYF103Z50
	C123-C126, C133, C134, C140		CKSQYF103Z50
	C151, C162, C164, C167		CKSQYF103Z50
	C171-C174, C201, C202		CKSQYF103Z50
	C180, C181, C189		CKSQYF104Z50
	C144		CKSQYF474Z16
	C111, C112		CKSYF105Z16
RESISTORS			
	All Resistors		RS1/10S□□□J
OTHERS			
	CN104 KR CONNECTOR 2P		B2B-PH-K
	CN102 3P TOP POST		B3B-EH
	CN101 KR CONNECTOR 3P		B3B-PH-K-E
	CN105 B TO B CONNECTOR 20P		BTFN20P-3RD7
			VNE1948
KQTB ASSY			
SEMICONDUCTORS			
	IC1, IC2		TC74HC123AP
	Q2, Q4		DTA124ES
	Q1, Q3, Q5, Q6		DTC124ES
	D1		1SS254
CAPACITORS			
	C2, C8		CEAL010M50
	C1		CEAL470M10
	C12		CEAL47M50
	C5		CFTXA104J50
	C9		CFTXA474J50
	C10		CKPUYB221K50
	C11, C3		CKPUYF103Z25
RESISTORS			
	All Resistors		RD1/6PM□□□J
OTHERS			
	CN1 CONNECTOR		B3B-PH-K-S
	CN2 CONNECTOR		B5B-PH-K-S

5.SELF-DIAGNOSTIC FUNCTIONS

5.1 SELF-DIAGNOSTIC FUNCTIONS

The self-diagnostic functions automatically display an error code on the TV screen and front panel fluorescent display section when there is an error. The customer checks the error code and conveys it to the service personnel to make repairs more efficient.

After an error occurs, even if the error code goes off, you can display the error code again by holding down the **CLEAR** key for 10 seconds (except a loading error **L *** display). At that time, partial error is displayed with the mechanism switch information. However, if the power cord is unplugged, the error code information is lost.

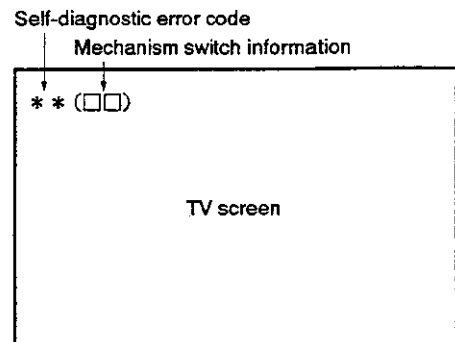

Fig. 1 TV screen display

This table explains the information for analyzing the cause when an error occurs with the CLD player.

Self-diagnostic error code	Contents	Conditions	Probable cause
H0	Spindle overcurrent detection error.	In the play state, overcurrent was detected in the spindle motor. Monitoring starts 5 seconds after the start of play or special playback mode, this error is detected if the overcurrent port is "L" for 4 seconds.	<ul style="list-style-type: none"> • Motor NG • Clamper rubbing
U0	FG abnormality error	<ol style="list-style-type: none"> ① At LD startup, the rate of rotation calculated from the FG was less than 15 rpm for 5 consecutive seconds from the spindle run command. ② At CD startup, there was less than 1/8th rotation even after 5 seconds had passed since the end of acceleration. ③ During play search, CD : subcodes are being read/LD : Phillips codes are being read and the spindle is locked, but a state in which the rate of rotation calculated from the FG was less than 15 rpm continued for 5 seconds or more. In the above case, it is judged that an abnormality has occurred in the FG sensor and that accurate rotation rate calculation has become impossible. 	<ul style="list-style-type: none"> • FG sensor abnormality, FG signal not coming to mechanism controller • FG sensor clogged • Rubbing between FG sensor and slit • Turntable dropped • FG slit deposition NG
H1	Partial short error	<ol style="list-style-type: none"> ① At LD startup, the speed did not reach 1200 rpm within a certain time (12 seconds) after the spindle run command. ② At CD startup, a certain speed (313 rpm) was not reached within 6 seconds from the end of spindle acceleration. 	<ul style="list-style-type: none"> • Spindle motor NG • Commutator NG • Bearing too tight • Power supply NG
H2 A0	Power supply abnormality error	<p>– 5V power supply abnormality detected.</p> <p>The power supply abnormality port is constantly monitored and if its signal stays high for about 1 second consecutively, the power supply is judged to be abnormal.</p>	<ul style="list-style-type: none"> • – 5V not fed from SYPS assy • Parts shorted
L *	Loading error	<ol style="list-style-type: none"> ① When loading operation goes over time (approx. 10 sec.). ② When assist at disc sense entry ends and is not tilt neutral. ③ When assist at set up entry ends and is not tilt neutral. 	<ul style="list-style-type: none"> • Tilt switch 1, 2, 3 abnormal, so tilt/loading state not read in correctly • Tilt/loading mechanism mechanically locked • Drive IC NG • Power supply NG
E *	Slider error	During slider movement, a time over-run occurred (track count search 20 seconds, mandatory movement 10 seconds)	<ul style="list-style-type: none"> • Slider ceased being able to run • The slider mechanism is mechanically locked and can no longer move to its target. • Slider position switch NG • Flexible cable pulled out • Drive IC NG • Power supply abnormal
U1	Miss clamp error	<ol style="list-style-type: none"> ① During LD setup, after 1/8th rotation, the track count during 1/8 rotation exceeded 511. ② During start-up, the focus was lost once and refocusing was attempted, but the focus could not be locked. ③ Two FG pulses did not come within 800 ms from from the start of LD start-up. ④ The disc clamp operation did not end within 5 seconds. 	<ul style="list-style-type: none"> • Disc sandwiched • Disc shifted • Spindle motor NG • Disc scratched or dirty defocused during start up • Two discs loaded • PU actuator NG • Tilt sensor NG • Tilt neutral NG (tilt base NG)

Self-diagnostic error code	Contents	Conditions	Probable cause
P *	Spindle error	① During TOC reading with an LD, the spindle servo was not locked within 60 seconds from the start of the spindle run. ② When CAV/CLV determination is not finished within 60 seconds from spindle servo lock. ③ The codes could not be read for 10 - 15 seconds consecutively for an LD or 7 - 10 seconds for a CD/CDV and the spindle servo was not locked. ④ The speed exceeded 2100 rpm during LD start up.	P0: PH code, SUB-Q code can not be read •VCO, PLL offset out of adjustment •Disc defect P5: PAL disc, mirror disc, etc. PLAY •No RF P6: Spindle servo does not lock •Spindle motor NG
F *	Focus error	① "In the "no disc" state, a setup command was received from the mode controller. ② When LD is out of focus when slider is moved to starting position during set up. In case of CD/CDV is NG even after three focus tries. ③ During start-up, the maximum slider servo duty continued for 3 loops or more.	F5: CD, LD on top of each other •LD scratched or dirty defocused during slider movement •Disc NG •Slider position switch NG F6: Inner edge of disc scratched or dirty •Slider ran into inner edge mechanical stopper

* Besides the above errors, there is the "U2" communications error (the mode controller could not communicate normally with the mechanism controller)
 The probable cause is a defective mechanism controller, disconnected cable, etc..

- * Mechanism mode contents (meaning of * for L * etc.)
- | | | |
|----------------|----------------------------|---------------------|
| 0 : Play | 5 : Setup (rotation start) | 9 : Side A → Side B |
| 1 : Open | 6 : TOC read | A : Side B → Side A |
| 2 : Standby | 7 : Play | |
| 3 : Clamp | 8 : Search | |
| 4 : Disc sense | | |

5.2 FORMAT OF THE MECHANISM SWITCH INFORMATION WHICH IS TRANSMITTED TO THE MODE CONTROL IN THE ERROR OCCURRENCE

• Mechanism switch information (1 7)

Mechanism control → Mode control
 Communication byte address 5 (COMBUF5)
 (Mode control displays this value as it is.)

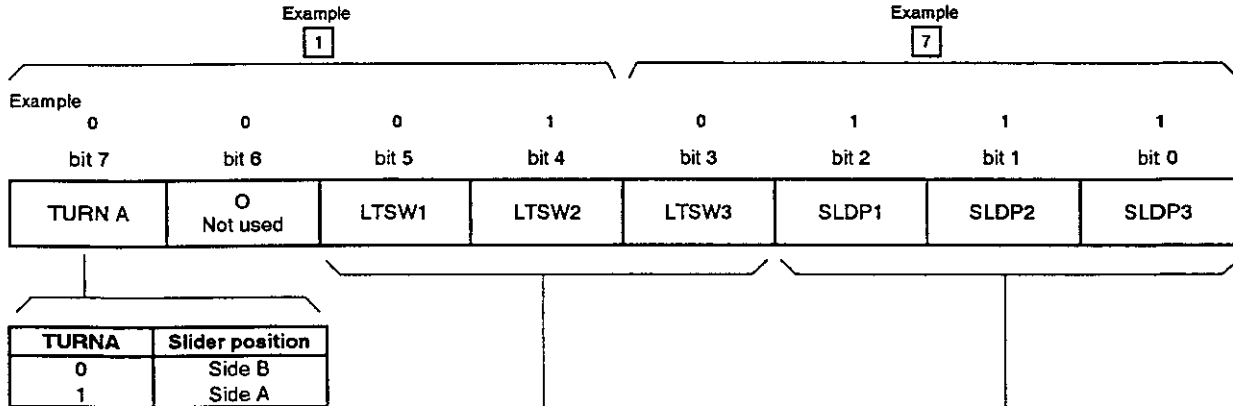

Example of 1 7 is indicated as follows.

(Slider : Side B
 Tilt : Tilt +
 Position : B-INSIDE)

LTSW			Loading/tilt position
1	2	3	
0	1	1	Open (Tray open state)
0	0	1	Loading (During move the tray horizontally)
1	0	1	Standby (Tray close & spindle down state)
1	0	0	Clamp (During spindle up or down)
0	0	0	Tilt - (Clamp state)
0	1	0	Tilt + (Clamp state)
1	1	0	Tilt limit (Clamp state)

SLDP			Slider position
1	2	3	
1	0	0	CD active position
1	0	1	CDV active position
1	1	0	LD active position
0	1	1	CD inside position
1	1	1	Side B inside position

6. ADJUSTMENTS

6.1 Test Mode

1) How to start the test mode

On the MOTHER ASSY, Short circuit the test mode JP W490 and W491, the test mode is started by pressing the power switch ON. (Fig. 1)

After confirming that all FL indicators are lit, remove test mode jumper wire and GND connection. If you have test mode remote control unit (GGF1067), press ESC key and TEST key in order with power switch ON.

2) How to cancel the test mode

Turn power switch OFF. Or, press test mode remote control ESC key.

3) Functions and key control when in test mode

Note : For keys not on player or on accompanying remote control, use test mode remote control unit (GGF1067).

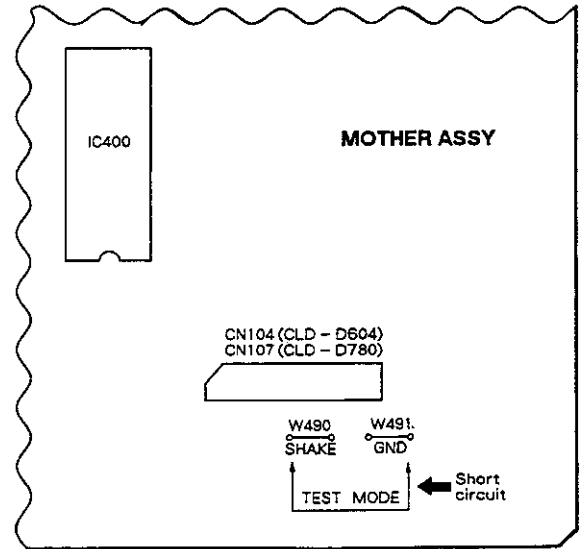

Fig. 1

Note : When you open the tray in test mode, the screen displays goes out. To display the screen again, press the **DISPLAY** key.

• Key Operation in the Test Mode

Player Status	Key Operation	Function	TV Screen Display
Tray Open	⏪ / ⏩ SKIP (Refer to Note 1)	⏪ : Shifts the tray in the closed direction and also raises the turn table while pressing the key. ⏩ : Shifts the tray in the open direction and also lowers the turn table while pressing the key.	
Tray Open	▶ PLAY	Clamps	
Clamp	▶ PLAY	Turns the disc through TRK Servo OFF	TRK-OFF
TRK Servo OFF	▶ PLAY	TRK Servo ON	TRK-ON
TRK Servo ON	▶ PLAY	TRK Servo OFF	TRK-OFF
TILT Neutral	+ MULTI-SPEED	TILT Servo ON	T-□:ON
TILT ON	- MULTI-SPEED	TILT Neutral	T-□:N
TILT Neutral or ON	⏪ / ⏩ SKIP	Setting TILT Servo to OFF, can force TILT to move.	T-1 to T-E
Clamp	◀ / ▶ SCAN	Can force the slider to move	S-LD S-BIN S-CDV S-CD S-IN
Play	PAUSE	Still	
Play	■ STOP	Stop	
Stop	▲ OPEN	Open	
Play	+10 ↓ 0 to 9 ↓ ▶ PLAY	Set to SEARCH lead address input mode. Designates the SEARCH lead address through keys 0 to 9. Press the CLEAR [C] key if the designated address is incorrect. Searches the designated address upon pressing the PLAY key.	

Note 1 : Press SKIP (⏪ / ⏩) keys after the tray is set to open state by pressing OPEN (▲) key.

Because, in tray open state, pressing PLAY (▶) key causes is to set to clamp state and SKIP (⏪ / ⏩) keys can not function properly.

Table 1

• **Player Operation in the Test Mode**
(Disc tray is removed)

Operate the player by selecting a test mode function with the keys on the player or on the remote control unit.

• **CD PLAYBACK**

- ① Place the CD disc on the turn table.

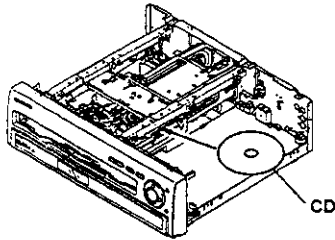

Fig. 2

- ② Press the PLAY (▶) key once.
(Twin gear starts to move.)
- ③ Push the cam plate (Fig. 3) in the direction of the arrow and wait until the CD disc is clamped.

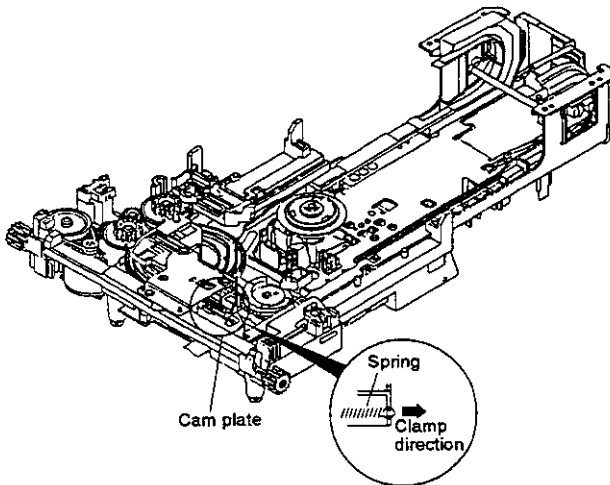
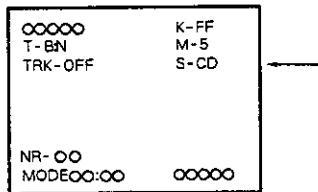

Fig. 3

- ④ Press the ◀◀ or ▶▶ keys to appear "S-CD" on the TV screen display.



TV screen display

Fig. 4

- ⑤ Press the PLAY (▶) key twice, disc will be normally playbacked.

• **LD PLAYBACK**

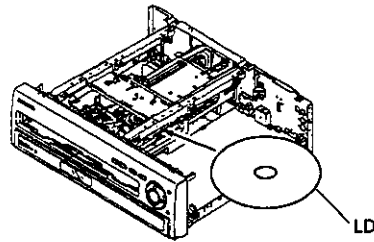
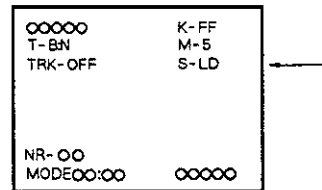

Fig. 5

- ① Press the SKIP REV (◀◀) key to raise the turn table (spindle motor section) while pressing the cam plate (Fig. 3) in the direction of the arrow. Raise it to the position where the LD disc can be easily placed on the turn table. If the turn table is raised too high, lower it with the SKIP FWD (▶▶) key.
- ② Place the LD disc on the turn table and press the PLAY (▶) key once to clamp the disc.
- ③ Press the ◀◀ or ▶▶ keys to appear "S-LD" on the TV screen display.



TV screen display

Fig. 6

- ④ Press the PLAY (▶) key twice, disc will be normally playbacked.

6.2 ADJUSTMENT PRECAUTIONS

• Equipment and jigs needed for adjustment

- CD test disc (YEDS-7)
- LD test disc (GGV1012)
- Medium-sized blade screwdriver
- Small blade screwdriver
- Large Phillips screwdriver
- Medium-sized Phillips screwdriver
- Two-channel oscilloscope (with delay)
- Frequency counter
- TV monitor

• Preparation for Adjustment

1. Disc tray removal

1. Remove the seven screws (A) fastening the bonnet and remove the bonnet.
2. With the power supply on, press the OPEN/CLOSE (LD) button and put the disc tray in the open position.
3. While pushing the hooks (B) on both sides of the rear of the disc tray inwards, pull out the disc tray.

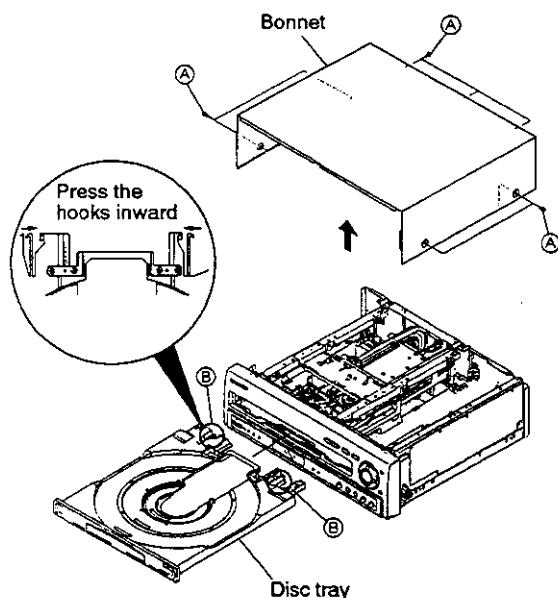

Fig. 7

Note: The adjustments other than "Electrical Adjustments 3. PLL OFFSET Adjustment" can be carried out with the disc tray mounted.

2. Diagnostic method of MOTHER assy

1. Remove the four screws (C) fastening the rear panel (L). (Fig. 8)

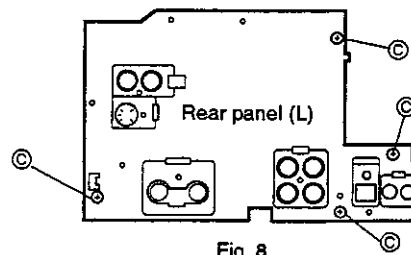

Fig. 8

2. Remove a screw (D) fastening the front side of PCB holder. (Fig. 9)
3. Remove the two screws (E) fastening the MOTHER assy. (Fig. 9)

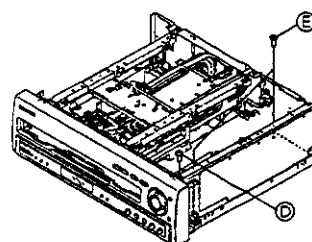

Fig. 9

4. Loosen the binder for fixing flat cable in the MOTHER assy.
5. While pulling up the rear panel (L) toward the rear, MOTHER assy will be removed with the rear panel (L). Then MOTHER assy can be diagnosed by standing it as shown in Fig. 10.

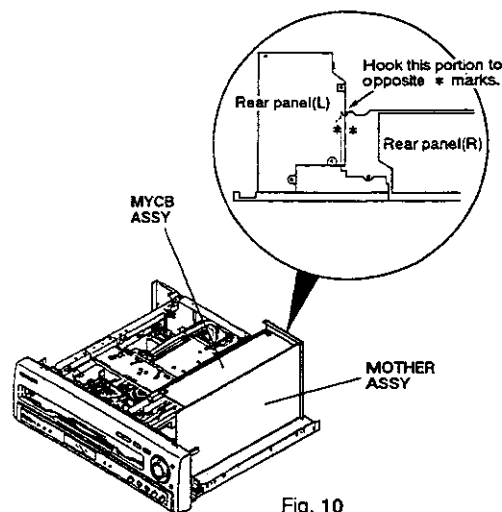

Fig. 10

Note 1: The MOTHER assy can be diagnosed with the disc tray mounted.

Note 1: When inserting the disc tray, please hold down the flat cable without hanging to the tray.

• Before adjusting mechanism system

• Centering adjustment screw and TAN adjustment screw

Note: Be careful not to turn centering adjustment screw and TAN adjustment screw past their adjustment range.

After the adjustments, apply the lock-tight to centering and TAN adjustment screws.

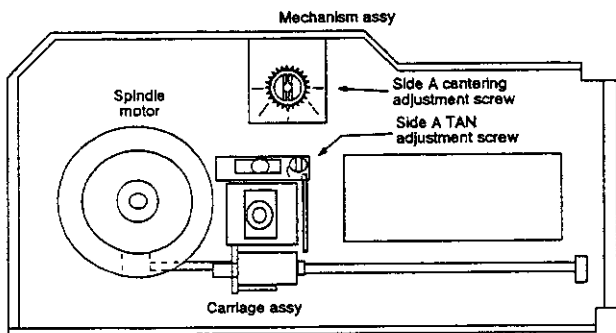

Do not turn the centering and TAN adjustment screws past their ranges, which are $\pm 0.75\text{mm}$ and $\pm 80^\circ$ from center. Apply the lock-tight after the adjustment.

Fig. 11 Mechanism assy adjustment (side A)

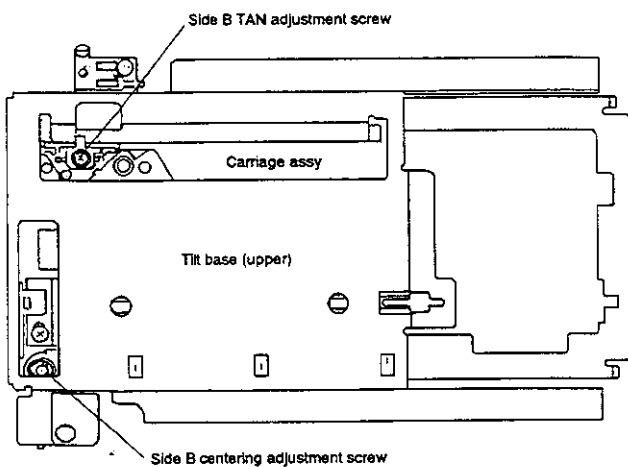

Centering adjustment range $\pm 90^\circ$
TAN adjustment range \pm two turns

Fig. 12 Mechanism assy adjustment (side B)

• The mechanical adjustments can all be carried out with disc tray mounted.

• Notes when adjusting centering

If waveform S/N is bad and difficult to observe in "3 and 8. SPDL motor centering adjustment" use the low pass filter in diagram. (Fig. 13)

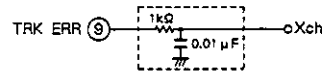

Fig. 13 Low pass filter

• Carriage assy position when adjusting centering

When moving slider to inner position to adjust the innermost track of disc during centering adjustment, be careful not to keep the mechanism stopper and carriage assy from bumping each other. (Fig. 14)

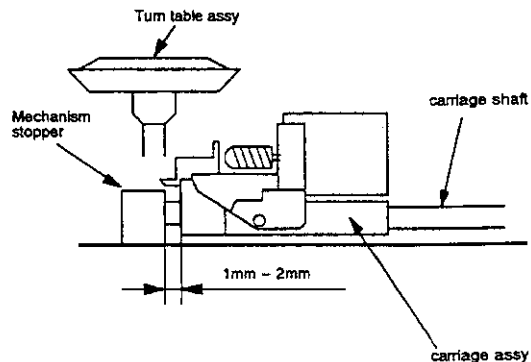

Fig. 14

• Notes when adjusting pickup assy

Please clean lens first when readjusting the pickup assy that is on this product. Also, when changing pickup assy, change whole carriage assy (VWT1100).

6.3 HOW TO REPLACE THE FLEXIBLE CABLE

① Bend the flexible cable as shown below.

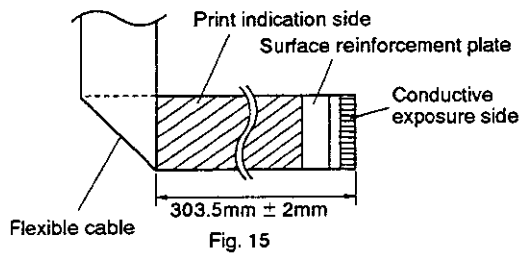

Fig. 15

② Put the bended portion to hook (A) of the large hill.

③ Bend the flexible cable along the wall of large hill.

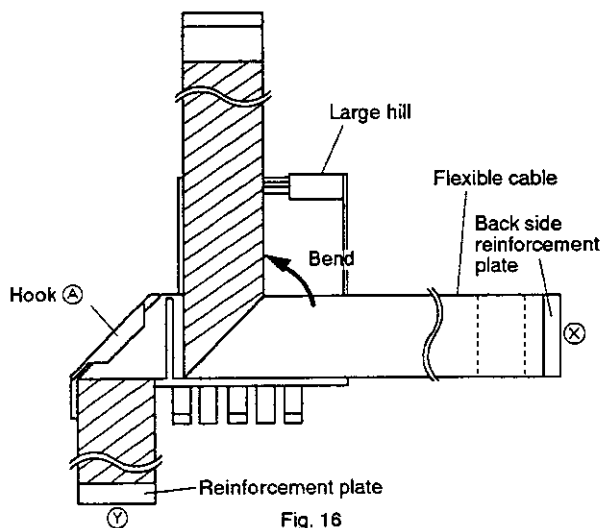

Fig. 16

④ Pull the flexible cable not to slackened after passing the (X) edge side of flexible cable through the large hill as shown in Fig. 17.

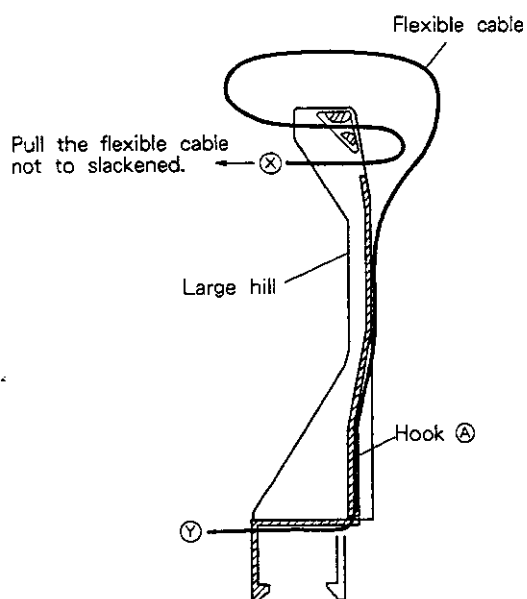

Fig. 17 Sectional plan

⑤ Put the flexible cable to hook (B) after the (Y) edge side of flexible cable is bended along the hook (B) position of the tilt base (lower), then insert to connector CN103 of the MOTHER assy.

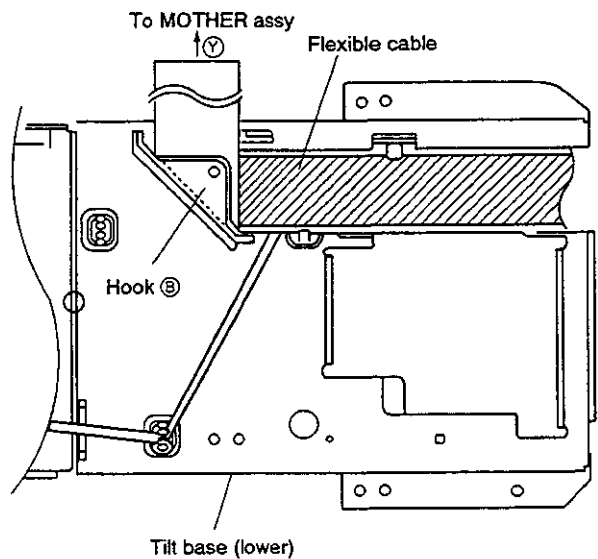

Fig. 18

⑥ Insert the (X) edge side of flexible cable to connector of the carriage assy after passing through the FFC holder.

⑦ Move the FFC holder to touch the connector, lock the FFC holder to turn up the flexible cable to lower side.

Caution: Be sure to insert the MOTHER assy first of all for prevent the static electricity.

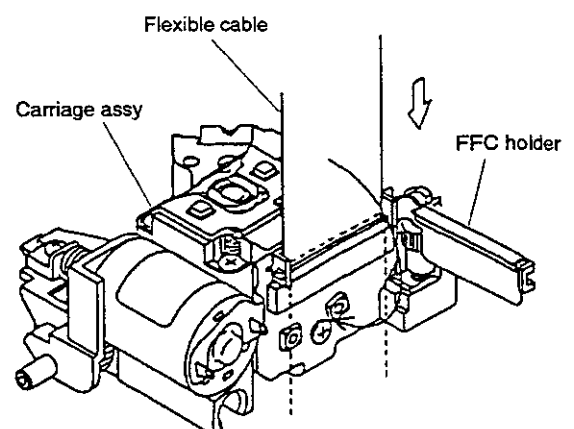

Fig. 19

6.4 ADJUSTMENT LOCATION

- VR607 : Side A tilt offset adjustment
- VR608 : Side B tilt offset adjustment
- VR604 : Focus servo loop gain adjustment
- VR603 : Tracking servo loop gain adjustment
- VC901 : Master clock adjustment
- VR450 : Output video level adjustment
- VR612 : PLL offset adjustment
(Orderin adjustment)

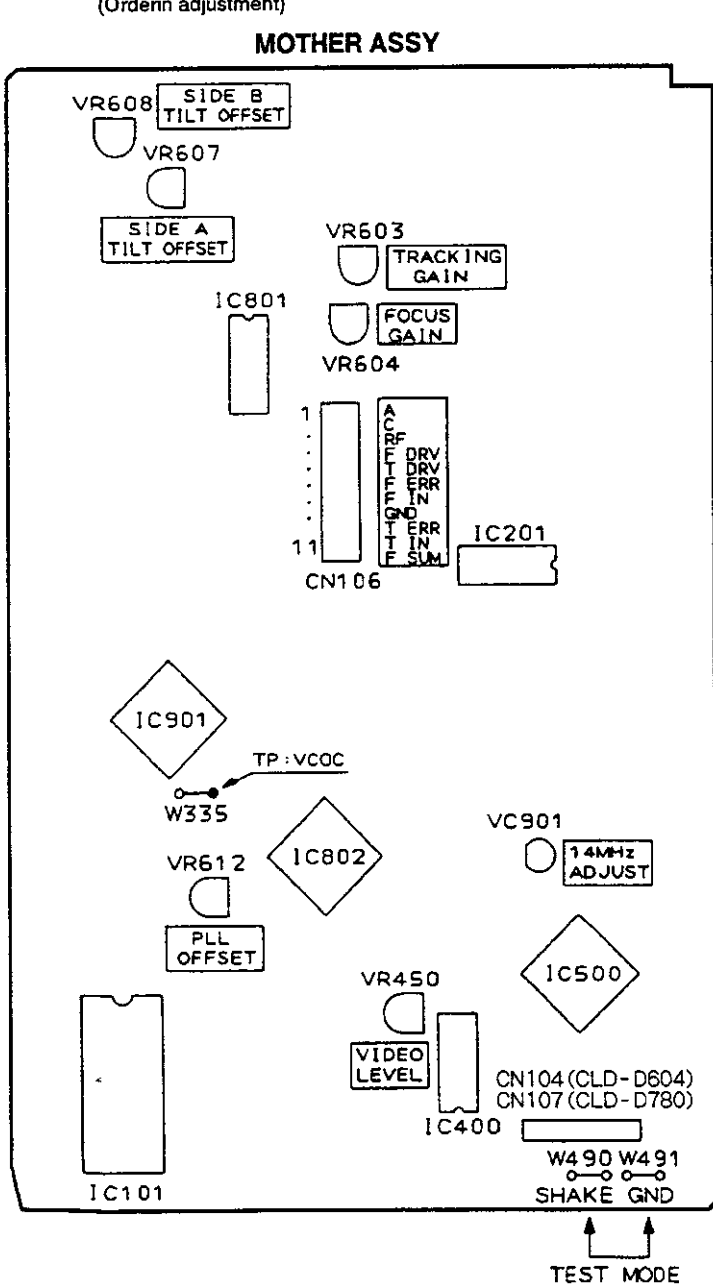

Fig. 20 Adjustment diagram of MOTHER assy

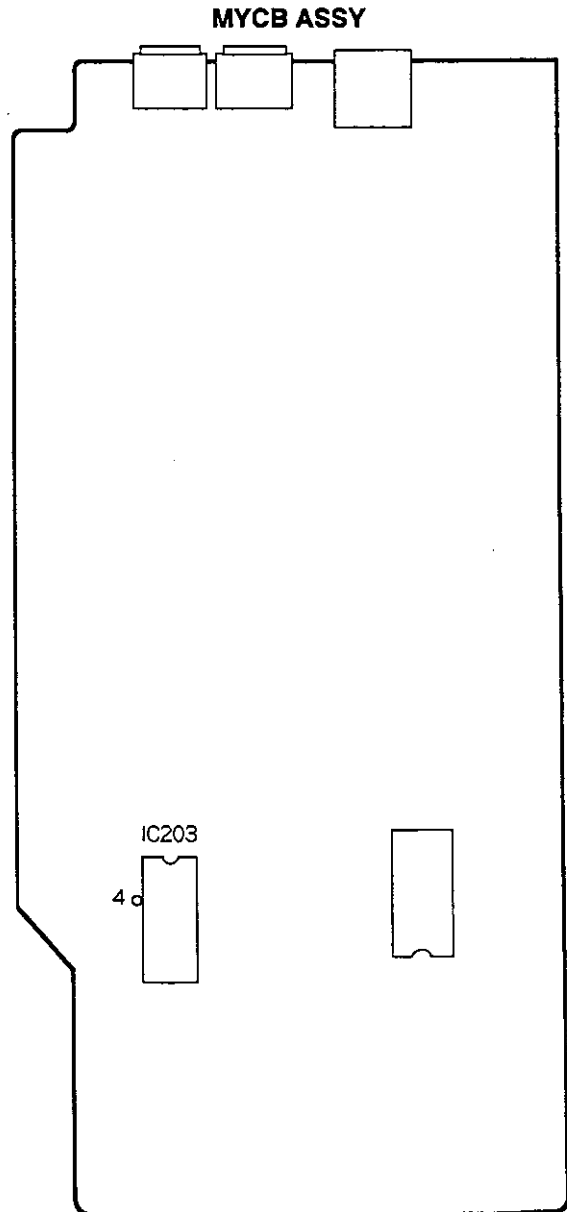

Fig. 21 Adjustment diagram of MYCB assy

6.5 ADJUSTMENT METHOD

• Mechanical adjustment

Step	Adjustment name	Adjustment point	Measuring point and measuring mode	Player condition	Adjustment procedure	Waveform and connection diagram
1	Tilt offset adjustment	MOTHER assy VR607, VR608 (TILT OFFSET)		Test mode Disc not installed	Check the positions of VR607 and VR608 to the mechanical center with eyes. If there positions are shifted, set to the center.	Set to the mechanical center
2	Tangential direction angle adjustment (side A)	Carriage assy TAN adjustment screw (side A)	CN106-3 (RF)	CD test disc outer track play (See position for TAN adjustment screw) TRKG - ON, TILT - ON	Adjust so that the amplitude of the RF waveform reaches its maximum and the envelope is very clear. Apply the lock-tight after the adjustment.	V:20mV/div H:1 μsec/div AC mode RF (3) → Probe → CH1 (10:1) Adjust until the amplitude reaches its maximum and the envelope is very clear.
3	Spindle motor centering adjustment (side A)	Mechanism assy Centering adjustment screw (side A)	CN106-9 (TRKG error)	CD test disc inner track play (CD inside position in the program area) TRKG - OFF, TILT - ON	Adjust so that the amplitude of the tracking error waveform reaches its maximum and the envelope is very clear. Apply the lock-tight after the adjustment.	V:50mV/div H:10msec/div DC mode CN106 T ERR (9) → Probe → CH1 (10:1) Adjust until the amplitude reaches its maximum and the envelope is very clear.
4	Crosstalk check and tilt offset re-adjustment (side A)	MOTHER assy VR607 (side A) (TILT OFFSET)	TV monitor Crosstalk monitor check	LD test disc #115 still TRKG - ON, TILT - ON	If the crosstalk is pronounced, adjust VR607 until the crosstalk is not noticeable.	 If the crosstalk is pronounced adjust until the crosstalk is not noticeable.
5	Focus servo loop gain adjustment	MOTHER assy VR604 (FOCUS GAIN)	CN106-6 (FOCUS error) CH2 "X-Y mode"	LD test disc (PLAY STANDBY) Short CN106-7 (F IN) and 8 (GND), then press the PLAY key (disc not turn)	Adjust VR604 until the waveform level is $4.8 \pm 0.5V$.	Y: 50mV/div DC mode CN106 FOCUS ERR (6) → Probe → X-Y mode (10:1) $4.8 \pm 0.5V$
6	Tracking servo loop gain adjustment	MOTHER assy VR603 (TRACKING GAIN)	CN106-9 (TRKG error) CH2 "X-Y mode"	LD test disc #115 still TRKG - ON, TILT - ON	Adjust VR603 until the waveform level is $1.8 \pm 0.2V$.	Y: 50mV/div DC mode CN106 TRK ERR (6) → Probe → X-Y mode (10:1) $1.8 \pm 0.2V$
7	Tangential direction angle adjustment (side B)	Carriage assy TAN adjustment screw (side B)	CN106-3 (RF)	LD test disc #115 still TRKG - ON, TILT - ON	Adjust so that the amplitude of the RF waveform reaches its maximum and the envelope is very clear. Apply the lock-tight after the adjustment.	V:20mV/div H:1 μsec/div AC mode CN106 RF (3) → Probe → CH1 (10:1) Adjust until the amplitude reaches its maximum and the envelope is very clear.
8	Spindle motor centering adjustment (side B)	Mechanism assy Centering adjustment screw (side B)	CN106-9 (TRKG error)	LD test disc #115 still TRKG - OFF, TILT - ON	Adjust so that the amplitude of the tracking error waveform reaches its maximum and the envelope is very clear. Apply the lock-tight after the adjustment.	V:50mV/div H:10msec/div DC mode CN106 T ERR (9) → Probe → CH1 (10:1) Adjust until the amplitude reaches its maximum and the envelope is very clear.
9	Crosstalk check and tilt offset re-adjustment (side B)	MOTHER assy VR607 (side B) (TILT OFFSET)	TV monitor Crosstalk monitor check	LD test disc #115 still TRKG - ON, TILT - ON	If the crosstalk is pronounced, adjust VR607 until the crosstalk is not noticeable.	 If the crosstalk is pronounced adjust until the crosstalk is not noticeable.

(NOTE) • This adjustment can be thought to be about the same adjustment as on the manufacturing line with differing adjustment tools. Follow the adjustment procedures even for checking the adjustments.
 • When you open the tray in test mode, the screen displays goes out. To display the screen again, press the **[DISPLAY]** key.
 • The mechanical adjustment can be all carried out with disc tray mounted.

• Electrical adjustment

Step	Adjustment name	Adjustment point	Measurement point	Player condition	Adjustment procedure	Waveform and connection diagram
1	Master clock adjustment	MOTHER assy VC901	MYCB assy IC203-4 (2 fsc)	Power ON	Adjust VC901 so that frequency with power on is $7.159090\text{MHz} \pm 20\text{Hz}$. Connect video output terminal and oscilloscope. (Video output terminal is terminated with 75Ω)	
2	Output video level adjustment	MOTHER assy VR450 (VIDEO LEVEL)	Video output terminal	Normal mode LD test disc #19,900 still	Adjust VR450 so that level from video signal sync tip to 100% white becomes $1\text{Vp-p} \pm 5\%$. (It's possible to terminate video output terminal with 75Ω by connecting TV monitor)	
3	PLL OFFSET adjustment	MOTHER assy VR612 (PLL OFFSET)	MOTHER assy W335 (PLL OFFSET TP)	Test mode CD test disc play TRKG servo OFF/ON	Note: Before adjusting remove disc tray. With the tracking servo off, playback digital audio and roughly adjust VR612 so that the sound is audible. Connect W335 and a DC voltmeter and while playing back digital audio, switch the tracking servo on and off and adjust VR612 so that the difference between the DC voltage when the tracking servo is on and when it is off is no greater than $0 \pm 0.1\text{V}$.	

7. IC INFORMATION

- The information shown in the list is basic information and may not correspond exactly to that shown in the schematic diagrams.

■ PD3304A (CLD - D604)
PD3303B (CLD - D780)
(FLKY ASSY IC101)
• MODE CONTROL IC

• Pin Function

No.	Mark	Pin Name	I/O	Function	No.	Mark	Pin Name	I/O	Function
1	VCC	—	I	+5V	33	P46	XMIC ON	O	MIC MIX L : ON, H : OFF
2	P90	xRESET OUT	O	Mother board reset output.	34	P45	SEG N	O	Display segment output.
3	SCKI	xS - CLOCK	I/O	Serial communication clock. (Mech. control and character generator)	35	P44	KSCAN4/SEG M	O	Key scan output / Display segment output.
4	S11	S-MTOF	I	Serial communication data input. (Mech. control)	36	P43	KSCAN3/SEG L	O	
5	SO1	S-FTOM	O	Serial communication data output. (Mech. control and character generator)	37	P42	KSCAN2/SEG K	O	
6	P94	xCS	O	Character generator (PD0175A, PD9004A) CS output. (L : enable)	38	P41	KSCAN1/SEG J	O	
7	P95	LED(DISPOFF)	O	LED output : Display OFF indication.	39	P40	KSCAN0/SEG I	O	Display segment output.
8	P96	LED(Q TURN)	O	LED output : Quick turn indication.	40	P50	SEG H	O	
9	P97	POWCTL	O	Mother board power supply SW output.	41	P51	SEG G	O	
10	AVCC	—	I	+5V	42	P52	SEG F	O	
11	P00	KIN0	I	Key data input.	43	P53	SEG E	O	
12	P01	KIN1	I		44	P54	SEG D	O	
13	P02	KIN2	I		45	P55	SEG C	O	
14	P03	KIN3	I		46	P56	SEG B	O	
15	P04	KARXNOR	I	MIC SW L : OFF normal mode H : ON karaoke mode	47	P57	SEG A	O	
16	P05	XE LETE (PD3303A)	I	ELETE selection port. L : 59, H : D780	48	VDISP	—	I	
		Not used (PD3304A)	I	GND					
17	P06	ENGXJAP (PD3303A)	I	Japanese / English selection port L : Japanese, H : English	49	P60	G8	O	Display grid output.
		ECHVOL (PD3304A)	I	Echo volume.	50	P61	G7	O	
18	P07	Not used (PD3303A)	I	GND	51	P62	G6	O	
		OEMSEL (PD3304A)	I	OEM selection port. L : PIONNER, H : YAMAHA	52	P63	G5	O	
19	AVSS	—	I	GND	53	P64	G4	O	
20	TEST	Not used	I	GND	54	P65	G3	O	
21	X2	Not used	O	NC (OPEN)	55	P66	G2	O	
22	X1	Not used	I	+5V	56	P67	G1	O	
23	VSS	GND	I	GND	57	P70	LED(LD)	O	LED output : LD indication
24	OSC1	—	I	Main system clock oscillation (8MHz)	58	P71	LED(CD)	O	LED output : CD indication
25	OSC2	—	O		59	P72	LED(SIDE B)	O	LED output : Side B indication
26	xRST	xRESET IN	I	CPU reset (L : reset)	60	P73	LED(SIDE A)	O	LED output : Side A indication
27	IRQ0	SHAKE	I/O	Mech. control serial communication requirement.	61	P74	LED(GRP) (PD3303A)	O	LED output : Graphics indication
28	IRQ1	SEL IR	I	Remote control input.			BASBST1 (PD3304A)	O	Bus boost switch. (OFF : P74=H and P75=H, ON : others)
29	P14	FSX	I	For measuring the error rate.	62	P75	MUTEOUT (PD3303A)	O	Graphics decoder and data mute output.
30	P15	EFLG	I	For measuring the error rate.			BASBST2 (PD3304A)	O	Bus boost switch.
31	P16	Not used	I	GND	63	P76	CDGMODE (PD3303A)	O	Graphics decoder and graphics mode input.
							XDSPCS (PD3304A)	O	DSP (PDQ001A) CS output. (L : enable)
32	P47	DOGFOOD	O	Pulse output for watch dog.	64	P77	XGRPCS (PD3303A)	O	Graphics decoder (PDC016A) and communication requirement output.
							XDSP ON (PD3304A)	O	DSP L : ON, H : Through

■ PD9004A (MYCB ASSY IC203)
 ·OSD IC

● Block Diagram

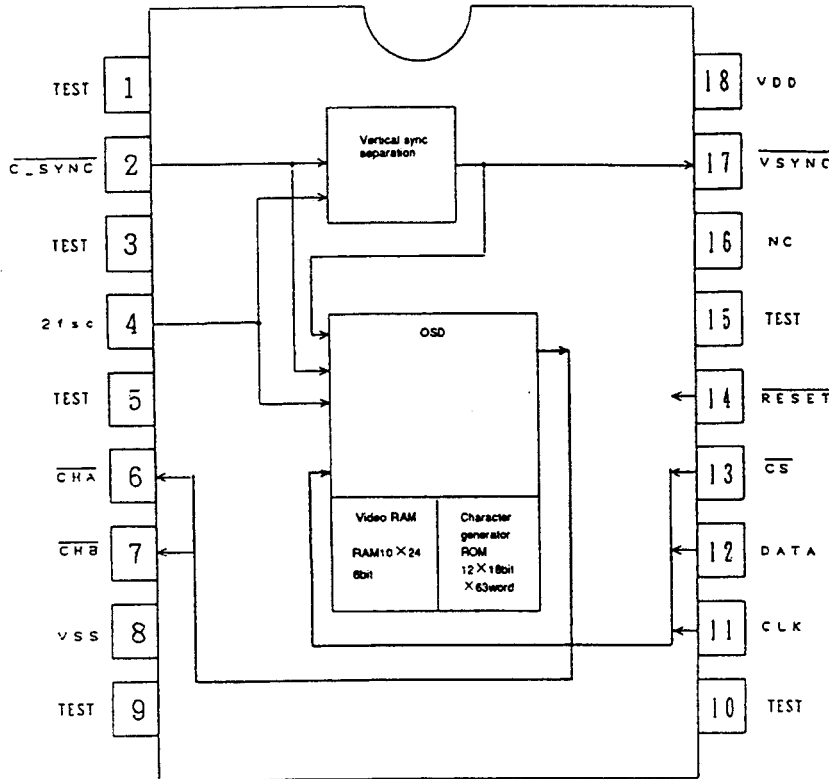

● Pin Function

Pin No	Code	I/O	Logic	Function
1	TEST	-	-	Do not connect any external components.
2	CSYNC	I	Negative	Composite sync signal input
3	TEST	-	-	Do not connect any external components.
4	2fsc	I	-	Color subcarrier frequency 2× clock input (NTSC about 7.14 MHz PAL about 8.8 MHz)
5	TEST	-	-	Do not connect any external components.
6	CHA	O	Negative	Character timing output
7	CHB	O	Negative	Blanking timing output
8	VSS	-	-	Connected to system ground
9	TEST	-	-	Do not connect any external components.
10	TEST	-	-	Do not connect any external components.
11	CLK	I	↑	Data read-in clock input pin; the data applied to the Data pin is read-in at the rising edge of the clock.
12	DATA	I	Positive	Control data input pin; the data is read-in synchronized with the clock applied to the CLK pin.
13	CS	I	Negative	Low for serial communications
14	RESET	I	Negative	Hardware reset with pull-up resistance
15	TEST	-	-	Do not connect any external components.
16	NC	-	-	Not connected
17	VSYNC	O	Negative	Signal with V sync separated from C sync
18	VDD	-	-	Power supply (+5V) pin

■ PAC005B (MOTHER ASSY IC400)
-VIDEO IC

● Block Diagram

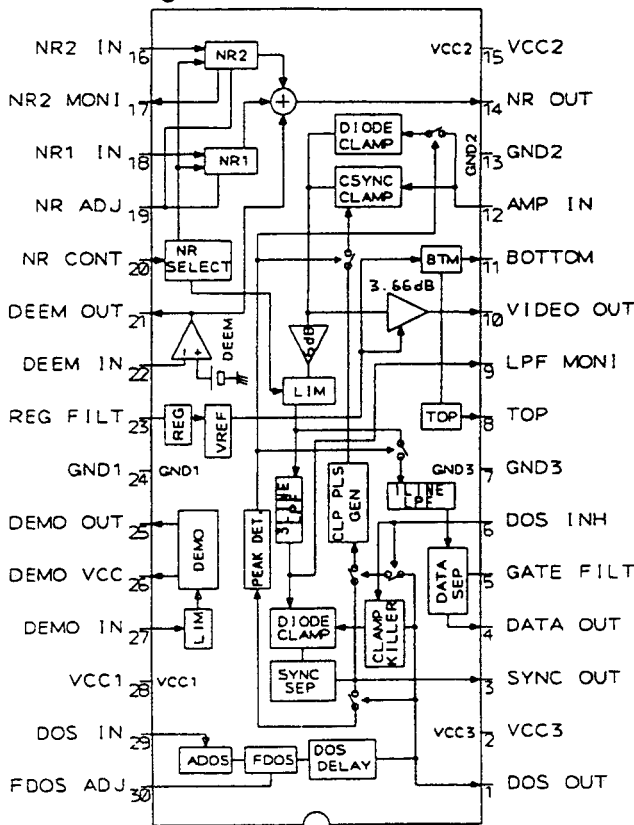

● Pin Function

No.	Pin Name	Function
1	DOS OUT	Drop out pulse output.
2	VCC3	VCC for SYNC SEP section.
3	SYNC OUT	Composite sync output.
4	DATA OUT	Data pulse output.
5	GATE FILT	Connect a capacitor for Gate - Gate.
6	DOS INH	Clamp pulse and clamp killer control.
7	GND3	GND for SYNC SEP section.
8	TOP	Reference DC (TOP) for A/D.
9	LPF MONI	Monitor the LPF for SYNC SEP.
10	VIDEO OUT	Signal output for A/D.
11	BOTTOM	Reference DC (BOTTOM) for A/D.
12	AMP IN	Sync chip clamp input.
13	GND2	GND for VIDEO.
14	NR OUT	Noise reduction output.
15	VCC2	VCC for VIDEO section.
16	NR2 IN	Signal input (2) for noise reduction.
17	NR2 MONI	Limiter output for noise reduction.
18	NR1 IN	Signal input (1) for noise reduction.
19	NR ADJ	Limiter level adjusting pin for noise reduction.
20	NR CONT	Noise reduction (1, 2) select and limiter control.
21	DEEM OUT	De-emphasis output.
22	DEEM IN	De-emphasis input.
23	REG FILT	Connect a capacitor for regulator.
24	GND1	GND for RF section.
25	DEMO OUT	Demodulation output of RF signal.
26	DEMO VCC	VCC for FM demodulation output.
27	DEMO IN	RF input for FM demodulation.
28	VCC1	VCC for RF section.
29	DOS IN	RF input for DOS.
30	FDOS ADJ	FDOS sensitivity adjustment.

■ PD0192A (MOTHER ASSY IC500)
• DIGITAL VIDEO PROCESSOR

● Block Diagram

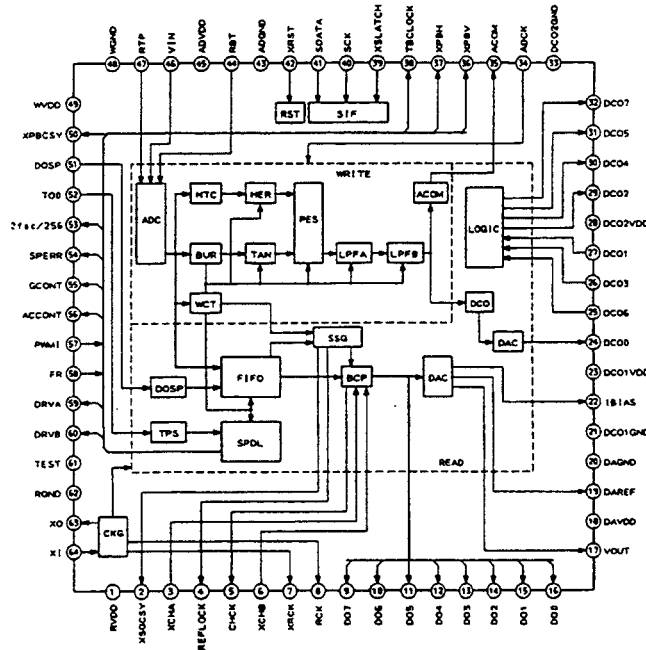

● Pin Function

No.	Pin Name	Function
1	RVDD	Power pin for reference system. Connect to +5V.
2	XGCSY	Reference composite sync. is output at negative logic. Delay can be controlled by serial command.
3	WFM	MEMSYS : 1 Field monitor output for write system. Outputs "H" when in odd field.
	XCHA	MEMSYS : 0 Character input pin. Inputs "L" during character insertion.
4	XTBCH	MEMSYS : 1 TBC H sync. output. Outputs time base-corrected (TBC) H sync. at negative logic.
	REFLOCK	MEMSYS : 0 SSG phase detection signal output. Outputs "H" when phase difference of H, V sync. between Playbacksystem (after TBC) and SSG system is small enough.
5	XTBCV	MEMSYS : 1 TBC V sync. output. Outputs time base-corrected V sync. at negative logic.
	GHCK	MEMSYS : 0 Clock output for character generator. Output 2fsc.
6	FCH	MEMSYS : 1 Field change input. Switches field of SSG when "H".
	XCHB	MEMSYS : 0 Character frame input pin. Inputs "L" when character frame is inserted.
7	XRCK	Reference CLK is reversed and output.
8	RCK	Reference CLK output.
9	DO7	Data output 7
10	DO6	Data output 6
11	DO5	Data output 5
12	DO4	Data output 4
13	DO3	Data output 3
14	DO2	Data output 2
15	DO1	Data output 1
16	DO0	Data output 0
Outputs TBC (time base-corrected) video signal to support memory. This setting performs by serial command. DO7 is MSB, DO0 is LSB.		
17	VOUT	DAC output of TBC video signal.
18	DAVDD	Power pin for D/A converter. Connect to +5V.
19	DAREF	D/A converter reference for video. Normally connect to DAGND via 0.1 μF of laminated ceramic capacitor.
20	DAGND	Ground pin for D/A converter. Connect to GND.
21	DCO1GND	Ground pin for DCO. Connect to GND.
22	IBIAS	Current setting pin of bias circuit. Normally connect to DAGND via external resistor (10k Ω).
23	DCO1VDD	Power pin for DCO. Connect to +5V.

No.	Pin Name	Function
24	DCO0	DCO output pin. ADCK is generated by multiplying this signal by 4.
25	DCO6	Waveform shaping input pin 6. Inputs signal of DCO5 output signal that is delayed 35 ns (self-biased).
26	DCO3	Waveform shaping input pin 3. Inputs signal of DCO2 output signal that is delayed 70 ns (self-biased).
27	DCO1	Waveform shaping input pin 1. Inputs DCO0 signal via band-pass filter of fsc (self-biased).
28	DCO2VDD	Power supply pin for multiplied by 4 section. Connect to +5V.
29	DCO2	Waveform shaping output pin 2. Outputs signal of waveform of DCO1 signal that is shaped.
30	DCO4	Waveform shaping output pin 4. Outputs signal of waveform of DCO3 signal that is shaped.
31	DCO5	Waveform shaping output pin 5. Outputs signal multiplied by 2.
32	DCO7	Waveform shaping output pin 7. Outputs signal multiplied by 4.
33	DCO2GND	Ground pin for multiplied by 4 section. Connect to GND.
34	ADCK	CLK input pin for write system. Inputs signal of DCO7 output signal that is filtered through 4 fsc ceramic filter. (self-biased)
35	ACOM	Jitter correction signal output for analog audio. Used to cancel the jitter of analog audio.
36	XPBV	V sync. output for playback system. Outputs signal that has V sync. separated from pin 50 (XPBCSY) signal at negative logic.
37	XPBH	H sync. output for playback system. Outputs signal that has H sync. separated from pin 50 (XPBCSY) signal at negative logic.
38	TBCLOCK	PLL LOCK detection signal output. Outputs "H" when spindle servo loop and TBC servo loop are locked.
39	XSLATCH	Serial interface latch signal input. Generates timing to latch data that was input to serial interface. (latched at L, Schmitt trigger input)
40	SCK	Serial interface CLK input. CLK input for serial interface. SDATA value is read at rising edge. (Schmitt trigger input)
41	SDATA	Serial interface data input. Inputs data to serial interface. (Schmitt trigger input)
42	XRST	System reset input. Initializes internal registers of IC at negative logic. (Schmitt trigger input)
43	ADGND	Ground pin for A/D converter. Connect to GND.
44	RBT	A/D converter bottom reference input. Inputs bottom reference voltage of A/D converter.
45	ADVDD	Power supply pin for A/D converter. Connect to +5V.
46	VIN	A/D converter input. Inputs composite video signal.
47	RTP	A/D converter top reference input. Inputs top reference voltage of A/D converter.
48	WGND	Ground pin for write system. Connect to GND.
49	WVDD	Power pin for write system. Connect to +5V.
50	XPBCSY	Composite sync. input for playback system. Inputs composite sync. for playback system at negative logic. (Schmitt trigger input)
51	DOSP	Drop out pulse input. Inputs drop out detection pulse at positive logic. (Schmitt trigger input)
52	TO0	Tracking open pulse input. Inputs tracking open pulse at positive logic. (Schmitt trigger input)
53	XI/512	Master clock 512 division output. Outputs clock of master clock (4fsc) that is divided by 512.
54	SPERR	Spindle error PFD error output. Outputs result after performing PFD on PBH and RefH at tri-state.
55	GCONT	Spindle gain control output. Outputs PWM signal according to set value (GD0 – GD3), using serial instructions.
56	ACCNT	Accelerated control output. Outputs acceleration/deceleration signal by forced acceleration/deceleration and PBH sync. frequency detection at tri-state.
57	PWMI	Spindle error PWM input. Inputs signals that have voltage compared between spindle errors that passed through a loop filter and chopping waves. (Schmitt trigger input)
58	FR	Spindle error direction component input. Inputs signals that have voltage compared between spindle errors that passed through a loop filter and target voltage. (Schmitt trigger input)
59	DRVA	Transistor control signal output pin for spindle motor drive. This setting is performed by the interface corresponding to the brush motor and brushless motor.
60	DRVB	Transistor control signal output pin for spindle motor drive. This setting is performed by the interface corresponding to the brush motor and brushless motor.
61	TEST	Input pin for IC test. Fixed to "L".
62	RGND	Ground pin for reference system. Connect to GND.
63	XO	Oscillation output. Connect the X'tal (4 fsc) for oscillation.
64	XI	Oscillation input. Connect the X'tal (4 fsc) for oscillation.

■ PD0212A (MOTHER ASSY IC101)
 • MECHANISM CONTROL IC

● Pin Function

No.	Pin Name	I/O	Function
1	VCC	I	Power supply pin. Apply 5V ± 10%.
2	RFCORR	O	RF correction switch signal output. "H"=gain UP CD,CDV - A:Low, CAV inner circuit gain up, others are High.
3	MUTE	O	Audio mute control signal output of audio system. L : Release MUTE , H : MUTE
4	SRDMUTE	O	Mute control signal output for AC3. Release MUTE during playback. L : Release MUTE, H : MUTE
5	TILT ON	O	(For debugging)Tilt operation information. H : during operation for checking tilt operation.
6	TILTERR	I A/D	This signal is A/D converted as the tilt servo control input. Control the tilt motor so that this signal becomes 2.5V.
7	TBALERR	I A/D	Tracking error balance signal input. This signal is A/D converted as the tracking offset control input.
8	SLDERR	I A/D	This signal is A/D converted as the slider servo control input. Control the tilt motor so that this signal becomes 2.5V.
9	SLDPOS	I A/D	Pickup position detection switch input. Detect the position by reading A/D input value which each switches are resistance divided.
10	XFOK	I	Focus servo lock signal input. L : Lock , H : Unlock Use for lock detection of focus servo.
11	SINGLE	I	ATT- SW of rear panel use for the single mode.This information transmit to mode control by communication. L : Single H : Normal
12	TBALDRV	O PWM	Output the tracking offset signal to PWM output, then use for auto tracking offset. 910 μsec period, tri-state control H, L, Z
13	XCD	O	LD/CD switch signal output pin. L : CD H : LD
14	XPLAY	O	Signal output during spindle servo. L : during servo H :during acceleration, brake and stop
15	SQOUT	I	Command data input from DSP. Read out SUBQ.
16	COIN	O	Command data output to DSP.
17	CQCK	O	DSP reading/writing command clock output pin. read at rising edge.
18	SLDDRIV	O PWM	Slider control signal output pin. 5V=FWD, 0V=REV, 2.5V=STOP 910 μ sec period, tri-state control H, L, Z
19	SI1	I	Data input from the mode control IC.
20	SO1	O	Serial data output to the mode control IC.
21	SCK1	I/O	Clock for serial communication with the mode control IC. Becomes input mode without communicate with the mode control IC.
22	TZC	I INT	Tracking error zero cross signal input pin. Monitor this signal when searching track count in the miss clamp detection.
23	SHAKE	I/O	Hand shake signal for data communication with the mode control IC. Each microcomputer controls input/output by bilateral data line.
24	TILTDRV	I/O	LOAD/TILT control output pin. 0.5V - tray IN, OUT/tilt DOWN, UP 2.5V - STOP Use for tilt servo that tilt drive is PWM output.
25	XANA	O	Digital/Analog audio switch signal output. L : Analog H : Digital
26	XPBV	I	Playback vertical sync. signal input of LD/CDV. L :during vertical sync.
27	CNVss	I	Ground pin for A/D conversion.
28	XRESET	I	Reset signal input. L : Reset H : Release reset Mode control is controlled.
29	XIN	I	9MHz clock oscillation input pin.
30	XOUT	O	9MHzclock oscillation output pin.
31	N.C.	O	Not used.
32	GND	I	Ground.
33	SW1	I	Switch input for Loading/Tilt position detection
34	SW3	I	
35	SW2	I	

No.	Pin Name	I/O	Function
36	N.C.	I	Not used.
37	FG	I	Spindle motor FG signal input. 16 outputs per rotation. Used after dividing by 2 in microcomputer.
38	DATA	I	Input pin for Phillips code decoder with built in mechanism controller.
39	XPBH	I	Playback H-SYNC input for Phillips code decoder.
40	XPBV	I	Playback V-SYNC input for Phillips code decoder.
41	TURNA	I	Turn switch input. H : side A L : side B
42	BINSIDE	I	Side B inside switch input. L : Side B inside H : others
43	MEMLAT	O	Serial control latch output of memory control IC (PD4510A). Latches at falling edge.
44	MEMORY	I	Memory yes/no determination input pin. H :memory yes L : memory no
45	DOCINH	O	Control the clamp pulse and clamp killer by tri-state values.
46	DETPOW	I	Use for power abnormal signal input port. L : Normal H : Abnormal
47	NROFF	O	Control output of the noise reduction by VDEM. L : Normal H : Not NR
48	WFM	I	Field determination signal from DVP. L : EVEN H : ODD
49	SQ1	O	Analog audio switch signal output 1/L. L : squelch OFF H : squelch ON
50	SQ2	O	Analog audio switch signal output 2/R. L : squelch OFF H : squelch ON
51	XCX	O	Analog audio CX noise reduction switch signal output. L : CX ON H : CX OFF
52	XVCECAN	O	Voice cancel output. L : CANCEL ON , H : OFF
53	SO3	O	Serial 3 data signal output. Serial signal is commoned, signal distinguish by latch signal (DVPLAT, TLAT).
54	SCK3	O	Serial 3 clock signal output.
55	DVPLAT	O	PD0192A serial latch signal output pin. Latches at falling edge.
56	TBCLOCK	I	Spindle lock signal input pin. L : Unlock , H : Lock
57	TLATCH	O	DAC & digital filter PD2026B serial control latch signal output pin. Latches at falling edge.
58	XREV	O	Side A/side B switch pin. H : side A , L : side B
59	DETAMP	I	Spindle over-current detection signal input pin. L : over current , H : Normal
60	FSEQ	I	Subcode sync. conformity detection signal input pin. L : Not conformity , H : Conformity
61	THOLD	I	Track jump accelerating/decelerating signal input pin. L : other H : accelerating/decelerating
62	WRQ	I	Subcode Q reading OK signal input pin. L : NG , H : OK This pin will be H when Subcode Q data passed by CRC check.
63	RWC	O	DSP read/write command signal output pin. L : READ H : WRITE
64	RWC2	I	Set to input port without influence when this pin short-circuit to pin 63.

■ PD4510A (MYCB ASSY IC102)
 • MEMORY CONTROL IC

• Block Diagram

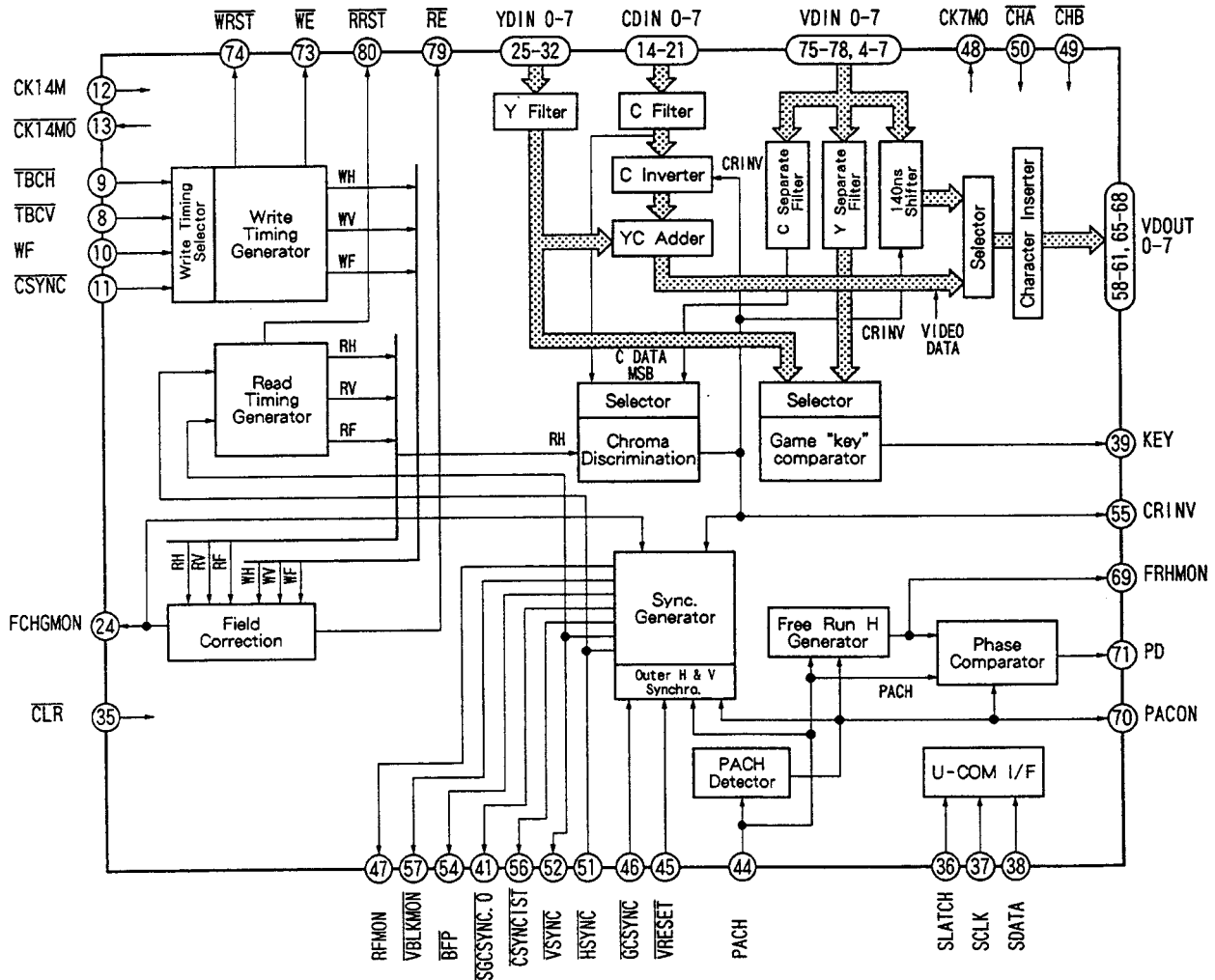

• Pin Function

No.	Pin Name	Name	I/O	Function
1	NC	No connection	—	To be an open circuit.
2	VDD	Power supply	—	Connect to +5 V power supply voltage.
3	GND	Ground	—	Connect to GND.
4	VDIN4	Video input 4	I	Inputs of the upper 4 bits of the data output from field memory. VDIN0 (pin 75) is the LSB and VDIN7 is the MSB.
5	VDIN5	Video input 5		
6	VDIN6	Video input 6		
7	VDIN7	Video input 7		
8	TBCV	TBC V sync input	I	Negative-logic input of time-base-corrected V sync from DVP. Used to control a write operation to field memory.
9	TBCH	TBC H sync input	I	Negative-logic input of time-base corrected H sync from DVP. Used to control a write operation to field memory.
10	WF	Field input of write system	I	Input of the field monitor signal from DVP, "H" for odd fields and "L" for even fields. Used to control a write operation to field memory.
11	CSYNC	Composite sync input of reference system	I	Negative-logic input of reference composite sync from DVP. Used for write control at squelch. (Switching between the reference sync and TBC sync is performed through a command input to the serial interface.)

No.	Pin Name	Name	I/O	Function
12	CK14M	14MHz clock input	I	Clock input. Use the same clock as DVP. To superimpose a game picture, synchronizing with the game pack is required.
13	$\overline{\text{CK14M0}}$	14MHz reversing clock output	O	Clock output obtained by reversing CK14M input.
14	CDIN0	Chroma data input 0	I	Inputs of the chroma data output from the Y/C separation IC. CDIN0 is the LSB and CDIN7 is the MSB. When the output data is in 9 bits or more, input the upper 8 bits. To be fixed at "L" when no Y/C separation IC is used.
15	CDIN1	Chroma data input 1		
16	CDIN2	Chroma data input 2		
17	CDIN3	Chroma data input 3		
18	CDIN4	Chroma data input 4		
19	CDIN5	Chroma data input 5		
20	CDIN6	Chroma data input 6		
21	CDIN7	Chroma data input 7		
22	GND	Ground	—	Connect to GND.
23	VDD	Power supply	—	Connect +5 V power supply voltage.
24	FCHGMON	Field change signal monitor output	O	Monitor output of a field change signal which switches an even field to an odd field in the built-in sync generator block. (Do not connect to the FCHANGE input of DVP.)
25	YDIN0	Luminance data input 0	I	Input of the luminance data output from the Y/C separation IC. YDIN0 is the LSB and YDIN7 is the MSB. When the output data is in 9 bits or more, input the upper 8 bits. To be fixed at "L" when no Y/C separation IC is used.
26	YDIN1	Luminance data input 1		
27	YDIN2	Luminance data input 2		
28	YDIN3	Luminance data input 3		
29	YDIN4	Luminance data input 4		
30	YDIN5	Luminance data input 5		
31	YDIN6	Luminance data input 6		
32	YDIN7	Luminance data input 7		
33	GND	Ground	—	Connect to GND.
34	TEST	IC test input	I	For IC testing. To be open.
35	$\overline{\text{CLR}}$	Clear input	I	Input for IC initializing. When "L," all registers and counters in the IC are set to the default values.
36	SLATCH	Serial interface latch signal input	I	Supplies a timing to latch the data input to the serial interface. "Through" in the rise period. The register contents do not change in the L/H and fall periods.
37	SCLK	Serial interface clock input	I	Clock input for the serial interface. The value of SDATA is read at the rising edge.
38	SDATA	Serial interface data input	I	Provides the serial interface with data.
39	KEY	Luminance key signal output	O	Output of L or H level to indicate the result of comparison between the luminance level of the video data input or the luminance data input with the register contents. It will be "L" when the input is larger than the reference and "H" when smaller. Input selection and reference data can be specified by changing the register contents through the serial interface. This output is delayed for 1 clock cycle with respect to the video data output.
40	TSELCT	Test mode selection input	I	Used to select the IC test mode. To be open.
41	$\overline{\text{SGCSYNC0}}$	Composite sync output of read system (no 140ns shift)	O	Negative-logic output of composite sync from the built-in sync generator block. (For details, see pin 53.) No 140-ns shift is performed here.
42	VDD	Power supply	—	Connect +5 V power supply voltage.
43	GND	Ground	—	Connect to GND.
44	PACH	Game pack H sync input	I	Positive-logic input of the H sync from the game pack. To be open when not synchronizing with the game pack.
45	$\overline{\text{VRESET}}$	Game pack V reset input	I	Negative-logic input of the V reset signal from the game pack. To be open when not synchronizing with the game pack.
46	$\overline{\text{CGSYNC}}$	Game pack composite sync input	I	Negative-logic input of composite sync from the game pack. To be open when not synchronizing with the game pack.

No.	Pin Name	Name	I/O	Function
47	RFMON	Read field monitor output	O	Monitoring output of the field signal of the built-in sync generator block. "H" for odd fields and "L" for even fields. Fixed at "H" in vertical synchronization with the game pack.
48	CK7MO	7MHz clock output	O	Output of the clock obtained through 2-division processing on the CK14M input. It is reset at every falling edge of H sync of the read system. (When H sync falls, this clock also falls.) Used as clock input for the OSD IC.
49	$\overline{\text{CHB}}$	Character frame input	I	Connect the character frame output of the OSD IC when using the character superimpose function. When this is "L" and CHA is "H", the gray level is imposed on the video data. To be open when the character superimpose function is not used.
50	$\overline{\text{CHA}}$	Character input	I	Connect the character output of the OSD IC when using the character superimpose function. When this is "L," the white level is imposed on the video data. To be open when the character superimpose function is not used.
51	$\overline{\text{HSYNC}}$	H sync output of read system	O	Negative-logic output of H sync from the built-in sync generator block. When the built-in 140-ns shift function is enabled, the output is shifted for 140 ns when the CRINV signal is "H".
52	$\overline{\text{VSYNC}}$	V sync output of read system	O	Negative-logic output of V sync from the built-in sync generator block.
53	$\overline{\text{SGCSYNC}}$	Composite sync output of read system	O	Negative-logic output of composite sync from the built-in sync generator block. Read control from field memory is performed using this signal as the reference. The output is delayed for 1 clock cycle with respect to the video data output. It is in synchronization with HSYNC and VSYNC. When the built-in 140-ns shift function is enabled, the output is shifted for 140 ns when the CRINV signal is "H". Synchronizing with the game pack requires signal inputs such as PACH, $\overline{\text{VRESET}}$ and GCSYNC as well as command input from the serial interface. In this case, the same 262H or 263 single field (noninterlace) mode with the composite sync of the game pack is selected. Interface mode which uses only H sync and no V sync, can also be specified.
54	$\overline{\text{BFP}}$	Burst flag pulse output	O	Output of pulses to indicate the position of color burst on the video data output. It will be "L" for the position of color burst.
55	CRINV	Chroma invert output	O	Output of the result of the chroma continuity determination on the video data input or chroma data input. When "H," chroma data of the built-in Y/C data adder is inverted, or the video data output, $\overline{\text{HSYNC}}$ and $\overline{\text{SGCSYNC}}$ signals are shifted for 140 ns by the built-in 140-ns shift function. This can be used for equivalent functions on external devices.
56	$\overline{\text{CSYNCIST}}$	Sync output for insertion	O	Output to insert sync on the D/A-converted video signal. It is in complete synchronization with the $\overline{\text{SGCSYNC}}$ signal.
57	$\overline{\text{VBLKMON}}$	Monitor output of V blanking period	O	Negative-logic output of the V blanking period (half the H period) from the built-in sync generator block. For monitoring, but can be used on external devices.
58	VDOUT0	Video data output 0	O	Outputs of the lower 4 bits of the video data or data obtained by adding luminance data and chroma data. The output normally has a delay of 3 clock cycles with respect to the input. When the 140-ns shift function is enabled, the output is delayed for 5 clock cycles. VDOUT0 is the LSB and VDOUT7 (pin 68) is the MSB. Connect to the data input of the D/A converter.
59	VDOUT1	Video data output 1		
60	VDOUT2	Video data output 2		
61	VDOUT3	Video data output 3		
62	GND	Ground	—	Connect GND.
63	VDD	Power supply	—	Connect +5 V power supply voltage.
64	NC	No connection	—	To be an open circuit.
65	VDOUT4	Video data output 4	O	Outputs of the upper 4 bits of the video data input or the data obtained by adding the luminance data and chroma data. (For details, see pins 53 through 61.)
66	VDOUT5	Video data output 5		
67	VDOUT6	Video data output 6		
68	VDOUT7	Video data output 7		
69	FRHMON	Free-run H sync monitor output	O	H sync monitor output of the built-in free-run H sync generator block. When the PACH signal is being supplied, this output is compared with the PACH signal. After the PACON signal is set to "L," it continues providing 910-division clocks in free-run mode as long as "L" is not input to $\overline{\text{CLR}}$. It is not synchronized with the write or read timing. It can be used on external devices.

No.	Pin Name	Name	I/O	Function
70	PACON	Game pack H sync detection output	O	Outputs "H" when PACH signal input is detected. For the detection, input of fifteen or more PACH pulses is required. If six or more pulses continuously fail, it is set to "L." It turns on and off the function of the built-in sync generator block to synchronize with the game pack. It is also used for VCXO on/off at external devices.
71	PD	PACH, Free-run H sync phase difference output	O	Output of L/H pulses to indicate the phase difference between the rising edge of the PACH signal and that of the H sync signal of the built-in free-run H sync generator block. An L pulse is output when PACH advances, and an H pulse when PACH follows. The pulse width indicates the phase difference. When there is no difference or when input from neither is obtained, the output is set to the high-impedance status. It can be synchronized with the game pack when connected to an external VCXO.
72	NC	No connection	—	To be open.
73	\overline{WE}	Write enable output	O	Controls a write operation to field memory. "L" enables the operation and "H" disables it. Connect to the \overline{WE} input of field memory.
74	\overline{WRST}	Write reset output	O	Signal to initialize the write address of field memory. An L pulse for 1 clock cycle is output every other write field. Connect to the \overline{WRST} input of field memory.
75	VDIN0	Video data input 0	I	Inputs of the lower 4 bits of data output of field memory. (For details, see pins 4 through 7.)
76	VDIN1	Video data input 1		
77	VDIN2	Video data input 2		
78	VDIN3	Video data input 3		
79	\overline{RE}	Read enable output	O	Controls a read operation from field memory. "L" enables the operation and "H" disables it. Connect to the \overline{RE} input of field memory.
80	\overline{RRST}	Read set output	O	Signal to initialize the read address of field memory. An L pulse for 1 clock cycle is output every other read field. Connect to the \overline{RRST} input of field memory.

8. FL INFORMATION

■ VAW1035 (FLKY ASSY V101)
FL TUBE

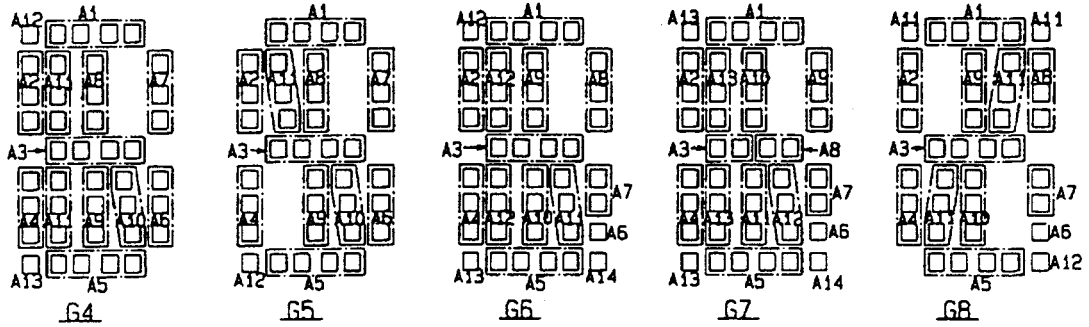
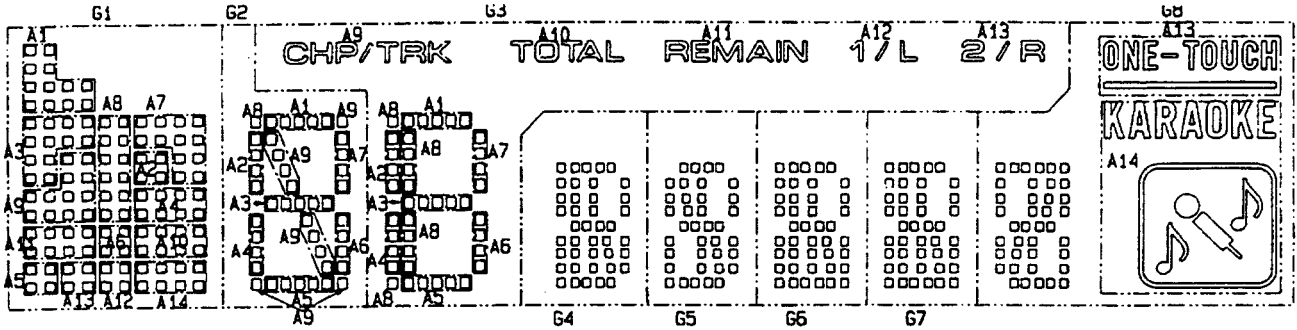

ANODE GRID ASSIGNMENT & PIN ASSIGNMENT

	G1	G2	G3	G4	G5	G6	G7	G8
P1	A1	A1	A1	A1	A1	A1	A1	A1
P2	A2	A2	A2	A2	A2	A2	A2	A2
P3	A3	A3	A3	A3	A3	A3	A3	A3
P4	A4	A4	A4	A4	A4	A4	A4	A4
P5	A5	A5	A5	A5	A5	A5	A5	A5
P6	A6	A6	A6	A6	A6	A6	A6	A6
P7	A7	A7	A7	A7	A7	A7	A7	A7
P8	A8	A8	A8	A8	A8	A8	A8	A8
P9	A9	A9	CHP/TRK	A9	A9	A9	A9	A9
P10	A10		TOTAL	A10	A10	A10	A10	A10
P11	A11		REMAIN	A11	A11	A11	A11	A11
P12	A12		1/L	A12	A12	A12	A12	A12
P13	A13		2/R	A13		A13	A13	ONE-TOUCH
P14	A14					A14	A14	KARAOKE

PIN ASSIGNMENT

Pin No.	1	2	3	4	5	6	7	8	9	10	11	12	13	14	15	16	17
Assignment	F	F	NP	NL	NL	NL	NL	G1	G2	G3	G4	G5	G6	G7	G8	P1	P2

Pin No.	18	19	20	21	22	23	24	25	26	27	28	29	30	31	32	33	34
Assignment	P3	P4	P5	P6	P7	P8	P9	P10	P11	P12	P13	P14	NL	NL	NP	F	F

F:Filament G1-G8:Grid P1-P14:Anode NP:No pin NL:No Lead

9. BLOCK DAIGRAM

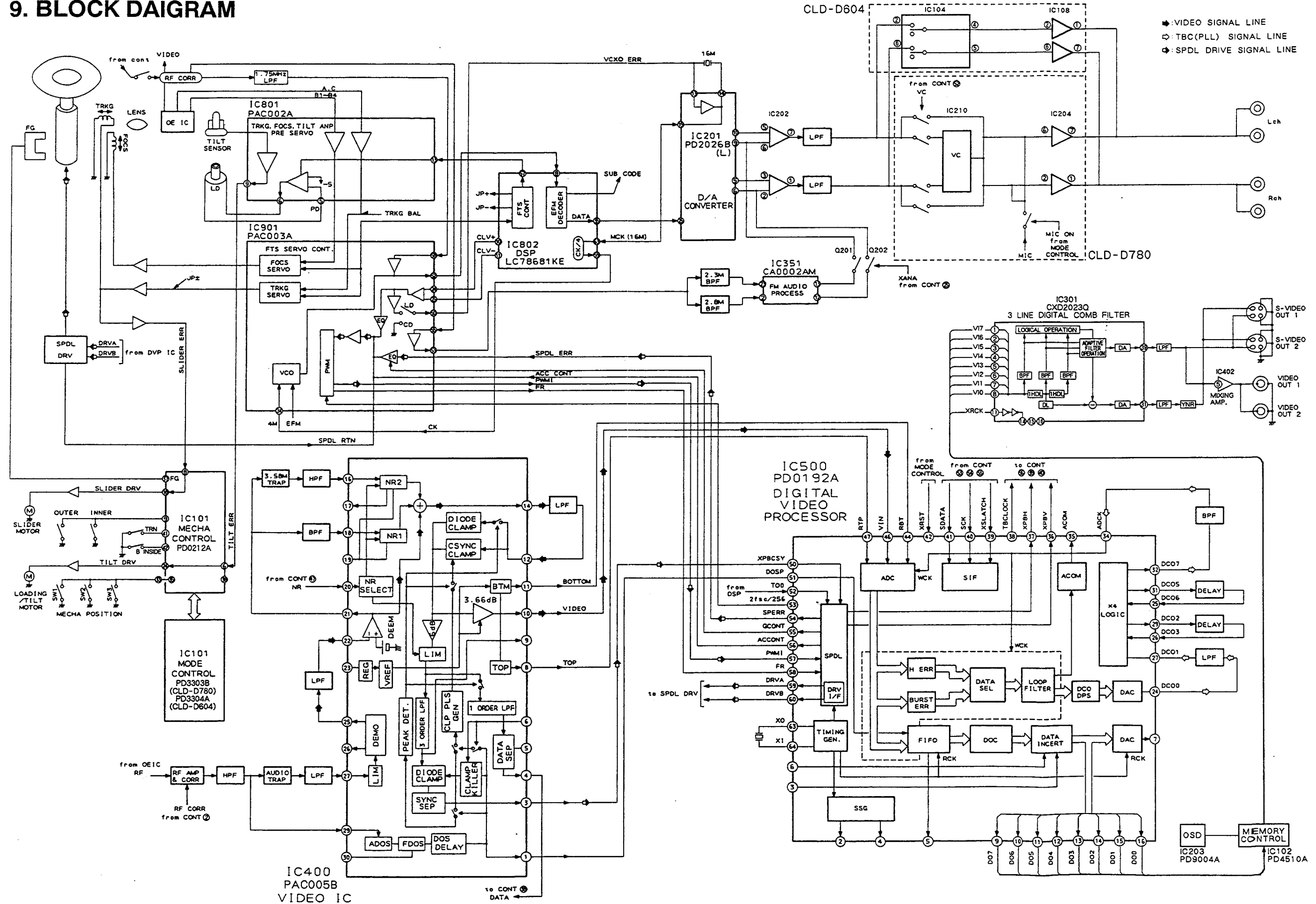

10. PANEL FACILITIES

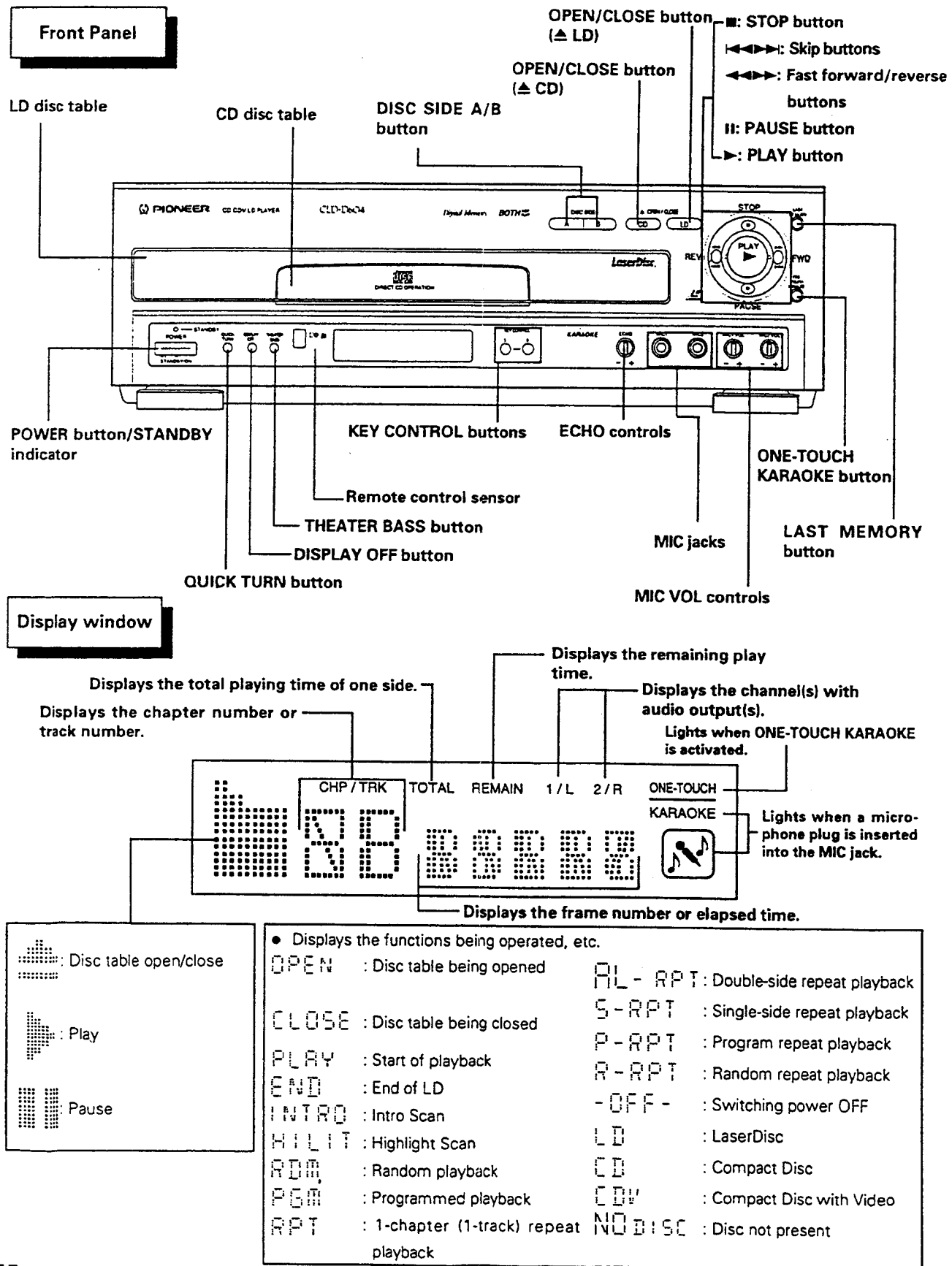

11. SPECIFICATIONS

• For CLD - D604

General

System LaserVision Disc system and Compact Disc digital audio system
 Laser Semiconductor laser wavelength 780 nm
 Power requirement AC 120 V, 60 Hz
 Power consumption 37 W
 Weight 6.8 kg (15 lbs)
 Dimensions 420 (W) x 404 (D) x 132 (H) mm
 16-9/16 (W) x 15-15/16 (D) x 5-3/16 (H) in
 Operating temperature +5°C ~ +35°C
 (41°F ~ 95°F)
 Operating humidity 5% ~ 85%
 (There should be no condensation of moisture.)

Video characteristics (2 pairs)

Format NTSC specifications
 Video output
 Level 1 Vp-p nominal, sync. negative, terminated
 Impedance 75 Ω unbalanced
 Jacks RCA jacks

S VIDEO output (2 pairs)

Y output level 1 Vp-p (75Ω)
 C output level 286 mVp-p (75Ω)
 Jacks S VIDEO jacks

Audio characteristics (2 pairs)

Output level
 During analog audio output 200 mVrms
 (1 kHz, 40%)
 During digital audio output 200 mVrms
 (1 kHz, -20 dB)
 Jacks Both RCA jacks
 Number of channels 2 (Stereo)

Digital Audio Characteristics

Frequency response	4 Hz - 20 kHz
SN ratio	115 dB (EIAJ)
Dynamic range	96 dB (EIAJ)
Total harmonic distortion	Below 0.0035%
Wow and flutter	Below measurable limit (± 0.001% W.PEAK) (EIAJ)

LD is in compliance with EIAJ.

Other terminals

Control input/output Both miniature jacks
 Optical digital output Optical digital jack
 AC-3 RF OUT RCA jack

Accessories

Remote control unit 1
 Size "AAA" (IEC R03) dry cell batteries 2
 Microphone 1
 Video cord 1
 Audio cord 1
 Operating instructions 1
 Warranty card 1

NOTE:

The specifications and design of this product are subject to change without notice, due to improvement.

• For CLD - D780

General

System LaserVision Disc system and Compact Disc digital audio system
 Laser Semiconductor laser wavelength 780 nm
 Power requirement AC 110 - 240 V, 50/60 Hz (automatic select)
 Power consumption 35 W
 Weight 6.8 kg (15 lb)
 Dimensions 420 (W) x 404 (D) x 132 (H) mm
 16-9/16 (W) x 15-15/16 (D) x 5-3/16 (H) in
 Operating temperature +5°C ~ +35°C
 (41°F ~ 95°F)
 Operating humidity 5% ~ 85%
 (There should be no condensation of moisture.)

Video characteristics (2 pairs)

Format NTSC specifications
 Video output
 Level 1 Vp-p nominal, sync. negative, terminated
 Impedance 75 Ω unbalanced
 Jacks RCA jacks

S VIDEO output (2 pairs)

Y output level 1 Vp-p (75Ω)
 C output level 286 mVp-p (75Ω)
 Jacks S VIDEO jacks

Audio characteristics (2 pairs)

Output level
 During analog audio output 200 mVrms
 (1 kHz, 40%)
 During digital audio output 200 mVrms
 (1 kHz, -20 dB)
 Jacks Both RCA jacks
 Number of channels 2 (Stereo)

Digital Audio Characteristics

Frequency response	4 Hz - 20 kHz
SN ratio	115 dB (EIAJ)
Dynamic range	96 dB (EIAJ)
Total harmonic distortion	Below 0.0035%
Wow and flutter	Below measurable limit (± 0.001% W.PEAK) (EIAJ)

LD is in compliance with EIAJ.

Other terminals

Control input/output Both miniature jacks
 Optical digital output Optical digital jack
 AC-3 RF OUT RCA jack

Accessories

Remote control unit 1
 Size "AAA" (IEC R03) dry cell batteries 2
 Video cord 1
 Audio cord 1
 Power cord 1
 Operating instructions 1
 Warranty card 1

NOTE:

The specifications and design of this product are subject to change without notice, due to improvement.