

# Service Manual

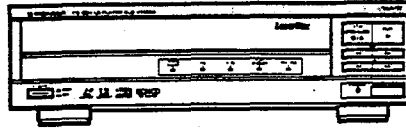

ORDER NO.  
ARP2599

CD CDV LD PLAYER

# CLD-V2300D

CLD-V2300D HAS THE FOLLOWING :

Type	Power Requirement	Remarks
WGZ	AC220-240V	

● This manual is applicable to the WGZ.

## CONTENTS

1. SAFETY INFORMATION.....	2	5. PCB PARTS LIST.....	63
2. EXPLODED VIEWS, PACKING AND PARTS LIST .....	3	6. ADJUSTMENTS.....	68
3. PCB LOCATION.....	15	7. PANEL FACILITIES .....	75
4. SCHEMATIC AND PCB CONNECTION DIAGRAMS.....	16	8. SPECIFICATIONS.....	78

# 1. SAFETY INFORMATION

(FOR EUROPEAN MODEL ONLY)

**VARO!**  
AVATTAESSA JA SUOJALUKITUS  
OHITETTAESSA OLET ALTTIINA  
NÄKYMÄTTÖMÄLLE LASERSÄTEILYLLE.  
ÄLÄ KATSO SÄTEESEEN.

**ADVERSEL:**  
USYNLIG LASERSTRÅLING VED ÅBNING  
NÅR SIKKERHEDSAFBRYDERE ER UDE AF  
FUNKTION UNDGÅ UDSÆTTELSE FOR  
STRÅLING.

**VARNING!**  
OSYNLIG LASERSTRÅLNING NÅR DENNA  
DEL ÄR ÖPPNAD OCH SPÄRREN  
ÄR URKOPPLAD. BETRAKTA EJ STRÅLEN.



LASER  
Kuva 1  
Lasersäteilyn  
varoituserkki

**WARNING!**  
DEVICE INCLUDES LASER DIODE WHICH  
EMITS INVISIBLE INFRARED RADIATION  
WHICH IS DANGEROUS TO EYES. THERE IS  
A WARNING SIGN ACCORDING TO PICTURE  
1 INSIDE THE DEVICE CLOSE TO THE LASER  
DIODE.



LASER  
Picture 1  
Warning sign for  
laser radiation

**IMPORTANT**  
THIS PIONEER APPARATUS CONTAINS  
LASER OF CLASS 1.  
SERVICING OPERATION OF THE APPARATUS  
SHOULD BE DONE BY A SPECIALLY  
INSTRUCTED PERSON.

**LASER DIODE CHARACTERISTICS**  
MAXIMUM OUTPUT POWER: 5 mw  
WAVELENGTH: 780-785 nm

## LABEL CHECK

**ADVARSEL**  
USYNLIG LASERSTRÅLING VED ÅBNING NÅR SIKKERHED SAF-  
BRYDERE ER UDE AF FUNKTION.  
UNDGÅ UDSÆTTELSE FOR STRÅLING.  
**VORSICHT!**  
UNSIHTBARE LASER-STRÅLUNG TRITT AUS, WEHN DECKEL  
(ODER KLAPPE) GEDÖFFNET IST! NICHT DEM STRAHL AUSSETZEN!  
VRW1094

**VARO!**  
Avattassa ja suojalukitus ohitetta-  
essa olet alttiina näkymättömälle  
lasersäteilylle. Älä katso säteeseen.  
**VARNING!**  
Osynlig laserstråling när denna del  
är öppnad och spärren är urkopplad.  
Betrakta ej strålen.  
VRW1297

**CAUTION**  
INVISIBLE LASER  
RADIATION WHEN OPEN,  
AVOID EXPOSURE  
TO BEAM  
PRW1018

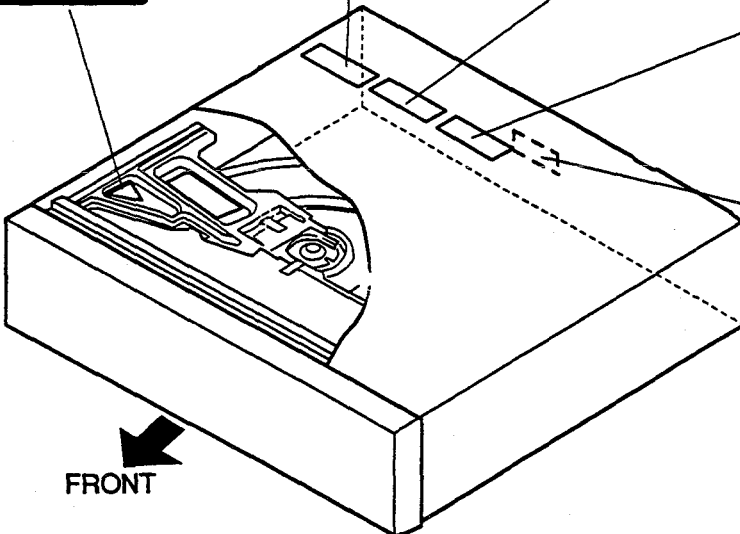

**CLASS 1 LASER PRODUCT**  
LASER KLASSE 1  
DRW1104-A

## 2. EXPLODED VIEWS, PACKING AND PARTS LIST

**NOTES:**

- A**
- Parts marked by "NSP" are generally unavailable because they are not in our Master Spare Parts List.
  - The  $\Delta$  mark found on some component parts indicates the importance of the safety factor of the part. Therefore, when replacing, be sure to use parts of identical designation.
  - Parts marked by "⊙" are not always kept in stock. Their delivery time may be longer than usual or they may be unavailable.

### 2.1 EXTERIOR SECTION

**Parts List**

Mark No.	Description	Part No.	Mark No.	Description	Part No.
1	Bonnet S	DXX2017	NSP 101	Center angle	VNE1305
2	Disc pad (L)	VEC1191	NSP 102	Cushion	VEC1004
3	Disc pad (S)	VEC1192	NSP 103	Tray angle	VNE1309
4	Tray assembly	VXX1453	NSP 104	Carry label	VRW1289
5	Tray rubber	VEB1089	NSP 105	Tray reinforced plate	VNE1528
6	Screw	BBZ30P060FCC	NSP 106	Tray	VNK1354
7	Screw	ECT40P060FNI	NSP 107	Side plate	VNE1362
8	Screw	BPZ30P080FCU	NSP 108	Reinforced bridge	DNF1390
9	Screw	CPZ30P100FMC			
10	Screw	BPZ30P140FMC			
11	Screw	BBT30P060FNI			
12	Screw	PCZ30P080FMC			

**B**

**C**

**D**

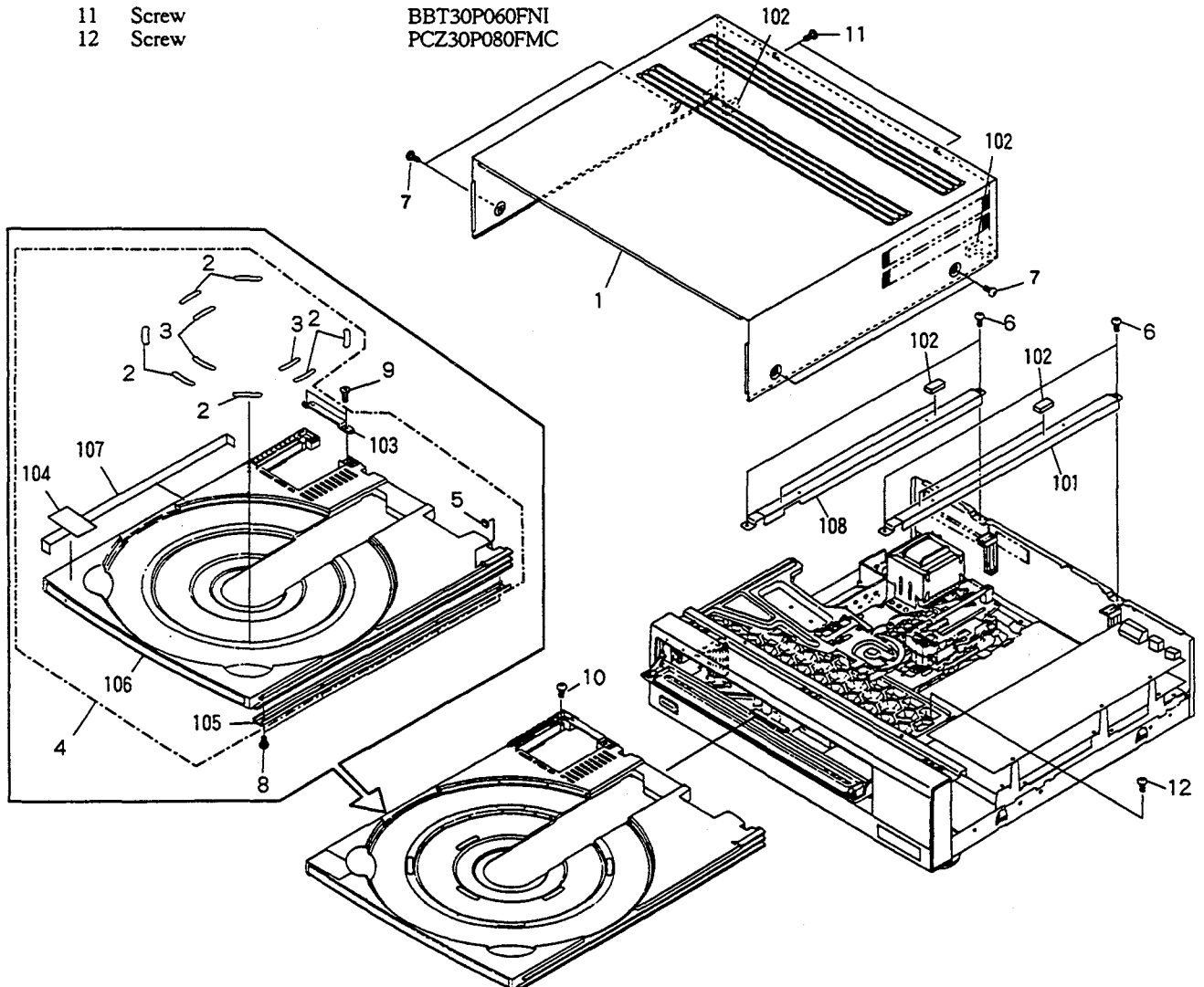

**2.2 TOP VIEW SECTION**

**Parts List**

<b>Mark</b>	<b>No.</b>	<b>Description</b>	<b>Part No.</b>	<b>Mark</b>	<b>No.</b>	<b>Description</b>	<b>Part No.</b>
	1	Clamper arm (A) assembly	VXA1319	NSP	101	Rack assembly	VWT1061
	2	Rubber (A)	VEB1084	NSP	102	Mechanism assembly	VWT1076
	3	Clamper spring	VBH1094	NSP	103	Front angle	VNE1304
	4	Arm spring	VBH1093	NSP	104	Side stay (L)	VNE1306
	5	Side stay (R) assembly	VXA1529	NSP	105	SM head holder	VNE1592
	6	Carriage shaft	VLL1177	NSP	106	Clamper arm (B)	VNE1308
	7	Clamper pad	VEC1264	NSP	107	Earth plate	DNF1001
	8	Screw (B)	VBA1018	NSP	108	Stabilizer	VN 33
	9	Screw (B)	VBA1008	NSP	109	SW1 board assembly	VWG1212
	10	Screw	IPZ30P060FCC	NSP	110	FG board assembly	VWG1214
	11	Power knob	DNK2554	NSP	111	PALB board assembly	DWV1112
	12	Parallel link	VNL1254	NSP	112	MCRS board assembly	DWG1303
	13	Plate spring	VBK1014	NSP	113	PCB spacer (30)	DEC1389
	14	Ball holder	VNL1289	NSP	114	PC support	VEC1508
	15	Clamper S	VNL1248	NSP	115	PCB holder	DNE1188
	16	Clamper holder	VNL1205				
	17	Rubber sheet	VEB1114				
	18	Thrust holder	VBK1018				
	19	Screw	CPZ20P050FMC				
	20	Screw	BBZ30P080FCC				
◎	21	VDTB board assembly	DWS1170				
	22	Bolt (#4-40/M3)	DBA1038				
	23	Screw	IPZ30P060FCC				

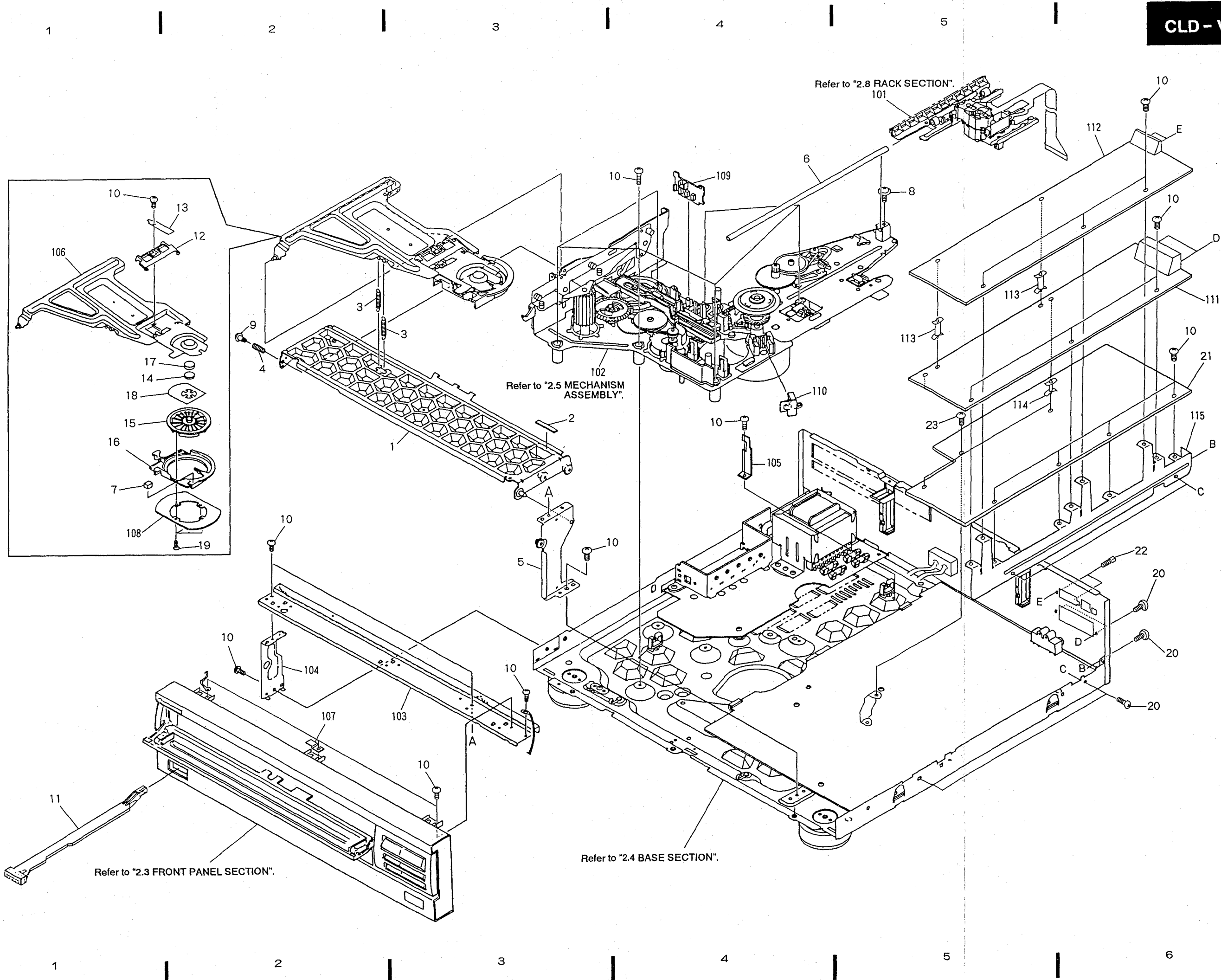

2.3 FRONT PANEL SECTION

Parts List

Mark No.	Description	Part No.	Mark No.	Description	Part No.
1	Door assembly - S	DXX2018	NSP 101	Door plate	VNE1311
2	Door damp rubber	VEB1033	NSP 102	Spacer	VEC-244
3	Roller	VNL1042	NSP 103	Name plate	DAM1046
4	Sub panel (R)	DNK2549	NSP 104	TSWB board assembly	DWX1294
5	Damper assembly	VXA1053	NSP 105	LEDB board assembly	DWX1320
6	Front door assembly	DXA1525	NSP 106	Spacer	VEB1123
7	Door spring	VBH1085			
8	Screw	IPZ26P060FMC			
9	Front panel assembly - S	DXX2019			
10	Screw	BPZ26P080FZK			
11	Function button	DNK2553			
12	Screw	BPZ20P040FZK			
13	Display sheet	DEC1572			
14	Front panel assembly	DXA1524			
15	IR sheet	DEC1579			

2.4 BASE SECTION

Parts List

Mark No.	Description	Part No.	Mark No.	Description	Part No.
1	Power transformer	DTT1085	NSP 101	P. C. B spacer	PNY-404
2	SYPS board assembly	DWR1135	NSP 102	P plate holder	PNY-405
3	3P Inlet assembly	DKN1080	NSP 103	Wire crip (B)	VEC1012
4	Fuse (FU203, FU204)(1.25A)	REK-101	NSP 104	Base chassis	VNA1121
5	Fuse (FU201, FU202)(3.15A)	REK-105	NSP 105	Rear panel	DNC1280
6	Tray stopper	VNL1202	NSP 106	Stopper	VEC1224
7	Insulator assembly	DXA1527	NSP 107	Insulator	DNK2552
8	Door damp rubber	VEB1033	NSP 108	ASCB board assembly	DWX1293
9	Insulator assembly	DXA1526	NSP 109	Cord holder	VNF-069
10	Screw	IBZ30P060FCC	NSP 110	PCB holder (C)	VNE1329
11	Screw	IPZ30P160FMC	NSP 111	Insulator	DNK2551
12	Screw	BBZ30P080FCC	NSP 112	Earth plate	DNF1001
13	Screw	BBZ30P060FCC	NSP 113	Wire clamp	VEC1237
14	Screw	BCZ40P080FUC	NSP 114	Wire clip	VEC-139
15	Screw	BBT30P060FZK			

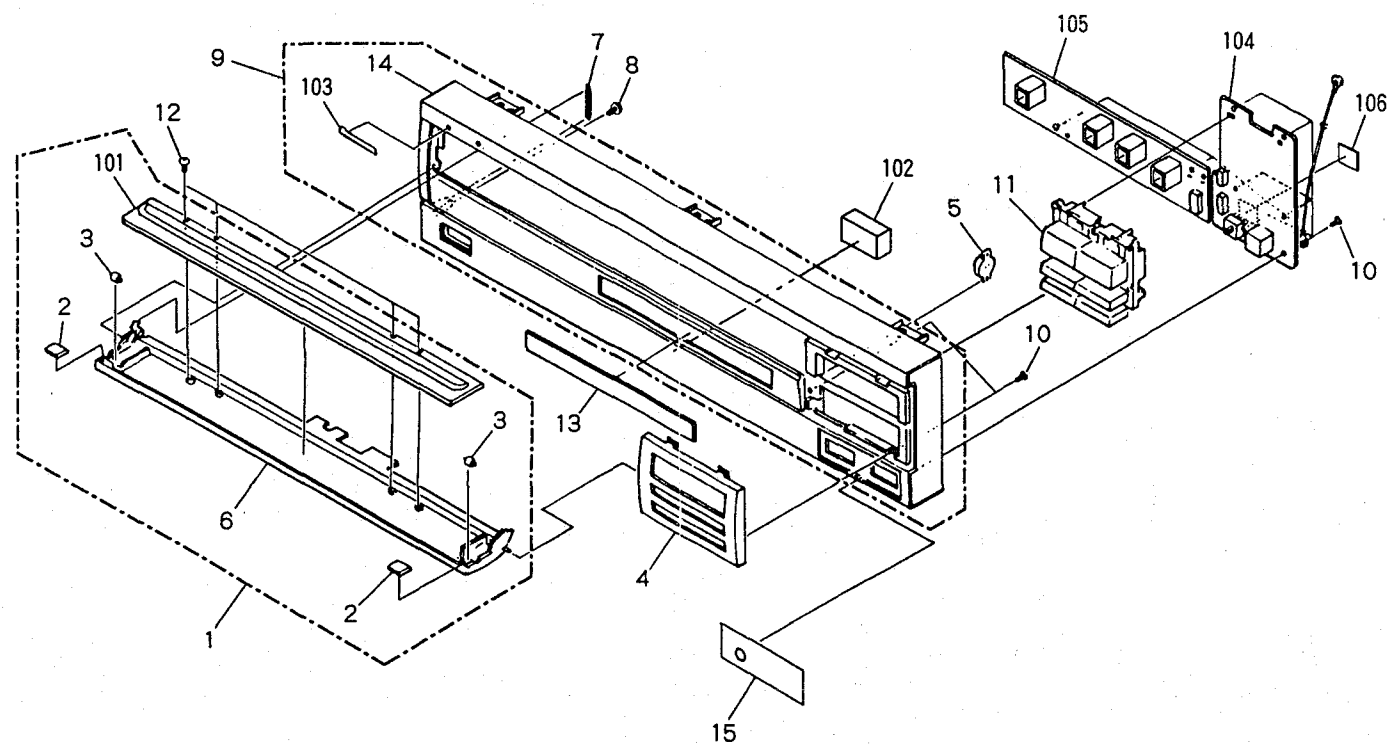

A

B

C

D

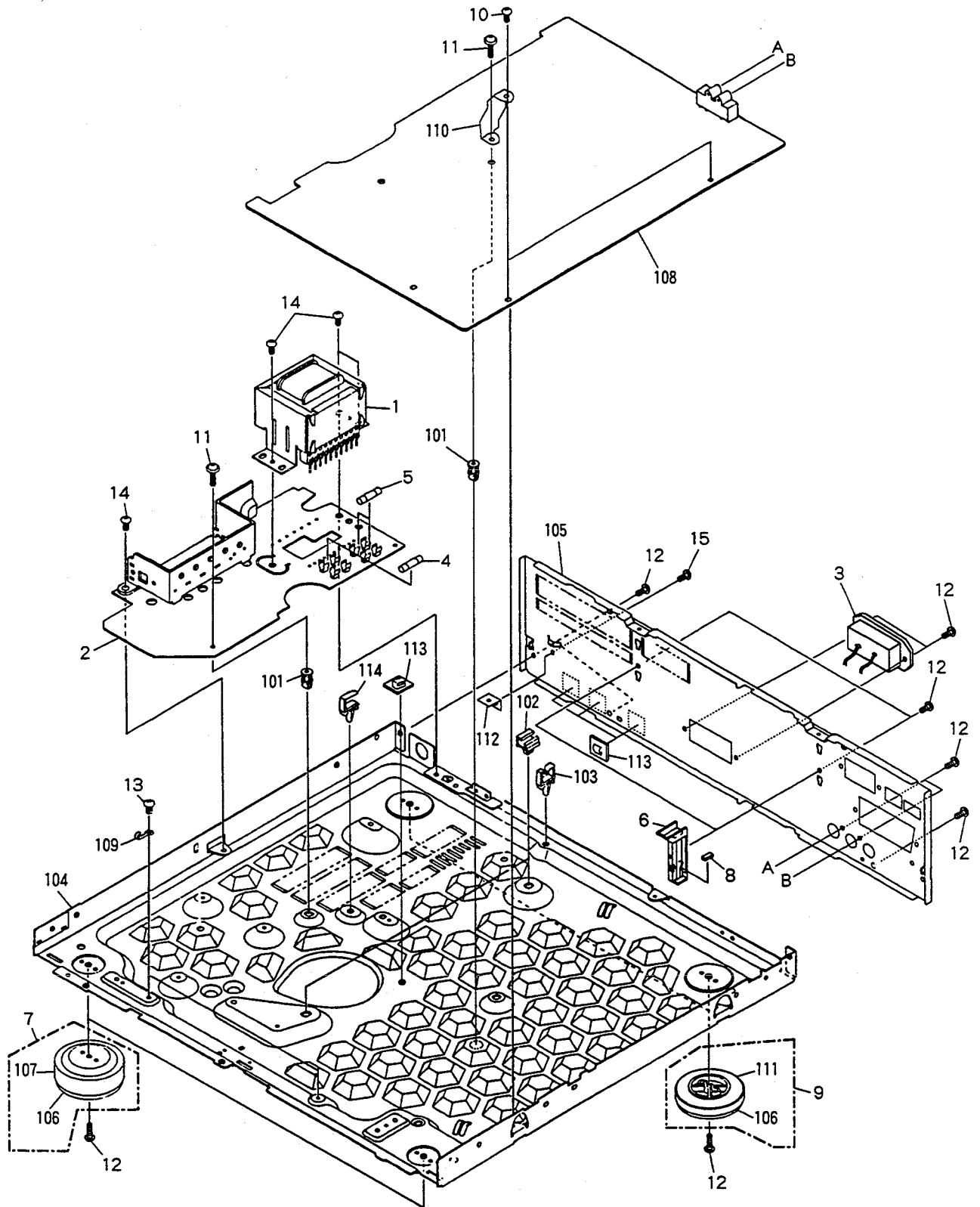

1

2

1

2

3

9

## 2.5 MECHANISM ASSEMBLY

### Parts List

Mark No.	Description	Part No.	Mark No.	Description	Part No.
1	Plate spring	VBK1013	NSP 101	Cam head stopper	VNE1331
2	Thrust spring	VBH1073			
3	Tilt shaft	VLL1175			
4	Tilt pulling spring	VBH1074			
5	Belt	PEB1013			
6	Screw	ABZ26P050FMC			
7	Screw	PMA30P050FMC			

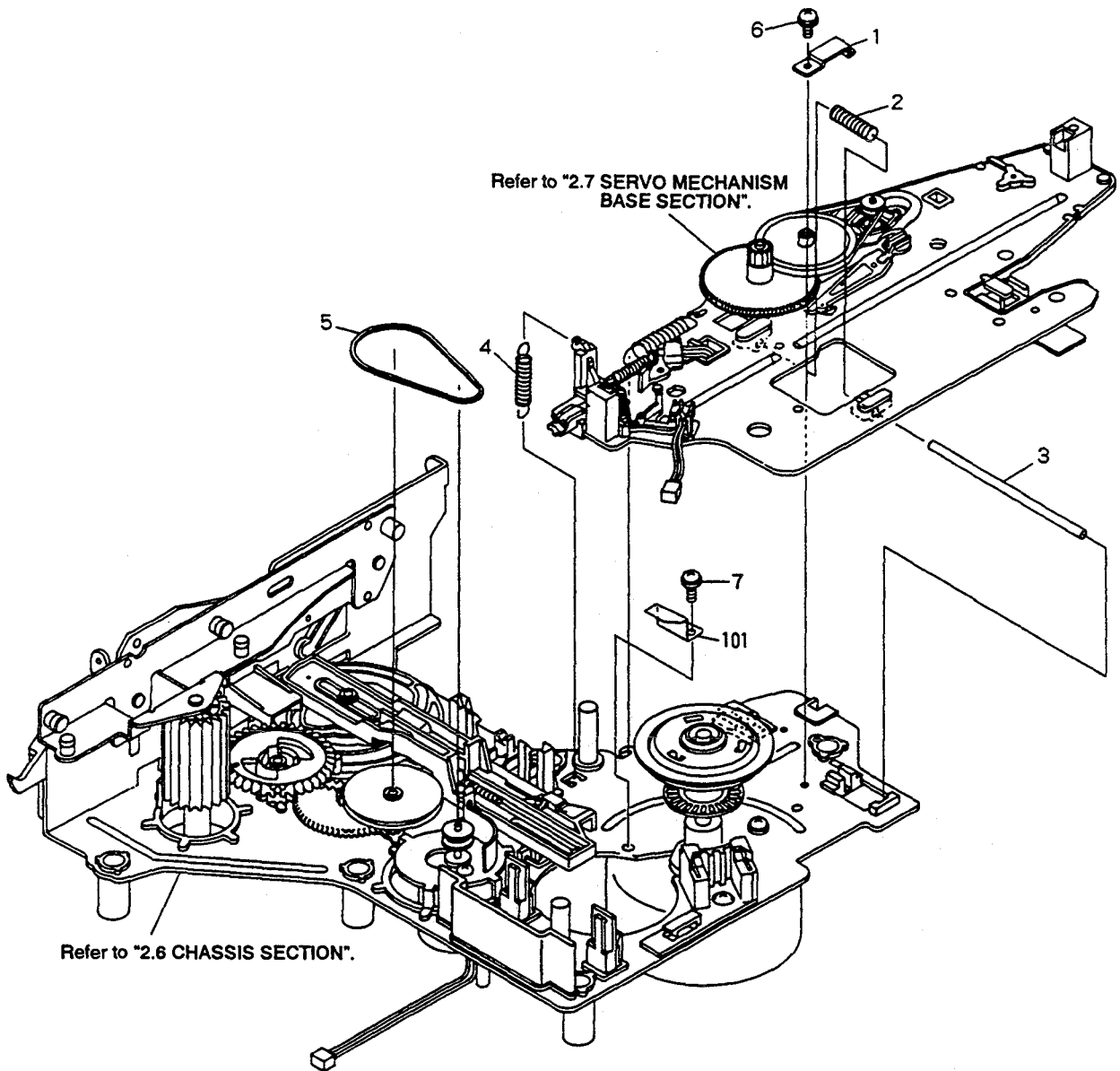



## 2.6 CHASSIS SECTION

### Parts List

Mark No.	Description	Part No.	Mark No.	Description	Part No.
1	Spring slanting cam	VNL1191	21	Screw	PMA30P050FMC
2	Cam spring	VBH1082	22	Washer	WA32D060D025
3	Belt	PEB1013	23	Loading motor	VXM1034
4	Gear pulley	VNL1249	24	Stop ring	VEB1091
5	Follow gear	VNL1194	25	Chassis assembly	VXA1575
6	Roller plate assembly	VXA1531			
7	Slide cam	VNL1188			
8	E ring	YE23FUC	NSP 101	Motor pulley	VLL1176
9	Loading motor assembly	VXX1262	NSP 102	Rubber sheet	VEB1103
10	Spindle motor assembly	VXA1474	NSP 103	Turn table assembly	VXA1283
11	Centering hab	VNL1174	NSP 104	Oil stopped washer	VBF1002
12	Centering spring	VBH1083	NSP 105	Spindle motor	VXM1032
13	Door lever	VNL1407			
14	Washer	WT26D047D025	NSP 106	Housing assembly	VKP1566
15	Two stair gear	VNL1193	NSP 107	Housing assembly	VKP1862
16	Cam gear	VNL1529	NSP 108	Slider gear	VNL1189
17	Screw (C)	VBA1015			
18	Screw (B)	VBA1008			
19	Nylon washer	WA32N080W020			
20	Screw	PMZ30P040FMC			

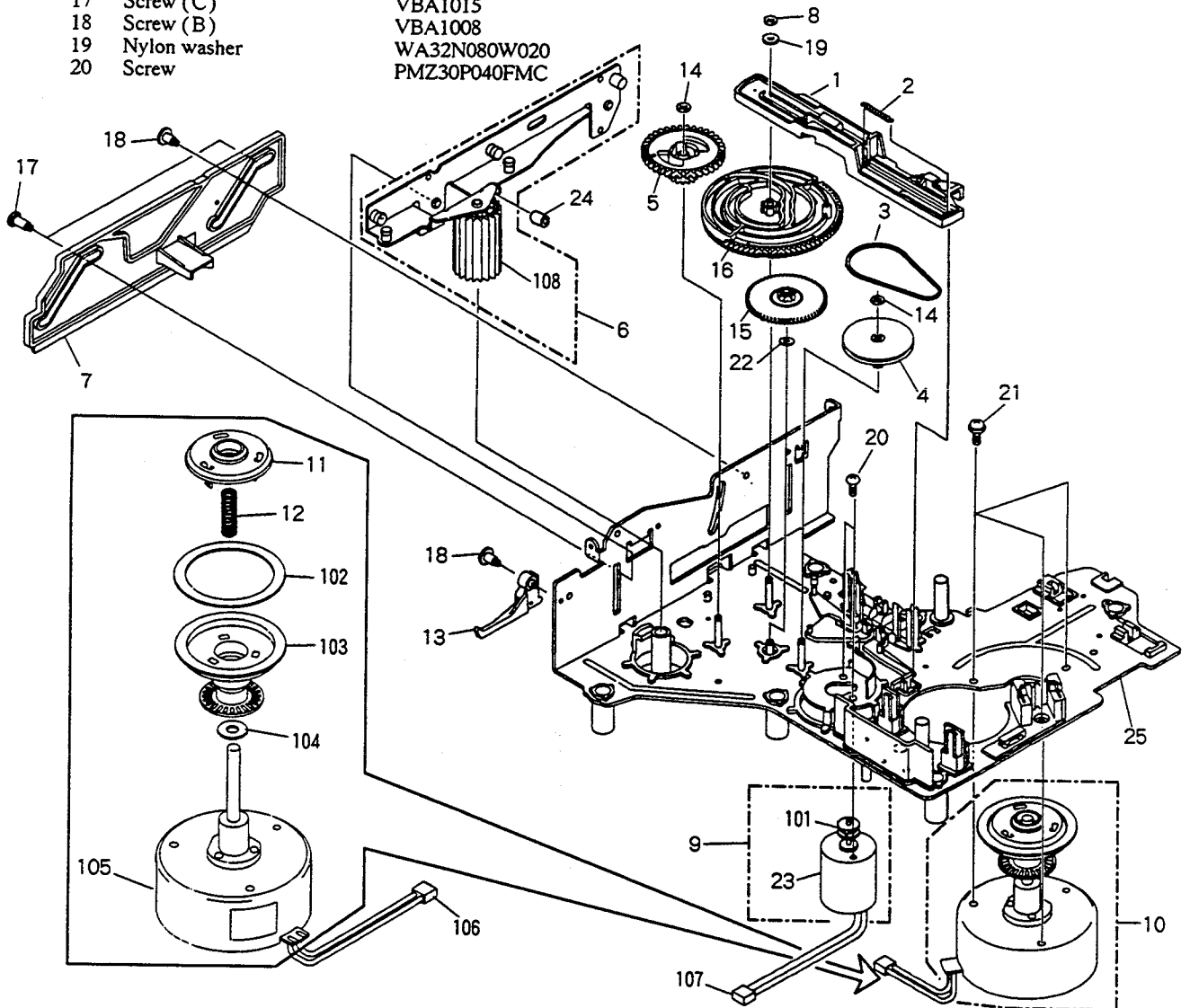

2.7 SERVO MECHANISM BASE SECTION

Parts List

Mark No.	Description	Part No.	Mark No.	Description	Part No.
1	CA gear (3)	VNL1196	11	Screw	PMZ26P040FMC
2	Switch pulling spring	VBH1079	12	Screw	BPZ26P050FMC
3	TC pulling spring	VBH1181	13	Washer	WT26D047D025
4	Push switch (S5:OUTER)	DSG1014	14	FLE base	VNL1341
5	CA pulley (1)	VNL1197	15	Servo mechanism base assembly - S	VXX1583
6	Carriage motor assembly	VXX1261			
7	Push switch (S4:INNER)	DSG1014	NSP 101	Carriage motor	VXM1033
8	CA belt	VEB1077	NSP 102	Housing assembly	VKP1553
9	CA pulley (2)	VNL1198	NSP 103	Housing assembly	VKP1861
10	Screw	SMF30H080FBT	NSP 104	Housing assembly	VKP1554
			NSP 105	Holder A	VNV1022
			NSP 106	Holder B	VNV1023

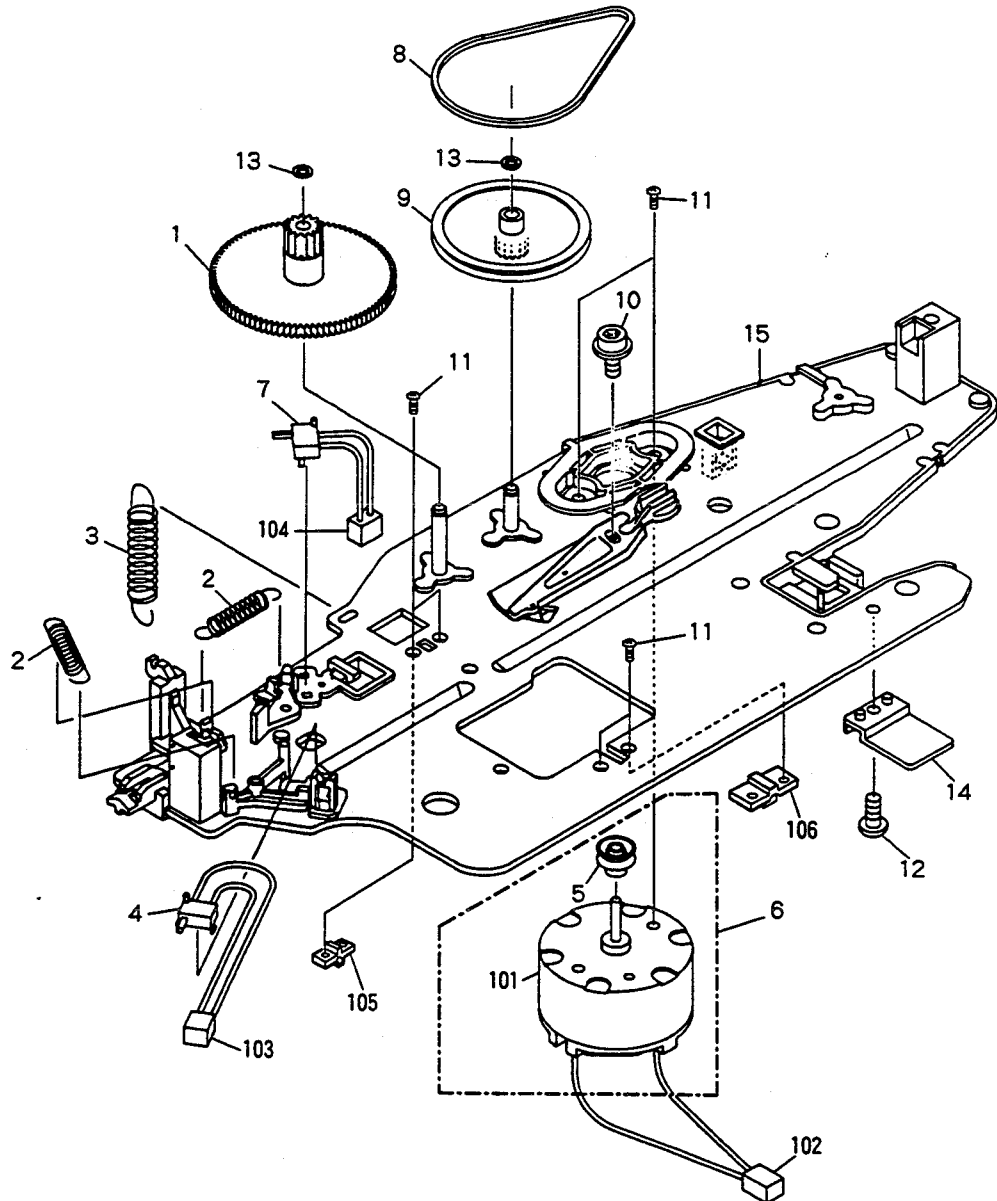

2.8 RACK SECTION

Parts List

Mark No.	Description	Part No.	Mark No.	Description	Part No.
1	PU base	VNL1209	11	TAN base	VNL1199
2	LP center spring	VBH1075	12	Screw	PMZ20P040FMC
3	PU pulling spring	VBH1089	13	Screw	PMA20P040FMC
4	L-2 spring	VBH1090	14	Screw	AMZ20P050FMC
5	Washer	WA32F070M080	15	Slider assembly	VWT1060
6	Screw	VBA1007	16	PU mount base assembly	VXA1762
7	Screw (2.6 x 10)	VLL1192	17	Spacer (S)	VEC1284
8	Rack	VNL1186	18	TAN plate (1)	VNE1606
9	Screw	BMZ26P080FMC	NSP 101	TAN plate (2)	VNE1303
10	TAN spring	VBH1081	NSP 102	Pickup assembly	VWY1021

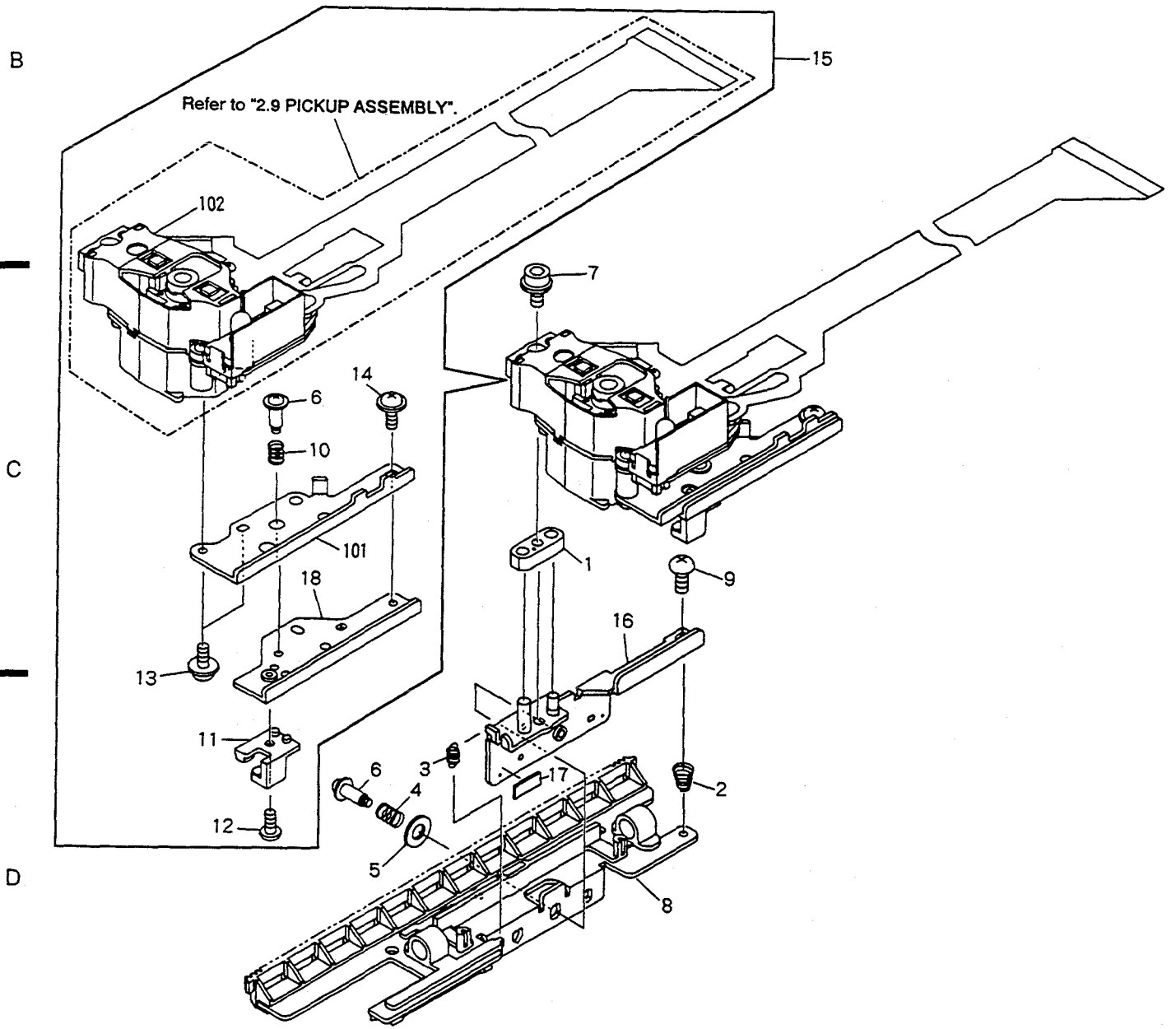

**2.9 PICKUP ASSEMBLY**

**Parts List**

Mark No.	Description	Part No.
1	Actuator assembly	VXX1551
2	Sensor assembly	VEX1018
3	Pre-pickup assembly	VXX1413
4	Sensor stay	VNH1037
5	Screw	PMA20P060FMC
6	Screw	PMA20P080FMC
7	Screw	PMA20P160FMC
8	Screw	BMZ20P060FMC
9	Sensor spring	VBH1087
NSP 101	HEAD assembly	VWV1119

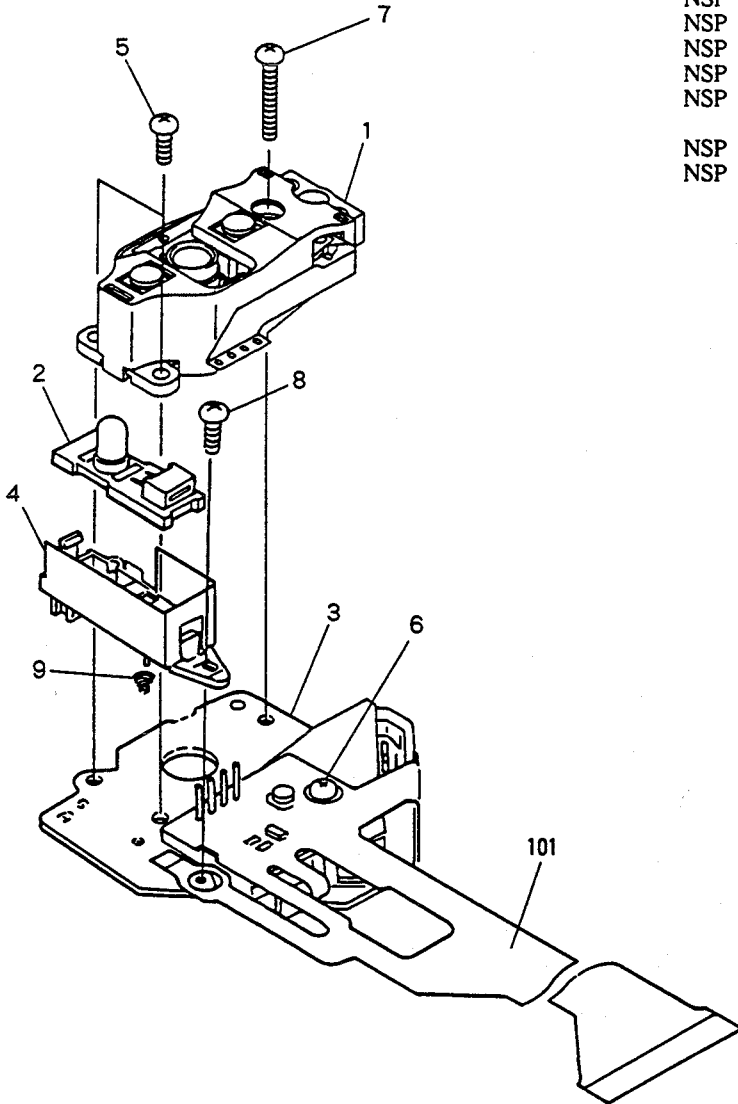

**2.10 PACKING**

**Parts List**

Mark No.	Description	Part No.
1	Packing case	DHG1439
2	Under pad	DHA1162
3	Battery cover	DNK1958
4	Top pad (L)	DHA1160
5	Top pad (R)	DHA1161
6	Remote control unit (CU-V113)	DXR1006
7	Mirror mat	VHL1006
8	Cord with plug	VDE-055
9	Video cable	VDE-056
10	Operating instructions (English/French/German/Italian/Spanish)	DRE1017
NSP 101	Battery (R6P, AA)	VEM-013
NSP 102	Caution card (UC)	VRM1039
NSP 103	Caution card (EW)	VRM1027
NSP 104	Polyethelene bag	VHL-014
NSP 105	Polyethelene bag	Z21-029
NSP 106	Caution card	VRR1009
NSP 107	Bar code sheet	DRY1129

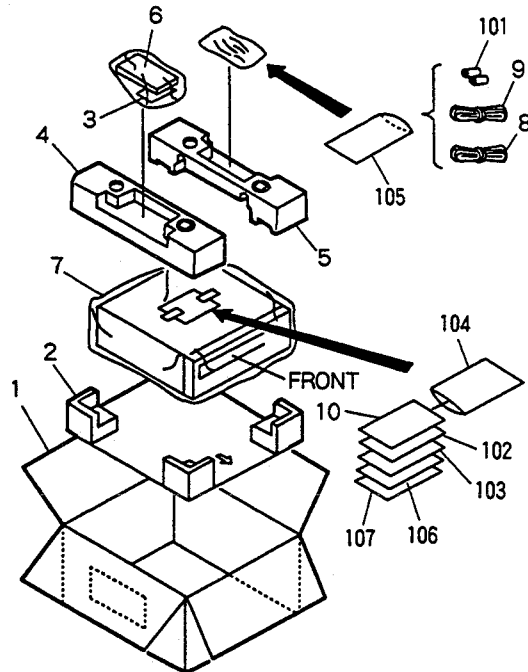

### 3. PCB LOCATION

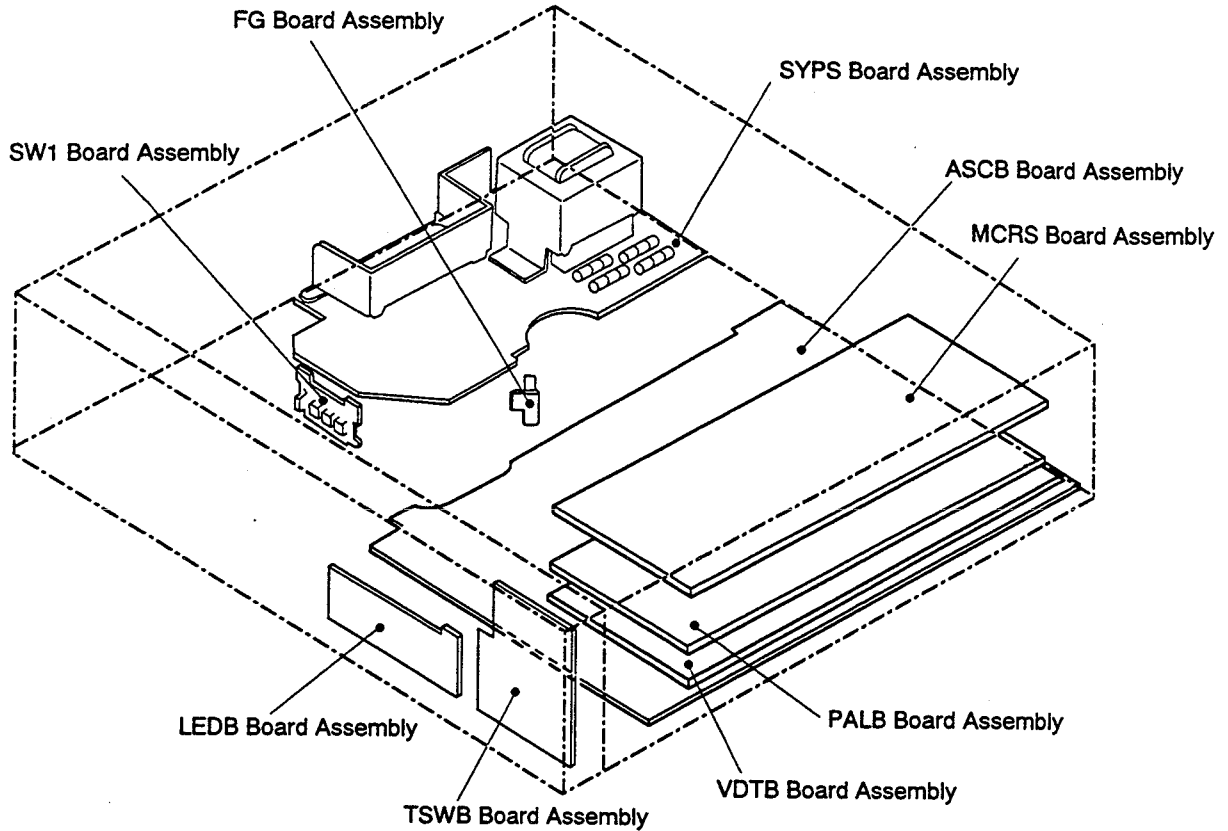

- ASCB : AUDIO SERVO CONTROL BOARD
- FG : FG COUNTER BOARD
- SW1 : SW1 BOARD
- VDTB : VIDEO AND TBC BOARD
- SYPS : SYSTEM POWER SUPPLY
- LEDB : LED BOARD
- PALB : PAL BOARD
- TSWB : TACT SWITCH BORAD
- MCRS : MICROCOMPUTER SECTION BOARD

# 4. SCHEMATIC AND PCB CONNECTION DIAGRAMS

## ● SCHEMATIC DIAGRAM

Note: (Type 4)

1. When ordering service parts, be sure to refer to "PARTS LIST of EXPLODED VIEWS" or "PCB PARTS LIST".

2. Since these are basic circuits, some parts of them or the values of some components may be changed for improvement.

### 3. RESISTORS:

Unit: k: kΩ, M: MΩ, or Ω unless otherwise noted.  
 Rated power: 1/4W, 1/6W, 1/8W, 1/10W unless otherwise noted.  
 Tolerance: (F): ±1%, (G): ±2%, (K): ±10%, (M): ±20% or ±5% unless otherwise noted.

### 4. CAPACITORS:

Unit: p: pF or μ: μF unless otherwise noted.  
 Ratings: capacitor (μF) / voltage (V) unless otherwise noted.  
 Rated voltage: 50V except for electrolytic capacitors.

### 5. COILS:

Unit: m: mH or μ: μH unless otherwise noted.

### 6. VOLTAGE AND CURRENT:

□: DC voltage (V) in PLAY mode unless otherwise noted.  
 ⇐ mA or ⇐ mA: DC current in PLAY mode unless otherwise noted.  
 Value in ( ) is DC current in STOP mode.

### 7. OTHERS

- ⇐ Signal route.
- ⊗ Adjusting point.
- ▼ (F): Measurement point.
- The mark found on some component parts indicates the importance of the safety factor of the parts. Therefore, when replacing, be sure to use parts of identical designation.

### 8. SWITCHES (Underline indicates switch position):

OUT OF P.C.BOARD ASSEMBLY

- S4: INNER
- S5: OUTER
- S6: TRAY IN

SW1 BOARD ASSEMBLY

- S1:
- S2: ] LOADING/TILT
- S3:

MCRS BOARD ASSEMBLY

- S301: DIP SW 1-4 ON-OFF
- S302: MODE SELECTOR PAL-NTSC3.58

TSWB BOARD ASSEMBLY

- S601: ■ / ▲ STOP OPEN/CLOSE
- S602: ◀ ▶ SKIP
- S603: ◀ ▶ SKIP
- S604: ▶ PLAY
- S605: ▶▶ SCAN
- S606: ▶▶ SCAN

SYPS BOARD ASSEMBLY

- S201: POWER ON-OFF

## ● PCB CONNECTION DIAGRAMS

P.C.B. pattern diagram indication	Corresponding part symbol	Part name
		Transistor
		FET
		Diode
		Zenner diode
		LED
		Varactor
		Tact switch
		Inductor
		Coil
		Transformer
		Filter
		Ceramic capacitor
		Mylar capacitor
		Styrol capacitor
		Electrolytic capacitor (Non polarized)
		Electrolytic capacitor (Noiseless)
		Electrolytic capacitor (Polarized)
		Electrolytic capacitor (Polarized)
		Power capacitor
		Semi-fixed resistor
		Resistor array
		Resistor
		Resonator
		Thermistor

1. The parts which have been mounted on the board can be replaced with those shown with the corresponding wiring symbols listed in the above Table.
2. The capacitor terminal marked with □ shows negative terminal.
3. The diode marked with ○ shows cathode side.
4. The transistor terminal marked with □ shows emitter.

1. OVERALL WIRING DIAGRAM

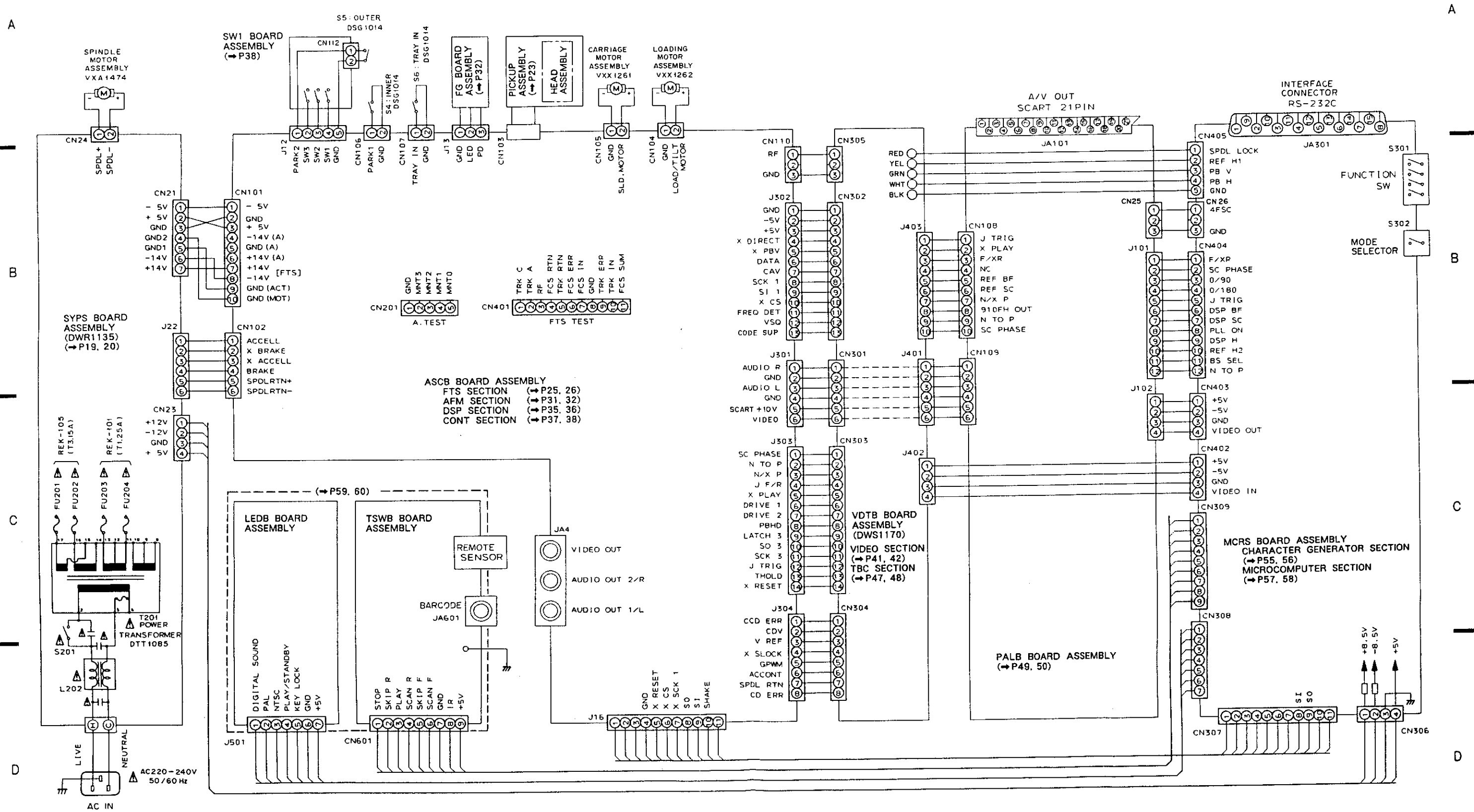

**2. SYPS BOARD ASSEMBLY**

SYPS BOARD ASSEMBLY  
(DWR1135)

- C207 : VCH1050
- C208 : VCH1053
- C216-218 : VCG-04B
- D216-219 : 11ES2
- R213, 214, 219, 220 : DCN1003
- R221 : RS1PMFR51J

A

B

C

D

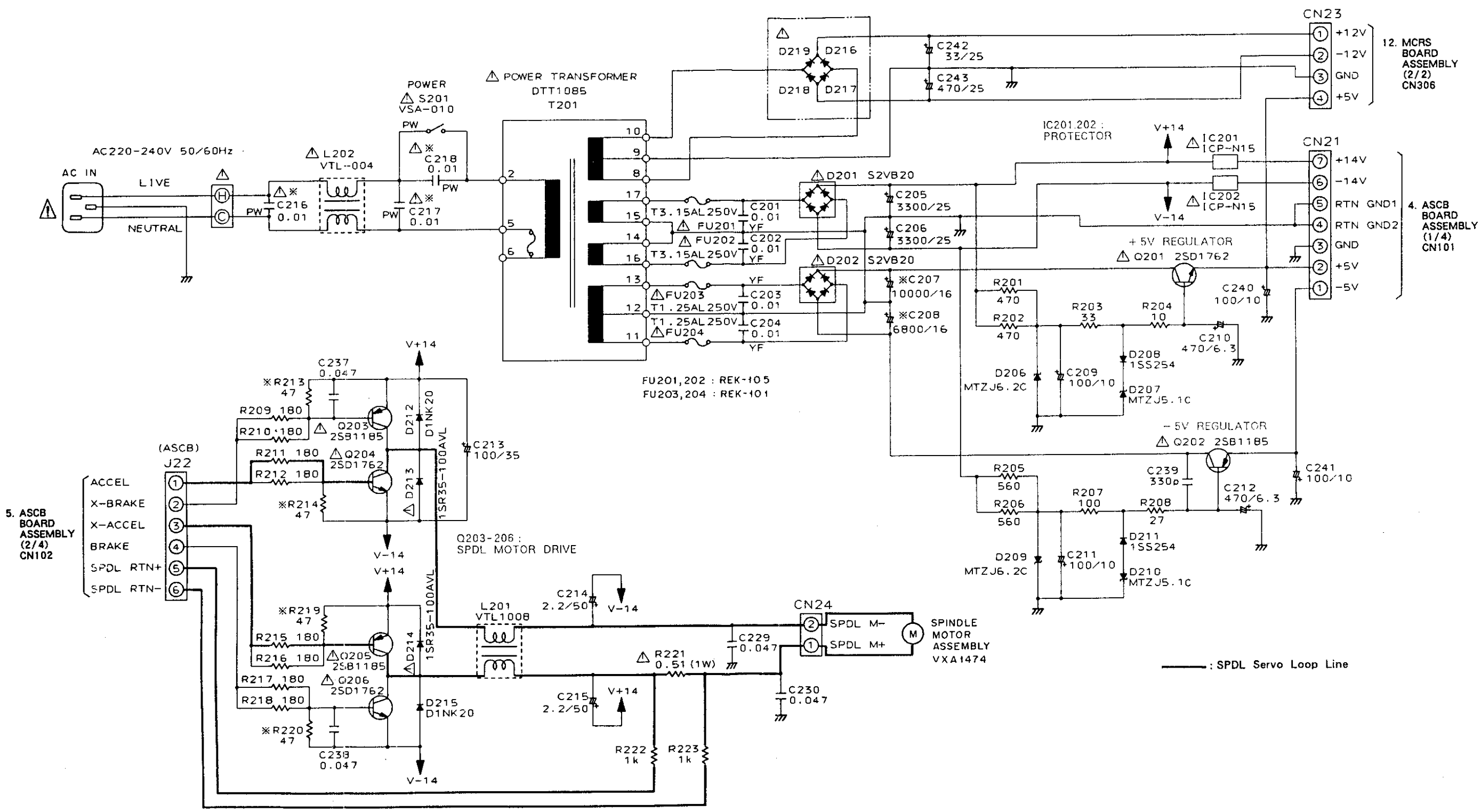

12. MCRS BOARD ASSEMBLY (2/2) CN306

4. ASCB BOARD ASSEMBLY (1/4) CN101

5. ASCB BOARD ASSEMBLY (2/4) CN102

SPINDLE MOTOR ASSEMBLY VXA1474

— : SPDL Servo Loop Line



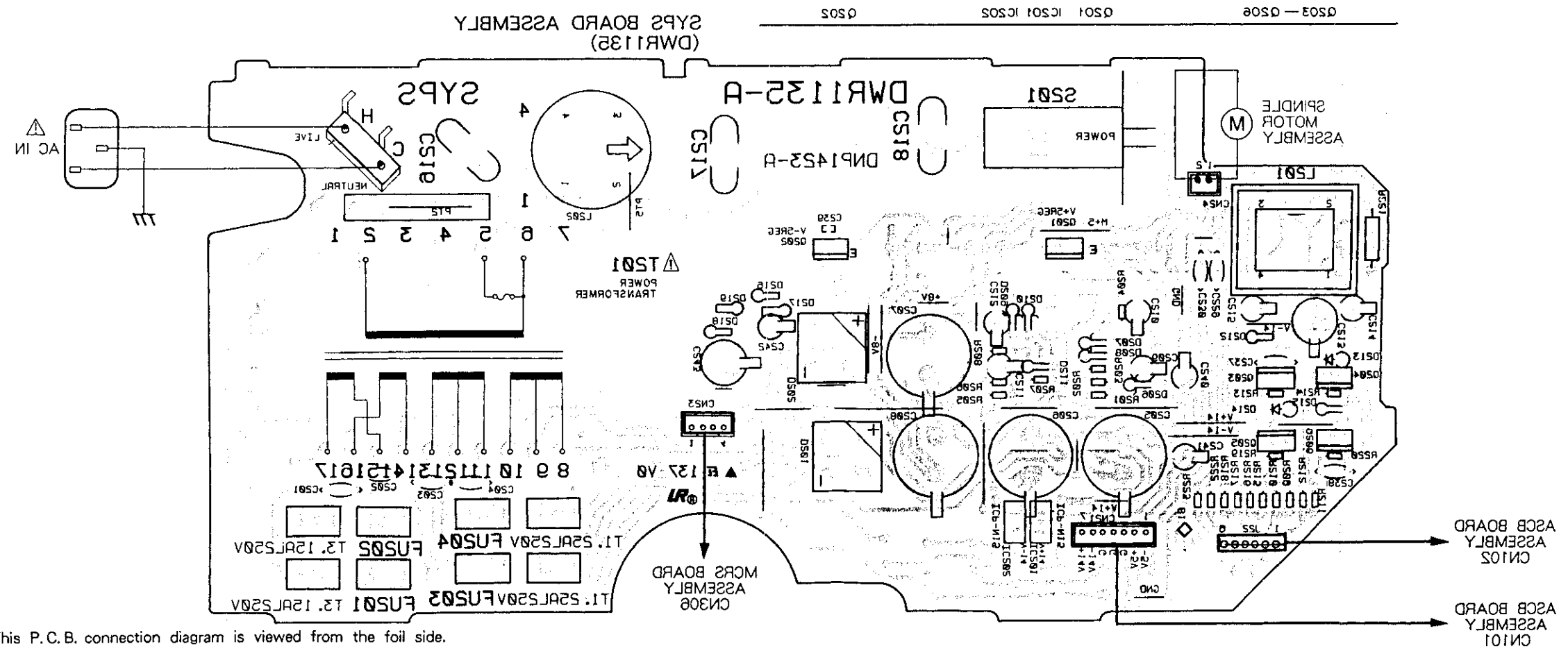
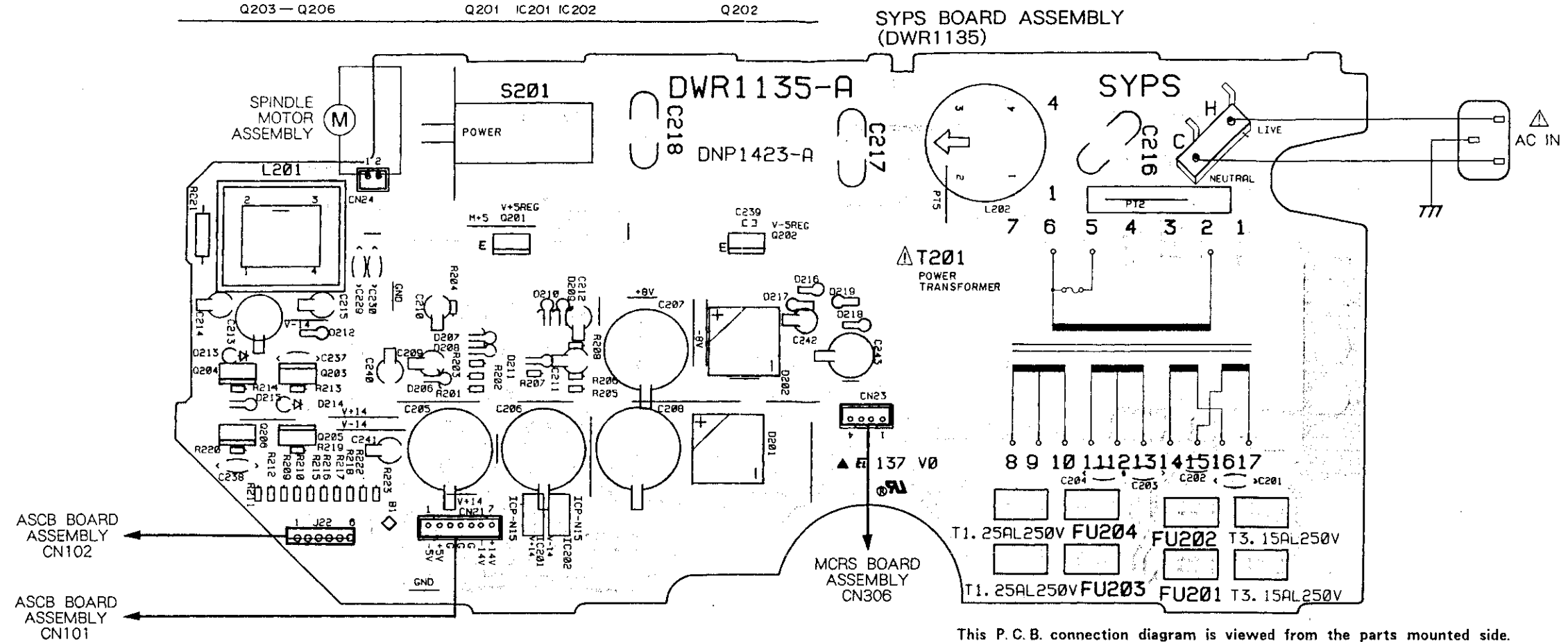

3. PICKUP ASSEMBLY

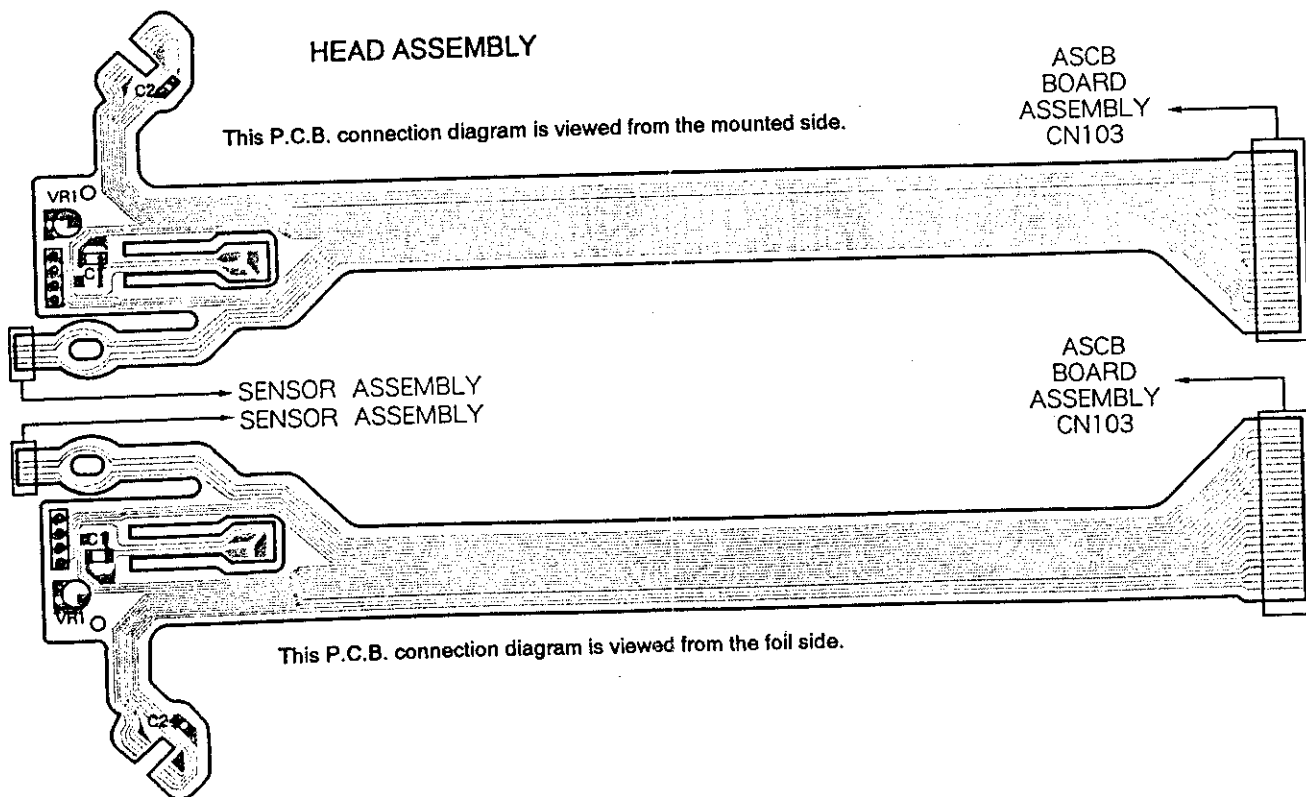
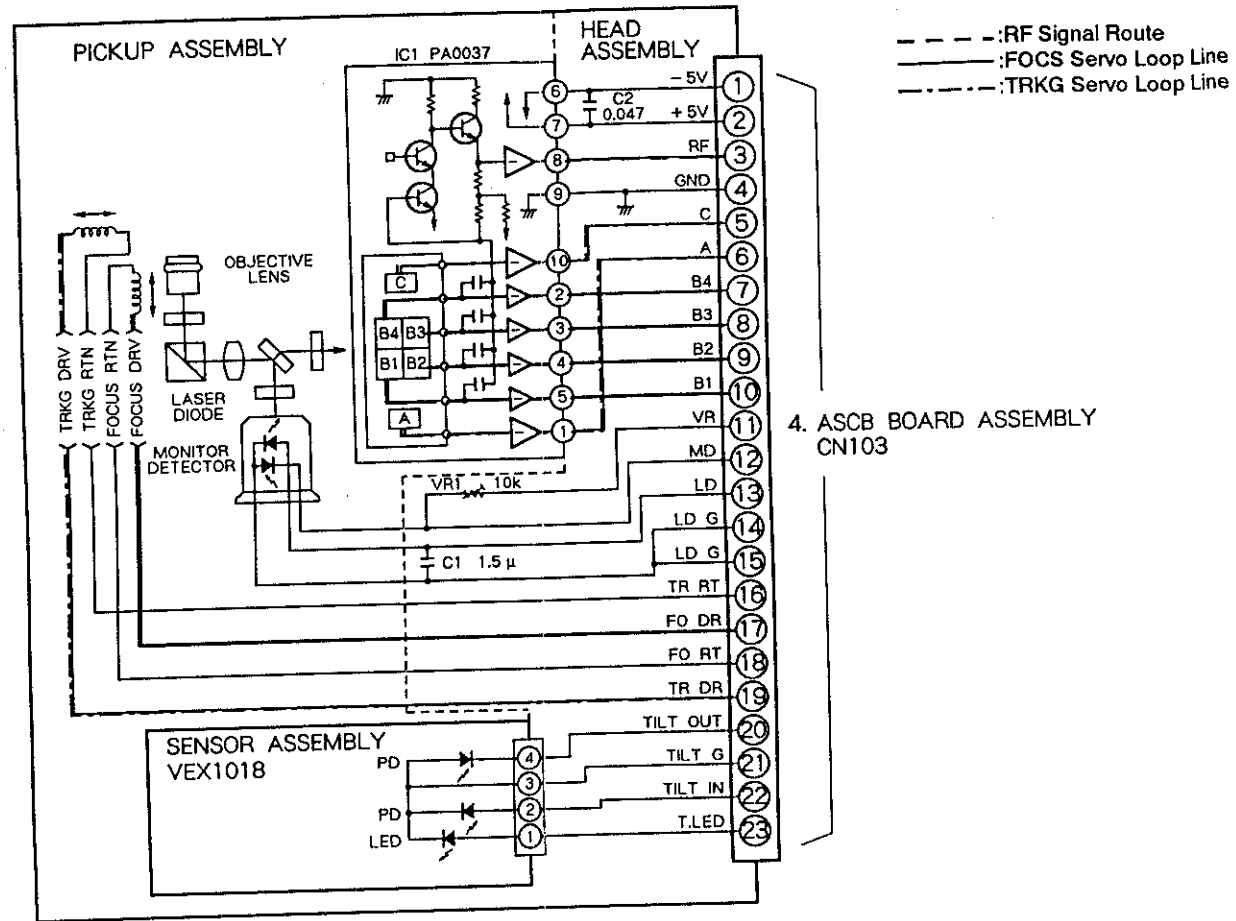

FTS SECTION

Note: (No.) in the table correspond to the pin No.

IC801 (CXA1081S)		CN401		IC803 (PM3003)		Other points	
① 1.5Vp-p	② 400mVp-p	③ 300mVp-p	① 300mVp-p	③ 1Vp-p	① Q810 Collector 400mVp-p		
② 1.5Vp-p	② 700mVp-p	④ 5Vp-p	⑧ 2Vp-p	④ 200mVp-p	② CN103 Pin 16 200mVp-p		
⑦ 40mVp-p	② 10Vp-p :still	⑤ 4Vp-p	③ 500mVp-p :still	④ 1.5Vp-p	③ Q828 Collector 400mVp-p		
⑫ 200mVp-p	③ 2Vp-p	⑧ 600mVp-p	⑤ 1Vp-p	④ 150mVp-p	④ CN103 Pin 17 15Vp-p		
⑮ 400mVp-p	⑦ 3Vp-p	⑦ 1.5Vp-p	⑥ 2Vp-p	⑤ 250mVp-p	⑤ CN103 Pin 18 20Vp-p		
		⑧ 1.25Vp-p	③ 2Vp-p	⑥ 250mVp-p	⑥ IC804 Pin 8 3Vp-p		
		⑩ 1.25Vp-p					
		⑪ 500mVp-p					

4. ASCB BOARD ASSEMBLY (1/4 : FTS SECTION)

Note : Abbreviations listed indicate circuit connections.

- FTS : 4. ASCB BOARD ASSEMBLY (1/4)
- AFM : 5. ASCB BOARD ASSEMBLY (2/4)
- DSP : 6. ASCB BOARD ASSEMBLY (3/4)
- CONT : 7. ASCB BOARD ASSEMBLY (4/4)

- : RF Signal Route
- : FOCUS Servo Loop Line
- : TRKG Servo Loop Line

A ASCB BOARD ASSEMBLY (1/4)  
● FTS SECTION

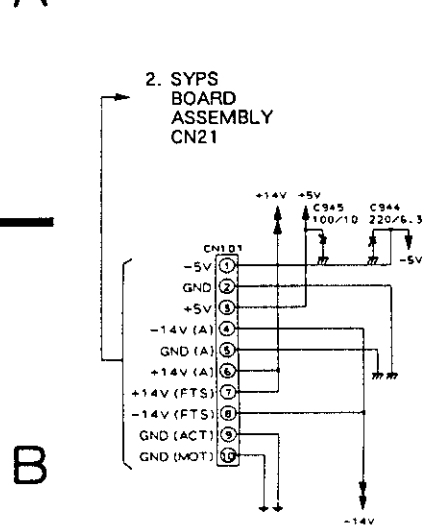

B

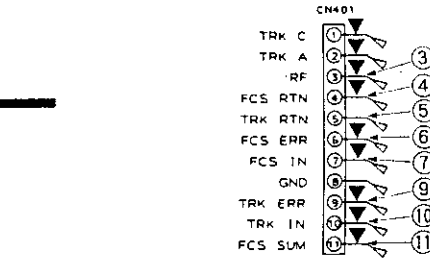

C



D

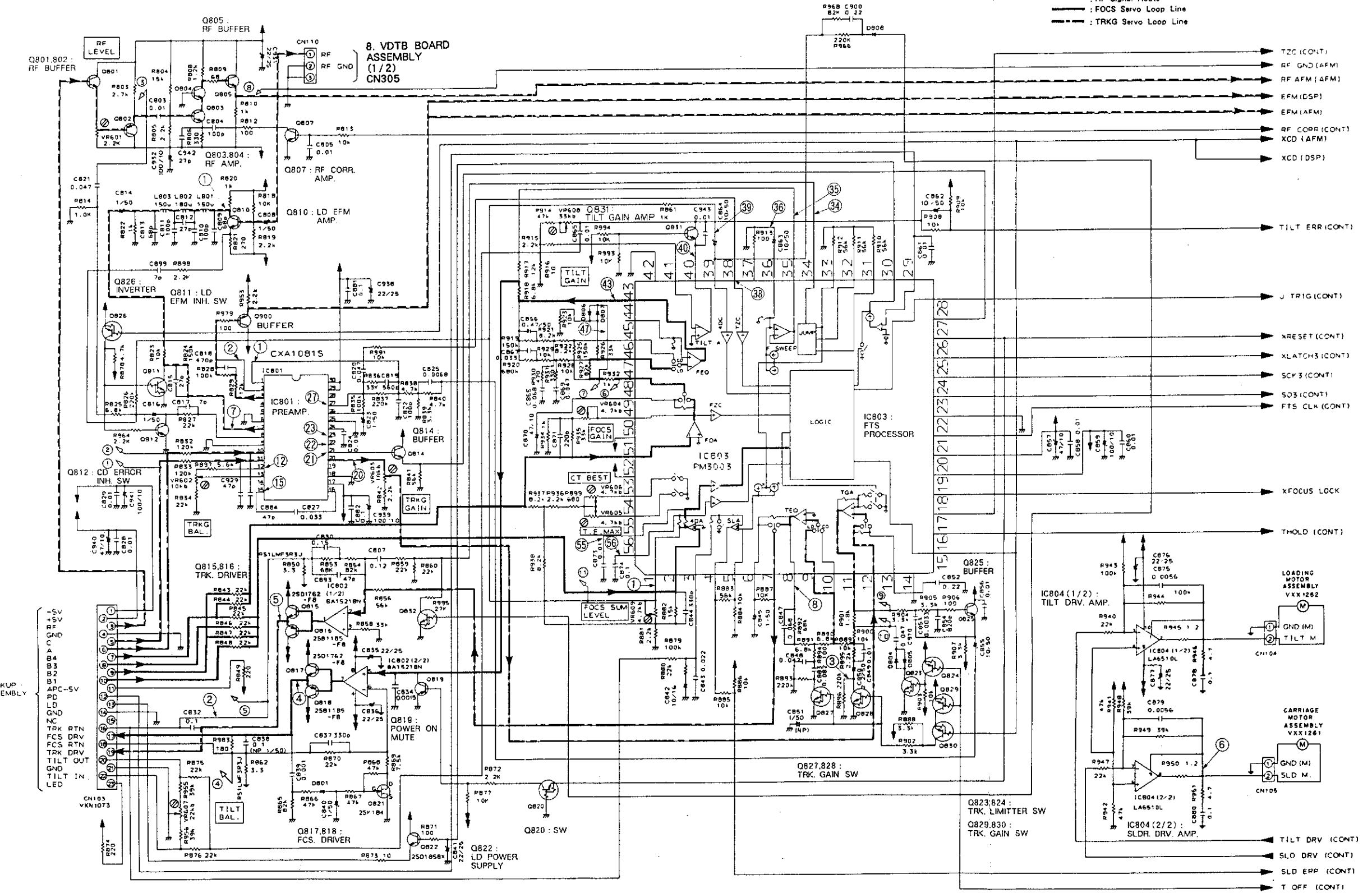

- 155254: D801, 804, 805, 806, 807, 808
- 25A1037K: Q802, 812, 819, 900
- 25C2412K: Q801, 803, 804, 805, 807, 810
- Q814, 825, 831
- DTA124EK: Q820, 824, 826, 829, 830
- DTC124EK: Q811, 823, 827, 828, 832

1

2

3

4

5

6

- T2C (CONT)
- RF GND (AFM)
- RF AFM (AFM)
- EFM (DSP)
- EFM (AFM)
- RF CORR (CONT)
- XCD (AFM)
- XCD (DSP)
- TILT ERR (CONT)
- J TRIG (CONT)
- XRESET (CONT)
- XLATCH3 (CONT)
- SCF3 (CONT)
- S03 (CONT)
- FTS CLK (CONT)
- XFOCUS LOCK
- THOLD (CONT)
- LOADING MOTOR ASSEMBLY VXX1262
- GND (M)
- TILT M.
- CARRIAGE MOTOR ASSEMBLY VXX1261
- GND (M)
- SLD M.
- TILT DRV (CONT)
- SLD DRV (CONT)
- SLD ERR (CONT)
- T OFF (CONT)

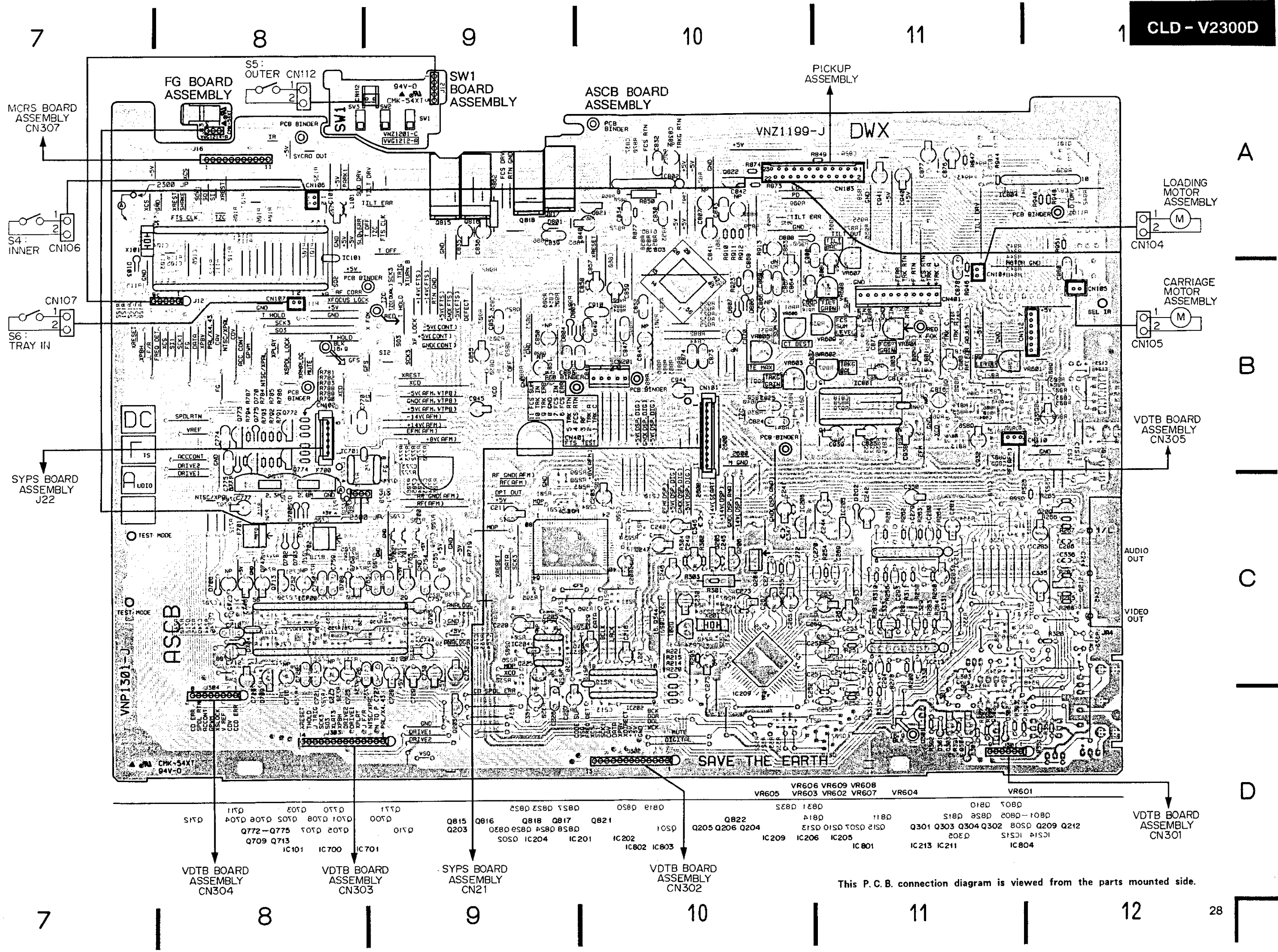

This P.C.B. connection diagram is viewed from the parts mounted side.

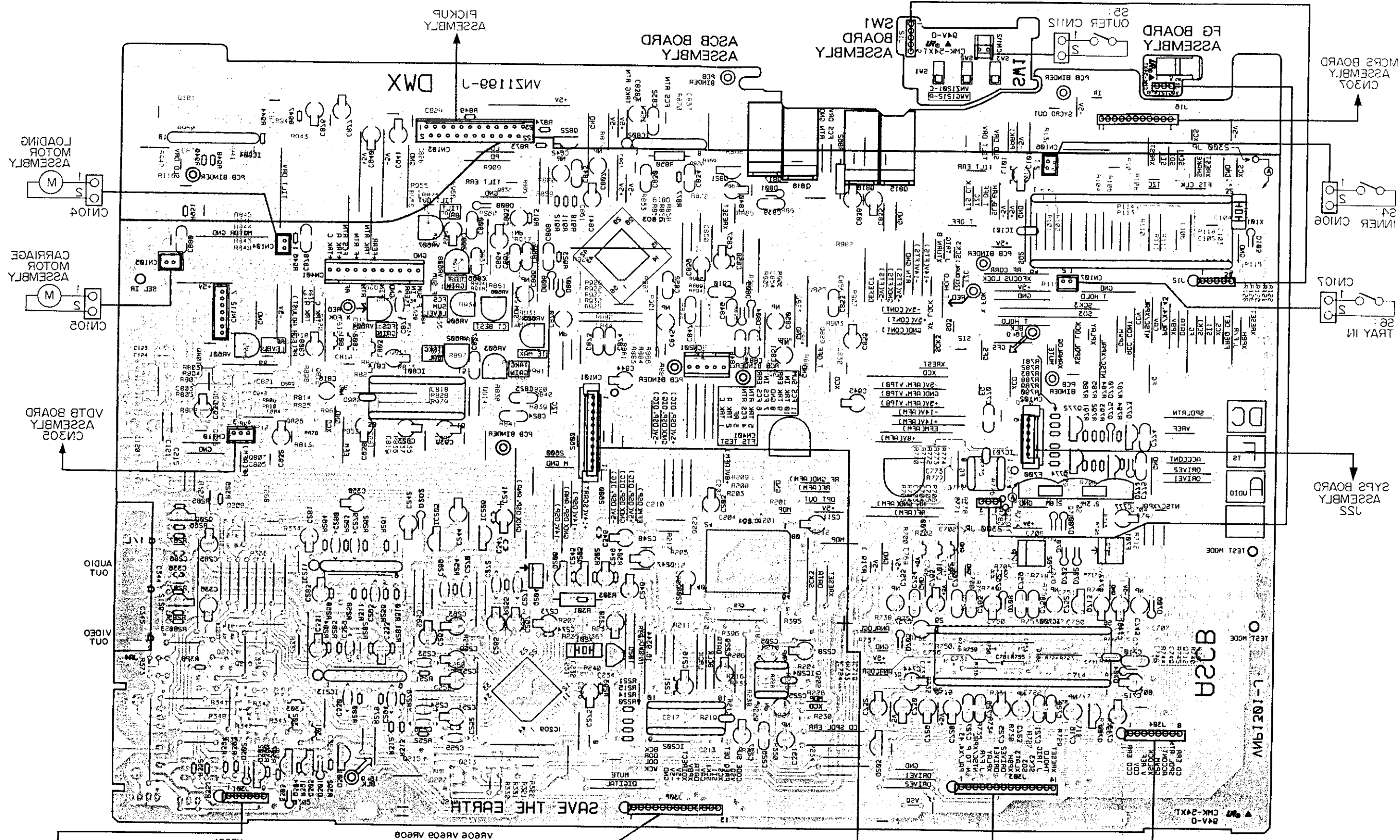

This P.C.B. connection diagram is viewed from the foil side.



5. ASCB (2/4 : AFM SECTION) AND FG BOARD ASSEMBLIES

ASCB BOARD ASSEMBLY (2/4)  
● AFM SECTION

Note: Abbreviations listed indicate circuit connections.

FTS : 4. ASCB BOARD ASSEMBLY (1/4)  
AFM : 5. ASCB BOARD ASSEMBLY (2/4)  
DSP : 6. ASCB BOARD ASSEMBLY (3/4)  
CONT : 7. ASCB BOARD ASSEMBLY (4/4)

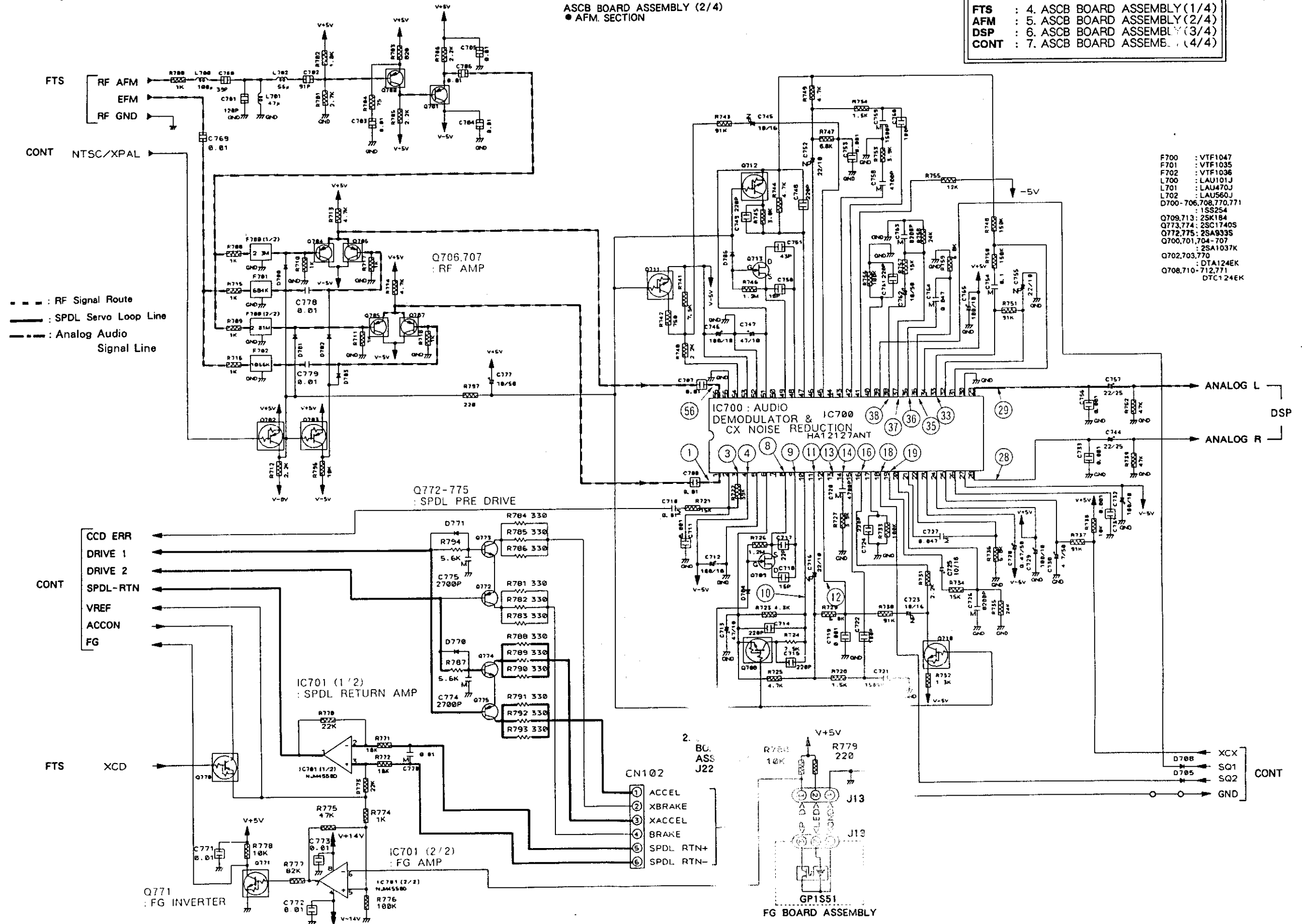

A







B

C

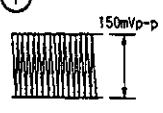
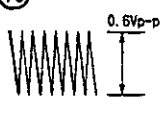
D

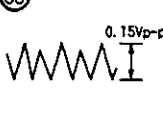
**AFM SECTION**

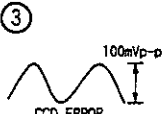
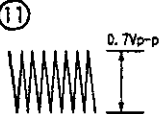
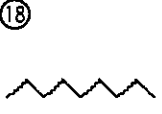
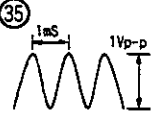
● IC700 (HA12127ANT) Note: (No.) in the table correspond to the pin No.

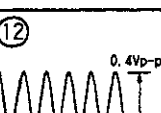
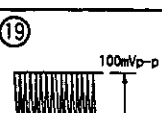
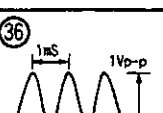
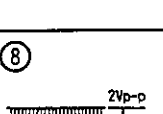
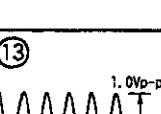
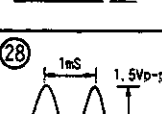
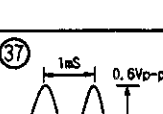
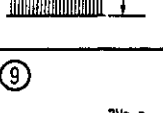
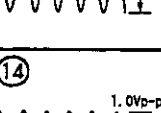
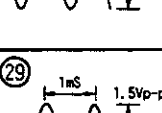
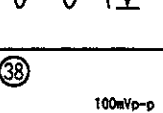
① 	⑩ 	⑯ 	③③ 	⑤⑥ 
③ 	⑪ 	⑱ 	③⑤ 	
④ 	⑫ 	⑲ 	③⑥ 	
⑧ 	⑬ 	⑳ 	③⑦ 	
⑨ 	⑭ 	㉑ 	③⑧ 	

DSP SECTION

Note: Waveforms and voltages are at the PLAY.

IC201 (CXD2500AQ)

Pin No.	Voltage	Pin No.	Voltage	Pin No.	Voltage	Pin No.	Voltage	Pin No.	Voltage	Pin No.	Voltage
1	0	15	0	29	0	43	*	57	*	71	*
2	0	16	4.8	30	0	44	0	58	*	72	5
3	0	17	0	31	*	45	4.8	59	5	73	5
4	*	18	*	32	*	46	*	60	*	74	*
5	0	19	2.4	33	4.8	47	*	61	5	75	0
6	4.8	20	*	34	*	48	*	62	*	76	0
7	0	21	0	35	*	49	*	63	*	77	*
8	4.8	22	2.3	36	*	50	*	64	*	78	*
9	0	23	4.8	37	*	51	*	65	0	79	*
10	0	24	*	38	*	52	0	66	*	80	0
11	0	25	0	39	0	53	*	67	*		
12	0	26	0	40	4.8	54	*	68	0		
13	0	27	*	41	*	55	0	69	*		
14	0	28	0	42	*	56	*	70	5		

\*: Refer to waveforms

IC202 (SM5840AP)

Pin No.	Voltage	Pin No.	Voltage
1	5	10	*
2	*	11	*
3	*	12	*
4	*	13	*
5	0	14	5
6	*	15	*
7	*	16	*
8	5	17	*
9	5	18	*

IC201 (CXD2500AQ) Note: (No.) in the table correspond to the pin No.

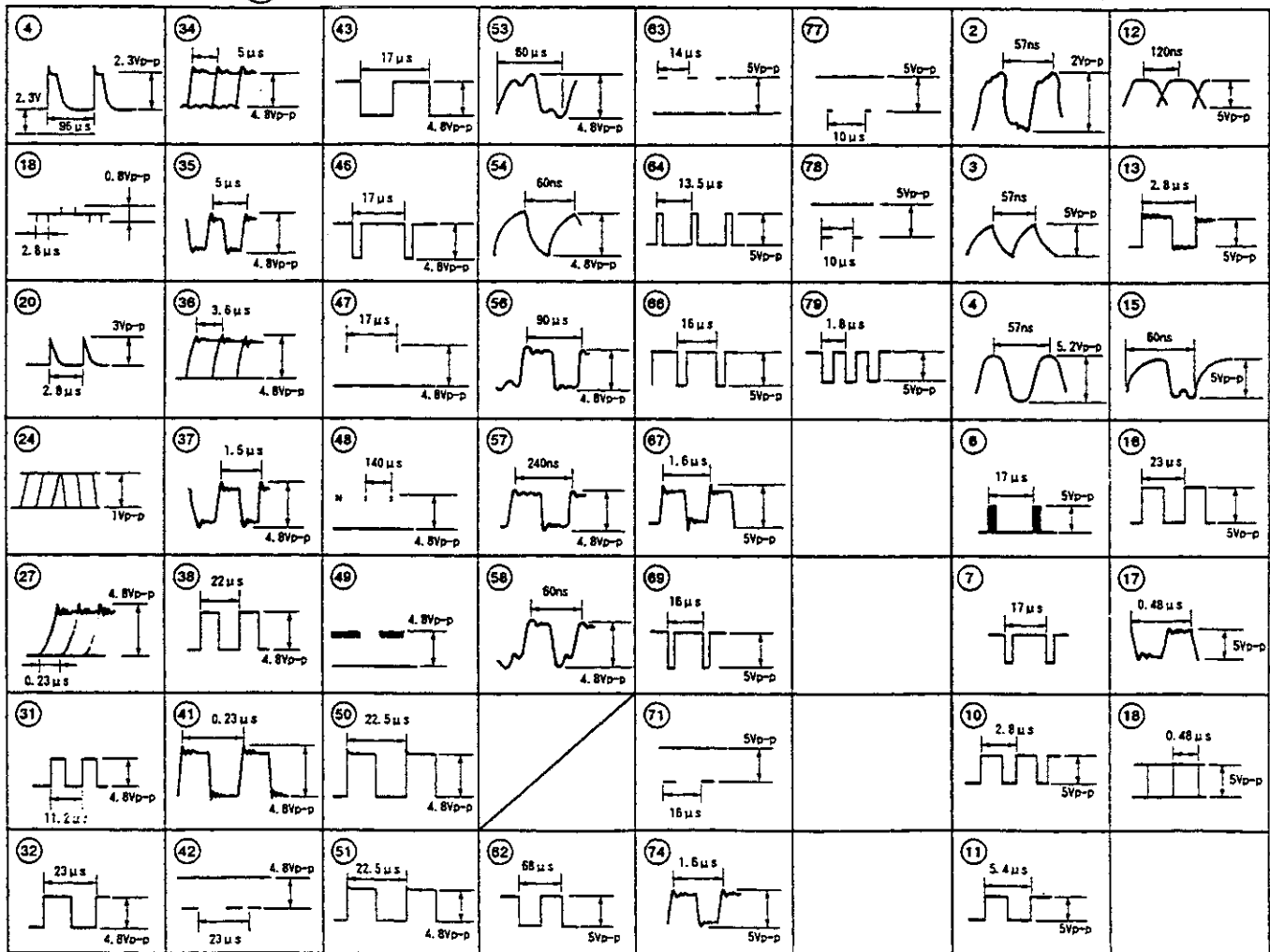



6. ASCB BOARD ASSEMBLY (3/4 : DSP SECTION)

Note: Abbreviations listed indicate circuit connections.

- FTS : 4. ASCB BOARD ASSEMBLY (1/4)
- AFM : 5. ASCB BOARD ASSEMBLY (2/4)
- DSP : 6. ASCB BOARD ASSEMBLY (3/4)
- CONT : 7. ASCB BOARD ASSEMBLY (4/4)

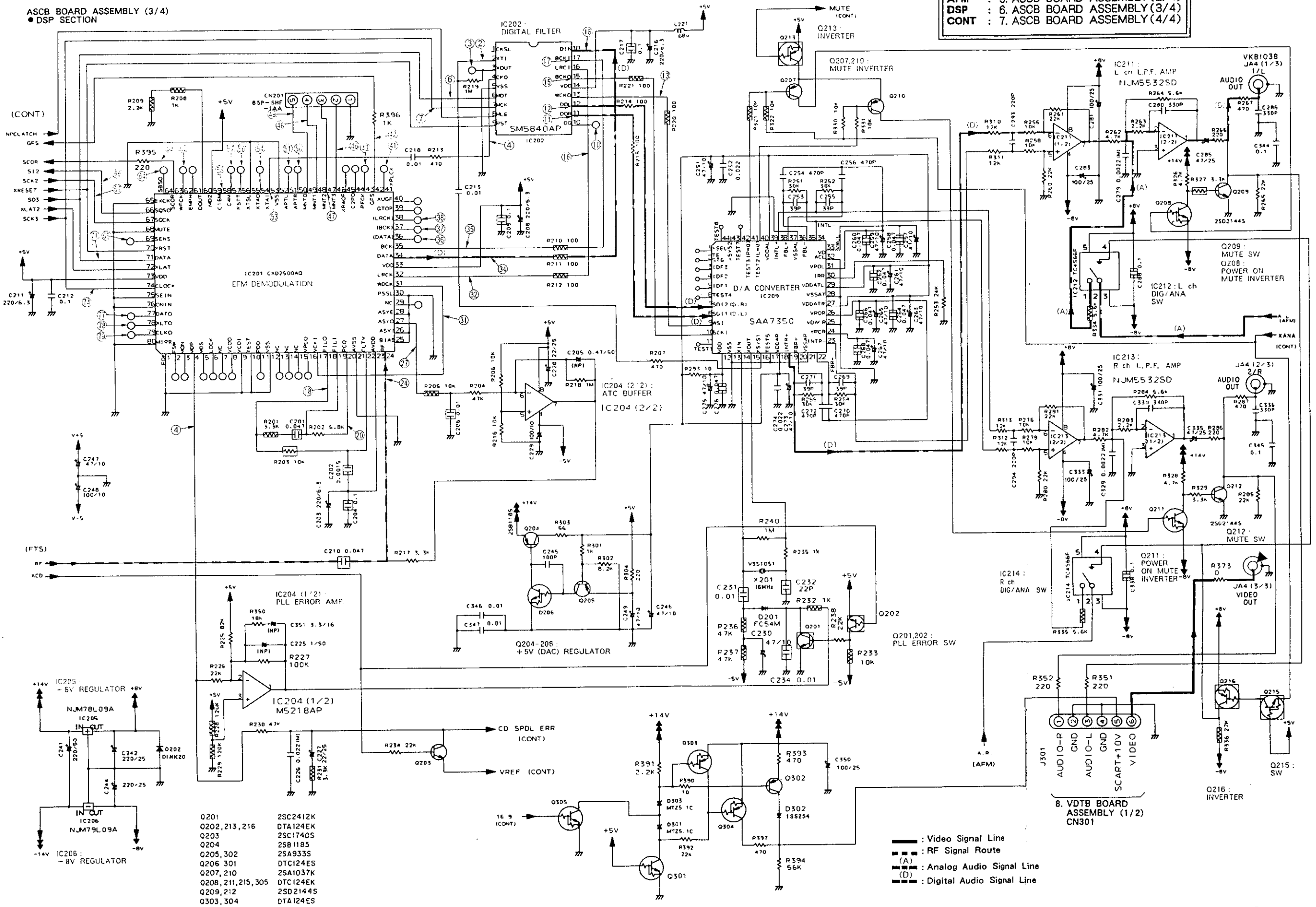

- Q201 25C2412K
- Q202, 213, 216 DTA124EK
- Q203 25C1740S
- Q204 25B118S
- Q205, 302 25A933S
- Q206 301 DTC124ES
- Q207, 210 25A1037K
- Q208, 211, 215, 305 DTC124EK
- Q209, 212 25D2144S
- Q303, 304 DTA124ES

- : Video Signal Line
- - - : RF Signal Route
- (A) : Analog Audio Signal Line
- (D) : Digital Audio Signal Line

7. ASCB (4/4 : CONT SECTION) AND SW1 BOARD ASSEMBLIES

Note: Abbreviations listed indicate circuit connections.

- FTS : 4. ASCB BOARD ASSEMBLY (1/4)
- AFM : 5. ASCB BOARD ASSEMBLY (2/4)
- DSP : 6. ASCB BOARD ASSEMBLY (3/4)
- CONT : 7. ASCB BOARD ASSEMBLY (4/4)

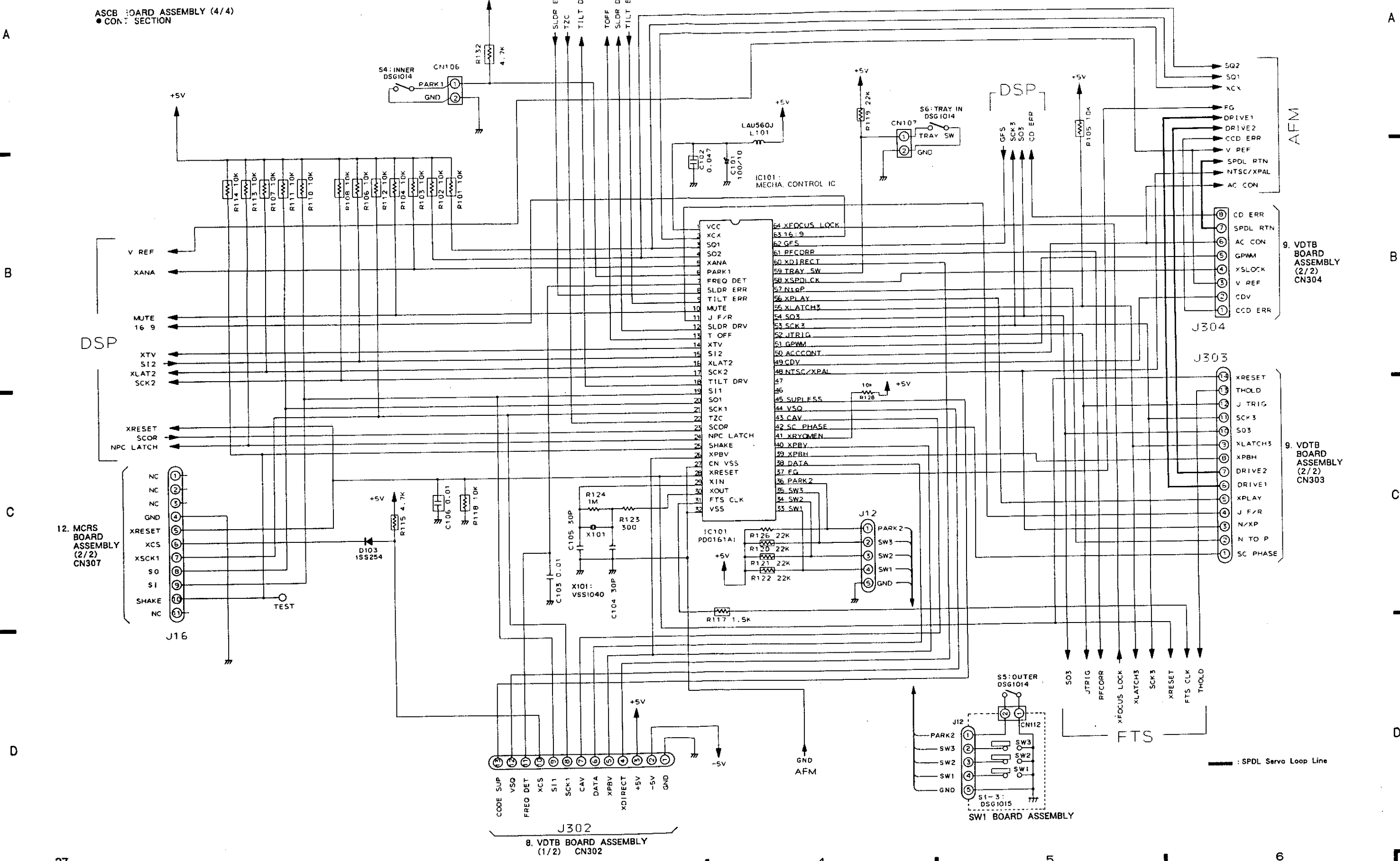



VIDEO SECTION

Note: (No.) in the table correspond to the pin No.

IC401 (PA5013A)				IC404 (PA0017-P)
(1)	(14)	(28)	(46)	(9)
(3)	(15)	(31)	IC402 (PM0001)	
(4)	(16)	(32)		
(5)	(17)	(33)	(2)	(5)
(8)	(19)	(34)	(8)	
(7)	(23)	(35)	IC403 (CXL1009P)	
(10)	(24)	(39)		
(11)	(25)	(44)	(1)	(4)

8. VDTB BOARD ASSEMBLY (1/2 : VIDEO SECTION)

Note: Abbreviations listed indicate circuit connections.

VIDEO : 8. VDTB BOARD ASSEMBLY (1/2)  
TBC : 9. VDTB BOARD ASSEMBLY (2/2)

A  
B  
C  
D

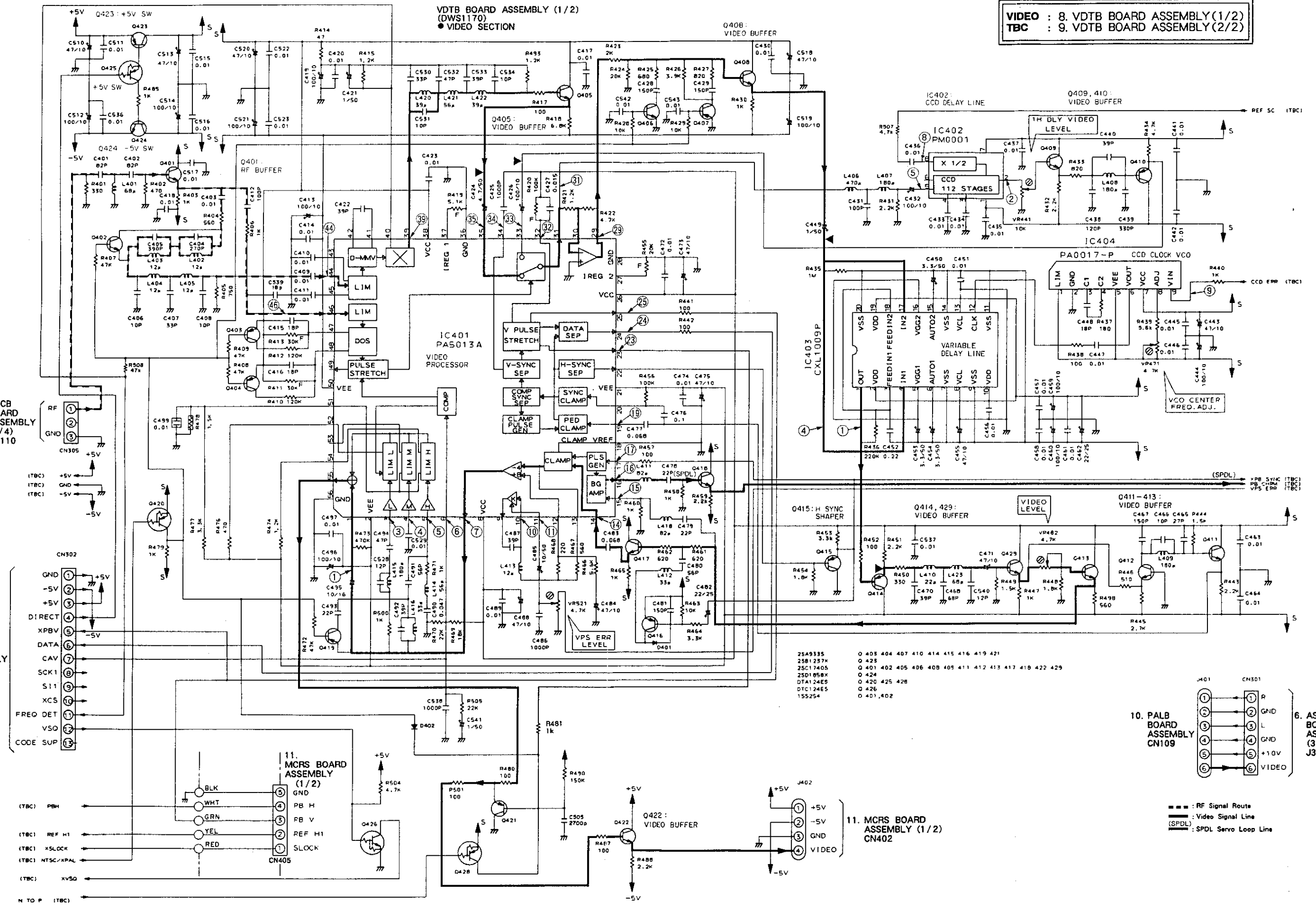

4. ASCB BOARD ASSEMBLY (1/4) CN110

7. ASCB BOARD ASSEMBLY (4/4) J302

11. MCRS BOARD ASSEMBLY (1/2) CN405

10. PALB BOARD ASSEMBLY CN109

11. MCRS BOARD ASSEMBLY (1/2) CN402

6. ASCB BOARD ASSEMBLY (3/4) J301

- 25A9335
- 25B1237X
- 25C17405
- 25D1058X
- DTA124ES
- DTC124ES
- 155254

- Q 405 404 407 410 414 415 416 419 421
- Q 425
- Q 401 402 405 406 408 409 411 412 413 417 418 422 429
- Q 424
- Q 420 425 428
- Q 426
- Q 401, 402

--- : RF Signal Route  
— : Video Signal Line  
—(L)— : SPDL Servo Loop Line

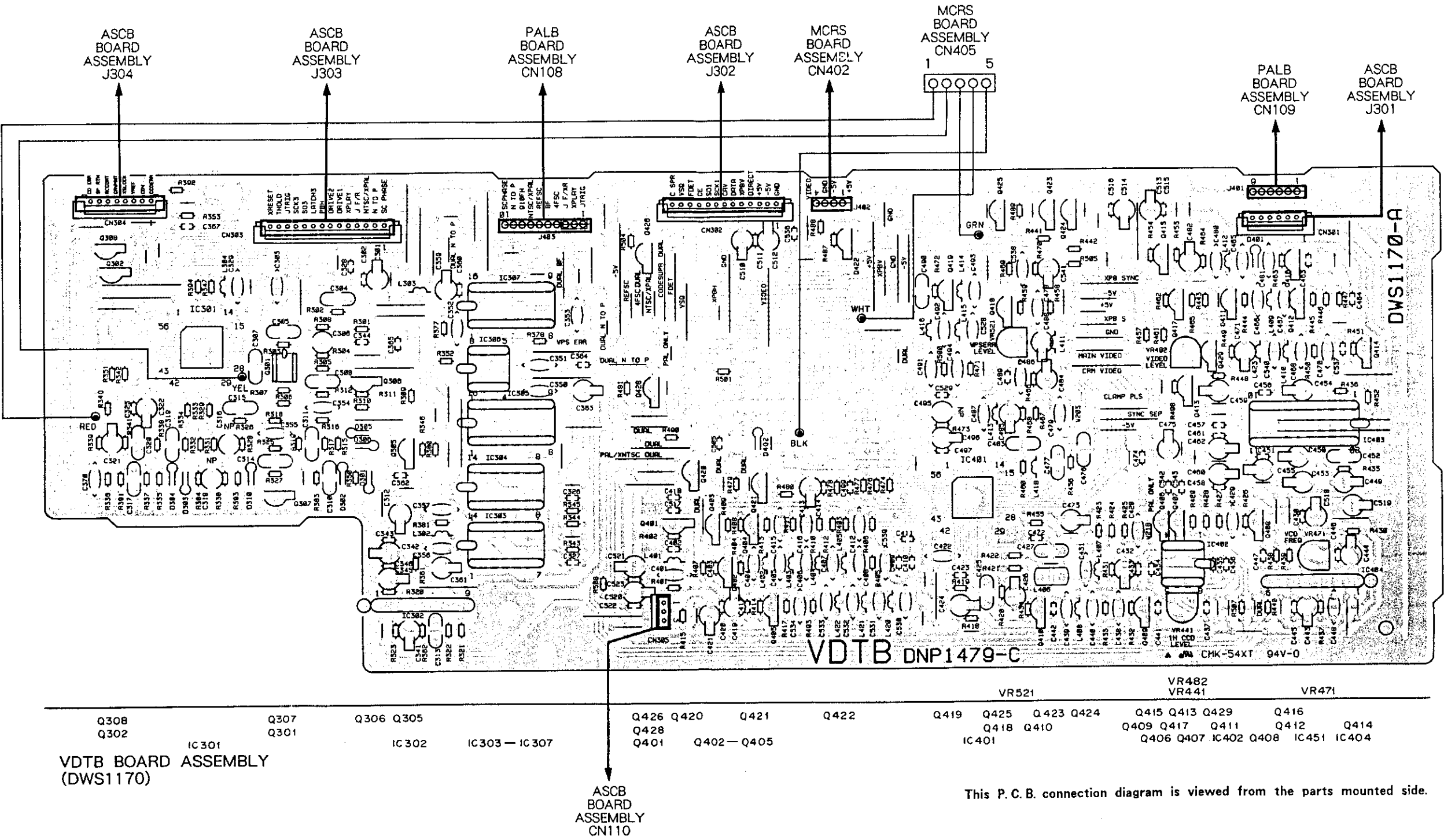

A

B

C

D

A

B

C

D

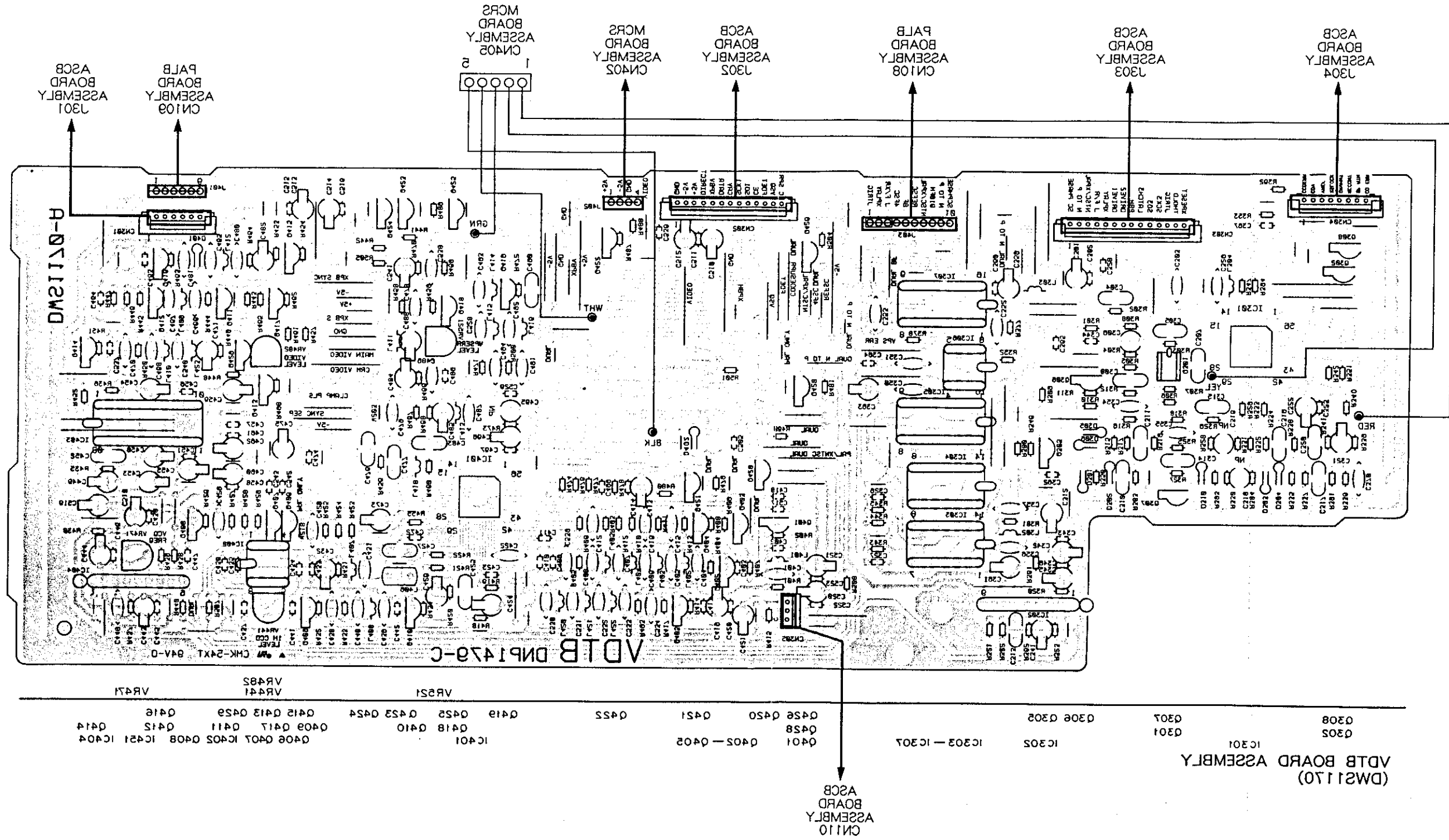

This P.C.B. connection diagram is viewed from the foil side

### 9. VDTB BOARD ASSEMBLY (2/2 : TBC SECTION)

VDTB BOARD ASSEMBLY (2/2)  
(DWS1170)  
● TBC SECTION

Note: Abbreviations listed indicate circuit connections.  
**VIDEO** : 8. VDTB BOARD ASSEMBLY (1/2)  
**TBC** : 9. VDTB BOARD ASSEMBLY (2/2)

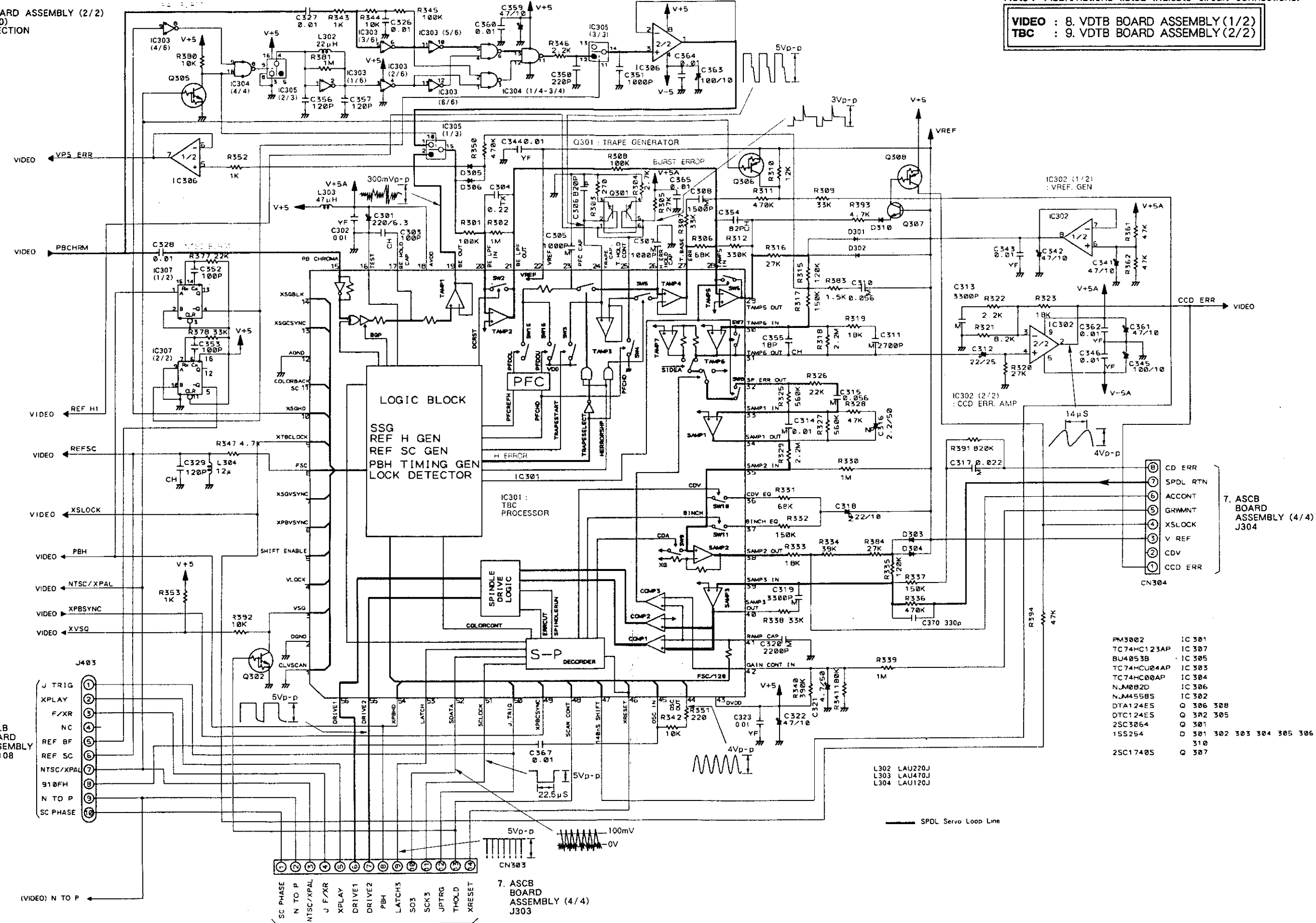

10. PALB BOARD ASSEMBLY CN108

7. ASCB BOARD ASSEMBLY (4/4) J304

- PM3002 IC 301
- TC74HC123AP IC 307
- BU4053B IC 305
- TC74HC04AP IC 303
- TC74HC00AP IC 304
- NJM082D IC 306
- NJM555BS IC 302
- DTA124ES Q 306 308
- DTC124ES Q 302 305
- 2SC3064 Q 301
- 1S5254 D 301 302 303 304 305 306 310
- 2SC1740S Q 307

L302 LAU220J  
L303 LAU470J  
L304 LAU120J

7. ASCB BOARD ASSEMBLY (4/4) J303

A

B

C

D



# 10. PALB BOARD ASSEMBLY

PALB BOARD ASSEMBLY

A

B

C

D

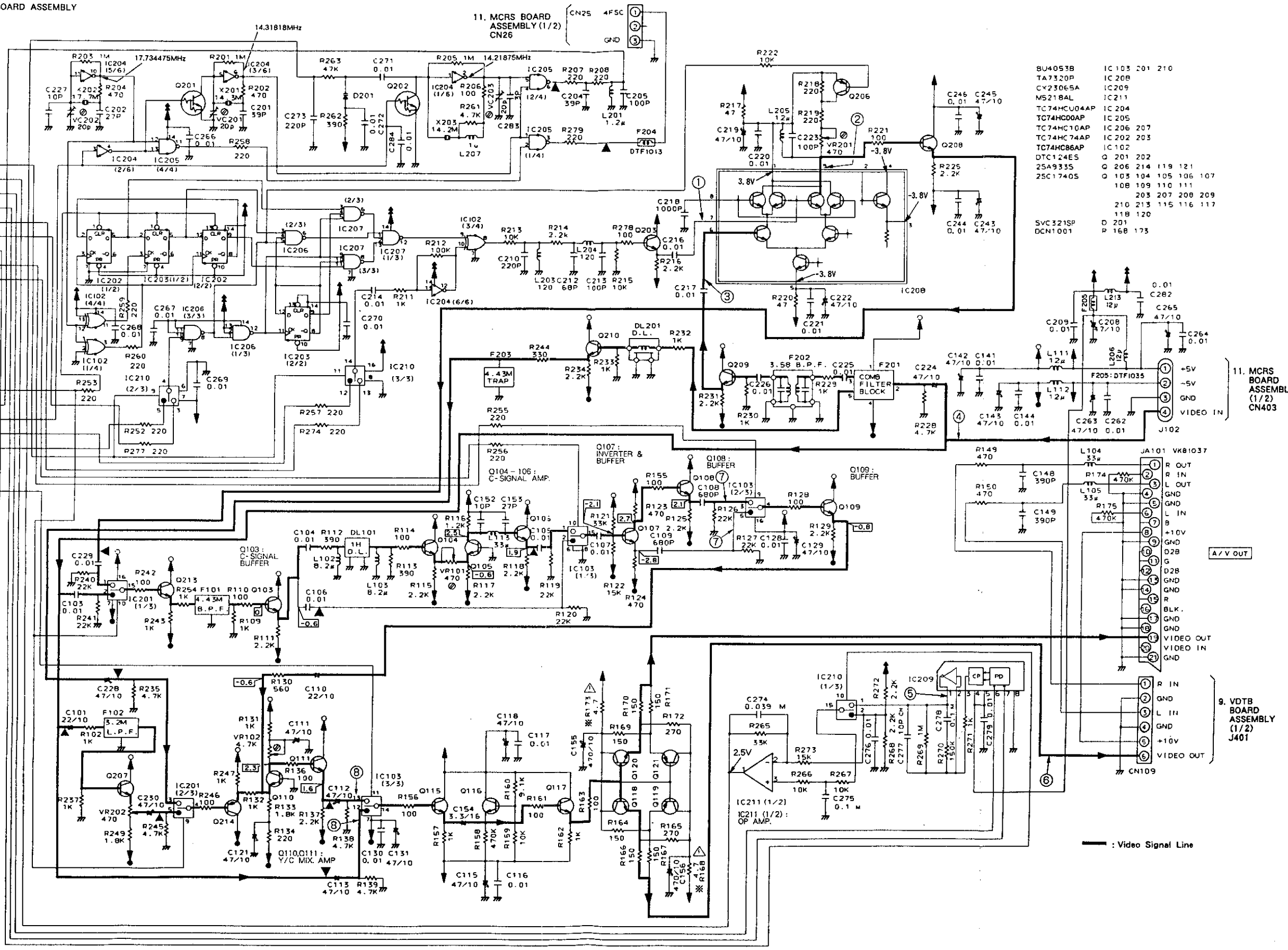
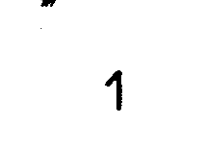
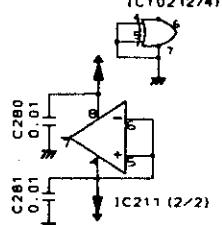
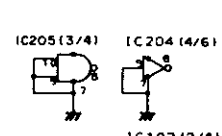
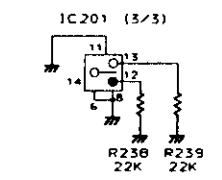
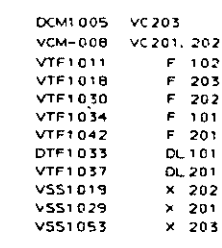
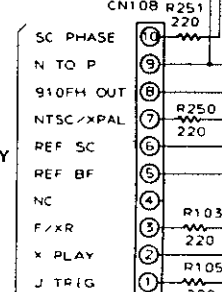
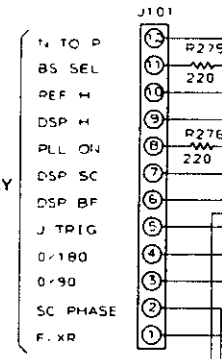

BU4053B	IC 103	201	210
TA7320P	IC 208		
CX23065A	IC 209		
MS218AL	IC 211		
TC74HC04AP	IC 204		
TC74HC00AP	IC 205		
TC74HC10AP	IC 206	207	
TC74HC74AP	IC 202	203	
TC74HC86AP	IC 102		
DTL124ES	Q 201	202	
25A9335	Q 206	214	119 121
25C17405	Q 103	104	105 106 107
	108	109	110 111
		203	207 208 209
		210	213 115 116 117
		118	120
SVC321SP	D 201		
DCN1001	P 168	173	

Note: (No) in to the pin n

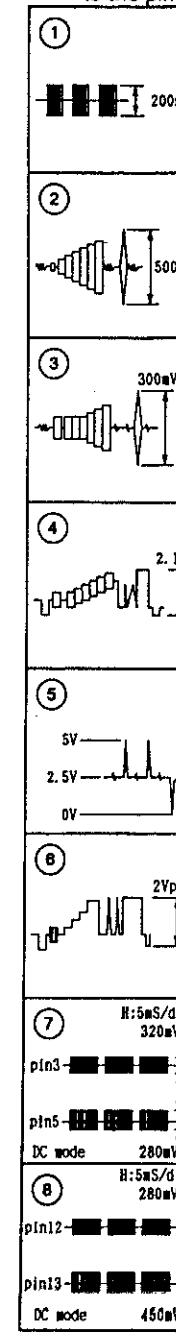

1

2

3

4

5

6

PALB BOARD ASSEMBLY

Note: (No.) in the table correspond to the pin number.

IC211 Q202 Q201	IC102 IC204 IC205	IC202 IC206	IC203 IC207 IC210	IC209	IC208 Q208 Q206	Q203	Q209	Q210	Q207	IC201 Q213 Q214	Q103 Q107-Q111	IC103 Q119 Q104-Q106	Q118 Q115-Q117	Q120	Q121
-----------------------	-------------------------	----------------	-------------------------	-------	-----------------------	------	------	------	------	-----------------------	-------------------	----------------------------	-------------------	------	------

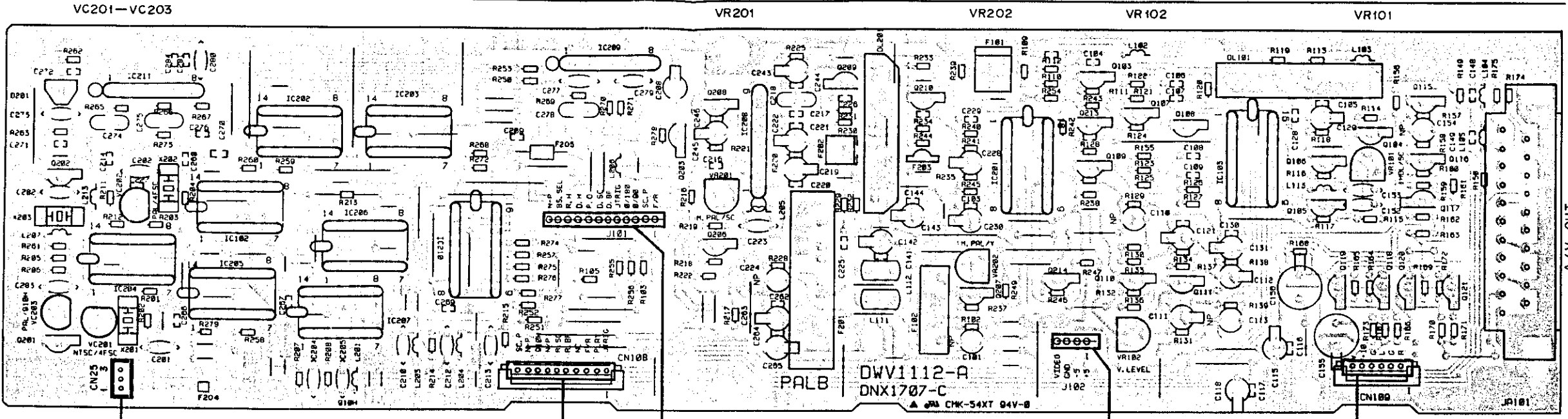
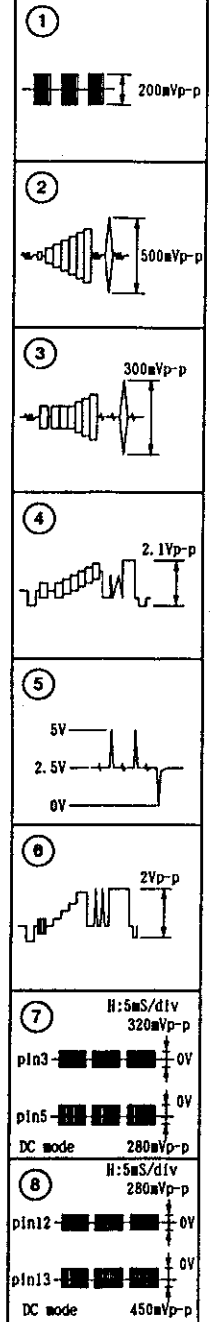

SYPS BOARD ASSEMBLY CN23

ASCB BOARD ASSEMBLY J16

TSWB BOARD ASSEMBLY CN601

LEDB BOARD ASSEMBLY J501

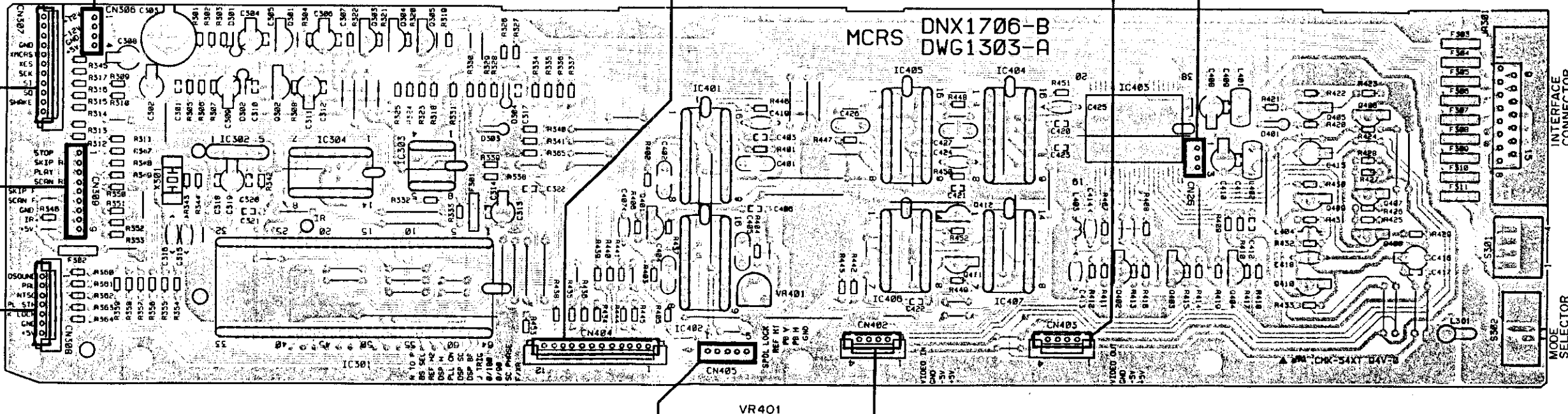

MCRS BOARD ASSEMBLY

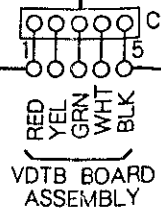

This P.C.B. connection diagram is viewed from the parts mounted side.

PALB BOARD ASSEMBLY

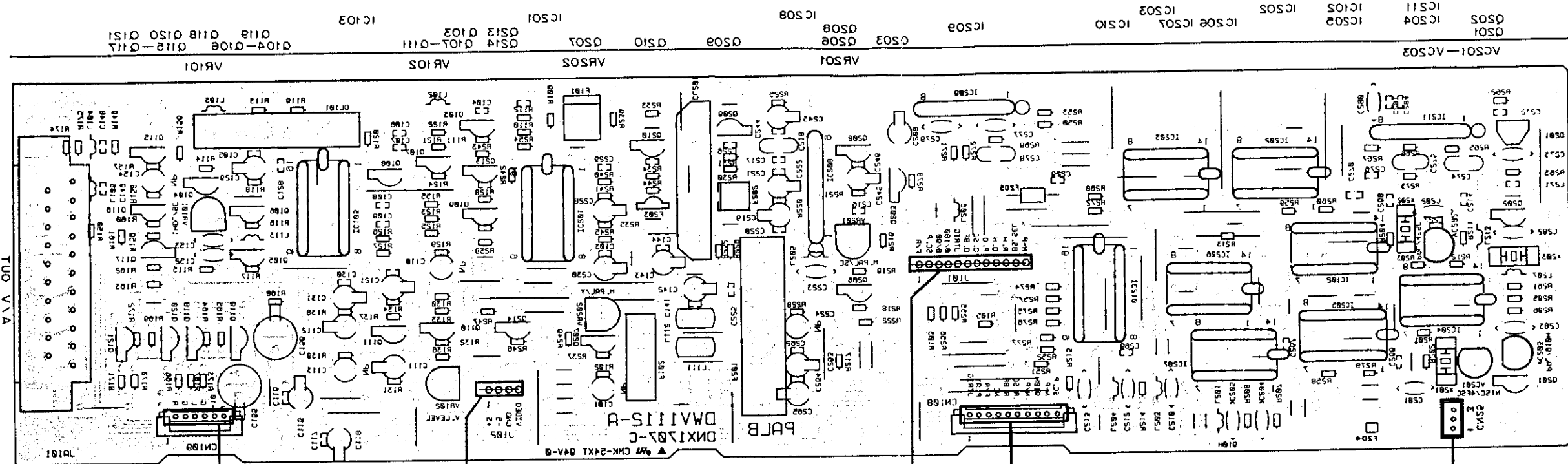

7A01 VDTB BOARD ASSEMBLY

7A03 VDTB BOARD ASSEMBLY

7A03 2YP2 BOARD ASSEMBLY

7A01 ASGB BOARD ASSEMBLY

7A01 2SWB BOARD ASSEMBLY

7A01 LEDB BOARD ASSEMBLY

CONNECTOR INTERFERENCE

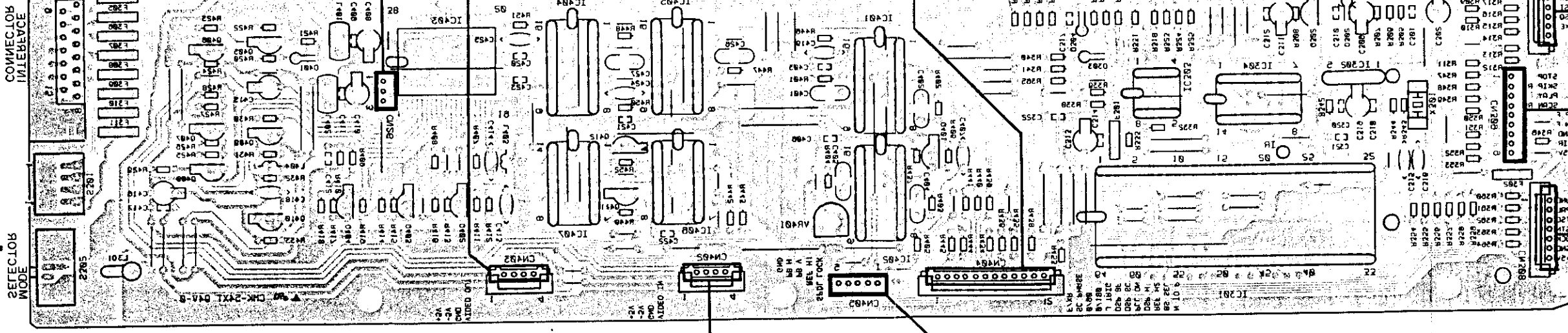

7A05 VDTB BOARD ASSEMBLY

7A05 VDTB BOARD ASSEMBLY

7A05 VDTB BOARD ASSEMBLY

MCR2 BOARD ASSEMBLY

This P.C.B. connection diagram is viewed from the foil side.

7 8 9 10 11 12

# 11. MCRS BOARD ASSEMBLY (1/2 : CHARACTER GENERATOR SECTION)

MCRS BOARD ASSEMBLY (1/2)  
● CHARACTER GENERATOR SECTION

Note: Abbreviations listed indicate circuit connections.  
**CHARACTER GENERATOR** : 11. MCRS BOARD ASSEMBLY (1/2)  
 : 12. MCRS BOARD ASSEMBLY (2/2)

(MICROCOMPUTER)  
 BS SEL  
 SPDL LOCK  
 PLL ON  
 Vsync  
 DSP V  
 BUSY  
 CS  
 SO  
 SCK  
 RESET

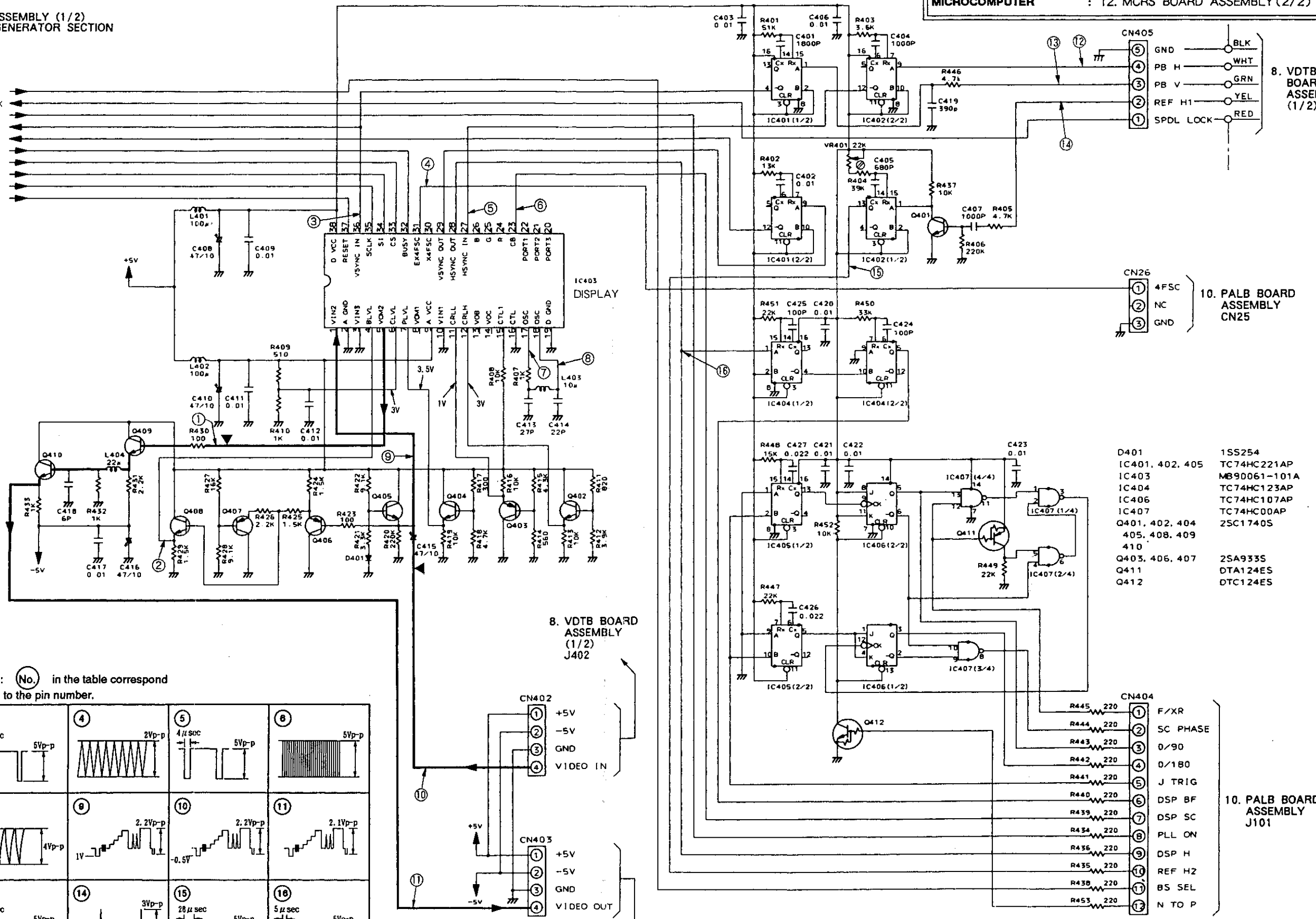

8. VDTB BOARD ASSEMBLY (1/2)  
 ⑤ GND — BLK  
 ④ PB H — WHT  
 ③ PB V — GRN  
 ② REF H1 — YEL  
 ① SPDL LOCK — RED

10. PALB BOARD ASSEMBLY CN25  
 ① 4FSC  
 ② NC  
 ③ GND

- D401 1SS254
- IC401, 402, 405 TC74HC221AP
- IC403 MB90061-101A
- IC404 TC74HC123AP
- IC406 TC74HC107AP
- IC407 TC74HC00AP
- Q401, 402, 404 2SC1740S
- 405, 408, 409 410
- Q403, 406, 407 2SA933S
- Q411 DTA124ES
- Q412 DTC124ES

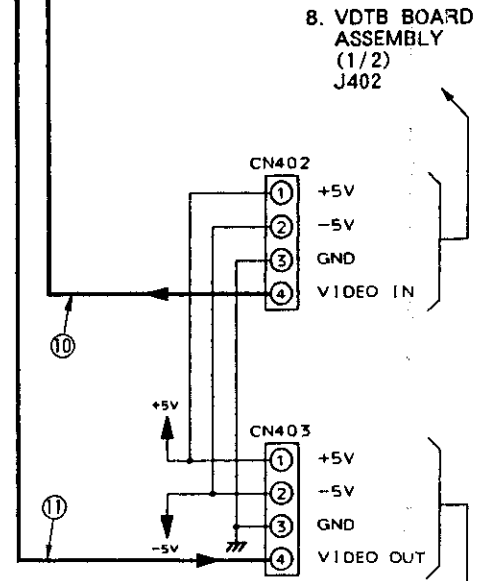
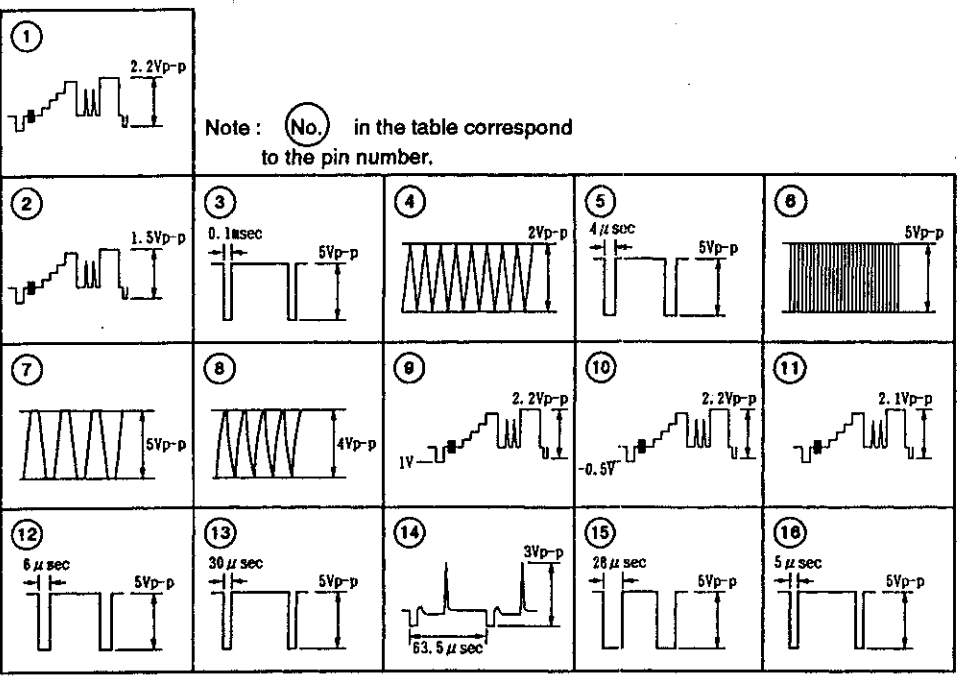

10. PALB BOARD ASSEMBLY J101

① F/XR  
 ② SC PHASE  
 ③ 0/90  
 ④ 0/180  
 ⑤ J TRIG  
 ⑥ DSP BF  
 ⑦ DSP SC  
 ⑧ PLL ON  
 ⑨ DSP H  
 ⑩ REF H2  
 ⑪ BS SEL  
 ⑫ N TO P

Video Signal Line

A  
 B  
 C  
 D

12. MCRS BOARD ASSEMBLY (2/2 : MICROCOMPUTER SECTION)

MCRS BOARD ASSEMBLY (2/2)  
● MICROCOMPUTER SECTION

Note: Abbreviations listed indicate circuit connections.  
**CHARACTER GENERATOR** : 11. MCRS BOARD ASSEMBLY (1/2)  
**MICROCOMPUTER** : 12. MCRS BOARD ASSEMBLY (2/2)

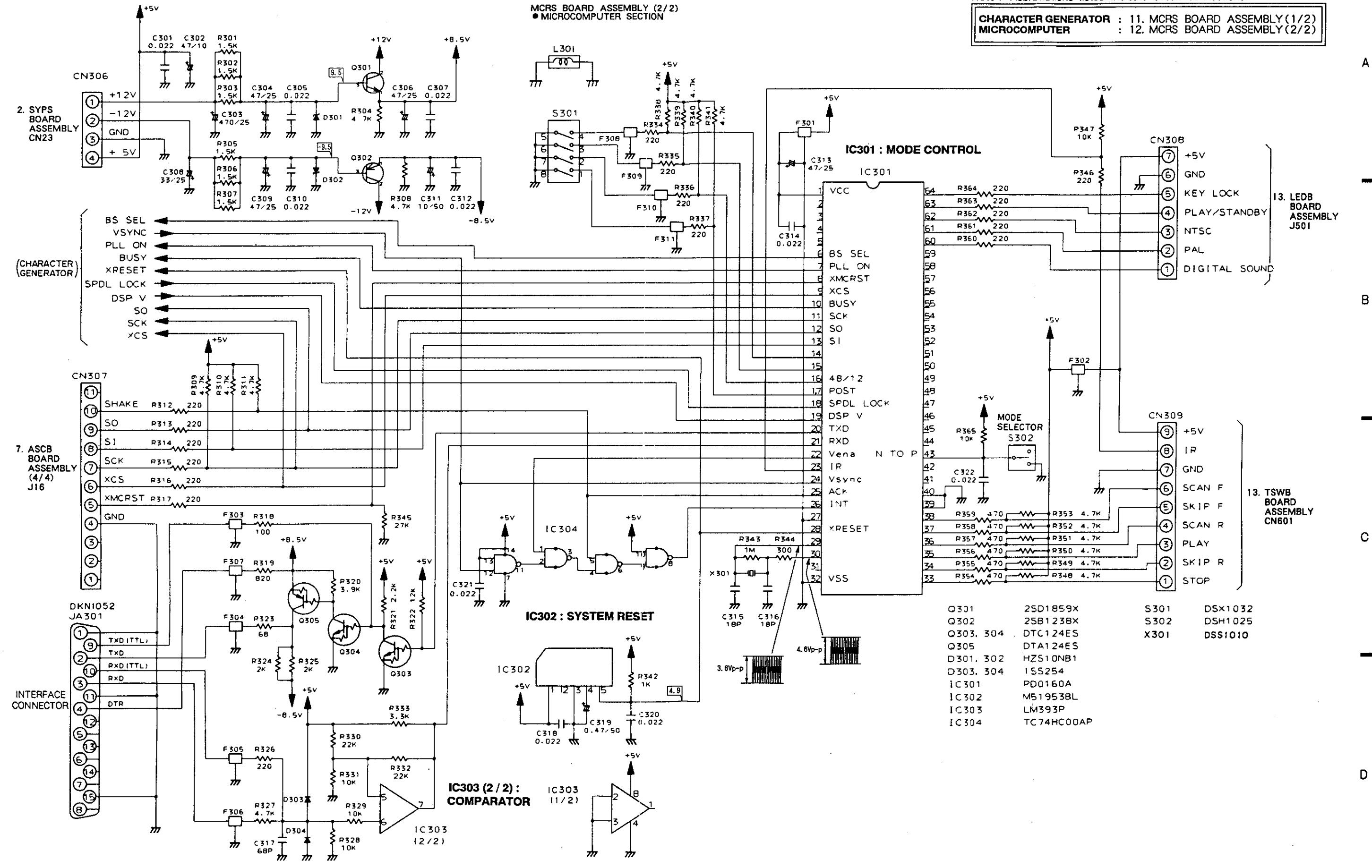

Q301	25D1859X	S301	DSX1032
Q302	25B1238X	S302	DSH1025
Q303, 304	DTC124ES	X301	DSS1010
Q305	DTA124ES		
D301, 302	HZS10NB1		
D303, 304	1S5254		
IC301	PD0160A		
IC302	M51953BL		
IC303	LM393P		
IC304	TC74HC00AP		

13. LEDB AND TSWB BOARD ASSEMBLIES

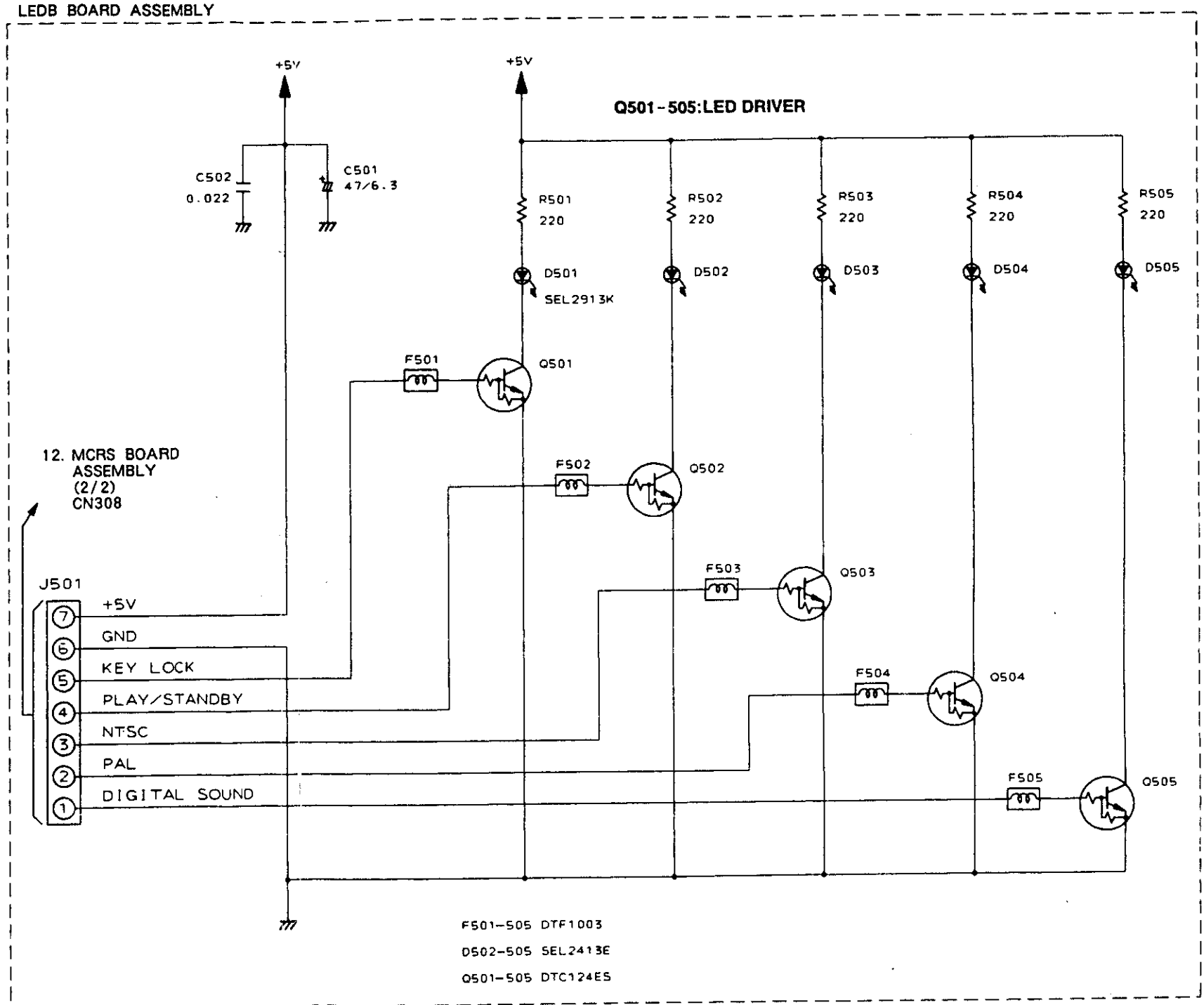
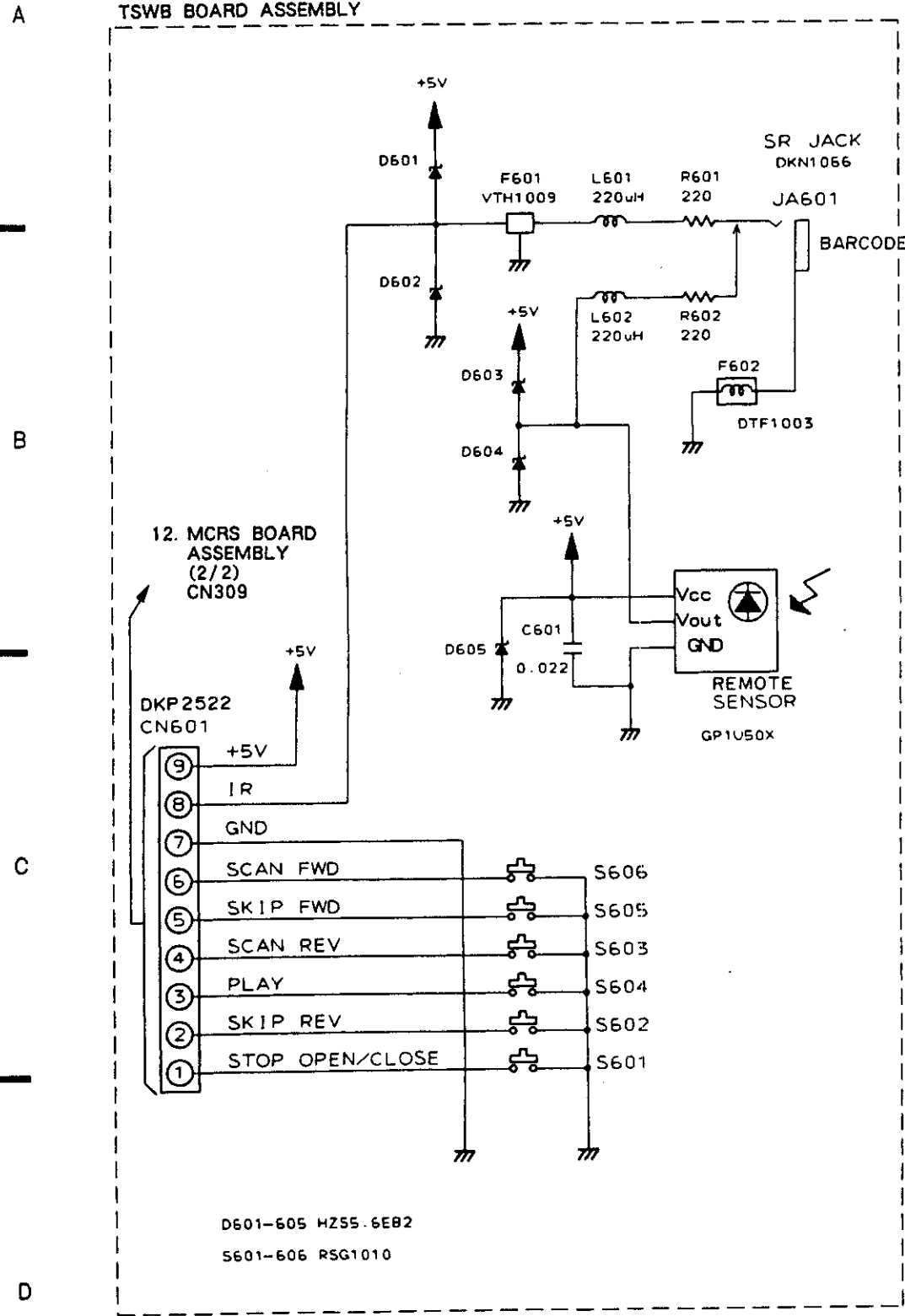

TSWB BOARD ASSEMBLY

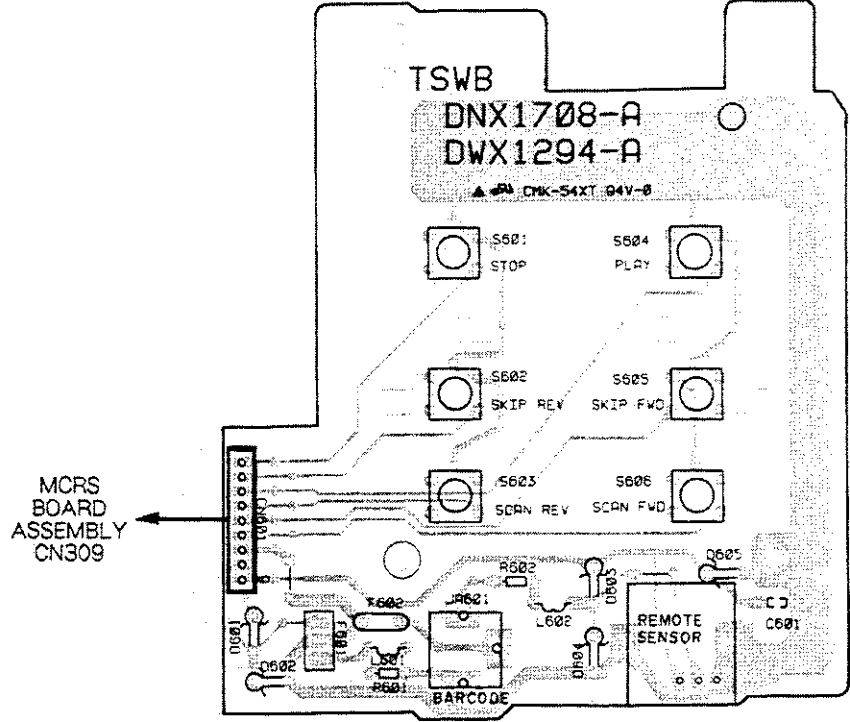

LEDB BOARD ASSEMBLY

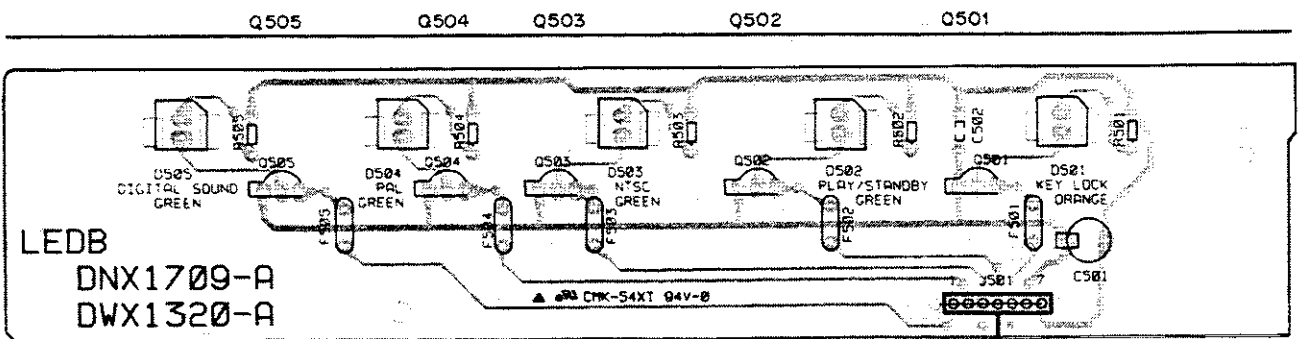

This P.C.B. connection diagram is viewed from the parts mounted side.





# 5. PCB PARTS LIST

**NOTES:**

- Parts marked by "NSP" are generally unavailable because they are not in our Master Spare Parts List.
- The  $\Delta$  mark found on some component parts indicates the importance of the safety factor of the part. Therefore, when replacing, be sure to use parts of identical designation.
- Parts marked by "⊙" are not always kept in stock. Their delivery time may be longer than usual or they may be unavailable.
- When ordering resistors, first convert resistance values into code form as shown in the following examples.
  - Ex.1 When there are 2 effective digits(any digit apart from 0), such as 560 ohm and 47k ohm(tolerance is shown by J=5%, and K=10%).
    - 560  $\Omega$   $\rightarrow$   $56 \times 10^1 \rightarrow 561$ ..... RD1/8PM **561J**
    - 47k  $\Omega$   $\rightarrow$   $47 \times 10^3 \rightarrow 473$ ..... RD1/4PS **473J**
    - 0.5  $\Omega$   $\rightarrow$  0R5 ..... RN2H **0R5K**
    - 1  $\Omega$   $\rightarrow$  010 ..... RS1P **010K**
  - Ex.2 When there are 3 effective digits(such as in high precision metal film resistors).
    - 5.62k  $\Omega$   $\rightarrow$   $562 \times 10^1 \rightarrow 5621$  ..... RN1/4PC **5621F**

Mark	No.	Description	Part No.	Mark	No.	Description	Part No.
<b>LIST OF ASSEMBLIES</b>							
⊙		MAIN BOARD ASSEMBLY	DWM1290		Q203, Q773, Q774		2SC1740S
NSP		└ ASCB BOARD ASSEMBLY	DWX1293		Q201, Q801, Q803-Q805, Q807, Q810, Q814,		2SC2412K
NSP		└ SW1 BOARD ASSEMBLY	YWG1212		Q825, Q831		
NSP		└ FG BOARD ASSEMBLY	YWG1214		Q815, Q817		2SD1762-F8
					Q822		2SD1858X
⊙		MPTL BOARD ASSEMBLY	DWM1292		Q209, Q212		2SD2144S
NSP		└ MCRS BOARD ASSEMBLY	DWG1303		Q709, Q713, Q821		2SK184
NSP		└ PALB BOARD ASSEMBLY	DWY1112		Q202, Q213, Q216, Q702, Q703, Q770, Q820,		DTA124EK
NSP		└ TSWB BOARD ASSEMBLY	DWX1294		Q824, Q826, Q829, Q830		
NSP		└ LEDB BOARD ASSEMBLY	DWX1320		Q303, Q304		DTA124ES
⊙		SYPS BOARD ASSEMBLY	DWR1135		Q208, Q211, Q215, Q305, Q708, Q710-Q712,		DTC124EK
⊙		VDTB BOARD ASSEMBLY	DWS1170		Q771, Q811, Q823, Q827, Q828, Q832		
NSP		HEAD ASSEMBLY	VWV1119		Q206, Q301		DTC124ES
					D103, D302, D700-D706, D708, D770, D771,		1SS254
					D801, D804-D808		
					D202		D1NK20
					D201		FC54M
					D301, D303		MTZ5. 1C

## ASCB BOARD ASSEMBLY

### SEMICONDUCTORS

IC802	BA15218N
IC801	CXA1081S
IC201	CXD2500AQ
IC700	HA12127ANT
IC804	LA6510L
IC204	M5218AP
IC701	NJM4558D
IC211, IC213	NJM5532SD
IC205	NJM78L09A
IC206	NJM79L09A
IC101	PD0161A1
IC803	PM3003
IC209	SAA7350
IC202	SM5840AP
IC212, IC214	TC4S66F-TR
Q207, Q210, Q700, Q701, Q704-Q707, Q802, Q812, Q819, Q900	2SA1037K
Q205, Q302, Q772, Q775	2SA933S
Q204	2SB1185
Q816, Q818	2SB1185-F8

## COILS AND FILTERS

L700	LAU101J
L801, L803	LAU151J
L802	LAU181J
L301-L303	LAU2R2M
L701	LAU470J
L101, L702	LAU560J
L221	LAU680J
F701	VTF1035
F702	VTF1036
F700	VTF1047

## CAPACITORS

C293, C294	CCOCH221J50
C253, C255, C269, C271	CCOCH390J50
C871	CCCSL221J50
C280, C330	CCCSL331J50
C254, C256, C270, C272	CCCSL471J50
C817, C899	CCSQCH070D50
C722, C760, C804, C810, C811, C822	CCSQCH101J50
C701	CCSQCH121J50
C718	CCSQCH150J50
C750	CCSQCH180J50

Mark	No.	Description	Part No.
	C232, C717 C714, C715, C724, C748, C749, C761 C812, C815, C942 C104, C105 C700		CCSQCH220J50 CCSQCH221J50 CCSQCH270J50 CCSQCH300J50 CCSQCH390J50
	C751 C884, C893, C929 C809, C813 C702 C837, C844		CCSQCH430J50 CCSQCH470J50 CCSQCH680J50 CCSQCH910J50 CCSQL331J50
	C818 C819 C225, C816, C845, C851 C745, C842, C863 C716, C752, C755		CCSQL471J50 CCSQL561J50 CEANP010M50 CEANP100M16 CEANP220M10
	C850 C351 C870 C205, C866 C808, C814, C823, C840		CEANP2R2M50 CEANP3R3M16 CEANP470M10 CEANPR47M50 CEAS010M50
	C762, C777, C855, C862, C864 C101, C229, C248, C712, C729, C732, C746, C765, C859, C932, C939, C941, C945 C281, C283, C331, C333, C350 C227, C228, C744, C757, C835, C836, C841, C876, C877, C931, C938		CEAS100M50 CEAS101M10 CEAS101M25 CEAS220M25
	C242, C244 C241 C203, C208, C211, C216, C944 C230, C246, C247, C249, C251, C257, C259, C261, C263, C265, C267, C273, C275, C713, C747, C857, C940		CEAS221M25 CEAS221M50 CEAS221M6R3 CEAS470M10
	C285, C335 C730 C728 C725 C723		CEAS470M25 CEAS4R7M50 CEASR47M50 CEJA100M16 CEJANP100M16
	C710, C770, C824, C849, C865, C873 C754, C832, C838, C874, C878, C880 C807 C721, C759 C830		CFTXA103J50 CFTXA104J50 CFTXA124J50 CFTXA152J50 CFTXA154J50
	C226, C843 C852, C900 C827, C867 C720, C758 C727, C764, C848, C869, C910		CFTXA223J50 CFTXA224J50 CFTXA333J50 CFTXA472J50 CFTXA473J50
	C847, C868 C726, C763 C883 C245 C286, C336		CFTXA683J50 CFTXA822J50 CFTXA823J50 CKPUYB101K50 CKPUYB331K50
	C252, C274 C346, C858 C711, C719, C731, C733, C753, C756 C202 C875, C879		CKPUYF223225 CKPUY103N16 CKSQYB102K50 CKSQYB152K50 CKSQYB562K50

Mark	No.	Description	Part No.
	C854 C103, C106, C206, C213, C218, C231, C234, C703-C708, C769, C771-C773, C778, C779, C803, C805, C828, C829, C856, C860, C861, C943		CKSQYB821K50 CKSQYF103Z50
	C204, C209, C212, C217, C288, C338, C344, C345, C881, C882 C102, C201, C210, C258, C260, C262, C264, C266, C268, C276, C352, C820, C821 C839		CKSQYF104Z25 CKSQYF473Z25 CQMA102J50
	C834 C279, C329 C774, C775 C853 C825		CQMA152J50 CQMA222J50 CQMA272J50 CQMA332J50 CQMA682J50

**RESISTORS**

VR602, VR603	(10kΩ)	VRTB6VS103
VR601	(2.2kΩ)	VRTB6VS222
VR607	(22kΩ)	VRTB6VS223
VR608	(33kΩ)	VRTB6VS333
VR604-VR606, VR609	(4.7kΩ)	VRTB6VS472
R293, R390, R873 R214, R215, R220, R221, R913 R301 R256, R258, R276, R278, R877, R923 R944		RD1/6PM100J RD1/6PM101J RD1/6PM102J RD1/6PM103J RD1/6PM104J
R310-R313 R266, R286, R304, R351, R352, R849, R874 R263, R283, R391 R260, R261, R265, R280, R281, R285, R392, R947		RD1/6PM123J RD1/6PM221J RD1/6PM222J RD1/6PM223J
R251, R252, R254, R255 R781-R786, R788-R793 R948, R949 R267, R287, R393, R397 R262, R282, R326, R328		RD1/6PM303J RD1/6PM331J RD1/6PM393J RD1/6PM471J RD1/6PM472J
R946, R951 R264, R284, R787, R794 R394, R910-R912 R302 R850, R862		RD1/6PM4R7J RD1/6PM562J RD1/6PM563J RD1/6PM822J RS1LMF3R3J
R303 Other resistors		RS2LMF560J RS1/10S□□□J

**OTHERS**

CN201	5P TOP POST (NH)	B5P-SHF-1AA
JA4	3P PIN JACK	VKB1038
CN103	23P TOP CONNECTOR CONNECTOR ASSEMBLY IC SOCKET	VKN1073 DKP2548 VKH-029
X101	CERAMIC RESONATOR (9.00MHz)	VSS1040
X201	CRYSTAL RESONATOR (16MHz)	VSS1051

Mark No.	Description	Part No.
<b>SW1 BOARD ASSEMBLY</b>		
<b>SWITCHES</b>		
S1-S3		DSG1015
<b>FG BOARD ASSEMBLY</b>		
<b>SEMICONDUCTOR</b>		
D		GP1S51
<b>MCRS BOARD ASSEMBLY</b>		
<b>SEMICONDUCTORS</b>		
IC303		LM393P
IC302		M51953BL
IC403		MB90061-101A
IC301		PD0160A
IC304, IC407		TC74HC00AP
IC406		TC74HC107AP
IC404		TC74HC123AP
IC401, IC402, IC405		TC74HC221AP
Q403, Q406, Q407		2SA933S
Q302		2SB1238X
Q401, Q402, Q404, Q405, Q408-Q410		2SC1740S
Q301		2SD1859X
Q305, Q411		DTA124ES
Q303, Q304, Q412		DTC124ES
D303, D304, D401		1SS254
D301, D302		HZS10NB1
<b>SWITCHES</b>		
S302		DSH1025
S301		DSX1032
<b>COILS AND FILTERS</b>		
L403		LAU100J
L404		LAU220J
L401, L402		LFA101J
L301		VTH1024
F301, F302		VTH1001
F303-F311		VTH1009
<b>CAPACITORS</b>		
C418		CCCCH060D50
C424, C425		CCCCH101J50
C315, C316		CCCCH180J50
C414		CCCCH220J50
C413		CCCCH270J50
C419		CCCCL391J50
C317		CCPUSL680J50
C311		CEAS100M50
C308		CEAS330M25
C302, C408, C410, C415, C416		CEAS470M10
C304, C306, C309, C313		CEAS470M25
C303		CEAS471M25
C319		CEASR47M50
C407		CKCYB102K50
C301, C305, C307, C310, C312, C314, C318, C320-C322		CKPUYF223Z25

Mark No.	Description	Part No.
C403, C406, C409, C411, C412, C417, C420, C421-C423		CKPUY103N16
C404		CQMA102J50
C402		CQMA103J50
C401		CQMA182J50
C426, C427		CQMA223J50
C405		CQMA681J50
<b>RESISTORS</b>		
VR401 (22kΩ)		VRTB6VS223
Other resistors		RD1/6PM□□□J
<b>OTHERS</b>		
JA301	15P D-SUB SOCKET	DKN1052
X301	CRYSTAL RESONATOR (9.8304MHz)	DSS1010
	IC SOCKET	VKH-029
<b>PALB BOARD ASSEMBLY</b>		
<b>SEMICONDUCTORS</b>		
IC103, IC201, IC210		BU4053B
IC209		CX23065A
IC211		M5218AL
IC208		TA7320P
IC205		TC74HC00AP
IC206, IC207		TC74HC10AP
IC202, IC203		TC74HC74AP
IC102		TC74HC86AP
IC204		TC74HCU04AP
Q119, Q121, Q206, Q214		2SA933S
Q103-Q111, Q115-Q118, Q120, Q203, Q207-Q210, Q213		2SC1740S
Q201, Q202		DTC124ES
D201		SVC321SP
<b>COILS AND FILTERS</b>		
L207		LAU010K
L205, L206, L213		LAU120J
L203, L204		LAU121J
L201		LAU1R2J
L104, L105, L113		LAU330J
L102, L103		LAU8R2J
L111, L112		LFA120K
F204		DTF1013
F205		DTF1035
F102		VTF1011
F203		VTF1018
F202		VTF1030
F101		VTF1034
F201		VTF1042
<b>CAPACITORS</b>		
C283		CCCCH030C50
C152, C277		CCCCH100D50
C205, C213, C223		CCCCH101J50
C273		CCCCH221J50
C153, C202		CCCCH270J50

Mark	No.	Description	Part No.
	C201, C204		CCCCH390J50
	C212		CCCCH680J50
	C210		CCCSL221J50
	C227		CCPUCH100J50
	C101, C110		CEANP220M10
	C154		CEANP3R3M16
	C113, C224		CEANP470M10
	C111, C112, C115, C118, C121, C129, C131, C142, C143, C208, C219, C222, C228, C230, C243, C245, C263, C265		CEAS470M10
	C155, C156		CEAS471M10
	C279, C280		CKCYF103Z50
	C148, C149		CKPUYB391K50
	C108, C109		CKPUYB681K50
	C103-C107, C116, C117, C128, C130, C141, C144, C209, C214, C216, C217, C220, C221, C225, C226, C229, C244, C246, C262, C264, C266-C272, C276, C281, C282, C284		CKPUYY103N16
	C218		CQMA102J50
	C275, C278		CQMA104J50
	C274		CQMA393J50
	VC203 (20pF)		DCM1005
	VC201, VC202 (20pF)		VCM-008

**RESISTORS**

VR101, VR201, VR202	(470Ω)	VRTB6VS471
VR102	(4.7kΩ)	VRTB6VS472
R168, R173	(4.7Ω)	DCN1001
Other resistors		RD1/6PM□□□J

**OTHERS**

JA101	RGB CONNECTOR	VKB1037
DL101	64 μsec DELAY LINE	DTF1033
DL201	75nsec DELAY LINE	VTF1037
X202	CRYSTAL RESONATOR (17.734MHz)	VSS1019
X201	CRYSTAL RESONATOR (14.318MHz)	VSS1029
X203	CRYSTAL RESONATOR (14.22MHz)	VSS1053

**TSWB BOARD ASSEMBLY**

**SEMICONDUCTORS**

D601-D605	HZS5. 6EB2
-----------	------------

**SWITCHES**

S601-S606	RSG1010
-----------	---------

**COIL AND FILTERS**

L601, L602	LFA221J
F602	DTF1003
F601	VTH1009

**CAPACITOR**

C601	CKPUYF223Z25
------	--------------

**RESISTORS**

R601, R602	RD1/6PM221J
------------	-------------

Mark	No.	Description	Part No.
<b>OTHERS</b>			
	JA601	SR JACK	DKN1066
	CN601	CONNECTOR ASSEMBLY	DKP2522
		IR SENSOR UNIT	GP1U50X

**LEDB BOARD ASSEMBLY**

**SEMICONDUCTORS**

Q501-Q505	DTC124ES
D502-D505	SEL2413E
D501	SEL2913K

**FILTERS**

F501-F505	DTF1003
-----------	---------

**CAPACITORS**

C501	CEAL470M6R3
C502	CKPUYF223Z25

**RESISTORS**

R501-R505	RD1/6PM221J
-----------	-------------

**SYPS BOARD ASSEMBLY**

**SEMICONDUCTORS**

△ IC201, IC202	ICP-N15
△ Q202, Q203, Q205	2SB1185
△ Q201, Q204, Q206	2SD1762
△ D216-D219	11ES2
△ D213, D214	1SR35-100AVL
D208, D211	1SS254
D212, D215	D1NK20
D207, D210	MTZJ5. 1C
D206, D209	MTZJ6. 2C
△ D201, D202	S2VB20

**SWITCH**

△ S201	VSA-010
--------	---------

**COIL**

△ L202	VTL-004
L201 (10mH)	VTL1008

**CAPACITORS**

C209, C211, C240, C241	CEAS101M10
C213	CEAS101M35
C214, C215	CEAS2R2M50
C242	CEAS330M25
C205, C206	CEAS332M25

C243	CEAS471M25
C210, C212	CEAS471M6R3
C227, C230, C237, C238	CGCYX473M25
C235	CKPUYB331K50
C201-C204	CKPUYF103Z25

△ C216-C218 (0.01 μ/AC400V)	VCG-048
C207 (10000p/16)	VCH1050
C208 (6800p/16)	VCH1053

**RESISTORS**

R213, R214, R219, R220 (47Ω)	DCN1003
△ R221	RS1PMFR51J
Other resistors	RD1/6PM□□□J

Mark	No.	Description	Part No.
<b>VDTB BOARD ASSEMBLY</b>			
<b>SEMICONDUCTORS</b>			
	IC305		BU4053B
	IC403		CXL1009P
	IC306		NJM082D
	IC302		NJM4558S
	IC404		PA0017-P
	IC401		PA5013A
	IC402		PM0001
	IC301		PM3002
	IC304		TC74HC00AP
	IC307		TC74HC123AP
	IC303		TC74HCU04AP
	Q403, Q404, Q407, Q410, Q414-Q416, Q419, Q421		2SA933S
	Q423		2SB1237X
	Q307, Q401, Q402, Q405, Q406, Q408, Q409, Q411-Q413, Q417, Q418, Q422, Q429		2SC1740S
	Q301		2SC3064
	Q424		2SD1858X
	Q306, Q308, Q420, Q425, Q428		DTA124ES
	Q302, Q305, Q426		DTC124ES
	D301-D310, D401, D402		ISS254
<b>COILS</b>			
	L304, L402-L405, L413		LAU120J
	L407-L409, L415		LAU181J
	L302, L410		LAU220J
	L412, L416		LAU330J
	L420, L422		LAU390J
	L303		LAU470J
	L414, L421		LAU560J
	L401, L423		LAU680J
	L411, L418		LAU820J
	L406		LRA471K
<b>CAPACITORS</b>			
	C303, C352, C353, C412, C431		CCCCH101J50
	C528, C540		CCCCH120J50
	C329, C356, C357, C438		CCCCH121J50
	C428, C429, C467, C481		CCCCH151J50
	C448, C539		CCCCH180J50
	C478, C479, C493		CCCCH220J50
	C465		CCCCH270J50
	C407, C530		CCCCH330J50
	C422, C440, C470, C487, C492, C533		CCCCH390J50
	C494, C532		CCCCH470J50
	C480, C491		CCCCH560J50
	C468		CCCCH680J50
	C354, C401, C402		CCCCH820J50
	C350		CCCSL221J50
	C404		CCCSL271J50
	C439		CCCSL331J50
	C405		CCCSL391J50
	C406, C408, C466, C531, C534		CCPUCH100J50
	C355, C415, C416		CCPUCH180J50
	C495		CEANP100M16

Mark	No.	Description	Part No.
	C318		CEANP220M10
	C316		CEANP2R2M50
	C421, C449, C541		CEAS010M50
	C485		CEAS100M50
	C345, C363, C413, C419, C426, C432, C444, C459, C460, C496, C512, C514, C519, C521		CEAS101M10
	C312, C462, C482		CEAS220M25
	C301		CEAS221M6R3
	C450, C453, C454		CEAS3R3M50
	C322, C341, C342, C359, C361, C443, C455, C471, C473, C475, C484, C488, C510, C513, C518, C520		CEAS470M10
	C321, C424		CEAS4R7M50
	C304, C452		CFTNA224J50
	C314		CFTXA103J50
	C476		CFTXA104J50
	C427		CFTXA153J50
	C317		CFTXA223J50
	C490		CFTXA473J50
	C310, C315		CFTXA563J50
	C477, C483		CFTXA683J50
	C351, C486, C538		CKCYB102K50
	C370		CKPUYB331K50
	C505		CKPUYX272M16
	C302, C323, C326-C328, C343, C344, C346, C360, C362, C364, C365, C367, C403, C409, C410, C411, C414, C417, C418, C420, C423, C430, C433-C437, C441, C442, C445-C447, C451, C456-C458, C461, C463, C464, C472, C474, C489, C497, C499, C511, C515-C517, C522, C523, C529, C536, C537, C542, C543		CKPUYY103N16
	C305, C307, C425		CQMA102J50
	C308		CQMA152J50
	C320		CQMA222J50
	C311		CQMA272J50
	C313, C319		CQMA332J50
	C306		CQPA821J100
<b>RESISTORS</b>			
	VR441	(10kΩ)	VRTB6VS103
	VR471, VR482, VR521	(4.7kΩ)	VRTB6VS472
	R420, R455, R411, R413, R419		RN1/6PQ□□□□F
	Other resistors		RD1/6PM□□□□J
<b>OTHERS</b>			
	CONNECTOR ASSEMBLY		DKP2551
<b>HEAD ASSEMBLY</b>			
<b>CAPACITORS</b>			
	C1		CKSQYF473Z50
	C5		CKSYF105Z16
<b>RESISTOR</b>			
	VR1	(10kΩ)	VCP1040

## 6. ADJUSTMENTS

### 6.1 TEST MODE

#### Test Mode

The player has a test mode function which allows the servicer to check the player's status on the TV screen by executing the respective key operation.

Also, since the TRK servo opens and closes easily, the test mode is especially useful for mechanical adjustments.

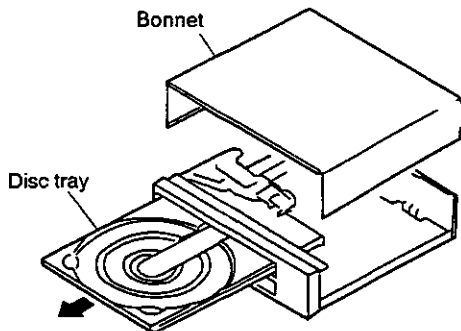

#### Test Mode Cancellation

Turn off the power switch.

#### Player Operation in the Test Mode

Operate the player by selecting a test mode function with the keys on the player or on the remote control unit.

#### ● CD PLAYBACK

- Place the CD disc on the turn table. (Clamper is already lifted up.)

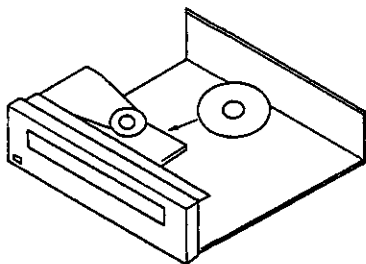

- Press the or key to appear "S-CD" on the TV screen display.

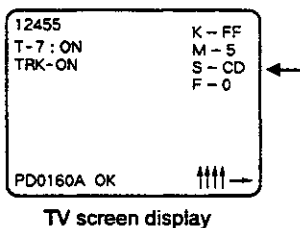

- Clamp the disc by pressing the PLAY () key once. Then, press the PLAY () key twice, disc will be normal playbacked.

#### ● LD PLAYBACK

- Place the LD disc on the turn table. (Clamper is already lifted up.)

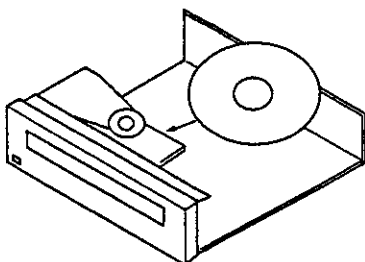

- Press the or key to appear "S-LD" on the TV screen display.

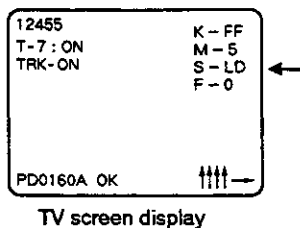

- Clamp the disc by pressing the PLAY () key once. Then, press the PLAY () key twice, disc will be normal playbacked.

#### Test Mode Initiation

[Procedure]

- Remove the bonnet and disc tray.
- Connect the TP (TEST MODE) in the ASCB board assembly to GND.
- Turn on the power switch.
- Disconnect the TP from GND.

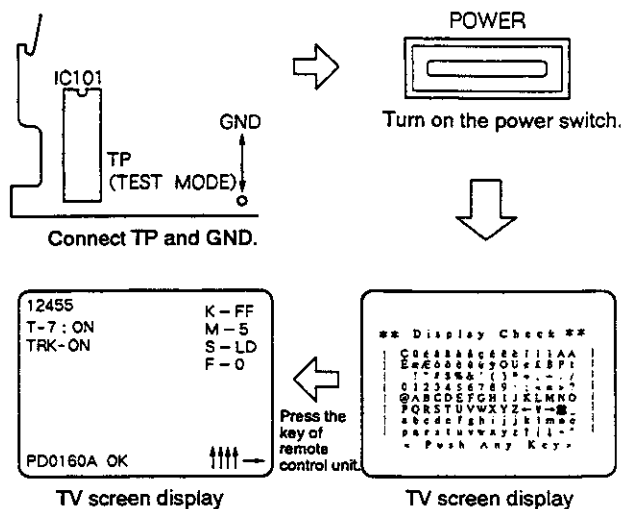

**6.2 REQUIRED INSTRUMENTS**

- Small screwdriver (7 cm shaft)
- Small Phillips screwdriver (15 cm shaft)
- Low - pass filter (47k ohms+1  $\mu$ F / BP)
- Dual - trace oscilloscope (with delay)
- AF oscillator
- Frequency counter
- LD test disc  
NTSC ...GGV1003  
PAL ...GGV - 145
- Short clip
- TV monitor
- Resistor (1k ohms, 47k ohms)
- Capacitor (0.01  $\mu$ F, 0.0027  $\mu$ F)
- Remote control unit
- 2mm hexagonal wrench

**6.3 ADJUSTMENT PREPARATION AND NOTES**

**1. Player Preparation**

Before perform the adjustment, remove the bonnet and the disc tray. Then place the player horizontally on a flat surface.

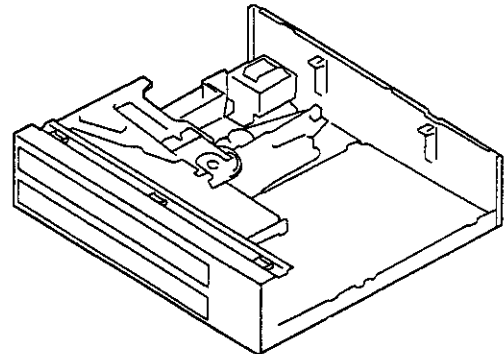

**2. Disc Insertion**

Insert the disc from the rear of the player. Place it securely on the turntable. When the PLAY key is pressed, the clamper will go down and secure the disc. Playback will then begin.

**3. Use All the Oscilloscope's Probes at 10:1.**

**Required adjustment after Replacement of major parts.**

Adjustments	Replacement assemblies				
	Pickup	Actuator	Pre-pickup	Spindle motor	Sensor
1. Tilt Servo Gain Adjustment	⊙				⊙
2. Coarse Adjustment of Grating and TRK Balance Adjustment	⊙	⊙	⊙		
3. Slider Shaft Horizontal Adjustment	⊙	⊙	⊙	○	⊙
4. Pickup Inclination Adjustment	⊙	⊙	⊙	○	○
5. TRKG Error Best / Crosstalk Best Adjustment	⊙	⊙	⊙	○	○
6. FOCUS SUM Level Adjustment	⊙	⊙	⊙	○	○
7. Tilt Sensor Inclination / Tilt Balance Adjustment	⊙	⊙	⊙	○	⊙
8. Verification and Adjustment of Spindle Motor Centring	⊙	⊙	⊙	⊙	
9. Fine Grating Adjustment / TRK Balance Adjustment	⊙	⊙	⊙		
10. FCS Servo Loop Gain Adjustment	⊙	⊙	⊙		
11. TRKG Servo Loop Gain Adjustment	⊙	⊙	⊙		
12. RF Gain Adjustment	⊙	⊙	⊙		

*Note: Adjustments indicated by a ○ are made only when there is crosstalk.*

## 6.4 ADJUSTMENT

### 6.4.1 Mechanical Adjustment

Note: Use the GGV1003 NTSC test disc for all the adjustments of the ASCB board assembly.

	Adjustment	Adjusting Point	Measurement equipment Connecting Point	Player Status	Adjusting Specification
1	Tilt Servo Gain Adjustment	VR608	None	Power off	<ul style="list-style-type: none"> <li>Making of Tilt GAIN VR position Red : Turn to Right Clear : Center Blue : Turn to Left</li> </ul>
2	Coarse Adjustment of Grating and TRK Balance Adjustment	Grating/VR602	CN401-9 (TRK ERR)	<ul style="list-style-type: none"> <li>Test mode #15,000 still TRK servo loop open</li> </ul>	<ul style="list-style-type: none"> <li>Null point → TRK error MAX</li> <li>Adjust VR602 so that the TRK error waveform amplitude's positive and negative level become equal.</li> </ul>
3	Slider Shaft Horizontal Adjustment	Player SKIP key	CN401-4 (FCS RTN)	<ul style="list-style-type: none"> <li>Test mode Tilt servo loop off TRK servo loop open #5,200 still</li> </ul>	<ul style="list-style-type: none"> <li>Use the SKIP key to adjust to 0V ± 20mV.</li> </ul>
4	Pickup Inclination Adjustment	Pickup Assembly TAN / TRK inclination adjustment screw	CN401-3(RF)	<ul style="list-style-type: none"> <li>Test mode #2,251 still TRK servo loop close / open</li> </ul>	<ul style="list-style-type: none"> <li>RF waveform's amplitude MAX (Pickup TAN / TRK adjustment screw)</li> <li>Minimized crosstalk.</li> </ul>
5	TRKG Error Best / Crosstalk Best Adjustment	VR605 (TE BEST) VR606 (CT BEST)	CN401-9 (TRK ERR) CN401-3(RF)	<ul style="list-style-type: none"> <li>Test mode TRK servo close / open Tilt servo loop off</li> </ul>	<ul style="list-style-type: none"> <li>RF MAX (VR606) TRK error MAX (VR605)</li> </ul>
6	FOCS SUM Level Adjustment	VR609	CN401-11 (FCS SUM)	<ul style="list-style-type: none"> <li>Play mode</li> </ul>	<ul style="list-style-type: none"> <li>Adjust VR 609 so that the voltage becomes 1.5VDC.</li> </ul>
7	Tilt Sensor Inclination / Tilt Balance Adjustment	Tilt sensor inclination adjustment screw VR807(TILT BAL)	TV monitor Test mode screen	<ul style="list-style-type: none"> <li>Test mode #18,200 / #115 still TRK servo loop close Tilt servo loop off</li> </ul>	<ul style="list-style-type: none"> <li>Set VR 807 to the center.</li> <li>Adjust the adjustment screw so that the tilt error display code is 8.7, or 8.</li> <li>Adjust VR807 so that the tilt error display</li> </ul>
8	Verification and Adjustment of Spindle Motor Centering	Spindle motor centering adjustment screw.	CH1:CN401-9 (TRK ERR) CH2:CN401-1,2 (TRK SUM) (X-Y mode)	<ul style="list-style-type: none"> <li>Test mode #23,800 / #3,000 still TRK servo loop open Tilt servo loop on</li> </ul>	<ul style="list-style-type: none"> <li>Adjust the centering adjustment screw so that the lissajous figures of #3,000 and #23,800 are the same.</li> </ul>
9	Fine Adjustment of Grating and TRK Balance Adjustment	Grating / VR602	CH1:CN401-9 (TRK ERR) CH2:CN401-1,2 (TRK SUM) (X-Y mode)	<ul style="list-style-type: none"> <li>Test mode TRK servo loop open Tilt servo loop on</li> </ul>	<ul style="list-style-type: none"> <li>Minimize the Y direction of the lissajous figure.</li> <li>Level of the X direction of the lissajous figures are equal.</li> </ul>
10	FCS Servo Loop Gain Adjustment	VR604	CH1:CN401-7 (FCS IN) CH2:CN401-8 (FCS ERR) (X-Y mode) (Fig.1)	<ul style="list-style-type: none"> <li>Test mode #15,000 still TRK servo loop close Tilt servo loop on</li> </ul>	<ul style="list-style-type: none"> <li>Adjust VR604 so that the lissajous figure is symmetric with respect to the X and Y axes.</li> </ul>
11	TRK Servo Loop Gain Adjustment	VR603	CH1:CN401-10 (TRK IN) CH2:CN401-9 (TRK ERR) (X-Y mode) (Fig.2)	<ul style="list-style-type: none"> <li>Test mode #15,000 still TRK servo loop close Tilt servo loop on</li> </ul>	<ul style="list-style-type: none"> <li>Adjust VR603 so that the lissajous figure is symmetric with respect to the X and Y axes.</li> </ul>
12	RF Gain Adjustment	VR601	CN401-3(RF)	<ul style="list-style-type: none"> <li>#15,000 still</li> </ul>	<ul style="list-style-type: none"> <li>Adjust VR601 so that the RF level becomes 300mV ± 50mV.</li> </ul>

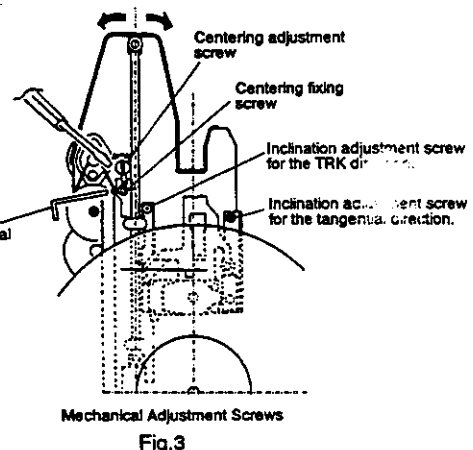
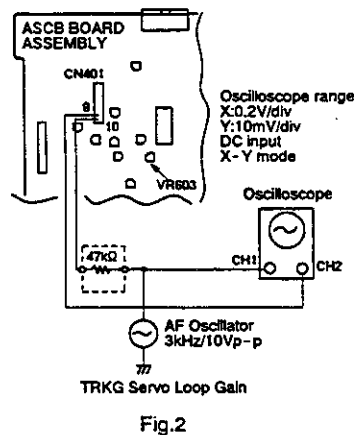
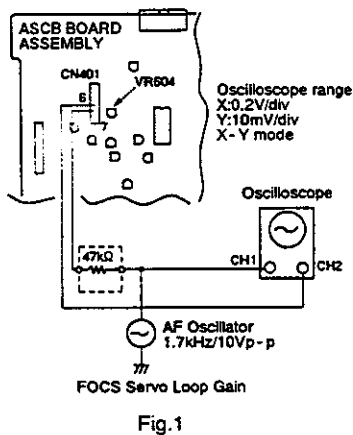
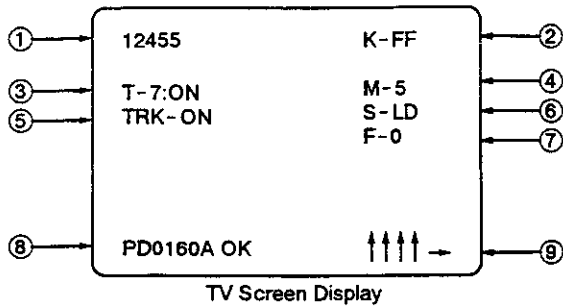



Table. Operation in the test mode.

Function	Player Status	Key Operation	Remarks
Open Tray	STOP mode	▲	
Close Tray	Tray open	▲	
Stop	PLAY mode	■	
Play	Disc placement and tray closed.	▶	<ul style="list-style-type: none"> <li>• Start play with the TRK servo open.</li> <li>• Start play with tilt neutral.</li> <li>• The disc type (LD/CD/CDV) is determined when playback starts at the SLDR position during start play.</li> </ul>
TRK Servo Open/Close	PLAY mode	▶	<ul style="list-style-type: none"> <li>• Each time the PLAY button (▶) is pressed, the TRK servo will open or close alternately.</li> </ul>
Still	PLAY mode TRK servo closed.	(Remote control unit key)	<ul style="list-style-type: none"> <li>• Each time the PAUSE button (  ) is pressed, the player will switch between the PLAY and STILL modes alternately.</li> </ul>
SLDR REV SCAN	PLAY mode	◀◀	<ul style="list-style-type: none"> <li>• Counterclockwise</li> <li>• With the TRK servo open, the pickup can be damaged if the SLD moves further inward than the lead-in area on the disc. Do not allow the SLD to move further inward than the lead-in area.</li> </ul>
SLDR FWD SCAN	PLAY mode	▶▶	<ul style="list-style-type: none"> <li>• Clockwise</li> <li>• With the TRK servo open, the pickup can be damaged if the SLD moves further outward than the lead-in area on the disc. Do not allow the SLD to move further outward than the lead-in area.</li> </ul>
TILT Neutral	POWER switch ON	RCV SPEED DOWN	
TILT Servo ON	PLAY mode	RCV SPEED UP	
TILT Minus TILT Servo OFF	PLAY mode	◀◀	<ul style="list-style-type: none"> <li>• Press and hold down the keys.</li> </ul>
TILT Plus TILT Servo OFF	PLAY mode	▶▶	<ul style="list-style-type: none"> <li>• Press and hold down the keys.</li> </ul>
Screen Display ON/OFF	POWER switch ON	ON → RCV DISPLAY OFF → AUDIO MONITOR	
Frame search	PLAY mode	+10 key ↓ 0-9 key ↓ RCV CHAP/FRM	<ul style="list-style-type: none"> <li>• In the PLAY mode, press the +10 key. (The player will standby for the frame No. entry.)</li> <li>• Use the numeric keys(0 - 9) to enter the frame No.. Then press the player's PLAY key to search.</li> <li>• After the search is completed, the player will return to the previous mode before the search was performed.</li> </ul>
Loading Motor Rotation Clockwise Counterclockwise	Tray open	▶▶ ◀◀	<ul style="list-style-type: none"> <li>• FWD:Unloading</li> <li>• REV :Loading</li> </ul>
FOCS OFFSET (CT BEST) VR606 Check	PLAY mode (TRK servo OPEN)	(Remote control unit) MULTI-SPEED FWD → F-0 REV → F-1 (Player) HILITE INTRO SCAN	<ul style="list-style-type: none"> <li>• For checking VR604</li> <li>F-0 : Normal mode</li> <li>•When closing the TRK servo, VR606 (CT BEST) is effectived.</li> <li>•When opening the TRK servo, VR605 (TE MAX) is effectived.</li> <li>F-1 : When opening the TRK servo, VR606 (CT BEST) is also effectived.</li> </ul>

**TV Screen and LED Displays in the Test Mode**



① The part number of the mechanical control IC is displayed in stop mode. During playback, a frame number is displayed. "F" appears for the lead-in area and "E" appears for the lead-out area at the uppermost digit.

**② Key Status**

Data on the keys being pressed on the main unit or the remote control unit are displayed. Note that the data on the remote control unit keys are displayed in converted values which are different from the original values. "FF" will be shown when no key is pressed.

Code	Function	Code	Function	Code	Function	Code	Function
00	0	1A		2A		40	TEST
01	1	1B		2B		41	ESC
02	2	1C		2C		42	CX
03	3	1D		2D		43	+10
04	4	1E		2E		44	REPEAT A
05	5	1F		2F		45	TV/LDP
06	6	20	PAUSE	30	STEP FWD	46	
07	7	21	SEARCH	31	STEP REV	47	
08	8	22	SKIP FWD	32	MULTI FWD	48	
09	9	23	SKIP REV	33	MULTI REV	49	
0A		24	CHP/FRM	34	SPEED UP	4A	
0B		25	SCAN FWD	35	SPEED DOWN	4B	
0C		26	SCAN REV	36		4C	
0D		27	REPEAT MODE	37		4D	
0E				38		4E	
0F		28		39		4F	
10	PLAY	29		3A			
11	REJECT			3B			
12	OPEN/CLOSE			3C			
13	AUDIO MON			3D			
14	DISPLAY			3E			
15	CLEAR			3F			
16							
17							
18							
19							

**③ TILT Status (0 - F)**

- N ...Tilt neutral
- ON ...Tilt servo on
- OFF ...Tilt servo off

**④ Loading Position (0 - 7)**

- 0 ... Tray open
- 1 ... Loading
- 2 ... Standby
- 3 ... Clamped
- 4 ... Tilt minus
- 5 ... Tilt plus
- 6 ... Tilt limit

**⑤ TRK Servo Status (ON, OFF)**

- ON ...TRK servo close
- OFF ...TRK servo open

**⑥ SLD Position**

- IN ... CD TOC area
- CD ... CD active area
- CDV ... CDV video area
- LD ... LD active area

**⑦ Focus Balance Mode**

Focus balance is accordingly set normal playback or for jump operation.  
 0 ...For normal playback  
 1 ...For jump operation

**⑧ Part Number of the Mode Control IC**

When the ROM data have been accepted as correct, "OK" is displayed after the part number. If any error is detected, "NG" will be shown with the check sum.

**⑨ Status display for the switches on the rear panel**

## 6.4.2 Electrical Adjustment

Note: This unit automatically switches between the NTSC and PAL systems by reading the Phillips code on the test disc. Use the GGV-145 PAL disc for the items marked for PAL mode in the Remarks column and the GGV1003 NTSC disc for the items marked for NTSC mode.

	Adjustment	Board to be adjusted	Adjusting Point	Adjustment value (Inspection Standard)	Check point	Player status	Adjusting procedure or instrument
1	NTSC 4Fsc VCXO Adjustment	PALB board assembly	VC201	14.318180MHz ( $\pm 50$ Hz)	Lead wire of R279	STOP NTSC mode No disc	1. Set Function switch No.3 on the rear panel of the unit to ON (See Note 1), then set the Power switch of the unit to ON. 2. Adjust VC201 so that the clock frequency becomes 14.318180 MHz. (Set the frequency counter input to high-impedance mode.)
2	PAL 4Fsc VCXO Adjustment		VC202	17.734475MHz ( $\pm 50$ Hz)	Lead wire of R279	STOP PAL mode No disc	1. Set Function switch No.3 on the rear panel of the unit to OFF (See Note 1), then set the Power switch of the unit to ON. 2. Adjust VC202 so that the clock frequency becomes 17.734475 MHz. (Set the frequency counter input to high-impedance mode.)
3	PAL 910Fh VCXO Adjustment		VC203	14.218750MHz ( $\pm 50$ Hz)	Lead wire of R207	STOP PAL mode No disc	1. Set Function switch No.3 on the rear panel of the unit to OFF (See Note 1), then set the Power switch of the unit to ON. 2. Adjust VC203 to set the clock frequency to 14.218750 MHz. (Set the frequency counter input to high-impedance mode.)
4	CCD input VCO center frequency Adjustment	VDTB board assembly	VR471	1H+11 $\mu$ sec =74.5 ( $\pm 2 \mu$ sec)	C449 : Ch1 Q414(Emitter) : Ch2	STILL NTSC mode 10 steps (See Note 2)	1. Trigger at channel 1 of the oscilloscope. 2. Adjust VR471 so that the center of the jitter component in the horizontal sync section of channel 2 delays 1 H + 11 $\mu$ sec. when compared to that of channel 1. (It may be easier to check with pin 9 of IC404 grounded.)
5	Video level Adjustment		VR482	1.0Vp-p ( $\pm 50$ mV)	Unit JA4 (Video output)	STILL NTSC mode 100% WHITE Video	1. Connect the video output terminal to the monitor (with 75 $\Omega$ termination). 2. Adjust VR482 so that the video level between sync chip of the video signal and white 100% becomes 1 Vp-p.
6	1H delay video level Adjustment		VR441	See Fig.1.	C424 : Ch1 C426 : Ch2	STILL NTSC mode 10 steps (See Note 2)	Adjust VR441 so that the video level of channel 2 is the same as that of channel 1 (within $\pm 3\%$ ). See Fig.4.
7	VPS error level Adjustment		VR521	Visual observation	TV monitor	STILL NTSC mode MAGENTA	While reproducing the magenta picture, adjust VR521 to minimize the color ununiformity.
8	Quasi-PAL Y level Adjustment	PALB board assembly	VR202	within $\pm 3\%$	C228 : Ch1 C230 : Ch2	STILL Quasi-PAL mode 10steps (See Note 2)	1. Trigger at channel 1 of the oscilloscope. 2. Adjust VR202 so that the video level of channel 2 is the same as that of channel 1 (within $\pm 3\%$ ).
9	Quasi-PAL SC (Sub Carrier) level Adjustment		VR201	within $\pm 10\%$	C101 : Ch1 C229 : Ch2	STILL Quasi-PAL mode 10steps (See Note 2)	1. Trigger at channel 1 of the oscilloscope. 2. Adjust VR201 so that the SC level of channel 2 is the same as that of channel 1 (within $\pm 10\%$ ).
10	1H delay SC level Adjustment		VR101	within $\pm 10\%$	C108 : Ch1 C105 : Ch2	STILL PAL mode 10steps (See Note 2)	1. Connect the video output of the unit to the EXT input of the oscilloscope and trigger at EXT. 2. Adjust VR101 so that the SC level of channel 2 is the same as that of channel 1 (within $\pm 10\%$ ).
11	Video level Adjustment		VR102	within $\pm 3\%$	C113 : Ch1 C112 : Ch2	STILL PAL mode 10steps (See Note 2)	1. Trigger at channel 1 of the oscilloscope. 2. Adjust VR102 so that the video level of channel 2 is the same as that of channel 1 (within $\pm 3\%$ ).
12	PAL character position Adjustment	MCRS board assembly	VR401	See Fig.2. (within $\pm 0.5 \mu$ sec)	R430 : Ch1 C415 : Ch2	PAUSE PAL mode 10steps (See Note 2)	1. Trigger at channel 1 of the oscilloscope. 2. Adjust VR401 so that the rising edge of H sync of channel 2 is synchronized with that of channel 1. See Fig. 5.

Note 1 : On Function switch

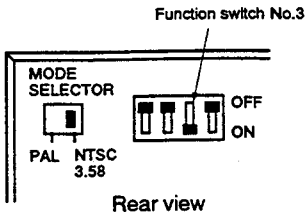

Normally set pins 1 through 4 of Function switch all to OFF.

Function switch Function table

1	ON	AUTO START ON
	OFF	AUTO START OFF
2	ON	BAUD RATE 1.2kbps
	OFF	BAUD RATE 4.8kbps
3	ON	INITIAL TV SYSTEM NTSC
	OFF	INITIAL TV SYSTEM PAL
4	N.C.	

Note 2 : On 10steps

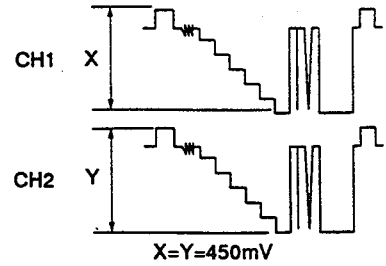
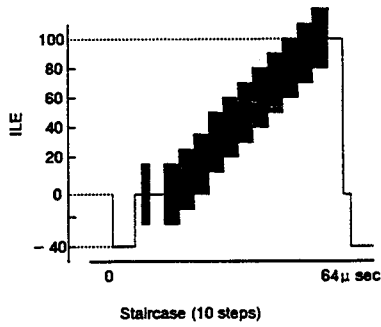

Fig. 4

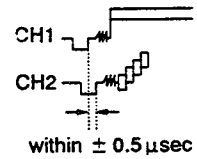
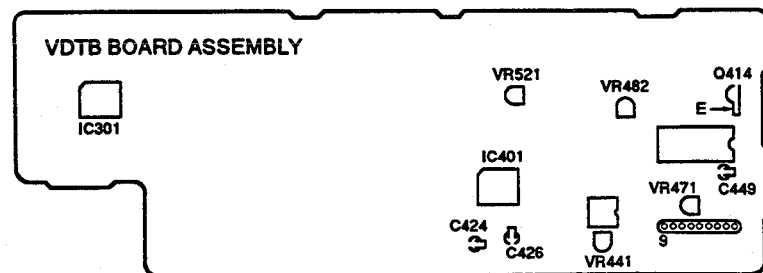
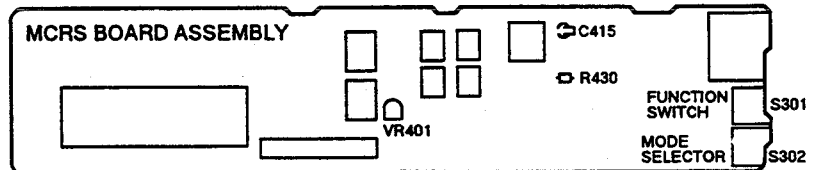
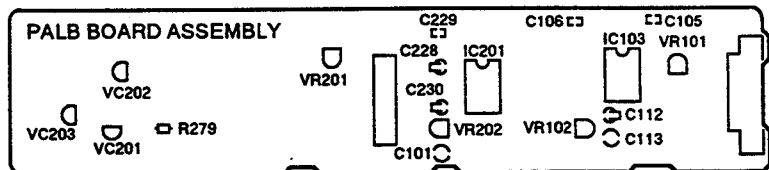
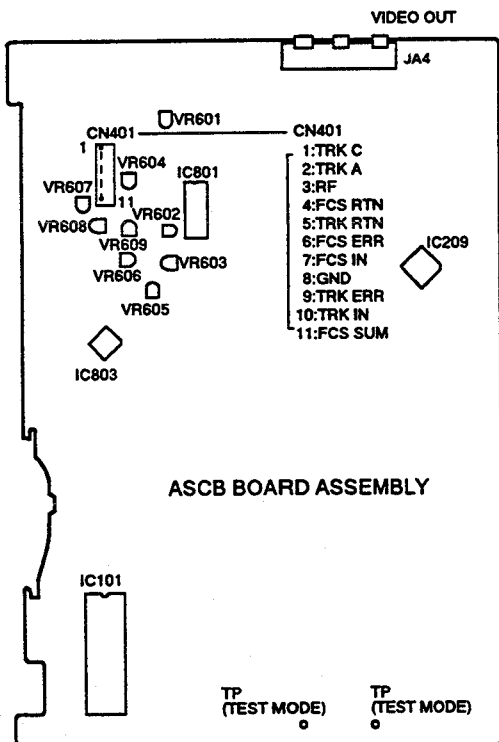

Fig. 5

### 6.4.3 Adjustment Points



## 7. PANEL FACILITIES

### STOP OPEN/CLOSE (■ / ▲) button

This button is used to open and close the disc table. Setting a disc on the disc table then pressing this button retracts the disc table into the player. Pressing this button during player stops play. When pressed again, the table will be extended from the player.

### PLAY (▶) button

Used to start playback or to return to ordinary playback from still image or pause.

### Door/Disc table

Press the STOP OPEN/CLOSE button to open the door and eject the disc table to the specified position. Place a disc on the disc table.

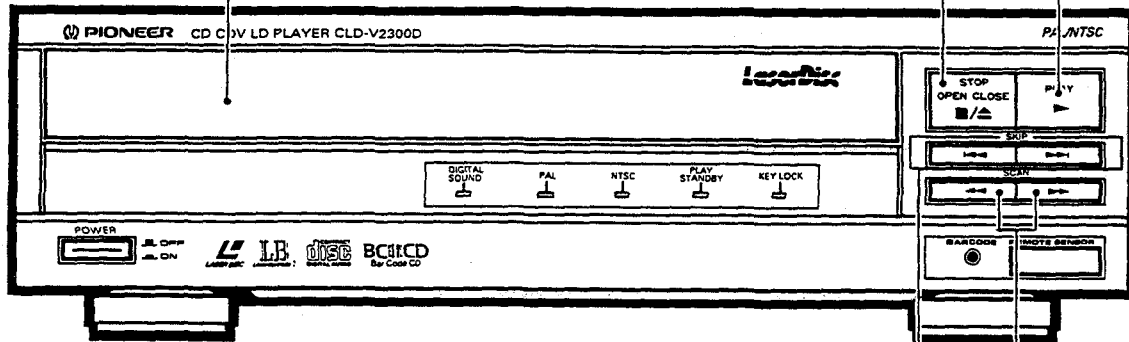

### SKIP (◀◀, ▶▶) buttons

The SKIP buttons function only when one of the following buttons have been pressed:

- ◀◀: Pressing this button once will return the player to the beginning of the current chapter or track. Pressing this button continuously before pictures are displayed will return the player to the previous chapter or track to start playback.
- ▶▶: The player advances to the next chapter or track and starts playback every time this button is pressed.

### SCAN (◀◀, ▶▶) buttons

Function only when one of the following buttons are pressed.

- ▶▶: Forward direction
- ◀◀: Reverse direction

### PAL and NTSC indicators

- Displays the TV system of disc being played back during disc playback.
- In standby status after the power has been turned on, indicates the setting of the function (3) switch on the rear panel.

### PLAY/STANDBY indicator

- Lights during playback in the play mode (PLAY).
- At the beginning of playback or during a search operation, the PLAY/STANDBY indicator flashes until the picture appears (STANDBY).

### DIGITAL SOUND indicator

Lights up when the power supply is switched ON. Keeps lighting when a digital disc is played back. Goes off when an analog disc is played back.

### KEY LOCK indicator

Lit when the KEY LOCK command is entered from the external control unit.

When this indicator is lit, entries are not accepted from operation buttons other than the power switch. Also, entries are not accepted from the operation button of the control unit.

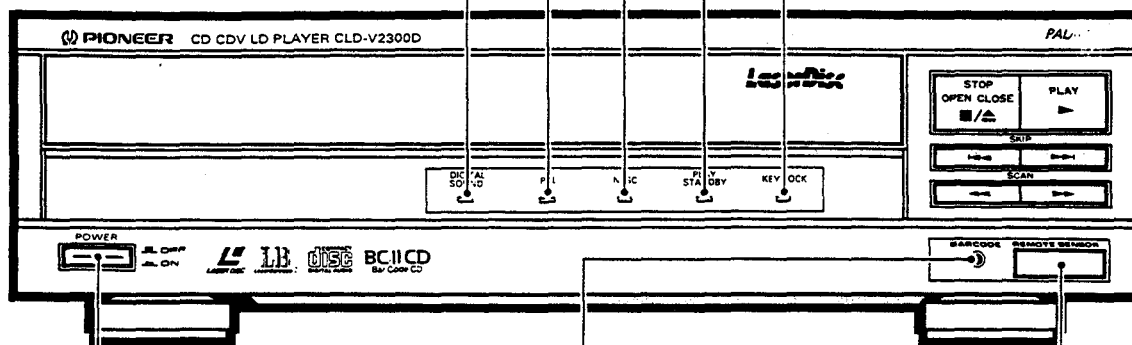

### POWER switch

Press this button to turn the power on and off.

### REMOTE SENSOR window

When using the remote control unit or Barcode reader in the wireless format, the infrared commands from the unit are received here.

### BARCODE jack

Connect the Barcode reader.

Before connecting appliances, turn off the power to this player and all the appliances to be connected. Remove all appliance power plugs from electric wall sockets. Replace plugs and switch on power after all connections have been completed.

Host computer (controller)

Speaker system

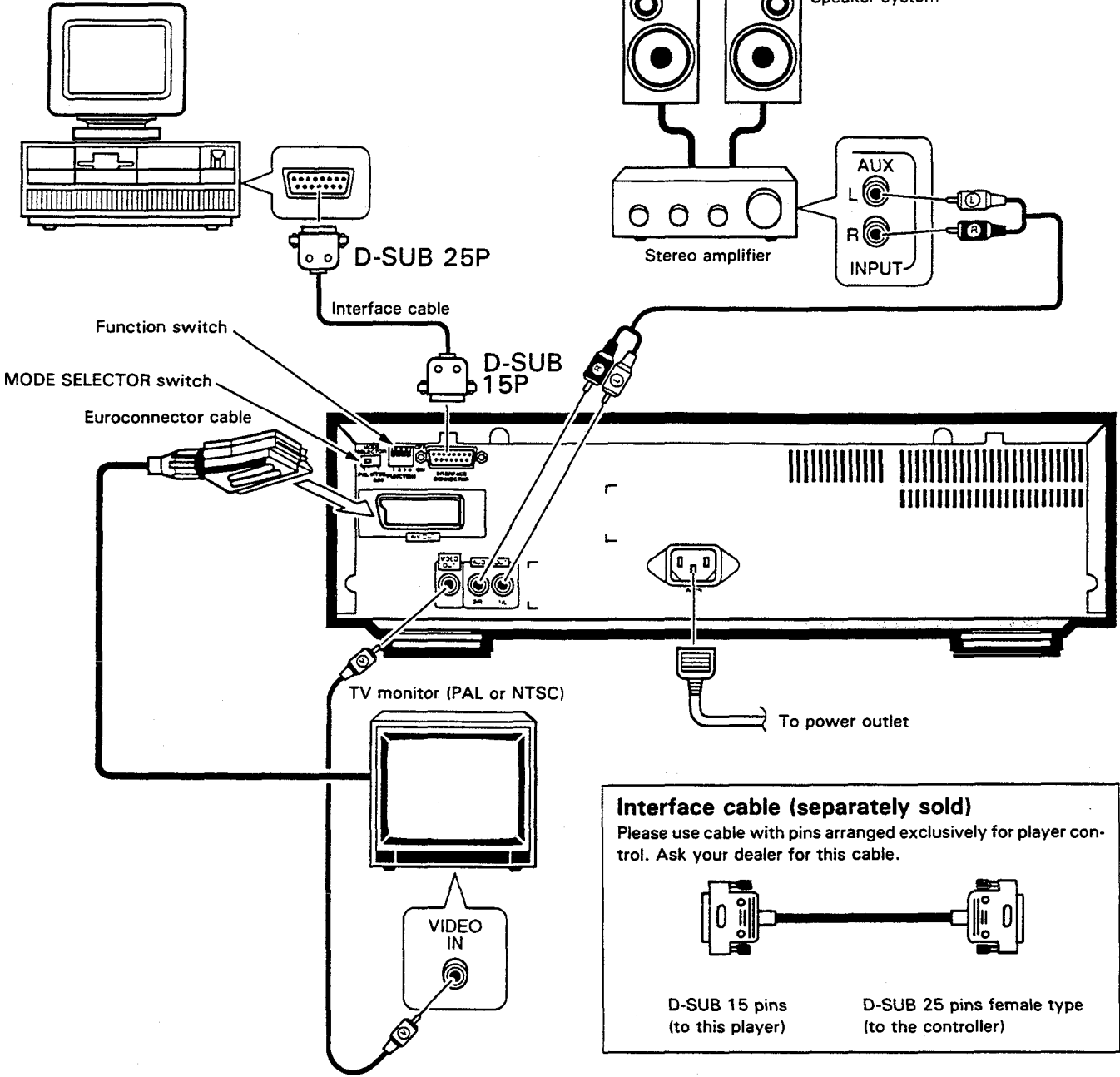

**Interface cable (separately sold)**  
 Please use cable with pins arranged exclusively for player control. Ask your dealer for this cable.

D-SUB 15 pins (to this player)      D-SUB 25 pins female type (to the controller)

**NOTE:**  
 Be sure not to connect the power plug for this player in series with the amplifier or other appliance (so that turning off the amplifier, etc. will turn off the player as well).  
 When the power to this player is cut by switching off the power through the amplifier or by simply pulling out the power plug, the disc anti-warp mechanism will not operate. Turning the power off by any means other than pushing the player power button may damage your disc.





[Operations by a separately sold remote control unit]

Function	CAV disc	CLV disc
PLAY	YES	YES
PAUSE	YES	YES
REJECT	YES	YES
REPEAT MODE	YES	YES
STILL/STEP FWD.REV, STILL	YES	NO
MULTI-SPEED FWD.REV	YES	NO
SCAN FWD.REV	YES	YES
AUDIO SELECT	YES	YES
DISPLAY ON/OFF	YES	YES
CLEAR	YES	YES
FRAME NUMBER SEARCH	YES	NO
TIME NUMBER SEARCH	YES	YES
CHAPTER NUMBER SEARCH	YES	YES*

\* Enabled when a disc with recorded chapter numbers is played back.

[Other Function]

- CX system...Auto selection operation when a disc with recorded CX auto selection codes is played back.

**6. Other Terminals**

- BARCODE (front panel) ..... Stereo miniature phone jack
- INTERFACE CONNECTOR (rear panel)... 15 pin, D-SUB connector

AV connector output..... 21-pin connector  
 This connector provides the video and audio signals for connection to a colour video TV monitor (or TV set) which has a "AV CONNECTOR" terminal.

**PIN assignment**

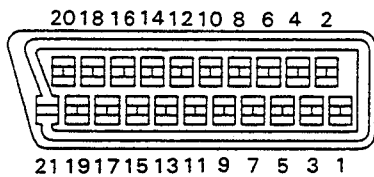

PIN No.	1 Audio 2/R out	17 GND
	3 Audio 1/L out	19 Video out
	4 GND	21 GND
	8 Status	

**7. Accessories**

- Operating instructions ..... 1
- Audio connecting cord ..... 1
- Video connecting cord ..... 1
- Remote control unit (CU-V113) ..... 1
- Size "AA" (IEC R6) dry cell batteries ..... 2
- Barcode sheet ..... 1

*NOTE:*  
 Specifications and design subject to possible modifications without notice, due to improvements.



This equipment accepts softwares with the LaserBarcode mark or the LaserBarcode2 mark.



This mark expresses compatibility with Bar Code CD systems.  
 Please use only bar codes displaying this mark.