

Service Manual

PIONEER
The Art of Entertainment

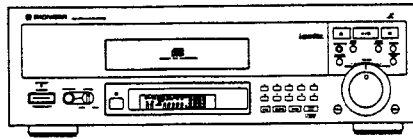

ORDER NO.
ARP2833

CD CDV LD PLAYER

CLD-S360

CLD-S260

THIS MANUAL IS APPLICABLE TO THE FOLLOWING MODEL (S) AND TYPE (S).

Type	Model		Power Requirement	Remarks
	CLD-S360	CLD-S260		
SD	○	○	AC110V/120-127V/220V/240V	With the voltage selector

● For CLD-S260/SD, refer to page 67.

CONTENTS

1. EXPLODED VIEWS, PACKING AND PARTS LIST	2	6. ADJUSTMENTS	44
2. FL INFORMATION	15	7. IC INFORMATION	53
3. BLOCK DIAGRAM	16	8. FOR CLD-S260/SD	67
4. SCHEMATIC AND PCB CONNECTION DIAGRAMS	18	9. CONNECTIONS	70
5. PCB PARTS LIST	39	10. PANEL FACILITIES	72
		11. SPECIFICATIONS	74

PIONEER ELECTRONIC CORPORATION 4-1, Meguro 1-Chome, Meguro-ku, Tokyo 153, Japan
PIONEER ELECTRONICS SERVICE INC. P.O. Box 1760, Long Beach, California 90801 U.S.A.
PIONEER ELECTRONICS OF CANADA, INC. 300 Allstate Parkway Markham, Ontario L3R 0P2 Canada
PIONEER ELECTRONIC [EUROPE] N.V. Haven 1087 Keetberglaan 1, 9120 Melsele, Belgium
PIONEER ELECTRONICS AUSTRALIA PTY. LTD. 178-184 Boundary Road, Braeside, Victoria 3195, Australia TEL: [03] 580-9911
© PIONEER ELECTRONIC CORPORATION 1993

AO SEPT. 1993 Printed in Japan

1. EXPLODED VIEWS, PACKING AND PARTS LIST

NOTES:

- Parts marked by "NSP" are generally unavailable because they are not in our Master Spare Parts List.
- The \triangle mark found on some component parts indicates the importance of the safety factor of the part. Therefore, when replacing, be sure to use parts of identical designation.
- Parts marked by "⊙" are not always kept in stock. Their delivery time may be longer than usual or they may be unavailable.

(1) PACKING

Part List

Mark	No.	Description	Part No.	Mark	No.	Description	Part No.
NSP	1	Warranty card	ARW1020		10	Video cable	VDE-056
NSP	2	Caution card (UC)	VRM1026	NSP	11	Battery (R03, AAA)	VEM-022
NSP	3	Caution card	VRR1009		12	Remote control unit (CU-CLD093)	VXX1921
	4	Operating Instructions (English)	VRB1095		13	Battery cover	VNK2431
	5	Operating Instructions (Chinese)	VRC1026	NSP	14	Vinyl bag	Z21-029
	6	Operating Instructions (Spanish)	VRK1006		15	Pad (F)	VHA1138
NSP	7	Vinyl bag	VHL-014		16	Mirror mat sheet	VHL1006
	8	Pad (R)	VHA1106		17	Packing case	VHG1299
	9	Cord with plug	VDE-055	NSP	18	Caution 220V	ARR-003

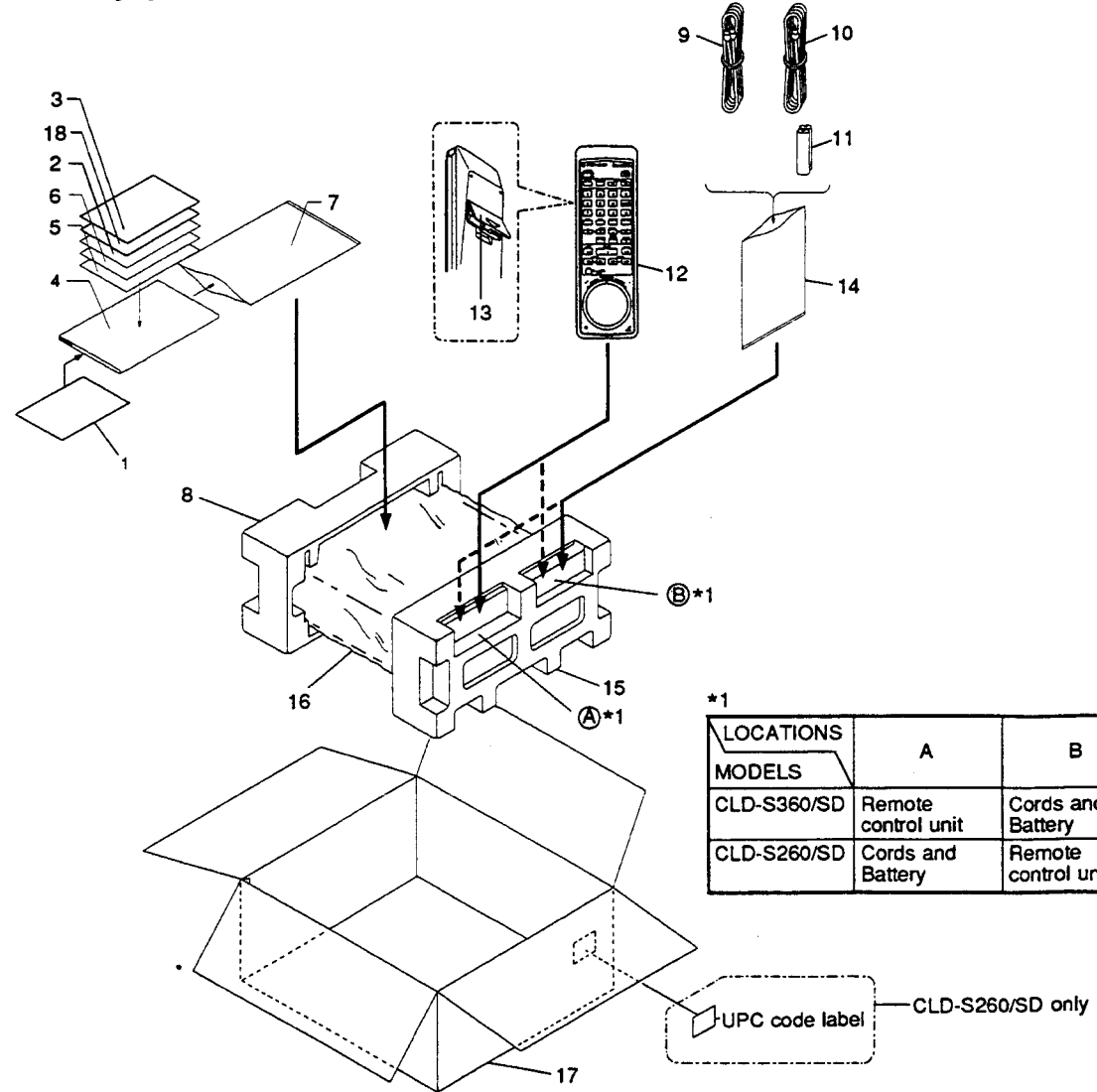

(2) EXTERIOR SECTION

Parts List

Mark	No.	Description	Part No.	Mark	No.	Description	Part No.
	1	Guide plate (L)	VNE1805	NSP	16	Tray panel	VNK2319
	2	Guide plate (R)	VNE1806		17	Door holder	VNE1905
	3	Lock plate spring	VBH1188		18	Door shaft	VLL1441
	4	Lock plate	VNL1513		19	
	5	CD tray	VNK1992		20	Damper ass'y	VXA1999
	6	Tray ass'y-S	VXX1885	NSP	21	Damp cushion	VEC1110
NSP	7	LD tray	VNK1991	NSP	22	PCB holder	VNE1830
	8	Disc pad	VEC1657		23	Screw	BPZ30P060FCU
	9	Disc pad (C)	VEC1658		24	Screw	BPZ30P080FCU
NSP	10	Carry label	VRW1289		25	Screw	BBZ30P080FCC
	11	Bonnet case S	VXX1898		26	Screw	BCZ40P060FZK
	12	Door spring	VBH1223		27	Screw	IPZ20P050FMC
NSP	13	Laserdisc plate	VAM1029		28	Screw	VBA1032
	14	Tray panel ass'y-S	VXX1931		29	Tray rubber	VEB1091
B	15	CD door	VNK2320	NSP	30	Cushion	VEC1618

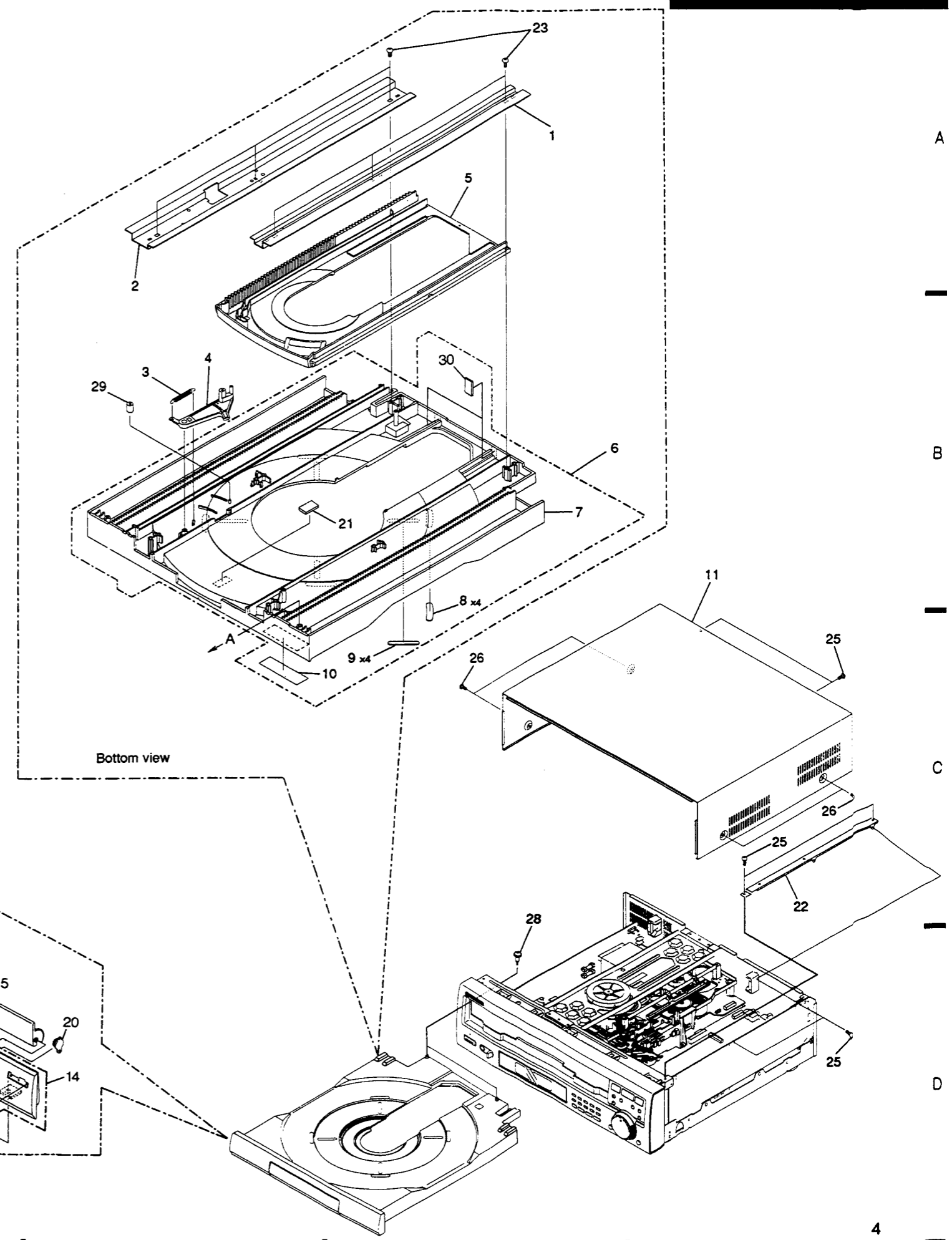

NOTE: Screws adjacent to ▼ mark on the product are used for disassembly.

(3) TOP VIEW SECTION

Parts List

Mark	No.	Description	Part No.
A	1	Clamper holder	VNL1514
	2	Rubber sheat	VEB1114
	3	Thrust holder	VNL1289
	4	Clamper head	VNL1615
	5	Clamper	VNL1515
	6	Clamp spring	VBH1192
	7	Clamper arm	VNE1804
	8	Stabilizer	VNE1807
	9	Rack ass'y	VWT1103
	10	Slider shaft	VLL1434
NSP	11	Side stay (R)	VNE1810
NSP	12	Front angle	VNE1808
	13	Screw	CPZ20P050FMC
	14	Screw	BBZ30P080FCC
B	15	Screw	IBZ30P060FCC
	16	Screw	IPZ30P060FMC
NSP	17	Earth plate	VNE1518
	18	Screw	PCZ30P060FMC
	19	22P flexible cable	VDA1448
	20	Screw	BBZ30P060FMC
NSP	21	Mechanism ass'y	VWT1092

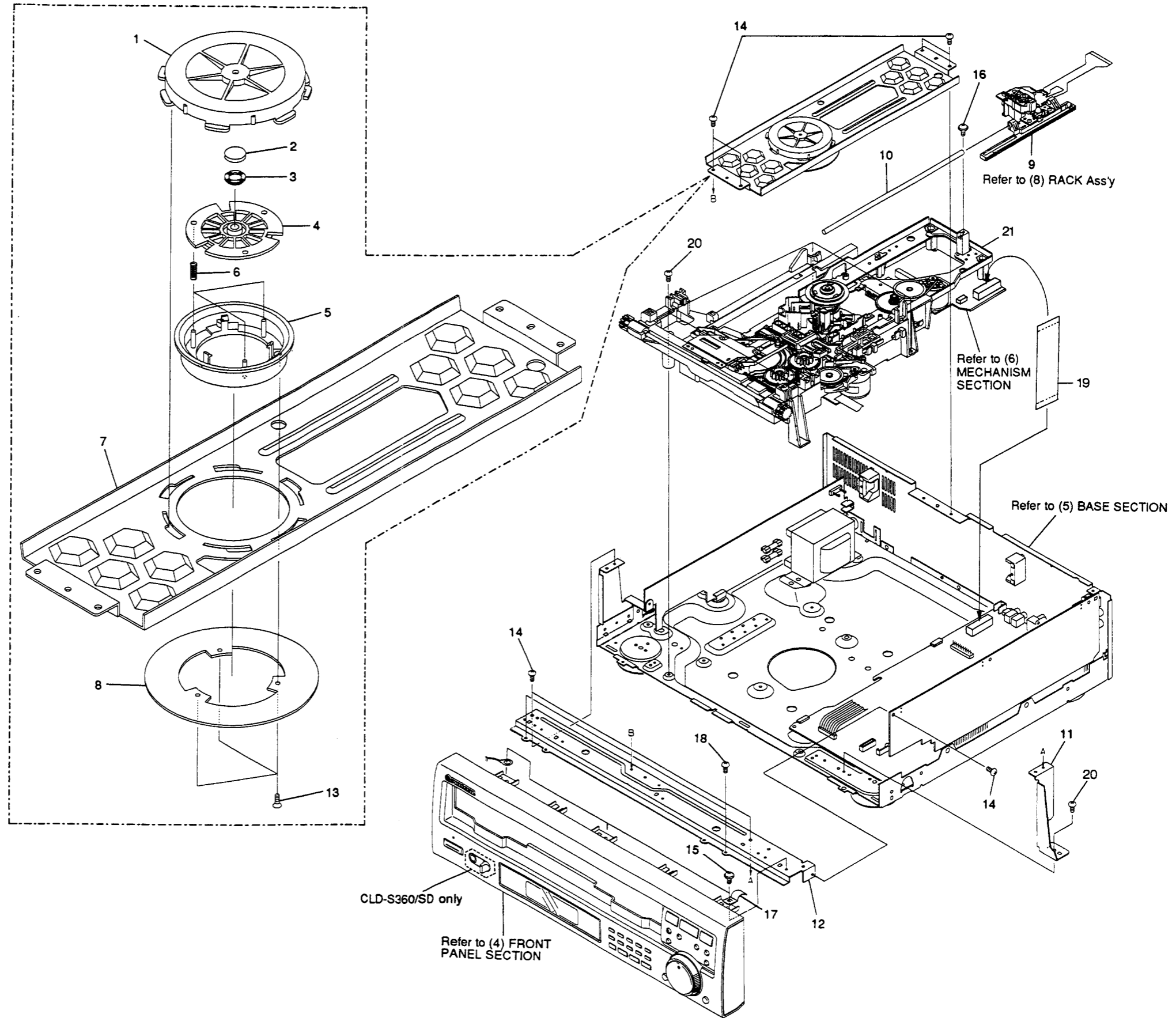

A

B

C

D

(4) FRONT PANEL SECTION

Parts List

Mark	No.	Description	Part No.	Mark	No.	Description	Part No.
NSP	1	PWSB ass'y	VWG1404	NSP	11	Front panel	VNK2408
	2	PW button	VNK2329		12	FL lens	VEC1632
	3	LED lens	PNW2019		13	Skip key L	VNK2322
NSP	4	FLKY ass'y	VWG1403		14	Skip key R	VNK2323
	5	Pioneer plate	VAM1032		15	Snap plate	VNE1102
	6	10 key	VNK2331		16	Headphone knob	PAC1707
	7	Main key	VNK2324	NSP	17	Jack holder	VNE1609
	8	LED lens A	VNK2325	NSP	18	HEPB ass'y	VWV1292
	9	Shuttle knob	VNK2321		19	Screw	BPZ26P060FCU
	10	Sub panel	VNK2327		20	Front panel ass'y-S	VXX1930

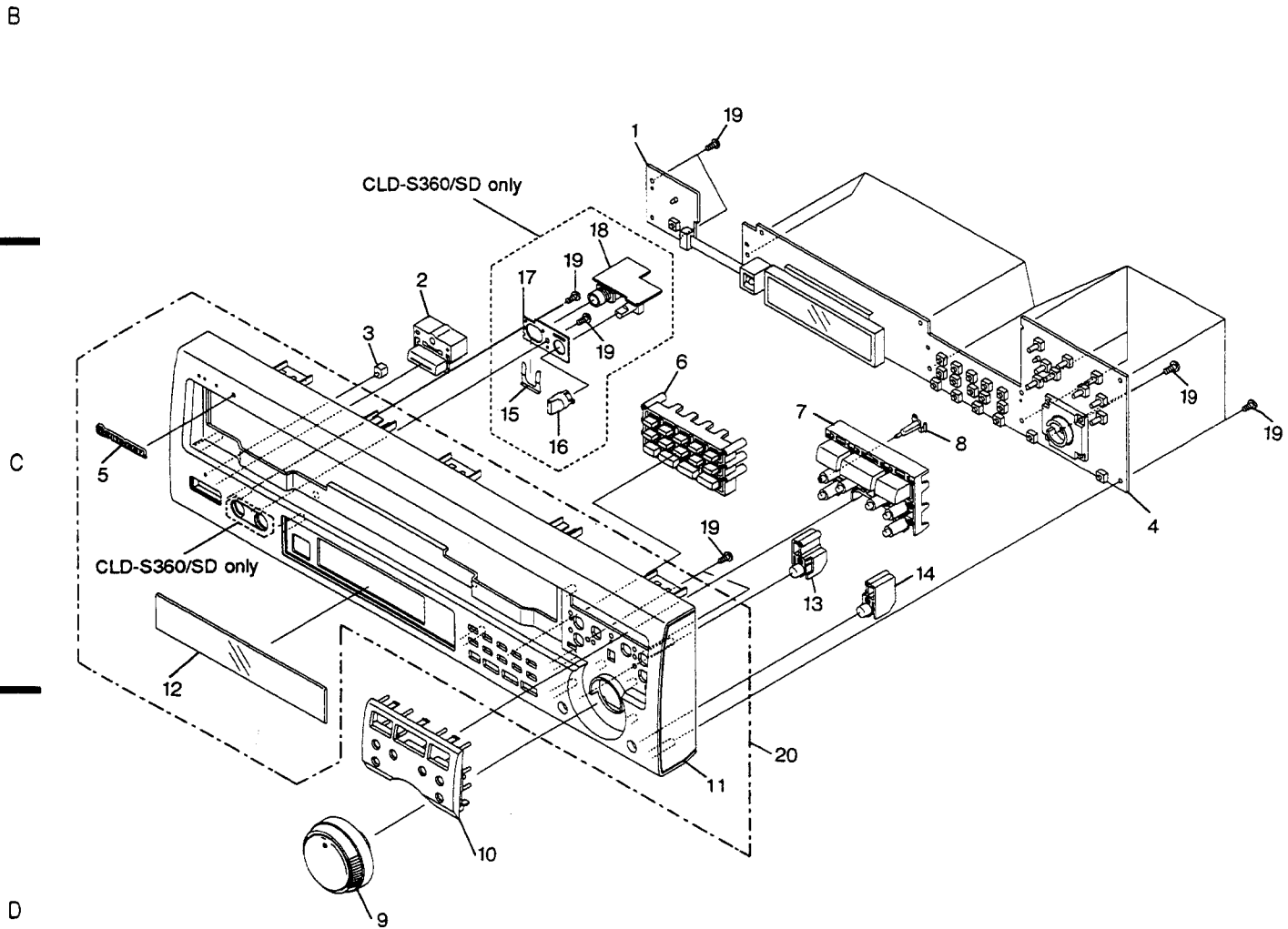

(5) BASE SECTION

Parts List

Mark	No.	Description	Part No.	Mark	No.	Description	Part No.
	1	Main ass'y	VWS1110		16	Insulator (ABS)	PNW1912
	2	Cord stopper	CM-22B	NSP	17	Base chassies	VNA1255
	3	SYPS ass'y	VWR1206		18	Insulator ass'y	VXA1881
	4	Tray stopper	VNL1519		19	Screw	BBZ30P080FCC
△	5	AC power cord SD	PDG1013		20	Screw	BBZ30P040FMC
NSP	6	PCB spacer	PNY-404		21	Screw	BCZ40P060FZK
	7	Rear panel (FE)	VNA1366		22	Screw	BCZ30P080FMC
△	8	Fuse (1A)	REK-100		23	Screw	BPZ30P140FMC
NSP	9	Cord clamper	Z09-060	NSP	24	Heat shink	VNE1854
NSP	10	PCB holder	VEC1174	NSP	25	Cushion	VEC1601
△	11	Power transformer	VTT1123		26	Screw	BCZ30P060FCC
△	12	Fuse (3.15A)	REK-105	NSP	27	VSBA ass'y	VWR1207
NSP	13	PCB holder	PNY-405				
NSP	14	Side stay (L)	VNE1809				
NSP	15	Cord clamper	Z09-061				

A

B

C

D

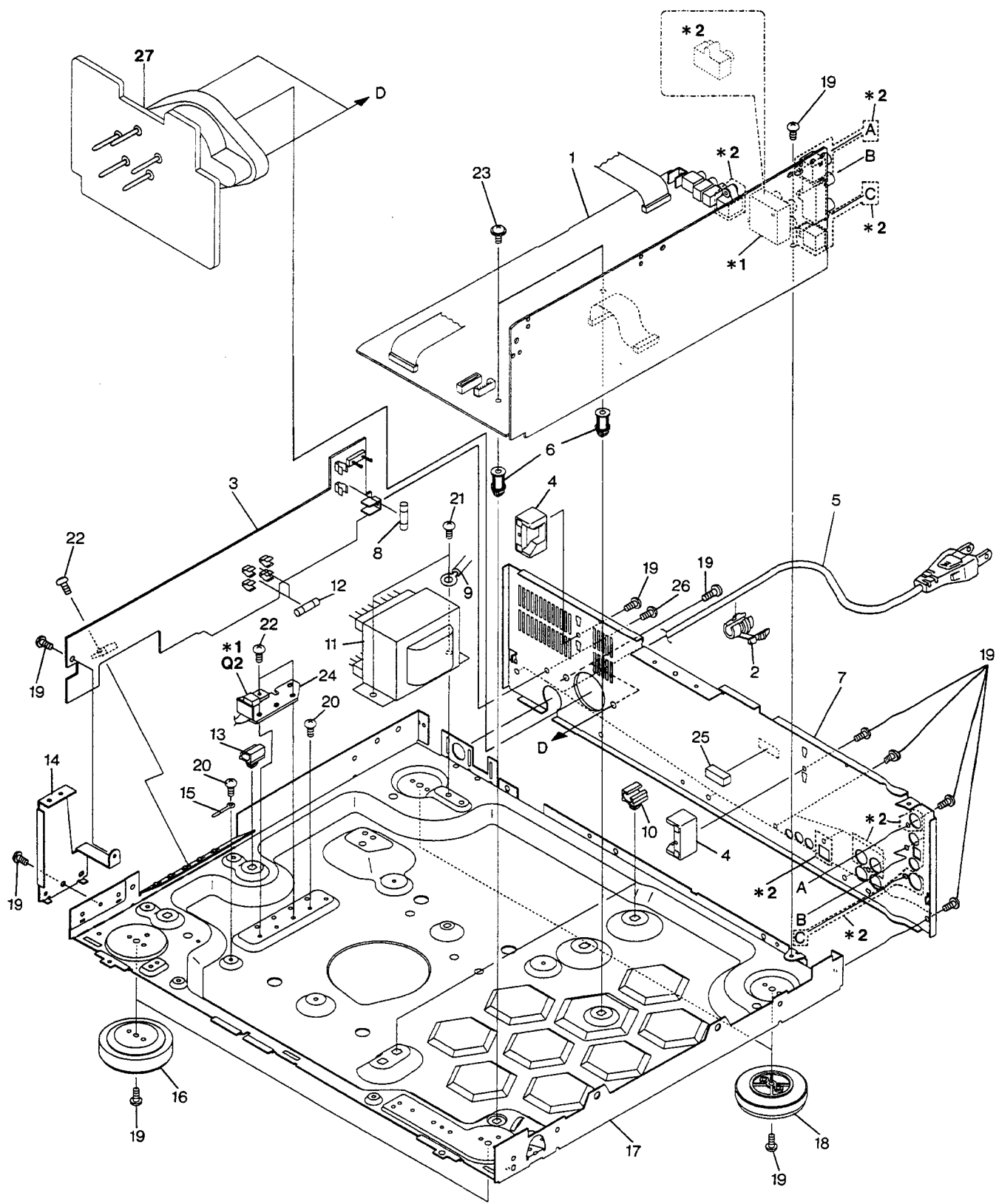

Note :
 *1 : Q2 is component of the SYPS Ass'y.
 *2 : CLD-S360/SD only.

(6) MECHANISM SECTION

Parts List

<u>Mark</u>	<u>No.</u>	<u>Description</u>	<u>Part No.</u>	<u>Mark</u>	<u>No.</u>	<u>Description</u>	<u>Part No.</u>
	1	Mechanism base	VNK1990		14	L-SW lever	VNL1504
	2			15	C-SW lever	VNL1505
	3	Clamp cam	VNL1500		16	R-SW lever	VNL1506
	4	Shaft holder	VNE1817		17	LOSB ass'y	VWG1419
	5	Cam plate	VNL1511	NSP	18	Synchro gear ass'y	VXA1822
	6	CAS spring	VBH1190		19	Roller	VNL1042
	7	Cam gear	VNL1507	NSP	20	LOMB ass'y	VWG1420
	8	CD plate	VNL1512		21	Loading motor ass'y	VXX1712
	9	CDP spring	VBH1191		22	Slider motor	VXM1033
	10	Rubber belt	VEB1184	NSP	23	Motor pulley	PNW1643
	11	Gear pulley	VNL1510		24	Screw	Z39-019
	12	Twin gear	VNL1508		25	Screw	BMZ26P040FMC
	13	Center gear	VNL1509				

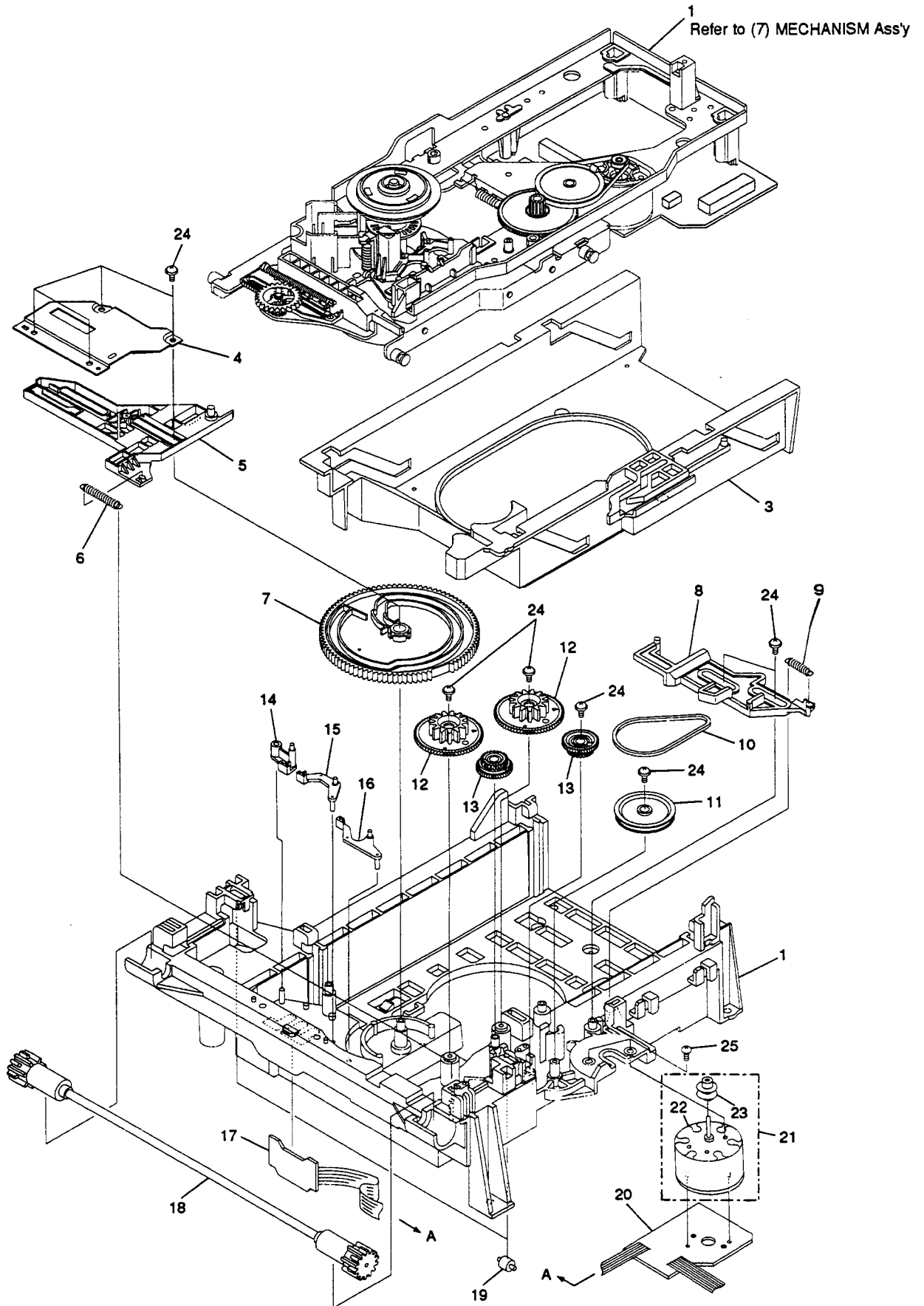

(7) MECHANISM Ass'y

Parts List

<u>Mark</u>	<u>No.</u>	<u>Description</u>	<u>Part No.</u>	<u>Mark</u>	<u>No.</u>	<u>Description</u>	<u>Part No.</u>
	1	CA belt	VEB1077		16	Y gear	VNL1501
	2	CA pulley	VNL1496		17	Tilt cam spring	VBH1189
	3	CA gear	VNL1497		18	Tilt cam	VNL1502
	4	Tilt base	VNL1499		19	Spindle motor ass'y	VXA2010
	5	CA-SW lever	VNL1498		20	Centering hab	VNL1174
NSP	6	CAMB ass'y	VWG1418		21	Centering spring	VBH1083
	7	Carriage motor ass'y	VXX1261	NSP	22	Rubber sheet	VEB1103
NSP	8	Slider motor	VXM1033	NSP	23	Turn table ass'y	VXA1283
	9	CA pulley (1)	VNL1197	NSP	24	Oil stopper	VBF1002
NSP	10	PASB ass'y	VWG1417	NSP	25	Spindle motor	VXM1053
	11	Radial spring	VBH1201		26	Motor base	VNE1803
	12	Thrust spring	VBH1200		27	Screw	BMZ26P040FMC
	13	Tilt tension	VBH1187		28	Screw	ABZ30P300FMC
NSP	14	FG ass'y	VWG1416		29	Screw	PMA30P050FMC
	15	FG base	VNL1503		30	Washer	WT26D060D025

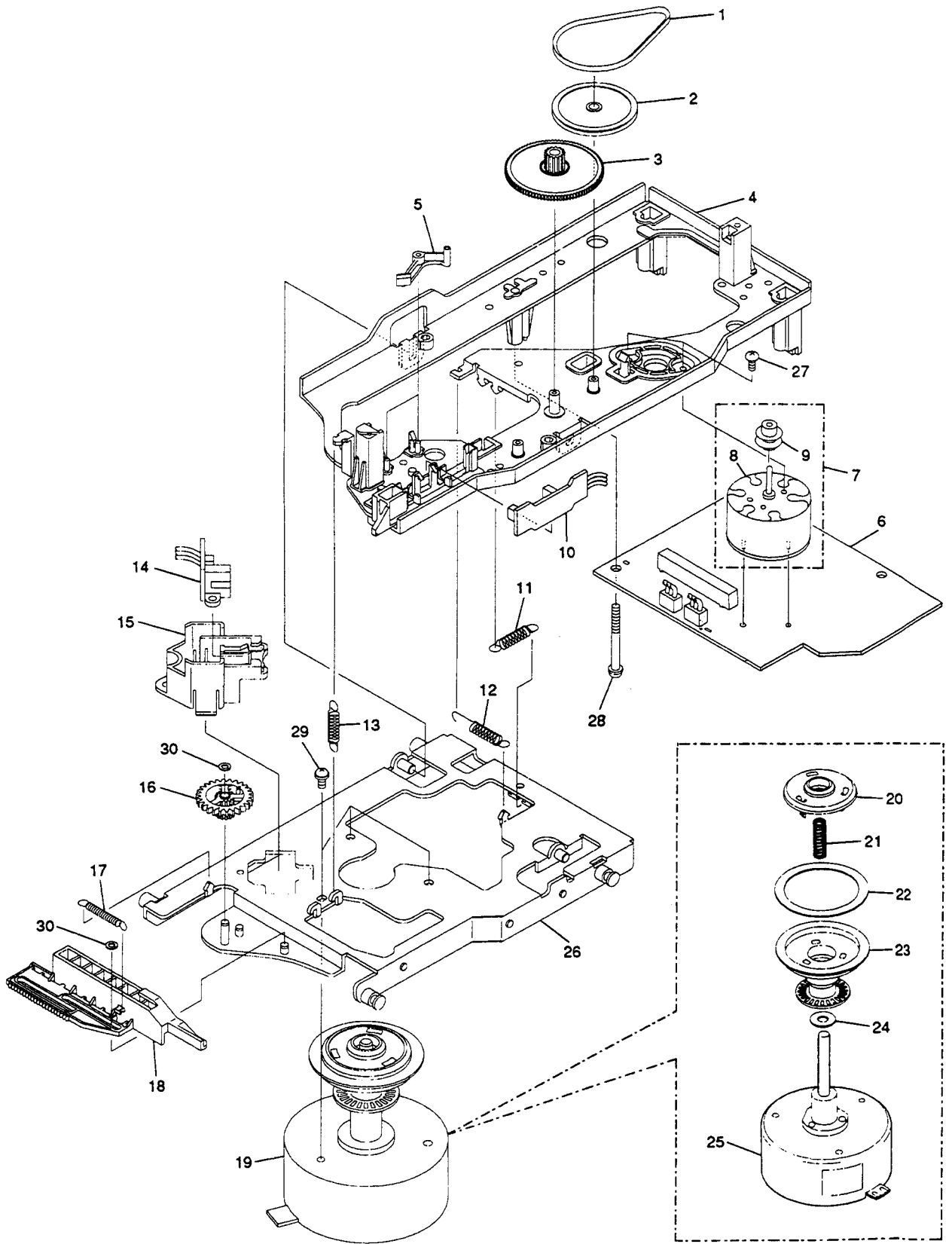

(8) RACK Ass'y

Parts List

Mark	No.	Description	Part No.
NSP	1	Sensor stay	VBK1036
NSP	2	Tilt sensor	SG-302
NSP	3	Pickup ass'y	VWY1030
	4	Rack	VNL1495
	5	Tan. base	VNL1494
	6	Screw	PBB26P080FMC
	7	Screw	PMA20P060FMC
	8	Screw	PMA20P080FMC
	9	Screw	PMH20P040FMC
	10	Screw	SMZ20H120FZK

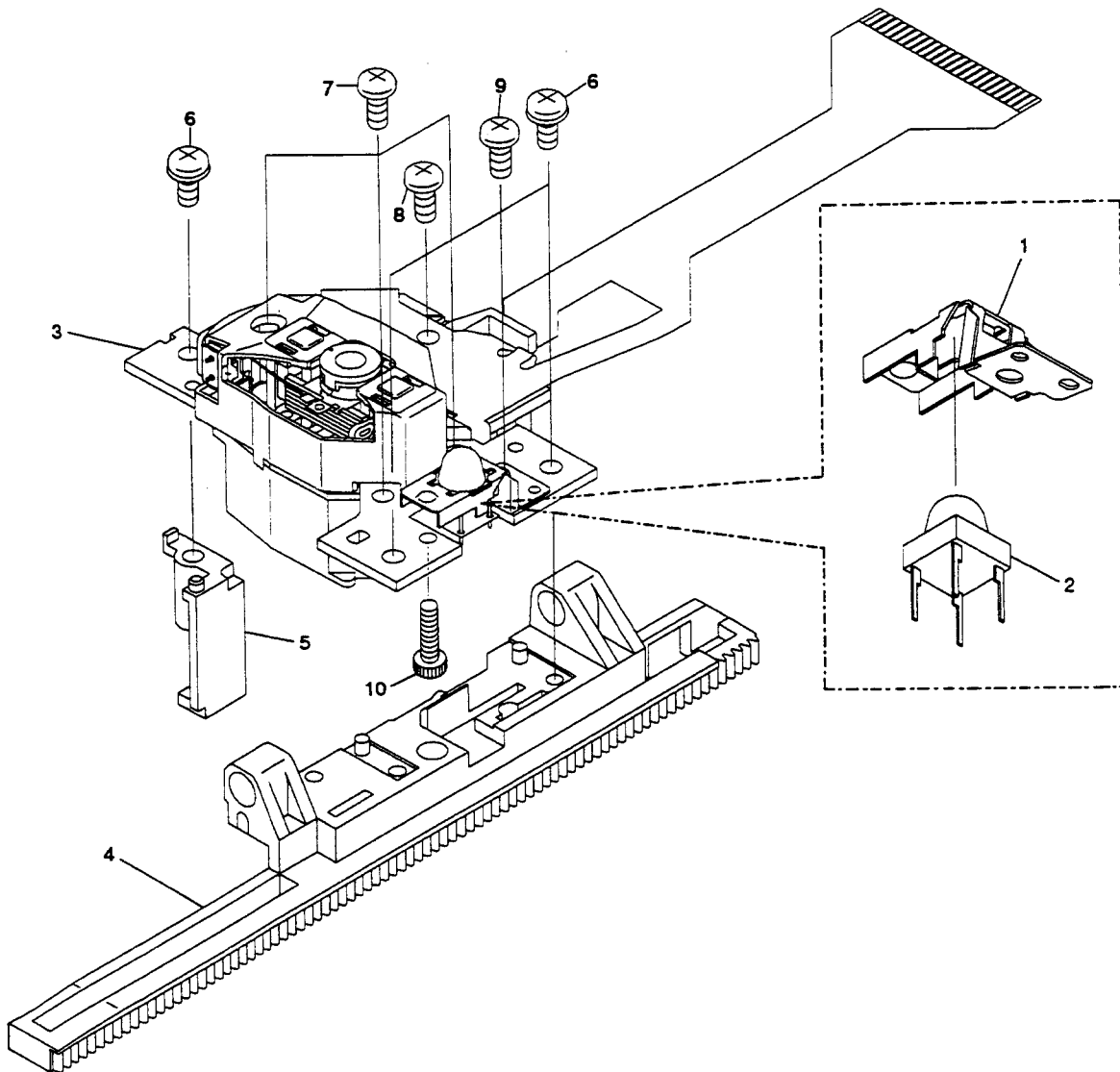

A

B

C

D

2. FL INFORMATION

●VAW1033 (V201)

PIN LOCATION

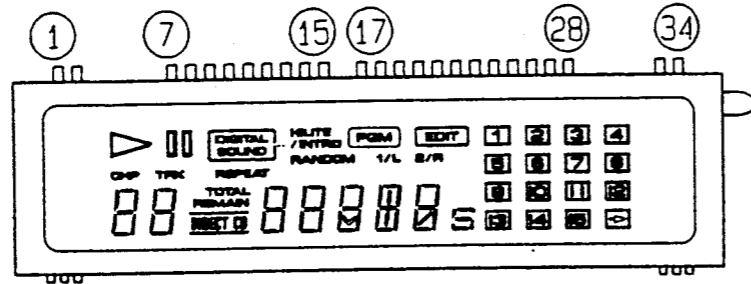

PIN ASSIGNMENT

PIN ASSIGNMENT																	
Pin No.	1	2	3	4	5	6	7	8	9	10	11	12	13	14	15	16	17
Assignment	F	F	NP	NP	NP	NP	G1	G2	G3	G4	G5	G6	G7	G8	G9	NP	P1
Pin No.	18	19	20	21	22	23	24	25	26	27	28	29	30	31	32	33	34
Assignment	P2	P3	P4	P5	P6	P7	P8	P9	P10	P11	P12	NP	NP	NP	NP	F	F

F:Filament G1-G9:Grid P1-P12:Anode NP:No pin

ANODE GRID ASSIGNMENT & PIN ASSIGNMENT

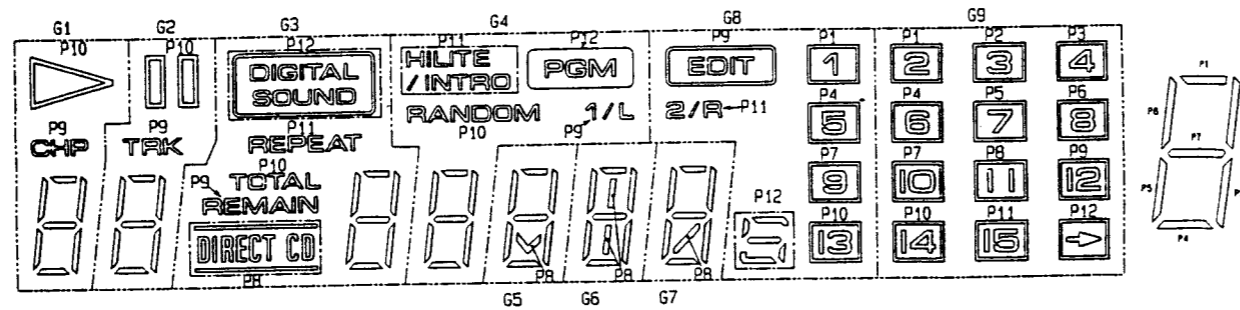

ANODE GRID ASSIGNMENT

	G1	G2	G3	G4	G5	G6	G7	G8	G9
P1	P1	P1	P1	P1	P1	P1	P1	1	2
P2	P2	P2	P2	P2	P2	P2	P2		3
P3	P3	P3	P3	P3	P3	P3	P3		4
P4	P4	P4	P4	P4	P4	P4	P4	5	6
P5	P5	P5	P5	P5	P5	P5	P5		7
P6	P6	P6	P6	P6	P6	P6	P6		8
P7	P7	P7	P7	P7	P7	P7	P7	9	10
P8			DIRECT CD						11
P9	CHP	TRK	REMAIN	1/L				EDIT	12
P10			TOTAL	RANDOM				13	14
P11			REPEAT	HILITE / INTRO				2/R	15
P12			DIGITAL SOUND	PGM					16

3. BLOCK DIAGRAM

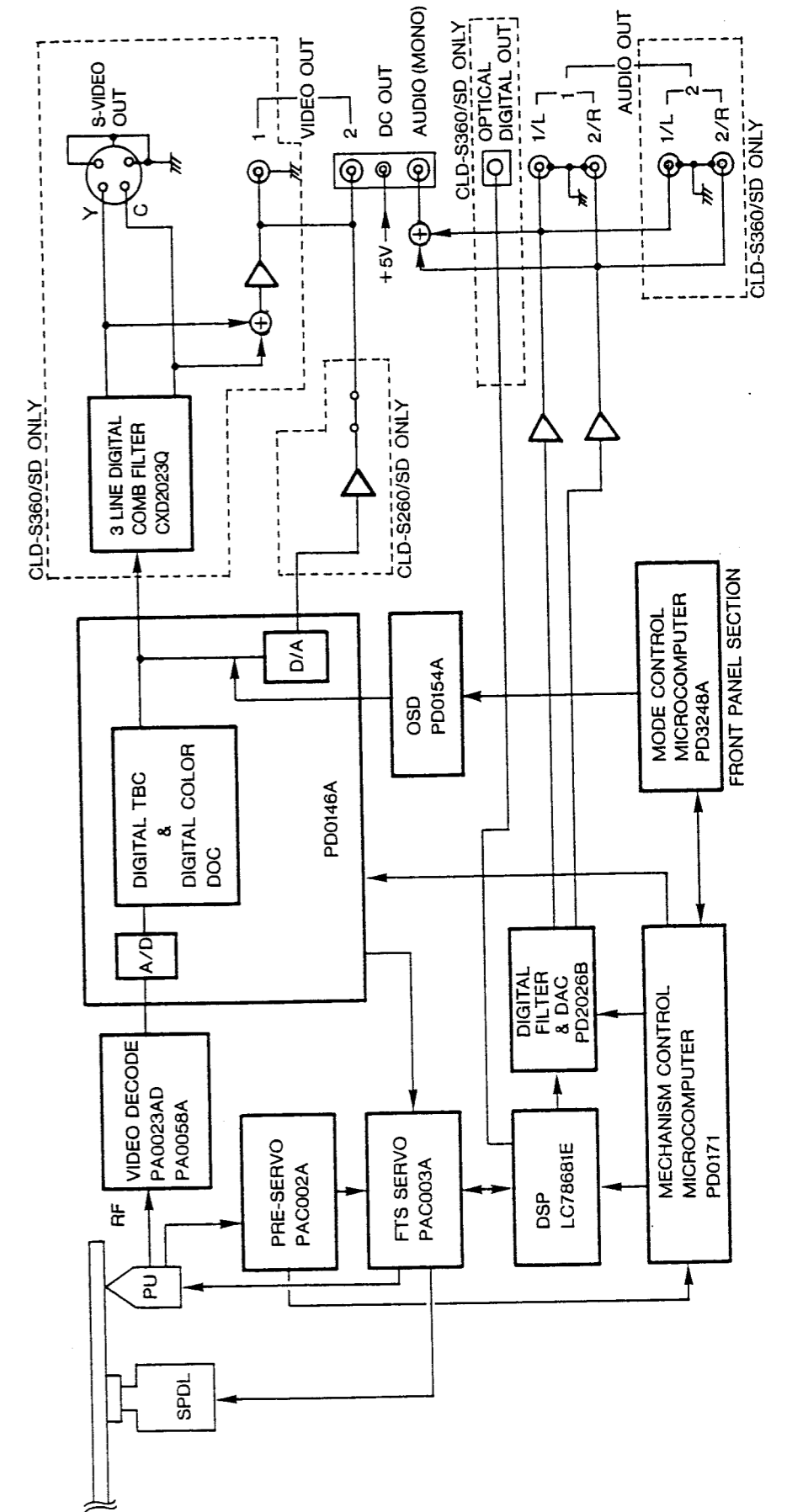

4. SCHEMATIC AND PCB CONNECTION DIAGRAMS

4.1 FLKY, PWSB, SYPS, CAMB, LOSB, LOMB, FG, PASB, HEPB Ass'y AND OVERALL WIRING DIAGRAM

FLKB Ass'y VWM1356 (CLD-S360/SD) VWM1372 (CLD-S260/SD)

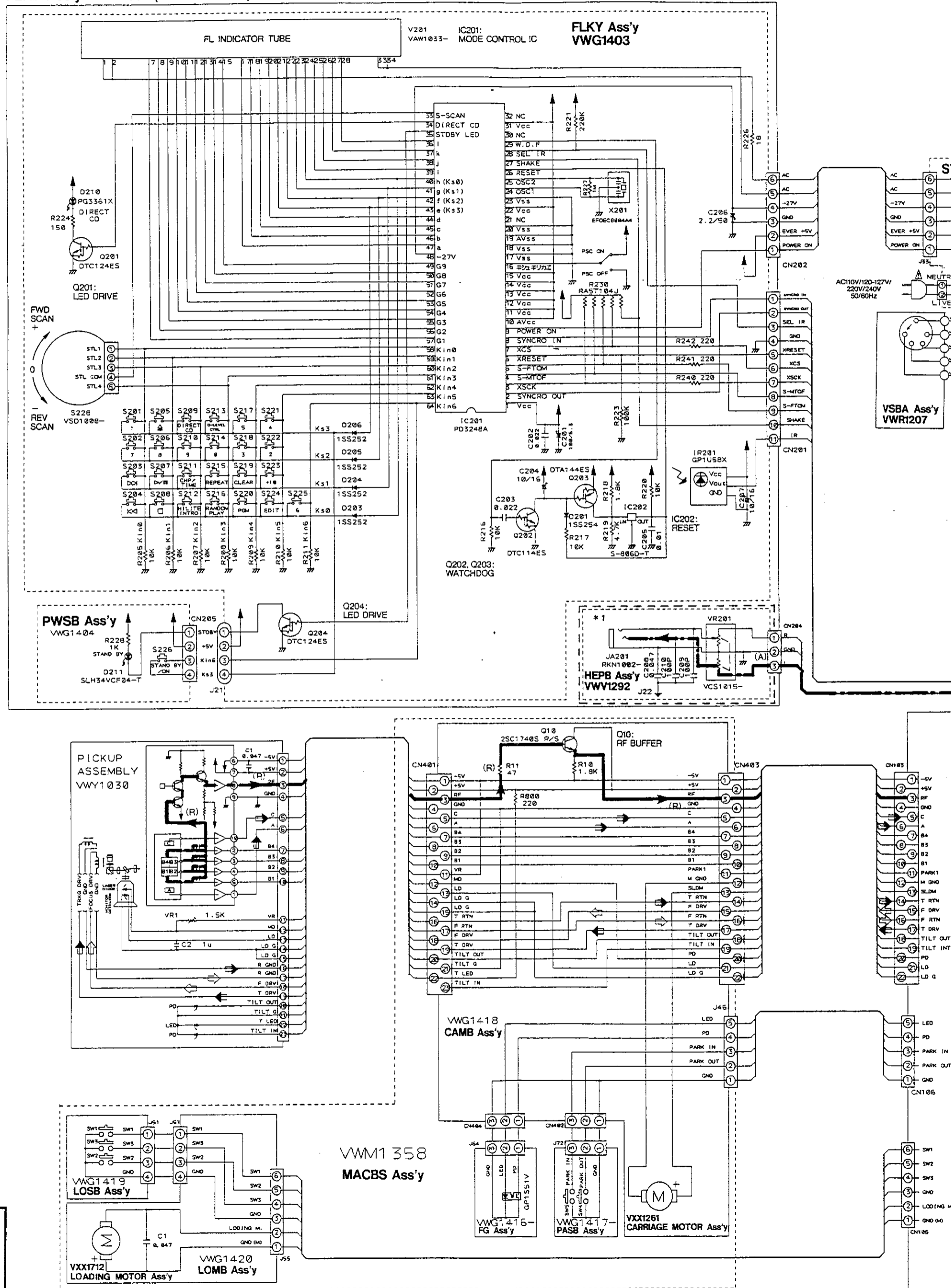

OVERALL WIRING DIAGRAM
SCH-1

A

B

C

D

E

- (R) : RF Signal Line
- (A) : Audio Signal Line
- ▬ : Tracking Servo Loop Line
- ◁ : Focus Servo Loop Line
- ▨ : Spindle Drive Signal Line

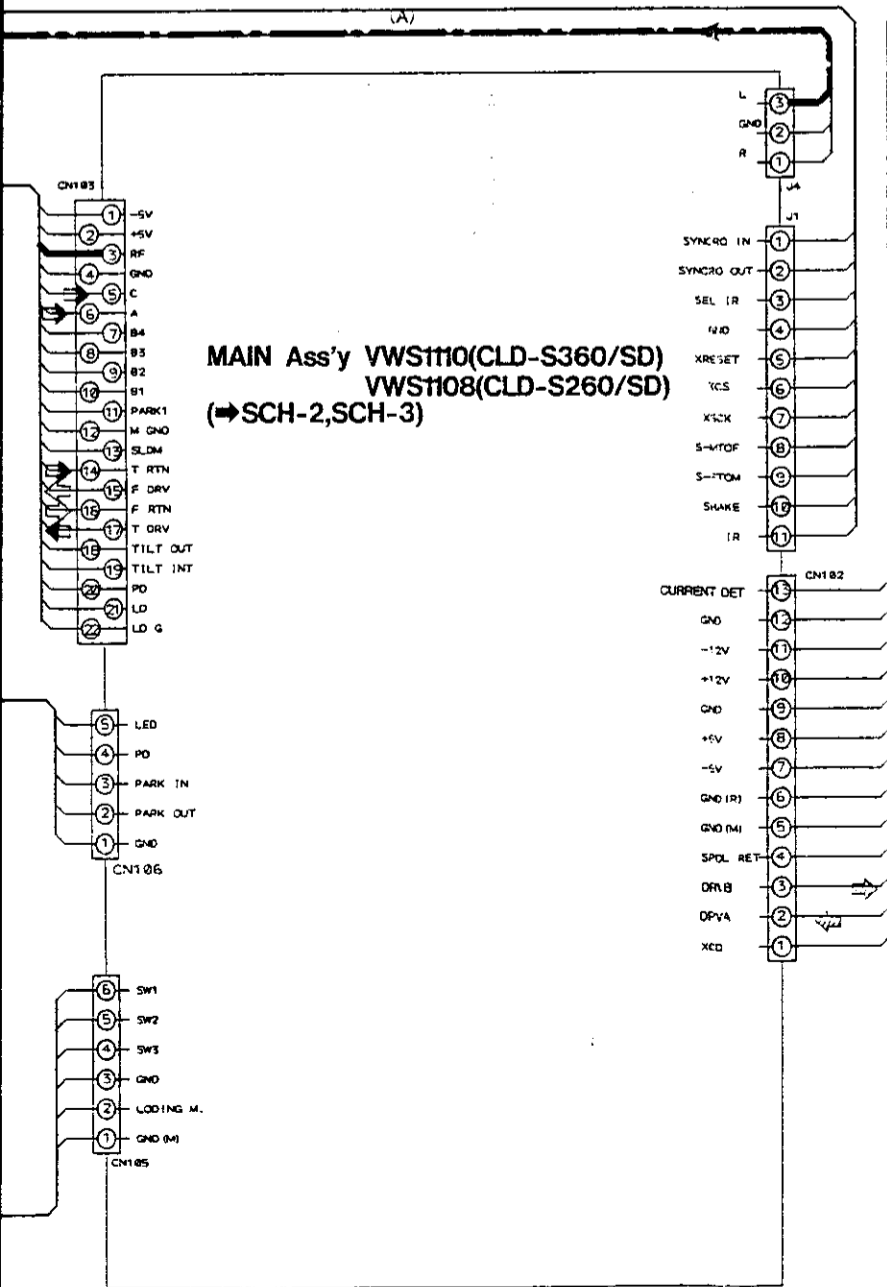
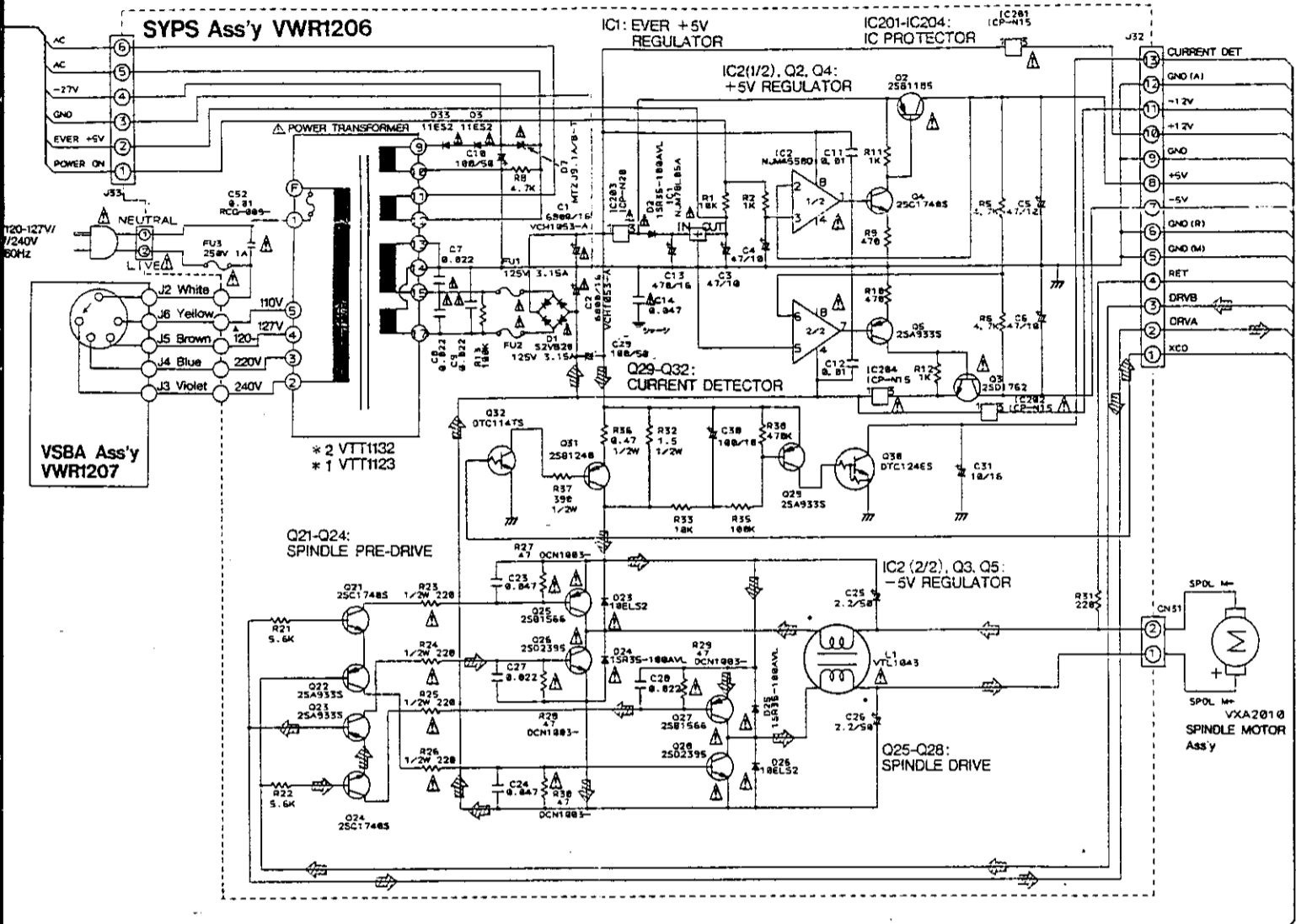

NOTE FOR SCHEMATIC DIAGRAMS (Type 4A)

- When ordering service parts, be sure to refer to "PARTS LIST OF EXPLODED VIEWS" or "PCB PARTS LIST".
- Since these are basic circuits, some parts of them or the values of some components may be changed for improvement.
- RESISTORS:**
Unit: k: kΩ, M: MΩ, or Ω unless otherwise noted.
Rated power: 1/4W, 1/6W, 1/8W, 1/10W unless otherwise noted.
Tolerance: (F): ±1%, (G): ±2%, (K): ±10%, (M): ±20% or ±5% unless otherwise noted.
- CAPACITORS:**
Unit: p: pF or μF unless otherwise noted.
Ratings: capacitor (μF)/voltage (V) unless otherwise noted.
Rated voltage: 50V except for electrolytic capacitors.
- COILS:**
Unit: m: mH or μH unless otherwise noted.
- VOLTAGE AND CURRENT:**
□ or - V : DC voltage (V) in PLAY mode unless otherwise noted.
⊕ mA or - mA : DC current in PLAY mode unless otherwise noted.
Value in () is DC current in STOP mode.
- OTHERS:**
• ⊕ or ⊖ : Adjusting point.
• - : Measurement point.
• The Δ mark found on some component parts indicates the importance of the safety factor of the parts. Therefore, when replacing, be sure to use parts of identical designation.
- SCH-□ ON THE SCHEMATIC DIAGRAM:**
• SCH-□ indicates the drawing number of the schematic diagram. (SCH stands for schematic diagram.)

9. **SWITCHES** (Underline indicates switch position):
- | | |
|-----------------------------|-------------------------|
| FLXY Ass'y | PWSB Ass'y |
| S201: 1 | S226: POWER(STANDBY/ON) |
| S202: 7 | |
| S203: ▬▬ | PASB Ass'y |
| S204: ▬▬▬ | S4 : PARK OUT |
| S205: ▲ | S5 : PARK IN |
| S206: 8 | |
| S207: ▬/▬▬ | LOSB Ass'y |
| S208: ■ | S1 : TILT, LOADING 1 |
| S209: DIRECT CD | S2 : TILT, LOADING 2 |
| S210: 9 | S3 : TILT, LOADING 3 |
| S211: CHAP/TIME | |
| S212: HILITE INTRO | |
| S213: D-LEVEL CONTROL | |
| S214: 0 | |
| S215: REPEAT | |
| S216: RANDOM PLAY | |
| S217: 5 | |
| S218: 3 | |
| S219: CLEAR | |
| S220: PGM | |
| S221: 4 | |
| S222: 2 | |
| S223: +10 | |
| S224: PGM EDIT | |
| S225: 6 | |
| S228: SCAN (ROTARY ENCODER) | |

Note:
*1 : CLD-S360/SD only
*2 : CLD-S260/SD only

OVERALL WIRING DIAGRAM **SCH-1**

IC202 Q202 Q203

Q201

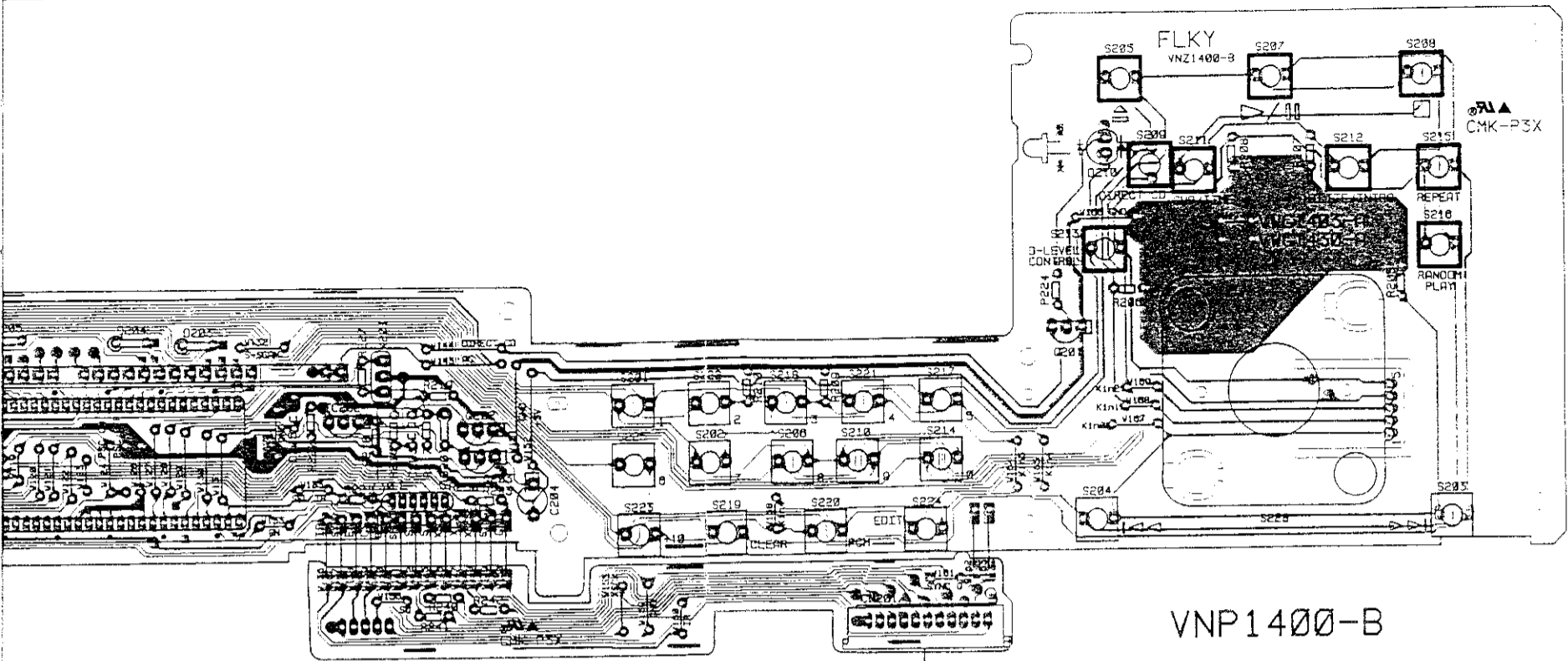

To MAIN Ass'y J1

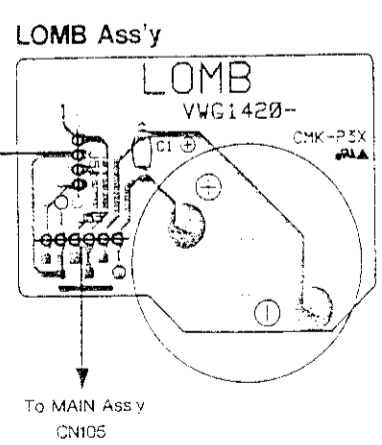
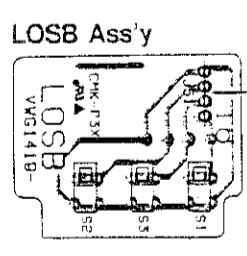
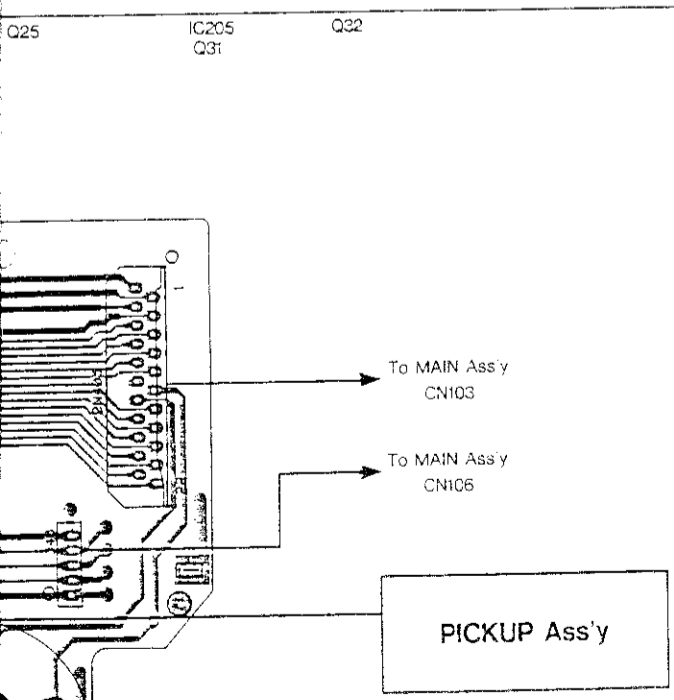
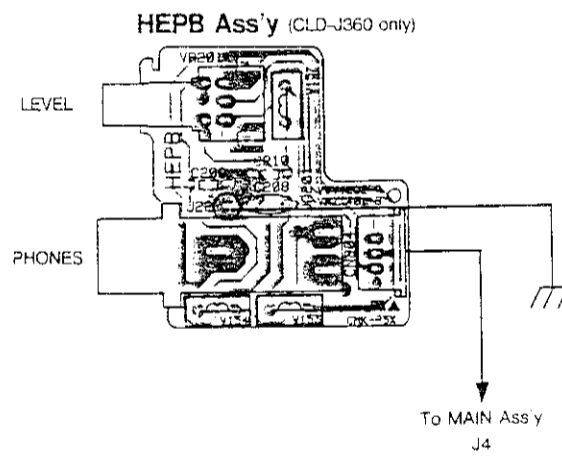
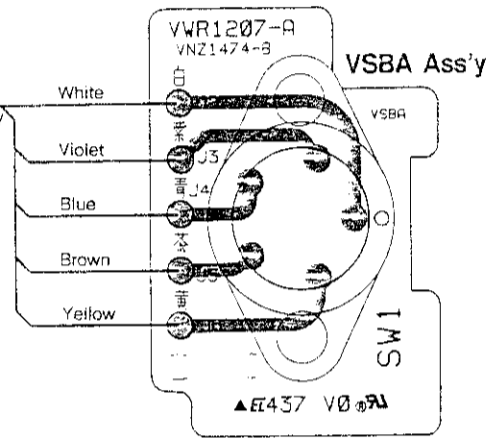
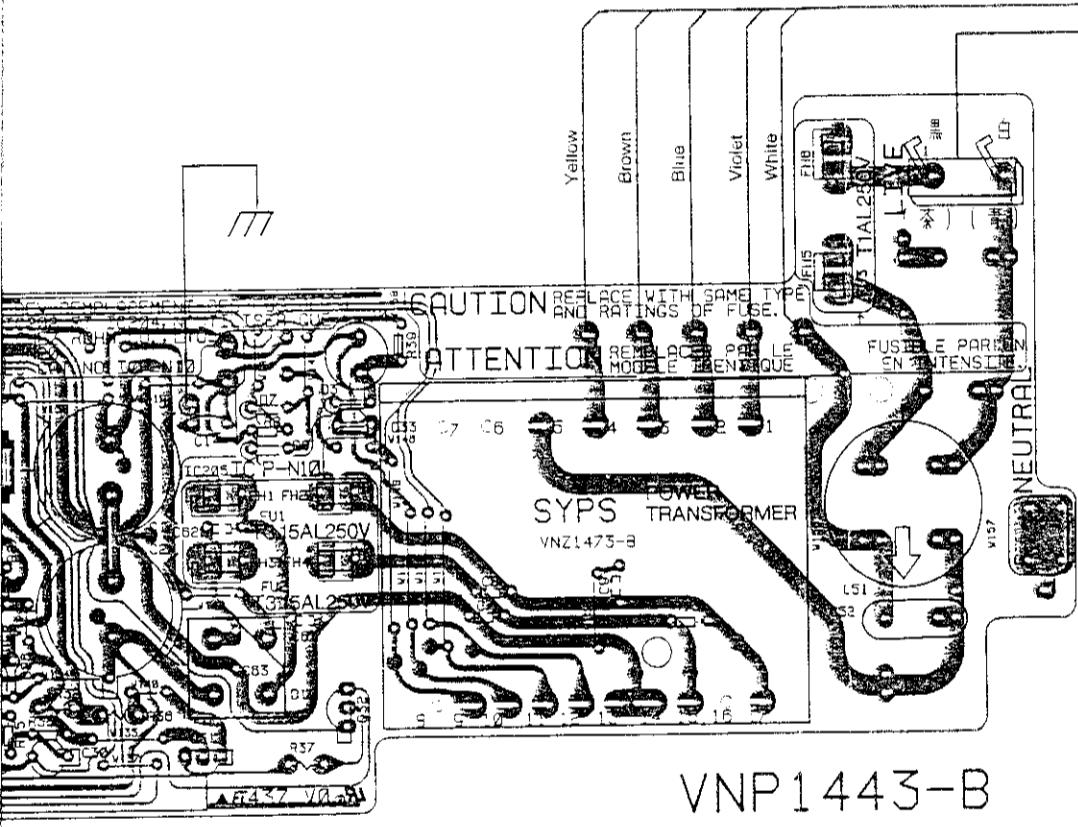

This PCB connection diagram is viewed from the parts mounted side.

VNP1396-A

A

B

C

D

M

IT

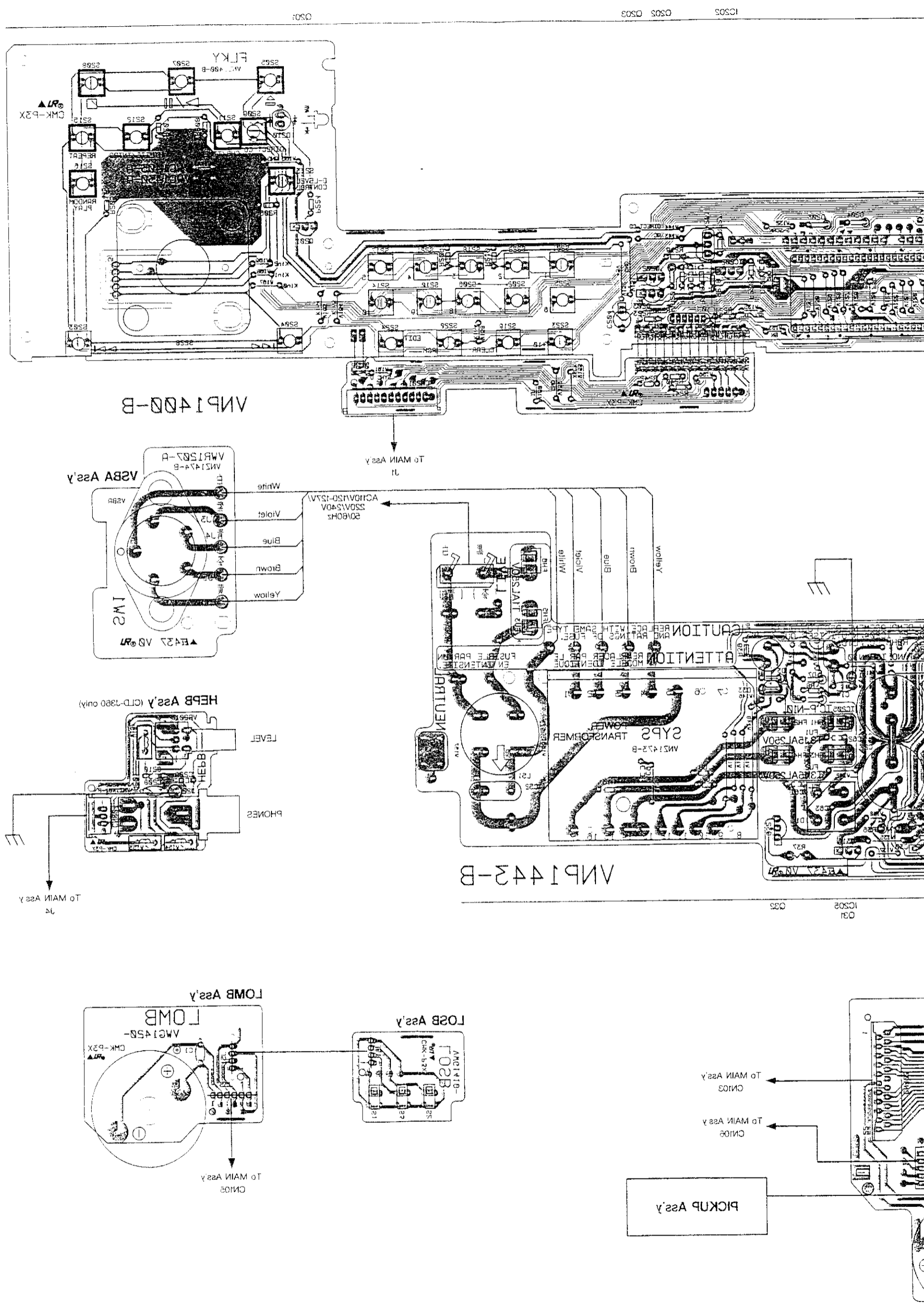

This PCB connection diagram is viewed from the foil side.

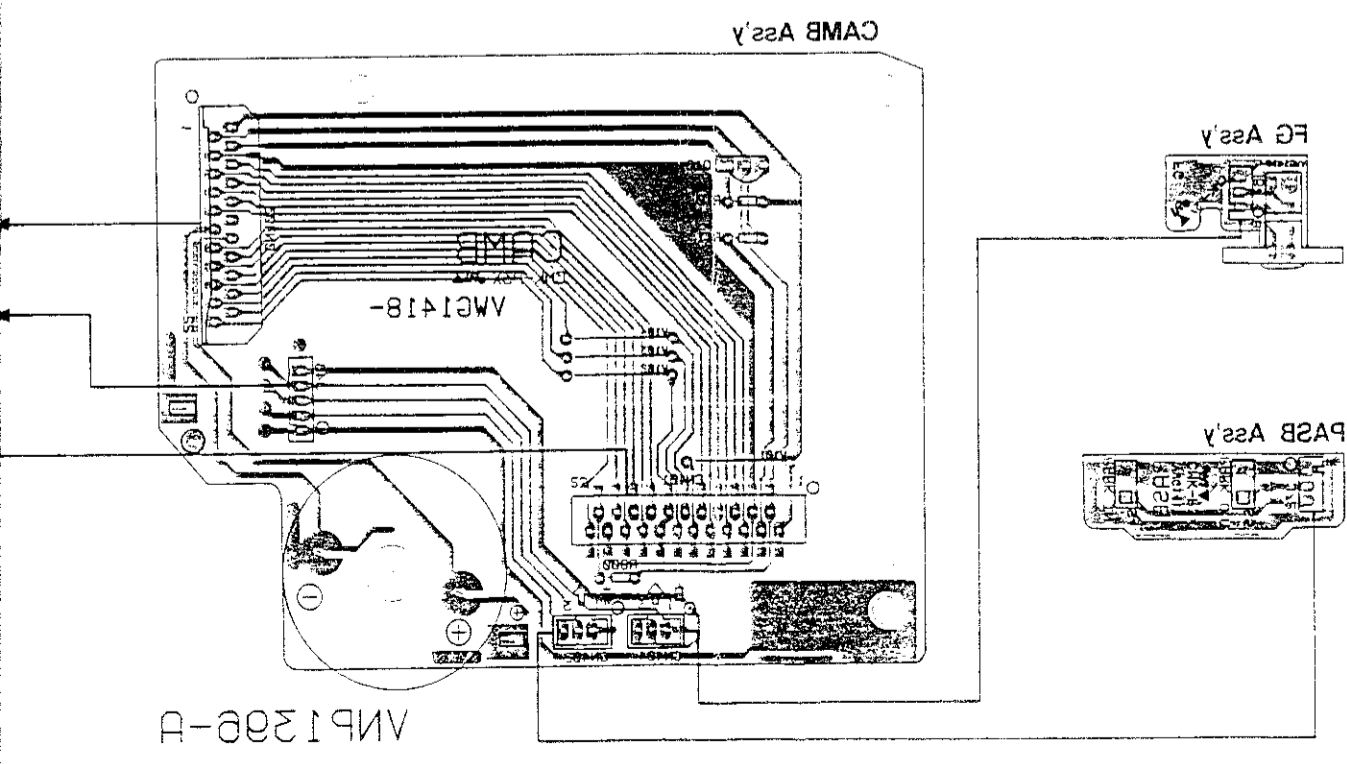
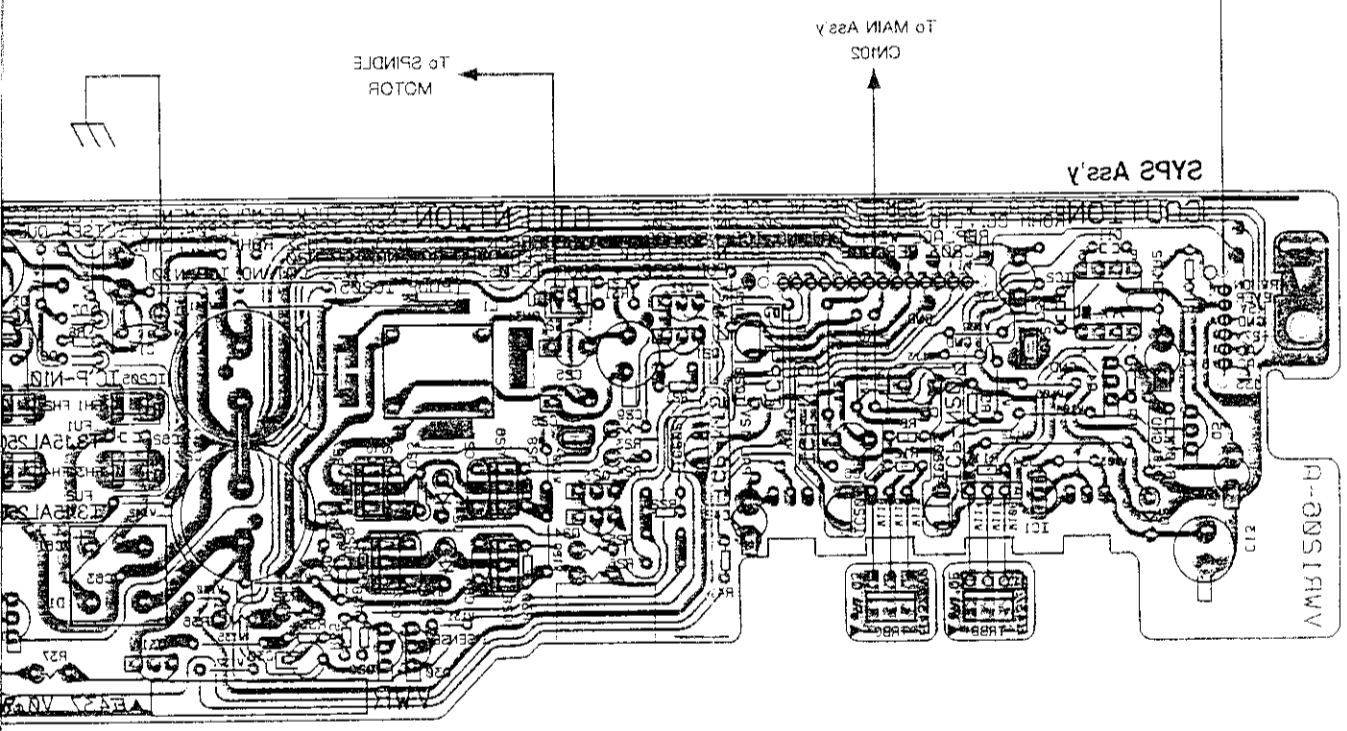
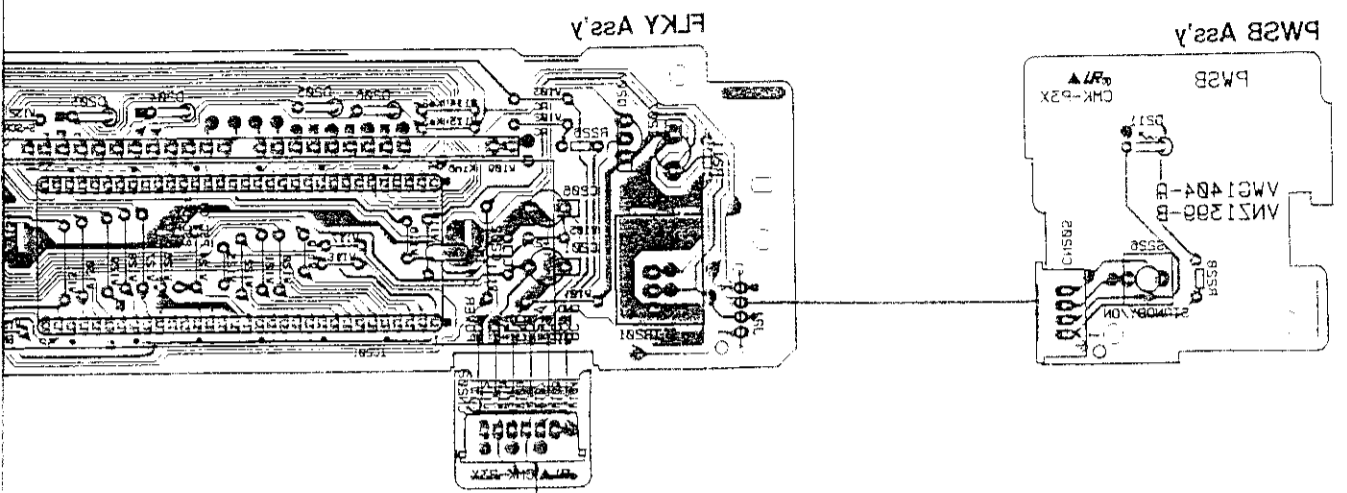

Q301 Q304

Q31 Q34

A B C D E F G H I J K L M N O P Q R S T U V W X Y Z

WAVEFORMS FTS AND AUDIO SECTION

Note: No. in the table correspond to the pin number.

Measurement Conditions: (D. audio) was measured when a disk to which digital audio is written to, was played back.

IC801(PAC002A)	IC802(LC78681E)	IC803(LA6510)	IC901(PAC003A)	CN106
<p>②, ③ 1mS/Div. 16mVp-p</p> <p>AC mode</p>	<p>② 0.1μS/Div. 4.3Vp-p</p> <p>AC mode(D.audio)</p>	<p>① 2mS/Div. 1.8Vp-p</p> <p>DC mode</p>	<p>② 0.2mS/Div. 74mVp-p</p> <p>DC mode</p>	<p>①, ② 5mS/Div. 65mVp-p</p> <p>DC mode</p>
<p>⑦, ⑧ 1mS/Div. 67mVp-p</p> <p>DC mode</p>	<p>③③ 10μS/Div. 4.2Vp-p</p> <p>AC mode(D.audio)</p>		<p>⑦ 0.2mS/Div. 74mVp-p</p> <p>DC mode</p>	<p>③ 0.5mS/Div. 300mVp-p</p> <p>AC mode</p>
<p>⑨ 5mS/Div. 0.1Vp-p</p> <p>DC mode</p>	<p>③⑤ 0.2μS/Div. 4.4Vp-p</p> <p>AC mode(D.audio)</p>		<p>①⑥ 0.2mS/Div. 0.61Vp-p</p> <p>DC mode</p>	<p>④ 5mS/Div. 15Vp-p</p> <p>DC mode</p>
	<p>③⑥ 0.2μS/Div. 4.5Vp-p</p> <p>AC mode(D.audio)</p>		<p>④⑧ 50μS/Div. 6.2Vp-p</p> <p>DC mode</p>	<p>⑤ 5mS/Div. 5.8Vp-p</p> <p>DC mode</p>
	<p>④③ 0.1μS/Div. 4.5Vp-p</p> <p>AC mode(D.audio)</p>		<p>⑤② 0.2μS/Div. 2.1Vp-p</p> <p>AC mode</p>	<p>⑥ 5mS/Div. 3.5Vp-p</p> <p>DC mode</p>
	<p>⑤⑨ 0.1μS/Div. 2Vp-p</p> <p>AC mode(D.audio)</p>		<p>⑤⑦ 1mS/Div. 0.53Vp-p</p> <p>DC mode</p>	<p>⑨ 5mS/Div. 1.25Vp-p</p> <p>DC mode</p>
			<p>⑤⑧ 0.2mS/Div. 0.32Vp-p</p> <p>DC mode</p>	<p>①① 10mS/Div. 1.7Vp-p</p> <p>DC mode</p>

4.2 MAIN Ass'y (1/2)

● FTS and Audio Section

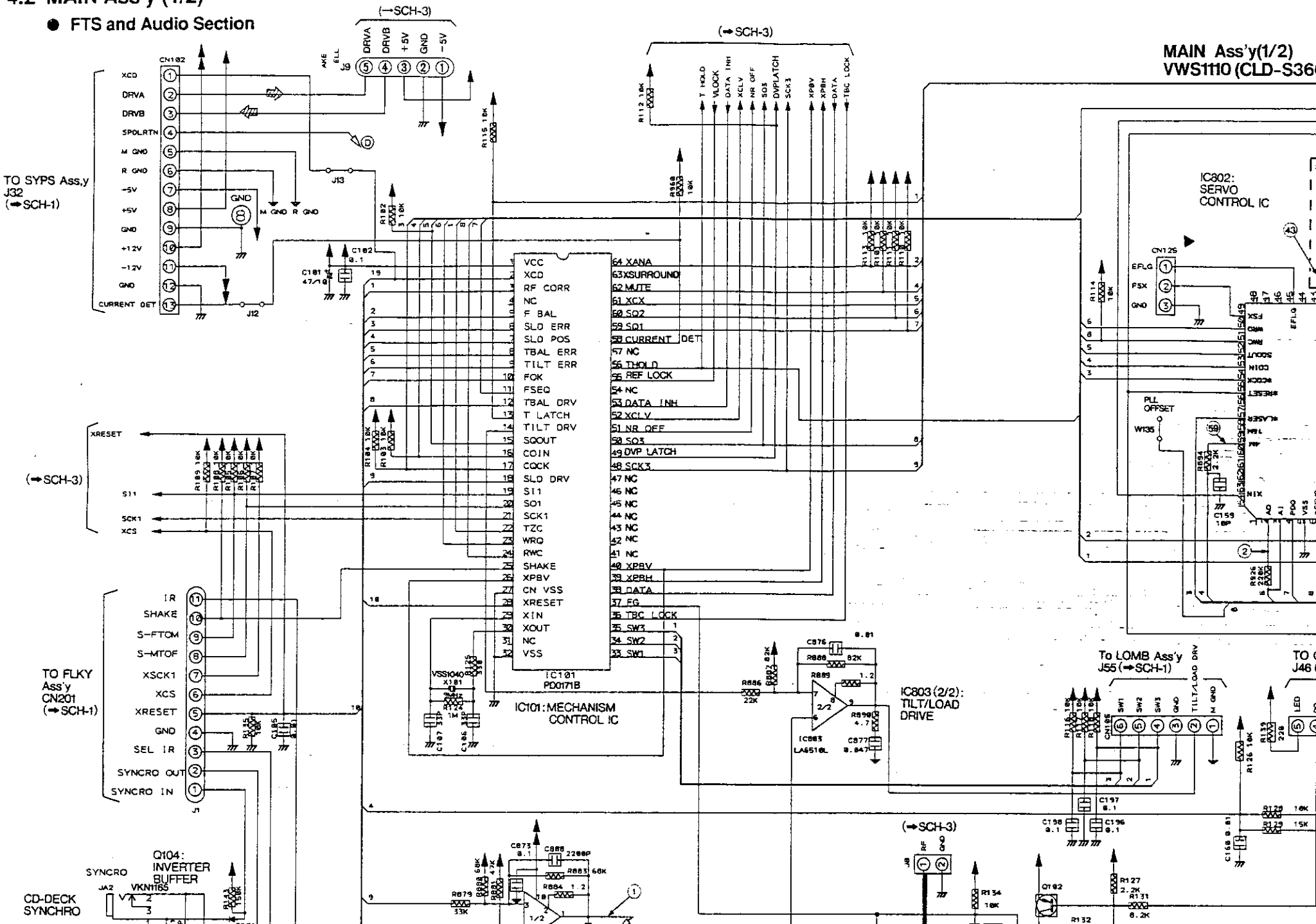

MAIN Ass'y(1/2)
VWS1110 (CLD-S36)

IC802:
SERVO
CONTROL IC

IC101:
MECHANISM
CONTROL IC

IC803 (2/2):
TILT/LOAD
DRIVE

Q104:
INVERTER
BUFFER

TO SYPS Ass'y
J32 (SCH-1)

TO FLKY
Ass'y
CN201 (SCH-1)

To LOMB Ass'y
J55 (SCH-1)

TO
J46

A

B

C

4.2 MAIN Ass'y (1/2)

● FTS and Audio Section

MAIN Ass'y(1/2)
VWS1110 (CLD-S36)

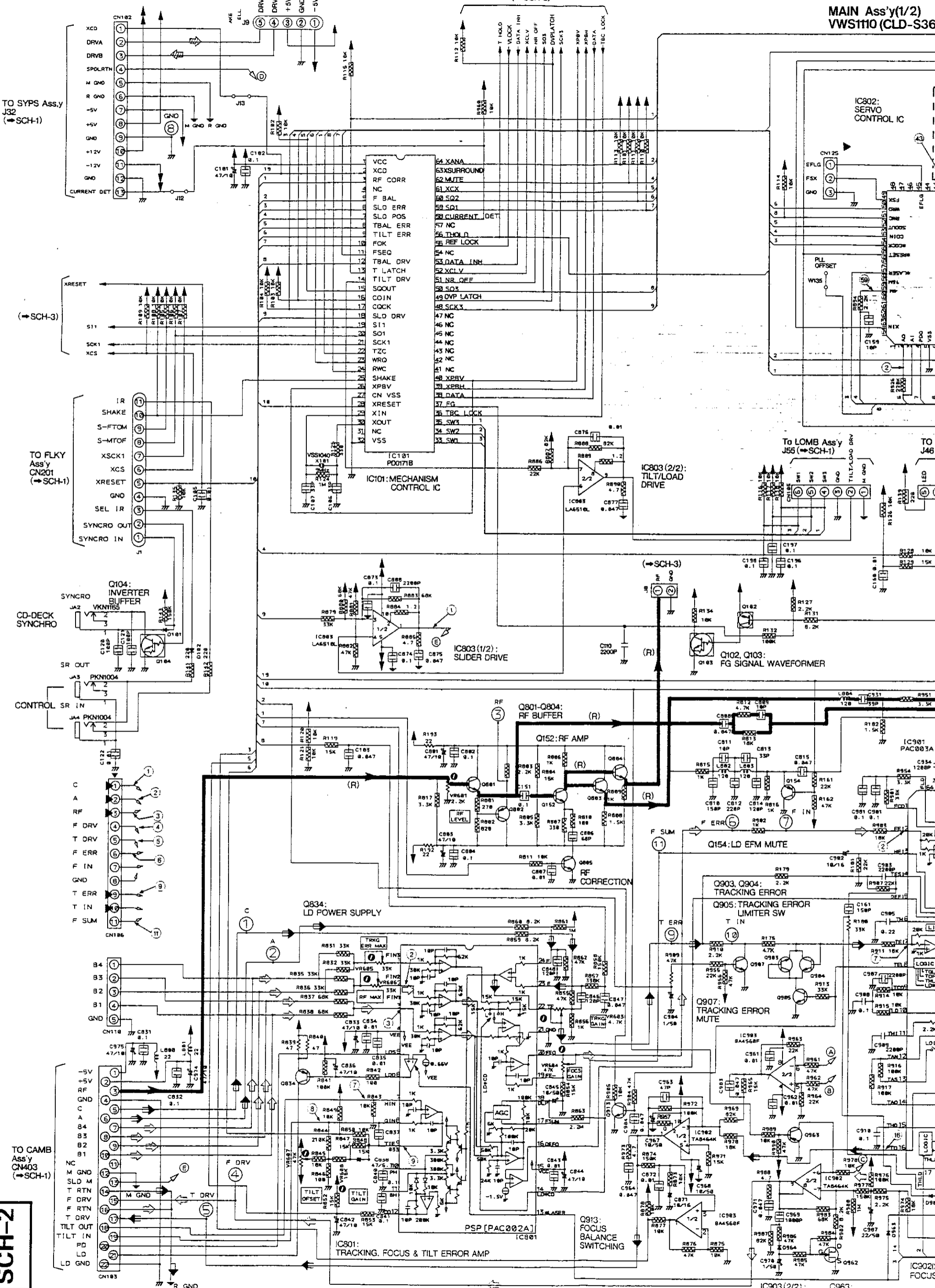

MAIN Ass'y (1/2)
SCH-2

A
B
C
D
E
F

MAIN Ass'y(1/2)
VWS110(CLD-S360/SD) VWS108(CLD-S260/SD)

(R) : RF Signal Line
 (A) : Audio Signal Line
 --- : Digital Signal Line
 ⊙ : Tracking Servo Loop Line
 ⊕ : Focus Servo Loop Line
 ⊛ : Spindle Drive Signal Line

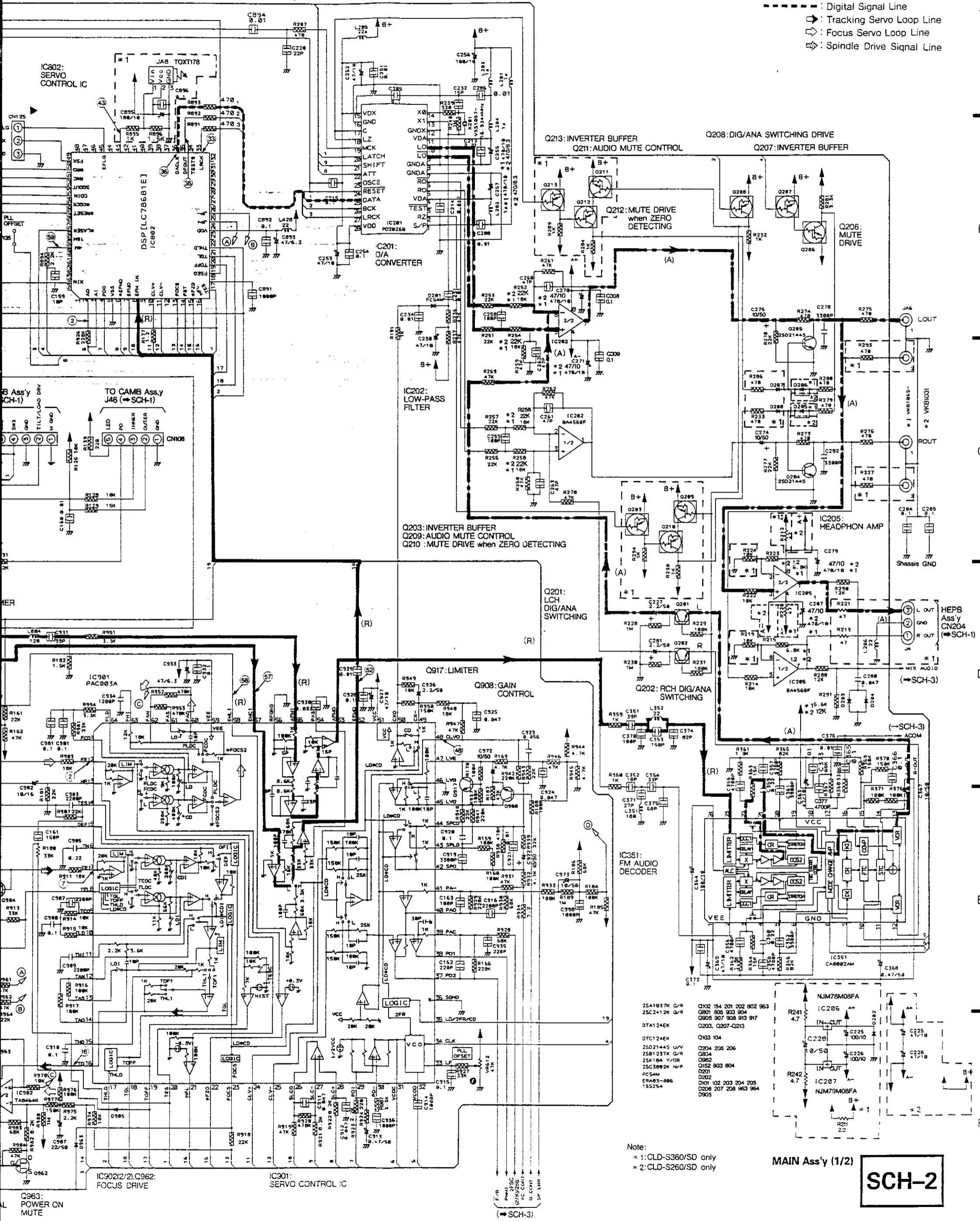

Note:
 * 1: CLD-S360/SD only
 * 2: CLD-S260/SD only

MAIN Ass'y (1/2)
SCH-2

4.3 MAIN Ass'y (2/2)
● VIDEO Section

A

B

C

D

E

F

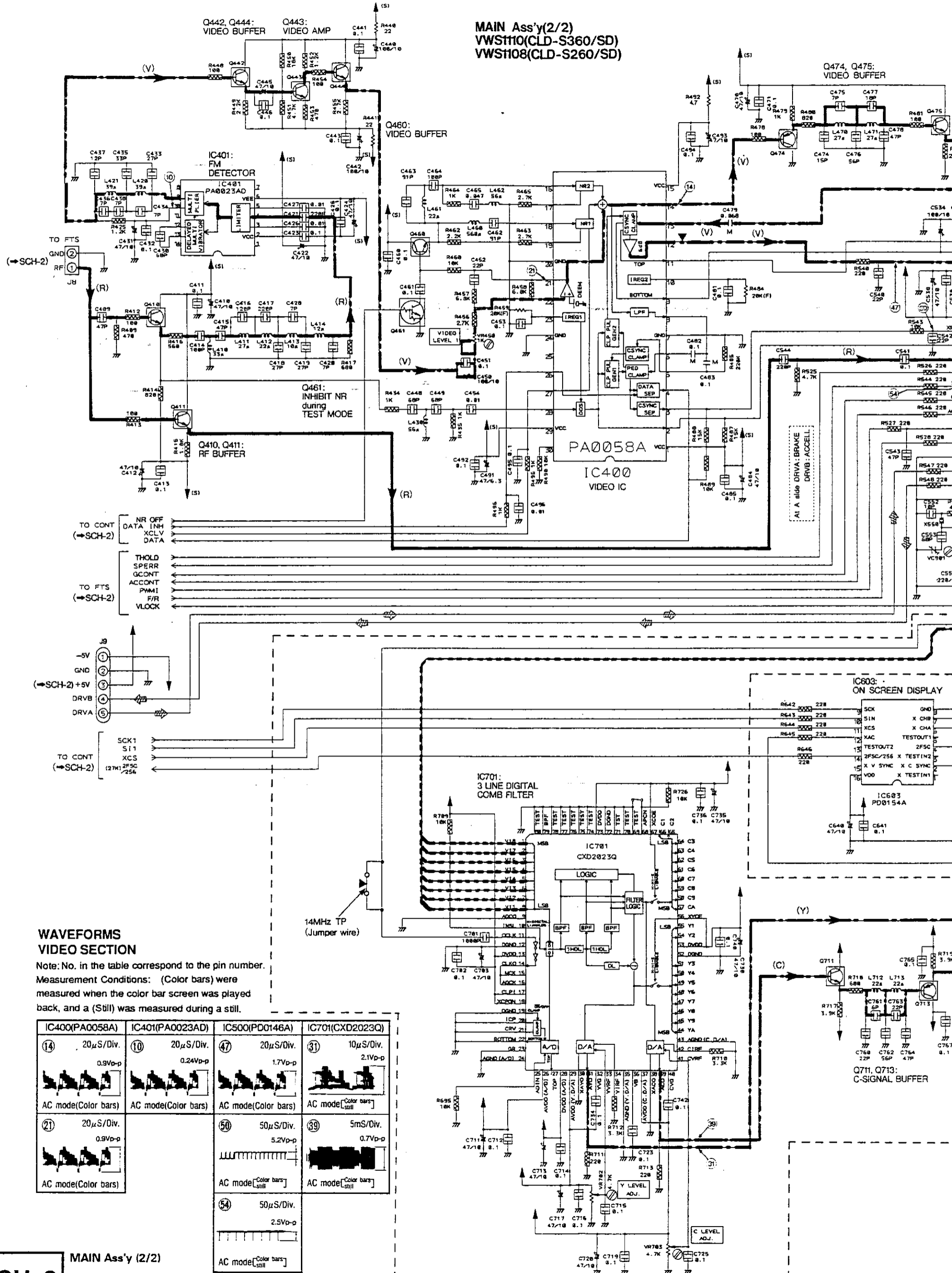

WAVEFORMS
VIDEO SECTION

Note: No. in the table correspond to the pin number.
Measurement Conditions: (Color bars) were measured when the color bar screen was played back, and a (Still) was measured during a still.

IC400(PA0058A)	IC401(PA0023AD)	IC500(PD0146A)	IC701(CXD2023Q)
<p>⑭ 20μS/Div. 0.9Vp-p</p> <p>AC mode (Color bars)</p>	<p>⑩ 20μS/Div. 0.24Vp-p</p> <p>AC mode (Color bars)</p>	<p>④⑦ 20μS/Div. 1.7Vp-p</p> <p>AC mode (Color bars)</p>	<p>③① 10μS/Div. 2.1Vp-p</p> <p>AC mode (Color bars)</p>
<p>⑰ 20μS/Div. 0.9Vp-p</p> <p>AC mode (Color bars)</p>	<p>⑤① 50μS/Div. 5.2Vp-p</p> <p>AC mode (Color bars)</p>	<p>③③ 5mS/Div. 0.7Vp-p</p> <p>AC mode (Color bars)</p>	
	<p>⑤④ 50μS/Div. 2.5Vp-p</p> <p>AC mode (Color bars)</p>		

SCH-3 MAIN Ass'y (2/2)

2SA1037K Q400 441 474 591 684 712 713 770 780 790 795
 2SC2412K Q410 411 440 442 443 444 460 475 611 612 613
 621 681 682 683 710 711 791 792
 2SC1740S Q781 782 786 794 795
 DTA124EK Q787
 DTC124EK Q461 701
 2SB1237X-T Q401
 2SD1858X-T Q402
 ISS254 0510

(R) : RF Signal Line
 (V) : Video Signal Line
 (Y) : Y-Signal Line
 (C) : C-Signal Line
 --- : Digital Signal Line
 ⚡ : Spindle Drive Signal Line

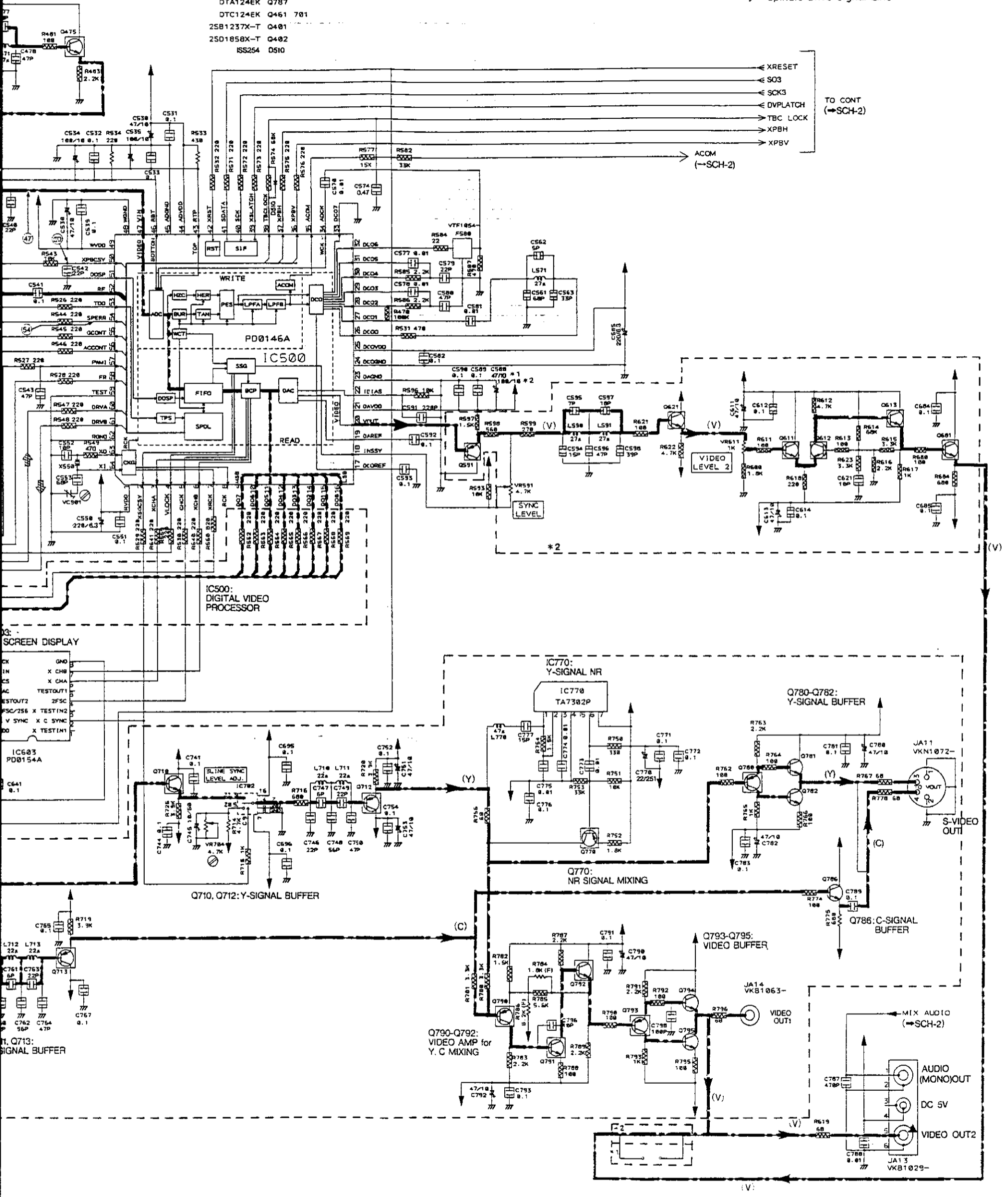

Note :
 * 1 : CLD-S360/SD only
 * 2 : CLD-S260/SD only

MAIN Ass'y (2/2)

SCH-3

MAIN Ass'y

Q794 *1 Q786 Q795 Q782 Q781 IC770
 IC702 IC701 VR703 VR702 VR704
 IC603 IC411 IC410 Q401 IC401 IC400
 VR450
 IC204 Q205 IC801 IC204 IC203 Q834 IC202 IC902 IC201 Q962 IC802 IC901 IC351 IC803 IC101
 VR605 VR606 VR603 VR604 VR607 VR608 VR601 VR612

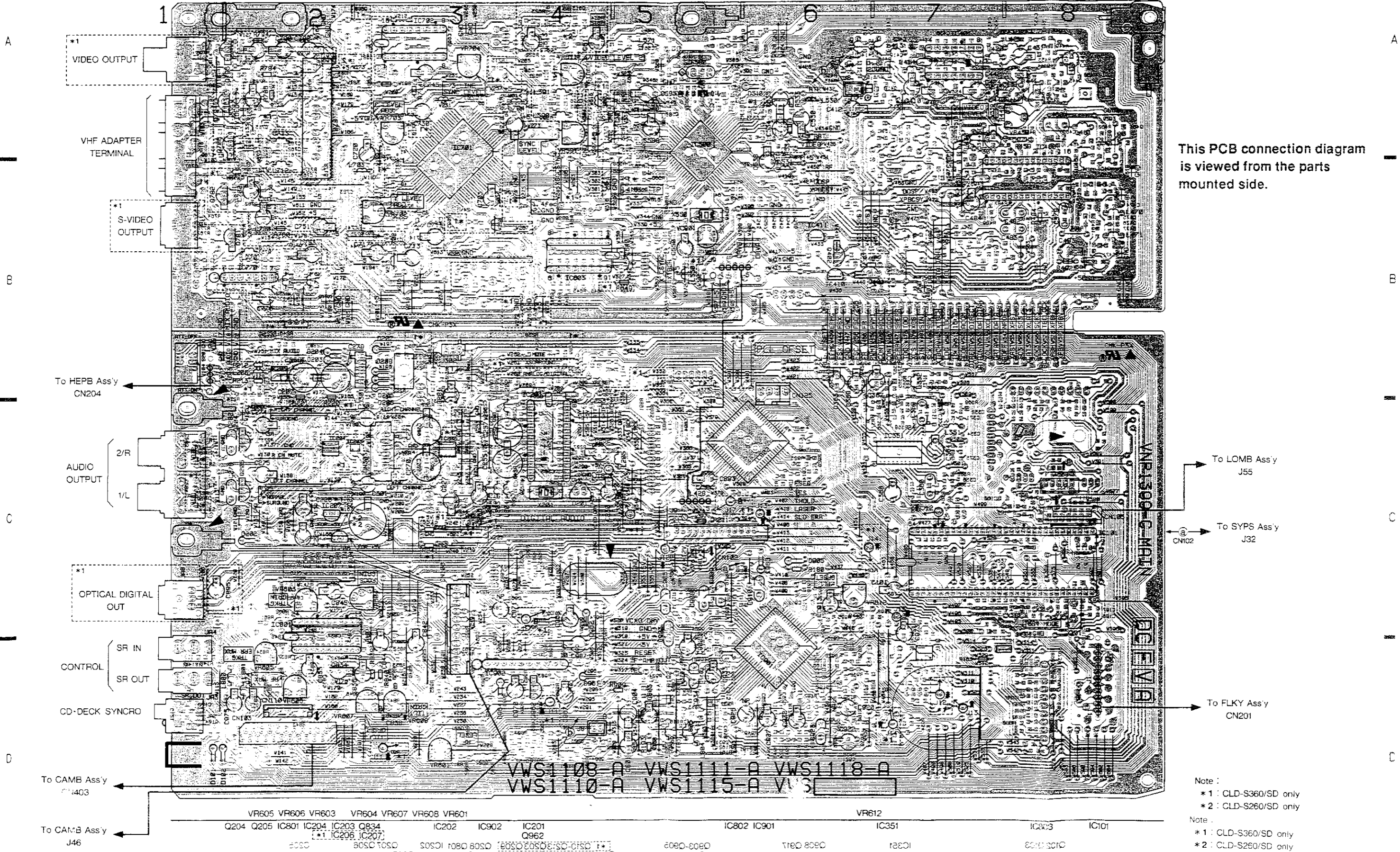

This PCB connection diagram is viewed from the parts mounted side.

Note :
 * 1 : CLD-S360/SD only
 * 2 : CLD-S260/SD only

Q474 Q475	Q41C Q411	IC500	Q613 Q612	IC701	Q712 Q792 Q793	Q770 Q713 Q780	Q784 Q785
Q461 Q460 Q443 Q442 Q444	IC401	IC411 IC410 Q401	Q611 Q621	IC803	Q791 Q790	Q790 Q791	Q788 Q789
IC400	IC401	IC411 IC410 Q401	IC803	IC701	IC702	IC703	IC704
VR480	VR401	VR411 VR410 VR401	VR803	VR704	VR703 VR705	VR704 VR705	VR704 VR705

MAIN Ass'y

This P.C.B. connection diagram is viewed from the foil side.

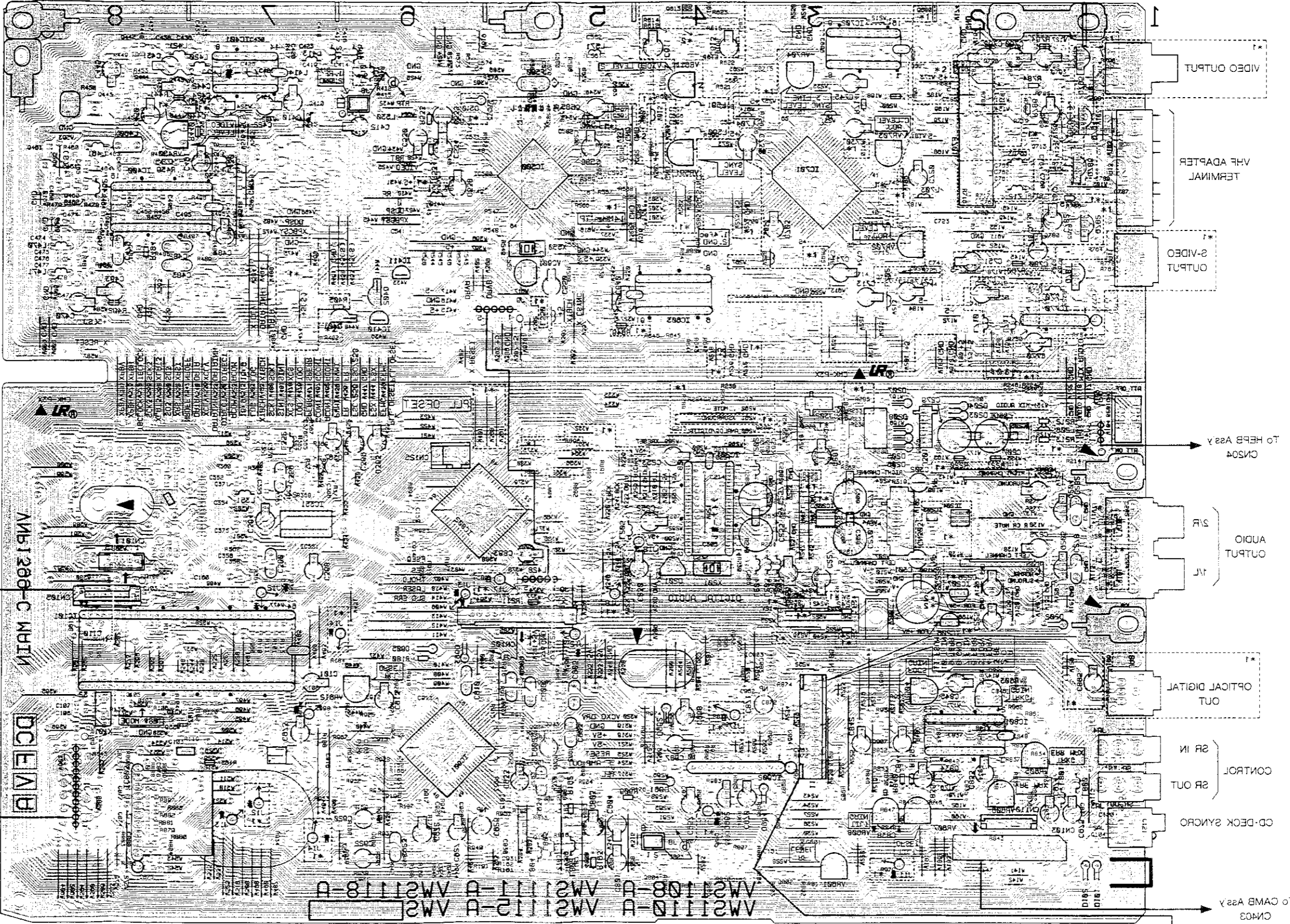

Note:
 * 1: CLD-2380/2D only
 * 2: CLD-250/2D only
 * 3: CLD-280/2D only

5. PCB PARTS LIST

NOTES:

- Parts marked by "NSP" are generally unavailable because they are not in our Master Spare Parts List.
- The Δ mark found on some component parts indicates the importance of the safety factor of the part. Therefore, when replacing, be sure to use parts of identical designation.
- Parts marked by "●" are not always kept in stock. Their delivery time may be longer than usual or they may be unavailable.
- When ordering resistors, first convert resistance values into code form as shown in the following examples.

Ex. 1 When there are 2 effective digits (any digit apart from 0), such as 560 ohm and 47k ohm (tolerance is shown by J = 5%, and K = 10%).

560 Ω \rightarrow 56 \times 10¹ \rightarrow 561 RD1/8PM \square \square \square J
 47k Ω \rightarrow 47 \times 10³ \rightarrow 473 RD1/4PS \square \square \square J
 0.5 Ω \rightarrow 0R5 RN2H \square \square \square K
 1 Ω \rightarrow 010 RS1P \square \square \square K

Ex. 2 When there are 3 effective digits (such as in high precision metal film resistors).

5.62k Ω \rightarrow 562 \times 10¹ \rightarrow 5621 RN1/4PC \square \square \square F

Mark No.	Description	Part No.	Mark No.	Description	Part No.
LIST OF ASSEMBLIES			Q102, Q154, Q474, Q712, Q713, Q770, Q780, Q790, Q793, Q802, Q963		2SA1037K
	MAIN Ass'y	VWS1110	Q103, Q104, Q206, Q461		DTC124EK
NSP	FLKB Ass'y	VWM1356	Q152, Q803, Q804		2SC302K
	└ FLKY Ass'y	VWG1403	Q201, Q202, Q410, Q411, Q442- Q444, Q460, Q475, Q710, Q711, Q791, Q792, Q801, Q805, Q903- Q905, Q907, Q908, Q913, Q917		2SC242K
NSP	└ PWSB Ass'y	VWG1404	Q203, Q207-Q213		DTA124EK
NSP	└ HEPB Ass'y	VWV1292	Q204, Q205		2SD244S
NSP	PWSB Ass'y	VWM1436	Q781, Q782, Q786, Q794, Q795		2SC140S
	└ SYPS Ass'y	VWR1206	Q834		2SB137X
NSP	└ VSBA Ass'y	VWR1207	Q962		2SK114
NSP	MACBS Ass'y	VWM1358	D101, D102, D203-D208, D510, D905, D963, D964		1SS24
NSP	└ FG Ass'y	VWG1416	D201		FC54M
NSP	└ PASB Ass'y	VWG1417	D202		ERA8-006
NSP	└ CAMB Ass'y	VWG1418	COILS AND FILTER		
NSP	└ LOSB Ass'y	VWG1419	L201-L204		LAU10K
NSP	└ LOMB Ass'y	VWG1420	L205, L206, L352, L412, L461, L710-L713, L800, L801		LAU20J
			L351		LAU81J
			L410		LAU30J
			L411, L470, L471, L571		LAU70J
			L413		LAU00J
			L414		LAU20J
			L420, L421		LAU90J
			L430, L462		LAU50J
			L460		LFAS1J
			L770		LAU70J
			L802-L804		LAU21J
			F580(14.3MHz Filter)		VTF054
MAIN Ass'y					
SEMICONDUCTORS					
	IC101	PD0171B			
	IC201	PD2026B			
	IC202, IC205, IC903	BA4560F			
	IC206	NJM78M08FA			
	IC207	NJM79M08FA			
	IC351	CA0002AM			
	IC400	PA0058A			
	IC401	PA0023AD			
	IC500	PD0146A			
	IC603	PD0154A			
	IC701	CXD2023Q			
	IC702	BU4053B			
	IC770	TA7302P			
	IC801	PAC002A			
	IC802	LC78681E			
	IC803	LA6510L			
	IC901	PAC003A			
	IC902	TA8464K			

CLD-S360, CLD-S260

Mark No.	Description	Part No.	Mark No.	Description	Part No.
CAPACITORS					
C101, C230, C252, C253, C363, C369, C410, C412, C422, C424, C431, C445, C470, C484, C493, C530, C538, C588, C640, C703, C711, C713, C717, C720, C730, C735, C751, C753, C780, C782, C790, C792, C801, C803, C833, C836, C842, C844, C927, C974, C975		CEAS470M10	C220, C452, C540, C542, C579, C746, C749, C760, C763		CCSQCH220J50
C102, C151, C196-C198, C215, C254, C284, C285, C305, C308, C309, C365, C366, C372, C373, C411, C413, C423, C425, C432, C441, C443, C446, C451, C453, C460, C641, C471, C481, C485, C492, C494, C495, C531-C533, C539, C541, C551, C582, C589, C590, C592, C593, C641, C695, C696, C702, C712, C714-C716, C719, C723, C725, C734, C736, C740-C742, C744, C752, C754, C765, C767, C771, C772, C776, C781, C783, C789, C791, C793, C802, C804, C831, C832, C840, C841, C873, C874, C892, C896, C901, C915, C928, C932, C981		CKSQYF104Z25	C225, C226, C256, C364, C440, C442, C450, C534, C535, C895		CEAS101M10
C103, C214, C280, C465, C808, C815, C847, C875, C877, C911, C912, C924, C925, C964, C971, C983, C984		CKSQYF473Z25	C926		CEANP2R2M50
C105, C122, C160, C231, C234, C251, C286, C288, C376, C454, C496, C570, C577, C578, C581, C773-C775, C788, C807, C834, C835, C843, C872, C876, C894, C921, C929, C961, C962		CKSQYF103Z50	C227, C281, C228, C274, C275, C367, C745, C845, C922, C972, C973		CEAS2R2M50
C106, C107, C354, C435, C563, C813		CCSQCH330J50	C232, C474, C777		CEAS100M50
C110		CKDYB222K50	C260-C263, C409, C415, C478, C543, C580, C750, C764, C963		CCSQCH150J50
C120, C121, C163, C258, C259, C370, C414, C464, C798		CCSQCH101J50	C278, C282		CCSQCH470J50
C159, C552, C796, C809, C811		CCSQCH100D50	C351, C931		CFTXA332J50
C161, C353, C810		CCSQCH151J50	C352, C477		CCSQCH390J50
C162, C417, C421, C544, C591, C812, C935		CCSQCH221J50	C355-C358, C377		CCSQCH180J50
C207, C255, C257, C270, C271, C279		CEAS471M10	C359, C360, C905		CKSQYB472K50
			C361, C362		CFTYA224J50
			C368, C913		CKSQYB392K50
			C371, C418, C419, C433		CEASR47M50
			C374		CCSQCH270J50
			C375, C430, C448, C449, C553, C561, C806		CCSQCH820J50
			C574		CCSQCH680J50
			C416, C814, C846, C848		CKSQYF474Z16
			C420, C428, C434, C436, C438		CCSQCH121J50
			C475		CCSQCH070D50
			C426, C427		CKSQYB103K50
			C437		CCSQCH120J50
			C462, C463		CCSQCH910J50
			C476, C748, C762		CCSQCH560J50
			C479		CFTYA683J50
			C482, C483, C908, C910, C920		CFTYA104J50
			C491, C893, C933		CEAL470M6R3
			C550, C585		CEAS221M6R3
			C562		CCSQCH050C50
			C701		CCSQSL102J50
			C747, C761		CCSQCH060D50
			C770		CEAS220M25
			C787		CCSQCH471J50
			C837, C930		CKSQYF333Z25
			C838		CEANP470M6R3
			C871		CEALNP100M16
			C888, C907, C916		CKSQYB222K50
			C891, C914, C936, C969, C998		CKSQYB102K50
			C902		CEAL100M16
			C903, C909		CQMA222J50

Mark No.	Description	Part No.
C904		CEAS010M50
C919		CKSQYB332K50
C923		CFTYA563J50
C934		CQMA122J50
C967, C968		CEHAQ100M50
C970		CEHAQ010M50
C987		CEHAQ220M50
VC901	VARIABLE CAPACITOR(20P)	VCM-008

RESISTORS

R180	RD1/6PM333J
R192, R193, R440, R441	RD1/6PM220J
R211	RD1/6PM2R2J
R212, R213, R220, R221, R839, R840	RD1/6PM470J
R459, R484	RN1/6PQ2002F
R241, R242, R492(4.7Ω 1/6W)	DCN1001
R533	RD1/6PM431J
R534	RD1/6PM221J
R714	RD1/6PM472J
R775	RD1/6PM681J

R784	RN1/6PQ1801F
R786	RN1/6PQ8201F
R909	RD1/6PM473J
Other resistors	RS1/10S□□□□J

VR450	VRTB6VS102
VR601	VRTB6VS222
VR603, VR702, VR703, VR704	VRTB6VS472
VR604, VR607, VR612	VRTB6VS473
VR605, VR606	VRTB6VS333

OTHERS

CN103 22P FFC Conector	52045-2245
CN105 6P Jumper Connector	SBRK06S
CN106 11P Top post	B11P-SHF-1AA
CN110 5P Top post	B5B-EH
CN125 4P Top post(NH)	B4P-SHF
J1 11p Lead wire	D20PDY1120G
J8 Housing Ass'y	VKP2008
JA2 Mini jack	VKN1165
JA3, JA4 Remote Control jack/12V	PKN1004
JA6 4P Pin jack	VKB1065
JA8 Optical module	TOTX178
JA11 4P Mini DIN jack	VKN1072
JA13 RF Pin jack	VKB1029
JA14 1P Pin jack	VKB1063
X101 Ceramic resonator(9.00MHz)	VSS1040
X201 Crystal resonator(16.934MHz)	VSS1057

Mark No.	Description	Part No.
X550	Crystal resonator(14.318MHz)	VSS1026
	3P Cable holder	51048-0300
	PCB Binder	VEF1040
	Earth terminal	VNF-091
	Screw	BBZ30P060FCC
	Screw terminal	VNE1841

FLKY Ass'y

SEMICONDUCTORS

IC201	PD3248A
IC202	S-806D
Q201, Q204	DTC124ES
Q202	DTC114ES
Q203	DTA144ES
D201	1SS254
D203-D206	1SS252
D210	PG3361X

CAPACITORS

C201	CEAL01M6R3
C202, C203	CKPUYF223Z25
C204	CEAL00M16
C205	CKPUYF103Z25
C206	CEALR2M50
C207	CEAS00M16

SWITCHS

S201-S204, S206, S210, S214, S217-S225	RSG1030
S205, S207-S209, S211-S213, S215, S216	RSG1034
S228	VSD108

RESISTORS

R230(100KΩ 1W)	RA5T04J
Other resistors	RD1/6PM□□□□J

OTHERS

J21 4P Wire	VDA140
V201 FL indicator tube	VAW1033
X201 Ceramic resonator(8.00MHz)	EFOE08004A4
FL holder	VNF178
Spacer	VEC159
Remote sensor	GP1U5X

CLD-S360, CLD-S260

Mark No.	Description	Part No.
PWSB Ass'y		
SEMICONDUCTOR		
D211		SLH34VCF04
SWITCH		
S226		RSG1030
RESISTOR		
R228		RD1/6PM102J
HEPB Ass'y		
CAPACITORS		
C208		CGCYF473Z25
C209		CKPUYB101K50
C210		CKPUYB101K50
RESISTOR		
VR201 (0.5KB)		VCS1015
OTHERS		
CN204 3P Jumper wire		52151-0310
JA201 Headphone jack		RKN1002
SYPS Ass'y		
SEMICONDUCTORS		
△ IC1		NJM78L05A
△ IC2		NJM4558D
△ IC201, IC202, IC204		ICP-N15
△ IC203		ICP-N20
△ Q2		2SB1185
△ Q3		2SD1762
Q4, Q21, Q24		2SC1740S
Q5, Q22, Q23, Q29		2SA933S
△ Q25, Q27		2SB1566
△ Q26, Q28		2SD2395
Q30		DTC124ES
Q31		2SB1240
Q32		DTC114TS
△ D1		S2VB20
△ D2, D24, D25		1SR35-100AVL
△ D3, D33		11ES2
△ D7		MTZJ9.1A
△ D23, D26		10ELS2
COIL		
△ L1 (330μH)		VTL1043

Mark No.	Description	Part No.
CAPACITORS		
△ C1, C2 (6800μF/16V)		VCH1053
C3-C6		CEAS470M10
△ C7-C9		CKPUYF223Z25
C10, C29		CEAS101M50
C11, C12		CKPUYF103Z25
C13		CEAS471M16
△ C14		CGCYX473M25
C23, C24		CGCYX473M25
C25		CEJA2R2M50
C26		CEAS2R2M50
C27, C28		CQMA223J50
C30		CEAS101M10
C31		CEAS100M16
△ C52 (0.01μF/400V)		RCG-009
RESISORS		
△ R23-R26		RD1/2VM221J
△ R27-R30 (47Ω 1/6W)		DCN1003
△ R32		RD1/2VM1R5J
R36		RD1/2PMR47J
R37		RD1/2VM391J
Other resistors		RD1/6PM□□□□
OTHERS		
CN31 KP Connector		B2B-PH-K
J2 Lead wire (White)		VDF1443
J3 Lead wire (Violet)		VDF1447
J4 Lead wire (Blue)		VDF1446
J5 Lead wire (Brown)		VDF1445
J6 Lead wire (Yellow)		VDF1444
△ J32 13P Lead wire		D20PYY1360G
6P Cable holder		51048-0600
△ P.S. terminal		VKC-019
△ Fuse holder		VKR1001
△ Screw terminal		VNE1646
VSBA Ass'y		
SWITCH		
△ Line selector switch		VSBI007
FG Ass'y		
SEMICONDUCTOR		
D1		GP1S51V
OTHER		
64P Housing Ass'y		VKP1950

Mark No.	Description	Part No.
PASB Ass'y		
SWITCHS		
	S4, S5	DSG1015
OTHERS		
	72P Housing Ass'y	VKP1951
CAMB Ass'y		
SEMICONDUCTOR		
	Q10	2SC1740S
RESISTOR		
	R10	RD1/6PM182J
	R11	RD1/6PM470J
	R800	RD1/6PM391J
OTHERS		
	CN401 23P Connector	VKN1073
	CN402 KR Connector	B3B-PH-K-R
	CN403 22P FFC Connector	52045-2245
	CN404 3P KR Connector	B3B-PH-K
	Housing Ass'y	VKP2009
LOSB Ass'y		
SWITCHS		
	S1-S3	DSG1015
LOMB Ass'y		
CAPACITOR		
	C1	CGCYX473M25
OTHER		
	J55 6P Lead wire	D20PWY0615G

6. ADJUSTMENTS

6.1 PRELIMINATIES

● JIGS FOR ADJUSTMENT

- CD test disc (STD-901 or STD-902)
- LD test disc (GGV1003)
- (-) Screwdriver (medium)
- (-) Screwdriver (small)
- Hexagonal wrench driver (straight type, size: 3 mm)
- Resistors (10 kΩ × 2, 47 kΩ)
- Dual-trace oscilloscope (with delay)
- AF oscillator
- Frequency counter
- Digital voltmeter
- TV monitor
- Low-pass filter

Use the low-pass filters below in the coarse centering adjustment 2. and fine centering adjustment (L.P.F.1 and L.P.F.2) 6. and PLL OFFSET adjustment (L.P.F.3) 16. when the S/N of the waveform is hard to observe.

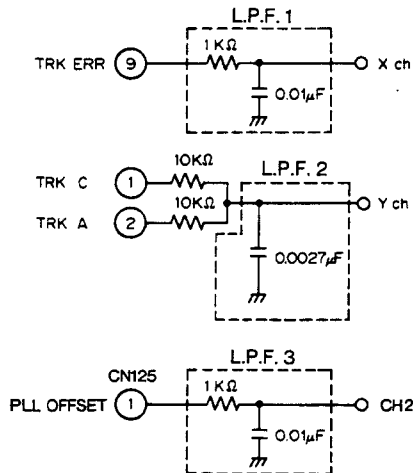

● RACK ASSEMBLY DURING CENTERING ADJUSTMENT

The S-IN position (without hitting the mechanism stopper) of the rack assembly during centering adjustment is indicated below.

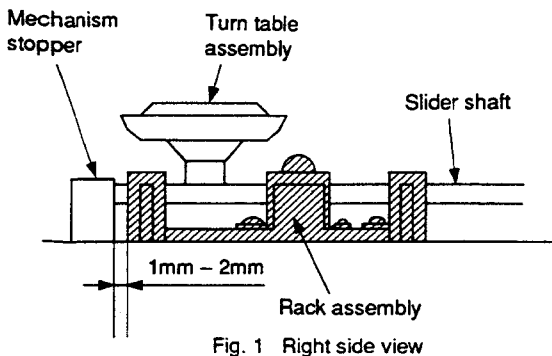

● ADJUSTMENT LOCATIONS

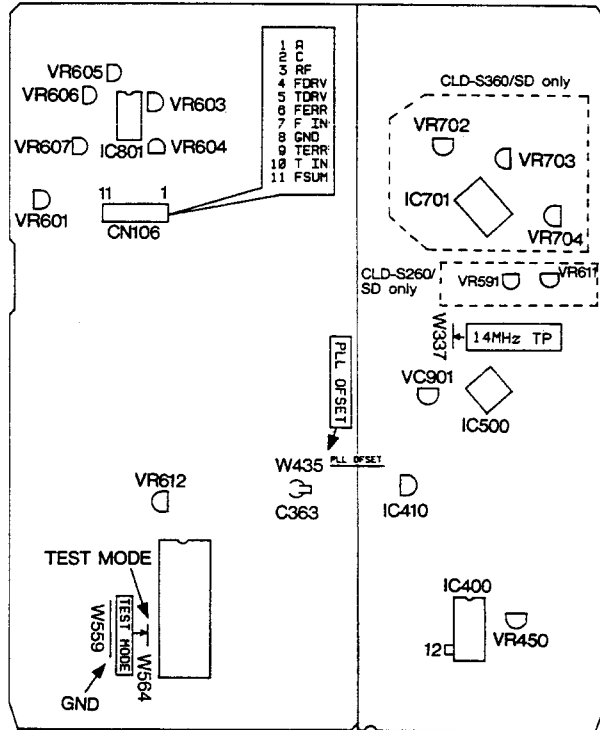
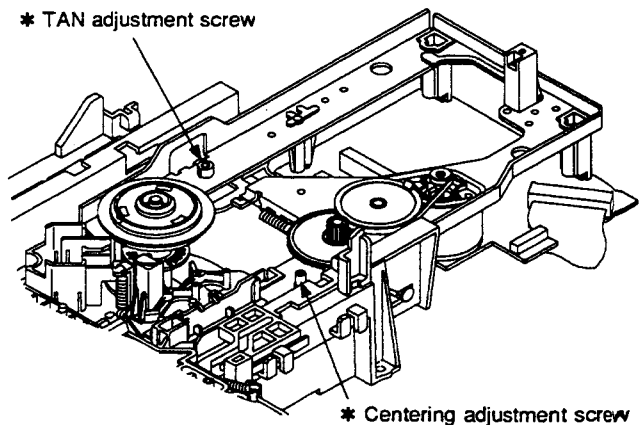

Fig. 2 MAIN assembly section



* : As the adjustment range of both the TAN and centering adjustment screws is only ±90° from the center, do not turn the screws beyond this range.

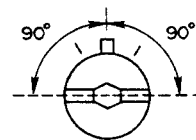

Fig. 3 TILT base section

● TEST MODE

1) Activating the Test Mode

1. While power is ON, connect the Test mode jumper wire W564 (Fig. 2) to the GND (Jumper wire W559 or Chassies) for about one second.
2. After checking whether the FL display device is fully lit, disconnect the Test mode jumper wire from GND.

2) Canceling the Test Mode

1. Turn the power OFF.

● Key operation in the Test mode

Player Status	Key Operation	Function	Remarks
Tray Open	◀◀/▶▶ SKIP (Refer to Note 1)	◀◀ : Shifts the tray in the closed direction and also raises the turn table while pressing the key. ▶▶ : Shifts the tray in the open direction and also lowers the turn table while pressing the key.	
Tray Open	▶ PLAY	Clamps	
Clamp	▶ PLAY	Turns the disc through TRK Servo Open	TRK-OFF
TRK Servo Open	▶ PLAY	TRK Servo Close	TRK-ON
TILT Neutral	+ MULTI-SPEED	TILT Servo Close	T-□: ON
TILT ON	- MULTI-SPEED	TILT Neutral	T-□: N
TILT Neutral or ON	◀◀/▶▶ SKIP	Setting TILT Servo to OFF, can force TILT to move.	T-1 to T-E
Clamp	◀◀/▶▶ SCAN	Can force the slider to move	S-LD S-CDV S-CD S-IN
Play	⏸ PAUSE	Still	
Play	■ STOP	Stop	
Stop	▲ OPEN	Open	
Play	<div style="text-align: center;"> +10 ↓ 0 to 9 ↓ ▶ PLAY </div>	Sets to SEARCH Lead Address Input mode. Designates the SEARCH lead address through keys 0 to 9. Press the CLEAR C key if the designated address is incorrect. Searches the designated address upon pressing the PLAY key.	
Power ON	◀◀/▶▶ STEP	Can select the focus balance. ◀◀ : Press to select RF MAX as the focus balance. ▶▶ : Press to select T ERR MAX as the focus balance.	

Note 1 : Press SKIP (◀◀ / ▶▶) Keys after the tray is set to open state by pressing Open (▲) key. Because, in tray open state, pressing PLAY (▶) key causes it to set to TILT control state and SKIP (◀◀ / ▶▶) keys can not function properly.

● **PLAYER OPERATION IN THE TEST MODE**

Operate the player by selecting a test mode function with the keys on the player or on the remote control unit.

• **CD PLAYBACK**

- ① Place the CD disc on the turn table.

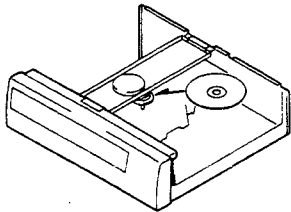

- ② Press the **PLAY (▶)** key once. (Twin gear starts to move.)
- ③ Push the cam plate (Fig. 4) in the direction of the arrow and wait until the CD disc is clamped.

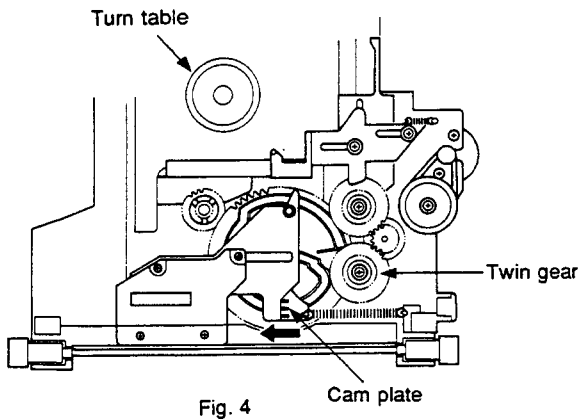
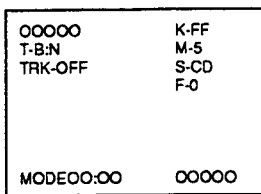

Fig. 4

- ④ Press the **◀◀** or **▶▶** keys to appear "S-CD" on the TV screen display.



TV screen display

- ⑤ Press the **PLAY (▶)** key twice, disc will be normally playbacked.

• **LD PLAYBACK**

- ① Place the LD disc on the turn table.

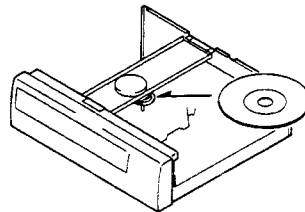

- ② Press the **PLAY (▶)** key once. (Twin gear starts to move.)
- ③ Press the **SKIP REV (⏮)** key to raise the turn table (spindle motor section) while pressing the cam plate (Fig. 4) in the direction of the arrow. Raise it to the position where the LD disc can be easily placed on the turn table. If the turn table is raised too high, lower it with the **SKIP FWD (⏭)** key.
- ④ Place the LD disc on the turn table and press the **PLAY (▶)** key once to clamp the disc.
- ⑤ Press the **◀◀** or **▶▶** keys to appear "S-LD" on the TV screen display.

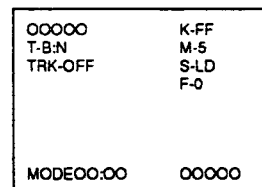

TV screen display

- ⑥ Press the **PLAY (▶)** key twice, disc will be normally playbacked.

6.2 ADJUSTMENT TABLE

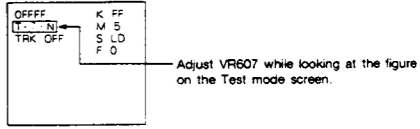
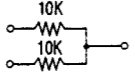
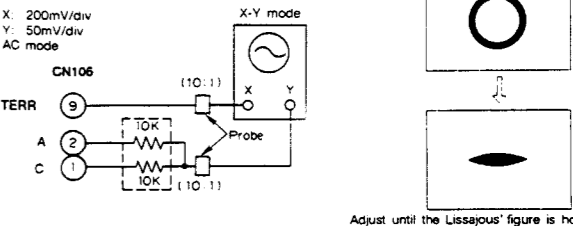
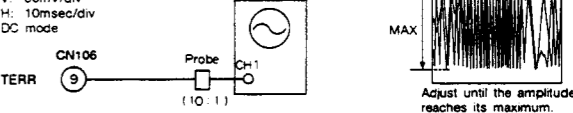
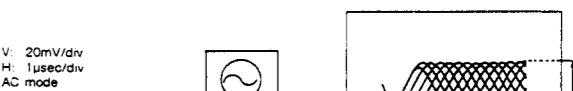
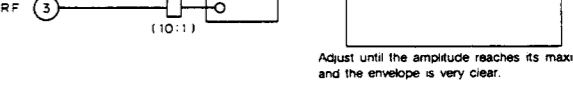
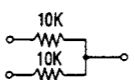
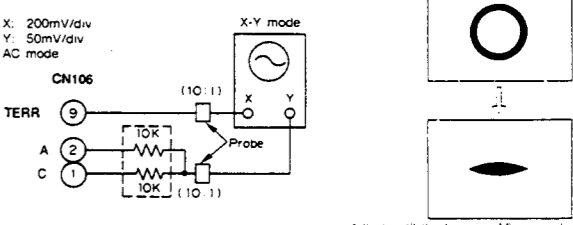
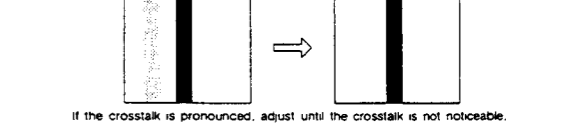
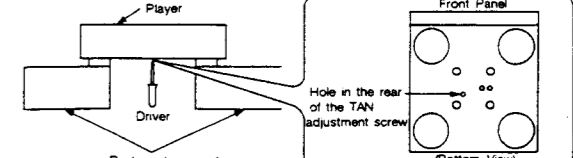
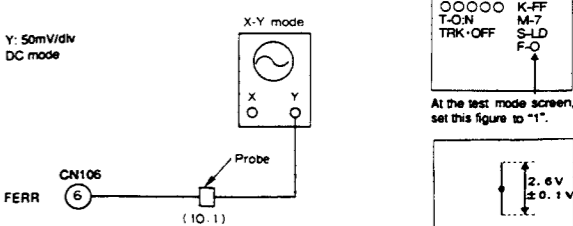
Adjustment name	Adjustment point	Measuring equipment and jigs	Measurement point	Player condition	Adjustment procedure	Waveform and connection diagram
1 Tilt Offset Check and Adjustment	VR607	TV monitor	Tilt indication on Test mode screen	<ul style="list-style-type: none"> • Power ON • Test mode • Disc not installed 	<ol style="list-style-type: none"> 1. Check if the tilt indication on the Test mode screen is at T-6 to T-8. 2. If the tilt indication is not at T-6 to T-8, adjust VR607 until the tilt indication reaches T-6 to T-8. 	
2 Coarse centering adjustment	Tilt base Centering adjustment screw	<ul style="list-style-type: none"> • Oscilloscope • STD-901 or STD-902 • MIX resistor 	CN106 X: ⑨ Pin (TERR) Y: ① + ② Pin (TRK SUM)	<ul style="list-style-type: none"> • Test mode • TRK Servo Open • Tilt servo ON • Innermost track of STD-901 or STD-902 which does not come in contact with the mechanical stopper. 	<ol style="list-style-type: none"> 1. Move the slider until it does not come in contact with the mechanical stopper at the slider position indication S-IN. 2. Observe TERR (Xch) and TRK SUM (Ych) at the X-Y mode during TRK Servo Open. 3. Turn the centering adjustment screw until the Lissajous' figure is horizontal. 	 <p>Adjust until the Lissajous' figure is horizontal.</p>
3 FCS balance adjustment (1) TRK ERR MAX	VR605	<ul style="list-style-type: none"> • Oscilloscope • STD-901 or STD-902 	CN106 ⑨ Pin (TERR)	<ul style="list-style-type: none"> • Test mode • TRK Servo Open • Tilt servo ON • Inner track of STD-901 or STD-902 	<ol style="list-style-type: none"> 1. Observe TERR at CH1 of the oscilloscope during TRK Servo Open. 2. Adjust VR605 until the amplitude of the waveform reaches its maximum. 	 <p>Adjust until the amplitude reaches its maximum.</p>
4 FCS balance adjustment (2) RF MAX	VR606	<ul style="list-style-type: none"> • Oscilloscope • STD-901 or STD-902 	CN106 ③ Pin (RF)	<ul style="list-style-type: none"> • Test mode • TRK Servo Close • Tilt servo ON • Inner track of 	<ol style="list-style-type: none"> 1. Close the TRK Servo and observe RF at CH1 of the oscilloscope. 2. Adjust VR606 until the amplitude of the waveform reaches its maximum and the envelope is very clear. 	 <p>Adjust until the amplitude reaches its maximum and the envelope is very clear.</p>
5 Tangential direction angle adjustment	Tilt base TAN adjustment screw	<ul style="list-style-type: none"> • Oscilloscope • STD-901 or STD-902 	CN106 ③ Pin (RF)	<ul style="list-style-type: none"> • Test mode • TRK Servo Close • Tilt servo ON • Inner track of STD-901 or STD-902 	<ol style="list-style-type: none"> 1. Observe RF at CH1 of the oscilloscope during TRK Servo Close. 2. Adjust the TAN adjustment screw until the amplitude of the waveform reaches its maximum and the envelope is very clear. 	 <p>Adjust until the amplitude reaches its maximum and the envelope is very clear.</p>
6 Fine centering adjustment	Tilt base Centering adjustment screw	<ul style="list-style-type: none"> • Oscilloscope • STD-901 or STD-902 • MIX resistor 	CN106 X: ⑨ Pin (TERR) Y: ① + ② Pin (TRK SUM)	<ul style="list-style-type: none"> • Test mode • TRK Servo Open • Tilt servo ON • Innermost track of STD-901 or STD-902 which does not come in contact with the mechanical stopper. 	Perform fine centering adjustment by following the same procedure as in "Coarse centering adjustment" (2).	 <p>Adjust until the Lissajous' figure is horizontal.</p>
7 Crosstalk check and Tilt offset adjustment	VR607	<ul style="list-style-type: none"> • TV monitor • GGV1003 	Crosstalk check screen	<ul style="list-style-type: none"> • Test mode • TRK Servo Close • Tilt servo ON • GGV1003 #115 STILL 	<ol style="list-style-type: none"> 1. Search for address 115 of GGV1003 and still the address. 2. Check the crosstalk. If the crosstalk is pronounced, adjust VR607 until the crosstalk is not noticeable. 	
<p>When the crosstalk is still noticeable in spite of the adjustment in (7), use a hexagonal wrench driver (straight type, size: 3 mm) to adjust the TAN adjustment screw on the bottom side of the player through the GGV1003 # 115 STILL screen. Afterwards, perform the adjustment procedures from (6).</p>						
8 FCS Servo loop gain adjustment	VR604	<ul style="list-style-type: none"> • Oscilloscope • GGV1003 	CN106 X: No connection Y: ⑥ Pin (FERR)	<ul style="list-style-type: none"> • Power ON • Test mode • GGV1003 • Disc mounted state 	<ol style="list-style-type: none"> 1. Short CN106 pin No. 7 (F IN) with CN106 pin No. 8 (GND). 2. Press the play (▶) key to make a focus sweep. 3. Press the step reverse key (◀) to set the focus balance to F-1. 4. Observe FERR output at Ych on the oscilloscope. 5. Adjust VR604 so that the amplitude of FERR output is 2.6V±0.1V. 	 <p>At the test mode screen, set this figure to "1".</p>

Adjustment name	Adjustment point	Measuring equipment and jigs	Measurement point	Player condition	Adjustment procedure	Waveform and connection diagram
9 TRK Servo loop gain adjustment	VR603	• Oscilloscope • GGV1003	CN106 X: No connection Y: ⑨ Pin (TERR)	• Test mode TRK Servo Close Tilt servo ON • GGV1003 #15,000 STILL	1. Observe TERR output at Ych on the oscilloscope. 2. Adjust VR603 so that the amplitude of TERR output is 1.5V±0.1V.	
10 RF level adjustment	VR601	• Oscilloscope • GGV1003	CN106 ③ Pin (RF)	• Test mode TRK Servo Close Tilt servo ON • GGV1003 #15,000 STILL	1. Search for address 15,000 of GGV1003 and still the address. Observe RF at CH1 of the oscilloscope. 2. Adjust VR601 until the RF amplitude is 300 mV ±50 mVp-p.	
11 Master clock adjustment	VC901	Frequency counter	14 MHz TP (W616 jumper wire)	• Power ON • Stop mode	Adjust until frequency of 14 MHz TP (jumper wire) becomes 14.31818 MHz ±10 Hz	
12 Video level adjustment before A/D	VR450	• Oscilloscope • GGV 1003	IC 400 (PA 0058A) ⑫ pin	• Normal mode • GGV 1003 # 19,900 still	Adjust until level from sync tip of composite test signal to 100% white becomes 1.633 Vp-p ± 3%	
13 Y output level adjustment [CLD-S360/SD ONLY]	VR702	• TV monitor • Oscilloscope • GGV 1003	Video output pin	• Normal mode • GGV 1003 # 19,900 still	Terminate output pin with 75Ω (connect to TV monitor), and adjust until level from pedestal to 100% white becomes 0.714 Vp-p = 5%.	
14 S-composite sync level adjustment [CLD-S360/SD ONLY]	VR704	• TV monitor • Oscilloscope • GGV 1003	Video output pin	• Normal mode • GGV 1003 # 19,900 still	Terminate output pin with 75Ω (connect to TV monitor), and adjust until level from sync tip to 100% white becomes 1.0 Vp-p ± 5%.	
15 C output level adjustment [CLD-S360/SD ONLY]	VR703	• TV monitor • Oscilloscope • GGV 1003	CH1: Video output pin CH2: IC400 (PA0058A) ⑫ pin	• Normal mode • GGV 1003 # 19,900 still	1. Terminate the connect output pin (or connect to TV monitor) with 75Ω, and connect the output to CH1 of an oscilloscope. 2. Connect CH2 of an oscilloscope to the IC400-⑫ pin. 3. Adjust the input level knob (V/div) of CH2 of the oscilloscope until the level from the sync tip of the video signal of CH2 to 100% white becomes the same level from the sync tip of CH1 to 100% white. 4. Adjust VR703 until the chroma signal level of CH1 becomes the same as the chroma signal of CH2.	

Adjustment name	Adjustment point	Measuring equipment and jigs	Measurement point	Player condition	Adjustment procedure	Waveform and connection diagram
16 Video level adjustment after D/A [CLD-S260/SD ONLY]	VR611	<ul style="list-style-type: none"> • TV monitor • Oscilloscope • GGV 1003 	Video output pin	<ul style="list-style-type: none"> • Normal mode • GGV 1003 • # 19,900 still 	Terminate output pin with 75Ω (connect to TV monitor), and adjust until level from pedestal to 100% white becomes 0.714 Vp-p ± 5%.	
17 Composite sync level adjustment [CLD-S260/SD ONLY]	VR591	<ul style="list-style-type: none"> • TV monitor • Oscilloscope • GGV 1003 	Video output pin	<ul style="list-style-type: none"> • Normal mode • GGV 1003 • # 19,900 still 	Terminate output pin with 75Ω (connect to TV monitor), and adjust until level from sync tip to 100% white becomes 1.0 Vp-p ± 5%.	
18 PLL OFFSET	VR612	<ul style="list-style-type: none"> • Oscilloscope • STD-901 or STD-901 or LD with digital audio 	• PLL OFFSET TP (W435 Jumper wire)	<ul style="list-style-type: none"> • Test mode Tilt servo ON • STD-901 or STD-902 or LD with digital audio playback 	<ol style="list-style-type: none"> 1. Roughly adjust VR612 until sound is output from audio output pin when TRK servo is open. 2. Check that the difference of DC voltage of PLL OFFSET TP (W435 Jumper wire) output between when TRK servo is open and when closed is 0 ± 0.15 V. If not, perform fine adjustment of VR612 to match this standard. 	

7. IC INFORMATION

Note: The information in this list is basic information, and may not correspond exactly to what is shown in the diagrams.

- CXD2023Q (IC701)
3Line Digital Comb Filter

● Pin Function

No.	Pin Name	I/O	Function
1	V18	I	Digital input (MSB) (connected to DV _{SS} or DV _{DD} when not used)
2	V17	I	Digital input (connected to DV _{SS} or DV _{DD} when not used)
3	V16	I	Digital input (connected to DV _{SS} or DV _{DD} when not used)
4	V15	I	Digital input (connected to DV _{SS} or DV _{DD} when not used)
5	V14	I	Digital input (connected to DV _{SS} or DV _{DD} when not used)
6	V13	I	Digital input (connected to DV _{SS} or DV _{DD} when not used)
7	V12	I	Digital input (connected to DV _{SS} or DV _{DD} when not used)
8	V11	I	Digital input (LSB) (connected to DV _{SS} or DV _{DD})
9	ADCO	I	H: AD converter, outputs video signal fetched from (input pin ADIN) from Y output pins (YA-Y3) as 8-bit digital data. L: normal mode
10	INSL	I	Input switching, switches input of comb filter. H: digital input L: analog input
11	OCLK	I	Clock amplifier input (Inputs clock that has a DC cut at capacitor by 0.8Vp-p or more)
12	DV _{SS}	-	Digital ground
13	DV _{DD}	-	Digital power supply (5V)
14	CLKO	O	Clock amplifier output
15	MCK	I	Clock input (inputs 4 fsc clock, that is locked to color burst). Normally connected to pin 14 clock amplifier output.
16	ADCK	I	Clock input for A/D converter (inputs same clock as MCK). Normally connected to pin 14 clock amplifier output.
17	CLPI	I	Clamp pulse input for A/D converter. Clamps signal voltage between low blocks of clamp pulse (connected to DV _{DD} when clamp function is "OFF").
18	XCPON	I	H: clamp function becomes "OFF", has normal A/D converter function only. L: clamp function operates
19	ADVS	-	Digital ground for A/D converter
20	ICP	I	Voltage integration pin for clamp control, connected to about a 0.01 μF capacitor (connected to ground if clamp is not used).
21	CRV	I	Clamp reference voltage input. Equalizes reference voltage and input voltage of clamp block (connected to ground if clamp is not used).
22	RB	O	Reference voltage (bottom) standard value (0.5V)
23	GR	-	Guard ring (connected to analog ground)
24	AAVS	-	Analog ground for A/D converter
25	ADIN	I	Communication filter analog input (A/D converter input)
26	AAVD	-	Analog power supply for A/D converter (5V)
27	RT	O	Reference voltage (top) standard value (2.6V)
28	ADVD	-	Digital power supply (5V) for A/D converter

No.	Pin Name	I/O	Function
29	YV _{DD}	-	Power supply for Y/DA converter (5V)
30	XAYO	O	AYO inverted current output pin (connected to analog ground YV _{SS})
31	AYO	O	Analog luminance signal output (outputs by connecting resistance)
32	YVG	O	Connected to about a 0.1 μF capacitor
33	YVRF	I	Sets full scale value of analog luminance signal
34	YIRF	O	Connected to resistance "16R", which is 16 times output resistance "R" of AYO pin.
35	YV _{SS}	-	Analog ground for Y/DA converter
36	VB	O	Connected to about a 0.1 μF capacitor
37	CV _{DD}	-	Analog power supply (5V) for C/DA converter
38	XACO	O	ACO inverted current output pin (connected to analog ground CV _{SS})
39	ACO	O	Analog chroma signal output (outputs by connecting resistance)
40	CVG	O	Connected to about a 0.1 μF capacitor
41	CVRF	I	Sets full scale value of analog chroma signal
42	CIRF	O	Connected to resistance "16R", which is 16 times output resistance "R" of ACO pin
43	CV _{SS}	-	Ground for C/DA converter
44	YA	O	Digital luminance signal output (MSB)
45	Y9	O	Digital luminance output
46	Y8	O	Digital luminance output
47	Y7	O	Digital luminance output
48	Y6	O	Digital luminance output
49	Y5	O	Digital luminance output
50	Y4	O	Digital luminance output
51	Y3	O	Digital luminance output
52	DV _{SS}	-	Digital ground
53	DV _{DD}	-	Digital power supply (5V)
54	Y2	O	Digital luminance signal output
55	Y1	O	Digital luminance signal output (LSB)
56	XYOE	I	Digital luminance signal output control H: high impedance L: enable
57	CA	O	Digital chroma signal output (MSB)
58	C9	O	Digital chroma signal output
59	C8	O	Digital chroma signal output
60	C7	O	Digital chroma signal output
61	C6	O	Digital chroma signal output
62	C5	O	Digital chroma signal output
63	C4	O	Digital chroma signal output
64	C3	O	Digital chroma signal output
65	C2	O	Digital chroma signal output
66	C1	O	Digital chroma signal output (LSB)
67	XCOE	I	Digital chroma signal output control H: high impedance L: enable
68	APCN	I	Aperture correction H: corrects function deterioration by aperture effect Aperture correction is on Y output, performed by through mode (TST ON) as well. L: standard mode
69	TEST	I	Test pin (fixed to "L")

No.	Pin Name	I/O	Function
70	TEST	I	Test pin (fixed to "L")
71	TST	I	Y output through mode H: Y output outputs input composite video signal. 1H + 18 clocks of delay occurs to input at this time (during digital input). C signal, in which Y/C are separated, is output as C output. L: Y/C separation mode
72	DV _{ss}	-	Digital ground
73	DV _{DD}	-	Digital power supply (5V)
74	TEST	I	Test pin (fixed to "L")
75	TEST	I	Test pin (fixed to "L")
76	TEST	I	Test pin (fixed to "L")
77	TEST	I	Test pin (fixed to "L")
78	TEST	I	Test pin (fixed to "L")
79	BPF	I	H: fixed to BPF separation L: standard mode
80	TEST	I	Test pin (fixed to "L")

■ LC78681E (IC 802)
Servo-control & EFM Demodulation

● Outline of Functions

- 1) If HF signal is input, slices HF signal at accurate level, and converts it to EFM signal. After this compares the phase with VCO, and regenerates an average 4.3218 MHz PLL clock.
- 2) Controls rotation of spindle motor by the frame phase difference signal generated from the playback clock and reference clock.
- 3) Demodulates and converts EFM signal to 8-bit symbol data.
- 4) Separates subcode from EFM demodulation signal, and outputs to external microprocessor.
- 5) Buffers EFM demodulation signal at internal ROM, and performs jitter-absorption by disk rotation fluctuation of ± 4 frames.
- 6) Performs unscramble and deinterleaving to rearrange EFM demodulation signals in a specified order.
- 7) Detects and corrects error signals, and performs a flag process (C1, double; C2, double correction system).

● Block Diagram

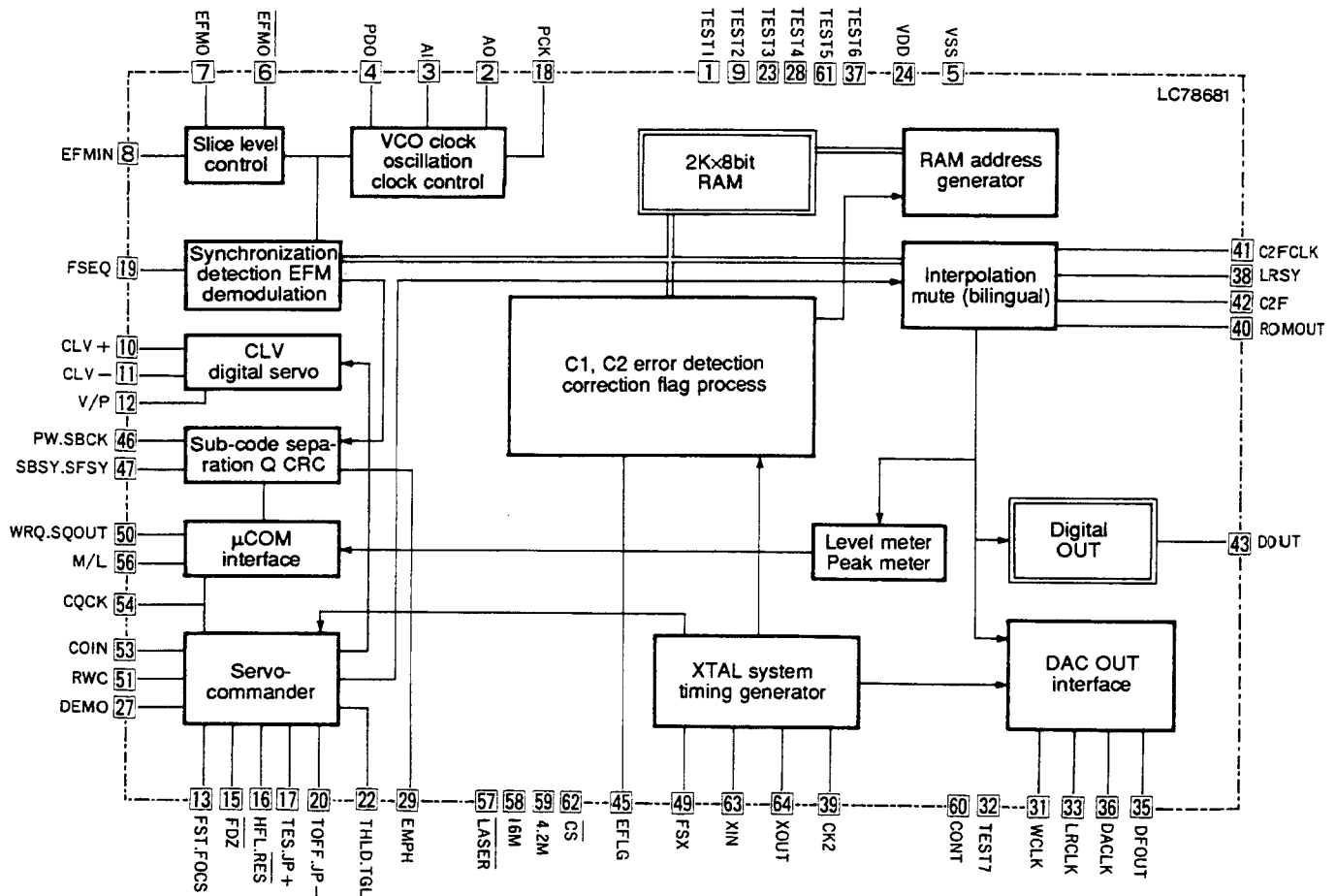

No.	Pin Name	I/O	Function															
1	TEST1	I	LSI test pin (normally unconnected)															
2	AO	O	Pin to input the output from PAC003A internal VCO (8.6436 MHz)															
3	AI	I																
4	PDO	O																
5	V _{ss}	-	GND															
6	EFMO	O	EFMIN is input pin of 1-2Vp-p of HF signal. EFM signals having reverse phase, that went through the amplitude limiter, are output from EFMO, EFMO pins. These EFM signals are input to the EFMIN pin via the low pass filter in PAC003A. These signals control slice level.															
7	EFMO	O																
8	EFMIN	I																
9	TEST2	I	LSI test pin (normally unconnected)															
10	CLV ⁺	O	<p>Output for disk motor control CLV⁺ is a signal to accelerate the disk in a positive direction, and CLV⁻ is a signal to decelerate a disk.</p> <table border="1" style="float: right;"> <thead> <tr> <th>MODE</th> <th>CLV⁺</th> <th>CLV⁻</th> </tr> </thead> <tbody> <tr> <td>Accelerate</td> <td>H</td> <td>L</td> </tr> <tr> <td>Decelerate</td> <td>L</td> <td>H</td> </tr> <tr> <td>CLV</td> <td>*</td> <td>*</td> </tr> <tr> <td>Stop</td> <td>L</td> <td>L</td> </tr> </tbody> </table> <p>One mode is selected from accelerate, decelerate, CLV and stop modes by a command from the microcomputer. The CLV⁺ and CLV⁻ output in each mode are shown in the table to the right.</p> <p>The TOFF terminal is Low only when the CLV servo control command is in the CLV mode. In other modes, the TOFF terminal is High. Command-driven control of the TOFF terminal is enabled in the CLV mode.</p>	MODE	CLV ⁺	CLV ⁻	Accelerate	H	L	Decelerate	L	H	CLV	*	*	Stop	L	L
MODE	CLV ⁺	CLV ⁻																
Accelerate	H	L																
Decelerate	L	H																
CLV	*	*																
Stop	L	L																
11	CLV ⁻	O																
12	V/P	O	Outputs "H" during CLV rough servo Outputs "L" during phase control															
13	FOCS	O	Focus servo becomes OFF when FOCS pin is "H". Lens lowers by FST pin output, and gradually rises when FOCS pin is "H". If FZD is output, FOCS is reset. These pins are for focus retraction.															
14	FST	O																
15	FZD	I																
16	HFL	I	Used as a pair with TOFF, TGL, THLD, JP+ and JP- output pins. Generates a kick pulse, JP+, and JP- according to the track jump command. Jumps the specified number of tracks (1, 4, 16, 64).															
17	TES	I																
18	PCK	O	4.8218 MHz. PCK monitor pin															
19	FSEQ	O	Becomes 1 when SYNC (true FS) detected from EFM signal and SYNC (inserted FS) of counter match. (1 frame latch output)															
20	TOFF	O	Generates a kick pulse, JP+, and JP- according to the track jump command. Jumps the specified number of tracks (1, 4, 16, 64).															
21	TGL	O																
22	THLD	O																
23	TEST3	I	LSI test pin (normally not connected)															
24	VDD	-	+5V															
25	JP ⁺	O	Generates a kick pulse, JP+, and JP- according to the track jump command. Jumps the specified number of tracks (1, 4, 16, 64).															
26	JP ⁻	O																
27	DEMO	I	For set adjusting process. Input pin for sound function.															
28	TEST4	I	LSI test pin (normally not connected)															
29	EMPH	O	De-emphasis is necessary when EMPH is "H".															
30	NC	-	Not connected															
31	WCLK	O	Outputs signal to D/A converter. Signal for sample hold.															
32	TEST7	O	LSI test pin (normally not connected)															
33	LRCLK	O	Outputs signal to D/A converter. L/R switching signal															

No.	Pin Name	I/O	Function
34	NC	-	Not connected
35	DFOUT	O	Outputs signal to D/A converter. Data output.
36	DACLK	O	Outputs signal to D/A converter. Data transfer clock.
37	TEST6	O	LSI test pin (not connected)
38	LRSY	O	For CD ROM corresponding signal output
39	CK2	O	
40	ROMOUT	O	
41	C2FCLK	O	
42	C2F	O	
43	DOUT	O	Output for DIGITAL OUT
44	SBSY	O	Outputs synchronous signal of subcode block
45	EFLG	O	For C1, C2, signal, double correction monitor
46	PW	O	SFSY is synchronous signal of subcode frame, reads subcode of P, Q, R, S, T, U, V and W by sending clock to SBCK 8 times.
47	SFSY	O	
48	SBCK	I	
49	FSX	O	Outputs 7.35 kHz synchronous signal
50	WRQ	O	WRQ becomes "H" if data of sub-code Q passed CRC check. By detecting "H" externally, and sending \overline{CQCK} , data is read from SQOUT. After RWC is set to "H" by microcomputer, a command is sent synchronizing with \overline{CQCK} command data.
51	RWC	I	
52	SQOUT	O	
53	COIN	I	
54	CQCK	I	
55	RES	I	Reset input. Set to "L" when power is turned ON.
56	M/L	I	If data of SQOUT pin is needed with LSB first, set this M/L pin to "L".
57	LASER	O	Output pin to control using serial control from microcomputer.
58	16M	O	16.9344 MHz. output pin
59	4M	O	4.2336 MHz. output pin
60	COIN	O	Output pin to control using serial control from microcomputer.
61	TEST5	I	LSI test pin (normally not connected).
62	CS	I	Chip select pin. If this pin is "L", LC78681R becomes active (with pull-down resistance)
63	X _{IN}	I	16.9344 MHz. crystal oscillator connection pin.
64	X _{OUT}	O	

■ PA0023AD (IC401)
FM Detector

● Pin Function

No.	Pin name	Function	No.	Pin name	Function
1	NC1	NC	8	NC3	NC
2	VCC	+5V power pin	9	OUT	Output pin
3	BIAS	BIAS pin	10	VREG	Constant voltage pin
4	+IN	RF input pin (positive)	11	NC4	NC
5	-IN	RF input pin (negative)	12	C1	Delay time setting pin
6	VEE	-5V power pin	13	C2	Delay time setting pin
7	NC2	NC	14	NC5	NC

■ PA0058A (IC400)
Video Demodulator

● Pin name

No.	Pin name	Function	No.	Pin name	Function
1	VCC1	Power pin	15	VCC2	Power pin
2	DOP	Drop-out pulse output pin Outputs drop-out pulse if drop out is detected. H level (during drop-out) → 4.3V L level (when normal) → 0.2V	16	NRIN2	Noise reduction 2 input pin
			17	NRR2	Adjusts noise reduction level using value of resistance inserted between this pin and GND.
			19	NRR1	
3	CSYNC	Composite sink pulse output pin. Open collector output. → 15K Ω H level → Vcc L level → 0.2V	18	NRIN1	Noise reduction 1 Input pin
			20	GND2	GND
4	DATA	Phillips code pulse output pin H level → 4.3V L level → 0.2V	21	DEEM	De-emphasis amplifier output pin Appropriate feedback circuit is inserted between this pin and de-emphasis amplifier input pin. Output level → 1.1 V p-p
5	CSIN	Input pin for synchronization separation Diode clamp input Clamp level → about 1.9V	22	DEEMIN	De-emphasis amplifier input pin Input level → 200 mV p-p
6	PEDIN	Input pin for synchronization separation Hard-clamped at pedestal level Clamp level → about 2.7V	23	RDOS	DOS frequency sensitivity adjustment pin Adjusts frequency sensitivity of DOS using resistance inserted between this pin and GND. Recommended resistance → 20 KΩ
7	GND1	GND	24	GND3	GND
8	LPF	LPF output pin for synchronization separation Output level → 1V p-p (GAIN 0dB)			
9	BOTTOM	Low side reference voltage pin for A/D conversions	25	CINH	Clamp inhibit pin Controls clamp operation of 5, 6, 13 pins 0V → clamp 5V → clamp inhibit
10	RE20K	Resistance pin for internal constant current supply. Connected to 20K Ω resistance.			
11	TOP	HIGH side reference voltage pin for A/D conversion	26	DINH	Phillips code pulse output control pin 0V → output inhibit 5V → output
12	VOUT	Outputs video signal that is clamped by synchronization chip for A/D conversion. Output level → 2V p-p (GAIN 6dB) Synchronization signal level → about 1.67V	27	NRINI	Noise reduction 1 Control pin 0V → ON 5V → OFF
13	SCLPIN	Synchronization signal clamp input pin Input level → 1V p-p Clamp level → about 1.67V	28	DOSIN	DOS input pin Input level → 500 mV p-p
			29	VCC3	Power pin
14	NROUT	Noise reduction circuit output pin Output level → 1.1 V p-p	30	NC2	NC pin

■ PD0146A (IC500)
Digital Video Processor

● Pin Function

No.	Pin name	Function	
1	RVDD	Power pin for reference system Connected to +5V.	
2	XSGCSY	Reference composite synchronization output Reference composite synchronization is output at negative logic. Delay can be controlled by serial command.	
3	WFM	MMEMSYS:1	Field monitor output for write system Outputs "H" when in odd field.
	XCHA	MEMSYS:0	Character input pin for write system Inputs "L" during character insertion.
4	XTBCH	MEMSYS:1	TBC H synchronization output Outputs time base-corrected H synchronization at negative logic.
	REFLOCK	MEMSYS:0	SSG phase detection signal output Outputs "H" when phase difference of H, V synchronization between Playback system (after TBC) and SSG system is small enough.
5	XTBCV	MEMSYS:1	TBC V synchronization output Outputs time base-corrected V synchronization at negative logic.
	CHCK	MEMSYS:0	Clock output for character generation Outputs 2Fsc.
6	FCH	MEMSYS:1	Field change input Switches field of SSG when "H".
	XCHB	MEMSYS:0	Character frame input pin Inputs "L" when character frame is inserted.
7	XRCK	Reference inverted CLK output Reference CLK is reversed and output.	
8	RCK	Reference CLK output	
9	DO7	Data output 7	Outputs TBC (time base-corrected) video signal to support memory. Serial interface performs this setting. D07 is MSB, DO0 is LSB.
10	DO6	Data output 6	
11	DO5	Data output 5	
12	DO4	Data output 4	
13	DO3	Data output 3	
14	DO2	Data output 2	
15	DO1	Data output 1	
16	DO0	Data output 0	
17	DCOREF	D/A converter reference for DCO Normally connected to DAGND via 0.1 μ F of laminated ceramic capacitor.	
18	INSSY	Synchronization output for insertion Synchronization insert pin. OPEN DRAIN output.	
19	DAREF	D/A converter reference for video Normally connected to DAGND via 0.1 μ F of laminated ceramic capacitor.	
20	VOUT	TBC (time base-corrected) video output pin Synchronization must be inserted by pin 18 (INSSY).	

Note) Pin functions of pins 3 - 6 differ depending on the mode (MEMSYS) of interface.

No.	Pin name	Function
21	DAVDD	Power pin for D/A converter Connected to +5V.
22	IBIAS	Bias circuit current control pin for A/D, D/A converter Normally connected to DAGND via external resistance.
23	DAGND	Ground pin for D/A converter Connect to GND.
24	DCOGND	Ground pin for DCO Connect to GND.
25	DCOVDD	Power pin for DCO Connect to +5V.
26	DCO0	DCO output pin ADCK is generated by multiplying this signal by 4.
27	DCO1	Waveform shaping input pin 1 Inputs DCO0 signal via band pass filter of fsc. (self-biased)
28	DCO2	Waveform shaping output pin 2 Outputs signal of waveform of DCO1 signal that is shaped.
29	DCO3	Waveform shaping input pin 3 Inputs signal of DCO2 output signal that is delayed 70 ns (self-biased).
30	DCO4	Waveform shaping output pin 4 Outputs signal multiplied by 2.
31	DCO5	Waveform shaping input pin 5 Inputs signal of DCO4 output signal that is delayed 35 ns (self-biased).
32	DCO6	Waveform shaping output pin 6 Outputs signal multiplied by 4. This signal is filtered through 4 fsc of the ceramic filter, and is used as a write system CLK.
33	WGND	Ground pin for write system Connect to GND.
34	ADCK	CLK input pin for write system Inputs signal of DCO6 output signal that is filtered through 4 fsc ceramic filter. (self-biased)
35	ACOM	Jitter correction control output for audio Outputs signal that has a duty in accord with error amount generated at internal phase comparator. Used to correct audio jitter.
36	XPBV	V synchronization output for playback system Outputs signal that has V synchronization separated from pin 50 (XPBCSY) signal at negative logic.
37	XPBH	H synchronization output for playback system Outputs signal that has H synchronization separated from pin 50 (XPBCSY) signal at negative logic.
38	TBCLOCK	PLL LOCK detection signal Outputs "H" when SPDL servo loop and TBC servo loop are locked.
39	SLATCH	Serial interface latch signal Generates timing to latch data that was input to serial interface (latched at fall edge).
40	SCLK	Serial interface CLK input Inputs CLK for serial interface. SDATA value is read at rise edge.
41	SDATA	Serial interface data input Inputs data to serial interface.
42	XRST	System reset Initializes internal registers of IC at negative logic. (Schmitt trigger input)
43	RTP	A/D converter top reference input Inputs top reference voltage of A/D converter.

No.	Pin name	Function
44	ADVDD	Power pin for A/D converter Connect to +5V.
45	ADGND	Ground pin for A/D converter Connect to GND.
46	RBT	A/D converter bottom reference input Inputs bottom reference voltage of A/D converter.
47	VIN	A/D converter input pin Inputs composite video signal.
48	WGND	Ground pin for write system Connect to GND.
49	WVDD	Power pin for write system Connect to +5V.
50	XPBCSY	Composite synchronization input for playback system Input composite synchronization at negative logic. (Schmitt trigger input)
51	DOSP	Drop out detection pulse input (Schmitt trigger input)
52	RF	RF signal input Inputs RF signal for spindle servo-circuit.
53	TOO	Tracking open pulse input (Schmitt trigger input)
54	SPERR	Spindle error PFD error output pin Outputs result after performing PFD on PBH and RefH at tri-state.
55	GCONT	Gain control output Outputs PWM signal according to set value (GD0-DG3), using serial instructions.
56	ACCNT	Accelerated control output Outputs acceleration/deceleration signal by forced acceleration/deceleration, by error detection by RF, and by error detection by H synchronization with tri-state.
57	PWMI	Spindle error PWM input Inputs signals that have voltage compared between spindle errors that passed through a loop filter and chopping waves. (Schmitt trigger input)
58	FR	Spindle error direction component input Inputs signals that have voltage compared between spindle errors that passed through a loop filter and target voltage. (Schmitt trigger input)
59	TEST	Input pin for IC test. Fixed to "L".
60	DRVA	Transistor control signal output pin for spindle motor drive This setting is performed by the interface corresponding to the brush motor and brushless motor.
61	DRVB	Transistor control signal output pin for spindle motor drive This setting is performed by the interface corresponding to the brush motor and brushless motor.
62	RGND	Ground pin for reference system Connect to GND.
63	XO	Oscillation output Connects X'tal (4 fsc) for oscillation.
64	XI	Oscillation input Connects X'tal (4 fsc) for oscillation.

■ PD0154A (IC603)
On Screen Display

● Block Diagram

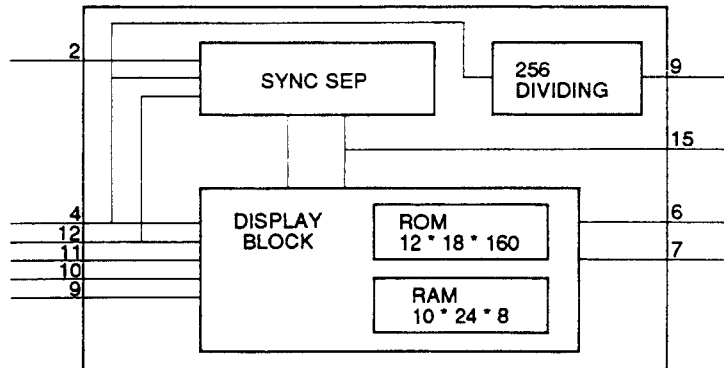

● Pin Function

No.	Pin name	Function
1	TESTIN1	Test input 1 Input pin for IC test. Normally set to OPEN (with pull-up resistance).
2	C-SYNC	Composite synchronization input Inputs composite synchronization signal at negative logic (Schmitt trigger input).
3	TESTIN2	Test input 2 Input pin for IC test. Normally set to OPEN (with pull-up resistance).
4	2fsc	Master Clock Inputs clock that is 2 times the color sub-carrier frequency (Schmitt trigger input).
5	TESTOUT1	Test output 2 Output pin to IC test. Normally set to OPEN.
6	CHA	Channel A output Outputs character timing at negative logic.
7	CHB	Channel B output Outputs logical sum of character timing and blanking timing at negative logic when blanking function is ON.
8	VSS	Ground pin Grounded to GND.
9	SCK	Serial clock input Inputs clock for serial communication. SIN value is read at rise edge (with pull-up resistance, Schmitt trigger input).
10	SIN	Serial data input Inputs data for serial communication (with pull-up resistance).
11	CS	Chip select input Set to "L" when serial communication is performed (with pull-up resistance).
12	AC	Auto clear input Initializes internal IC when "L" content of RAM, that stores character code, does not change (with pull-up resistance, Schmitt trigger input).
13	TESTOUT2	Test output 2 Output pin for IC test. Normally set to OPEN.
14	2fsc/256	Master clock 256 division Outputs clock of master clock (2fsc) that is divided by 256.
15	VSYNC	V synchronization output Outputs signal of V synchronization that is separated from pin 2 signal (C-SYNC).
16	VDD	Power pin Connected to +5V.

■ PD0171B (IC101)
Mechanism Control

● Pin Function

No.	Pin name	I/O	Function	No.	Pin name	I/O	Function
1	Vcc	I	Power connection pin Applies 5V ± 10%.	14	TILT/ LOAD DRV	O	Loading and tilt control signal output pin Outputs tilt drive after PWM, and is used in loading and tilt servo-mechanism.
2	XCD	O	LD/CD switching signal output pin. LD: H; CD: L.	15	SQOUT	I	DSP read command data input pin SUBQ is read.
3	RF CORR	O	RF correction switching signal output pin H: increases gain Increases gain at internal circumference of CAV. #8000 to #8100. Fixed to gain increase side, except for CAV.	16	COIN	O	DSP write command data output pin
4	N.C.	O	Not used	17	CQCK	O	DSP read/write command clock output pin Reads at rise edge.
5	FBAL	O	Control focus balance 1: RFMAX; 0: TEMAX Changes only in test mode. Fixed to "High" in normal mode.	18	SLD DRV	O	Slider control signal output pin Outputs slider drive after PWM and is used in slider servo-mechanism. Cycle 910 msec., ternary control: H, L, Z.
6	SLD ERR	I	Slider error signal input pin (A/D input port) This is an A/D converted signal that is input as slider servo control.	19	SI1	I	Data input pin from mode control IC Serial front T0 mechanism. Shared with data signal to character generation IC.
7	SLD POS	I	Pickup position detection switch input pin (A/D input port) Divides resistance among switches, reads the value of the A/D input, and detects the position.	20	SO1	O	Serial data output to mode control IC Serial front T0 mechanism.
8	TBAL ERR	I	Tracking balance error signal input pin. (A/D input port) Signal is A/D converted and is input as the tracking offset control.	21	SCK1	O	Clock for serial communication with mode control IC Becomes input mode, except during communication with mode control IC. Shared with clock signal to character generation IC.
9	TILT ERR	I	Tilt sensor output signal input pin. (A/D input port) Inputs signal of amplified output of tilt sensor at 40 to 50 dB (0 to 5V). Signal is A/D converted and is input as the tilt servo control. Controls the tilt motor until this signal is 2.5V.	22	TZC	I	Tracking error zero cross signal input pin This signal is a comparator tracking error signal. Slider motor is controlled during a track count search by counting this signal.
10	XFOK	I	Focus servo lock signal input pin Lock: L; unlock: H Used to detect lock of focus servo- mechanism.	23	WRQ	I	Subcode Q read OK signal input pin OK: h; NG:L If sub-code Q data passed CRC check, this pin becomes H. Corresponds to SCOR of 2500.
11	FSEQ	I	Subcode synchronization coincidence detection signal input pin Match: H; other: L Becomes "H" if SYNC (true frame sync) detected from EFM signal and SYNC (inserted frame sync) of counter match. Latches output during 1 frame.	24	RWC	O	DSP read/write command signal output pin READ: L; WRITE:H
12	TBAL DRV	O	Tracking offset control signal output pin Outputs tracking offset to PWM and uses it as auto tracking offset. Cycle 910msec., ternary control: H, L, Z.	25	SHAKE	I/O	Handshake signal pin for data communication with mode control IC This pin has a bi-directional data line, and each microcomputer transmits timing of data transfer by switching output/input mode.
13	T LATCH	O	DACR digital filter PD2026 serial control Latch signal output pin. Latches at fall edge.	26	XPBV	I	LD/CDV playback vertical synchronous signal input pin During vertical synchronization: L This IC basically operates synchronizing with this signal (fall edge). In CAV special playback mode, jump timing is generated using this signal as a reference.
				27	CN Vss	I	GND ground pin for A/D conversion.

No.	Pin name	I/O	Function	No.	Pin name	I/O	Function
28	XRESET	I	Reset signal input pin "L" = reset; "H" = reset clear Controlled by mode control IC.	52	XCLV	O	CAV/CEV switching signal output pin "H" = CAV; "L" = CLV Connected to PA5013, pin 6, and used as video NR switching signal.
29	XIN	I	9 MHz clock oscillation input pin	53	DATAINII	O	Output pin to inhibit data H: normal ; L: inhibit Does not inhibit when reading data in 16H, 17H, 18H, play, pause, still, step and FWD. * Fixed to "High" except for 1.
30	XOUT	O	9 MHz clock oscillation output pin				
31	N.C.	O	Not used. Used only for ø output.				
32	Vss	I	GND ground pin.	54	DIRECT	O	CD direct: H; normal: L "H" = video system power supply OFF; "L" = Normal
33	SW1	I	Switch input pin for loading/tilt position detection				
34	SW2	I	Switch input pin for loading/tilt position detection	55	TBCH	I	Vertical synchronous lock detection signal input pin H for a specified time when phase of REFV and PBV match. H for a specified time when phase of REF-V for CLV clear scan and PBV match. Not used for models with memory, since it has no clear scan function.
35	SW3	I	Switch input pin for loading/tilt position detection				
36	TBCLOCK	I	Spindle lock signal input pin Lock: H; unlock: L				
37	FG	I	Spindle motor FG signal input pin 24 outputs per rotation. Used after dividing by 3 in microcomputer.	56	TIILD	I	Track jump accelerating/decelerating signal input pin During accelerating/decelerating: H; other: L
38	DATA	I	Input pin for Phillips code decoder in mechanism controller				
39	XPBH	I	Playback H-SYNC input For Phillips code decoding.	57	N.C.	O	Not used
40	XPBV	I	Playback V-SYNC input For Phillips code decoding.	58	DETAMP	I	Spindle overcurrent detection signal input pin Overcurrent: L; normal: H
41	16:9	O	16:9 switching signal output pin. 16:9 "H"; 4:3 (normal) "L"	59	SQ1	O	Analog audio selecting signal output pin 1/L Squelch: H EFM decoder IC: CXD2500 AQ control digital audio
42	LDG		Used in LD-G mode "H" = LDG; "L" = normal - LD-G switching timing occurs during V block. OE command of DVP changes synchronizing with this signal.				
43	N.C.	O	Note used	60	SQ2	O	Analog audio selecting signal output pin 2/R Squelch: H
44	N.C.	O	Note used				
45	ATB ON		This port becomes "H" during ATB operation, and is for ATB operation check	61	XCX	O	Analog audio CX noise reduction switching signal output pin ON: L; OFF: H
46	N.C.	O	Not used				
47	N.C.	O	Not used	62	MUTE	O	Audio system audio mute control signal output pin MUTE: H; MUTE clear: L
48	SCK3	O	Serial 3 clock signal output pin Read at rise edge. "H" block 2 µsec.; "L" block 20 µsec.				
49	DVPLAT	O	PD0146 serial latch signal output pin Latches at fall edge.	63	XSURROUND	O	Surround ON/OFF switching signal output pin Surround ON: L; OFF: H
50	SO3	O	Serial 3 data signal output pin Serial signal is common, and is distinguished by latch signal (XLAT3, XLAT2, TLTACH) LSB first.				
51	NRINH	O	Noise reduction control output pin by VDEM 0: normal; 1: no noise reduction Set to low in normal status, fixed to high in test mode.	64	XANA	O	Digital/analog audio switching signal output pin "H" = digital; "L" = analog This signal switches the signal output to lineout and headphone.

CLD-S360, CLD-S260

■ PD3248A (IC201) Mode Control

● Pin Function

Note:

H : High level $\bar{}$: High impedance
L : Low level \square : Pulse I/O

No.	Pin name	I/O	Function	Reset	No.	Pin name	I/O	Function	Reset
1	VCC	I	+5V.	-	33	SHTLSCAN	O	Shuttle scan output	L
2	SYNCOUT	O	CD deck synchro output pin	L	34	LED (DRCTCD)	O	LED output: DIRECT CD indication	L
3	xS-CLOCK	I/O	Serial communication clock (mechanism control IC, character generator)	L	35	LED (STNBY)	O	LED output: standby indication	H
4	S-MTOF	I	Serial communication data input (mechanism control IC)	L	36	SEGL	O	Display segment output	-27V
5	S-FTOM	O	Serial communication data output (mechanism control IC, character generator)	L	37	SEGK	O	Display segment output	-27V
					38	SEGJ	O	Display segment output	-27V
					39	SEGI	O	Display segment output	-27V
6	xRESET OUT	O	Motherboard reset output	L	40	KSCAN0/ SEG H	O	Key scan output/display segment output	-27V
7	xCS	O	Character generator (PD0175A) CS output (L: enable)	L	41	KSCAN1/ SEG G	O	Key scan output/display segment output	-27V
8	SYNCIN	I	CD deck synchro input pin	L	42	KSCAN2/ SEG F	O	Key scan output/display segment output	-27V
9	POWER ON	O	Motherboard power supply switching output	L	43	KSCAN3/ SEG E	O	Key scan output/display segment output	-27V
10	AVCC	I	+5V.	-	44	SEG D	O	Key scan output/display segment output	-27V
11	AN0	I	+5V (Not used)	H	45	SEG C	O	Key scan output/display segment output	-27V
12	AN1	I	+5V (Not used)	H					
13	PO2	I	+5V (Not used)	H					
14	PO3	I	+5V (Not used)	H	46	SEG B	O	Key scan output/display segment output	-27V
15	PO4	I	+5V (Not used)	H	47	SEG A	O	Key scan output/display segment output	-27V
16	D-CDSEL	I	FL display select port for DIRECT CD (+5V OFF)	H					
17	OEMN01	I	OEM select port #1* ¹	L	48	VDISP	I	-27V	-
18	OEMN02	I	OEM select port #2* ¹	L	49	G9	O	Display grid output	-27V
19	AVSS	I	GND.	-	50	G8	O	Display grid output	-27V
20	TEST	I	GND. (Not used)	L	51	G7	O	Display grid output	-27V
21	X2	O	NC (OPEN). (Not used)	-	52	G6	O	Display grid output	-27V
22	X1	I	+5V. (Not used)	H	53	G5	O	Display grid output	-27V
23	VSS	I	GND.	-	54	G4	O	Display grid output	-27V
24	OSC1	I	Main system clock oscillation (8 MHz)	\square	55	G3	O	Display grid output	-27V
					56	G2	O	Display grid output	-27V
25	OSC2	O		\square	57	G1	O	Display grid output	-27V
26	xRESET IN	I	CPU reset (L: reset)	H	58	KIN0	I	Key data input	L
27	SHAKE	I	Mechanism control IC serial communication request	L	59	KIN1	I	Key data input	L
					60	KIN2	I	Key data input	L
28	SEL IR	I	Remote control input	H	61	KIN3	I	Key data input	L
29	DOGFOOD	O	Pulse output for WATCHDOG	\square	62	KIN4	I	Key data input	L
30	P15	O	NC (OPEN). (Not used)	-	63	KIN5	I	Key data input	L
31	P16	I	+5V. (Not used)	H	64	KIN6	I	Key data input	L
32	P47	O	NC (OPEN). (Not used)	-					

* 1 OEM select port (#1, #2) (L,L): Pioneer, (L,H): RCA, (H,L): Marantz, (H,H): TEAC

8. FOR CLD-S260/SD

NOTES:

- Parts marked by "NSP" are generally unavailable because they are not in our Master Spare Parts List.
- The Δ mark found on some component parts indicates the importance of the safety factor of the part. Therefore, when replacing, be sure to use parts of identical designation.
- Parts marked by "☉" are not always kept in stock. Their delivery time may be longer than usual or they may be unavailable.

CLD-S260/SD and CLD-S360/SD have the same construction except for the following:

Mark	Symbol & Description	Parts No.		Remarks
		CLD-S360/SD	CLD-S260/SD	
NSP	MAIN Ass'y	VWS1110	VWS1108	
NSP	FLKB Ass'y	VWM1356	VWM1372	
NSP	HEPB Ass'y	VWV1292	-----	
Δ	T1 power transformer (AC110/120-127/220/240V)	VTT1123	VTT1132	
	Rear panel (FE)	VNA1366	VNA1365	
	Front panel Ass'y-S	VXX1930	VXX1929	
NSP	Front panel (ABS)	VNK2408	VNK2407	
	Snap plate	VNE1102	-----	
	Jack holder	VNE1609	-----	
	Headphone knob	PAC1707	-----	
	UPC code label	-----	VRW1354	*1
	Remote control unit (CU-CLD093)	VXX1921	-----	
	Remote control unit (CU-CLD067)	-----	VXX1732	
	Battery cover	VNK2431	PZN1010	
	Packing case	VHG1299	VHG1298	

*1: Refer to page 2.

MAIN Ass'y

WWS1108 and WWS1110 have the same construction except for following:

Mark	Symbol & Description	Parts No.		Remarks
		WWS1110	WWS1108	
	IC206	NJM78M08FA	-----	
	IC207	NJM79M08FA	-----	
	IC701	CXD2023Q	-----	
	IC702	BU4053B	-----	
	IC770	TA7302P	-----	
	Q203,Q209-Q213	DTA124EK	-----	
	Q591	-----	2SA1037K	
	Q611-Q613,Q621,Q681	-----	2SC2412K	
	Q710,Q711,Q791,Q792	2SC2412K	-----	
	Q712,Q713,Q770,Q780,Q790,Q793	2SA1037K	-----	
	Q781,Q782,Q786,Q794,Q795	2SC1740S	-----	
	D202	ERA-83-006	-----	
	D205-D208	1SS254	-----	
	L206,L710-L713	LAU220J	-----	
	L590,L591	-----	LAU270J	
	L770	LAU470J	-----	
	C207	CEAS471M10	CEAS470M10	

CLD-S360, CLD-S260

Mark	Symbol & Description	Parts No.		Remarks
		VWS1110	VWS1108	
C225,C226 C228 C255,C257 C270,C271,C279		CEAS101M10 CEAS100M50 CEAS471M10 CEAS471M10	CEAS470M10 ----- CEAS471M6R3 CEAS470M10	
C401 C409 C588 C594 C595		----- CCSQCH470J50 CEAS470M10 ----- -----	CCSQCH470J50 ----- CEAS101M10 CCSQCH150J50 CCSQCH070D50	
C596 C597 C598 C611,C613 C612,C614,C684,C685		----- ----- ----- ----- -----	CCSQCH470J50 CCSQCH180J50 CCSQCH390J50 CEAS470M10 CKSQYF104Z25	
C621 C695,C696,C702,C712,C714-C716, C719,C723,C725,C734,C736,C740, C741,C742,C744,C752,C754,C765, C767,C771,C772,C776,C781,C783, C789,C791,C793,C896 C701 C703,C711,C713,C717,C720,C730, C735,C751,C753,C780,C782,C790, C792		----- CKSQYF104Z25 CCSQSL102J50 CEAS470M10	CCSQCH100D50 ----- ----- -----	
C745 C746,C749,C760,C763 C747,C761 C748,C762 C750,C764		CEAS100M50 CCSQCH220J50 CCSQCH060D50 CCSQCH560J50 CCSQCH470J50	----- ----- ----- ----- -----	
C770 C773-C775 C777 C796 C798 C895		CEAS220M25 CKSQYF103Z50 CCSQCH150J50 CCSQCH100D50 CCSQCH101J50 CEAS101M10	----- ----- ----- ----- ----- -----	
R211 R212,R213,R220,R221 R215,R223 R219,R224,R593,R695,R709,R726, R751		RD1/6PM2R2J RD1/6PM470J RS1/10S682J RS1/10S103J	----- ----- RS1/10S1R2J -----	
R227,R233,R286,R293,R409 R238,R284,R289,R294,R715,R765, R793,R895 R241,R242 (4.7Ω, 1/6W) R252,R254,R256,R258 R291		RS1/10S471J RS1/10S102J DCN1001 RS1/10S183J RS1/10S562J	----- ----- ----- RS1/10S223J RS1/10S123J	
R402 R562-R569,R711,R713 R597 R598 R599 R600		----- RS1/10S221J ----- ----- ----- -----	RS1/10S471J ----- RS1/10S152J RS1/10S561J RS1/10S271J RS1/10S182J	

Mark	Symbol & Description	Parts No.		Remarks
		VWS1110	VWS1108	
	R611,R613,R621,R680	-----	RS1/10S101J	
	R612,R622	-----	RS1/10S472J	
	R614	-----	RS1/10S683J	
	R615	-----	RS1/10S322J	
	R616	-----	RS1/10S222J	
	R617	-----	RS1/10S102J	
	R618	-----	RS1/10S221J	
	R623	-----	RS1/10S332J	
	R684	-----	RS1/10S681J	
	R710,R712,R780,R781	RS1/10S332J	-----	
	R714	RS1/10S472J	-----	
	R716,R718	RS1/10S681J	-----	
	R717,R719,R720,R725	RS1/10S392J	-----	
	R750	RS1/10S331J	-----	
	R752	RS1/10S182J	-----	
	R753	RS1/10S333J	-----	
	R754,R782,R896	RS1/10S152J	-----	
	R756,R767,R778,R796	RS1/10S680J	-----	
	R762,R764,R766,R774,R788,R790, R792,R795	RS1/10S101J	-----	
	R763,R783,R787,R789,R791	RS1/10S222J	-----	
	R775	RD1/6PM681J	-----	
	R784	RN1/6PQ1801F	-----	
	R785	RS1/10S562J	-----	
	R786	RN1/6PQ8201F	-----	
	VR591	-----	VRTB6VS472	
	VR611	-----	VRTB6VS102	
	VR702-VR704	VRTB6VS472	-----	
	JA6	VKB1065	VKB1031	
	JA8	TOTX178	-----	
	JA11	VKN1072	-----	
	JA14	VKB1063	-----	

9. CONNECTIONS

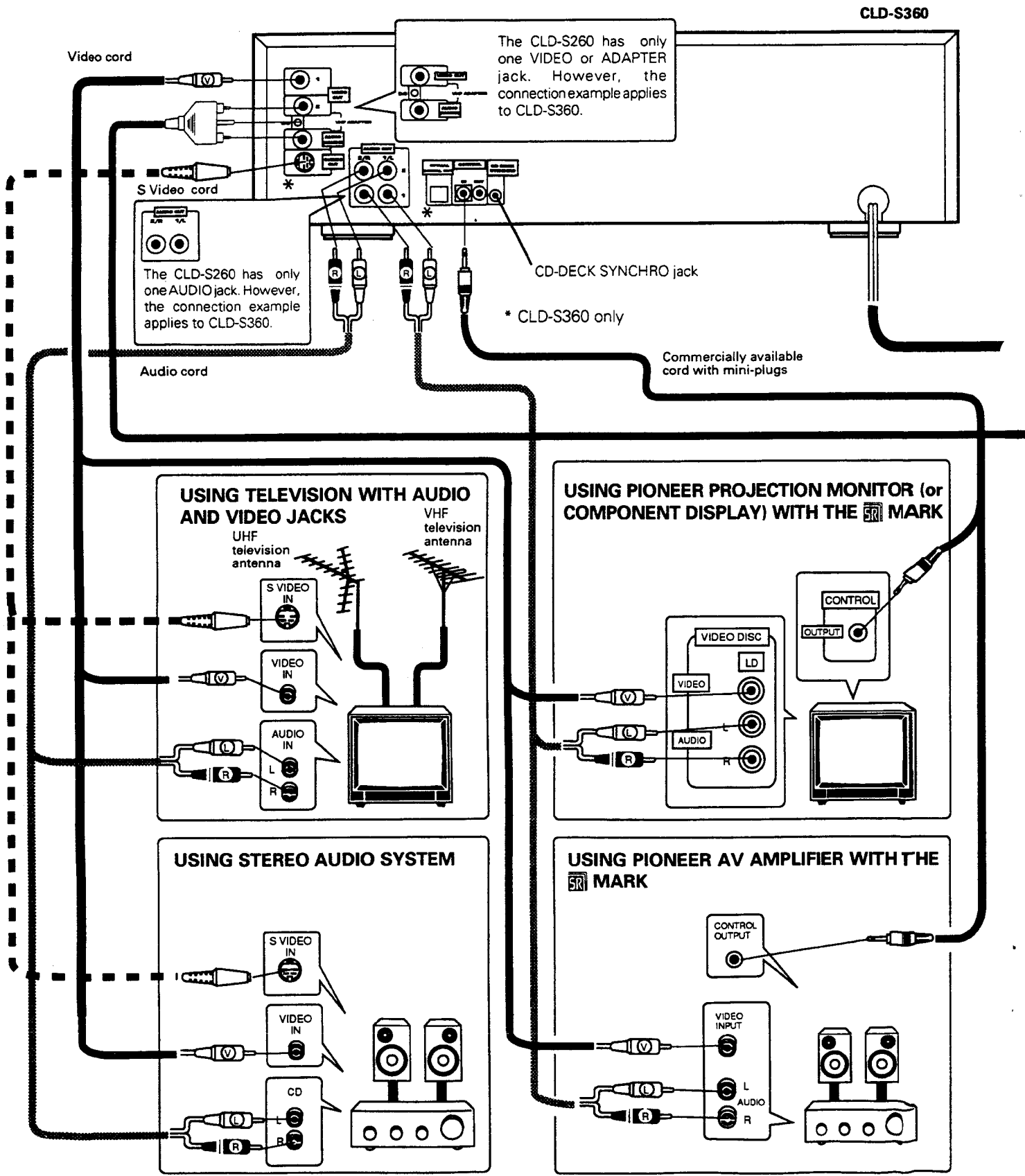

PLUG THE POWER CORDS INTO AC OUTLET

Plug the AC power cords of the player, stereo amplifier and TV set into an AC outlet. When the power cord of this unit is connected to an AC outlet, power is supplied to the unit's internal memory (such as the last memory) even when the POWER switch is off (STANDBY). Therefore, be sure to connect the power cord directly to a wall outlet. If the power cord is connected to an outlet such as a switched outlet on an amplifier, the various memory contents will be erased whenever the amplifier's power switch is turned off.

NOTE:

Optional RF modulator (JA-RF3L) is sold in the U.S. and Canada only.

USING TELEVISION WITHOUT AUDIO AND VIDEO JACKS

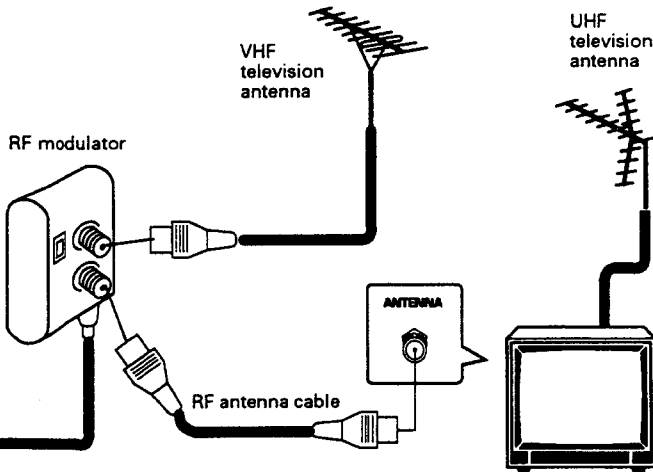

1. Detach the VHF antenna cable from the VHF antenna terminal of your TV set, and connect the cable to the VHF IN terminal of the RF modulator JA-RF3L.
2. Connect the VHF OUT terminal of the RF modulator to the VHF antenna terminal of your TV set.
3. Connect the socket (3-pin) of the RF modulator to the VHF ADAPTER OUTPUT jacks.

CONNECTING TV AND STEREO AMPLIFIER

- Connect the VIDEO OUT jack of the player to the video input jack of the monitor television.
- Connect the AUDIO OUT jacks to the stereo amplifier AUX, CD, LD, VDP or other jacks, except the PHONO input jacks. The television speakers can also be used by connecting the television audio input jacks and the player AUDIO OUT jacks, however connection to a stereo amplifier is recommended to obtain superior audio playback quality for Compact Discs and LaserDiscs. Do not change the television antenna and VCR connections.

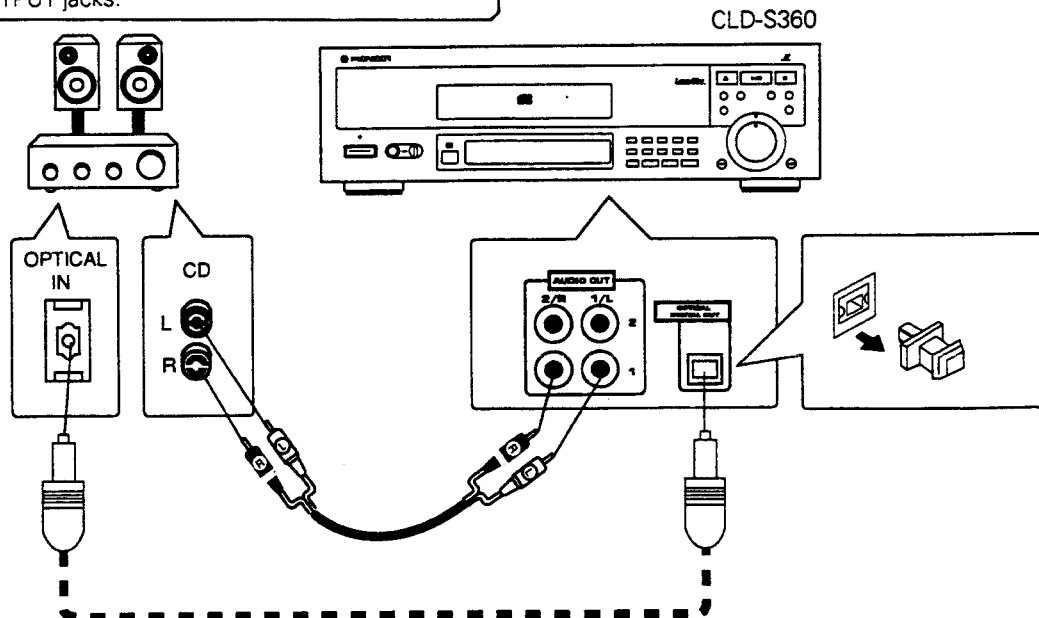

10. PANEL FACILITIES

Front panel:

PHONES LEVEL control (CLD-S360 only)

Turn this control in the "MAX" direction to increase the output level from the PHONES jack. Turn this control in the "MIN" direction to decrease the output level from the PHONES jack.

PHONES jack (CLD-S360 only)

POWER STANDBY/ON switch and STANDBY indicator
Press to turn the power on and off.

REMOTE SENSOR

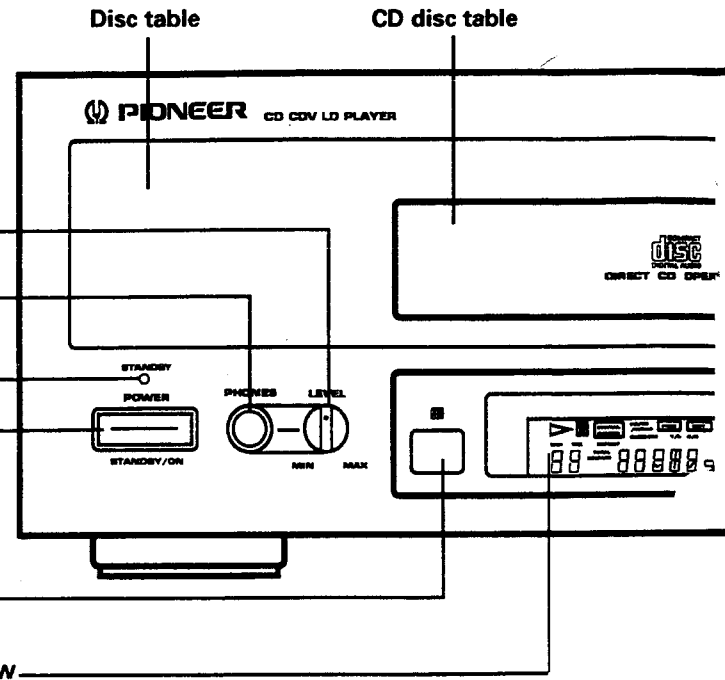

Display window

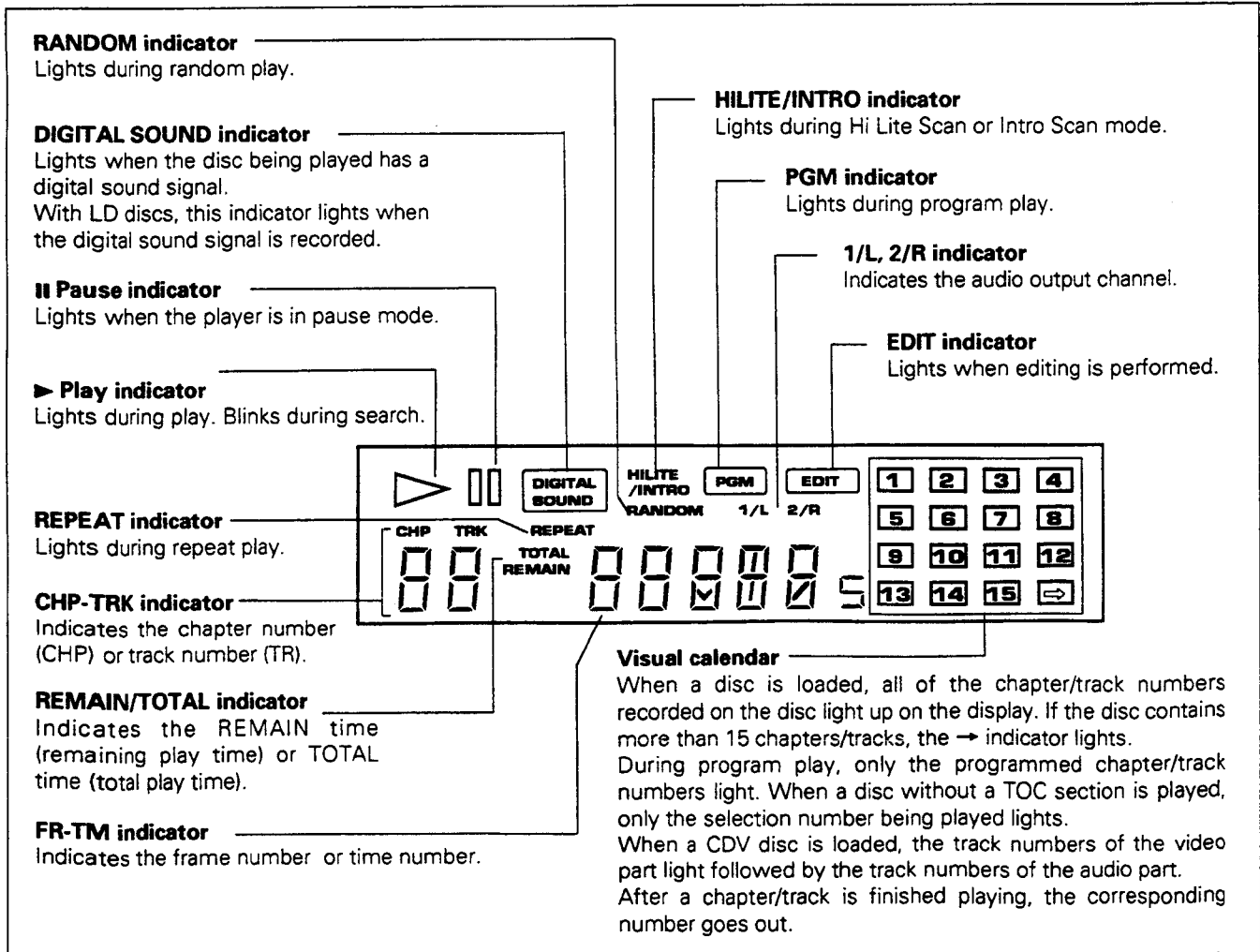

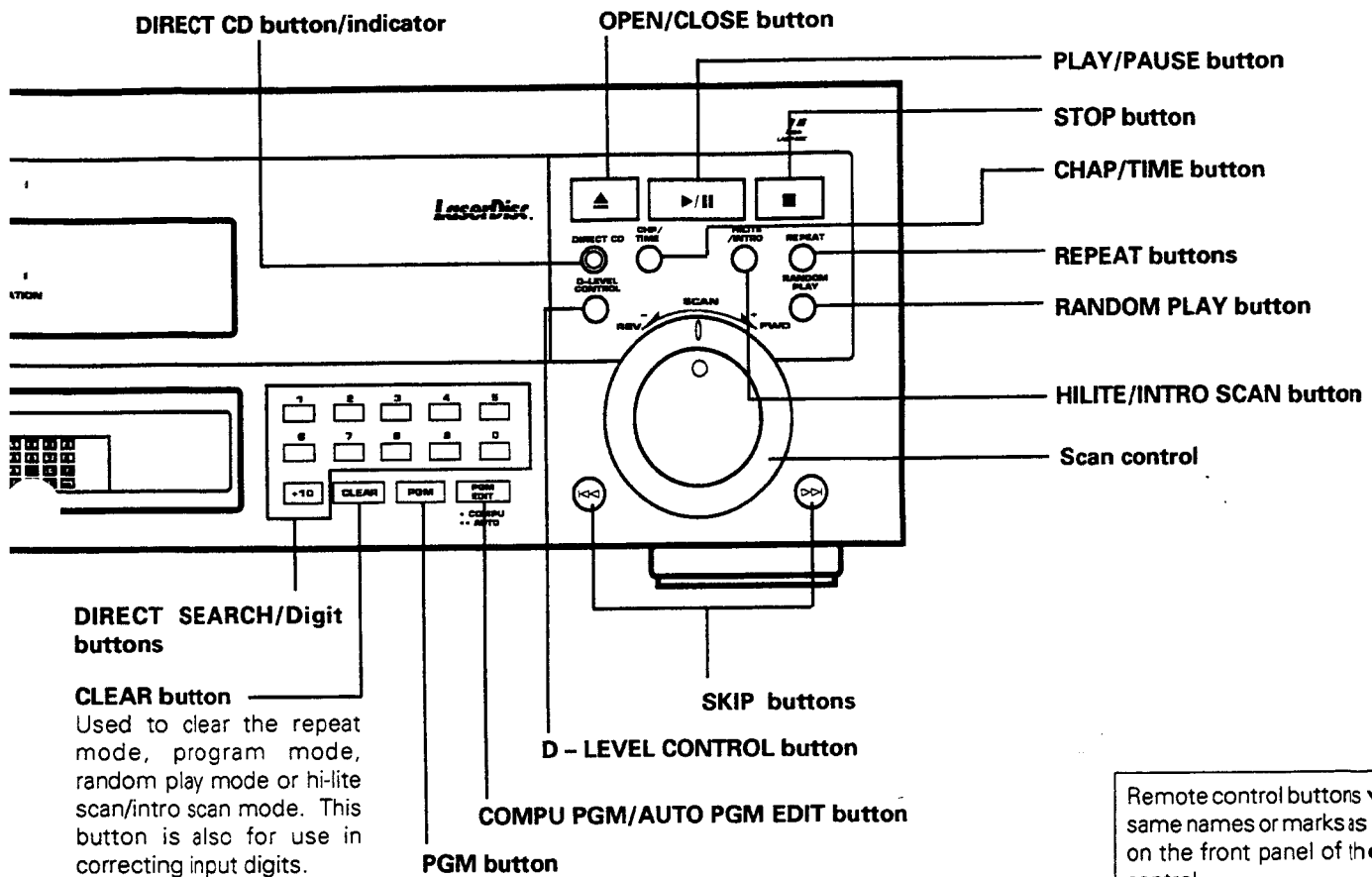

Remote control unit:

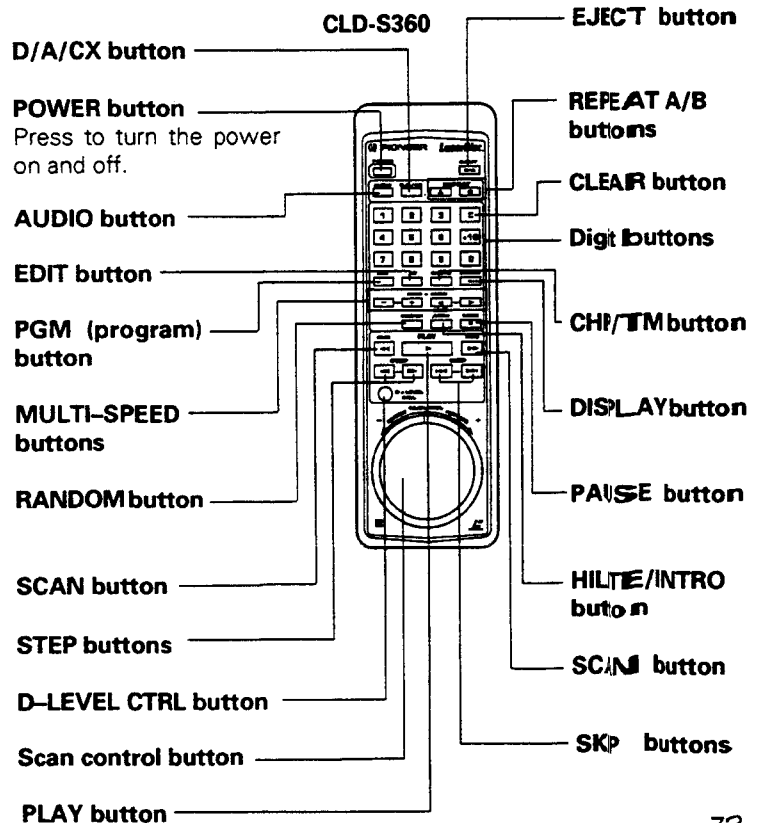
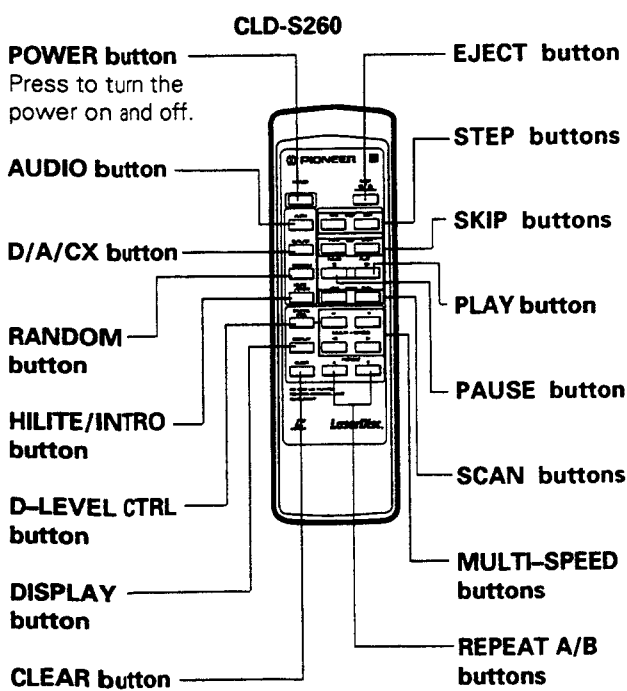

11. SPECIFICATIONS

1. General

System LaserVision Disc system and Compact Disc digital audio system
 Laser Semiconductor laser wavelength 780 nm
 Power requirements AC 110V/120 -127V/220V/240V (Switchable), 50/60 Hz
 Power consumption
 CLD - S360 41W
 CLD - S260 39W
 Weight 7.1kg (15 lbs 10 oz)
 Dimensions 420 (W) x 390 (D) x 122 (H) mm
 16-9/16(W) x 15-3/8(D) x 4-13/16(H) in
 Operating temperature +5°C ~ +35°C
 (41°F - 95°F)
 Operating humidity 5% ~ 85%
 (There should be no condensation of moisture.)

2. Disc

LaserVision Discs

*Maximum playing times
 30 cm standard play disc 1 hours/both sides
 30 cm extended play disc 2 hours/both sides
 20 cm standard play disc 28 min/both sides
 14 min/one side
 20 cm extended play disc 40 min/both sides
 20 min/one side
 Spindle motor speed
 Standard play disc 1,800 rpm
 Extended play disc 1,800 rpm (inner circumference)
 to 600 rpm (outer circumference)
 (For a 30 cm disc)

Compact Discs

DISC Diameter: 12 cm, 8 cm, Thickness: 1.2 mm
 Rotation direction (pickup side) Counterclockwise
 Liner speed 1.2 ~ 1.4m/sec
 *Maximum playing time
 74 min. 12 cm discs
 20 min. 8 cm discs
 (For stereo playback)

Compact Discs with Video

Disc Diameter: 12 cm, Thickness: 1.2 mm
 Rotation direction (pickup side) Counterclockwise
 Linear speed Audio portion: 1.2 ~ 1.4m/sec
 Video portion: 11 ~ 12m/sec
 *Maximum playing time Video portion: 5 min. (CLV)
 Audio portion: 20 min. (Digital)

* Actual playback time differs for each disc.

3. Video characteristics (CLD-S360: two pairs, CLD-S260: one pair)

Format NTSC specifications
 Video output
 Level 1 Vp-p nominal, sync. negative, terminated
 Impedance 75 Ω unbalanced
 Jack RCA jack

4. S-Video output (CLD-S360 only)

Y (luminance) - Output level 1Vp-p (75 Ω)
 C (color) - Output level 286 mVp-p (75 Ω)
 Jack S-VIDEO jack

5. Audio characteristics (CLD-S360: two pairs, CLD-S260: one pair)

Output level
 During analog audio output 200 mVrms
 (1 kHz, 40%)
 During digital audio output 200 mVrms
 (1 kHz, -20 dB)
 Jacks Both RCA jacks
 Number of channels 2 (Stereo)

Digital Audio Characteristics (CLD-S360)

Frequency response	4 Hz - 20 kHz (EIAJ)
SN ratio	115 dB (EIAJ)
Dynamic range	98 dB (EIAJ)
Total harmonic distortion	0.0025% (EIAJ)
Wow and flutter	Limit of measurement (EIAJ)

Digital Audio Characteristics (CLD-S260)

Frequency response	4 Hz - 20 kHz
SN ratio	102 dB (EIAJ)
Dynamic range	96 dB (EIAJ)
Total harmonic distortion	0.003% (EIAJ)
Wow and flutter	Limit of measurement (EIAJ)

6. Other Terminals

Control input/output Both miniature jacks
 CD- DECK synchro Miniature jack
 VHF adapter output (Video/Audio) Both RCA jacks
 with DC jack
 Optical digital output (CLD-S360 only) Optical digital jack

7. Accessories

Remote control unit 1
 Size "AAA" (IEC R03) dry cell batteries 2
 Video cord 1
 Audio cord 1
 Operating instructions 1
 Warranty card 1

8. Functions

	Function	Standard play Disc (CAV)	Extended play Disc (CLV)	Compact Disc with Video	Compact Disc
Basic Functions	Single-side play	YES	YES	YES	YES
	Pause	YES	YES	YES	YES
	Stop	YES	YES	YES	YES
Search	Fast forward (forward and reverse)	YES	YES	YES	YES
	Chapter/Track skip	YES	YES	YES	YES
	Direct chapter/Track number search	YES	YES	YES	YES
	Frame number search	YES	NO	NO	NO
	Time number search	NO	YES	YES	YES
	Absolute time search	NO	NO	NO	YES
Program	Chapter/Track program play	YES	YES	YES	YES
	Program correction	YES	YES	YES	YES
Repeat	Repeat between 2 points	YES	YES	YES	YES
	Memory repeat	YES	YES	YES	YES
	Chapter/Track repeat	YES	YES	YES	YES
	One-side repeat	YES	YES	YES	YES
	Program repeat	YES	YES	YES	YES
	Random repeat	YES*1	YES*1	YES	YES
	Program random repeat	YES	YES	YES	YES
	Still/Step	YES	NO	NO	NO
	Multi-speed (Forward/reverse 9-level variable)	YES	NO	NO	NO
Time display	Elapsed time display	NO	YES	YES	YES
	Absolute time display	YES*	NO	NO	YES
	Remaining track time display	NO	NO	YES	YES
	Remaining total time display	YES*1	YES*1	YES	YES
	Total number of selections, total time display	YES*1	YES*1	YES	YES
Others	Hi-Lite scan	NO	NO	YES*3	YES
	Intro scan	YES	YES	YES*4	NO
	CX system ON/OFF	YES*2	YES*2	NO	NO
	Audio channel selection (Stereo, 1/L, 2/R)	YES	YES	YES	YES

*1 Only discs with TOC

*2 Valid for analog sound playing a disc with the  mark.

*3 Audio part only

*4 Video part only

NOTE:

The specifications and design of this product are subject to change without notice, due to improvement.

PLAYER FUNCTIONS

- Display, Visual Calendar Display
- Intro Scan, Hi-Lite Scan, Random Playback, Program Random Playback and Compu Program/Auto Program Edit
- Digital Sound for LaserVision Discs
- Last Memory

Published by Pioneer Electronic Corporation.
Copyright © 1993 Pioneer Electronic Corporation.
All rights reserved.

LaserDisc is a trademark of Pioneer Electronic Corporation.