

Service Manual

PIONEER
The Art of Entertainment

ORDER NO.
RRV1588

CD CDV LD PLAYER

CLD-S315

- Refer to the service manual RRV1354 for CLD-S315/WBW.

THIS MANUAL IS APPLICABLE TO THE FOLLOWING MODEL(S) AND TYPE(S).

Type	Model	Power Requirement	Remarks
	CLD-S315		
WBW1	○	AC220-240V	
WEZ1	○	AC220-240V	
WPW1	○	AC220-240V	

- This product (WBW1, WEZ1 and WPW1 types) is the addition model which is added to the DOLBY AC-3 function with the current model (WBW, WEZ and WPW types).

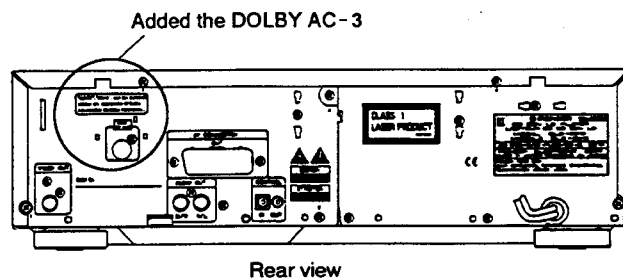

PIONEER ELECTRONIC CORPORATION 4-1, Meguro 1-Chome, Meguro-ku, Tokyo 153, Japan
PIONEER ELECTRONICS SERVICE, INC. P.O. Box 1760, Long Beach, CA 90801-1760, U.S.A.
PIONEER ELECTRONIC (EUROPE) N.V. Haven 1087, Keetberglaan 1, 9120 Melsele, Belgium
PIONEER ELECTRONICS ASIACENTRE PTE. LTD. 501 Orchard Road, #10-00 Lane Crawford Place, Singapore 0923
 © PIONEER ELECTRONIC CORPORATION 1996

T-IFB APR. 1996 Printed in Japan

1. CONTRAST OF MISCELLANEOUS PARTS

NOTES:

- Parts marked by "NSP" are generally unavailable because they are not in our Master Spare Parts List.
- The Δ mark found on some component parts indicates the importance of the safety factor of the part. Therefore, when replacing, be sure to use parts of identical designation.
- Parts marked by "⊙" are not always kept in stock. Their delivery time may be longer than usual or they may be unavailable.
- When ordering resistors, first convert resistance values into code form as shown in the following examples.

Ex.1 When there are 2 effective digits(any digit apart from 0), such as 560 ohm and 47k ohm(tolerance is shown by J=5%, and K=10%).

560 Ω \rightarrow 56 \times 10' \rightarrow 561..... RD1/4PU $\boxed{5}\boxed{6}\boxed{1}J$
 47k Ω \rightarrow 47 \times 10' \rightarrow 473..... RD1/4PU $\boxed{4}\boxed{7}\boxed{3}J$
 0.5 Ω \rightarrow 0R5..... RN2H $\boxed{0}\boxed{R}\boxed{5}K$
 1 Ω \rightarrow 1R0..... RSIP $\boxed{1}\boxed{R}\boxed{0}K$

Ex.2 When there are 3 effective digits(such as in high precision metal film resistors).

5.62k Ω \rightarrow 562 \times 10' \rightarrow 5621..... RN1/4PC $\boxed{5}\boxed{6}\boxed{2}\boxed{1}F$

CLD-S315/WBW1, WEZ1, WPW1 and CLD-S315/WBW have the same construction except for the following :

Mark	Symbol & Description	Part No.				Remarks
		WBW	WBW1	WEZ1	WPW1	
NSP	MOTHER ASSY	VWM1600	VWM1708	VWM1708	VWM1708	
	MOTHER ASSY	VWS1196	VWS1269	VWS1269	VWS1269	
	AC3B ASSY	Not used	VWV1499	VWV1499	VWV1499	No.1
	● PACKING SECTION					
	Caution (UC)	VRR1020	VRR1020	Not used	VRR1020	
NSP	Caution (EW)	Not used	Not used	VRM1027	Not used	*
NSP	Caution	Not used	Not used	VRR1009	Not used	*
	Operating Instructions (English/French/German/Italian)	VRE1035	VRE1035	VRE1035	VRE1035	
	Operating Instructions (Dutch/Swedish/Spanish/Portugueses)	Not used	Not used	VRF1034	Not used	*
NSP	Warranty Card	ARW-088	ARW-088	ARW-088	PRY1002	
	Instruction Sheet (AC3)	Not used	VRL1002	VRL1002	VRL1002	
	● EXTERIOR AND DISC TRAY SECTION					
	Caution Label	PRW1018	PRW1018	VRW1094	PRW1018	
NSP	Caution Label HE	Not used	Not used	VRW1297	Not used	*
	● FRONT PANEL SECTION					
NSP	Front Panel	VNK3192	VNK3830	VNK3830	VNK3830	
	FL Lens	VEC1791	VEC1791	VEC1791	VEC1790	
	Front Panel Assy-S	VXX2292	VXX2448	VXX2448	VXX2455	
	● BOTTOM VIEW SECTION					
Δ	AC Power Cord	VDG1063	VDG1063	VDG1061	VDG1065	
	Rear Panel R	VNA1598	VNA1781	VNA1781	VNA1781	
NSP	Rear Panel L	VNA1574	Not used	Not used	Not used	
	Rear Panel L	Not used	VNA1780	VNA1780	VNA1780	
	Flexible Cable (7P)	Not used	VDA1468	VDA1468	VDA1468	No.2

Notes : The numbers in the remarks column correspond to the numbers on the Exploded view.

* : Refer to the service manual RRV1354.

MOTHER ASSY

VWS1269 and VWS1196 have the same construction except for the following :

Mark	Symbol & Description	Part No.		Remarks
		VWS1196	VWS1269	
	IC400 IC801 IC901	PAC005B PAC002A PAC003A	LA7133 LA9425 LA9420M	* * *
	R194 R220,R222 (4.7 Ω ,1/6W)	Not used DCN1001	RS1/10S000J RFA1/6PU4R7J	Refer to "SCH-2F" *
	CN203 7P FFC Connector	Not used	52045-0745	Refer to "SCH-2F"

Note * : Although those parts are different in part number, they are interchangeable each other because of the same specifications.

EXPLODED VIEW

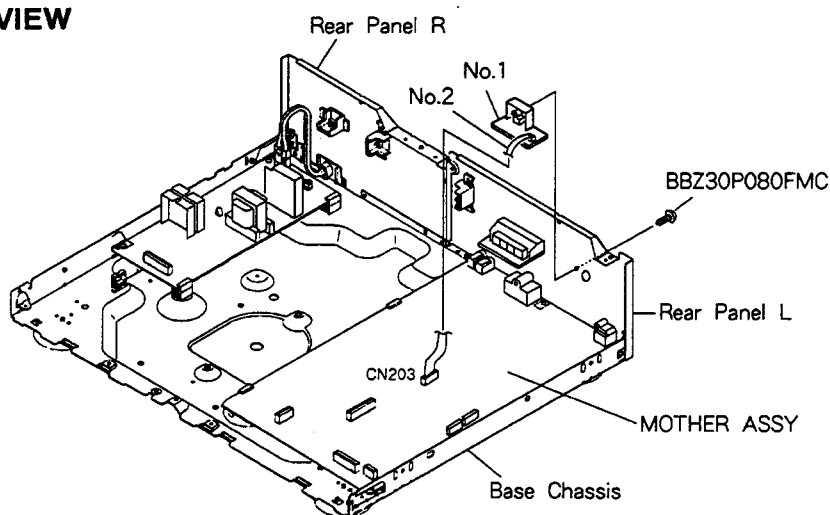

PCB PARTS LIST

Mark No.	Description	Part No.
AC3B ASSY (VWV1499)		
SEMICONDUCTORS		
Q301, Q302		2SC1740S
Q303		DTA124ES
CAPACITORS		
C301-C303		CKPUYF223Z25
RESISTORS		
All Resistors		RD1/4PU□□□J
OTHERS		
CN301	7P FFC CONNECTOR	52045-0745
JA17	1P PIN JACK	VKB1077
	PIN JACK HOLDER	VNE2043

2. SCHEMATIC AND PCB DIAGRAMS

NOTE FOR SCHEMATIC DIAGRAMS

1. When ordering service parts, be sure to refer to "PARTS LIST of EXPLODED VIEWS" or "PCB PARTS LIST". (Type 4A)

2. Since these are basic circuits, some parts of them or the values of some components may be changed for improvement.

3. RESISTORS:

Unit: k Ω , M Ω , or Ω unless otherwise noted.
 Rated power: 1/4W, 1/6W, 1/8W, 1/10W unless otherwise noted.
 Tolerance: (F): $\pm 1\%$, (G): $\pm 2\%$, (K): $\pm 10\%$, (M): $\pm 20\%$ or $\pm 5\%$ unless otherwise noted.

4. CAPACITORS:

Unit: p μ F or μ F unless otherwise noted.
 Ratings: capacitor (μ F)/voltage (V) unless otherwise noted.
 Rated voltage: 50V except for electrolytic capacitors.

5. COILS:

Unit: m μ H or μ H unless otherwise noted.

6. VOLTAGE AND CURRENT:

\square or \leftarrow V: DC voltage (V) in PLAY mode unless otherwise noted.
 \Leftrightarrow mA or \leftarrow mA: DC current in PLAY mode unless otherwise noted.
 Value in () is DC current in STOP mode.

7. OTHERS:

- or ○ : Adjusting point.
- ◀ : Measurement point.
- The Δ mark found on some component parts indicates the importance of the safety factor of the parts. Therefore, when replacing, be sure to use parts of identical designation.

8. SCH - \square ON THE SCHEMATIC DIAGRAM:

● SCH- \square indicates the drawing number of the schematic diagram. (SCH stands for schematic diagram.)

9. SWITCHES (Underline indicates switch position):

LMSB ASSY
 S101 : SW1
 S102 : SW2
 S103 : SW3







PKSB ASSY
 S104 : OUTER SW
 S105 : INNER SW

KEYB ASSY
 S201 : CD OPEN/CLOSE(\blacktriangle)
 S202 : LD OPEN/CLOSE(\blacktriangle)
 S203 : $\blacktriangle\blacktriangle$
 S204 : \parallel
 S205 : \blacktriangleright
 S206 : $\blacktriangleright\blacktriangleright$
 S207 : \blacksquare
 S208 : MENU

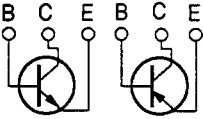
FLKY ASSY
 S101 : POWER ON STAND BY

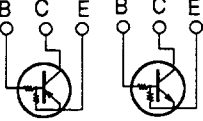
NOTE FOR PCB DIAGRAMS:

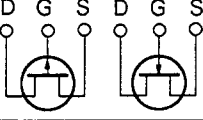
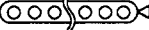
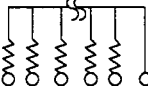
1. Part numbers in PCB diagrams match those in the schematic diagrams.
2. A comparison between the main parts of PCB and schematic diagrams is shown below.

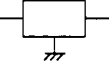
Symbol in PCB Diagrams	Symbol in Schematic Diagrams	Part Name
		Transistor
		Transistor with resistor
		Field effect transistor
		Resistor array
		3-terminal regulator

2.1 OVERALL CONNECTIONS, KEYB, FLKY, SYPS, PKSB, FG, LMSB, CARRIAGE AND AC3B ASSEMBLIES

A

B

C

D

E

F

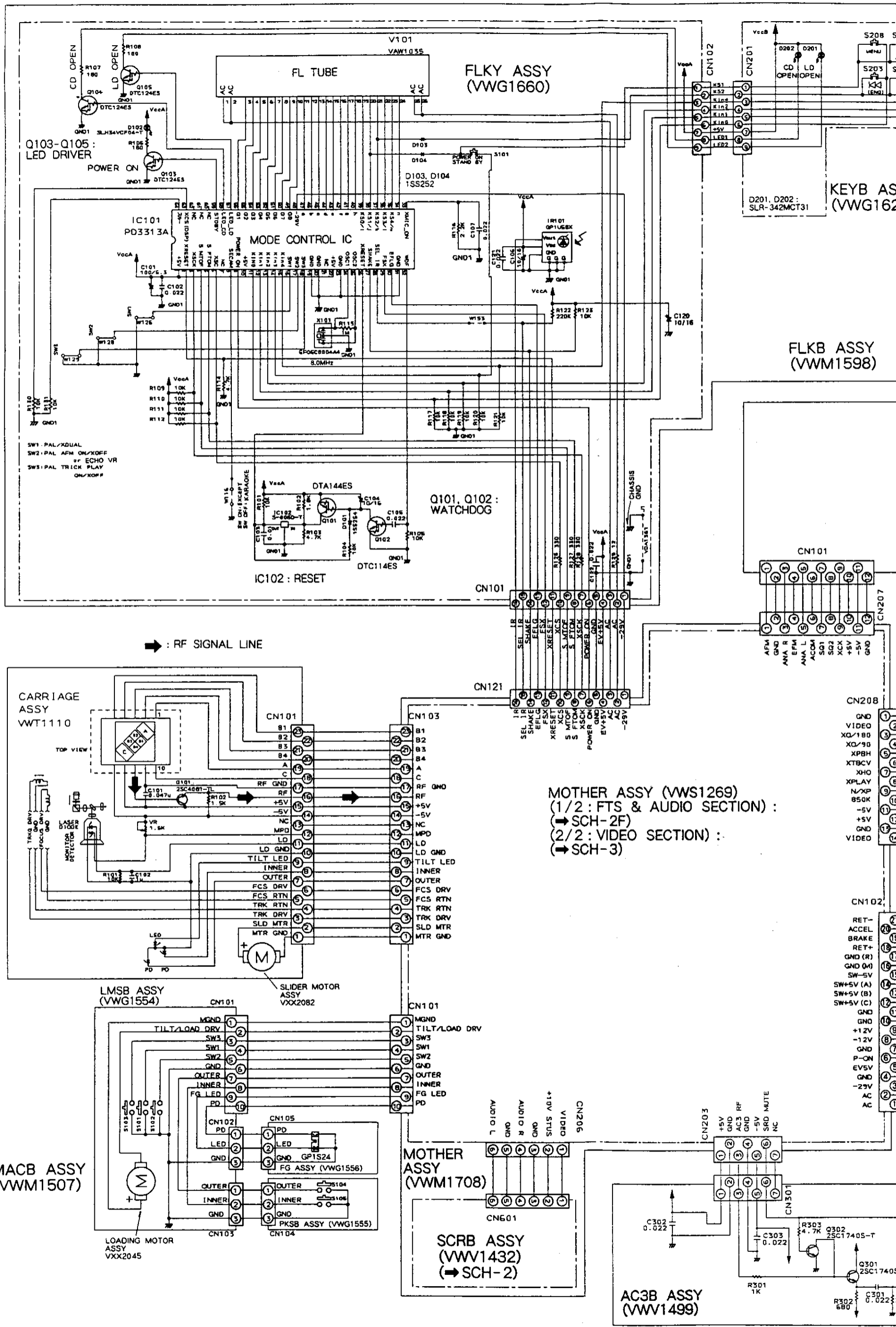

SCH-1F OVERALL CONNECTIONS, KEYB ASSY, FLKY ASSY, SYPS ASSY, PKSB ASSY, FG ASSY, LMSB ASSY, CARRIAGE ASSY, AC3B ASSY

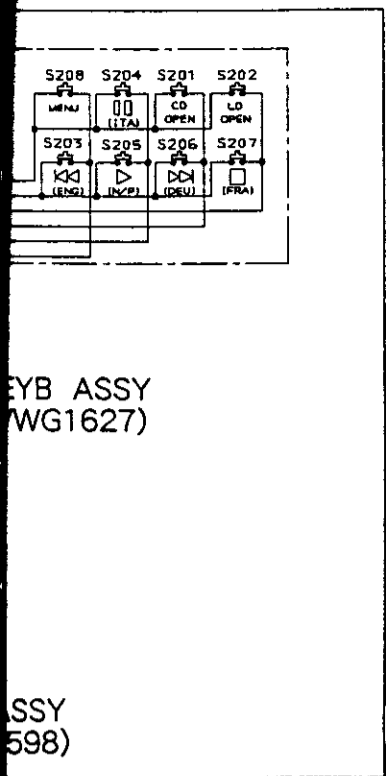

SCH-1F

AC3B ASSY

PCB-1F

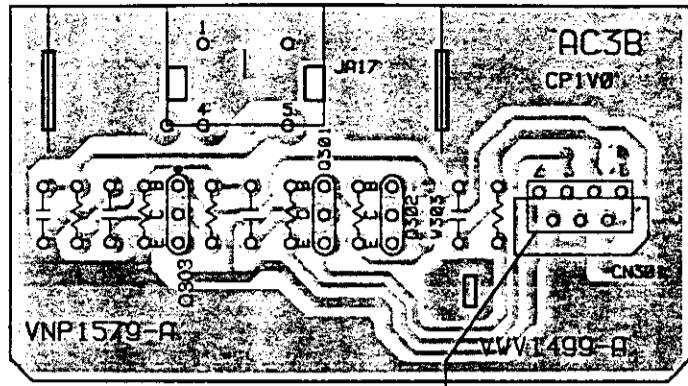

MOTHER ASSY
CN203

- This diagram is viewed from the mounted parts side.
- The parts mounted on this PCB include all necessary parts for several destinations.
For further information for respective destinations, be sure to check with the schematic diagram.

SSY
598)

PALB ASSY (VWV1430)
(→SCH-4)

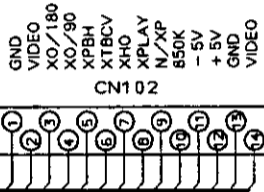

«Caution on repair the primary side parts of the SYPS assy»

- During repair, those other than the specified parts cannot be used to prevent the occurrence of an accident.
- Mark ✓ must be written in red on the board when the primary part of the power block is repaired.
- During part replacement, maintain the air clearance so that the replaced parts do not touch other parts.

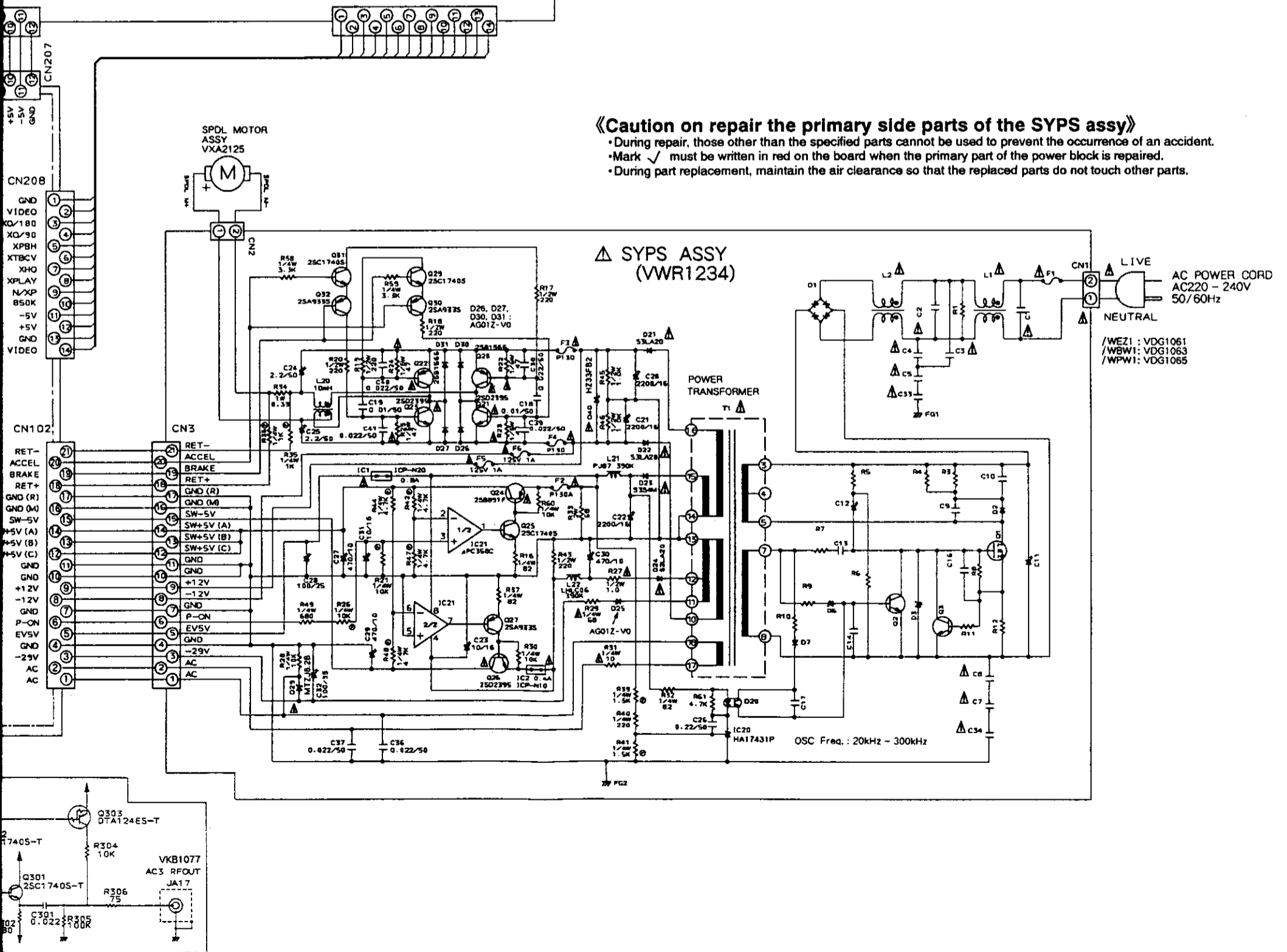

OVERALL CONNECTIONS, KEYB ASSY,
FLKY ASSY, SYPS ASSY, PKSB ASSY,
FG ASSY, LMSB ASSY, CARRIAGE ASSY,
AC3B ASSY

SCH-1F

A
B
C
D
E
T

SCH-2F

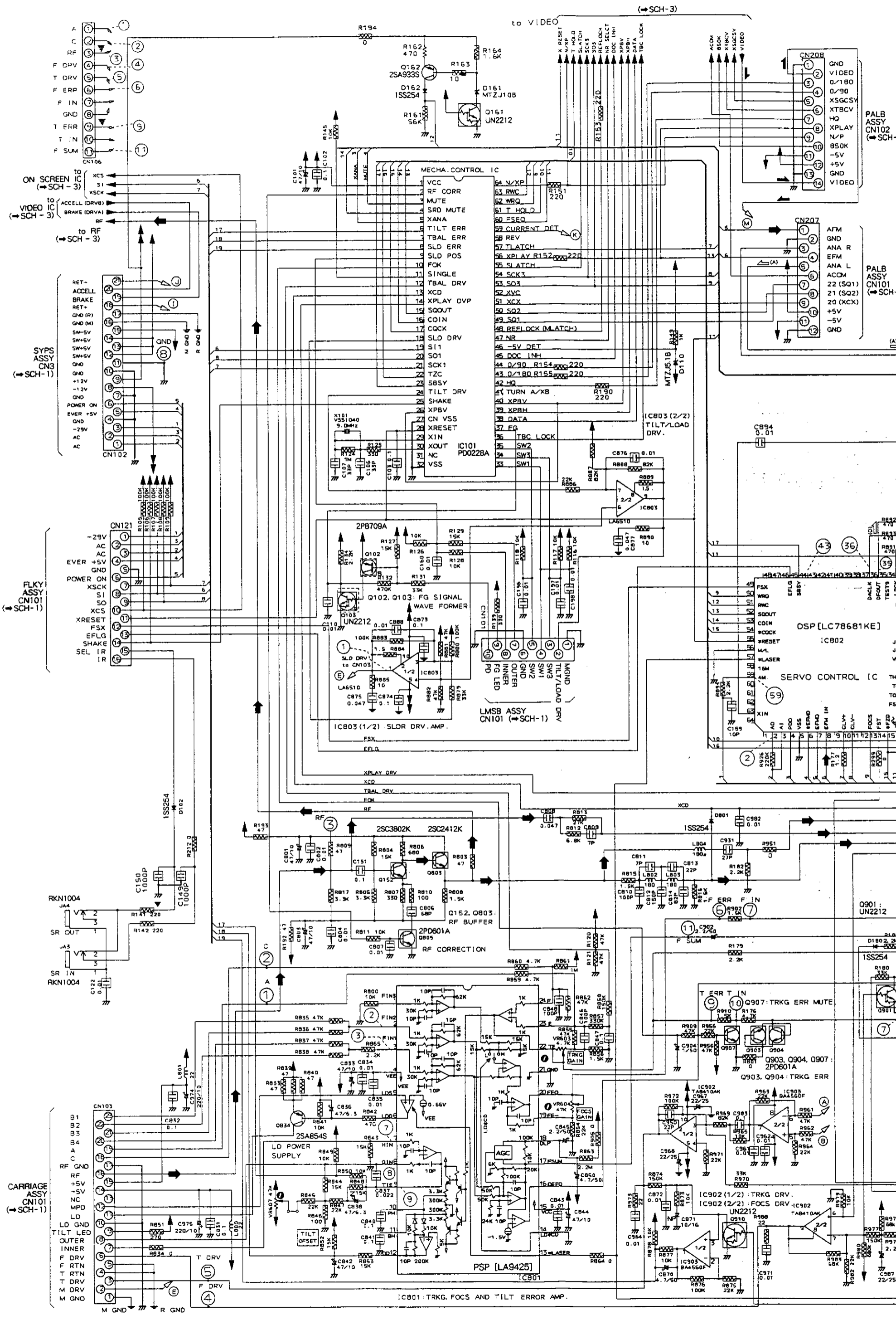

ON SCREEN IC (SCH-3)

SYPS ASSY CN3 (SCH-1)

FLKY ASSY CN101 (SCH-1)

CARRIAGE ASSY CN101 (SCH-1)

MOTHER ASSY (1/2), SCRIB ASSY

PALB ASSY CN102 (SCH-3)

PALB ASSY CN101 (SCH-3)

DSP [LC78681KE] IC802

SERVO CONTROL IC

Q901: UN2212

Q903, Q904: 2PD601A

IC902 (1/2): TRNG DRV.

IC902 (2/2): FOCUS DRV.

IC902

IC902

IC902

MOTHER ASSY (1/2) (VWS1269)
 FTS & AUDIO SECTION

SCH-2F

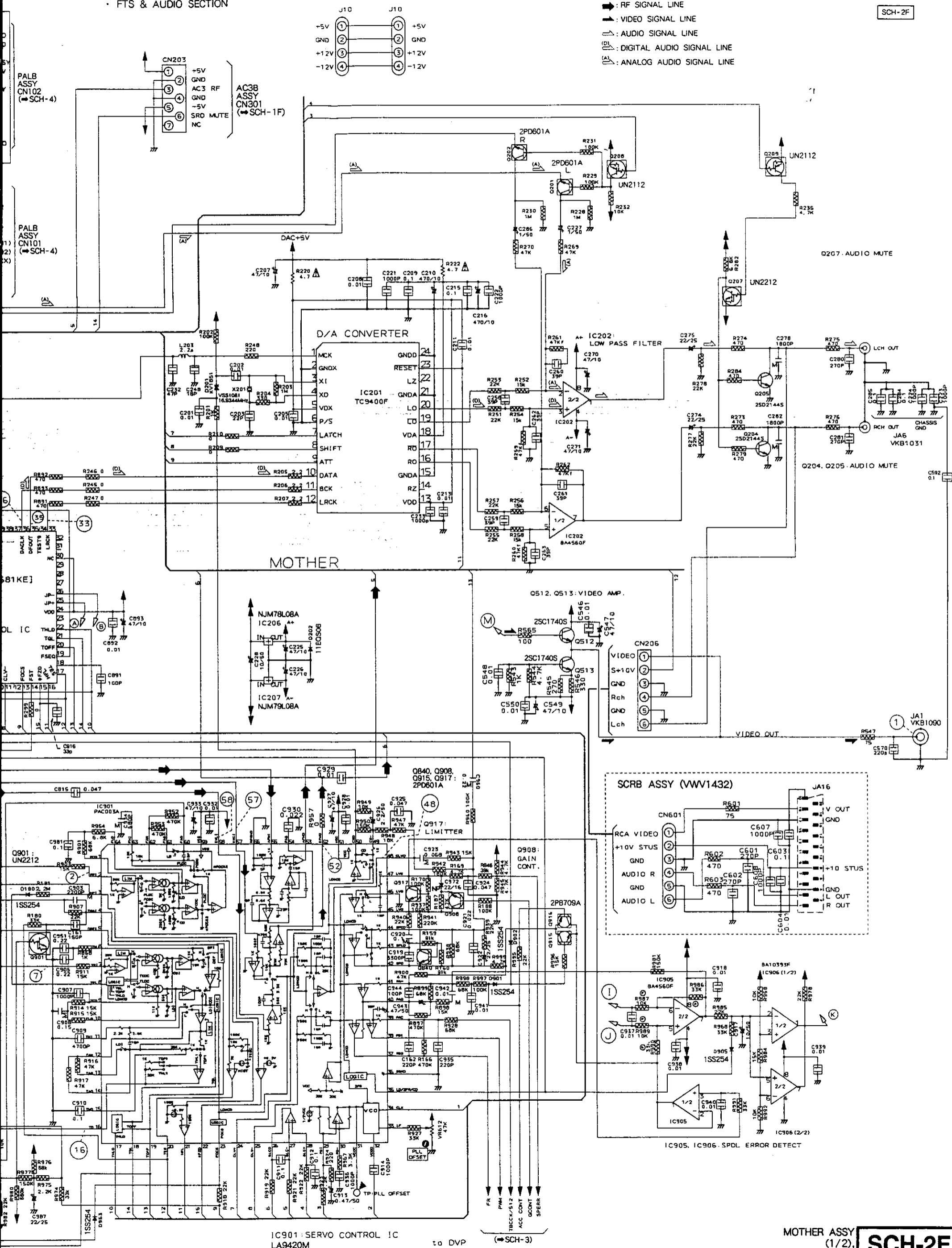

- RF SIGNAL LINE
- VIDEO SIGNAL LINE
- AUDIO SIGNAL LINE
- DIGITAL AUDIO SIGNAL LINE
- ANALOG AUDIO SIGNAL LINE

IC901: SERVO CONTROL IC
 LA9420M to DVP (SCH-3)

MOTHER ASSY (1/2)
 SCR B ASSY **SCH-2F**

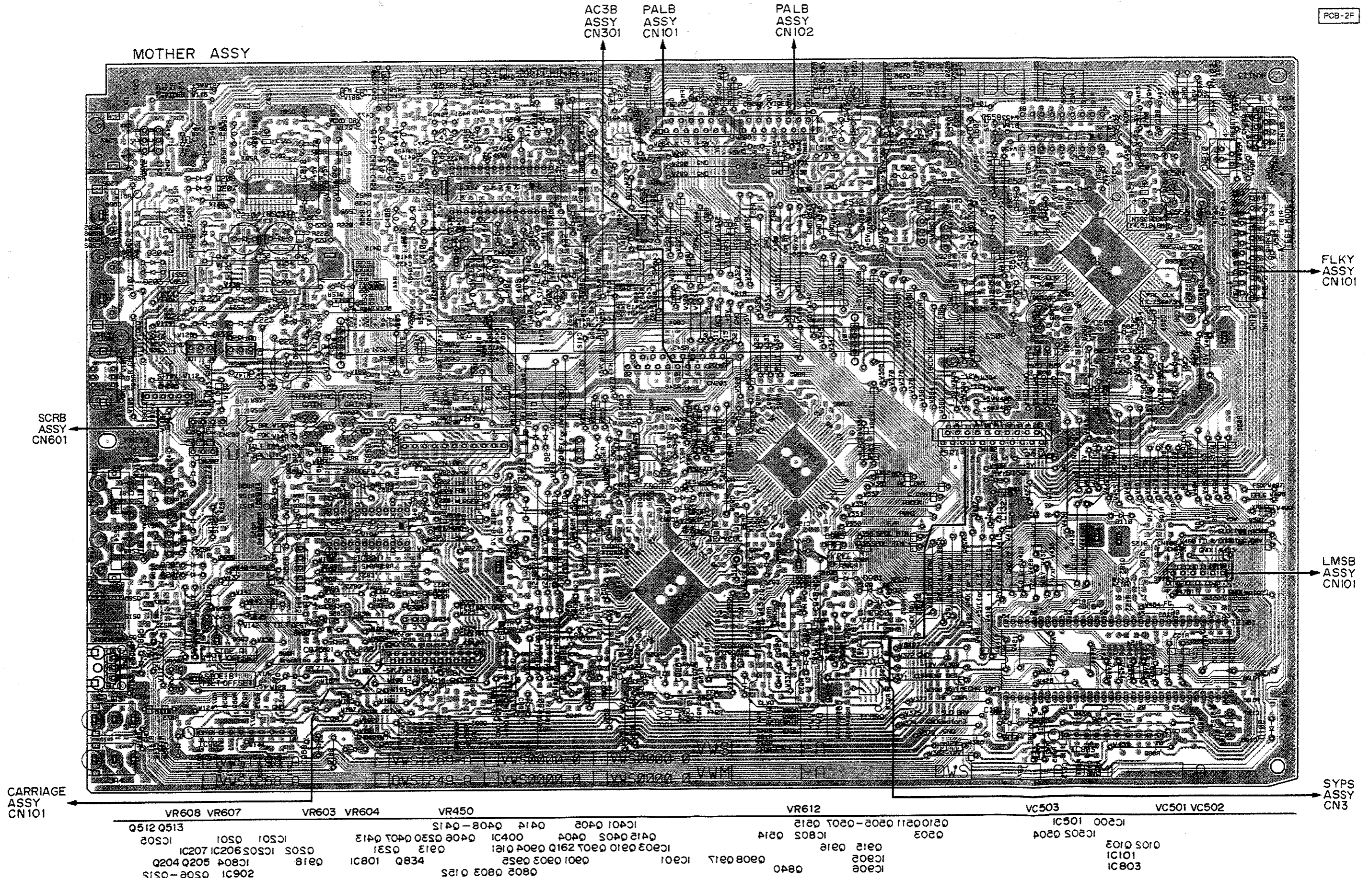

● This diagram is viewed from the mounted parts side.

● The parts mounted on this PCB include all necessary parts for several destinations. For further information for respective destinations, be sure to check with the schematic diagram.

Service Manual

PIONEER
The Art of Entertainment

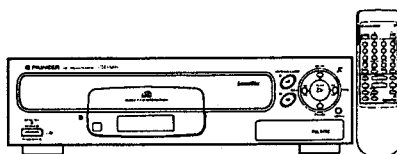

ORDER NO.
RRV1354

CD CDV LD PLAYER

CLD-S315

THIS MANUAL IS APPLICABLE TO THE FOLLOWING MODEL(S) AND TYPE(S).

Type	Model	Power Requirement	Remarks
	CLD-S315		
WBW	○	AC220-240V	
WEZ	○	AC220-240V	
WPW	○	AC220-240V	

CONTENTS

1. SAFETY INFORMATION.....	2	6. ADJUSTMENTS	38
2. PACKING, EXPLODED VIEWS AND PARTS LIST	3	7. IC INFORMATION	47
3. SCHEMATIC AND PCB CONNECTION DIAGRAMS	13	8. FL INFORMATION	58
4. PCB PARTS LIST	32	9. BLOCK DIAGRAM.....	59
5. SELF-DIAGNOSTIC FUNCTIONS	36	10. PANEL FACILITIES.....	61
		11. SPECIFICATIONS	62

PIONEER ELECTRONIC CORPORATION 4-1, Meguro 1-Chome, Meguro-ku, Tokyo 153, Japan
PIONEER ELECTRONICS SERVICE, INC. P.O. Box 1760, Long Beach, CA 90801-1760, U.S.A.
PIONEER ELECTRONIC (EUROPE) N.V. Haven 1087, Keetberglaan 1, 9120 Melsele, Belgium
PIONEER ELECTRONICS ASIACENTRE PTE. LTD. 501 Orchard Road, #10-00 Lane Crawford Place, Singapore 0923
 © PIONEER ELECTRONIC CORPORATION 1995

T-IFB JUNE 1995 Printed in Japan

1. SAFETY INFORMATION

(FOR EUROPEAN MODEL ONLY)

VARO!
AVATTAESSA JA SUOJALUKITUS OHITETTAESSA OLET ALTTIINA NÄKYMÄTTÖMÄLLE LASERSÄTEILYLLE. ÄLÄ KATSO SÄTEESEEN.

ADVERSEL:
USYNLIG LASERSTRÅLING VED ÅBNING NÅR SIKKERHEDSAFBRYDERE ER UDE AF FUNKTION. UNDGÅ UDSÆTTELSE FOR STRÅLING.

VARNING!
OSYNLIG LASERSTRÅLNING NÅR DENNA DEL ÄR ÖPPNAD OCH SPÄRREN ÄR URKOPPLAD. BETRAKTA EJ STRÅLEN.



LASER
Kuva 1
Lasersäteilyn varoitusmerkki

WARNING!
DEVICE INCLUDES LASER DIODE WHICH EMITS INVISIBLE INFRARED RADIATION WHICH IS DANGEROUS TO EYES. THERE IS A WARNING SIGN ACCORDING TO PICTURE 1 INSIDE THE DEVICE CLOSE TO THE LASER DIODE.



LASER
Picture 1
Warning sign for laser radiation

IMPORTANT
THIS PIONEER APPARATUS CONTAINS LASER OF CLASS 1. SERVICING OPERATION OF THE APPARATUS SHOULD BE DONE BY A SPECIALLY INSTRUCTED PERSON.

LASER DIODE CHARACTERISTICS
MAXIMUM OUTPUT POWER: 5 mw
WAVELENGTH: 780-785 nm

LABEL CHECK

WBW and WPW types



WEZ type

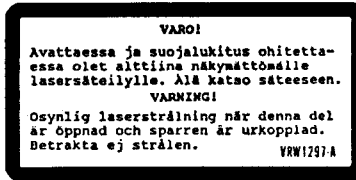

All types



WEZ type

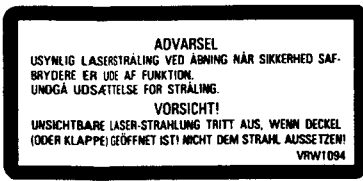

All types

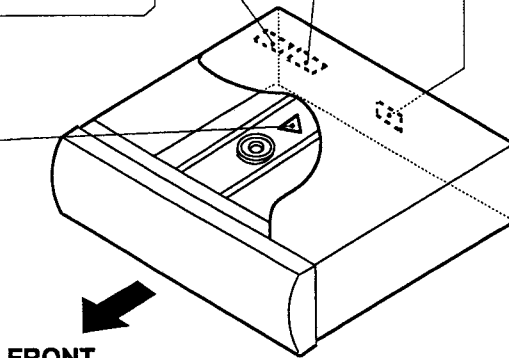

FRONT

Additional Laser Caution

- The ON/OFF statuses of the slider-position detection switches (PARK INNER, PARK OUTER on the PKSB assy), loading-status detection switches (SW 1, 2 and 3 on LMSB assy) are detected by the microprocessor (IC101 in the MOTHER assy). To permit the laser diode to oscillate, it is required to set the slider-position detection switch for the LD ACTIVE status (PARK INNER : OFF, PARK OUTER : OFF), and to set the loading-status detection switch for tilt neutral state (SW1 : OFF, SW2 : OFF, SW3 : ON). As long as these requirements are not satisfied, the laser diode will not oscillate. When the requirements are met in any way, the laser diode can oscillate. The laser diode oscillation will continue if pin 13 of IC801 is shorted to GND or the emitter and collector of Q834 are shorted each other (fault condition) in MOTHER assy.
In test mode * , the laser diode oscillates when microprocessor detects a PLAY signal, or when the PLAY key is pressed (S205 ON on the KEYB assy), with the above requirements satisfied.
- When the cover is open, close viewing through the objective lens with the naked eye will cause exposure to a Class 1 laser beam.

* : Refer to page 38.

2. PACKING, EXPLODED VIEWS AND PARTS LIST

NOTES:

- Parts marked by "NSP" are generally unavailable because they are not in our Master Spare Parts List.
- The Δ mark found on some component parts indicates the importance of the safety factor of the part. Therefore, when replacing, be sure to use parts of identical designation.
- Parts marked by "⊙" are not always kept in stock. Their delivery time may be longer than usual or they may be unavailable.
- Parts list without notice are common for CLD-S315/WBW, WEZ and WPW.

2.1 PACKING

(1) CONTRAST OF CLD-S315/WBW, WEZ and WPW

CLD-S315/WBW, WEZ and WPW have the same construction except for the following:

Mark	No.	Symbol & Description	Part No.			Remarks
			CLD-S315 /WBW	CLD-S315 /WEZ	CLD-S315 /WPW	
NSP	1	Caution (UC)	VRR1020	Not used	VRR1020	
	1	Caution (EW)	Not used	VRM1027	Not used	
	2	Caution	Not used	VRR1009	Not used	
	4	Operating instructions (Dutch/Swedish/Spanish/Portuguese)	Not used	VRF1034	Not used	
NSP	14	Warranty card	ARW-088	ARW-088	PRY1002	

(2) PARTS LIST FOR CLD-S315/WBW

Mark	No.	Description	Part No.	Mark	No.	Description	Part No.
	1	Caution (UC)	VRR1020		10	Battery cover	VNK2806
	2		NSP	11	Polyethylene bag	VHL-014
	3	Operating instructions (English/French/German/Italian)	VRE1035		12	Protector B	VHB1012
	4		NSP	13	Mirror mat sheet	Z23-007
	5	Protector	VHB1007		14	Warranty card	ARW-088
	6			15	Packing case	VHG1447
	7					
NSP	8	Battery (R6P, AA)	VEM-013				
	9	Remote control unit	VXX2115				

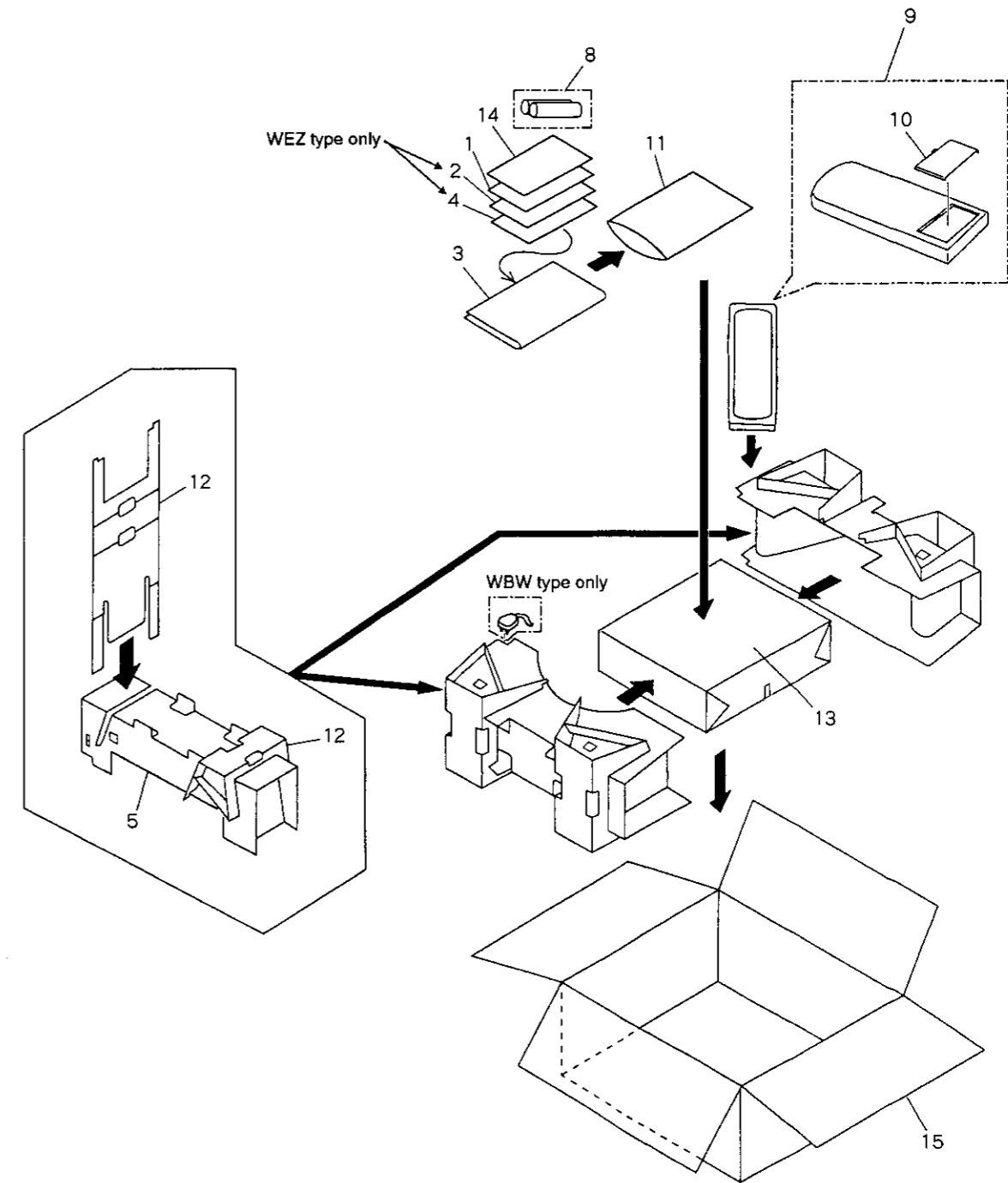

2.2 EXTERIOR AND DISC TRAY SECTION

(1) CONTRAST OF CLD - S315/WBW, WEZ and WPW

CLD - S315/WBW, WEZ and WPW have the same construction except for the following:

Mark	No.	Symbol & Description	Part No.			Remarks
			CLD - S315 /WBW	CLD - S315 /WEZ	CLD - S315 /WPW	
	4	Caution label	PRW1018	VRW1094	PRW1018	
	23	Caution label HE	Not used	VRW1297	Not used	

(2) PARTS LIST FOR CLD - S315/WBW

Mark	No.	Description	Part No.	Mark	No.	Description	Part No.
	1	Bonnet - S	VXX2117	11	Damp cushion	VEC1683	
	2	Screw	BBZ30P080FMC	12	Door spring	VBH1247	
	3	Screw	BCZ40P060FZK	13	Door holder	VNL1658	
	4	Caution label	PRW1018	14	Screw	BBZ30P080FMC	
	5	Guide plate (R)	VNE1939	15	Door shaft	VLL1455	
B	6	Guide plate (L)	VNE1938	16	CD door	VNK2791	
	7	CD tray	VNK2687	17	Damper assy	VXA1999	
	8	Lock plate	VNL1703	18	Tray panel	VNK2801	
	9	Lock plate spring	VBH1188	19	Disc pad	VEC1682	
NSP	10	LD tray	VNK2686	20	Tray assy - S	VXX2171	
				NSP	21	Label	VRW1289
				NSP	22	Caution label (F)	VRW - 328
					23	

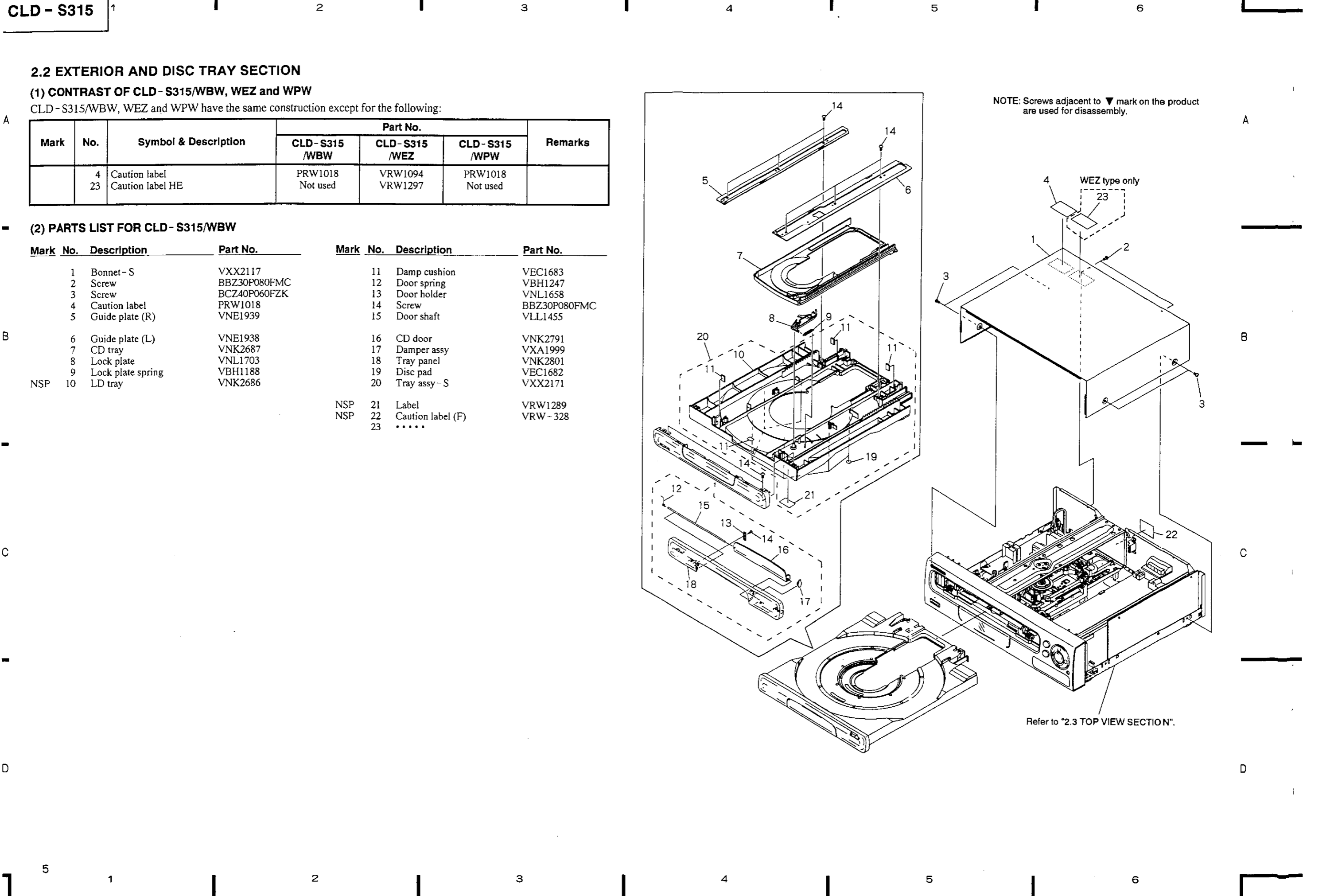
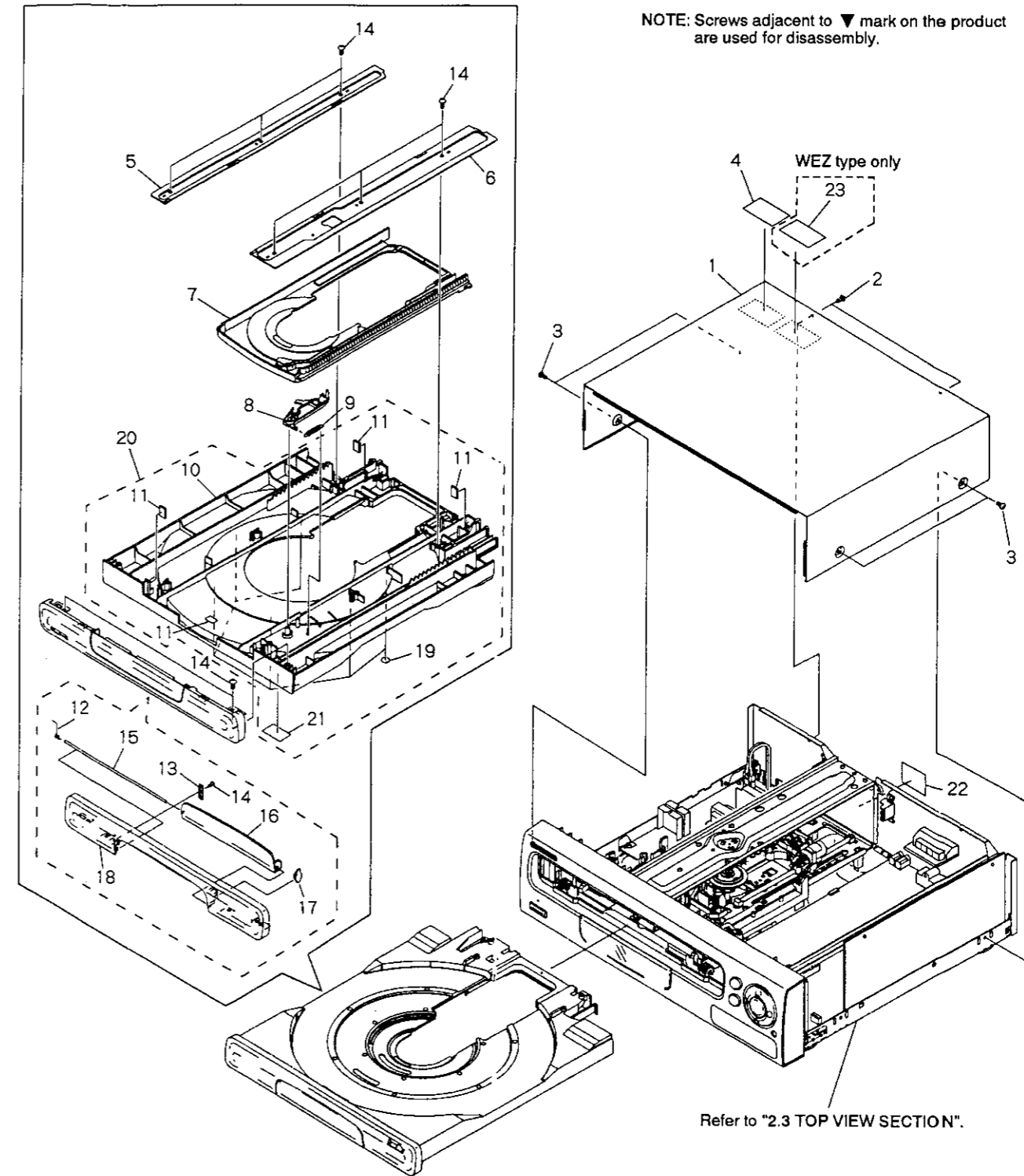

2.3 TOP VIEW SECTION

Parts List

Mark No.	Description	Part No.	Mark No.	Description	Part No.
1	Clamper arm	VNE1940	11	CA hook	VNL1641
2	Screw	BBZ30P080FMC	12	PCB holder	VNE2034
3	Rubber sheet	VEB1114	13	FFC holder	VNL1656
4	Thrust holder	VNL1663	14	Screw	BBZ30P100FMC
5	Clamper head	VNL1649	15	Panel holder	VNA1464
6	Clamp spring	VBH1192	16	Carriage assy	VWT1110
7	Clamper	VNL1648	17	Caution label (G)	VRW-329
8	Clamper holder	VNL1636	18	PALB assy	VWV1430
9	Guide bar	VLL1453	19	Mini clamper	DEC1679
10	Screw	IBZ30P080FMC	20	Earth lead unit	VDF-521

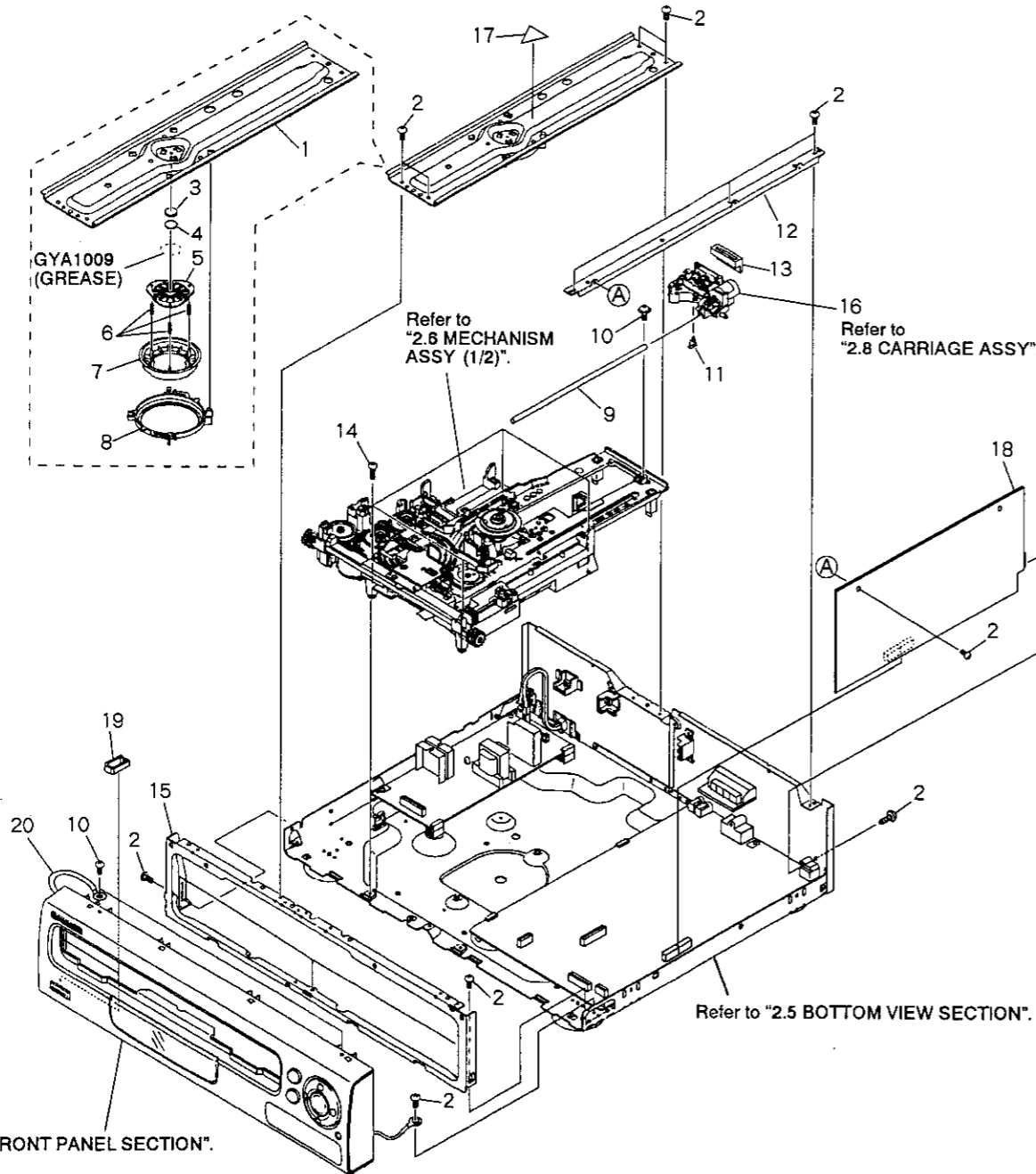

2.4 FRONT PANEL SECTION

(1) CONTRAST OF CLD - S315/WBW, WEZ and WPW

CLD - S315/WBW, WEZ and WPW have the same construction except for the following:

Mark	No.	Symbol & Description	Part No.			Remarks
			CLD - S315 /WBW	CLD - S315 /WEZ	CLD - S315 /WPW	
	3	FL lens	VEC1791	VEC1791	VEC1790	

(2) PARTS LIST FOR CLD - S315/WBW

Mark No.	Description	Part No.	Mark No.	Description	Part No.		
NSP	1	Front panel	VNK3192	6	PW button	VNK2329	
	2	Pioneer badge	PAM1608	7	L key	VNK2812	
	3	FL lens	VEC1791	8	Main key	VNK3181	
	4	Key A	VNK2793	9	Screw	BBZ30P080FMC	
	5	LED lens	PNW2019	10	FLKY assy	VWG1660	
				NSP	11	KEYB assy	VWG1627
					12	Front panel assy - S	VXX2292

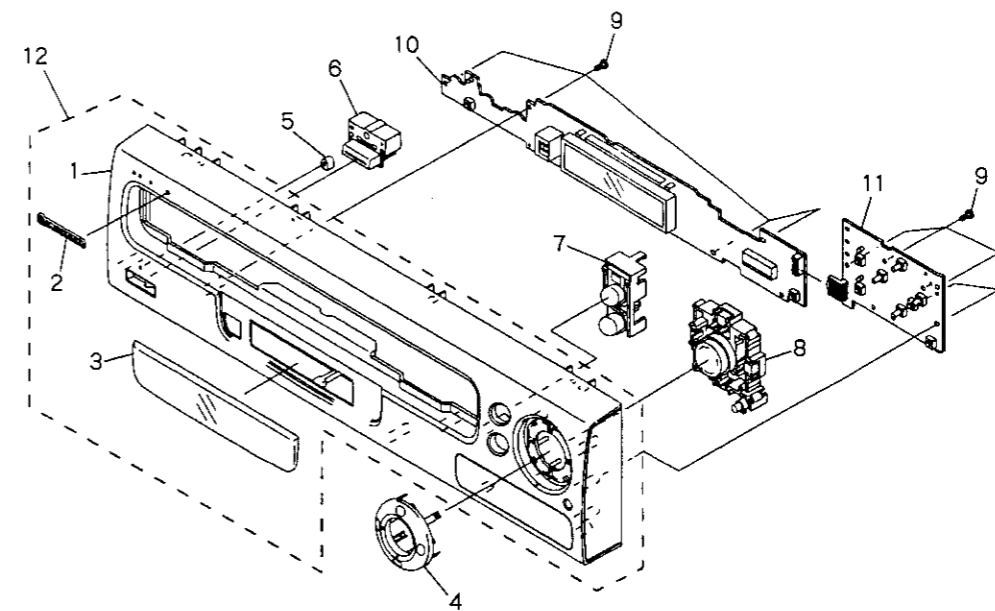

2.5 BOTTOM VIEW SECTION

(1) CONTRAST OF CLD - S315/WBW, WEZ and WPW

CLD - S315/WBW, WEZ and WPW have the same construction except for the following:

Mark	No.	Symbol & Description	Part No.			Remarks
			CLD - S315 /WBW	CLD - S315 /WEZ	CLD - S315 /WPW	
△	4	AC power cord	VDG1063	VDG1061	VDG1065	
△	21	Fuse holder	VKR1003	Not used	Not used	
△	22	Fuse (5A)	PEK1003	Not used	Not used	

(2) PARTS LIST FOR CLD - S315/WBW

Mark	No.	Description	Part No.	Mark	No.	Description	Part No.
NSP	1	MOTHER assy	VWS1196	NSP	11	Wire clip (H)	VEC1181
	2	Screw	BBZ30P080FMC		12	Insulator	PNW1912
△	3	SYPS assy	VWR1234		13	Card spacer A	VEC1708
△	4	AC power cord	VDG1063	NSP	14	Base chassis	VNA1461
△	5	Cord stopper	CM - 22B	NSP	15	Rear panel L	VNA1574
	6	Tray stopper	VNL1657		16	Flexible cable (23P)	VDA1464
	7	Rear panel R	VNA1598		17	Flexible cable (21P)	VDA1465
NSP	8	P plate holder	PNY - 405		18	Flexible cable (16P)	VDA1469
NSP	9	PC support	VEC - 269	NSP	19	Earth lead unit	XDF - 507
NSP	10	PCB hinge	VEC1174	NSP	20	SCRB assy	VWV1432
				△	21	Fuse holder	VKR1003
				△	22	Fuse (5A)	PEK1003
				NSP	23	Spacer	REB1171

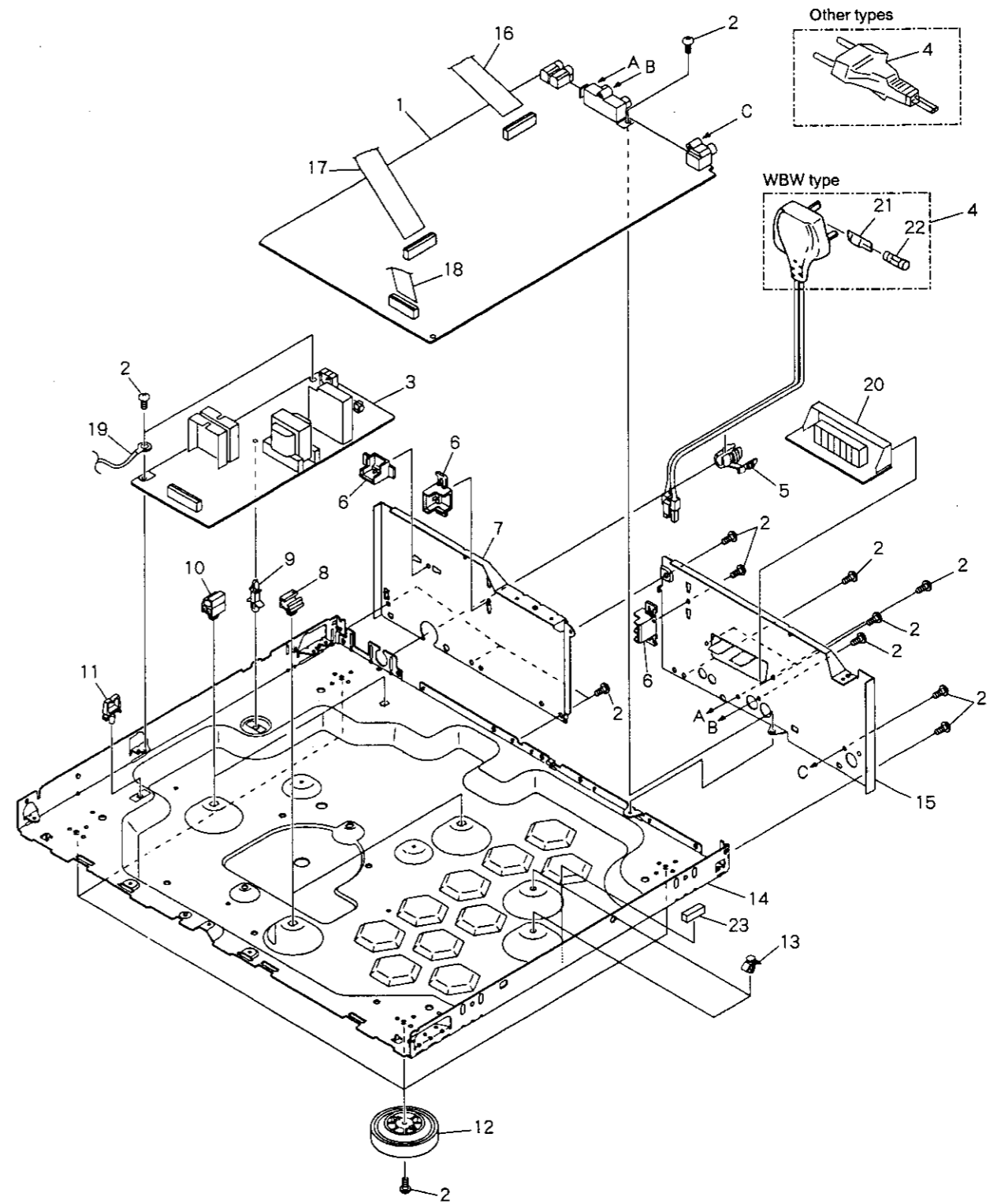

A
B
C
D

2.6 MECHANISM ASSY (1/2)

Parts List

Mark No.	Description	Part No.	Mark No.	Description	Part No.
1	Clamp cam	VNL1633	NSP 14	LMSB assy	VWG1554
2	CDP spring	VBH1191	15	
3	Screw	Z39-019	NSP 16	Carriage motor	VXM1033
4	CD plate	VNL1632	17	Shaft holder	VNE1942
5	Rubber belt	VEB1184	18	CAS spring	VBH1190
6	Gear pulley	VNL1662	19	Cam plate	VNL1631
7	Twin gear	VNL1626	20	Cam gear	VNL1625
8	Center gear	VNL1660	21	Loading motor assy	VXX2045
9	Mechanism base	VNK3239	22	MB-SW lever	VNL1664
10	Screw	BMZ26P040FMC	23	Slider (R)	VNL1666
NSP 11	Roller	VNL1042	24	Slider (L)	VNL1665
NSP 12	Motor pulley	VNL1630	25	Double gear	VNL1661
NSP 13	Synchro gear assy	VXA2105	26	Flexible cable (10P)	VDA1466

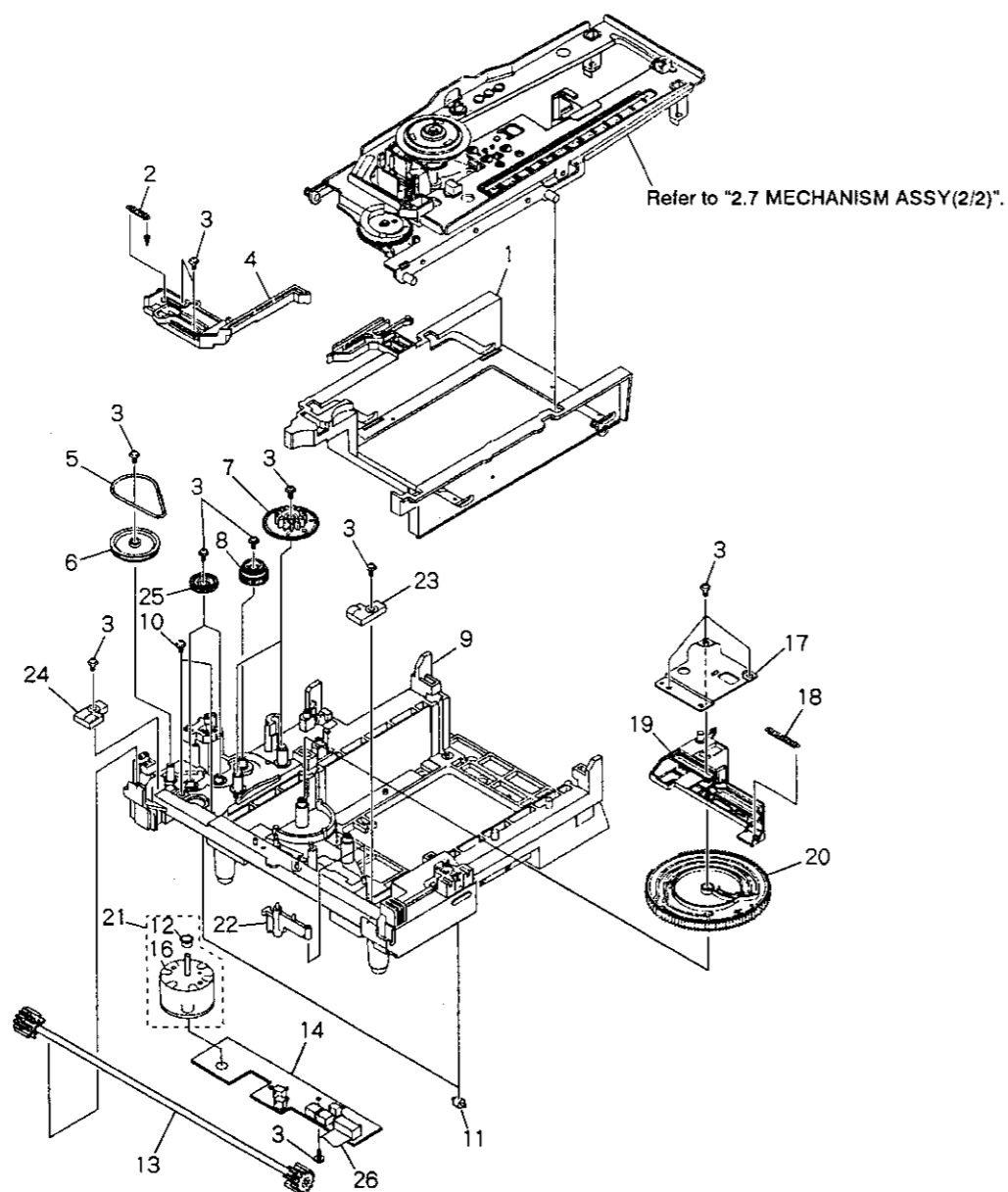

2.7 MECHANISM ASSY (2/2)

Parts List

Mark No.	Description	Part No.
1	CA rack	VNL1647
2	Screw	IBZ26P060FMC
3	Tilt base	VNL1642
4	Radial spring	VBH1246
5	Thrust spring	VBH1245
6	CA-switch lever	VNL1644
NSP 7	PKSB assy	VWG1555
8	Tilt tension spring	VBH1244
NSP 9	FG assy	VWG1556
10	Screw	PMA30P050FMC
11	FG base	VNL1645
12	Tilt cam	VNL1643
13	Tilt cam spring	VBH1243
14	Motor base	VNE1941
15	Spindle motor assy	VXA2125
16	Screw	IBZ26P120FMC
17	
18	Centering hab	VNL1623
19	Centering spring	VBH1083
20	
NSP 21	Turn table assy	VXA2106
22	
NSP 23	Spindle motor	VXM1057
24	Housing assy (3P:blue)	VKP2045
25	Housing assy (3P:yellow)	VKP2046
NSP 26	Earth lead unit	XDF-507

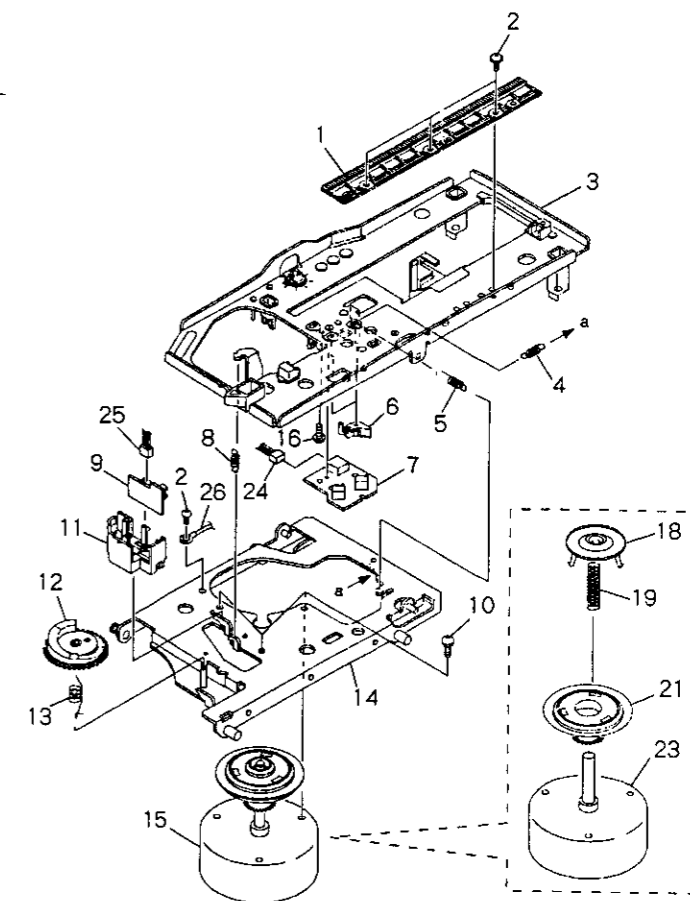

2.8 CARRIAGE ASSY

Parts List

Mark No.	Description	Part No.
1	CA gear (A)	VNL1638
2	CA gear (B)	VNL1639
3	Slider motor assy	VXX2082
4	Motor holder	VNL1700
5	Screw	PBZ20P050FMC
6	Screw	PMZ20P030FMC

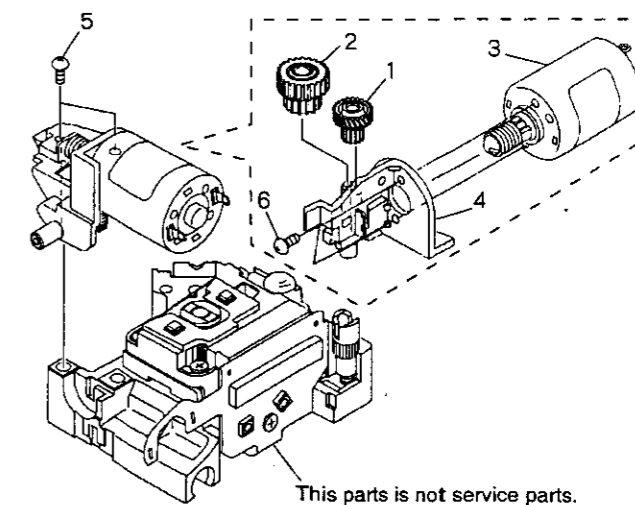

3. SCHEMATIC AND PCB CONNECTION DIAGRAMS

3.1 OVERALL CONNECTIONS, KEYB, FLKY, SYPS, PKSB, FG, LMSB AND CARRIAGE ASSEMBLIES

PCB - 1

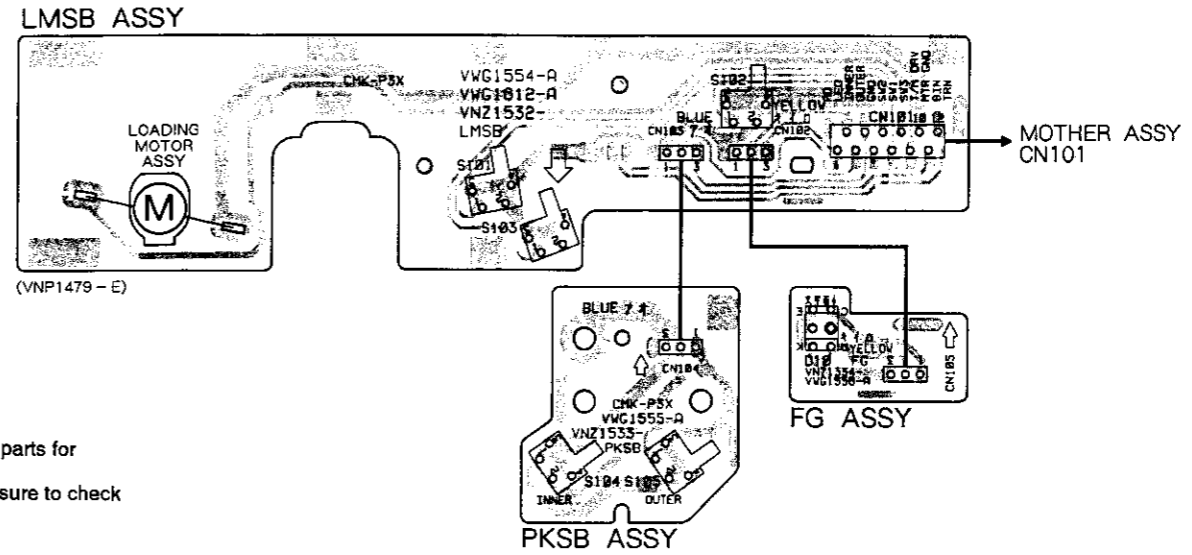
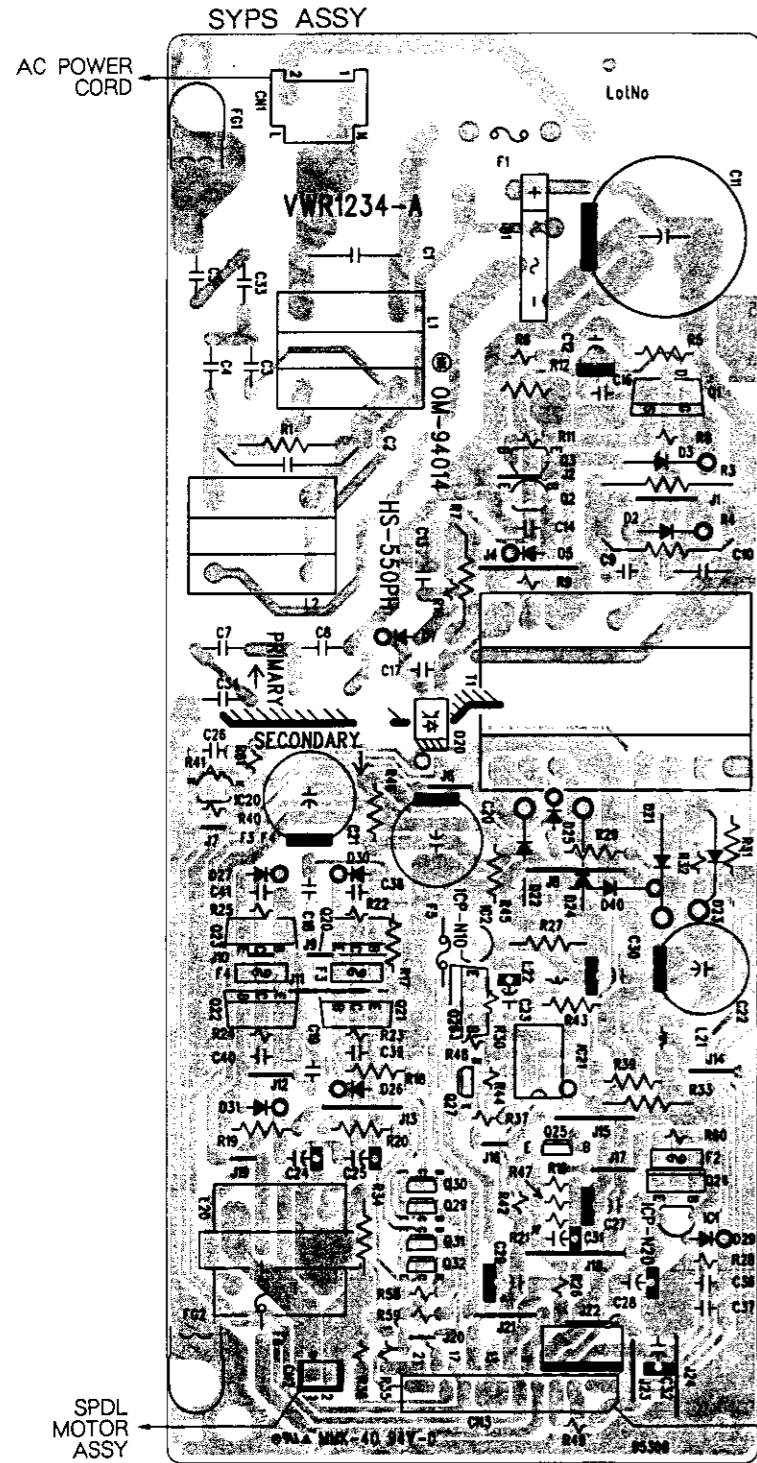

- This diagram is viewed from the mounted parts side.
- The parts mounted on this PCB include all necessary parts for several destinations. For further information for respective destinations, be sure to check with the schematic diagram.

NOTE FOR PCB DIAGRAMS:
 1. Part numbers in PCB diagrams match those in the schematic diagrams.
 2. A comparison between the main parts of PCB and schematic diagrams is shown below.

Symbol in PCB Diagrams	Symbol in Schematic Diagrams	Part Name
		Transistor
		Transistor with resistor
		Field effect transistor
		Resistor array
		3-terminal regulator

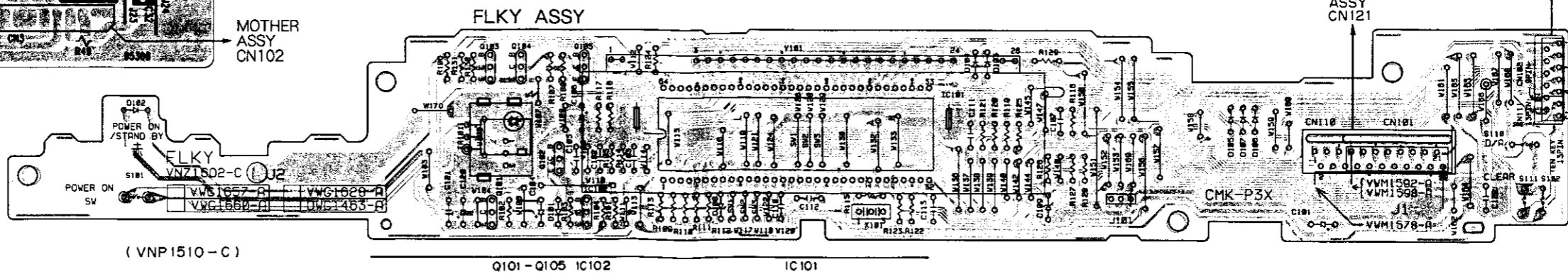
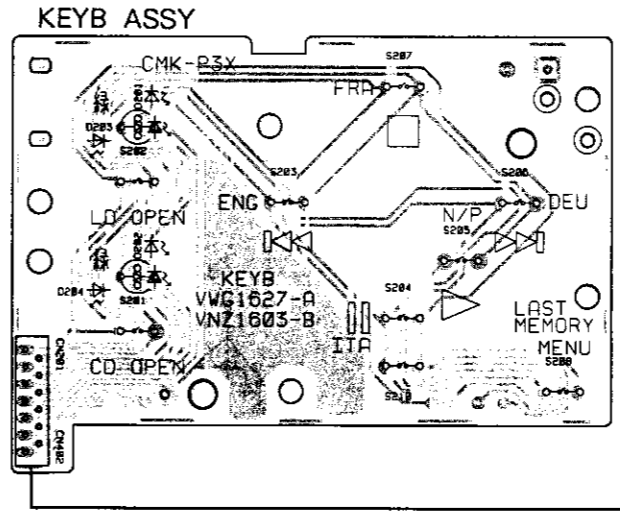

A
3
C
D

A
B
C
D

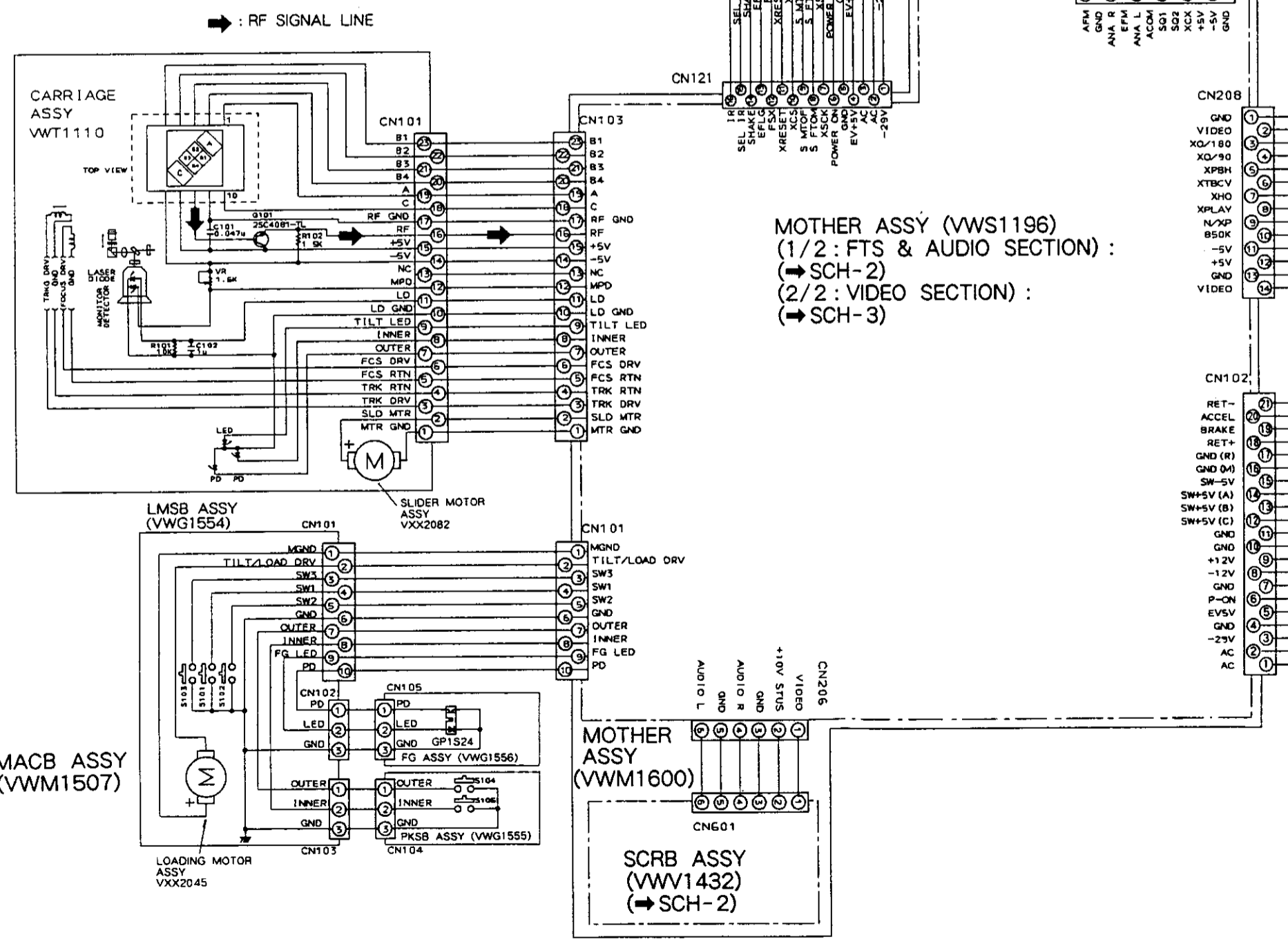
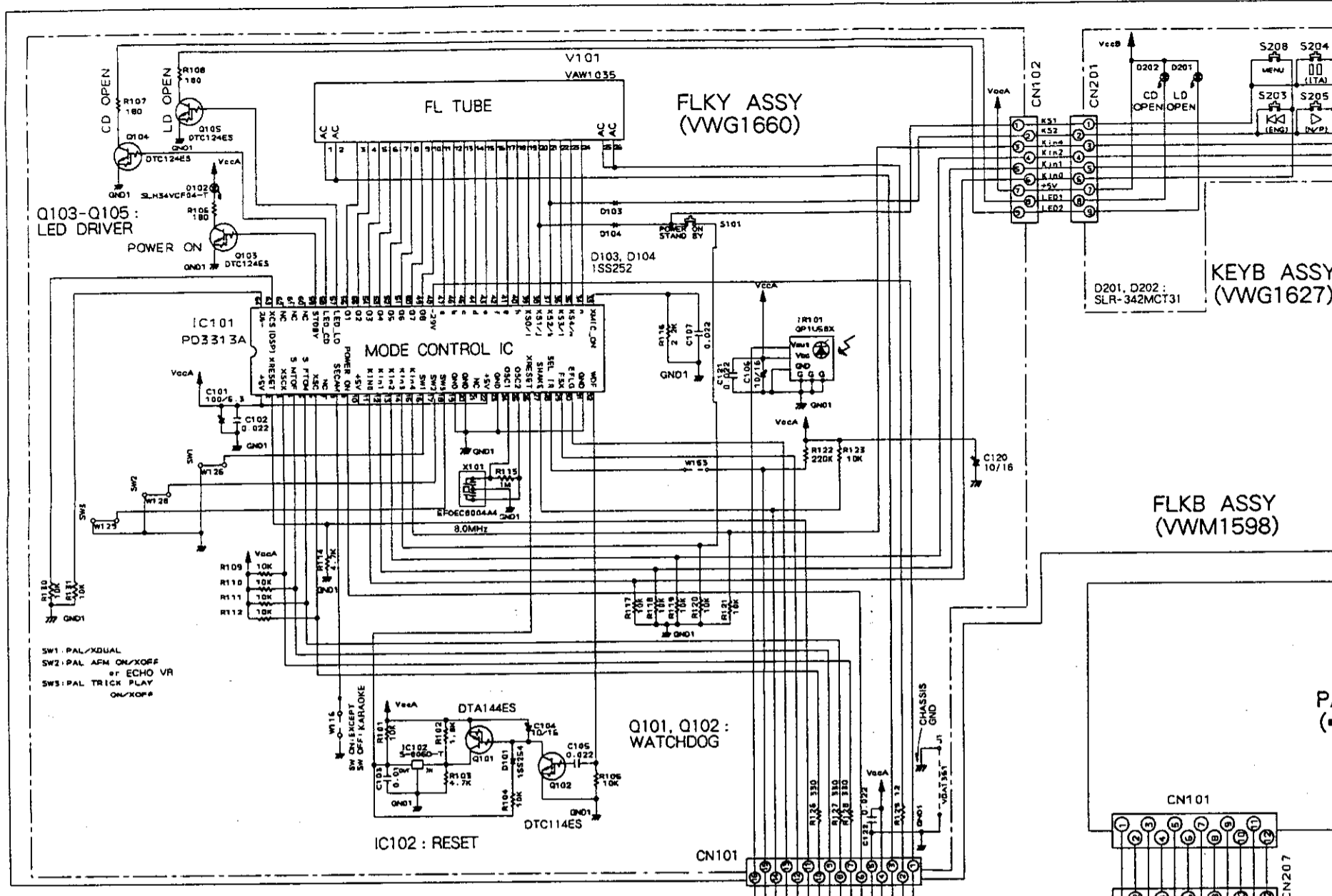

SCH-1 OVERALL CONNECTIONS, KEYB ASSY, FLKY ASSY, SYPS ASSY, PKSB ASSY, FG ASSY, LMSB ASSY, CARRIAGE ASSY

SCH - 1

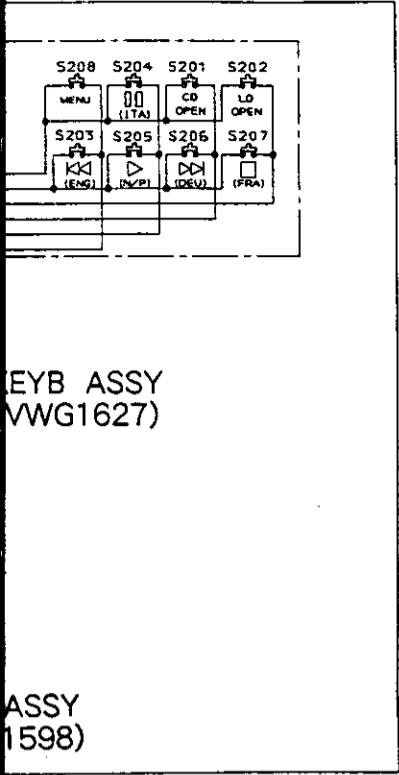

ASSY (1598)

NOTE FOR SCHEMATIC DIAGRAMS (Type 4A)

- When ordering service parts, be sure to refer to "PARTS LIST of EXPLODED VIEWS" or "PCB PARTS LIST".
- Since these are basic circuits, some parts of them or the values of some components may be changed for improvement.
- RESISTORS:**
Unit: k Ω , M Ω , or Ω unless otherwise noted.
Rated power: 1/4W, 1/8W, 1/8W, 1/10W unless otherwise noted.
Tolerance: (F): $\pm 1\%$, (G): $\pm 2\%$, (K): $\pm 10\%$, (M): $\pm 20\%$ or $\pm 5\%$ unless otherwise noted.
- CAPACITORS:**
Unit: pF or μF unless otherwise noted.
Ratings: capacitor (μF) / voltage (V) unless otherwise noted.
Rated voltage: 50V except for electrolytic capacitors.
- COILS:**
Unit: mH or μH unless otherwise noted.
- VOLTAGE AND CURRENT:**
□ or - V : DC voltage (V) in PLAY mode unless otherwise noted.
mA or - mA : DC current in PLAY mode unless otherwise noted.
Value in () is DC current in STOP mode.
- OTHERS:**
⊙ or ⊛ : Adjusting point.
◀ : Measurement point.
△ : The Δ mark found on some component parts indicates the importance of the safety factor of the parts. Therefore, when replacing, be sure to use parts of identical designation.

8. SCH - □ ON THE SCHEMATIC DIAGRAM:

- SCH-□ indicates the drawing number of the schematic diagram. (SCH stands for schematic diagram.)

9. SWITCHES (Underline indicates switch position):

LMSB ASSY

- S101 : SW1
- S102 : SW2
- S103 : SW3

PKSB ASSY

- S104 : OUTER SW
- S105 : INNER SW

KEYB ASSY

- S201 : CD OPEN/CLOSE (▲)
- S202 : LD OPEN/CLOSE (▲)
- S203 : ◀◀
- S204 : ||
- S205 : ▶▶
- S206 : ▶◀
- S207 : ■
- S208 : MENU

FLKY ASSY

- S101 : POWER ON STAND BY

PALB ASSY (VWV1430) (→ SCH-4)

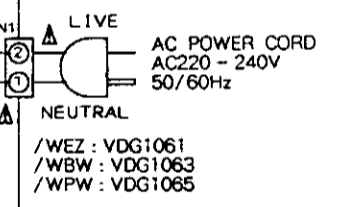
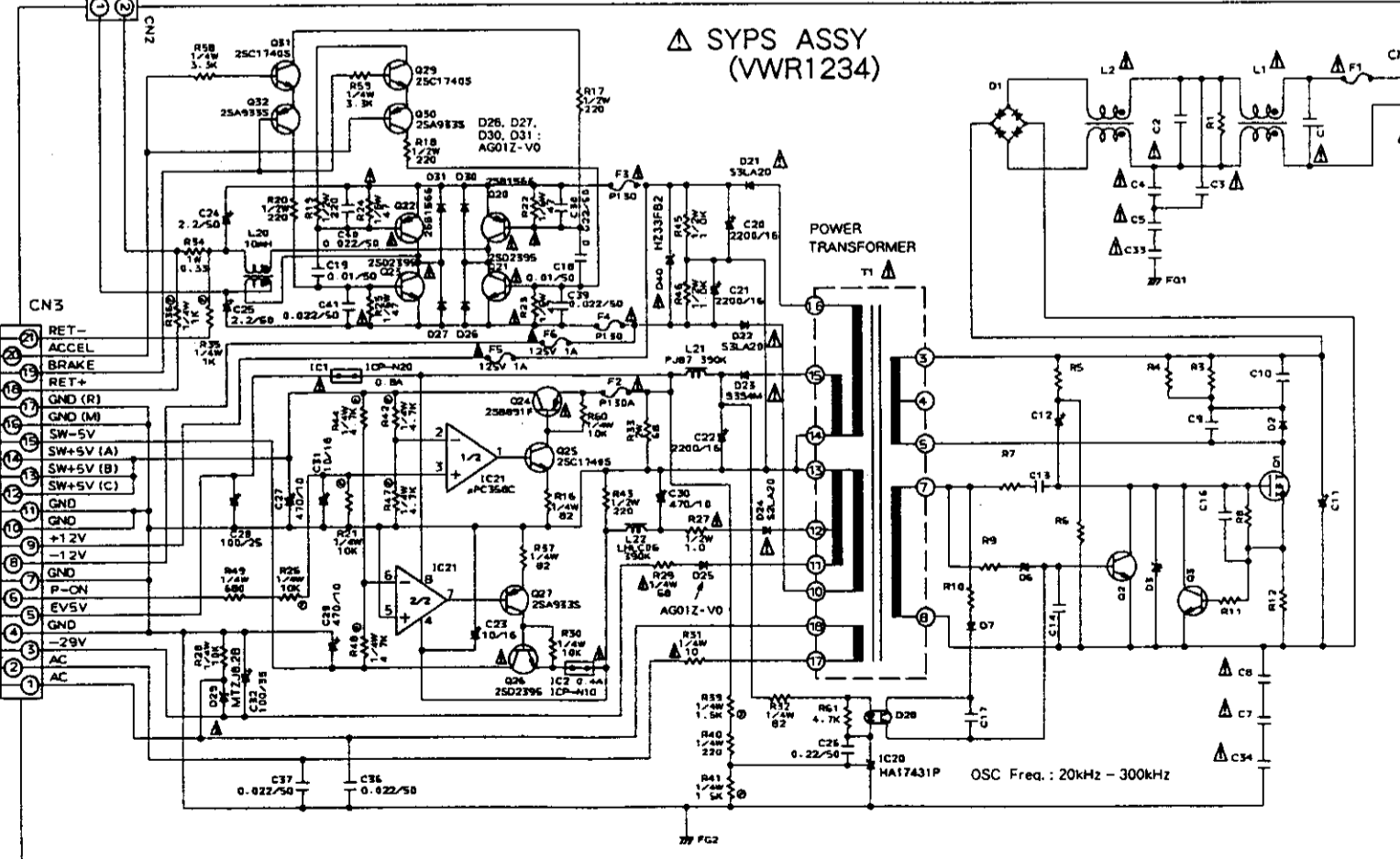
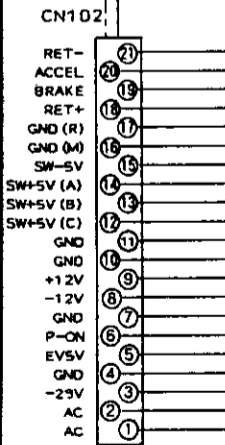
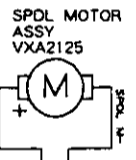
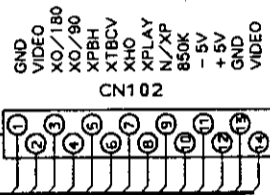
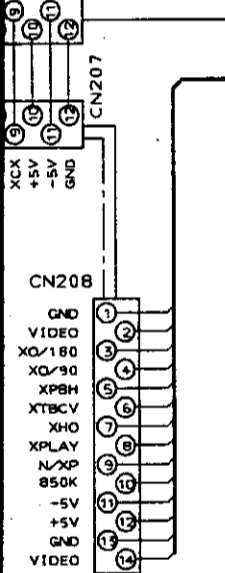

OVERALL CONNECTIONS, KEYB ASSY, FLKY ASSY, SYPS ASSY, PKSB ASSY, FG ASSY, LMSB ASSY, CARRIAGE ASSY

SCH-1

3.2 MOTHER ASSY (1/2 : FTS AND AUDIO SECTION) AND SCRIB ASSY

A

B

C

D

E

F

SCH-2

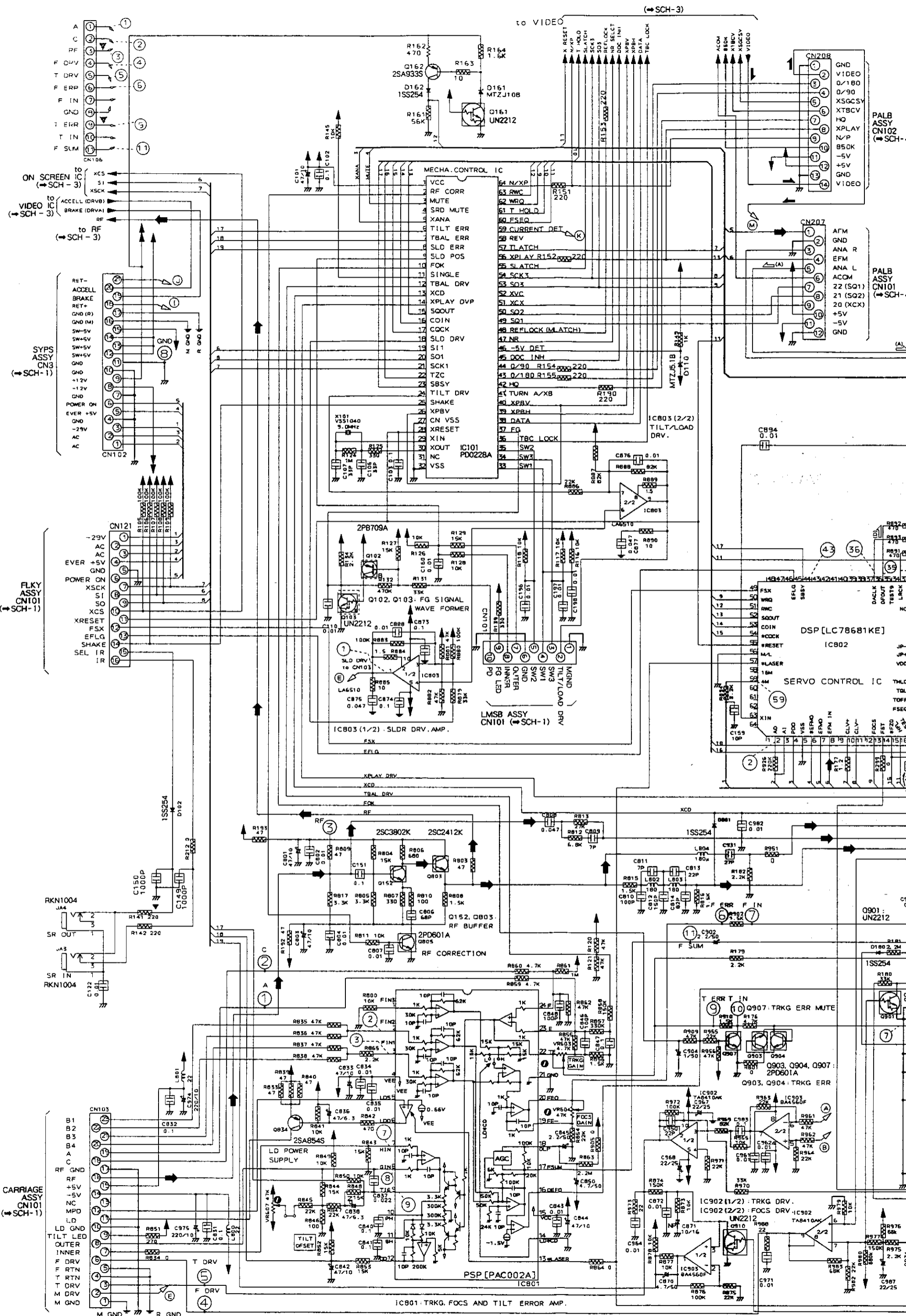

MOTHER ASSY (1/2) (VWS1196)
 - FTS & AUDIO SECTION

SCH - 2

- RF SIGNAL LINE
- VIDEO SIGNAL LINE
- AUDIO SIGNAL LINE
- DIGITAL AUDIO SIGNAL LINE
- ANALOG AUDIO SIGNAL LINE

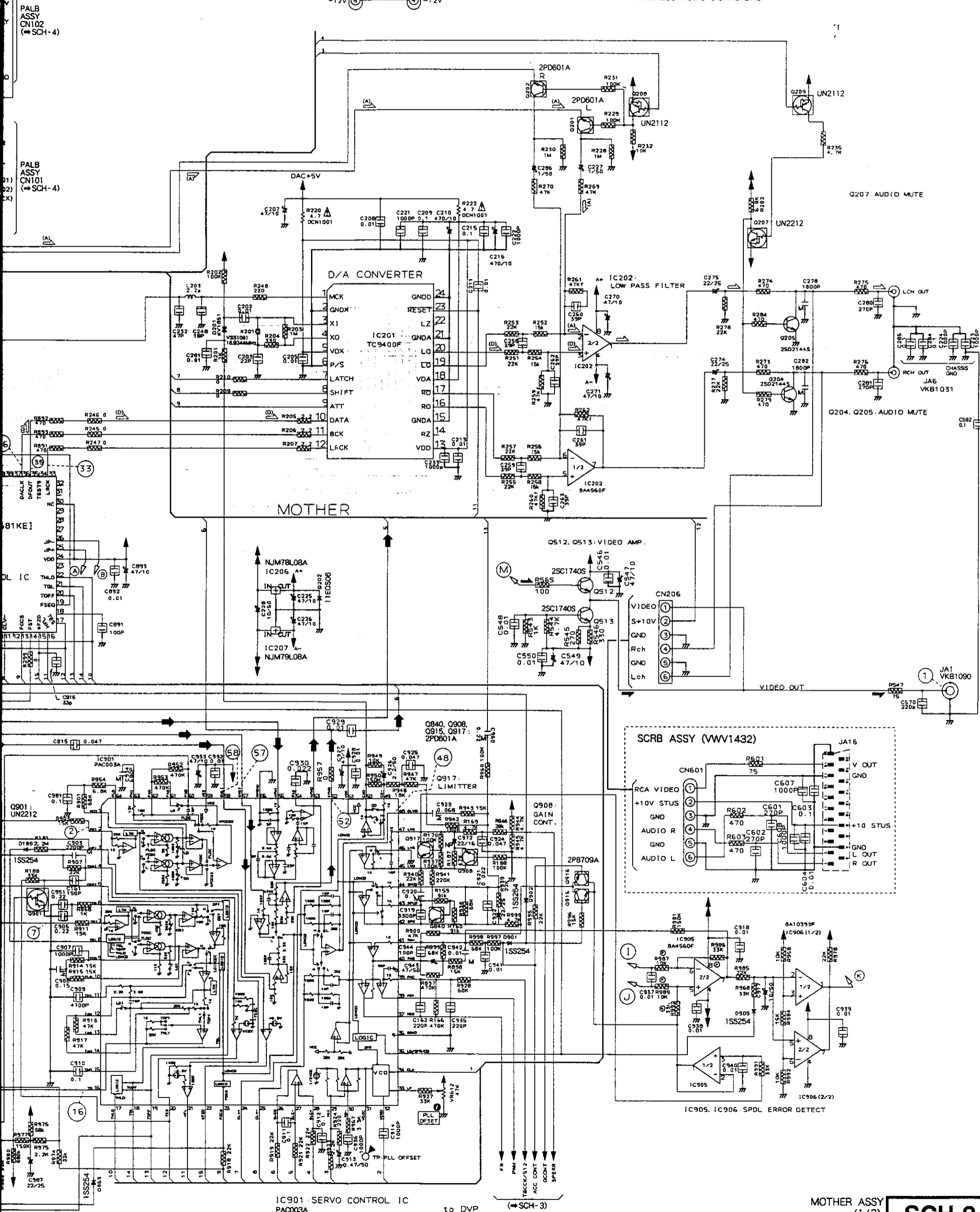
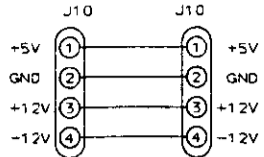

IC901: SERVO CONTROL IC
 PAC003A to DVP

(SCH-3)

MOTHER ASSY (1/2),
 SCRIB ASSY **SCH-2**

3.3 MOTHER ASSY (2/2 : VIDEO SECTION)

MOTHER ASSY (2/2) (VWS1196) - VIDEO SECTION

SCH - 3

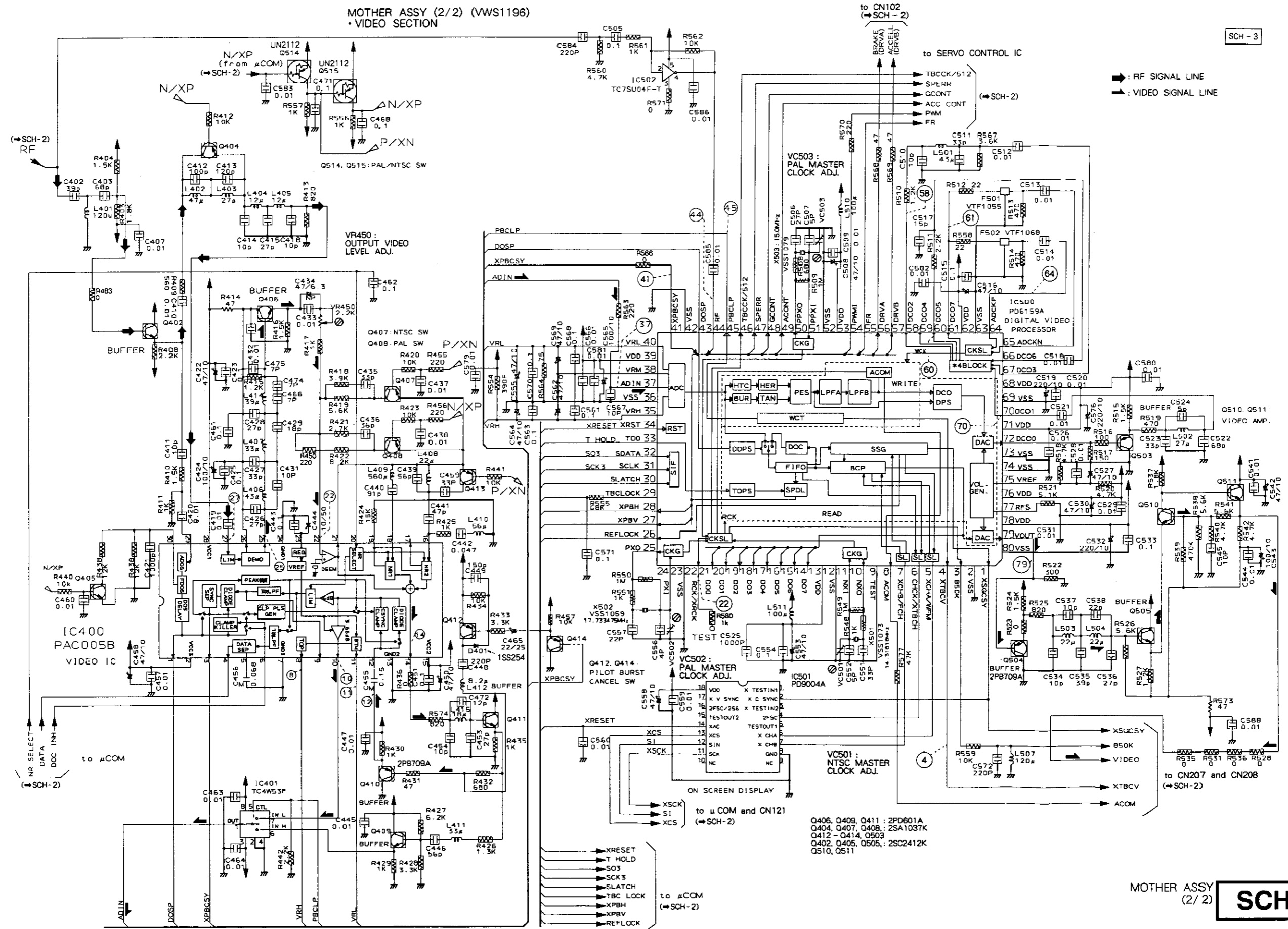

MOTHER ASSY (2/2) SCH-3

MOTHER ASSY (2/2) SCH-3

3.4 PALB ASSY

PALB ASSY (VWV1430)

VIDEO

RF SIGNAL LINE
VIDEO SIGNAL LINE
ANALOG AUDIO SIGNAL LINE

SCH - 4

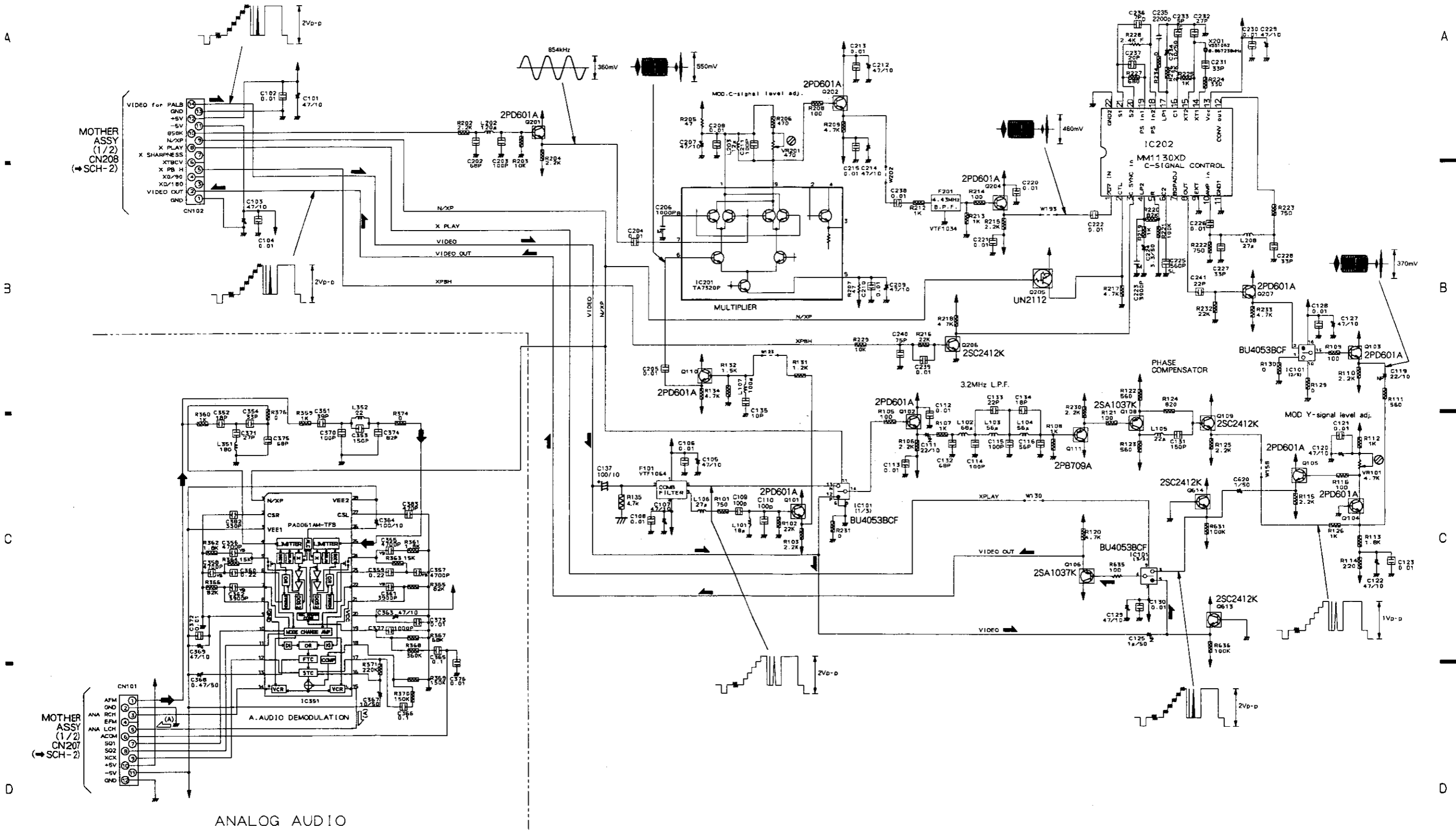

SCH-4

PALB ASSY

SCH-4

PALB ASSY

PCB - 3

PALB ASSY

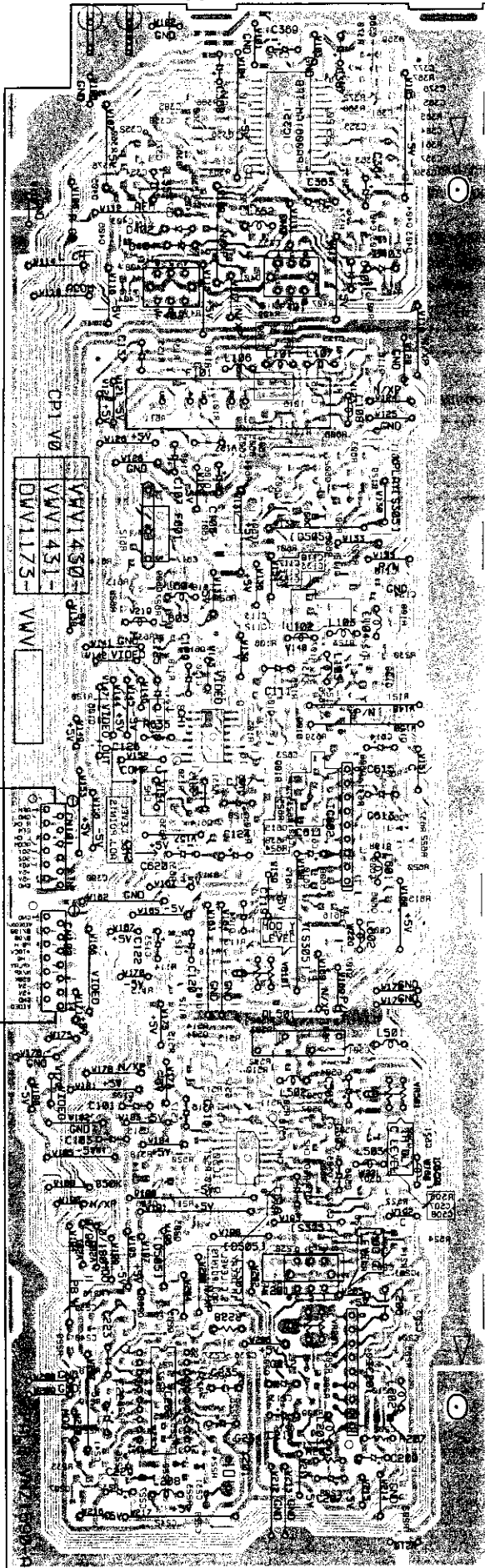

12E01

1040
2040

0110

1010

1120

1020

2020

1020

2020

0120

2010

2010

2010

2010

1020

2020

2010

2010

2010

2020

1020

2020

1020

2020

2020

2020

2020

2020

1C201

1C202

2020

(VNP1519-C)

- This diagram is viewed from the mounted parts side.
- The parts mounted on this PCB include all necessary parts for several destinations. For further information for respective destinations, be sure to check with the schematic diagram.

4. PCB PARTS LIST

NOTES:

- Parts marked by "NSP" are generally unavailable because they are not in our Master Spare Parts List.
- The Δ mark found on some component parts indicates the importance of the safety factor of the part. Therefore, when replacing, be sure to use parts of identical designation.
- Parts marked by "⊙" are not always kept in stock. Their delivery time may be longer than usual or they may be unavailable.
- When ordering resistors, first convert resistance values into code form as shown in the following examples.

Ex.1 When there are 2 effective digits (any digit apart from 0), such as 560 ohm and 47k ohm (tolerance is shown by J=5%, and K=10%).

560 Ω \rightarrow 56 \times 10¹ \rightarrow 561..... RD1/8PM **561J**
 47k Ω \rightarrow 47 \times 10³ \rightarrow 473..... RD1/4PS **473J**
 0.5 Ω \rightarrow 0R5..... RN2H **0R5K**
 1 Ω \rightarrow 010..... RS1P **010K**

Ex.2 When there are 3 effective digits (such as in high precision metal film resistors).

5.62k Ω \rightarrow 562 \times 10¹ \rightarrow 5621..... RN1/4PC **5621F**

Mark	No.	Description	Part No.
LIST OF ASSEMBLIES			
NSP		MACB ASSY	VWM1507
NSP		└ LMSB ASSY	VWG1554
NSP		└ PKSB ASSY	VWG1555
NSP		└ FG ASSY	VWG1556
NSP		FLKB ASSY	VWM1598
NSP		└ KEYB ASSY	VWG1627
NSP		└ FLKY ASSY	VWG1660
		MOTHER ASSY	VWM1600
NSP		└ MOTHER ASSY	VWS1196
NSP		└ SCRB ASSY	VWV1432
		PALB ASSY	VWV1430
Δ		SYPS ASSY	VWR1234

MACB ASSY

OTHERS
 PC board MACB VNP1479

LMSB ASSY

SWITCHES
 S101-S103 DSG1017

OTHERS
 CN101 10P FFC CONNECTOR 52044-1045

PKSB ASSY

SWITCHES
 S104, S105 DSG1017

FG ASSY

SEMICONDUCTOR
 D101 GP1S24

Mark	No.	Description	Part No.
FLKB ASSY			
OTHERS			
		PC board FLKB	VNP1510

KEYB ASSY

SEMICONDUCTORS
 D201, D202 SLR-342MCT31

SWITCHES
 S201, S202, S205, S208 RSG1030
 S203, S204, S206, S207 RSG1034

OTHERS
 CN201 1.25FJ CONNECTOR 09P-1.25FJ

FLKY ASSY

SEMICONDUCTORS
 IC101 PD3313A
 IC102 S-806D
 Q101 DTA144ES
 Q102 DTC114ES
 Q103-Q105 DTC124ES

D103, D104 1SS252
 D101 1SS254
 D102 SLH34VCF04

SWITCH
 S101 RSG1030

CAPACITORS
 C104, C106, C120 CEAL100M16
 C101 CEAL101M6R3
 C103 CKPUYF103Z25
 C102, C105, C107, C121, C122 CKPUYF223Z25

RESISTORS
 All Resistors RD1/6PM□□□J

Mark No.	Description	Part No.
OTHERS		
CN102	1. 25FJ CONNECTOR	09R-1. 25FJ
CN101	FFC BOTTOM CONNECTOR 16P	52492-1620
X101	CERAMIC RESONATOR(9.0MHz)	EFOEC8004A4
IR101	REMOTE SENSOR	GP1U58X
V101	FL TUBE	VAW1035
	SPACER	VEC1599
	FL HOLDER	VNF1085

MOTHER ASSY

SEMICONDUCTORS

IC906	BA10393F
IC202, IC903, IC905	BA4560F
IC803	LA6510
IC802	LC78681KE
IC206	NJM78L08A
IC207	NJM79L08A
IC801	PAC002A
IC901	PAC003A
IC400	PAC005B
IC101	PD0228A
IC500	PD6159A
IC501	PD9004A
IC902	TA8410AK
IC401	TC4W53F
IC502	TC7SU04F
IC201	TC9400F
Q102, Q410, Q504, Q916	2PB709A
Q201, Q202, Q406, Q409, Q411	2PD601A
Q805, Q840, Q903, Q904	2PD601A
Q907, Q908, Q915, Q917	2PD601A
Q404, Q407, Q408, Q412-Q414	2SA1037K
Q503	2SA1037K
Q834	2SA854S
Q162	2SA933S
Q512, Q513	2SC1740S
Q402, Q405, Q505, Q510, Q511	2SC2412K
Q803	2SC2412K
Q152	2SC3802K
Q204, Q205	2SD2144S
Q208, Q209, Q514, Q515	UN2112
Q103, Q161, Q207, Q901, Q910	UN2212
D202	11EQS06
D102, D162, D180, D401, D801	1SS254
D901, D902, D905, D963	1SS254
D201	KV1851
D161	MTZJ10B
D110	MTZJ5. 1B

COILS AND FILTERS

L510, L511	LAU101J
L404, L405	LAU120J
L401, L507	LAU121J
L415	LAU180J
L802-L804	LAU181J

Mark No.	Description	Part No.
L408, L503, L504, L800, L801		LAU220J
L403, L502		LAU270J
L203		LAU2R2J
L407, L411		LAU330J
L414		LAU390J
L406, L501		LAU430J
L402		LAU470J
L410		LAU560J
L412		LAU8R2J
L409		LFA561J
F501		VTF1055
F502		VTF1068

CAPACITORS

C556	CCSQCH040C50
C507, C524, C552	CCSQCH050C50
C466, C474, C475, C809, C811	CCSQCH070D50
C159, C411, C414, C418, C431	CCSQCH100D50
C454, C510, C534, C537, C545	CCSQCH100D50
C567	CCSQCH100D50
C412, C810, C846, C848, C891	CCSQCH101J50
C944	CCSQCH101J50
C472	CCSQCH120J50
C413	CCSQCH121J50
C517	CCSQCH150J50
C161, C449, C812	CCSQCH151J50
C248, C429	CCSQCH180J50
C203, C538, C557, C813, C950	CCSQCH220J50
C162, C448, C572, C577, C584	CCSQCH221J50
C935	CCSQCH221J50
C415, C426, C428, C473, C506	CCSQCH270J50
C536, C931	CCSQCH270J50
C280, C281	CCSQCH271J50
C106, C107, C427, C435, C459	CCSQCH330J50
C511, C523, C551, C916	CCSQCH360J50
C436	CCSQCH390J50
C258-C263, C402, C535	CCSQCH470J50
C232, C441	CCSQCH560J50
C439, C446	CCSQCH560J50
C403, C522, C806	CCSQCH680J50
C814	CCSQCH820J50
C440	CCSQCH910J50
C836	CEAL40M6R3
C838	CEALN470M6R3
C871	CEANP10M16
C972	CEANP20M16
C434	CEANP70M6R3
C227, C286, C904	CEAS010M50
C228, C444, C917	CEAS110M50
C424, C543, C565	CEAS111M10
C274, C275, C465, C922	CEAS210M25
C967, C968, C987	CEAS210M25
C519, C532, C576, C974, C975	CEAS211M10
C845, C902, C926	CEAS221M50
C101, C207, C225, C226	CEAS40M10
C270, C271, C422, C450, C458	CEAS40M10
C508, C516, C527, C530, C542	CEAS40M10
C547, C549, C553, C555, C558	CEAS40M10
C562, C564, C569, C801, C803	CEAS40M10

Mark	No.	Description	Part No.
	C833, C842, C844, C893, C927 C933 C210, C216 C850, C870 C913, C943		CEAS470M10 CEAS470M10 CEAS471M10 CEAS4R7M50 CEASR47M50
	C149, C150, C220-C224, C233 C421, C525, C907, C914, C936 C919 C909 C110, C122, C160, C196-C198		CKSQYB102K50 CKSQYB102K50 CKSQYB332K50 CKSQYB472K50 CKSQYF103Z50
	C201, C202, C205, C208, C211 C213, C407, C410, C419, C420 C432, C433, C437, C438, C445 C447, C457, C460, C463, C464 C509, C512-C514, C518		CKSQYF103Z50 CKSQYF103Z50 CKSQYF103Z50 CKSQYF103Z50 CKSQYF103Z50
	C520, C521, C526, C528, C529 C541, C544, C546, C548, C550 C559, C560, C566, C579-C583 C585, C586, C588, C802, C804 C807, C834, C835, C843, C872		CKSQYF103Z50 CKSQYF103Z50 CKSQYF103Z50 CKSQYF103Z50 CKSQYF103Z50
	C876, C888, C892, C894, C918 C928, C929, C932, C937-C939 C941, C961, C962, C964, C971 C982 C102, C103, C151, C209, C215		CKSQYF103Z50 CKSQYF103Z50 CKSQYF103Z50 CKSQYF103Z50 CKSQYF104Z25
	C284, C285, C423, C425, C443 C451, C461, C462, C468, C471 C505, C515, C533, C554, C561 C563, C568, C570, C571, C592 C831, C832, C840, C841, C847		CKSQYF104Z25 CKSQYF104Z25 CKSQYF104Z25 CKSQYF104Z25 CKSQYF104Z25
	C873, C874, C910-C912, C940 C981, C983 C837, C921, C930 C905, C951 C442, C808, C815, C875, C877		CKSQYF104Z25 CKSQYF104Z25 CKSQYF223Z50 CKSQYF224Z25 CKSQYF473Z25
	C924, C925 C942 C920 C455, C908 C278, C282		CKSQYF473Z25 CQMA103J50 CQMA104J50 CQMA154J50 CQMA182J50
	C903 C960 C934 C456, C923 VC501-VC503 (20pF)		CQMA222J50 CQMA224J50 CQMA681J50 CQMA683J50 VCM-008

RESISTORS

△	R220, R222 (4.7Ω, 1/6W)	DCN1001
	R414, R573	RD1/6PM470J
	R162	RD1/6PM471J
	R987, R989	RN1/10SE103D
	R986, R990	RN1/10SE333D
	R554	RN1/10SE391D
	R259-R262	RN1/10SE473D
	VR607, VR612 (47kΩ)	PCP1031
	VR450 (2.2kΩ)	RCP1019
	VR603 (4.7kΩ)	RCP1020
	VR604 (47kΩ)	RCP1047
	Other Resistors	RS1/10S□□□J

Mark	No.	Description	Part No.
OTHERS			
		4P CABLE HOLDER	51048-0400
	CN101	10P FFC CONNECTOR	52045-1045
	CN121	16P FFC CONNECTOR	52045-1645
	CN102	21P FFC CONNECTOR	52045-2145
	CN103	23P FFC CONNECTOR	52233-2310
	CN106	11P TOP POST	B11P-SHF-1AA
	CN206	KR CONNECTOR	B6B-PH-K-S
	CN207	B TO B CONNECTOR 12P	BTFN12S-3SB7
	CN208	B TO B CONNECTOR 14P	BTFN14S-3SB7
	JA3, JA4	REMOTE CONTROL JACK	RKN1004
		PCB BINDER	VEF1040
	JA6	2P PIN JACK	VKB1031
	JA1	1P PIN JACK	VKB1090
		SCREW TERMINAL	VNE1948
	KN101, KN102	EARTH PLATE	VNF1084
	X101	CERAMIC RESONATOR (9.0MHz)	VSS1040
	X502	CRYSTAL RESONATOR (17.734MHz)	VSS1059
	X501	CRYSTAL RESONATOR (14.318MHz)	VSS1073
	X503	CRYSTAL RESONATOR (15.0MHz)	VSS1079
	X201	CRYSTAL RESONATOR (16MHz)	VSS1081

SCRB ASSY

CAPACITORS

C601, C602	CCSQCH271J50
C607, C608	CKSQYB102K50
C604	CKSQYF103Z50
C603	CKSQYF104Z25

RESISTORS

All Resistors	RS1/10S□□□J
---------------	-------------

OTHERS

CN601	KR CONNECTOR	B6B-PH-K-S
	PCB BINDER	VEF1040
JA16	RGB CONNECTOR	VKB1037

PALB ASSY

SEMICONDUCTORS

IC101	BU4053BCF
IC202	MM1130XD
IC351	PA0061AM
IC201	TA7320P
Q111	2PB709A
Q101-Q105, Q110, Q201, Q202	2PD601A
Q204, Q207	2PD601A
Q106, Q108	2SA1037K
Q109, Q206, Q613, Q614	2SC2412K
Q205	UN2112

COILS AND FILTERS

L107	LAU101J
L203	LAU120J
L202	LAU121J
L101	LAU180J
L351	LAU181J

Mark	No.	Description	Part No.
	L105, L352		LAU220J
	L106, L208		LAU270J
	L103, L104		LAU560J
	L102		LAU680J
	F201		VTF1034
	F101		VTF1064

CAPACITORS

C233	CCSQCH050C50
C236	CCSQCH070D50
C135	CCSQCH100D50
C109, C110, C114, C115, C203	CCSQCH101J50
C211, C370	CCSQCH101J50
C131, C353	CCSQCH151J50
C134, C352	CCSQCH180J50
C237	CCSQCH200J50
C133, C241	CCSQCH220J50
C232, C371	CCSQCH270J50
C227, C228, C231, C354	CCSQCH330J50
C382	CCSQCH331J50
C351	CCSQCH390J50
C383	CCSQCH471J50
C116	CCSQCH560J50
C132, C202, C375	CCSQCH680J50
C240	CCSQCH750J50
C374	CCSQCH820J50
C225	CCSQSL561J50
C125, C620	CEANP010M50
C111, C119	CEANP220M10
C234, C367	CEAS100M50
C137, C364	CEAS101M10
C224	CEAS3R3M50
C101, C103, C105, C107, C120	CEAS470M10
C122, C127, C129, C207, C209	CEAS470M10
C212, C214, C229, C363, C369	CEAS470M10
C368	CEASR47M50
C377	CKSQYB102K50
C361, C362	CKSQYB392K50
C355-C358	CKSQYB472K50
C102, C104, C106, C108	CKSQYF103Z50
C112, C113, C121, C123, C128	CKSQYF103Z50
C130, C204, C205, C208, C210	CKSQYF103Z50
C213, C215, C220-C222, C226	CKSQYF103Z50
C230, C238, C239, C372, C373	CKSQYF103Z50
C376	CKSQYF103Z50
C365, C366	CKSQYF104Z25
C359, C360	CKSQYF224Z25
C206	CQMA102J50
C235	CQMA222J50
C223	CQMA392J50

RESISTORS

R635	RD1/6PM101J
R205, R207	RD1/6PM470J
R228	RN1/6PQ2401F
VR101 (4.7kΩ)	RCP1020
VR201 (470Ω)	RCP1120
Other Resistors	RS1/10S□□□J

Mark	No.	Description	Part No.
OTHERS			
	CN101	B TO B CONNECTOR 12P	BTFN12P-3RD7
	CN102	B TO B CONNECTOR 14P	BTFN14P-3RD7
		SCREW TERMINAL	VNE1948
	X201	CRYSTAL RESONATOR(8.867238MHz)	VSS1062

SYPS ASSY

SEMICONDUCTORS

△	IC1	ICP-N20
△	IC2	ICP-N10
	IC20	HA17431P
	IC21	UPC358C
	Q27, Q30, Q32	2SA933S
△	Q20, Q22	2SB1566
△	Q24	2SB891F
	Q25, Q29, Q31	2SC1740S
△	Q21, Q23, Q26	2SD2395
	D25-D27, D30, D31	AG01Z-V0
△	D29	MTZJ8.2B
△	D40	RD33FB2
△	D24	S2LA20
△	D21, D22	S3LA20
△	D23	S3S4M

RESISTORS

△	R22-R25	(47Ω, 1/6W)	VCN1033
△	R27	(1Ω, 1/2W)	VCN1047
△	R31	(10Ω, 1/4W)	VCN1051
△	R29	(68Ω, 1/4W)	VCN1052

OTHERS

△	F2	FUSE	VEK1033
△	F3, F4	FUSE	VEK1034
△	F5, F6	FUSE(1.0A/125V)	VEK1036

5. SELF-DIAGNOSTIC FUNCTIONS

5.1 SELF-DIAGNOSTIC FUNCTIONS

The self-diagnostic functions automatically display an error code on the TV screen and front panel fluorescent display section when there is an error. The customer checks the error code and conveys it to the service personnel to make repairs more efficient.

After an error occurs, even if the error code goes off, you can display the error code again by holding down the **CLEAR** key for 10 seconds (except a loading error **L *** display). However, if the power cord is unplugged, the error code information is lost.

Self-diagnostic error code

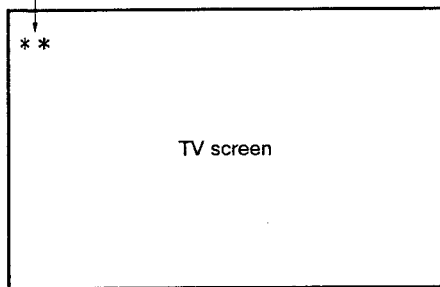

This table explains the information for analyzing the cause when an error occurs with the CLD player.

Self-diagnostic error code	Contents	Conditions	Probable cause
H0	Spindle overcurrent detection error.	In the play state, overcurrent was detected in the spindle motor. Monitoring starts 5 seconds after the start of play or special playback mode, this error is detected if the overcurrent port is "L" for 4 seconds.	<ul style="list-style-type: none"> • Motor NG • Clamper rubbing
U0	FG abnormality error	<ol style="list-style-type: none"> ① At LD start-up, the rate of rotation calculated from the FG was less than 15 rpm for 5 consecutive seconds from the spindle run command. ② At CD start-up, there was less than 1/8th rotation even after 5 seconds had passed since the end of acceleration. ③ During play search, CD : subcodes are being read/LD : Phillips codes are being read and the spindle is locked, but a state in which the rate of rotation calculated from the FG was less than 15 rpm continued for 5 seconds or more. In the above case, it is judged that an abnormality has occurred in the FG sensor and that accurate rotation rate calculation has become impossible. 	<ul style="list-style-type: none"> • FG sensor abnormality, FG signal not coming to mechanism controller • FG sensor clogged • Rubbing between FG sensor and slit • Turntable dropped • FG slit deposition NG
H1	Partial short error	<ol style="list-style-type: none"> ① At LD start-up, the speed did not reach 1200 rpm within a certain time (12 seconds) after the spindle run command. ② At CD start-up, a certain speed (313 rpm) was not reached within 6 seconds from the end of spindle acceleration. 	<ul style="list-style-type: none"> • Spindle motor NG • Commutator NG • Bearing too tight • Power supply NG
H2	Power supply abnormality error	<p>– 5V power supply abnormality detected.</p> <p>The power supply abnormality port is constantly monitored and if its signal stays high for about 1 second consecutively, the power supply is judged to be abnormal.</p>	<ul style="list-style-type: none"> • – 5V not fed from SPDR unit • Parts shorted
L *	Loading error	<ol style="list-style-type: none"> ① When loading operation goes over time (approx. 10 sec.). ② When assist at disc sense entry ends and is not tilt neutral. ③ When assist at set up entry ends and is not tilt neutral. 	<ul style="list-style-type: none"> • Tilt switch 1, 2, 3 abnormal, so tilt/loading state not read in correctly • Tilt/loading mechanism mechanically locked • Drive IC NG • Power supply NG

Self-diagnostic error code	Contents	Conditions	Probable cause
E *	Slider error	During slider movement, a time over run occurred (track count search 20 seconds, mandatory movement 10 seconds)	<ul style="list-style-type: none"> •Slider ceased being able to run •The slider mechanism is mechanically locked and can no longer move to its target. •Slider position switch NG •Flexible cable pulled out •Drive IC NG •Power supply abnormal
U1	Mis clamp error	<ol style="list-style-type: none"> ① During LD setup, after 1/8th rotation, the track count during 1/8 rotation exceeded 511. ② During start-up, the focus was lost once and refocusing was attempted, but the focus could not be locked. ③ When the spindle motor rotation is stopped once before CDV A ↔ V area change, but stop is not carried out within 2.0 seconds, it is determined that there are two discs on each other and clamp error is set. ④ Two FG pulses did not come within 800 ms from the start of LD start-up. ⑤ During CD start-up, it took more than 860 ms to reach 416 rpm (CD+LD both mounted detected). ⑥ The disc clamp operation did not end within 5 seconds. 	<ul style="list-style-type: none"> •Disc sandwiched •Disc shifted •Spindle motor NG •Disc scratched or dirty defocused during start-up •Two discs loaded •PU actuator NG •Tilt sensor NG •Tilt neutral NG (tilt base NG)
P *	Spindle error	<ol style="list-style-type: none"> ① During TOC reading with an LD, the spindle servo was not locked within 60 seconds from the start of the spindle run. ② When CAV/CLV determination is not finished within 60 seconds from spindle servo lock. ③ The codes could not be read for 10 – 15 seconds consecutively for an LD or 7 – 10 seconds for a CD/CDV and the spindle servo was not locked. ④ The speed exceeded 2100 rpm during LD start-up. 	<p>P0:•PH code, SUB - Q code can not be read</p> <ul style="list-style-type: none"> •VCO, PLL offset out of adjustment •Disc defect <p>P5:•PAL disc, mirror disc, etc. PLAY</p> <ul style="list-style-type: none"> •No RF <p>P6:•Spindle servo does not lock</p> <ul style="list-style-type: none"> •Spindle motor NG
F *	Focus error	<ol style="list-style-type: none"> ① "In the "no disc" state, a setup command was received from the mode controller. ② When LD is out of focus when slider is moved to starting position during set up. In case of CD/CDV is NG even after three focus tries. ③ During start-up, the maximum slider servo duty continued for 3 loops or more. 	<p>F5:•CD, LD on top of each other</p> <ul style="list-style-type: none"> •LD scratched or dirty defocused during slider movement •DISC NG •Slider position switch NG <p>F6:•Inner edge of disc scratched or dirty</p> <ul style="list-style-type: none"> •Slider ran into inner edge mechanical stopper

※ Besides the above errors, there is the "U2" communications error (the mode controller could not communicate normally with the mechanism controller).

※ The probable cause is a defective mechanism controller, disconnected cable, etc..

Mechanism mode contents (meanig of * for L * etc.)

- | | |
|----------------|----------------------------|
| 0 : Play | 5 : Setup (rotation start) |
| 1 : Open | 6 : TOC read |
| 2 : Standby | 7 : Play |
| 3 : Clamp | 8 : Search |
| 4 : Disc sense | F : Recovery mode |

- ※ 0 : Normal playing
- 7 : Moving to play operation

6. ADJUSTMENTS

6.1 TEST MODE

1) How to start the test mode

On the MOTHER ASSY, Short circuit the test mode JP W503 and W502, the test mode is started by pressing the power switch ON. (Fig. 1)

After confirming that all FL indicators are lit, remove test mode jumper wire and GND connection. If you have test mode remote control unit (GGF1067), press ESC key and TEST key in order with power switch ON.

2) How to cancel the test mode

Turn power switch OFF. Or, press test mode remote control ESC key.

3) Functions and key control when in test mode

Note : For keys not on player or on accompanying remote control, use test mode remote control unit (GGF1067).

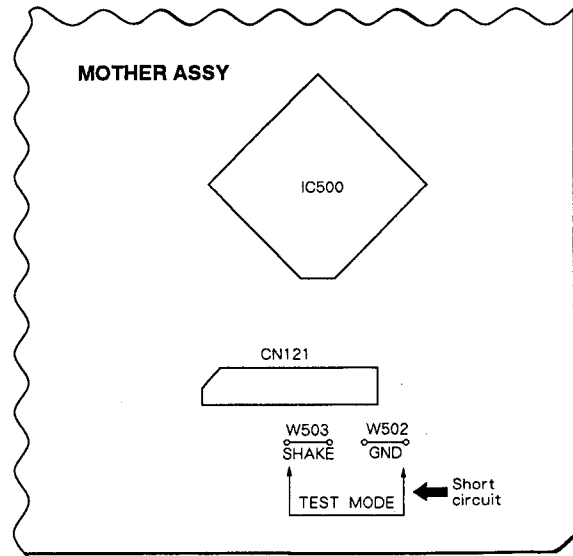

Fig. 1

Note : When you open the tray in test mode, the screen displays goes out. To display the screen again, press the **DISPLAY** key.

• Key Operation in the Test Mode

Player Status	Key Operation	Function	TV Screen Display
Tray Open	⏮/⏭ SKIP (Refer to Note 1)	⏮ : Shifts the tray in the closed direction and also raises the turn table while pressing the key. ⏭ : Shifts the tray in the open direction and also lowers the turn table while pressing the key.	
Tray Open	▶ PLAY	Clamps	
Clamp	▶ PLAY	Turns the disc through TRK Servo OFF	TRK - OFF
TRK Servo OFF	▶ PLAY	TRK Servo ON	TRK - ON
TRK Servo ON	▶ PLAY	TRK Servo OFF	TRK - OFF
TILT Neutral	+ MULTI-SPEED	TILT Servo ON	T-□:ON
TILT ON	- MULTI-SPEED	TILT Neutral	T-□:N
TILT Neutral or ON	⏮/⏭ SKIP	Setting TILT Servo to OFF, can force TILT to move.	T-1 to T-E
Clamp	⏮/⏭ SCAN	Can force the slider to move	S-LD S-CDV S-CD S-IN
Play	PAUSE	Still	
Play	■ STOP	Stop	
Stop	▲ OPEN	Open	
Play	+10 ↓ 0 to 9 ↓ ▶ PLAY	Set to SEARCH lead address input mode. Designates the SEARCH lead address through keys 0 to 9. Press the CLEAR [C] key if the designated address is incorrect. Searches the designated address upon pressing the PLAY key.	

Note 1 : Press SKIP (⏮/⏭) keys after the tray is set to open state by pressing OPEN (▲) key. Because, in tray open state, pressing PLAY (▶) key causes it to set to clamp state and SKIP (⏮/⏭) keys can not function properly.

Table 1

• **Player Operation in the Test Mode**
(Disc tray is removed)

Operate the player by selecting a test mode function with the keys on the player or on the remote control unit.

• **CD PLAYBACK**

- ① Place the CD disc on the turn table.

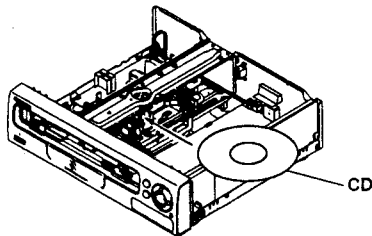

Fig. 2

- ② Press the PLAY (▶) key once.
 (Twin gear starts to move.)
- ③ Push the cam plate (Fig. 3) in the direction of the arrow and wait until the CD disc is clamped.

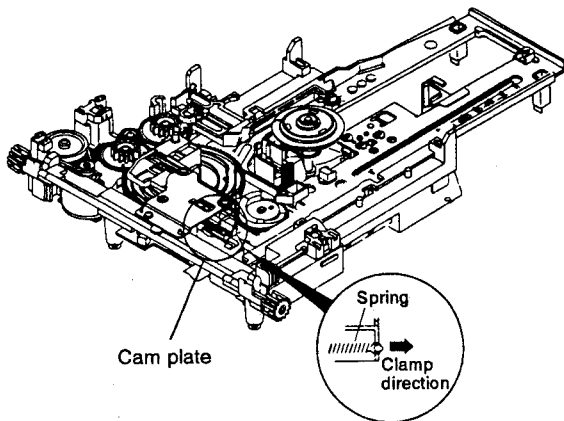
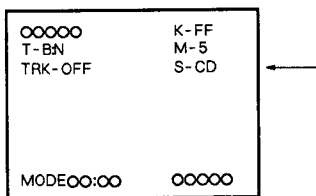

Fig. 3

- ④ Press the ◀◀ or ▶▶ keys to appear "S- CD" on the TV screen display.



TV screen display

Fig. 4

- ⑤ After pressing the PLAY (▶) key once to clamp the disc, press the PLAY (▶) key twice, disc will be normally playbacked.

• **LD PLAYBACK**

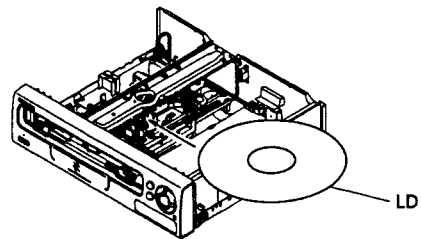
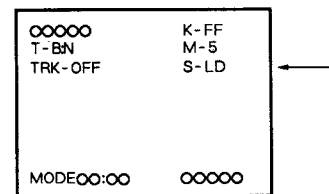

Fig. 5

- ① press the PLAY (▶) key once.
 (Twin gear starts to move.)
- ② Press the SKIP REV (◀◀) key to raise the turn table (spindle motor section) while pressing the cam plate (Fig. 3) in the direction of the arrow. Raise it to the position where the LD disc can be easily placed on the turn table. If the turn table is raised too high, lower it with the SKIP FWD (▶▶) key.
- ③ Place the LD disc on the turn table and press the PLAY (▶) key once to clamp the disc.
- ④ Press the ◀◀ or ▶▶ keys to appear "S- LD" on the TV screen display.



TV screen display

Fig. 6

- ⑤ After pressing the PLAY (▶) key once to clamp the disc, press the PLAY (▶) key twice, disc will be normally playbacked.

6.2 ADJUSTMENT PRECAUTIONS

• Equipment and jigs needed for adjustment

- CD test disc (YEDS - 7)
- NTSC test disc (GGV1012)
- PAL test disc (GGV1007)
- Medium - sized blade screwdriver
- Small blade screwdriver
- Large Phillips screwdriver
- Medium - sized Phillips screwdriver
- Two - channel oscilloscope (with delay)
- Frequency counter
- TV monitor

• Preparation for Adjustment

1. Disc tray removal

- (1) Remove the six screws (A) fastening the bonnet and remove the bonnet.
- (2) With the power supply on, press the OPEN/CLOSE (LD) button and put the disc tray in the open position.
- (3) While pushing the hooks (B) on both sides of the rear of the disc tray inwards, pull out the disc tray.

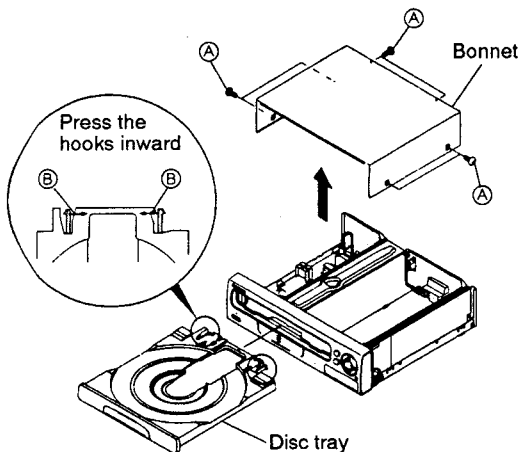

Fig. 7

Note: The adjustments other than "Electrical Adjustments 5. PLL OFFSET Adjustment" can be carried out with the disc tray mounted.

2. Diagnostic method of MOTHER assy

- (1) Remove the three screws (C) fastening the rear panel (L). (Fig. 8)

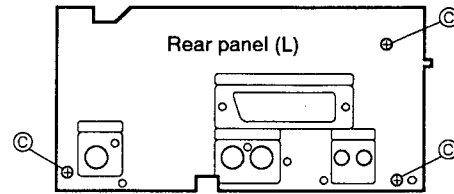

Fig. 8

- (2) Remove the two screws (D) holding the PCB holder. Remove the two screws (E) fastening the MOTHER assy. (Fig. 9)

- The ► mark is printed near the (C) and (E) screws.

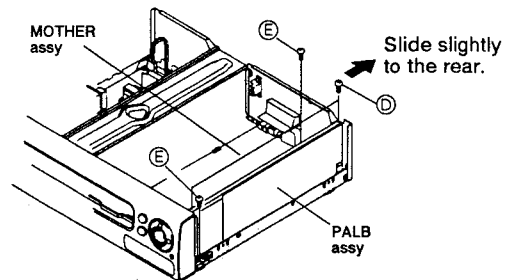

Fig. 9

- (3) When you slide the rear panel (L) slightly to the rear, you can remove it together with the MOTHER assy. You can stand it up within the set as in the figure and diagnose the MOTHER assy. (Fig. 10)

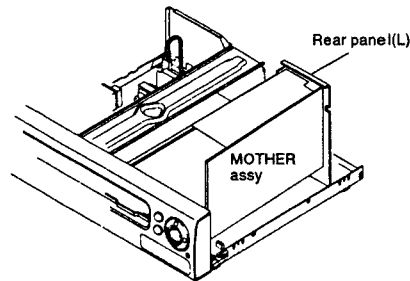
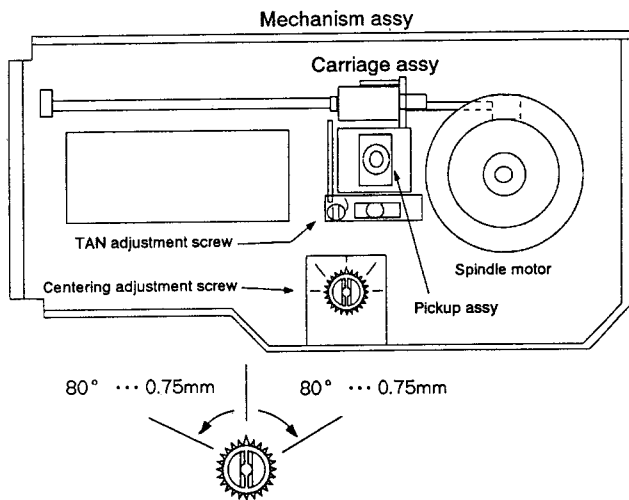

Fig. 10

Note :The MOTHER assy can be diagnosed with the disc tray mounted.

● Before Adjustment Mechanism System

- Centering adjustment screw and TAN adjustment screw
 Note : Be careful not to turn centering adjustment screw and TAN adjustment screw past their adjustment range.



Do not turn the Centering and TAN adjustment screws past their ranges, which are $\pm 0.75\text{mm}$ and $\pm 80^\circ$ from center. After the completion of adjustment, apply lockite or the like to the Centering and TAN adjustment screws. Apply at least 1/3 the circumference about 1/2 half the circumference as in the figure.

Fig. 11 Mechanism assy adjustment

- The mechanical adjustments can all be carried out with disc tray mounted.

- Notes When Adjusting Centering
 If waveform S/N is bad and difficult to observe in "3. Spindle motor centering adjustment" use the low pass filter in diagram.

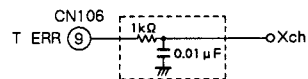

Fig. 12 Low pass filter

- Carriage Assy Position When Adjusting Centering
 When moving slider to inner position to adjust the innermost track of disc during centering adjustment, be careful not to keep the mechanism stopper and Carriage assy from bumping each other. (Fig. 13)

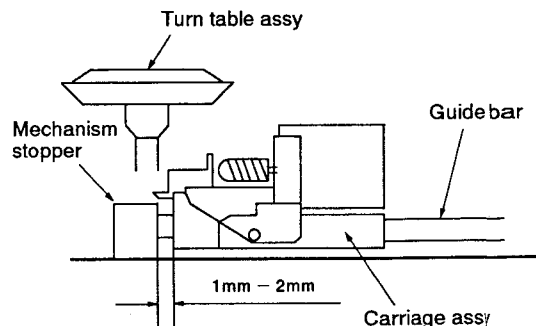

Fig. 13

- Notes When Adjusting Pickup Assy
 Please clean lens first when readjusting the PICKUP assy that is on this product. Also, when changing PICKUP assy, change whole CARRIAGE assy (VWT1110).

6.3 ADJUSTMENT LOCATION

- VR607: Tilt offset adjustment
- VR604: Focus servo loop gain adjustment
- VR603: Tracking servo loop gain adjustment
- VC502: PAL master clock adjustment (1)
- VC501: NTSC master clock adjustment
- VC503: PAL master clock adjustment (2)
- VR450: Output video level adjustment
- VR612: PLL OFFSET adjustment
(Order in adjustment)

- VR101: MOD Y-signal level adjustment
- VR201: MOD C-signal level adjustment

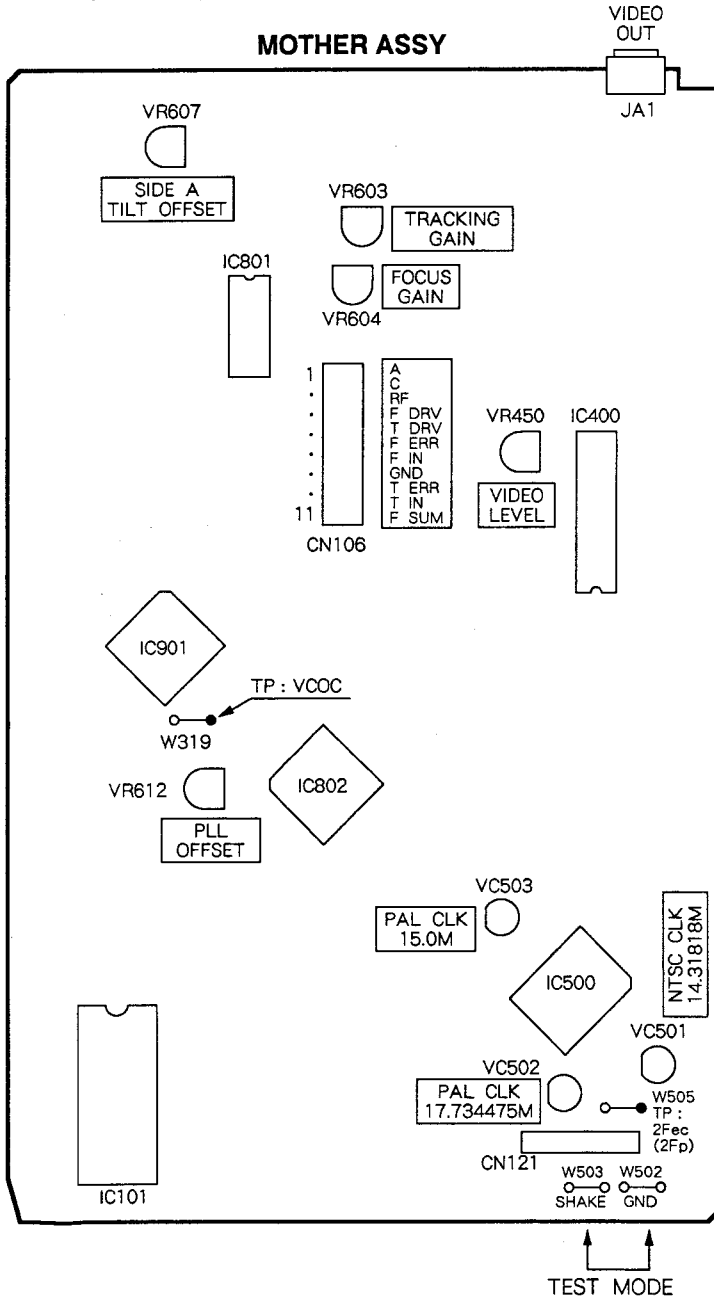

Fig. 14 Adjustment diagram of MOTHER assy

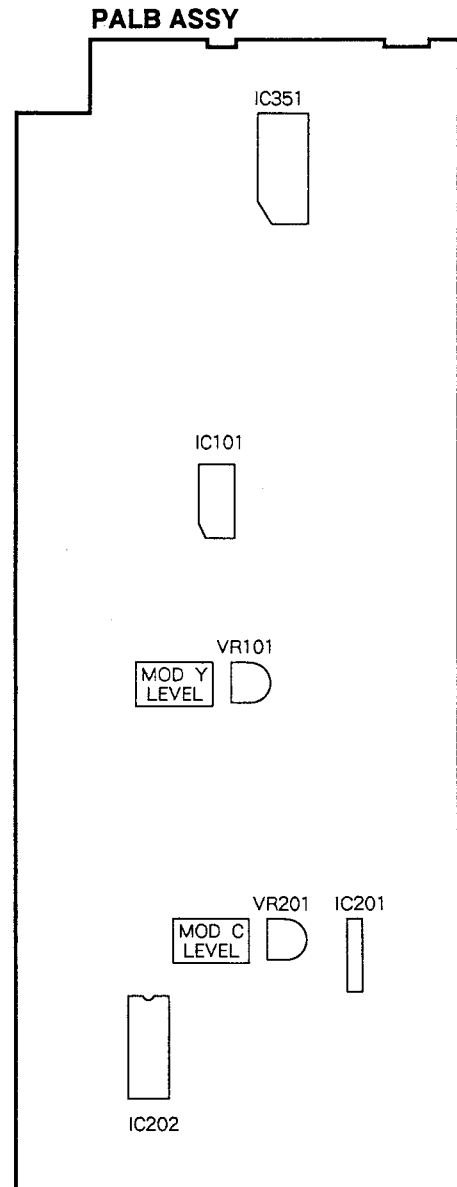

Fig. 15 Adjustment diagram of PALB assy

6.4 ADJUSTMENT METHOD

• Mechanical Adjustments

Step	Adjustment name	Adjustment point	Measuring point and measuring mode	Player condition	Adjustment procedure	Waveform and connection diagram
1	Tilt offset adjustment	MOTHER assy VR607 (TILT OFFSET)	TV monitor	Test mode Disc not installed	Adjust VR607 so that the tilt indication reaches T-6 to T-8. (See test mode function and key operation)	
2	Tangential direction angle adjustment	Carriage assy TAN adjustment screw	MOTHER assy CN106-3 (RF)	Test mode CD test disc play (CD INSIDE POSITION) TRKG-ON, TILT-ON	Adjust so that the amplitude of the RF waveform reaches its maximum and the envelope is very clear.	
3	Spindle motor centering adjustment	Mechanism assy Centering adjustment screw	MOTHER assy CN106-9 (TERR)	Test mode CD test disc play (CD INSIDE POSITION) TRKG-OFF, TILT-ON	Adjust so that the amplitude of the tracking error waveform reaches its maximum and the envelope is very clear.	
4	Cross talk check and tilt offset adjustment	MOTHER assy VR607 (TILT OFFSET)	TV monitor Crosstalk monitor check	Test mode NTSC test disc #115 STILL TRKG-ON, TILT-ON	If the crosstalk is pronounced, adjust VR607 until the crosstalk is not noticeable.	
5	Focus servo loop gain adjustment	MOTHER assy VR604 (FOCUS GAIN)	MOTHER assy CN106-6 (FERR) CH2 "X-Y mode"	Test mode NTSC test disc (PLAY STANDBY) Short CN106-7 (FIN) and 8 (GND), then PLAY (disc not turn)	Adjust VR604 until the waveform level is $4.8 \pm 0.5V$.	
6	Tracking servo loop gain adjustment	MOTHER assy VR603 (TRKG GAIN)	MOTHER assy CN106-9 (TERR) CH2 "X-Y mode"	Test mode NTSC test disc #115 STILL TRKG-ON, TILT-ON	Adjust VR603 until the waveform level is $1.8 \pm 0.2V$.	
7	RF level check	—	MOTHER assy CN106-3 (RF)	Test mode NTSC test disc #115 STILL TRKG-ON, TILT-ON	Check that the RF waveform amplitude is within the range 280mVp-p to 630mVp-p. * There is some variation according to the pickup, but it is about 400mVp-p.	

(NOTE)

- This adjustment can be thought to be about the same adjustment as on the manufacturing line with differing adjustment tools. Follow the adjustment procedures even for checking the adjustments.
- When you open the tray in test mode, the screen displays goes out. To display the screen again, press the **DISPLAY** key.
- The mechanical adjustment can be all carried out with disc tray mounted.

• Electrical Adjustment

MOTHER ASSY							
Step	Adjustment name	Adjustment point	Measurement point	Player condition	Adjustment procedure	Waveform and connection diagram	
1	PAL master clock adjustment (1)	MOTHER assy VC502	MOTHER assy W505 (4fsc)	Normal mode Play the PAL test disc, and next to the stop mode.	Adjust VC502 so that the frequency of W505 becomes 17.734475MHz ± 40Hz.		
2	NTSC master clock adjustment	MOTHER assy VC501	MOTHER assy W505 (4fsc)	Normal mode Play the NTSC test disc, and next to the stop mode.	Adjust VC501 so that the frequency of W505 becomes 14.31818MHz ± 40Hz.		
3	PAL master clock adjustment (2)	MOTHER assy VC503	MOTHER assy W505 (4fp)	Play the PAL test disc	Adjust VC503 so that the frequency of W505 becomes 15.0MHz ± 40Hz.		
4	Output video level adjustment	MOTHER assy VR450 (VIDEO LEVEL)	MOTHER assy Video output terminal	Normal mode Play the PAL test disc	Adjust VR450 so that the voltage level of composite video signal between sync tip to 100% white level becomes 1Vp-p ± 5%.		
5	PLL OFFSET adjustment	MOTHER assy VR612 (PLL OFFSET)	MOTHER assy W319 (VCOC)	Test mode TRKG servo OFF Play the CD test disc	1. In the TRKG servo OFF, connect an oscilloscope via low pass filter. 2. Adjust VR612 so that the voltage difference between the PLL OFFSET voltage at FSEQ signal completely down to the GND level and the voltage at normal PLAY state becomes 0V ± 0.1V.		
PALB ASSY							
6	MOD Y-signal level adjustment	PALB assy VR101	PALB assy IC101 - pin 5 : CH1 IC101 - pin 3 : CH2	#19,900 STILL Play the NTSC test disc	Adjust VR101 so that the level of Y signal at IC101 - 5 pin between the sync tip and the white 100% becomes the same as that of the Y signal at IC101 - 3 pin.		
7	MOD C-signal level adjustment	PALB assy VR201	PALB assy IC101 - pin 5 : CH1 IC101 - pin 3 : CH2	#19,900 STILL Play the NTSC test disc	Adjust VR201 so that the level of C signal at IC101 - 5 pin between the sync tip and the white 100% becomes the same as that of the C signal at IC101 - 3 pin.		

7. IC INFORMATION

- The information shown in the list is basic information and may not correspond exactly to that shown in the schematic diagrams.

■ PAC005B (MOTHER ASSY : IC400) • VIDEO IC

• Block Diagram

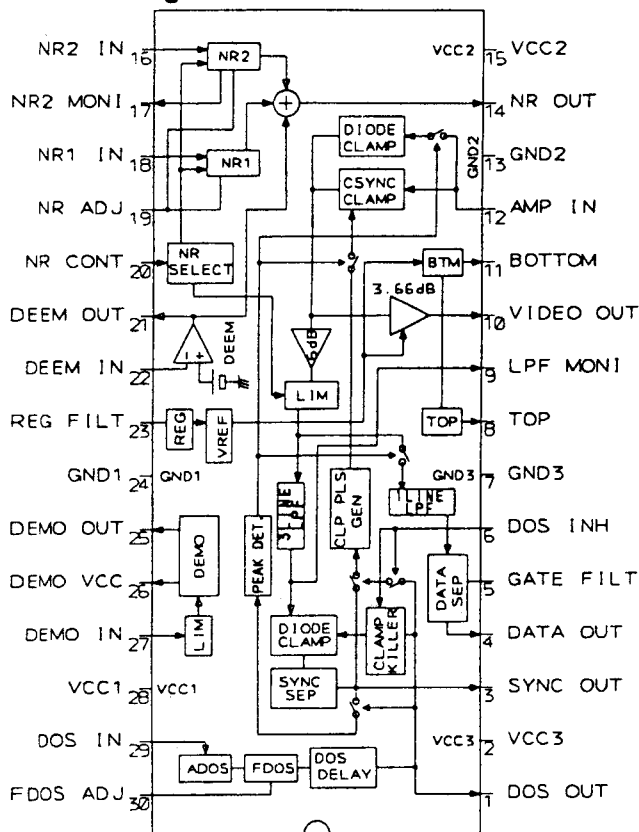

• Pin Function

No.	Pin Name	Function
1	DOS OUT	Drop out pulse output.
2	VCC3	VCC for SYNC SEP section.
3	SYNC OUT	Composite sync output.
4	DATA OUT	Data pulse output.
5	GATE FILT	Connect a capacitor for Gate - Gate.
6	DOS INH	Clamp pulse and clamp killer control.
7	GND3	GND for SYNC SEP section.
8	TOP	Reference DC (TOP) for A/D.
9	LPF MONI	Monitor the LPF for SYNC SEP.
10	VIDEO OUT	Signal output for A/D.
11	BOTTOM	Reference DC (BOTTOM) for A/D.
12	AMP IN	Sync chip clamp input.
13	GND2	GND for VIDEO.
14	NR OUT	Noise reduction output.
15	VCC2	VCC for VIDEO section.
16	NR2 IN	Signal input (2) for noise reduction.
17	NR2 MONI	Limiter output for noise reduction.
18	NR1 IN	Signal input (1) for noise reduction.
19	NR ADJ	Limiter level adjusting pin for noise reduction.
20	NR CONT	Noise reduction (1, 2) select and limiter control.
21	DEEM OUT	De-emphasis output.
22	DEEM IN	De-emphasis input.
23	REG FILT	Connect a capacitor for regulator.
24	GND1	GND for RF section.
25	DEMO OUT	Demodulation output of RF signal.
26	DEMO VCC	VCC for FM demodulation output.
27	DEMO IN	RF input for FM demodulation.
28	VCC1	VCC for RF section.
29	DOS IN	RF input for DOS.
30	FDOS ADJ	FDOS sensitivity adjustment.

■ PD9004A (MOTHER ASSY : IC501)

• OSD IC

● Block Diagram

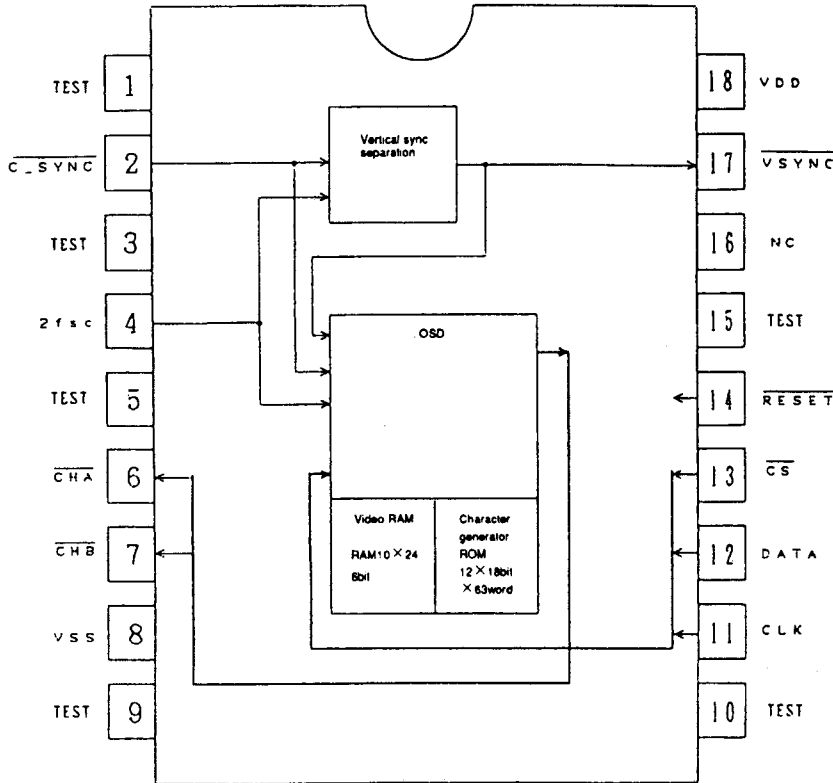

● Pin Function

Pin No	Code	I/O	Logic	Function
1	TEST	-	-	Do not connect any external components.
2	CSYNC	I	Negative	Composite sync signal input
3	TEST	-	-	Do not connect any external components.
4	2fsc	I	-	Color subcarrier frequency 2 x clock input (NTSC about 7.14 MHz PAL about 8.8 MHz)
5	TEST	-	-	Do not connect any external components.
6	CHA	O	Negative	Character timing output
7	CHB	O	Negative	Blanking timing output
8	VSS	-	-	Connected to system ground
9	TEST	-	-	Do not connect any external components.
10	TEST	-	-	Do not connect any external components.
11	CLK	I	↑	Data read-in clock input pin; the data applied to the Data pin is read-in at the rising edge of the clock.
12	DATA	I	Positive	Control data input pin; the data is read-in synchronized with the clock applied to the CLK pin.
13	CS	I	Negative	Low for serial communications
14	RESET	I	Negative	Hardware reset with pull-up resistance
15	TEST	-	-	Do not connect any external components.
16	NC	-	-	Not connected
17	VSYNC	O	Negative	Signal with V sync separated from C sync
18	VDD	-	-	Power supply (+5V) pin

■ PD0228A (MOTHER ASSY : IC101)
 • MECHANISM CONTROL IC

● Pin Assignment (Top view)

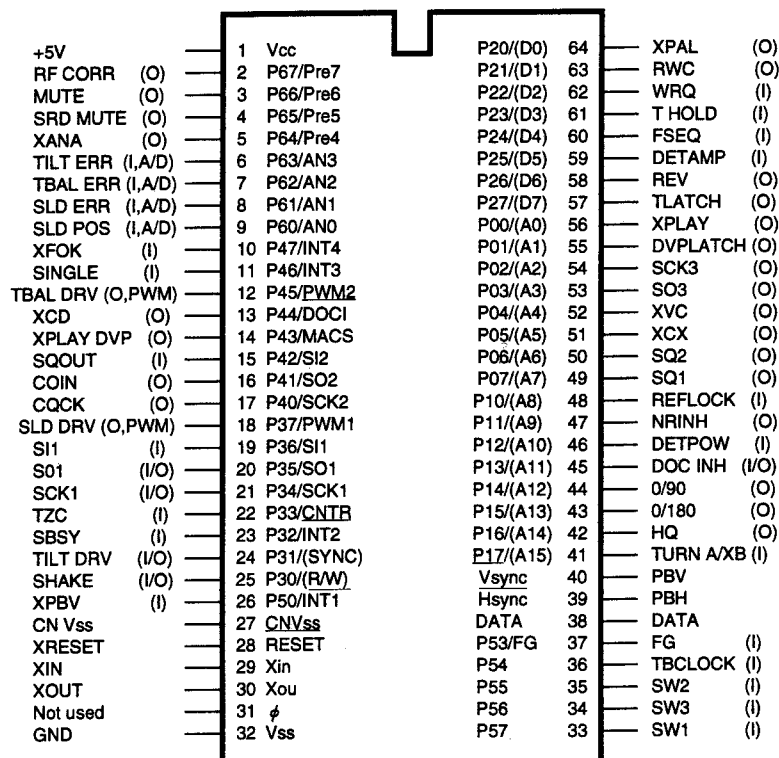

● Pin Function

No.	Pin name	I/O	Function
1	Vcc	I	Power supply connection pin. 5V±10% applied.
2	RF CORR	O	RF correction switch signal output pin. "H" =Gain up "H" =Rise up CAV, within #8000 at TOC reading. "L" =others (#8000 - #8100 : hold the previous state.)
3	MUTE	O	Audio system audio mute control signal output pin. "H" =Mute ON, "L" =Mute OFF
4	SRDMUTE	O	AC3 mute control signal output pin. Release mute only during play. "L" =Mute, "H" =Release mute
5	XANA	O	Digital/Analog audio switching signal output pin. "H" =Digital, "L" =Analog
6	TILT ERR	I A/D	Tilt sensor output signal input pin. The tilt motor is controlled to make this signal 2.5V.
7	TBAL ERR	I A/D	Tracking balance error signal input pin(A/D input port). This signal is converted from analog to digital and used for tracking offset control input.
8	SLD ERR	I A/D	Slider error signal input pin (A/D input port). This signal is converted from analog to digital and used for sliderservo control input.
9	SLD POS	I A/D	Pickup position detection switch input pin (A/D input port). The switches are resistance divided, the A/D input value read in, and the position detected.
10	XFOK	I	Focus servo lock signal input pin. "L" =lock, "H" =unlock Used for focus servo lock detection.
11	SINGLE	I	Uses the rear panel ATT switch in single mode and communicates this data to the mode controller. "L" =normal, "H" =single
12	TBAL DRV	O PWM	Tracking offset control signal output pin. PWM outputs the tracking offset for use as the auto tracking offset. Period 910 μsec, 3-value control : H, L, Z
13	XCD	O	LD/CD switching signal output pin.
14	XPLAY DVP	O	Spindle servo signal output pin. "L" =during servo, "H" =acceleration, brake, during servo
15	SQOUT	I	DSP reading command data input pin. SUBQ is read out.
16	COIN	O	DSP writing command data output pin.
17	CQCK	O	DSP read/write command clock output pin. Read in at rising edge.
18	SLD DRV	O PWM	Slider control signal output pin. Side A : 5V=FWD, 0V=REV, Side B : 0V=FWD, 5V=REV, 2.5V=STOP, Period 910 μsec, 3-value control : H, L, Z

No.	Pin name	I/O	Function
19	SI1	I	Data input pin from mode controller IC.
20	SO1	O	Serial data output pin to mode controller IC.
21	SCK1	I/O	Clock for serial communication with mode controller IC. Other than when communicating with mode controller IC, input mode.
22	TZC	I	Tracking error zero cross signal input pin. Control the slider motor which is counted this signal in the track count search.
23	SBSY	I	Subcode block sync. signal input pin. "H" =S0, S1, "L" =others
24	TILT DRV	I/O	Load/tilt control output pin. 0.5V - tray in, out/tilt down, up 2.5V - stop Use for tilt servo by PWM output the tilt drive.
25	SHAKE	I/O	Handshake signal pin for data communications with mode controller IC. This pin is a bidirectional data line and control the input/output by the respective microcomputers.
26	XPBV	I	LD/CDV playback vertical sync signal input pin. "L" =during vertical sync.
27	CN Vss	I	Ground for A/D conversion.
28	XRESET	I	Reset signal input pin. "L" =reset, "H" =release reset Controlled by mode controller IC.
29	XIN	I	9MHz clock oscillation input pin.
30	XOUT	O	9MHz clock oscillation output pin.
31	N.C.	O	Dedicated output pin, so other uses prohibited.
32	Vss	I	Ground
33	SW1	I	Switch input pin for loading/tilt position detection.
34	SW3	I	Switch input pin for loading/tilt position detection.
35	SW2	I	Switch input pin for loading/tilt position detection.
36	TBCLOCK	I	Spindle lock signal input pin. "H" =Lock, "L" =Unlock
37	FG	I	Spindle motor FG signal input pin. 16 pulses per rotation, used within microcomputer frequency divided by 2.
38	DATA	I	Mechanism controller built-in Phillips code/decode input pin.
39	XPBH	I	Playback HSYNC input for Phillips coding/decoding.
40	XPBV	I	Playback VSYNC input for Phillips coding/decoding.
41	TURN A/XB	I	Double sided mech. turn switch. "H" =side A, "L" =side B
42	HQON	O	High quality circuit (analog NR) control signal output pin. "H" =through the HQ circuit, "L" =Not through
43	0/180	O	Phase switch signal output pin at PAL trick play. "H" =through the inverter, "L" =through
44	0/90	O	Phase switch signal output pin at PAL trick play. "H" =through the 1H delay line, "L" =through
45	DOC INH	I/O	Control the clamp pulse and clamp killer circuits by 3-value.
46	DETPOW	I	Used as power supply abnormality signal input port. "L" =normal, "H" =abnormal
47	NRINH	O	VDEM noise reduction control output pin. "L" =normal, "H" =no NR
48	REFLOCK	I	Reference signal input pin from DVP. "L" =phase not aligned, "H" =phase aligned
49	SQ1	O	Analog audio switching signal output pin. 1/L squelch : H
50	SQ2	O	Analog audio switching signal output pin. 2/R squelch : H
51	XCX	O	Analog audio CX noise reduction switching signal output pin. "L" =ON, "H" =OFF
52	XVC	O	Voice cancel output. "L" =cancel, "H" =OFF
53	SO3	O	Serial 3 data signal output pin. The serial signals are common and are distinguished with the latch signals (XLAT3, XLAT2 and-T LATCH).
54	SCK3	O	Serial 3 clock signal output pin. Reading at rising edge. "H" period : 2 μ sec "L" period : 20 μ sec
55	DVPLATCH	O	PD6159 serial latch signal output pin. Latches at falling edge.
56	XPLAY	O	In the PAL trick play, video path switching signal output pin at quasi-PAL. "H" =through the PAL special playback circuit. "L" =not through
57	T LATCH	O	Latch signal output pin of serial control for DAC & digital filter IC PD2026A. Latches at falling edge.
58	REV	O	Pickup tension signal output pin at reverse. "H" =side B, "L" =side A
59	DETAMP	I	Spindle overcurrent detection signal input pin. "L" =overcurrent, "H" =normal
60	FSEQ	I	Subcode sync match detection signal input pin. "H" =matches, "L" =does not match
61	T HOLD	I	Track jump accelerating/decelerating signal input pin. "H" =during accelerating/decelerating, "L" =neither
62	WRQ	I	Subcode Q read OK signal input pin. "L" =NG, "H" =This pin goes high when the subcode Q data passes the CRC check.
63	RWC	O	DSP read/write command signal output pin. "L" =read, "H" =write
64	XPAL	O	PAL/NTSC switching signal output pin. "H" =NTSC, "L" =PAL

■ PD6159A (MOTHER ASSY : IC500)
• DUAL DIGITAL VIDEO PROCESSOR IC

• Descriptions

The PD6159A is a digital video processor (DVP) IC designed for dual-CLD players. It supplies time-base-corrected (TBC) video signals (conforming to both PAL and NTSC formats), which have a jitter right after the RF demodulation. It also generates sync signals which synchronize with these output video signals. In addition, various signals required for spindle control are generated by the IC. The PD6159A features the following.

The main functions are compatible with those of the PD0146A (NTSC-exclusive DVP).

Clocks NTSC : 4 fsc
 PAL : 4 fp (4x pilot burst for disc video)
 4 fsc (for squelch)

Digital TBC
 Sync signal generation and synchronization
 Generation of a signal for spindle control
 Dropout compensation NTSC : Color
 PAL : Monochrome
 Character-superimpose function
 Blue-background generation

• Block Diagram

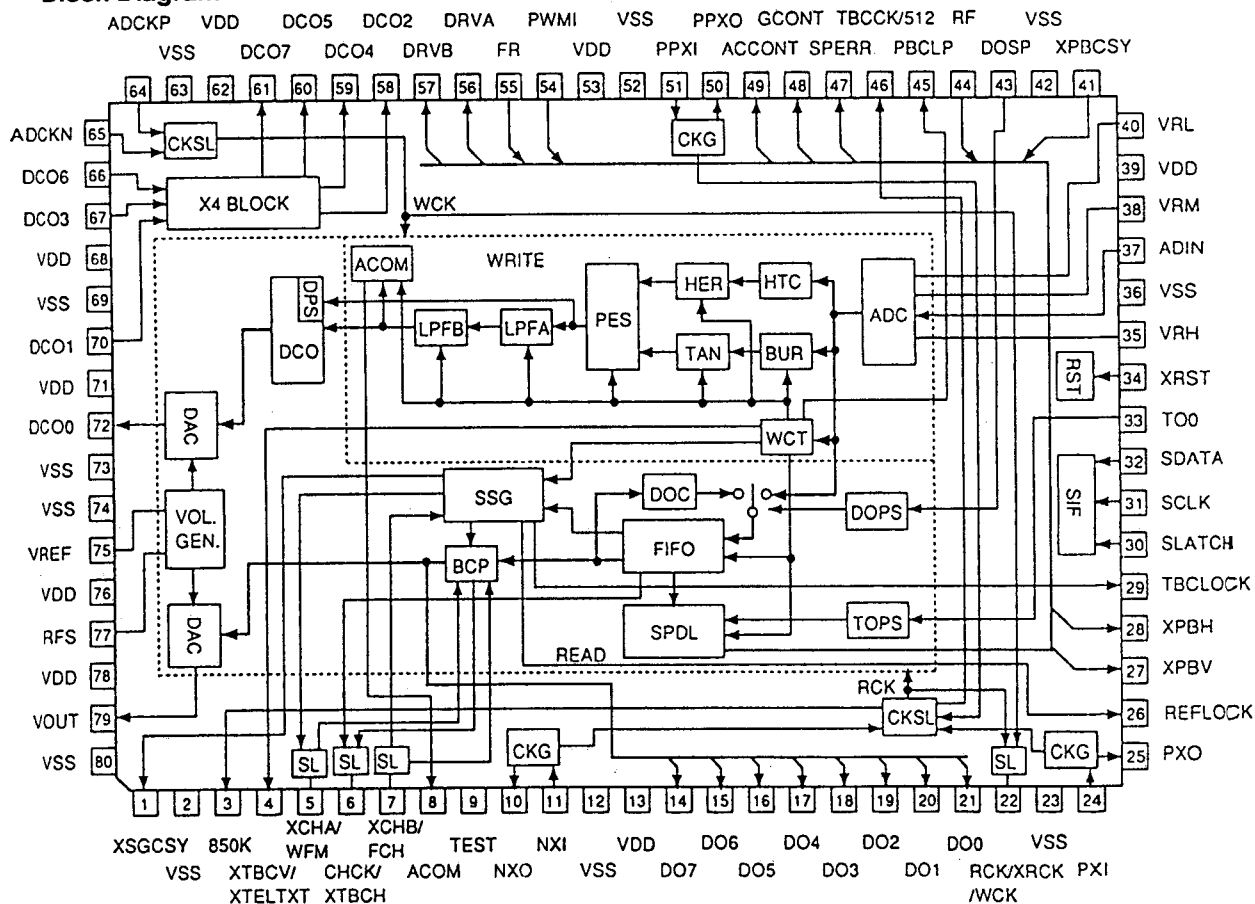

● Pin Function

No.	Pin Name	I/O	Function	
1	XSGCSY	O	Outputs the reference composite sync from SG with negative logic. While normally in synchronization with the output video signal, it can be specified for free run in memory system mode. (Always synchronized in squelch mode) It can also be delayed by a command with a specified delay duration (SYD0-5).	
2	VSS	-	To be connected to GND. (VSS associated with the logic)	
3	850K	O	Output obtained by exclusive-ORing the NTSC fsc wave with the PAL fsc wave. After passing through an external filter, it can be used as an 850-kHz wave required for NTSC-to-PAL conversion.	
4	XTBCV	O	TELSEL=0	Outputs time-base-corrected V sync with negative logic. In PAL, the timing of the rising can be set to the ends of 23H and 336H by a command (XTBCVSEL).
	XTELTXT	O	TELSEL=1 & NTSC/XPAL=0	Outputs "L" to indicate the teletext data positions (video portion at 20H, 21H, 333H, 334H) in PAL. Fixed to "H" in NTSC.
5	XCHA	I	XCGEN=0	To be connected to the character output of the OSD IC when using the character-superimpose function. When "L" the white level is imposed to the video output.
	WFM	O	XCGEN=1	Outputs "H" for the first field and "L" for the second field.
6	CHCK	O	XCGEN=0	Outputs 2-fsc (2-fp) waves for the OSD IC when using the character-superimpose function. It is synchronized with the RCK/XRCK output.
	XTBCH	O	XCGEN=1	Outputs the time-base-corrected H sync with negative logic.
7	XCHB	I	XCGEN=0	Accepts the character-frame output of the OSD IC when using the character(-frame)-superimpose function. When the input to this pin is "L" and to XCHA is "H" the gray level is imposed on the video output.
	FCH	I	XCGEN=1 & MEMSYS=1	Accepts the field-change signal from the memory controller in memory system mode. "H" at 268H in NTSC or "H" at 315H in PAL during the second field switches the second field to the first field. To be fixed to "L" when not used.
8	ACOM	O	Outputs a signal representing the duty, which depends on the error level obtained at the internal phase comparator. To be used for audio jitter compensation.	
9	TEST	I	To be used when testing the IC. Fix it to "L".	
10	NXO	O	To be connected to the NTSC 4-fsc crystal oscillator.	
11	NXI	I	To be connected to the NTSC 4-fsc crystal oscillator.	
12	VSS	-	To be connected to GND. (VSS associated with the logic)	
13	VDD	-	To be connected to +5 V. (VDD associated with the logic)	
14	DO7	O	To be used normally when OE=1 and OSD0/OSD01=0. A time-base-corrected digital video signal is obtained here in memory mode. DO0 yields the LSB and DO7 the MSB. The signal is in synchronization with the RCK/XRCK output. The squelch data will be output in squelch mode. The data to be output can be selected by commands OSD0/OSD1. When OE=0, these pins are fixed to "L".	
15	DO6			
16	DO5			
17	DO4			
18	DO3			
19	DO2			
20	DO1			
21	DO0			
22	RCK/XRCK	O	OTHERS	Outputs the reference clock (4 fsc for NTSC, 4 fp for PAL video, or 4 fsc for PAL squelch). Positive or negative phase can be selected by a command (RCKSEL).
	WCK	O	OE=1 & OSD=1	Outputs the write clock (4 fsc for NTSC or 4fp for PAL).
23	VSS	-	To be connected to GND. (VSS associated with the logic)	
24	PXI	I	To be connected to the PAL 4-fsc crystal oscillator.	
25	PXO	O	To be connected to the PAL 4-fsc crystal oscillator.	
26	REFLOCK	O	Outputs "H" when the phase difference of H/V sync associated with PB (after TBC) and those associated with SSG is small enough.	
27	XPBV	O	Outputs the signal obtained by separating V sync from the signal at XPBCSY (pin 41) with negative logic.	
28	XPBH	O	Outputs the signal obtained by separating H sync from the signal at XPBCSY (pin 41) with negative logic.	
29	TBCLOCK	O	Outputs "H" when the spindle loop and the TBS loop are locked.	
30	SLATCH	I	Gives the latch timing for data applied to the serial interface. (Through at the rising and no change in register contents during L/H periods and at the falling.)	
31	SCLK	I	Clock inputs for the serial interface. The SDATA value will be read at the rising edge.	
32	SDATA	I	Provides the serial interface with data.	
33	TO0	I	Accepts a tracking-open pulse. The pulse will be internally stretched. The stretch volume is set by a command (STD0 to STD3).	
34	XRST	I	Input for initializing the IC. When "L" all the registers and counters of the IC are set to their initial values.	
35	VRH	I	Provides the AC converter with the reference voltage of the H side.	
36	VSS	-	To be connected to GND. (VSS for the AD converter)	
37	ADIN	I	Input for the AD converter. Accepts a composite video signal having a jitter. In PAL, the pilot burst wave must be in a range of the half the difference between the H reference voltage and the L reference voltage. (See the example of input specifications.)	
38	VRM	I	Intertap pin between the reference resistors. A bypass capacitor can be connected for stabilization.	

No.	Pin Name	I/O	Function
39	VDD	-	To be connected to +5 V. (VDD for the AD converter)
40	VRL	I	Provides the AD converter with the reference voltage for the L side.
41	XPBCSY	I	The PB composite sync is to be supplied here with negative logic.
42	VSS	-	To be connected to GND. (VSS associated with the logic)
43	DOSP	I	Accepts the dropout detection pulse. The pulse will be internally stretched. The stretch volume is set by a command (STD0-3).
44	RF	I	Accepts an RF signal for the spindle servo.
45	PBCLP	O	Flag output to indicate the positions for level clamp of the pilot-burst signal in PAL. (See the example of input specifications.)
46	TBCCK/512	O	Outputs a 1/512th division (approx. 28 kHz) of the clock (NTSC: 4 fsc, PAL: 4 fp) used for TBC. It is used to generate a chopping wave for spindle control.
47	SPERR	O	Output pin for a phase-frequency error of the spindle errors. It outputs the result of comparison between PBH and reference H in tristate. The polarity can be set by a command (PERPOL).
48	GCONT	O	Outputs a PWM signal according to the command-specified value (CD0-3).
49	ACCONT	O	Tristate output of the acceleration/deceleration signal, which depends either on the forced acceleration/deceleration signal, the error detection by RF or error detection by H sync. The acceleration/deceleration volume is determined by setting the duty of the PWM output by commands (RFGD0-3, HFGD0-3). The polarity can be set by a command (ACCPOL).
50	PPXO	O	To be connected to the PAL 4-fp crystal oscillator.
51	PPXI	I	To be connected to the PAL 4-fp crystal oscillator.
52	VSS	-	To be connected to GND. (VSS associated with the logic)
53	VDD	-	To be connected to +5 V. (VDD associated with the logic)
54	PWMI	I	Accepts a signal obtained through the voltage comparison between the spindle error which has passed through a loop filter and the chopping wave externally generated from TBCCK/512.
55	FR	I	Accepts a signal obtained through the voltage comparison between the spindle error which has passed through a loop filter and the destination voltage.
56	DRVA	O	Control signal output for Tr which drives the spindle motor. It is applicable to either a brush motor or brushless motor, selection of which is by a command (BLM). (See the functional block diagram for the logic.)
57	DRVB	O	
58	DCO2	O	Outputs a signal obtained through waveformshaping of the DCO1 signal.
59	DCO4	O	Outputs a signal obtained through waveformshaping of the DCO3 signal.
60	DCO5	O	Outputs a signal multiplied by 2.
61	DCO7	O	Outputs a signal multiplied by 4, which is used as the write clock after passing through a 4-fp or 4-fsc filter.
62	VDD	-	To be connected to +5 V. (VDD for output multiplied by 4).
63	VSS	-	To be connected to GND. (VSS for output multiplied by 4).
64	ADCKP	I	Write clock input for PAL. Accepts the DCO7 output via a 4-fp filter.
65	ADCKN	I	Write clock input for NTSC. Accepts the DCO7 output via a 4-fsc filter.
66	DCO6	I	Accepts a signal obtained by delaying the DCO5 signal by approx. 35 ns.
67	DCO3	I	Accepts a signal obtained by delaying the DCO2 signal by approx. 70 ns.
68	VDD	-	To be connected to +5 V. (VDD for input multiplied by 4).
69	VSS	-	To be connected to GND. (VSS for input multiplied by 4).
70	DCO1	I	Accepts the DCO0 signal via a low-pass filter.
71	VDD	-	To be connected to +5 V. (VDD for the DA converter for DCO0 output).
72	DCO0	O	DCO output. The signal here is multiplied by 4 to produce ADCK. It can be fixed to the minimum potential by a command (DCOINH).
73	VSS	-	To be connected to GND. (VSS for the DA converter for DCO0 output).
74	VSS	-	To be connected to GND. (VSS for the internal power source for the DA converter).
75	VREF	I	Input to show the reference voltage to the internal power source for the DA converter.
76	VDD	-	To be connected to +5 V. (VDD for the internal power source for the DA converter).
77	RFS	IO	Pin to specify the internal current of the internal power source for the DA converter. Connect 5.1 kohms as standard between this pin and GND.
78	VDD	-	To be connected to +5 V. (VDD for the DA converter for VOUT output).
79	VOUT	O	Time-base-corrected video output. While a composite sync is normally inserted, the sync position will be found at the pedestal level in memory system mode. (However, some half-H pulses etc. may partly remain near Vsync.)
80	VSS	-	To be connected to GND. (VSS for the DA converter for VOUT output)

TC9400F (MOTHER ASSY : IC201)
• D/A CONVERTER IC

• Block Diagram

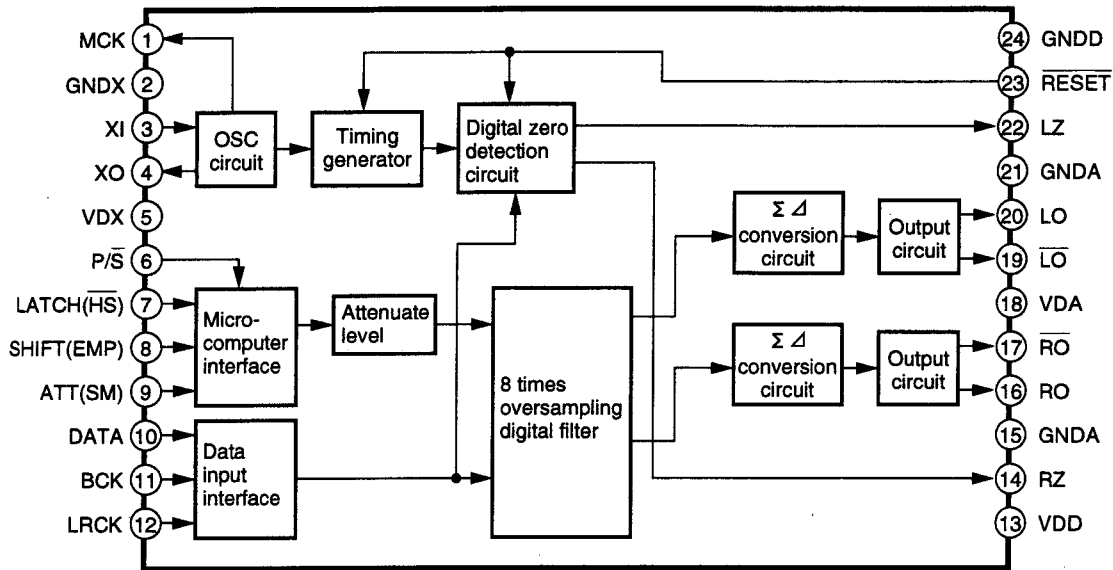

• Pin Function

No.	Pin name	I/O	Function
1	MCK	O	System clock supply pin.
2	GNDX	—	Ground pin of oscillation section.
3	XI	I	Crystal oscillator connection pin. Generates a clock for system.
4	XO	O	
5	VDX	—	Power supply pin for oscillation section.
6	P/S	I	Parallel/serial control switching pin. (Schmitt input and pull-up resistor)
7	LATCH (HS)	I	In the serial control, data latch signal input pin for attenuator. In the parallel control, normal/double speed mode selection pin. (Schmitt input and pull-up resistor)
8	SHIFT (EMP)	I	In the serial control, shift clock input pin for attenuator. In the parallel control, deemphasis filter ON/OFF control pin. (Schmitt input and pull-up resistor)
9	ATT (SM)	I	In the serial control, data I input pin for attenuator. In the parallel control, soft mute control pin. (Schmitt input and pull-up resistor)
10	DATA	I	Data input pin. (Schmitt input)
11	BCK	I	Bit clock input pin. (Schmitt input)
12	LRCK	I	LR clock input pin. (Schmitt input)
13	VDD	—	Power supply pin for digital section.
14	RZ	O	R-ch digital zero detection output pin.
15	GNDA	—	Ground pin for R-ch analog section.
16	RO	O	R-ch data positive-phase output pin.
17	R \bar{O}	O	R-ch data negative-phase output pin.
18	VDA	—	Power supply pin for analog section.
19	L \bar{O}	O	L-ch data negative-phase output pin.
20	LO	O	L-ch data positive-phase output pin.
21	GNDA	—	Ground pin for L-ch analog section.
22	LZ	O	L-ch digital zero detection output pin.

■ PD3313A (FLKY ASSY : IC101)

● MODE CONTROL IC

● Pin Function

Note : H : HIGH level , L : LOW level , — : High impedance, P : Pulse

No.	Pin name	I/O	Function	No.	Pin name	I/O	Function	
1	Vcc	—	+5V power supply.	33	XMIC ON	O	Mic circuit output mute cancel. (L : enable)	
2	XRESET	O	MOTHER ASSY reset output.	34	n	O	Display segment output.	
3	XSCK	I/O	Serial communication clock. (mechanism control and character generator)	35	KS4/m	O	Key scan output/Display segment output.	
4	S MTOF	I	Serial communication data input. (mechanism control)	36	KS3/l	O	Key scan output/Display segment output.	
5	S FTOM	O	Serial communication data output. (mechanism control and character generator)	37	KS2/k			
6	XCS	O	Character generator (PD9004A) chip select output. (L : enable)	38	KS1/j			
7	NC	O	Not used.	39	KS0/i			
8	SECAM	I	Trident TV correspondence. H:correspondend, L:not correspondend	40	h	O	Display segment output.	
9	POWER ON	O	Power supply switching output of the MOTHER ASSY.	41	g			
10	AVcc	—	+5V power supply.	42	f			
11	KIN0	I	Key data input.	43	e			
12	KIN1			44	d			
13	KIN2			45	c			
14	KIN3			46	b			
15	KIN4			47	a			
16	SW1	I	H : PAL model, L : DUAL model	48	Vdisp	—	Power supply for VFD (-29V) .	
17	SW2	I	PAL AFM H : present, L : absent	49	G8	O	Display grid output.	
18	SW3	I	PAL trick play H : present, L : absent	50	G7			
19	AVss	—	GND.	51	G6			
20	TEST	I	Connect to GND. (not used)	52	G5			
21	X1	I	NC (not used)	53	G4			
22	X2	I	Connect to +5V. (not used)	54	G3			
23	Vss	—	GND	55	G2			
24	OSC1	I	System clock oscillator connection pin.	56	G1			
25	OSC2	O		57	LED_LD			O
26	XRESET	I	CPU reset (L : reset)	58	LED_CD			O
27	SHAKE	I/O	Mechanism control serial communication requirement.	59	STDBY	O	Standby LED output.	
28	SEL IR	I	Remote control input.	60	NC	O	NC	
29	FSX	I	7.35MHz frame sync. signal of EFM decoder.	61	NC	O	NC	
30	EFLG	I	Error correction state signal of EFM decoder.	62	NC	O	NC	
31	GND	—	Ground	63	NC	O	NC	
32	WDF	O	For WATCHDOG pulse output.	64	NC	O	NC	

■ PA0061AM (PALB ASSY : IC351)
 • ANALOG AUDIO IC

● Block Diagram

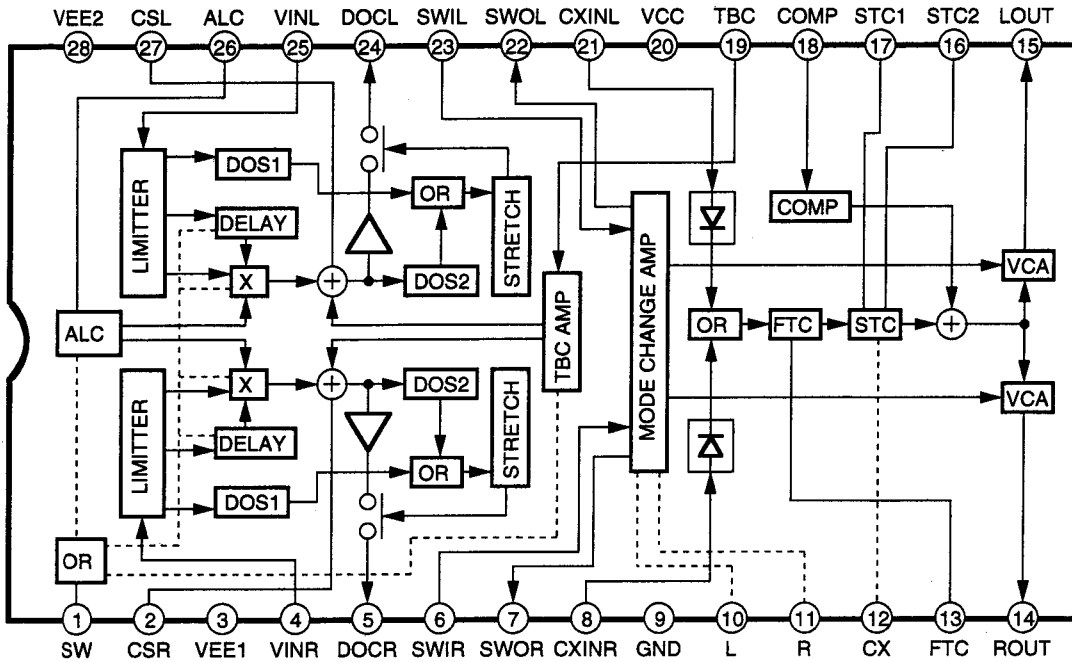

● Pin Function

No.	Pin name	Function
1	SW	PAL/NTSC switch pin.
2	CSR	Capacitor connection pin for eliminating carrier.
3	VEE1	Power supply pin.
4	VINR	FM signal input pin.
5	DOCR	Drop out correction switch output pin.
6	SWIR	Mode switch amp input pin.
7	SWOR	Mode switch amp output pin.
8	CXINR	CX control signal input pin.
9	GND	Ground.
10	L	Mode switch pin L.
11	R	Mode switch pin R.
12	CX	CX ON-OFF switch pin.
13	FTC	Capacitor connection pin for FTC.
14	ROUT	R ch output pin.
15	LOUT	L ch output pin.
16	STC2	STC pin 2.
17	STC1	STC pin 1.
18	COMP	Compensator pin.
19	TBC	TBC error signal input pin.
20	VCC	Power supply pin.
21	CXINL	CX control signal input pin.
22	SWOL	Mode switch amp output pin.
23	SWIL	Mode switch amp input pin.
24	DOCL	Drop out correction switch output pin.
25	VINL	FM signal input pin.
26	ALC	Capacitor connection pin for ALC.
27	CSL	Capacitor connection pin for eliminating carrier.
28	VEE2	Power supply pin.

● Truth Table of Mode Switch

MODE	SW (pin1)
PAL	Low (0V)
NTSC	High (5V)

MODE	L (pin 10)	R (pin 11)
STEREO	Low (0V)	Low (0V)
MONO (L)	Low (0V)	High (5V)
MONO (R)	High (5V)	Low (0V)
SQUELCH	High (5V)	High (5V)

MODE	CX (pin 12)
CX ON	Low (0V)
CX OFF	High (5V)

8. FL INFORMATION

■ VAW1035 (FLKY ASSY : V101)
FL TUBE

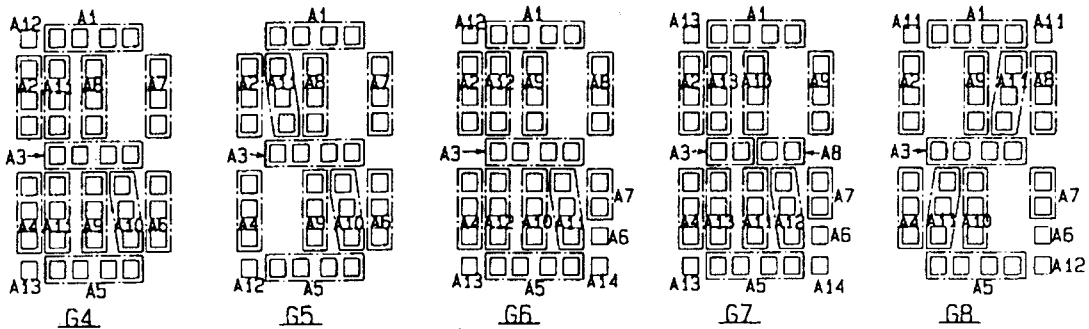
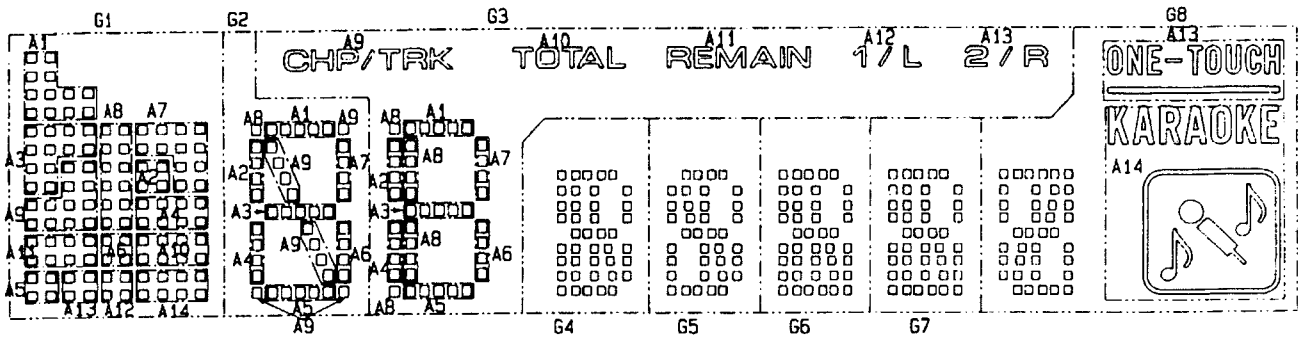

ANODE GRID ASSIGNMENT & PIN ASSIGNMENT

	G1	G2	G3	G4	G5	G6	G7	G8
P1	A1	A1	A1	A1	A1	A1	A1	A1
P2	A2	A2	A2	A2	A2	A2	A2	A2
P3	A3	A3	A3	A3	A3	A3	A3	A3
P4	A4	A4	A4	A4	A4	A4	A4	A4
P5	A5	A5	A5	A5	A5	A5	A5	A5
P6	A6	A6	A6	A6	A6	A6	A6	A6
P7	A7	A7	A7	A7	A7	A7	A7	A7
P8	A8	A8	A8	A8	A8	A8	A8	A8
P9	A9	A9	CHP/TRK	A9	A9	A9	A9	A9
P10	A10		TOTAL	A10	A10	A10	A10	A10
P11	A11		REMAIN	A11	A11	A11	A11	A11
P12	A12		1/L	A12	A12	A12	A12	A12
P13	A13		2/R	A13		A13	A13	ONE-TOUCH
P14	A14					A14	A14	KARAOKE

PIN ASSIGNMENT

Pin No.	1	2	3	4	5	6	7	8	9	10	11	12	13	14	15	16	17
Assignment	F	F	NP	NL	NL	NL	NL	G1	G2	G3	G4	G5	G6	G7	G8	P1	P2

Pin No.	18	19	20	21	22	23	24	25	26	27	28	29	30	31	32	33	34
Assignment	P3	P4	P5	P6	P7	P8	P9	P10	P11	P12	P13	P14	NL	NL	NP	F	F

F:Filament G1-G8:Grid P1-P14:Anode NP:No pin NL:No Lead

9. BLOCK DIAGRAM

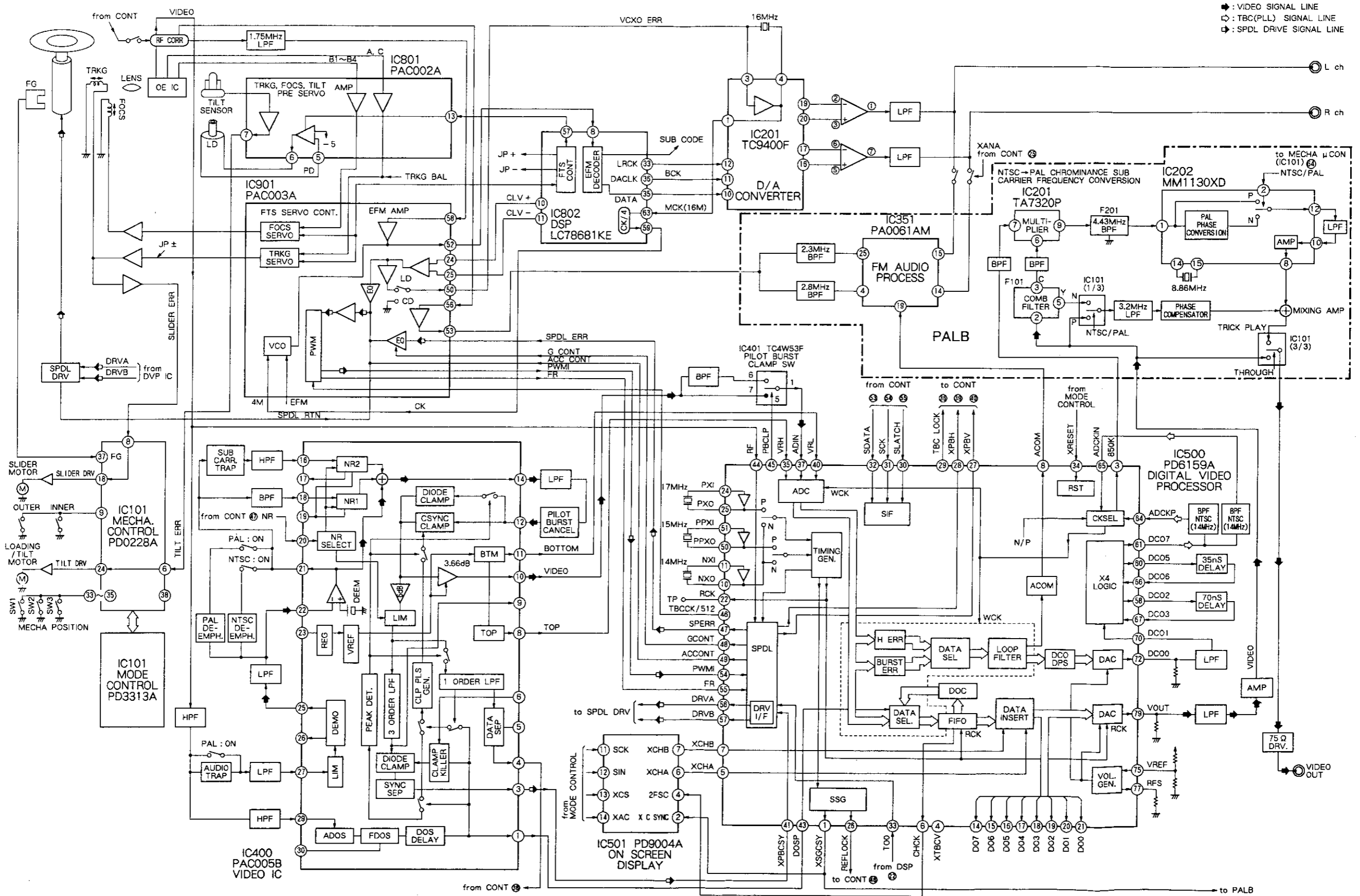

10. PANEL FACILITIES

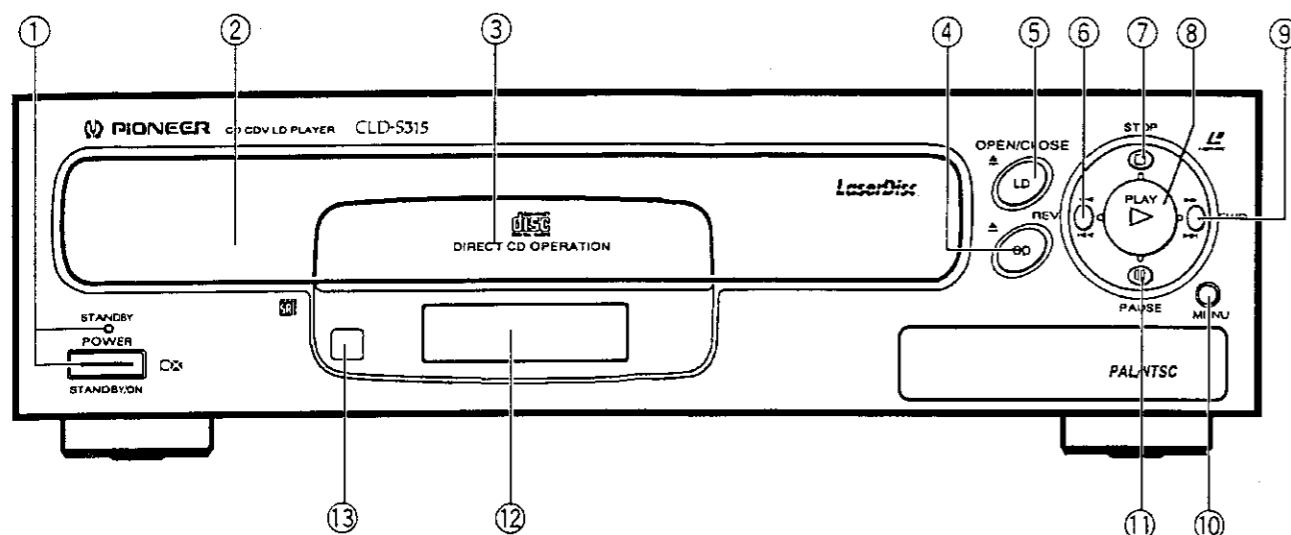

- ① **POWER STANDBY/ON switch and STANDBY indicator**
Press to turn the power on and off.
- ② **Disc table**
- ③ **CD disc table**
- ④ **CD OPEN/CLOSE (▲) button**
- ⑤ **LD OPEN/CLOSE (▲) button**
- ⑥ **Track/manual search (|◀◀ ◀◀) button**
- ⑦ **STOP button (■)**
- ⑧ **PLAY button (▶)**
- ⑨ **Track/manual search (▶▶ ▶▶) button**
- ⑩ **MENU button**
- ⑪ **PAUSE button (||)**
- ⑫ **Display window**
- ⑬ **Remote sensor**

11. SPECIFICATIONS

1. General

System LaserVision Disc system and Compact Disc digital audio system
 Laser Semiconductor laser wavelength 780 nm
 Power requirements AC 220 ~ 240 V, 50/60 Hz
 Power consumption 33 W
 Weight 5.8 kg
 Dimensions 420 (W) x 381 (D) x 120 (H) mm
 Operating temperature +5°C ~ +35°C
 Operating humidity 5% ~ 85%
 (There should be no condensation of moisture.)

2. Video characteristics

Format PAL/NTSC specifications
 Video output
 Level 1 Vp-p nominal, sync. negative, terminated
 Impedance 75Ω unbalanced
 Jack RCA jack

3. Audio characteristics

Output level
 During analog audio output 200 mVrms (1 kHz, 40%)
 During digital audio output 200 mVrms (1 kHz, -20 dB)
 Jacks Both RCA jacks
 Number of channels 2

Digital Audio Characteristics

Frequency response	4 Hz - 20 kHz
SN ratio	98 dB (EIAJ)
Dynamic range	94 dB (EIAJ)
Total harmonic distortion	0.005 % (EIAJ)
Wow and flutter	Limit of measurement (EIAJ)

4. Other Terminals

Control input/output Both miniature jacks
 AV connector output 21-pin connector
 This connector provides the video and audio signals for connection to a colour video TV monitor (or TV set) which has a "AV CONNECTOR" terminal.

PIN assignment

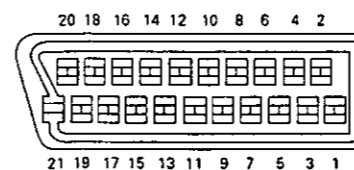

PIN no.	1 Audio 2/R out	17 GND
	3 Audio 1/L out	19 Video out
	4 GND	21 GND
	8 Status	

5. Accessories

Remote control unit 1
 Size "AA" (IEC R6P) dry cell batteries 2
 Operating instructions 1
 Warranty card 1

NOTE:

The specifications and design of this product are subject to change without notice, due to improvements.

WAVEFORMS AND VOLTAGE FTS AND AUDIO SECTION

Note : (No) in the table correspond to the pin number.

Measurement condition : In case when (D. audio) is written, at time when disc that has digital audio recording is played.

IC801(PAC002A)	IC802(LC78681KE)	IC803(LA6510)	IC901(PAC003A)	CN106	Video output pin
②, ③ 1mS/Div. 16mVp-p AC mode	② 0.1μS/Div. 4.3Vp-p AC mode(D. audio)	① 2mS/Div. 1.8Vp-p DC mode	② 0.2mS/Div. 74mVp-p DC mode	①, ② 5mS/Div. 65mVp-p DC mode	① approx. 1Vp-p (75Ω termination) V : 20mV/Div H : 10mS/Div
⑦, ⑧ 1mS/Div. 67mVp-p DC mode	③③ 10μS/Div. 4.2Vp-p AC mode(D. audio)		⑦ 0.2mS/Div. 74mVp-p DC mode	③ 0.5mS/Div. 300mVp-p AC mode	
⑨ 5mS/Div. 0.1Vp-p DC mode	③⑤ 0.2μS/Div. 4.4Vp-p AC mode(D. audio)		①⑥ 0.2mS/Div. 0.61Vp-p DC mode	④ 5mS/Div. 15Vp-p DC mode	
	③⑥ 0.2μS/Div. 4.5Vp-p AC mode(D. audio)		④⑧ 50μS/Div. 6.2Vp-p DC mode	⑤ 5mS/Div. 5.8Vp-p DC mode	
	④③ 0.1μS/Div. 4.5Vp-p AC mode(D. audio)		⑤② 0.2μS/Div. 2.1Vp-p AC mode	⑥ 5mS/Div. 3.5Vp-p DC mode	
	⑤⑨ 0.1μS/Div. 2Vp-p AC mode(D. audio)		⑤⑦ 1mS/Div. 0.53Vp-p DC mode	⑨ 5mS/Div. 1.25Vp-p DC mode	
			⑤⑧ 0.2mS/Div. 0.32Vp-p DC mode	⑪ 10mS/Div. 1.7Vp-p DC mode	

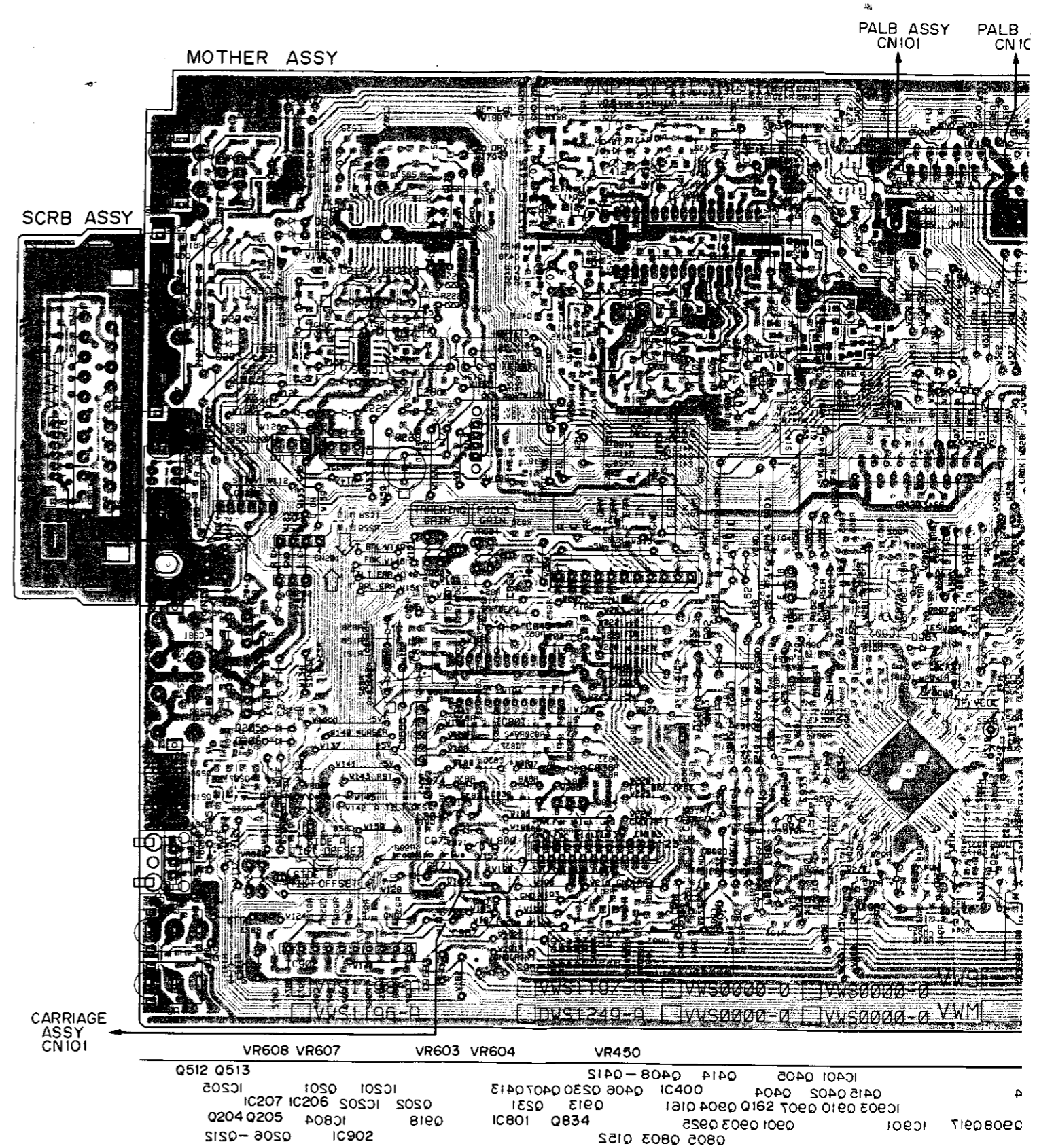

• This diagram is viewed from the mounted parts side.

A

B

C

D

Y22A PALB ASSY
CN101

MOTHER ASSY

SCRIB ASSY

FLKY
ASSY
Y22A
CN101

LMSB
ASSY
Y22A
CN101

CN3
Y22A
ASSY

CARRIAGE
ASSY
CN101

VC201 VC205	VC203	VR21V	VR20	VR203 VR204	VR207	VR208 VR210	VR213	
IC500 Q102 Q103 IC101 Q803	IC502 Q504	Q510 Q511 Q505-Q507 Q503	IC802 Q514	IC401 Q405 Q414 Q408-Q412 Q415 Q402 Q404 Q00Q1 Q406 Q230 Q407 Q413 IC903 Q910 Q907 S810 Q904 Q161 Q913 Q231	IC201 Q201 Q202 IC202 Q203 IC205	Q915 Q916 IC905 IC906	Q908 Q917 IC901 Q901 Q903 Q925 Q805 Q803 Q152	Q206-Q212 Q918 IC804 Q0S0 Q0S0 Q0S0

• This diagram is viewed from the foil side.

WAVEFORM VIDEO SECTI

Note: (No) in the Measurement con

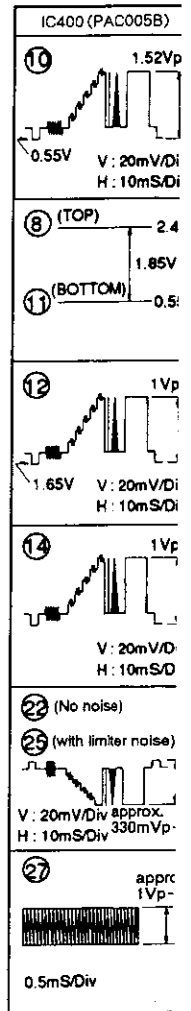

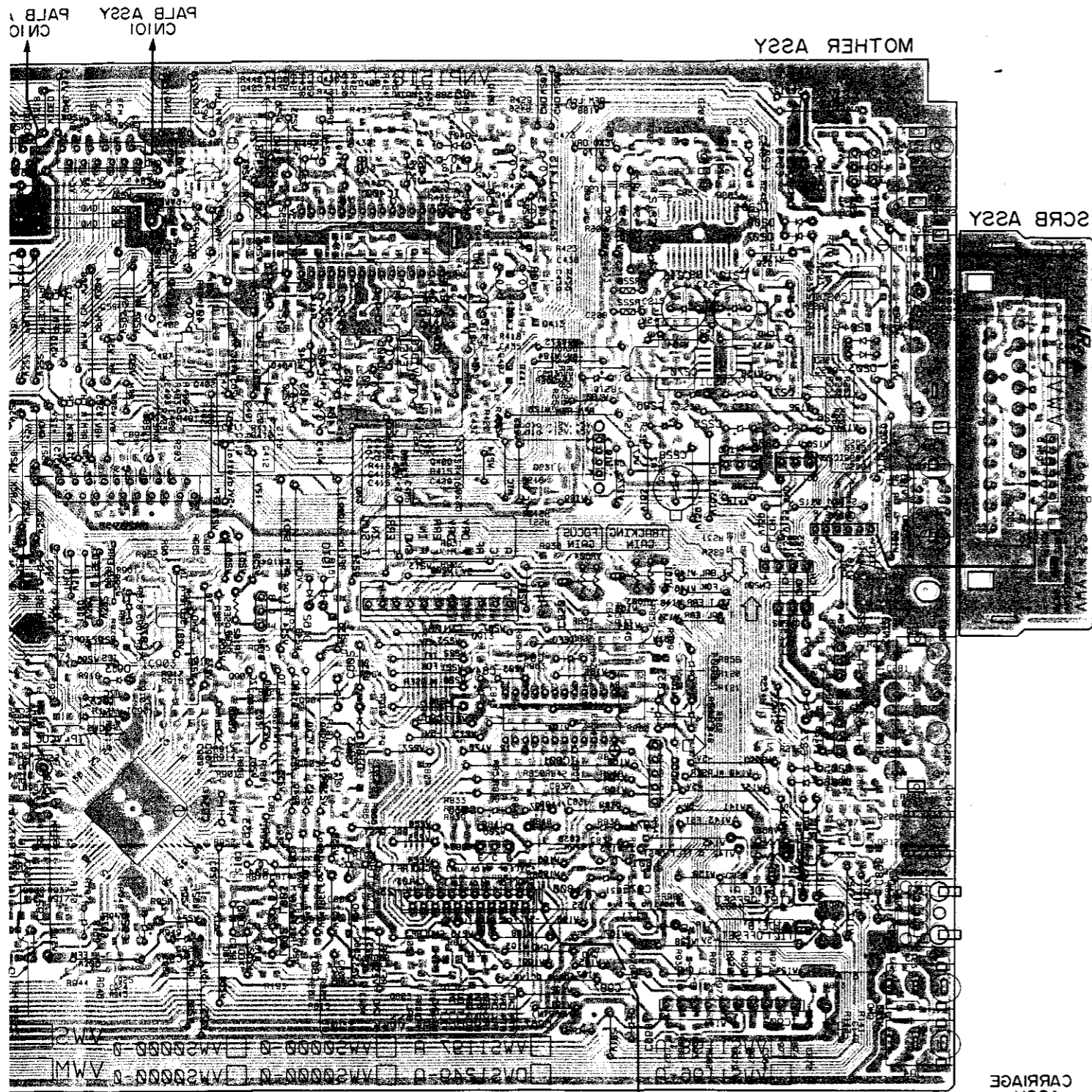

IC401 Q405 Q414 Q408-Q412
 Q415 Q402 Q404 Q0401 Q406 Q230 Q407 Q413
 IC903 Q910 Q907 S910 Q904 Q161 Q913 Q231 Q202 IC202 803C1 T05C1 IC205
 Q908 Q917 IC901 Q901 Q903 Q925 Q880 Q803 Q152 IC804 8050 P050
 Q805 Q803 Q152 S05C1 Q206-Q212

• This diagram is viewed from the foil side.

WAVEFORMS AND VOLTAGE VIDEO SECTION

Note: (No) in the table correspond to the pin number.

Measurement condition: In case when (D. audio) is written, at time when disc that has digital audio recording is played.

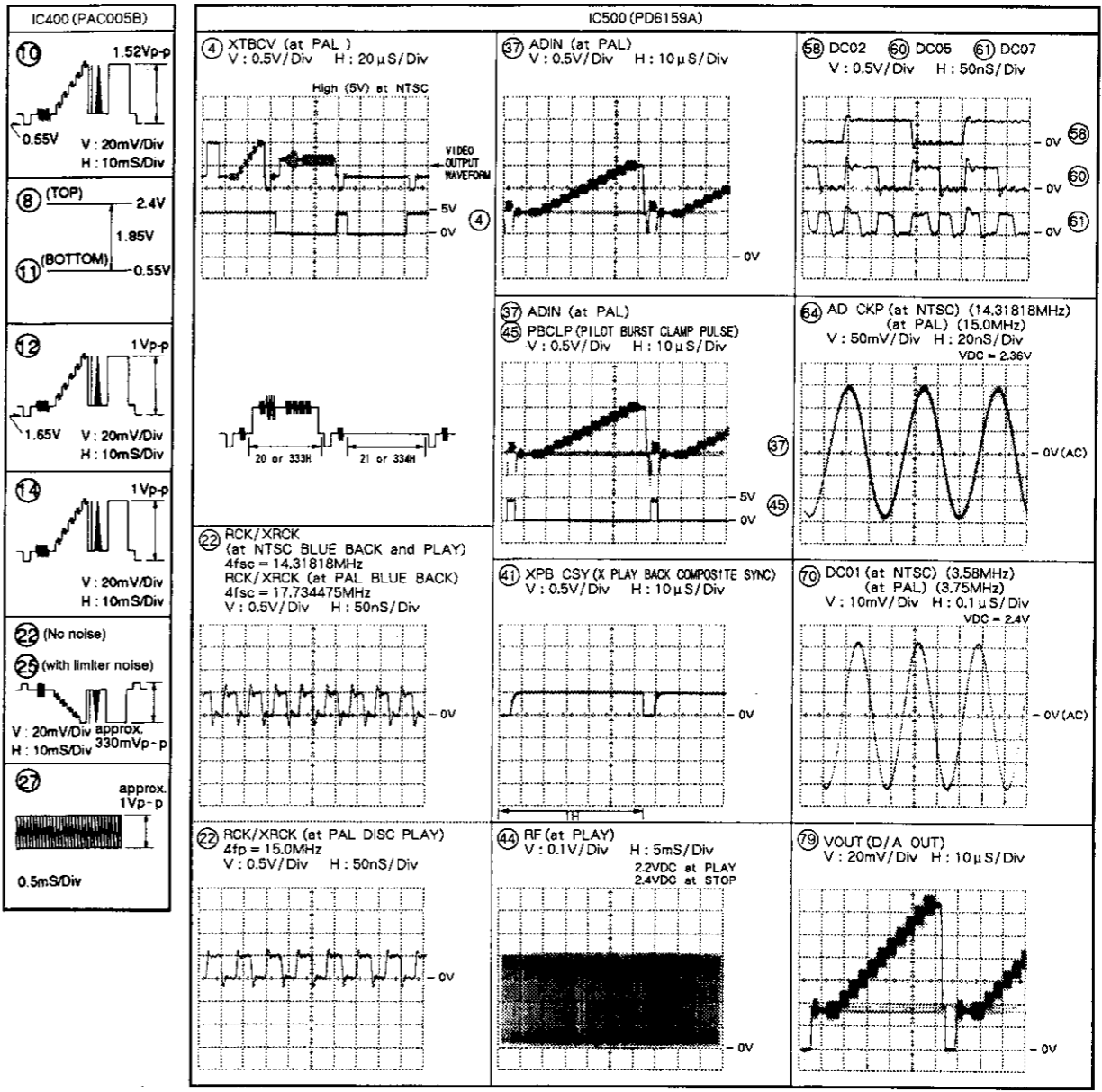

Pin	VDC (V)
35	2.40
38	1.475
40	0.55
75	2.5
77	2.5

A
B
C
D