

Service Manual

Pioneer

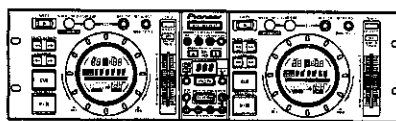

CU-V160

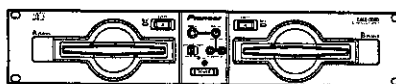

CMX-5000

ORDER NO.
RRV2260

COMPACT DISC PLAYER

CMX-5000

REMOTE CONTROLLER

CU-V160

THIS MANUAL IS APPLICABLE TO THE FOLLOWING MODEL(S) AND TYPE(S).

Type	Model		Power Requirement	Remarks
	CMX-5000	CU-V160		
KUC	<input type="radio"/>	<input type="radio"/>	AC120V	
TL	<input type="radio"/>	<input type="radio"/>	AC110-240V	
WY	<input type="radio"/>	<input type="radio"/>	AC220-240V	

CONTENTS

1. SAFETY INFORMATION	2	7. GENERAL INFORMATION	66
2. EXPLODED VIEWS AND PARTS LIST	4	7.1 DIAGNOSIS	66
3. BLOCK DIAGRAM AND SCHEMATIC DIAGRAM ...	12	7.1.1 TEST MODE	66
4. PCB CONNECTION DIAGRAM	45	7.1.2 POWER ON SEQUENCE	71
5. PCB PARTS LIST	59	7.1.3 DISASSEMBLY	72
6. ADJUSTMENT	64	7.2 PARTS	75
		7.2.1 IC	75
		7.2.2 DISPLAY	78
		8. PANEL FACILITIES AND SPECIFICATIONS	80

PIONEER CORPORATION 4-1, Meguro 1-chome, Meguro-ku, Tokyo 153-8654, Japan
PIONEER ELECTRONICS SERVICE, INC. P.O. Box 1760, Long Beach, CA 90801-1760, U.S.A.
PIONEER EUROPE N.V. Haven 1087, Keetberglaan 1, 9120 Melsele, Belgium
PIONEER ELECTRONICS ASIACENTRE PTE. LTD. 253 Alexandra Road, #04-01, Singapore 159936
 © PIONEER CORPORATION 2000

1. SAFETY INFORMATION

This service manual is intended for qualified service technicians ; it is not meant for the casual do-it-yourselfer. Qualified technicians have the necessary test equipment and tools, and have been trained to properly and safely repair complex products such as those covered by this manual. Improperly performed repairs can adversely affect the safety and reliability of the product and may void the warranty. If you are not qualified to perform the repair of this product properly and safely, you should not risk trying to do so and refer the repair to a qualified service technician.



WARNING

This product contains lead in solder and certain electrical parts contain chemicals which are known to the state of California to cause cancer, birth defects or other reproductive harm.

Health & Safety Code Section 25249.6 – Proposition 65



NOTICE

(FOR CANADIAN MODEL ONLY)

Fuse symbols  (fast operating fuse) and/or  (slow operating fuse) on PCB indicate that replacement parts must be of identical designation.

REMARQUE

(POUR MODÈLE CANADIEN SEULEMENT)

Les symboles de fusible  (fusible de type rapide) et/ou  (fusible de type lent) sur CCI indiquent que les pièces de remplacement doivent avoir la même désignation.

(FOR USA MODEL ONLY)

1. SAFETY PRECAUTIONS

The following check should be performed for the continued protection of the customer and service technician.

LEAKAGE CURRENT CHECK

Measure leakage current to a known earth ground (water pipe, conduit, etc.) by connecting a leakage current tester such as Simpson Model 229-2 or equivalent between the earth ground and all exposed metal parts of the appliance (input/output terminals, screwheads, metal overlays, control shaft, etc.). Plug the AC line cord of the appliance directly into a 120V AC 60Hz outlet and turn the AC power switch on. Any current measured must not exceed 0.5mA.

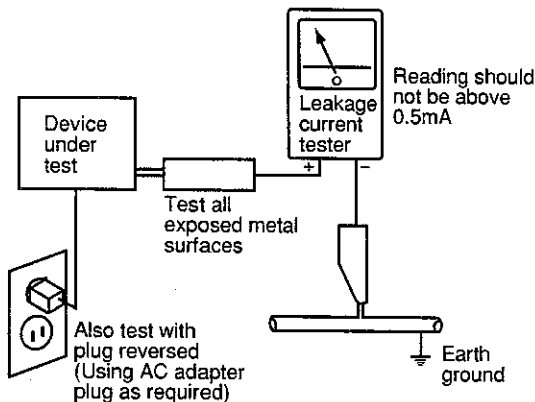

AC Leakage Test

ANY MEASUREMENTS NOT WITHIN THE LIMITS OUTLINED ABOVE ARE INDICATIVE OF A POTENTIAL SHOCK HAZARD AND MUST BE CORRECTED BEFORE RETURNING THE APPLIANCE TO THE CUSTOMER.

2. PRODUCT SAFETY NOTICE

Many electrical and mechanical parts in the appliance have special safety related characteristics. These are often not evident from visual inspection nor the protection afforded by them necessarily can be obtained by using replacement components rated for voltage, wattage, etc. Replacement parts which have these special safety characteristics are identified in this Service Manual.

Electrical components having such features are identified by marking with a Δ on the schematics and on the parts list in this Service Manual.

The use of a substitute replacement component which does not have the same safety characteristics as the PIONEER recommended replacement one, shown in the parts list in this Service Manual, may create shock, fire, or other hazards.

Product Safety is continuously under review and new instructions are issued from time to time. For the latest information, always consult the current PIONEER Service Manual. A subscription to, or additional copies of, PIONEER Service Manual may be obtained at a nominal charge from PIONEER.

<p>— IMPORTANT —</p> <p>THIS PIONEER APPARATUS CONTAINS LASER OF CLASS 1. SERVICING OPERATION OF THE APPARATUS SHOULD BE DONE BY A SPECIALLY INSTRUCTED PERSON.</p>	<p>— LASER DIODE CHARACTERISTICS —</p> <p>MAXIMUM OUTPUT POWER: 5 mW WAVELENGTH: 780 – 785 nm</p>
---	---

LABEL CHECK (for WY and TL types)

<p>VARO!</p> <p>Avettaessa ja suojauslaitus ohitettessa olet silttina näkyvällä laserlähtöyksillä. Älä katso suoraan.</p> <p>VAROING!</p> <p>Osynlig laserstrålning när denna del är öppnad och spärren är urkopplad. Betrakta ej strålen.</p> <p style="text-align: right;">YRW1297-A</p>	<p>ADVARSEL</p> <p>USYNLIG LASERSTRÅLING VED ÅBNING NÅR SIKKERHED SAF-BRYDERE ER UDE AF FUNKTION. UNDGÅ UDSÆTTELSE FOR STRÅLING.</p> <p>VORSICHT!</p> <p>UNSICHTBARE LASER-STRÄHLUNG TRITT AUS, WENN DECKEL (ODER KLAPPE) GEÖFFNET IST! NICHT DEM STRAHL AUSSETZEN!</p> <p style="text-align: right;">YRW1094</p>
--	---

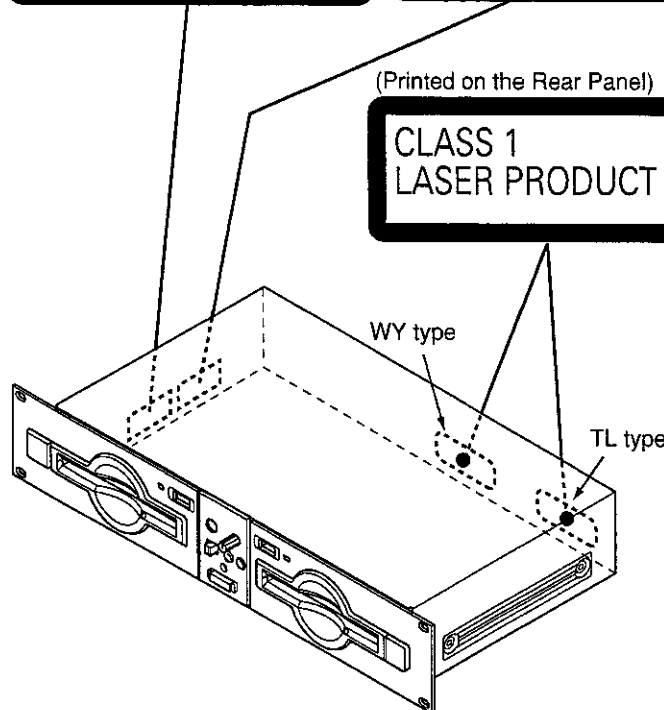

Additional Laser Caution

1. Laser Interlock Mechanism

The position of the switch (S1) for detecting loading completion is detected by the system microprocessor, and the design prevents laser diode oscillation when the switch is not in $\overline{LPS1}$ terminal side (when the mechanism is not clamped and $\overline{LPS1}$ signal is high level.) Thus, the interlock will no longer function if the switch is deliberately set to $\overline{LPS1}$ terminal side. (If $\overline{LPS1}$ signal is low level).

In the test mode* the interlock mechanism will not function. Laser diode oscillation will continue, if pin 2 of AN8847SB (IC201) on the CDPB Assy is connected to GND, or pin 19 of IC201 (\overline{LDON}) is connected to low level (ON), or else the terminals of Q201 are shorted to each other (fault condition).

2. When the cover is opened, close viewing of the objective lens with the naked eye will cause exposure to a Class 1 laser beam.

* : Refer to page 69.

CMX-5000, CU-V160

2. EXPLODED VIEWS AND PARTS LIST

- NOTES:
- Parts marked by "NSP" are generally unavailable because they are not in our Master Spare Parts List.
 - The Δ mark found on some component parts indicates the importance of the safety factor of the part. Therefore, when replacing, be sure to use parts of identical designation.
 - Screws adjacent to \blacktriangledown mark on the product are used for disassembly.

2.1 PACKING

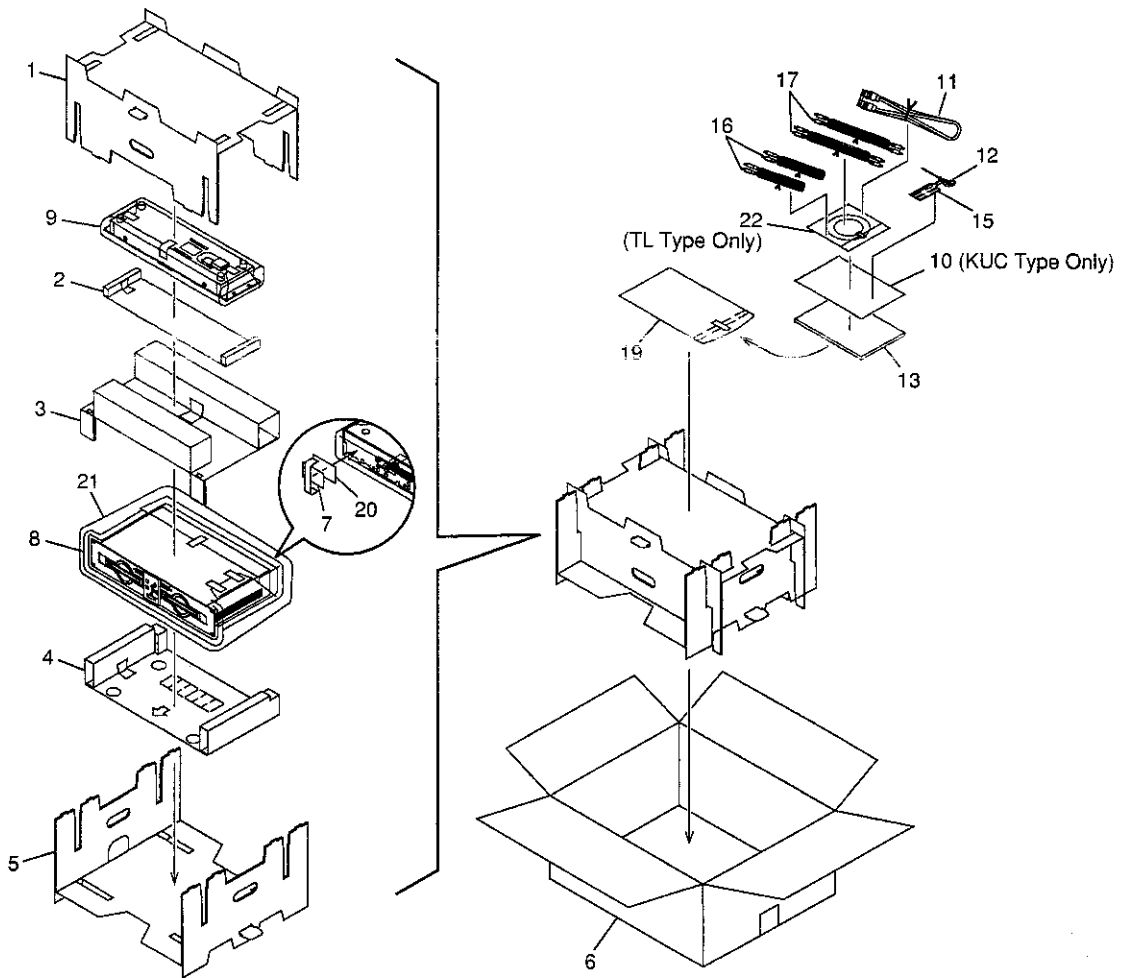

(1) PACKING PARTS LIST

Mark	No.	Description	Part No.
	1	Pad A	DHA1448
	2	Pad B	DHA1449
	3	Pad C	DHA1450
	4	Pad D	DHA1451
	5	Pad E	DHA1474
NSP	6	Packing Case	See Contrast table (2)
	7	Caution SG	DRM1199
	8	Sheet	RHX1006
	9	Mirror Mat Sheet (550 × 550 × 0.5)	Z23-026
NSP	10	Limited Warranty	See Contrast table (2)
	11	Specialized Connection Cable for The Remote Controller	DDE1115
	12	Forced Ejection Pin	DEX1013
	13	Operating Instructions	See Contrast table (2)
	14	*****	
	15	Caution Tag AP	DRW1897
	16	Control Cord	PDE1247
	17	Audio Cable (L=1.5m)	VDE1033
	18	*****	
	19	Polyethylene Bag (0.03 × 230 × 340)	Z21-038
NSP	20	Silica Gel	AEN7001
NSP	21	Polyethylene Bag	AHG7047
	22	Adaptor for 8cm discs	See Contrast table (2)

(2) CONTRAST TABLE

CMX-5000/KUC, TL and WY are constructed the same except for the following :

Mark	No.	Symbol and Description	Part No.			Remarks
			KUC Type	TL Type	WY Type	
NSP	6	Packing Case	DHG1961	DHG1960	DHG1953	
	10	Limited Warranty	ARY7043	Not used	Not used	
	13	Operating Instructions (English)	DRB1254	Not used	Not used	
	13	Operating Instructions (English/Spanish/Chinese)	Not used	DRB1256	Not used	
	13	Operating Instructions (English/French/German/Italian/Dutch/Spanish)	Not used	Not used	DRB1255	
	22	Adaptor for 8cm discs	Not used	DEX1012	Not used	

CMX-5000, CU-V160

2.2 EXTERIOR

A PLAYER

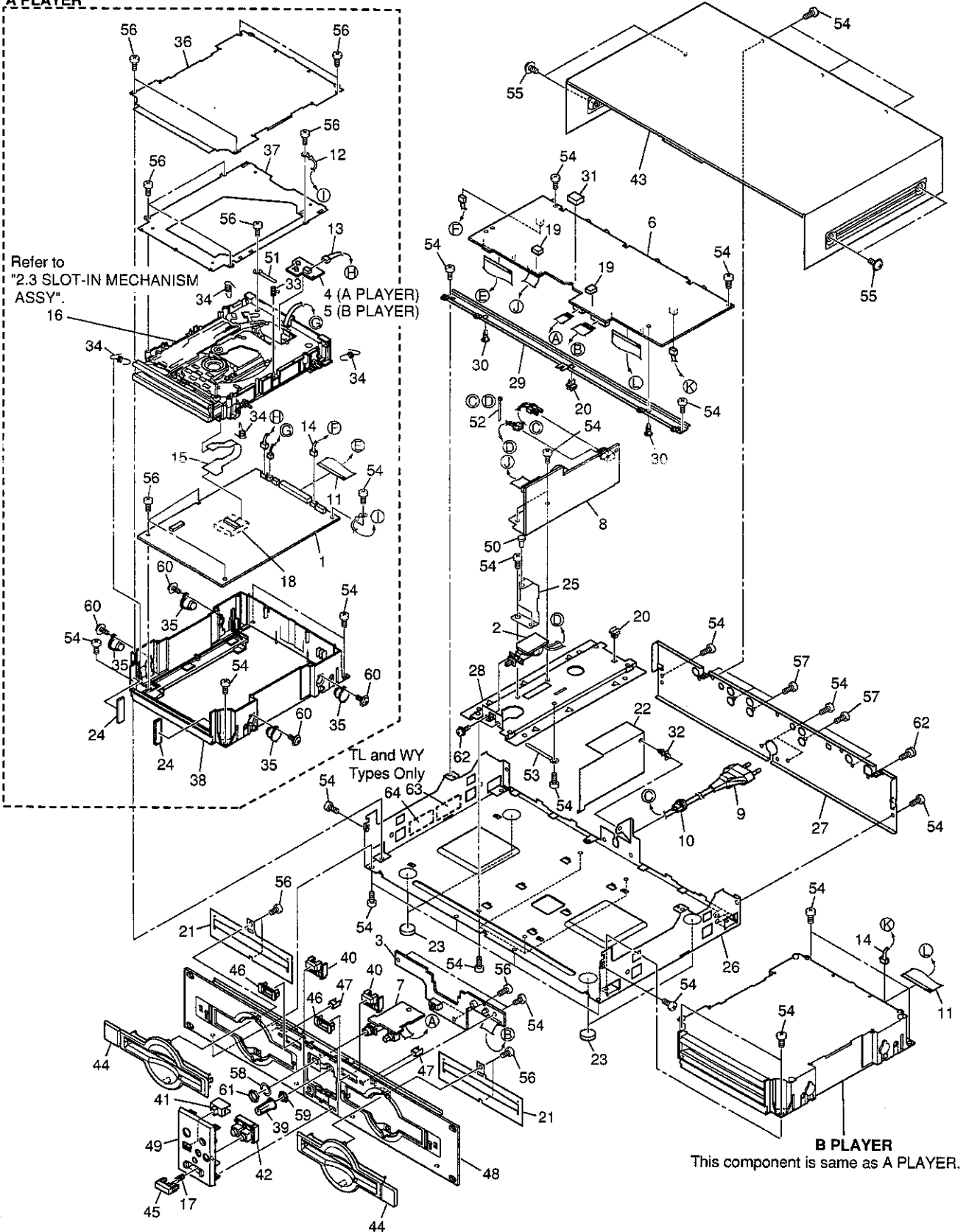

CMX-5000, CU-V160

(1) EXTERIOR PARTS LIST

Mark	No.	Description	Part No.	Mark	No.	Description	Part No.
	1	CDPB ASSY	DWG1540	NSP	31	Spacer	VEC1585
	2	PSWB ASSY	DWS1301		32	PCB Spacer	VEC2077
	3	SELB ASSY	DWS1302		33	Earth Spring	DBH1398
	4	SLM1 ASSY	DWS1303		34	Float Spring	DBH1428
	5	SLM2 ASSY	DWS1304		35	Damper	DEC2236
	6	TRMB ASSY	DWX2066		36	Cover A	DNF1636
	7	HPJB ASSY	DWX2067		37	Mecha Holder	DNH2339
△	8	SW POWER SUPPLY ASSY	DWR1330		38	Damper Stay	DNK3751
△	9	AC Power Cord	See Contrast table (2)		39	VR Knob	DAA1145
	10	Strain Relief	See Contrast table (2)		40	Eject Knob	DAC1924
	11	37P F•F•C/60V	DDD1159		41	Slide SW Knob	DAC1926
	12	Earth Lead Unit	DDF1010		42	Monitor Select Knob	DAC1939
	13	SL Connecto Assy 3P	DKP3403		43	Bonnet	DNE1382
	14	Connector Assy 3P	DKP3514		44	Front Bezel	DNK3724
	15	S Flexible Cable	DNP1748		45	Power Knob	DNK3725
NSP	16	Slot-in Mechanism Assy	DXA1845		46	Eject Guide	DNK3727
	17	Power Knob Spring	DBH1469		47	Disc Indicator	DNK3729
	18	Silicon Seat	DEB1449		48	Front Panel Assy	DXB1729
	19	Rubber Spacer	DEB1455		49	Function Panel Assy	DXB1732
	20	PCB Holder	DEC1231		50	Nylon Rivet (3 × 4.5)	RBM-003
	21	Bezel Sheet	DEC2346		51	Cord Clamper	RNH-184
	22	Power Supply Cover	DEC2347		52	Binder	ZCA-SKB90BK
	23	Insulator	DEC2348	NSP	53	Cord Stopper	ZCB-069Z
	24	Bezel Cushion C	DEC2350		54	Screw	BBZ30P060FZK
	25	Power Supply Shield	DEC2391		55	Screw	BBZ40P060FZK
NSP	26	Chassis	DNA1253		56	Screw	BPZ30P080FMC
	27	Rear Panel	See Contrast table (2)		57	Screw	BPZ30P080FZK
	28	Power Supply Plate	DNF1637		58	Washer	DBE1010
	29	PCB Frame	DNH2446		59	Flange Nut	DBN1004
NSP	30	PCB Holder	PNW1861		60	Screw	IPZ20P080FMC
					61	Nut	NKX2FLJC
					62	Screw	PMH30P060FMC
					63	Caution Label	See Contrast table (2)
				NSP	64	Caution Label HE	See Contrast table (2)

(2) CONTRAST TABLE

CMX-5000/KUC, TL and WY are constructed the same except for the following :

Mark	No.	Symbol and Description	Part No.			Remarks
			KUC Type	TL Type	WY Type	
△	9	AC Power Cord	ADG7024	VDG1061	VDG1061	
	10	Strain Relief	CM-22C	CM-22B	CM-22B	
	27	Rear Panel	DNC1520	DNC1519	DNC1516	
	63	Caution Label	Not used	VRW1094	VRW1094	
NSP	64	Caution Label HE	Not used	VRW1297	VRW1297	

CMX-5000, CU-V160

2.3 SLOT-IN MECHANISM ASSY

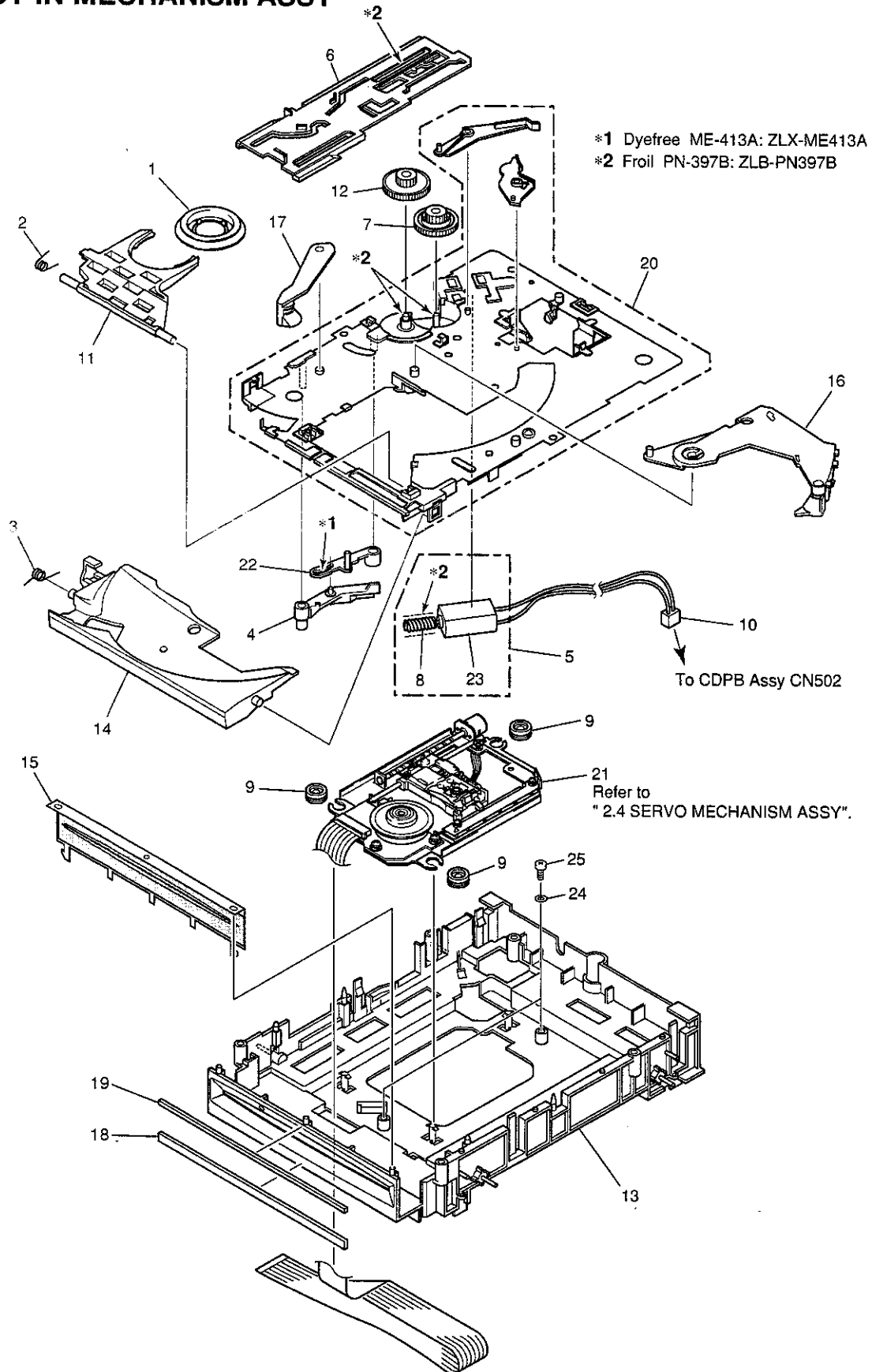

● SLOT-IN MECHANISM ASSY PARTS LIST

Mark No.	Description	Part No.	Mark No.	Description	Part No.
1	Clamper Assy	DXA1821	11	Clamp Arm	DNK3404
2	Clamp Spring	DBH1374	12	Drive Gear	DNK3565
3	Guide Spring	DBH1375	13	Float Base Assy	DXB1683
4	Lever B	DNK3558	14	Disc Guide	DNK3478
5	Loading Motor Assy-S	DEA1008	15	Front Sheet	DED1132
6	Main Cam	DNK3407	16	Eject Lever	DNK3684
7	Loading Gear	DNK3409	17	Loading Lever	DNK3406
8	Worm Gear	DNK3410	18	Bezel Cushion A	DEC2257
9	Mount Bush	DEB1328	19	Bezel Cushion B	DEC2258
10	Connector Assy	PF02PY-B27	20	Loading Base	DNK3637
			21	Servo Mechanism Assy	DXB1684
			22	Lever A	DNK3564
			23	Loading Motor	DXM1093
			24	PC Washer	DEC2332
			25	Screw	BPZ30P080FZK

2.4 SERVO MECHANISM ASSY

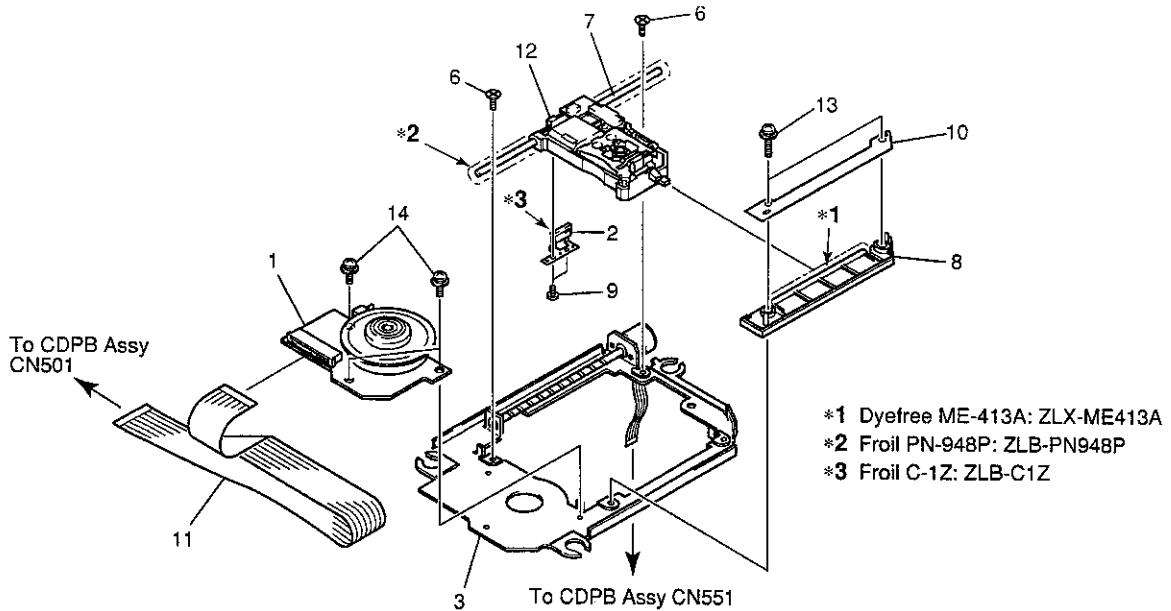

● SERVO MECHANISM ASSY PARTS LIST

Mark No.	Description	Part No.	Mark No.	Description	Part No.
1	Spindle Motor	DXM1122	11	SPD Card	DDX1165
2	Screw Guide	DNK3238	12	Pickup Assy	DWY1069
3	Pulse Motor Frame	DXM1125	13	Screw	PMA20P080FMC
4		14	Screw	PMH20P040FMC
5				
6	Screw	CMZ20P060FMC			
7	Guide Shaft	DLA1731			
8	Sub Guide Shaft	DNK3638			
9	Screw	ABA7022			
10	Stopper	DNH2355			

CMX-5000, CU-V160

2.5 REMOTE CONTROLLER (CU-V160)

*1 Grease PN-92KB
Check that the JOG dial moves smoothly after a small quantity put grease on.

Do not use the alcohol when cleans a JOG dial because acrylic section clouds over.

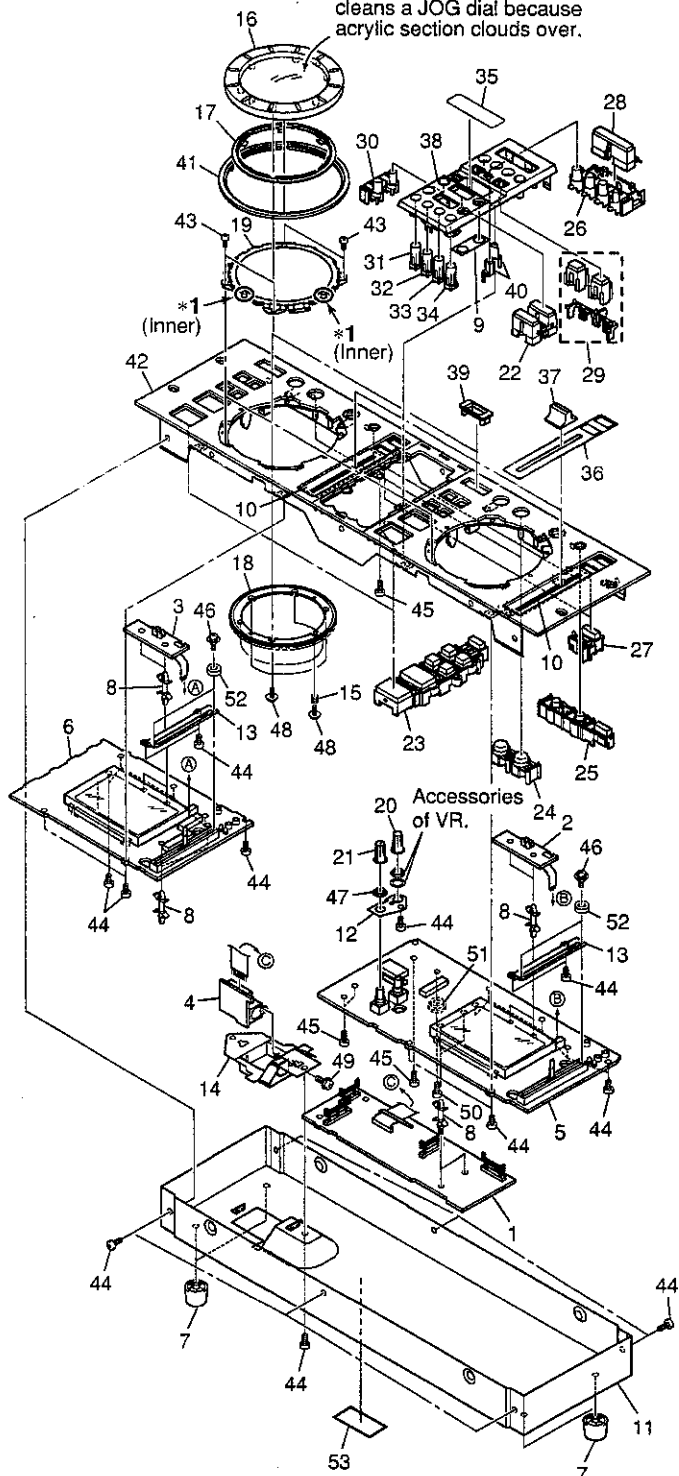

(1) REMOTE CONTROLLER (CU-V160) PARTS LIST

Mark	No.	Description	Part No.
	1	CNNB ASSY	DWG1534
	2	PHT1 ASSY	DWG1535
	3	PHT2 ASSY	DWG1536
	4	CTJB ASSY	DWG1537
	5	FLK1 ASSY	DWG1538
	6	FLK2 ASSY	DWG1539
	7	Foot Assy	AEC1531
	8	PCB Spacer (10)	DEC1388
	9	Rotary VR Packing	DED1151
	10	Slide VR Packing	DED1154
	11	Cover	DNE1383
	12	VR Stay	DNF1635
	13	VR Holder	DNF1638
	14	Terminal Holder	DNH2448
	15	Jog Spring	DBH1460
	16	Jog Dial	DNK3797
	17	J Ring A	DNK3723
	18	J Ring B	DNK3732
	19	Jog Stay Assy	DXB1727
	20	BPM Knob	DAA1144
	21	VR Knob	DAA1145
	22	BPM Knob	DAC1925
	23	Knob (PLAY)	DAC1927
	24	Knob (LOOP)	DAC1928
	25	Knob (TEMPO)	DAC1929
	26	Mode Select Knob	DAC1930
	27	MT Knob	DAC1931
	28	MIX Knob	DAC1932
	29	Player Select Knob	DAC1933
	30	Start Knob	DAC1934
	31	Knob A	DAC1935
	32	Knob B	DAC1936
	33	Knob C	DAC1937
	34	Knob D	DAC1938
	35	Display Plate	DAH1937
	36	Slide Sheet	DAH1938
	37	Slide Knob	DNK2936
	38	Function Panel (C)	DNK3726
	39	Eject Guide	DNK3727
	40	Lens	DNK3730
	41	Jog Guard	DNK3731
	42	Control Panel Assy	DXB1728
	43	Screw	BBZ26P060FMC
	44	Screw	BBZ30P060FZK
	45	Screw	BPZ30P080FMC
	46	Screw	PMB20P060FMC
	47	Flange Nut M9	DBN1004
	48	Screw	PBA1062
	49	Screw	PMH30P060FMC
	50	Screw	BPZ30P120FCU
	51	POM Bush	DEC2397
	52	Spacer	DLA1801
	53	Label	See Contrast table (2)

(2) CONTRAST TABLE

CMX-5000/KUC, TL and WY are constructed the same except for the following :

Mark	No.	Symbol and Description	Part No.			Remarks
			KUC Type	TL Type	WY Type	
	53	Label	DAL1134	DAL1134	DAL1135	

3. BLOCK DIAGRAM AND SCHEMATIC DIAGRAM

3.1 BLOCK DIAGRAM

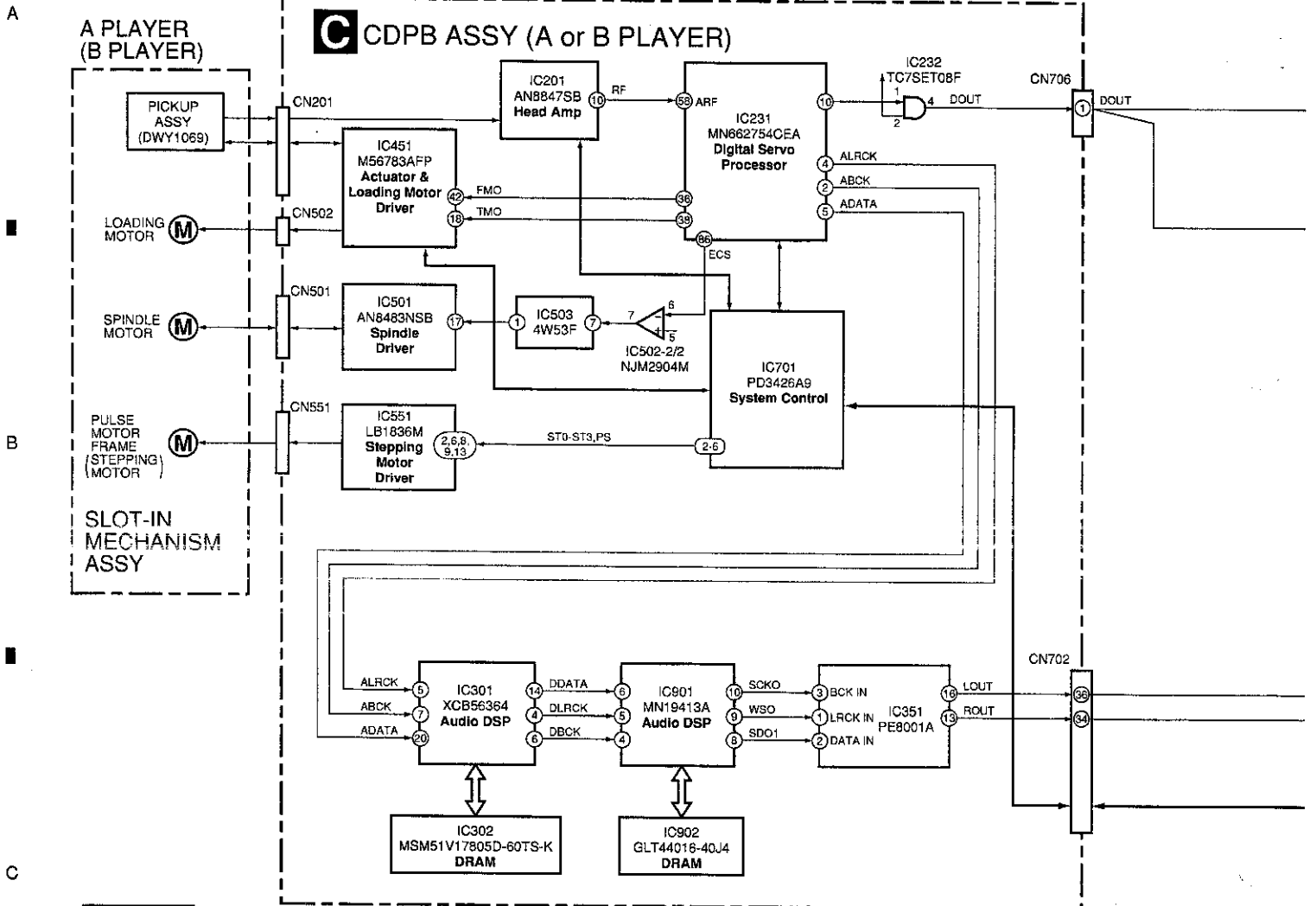

Player

Remote Controller

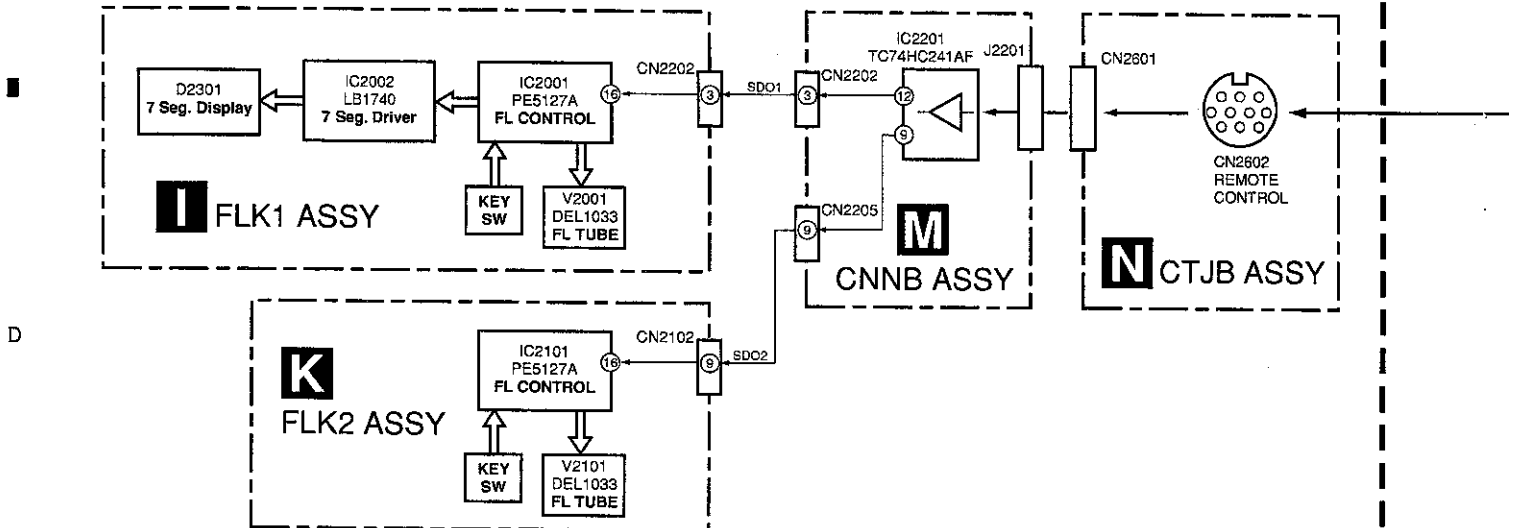

CMX-5000, CU-V160

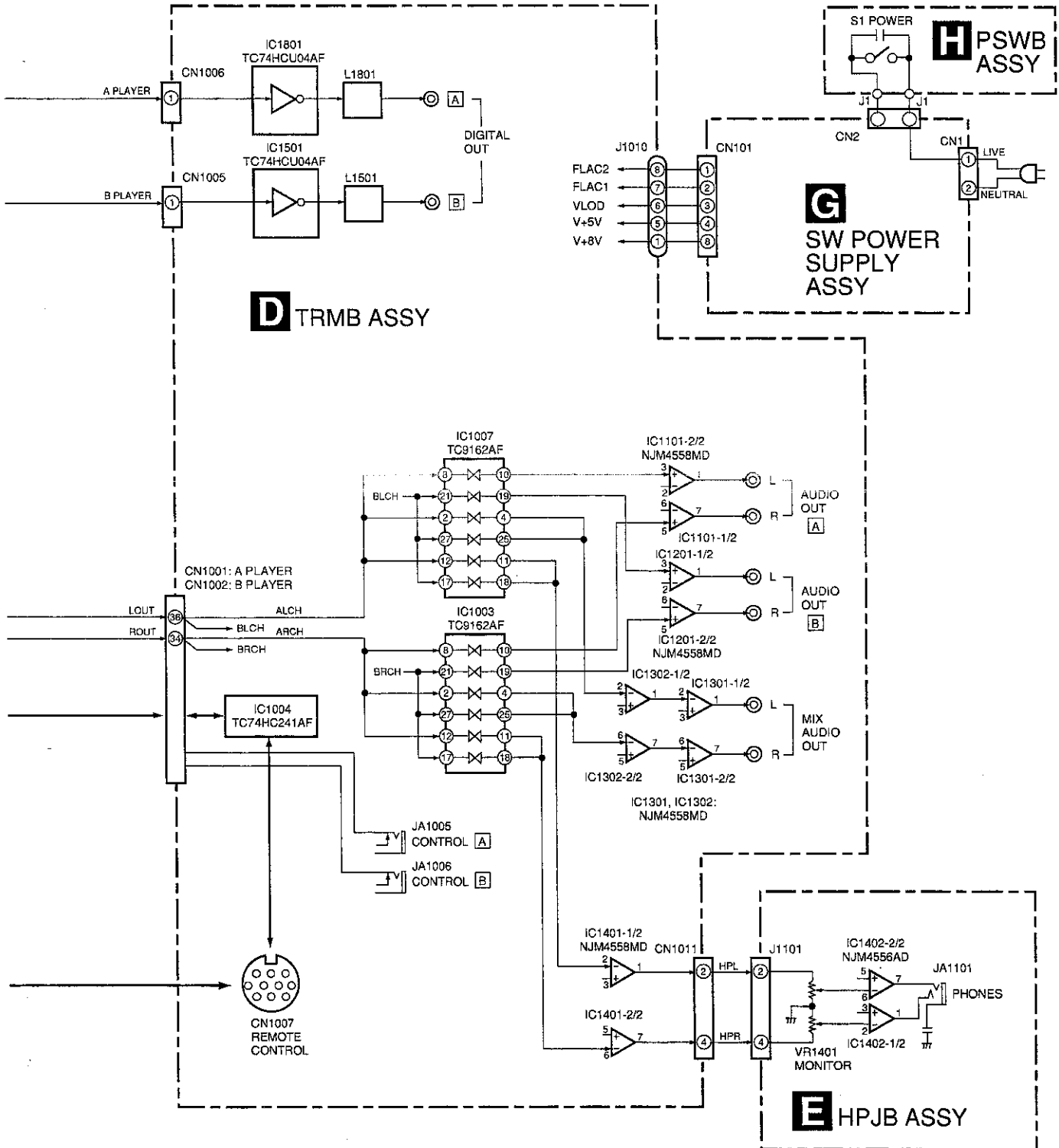

CMX-5000, CU-V160

3.2 OVERALL WIRING DIAGRAM, SLM1 and SLM2 ASSYS

A

B

C

D

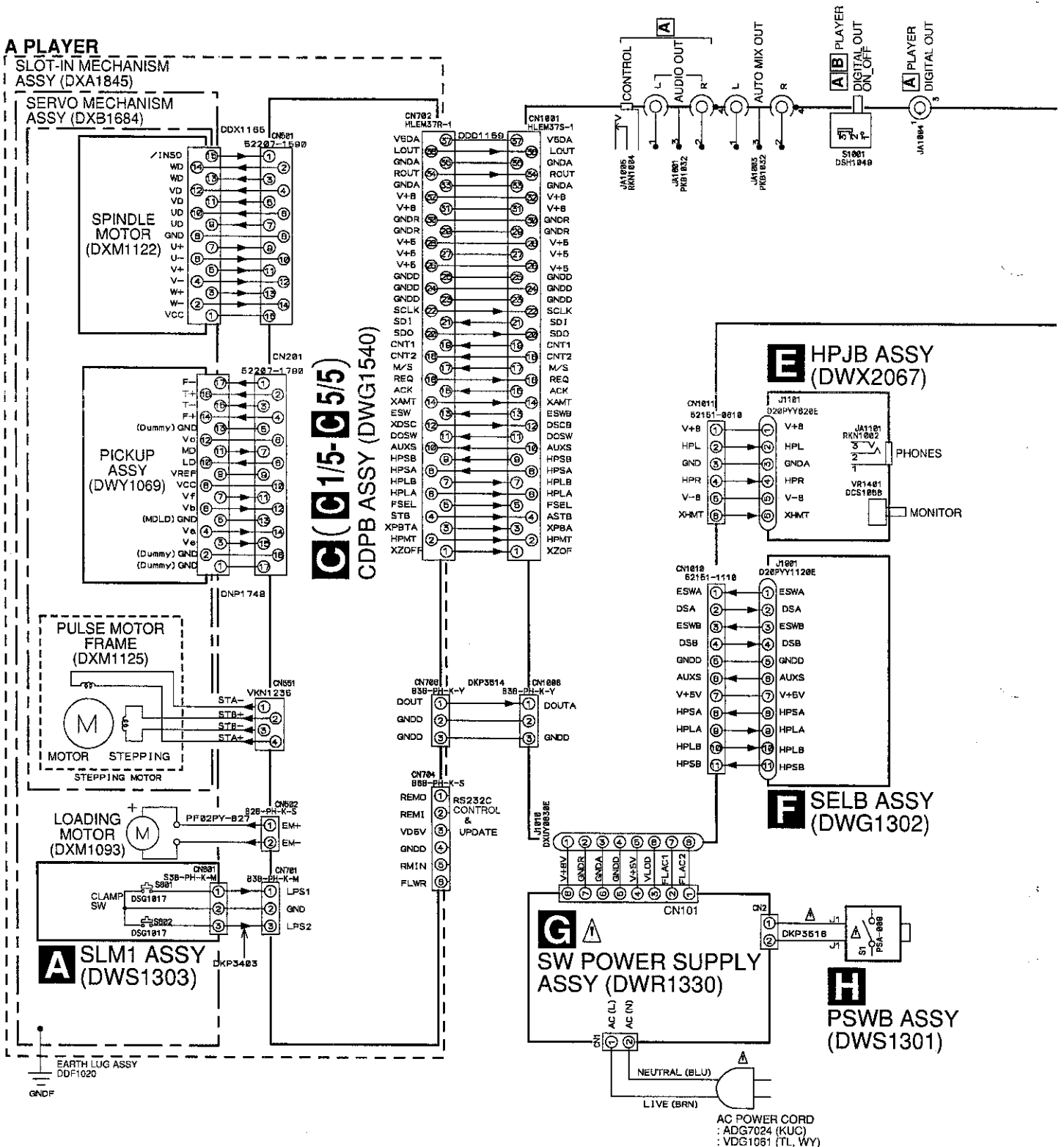

CMX-5000, CU-V160

Note : When ordering service parts, be sure to refer to "EXPLODED VIEWS and PARTS LIST" or "PCB PARTS LIST".

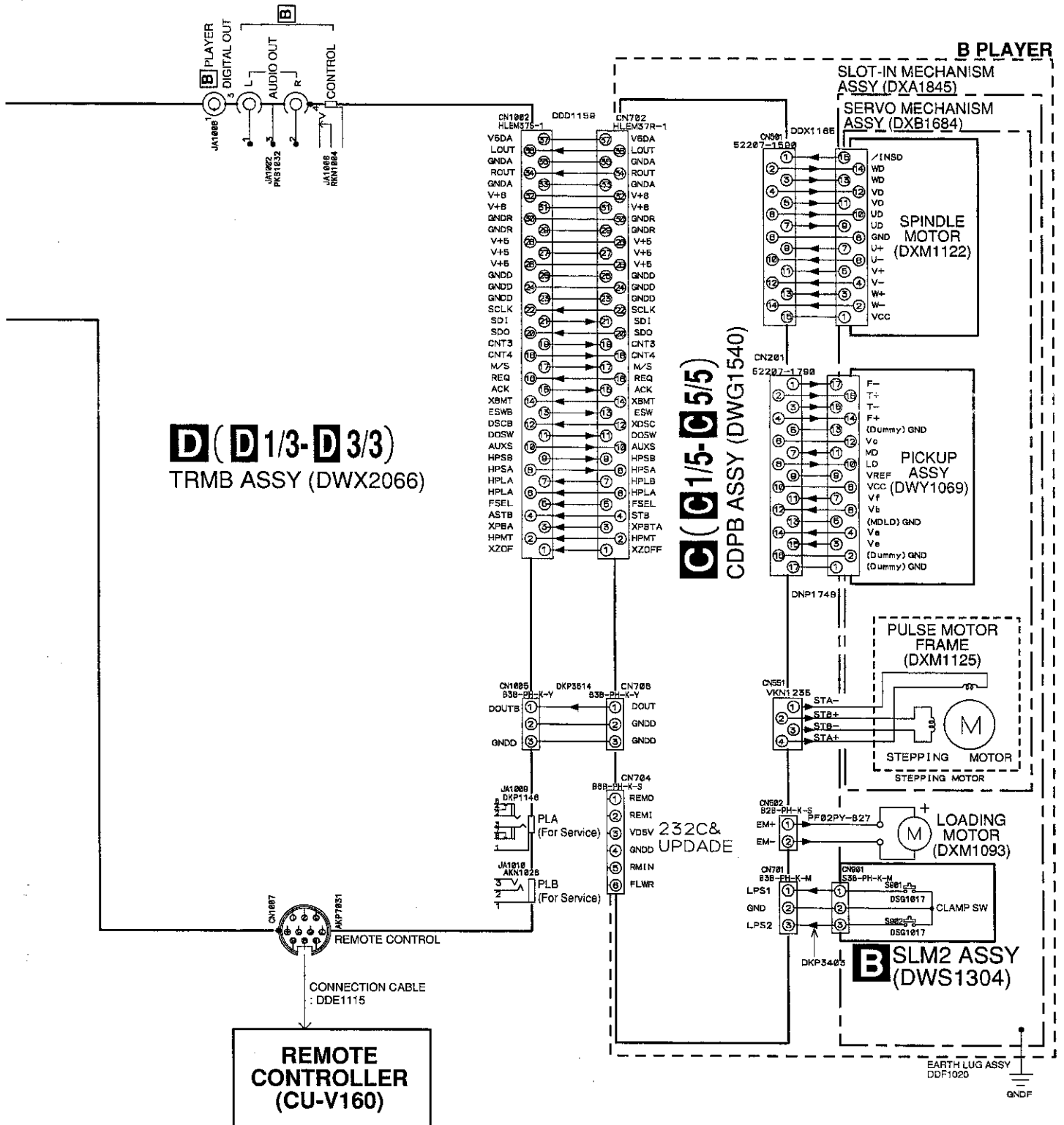

CMX-5000, CU-V160

3.3 CDPB ASSY (1/5)

C1/5 CDPB ASSY (DWG1540)

A

- A** CN801 (For A PLAYER)
- B** CN901 (For B PLAYER)
- D3/3** CN1006 (For A PLAYER)
- B** CN1005 (For B PLAYER)

B

C5/5 WFSH1

C

232C & UPDATE
 REMD (1)
 REMI (2)
 VD5V (3)
 RMIN (4)
 FLWR (5)
 GNDD (6)

GNDD2 GNDD
 232C: 3-5 short
 UPDATE: 3-5-8 short

C5/5 TSWM

D

- D2/3** CN1001 (For A PLAYER)
- D2/3** CN1002 (For B PLAYER)

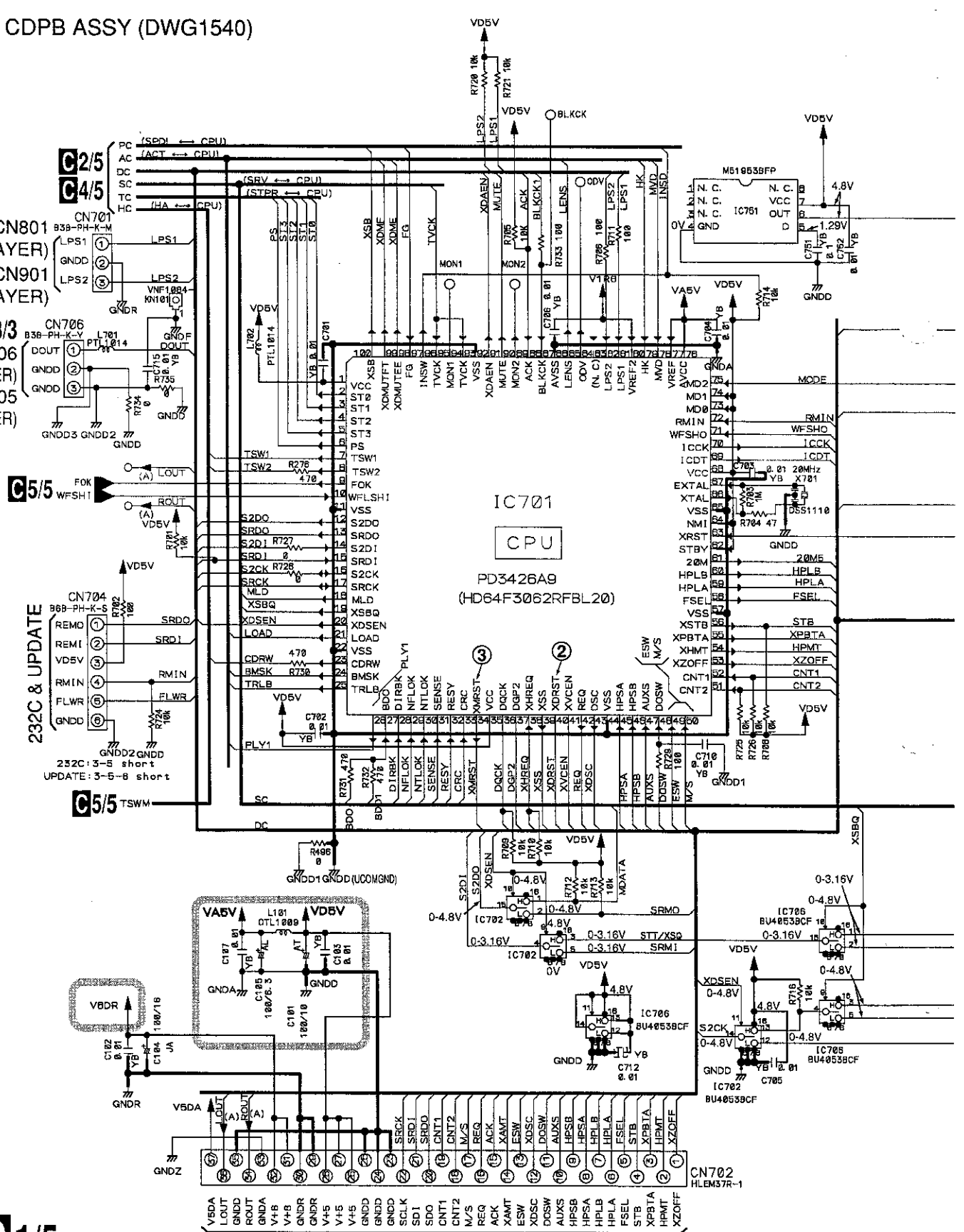

CMX-5000, CU-V160

NOTES

RESISTORS : Ω

~W~ : RS1/10S□□□

CAPACITORS : μF

YB : CKSQYB (2125 CHIP), CKSR (1608 CHIP)

CH : CCSQCH (2125 CHIP), CCSR (1608 CHIP)

□□□ : 1608 SIZE CHIP

- (F) Focus Servo Loop
- (T) Tracking Servo Loop
- (L) Loading Drive
- (RF) RF Signal
- (SP) Spindle Servo
- (A) Audio

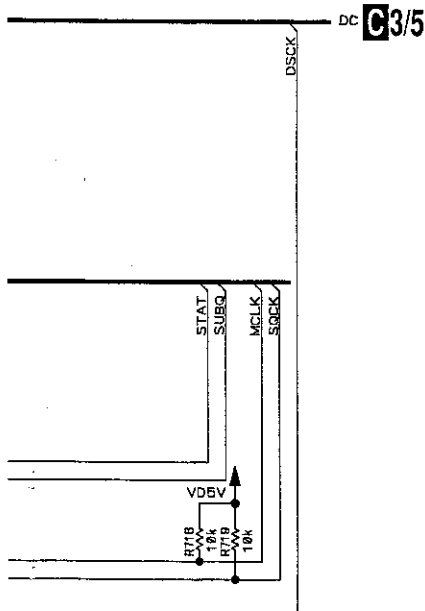
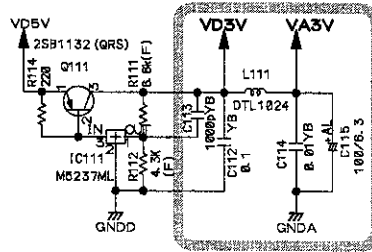
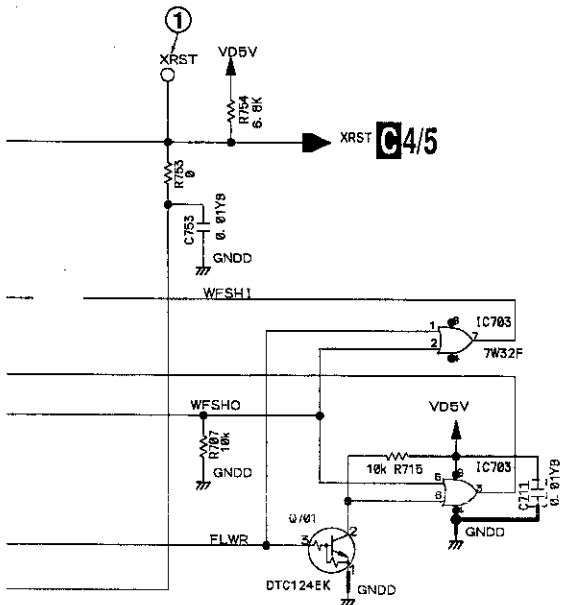

IC701

Pin No.	Voltage (V)	Pin No.	Voltage (V)	Pin No.	Voltage (V)	Pin No.	Voltage (V)
1	4.8	26	0	51	4.8	76	4.8
2	4.8	27	0	52	0	77	0
3	0 to 4.8	28	3.3	53	0	78	2.2
4	0 to 4.8	29	0	54	4.8	79	2.2
5	4.8	30	0 to 3.3	55	0 to 4.8	80	2.2
6	4.8	31	0 to 3.3	56	0	81	4.8
7	0	32	0 to 3.3	57	0	82	0 to 3.3
8	4.8	33	0 to 3.3	58	0	83	0
9	4.8	34	4.8	59	0 to 4.8	84	0
10	0	35	4.8	60	0	85	2.2
11	0	36	0	61	0 to 4.8	86	0
12	0 to 4.8	37	3.3	62	4.8	87	0 to 3.3
13	0 to 4.8	38	0	63	0	88	0 to 4.8
14	0 to 3.3	39	4.8	64	0	89	0
15	0 to 4.8	40	4.8	65	0	90	0
16	0 to 4.8	41	4.8	66	0	91	4.8
17	0 to 4.8	42	0 to 4.8	67	1.0 to 3.8	92	0
18	0 to 4.8	43	0	68	4.8	93	0
19	0 to 4.8	44	0	69	4.8	94	0
20	0 to 4.8	45	4.8	70	4.8	95	0
21	0	46	4.8	71	0	96	4.8
22	0	47	4.8	72	0	97	0 to 4.8
23	0	48	4.8	73	0	98	0
24	0 to 4.8	49	4.8	74	4.8	99	4.8
25	0	50	4.8	75	4.8	100	0

: The power supply is shown with the marked box.

1 2 3 4

CMX-5000, CU-V160

3.4 CDPB ASSY (2/5)

C2/5 CDPB ASSY (DWG1540)

A

To PICKUP ASSY

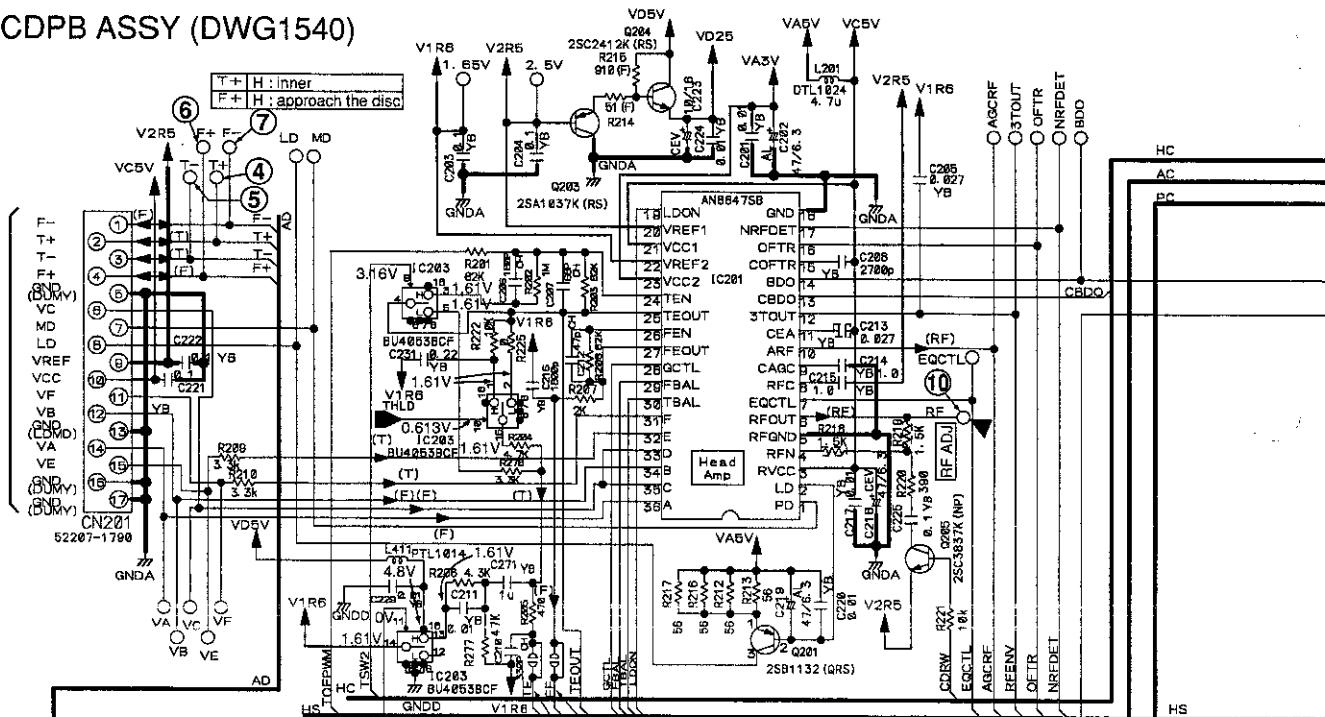

B

C

D

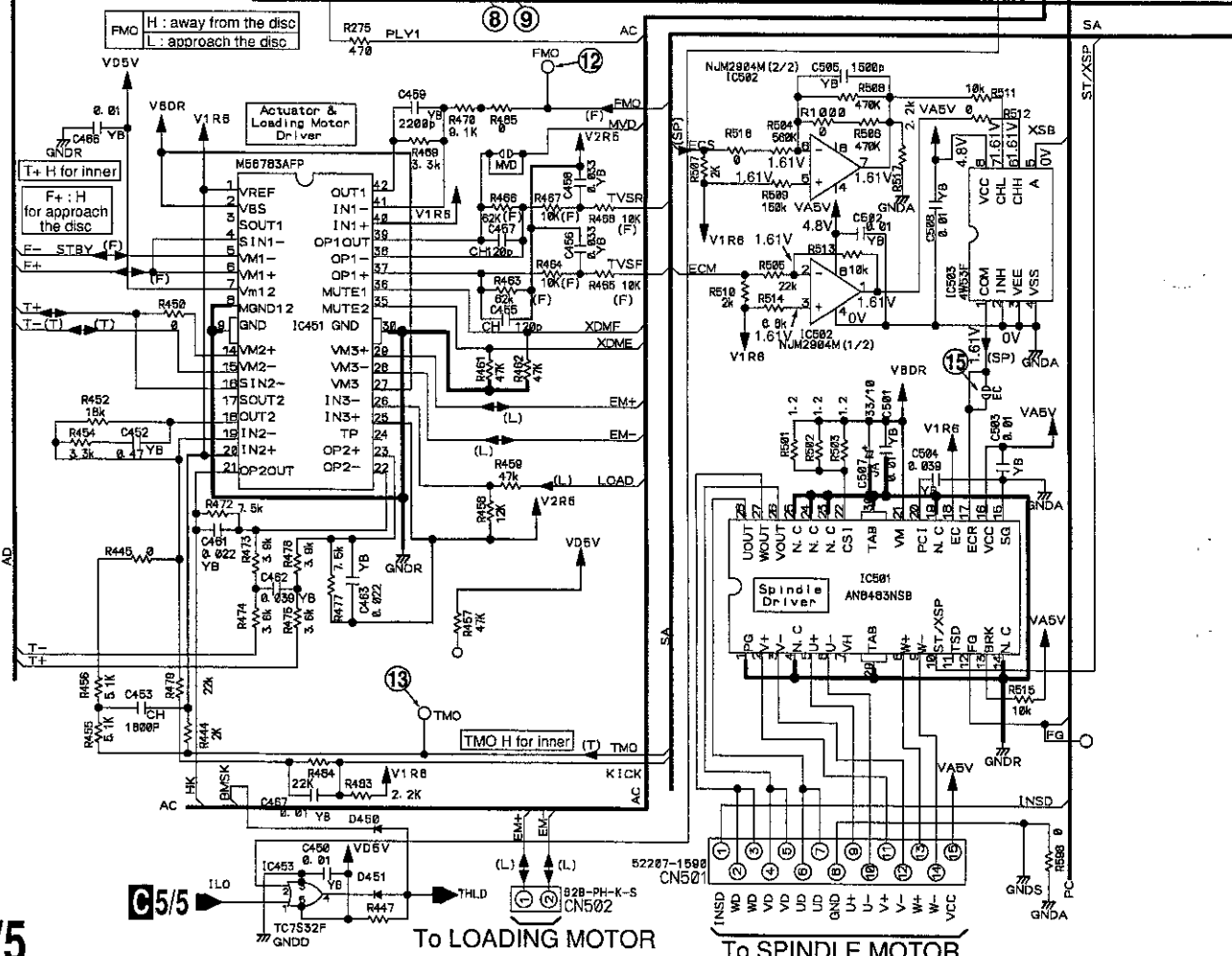

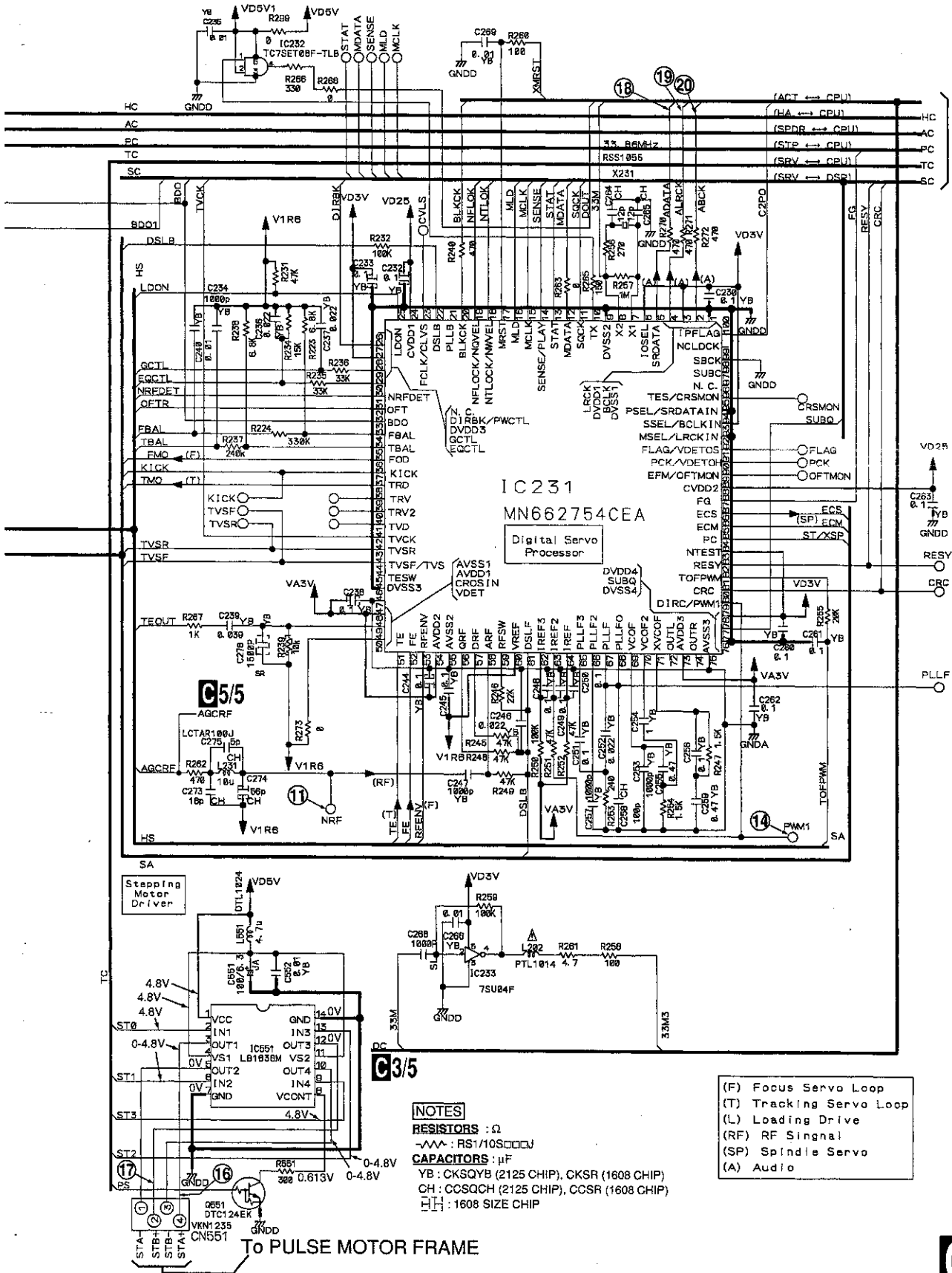

C1/5

C5/5

C3/5

NOTES

- RESISTORS : Ω
- ~: RS1/10S000Ω
- CAPACITORS : μF
- YB : CKSQYB (2125 CHIP), CKSR (1608 CHIP)
- CH : CCSQCH (2125 CHIP), CCSR (1608 CHIP)
- HH : 1608 SIZE CHIP

- (F) Focus Servo Loop
- (T) Tracking Servo Loop
- (L) Loading Drive
- (RF) RF Singnal
- (SP) Spindle Servo
- (A) Audio

To PULSE MOTOR FRAME

C2/5

CMX-5000, CU-V160

3.5 CDPB ASSY (3/5)

C3/5 CDPB ASSY (DWG1540)

A

B

C

D

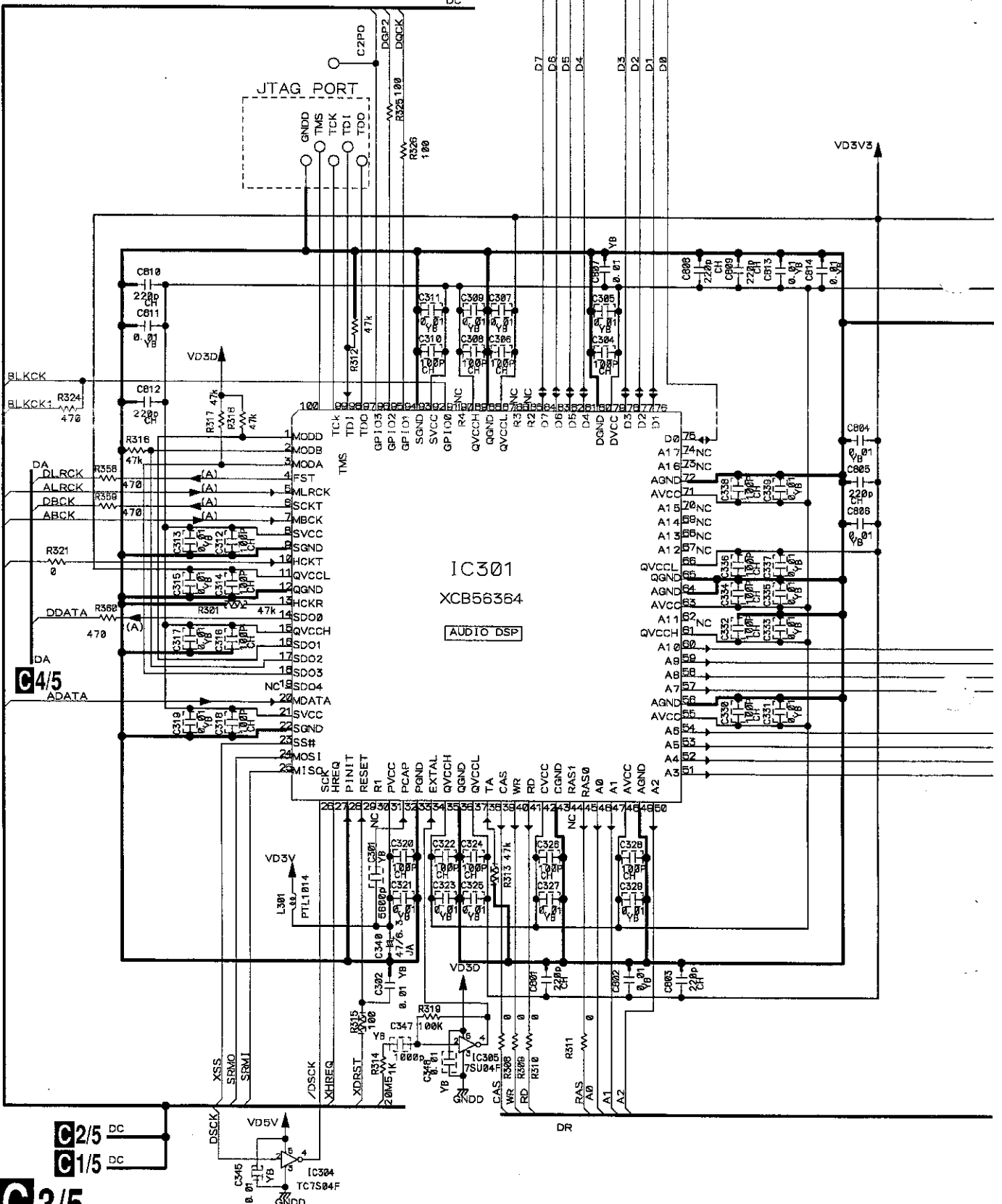

C2/5 DC

C1/5 DC

C3/5

CMX-5000, CU-V160

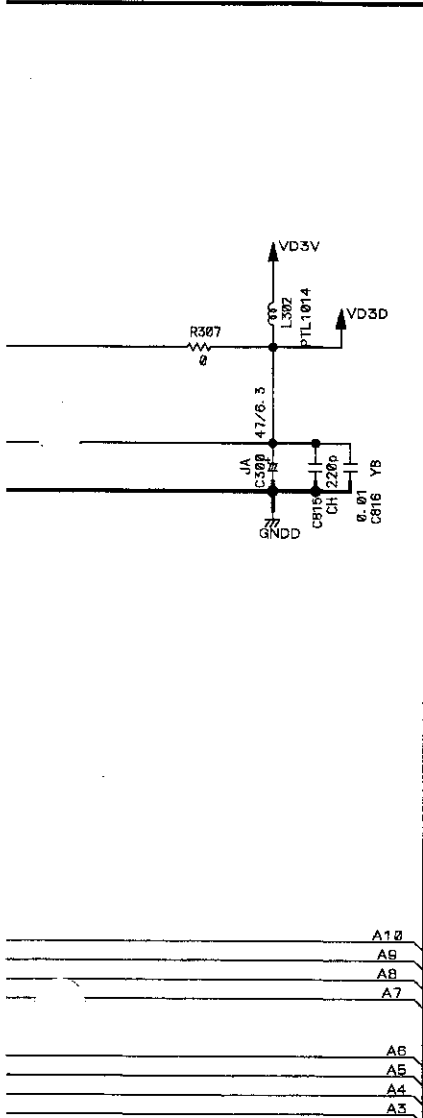

IC301

Pin No.	Voltage (V)	Pin No.	Voltage (V)	Pin No.	Voltage (V)	Pin No.	Voltage (V)
1	3.16	26	0	51	3.16	76	0
2	3.16	27	0	52	3.16	77	0
3	3.16	28	0	53	3.16	78	0
4	0 to 3.16	29	4.8	54	0	79	3.16
5	0 to 3.16	30	0	55	3.16	80	0
6	0 to 3.16	31	3.16	56	0	81	0
7	0 to 3.16	32	1.2	57	0	82	0
8	3.16	33	0	58	0	83	0
9	0	34	0.8 to 2.0	59	3.16	84	0
10	1.0 to 2.5	35	3.16	60	0	85	0
11	0	36	0	61	3.16	86	0
12	0	37	3.16	62	3.16	87	3.16
13	0	38	0	63	3.16	88	0
14	0	39	0 to 3.16	64	0	89	3.16
15	3.16	40	3.16	65	0	90	0
16	3.16	41	3.16	66	3.16	91	0 to 3.16
17	3.16	42	3.16	67	0	92	3.16
18	3.16	43	0	68	3.16	93	0
19	0 to 3.16	44	3.16	69	3.16	94	0
20	0 to 3.16	45	0 to 3.16	70	3.16	95	3.16
21	3.16	46	3.16	71	3.16	96	0
22	0	47	3.16	72	0	97	0
23	4.8	48	3.16	73	3.16	98	1.5
24	4.8	49	0	74	3.16	99	3.16
25	0	50	3.16	75	0	100	3.16

IC302

Pin No.	Voltage (V)
1	3.16
2	0
3	3.16
4	3.16
5	3.16
6	3.16
7	3.16
8	0
9	0 to 3.16
10	0 to 3.16
11	0 to 3.16
12	0 to 3.16
13	0 to 3.16
14	3.16
15	0
16	0 to 3.16
17	0 to 3.16
18	0 to 3.16
19	0 to 3.16
20	0 to 3.16
21	0 to 3.16
22	0 to 3.16
23	0 to 3.16
24	0 to 3.16
25	0 to 3.16
26	0 to 3.16
27	0 to 3.16
28	0

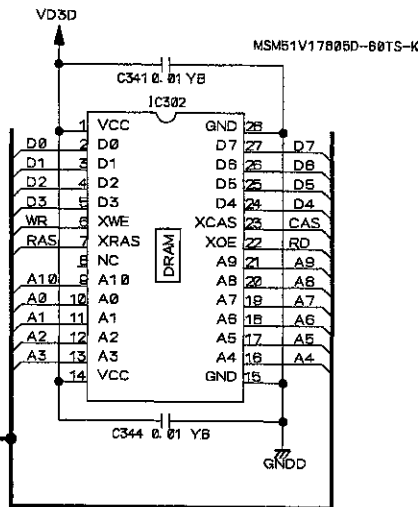
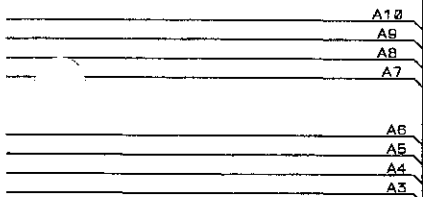

NOTES

RESISTORS : Ω
 ~~~ : RS1/10S000J  
 CAPACITORS : μF  
 YB : CKSQYB (2125 CHIP), CKSR (1608 CHIP)  
 CH : CCSQCH (2125 CHIP), CCSR (1608 CHIP)  
 □ : 1608 SIZE CHIP

- (F) Focus Servo Loop
- (T) Tracking Servo Loop
- (L) Loading Drive
- (RF) RF Signal
- (SP) Spindle Servo
- (A) Audio

1 2 3 4

# CMX-5000, CU-V160

## 3.6 CDPB ASSY (4/5)

### C 4/5 CDPB ASSY (DWG1540)

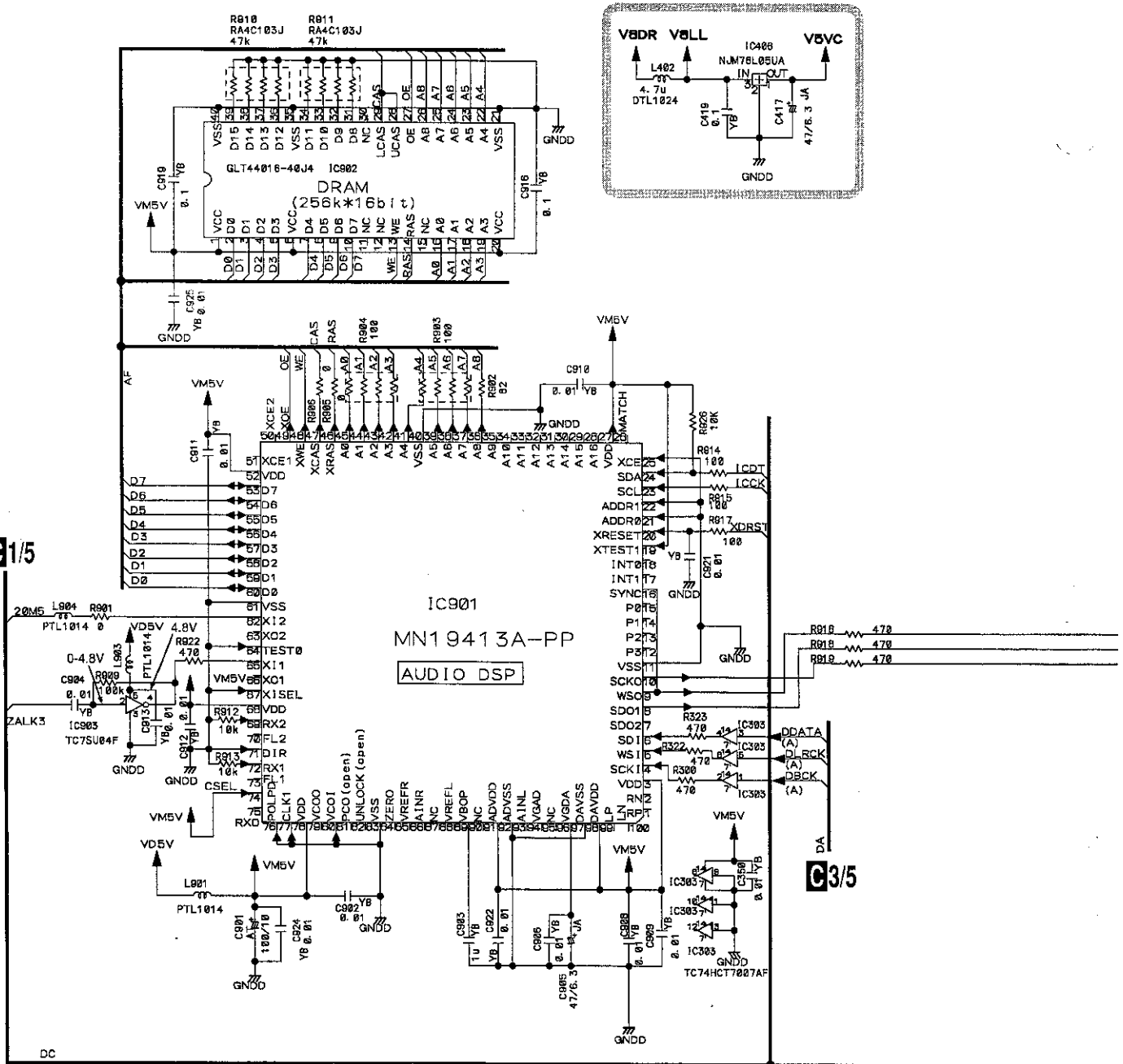

 : The power supply is shown with the marked box.

- (F) Focus Servo Loop
- (T) Tracking Servo Loop
- (L) Loading Drive
- (RF) RF Signal
- (SP) Spindle Servo
- (A) Audio

**NOTES**

**RESISTORS** :  $\Omega$

 : RS1/10S

**CAPACITORS** :  $\mu F$

YB : CKSOYB (2125 CHIP), CKSR (1608 CHIP)

CH : CCSQCH (2125 CHIP), CCSR (1608 CHIP)

 : 1608 SIZE CHIP

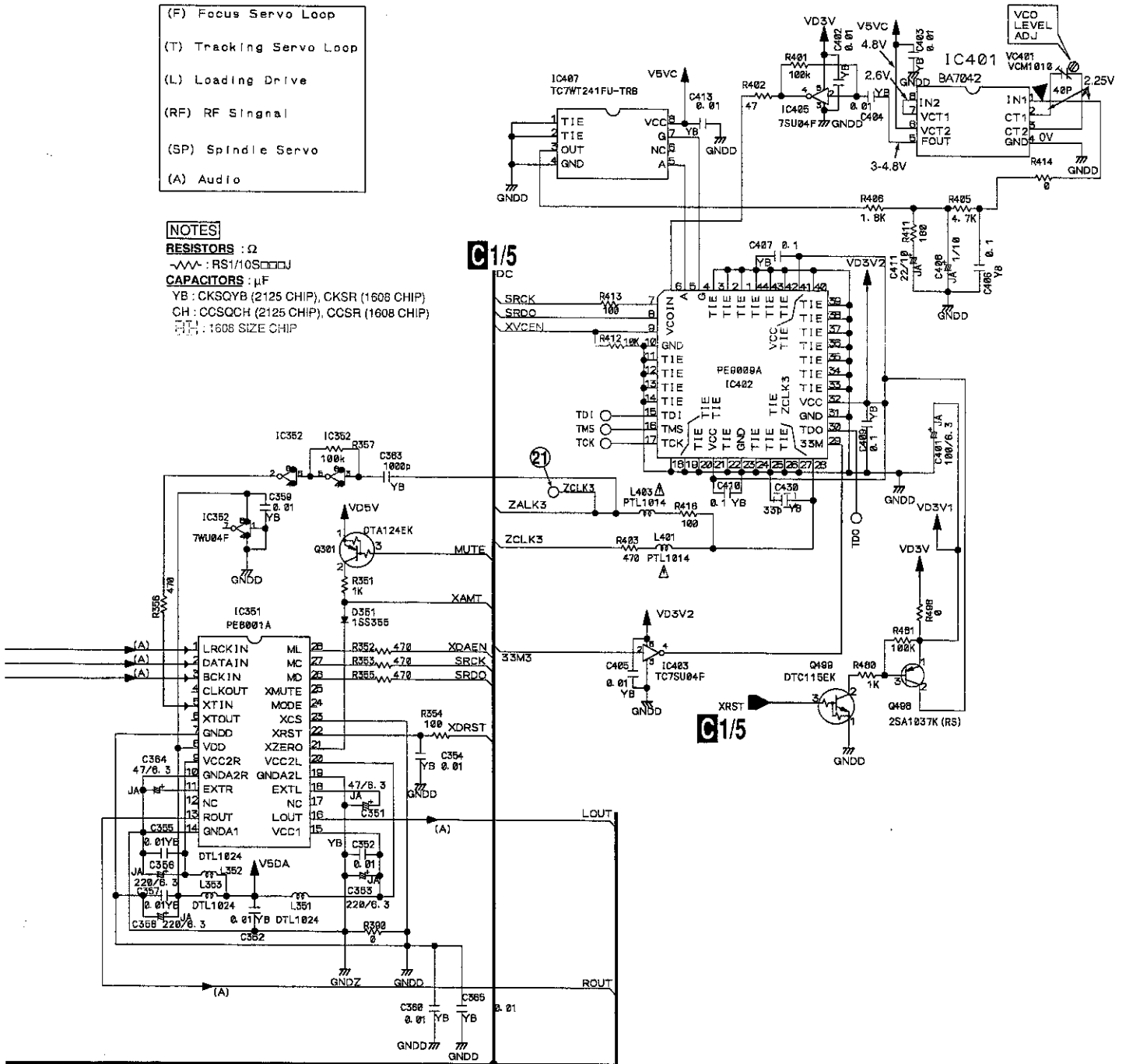

1 2 3 4

# CMX-5000, CU-V160

## 3.7 CDPB ASSY (5/5)

A **C5/5** CDPB ASSY (DWG1540)

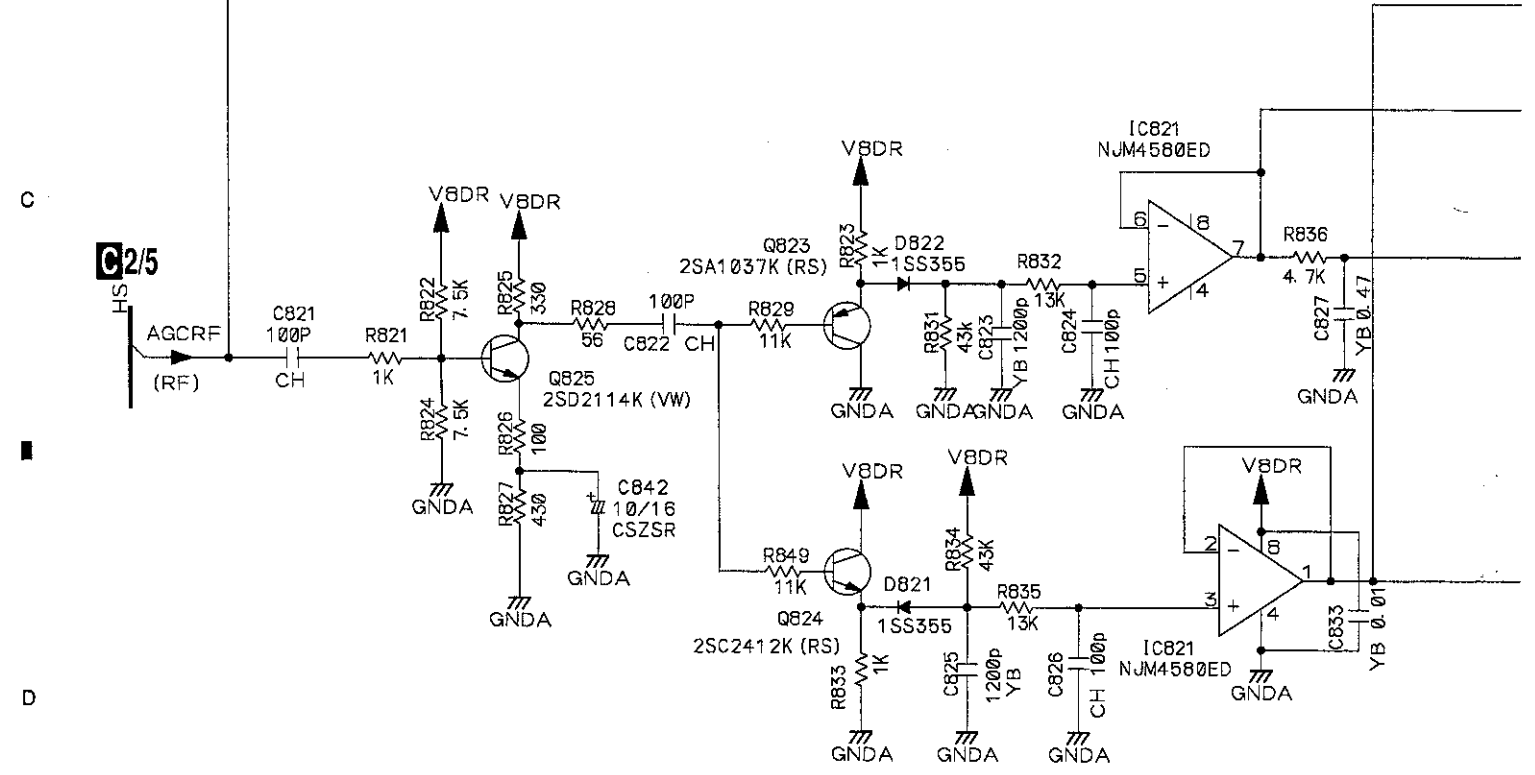
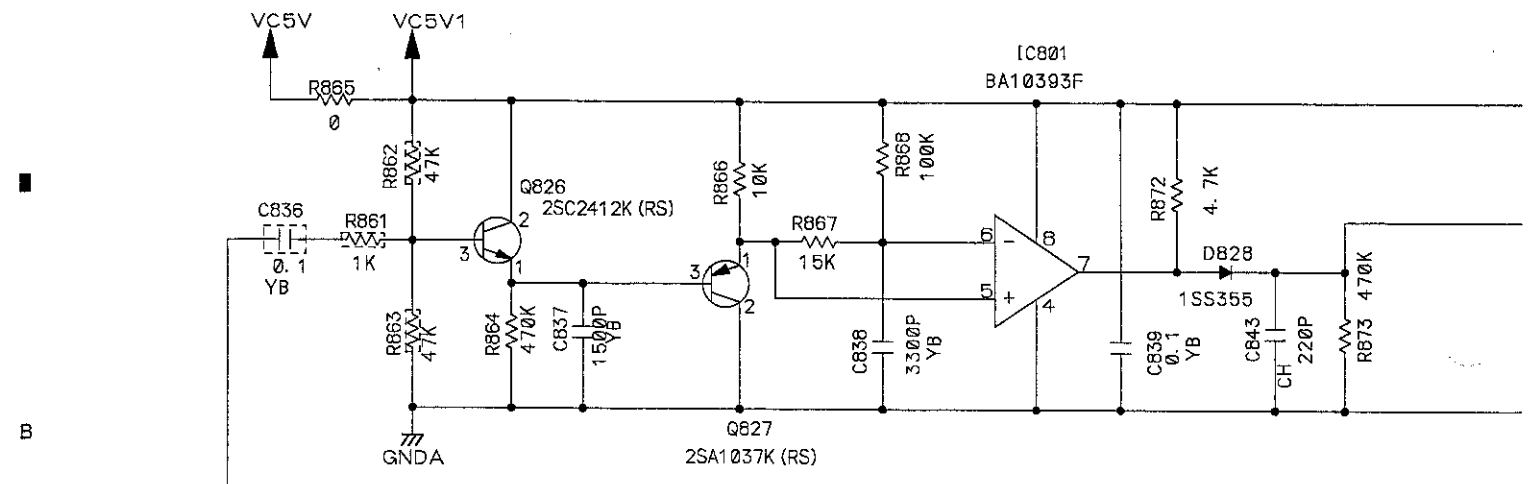



# CMX-5000, CU-V160

### NOTES

RESISTORS : Ω

RESISTORS : RS1/10S□□□□

CAPACITORS : μF

YB : CKSQYB (2125 CHIP), CKSR (1608 CHIP)

CH : CCSQCH (2125 CHIP), CCSR (1608 CHIP)

□□ : 1608 SIZE CHIP

- (F) Focus Servo Loop
- (T) Tracking Servo Loop
- (L) Loading Drive
- (RF) RF Signal
- (SP) Spindle Servo
- (A) Audio

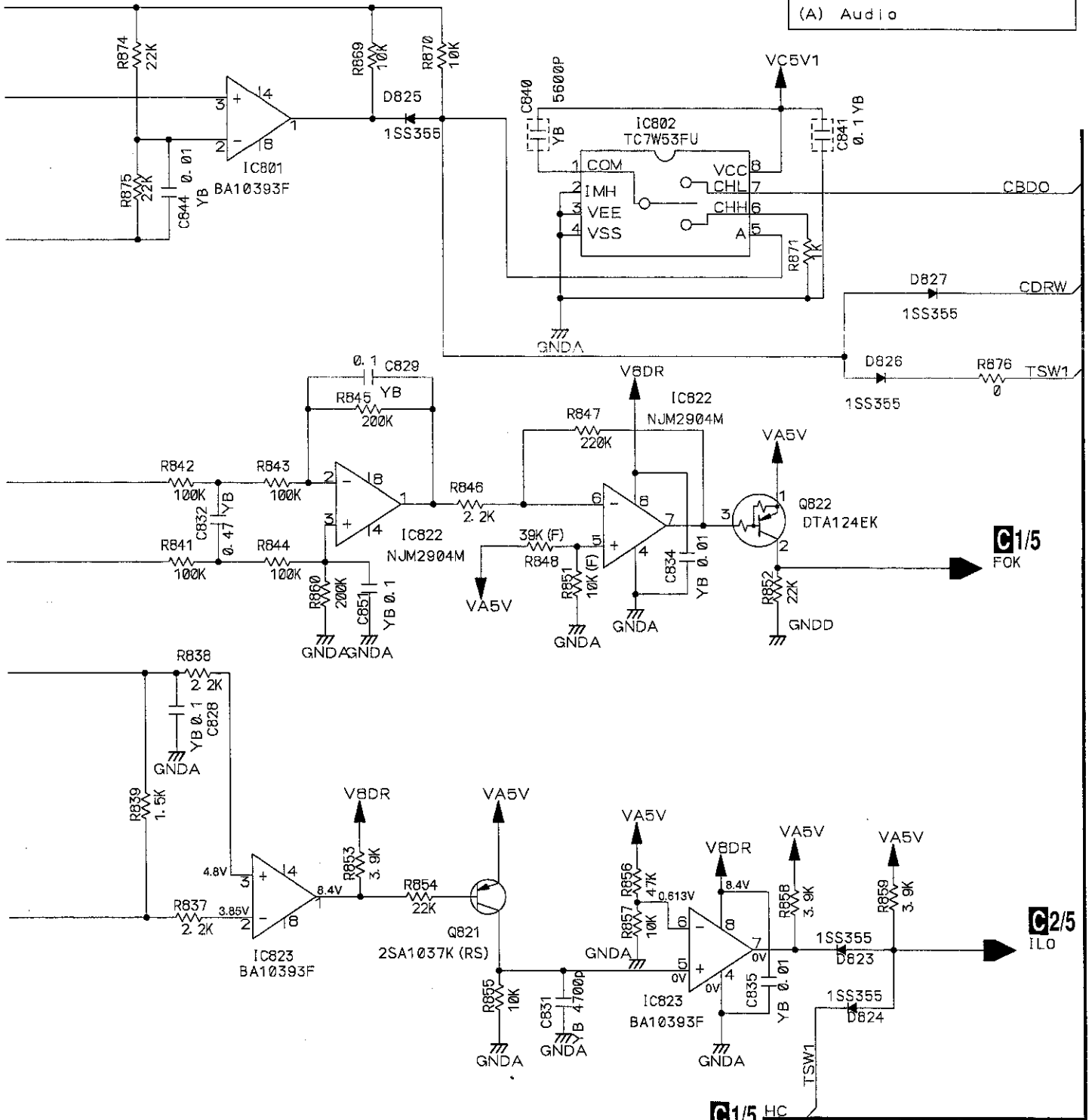

1 2 3 4

# CMX-5000, CU-V160

## 3.8 TRMB ASSY (1/3)

A

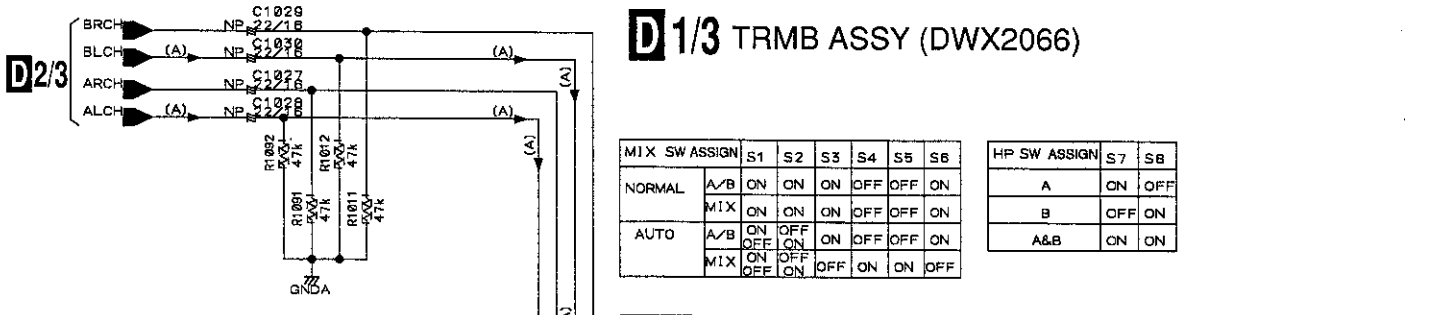

**D1/3** TRMB ASSY (DWX2066)

| MIX SW ASSIGN | S1     | S2  | S3 | S4  | S5  | S6  |
|---------------|--------|-----|----|-----|-----|-----|
| NORMAL        | A/B ON | ON  | ON | OFF | OFF | ON  |
| MIX           | ON     | ON  | ON | OFF | OFF | ON  |
| AUTO          | A/B ON | OFF | ON | OFF | OFF | ON  |
|               | OFF    | ON  | ON | OFF | OFF | ON  |
|               | ON     | OFF | ON | ON  | ON  | OFF |

  

| HP SW ASSIGN | S7  | S8  |
|--------------|-----|-----|
| A            | ON  | OFF |
| B            | OFF | ON  |
| A&B          | ON  | ON  |

B

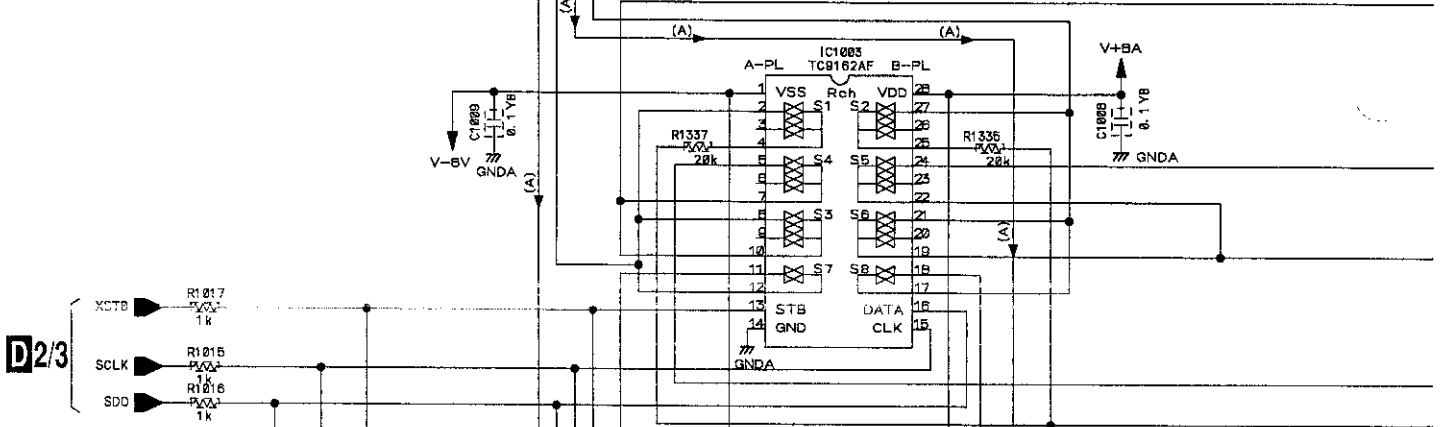

C

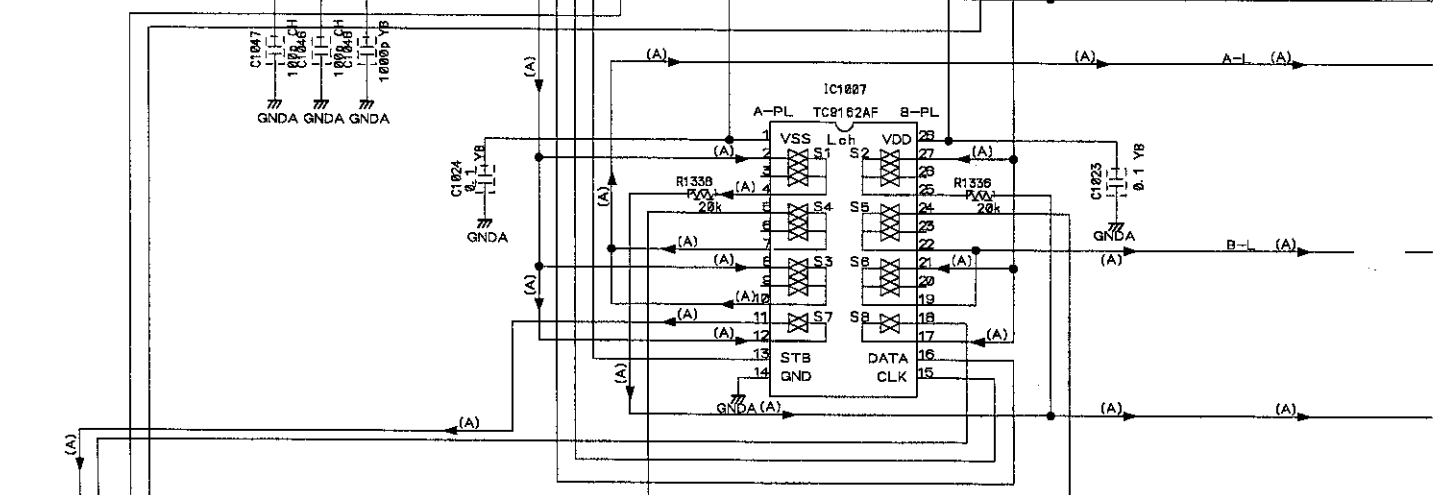

D

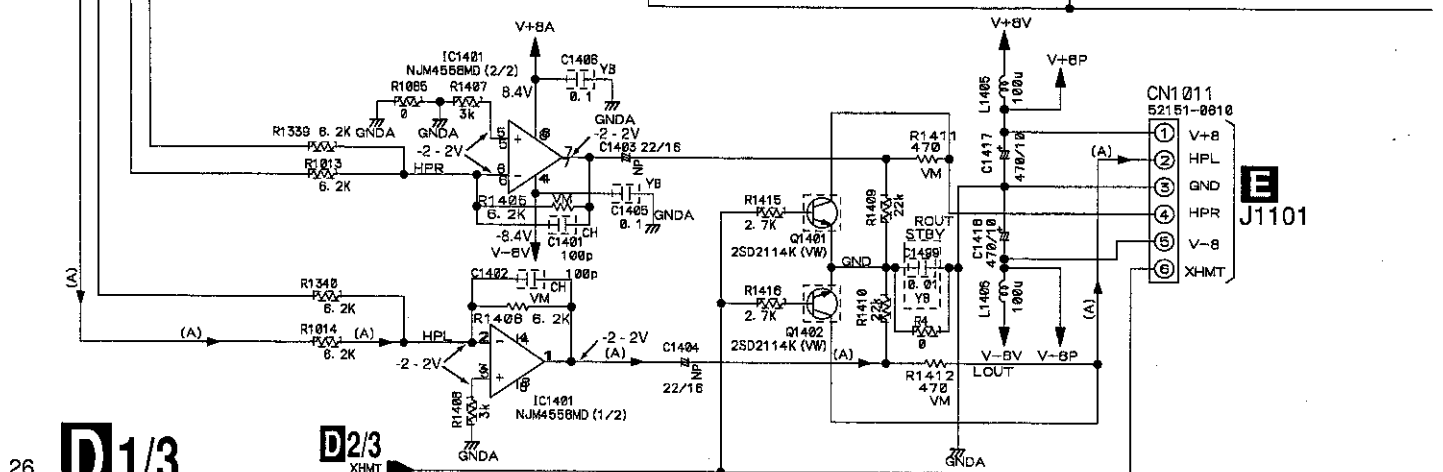

26 **D1/3**

**D2/3**  
XHMT

**E**  
J1101

1

2

3

4

# CMX-5000, CU-V160

### NOTES

RESISTORS : Ω

~W~ : RS1/4W□□□□ or RS1/10W□□□□

VM : RD1/4VM□□□□

CAPACITORS : μF (CEAT)

JA : CEJA

YB : CKSQYB

CH : CCSQCH

M : CQMA

(A) Audio

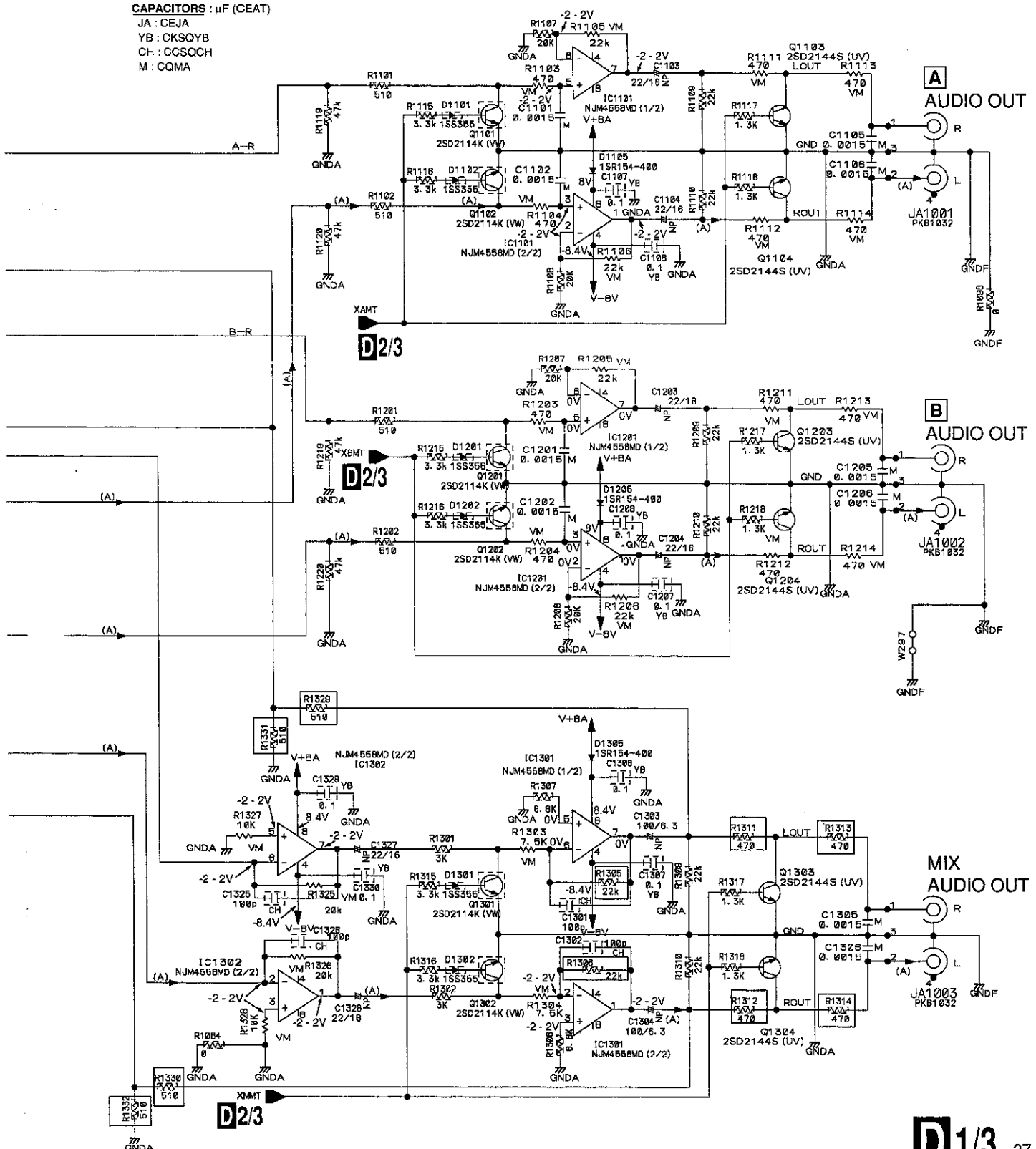

1 2 3 4

# CMX-5000, CU-V160

## 3.9 TRMB ASSY (2/3)

### D 2/3 TRMB ASSY (DWX2066)

A

B

C

D

C1/5 CN702 (To A PLAYER)

C1/5 CN702 (To B PLAYER)

28 D 2/3

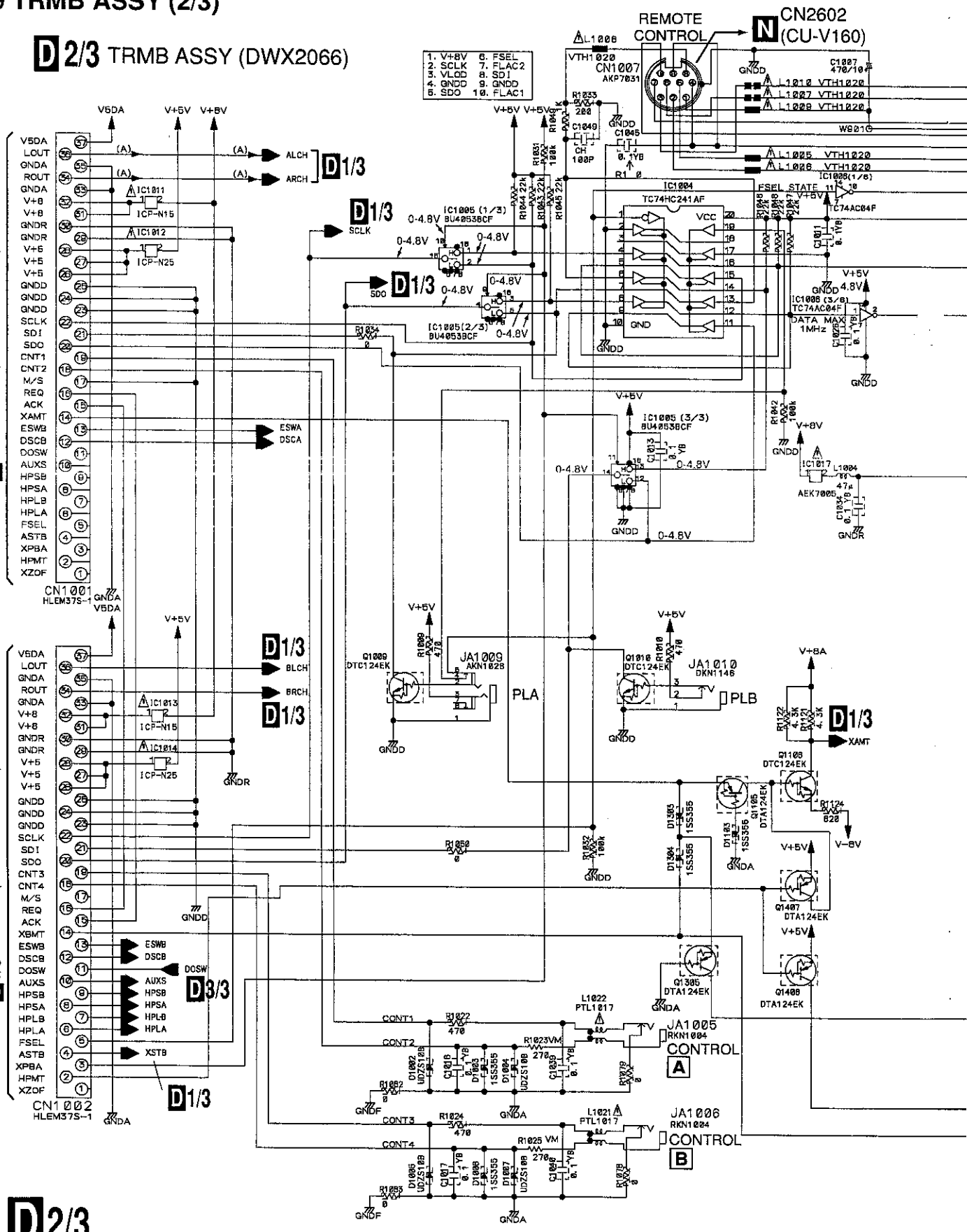

1

2

3

# CMX-5000, CU-V160

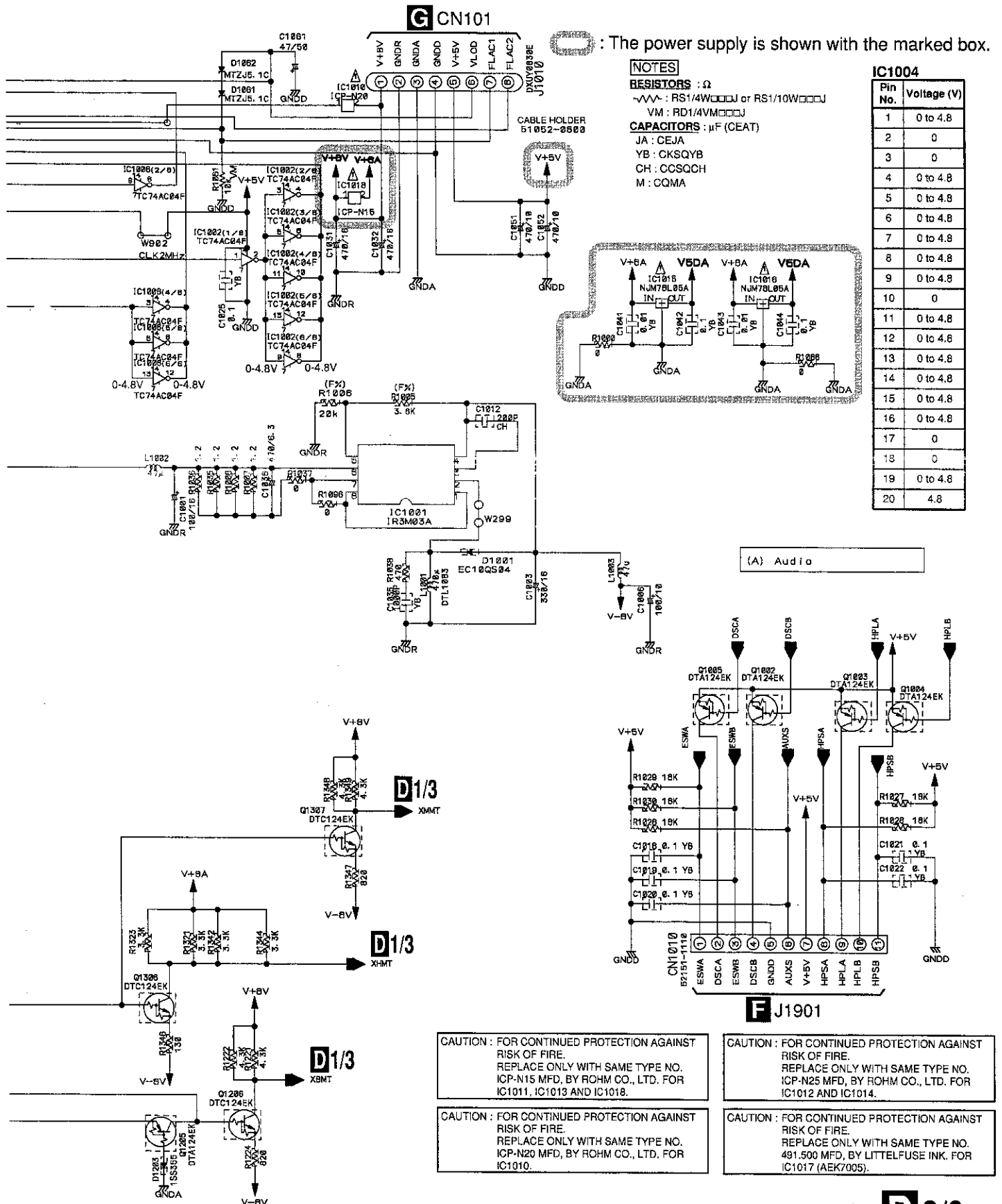

1 2 3 4

# CMX-5000, CU-V160

## 3.10 TRMB ASSY (3/3)

### D3/3 TRMB ASSY (DWX2066)

A

B

C

D

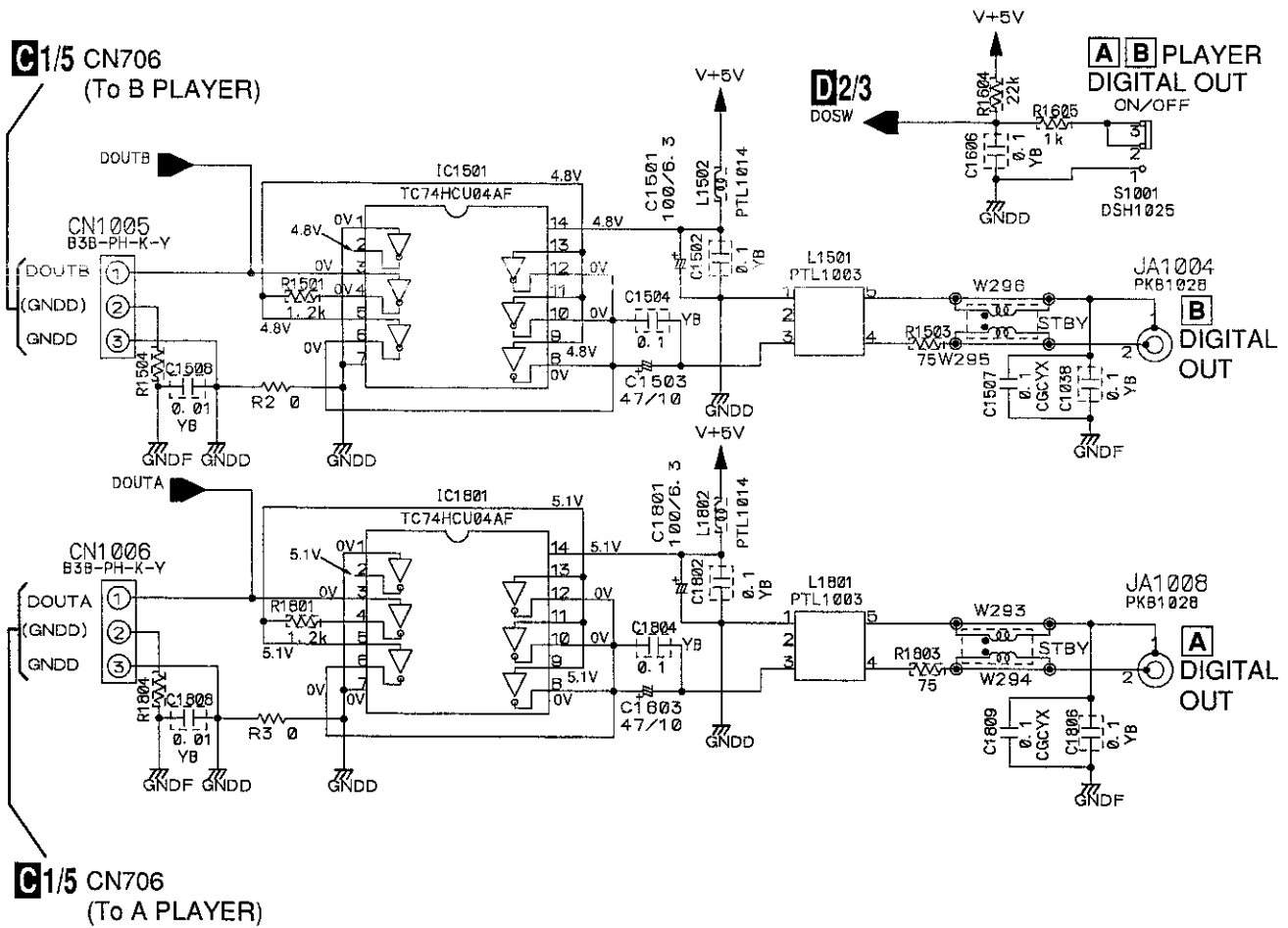

### 3.11 HPJB and SELB ASSYS

#### E HPJB ASSY (DWX2067)

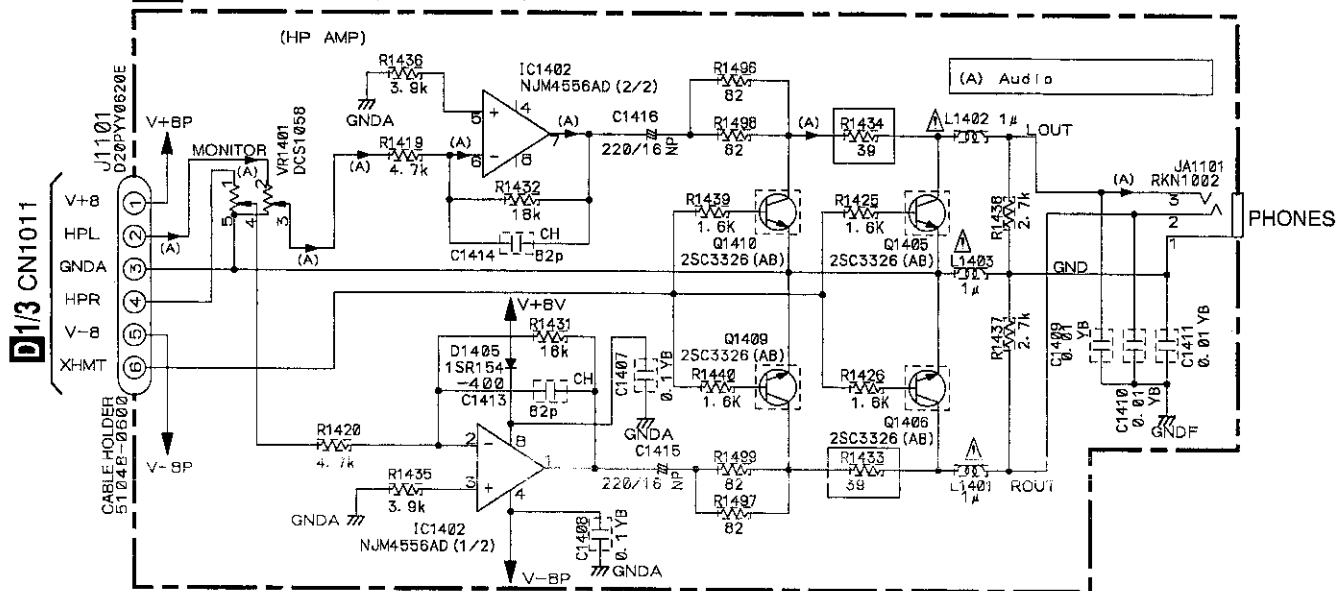

#### F SELB ASSY (DWS1302)

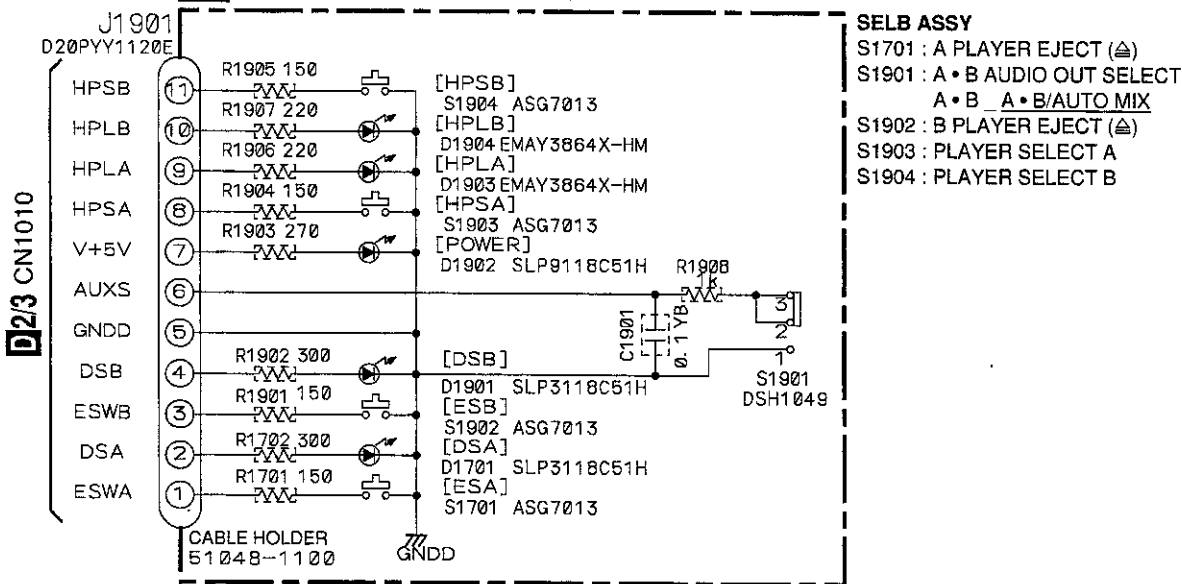

3.12 SW POWER SUPPLY and PSWB ASSYS

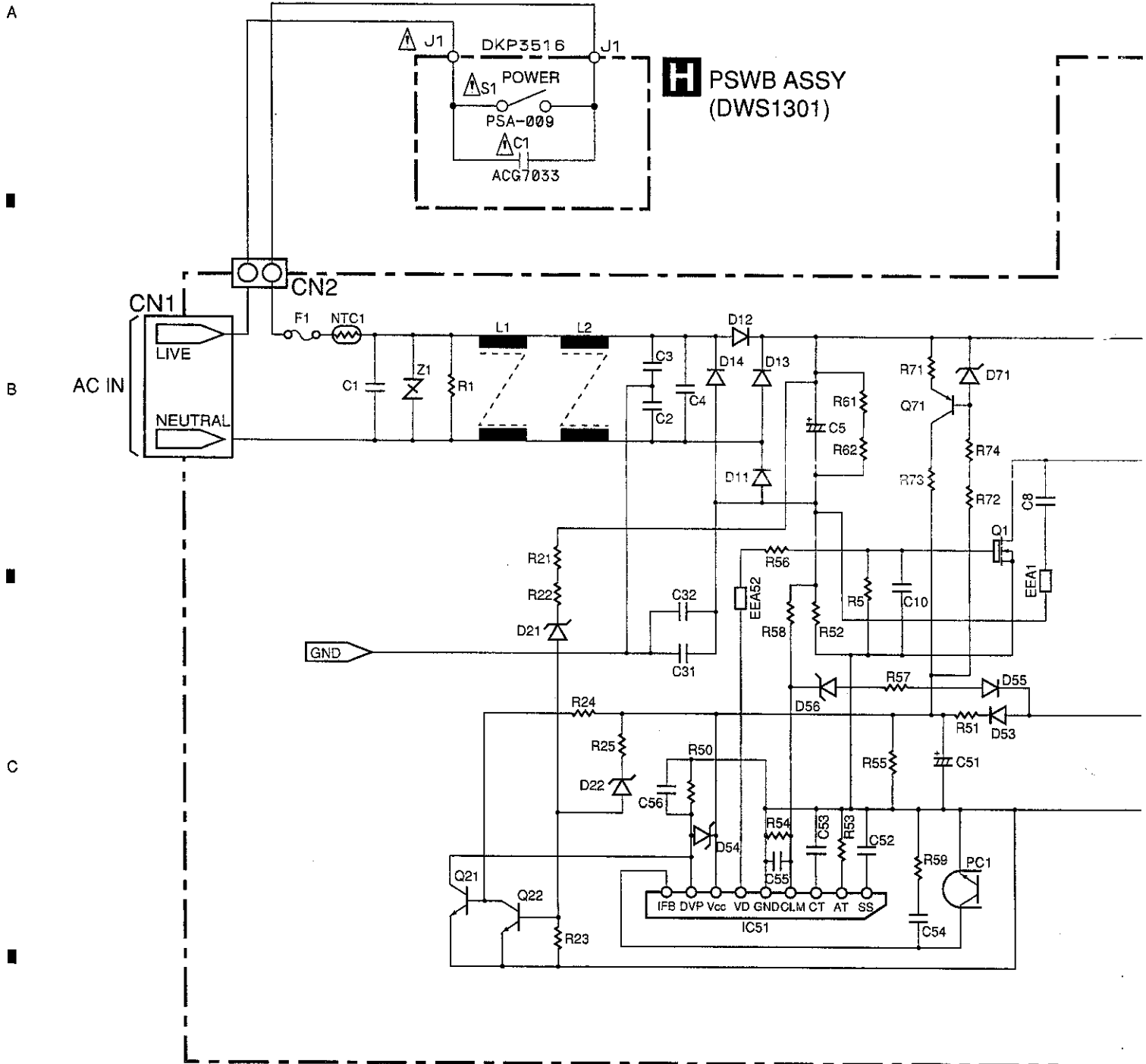

• NOTE FOR FUSE REPLACEMENT  
**CAUTION** -FOR CONTINUED PROTECTION AGAINST RISK OF FIRE.  
 REPLACE WITH SAME TYPE AND RATINGS ONLY.



**G**  SW POWER SUPPLY ASSY (DWR1330)

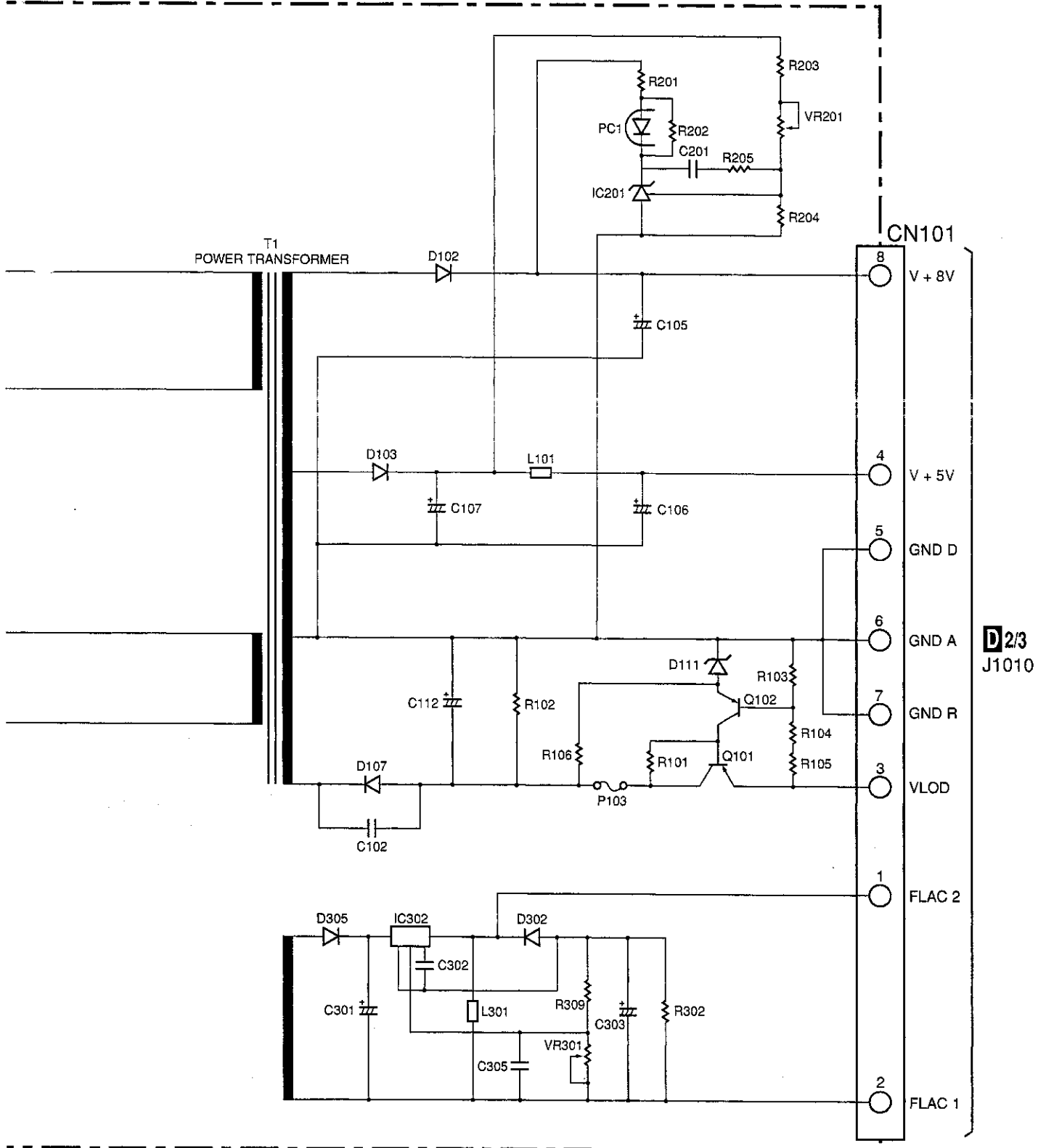

**D** 2/3  
J1010

3.13 OVERALL WIRING DIAGRAM FOR REMOTE CONTROLLER (CU-V160)

A

REMOTE CONTROLLER (CU-V160)

B

C

D

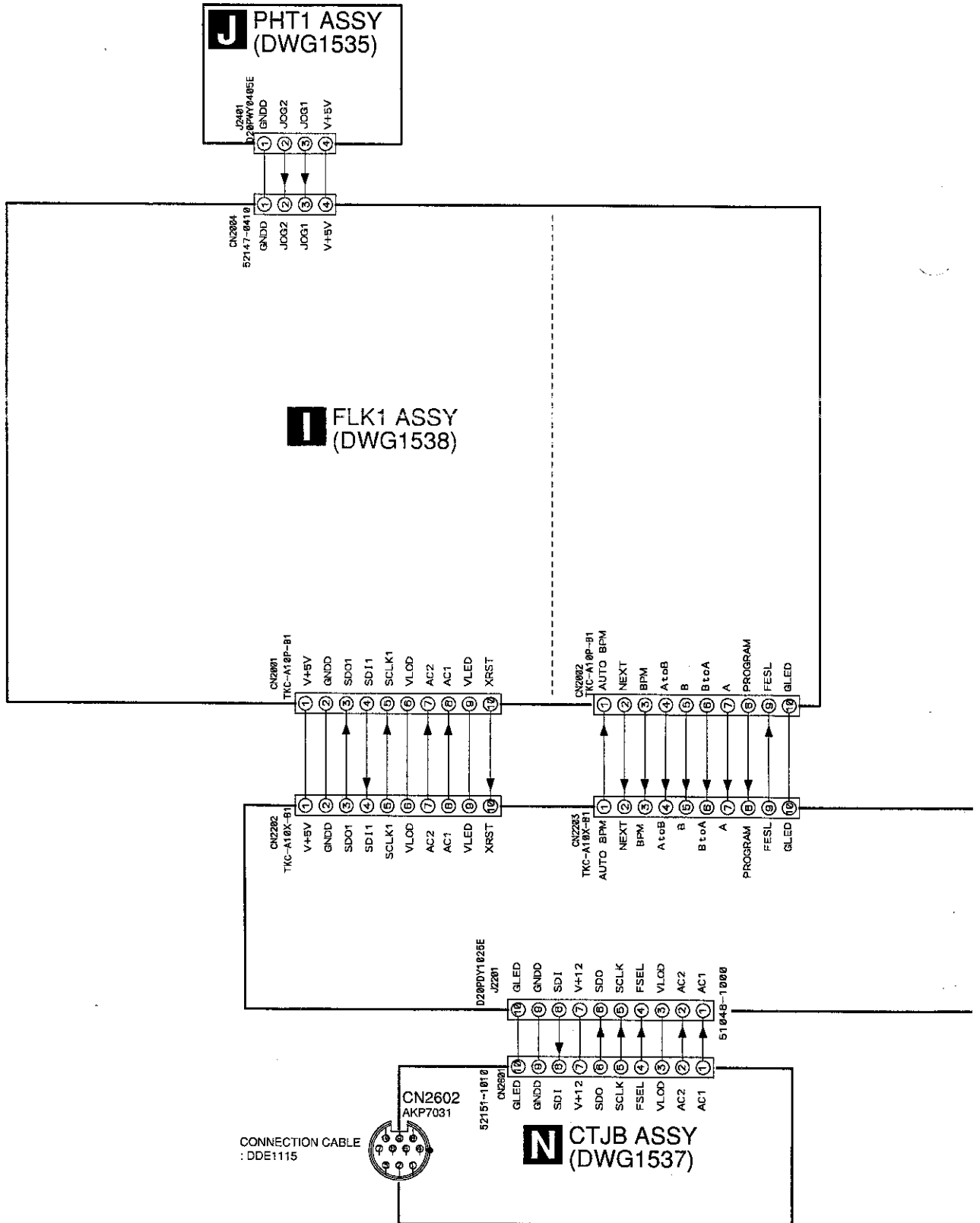

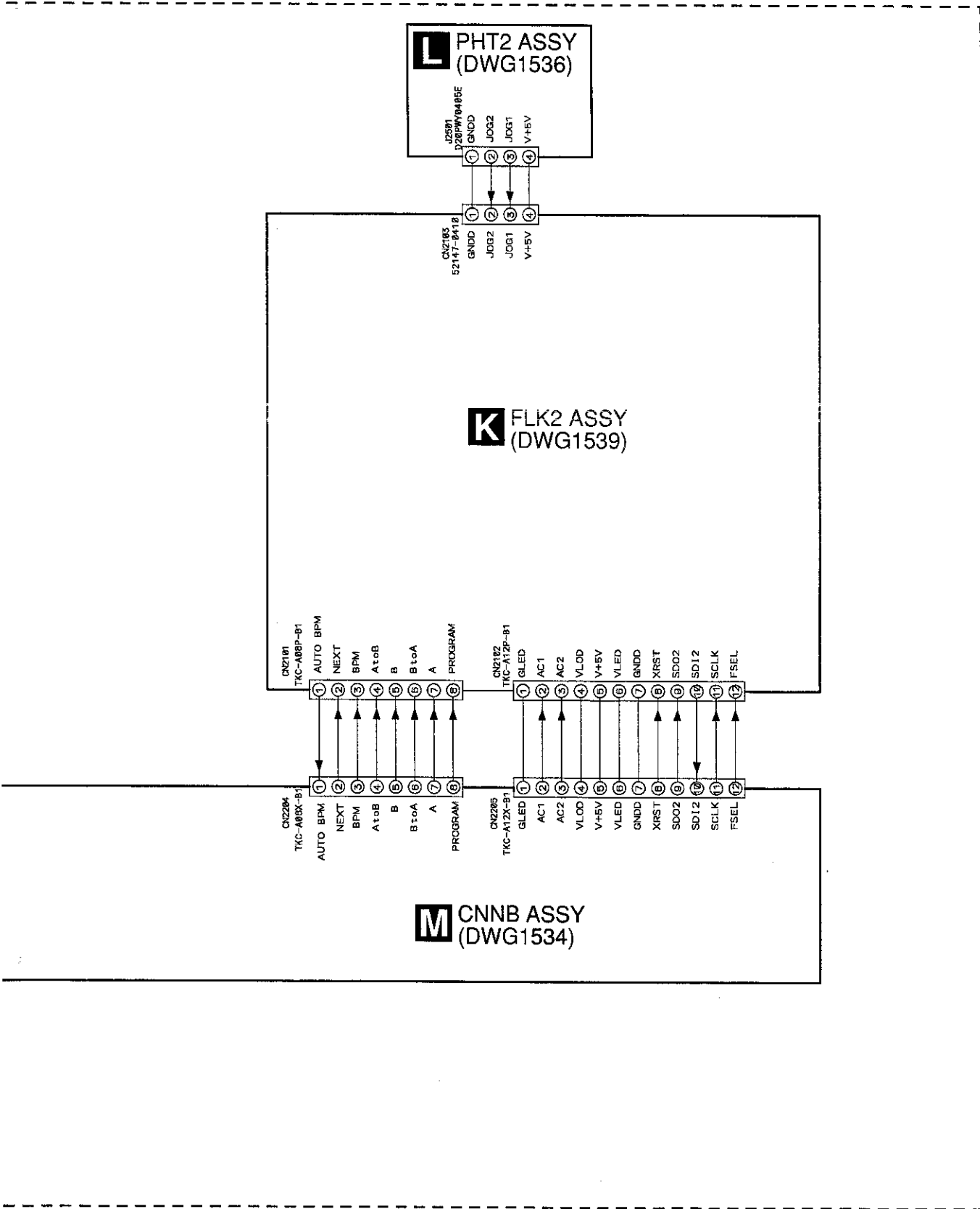

**3.14 FLK1 and PHT1 ASSYS**

A

B

C

D

**M** CN2202

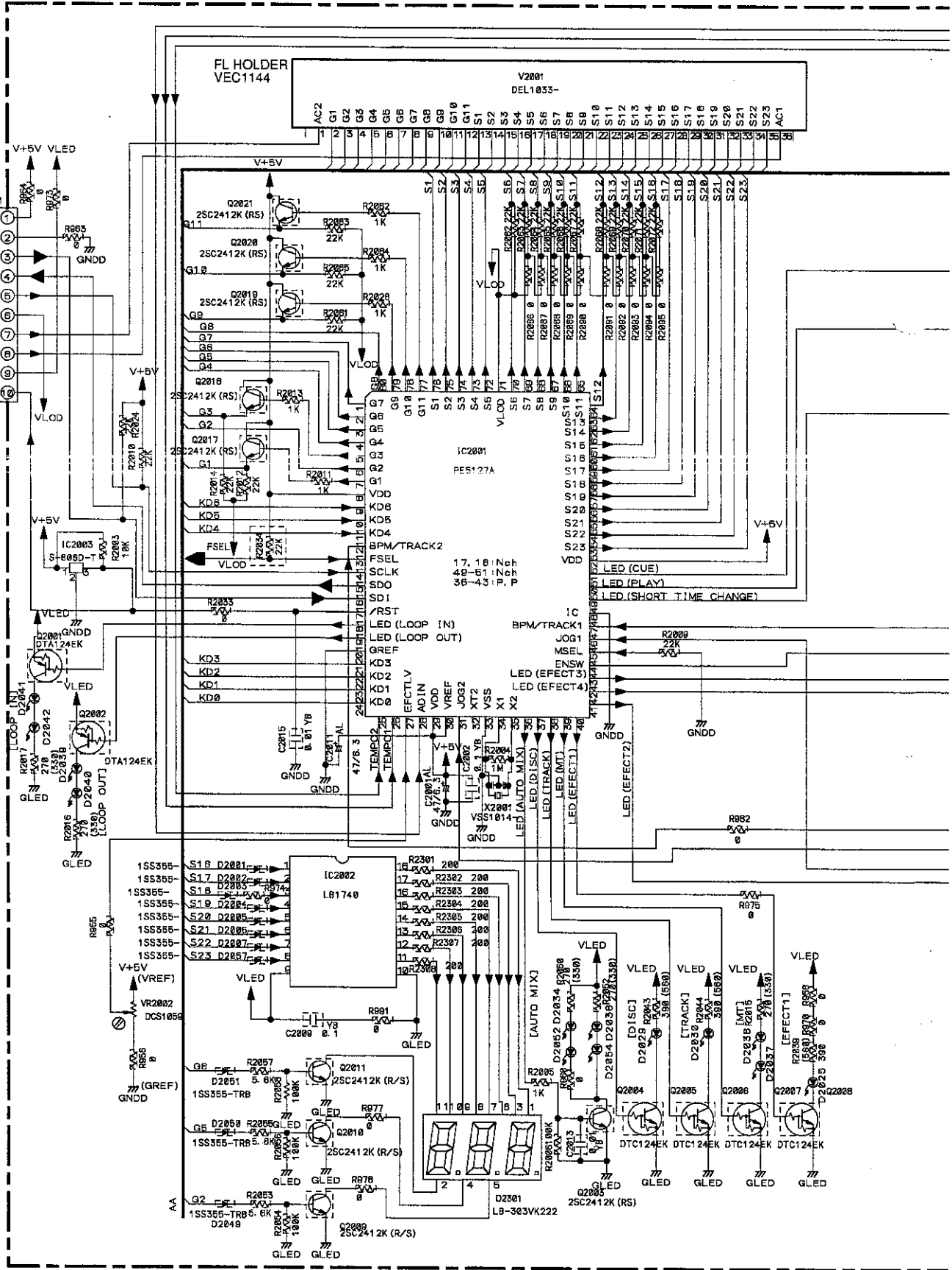

1

2

3

4

FLK1 ASSY (DWG1538)

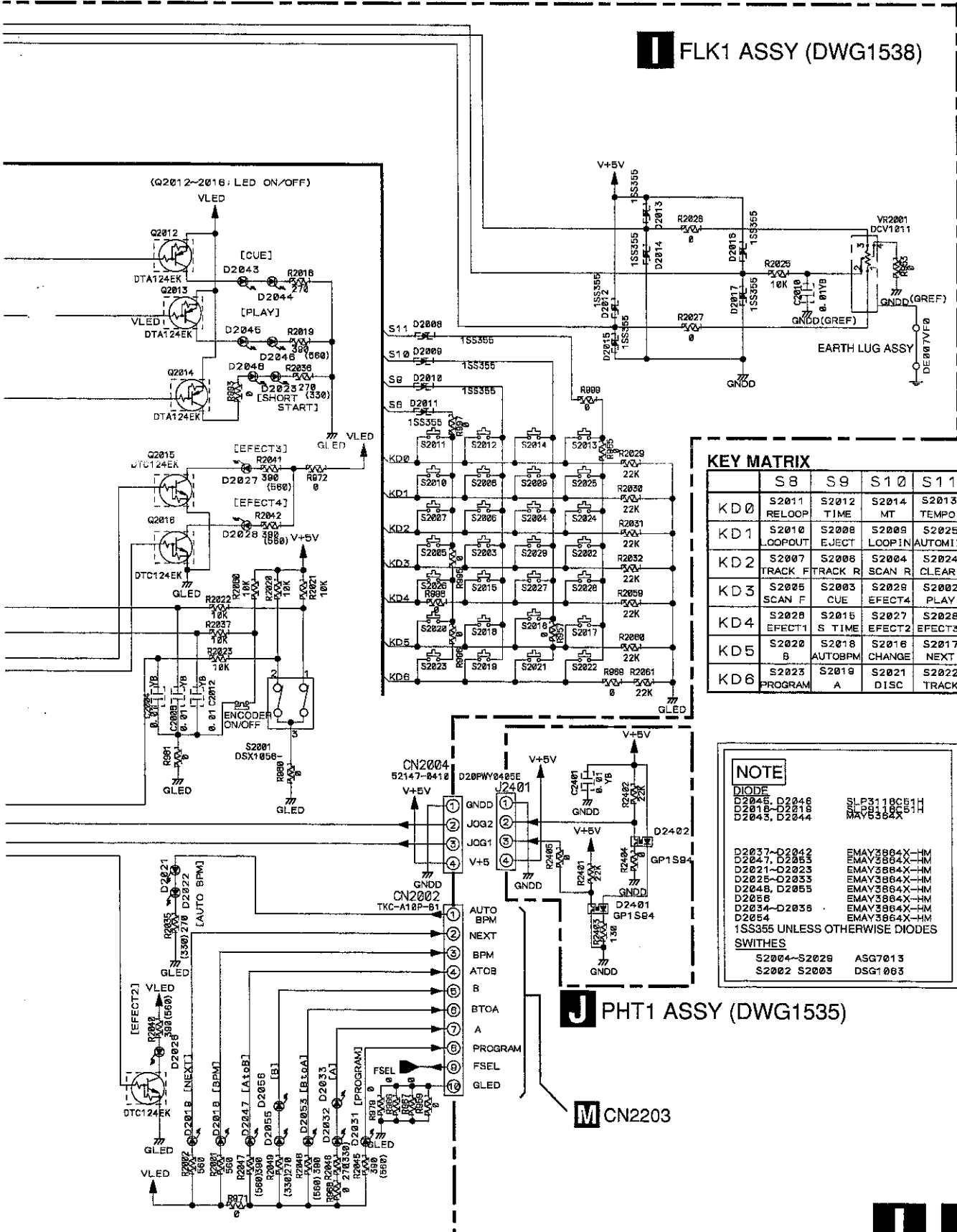

KEY MATRIX

|     | S8               | S9               | S10              | S11              |
|-----|------------------|------------------|------------------|------------------|
| KD0 | S2011<br>RELOOP  | S2012<br>TIME    | S2014<br>MT      | S2013<br>TEMPO   |
| KD1 | S2010<br>LOOPOUT | S2008<br>EJECT   | S2009<br>LOOPIN  | S2025<br>AUTOMIX |
| KD2 | S2007<br>TRACK F | S2006<br>TRACK R | S2004<br>SCAN R  | S2024<br>CLEAR   |
| KD3 | S2005<br>SCAN F  | S2003<br>CUE     | S2029<br>EFFECT  | S2002<br>PLAY    |
| KD4 | S2028<br>EFFECT1 | S2015<br>S TIME  | S2027<br>EFFECT2 | S2028<br>EFFECT3 |
| KD5 | S2020<br>B       | S2018<br>AUTOBPM | S2016<br>CHANGE  | S2017<br>NEXT    |
| KD6 | S2023<br>PROGRAM | S2019<br>A       | S2021<br>DISC    | S2022<br>TRACK   |

NOTE

**DIODE**  
D2045, D2046      M202 L3118C61H  
D2016, D2018      M202 L3118C61H  
D2043, D2044      M202 L3118C61H

D2037-D2042      EMAY3864X-HM  
D2047, D2055      EMAY3864X-HM  
D2021-D2023      EMAY3864X-HM  
D2025-D2033      EMAY3864X-HM  
D2048, D2055      EMAY3864X-HM  
D2058              EMAY3864X-HM  
D2034-D2036      EMAY3864X-HM  
D2054              EMAY3864X-HM

1SS355 UNLESS OTHERWISE DIODES

**SWITCHES**  
S2004-S2026      ASG7013  
S2002 S2003      DSG1063

PHT1 ASSY (DWG1535)

CN2203



**3.15 FLK2 and PHT2 ASSYS**

A

B

C

D

**M** CN2205

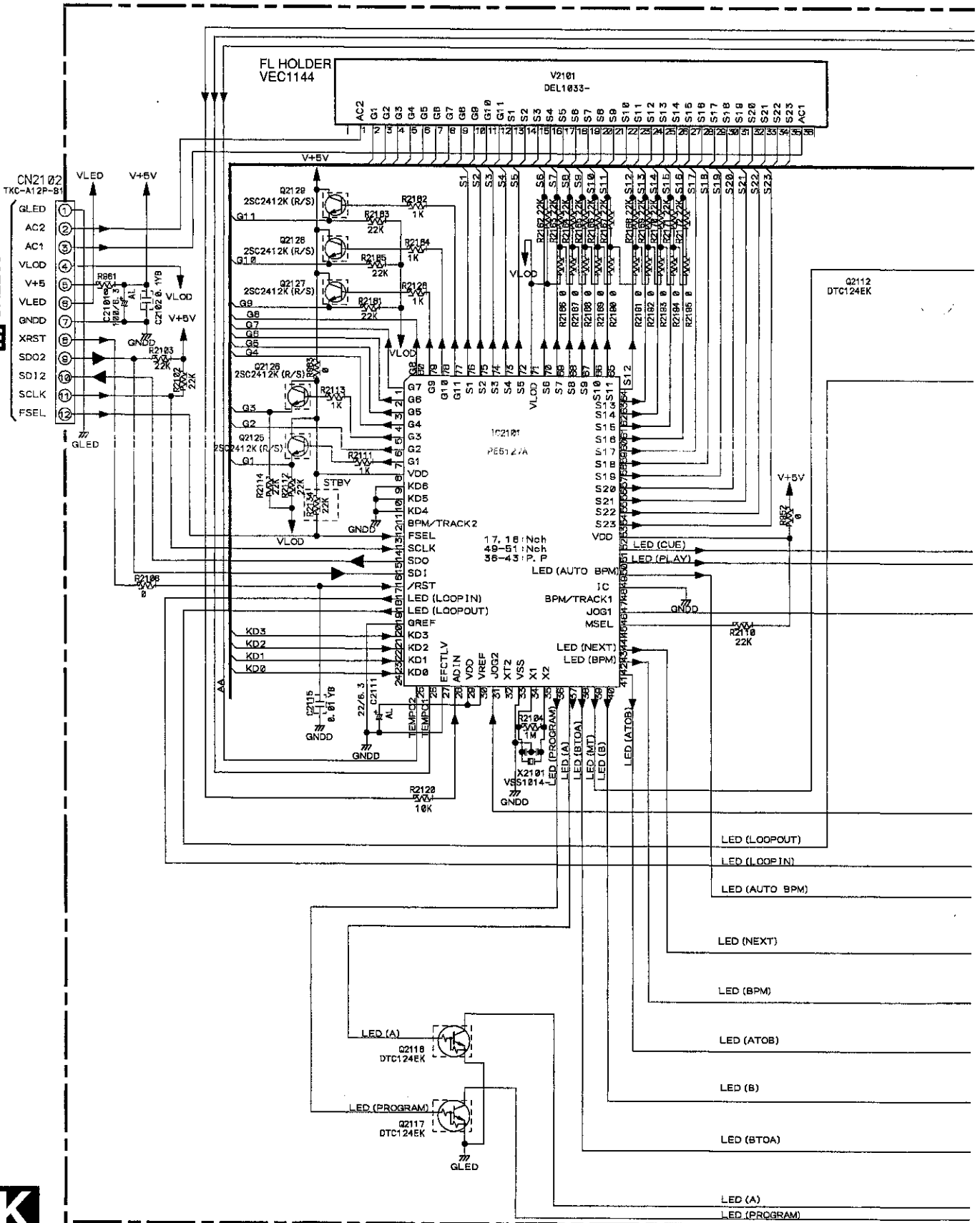

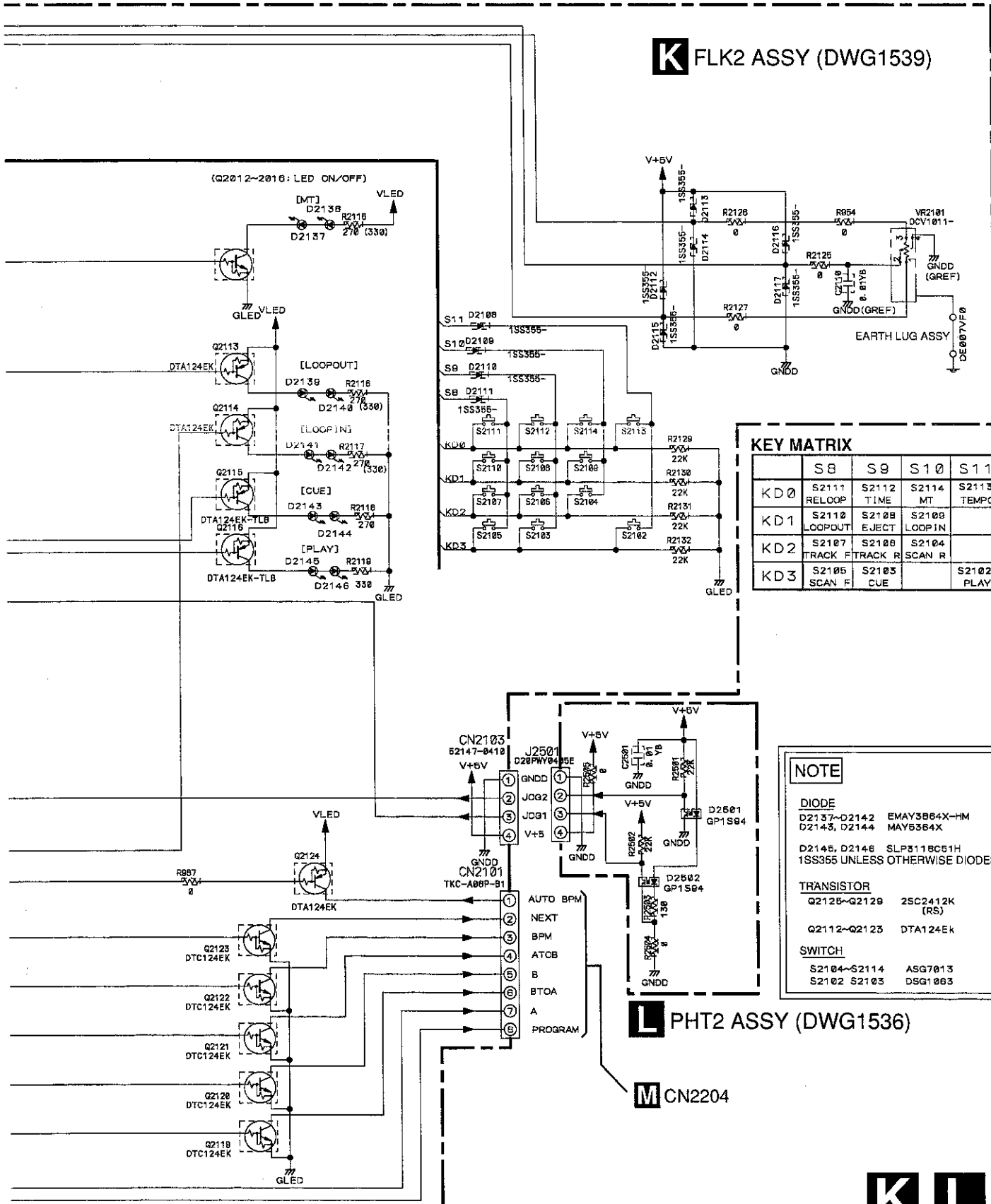

## 3.16 CNNB and CTJB ASSYS

A

B

C

D

### M CNNB ASSY (DWG1534)

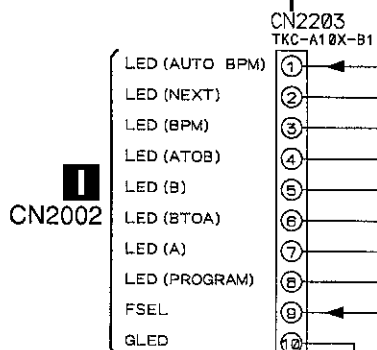

CN2203  
TKC-A10X-B1

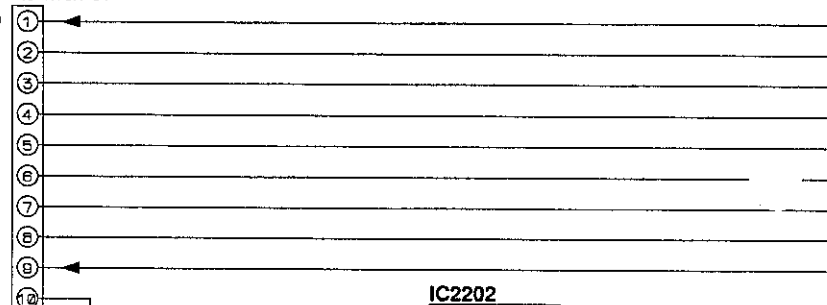

**IC2202**

| Pin No. | Voltage (V) |
|---------|-------------|
| 1       | 0 to 5.0    |
| 2       | 0 to 5.0    |
| 3       | 0 to 5.0    |
| 4       | 0 to 5.0    |
| 5       | 0 to 5.0    |
| 6       | 0 to 5.0    |
| 7       | 0           |
| 8       | 0 to 5.0    |
| 9       | 0 to 5.0    |
| 10      | 0 to 5.0    |
| 11      | 0 to 5.0    |
| 12      | 0 to 5.0    |
| 13      | 0 to 5.0    |
| 14      | 5           |

### N CTJB ASSY (DWG1537)

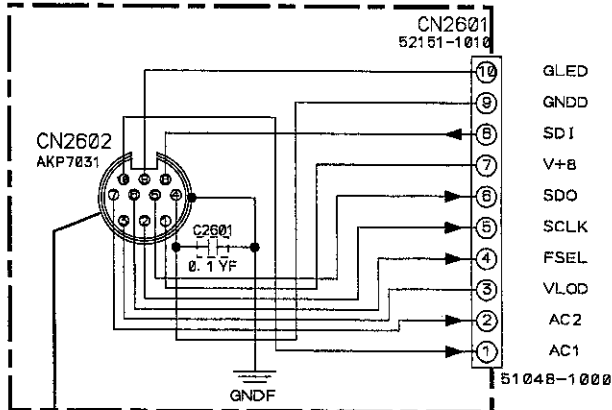

**CN2602 PIN SIGNAL**

|    |       |
|----|-------|
| 1  | V+8V  |
| 2  | SCLK  |
| 3  | VLOD  |
| 4  | GNDD  |
| 5  | SDO   |
| 6  | FSEL  |
| 7  | FLAC2 |
| 8  | SDI   |
| 9  | GNDD  |
| 10 | FLAC1 |

To PLAYER  
D/2/3 CN1007

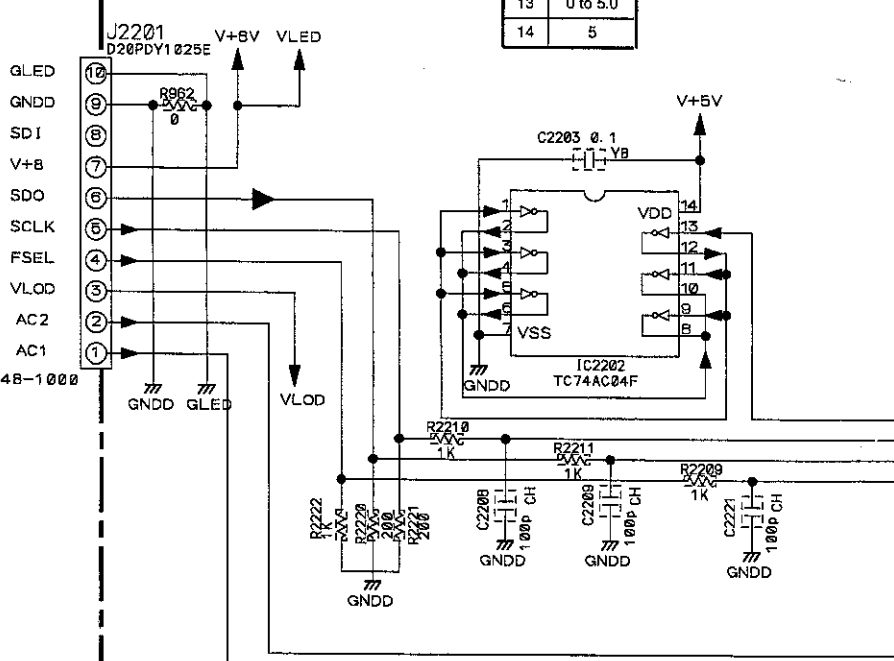



# CMX-5000, CU-V160

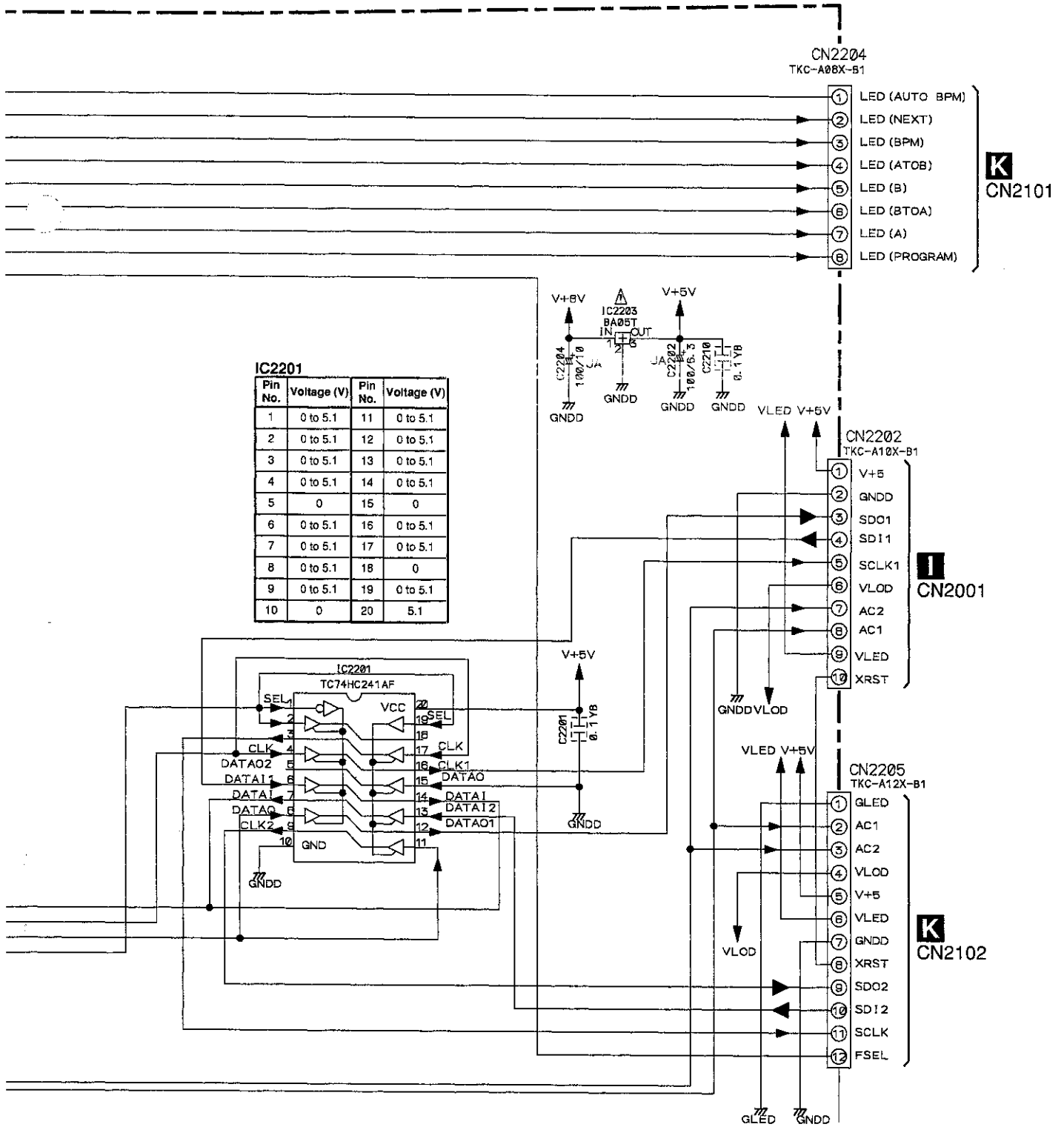

**K**  
CN2101

**I**  
CN2001

**K**  
CN2102

# CMX-5000, CU-V160

## WAVEFORMS and VOLTAGES

Note :

The encircled numbers denote measuring point in the schematic diagram.

### CDPB ASSY

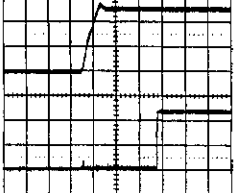
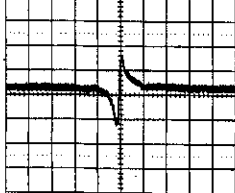
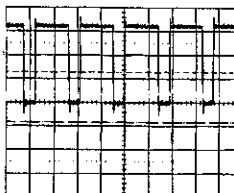
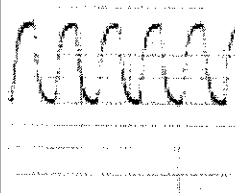
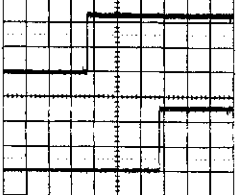
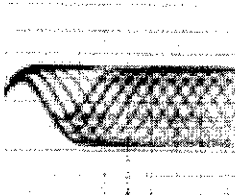
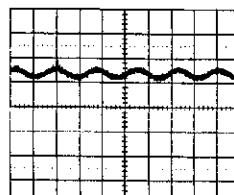
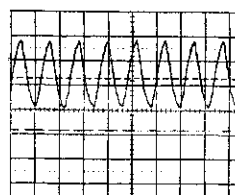
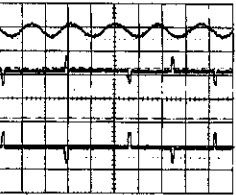
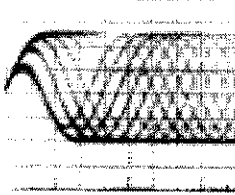
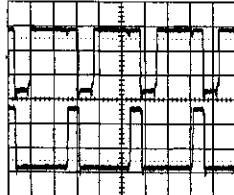
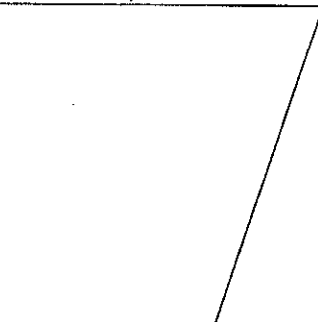
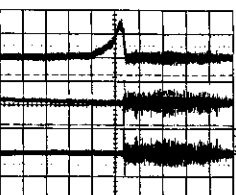
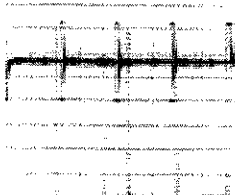
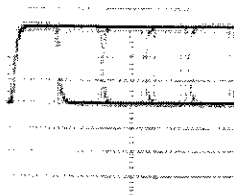
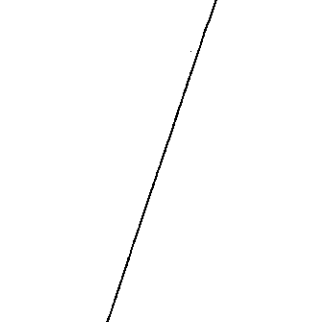
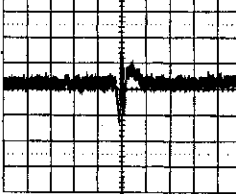
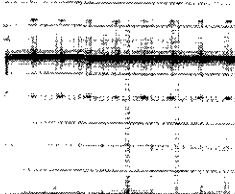
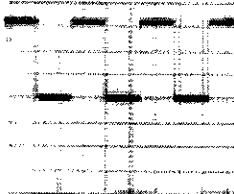
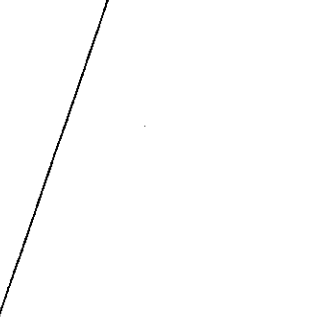
|                                                                                                                                                                                                                                   |                                                                                                                                                                 |                                                                                                                                                                                                                             |                                                                                                                                                                       |
|-----------------------------------------------------------------------------------------------------------------------------------------------------------------------------------------------------------------------------------|-----------------------------------------------------------------------------------------------------------------------------------------------------------------|-----------------------------------------------------------------------------------------------------------------------------------------------------------------------------------------------------------------------------|-----------------------------------------------------------------------------------------------------------------------------------------------------------------------|
| <p>① TP XRST<br/>V: 2V/div. H: 10msec/div.<br/>② IC701 - pin 40 (XDRST)<br/>V: 2V/div. H: 10msec/div.<br/>(Power ON)</p>                         | <p>⑨ TP FE<br/>V: 0.5V/div. H: 2msec/div.<br/>(Focus up/down)</p>              | <p>⑭ TP PWM1<br/>V: 1V/div. H: 2μsec/div.<br/>(Trase x4 only)</p>                                                                         | <p>⑳ IC231 - pin 2 (ABCK)<br/>V: 0.1V/div. H: 0.1μsec/div.<br/>(x4 Play mode)</p>  |
| <p>① TP XRST<br/>V: 2V/div. H: 0.2sec/div.<br/>③ IC701 - pin 34 (XMRST)<br/>V: 2V/div. H: 0.2sec/div.<br/>(Power ON)</p>                        | <p>⑩ TP RF<br/>V: 20mV/div. H: 100nsec/div.<br/>(Play mode x4)</p>            | <p>⑮ TP EC<br/>V: 1.772V/div. H: 20msec/div.<br/>(Play)</p>                                                                              | <p>㉑ TP ZCLK3<br/>V: 1V/div. H: 50nsec/div.</p>                                   |
| <p>④ TP T+<br/>V: 2V/div. H: 0.1msec/div.<br/>⑤ TP T-<br/>V: 2V/div. H: 0.1msec/div.<br/>⑧ TP TE<br/>V: 2V/div. H: 0.1msec/div. (Search)</p>   | <p>⑪ TP NRF (AGCRF)<br/>V: 20mV/div. H: 100nsec/div.<br/>(x4 Play mode)</p>  | <p>⑯ CN551 - pin 4 (STA+)<br/>V: 4.75V/div. H: 10μsec/div.<br/>⑰ CN551 - pin 2 (STB+)<br/>V: -0.07V/div. H: 10μsec/div.<br/>(Play)</p>  |                                                                                  |
| <p>⑥ TP F+<br/>V: 2V/div. H: 10msec/div.<br/>⑦ TP F-<br/>V: 2V/div. H: 10msec/div.<br/>⑨ TP FE<br/>V: 0.5V/div. H: 10msec/div. (Focus in)</p>  | <p>⑫ TP FMO<br/>V: 0.1V/div. H: 5μsec/div.<br/>(Play mode)</p>               | <p>⑱ IC231 - pin 5 (ADATA)<br/>V: 0.1V/div. H: 0.1μsec/div.<br/>(x4 Play mode)</p>                                                      |                                                                                  |
| <p>⑧ TP TE<br/>V: 0.5V/div. H: 2msec/div.<br/>(1 Tr Jump)</p>                                                                                  | <p>⑬ TP TMO<br/>V: 0.1V/div. H: 5μsec/div.<br/>(Play mode)</p>               | <p>⑲ IC231 - pin 4 (ALRCK)<br/>V: 0.1V/div. H: 2μsec/div.<br/>(x4 Play mode)</p>                                                        |                                                                                  |

• CDPB ASSY

C 2/5

IC201

| Pin No. | Voltage (V) | Pin No. | Voltage (V) |
|---------|-------------|---------|-------------|
| 1       | 0           | 19      | 1.61        |
| 2       | 3.33        | 20      | 2.35        |
| 3       | 4.8         | 21      | 4.8         |
| 4       | 2.35        | 22      | 1.61        |
| 5       | 0           | 23      | 3.16        |
| 6       | 2.35        | 24      | 1.61        |
| 7       | 1.61        | 25      | 1.61        |
| 8       | 2.35        | 26      | 1.61        |
| 9       | 1.61        | 27      | 1.61        |
| 10      | 1.61        | 28      | 0.8         |
| 11      | 3.33        | 29      | 1.61        |
| 12      | 1.61        | 30      | 1.61        |
| 13      | 2.8         | 31      | 2.35        |
| 14      | 0           | 32      | 2.35        |
| 15      | 2.8         | 33      | 2.35        |
| 16      | 0           | 34      | 2.35        |
| 17      | 0           | 35      | 2.35        |
| 18      | 0           | 36      | 2.35        |

C 2/5

IC451

| Pin No. | Voltage (V) | Pin No. | Voltage (V) |
|---------|-------------|---------|-------------|
| 1       | 1.61        | 22      | 2.35        |
| 2       | 8.4         | 23      | 2.35        |
| 3       | 1.61        | 24      | 0           |
| 4       | 2.35        | 25      | 2.35        |
| 5       | 2.35        | 26      | 1.61        |
| 6       | 2.35        | 27      | 8.4         |
| 7       | 4.8         | 28      | 0           |
| 8       | 0           | 29      | 0           |
| 9       | 0           | 30      | 0           |
| 10      | -           | 31      | -           |
| 11      | -           | 32      | -           |
| 12      | -           | 33      | -           |
| 13      | -           | 34      | -           |
| 14      | 2.35        | 35      | 0           |
| 15      | 2.35        | 36      | 4.8         |
| 16      | 2.35        | 37      | 2.35        |
| 17      | 1.61        | 38      | 2.35        |
| 18      | 1.61        | 39      | 2.35        |
| 19      | 1.61        | 40      | 1.61        |
| 20      | 1.61        | 41      | 1.61        |
| 21      | 2.35        | 42      | 1.61        |

C 2/5

IC231

| Pin No. | Voltage (V) | Pin No. | Voltage (V) | Pin No. | Voltage (V) | Pin No. | Voltage (V) |
|---------|-------------|---------|-------------|---------|-------------|---------|-------------|
| 1       | 0           | 26      | 0           | 51      | 1.61        | 76      | 0           |
| 2       | 0 to 3.16   | 27      | 3.16        | 52      | 1.61        | 77      | 0 to 3.16   |
| 3       | 3.16        | 28      | 3.16        | 53      | 1.61        | 78      | 3.16        |
| 4       | 0 to 3.16   | 29      | 0           | 54      | 3.16        | 79      | 0 to 3.16   |
| 5       | 0 to 3.16   | 30      | 0 to 3.16   | 55      | 0           | 80      | 3.16        |
| 6       | 3.16        | 31      | 0           | 56      | 1.61        | 81      | 0 to 3.16   |
| 7       | 1.0 to 2.5  | 32      | 0           | 57      | 1.61        | 82      | 0 to 3.16   |
| 8       | 0 to 3.16   | 33      | 0           | 58      | 1.61        | 83      | 3.16        |
| 9       | 0           | 34      | 0           | 59      | 1.61        | 84      | 3.16        |
| 10      | 0           | 35      | 0 to 1.5    | 60      | 1.61        | 85      | 0 to 3.16   |
| 11      | 0 to 4.8    | 36      | 0 to 3.16   | 61      | 1.61        | 86      | 0 to 3.16   |
| 12      | 0 to 4.8    | 37      | 0 to 3.16   | 62      | 3.16        | 87      | 0 to 4.8    |
| 13      | 0 to 3.16   | 38      | 0 to 3.16   | 63      | 1           | 88      | 2.35        |
| 14      | 0           | 39      | 0 to 3.16   | 64      | 1           | 89      | 0 to 3.16   |
| 15      | 0 to 4.8    | 40      | 0           | 65      | 1           | 90      | 0           |
| 16      | 0 to 4.8    | 41      | 0           | 66      | 1           | 91      | 0           |
| 17      | 0 to 4.8    | 42      | 0           | 67      | 1           | 92      | 0           |
| 18      | 0 to 3.16   | 43      | 2.35        | 68      | 1           | 93      | 3.16        |
| 19      | 0           | 44      | 2.35        | 69      | 1           | 94      | 0           |
| 20      | 0 to 3.16   | 45      | 0           | 70      | 0           | 95      | 0 to 3.16   |
| 21      | 1           | 46      | 0           | 71      | 0           | 96      | 0           |
| 22      | 0 to 3.16   | 47      | 0           | 72      | 1.61        | 97      | 0           |
| 23      | 0 to 3.16   | 48      | 0           | 73      | 3.16        | 98      | 0           |
| 24      | 3.16        | 49      | 1.61        | 74      | 1.61        | 99      | 0 to 3.16   |
| 25      | 0           | 50      | 1.61        | 75      | 0           | 100     | 0 to 3.16   |

C 2/5

IC501

| Pin No. | Voltage (V) | Pin No. | Voltage (V) |
|---------|-------------|---------|-------------|
| 1       | 0           | 16      | 4.8         |
| 2       | 2.2 to 2.6  | 17      | 1.61        |
| 3       | 2.2 to 2.6  | 18      | 1.61        |
| 4       | 0           | 19      | 0           |
| 5       | 2.2 to 2.6  | 20      | 0.613       |
| 6       | 2.2 to 2.6  | 21      | 8.25        |
| 7       | 0.613       | 22      | 8.25        |
| 8       | 2.2 to 2.6  | 23      | 0           |
| 9       | 2.2 to 2.6  | 24      | 0           |
| 10      | 3.16        | 25      | 0           |
| 11      | 4.8         | 26      | 4.0 to 8.25 |
| 12      | 0 to 4.8    | 27      | 4.0 to 8.25 |
| 13      | 3.83        | 28      | 4.0 to 8.25 |
| 14      | 0           | 29      | 0           |
| 15      | 0           | 30      | 0           |

C 4/5

IC303

| Pin No. | Voltage (V) |
|---------|-------------|
| 1       | 0 to 3.0    |
| 2       | 0 to 4.8    |
| 3       | 0 to 3.0    |
| 4       | 0 to 4.8    |
| 5       | 0 to 3.0    |
| 6       | 0 to 4.8    |
| 7       | 0           |
| 8       | 0           |
| 9       | 0           |
| 10      | 0           |
| 11      | 0           |
| 12      | 0           |
| 13      | 0           |
| 14      | 4.8         |

C 4/5

IC351

| Pin No. | Voltage (V) |
|---------|-------------|
| 1       | 0 to 4.8    |
| 2       | 0 to 4.8    |
| 3       | 0 to 4.8    |
| 4       | 0 to 4.8    |
| 5       | 0 to 4.8    |
| 6       | 0 to 4.8    |
| 7       | 0           |
| 8       | 4.8         |
| 9       | 4.8         |
| 10      | 0           |
| 11      | 2.38        |
| 12      | 0           |
| 13      | 2.38        |
| 14      | 0           |
| 15      | 4.8         |
| 16      | 0.8 to 4.8  |
| 17      | 0           |
| 18      | 2.38        |
| 19      | 0           |
| 20      | 4.8         |
| 21      | 3.5         |
| 22      | 4.8         |
| 23      | 0           |
| 24      | 4.8         |
| 25      | 4.8         |
| 26      | 0 to 4.8    |
| 27      | 0 to 4.8    |
| 28      | 4.8         |

C 4/5

IC402

| Pin No. | Voltage (V) | Pin No. | Voltage (V) |
|---------|-------------|---------|-------------|
| 1       | 0           | 23      | 0           |
| 2       | 0           | 24      | 0           |
| 3       | 0           | 25      | 0           |
| 4       | 0           | 26      | 0           |
| 5       | 3.16        | 27      | 0           |
| 6       | 0 to 3.0    | 28      | 0 to 3.0    |
| 7       | 0 to 4.8    | 29      | 0           |
| 8       | 0 to 4.8    | 30      | 0           |
| 9       | 4.8         | 31      | 0           |
| 10      | 0           | 32      | 3.16        |
| 11      | 0           | 33      | 0           |
| 12      | 0           | 34      | 0           |
| 13      | 0           | 35      | 0           |
| 14      | 0           | 36      | 0           |
| 15      | 3.16        | 37      | 0           |
| 16      | 3.16        | 38      | 0           |
| 17      | 0           | 39      | 0           |
| 18      | 0           | 40      | 0           |
| 19      | 0           | 41      | 3.16        |
| 20      | 0           | 42      | 0           |
| 21      | 3.16        | 43      | 0           |
| 22      | 0           | 44      | 0           |

# CMX-5000, CU-V160

## • TRMB ASSY

C 4/5

IC901

| Pin No. | Voltage (V) | Pin No. | Voltage (V) | Pin No. | Voltage (V) | Pin No. | Voltage (V) |
|---------|-------------|---------|-------------|---------|-------------|---------|-------------|
| 1       | 1.45        | 26      | 0           | 51      | 4.8         | 76      | 0           |
| 2       | 1.45        | 27      | 4.8         | 52      | 4.8         | 77      | 0           |
| 3       | 4.8         | 28      | 0           | 53      | 0           | 78      | 4.8         |
| 4       | 0 to 4.8    | 29      | 0           | 54      | 0           | 79      | 0           |
| 5       | 0 to 4.8    | 30      | 0           | 55      | 0           | 80      | 0           |
| 6       | 0 to 4.8    | 31      | 0           | 56      | 0           | 81      | 4.8         |
| 7       | 0           | 32      | 0           | 57      | 0           | 82      | 4.8         |
| 8       | 0 to 4.8    | 33      | 0           | 58      | 0           | 83      | 0           |
| 9       | 0 to 4.8    | 34      | 0           | 59      | 0           | 84      | 0           |
| 10      | 0 to 4.8    | 35      | 0           | 60      | 0           | 85      | 1           |
| 11      | 0           | 36      | 0           | 61      | 0           | 86      | 0           |
| 12      | 4.8         | 37      | 4.8         | 62      | 0.5 to 4.0  | 87      | 0           |
| 13      | 4.8         | 38      | 4.8         | 63      | 0 to 4.8    | 88      | 1           |
| 14      | 4.8         | 39      | 0           | 64      | 0           | 89      | 2.38        |
| 15      | 4.8         | 40      | 0           | 65      | 0 to 4.8    | 90      | 0           |
| 16      | 0 to 4.8    | 41      | 4.8         | 66      | 0 to 4.8    | 91      | 4.8         |
| 17      | 0           | 42      | 4.8         | 67      | 0           | 92      | 0           |
| 18      | 0           | 43      | 4.8         | 68      | 4.8         | 93      | 0           |
| 19      | 4.8         | 44      | 4.8         | 69      | 0           | 94      | 2.38        |
| 20      | 4.8         | 45      | 0           | 70      | 0           | 95      | 0           |
| 21      | 0           | 46      | 4.8         | 71      | 4.8         | 96      | 1.45        |
| 22      | 0           | 47      | 4.8         | 72      | 0           | 97      | 0           |
| 23      | 4.8         | 48      | 4.8         | 73      | 4.8         | 98      | 4.8         |
| 24      | 4.8         | 49      | 4.8         | 74      | 4.8         | 99      | 1.45        |
| 25      | 0           | 50      | 4.8         | 75      | 0           | 100     | 1.45        |

C 4/5

IC902

| Pin No. | Voltage (V) | Pin No. | Voltage (V) |
|---------|-------------|---------|-------------|
| 1       | 4.8         | 21      | 0           |
| 2       | 0           | 22      | 0 to 4.8    |
| 3       | 0           | 23      | 0 to 4.8    |
| 4       | 0           | 24      | 0 to 4.8    |
| 5       | 0           | 25      | 0 to 4.8    |
| 6       | 4.8         | 26      | 0 to 4.8    |
| 7       | 0           | 27      | 0 to 4.8    |
| 8       | 0           | 28      | 0 to 4.8    |
| 9       | 0           | 29      | 0 to 4.8    |
| 10      | 0           | 30      | 0           |
| 11      | 0           | 31      | 0           |
| 12      | 0           | 32      | 0           |
| 13      | 0 to 4.8    | 33      | 0           |
| 14      | 0 to 4.8    | 34      | 0           |
| 15      | 0           | 35      | 0           |
| 16      | 0 to 4.8    | 36      | 0           |
| 17      | 0 to 4.8    | 37      | 0           |
| 18      | 0 to 4.8    | 38      | 0           |
| 19      | 0 to 4.8    | 39      | 0           |
| 20      | 4.8         | 40      | 0           |

D 1/3

IC1003

| Pin No. | Voltage (V) | Pin No. | Voltage (V) |
|---------|-------------|---------|-------------|
| 1       | -8.4        | 15      | 0 to 4.8    |
| 2       | -2.0 to 2.0 | 16      | 0 to 4.8    |
| 3       | -2.0 to 2.0 | 17      | 0           |
| 4       | -2.0 to 2.0 | 18      | 0           |
| 5       | -2.0 to 2.0 | 19      | 0           |
| 6       | 0           | 20      | 0           |
| 7       | -2.0 to 2.0 | 21      | 0           |
| 8       | -2.0 to 2.0 | 22      | 0           |
| 9       | 0           | 23      | 0           |
| 10      | -2.0 to 2.0 | 24      | 0           |
| 11      | -2.0 to 2.0 | 25      | 0           |
| 12      | -2.0 to 2.0 | 26      | 0           |
| 13      | 0           | 27      | 0           |
| 14      | 0           | 28      | 8.4         |

D 1/3

IC1007

| Pin No. | Voltage (V) | Pin No. | Voltage (V) |
|---------|-------------|---------|-------------|
| 1       | -8.4        | 15      | 0 to 4.8    |
| 2       | -1.0 to 1.0 | 16      | 0 to 4.8    |
| 3       | 0           | 17      | 0           |
| 4       | -1.0 to 1.0 | 18      | 0           |
| 5       | -1.0 to 1.0 | 19      | 0           |
| 6       | 0           | 20      | 0           |
| 7       | -1.0 to 1.0 | 21      | 0           |
| 8       | -1.0 to 1.0 | 22      | 0           |
| 9       | 0           | 23      | 0           |
| 10      | -1.0 to 1.0 | 24      | -1.0 to 1.0 |
| 11      | -1.0 to 1.0 | 25      | -1.0 to 1.0 |
| 12      | -1.0 to 1.0 | 26      | -1.0 to 1.0 |
| 13      | 0 to 4.8    | 27      | -1.0 to 1.0 |
| 14      | 0           | 28      | 8.4         |

## FLK1 ASSY

IC2001

| Pin No. | Voltage (V) | Pin No. | Voltage (V) | Pin No. | Voltage (V) | Pin No. | Voltage (V) |
|---------|-------------|---------|-------------|---------|-------------|---------|-------------|
| 1       | -35 to 4.8  | 21      | 0           | 41      | 0           | 61      | -35 to 4.8  |
| 2       | -35 to 4.8  | 22      | 0           | 42      | 0           | 62      | -35 to 4.8  |
| 3       | -35 to 4.8  | 23      | 0           | 43      | 0           | 63      | -35 to 4.8  |
| 4       | -35 to 4.8  | 24      | 0           | 44      | 0           | 64      | -35 to 4.8  |
| 5       | -35 to 4.8  | 25      | 0 to 4.8    | 45      | 0           | 65      | -35 to 4.8  |
| 6       | -35 to 4.8  | 26      | 0 to 4.8    | 46      | 0           | 66      | 0           |
| 7       | -35 to 4.8  | 27      | 2.8         | 47      | 4.8         | 67      | -35 to 4.8  |
| 8       | 4.8         | 28      | 0           | 48      | 0           | 68      | -35 to 4.8  |
| 9       | 0           | 29      | 4.8         | 49      | 7.6         | 69      | -35 to 4.8  |
| 10      | 0           | 30      | 4.8         | 50      | 0           | 70      | 0           |
| 11      | 0           | 31      | 0           | 51      | 0           | 71      | -35.0       |
| 12      | 4.8         | 32      | 4.8         | 52      | 4.8         | 72      | -35 to 4.8  |
| 13      | 0           | 33      | 0           | 53      | -35 to 4.8  | 73      | 0           |
| 14      | 0 to 4.8    | 34      | 0 to 4.8    | 54      | -35 to 4.8  | 74      | -35 to 4.8  |
| 15      | 0 to 4.8    | 35      | 0 to 4.8    | 55      | -35 to 4.8  | 75      | -35 to 4.8  |
| 16      | 0 to 4.8    | 36      | 4.8         | 56      | -35 to 4.8  | 76      | -35 to 4.8  |
| 17      | 4.8         | 37      | 0           | 57      | -35 to 4.8  | 77      | -35 to 4.8  |
| 18      | 0           | 38      | 4.8         | 58      | -35 to 4.8  | 78      | -35 to 4.8  |
| 19      | 0           | 39      | 0           | 59      | -35 to 4.8  | 79      | -35 to 4.8  |
| 20      | 0           | 40      | 0           | 60      | -35 to 4.8  | 80      | -35 to 4.8  |

## FLK2 ASSY

IC2101

| Pin No. | Voltage (V) | Pin No. | Voltage (V) | Pin No. | Voltage (V) | Pin No. | Voltage (V) |
|---------|-------------|---------|-------------|---------|-------------|---------|-------------|
| 1       | -35 to 4.8  | 21      | 0           | 41      | 0           | 61      | -35 to 5.0  |
| 2       | -35 to 4.8  | 22      | 0           | 42      | 4.8         | 62      | -35 to 5.0  |
| 3       | -35 to 4.8  | 23      | 0           | 43      | 0           | 63      | -35 to 5.0  |
| 4       | -35 to 4.8  | 24      | 0           | 44      | 0           | 64      | -35 to 5.0  |
| 5       | -35 to 4.8  | 25      | 0           | 45      | 4.8         | 65      | -35 to 5.0  |
| 6       | -35 to 4.8  | 26      | 4.8         | 46      | 4.8         | 66      | -35 to 5.0  |
| 7       | -35 to 4.8  | 27      | 0           | 47      | 0           | 67      | -35 to 5.0  |
| 8       | 4.8         | 28      | 0           | 48      | 0           | 68      | -35 to 5.0  |
| 9       | 0           | 29      | 4.8         | 49      | 0           | 69      | -35 to 5.0  |
| 10      | 0           | 30      | 4.8         | 50      | 0           | 70      | -35 to 5.0  |
| 11      | 0           | 31      | 0           | 51      | 8.4         | 71      | -35         |
| 12      | 0           | 32      | 4.8         | 52      | 4.8         | 72      | -35 to 5.0  |
| 13      | 0           | 33      | 0           | 53      | -35 to 5.0  | 73      | -35 to 5.0  |
| 14      | 0 to 4.8    | 34      | 0 to 4.8    | 54      | -35 to 5.0  | 74      | -35 to 5.0  |
| 15      | 0 to 4.8    | 35      | 0 to 4.8    | 55      | -35 to 5.0  | 75      | -35 to 5.0  |
| 16      | 0 to 4.8    | 36      | 4.8         | 56      | -35 to 5.0  | 76      | -35 to 5.0  |
| 17      | 4.8         | 37      | 0           | 57      | -35 to 5.0  | 77      | -35 to 5.0  |
| 18      | 0           | 38      | 4.8         | 58      | -35 to 5.0  | 78      | -35 to 5.0  |
| 19      | 0           | 39      | 0           | 59      | -35 to 5.0  | 79      | -35 to 5.0  |
| 20      | 0           | 40      | 4.8         | 60      | -35 to 5.0  | 80      | -35 to 5.0  |

## 4. PCB CONNECTION DIAGRAM

### NOTE FOR PCB DIAGRAMS :

1. Part numbers in PCB diagrams match those in the schematic diagrams.
2. A comparison between the main parts of PCB and schematic diagrams is shown below.

| Symbol In PCB Diagrams | Symbol In Schematic Diagrams | Part Name                |
|------------------------|------------------------------|--------------------------|
|                        |                              | Transistor               |
|                        |                              | Transistor with resistor |
|                        |                              | Field effect transistor  |
|                        |                              | Resistor array           |
|                        |                              | 3-terminal regulator     |

3. The parts mounted on this PCB include all necessary parts for several destinations.
- For further information for respective destinations, be sure to check with the schematic diagram.
4. View point of PCB diagrams.

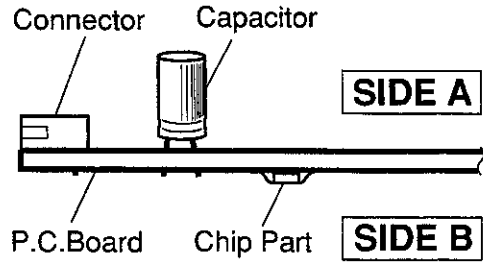

### 4.1 SLM1 and SLM2 ASSYS

#### A SLM1 ASSY

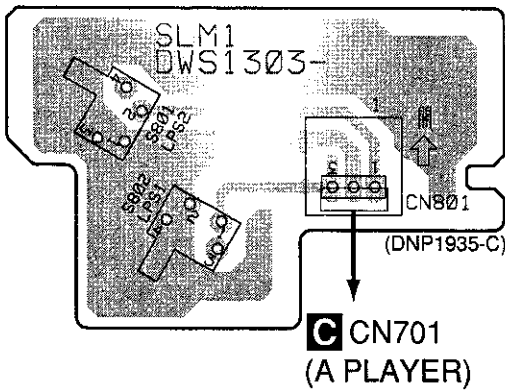

#### A SLM1 ASSY

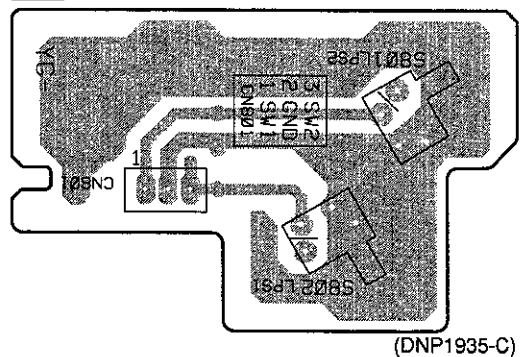

#### B SLM2 ASSY

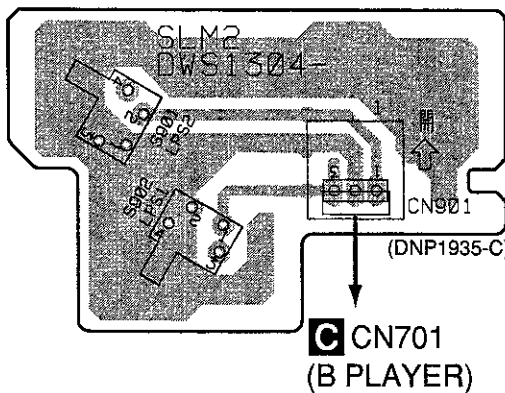

#### B SLM2 ASSY

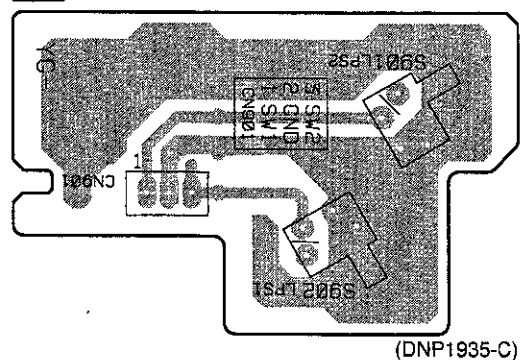

**SIDE A**

**SIDE B**

1 2 3 4

# CMX-5000, CU-V160

## 4.2 CDPB ASSY

### C CDPB ASSY

- A **A** CN801 (A PLAYER)    **D** CN1001 (A PLAYER)    **D** CN1006 (A PLAYER)  
 B **B** CN901 (B PLAYER)    **D** CN1002 (B PLAYER)    **D** CN1005 (B PLAYER)

A

B

C

D

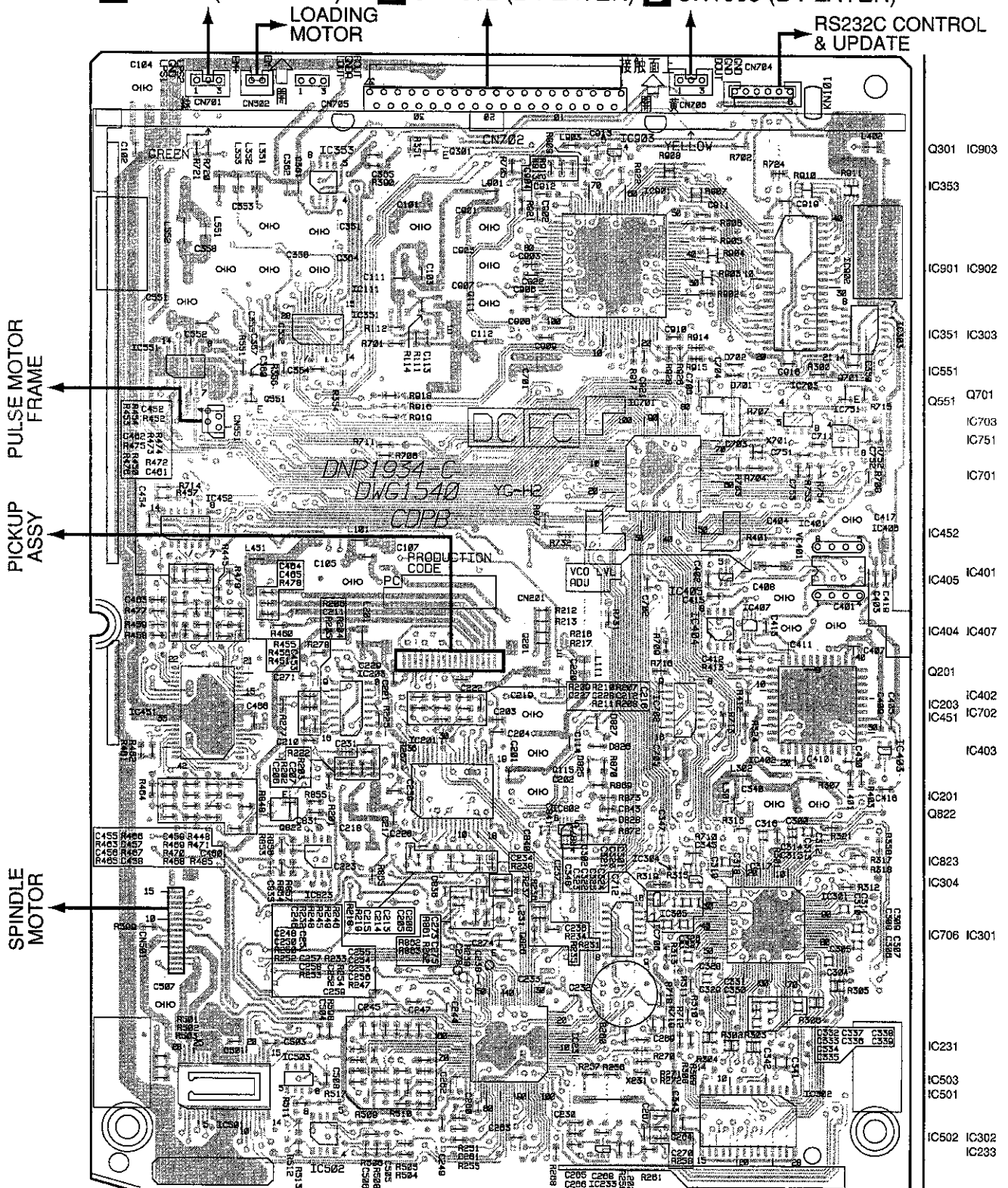

- Q301 IC903
- IC353
- IC901 IC902
- IC351 IC303
- IC551
- Q551 Q701
- IC703
- IC751
- IC701
- IC452
- IC405
- IC401
- IC404 IC407
- Q201
- IC203 IC702
- IC403
- IC201
- Q822
- IC823
- IC304
- IC706 IC301
- IC231
- IC503
- IC501
- IC502 IC302
- IC233

SIDE A

(DNP1934-C)



**C** CDPB ASSY

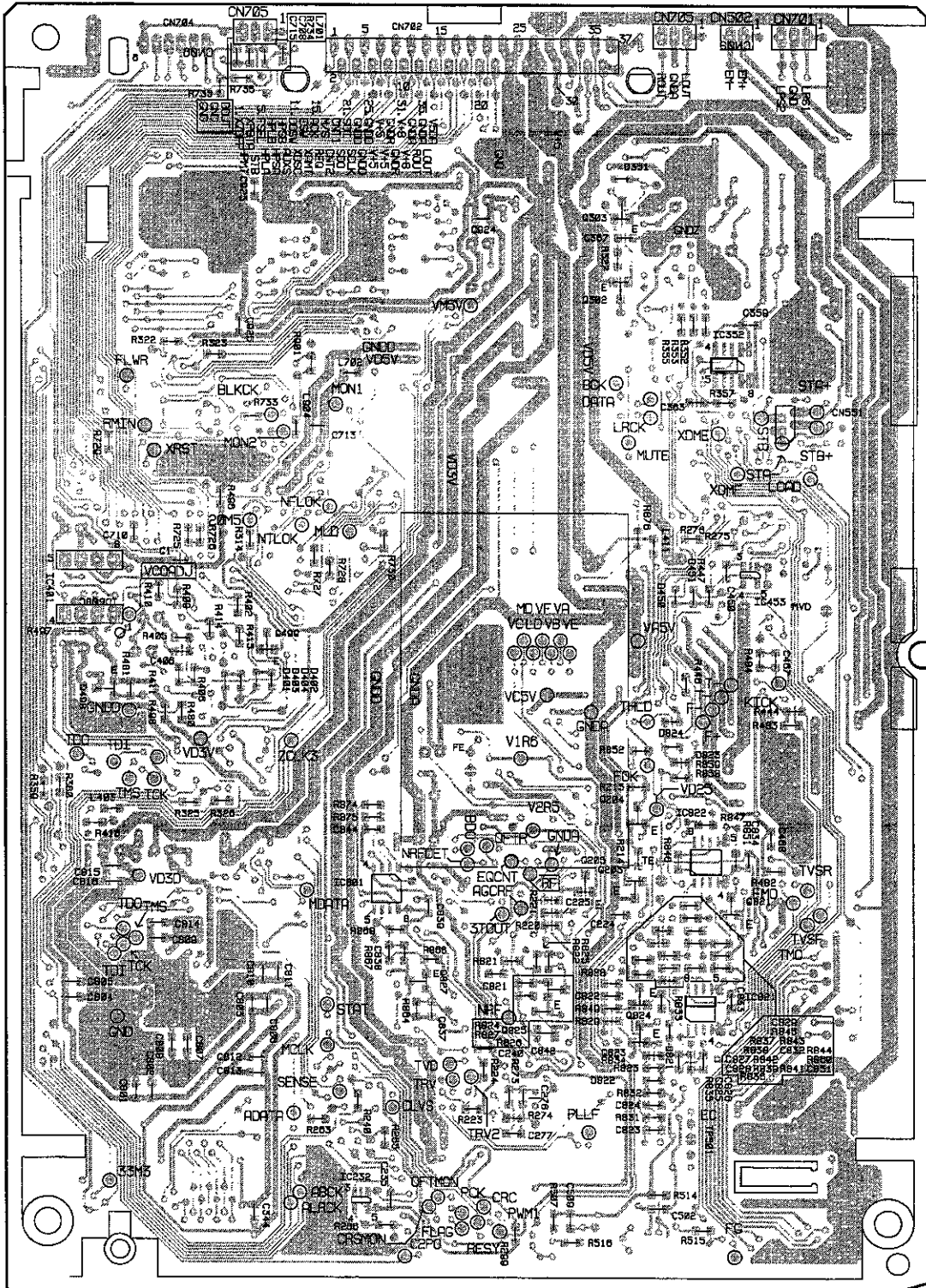

IC352

IC453  
IC401

Q498

Q204

IC822  
Q205  
Q203  
Q821

Q825  
Q824  
IC821  
Q823

IC232

**SIDE B**

(DNP1934-C)



1 2 3 4

CMX-5000, CU-V160

4.3 TRMB and HPJB ASSYS

A **D** TRMB ASSY

IC1008 IC1009 IC1010 IC1016 Q1203 Q1204 IC1013 IC1014

**N** CN2602  
(CU-V106)

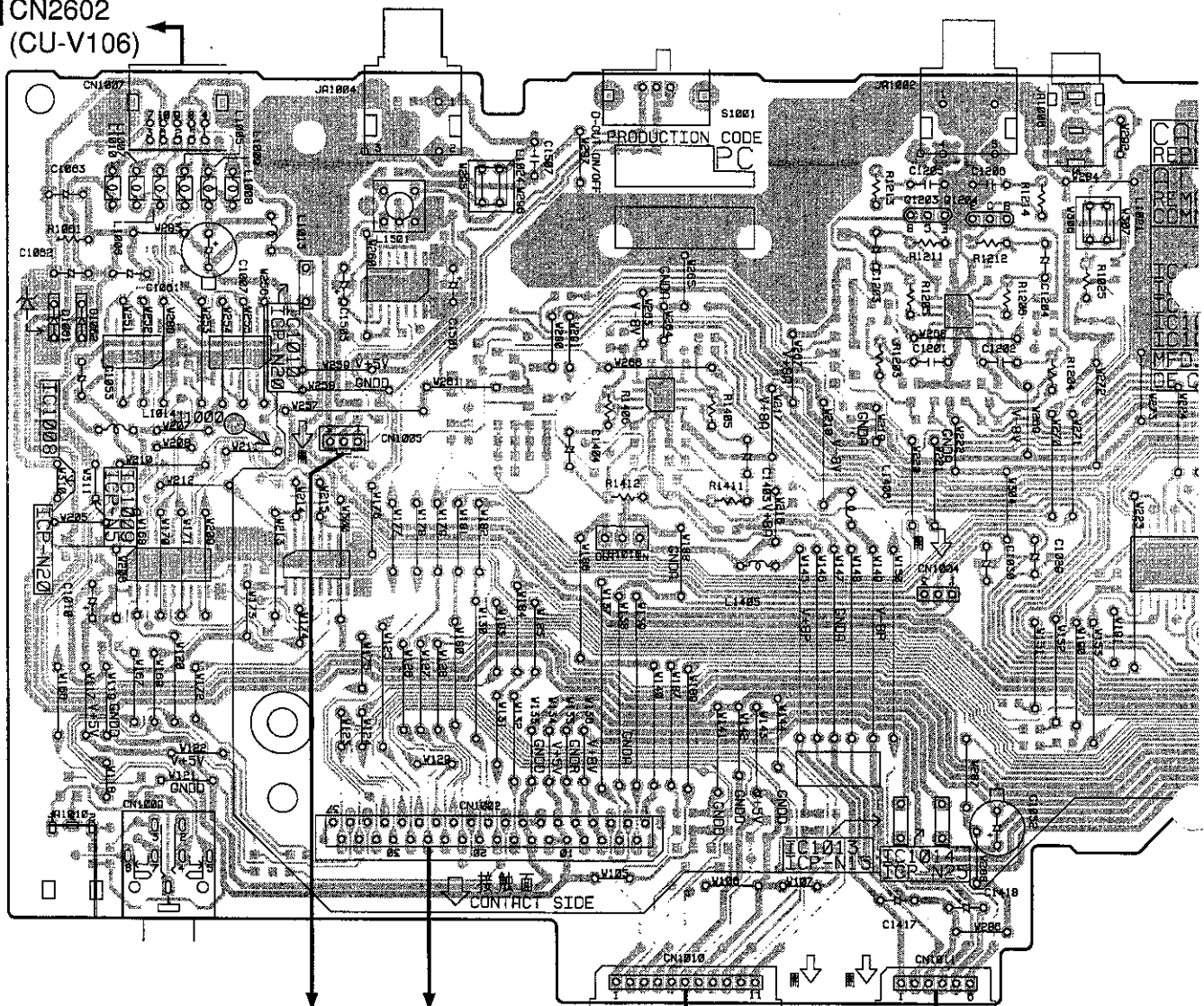

**C** CN706 **C** CN702  
B PLAYER

**F** J1901

**E** HPJB ASSY

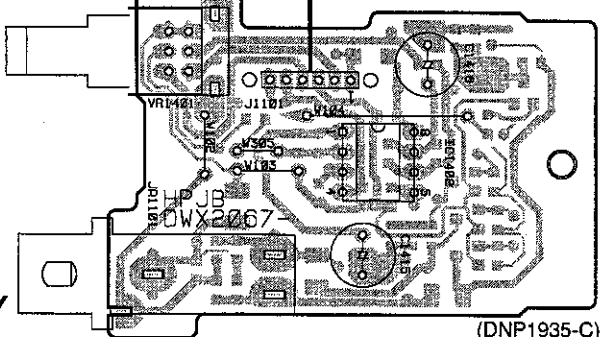



# CMX-5000, CU-V160

Q1303 Q1304

Q1103 Q1104  
IC1017 IC1015  
IC1012  
IC1011

Q1006  
IC1001

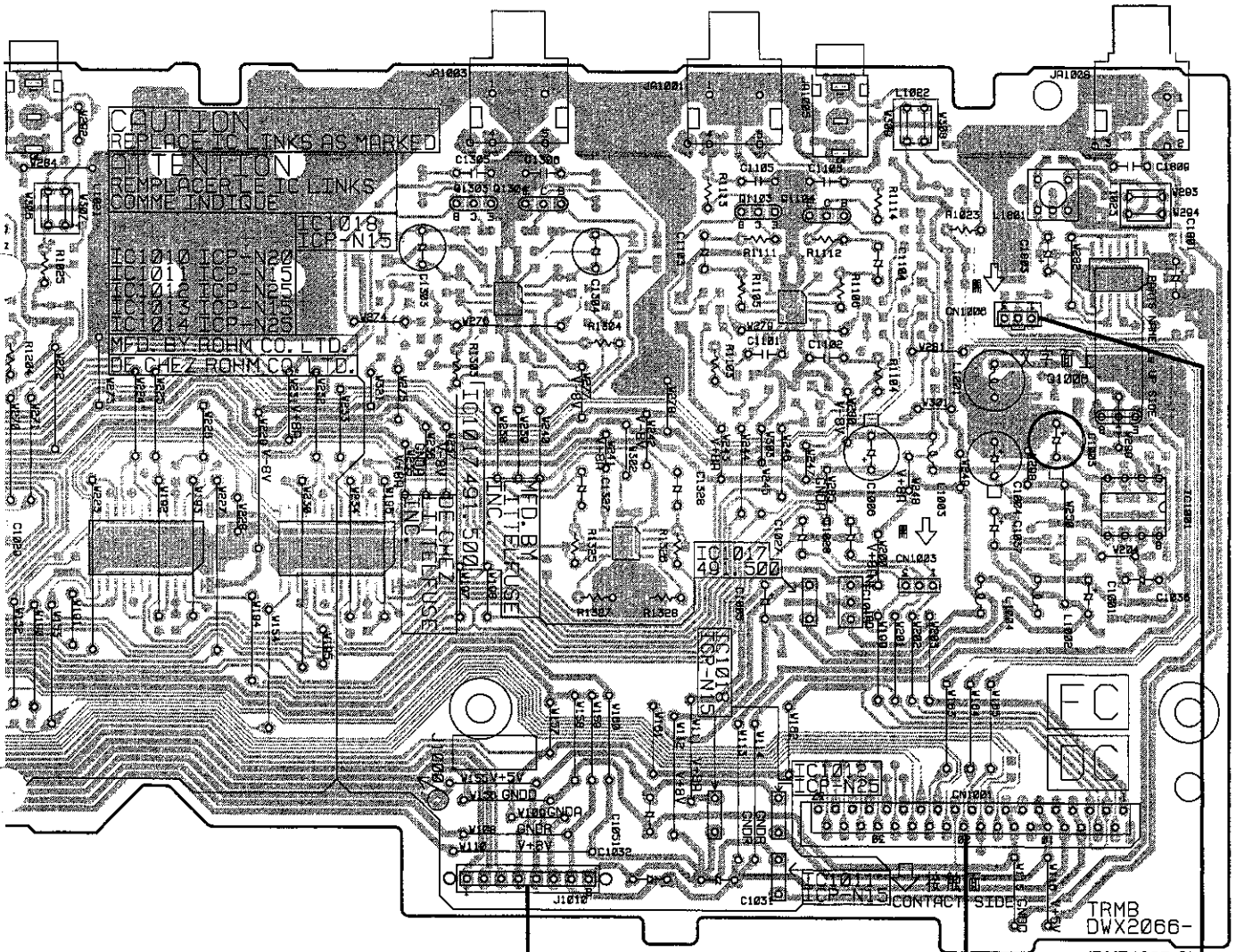

**G** CN101

**G** CN702

**G** CN706

A PLAYER

**SIDE A**

1 2 3 4

# CMX-5000, CU-V160

A

## D TRMB ASSY

IC1801 Q1001 Q1106 Q1105 IC1101 Q1102 Q1101 IC1302 Q1302 Q1301 IC1007 IC1003

B

C

D

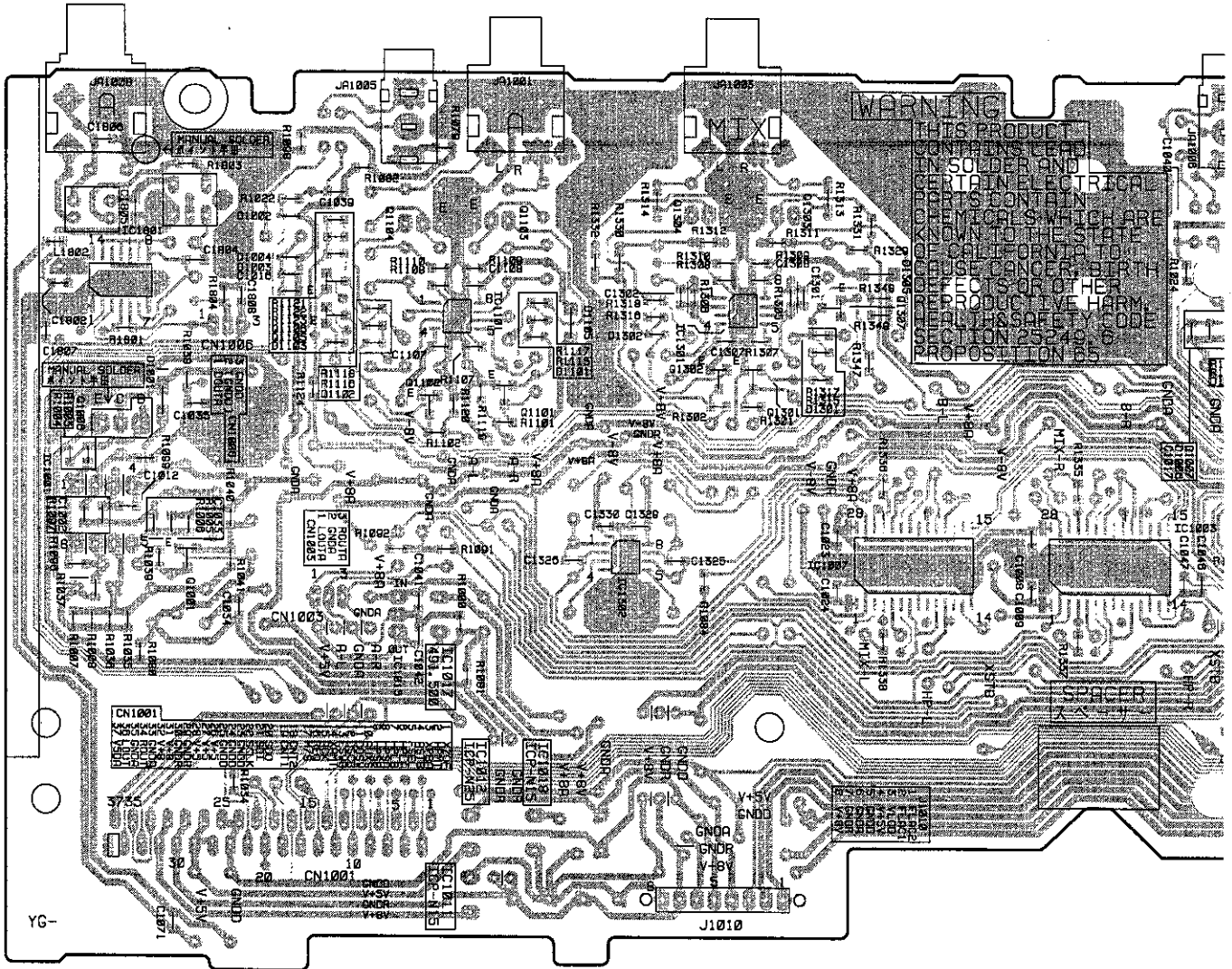

**SIDE B**



4.4 SELB ASSY

A

**F** SELB ASSY

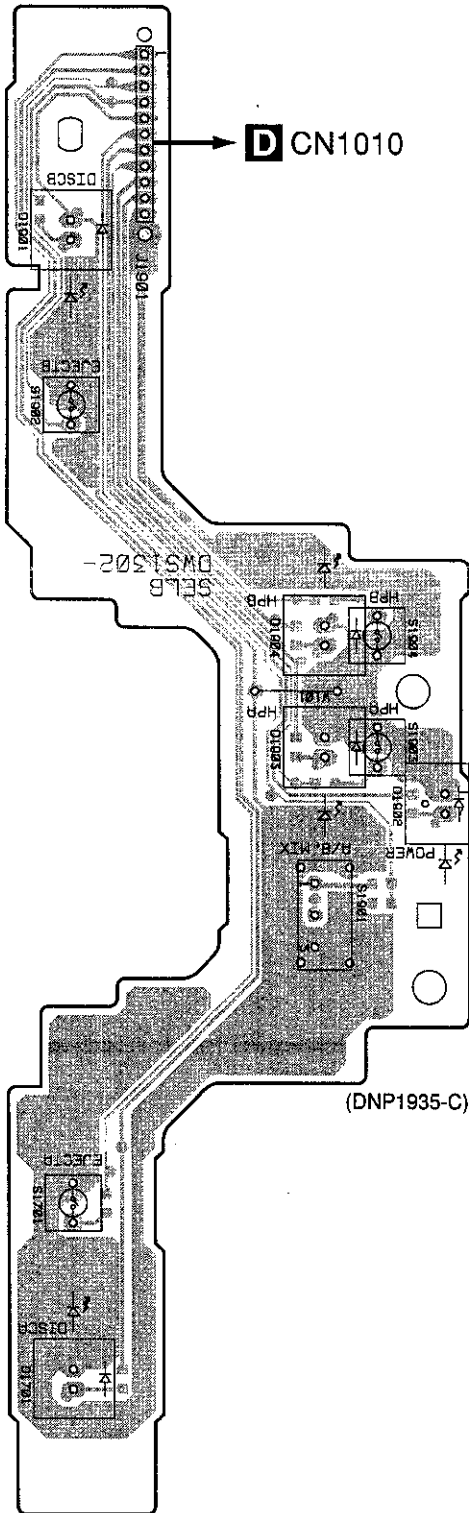

**F** SIDE A

**F** SELB ASSY

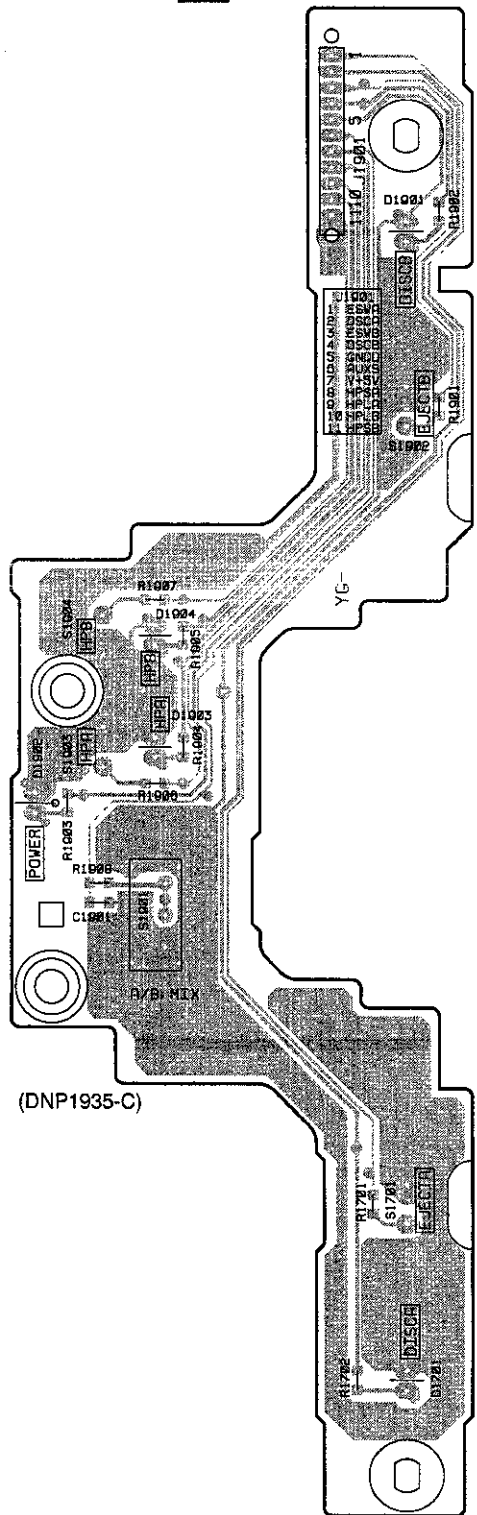

**F** SIDE B

4.5 SW POWER SUPPLY and PSWB ASSYS

**G** SW POWER SUPPLY ASSY

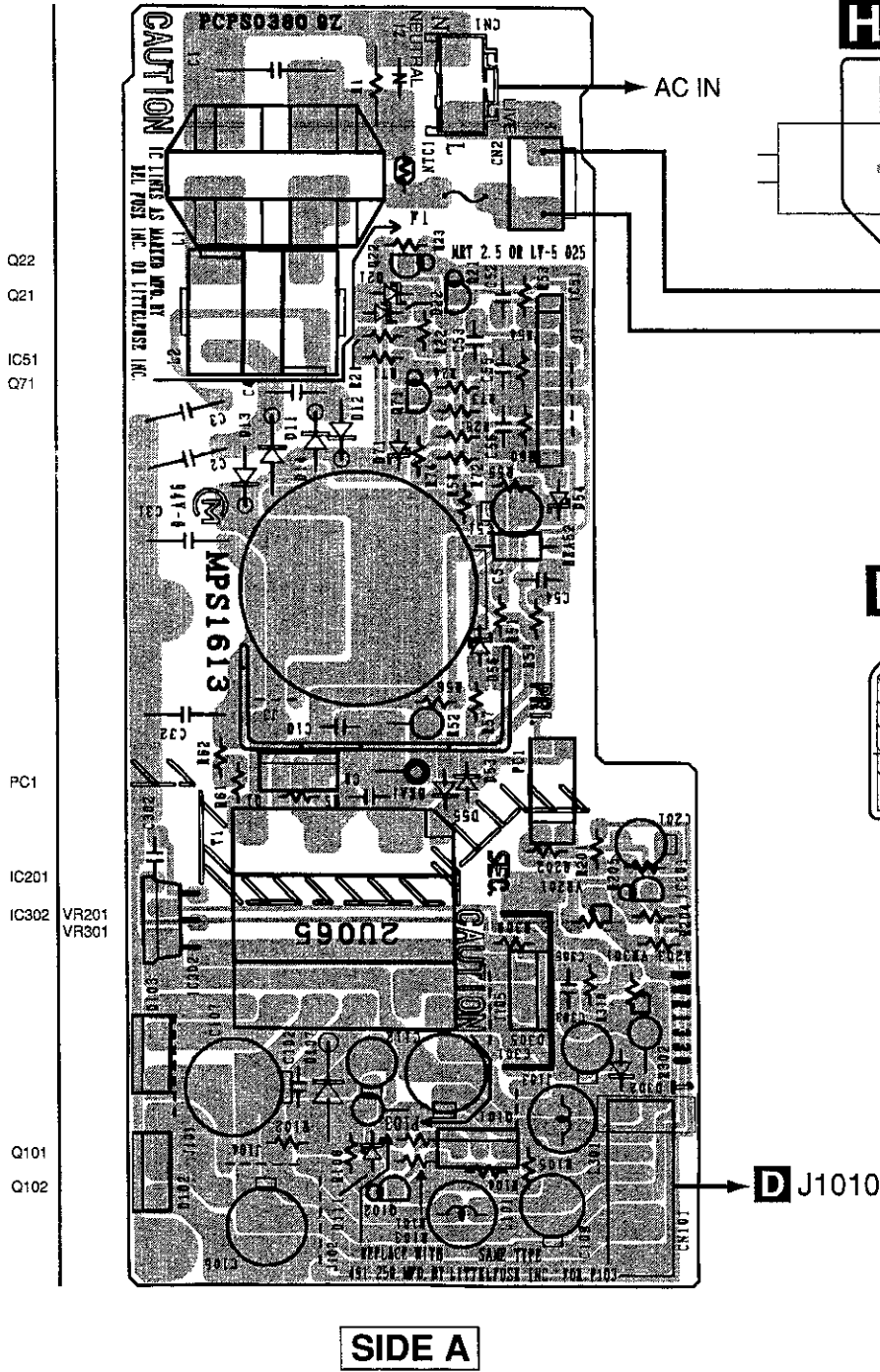

**H** PSWB ASSY

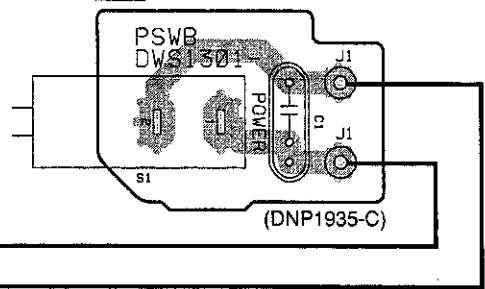

**SIDE A**

**H** PSWB ASSY

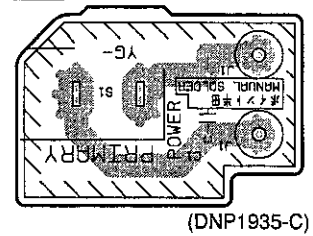

**SIDE B**

1 2 3 4

# CMX-5000, CU-V160

## 4.6 FLK1 and PHT1 ASSYS

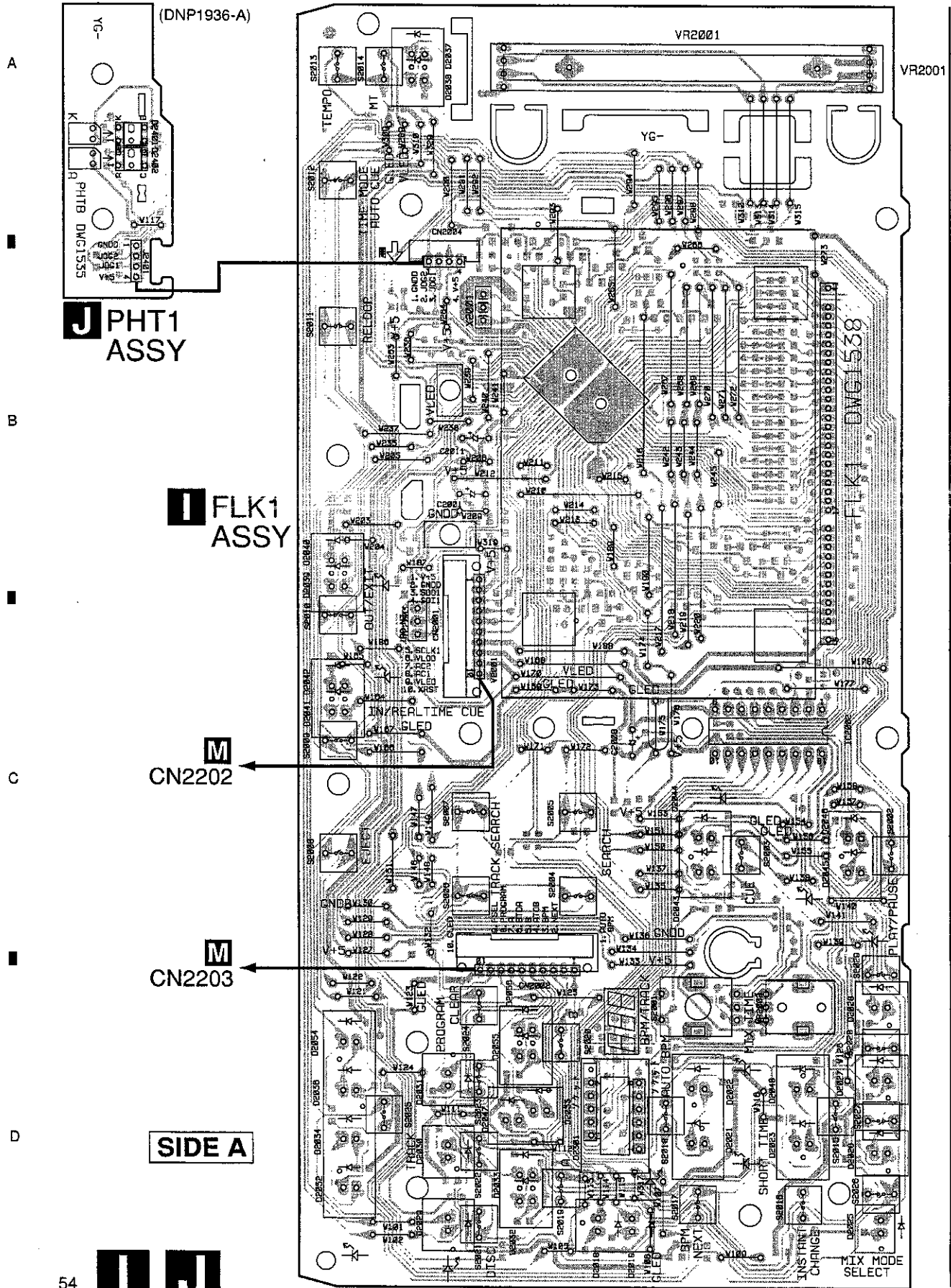

1 2 3 4

Q2015-Q2016  
Q2003-Q2008

IC2001

Q2002  
Q2017-Q2021  
Q2001  
Q2009-Q2011

IC2002

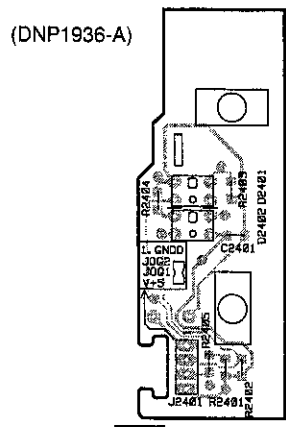
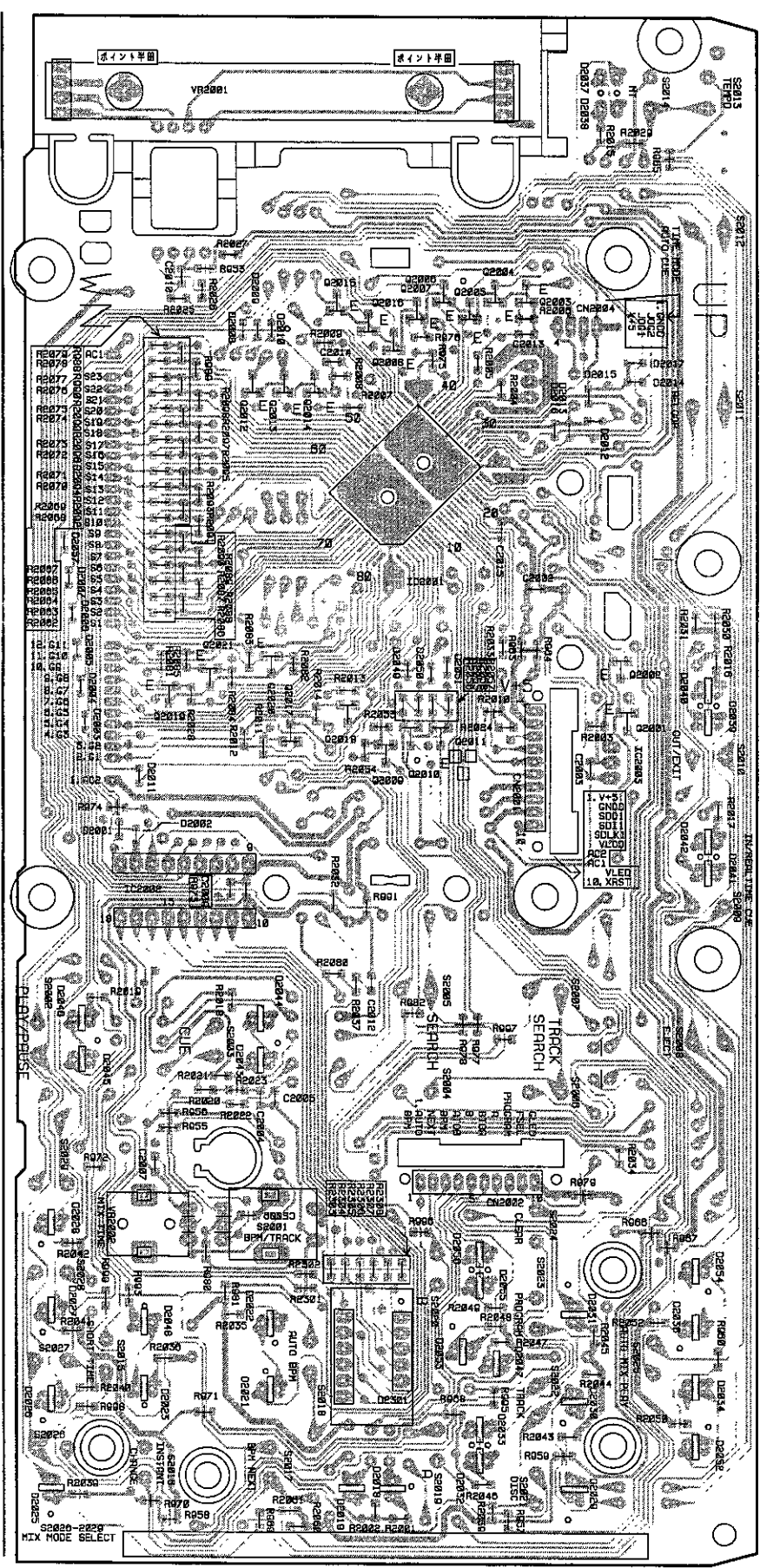

**J** PHT1  
ASSY

**I** FLK1  
ASSY

**SIDE B**

**I J**

1 2 3 4

4.7 FLK2 and PHT2 ASSYS

A

**L** PHT2 ASSY

**K** FLK2 ASSY

**M** CN2204 **M** CN2205

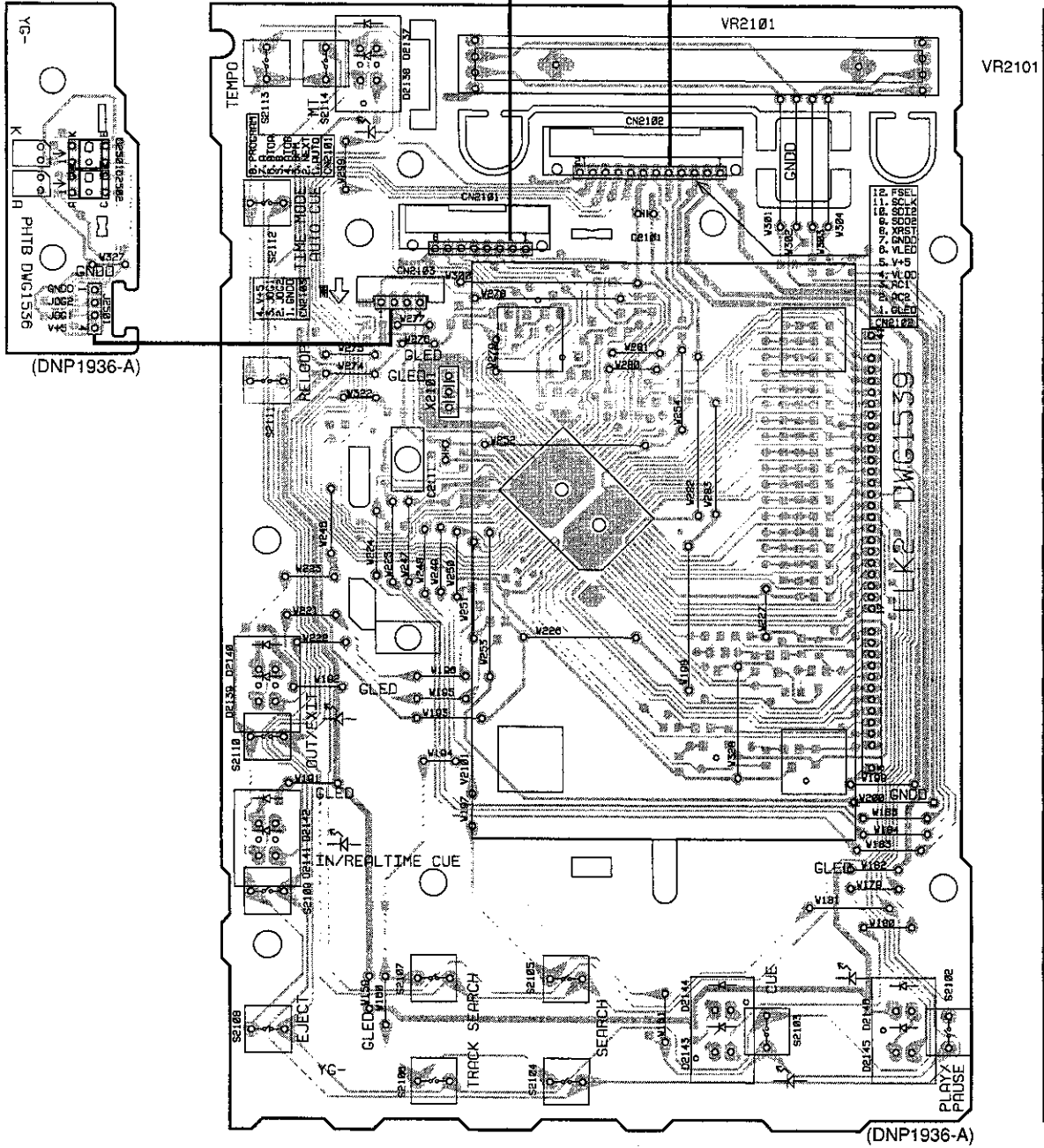

B

C

D

**SIDE A**



# K FLK2 ASSY

# L PHT2 ASSY

- Q2112
- Q2115-Q2124
- IC2101
- Q2114 Q2113
- Q2125-Q2129

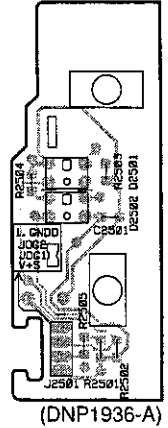
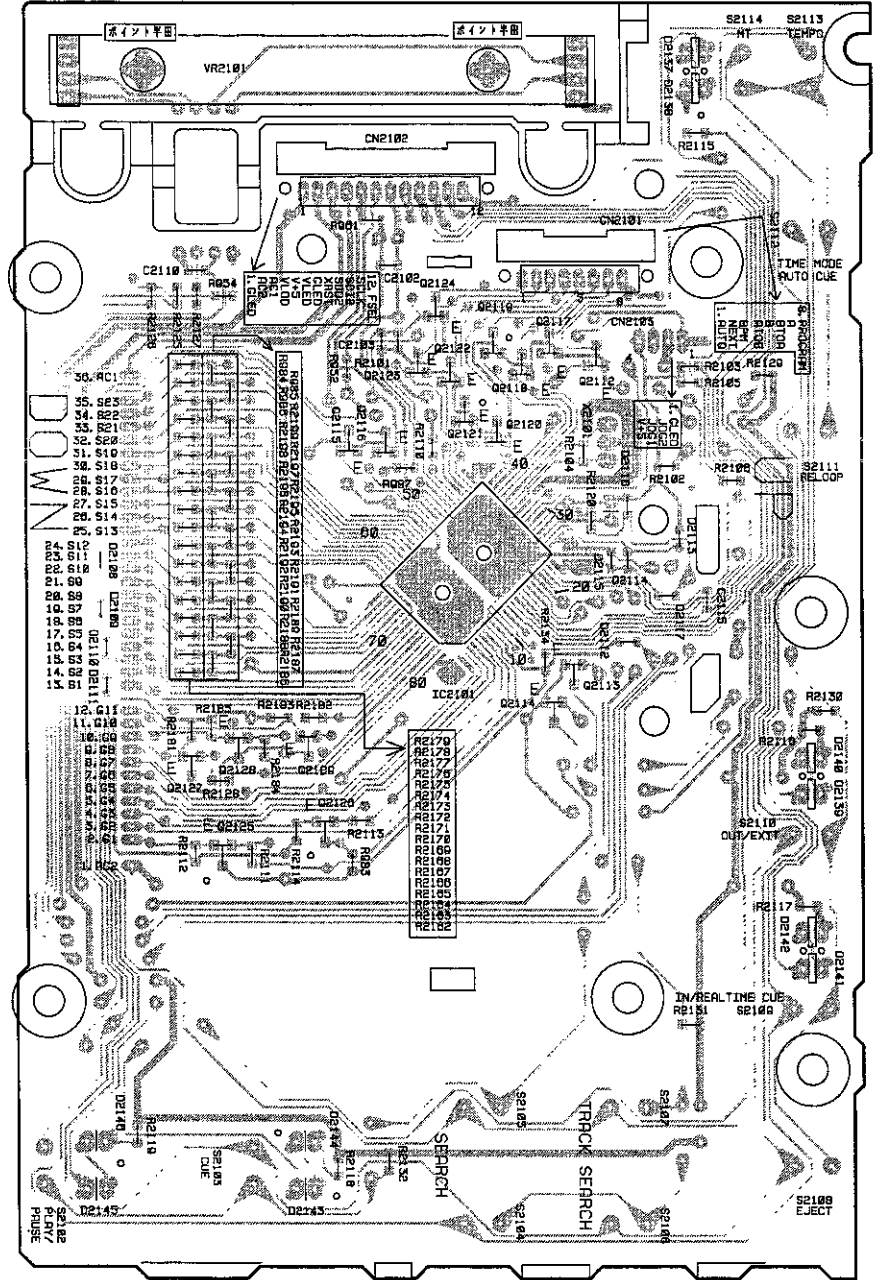

(DNP1936-A)

SIDE B

# CMX-5000, CU-V160

## 4.8 CNNB and CTJB ASSYS

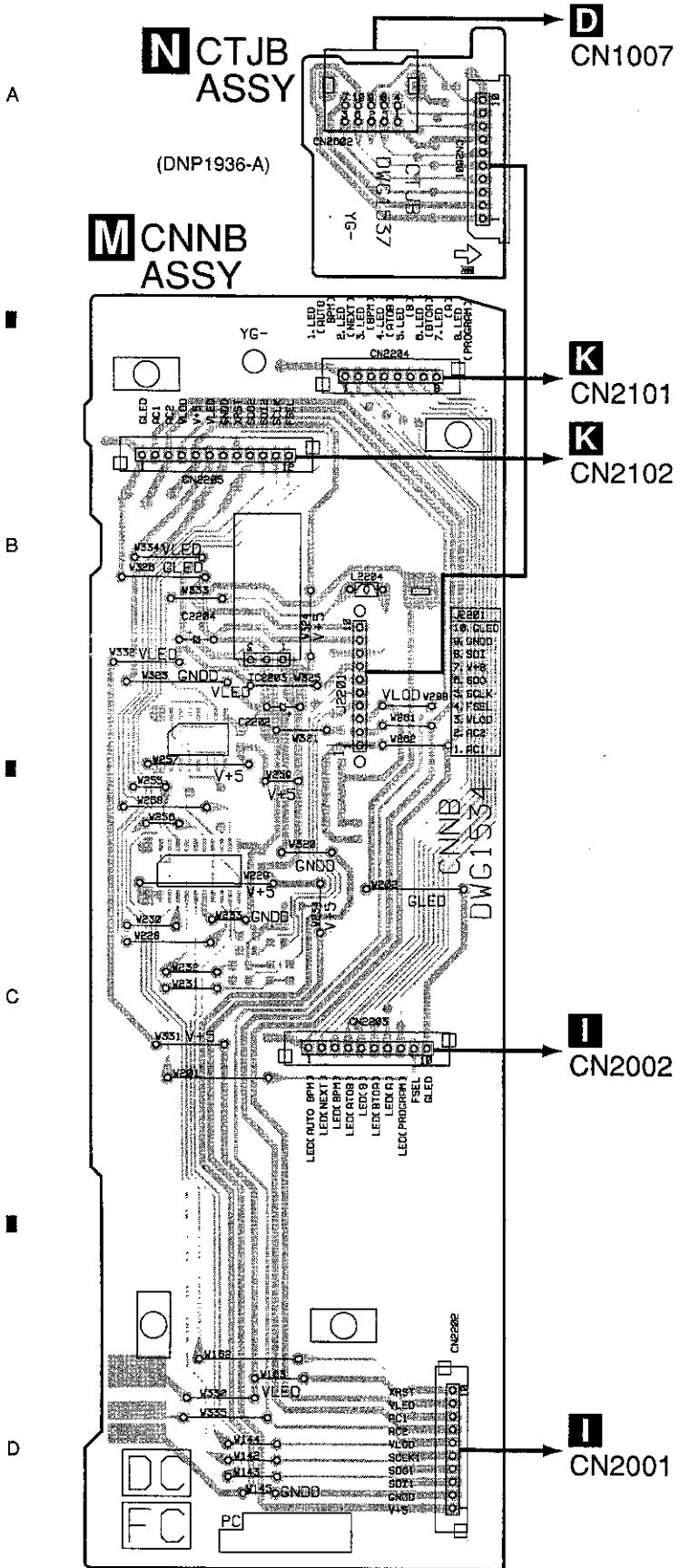

## 5. PCB PARTS LIST

NOTES: ●Parts marked by "NSP" are generally unavailable because they are not in our Master Spare Parts List.

●The Δ mark found on some component parts indicates the importance of the safety factor of the part. Therefore, when replacing, be sure to use parts of identical designation.

●When ordering resistors, first convert resistance values into code form as shown in the following examples.

Ex.1 When there are 2 effective digits (any digit apart from 0), such as 560 ohm and 47k ohm (tolerance is shown by J=5%, and K=10%).

560 Ω → 56 × 10<sup>1</sup> → 561 ..... RD1/4PU 5 6 1 J  
 47k Ω → 47 × 10<sup>3</sup> → 473 ..... RD1/4PU 4 7 3 J  
 0.5 Ω → R50 ..... RN2H R 5 0 K  
 1 Ω → 1R0 ..... RS1P 1 R 0 K

Ex.2 When there are 3 effective digits (such as in high precision metal film resistors).

5.62k Ω → 562 × 10<sup>1</sup> → 5621 ..... RN1/4PC 5 6 2 1 F

| Mark No.                  | Description          | Part No. |
|---------------------------|----------------------|----------|
| <b>LIST OF ASSEMBLIES</b> |                      |          |
|                           | CDPB ASSY            | DWG1540  |
|                           | JACB ASSY            | DWM2113  |
|                           | └ SLM1 ASSY          | DWS1303  |
|                           | └ SLM2 ASSY          | DWS1304  |
|                           | └ TRMB ASSY          | DWX2066  |
|                           | └ HPJB ASSY          | DWX2067  |
|                           | └ SELB ASSY          | DWS1302  |
|                           | └ PSWB ASSY          | DWS1301  |
| Δ                         | SW POWER SUPPLY ASSY | DWR1330  |
| NSP                       | REMOTE CONTROLLER    | CU-V160  |
|                           | └ DISP ASSY          | DWM2114  |
|                           | └ FLK1 ASSY          | DWG1538  |
|                           | └ PHT1 ASSY          | DWG1535  |
|                           | └ FLK2 ASSY          | DWG1539  |
|                           | └ PHT2 ASSY          | DWG1536  |
|                           | └ CNNB ASSY          | DWG1534  |
|                           | └ CTJB ASSY          | DWG1537  |

### A SLM1 ASSY

#### SWITCHES

S801, S802 DSG1017

#### OTHERS

CN801 KR CONNECTOR (3P) S3B-PH-K

### B SLM2 ASSY

#### SWITCHES

S901, S902 DSG1017

#### OTHERS

CN901 KR CONNECTOR (3P) S3B-PH-K

| Mark No.              | Description                       | Part No.            |
|-----------------------|-----------------------------------|---------------------|
| <b>C CDPB ASSY</b>    |                                   |                     |
| <b>SEMICONDUCTORS</b> |                                   |                     |
|                       | IC501                             | AN8483NSB           |
|                       | IC201                             | AN8847SB            |
|                       | IC801, IC823                      | BA10393F            |
|                       | IC401                             | BA7042              |
|                       | IC203, IC702, IC706               | BU4053BCF           |
|                       | IC902                             | GLT44016-40J4       |
|                       | IC551                             | LB1836M             |
|                       | IC751                             | M51953BFP           |
|                       | IC111                             | M5237ML             |
|                       | IC451                             | M56783AFP           |
|                       | IC901                             | MN19413A-PP         |
|                       | IC231                             | MN662754CEA         |
|                       | IC302                             | MSM51V17805D-60TS-K |
|                       | IC502, IC822                      | NJM2904M            |
|                       | IC821                             | NJM4580ED           |
|                       | IC406                             | NJM78L05UA          |
|                       | IC701                             | PD3426A9            |
|                       | IC351                             | PE8001A             |
|                       | IC402                             | PE9009A             |
|                       | IC503                             | TC4W53F             |
|                       | IC303                             | TC74HCT7007AF       |
|                       | IC304                             | TC7S04F             |
|                       | IC453                             | TC7S32F             |
|                       | IC232                             | TC7SET08F           |
|                       | IC233, IC305, IC403, IC405, IC903 | TC7SU04F            |
|                       | IC703                             | TC7W32F             |
|                       | IC802                             | TC7W53FU            |
|                       | IC407                             | TC7WT241FU          |
|                       | IC352                             | TC7WU04F            |
|                       | IC301                             | XCB56364            |
|                       | Q203, Q498, Q821, Q823, Q827      | 2SA1037K            |
|                       | Q111, Q201                        | 2SB1132             |
|                       | Q204, Q824, Q826                  | 2SC2412K            |
|                       | Q205                              | 2SC3837K            |
|                       | Q825                              | 2SD2114K            |
|                       | Q301, Q822                        | DTA124EK            |
|                       | Q499                              | DTC115EK            |
|                       | Q551, Q701                        | DTC124EK            |
|                       | D351, D450, D451, D821-D828       | 1SS355              |

# CMX-5000, CU-V160

| Mark No.     | Description              | Part No.     |
|--------------|--------------------------|--------------|
| <b>COILS</b> |                          |              |
|              | L111,L201,L351-L353,L402 | DTL1024      |
|              | L551                     | DTL1024      |
|              | L231                     | LCTA100J2520 |
|              | L101                     | OTL1009      |
| Δ            | L202,L401,L403           | PTL1014      |
|              | L301,L302                | PTL1014      |
|              | L411,L701,L702,L901      | PTL1014      |
|              | L903,L904                | PTL1014      |

| Mark No.          | Description              | Part No.     |
|-------------------|--------------------------|--------------|
| <b>CAPACITORS</b> |                          |              |
|                   | C258,C824,C826,C821,C822 | CCSQCH101J50 |
|                   | C264,C265                | CCSQCH120J50 |
|                   | C455,C457                | CCSQCH121J50 |
|                   | C273                     | CCSQCH180J50 |
|                   | C206                     | CCSQCH181J50 |
|                   | C801,C803,C805,C808-C810 | CCSQCH221J50 |
|                   | C812,C815,C843           | CCSQCH221J50 |
|                   | C210                     | CCSQCH331J50 |
|                   | C212                     | CCSQCH470J50 |
|                   | C275                     | CCSQCH5R0C50 |
|                   | C207                     | CCSQCH680J50 |
|                   | C304,C306,C308,C310,C312 | CCSRCH101J50 |
|                   | C314,C316,C318,C320,C322 | CCSRCH101J50 |
|                   | C324,C326,C328,C330,C332 | CCSRCH101J50 |
|                   | C334,C336,C336           | CCSRCH101J50 |
|                   | C430                     | CCSRCH330J50 |
|                   | C274                     | CCSRCH560J50 |
|                   | C105,C115                | CEAL101M6R3  |
|                   | C202,C219                | CEAL470M6R3  |
|                   | C101,C901                | CEAT101M10   |
|                   | C104                     | CEJA101M16   |
|                   | C401,C551                | CEJA101M6R3  |
|                   | C408                     | CEJA1R0M50   |
|                   | C411                     | CEJA220M10   |
|                   | C353,C356,C358           | CEJA221M6R3  |
|                   | C507                     | CEJA330M10   |
|                   | C300,C340,C351,C364,C417 | CEJA470M6R3  |
|                   | C905                     | CEJA470M6R3  |
|                   | C223                     | CEV100M16    |
|                   | C218                     | CEV470M6R3   |
|                   | C113,C234,C247,C253,C257 | CKSQYB102K50 |
|                   | C363                     | CKSQYB102K50 |
|                   | C102,C103,C107,C114,C201 | CKSQYB103K50 |
|                   | C211,C217,C220,C224,C229 | CKSQYB103K50 |
|                   | C235,C240,C266,C268,C269 | CKSQYB103K50 |
|                   | C341,C344,C350,C352      | CKSQYB103K50 |
|                   | C354,C355,C357,C359,C360 | CKSQYB103K50 |
|                   | C362,C402-C405,C450      | CKSQYB103K50 |
|                   | C466,C467,C501-C503,C508 | CKSQYB103K50 |
|                   | C552,C701-C706,C710,C711 | CKSQYB103K50 |
|                   | C715,C752,C753,C802,C804 | CKSQYB103K50 |
|                   | C806,C807,C811,C813,C814 | CKSQYB103K50 |
|                   | C816,C833-C835,C844,C902 | CKSQYB103K50 |
|                   | C904,C906,C908-C913      | CKSQYB103K50 |
|                   | C921,C922,C924,C925      | CKSQYB103K50 |
|                   | C112,C203,C204,C221,C222 | CKSQYB104K25 |
|                   | C225,C230,C245,C248-C251 | CKSQYB104K25 |
|                   | C256,C260-C263,C365      | CKSQYB104K25 |
|                   | C406,C407,C409,C410,C413 | CKSQYB104K25 |
|                   | C419,C751,C828,C829,C839 | CKSQYB104K25 |

| Mark No. | Description              | Part No.     |
|----------|--------------------------|--------------|
|          | C851,C916,C919           | CKSQYB104K25 |
|          | C214,C215,C254,C271      | CKSQYB105K10 |
|          | C903                     | CKSQYB105K10 |
|          | C823,C825                | CKSQYB122K50 |
|          | C505,C837                | CKSQYB152K50 |
|          | C216,C453                | CKSQYB182K50 |
|          | C459                     | CKSQYB222K50 |
|          | C236,C237,C246,C252,C461 | CKSQYB223K50 |
|          | C463                     | CKSQYB223K50 |
|          | C231                     | CKSQYB224K16 |
|          | C208                     | CKSQYB272K50 |
|          | C205                     | CKSQYB273K50 |
|          | C838                     | CKSQYB332K50 |
|          | C456,C458                | CKSQYB333K50 |
|          | C239,C462,C504           | CKSQYB393K50 |
|          | C831                     | CKSQYB472K50 |
|          | C255,C259,C452           | CKSQYB474K16 |
|          | C827,C832                | CKSQYB474K16 |
|          | C347                     | CKSRYB102K50 |
|          | C302,C305,C307,C309,C311 | CKSRYB103K50 |
|          | C313,C315,C317,C319,C321 | CKSRYB103K50 |
|          | C323,C325,C327,C329,C331 | CKSRYB103K50 |
|          | C333,C335,C337,C339,C345 | CKSRYB103K50 |
|          | C348,C712                | CKSRYB103K50 |
|          | C232,C233,C238,C244,C836 | CKSRYB104K16 |
|          | C841                     | CKSRYB104K16 |
|          | C278                     | CKSRYB152K50 |
|          | C213                     | CKSRYB273K16 |
|          | C301,C840                | CKSRYB562K50 |
|          | C842                     | CSZSR100M16  |
|          | VC401 (40pF)             | VCM1010      |

| Mark No.         | Description              | Part No.     |
|------------------|--------------------------|--------------|
| <b>RESISTORS</b> |                          |              |
|                  | R903,R904                | RA4C101J     |
|                  | R910,R911                | RA4C473J     |
|                  | R464,R465,R467,R468,R851 | RS1/10S1002F |
|                  | R848                     | RS1/10S3902F |
|                  | R112                     | RS1/10S4301F |
|                  | R214                     | RS1/10S51R0F |
|                  | R463,R466                | RS1/10S6202F |
|                  | R111                     | RS1/10S6801F |
|                  | R215                     | RS1/10S9100F |
|                  | R315                     | RS1/16S101J  |
|                  | R861                     | RS1/16S102J  |
|                  | R239                     | RS1/16S103J  |
|                  | R218,R219                | RS1/16S152J  |
|                  | R862,R863                | RS1/16S473J  |
|                  | Other Resistors          | RS1/10S□□□□  |

| Mark No.      | Description                    | Part No.   |
|---------------|--------------------------------|------------|
| <b>OTHERS</b> |                                |            |
| CN501         | CONNECTOR (15P)                | 52207-1590 |
| CN201         | CONNECTOR (17P)                | 52207-1790 |
| CN502         | KR CONNECTOR (2P)              | B2B-PH-K-S |
| CN701         | KR CONNECTOR (3P)              | B3B-PH-K   |
| CN706         | KR CONNECTOR (3P)              | B3B-PH-K-Y |
| CN704         | KR CONNECTOR (6P)              | B6B-PH-K-S |
|               | PC BOARD CDPB                  | DNP1934    |
| X701          | CHIP CERAMIC RESONATOR (20MHz) | DSS1110    |
| CN702         | FFC CONNECTOR (37P)            | HLEM37R-1  |
| X231          | CRYSTAL RESONATOR (33.8MHz)    | RSS1055    |
| CN551         | 4P FFC CONNECTOR               | VKN1235    |
| KN101         | EARTH METAL FITTING            | VNF1084    |

# CMX-5000, CU-V160

| Mark                  | No.                                | Description  | Part No. |
|-----------------------|------------------------------------|--------------|----------|
| <b>D TRMB ASSY</b>    |                                    |              |          |
| <b>SEMICONDUCTORS</b> |                                    |              |          |
| △                     | IC1017 (0.5A)                      | AEK7005      |          |
|                       | IC1005                             | BU4053BCF    |          |
| △                     | IC1011,IC1013,IC1018 (0.6A)        | ICP-N15      |          |
| △                     | IC1010 (0.8A)                      | ICP-N20      |          |
| △                     | IC1012,IC1014 (1A)                 | ICP-N25      |          |
|                       | IC1001                             | IR3M03A      |          |
| △                     | IC1101,IC1201,IC1301,IC1302,IC1401 | NJM4558MD    |          |
|                       | IC1015,IC1016                      | NJM78L05A    |          |
|                       | IC1002,IC1006                      | TC74AC04F    |          |
|                       | IC1004                             | TC74HC241AF  |          |
|                       | IC1501,IC1801                      | TC74HCU04AF  |          |
|                       | IC1003,IC1007                      | TC9162AF     |          |
|                       | Q1101,Q1102,Q1201,Q1202            | 2SD2114K     |          |
|                       | Q1301,Q1302,Q1401,Q1402            | 2SD2114K     |          |
|                       | Q1103,Q1104,Q1203,Q1204            | 2SD2144S     |          |
|                       | Q1303,Q1304                        | 2SD2144S     |          |
|                       | Q1002-Q1005,Q1105,Q1205,Q1305      | DTA124EK     |          |
|                       | Q1407,Q1408                        | DTA124EK     |          |
|                       | Q1009,Q1010,Q1106,Q1206,Q1306      | DTC124EK     |          |
|                       | Q1307                              | DTC124EK     |          |
|                       | D1105,D1205,D1305                  | 1SR154-400   |          |
|                       | D1003,D1006,D1101-D1103            | 1SS355       |          |
|                       | D1201-D1203,D1301-D1304            | 1SS355       |          |
|                       | D1001                              | EC10QS04     |          |
|                       | D1061,D1062                        | MTZJ5.1C     |          |
|                       | D1002,D1004,D1005,D1007            | UDZS10B      |          |
| <b>COILS</b>          |                                    |              |          |
|                       | L1001 (470μH)                      | DTL1083      |          |
|                       | L1405,L1406                        | LFA101J      |          |
|                       | L1002-L1004                        | LFA470J      |          |
|                       | L1501,L1801                        | PTL1003      |          |
|                       | L1502,L1802                        | PTL1014      |          |
| △                     | L1021,L1022                        | PTL1017      |          |
| △                     | L1005-L1010                        | VTH1020      |          |
| <b>SWITCH</b>         |                                    |              |          |
|                       | S1001                              | DSH1025      |          |
| <b>CAPACITORS</b>     |                                    |              |          |
|                       | C1046,C1047,C1049,C1301,C1302      | CCSQCH101J50 |          |
|                       | C1325,C1326,C1401,C1402            | CCSQCH101J50 |          |
|                       | C1012                              | CCSQCH201J50 |          |
|                       | C1303,C1304                        | CEANP101M6R3 |          |
|                       | C1027-C1030,C1103,C1104            | CEANP220M16  |          |
|                       | C1203,C1204,C1327,C1328            | CEANP220M16  |          |
|                       | C1403,C1404                        | CEANP220M16  |          |
|                       | C1062                              | CEAT100M50   |          |
|                       | C1006                              | CEAT101M10   |          |
|                       | C1001                              | CEAT101M16   |          |
|                       | C1501,C1801                        | CEAT101M6R3  |          |
|                       | C1003                              | CEAT331M16   |          |
|                       | C1503,C1803                        | CEAT470M10   |          |
|                       | C1061                              | CEAT470M50   |          |
|                       | C1007,C1051,C1052,C1417,C1418      | CEAT471M10   |          |
|                       | C1031,C1032                        | CEAT471M16   |          |
|                       | C1036                              | CEAT471M6R3  |          |
|                       | C1507,C1809                        | CGCYX104M25  |          |
|                       | C1048                              | CKSQYB102K50 |          |
|                       | C1041,C1043,C1508,C1808            | CKSQYB103K50 |          |

| Mark             | No.                           | Description   | Part No. |
|------------------|-------------------------------|---------------|----------|
|                  | C1008,C1009,C1011,C1013       | CKSQYB104K25  |          |
|                  | C1016-C1026,C1034,C1038-C1040 | CKSQYB104K25  |          |
|                  | C1042,C1044,C1107,C1108       | CKSQYB104K25  |          |
|                  | C1207,C1208,C1307,C1308       | CKSQYB104K25  |          |
|                  | C1329,C1330,C1405,C1406,C1502 | CKSQYB104K25  |          |
|                  | C1504,C1606,C1802,C1804,C1806 | CKSQYB104K25  |          |
|                  | C1101,C1102,C1105,C1106       | CQMA152J50    |          |
|                  | C1201,C1202,C1205,C1206       | CQMA152J50    |          |
|                  | C1305,C1306                   | CQMA152J50    |          |
| <b>RESISTORS</b> |                               |               |          |
|                  | R1061,R1327,R1328,R1405,R1406 | RD1/4VM103J   |          |
|                  | R1325,R1326                   | RD1/4VM203J   |          |
|                  | R1105,R1106,R1205,R1206       | RD1/4VM223J   |          |
|                  | R1305,R1306                   | RN1/10SE2202D |          |
|                  | R1023,R1025                   | RD1/4VM271J   |          |
|                  | R1103,R1104,R1111-R1114       | RD1/4VM471J   |          |
|                  | R1203,R1204,R1211-R1214       | RD1/4VM471J   |          |
|                  | R1411,R1412                   | RD1/4VM471J   |          |
|                  | R1311-R1314                   | RN1/10SE4700D |          |
|                  | R1329-R1332                   | RN1/10SE5100D |          |
|                  | R1303,R1304                   | RD1/4VM752J   |          |
|                  | R1006                         | RS1/10S2002F  |          |
|                  | R1005                         | RS1/10S3601F  |          |
|                  | Other Resistors               | RS1/10S□□□□   |          |
| <b>OTHERS</b>    |                               |               |          |
|                  | CABLE HOLDER (8P)             | 51052-0800    |          |
|                  | CN1011 6P JUMPER CONNECTOR    | 52151-0610    |          |
|                  | CN1009 MINI JACK              | AKN1028       |          |
|                  | CN1007 10P MINI DIN SOCKET    | AKP7031       |          |
|                  | CN1005,CN1006                 | B3B-PH-K-Y    |          |
|                  | KR CONNECTOR (3P)             |               |          |
|                  | JA1010 MINI JACK              | DKN1146       |          |
|                  | J1010 JUMPER WIRE             | DXUY0830E     |          |
|                  | CN1001,CN1002                 | HLEM37S-1     |          |
|                  | FFC CONNECTOR 37P             |               |          |
|                  | JA1004,JA1008 1P JACK         | PKB1028       |          |
|                  | JA1001-JA1003 2P PIN JACK     | PKB1032       |          |
|                  | JA1005,JA1006 JACK (REMOTE)   | RKN1004       |          |

## **E** HPJB ASSY SEMICONDUCTORS

|                   |                         |              |
|-------------------|-------------------------|--------------|
|                   | IC1402                  | NJM4556AD    |
|                   | Q1405,Q1406,Q1409,Q1410 | 2SC3326      |
|                   | D1405                   | 1SR154-400   |
| <b>COILS</b>      |                         |              |
| △                 | L1401-L1403             | LCTA1R0J3225 |
| <b>CAPACITORS</b> |                         |              |
|                   | C1413,C1414             | CCSQCH820J50 |
|                   | C1415,C1416             | CEANP221M16  |
|                   | C1409-C1411             | CKSQYB103K50 |
|                   | C1407,C1408             | CKSQYB104K25 |
| <b>RESISTORS</b>  |                         |              |
|                   | VR1401 (10kΩ-B)         | DCS1058      |
|                   | Other Resistors         | RS1/10S□□□□  |

# CMX-5000, CU-V160

| Mark No.      | Description     | Part No.    |
|---------------|-----------------|-------------|
| <b>OTHERS</b> |                 |             |
|               | 6P CABLE HOLDER | 51048-0600  |
| J1101         | JUMPER WIRE     | D20PYY0620E |
| JA1101        | HEADPHONE JACK  | RKN1002     |

## **F** SELB ASSY SEMICONDUCTORS

|              |  |              |
|--------------|--|--------------|
| D1903, D1904 |  | EMAY3864X-HM |
| D1701, D1901 |  | SLP3118C51H  |
| D1902        |  | SLP9118C51H  |

| Mark No.           | Description | Part No. |
|--------------------|-------------|----------|
| <b>SWITCHES</b>    |             |          |
| S1701, S1902-S1904 |             | ASG7013  |
| S1901              |             | DSH1049  |

| Mark No.         | Description | Part No.     |
|------------------|-------------|--------------|
| <b>CAPACITOR</b> |             |              |
| C1901            |             | CKSQYB104K25 |

| Mark No.         | Description | Part No.    |
|------------------|-------------|-------------|
| <b>RESISTORS</b> |             |             |
| All Resistors    |             | RS1/10S□□□□ |

| Mark No.      | Description      | Part No.    |
|---------------|------------------|-------------|
| <b>OTHERS</b> |                  |             |
|               | 11P CABLE HOLDER | 51048-1100  |
| J1901         | JUMPER WIRE 11P  | D20PYY1120E |

## **G** SW POWER SUPPLY ASSY

There is no service parts.

## **H** PSWB ASSY SWITCH

|      |  |         |
|------|--|---------|
| △ S1 |  | PSA-009 |
|------|--|---------|

| Mark No.         | Description | Part No. |
|------------------|-------------|----------|
| <b>CAPACITOR</b> |             |          |
| △ C1             |             | ACG7033  |

| Mark No.      | Description | Part No. |
|---------------|-------------|----------|
| <b>OTHERS</b> |             |          |
| △ J1          |             | DKP3516  |

## **I** FLK1 ASSY SEMICONDUCTORS

|                                 |  |          |
|---------------------------------|--|----------|
| IC2002                          |  | LB1740   |
| IC2001                          |  | PE5127A  |
| IC2003                          |  | S-806D   |
| Q2003, Q2009-Q2011, Q2017-Q2021 |  | 2SC2412K |
| Q2001, Q2002, Q2012-Q2014       |  | DTA124EK |

|                                 |  |              |
|---------------------------------|--|--------------|
| Q2004-Q2008, Q2015, Q2016       |  | DTC124EK     |
| D2001-D2017, D2049-D2051, D2057 |  | 1SS355       |
| D2021-D2023, D2025-D2034        |  | EMAY3864X-HM |
| D2036-D2042, D2047, D2048       |  | EMAY3864X-HM |
| D2052-D2056                     |  | EMAY3864X-HM |

|              |  |             |
|--------------|--|-------------|
| D2301        |  | LB-303VK222 |
| D2043, D2044 |  | MAY5364X    |
| D2045, D2046 |  | SLP3118C51H |
| D2018, D2019 |  | SLP9118C51H |

| Mark No.        | Description | Part No. |
|-----------------|-------------|----------|
| <b>SWITCHES</b> |             |          |
| S2004-S2029     |             | ASG7013  |
| S2002, S2003    |             | DSG1063  |
| S2001           |             | DSX1056  |

| Mark No.                          | Description | Part No.     |
|-----------------------------------|-------------|--------------|
| <b>CAPACITORS</b>                 |             |              |
| C2001, C2011                      |             | CEAL470M6R3  |
| C2004, C2005, C2010, C2012, C2013 |             | CKSQYB103K50 |
| C2015                             |             | CKSQYB103K50 |
| C2002, C2009                      |             | CKSQYB104K25 |

| Mark No.         | Description | Part No.    |
|------------------|-------------|-------------|
| <b>RESISTORS</b> |             |             |
| VR2002 (10kΩ-B)  |             | DCS1059     |
| VR2001 (50kΩ-B)  |             | DCV1011     |
| Other Resistors  |             | RS1/10S□□□□ |

| Mark No.       | Description                 | Part No.    |
|----------------|-----------------------------|-------------|
| <b>OTHERS</b>  |                             |             |
| X2001          | CERAMIC RESONATOR (4.19MHz) | VSS1014     |
| CN2004         | 4P JUMPER CONNECTOR         | 52147-0410  |
| V2001          | FL INDICATOR TUBE           | DEL1033     |
|                | IC SOCKET 6P                | DKN1203     |
| CN2001, CN2002 | B TO B CONNECTOR            | TKC-A10X-B1 |

## **J** PHT1 ASSY SEMICONDUCTORS

|              |  |        |
|--------------|--|--------|
| D2401, D2402 |  | GP1S94 |
|--------------|--|--------|

| Mark No.         | Description | Part No.     |
|------------------|-------------|--------------|
| <b>CAPACITOR</b> |             |              |
| C2401            |             | CKSQYB103K50 |

| Mark No.         | Description | Part No.    |
|------------------|-------------|-------------|
| <b>RESISTORS</b> |             |             |
| All Resistors    |             | RS1/10S□□□□ |

| Mark No.      | Description    | Part No.    |
|---------------|----------------|-------------|
| <b>OTHERS</b> |                |             |
| J2401         | JUMPER WIRE 4P | D20PWY0405E |

## **K** FLK2 ASSY SEMICONDUCTORS

|                    |  |          |
|--------------------|--|----------|
| IC2101             |  | PE5127A  |
| Q2125-Q2129        |  | 2SC2412K |
| Q2113-Q2116, Q2124 |  | DTA124EK |
| Q2112, Q2117-Q2123 |  | DTC124EK |
| D2108-D2117        |  | 1SS355   |

|              |  |              |
|--------------|--|--------------|
| D2137-D2142  |  | EMAY3864X-HM |
| D2143, D2144 |  | MAY5364X     |
| D2145, D2146 |  | SLP3118C51H  |

| Mark No.        | Description | Part No. |
|-----------------|-------------|----------|
| <b>SWITCHES</b> |             |          |
| S2104-S2114     |             | ASG7013  |
| S2102, S2103    |             | DSG1063  |

| Mark No.          | Description | Part No.     |
|-------------------|-------------|--------------|
| <b>CAPACITORS</b> |             |              |
| C2101             |             | CEAL101M6R3  |
| C2111             |             | CEAL220M6R3  |
| C2110, C2115      |             | CKSQYB103K50 |
| C2102             |             | CKSQYB104K25 |

| Mark | No. | Description | Part No. |
|------|-----|-------------|----------|
|------|-----|-------------|----------|

**RESISTORS**

|  |        |                 |             |
|--|--------|-----------------|-------------|
|  | VR2101 | (50kΩ-B)        | DCV1011     |
|  |        | Other Resistors | RS1/10S□□□J |

**OTHERS**

|  |        |                                |             |
|--|--------|--------------------------------|-------------|
|  | X2101  | CERAMIC RESONATOR<br>(4.19MHz) | VSS1014     |
|  | CN2103 | 4P JUMPER CONNECTOR            | 52147-0410  |
|  | V2101  | FL INDICATOR TUBE              | DEL1033     |
|  | CN2101 | B TO B CONNECTOR               | TKC-A08X-B1 |
|  | CN2102 | B TO B CONNECTOR               | TKC-A12X-B1 |



**L PHT2 ASSY**

**SEMICONDUCTORS**

|  |              |  |        |
|--|--------------|--|--------|
|  | D2501, D2502 |  | GP1S94 |
|--|--------------|--|--------|

**CAPACITOR**

|  |       |  |              |
|--|-------|--|--------------|
|  | C2501 |  | CKSQYB103K50 |
|--|-------|--|--------------|

**RESISTORS**

|  |  |               |             |
|--|--|---------------|-------------|
|  |  | All Resistors | RS1/10S□□□J |
|--|--|---------------|-------------|

**OTHERS**

|  |       |                |             |
|--|-------|----------------|-------------|
|  | J2501 | JUMPER WIRE 4P | D20PWY0405E |
|--|-------|----------------|-------------|



**M CNNB ASSY**

**SEMICONDUCTORS**

|   |        |  |             |
|---|--------|--|-------------|
| △ | IC2203 |  | BA05T       |
|   | IC2202 |  | TC74AC04F   |
|   | IC2201 |  | TC74HC241AF |

**CAPACITORS**

|  |                     |  |              |
|--|---------------------|--|--------------|
|  | C2208, C2209, C2221 |  | CCSQCH101J50 |
|  | C2204               |  | CEJA101M10   |
|  | C2202               |  | CEJA101M6R3  |
|  | C2201, C2203, C2210 |  | CKSQYB104K25 |

**RESISTORS**

|  |  |               |             |
|--|--|---------------|-------------|
|  |  | All Resistors | RS1/10S□□□J |
|--|--|---------------|-------------|

**OTHERS**

|  |                |                  |             |
|--|----------------|------------------|-------------|
|  |                | 10P CABLE HOLDER | 51048-1000  |
|  | J2201          | JUMPER WIRE 10P  | D20PDY1025E |
|  | CN2204         | CONNECTOR PLUG   | TKC-A08P-B1 |
|  | CN2202, CN2203 | CONNECTOR PLUG   | TKC-A10P-B1 |
|  | CN2205         | B TO B CONNECTOR | TKC-A12P-B1 |
|  |                | PCB BINDER       | VEF1040     |



**N CTJB ASSY**

**CAPACITOR**

|  |       |  |              |
|--|-------|--|--------------|
|  | C2601 |  | CKSQYB104K25 |
|--|-------|--|--------------|

**OTHERS**

|  |        |                     |         |
|--|--------|---------------------|---------|
|  | CN2602 | 10P MINI DIN SOCKET | AKP7031 |
|--|--------|---------------------|---------|

## 6. ADJUSTMENT

### 6.1 ADJUSTMENT ITEMS AND LOCATION

#### ■ Adjustment Points (PCB Part)

##### C CDPB ASSY

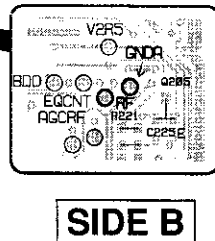
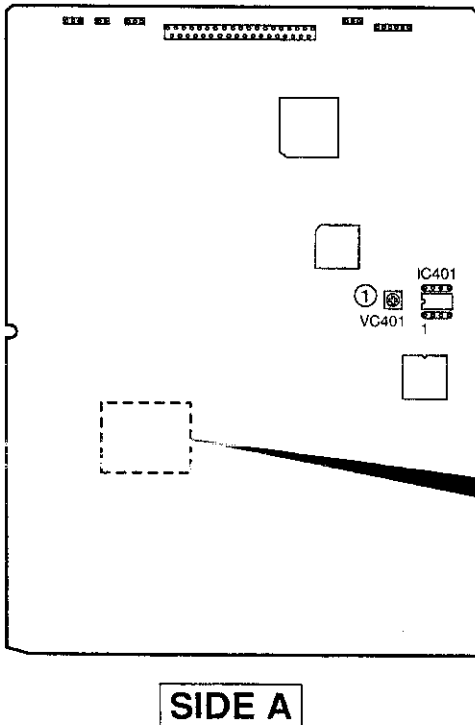

##### D TRMB ASSY

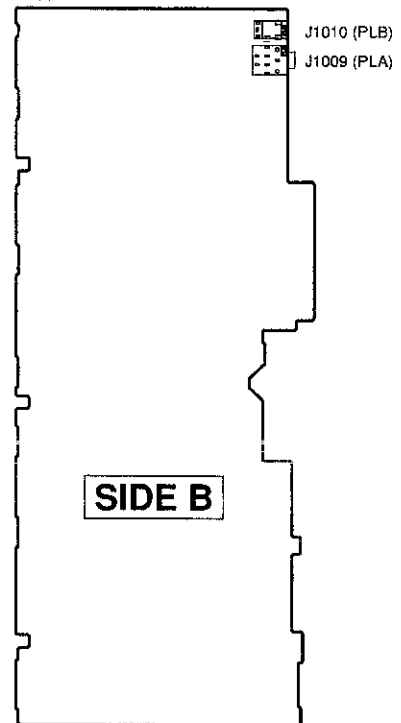

#### ■ Adjustment Items

[Electrical Part]

- ① VCO Free-running Adjustment
- ② RF Level Adjustment

### 6.2 JIGS AND MEASURING INSTRUMENTS

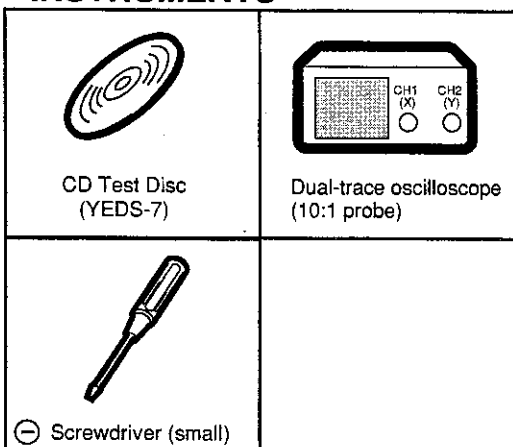

### 6.3 NECESSARY ADJUSTMENT POINTS

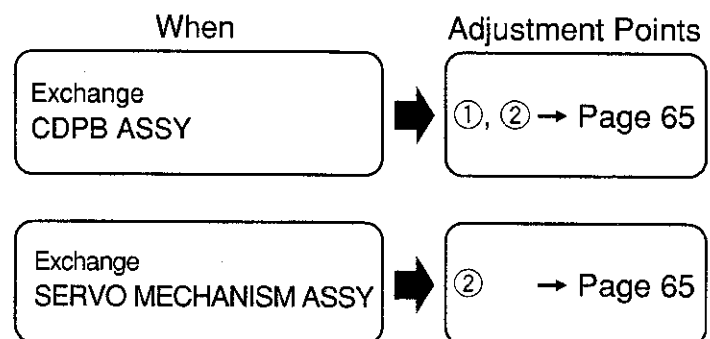



## 6.4 ELECTRICAL ADJUSTMENT

### ① VCO Free-running Adjustment

Note: Adjustment of VC401 may not be made if the SLOT-IN MECHANISM ASSY is installed. Before adjustment, remove the SLOT-IN MECHANISM ASSY..

Objective : To optimize the VCO free-running frequency

When not properly adjusted :

- Master Tempo does not function normally
- The output does not appear in indication and occasion when turned a Tempo adjustment into + side.

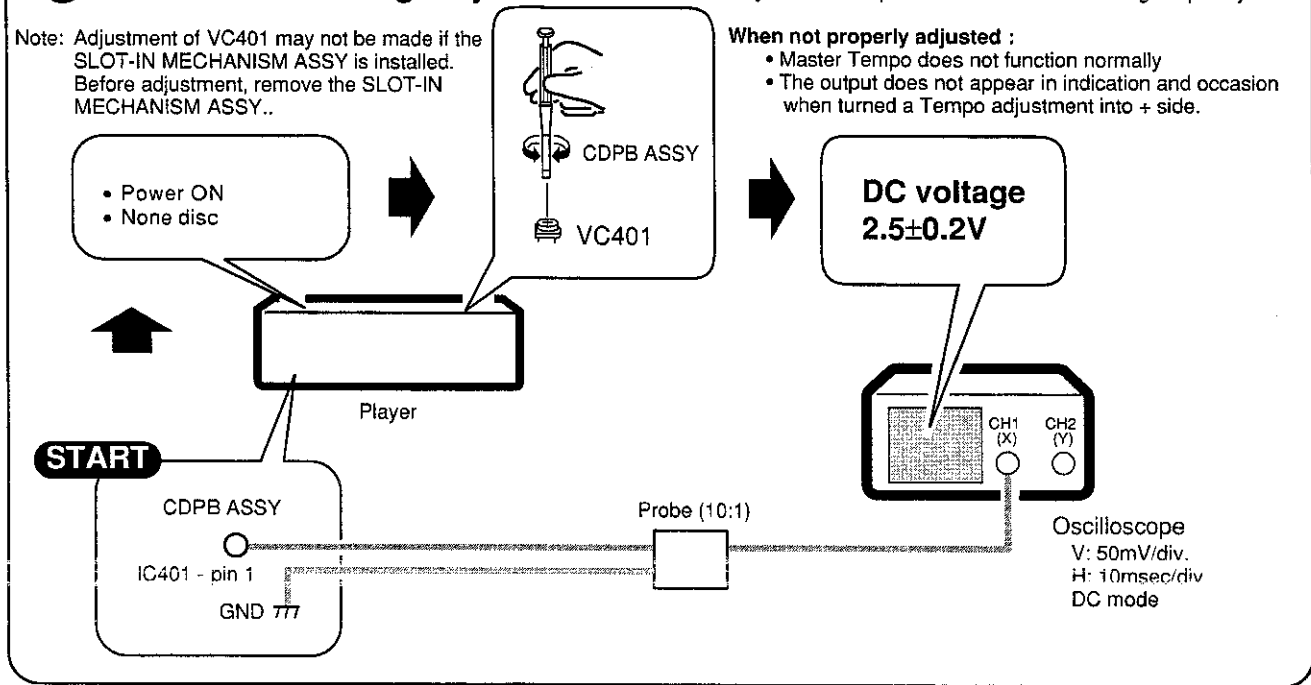

### ② RF Level Adjustment

- Test mode  
Enter the RF ADJ mode by pressing "C-MODE" button on the remote control unit for servicing.
- Move the pickup to the RF ADJ position (disc outer circumference) by pressing the "PLAY" button on the remote control unit for servicing.

Objective : To adjust the amplitude of playback RF signal

When not properly adjusted :

Player does not playback, track search is impossible.

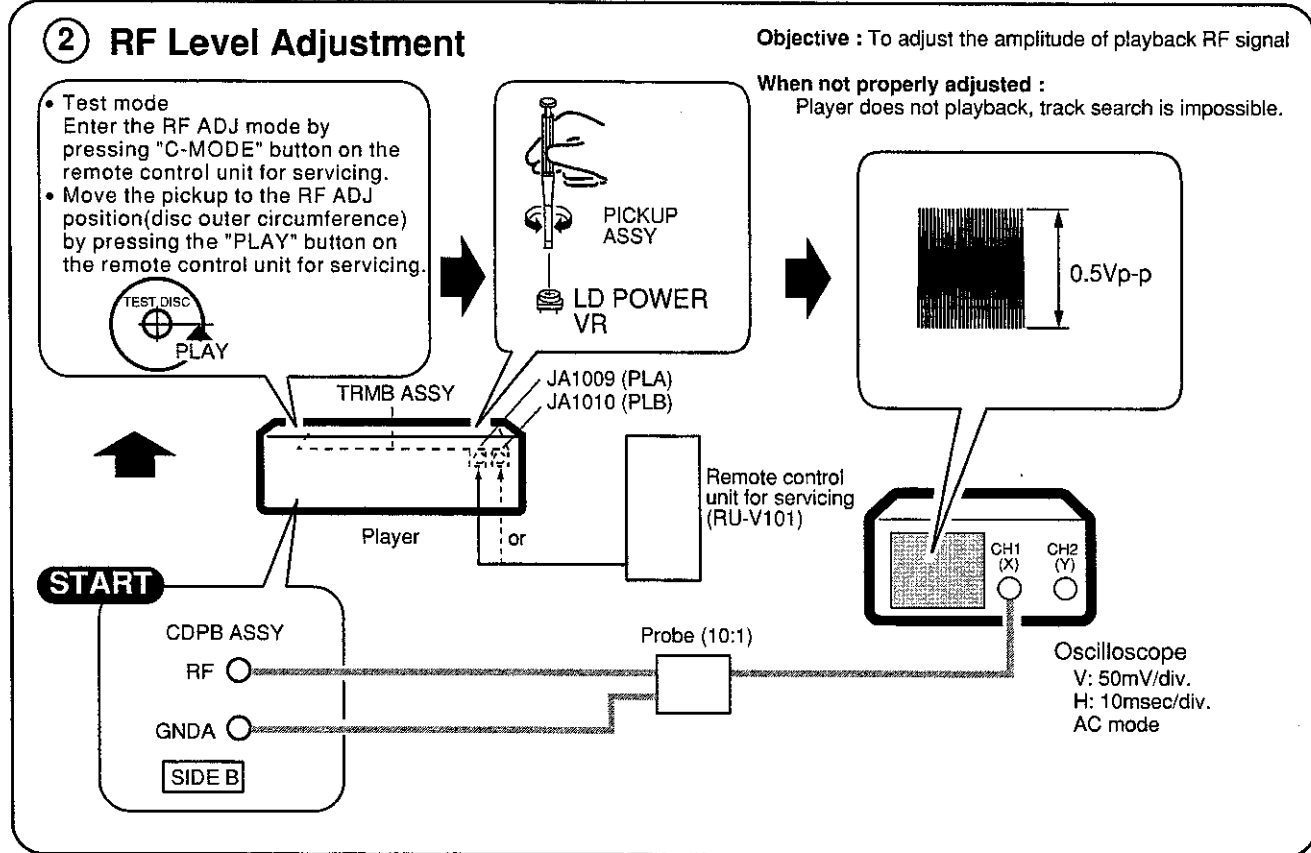

## 7. GENERAL INFORMATION

### 7.1 DIAGNOSIS

#### 7.1.1 TEST MODE

##### 7.1.1.1 Outline of the Test Mode

Three kinds of test modes (Mode 1-3) are prepared.

##### (1) Confirm the button and display function of the Controller with the test mode

**Mode 1** When connect the Controller to the Player, and confirm it.

**Mode 2** When confirm it with Controller being simple (use DC power supply). However, FL cannot confirm.

##### (2) Confirm the button display function and movement of the Player, with the test mode

**Mode 3** When connect the remote control unit (RU-V101) for service only with the player, and confirm it.

##### 7.1.1.2 How to enter the test mode of the controller, and the function that can confirm with the test mode

###### (1) How to enter the test mode

###### Mode 1

Enter the test mode when power is turned on while pressing the PLAYER SELECT A and B buttons of monitor section of the player. Indication of the controller becomes as follows. (Refer to Fig. 2.)

"TEST" is indicated by time display part of the FL. TRACK (Fig. 2 - ①), TEMPO (Fig. 2- ③), M S F (Fig. 2- ⑥ ⑦ ⑧ ), calendar indication "1" (Fig. 2- ⑩), REMAIN (Fig. 2- ④), ± 16 (Fig. 2- ②), BPM (Fig. 2- ⑪) and : (Fig. 2- ⑮) are lighted in the FL indication.

BPM/TRACK number indication (three columns of LED) and the AUTO MIX PLAY button of the controller light.

###### Mode 2

**When confirm the function only with the Controller**

Use a DC (direct current) power supply, and connect GND and VLOD of land for the test mode of CNNB Assy to ground together and connect +7V to a power supply (+7V ± 1V).

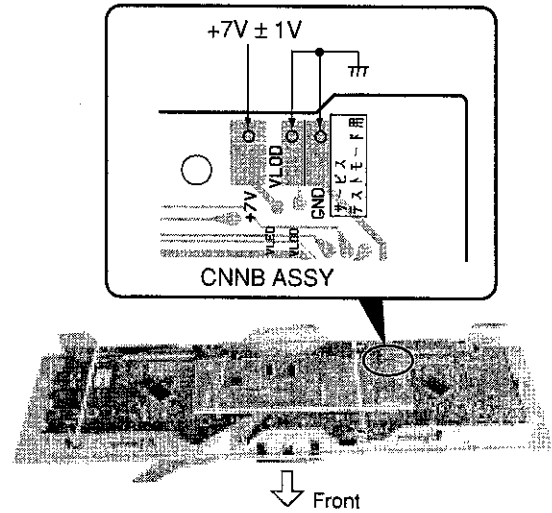
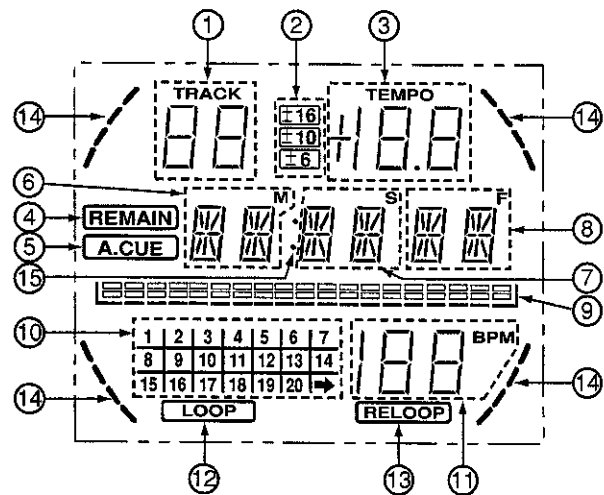

Fig.2 Land position for the test mode

Following LEDs blink less than about 1 second when inputs DC power supply while pressing the TEMPO button and AUTO MIX PLAY button of the PLAYER A simultaneously.

(CUE, PLAY/PAUSE, LOOP IN•LOOP OUT and MT LED)

LEDs of BPM/TRACK No. indication (three columns of LED) and AUTO MIX PLAY turns on, and become the test mode. However, FL does not light.



- ① TRACK No. indication
- ② Tempo setting (± 6•10•16%)
- ③ Tempo setting (± 6 to 16%)
- ④ REMAIN indication
- ⑤ AUTO CUE indication
- ⑥ MINUTES (time indication)
- ⑦ SECONDS (time indication)
- ⑧ FRAMES (frame indication)
- ⑨ Music performance position indication
- ⑩ Calendar indication
- ⑪ BPM indication
- ⑫ LOOP indication
- ⑬ RELOOP indication
- ⑭ Player indication at AUTO MIX PLAY
- ⑮ Colon

Fig. 2 FL indication for Mode 1

**(2) The function that can confirm (controller section)**

Perform the following movement with the function button of the product.

**Mode 1**

1. EJECT button:  
Indicate "EJECT" in the time indication segment section of FL, and lights/turns off the light whenever pressing the button.
2. TRACK SEARCH button:  
TRACK No. in FL indication (Fig. 2-①) and number of the calendar (Fig. 2-⑩) do UP/DOWN in sequence.  
TRACK : 00, 11, 22, ....., 99, 00, .....  
Calendar : 1, 2, 3, ....., 20, → 1, .....
3. SEARCH button:  
Indication of music performance position indication (Fig. 2-⑨) changes at the same time that the value of MIN • SEC • FRAME in FL indication (Fig. 2-⑥ ⑦ ⑧ ) changes like next.  
00:0000, ..... 99:9999, XX:XXXX, ..... ZZ:ZZZZ
4. CUE button:  
Lights/turns off the light whenever pressing the button.
5. PLAY/PAUSE button:  
Lights/turns off the light whenever pressing the button.
6. TIME MODE button:  
A. CUE (Fig. 2-⑤) and REMAIN of FL indication (Fig. 2-④) indicate it in alternately whenever pressing the button, and turn on.
7. TEMPO button:  
± 16, ± 10 and ± 6 of FL indication (Fig. 2-②) turn on sequentially whenever pressing the button.
8. MASTER TEMPO button:  
MT button lights/turns off the light.
9. RELOOP button:  
Lights/turns off the "RELOOP" of the FL indication whenever pressing the button.
10. IN/REALTIME CUE button:  
Lights/turns off the IN/REALTIME CUE button and "LOOP" (Fig. 2-⑫) of the FL indication whenever pressing the button.
11. OUT/EXIT button:  
Lights/turns off the OUT/EXIT button whenever pressing the button.
12. JOG:  
A segment in FL indication (Fig. 2-⑭) flashes according to the direction to turn.
13. Slider:  
A value of TEMPO and BPM (Fig. 2-③, ⑪) in FL indication change by moving the slider to + direction and - direction as follows.

• TEMPO

+ direction +1.1 +2.2 ..... +10.0  
Center 0.0  
- direction - 1.1 -2.2 ..... - 10.0

• BPM

+ direction 11 22 ..... 100  
Center 00  
- direction 11 22 ..... 100

14. CLEAR button of PLAY MODE SELECT:

Following LEDs turn on sequentially whenever pressing the button.

AUTO MIX PLAY, DISC, TRACK, PROGRAM, A, <, >, B, BPM, NEXT, BPM SYNC, SHORT TIME, Cut in button, ZIP button, Echo button, Cross fade button

15. Perform 1 to 9 and A to F indication corresponding to a figure of 1 of BPM/TRACK No. indication (three digits of LED) by pressing the following buttons.

AUTO MIX PLAY button : [1]  
DISC button : [2]  
TRACK button : [3]  
PROGRAM button : [4]  
PLAYER SELECT A button : [5]  
PLAYER SELECT B button : [6]  
BPM/NEXT button : [7]  
BPM SYNC button : [8]  
PUSH ENTER button : [9]  
INSTANT CHANGE button : [A]  
SHORT TIME button : [b]  
Cut in button : [C]  
ZIP button : [d]  
Echo button : [E]  
Cross fade button : [F]

16. BPM/TRACK knob:

A number of 0-9 is indicated sequentially in the figure of 10 of BPM/TRACK No. indication of center part (three digits of LED) as turns it.

17. MIX TIME:

A number of 0-9 is indicated sequentially in the figure of 100 of BPM/TRACK No. indication (three digits of LED) as turns it.

# CMX-5000, CU-V160

## Mode 2

1. EJECT button:  
While pressing a button, an IN/REAL TIME CUE button of pressed the player side lights up.
2. TRACK SEARCH BACK button:  
While pressing a button, an IN/REAL TIME CUE button of pressed the player side lights up.

### TRACK SEARCH FWD button:

While pressing a button, an OUT/EXIT button of pressed the player side lights up.

3. SEARCH BACK button:  
While pressing a button, an IN/REAL TIME CUE button of pressed the player side lights up.

### SEARCH FWD button:

While pressing a button, an OUT/EXIT button of pressed the player side lights up.

4. CUE button:  
While pressing a button, a CUE button of pressed the player side lights up.

5. PLAY/PAUSE button:  
While pressing a button, a PLAY/PAUSE button of pressed the player side lights up.

6. TIME MODE button:  
While pressing a button, an OUT/EXIT button of pressed the player side lights up.

7. TEMPO button:  
While pressing a button, an OUT/EXIT button of pressed the player side lights up.

8. MASTER TEMPO button:  
While pressing a button, a MASTER TEMPO button of pressed the player side lights up.

9. RELOOP button:  
While pressing a button, an OUT/EXIT button of pressed the player side lights up.

10. IN/REALTIME CUE button:  
While pressing a button, an IN/REAL TIME CUE button of pressed the player side lights up.

11. OUT/EXIT button:  
While pressing a button, an OUT/EXIT button of pressed the player side lights up.

12. JOG  
BACK : An IN/REALTIME CUE button of correspondence player side lights up.  
FWD : An OUT/EXIT button lights up in the same way.  
(Turn off the lights when you stop the rotation of the JOG dial.)

13. slider:  
An IN/REALTIME CUE button lights up during movement of the slider. Turn off the light after 0.5 second.

\* AUTO MIX PLAY section is the same as that of **Mode 1**. (steps 14 to 17).

## (3) The function that can confirm (Player section)

### Mode 1

1. LED of EJECT:  
Both players of A and B always flashes on and off.
2. EJECT button:  
Eject the DISC.
3. PLAYER SELECT button of the monitor section:  
Both LEDs of A and B players turn on whenever pressing the button, and turn off the light.
4. Audio output select switch (A/B • MIX):  
LED of monitor A turns on when switch is selected to A•B side.  
LED of monitor B turns on when switch is selected to A•B AUTO MIX side.
5. Digital out ON/OFF switch:  
Sound does not out when pressing the PLAY button of **Mode 3** with OFF (in fourfold speed playback) state, and sound outputs by ON (in normal speed playback) state.

\* As for the lighting of A and B button LEDs, mode 3 takes first priority.

### 7.1.1.3 How to enter the test mode of the player, and the function that can confirm with the test mode

#### (1) How to enter the test mode

##### Mode 3

Enter the test mode when the power is on while pressing the PLAYER SELECT A and B buttons of monitor section of the player. Connect the remote control unit (RU-V101) for service to JA1009 (A PLAYER) or JA1010 (B PLAYER) of the TRMB Assy.

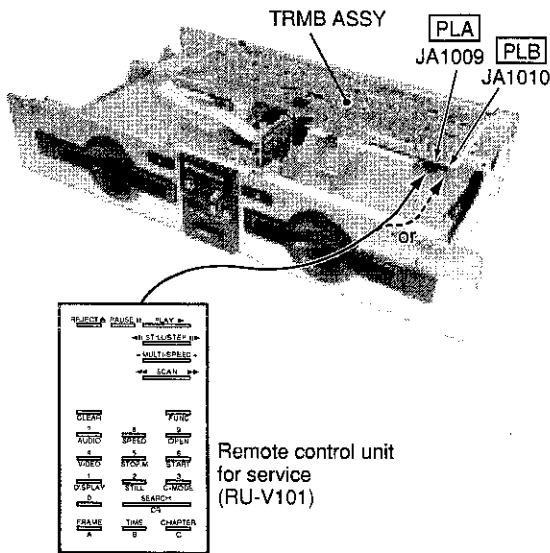
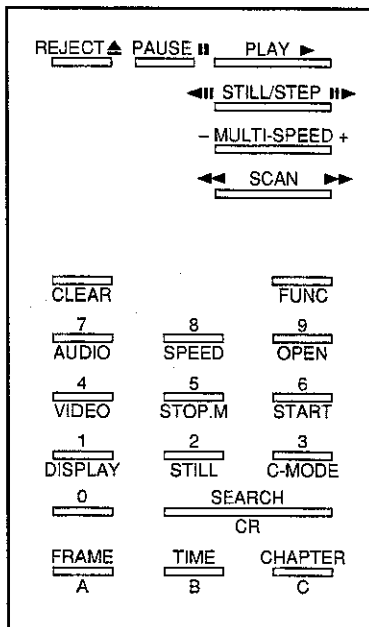

Fig. 3 Connection of the remote control unit for service

#### ● Function of the remote control unit for service (RU-V101)



|                    |   |                                           |
|--------------------|---|-------------------------------------------|
| REJECT             | : | stop                                      |
| PAUSE              | : | Pause                                     |
| PLAY               | : | Play                                      |
| STILL/STEP ►►      | : | 1 track FWD jump                          |
| STILL/STEP ◄◄      | : | 1 track REV jump                          |
| MULTI-SPEED +      | : | Multi FWD jump                            |
| MULTI-SPEED -      | : | Multi REV jump                            |
| SCAN ►►            | : | Not used                                  |
| SCAN ◄◄            | : | Not used                                  |
| CLEAR              | : | Clear                                     |
| FRAME              | : | Not used                                  |
| TIME               | : | Time set                                  |
| CHAPTER            | : | Track set                                 |
| SEARCH             | : | Search                                    |
| 10 key             | : | Numerical input                           |
| DISPLAY (FUNC + 1) | : | Not used                                  |
| STILL (FUNC + 2)   | : | Not used                                  |
| C-MODE (FUNC + 3)  | : | RF Level Adjustment                       |
| VIDEO (FUNC + 4)   | : | Not used                                  |
| STOP.M (FUNC + 5)  | : | Not used                                  |
| START (FUNC + 6)   | : | Search for first piece of music and pause |
| AUDIO (FUNC + 7)   | : | Track search                              |
| SPEED (FUNC + 8)   | : | Tempo                                     |
| OPEN (FUNC + 9)    | : | Disc eject                                |

#### (2) The function that can confirm (Player section)

Note: • ON side of DIGITAL OUT select switch on the Rear Panel is normal speed, and OFF side is fourfold speed.  
• Show explanation about operation content of the remote control unit (RU-V101) for service and a state of the player.

1. Insert a DISC, and enter the play mode when pressing the PLAY button of the remote control unit in the state that there is a loading mechanism at the clamp position. (Both normal and fourfold speeds can confirm a sound.)
2. Search TRk No. when pressing the Trk (number) → FUNC → AUDIO button sequentially, and output a sound. (Both normal and fourfold speeds can confirm a sound.)
  - Only operation of steps 3 and 4 can perform when this operation was done.
  - When the operation after step 5 is done, eject a disc and insert it again.
3. When pressing the FUNC → OPEN button sequentially, eject the DISC.
4. When pressing the \* \* \* (number three columns of input) → SPEED button sequentially, tempo will be able to change. (only fourfold speed)
  - 100-place is 0 : - (minus) or 1 : Specify + (plus)
  - Set the tempo by rest of two columns. (until ±16%)

## CMX-5000, CU-V160

[Example]

101 → SPEED button : +1%

010 → SPEED button : -10%

116 → SPEED button : +16%

5. Play by pressing the PLAY button. (Confirmation by playback sound is possibly only in normal speed. Fourfold speed is no sound.)
6. Stop by pressing the REJECT button. (Stops the disk rotation, and servo is off.)
7. During plays, pause by pressing the FUNC → PAUSE button sequentially.
8. During plays, search the first piece and pause by pressing the FUNC → START button sequentially.
9. During plays, perform 1Tr JUMP FWD by pressing the right side of the STILL/STEP button.
10. During plays, perform 1Tr JUMP REW by pressing the left side of the STILL/STEP button.
11. During plays, perform the MULTI REV JUMP only the number that was specified by pressing the number → - (minus) side of MULTI•SPEED.
12. During plays, perform the MULTI FWD JUMP only the number that was specified by pressing the number → + (plus) side of SPEED/SPEED. (until 999 track jump)
  - When there is not number appointment, perform the 10 Tr FWD/REV JUMP.
13. Search for time appointment by pressing the TIME button → time appointment → SEARCH sequentially, then pause.
  - How to set the time appointment: \* \* \* \* (four columns)

[Example]  
When search for 50 minutes:  
TIME button → 5000 (for 00 minutes 00 seconds) → SEARCH

  - When pressing the SEARCH button without time appointment:  
Search for two minutes ago of the disc end time and after two seconds of the disc start time whenever pressing the key.

[Example]  
Time of DISC is 70 minutes. Search for 68 minutes before two minutes of disc end time whenever pressing the SEARCH button, and pause. ↔ Search for after two seconds of the playback start time of DISC, and pause.
14. Search for appointed Tr No. by pressing the CHAPTER button → Tr No. appointment (number) → SEARCH sequentially, then pause.
  - When pressing the SEARCH button without time appointment:  
Search for two minutes ago of the disc end time and after two seconds of the disc start time whenever pressing the key.

[Example]  
Time of DISC is 70 minutes. Search for 68 minutes before two minutes of disc end time whenever pressing the SEARCH button, and pause. ↔ Search for after two seconds of the playback start time of DISC, and pause.
15. Enter the RF level adjustment mode by pressing the FUNC → C-MODE button sequentially. (Refer to 6. ADJUSTMENT.)
16. Cannot operate the following buttons of the remote control unit. VIDEO, STOP M., DISPLAY, STILL, FRAME and SCAN

### 7.1.1.4 Error Indication

When trouble occurred in movement of the player in normal use, indicate the error number in FL.

| Error Number | Error Name     | Contents                                                            | Cause Example                                 |
|--------------|----------------|---------------------------------------------------------------------|-----------------------------------------------|
| E-72 01      | TOC READ ERROR | Even if TOC data of a disc passed for 20 seconds, was not readable. | Disc is dirty.                                |
| E-83 01      | PLAYER ERROR   | Disc does not PLAY normally.<br>FOCUS NG                            | Disc is dirty.<br>There is crack on the disc. |
| E-83 02      | PLAYER ERROR   | DISC does not PLAY normally.<br>TRACKING NG                         | Disc is dirty.<br>There is crack on the disc. |
| E-83 03      | PLAYER ERROR   | DISC does not PLAY normally.<br>QDATA NG                            | Disc is dirty.<br>There is crack on the disc. |

7.1.2 POWER ON SEQUENCE

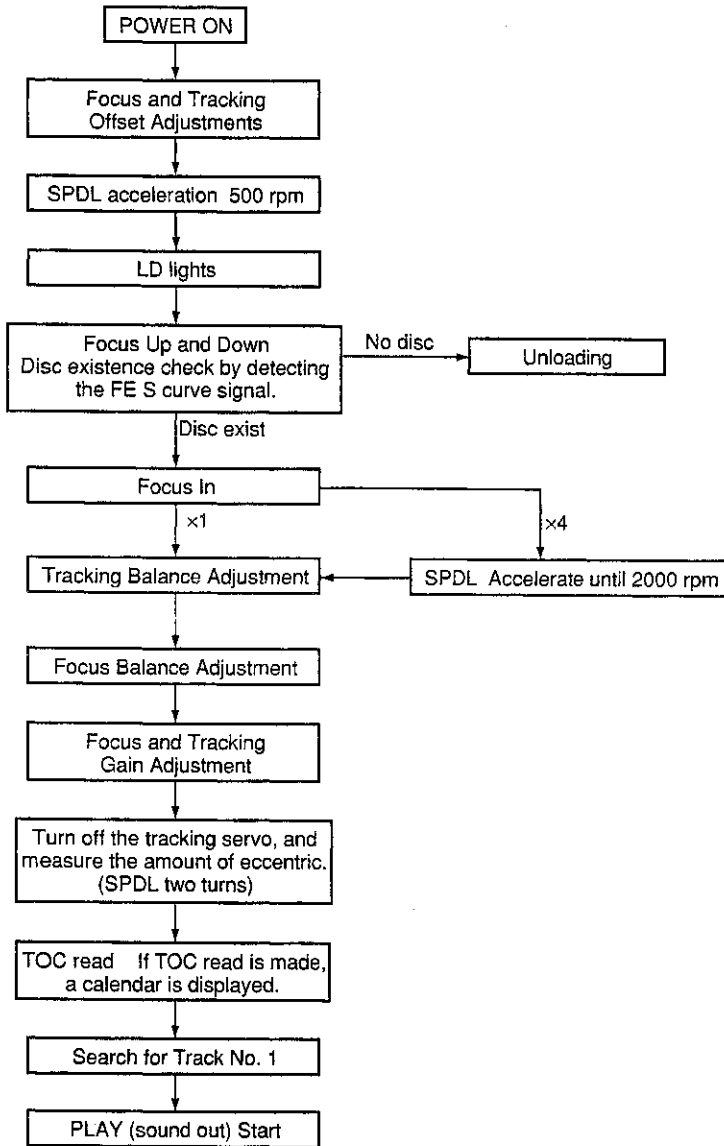

# CMX-5000, CU-V160

## 7.1.3 DISASSEMBLY

### (1) CMX-5000

#### ■ Bonnet

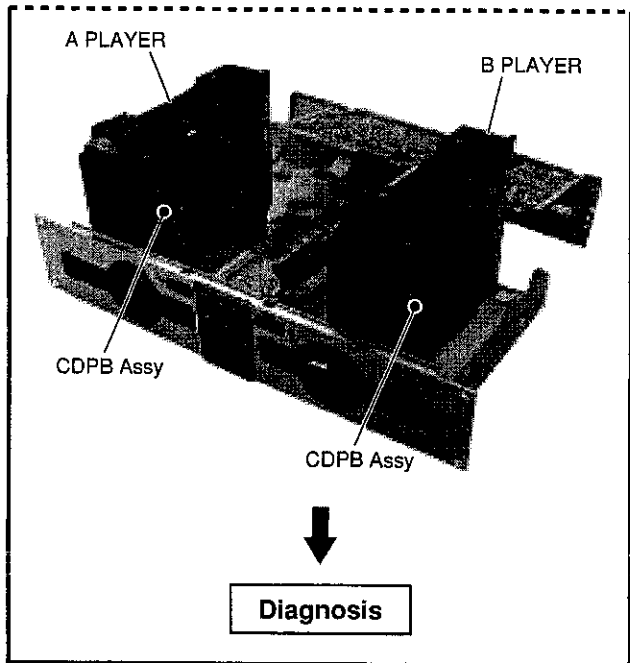
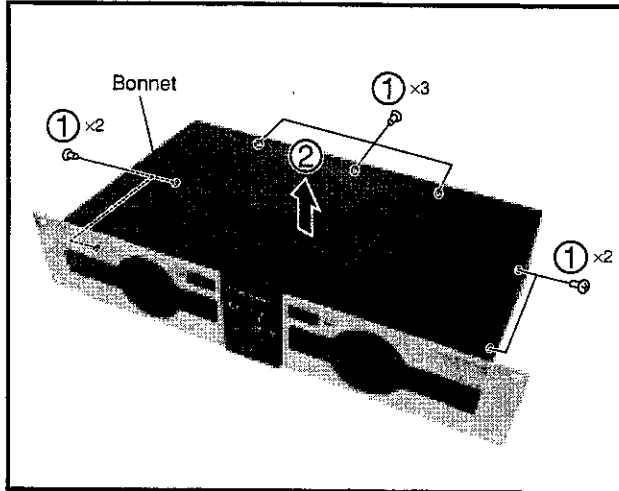

#### ■ TRMB Assy - PLAYER Section

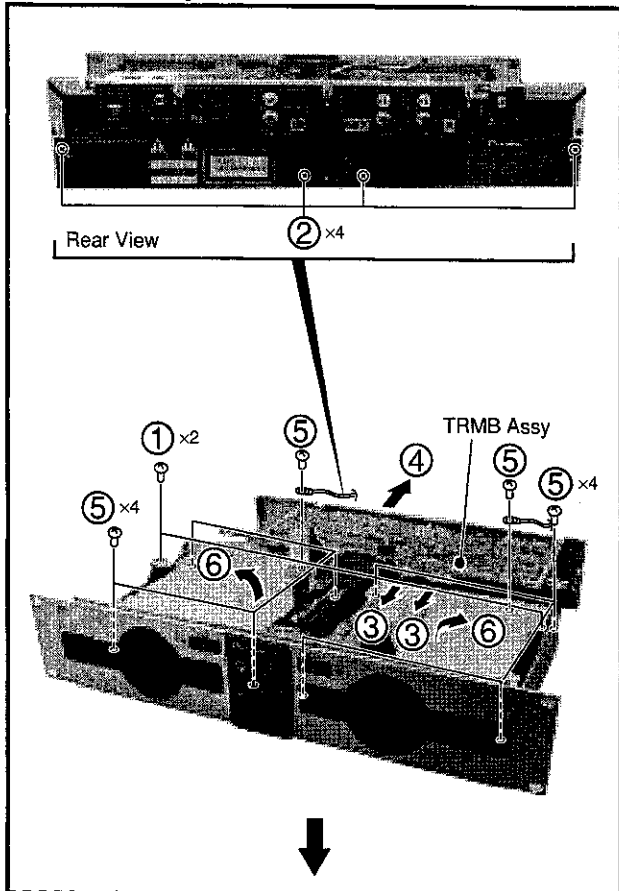

#### ■ Front Panel Section

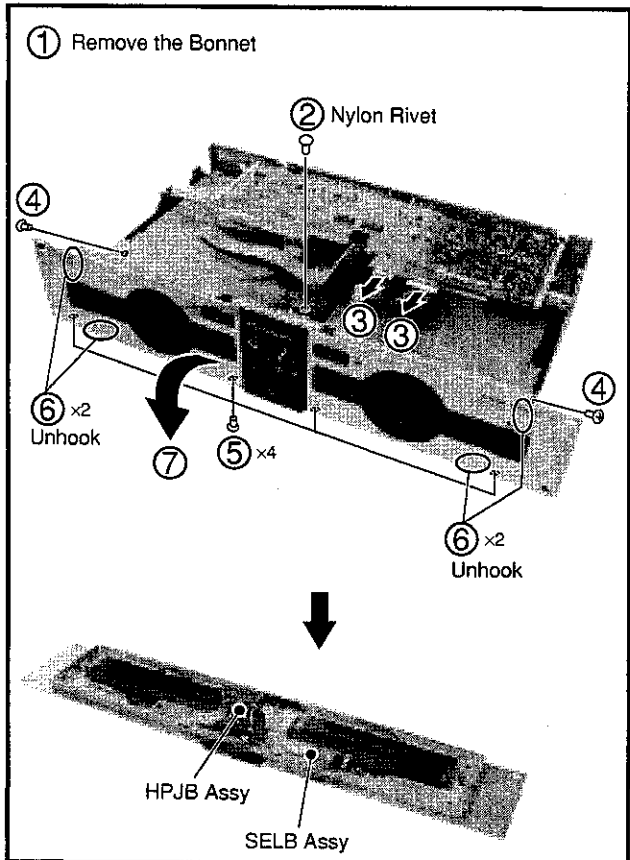





**SLOT-IN MECHANISM Assy**

A procedure of B PLAYER is same as A PLAYER.

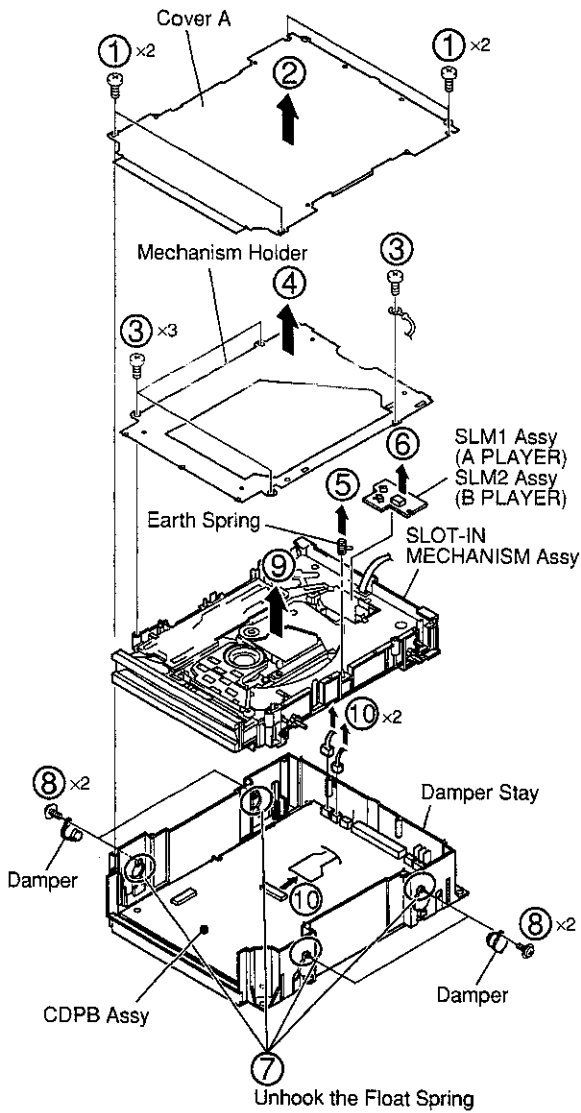

Note :  
CDPB Assy can diagnose from the backside.



**SERVO MECHANISM Assy**

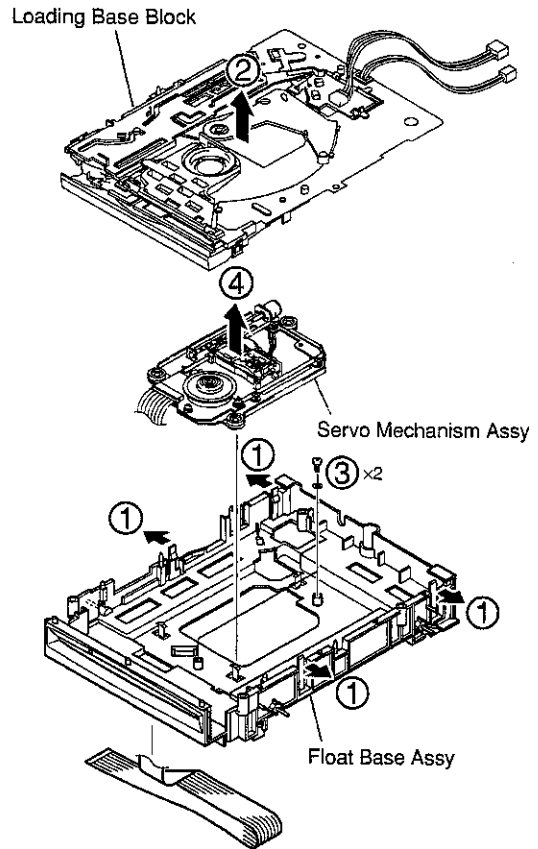

# CMX-5000, CU-V160

## (2) REMOTE CONTROLLER (CU-V160)

### ■ Cover

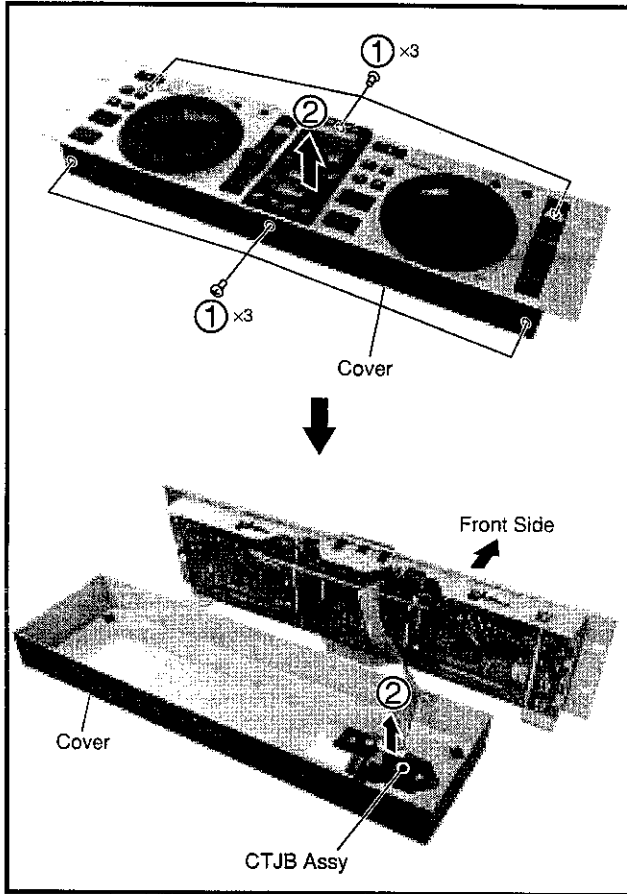

### ■ CNNB Assy

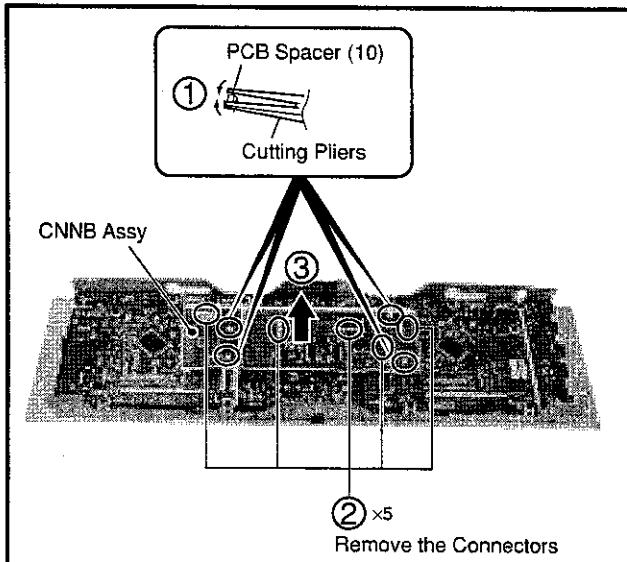

### ■ FLK1, FLK2 Assy

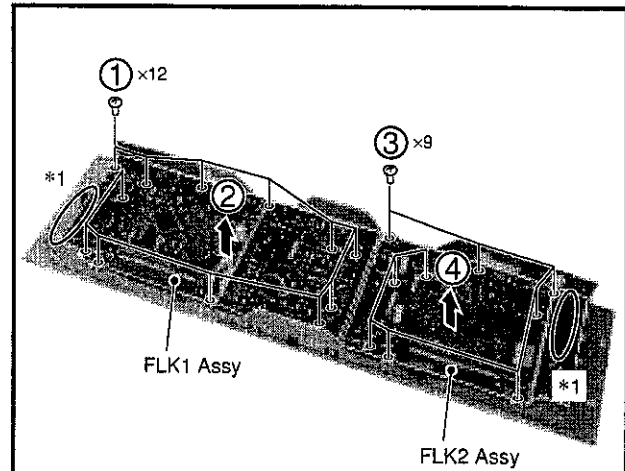

Note \*1 :  
When cuts PC Board with a ripper and replaced slide VR, positioning becomes invalid. Please align it by visual inspection when installs it. (Refer to the following diagram.)

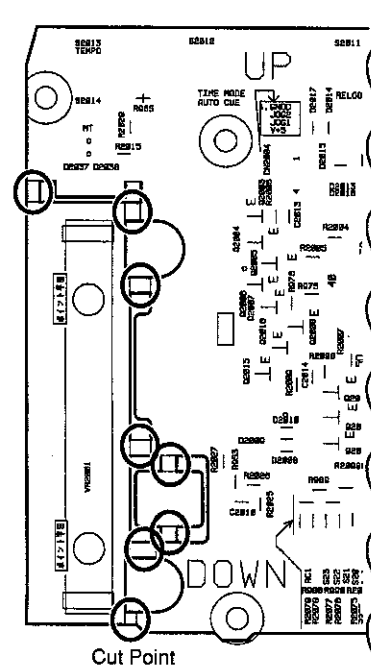

This illustration is FLK1 Assy.

## 7.2 PARTS

### 7.2.1 IC

• The information shown in the list is basic information and may not correspond exactly to that shown in the schematic diagrams.

● **List of IC**

NSM51V17805D-60TS-K, GLT44016-40J4, PE9009A, TC74HC241AF

■ **MSM51V17805D-60TS-K (CDPB ASSY : IC302)**

• 16M DRAM with EDO

● **Block Diagram**

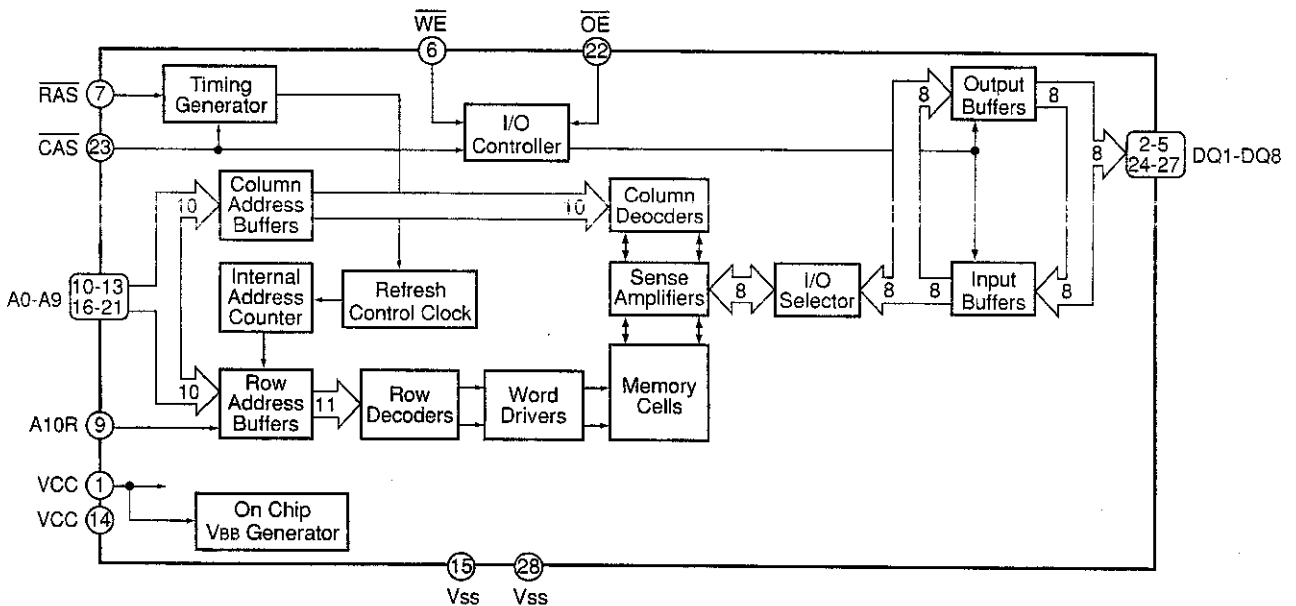

● **Pin Function**

| No. | Pin Name | Pin Function           | No.                 | Pin Name | Pin Function  |                       |
|-----|----------|------------------------|---------------------|----------|---------------|-----------------------|
| 1   | VCC      | Power supply (3.3V)    | 15                  | VSS      | Ground (0V)   |                       |
| 2   | DQ1      | Data input/Data output | 16                  | A4       | Address input |                       |
| 3   | DQ2      |                        |                     |          |               |                       |
| 4   | DQ3      |                        |                     |          |               |                       |
| 5   | DQ4      |                        |                     |          |               |                       |
| 6   | WE       | Write enable           | 17                  | A5       |               |                       |
| 7   | RAS      | Row address strobe     | 18                  | A6       |               |                       |
| 8   | NC       | Non connection         | 19                  | A7       |               |                       |
| 9   | A10R     | Address input          | 20                  | A8       |               |                       |
| 10  | A0       |                        |                     |          |               |                       |
| 11  | A1       |                        |                     |          |               |                       |
| 12  | A2       |                        |                     |          |               |                       |
| 13  | A3       | Data input/Data output | 21                  | A9       |               |                       |
| 14  | VCC      |                        | Power supply (3.3V) | 22       | OE            | Output enable         |
|     |          |                        |                     | 23       | CAS           | Column address strobe |
|     |          |                        |                     | 24       | DQ5           |                       |
|     |          |                        | 25                  | DQ6      |               |                       |
|     |          |                        | 26                  | DQ7      |               |                       |
|     |          |                        | 27                  | DQ8      |               |                       |
|     |          |                        | 28                  | VSS      | Ground (0V)   |                       |

# CMX-5000, CU-V160

## ■ GLT44016-40J4 (CDPB ASSY : IC902)

• 256k X 16 CMOS Dynamic RAM

### ● Block Diagram

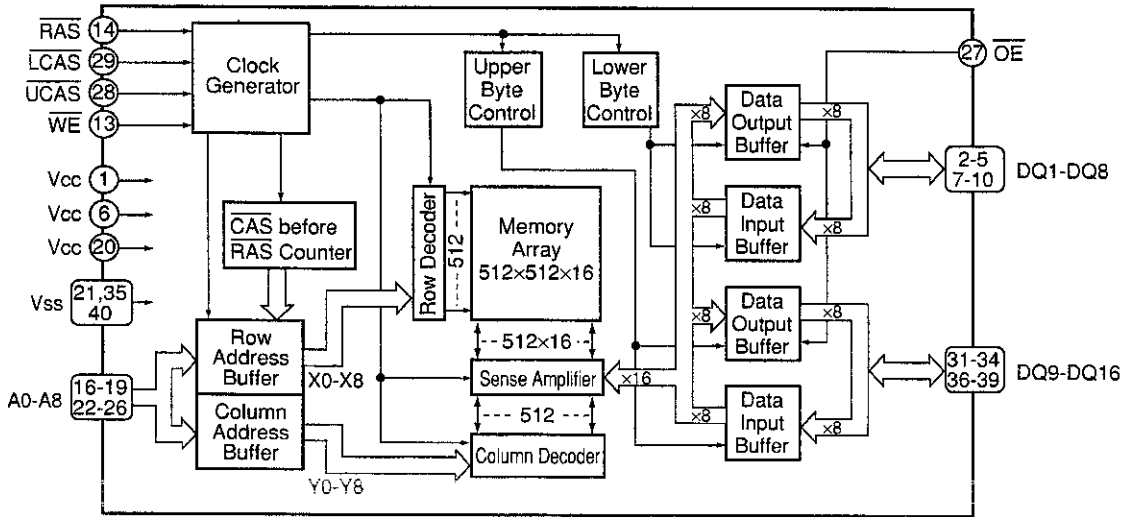

### ● Pin Function

| No. | Pin Name | Pin Function          | No.              | Pin Name | Pin Function                             |
|-----|----------|-----------------------|------------------|----------|------------------------------------------|
| 1   | VCC      | +5V power supply      | 21               | Vss      | Ground                                   |
| 2   | DQ1      | Data inputs / Outputs | 22               | A4       | Address inputs                           |
| 3   | DQ2      |                       |                  |          |                                          |
| 4   | DQ3      |                       |                  |          |                                          |
| 5   | DQ4      |                       |                  |          |                                          |
| 6   | VCC      |                       | +5V power supply | 23       |                                          |
| 7   | DQ5      | Data inputs / Outputs | 24               | A6       |                                          |
| 8   | DQ6      |                       |                  |          |                                          |
| 9   | DQ7      |                       |                  |          |                                          |
| 10  | DQ8      |                       |                  |          |                                          |
| 11  | NC       | No connection         | 25               | A7       |                                          |
| 12  | NC       | No connection         | 26               | A8       |                                          |
| 13  | WE       | Write enable          | 27               | OE       | Output enable                            |
| 14  | RAS      | Row address strobe    | 28               | UCAS     | Column address strobe/Upper byte control |
| 15  | NC       | No connection         | 29               | LCAS     | Column address strobe/Lower byte control |
| 16  | A0       | Address inputs        | 30               | NC       | No connection                            |
| 17  | A1       |                       |                  |          |                                          |
| 18  | A2       |                       |                  |          |                                          |
| 19  | A3       |                       |                  |          |                                          |
| 20  | VCC      | +5V power supply      | 31               | DQ9      | Data inputs / Outputs                    |
|     |          |                       | 32               | DQ10     |                                          |
|     |          |                       | 33               | DQ11     |                                          |
|     |          |                       | 34               | DQ12     |                                          |
|     |          |                       | 35               | Vss      | Ground                                   |
|     |          |                       | 36               | DQ13     | Data inputs / Outputs                    |
|     |          |                       | 37               | DQ14     |                                          |
|     |          |                       | 38               | DQ15     |                                          |
|     |          |                       | 39               | DQ16     |                                          |
|     |          |                       | 40               | Vss      | Ground                                   |

■ PE9009A (CDPB ASSY : IC402)

• In-System Programming (ISP) CPLD

● Block Diagram

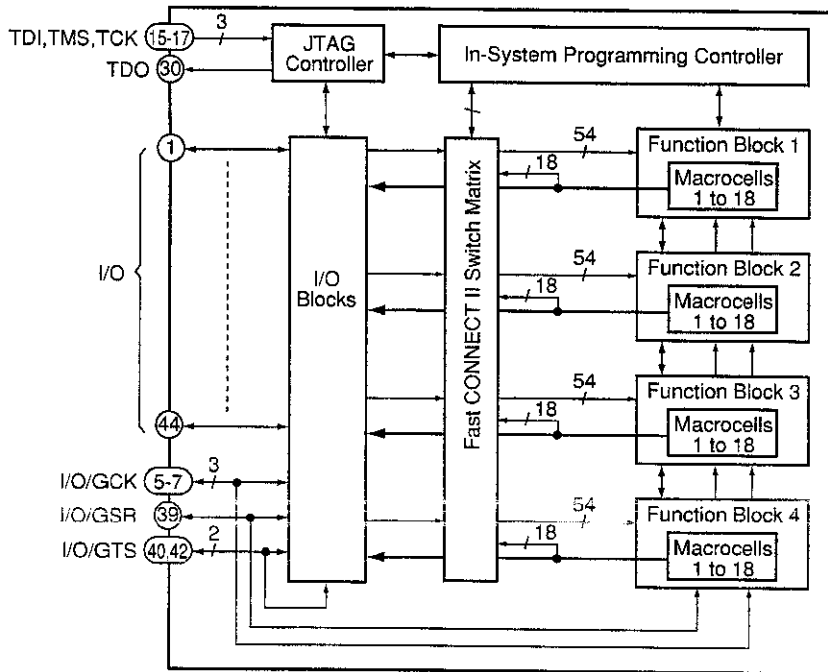

■ TC74HC241AF (TRMB ASSY : IC1004)

• Octal Bus Buffer

● Pin Assignment (Top view)

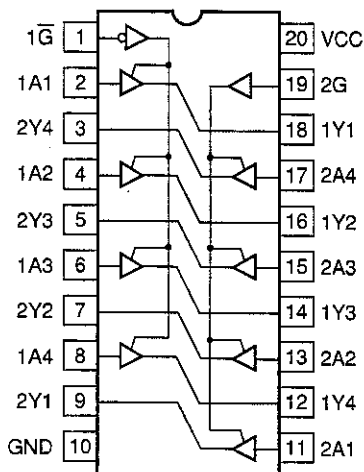

● Truth Table

| INPUTS |                | OUTPUTS        |
|--------|----------------|----------------|
| G      | A <sub>n</sub> | Y <sub>n</sub> |
| H      | L              | L              |
| H      | H              | H              |
| L      | X              | Z              |

X : Don't care  
Z : High impedance

● IEC Logic Symbol

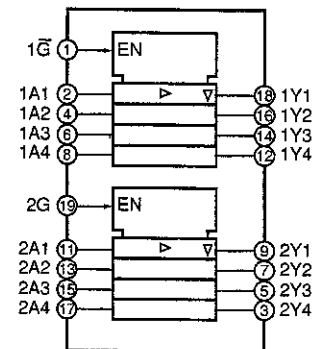

# CMX-5000, CU-V160

## 7.2.2 DISPLAY

### ■ DEL1033 (FLKY1 ASSY: V2001, FLKY2 ASSY: V2101)

• FL Display

#### ● Pin Assignment

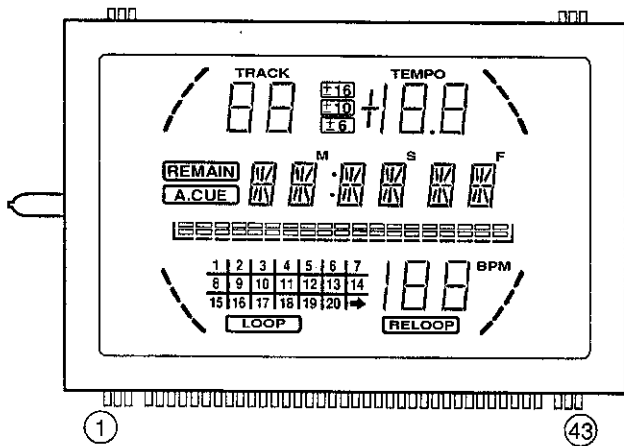

#### ● Pin Connection

|            |         |         |    |     |     |     |     |     |     |     |     |     |     |     |     |     |     |    |    |         |         |    |
|------------|---------|---------|----|-----|-----|-----|-----|-----|-----|-----|-----|-----|-----|-----|-----|-----|-----|----|----|---------|---------|----|
| Pin No.    | 1       | 2       | 3  | 4   | 5   | 6   | 7   | 8   | 9   | 10  | 11  | 12  | 13  | 14  | 15  | 16  | 17  | 18 | 19 | 20      | 21      | 22 |
| Assignment | NL (F1) | NL (F1) | F1 | NP  | G1  | G2  | G3  | G4  | G5  | G6  | G7  | G8  | G9  | G10 | G11 | NL  | S1  | S2 | S3 | S4      | S5      | S6 |
| Pin No.    | 23      | 24      | 25 | 26  | 27  | 28  | 29  | 30  | 31  | 32  | 33  | 34  | 35  | 36  | 37  | 38  | 39  | 40 | 41 | 42      | 43      |    |
| Assignment | S7      | S8      | S9 | S10 | S11 | S12 | S13 | S14 | S15 | S16 | S17 | S18 | S19 | S20 | S21 | S22 | S23 | NP | F2 | NL (F2) | NL (F2) |    |

F1, F2 : Filament, G1 - G11 : Grid, S1 - S23 : Anode, NP : No Pin, NL : No Lead

#### ● Anode and Grid Assignment

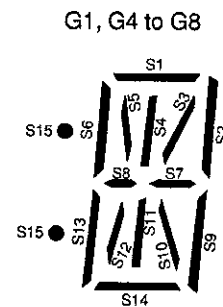
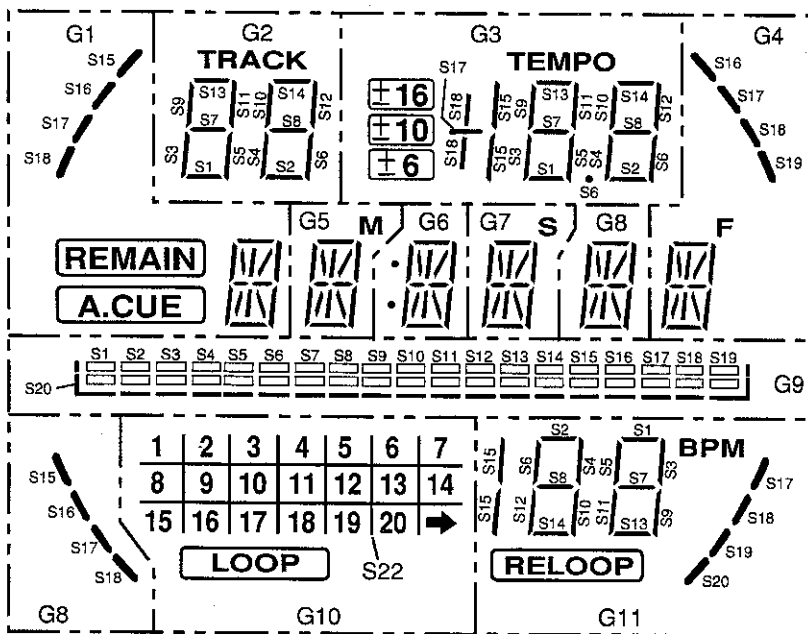

● Anode and Grid Assignment

|     | G1     | G2    | G3    | G4    | G5    | G6    | G7    | G8    | G9    | G10  | G11    |
|-----|--------|-------|-------|-------|-------|-------|-------|-------|-------|------|--------|
| S1  | S1     | S1    | S1    | S1    | S1    | S1    | S1    | S1    | S1    | 1    | S1     |
| S2  | S2     | S2    | S2    | S2    | S2    | S2    | S2    | S2    | S2    | 2    | S2     |
| S3  | S3     | S3    | S3    | S3    | S3    | S3    | S3    | S3    | S3    | 3    | S3     |
| S4  | S4     | S4    | S4    | S4    | S4    | S4    | S4    | S4    | S4    | 4    | S4     |
| S5  | S5     | S5    | S5    | S5    | S5    | S5    | S5    | S5    | S5    | 5    | S5     |
| S6  | S6     | S6    | S6    | S6    | S6    | S6    | S6    | S6    | S6    | 6    | S6     |
| S7  | S7     | S7    | S7    | S7    | S7    | S7    | S7    | S7    | S7    | 7    | S7     |
| S8  | S8     | S8    | S8    | S8    | S8    | S8    | S8    | S8    | S8    | 8    | S8     |
| S9  | S9     | S9    | S9    | S9    | S9    | S9    | S9    | S9    | S9    | 9    | S9     |
| S10 | S10    | S10   | S10   | S10   | S10   | S10   | S10   | S10   | S10   | 10   | S10    |
| S11 | S11    | S11   | S11   | S11   | S11   | S11   | S11   | S11   | S11   | 11   | S11    |
| S12 | S12    | S12   | S12   | S12   | S12   | S12   | S12   | S12   | S12   | 12   | S12    |
| S13 | S13    | S13   | S13   | S13   | S13   | S13   | S13   | S13   | S13   | 13   | S13    |
| S14 | S14    | S14   | S14   | S14   | S14   | S14   | S14   | S14   | S14   | 14   | S14    |
| S15 | S15    | TRACK | S15   | F     | M     | S15   | S     | S15   | S15   | 15   | S15    |
| S16 | S16    | _____ | S16   | S16   | _____ | _____ | _____ | S16   | S16   | 16   | BPM    |
| S17 | S17    | _____ | S17   | S17   | _____ | _____ | _____ | S17   | S17   | 17   | S17    |
| S18 | S18    | _____ | S18   | S18   | _____ | _____ | _____ | S18   | S18   | 18   | S18    |
| S19 | REMAIN | _____ | ±16   | S19   | _____ | _____ | _____ | S19   | S19   | 19   | S19    |
| S20 | A. CUE | _____ | ±10   | _____ | _____ | _____ | _____ | S20   | S20   | 20   | S20    |
| S21 | _____  | _____ | ±6    | _____ | _____ | _____ | _____ | _____ | _____ | ➡    | RELOOP |
| S22 | _____  | _____ | TEMPO | _____ | _____ | _____ | _____ | _____ | _____ | S22  | _____  |
| S23 | _____  | _____ | _____ | _____ | _____ | _____ | _____ | _____ | _____ | LOOP | _____  |

# CMX-5000, CU-V160

## 8. PANEL FACILITIES AND SPECIFICATIONS

### 8.1 PANEL FACILITIES

#### Player

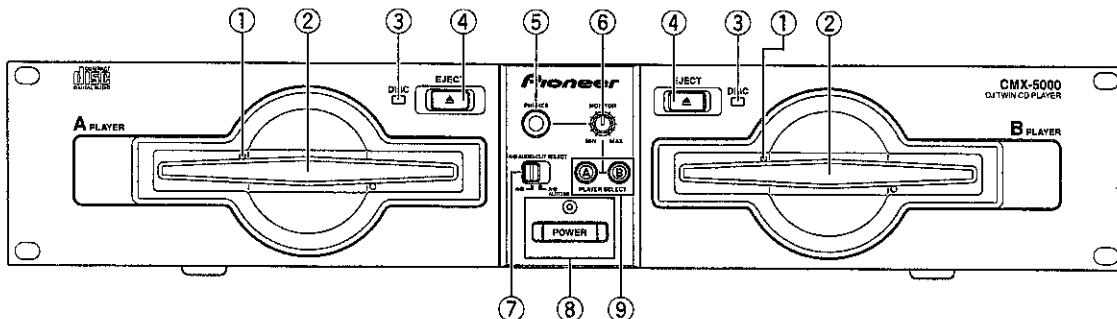

- ① Manual ejection hole
- ② Disc insertion slot  
When using 3 inch/8 cm discs, discs must be inserted in the commercially available CD adapter before insertion.
- ③ Disc loading indicator (DISC)  
This indicator flashes when a disc is being inserted into or ejected from the disc insertion slot and lights up when a disc has been inserted.
- ④ Eject button (EJECT ▲)  
Pressing this button while cueing is on standby or play is paused will eject the disc from the player.
- ⑤ Headphone jack (PHONES)
- ⑥ Headphone volume (MONITOR)
- ⑦ Audio output select switch (A/B AUDIO OUT SELECT)  
Used to switch between A and B audio output.
- ⑧ Power switch (POWER) and indicator
- ⑨ Monitor select button (PLAYER SELECT)

#### Remote control unit

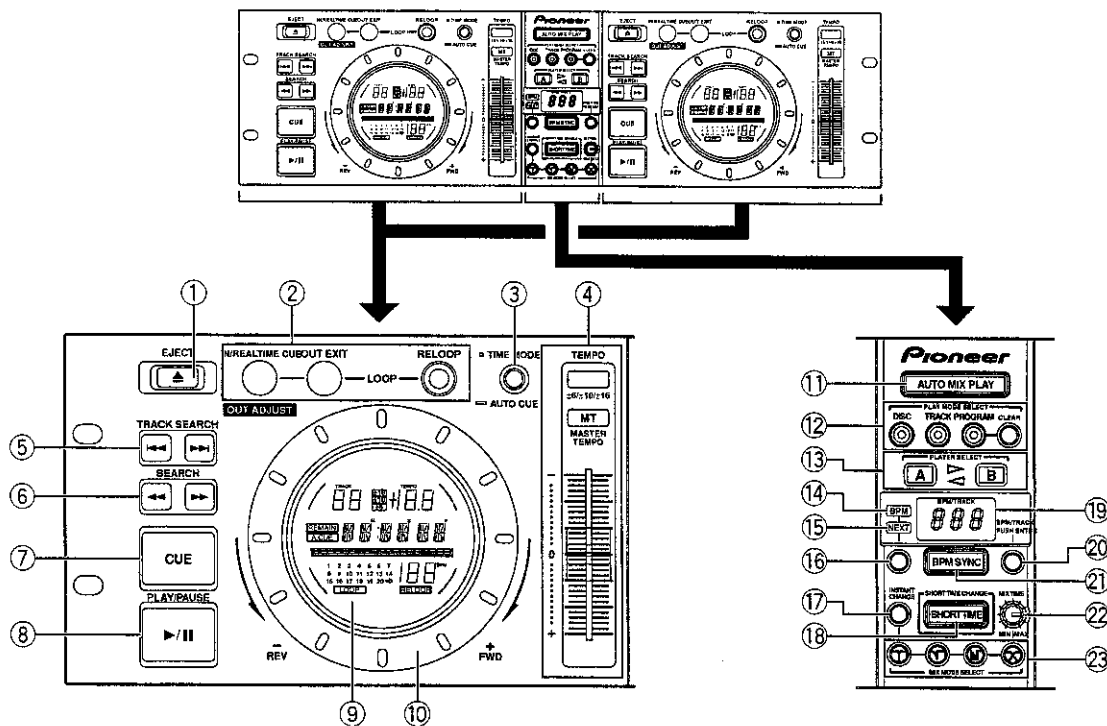

- ① Eject button (EJECT ▲)
- ② Loop control button (LOOP)
- ③ Time mode/Auto cueing button (TIME MODE/AUTO CUE)  
**TIME MODE:**  
Pressing this button causes the elapsed time and remaining time (REMAIN) of the current track to be displayed in succession on the time display of the display unit.
- ④ Tempo controls (TEMPO)  
**Tempo control range button (±6, ±10, ±16):**  
Pressing this button causes the variable range of the tempo adjustment knob to change each time the button is pressed.
- When unit is first powered on, time displayed consists of remaining time.

#### AUTO CUE:

- When unit is first powered on, auto cueing is set to on.



## Display Section

- Variable range is set to  $\pm 10\%$  when power to the unit is first turned on.

### Master tempo button (MASTER TEMPO) and indicator:

Pressing this button causes the master tempo feature to be powered on or off each time it is pressed.

### Tempo control slide:

Moving this dial in the positive (+) direction away from the center position (normal playback tempo) causes the tempo to become faster, and moving it in the negative (-) direction causes the tempo to become slower.

- ⑤ **Track search button (TRACK SEARCH ◀▶)**
- ⑥ **Search button (SEARCH ◀▶)**
- ⑦ **Cue button (CUE) and indicator**  
Cueing point settings  
Cueing point sampler  
Back cueing  
Cueing point adjust
- ⑧ **Play/Pause button (PLAY ▶/PAUSE II) and indicator**
- ⑨ **Display**
- ⑩ **Jog dial (+ FWD/- REV)**
- ⑪ **Auto mix play button (AUTO MIX PLAY) and indicator**  
Pressing this button causes auto mixing to be turned on or off each time it is pressed.
- ⑫ **Play mode select button (PLAY MODE SELECT)**  
This button is used to select the auto mixing play mode and to specify program settings.
- ⑬ **Player select button (PLAYER SELECT) and indicator**  
This button is used to select discs when using auto mixing.
- ⑭ **BPM indicator**
- ⑮ **NEXT indicator**
- ⑯ **BPM/NEXT button**
- ⑰ **Instant change button (INSTANT CHANGE) and indicator**
- ⑱ **Short time change button (SHORT TIME) and indicator**  
Pressing this button causes short time changing to be turned on or off each time it is pressed.
- ⑲ **BPM/TRACK display (BPM/TRACK)**  
This display is used to display the track number and BPM when using auto mixing or preprogrammed program settings.
- ⑳ **BPM/TRACK dial (BPM/TRACK, PUSH ENTER)**  
This dial is used to switch between different BPM values when using BPM synchro playback and to select and confirm track numbers when playing in program mode.  
\* Press down on the dial after making a selection to confirm your choice. (Note that this does not include the switching of BPM settings.)
- ㉑ **BPM synchro button (BPM SYNC)**  
When BPM SYNC is turned on (i.e., when the BPM SYNC button is lit), the tempo will be automatically changed so that the number of beats per minute matches between tracks mixing into each other. Pressing this button causes the BPM synchro count feature to be turned on or off each time it is pressed.
- ㉒ **Mix time control dial (MIX TIME)**  
This dial is used to specify the mixing time when using the mix button to perform cross fade mixing.
- ㉓ **Mix mode selection button (MIX MODE SELECT) and indicator**  
This button is used to select cut-in, zip, echo or cross fade mixing as the type of mixing to be used when segueing between tracks.

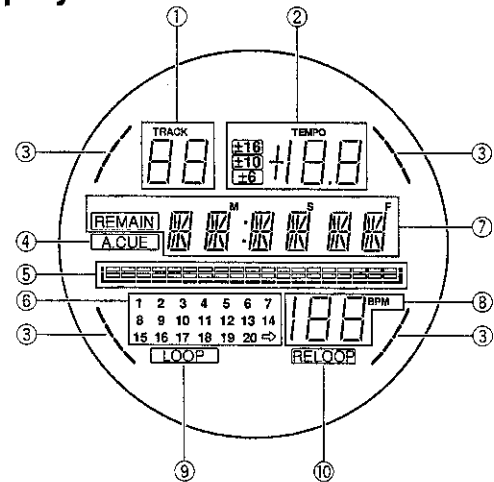

- ① **Track number display**  
Displays the track number of the track currently being played.
- ② **Playback speed display**  
**Tempo control range display ( $\pm 6, \pm 10, \pm 16$ )**  
Displays the variable range mode specified using the tempo control slide.  
**Tempo change rate display**  
Displays the rate of change of the tempo as specified using the tempo control slide.
- ③ **Auto mixing playback player display**  
The display on the side of the player currently in operation will flash.
- ④ **Auto cueing indicator (A. CUE)**  
Lights up when auto cueing is turned on.
- ⑤ **Playback position display**  
Used to display a full-scale bar graph for the track being played to make it possible to get an intuitive feel of the elapsed and remaining play time.
  - Display as it appears when displaying elapsed time:  
All indicators unlit and then indicators light up in sequence from left
  - Display as it appears when displaying remaining time:  
All indicators lit and then indicators are turned off in sequence from left
  - Display as it appears when there are less than 30 seconds remaining in a track: Slow flashing
  - Display as it appears when there are less than 15 seconds remaining in a track: Rapid flashing
- ⑥ **Track number calendar display**  
The number corresponding to the track currently being played is lit. The right-facing arrow is lit for tracks with a track number of 21 or higher.  
Programmed track numbers are lit, and the light for each number for tracks which have already been played are turned off once the tracks are played.
- ⑦ **Time display**  
Used to display the elapsed playback time (when the remain indicator is unlit) or the remaining playback time (when the remain indicator is lit) of the current track in minutes (M), seconds (S), and frames (F). Note that the amount of time remaining is displayed by default when the power is first turned on.
- ⑧ **BPM display**  
Used to display the number of BPM for the current track. Note that depending on the track there may be times when the BPM counter is unable to count the number of BPM.
- ⑨ **Looping indicator (LOOP)**  
Lights up when playing back in loop mode.
- ⑩ **Relooping indicator (RELOOP)**  
Lights up when recording a loop.

# CMX-5000, CU-V160

## 8.2 SPECIFICATIONS

### 1. General

|                             |                                                |
|-----------------------------|------------------------------------------------|
| System .....                | Compact disc digital audio system              |
| Discs used.....             | Compact discs                                  |
| Power requirements .....    | AC 120 V, 60 Hz                                |
| Power consumption.....      | 40 W                                           |
| Operating temperature ..... | +5°C to +35°C (+41°F to +95°F)                 |
| Operating humidity .....    | 5% to 85%                                      |
|                             | (There should be no condensation of moisture.) |
| Weight                      |                                                |
| Remote controller .....     | 2.1 kg (4 lbs 10 oz)                           |
| Player .....                | 5.4 kg (11 lbs 15 oz)                          |
| Dimensions                  |                                                |
| Remote controller .....     | 482 (W) x 73 (D) x 132 (H) mm                  |
|                             | 18-31/32 (W) x 2-7/8 (D) x 5-3/16 (H) in.      |
| Player .....                | 482 (W) x 268 (D) x 90 (H) mm                  |
|                             | 18-31/32 (W) x 10-9/16 (D) x 3-9/16 (H) in.    |

### 2. Audio section

|                             |                |
|-----------------------------|----------------|
| Frequency response .....    | 4 Hz to 20 kHz |
| Signal-to-noise ratio ..... | 115 dB or more |
| Distortion rate .....       | 0.006%         |

### 3. Accessories

|                                                            |   |
|------------------------------------------------------------|---|
| ● Operating instructions.....                              | 1 |
| ● Audio cable .....                                        | 2 |
| ● Control cord .....                                       | 2 |
| ● Forced ejection pin .....                                | 1 |
| ● Specialized connection cable for the remote controller . | 1 |
| ● Limited warranty .....                                   | 1 |

#### NOTE:

Specifications and design are subject to possible modification without notice.