

ADDITIONAL

 PIONEER®

Service Manual

ORDER NO.
ARP - 096-0

STEREO CASSETTE TAPE DECK

CT-8R

KU, KC, HE,
HB, HP, D, D/G

- In CT-8R, a one-chip IC (PA3012) is incorporated in the DOLBY NR circuit with the following Serial No.

Type	Serial No.	
KU	3607001	~
KC	3401001	~
HE	8403601	~
HB	8500401	~
HP	8600201	~
D	9302401	~
D/G	9301101	~

- For the contents other than those described in this additional service manual, please see the original service manual.

- The Part No. of the P.C. board was changed as follows:

P.C. Board Type	Mother Assembly		DOLBY NR Assembly		Sub Amp Assembly		MIC Amp Assembly	
	Old	New	Old	New	Old	New	Old	New
KU	RWX-535	RWX-578	RWX-551 and RWX-547	RWX-579	RWF-097	RWF-102	RWF-099	RWF-103
KC								
HE								
HB								
HP								
D								
D/G								

Continued on page 2

PIONEER ELECTRONIC CORPORATION 4-1, Meguro 1-Chome, Meguro-ku, Tokyo 153, Japan
PIONEER ELECTRONICS (USA) INC. 1925 E. Dominguez St., Long Beach, California 90810 U.S.A.
PIONEER ELECTRONIC (EUROPE) N.V. Luithagen-Haven 9, 2030 Antwerp, Belgium
PIONEER ELECTRONICS AUSTRALIA PTY. LTD. 178-184 Boundary Road, Braeside, Victoria 3195, Australia

Continued from page 1

P.C. Board Type	Headphones Amp Assembly		Power Supply Assembly		Voltage Change Assembly		Remarks
	Old	New	Old	New	Old	New	
KU	RWF-098	RWF-104	RWR-085	RWR-089	Non-use	RWX-603	
KC			RWR-088	RWR-090			
HE			RWR-086	RWR-091			
HB							
HP							
D			RWR-087	RWR-092		RWX-590	
D/G							

When replacing the DOLBY NR IC PA3012 in 3-head decks:

1. As a rule, replace ICs with only ICs of the same rank within each channel (right or left).
2. If an IC of the same rank is not available, the IC of one rank higher or lower (see table 1 below) can be used instead. However, after replacement, the ICs on the recording side and the playback side must not differ by more than one rank.
3. The colors in table 1 refer to the color marking on the top surface of the IC package (see fig.1).

Example:

Acceptable replacement:

	Lch	Rch
Recording Side	PA3012-01-R	PA3012-01-Y
Playback Side	PA3012-01-R	PA3012-01-Y

	Lch	Rch
Recording Side	PA3012-01-O	PA3012-01-V
Playback Side	PA3012-01-O	PA3012-01-G

- Rank does not differ within each channel.

Unacceptable replacement:

	Lch	Rch
Recording Side	PA3012-01-O	PA3012-01-Y
Playback Side	PA3012-01-O	PA3012-01-V

- In this example, the rank of yellow and violet are more than one rank.

Ranking color

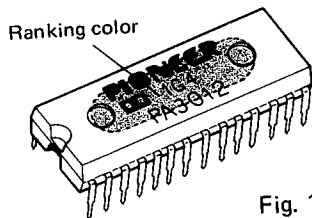

Fig. 1

	Rank	Part No.	Color
HIGH ↑	1	PA3012-01-R	Red
	2	PA3012-01-V	Violet
	3	PA3012-01-G	Green
	4	PA3012-01-Y	Yellow
	5	PA3012-01-O	Orange
↓ LOW	6	PA3012-01-B	Blue

Table 1

1. PARTS LIST

NOTES:

- When ordering resistors, first convert resistance values into code form as shown in the following examples.
Ex. 1 When there are 2 effective digits (any digit apart from 0), such as 560 ohm and 47k ohm (tolerance is shown by J = 5%, and K = 10%).
 560Ω 56 × 10¹ 561 RD¼PS 561J
 47kΩ 47 × 10³ 473 RD¼PS 473J
 0.5Ω 0R5 RN2H 0R5K
 1Ω 010 RS1P 010K
Ex. 2 When there are 3 effective digits (such as in high precision metal film resistors).
 5.62kΩ 562 × 100 5621 RN¼SR 5621F
- The Δ mark found on some component parts indicates the importance of the safety factor of the part. Therefore, when replacing, be sure to use parts of identical designation.
- For your Parts Stock Control, the fast moving items are indicated with the marks **★★** and **★**.
★★ GENERALLY MOVES FASTER THAN ★.
 This classification shall be adjusted by each distributor because it depends on model number, temperature, humidity, etc.

Miscellaneous Parts List

P.C. BOARD ASSEMBLIES

Mark	Part No.	Symbol & Description
	RWX-578	Mother assembly
	RWX-579	DOLBY NR assembly
	RWX-536	Equalizer assembly
	RWF-102	Sub amplifier assembly
	RWF-103	MIC amplifier assembly
	RWX-534	Meter drive assembly
	RWF-104	Headphones amplifier assembly
	RWR-089	Power supply assembly (KU type)
	RWR-090	(KC type)
	RWR-091	(HE, HB and HP types)
	RWR-092	(D and D/G types)
	RWS-152	Function switch assembly
	RWX-603	Voltage change assembly (KU, KC, HE, HB and HP types)
	RWX-590	(D and D/G types)
	RWX-589	Reel motor control assembly D
	RWX-585	Capstan motor control assembly F
	RXX-359	Reel motor assembly C (Included in the reel motor drive assembly C and the reel motor drive coil).
	RXX-361	Capstan motor coil assembly (Included in the capstan motor drive coil.)

OTHERS

Mark	Part No.	Symbol & Description
Δ ★	RTT-231	Power transformer (120V; KU type)
	RTT-263	(120V; KC type)
	RTT-251	(220V/240V; HE, HB, HP types)
	RTT-252	(120V/220V/240V; D, D/G types)
Δ ★★	RSA-049	Power switch (KU, KC types)
	RSA-052	(HE, HB, HP types)
	RSA-043	(D, D/G types)
Δ	RDG-022	AC power cord (KU, KC types)
	(RDG-030)	
	RDG-027	(HE type)
	RDG-032	(HB type)
	RDG-029	(HP type)
	RDG-024	(D, D/G types)
Δ	RWX-234	Spark killer (KU type)
	RWX-235	(KC type)
	C43-003	(D, D/G types)
Δ ★★	REK-055	Fuse T2A (KU, KC types)
	REK-064	T800mA (HE, HB, HP types)
	REK-054	T2.5A (HE, HB, HP types)
	REK-047	T3.15A (HE, HB, HP types)
	REK-051	T1A (D type)
	REK-063	T1.5A (D/G type)
	RSX-045	Line Voltage Selector (Switchable 2 positions; 220V/240V)
	RSX-020	(switchable 3 positions; 120V/220V/240V)
★	RAW-164	Display assembly
★	RAW-166	Level meter assembly
★★	SLF-201C	Half LED
★★	RXX-337	Head assembly
★	RPB-095	Erase Head
★	RXP-111	Plunger solenoid
	RXX-334	FC coil assembly

Mother Assembly (RWX-578)

CAPACITORS

Mark	Part No.	Symbol & Description
	CKDYF 473Z 50	C301, C318, C335, C363
	CEA R10M 50	C362
	CEA R22M 50	C327, C328, C339, C343
	CEA R47M 50	C325, C326, C354, C357, C364
	CEA 010M 50	C314, C355, C356, C366
	CEA 4R7M 50	C371, C384
	CEA 3R3M 50	C329, C330
	CEA 100M 25	C313
	CEA 220M 25	C304, C374, C383
	CEA 470M 25	C303
	CEA 101M 25	C365
	CEA 100M 16	C323, C324, C359, C370, C377, C386
	CEA 220M 16	C369
	CEA 221M 16	C302, C321, C368, C376
	CEA 222M 10	C345
	CEA 470M 10	C306, C322
	CEA 221M 6R3	C361
	CEA 101M 6R3	C360, C372
	CQMA 152J 50	C346, C350
	CQMA 122J 50	C342
	CQMA 332J 50	C307, C308, C347, C351
	CQMA 682J 50	C348, C352
	CQMA 272J 50	C319, C320
	CQMA 272K 50	C381, C382
	CQMA 123J 50	C338, C349, C353
	CQMA 103J 50	C309, C310
	CQMA 683K 50	C336, C337
	CQMA 123K 50	C340, C341
	CQMA 103K 50	C312
	CQMA 473K 50	C367
	CQMA 682K 50	C315
	CQMA 472K 50	C358
	CCDSL 220K 50	C378, C379
	CKDYF 103Z 50	C305, C375, C385
	COSH 181K 50	C316, C317
	CQPA 182J 100	C311

RESISTORS

Note: When ordering resistors, convert the resistance value into code form, and then rewrite the part no. as before.

Mark	Part No.	Symbol & Description
★	RCP-195 (RCP-150)	VR301, VR305-VR307 Semi-fixed (22k-B)
★	RCP-189 (RCP-145)	VR302 Semi-fixed (2.2k-B)
★	RCP-196 (RCP-151)	VR303, VR304 Semi-fixed (33k-B)
★	RCP-199 (RCP-154)	VR309 Semi-fixed (100k-B)
★	RCP-197 (RCP-152)	VR308 Semi-fixed (47k-B)

Mark	Part No.	Symbol & Description
△	RS1PF 101J	R444
	RM10-273J	R397
	RM11-103J	R423
	RM5-103J	R424
	RM5-223J	R402
	RM8-223J	R463

RD¼PM □□□J	R301-R332, R335, R337, R339-R350, R354, R355, R364-R369, R371-R377, R379-R381, R383, R385-R396, R399-R401, R403, R405-R421, R425-R443, R445, R446, R448-R451, R454-R462, R464
------------	---

SEMICONDUCTORS

Mark	Part No.	Symbol & Description
★★	NJM4558D (BA4558) (AN6552)	IC301
★★	PD6006	IC310
★★	PD4012	IC306
★★	PM3001	IC309
★★	PA3010	IC311
★★	PM9001A	IC305
★★	μPD4011BC	IC303, IC304
★★	TC4001BP (HD14001B) (MB84001BM) (μPD4001C)	IC307
★★	BA619	IC308
★★	2SC2497 (2SD1189)	Q301
★★	2SD1189 (2SC2497) (2SD882)	Q303, Q304
★★	2SC2060 (2SC2673) (2SC1383NC)	Q302, Q306
★★	2SA934 (2SA881)	Q307
★★	2SC1740LN (2SC2021) (2SC1815) (2SC2634NC)	Q305, Q314-Q316, Q319-Q321, Q323, Q325, Q326, Q328
★★	2SC1740LN	Q309-Q312
★★	2SA1015 (2SA933LN) (2SA937) (2SA1127NC)	Q317, Q322, Q324, Q327
★	1S2473 (US1040)	D301-D305, D314-D336

COILS

Mark	Part No.	Symbol & Description
	RTF-057	L301 Line coil
	RTF-067	L305, L306 Peaking coil (5mH)
	RTF-084	L307, L308 Trap coil
	RTD-015	L309 OSC coil
	RTD-018	L303 Transformer
	RTD-027	L302 OSC coil

OTHERS

Mark	Part No.	Symbol & Description
★★	RSG-128	S301 Push switch assembly
	RKB-018	Terminal (LINE)
	RKP-506	Connector assembly (3P)
	RKP-362	Connector assembly (5P)
	RKP-361	Connector assembly (11P)
	RKP-501	Connector assembly (3P)
	RSS-033	X301 (C373) Ceramic resonator assembly
	RBF-041	Spacer

DOLBY NR Assembly (RWX-579)

CAPACITORS

Mark	Part No.	Symbol & Description
	CEA 101M 16	C601, C602, C659, C660, C711
	CEA R33M 50	C619—C622, C675—C678
	CEA R47M 50	C647, C648, C703, C704
	CEA R15M 50	C645, C646, C701, C702
	CEA 010M 50	C603, C604, C623—C626, C679—C682
	CEA 4R7M 35	C617, C618, C643, C644, C673, C674, C699, C700
	CEA 100M 16	C651—C654, C657, C658, C683, C684, C707—C710
	CEA 470M 25	C712, C714
	CEA 220M 25	C716, C719
	CEA 221M 10	C605, C606, C661, C662
	CEANL 100M 16	C609, C610, C639, C640, C665, C666, C695, C696
	CQMA 182J 50	C649, C650, C705, C706
	CQMA 102K 50	C629, C630, C689, C690
	CQMA 562K 50	C631, C632, C687, C688
	CQMA 103K 50	C607, C608, C633, C634, C667, C668, C691, C692
	CQMA 123K 50	C635, C636, C655, C656
	CQMA 153K 50	C611—C614, C637, C638, C663, C664, C669, C670, C693, C694
	CQMA 183K 50	C615, C616, C671, C672
	CQMA 823K 50	C641, C642, C697, C698
	CKDYF 103Z 50	C713, C715
	CCDSL 390K 50	C627, C628, C685, C686
	CCDSL 221K 50	C717, C718

RESISTORS

Note: When ordering resistors, convert the resistance value into code form, and then rewrite the part no. as before.

Mark	Part No.	Symbol & Description
	RD¼PM □□□J	R601—R715, R717, R718

SEMICONDUCTORS

Mark	Part No.	Symbol & Description
*★★	PA3012-01-R (PA3012-01-V) (PA3012-01-G) (PA3012-01-Y) (PA3012-01-O) (PA3012-01-B)	IC601—IC604

*** NOTE:**

Always read the precautions on page 2 before performing IC replacement.

★★	2SD880 (2SD313)	Q601
★★	2SC1740LN (2SC2021) (2SC1815) (2SC2634NC)	Q602—Q604
★★	2SA1015 (2SA933LN) (2SA937) (2SA1127NC)	Q605
★★	2SC2060 (2SC2673) (2SC1383NC)	Q606
★	1S2473 (US1040)	D601—D605
★	WZ-150	ZD601

OTHERS

Mark	Part No.	Symbol & Description
	RSR-035	RL1 Relay
	RTF-091	L601, L602 Coil 36mH
	RTF-092	L603, L604 Coil 36mH
	RTF-083	L607, L608 MPX filter block
	RTF-096	L605, L606 Trap coil

Equalizer Assembly (RWX-536)

CAPACITORS

Mark	Part No.	Symbol & Description
	CQMA 562K 50	C1313, C1314
	CQMA 272K 50	C1307, C1308
	CQMA 223K 50	C1311, C1312
	CQMA 682K 50	C1303, C1304

RESISTORS

Note: When ordering resistors, convert the resistance value into code form, and then rewrite the part no. as before.

Mark	Part No.	Symbol & Description
	RD¼PM □□□J	R1301-R1312, R1315-R1318

SEMICONDUCTOR

Mark	Part No.	Symbol & Description
★★	TD62504P	IC1301

Sub Amplifier Assembly (RWF-102)

CAPACITORS

Mark	Part No.	Symbol & Description
	CEANL 100M 16	C1701, C1702
	CEA 4R7M 35	C1719, C1720
	CEA 010M 50	C1727, C1728
	CEA 100M 16	C1717, C1718, C1729, C1730, C1733, C1734
	CEA 220M 25	C1723
	CEA 330M 16	C1705, C1706
	CEA 471M 10	C1715, C1716
	CEA 331M 25	C1724, C1742, C1752
	CQSH 331K 50	C1703, C1704
	CQMA 822K 50	C1713, C1714
	CQMA 473K 50	C1725, C1726
	CQSH 220K 50	C1709, C1710
	CCDSL 471K 50	C1731, C1732
	CQSH 101K 50	C1707, C1708
	CKDYF 473Z 50	C1737
	CCDSL 221K 50	C1739, C1740

RESISTORS

Note: When ordering resistors, convert the resistance value into code form, and then rewrite the part no. as before.

Mark	Part No.	Symbol & Description
★	RCP-032 (RCP-088)	VR1701, VR1702 Semi-fixed (10k-B)
★	RCP-089 (RCP-009)	VR1703, VR1704 Semi-fixed (22k-B)
	RD¼PM □□□J	R1701-R1705, R1707-R1730, R1733-R1739, R1741-R1756, R1763-R1768, R1771, R1772, R1793
★	33D28 (TD5-C225D)	TH1701, TH1702 Thermistor

SEMICONDUCTORS

Mark	Part No.	Symbol & Description
★★	NJM4558D (BA4558) (AN6552)	IC1701
★★	2SC2240	Q1701, Q1702
★★	2SC1740LN	Q1703, Q1704
★★	2SC1740LN (2SC2021) (2SC1815) (2SC2634NC)	Q1705-Q1710
★	1S2473 (US1040)	D1701

OTHERS

Mark	Part No.	Symbol & Description
	RTF-058 RKP-444	L1701, L1702 Trap coil Connector assembly (3P)

MIC Amplifier Assembly (RWF-103)

CAPACITORS

Mark	Part No.	Symbol & Description
	CEA R47M 50	C1501, C1502
	CEA 010M 50	C1515, C1516
	CEA 470M 25	C1509
	CEA 100M 16	C1507, C1508
	CEA 470M 16	C1510
	CEA 101M 16	C1505, C1506
	CKDYB 332K 50	C1511, C1512
	CKDYF 473Z 50	C1513
	CCDSL 101K 50	C1503, C1504

RESISTORS

Note: When ordering resistors, convert the resistance value into code form, and then rewrite the part no. as before.

Mark	Part No.	Symbol & Description
	RD¼PM □□□J	R1501-R1514, R1517

SEMICONDUCTORS

Mark	Part No.	Symbol & Description
★★	NJM4558D (AN6552) (BA4558)	IC1501
★	1S2473 (US1040)	D1501, D1502

OTHERS

Mark	Part No.	Symbol & Description
	RKN-075	J1501 Jack assembly
★★	RSG-134	S1501 Push switch

Motor Drive Assembly (RWX-534)

CAPACITORS

Mark	Part No.	Symbol & Description
	CEA 010M 50	C903, C904
	CEA R47M 50	C907, C908
	CEA 4R7M 35	C914
	CEA 2R2M 50	C909, C910
	CEA 470M 25	C912
	CEA 330M 16	C915
	CEA 220M 16	C913

RESISTORS

Note: When ordering resistors, convert the resistance value into code form, and then rewrite the part no. as before.

Mark	Part No.	Symbol & Description
★	RCP-056 (RCP-093)	VR901, VR902 Semi-fixed (100k-B)
	RD¼M □□□J	R901-R906, R909-R949

SEMICONDUCTORS

Mark	Part No.	Symbol & Description
★★	1R2408	IC901
★★	2SC1740LN (2SC2021) (2SC1815) (2SC2634NC)	Q901-Q905, Q909
★★	2SA1015 (2SA933LN) (2SA937) (2SA1127NC)	Q906-Q908, Q910-Q912
★	1K34A (1K60A) (0A90)	D901-D904
★	1S2473 (US1040)	D905-D907
★	BZ100	ZD901

HEADPHONES Amplifier Assembly (RWF-104)

CAPACITORS

Mark	Part No.	Symbol & Description
	CEA 010M 50	C1601, C1602
	CEA 470M 25	C1603-C1605, C1607
	CKDYF 473Z 50	C1606

RESISTORS

Note: When ordering resistors, convert the resistance value into code form, and then rewrite the part no. as before.

Mark	Part No.	Symbol & Description
★	RCV-097	VR1601 Variable (20k-B)
★	RCV-096	VR1602 Variable (100k-A)
⚠	RS1PF 331J	R1607, R1608
⚠	RD¼PSF 181J	R1619, R1623
⚠	RD¼PM □□□J	R1601-R1606, R1609-R1618, R1620-R1622

SEMICONDUCTORS

Mark	Part No.	Symbol & Description
★★	2SC2060 (2SC2673) (2SC1383NC)	Q1601, Q1602
★★	2SC1740LN	Q1603, Q1604

OTHERS

Mark	Part No.	Symbol & Description
	RBF-041	Spacer

Power Supply Assembly (RWR-089; KU), (RWR-090; KC), (RWR-091; HB, HE and HP), (RWR-092; D and D/G)

CAPACITORS

Mark	Part No.	Symbol & Description
	CEA 222M 25	C1201, C1202
	CEA 222M 50	C1203
	CEA 4R7M 35	C1217
	CEA 221M 25	C1213
	CEA 331M 25	C1206

★	W03B (W03C)	D1201, D1202
★	S2VB10F	D1203, D1204
★	1S2473 (US1040)	D1209-D1211
⚠	RD3.0EB2 (XZ031)	ZD1201
⚠	RD5.6EB2 (WZ-056)	ZD1202
⚠	RD4.7EB2 (WZ-044)	ZD1204
⚠	RD10EB3 (WZ-100)	ZD1203
★	WZ-085 (RD8.2EB2) (RD8.2EB3)	ZD1205

RESISTORS

Note: When ordering resistors, convert the resistance value into code form, and then rewrite the part no. as before.

Mark	Part No.	Symbol & Description
	RS1PF 6R8J	R1221 (KU type)
	RS¼PSF 101J	R1202
	RS¼PSF 271J	R1205
	RD¼PM □□□J	R1201, R1203, R1207-R1210, R1213, R1214, R1218, R1224
	RD¼PM □□□J	R1204, R1206, R1211, R1212, R1215-R1217, R1219, R1220, R1222, R1223, R1225

SEMICONDUCTORS

Mark	Part No.	Symbol & Description
★★	2SD880 (2SD313)	Q1201, Q1204
★★	2SB772 (2SA1096)	Q1203

The Power Supply Assembly (RWR-090) (RWR-091) and (RWR-092) are the same as the Power Supply Assembly (RWR-089) except for following sections.

Mark	Symbol & Description	Part No.			
		KU type (RWR-089)	KC type (RWR-090)	HE, HB, HP type (RWR-091)	D, D/G types (RWR-092)
	R1211 Resistor	RD¼PM 822J	RD¼PM 682J	RD¼PM 682J	RD¼PM 682J
	R1221 Resistor	RS1PF 6R8J
	Spacer	RBF-041
	Fuse holder C	Be used	Be used
	Fuse holder B	Be used

Mark	Part No.	Symbol & Description
★★	2SC1740LN (2SC2021) (2SC1815) (2SC2634NC)	Q1202, Q1207, Q1208
★★	2SA933LN (2SA937) (2SA1015) (2SA1127NC)	Q1206
★★	2SC1740LN (2SC2240)	Q1205, Q1209

Mark	Part No.	Symbol & Description
★	W03B (W03C)	D1201, D1202
★	S2VB10F	D1203, D1204
★	1S2473 (US1040)	D1209-D1211
⚠	RD3.0EB2 (XZ031)	ZD1201
⚠	RD5.6EB2 (WZ-056)	ZD1202
⚠	RD4.7EB2 (WZ-044)	ZD1204
⚠	RD10EB3 (WZ-100)	ZD1203
★	WZ-085 (RD8.2EB2) (RD8.2EB3)	ZD1205

OTHERS

Mark	Part No.	Symbol & Description
	RBF-041	Spacer (KU type)
	REE-051	Insulator
	RKH-005	Insulator
	RBA-026	Special screw
	RKP-366	Connector assembly (7P)
	RKP-475	Connector assembly (3P)
		Fuse holder C (KU and KC types)
		Fuse holder B (HE, HB and HP types)

Function Switch Assembly (RWS-152)

SWITCHES

Mark	Part No.	Symbol & Description
★★	RSG-114	S1001 Push switch
★★	RSG-063	S1006, S1008-S1015 Function switch
★★	RSG-088	S1002-S1005, S1007 Function switch
★★	RSB-031	S1016, S1017 Rotary switch

OTHERS

Mark	Part No.	Symbol & Description
	RKP-365	Connector assembly (4P)

Voltage Change Assembly (RWX-603); KU, KC, HE, HB and HP types) (RWX-590; D and D/G types)

RESISTORS

Note: When ordering resistors, convert the resistance value into code form, and then rewrite the part no. as before.

Mark	Part No.	Symbol & Description
⚠	RS2PF 111J	R2001
⚠	RD¼PM □□□J	R2002-R2005
⚠	RD1/8PM 8R2J	R2006, R2007

SEMICONDUCTORS

Mark	Part No.	Symbol & Description
★★	2SA934 (2SA881)	Q201
★★	2SA934 (2SA881)	Q2001
★★	2SC1740LN (2SC2021) (2SC1815) (2SC2634NC)	Q2002

OTHERS

Mark	Part No.	Symbol & Description
	RBF-041	Spacer (KU, KC, HE, HB and HP types)

NOTE:

The voltage change assemblies (RWX-603 and RWX-590) have basically the same circuits.

Reel Motor Control Assembly D (RWX-589)

CAPACITORS

Mark	Part No.	Symbol & Description
	CEA 4R7M 35	C201, C204, C212
	CEA R47M 50	C205
	CEA 2R2M 50	C211
	CEA 101M 6R3	C209
	CEA 4R7M 35	C202, C203
	CQMA 473K 50	C213
	CKDYF 103Z 50	C207
	CKDYF 473Z 50	C215

RESISTORS

Note: When ordering resistors, convert the resistance value into code form, and then rewrite the part no. as before.

Mark	Part No.	Symbol & Description
★	RCP-009	VR201 Semi-fixed (22k-B)
★	RCP-056	VR202 Semi-fixed (100k-B)
	RD¼PM □□□J	R201, R204, R205, R207-R209
	RD¼PS 1R8J	R203

SEMICONDUCTORS

Mark	Part No.	Symbol & Description
★★	PA2009	IC201
★★	PA2010	IC202
★★	2SA934 (2SA881)	Q201
★★	2SD882 (2SC2497) (2SD1189)	Q202
★★	2SC2458	Q205
★★	2SC1173	Q204

OTHERS

Mark	Part No.	Symbol & Description
	REE-051	Insulator
	RKH-005	Insulator
	RBA-026	Special screw

Capstan Motor Control Assembly F (RWX-585)

CAPACITORS

Mark	Part No.	Symbol & Description
	CQSH 822K 50	C101
	CEA R47M 50	C104, C111, C114
	CEA 100M 16	C107, C109
	CEA 100M 25	C110
	CQMA 272K 50	C103
	CQMA 273K 50	C102, C121
	CKDYF 103Z 50	C106, C122
	CKDYF 102Z 50	C105
	CKDYF 473Z 50	C117

RESISTORS

Note: When ordering resistors, convert the resistance value into code form, and then rewrite the part no. as before.

Mark	Part No.	Symbol & Description
★	RCP-117	VR101 Semi-fixed (15k-B)
	RD¼PM □□□J	R101, R103, R104, R107, R108
	RN¼PR 2002F	R102
	RD¼PF 2R7J	R105

SEMICONDUCTORS

Mark	Part No.	Symbol & Description
★★	PA2007	IC101
★★	PA2012	IC102
★	W03B (W03C)	D101, D102
★	RCX-010 (RCX-012)	H101, H102 Hall device

SWITCHES

Mark	Part No.	Symbol & Description
★★	RSC-116	S101, S102, S105, S106 Push switch
★★	RSH-063	S103 Slide switch

Capstan Motor Coil Assembly (RXX-361)

Mark	Part No.	Symbol & Description
		Bottom plate A Capstan motor drive coil

2. P.C. BOARD PATTERNS

MIC AMPLIFIER Ass'y RWF-103

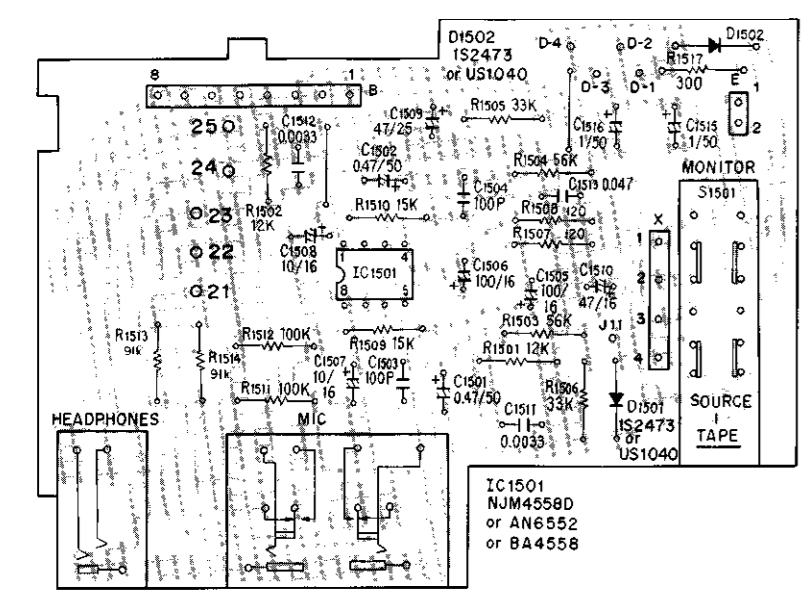

CONNECTOR Ass'y

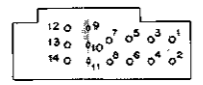

SUB AMPLIFIER Ass'y RWF-102

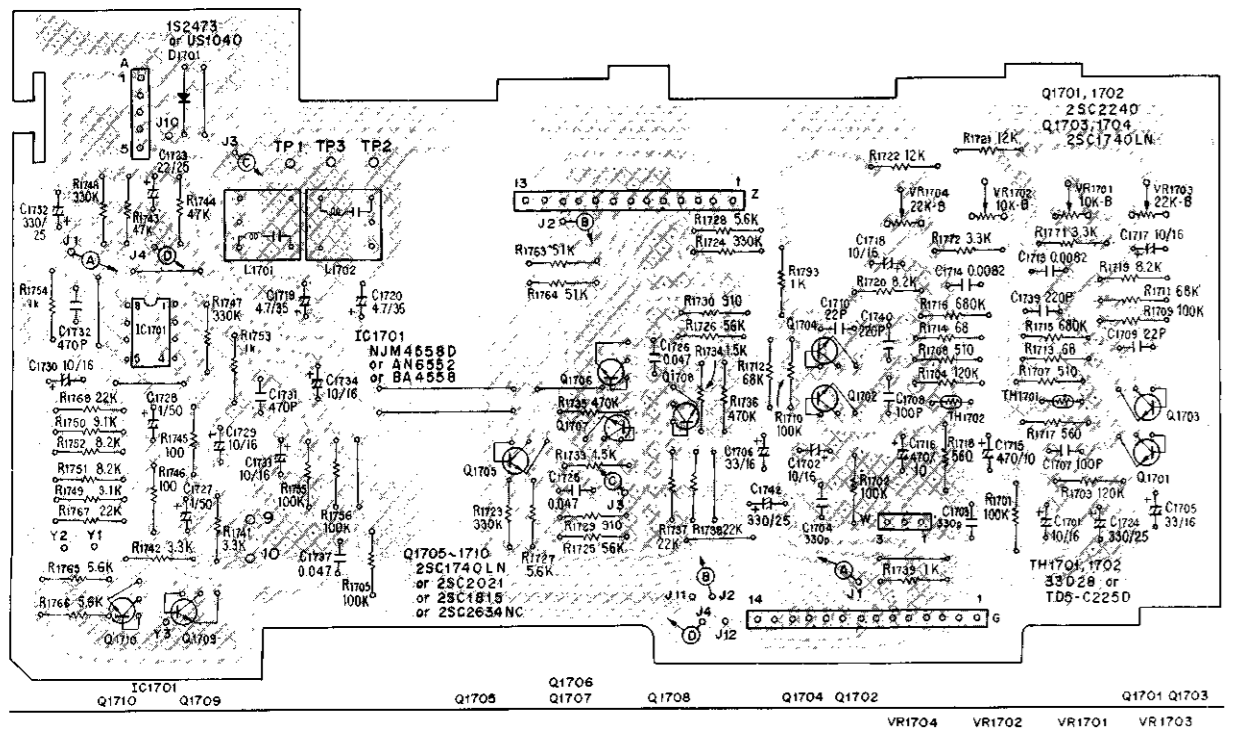

HEADPHONES AMPLIFIER Ass'y RWF-104

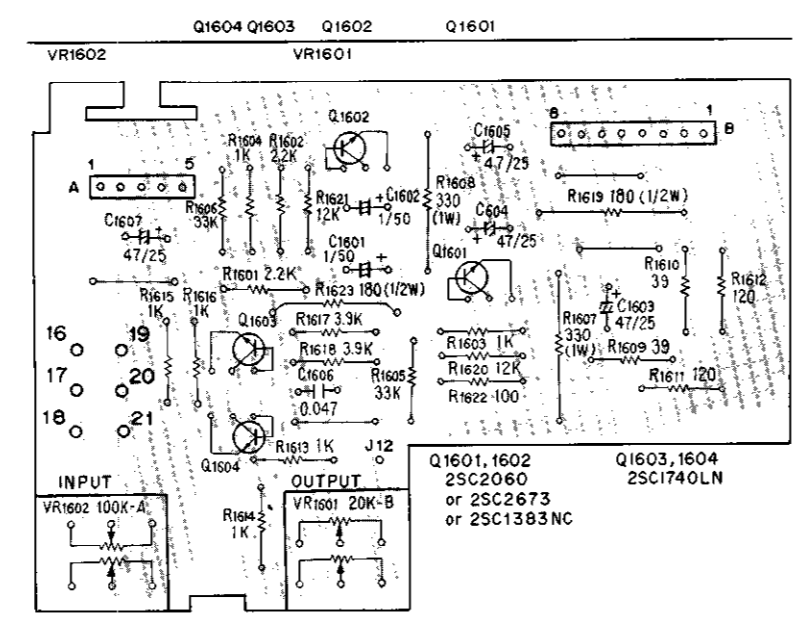

POWER SUPPLY Ass'y RWR-089

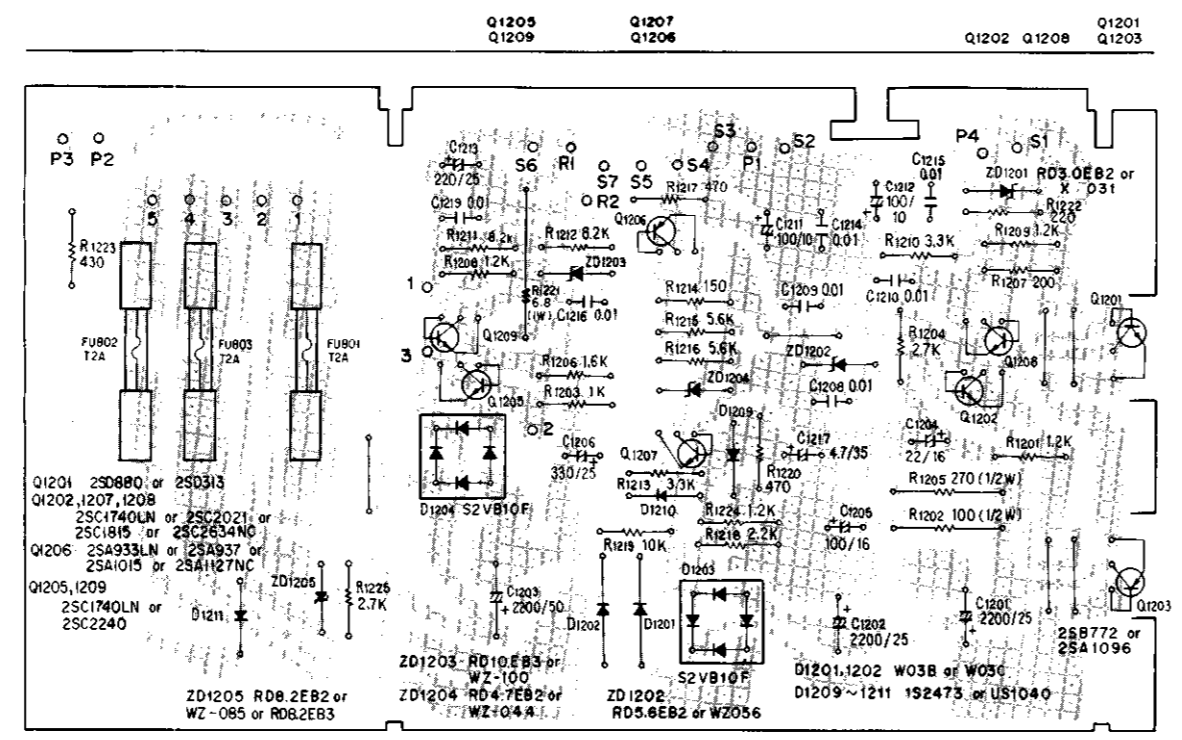

MOTHER Ass'y RWX-578

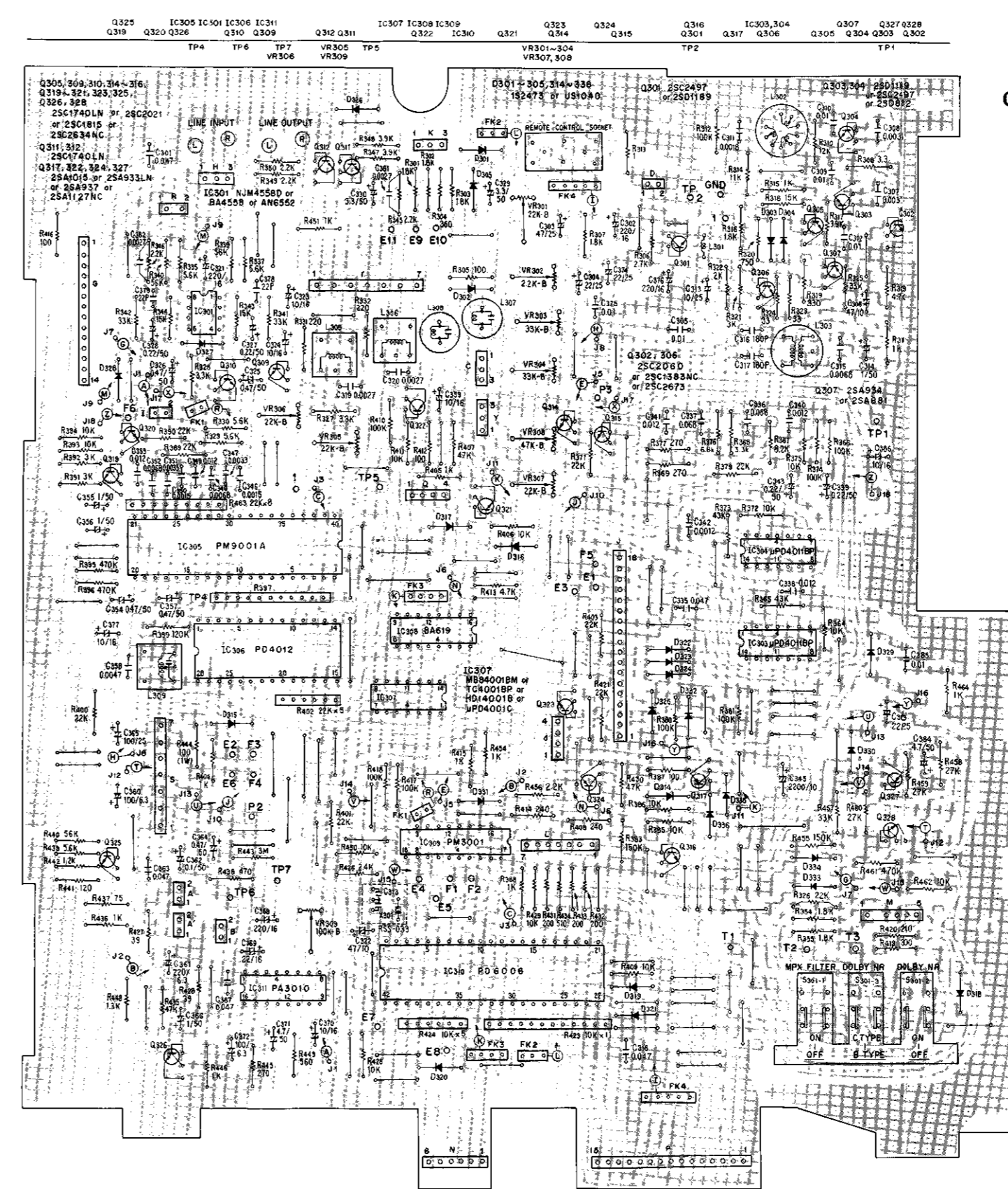

EQUALIZER Ass'y RWX-536

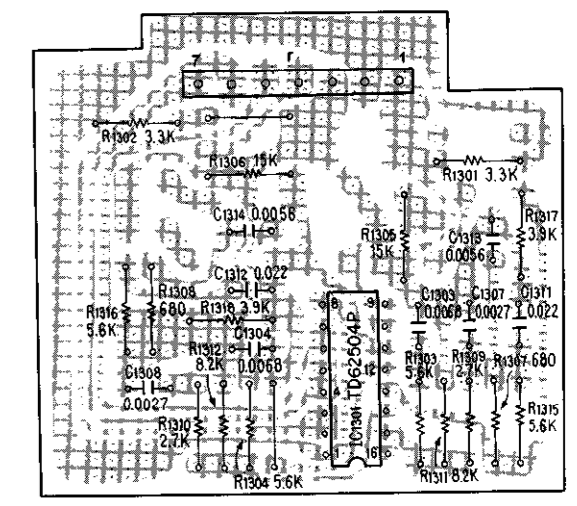

CONNECTOR Ass'y

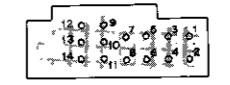

FUNCTION SWITCH Ass'y (RWS-152)

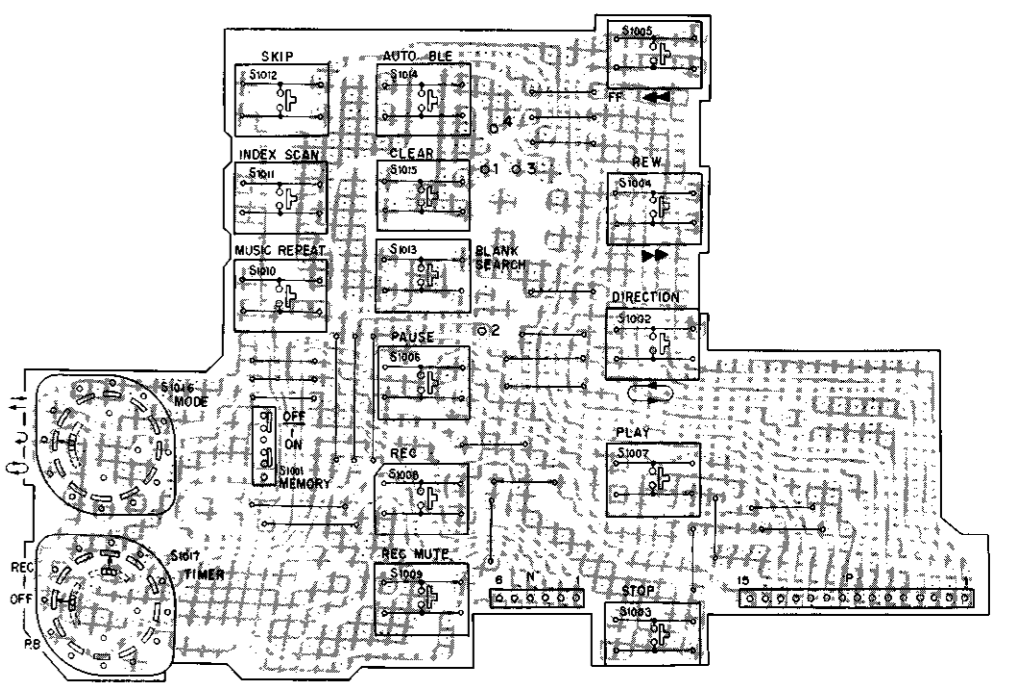

**DOLBY NR Ass'y
RWX-579**

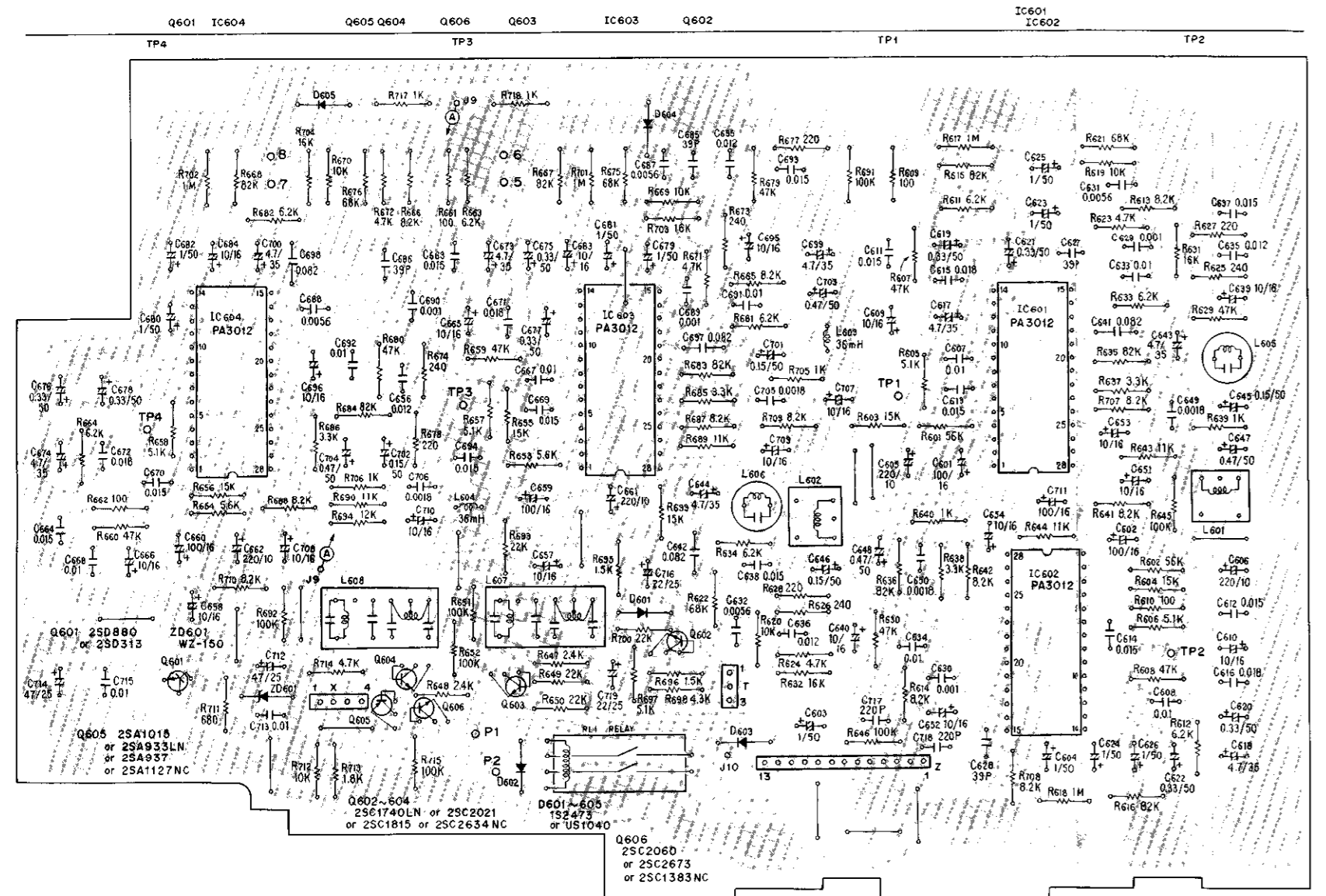

**CAPSTAN MOTOR CONTROL Ass'y F
RWX-585**

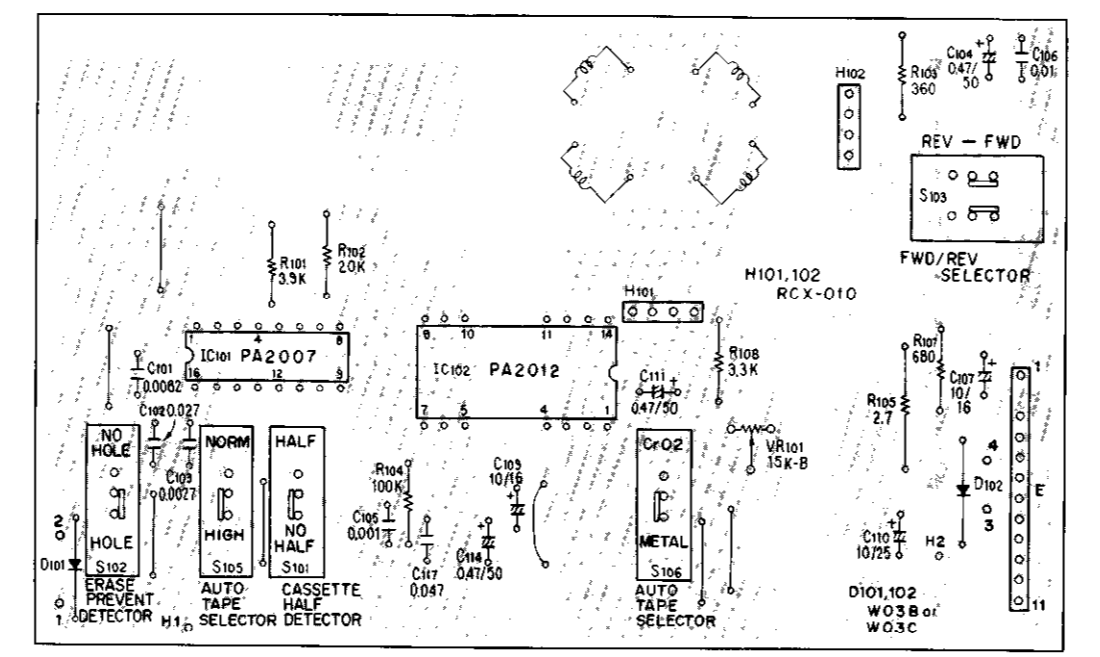

**VOLTAGE CHANGE Ass'y
RWX-603**

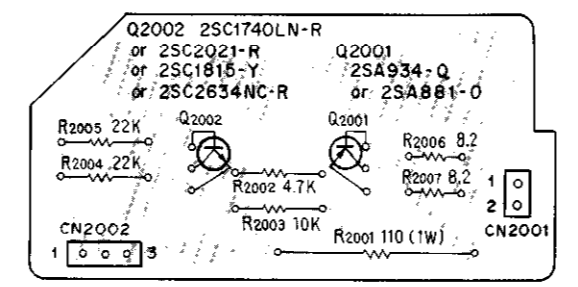

**REEL MOTOR Ass'y C
RXX-359**

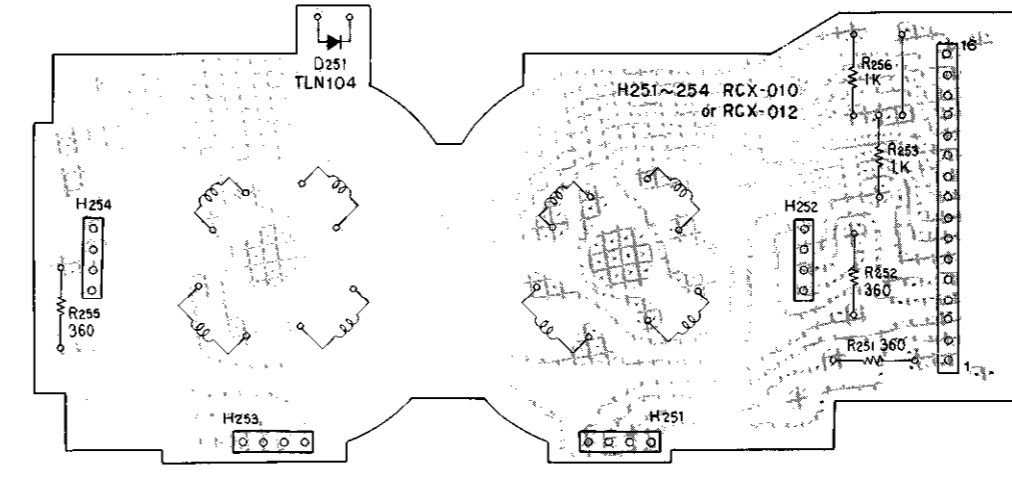

**REEL MOTOR CONTROL Ass'y D
RWX-589**

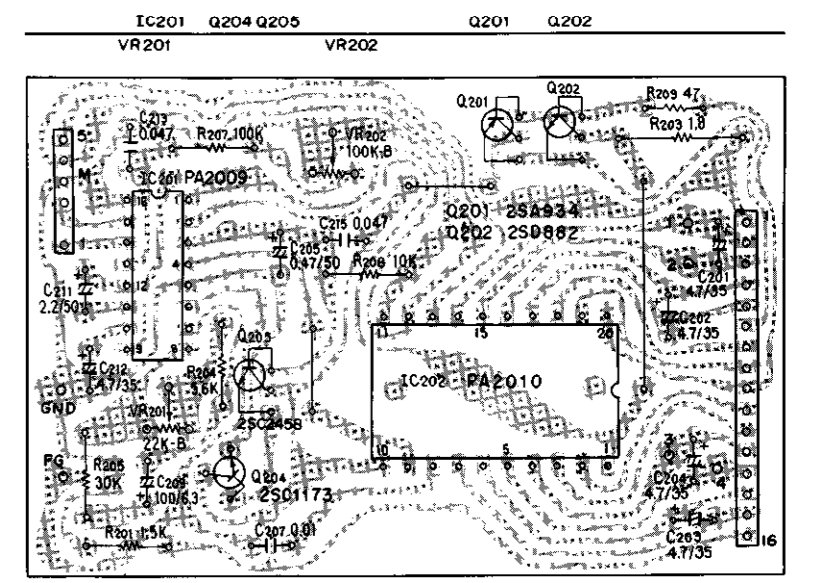

**METER DRIVE Ass'y
RWX-534**

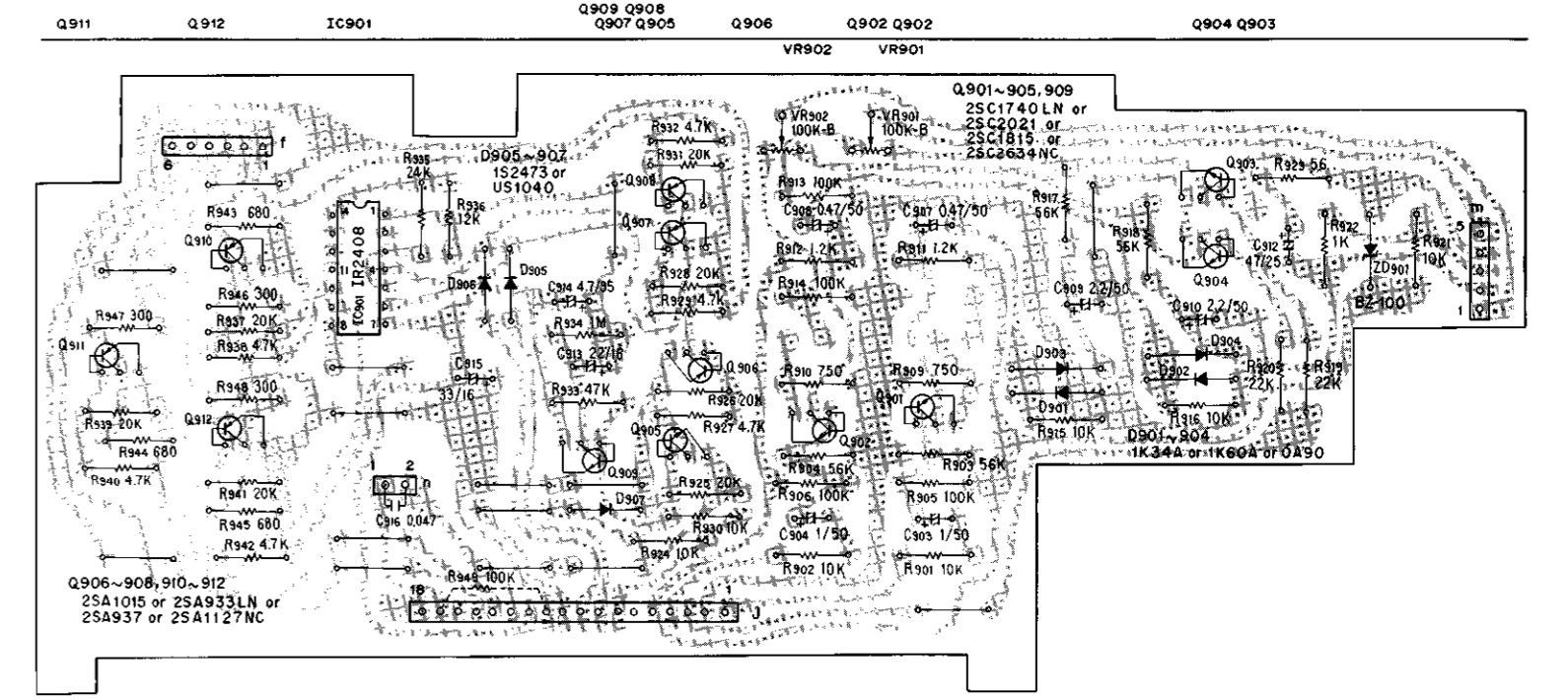

3. SCHEMATIC DIAGRAM

SIGNAL SECTION

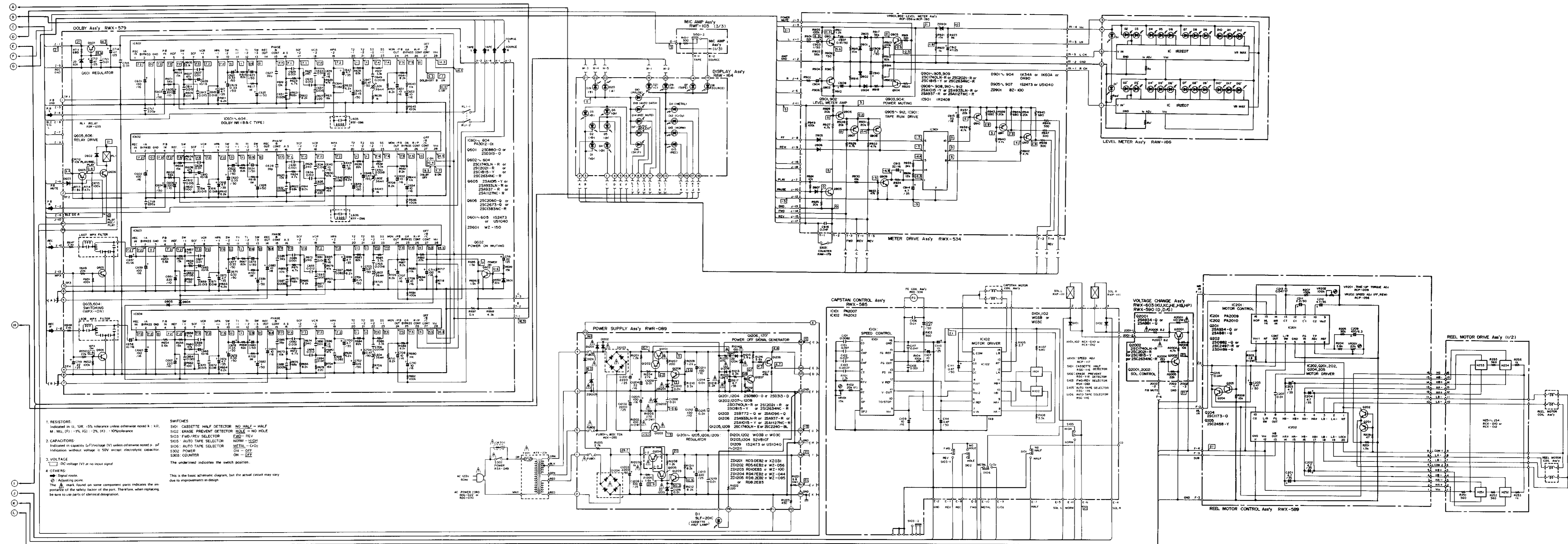

CONTROL SECTION

NOTE: The indicated semiconductors are representative ones only. Other alternative semiconductors may be used and are listed in the parts list.

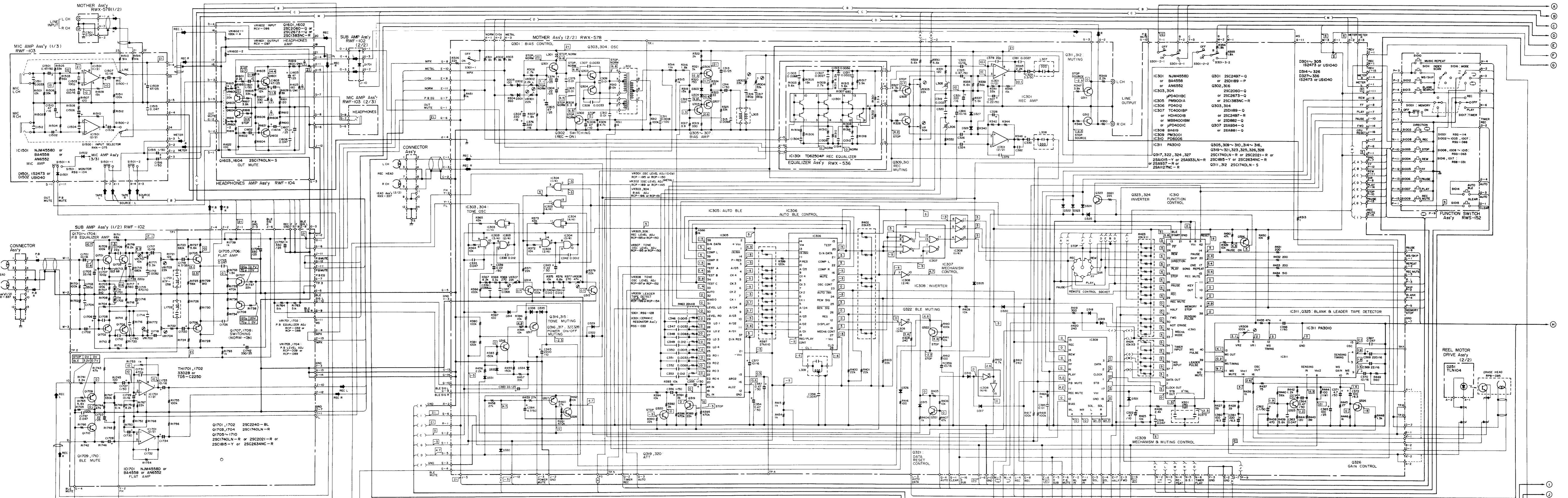

SWITCHES	S1001: MPX FILTER	S1002: DIRECTION	S1007: PLAY	S1012: MS/SKIP	S1017: TIMER
	S301-1: STOP	S1003: REC	S1008: REC	S301-2: BLANK SEARCH	S1000: INPUT SELECTOR
	S301-2: DOLBY NR	S1004: REW	S1009: REC MUTE	S1003: BLANK SEARCH	S1501: MONITOR
	S301-3: DOLBY NR	S1005: FF	S1010: MUSIC REPEAT	S1004: AUTO BLE	
	S1001: MEMORY	S1006: PAUSE	S1011: INDEX SCAN	S1005: CLEAR	
				S1012: MODE	

The underlined indicates the switch position.

POWER SUPPLY

For KC model

For HE, HB, HP models

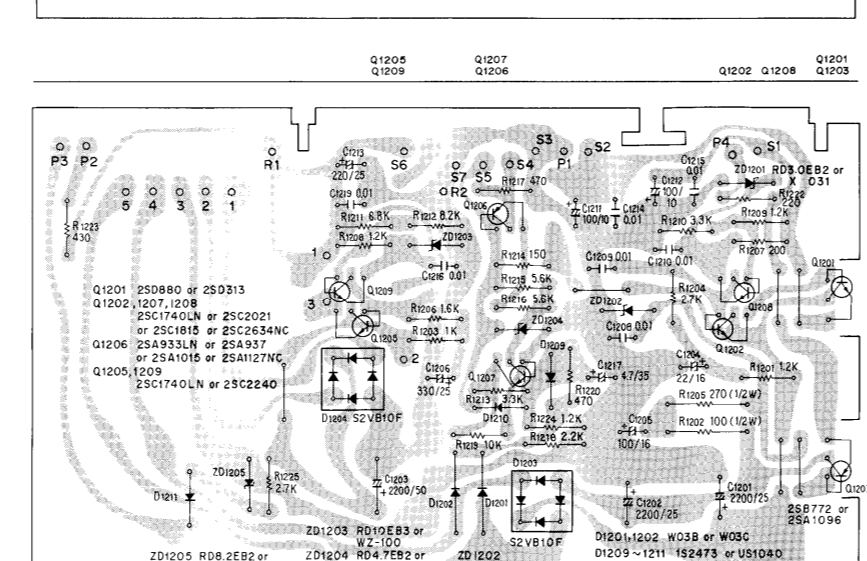
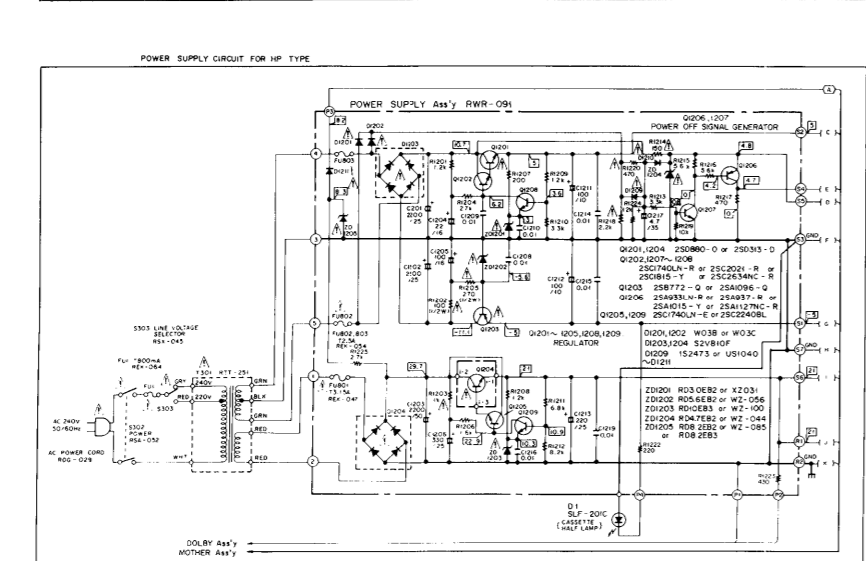
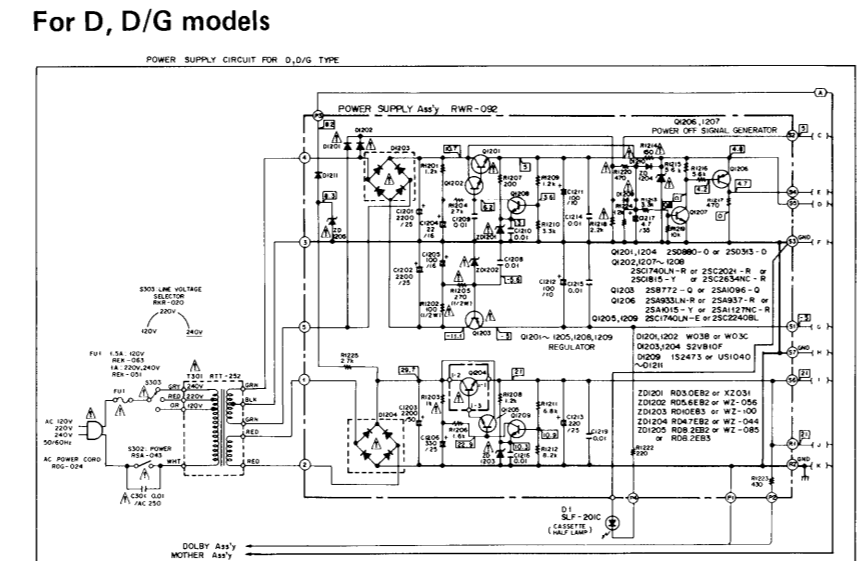
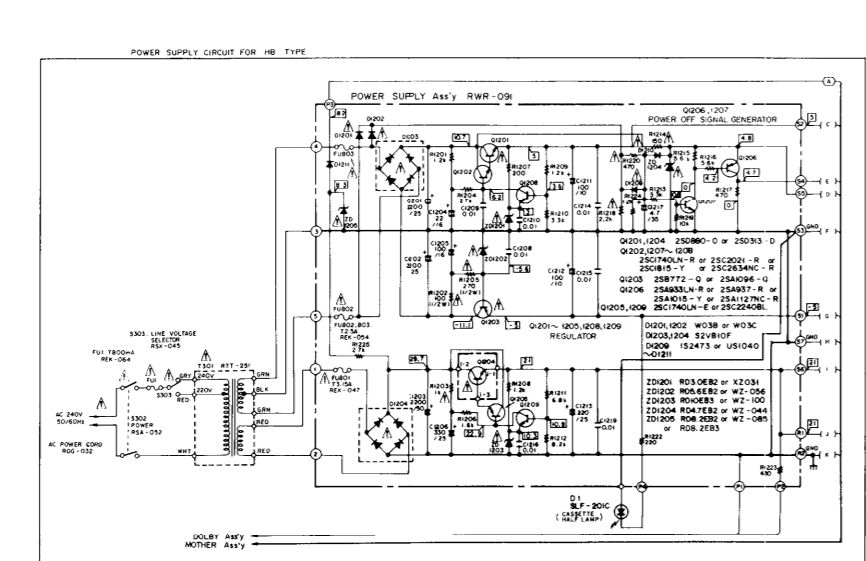
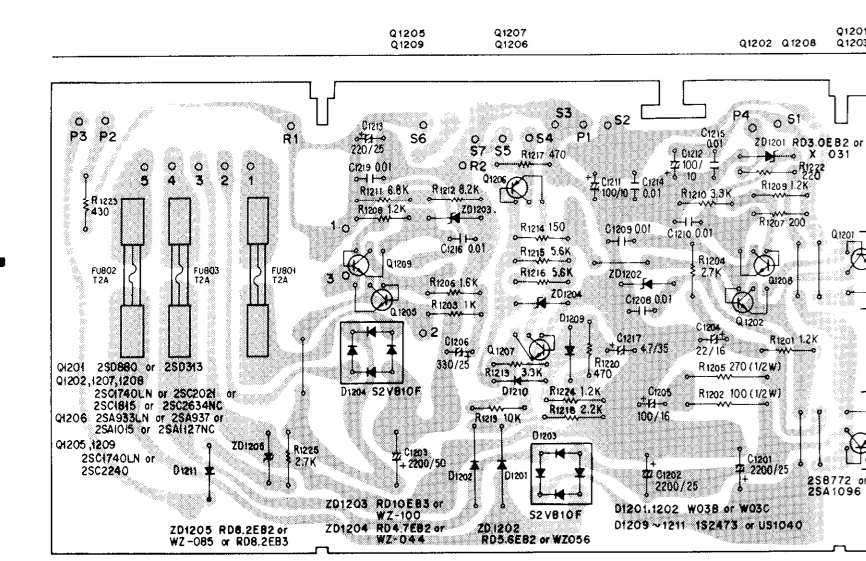
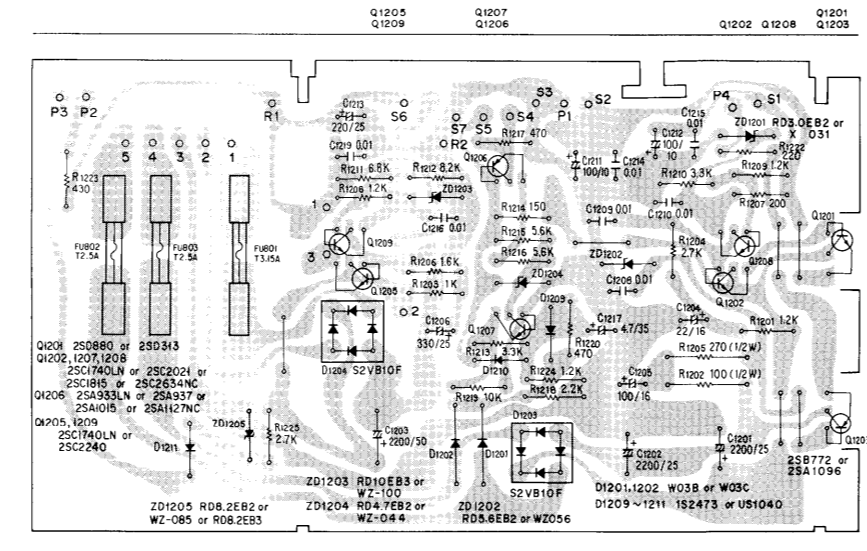
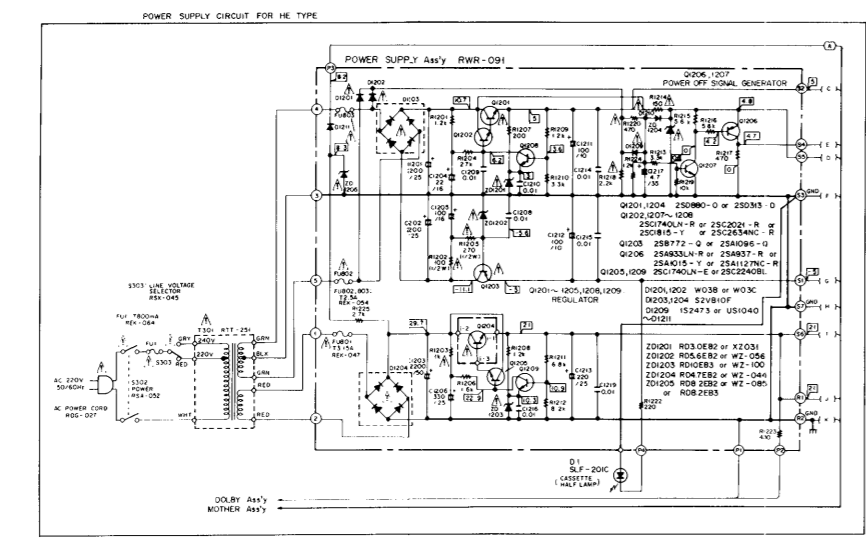
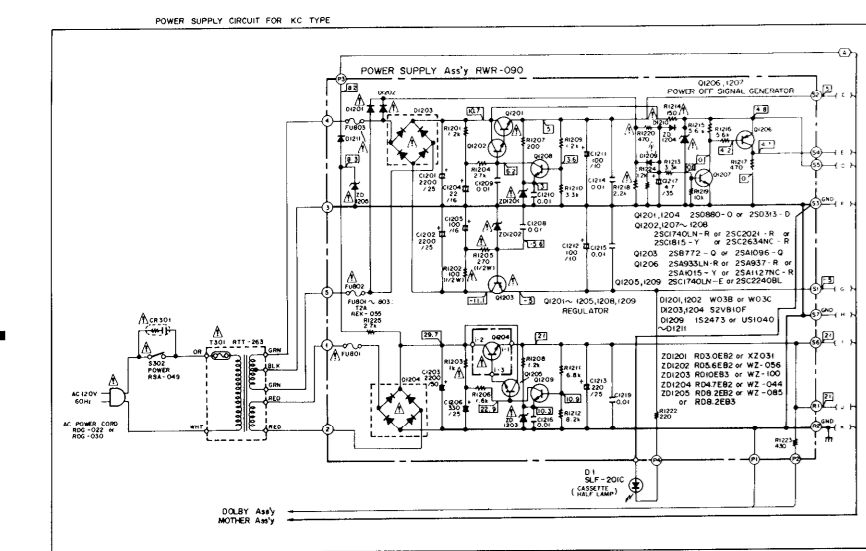

4. MECHANICAL ADJUSTMENTS

4.1 Pinch Roller Pressure Check

- Put the tape deck into the playback mode (FORWARD and REVERSE).
- Gently push against the pinch roller arm with the tension gauge (Part No. GGK-047) and read the value when the pinch roller stops rotating. If the reading fails to lie within 250 ~ 400g, replace the pinch roller pressure spring.

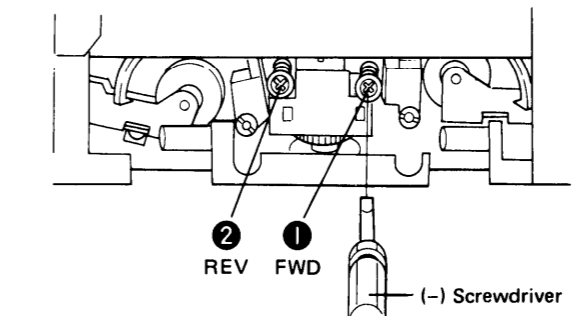

Fig. 4-3 Azimuth preadjustment

4.3 Tape Transport Adjustment

- Load a mirror-equipped cassette half.
- Set the DIRECTION switch to FORWARD and then the mode to PLAY.
- Adjust the adjust nut ① so that no curling takes place on REC/PB head guide and erase head guide as shown in Fig. 4-4.
- Set the DIRECTION switch to REVERSE.
- Adjust the adjust nut ② so that no curling occurs on REC/PB head guide and dummy head guide.
- Play a tape in both FORWARD and REVERSE directions and check that no curling on tape is found.

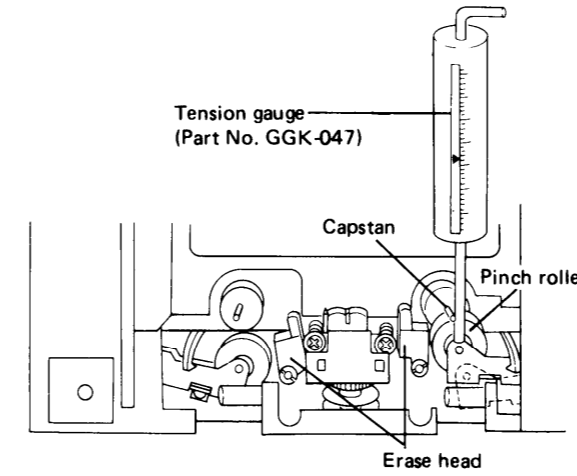

Fig. 4-1 Pinch roller pressure adjustment

4.2 Azimuth Preadjustment

- Set the DIRECTION switch to FORWARD and then the mode to STOP.
- Adjust the azimuth screw ① using a (-) screwdriver as shown in Fig. 4-2, 3 so that the distance (A) between housing and rotating base is 1.5 mm.
- Set the DIRECTION switch to REVERSE.
- Adjust the azimuth screw ② using a (-) screwdriver as shown in Fig. 4-2, 3 so that the distance (B) between housing and rotating base is 1.5 mm.

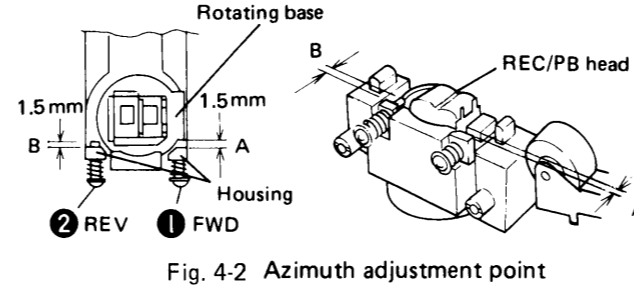

Fig. 4-2 Azimuth adjustment point

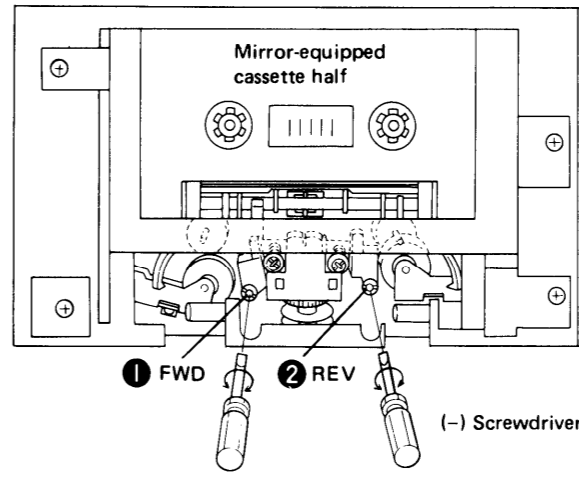
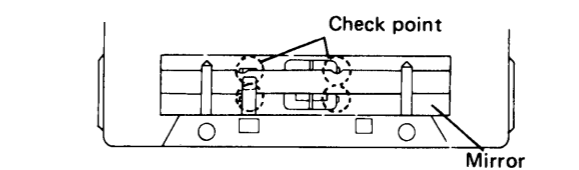

Fig. 4-4 Tape transport adjustment

4.4 FF/REW Rotating Speed Adjustment

- Connect the frequency counter between FG of reel motor control assembly and GND (Fig. 4-5).
- Set the DIRECTION switch to FORWARD and then the mode to FF.
- Adjust VR202 so that the frequency counter indicates 72 Hz ± 2Hz.
- Set the mode to REW and at this time check that a reading of frequency counter is within 72 Hz ± 5 Hz.

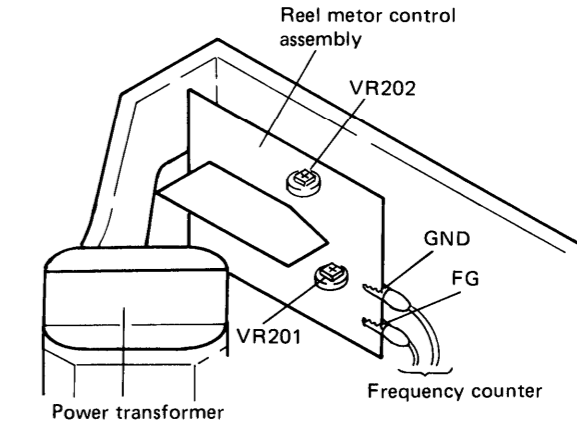

Fig. 4-5 FF/REW Rotating speed adjustment

4.5 TAKE-UP Torque Adjustment

- Mount a cassette type torque meter.
- Set the DIRECTION switch to FORWARD and then the mode to PLAY.
- Adjust VR201 so that the take-up torque is 45 ± 5 g-cm (Fig. 4-5).
- Set the DIRECTION switch to REVERSE.
- Check that the take-up torque is within 35~55g-cm (Fig. 4-6).

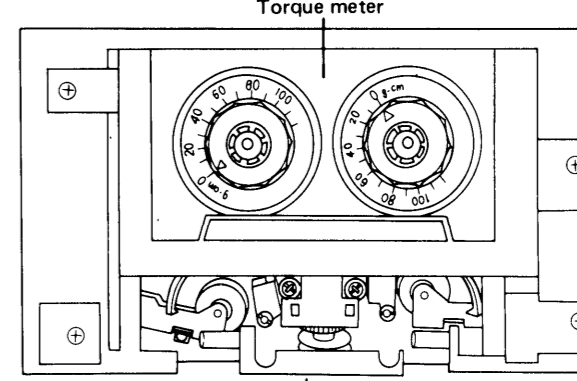

Fig. 4-6 Take-up torque adjustment

4.6 Tape Speed Adjustments

- Connect the frequency counter to the OUTPUT terminal (L or R).
- Load the STD-301 test tape and set it at the beginning of REW.
- Set the DIRECTION switch to FORWARD and then the mode to PLAY.
- Adjust VR101 so that a reading of frequency counter is 3005 ± 10 Hz at the beginning of tape rewinding.
- Set the DIRECTION switch to REVERSE and a reading of frequency counter is within 3000±30Hz at the beginning of tape rewinding.

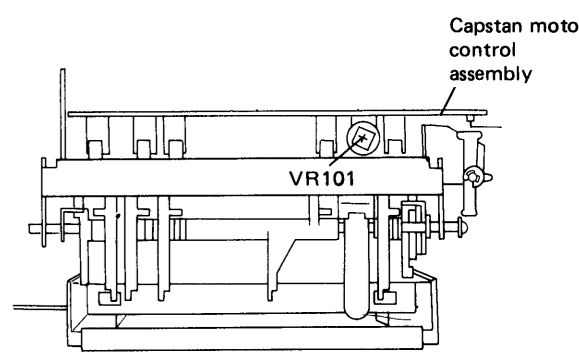

Fig. 4-7 Tape speed adjustment

4.7 Fast Torque Check

- Mount a cassette type torque meter.
- Set the DIRECTION switch to FORWARD and then the mode to FF.
- Check that the FAST torque is within 100 ± 30 g-cm in the condition described in above 2.
- Set the mode to REW and at this time check that the FAST torque is within 100 ± 30 g-cm.

4.8 Reel Base Back Tension Torque

- Mount a cassette type torque meter.
- Set the DIRECTION switch to FORWARD and then the mode to PLAY.
- At this time, check that the back tension on a supply reel side (left reel base) is within 3.5 ± 1.5 g-cm.
- Set the DIRECTION switch to REVERSE.
- At this time, check that the back tension on the supply reel side (right reel base) is within 3.5 ± 1.5 g-cm.

5. ELECTRICAL ADJUSTMENT

Precaution

- Mechanical adjustment should be completed.
- Clean the following parts with an alcohol moistened swab; Record/Playback head, Pinch roller, Erase head, Rubber belts and Capstan.
- Demagnetize record/playback head with a head demagnetizer.
- Do not use magnetized screwdriver for adjustments.
- Adjustment and measurements should be performed for both L-ch and R-ch with rated power supply voltage.
- Adjustments should be performed in the order given in this service manual. Altering the order can hinder proper adjustments, resulting in loss of performance.
- Level during measurements are based on $0\text{dBv}=1\text{V}$. Connect a $50\text{k}\Omega$ dummy resistor across the OUTPUT terminals.
- Let the CT-9R warm up (aging) for a few minutes before proceeding with the adjustment.
- Set the DOLBY NR switch OFF and MONITOR switch TAPE unless directed otherwise.

Test Equipment/Tools Required;

- Test tape
 STD-331A for general playback purpose
 STD-341A for playback adjustment
 STD-608A NORMAL blank tape
 STD-603 CrO_2 blank tape
 STD-604 METAL blank tape
- Audio oscillator
- AC millivoltmeter (AC mV)
- Attenuator
- Oscilloscope
- Resistor $50\text{k}\Omega$ (1/4W)

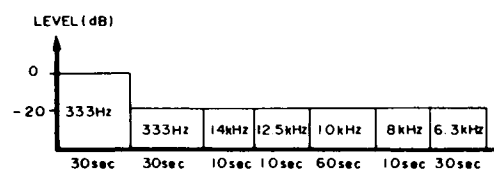

Fig. 5-1 Contents of test tape STD-331A

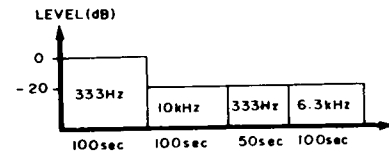

Fig. 5-2 Contents of the test tape STD-341A

5.1 Head Azimuth Adjustment

Setting:

Mode Playback (FWD and REV)
 Test tape STD-341A, 10kHz portion
 AC mV meter OUTPUT terminals
 OUTPUT level control . Max.

Procedure:

Play back the test tape in both FWD and REV directions. Adjust the head azimuth screw to the position of maximum output level.

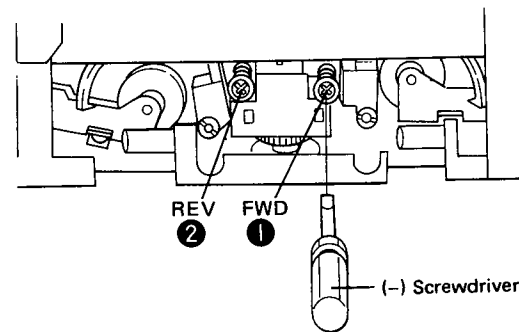

Fig. 5-3 Azimuth adjustment points

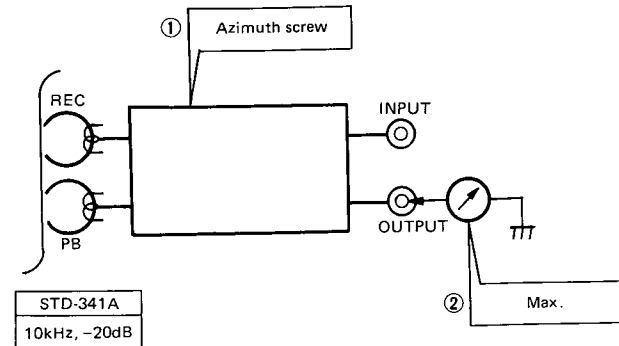

Fig. 5-4 Head azimuth adjustment

5.2 Playback Equalizer Adjustment

Setting:

Mode Playback (FWD and REV)
 Test tape STD-331A, 333Hz and 10kHz portions
 AC mV meter OUTPUT terminals
 VR1703, VR1704 Max.
 VR1701, VR1702 Center position

Procedure:

- Set the CT-8R to FWD direction and play back 333Hz and 10kHz portions of the test tape.
- Adjust the VR1701 (Lch) and VR1702 (Rch) so that the 10kHz playback level reads 2dB higher than that of 333Hz.
- Set to the REV direction and play back the 10kHz portion, then confirm that the playback output deviation is within $\pm 2\text{dB} \pm 1\text{dB}$ of the 333Hz portion.
- Set to the FWD direction and play back the 14kHz portion, then the difference from the 333Hz portion should lie within the -1 to $+4\text{dB}$ range.
- Set to the REV direction and repeat step 4.

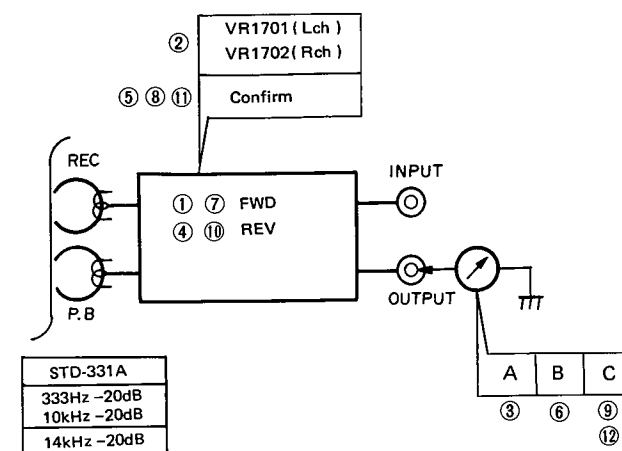

(Level = Playback level)	
A	10kHz level - 333Hz level = +2dB
B	10kHz level - 333Hz level = $\pm 2\text{dB} \pm 1\text{dB}$
C	14kHz level - 333Hz level = $0\text{dB} \pm 4\text{dB}$

Fig. 5-5 Playback equalizer adjustment

5.3 Playback Level Adjustment

Since this adjustment determines the DOLBY NR level during playback, it should be performed precisely.

Setting:

Mode Playback (FWD and REV)
 Test tape STD-341A, 333Hz 0dB portion
 AC mV meter TP1 (Lch) and TP2 (Rch) for the DOLBY NR assembly

Procedure:

- Set the CT-8R the FWD direction, then adjust the VR1703 (Lch) and VR1704 (Rch) of the Sub amplifier assembly so that the AC mV meter reads -3.7dBv (653mV).
- Next set to the REV direction and confirm that the AC mV meter reads $-3.7\text{dBv} \pm 0.5\text{dB}$ (691mV~616mV)

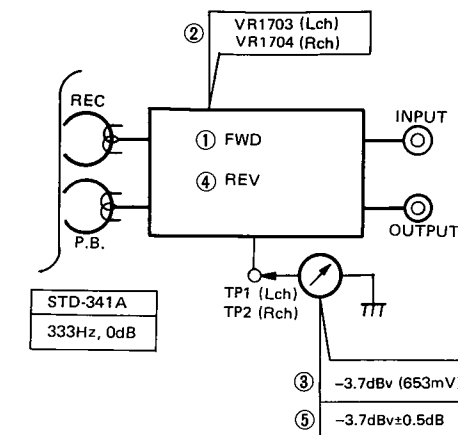

Fig. 5-6 Playback level adjustment

5.4 Level Meter Check

- Step 1.**
Setting:
 Mode STOP
 MONITOR switch SOURCE
 Input Signal 333Hz, -10dBv (316mV)
 (from INPUT)
 AC mV meter TP3 (Lch) and TP4 (Rch)
 for the DOLBY NR assembly
- Procedure:**
 Adjust the INPUT level control so that the level meter reads -7.7dBv (412mV).
- Step 2.**
Setting:
 Mode STOP
 Input Signal 333Hz, -10dBv (316mV)
 (from INPUT)
- Procedure:**
 Adjust the VR901 (Lch) and VR902 (Rch) so that the level meter reads 0dB.

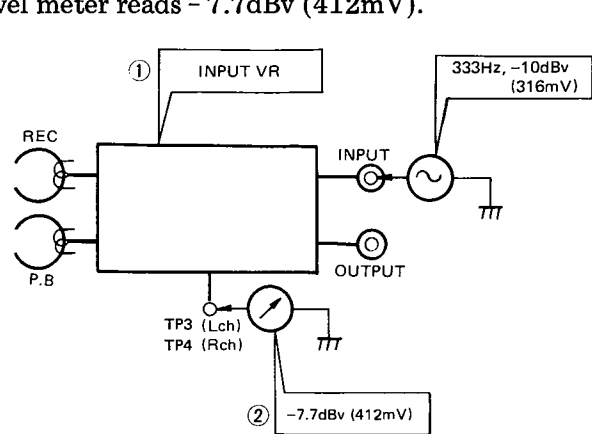

Fig. 5-7 Level meter check

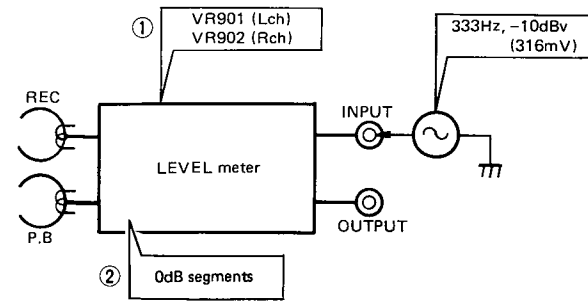

Fig. 5-8 Level meter check

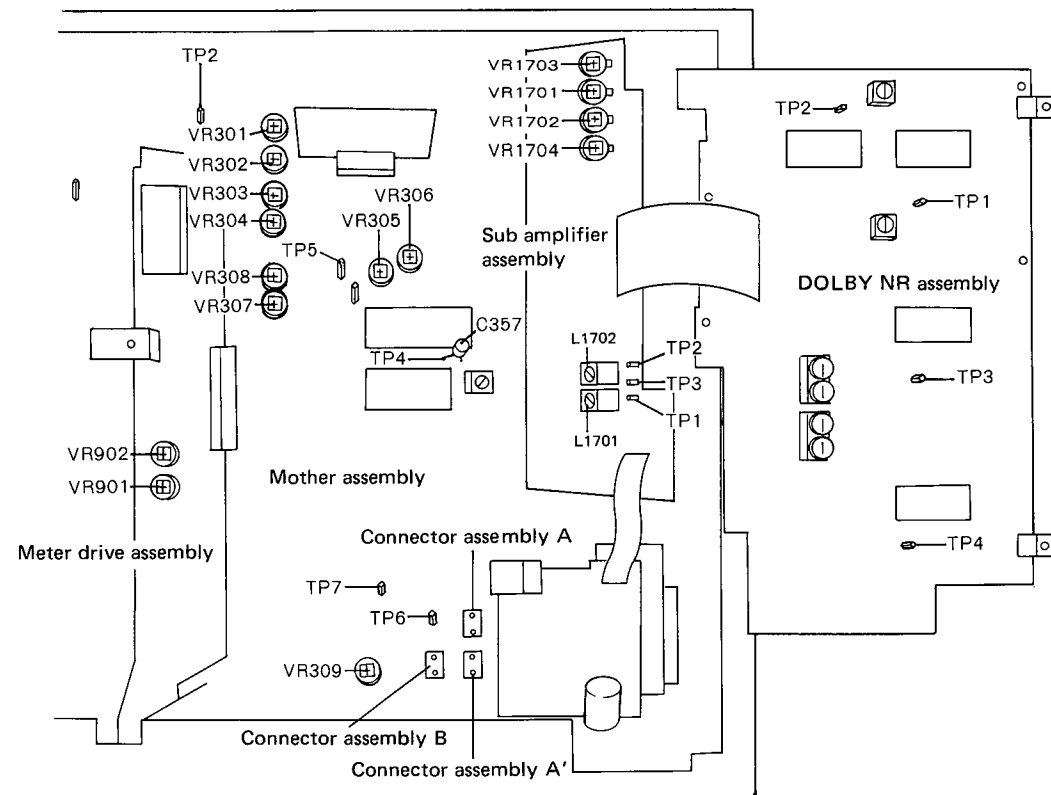

Fig. 5-9 Adjust point

5.5 Erasure Current Adjustment

- Setting:**
 Mode Record
 Test tape STD-604
 INPUT level control ... Min.
 AC mV meter TP2 of the Mother assembly

- Procedure:**
 Adjust the VR302 so that the AC mV meter reads 160mV.

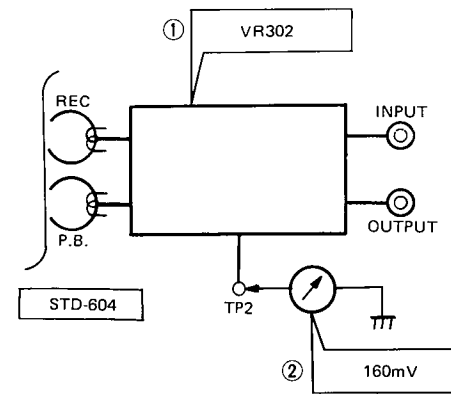

Fig. 5-10 Erasure current adjustment

5.6 Bias Trap Adjustment

- Setting:**
 Mode Record
 MONITOR switch TAPE
 OUTPUT level control . Max.
 AC mV meter OUTPUT terminals
 Oscilloscope OUTPUT terminals

- Procedure:**
 Adjust the L1701 (Lch) and L1702 (Rch) so that the AC mV meter reads minimum level.

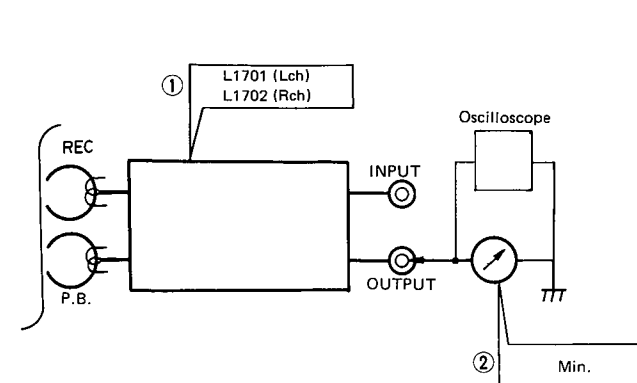

Fig. 5-11 Bias trap adjustment

5.7 Recording Bias Adjustment

- Setting:**
 Mode Record
 MONITOR switch SOURCE
 Input Signal 6.3kHz, -20dBv (100mV)
 OUTPUT level control . Max.
 Test tape STD-608A
 AC mV meter OUTPUT terminals
 VR303, VR304 Min.

- Procedure:**
1. Adjust the INPUT level control so that the AC mV meter reads -14dBv (199mV).
 2. Set the MONITOR switch to the TAPE position.
 3. Adjust the VR303 (Lch) and VR304 (Rch) so that the AC mV meter reads the maximum output level, and then bring back until the output level drops 2dB (Fig. 5-12).

As VR303 and VR304 interact with one another, carry out the above procedures by alternatively and repetitively adjusting VR303 and VR304.

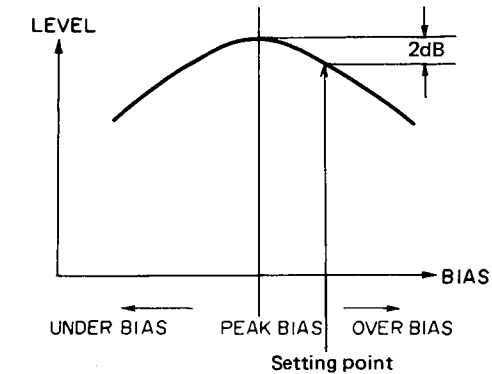

Fig. 5-12 Bias setting point

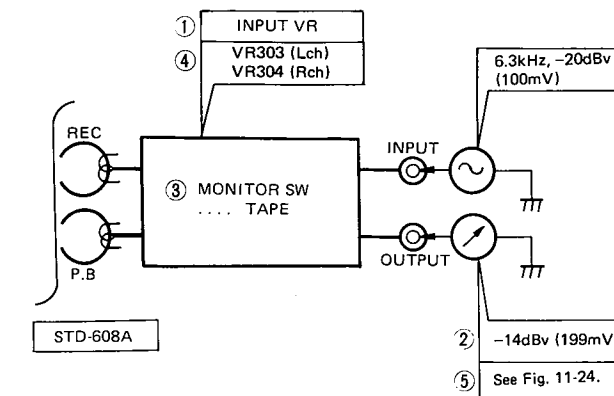

Fig. 5-13 Recording bias adjustment

5.8 Recording Level Adjustment

Setting:

Mode Record
 Input Signal 333Hz, -10dBv (316mV)
 Test tape STD-608A
 AC mV meter 1 TP1 (Lch) and TP2 (Rch) for the DOLBY NR assembly
 AC mV meter 2 TP3 (Lch) and TP4 (Rch) for the DOLBY NR assembly

Procedure:

1. Adjust the INPUT level control so that the AC mV meter 1 reads -7.7dBv (412mV).
2. Adjust the VR305 (Lch) and VR306 (Rch) so that the AC mV meter 2 reads -7.7dBv (412mV)

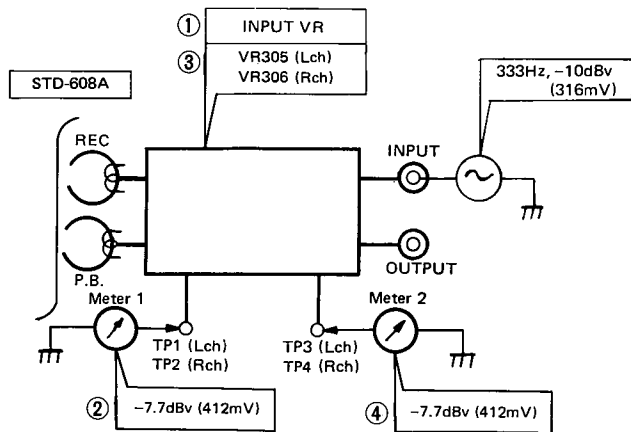

Fig. 5-14 Recording level adjustment

Procedure:

1. Adjust the INPUT level control so that the AC mV meter reads -24dBv (61.3mV).
2. Set the MONITOR switch to the TAPE position.
3. Record and play back the input signals (333Hz and 10kHz, -30dBv) onto the STD-608A. Adjust the VR303 (Lch) and VR304 (Rch) so that the 10kHz playback level reads 1.0dB higher than that of 333Hz.
4. Record and play back the input signals onto the STD-603. Adjust the VR301 so that the 10kHz playback level reads within ± 0.5 dB ± 0 dB at 333Hz.
5. Likewise record and playback the input signals onto the STD-604. Confirm that the playback level meet specifications. If the playback level does not meet the specifications, adjust VR302 on the condition that erase current is within 160 ± 15 mA, to meet the specifications.
6. As listed in the specifications in Fig. 5-16 check to see that performance meets specifications.

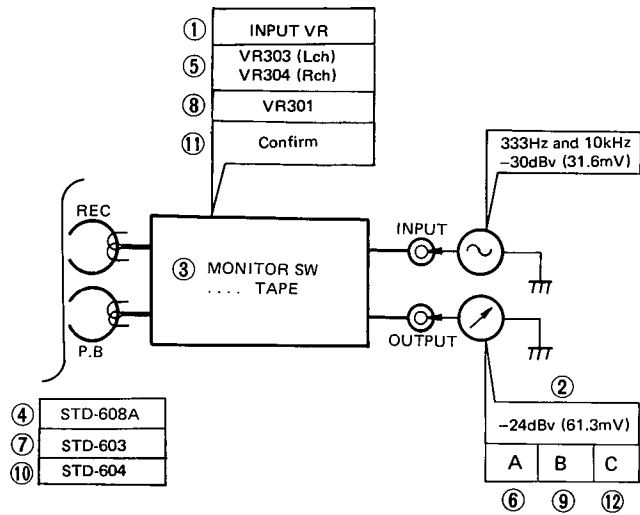

Fig. 5-15 Recording/Playback frequency response adjustment

5.9 Recording/Playback Frequency Response Adjustment

Setting:

Mode Record/Playback
 MONITOR switch SOURCE
 Input Signal 333Hz, -30dBv (31.6mV)
 10kHz, -30dBv (31.6mV)
 Test Tape STD-608A, STD-603 and STD-604
 AC mV meter OUTPUT terminals

	Level = Playback level
A	10kHz level - 333Hz level = +1.0dB
B	10kHz level - 333Hz level = $0.5\text{dB} \pm 0.5$ dB
C	See Fig. 11-28.

Frequency Response

Using STD-331A with DOLBY NR OFF

However, the right channel is compensated by -1dB at 63Hz, and -0.5dB of 125Hz because of the insulation effect.

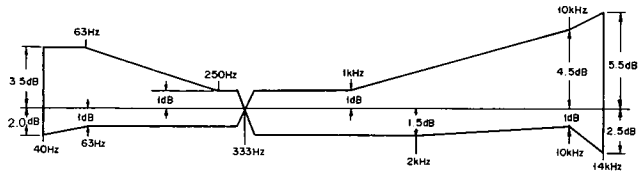

Overall Frequency Response

Using STD-608A with DOLBY NR OFF

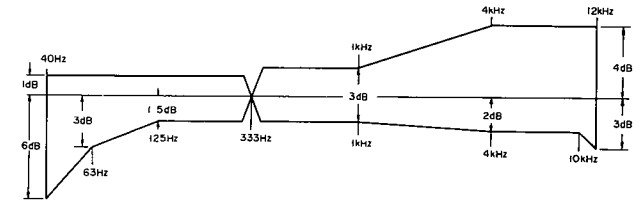

Using STD-608A with DOLBY NR ON (B and C type)

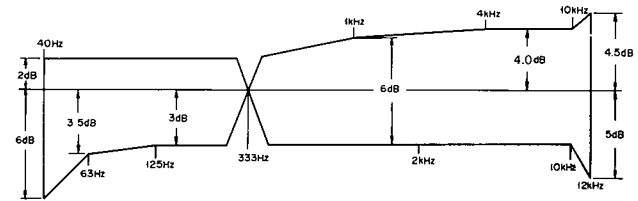

Using STD-603 with DOLBY NR OFF

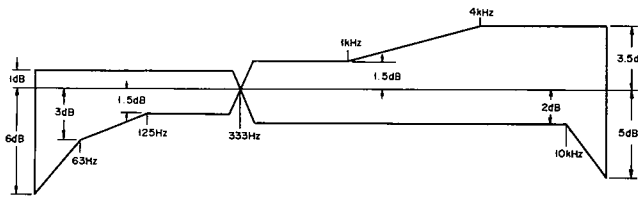

Using STD-603 with DOLBY NR ON (B and C type)

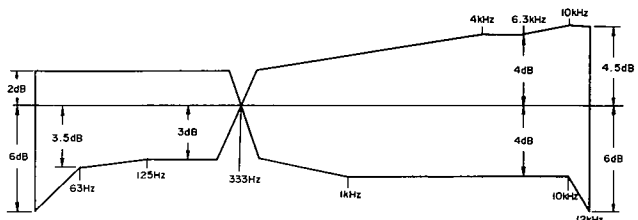

Using STD-604 with DOLBY NR OFF

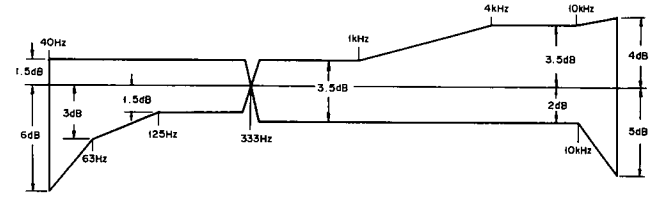

Using STD-604 with DOLBY NR ON (B and C type)

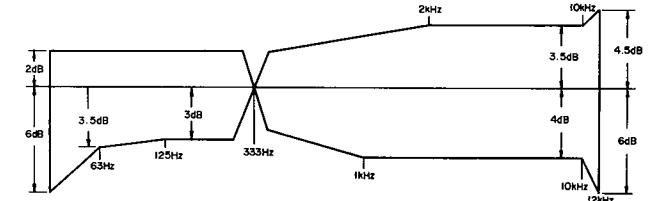

Overall Frequency Response after AUTO B.L.E. has been adjusted.

Using STD-608A, STD-603 and STD-604 with DOLBY NR OFF

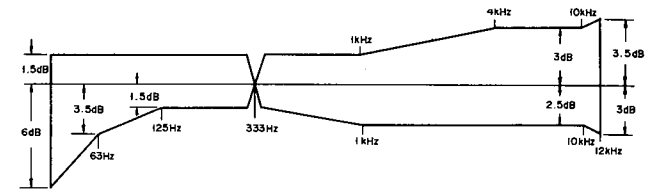

Using STD-608A, STD-603 and STD-604 with DOLBY NR ON (B and C types)

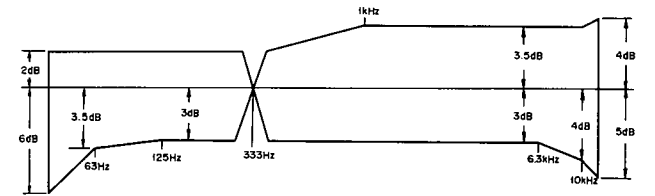

Fig. 5-16 Frequency response

5.10 B.L.E. Adjustment

Setting:

- Mode STOP
- TIMER switch OFF
- Test tape STD-608A
- Oscilloscope Between C357 (+) terminal of mother assembly and ground

Procedure:

1. Connect the jumper cord between TP5 and ground momentarily and then depress the REC button.
2. Adjust the VR307 so that the DC mV meter reads 2V and depress the STOP button.
3. Set the CT-9R to REW mode and then REC mode.
4. Adjust the VR308 so that the DC mV meter reads 2V and depress the STOP and RESET buttons.

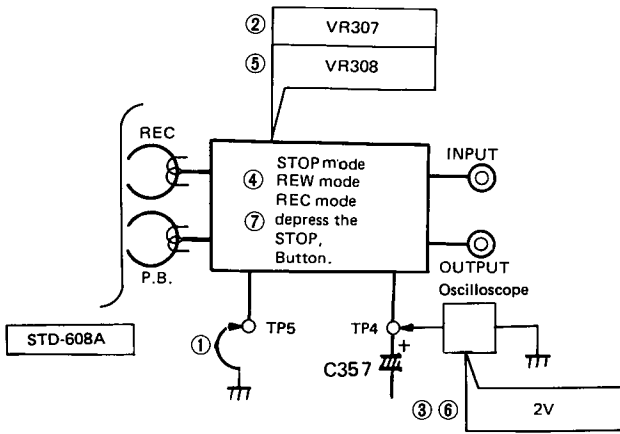

Fig. 5-17 B.L.E. adjustment

5.11 Leader Tape Detect Adjustment

Step 1.

Setting:

- Mode STOP
- Input Signal 2kHz, -17dBv (0.4V P-P Sine wave) to TP6 of the Mother assembly
- DC mV meter TP7 of the Mother assembly

Procedure:

1. Remove the connector B of the Mother assembly.
2. Adjust the VR309 so that the DC mV meter reads 10.5V±0.25V.
3. Return the connector B to the original position.

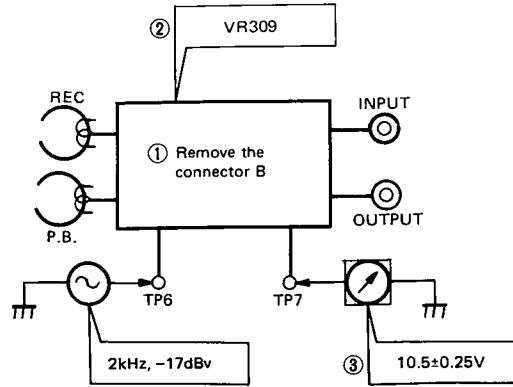

Fig. 5-18 Leader tape detect adjustment

Step 2.

Setting:

- Mode Playback
- Tape Cassette half without tape
- AC mV meter TP6 of the Mother assembly

Procedure:

1. Confirm that the AC mV meter reads -10dBv (0.6V P-P square wave).
2. If -10dBv is exceeded, substitute the connector assembly A for the connector assembly A'.

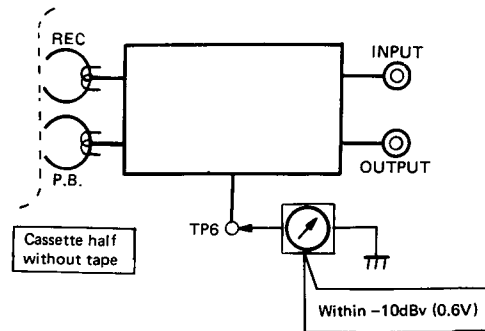
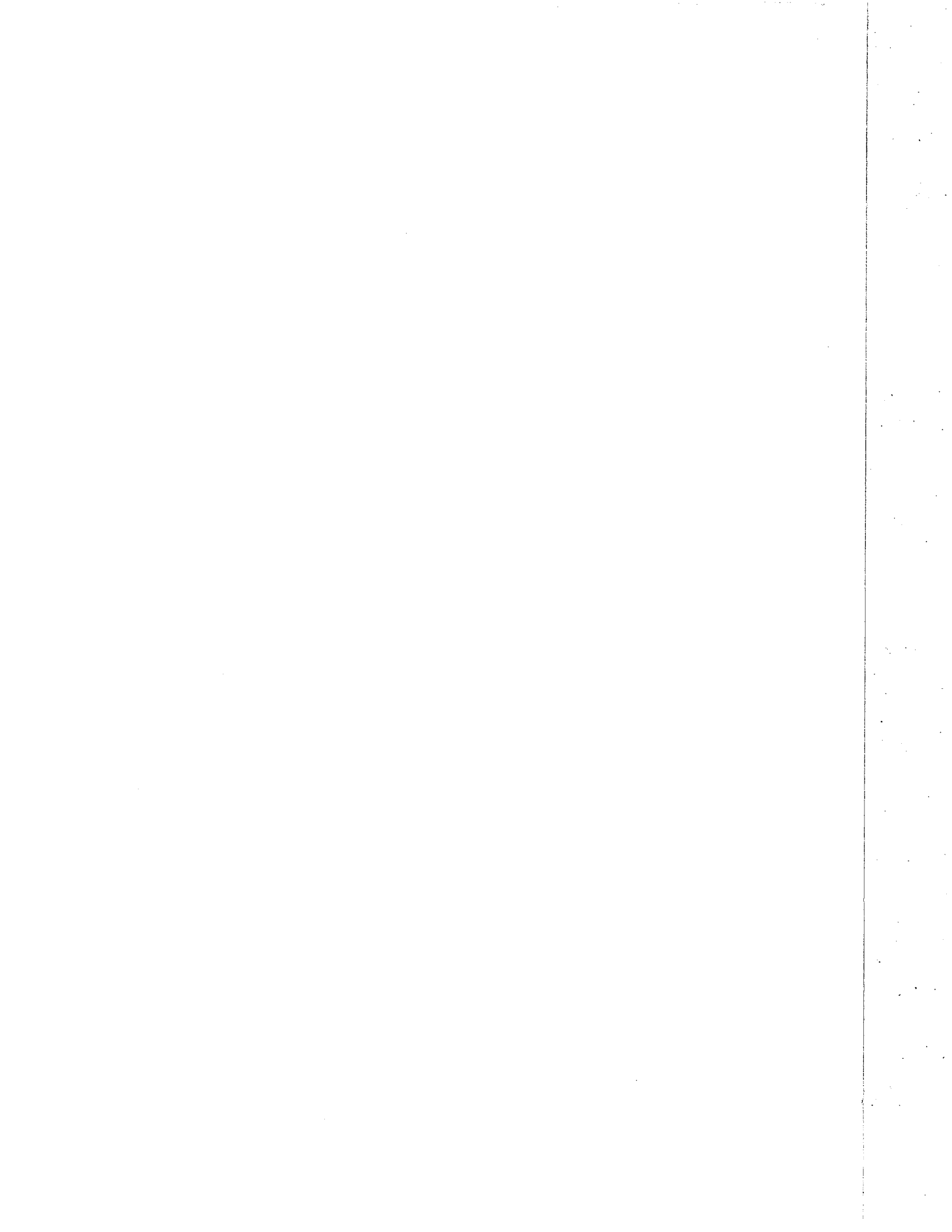

Fig. 5-19 Leader tape detect adjustment



CORRECTION TO SERVICE MANUAL

MODEL: CT-8R

(ART-663)

PAGE: 13

KEY No. : 44

DESCRIPTION: Front Panel R

Part No. of Front Panel R is misprinted.
Please correct Service Manual as follows:

Part No.	
Original	Correction
RNL-363	RNL-364

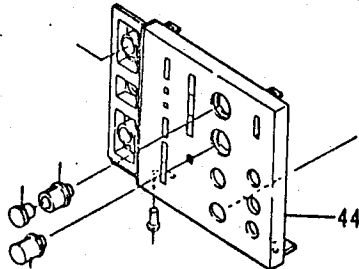

(J-B-C)

