

Service Manual

**CIRCUIT & MECHANISM DESCRIPTIONS
REPAIR & ADJUSTMENTS**

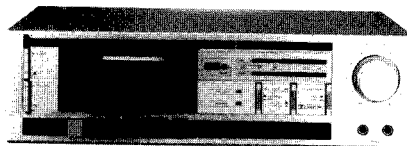

Shown in this photo is Model CT-301.

STEREO CASSETTE TAPE DECK

CT-301

CT-350

**ORDER NO.
ARP-513-0**

- CT-350 differs from CT-301 in style design (color).
- Models CT-301 and CT-350 come in versions distinguished as follows:

Type	Applicable model		Power requirement	Export destination
	CT-301	CT-350		
HEM	○	○	AC220V (240V)*	European continent
HB	○	—	AC240V (220V)*	United Kingdom
HP	○	○	AC240V (220V)*	Australia
KU	○	○	AC120V only	U.S.A.
KC	○	—	AC120V only	Canada
D	○	○	AC120V/220V/240V (switchable)	General export

* Change the primary wiring of the power transformer.

- This service manual is applicable to the HEM type. For servicing of the KU type, please refer to pp. 51, 52.
- Ce manuel d'instruction se réfère au mode de réglage, en français.
- Este manual de servicio trata del método de ajuste escrito en español.

PIONEER ELECTRONIC CORPORATION 4-1, Meguro 1-Chome, Meguro-ku, Tokyo 153, Japan
PIONEER ELECTRONICS (USA) INC. P.O. Box 1760, Long Beach, California 90801 U.S.A.
 TEL: (800) 421-1404, (213) 420-5914
PIONEER ELECTRONIC (EUROPE) N.V. Keetberglaan 1, 2740 Beveren, Belgium TEL: 03/775-2808
PIONEER ELECTRONICS AUSTRALIA PTY. LTD. 178-184 Boundary Road, Braeside, Victoria 3195, Australia
 TEL: (03) 580-9911

CONTENTS

1. SPECIFICATIONS	2	9. BLOCK DIAGRAM	15
2. FRONT PANEL FACILITIES	3	10. EXPLODED VIEW	16
3. DISASSEMBLY	4	11. ADJUSTMENTS	23
4. PARTS LOCATION	6	RÉGLAGE	29
5. ELECTRICAL PARTS LIST	7	AJUSTE	35
6. PACKING	9	12. IC DATA	41
7. P.C. BOARDS CONNECTION DIAGRAM	10	13. MECHANISM DESCRIPTIONS	42
8. SCHEMATIC DIAGRAM	13	14. SUPPLEMENT FOR KU TYPE	51

1. SPECIFICATIONS

Systeme	4-track, 2-channel stereo
Heads	"Hard Permalloy" recording/playback head x 1 "Ferrite" erasing head x 1
Motor	DC servo motor x 1
Wow and Flutter	No more than 0.06% (WRMS) No more than ±0.18% (DIN)
Fast Winding Time	Approximately 110 seconds (C-60 tape)
Frequency Response	
-20dB recording:	
Normal tape	35 to 13000Hz
Chrome tape	35 to 14000Hz
Metal tape	35 to 15000Hz
Signal-to-Noise Ratio	
Dolby NR OFF	More than 57dB
Noise Reduction Effect	
Dolby NR ON	More than 10dB (at 5kHz)
Harmonic Distortion	No more than 1.5% (0dB)
Input	
(Sensitivity)	
MIC (L, R)	0.3mV, 6mm diam. jack (Source impedance 10kΩ)
LINE (INPUT)	50mV (Input impedance 75kΩ)
Output (Reference level)	
LINE (OUTPUT)	330mV (Output impedance 50kΩ)

Furnished Parts

Operating instructions	1
Connection cord with pin plugs	2

Subfunctions

- Dolby NR system (ON/OFF) B type
- 3 position tape selector (NORM/CrO₂/METAL)
- Air damped eject function
- Full automatic stop function
- Timer stand-by function
- LED level meter
- One-touch recording

Miscellaneous

Power requirements	
KU, KC models	AC120V, 60Hz
HEM model	AC220V, 50/60Hz
HB, HP models	AC240V, 50/60Hz
D, D/G model	AC120V/220V/240V, 50/60Hz (switchable)
Power Consumption	
KU, KC models	14 watts
HEM, HB, HP model	19 watts
D, D/G models	14 watts
Dimensions	420 (W) x 120 (H) x 238 (D) mm 16-9/16 (W) x 4-6/8 (H) x 9-3/8 (D) in
Weight (without package)	3.8kg (8 lb 6 oz)

NOTE:

Specifications and the design subject to possible modifications without notice due to improvements.

2. FRONT PANEL FACILITIES

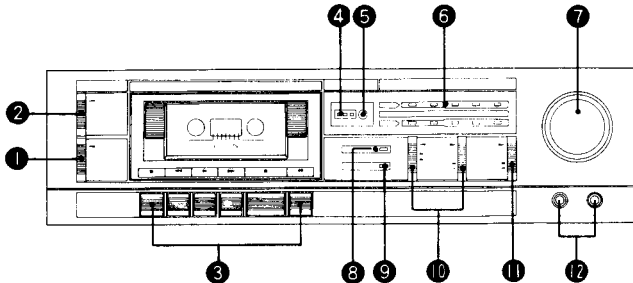

1 POWER SWITCH

2 EJECT BUTTON

Push this button to open the cassette door.

3 OPERATION SWITCHES

- (Rec) : Push this switch to start recording. When depressed to the ON position, the REC indicator lights. The switch does not work when a cassette is not loaded or when the erasure prevention tabs of a loaded cassette have been broken off.
- ◀◀ (REW) : Push this switch to rewind the tape quickly.
- ▶ (Play) : Push this switch to start tape playback.
- ▶▶ (FF) : Push this switch to send the tape forward quickly.
- (Stop) : Push this switch to stop the tape running and to release the function switches.
- || (Pause) : Push this switch to stop the tape temporarily. Release it to resume running.
The tape does not stop during fast forward or rewind operations even when the || (pause) switch is pushed.

4 TAPE COUNTER

5 RESET BUTTON

Push this button to reset the tape counter display to 000.

6 LEVEL METER

7 REC LEVEL CONTROL

8 REC INDICATOR

This lights during the recording mode.

9 POWER INDICATOR

10 TAPE SELECTOR

These selectors allow the tape's bias and equalization characteristics to be selected during recording and the equalization characteristics during playback, in line with the type of tape being used.

Normal tape : Release the left switch (NORM).

Chrome tape : Depress the left switch (HIGH) and release the right switch (CrO₂).

Metal tape : Depress both the right and left switches (HIGH, METAL).

11 *DOLBY NR SWITCH

Push this switch to ON when recording with the built-in Dolby noise reduction system and when playing back tapes which have been recorded using the system.

*Noise Reduction manufactured under license from Dolby Laboratories Licensing Corporation.

"Dolby" and the double-D symbol are trademarks of Dolby Laboratories licensing Corporation.

12 MIC JACKS

These are the input jacks for microphone recording.

3. DISASSEMBLY

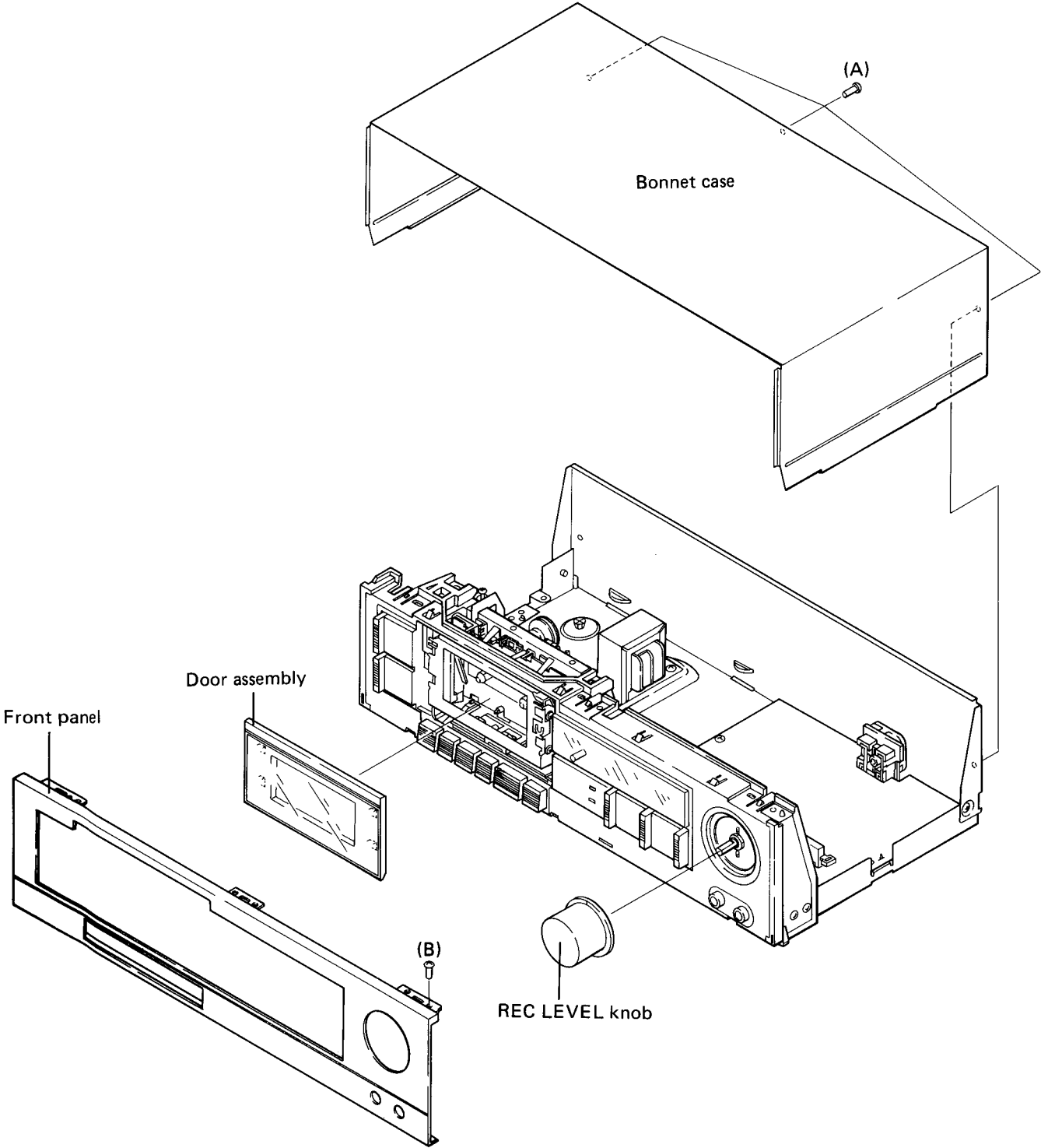

- **Bonnet Case**
Remove screws (A) (rear side).
- **Front Panel**
Pull off the REC LEVEL knob, and remove screw (B), and remove the upper and lower retaining hooks.
- **Door Assembly**
Press the EJECT button to open the cassette holder. Lift the door assembly upward and pull outward.
- **Tape Transport Unit**
Remove the counter belt and REC joint. Remove screws (C) (bottom side) and screws (D) (top side).

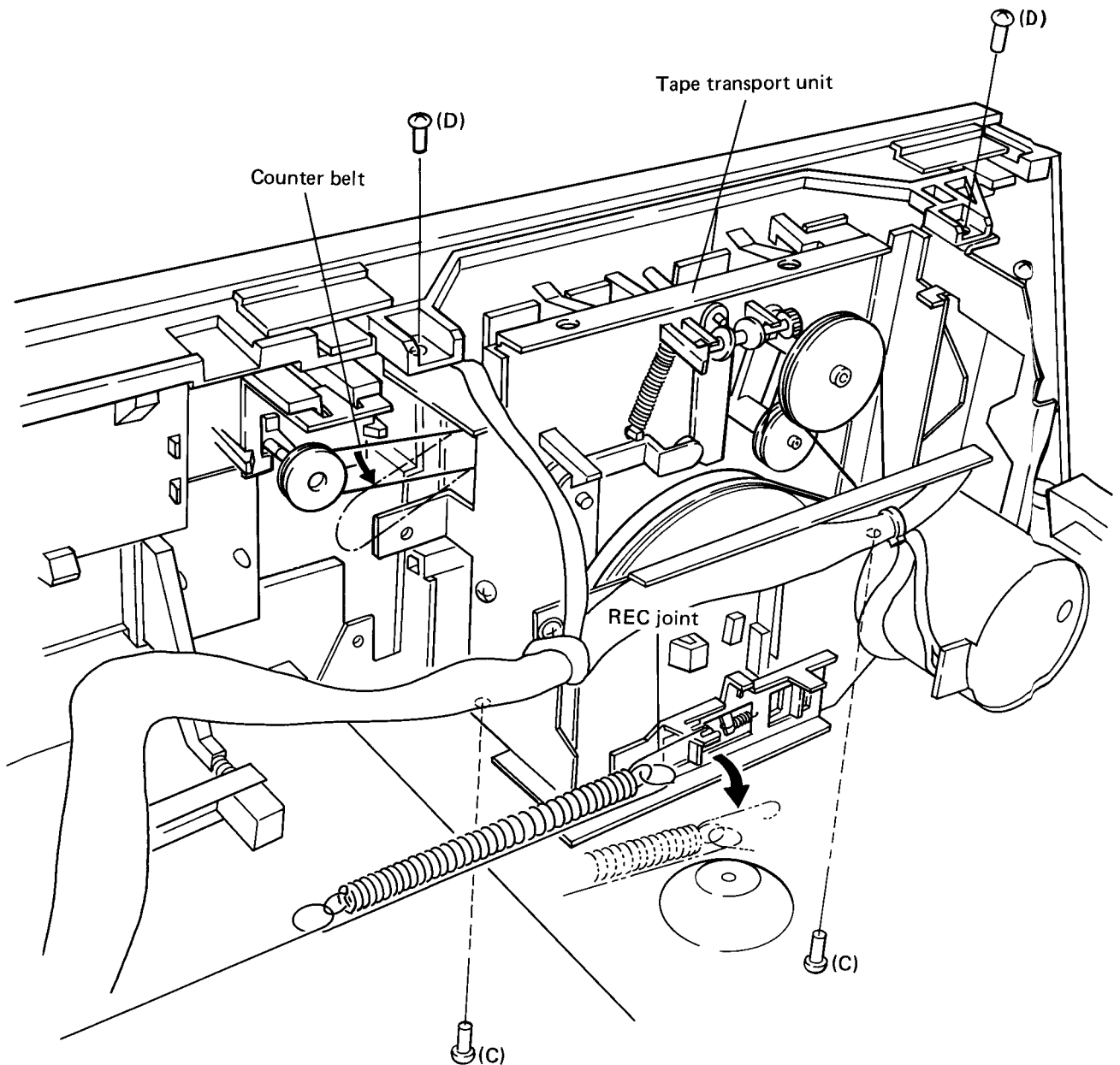

4. PARTS LOCATION

- Parts without part number cannot be supplied.
- The Δ mark found on some component parts indicates the importance of the safety factor of the part. Therefore, when replacing, be sure to use parts of identical designation.
- For your Parts Stock Control, the fast moving items are indicated with the marks **★★** and **★**.
★★ GENERALLY MOVES FASTER THAN ★.
This classification shall be adjusted by each distributor because it depends on model number, temperature, humidity, etc.

Front Panel View

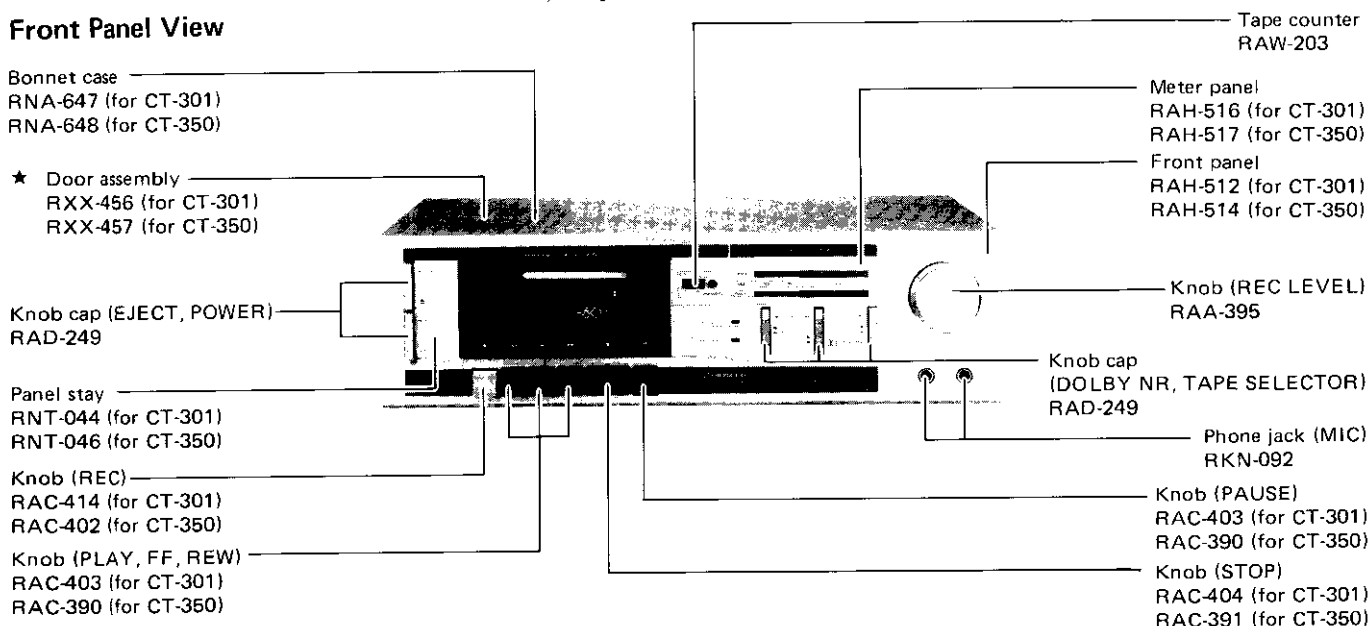

Rear Panel View

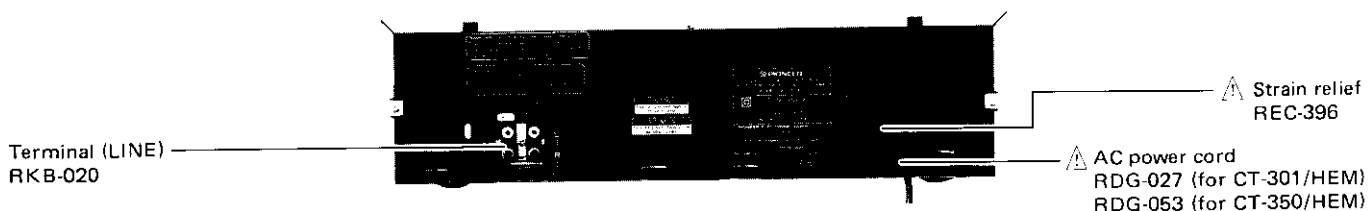

Top View

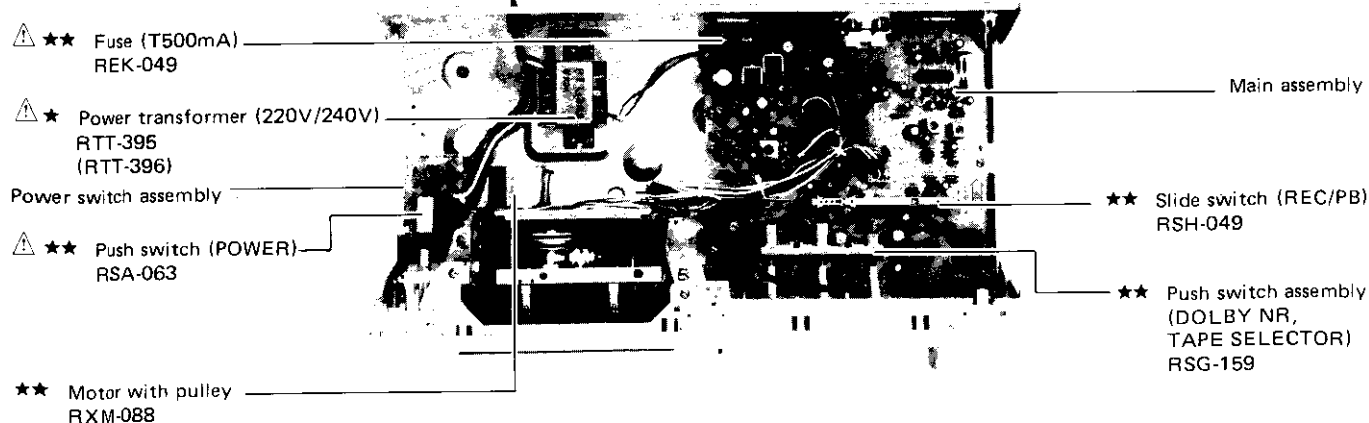

5. ELECTRICAL PARTS LIST

NOTES:



- When ordering resistors, first convert resistance values into code form as shown in the following examples.
 - Ex. 1 When there are 2 effective digits (any digit apart from 0), such as 560 ohm and 47k ohm (tolerance is shown by J = 5%, and K = 10%).
 - 560Ω 56 × 10¹ 561 RD½PS 561J
 - 47kΩ 47 × 10³ 473 RD½PS 473J
 - 0.5Ω 0R5 RN2H 0R5K
 - 1Ω 010 RS1P 010K
 - Ex. 2 When there are 3 effective digits (such as in high precision metal film resistors).
 - 5.62kΩ 562 × 10¹ 5621 RN½SR 5621F
- The  mark found on some component parts indicates the importance of the safety factor of the part. Therefore, when replacing, be sure to use parts of identical designation.
- For your Parts Stock Control, the fast moving items are indicated with the marks **★★** and **★**.
 - ★★** GENERALLY MOVES FASTER THAN **★**.
 - This classification shall be adjusted by each distributor because it depends on model number, temperature, humidity, etc.

Miscellaneous Parts

P.C. BOARD ASSEMBLIES

Mark	Symbol & Description	Part No.
	Main assembly	Non supply
	Meter assembly	Non supply
	LED assembly	Non supply
	Level control assembly	Non supply
	Power switch assembly	Non supply



OTHERS

Mark	Symbol & Description	Part No.
 ★★	FU1 Fuse (T500mA)	REK-049
 ★	T1 Power transformer (220V/240V)	RTT-395 (RTT-396)
★★	S1 Lever switch (PLAY)	RSN-034
★★	S2 Lever switch (FF)	RSN-033
★★	S3 Spring switch (REC)	RSN-025
★★	Motor with pulley	RXM-088
★★	REC/PB head	RPB-118
★	Erase head	RPB-085
	AC power cord (for CT301/HEM)	RDG-027
	AC power cord (for CT-350/HEM)	RDG-053

Main Assembly (RWX-894)

SEMICONDUCTORS

Mark	Symbol & Description	Part No.
★★	Q301	HA12045
★★	Q302	M5218L
★★	Q101, Q102, Q201, Q202	2SC2240
★★	Q103-Q106, Q203-Q206, Q308, Q309	2SC1740LN
★★	Q306, Q307	2SC1740LN-S

Mark	Part No.	Symbol & Description
★★	Q305	2SC1741
 ★★	Q303, Q304	2SD1265
★★	Q310	2SA933LN
 ★	D301	WL02-5004L
★	D302	1SR35-100A
★	D305, D307, D308, D310-D315	1S2473
 ★	D303, D304	RD13EB1 (RD13EB2) (MTZ13A) (MTZ13B)
★	D306	RD5.1EB2 (MTZ5.1B)
★	D309	RD15FB1

SWITCHES

Mark	Symbol & Description	Part No.
★★	S301 Slide switch (REC/PB)	RSH-049
★★	S302-S304 Push switch assembly (TAPE SELECTOR, DOLBY NR)	RSG-159

COILS



Mark	Symbol & Description	Part No.
	L101, L201 MPX filter	RTF-138
	L102, L202 Trap coil	RTF-152
	L103, L203 Peaking coil (12mH)	RTF-129
	L301 Oscillator coil	RTD-032
	L302 Line coil	RTF-101

CAPACITORS

Mark	Symbol & Description	Part No.
	C120, C220	CEA R27M 50
	C125, C225	CEA R33M 50
	C121, C221	CEA R82M 50
	C118, C122, C124, C130, C133, C308, C218, C222, C224, C230, C233	CEA 010M 50
	C117, C217	CEANL 4R7M 50
	C103, C203, C112, C212, C113, C213	CEANL 100M 16
	C107, C109, C111, C114, C126, C207, C209, C211, C214, C226	CEA 100M 16
	C315, C317, C318, C327, C328	CEA 220M 16
	C106, C206, C316	CEA 330M 16
	C104, C204, C305, C306	CEA 470M 16
	C322	CEA 101M 10
	C303, C307, C320	CEA 101M 16
	C323	CEA 4R7M 50
	C319, C321	CEA 221M 16
	C314, C302	CEA 101M 35
	C301	CEA 102M 35
	C304	CEA 471M 16
	C123, C223	CCDSL 271J 50
	C310, C311	CQMA 332K 50
	C116, C216	CQMA 472J 50
	C128, C228, C309	CQMA 682J 50
	C129, C229	CQMA 562J 50
	C127, C227	CQMA 822J 50
	C110, C210, C312	CQMA 153J 50
	C115, C215	CQMA 333J 50
	C119, C219	CQMA 183J 50
	C108, C208	CQMA 103J 50
	C313	CQPA 562J 100
	C101, C201	CQSA 471K 50
	C132, C232	CCDSL 101K 500
	C105, C205	CCDSL 220K 500
	C101, C131, C201, C231	CCDSL 471K 50
	C324-C326	CKDYF 473Z 50

RESISTORS

Note: When ordering resistors, convert the resistance value into code form, and then rewrite the part no. as before.

Mark	Symbol & Description	Part No.
★	V101, V102, V201, V202 Semi-fixed 22k-B	RCP-223
★	V103, V203 Semi-fixed 150k-B	RCP-228
	R312	RS1LF 181J
	R301, R303	RD½PMF 561J
	R324	RD½PMF 271J
	R105, R205	RD½PM 753JNL
	Other resistors	RD½PM □□□ J

OTHERS

Mark	Symbol & Description	Part No.
	S101, S201 Phone jack with switch (MIC L, R)	RKN-092
	Terminal (LINE)	RKB-020
	Shield case	RNH-209

Meter Assembly

SEMICONDUCTORS

Mark	Symbol & Description	Part No.
★★	Q401, Q402	BA6124
★	LED array	LN101207PH

CAPACITORS

Mark	Symbol & Description	Part No.
	C401, C402	CEA 100M 16
	C403	CKDYF 473Z 50

RESISTORS

Note: When ordering resistors, convert the resistance value into code form, and then rewrite the part no. as before.

Mark	Symbol & Description	Part No.
	R401, R402	RD½PMF 680J
	R403, R404	RD½PM 103J

LED Assembly

Mark	Symbol & Description	Part No.
★	D501, D502	LN248RPH
	R501, R502	RD½PM 102J



Level Control Assembly

RESISTORS

Note: When ordering resistors, convert the resistance value into code form, and then rewrite the part no. as before.

Mark	Symbol & Description	Part No.
★	VR601 2-gang variable (REC LEVEL)	RCV-118

Power Switch Assembly

Mark	Symbol & Description	Part No.
 ★★	S701 Push switch (POWER)	RSA-063
	C701 Ceramic capacitor (0.01/AC400V)	RCG-009

External Appearance of Transistors and ICs

HA12045

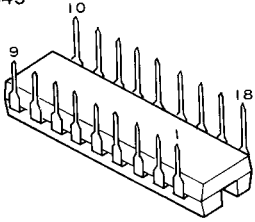

M5218L

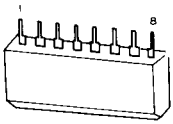

2SC2240

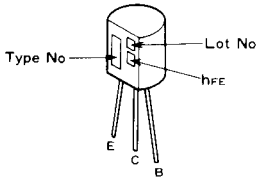

BA6124

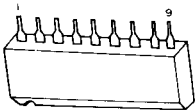

2SA933LN
2SC1740LN

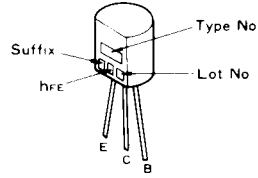

2SD1265

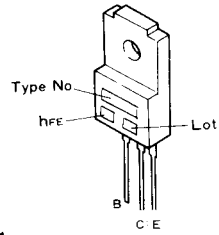

2SC1741

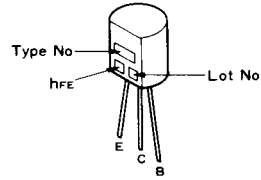

6. PACKING

Mark	No.	Part No.	Description
	1.	RHA-262	Side pad
	2.	RHG-711 (for CT-301) RHG-717 (for CT-350)	Packing case
	3.	RRE-062 (for CT-301) RRE-066 (for CT-350)	Operating instructions
	4.	RDE-010	Connection cord

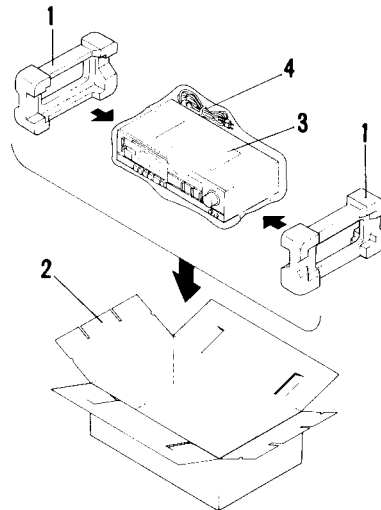

7. P.C. BOARDS CONNECTION DIAGRAM

MAIN ASSEMBLY

A

B

C

D

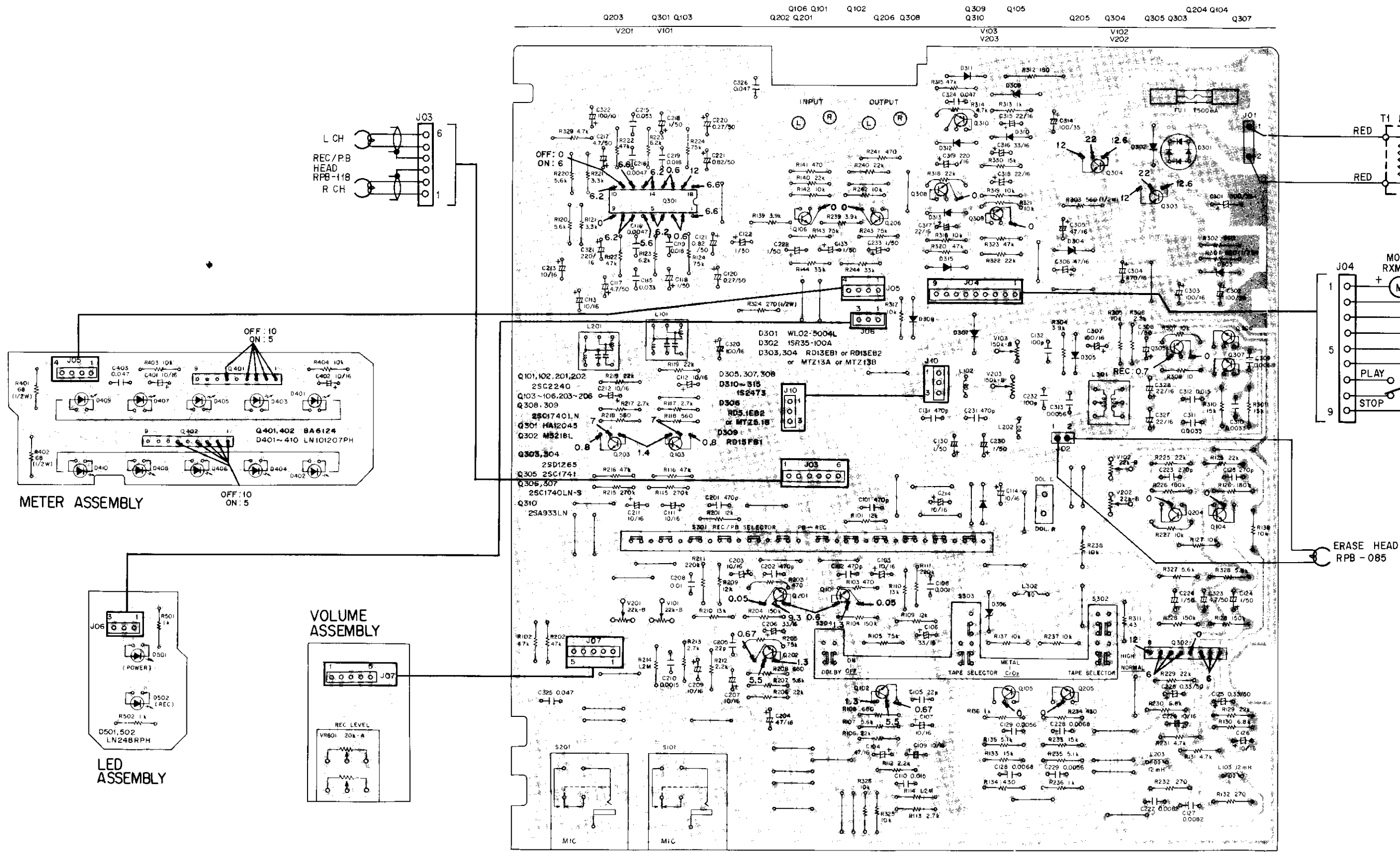

MAIN ASSEMBLY

POWER SWITCH ASSEMBLY

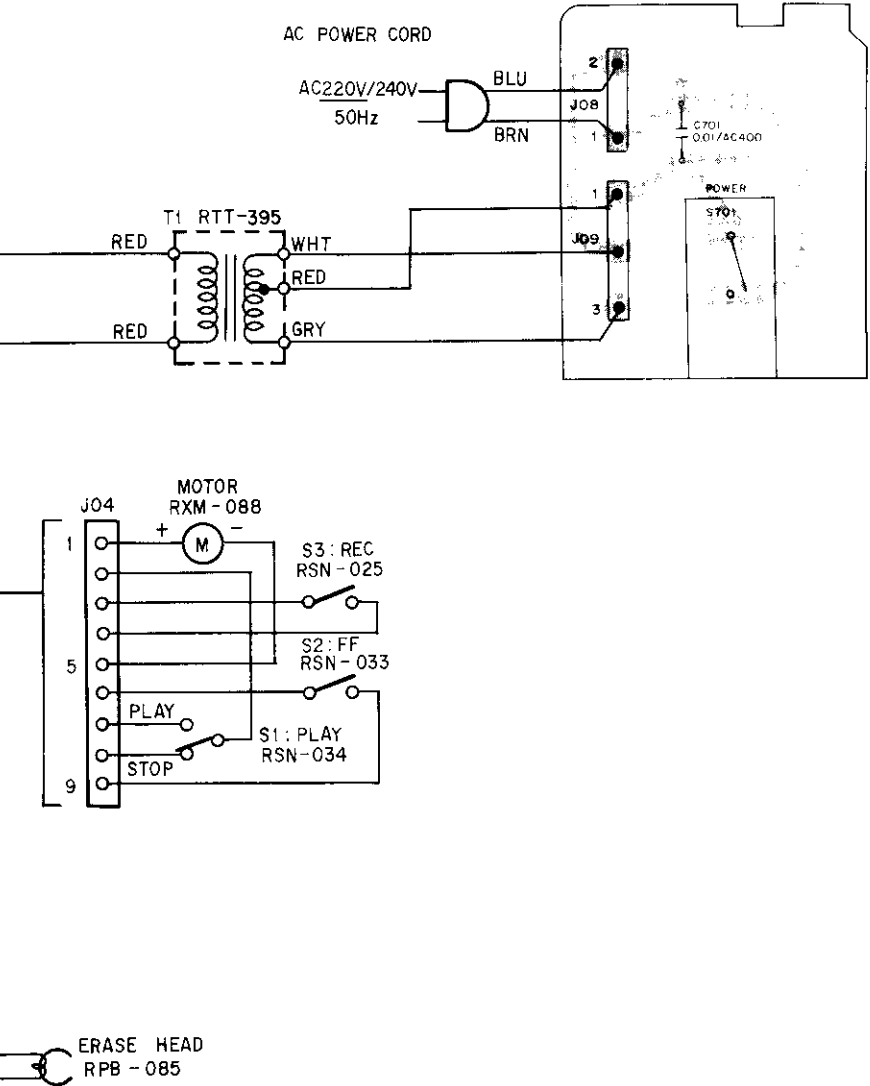
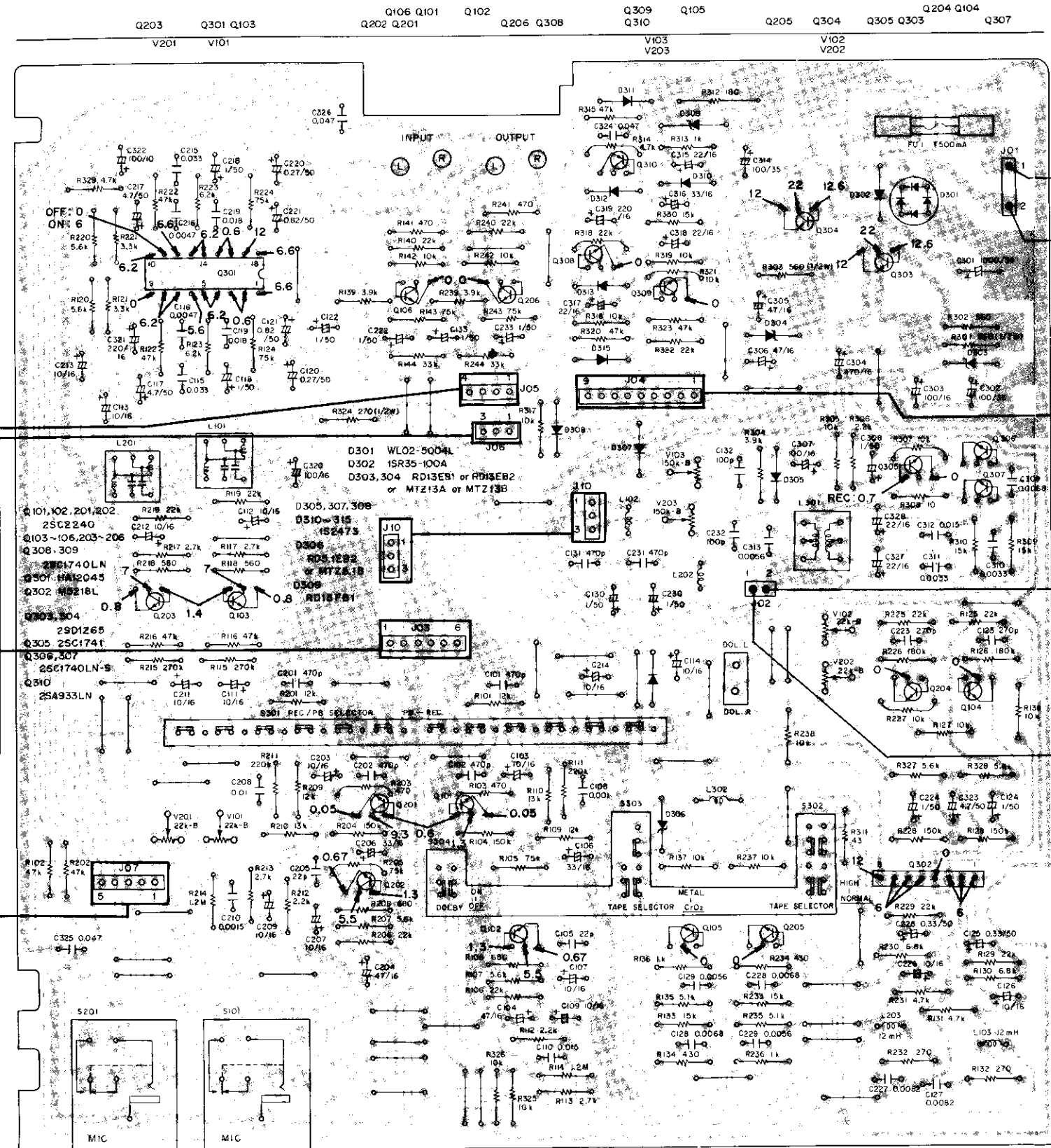

A

B

C

D

8. SCHEMATIC DIAGRAM

NOTE:
The indicated semiconductors are representative ones only.
Other alternative semiconductors may be used and are listed in the parts list.

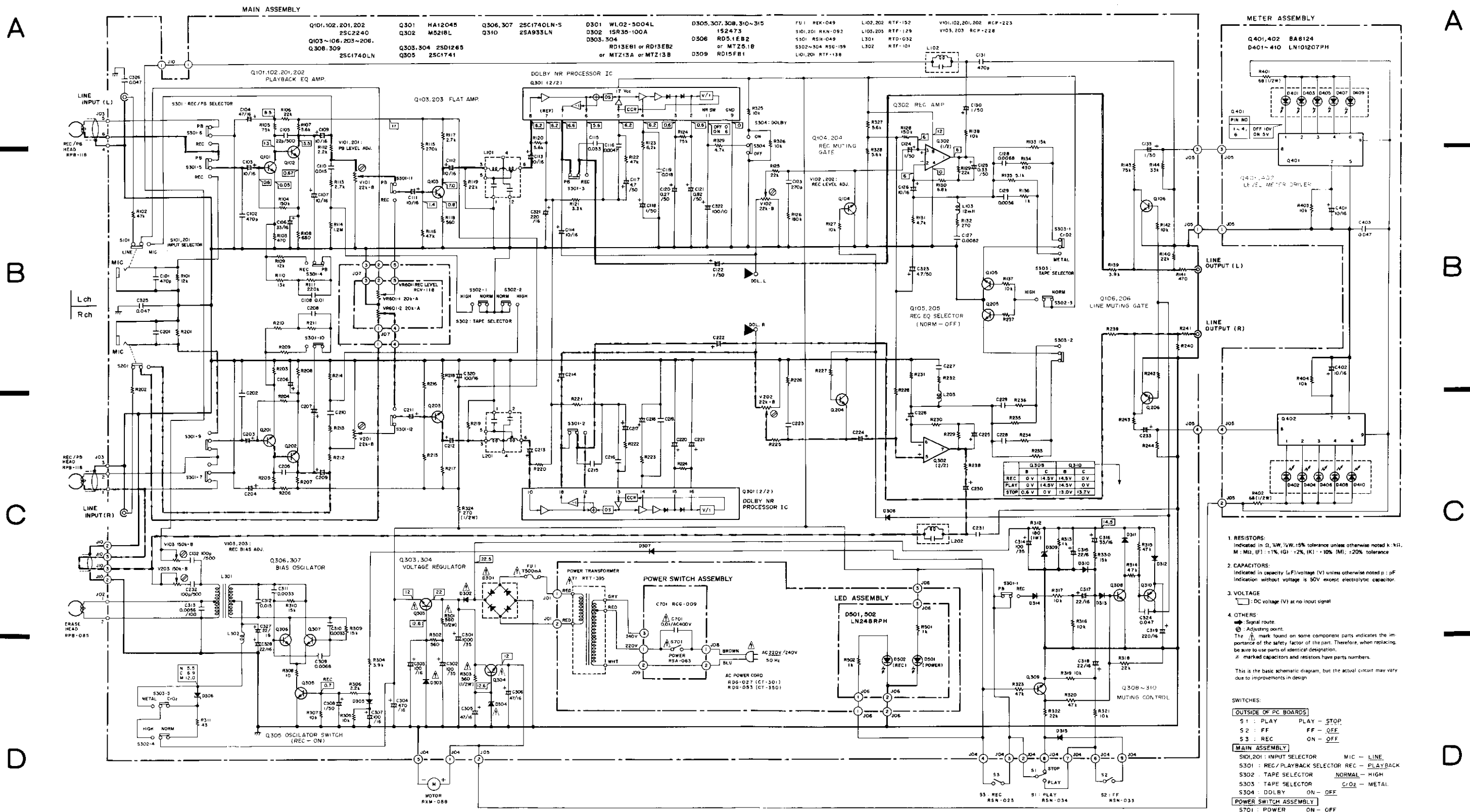

NOTE:
Playback signal route (Lch) ———
Recording signal route (Rch) - - - - -

- RESISTORS:**
Indicated in Ω, kΩ, MΩ, %W, 15% tolerance unless otherwise noted k: kΩ, M: MΩ, (F): 1%, (G): 2%, (K): 10%, (M): ±20% tolerance
- CAPACITORS:**
Indicated in capacity (μF) voltage (V) unless otherwise noted p: pF Indication without voltage is 50V except electrolytic capacitor.
- VOLTAGE:**
□: DC voltage (V) at no input signal
- OTHERS:**
⊙: Signal route
⊙: Adjusting point
The ⊙ mark found on some component parts indicates the importance of the safety factor of the part. Therefore, when replacing, be sure to use parts of identical designation.
* marked capacitors and resistors have parts numbers.

- This is the basic schematic diagram, but the actual circuit may vary due to improvements in design.
- SWITCHES:**
- OUTSIDE OF PC BOARDS**
- S1: PLAY PLAY - STOP
 - S2: FF FF - OFF
 - S3: REC ON - OFF
- MAIN ASSEMBLY**
- S101,201: INPUT SELECTOR MIC - LINE
 - S301: REC/PLAYBACK SELECTOR REC - PLAYBACK
 - S302: TAPE SELECTOR NORMAL - HIGH
 - S303: TAPE SELECTOR C.O.E - METAL
 - S304: DOLBY ON - OFF
- POWER SWITCH ASSEMBLY**
- S701: POWER ON - OFF
- The underlined indicates the switch position.

9. BLOCK DIAGRAM

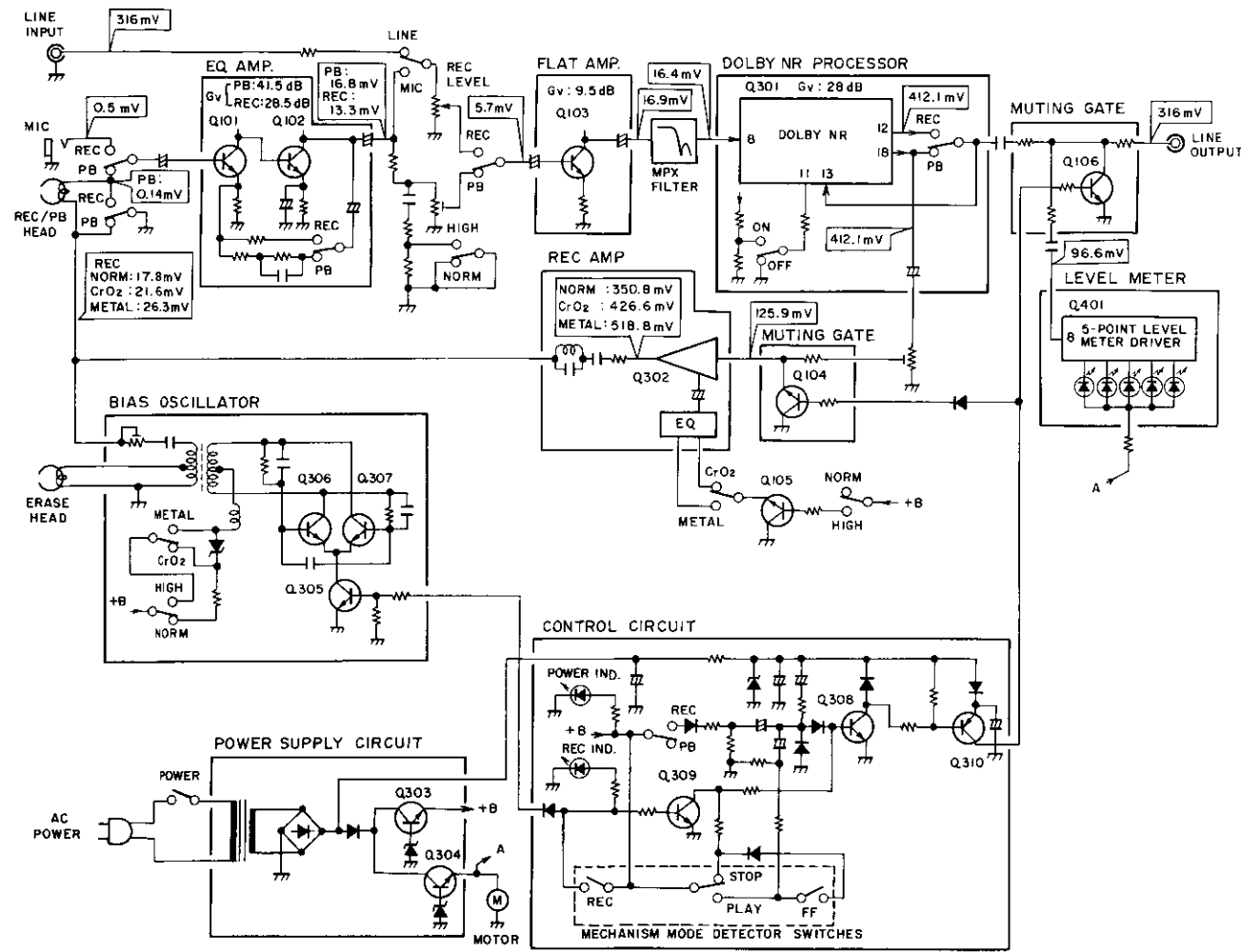

10. EXPLODED VIEW AND PARTS LIST

- Parts without part number cannot be supplied.
- The Δ mark found on some component parts indicates the importance of the safety factor of the part. Therefore, when replacing, be sure to use parts of identical designation.
- For your Parts Stock Control, the fast moving items are indicated with the marks **★★** and *****.
★★ GENERALLY MOVES FASTER THAN *.
 This classification shall be adjusted by each distributor because it depends on model number, temperature, humidity, etc.

Parts List of Exterior

Mark	No.	Part No.	Description	Mark	No.	Part No.	Description
	1.	RNA-647 (for CT-301) RNA-648 (for CT-350)	Bonnet case	★★	18.	REB-369	Counter belt
	2.	BBZ30P080FMC	Screw 3 x 8		19.	RAW-203	Tape counter
	3.	RBL-061	Eject spring		20.	RBL-062	REC joint
	4.	RNL-845	Eject knob	Δ ★★	21.	REK-049	Fuse (T500mA)
	5.	RAD-249	Knob cap		22.	RNL-846	Rod
	6.	RNT-044 (for CT-301) RNT-046 (for CT-350)	Panel stay	Δ *	23.	RTT-395	Power transformer (220V/240V)
	7.	REB-513	Skid	Δ	24.	RDG-027 (for CT-301) RDG-053 (for CT-350)	AC power cord
	8.	RAA-395	Knob (REC LEVEL)	Δ	25.	REC-396	Strain relief
★★	9.	RXX-456 (for CT-301) RXX-457 (for CT-350)	Door assembly		26.	RNL-844	Power knob
	10.			27.	REC-369	Foot assembly
	11.	RAH-516 (for CT-301) RAH-517 (for CT-350)	Meter panel		28.	PMA30P060FMC REC-371	Screw 3 x 6 Cord binder
	12.	RAH-512 (for CT-301) RAH-514 (for CT-350)	Front panel		31.	Refer to pp. 19-22	Tape transport unit
	13.	RNL-838	Cassette plate		32.		LED assembly
	14.	REE-081	Shining paper		33.		Counter holder
	15.	RAC-414 (for CT-301) RAC-402 (for CT-350)	Knob (REC)		34.		Meter assembly
					35.		Level control assembly
	16.	RAC-403 (for CT-301) RAC-390 (for CT-350)	Knob (PLAY, FF, REW, PAUSE)		36.		Grounding plate
					37.		Main assembly
					38.		Power switch assembly
	17.	RAC-404 (for CT-301) RAC-391 (for CT-350)	Knob (STOP)		39.		Chassis
					40.	

Exterior

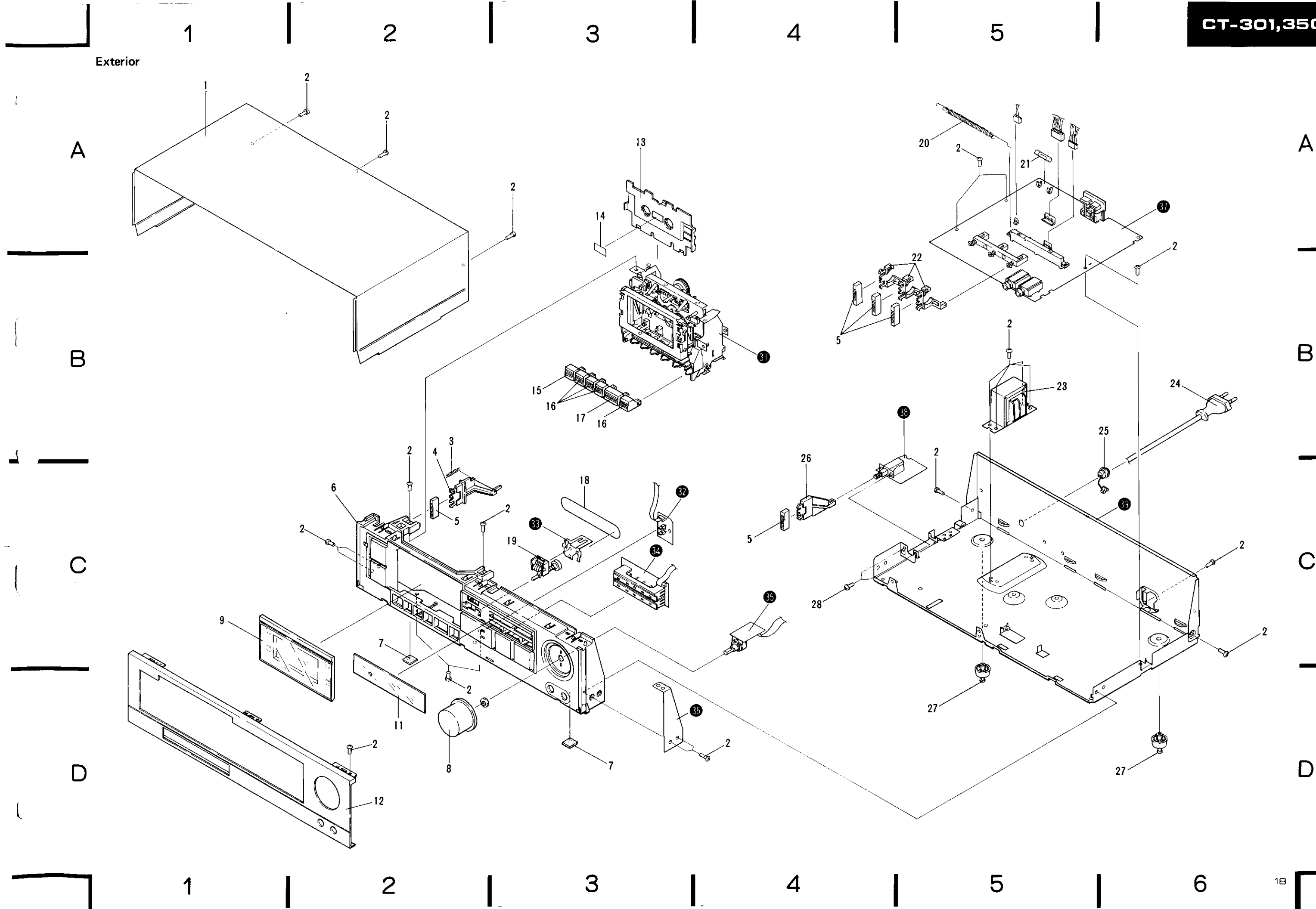

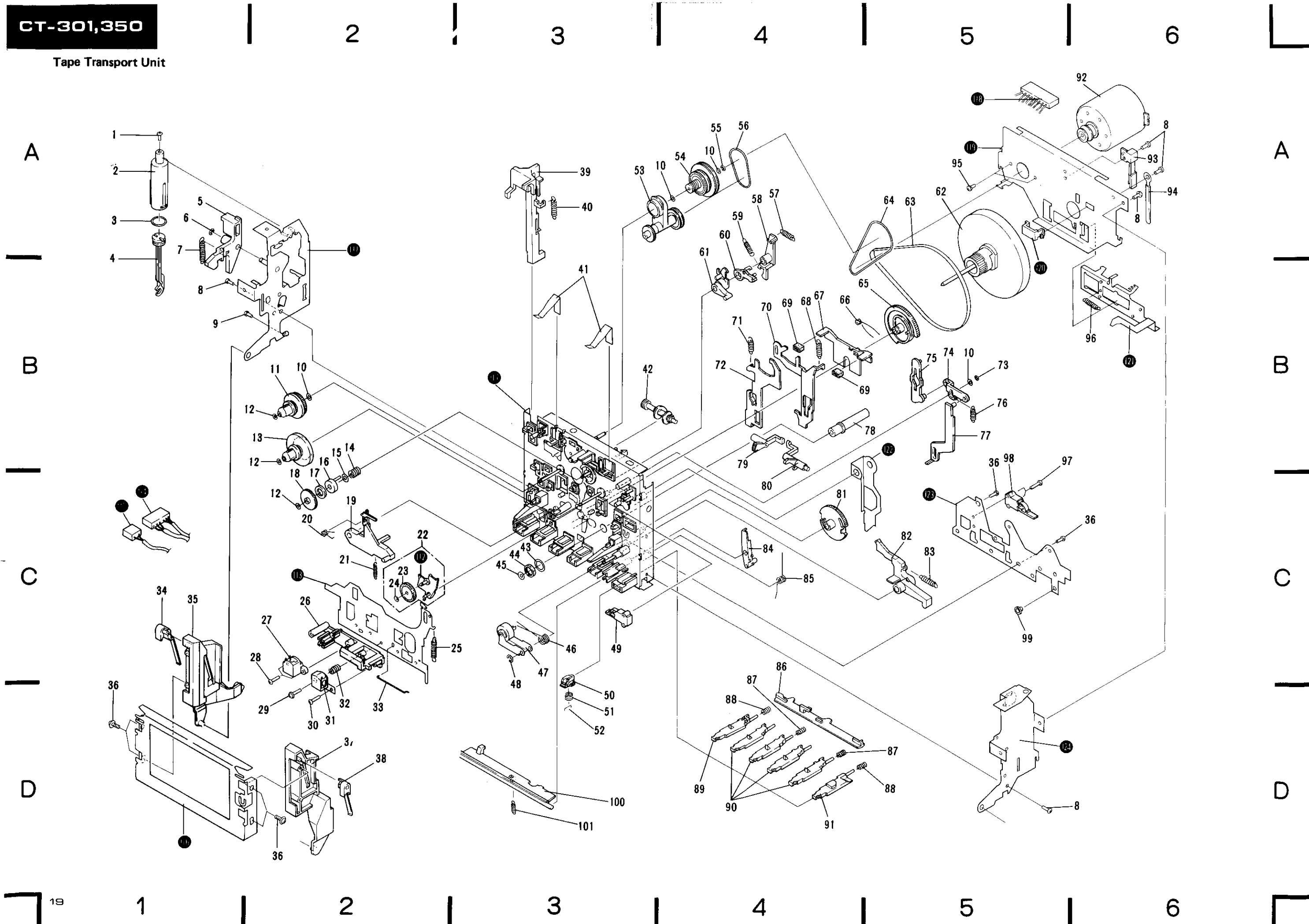

- *Parts without part number cannot be supplied.*
- *The Δ mark found on some component parts indicates the importance of the safety factor of the part. Therefore, when replacing, be sure to use parts of identical designation.*
- *For your Parts Stock Control, the fast moving items are indicated with the marks **★★** and **★**.
★★ *GENERALLY MOVES FASTER THAN* **★**.
*This classification shall be adjusted by each distributor because it depends on model number, temperature, humidity, etc.**

Parts List of Tape Transport Unit

Mark	No.	Part No.	Description	Mark	No.	Part No.	Description
	1.	VCZ26P090FMC	Screw 2.6 x 9		41.	RBK-166	Half set spring
	2.	RNK-995	Cylinder		42.	RNL-322	Cam gear
	3.	REB-447	O-ring		43.	RBE-021	Washer
	4.	RNL-329	Piston		44.	NK90FCr	Nut
	5.	RNL-291	Eject lever		45.	RFB-030	Oil stopper
	6.	YE25FUC	Washer E-type		46.	RBH-890	Pinch pressure spring
	7.	RBH-871	Pocket return spring	★★	47.	RXB-495	Pinch arm assembly
	8.	VCZ26P060FMC	Screw 2.6 x 6		48.	YE20FUC	Washer E-type
	9.	PSZ20P060FMC	Screw 2 x 6	★★	49.	RSN-034	Lever switch (S1)
	10.	WA21D040D25	Washer		50.	RNL-334	Ratchet holder
★★	11.	RXB-377	Supply reel base assembly		51.	RBH-888	Ratchet spring
	12.	RFB-057	Washer		52.	RBH-870	Ratchet pin
★★	13.	RXB-360	TU reel base assembly		53.	RXB-577	Drive arm full assembly
	14.	RBH-885	Detector spring		54.	RXB-976	Drive pulley assembly
	15.	RFB-071	Washer		55.	YE15FUC	Washer E-type
	16.	RNL-318	Detector disk	★★	56.	REB-455	Drive belt B
	17.	RED-194	Detector felt		57.	RBH-876	Gear lever spring A
	18.	RNK-998	Idler gear		58.	RNL-297	Gear lever A
	19.	RNL-298	Action lever		59.	RBH-877	Gear lever spring B
	20.	RBH-873	Idler pressure spring		60.	RNL-282	Gear lever B
	21.	RBH-875	Action lever spring		61.	RNL-296	Gear lever C
	22.	RXB-579	Idler arm full assembly		62.	RXB-576	Flywheel assembly
★★	23.	RNL-337	TU idler	★★	63.	REB-453	Capstan belt
	24.	WA17D040D025	Washer	★★	64.	REB-454	Drive belt A
	25.	RBH-874	HB return spring		65.	RNL-288	Cam gear
	26.	RNL-050	Sub-head base		66.	RBH-879	Trigger spring
★	27.	RPB-085	Erase head		67.	RNL-280	Brake plate
	28.	PMZ20P130FMC	Screw 2 x 13		68.	RBH-884	Action plate spring
	29.	iMZ20Y120FMC	Screw 2 x 12		69.	REB-466	Brake shoe
	30.	PMZ20P120FMC	Screw 2 x 12		70.	RNL-811	FF action plate
★★	31.	RPB-118	REC/PB head		71.	RBH-916	Action plate spring L
	32.	RBH-723	Head adjust spring		72.	RNL-810	REW action plate
	33.	RBH-782	HB drive spring		73.	YS20FBT	Washer C-type
	34.	RNL-057	Pocket spring L		74.	RNL-275	Link
	35.	RNL-439	Pocket L		75.	RNL-274	Detector lever
	36.	BBZ26P080FZK	Screw 2.6 x 8		76.	RBH-886	Link return spring
	37.	RNL-440	Pocket R		77.	RNL-289	Stop lever
	38.	RNL-058	Pocket spring R		78.	RXB-670	Metal holder A assembly
	39.	RNL-284	REC detector arm		79.	RNL-812	Joint L
	40.	RBH-883	Detector arm spring		80.	RNL-276	Joint R

Mark	No.	Part No.	Description
	81.	RNL-831	Cam gear R
	82.	RNL-295	Pause lever
	83.	RBH-880	Pause lever spring
	84.	RNL-281	Gear lever R
	85.	RBH-881	Trigger spring R
	86.	RNL-486	REC connection arm
	87.	RBH-889	Button return spring
	88.	RBH-909	Pause button spring
	89.	RNL-487	REC button
	90.	RNL-287	Function button
	91.	RNL-279	Pause button
★★	92.	RXM-088	Motor with pulley
★★	93.	RSN-025	Spring switch (S3)
	94.	RNE-605	UL cord clamber D
	95.	PMA26P040FMC	Screw 2.6 x 4
	96.	RBH-882	REC return spring
	97.	PMZ20P080FMC	Screw 2 x 8
★★	98.	RSN-033	Lever switch (S2)
	99.	RLB-469	Collar
	100.	RNL-303	Lock plate
	101.	RBH-922	Lock plate spring
		REC-371	Cord binder
	111.		Side plate L assembly B
	112.		Idler arm assembly
	113.		Head base
	114.		Connector assembly 6-P
	115.		Connector assembly 2-P
	116.		Pocket frame B
	117.		Chassis assembly
	118.		Connector socket 9-P
	119.		Flywheel receptacle
	120.		Thrust receptacle
	121.		REC action plate
	122.		REC action lever
	123.		Plate
	124.		Side plate R
	125.	

11. ADJUSTMENTS

11.1 MECHANICAL ADJUSTMENTS

Prior to Adjustment

Clean the both reel base, the capstan and the pinch roller with an alcohol moistened swab.

Pinch Roller Pressure Adjustment

1. Put the tape deck into the playback mode.
2. Gently push against the pinch roller arm with the tension gauge and separate the pinch roller slightly from the capstan.
3. Then the pinch roller back onto the capstan, and read the value when the pinch roller starts to rotate. If the reading fails to lie within 300g~500g, replace the pinch pressure spring.

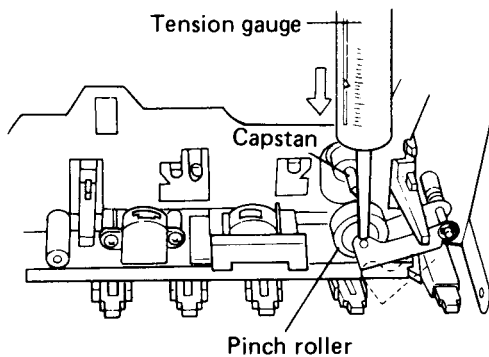

Fig. 11-1 Pinch roller pressure adjustment

Reel Base Torque Adjustment

Measure the torque with the torque meter during playback, fast forward (FF) and rewind (REW) modes. The measured values should normally lie within the allowable ranges listed in the table 1.

If the measured values lie outside the relevant ranges, replace the TU (take-up) reel base assembly and/or supply reel base assembly, TU idler, or drive arm full assembly.

Table 1

	TU reel base	Supply reel base
Playback mode	38 – 57g.cm	* 1.5 – 5g.cm
FF mode	75 – 135g.cm	* 1.5 – 5g.cm
REW mode	* 1.5– 5g.cm	75 – 135g.cm

* Denotes back tension torque.

Tape Speed Adjustment

1. Connect the frequency counter to the LINE OUTPUT terminals.
2. Play back the 3kHz portion of the STD-301 test tape. At the beginning, the frequency should be lie within the 3000Hz~3010Hz range, and may be adjusted by turning the semi-fixed resistor located in the capstan motor adjustment hole as shown in Fig. 11-2.

NOTE:

Tape speed is increased by turning the semi-fixed resistor clock-wise, and decreased by turning counter-clockwise.

REC Switch Adjustment

1. Depress REC button. REC action lever moves to A direction. At this time, check that REC switch is ON.
2. Depress STOP button. The REC action lever moves slightly to B direction. At this time, bend and adjust the REC action lever so that a contact distance of REC switch is 0.2~0.5mm.

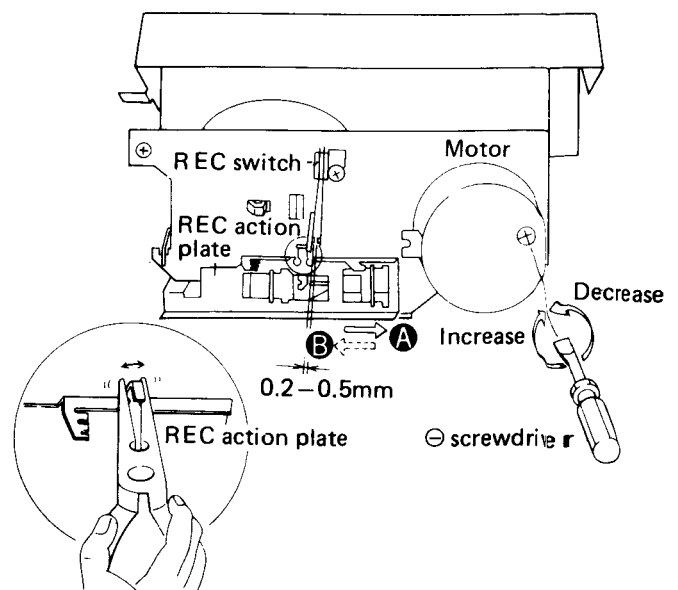

Fig. 11-2 Tape speed and REC switch adjustment

Door Damping Check and Adjustment

1. Press the EJECT button without a cassette loaded in the cassette compartment, and check that the door opens smoothly without stepwise movement, or rebounding after fully opening.
2. If these conditions are not satisfied, adjust by turning the adjustment screw in the head of the cylinder.

Turn the screw counter clockwise if the door opens stepwise in two stages.

Turn the screw clockwise if the door bounces back after fully opening.

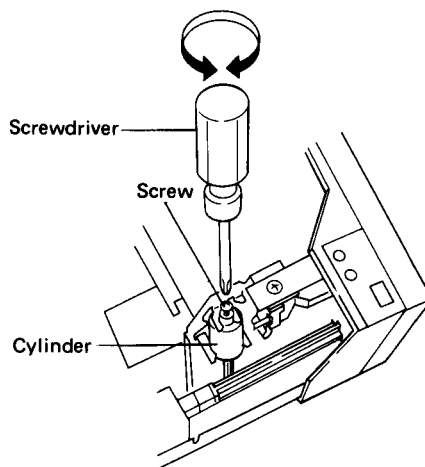

Fig. 11-3 Door damping check and adjustment

REC Joint Check and Adjustment

1. Check that the gap F between the REC joint and slide switch is 0 to 0.3mm when the transport mechanism is stationary (and check that the slide switch does not move).
2. Move the REC joint mechanism catching position backwards if the gap F is greater than 1.0 mm, but move it forwards if there is no gap and the slide switch is moving.
3. If the prescribed gap F cannot be obtained by the above adjustment, bend the hook section of the REC joint with a pair of pliers by an appropriate degree.
4. Check that the slide switch is fully switched when the transport mechanism is in recording mode.
5. Also check that the mechanism spring switch is shorted.

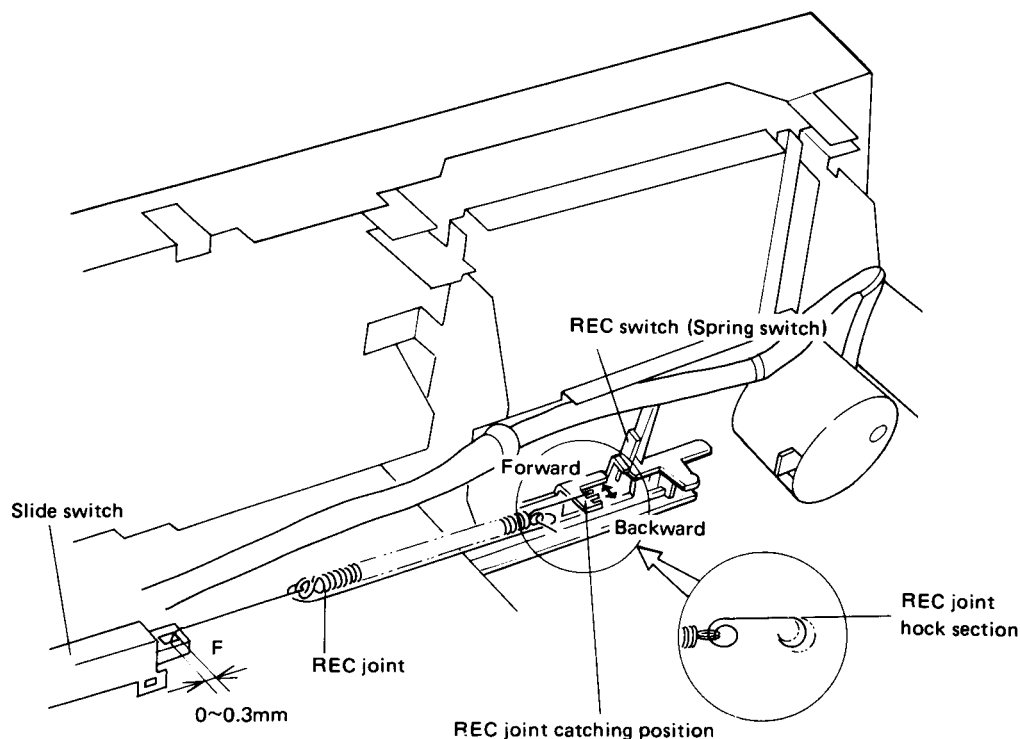

Fig. 11-4 Rec joint check and adjustment

11.2 ELECTRICAL ADJUSTMENTS

Adjustment Conditions

1. The mechanical adjustments must be completed first.
2. The head must be cleaned and demagnetized.
3. Allow the deck to age for at least a few minutes before commencing any electrical adjustments.
4. The reference signal is 0dB=1Vrms.
5. Connect a 50 kilo-ohm (or between 47 to 52 kilo-ohm) load resistance to the OUTPUT terminals.
6. Unless otherwise specified, the switches listed below are left in the positions indicated.

DOLBY NR : OFF
 TAPE SELECTOR : NORM

Test Tapes

- STD-331B : Playback adjustments
 (See Fig. 11-5)
 STD-608A : NORMAL blank tape
 STD-603 : CrO₂ blank tape
 STD-610 : METAL blank tape

List of Adjustments

1. Head azimuth adjustment
2. Playback equalizer check
3. Playback level adjustment
4. Level meter check
5. Recording and playback frequency response adjustment
6. Recording level adjustment

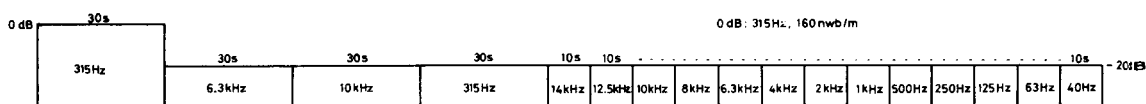

Fig. 11-5 Contents of the test tape STD-331B

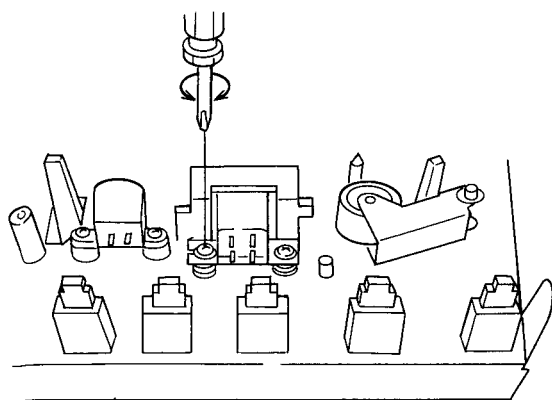

Fig. 11-6 Head azimuth adjustment

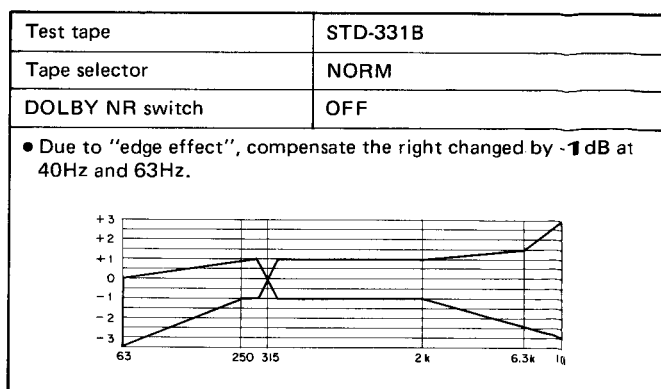

Fig. 11-7 Allowable playback frequency response zone

- Set the DOLBY NR switch to the OFF position.

1. Head Azimuth Adjustment						
• Turn V101 and V201 to maximum position (fully clockwise).						
	Mode	Input signal & test tape	Adjustment location	Measuring location	Adjustment value	Remarks
1	STOP	Set the TAPE SELECTOR switch to the NORM position.				
2	PLAY	Play the 10kHz/-20dB section of the STD-331B test tape.	Head azimuth adjustment screw. (See Fig. 11-6)	Left and right OUTPUT terminals.	Maximum playback signal level.	
3	STOP	Lock the screw with screw lock after completing the adjustment.				
2. Playback Equalizer Check						
	Mode	Input signal & test tape	Adjustment location	Measuring location	Adjustment value	Remarks
1	STOP	Set the TAPE SELECTOR switch to the NORM position.				
2	PLAY	Play the 315Hz/-20dB and 6.3kHz/-20dB section of the STD-331B test tape.	Confirm	Left and right OUTPUT terminals.	The 6.3kHz playback level is -0.5 ± 2 dB against 315Hz level.	
3	STOP	Set the TAPE SELECTOR switch to the CrO ₂ or METAL position.				
4	PLAY	Play the 315Hz/-20dB and 6.3kHz/-20dB section of the STD-331B test tape.	Confirm	Left and right OUTPUT terminals.	The 6.3kHz playback level is -4.5 ± 2 dB against 315Hz level.	

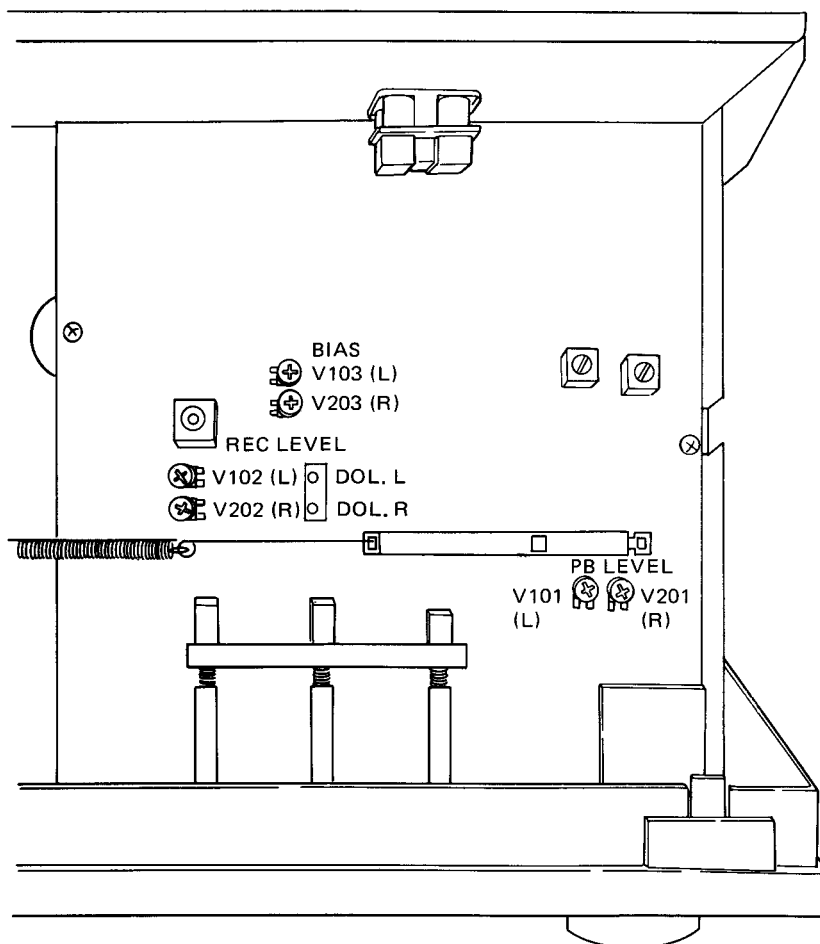
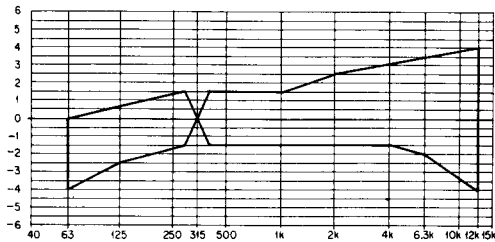

Fig. 11-8 Adjustments locations

3. Playback Level Adjustment						
● This adjustment determines the DOLBY NR level, and must be performed with great care.						
	Mode	Input signal & test tape	Adjustment location	Measuring location	Adjustment value	Remarks
1	STOP	Set the TAPE SELECTOR switch to the NORM position.				
2	PALY	Play the 315Hz/0dB section of the STD-331B test tape.	V101 (Left channel) V201 (Right channel)	DOL. L (L ch.) DOL. R (R ch.)	-7.7dBv (412.1mV)	
4. Level Meter Check						
	Mode	Input signal & test tape	Adjustment location	Measuring location	Adjustment value	Remarks
1	REC-PAUSE	Apply a 315Hz/-10dBv (316mV) signal to the LINE INPUT terminals.	REC LEVEL control	Left and right OUTPUT terminals.		Check that the level meters "0dB" light up within -10dBv±1.8dB of the signal output level.
5. Recording and Playback Frequency Response Adjustment						
	Mode	Input signal & test tape	Adjustment location	Measuring location	Adjustment value	Remarks
1	STOP	Set the TAPE SELECTOR switch to the NORM position.				
2	REC-PAUSE	Apply a 315Hz/-30dBv (31.6mV) signal to the LINE INPUT terminals.	REC LEVEL control	Left and right OUTPUT terminals.	-30dBv (31.6mV)	
3	REC/PLAY	Record the above signal level onto the STD-608A test tape at 315Hz and 6.3kHz, and play back.	V103 (Left channel) V203 (Right channel)	Left and right OUTPUT terminals.		Adjust the 6.3kHz playback level to +0.5dB higher than the 315Hz level.
4		Record and play back signal up to 12kHz onto the STD-608A test tape, and check that the allowable frequency response zone shown in Fig. 11-9 is satisfied. If the response zone is not met, change the adjustment value of step 3 within $+1_{-0.5}$ dB and readjust step 3.				
5		Set the DOLBY NR switch to the ON position. Record and play back signals up to 12kHz onto the STD-608A test tape, and check that the allowable frequency response zone shown in Fig. 11-9 is satisfied.				
6		Set the TAPE SELECTOR switch to the CrO ₂ position. Record and play back signals up to 12kHz onto the STD-603 test tape, and check that the allowable frequency response zone shown in Fig. 11-10 is satisfied (for DOLBY NR ON, and OFF).				
7		Set the TAPE SELECTOR switch to the METAL position. Record and play back signals up to 12kHz onto the STD-610 test tape, and check that the allowable frequency response zone shown in Fig. 11-11 is satisfied (for DOLBY NR ON, and OFF).				
6. Recording Level Adjustment						
	Mode	Input signal & test tape	Adjustment location	Measuring location	Adjustment value	Remarks
1	STOP	Set the TAPE SELECTOR switch to the NORM position.				
2	REC-PAUSE	Apply a 315Hz/-10dBv (316mV) signal to the LINE INPUT terminals.	REC LEVEL control	DOL. L (L ch.) DOL. R (R ch.)	-7.7dBv (412.1mV)	
3		Set the DOLBY NR switch to the ON position.				
4	REC/PLAY	Record the above signal level onto the STD-608A test tape, and play back.	V102 (Left channel) V202 (Right channel)	DOL. L (L ch.) DOL. R (R ch.)	-7.7dBv (412.1mV)	
5		Set the TAPE SELECTOR switch to the CrO ₂ position.				
6		Record the above signal onto the STD-603 test tape, and play back.	Confirm	DOL. L (L ch.) DOL. R (R ch.)	-7.7dBv±1.5dB	
7		Set the TAPE SELECTOR switch to the METAL position.				
8		Record the above signal onto the STD-610 test tape, and play back.	Confirm	DOL. L (L ch.) DOL. R (R ch.)	-7.7dBv±1.5dB	

Test tape	STD-608A
Tape selector	NORM
DOLBY NR switch	OFF



Test tape	STD-608A
Tape selector	NORM
DOLBY NR switch	ON

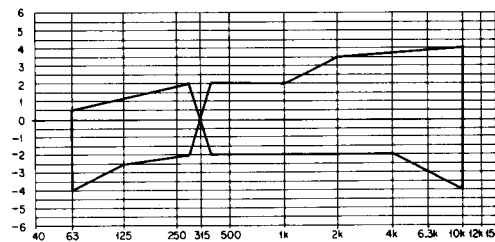
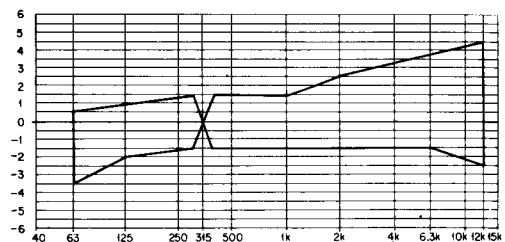

Fig. 11-9 Allowable recording and playback frequency response zone (NORM)

Test tape	STD-610
Tape selector	METAL
DOLBY NR switch	OFF



Test tape	STD-610
Tape selector	METAL
DOLBY NR switch	ON

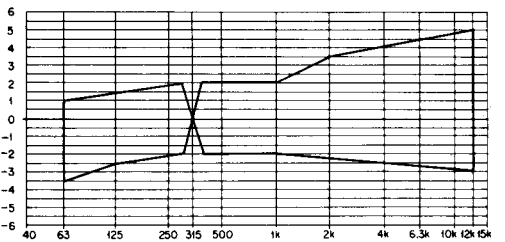
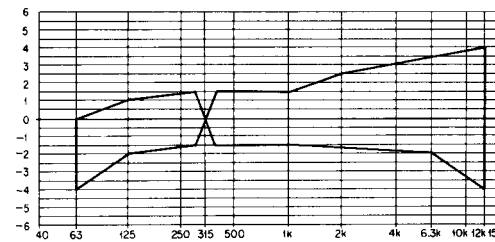

Fig. 11-11 Allowable recording and playback frequency response zone (METAL)

Test tape	STD-603
Tape selector	CrO ₂
DOLBY NR switch	OFF



Test tape	STD-603
Tape selector	CrO ₂
DOLBY NR switch	ON

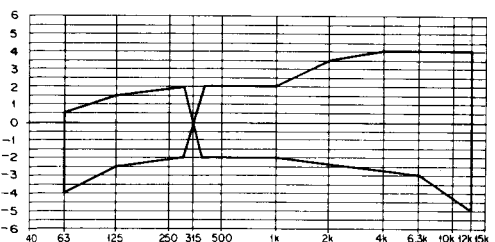

Fig. 11-10 Allowable recording and playback frequency response zone (CrO₂)

11. RÉGLAGE

11.1 RÉGLAGES DES MÉCANISMES

Avant de faire les réglages

Nettoyer les deux supports de bobine, le cabestan et le galet-presseur avec un bâtonnet imprégné d'alcool.

Réglage de pression du galet-presseur

1. Régler la platine-cassette en mode de lecture.
2. Repousser progressivement le bras supportant le galet-presseur à l'aide du tensiomètre et séparer légèrement le galet-presseur du cabestan.
3. Laisser revenir le galet-presseur contre le cabestan et interpréter la valeur indiquée dès que le galet-presseur commence à tourner. Si l'indication obtenue ne se trouve pas dans les limites de 300 à 500 gr., remplacer le ressort du galet-presseur.

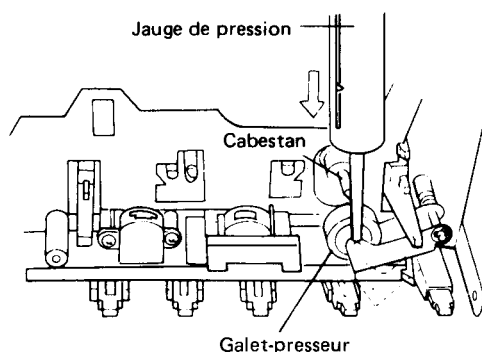

Fig. 11-1 Réglage de la force d'appui du galet-presseur

Réglage du couple de support de bobine

Mesurer le couple du support de bobine à l'aide d'un couplemètre au cours des modes de lecture, avance rapide (FF) et de retour rapide (REW). Les valeurs relevées doivent normalement se trouver dans les limites admissibles qui sont indiquées dans le tableau 1.

Si les valeurs mesurées sont en-dehors de la gamme indiquée, remplacer l'ensemble support de bobine réceptrice (TU) et/ou l'ensemble support de bobine débitrice, la poulie intermédiaire TU ou l'ensemble complet du bras d'entraînement.

Tableau 1

	Support de bobine débitrice	Support de bobine réceptrice
Mode de lecture	38 à 57 gr.cm	*1,5 à 5 gr.cm
Mode d'avance rapide	75 à 135 gr.cm	*1,5 à 5 gr.cm
Mode de retour rapide	*1,5 à 5 gr.cm	75 à 135 gr.cm

* Indiquent des valeurs de contre-tension.

Réglage de la vitesse de défilement de la bande

1. Raccorder un fréquencemètre aux prises de sortie de ligne "LINE OUTPUT".
2. Lire le passage préenregistré de 3kHz de la bande d'étalonnage STD-301. Dès le début, la fréquence indiquée doit se trouver entre 3000 et 3010Hz, celle-ci pouvant être ajustée en tournant la résistance ajustable qui se trouve dans le trou de réglage du moteur d'entraînement du cabestan, comme représenté sur la figure 11-2.

REMARQUE:

La vitesse de défilement de la bande augmente lorsque la résistance variable est tournée dans le sens des aiguilles d'une montre et diminue lorsque la résistance est tournée dans le contraire des aiguilles d'une montre.

Réglage du commutateur d'enregistrement "REC"

1. Appuyer sur la touche d'enregistrement (REC). Le levier de commande d'enregistrement se déplace dans la direction **A**. Quand ces conditions sont obtenues, vérifier si le commutateur d'enregistrement est enclenché.
2. Appuyer sur la touche d'arrêt (STOP). Le levier de commande d'enregistrement se déplace dans la direction **B**. Quand ces conditions sont obtenues, replier et ajuster le levier de commande d'enregistrement pour que la distance nécessaire à la mise en contact du commutateur d'enregistrement soit comprise entre 0,2 et 0,5mm.

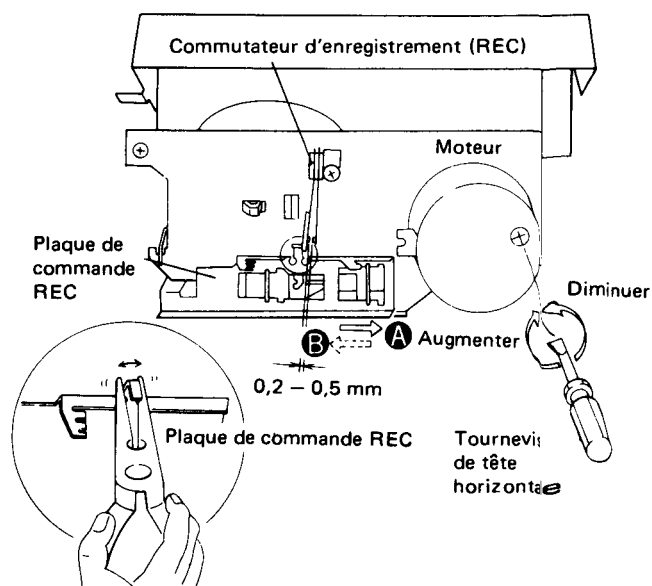

Fig. 11-2 Réglage de la vitesse de défilement de la bande et du commutateur d'enregistrement (REC)

Contrôle et réglage d'amortissement de la trappe à cassettes

1. Appuyer sur la touche d'éjection (EJECT) sans charger de cassette dans la trappe à cassettes et vérifier si la trappe s'ouvre normalement, progressivement et sans à-coups ni rebonds après son ouverture totale.
2. Si ces conditions ne sont pas satisfaites, effectuer un réglage à l'aide de la vis incorporée à la tête du cylindre.

Tourner la vis dans le sens contraire des aiguilles d'une montre si la trappe s'ouvre par à-coups en deux étapes.

Tourner la vis dans le sens des aiguilles d'une montre si la trappe rebondit après s'être ouverte complètement

Contrôle et réglage du raccord d'enregistrement

1. Vérifier si l'écartement F entre le raccord d'enregistrement et le commutateur à curseur se trouve entre 0 et 0,3mm lorsque le mécanisme d'entraînement est immobile et contrôler si le commutateur à curseur ne bouge pas.
2. Déplacer la position d'accrochage du mécanisme d'enregistrement vers l'arrière si l'écartement F est supérieur à 1mm et la déplacer vers l'avant quand il n'a aucun écart et que le commutateur à curseur bouge.
3. Si l'écartement F décrit plus haut ne peut pas être obtenu en procédant à ce réglage, replier la section du crochet de raccord d'enregistrement avec un paire de pinces sur la longueur appropriée.
4. Vérifier si le commutateur à curseur est parfaitement enclenché lorsque le mécanisme d'entraînement est placé en position d'enregistrement.
5. Vérifier également si le commutateur du ressort du mécanisme d'entraînement est court-circuité.

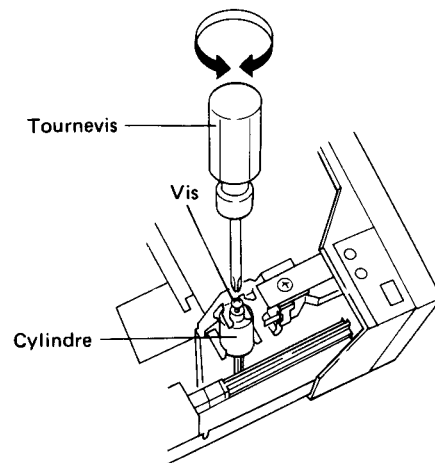

Fig. 11-3 Contrôle et réglage de l'amortissement de la trappe

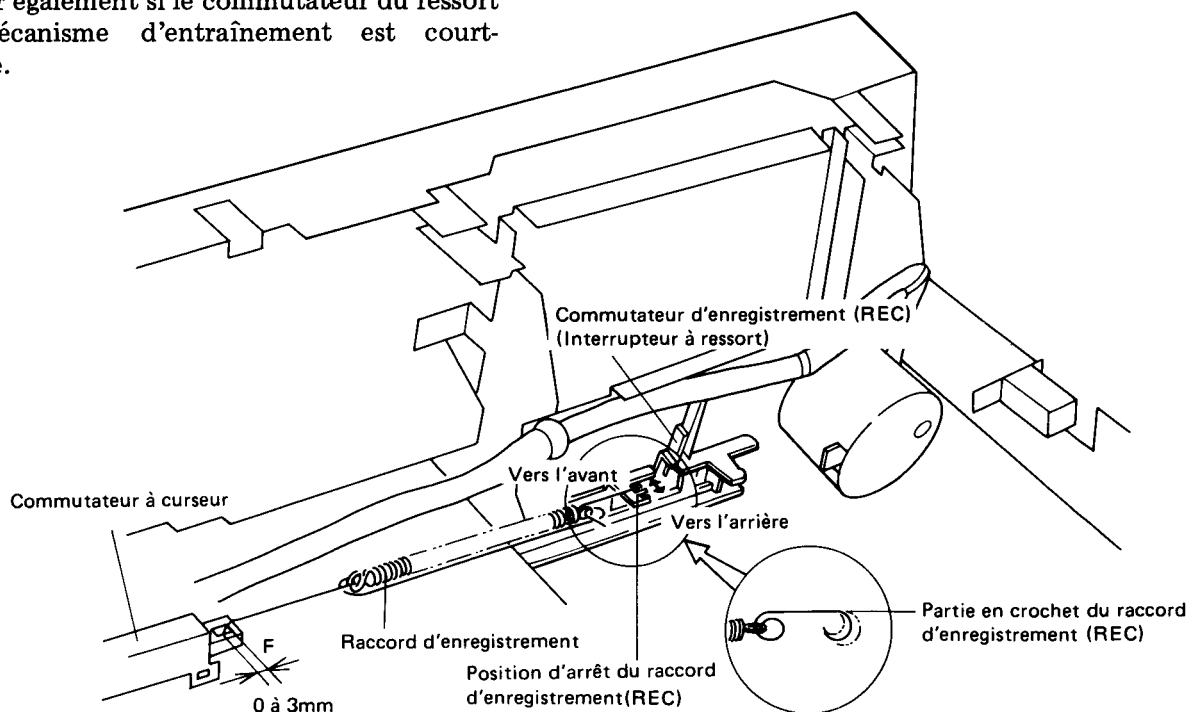

Fig. 11-4 Contrôle et réglage du raccord d'enregistrement

11.2 RÉGLAGES ÉLECTRIQUES

Conditions nécessaires pour effectuer les réglages

1. Les réglages des mécanismes doivent avoir été faits avant.
2. La tête magnétique doit être propre et démagnétisée.
3. La platine-cassette doit avoir fonctionné pendant quelques minutes avant de commencer les réglages électriques.
4. Le signal de référence est de 0dB=1V effi.
5. Raccorder une résistance de charge de 50 k-ohms (ou de 47 à 52 k-ohms) aux prises de sortie "OUTPUT".
6. A moins d'une indication contraire, les commutateurs mentionnés ci-dessous doivent se trouver dans la position indiquée.

DOLBY NR : Sur OFF
 TAPE SELECTOR : Sur NORM

Bandes de mesure

- STD-331B : Réglages de lecture (Fig. 11-5)
 STD-608A : Bande vierge ordinaire (NORMAL)
 STD-603 : Bande vierge au chrome (CrO₂)
 STD-610 : Bande vierge au fer (METAL)

Liste des réglages à exécuter

1. Réglage d'azimut de tête magnétique
2. Contrôle de l'égaliseur de lecture
3. Réglage de niveau de lecture
4. Contrôle de fonctionnement de décibel-mètre
5. Calage de réponse en fréquence d'enregistrement et de lecture
6. Réglage du niveau d'enregistrement

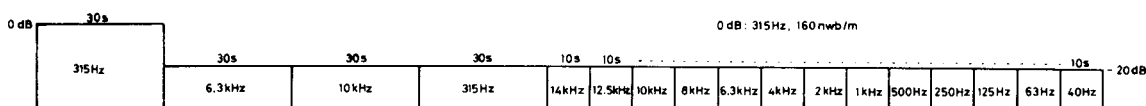

Fig. 11-5 Signaux préenregistrés sur la bande d'étalonnage STD-331B

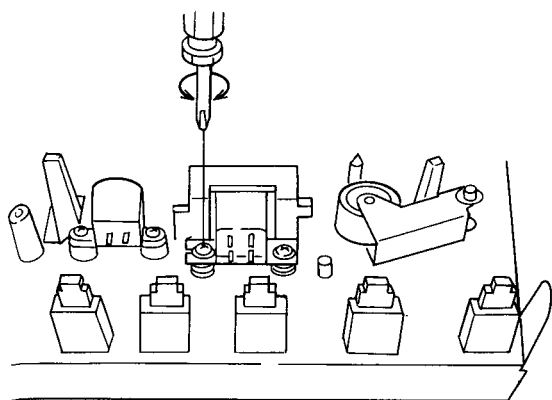

Fig. 11-6 Réglage d'azimut de tête magnétique

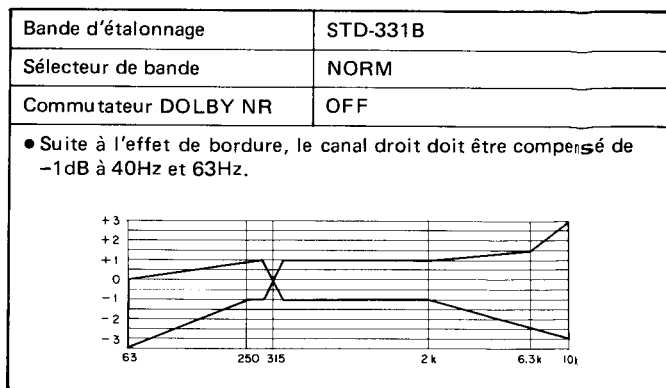

Fig. 11-7 Réponse en fréquence admissible en lecture

- Le commutateur DOLBY NR doit être placé en position OFF.

1. Réglage d'azimut de tête magnétique						
• Tourner V101 et V201 sur leur position maximum (dans le sens maximum des aiguilles d'une montre)						
	Mode	Signal appliqué et bande d'étalonnage	Emplacement du réglage	Emplacement de la borne de mesure	Valeur relevée	Observations
1	ARRÊT	Placer le sélecteur de bande (TAPE SELECTOR) en position "NORM".				
2	LECTURE	Lire le passage préenregistré de 10kHz/-20dB de la bande d'étalonnage STD-331B.	Vis de réglage d'azimut de tête. (Consulter la figure 11-6).	Bornes de sortie droite et gauche "OUTPUT".	Niveau maximal du signal de lecture.	
3	ARRÊT	Bloquer la vis de réglage à la peinture lorsque le réglage est terminé.				
2. Contrôle de l'égaliseur de lecture						
	Mode	Signal appliqué et bande d'étalonnage	Emplacement du réglage	Emplacement de la borne de mesure	Valeur relevée	Observations
1	ARRÊT	Placer le sélecteur de bande (TAPE SELECTOR) en position "NORM".				
2	LECTURE	Lire le passage préenregistré de 315kHz/-20dB et de 6,3kHz/-20dB de la bande d'étalonnage STD-331B.	Contrôler	Bornes de sortie droite et gauche "OUTPUT".	Le niveau de lecture de 6,3kHz est de $-0,5 \pm 2$ dB par rapport au niveau de 315Hz.	
3	ARRÊT	Placer le sélecteur de bande (TAPE SELECTOR) en position "CrO ₂ " ou "METAL".				
4	LECTURE	Lire le passage préenregistré de 315kHz/-20dB et de 6,3kHz/-20dB de la bande d'étalonnage STD-331B.	Contrôler	Bornes de sortie droite et gauche "OUTPUT".	Le niveau de lecture de 6,3kHz est de $-4,5 \pm 2$ dB per rapport au niveau de 315Hz.	

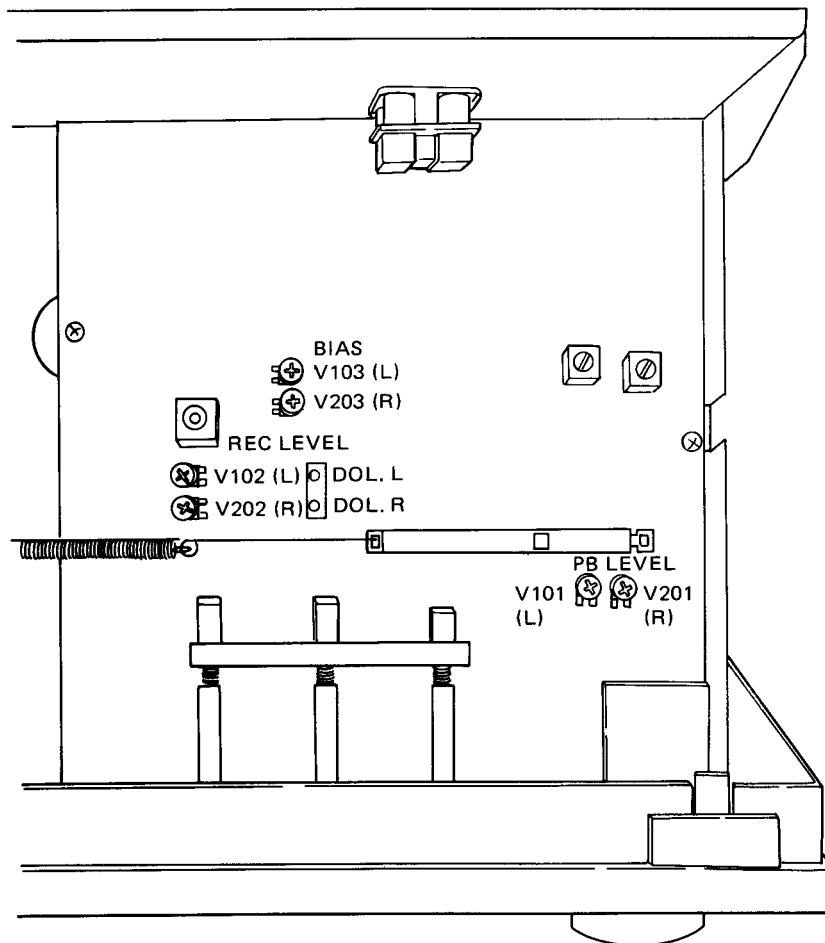

Fig. 11-8 Emplacements des dispositifs de réglage

3. Réglage du niveau de lecture						
• Ce réglage servant à étalonner le niveau DOLBY NR doit être exécuté avec un grand soin.						
Mode	Signal appliqué et bande d'étalonnage	Emplacement du réglage	Emplacement de la borne de mesure	Valeur relevée	Observations	
1 ARRÊT	Placer le sélecteur de bande (TAPE SELECTOR) en position "NORM".					
2 LECTURE	Lire le passage préenregistré de 315kHz/0dB de la bande d'étalonnage STD-331B.	V101 (canal gauche) V201 (canal droit)	DOL. L (canal gauche) DOL. R (canal droit)	-7,7dBv (412,1mV)		
4. Contrôle de fonctionnement des décibel mètres						
Mode	Signal appliqué et bande d'étalonnage	Emplacement du réglage	Emplacement de la borne de mesure	Valeur relevée	Observations	
1 PAUSE À L'EN-REGISTREMENT	Injecteur un signal de 315Hz/ -10dBv (316mV) par les bornes d'entrée de ligne "LINE INPUT".	Potentiomètre de réglage de niveau d'enregistrement "REC LEVEL".	Bornes de sortie droite et gauche "OUTPUT".		Vérifier si les décibel mètres "0dB" s'allument sous un niveau de sortie de signal de -10dBv±1,8dB.	
5. Calage de réponse en fréquence d'enregistrement et de lecture						
Mode	Signal appliqué et bande d'étalonnage	Emplacement du réglage	Emplacement de la borne de mesure	Valeur relevée	Observations	
1 ARRÊT	Placer le sélecteur de bande (TAPE SELECTOR) en position "NORM".					
2 PAUSE À L'EN-REGISTREMENT	Injecter un signal de 315Hz/ -30dBv (31,6mV) par les bornes d'entrée de ligne "LINE INPUT".	Potentiomètre de réglage de niveau d'enregistrement "REC LEVEL".	Bornes de sortie droite et gauche "OUTPUT".	-30dBv (31,6mV)		
3 EN-REGISTREMENT/LECTURE	Enregistrer le niveau de signal indiqué plus haut sur la bande d'étalonnage STD-608A à 315Hz et 6,3kHz et lire ce passage.	V103 (canal gauche) V203 (canal droit)	Bornes de sortie droite et gauche "OUTPUT".		Ajuster le niveau de lecture du signal 6,3kHz à +0,5 dB ou au-dessus puis le niveau de 315Hz.	
4	Enregistrer le lire le signal jusqu'à 12kHz sur la bande d'étalonnage STD-608A et contrôler si la zone de réponse en fréquence admissible qui est représentée sur la courbe de la figure 11-9 est satisfaite. Si la courbe de fréquence représentée n'est pas atteinte, modifier la valeur du réglage de l'opération 3 dans les limites de ±0,5dB et refaire le réglage indiqué dans l'opération 3.					
5	Régler le commutateur DOLBY NR en position ON. Enregistrer et lire les signaux jusqu'à 12kHz sur la bande d'étalonnage STD-608A et contrôler si la zone de réponse en fréquence admissible qui est représentée sur la courbe de la figure 11-9 est satisfaite.					
6	Placer le sélecteur de bande (TAPE SELECTOR) en position "CrO ₂ ". Enregistrer et lire les signaux jusqu'à 12kHz sur la bande d'étalonnage STD-603 et contrôler si la zone de réponse en fréquence admissible qui est représentée sur la courbe de la figure 11-10 est satisfaite (lorsque le commutateur DOLBY NR est en position ON et position OFF.)					
7	Placer le sélecteur de bande (TAPE SELECTOR) en position "METAL". Enregistrer et lire les signaux jusqu'à 12kHz sur la bande d'étalonnage STD-610 et contrôler si la zone de réponse en fréquence admissible qui est représentée sur la courbe de la figure 11-11 est satisfaite (lorsque le commutateur DOLBY NR est en position ON et position OFF.)					
6. Réglage du niveau d'enregistrement						
Mode	Signal appliqué et bande d'étalonnage	Emplacement du réglage	Emplacement de la borne de mesure	Valeur relevée	Observations	
1 ARRÊT	Placer le sélecteur de bande (TAPE SELECTOR) en position "NORM".					
2 PAUSE À L'EN-REGISTREMENT	Injecter un signal de 315Hz/ -10dBv (316mV) par les bornes d'entrée de ligne "LINE INPUT".	Potentiomètre de réglage de niveau d'enregistrement "REC LEVEL".	DOL. L (canal gauche) DOL. R (canal droit)	-7,7dBv (412,1mV)		
3	Régler le commutateur DOLBY NR en position ON.					
4 EN-REGISTREMENT/LECTURE	Enregistrer le niveau de signal indiqué plus haut sur la bande d'étalonnage STD-608A et lire ce passage.	V102 (canal gauche) V202 (canal droit)	DOL. L (canal gauche) DOL. R (canal droit)	-7,7dBv (412,1mV)		
5	Placer le sélecteur de bande (TAPE SELECTOR) en position "CrO ₂ ".					
6	Enregistrer le niveau de signal indiqué plus haut sur la bande d'étalonnage STD-603 et lire ce passage.	Contrôler	DOL. L (canal gauche) DOL. R (canal droit)	-7,7dBv±1,5dB		
7	Placer le sélecteur de bande (TAPE SELECTOR) en position "METAL".					
8	Enregistrer le niveau de signal indiqué plus haut sur la bande d'étalonnage STD-610 et lire ce passage.	Contrôler	DOL. L (canal gauche) DOL. R (canal droit)	-7,7dBv±1,5dB		

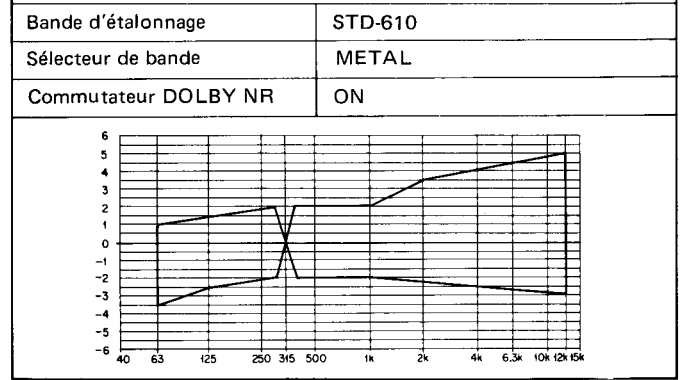
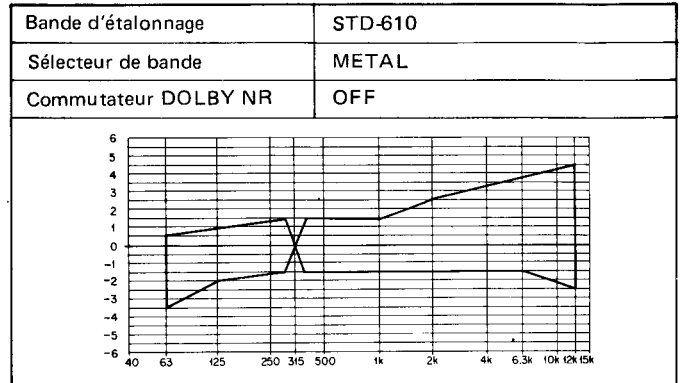
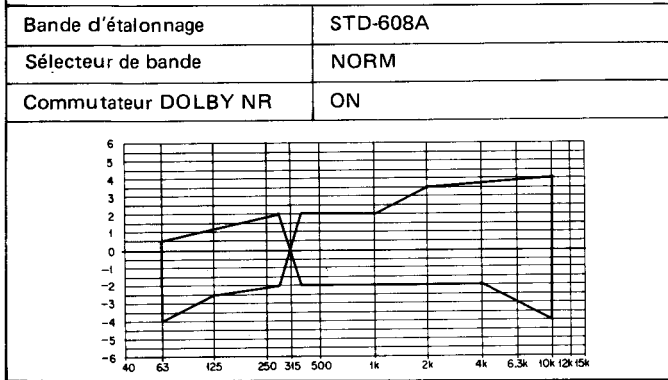
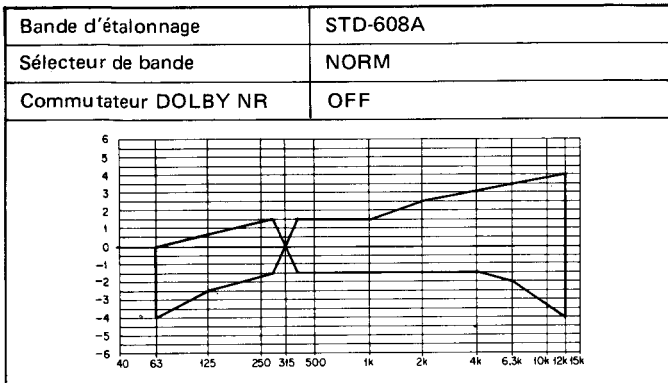

Fig. 11-9 Zone de réponse en fréquence admissible de lecture et d'enregistrement (NORM)

Fig. 11-11 Zone de réponse en fréquence admissible de lecture et d'enregistrement (METAL)

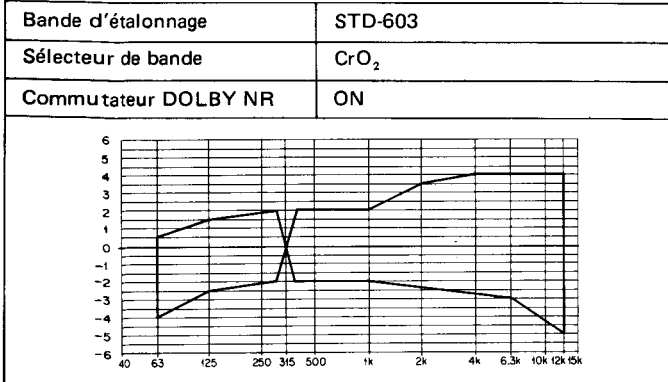
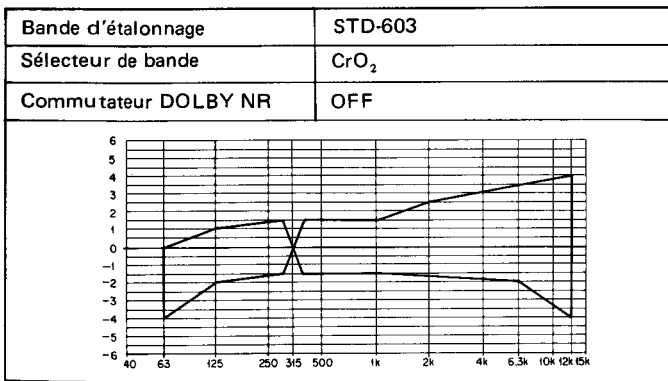

Fig. 11-10 Zone de réponse en fréquence admissible de lecture et d'enregistrement (CrO₂)

11. AJUSTE

11.1 AJUSTES MECANICOS

Antes del ajuste

Limpiar ambas bases de los carretes, el eje de arrastre y el rodillo de presión con algodón remojado en alcohol.

Ajuste de la presión del rodillo de presión

1. Establecer el magnetófono en el modo de reproducción.
2. Con el calibrador de tensión, presionar ligeramente contra el brazo del rodillo de presión y separar un poco dicho rodillo del eje de arrastre.
3. Luego reponer el rodillo de presión sobre el eje de arrastre, y leer el valor en el momento que el rodillo de presión empieza a girar. Si la indicación no está dentro de 300~500g, reemplazar el muelle del rodillo de presión.

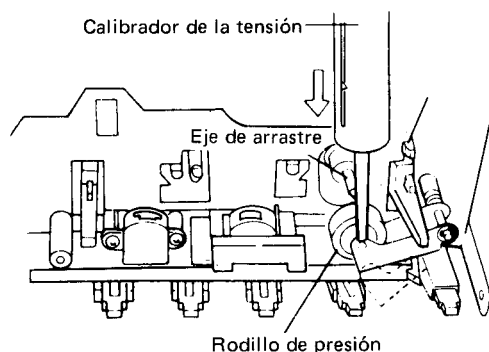

Fig. 11-1 Ajuste de la presión del rodillo de presión

Ajuste de la torsión de la base del carrete

Utilizar el medidor de torsión para medir la torsión durante las funciones de reproducción, avance rápido (FF) y rebobinado (REW). Los valores obtenidos deben estar normalmente dentro de los límites permisibles enumerados en la tabla 1.

Si los valores obtenidos no están dentro de tales límites, reemplazar el conjunto de la base del carrete tensor (TU) y/o el conjunto de la base del carrete de suministro, la rueda de guía TU, o todo el conjunto del brazo de arrastre.

Tabla 1

	Base del carrete TU	Base del carrete de suministro
Modo de reproducción	38 – 57g.cm	*1,5 – 5g.cm
Modo de avance rápido	75 – 135g.cm	*1,5 – 5g.cm
Modo de rebobinado	1,5 – 15g.cm	75 – 135g.cm

* Indica par de torsión de contratensión.

Ajuste de la velocidad de la cinta

1. Conectar el frecuencímetro a los terminales de salida de línea (LINE OUTPUT).
2. Reproducir la parte de 3kHz de la cinta de prueba STD-301. Al principio, la frecuencia deberá estar entre 3000Hz~3010Hz, y podrá ajustarse girando el resistor semifijo ubicado en el orificio de ajuste del motor, como se muestra en la Fig. 11-2.

NOTA:

La velocidad de la cinta aumentará al girar a la derecha el resistor semifijo, y se reducirá al girarlo a la izquierda.

Ajuste del interruptor de grabación (REC)

1. Presionar el botón REC. La palanca de accionamiento de REC se mueve en la dirección **A**. En este momento, comprobar que el interruptor REC está en la posición ON.
2. Presionar el botón de parada (STOP). La palanca de accionamiento de REC se mueve ligeramente en la dirección **B**. Entonces, doblar y ajustar la palanca de accionamiento de REC de modo que la distancia de contacto del interruptor REC sea de 0,2~0,5mm.

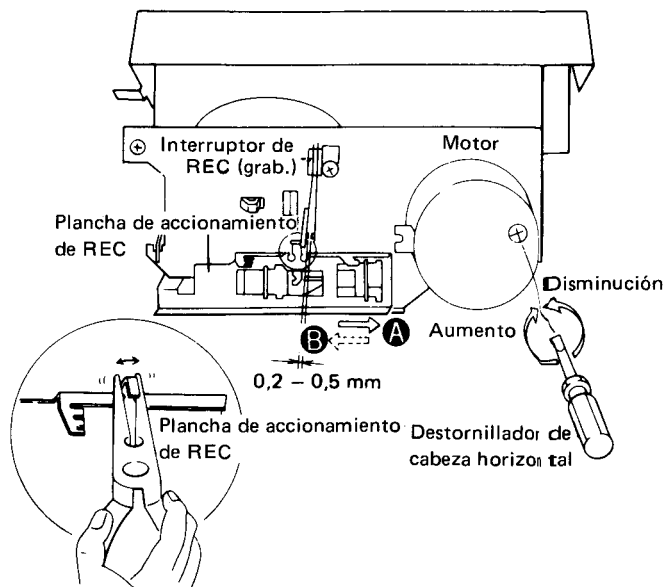

Fig. 11-2 Ajuste de la velocidad de la cinta y del interruptor de grabación (REC)

Comprobación y ajuste del amortiguamiento de la puerta

1. Presionar el botón de expulsión (EJECT) sin haber ningún casete insertado en el compartimiento del casete, y comprobar que la puerta se abre suavemente sin movimientos interrumpidos ni rebote después de haberse abierto por completo.
2. Si no se satisfacen estas condiciones, ajustar girando el tornillo de ajuste del cabezal del cilindro.

Girar el tornillo hacia la izquierda si la puerta se abre con interrupciones en dos etapas.

Girar el tornillo hacia la derecha si la puerta rebota después de haberse abierto por completo.

Comprobación y ajuste de la unión de grabación REC

1. Comprobar que el entrehierro F entre la unión REC y el conmutador deslizante es de 0 a 0,3 mm cuando el mecanismo de transporte está detenido (y comprobar que no se mueve el conmutador deslizante).
2. Mover la posición de engrane del mecanismo de unión REC hacia atrás si el entrehierro F es mayor a 1mm, y moverla hacia adelante si no hay entrehierro y se mueve el conmutador deslizante.
3. Si el entrehierro F descrito no puede obtenerse mediante el ajuste mencionado, doblar la sección de gancho de la unión REC con un alicates.
4. Comprobar que el conmutador deslizante está completamente conmutado cuando el mecanismo de transporte está en el modo de grabación.
5. Comprobar también que el interruptor de muelle del mecanismo está cortocircuitado.

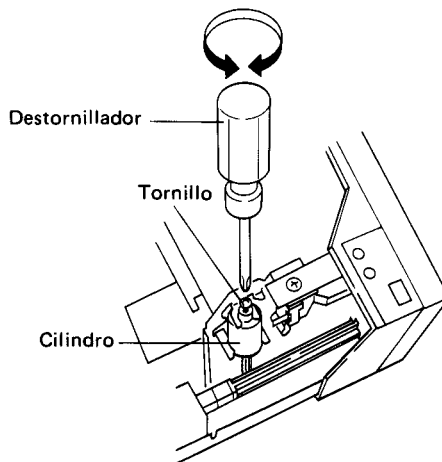

Fig. 11-3 Comprobación y ajuste del amortiguamiento de la puerta

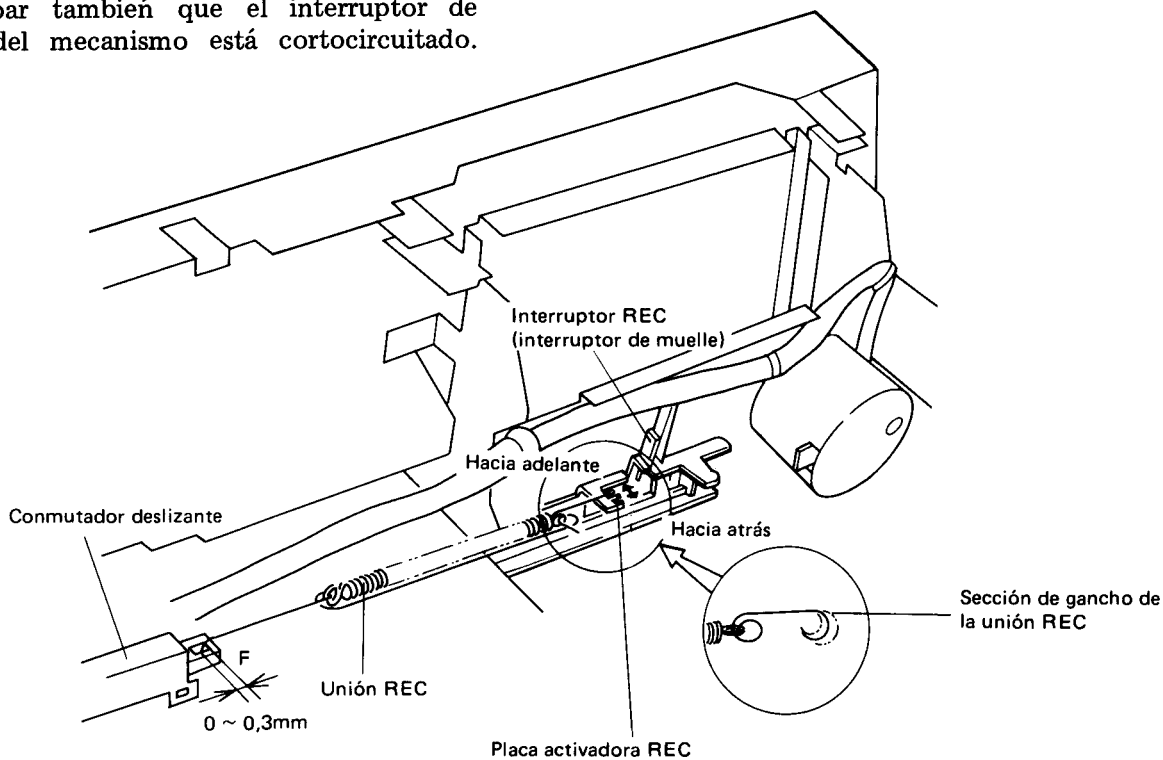

Fig. 11-4 Comprobación y ajuste de la union de grabacion

11.2 AJUSTES ELECTRICOS

Condiciones de ajuste

1. Los ajustes mecánicos deben terminarse primero.
2. Limpiar y desmanar la cabeza de grabación.
3. Dejar que el magnetófono se precaliente por unos minutos antes de iniciar los ajustes eléctricos.
4. La señal de referencia es de $0dB=1V_{rms}$.
5. Conectar una resistencia de carga de 50 kilo-ohmios (o entre 47 y 52 kilo-ohmios) a los terminales de salida (OUTPUT).
6. A menos que se especifique de otra manera, los siguientes interruptores deben estar en las posiciones indicadas:
 DOLBY NR : OFF
 SELECTOR DE CINTA : NORM

Cintas de prueba

- STD-331B : Para ajustes de reproducción (Referirse a la Fig. 11-5)
- STD-608A : Cinta NORMAL en blanco.
- STD-603 : Cinta CrO₂ en blanco.
- STD-610 : Cinta de METAL en blanco.

Lista de ajustes y comprobaciones

1. Ajuste azimutal de la cabeza de grabación
2. Comprobación del ecualizador de reproducción
3. Ajuste del nivel de reproducción
4. Comprobación del indicador de nivel
5. Ajuste de la respuesta de frecuencia de grabación y reproducción
6. Ajuste del nivel de grabación

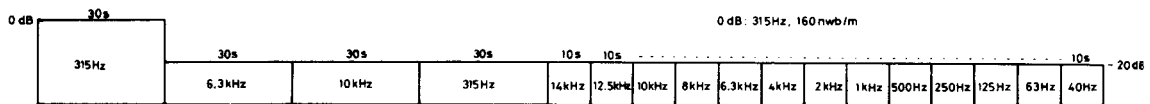

Fig. 11-5 Contenido de la cinta de prueba STD-331B

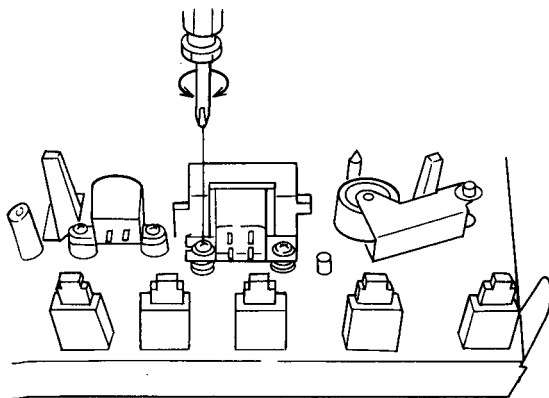

Fig. 11-6 Ajuste azimutal de la cabeza de grabación

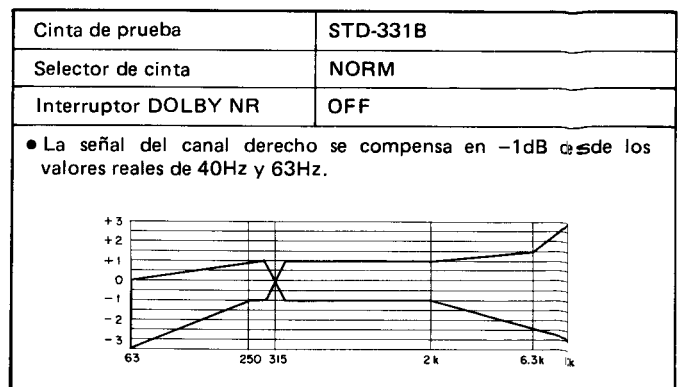

Fig. 11-7 Zona de respuesta de frecuencia de reproducción permisible

- Poner el interruptor DOLBY NR en la posición OFF.

1. Ajuste azimutal de la cabeza de grabación						
• Girar V101 y V201 a la posición máxima (completamente a la derecha)						
	Modo	Señal de entrada y cinta de prueba	Punto de ajuste	Punto de medición	Valor de ajuste	Observaciones
1	Parada (STOP)	Regular el interruptor selector de cinta (TAPE SELECTOR) a la posición NORM.				
2	Reproducción (PLAY)	Reproducir la parte de 10kHz/-20dB de la cinta de prueba STD-331B.	Tornillo de ajuste azimutal de la cabeza de reproducción. (Referirse a la Fig. 11-6)	Terminales de salida (OUTPUT) derecho e izquierdo.	Nivel máximo de la señal de reproducción.	
3	Parada (STOP)	Dejar trabado el tornillo después de terminar el ajuste.				
2. Comprobación del ecualizador de reproducción.						
	Modo	Señal de entrada y cinta de prueba	Punto de ajuste	Punto de medición	Valor de ajuste	Observaciones
1	Parada (STOP)	Regular el interruptor selector de cinta (TAPE SELECTOR) a la posición NORM.				
2	Reproducción (PLAY)	Reproducir las partes de 315Hz/-20dB y 6,3kHz/-20dB de la cinta de prueba STD-331B.	Confirmación	Terminales de salida (OUTPUT) derecho e izquierdo.	El nivel de reproducción de 6,3kHz es de $-0,5 \pm 2$ dB con relación al nivel de 315Hz.	
3	Parada (STOP)	Regular el interruptor selector de cinta (TAPE SELECTOR) a la posición CrO ₂ o METAL.				
4	Reproducción (PLAY)	Reproducir las partes de 315Hz/-20dB y 6,3kHz/-20dB de la cinta de prueba STD-331B.	Confirmación	Terminales de salida (OUTPUT) derecho e izquierdo.	El nivel de reproducción de 6,3kHz es de $-4,5 \pm 2$ dB con relación a al nivel de 315Hz.	

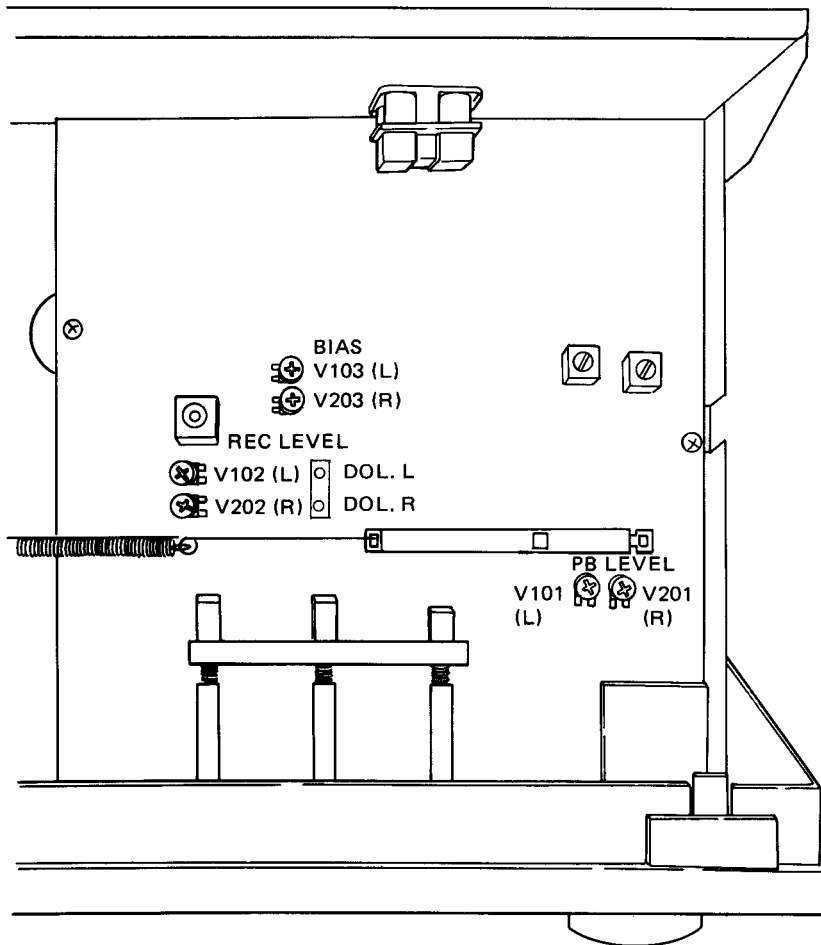

Fig. 11-8 Puntos de ajuste

3. Ajuste del nivel de reproducción						
● Este ajuste determina el nivel DOLBY NR, y debe efectuarse con sumo cuidado.						
	Modo	Señal de entrada y cinta de prueba	Punto de ajuste	Punto de medición	Valor de ajuste	Observaciones
1	Parada (STOP)	Regular el interruptor selector de cinta (TAPE SELECTOR) a la posición NORM.				
2	Reproducción (PLAY)	Reproduce la parte de 315Hz/0dB de la cinta de prueba STD-331B.	V101 (Canal izquierdo) V201 (Canal derecho)	DOL. L (Canal izq.) DOL. R (Canal der.)	-7,7dBv (412,1mV)	
4. Comprobación del indicador de nivel						
	Modo	Señal de entrada y cinta de prueba	Punto de ajuste	Punto de medición	Valor de ajuste	Observaciones
1	Grabación/pausa (REC/PAUSE)	Aplicar una señal de 315Hz/-10dBv (316mV) a los terminales de entrada de línea (LINE INPUT).	Control del nivel de grabación. (REC LEVEL)	Terminales de salida (OUTPUT) derecho e izquierdo.		Comprobar que los indicadores de nivel "0dB" se encienden dentro de $-20dBv \pm 1,8dB$ del nivel de señal de salida.
5. Ajuste de la respuesta de frecuencia de grabación y reproducción.						
	Modo	Señal de entrada y cinta de prueba	Punto de ajuste	Punto de medición	Valor de ajuste	Observaciones
1	Parada (STOP)	Regular el interruptor selector de cinta (TAPE SELECTOR) a la posición NORM.				
2	Grabación/pausa (REC/PAUSE)	Aplicar una señal de 315Hz/-30dBv (31,6mV) a los terminales de entrada de línea (LINE INPUT).	Control de nivel de grabación (REC LEVEL).	Terminales de salida (OUTPUT) derecho e izquierdo.	-30dBv (31,6mV)	
3	Grabación/reproducción (REC/PLAY)	Grabar el nivel de señal en la cinta de prueba STD-608A a 315Hz y 6,3kHz, y reproducir.	V103 (Canal izquierdo) V203 (Canal derecho)	Terminales de salida (OUTPUT) derecho e izquierdo.	Ajustar el nivel de reproducción de la parte 6,3kHz a +0,5dB mayor y luego el nivel de 315Hz.	
4		Grabar y reproducir la señal hasta de 12kHz en la cinta de prueba STD-608A, y comprobar que la zona de respuesta de frecuencia permisible está de acuerdo con lo indicado en la Fig. 11-9. En caso contrario, cambiar el valor de ajuste del procedimiento 3 dentro de $\pm 0,5dB$ y reajustar el valor del procedimiento 3.				
5		Regular el interruptor DOLBY NR a la posición ON. Grabar y reproducir las señales de hasta 12kHz en la cinta de prueba STD-608A, y comprobar que la zona de respuesta de frecuencia permisible está de acuerdo con la mostrada en la Fig. 11-9.				
6		Regular el interruptor selector de cinta (TAPE SELECTOR) a la posición CrO ₂ . Grabar y reproducir las señales de hasta 12kHz en la cinta de prueba STD-603, y comprobar que la zona de respuesta de frecuencia permisible está de acuerdo con la mostrada en la Fig. 11-10 (para DOLBY NR ON, y OFF).				
7		Regular el interruptor selector de cinta (TAPE SELECTOR) a la posición METAL. Grabar y reproducir las señales hasta de 12kHz en la cinta de prueba STD-610, y comprobar que la zona de respuesta de frecuencia permisible está de acuerdo con la mostrada en la Fig. 11-11 (para DOLBY NR ON, y OFF).				
6. Ajuste del nivel de grabación						
	Modo	Señal de entrada y cinta de prueba	Punto de ajuste	Punto de medición	Valor de ajuste	Observaciones
1	Parada (STOP)	Regular el interruptor selector de cinta (TAPE SELECTOR) a la posición NORM.				
2	Grabación/pausa (REC/PAUSE)	Aplicar una señal de 315Hz/-10dBv (316mV) a los terminales de entrada de línea (LINE INPUT).	Control de nivel de grabación (REC LEVEL)	DOL. L (Canal izq.) DOL. R (Canal der.)	-7,7dBv (412,1mV)	
3		Regular el interruptor DOLBY NR a la posición ON.				
4	Grabación/reproducción (REC/PLAY)	Grabar el nivel de señal en la cinta de prueba STD-608A, y reproducir.	V102 (Canal izquierdo) V202 (Canal derecho)	DOL. L (Canal izq.) DOL. R (Canal der.)	-7,7dBv (412,1mV)	
5		Regular el interruptor selector de cinta (TAPE SELECTOR) a la posición CrO ₂ .				
6		Grabar la señal en la cinta de prueba STD-603, y reproducir.	Confirmación	DOL. L (Canal izq.) DOL. R (Canal der.)	-7,7dBv $\pm 1,5dB$	
7		Regular el interruptor selector de cinta (TAPE SELECTOR) a la posición METAL.				
8		Grabar la señal en la cinta de prueba STD-610, y reproducir.	Confirmación	DOL. L (Canal izq.) DOL. R (Canal der.)	-7,7dBv $\pm 1,5dB$	

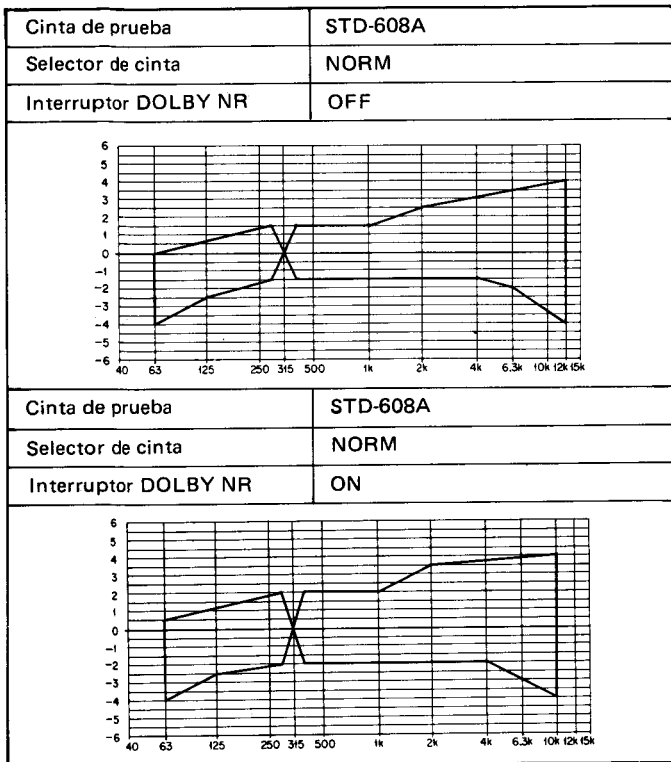

Fig. 11-9 Zona de respuesta de frecuencia de grabación y reproducción permisible (NORM)

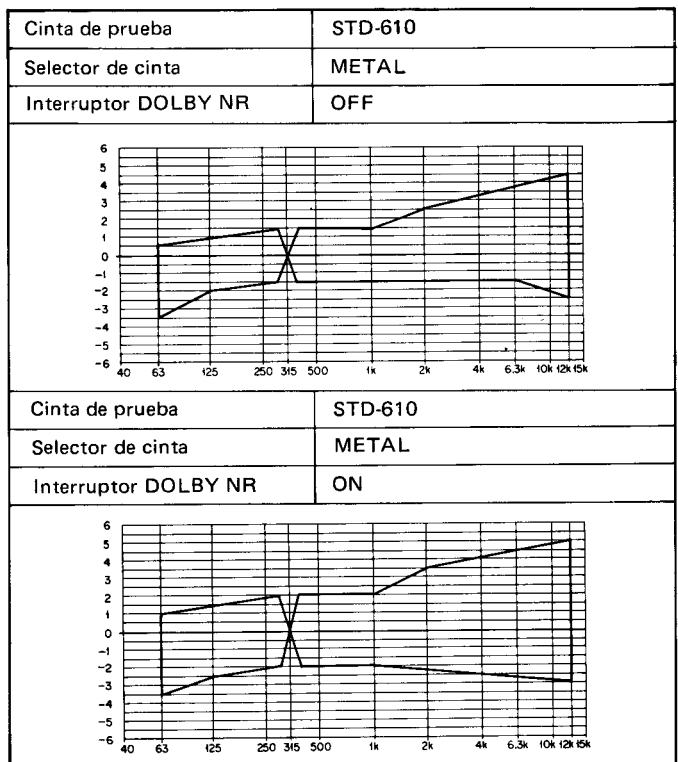

Fig. 11-11 Zona de respuesta de frecuencia de grabación y reproducción permisible (METAL)

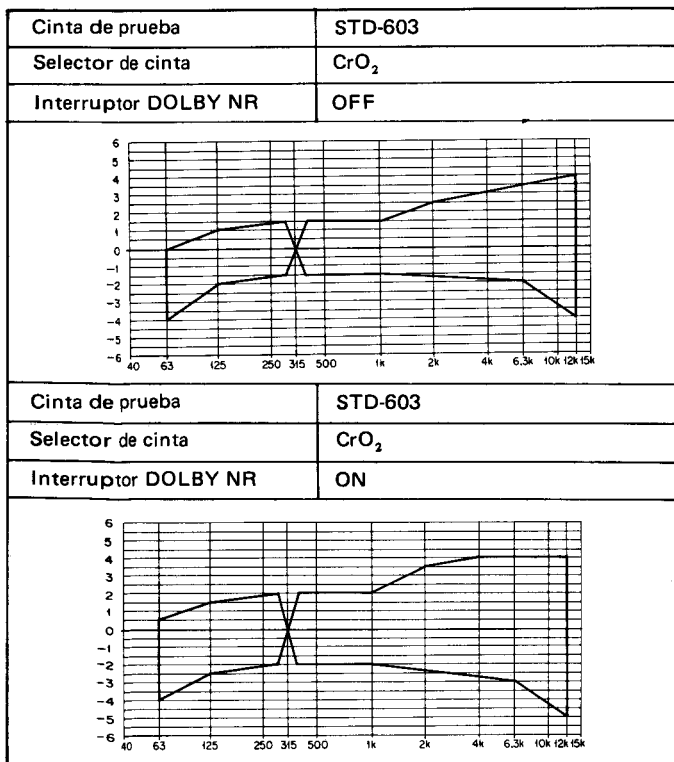
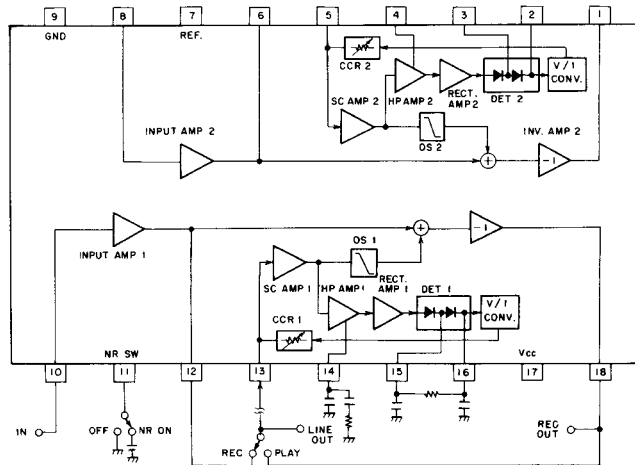

Fig. 11-10 Zona de respuesta de frecuencia de grabación y reproducción permisible (CrO₂)

12. IC DATA (HA12045)

Block Diagram



Pin Description

Pin No.	I/O	Name	Description
1	Output	REC OUT	Inv. amp. output.
2	—	T22	Detector filter.
3	—	T21	Detector filter.
4	—	HPA-2	Filter network (2).
5	Input	VCR-2	Side chain amp. input (2).
6	Output	MONI. OUT	Input amp. output (2).
7	Output	REF	Reference voltage output.
8	Input	IN-2	Audio input (2).
9	—	GND	Ground.
10	Input	IN-1	Audio input (1).
11	Input	NR SW	Noise reduction switch (High active).
12	Output	MONI. OUT	Input amp. output (1)
13	Input	VCR-1	Side chain amp. input (1).
14	—	HPA-1	Filter network (1).
15	—	T11	Detector filter.
16	—	T12	Detector filter.
17	—	Vcc	DC power.
18	Output	REC OUT	Inv. amp. output.

13. MECHANISM DESCRIPTION

The mechanical portion of the CT-301 (350) uses separate power assist mechanisms for the PLAY and REC system for light-touch operation. A mechanical auto-stop function is also built-in.

STOP Mode

Fig. 13-1 shows the PLAY and REC power assist mechanisms in the stop mode. In this status, the cam gear stopper A is making contact with gear lever A, so the cam gear and capstan gear (flywheel) are not meshed. (When the power switch is ON, the motor continues rotating, driving the capstan gear via the belt).

PLAY Operating (Fig. 13-2, 13-3)

1. When the PLAY button is pressed down, the shape of the button forces gear lever A in the ① direction. Also, at the same time, gear lever B travels in the ① direction, and gear lever A and cam gear stopper A are disengaged.
2. The cam gear is forced in the direction ② by the trigger spring. Consequently, it starts rotating in the direction ② (CCW) and meshes with the capstan gear (flywheel).
3. As the capstan gear and cam gear are now engaged, the force transmitted by the motor and flywheel rotate the cam gear further, until stopper C makes contact with gear lever B. It stops in that position. At this point, the capstan gear and cam gear are no longer meshed. (See right side of Fig. 13-2).
4. Now, the projection on the cam gear boss is forcing the brake-plate down in the direction ③, and braking force is released from the reel base.
5. Also, the cam shape of the cam gear is moving the action lever in the ④ direction.
6. The head base is lifted by the action of this action lever, placing it in the PLAY position and throwing the PLAY switch to the PLAY side. (See Fig. 13-3). This action also presses down on the pinch roller pressure spring causing pressure contact between the pinch roller and capstan, and starting tape travel.
7. At the same time, the TU (take-up) idler is forced up into contact with the take-up reel base to start it rotating, and the PLAY mode is entered.

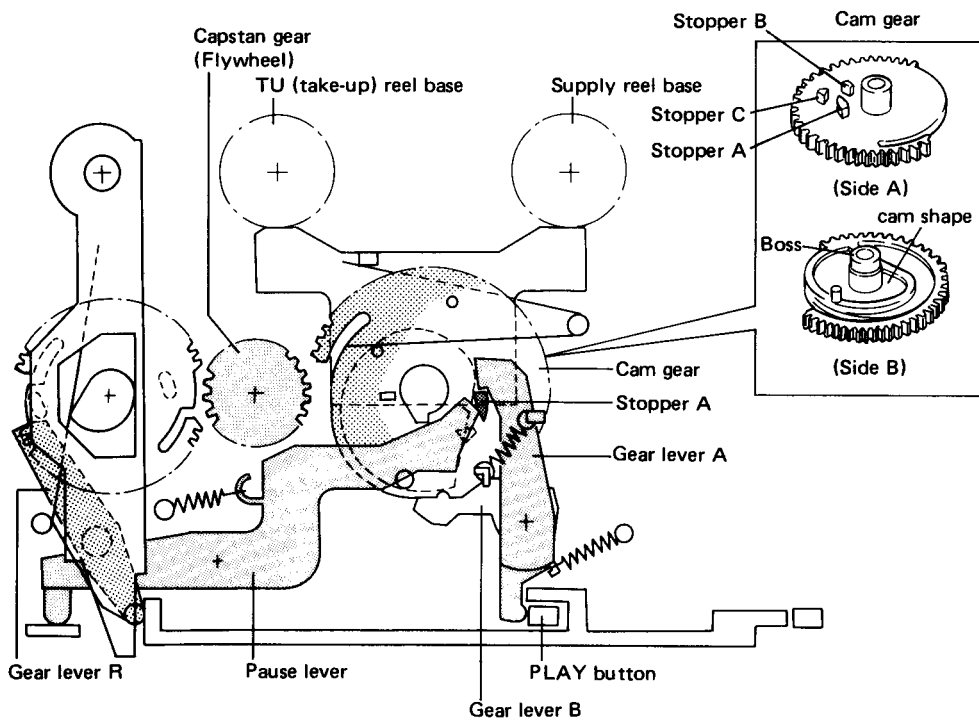

Fig. 13-1 Mechanism in STOP mode (Rear View)

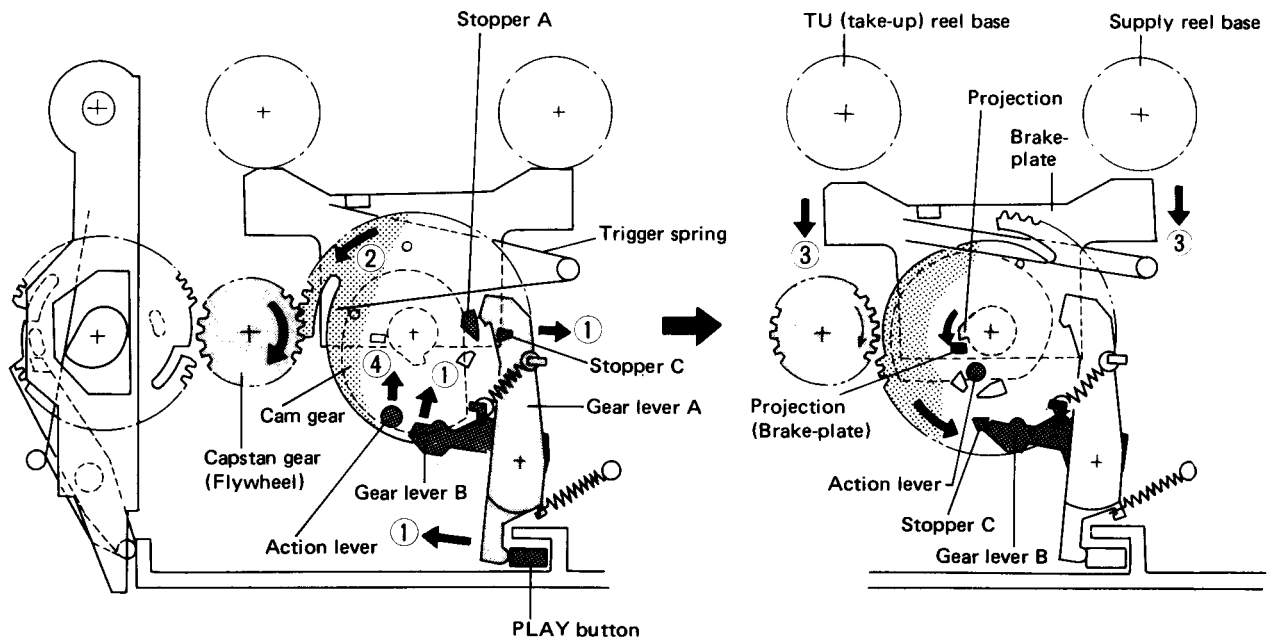

Fig. 13-2 STOP → PLAY operation

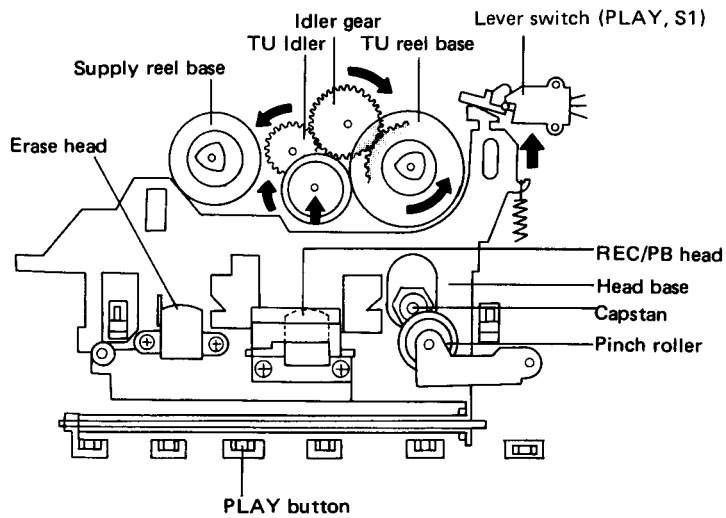

Fig. 13-3 PLAY operation

PLAY – STOP Operation (Fig. 13-4)

1. When the STOP button is pressed, the PLAY button lock is released, and the force of gear lever spring A returns gear lever A and B in the direction ⑤. This action separates cam gear stopper C from gear lever B.
2. As cam gear stopper C moves away from gear lever B, the compression force of the trigger spring rotates the cam gear in the direction ② until stopped by contact between cam gear stopper A and gear lever A. (See the right side of Fig. 13-4).
3. This rotating action releases the brake-plate from the projection on the cam gear boss. The brake-plate is returned to its up position by the force of the trigger spring, stopping the rotation of the supply and take-up reel base.
4. At the same time, the shape of the cam (machined on the upper surface of the cam gear) returns the action lever in the ⑥ direction, releasing the pressure contact the pinch roller and TU idler are placing on the reel base. The head base also returns to the STOP position, and the PLAY switch is thrown to the STOP side, completing entry into the STOP mode.

PLAY – PAUSE Operation – PAUSE Release (Fig. 13-5)

1. When the PAUSE button is pressed (unit in PLAY mode), the cam on the PAUSE button moves the pause lever in the ⑦ direction.
2. The pause lever pushes gear lever B up in the ⑧ direction, releasing the cam gear stopper C. The cam gear starts rotating in the ⑨ direction, stopping at the point cam gear stopper A makes contact with the pause lever tip.
3. The rotation of the cam gear causes the brake plate, pinch roller, TU idler, head base, and PLAY switch to all return to the STOP position (See PLAY → STOP Operation), entering the PAUSE mode.

PAUSE Mode Release:

4. Once again pressing the PAUSE button releases the pause ratchet mechanism, and the pause button (presently in contact with the return spring) returns to its original position.
5. Since the pause lever is moved in the ⑩ direction by the pause lever return spring, stopper A on the cam gear is released from the pause lever.
6. The force of the trigger spring moves the cam gear in the ⑨ direction and starts meshing the cam gear with the capstan gear. From this point, all operations are the same as in the PLAY mode, and tape travel is re-started.

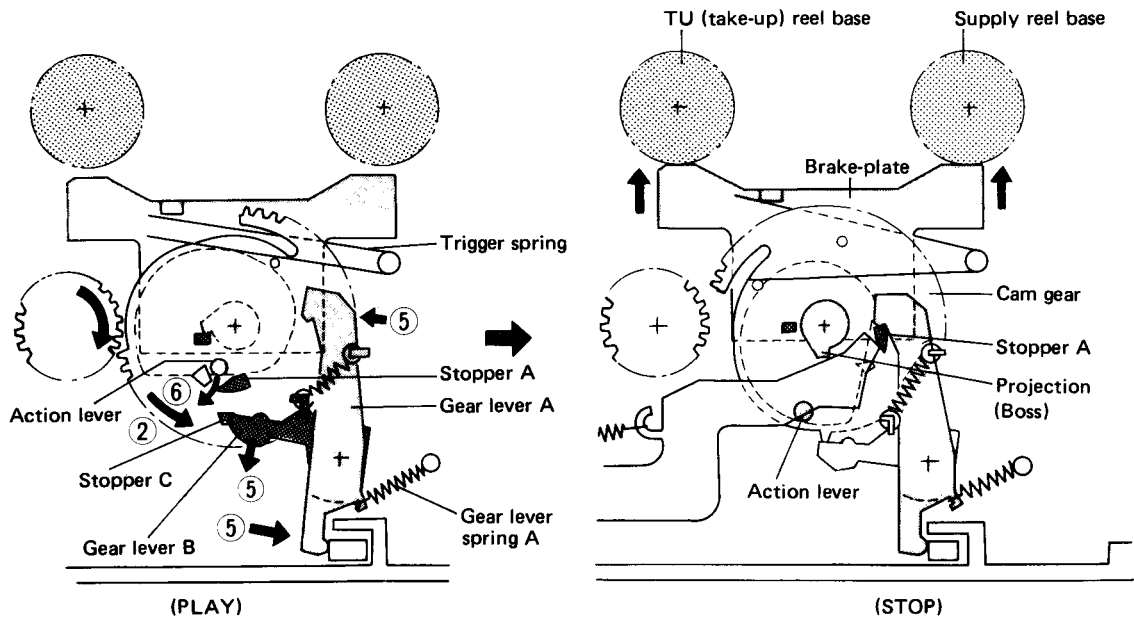

Fig. 13-4 PLAY → STOP operation

REC Operations (Fig. 13-6, 13-7)

1. When the REC button is pressed, the cam on the REC button moves the REC connection arm in the ① direction, gear lever R in the ② direction, and gear lever A in the ③ direction.
2. With the movement of gear lever R, stopper A on cam gear R is released from gear lever R, cam gear forced down by the pressure exerted by trigger spring R, and starts rotating in the ④ direction. It then commences to mesh with the capstan gear.
3. As cam gear R becomes meshed with the capstan gear, cam gear R continues rotating until stopper B (on cam gear R) makes contact with gear lever R, stopping it in that position.
4. At this time, the shape of the cam on cam gear R causes the REC action lever to move in the ⑤ direction, pressing on the REC action plate. (Fig. 13-7).
5. The function of the REC action plate is to throw the REC switch and REC/PLAY switch to the REC side.

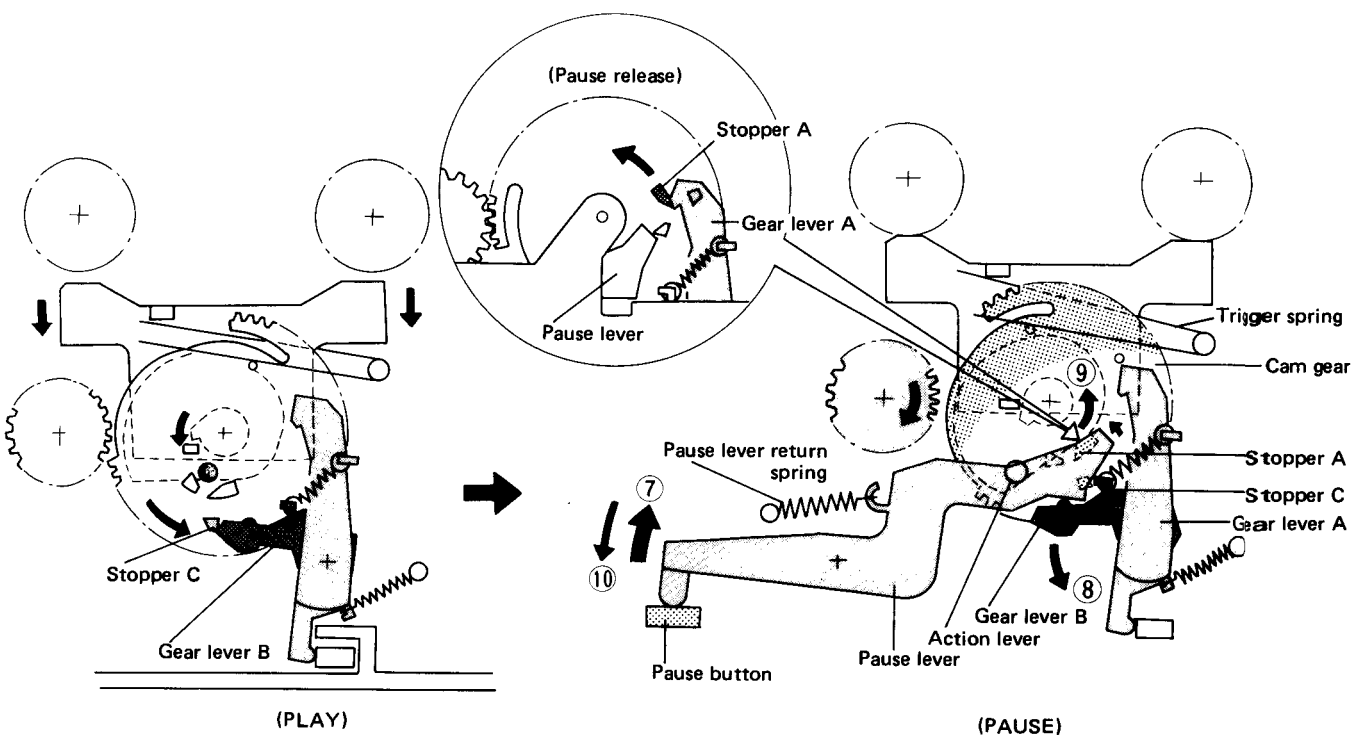

Fig. 13-5 PLAY → PAUSE operation

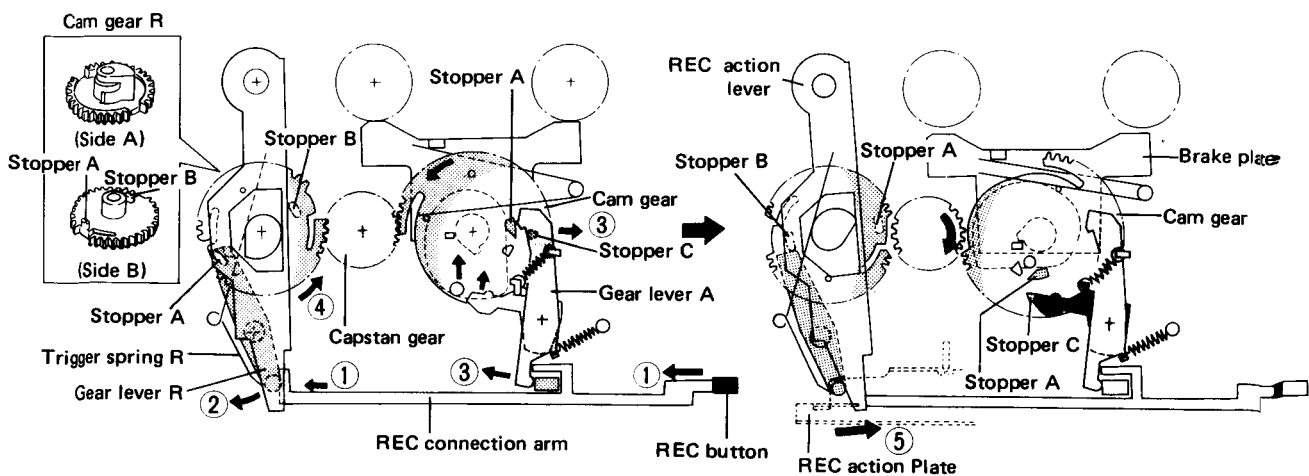

Fig. 13-6 STOP → REC operation

- Also, as gear lever A becomes released from stopper A on the cam gear (noted in step 1. above), the cam gear meshes with the capstan gear to start tape travel, and as the PLAY switch is also thrown to the PLAY side (see PLAY Operations), the REC mode is entered.

REC – PAUSE Operation – PAUSE Release

- In going from REC to PAUSE, all operations are as outlined in PLAY → PAUSE Operation. In other words, when the REC switch and the REC/PLAY switch remain on the REC side, tape travel is stopped by only the PLAY switch being thrown to the STOP side.
- PAUSE release also conforms to the operations outlined in PLAY → PAUSE Operation → PAUSE Release. Here, the PLAY switch is thrown to the PLAY side, and re-starting tape travel causes entry into the REC mode.

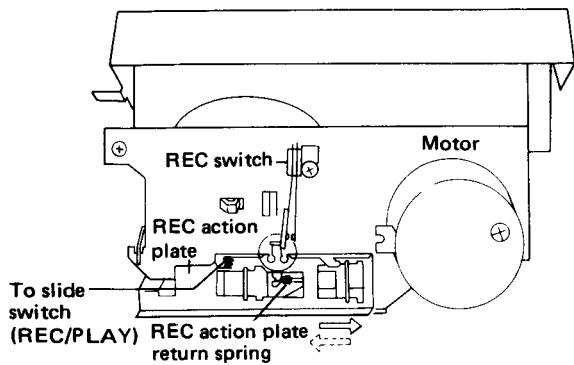

Fig. 13-7 STOP → REC operation (REC switch ON)

REC – STOP Mode (Fig. 13-8)

- When the STOP button is pressed releasing the REC button lock, the trigger spring R returns the REC connection arm and gear lever R in the (6) direction, breaking contact with stopper B on cam gear R.
- The REC action plate return spring rotates cam gear R in the (7) direction, and starts meshing it with the capstan gear.
- Cam gear R continues to rotate until stopper A (on cam gear R) makes contact with gear lever R, stopping it in the former position of stopper B.
- The shape of the cam on cam gear R returns the REC action lever and REC action plate to the STOP position, and throws the REC switch and REC/PLAY switch to the PLAY side.
- Also, the action of gear lever A returning to the STOP position throws the PLAY switch to the STOP side, halting tape travel. (Refer to PLAY → STOP Operation).
* In the REC → STOP cycle, cam gear R and the capstan gear are meshed to have the switch timing of the PLAY and REC/PLAY switches.

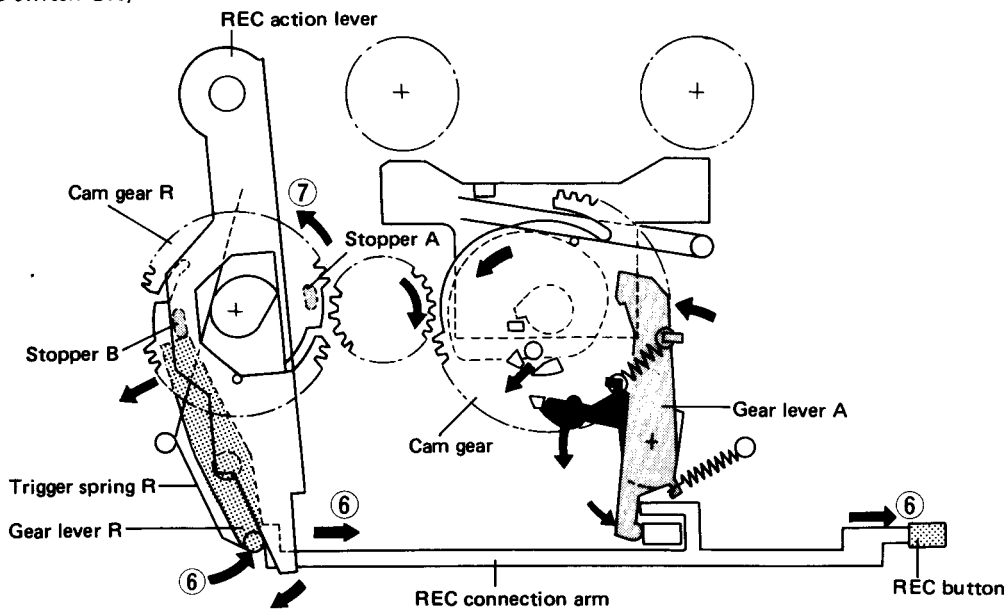

Fig. 13-8 REC → STOP operation

FF (or REW) Operations (Fig. 13-9 – 13-11)

1. When the FF (or REW) button is pressed, joint R (L) moves in the direction of ①, pressing down ① direction) on the FF (REW) action plate. At the same time, the lever switch is thrown to the ON position (Fig. 13-9, 13-10).
2. Next, the brake-plate is pressed down by the FF (REW) action plate, and at this time the driving arm is forced in the ③ (or ④) direction to start the reel base rotating in the FF (or REW) mode.
3. At the same time, gear lever C moves in the ⑤ direction and the head base (HB) lock lever moves in the ⑥ (or ⑦) direction. (This procedure also applies to MS operations).

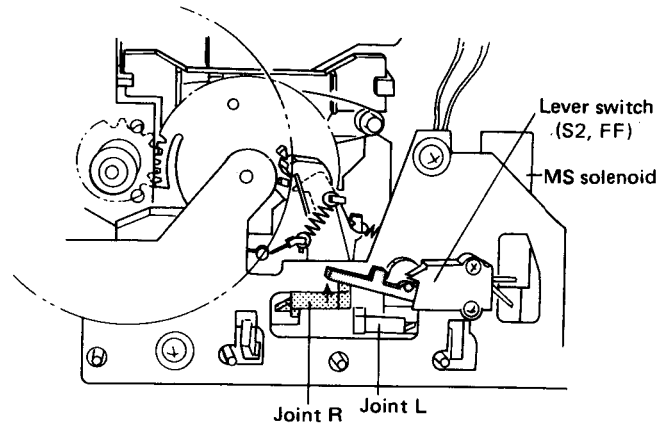

Fig. 13-9 FF (REW), MS operation 1 (Lever switch ON)

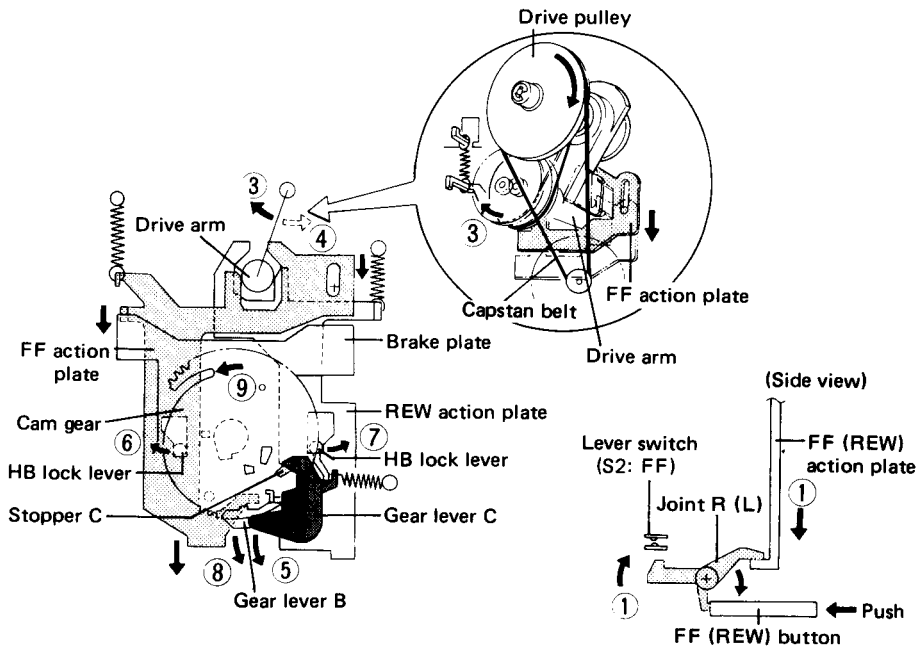

Fig. 13-10 FF (REW) operation, MS operation II

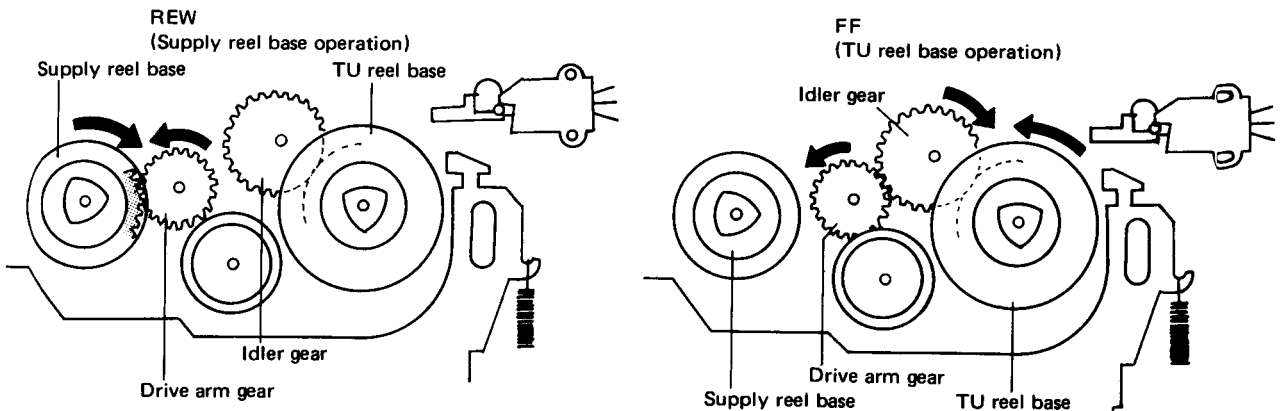

Fig. 13-11 FF, REW operation III

Auto-stop Operations (Fig. 13-12)

1. In each of the previously covered operation cycles, when the brake-plate is moved in the direction of ⑪, the detector lever is pulled in the ⑫ direction by the force of the link return spring. As the cam gear rotates, pin (A) on the detector lever makes contact with cam (A) or cam (B) on the cam gear.
2. The cam gear normally turns with motor rotation, and with each revolution of the cam gear, the detector lever is moved to a center position relative to cam (A) (PLAY, REC, FF) or cam (B) (REW).
3. After the detector lever has been moved to the center position, if the reel base is still rotating, the friction torque of the detector disc again moves it to the right (in REW) or left (in PLAY, REC, FF). When the take-up reel base is rotating, the friction torque of the detector disc is generated by the rubbing action of the detector spring and detector felt placed between the idler gear and the detector disc,

- and this torque exerts its force in the opposite direction of take-up reel rotation. This friction torque is used to move the detector lever to the right (or left). As long as the reel base continues to rotate, the back and forth motion of the detector lever will also continue.
4. When the tape is fully taken up and the reel base stops, the shape of the cam (on the cam gear) and the friction torque of the detector disc act to position the detector lever in the center position.
5. Next, the cam gear continues to rotate, so pin (B) of the cam gear presses pin (A) of the detector lever.
6. The detector lever, being moved by the cam gear, moves the stop lever (via the coupling link) in the direction of ⑬ and pulls the lock plate in the ⑭ direction to release the button lock. All mechanisms are returned to STOP mode.

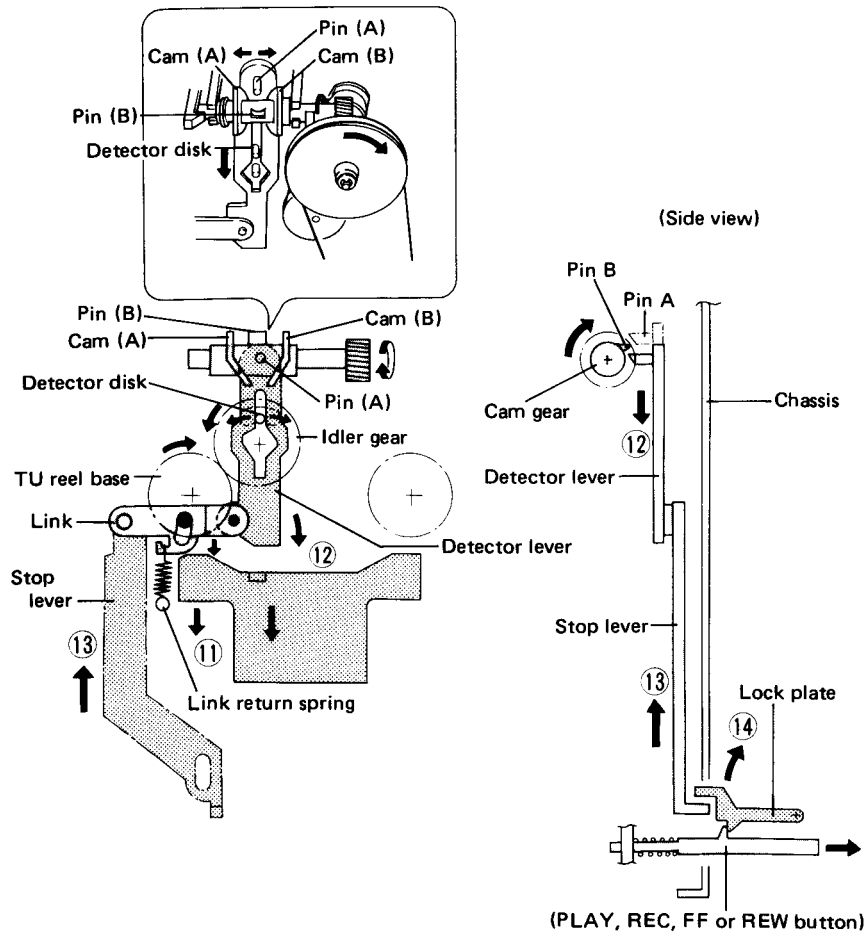
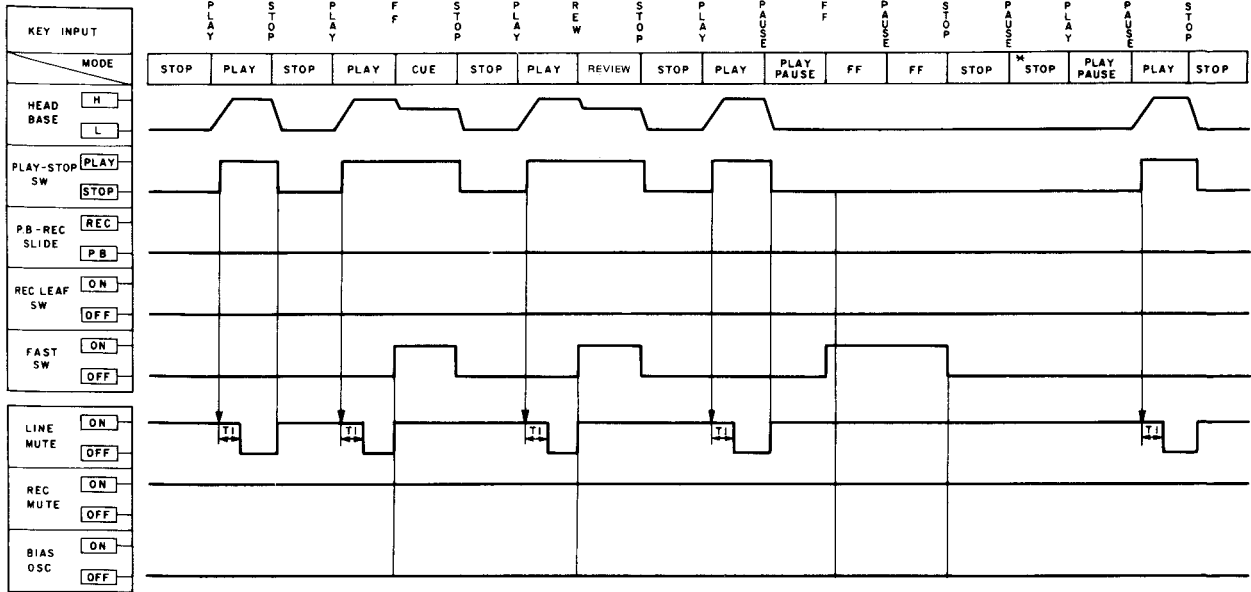

Fig. 13-12 AUTO-STOP operation

Timing Charts

PLAY

• The MS function (CUE and REVIEW) does not apply to the CT-301 (350).



DELAY TIME
T1 400mS
T2 1S

REC

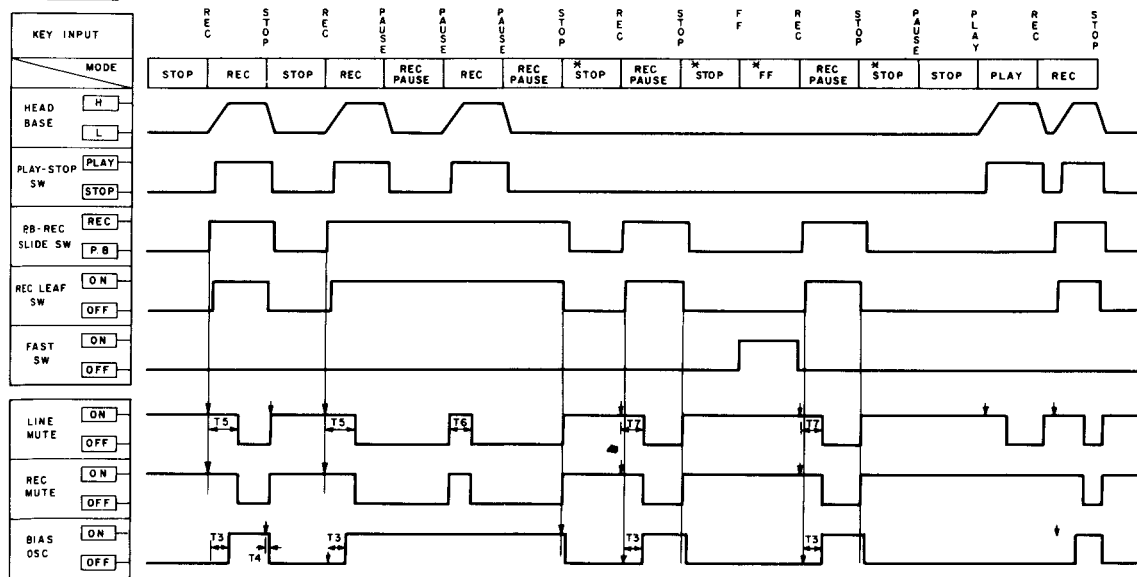

DELAY TIME
T3 25mS
T4 15mS
T5 800mS
T6 400mS
T7 400mS

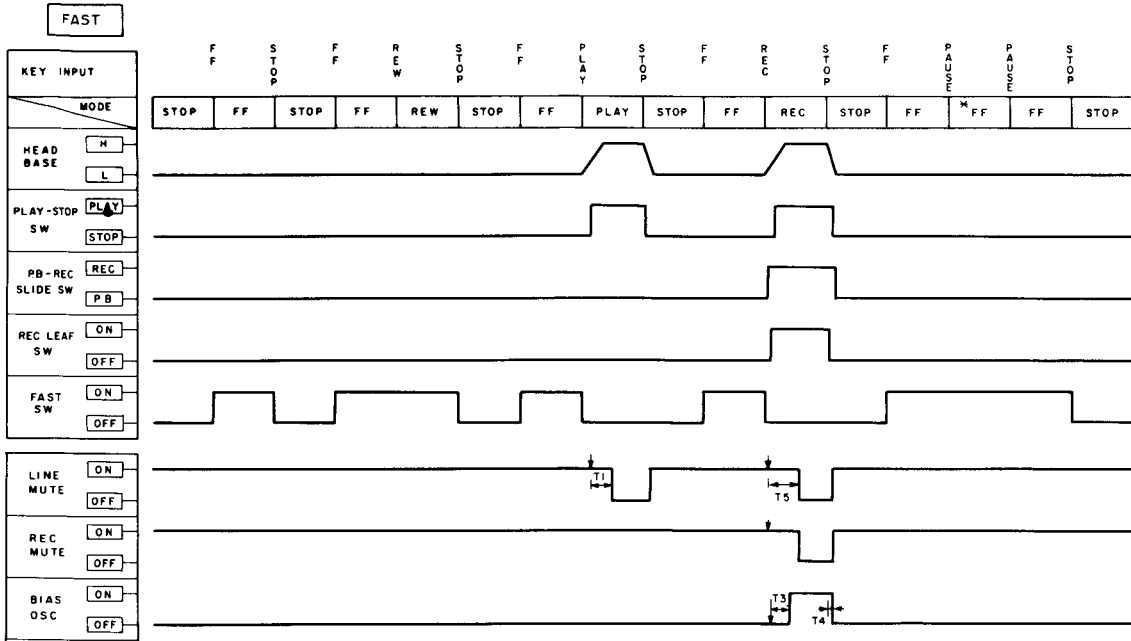

DELAY TIME
 T1 400mS
 T3 25mS
 T4 15mS
 T5 800mS

14. SUPPLEMENT FOR KU TYPE

The KU type (U.S.A. model) is the same as the HEM type (European continent model) with the exception of this supplement.

- Parts without part number cannot be supplied.
- The Δ mark found on some component parts indicates the importance of the safety factor of the part. Therefore, when replacing, be sure to use parts of identical designation.
- For your Parts Stock Control, the fast moving items are indicated with the marks $\star\star$ and \star .
 $\star\star$ *GENERALLY MOVES FASTER THAN \star .*
This classification shall be adjusted by each distributor because it depends on model number, temperature, humidity, etc.

Contrast of Miscellaneous Parts

ELECTRICAL COMPONENTS

Mark	Symbol & Description	Part No.		Remarks
		HEM type	KU type	
Δ \star	T1 Power transformer (220V/240V) Power transformer (120V)	RTT-395 RTT-370	
Δ $\star\star$	FU1 Fuse (T500mA)	REK-049	
Δ	AC power cord (for CT-301)	RDG-027	RDG-048	
	AC power cord (for CT-350)	RDG-053	RDG-048	

P.C. BOARD ASSEMBLIES

Mark	Symbol & Description	Part No.		Remarks
		HEM type	KU type	
	Main assembly	Non supply	Non supply	Fuse holder for FU1 C701
	Power switch assembly	Non supply	Non supply	

OTHERS

Mark	Symbol & Description	Part No.		Remarks
		HEM type	KU type	
	Operating instructions (for CT-301)	RRE-062 RRB-233	English/German/French/Italian English
	Operating instructions (for CT-350)	RRE-066 RRB-239	English/German/French/Italian English

• Main Assembly

The main assembly for KU type is the same as the main assembly for HEM type with the exception of following sections.

Symbol & Description	For HEM type	for KU type
Fuse clip (for FU1)	Non supply

• Power Switch Assembly

The power switch assembly for KU type is the same as the power switch assembly for HEM type with the exception of following sections.

Symbol & Description	for HEM type	for KU type
C701 Ceramic capacitor	RCG-009 (0.01/AC400V)	RCG-008 (0.01/AC250V)

Power Supply Circuit for KU type

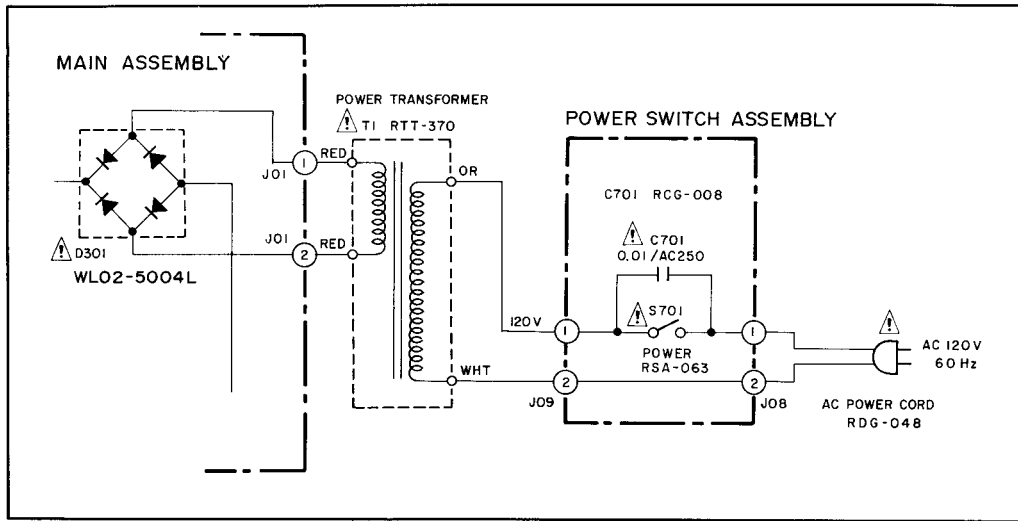

Safety Information for KU type

1. SAFETY PRECAUTIONS

The following check should be performed for the continued protection of the customer and service technician.

LEAKAGE CURRENT CHECK

Measure leakage current to a known earth ground (water pipe, conduit, etc.) by connecting a leakage current tester such as Simpson Model 229-2 or equivalent between the earth ground and all exposed metal parts of the appliance (input/output terminals, screwheads, metal overlays, control shaft, etc.). Plug the AC line cord of the appliance directly into a 120V AC 60Hz outlet and turn the AC power switch on. Any current measured must not exceed 0.5mA.

ANY MEASUREMENTS NOT WITHIN THE LIMITS OUTLINED ABOVE ARE INDICATIVE OF A POTENTIAL SHOCK HAZARD AND MUST BE CORRECTED BEFORE RETURNING THE APPLIANCE TO THE CUSTOMER.

2. PRODUCT SAFETY NOTICE

Many electrical and mechanical parts in the appliance have special safety related characteristics. These are often not evident from visual inspection nor the protection afforded by them necessarily can be obtained by using replacement components rated for voltage, wattage, etc. Replacement parts which have these special safety characteristics are identified in this Service Manual.

Electrical components having such features are identified by marking with a Δ on the schematics and on the parts list in this Service Manual.

The use of a substitute replacement component which does not have the same safety characteristics as the PIONEER recommended replacement one, shown in the parts list in this Service Manual, may create shock, fire, or other hazards.

Product Safety is continuously under review and new instructions are issued from time to time. For the latest information, always consult the current PIONEER Service Manual. A subscription to, or additional copies of, PIONEER Service Manual may be obtained at a nominal charge from PIONEER.

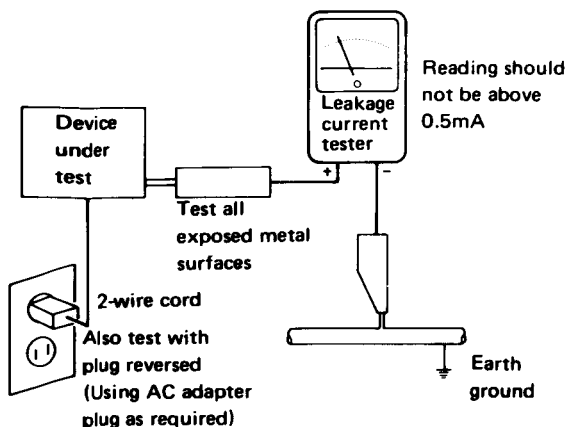

AC Leakage Test