

KP-5500 E KP-5501 E KP-5800 E

CASSETTE CAR STEREO
WITH MW/FM-STEREO

CASSETTE CAR STEREO
WITH AM/FM-STEREO

CASSETTE CAR STEREO
WITH LW/MW/FM-STEREO

SERVICE MANUAL



Subject:

For Cassette Mechanism, refer to the Service Manual of unit number X-100A/B.

Original

SPECIFICATIONS

General

Power source DC 13.8V (11 ~ 16V allowable)
Grounding system Negative type
Max. current consumption 1.2A
Power output (max.) 6W + 6W
(continuous) 5W + 5W
Load impedance 4Ω (2 ~ 8Ω allowable)
Dimensions (W × H × D) 180 × 50 × 150 mm
Nose size (W × H × D) 105 × 42 × 16 mm
Shaft interval 130 mm
Weight 1.9 kg

Tape player

Tape Compact cassette tape (C-30 ~ C-90)
Tape speed 4.76 cm/sec. (+0.19 cm/sec., -0.05 cm/sec.)
Fast forward time Within 100 sec. for C-60
Rewind time Within 100 sec. for C-60
Wow & flutter No more than 0.28% (WRMS)
Frequency response 50 ~ 12,000 Hz (±3 dB)
Cross talk More than 40 dB
Signal-to-noise ratio More than 45 dB

AM (MW) tuner

Frequency range 525 ~ 1,620 kHz
Usable sensitivity 25μV
Selectivity 25 dB (±9 kHz)
Max. input signal (distortion 5%) 130 dB

FM tuner

Frequency range 88 ~ 108 MHz
88 ~ 104 MHz (KP-5800 only)
Usable sensitivity 26.4 dBf (8.0μV/150Ω)
25.2 dBf (5μV/75Ω) (KP-5501 only)
50 dB quieting sensitivity 26.6 dBf (8.2μV/150Ω)
25.7 dBf (5.3μV/75Ω) (KP-5501 only)
Signal-to-noise ratio 60 dB
Capture ratio 3 dB
Selectivity 50 dB (±400 kHz)
Distortion 1% (at 65 dBf, 1 kHz, stereo)
Frequency response 50 ~ 10,000 Hz (±3 dB)
Stereo separation 35 dB (at 65 dBf, 1 kHz)

LW tuner (KP-5800 only)

Frequency range 150 ~ 280 kHz
Usable sensitivity 180μV
Selectivity 25 dB (±9 kHz)
Max. input signal (distortion 5%) 130 dB

Note:

Specifications and the design subject to possible modification without notice due to improvements.

 **PIONEER**

CONTENTS

1. PARTS LOCATION	1
2. CIRCUIT DESCRIPTION	2
3. ADJUSTMENT	
3.1 FM IF Adjustment	6
3.2 FM MPX Adjustment	6
3.3 FM Tracking Adjustment	7
3.4 AM (MW) IF Adjustment (KP-5500, KP-5501)	8
3.5 AM (MW) Tracking Adjustment (KP-5500, KP-5501)	9
3.6 MW/LW IF Adjustment (KP-5800)	10
3.7 MW/LW Tracking Adjustment (KP-5800)	11
4. SCHEMATIC CIRCUIT DIAGRAM (KP-5500, KP-5501)	13
5. CONNECTION DIAGRAM (KP-5500, KP-5501)	15
6. SCHEMATIC CIRCUIT DIAGRAM (KP-5800)	19
7. CONNECTION DIAGRAM (KP-5800)	21
8. CABINET EXPLODED VIEW	24
9. CHASSIS EXPLODED VIEW (KP-5500, KP-5501)	25
10. CHASSIS EXPLODED VIEW (KP-5800)	27
11. PACKING METHOD	29
12. PARTS LIST	30

1. PARTS LOCATION

KP-5500
 KP-5501
 KP-5800

• Top View

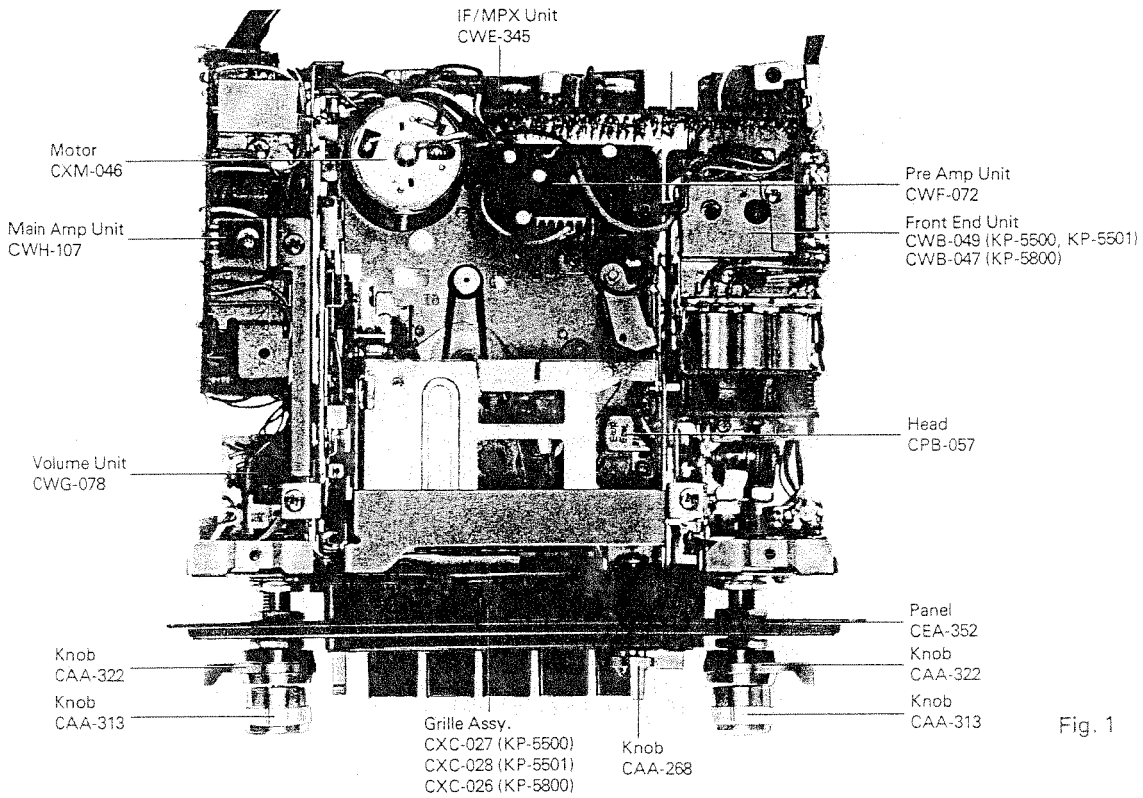

Fig. 1

• Bottom View (KP-5500, KP-5501)

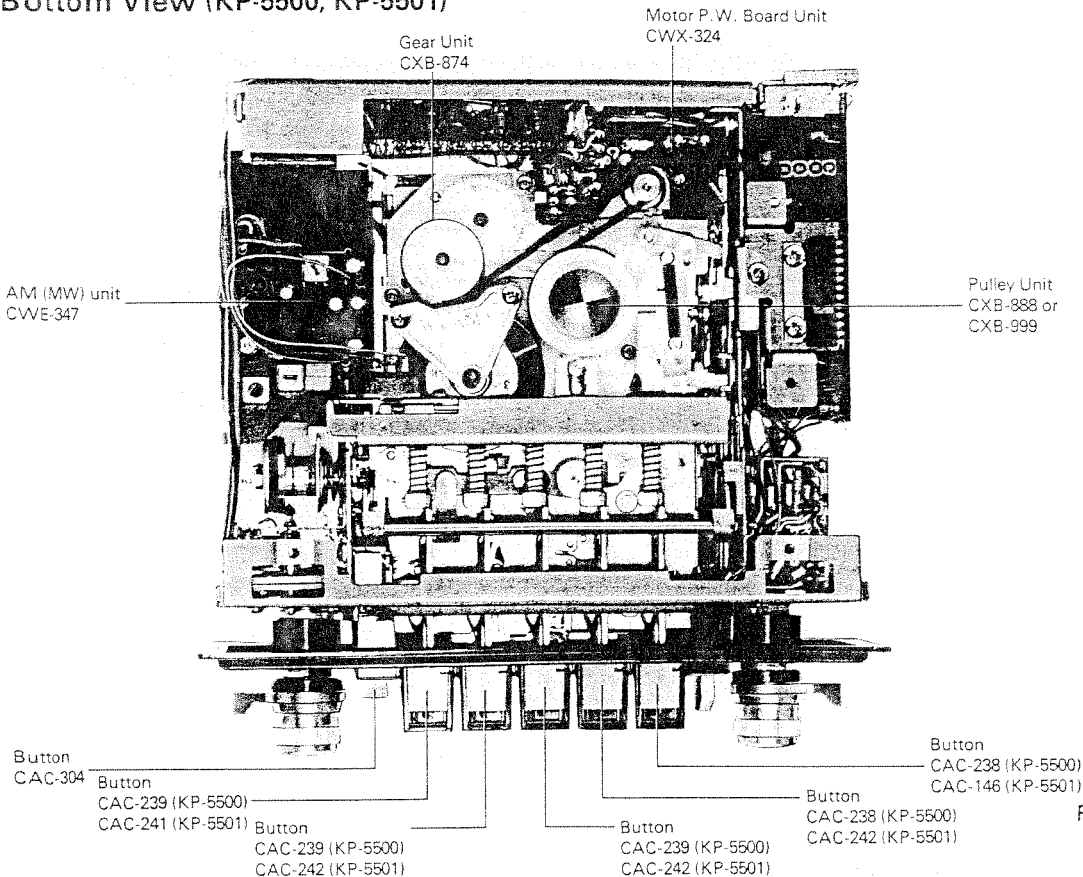

Fig. 2

• Bottom View (KP-5800)

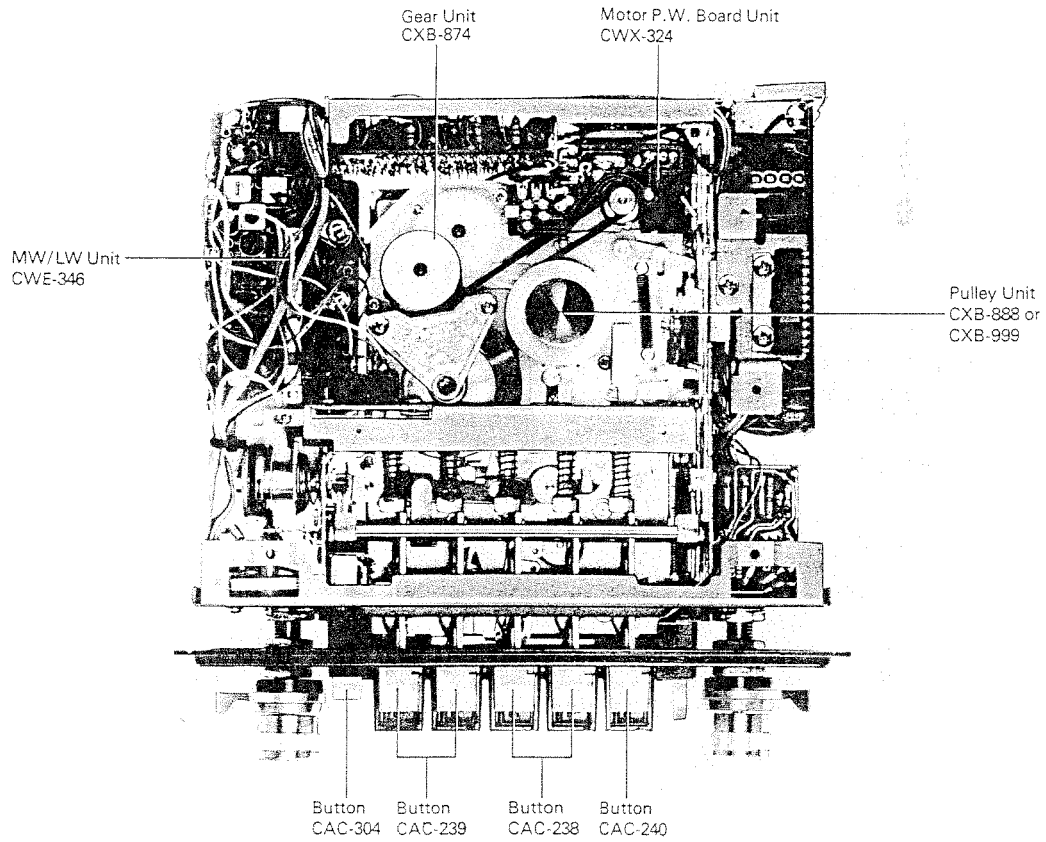

Fig. 3

2. CIRCUIT DESCRIPTION

• Level Diagram

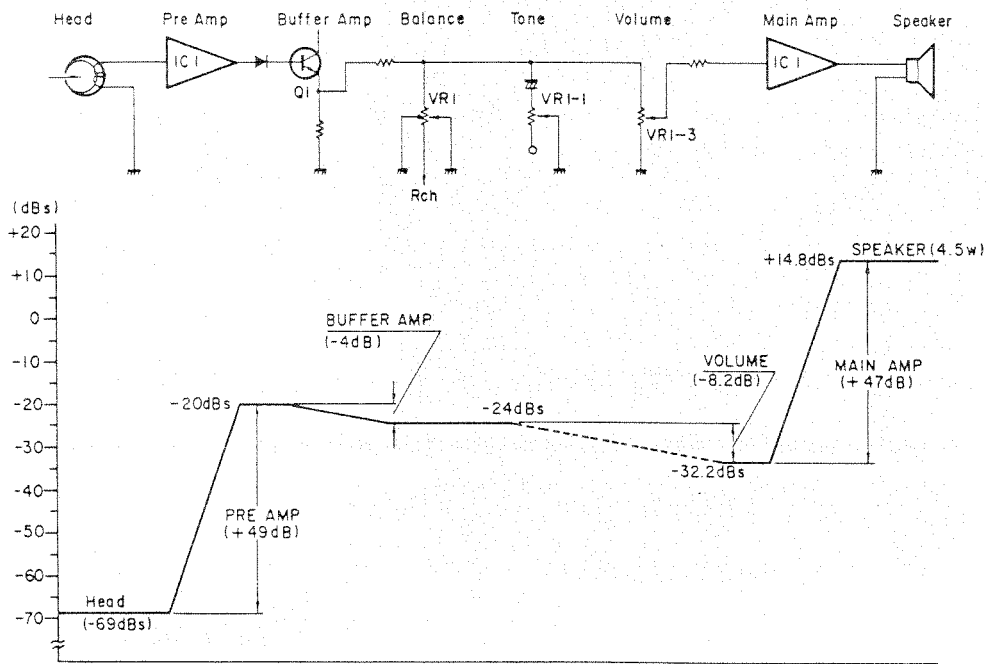

Fig. 4

• Block Diagram (KP-5500, KP-5501)

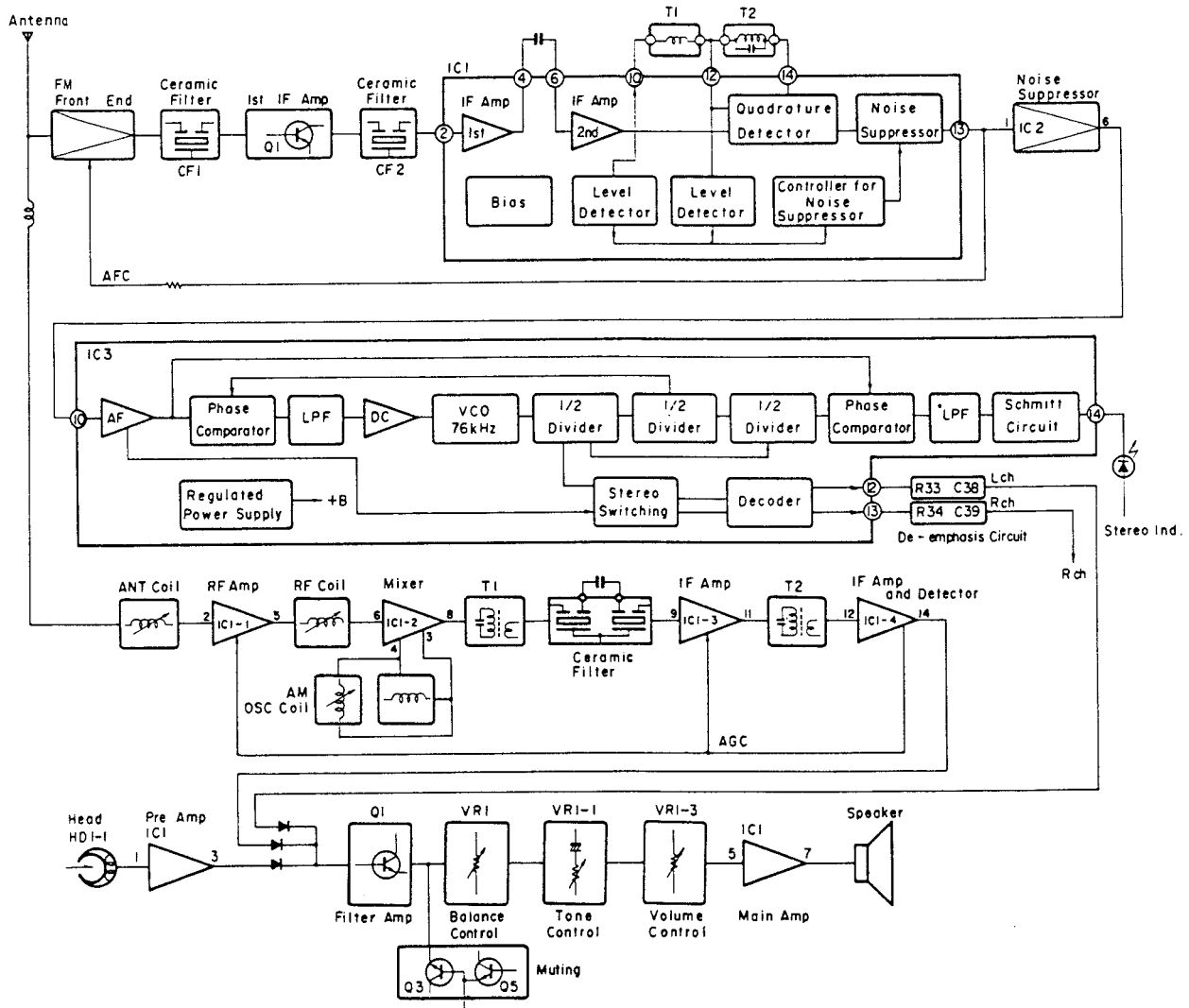

Fig. 5

• Block Diagram (KP-5800)

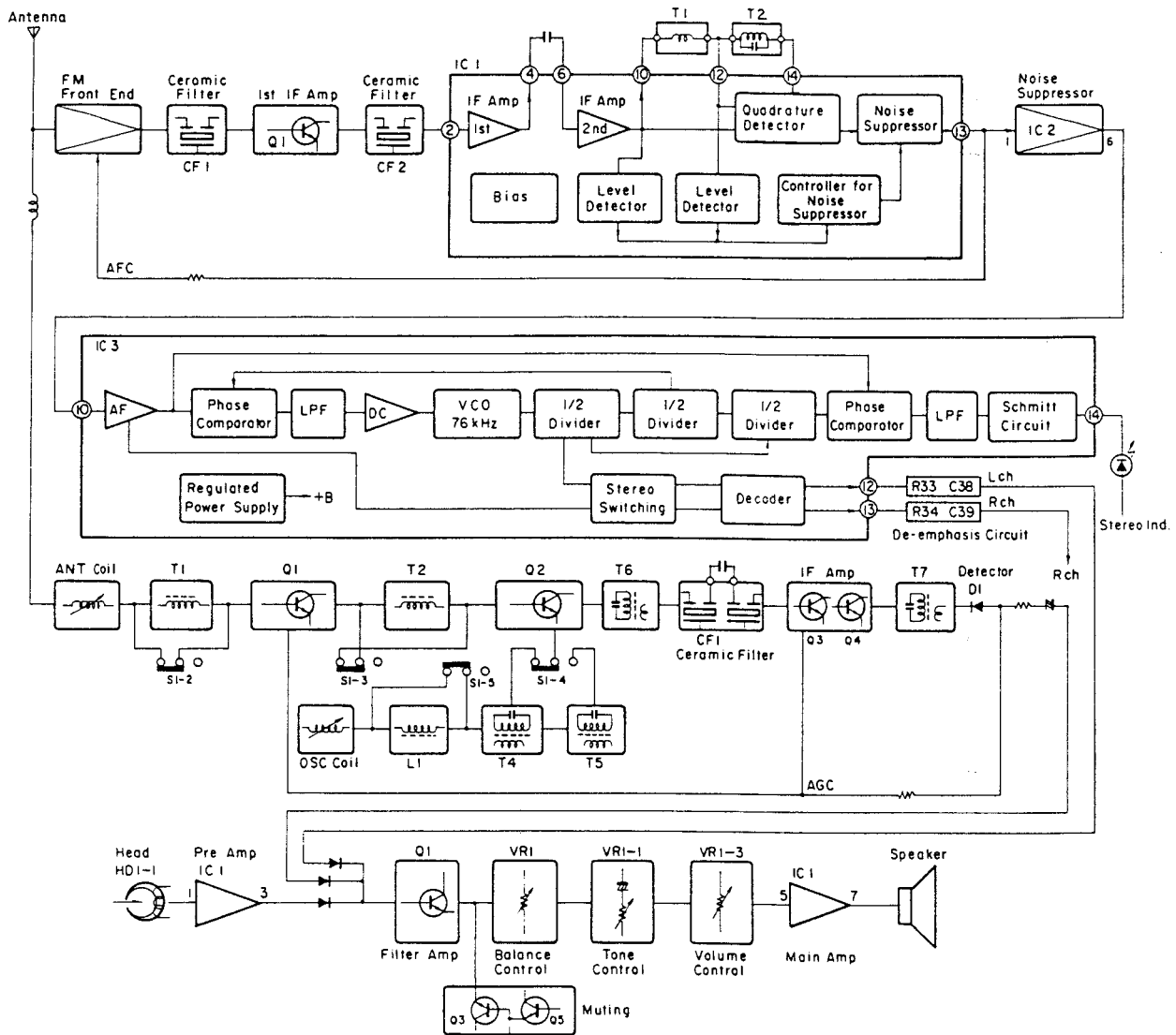

Fig. 6

• **Noise Suppressor**

The input signal containing the pulsive noise as illustrated in Waveform-1 is first impedance-covered by the buffer amplifier, then coupled to the gate circuit via the low-pass filter.

Meanwhile, the high-pass filter filters out only the pulsive noise component from the input signal and feeds the noise detector where it is amplified and rectified. (See Waveform-2)

To cope with weak-signal noise, the noise detector is supported with the AGC (Automatic Gain Control) circuit. The noise component from the noise detector output is waveform-shaped by the mono-stable multivibrator (See Wave-

form-3). The output from the mono-stable multivibrator then couples to the gate circuit as a control-pulse array which is used to cut out only the pulsive noise component from the audio signal.

The memory provided at where holds the audiosignal level constant while the gate circuit is "closed"

The 19 kHz pilot-hold circuit serves to prevent stereo pilot-signal intermission.

The audio signal then sustains high-frequency-phase compensation to compensate for the phase shift due to the low-pass filter, then is coupled to the output terminal.

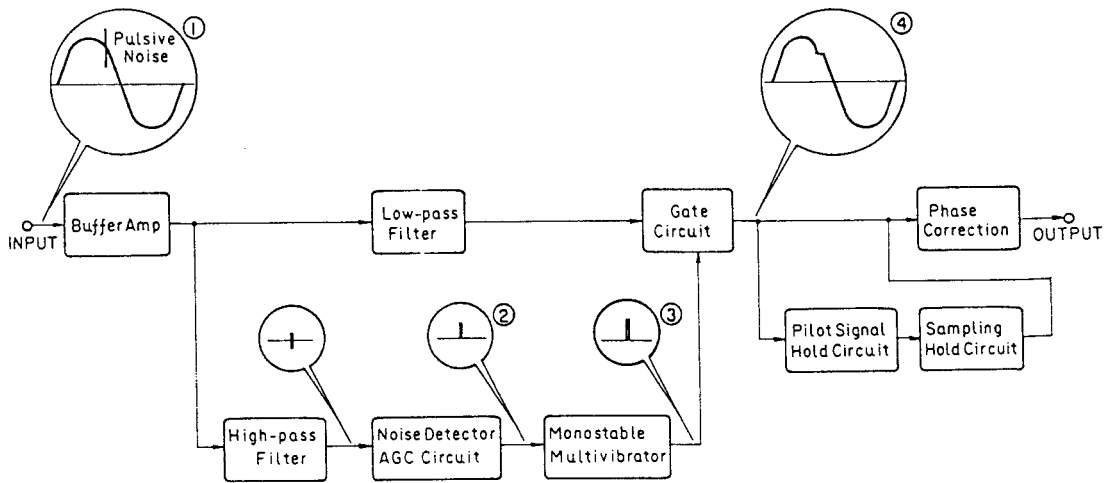

Fig. 7

3. ADJUSTMENT

3.1 FM IF ADJUSTMENT

• Connection Diagram

Switch positions
 FM Pre set Button Push (ON)
 Mono/Stereo Switch Stereo

NOTE:
 The 10.7 MHz marker need not be center positioned on the waveform.

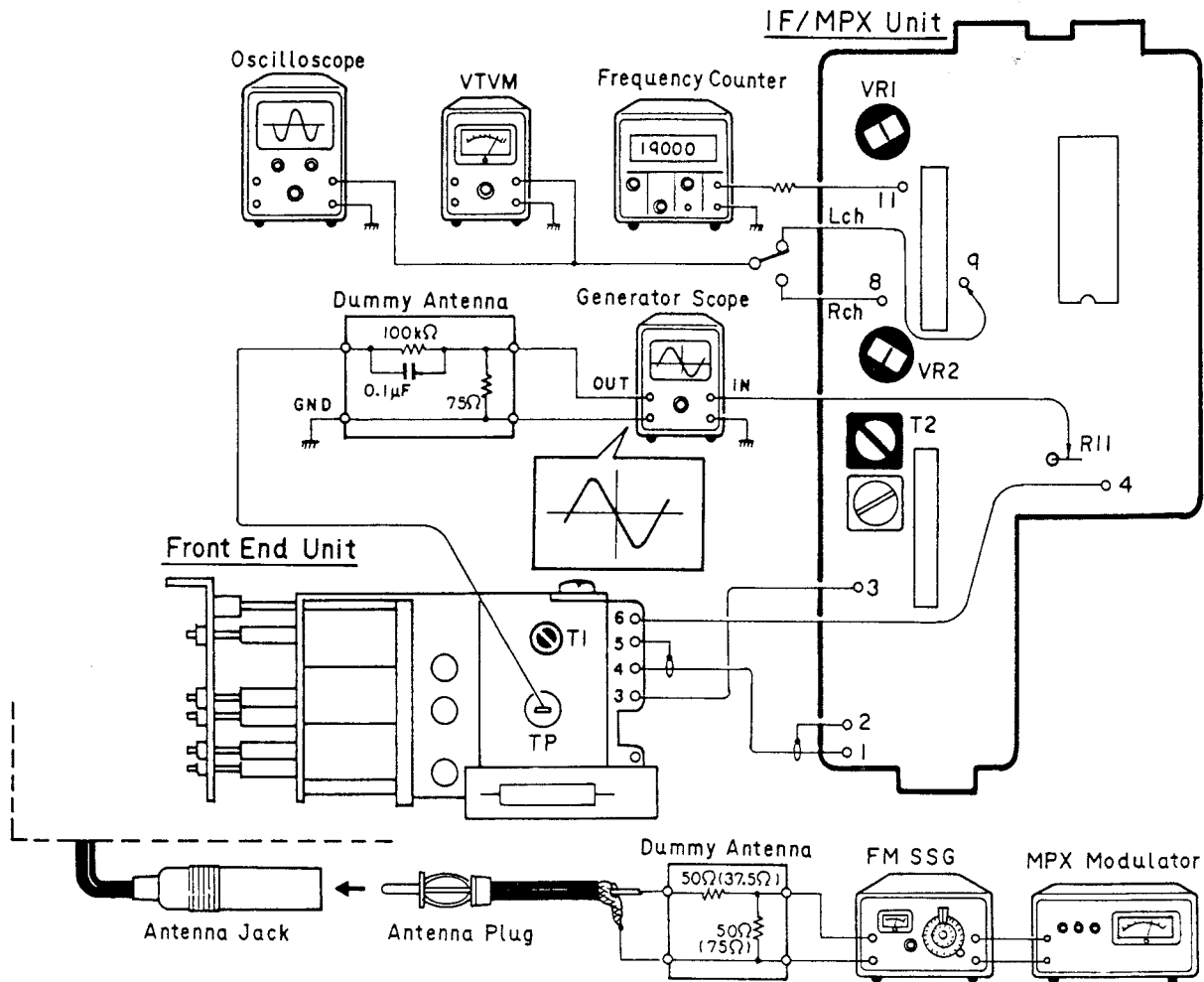

Fig. 8

• To Adjust

- Set Generator Scope as follows:
 Frequency centering on sweep 10.7 MHz
 Input level 0.2 Vp-p/cm
 Output level 1.8 mV ~ 5 mV
- A waveform shown in Fig. 8 is obtained on the generator scope when the hook-up is made as illustrated above and the power source is applied to.
- Adjust the core of T2 so that maximum amplitude and optimum linearity are obtained.
- Add output signal of 98 MHz 15 dB (μV) from SSG and tune to 98 MHz on the dial.
- Adjust the core of T1 (Front End Unit) so that the VTVM pointer indicates the maximum output.

3.2 FM MPX ADJUSTMENT

• Connection Diagram (Shown in Fig. 8.)

• To Adjust

- Add output signal of 98 MHz 15 dB (μV) from SSG and tune to 98 MHz on the dial.
- Add unmodulated signal of 98 MHz 60 dB (μV) from SSG and adjust VR1 so that the frequency counter will indicate 19 kHz ± 30 Hz.
- Add stereo modulation signal of 60 dB (μV) from SSG and adjust VR2 to secure maximum separation.

3.3 FM TRACKING ADJUSTMENT

• Connection Diagram

Switch position
 FM Pre set Button Push (ON)

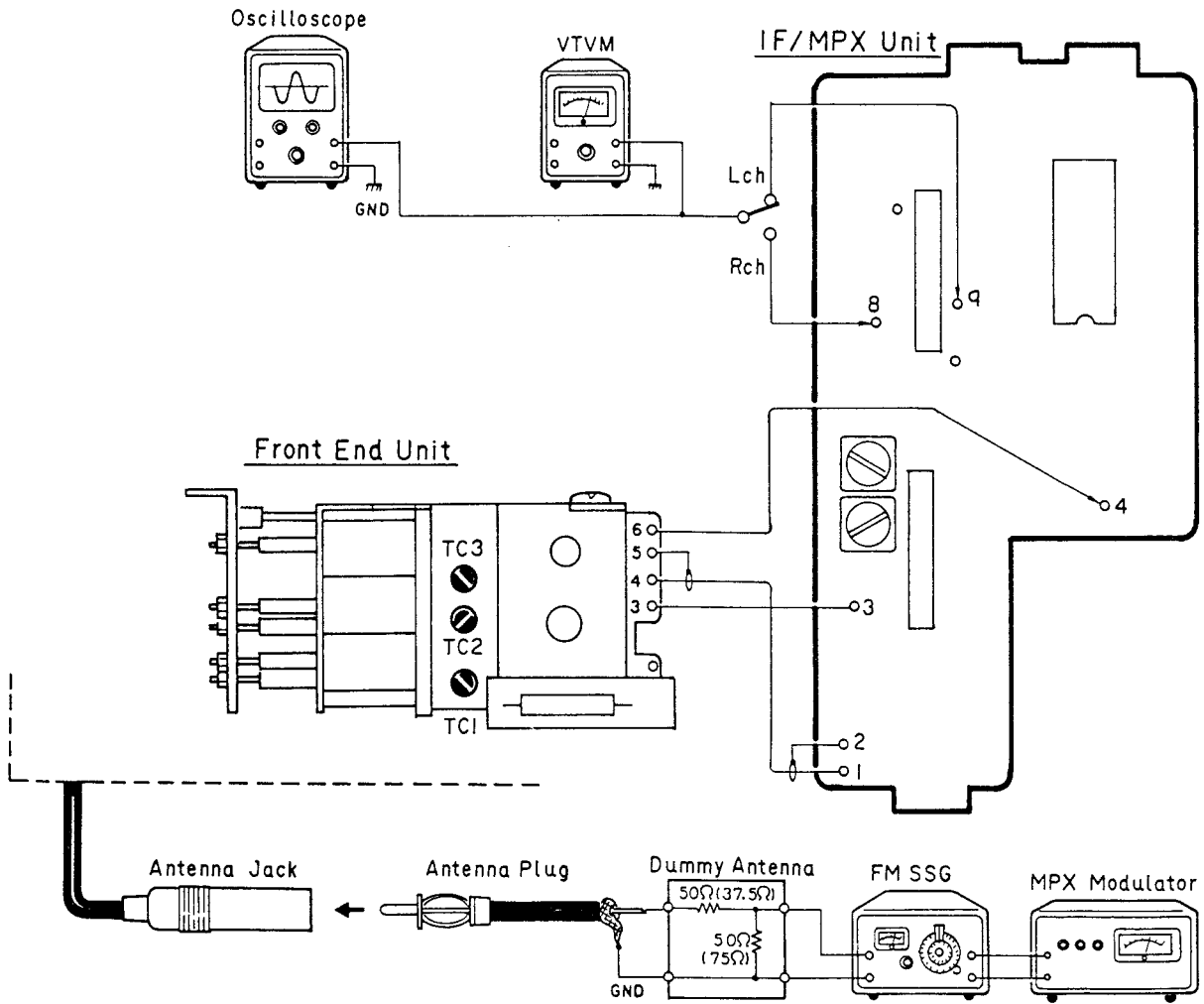

Fig. 9

• To Adjust

SSG Frequency	Pointer Position	Adjustment Point	Note
1. 87.5 MHz (400Hz, 100% modulation), output level 15dB (μV)	Minimum	TC3	87.5 MHz can be received
2. 108.5 MHz (400Hz, 100% modulation), output level 15dB (μV)	Maximum	TC1, TC2	Check if 108.5 MHz can be received
3. 98 MHz (400Hz, 100% modulation), output level 15dB (μV)	Tuned position		Maximum output

3.4 AM (MW) IF ADJUSTMENT (KP-5500, KP-5501)

• Connection Diagram

Switch position

AM (MW) Pre set Button Push (ON)

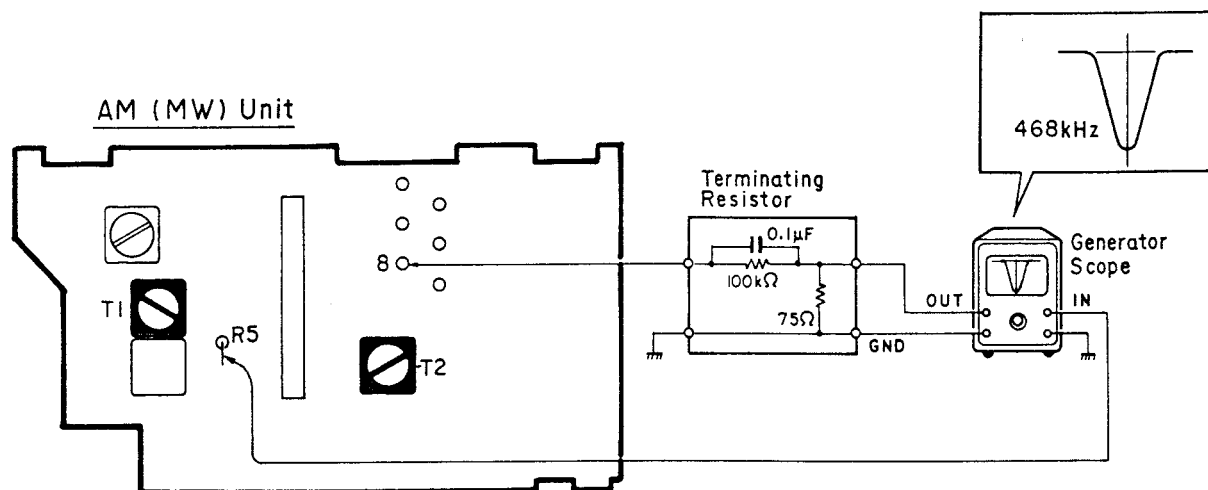

Fig. 10

• To Adjust

1. Set Generator Scope as Follows:

- Frequency centering on sweep 468 kHz
- Input level 0.3Vp-p/cm
- Output level 3mV ~ 10mV

2. Turn the cores (yellow and white) of T1 and T2 and adjust so that U-curve will be at maximum amplitude and best symmetry.

3.5 AM (MW) TRACKING ADJUSTMENT (KP-5500, KP-5501)

• Connection Diagram

Switch position

AM (MW) Pre set Button Push (ON)

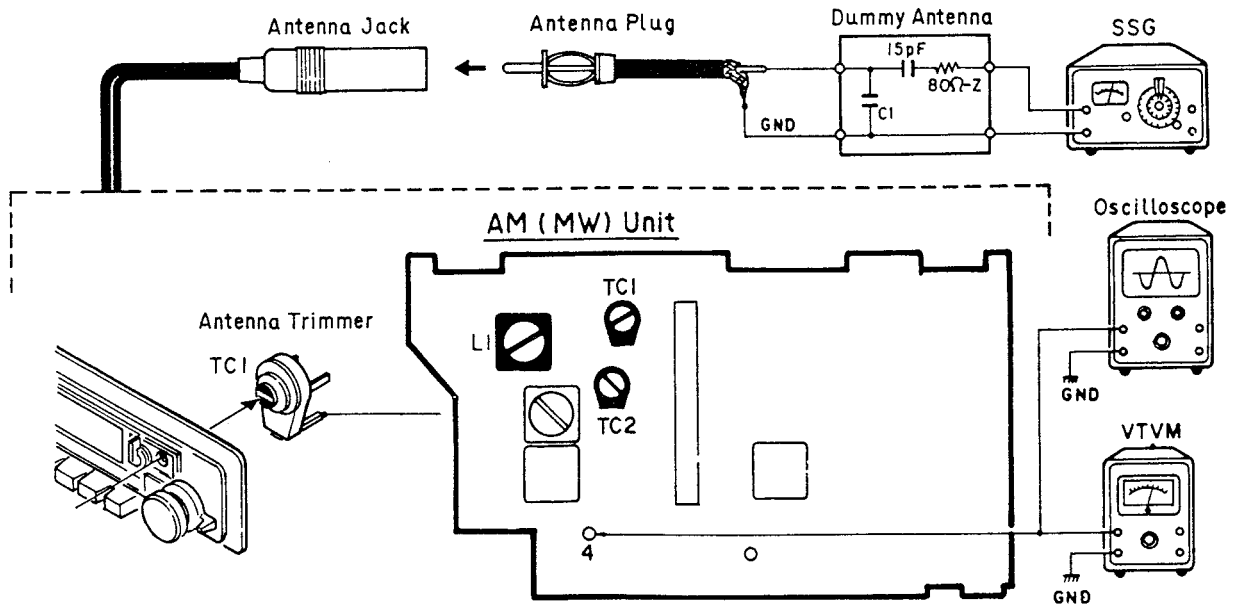

Fig. 11

NOTICE:

Select C1 so that total capacity of 80pF is attained from the direction of receiver jack.

Z: Output impedance of the S.S.G.

• To Adjust

SSG Frequency	Pointer Position	Adjustment Point	Note
1. 515 kHz (400Hz, 30% modulation), output level 20dB (μ V)	Minimum	L1	515 kHz can be received
2. 1,650 kHz (400Hz, 30% modulation), output level 20dB (μ V)	Maximum	TC1	1,650 kHz can be received
3. Repeat (1) and (2) alternately and adjust so that broadcast can be received at the frequency between 515 kHz and 1,650 kHz.			
4. 1,000 kHz (400Hz, 30% modulation), output level 20dB (μ V)	Tune to 1,000 kHz	TC2, Antenna trimmer (TC1)	VTVM at maximum

3.6 MW/LW IF ADJUSTMENT (KP-5800)

• Connection Diagram

Switch position

MW or LW Pre set Button Push (ON)

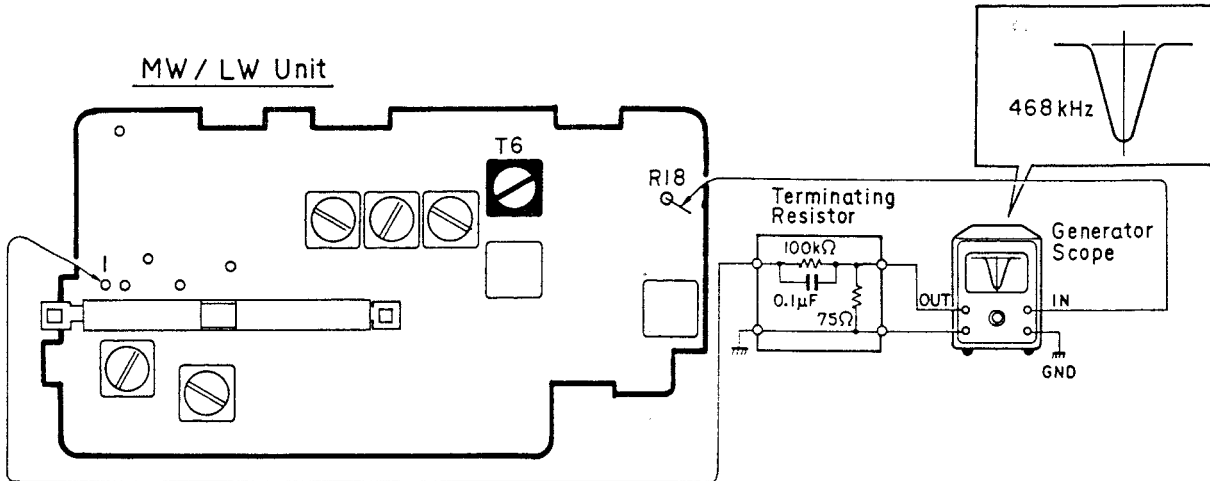

Fig. 12

• To Adjust

1. Set Generator Scope as Follows:
 - Frequency centering on sweep 468 kHz
 - Input level 0.3Vp-p/cm
 - Output level 3mV ~ 10mV
2. Turn the core (yellow) of T6 and adjust so that U-curve will be at maximum amplitude and best symmetry.

3.7 MW/LW TRACKING ADJUSTMENT (KP-5800)

In case of MW

• Connection Diagram

Switch position
MW Pre set Button Push (ON)

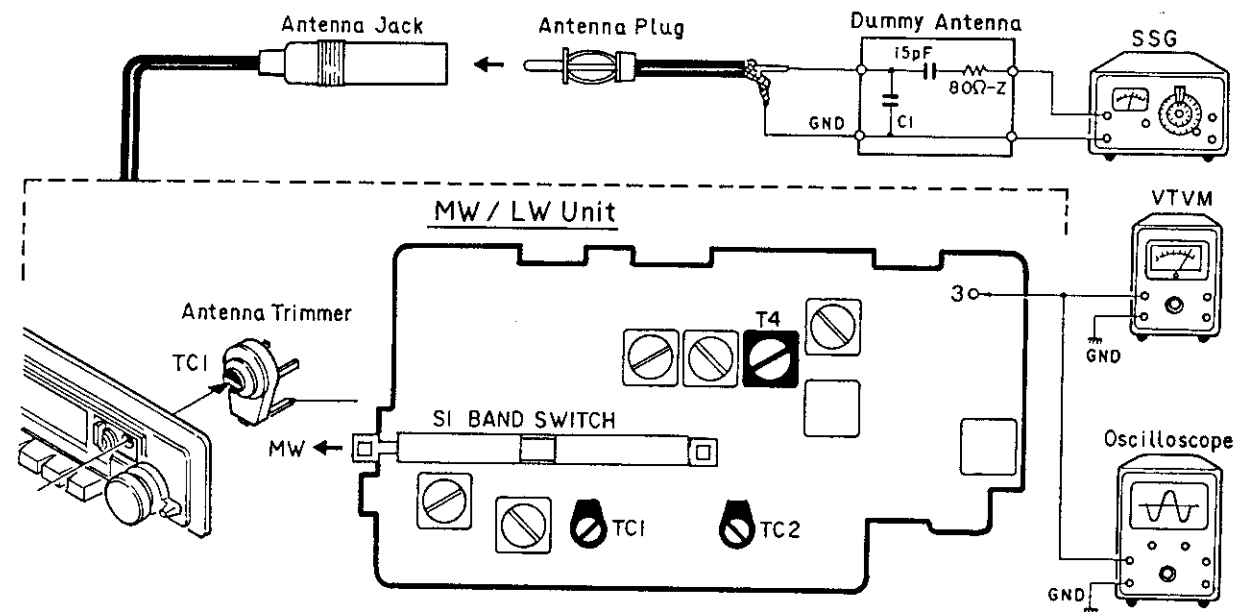

Fig. 13

NOTICE:
Select C1 so that total capacity of 80pF is attained from the direction of receiver jack.
Z: Output impedance of the S.S.G.

• To Adjust

SSG Frequency	Pointer Position	Adjustment Point	Note
1. 515 kHz (400Hz, 30% modulation), output level 20dB (μV)	Minimum	T4	515 kHz can be received
2. 1,650 kHz (400Hz, 30% modulation), output level 20dB (μV)	Maximum	TC2	1,650 kHz can be received
3. Repeat (1) and (2) alternately and adjust so that broadcast can be received at the frequency between 515 kHz and 1,650 kHz.			
4. 1,000 kHz (400Hz, 30% modulation), output level 20dB (μV)	Tune to 1,000 kHz	TC1, Antenna trimmer (TC1)	VTVM at maximum

In case of LW

• Connection Diagram

Switch position
LW Pre set Button Push (ON)

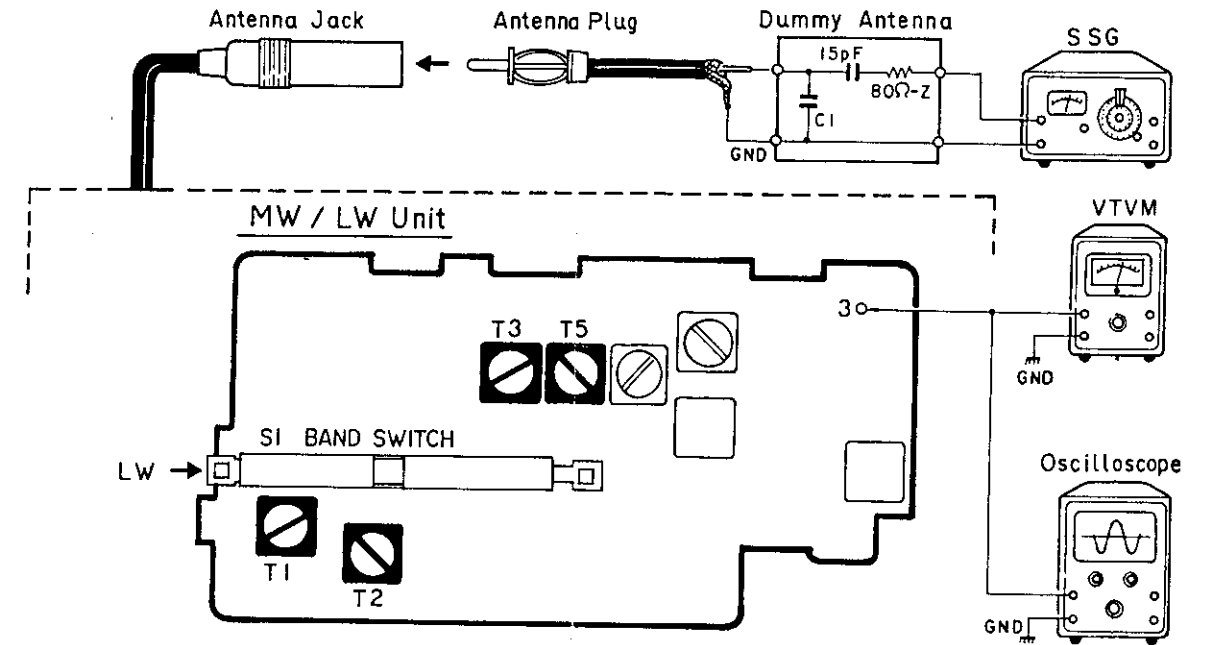

Fig. 14

NOTICE:
Select C1 so that total capacity of 80pF is attained from the direction of receiver jack.
Z: Output impedance of the S.S.G.

• To Adjust

SSG Frequency	Pointer Position	Adjustment Point	Note
1. 140 kHz (400Hz, 30% modulation), output level 40dB (μV)	Minimum	T5	140 kHz can be received
2. 295 kHz (400Hz, 30% modulation), output level 40dB (μV)	Maximum	T3	295 kHz can be received
3. Repeat (1) and (2) alternately and adjust so that broadcast can be received at the frequency between 140 kHz and 295 kHz.			
4. 215 kHz (400Hz, 30% modulation), output level 40dB (μV)	Tune to 215 kHz	T1, T2	VTVM at maximum

4. SCHEMATIC CIRCUIT DIAGRAM (KP-5500, KP-5501, KP-5800)

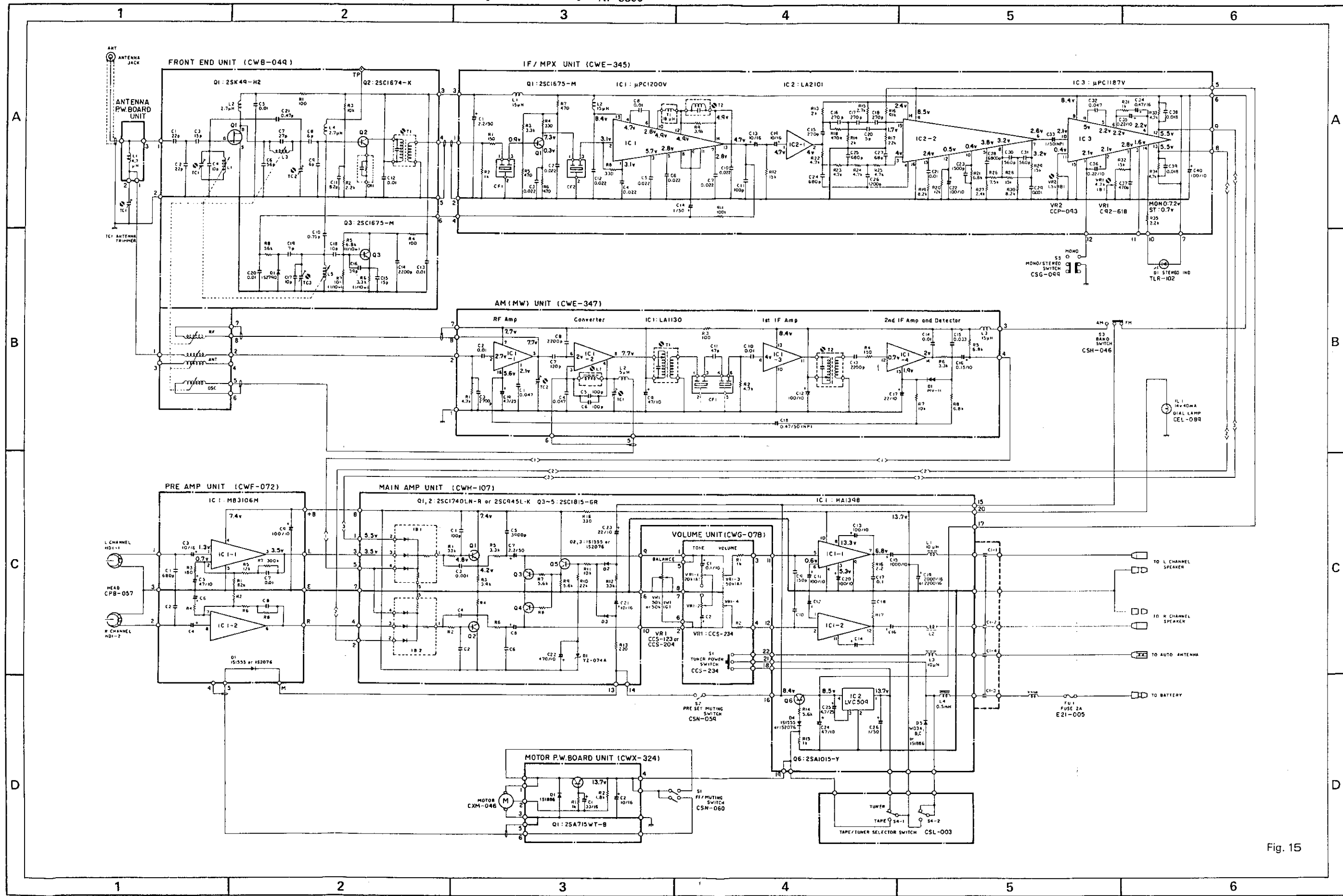
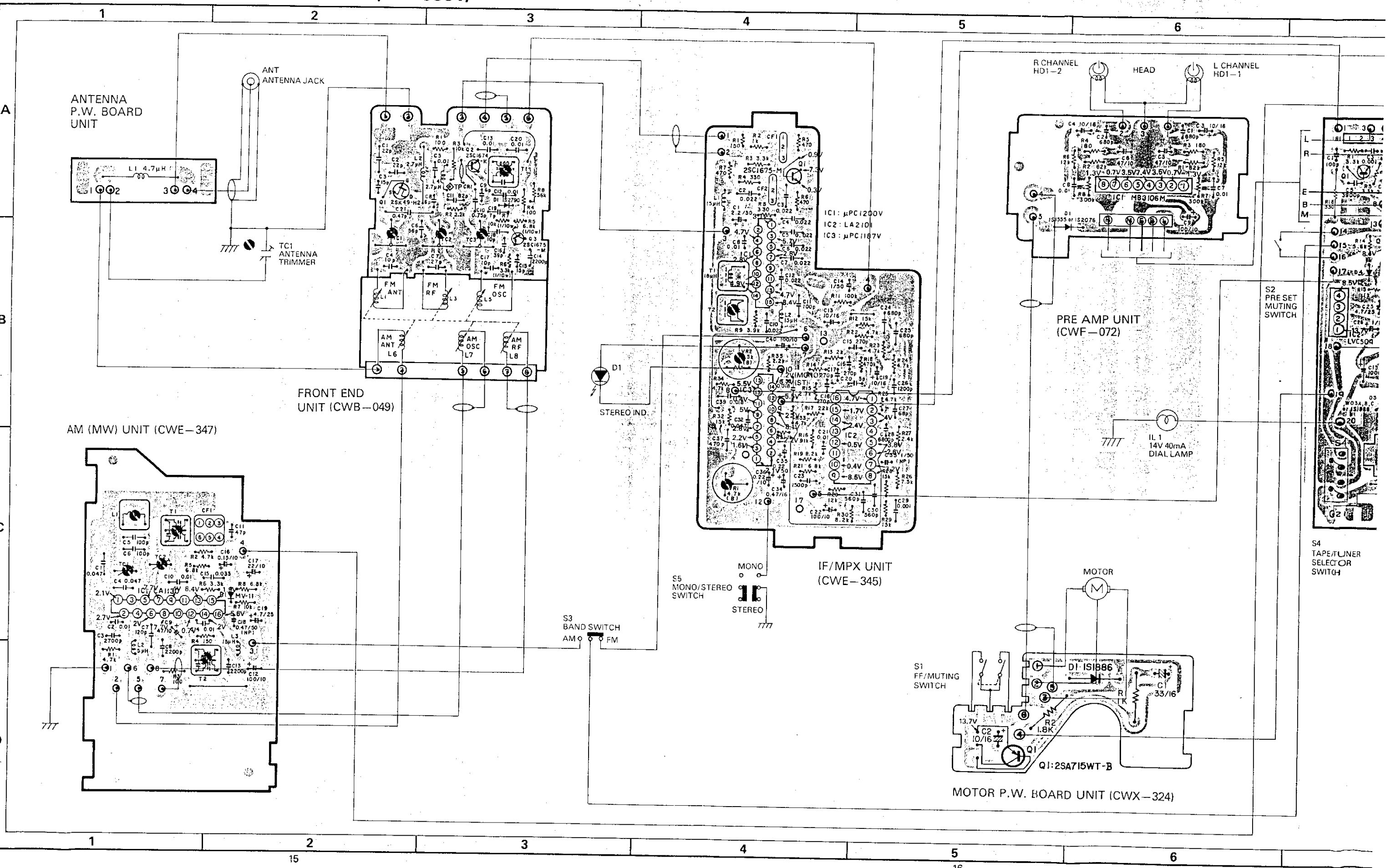

Fig. 15

5. CONNECTION DIAGRAM (KP-5500, KP-5501)



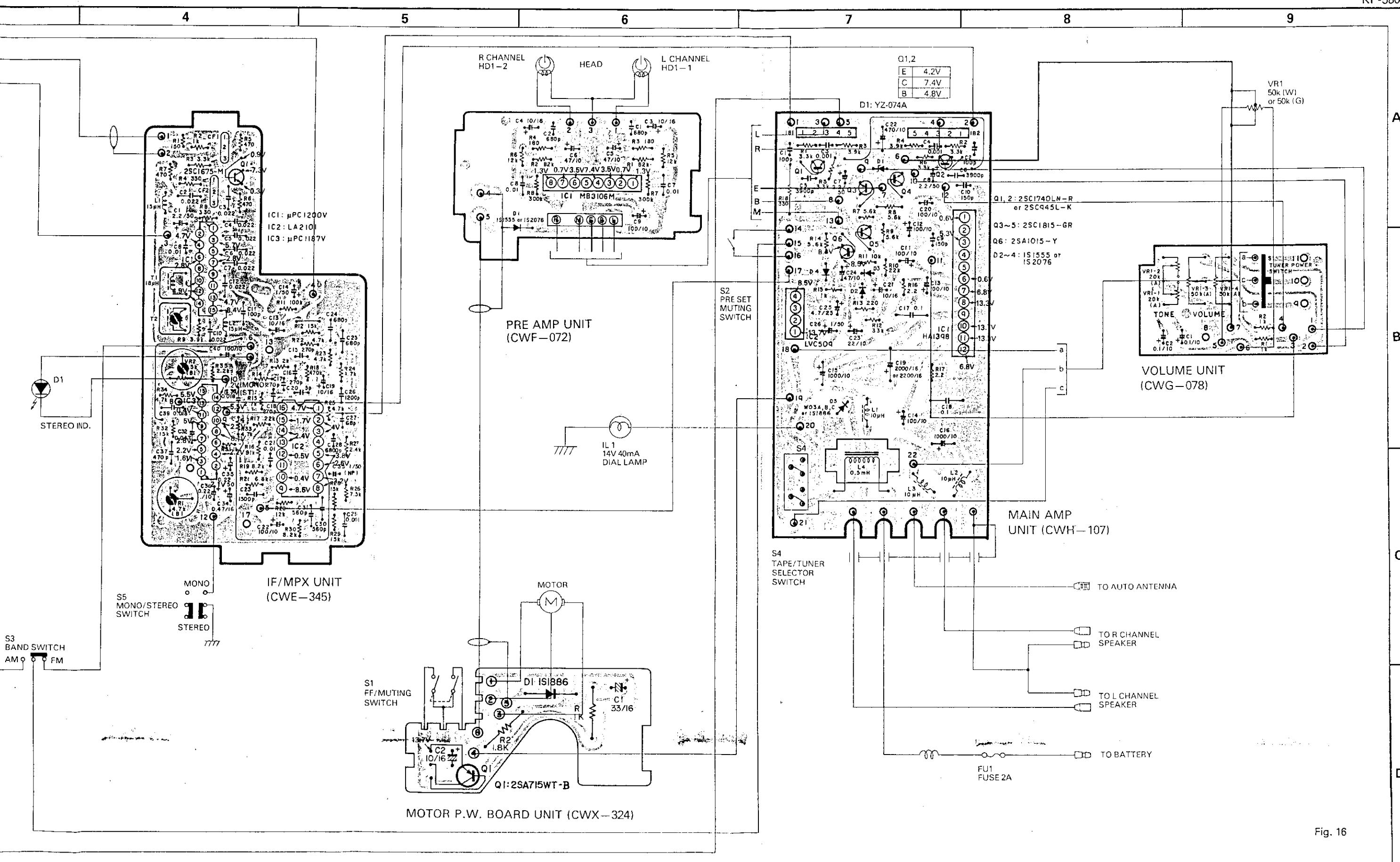
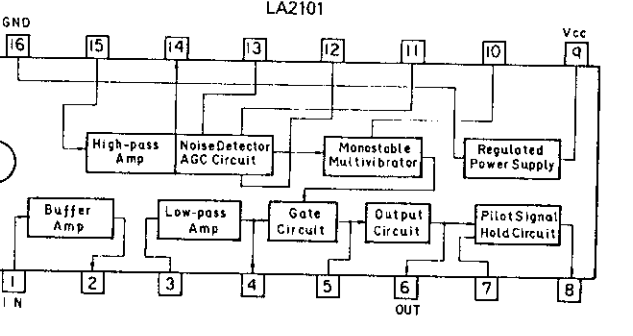
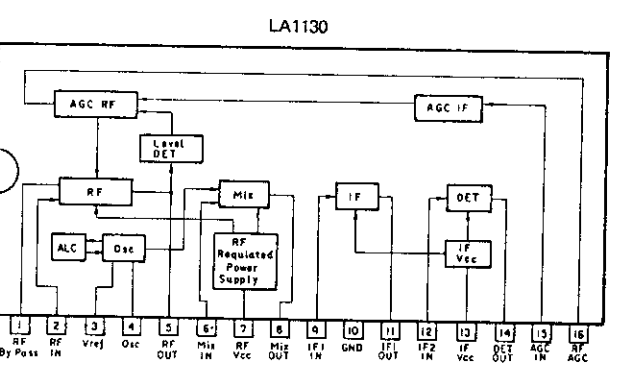
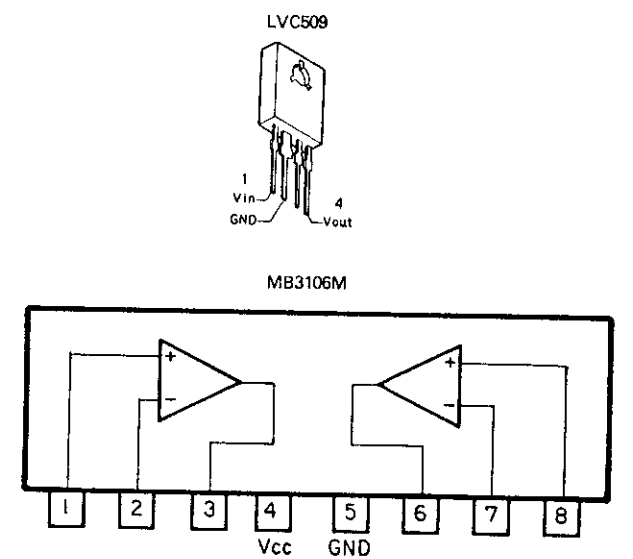
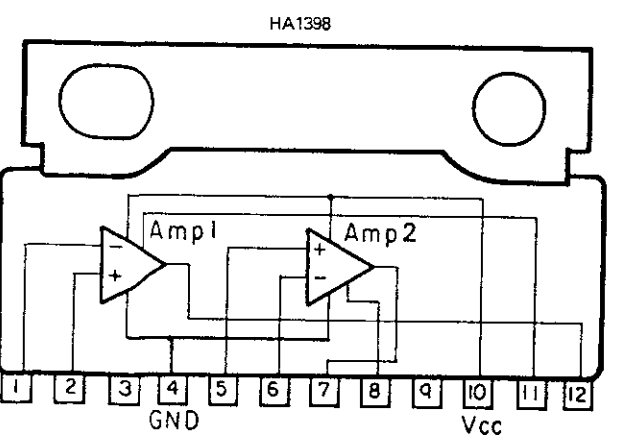
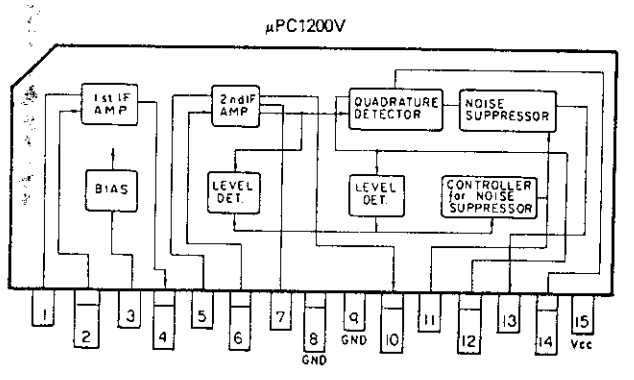
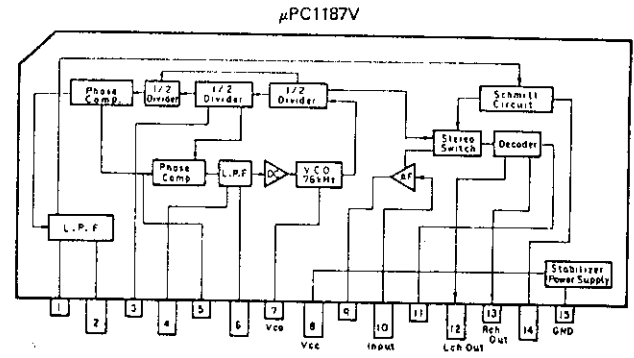
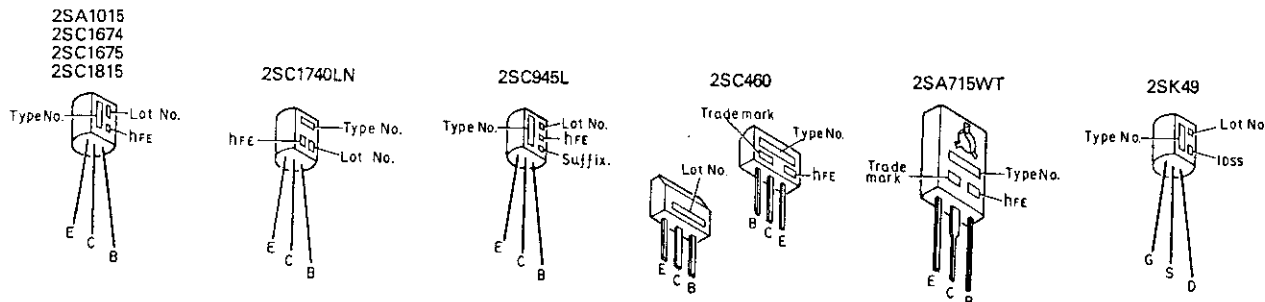

Fig. 16

• IC's and Transistors



6. SCHEMATIC CIRCUIT DIAGRAM (KP-5800)

KP-5500
KP-5501
KP-5800

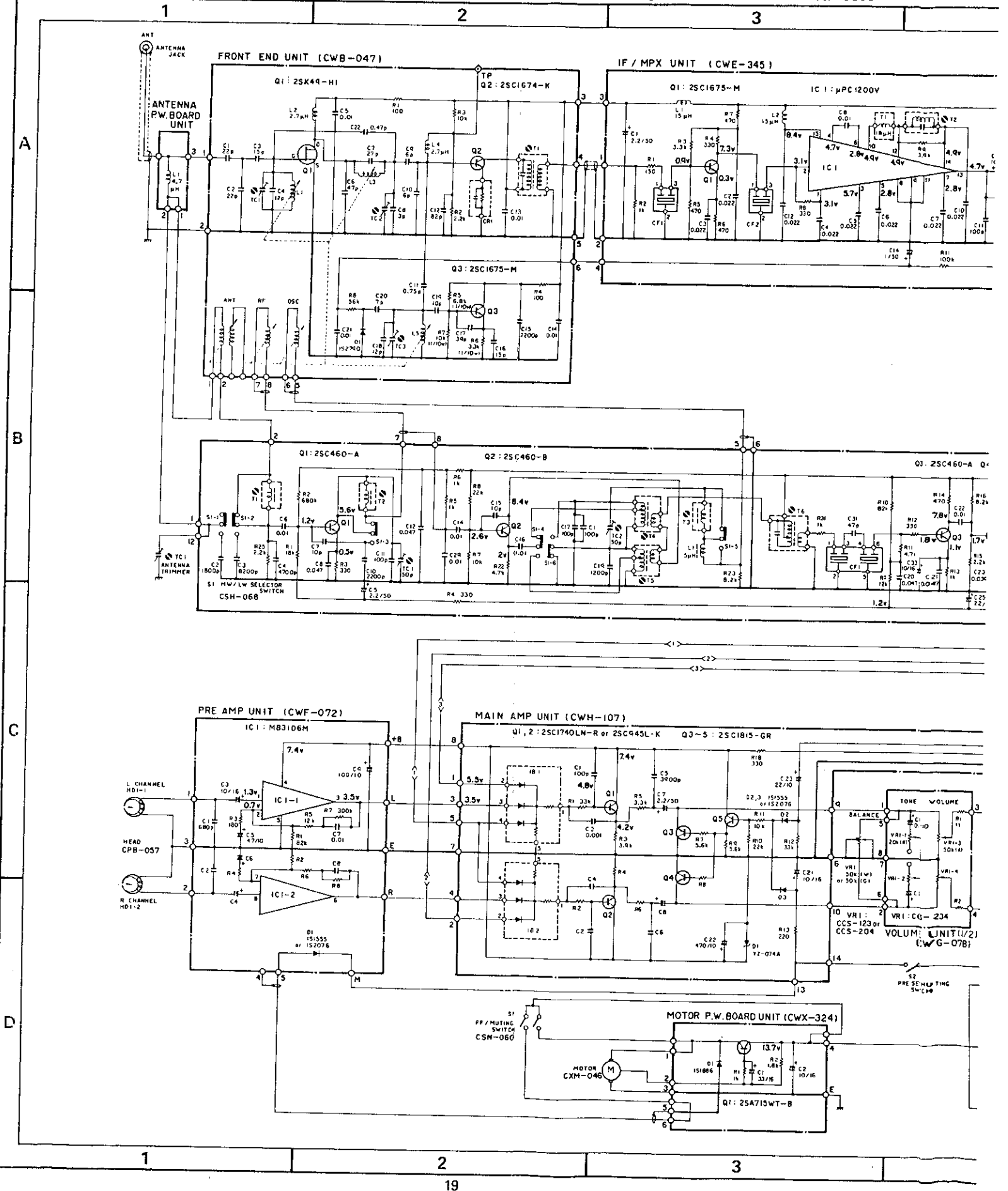

6. SCHEMATIC CIRCUIT DIAGRAM (KP-5800)

KP-5500
 KP-5501
 KP-5800

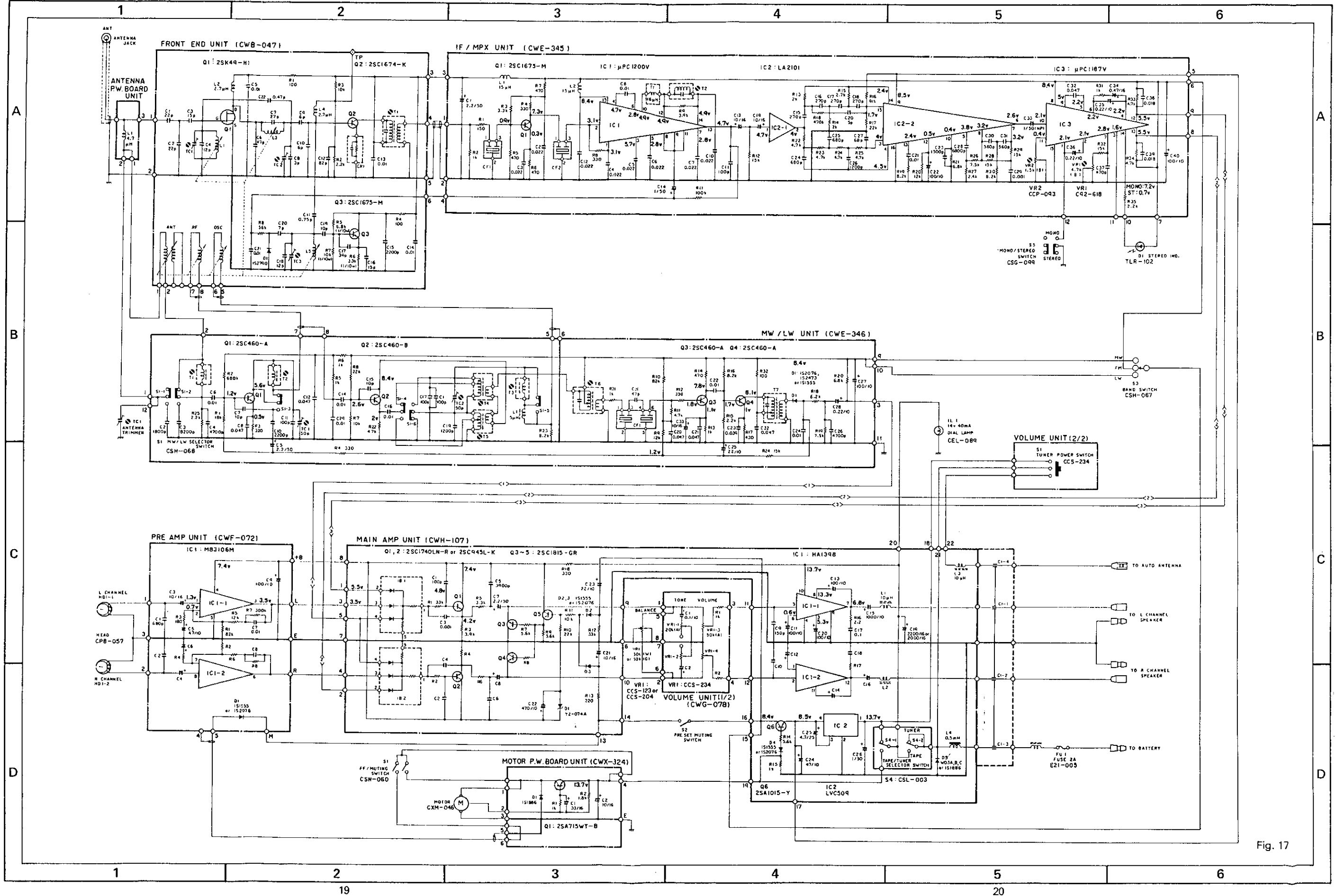
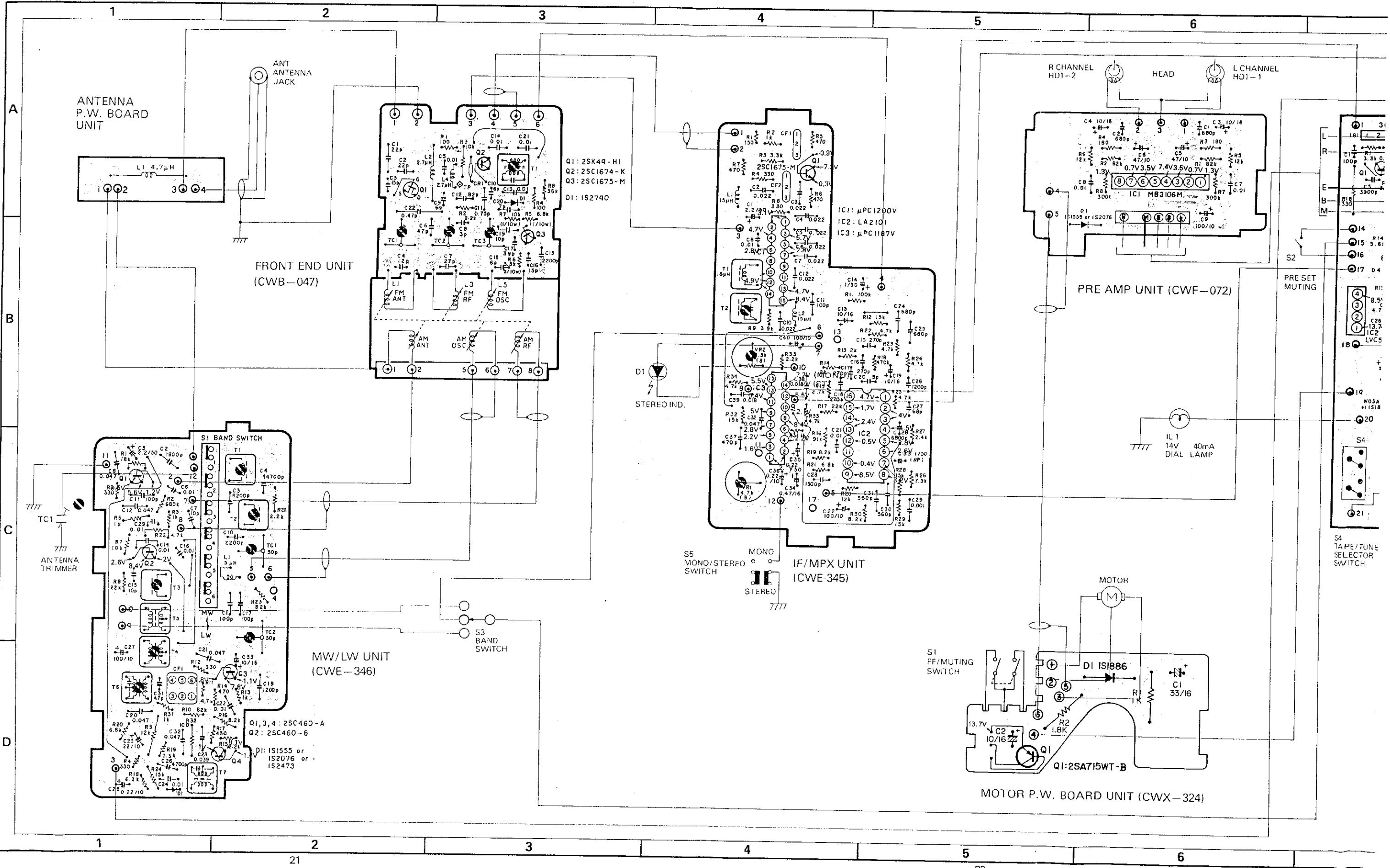

Fig. 17

7. CONNECTION DIAGRAM (KP-5800)



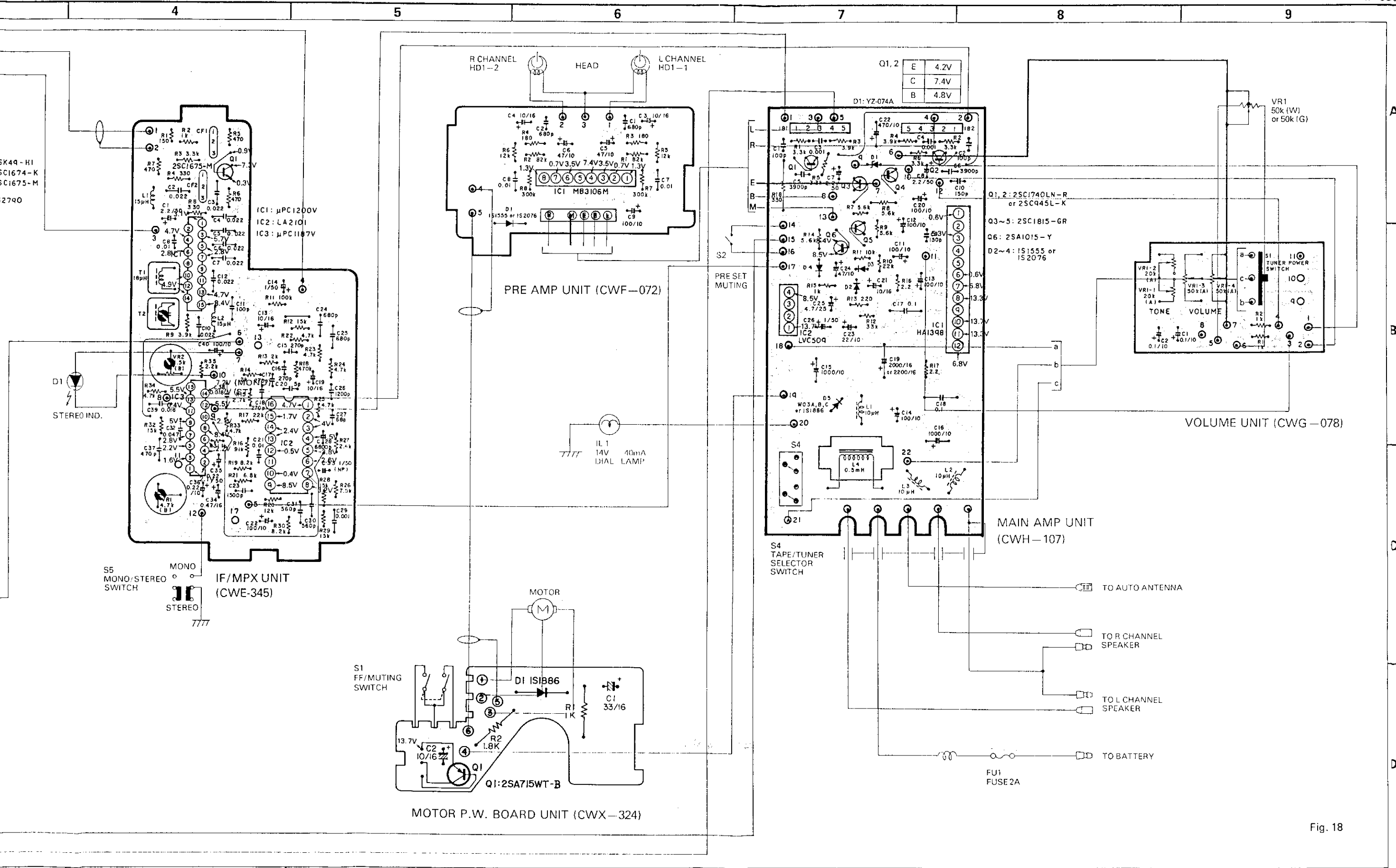

Fig. 18

8. CABINET EXPLODED VIEW

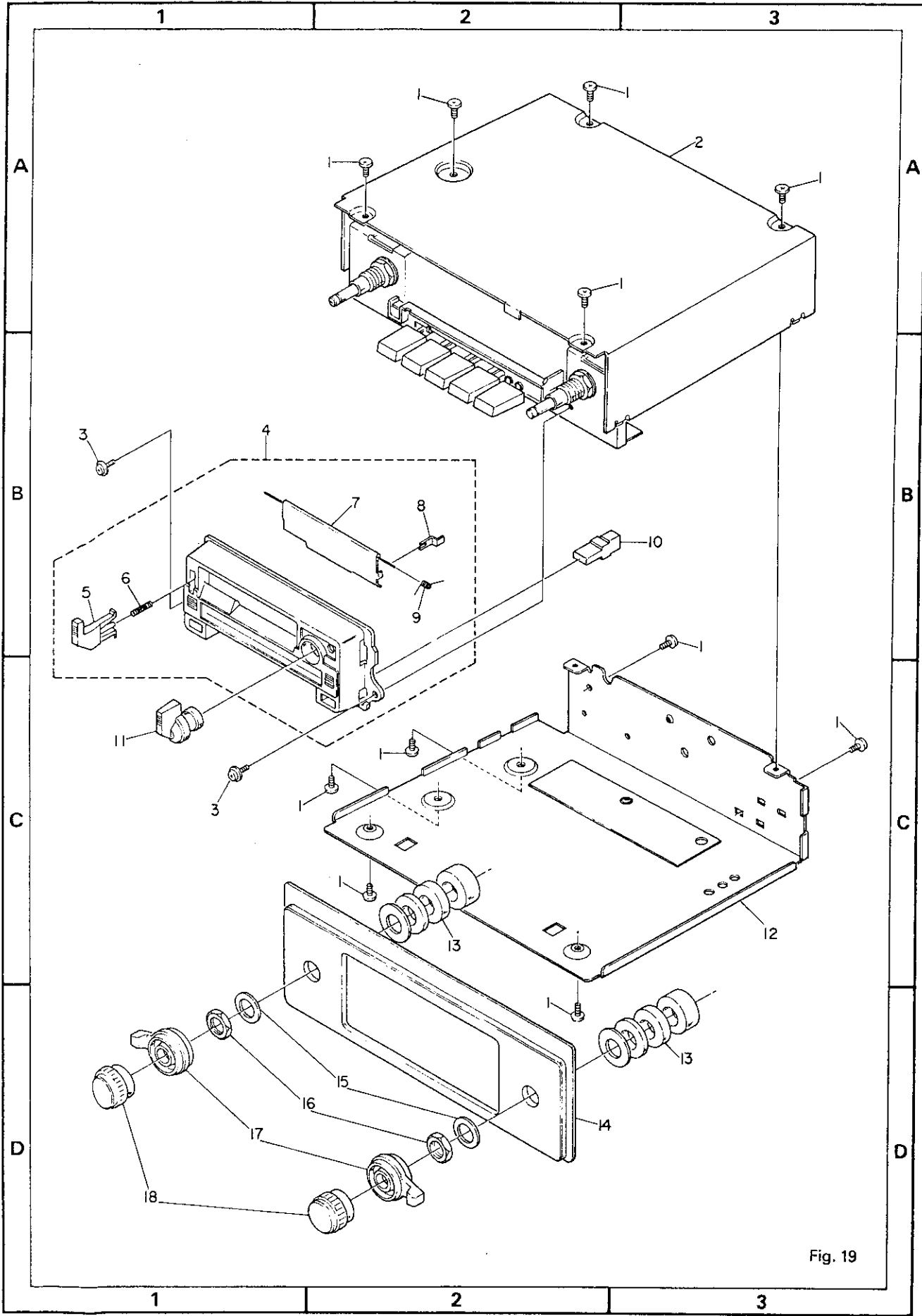
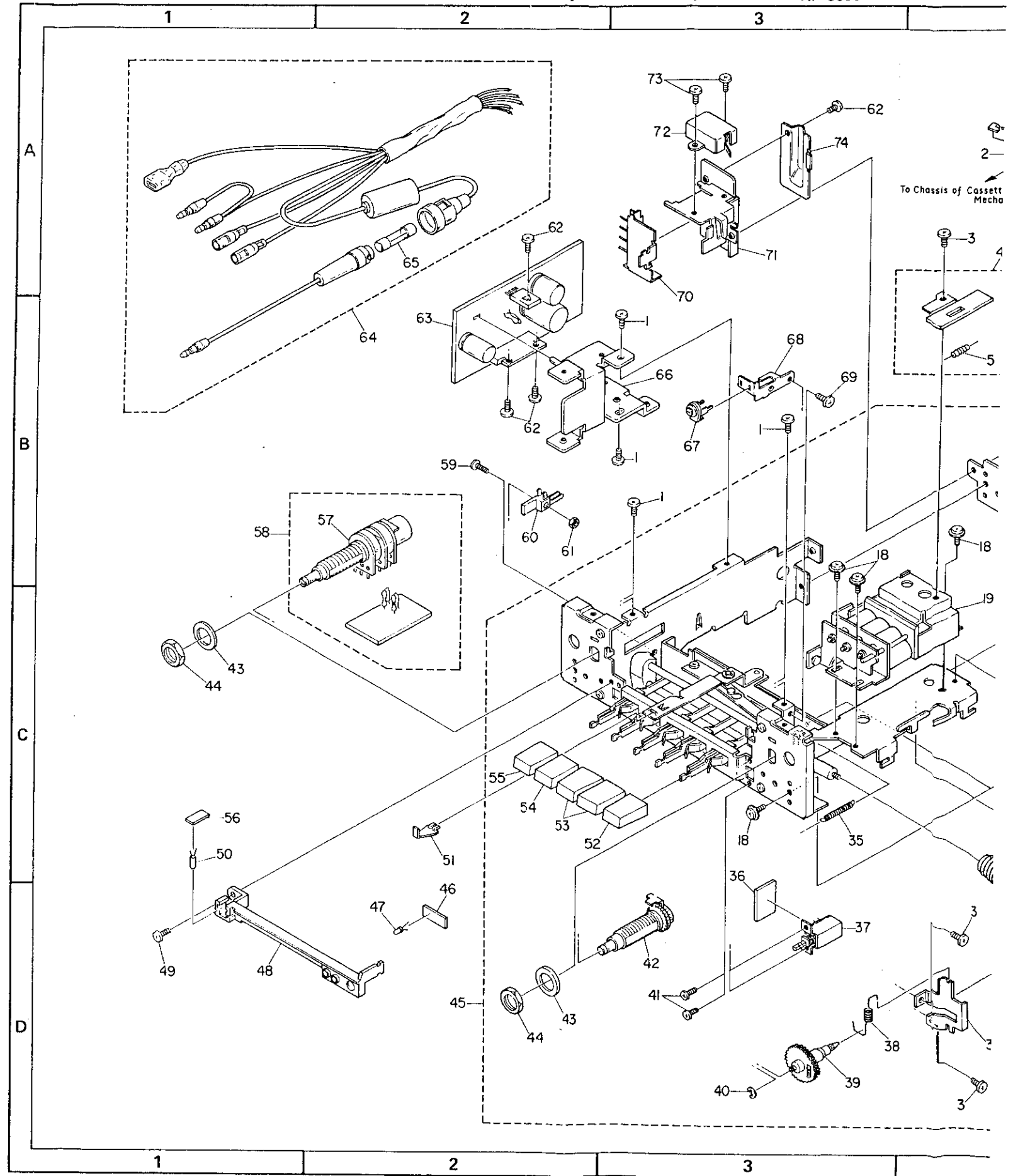

Fig. 19

9. CHASSIS EXPLODED VIEW (KP-5500, KP-5501)

KP-5500
 KP-5501
 KP-5800



To Chassis of Cassett Mecho

9. CHASSIS EXPLODED VIEW (KP-5500, KP-5501)

KP-5500
KP-5501
KP-5800

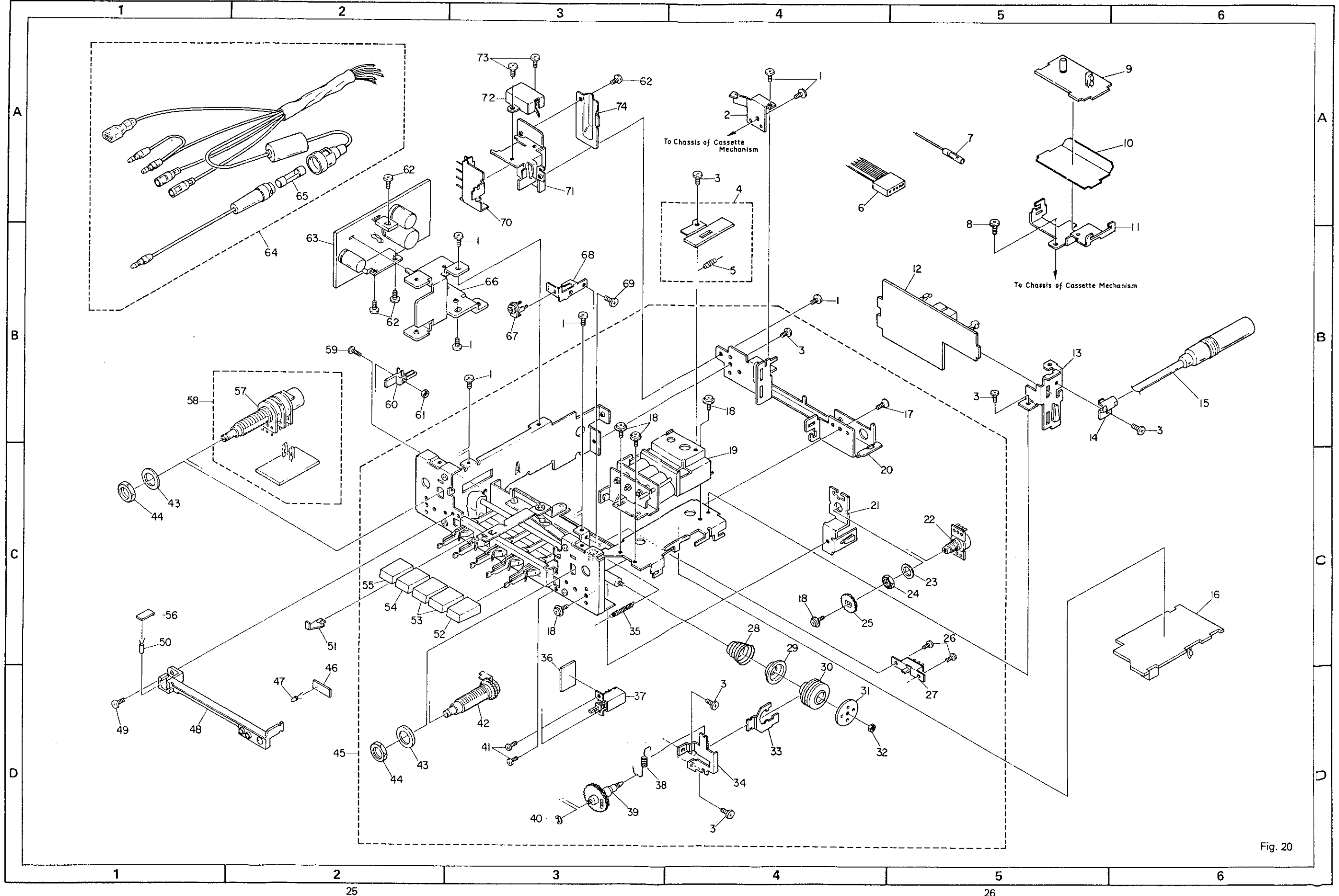

Fig. 20

10. CHASSIS EXPLODED VIEW (KP-5800)

KP-5500
KP-5501
KP-5800

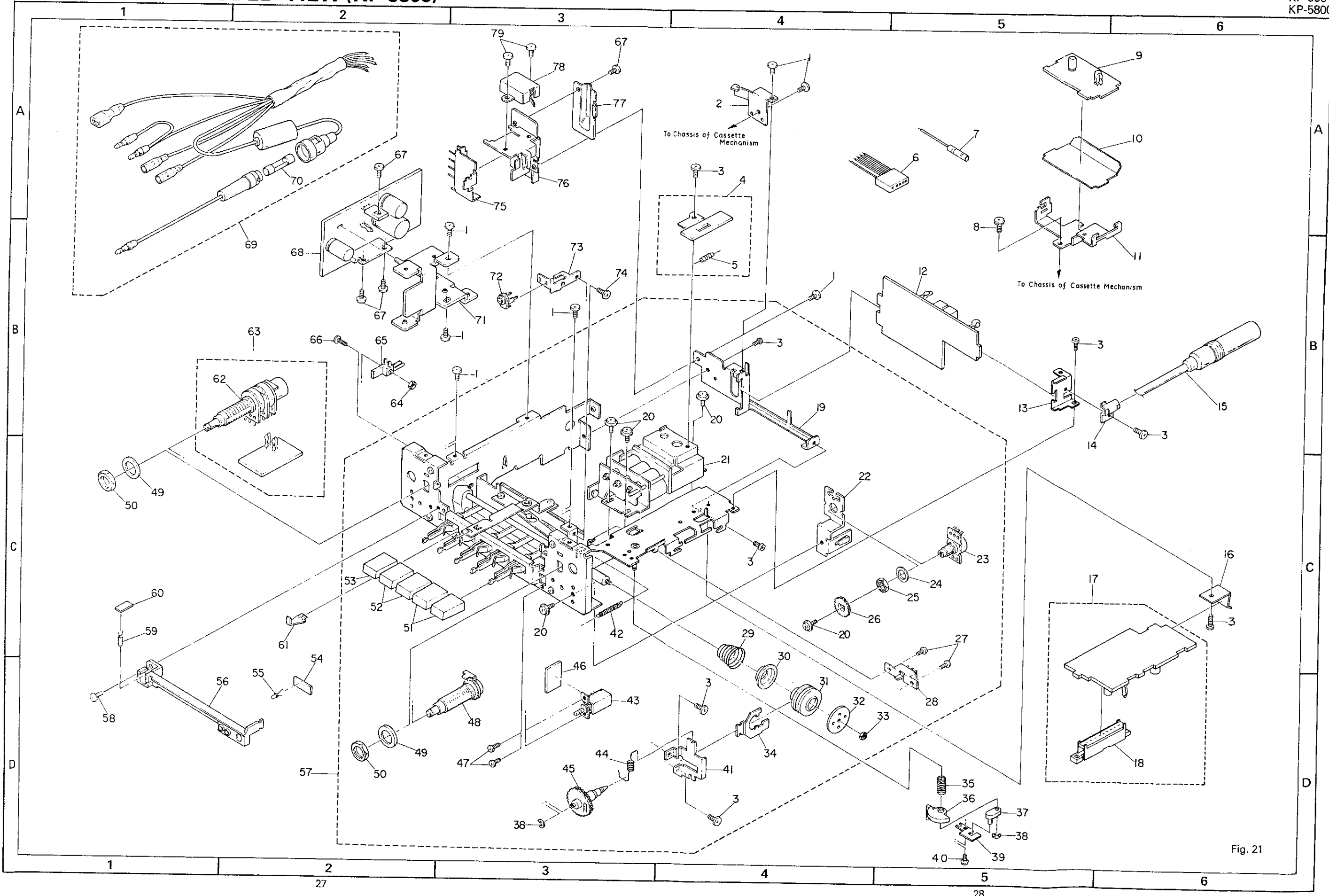

Fig. 21

11. PACKING METHOD

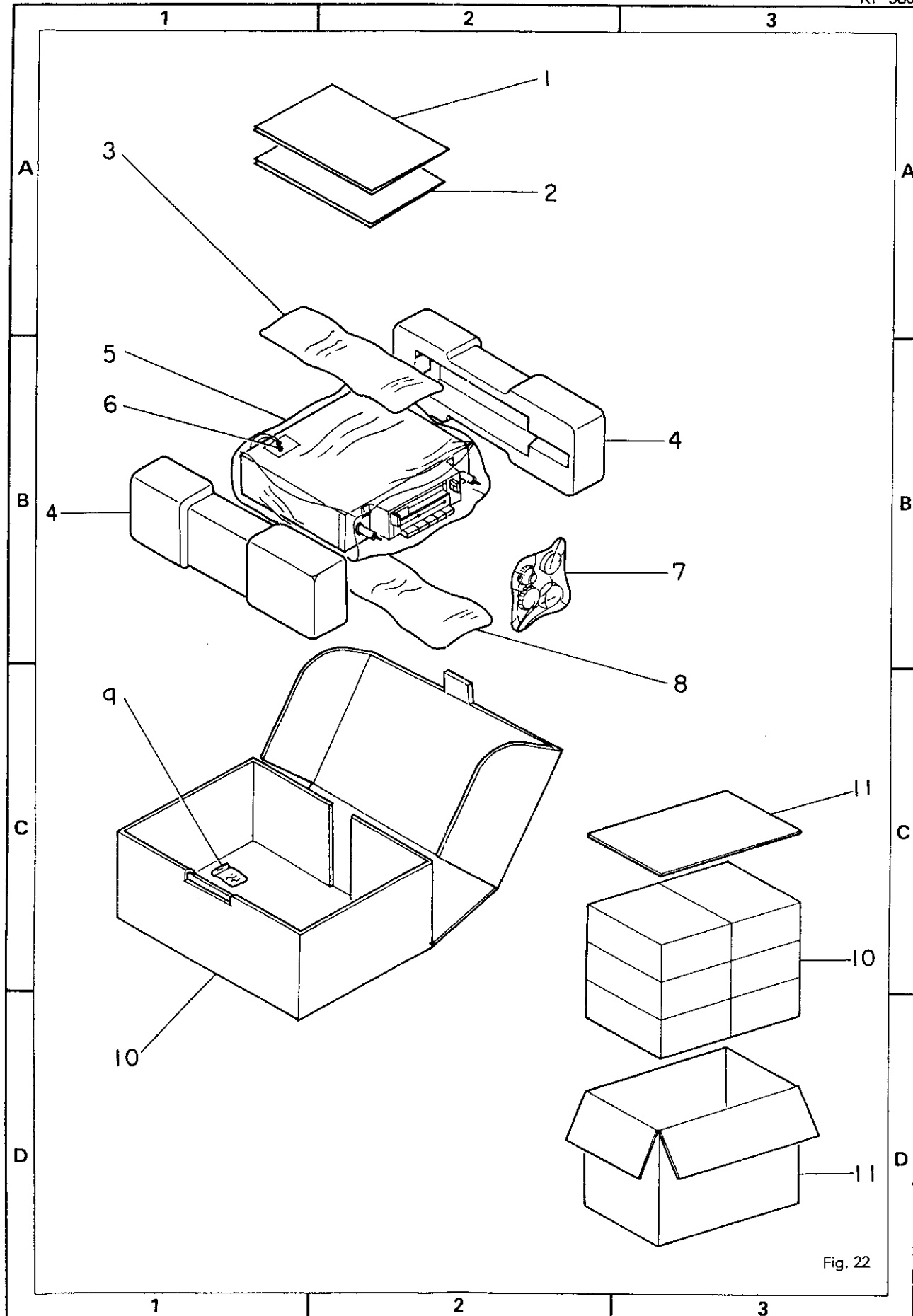

Fig. 22

12. PARTS LIST

NOTE:

When ordering resistors, first convert resistance values into code form as shown in the following examples.

Ex. 1 When there are 2 effective digits (any digit apart from 0), such as 560 ohm and 47k ohm (tolerance is shown by J = 5%, and K = 10%).

560Ω	56 × 10 ¹	561	RD1/4PS	561 J
47kΩ	47 × 10 ³	473	RD1/4PS	473 J
0.5Ω	0R5		RN2H	0R5 K
1Ω	010		RS1P	010 K

Ex. 2 When there are 3 effective digits (such as in high precision metal film resistors).

5.62 kΩ	562 × 10 ¹		RN1/4SR	562 F
---------	-----------------------	--	-------	---------	-------

- Parts whose parts numbers are omitted are subject to being not supplied.

Front End Unit (CWB-049) (KP-5500, KP-5501)

MISCELLANEOUS

Part No.	Symbol & Description	Part No.	Symbol & Description
2SK49-H2	Q1	CKDYD103M50	C12
2SC1674	Q2	CKDYB222K50	C14
2SC1675-M	Q3	CCDTH150J50	C15
1S2790	D1	CCDTH390J50	C16
	L1	CCDTH100F50	C17, C18
	L2	CCDCH070D50	C19
CTF-039 or CTF-065	L2	CGBR47K500	C21
	L3		
CTF-039	L4		
	L5		

Front End Unit (CWB-047) (KP-5800)

MISCELLANEOUS

Part No.	Symbol & Description	Part No.	Symbol & Description
CTC-043	T1	2SK49-H1	Q1
CCG-008	TC1 - TC3	2SC1674	Q2
CCX-001	CR1	2SC1675-M	Q3
		1S2790	D1
			L1
			FM Coil
		CTF-039 or CTF-065	L2
			Ferri Inductor, 2.7μH
			L3
			FM Coil
		CTF-039	L4
			Ferri-Inductor, 2.7μH
			L5
			FM Coil
		CTC-043	T1
		CCG-008	TC1 - TC3
		CCX-001	CR1
			1kΩ/2200pF

RESISTORS

Part No.	Symbol & Description
RD1/4VME11111J	R1 - R4, R8
RD1/10PSE11111J	R5 - R7

CAPACITORS

Part No.	Symbol & Description
CCDSL220K500	C1
CCDSL220J50	C2
CCDSL150J50	C3
CCDRH100F50	C4
CKDYF103Z25	C5, C13, C20
CCDSL560J50	C6
CCDRH270J50	C7
CCDCH060D50	C8, C9
CGBR75K500	C10
CCDSL820J50	C11

RESISTORS

Part No.	Symbol & Description
RD1/4M11111J	R1 - R4, R8
RD1/10PSE11111J	R5 - R7

PARTS LIST

CAPACITORS

Part No.	Symbol & Description
CCDSL220K500	C1
CCDSL220J50	C2
CCDSL150J50	C3
CCDPH120J50	C4
CKDYF103Z25	C5, C14, C21
CCDSL470J50	C6
CCDRH270J50	C7
CCDCH030C50	C8
CCDCH060D50	C9, C10
CGBR75K500	C11
CCDSL820J50	C12
CKDYD103M50	C13
CKDYB222K50	C15
CCDTH150J50	C16
CCDTH390J50	C17
CCDRH120J50	C18
CCDTH100F50	C19
CCDCH070D50	C20
CGBR47K500	C22

AM (MW) Unit (CWE-347) (KP-5500, KP-5501)

MISCELLANEOUS

Part No.	Symbol & Description
LA1130	IC1
MV-11	D1
CTB-094	L1 Coil
CTF-005	L2 Ferri-Inductor, 5 μ H
CTF-016	L3 Ferri-Inductor, 15 μ H
CTE-105	T1 IF Transformer
CTE-106	T2 IF Transformer
CCG-041	TC1, TC2 Ceramic Trimmer
CTF-122	CF1 Ceramic Filter

RESISTORS

Part No.	Symbol & Description
RD1/4VM□□□J	R1-R5, R7, R8
RD1/4PM□□□J	R6

CAPACITORS

Part No.	Symbol & Description
CKDBC473K25	C1, C4
CKDBC103K25	C2, C14
CQMA272J50	C3
CCDLH101K50L	C5, C6
CCDLH121K50L	C7

Part No.	Symbol & Description
CQMA222J50	C8, C13
CEA470M10L	C9
CQMA103K50	C10
CCDSL470K50L	C11
CEA101M10L	C12
CKDBC333K25	C15
CSYAR15M10	C16
CEA220M10L	C17
CEAR47M50NP	C18
CEA4R7M25L	C19

MW/LW Unit (CWE-346) (KP-5800)

MISCELLANEOUS

Part No.	Symbol & Description
2SC460-A	Q1, Q3, Q4
2SC460-B	Q2
1S1555 or	D1
1S2473 or	
1S2076	
CTF-005	L1 Ferri-Inductor, 5 μ H
CTE-058	T1, T2 Coil
CTE-025	T3 Coil
CTB-093	T4 Coil
CTE-024	T5 Coil
CTE-105	T6 IF Transformer
CTE-104	T7 IF Transformer
CCG-062	TC1, TC2 Ceramic Trimmer, 50pF
CTF-122	CF1 Ceramic Filter
CSH-068	S1 Switch

RESISTORS

Part No.	Symbol & Description
RD1/4VM□□□J	R1-R17, R19, R20, R22-R25, R31, R32
RD1/4PS□□□J	R18
VACANT	R21, R26-R30

CAPACITORS

Part No.	Symbol & Description
CCDPH101K50L	C1, C17
CQSAH182J50	C2
CQMA822J50	C3
CQMA472J50	C4
CEA2R2M50L	C5
CKDBB103K25	C6, C14, C16, C29
CCDSL100F50L	C7, C15
CKDBC473M25	C8, C12, C20, C21, C32
VACANT	C9, C13, C18
CQMA222J50	C10

PARTS LIST

Part No.	Symbol & Description
CCDLH101K50L	C11
CQSAH122J50	C19
CQMA103K50	C22, C24
CQMA393M50	C23
CEA220M10L	C25
CQMA472K50	C26
CEA101M10L	C27
CSYAR22M10	C28
VACAMT	C30
CCDSL470K50L	C31
CEA100M16L	C33

IF/MPX Unit (CWE-345)

MISCELLANEOUS

Part No.	Symbol & Description
μPC1200V	IC1
LA2101	IC2
μPC1187V	IC3
2SC1675-M	Q1
CTF-016	L1, L2 Ferris-Inductor, 15μH
CTC-108	T1 Coil, 18μH
CTC-118	T2 Coil
C92-618	VR1 Semi-fixed, 4.7kΩ (B)
CCP-093	VR2 Semi-fixed, 1.5kΩ (B)
CTF-040	CF1, CF2 Ceramic Filter

RESISTORS

Part No.	Symbol & Description
RD1/4VM□□□J	R1-R9, R11, R13-R15, R17-R35
VACANT	R10
RD1/4PS□□□J	R12, R16

CAPACITORS

Part No.	Symbol & Description
CEA2R2M50L	C1
CKDBC223K25	C2-C7, C10, C12
CKDBC103K25	C8, C21
VACANT	C9
CCDSL101K50	C11
CEA100M16L	C13, C19
CEA010M50L	C14
CKDSA271J50	C15-C18
CCDSL050D50L	C20
CEA101M10L	C22, C40
CQMA152J50	C23
CKDSA681J50	C24, C25
CQMA122J50	C26
CKDSA680J50	C27
CKDBC682K25	C28

Part No.	Symbol & Description
CKDSA102J50	C29
CKDSA561J50	C30, C31
CKDBC473K25	C32
CEA010M50NP	C33
CSYAR47M16	C34
CSYAR22M10	C35, C36
CQSAH471K50	C37
CQMA183K50	C38, C39

Volume Unit (CWG-078)

Part No.	Symbol & Description
CCS-234	VR1 Volume/Switch, 20kΩ (A), 50kΩ (A)
RD1/4VM□□□J	R1, R2
CSYAOR1M10	C1, C2
CCS-234	S1 Volume/Switch

Pre Amp Unit (CWF-072)

Part No.	Symbol & Description
MB3106M	IC1
1S1555 or 1S2076	D1
RD1/4VM□□□J	R1-R8
CKDYB681K50L	C1, C2
CEANL100M16L	C3, C4
CEA470M10L	C5, C6
CQMA103J50	C7, C8
CEA101M10L	C9

Antenna P.W. Board Unit

Part No.	Symbol & Description
CTH-025	L1 Coil, 4.7μH

Motor P.W. Board Unit (CWX-324)

Part No.	Symbol & Description
2SA715WT	Q1
1S1886	D1
RD1/4PS□□□J	R1, R2
CEA330P16	C1
CEA100P16	C2

PARTS LIST

Main Amp Unit (CWH-107)

MISCELLANEOUS

Part No.	Symbol & Description
HA1398	IC1
LVC509	IC2
2SC1740LN or 2SC945L	Q1, Q2
2SC1815	Q3-Q5
2SA1015-Y	Q6
YZ-074A	D1
1S1555 or 1S2076	D2-Q4
W03A, B, C or 1S1886	D5
CTH-035	L1-L3 Coil, 10 μ H
CTH-018	L4 Coil, 0.5mH
CWW-049	IB1, IB2

RESISTORS

Part No.	Symbol & Description
RD1/4VM□□□J	R1-R15
RD1/4VS□□□J	R16, R17
RD1/4PS□□□J	R18

CAPACITORS

Part No.	Symbol & Description
CKDYB101K50L	C1, C2
CQMA102J50	C3, C4
CQMA392J50	C5, C6
CEA2R2M50L	C7, C8
CKDYB151K50L	C9, C10
CEA101M10L	C11-C14, C20
CEA102M10L	C15, C16
CQMA104K50	C17, C18
CCH-050	C19 2000 μ F/16V or 2200 μ F/16V
CEA100M16L	C21
CEA471M10L	C22
CEA220M10L	C23
CEA470M10L	C24
CEA4R7M25L	C25
CEA010M50L	C26

Miscellaneous Parts List

Part No.	Symbol & Description
TLR-102	D1 LED
CCS-123 or CCS-204	VR1 Volume, 50k Ω (W) or 50k Ω (G)
CCG-022	TC1 Ceramic Trimmer
CEL-089	IL1 Lamp, 14V 40mA
E21-005	FU1 Fuse, 2A
CPB-057	HD1 Head
CXM-046	M Motor
CSN-060	S1 Switch
CSN-059	S2 Switch
CSH-046	S3 Switch (KP-5500, KP-5501)
CSH-067	S3 Switch (KP-5800)
CSL-003	S4 Switch
CSG-099	S5 Switch
CCL-094	C1 Feed through Capacitor

Cabinet

Key No.	Part No.	Description
1.	BMZ30P040FMC	Screw
2.	CXC-029	Case Unit
3.	BMF26P060FMC	Screw
4.	CXC-027	Grille Unit (KP-5500)
	CXC-028	Grille Unit (KP-5501)
	CXC-026	Grille Unit (KP-5800)
5.		Button
6.		Spring
7.	CAT-089	Door
8.	CNE-230	Holder
9.	CBH-516	Spring
10.	CAC-304	Button
11.	CAA-268	Knob
12.	CXC-031	Case Unit
13.	CNV-769	Washer
14.	CEA-352	Panel
15.	CND-646	FW10 \emptyset x 1t
16.	CBN-016	N10 \emptyset x 3t
17.	CAA-322	Knob
18.	CAA-313	Knob

PARTS LIST

Chassis (KP-5500, KP-5501)

Key No.	Part No.	Description
1.	BMZ30P050FMC	Screw
2.		Bracket
3.	BMZ26P040FMC	Screw
4.		Antenna P.W.Board Unit
5.	CTH-025	Coil, 4.7 μ H
6.	CDE-570	Connector
7.		Connector
8.	PMA26P060FUC	Screw
9.	CWF-072	Pre Amp Unit
10.		Insulator
11.		Bracket
12.	CWE-345	IF/MPX Unit
13.		Holder
14.		Clamper
15.	CDH-026	Antenna Cable
16.	CWE-347	AM (MW) Unit
17.	CMZ26P040FMC	Screw
18.	PMS26P040FUC	Screw
19.	CWB-049	Front End Unit
20.		Frame
21.		Bracket
22.	CCS-123 or CCS-204	Volume, 50k Ω (W) or 50k Ω (G)
23.	CBE-012	FW7 ϕ \times 0.5t
24.	CBN-003	N7 ϕ \times 2t
25.		Gear
26.	BMZ20P030FMC	Screw
27.	CSH-046	Switch
28.		Spring
29.		Washer
30.	CXB-415	Friction Unit
31.	CND-647	Friction Plate
32.	NA30FMC	Nut
33.		Arm
34.		Holder
35.		Spring
36.		P.W. Board
37.	CSG-099	Switch
38.	CBH-141	Spring
39.		Gear Assy
40.	YE20FUC	Washer
41.	PMZ20P040FMC	Screw
42.		Tuning Shaft Assy
43.	CND-646	FW10 ϕ \times 1t
44.	CBN-016	N10 ϕ \times 3t
45.	CPN-806 CPN-809	AM/FM Pre-set Tuner (KP-5500) AM/FM Pre-set Tuner (KP-5501)
46.		P.W. Board
47.	TLR-102	LED
48.		Holder

Key No.	Part No.	Description
49.	PMZ26P040FMC	Screw
50.	CEL-089	Lamp, 14V 40mA
51.	CAF-034	Pointer
52.	CAC-239	Button (KP-5500)
	CAC-241	Button (KP-5501)
53.	CAC-239	Button (KP-5500)
	CAC-242	Button (KP-5501)
54.	CAC-238	Button (KP-5500)
	CAC-242	Button (KP-5501)
55.	CAC-238	Button (KP-5500)
	CAC-146	Button (KP-5501)
56.		P.W. Board
57.	CCS-234	Volume/Switch
58.	CWG-078	Volume Unit
59.	BMZ20P080FMC	Screw
60.	CSN-059	Switch
61.	NA20FMC	Nut
62.	BMZ30P060FMC	Screw
63.	CWH-107	Main Amp Unit
64.	CDE-725	Cord
65.	E21-005	Fuse, 2A
66.		Heat Sink
67.	CCG-022	Ceramic Trimmer
68.		Holder
69.	PMA26P050FMC	Screw
70.	CCL-094	Feed through Capacitor
71.		Holder
72.	CSL-003	Switch
73.	PMZ30P040FMC	Screw
74.		Clamper

Chassis (KP-5800)

Key No.	Part No.	Description
1.	BMZ30P050FMC	Screw
2.		Bracket
3.	BMZ26P040FMC	Screw
4.		Antenna P.W. Board Unit
5.	CTH-025	Coil, 4.7 μ H
6.	CDE-570	Connector
7.		Connector
8.	PMA26P060FUC	Screw
9.	CWF-072	Pre Amp Unit
10.		Insulator
11.		Bracket
12.	CWE-345	IF/MPX Unit
13.		Holder
14.		Clamper
15.	CDH-026	Antenna Cable
16.	CBL-130	Spring
17.	CWE-346	MW/LW Unit
18.	CSH-068	Switch
19.		Frame
20.	PMS26P040FUC	Screw

PARTS LIST KP-5500
KP-5501
KP-5800

Key No.	Part No.	Description	Key No.	Part No.	Description
21.	CWB-047	Front End Unit	70.	E21-005	Fuse, 2A
22.		Bracket	71.		Heat Sink
23.	CCS-123 or CCS-204	Volume, 50kΩ (W) or 50kΩ (G)	72.	CCG-022	Ceramic Trimmer
24.	CBE-012	FM7ø × 0.5t	73.		Holder
25.	CBN-003	N7ø × 2t	74.	PMA26P050FMC	Screw
26.		Gear	75.	CCL-094	Feed through Capacitor
27.	BMZ20P030FMC	Screw	76.		Holder
28.	CSH-067	Switch	77.		Clamper
29.		Spring	78.	CSL-003	Switch
30.		Washer	79.	PMZ30P040FMC	Screw
31.	CXB-415	Friction Unit	Packing Method		
32.	CND-647	Friction Plate	Key No.	Part No.	Description
33.	NA30FMC	Nut	1.	CRD-109	Owner's Manual (KP-5500)
34.		Arm		CRD-111	Owner's Manual (KP-5501)
35.	CBH-579	Spring		CRD-107	Owner's Manual (KP-5800)
36.		Lever	2.	CRD-110	Owner's Manual (KP-5500)
37.		Lever		CRD-108	Owner's Manual (KP-5800)
38.	YE20FUC	Washer	3.	CEA-352	Panel
39.		Lever	4.	CHA-906	Styrofoam (1 set pair)
40.	BMZ20P050FMC	Screw	5.	E36-622	Polyethylene Bag
41.		Holder	6.		Tag
42.		Spring	7.	CEA-362	Knob Kit
43.	CSG-099	Switch	7-1.	CAA-322	Knob
44.	CBH-141	Spring	7-2.	CAA-313	Knob
45.		Gear Assy	8.	CEA-300	Accessory Kit
46.		P.W. Board	8-1.	CNC-975	Strap
47.	PMZ20P040FMC	Screw	8-2.	CDE-437	Cord
48.		Tuning Shaft Assy	8-3.	CNV-769	Washer
49.	CND-646	FW10ø × 1t	8-4.	CEA-215	Screw Kit
50.	CBN-016	N10ø × 3t	8-4-1.	CBA-028	Screw for Strap
51.	CAC-239	Button	8-4-2.	B70-055-A	WN4ø × 4.5t
52.	CAC-238	Button	8-4-3.	WS40FMC	Washer
53.	CAC-240	Button	8-4-4.	PMB50P200	Screw
54.		P.W. Board	8-4-5.	B70-056-A	WN5ø × 5.3t
55.	TLR-102	LED	8-4-6.	CND-646	FW10ø × 1t
56.		Holder	8-4-7.	CBN-016	N10ø × 3t
57.	CPN-805	AM/FM Pre-set Tuner	9.	CEA-253	Holder Kit
58.	PMZ26P040FMC	Screw	9-1.	BMZ40P060FMC	Screw
59.	CEL-089	Lamp, 14V 40mA	9-2.	WHX0FMC	Washer
60.		P.W. Board	10.	CHB-800	Carton (KP-5500)
61.	CAF-034	Pointer		CHB-802	Carton (KP-5501)
62.	CCS-234	Volume/Switch		CHB-798	Carton (KP-5800)
63.	CWG-078	Volume Unit			
64.	NA20FMC	Nut			
65.	CSN-059	Switch			
66.	BMZ20P080FMC	Screw			
67.	BMZ30P060FMC	Screw			
68.	CWH-107	Main Amp Unit			
69.	CDE-725	Cord			

PIONEER ELECTRONIC CORPORATION

4-1, Meguro 1 chome, Meguro-ku, TOKYO, 153, JAPAN

PIONEER ELECTRONICS OF AMERICA

1925 E. Dominguez St. Long Beach, Calif. 90810

PIONEER ELECTRONIC (EUROPE) N.V.

Luithagen-Haven 9, 2030 Antwerp, Belgium

PIONEER ELECTRONICS AUSTRALIA PTY. LTD.

178-184 Boundary Road, Braeside, Victoria 3195, Australia

<80E01E02K>

© FEB. 1980

<CRT-207-0>
Printed in Japan
