

Service Manual

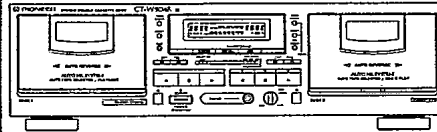

ORDER NO.
RRV1206

STEREO DOUBLE CASSETTE DECK

CT-W504R

THIS MANUAL IS APPLICABLE TO THE FOLLOWING MODEL(S) AND TYPE(S).

Type	Model	Power Requirement	Remarks
KUXJ	○	AC120V	

CONTENTS

1. SAFETY INFORMATION	2
2. BLOCK DIAGRAM	3
3. EXPLODED VIEWS, PACKING AND PARTS LIST ..	4
4. TEST MODE	10
5. ADJUSTMENTS	11
6. PCB CONNECTION DIAGRAM	15
7. SCHEMATIC DIAGRAM	21
8. PCB PARTS LIST	24
9. FL INFORMATION	27
10. PANEL FACILITIES	28
11. SPECIFICATIONS	29

1. SAFETY INFORMATION

This service manual is intended for qualified service technicians; it is not meant for the casual do-it-yourselfer. Qualified technicians have the necessary test equipment and tools, and have been trained to properly and safely repair complex products such as those covered by this manual.

Improperly performed repairs can adversely affect the safety and reliability of the product and may void the warranty. If you are not qualified to perform the repair of this product properly and safely, you should not risk trying to do so and refer the repair to a qualified service technician.



WARNING

Lead in solder used in this product is listed by the California Health and Welfare agency as a known reproductive toxicant which may cause birth defects or other reproductive harm (California Health & Safety Code, Section 25249.5).

When servicing or handling circuit boards and other components which contain lead in solder, avoid unprotected skin contact with the solder. Also, when soldering do not inhale any smoke or fumes produced.



NOTICE

(FOR CANADIAN MODEL ONLY)

Fuse symbols  (fast operating fuse) and/or  (slow operating fuse) on PCB indicate that replacement parts must be of identical designation.

REMARQUE

(POUR MODÈLE CANADIEN SEULEMENT)

Les symboles de fusible  (fusible de type rapide) et/ou  (fusible de type lent) sur CCI indiquent que les pièces de remplacement doivent avoir la même désignation.

(FOR USA MODEL ONLY)

1. SAFETY PRECAUTIONS

The following check should be performed for the continued protection of the customer and service technician.

LEAKAGE CURRENT CHECK

Measure leakage current to a known earth ground (water pipe, conduit, etc.) by connecting a leakage current tester such as Simpson Model 229-2 or equivalent between the earth ground and all exposed metal parts of the appliance (input/output terminals, screwheads, metal overlays, control shaft, etc.). Plug the AC line cord of the appliance directly into a 120V AC 60Hz outlet and turn the AC power switch on. Any current measured must not exceed 0.5mA.

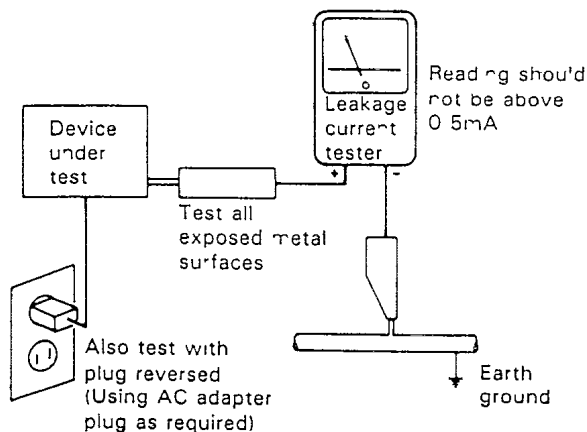

AC Leakage Test

ANY MEASUREMENTS NOT WITHIN THE LIMITS OUTLINED ABOVE ARE INDICATIVE OF A POTENTIAL SHOCK HAZARD AND MUST BE CORRECTED BEFORE RETURNING THE APPLIANCE TO THE CUSTOMER.

2. PRODUCT SAFETY NOTICE

Many electrical and mechanical parts in the appliance have special safety related characteristics. These are often not evident from visual inspection nor the protection afforded by them necessarily can be obtained by using replacement components rated for voltage, wattage, etc. Replacement parts which have these special safety characteristics are identified in this Service Manual.

Electrical components having such features are identified by marking with a Δ on the schematics and on the parts list in this Service Manual.

The use of a substitute replacement component which does not have the same safety characteristics as the PIONEER recommended replacement one, shown in the parts list in this Service Manual, may create shock, fire, or other hazards.

Product Safety is continuously under review and new instructions are issued from time to time. For the latest information, always consult the current PIONEER Service Manual. A subscription to, or additional copies of, PIONEER Service Manual may be obtained at a nominal charge from PIONEER.

2. BLOCK DIAGRAM

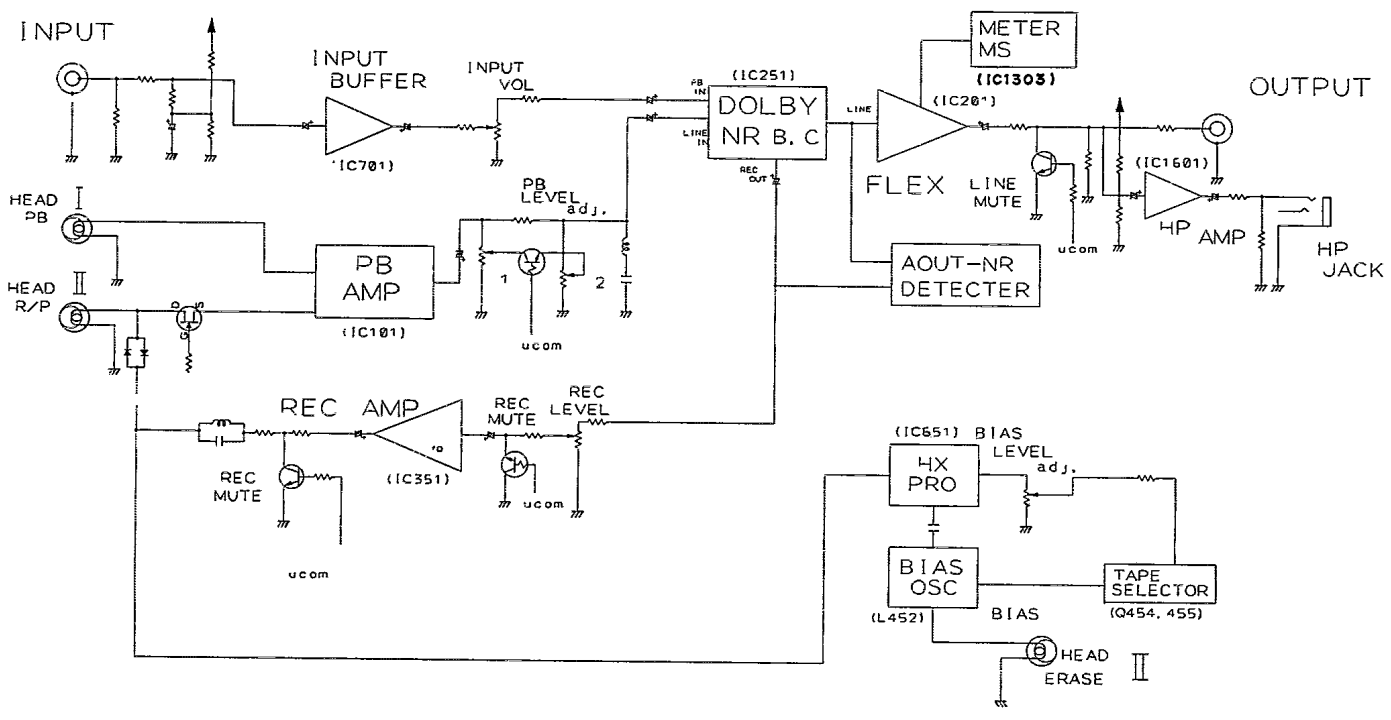

3. EXPLODED VIEWS, PACKING AND PARTS LIST

NOTES:

- Parts marked by “NSP” are generally unavailable because they are not in our Master Spare Parts List.
- The Δ mark found on some component parts indicates the importance of the safety factor of the part. Therefore, when replacing, be sure to use parts of identical designation.
- Parts marked by “ \odot ” are not always kept in stock. Their delivery time may be longer than usual or they may be unavailable.

1. EXTERIOR AND PACKING

Parts List

Mark	No.	Description	Part No.	Mark	No.	Description	Part No.
	1	Main Unit	RWZ3553		46	Slide Knob	REA1078
	2	Sub Unit	RWZ3554		47	Control Knob	RAC1878
NSP	3	Transformer 1 PCB	RNZ2602		48	Bonnet	REA1077
NSP	4	Transformer 2 Unit	RWZ3555		49	Eject Lever L	RNK2045
Δ	5	Strain Relief	CM - 22C		50	Eject Lever R	RNK2046
Δ	6	FU1001, FU1002 Fuse (1.5A)	REK1059		51	LED Lens	PNW2019
Δ	7	AC Power Cord	PDG1015		52	65 Label	ORW1089
	8	Lead Card 31P	RDD1299	NSP	53	Screw	BSZ26P120FMC
Δ	9	Power Transformer	RTT1223	NSP	54	Eject Collar	RLA1283
	10	1 Mechanism Unit (DECK I)	RYM1237		55	Arm Collar	RLA1290
	11	2 Mechanism Unit (DECK II)	RYM1238		56	Connector Assy 3P	RKP1678
	12	Rubber Sheet	AEB1111		57	Connector Assy 5P	RKP1677
	13	PCB Spacer	PNY - 404	NSP	58	Fuse Caution Label	RRW - 111
	14	Foot Assy	AEC1531		59	Connection Cord with Mini Plug (For SR terminal)	PDE - 319
	15	Door Spring L	RBH1304		60	Connection Cord Assy	RDE1036
	16	Door Spring R	RBH1305		61	Operating Instructions (English)	RRB1155
	17	Half Pressure Spring	RBK1004		62	Pad	RHA1115
NSP	18	Spacer	REB1267		63	Pad R	RHA1116
	19	Damper Assy	REC1005		64	Packing Case	RHG1635
	20	Knob Spacer	REC1195		65	Control Cord (For CD • DECK SYNCRO)	RDE1030
NSP	21	Main Chassis	RNB1091		66	Sheet	Z23 - 007
NSP	22	Earth Lead Unit	XDF - 504				
	23	Eject Spring L	RBH1379				
	24	Cord Clamper	RNH - 184				
	25	Balance Knob	RAC1705				
	26	Eject Knob L	RAC1881				
	27	Eject Knob R	RAC1882				
	28	Power Knob	RAC1883				
	29	Eject Spring R	RBH1380				
	30	REC Knob B	RAC1788				
	31	FL Lens	RAH2374				
	32	Front Panel	RAH2509				
	33	Door Pocket L	RAH2396				
	34	Door Pocket R	RAH2398				
	35	Door Lens	RAH2435				
	36	Name Plate	RAM1007				
	37	Remain Display Paper	REE - 113				
	38	Rear Panel	RNA1907				
	39	Eject Arm L	RNE1763				
	40	Screw	BCZ26P050FMC				
	41	Screw	BBZ30P060FMC				
	42	Screw	BBZ30P080FZK				
	43	Screw	IBZ30P150FCU				
NSP	44	Binder	Z09 - 057				
	45	Eject Arm R	RNE1764				

Packing

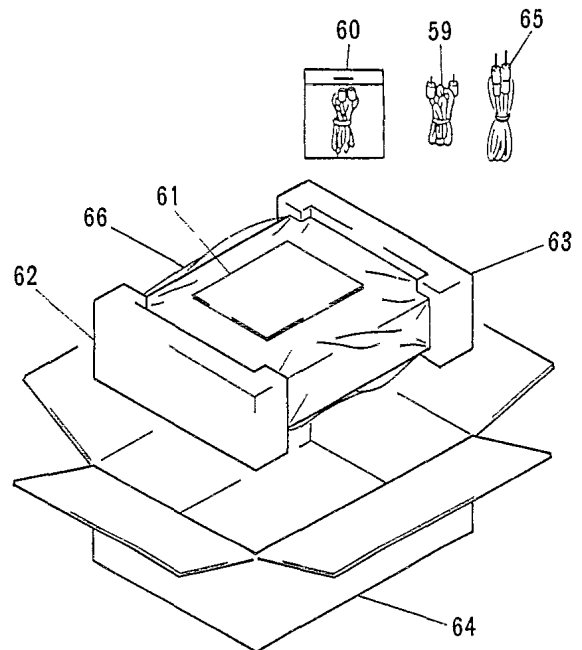

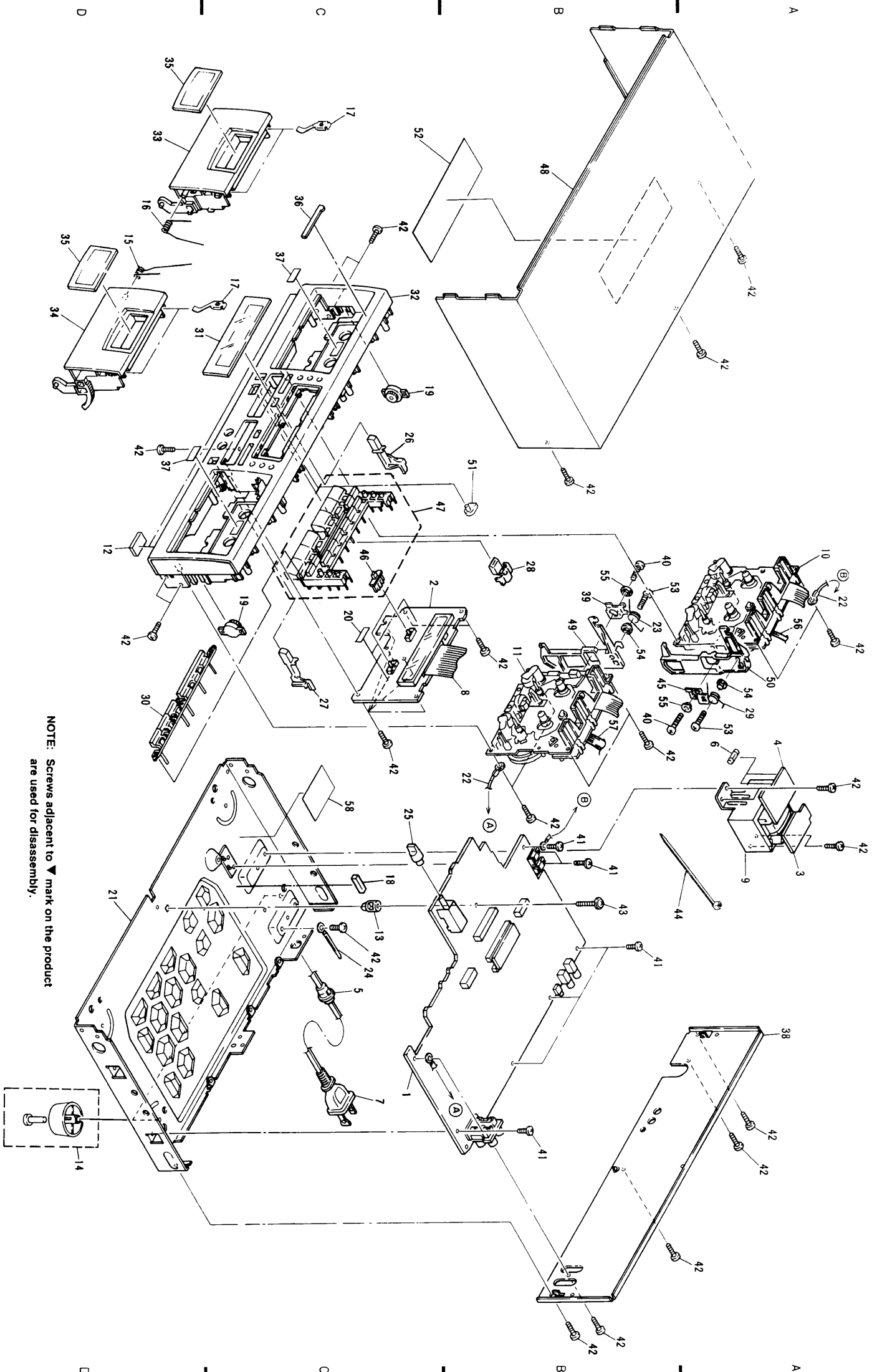

NOTE: Screws adjacent to ▼ mark on the product are used for disassembly.

2. 1 MECHANISM UNIT AND 2 MECHANISM UNIT

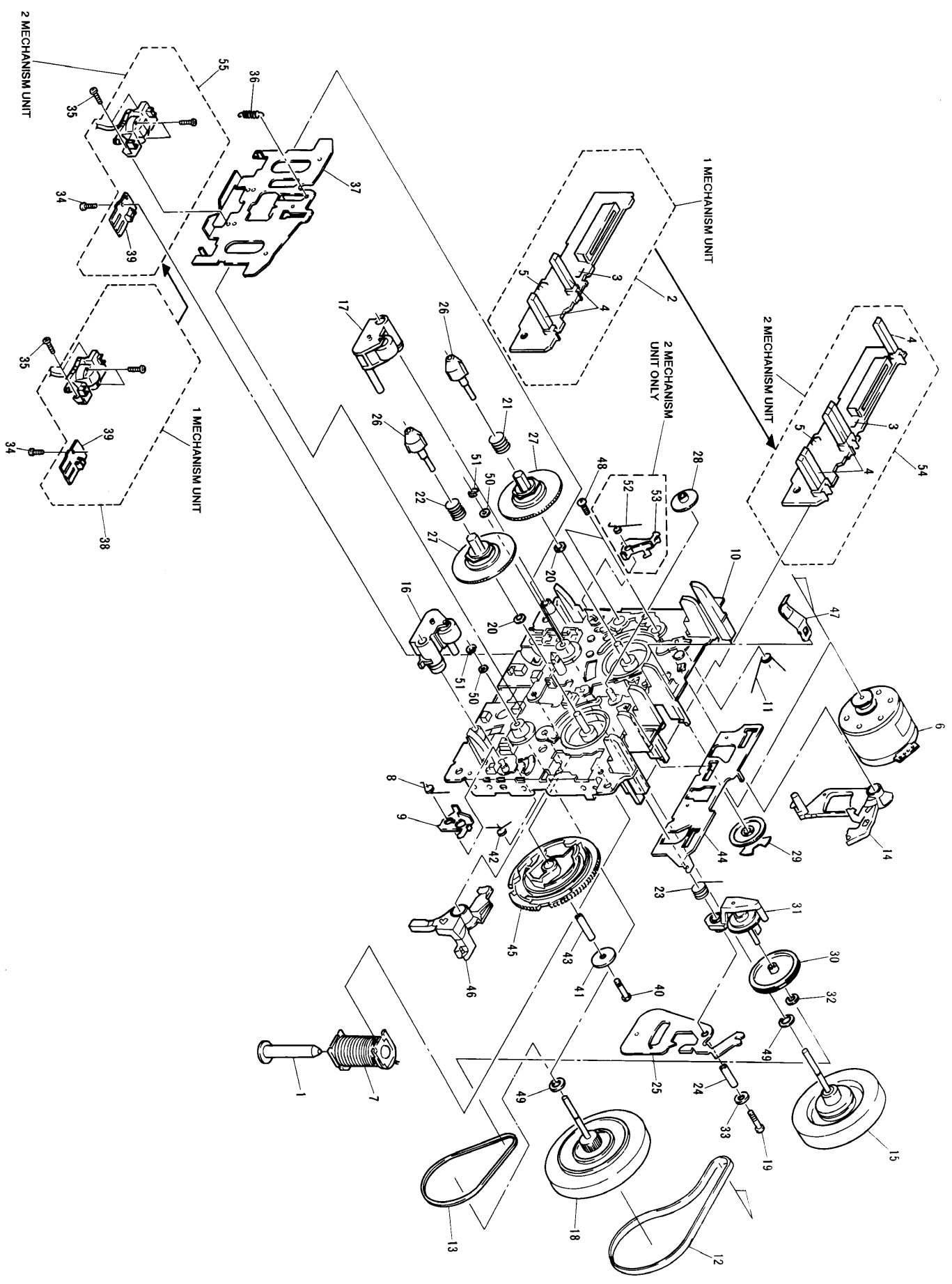

7 1 2 3 4 5 6

Parts List

Mark	No.	Description	Part No.	Mark	No.	Description	Part No.
	1	PLUNGER	RLA1288		51	STOP RING	YE15FUC
	2	PCB CONTROL BLK (1 MECHANISM UNIT)	RXA1623		52	SPRING INTERLOCK L (2 MECHANISM UNIT ONLY)	RBH1385
	3	PUSH SWITCH	RSG1018		53	ARM INTERLOCK L (2 MECHANISM UNIT ONLY)	RNE1780
	4	SPLF	RSN1023		54	PCB CONTROL BLK (2 MECHANISM UNIT)	RXA1624
	5	PHOTO - TRANSISTOR	SPI33534FG		55	PLATE HD BLK (2 MECHANISM UNIT)	RXA1683
	6	MTR MAIN BLK	RXM1081				
	7	SOLENOID BLK	RXP1021				
	8	SPRING INTERLOCK R	RBH1386				
	9	ARM INTERLOCK R	RNE1781				
	10	CHASSIS BASE BLK	RXA1626				
	11	SPRING BRAKE	RBH1387				
	12	MAIN BELT	REB1157				
	13	F/R BELT	REB1254				
	14	LEVER BRAKE	RNK2071				
	15	F/W ASSY	RXA1428				
	16	PINCH ROLLER BLK R	RXA1628				
	17	PINCH ROLLER BLK L	RXA1629				
	18	CLUTCH BLK ASSY	RXA1631				
	19	SCREW	RBA1113				
	20	WASHER 2.1x0.25T	RBF1038				
	21	SPRING REEL (L)	RBH1388				
	22	SPRING REEL (R)	RBH1389				
	23	CAM SPRING	RBH1393				
	24	SPACER	RLA1286				
	25	LEVER F/R	RNE1782				
	26	REEL FEATHER	RNK2072				
	27	REEL BASE	RNK2073				
	28	PLAY GEAR (A)	RNK2074				
	29	FF GEAR (A)	RNK2075				
	30	F/R PULLEY	RNK2076				
	31	CLUTCH BLK ASSY	RXA1632				
	32	WASHER	WA17D040D025				
	33	WASHER	WA23F060M040				
	34	SCREW	PCZ20P040FMC				
	35	SCREW	RBA1077				
	36	SPRING HB	RBH1390				
	37	HEAD BASE	RNE1783				
	38	PLATE HD BLK (1 MECHANISM UNIT)	RXA1682				
	39	HD PCB 5P	RXA1635				
	40	SCREW	RBA1113				
	41	WASHER 2.0x0.3	RBE1009				
	42	SPRING ARM PLAY	RBH1392				
	43	SPACER	RLA1286				
	44	PLATE SLIDE	RNE1785				
	45	CAM GEAR	RNK2078				
	46	ARM PLAY	RNK2079				
	47	SPRING CASSETTE	RNE1786				
	48	SCREW	BMZ26P040FZK				
	49	WASHER	WA26D045D025				
	50	WASHER	WA26D047D050				

4. TEST MODE

1. Entering the Test Mode

- To enter the test mode, set both DECK I and DECK II into the STOP mode and press the TIME/COUNT key of DECK I, RESET key of DECK I and PAUSE key of DECK II all together. (Refer to Fig.1)

Exiting the Test Mode

To exit the test mode, press the RESET key of DECK I or turn off the power.

2. Tape Speed Adjustment, Auto Stop Check Mode

- The following adjustments and check are possible in the test mode.

MODE No. (Deck II Display)	Adjustment and Check (The mechanism will operate even in the "no-half" state only for this mode.)
0	<ul style="list-style-type: none"> Tape speed adjustment mode During play (except during the assist), the speed can be doubled by pressing the FAST key (FF or REW key of DECK I or II). During double speed play, the play can be returned to normal speed by pressing the FWD or REV key.
0	<ul style="list-style-type: none"> Auto-stop check The RELAY mode will be turned on forcibly. But the REC is not relayed from DECK II to DECK I. Auto stop is carried out at tape end for one second only in this mode. (Usually four seconds.) Reverse is carried out as normally, but if the reverse is carried out in double speed, the tape will be played at constant speed.

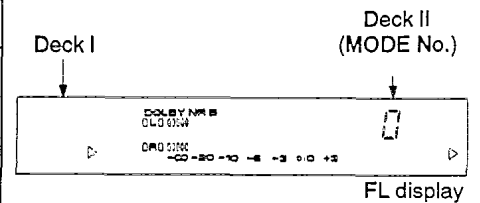

Fig. 1 FL display example 1
(The state of TEST MODE)

3. CD SYNCHRO, SW Check Modes

- Test mode setting.

MODE No. (Deck II Display)	Key Input	LINE MUTE	REC MUTE	BIAS	Adjustment and Check
	CD SYNC	ON	ON	OFF	<ul style="list-style-type: none"> CD SYNCHRO Check Short-circuit one of the CD SYNCHRO cord's plugs. Connect the other plug to the CD SYNCHRO jack of the cassette deck. Press the CD SYNC key. If "CD SYNC" is displayed, the CD SYNCHRO mode is normal.
1 (When there is no half on the deck II side, "HALF" will be displayed.)	TIME/COUNT for Deck I	ON	ON	OFF	<ul style="list-style-type: none"> SW Check When there is no-half, the corresponding counter will display "HALF". Mistaken Erasure Detection Check When FWD recording is possible : "▶" lights up When REV recording is possible : "◀" lights up Reverse SW Check ⎓ : "I" lights up Ⓞ : "II" lights up

- To change the MODE, press the STOP key and change the Mode No. to "0".

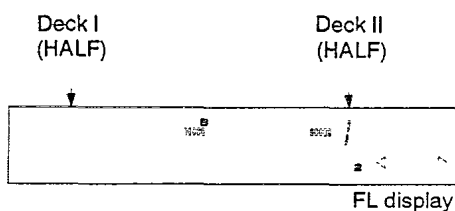

Fig. 2 FL display example 2
(The state of TIME/COUNT key ON on the Deck I side)

5. ADJUSTMENTS

5.1 MECHANICAL ADJUSTMENT

5.1.1 Door Damping Check and Adjustment

Set the door spring of the DECK I side to position (A) as shown in Fig. 5-1 Then, erect the front panel assembly vertically. Open the doors of DECK I and DECK II at the same time. At this point, confirm that the difference between the door completely opened and the other door is within 15mm. If this standard is not satisfied install the door spring of DECK I at another position and adjust as follows:

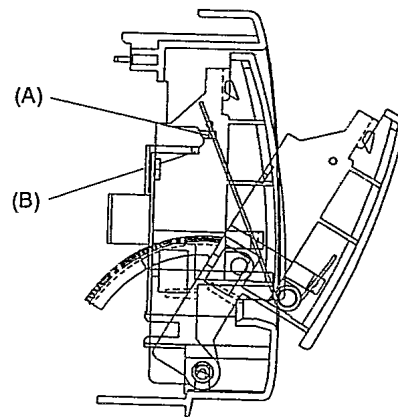

Fig. 5-1

- When the door of DECK I opens later than that of DECK II :
Change the door spring of DECK II from A to B.
- When the door of DECK I opens faster than that of DECK II :
Change the door spring of DECK I from A to B.

5.1.2 Tape Speed

- Perform this adjustment in the test mode.
 - TEST mode setting.
1. Press the TIME/COUNT and RESET keys of DECK I together with the PAUSE key of DECK II.
 2. The speed becomes normal when the PLAY key is pressed, and double when the FF key is pressed.
 3. To cancel the TEST mode, press the RESET key of DECK I or turn off the power.

1. Tape Speed Adjustment and Check						
No.	Deck	Mode	Test tape	Adjusting points	Specifications/Ratings (playback frequency)	Remarks
1	I	Double speed PLAY	STD-301 (3 kHz)	check	6000 Hz \pm 600 Hz	
2	II			VR851	Within \pm 10 Hz against the measurement value of the step 1 (deck I)	
3	I	NORMAL speed PLAY		VR801	2980 Hz \pm 5 Hz	
4	II			VR852	Within \pm 5 Hz against the measurement value of the step 3 (deck I)	

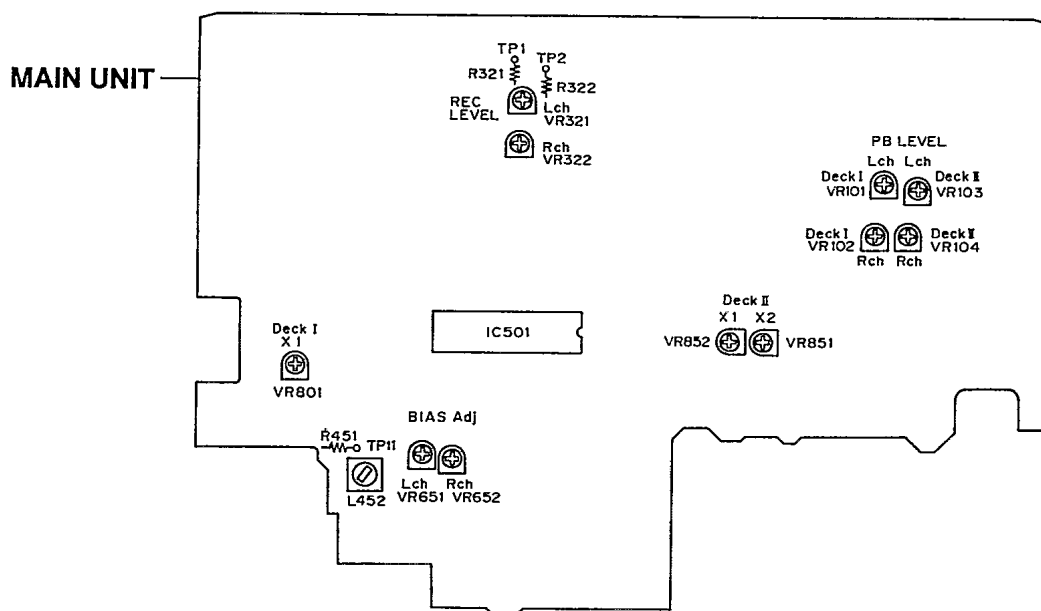

Fig. 5-2 Adjusting points

5.2 ELECTRICAL ADJUSTMENTS

Adjustment Conditions

1. The mechanical adjustments must be completed first.
2. The head must be cleaned and demagnetized.
3. Turn power on allow the deck to warm up for at least a few minutes before commencing any electrical adjustments.
4. The reference signal is 0 dBV=1 Vrms.
5. Connect a 10 kΩ load resistance to the OUTPUT terminals.
6. Unless otherwise specified, the switches listed below are left in the positions indicated.

DOLBY NR : OFF
 TAPE SELECTOR : NORM

Test Tapes

- STD-331E : Playback adjustments
 (See Fig. 5-3)
- STD-631 or STD-632 : NORMAL blank tape
- STD-621 : CrO2 blank tape
- STD-610 : METAL blank tape

* As the reference recording level is 250 nwb/m for STD-331E, the recording level will be higher by 4 dB for STD-331B (160 nwb/m). When adjusting, pay carefull attention to the type of tape used.

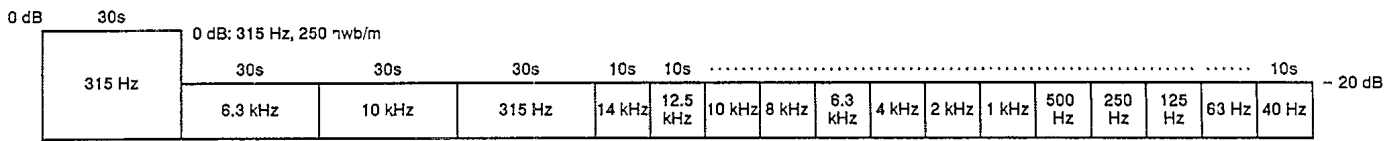
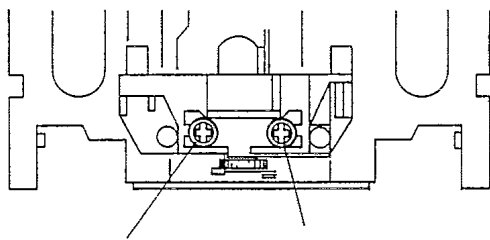

Fig. 5-3 Constants of the test tape STD-331E

DECK I



REV azimuth adjustment screw FWD azimuth adjustment screw

DECK II

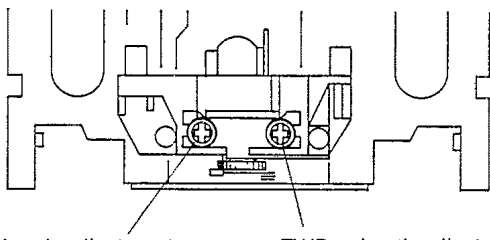

REV azimuth adjustment screw FWD azimuth adjustment screw

Fig. 5-4 Head azimuth adjustment

List of Adjustments

Playback sections

1. Head azimuth adjustment.
2. Playback level adjustment.

Recording sections

1. Bias oscillator adjustment.
2. Recording bias adjustment.
3. Recording level adjustment.
4. Level meter check.

NOTE: This unit has an automatic tape selection feature.

Dolby noise reduction and HX Pro headroom extension manufactured under license from Dolby Laboratories Licensing Corporation. HX Pro originated by Bang & Olufsen. "DOLBY", the double-D symbol and "HX PRO" are trademarks of Dolby Laboratories Licensing Corporation.

PLAY BACK

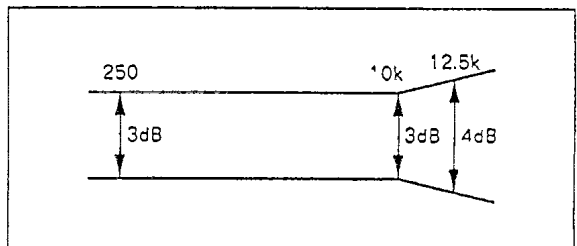

RECORDING

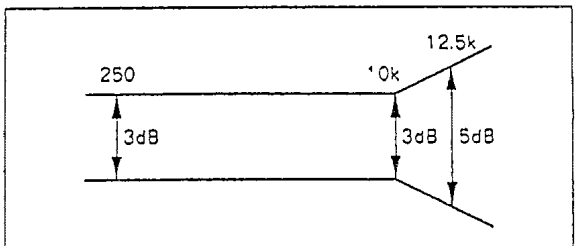

Fig. 5-5 Frequency response zone

PLAYBACK SECTION

1. Head Azimuth Adjustment

- Turn VR101, 102 (Deck I) or VR103, 104 (Deck II) to mechanical center positions.

No.	Mode	Input signal & test tape	Adjustment location	Measuring location	Adjustment value	Remarks	
1.	PLAY	Play the 10 kHz/-20 dB section of STD-331E test tape.	Head azimuth adjustment screw. (See Fig. 5-4)	LINE OUT	Maximum playback signal level.		
2.	STOP	Lock the screw with silicon bond after completing adjustment.					

2. Playback Level Adjustment

- This adjustment determines the DOLBY NR level, and must be performed with great care.

No.	Mode	Input signal & test tape	Adjustment location	Measuring location	Adjustment value	Remarks	
1.	PLAY	Play the 315 Hz/0 dB section of the STD-331E test tape.	Deck II	VR 103 (Lch) VR 104 (Rch)	TP. 1 (Lch) TP. 2 (Rch)	-6.7 dBV	
			Deck I	VR 101 (Lch) VR 102 (Rch)			

RECORDING SECTION

1. Bias Oscillator Adjustment

No.	Mode	Input signal & test tape	Adjustment location	Measuring location	Adjustment value	Remarks	
1.	REC	Load the STD-810 test tape with no input signal.	Deck II	L 452	TP. 11	105 kHz \pm 0.3kHz	If the adjustment value on the left cannot be obtained values within 105kHz \pm 0.3 kHz are also satisfactory.

2. Recording Bias Adjustment

- After the adjustment, caution should be exercised so as not to become under bias by checking the distortion rate.

No.	Mode	Input signal & test tape	Adjustment location	Measuring location	Adjustment value	Remarks
1.	REC	Record the 315 Hz and 10 kHz signals at -20 dBV input level and playback. (STD-631 or STD-632)	Deck II	VR651(Lch) VR652(Rch)	LINE OUT	Repeatedly record, playback and adjust so that the playback level of 10 kHz signal becomes 0 dB \pm 0.5 dB when compared with the 315 Hz signal.

3. Recording Level Adjustment

- Turn the DOLBY NR switch OFF.

No.	Mode	Input signal & test tape	Adjustment location		Measuring location	Adjustment value	Remarks
1.	REC PAUSE	Apply a 315 Hz/0 dBV signal to the line input terminals. load the STD-631 or STD-632 test tape.	REC level control volume		TP. 1 (Lch) TP. 2 (Rch)	-11.2 dBV	
2.	REC/ PLAY	Record the above signal onto the STD-631 or STD-632 test tape, and playback.	Deck II	VR321 (Lch) VR322 (Rch)		Repeatedly record, playback and adjust so that the playback signal level becomes - 11.2 dBV.	
3.	REC/ PLAY	Record the above signal onto the STD-621 test tape, and playback.	Check			-11.2 dBV ± 1.5dB	
4.	REC/ PLAY	Record the above signal onto the STD-610 test tape, and playback.	Check			-11.2 dBV ± 1.5dB	

4. Level Meter Check

No.	Mode	Input signal & test tape	Adjustment location	Measuring location	Adjustment value	Remarks
1.	REC PAUSE	Apply a 315 Hz/-6 dBV (500 mV) signal to the Line Input terminals.	REC level control volume	TP. 1 (Lch) TP. 2 (Rch)	Check that the level meters "0 dB" light up within -7.2 dBV ± 2 dB of the signal output level.	

• This diagram is viewed from the mounted parts side.

NOTE FOR PCB DIAGRAMS:

- 1. Part numbers in PCB diagrams match those in the schematic.
- 2. A comparison between the main parts of PCB and schematic diagrams is shown below.

Symbol in PCB Diagrams	Symbol in Schematic	Part Name
		Resistor
		Capacitor
		Diode
		Transistor
		IC
		Variable capacitor
		Variable inductor
		Relay
		Resistor array
		3-terminal capacitor

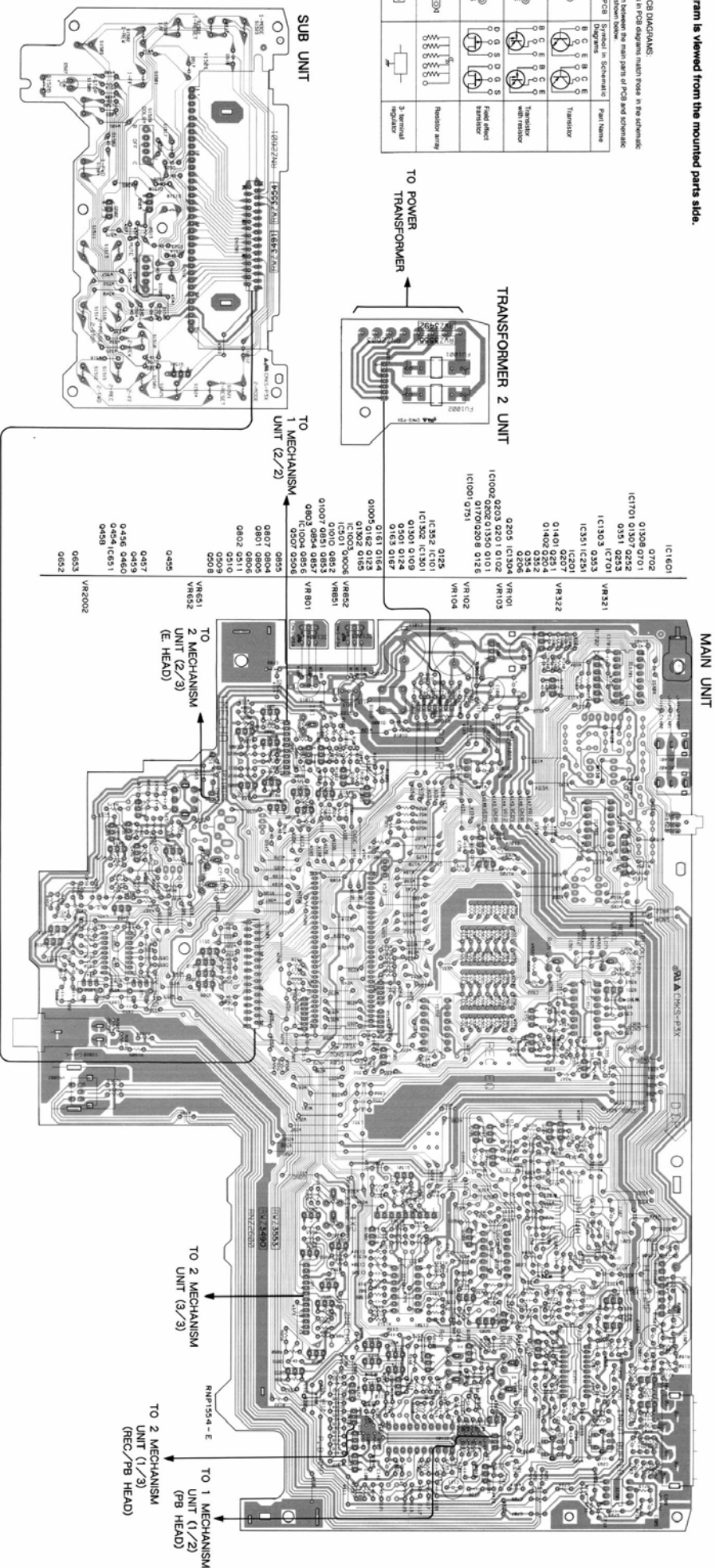

7. SCHEMATIC DIAGRAM

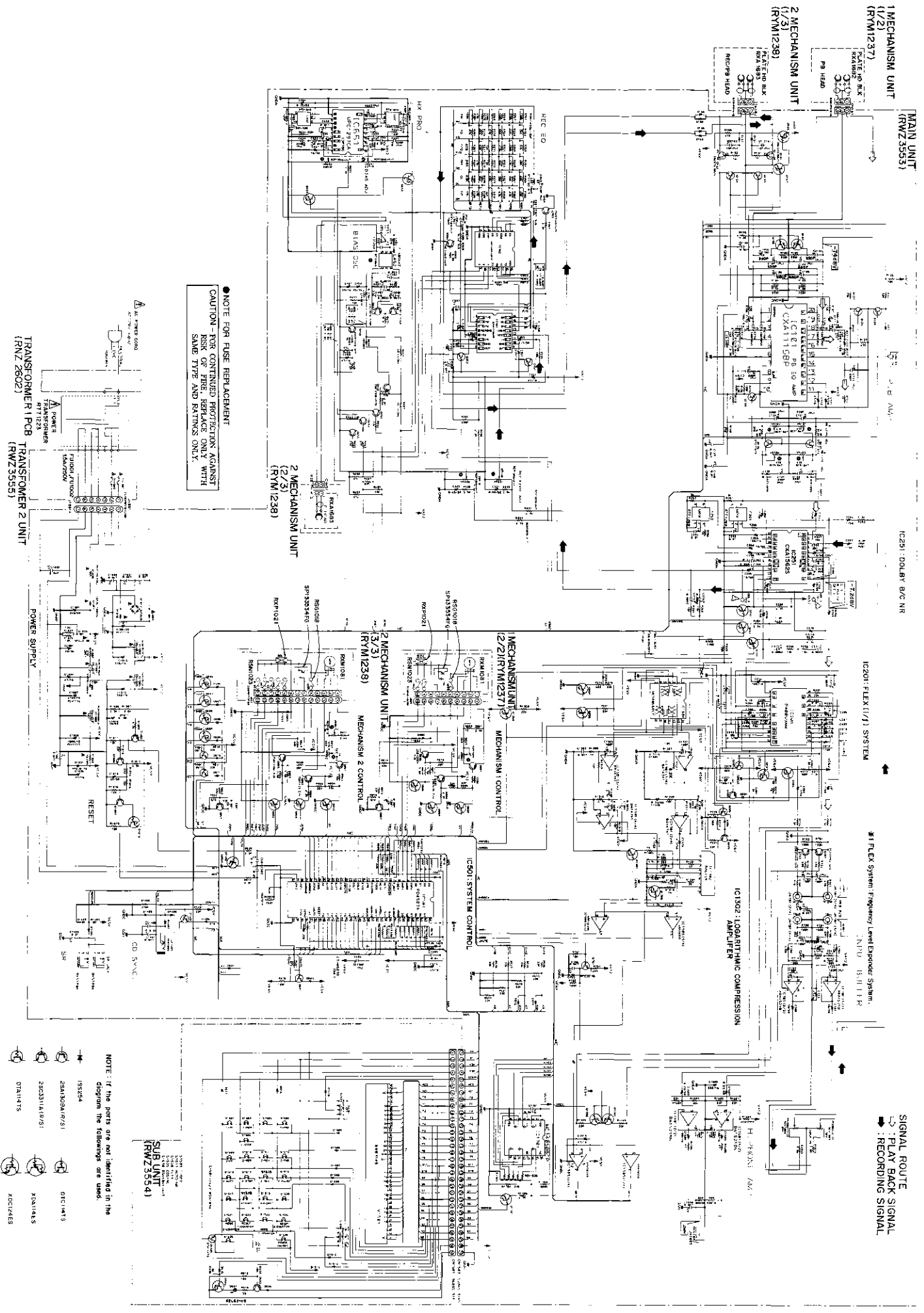

NOTE FOR FUSE REPLACEMENT
 CAUTION - FOR CONTINUED PROTECTION AGAINST
 RISK OF FIRE, REPLACE ONLY WITH
 SAME TYPE AND RATINGS ONLY.

NOTE: If the parts are not identified in the
 diagram the followings are used.

- 1S5524
- 2SA3204A(N/S)
- 2SC3211A(N/S)
- 07A1475
- 07A1475
- X002465

SIGNAL ROUTE
 ●: PILOT BACK SIGNAL
 ○: RECORDING SIGNAL

CT-WS04R

8. PCB PARTS LIST

NOTES:

- Part marked by "NSP" are generally unavailable because they are not in our Master Spare Parts List.
The "A" mark found on some component parts indicates the importance of the safety factor of the part.
Parts marked by "Q" are not always kept in stock.
When ordering resistors, first convert resistance values into code form as shown in the following examples.
Ex.1 When there are 2 effective digits (say digit apart from 0), such as 500 ohm and 47k ohm (tolerance is shown by J, K, M, and N values)
Ex.2 When there are 3 effective digits (such as in high precision metal film resistors)
Ex.3 When there are 4 effective digits (such as in high precision metal film resistors)

LIST OF ASSEMBLIES

Table with 4 columns: Mark No., Description, Part No., Mark No. This table lists various assemblies and their corresponding part numbers.

MAIN UNIT

Table with 4 columns: Mark No., Description, Part No., Mark No. This table lists components for the main unit, including semiconductors like regulators and transistors.

SEMICONDUCTORS

Table with 4 columns: Mark No., Description, Part No., Mark No. This table lists semiconductor components like diodes, transistors, and thyristors.

Mark No. Description Part No.

Table with 4 columns: Mark No., Description, Part No., Mark No. This table lists various electronic components.

COILS AND FILTERS

Table with 4 columns: Mark No., Description, Part No., Mark No. This table lists coils and filter components.

CAPACITORS

Table with 4 columns: Mark No., Description, Part No., Mark No. This table lists capacitor components.

Mark No. Description Part No.

Table with 4 columns: Mark No., Description, Part No., Mark No. This table lists various electronic components.

RESISTORS

Table with 4 columns: Mark No., Description, Part No., Mark No. This table lists resistor components.

OTHERS

Table with 4 columns: Mark No., Description, Part No., Mark No. This table lists other miscellaneous components.

Mark No. Description Part No.

Table with 4 columns: Mark No., Description, Part No., Mark No. This table lists various electronic components.

SUB UNIT

Table with 4 columns: Mark No., Description, Part No., Mark No. This table lists sub-unit components.

SEMICONDUCTORS

Table with 4 columns: Mark No., Description, Part No., Mark No. This table lists semiconductor components.

SWITCHES AND RELAYS

Table with 4 columns: Mark No., Description, Part No., Mark No. This table lists switches and relays.

RESISTORS

Table with 4 columns: Mark No., Description, Part No., Mark No. This table lists resistor components.

OTHERS

Table with 4 columns: Mark No., Description, Part No., Mark No. This table lists other miscellaneous components.

Mark No. Description Part No.

Table with 4 columns: Mark No., Description, Part No., Mark No. This table lists various electronic components.

TRANSFORMER 2 UNIT

Table with 4 columns: Mark No., Description, Part No., Mark No. This table lists transformer components.

OTHERS

Table with 4 columns: Mark No., Description, Part No., Mark No. This table lists other miscellaneous components.

NOTE FOR SCHEMATIC DIAGRAMS
PARTS LIST
1. When ordering, please refer to this list.
2. The "A" mark found on some component parts indicates the importance of the safety factor of the parts.
3. The "Q" mark found on some component parts indicates that they are not always kept in stock.
4. When ordering resistors, first convert resistance values into code form as shown in the following examples.
5. DC current in STOP mode is shown in the schematic diagram.
6. DC current in STOP mode is shown in the schematic diagram.
7. Others:
8. The "A" mark found on some component parts indicates the importance of the safety factor of the parts.
9. The "Q" mark found on some component parts indicates that they are not always kept in stock.

9. FL INFORMATION

RAW1145 (V1501)

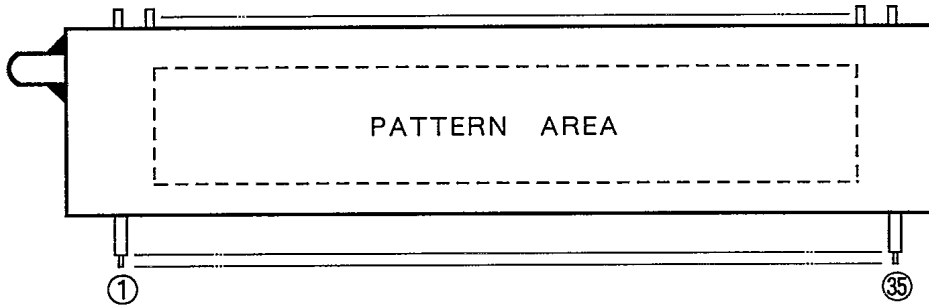

Pin Connection

PIN NO.	1	2	3	4	5	6	7	8	9	10	11	12	13	14	15	16	17	18	19	20	21	22	23	24	25	26	27	28	29	30	31	32	33	34	35	
CONNECTION	F	F	N	N	1	1	1	1	N	5G	N	4	3	2	1	N	N	P	P	P	P	P	P	P	P	P	P	P	P	P	P	P	N	N	F	F
	1	1	P	C	G	G	G	G	C	G	G	G	G	C	2	1	0	9	8	C	7	6	5	4	3	2	1	C	P	2	2					

- NOTE 1) F1, F2 --- Filament
 2) NP ----- No pin
 3) NC ----- No connection.
 4) 1G~10G --- Grid

Grid Assignment

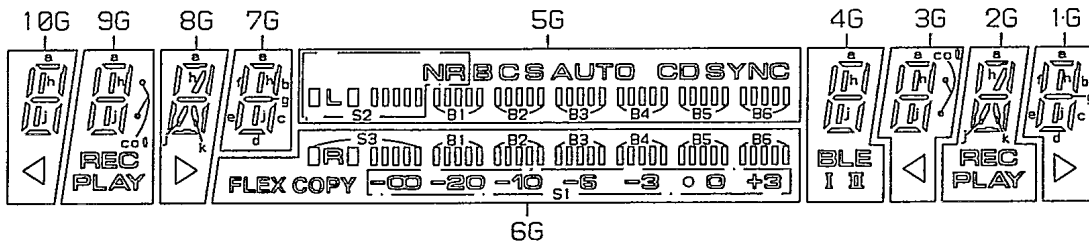

Anode Connection

	10G	9G	8G	7G	6G	5G	4G	3G	2G	1G
P1	a	a	a	a	B1	B1	a	a	a	a
P2	b	b	b	b	B2	B2	b	b	b	b
P3	f	f	f	f	B3	B3	f	f	f	f
P4	g	g	g	g	B4	B4	g	g	g	g
P5	c	c	c	c	B5	B5	c	c	c	c
P6	e	e	e	e	B6	B6	e	e	e	e
P7	d	d	d	d	-	CD SYNC	d	d	d	d
P8	h, j	h, j	h, j	h, j	-	B	h, j	h, j	h, j	h, j
P9	-	col	k	-	COPY	AUTO	BLE	col	k	-
P10	◀	PLAY	▶	-	FLEX	C	I	◀	PLAY	▶
P11	-	REC	-	-	S1	S	II	-	REC	-
P12	-	-	-	-	S3	S2	-	-	-	-

10. PANEL FACILITIES

The illustration shows model CT-W504R.

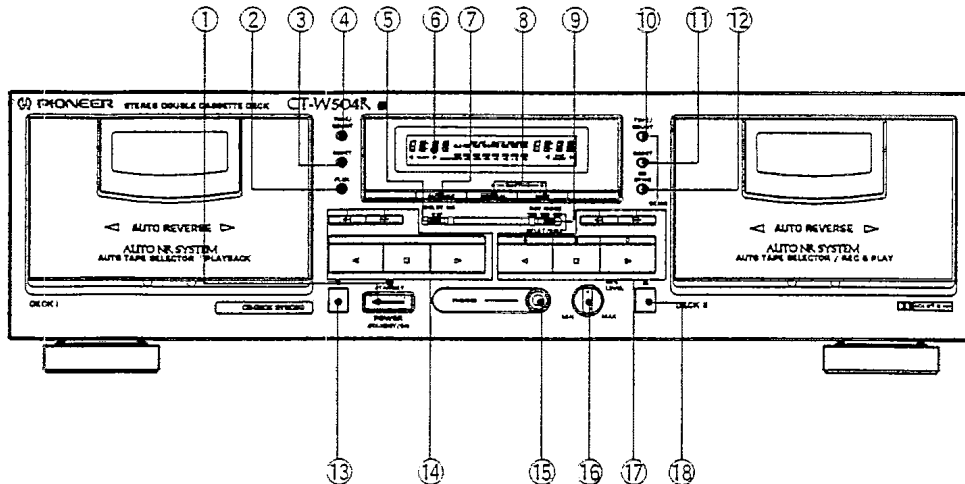

① **POWER STANDBY/ON switch/indicator**

The POWER switch activates the secondary transformer only. Even when the switch is in the STANDBY position, there will be a power flow to the deck's circuits as long as the power cord is connected to a power outlet.

② **FLEX button (CT-W504R only)**

②' **Deck I REWIND AUTO PLAY button (CT-W404R/CT-W204 only)**

③ **DECK I counter reset button (RESET)**

④ **DECK I counter mode button (TIME/COUNT)**

⑤ **DOLBY* NR switch (B/OFF/C)**

- *
 • *Dolby noise reduction and HX Pro headroom extension manufactured under license from Dolby Laboratories Licensing Corporation. HX Pro originated by Bang & Olufsen.*
 • *"DOLBY", the double-D symbol and "HX PRO" are trade-marks of Dolby Laboratories Licensing Corporation.*

⑥ **Function display**

⑦ **AUTO-NR button (CT-W504R only)**

Synchro copy button (COPY I▶II/NORMAL) (CT-W404R/CT-W204 only)

Normal speed copy.

⑧ **Synchro copy buttons (COPY I▶II)**

NORMAL: Normal speed copy (CT-W504R only)

HIGH : Double speed copy

⑨ **Reverse mode switch (RELAY/SKIP) (CT-W504R/CT-W404R only)**

⑨ **RELAY/SKIP ON/OFF switch (CT-W204 only)**

⑩ **DECK II counter mode button (TIME/COUNT)**

⑪ **DECK II counter reset button (RESET)**

⑫ **CD-DECK SYNCHRO recording button (CD SYNC) (CT-W504R only)**

⑫' **Deck II REWIND AUTO PLAY button (CT-W404R/CT-W204 only)**

⑬ **DECK I eject button (▲)**

- If the tape is moving (playback, tape winding, etc.), press the stop (■) button before pressing this button.

NOTE:

If the power is turned off while the tape is moving, the cassette door may remain locked. In this case, turn the power on before pressing the eject (▲) button.

⑭ **Deck I operation buttons**

◀ : Reverse playback (CT-W504R / CT-W404R)

▶ : Forward playback

◀◀/MS : Fast reverse/music search

■ : Stop

▶▶/MS : Fast forward/music search

⑮ **Headphones jack (PHONES) (CT-W504R only)**

⑯ **Recording level control (REC LEVEL)**

⑰ **DECK II operation buttons**

◀ : Reverse playback (CT-W504R/CT-W404R)

▶ : Forward playback

◀◀/MS : Fast reverse/music search

■ : Stop

▶▶/MS : Fast forward/music search

○ : Recording mute

|| : Pause

● : Recording

⑱ **DECK II eject button (▲)**

- If the tape is moving (recording, playback, tape winding, etc.), press the stop (■) button before pressing this button.

NOTE:

If the power is turned off while the tape is moving, the cassette door may remain locked. In this case, turn the power on before pressing the eject (▲) button.

11. SPECIFICATIONS

System	4-track, 2-channel stereo
Heads	"Hard Permalloy" recording/playback head X 1 "Hard Permalloy" playback head X 1 "Ferrite" erasing head X 1
Motor	DC servo motor X 2
Wow and Flutter	0.09% (WRMS)
Fast Winding Time	Approximately 100 seconds (C-60 tape)
-20 dB recording:	
TYPE IV (Metal) tape	20 to 16,500 Hz
TYPE II (High/CrO ₂) tape	20 to 16,000 Hz
TYPE I (Normal) tape	20 to 16,000 Hz
Signal-to-Noise Ratio	
Dolby NR OFF	More than 57 dB
Noise Reduction Effect	
Dolby B-type NR ON	More than 10 dB (at 5 kHz)
Dolby C-type NR ON	More than 19 dB (at 5 kHz)
Harmonic Distortion	
CT-W504R/CT-W404R	No more than 0.8%
CT-W204	No more than 1% (at -4 dB: 160 nwb/m)
Input (Sensitivity)	
LINE (INPUT)	100 mV (Input impedance 68 k Ω)
Output (Reference level)	
LINE (OUTPUT)	0.5 V (Output impedance 1.9 k Ω (CT-W504R) 1.7 k Ω (CT-W404R/CT-W204))
Headphones	1.33 mW (Load impedance 32 Ω) (CT-W504R only)

Subfunctions

- Automatic reverse (Except for CT-W204)
- DOLBY HX PRO recording function (Except for CT-W204)
- DOLBY B/C type NR
- Music search over ± 15 selections
- Synchronized copy start
- High-speed and normal-speed copy (Deck I \rightarrow Deck II)
- Relay playback/blank skip
- CD • DECK SYNCHRO recording capability (CT-W504R only)
- Peak level meter with peak-hold function
- Automatic space recording mute
- Automatic tape selector
-  System remote control available (CT-W504R/CT-W404R/CT-W204: Australian models)
- 2-mode electronic 4-digit twin tape counter
- Headphone jack (CT-W504R only)
- FLEX system (CT-W504R only)
- Rewind-Auto play (CT-W404R/CT-W204)
- Auto NR system (CT-W504R only)

Miscellaneous

Power Requirements	
U.S. and Canadian mode	AC 120 V, 60 Hz
U.K. and Australian model	AC 230-240 V, 50/60 Hz
Power Consumption	
CT-W504R/CT-W404R	17 W
CT-W204	16 W
Dimensions	420(W) X 125(H) X 250(D) mm 16-1/2(W) X 4-7/8(H) X 9-13/16(D) in.
Weight (without package)	
CT-W504R	4.2 kg (9lb 4oz.)
CT-W404R	4.1 kg (9lb 1oz.)
CT-W204	4.0 kg (8lb 13oz.)

Accessories

Operating instructions	1
Connection cord with pin plugs	2
 Remote control cord (CT-W504R/CT-W404R/CT-W204: Australian models)	1
CD • DECKSYNCHRO control cord (CT-W504R only)	1

NOTE:

Specifications and design subject to possible modifications without notice, due to improvements.

