

AM/FM STEREO RECEIVER

SX-980

SERVICE MANUAL

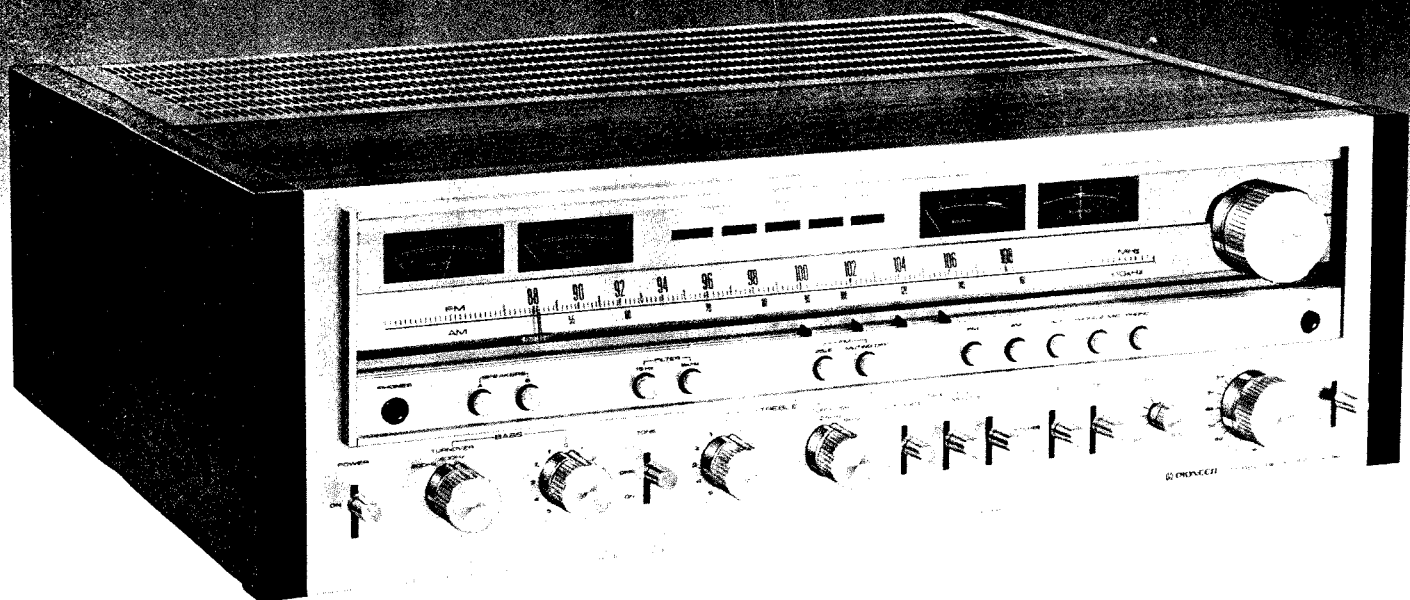

 PIONEER

MODEL SX-980 COMES IN FIVE VERSIONS DISTINGUISHED AS FOLLOWS:

Type	Voltage	Remarks
KU	120V only	U.S.A. model
KC	120V only	Canada model
HG	220V and 240V (Switchable)	Europe or Oceania model
S	110V, 120V, 220V and 240V (Switchable)	General export model
S/G	110V, 120V, 220V and 240V (Switchable)	U.S. Military model

NOTICE:

- This service manual is applicable to the SX-980/KU.
- The SX-980/HG, S, S/G service manual is issued as an appendix.

CONTENTS

1.	SPECIFICATIONS	3
2.	FRONT PANEL FACILITIES	5
3.	CONNECTION DIAGRAM.....	8
4.	LEVEL DIAGRAM.....	10
5.	BLOCK DIAGRAM	11
6.	CIRCUIT DESCRIPTIONS	
6.1	AM·FM Tuner	13
6.2	Phono, Mic Input Circuit	14
6.3	Flat Amplifier	14
6.4	Tone Control	14
6.5	Power Amplifier	14
6.6	Meter Amplifier	15
6.7	Protection Circuit.....	15
6.8	Power Supply	16
7.	DISASSEMBLY	17
8.	PARTS LOCATIONS	
8.1	Front Panel View	18
8.2	Top View	19
8.3	Front View with Panel Removed	20

8.4	Bottom View	21
8.5	Rear Panel View	21
9.	ADJUSTMENTS	
9.1	AM Tuner	22
9.2	FM Tuner	23
9.3	FM MPX	24
9.4	Power Amplifier	25
9.5	Meter Amplifier	25
10.	DIAL CORD STRINGING	26
11.	EXPLODED VIEWS	27
11.1	Part I.....	29
11.2	Part II	31
11.3	Part III	33
11.4	Packing	34
12.	SCHEMATIC DIAGRAMS, P.C. BOARD PATTERN AND PARTS LIST	
12.1	Miscellaneous Parts List	35
12.2	Schematic Diagram	37
12.3	Tuner Assembly (AWE-094)	39
12.4	Input Terminal Assembly (GWS-127)	45
12.5	Function and Equalizer Assembly (GWS-125)	46
12.6	Terminal Assembly (GWS-126)	50
12.7	Flat Amplifier Assembly (GWG-112)	51
12.8	Tone Amplifier Assembly (AWG-056)	55
12.9	Filter Assembly (AWT-002)	58
12.10	Power Amplifier Assembly (AWH-073).....	60
12.11	Speaker Switch Assembly (GWS-131)	64
12.12	Speaker Terminal Assembly (GWS-132)	67
12.13	Protection Assembly (AWM-124)	68
12.14	Power Supply Assembly (AWR-156).....	70
	Additional Service Manual	75

1. SPECIFICATIONS

Semiconductors

FETs	3
ICs	8
Transistors	35
Diodes	45

Power Amplifier Section

Continuous power output of 80 watts* per channel, min., at 8 ohms or 100 watts* per channel at 4 ohms from 20 Hertz to 20,000 Hertz with no more than 0.05% total harmonic distortion.

Total Harmonic Distortion (20 Hertz to 20,000 Hertz)

Continuous Rated Power Output . . . No more than 0.05%
40 watts per channel power

output, 8 ohms No more than 0.02%

1 watt per channel power

output, 8 ohms No more than 0.02%

Intermodulation Distortion (50 Hertz: 7,000 Hertz = 4:1)

Continuous Rated Power Output . . . No more than 0.05%

40 watts per channel power

output, 8 ohms No more than 0.02%

1 watt per channel power

output, 8 ohms No more than 0.02%

Frequency Response . . . 5 Hertz to 100,000 Hertz ± 0.5 dB

Input Sensitivity/Impedance

POWER AMP IN 1V/50 kilohms

Output

SPEAKERS A, B, A+B

Damping Factor

(20 Hertz to 20,000 Hertz, 8 ohms) 30

Hum and Noise (IHF, short-circuited, A Network) . . 100dB

Preamplifier Section

Input (Sensitivity/Impedance)

PHONO 1, 2 2.5mV/50 kilohms

MIC 7.5mV/50 kilohms

AUX 150mV/50 kilohms

TAPE PLAY 1 150mV/50 kilohms

TAPE PLAY 2 150mV/50 kilohms

PHONO Overload Level (1kHz; T.H.D.: 0.05%)

PHONO 1, 2 200mV

Output Level/Impedance

TAPE REC 1 150mV

TAPE REC 2 150mV

PRE OUT 1V/1 kilohms

Total Harmonic Distortion

(20Hz to 20,000Hz, 1V output) No more than 0.05%

Frequency Response

PHONO (RIAA equalization) 20Hz to 20,000Hz ± 0.2 dB

AUX, TAPE PLAY 5Hz to 100,000Hz ± 0.3 dB

Tone Control

BASS ± 7 dB/ ± 10 dB (100Hz)
Turnover Frequency 200Hz, 400Hz

TREBLE ± 7 dB/ ± 10 dB (10kHz)
Turnover Frequency 5kHz/2.5kHz

Filter

LOW 15Hz (6dB oct.)

HIGH 6kHz (6dB oct.)

Loudness Contour (Volume control set

at -40 dB position) -6 dB (100Hz), $+3$ dB (10kHz)

Hum and Noise

(IHF, short-circuited, A Network)

PHONO 76dB

AUX, TAPE PLAY 90dB

Muting -20 dB

FM Tuner Section

Usable Sensitivity

MONO 9.8dBf (1.7 μ V)

50dB Quieting Sensitivity

MONO 14.2dBf (2.8 μ V)

STEREO 37dBf (39 μ V)

Signal-to-Noise Ratio

(at 75dBf) . . . STEREO 74dB

(at 65dBf) . . . MONO 80dB

STEREO 71dB

Distortion (at 65dBf)

100Hz MONO/STEREO 0.1%/0.2%

1kHz MONO/STEREO 0.1%/0.15%

6kHz MONO/STEREO 0.1%/0.2%

Frequency Response 30Hz to 15,000Hz ± 0.5 dB

Capture Ratio 1.0dB

Alternate Channel Selectivity 80dB

Spurious Response Ratio 100dB

Image Response Ratio 90dB

IF Response Ratio 100dB

AM Suppression Ratio 55dB

Muting Threshold 19.2dBf (5 μ V)

Stereo Separation 50dB (1kHz), 35dB (30Hz - 15kHz)

Subcarrier Product Ratio 65dB

SCA Rejection Ratio 65dB

Antenna Input 300 ohms balanced

75 ohms unbalanced

AM Tuner Section

Sensitivity (IHF, Ferrite antenna)	300 μ V/m
(IHF, Ext. antenna)	15 μ V
Selectivity	30dB
Signal-to-Noise Ratio	50dB
Image Response Ratio	40dB
IF Response Ratio	40dB
Antenna	Built-in Ferrite Loopstick Antenna

Miscellaneous

Power Requirements	120V 60Hz
Power Consumption	260W (UL), 560VA (CSA) 800W (max.)
Dimensions	526(W) x 176(H) x 440(D) mm 21-11/16(W) x 6-15/16(H) x 17-5/16(D) in
Weight Without Package	18.8kg (41lb 6oz)
With Package	21.7kg (47lb 12oz)

Furnished Parts

FM T-type Antenna	1
Operating Instructions	1
Hex. Wrench	1

**Measured pursuant to Federal Trade Commission's Trade Regulation rule on Power Output Claims for Amplifiers.*

NOTE:

Specifications and the design subject to possible modification without notice due to improvements.

HEX WRENCH

The accessory hexagonal wrench is provided for removing the TUNING knob and VOLUME knob or tightening their set screws should they become loose.

If required, loose the set screw by inserting the wrench into the hole on the side of the knob and turning the wrench counter-clockwise. Be particularly careful not to scratch the front panel when employing the wrench.

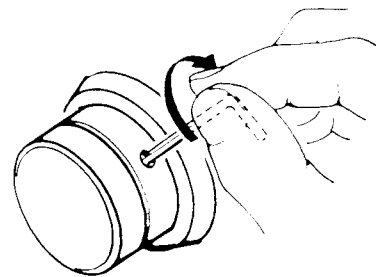

2. FRONT PANEL FACILITIES

POWER SWITCH

Flip this switch to the ON position to supply power to the stereo receiver. There will be a short delay when it is set to ON, because the muting circuit has been actuated to suppress the unpleasant noise that is sometimes generated when the power is switched on and off.

PHONES JACK

Plug the headphones into this jack when you want to listen through your stereo headphones. Release both SPEAKERS buttons if you want to listen to the sound through your headphones only. (This means that both buttons will be released).

POWER METERS

These power meters allow you to read out the rated power level when speakers with a nominal impedance of 8 ohms are connected to the receiver's speaker terminals.

NOTE:
These values are related to the impedance of the speakers and they vary according to the frequency. In order to find out the exact output level, connect an 8-ohm dummy load instead of the speakers.

FUNCTION INDICATOR

MEMORY MARKERS

These are very convenient for frequent tuning in to the same broadcasting station.

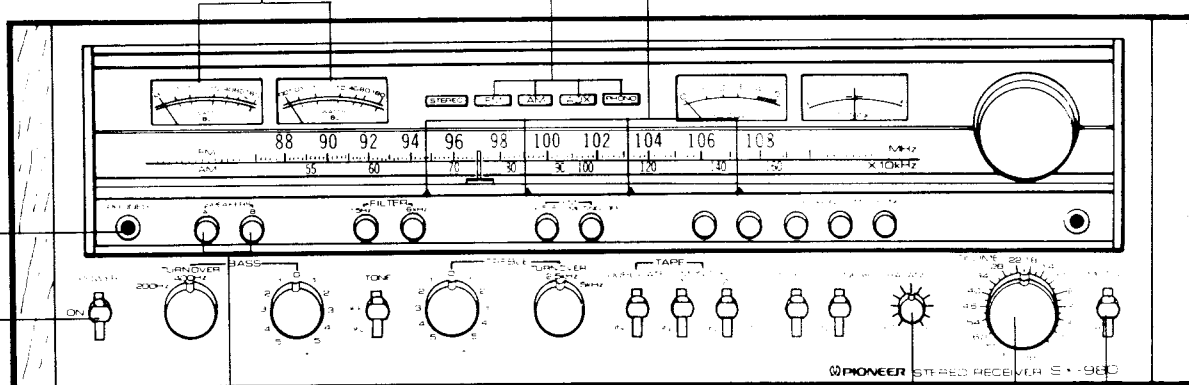

SPEAKERS BUTTONS

Press the button corresponding to the speakers connected to the SPEAKERS terminals (A or B) on the rear panel. You can press both of these buttons to listen to sound from two pairs of speaker systems at the same time.

BALANCE CONTROL

Use this control to balance the volume of the left and right channels. First, however, set the MODE switch to MONO, and adjust so that the sound appears to come from somewhere exactly between the two speakers. If the sound appears to be louder on the right, it means that the volume of the right channel is higher. Turn the BALANCE control to the left and adjust. Conversely, if the sound appears to be louder on the left, it means that the volume of the left channel is higher. Therefore, turn the BALANCE control to the right and adjust. After adjusting, return the MODE switch to STEREO.

MUTING SWITCH

Set this switch to the -20dB position to attenuate the audio output indicated by the VOLUME control by 20dB. There is no need to adjust the VOLUME control if you use this switch when turning down the audio output temporarily and when changing over records or tapes.

VOLUME CONTROL

Use this control to adjust the output level to the speakers and headphones. Turn it clockwise to increase the output level. No sound will be heard if you set it to ∞. The scale is graduated in dB which indicate the attenuation when the maximum output level is 0dB.

TONE SWITCH

Set this switch to ON when adjusting the BASS and TREBLE controls. In the OFF position, it causes the amplifier to operate with a flat frequency response.

FUNCTION BUTTONS

Press the function button which corresponds to the program source. Turn the VOLUME control down first before selecting a different function button while the sound from one program source is being reproduced.

FM Press this button for FM broadcasts. The FM STEREO indicator lights up when the receiver is tuned into an FM stereo broadcast. The sound is automatically received monophonically during FM monophonic broadcasts.

AM Press this button for AM broadcasts.
AUX Press this button when listening to an audio component connected to the AUX input jacks.
PHONO 2/MIC Press this button when playing a record on the turntable connected to the PHONO 2 jacks, or when using a microphone which you have plugged into the MIC jack.
PHONO 1 Press this button when playing a record on the turntable connected to the PHONO 1 jacks.

NOTES:

1. Unplug the microphone from the MIC jack when you do not intend to use the microphone otherwise you will not be able to use the PHONO 2 jacks.
2. Only one function button should be pressed at a time.

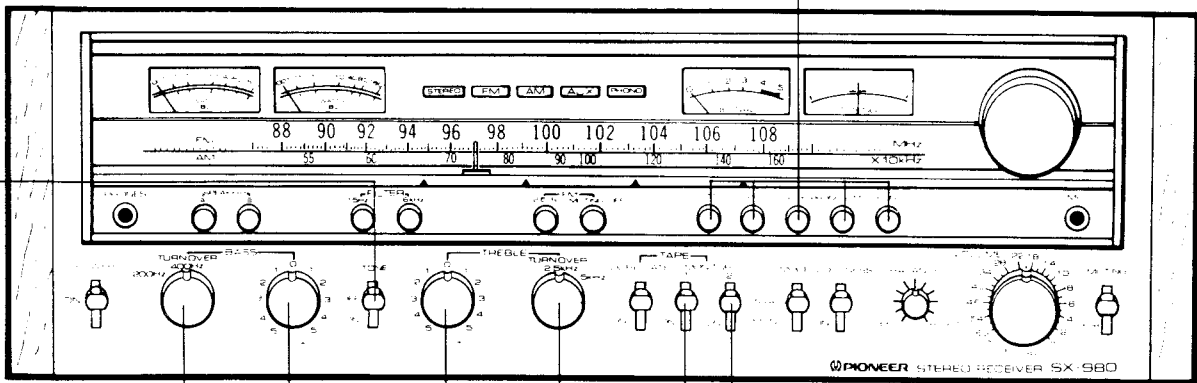

BASS AND TREBLE CONTROLS

Use these controls to adjust the bass and the treble. If you set the TONE switch to ON and turn the BASS control to the right from its center position, you will be able to emphasize the sound in a frequency range which is lower than that selected by the BASS TURNOVER switch. Conversely, turning this control from the center position to the left will attenuate the sound. You can use the TREBLE control to adjust the sound in a frequency higher than that selected by the TREBLE TURNOVER switch.

BASS TURNOVER SWITCH

Use this switch to change over the frequency at which the sound adjustment with the BASS control is starting to take effect. Select 200Hz or 400Hz in accordance with the characteristics of your listening room and of your speakers, and with your general preference.

TAPE MONITOR SWITCHES (1, 2)

Set switch 1 to ON with a tape deck which is connected to the TAPE 1 jacks (REC and PLAY) when you want to monitor the playback or recording of a tape. The tape on a deck which is connected to the TAPE 2 jacks (REC and PLAY) can be similarly monitored by setting switch 2 to ON.

NOTE:

Set these switches to the upper (off) position when listening to records or a broadcast.

TREBLE TURNOVER SWITCH

Use this switch to change over the frequency at which the sound adjustment with the TREBLE control is starting to take effect. Select 2.5kHz or 5kHz in accordance with the characteristics of your listening room and of your speakers, and with your general preference.

TUNING METER

When tuning in to an FM station, the optimum reception position is indicated when the meter pointer deflects to dead center. Check that the SIGNAL meter pointer has deflected as far to the right as possible.

SIGNAL METER

When tuning in to an AM or FM station, the optimum reception position is indicated by the maximum deflection of the meter pointer to the right.

FM MUTING BUTTON

ON (released position) . . . Release this button to suppress unpleasant inter-station noise when tuning between FM stations.
 OFF (depressed position) Depress this button to pick up weak stations.

MIC JACK

Plug your microphone into this jack.
 The microphone signals are reproduced in mono through the left and right speakers.

NOTE:
 A high impedance (approx. 50 kilohms) dynamic type microphone with a standard plug can be connected to this jack.

TUNING KNOB

Use this to tune in to broadcasting stations.
 Select the station and tune for optimum reception by observing the SIGNAL meter for AM stations and both the SIGNAL and TUNING meters for FM stations.

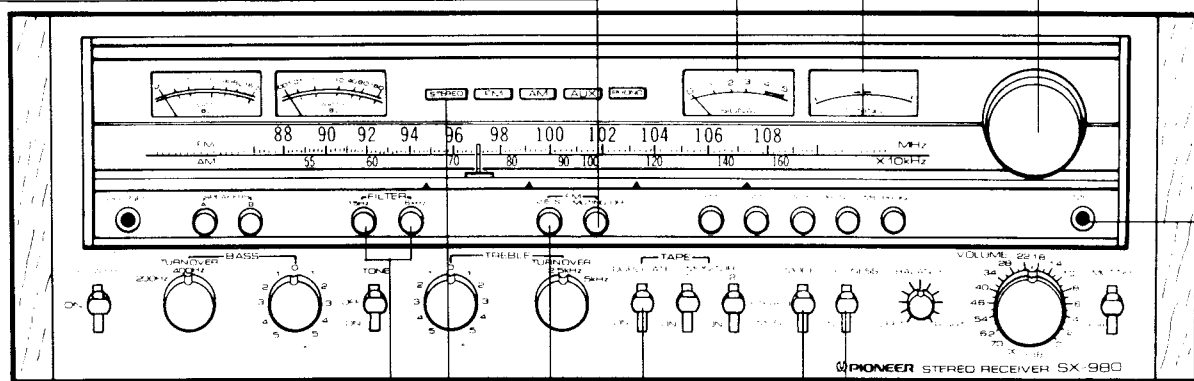

STEREO INDICATOR

This indicator lights up when the receiver is tuned to receive a stereo broadcast.

FILTER BUTTONS

15Hz . . . When this button is pressed, a 6dB/oct attenuation can be provided for frequencies below 15Hz. This means that you can cancel out noise in the ultra-low frequencies which is generated by low-pitched rumble from a turntable and other forms of distortion. Although this noise cannot be heard, it can generate intermodulation distortion and damage the speakers.

6kHz . . . Press this button to provide a 6dB/oct attenuation at frequencies above 6kHz. Set it to this position when you find high-frequency noise, such as that from scratched records, unpleasant.

FM 25μs BUTTON

Press this button when listening to a Dolby* FM broadcast; otherwise keep this button at the released position.

LOUDNESS SWITCH

Set this switch to ON when listening at a low volume. The frequency response of the human ear varies according to the listening volume, and setting this switch to the ON position compensates for hearing response by emphasizing the bass and treble.

MODE SWITCH

Use this switch for selecting mono or stereo performances.
STEREO: Set to this position for normal stereo operation.
MONO: When set to this position, the left and right channel signals will be mixed and reproduced monophonically from both speaker systems.

TAPE DUPLICATE SWITCH

Set this switch to ON when you want to duplicate or edit a pre-recorded tape using two tape decks.

3. CONNECTION DIAGRAM

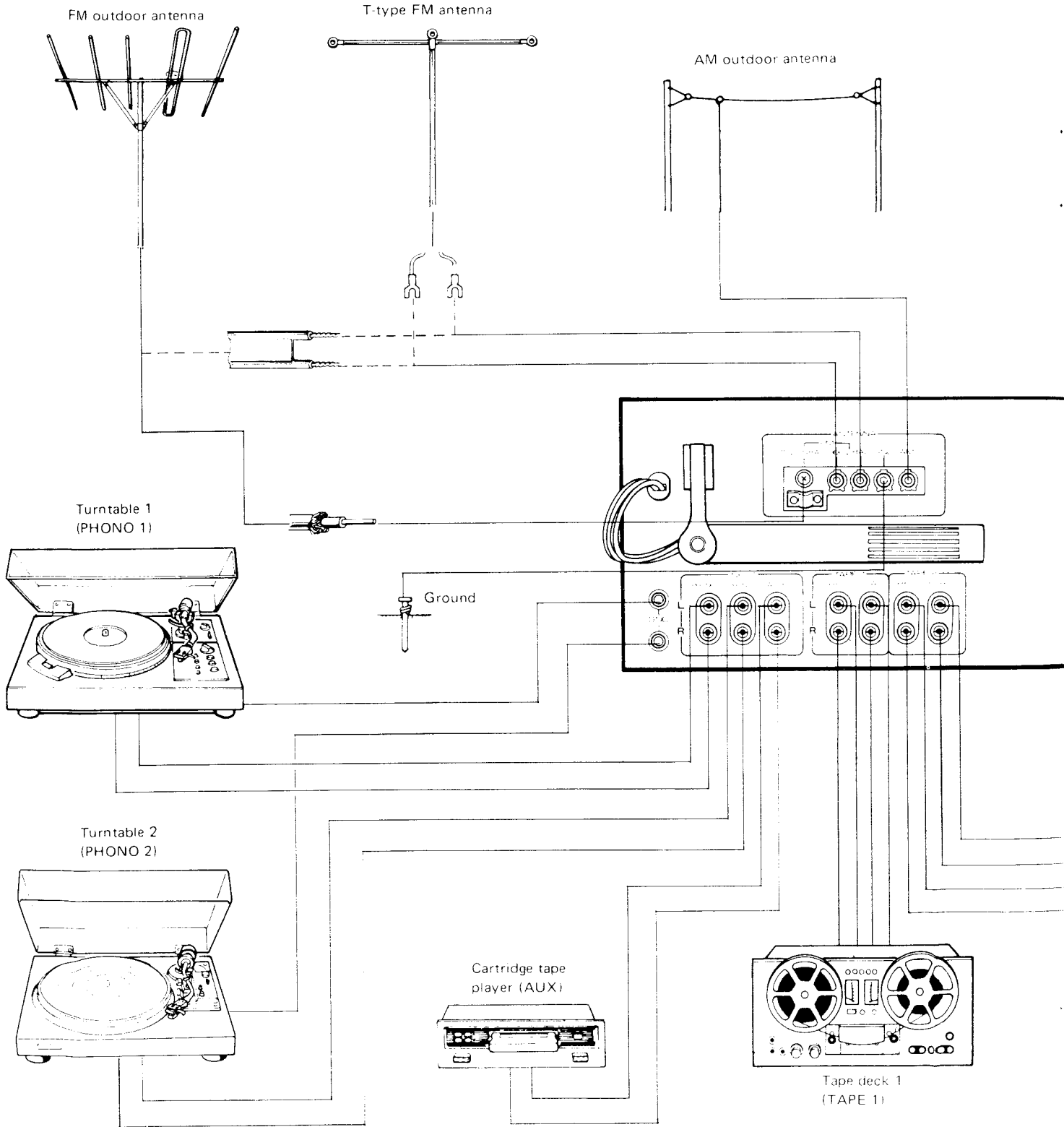

PRE/POWER AMP

The bridge connecting plugs between PRE AMP OUT and POWER AMP IN jacks should always be left in position in normal use. If they are disconnected or removed no sound will come from the speakers. Always be sure to switch off the power supply before attempting to remove them.

CONVENIENCE OUTLETS

SWITCHED:
(150W MAX)

A frequently used component (turntable, tape deck, etc.) can be plugged into this outlet. By leaving the power switch of that component in the ON position, power supply to the component will be coupled with the receiver switch operation.

UNSWITCHED:
(TOTAL
200W MAX)

Less frequently used components, which do not require coupled power, can be plugged into either of these outlets.

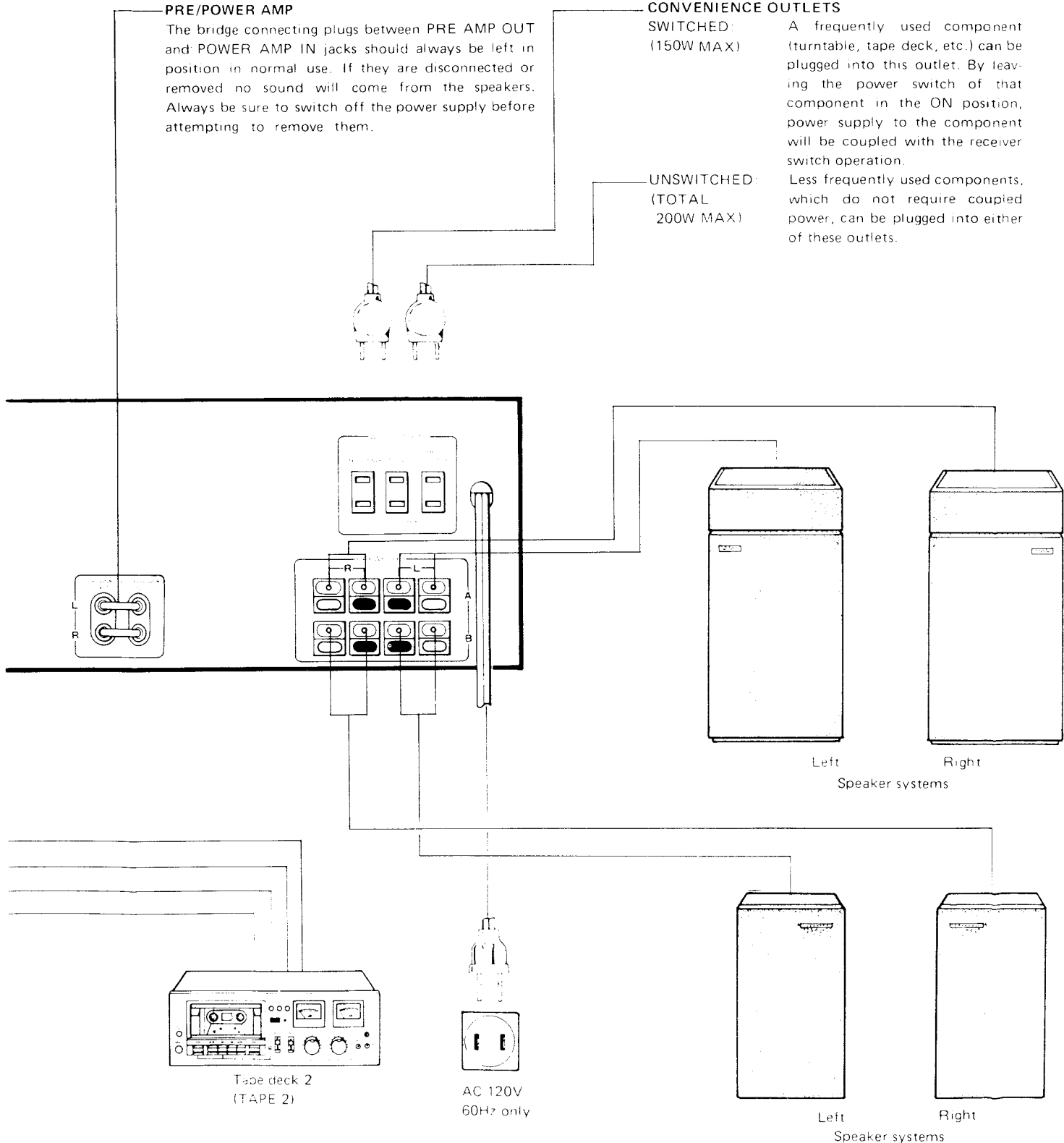

4. LEVEL DIAGRAM

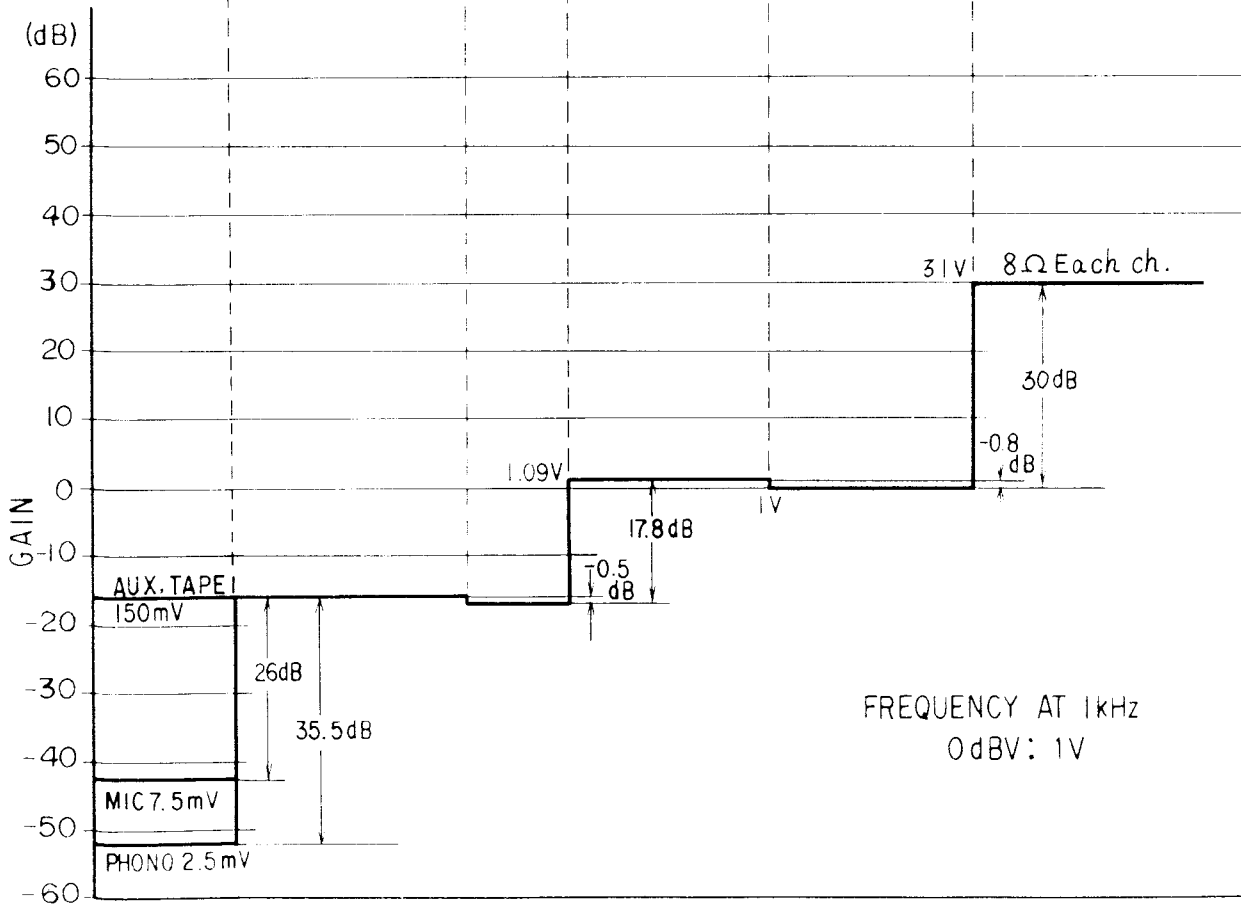
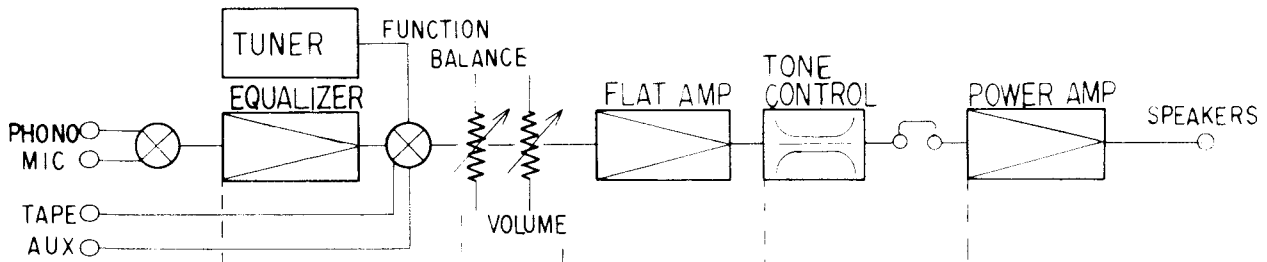

5. BLOCK DIAGRAM

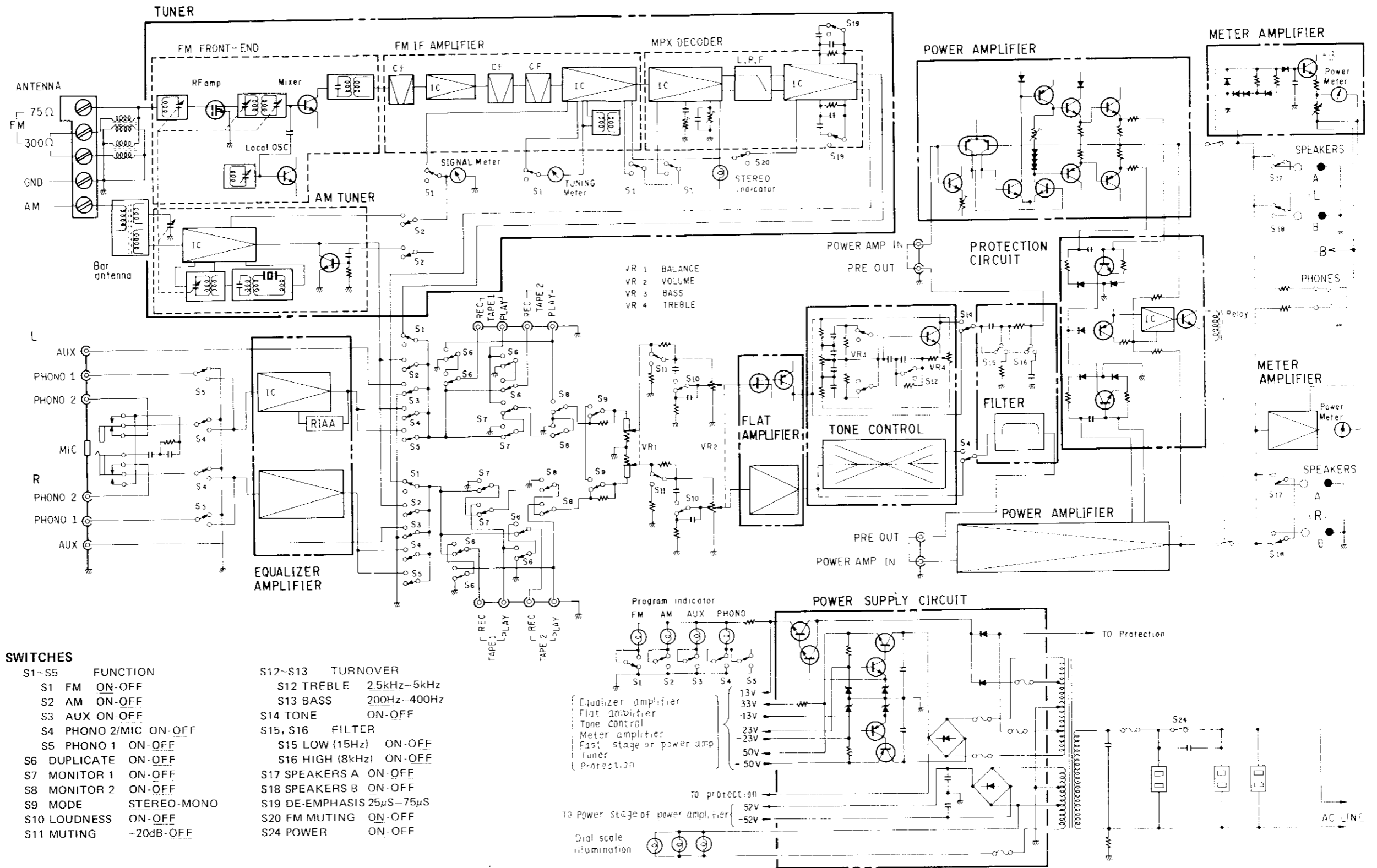

FM Multiplex Decoder

1. The FM multiplex decoder is a PLL (Phase-Locked Loop) MPX IC (PA1001-A). Its block diagram is given in Fig. 3.

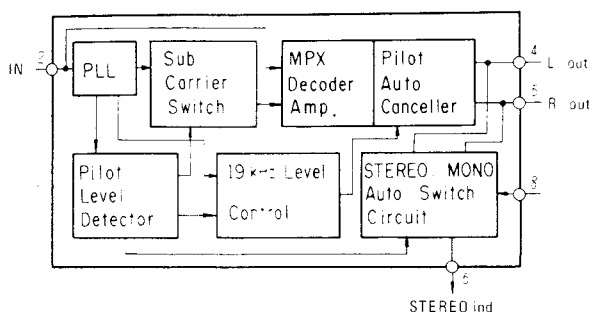

Fig. 3 Block diagram of PA1001-A

2. PA1001-A contains a PLL VCO circuit, double-balance type differential demodulator with NFB amplifier, and pilot auto cancel circuit to improve the distortion characteristics, frequency response, and S/N.

The nonlinear distortion produced at the demodulator has been improved by adding the NFB amplifier to the double balance type differential demodulator.

The pilot auto cancel circuit eliminates carrier leakage (19kHz), without a loss of demodulated signal frequency response. Moreover, since the cancel signal level tracks the input pilot signal level, the rejection ratio does not drop even if the input pilot signal level changes.

FM Output Amplifier

The FM output amplifier is an IC (PA1002-A). PA1002-A contains an AF amplifier, muting gate circuit and power ON/OFF muting control circuit. Its block diagram is given in Fig. 4.

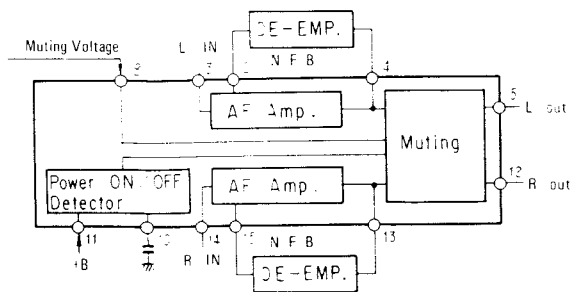

Fig. 4 Block diagram of PA1002-A

The AF amplifier is a differentially coupled NFB amplifier featuring excellent dynamic ranges, S/N and distortion characteristics. A de-emphasis

characteristic is obtained by providing a frequency selection characteristic at the NFB loop of this amplifier.

The muting circuit electronically grounds the signal circuit when a control voltage of 1.4V or greater has been applied to pin 8 of the PA1002-A. This control voltage is applied from pin 12 of the PA3001-A thru the MUTING switch. A 1.4V DC voltage is generated at pin 12 of the PA3001-A when de-tuned more than $\pm 70\text{kHz}$ and at weak inputs (antenna input conversion $5\mu\text{V}$ or less).

6.2 PHONO, MIC INPUT CIRCUIT

PHONO 1, PHONO 2/MIC input switching is performed by the switch and the MIC jack.

When a microphone plug is inserted into the MIC jack, the input is switched to MIC at both the L and R channels. Since the IC (HA1457) is used as both a microphone amplifier and equalizer amplifier, a circuit having a reverse RIAA curve is provided at the MIC input circuit to obtain a flat frequency response.

6.3 FLAT AMPLIFIER

This amplifier is located in front of the tone control circuit. It amplifies the signal to the required level and sends a low impedance signal to the control circuit.

6.4 TONE CONTROL

The tone control circuit is an NFB type inserted in front of the power amplifier.

Bass turnover (200Hz \leftrightarrow 400Hz) and treble turnover (2.5kHz \leftrightarrow 5kHz) switches and a tone defeat circuit which bypasses the tone control circuit to obtain a flat characteristic are provided, in addition to a variable resistor, which adjusts the rise and fall.

6.5 POWER AMPLIFIER

The power amplifier is an all-stage direct-coupled pure complementary OCL circuit having a differential amplifier at the first stage, current mirror circuit at the predriver stage. (Fig. 5)

The first stage (Q_1) is a PNP type dual transistor differential amplifier that amplifies the input signal and stabilizes the center voltage of the power stage. Q_3 and Q_4 are driven by the opposite phases of the output of Q_1 . The output of Q_4 is applied to the current mirror circuit consisting of D_2 and Q_5 and phase inverted.

Consequently, Q_3 and Q_5 are in-phase signals, and are operated as a push-pull predriver.

6. CIRCUIT DESCRIPTIONS

Refer to the block diagram on page 11 and the schematic on page 37 for the circuit composition of this unit.

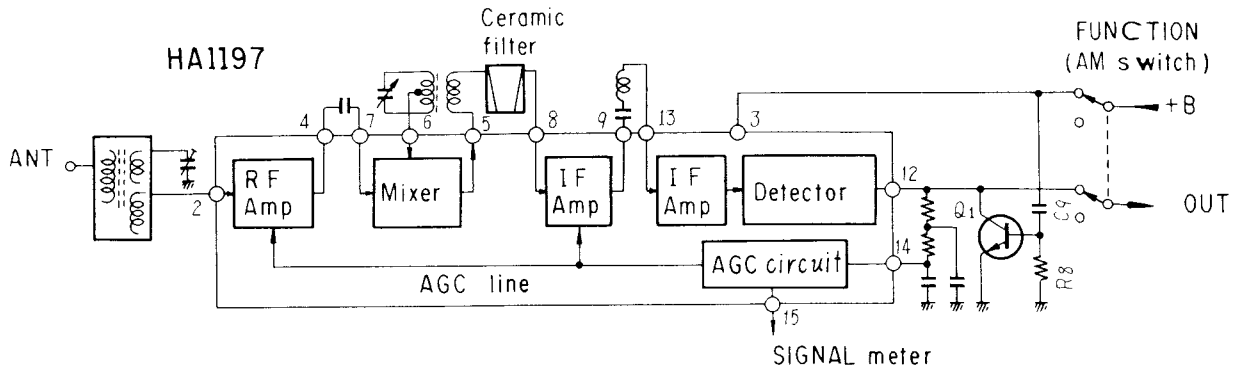

Fig. 1 Block diagram of AM tuner

6.1 AM-FM TUNER

AM Tuner

The AM tuner employs a 2-stage variable capacitor, one IC (HA1197) and one AM ceramic filter. Its block diagram is given in Fig. 1. HA1197 is an IC containing an RF amplifier, converter, 2-stage IF amplifier, detector, and AGC circuit, and features excellent AF frequency response and distortion. Q_1 of the output circuit is a special AM muting circuit. This circuit is operated until the AM tuner stabilizes immediately after the FUNCTION AM switch has been set to ON. The instant the AM switch is set to ON, +B is supplied to R_8 , thru C_9 , and the base of Q_1 is forward biased. Consequently, Q_1 is turned ON, and the AM output signal is shorted to ground during the time constant of C_9 , R_8 .

FM Front End

The FM front end employs a 4-stage variable capacitor in the tuning circuit, dual gate MOS FET at the RF amplifier and the local oscillator is a variation of a Clapp circuit.

The FM front-end input is a 75Ω unbalanced single-tuned circuit. The RF amplifier is a dual gate MOS FET. An M-coupled double-tuned circuit is inserted between stages. The dual gate FET is an amplifying element suitable for RF circuits, and features extremely stable amplification because of its low NF (Noise Figure), high PG (Power Gain) and low feedback capacitance. Local oscillator

voltage is passed through a low value capacitor to the mixer transistor base.

IF Amplifier

Three 2-dual element ceramic filters are used as the selection elements, and one IC (HA1201) containing one differential amplifiers and one FM IF IC (PA3001-A) are used as the amplification elements.

The HA1201 compensates for the filter insertion loss, and also limits the amplitude of the FM signal. The PA3001-A performs IF amplification, amplitude limiting and FM detection. It also drives the TUNING and SIGNAL meters and controls muting.

The block diagram of the PA3001-A is given in Fig. 2.

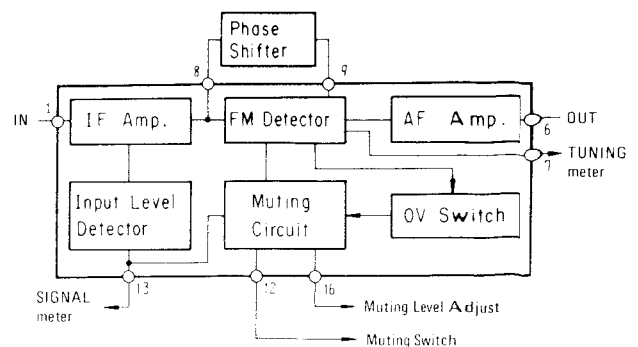

Fig. 2 Block diagram of PA3001-A

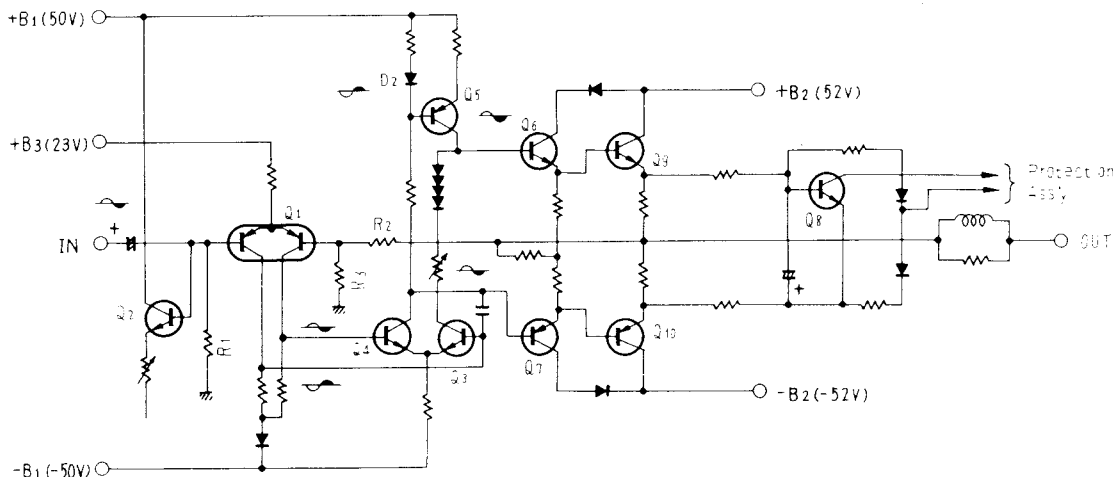

Fig. 5 Block diagram of power amplifier

Low distortion and improved rise characteristic at high amplitudes have been realized by making the predriver stage push-pull.

Overcurrent is detected and destruction of the power transistor prevented by Q_8 .

Q_2 is a Q_1 temperature compensation transistor which prevents changes in the center voltage due to the temperature characteristic of Q_1 . Since the output center voltage is applied to the feedback side base of Q_1 by R_2 and R_3 , the input side base potential of Q_1 becomes the standard. Therefore, the input side base potential of Q_1 must be maintained constant at 0V. The voltage generated across R_1 by the input side base current of Q_1 is cancelled by the base current of Q_2 to maintain the input side base potential of Q_1 constant at 0V.

6.6 METER AMPLIFIER

In order to indicate the 0.01W-160W range with one meter without range switching, a logarithmic indication type meter must be employed and the input signal must be logarithmically compressed. The meter amplifier circuit is shown in Fig. 6. This circuit consists of a logarithmic compression circuit and a meter drive circuit. The output signal of the power amplifier is applied

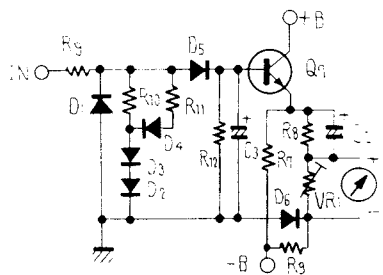

Fig. 6 Schematic diagram of meter amplifier

to the logarithmic compression circuit, and its dynamic range is compressed. The principles of the logarithmic compression circuit are given in Fig. 7. The output voltage of this circuit is the value divided by R_9 and Z . The attenuation at low signal input is reduced and the attenuation at large signal input is increased, by using the rise of the diode current - voltage characteristic at Z .

The compressed signal is shaped by D_5 and applied to Q_1 of the meter drive circuit. Q_1 current amplifies the DC voltage from D_5 to drive the power meter.

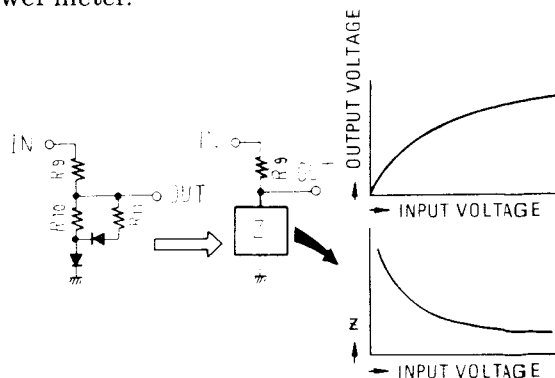

Fig. 7 Schematic diagram of logarithmic compressor

6.7 PROTECTION CIRCUIT

The purpose of this circuit is to protect both the speakers and the power amplifiers. The relay in the output circuit is automatically opened in any of the following cases:

1. During the "transient operations" when the power supply is turned on and off.
2. Upon detection of an overload, caused by a short circuit in the load.
3. Upon detection of a DC voltage in the output circuit, caused by component failure or accident.

An outline of this circuit is shown in Fig. 8. The relay-activating transistor (Q_r) is controlled by the IC (PA3004).

Muting Operation When Power Supply Is turned Off and On

When the power supply is first turned on, the voltages on pins 1, 7 and 6 of PA3004 will exceed a prescribed level. If there is no input (DC) on pin no.4, S_2 will be off, and a charging current will commence to flow to the timing capacitor (C_t) connected to pin no.8. Once C_t has been charged up to a level where the voltage on pin no.8 exceeds a prescribed level, S_1 will turn on, thereby applying a bias current from pin no.3 to the relay driving transistor (Q_r). Consequently Q_r will turn on, and current will flow through the relay coil to activate the relay, and close the connection in the output circuit. The time required for this connection to close after the power supply is first turned on is several seconds. During this period, any unwanted transient noises will be therefore muted.

When the power supply is turned off, the input (AC) applied to pin no.7 ceases immediately, resulting in S_2 turning on, C_t discharging rapidly, and S_1 and Q_r both turning off. The relay is thus opened, disconnecting the output circuit.

DC Voltage Detector

The output circuit is connected to pin no.4 via a low-pass filter (R_8 and C_2). Any DC voltages appearing in the output circuit will also be applied to pin no.4, turning S_2 on. C_t will thus discharge rapidly, turning S_1 and Q_r off, thereby releasing the relay, and disconnecting the output circuit from the load.

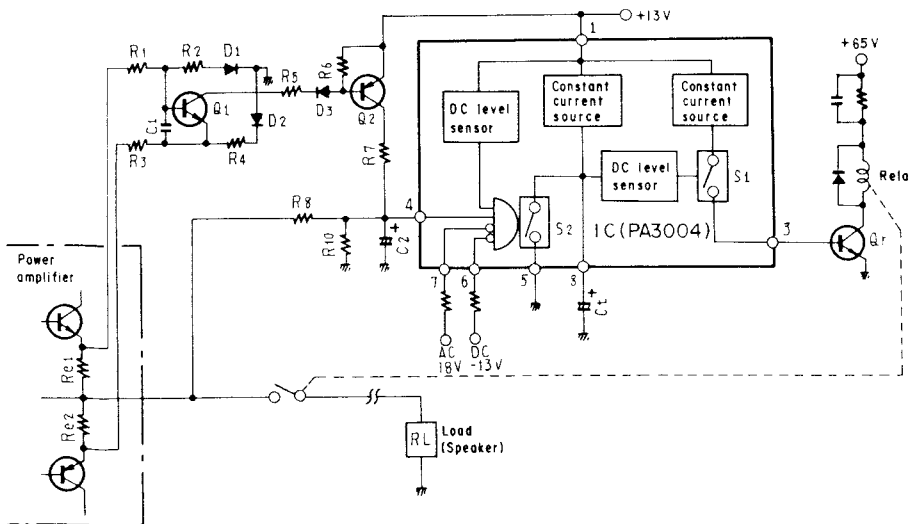

Fig. 8 Schematic diagram of protection

Overload Detection

The overload detector circuit incorporates the load (R_L) in one side of a Wheatstone bridge (see Fig. 8-1). The base and emitter of a sensing transistor (Q_1) are connected to the opposite corners of the bridge, so if R_L decreases, Q_1 will become forward biased. If R_L falls below a prescribed value, Q_1 will turn on, thereby passing a current through R_5 , D_3 and R_6 . Due to the voltage difference generated across R_6 , Q_2 will become forward biased, and consequently turn on. A DC voltage will then be applied to pin no.4, turning S_2 on, and resulting in the rapid discharge of C_t , and S_1 and Q_r both turning off. The relay will again be released to disconnect the output circuit.

6.8 POWER SUPPLY

The power amplifier and power stage plus and minus supply voltages ($\pm 50V$) are obtained by means of a bridge full-wave rectification system. 18,000 $\mu F/63V \times 2$ electrolytic capacitors are used.

Plus and minus voltages are supplied to the small signal circuit of the AF section thru a constant voltage circuit by full-wave rectification from a winding separate from the power stage supply. Tuner section, lamp circuit and protection circuit power is supplied thru transistor (Q_5 , Q_6) Darlington connected ripple filter, after full-wave rectification.

(a) Positive half-cycle bridge

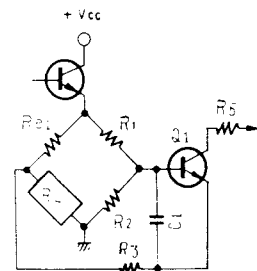

(b) Negative half-cycle bridge

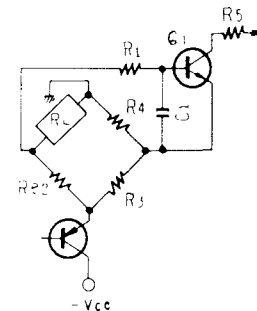
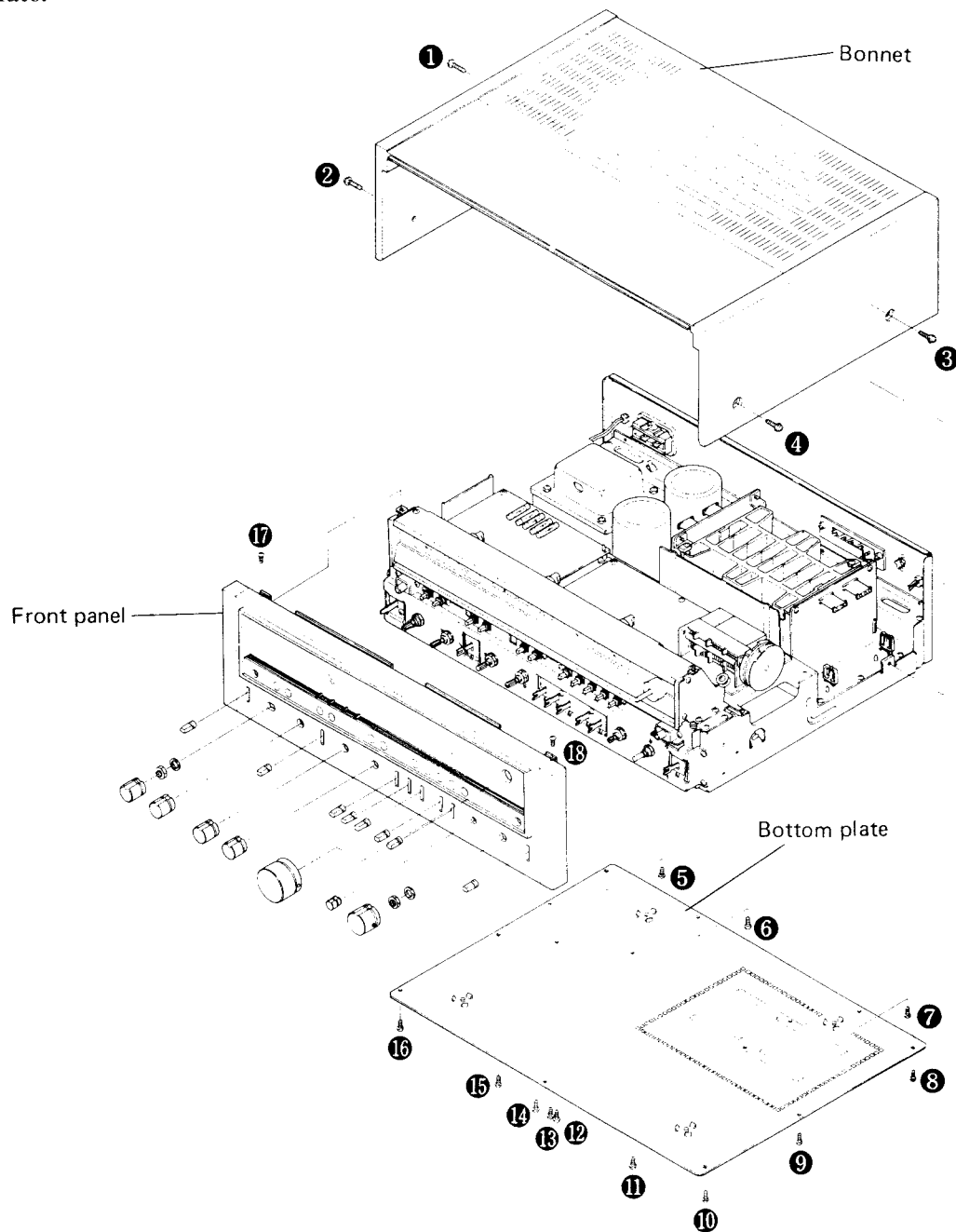

Fig. 8-1 Over load sensor

7. DISASSEMBLY

1. Remove screws ① - ④ and remove the bonnet.
2. Remove all the knobs, and remove the two nuts and two washers at the front panel.
(However, loosen the set screws with the accessory allen wrench before attempting to remove the TUNING and VOLUME knobs.)
Front panel can then be removed after taking out screws ⑰ and ⑱.
3. Remove Screws ⑤ - ⑯ and remove the bottom plate.



8. PARTS LOCATIONS

8.1 FRONT PANEL VIEW

Dial pointer assembly
AAF-065

Bonnet
AMM-066

Power meter
AAW-079

Double meter
AAW-075

Front panel assembly
ANB-550

Knob (TUNING)
AAA-047

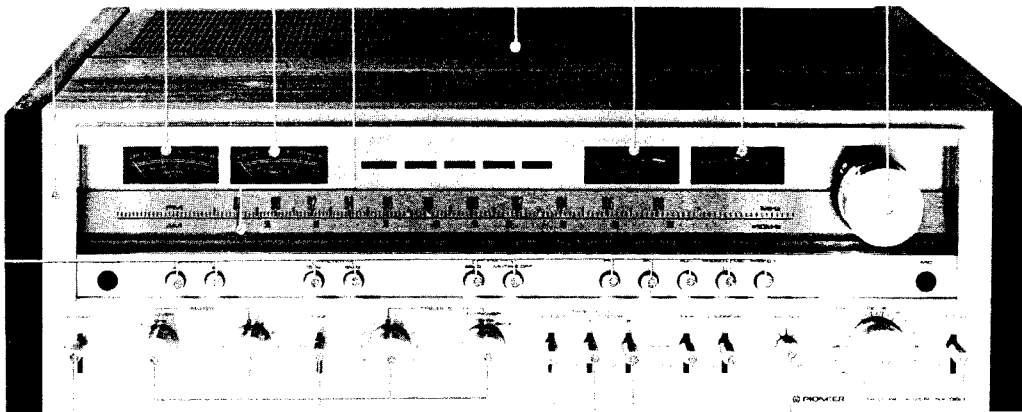

Push knob
AAD-140

Lever knob assembly (POWER)
AAD-139

Lever knob (MUTING)
AAD-138

Knob
AAB-175

Knob (VOLUME)
AAB-174

Lever knob
AAD-138

Knob (BALANCE)
AAB-176

8.2 TOP VIEW

Capacitor
ACH-047

Power amplifier assembly
AWH-073

Power transformer
ATT-449

Power amplifier assembly
AWH-073

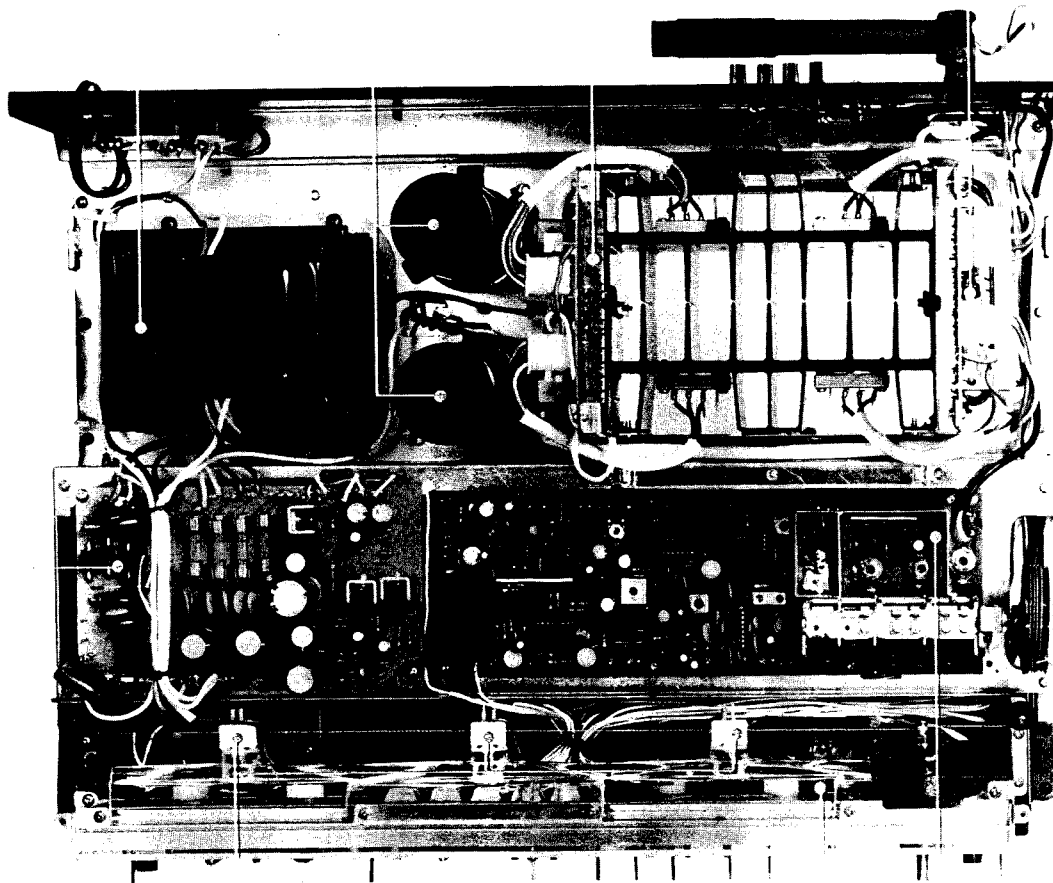

Power supply assembly
AWR-156

Tuner assembly
AWE-094

Wedge type pilot lamp
AEL-029

Acrylic board
ANR-020

8.3 FRONT VIEW WITH PANEL REMOVED

Push switch --
ASG-129

Push switch assembly (SPEAKERS)
ASG-133

Push switch (FUNCTION)
ASG-126

Phone jack (PHONES)
AKN-010

Phone jack (MIC)
AKN-012

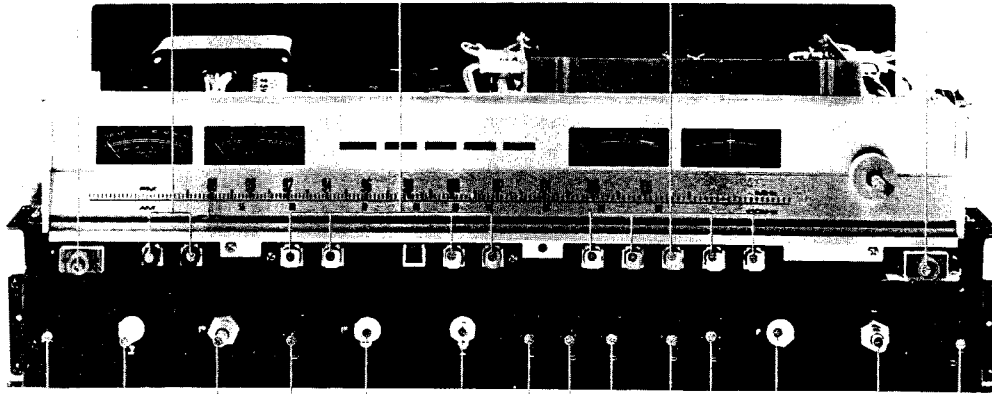

Lever switch (POWER)
ASK-080

Lever switch (MUTING)
ASK-144

Rotary switch (BASS, TURNOVER)
ASE-105

Variable resistor (VOLUME)
ACV-162

Variable resistor (BASS)
ACV-136

Variable resistor (BALANCE)
ACV-190

Lever switch (TONE)
ASK-144

Lever switch (LOUDNESS)
ASK-144

Variable resistor (TREBLE)
ACV-136

Lever switch (MODE)
ASK-144

Rotary switch (TREBLE, TURNOVER)
ASE-106

Lever switch (TAPE, MONITOR 1, 2)
ASK-144

Lever switch (DUPLICATE)
ASK-145

8.4 BOTTOM VIEW

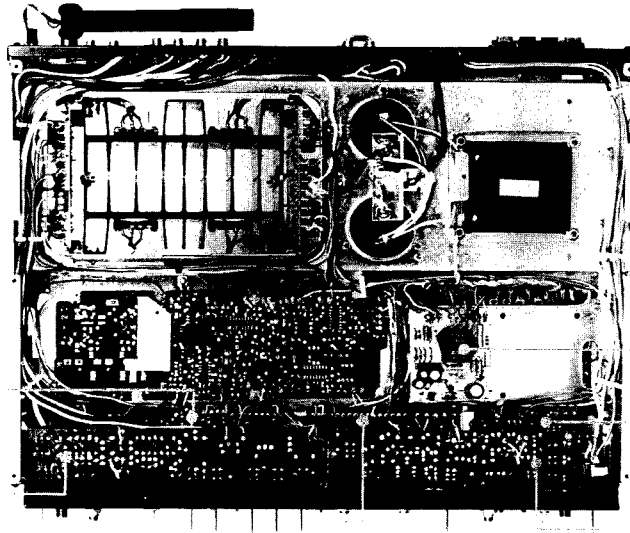

Function and equalizer
assembly
GWS-125

Flat amplifier assembly
GWS-112

Protection assembly
AWM-124

Speaker switch assembly
GWS-131

Tone control assembly
AWG-056

Filter assembly
AWT-002

8.5 REAR PANEL VIEW

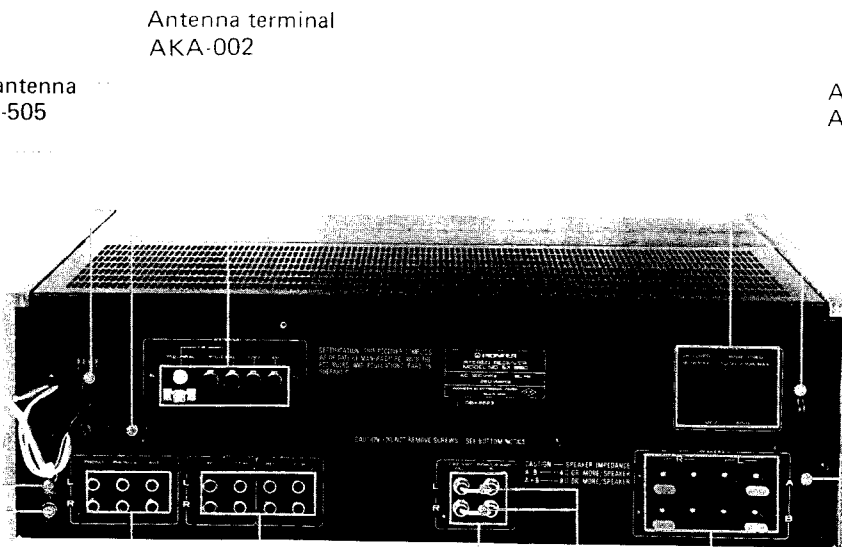

Antenna terminal
AKA-002

Bar antenna
ATB-505

AC socket
AKP-005

AC cord stopper
AEC-327

Bar antenna holder
AXB-012

Power cord
ADG-005

Terminal (GND)
AKE-031

Input terminal assembly
GWS-127

Plug
AKM-004

Speaker terminal assembly
GWS-132

Terminal assembly
GWS-126

4-P pin jack
AKB-035

9. ADJUSTMENTS

9.1 AM TUNER

Confirm that the dial pointer is at the start point.

Connect as shown in Fig. 9, and set the FUNCTION switch to "AM".

1. Set an AM signal generator to 400Hz, 30% modulation, 30dB output, at no input from AGC.
2. Set the AM signal generator and the SX-980 dial pointer to 600kHz, and adjust T_7 for maximum output.

3. Set the AM signal generator and the SX-980 dial pointer to 1,400kHz, and adjust TC_6 maximum output.
4. Repeat steps 2 and 3 until reception is perfect at 600kHz and 1,400kHz.
5. Adjust F_6 for maximum output.
6. Adjust the core of the bar antenna (at 600kHz reception) and trimmer TC_5 (at 1,400kHz reception) for maximum output and minimum output deviation at 600kHz and 1,400kHz.

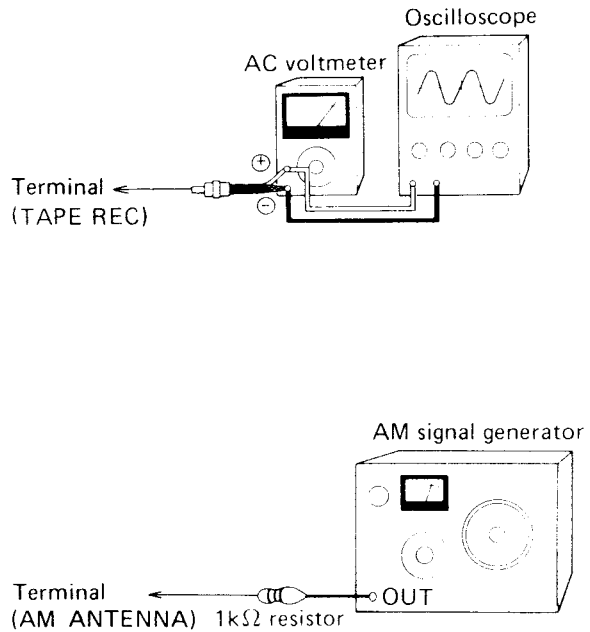
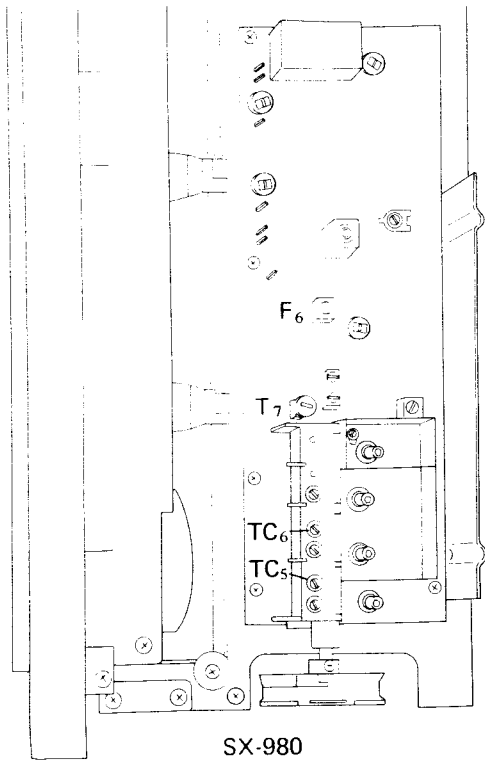

Fig. 9 Connection of AM tracking adjustment

9.2 FM TUNER

Confirm that the dial is set to the start point. Connect as shown in Fig. 10, and set the FUNCTION switch to "FM" and the MUTING switch to "OFF".

1. Set an FM signal generator to 400Hz, 100% modulation, 106dB output.
2. Set TC₄ to near center capacitance, set the FM signal generator and the SX-980 dial to 90MHz, and adjust T₄ for maximum deflection at the signal meter.
3. Under the state of "2" above, adjust the primary (bottom) core of T₆ so that the pointer of the tuning meter deflects to the center of the scale.
4. Set the FM signal generator output to 15dB, and adjust T₁, T₂, T₃ for maximum output.
5. Set the FM signal generator and the SX-980 dial pointer to 106MHz, and adjust TC₄ for maximum deflection at the signal meter. (Make the FM signal generator output 10dB.)
6. Set the FM signal generator output to 15dB, and adjust TC₁, TC₂, TC₃ for maximum output.

7. Repeat steps 2 - 6 until reception at 90MHz and 106MHz is perfect. At this time, adjust T₅ for maximum output.
8. Adjust the primary core (bottom) of T₆ so that the pointer of the tuning meter deflects to the center of the scale in the untuned state (noise only).
9. Set the FM signal generator output to 66dB, set the SX-980 dial pointer to 98MHz, and tune the FM signal generator at the tuning meter. (Pointer of tuning meter deflects to the center of the scale.)
10. Adjust the secondary side (top) of T₆ for minimum distortion.
11. Repeat steps 8 - 10 until the minimum distortion point does not change.
12. Set the FM signal generator output to 10dB, and adjust VR₂ for maximum deflection at the signal meter (Fig. 11).
13. Set the FM signal generator output to 26dB. Set the MUTING switch to "ON" and adjust VR₁ so that the output waveform disappears.

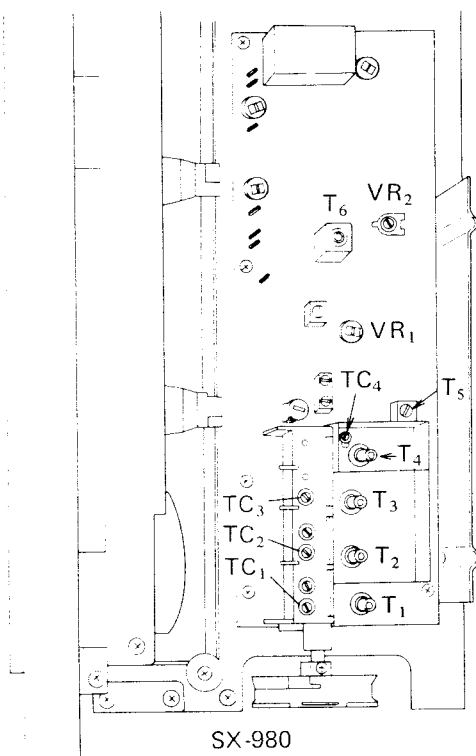

Fig. 10 Connection of FM tracking adjustment

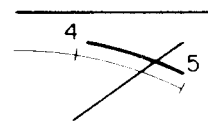
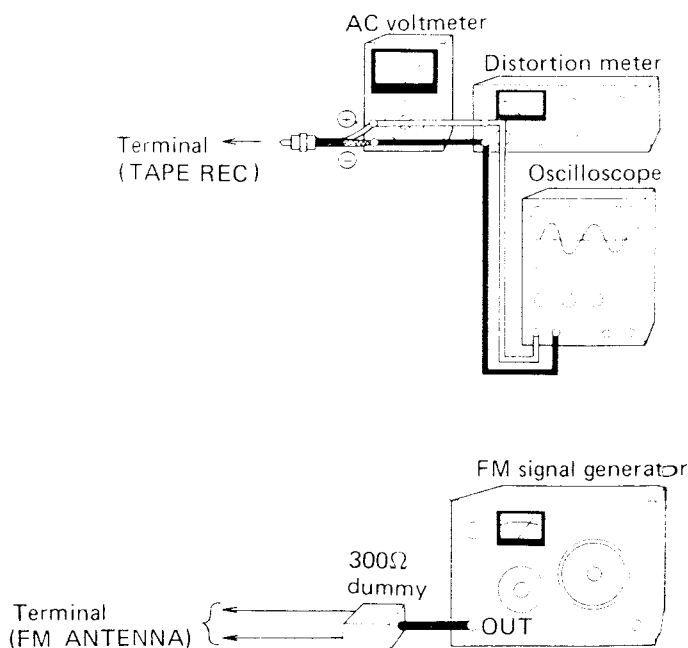

Fig. 11 Meter deflection



9.3 FM MPX

Connect as shown in Fig. 12, and set the FUNCTION switch to "FM" and the MUTING switch to "OFF".

1. Set the FM signal generator to 98MHz unmodulated, 66dB output.
2. Connect the output of the MPX SG PILOT OUT terminal to the horizontal axis input terminal of an oscilloscope and tuner assembly terminal 13 to the vertical axis input.
3. Set the SX-980 dial pointer to 98MHz and adjust the FM signal generator so that the tuning meter deflects to the center of the scale.
4. Adjust VR₃ so that a Lissajous pattern is traced on the oscilloscope (Fig. 13).

5. Next, set the MPX SG to 7.5kHz by pilot signal (19kHz).
6. Adjust VR₅ for minimum output.
7. Modulate the MPX SG at L + R (1kHz) to deviate the 67.5kHz pilot signal (19kHz) 7.5kHz.
8. Adjust T₅ for minimum L channel or R channel distortion. (However, within $\pm 90\%$ of the core adjustment range.)
9. Make the MPX SG main signal L or R and adjust VR₄ for best separation.

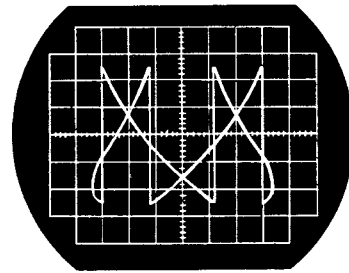

Fig. 13 Lissajous pattern

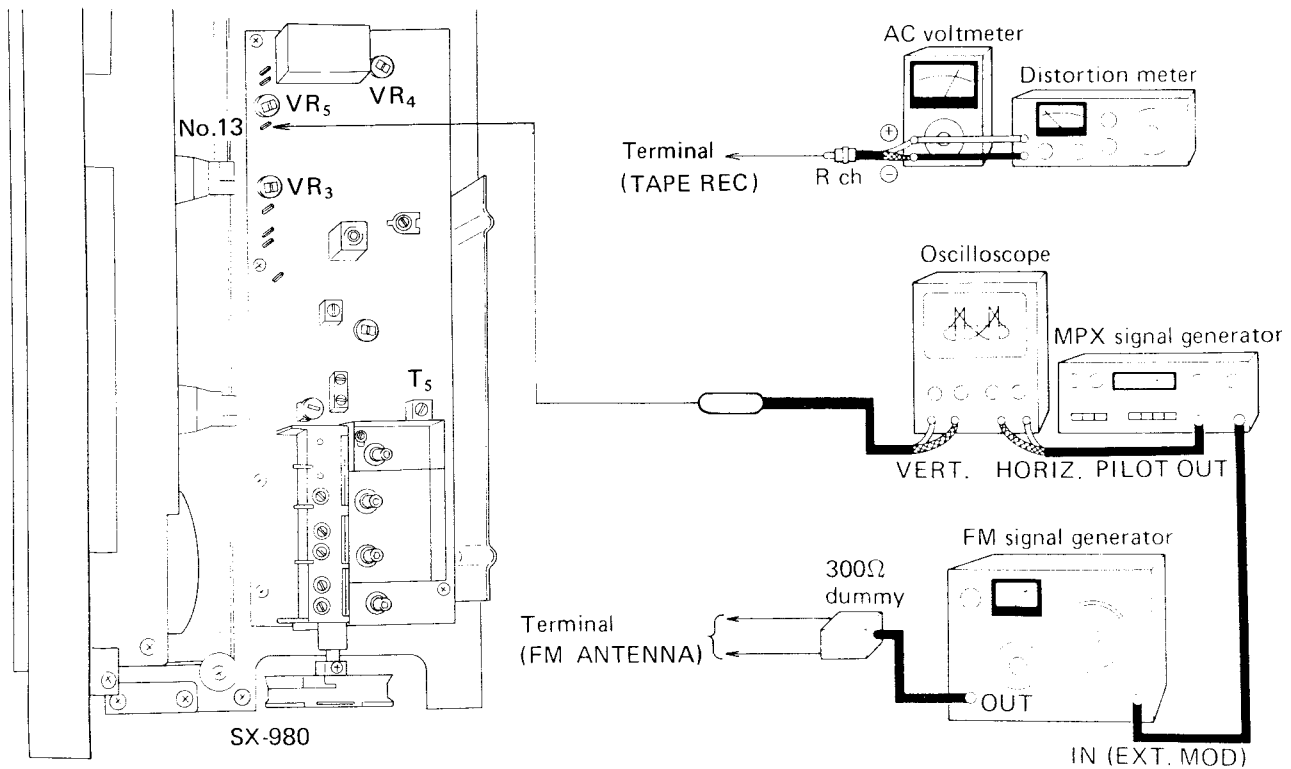

Fig. 12 Connection of FM MPX adjustment

9.4 POWER AMPLIFIER

Turn VR_1 (L and R) fully around in the clockwise direction, but set VR_2 (L and R) to the center positions. Without any, load or input signal, turn the POWER switch ON.

Center Voltage Adjustment

1. Connect a DC voltmeter between power amplifier assembly (AWH-073) L ch terminal 10 and ground as shown in Fig. 14.
2. Check if the voltage between terminal 10 and ground is 0V. When not 0V, adjust to 0V with VR_2 .
3. When 0V cannot be obtained by performing the adjustment of item 2 above, cut the jumper wire shown in Fig. 14 and adjust to $0V \pm 30mV$ with VR_2 .
4. The R ch also uses the power amplifier assembly (AWH-073). Check and adjust this channel in accordance with items 1 - 3 above.

Idle Current Adjustment

1. Connect a DC voltmeter between terminals 13 - 23 of the amplifier assembly (AWH-073) L ch side.
2. Set the power switch to "ON", wait 10 minutes, and then check if the DC voltmeter reads 30mV. If it doesn't read 30mA, adjust to 30mV by turning VR_1 (Fig. 14).
3. The R ch also uses the power amplifier assembly (AWH-073). Check and adjust this channel in accordance with items 1 - 2 above.

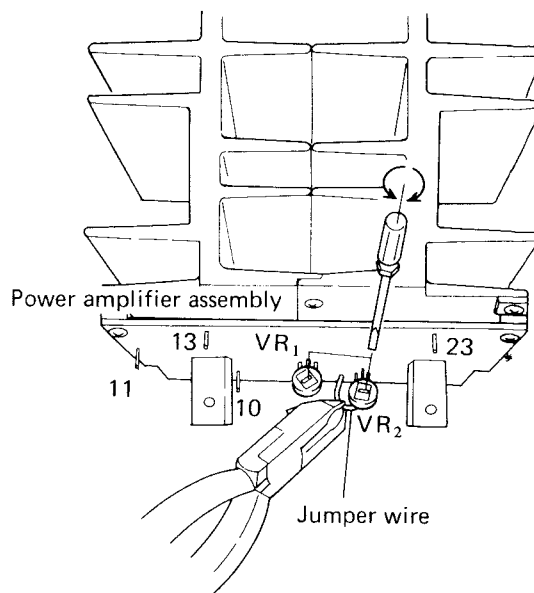

Fig. 14 Power amplifier adjustment

9.5 METER AMPLIFIER

1. Push speaker selector switch button "A".
2. Connect an AC voltmeter to speaker output terminal (A).
3. Apply a 1kHz sine wave to the input terminals (AUX) and adjust the input for an AC voltmeter reading of 28V.
4. Adjust VR_1 (L) and VR_2 (R) at the assembly No. AWM-120 printed circuit board for a meter indication of 0dB.

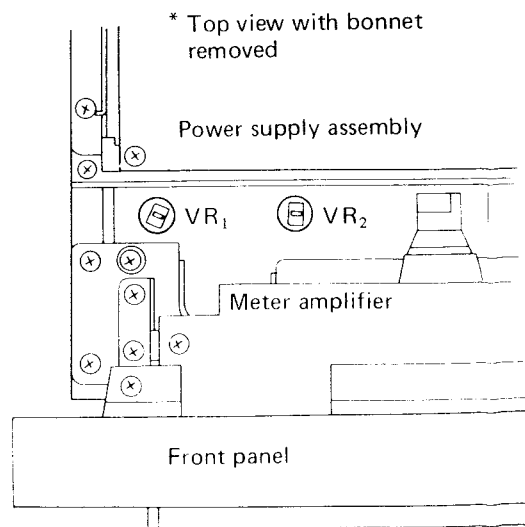

Fig. 15 Meter adjustment

10. DIAL CORD STRINGING

Remove the bonnet and front panel as described in "DISASSEMBLY" on page 17. Loosen screws ① - ③ and remove the blind sash as shown in Fig. 16.

1. Turn the variable capacitor shaft fully clockwise. (Vanes of capacitor fully inside.)
2. Tie one end of the string to the peg on the dial pulley.
3. Position the dial pulley so that the set screw is at the top and tighten the screw.
4. Pass the string through the notch in the dial pulley, wrap it 1/2 turn around the pulley and pass it thru pulley A → pulley B → pulley C → dial shaft (3 turns) → pulley D. Next, wrap the string two turns around the pulley, along the pulley grooves, and tie it to the spring hook.
5. Turn the dial shaft and confirm that the movement of the dial pulley and string is normal, and then cut off the surplus string.
6. Turn the dial shaft counter-clockwise (variable capacitor vanes fully outside) and set the dial pointer to the start point of the scale and attach it to the string.

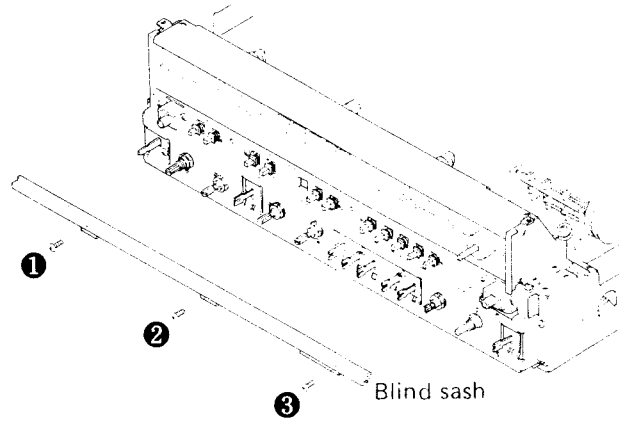

Fig. 16 Remove blind sash

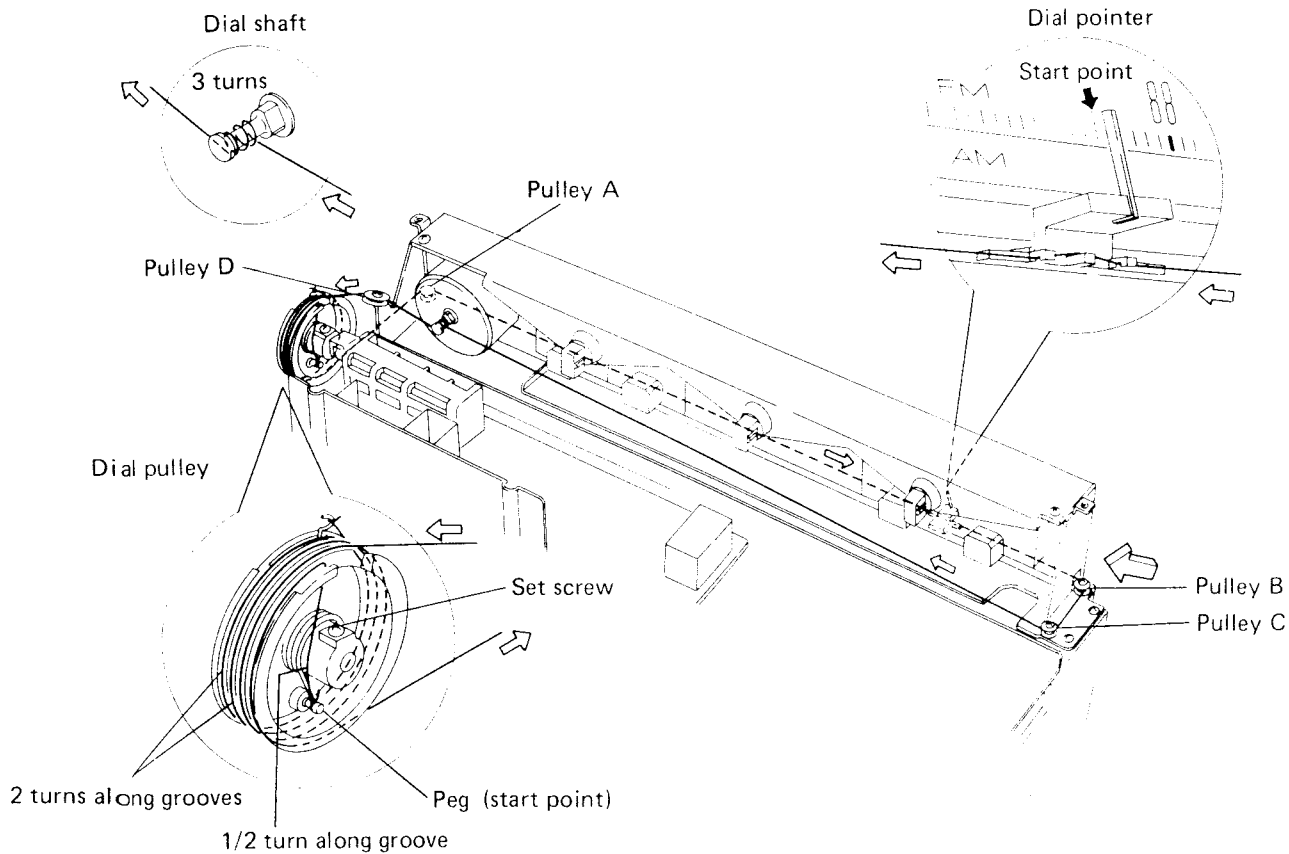
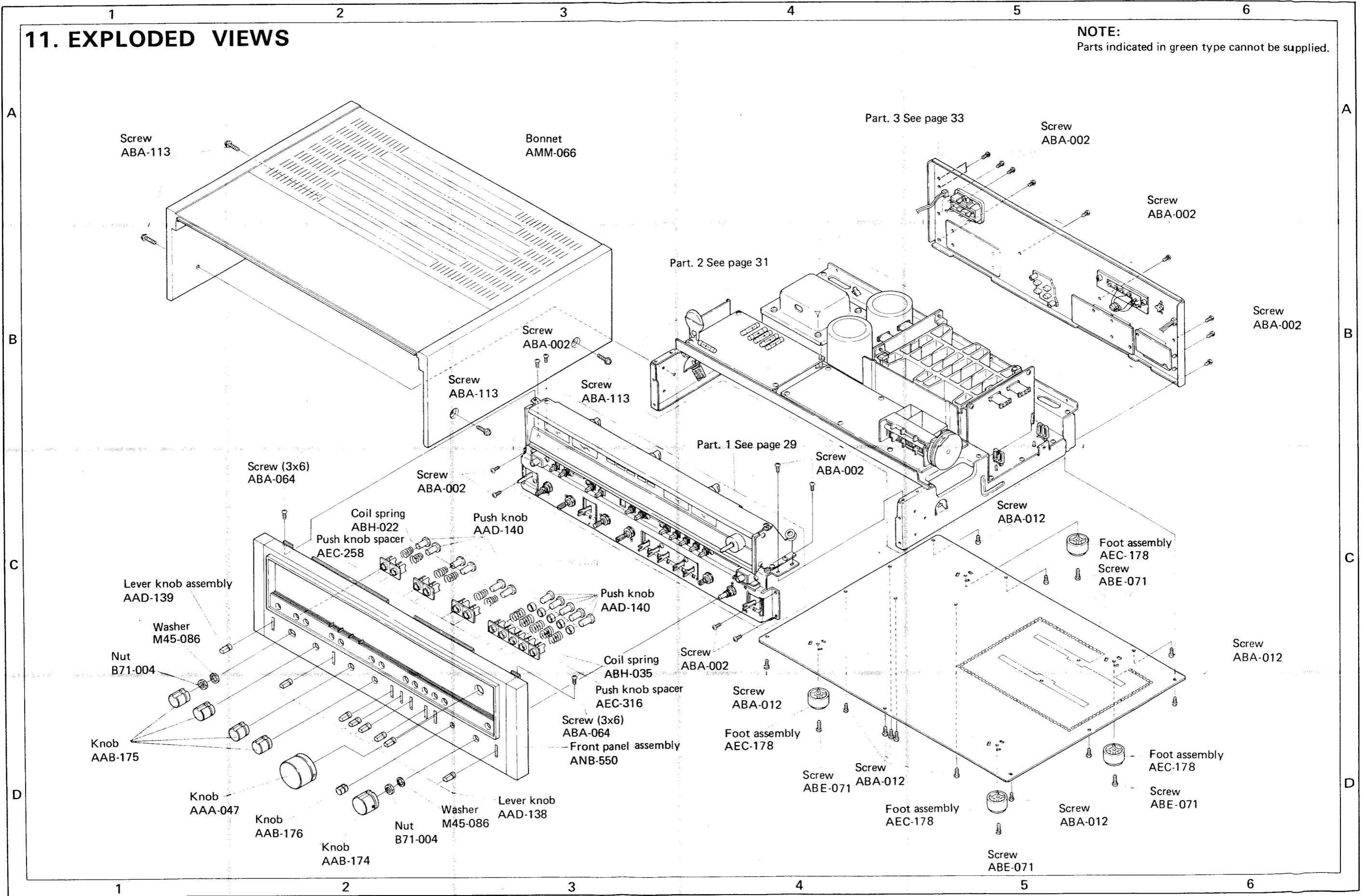

Fig. 17 Dial cord stringing

11. EXPLODED VIEWS

NOTE:
Parts indicated in green type cannot be supplied.



11.1 PART I

NOTE:
Parts indicated in green type cannot be supplied.

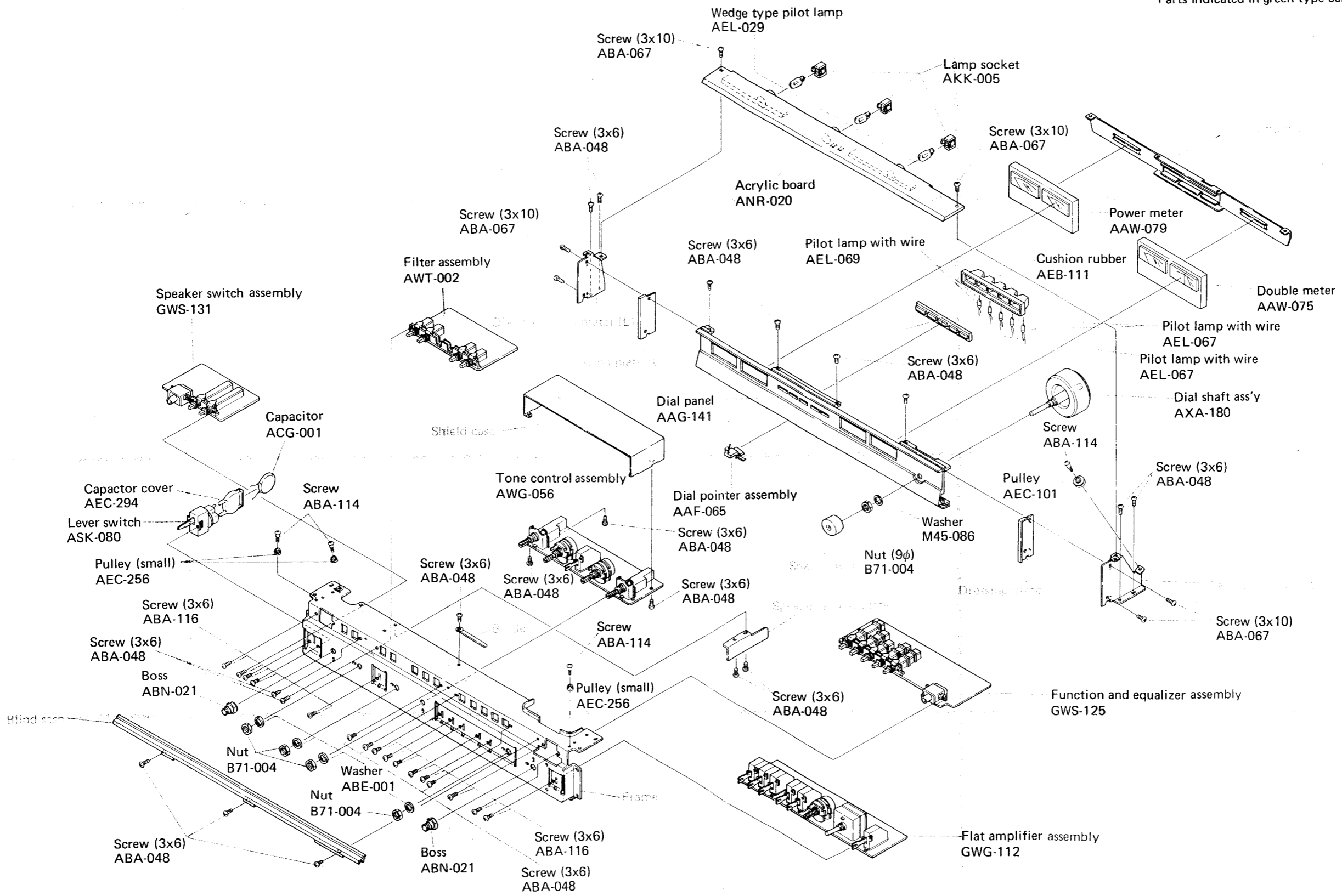

11.2 PART II

NOTE:
Parts indicated in green type cannot be supplied.

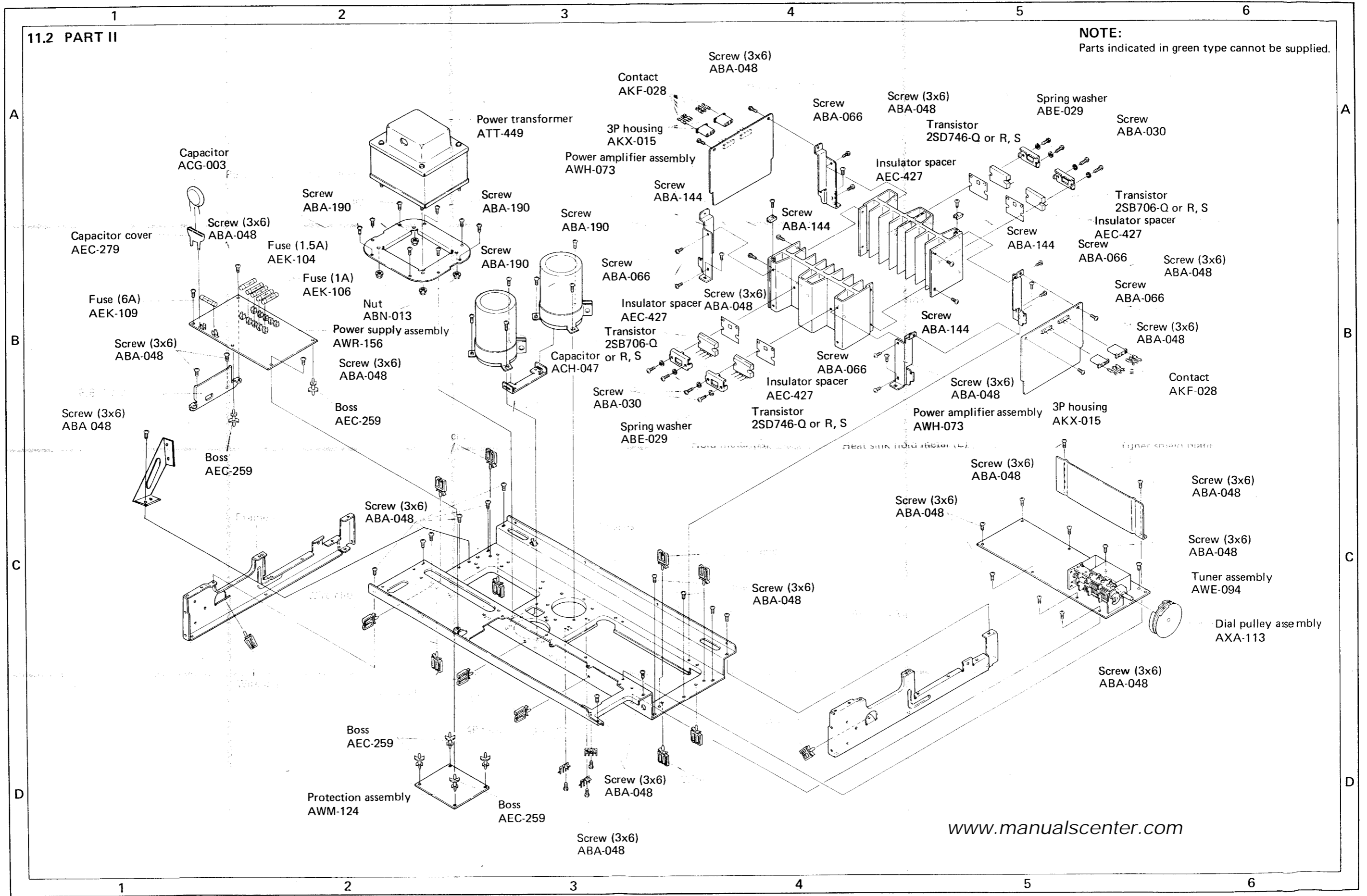

www.manualscenter.com

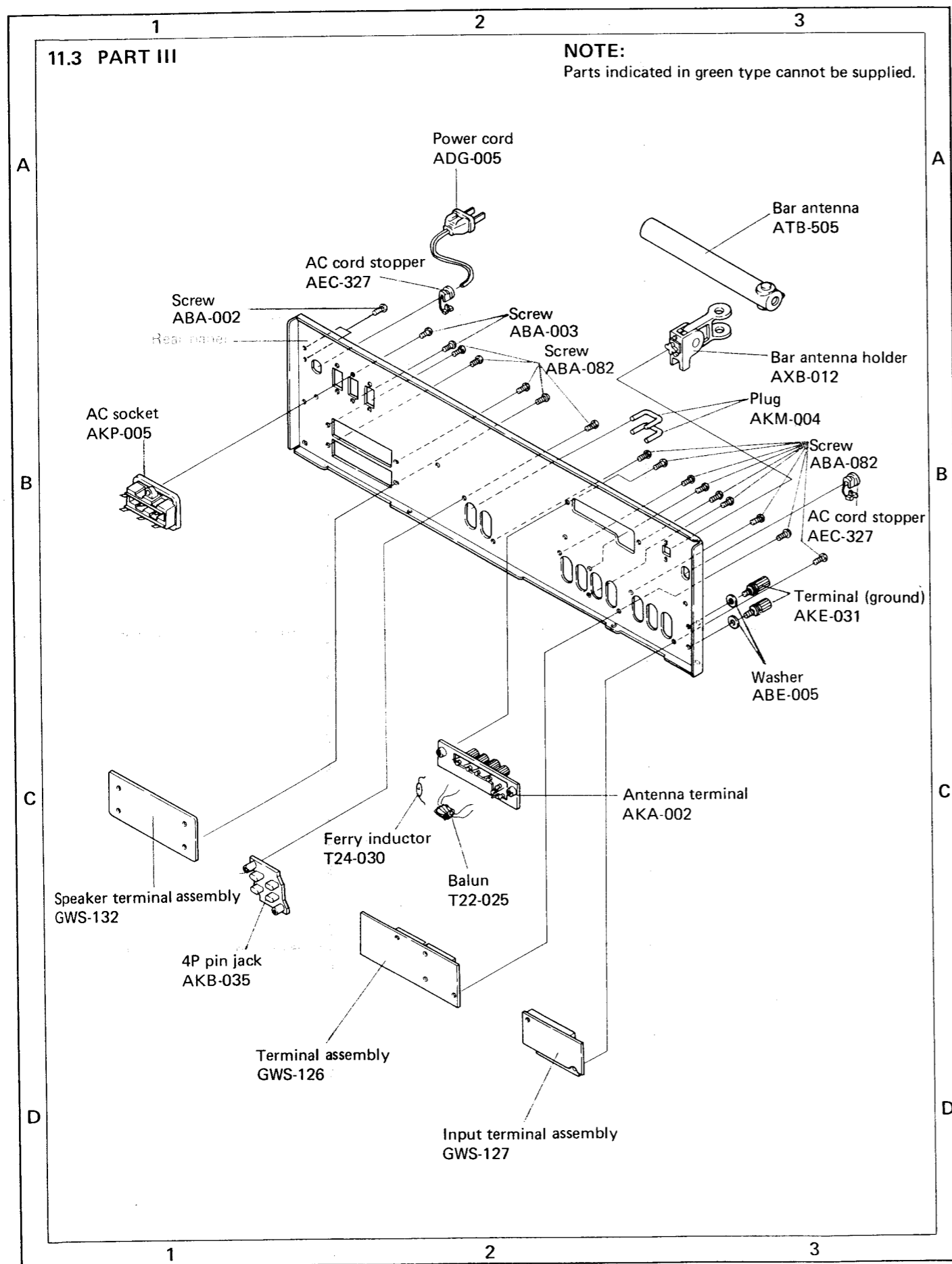

11.4 PACKING

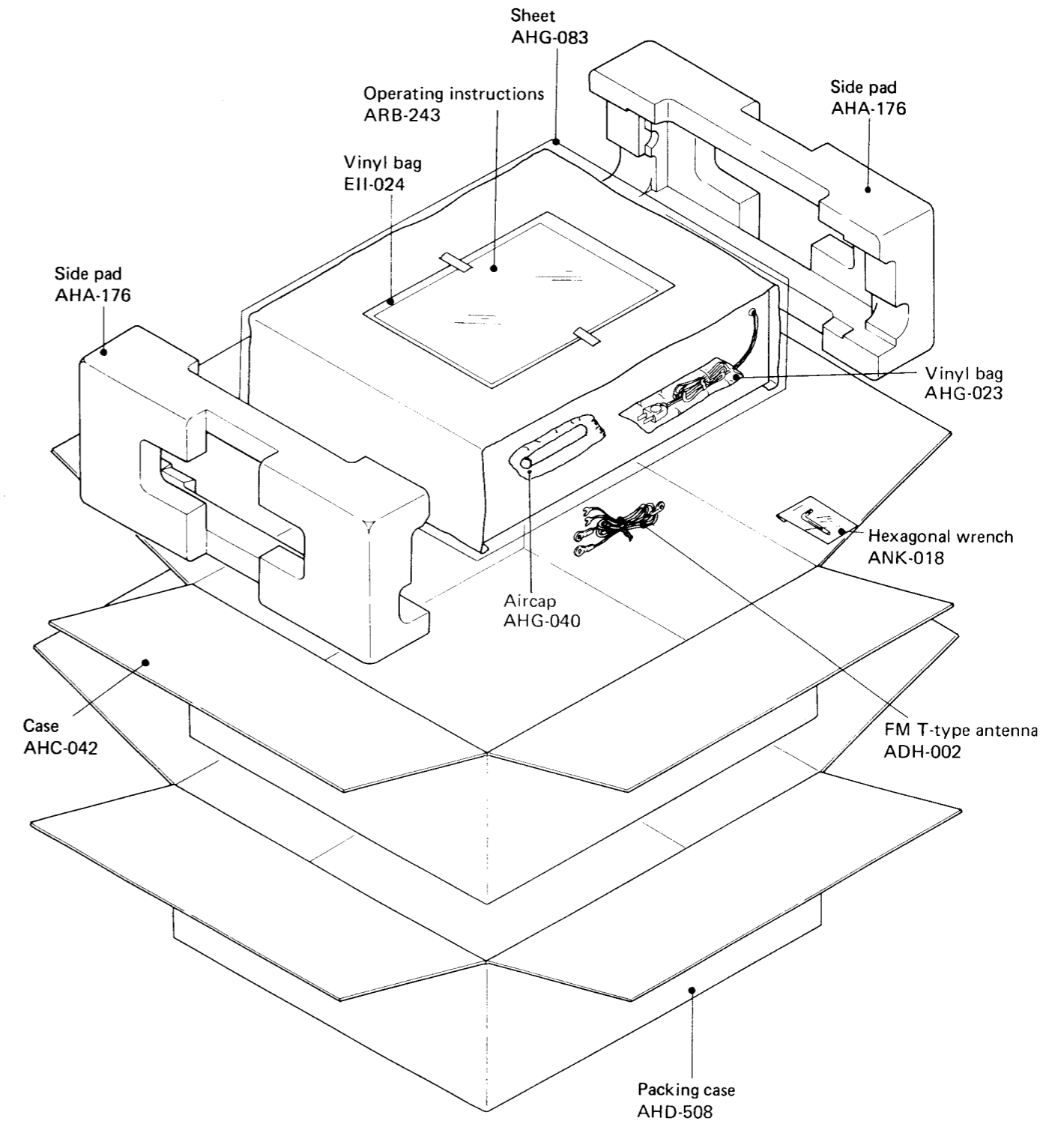

11.2 PART II

NOTE:
Parts indicated in green type cannot be supplied.

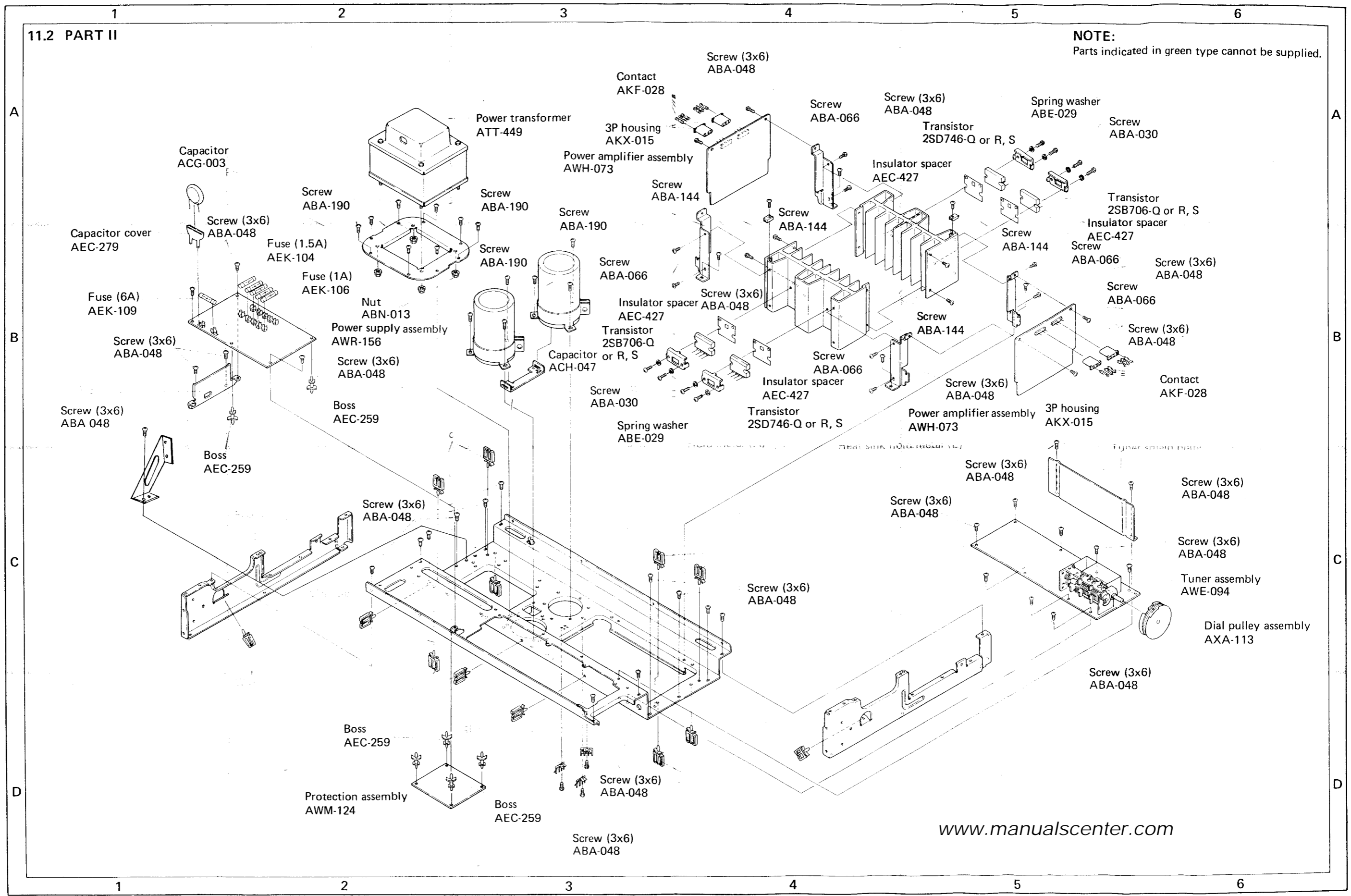

www.manualscenter.com

12. SCHEMATIC DIAGRAMS, P.C. BOARD PATTERNS AND PARTS LIST

12.1 MISCELLANEOUS PARTS LIST

NOTE:

- Capacitors: in μF unless otherwise noted P:pF.
- Resistors: in Ω , $\frac{1}{4}W$ unless otherwise noted k:k Ω , M:M Ω

COILS AND TRANSFORMER

Symbol	Part No.	Description
T1	T22-025	Balun
T2	ATB-505	Bar antenna
T3	T24-030	Ferry inductor
T4	ATT-449	Power transformer

LAMPS

Symbol	Part No.	Description
PL1	AEL-069	Pilot lamp with wire
PL2	AEL-067	Pilot lamp with wire
PL3	AEL-067	Pilot lamp with wire
PL4	AEL-067	Pilot lamp with wire
PL5	AEL-069	Pilot lamp with wire
PL7	AEL-029	Wedge type pilot lamp
PL8	AEL-029	Wedge type pilot lamp
PL9	AEL-029	Wedge type pilot lamp

FUSES

Symbol	Part No.	Description
FU1	AEK-109	Fuse 6A
FU2	AEK-104	Fuse 1.5A
FU3	AEK-106	Fuse 1A
FU4	AEK-106	Fuse 1A
FU5	AEK-106	Fuse 1A
FU6	AEK-106	Fuse 1A

SEMICONDUCTORS

Symbol	Part No.	Description
Q101	2SD746-Q or R, S	Transistor
Q102	2SB706-Q or R, S	Transistor
Q103	2SD746-Q or R, S	Transistor
Q104	2SB706-Q or R, S	Transistor

CAPACITORS

Symbol	Part No.	Description
C1	CKDBC 104Z 25	Ceramic 0.1 25V
C2	CKDBC 104Z 25	Ceramic 0.1 25V
C3	CKDBC 104Z 25	Ceramic 0.1 25V
C4	CKDBC 104Z 25	Ceramic 0.1 25V
C5	ACG-001	Ceramic 0.01 250V
C6	ACG-003	Ceramic 0.01 125V
C7	ACH-047	Electrolytic 18,000 63V
C8	ACH-047	Electrolytic 18,000 63V

RESISTOR

Symbol	Part No.	Description
R1	RD1/2PS225J	Carbon film 2.2M 1/2W
R2	RS2P 911J	Metal oxide 910 2W
R3	RS2P 911J	Metal oxide 910 2W

SWITCH

Symbol	Part No.	Description
S22	ASK-080	Lever switch (POWER)

ASSEMBLIES

Symbol	Part No.	Description
	AWE-094	Tuner assembly
	GWS-125	Function and equalizer assembly
	GWS-127	Input terminal assembly
	GWG-112	Flat amplifier assembly
	GWS-126	Terminal assembly
	AWG-056	Tone control assembly
	AWT-002	Filter assembly
	GWS-131	Speaker switch assembly
	GWS-132	Speaker terminal assembly
	AWH-073	Power amplifier assembly
	AWR-156	Power supply assembly
	AWM-124	Protection assembly

External Appearance of Transistors and ICs

2SA872A
2SC945A
2SC1775
2SC1438
2SC1400
2SC1915

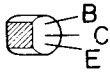

2SA850
2SC1735

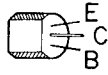

2SC535

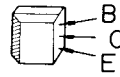

HA1201

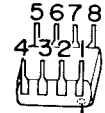

Index

2SA726S
2SC869
2SC1919
2SC1312
2SC1914
2SA904

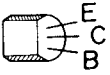

2SB536A
2SD381A

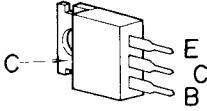

2SK34

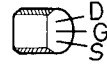

PA3004

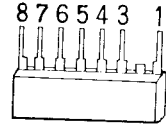

2SA684A
2SA912
2SC1885
2SC1384

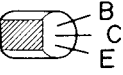

2SB507
2SD313
2SD712
2SB682C

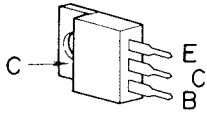

3SK45

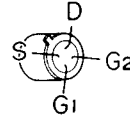

2SA979

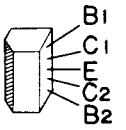

2SB706
2SD746

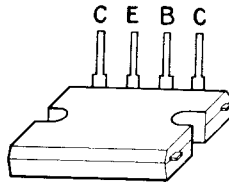

PA1001
PA1002
PA3001
HA1197

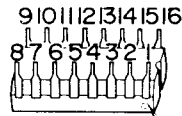

Index

Circuit Diagram of IC

HA1197

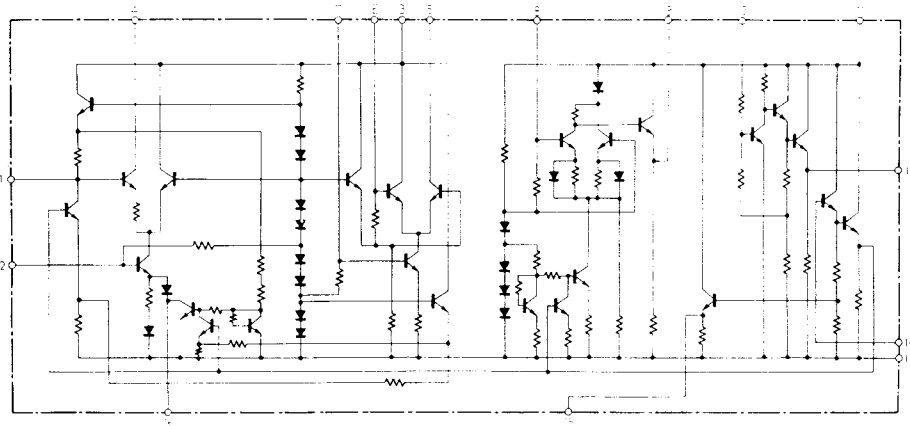

HA1201

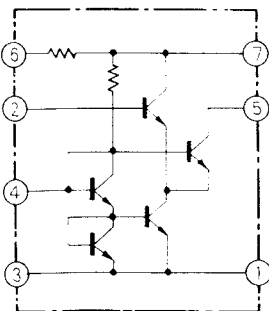

HA1457

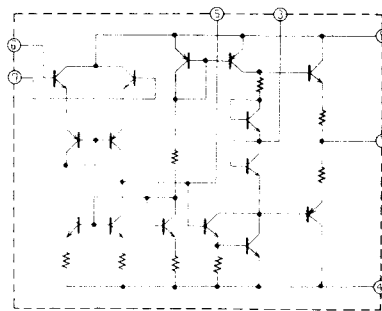

12.2 SCHEMATIC DIAGRAM

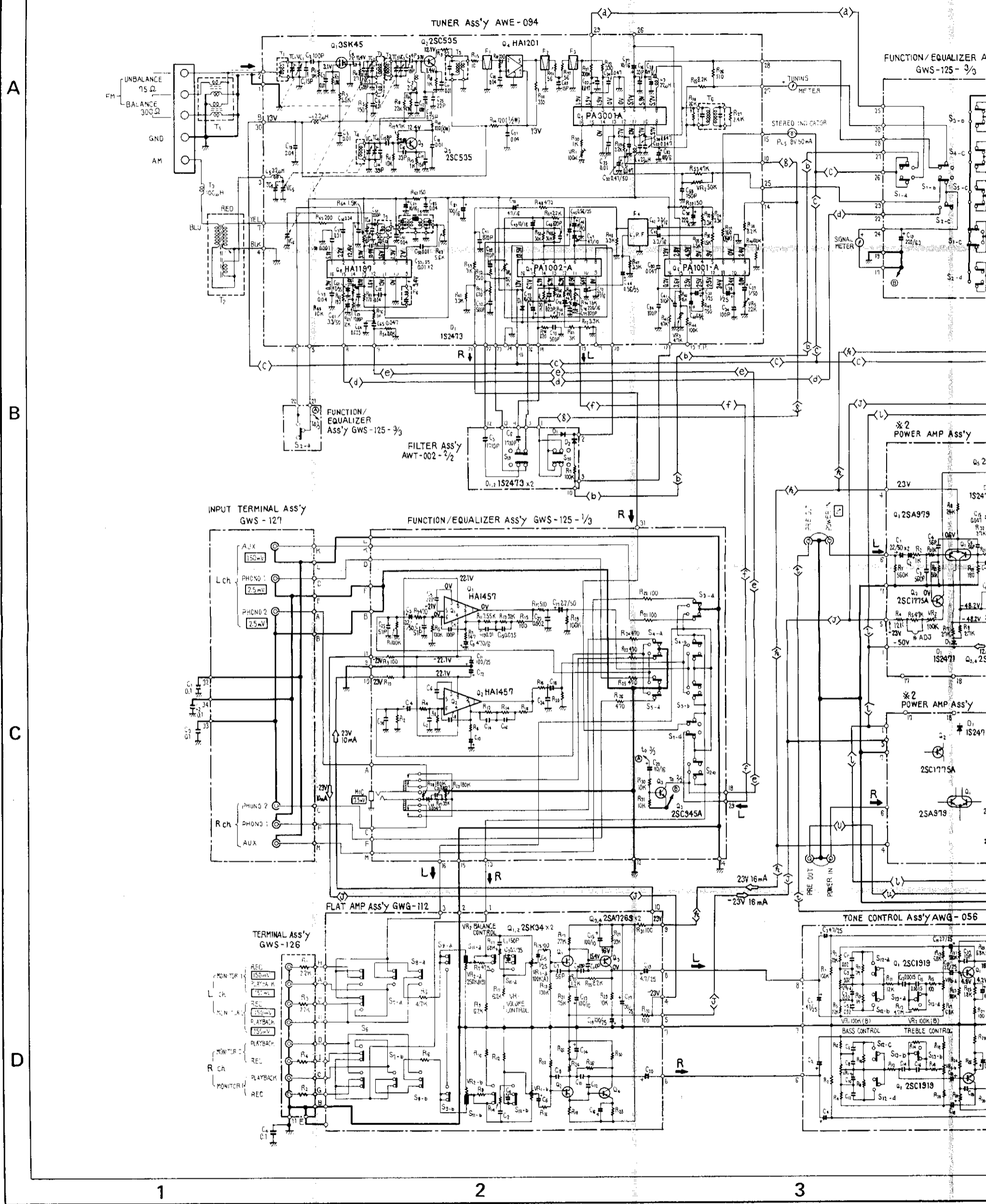

4

5

6

A

B

C

D

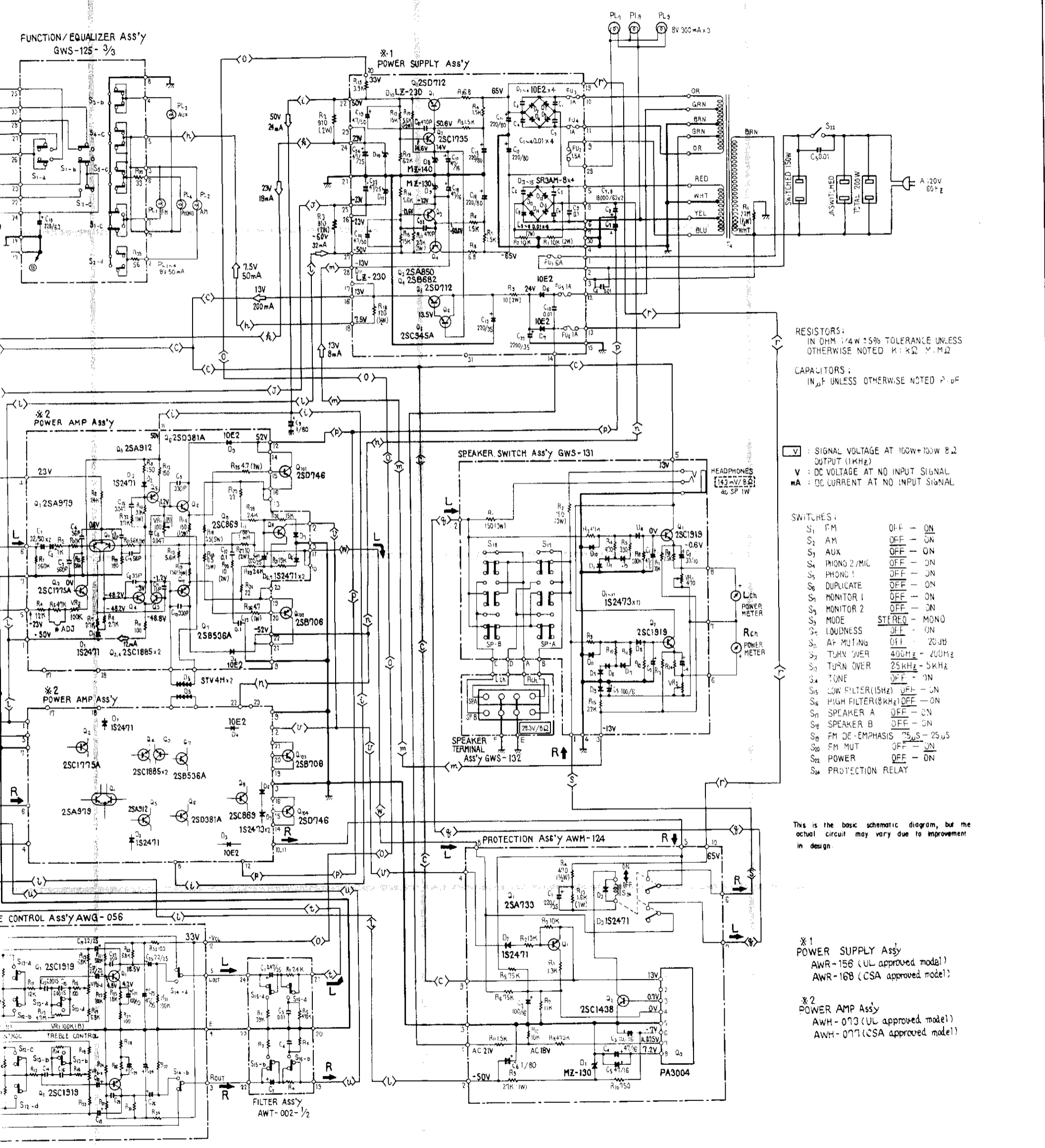

RESISTORS:
IN OHM 1/4 W ± 5% TOLERANCE UNLESS
OTHERWISE NOTED K: x 10³ M: x 10⁶

CAPACITORS:
IN μF UNLESS OTHERWISE NOTED P: μF

V: SIGNAL VOLTAGE AT 100W+100W 8Ω
OUTPUT (1KHz)

V: DC VOLTAGE AT NO INPUT SIGNAL

mA: DC CURRENT AT NO INPUT SIGNAL

SWITCHES:

S ₁	FM	OFF - ON
S ₂	AM	OFF - ON
S ₃	AUX	OFF - ON
S ₄	PHONE 2/MIC	OFF - ON
S ₅	PHONE 1	OFF - ON
S ₆	DUPLICATE	OFF - ON
S ₇	MONITOR 1	OFF - ON
S ₈	MONITOR 2	OFF - ON
S ₉	MODE	STEREO - MONO
S ₁₀	LOUDNESS	OFF - ON
S ₁₁	AF MUTING	OFF - 20dB
S ₁₂	TUN OVER	400Hz - 200Hz
S ₁₃	TUN OVER	25kHz - 5kHz
S ₁₄	ZONE	OFF - ON
S ₁₅	LOW FILTER (15Hz)	OFF - ON
S ₁₆	HIGH FILTER (8kHz)	OFF - ON
S ₁₇	SPEAKER A	OFF - ON
S ₁₈	SPEAKER B	OFF - ON
S ₁₉	FM DE-EMPHASIS	75μs - 25μs
S ₂₀	FM MUT	OFF - ON
S ₂₁	POWER	OFF - ON
S ₂₂	PROTECTION RELAY	

This is the basic schematic diagram, but the actual circuit may vary due to improvement in design.

*1
POWER SUPPLY ASS'y
AWR-156 (UL approved model)
AWR-168 (CSA approved model)

*2
POWER AMP ASS'y
AWH-073 (UL approved model)
AWH-077 (CSA approved model)

4

5

6

12.3 TUNER ASSEMBLY (AWE-094)

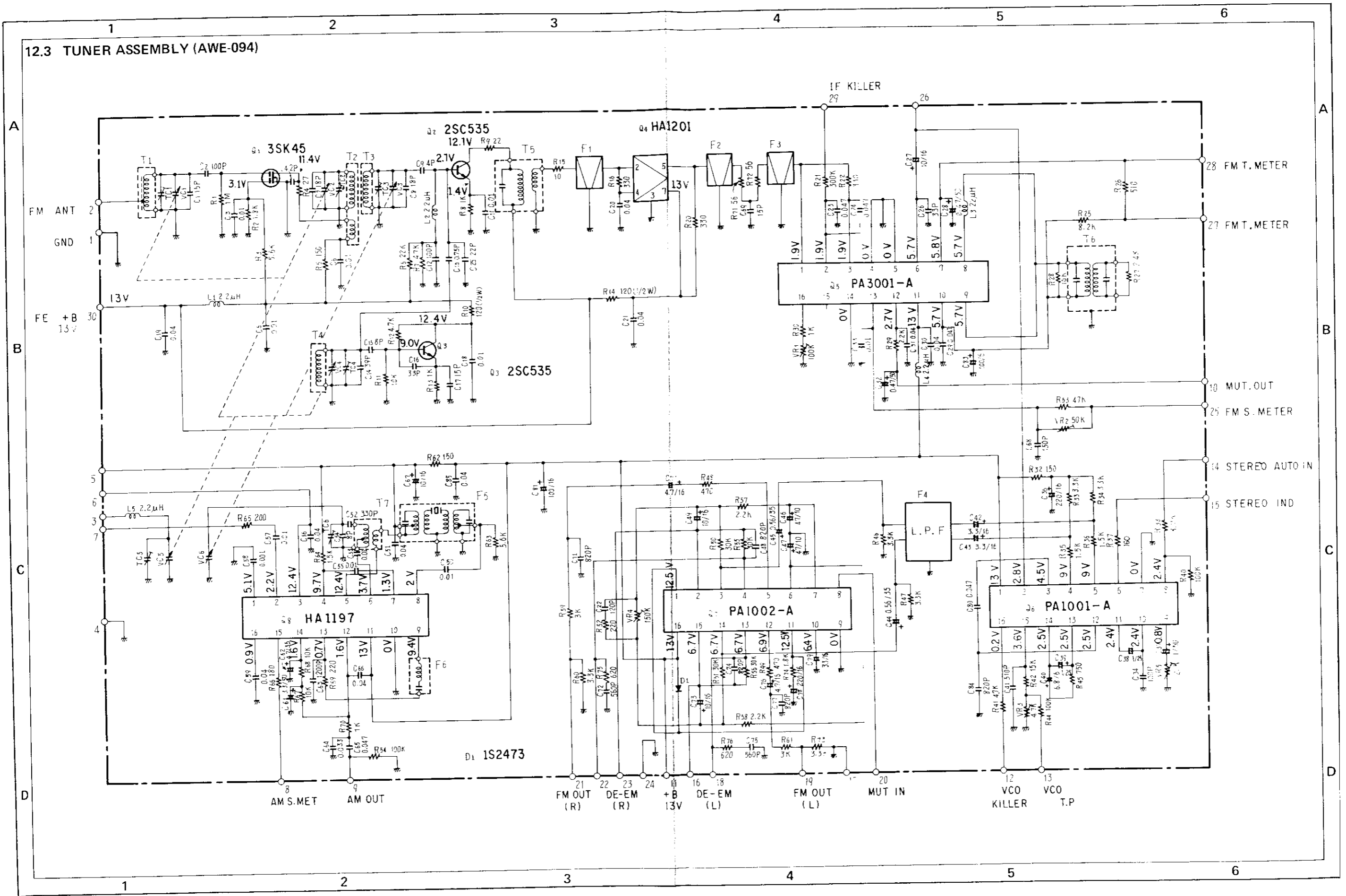

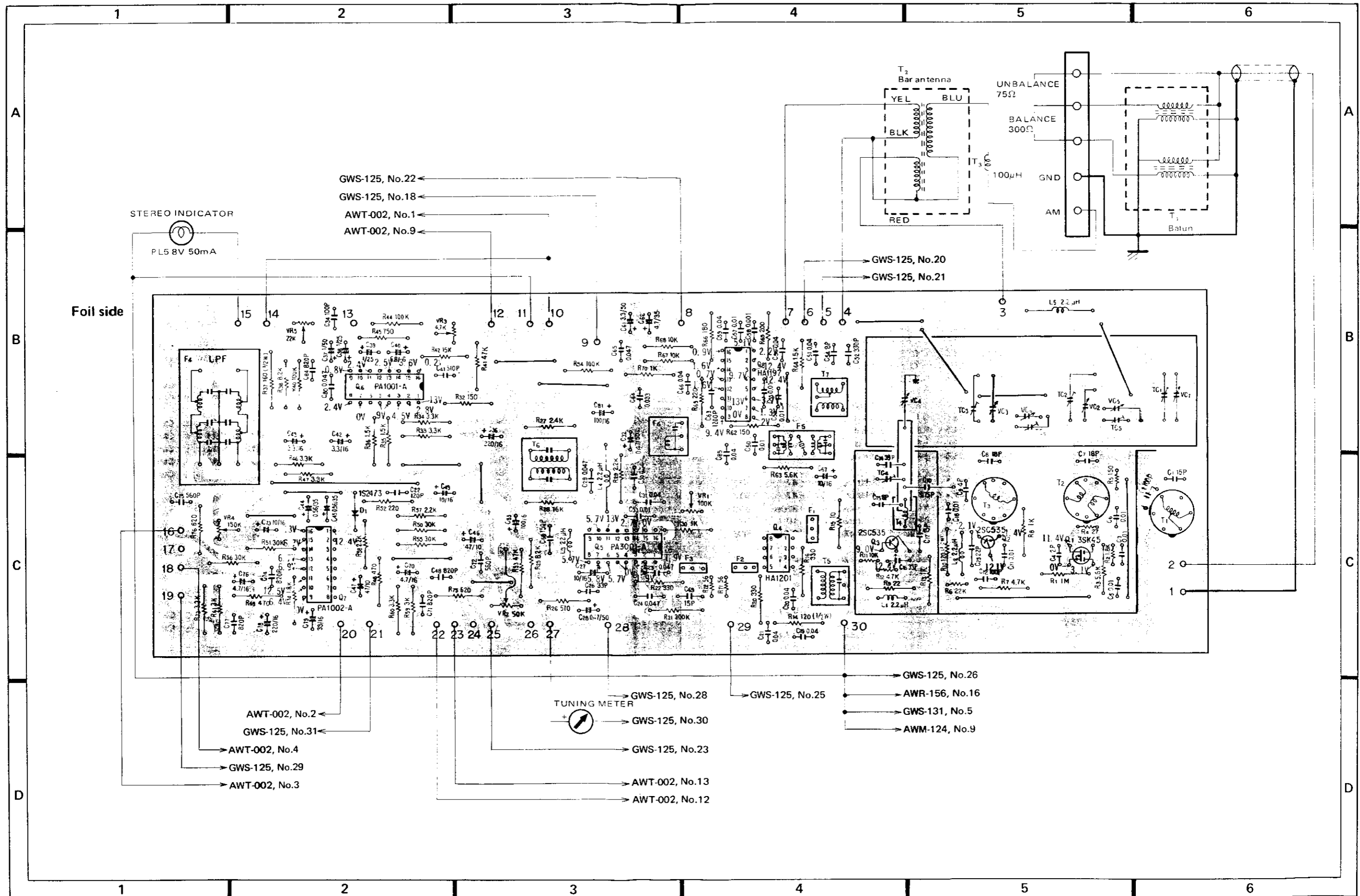

- ← GWS-125, No.22
- ← GWS-125, No.18
- ← AWT-002, No.1
- ← AWT-002, No.9

- GWS-125, No.20
- GWS-125, No.21

- ← AWT-002, No.2
- ← GWS-125, No.31
- ← AWT-002, No.4
- ← GWS-125, No.29
- ← AWT-002, No.3

- GWS-125, No.28
- GWS-125, No.30
- GWS-125, No.23
- AWT-002, No.13
- AWT-002, No.12

- GWS-125, No.26
- AWR-156, No.16
- GWS-131, No.5
- AWM-124, No.9

Parts List of Tuner Assembly (AWE-094)

TRANSFORMERS AND COILS

Symbol	Part No.	Description	Symbol	Part No.	Description
T1	ATC-021	FM antenna coil	C23	CKDBC 473Z 25	Ceramic 0.047 25V
T2	ATC-015	FM RF coil	C24	CKDBC 473Z 25	Ceramic 0.047 25V
T3	ATC-016	FM RF coil	C25	CCDSL 220K 50	Ceramic 22p 50V
T4	ATC-058	FM OSC coil			
T5	ATE-039	FM IF transformer	C26	CCDSL 330K 50	Ceramic 33p 50V
			C27	CSZA 100M 16	Electrolytic 10 16V
T6	ATE-030	FM DET transformer	C28	CEA R47P 50	Electrolytic 0.47 50V
T7	ATB-013	AM OSC coil	C29	CKDYF 403Z 50	Ceramic 0.04 50V
			C30	CKDYF 403Z 50	Ceramic 0.04 50V
F1	ATF-013	FM ceramic filter	C31	CKDYF 403Z 50	Ceramic 0.04 50V
F2	ATF-013	FM ceramic filter	C32	CEA 010P 50	Electrolytic 1 50V
F3	ATF-013	FM ceramic filter	C33	CKDYF 103Z 50	Ceramic 0.01 50V
F4	ATF-047	Low pass filter	C34	CCDSL 101K 50	Ceramic 100p 50V
F5	ATF-034	AM ceramic filter	C35	
F6	ATF-038	455kHz filter	C36	CEA 221P 16	Electrolytic 220 16V
L1	T24-028	RF choke coil	C37	CEA 010P 50	Electrolytic 1 50V
L2	T24-028	RF choke coil	C38	CSZA 010M 25	Electrolytic 1 25V
L3	ATH-014	Micro inductor	C39	CSZA 010M 25	Electrolytic 1 25V
L4	T24-028	RF choke coil	C40	CSZA 6R8M 6	Electrolytic 6.8 6V
L5	T24-028	RF choke coil			

CAPACITORS

Symbol	Part No.	Description	Symbol	Part No.	Description
TC4	ACM-006	Ceramic trimmer	C41	CQSH 511J 50	Polystyrene 510p 50V
	ACK-022	Variable capacitor	C42	CSZA 3R3M 16	Electrolytic 3.3 16V
C1	CCDTH 150K 50	Ceramic 15p 50V	C43	CSZA 3R3M 16	Electrolytic 3.3 16V
C2	CCDSL 101K 50	Ceramic 100p 50V	C44	CSZA R56K 35	Electrolytic 0.56 35V
C3	CCDYF 103Z 50	Ceramic 0.01 50V	C45	CSZA R56K 35	Electrolytic 0.56 35V
C4	CCDSL 020C 50	Ceramic 2p 50V	C46	CEA 470P 10	Electrolytic 47 10V
C5	CKDYF 103Z 50	Ceramic 0.01 50V	C47	CEA 470P 10	Electrolytic 47 10V
C6	CKDYF 103Z 50	Ceramic 0.01 50V	C48	COSA 821G 50	Polystyrene 820p 50V
C7	CCDTH 180K 50	Ceramic 18p 50V	C49	CEA 100P 16	Electrolytic 10 16V
C8	CCDTH 180K 50	Ceramic 18p 50V	C50	CKDYF 103Z 50	Ceramic 0.01 50V
C9	CCDSL 040D 50	Ceramic 4p 50V	C51	CKDYF 403Z 50	Ceramic 0.04 50V
C10	CGB R75 K500	Ceramic 0.75P 500V	C52	COSA 331J 50	Polystyrene 330p 50V
C11	CKDYB 103K 50	Ceramic 0.01 50V	C53	CKDYF 103Z 50	Ceramic 0.01 50V
C12	CCDSL 101K 50	Ceramic 100p 50V	C54	CCDXL 080F 50	Ceramic 8p 50V
C13		C55	CKDYF 103Z 50	Ceramic 0.01 50V
C14	CCDLH 390K 50	Ceramic 39p 50V	C56	CKDYF 403Z 50	Ceramic 0.04 50V
C15	CCDCH 080F 50	Ceramic 8p 50V	C57	CKDYF 103Z 50	Ceramic 0.01 50V
C16	CCDCH 330K 50	Ceramic 33p 50V	C58	CKDYB 102K 50	Ceramic 1000p 50V
C17	CCDCH 150K 50	Ceramic 15p 50V	C59	CKDYF 403Z 50	Ceramic 0.04 50V
C18	CKDYF 103Z 50	Ceramic 0.01 50V	C60	
C19	CKDYF 403Z 50	Ceramic 0.04 50V	C61	CEA 3R3P 50	Electrolytic 3.3 50V
C20	CKDYF 403Z 50	Ceramic 0.04 50V	C62	CEA 4R7P 35	Electrolytic 4.7 35V
C21	CKDYF 403Z 50	Ceramic 0.04 50V	C63	CKDYB 122K 50	Ceramic 1200p 50V
C22	CCDSL 121K 50	Ceramic 120p 50V	C64	CQMA 333J 50	Mylar 0.033 50V
			C65	CQMA 473J 50	Mylar 0.047 50V
			C66	CKDYF 403Z 50	Ceramic 0.04 50V
			C67	CEA 100P 16	Electrolytic 10 16V
			C68	CCDSL 151K 50	Ceramic 150p 50V
			C69	CCDSL 150K 50	Ceramic 15p 50V
			C70	CSZA 4R7M 16	Electrolytic 4.7 16V

Symbol	Part No.	Description	Symbol	Part No.	Description
C71	CKDYB 821K 50	Ceramic 820p 50V	R26	RD%PS 511J	Carbon film 510
C72	CKDYB 561K 50	Ceramic 560p 50V	R27	RD%PS 242J	Carbon film 2.4k
C73	CEA 100P 16	Electrolytic 10 16V	R28	RD%PS 163J	Carbon film 16k
C74	COSA 821G 50	Polystyrene 820p 50V	R29	RD%PS 222J	Carbon film 2.2k
C75	CKDYB 561K 50	Ceramic 560p 50V	R30	RD%PS 102J	Carbon film 1k
C76	CSZA 4R7M 16	Electrolytic 4.7 16V	R31	RD%PS 512J	Carbon film 5.1k
C77	CKDYB 821K 50	Ceramic 820p 50V	R32	RD%PS 151J	Carbon film 150
C78	CEA 221P 16	Electrolytic 220 16V	R33	RD%PS 332J	Carbon film 3.3k
C79	CEA 330P 16	Electrolytic 33 16V	R34	RD%PS 332J	Carbon film 3.3k
C80	CQMA 473J 50	Mylar 0.047 50V	R35	RD%PS 152J	Carbon film 1.5k
C81	CEA 101P 16	Electrolytic 100 16V	R36	RD%PS 152J	Carbon film 1.5k
C82		R37	RD%PS 161J	Carbon film 160 1/2W
C83	CEA 101P 6	Electrolytic 100 6V	R38	RD%PS 822J	Carbon film 8.2k
C84	CKDYB 821K 50	Ceramic 820p 50V	R40	RD%PS 104J	Carbon film 100k
C85	CKDYF 403Z 50	Ceramic 0.04 50V	R41	RD%PS 473J	Carbon film 47k

RESISTORS

Symbol	Part No.	Description	Symbol	Part No.	Description
VR1	C92-047	Semi fixed 100k	R42	RN%PR 1502F	Metal film 15k
VR2	ACP-043	Semi fixed 50k	R43	
VR3	C92-051	Semi fixed 4.7k	R44	RD%PS 104J	Carbon film 100k
VR4	ACP-057	Semi fixed 150k	R45	RD%PS 751J	Carbon film 750
VR5	ACP-056	Semi fixed 22k	R46	RD%PS 332J	Carbon film 3.3k
R1	RD%PS 105J	Carbon film 1M	R47	RD%PS 332J	Carbon film 3.3k
R2	RD%VS 182J	Carbon film 1.8k	R48	RD%PS 471J	Carbon film 470
R3	RD%PS 562J	Carbon film 5.6k	R49	RD%PS 471J	Carbon film 470
R4	RD%VS 270J	Carbon film 27	R50	RD%PS 303J	Carbon film 30k
R5	RD%VS 151J	Carbon film 150	R51	RD%PS 303J	Carbon film 30k
R6	RD%VS 223J	Carbon film 22k	R52	RD%PS 221J	Carbon film 220
R7	RD%PS 472J	Carbon film 4.7k	R53	RD%PS 473J	Carbon film 47k
R8	RD%PS 102J	Carbon film 1k	R54	RD%PS 104J	Carbon film 100k
R9	RD%PS 220J	Carbon film 22	R55	RD%PS 303J	Carbon film 30k
R10	RD%PS 121J	Carbon film 120 1/2W	R56	RD%PS 303J	Carbon film 30k
R11	RD%VS 103J	Carbon film 10k	R57	RD%PS 222J	Carbon film 2.2k
R12	RD%VS 472J	Carbon film 4.7k	R58	RD%PS 222J	Carbon film 2.2k
R13	RD%PS 102J	Carbon film 1k	R59	RD%PS 302J	Carbon film 3k
R14	RD%PS 121J	Carbon film 120 1/2W	R60	RD%PS 332J	Carbon film 3.3k
R15	RD%PS 100J	Carbon film 10	R61	RD%PS 302J	Carbon film 3k
R16	RD%PS 331J	Carbon film 330	R62	RD%PS 151J	Carbon film 150
R17	RD%PS 113J	Carbon film 11k	R63	RD%PS 562J	Carbon film 5.6k
R18		R64	RD%PS 152J	Carbon film 1.5k
R19		R65	RD%PS 201J	Carbon film 200
R20	RD%PS 331J	Carbon film 330	R66	RD%PS 181J	Carbon film 180
R21	RD%PS 304J	Carbon film 300k	R67	RD%PS 103J	Carbon film 10k
R22	RD%PS 331J	Carbon film 330	R68	RD%PS 103J	Carbon film 10k
R23		R69	RD%PS 221J	Carbon film 220
R24	RD%PS 224J	Carbon film 220k	R70	RD%PS 102J	Carbon film 1k
R25	RD%PS 822J	Carbon film 8.2k	R71	RD%VS 560J	Carbon film 56
			R72	RD%VS 560J	Carbon film 56
			R73	RD%PS 332J	Carbon film 3.3k
			R74	RD%PS 182J	Carbon film 1.8k
			R75	RD%PS 621J	Carbon film 620
			R76	RD%PS 621J	Carbon film 620

SEMICONDUCTORS

Symbol	Part No.	Description	Symbol	Part No.	Description
Q1	3SK45-B	Transistor	Q6	PA1001-A	IC
Q2	2SC535-B	Transistor	Q7	PA1002-A or PA1002	IC
Q3	2SC535-B	Transistor	Q8	HA1197	IC
Q4	HA1201	IC	D1	1S2473	Diode
Q5	PA3001-A	IC			

12.4 INPUT TERMINAL ASSEMBLY (GWS-127)

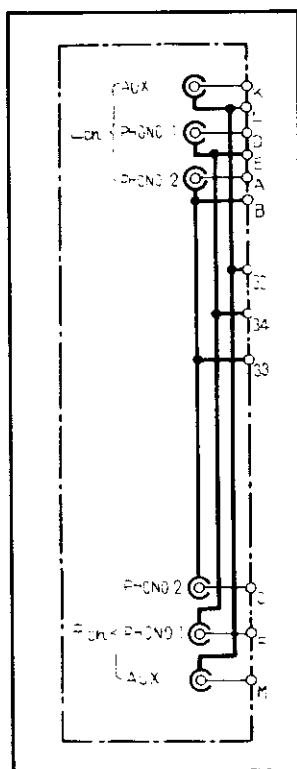
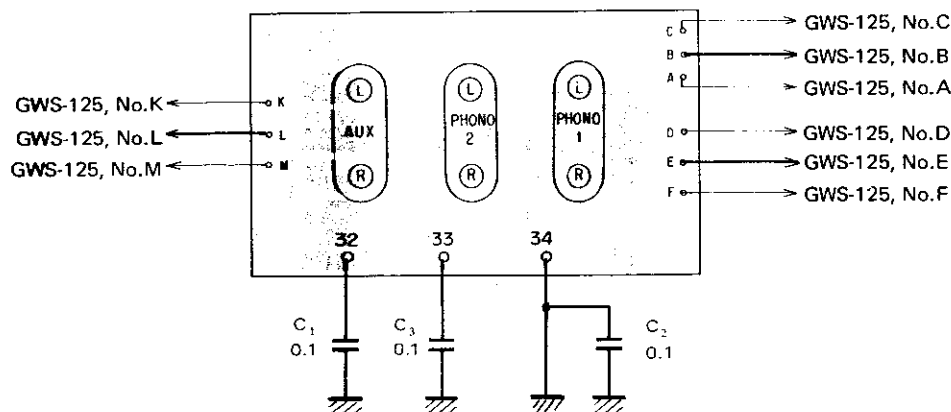

Part List

Symbol	Part No.	Description
	AKB-028	6-P Pin jack

12.5 FUNCTION AND EQUALIZER ASSEMBLY (GWS-125)

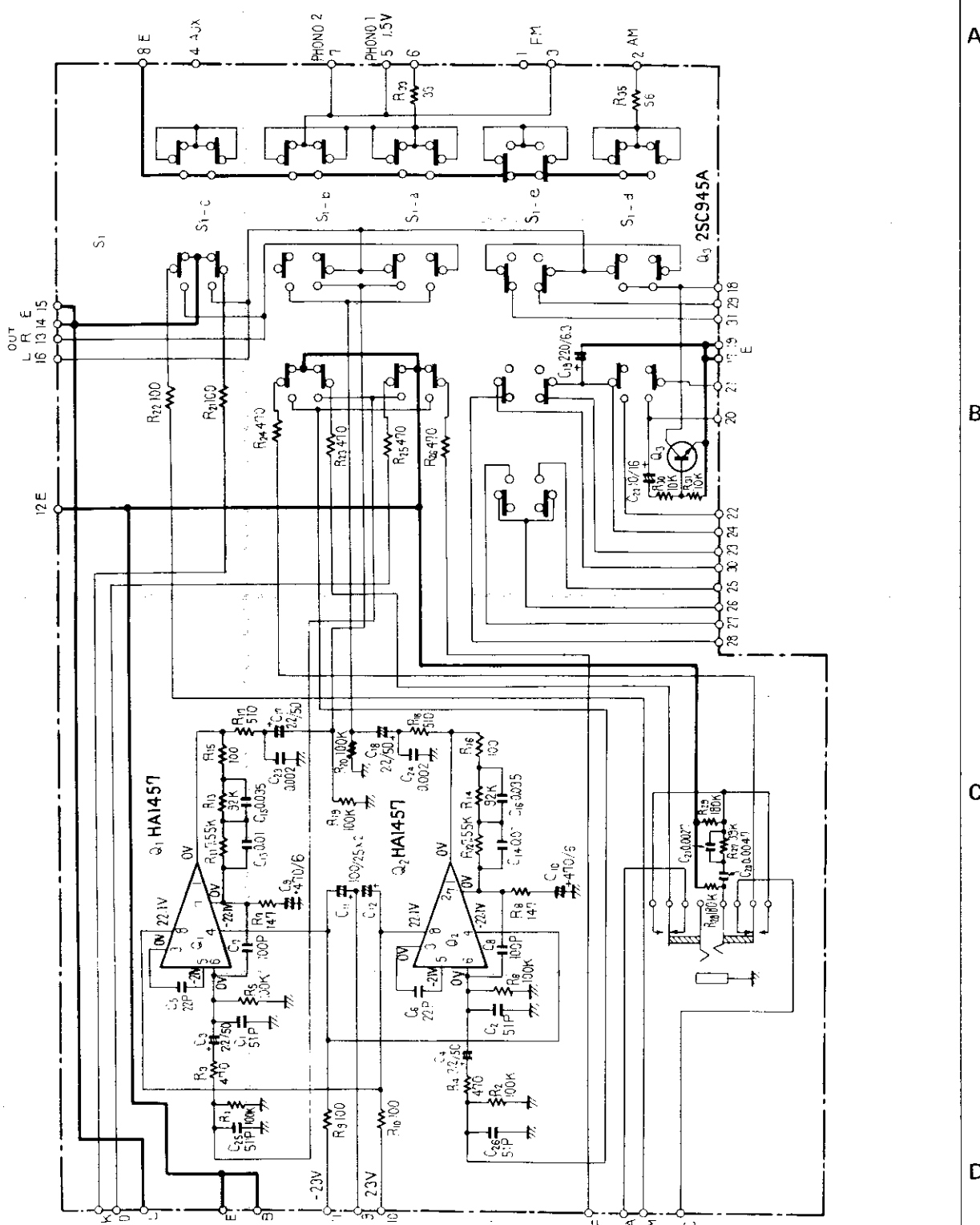

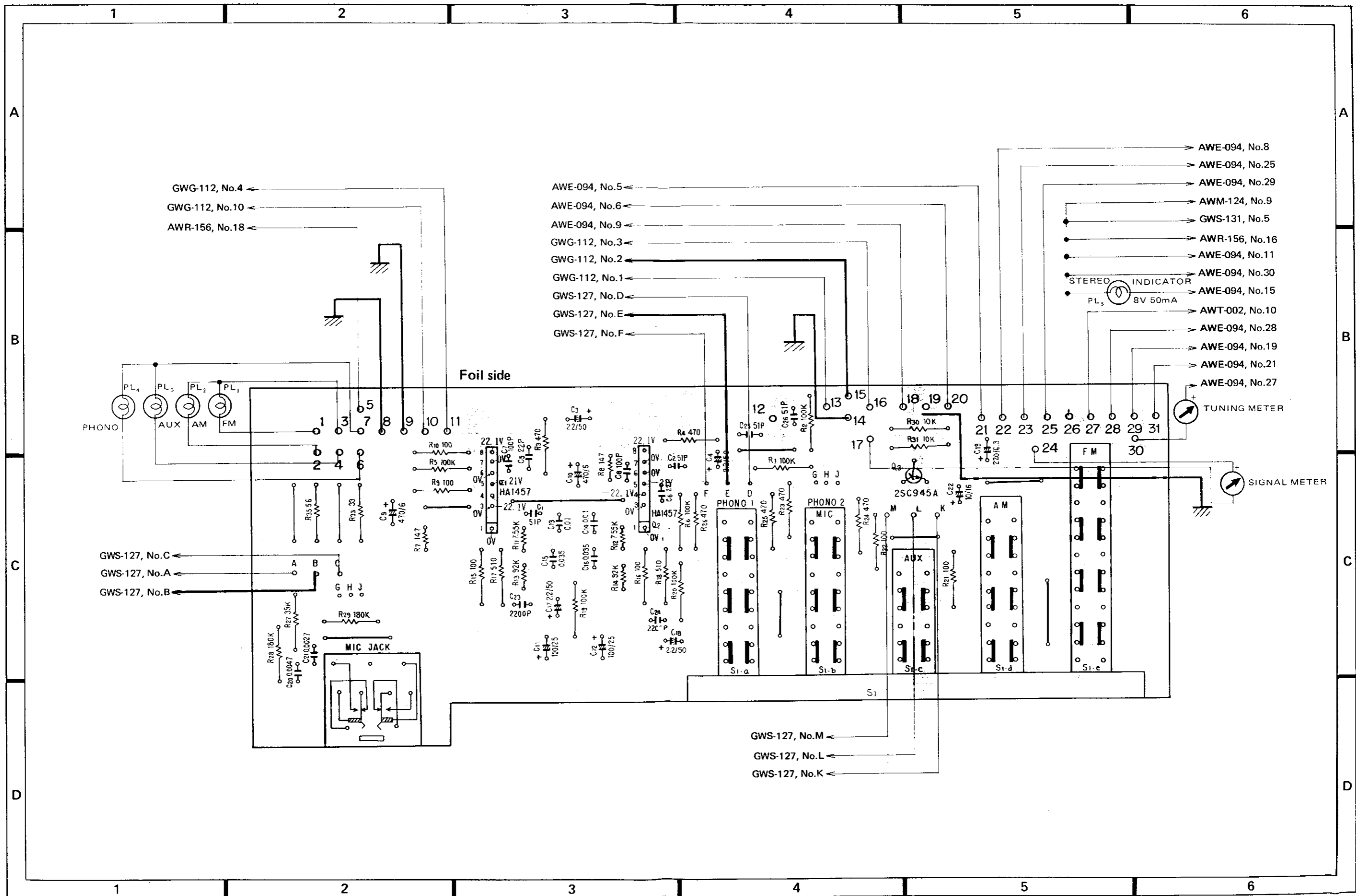

GWG-112, No.4
 GWG-112, No.10
 AWR-156, No.18

AWE-094, No.5
 AWE-094, No.6
 AWE-094, No.9
 GWG-112, No.3
 GWG-112, No.2
 GWG-112, No.1
 GWS-127, No.D
 GWS-127, No.E
 GWS-127, No.F

AWE-094, No.8
 AWE-094, No.25
 AWE-094, No.29
 AWM-124, No.9
 GWS-131, No.5
 AWR-156, No.16
 AWE-094, No.11
 AWE-094, No.30
 AWE-094, No.15
 AWT-002, No.10
 AWE-094, No.28
 AWE-094, No.19
 AWE-094, No.21
 AWE-094, No.27

GWS-127, No.C
 GWS-127, No.A
 GWS-127, No.B

GWS-127, No.M
 GWS-127, No.L
 GWS-127, No.K

Parts List of Function and Equalizer Assembly (GWS-125)

SWITCH

Symbol	Part No.	Description	Symbol	Part No.	Description
S1	ASG-126	Push switch (FUNCTION)	R11	ACN-011	Metal film 7.55k

CAPACITORS

Symbol	Part No.	Description	Symbol	Part No.	Description
C1	CCDSL 510J 50	Ceramic 51p 50V	R16	RD½PS 101J	Carbon film 100
C2	CCDSL 510J 50	Ceramic 51p 50V	R17	RD½PS 511J	Carbon film 510
C3	CEANL 2R2P 50	Electrolytic 2.2 50V	R18	RD½PS 511J	Carbon film 510
C4	CEANL 2R2P 50	Electrolytic 2.2 50V	R19	RD½PS 104J	Carbon film 100k
C5	CCDSL 220K 50	Ceramic 22p 50V	R20	RD½PS 104J	Carbon film 100k
C6	CCDSL 220K 50	Ceramic 22p 50V	R21	RD½PS 101J	Carbon film 100
C7	CCDSL 101K 50	Ceramic 100p 50V	R22	RD½PS 101J	Carbon film 100
C8	CCDSL 101K 50	Ceramic 100p 50V	R23	RD½PS 471J	Carbon film 470
C9	CEA 471P 6	Electrolytic 470 6V	R24	RD½PS 471J	Carbon film 470
C10	CEA 471P 6	Electrolytic 470 6V	R25	RD½PS 471J	Carbon film 470
C11	CEA 101P 25	Electrolytic 100 25V	R26	RD½PS 471J	Carbon film 470
C12	CEA 101P 25	Electrolytic 100 25V	R27	RD½PS 393J	Carbon film 39k
C13	CQPA 103G 50	Polypropylene 0.01 50V	R28	RD½PS 184J	Carbon film 180k
C14	CQPA 103G 50	Polypropylene 0.01 50V	R29	RD½PS 184J	Carbon film 180k
C15	CQPA 353G 50	Polypropylene 0.035 50V	R30	RD½PS 103J	Carbon film 10k
C16	CQPA 353G 50	Polypropylene 0.035 50V	R31	RD½PS 103J	Carbon film 10k
C17	CEANL 2R2P 50	Electrolytic 2.2 50V	R32
C18	CEANL 2R2P 50	Electrolytic 2.2 50V	R33	RD½PS 330J	Carbon film 33
C19	CEA 221P 6	Electrolytic 220 6V	R34
C20	CQMA 472K 50	Mylar 0.0047 50V	R35	RD½PS 560J	Carbon film 56
C21	CQMA 272K 50	Mylar 0.0027 50V			
C22	CEA 100P 16	Electrolytic 10 16V			
C23	CKDYF 222Z 50	Ceramic 2200p 50V			
C24	CKDYF 222Z 50	Ceramic 2200p 50V			
C25	CCDSL 510J 50	Ceramic 51p 50V			
C26	CCDSL 510J 50	Ceramic 51p 50V			

SEMICONDUCTORS

Symbol	Part No.	Description
Q1	HA 1457	IC
Q2	HA 1457	IC
Q3	2SC945A-Q or R (2SC1914-F)	Transistor

OTHER

Symbol	Part No.	Description
	AKN-012	Mic jack (MIC)

RESISTORS

Symbol	Part No.	Description
R1	RD½PS 104J	Carbon film 100k
R2	RD½PS 104J	Carbon film 100k
R3	RD½PS 471J	Carbon film 470
R4	RD½PS 471J	Carbon film 470
R5	RD½PS 104J	Carbon film 100k
R6	RD½PS 104J	Carbon film 100k
R7	RN1/5SQ 1470F	Metal film 147 1/5W
R8	RN1/5SQ 1470F	Metal film 147 1/5W
R9	RD½PS 101J	Carbon film 100
R10	RD½PS 101J	Carbon film 100

12.6 TERMINAL ASSEMBLY (GWS-126)

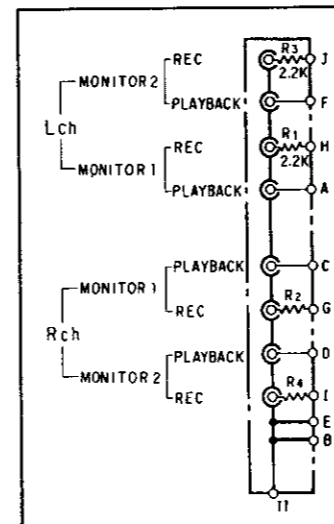
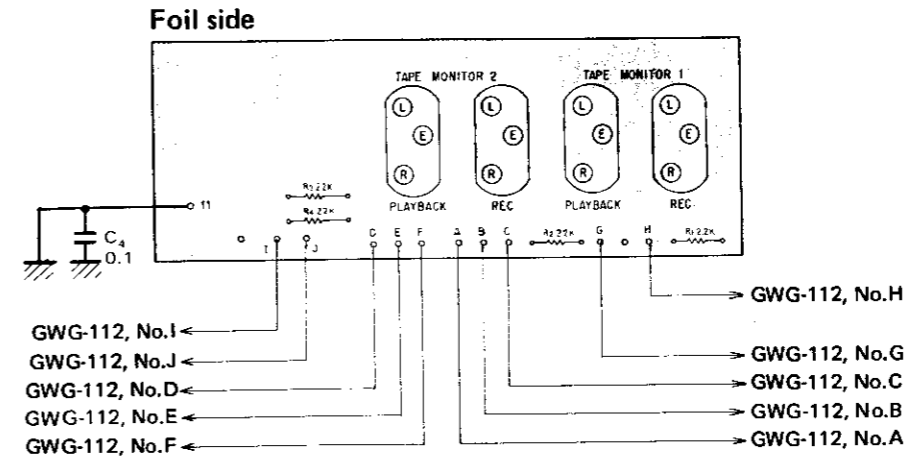

Parts List

RESISTORS

Symbol	Part No.	Description
R1	RD½PM 222J	Carbon film 2.2k
R2	RD½PM 222J	Carbon film 2.2k
R3	RD½PS 222J	Carbon film 2.2k
R4	RD½PS 222J	Carbon film 2.2k

OTHER

Symbol	Part No.	Description
	AKB-045	4-P Pin jack

12.7 FLAT AMPLIFIER ASSEMBLY (GWG-112)

Parts List

SWITCHES

Symbol	Part No.	Description	Symbol	Part No.	Description
S1	ASK-145	Lever switch (DUPLICATE)	R13	RD½PS 683J	Carbon film 68k
S2	ASK-144	Lever switch (TAPE MONITOR 1)	R14	RD½PS 683J	Carbon film 68k
S3	ASK-144	Lever switch (TAPE MONITOR 2)	R15	RD½PS 101J	Carbon film 100
S4	ASK-144	Lever switch (MODE)	R16	RD½PS 101J	Carbon film 100
S5	ASK-144	Lever switch (LOUDNESS)	R17	RD½PS 223J	Carbon film 22k
S6	ASK-144	Lever switch (MUTING)	R18	RD½PS 223J	Carbon film 22k

CAPACITORS

Symbol	Part No.	Description	Symbol	Part No.	Description
C1	CCDSL 151K 50	Ceramic 150P 50V	R23	RD½PS 122J	Carbon film 1.2k
C2	CCDSL 151K 50	Ceramic 150p 50V	R24	RD½PS 122J	Carbon film 1.2k
C3	CSZA 0R1M 35	Electrolytic 0.1 35V	R25	RD½PS 822J	Carbon film 8.2k
C4	CSZA 0R1M 35	Electrolytic 0.1 35V	R26	RD½PS 822J	Carbon film 8.2k
C5	CSZA 010M 25	Electrolytic 1 25V	R27	RD½PS 392J	Carbon film 3.9k
C6	CSZA 010M 25	Electrolytic 1 25V	R28	RD½PS 392J	Carbon film 3.9k
C7	CCDSL 560K 50	Ceramic 56p 50V	R29	RD½PS 103J	Carbon film 10k
C8	CCDSL 560K 50	Ceramic 56p 50V	R30	RD½PS 103J	Carbon film 10k
C9	CCDSL 680K 50	Ceramic 68p 50V	R31	RD½PS 101J	Carbon film 100
C10	CCDSL 680K 50	Ceramic 68p 50V	R32	RD½PS 101J	Carbon film 100
C11	CCDSL 100F 50	Ceramic 10p 50V	SEMICONDUCTORS		
C12	CCDSL 100F 50	Ceramic 10p 50V	Symbol	Part No.	Description
C13	CEANL 101P 10	Electrolytic 100 10V	Q1	2SK34-G or D (2SK68A-L or M)	FET
C14	CEANL 101P 10	Electrolytic 100 10V	Q2	2SK34-G or D (2SK68A-L or M)	FET
C15	CEANL 101P 10	Electrolytic 100 10V	Q3	2SA726S-F or G (2SA872A-D or E)	Transistor
C16	CEANL 101P 10	Electrolytic 100 10V	Q4	2SA726S-F or G (2SA872A-D or E)	Transistor
C17	CEA 101P 25	Electrolytic 100 25V			
C18	CEA 101P 25	Electrolytic 100 25V			
C19	CEANL 4R7P 25	Electrolytic 4.7 25V			
C20	CEANL 4R7P 25	Electrolytic 4.7 25V			

RESISTORS

Symbol	Part No.	Description
VR1	ACV-162	Variable resistor 100k A (VOLUME)
VR2	ACV-190	Variable resistor 250k HB (BALANCE)
R5	RD½PS 472J	Carbon film 4.7k
R6	RD½PS 472J	Carbon film 4.7k
R7	RD½PS 473J	Carbon film 47k
R8	RD½PS 473J	Carbon film 47k
R9	RD½PS 622J	Carbon film 6.2k
R10	RD½PS 622J	Carbon film 6.2k
R11	RD½PS 622J	Carbon film 6.2k
R12	RD½PS 622J	Carbon film 6.2k

Flat Amplifier Assembly (GWG-112)

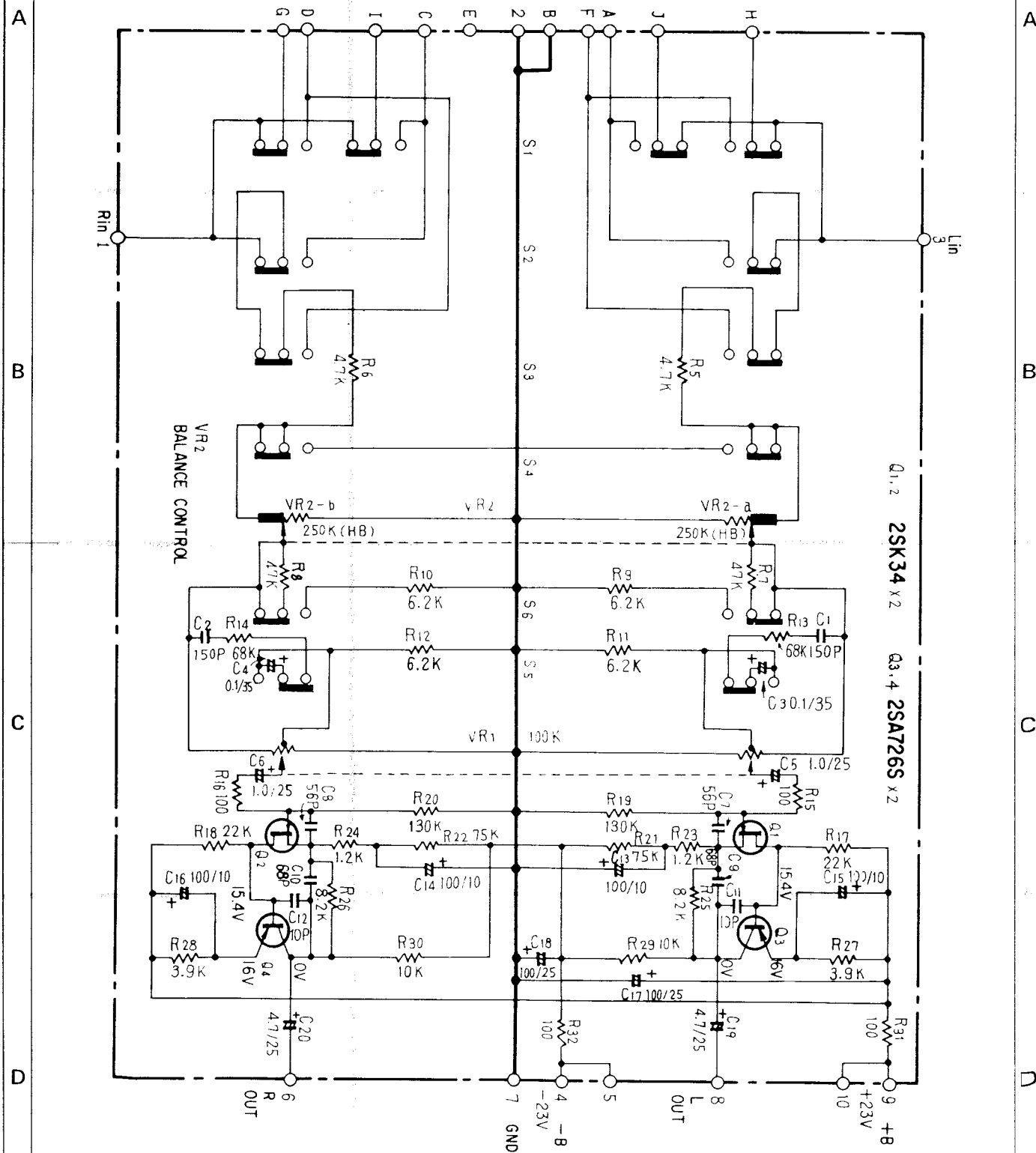

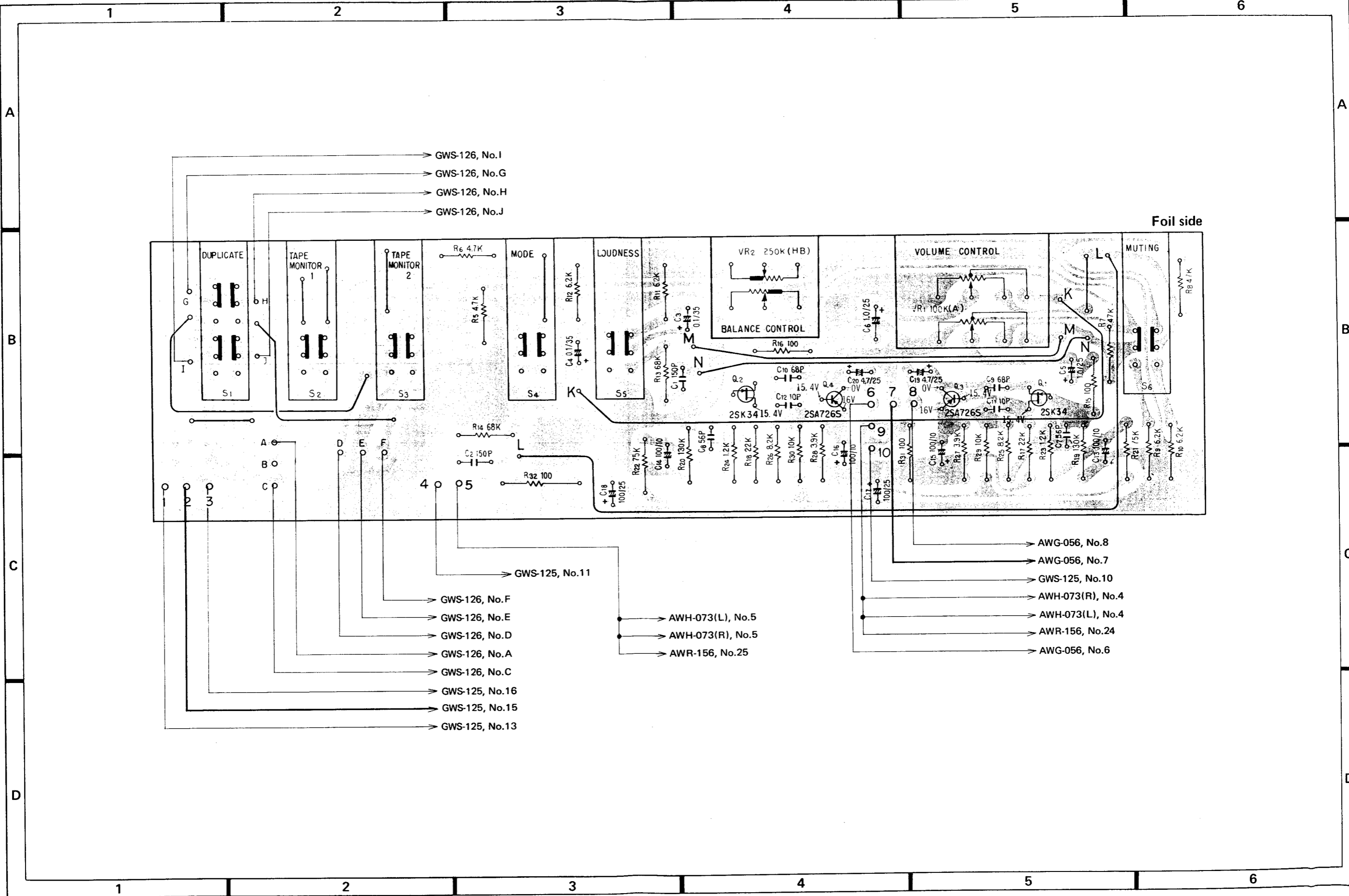

- GWS-126, No.I
- GWS-126, No.G
- GWS-126, No.H
- GWS-126, No.J

Foil side

- GWS-125, No.11
- GWS-126, No.F
- GWS-126, No.E
- GWS-126, No.D
- GWS-126, No.A
- GWS-126, No.C
- GWS-125, No.16
- GWS-125, No.15
- GWS-125, No.13

- AWH-073(L), No.5
- AWH-073(R), No.5
- AWR-156, No.25

- AWG-056, No.8
- AWG-056, No.7
- GWS-125, No.10
- AWH-073(R), No.4
- AWH-073(L), No.4
- AWR-156, No.24
- AWG-056, No.6

12.8 TONE AMPLIFIER ASSEMBLY (AWG-056)

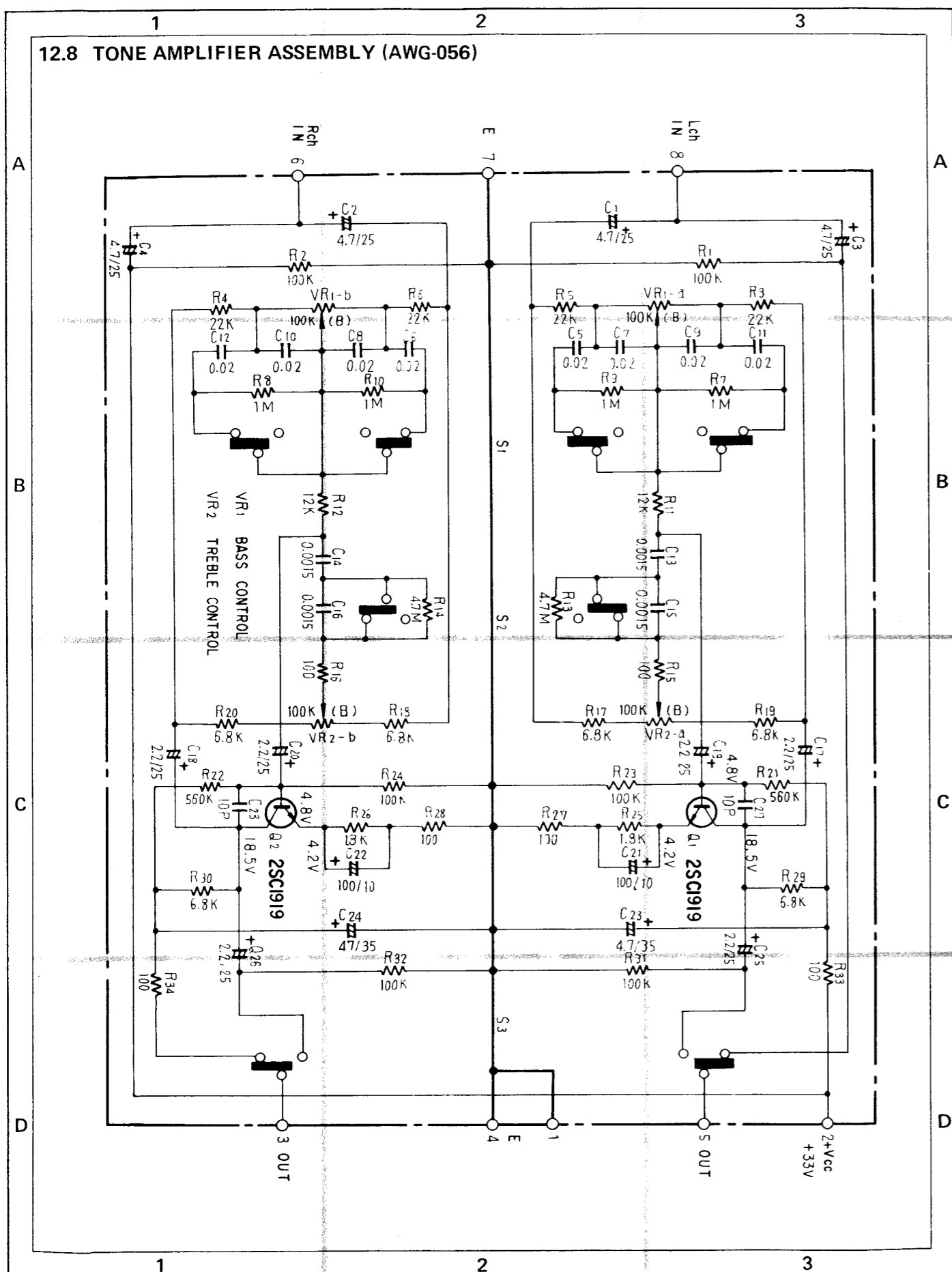

Foil side

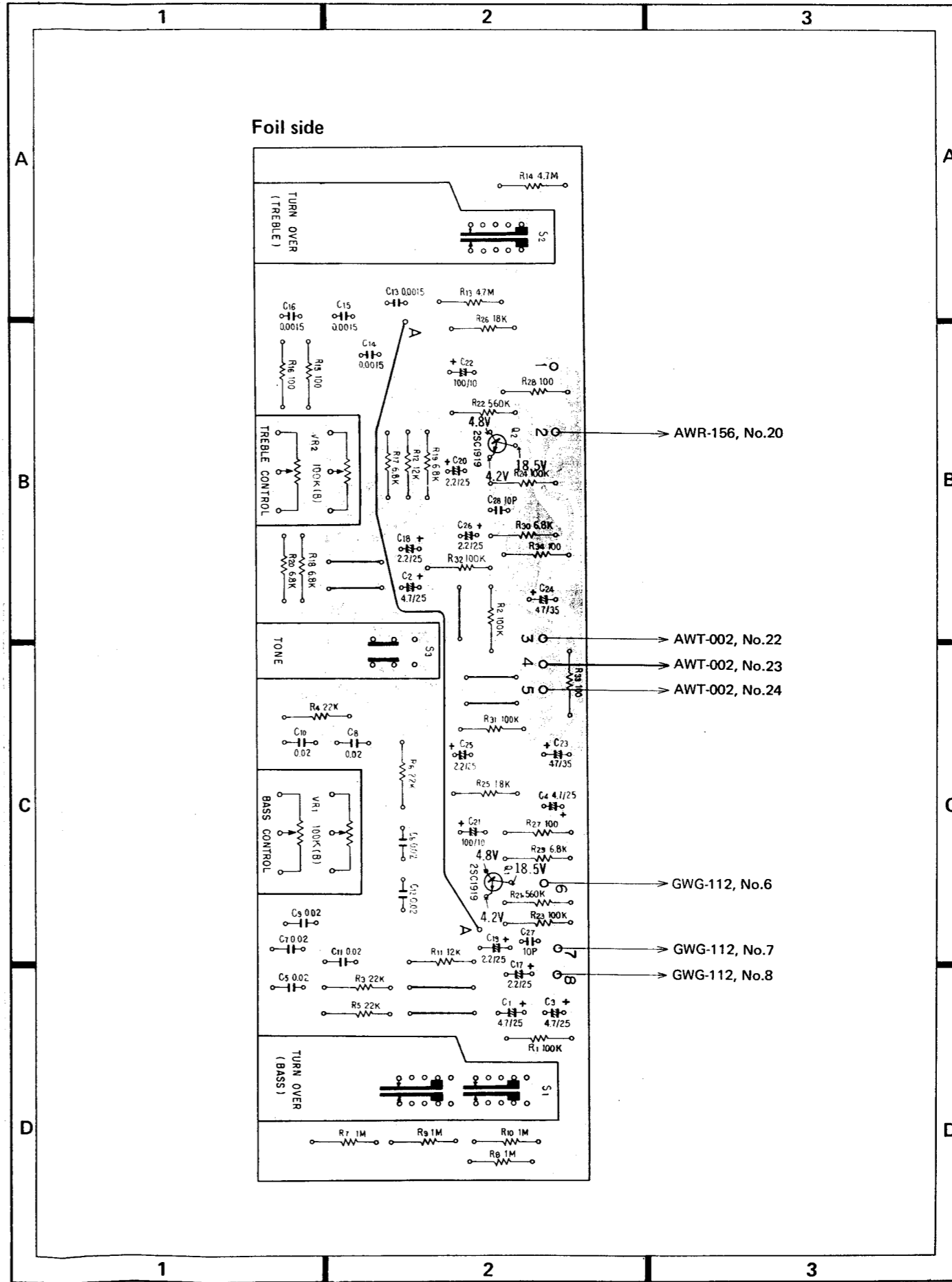

Parts List of Tone Amplifier Assembly (AWG-056)

SWITCHES

Symbol	Part No.	Description	Symbol	Part No.	Description
S1	ASE-105	Rotary switch (TURNOVER)	R6	RD%PS 223J	Carbon film 22k
S2	ASE-106	Rotary switch (TURNOVER)	R7	RD%PS 105J	Carbon film 1M
S3	ASK-144	Lever switch (TONE)	R8	RD%PS 105J	Carbon film 1M
			R9	RD%PS 105J	Carbon film 1M
			R10	RD%PS 105J	Carbon film 1M

CAPACITORS

Symbol	Part No.	Description	Symbol	Part No.	Description
C1	CEANL 4R7P 25	Electrolytic 4.7 25V	R11	RD%PS 123J	Carbon film 12k
C2	CEANL 4R7P 25	Electrolytic 4.7 25V	R12	RD%PS 123J	Carbon film 12k
C3	CEANL 4R7P 25	Electrolytic 4.7 25V	R13	RD%PS 475J	Carbon film 4.7M
C4	CEANL 4R7P 25	Electrolytic 4.7 25V	R14	RD%PS 475J	Carbon film 4.7M
C5	CQMA 203J 50	Mylar 0.02 50V	R15	RD%PS 101J	Carbon film 100
C6	CQMA 203J 50	Mylar 0.02 50V	R16	RD%PS 101J	Carbon film 100
C7	CQMA 203J 50	Mylar 0.02 50V	R17	RD%PS 682J	Carbon film 6.8k
C8	CQMA 203J 50	Mylar 0.02 50V	R18	RD%PS 682J	Carbon film 6.8k
C9	CQMA 203J 50	Mylar 0.02 50V	R19	RD%PS 682J	Carbon film 6.8k
C10	CQMA 203J 50	Mylar 0.02 50V	R20	RD%PS 682J	Carbon film 6.8k
C11	CQMA 203J 50	Mylar 0.02 50V	R21	RD%PS 564J	Carbon film 560k
C12	CQMA 203J 50	Mylar 0.02 50V	R22	RD%PS 564J	Carbon film 560k
C13	CKDYA 152J 50	Ceramic 0.0015 50V	R23	RD%PS 104J	Carbon film 100k
C14	CKDYA 152J 50	Ceramic 0.0015 50V	R24	RD%PS 104J	Carbon film 100k
C15	CKDYA 152J 50	Ceramic 0.0015 50V	R25	RD%PS 182J	Carbon film 1.8k
C16	CKDYA 152J 50	Ceramic 0.0015 50V	R26	RD%PS 182J	Carbon film 1.8k
C17	CEANL 2R2P 50	Electrolytic 2.2 50V	R27	RD%PS 101J	Carbon film 100
C18	CEANL 2R2P 50	Electrolytic 2.2 50V	R28	RD%PS 101J	Carbon film 100
C19	CEANL 2R2P 50	Electrolytic 2.2 50V	R29	RD%PS 682J	Carbon film 6.8k
C20	CEANL 2R2P 50	Electrolytic 2.2 50V	R30	RD%PS 682J	Carbon film 6.8k
C21	CEA 101P 10	Electrolytic 100 10V	R31	RD%PS 104J	Carbon film 100k
C22	CEA 101P 10	Electrolytic 100 10V	R32	RD%PS 104J	Carbon film 100k
C23	CEA 470P 35	Electrolytic 47 35V	R33	RD%PS 103J	Carbon film 10k
C24	CEA 470P 35	Electrolytic 47 35V	R34	RD%PS 103J	Carbon film 10k
C25	CEANL 2R2P 50	Electrolytic 2.2 50V			
C26	CEANL 2R2P 50	Electrolytic 2.2 50V			
C27	CCDSL 100F 50	Ceramic 10p 50V			
C28	CCDSL 100F 50	Ceramic 10p 50V			

SEMICONDUCTORS

Symbol	Part No.	Description
Q1	2SC1919-F or G (2SC1312-F or Q)	Transistor
Q2	2SC1919-F or G (2SC1312-F or Q)	Transistor

RESISTORS

Symbol	Part No.	Description
VR1	ACV-136	Variable resistor 100k B(BASS)
VR2	ACV-136	Variable resistor 100k B(TREBLE)
R1	RD%PS 104J	Carbon film 100k
R2	RD%PS 104J	Carbon film 100k
R3	RD%PS 223J	Carbon film 22k
R4	RD%PS 223J	Carbon film 22k
R5	RD%PS 223J	Carbon film 22k

OTHER

Symbol	Part No.	Description
	ANH-393-O	Shield cover

12.9 FILTER ASSEMBLY (AWT-002)

Foil side

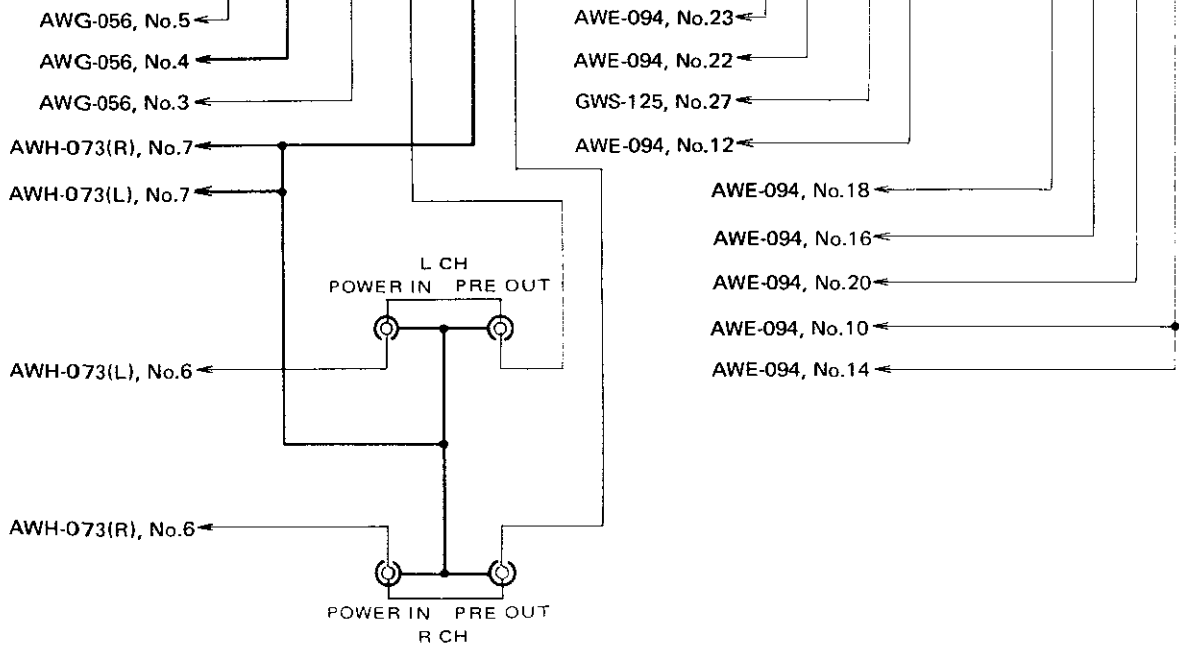
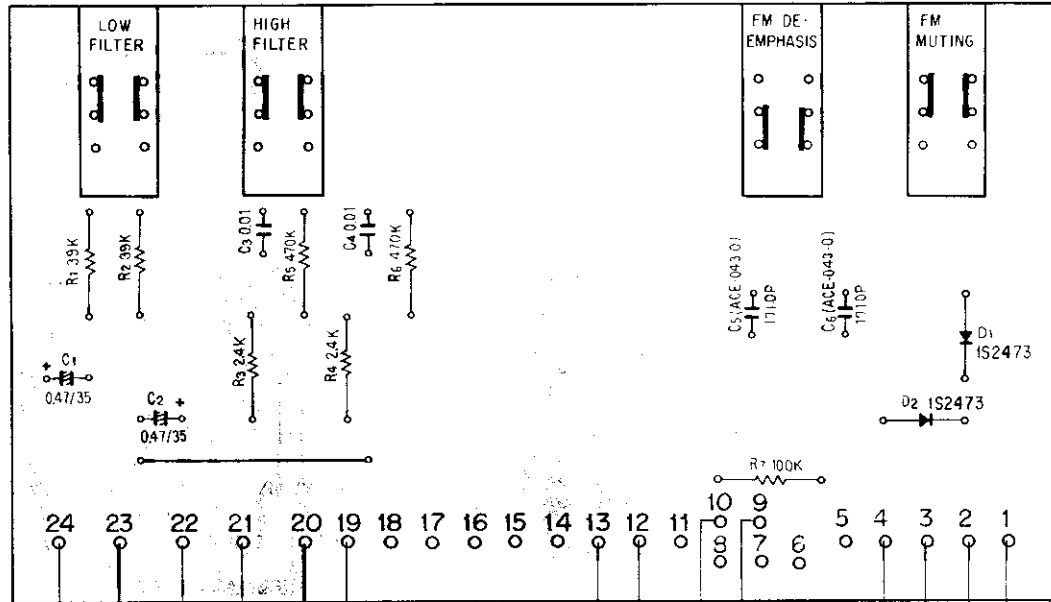

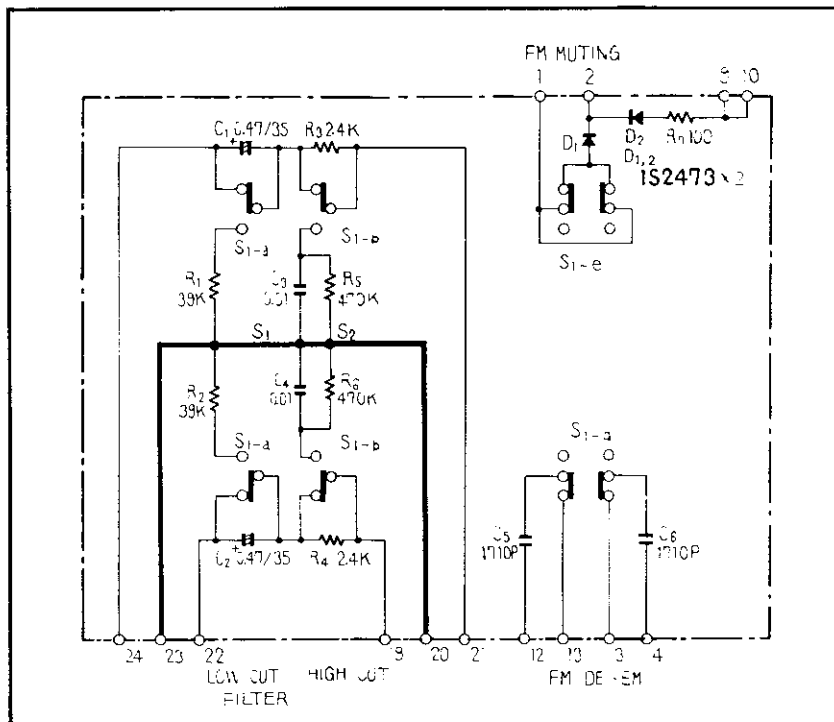

Parts List

CAPACITORS

Symbol	Part No.	Description
C1	CSZA R47M 35	Electrolytic 0.47 35V
C2	CSZA R47M 35	Electrolytic 0.47 35V
C3	CQMA 103K 50	Mylar 0.01 50V
C4	CQMA 103K 50	Mylar 0.01 50V
C5	ACE-043	Polystyrene 1710p 50V
C6	ACE-043	Polystyrene 1710p 50V

RESISTORS

Symbol	Part No.	Description
R1	RD%PS 393J	Carbon film 39k
R2	RD%PS 393J	Carbon film 39k
R3	RD%PS 242J	Carbon film 2.4k
R4	RD%PS 242J	Carbon film 2.4k
R5	RD%PS 474J	Carbon film 470k
R6	RD%PS 474J	Carbon film 470k
R7	RD%PS 104J	Carbon film 100k

SWITCH

Symbol	Part No.	Description
S1	ASG-129	Push switch

SEMICONDUCTORS

Symbol	Part No.	Description
D1	1S2473 (1S1555)	Diode
D2	1S2473 (1S1555)	Diode

12.10 POWER AMPLIFIER ASSEMBLY (AWH-073)

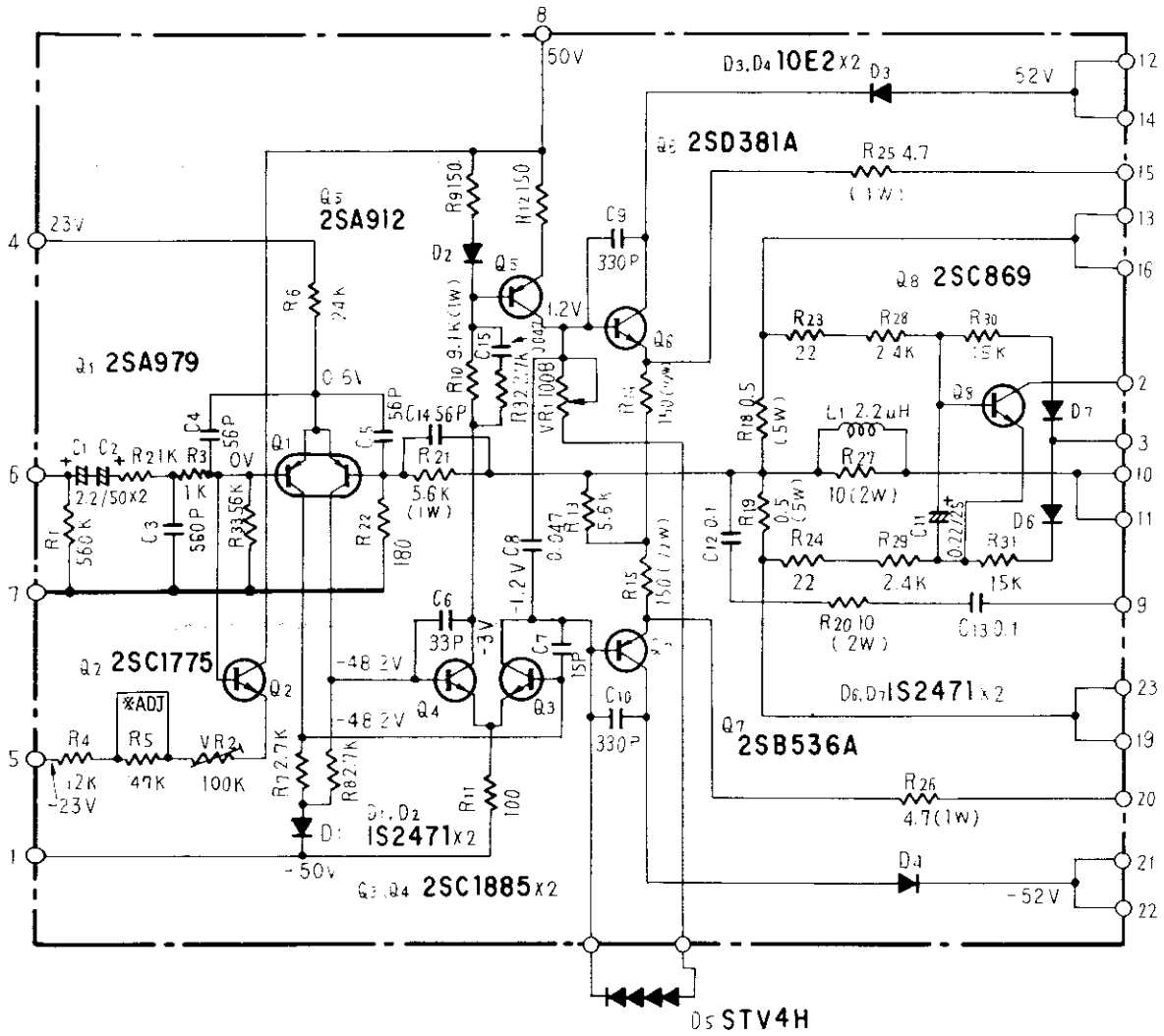

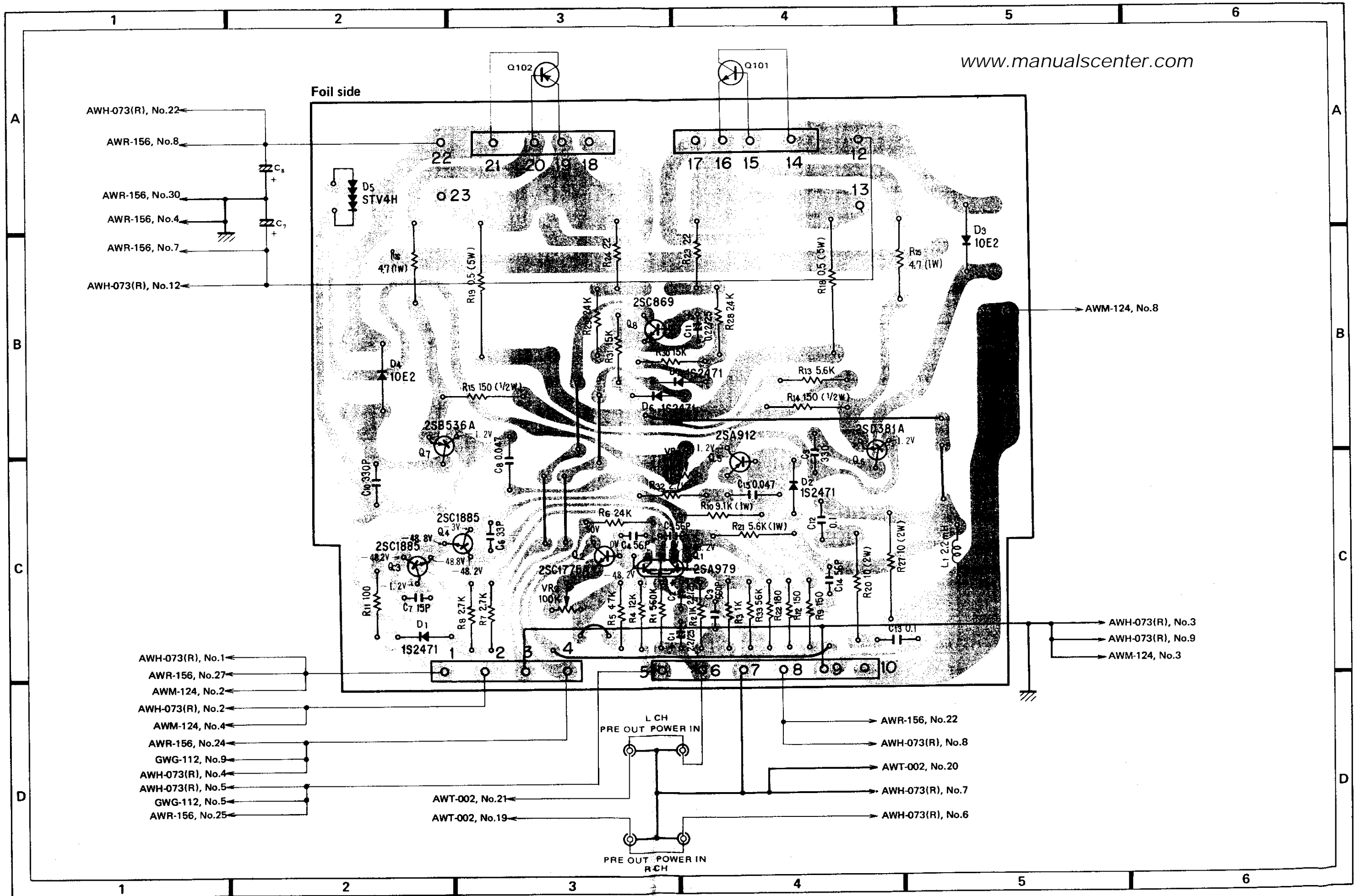

Parts List of Power Amplifier Assembly (AWH-073)

CAPACITORS

Symbol	Part No.	Description	Value	Voltage
C1	CEANL 2R2P 50	Electrolytic	2.2	50V
C2	CEANL 2R2P 50	Electrolytic	2.2	50V
C3	CKDYB 561K 50	Ceramic	560p	50V
C4	CCDSL 560K 50	Ceramic	56p	50V
C5	CCDSL 560K 50	Ceramic	56p	50V
C6	CCDSL 330K 500	Ceramic	33p	500V
C7	CCDSL 150K 500	Ceramic	15p	500V
C8	ACG-009	Ceramic	0.047	
C9	CCDSL 331K 500	Ceramic	330p	500V
C10	CCDSL 331K 500	Ceramic	330p	500V
C11	CSSA R22M 25	Electrolytic	0.22	25V
C12	CQMA 104K 50	Mylar	0.1	50V
C13	CQMA 104K 50	Mylar	0.1	50V
C14	CCDSL 560K 50	Ceramic	56p	50V
C15	ACG-009	Ceramic	0.047	150V

RESISTORS

Symbol	Part No.	Description	Value	Power
VR1	ACP-019	Semi fixed	100B	
VR2	ACP-066	Semi fixed	100k	
R1	RD%PS 564J	Carbon film	560k	
R2	RD%PS 102J	Carbon film	1k	
R3	RD%PS 102J	Carbon film	1k	
R4	RD%PS 123J	Carbon film	12k	
R5	RD%PS 473J	Carbon film	47k	
R6	RD%PS 243J	Carbon film	24k	
R7	RD%PSF 272J	Carbon film	2.7k	
R8	RD%PSF 272J	Carbon film	2.7k	
R9	RD%PSF 151J	Carbon film	150	
R10	RS1P 912J	Metal oxide film	9.1k	1W
R11	RD%PSF 101J	Carbon film	100	
R12	RD%PSF 151J	Carbon film	150	
R13	RD%PSF 562J	Carbon film	5.6k	
R14	RD%PSF 151J	Carbon film	150	1/2W
R15	RD%PSF 151J	Carbon film	150	1/2W
R18	RT5B 0R5K	Wire wound	0.5	5W
R19	RT5B 0R5K	Wire wound	0.5	5W
R20	RS2P 100J	Metal oxide film	10	2W
R21	RS1P 562J	Metal oxide film	5.6k	1W
R22	RD%PSF 181J	Carbon film	180	
R23	RD%PSF 220J	Carbon film	22	
R24	RD%PSF 220J	Carbon film	22	

Symbol	Part No.	Description	Value	Power
R25	RN1H 4R7K	Wire wound	4.7	1W
R26	RN1H 4R7K	Wire wound	4.7	1W
R27	RS2P 100J	Metal oxide film	10	2W
R28	RD%PSF 242J	Carbon film	2.4k	
R29	RD%PSF 242J	Carbon film	2.4k	
R30	RD%PS 153J	Carbon film	15k	
R31	RD%PS 153J	Carbon film	15k	
R32	RD%PS 272J	Carbon film	2.7k	
R33	RD%PS 563J	Carbon film	56k	

SEMICONDUCTORS

Symbol	Part No.	Description
Q1	2SA979-F	Transistor
Q2	2SC1775A-E	Transistor
Q3	2SC1885-Q or R	Transistor
Q4	2SC1885-Q or R	Transistor
Q5	2SA912-Q or R	Transistor
Q6	2SD381A-M or L	Transistor
Q7	2SB536A-M or L	Transistor
Q8	2SC869-D or C	Transistor
D1	1S 2471	Diode
D2	1S 2471	Diode
D3	10E 2	Diode
D4	(SIB01-02) 10E 2	Diode
D5	STV4H	Varistor
D6	1S 2471	Diode
D7	1S 2471	Diode

OTHERS

Symbol	Part No.	Description
L1	T63-009	AF choke coil
	AKM-018	Plug 3p
	ANH-203	Heat sink
	AEC-410	Transistor cover

12.11 SPEAKER SWITCH ASSEMBLY (GWS-131)

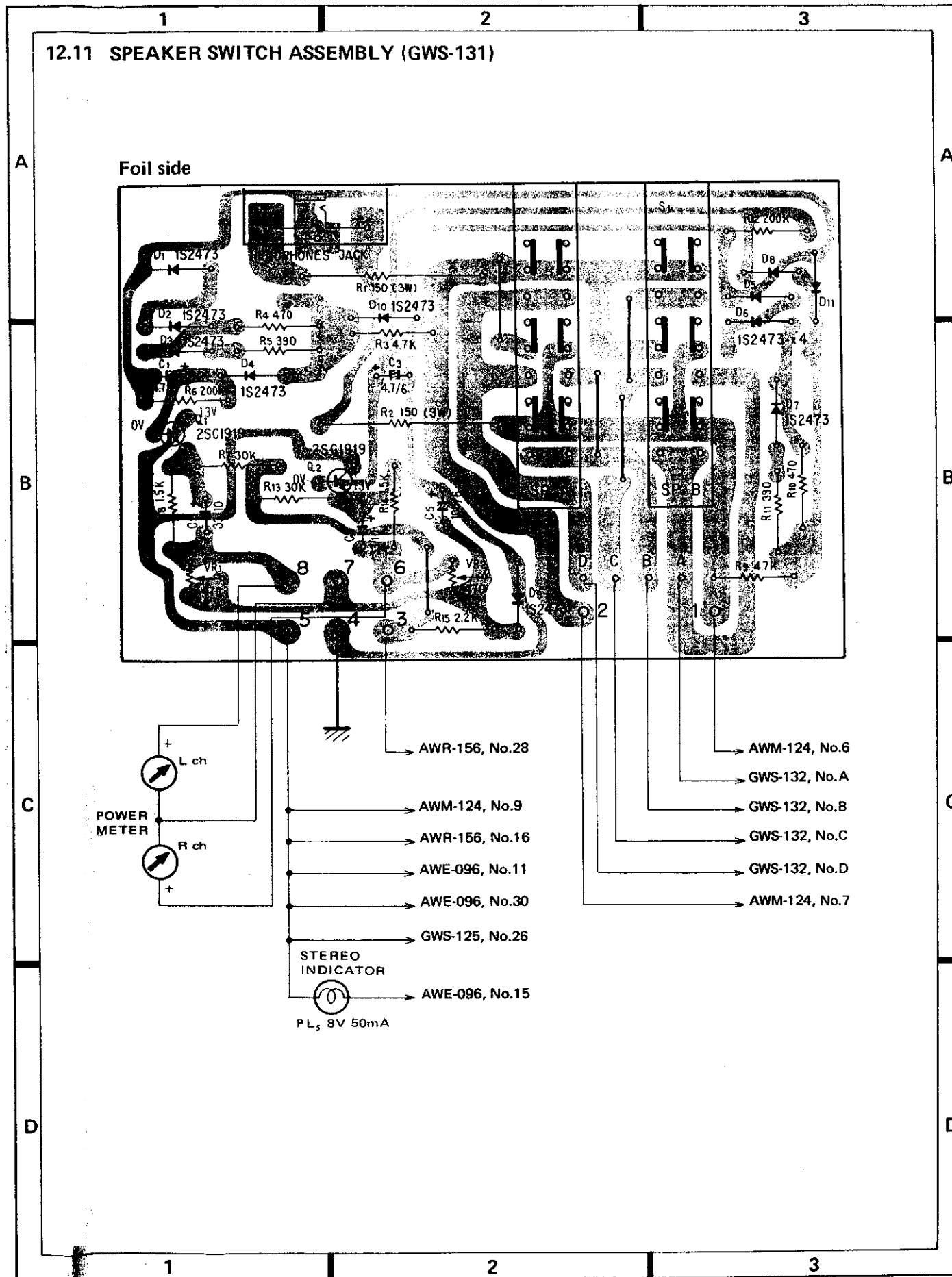

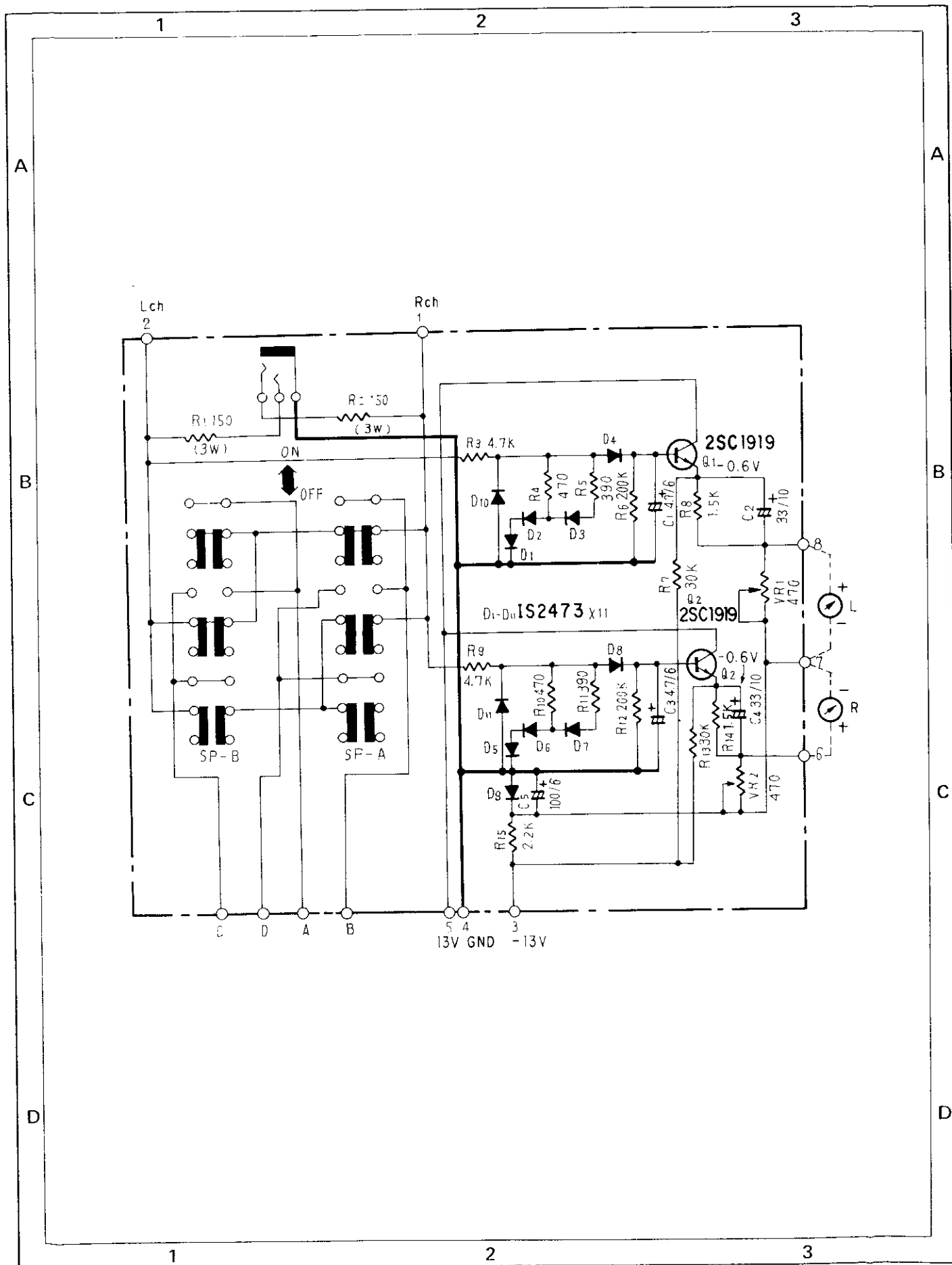

Parts List of Speaker Switch Assembly (GWS-131)

CAPACITORS

Symbol	Part No.	Description
C1	CSZA 4R7M 6	Electrolytic 4.7 6V
C2	CEA 330P 10	Electrolytic 33 10V
C3	CSZA 4R7M 6	Electrolytic 4.7 6V
C4	CEA 330P 10	Electrolytic 33 10V
C5	CEA 101P 6	Electrolytic 100 6V

RESISTORS

Symbol	Part No.	Description
VR1	ACP-006	Semi fixed 470
VR2	ACP-006	Semi fixed 470
R1	RS3P 151J	Metal oxide film 150 3W
R2	RS3P 151J	Metal oxide film 150 3W
R3	RD½PS 472J	Carbon film 4.7k
R4	RD½PS 471J	Carbon film 470
R5	RD½PS 391J	Carbon film 390
R6	RD½PS 204J	Carbon film 200k
R7	RD½PS 303J	Carbon film 30k
R8	RD½PS 152J	Carbon film 1.5k
R9	RD½PS 472J	Carbon film 4.7k
R10	RD½PS 471J	Carbon film 470
R11	RD½PS 391J	Carbon film 390
R12	RD½PS 204J	Carbon film 200k
R13	RD½PS 303J	Carbon film 30k
R14	RD½PS 152J	Carbon film 1.5k
R15	RD½PS 222J	Carbon film 2.2k

SEMICONDUCTORS

Symbol	Part No.	Description
Q1	2SC1919-G or F (2SC1400-E, F)	Transistor
Q2	2SC1919-G or F (2SC1400-E, F)	Transistor
D1	1S2473 (1S1555)	Diode
D2	1S2473 (1S1555)	Diode
D3	1S2473 (1S1555)	Diode
D4	1S2473 (1S1555)	Diode
D5	1S2473 (1S1555)	Diode
D6	1S2473 (1S1555)	Diode
D7	1S2473 (1S1555)	Diode
D8	1S2473 (1S1555)	Diode
D9	1S2473 (1S1555)	Diode
D10	1S2473 (1S1555)	Diode
D11	1S2473 (1S1555)	Diode

OTHERS

Symbol	Part No.	Description
	ASG-133	Push switch (SPEAKERS)
	AKN-010	Head phone jack (PHONES)

12.12 SPEAKER TERMINAL ASSEMBLY (GWS-132)

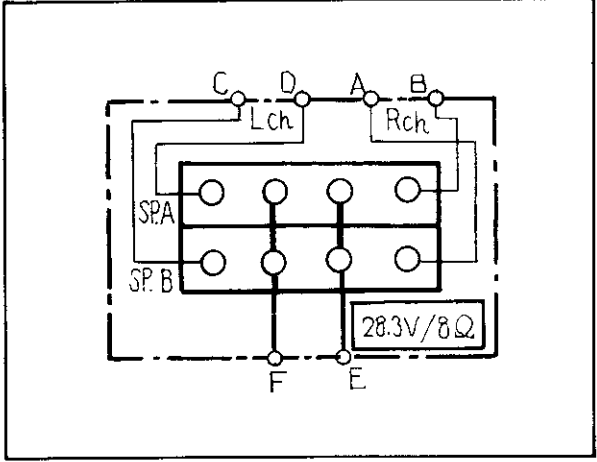
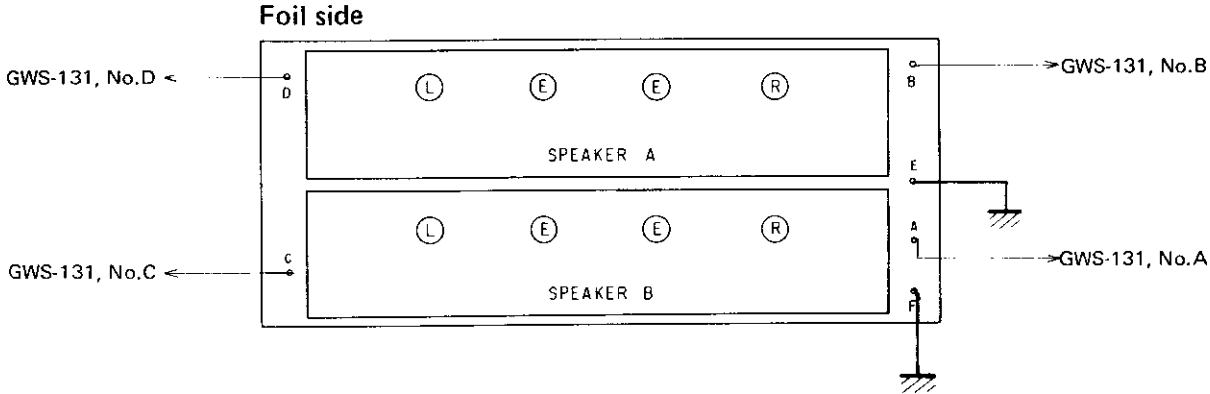

Parts List

Symbol	Part No.	Description
	AKE-029	Push terminal C

12.13 PROTECTION ASSEMBLY (AWM-124)

Foil side

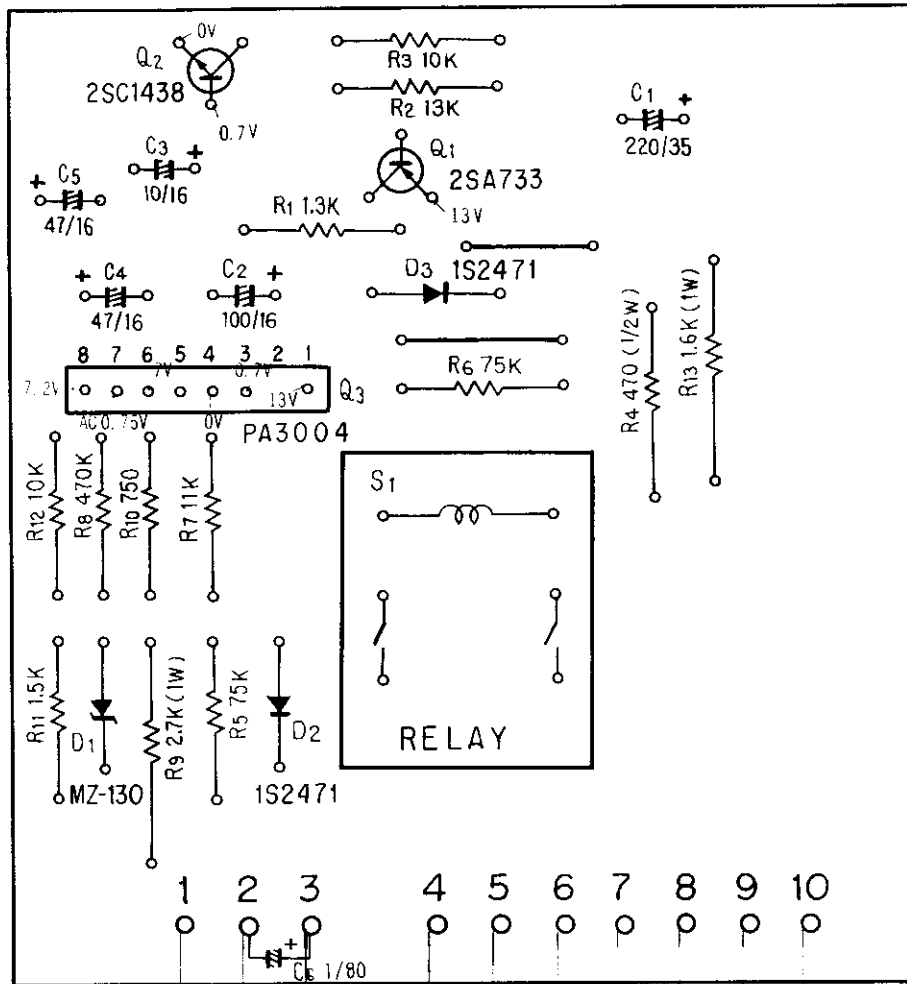

- | | |
|------------------|-------------------|
| AWR-156, No.14 | AWR-156, No.19 |
| AWH-073(R), No.1 | AWE-094, No.11 |
| AWR-156, No.27 | AWE-094, No.30 |
| AWH-073(L), No.1 | GWS-125, No.26 |
| AWH-073(R), No.9 | AWR-156, No.16 |
| AWH-073(R), No.3 | GWS-131, No.5 |
| AWH-073(L), No.3 | STEREO PLUG |
| AWH-073(L), No.9 | AWE-094, No.15 |
| | PLUG |
| AWH-073(R), No.2 | AWH-073(L), No.11 |
| AWH-073(L), No.2 | GWS-131, No.2 |
| | GWS-131, No.1 |
| | AWH-073(R), No.11 |

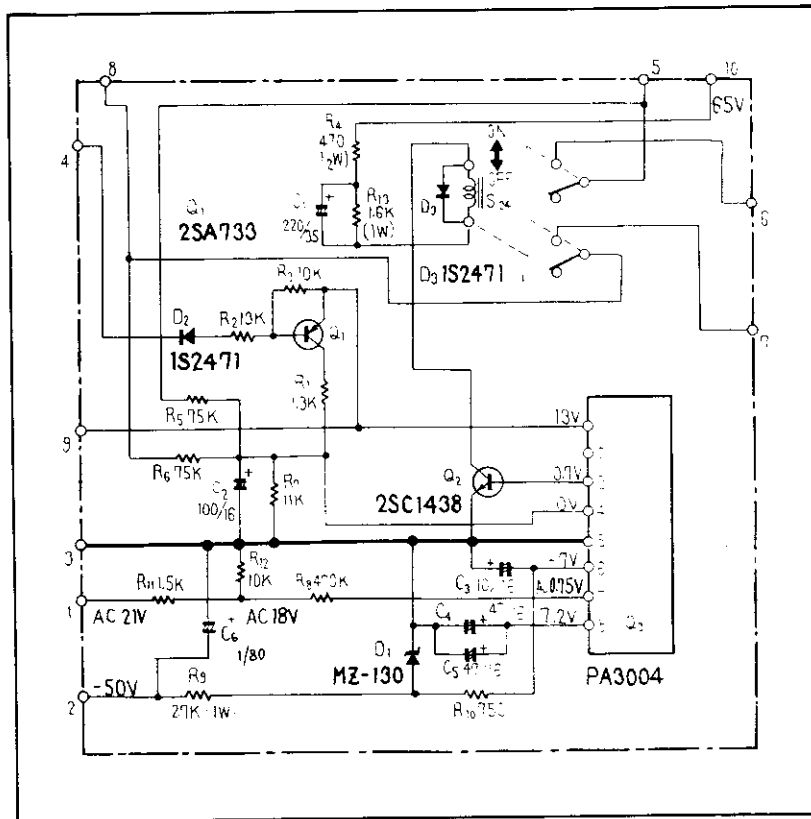

Part List

CAPACITORS

Symbol	Part No.	Description
C1	CEA 221P 35	Electrolytic 220 35V
C2	CEA 101P 16	Electrolytic 100 16V
C3	CEA 100P 16	Electrolytic 10 16V
C4	CEA 470P 16	Electrolytic 47 16V
C5	CEA 470P 16	Electrolytic 47 16V
C6	CEA 101P 80	Electrolytic 1 80V

RESISTORS

Symbol	Part No.	Description
R1	RD¼PS 132J	Carbon film 1.3k
R2	RD¼PS 133J	Carbon film 13k
R3	RD¼PS 103J	Carbon film 10k
R4	RD¼PSF 471J	Carbon film 470 ½W
R5	RD¼PS 753J	Carbon film 75k
R6	RD¼PS 753J	Carbon film 75k
R7	RD¼PS 113J	Carbon film 11k
R8	RD¼PS 474J	Carbon film 470k
R9	RS1P 272J	Metal oxide film 2.7k 1W
R10	RD¼PS 751J	Carbon film 750
R11	RD¼PS 152J	Carbon film 1.5k
R12	RD¼PS 103J	Carbon film 10k
R13	RS1P 162J	Metal oxide film 1.6k 1W

SEMICONDUCTORS

Symbol	Part No.	Description
Q1	2SA733-Q or R, (2SA904A-F)	Transistor
Q2	2SC1438-V or B, (2SC1915-E or F)	Transistor
Q3	PA3004	IC
D1	MZ-130 or (WZ-130)	Diode
D2	1S2471	Diode
D3	1S2471	Diode

OTHERS

Symbol	Part No.	Description
S1	ASR-048	Relay

12.14 POWER SUPPLY ASSEMBLY (AWR-156)

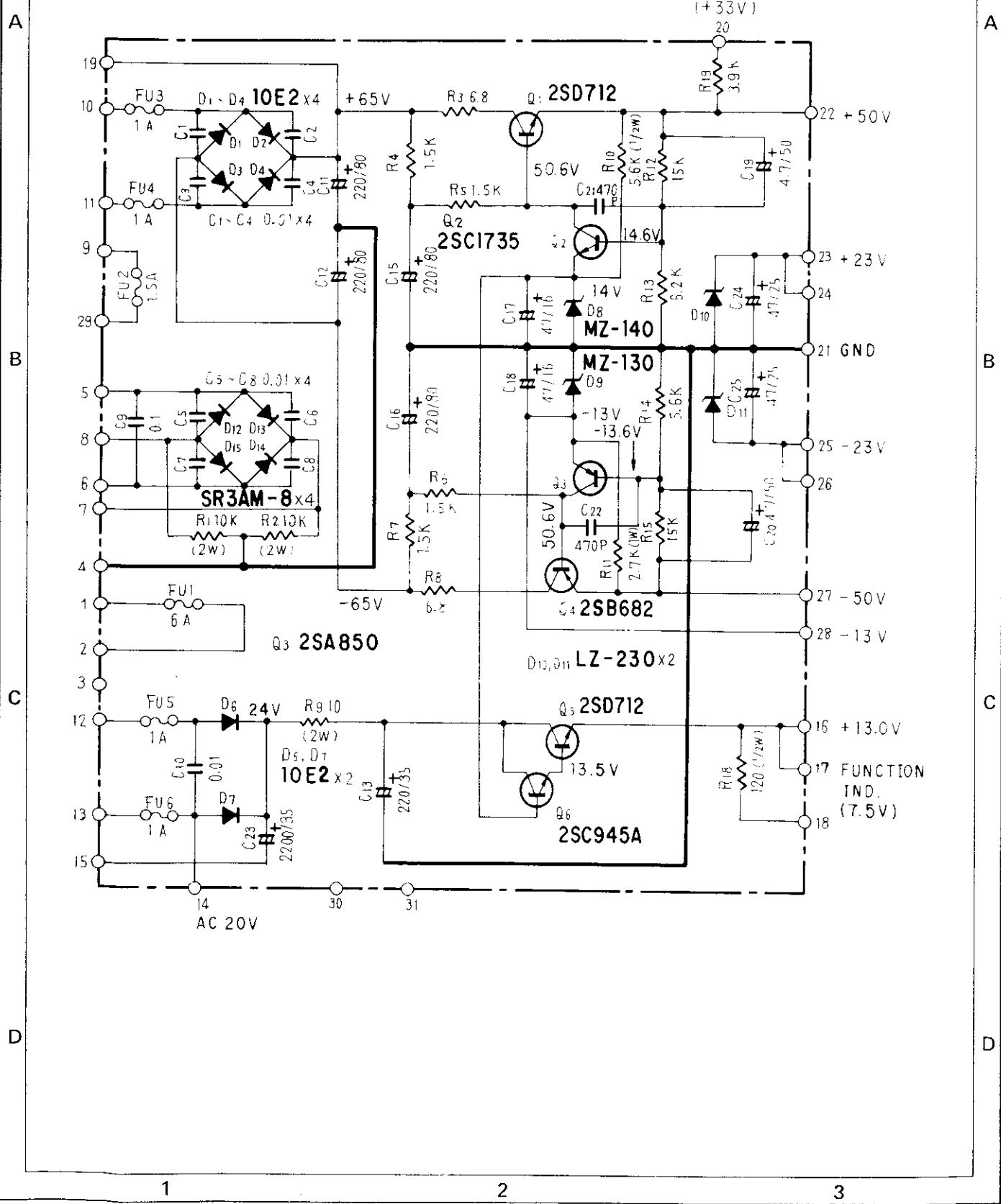

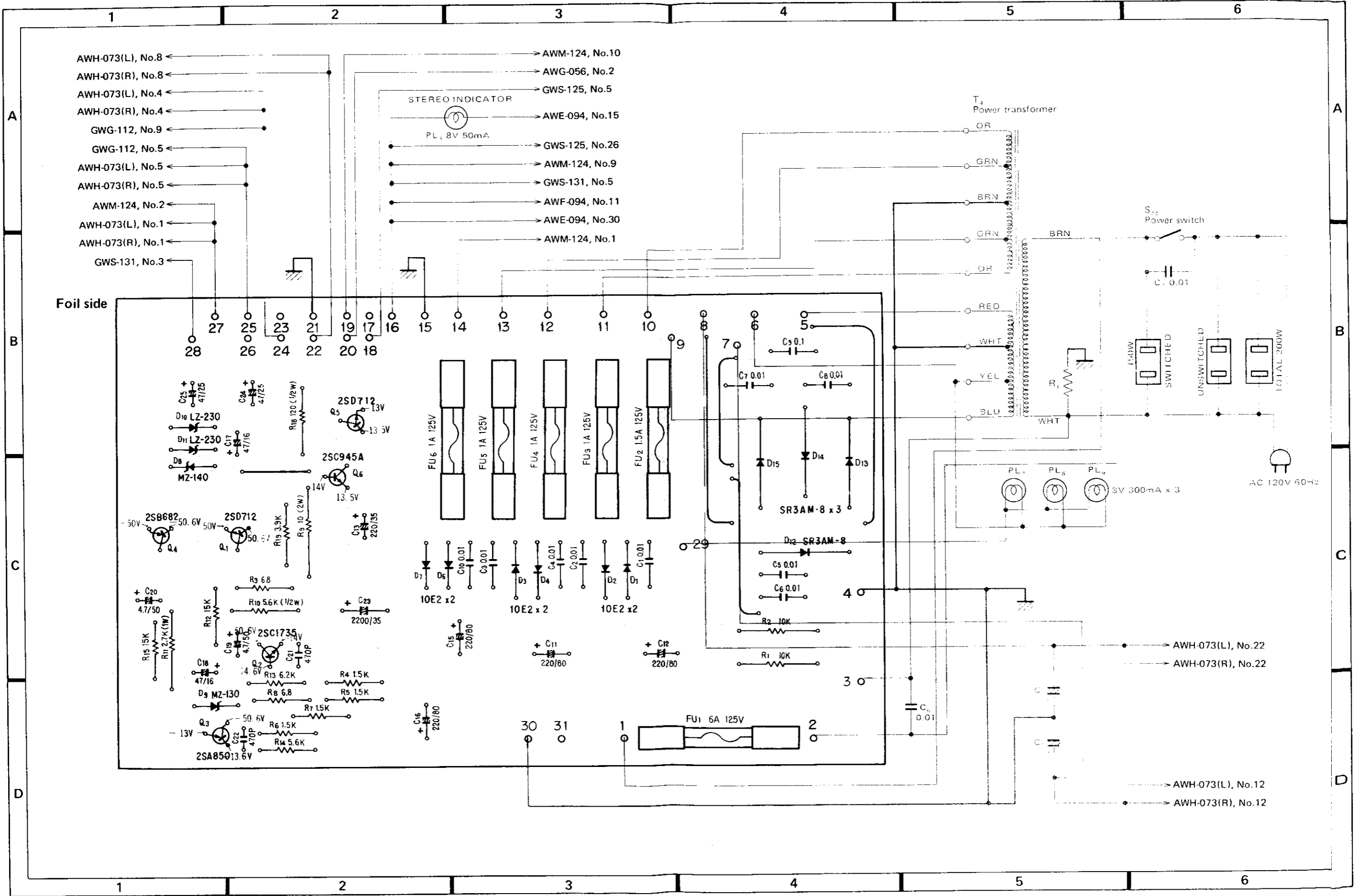

- AWH-073(L), No.8
- AWH-073(R), No.8
- AWH-073(L), No.4
- AWH-073(R), No.4
- GWG-112, No.9
- GWG-112, No.5
- AWH-073(L), No.5
- AWH-073(R), No.5
- AWM-124, No.2
- AWH-073(L), No.1
- AWH-073(R), No.1
- GWS-131, No.3

- AWM-124, No.10
- AWG-056, No.2
- GWS-125, No.5
- AWE-094, No.15
- GWS-125, No.26
- AWM-124, No.9
- GWS-131, No.5
- AWF-094, No.11
- AWE-094, No.30
- AWM-124, No.1

- AWH-073(L), No.22
- AWH-073(R), No.22
- AWH-073(L), No.12
- AWH-073(R), No.12

Parts List of Power Supply Assembly (AWR-156)

CAPACITORS

Symbol	Part No.	Description		
C1	ACG-004	Ceramic	0.01	150V
C2	ACG-004	Ceramic	0.01	150V
C3	ACG-004	Ceramic	0.01	150V
C4	ACG-004	Ceramic	0.01	150V
C5	ACG-004	Ceramic	0.01	150V
C6	ACG-004	Ceramic	0.01	150V
C7	ACG-004	Ceramic	0.01	150V
C8	ACG-004	Ceramic	0.01	150V
C9	QOMA 104K 250	Mylar	0.1	250V
C10	ACG-004	Ceramic	0.01	150V
C11	CEA 221P 80	Electrolytic	220	80V
C12	CEA 221P 80	Electrolytic	220	80V
C13	CEA 221P 35	Electrolytic	220	35V
C15	CEA 221P 80	Electrolytic	220	80V
C16	CEA 221P 80	Electrolytic	220	80V
C17	CEA 470P 16	Electrolytic	47	16V
C18	CEA 470P 16	Electrolytic	47	16V
C19	CEA 4R7P 50	Electrolytic	4.7	50V
C20	CEA 4R7P 50	Electrolytic	4.7	50V
C21	CKDYB 471K 50	Ceramic	470p	50V
C22	CKDYB 471K 50	Ceramic	470p	50V
C23	ACH-060	Electrolytic	2200	35V
C24	CEA 470P 25	Electrolytic	47	25V
C25	CEA 470P 25	Electrolytic	47	25V

RESISTORS

Symbol	Part No.	Description		
R1	RS2P 103J	Metal oxide film	10k	2W
R2	RS2P 103J	Metal oxide film	10k	2W
R3	RD¼PSF 6R8J	Carbon film	6.8	
R4	RD¼PSF 152J	Carbon film	1.5k	
R5	RD¼PSF 152J	Carbon film	1.5k	
R6	RD¼PSF 152J	Carbon film	1.5k	
R7	RD¼PSF 152J	Carbon film	1.5k	
R8	RD¼PSF 6R8J	Carbon film	6.8	
R9	RS2P 100J	Metal oxide film	10	2W
R10	RD¼PS 562J	Carbon film	5.6k	½W
R11	RS1P 272J	Metal oxide film	2.7k	1W
R12	RD¼PS 153J	Carbon film	15k	
R13	RD¼PS 622J	Carbon film	6.2k	
R14	RD¼PS 562J	Carbon film	5.6k	
R15	RD¼PS 153J	Carbon film	15k	
R16	RS2P 911J	Metal oxide film	910	2W
R17	RS2P 911J	Metal oxide film	910	2W
R18	RD¼PS 121J	Carbon film	120	½W
R19	RD¼PS 392J	Carbon film	3.9k	

SEMICONDUCTORS

Symbol	Part No.	Description
Q1	2SD712-C or D (2SD313-D, E)	Transistor
Q2	2SC1735-D or C (2S1384-Q, R)	Transistor
Q3	2SA850-D or C (2SA684A-Q, R)	Transistor
Q4	2SB682-C or D (2SB507-D, E)	Transistor
Q5	2SD712-C or D (2SD313-D, E)	Transistor
Q6	2SC945A-Q or R (2SC1914-F)	Transistor
D1	10E2 (SIB01-02)	Diode
D2	10E2 (SIB01-02)	Diode
D3	10E2 (SIB01-02)	Diode
D4	10E2 (SIB01-02)	Diode
D6	10E2 (SIB01-02)	Diode
D7	10E2 (SIB01-02)	Diode
D8	MZ140 (WZ140)	Zener Diode
D9	MZ130 (WZ130)	Zener Diode
D10	LZ230 (BZ230)	Zener Diode
D11	LZ230 (BZ230)	Zener Diode
D12	SR3AM-8	Diode
D13	SR3AM-8	Diode
D14	SR3AM-8	Diode
D15	SR3AM-8	Diode

OTHERS

Symbol	Part No.	Description
	ANH-203	Heat sink
	AKR-013	Fuse clip
	AKR-030	Fuse clip

ADDITIONAL

PIONEER

Service Manual

AM/FM STEREO RECEIVER

SX-980

KC, HG, S, S/G

MODEL SX-980 COMES IN FIVE VERSIONS DISTINGUISHED AS FOLLOWS:

Type	Voltage	Remarks
KU	120V only	U.S.A. model
KC	120V only	Canada model
HG	220V and 240V (Switchable)	Europe or Oceania model
S	110V, 120V, 220V and 240V (Switchable)	General export model
S/G	110V, 120V, 220V and 240V (Switchable)	U.S. Military model

NOTICE:

- This additional service manual is applicable to the SX-980/KC, HG, S, S/G. Connections, set handling, circuitry, and adjustment are basically the same as SX-980/KU.
- The parts which are different from the SX-980/KU are covered in this additional service manual. Please use this manual together with the SX-980/KU service manual which is previously issued when ordering parts and repair.

CONTENTS

1. SPECIFICATIONS	76
2. CONTRAST OF MISCELLANEOUS PART	77
3. SX-980/HG	
3.1 Miscellaneous Parts List	80
3.2 Schematic Diagram	81
3.3 Flat Amplifier Assembly (GWG-115)	83
3.4 Terminal Assembly (GWS-138)	87
3.5 Filter Assembly (AWT-006)	88
3.6 Power Amplifier Assembly (AWH-077)	90
3.7 Power Supply Assembly (AWR-165)	94
3.8 Rear Panel View	98
4. SX-980/S	
4.1 Rear Panel View	99
4.2 Miscellaneous Parts List	100
4.3 Schematic Diagram	101
4.4 Filter Assembly (AWT-005)	103
4.5 Power Supply Assembly (AWR-164)	105
5. SX-980/KC	109

1. SPECIFICATIONS

The specifications for "HG", "S" and "S/G" types are as "KU" type except for following sections.

HG TYPE

Preamplifier Section

Input (Sensitivity/Impedance)

TAPE PLAY 1, 2 150mV/50kilohms
TAPE PLAY 2 (DIN connector) 150mV/50kilohms

Output Level/Impedance

TAPE REC 1, 2 150mV
TAPE REC 2 (DIN connector) 30mV/80kilohms

Miscellaneous

Power Requirements 220V and 240V (Switchable)
50Hz/60Hz
Power Consumption 800W (max.)

S AND S/G TYPES

Preamplifier Section

Input (Sensitivity/Impedance)

TAPE PLAY 1, 2 150mV/50kilohms
TAPE PLAY 2 (DIN connector) 150mV/50kilohms

Output Level/Impedance

TAPE REC 1, 2 150mV
TAPE REC 2 (DIN connector) 30mV/80kilohms

Miscellaneous

Power Requirements 110V, 120V, 220V and
240V (Switchable) 50Hz/60Hz
Power Consumption 210W

Furnished Parts

Fuse 6A 1
3A 1

2. CONTRAST OF MISCELLANEOUS PART

NOTE:

- Capacitors: in μF unless otherwise noted $p:pF$
- Resistors: in Ω , $\frac{1}{4}W$ unless otherwise noted $k:k\Omega$, $M:M\Omega$

ASSEMBLIES

Symbol	Part Name	Part No.			
		KU type	HG type	S type	S/G type
	Flate amplifier assembly	GWG-112	GWG-115	GWG-115	GWG-115
	Tape input assembly	GWB-126	GWS-138	GWS-138	GWS-138
	Filter assembly	AWT-002	AWT-006	AWT-005	AWT-005
	Power amplifier assembly	AWH-073	AWH-077	AWH-073	AWH-073
	Power supply assembly	AWR-156	AWR-165	AWR-164	AWR-164

TRANSFORMER

Symbol	Part Name	Part No.			
		KU type	HG type	S type	S/G type
T4	Power transformer	ATT-449	ATT-466	ATT-478	ATT-479

SWITCHES

Symbol	Part Name	Part No.			
		KU type	HG type	S type	S/G type
S2	Lever switch (POWER)	ASK-080	ASA-505	ASK-080	ASK-080
S5	Plug in selector (Line voltage selector)	AKX-037	AKR-031	AKR-031
S6	Slide switch (De-emphasis)	ASH-016	ASH-016

RESISTOR

Symbol	Part Name	Part No.			
		KU type	HG type	S type	S/G type
R1	Carbon film 2.2M $\frac{1}{2}$	RD $\frac{1}{2}$ PS 225J

CAPACITOR

Symbol	Part Name	Part No.			
		KU type	HG type	S type	S/G type
C5	Ceramic 0.01 250V	ACG-001	ACG-001	ACG-001
C6	Ceramic 0.01 125V	ACG-003
	Ceramic 0.01 250V	ACG-001	ACG-001	ACG-001

FUSES

Symbol	Part Name	Part No.			
		KU type	HG type	S type	S/G type
FU1	Fuse 6A	AEK-109
	Fuse 3.15A	AEK-042
	Fuse 3A	AEK-101	AEK-101
FU2	Fuse 1.5A	AEK-104	AEK-104	AEK-104
	Fuse 1.6A	AEK-405
FU3	Fuse 1A	AEK-106	AEK-106	AEK-106
	Fuse 1A T	AEK-402
FU4	Fuse 1A	AEK-106	AEK-106	AEK-106
	Fuse 1A T	AEK-402
FU5	Fuse 1A	AEK-106	AEK-106	AEK-106
	Fuse 1A T	AEK-402
FU6	Fuse 1A	AEK-106	AEK-106	AEK-106
	Fuse 1A T	AEK-402

OTHERS

Symbol	Part Name	Part No.			
		KU type	HG type	S type	S/G type
	AC power cord	ADG-005	ADG-005	ADG-017
	AC socket (OUTLET)	AKP-005	AKP-022	AKP-022
	AC socket (INLET)	AKP-008
	Woodencabinet assembly	AMM-066	AMM-068	AMM-066	AMM-066
	Capacitor cover	AEC-294
	Capacitor cover	AEC-279
	Capacitor cover	AEC-099	AEC-099	AEC-099
	Terminal (ANTENNA)	AKA-004	AKA-005	AKA-004	AKA-004
	Screw	ABA-003
	Screw	ABA-181	ABA-181

FURNISHED PARTS

Symbol	Part Name	Part No.			
		KU type	HG type	S type	S/G type
	Operating instructions (English) (German/French)	ARB-243	ARB-249 ARD-114	ARB-250	ARB-250
	Fuse 6A	AEK-109	AEK-109
	Fuse 3A	AEK-101	AEK-101

PACKING

Symbol	Part Name	Part No.			
		KU type	HG type	S type	S/G type
	Packing case	AHD-508	AHD-518	AHD-508	AHD-509
	Cover	AHC-042	AHC-048	AHC-042	AHD-045
	Spacer	AHB-089

3. SX-980/HG

NOTES:

- Capacitors: in μF unless otherwise noted P:pF.
- Resistors: 1/4W unless otherwise noted k:k Ω , M:M Ω .

3.1 MISCELLANEOUS PARTS LIST

COILS AND TRANSFORMER

Symbol	Part No.	Description
T1	T22-025	Balun
T2	ATB-505	Bar antenna
T3	T24-030	Ferry inductor
T4	ATT-466	Power transformer

CAPACITORS

Symbol	Part No.	Description
C1	CKDBC 104Z 25	Ceramic 0.1 25V
C2	CKDBC 104Z 25	Ceramic 0.1 25V
C3	CKDBC 104Z 25	Ceramic 0.1 25V
C4	CKDBC 104Z 25	Ceramic 0.1 25V
C5	
C6	ACG-001	Ceramic 0.01 250V
C7	ACH-047	Electrolytic 18,000 63V
C8	ACH-047	Electrolytic 18,000 63V

LAMPS

Symbol	Part No.	Description
PL1	AEL-069	Pilot lamp with wire
PL2	AEL-067	Pilot lamp with wire
PL3	AEL-067	Pilot lamp with wire
PL4	AEL-067	Pilot lamp with wire
PL5	AEL-069	Pilot lamp with wire
PL7	AEL-029	Wedge type pilot lamp
PL8	AEL-029	Wedge type pilot lamp
PL9	AEL-029	Wedge type pilot lamp

RESISTORS

Symbol	Part No.	Description
R2	RS2P 911J	Metal oxide 910 2W
R3	RS2P 911J	Metal oxide 910 2W

ASSEMBLIES

Symbol	Part No.	Description
	AWE-094	Tuner assembly
	GWS-125	Function and equalizer assembly
	GWS-127	Input terminal assembly
	GWG-115	Flat amplifier assembly
	GWS-138	Terminal assembly
	AWG-056	Tone control assembly
	AWT-006	Filter assembly
	GWG-131	Speaker switch assembly (1)
	GWG-132	Speaker switch assembly (2)
	AWH-077	Power amplifier assembly
	AWR-165	Power supply assembly
	AWM-124	Protection assembly

FUSES

Symbol	Part No.	Description
FU1	AEK-042	Fuse 3.15A
FU2	AEK-405	Fuse 1.6A
FU3	AEK-402	Fuse 1A
FU4	AEK-402	Fuse 1A
FU5	AEK-402	Fuse 1A
FU6	AEK-402	Fuse 1A

SWITCHES

Symbol	Part No.	Description
S22	ASA-505	Lever switch (POWER)
S25	AKX-037	Plug in selector (Line voltage selector)

SEMICONDUCTORS

Symbol	Part No.	Description
Q101	2SD746-Q or R, S	Transistor
Q102	2SB706-Q or R, S	Transistor
Q103	2SB706-Q or R, S	Transistor
Q104	2SD746-Q or R, S	Transistor

3.2 SCHEMATIC DIAGRAM

A

B

C

D

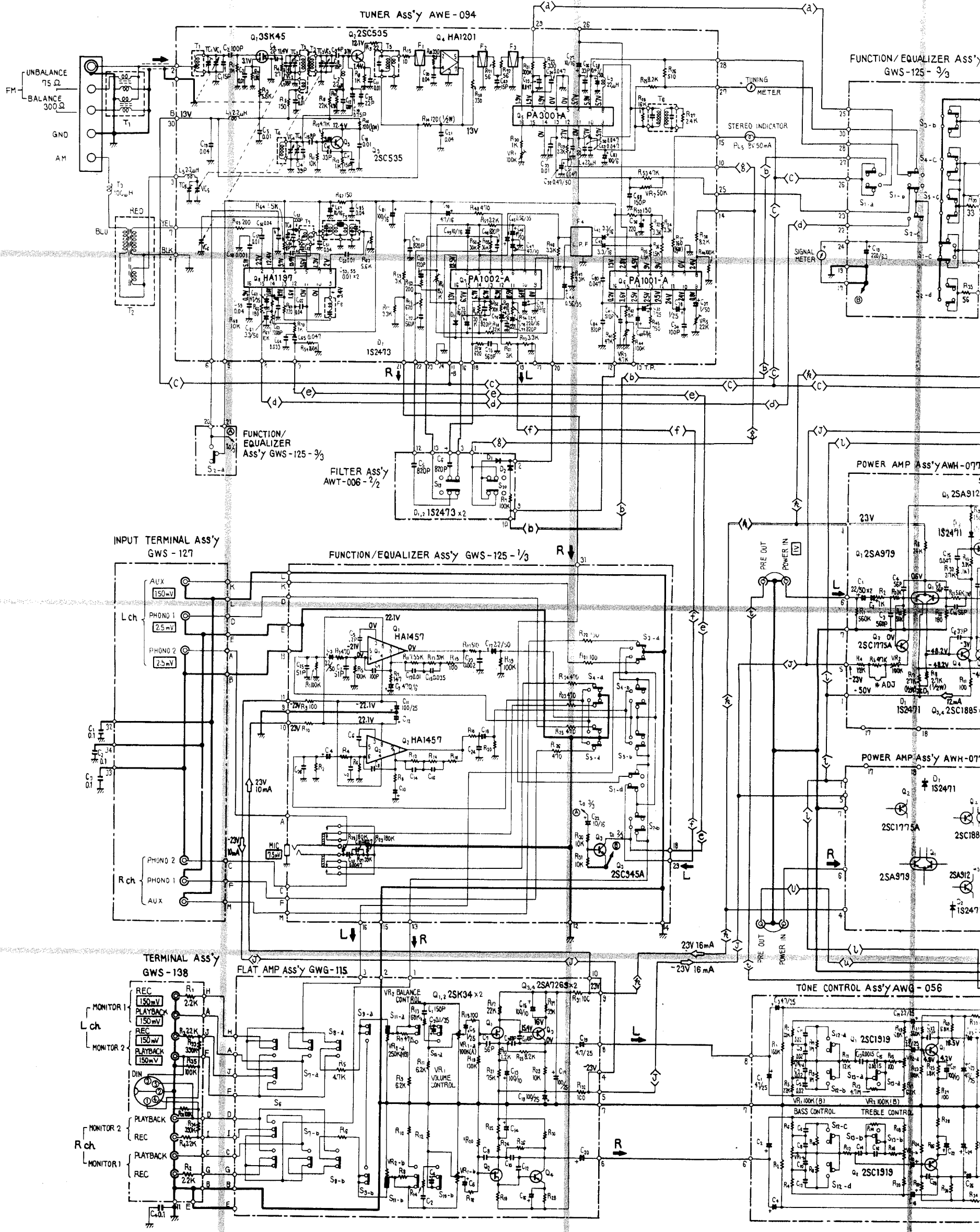

1

2

3

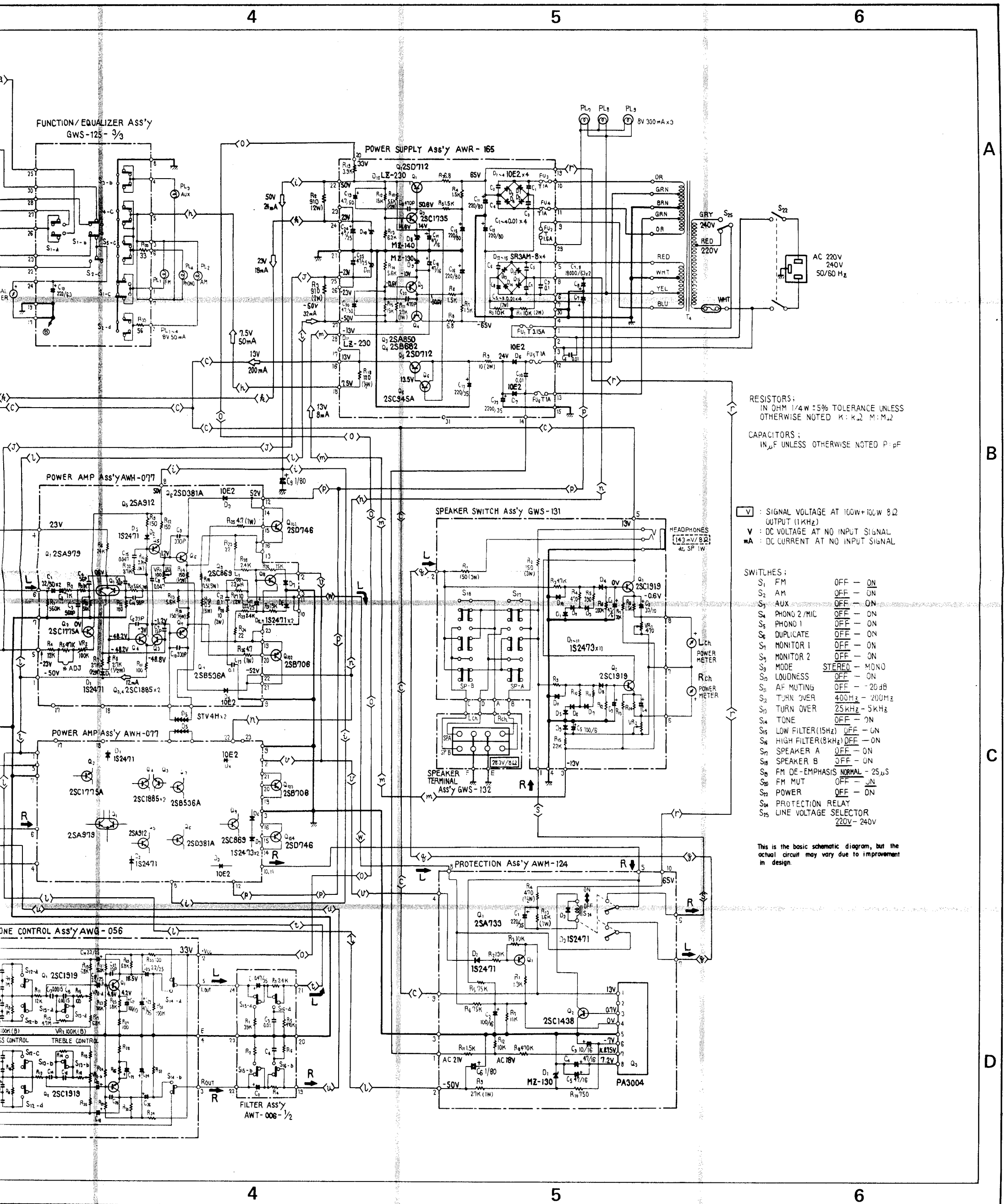

RESISTORS:
IN OHM 1/4W ±5% TOLERANCE UNLESS
OTHERWISE NOTED K: K.2 M: M.2

CAPACITORS:
IN μF UNLESS OTHERWISE NOTED P: pF

V : SIGNAL VOLTAGE AT 100W+100W 8Ω
OUTPUT (1KHz)

V : DC VOLTAGE AT NO INPUT SIGNAL
[143 mV/8Ω]
at SP 1W

mA : DC CURRENT AT NO INPUT SIGNAL

- SWITCHES:
- S₁ FM OFF - ON
 - S₂ AM OFF - ON
 - S₃ AUX OFF - ON
 - S₄ PHONO 2/MIC OFF - ON
 - S₅ PHONO 1 OFF - ON
 - S₆ DUPLICATE OFF - ON
 - S₇ MONITOR 1 OFF - ON
 - S₈ MONITOR 2 OFF - ON
 - S₉ MODE STEREO - MONO
 - S₁₀ LOUDNESS OFF - ON
 - S₁₁ AF MUTING OFF - 20dB
 - S₁₂ TURN OVER 400Hz - 200Hz
 - S₁₃ TURN OVER 25kHz - 5kHz
 - S₁₄ TONE OFF - ON
 - S₁₅ LOW FILTER(15Hz) OFF - ON
 - S₁₆ HIGH FILTER(8kHz) OFF - ON
 - S₁₇ SPEAKER A OFF - ON
 - S₁₈ SPEAKER B OFF - ON
 - S₁₉ FM DE-EMPHASIS NORMAL - 25μs
 - S₂₀ FM MUT OFF - ON
 - S₂₁ POWER OFF - ON
 - S₂₂ PROTECTION RELAY
 - S₂₃ LINE VOLTAGE SELECTOR 220V - 240V

This is the basic schematic diagram, but the actual circuit may vary due to improvement in design.

A

B

C

D

4

5

6

4

5

6

SX-980/HG

3.3 FLAT AMPLIFIER ASSEMBLY (GWG-115)

Foil side

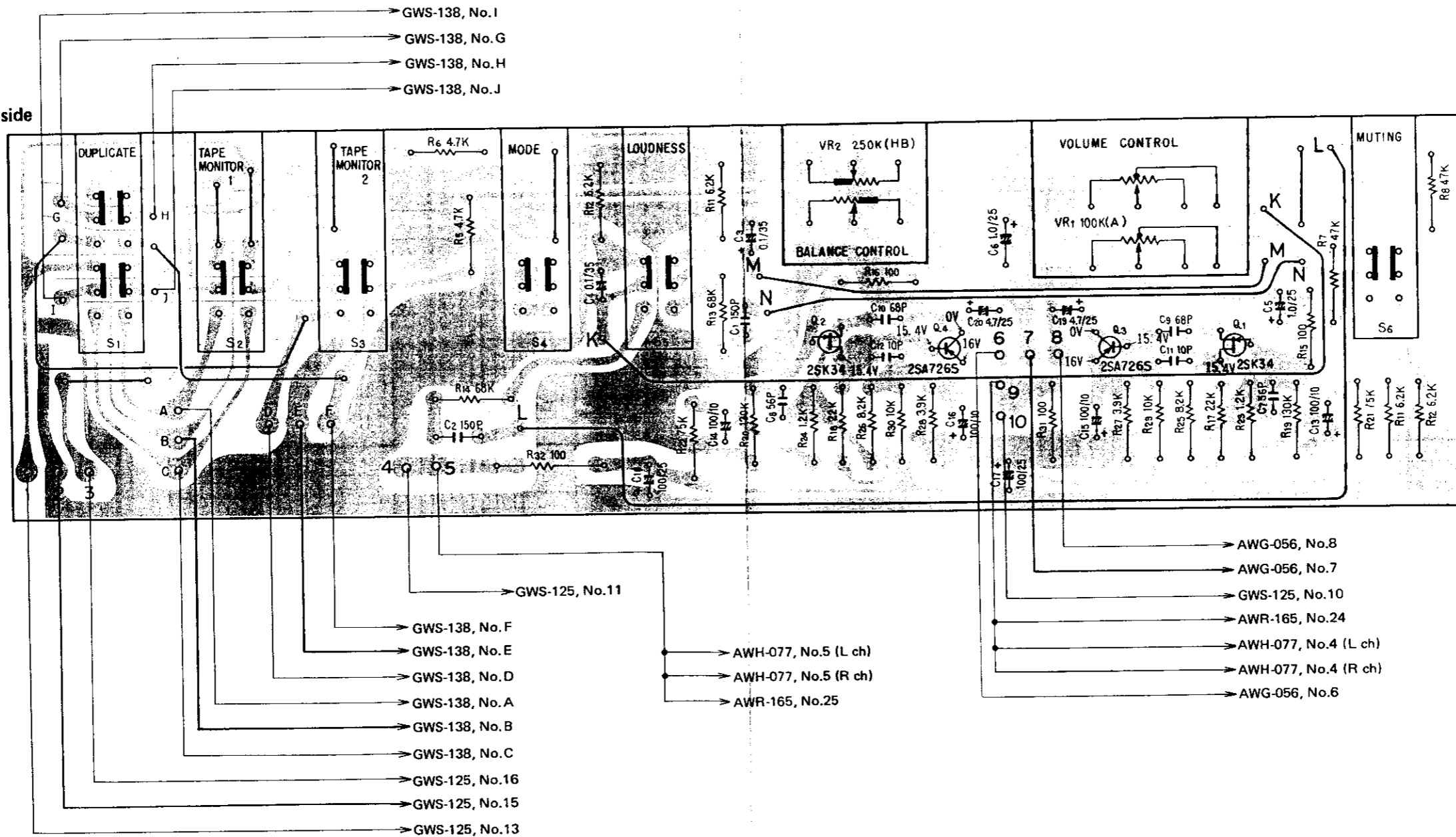

- GWS-138, No. I
- GWS-138, No. G
- GWS-138, No. H
- GWS-138, No. J

- GWS-125, No. 11
- GWS-138, No. F
- GWS-138, No. E
- GWS-138, No. D
- GWS-138, No. A
- GWS-138, No. B
- GWS-138, No. C
- GWS-125, No. 16
- GWS-125, No. 15
- GWS-125, No. 13

- AWH-077, No.5 (L ch)
- AWH-077, No.5 (R ch)
- AWR-165, No.25

- AWG-056, No.8
- AWG-056, No.7
- GWS-125, No.10
- AWR-165, No.24
- AWH-077, No.4 (L ch)
- AWH-077, No.4 (R ch)
- AWG-056, No.6

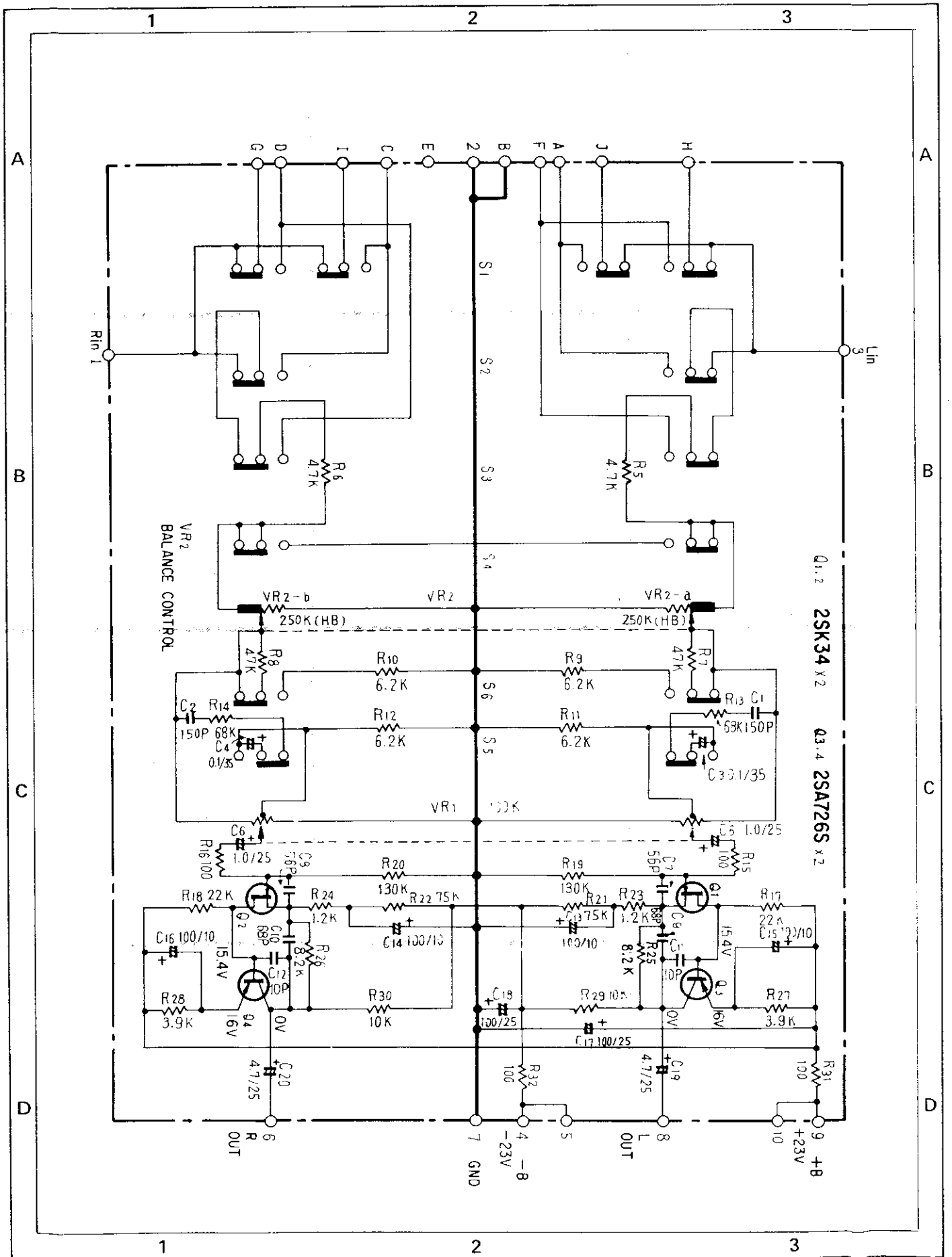

Parts List of Flat Amplifier Assembly (GWG-115)

SWITCHES

Symbol	Part No.	Description	Symbol	Part No.	Description
S1	ASK-145	Lever switch (DUPLICATE)	R17	RD¼PS 223J	Carbon film 22k
S2	ASK-144	Lever switch (TAPE MONITOR 1)	R18	RD¼PS 223J	Carbon film 22k
S3	ASK-144	Lever switch (TAPE MONITOR 2)	R19	RD¼PS 134J	Carbon film 130k
S4	ASK-144	Lever switch (MODE)	R20	RD¼PS 134J	Carbon film 130k
S5	ASK-144	Lever switch (LOUDNESS)	R21	RD¼PS 753J	Carbon film 75k
S6	ASK-144	Lever switch (MUTING)	R22	RD¼PS 753J	Carbon film 75k
			R23	RD¼PS 122J	Carbon film 1.2k
			R24	RD¼PS 122J	Carbon film 1.2k

CAPACITORS

Symbol	Part No.	Description	Symbol	Part No.	Description
C1	CCDSL 151K 50	Ceramic 150p 50V	R25	RD¼PS 822J	Carbon film 8.2k
C2	CCDSL 151K 50	Ceramic 150p 50V	R26	RD¼PS 822J	Carbon film 8.2k
C3	CSZA 0R1M 35	Electrolytic 0.1 35V	R27	RD¼PS 392J	Carbon film 3.9k
C4	CSZA 0R1M 35	Electrolytic 0.1 35V	R28	RD¼PS 392J	Carbon film 3.9k
C5	CSZA 010M 25	Electrolytic 1 25V	R29	RD¼PS 103J	Carbon film 10k
C6	CSZA 010M 25	Electrolytic 1 25V	R30	RD¼PS 103J	Carbon film 10k
C7	CCDSL 560K 50	Ceramic 56p 50V	R31	RD¼PS 101J	Carbon film 100
C8	CCDSL 560K 50	Ceramic 56p 50V	R32	RD¼PS 101J	Carbon film 100
C9	CCDSL 680K 50	Ceramic 68p 50V			
C10	CCDSL 680K 50	Ceramic 68p 50V			
C11	CCDSL 100F 50	Ceramic 10p 50V			
C12	CCDSL 100F 50	Ceramic 10p 50V			
C13	CEANL 101P 10	Electrolytic 100 10V			
C14	CEANL 101P 10	Electrolytic 100 10V			
C15	CEANL 101P 10	Electrolytic 100 10V			
C16	CEANL 101P 10	Electrolytic 100 10V			
C17	CEA 101P 25	Electrolytic 100 25V			
C18	CEA 101P 25	Electrolytic 100 25V			
C19	CEANL 4R7P 25	Electrolytic 4.7 25V			
C20	CEANL 4R7P 25	Electrolytic 4.7 25V			

SEMICONDUCTORS

Symbol	Part No.	Description
Q1	2SK34-C or D (2SK68A-L or M)	FET
Q2	2SK34-C or D (2SK68A-L or M)	FET
Q3	2SA726S-F or G (2SA872A-D or E)	Transistor
Q4	2SA726S-F or G (2SA872A-D or E)	Transistor

RESISTORS

Symbol	Part No.	Description
VR1	ACV-162	Variable resistor 100kA (VOLUME)
VR2	ACV-190	Variable resistor 250kHB (BALANCE)
R5	RD¼PS 472J	Carbon film 4.7k
R6	RD¼PS 472J	Carbon film 4.7k
R7	RD¼PS 473J	Carbon film 47k
R8	RD¼PS 473J	Carbon film 47k
R9	RD¼PS 622J	Carbon film 6.2k
R10	RD¼PS 622J	Carbon film 6.2k
R11	RD¼PS 622J	Carbon film 6.2k
R12	RD¼PS 622J	Carbon film 6.2k
R13	RD¼PS 683J	Carbon film 68 k
R14	RD¼PS 683J	Carbon film 68 k
R15	RD¼PS 101J	Carbon film 100
R16	RD¼PS 101J	Carbon film 100

3.4 TERMINAL ASSEMBLY (GWS-138)

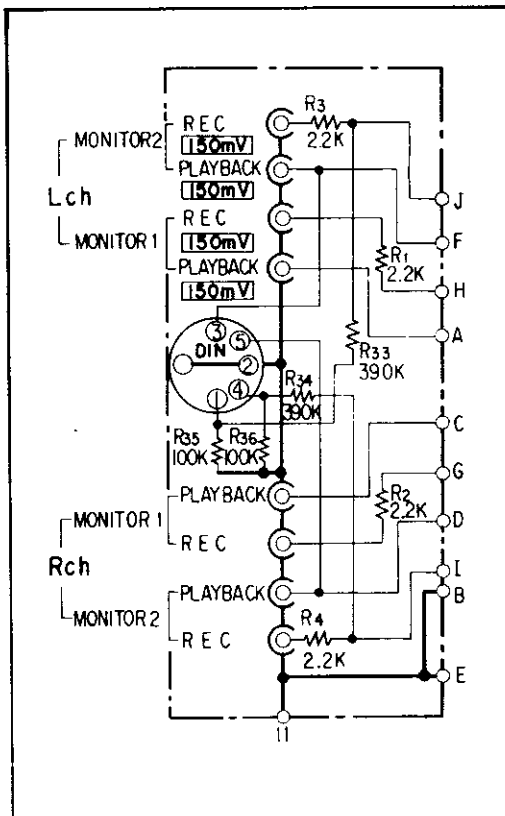
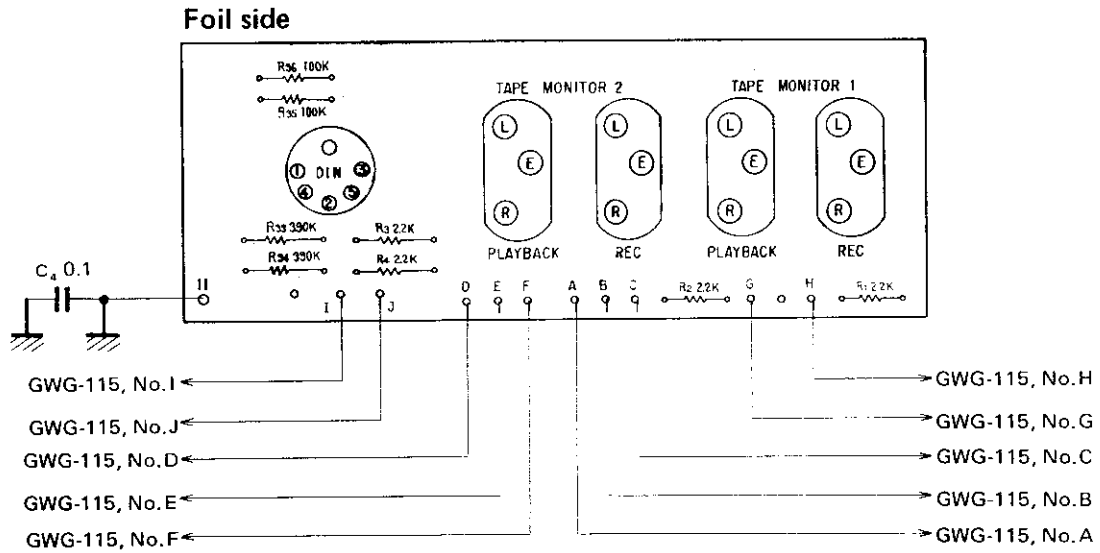

Parts List

RESISTORS

Symbol	Part No.	Description
R1	RD¼PM 222J	Carbon film 2.2k
R2	RD¼PM 222J	Carbon film 2.2k
R3	RD¼PS 222J	Carbon film 2.2k
R4	RD¼PS 222J	Carbon film 2.2k
R33	RD¼PS 394J	Carbon film 390k
R34	RD¼PS 394J	Carbon film 390k
R35	RD¼PS 104J	Carbon film 100k
R36	RD¼PS 104J	Carbon film 100k

OTHERS

Symbol	Part No.	Description
	AKB-045	4-P pin jack
	AKP-011	DIN connector

3.5 FILTER ASSEMBLY (AWT-006)

Foil side

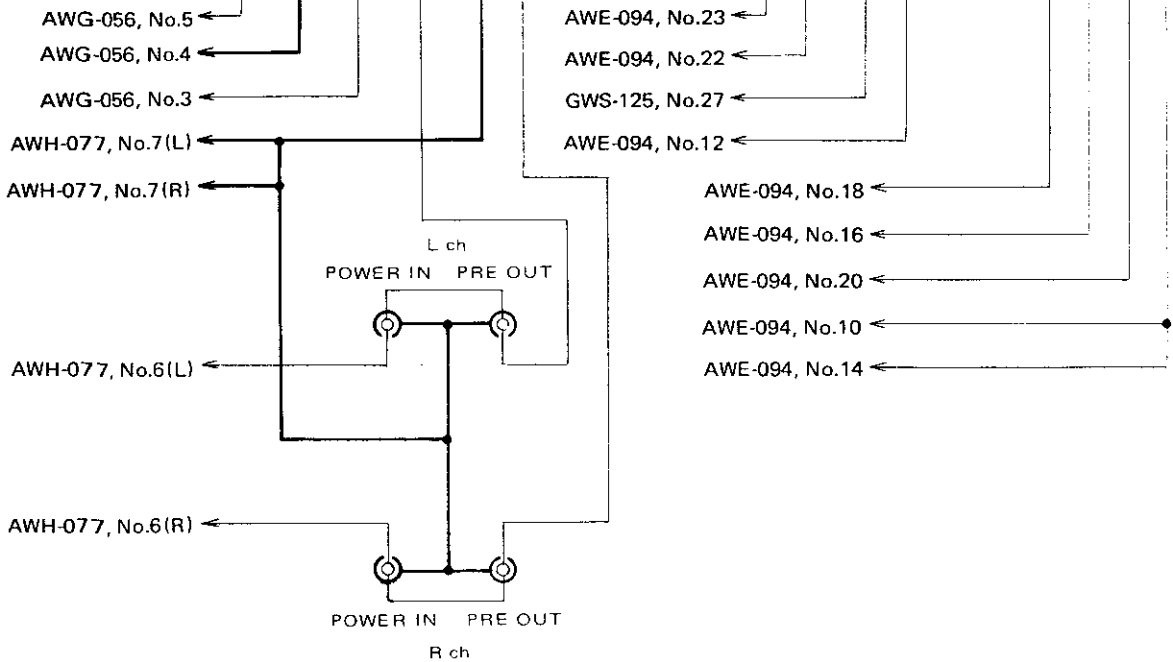
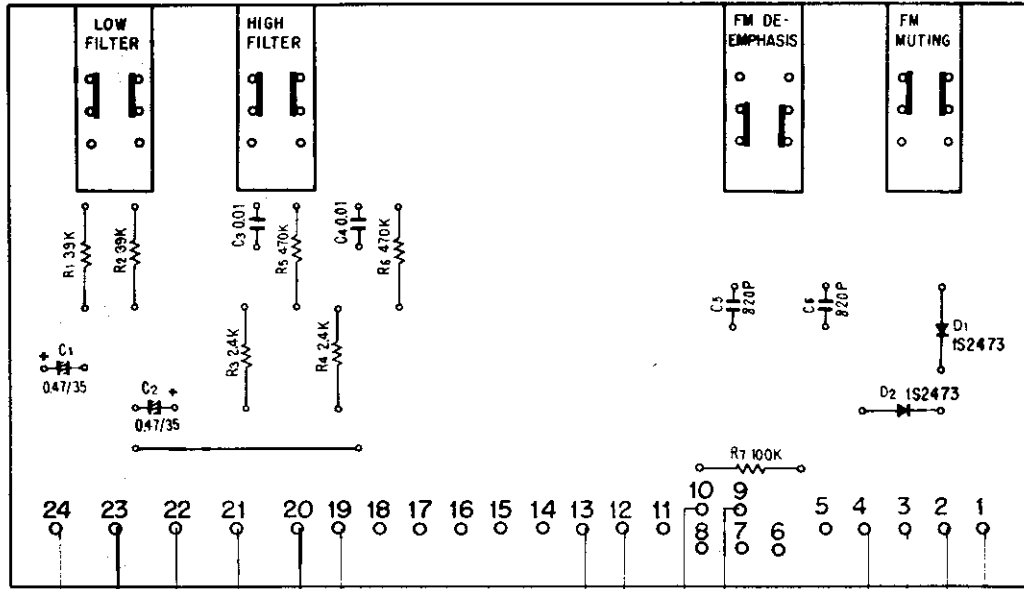

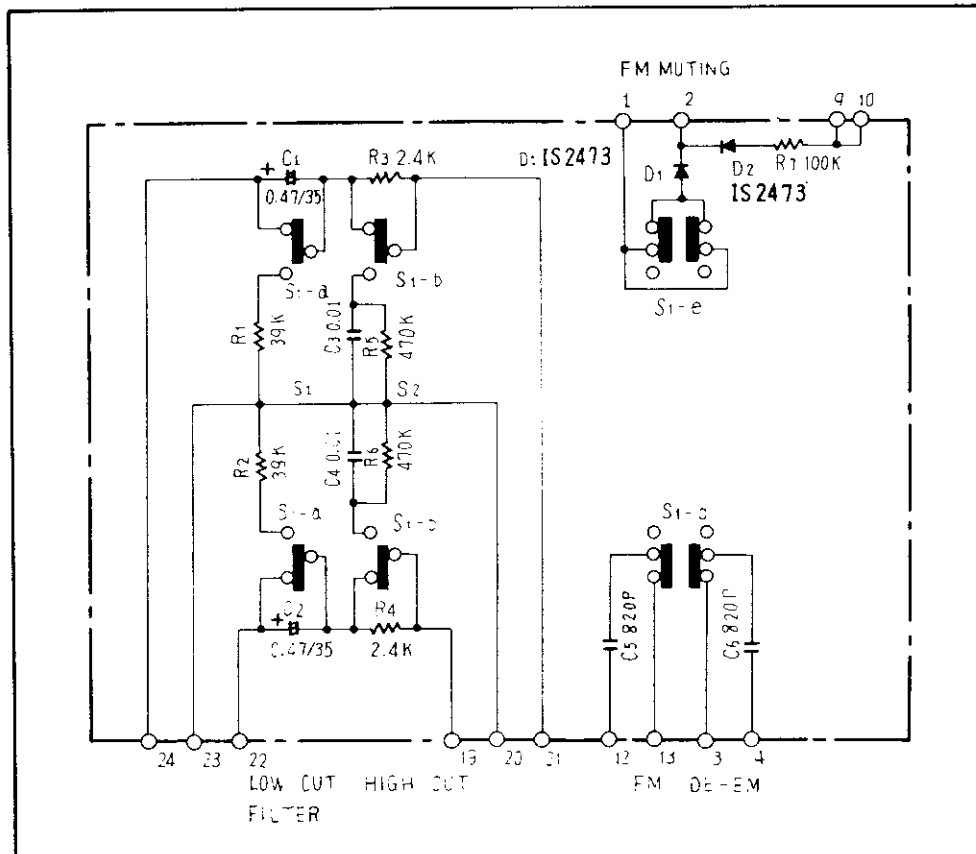

Parts List

SWITCH

Symbol	Part No.	Description
S1	ASG-129	Push switch

RESISTORS

Symbol	Part No.	Description
R1	RD½PS 393J	Carbon film 39k
R2	RD½PS 393J	Carbon film 39k
R3	RD½PS 242J	Carbon film 2.4k
R4	RD½PS 242J	Carbon film 2.4k
R5	RD½PS 474J	Carbon film 470k
R6	RD½PS 474J	Carbon film 470k
R7	RD½PS 104J	Carbon film 100k

CAPACITORS

Symbol	Part No.	Description
C1	CSZA R47M 35	Electrolytic 0.47 35V
C2	CSZA R47M 35	Electrolytic 0.47 35V
C3	CQMA 103K 50	Mylar 0.01 50V
C4	CQMA 103K 50	Mylar 0.01 50V
C5	CQSA 821G 50	Polystyrene 820p 50V
C6	CQSA 821G 50	Polystyrene 820p 50V

SEMICONDUCTORS

Symbol	Part No.	Description
D1	1S2473 (1S1555)	Diode
D2	1S2473 (1S1555)	Diode

3.6 POWER AMPLIFIER ASSEMBLY (AWH-077)

A

A

B

B

C

C

D

D

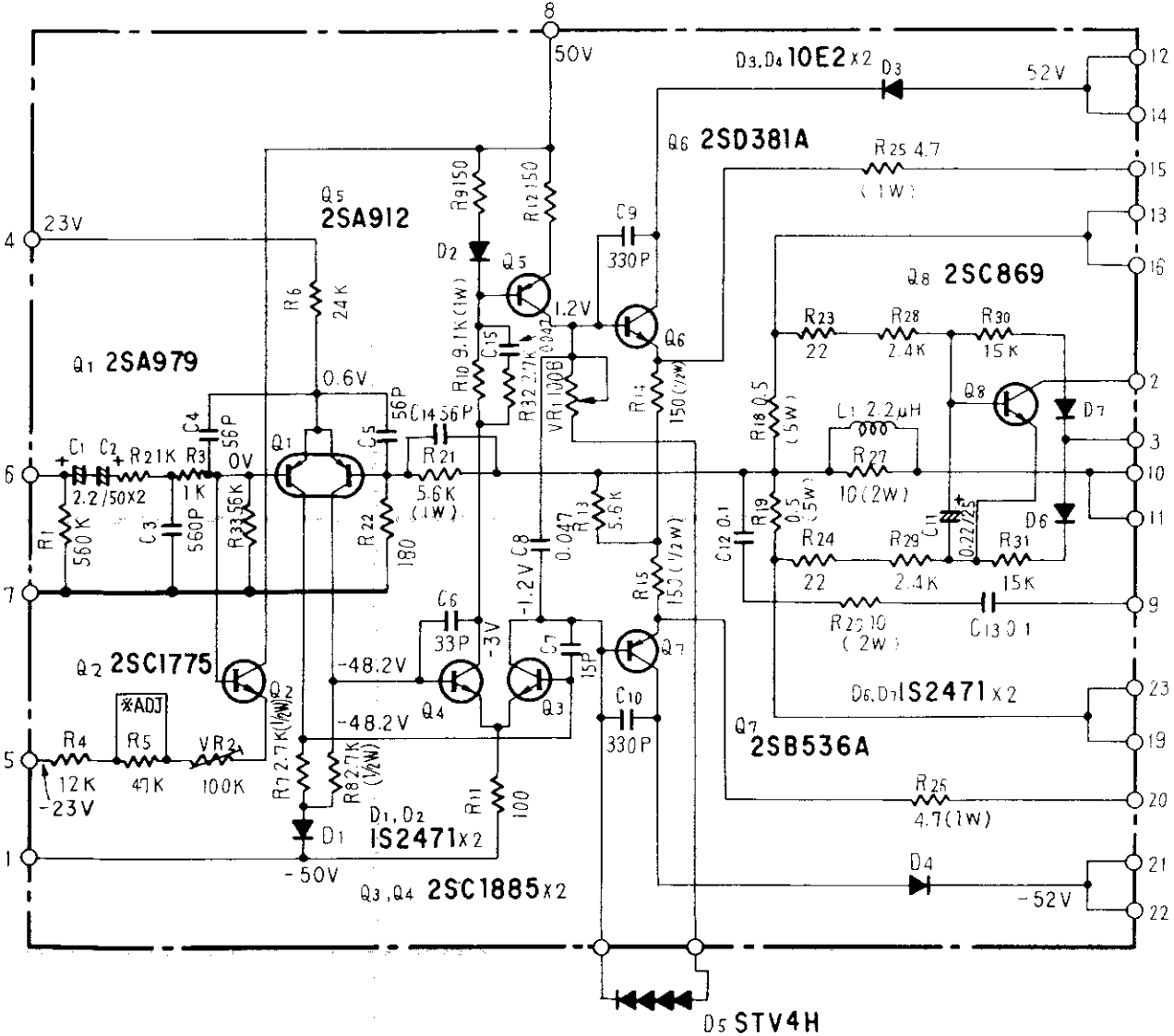

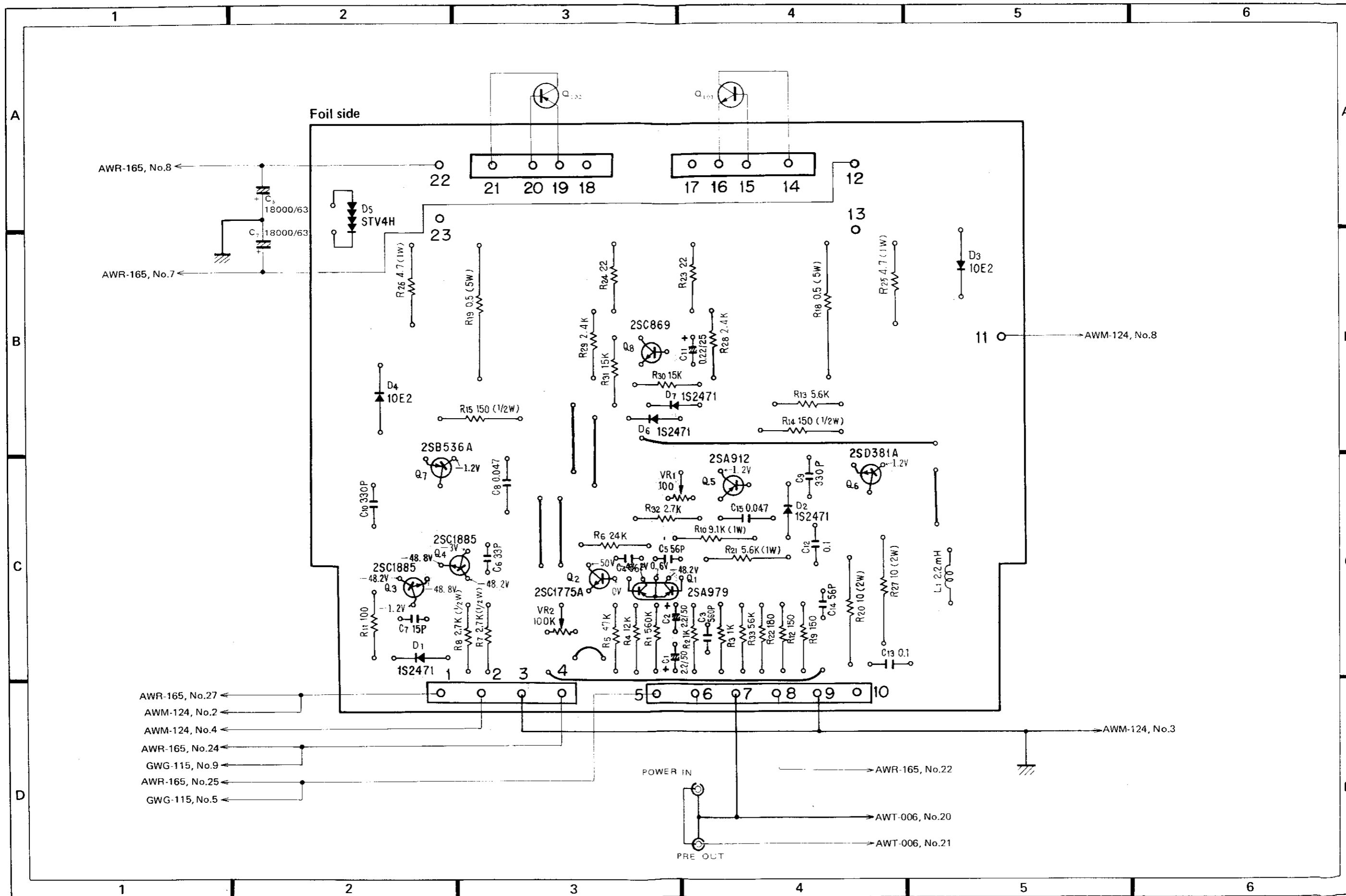

Parts List of Power Amplifier Assembly (AWH-077)

CAPACITORS

Symbol	Part No.	Description	Value	Voltage
C1	CEANL 2R2P 50	Electrolytic	2.2	50V
C2	CEANL 2R2P 50	Electrolytic	2.2	50V
C3	CKDYB 561K 50	Ceramic	560p	50V
C4	CCDSL 560K 50	Ceramic	56p	50V
C5	CCDSL 560K 50	Ceramic	56p	50V
C6	CCDSL 330K 500	Ceramic	33p	500V
C7	CCDSL 150K 500	Ceramic	15p	500V
C8	ACG-009	Ceramic	0.047	150V
C9	CCDSL 331K 500	Ceramic	330p	500V
C10	CCDSL 331K 500	Ceramic	330p	500V
C11	CSSA R22M 25	Electrolytic	0.22	25V
C12	CQMA 104K 50	Mylar	0.1	50V
C13	CQMA 104K 50	Mylar	0.1	50V
C14	CCDSL 560K 50	Ceramic	56p	50V
C15	ACG-009	Ceramic	0.047	150V

RESISTORS

Symbol	Part No.	Description	Value	Power
VR1	ACP-019	Semi-fixed resistor	100B	
VR2	ACP-066	Semi-fixed resistor	100k	
R1	RD½PS 564J	Carbon film	560k	
R2	RD½PS 102J	Carbon film	1k	
R3	RD½PS 102J	Carbon film	1k	
R4	RD½PS 123J	Carbon film	12k	
R5	RD½PS 473J	Carbon film	47k	
R6	RD½PS 243J	Carbon film	24k	
R7	RD½PSF 272J	Carbon film	2.7k	½W
R8	RD½PSF 272J	Carbon film	2.7k	½W
R9	RD½PSF 151J	Carbon film	150	
R10	RS1P 912J	Metal oxide	9.1k	1W
R11	RD½PSF 101J	Carbon film	100	
R12	RD½PSF 151J	Carbon film	150	
R13	RD½PSF 562J	Carbon film	5.6k	
R14	RD½PSF 151J	Carbon film	150	½W
R15	RD½PSF 151J	Carbon film	150	½W
R18	RT5B 0R5K	Metal oxide	0.5	5W
R19	RT5B 0R5K	Metal oxide	0.5	5W
R20	RS2P 100J	Metal oxide	10	2W
R21	RS1P 562J	Metal oxide	5.6k	1W
R22	RD½PSF 181J	Carbon film	180	
R23	RD½PSF 220J	Carbon film	22	
R24	RD½PSF 220J	Carbon film	22	
R25	RN1H 4R7K	Metal film	4.7	1W
R26	RN1H 4R7K	Metal film	4.7	1W
R27	RS2P 100J	Metal oxide	10	2W
R28	RD½PSF 242J	Carbon film	2.4k	
R29	RD½PSF 242J	Carbon film	2.4k	
R30	RD½PS 153J	Carbon film	15k	

Symbol	Part No.	Description	Value
R31	RD½PS 153J	Carbon film	15k
R32	RD½PS 272J	Carbon film	2.7k
R33	RD½PS 563J	Carbon film	56k

SEMICONDUCTORS

Symbol	Part No.	Description
Q1	2SA979-F	Transistor
Q2	2SC1775A-E	Transistor
Q3	2SC1885-Q or R	Transistor
Q4	2SC1885-Q or R	Transistor
Q5	2SA912-Q or R	Transistor
Q6	2SD381A-M or L	Transistor
Q7	2SB536A-M or L	Transistor
Q8	2SC869-D or C	Transistor
D1	1S2471	Diode
D2	1S2471	Diode
D3	10E2	Diode
D4	10E2 (SIB01-02)	Diode
D5	STV4H	Varistor
D6	1S2471	Diode
D7	1S2471	Diode

OTHERS

Symbol	Part No.	Description
L1	T63-009	AF choke coil
	AKM-018	3P plug
	ANH-203	Heat sink
	AEC-410	Transistor cover

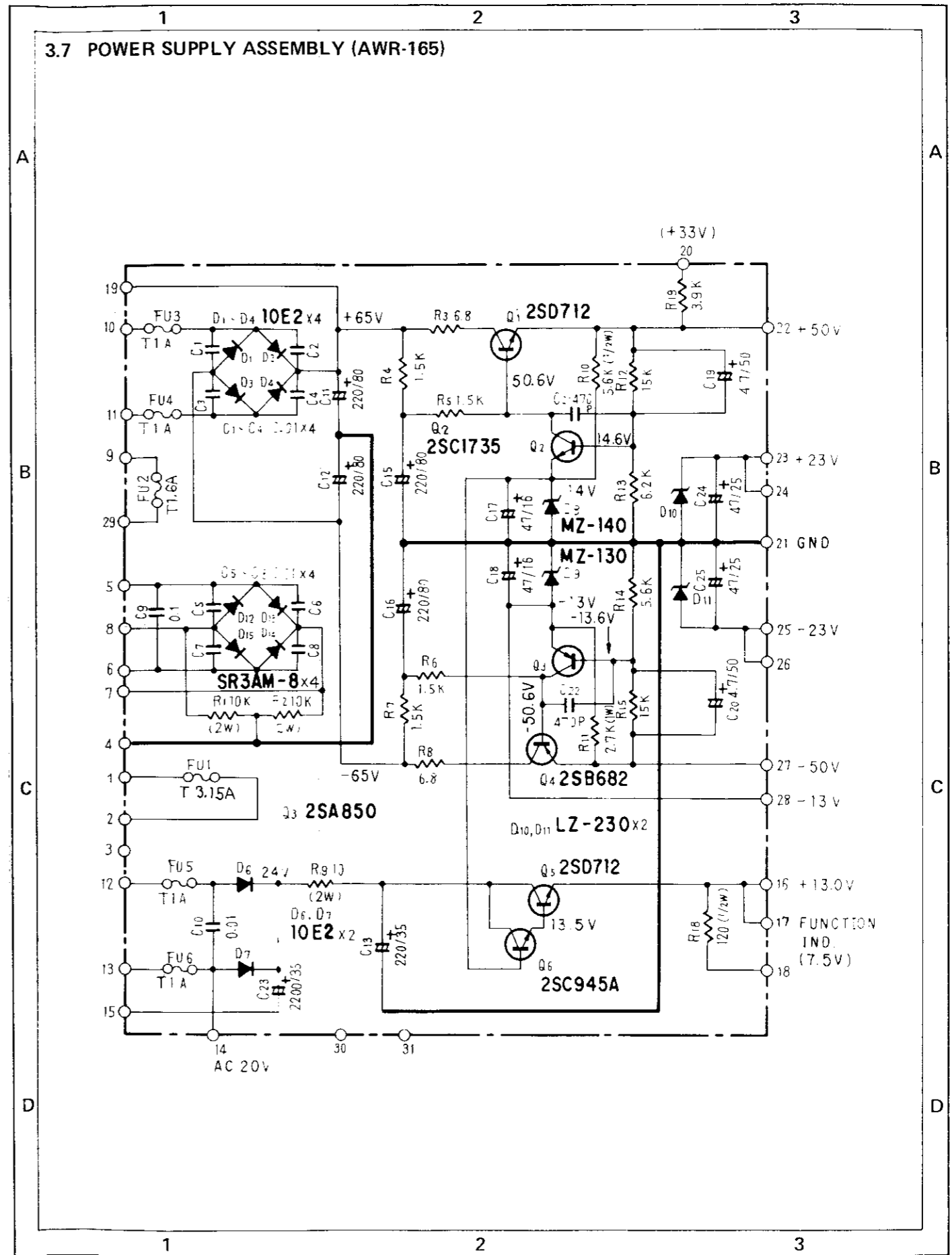

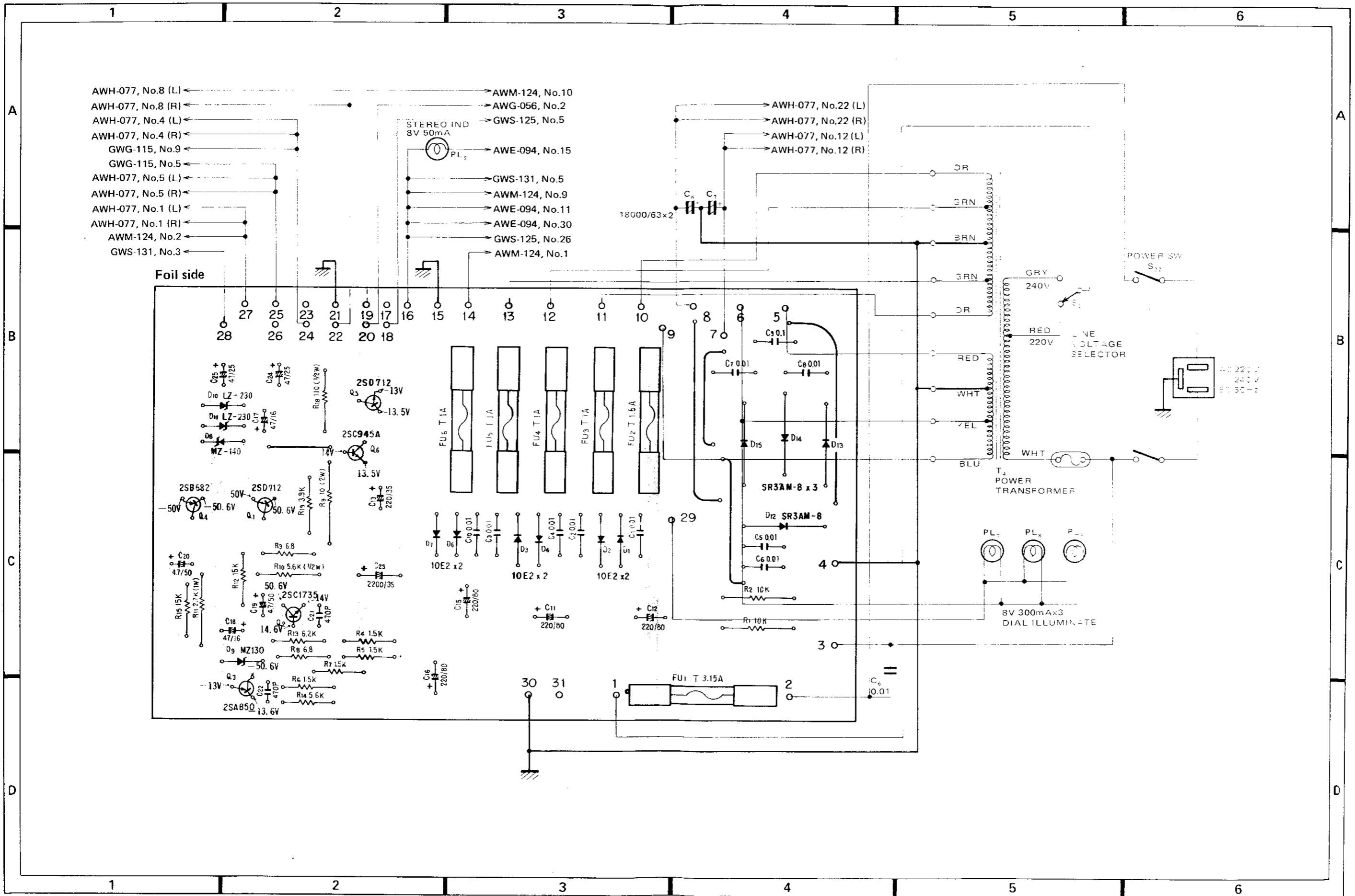

- AWH-077, No.8 (L) ←
- AWH-077, No.8 (R) ←
- AWH-077, No.4 (L) ←
- AWH-077, No.4 (R) ←
- GWG-115, No.9 ←
- GWG-115, No.5 ←
- AWH-077, No.5 (L) ←
- AWH-077, No.5 (R) ←
- AWH-077, No.1 (L) ←
- AWH-077, No.1 (R) ←
- AWM-124, No.2 ←
- GWS-131, No.3 ←
- AWM-124, No.10 →
- AWG-056, No.2 →
- GWS-125, No.5 →
- AWE-094, No.15 →
- GWS-131, No.5 →
- AWM-124, No.9 →
- AWE-094, No.11 →
- AWE-094, No.30 →
- GWS-125, No.26 →
- AWM-124, No.1 →

Foil side

POWER SW
S₁

LINE VOLTAGE SELECTOR

T₁ POWER TRANSFORMER

8V 300mA x 3 DIAL ILLUMINATE

Parts List of Power Supply Assembly (AWR-165)

CAPACITORS

Symbol	Part No.	Description		
C1	ACG-004	Ceramic	0.01	150V
C2	ACG-004	Ceramic	0.01	150V
C3	ACG-004	Ceramic	0.01	150V
C4	ACG-004	Ceramic	0.01	150V
C5	ACG-004	Ceramic	0.01	150V
C6	ACG-004	Ceramic	0.01	150V
C7	ACG-004	Ceramic	0.01	150V
C8	ACG-004	Ceramic	0.01	150V
C9	QMA 104K 250	Mylar	0.1	250V
C10	ACG-004	Ceramic	0.01	150V
C11	CEA 221P 80	Electrolytic	220	80V
C12	CEA 221P 80	Electrolytic	220	80V
C13	CEA 221P 35	Electrolytic	220	35V
C15	CEA 221P 80	Electrolytic	220	80V
C16	CEA 221P 80	Electrolytic	220	80V
C17	CEA 470P 16	Electrolytic	47	16V
C18	CEA 470P 16	Electrolytic	47	16V
C19	CEA 4R7P 50	Electrolytic	4.7	50V
C20	CEA 4R7P 50	Electrolytic	4.7	50V
C21	CKDYB 471K 50	Ceramic	470	50V
C22	CKDYB 471K 50	Ceramic	470	50V
C23	ACH-060	Electrolytic	220	35V
C24	CEA 470P 25	Electrolytic	47	25V
C25	CEA 470P 25	Electrolytic	47	25V

RESISTORS

Symbol	Part No.	Description		
R1	RS2P 103J	Metal oxide	10k	2W
R2	RS2P 103J	Metal oxide	10k	2W
R3	RD¼PSF 6R8J	Carbon film	6.8	
R4	RD¼PSF 152J	Carbon film	1.5k	
R5	RD¼PSF 152J	Carbon film	1.5k	
R6	RD¼PSF 152J	Carbon film	1.5k	
R7	RD¼PSF 152J	Carbon film	1.5k	
R8	RD¼PSF 6R8J	Carbon film	6.8	
R9	RS2P 100J	Metal oxide	10	2W
R10	RD¼PS 562J	Carbon film	5.6k	¼W
R11	RS1P 272J	Metal oxide	2.7k	1W
R12	RD¼PS 153J	Carbon film	15k	
R13	RD¼PS 622J	Carbon film	6.2k	
R14	RD¼PS 562J	Carbon film	5.6k	
R15	RD¼PS 153J	Carbon film	15k	
R16			
R17			
R18	RD¼PS 121J	Carbon film	120	¼W
R19	RD¼PS 392J	Carbon film	3.9k	

SEMICONDUCTORS

Symbol	Part No.	Description		
Q1	2SD712-C or D (2SD313P-D or E)	Transistor		
Q2	2SC1735-D or C (2SC1384-Q or R)	Transistor		
Q3	2SA850-D or C (2SA684A-Q or R)	Transistor		
Q4	2SB682-C or D (2SB507P-D or E)	Transistor		
Q5	2SD712-C or D (2SD313P-D or E)	Transistor		
Q6	2SC945A-Q or R (2SC1914-F)	Transistor		
D1	10E2 or SIB01-02	Diode		
D2	10E2 or SIB01-02	Diode		
D3	10E2 or SIB01-02	Diode		
D4	10E2 or SIB01-02	Diode		
D6	10E2 or SIB01-02	Diode		
D7	10E2 or SIB01-02	Diode		
D8	MZ-140 or WZ-140	Zener diode		
D9	MZ-130 or WZ-130	Zener diode		
D10	LZ-230 or BZ-230	Zener diode		
D11	LZ-230 or BZ-230	Zener diode		
D12	SR3AM-8	Diode		
D13	SR3AM-8	Diode		
D14	SR3AM-8	Diode		
D15	SR3AM-8	Diode		

OTHERS

Symbol	Part No.	Description
	ANH-203	Heat sink
	AKR-010	Fuse clip

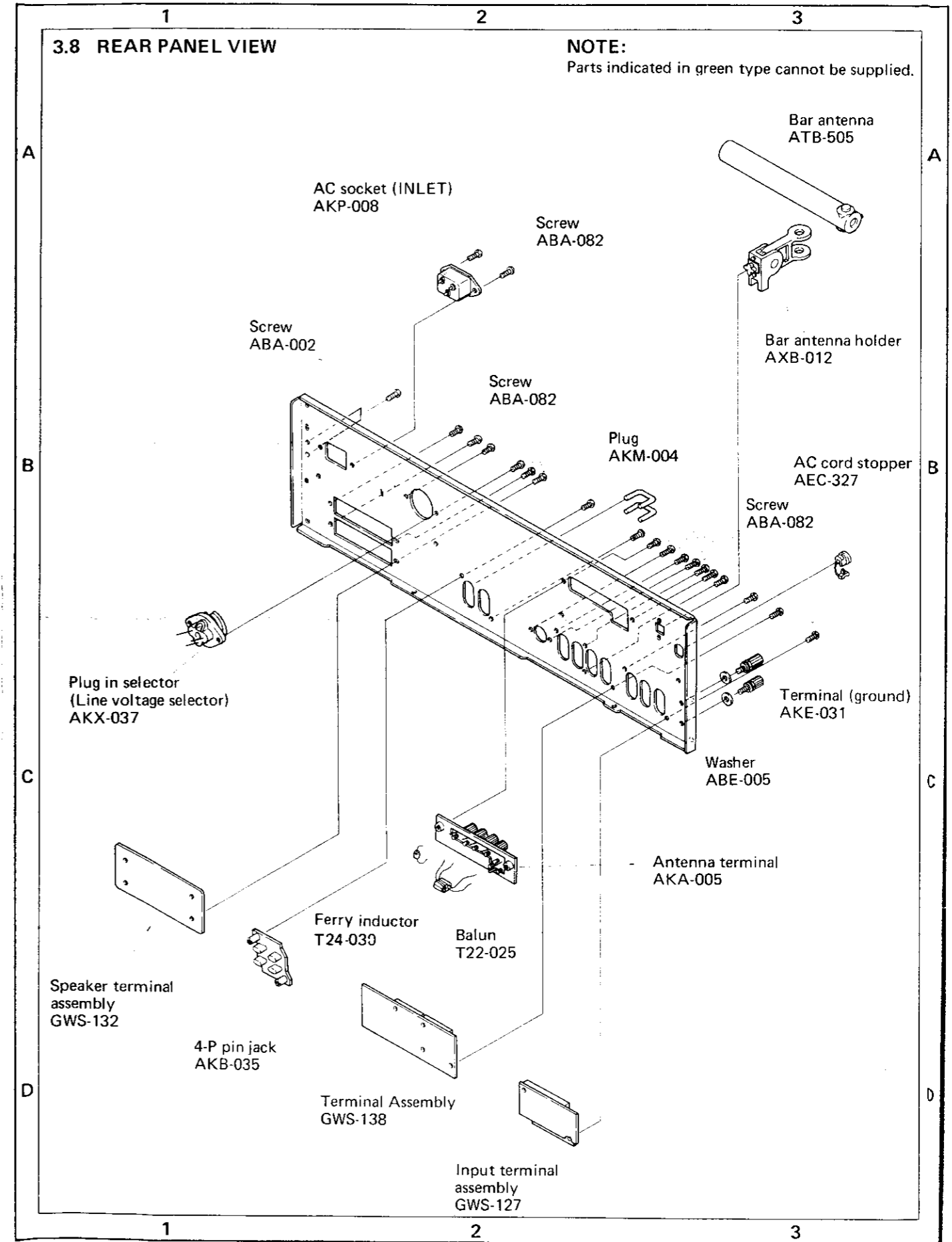

4. SX-980/S

4.1 REAR PANEL VIEW

NOTE:

Parts indicated in green type cannot be supplied.

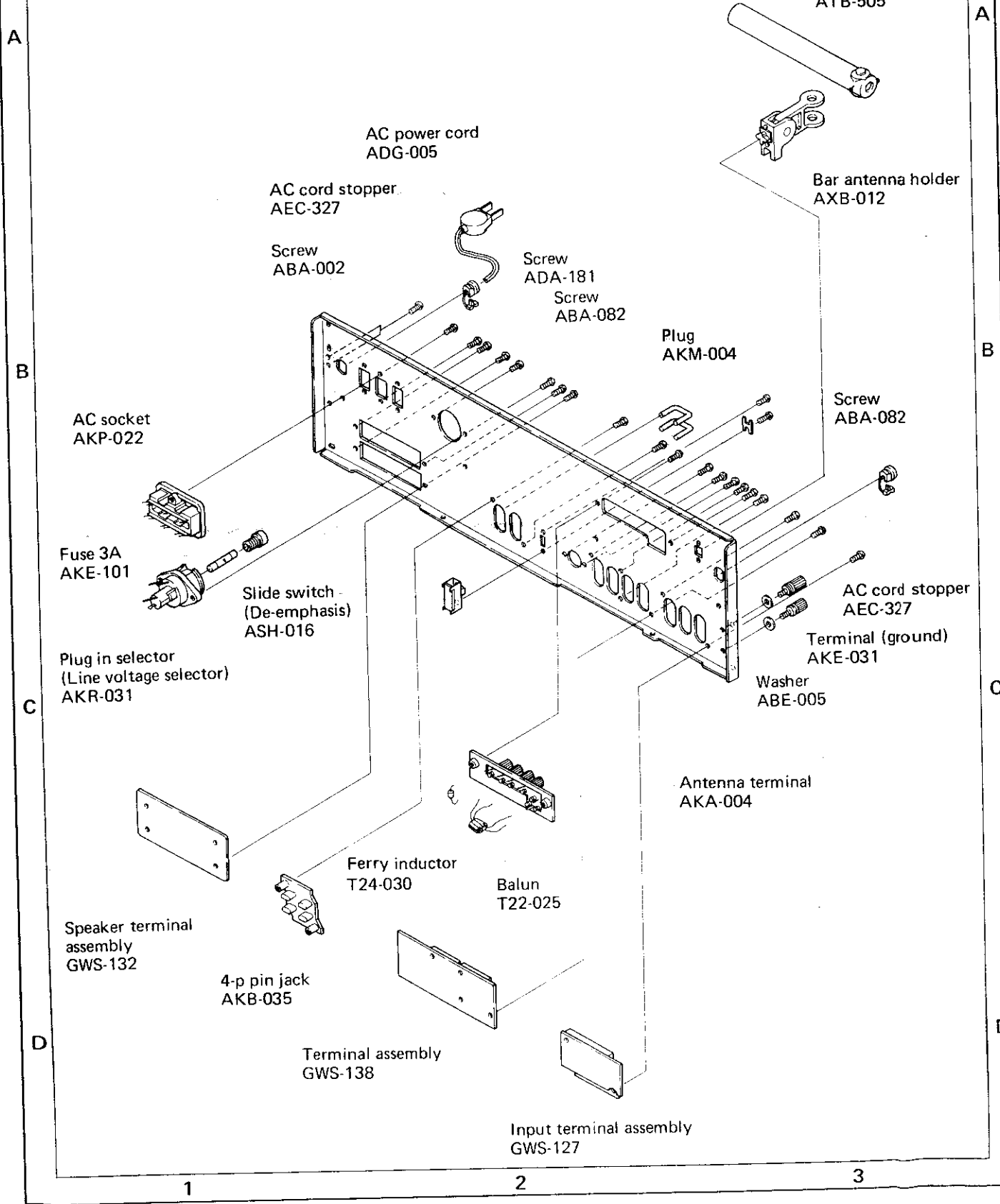

4.2 MISCELLANEOUS PARTS LIST

NOTES:

- Capacitors: in μF unless otherwise noted P:pF.
- Resistors: in Ω , 1/4W unless otherwise noted k:k Ω , M:M Ω .

COILS AND TRANSFORMER

Symbol	Part No.	Description
T1	T22-025	Balun
T2	ATB-505	Bar antenna
T3	T24-030	Ferry inductor
T4	ATT-478	Power transformer

CAPACITORS

Symbol	Part No.	Description
C1	CKDBC 104Z 25	Ceramic 0.1 25V
C2	CKDBC 104Z 25	Ceramic 0.1 25V
C3	CKDBC 104Z 25	Ceramic 0.1 25V
C4	CKDBC 104Z 25	Ceramic 0.1 25V
C5	ACG-001	Ceramic 0.01 250V
C6	ACG-001	Ceramic 0.01 250V
C7	ACH-047	Electrolytic 18,000 63V
C8	ACH-047	Electrolytic 18,000 63V

LAMPS

Symbol	Part No.	Description
PL1	AEL-069	Pilot lamp with wire
PL2	AEL-067	Pilot lamp with wire
PL3	AEL-067	Pilot lamp with wire
PL4	AEL-067	Pilot lamp with wire
PL5	AEL-069	Pilot lamp with wire
PL7	AEL-029	Wedge type pilot lamp
PL8	AEL-029	Wedge type pilot lamp
PL9	AEL-029	Wedge type pilot lamp

RESISTORS

Symbol	Part No.	Description
R2	RS2P 911J	Metal oxide 910 2W
R3	RS2P 911J	Metal oxide 910 2W

ASSEMBLIES

Symbol	Part No.	Description
	AWE-094	Tuner assembly
	GWS-125	Function and equalizer assembly
	GWS-127	Input terminal assembly
	GWG-115	Flat amplifier assembly
	GWS-138	Terminal assembly
	AWG-056	Tone control assembly
	AWT-005	Filter assembly
	GWS-131	Speaker switch assembly(1)
	GWS-132	Speaker switch assembly(2)
	AWH-073	Power amplifier assembly
	AWR-164	Power supply assembly
	AWM-124	Protection assembly

FUSES

Symbol	Part No.	Description
FU1	AEK-101	Fuse 3A
FU2	AEK-104	Fuse 1.5A
FU3	AEK-106	Fuse 1A
FU4	AEK-106	Fuse 1A
FU5	AEK-106	Fuse 1A
FU6	AEK-106	Fuse 1A

SWITCHES

Symbol	Part No.	Description
S22	ASK-080	Lever switch (POWER)
S25	AKR-031	Plug in selector (Line voltage selector)
S26	ASH-016	Slide switch (DE-EMPHASIS SWITCH)

SEMICONDUCTORS

Symbol	Part No.	Description
Q101	2SD746-Q or R, S	Transistor
Q102	2SB706-Q or R, S	Transistor
Q103	2SB706-Q or R, S	Transistor
Q104	2SD746-Q or R, S	Transistor

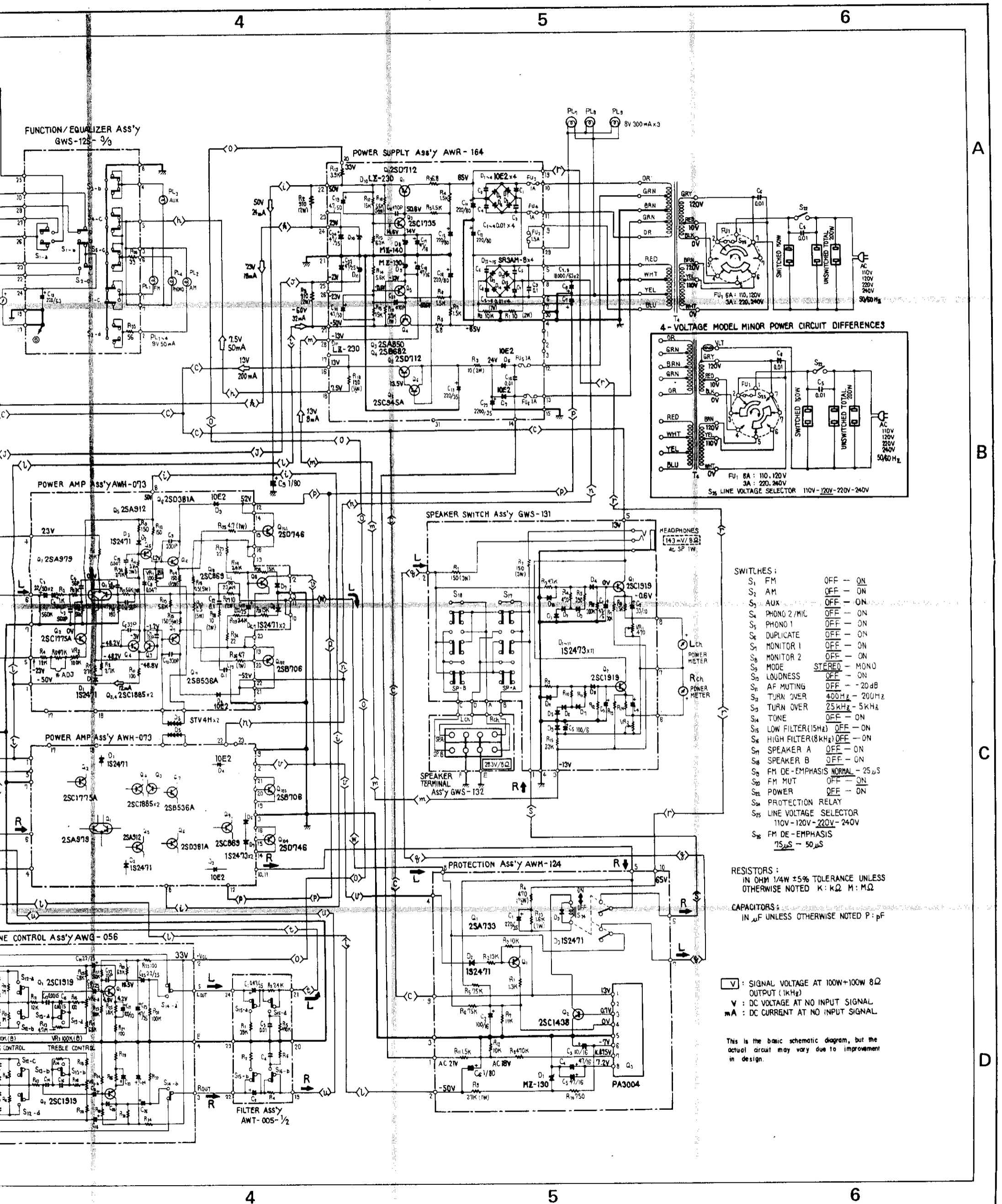

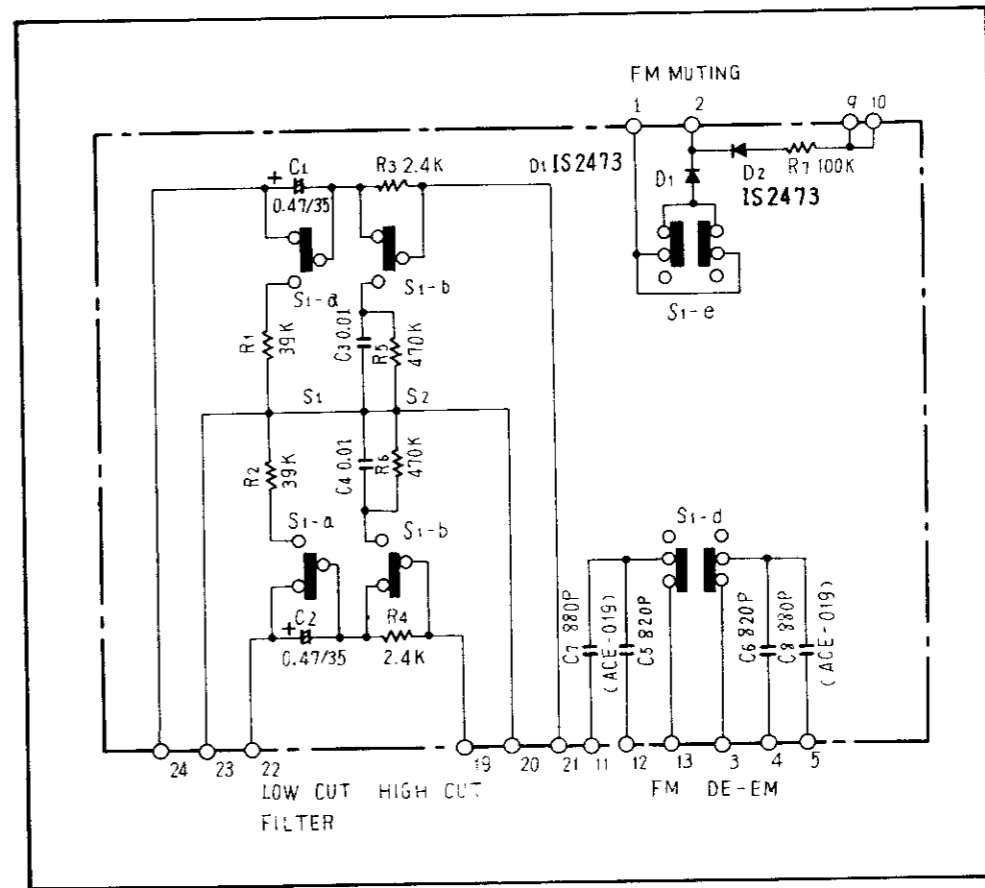
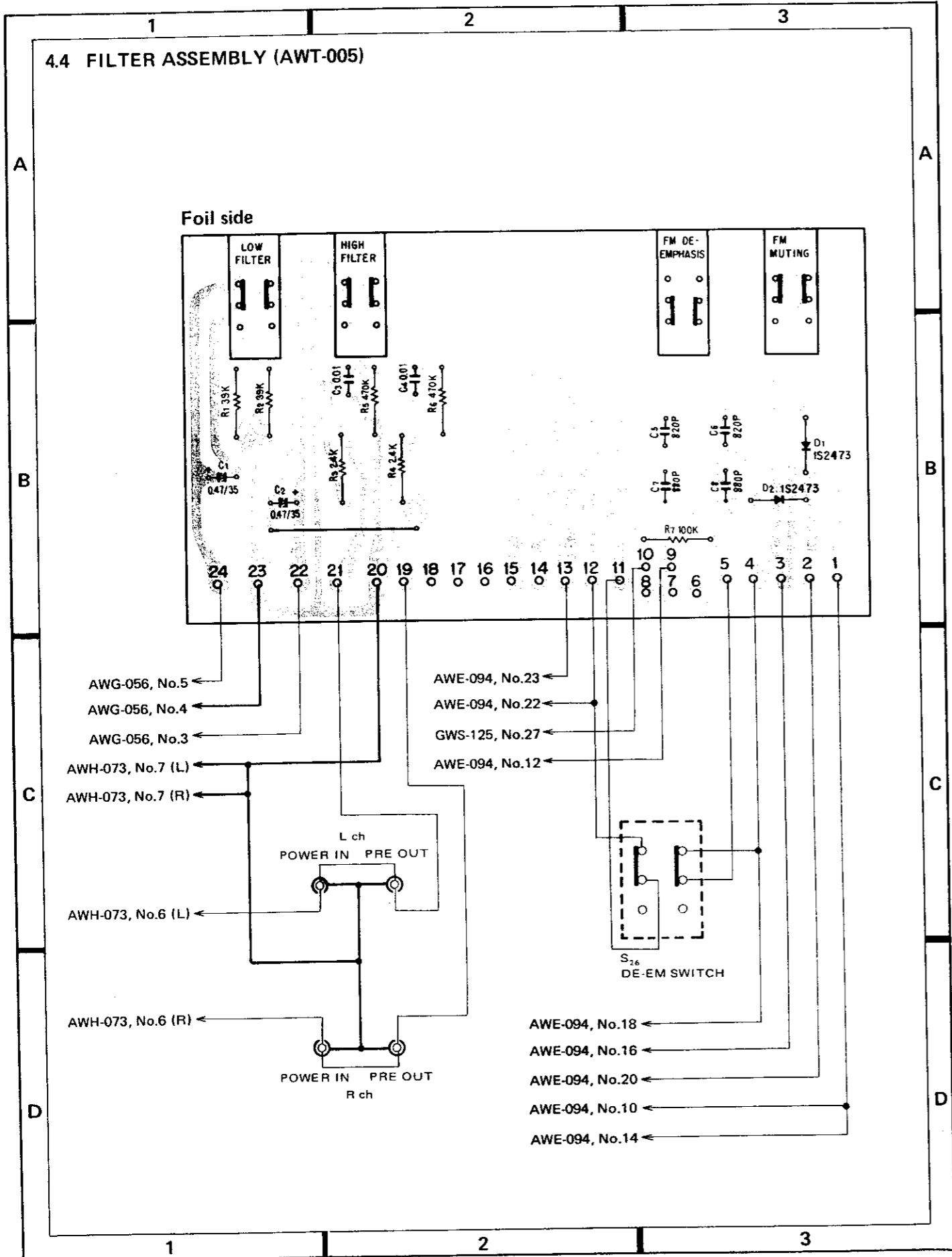

Parts List

SWITCH

Symbol	Part No.	Description
S1	ASG-129	Push switch

CAPACITORS

Symbol	Part No.	Description
C1	CSZA R47M 35	Electrolytic 0.47 35V
C2	CSZA R47M 35	Electrolytic 0.47 35V
C3	CQMA 103K 50	Mylar 0.01 50V
C4	CQMA 103K 50	Mylar 0.01 50V
C5	CQSA 821G 50	Polystyrene 820p 50V
C6	CQSA 821G 50	Polystyrene 820p 50V
C7	ACE-019	Styrol 880p 50V
C8	ACE-019	Styrol 880p 50V

RESISTORS

Symbol	Part No.	Description
R1	RD4PS 393J	Carbon film 39k
R2	RD4PS 393J	Carbon film 39k
R3	RD4PS 242J	Carbon film 2.4k
R4	RD4PS 242J	Carbon film 2.4k
R5	RD4PS 474J	Carbon film 470k
R6	RD4PS 474J	Carbon film 470k
R7	RD4PS 104J	Carbon film 100k

SEMICONDUCTORS

Symbol	Part No.	Description
D1	1S2473 (1S1555)	Diode
D2	1S2473 (1S1555)	Diode

4.5 POWER SUPPLY ASSEMBLY (AWR-164)

Parts List

CAPACITORS

Symbol	Part No.	Description		
C1	ACG-004	Ceramic	0.01	150V
C2	ACG-004	Ceramic	0.01	150V
C3	ACG-004	Ceramic	0.01	150V
C4	ACG-004	Ceramic	0.01	150V
C5	ACG-004	Ceramic	0.01	150V
C6	ACG-004	Ceramic	0.01	150V
C7	ACG-004	Ceramic	0.01	150V
C8	ACG-004	Ceramic	0.01	150V
C9	CQMA 104K 250	Mylar	0.1	250V
C10	ACG-004	Ceramic	0.01	150V
C11	CEA 221P 80	Electrolytic	220	80V
C12	CEA 221P 80	Electrolytic	220	80V
C13	CEA 221P 35	Electrolytic	220	35V
C15	CEA 221P 80	Electrolytic	220	80V
C16	CEA 221P 80	Electrolytic	220	80V
C17	CEA 470P 16	Electrolytic	47	16V
C18	CEA 470P 16	Electrolytic	47	16V
C19	CEA 4R7P 50	Electrolytic	4.7	50V
C20	CEA 4R7P 50	Electrolytic	4.7	50V
C21	CKDYB 471K 50	Ceramic	470p	50V
C22	CKDYB 471K 50	Ceramic	470p	50V
C23	ACH-060	Electrolytic	2200	35V
C24	CEA 470P 25	Electrolytic	47	25V
C25	CEA 470P 25	Electrolytic	47	25V

RESISTORS

Symbol	Part No.	Description		
R1	RS2P 103J	Metal oxide	10k	2W
R2	RS2P 103J	Metal oxide	10k	2W
R3	RD¼PSF 6R8J	Carbon film	6.8	
R4	RD¼PSF 152J	Carbon film	1.5k	
R5	RD¼PSF 152J	Carbon film	1.5k	
R6	RD¼PSF 152J	Carbon film	1.5k	
R7	RD¼PSF 152J	Carbon film	1.5k	
R8	RD¼PSF 6R8J	Carbon film	6.8	
R9	RS2P 100J	Metal oxide	10	2W
R10	RD¼PS 562J	Carbon film	5.6k	½W
R11	RS1P 272J	Metal oxide	2.7k	1W
R12	RD¼PS 153J	Carbon film	15k	
R13	RD¼PS 622J	Carbon film	6.2k	
R14	RD¼PS 562J	Carbon film	5.6k	
R15	RD¼PS 153J	Carbon film	15k	
R16	RS2P 911J	Metal oxide	910	2W
R17	RS2P 911J	Metal oxide	910	2W
R18	RD¼PS 121J	Carbon film	120	½W
R19	RD¼PS 392J	Carbon film	3.9k	

SEMICONDUCTORS

Symbol	Part No.	Description
Q1	2SD712-C or D (2SD313P-D or E)	Transistor
Q2	2SC1735-D or C (2SI384-Q or R)	Transistor
Q3	2SA850-D or C (2SA684A-Q or R)	Transistor
Q4	2SB682-C or D (2SB507P-D or E)	Transistor
Q5	2SD712-C or D (2SD313P-D or E)	Transistor
Q6	2SC945A-Q or R (2SC1914-F)	Transistor
D1	10E2 or SIB01-02	Diode
D2	10E2 or SIB01-02	Diode
D3	10E2 or SIB01-02	Diode
D4	10E2 or SIB01-02	Diode
D6	10E2 or SIB01-02	Diode
D7	10E2 or SIB01-02	Diode
D8	MZ-140 or WZ-140	Zener diode
D9	MZ-130 or WZ-130	Zener diode
D10	LZ-230 or BZ-230	Zener diode
D11	LZ-230 or BZ-230	Zener diode
D12	SR3AM-8	Diode
D13	SR3AM-8	Diode
D14	SR3AM-8	Diode
D15	SR3AM-8	Diode

OTHERS

Symbol	Part No.	Description
	ANH-203	Heat sink
	AKR-013	Fuse clip

Power Supply Assembly (AWR-164)

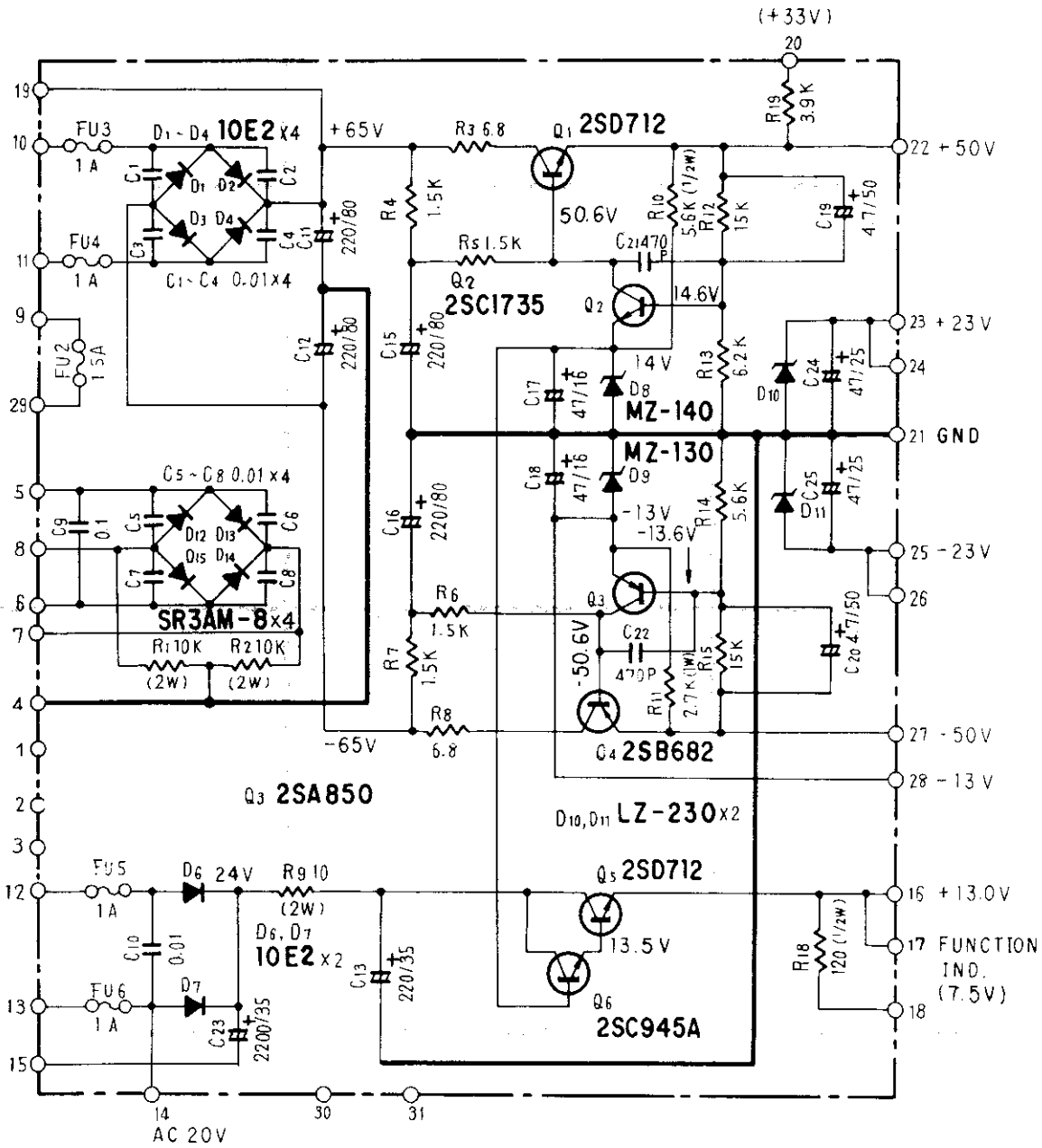

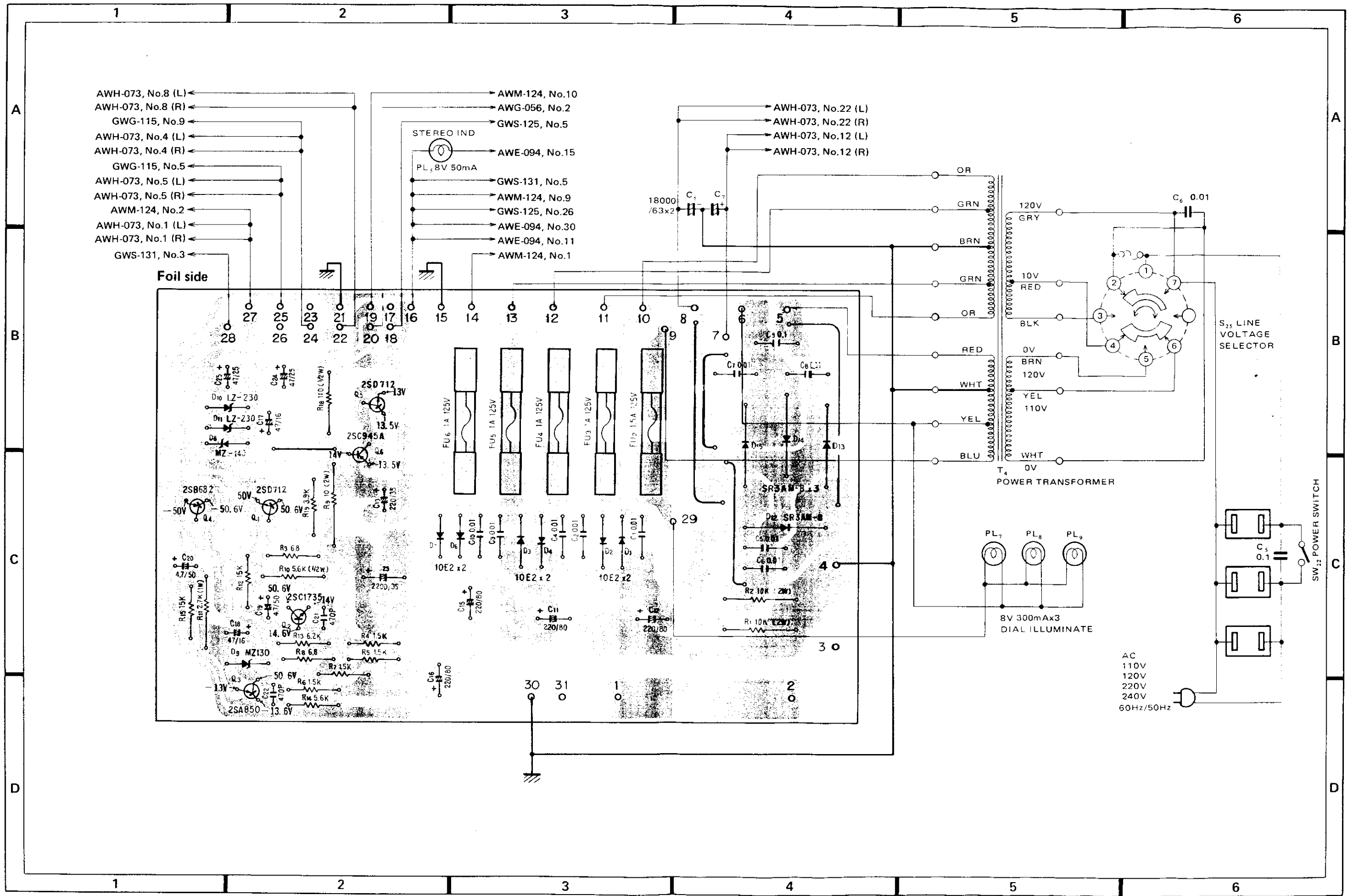

- AWH-073, No.8 (L) ←
 - AWH-073, No.8 (R) ←
 - GWG-115, No.9 ←
 - AWH-073, No.4 (L) ←
 - AWH-073, No.4 (R) ←
 - GWG-115, No.5 ←
 - AWH-073, No.5 (L) ←
 - AWH-073, No.5 (R) ←
 - AWM-124, No.2 ←
 - AWH-073, No.1 (L) ←
 - AWH-073, No.1 (R) ←
 - GWS-131, No.3 ←
- AWM-124, No.10 →
 - AWG-056, No.2 →
 - GWS-125, No.5 →
 - AWE-094, No.15 →
 - GWS-131, No.5 →
 - AWM-124, No.9 →
 - GWS-125, No.26 →
 - AWE-094, No.30 →
 - AWE-094, No.11 →
 - AWM-124, No.1 →

- AWH-073, No.22 (L) →
- AWH-073, No.22 (R) →
- AWH-073, No.12 (L) →
- AWH-073, No.12 (R) →

Foil side

AC
110V
120V
220V
240V
60Hz/50Hz

5. SX-980/KC

NOTICE:

- The contrast parts, KC type and KU type, are shown in below.
- The circuit diagram and pattern of the power supply assembly for the KC type (AWR-168) are same as the KU type (AWR-156). Only different is parts installation method.

Contrast of Miscellaneous Part

ASSEMBLYS

Symbol	Part Name	Part No.		Remarks
		KU type	KC type	
	Power amplifier assembly	AWH-073	AWH-077	See HG type
	Power supply assembly	AWR-156	AWR-168	

TRANSFORMER

Symbol	Part Name	Part No.		Remarks
		KU type	KC type	
T4	Power transformer	ATT-449	ATT-462	

CAPACITORS

Symbol	Part Name	Part No.		Remarks
		KU type	KC type	
C5	Ceramic 0.01 250V	ACG-001	
	Ceramic 0.01 125V	ACG-014	
C6	Ceramic 0.01 125V	ACG-003	
	Ceramic 0.01 125V	ACG-014	

OTHERS

Symbol	Part Name	Part No.		Remarks
		KU type	KC type	
	Capacitor cover	AEC-294	
	Capacitor cover	AEC-279	
	Capacitor cover	AEC-365	

PACKING

Symbol	Part Name	Part No.		Remarks
		KU type	KC type	
	Packing case	AHD-508	AHD-524	