



Shown in the photo is the model PL-600X with black cabinet.

Service Manual

STEREO TURNTABLE

PL-600
PL-600X

 **PIONEER®**

MODEL PL-600 (PL-600X) COMES IN SIX VERSIONS DISTINGUISHED AS FOLLOWS:

Type	Voltage	Remarks
KCT	120V only	Canada model (Without cartridge)
KUT	120V only	U.S.A. model (Without cartridge)
HET (PL-600X)	220V and 240V (Switchable)	Europe model (Without cartridge)
HBT (PL-600X)	220V and 240V (Switchable)	United Kingdom model (Without cartridge)
S	110V, 120V, 220V and 240V (Switchable)	General export model (Within cartridge)
S/G	110V, 120V, 220V and 240V (Switchable)	U.S. Military model (Within cartridge)

For descriptions of the D.D. motor and full auto mechanism employed in this model refer to the PL-630 service manual (ART-314).

CONTENTS

1. SPECIFICATIONS	3	9. PACKING (S/G, S)	26
2. PANEL FACILITIES	4	10. SCHEMATIC DIAGRAMS (S, S/G)	27
3. DISASSEMBLY	6	11. P.C. BOARD CONNECTION DIAGRAM	30
4. PARTS LOCATION	9	(S, S/G)	
5. ADJUSTMENT	11	11.1 Parts List of P.C. Board Assembly	
6. EXPLODED VIEW AND PARTS LIST		(S, S/G)	33
6.1 Cabinet	12	12. PACKING (HET, HBT)	34
6.2 Tonearm	15	13. SCHEMATIC DIAGRAM (PL-600X	
6.3 D.D. Motor	17	(HET, HBT)	35
6.4 Packing	18	14. P.C. BOARD CONNECTION DIAGRAM	38
7. SCHEMATIC DIAGRAM (KCT, KUT)	19	(HET, HBT)	
8. P.C. BOARD CONNECTION DIAGRAM	22	14.1 Parts List of P.C. Board Assembly	
(KCT, KUT)		(HET, HBT)	41
8.1 Parts List of P.C. Board Assembly			
(KUT, KCT)	25		

2. PANEL FACILITIES

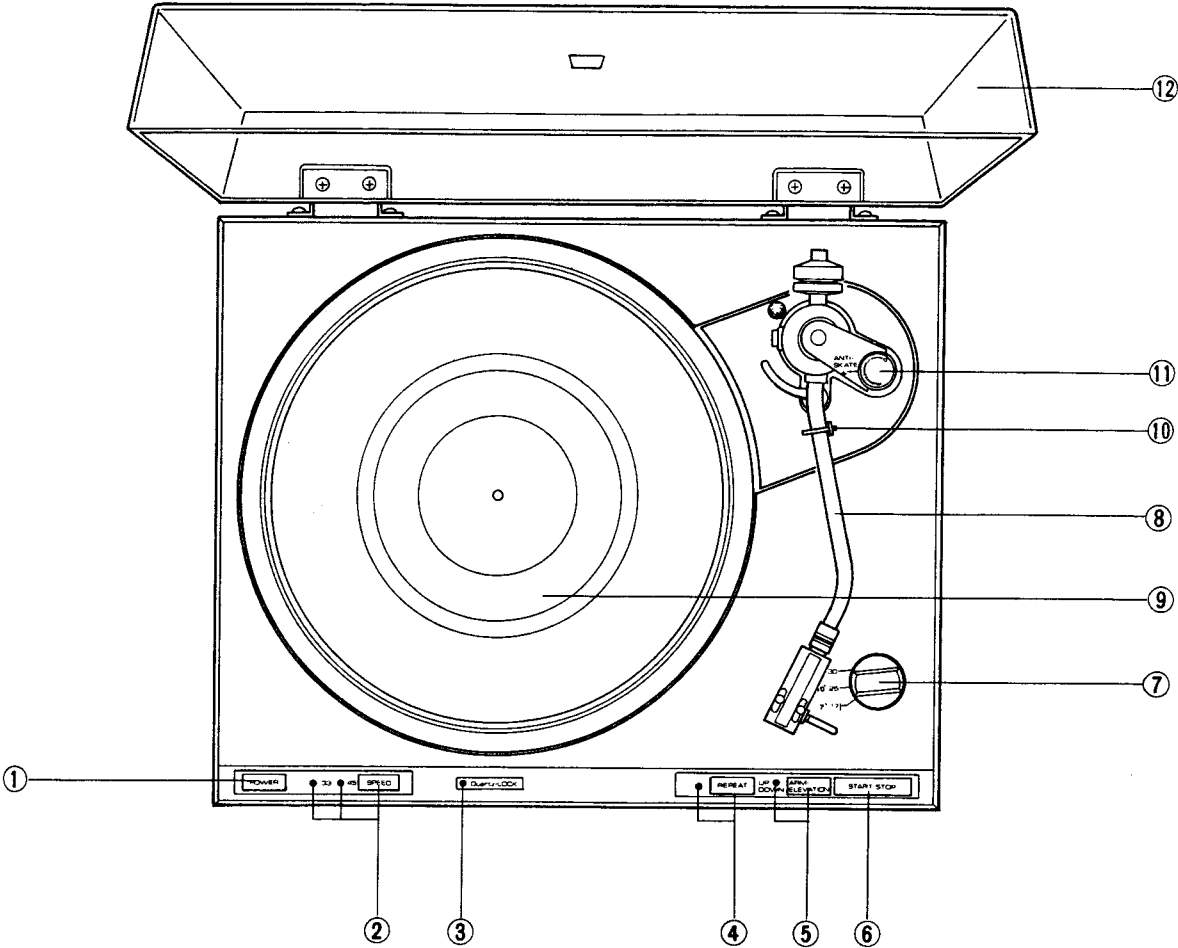

1. SPECIFICATIONS

Motor and Turntable

Drive System	Direct-drive
Motor	Quartz PLL Hall motor
Turntable Platter	330mm diam. aluminum alloy die-cast
Inertial Mass	330kg-cm ² (including platter mat mass)
Speeds	33-1/3 and 45rpm
Wow and Flutter	Less than 0.025% (WRMS)
Signal-to-Noise Ratio	More than 78dB (DIN-B)
	(with Pioneer cartridge model PC-200 or PC-150)

Rotational Characteristics

Build-up Time	Within 90° rotation at 33-1/3 rpm
Speed Deviation	Less than 0.002%
Speed vs. Load Characteristics	Stable up to 200 grams drag load
Speed Drift	Less than 0.00008%/h at 33-1/3rpm
	Less than 0.00003%/degree temp. change at 33-1/3rpm

Tonearm

Type	Static-balance type, S-shaped pipe arm
Effective Arm Length	237mm
Overhang	15mm
Usable Cartridge Weight	4g (min.) to 12.5 (max.)
	(For cartridge weights over 9g, attach the sub weight)
Arm Height Adjust Range	±3mm
Headshell weight	10.5g

Subfunctions

- Auto lead-in
- Auto-return
- Auto cut
- Quick play
- Anti-skating force control
- Stylus pressure direct-readout counterweight
- Arm height adjusting device
- Cueing device
- Free stop hinges

PC-200 Specifications (S model)

Type	Moving magnet type
Stylus	0.5 mil diamond (PN-200)
Output Voltage	2.5mV (1kHz, 50mm/s Peak velocity, LAT)
Tracking Force	1.7g to 2.3g (proper 2g)
Frequency Response	10 to 32,000Hz
Recommended Load	50kΩ +170 ~ 300pF

PC-150 Specifications (S/G model)

Type	Moving magnet type
Stylus	0.5 mil diamond (PN-150)
Output Voltage	3.5mV (1kHz, 50mm/s Peak velocity, LAT)
Tracking Force	1.7g to 2.5g (proper 2.2g)
Frequency Response	15 to 30,000Hz
Recommended Load	50kΩ +170 ~ 300pF

Semiconductors

ICs	7
Transistors	17
Diodes	5
Hall Elements	3
LED	6
Photo Transistors	2
CdS	1

Miscellaneous

Power Requirements

S, S/G	AC110/120/220/240V ~
	(switchable), 50, 60Hz
KCT, KUT	AC120V, 50, 60Hz
HET, HBT (PL-600X)	AC220/240V ~
	(switchable), 50, 60Hz

Power Consumption. 22W

Dimensions 456(W) x 140(H) x 384(D)mm
18(W) x 5-1/2(H) x 15-1/8(D) in.

Weight 11kg/24lb 4oz.

Accessories

EP Adapter	1
Screwdriver	1
Sub weight	1
Operating instructions	1

NOTE:

Specifications and design subject to possible modification without notice, due to improvements.

3. DISASSEMBLY

3.1 PANEL ASS'Y AND ARM BASE

1. Undo screw ① ~ ④ to remove the top cover unit.
2. Disconnect the AC power cord connector, and undo screws ⑤ and ⑥ to remove the cord support bracket.
3. Undo screws ⑦ ~ ⑩ to remove the base plate.
4. Move the tonearm across to the center shaft to enable the panel ass'y to be lifted off.
5. Undo screw ⑪ to disconnect the ground lead.
6. And finally undo screws ⑫ ~ ⑭ to remove the arm base.

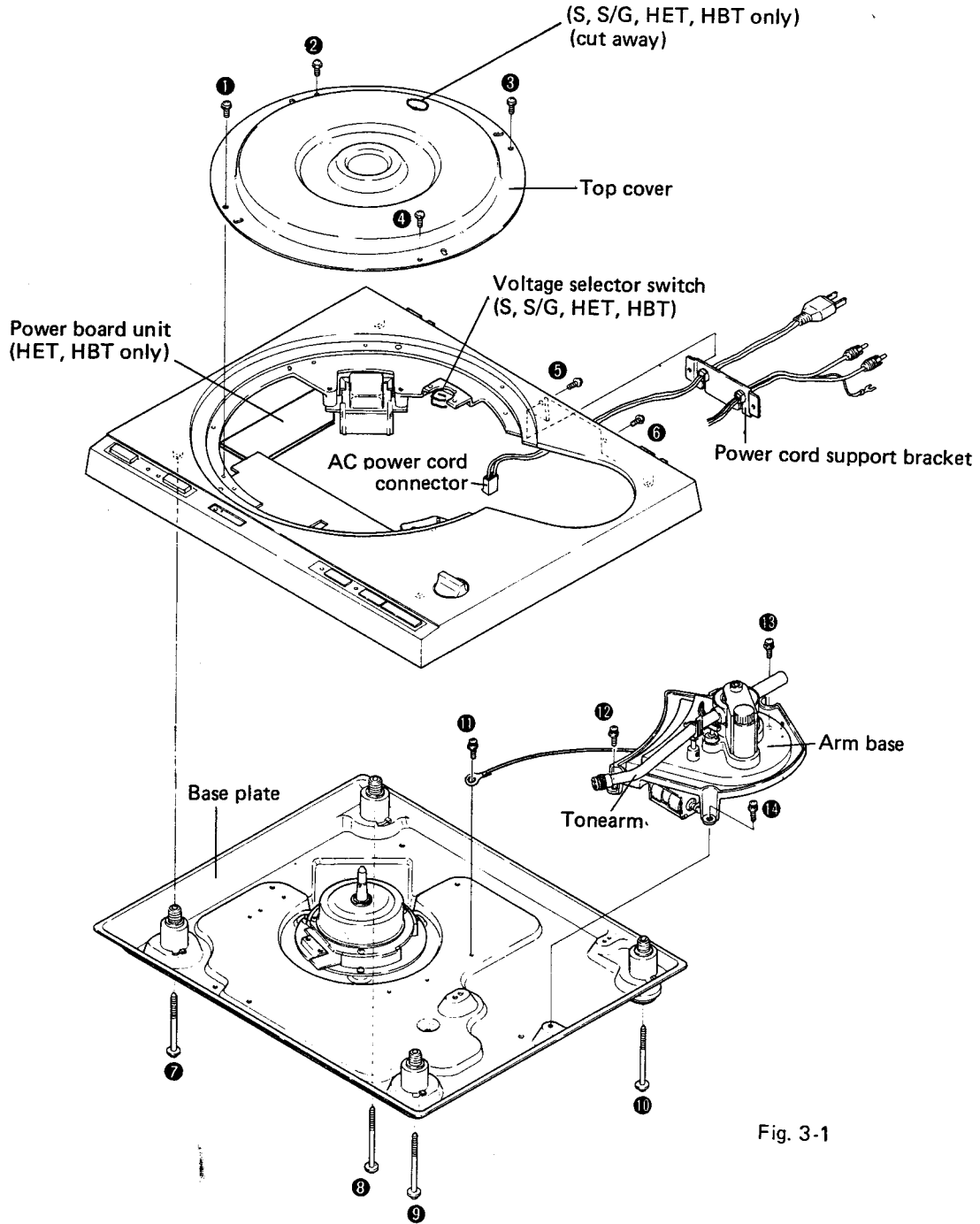

Fig. 3-1

① POWER SWITCH

ON Press this switch and the power will come on. The SPEED switch indicator (45 or 33) will light up.
 OFF The power will be cut off when this switch is released, and the indicator will go off.

NOTES:

- The platter will not rotate when the tonearm is on the arm-rest even when the POWER switch is set to ON.
- Always set the POWER switch to OFF when you do not intend to use your turntable.

② SPEED SWITCH

33 Set the switch to this position when playing a 33-1/3rpm record such as an LP. When it is depressed, the 33 indicator lights up, and the platter rotates at a speed of 33-1/3 rpm.
 45 Set the switch to this position when playing a 45rpm record like an EP. When it is depressed, the 45 indicator lights up, and the platter rotates at a speed of 45rpm.

③ QUARTZ LOCK INDICATOR

This indicator illuminates when the platter is revolving at the specified rate of 33 1/3 or 45 rpm.

NOTE:

If the platter speed varies, such as when the speed switch is changed from one position to another or when you press momentarily on the platter, the indicator will go off. As the platter revolution returns to the specified speed, the indicator will illuminate again.

④ REPEAT SWITCH

Press this switch for repeat play. When pressed, the indicator will light up, and the record will be played again. Press this switch again to release it. The indicator will go off and the repeat play function will be released.

NOTE:

- This switch cannot be operated even if depressed while the tonearm is moving out of contact with the record.

⑤ ARM ELEVATION SWITCH

Use this switch to interrupt play temporarily or to perform manual play.

When the DOWN position, the tonearm will descend and when the UP position, the tonearm will rise. These two operations will be performed alternately every time the switch is pressed.

NOTES:

- When the POWER switch is set to ON, the tonearm will descend and the DOWN position.
- Always set the switch to DOWN for auto play.
- When the switch is at UP, the auto return cancelling mechanism is actuated and so there will be no auto return or auto cut.

⑥ START/STOP SWITCH

Press this switch for auto play. The platter will start to rotate, the tonearm will automatically move over to the edge of the record and play will begin (auto lead-in).

If this switch is pressed during play, the tonearm will automatically return to the arm rest, the platter will stop rotating and play will be suspended (auto cut).

NOTE:

- This switch's STOP function has no effect on tonearm movement unless the tonearm is in contact with the record.

⑦ DISC SIZE SWITCH

Selects the switch that corresponds to the size of the record you want to hear for auto play operations.

12"30 For 30cm records
 10"25 For 25cm records
 7"17 For 17cm records

⑧ TONEARM

This tonearm is designed to apply the correct tracking force to the cartridge and to keep this force at the precise level for faithful tracking of the record grooves. It also has the job of switching the power on to the turntable.

- When the tonearm is moved from the arm rest to the platter, the power comes on, the platter rotates.
- When the tonearm is returned to the arm rest, the power to the turntable is cut off, the platter stops rotating.

⑨ PLATTER/RUBBER PLATTER MAT

When the tonearm is moved and power is supplied to the turntable, the platter will start rotating at the set rotation speed. The rubber platter mat stabilizes the records and also absorbs external vibration.

⑩ ARM REST/CLAMPER

The arm rest supports the tonearm when it is not being used. Set the tonearm on its rest when it is not playing records. Clamp it into position if you don't have any immediate plans to play records.

⑪ ANTI-SKATE KNOB

This knob is used to cancel out the harmful skating force which is generated during record play.

For further details, see "ANTI-SKATING ADJUSTMENT."

⑫ DUST COVER

Keep this closed unless operating the controls or tonearm, or changing over records. This serves to keep dust from adhering to the records during record play. When fully opened and pulled straight up, this dust cover can be removed from the cabinet.

3.3 REMOUNTING THE TONEARM

The tonearm is to be remounted in the reverse order of the disassembly process, taking particular note of the following points.

1. When securing the PU plate with screw (1), note that part A of the PU plate should be at right angles to the line connecting the tonearm rotation axis to the drive mechanism axis.
2. Adjust the AS knob to "0", and bring the bias lever into contact with the smallest diameter of the AS cam before securing the cam with screw (2).

3. When securing the arm stopper with screw (3) make sure that the arm stopper pin is aligned with the boss of part (B).

Note:

The arm base in the above diagram is viewed from below. Certain parts have been omitted to make the structure easier to understand.

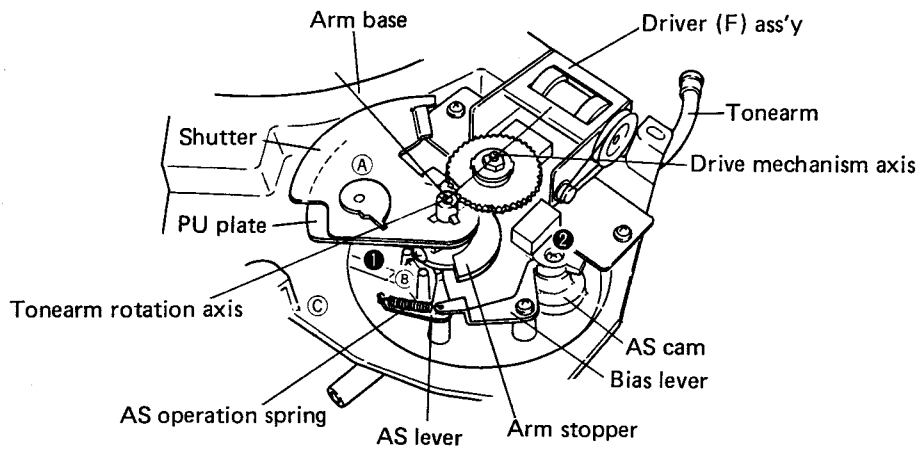

Fig. 3-3

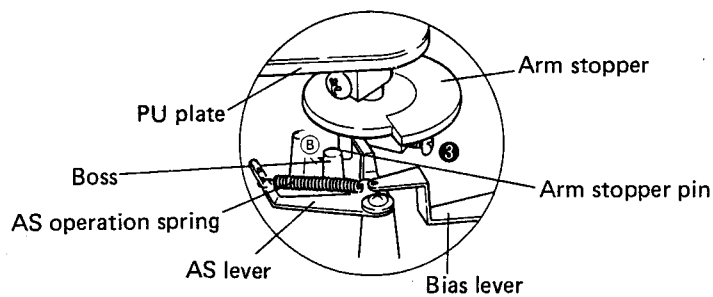

Fig. 3-4

3.2 TONEARM

1. Undo screw ① to remove the AS cam, AS spring washer, luminar washer, and the AS knob.
2. Disconnect the tonearm lead wires with a soldering iron.
3. Undo screw ② to remove the arm base board ass'y.
4. Undo screws ③ to ④ to remove the driver (F) ass'y.
5. Undo screw ⑤ to remove the arm stopper, and screw ⑥ to remove the PU plate.
6. Finally remove the tonearm by undoing screws ⑦ and ⑧.

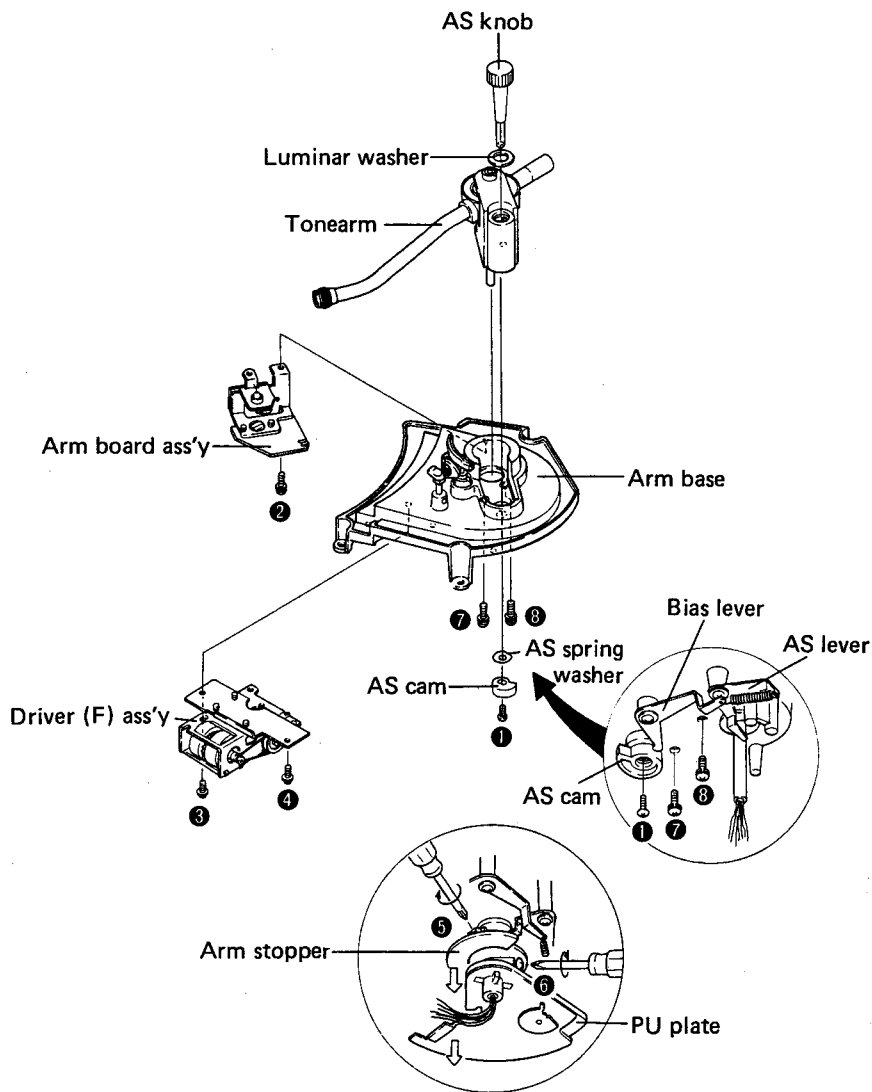
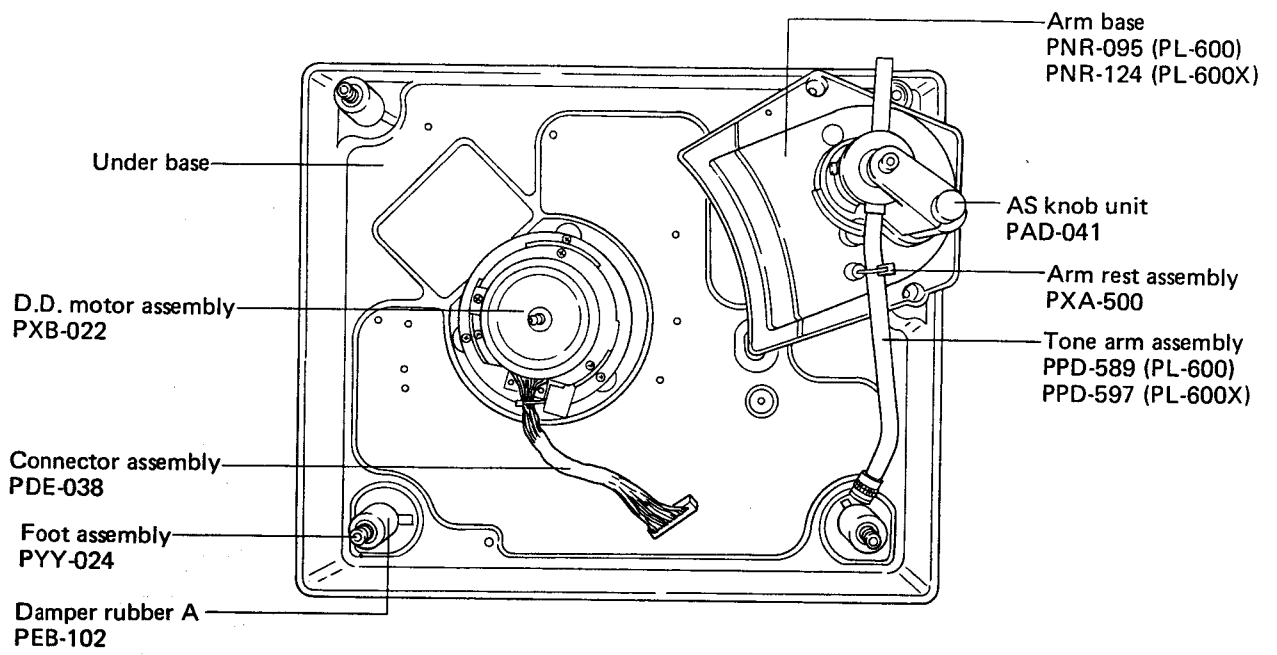

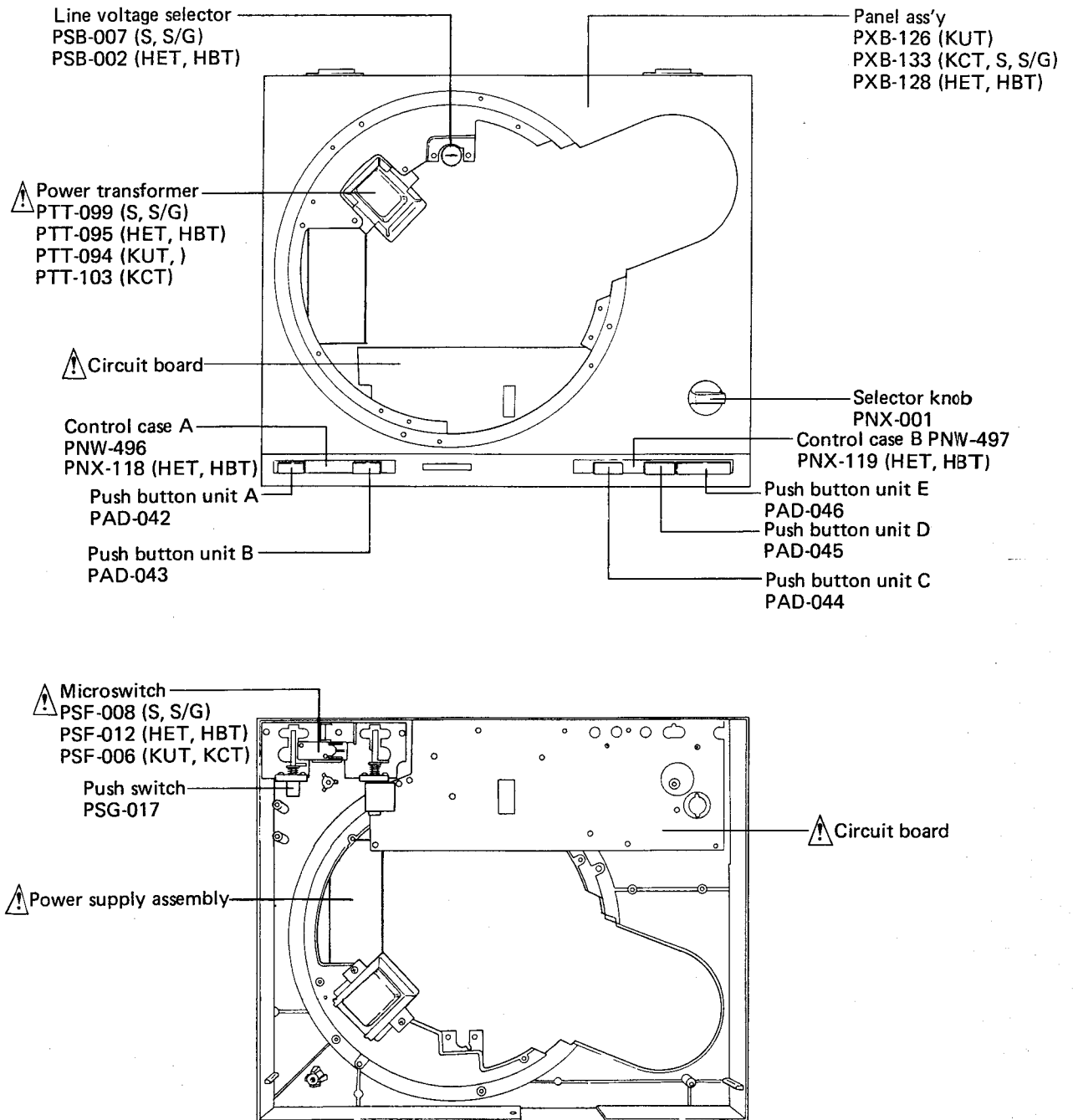

Fig. 3-2



4. PARTS LOCATION

- The  mark found on some component parts indicates the importance of the safety factor of the part. Therefore, when replacing, be sure to use parts of identical designation.



6. EXPLODED VIEW AND PARTS LIST

NOTES:

- Parts without part number cannot be supplied.
- The Δ mark found on some component parts indicates the importance of the safety factor of the part. Therefore, when replacing, be sure to use parts of identical designation.

6.1 CABINET

PARTS LIST OF CABINET

Key No.	Part No.	Description	Key No.	Part No.	Description
1.	PEA-035(KUT,S,S/G)	Rubber mat assembly	36.	PDE-029	Output cord
	PEA-036			PDE-031(KUT)	
2.	PNR-094	Turntable platter	37.		Angle
3.		Cover	38.	PNX-001	Selector knob
4.	PXB-126(KUT)	Panel assembly	39.	PNX-002	Collar
	PXB-133(KCT,S,S/G)		40.		Control case B assembly
	PXB-128(HET,HBT)				
5.		Washer faced taptite screw 3x8	41.	PAD-044	Push button C
			42.	PAD-045	Push button D
6.		Plate L	43.	PAD-046	Push button E
7.		Plate R	44.	PNW-497(PL-600)	Control case B
8.		Panel		PNX-119(PL-600X)	
Δ 9.	PTT-094 (KUT)	Power transformer	45.	PSB-008	Rotary switch
	PTT-095 (HET, HBT)				
	PTT-099 (S, S/G)		46.	PEB-102	Damper rubber A
	PTT-103 (KCT)		47.	PBH-155	Spring
10.		Control case A assembly	48.	PNW-484	Holder
11.	PAD-042	Push button A	49.	PNW-375	Ring
12.	PAD-043	Push button B	50.	PYY-024	Foot assembly
13.	PNW-496(PL-600)	Control case A			
	PNX-118(PL-600X)		51.	PBA-111	Screw
14.		Push nut 2 ϕ	52.	PBH-169	Spring
15.	GL-2PR1	LED	53.	
			54.	
Δ 16.		Circuit board	55.		PSF 3x8
17.	PSG-017	Push switch			
18.	PSG-016	Push switch	56.		Washer faced taptite screw 3x6
19.	PBA-086	Screw	57.		Washer faced taptite screw 3x8
20.	PNW-500	Lever	58.		Washer faced taptite screw 3x16
			59.		Washer faced taptite screw 3x15
21.		Switch base	60.		Washer faced taptite screw 3x6
Δ 22.	PSF-006(KUT, KCT)	Microswitch	61.		Taptite screw 3x6
	PSF-012(HET, HBT)		62.		Taptite screw 3x10
	PSF-008(S, S/G)		63.	(HET, HBT, KCT, KUT)	Polycarbonate screw 3x15
23.		Dust cover assembly		(S, S/G)	Washer faced taptite screw 3x15
24.	PNB-105	Plate	64.	PEC-059(KUT, KCT)	Insulator
25.		Name plate		PEC-052(HET, HBT)	
26.	PXA-380	Hinge assembly	65.	PWR-056(HET, HBT)	Power supply assembly
27.	PNV-025	Dust cover			
28.	PXB-022	D.D. motor	66.	PNW-406(HET, HBT)	Bush
29.	PDE-038	Connector assembly	67.	PNX-121(HET, HBT)	Collar
30.		Under base	68.	(HET, HBT, S, S/G)	Taptite screw 3x8
			69.	PSB-022(HET, HBT)	Line voltage selector
Δ 31.	PDF-127 (KCT)	AC power cord assembly		PSB-007(S, S/G)	
	PDF-122(HET)				
	PDF-123(HBT)				
	PDF-082(S, S/G)				
	PDF-121 (KUT)				
Δ 32.		AC power cord			
33.		Connector			
34.	E32-056(PL-600)	Strain relief			
	PEC-051(PL-600X)				
35.	PEC-051	Strain relief			

5. ADJUSTMENT

5.1 STYLUS DESCENT POSITION

1. Extract the rubber bush (see Fig. 5-1).
2. If the tonearm descends outside the lead-in groove, adjust by rotating the adjustment screw clockwise.
3. If the tonearm descends inside the lead-in groove, adjust by rotating the adjustment screw counter clockwise.

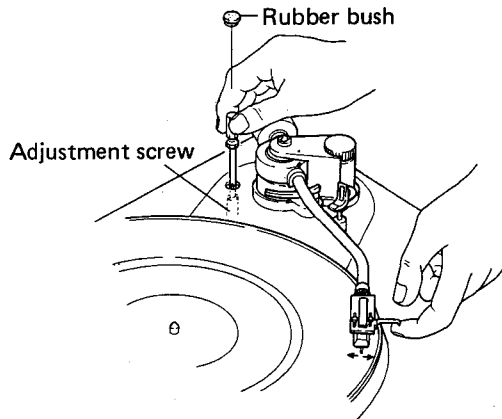

Fig. 5-1

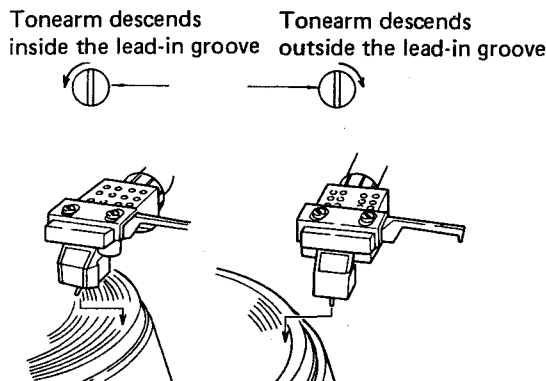

Fig. 5-2

Ratings when using test record.

Descent position for 30cm record:—

Tonearm to descend during count from 304 to 316

Descent position for 17cm record:—

Tonearm to descend during count from 174 to 185.

5.2 DD MOTOR OPERATION ADJUSTMENT

1. Rotate the turntable platter.
2. Connect a dual-image oscilloscope (or synchroscope) to the TP5 and TP6 terminals of the circuit board ass'y.

3. Adjust VR1 (for 33-1/3 rpm) and VR2 (for 45rpm) on the circuit board ass'y in order to bring the rising edge of the TP5 terminal waveform within the width of the TP6 terminal waveform as shown in Fig. 5-3.

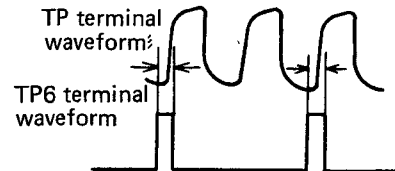

Fig. 5-3

5.3 CdS SENSITIVITY

1. Remove the turntable platter and the top cover unit.
2. The distance between the CdS block and shutter should be 2.5 to 3.5mm, and the distance between the CdS and the lamp 10mm (see Fig. 5-4). Also check that there is no other light source effecting the CdS.
3. Connect the (+) electrode of a DC voltmeter to the TP2 terminal of the circuit board ass'y, and the (-) electrode to the TP4 terminal.
4. Turn the power switch ON and set the arm elevation to the UP position. Then move the tonearm across towards the center shaft (to the lead-out groove).
If the TP3 terminal is connected to ground (TP4) at this time the rotating phono motor may be stopped.
5. Adjust VR3 to obtain a reading of 12.3 ~ 12.9V in the DC voltmeter.

Note:

This adjustment should be completed within 3 minutes after turning the power switch ON. Even if measurements show deviation from the above voltage range (due to drift) after completion of the adjustment, there is no need to readjust.

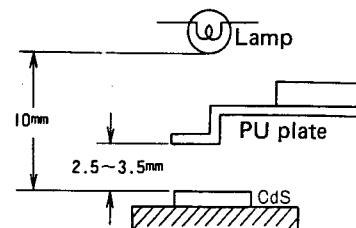
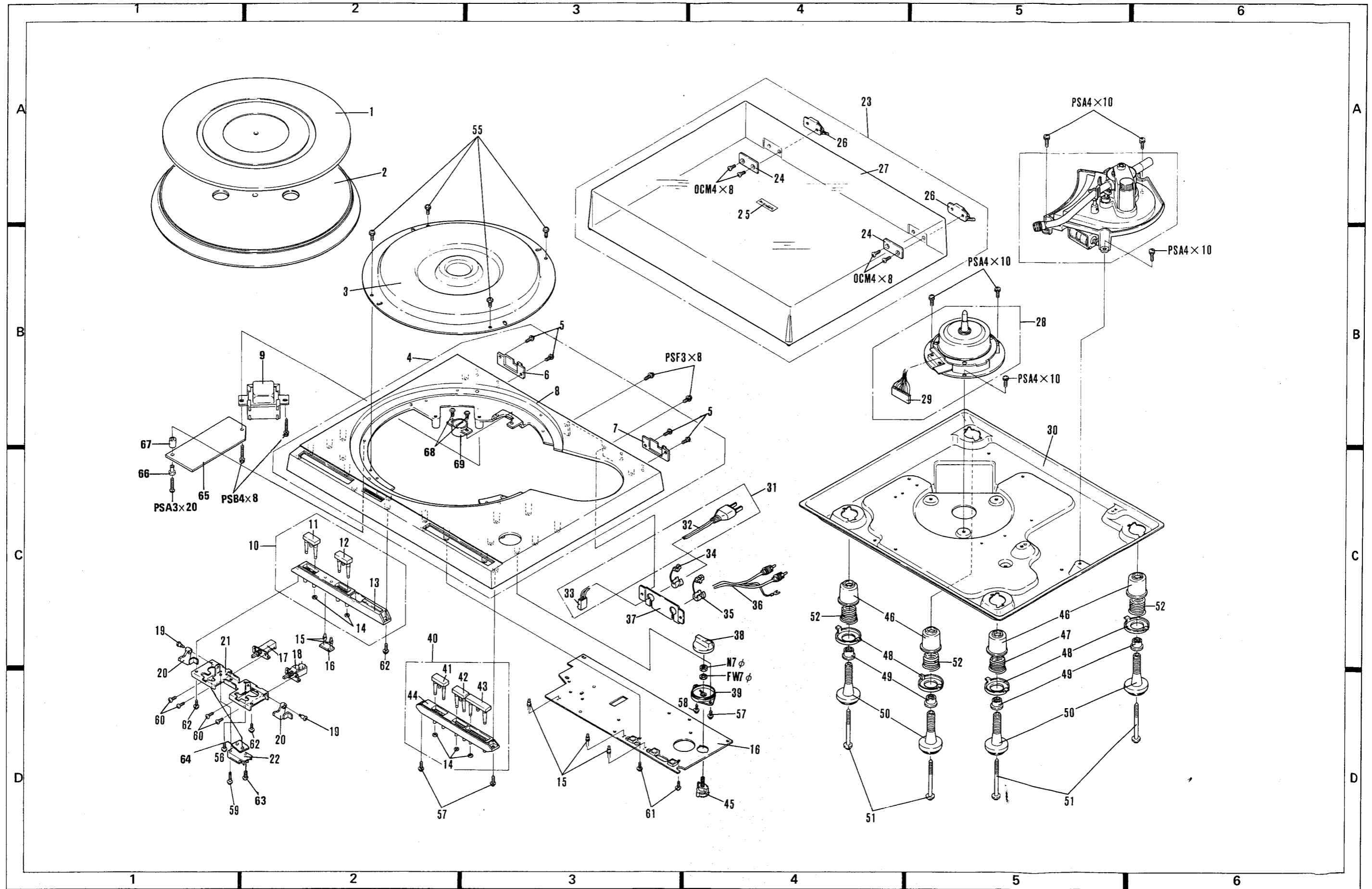
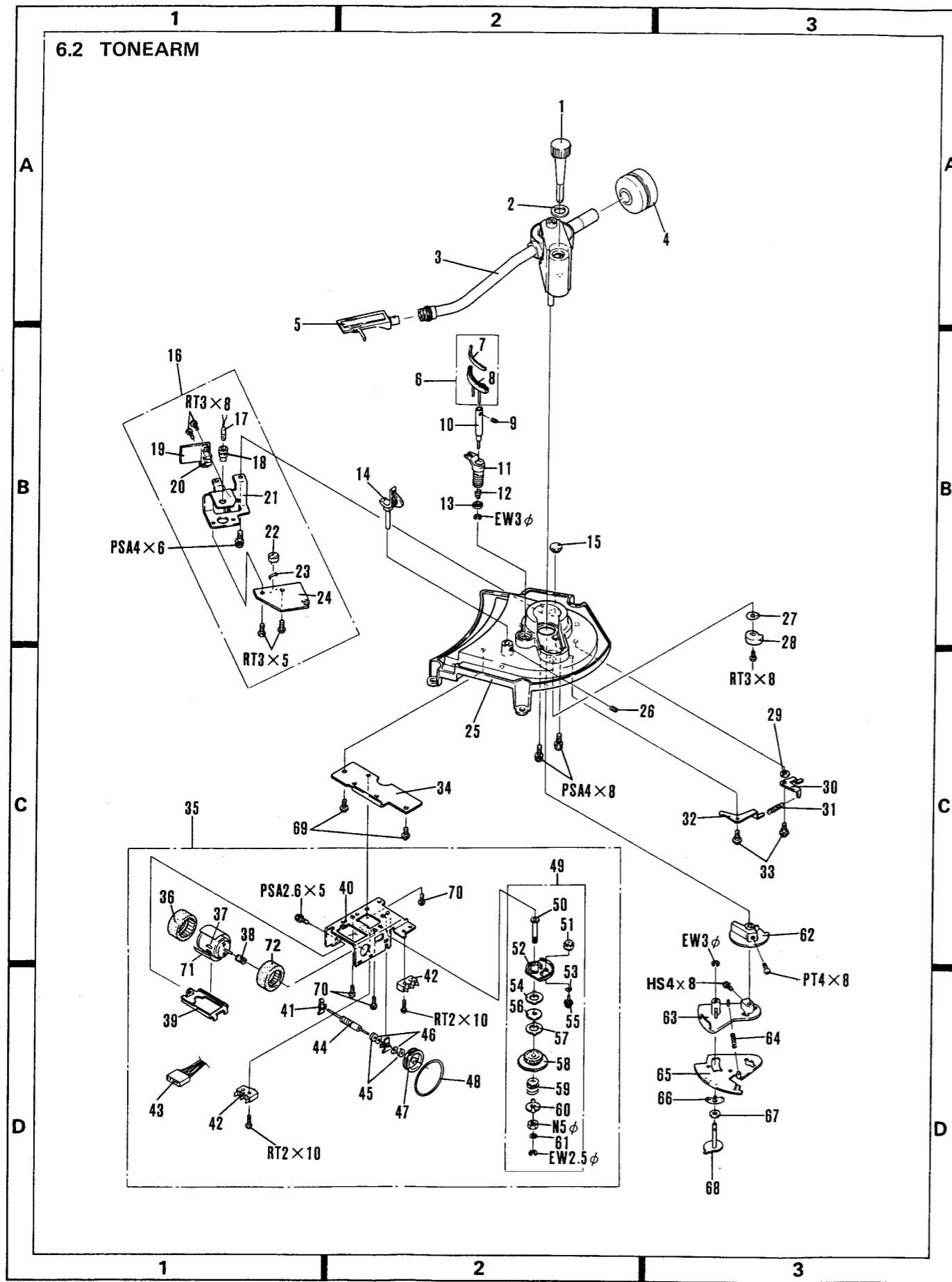

Fig. 5-4





PARTS LIST OF TONE ARM

NOTES:
 • Parts without part number cannot be supplied.

Key No.	Part No.	Description	Key No.	Part No.	Description
1.	PAD-041	AS knob unit	51.		Cam
2.	PBF-010	Washer	52.		Cam
3.	PPD-589 (PL-600)	Tonearm assembly	53.		Washer
	PPD-597 (PL-600X)		54.		Washer
4.	PXA-735	Weight assembly	55.		Gear unit
5.	PXA-736(PL-600)	Headshell assembly			
	PXA-809(PL-600X)		56.		Washer
6.	PXA-469	EV sheet assembly	57.		Washer
7.		EV sheet	58.		Gear F
8.		EV sheet unit	59.		Spring
9.		Set screw 2.6x2	60.		Guide
10.	PLA-356	EV shaft			
			61.		Polyethylene washer 3.1φx5.4φx0.5t
11.	PNX-003	EV shaft holder	62.	PNW-469	Stopper
12.	PBH-166	EV spring	63.	PNX-010	PU plate
13.	KNA-125	Cap	64.	PBH-251	Spring
14.	PXA-500	Arm rest assembly	65.	PNC-040	Plate
15.		Rubber bush			
			66.	PBK-023	Spring
16.		Photo detector assembly	67.	PEB-122	Washer
17.	PEL-040	Lamp	68.	PXT-243	PU adjust cam unit
18.	PEB-123	Bush	69.		Washer faced taptite screw 3x6
19.		Photo transistor board	70.		Taptite screw 3x6
20.	PCX-045	Photo coupler			
			71.		Shield plate
21.		Lamp base	72.	PEB-143	Tube
22.	PCX-031	cds	73.	PBH-207(KUT)	PU hold wire
23.		Spacer			
24.		Circuit board			
25.	PNR-095(PL-600)	Arm base			
	PNR-124(PL-600X)				
26.		Set screw 3x4			
27.	PBE-012	AS spring washer			
28.	PNW-379	AS cam			
29.		FW3			
30.	PNC-067	AS lever			
31.	PBH-151	AS spring			
32.	PNB-460	Bias lever			
33.	PBA-071	Screw			
34.		Angle			
35.		EV mechanism assembly			
36.	PEB-096	Tube			
37.	PXM-069	Motor			
38.	PNW-392	Pulley			
39.	PNC-044	Frame			
40.		Chassis unit F			
41.	PNW-391	Collar			
42.	PSF-005	Microswitch			
43.		Connector assembly 5P			
44.	PNW-485	Worm gear			
45.		Washer			
46.		Washer			
47.	PNW-393	Pulley			
48.	PEB-097	Belt			
49.	PYY-025	Gear assembly F			
50.		Screw			

6.3 D.D. MOTOR

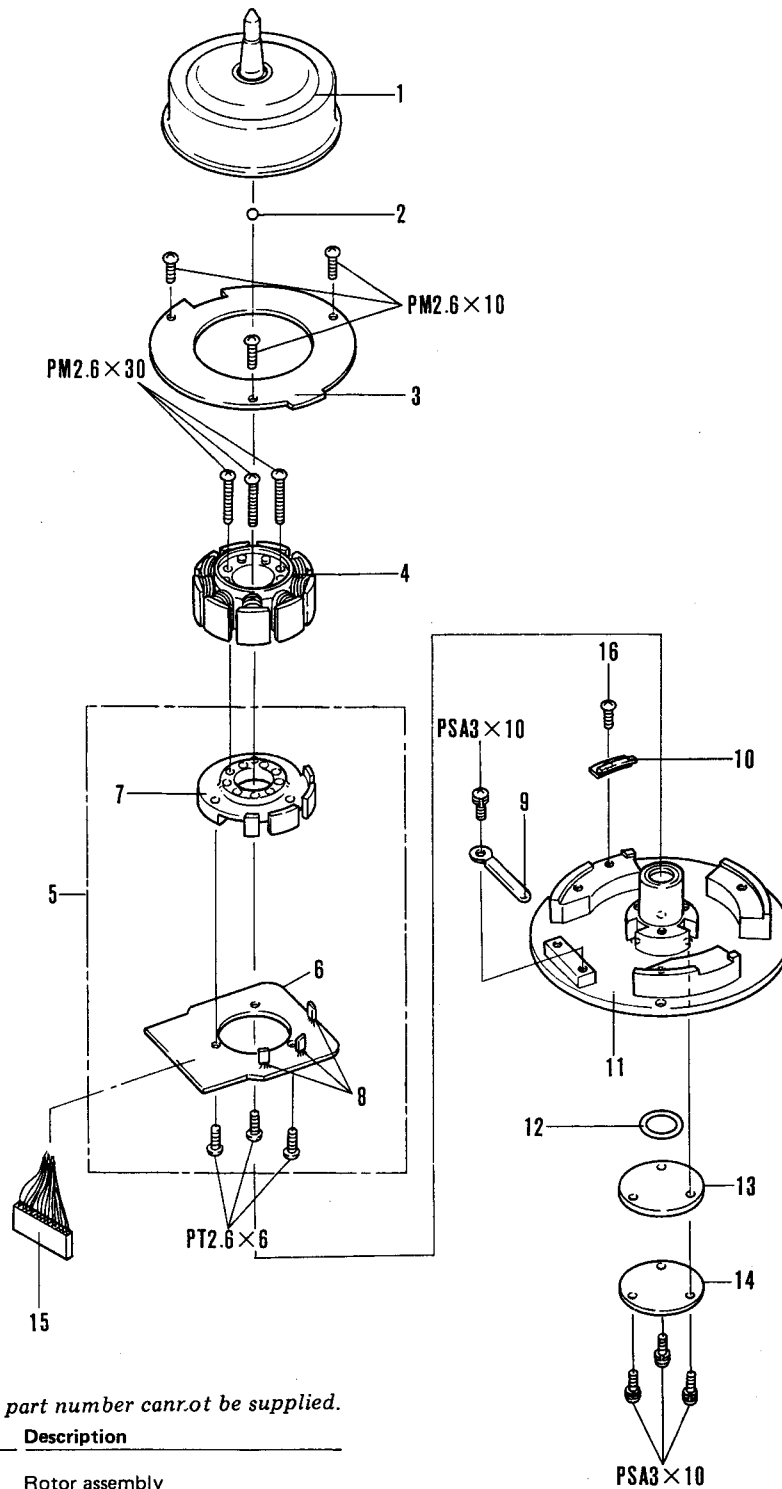

Parts List NOTES:

• Parts without part number can not be supplied.

Key No.	Part No.	Description
1.		Rotor assembly
2.	PEF-001	Steel ball
3.		Speed detector assembly
4.	PTL-003	Core unit
5.		Positional detector assembly
6.		P. CB
7.		Base
8.	PCX-039	Hall element
9.		Cord fixer
10.		Angle

Key No.	Part No.	Description
11.		Base
12.	MNT-001	Ring
13.	MNW-001	Plate
14.		Cover
15.	PDE-038	Connector assembly
16.		Tapite screw 3x8

6.4 PACKING

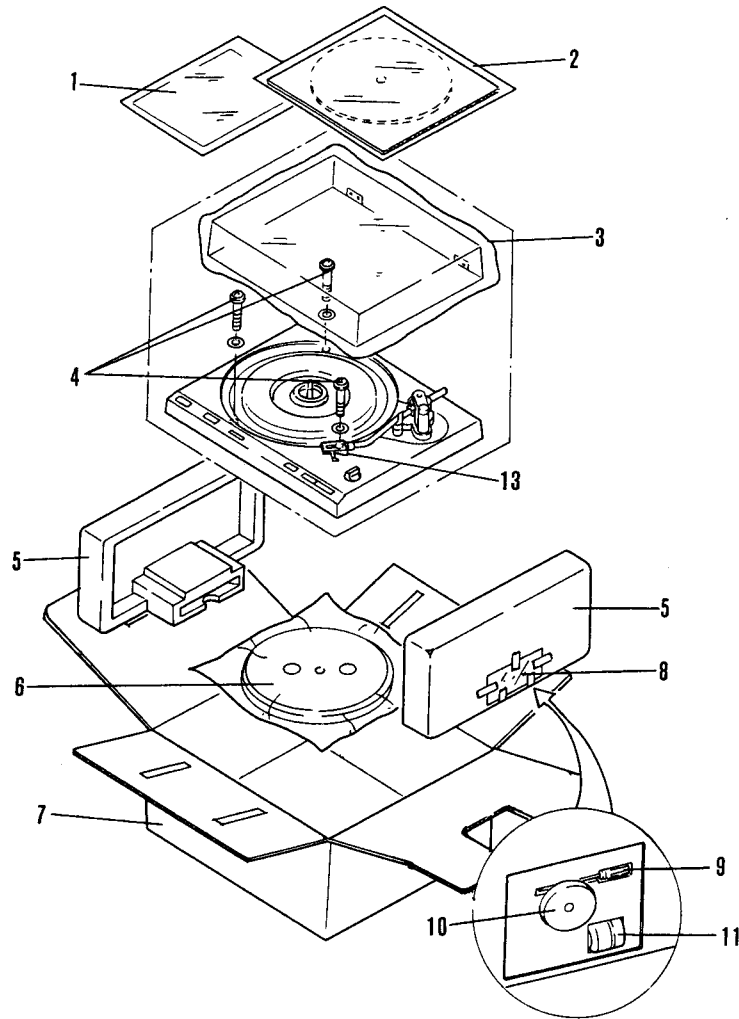

PL-600 PACKING (KCT, KUT)

NOTES:

• Parts without part number cannot be supplied.

Key No.	Part No.	Description	Key No.	Part No.	Description
1.	PRB-149	Operating instructions	10.	N93-603	45 adaptor
2.	PEA-035 (KUT) PEA-036 (KCT)	Rubber mat assembly	11.	PXA-735	Weight assembly
3.		Dust cover assembly	12.	PLA-210	Sub weight
4.	PBA-079	Screw	13.	PXA-736	Headshell assembly
5.	PHA-080	Protector	14.		Cartridge mounting screw assembly
6.	PNR-094	Turntable platter			
7.	PHG-376 (KUT) PHG-378 (KCT)	Packing case			
8.		Cover			
9.	KEX-002	Driver			

6.4 PACKING

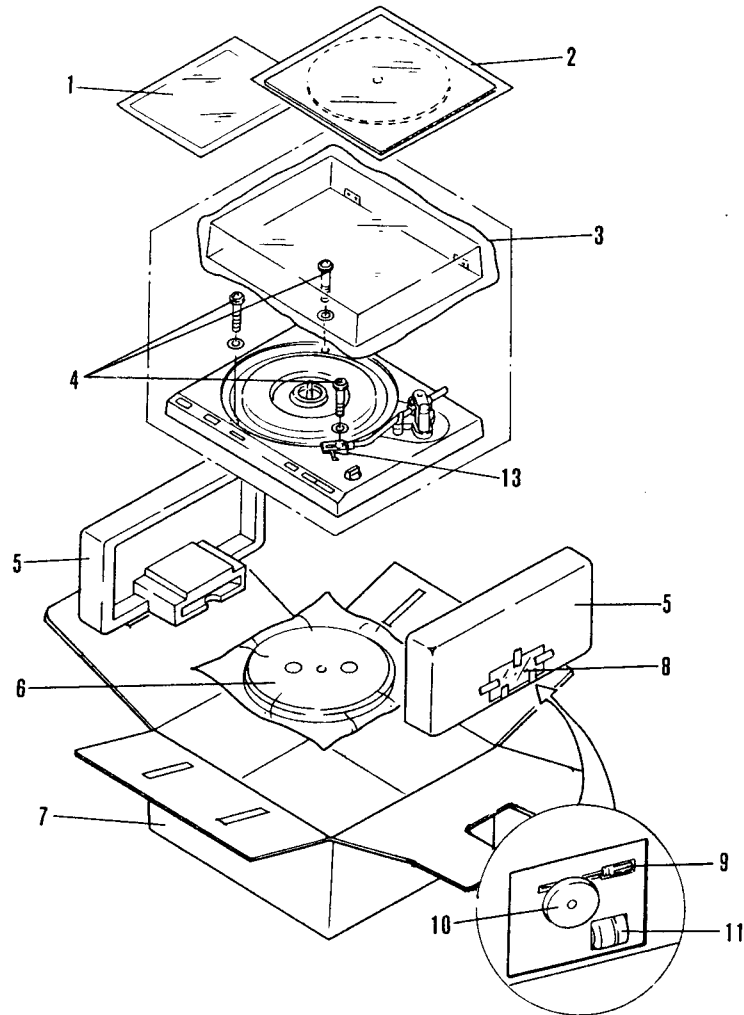

PL-600 PACKING (KCT, KUT)

Key No.	Part No.	Description
1.	PRB-149	Operating instructions
2.	PEA-035 (KUT) PEA-036 (KCT)	Rubber mat assembly
3.		Dust cover assembly
4.	PBA-079	Screw
5.	PHA-080	Protector
6.	PNR-094	Turntable platter
7.	PHG-376 (KUT) PHG-378 (KCT)	Packing case
8.		Cover
9.	KEX-002	Driver

NOTES:

• Parts without part number cannot be supplied.

Key No.	Part No.	Description
10.	N93-603	45 adaptor
11.	PXA-735	Weight assembly
12.	PLA-210	Sub weight
13.	PXA-736	Headshell assembly
14.		Cartridge mounting screw assembly

Appearance of Transistors and ICs

2SA733
2SC945

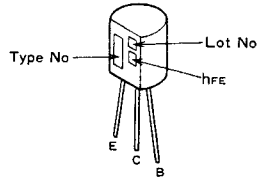

TA78L020P

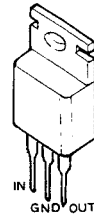

2SD880

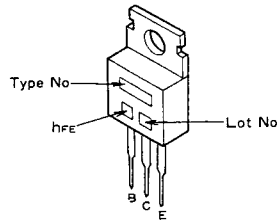

PD1003
PA2004

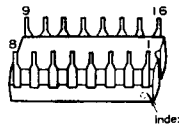

PM6001 A
PD6001 A

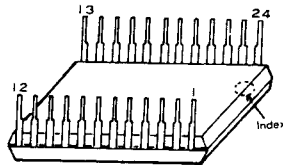

PA2005

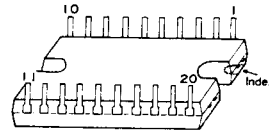

μPC14308H

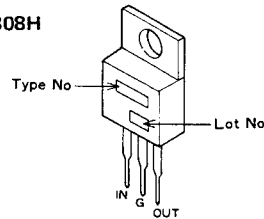

NOTES:

- When ordering resistors, first convert resistance values into code form as shown in the following examples.

Ex. 1 When there are 2 effective digits (any digit apart from 0), such as 560 ohm and 47k ohm (tolerance is shown by J = 5%, and K = 10%),

560Ω	56 × 10 ¹	561	RD¼PS	561J
47kΩ	47 × 10 ³	473	RD¼PS	473J
0.5Ω	0R5		RN2H	055K
1Ω	010		RSIP	010K

Ex. 2 When there are 3 effective digits (such as in high precision metal film resistors).

5.62kΩ	562 × 10 ¹	5621	RN¼SR	5621F
--------	-----------------------	------	-------	-------

- The Δ mark found on some component parts indicates the importance of the safety factor of the part. Therefore, when replacing, be sure to use parts of identical designation.

7. SCHEMATIC DIAGRAM (KCT, KUT)

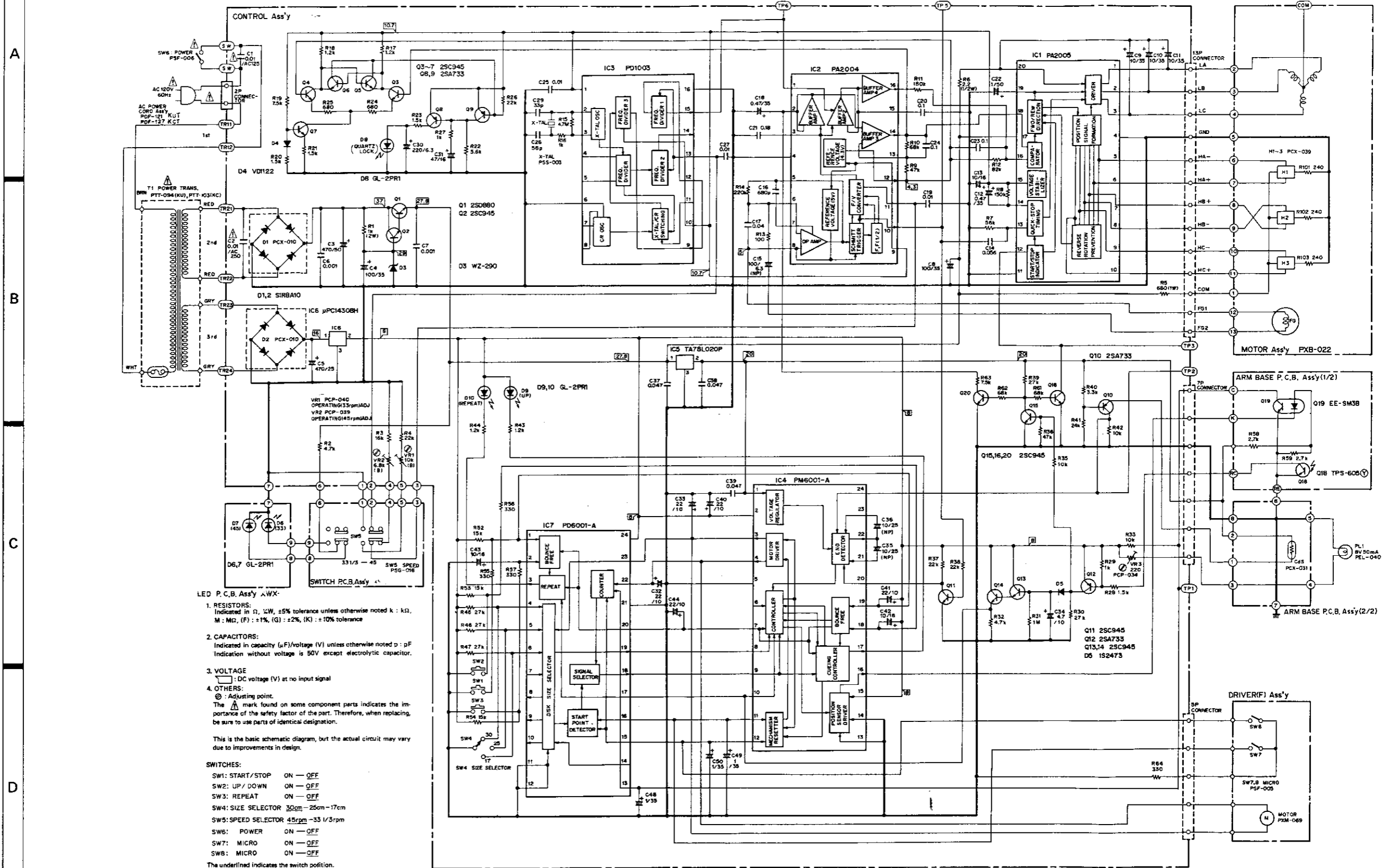

LED P.C.B. Ass'y AWX-

- RESISTORS:**
Indicated in Ω, kΩ, ±5% tolerance unless otherwise noted k : kΩ, M : MΩ, (F) : ±1%, (G) : ±2%, (K) : ±10% tolerance
 - CAPACITORS:**
Indicated in capacity (μF)/voltage (V) unless otherwise noted p : pF
Indication without voltage is 50V except electrolytic capacitor.
 - VOLTAGE**
⎓ : DC voltage (V) at no input signal
 - OTHERS:**
⊗ : Adjusting point.
⚠ : mark found on some component parts indicates the importance of the safety factor of the part. Therefore, when replacing, be sure to use parts of identical designation.
- This is the basic schematic diagram, but the actual circuit may vary due to improvements in design.
- SWITCHES:**
- SW1: START/STOP ON — OFF
 - SW2: UP / DOWN ON — OFF
 - SW3: REPEAT ON — OFF
 - SW4: SIZE SELECTOR 30cm — 25cm — 17cm
 - SW5: SPEED SELECTOR 45rpm — 33 1/3rpm
 - SW6: POWER ON — OFF
 - SW7: MICRO ON — OFF
 - SW8: MICRO ON — OFF
- The underlined indicates the switch position.

8. P.C. BOARD CONNECTION DIAGRAM (KCT, KUT)

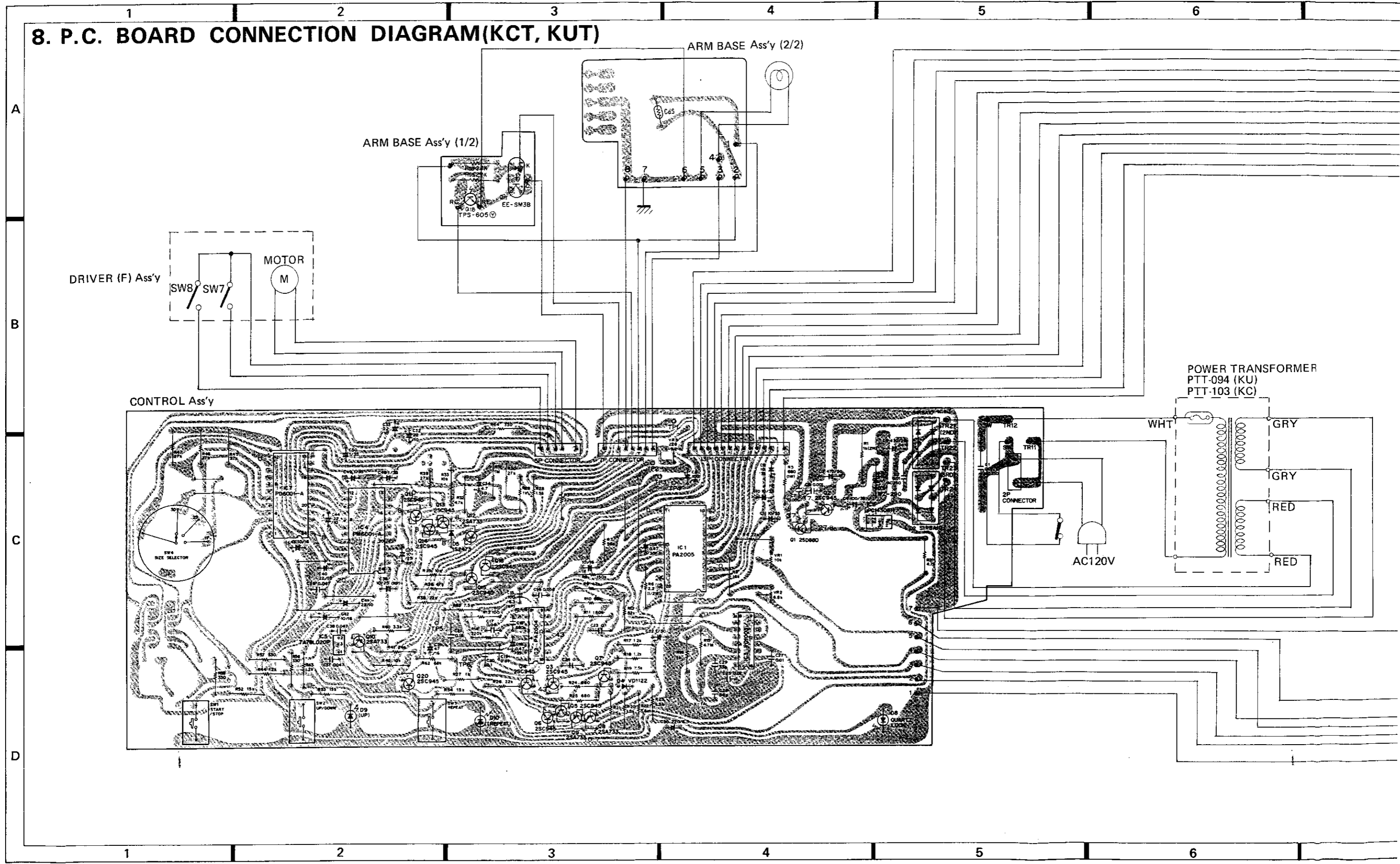

7

8

9

A

B

C

D

MOTOR Ass'y

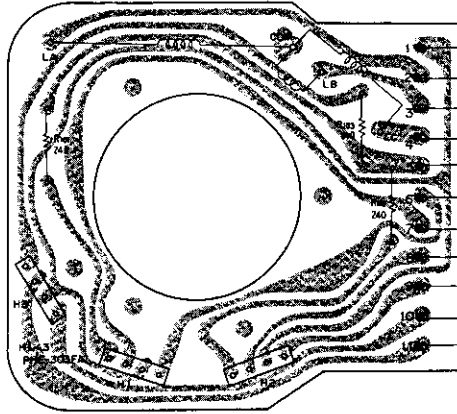

SFORMER

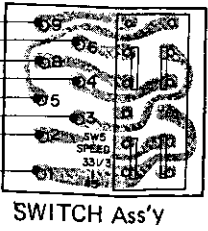
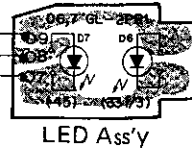
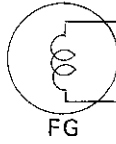
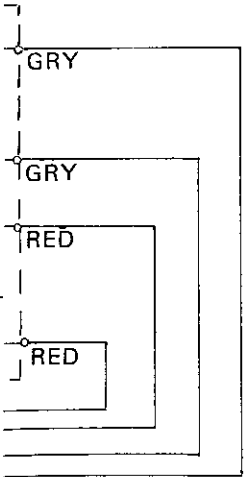

7

8

9

Led Ass'y

Switch Ass'y

Part No.	Symbol & Description
GL-2PR1	D6, D7

Part No.	Symbol & Description
PSG-016	SW5

9. PACKING(S/G, S)

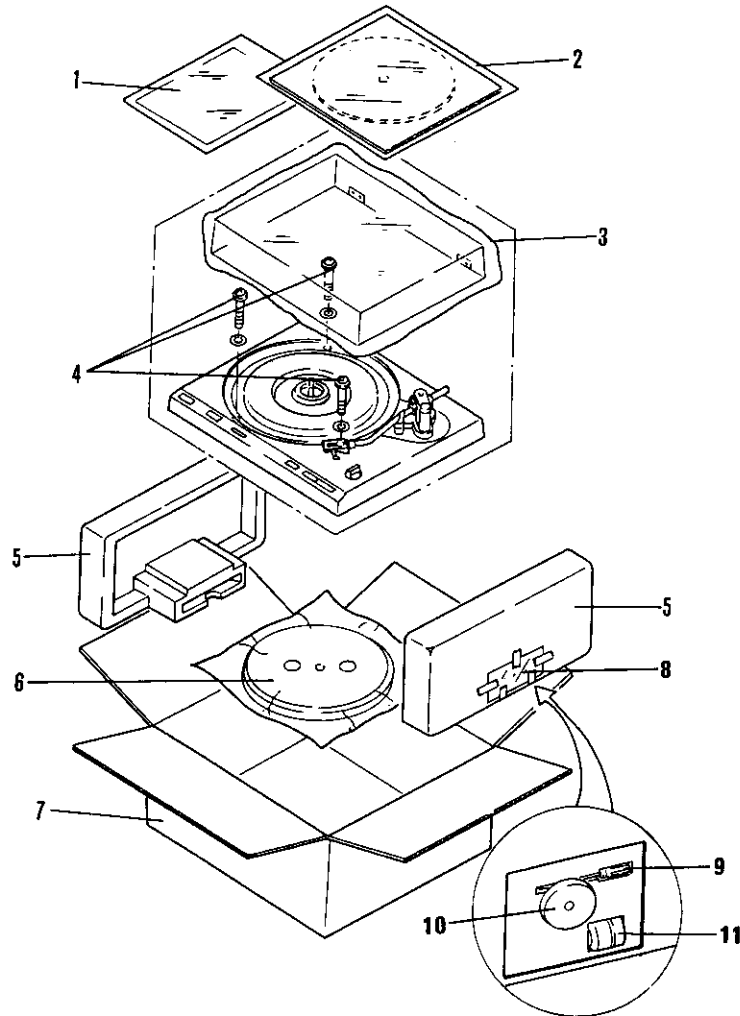

PL-600 PACKING (S, S/G)

NOTES:

• Parts without part number cannot be supplied.

Key No.	Part No.	Description
1.	PRB-155	Operating instructions
2.	PEA-035	Rubber mat assembly
3.		Dust cover assembly
4.	PBA-079	Screw
5.	PHA-080	Protector
6.	PNR-094	Turntable platter
7.	PHG-372	Packing case
	
8.		Cover
9.	KEX-002	Driver

Key No.	Part No.	Description
10.	N93-603	45 adaptor
11.	PXA-735	Weight assembly
12.	PLA-210	Sub weight
13.	PXA-736	Headshell assembly

8.1 PARTS LIST OF P.C. BOARD ASSEMBLY (KUT, KCT)

Control Assembly

SWITCHES

Part No.	Symbol & Description
PSG-009	SW1 (START/STOP)
PSG-009	SW2 (UP/DOWN)
PSG-009	SW3 (REPEAT)
PSB-008	SW4 (SIZE SELECTOR)

CAPACITORS

Part No.	Symbol & Description
PCL-036	C1 0.01/125V
PCL-032	C2 0.01/250V
CEA 471P 50	C3
CEA 101P 35	C4, C8
CEA 471P 25	C5
CKDYF 102Z 50	C6, C7
CEA 100P 35	C9, C10, C11
CSZA R47M 35	C12, C18
CSZA 100M 16	C13, C42, C43
CQMA 563K 50	C14
CEA 101M 6.3NP	C15
CKDYB 681K 50	C16
CKDYF 403Z 50	C17
CKDYF 103Z 50	C19, C25, C27
CQMA 104K 50	C20, C23, C24
CQMA 184J 50	C21
CEA 010P 50	C22
CCDCH 560J 50	C26
CCDCH 330J 50	C29
CEA 221P 6.3	C30
CEA 470P 16	C31
CEA 220P 10	C40, C44
CSZA 4R7M 10	C34
CEA 100M 25NP	C35, C36
CKDYF 473Z 50	C37, C38, C39
CSZA 220M 10	C41, C32, C33
CSZA 010M 35	C48, C49, C50

Note: When ordering resistors, convert the resistance value into code form, and then rewrite the part no. as before.

RESISTORS

Part No.	Symbol & Description
PCP-O40	VR1 10k-B
PCP-O39	VR2 6.8k-B
PCP-O34	VR3 220Ω-B
RS2P □□□J	R1
RD¼PS □□□J	R2-R4, R7-R64
RS1P □□□J	R5
RD¼PS □□□J	R6

SEMICONDUCTORS

Part No.	Symbol & Description
2SD880	Q1
2SC945	Q2-Q7, Q11, Q13-Q16, Q20
2SA733	Q8-Q10, Q12
PA2005	IC1
PA2004	IC2
PD1003	IC3
PM6001A	IC4
TA78L020P	IC5
μPC14308H	IC6
PD6001A	IC7
SIRBA10	D1, D2
WZ-290	D3
VD1122	D4
1S2473	D5

OTHERS

Part No.	Symbol & Description
PSS-003	Crystal
PNX-015	Insulator
PNM-013	Insulator
PBA-089	Screw 2.5x10
PKP-017	Connector 2P
PNC-037	Heat sink
PNC-118	Heat sink

Motor Assembly

Part No.	Symbol & Description
PHE-303FA	HA-HC Hoff element
RD¼PS 241J	R101-R103
PTL-003	Core unit

Arm Base Assembly (1/2, 2/2)

Part No.	Symbol & Description
PEL-040	PL1
TPS-605Y	Q18
PCX-031	cds
EE-SM3B	Q19 Photo capler
PEB-123	Rubber bush
RD¼PS 272J	R58, R59

Appearance of Transistors and ICs

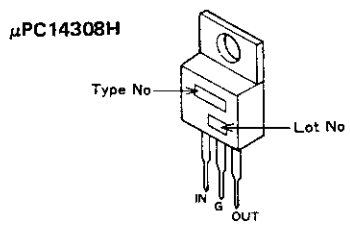
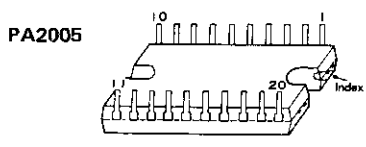
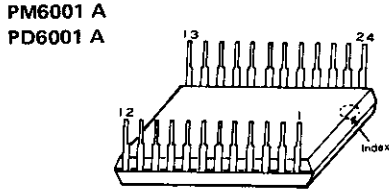
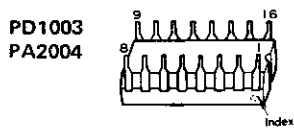
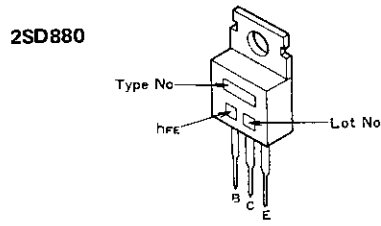
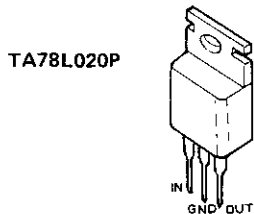
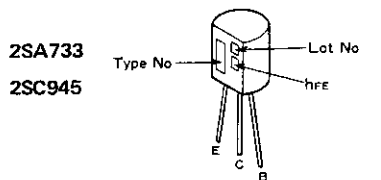

NOTES:

- When ordering resistors, first convert resistance values into code form as shown in the following examples.

Ex. 1 When there are 2 effective digits (any digit apart from 0), such as 560 ohm and 47k ohm (tolerance is shown by J = 5%, and K = 10%).

560Ω	56 × 10 ¹	561	RD¼PS	561J
47kΩ	47 × 10 ³	473	RD¼PS	473J
0.5Ω	0R5		RN2H	05K
1Ω	010		RS1P	010K

Ex. 2 When there are 3 effective digits (such as in high precision metal film resistors).

5.62kΩ	562 × 10 ¹	5621	RN¼SR	5621F
--------	-----------------------	------	-------	-------

- The Δ mark found on some component parts indicates the importance of the safety factor of the part. Therefore, when replacing, be sure to use parts of identical designation.

A
B
C
D

10. SCHEMATIC DIAGRAM(S, S/G)

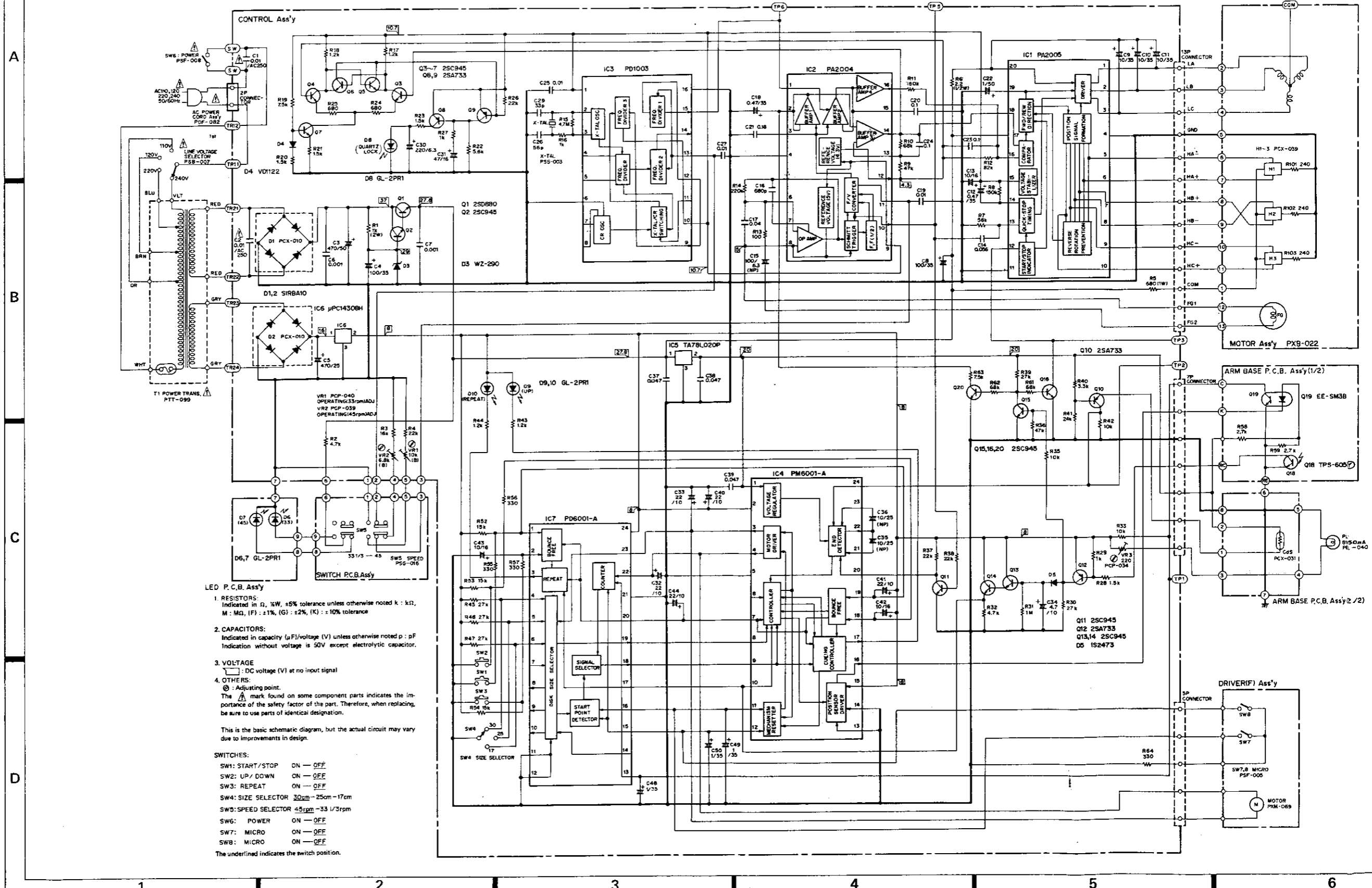

- LED P.C.B. Ass'y**
- RESISTORS:**
Indicated in Ω, kΩ, ±5% tolerance unless otherwise noted k: kΩ, M: MΩ, (F): ±1%, (G): ±2%, (K): ±10% tolerance
 - CAPACITORS:**
Indicated in capacity (μF)/voltage (V) unless otherwise noted p: pF
Indication without voltage is 50V except electrolytic capacitor.
 - VOLTAGE**
□: DC voltage (V) at no input signal
 - OTHERS:**
⊗: Adjusting point.
▲: The ▲ mark found on some component parts indicates the importance of the safety factor of the part. Therefore, when replacing, be sure to use parts of identical designation.
- This is the basic schematic diagram, but the actual circuit may vary due to improvements in design.
- SWITCHES:**
- SW1: START/STOP ON — OFF
 - SW2: UP/ DOWN ON — OFF
 - SW3: REPEAT ON — OFF
 - SW4: SIZE SELECTOR 30cm — 25cm — 17cm
 - SW5: SPEED SELECTOR 4.5rpm — 33 1/3rpm
 - SWG: POWER ON — OFF
 - SW7: MICRO ON — OFF
 - SW8: MICRO ON — OFF
- The underlined indicates the switch position.

11. P.C. BOARD CONNECTION DIAGRAM(S, S/G)

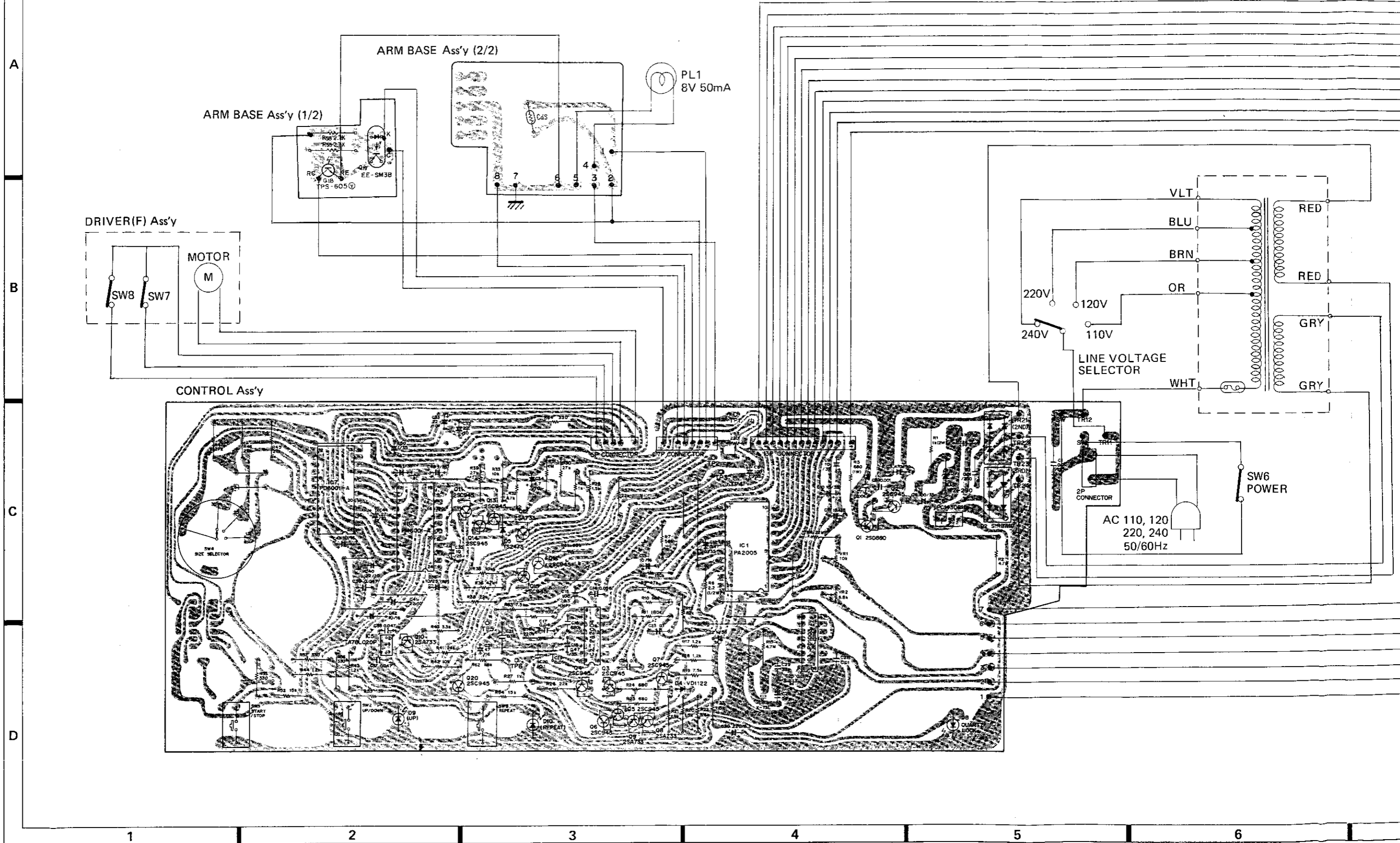

7

8

9

A

B

C

D

MOTOR Ass'y

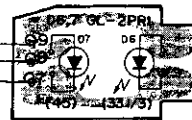
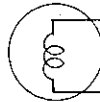
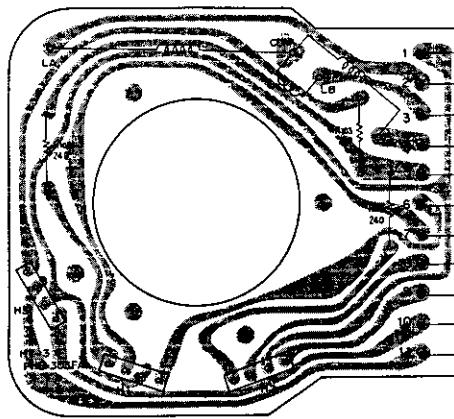

LED Ass'y

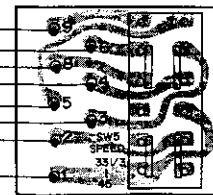

SWITCH Ass'y

7

8

9

Led Ass'y

Switch Ass'y

Part No.	Symbol & Description
GL-2PR1	D6, D7

Part No.	Symbol & Description
PSG-016	SW5

12. PACKING(HET, HBT)

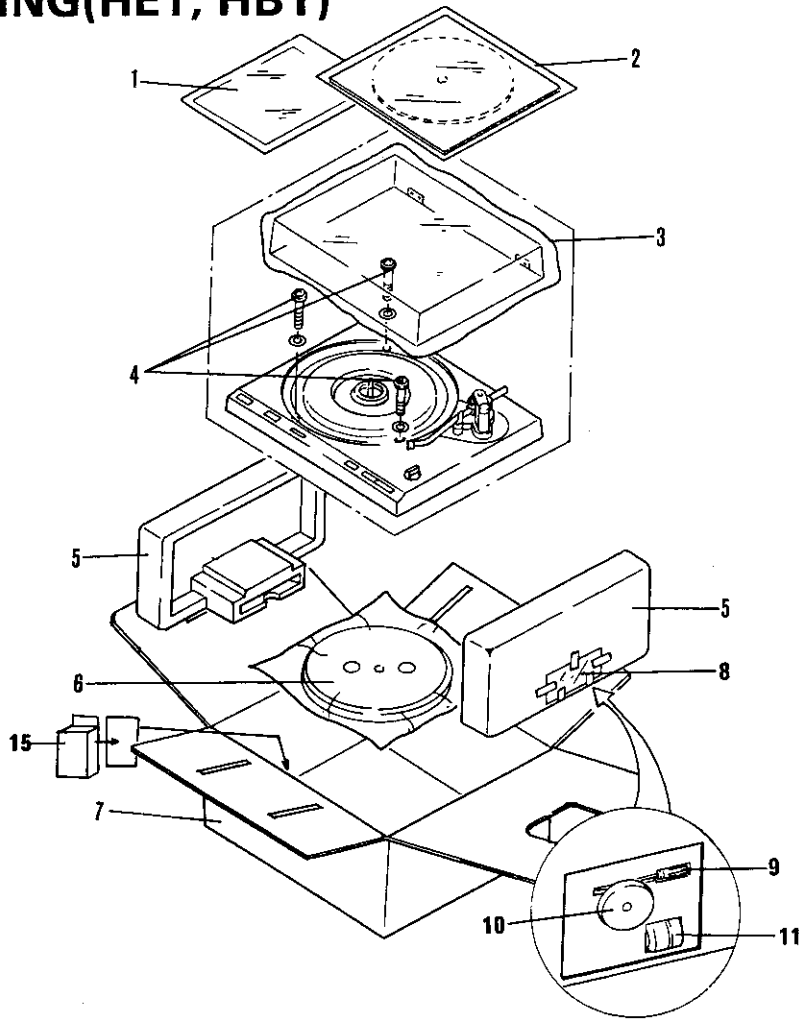

PL-600 PACKING (HET, HBT)

NOTES:

• Parts without part number cannot be supplied.

Key No.	Part No.	Description	Key No.	Part No.	Description
1.	PRB-148 PRD-050 (HET)	Operating instructions (English) Operating instructions (French/German)	10.	N93-603	45 adaptor
2.	PEA-036	Rubber mat assembly	11.	PXA-735	Weight assembly
3.		Dust cover assembly	12.	PLA-210	Sub weight
4.	PBA-079	Screw	13.	PXA-809	Headshell assembly
5.	PHA-080	Protector	14.		Cartridge mounting screw assembly
6.	PNR-094	Turntable platter	15.	PHN-008	Case
7.	PHG-372	Packing case			
8.		Cover			
9.	KEX-002	Driver			

11.1 PARTS LIST OF P.C. BOARD ASSEMBLY (S, S/G)

Control Assembly

SWITCHES

Part No.	Symbol & Description
PSG-009	SW1 (START/STOP)
PSG-009	SW2 (UP/DOWN)
PSG-009	SW3 (REPEAT)
PSB-008	SW4 (SIZE SELECTOR)

CAPACITORS

Part No.	Symbol & Description
PCL-032	C1 0.01/250V
PCL-032	C2 0.01/250V
CEA 471P 50	C3
CEA 101P 35	C4, C8
CEA 471P 25	C5
CKDYF 102Z 50	C6, C7
CEA 100P 35	C9, C10, C11
CSZA R47M 35	C12, C18
CSZA 100M 16	C13, C42, C43
CQMA 563K 50	C14
CEA 101M 6.3NP	C15
CKDYB 681K 50	C16
CKDYF 403Z 50	C17
CKDYF 103Z 50	C19, C25, C27
CQMA 104K 50	C20, C23, C24
CQMA 184J 50	C21
CEA 010P 50	C22
CCDCH 560J 50	C26
CCDCH 330J 50	C29
CEA 221P 6.3	C30
CEA 470P 16	C31
CEA 220P 10	C40, C44
CSZA 4R7M 10	C34
CEA 100M 25NP	C35, C36
CKDYF 473Z 50	C37, C38, C39
CSZA 220M 10	C41, C32, C33
CSZA 010M 35	C48, C49, C50

Note: When ordering resistors, convert the resistance value into code form, and then rewrite the part no. as before.

RESISTORS

Part No.	Symbol & Description
PCP-040	VR1 10k-B
PCP-039	VR2 6.8k-B
PCP-034	VR3 220Ω-B
RS2P □□□ J	R1
RD¼PS □□□ J	R2-R4, R7-R64
RS1P □□□ J	R5
RD¼PS □□□ J	R6

SEMICONDUCTORS

Part No.	Symbol & Description
2SD880	Q1
2SC945	Q2-Q7, Q11, Q13-Q16, Q20
2SA733	Q8-Q10, Q12
PA2005	IC1
PA2004	IC2
PD1003	IC3
PM6001A	IC4
TA78L020P	IC5
μPC14308H	IC6
PD6001A	IC7
SIRBA10	D1, D2
WZ-290	D3
VD1122	D4
1S2473	D5

OTHERS

Part No.	Symbol & Description
PSS-003	Crystal
PNX-015	Insulator
PNM-013	Insulator
PBA-089	Screw 2.5x10
PKP-017	Connector 2P
PNC-037	Heat sink
PNC-118	Heat sink

Motor Assembly

Part No.	Symbol & Description
PHE-303FA	HA-HC Holl element
RD¼PS 241J	R101-R103
PTL-003	Core unit

Arm Base Assembly (1/2, 2/2)

Part No.	Symbol & Description
PEL-040	PL1
TPS-605Y	Q18
PCX-031	cds
EE-SM3B	Q19 Photo captr
PEB-123	Rubber buh
RD¼PS 272J	R58, R59

7

8

9

Appearance of Transistors and ICs

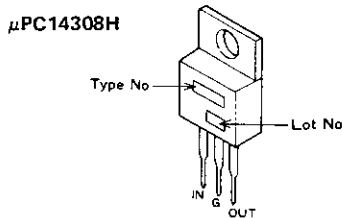
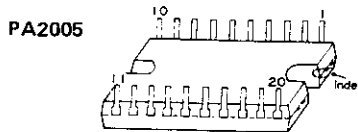
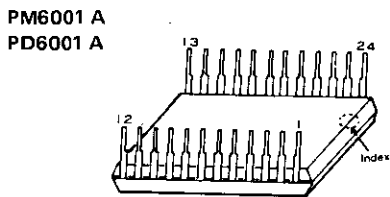
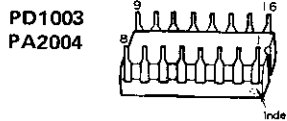
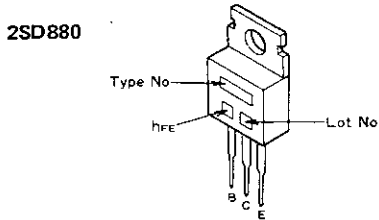
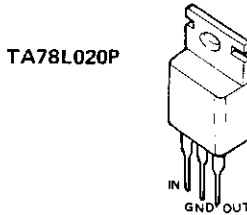
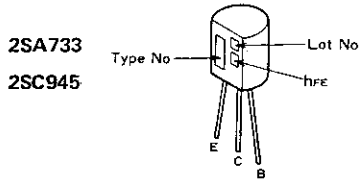

NOTES:

- When ordering resistors, first convert resistance values into code form as shown in the following examples.

Ex. 1 When there are 2 effective digits (any digit apart from 0), such as 560 ohm and 47k ohm (tolerance is shown by J = 5%, and K = 10%).

560Ω	56 × 10 ¹	561	RD¼PS	561J
47kΩ	47 × 10 ³	473	RD¼PS	473J
0.5Ω	0R5		RN2H	0R5K
1Ω	010		RSIP	010K

Ex. 2 When there are 3 effective digits (such as in high precision metal film resistors).

5.62kΩ	562 × 10 ¹	5621	RN¼SR	5621F
--------	-----------------------	------	-------	-------

- The Δ mark found on some component parts indicates the importance of the safety factor of the part. Therefore, when replacing, be sure to use parts of identical designation.

7

8

9

A

B

C

D

13. SCHEMATIC DIAGRAM (HET, HBT)

POWER SUPPLY CIRCUIT FOR U-K MODEL

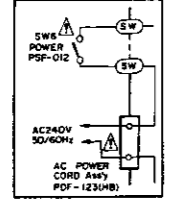

A
B
C
D

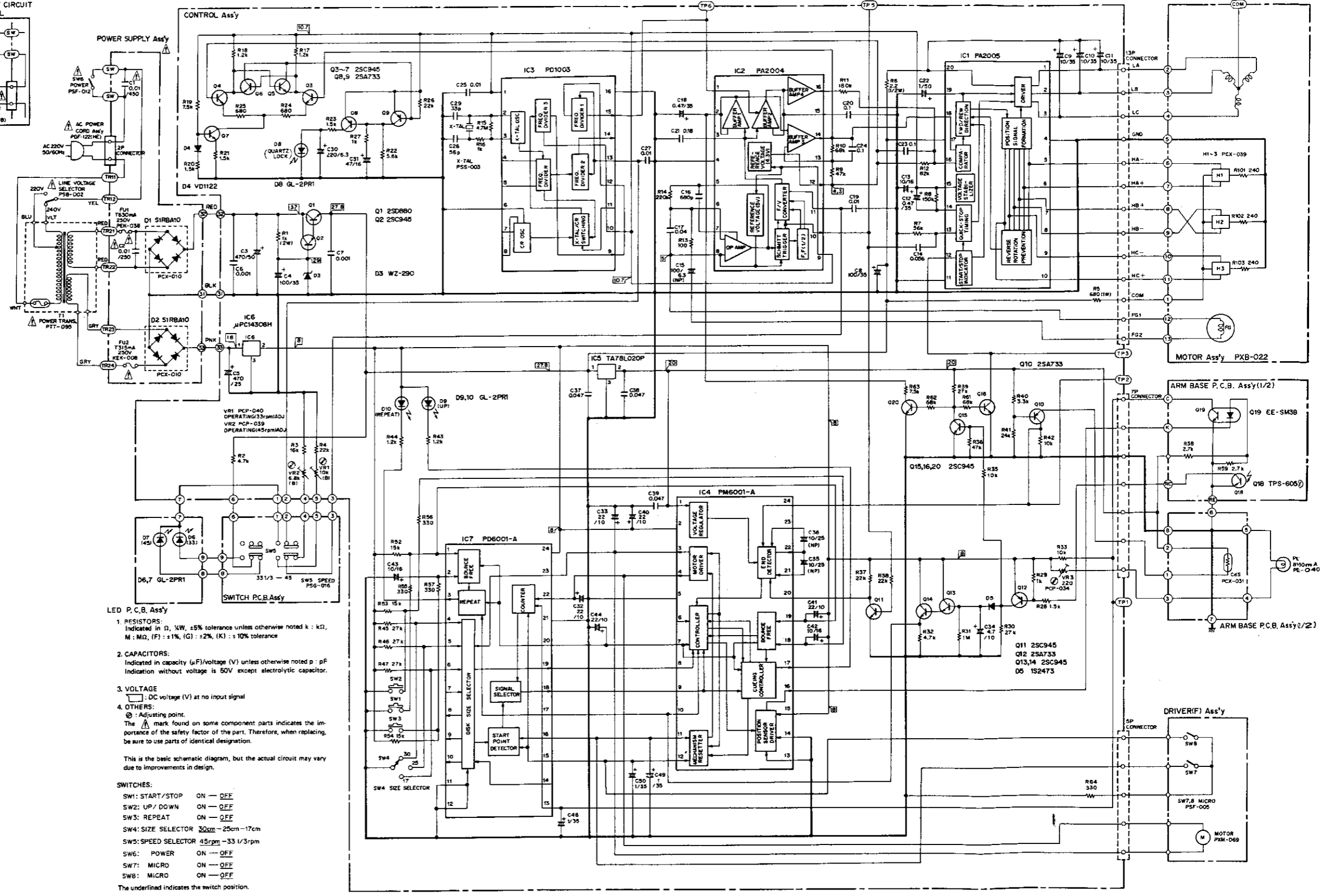

- LED P.C.B. Assy
- RESISTORS:**
Indicated in Ω, kΩ, ±5% tolerance unless otherwise noted k: kΩ, M: MΩ, (F): ±1%, (G): ±2%, (K): ±10% tolerance
 - CAPACITORS:**
Indicated in capacity (μF)/voltage (V) unless otherwise noted p: pF
Indication without voltage is 50V except electrolytic capacitor.
 - VOLTAGE**
□: DC voltage (V) at no input signal
 - OTHERS:**
⊗: Adjusting point.
⚠: The mark found on some component parts indicates the importance of the safety factor of the part. Therefore, when replacing, be sure to use parts of identical designation.
- This is the basic schematic diagram, but the actual circuit may vary due to improvements in design.
- SWITCHES:**
SW1: START/STOP ON — OFF
SW2: UP/ DOWN ON — OFF
SW3: REPEAT ON — OFF
SW4: SIZE SELECTOR 30cm — 25cm — 17cm
SW5: SPEED SELECTOR 45rpm — 33 1/3rpm
SW6: POWER ON — OFF
SW7: MICRO ON — OFF
SW8: MICRO ON — OFF
- The underlined indicates the switch position.

14. P.C. BOARD CONNECTION DIAGRAM (HET, HBT)

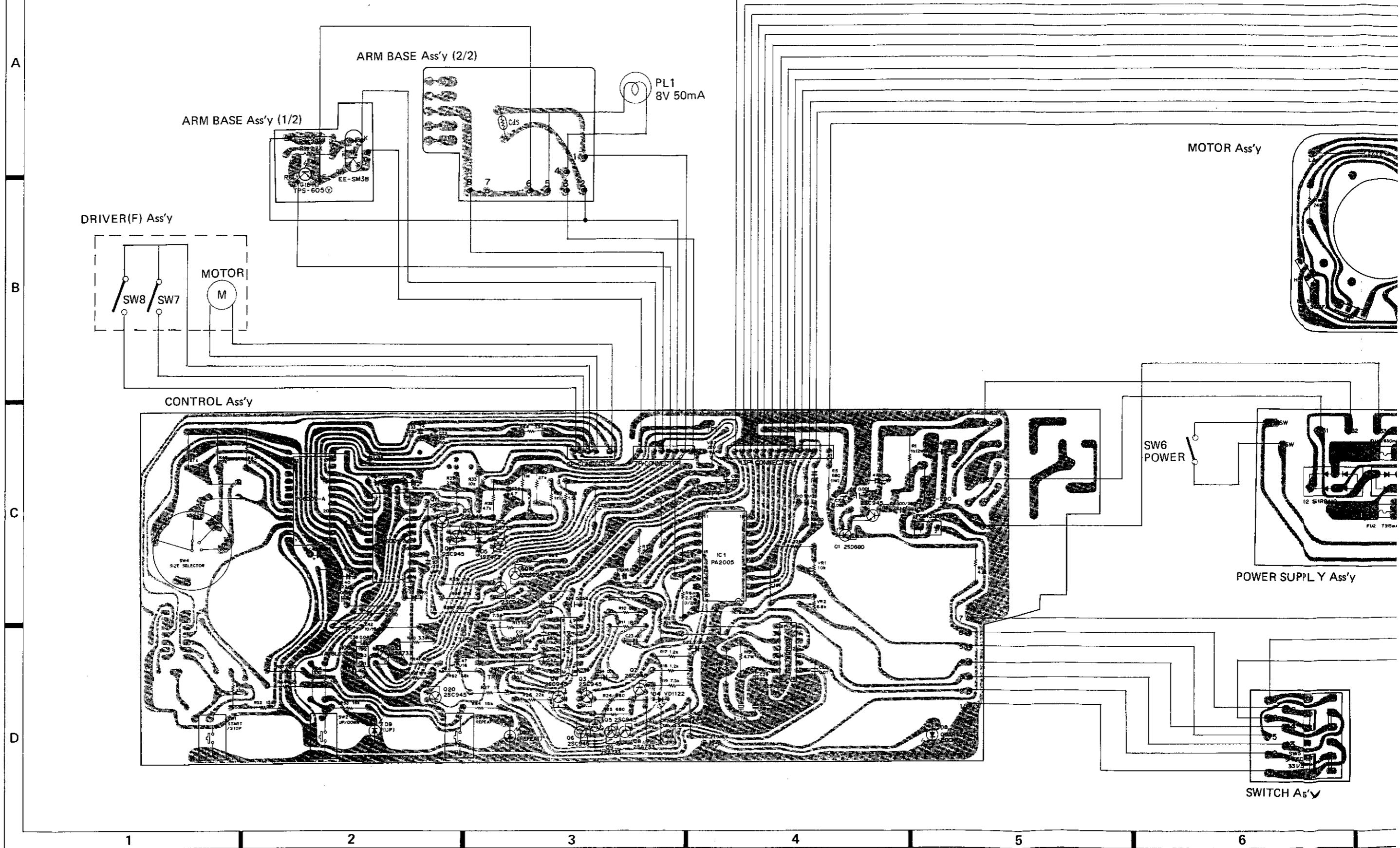

7

8

9

A

B

C

D

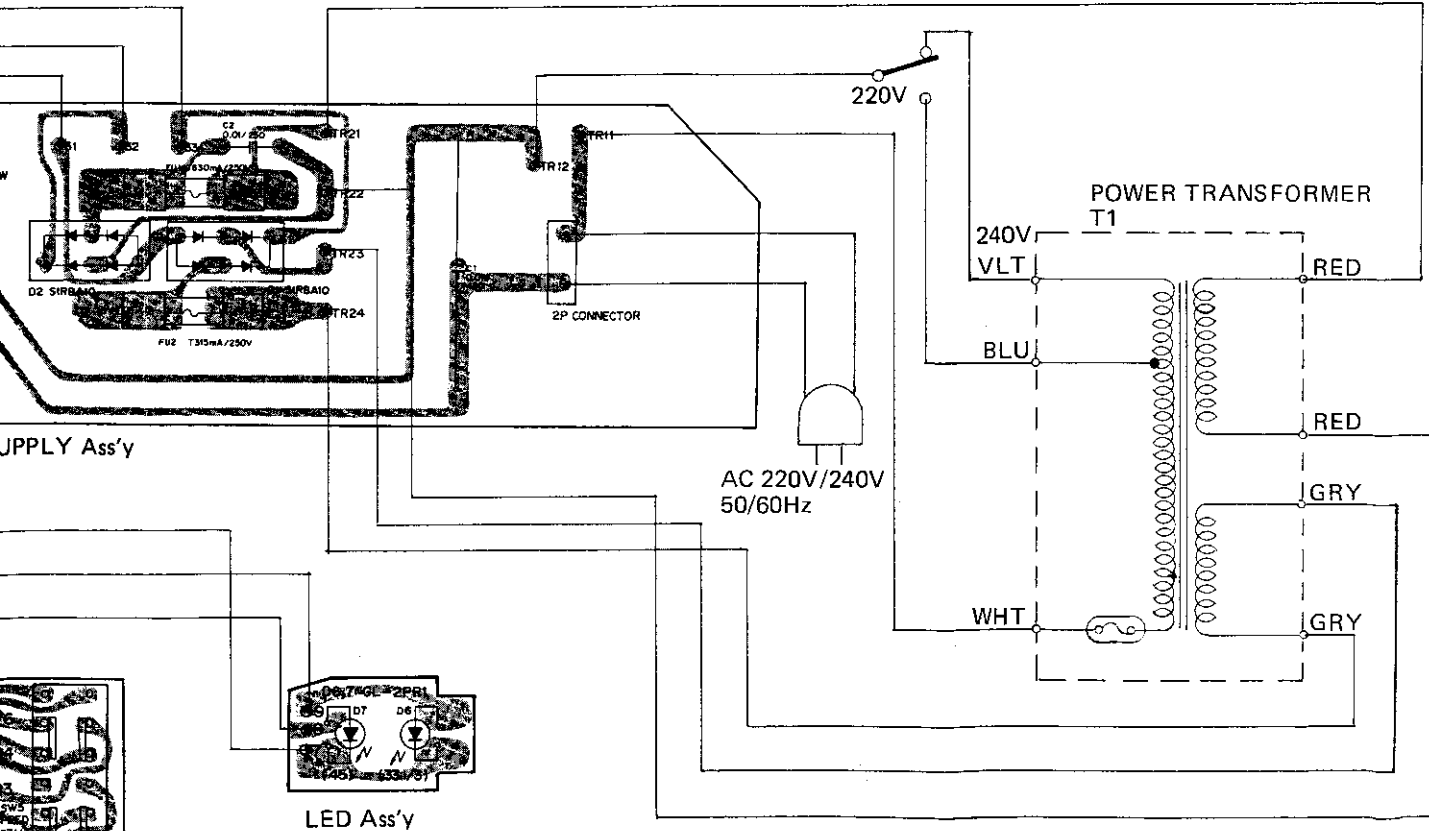
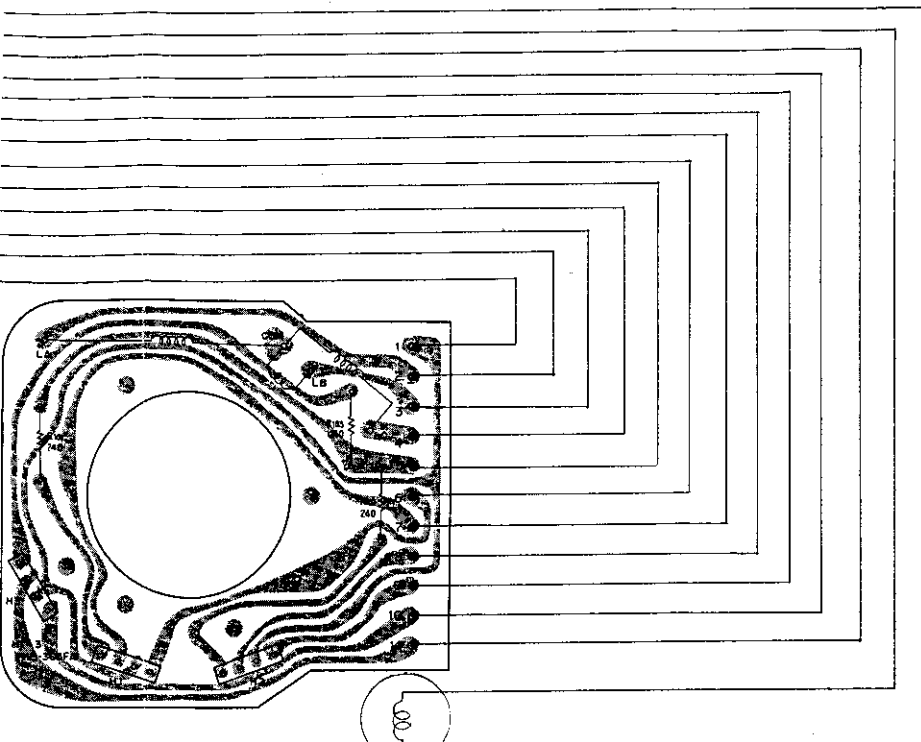

Ass'y

7

8

9

14.1 PARTS LIST OF P.C. BOARD ASSEMBLY (HET, HBT)

Control Assembly

SWITCHES

Part No.	Symbol & Description
PSG-009	SW1 (START/STOP)
PSG-009	SW2 (UP/DOWN)
PSG-009	SW3 (REPEAT)
PSB-008	SW4 (SIZE SELECTOR)

CAPACITORS

Part No.	Symbol & Description
CEA 471P 50	C3
CEA 101P 35	C4, C8
CEA 471P 25	C5
CKDYF 102Z 50	C6, C7
CEA 100P 35	C9, C10, C11
CSZA R47M 35	C12, C18
CSZA 100M 16	C13, C42, C43
CQMA 563K 50	C14
CEA 101M 6.3NP	C15
CKDYB 681K 50	C16
CKDYF 403Z 50	C17
CKDYF 103Z 50	C19, C25, C27
CQMA 104K 50	C20, C23, C24
CQMA 184J 50	C21
CEA 010P 50	C22
CCDCH 560J 50	C26
CCDCH 330J 50	C29
CEA 221P 6.3	C30
CEA 470P 16	C31
CEA 220P 10	C40, C44
CSZA 4R7M 10	C34
CEA 100M 25NP	C35, C36
CKDYF 473Z 50	C37, C38, C39
CSZA 220M 10	C41, C32, C33
CSZA 010M 35	C48, C49, C50

Note: When ordering resistors, convert the resistance value into code form, and then rewrite the part no. as before.

RESISTORS

Part No.	Symbol & Description
PCP-040	VR1 10k-B
PCP-039	VR2 6.8k-B
PCP-034	VR3 220Ω-B
RS2P □□□ J	R1
RD¼PS □□□ J	R2-R4, R7-R64
RS1P □□□ J	R5
RD¼PS □□□ J	R6

SEMICONDUCTORS

Part No.	Symbol & Description
2SD880	Q1
2SC945	Q2-Q7, Q11, Q13-Q16, Q20
2SA733	Q8-Q10, Q12
PA2005	IC1
PA2004	IC2
PD1003	IC3
PM6001A	IC4
TA78L020P	IC5
μPC14308H	IC6
PD6001A	IC7
WZ-290	D3
VD1122	D4
1S2473	D5

OTHERS

Part No.	Symbol & Description
PSS-003	Crystal
PNX-015	Insulator
PNM-013	Insulator
PBA-089	Screw 2.5x16
PKP-017	Connector 2P
PNC-037	Heat sink
PNC-118	Heat sink

Motor Assembly

Part No.	Symbol & Description
PHE-303FA	HA-HC Holl element
RD¼PS 241J	R101-R103
PTL-003	Core unit

Arm Base Assembly (1/2, 2/2)

Part No.	Symbol & Description
PEL-040	PL1
TPS-605Y	Q18
PCX-031	cds
EE-SM3B	Q19 Photo capler
PEB-123	Rubber bush
RD¼PS 272J	R58, R59

Led Ass'y

Part No.	Symbol & Description
GL-2PR1	D6, D7

Switch Ass'y

Part No.	Symbol & Description
PSG-016	SW5

Power Supply Assembly

Part No.	Symbol & Description
SIRBA10	D1, D2
PCL-034	C1 0.01/450V
PCL-032	C2 0.01/250V
PEK-034	F1 630mA
KEK-008	F2 315mA