



# *Service Manual*

STEREO TURNTABLE

# **PL-500X**

 **PIONEER®**

**MODEL PL-500X COMES IN TWO VERSIONS DISTINGUISHED AS FOLLOWS:**

Type	Voltage	Remarks
HET	220V and 240V (Switchable)	Europe model (Without cartridge)
HBT	220V and 240V (Switchable)	United Kingdom model (Without cartridge)

## **CONTENTS**

1. SPECIFICATIONS . . . . .	3
2. PANEL FACILITIES . . . . .	4
3. DISASSEMBLY	
3.1 Cabinet . . . . .	6
3.2 Tonearm . . . . .	7
4. ADJUSTMENTS	
4.1 D.D. Motor Operation Adjustment . . . . .	8
4.2 Mechanism Adjustments . . . . .	9
5. PACKING	
6. EXPLODED VIEWS AND PARTS LIST	
6.1 Cabinet . . . . .	11
6.2 Subpanel . . . . .	14
6.3 D.D. Motor . . . . .	16
7. SCHEMATIC DIAGRAM . . . . .	17
8. P.C. BOARD CONNECTION DIAGRAM	
8.1 Parts List of P.C. Board Assembly . . . . .	21

For description of the D. D. motor, refer to the PL-630 service manual (ART-314) and for full auto mechanism, refer to the PL-3000 service manual (ART-350).

# 1. SPECIFICATIONS

## Motor and Turntable

Drive System	Direct-drive
Motor	Quartz PLL Hall motor
Turntable Platter	330mm diam, aluminum alloy die-cast
Moment of Inertia	300kg-cm <sup>2</sup> (including platter mat)
Speeds	33-1/3 and 45rpm
Wow and Flutter	Less than 0.025% (WRMS)
Signal-to-Noise Ratio	More than 75dB (DIN-B)
	(with Pioneer cartridge model PC-200)

## Rotational Characteristics

Build-up Time	Within 120° rotation at 33-1/3rpm
Speed Deviation	Less than 0.002%
Speed vs. Load Characteristics	Stable up to 150 grams drag load
Speed Drift	Less than 0.00008%/h at 33-1/3rpm
	Less than 0.00003%/degree temp. change at 33-1/3rpm

## Tonearm

Type	Static-balance type, S-shaped pipe arm
Effective Arm Length	221mm
Overhang	15.5mm
Usable Cartridge Weight	4g (min.) to 10g (max.)

## Subfunctions

Full auto mechanism, Anti-skating force control, Stylus pressure direct-readout counterweight, Cueing device, Strobe light, Free stop hinges

## Semiconductors

ICs	3
-----	---

Transistors	3
Diodes	3
Hall Elements	3

## Miscellaneous

Power Requirements	220/240V ~ (switchable), 50, 60Hz
Power Consumption	.10W
Dimensions	440(W) x 140(H) x 388(D)mm
	17-15/16(W) x 5-1/2(H) x 15-1/4(D)in.
Weight	9.1kg/20 lb

## Accessories

EP Adapter	1
Screwdriver	1
Cartridge mounting parts	
Cartridge mounting screws	6
Cartridge mounting nuts	2
Cartridge mounting washers	2
Operating Instructions (French and German furnished on models for HET)	1

### NOTE:

Specifications and design subject to possible modification without notice, due to improvements.

# LINE VOLTAGE SELECTOR SWITCH

The line voltage selector switch is located on the top surface of the cabinet of this turntable. Before your turntable is shipped from the factory, the switch is set to the power requirements of the turntable's destination, check that it is set properly before plugging the power cord into the outlet. If the voltage is not properly set or if you move to an area where the voltage requirements differ, adjust the selector switch as follows:

1. Disconnect the power cord.
2. Provide yourself with a medium-sized screwdriver. Insert the tip of the screwdriver into the groove of the selector switch and turn it so that the power voltage marking of your area points to the white mark by the arrow on the label.

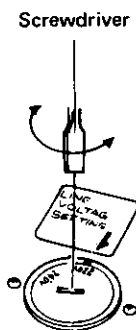

## 2. PANEL FACILITIES

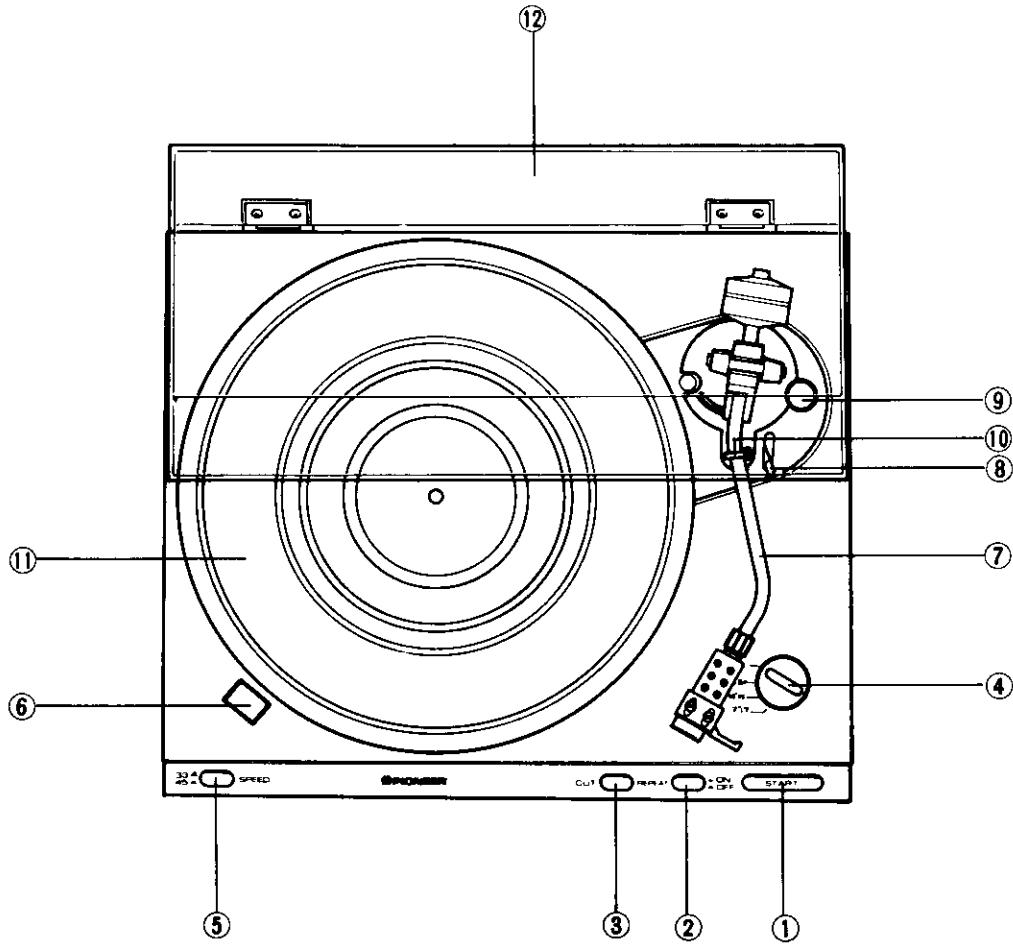

**① START BUTTON**

When this button is depressed, the power is turned on to the turntable, the strobe light comes on and the platter starts to rotate. With the RECORD SIZE SELECTOR set at one of the positions — 30, 25, or 17 — the tonearm moves automatically to the record disc as the platter starts rotating, thus starting record play

**② REPEAT BUTTON**

Push this button when you want to listen to the same record again. Press the button once more to release.

*NOTE:*

*All you have to do for repeat play is to press the REPEAT button. There is no need to push the START and CUT button again.*

**③ CUT BUTTON**

If this button is depressed while the record is playing, the tonearm automatically returns to the arm rest, and the power to the turntable will be cut off.

**④ RECORD SIZE SELECTOR**

This selector selects the size of the record for automatic play and also selects manual play.

7"17 . . . . For the automatic play of 17cm (7-inch) LP and EP records.

10"25 . . . . For the automatic play of 25cm (10-inch) LP records.

12"30 . . . . For the automatic play of 30cm (12-inch) LP records.

MANUAL. . . For the manual play of records.

*NOTE:*

*The tonearm will not be actuated when the RECORD SIZE SELECTOR is at the MANUAL position for play, even if the START button and the REPEAT button are pushed.*

**⑤ SPEED SELECTOR BUTTON**

45 . . . . . When this button is depressed, the platter will rotate at 45rpm. Depress for playing 45rpm records, singles or EP's.

33 . . . . . When this button is set to the release position, the platter will rotate at 33-1/3rpm. Release for playing 33-1/3rpm records like LP's.

**⑥ STROBE LIGHT**

This light comes on when the tonearm moves away from the arm rest toward the platter. It irradiates the stroboscope around the outside of the platter.

**⑦ TONEARM**

This tonearm is designed to apply the correct tracking force to the cartridge and to keep this force at the precise level for faithful tracking of the record grooves.

**⑧ ARM-ELEVATION LEVER**

This lever controls the ascent and descent of the tonearm.

UP (▼) . . . . . The tonearm rises.

DOWN (▲) . . . . . The tonearm descends gently.

Set to this position for auto play, auto repeat and other automatic operations.

*NOTE:*

*When the ARM ELEVATION lever is set to the UP position for automatic play, the tonearm will move over as far as the lead-in groove on the record but it will not descend and the record will therefore not be played.*

**⑨ ANTI-SKATE KNOB**

This knob is used to cancel out the harmful skating force which is generated during record play.

For further details, see "ANTI-SKATING ADJUSTMENT".

**⑩ ARM REST/CLAMPER**

The arm rest supports the tonearm when it is not being used. Set the tonearm on its rest when it is not playing records. Clamp it into position if you don't have any immediate plans to play records.

**⑪ PLATTER/RUBBER PLATTER MAT**

When the tonearm is moved and power is supplied to the turntable, the platter will start rotating at the set rotation speed. The rubber platter mat stabilizes the records and also absorbs external vibration.

**⑫ DUST COVER**

Keep this closed unless operating the controls or tonearm, or changing over records. This serves to keep dust from adhering to the records during record play. When fully opened and pulled straight up, this dust cover can be removed from the cabinet.

## 3. DISASSEMBLY

### 3.1 CABINET (See Fig. 3-1)

1. Remove the dust cover.
2. Undo the 4 screws securing the top cover.
3. Undo the 4 screws located in the rubber feet.
4. Move the tonearm over towards the center shaft as shown in the diagram.
5. Disconnect the connectors when lifting off the cabinet.

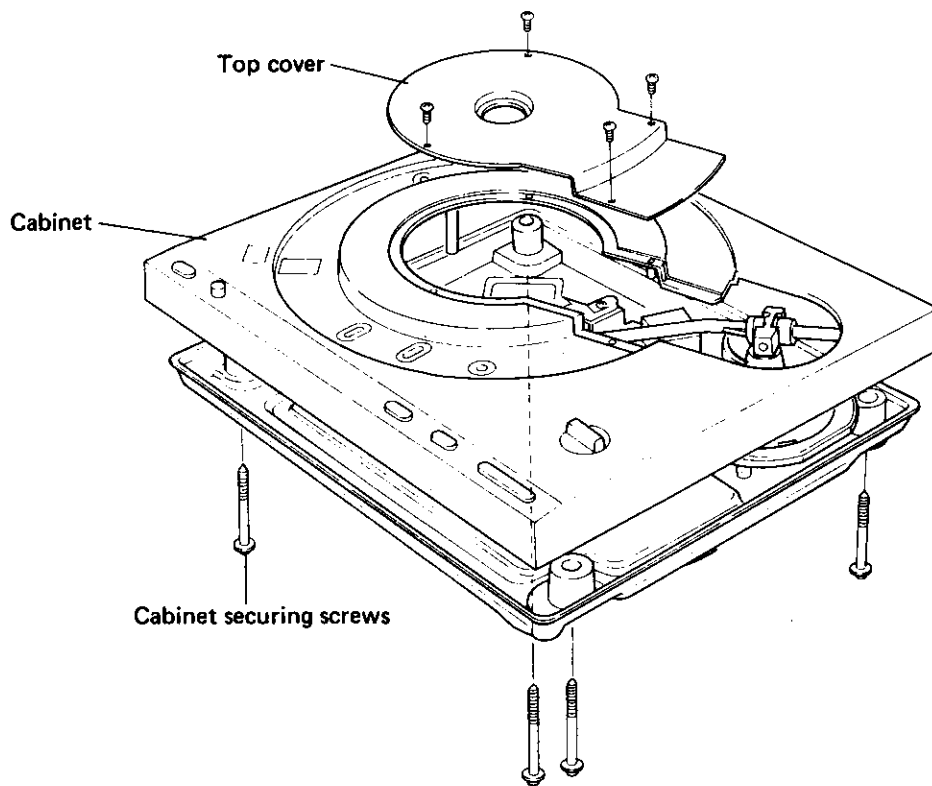

Fig. 3-1

### 3.2 TONEARM

1. Undo the 4 screws securing the arm base and the sub-panel (see Fig. 3-2).
2. Undo the 2 screws securing the arm base to the sub-panel (see Fig. 3-2).
3. Disconnect the tonearm lead wires from the PU board (see Fig. 3-2).  
Note that some of the lead wires have been soldered to the PU board, and must be disconnected with care.
4. Loosen the setscrews with a hexagonal wrench to remove the PU plate under the arm base (see Fig. 3-3).
5. Undo the screw securing the tonearm to the arm base (see Fig. 3-3)

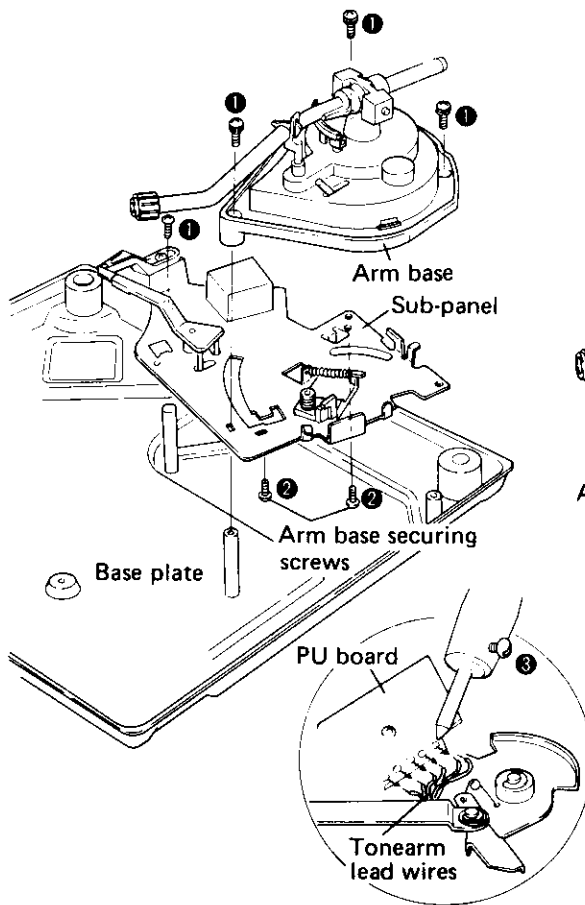

Fig. 3-2

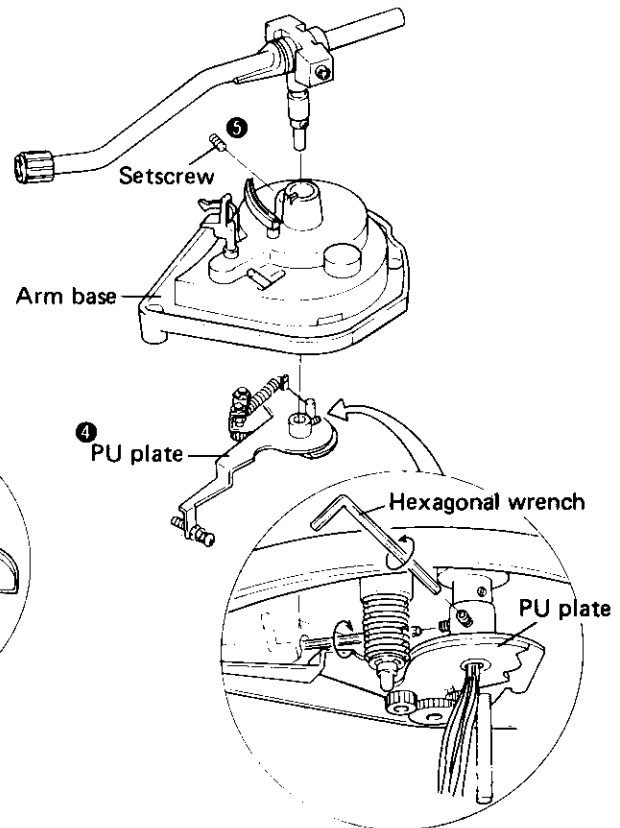

Fig. 3-3

# 4. ADJUSTMENTS

## 4.1 D.D MOTOR OPERATION ADJUSTMENT

1. Rotate the turntable platter.
2. Connect a dual-image oscilloscope (or synchroscope) to the TP3 and Q2 terminals of the circuit board ass'y.
3. Adjust VR1 (for 33-1/3 rpm) and VR2 (for 45rpm) on the circuit board ass'y in order to bring the rising edge of the TP5 terminal waveform within the width of the TP6 terminal waveform as shown in Fig. 4-2.

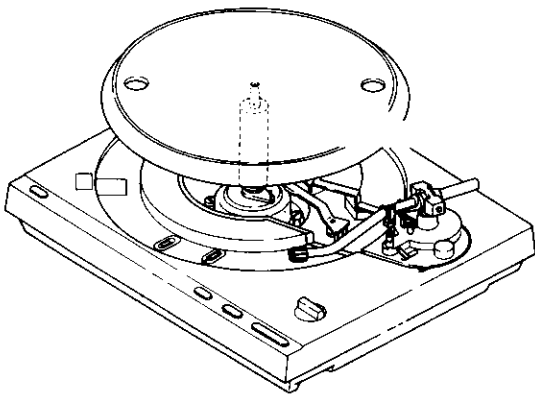
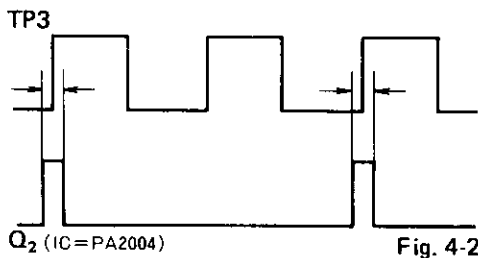
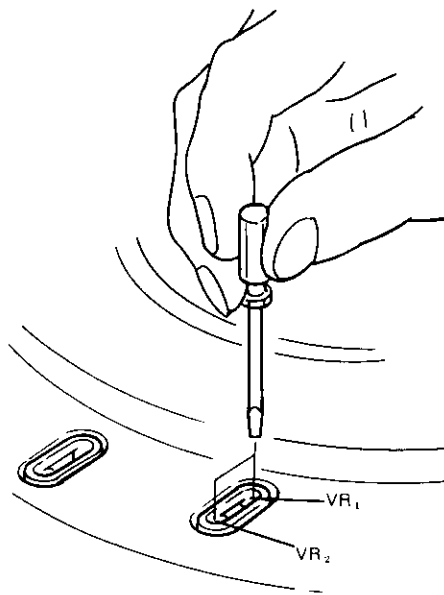

Fig. 4-1





## 4.2 MECHANISM ADJUSTMENTS

Prior to commencing any adjustments, check that the PU plate shaft moves along the center axis of the slot in the sub-panel as shown in Fig. 4-4.

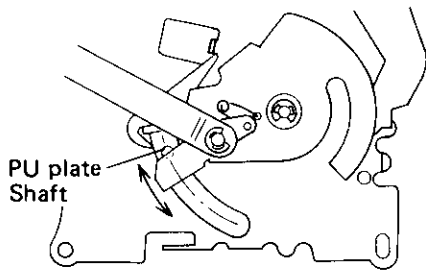

Fig. 4-4

### • Tonearm lowering position

Tonearm lowering position is adjusted by turning an adjustment screw located in the hole at the base of the tonearm (see Fig. 4-5).

Turn the screw clockwise to move the lowering position inwards.

Turn the screw counterclockwise to move the lowering position outwards.

This adjustment may be simplified by using a test record.

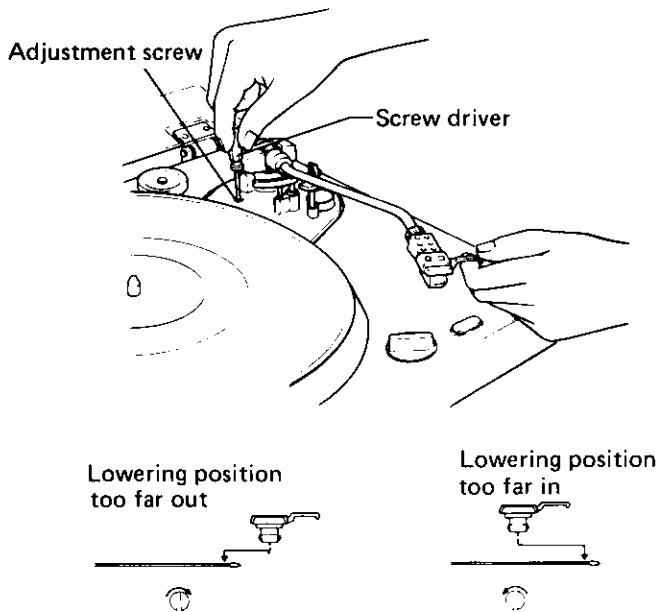

Fig. 4-5

### • Auto-return position

1. If the tonearm returns too early, screw the PU plate screw outwards (see Fig. 4-6).
2. If the tonearm returns too slow, screw the PU plate screw inwards.

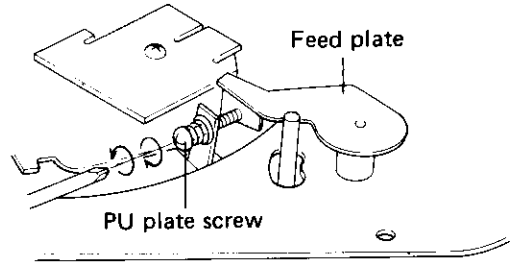

Fig. 4-6

### • Tonearm misoperation

If the tonearm should happen to stop midway during the lead-in operation, adjust the nut shown in Fig. 4-7.

*Note:*

*This nut should be neither too tight, nor too loose.*

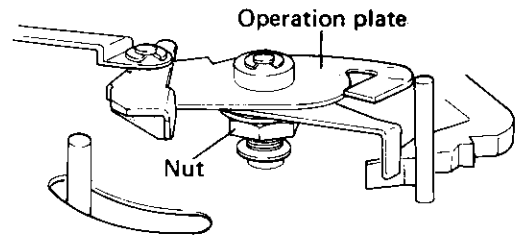

Fig. 4-7

### • Short switch

The short switch gap should be 0.5mm during record play. This gap may be adjusted by the screw shown in Fig. 4-8 below.

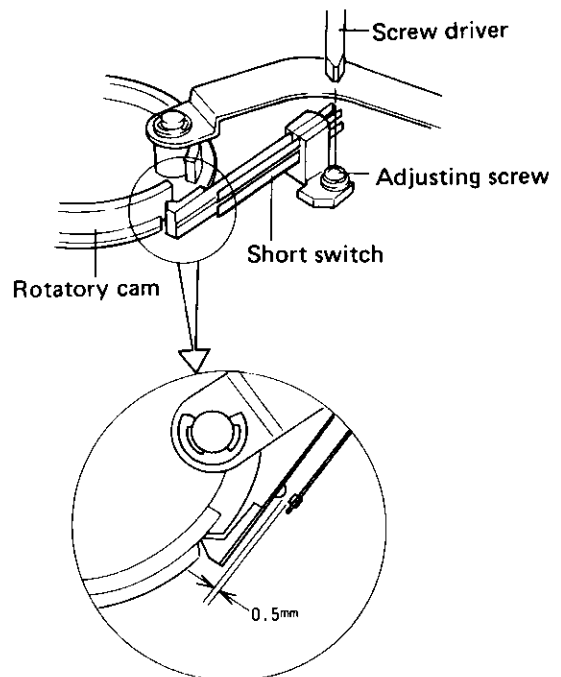
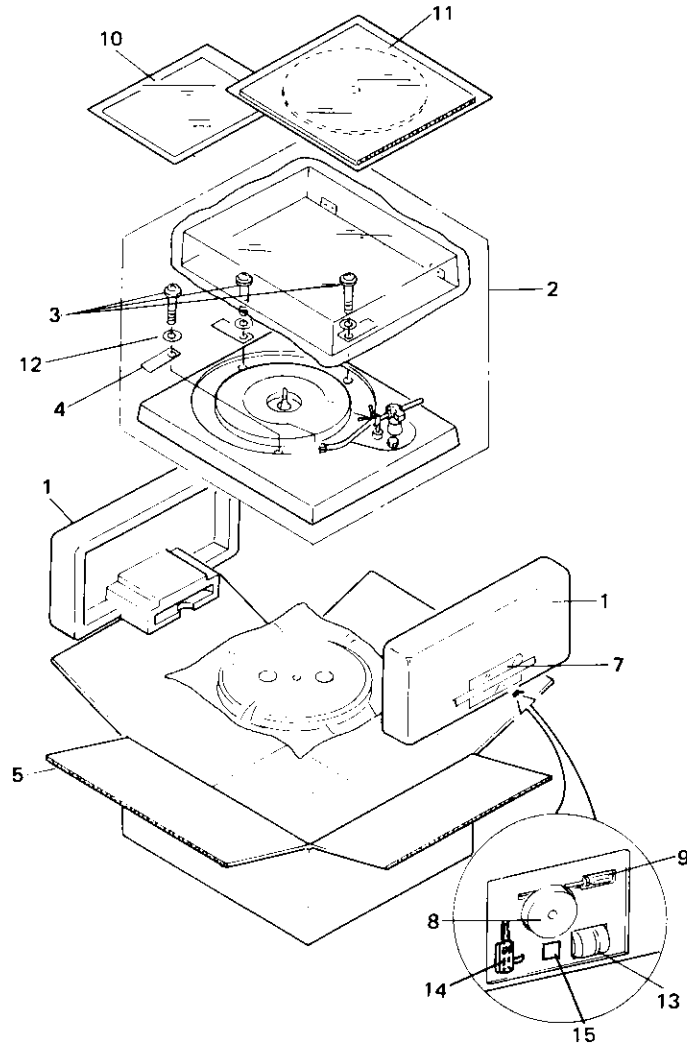

Fig. 4-8

# 5. PACKING



## Parts List

Key No.	Part No.	Description
1.	PHA-077	Protector
2.	H56-603	Vinyl bag
3.	PBA-079	Screw
4.	PRW-038	Caution label
5.	PHG-369	Packing case
6.	.....	Cover
7.	PHC-069	Cover
8.	N93-603	45 adaptor
9.	KEX-002	Driver
10.	PRB-135	Operating instructions (English)
	PRD-046	Operating instructions (French/German)
11.	PEA-032	Rubber mat assembly
12.	B22-026	Washer
13.	PXA-720	Weight assembly
14.	PXA-676	Headshell assembly
15.	PXB-125	Cartridge mounting screw assembly

# 6. EXPLODED VIEWS AND PARTS LIST

## 6.1 CABINET

A

B

C

D

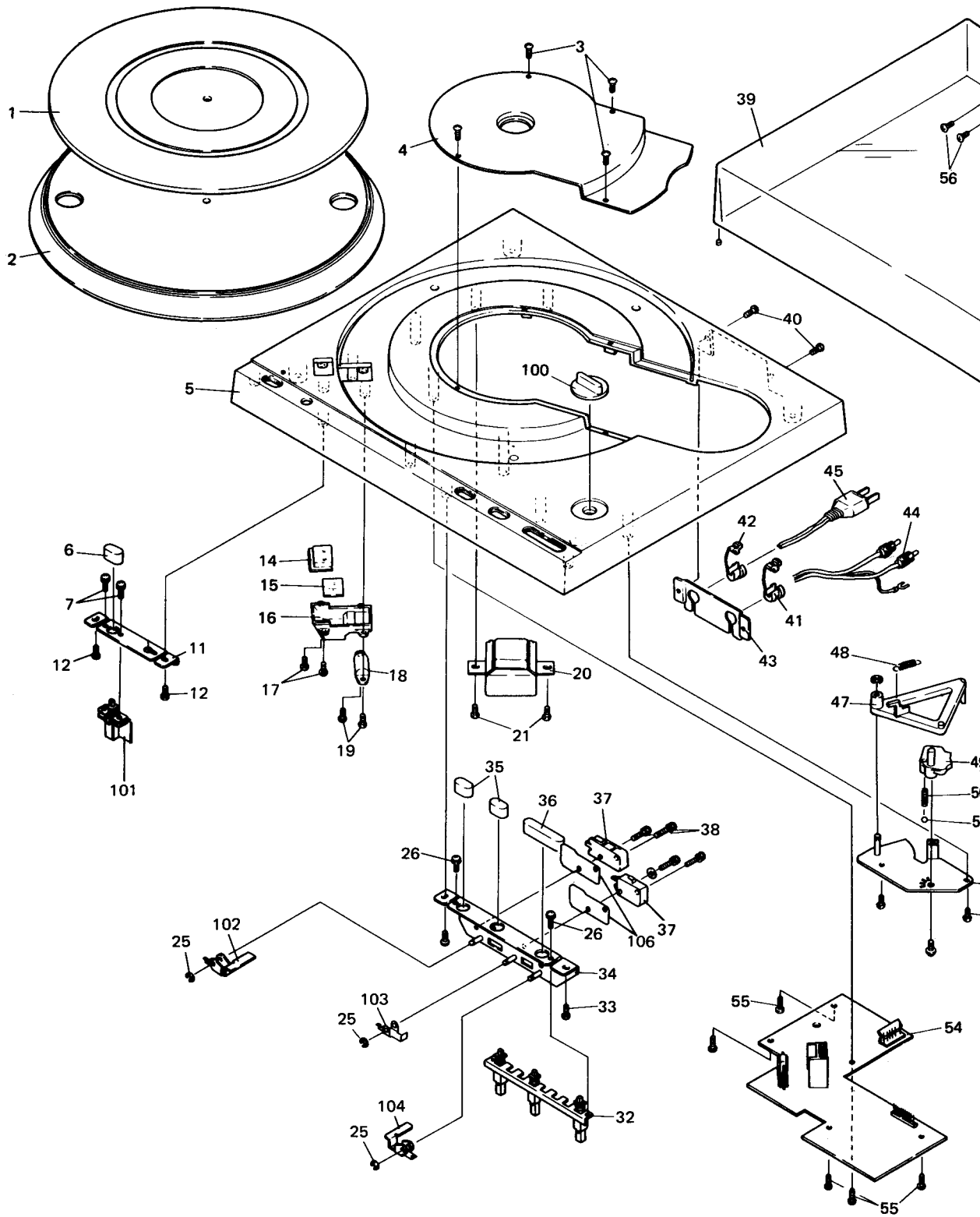

4

5

6

A

B

C

D

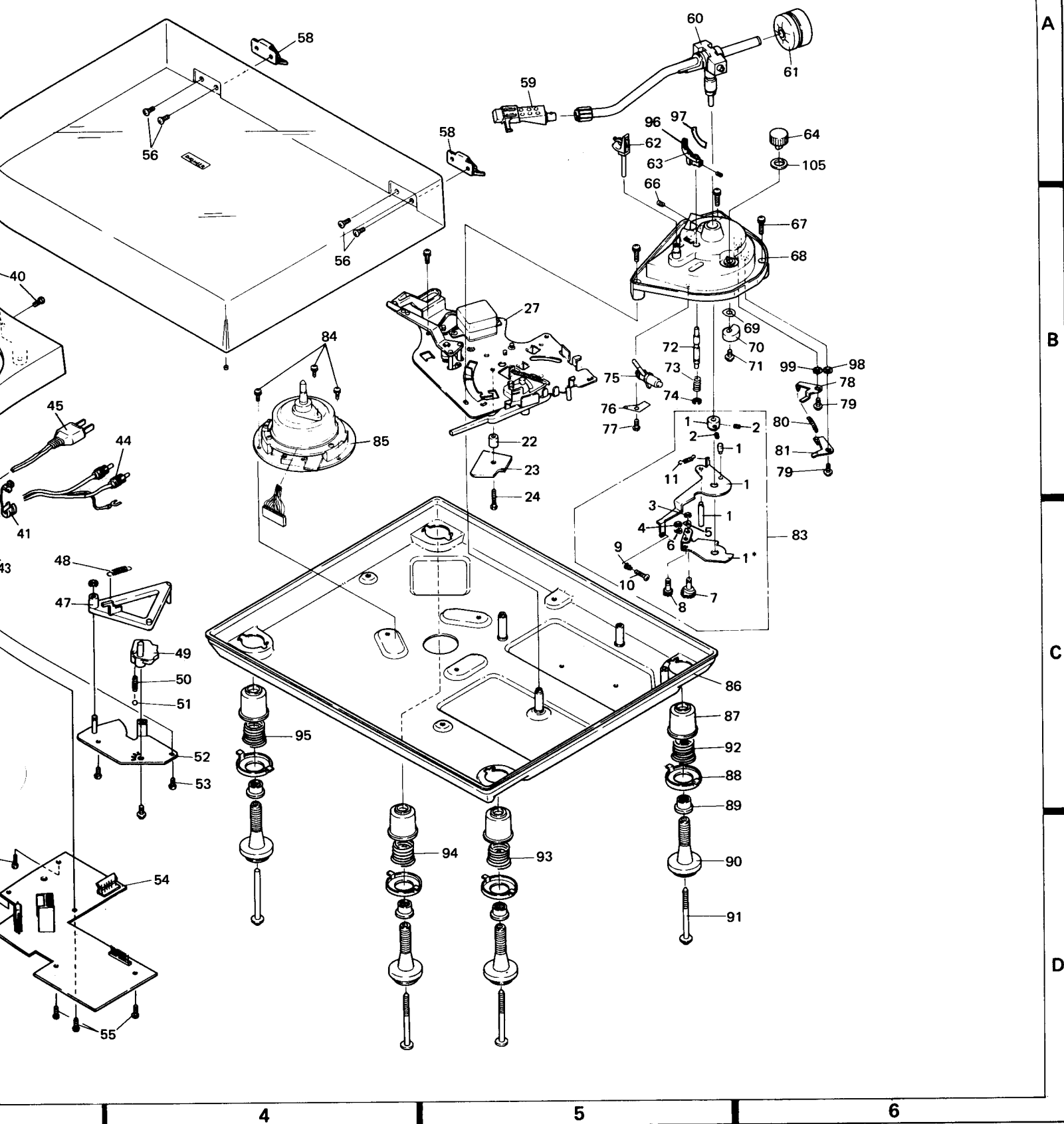

PARTS LIST OF CABINET

NOTES:

- Parts without part number cannot be supplied.
- The  $\Delta$  mark found on some component parts indicates the importance of the safety factor of the part. Therefore, when replacing, be sure to use parts of identical designation.

Key No.	Part No.	Description	Key No.	Part No.	Description
1.	PEA-032	Rubber mat assembly	51.		Steel ball 5/32"
2.	PNR-089	Turntable platter	52.		Selector base unit
3.		Taptite P screw 3x8	53.		Taptite P screw 3x10
4.		Cover	54.	XWM-033	Circuit board
5.	PNX-080	Panel	55.		Taptite P screw 3x10
6.	PAC-024	Push button	56.		Taptite screw 4x8
7.		PSA 3x5	57.	.....	
8.	.....		58.	PXA-323	Hinge assembly
9.	.....		59.	PXA-676	Headshell assembly
10.	.....		60.	PPD-580	Tonearm assembly
11.		Angle	61.	PXA-720	Weight assembly
12.		Taptite P screw 3x10	62.	PXB-002	Arm rest assembly
13.		Speed selector assembly	63.	PNW-577	Elevation sheet
14.	PNW-473	Lens	64.	PAC-026	AS knob
15.	PAG-001	Mirror	65.	.....	
16.	PNW-472	Holder	66.		Hexagon socket headless set screw 4x8
17.		Taptite P screw 3x10	67.		Plastic screw 3x8
18.	PNX-078	Neon lamp holder	68.	PNX-088	Arm base
19.		Taptite P screw 3x10	69.	PBE-012	AS spring washer
$\Delta$ 20.	PTT-093	Power transformer	70.	PNW-379	AS cam
21.		Taptite P screw 4x10	71.		Taptite screw 3x6
22.		Spacer	72.	PLA-396	Shaft
23.		Output terminal	73.	PBH-201	EV spring
24.		PSA 3x12	74.		EW4
25.		EW3	75.	PXT-301	EV lever unit
26.		PSA 3x5	76.	PBK-030	EV spring
27.	PXB-103	Sub panel assembly	77.	.....	
28.	.....		78.	PNC-068	AS lever
29.	.....		79.	PBA-085	AS screw
30.	.....		80.	PBH-250	AS spring
31.	.....		81.	PNB-460	Bias lever
32.	PXT-295	Push button unit	82.	.....	
33.		Taptite P screw 3x10	83.	PXB-001	PU plate assembly
34.		Button base	83-1.		PU plate
35.	PAC-024	Push button	83-2.		Hexagon socket headless set screw 4x6
36.	PAC-020	Start button	83-3.		EW2 (SUS)
$\Delta$ 37.	PSF-012	Microswitch	83-4.		EW3 (SUS)
38.		PSA 3x15	83-5.	PNB-224	Washer
39.	PNV-014	Dust cover	83-6.	PNB-519	AS washer
40.		PSF 3x8	83-7.	PXT-109	Adjust washer
41.	PEC-051	Strain relief	83-8.	PXT-201	Adjust shaft
42.	PEC-051	Strain relief	83-9.	PBH-045	Spring
43.		Angle	83-10.		Plastic screw 3x12
44.	PDE-044	Output cord	83-11.	PBH-193	Spring
$\Delta$ 45.	PDG-021 (HE)	AC power cord	84.		PSA 4x10
$\Delta$	PDG-022 (HB)		85.	PXB-010	D.D. motor
46.	.....		86.		Base
47.	PNW-475	Selector lever	87.	PEB-102	Damper cushion A
48.	.....		88.	PNW-484	Holder
49.	PNW-474	Selector cam	89.	PNW-375	Ring
50.	PBH-213	Spring	90.	PYY-024	Foot

**NOTES:**

• Parts without part number cannot be supplied.

Key No.	Part No.	Description	Key No.	Part No.	Description
91.	PBA-096	Screw	99.		FW3
92.	PBH-197	Spring	100.	PAC-023	Knob
93.	PBH-196	Spring	101.	XWX-013	Switch assembly
94.	PBH-198	Spring	102.	PXT-314	Actuator D
95.	PBH-198	Spring	103.	PBK-027	Actuator B
96.	PNW-577	EV sheet	104.	PXT-296	Actuator A
97.	PNT-516	Sheet cushion	105.	PBF-005	AS knob washer
98.		FW3	⚠ 106.	PEC-052	Insulator

**6.2 SUB PANEL**

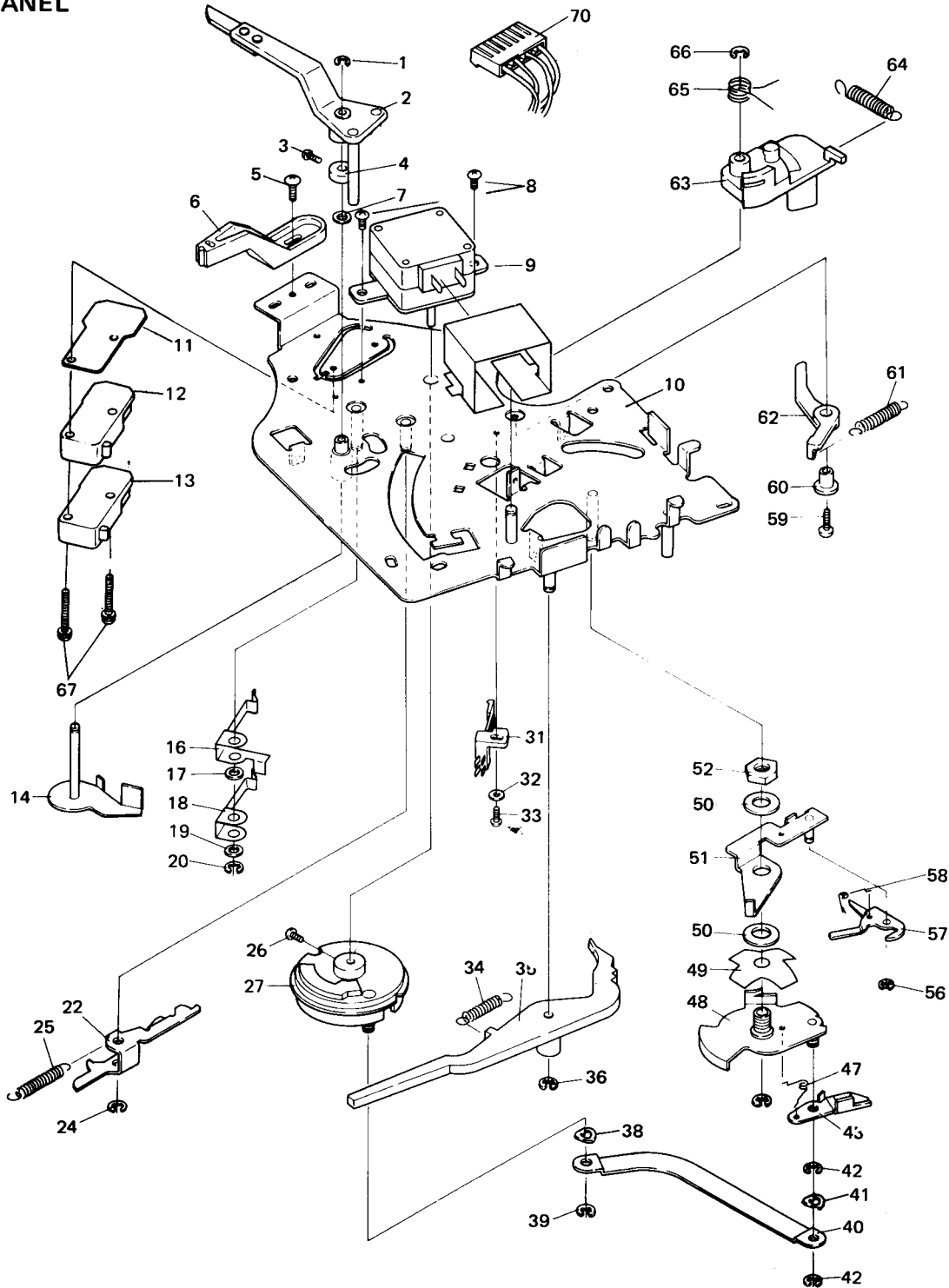

**PARTS LIST OF SUB PANEL**

**NOTES:**

● *Parts without part number cannot be supplied.*

Key No.	Part No.	Description
1.		EW2
2.	PXT-297	Stopper unit
3.		PM 2.6x6
4.	N51-786	Stopper
5.		Taptite screw 3x8
6.	PXT-219	Stopper rubber unit
7.		Polyethylene washer 4.1φx0.25t
8.		Taptite screw 3x5
△ 9.	PXM-080	Timing motor
10.		Sub panel unit
△ 11.	PEC-052	Insulator
△ 12.	PSF-009	Microswitch
△ 13.	PSF-009	Microswitch
14.	PXT-124	Plate
15.	.....	
16.	PBK-029	Actuator D
17.		Polyethylene washer 4.1φx0.25t
18.	KNA-101	Actuator A
19.		Polyethylene washer 4.1φx0.25t
20.		EW3
21.	.....	
22.	PNB-112	Lever
23.	.....	
24.		EW3
25.	PBH-096	Lever spring
26.		Taptite screw 2x2.6
27.	PNW-476	Cam
28.	.....	
29.	.....	
30.	.....	
31.	KSN-001	Switch
32.		FW2.6
33.		PM2.6x5
34.	PBH-194	Spring
35.	PNW-477	Selector plate
36.		EW3
36.		EW3
37.	.....	
38.	PNB-519	Washer
39.		EW3
40.		Lever
41.	PNB-519	Washer
42.		EW3
43.	PXT-310	Lever unit
44.	.....	
45.	.....	
46.	.....	
47.	B33-609	Spring
48.	PXT-308	Rotor unit
49.	PBK-006	Spring
50.	PBF-003	Washer

Key No.	Part No.	Description
51.	PXT-300	Start lever unit
52.	KLA-159	Nut
53.	.....	
54.	.....	
55.	.....	
56.		EW2
57.	PXT-312	Lock lever unit
58.	B33-635	Lock lever spring
59.		PM2.6x8
60.	PLA-404	Collar
61.	PBH-097	Spring
62.	PNW-490	Lever
63.	PNW-478	EV cam
64.	PBH-200	EV cam spring
65.	PBH-195	EV lever spring
66.		EW3
67.	.....	PSA 3x25
68.	.....	
69.	.....	
70.		Connector assembly

# 6.3 D.D. MOTOR

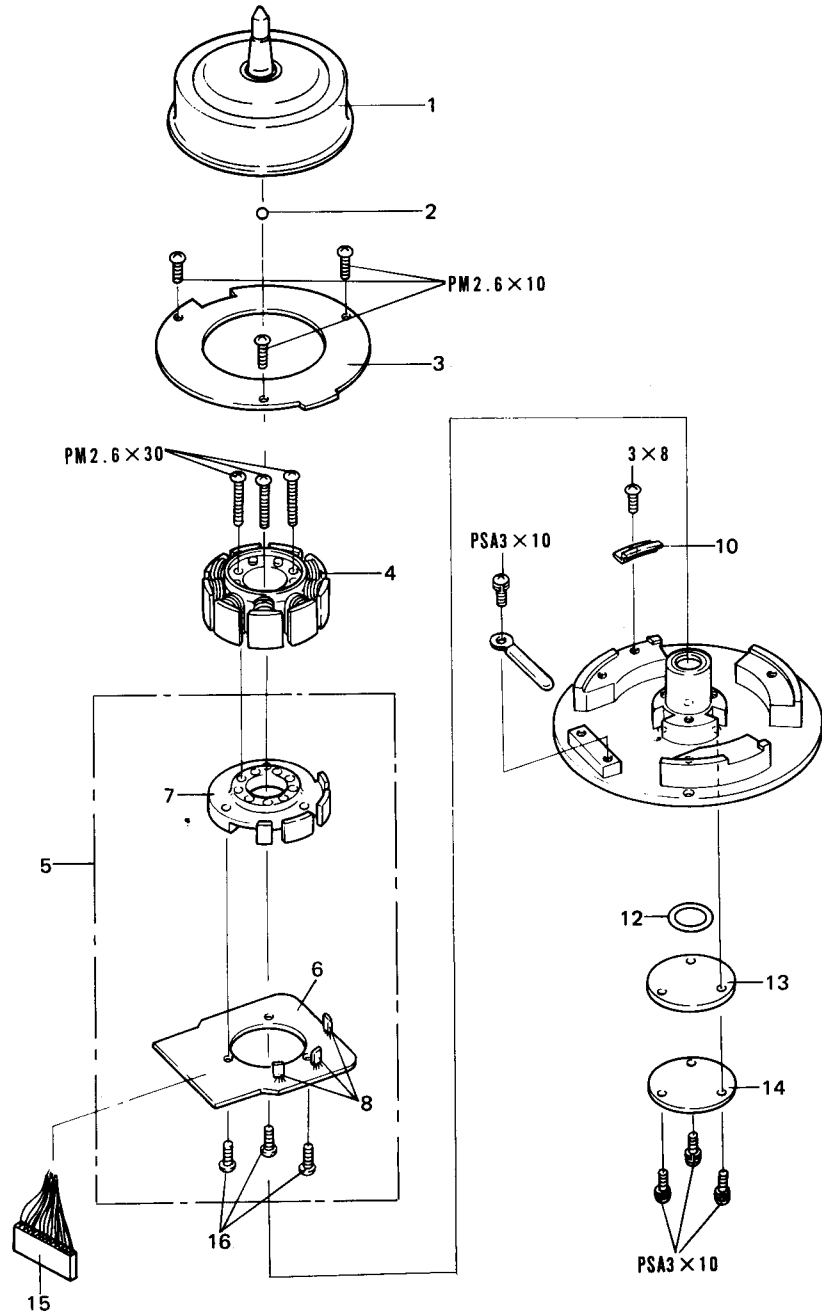

## Parts List

Key No.	Part No.	Description
1.		Rotor assembly
2.	PEF-001	Steel ball
3.		Speed detector assembly
4.	PTL-003	Core unit
5.		Positional detector assembly
6.		P. CB
7.		Base
8.	PHE-030FA	Hall element
9.		Cord fixer
10.		Angle

## NOTES:

• Parts without part number cannot be supplied.

Key No.	Part No.	Description
11.		Base
12.	MNT-001	Ring
13.	MNW-001	Plate
14.		Cover
15.	PDE-038	Connector assembly
16.		Taptite screw 3x8



# 7. SCHEMATIC DIAGRAM

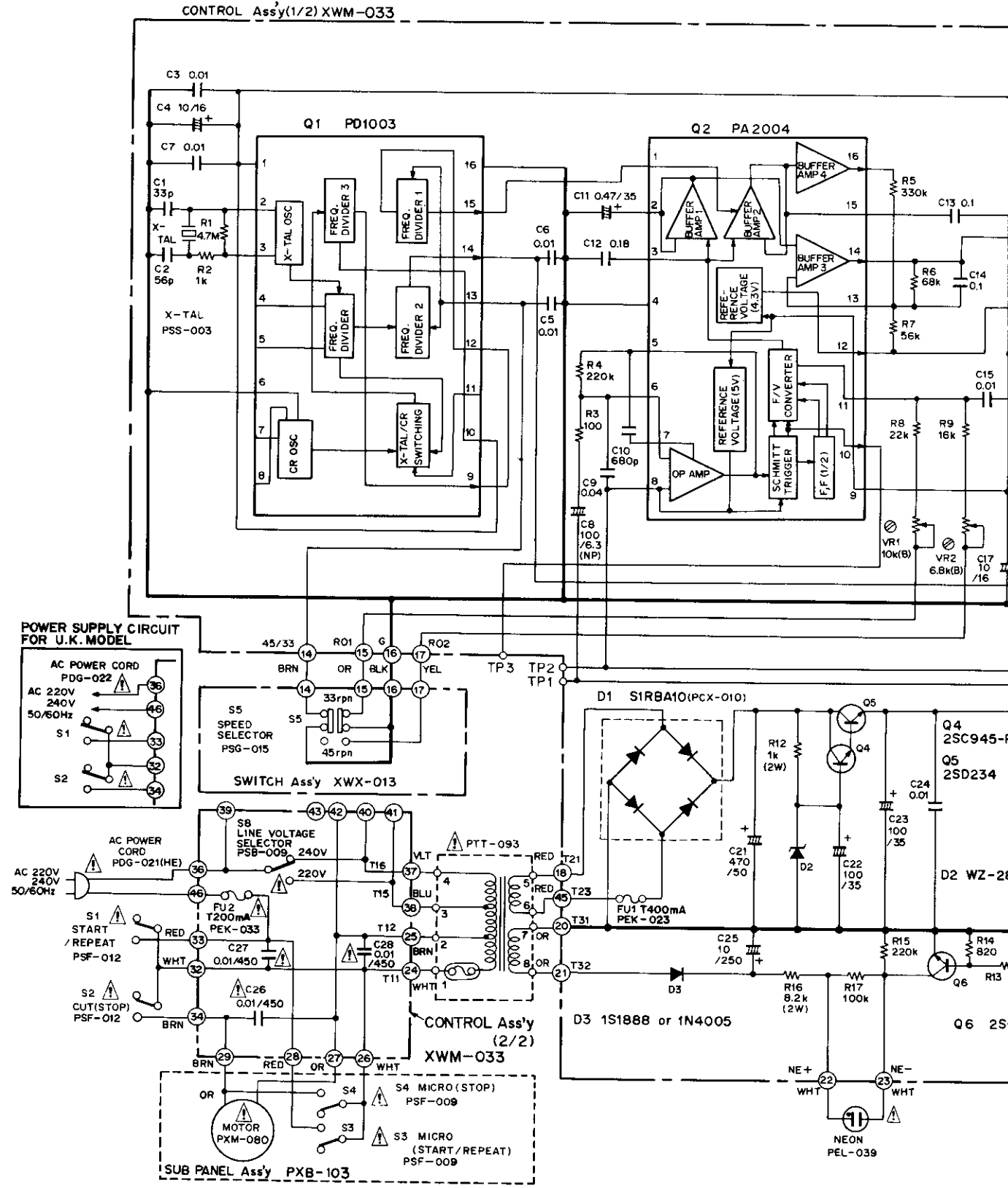

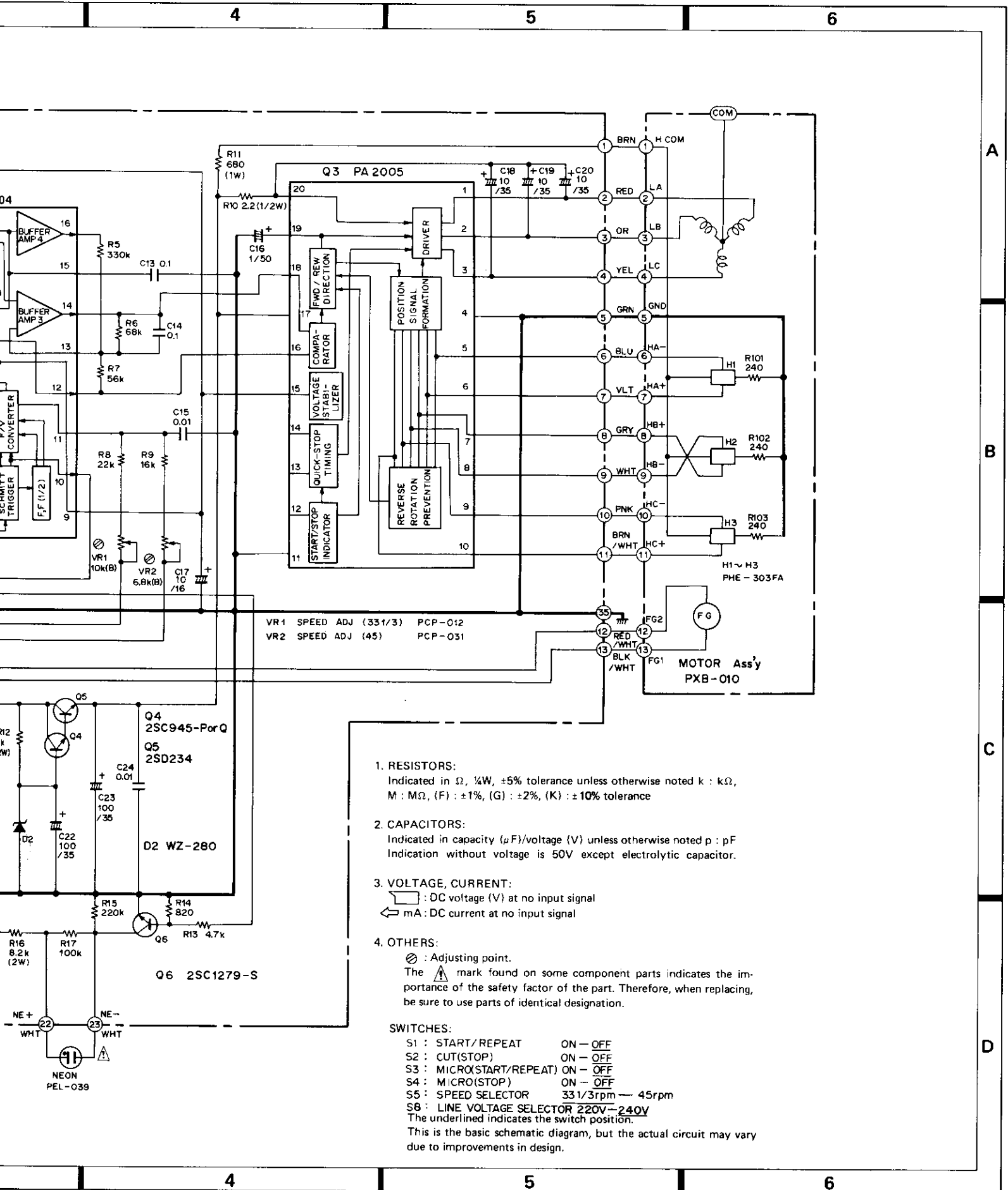

VR1 SPEED ADJ (331/3) PCP-012  
 VR2 SPEED ADJ (45) PCP-031

1. RESISTORS:  
 Indicated in  $\Omega$ ,  $\frac{1}{4}W$ ,  $\pm 5\%$  tolerance unless otherwise noted k : k $\Omega$ , M : M $\Omega$ , (F) :  $\pm 1\%$ , (G) :  $\pm 2\%$ , (K) :  $\pm 10\%$  tolerance
2. CAPACITORS:  
 Indicated in capacity ( $\mu F$ )/voltage (V) unless otherwise noted p : pF  
 Indication without voltage is 50V except electrolytic capacitor.
3. VOLTAGE, CURRENT:  
 : DC voltage (V) at no input signal  
 : mA : DC current at no input signal
4. OTHERS:  
 : Adjusting point.  
 The mark found on some component parts indicates the importance of the safety factor of the part. Therefore, when replacing, be sure to use parts of identical designation.

- SWITCHES:  
 S1 : START/REPEAT ON - OFF  
 S2 : CUT(STOP) ON - OFF  
 S3 : MICRO(START/REPEAT) ON - OFF  
 S4 : MICRO(STOP) ON - OFF  
 S5 : SPEED SELECTOR 331/3rpm - 45rpm  
 S8 : LINE VOLTAGE SELECTOR 220V-240V  
 The underlined indicates the switch position.  
 This is the basic schematic diagram, but the actual circuit may vary due to improvements in design.

A  
 B  
 C  
 D

4 5 6

4 5 6

# 8. P.C. BOARD CONNECTION DIAGRAM

CUT (STO

A

B

C

D

### MOTOR Ass'y PXB-010

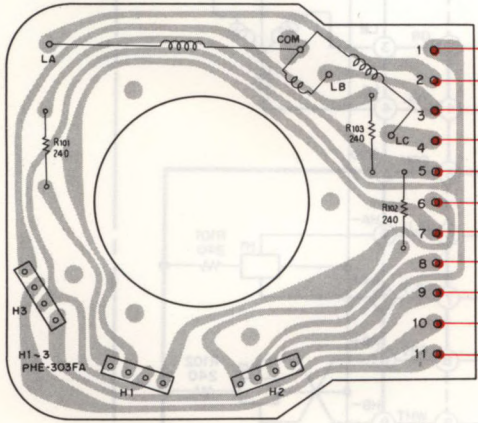

### SUB PANEL Ass'y PXB-103

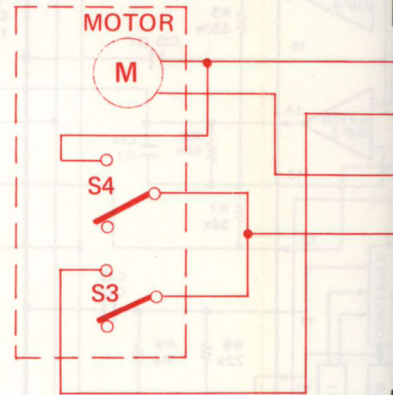

FG

### CONTROL Ass'y XWM-033

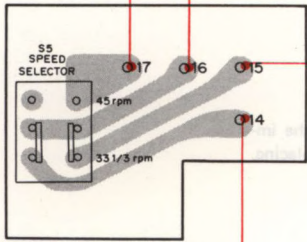
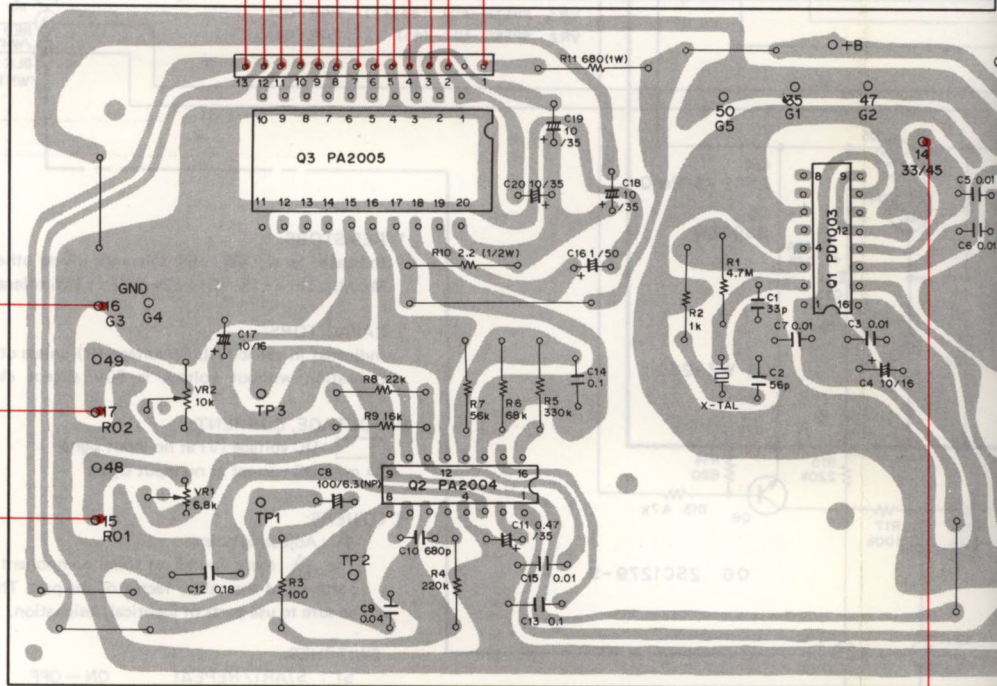

### SWITCH Ass'y XWX-013

1

2

3



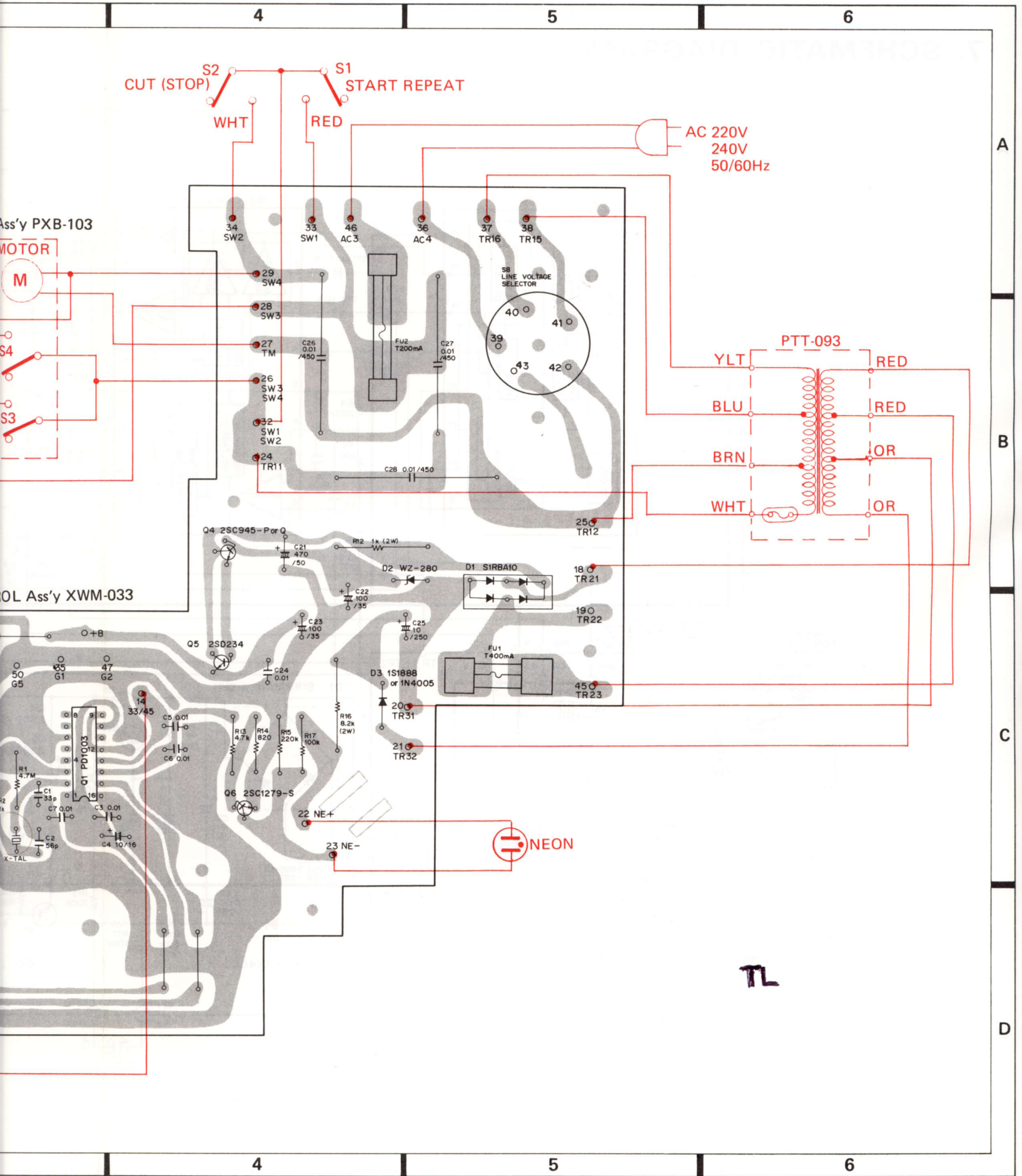

S2 CUT (STOP) WHT  
S1 START REPEAT RED

AC 220V  
240V  
50/60Hz

Ass'y PXB-103

MOTOR

M

S4

S3

OL Ass'y XWM-033

O+B

G5 G1 G2

X-TAL

NEON

TL

A

B

C

D

4

5

6

4

5

6

## 8.1 PARTS LIST OF P.C. BOARD ASSEMBLY

**NOTES:**

- When ordering resistors, first convert resistance values into code form as shown in the following examples.

Ex. 1 When there are 2 effective digits (any digit apart from 0), such as 560 ohm and 47k ohm (tolerance is shown by J = 5%, and K = 10%).

560Ω	56 × 10 <sup>1</sup>	561	RD¼PS	561J
47kΩ	47 × 10 <sup>3</sup>	473	RD¼PS	473J
0.5Ω	0R5		RN2H	0R5K
1Ω	010		RSIP	010K

Ex. 2 When there are 3 effective digits (such as in high precision metal film resistors).

5.62kΩ	562 × 10 <sup>1</sup>	5621	RN¼SR	5621F
--------	-----------------------	------	-------	-------

- The  $\Delta$  mark found on some component parts indicates the importance of the safety factor of the part. Therefore, when replacing, be sure to use parts of identical designation.

### CONTROL ASSEMBLY (XWM-033)

#### CAPACITORS

Part No.	Symbol & Description
CCDCH 330J 50	C1
CCDCH 560J 50	C2
CKDYF 103Z 50	C3, C5-C7, C15, C24
CKDYF 403Z 50	C9
CKDYB 681K 50	C10
CSZA R47K 35	C11
CQMA 184J 50	C12
CQMA 104K 50	C13
CQMA 104J 50	C14
CEA 010P 50	C16
CSZA 100K 16	C17
CEA 100P 35	C18-C20
CEA 471M50L	C21
CEA 101P 35	C22, C23
CEA 100M 250L	C25
CEA 100P 16	C4
CEA 101M 6.3NP	C8
$\Delta$ PCL-034	C26-C28

Note: When ordering resistors, convert the resistance value into code form, and then rewrite the part no. as before.

#### RESISTORS

Part No.	Symbol & Description
RD¼PS □□□ J	R1-R9, R15
RD¼PS 2R2J	R10
RS1P 681J	R11
RS2P 102J	R12
RS2P 822J	R16
PCP-012	VR1
PCP-031	VR2

#### SEMICONDUCTORS

Part No.	Symbol & Description
PD1003	Q1
PA2004	Q2
PA2005	Q3
2SC945-P	Q4
(2SC945-Q)	
2SD234	Q5
2SC1279S	Q6
SIRBA10	D1
WZ280	D2
1S1888 (1N4005)	D3

#### OTHERS

Part No.	Symbol & Description
PSS-003	Crystal
$\Delta$ PEL-039	Neon lamp
PNW-482	Neon lamp base
	PM3x5
	PSA3x8
$\Delta$ KKR-001	Fuse holder
$\Delta$ PEK-023	Fuse Fu1
$\Delta$ PEK-033	Fuse Fu2

### SWITCH ASSEMBLY (XWX-013)

Part No.	Symbol & Description
PSG-015	Push switch
	PSA3x5

### POSITIONAL DETECTOR ASSEMBLY

Part No.	Symbol & Description
PHE-303FA	Hall element (H1, H2, H3)
RD¼PS 241J	R101-R103

**PIONEER ELECTRONIC CORPORATION** 4-1, Meguro 1-Chome, Meguro-ku, Tokyo 153, Japan  
**U.S. PIONEER ELECTRONICS CORPORATION** 85 Oxford Drive, Moonachie, New Jersey 07074, U.S.A.  
**PIONEER ELECTRONIC (EUROPE) N.V.** Luithgen-Haven 9, 2030 Antwerp, Belgium  
**PIONEER ELECTRONICS AUSTRALIA PTY. LTD.** 17B-184 Boundary Road, Braeside, Victoria 3195, Australia