

Service Manual

 PIONEER®

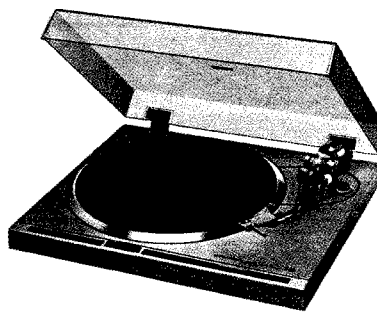

STEREO TURNTABLE

PL-300 PL-300X

KUT, KCT

KU

For descriptions and adjustment methods of the D.D. motor and the mechanism employed in this model, refer to the Supplementary Service Manual (ART-467) for the PL-200, PL-255, PL-300, and PL-400 models.

CONTENTS

1. SPECIFICATIONS2
2. EXPLODED VIEWS
 - 2.1 Main Panel3
 - 2.2 Sub Panel6
 - 2.3 D.D. Motor7
3. SCHEMATIC DIAGRAM AND PARTS LIST8
4. P.C. BOARD CONNECTION DIAGRAM11
5. PACKING13

PIONEER ELECTRONIC CORPORATION 4-1, Meguro 1-Chome, Meguro-ku, Tokyo 153, Japan
U.S. PIONEER ELECTRONICS CORPORATION 85 Oxford Drive, Moonachie, New Jersey 07074, U.S.A.
PIONEER ELECTRONIC (EUROPE) N.V. Luitthagen-Haven 9, 2030 Antwerp, Belgium
PIONEER ELECTRONICS AUSTRALIA PTY. LTD. 178-184 Boundary Road, Braeside, Victoria 3195, Australia
<ART-439-0 >

F ©JULY 1975 Printed in Japan

1. SPECIFICATIONS

Motor and Turntable

Drive System	Direct-drive
Motor	Quartz PLL Hall motor
Turntable Platter	310mm diam. aluminum alloy die-cast
Moment of Inertia	180kg-cm ² (including platter mat)
Speeds	33-1/3 and 45rpm
Wow and Flutter	Less than 0.025% (WRMS)
Signal-to-Noise Ratio	More than 75dB (DIN-B) (with Pioneer cartridge model PC-135)

Rotational Characteristics

Build-up Time	Within 120° rotation at 33-1/3rpm
Speed Deviation	Less than 0.002%
Speed Drift	Less than 0.00008%/h at 33-1/3rpm Less than 0.00003%/degree temp. change at 33-1/3rpm

Tonearm

Type	Static-balance type, S-shaped pipe arm
Effective Arm Length	221mm
Overhang	15.5mm
Usable Cartridge Weight	4g (min.) to 9g (max.)

Subfunctions

Auto return mechanism, Anti-skating force control, Stylus pressure direct-readout counterweight, Cueing device, Strobe light, Free stop hinges

Semiconductors

ICs	3
-----	---

Transistors	3
Diodes	6
Hall Elements	3

Miscellaneous

Power Requirements	AC120V, 50, 60Hz
Power Consumption	.8W
Dimensions	420(W) x 96(H) x 365(D)mm 16-1/2(W) x 3-13/16(H) x 14-3/8(D)in.
Weight	.65kg/14 lb 5 oz.

Accessories

EP Adapter	1
Cartridge mounting parts (KUT, KCT)	
Cartridge mounting screws	6
Cartridge mounting nuts	2
Cartridge mounting washers	2
Operating Instructions	1

PC-135 Specifications (PL-300X KU)

Type	Induced magnet type
Stylus	0.5 mil diamond (PN-135)
Output Voltage	3mV (1kHz, 50mm/s Peak velocity, LAT)
Tracking Force	1.5g to 2.3g (proper 2g)
Frequency Response	10 to 25,000Hz

NOTE:

Specifications and design subject to possible modification without notice, due to improvements.

2. EXPLODED VIEWS

2.1 MAIN PANEL

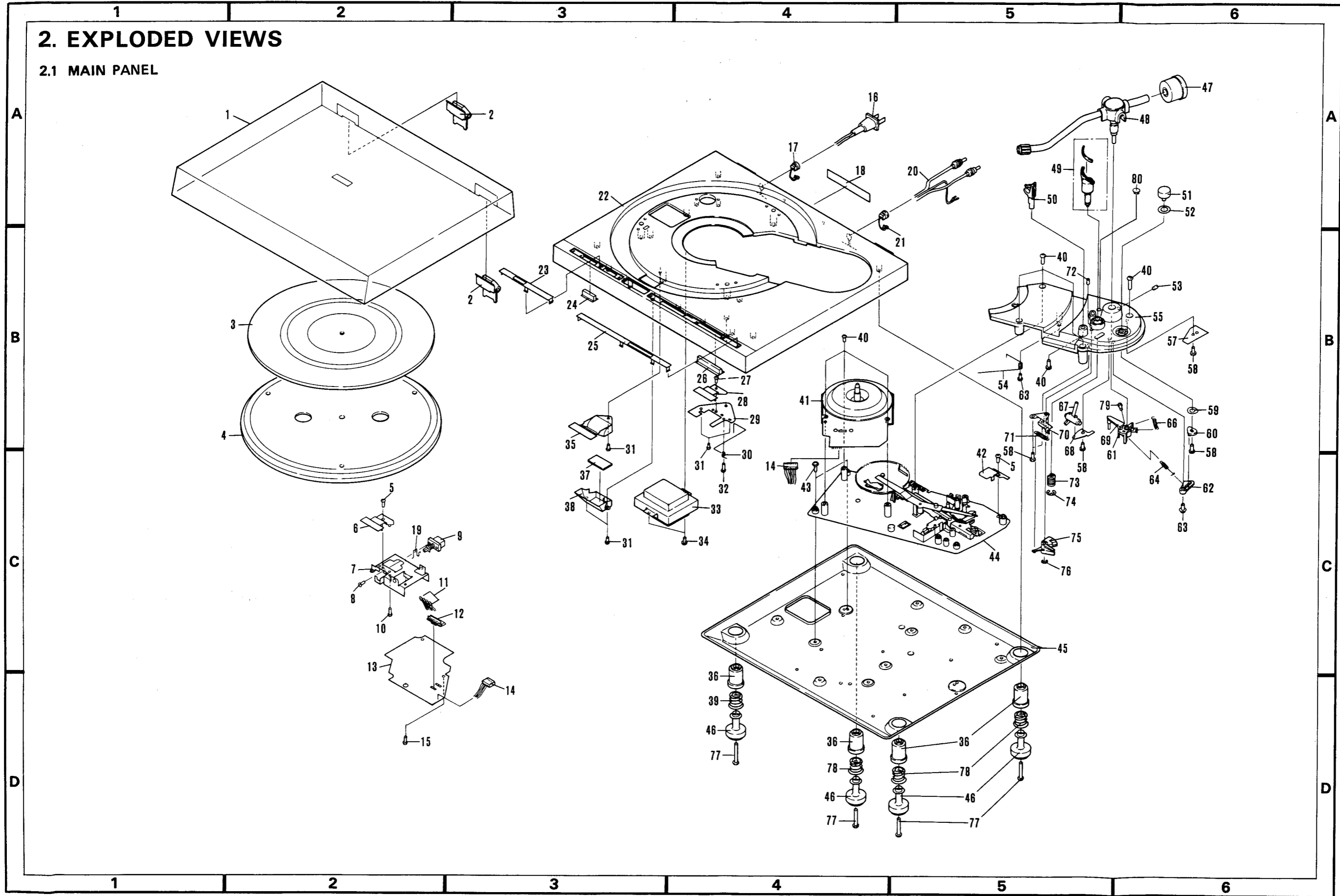

PL-300/KUT,KCT PL-300X/KU

Parts List of Main Panel

NOTE:

- Parts without part number cannot be supplied.
- The Δ mark found on some component parts indicates the importance of the safety factor of the part. Therefore, when replacing, be sure to use parts of identical designation.

Key No.	Part No.	Description	Key No.	Part No.	Description
1.	PNV-034	Dust cover	46.	PNX-062	Foot case
2.	PXB-155	Hinge assembly	47.	PXB-092	Weight assembly
3.	PEB-152 (KUT, KU)	Rubber mat assembly	48.	PPD-591 (PL-300)	Arm assembly
4.	PEB-150 (KCT)			PPD-593 (PL-300X)	
	PNR-115	Turntable platter	49.	PXB-107	EV sheet assembly
5.		Deltite screw 3 x 8	50.	PXB-094	Arm rest assembly
6.		Button guide C	51.	PAC-045 (PL-300)	AS knob
7.		Angle		PAC-041 (PL-300X)	
8.		Semes A screw 3 x 5	52.	PBF-005	AS washer
9.	PSG-020	Push switch	53.		Hexagon socket headless set screw 4 x 7
10.		Taptite P screw 3 x 8	54.	PXB-152	Cut spring B assembly
11.	BR5504S	LED	55.	PNX-053 (PL-300)	Arm base
12.		LED base		PNX-085 (PL-300X)	
Δ 13.		Power supply assembly	56.		-----
14.	PDE-062	Connector assembly	57.		OUTPUT terminal
15.		Taptite P screw 3 x 8	58.		Taptite P screw 3 x 8
Δ 16.	PDG-017	AC power cord	59.	PBE-012	Washer
17.	PEC-058	Strain relief	60.	PNX-054	AS adjusting plate
18.		Label	61.	PNX-061	PU plate B
19.	PBH-281	Spring	62.	PNX-055	Lever
20.	PDE-064	OUTPUT cord	63.		Washer faced taptite P screw 3 x 10
21.	PEC-056	Strain relief	64.	PBH-236	AS spring
22.	PNX-114 (PL-300)	Panel	65.		-----
	PNX-116 (PL-300X)		66.	PBH-244	PU plate spring
23.	PAM-062 (PL-300)	Name plate	67.	PXT-382	EV lever unit
	PAM-066 (PL-300X)		68.	PBK-042	EV plate spring A
24.	PAC-043	Push button	69.	PNX-060	PU plate A
25.	PAM-060 (PL-300)	Name plate	70.	PXT-385	EV plate spring B unit
	PAM-064 (PL-300X)		71.	PBH-238	EV cam spring
26.	PAC-044	Button	72.		Hexagon socket headless set screw 3 x 12
27.		Deltite screw 3 x 8	73.	PBH-237	EV spring
28.	PNX-052	Button guide A	74.		E type washer 7
29.		Button base	75.	PNX-059	EV cam
30.	PXB-151	Cut spring A assembly	76.		E type washer 3
31.		Taptite P screw 3 x 8	77.	PBA-099	Screw
32.	PBA-086	Screw	78.	PBH-241	Foot spring B
Δ 33.	PTT-078 (KUT, KU)	Power transformer	79.		Pan head screw 4 x 8
	PTT-091 (KCT)		80.	PEB-114 (KUT, KU)	Rubber bush
34.		Taptite P screw 4 x 10			
35.	PNX-051	Lens			
36.	PEB-163	Rubber cushion			
37.		Mirror			
38.		Lens holder			
39.	PBH-240	Foot spring			
40.	PBA-108	Screw			
41.	PXM-075	Motor			
42.		Protector			
43.	PBA-109	Screw			
Δ 44.		Subpanel assembly			
45.		Base			

2.2 SUB PANEL

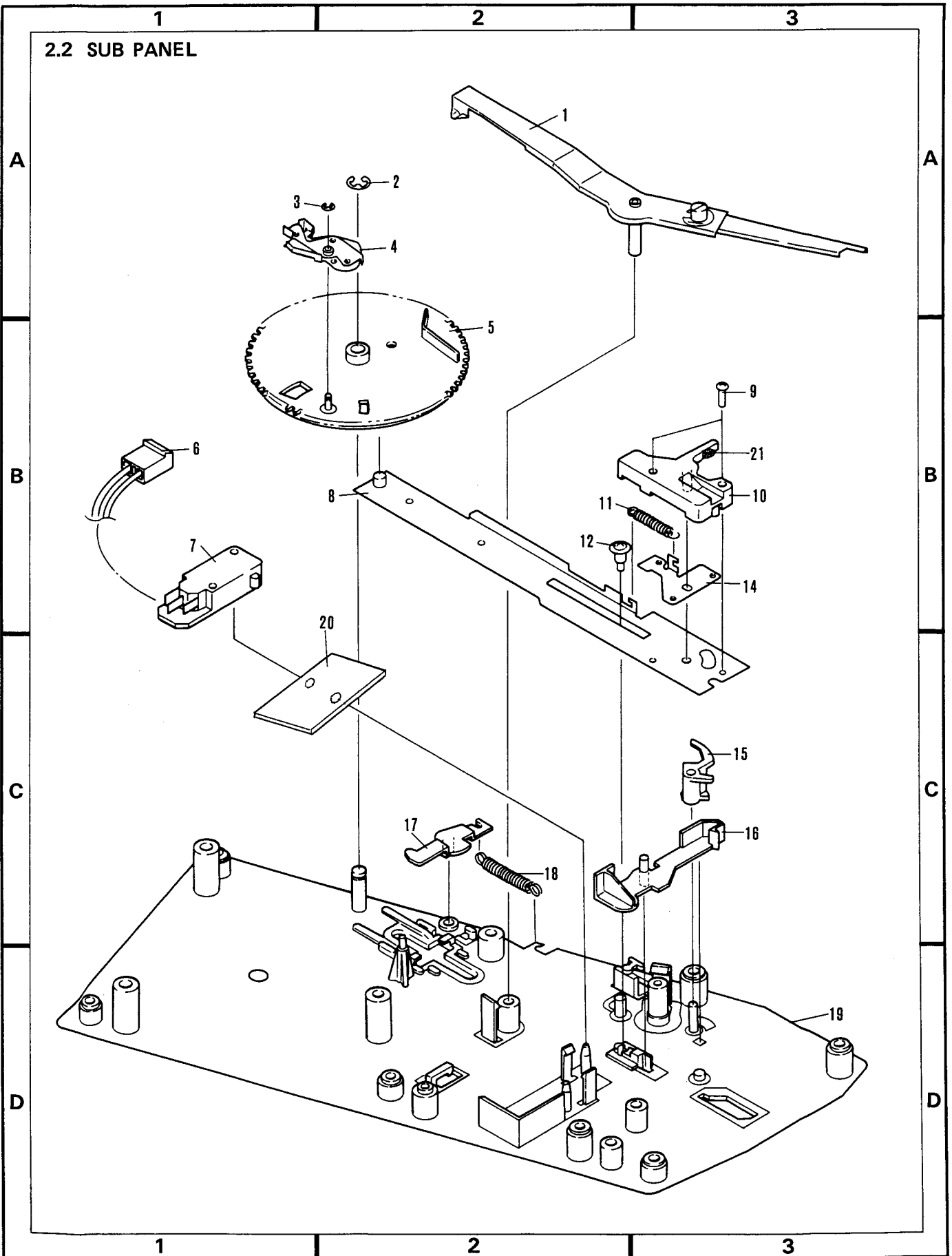

Parts List of Sub Panel

Key No.	Part No.	Description	Key No.	Part No.	Description
1.	PXT-355	Detector lever unit	11.	PBH-224	Spring
2.		E type washer 4	12.	PBA-103	Screw
3.		E type washer 1.5	13.		
4.	PYY-058	Return signal unit	14.	PNC-126	START plate
5.	PNX-036	Cam	15.	PNX-031	Switch plate
⚠ 6.	PDE-070	Connector assembly	16.	PNX-030	Switch lever
⚠ 7.	PSF-006	Microswitch	17.	PNX-035	Plate
8.		Plate	18.	PBH-225	Spring
9.		Pan head screw 2.6 x 10	19.		Sub panel unit
10.	PNX-033	EV cam	20.	PEC-057	Insulator
			21.	PEC-065	EV cam cushion

2.3 D.D. MOTOR

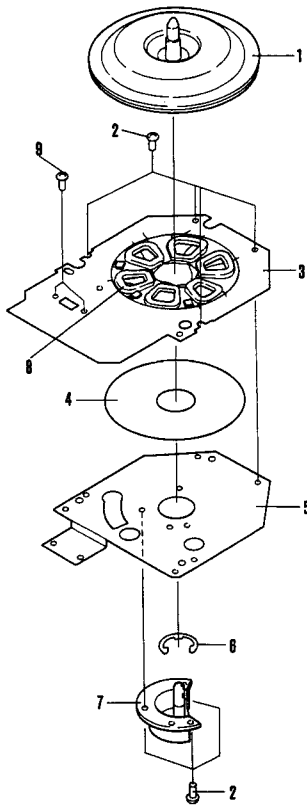

Key No.	Part No.	Description
1.		Rotor unit
2.		Taptite screw 3x5
3.		Control assembly
4.		Insulator
5.		Base unit
6.		EW12
7.		Shaft holder
8.		Coil
9.		Taptite screw 3x12

3. SCHEMATIC DIAGRAM AND PARTS LIST

NOTE:

- When ordering resistors, first convert resistance values into code form as shown in the following examples.

Ex. 1 When there are 2 effective digits (any digit apart from 0), such as 560 ohm and 47k ohm (tolerance is shown by J = 5%, and K = 10%).

560Ω — 56 × 10¹ — 561 RD½PS 561J
 47kΩ — 47 × 10³ — 473 RD½PS 473J
 0.5Ω — 0R5 RN2H 0R5K
 1Ω — 010 RS1P 010K

Ex. 2 When there are 3 effective digits (such as in high precision metal film resistors).

5.62kΩ 562 × 10¹ 5621 RN¼SR 5621F

- The Δ mark found on some component parts indicates the importance of the safety factor of the part. Therefore, when replacing, be sure to use parts of identical designation.

Parts List of D.D. motor (PXM-075)

CAPACITORS

Part No.	Symbol & Description
CEA 101M 6,3NP	C1
CKDYF 403Z 50	C2
CKDYB 681K 50	C3
CQMA 104J 50	C4
CSZA R47K 35	C5
CKDYF 103Z 50	C6, C13, C16—C18
CQMA 104K 50	C7, C20
CEA 010P 50	C8
CEA 100P 16	C9
CEA 471P 25	C10—C12
CCDCH 330J 50	C14
CCDCH 560J 50	C15
CEA 100P 25	C19

Note: When ordering resistors, convert the resistance value into code form, and then rewrite the part no. as before.

RESISTORS

Part No.	Symbol & Description
RD½PS □□□J	R1—R6, R9—R15
RD½PS □□□J	R7, R8
PCP-040	VR1 (10k-B)
PCP-039	VR2 (6.8k-B)

SEMICONDUCTORS AND OTHERS

Part No.	Symbol & Description
PD1003	IC1
PA2004	IC2
PA2005A	IC3
PHE-303FA	H1—H3 Hall element
PSS-003	Crystal

Parts List of Power Supply Assembly

Part No.	Symbol & Description
2SD880	Q1
2SC945	Q2
2SC1211	Q3
PCX-010	D1
WZ-220	D2
BR5504S	D3—D6
CKDYF 103Z 50	C4
CEA 471M 50L	C2
CEA 101M 25L	C3
Δ PCL-036	C1
RD½PS 272J	R3
RS2PF 181J	R2
RS1PF 332J	R1
RD½PS 562J	R4
PSG-020	S2 Speed selector
PDE-062	Connector assembly
PNX-015	Insulator
PBH-261	Push button spring

D.D. MOTOR
PXM-075

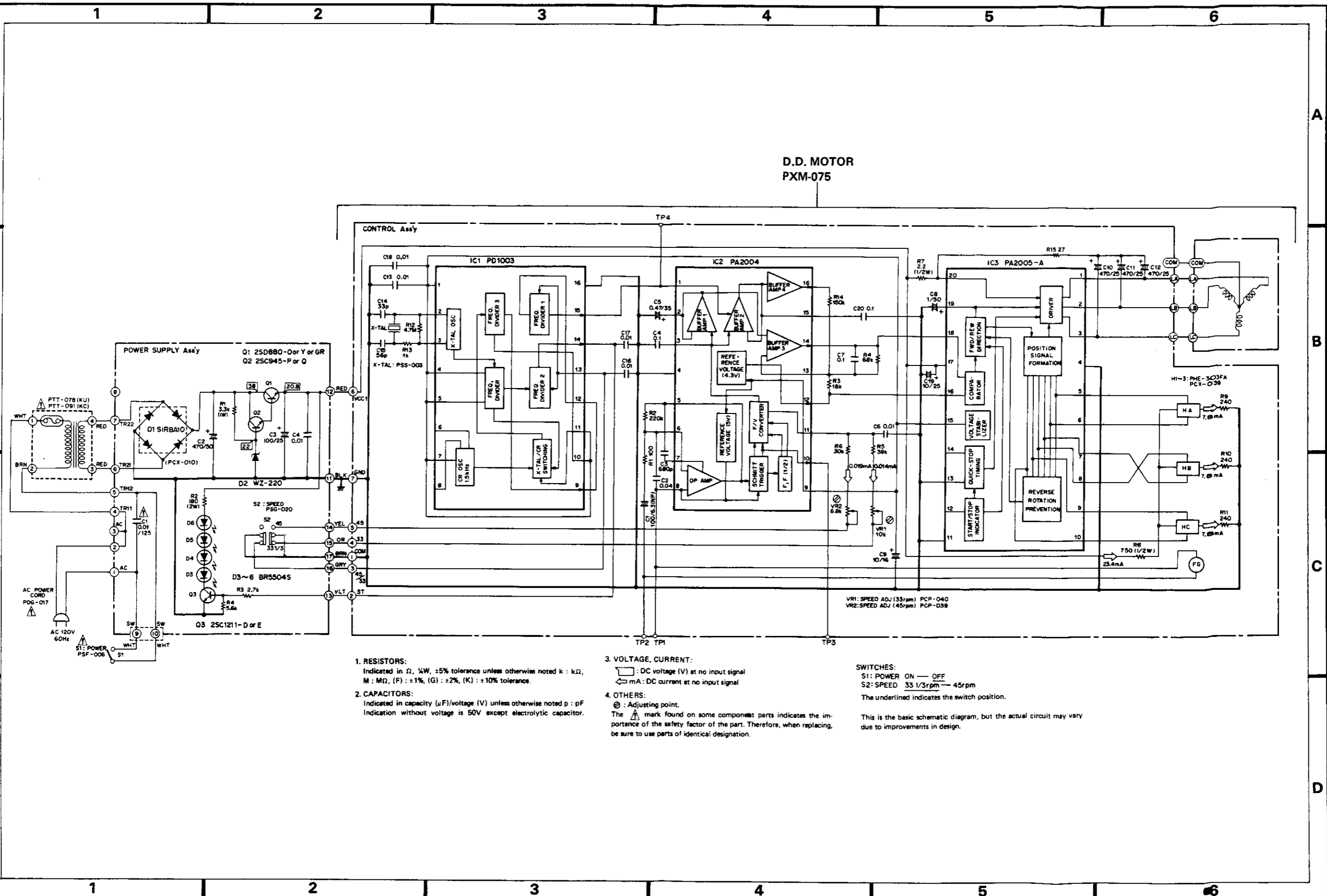

1. RESISTORS:

Indicated in Ω , $\frac{1}{4}W$, $\pm 5\%$ tolerance unless otherwise noted k : k Ω , M : M Ω , (F) : $\pm 1\%$, (G) : $\pm 2\%$, (K) : $\pm 10\%$ tolerance.

2. CAPACITORS:

Indicated in capacity (μF)/voltage (V) unless otherwise noted p : pF Indication without voltage is 50V except electrolytic capacitor.

3. VOLTAGE, CURRENT:

\square : DC voltage (V) at no input signal
 \leftarrow mA : DC current at no input signal

4. OTHERS:

\odot : Adjusting point.
The \triangle mark found on some component parts indicates the importance of the safety factor of the part. Therefore, when replacing, be sure to use parts of identical designation.

SWITCHES:

S1: POWER ON — OFF
S2: SPEED 33 1/3rpm — 45rpm
The underlined indicates the switch position.

This is the basic schematic diagram, but the actual circuit may vary due to improvements in design.

5. PACKING

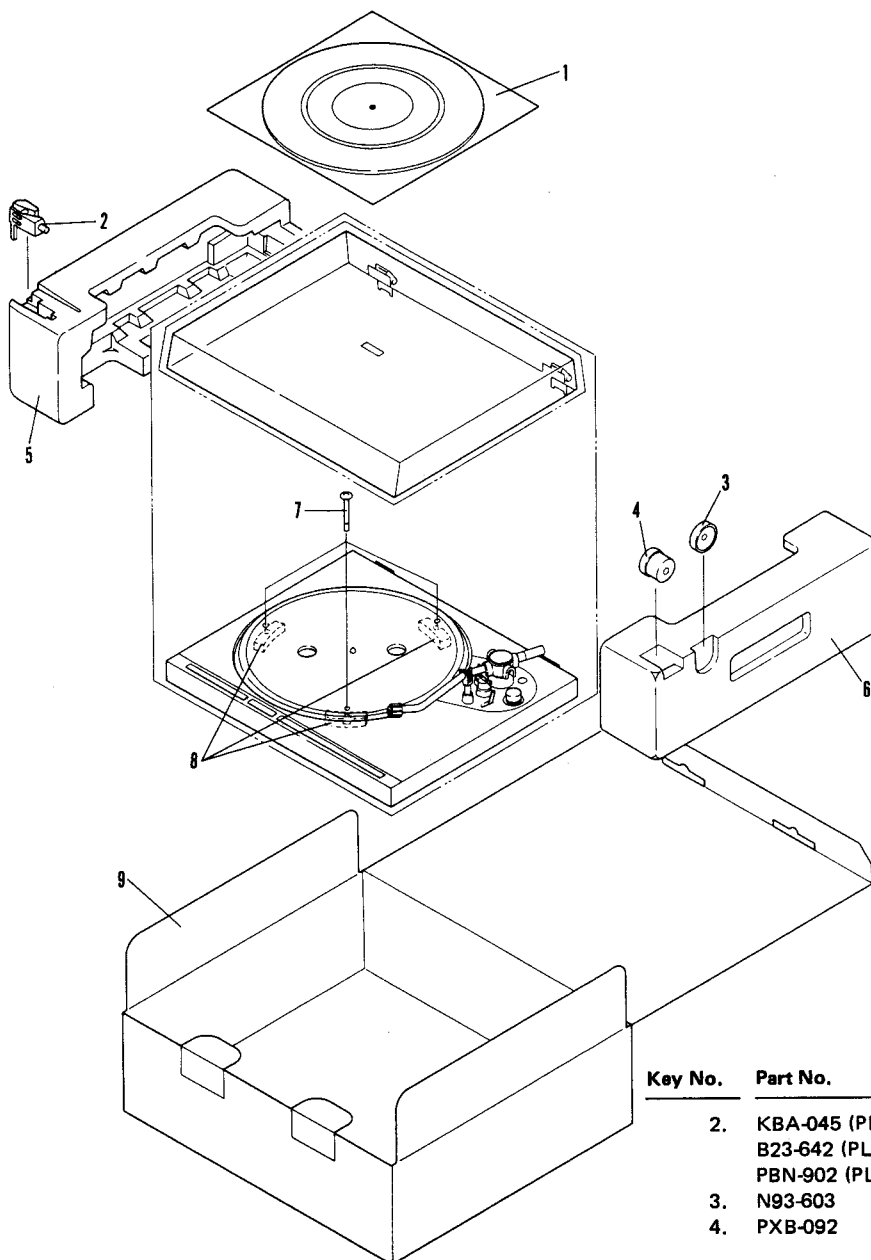

Parts List

Key No.	Part No.	Description
1.	PEB-150 (KCT) PEB-152 (KUT, KU)	Rubber mat assembly
2.	PXA-792 (PL-300) PXA-791 (PL-300X) PXT-941 (PL-300X)	Headshell assembly Cartridge assembly

Key No.	Part No.	Description
2.	KBA-045 (PL-300X) B23-642 (PL-300X) PBN-902 (PL-300X)	Cartridge mounting screw Cartridge mounting washer Cartridge mounting nut
3.	N93-603	45 adaptor
4.	PXB-092	Weight assembly
5.	PHA-107	Side protector L
6.	PHA-108	Side protector R
7.	PBA-100	Screw
8.	PNX-064	Turntable protector
9.	PHG-391 (PL-300/KCT) PHG-390 (PL-300/KUT) PHG-392 (PL-300X) PRB-144 (PL-300) PRB-145 (PL-300X) PXB-125 (PL-300) H56-603	Packing case Operating instructions Cartridge mounting screw assembly Vinyl bag