

STEREO TURNTABLE

# PL-512X

# PL-512XD

KUT

KU

## OPERATING INSTRUCTIONS

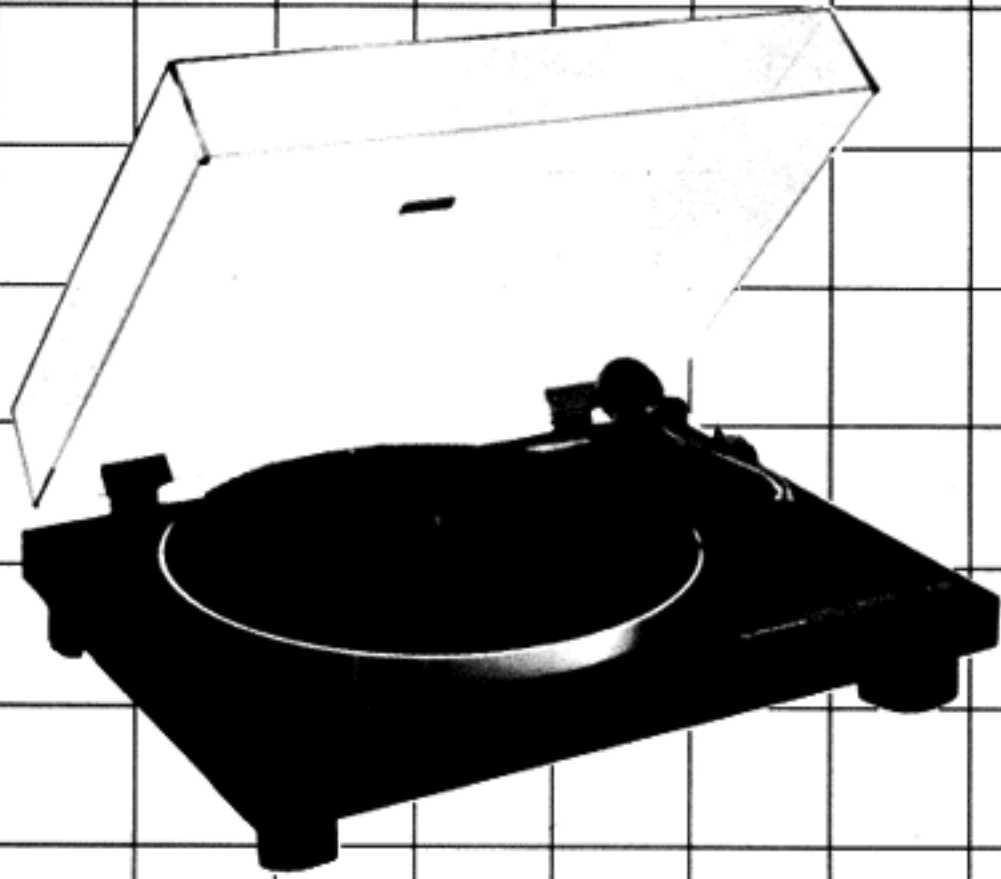

PL-512X: Black vinyl finish  
PL-512XD: Walnut grained vinyl finish

### IMPORTANT NOTICE

The serial number for this equipment is located on the rear.

Please write this serial number on your enclosed warranty card and keep in a secure area. This is for your security.

This turntable is available in two models: one with a Pioneer phono cartridge PC-135 (PL-512XD), and the other without a phono cartridge (PL-512X). The performance and functions are the same. These OPERATING INSTRUCTIONS are based on the latter PL-512X.

In addition, the former turntable (PL-512XD) has an walnut grained vinyl finish cabinet and the latter (PL-512X) has a black vinyl finish cabinet.

**WARNING: TO PREVENT FIRE OR SHOCK HAZARD,  
DO NOT EXPOSE THIS APPLIANCE TO RAIN OR  
MOISTURE.**

 **PIONEER**

# ASSEMBLY PROCEDURE

## 1. ACCESSORIES

The accessory parts are installed in the protective pad on the turntable cabinet (Fig. 5).

## 2. ATTACHING THE TURNTABLE PLATTER

Set the platter down over the center shaft, being careful not to apply excessive force to the shaft.

## 3. ATTACHING THE DRIVE BELT

Set the speed select lever to the 33 position.

After the belt has been properly positioned on the motor pulley, remove the ribbon and place the platter mat (Fig. 6).

## 4. ATTACHING THE COUNTERWEIGHT

Slide the counterweight onto the counterweight shaft at the rear end of the tonearm and turn it 3 to 4 times clockwise (Fig. 7).

## 5. ATTACHING THE HEADSHELL

Insert the headshell (with the cartridge already attached) into the end of the tonearm (align the guide pin with the groove as shown in Fig. 8), and secure by turning the locking collar.

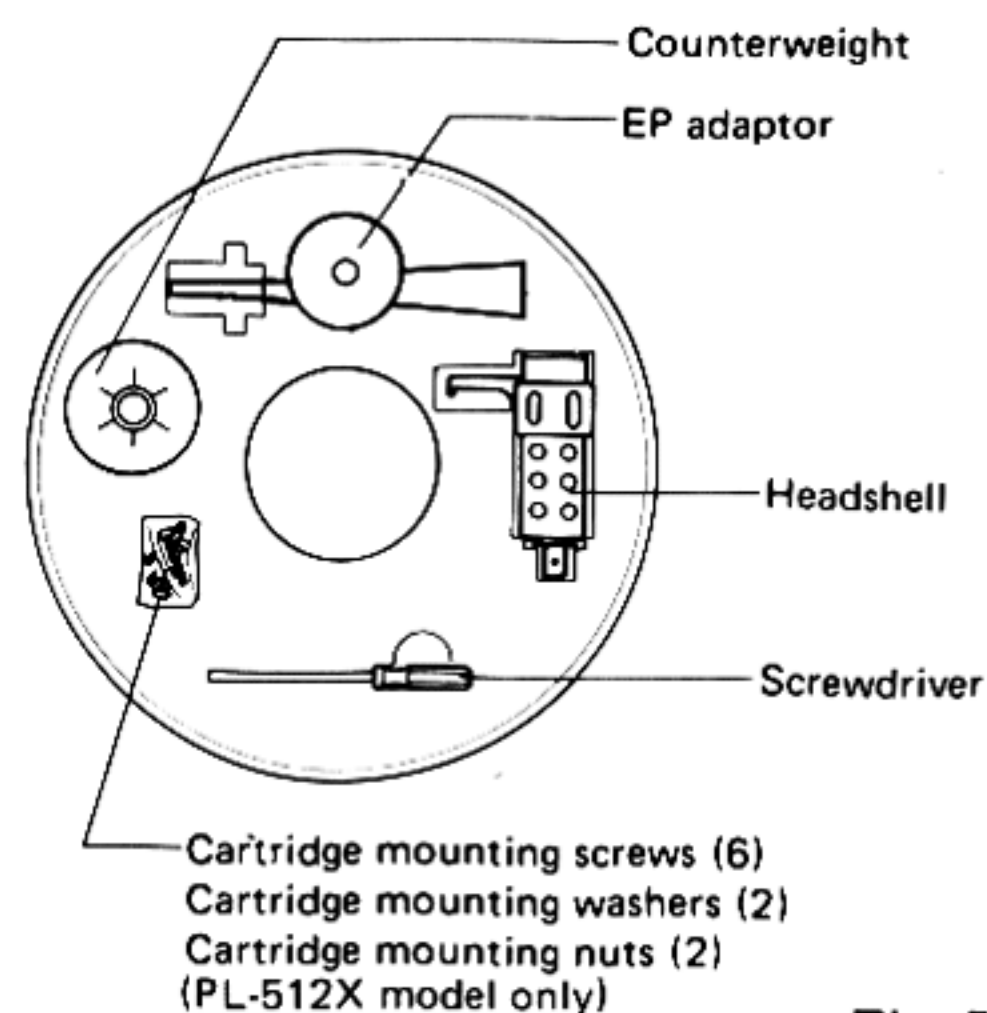

Fig. 5

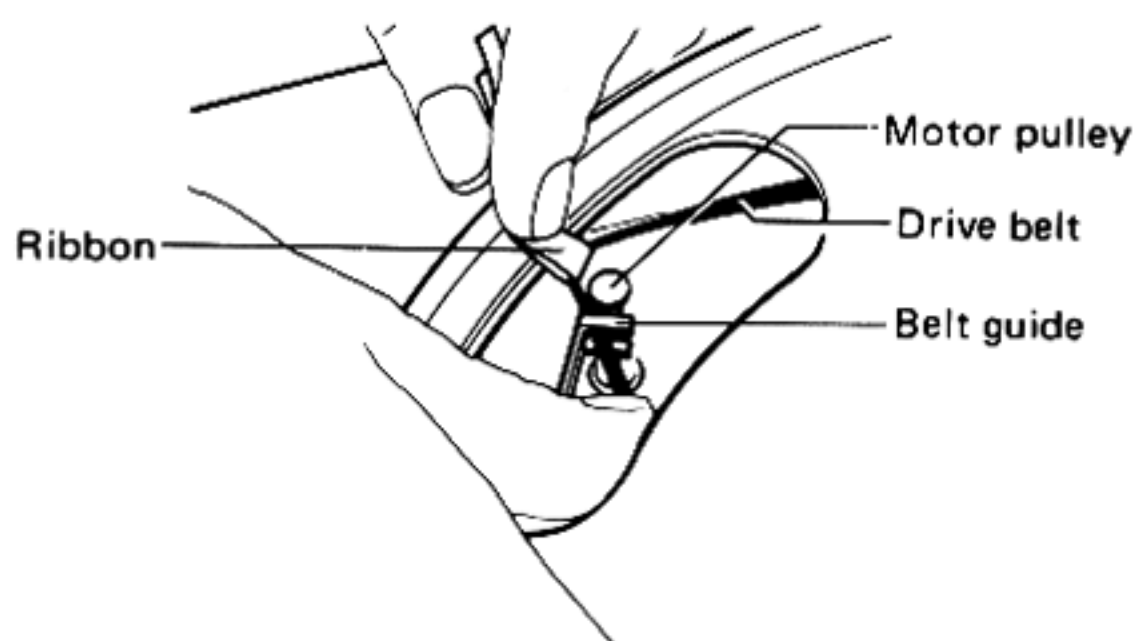

Fig. 6

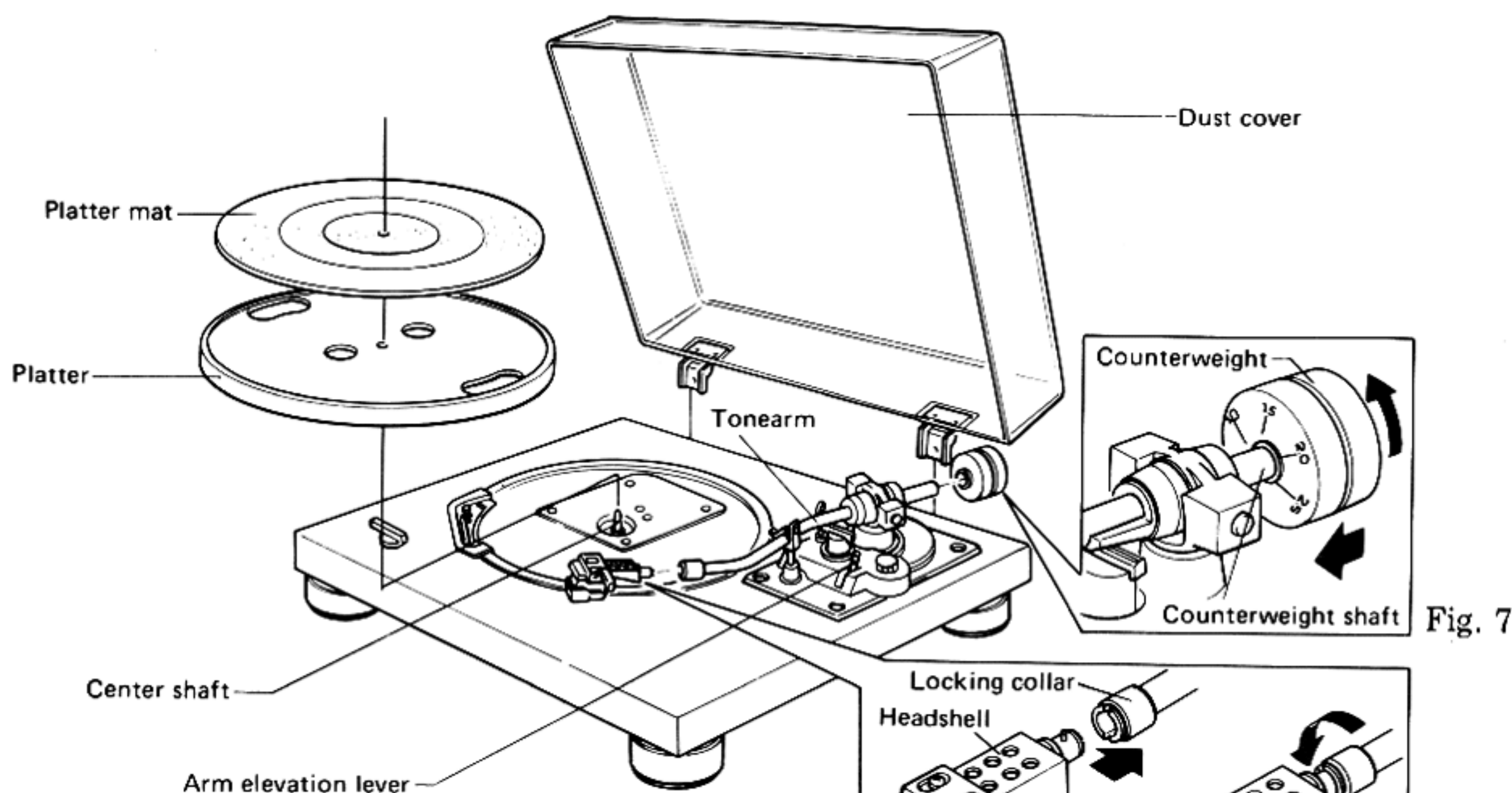

Fig. 7

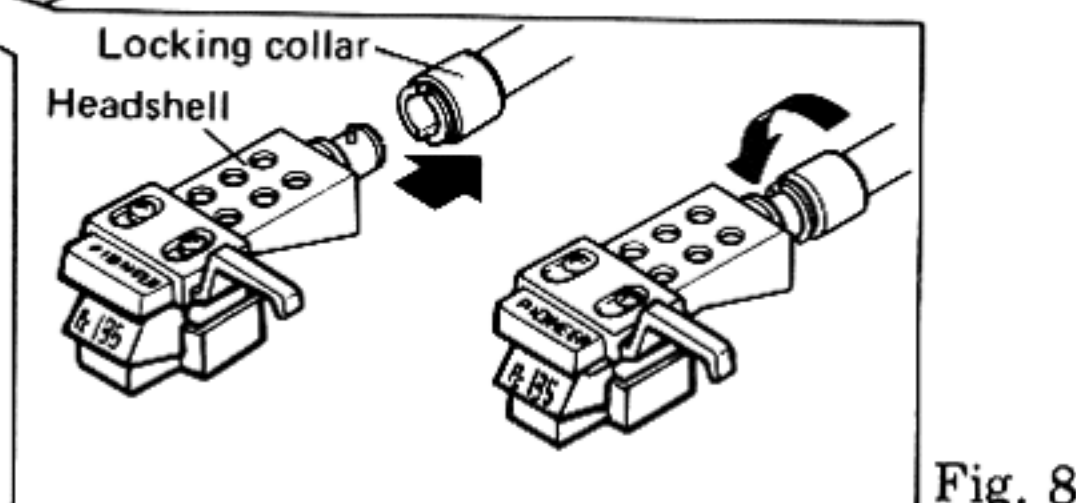

Fig. 8

# ADJUSTING THE TONEARM

## LEVEL BALANCE ADJUSTMENT

1. Set the ANTI-SKATE knob to "0".
2. Remove the cartridge stylus cover.
3. Set the ARM-ELEVATION lever to the ▼ position.
4. Release the arm clamp and move the tonearm to the space between the arm rest and the platter, taking care not to damage the stylus.
5. Support the headshell's finger-lift with one hand and attain the level balance by turning the counterweight either clockwise or counter-clockwise. "Level balance" means that the tonearm is parallel to the record on the platter, and that the tonearm pipe, therefore, should not tilt toward the counterweight side or the headshell side (see Fig. 9).
6. Return the tonearm to the arm rest and fasten the arm clamp.
7. Attach the stylus cover to protect the stylus.
8. Since the tracking force is zero when the tonearm is balanced level, turn just the tracking-force scale ring in front of the counterweight, and set the "0" on the scale to the index line on the shaft (Fig. 10). When doing so, be sure to hold the counterweight with the other hand so that it does not turn together with the scale ring.

## TRACKING FORCE ADJUSTMENT

Turning the counterweight, set the correct tracking force opposite the index line on the counterweight shaft (Fig. 11).

The tracking-force scale ring has 0.5g steps, and one full turn of the counterweight will yield a tracking force of 3g.

*The PC-135 cartridge that comes with the PL-512XD has a tracking force of 2 grams. Turn the counterweight to the 2 mark.*

## ANTI-SKATING ADJUSTMENT

To adjust the anti-skating mechanism, turn the ANTI-SKATE knob so that the number corresponding to the required tracking force is opposite the index line (Fig. 12).

The numbers on the ANTI-SKATE knob correspond to 1g of tracking force.

*When the tonearm is set to 2 grams for the PC-135, set 2 on the knob adjacent to the index line on the panel.*

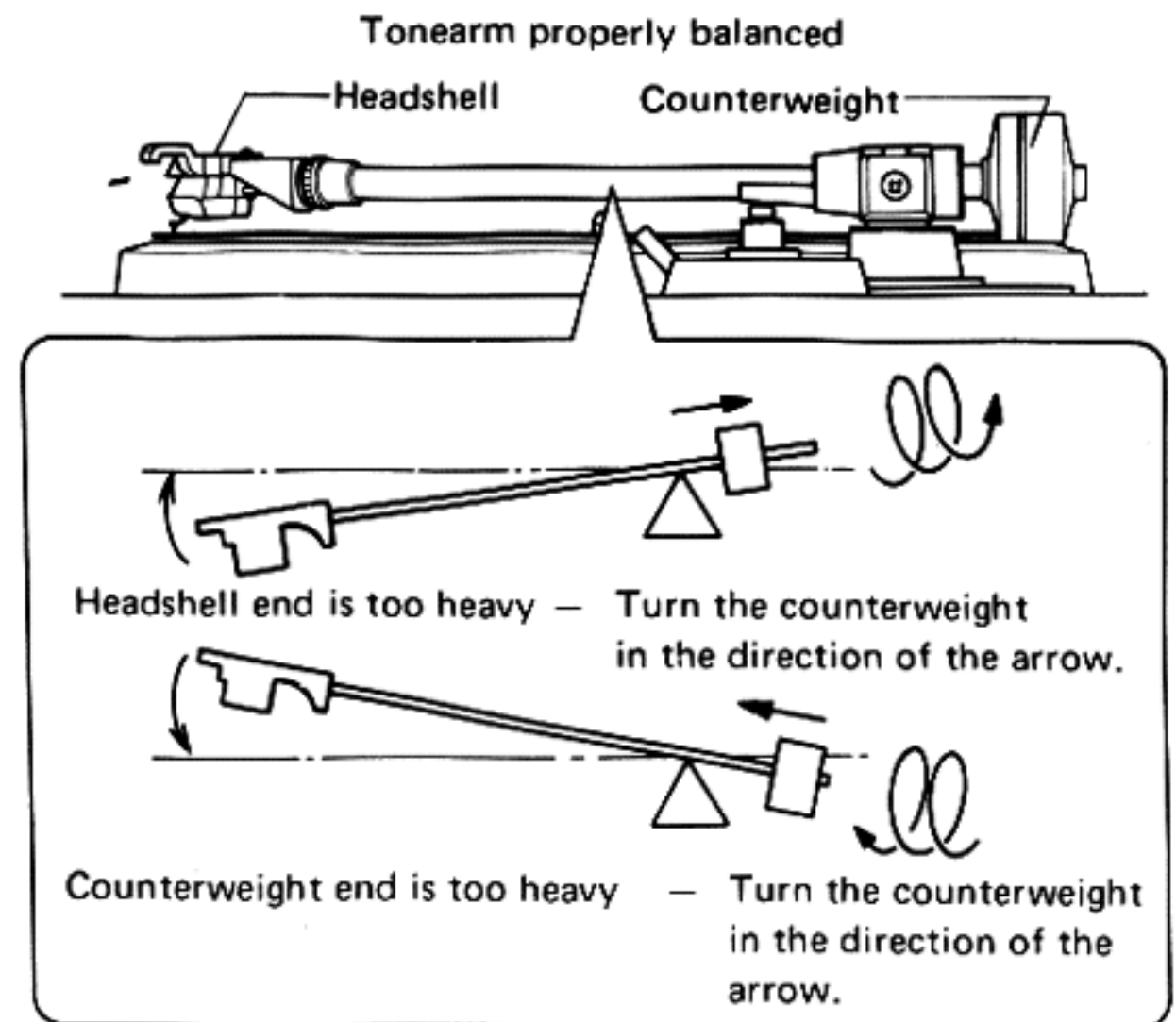
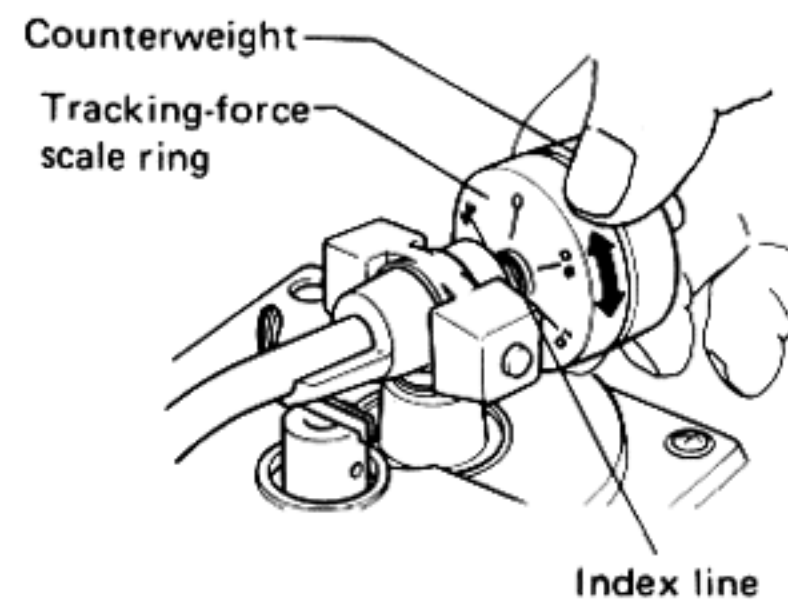

Fig. 9



Fi 10

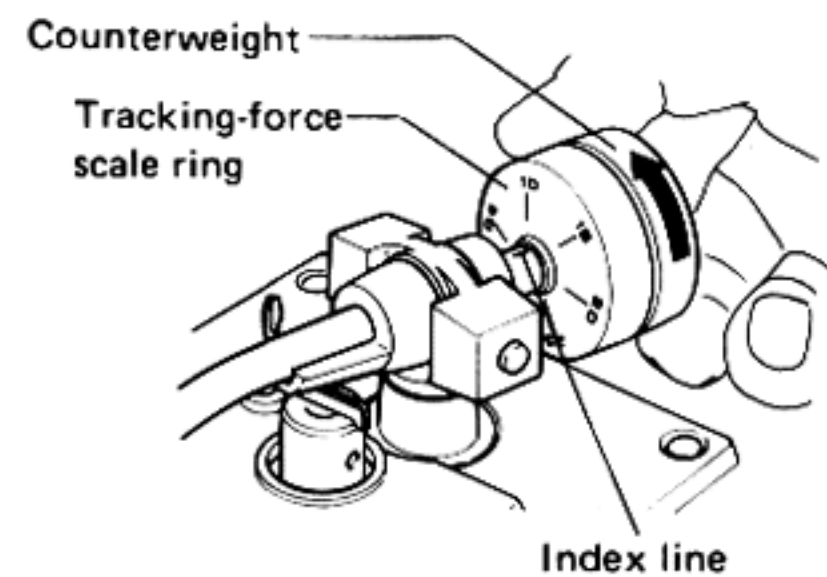

Fig. 11

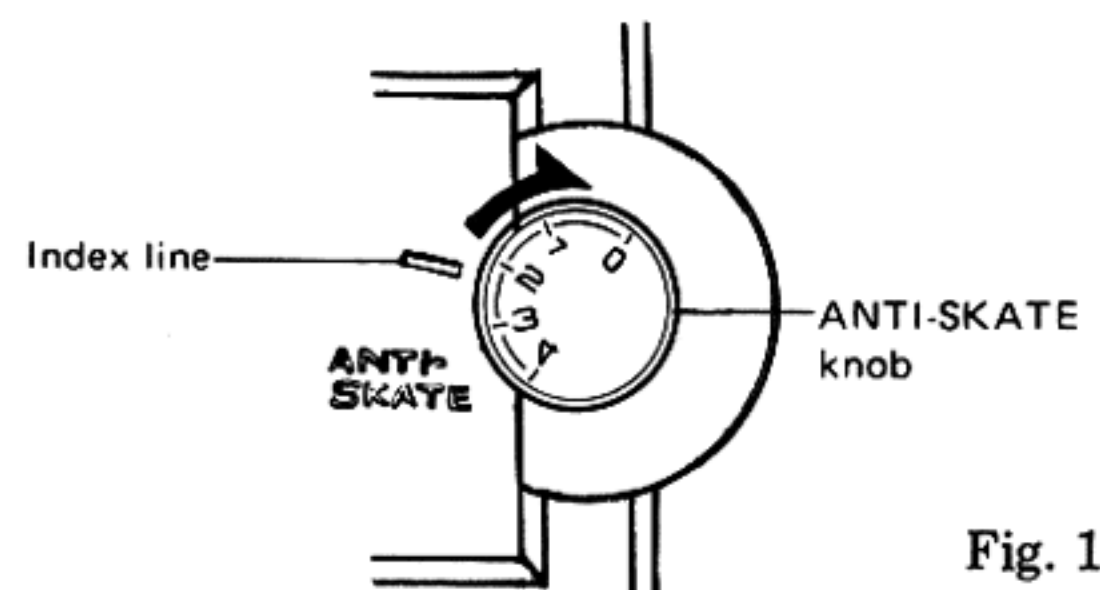

Fig. 12



# CONNECTIONS

The turntable phono cables and ground lead are attached to the rear panel of the turntable. The phono cable with the white plug is for the left channel and the one with the red plug is for the right channel. The thin wire with the Y-shaped connector at the end is the ground lead. This should be firmly connected to the ground terminal on the amplifier.

The way in which the phono cables are attached will depend on the type of cartridge used. Read the instructions in the booklet that comes with the cartridge as well as the operating instructions of the amplifier, and connect the phono cables properly.

Finally, plug the power cord into the power outlet.

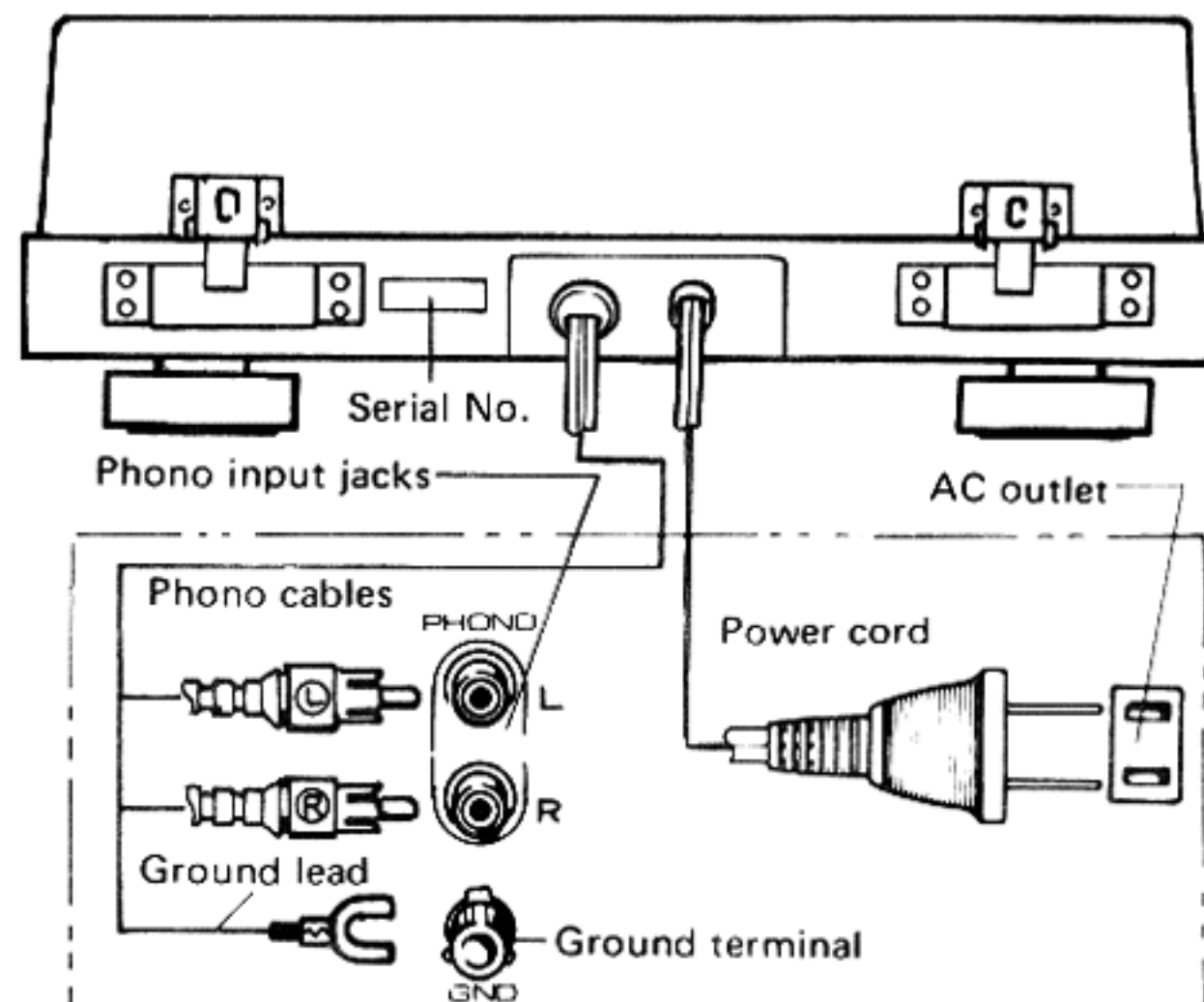

Fig. 13

-----  
*With the PL-512XD (the model with the PC-135 cartridge, plug the phono cables into the PHONO or PHONO MAG jacks of the stereo amplifier.*  
 -----

# INSTALLATION PRECAUTIONS

When installing this turntable, make sure that you avoid the following conditions:

Conditions to be avoided	Possible problems caused
(1) Exposure to direct sunlight, high temperatures or high humidity.	(1) Can cause rust or interfere with insulation.
(2) Unstable surfaces.	(2) Will interfere with normal operation of turntable (stylus will jump, etc.).
(3) Dirty or dusty locations.	(3) Can cause scratches.
(4) Exposure to heavy vibrations, such as on the top of speakers, etc.	(4) Can cause howl.
(5) Proximity to power transformer of the amplifier.	(5) Can cause hum.
(6) Locations where alcohol, insecticides, or flammable substances are frequently used.	(6) Can corrode dust cover or outside of cabinet.

If the turntable is brought into the warm from previously cold surroundings, or if the room temperature rises suddenly, moisture will form on the operating sections and the turntable will not be able to display its performance to the full.

If confronted with a situation like this, leave the turntable in its new environment for about an hour or try and increase the room temperature gradually before operation.

# PANEL FACILITIES AND OPERATION

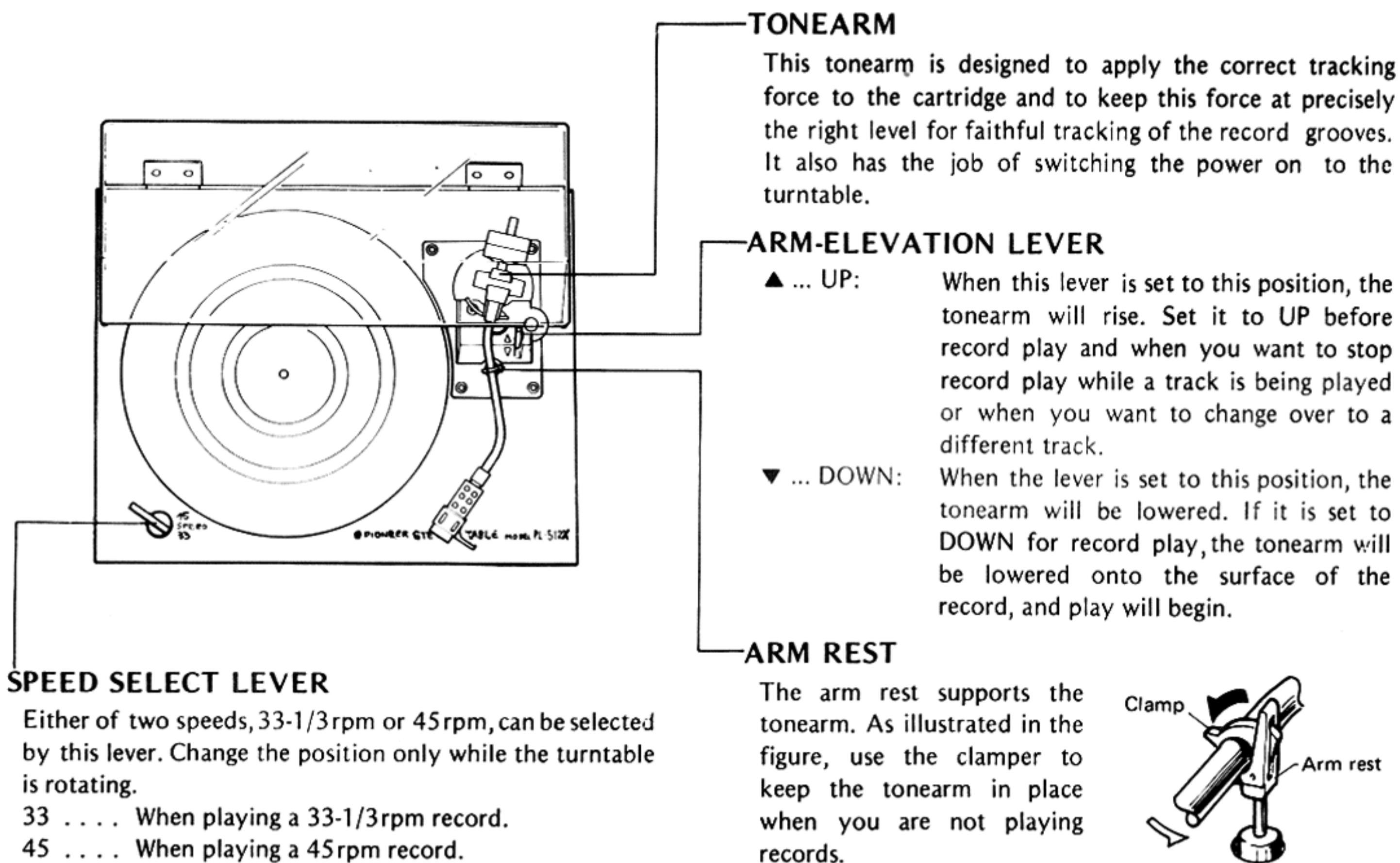

## TONEARM

This tonearm is designed to apply the correct tracking force to the cartridge and to keep this force at precisely the right level for faithful tracking of the record grooves. It also has the job of switching the power on to the turntable.

## ARM-ELEVATION LEVER

- ▲ ... UP: When this lever is set to this position, the tonearm will rise. Set it to UP before record play and when you want to stop record play while a track is being played or when you want to change over to a different track.
- ▼ ... DOWN: When the lever is set to this position, the tonearm will be lowered. If it is set to DOWN for record play, the tonearm will be lowered onto the surface of the record, and play will begin.

## ARM REST

The arm rest supports the tonearm. As illustrated in the figure, use the clammer to keep the tonearm in place when you are not playing records.

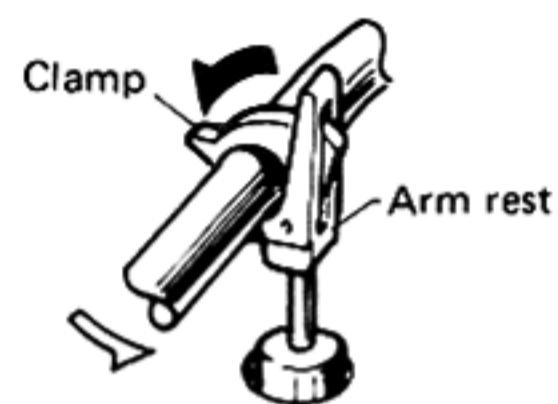

## SPEED SELECT LEVER

Either of two speeds, 33-1/3rpm or 45rpm, can be selected by this lever. Change the position only while the turntable is rotating.

- 33 . . . . . When playing a 33-1/3rpm record.
- 45 . . . . . When playing a 45rpm record.

## OPERATING PROCEDURE

1. Place the record to be played on the platter.
2. Set the arm-elevation lever to the ▲ position.
3. Remove the stylus cover and release the arm clamp.
4. Hold the headshell by the finger-lift and move the stylus over the record to the track you want played. The platter will begin to rotate.
5. Set the speed select lever to the speed at which the record is to be played.
6. Set the arm-elevation lever to the ▼ position. The stylus will descend slowly to the record and play will begin.
7. Adjust the volume and tone controls on the amplifier to the preferred levels, and then sit back and enjoy your record.
8. After the record has been played, set the arm-elevation lever to the ▲ position. Hold the headshell finger-lift and move the tonearm to the arm rest after raising the tonearm. At the same time, the power to the turntable is turned off, and the platter stops rotating.
9. Secure the tonearm to the arm rest with the arm clamp and attach the stylus cover to protect the stylus.

## OPERATION PRECAUTIONS

- Always clean the stylus both before and after playing a record with a soft brush and try to make it a rule to clean the records with a good quality cleaner.
- Be careful not to make the turntable vibrate while a record is playing, since this can result in damage to the stylus and record.
- When changing over the headshell, clamp the tonearm to the arm rest so that the tonearm shaft is not strained in any way.
- Place only one record at a time on the platter. If two or more records are stacked on the platter, the stylus will not make proper contact with the grooves, and this will impair the quality of reproduction.
- Do not disconnect the power cord while the stylus is still in a record groove, as this may result in damage to the stylus and record.
- Never obstruct the turntable with your hand while it is rotating. This may cause damage.



# PANEL FACILITIES AND OPERATION

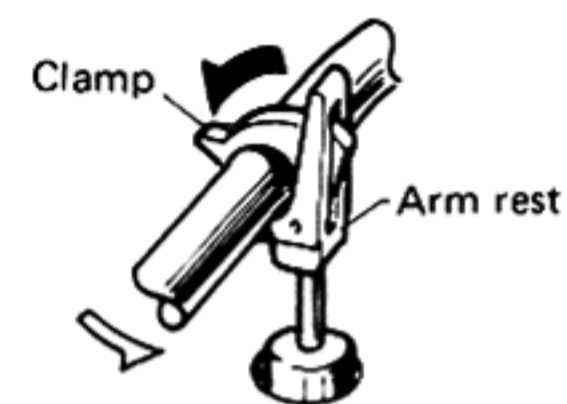
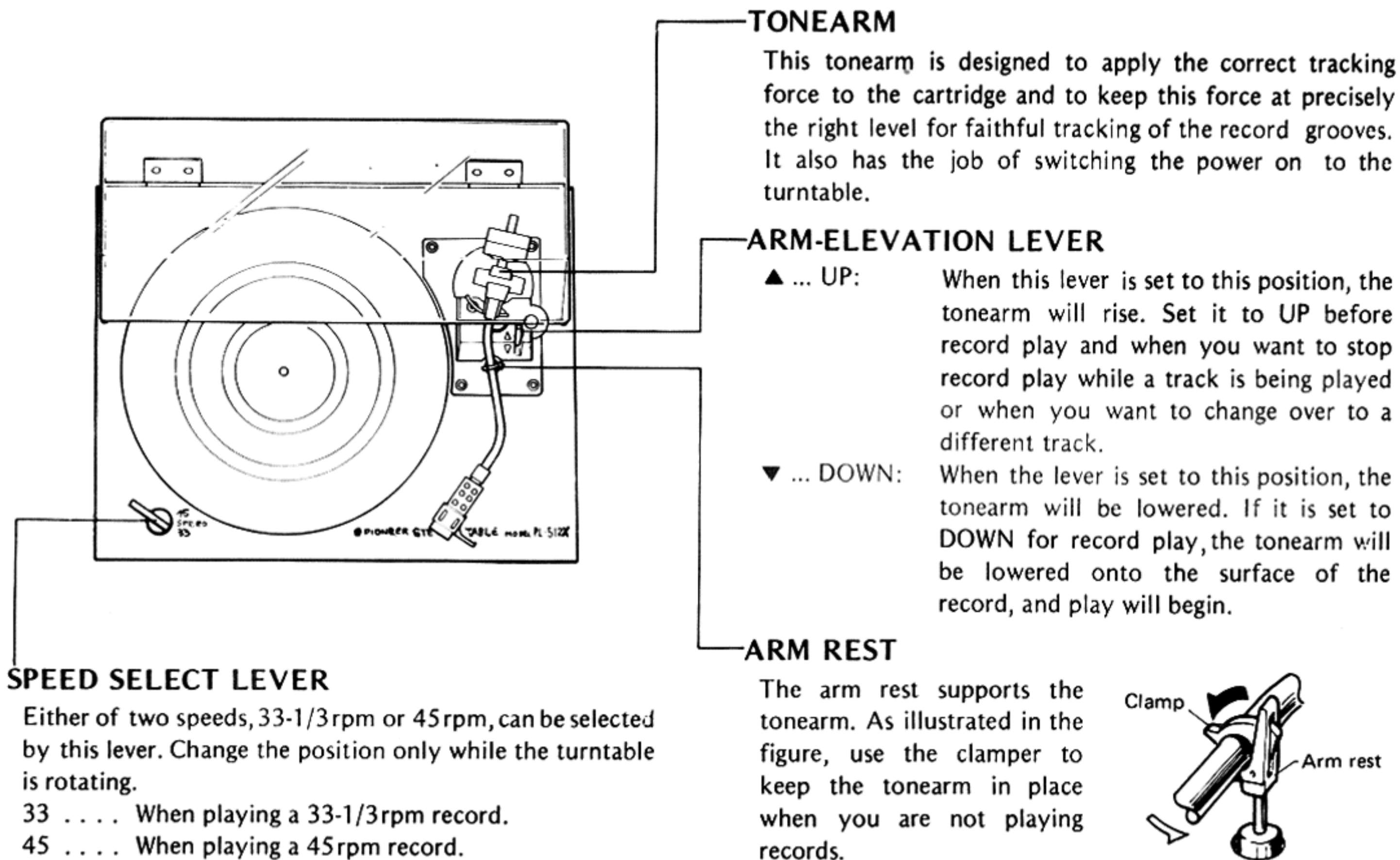

## OPERATING PROCEDURE

1. Place the record to be played on the platter.
2. Set the arm-elevation lever to the ▲ position.
3. Remove the stylus cover and release the arm clamp.
4. Hold the headshell by the finger-lift and move the stylus over the record to the track you want played. The platter will begin to rotate.
5. Set the speed select lever to the speed at which the record is to be played.
6. Set the arm-elevation lever to the ▼ position. The stylus will descend slowly to the record and play will begin.
7. Adjust the volume and tone controls on the amplifier to the preferred levels, and then sit back and enjoy your record.
8. After the record has been played, set the arm-elevation lever to the ▲ position. Hold the headshell finger-lift and move the tonearm to the arm rest after raising the tonearm. At the same time, the power to the turntable is turned off, and the platter stops rotating.
9. Secure the tonearm to the arm rest with the arm clamp and attach the stylus cover to protect the stylus.

## OPERATION PRECAUTIONS

- Always clean the stylus both before and after playing a record with a soft brush and try to make it a rule to clean the records with a good quality cleaner.
- Be careful not to make the turntable vibrate while a record is playing, since this can result in damage to the stylus and record.
- When changing over the headshell, clamp the tonearm to the arm rest so that the tonearm shaft is not strained in any way.
- Place only one record at a time on the platter. If two or more records are stacked on the platter, the stylus will not make proper contact with the grooves, and this will impair the quality of reproduction.
- Do not disconnect the power cord while the stylus is still in a record groove, as this may result in damage to the stylus and record.
- Never obstruct the turntable with your hand while it is rotating. This may cause damage.

# GENERAL PRECAUTIONS

## LUBRICATION

After a single oiling, the turntable can normally be used reliably for about 2000 to 2500 hours. This is equivalent to 1.5 to 2 years in normal usage (an average of 3 to 4 hours per day). Replenishing the oil once within the time period can assure continued high performance. Perform oiling carefully as described below:

1. Remove the dust cover.
2. Place the tonearm on the arm rest and clamp it.
3. Remove the belt from the motor pulley.
4. Lift the platter straight up by inserting fingers and thumb into the two openings.
5. Apply one or two drops of the lubricating oil to the hole (Fig. 1).

## CABINET

When the dust cover or the cabinet is dirty or dusty, wipe them clean with a polishing cloth or other soft cloth. Do not use furniture wax or bring the turntable into contact with benzine, insecticides or any other flammable material, since they will corrode the outside of the turntable.

# ATTACHING THE CARTRIDGE

(Applicable to PL-512X model only)

You can attach any cartridge to this turntable weighing between 4g and 10g on condition that only the accessory headshell is used with it. Follow the procedure outlined below for attaching the cartridge to the headshell.

1. Take out the headshell, cartridge mounting screws, nuts, washers and small screwdriver from the accessory box.  
The screws come in three different lengths so choose the screws according to the height of the cartridge you intend to attach.
2. The terminals on the accessory headshell are aligned as shown in Fig. 2. Check the location and polarity of each of the cartridge's terminal pins and then connect the lead wires, taking care not to get the polarities mixed up.
3. Attach the cartridge lightly to the headshell using the screws, nuts and washers (Fig. 3).
4. Adjust the position of the cartridge so that the stylus and the connector section of the headshell are 49mm apart and tighten up the screws. Make sure that the cartridge does not tilt to one side when you attach it (see Fig. 4).

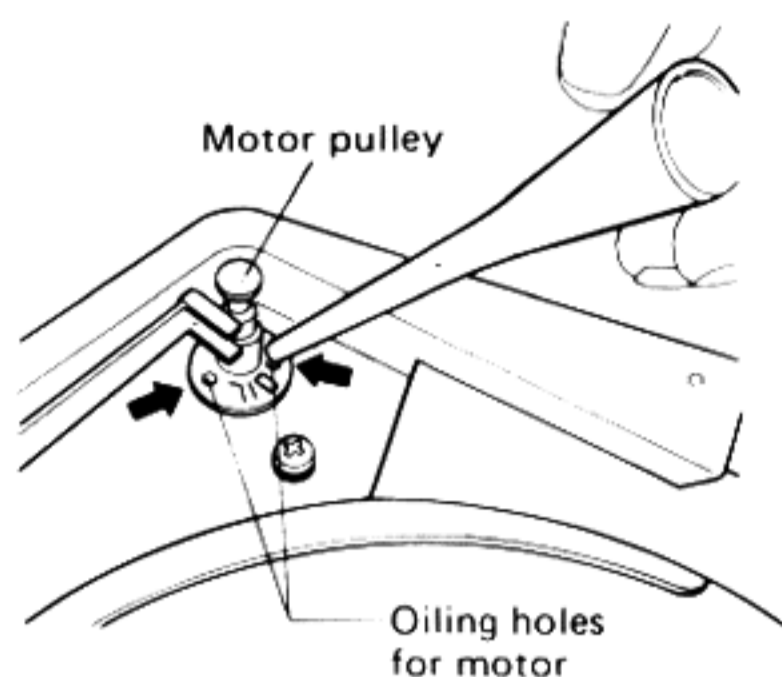

Fig. 1

### NOTE:

If oil should adhere to the motor pulley, inner rim, or belt, wipe it off with a cloth moistened with pure alcohol.

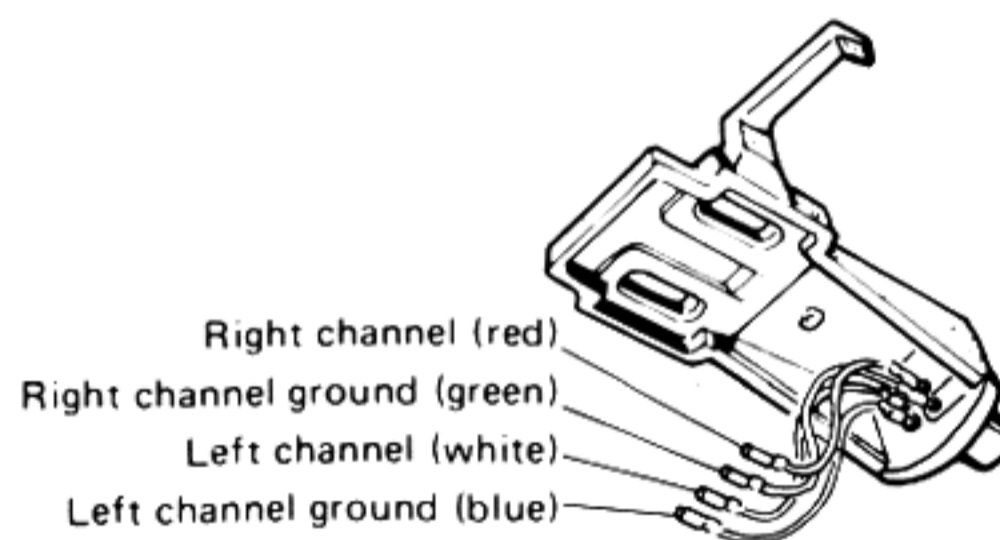

Fig. 2

### NOTE:

Do not solder when you connect the lead wires to the cartridge. If the lead wire lugs are loose, use a pair of tweezers or a similar object to pinch in the end lightly.

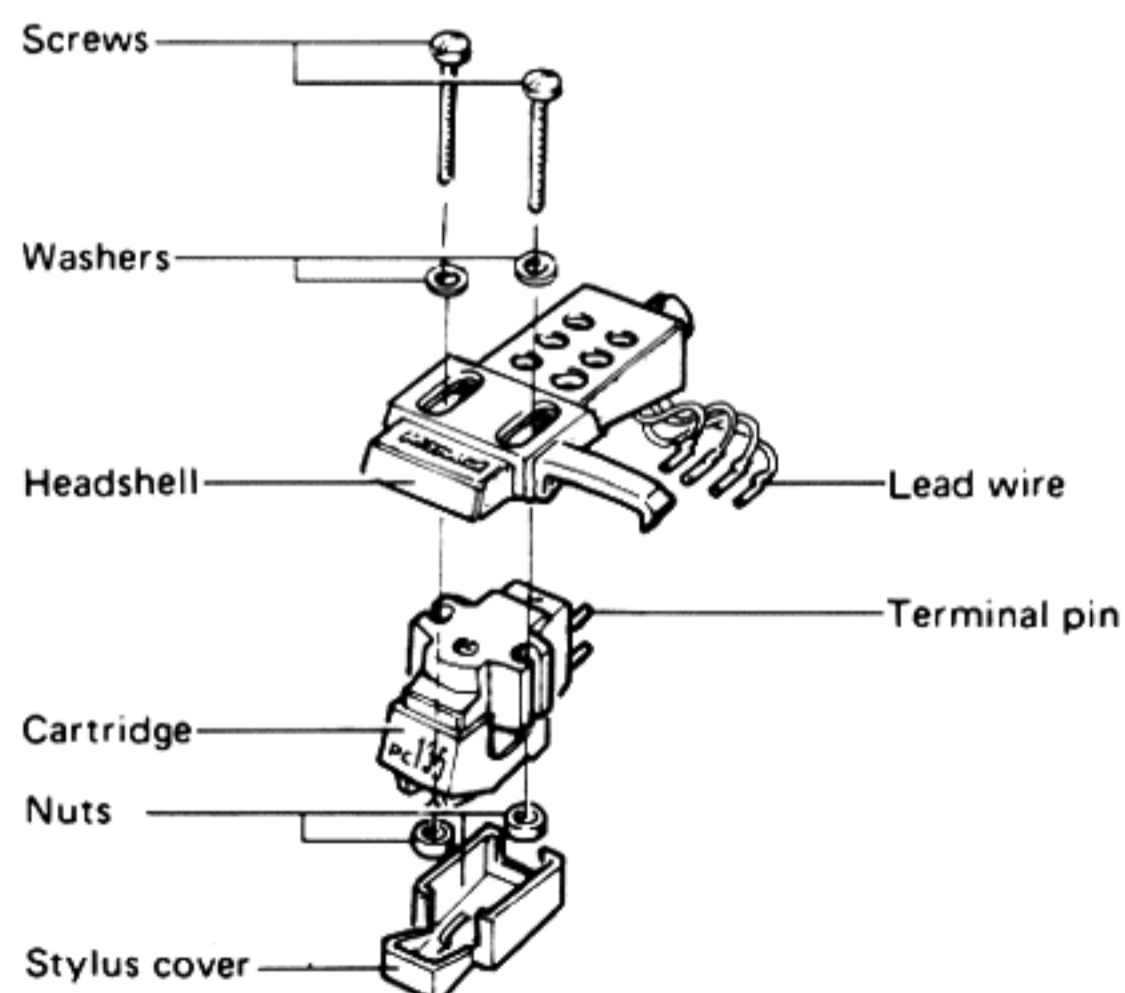

Fig. 3

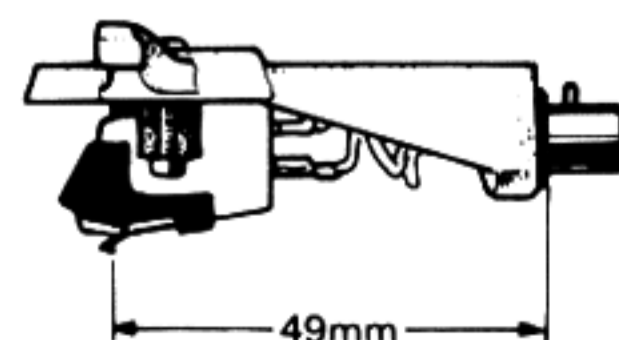

Fig. 4



# SPECIFICATIONS

## Motor and Turntable

Drive System:	Belt-drive
Motor:	4-pole synchronous
Turntable Platter:	300mm diam. aluminum alloy die-cast
Speeds:	33-1/3 and 45rpm
Wow and Flutter:	Less than 0.055% (WRMS)
Signal-to-Noise Ratio:	More than 65dB (DIN-B) (with Pioneer cartridge model PC-135)

## Tonearm

Type:	Static-balance type, S-shaped pipe arm
Effective Arm Length:	221mm
Overhang:	15.5mm
Tracking Error:	0.525 deg./in, 0.21 deg./cm
Usable Cartridge Weight:	4g (min.) to 10g (max.)

## Other Features

Cueing device, Detachable dust cover, Insulator feet  
 Plug-in type headshell, particle board cabinet  
 Anti-skating force control

## PC-135 Specifications

Type:	Induced magnet type
Stylus:	0.5-mil diamond (PN-135)
Output Voltage:	3mV (1kHz, 50mm/s Peak velocity, LAT)
Tracking Force:	1.5g to 2.3g (proper 2g)
Frequency Response:	10 to 25,000Hz

## Miscellaneous

Power Requirements:	AC 120V, 60Hz
Power Consumption:	10W
Dimensions:	440(W) x 132(H) x 365(D)mm 17-5/16(W) x 5-3/16(H) x 14-3/8(D) in
Weight:	6.5kg/14lb 5oz

## Accessories

EP adaptor	1
Screwdriver	1
Cartridge mounting screws	6
Cartridge mounting nuts	2
Cartridge mounting washers	2
Operating instructions	1

### NOTES:

- Specifications and design subject to possible modification without notice, due to improvements.
- The PL-512XD (with the accessory cartridge) does not come with cartridge mounting screws, nuts, or washers.

## PC-135 STYLUS REPLACEMENT

The life expectancy of the PC-135 stylus tip is 800—1000 hours. For the sake of maximum sound quality reproduction, we recommend replacement within the minimum time limit. The stylus tip is replaced by grasping the stylus holder and pulling it away from the body of the cartridge (Fig. A). The new stylus tip is then inserted by pushing it into the receptacle. The correct replacement tip is the PN-135. This may be obtained at your Pioneer dealer. Pioneer cannot guarantee performance or reliability if another type of stylus is employed.

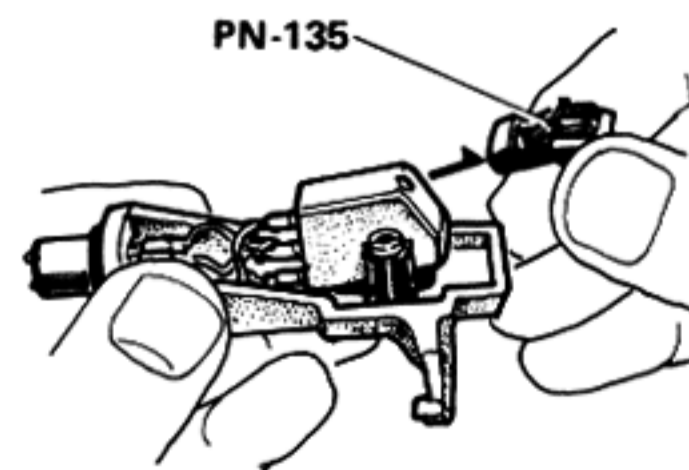

Fig. A



# TROUBLESHOOTING

Sometimes, an operational fault can be mistaken for a malfunction or failure. Check the following points and see if the symptoms of the trouble are outlined below before you get in touch with the serviceman. If you cannot remedy the symptoms, contact your nearest Pioneer Service Center, Service Station or authorized Pioneer dealer.

Symptom	Possible trouble	Remedy
Platter does not rotate.	<ol style="list-style-type: none"> <li>1. Power cord is unplugged.</li> <li>2. Drive belt is disconnected or loose.</li> </ol>	<ol style="list-style-type: none"> <li>1. Plug cord securely into wall outlet.</li> <li>2. Attach drive belt properly on motor pulley.</li> </ol>
No sound	<ol style="list-style-type: none"> <li>1. Phono cables are not connected properly.</li> <li>2. Headshell is not properly attached.</li> <li>3. Cartridge lead wires are loose.</li> <li>4. Amplifier is not being operated properly. (Function switch, tape monitor switch, speaker switches, etc. not set correctly).</li> </ol>	<ol style="list-style-type: none"> <li>1. Connect cables securely to the PHONO terminals on the amplifier.</li> <li>2. Firmly secure tonearm locking collar.</li> <li>3. Attach lead wires inside headshell properly.</li> <li>4. Read the operating instructions that come with amplifier.</li> </ol>
Musical tempo is off.	<ol style="list-style-type: none"> <li>1. Platter speed is not set properly.</li> <li>2. Drive belt is incorrectly fitted.</li> <li>3. Motor pulley and belt are dirty:</li> <li>4. The frequency of your power supply does not suit the PL-512X or PL-512XD.</li> </ol>	<ol style="list-style-type: none"> <li>1. Refer to "PANEL FACILITIES AND OPERATION."</li> <li>2. Attach drive belt properly to motor pulley.</li> <li>3. Wipe the motor pulley and belt clean with a soft cloth moistened with pure alcohol.</li> <li>4. Contact your nearest Pioneer Service Center, Service Station or authorized Pioneer dealer.</li> </ol>
Excessive noise	<ol style="list-style-type: none"> <li>1. Ground lead is not connected.</li> <li>2. Tracking force is not correct.</li> <li>3. Dust or dirt has collected on the stylus tip.</li> <li>4. Dust or dirt has collected on the record.</li> </ol>	<ol style="list-style-type: none"> <li>1. Connect properly to the amplifier's ground terminal.</li> <li>2. Refer to "TRACKING FORCE ADJUSTMENT."</li> <li>3. Clean the stylus tip with a soft brush.</li> <li>4. Clean the record with a good quality cleaner.</li> </ol>
Sound is distorted.	<ol style="list-style-type: none"> <li>1. Dust or dirt has collected on the stylus tip.</li> <li>2. Tracking force is not correct.</li> <li>3. Stylus is worn.</li> <li>4. Amplifier's tone controls set too high.</li> </ol>	<ol style="list-style-type: none"> <li>1. Clean the stylus tip with a soft brush.</li> <li>2. Refer to "TRACKING FORCE ADJUSTMENT."</li> <li>3. Replace with new stylus.</li> <li>4. Set tone controls to lower position.</li> </ol>
Intermittent sound	<ol style="list-style-type: none"> <li>1. Tracking force is not correct.</li> <li>2. Stylus is worn.</li> <li>3. Record is scratched or warped.</li> </ol>	<ol style="list-style-type: none"> <li>1. Refer to "TRACKING FORCE ADJUSTMENT."</li> <li>2. Replace with new stylus.</li> <li>3. Replace record.</li> </ol>

If you detect any trouble when playing records, the fault may not lie with the turntable but with another hi-fi component. Be sure to check the amplifier, speaker systems, and any other electrical equipment which you are using in the vicinity of the turntable.

**PIONEER ELECTRONIC CORPORATION**

4-1, Meguro 1-Chome, Meguro-ku, Tokyo 153, Japan

**U.S. PIONEER ELECTRONICS CORPORATION**

85 Oxford Drive, Moonachie, New Jersey 07074, U.S.A.

**PIONEER ELECTRONIC (EUROPE) N.V.**

Luithagen-Haven 9, 2030 Antwerp, Belgium

**PIONEER ELECTRONICS AUSTRALIA PTY. LTD.**

178-184 Boundary Road, Braeside, Victoria 3195, Australia

Printed in Republic of Korea