

3-MOTOR 3-HEAD SYSTEM TAPE DECK

RT-2022

RT-2044

KU

<ART-174-0>



 **PIONEER®**

CONTENTS

1.	SPECIFICATIONS	7
2.	TRANSPORT UNIT RTU-11 OPERATING	
2.1	Front Panel	9
2.2	Rear Panel	12
3.	AMPLIFIER UNIT TAU-11 OPERATION	
3.1	Front Panel	13
3.2	Rear Panel	15
4.	CONNECTION FOR RT-2022 SYSTEM	16
5.	CONNECTION FOR RT-2044 SYSTEM	17
6.	DISASSEMBLY	
6.1	Back Cover	18
6.2	Side Panels	18
6.3	Control Panel	19
6.4	Mechanical Panel	19
6.5	TAU-11	20
7.	BLOCKDIAGRAM	21
8.	LEVEL DIAGRAMS	
8.1	JT-2022T	23
8.2	JT-2044T	24
9.	TIMING CHARTS	25
10.	RTU-11 PARTS LOCATIONS	
10.1	Front View	27
10.2	Rear View	29
11.	TAU-11 PARTS LOCATIONS	
11.1	Front View	31
11.2	Front View (With Panel Removed)	33
11.3	Bottom View	35
11.4	Rear View	37
12.	RTU-11 EXPLODED VIEW	
12.1	Main Panel	39
12.2	Sub Panel	41
12.3	Frame Chassis	43
12.4	Control & Rear Panel	45
12.5	Handle	47
12.6	Side Panel	47
12.7	Control Panel	48

12.8	Back Cover B	48
12.9	Pinch Solenoid (SL3)	49
12.10	Shut-Off Switch	49
12.11	Capstan Motor	50
12.12	Cue Lever	51
12.13	Function Button	51
12.14	Take-up Motor	52
12.15	Supply Motor	53
12.16	Power Transformer	54
12.17	Control Chassis	55
12.18	Stop Button	55
12.19	EQ Bias Control	56
12.20	Rear Panel	57
12.21	RTU-11 Packing	58
13.	TAU-11 EXPLODED VIEW	59
13.1	Main Chassis	61
13.2	Sub Panel	63
13.3	Top Cover	65
13.4	Front Panel	66
13.5	Side Panel	66
13.6	Rear Panel	67
13.7	TAU-11 Packing	68
14.	JT-211 EXPLODED VIEW	69
14.1	Chassis	70
14.2	Front Panel	71
14.3	JT-211 Packing	72
15.	JT-2022T (JT-2044T) EXPLODED VIEW	73
15.1	JT-2022T (JT-2044T) Packing	74
16.	RTU-11 SCHEMATIC DIAGRAMS, P.C. BOARD PATTERNS AND PARTS LIST	
16.1	Schematic Diagram	75
16.2	Connection Diagram	77
16.3	Miscellaneous Parts	79
16.4	Control Assembly (RWG-050)	80
16.5	Indicator (A) Assembly (RWX-094)	84
16.6	Indicator (B) Assembly (RWX-095)	84
16.7	Function Switch Assembly (RWS-040)	85
16.8	Test O.S.C. Assembly (RWA-024)	86
16.9	REC/PB Amplifier Assembly (RWF-044)	89
16.10	Syncro Amplifier Assembly (RWF-052)	97
16.11	Power Switch Assembly (RWS-033)	103

16.12	Power Supply & O.S.C. Assembly (RWR-031)	104
16.13	Selector Switch Assembly (RWX-121)	108
17.	TAU-11 SCHEMATIC DIAGRAMS, P.C. BOARD PATTERNS AND PARTS LIST	
17.1	Schematic Diagram	111
17.2	Connection Diagram	113
17.3	Miscellaneous Parts	114
17.4	REC Switch Assembly (RWS-034)	115
17.5	Amplifier Assembly (RWF-046)	116
17.6	Monitor Switch Assembly (RWS-035)	121
17.7	Indicator (A) Assembly (RWX-094)	124
18.	JT-211 SCHEMATIC DIAGRAMS, P.C. BOARD PATTERNS AND PARTS LIST	
18.1	Schematic Diagram	125
18.2	Miscellaneous Parts	125
18.3	Function Switch Assembly (RWS-041)	126
18.4	Indicator (B) Assembly (RWX-095)	126
19.	MECHANICAL ADJUSTMENTS	
19.1	Reel Hub Height	127
19.2	Brake	127
19.3	Take-Up Torque and Back Tension	128
19.4	Pinch Pressure	129
19.5	Tape Guide Height	129
19.6	Tape Speed	129
19.7	Cue Operation	130
20.	HEAD ADJUSTMENT (JT-2022T & JT-2044T)	
20.1	Coarse Adjustments	131
20.2	Height Adjustments	131
20.3	Tilt Adjustments	131
20.4	Azimuth Adjustments	131
20.5	Head Fine Adjustments	131
20.6	Playback Head	131
20.7	Record Head	131
21.	ELECTRICAL ADJUSTMENTS	133
21.1	Playback Level	135
21.2	Playback Equalization	135
21.3	Oscillation Strength	135
21.4	Erase Head Dummy	135
21.4.1	Employing Frequency Counter	135
21.4.2	Without Frequency Counter	136
21.5	Bias Trap	136

21.6	Bias Voltage Variable Range	136
21.7	Recording Bias	137
21.8	Recording Level	137
21.9	Overall Frequency Response Check	138
21.10	Test Oscillator Output Voltage	138
21.11	Test O.S.C. 1kHz/10kHz Level Difference	138
22.	TAU-11 ADJUSTMENT	
22.1	Adjustment Conditions	139
22.2	Adjustment Steps	139
23.	CIRCUIT DESCRIPTION (RTU-11)	140
23.1	Power Supply ON	141
23.2	Play Operation	143
23.3	Recording Operation	143
23.4	FF Operation	144
23.5	REW Operation	144
23.6	Timing Operation	145
23.7	Pause Operation	145
23.8	Reduced Switching Time Through PAUSE Switch Operation	146
23.9	Playback Equalization Amplifier	147
23.10	Recording Equalization Amplifier	147
23.11	Test Oscillator Circuit	148
23.12	Sync Amp Circuit	148
23.13	2T-4T Automatic Selector Circuit	149
23.14	Erase Head Dummy	149
24.	NOMENCLATURE OF SCREW, WASHERS AND NUTS	150

1. SPECIFICATIONS

System	
RT-2022	Transport Unit; RTU-11/2T (Transport with 2-track 2-channel head assembly unit) Amplifier Unit; TAU-11
RT-2044	Transport Unit; RTU-11/QT (Transport with 4-track 4-channel head assembly unit) Amplifier Unit; TAU-11 (2 sets)
Heads and Track	
RT-2022	Head assembly unit (JT-2022T): Plug-in type, 2-track 2-channel. 3-head system / Erase (Ferrite), Recording (Permalloy), Playback (Permalloy) heads
RT-2044	Head assembly unit (JT-2044T): Plug-in type, 4-track 4-channel. 3-head system / Erase (Ferrite), Recording (Permalloy), Playback (Permalloy) heads
Motors	
.....	3-motors, Capstan belt drive (with 100φmm flywheel). Capstan motor: 4/8-pole large size hysteresis synchronous motor x 1. Reel motor: 6-pole inner rotor induction motor x 2.
Acceptable Reel Size	10-1/2in (26cm), 7in (17cm)
Tape Speeds	38cm/s (15ips), 19cm/s (7-1/2ips), ±0.8%
High Speed Wind Times	10-1/2in (26cm) reel; 110 sec at 740m (2,400feet) tape 7in (17cm) reel; 90 sec at 370m (1,200feet) tape
Wow and Flutter	38cm/s (15ips); 0.04% WRMS (0.06% RMS) 19cm/s (7-1/2ips); 0.08% WRMS (0.09% RMS)
Equalization	NAB curve (38cm/s, 19cm/s), IEC curve (38cm/s, T=35μs) with tape equalization selector switch
Bias	125kHz FIX: reference tape (Fixed) VARIABLE: LOW: -40% - -8%* HIGH: -15% - +38%*
* Variable range of bias current against "FIX" position	
Total Signal-to-Noise ratio	
RT-2022.....	More than 57dB More than 60dB at 38cm/s IEC position, over 5kHz
RT-2044	More than 55dB More than 58dB at 38cm/s IEC position, over 5kHz
Total Harmonic Distortion ..	No more than 0.8% (38cm/s) No more than 1.0% (19cm/s)
Frequency Response	30Hz to 28,000Hz ±3dB (38cm/s) 40Hz to 20,000Hz ±3dB (19cm/s)
Crosstalk (RT-2044 only)	More than 60dB (track interval)
Channel Separation	RT-2044; More than 53dB RT-2044; More than 50dB
Inputs (Sensitivity / Maximum allowable level / Input impedance)	
MIC	0.11mV - 100mV/27kΩ (with 20dB attenuator switch), 6φmm jack, Unbalance type, 2-channel
LINE	34mV - 25V/100kΩ, Pin jack (Rear panel) x2, 6φmm jack (Front panel), 2-channel
<ul style="list-style-type: none"> • Mixing control used for MIC and LINE input • RT-2044 provides 2 sets of inputs terminals 	

RTU-11/2T used only	
LINE	100mV/13kΩ fixed, Pin jack (Rear panel) x2, 2-channel
RTU-11/QT used only	
LINE	100mV/13kΩ fixed, Pin jack (Rear panel) x2, 4-channel
Outputs (Reference level / Maximum level / Load impedance)	
LINE	450mV - 900mV/50kΩ, Pin jack (Rear panel) x 2 or 6φmm jack (Front panel), 2-channel
PHONES	64mV(0.5mW) - 133mV (2.2mW)8Ω, 6φmm stereo jack (Front panel)
*RT-2044 provides 2 sets of output terminals	
RTU-11/2T used only	
LINE	100mV/40kΩ fixed, Pin jack (Rear panel), 2-channel
RTU-11/QT used only	
LINE	100mV/40kΩ fixed, Pin jack (Rear panel), 4-channel
Test Oscillator	Switchable (OFF/1kHz; for Bias adjustment /10kHz; for head azimuth adjustment etc.) with Test OSC signal output terminal (316mV/50kΩ fixed), 6φmm jack (Front panel).
Subfunctions	
Tape selector switch [RTU-11] / Test oscillator built-in [RTU-11] / Cueing mechanism with lock button [RTU-11] / Remote control mechanism (separately available full remote control unit JT-211) [RTU-11] / Pause switch (Locking, also used as lag canceller) [RTU-11] / Wide scale level meter (-40dB to +6dB) [TAU-11] / Level memory marker (for input and output) [TAU-11] / Three parts of LINE INPUT and OUTPUT terminals [TAU-11] / Sync. recording monitor function with REC. mode selector [TAU-11] / Cable storage pocket [TAU-11] / Carrying handle and Unit protective covers [RTU-11, TAU-11] / RTU-11, TAU-11 Mounting clamps [RTU-11, TAU-11].	
Furnished Parts	10-1/2in reel adaptors x 2 [RTU-11] / AC. Power cord x 1 [RTU-11] / 12-p dummy plug (used RTU-11 only) x 2 [RTU-11] / Head cleaning kit (Pioneer PP-203) x 1 [RTU-11] / Lock plug x 1 [RTU-11] / Pin plug cable x 2 [RTU-11] / Pin plug cable with color coding x 3 [TAU-11] / 12-p connector cable x 1 [TAU-11] / 6φmm plug cable x 2 [TAU-11] / Felt cushion x 2 [TAU-11] / Operating Instructions x 1
* RT-2044 provides 2 sets of TAU-11 furnished parts	
Power Requirements	AC 120V 60Hz
Power Consumption	155 watts, Max.
Weight	RTU-11 (Transport Unit): 23.3kg (51 lb 4 oz) TAU-11 (Amplifier Unit): 5.2kg (11 lb 5 oz)

- Test Conditions:**
1. Reference tape: Scotch #206
 2. Reference recording level: meter 0dB level (NAB standard reference level)
 3. Reference signal: 1,000Hz
 4. Wow & Flutter: at 3,000Hz weighted RMS
 5. Frequency response: measured at -10dB level (38cm/s)
measured at -20dB level (19cm/s)
 6. Signal-to-Noise ratio: measured at +6dB level
 7. Total Harmonic Distortion: measured at reference recording level
 8. Channel separation: measured at reference recording level
 9. Sensitivity: Input level (mV) for reference recording measured with input (recording) level control set at maximum position.
 10. Maximum allowable input level: measured at the point where the output signal wave is clipped while gradually turning the input control.
 11. Reference output level: meter 0dB level.
 12. Maximum output (playback) level: Output level to reference recording level, measured with output (playback) level control set at maximum position.

Dimensions RTU-11

393(H ₁) x 440(W ₁) x 207(D ₁)mm
15-1/2 x 17-5/16 x 8-3/16 in
411(H ₂) x 460(W ₂) x 274(D ₂)mm
16-3/16 x 18-1/8 x 10-13/16 in
TAU-11
123(H ₁) x 440(W ₁) x 207(D ₁)mm
4-13/16 x 17-5/16 x 8-3/16 in
141(H ₂) x 460(W ₂) x 274(D ₂)mm
5-9/16 x 18-1/8 x 10-13/16 in

NOTE:
Specifications and the design subject to possible modification without notice due to improvements.

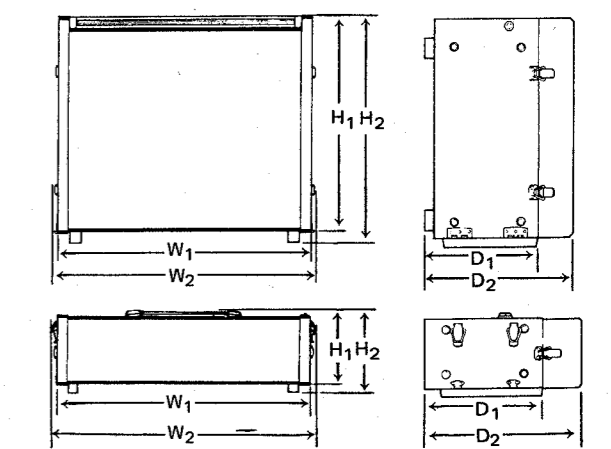

2. TRANSPORT UNIT RTU-11 OPERATING

2.1 FRONT PANEL

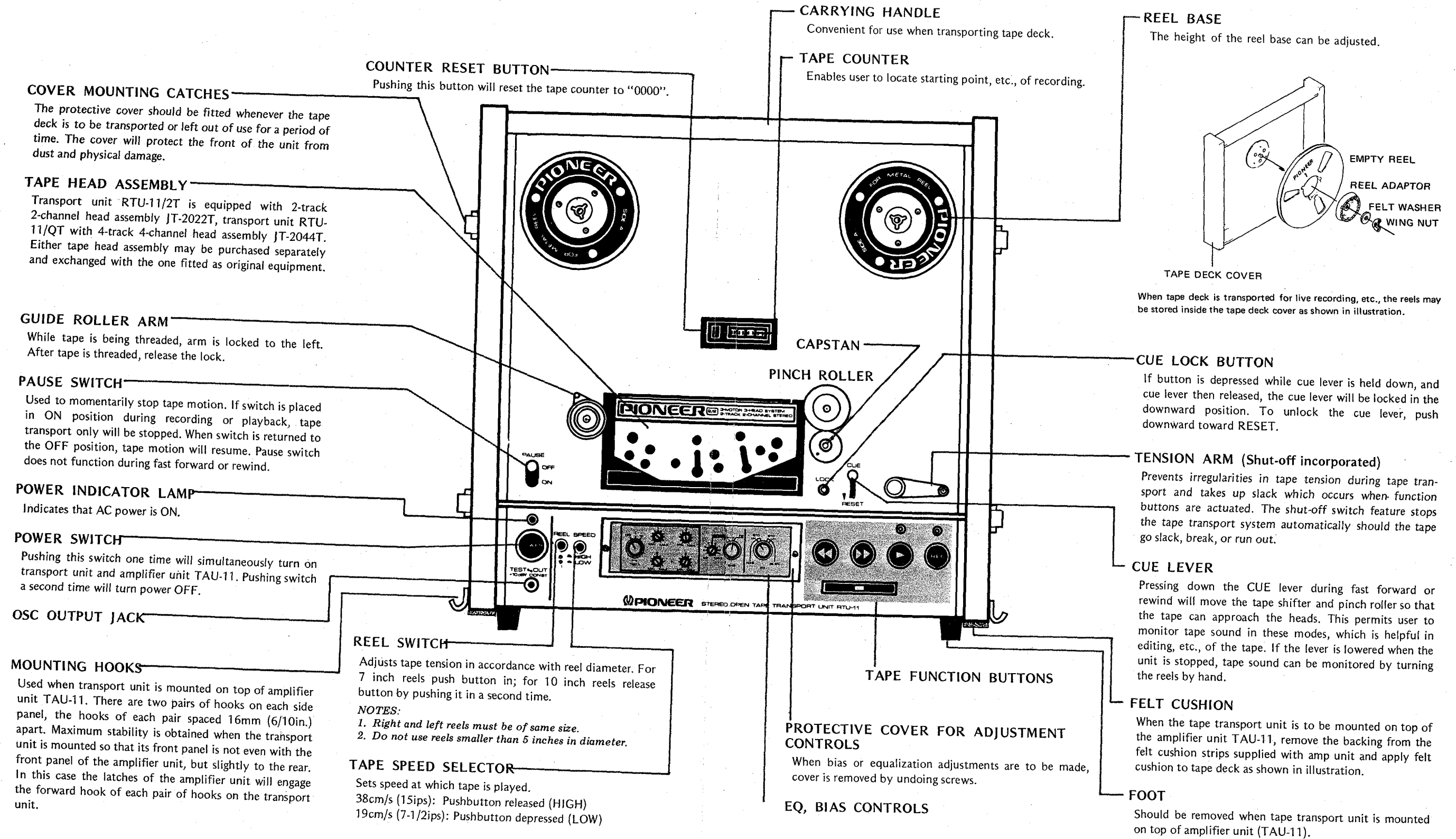

TEST OSC LEVEL CONTROLS

For adjusting level of TEST OSC signal. Signal level increases with clockwise rotation of controls. While there are four separate controls, only nos. 1 and 3 are used for model RT-2022 (2-track 2-channel). With RT-2044, all four controls are used. When a plug connector is inserted in the OSC output jack, the test signal will no longer be supplied to the tape deck circuit.

TEST OSC SELECTOR

The built-in test signal oscillator can be set to either 1kHz or 10kHz. 1kHz is used for bias adjustment, 10kHz for head and frequency response adjustments. During normal operation the selector must set in the OFF position.

POWER SWITCH

OSC OUTPUT JACK

The test oscillator signal can be tapped for adjustment and testing of other tape decks and amplifiers by use of the accessory 6mm. plug connector. Test signal frequency is controlled by the TEST OSC selector.

BIAS ADJUSTMENT CONTROL

For adjustment of bias current according to characteristics of particular recording tape used. For this purpose, BIAS selector should be set at either LOW or HIGH on the VARIABLE side.

BIAS SELECTOR

Set on FIX or VARIABLE according to type of recording tape used. FIX provides a standard bias current used for SCOTCH 206 low noise tape. VARIABLE is used for BIAS adjustment with other kinds of tape.

EQ SELECTOR

Selects recording equalization characteristics according to type of tape used. Playback equalization should be set at the same value used for recording the particular tape. For a tape speed of 38cm/s (15ips), it is possible to select either NAB (50μs) or IEC (35μs) standard equalization. In this case, equalization used in playback and recording should be the same. For further information, see page 22, "EQ and BIAS selector switches".

"PLAY" INDICATOR LAMP

When this lamp is lit, it indicates that (▶) function has been pushed.

RECORD INDICATOR LAMP (RED)

When this lamp is lit, unit is in record mode.

FUNCTION BUTTONS

- (◀◀) **REWIND:** Causes tape to be wound at high speed from right to left reel.
- (▶▶) **FAST-FORWARD:** Causes tape to be wound at high speed from left to right reel.
- (▶) **PLAY:** For tape playback, pushing this button will cause tape to be transported from left to right reel at a preset speed. For recording, this and REC button are depressed simultaneously.
- (REC) **RECORD:** To record, push this button and play (▶) button simultaneously.
- (■) **STOP:** Stops tape from any function and returns unit to neutral state.

NOTE:
With this tape deck, changing from any of the functions to any other function is done without first depressing the stop(■) button. If, for example, Play(▶) button is pushed while unit is in Fast forward or Rewind, tape will automatically come to a complete stop, and after a short pause, begin the Play mode. This feature permits rapid manipulation of tape functions, while eliminating the possibility of tape being damaged.

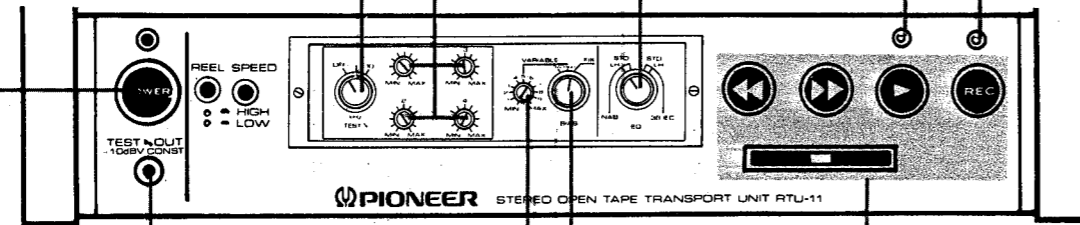

2.2 REAR PANEL

REMOTE CONTROL SELECTOR

For remote control operation selector should be in REMOTE position. If remote control is not being used, place selector in NORMAL position.

REMOTE CONTROL CONNECTOR

With use of remote control unit JT-211 which may be purchased separately, remote control of Play, Record, Fast-forward, Rewind, Stop, and Pause functions is possible.

AC POWER IN

Accessory AC power cord is connected here.

CONNECTOR (4-track 4-channel)

- 1-3 TRACK FRONT A:** Connection made using accessory cord supplied with tape deck. For 2-channel stereo tracks 1 and 3 are used.
- 2-4 TRACK BACK B:** For 4-channel stereo tape deck RT-2044 a second amplifier is connected here using the accessory cord. In this case, tracks 2 and 4 are used.

GND TERMINAL

If there is hum or externally induced noise, connect to GND terminal of amplifier, or directly to earth.

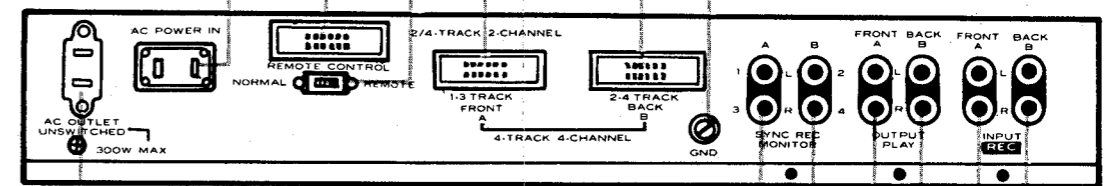

AC OUTLET

An AC power outlet (maximum 300W) which may be used as power source for other tape decks, amplifiers, etc.

SYNC REC MONITOR (A, B)

When the REC MODE selector of amplifier unit TAU-11 is set on SYNC, the recording head acts as both a recording and playback head. The playback signal from this head may be monitored from this terminal by connecting A side with the SYNC REC MONITOR terminals of amplifier unit TAU-11. With 4-channel stereo tape deck RT-2044, B side is connected to the second amplifier unit TAU-11.

INPUT REC TERMINALS (FRONT A, BACK B)

Recording input terminals of transport unit RTU-11. Connect OUTPUT REC (TO TRANSPORT) terminals on rear panel of amplifier unit TAU-11 to FRONT A side. For 4-channel stereo tape deck RT-2044 the second amplifier unit TAU-11 is connected to BACK B side.

OUTPUT PLAY TERMINALS (FRONT A, BACK B)

Playback output terminals of transport unit RTU-11. Connect INPUT PLAY (TO TRANSPORT) terminals on rear panel of amplifier unit TAU-11 to FRONT A side. For 4-channel stereo tape deck RT-2044, second amplifier unit TAU-11 is connected to BACK B side.

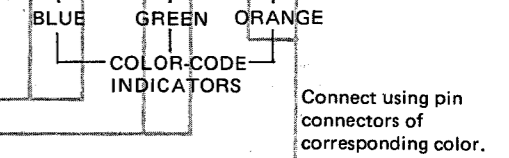

3. AMPLIFIER UNIT TAU-11 OPERATION

3.1 FRONT PANEL

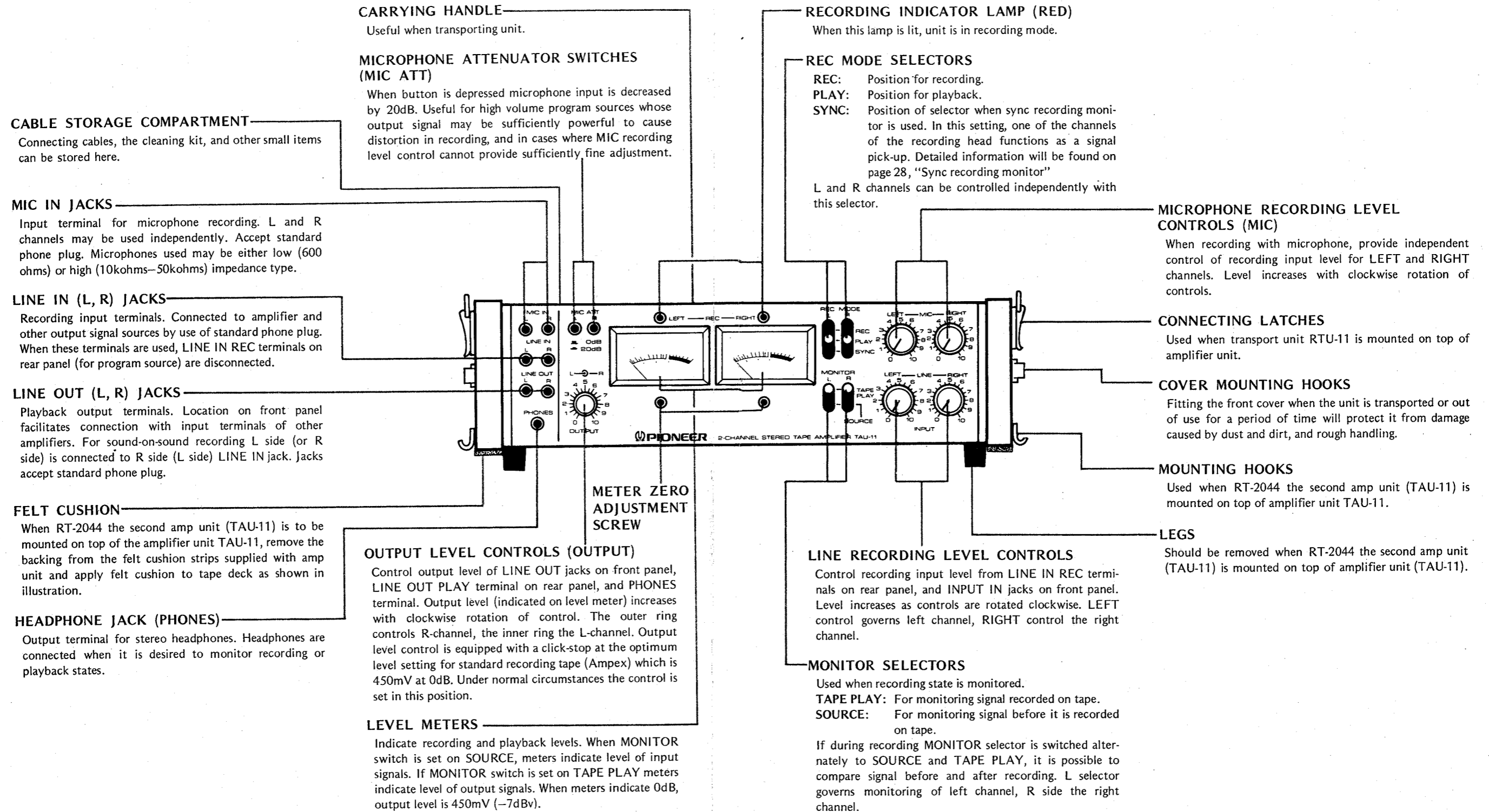

3.2 REAR PANEL

CONNECTOR

Connected to 2/4 TRACK 2-CHANNEL connector of transport unit. Second amplifier unit of the 4-channel tape deck RT-2044 is connected with 2-4 TRACK BACK B of the transport unit.

NOTE:

With 4-channel stereo tape deck RT-2044, the amplifier used for the front channel is connected to the CH.1, CH.3 side, and the rear channel amplifier to CH.2, CH.4 side.

LINE OUT (PLAY) TERMINALS

Playback output terminals connected to TAPE MONITOR or PLAY BACK terminals of stereo receiver (or stereo amplifier) using phono cable provided.

LINE IN (REC) TERMINALS

Recording input terminals. Connected to recording output (TAPE REC) terminals of stereo receiver (or stereo amplifier) using phono cable provided.

If a program source is connected to LINE IN on front panel, the signal coming from these terminals will be cut off.

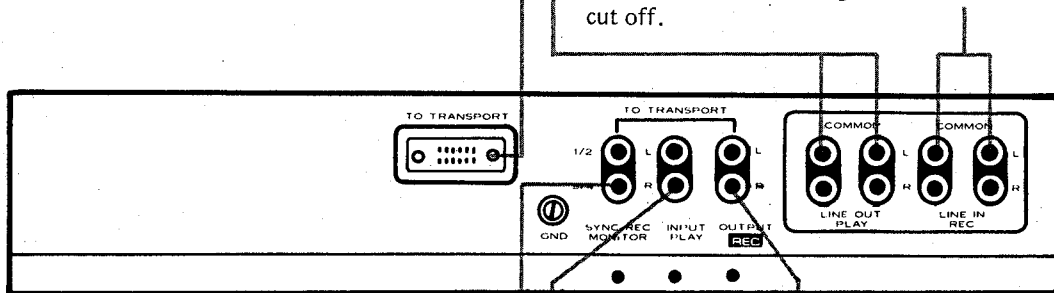

SYNC REC MONITOR (TO TRANSPORT) TERMINALS

Connected to SYNC REC MONITOR (A) on the rear panel of transport unit RTU-11 using the connecting cord provided. Second amplifier of 4-channel stereo tape deck RT-2044 is connected to SYNC REC MONITOR (B). When the recording head functions as a playback head, its output signal is tapped at these terminals.

INPUT PLAY (TO TRANSPORT) TERMINALS

Connected with OUTPUT PLAY (FRONT A) terminals on rear panel of transport unit RTU-11 using phono cables provided. Second amplifier unit of 4-channel stereo tape deck RT-2044 is connected to OUTPUT PLAY (BACK B) terminals.

OUTPUT REC (TO TRANSPORT) TERMINALS

Connected with INPUT REC (FRONT A) terminals on rear panel of transport unit RTU-11 using phono cable provided. Second amplifier unit of 4-channel stereo tape deck RT-2044 is connected with INPUT REC (BACK B) terminals.

USE OF INPUT TERMINALS

The two pairs of LINE IN REC terminals are wired in parallel. If one pair is connected to the stereo amplifier and the other pair to another tape deck (open reel or cassette), the program source output can be recorded at the same time in this and the other tape deck. If a program source is connected to the LINE IN jacks on the front panel, the signal coming from the LINE IN REC terminals on the rear panels will be cut off.

USE OF OUTPUT TERMINALS

Amplifier unit TAU-11 is equipped with two pairs of LINE OUT PLAY terminals (rear panel), and LINE OUT jacks (front panel), a total of 3 pairs of output terminals. One pair of LINE OUT PLAY terminals is connected to the playback terminals of the stereo amplifier. If one of the remaining pairs is connected to another tape deck, at the same time the stereo tape deck system is playing back a program source, a duplicate tape can be made on the other tape deck.

4. CONNECTION FOR RT-2022 SYSTEM

* A side of SYNC REC MONITOR, OUTPUT PLAY, and INPUT REC terminals of transport unit RTU-11 is connected to the corresponding terminals of amplifier unit TAU-11 by means of the appropriate color-coded pin connectors.

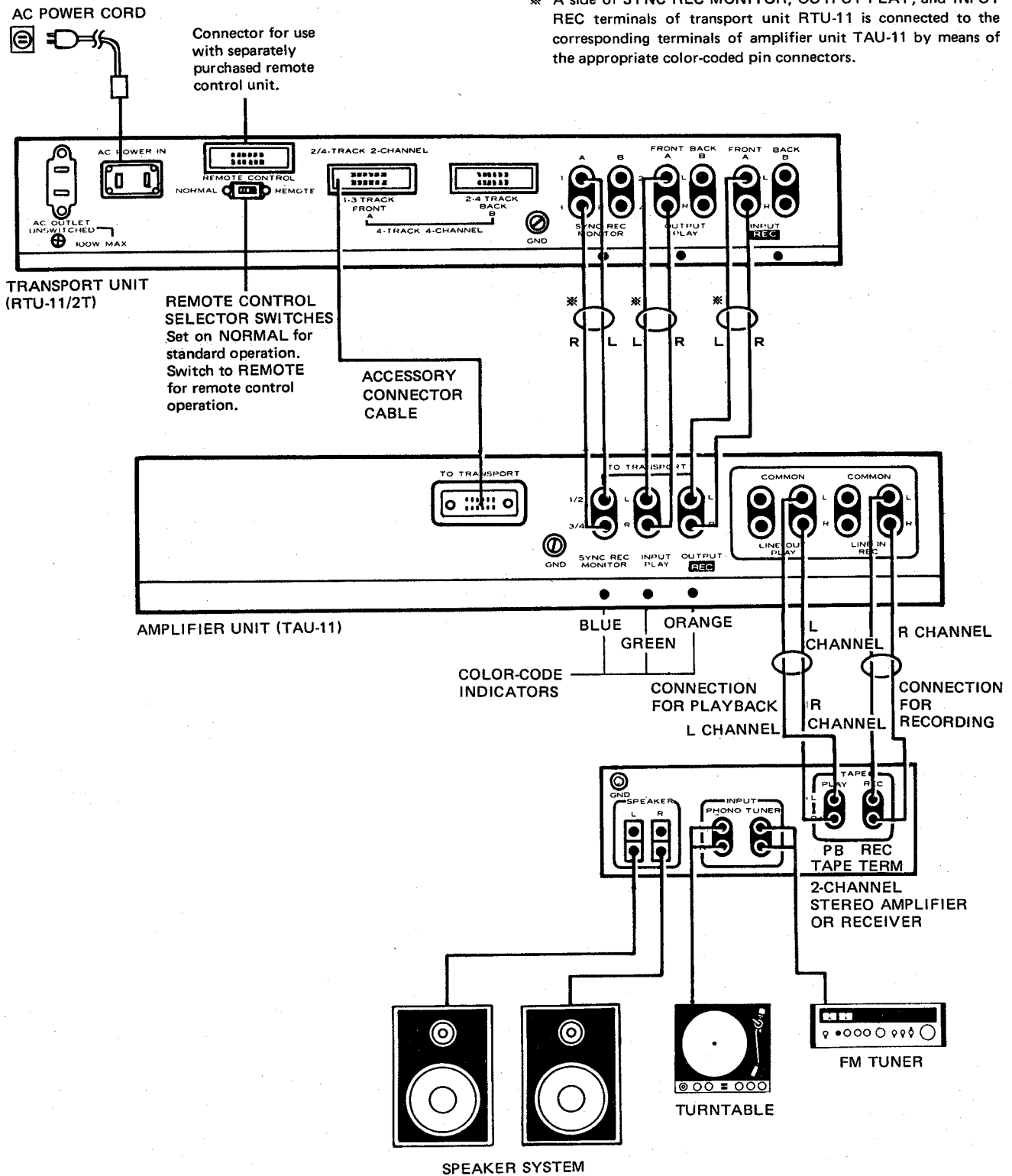

5. CONNECTION FOR RT-2044 SYSTEM

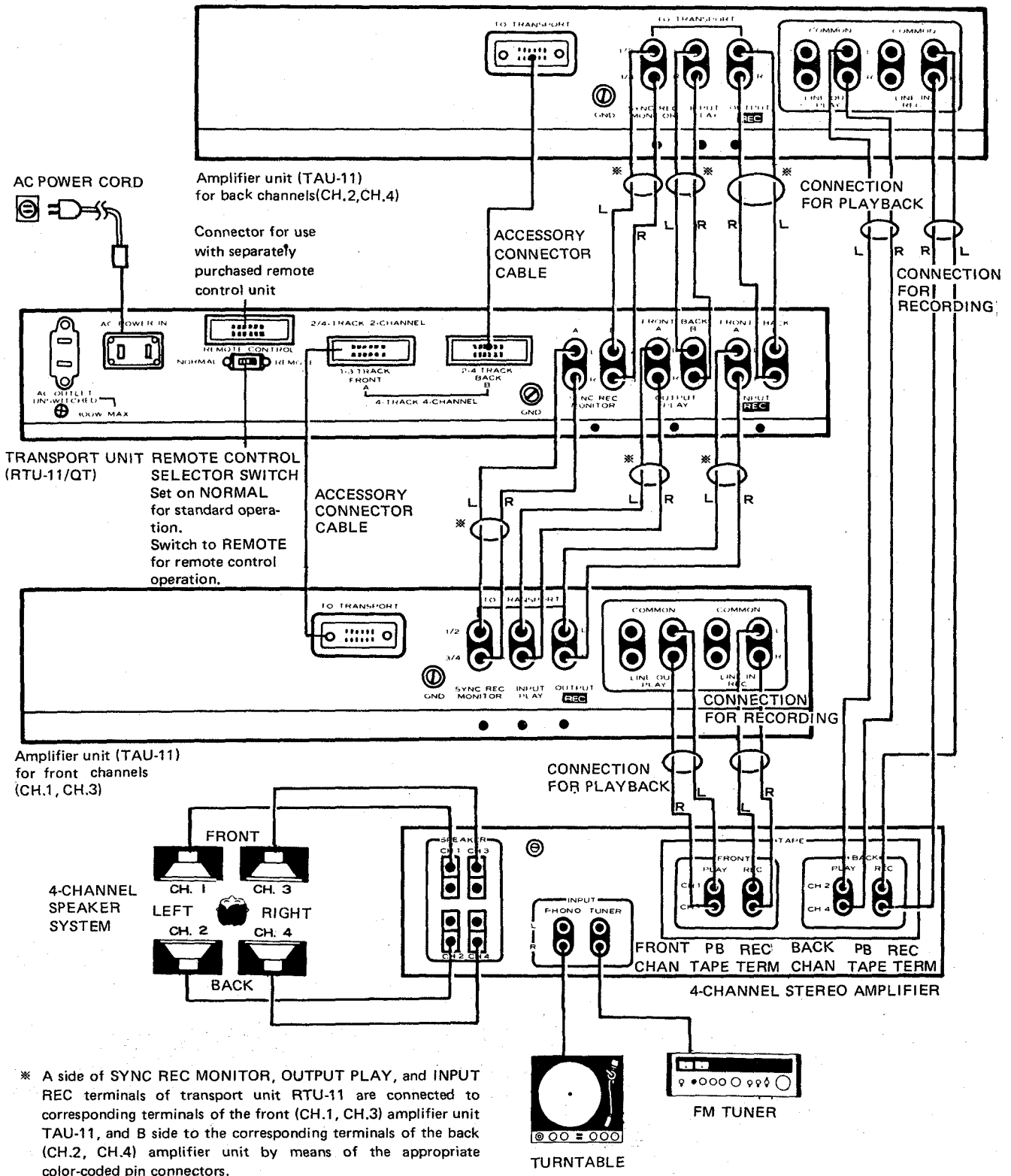

6. DISASSEMBLY

6.1 BACK COVER (Fig. 1)

1. Take out screws ①—④ and loosen screws ⑤—⑦ to remove back cover A.
2. Take out screws ⑧—⑬ to remove back cover B.

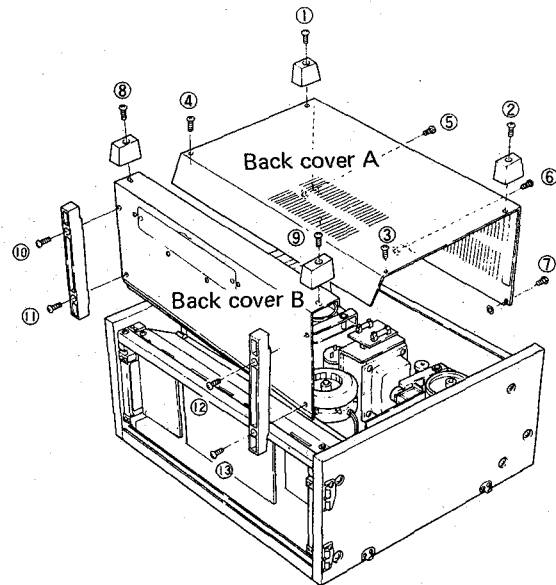

Fig. 1

6.2 SIDE PANELS (Fig. 2)

Loosen screws ① and ② about ③ turns, then take out screws ③—⑩ to remove side panels.

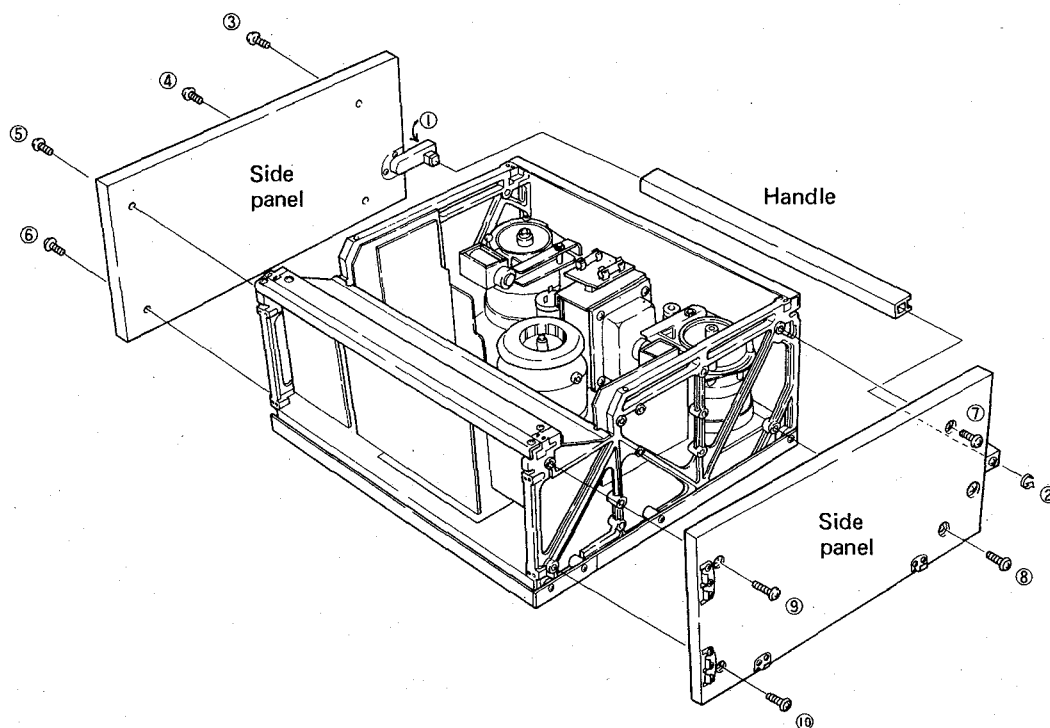

Fig. 2

6.3 CONTROL PANEL (Fig. 3)

1. Take out screws ①—④ to remove amp panel.

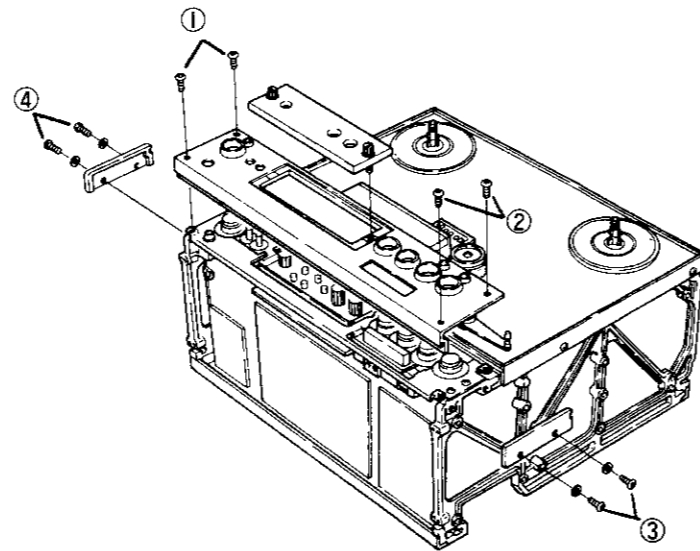

Fig. 3

6.4 MECHANICAL PANEL (Fig. 4)

1. Take out screws ① and ② to remove head unit (JT-2022T or JT-2044).
2. Pinch roller can be removed by taking out screw ③.
3. Take out screws ④—⑥ to remove center base.
4. Take out screws ⑦ and ⑧ to remove reel hubs.
5. Take out screws ⑨—⑪ to remove guide rollers.
6. Take out screw ⑫ and turn cap to remove tension arm.
7. Pull off PUASE knob, take out screws ⑬—⑰ to remove decorative frame. Mechanical panel can then be removed.

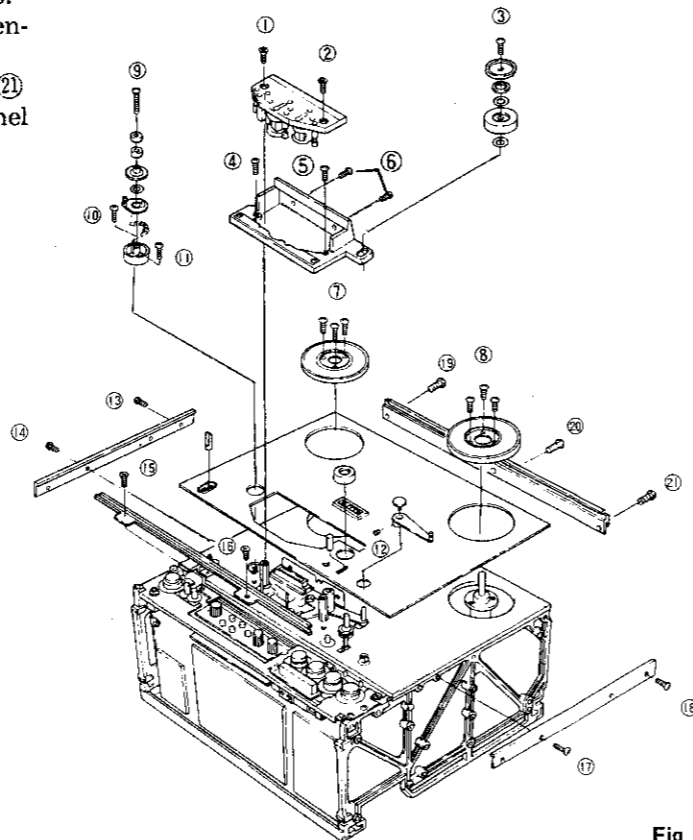

Fig. 4

6.5 TAU-11 (Fig. 5)

1. Remove all knobs from front panel and take out screws ①—④ (Fig. 5-a)
2. Remove screws ⑤—⑫ from side panels.
3. Take out screws ⑬—⑲ and loosen screws ⑳—㉓, then bottom plate can be removed together with feet.
4. Take out screws ㉔—㉙ and loosen screws ㉚—㉛ to remove cover.

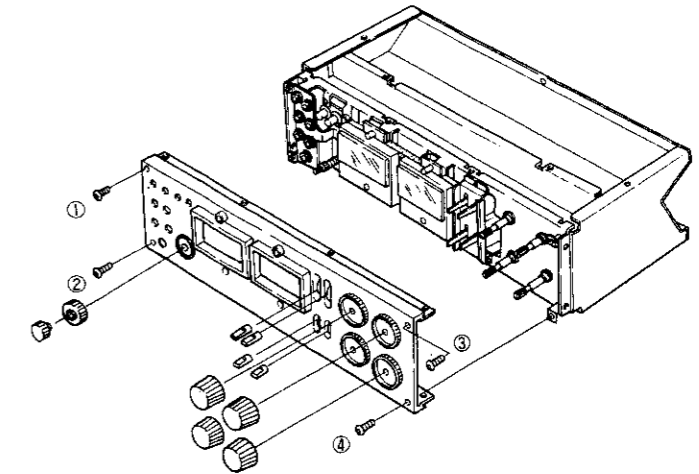

Fig. 5-a

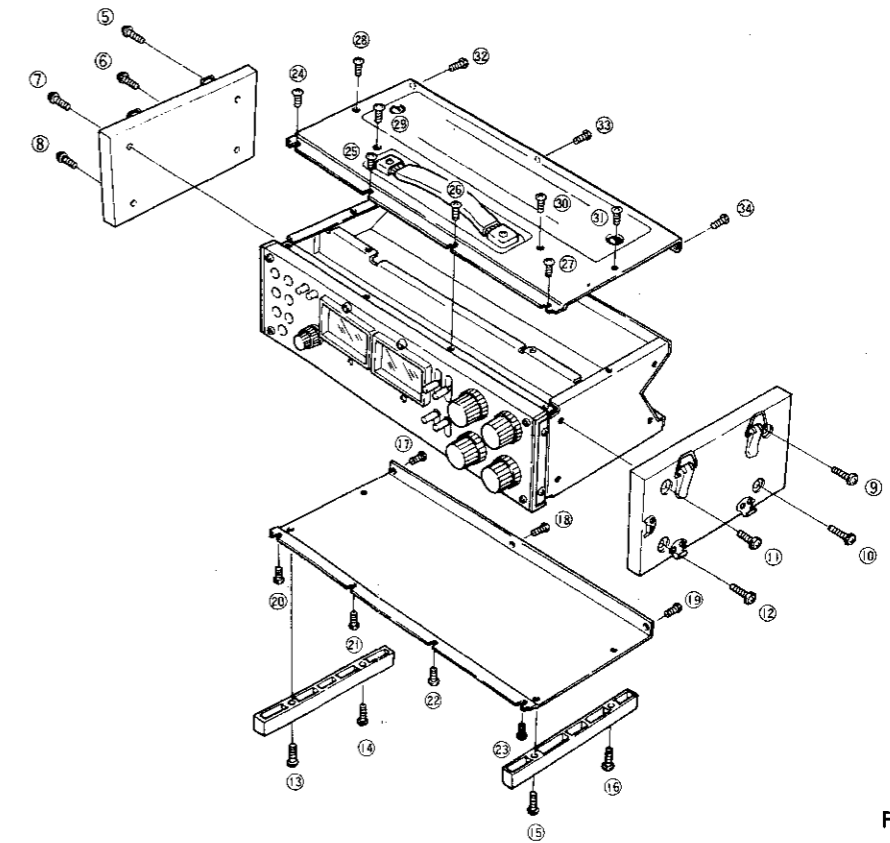
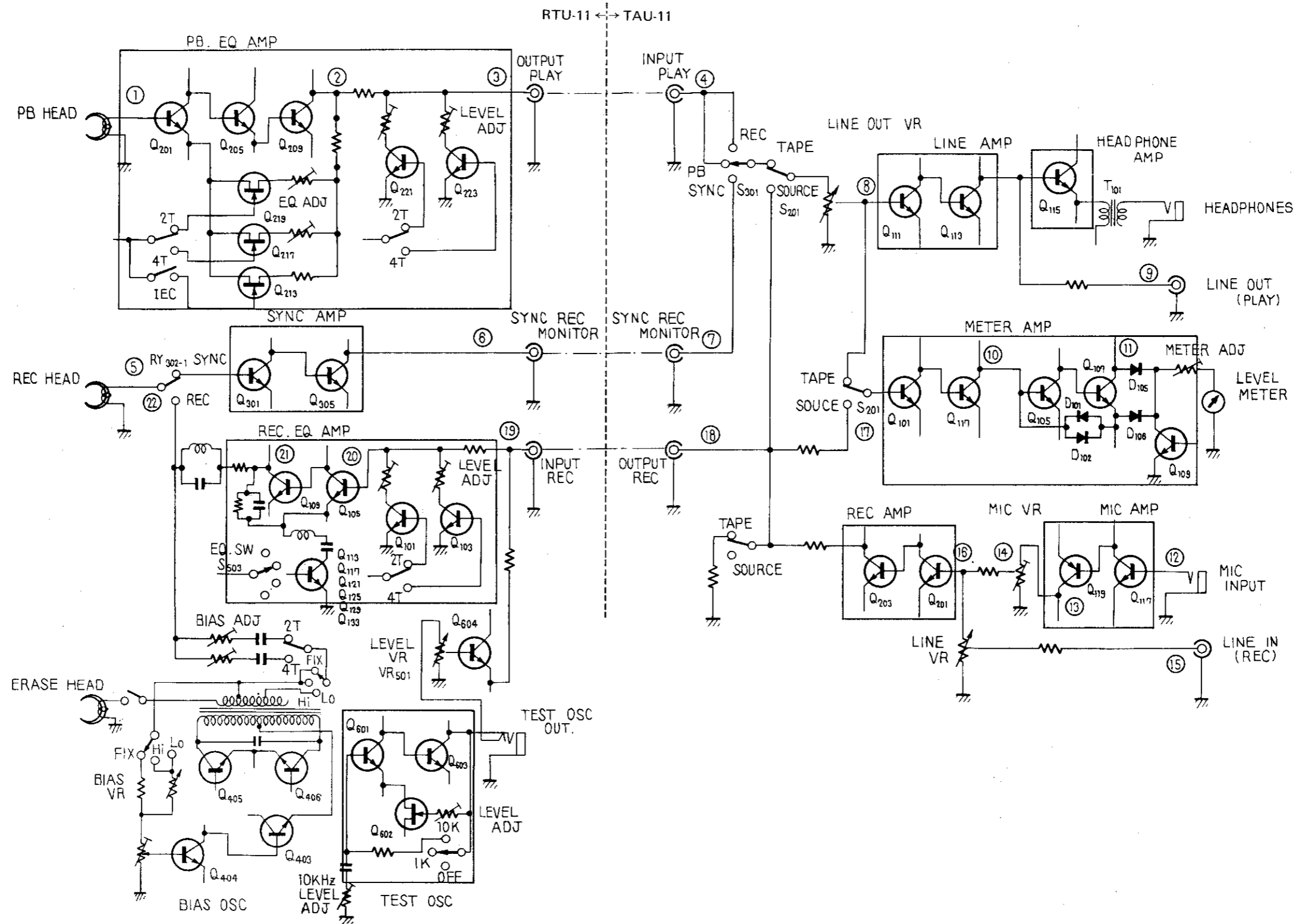

Fig. 5-b

7. BLOCK DIAGRAM



8. LEVEL DIAGRAMS

8.1 JT-2022T (0dBv = 1v)

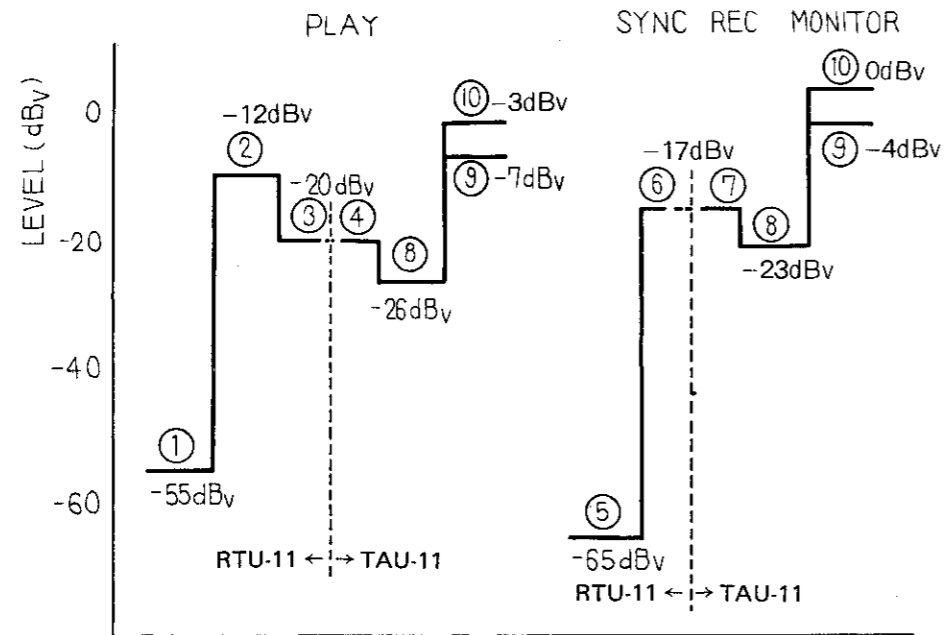

8.2 JT-2044J (0dBv = 1v)

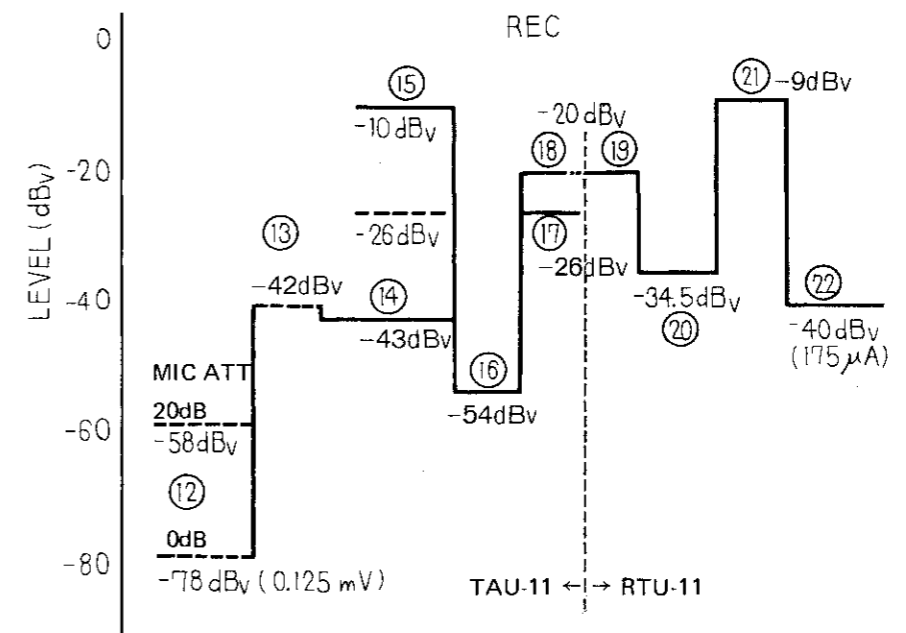
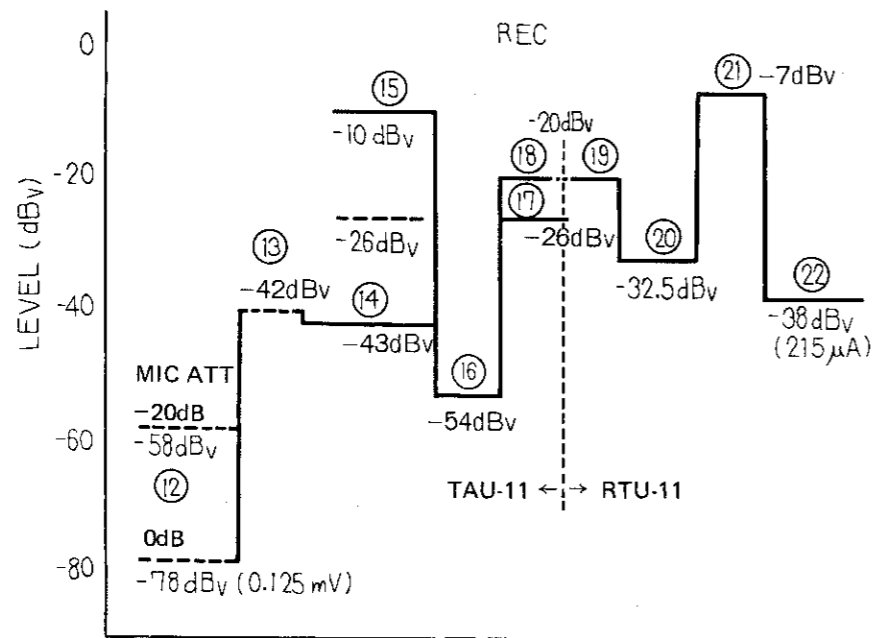
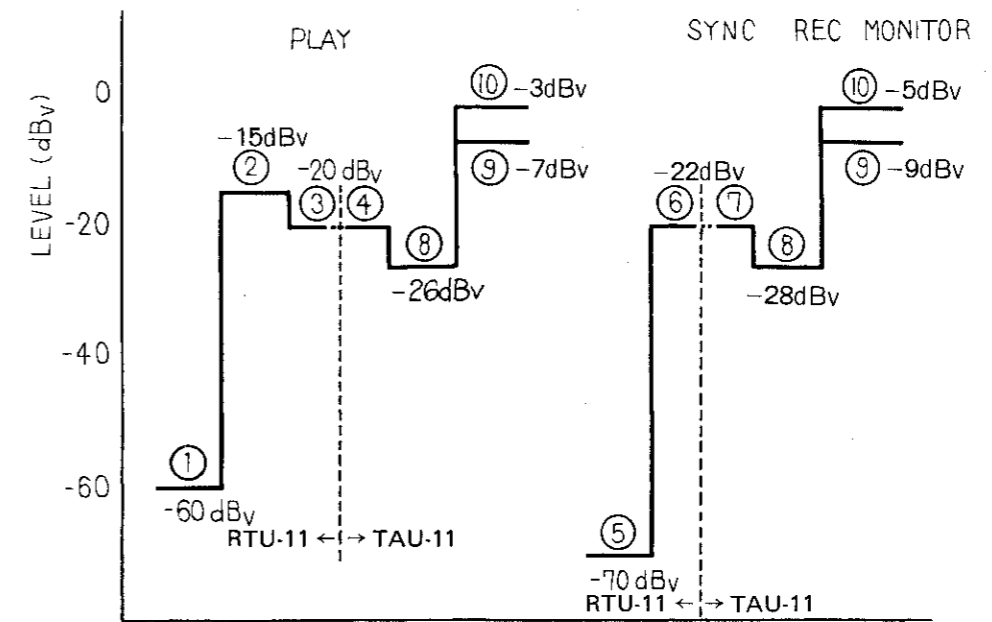

9. TIMING CHARTS

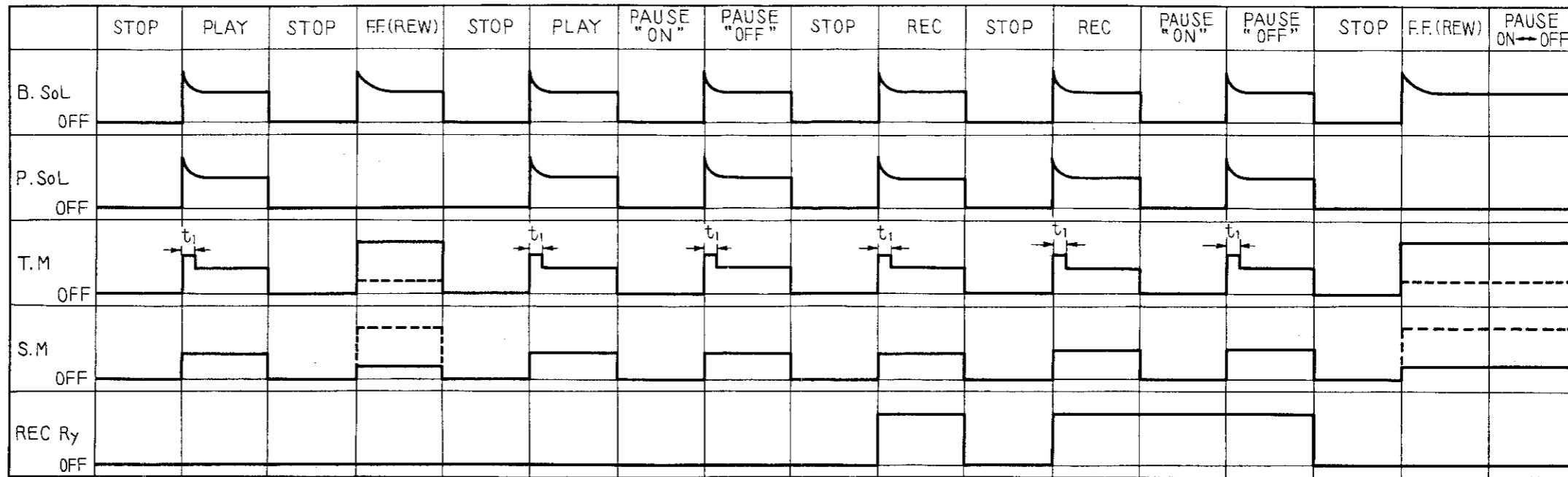

- t_1 --- T.M Torque up time(/sec)
- t_2 --- Switching time
- t_3 --- PAUSE SW ON
- t_4 --- Reduced switching time
- --- REW OPration
- TAU-11 Rec Mode switch REC position
- B.SoL Blake solenoid
- P.SoL Pinch solenoid
- TM Take up motor
- SM Supply motor

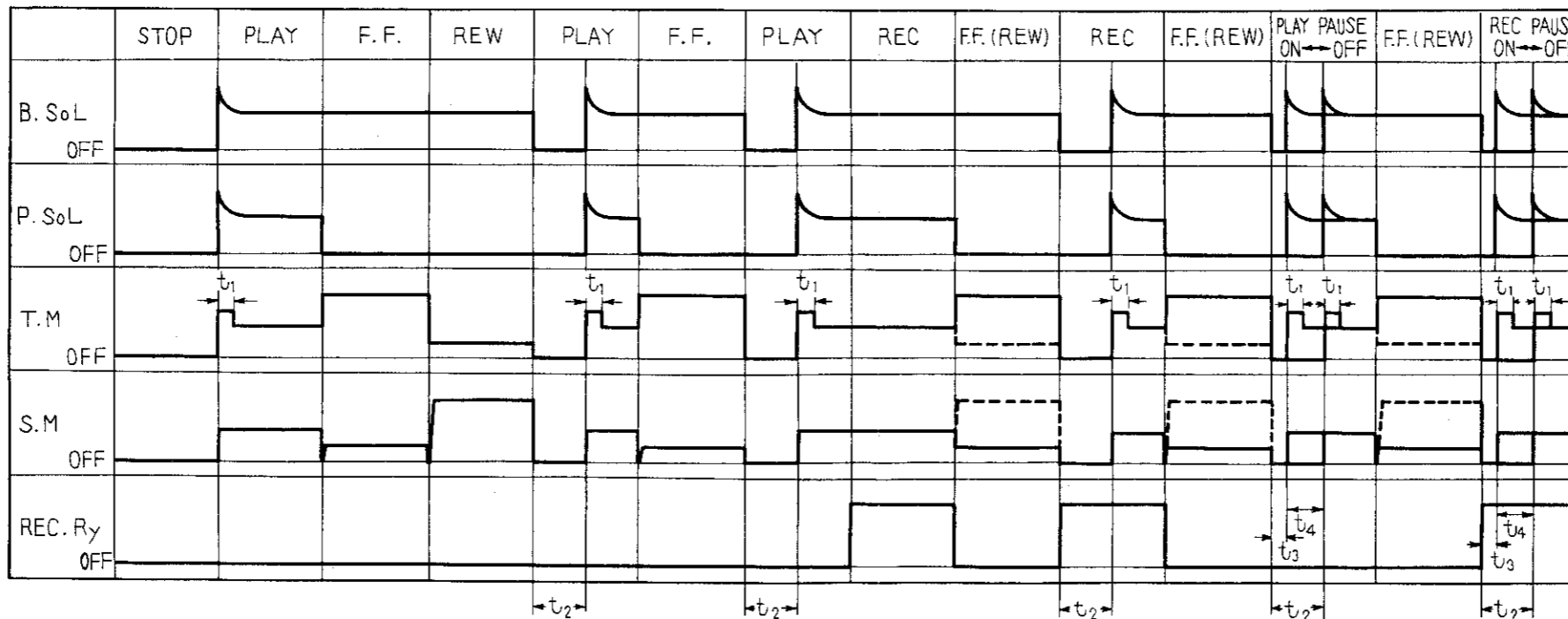

10. RTU-11 PARTS LOCATIONS

10.1 FRONT VIEW

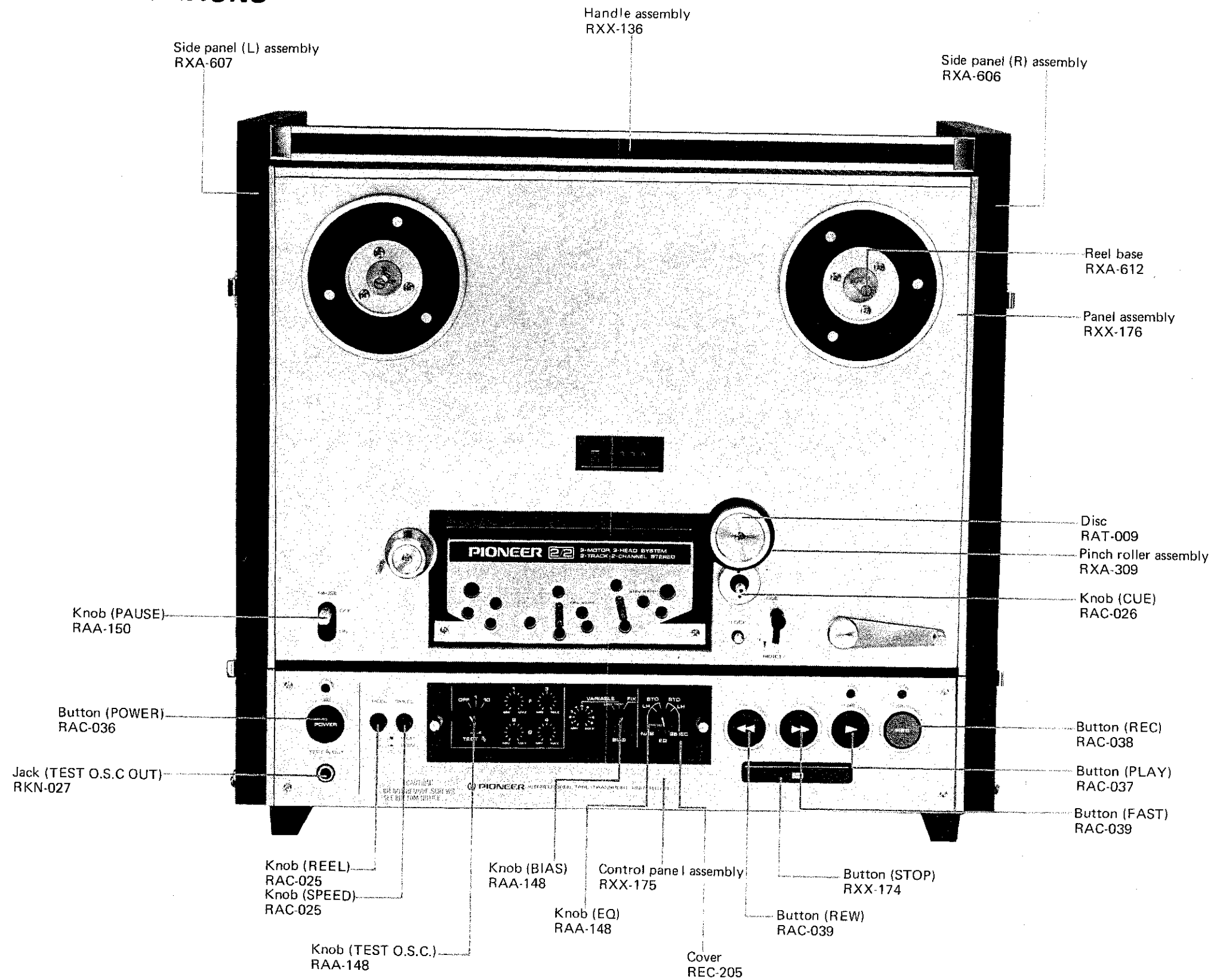

10.2 REAR VIEW

Motor fuse assembly
RWX-048
Wire wound resistor
RCN-024
Capacitor (C4)
RCL-010

Power transformer
PPT-083
Wire wound resistor
RCN-025
Capacitor (C3)
RCL-010

Motor (Take-up)
RXM-015

Solenoid (SL2)
PXP-020

Belt (counter)
REB-077

Power supply O.S.C assembly
RWR-031

Flywheel assembly
RXA-378

Motor (supply)
RXM-015

Solenoid (SL1)
RXP-020

Control assembly
RWG-050

Capstan motor
PXM-020

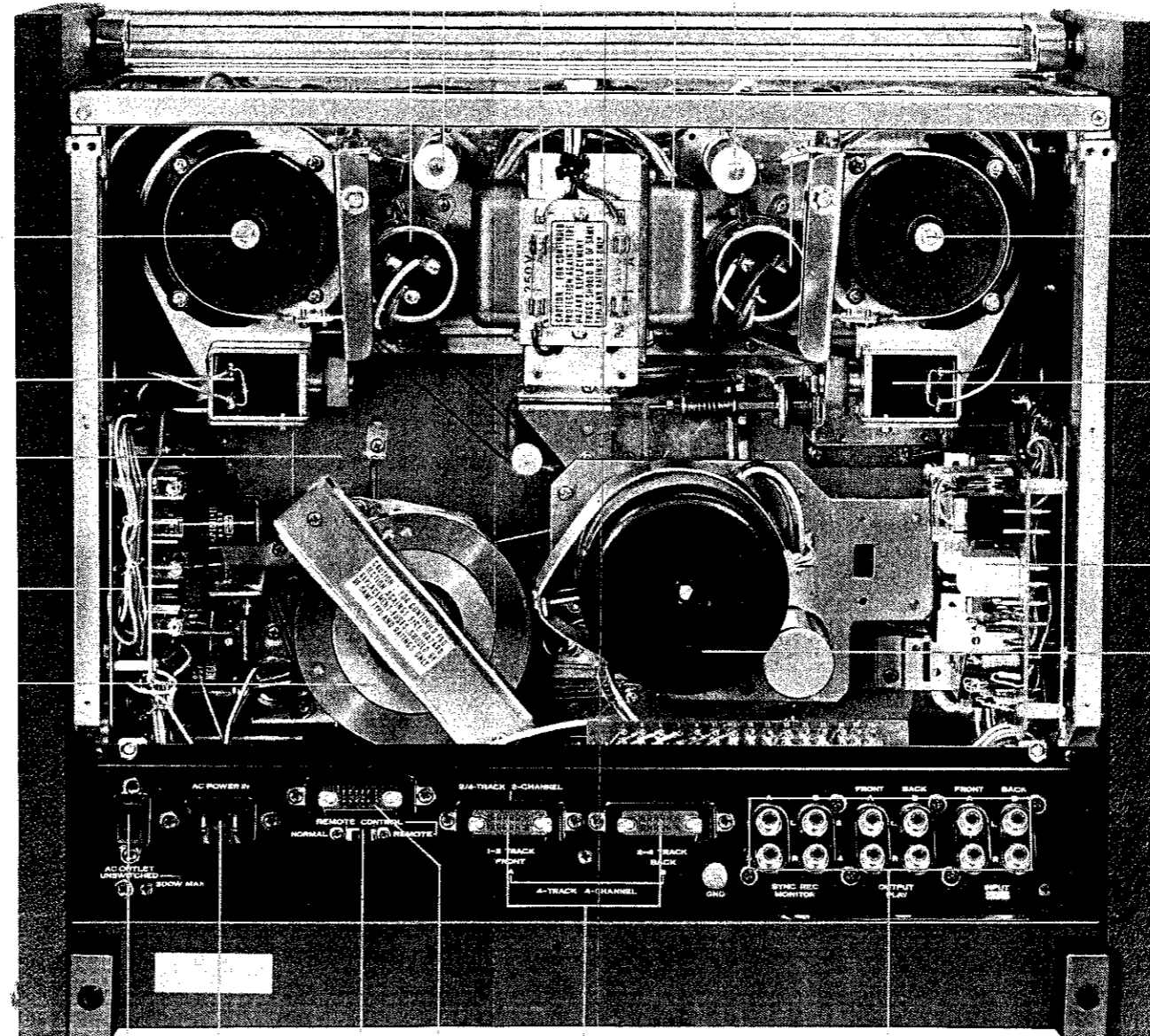

AC socket (OUTLET)
RKP-002

Phono jack (4P)
RKP-006

AC socket (INLET)
RKP-003

Socket A
RKP-011

Slide switch
RSH-018

Socket B
RKP-012

11. TAU-11 PARTS LOCATIONS

11.1 FRONT VIEW

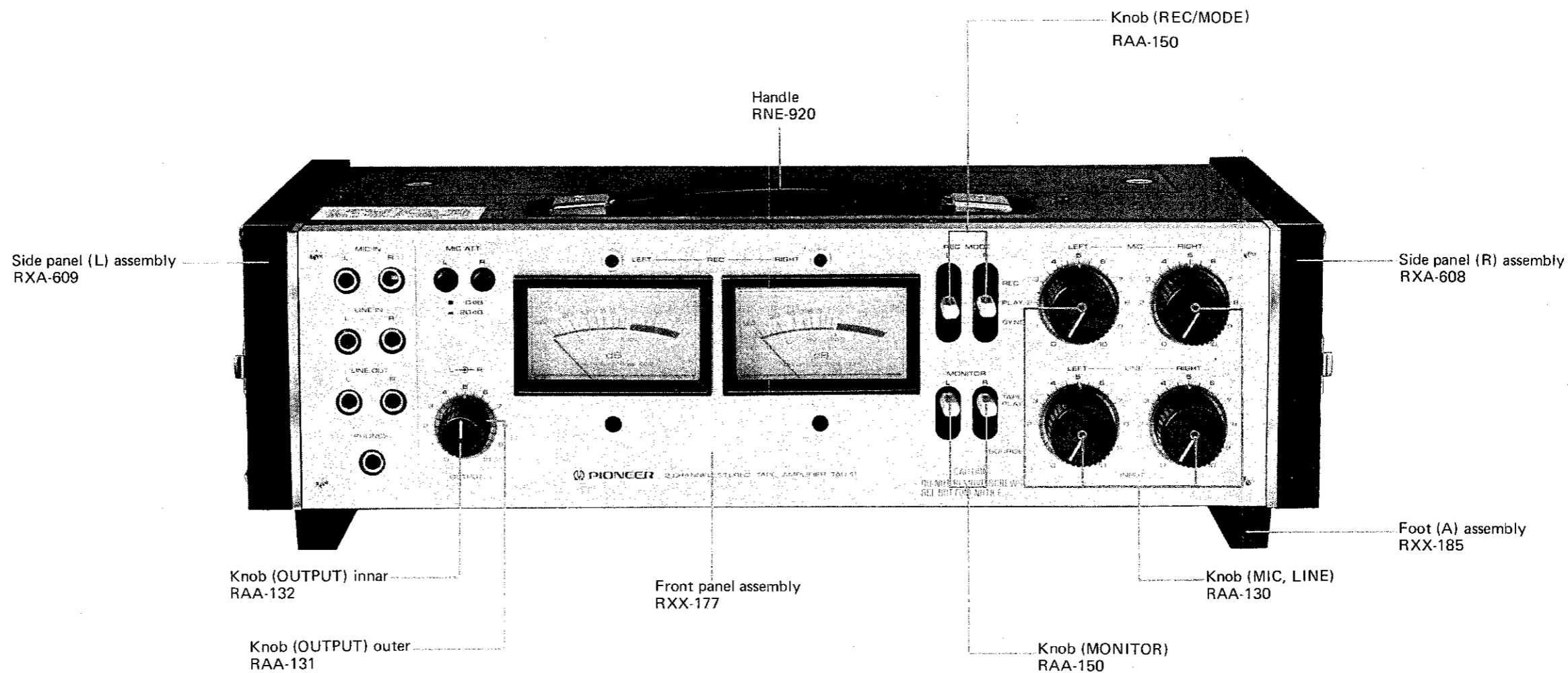

11.2 FRONT VIEW (WITH PANEL REMOVED)

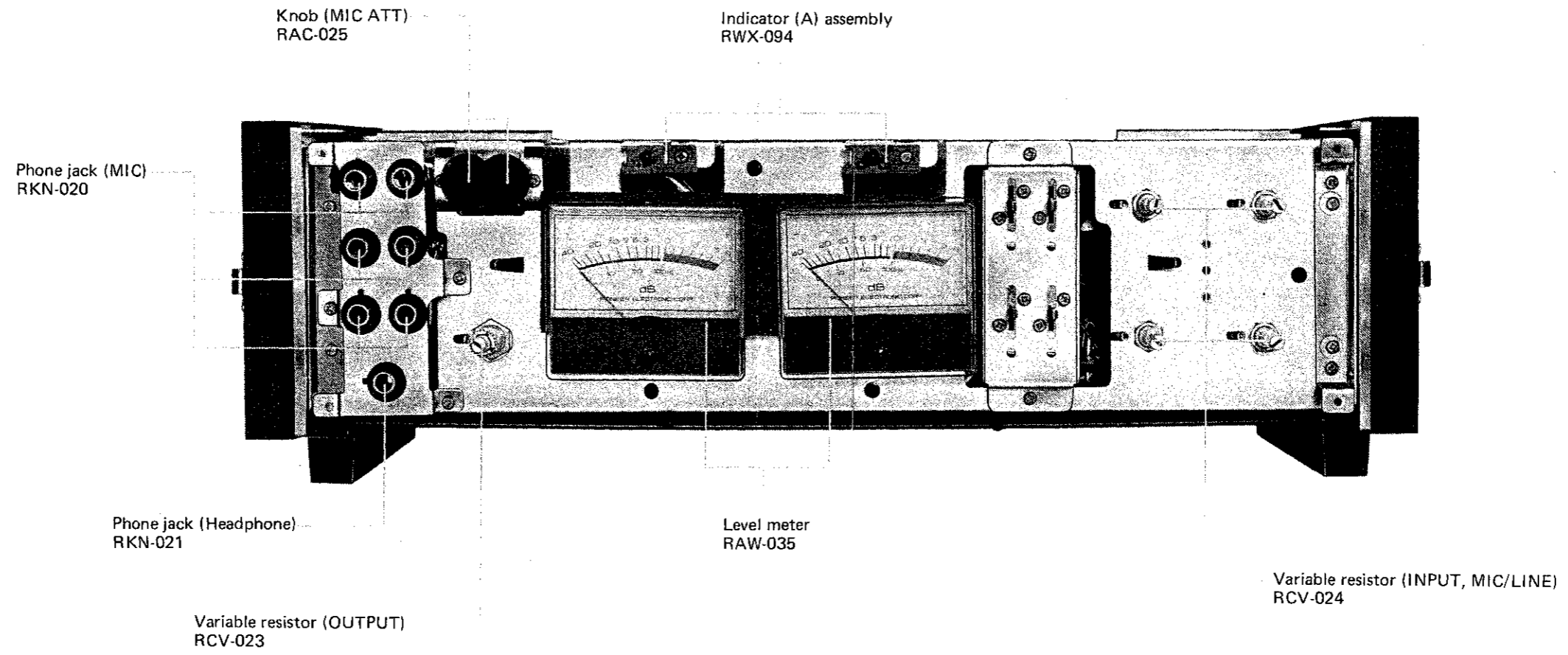

11.3 Bottom VIEW

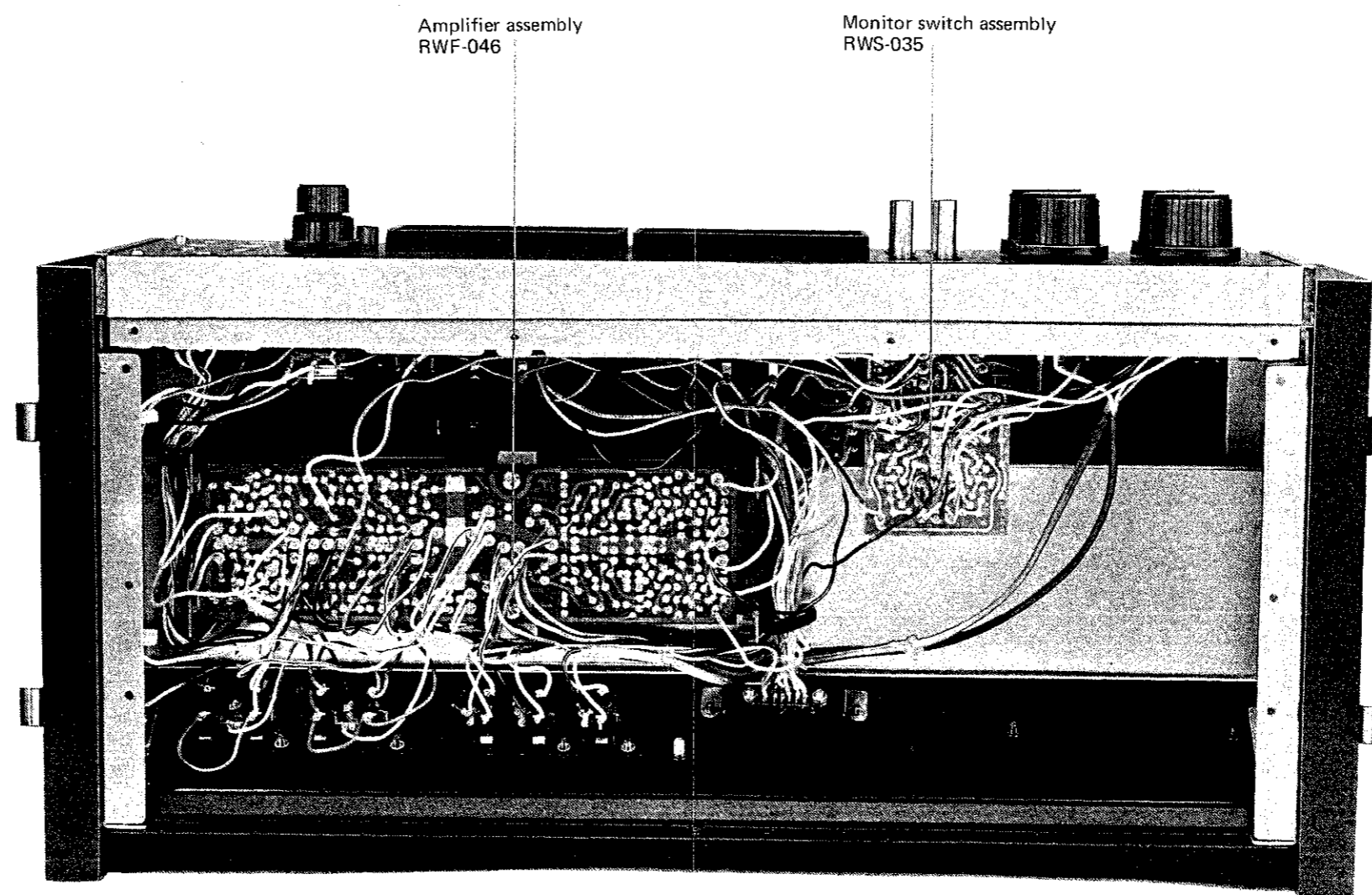

11.4 REAR VIEW

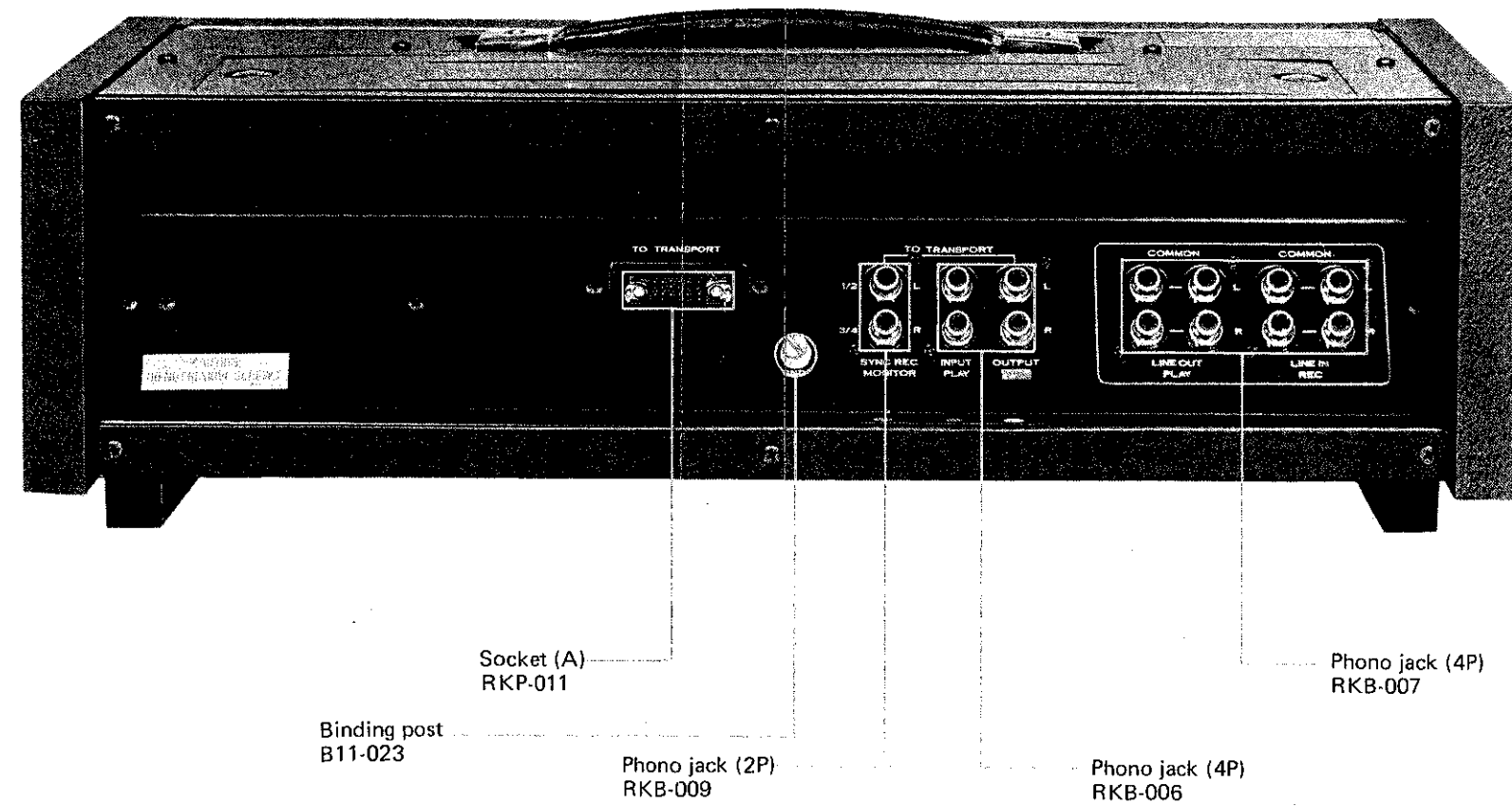

12. RTU-11 EXPLODED VIEW

12.1 MAIN PANEL

NOTE:
Parts indicated in green type cannot be supplied.

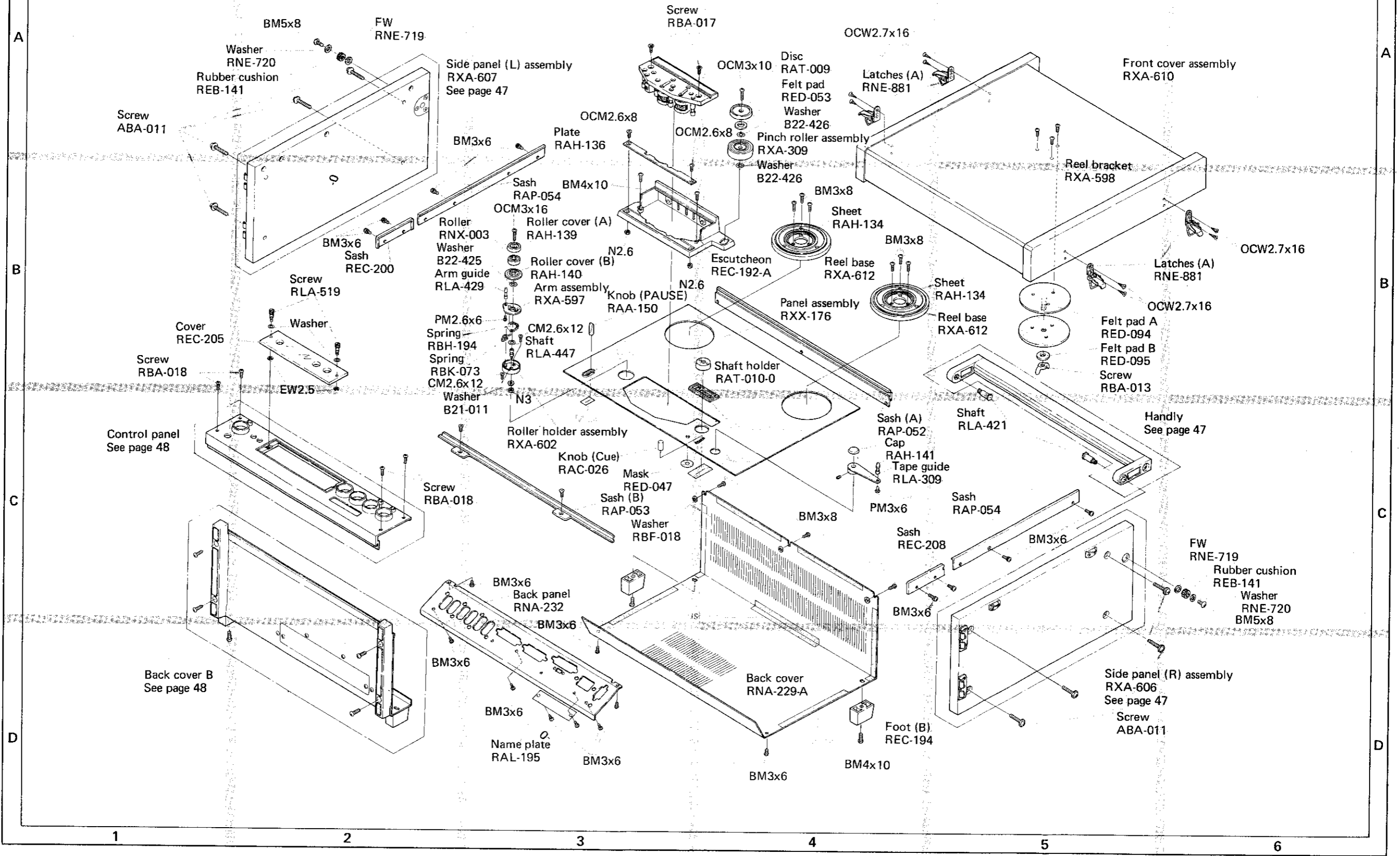

12.2 SUB PANEL

NOTE:
Parts indicated in green type cannot be supplied.

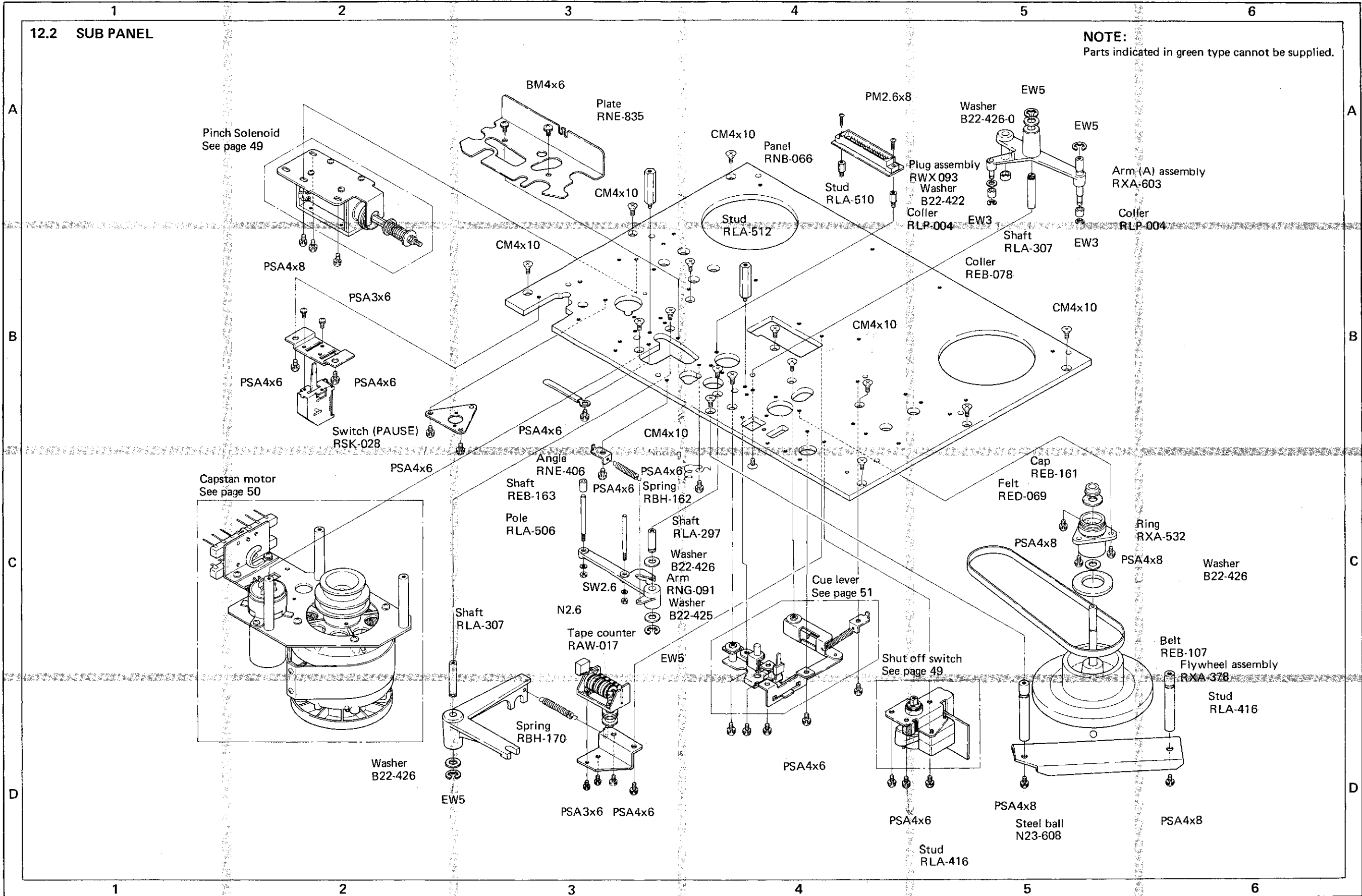

12.3 FRAME CHASSIS

NOTE:
Parts indicated in green type cannot be supplied.

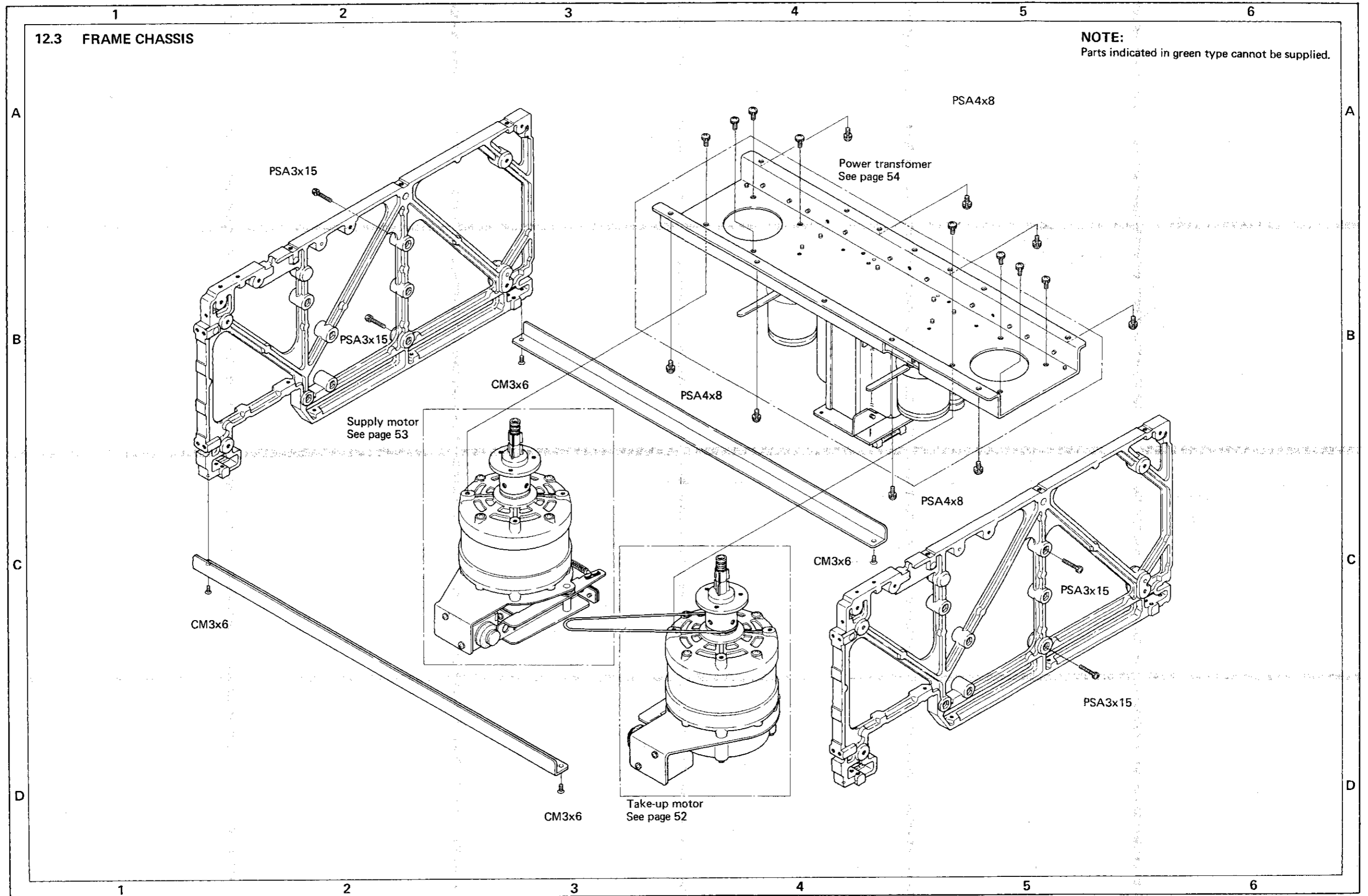

12.4 CONTROL & REAR PANEL

NOTE:
Parts indicated in green type cannot be supplied.

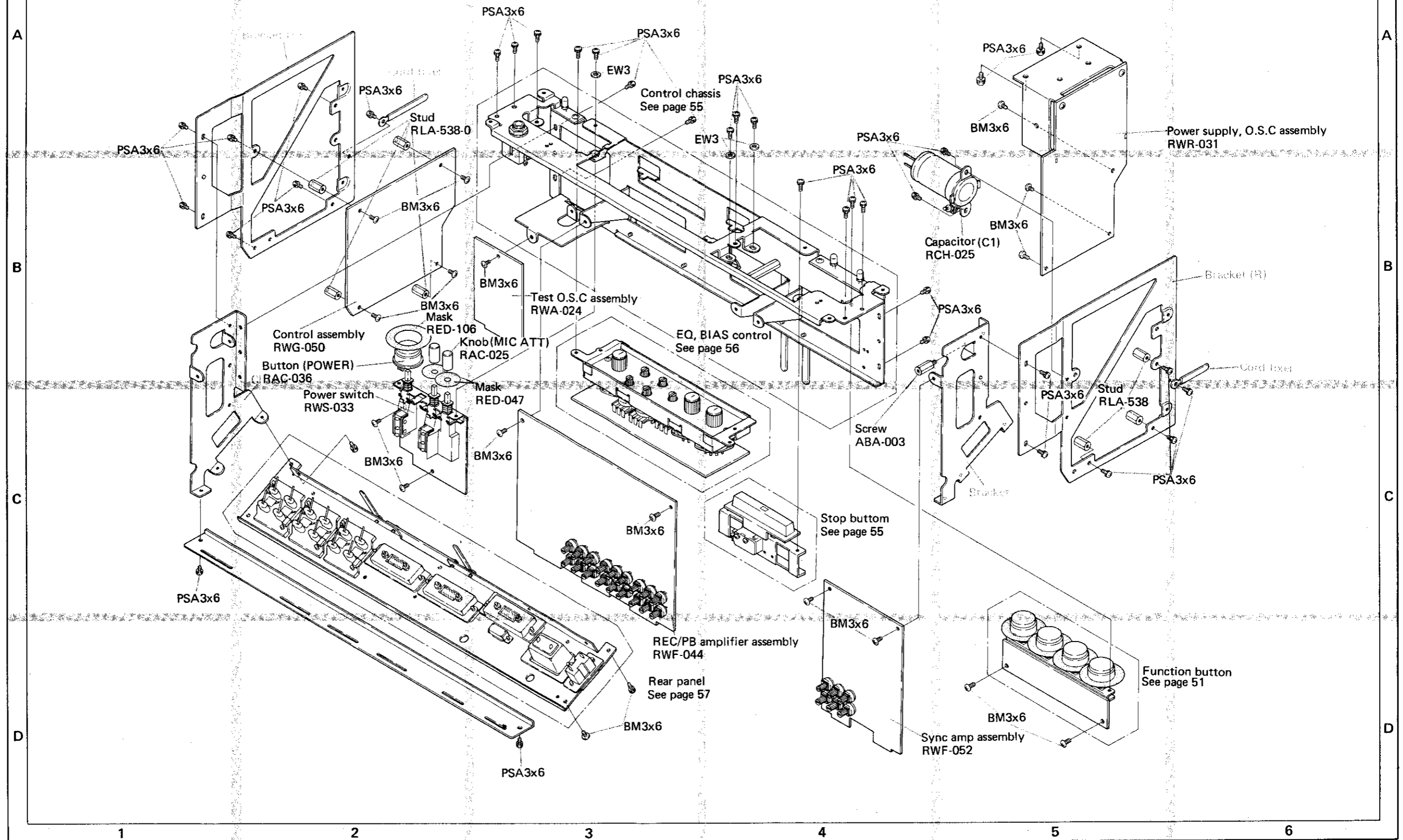

12.5 HANDLE

NOTE:

Parts indicated in green type cannot be supplied.

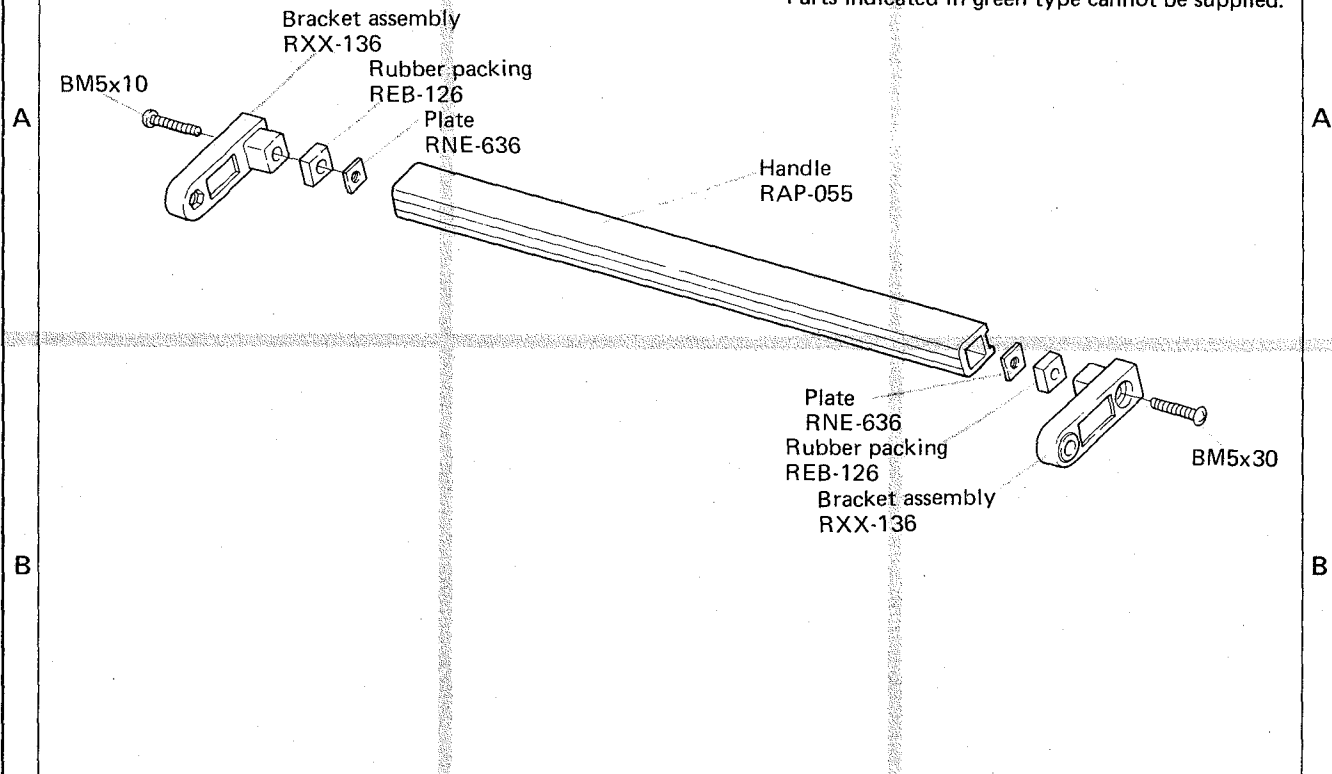

12.6 SIDE PANEL

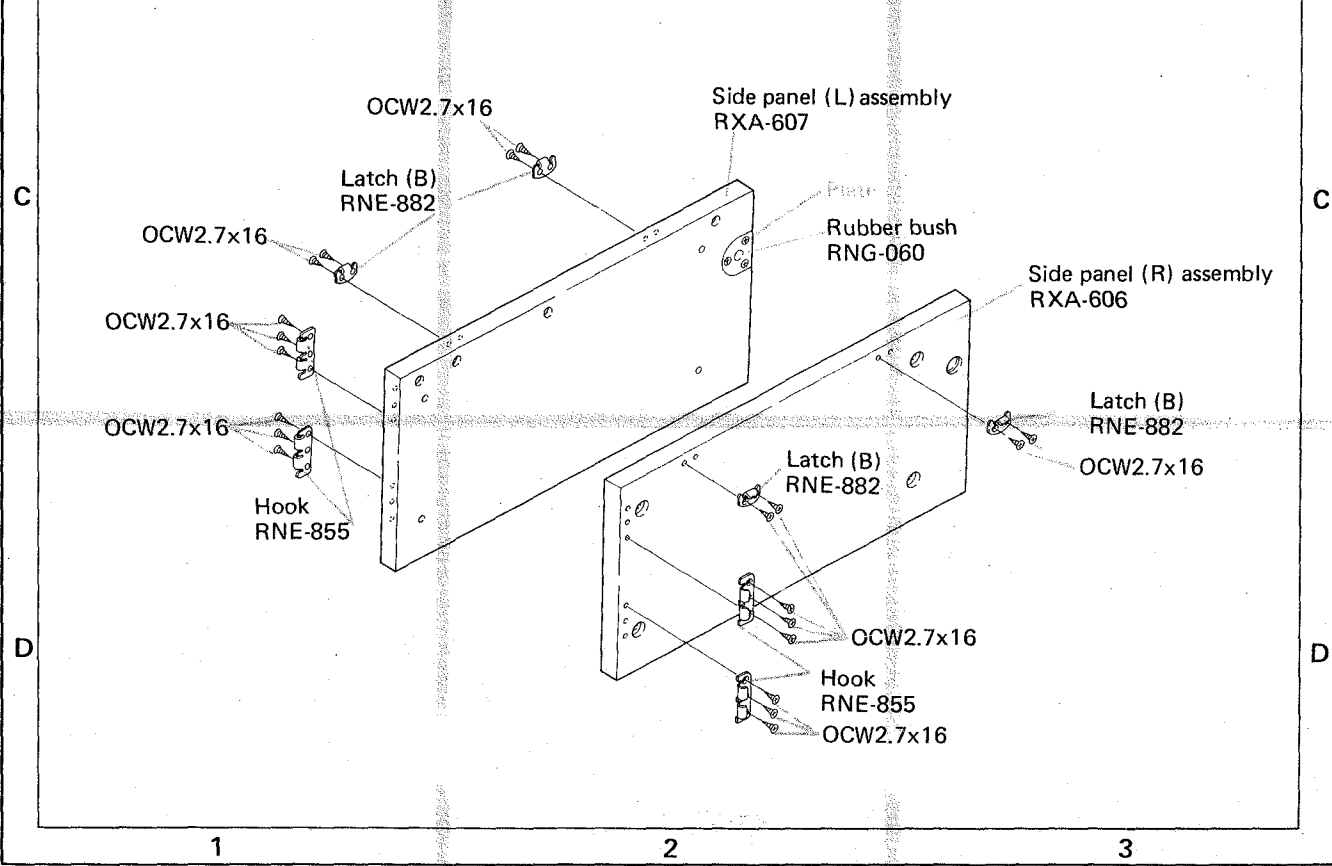

12.7 CONTROL PANEL

NOTE:
Parts indicated in green type cannot be supplied.

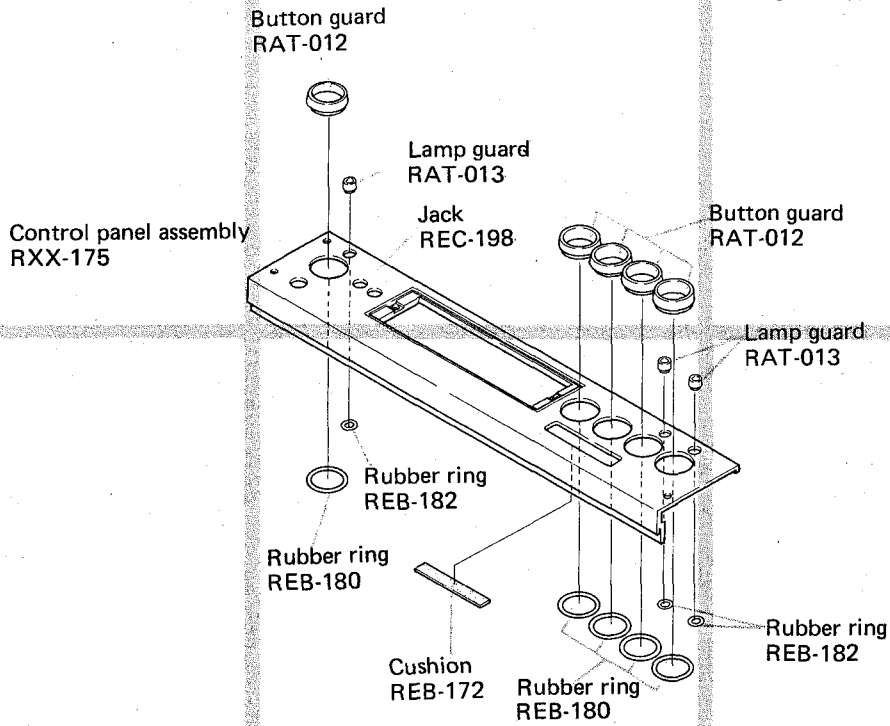

12.8 BACK COVER B

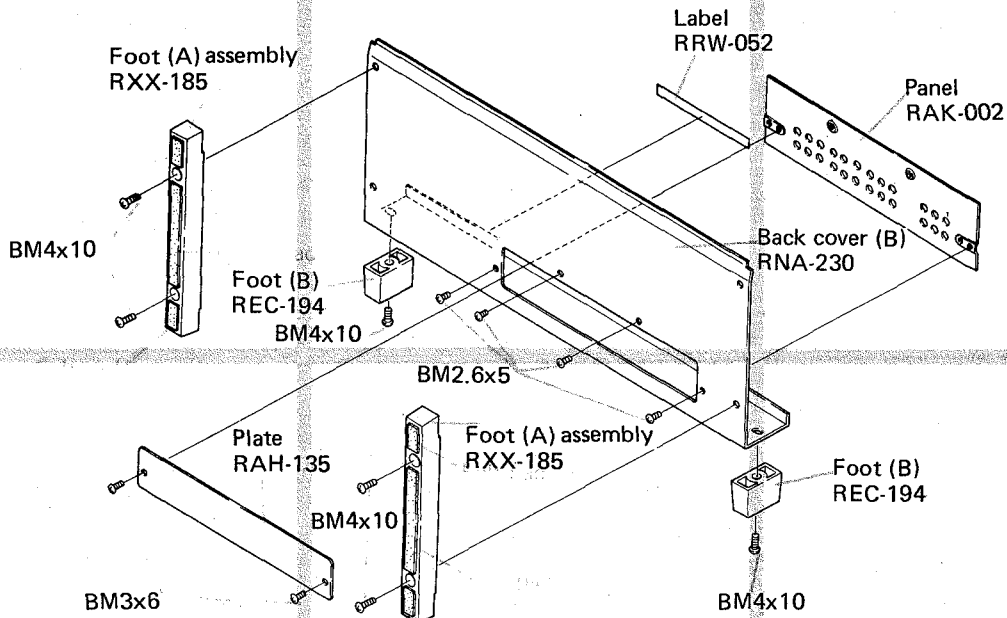

12.9 PINCH SOLENOID (SL3)

NOTE:
Parts indicated in green type cannot be supplied.

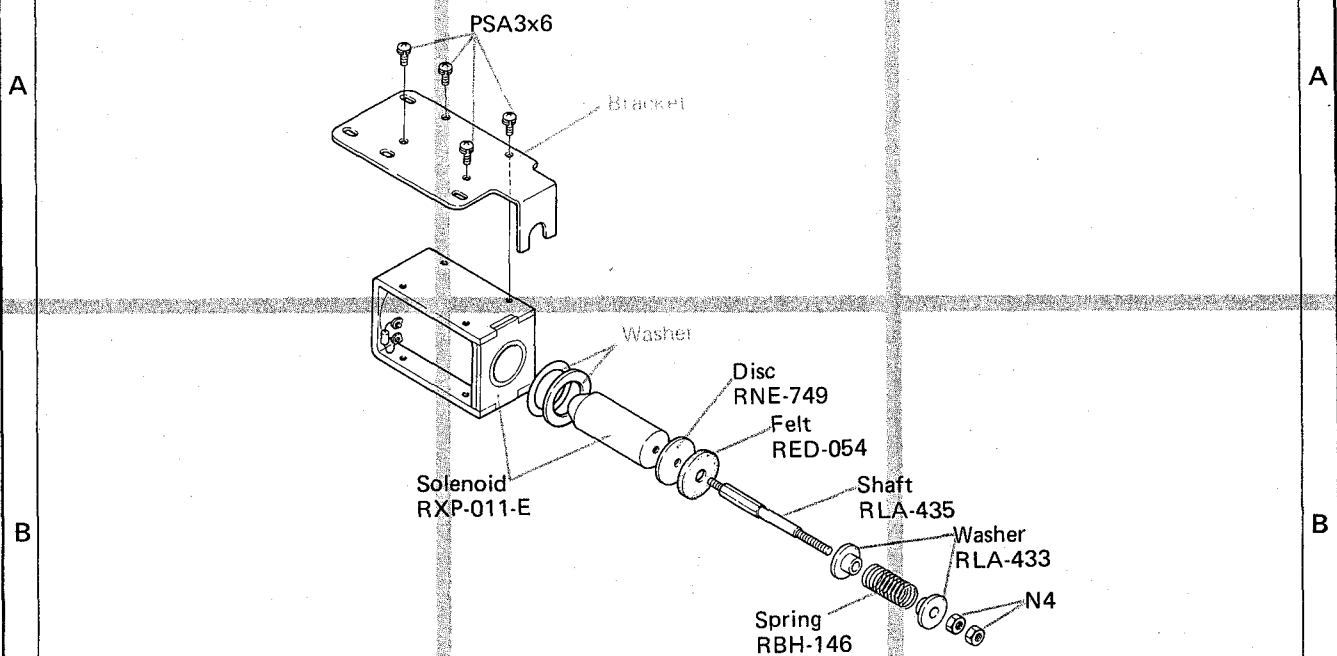

12.10 SHUT-OFF SWITCH

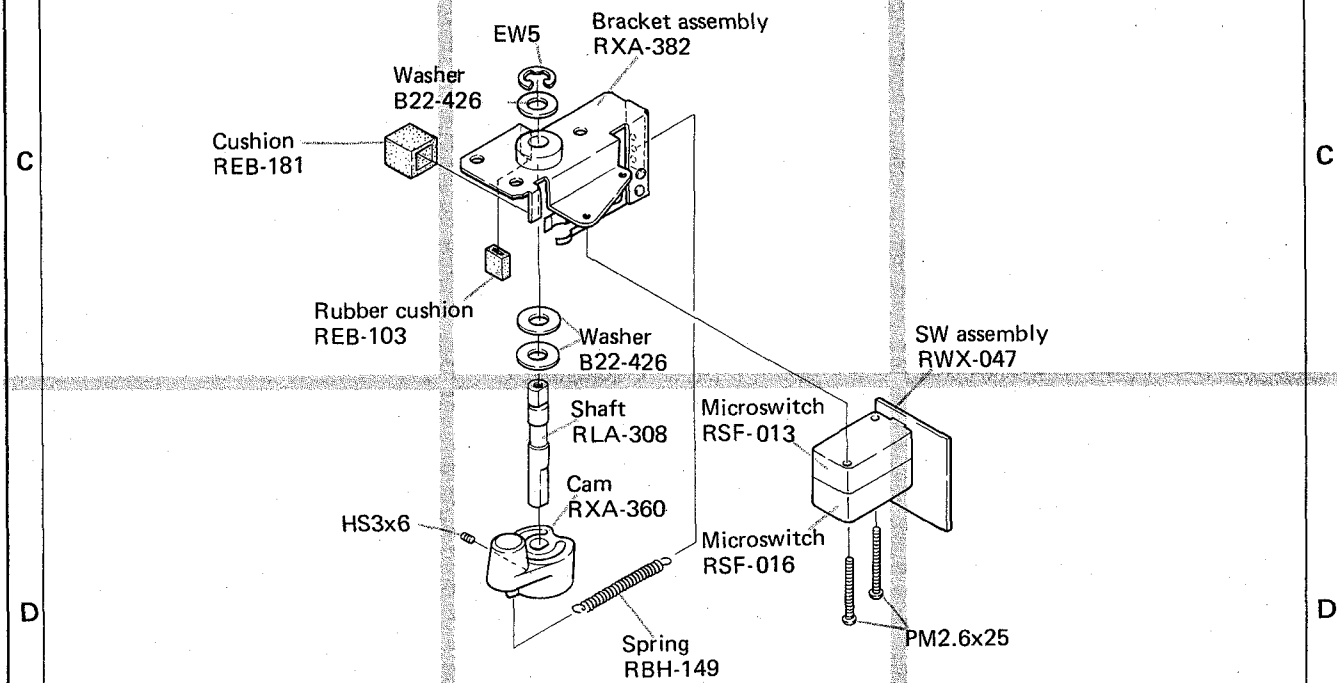

12.11 CAPSTAN MOTOR

NOTE:
Parts indicated in green type cannot be supplied.

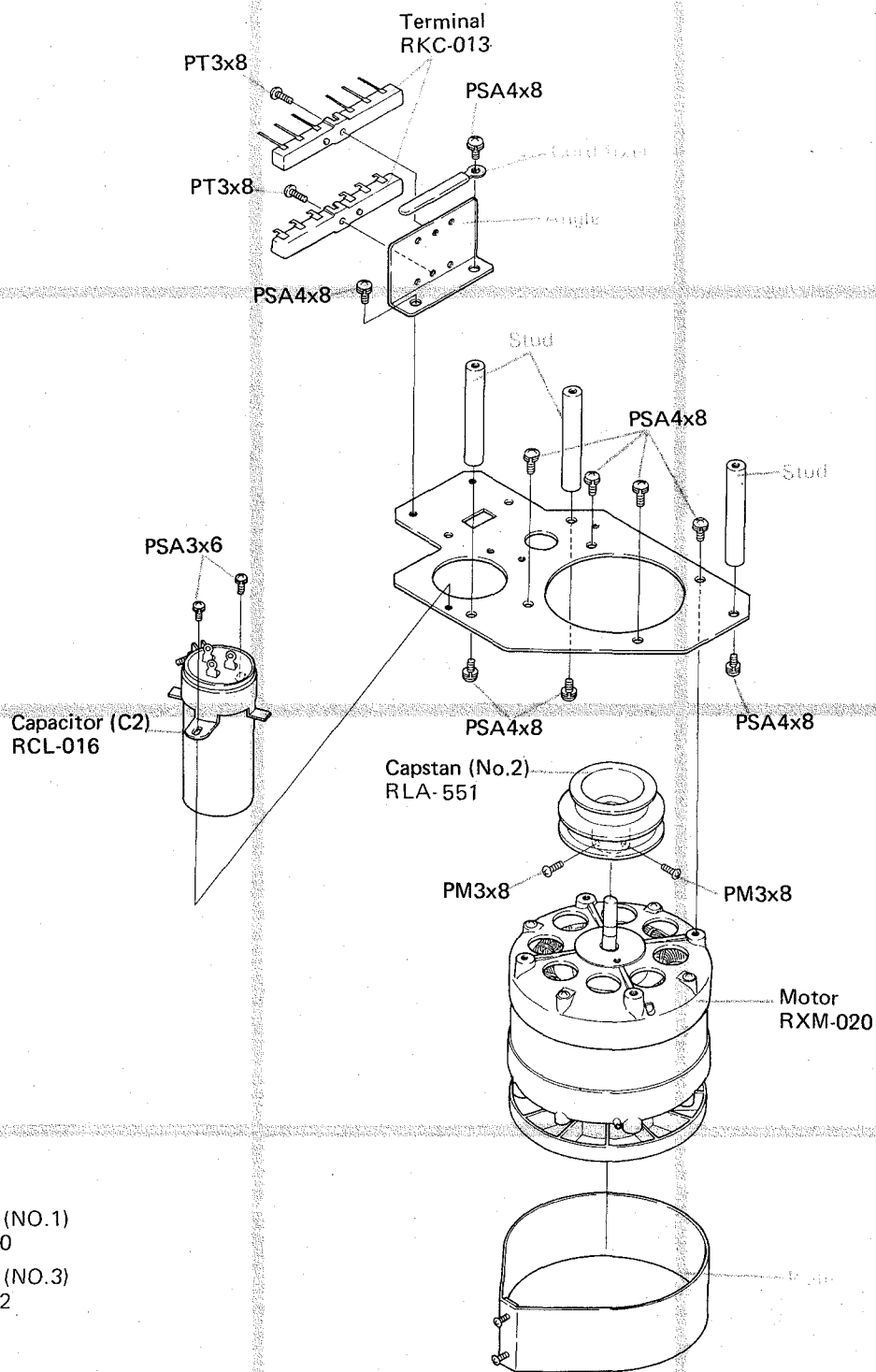

12.12 CUE LEVER

NOTE:
Part indicated in green type cannot be supplied.

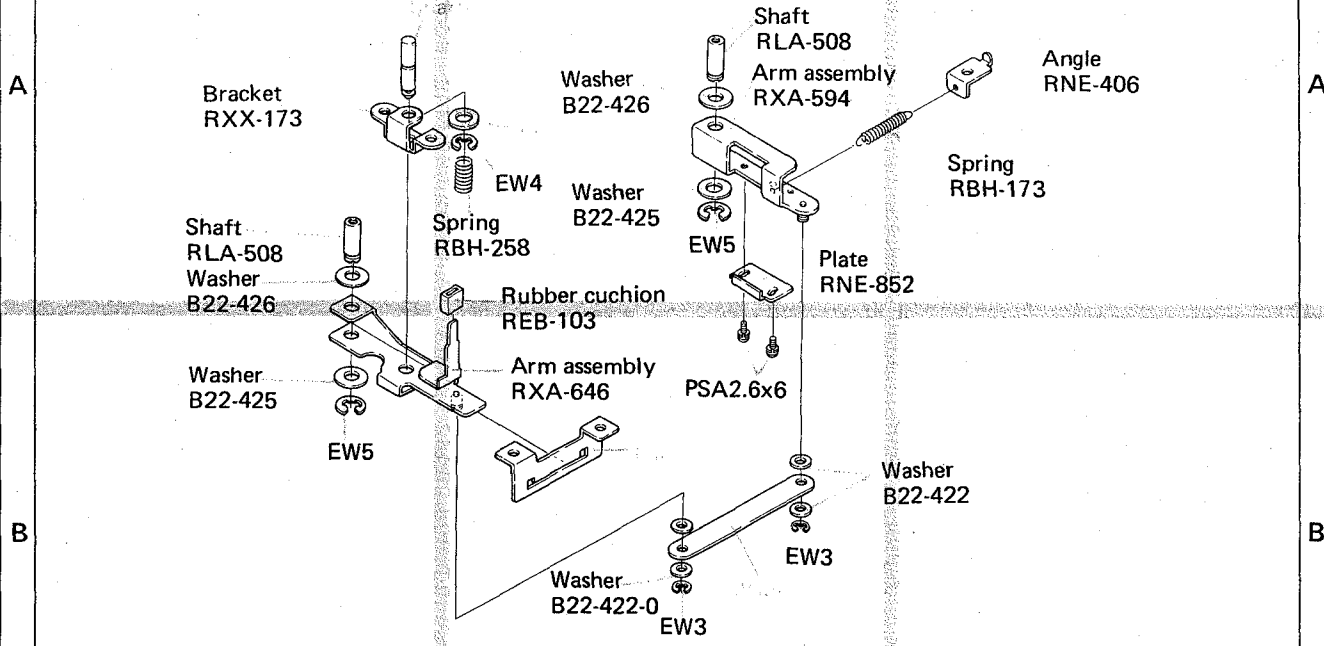

12.13 FUNCTION BUTTON

NOTE:
Parts indicated in green type cannot be supplied.

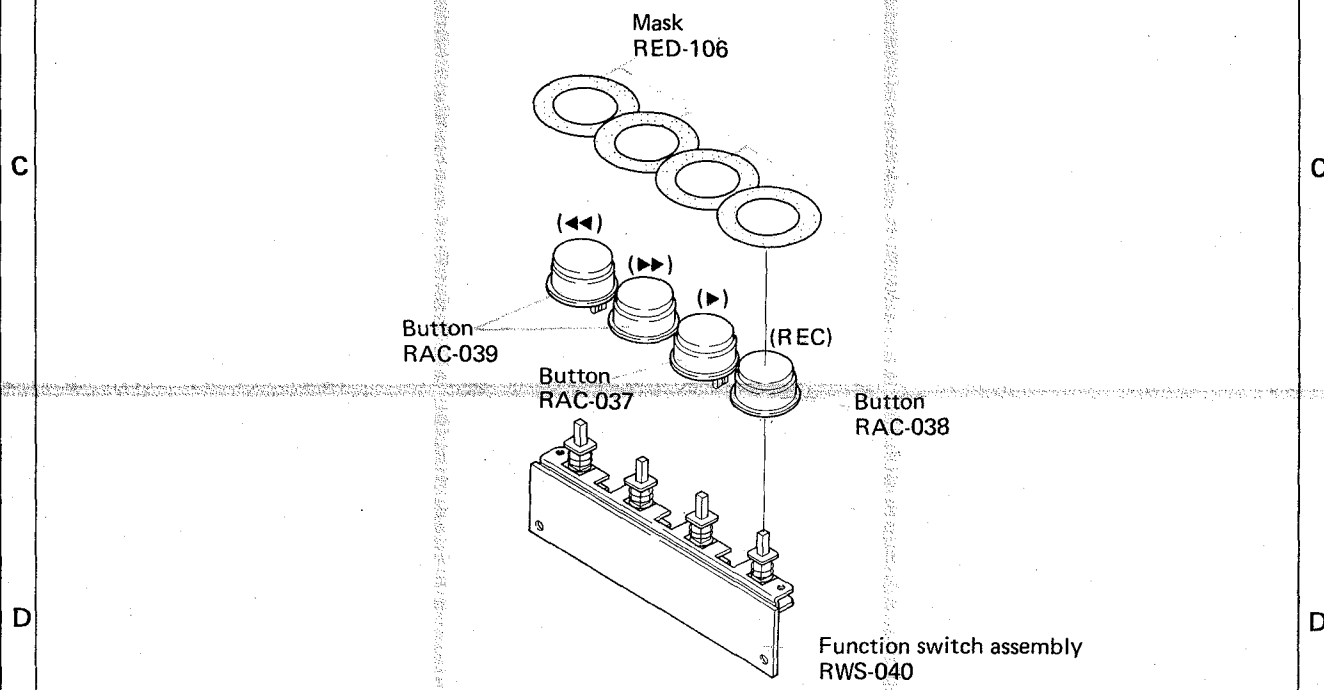

12.14 TAKE-UP MOTOR

NOTE:
Parts indicated in green type cannot be supplied.

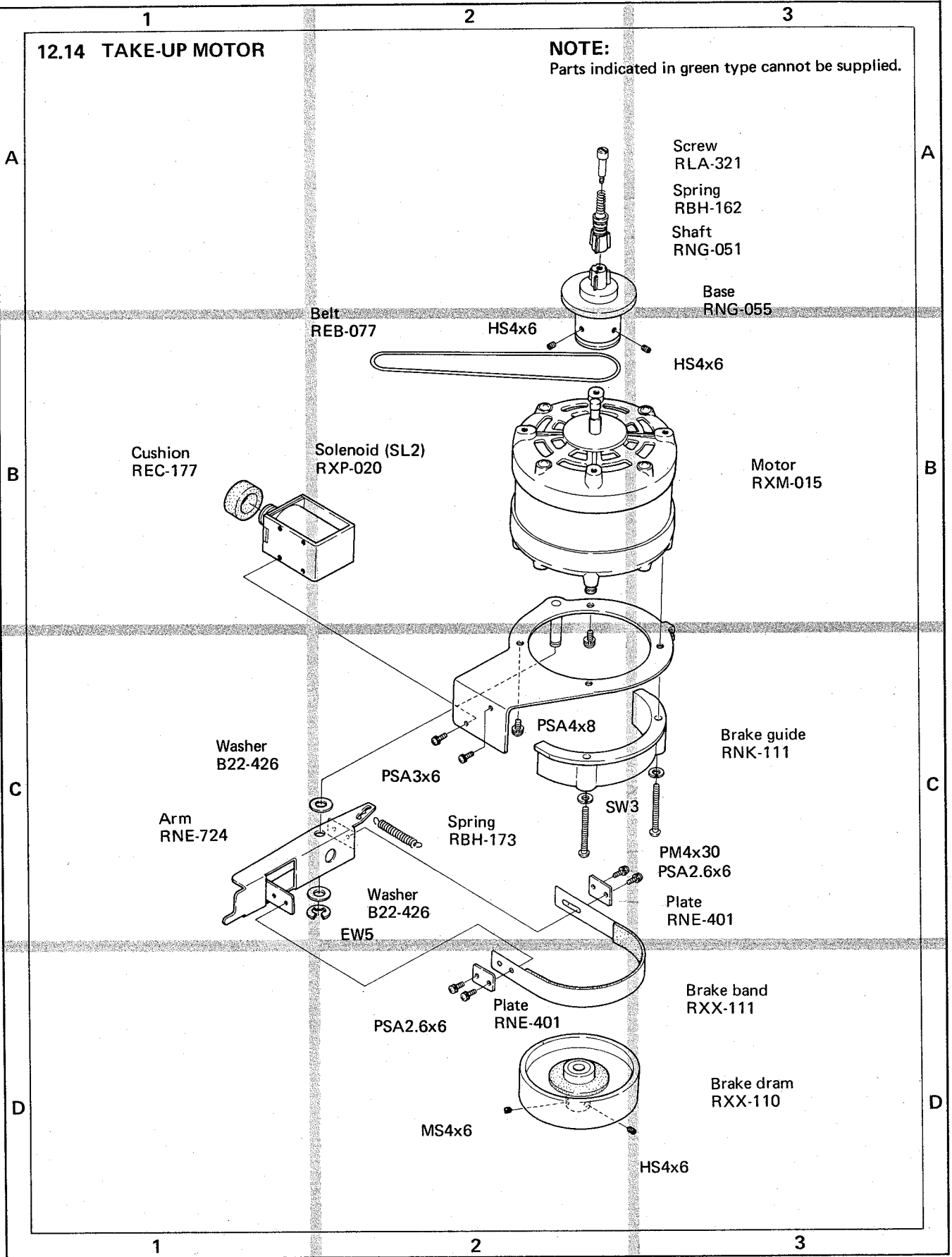

12.15 SUPPLY MOTOR

NOTE:

Parts indicated in green type cannot be supplied.

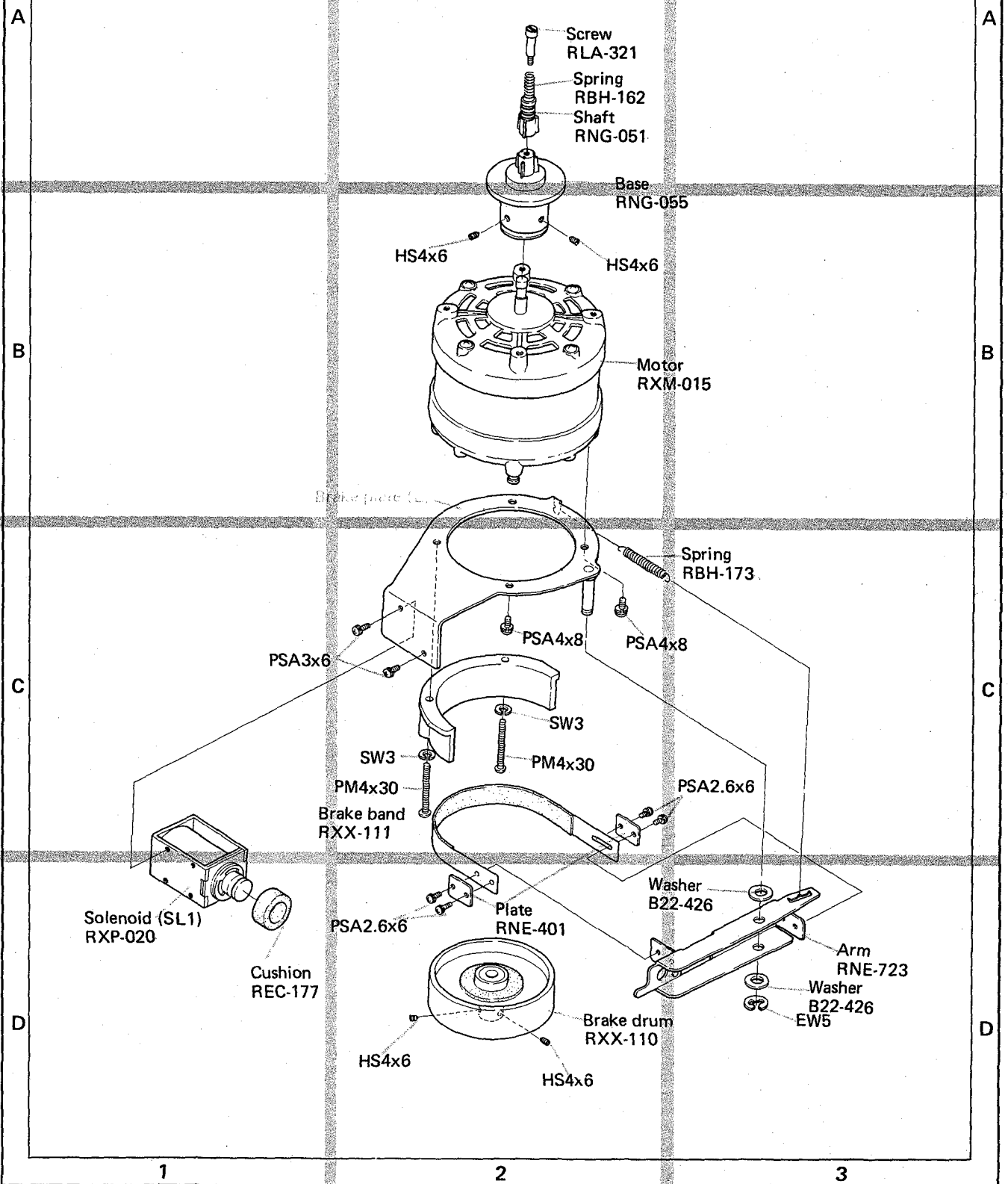

12.16 POWER TRANSFORMER

NOTE:
Parts indicated in green type cannot be supplied.

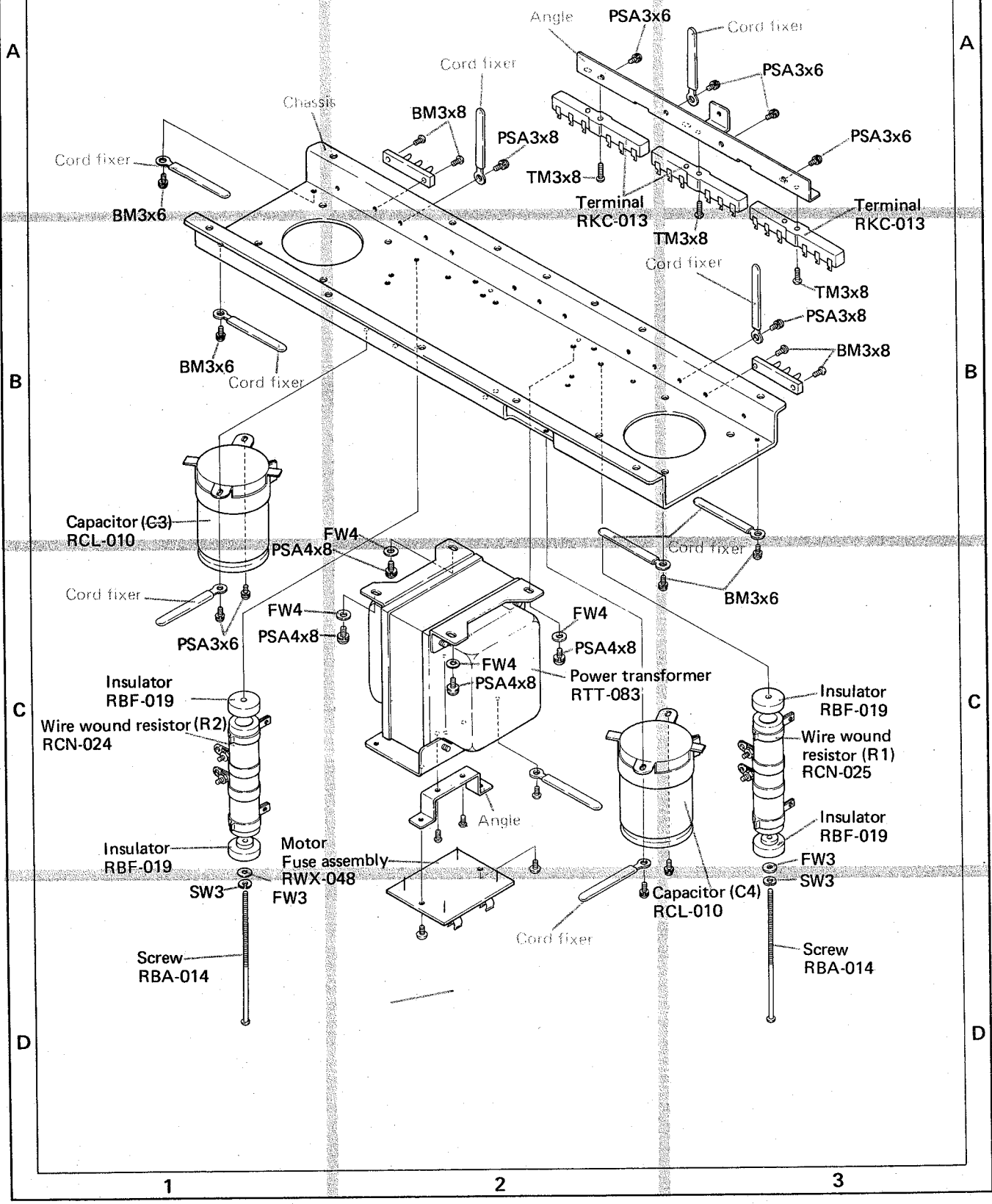

12.17 CONTROL CHASSIS

NOTE:
Parts indicated in green type cannot be supplied.

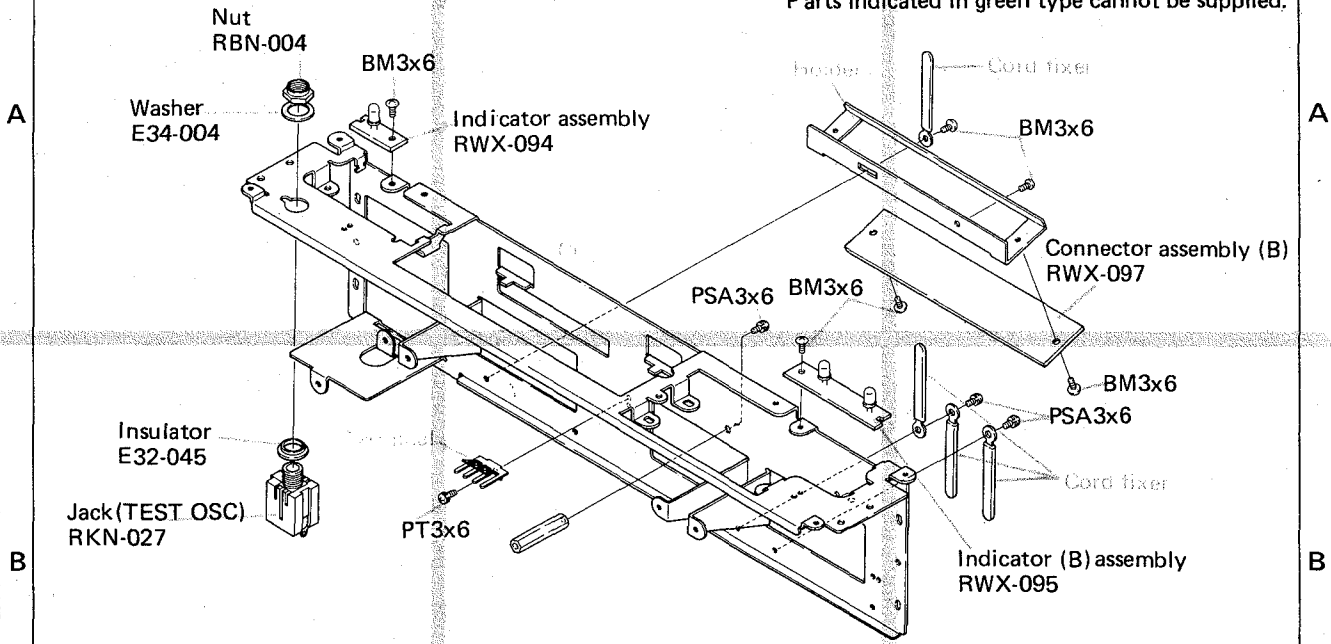

12.18 STOP BUTTON

NOTE:
Parts indicated in green type cannot be supplied.

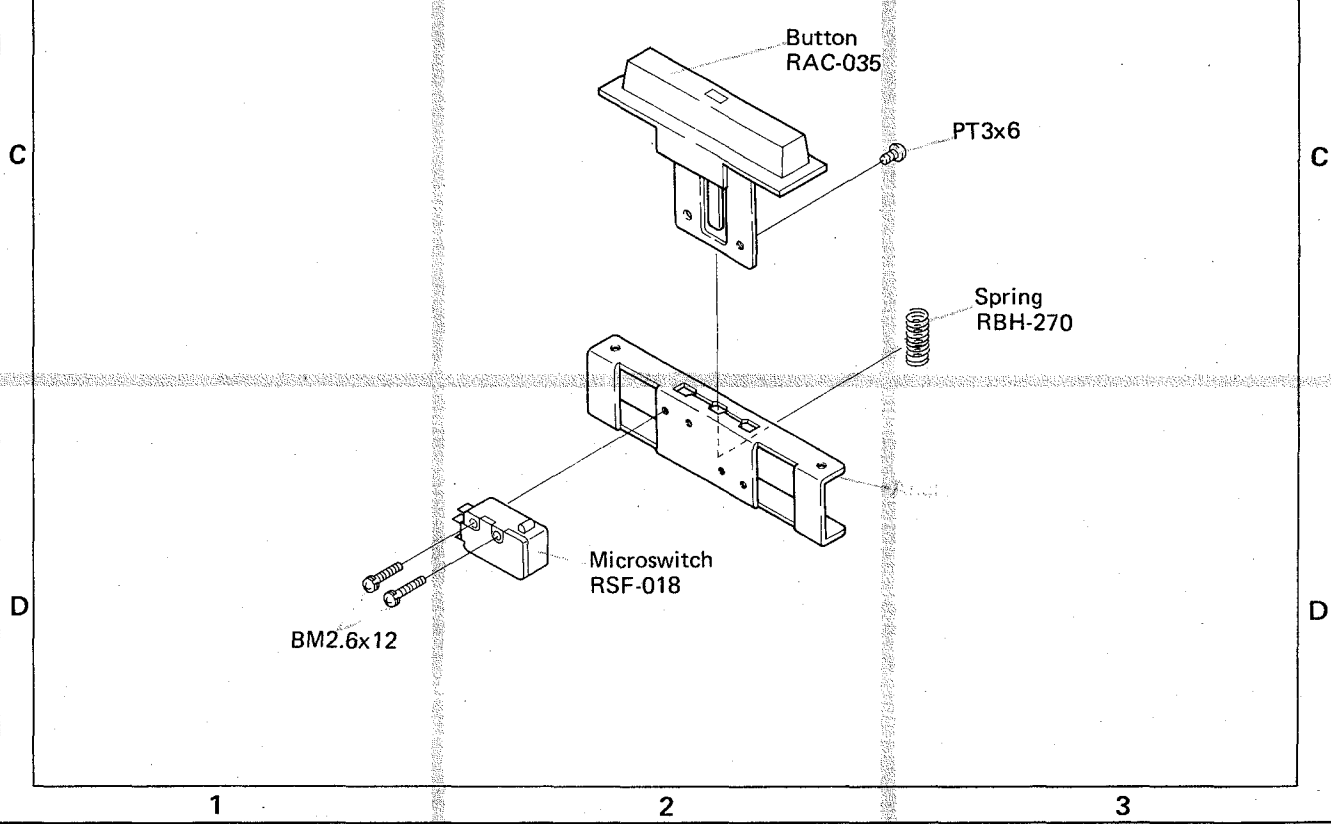

12.19 EQ BIAS CONTROL

NOTE:

Parts indicated in green type cannot be supplied.

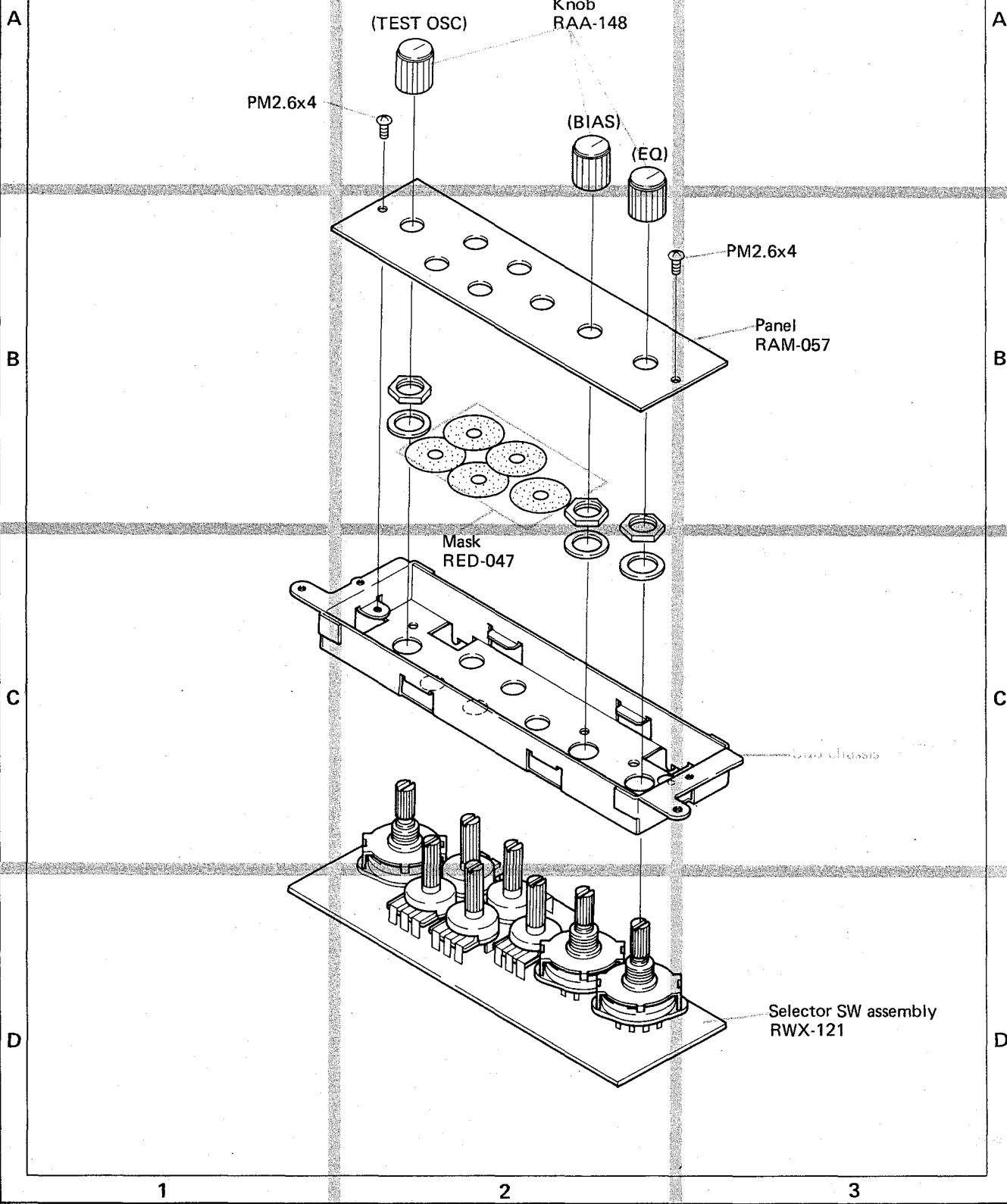

12.20 REAR PANEL

NOTE:
Parts indicated in green type cannot be supplied.

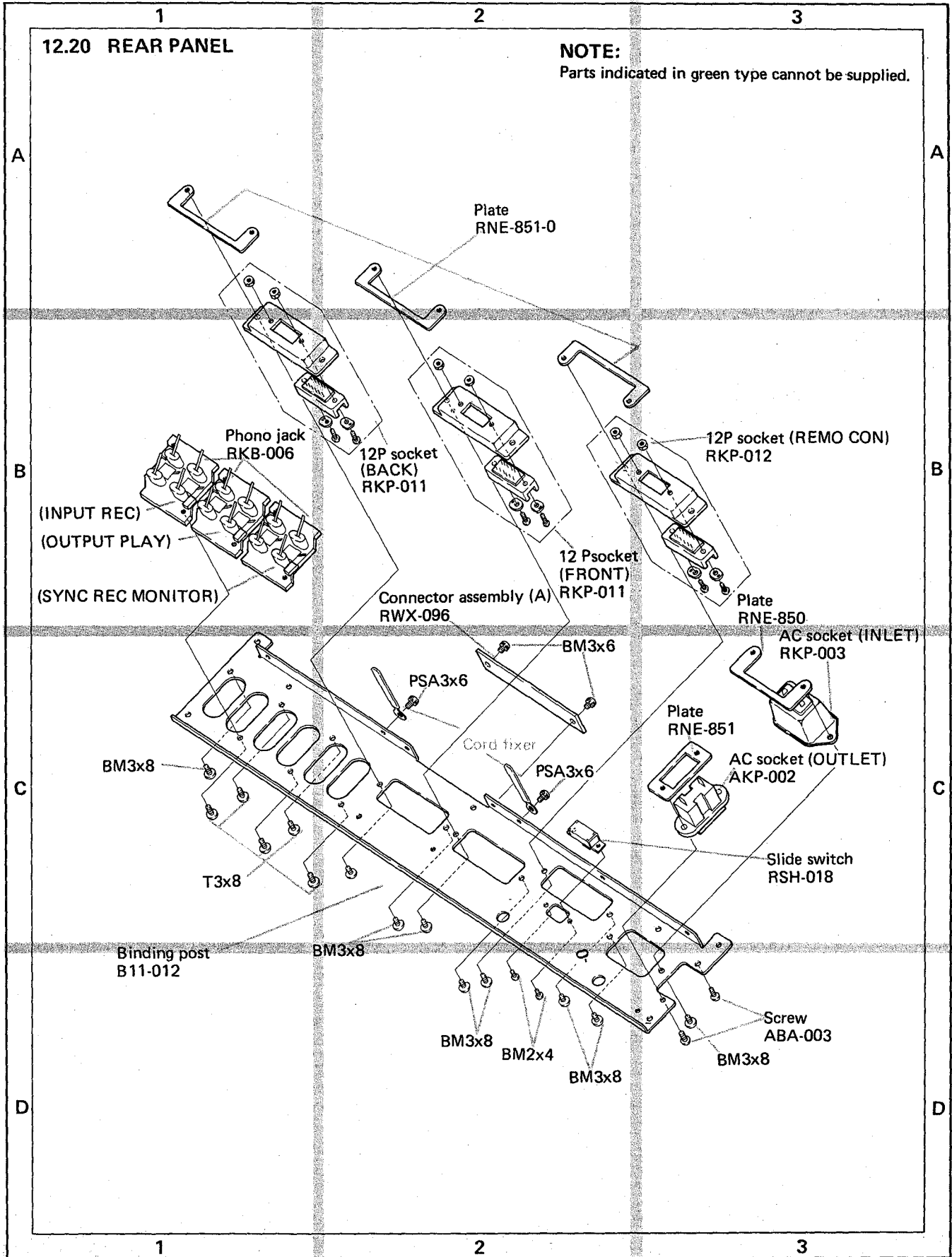

12.21 RTU-11 PACKING

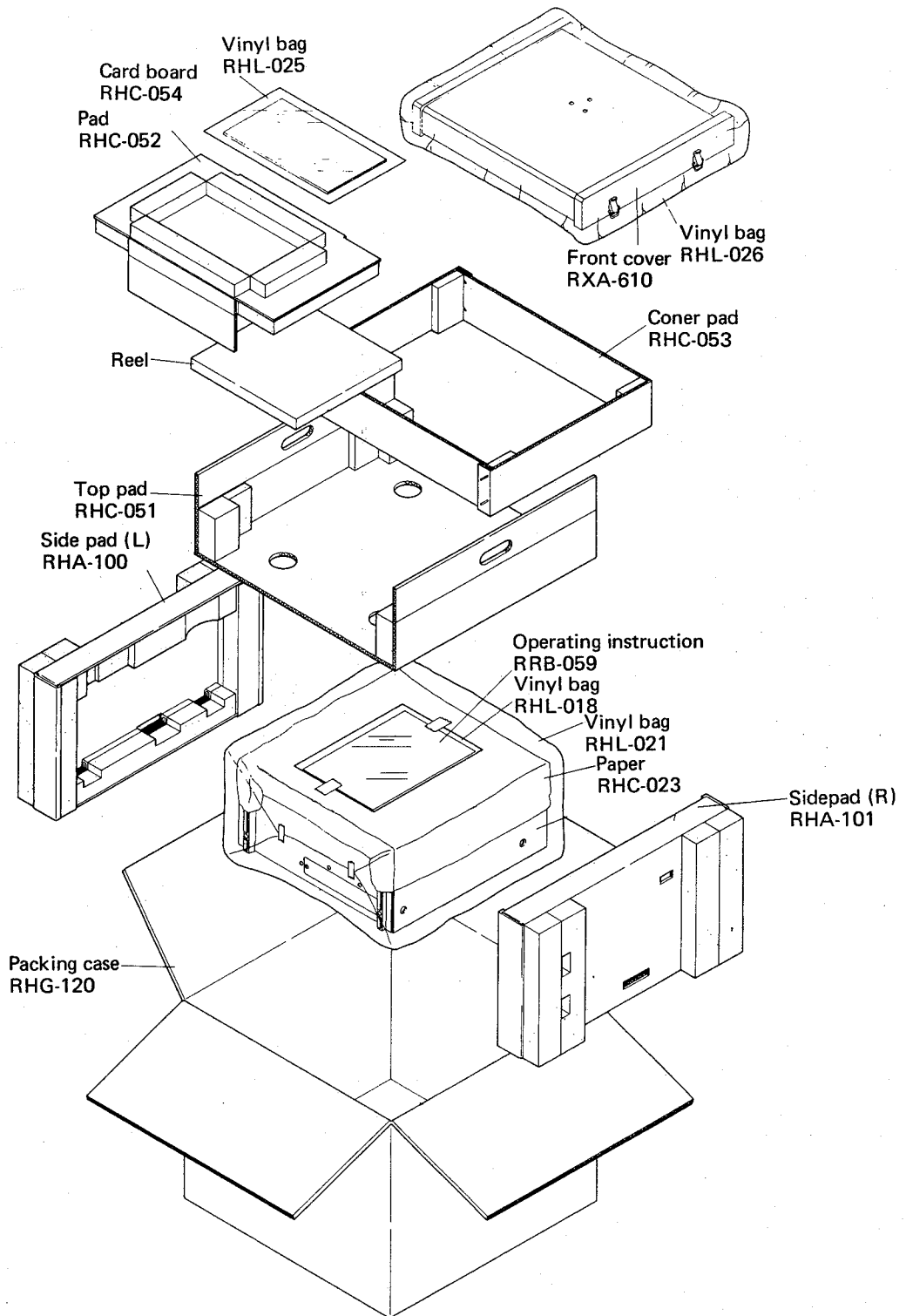

13. TAU-11 EXPLODED VIEW

NOTE:
Parts indicated in green type cannot be supplied.

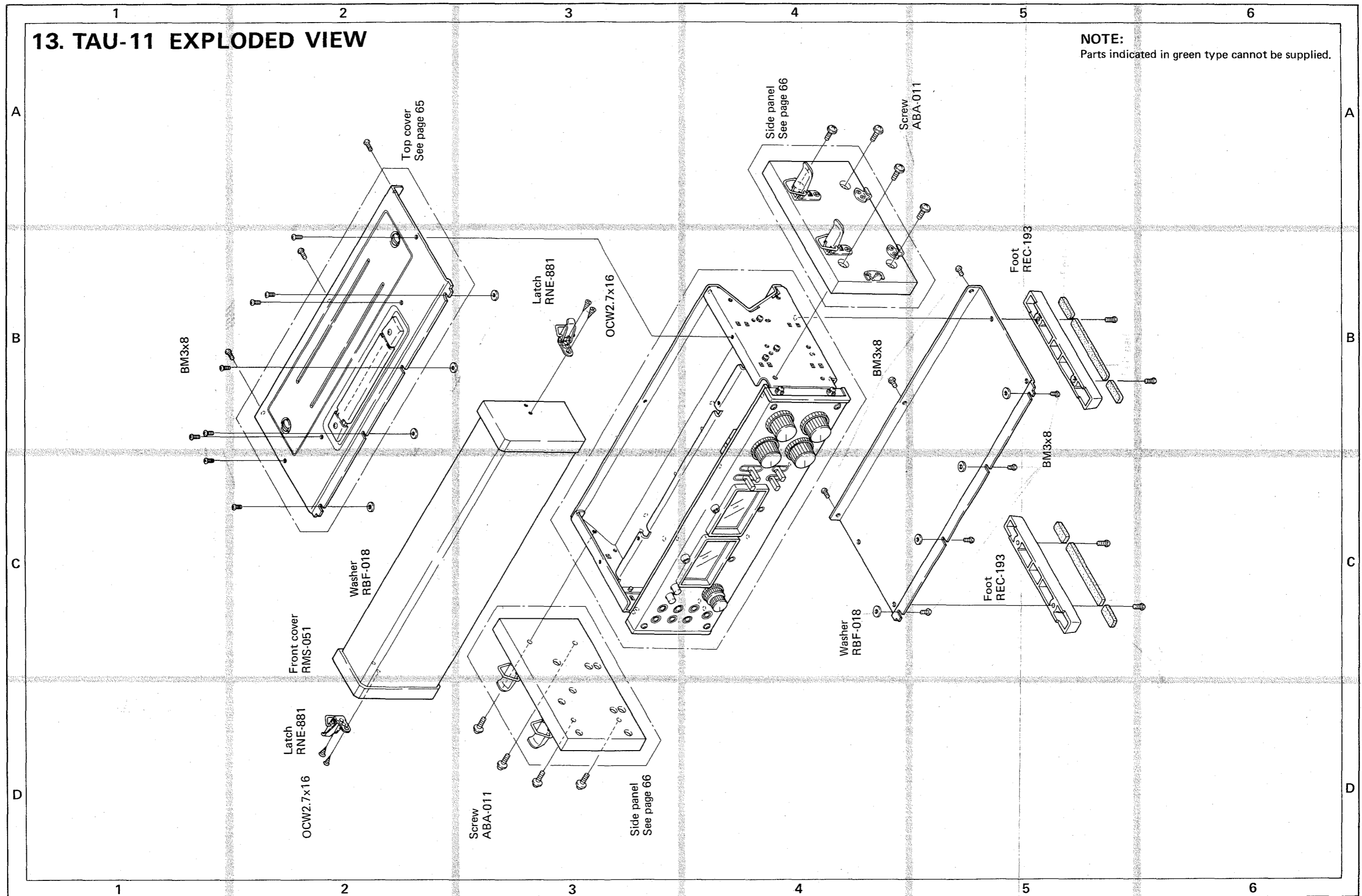

13.1 MAIN CHASSIS

NOTE:
Parts indicated in green type cannot be supplied.

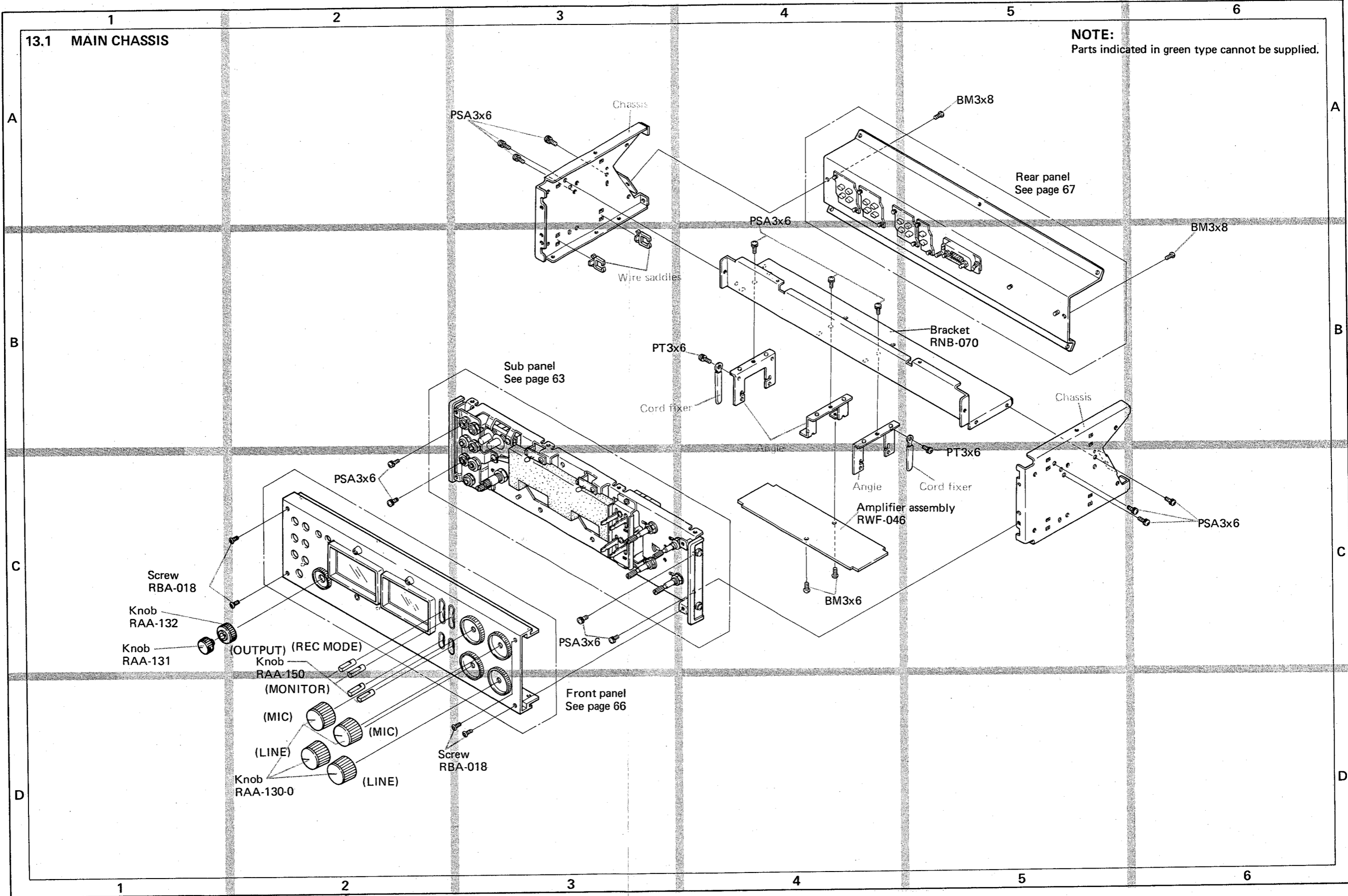

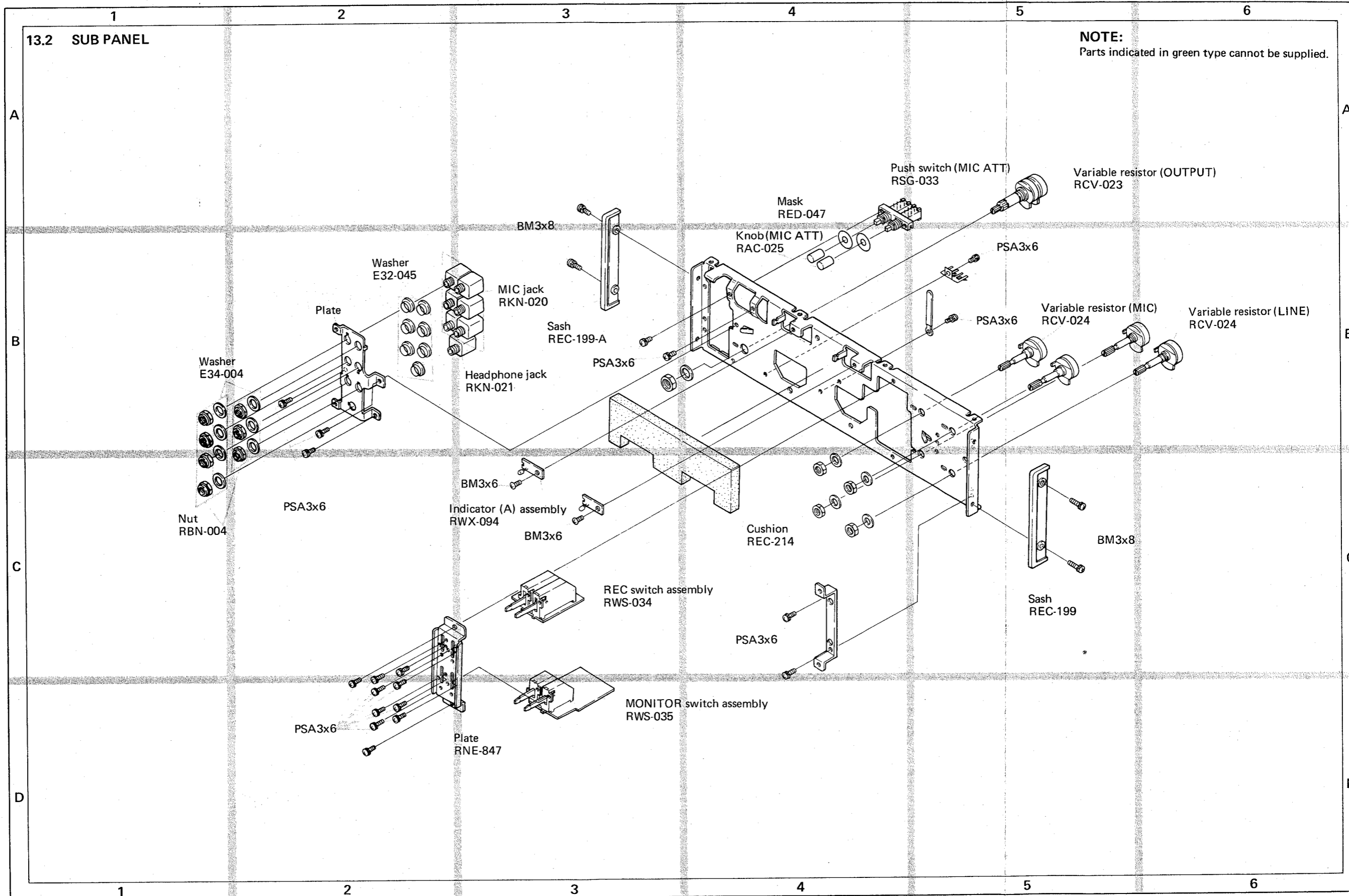

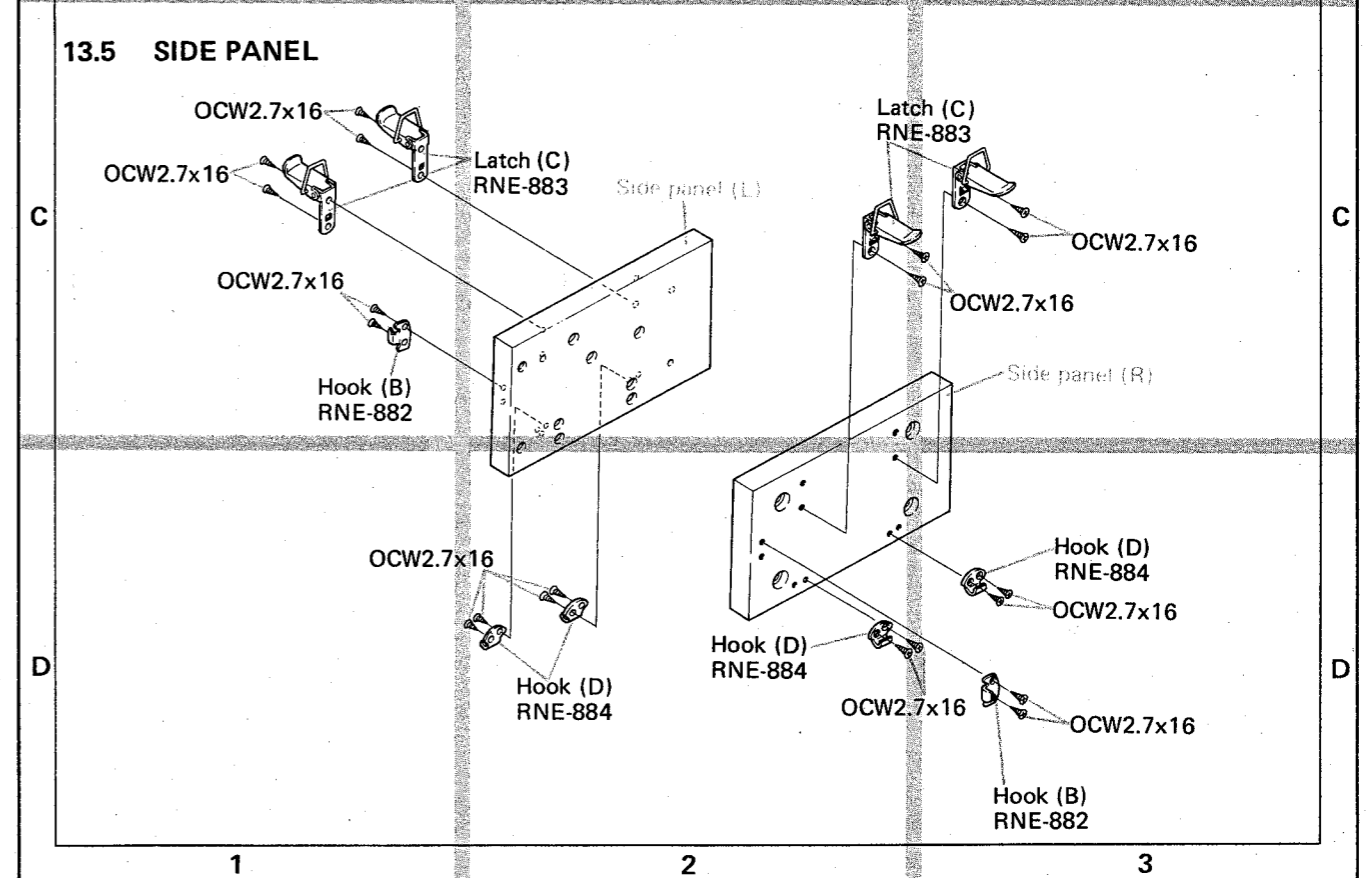
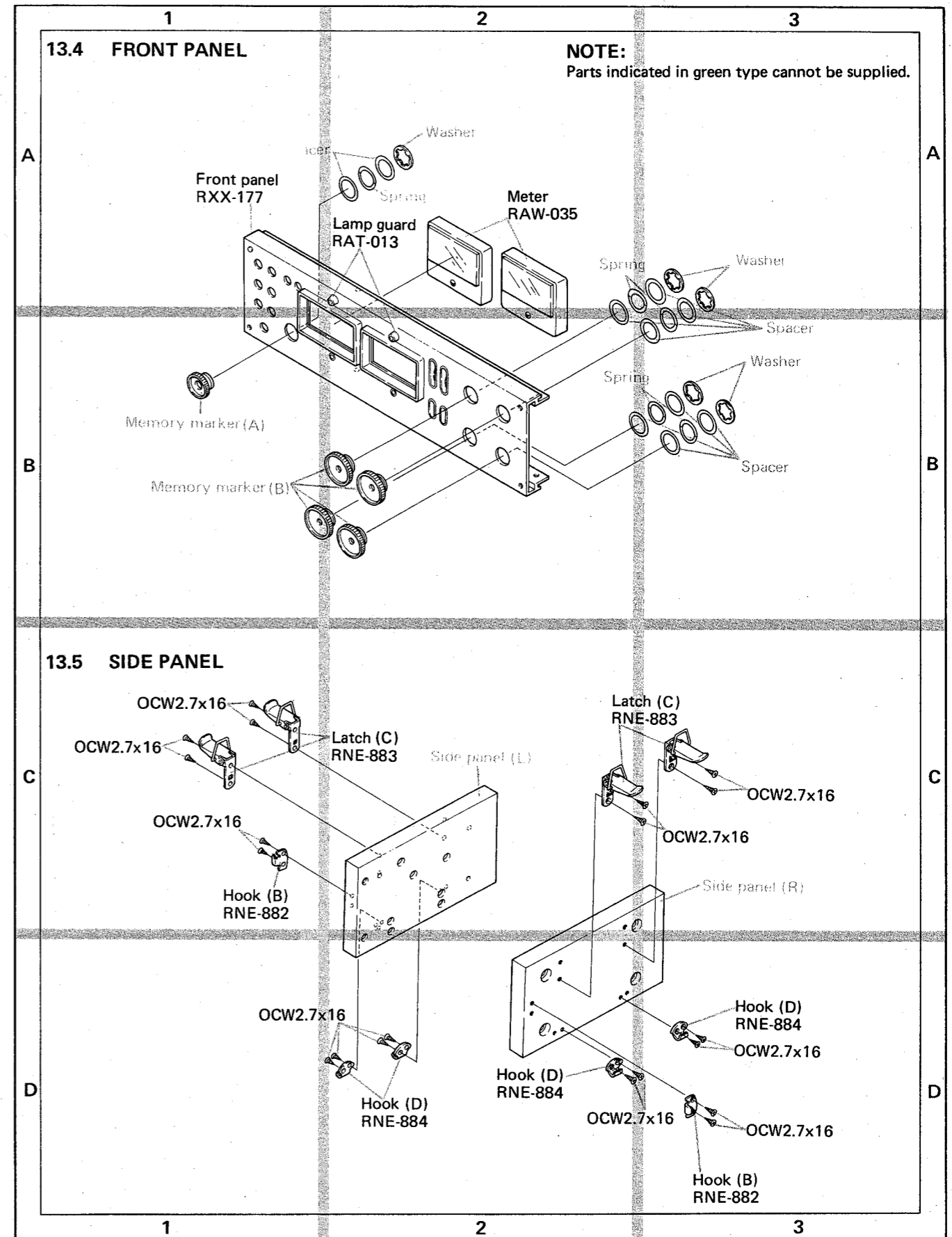
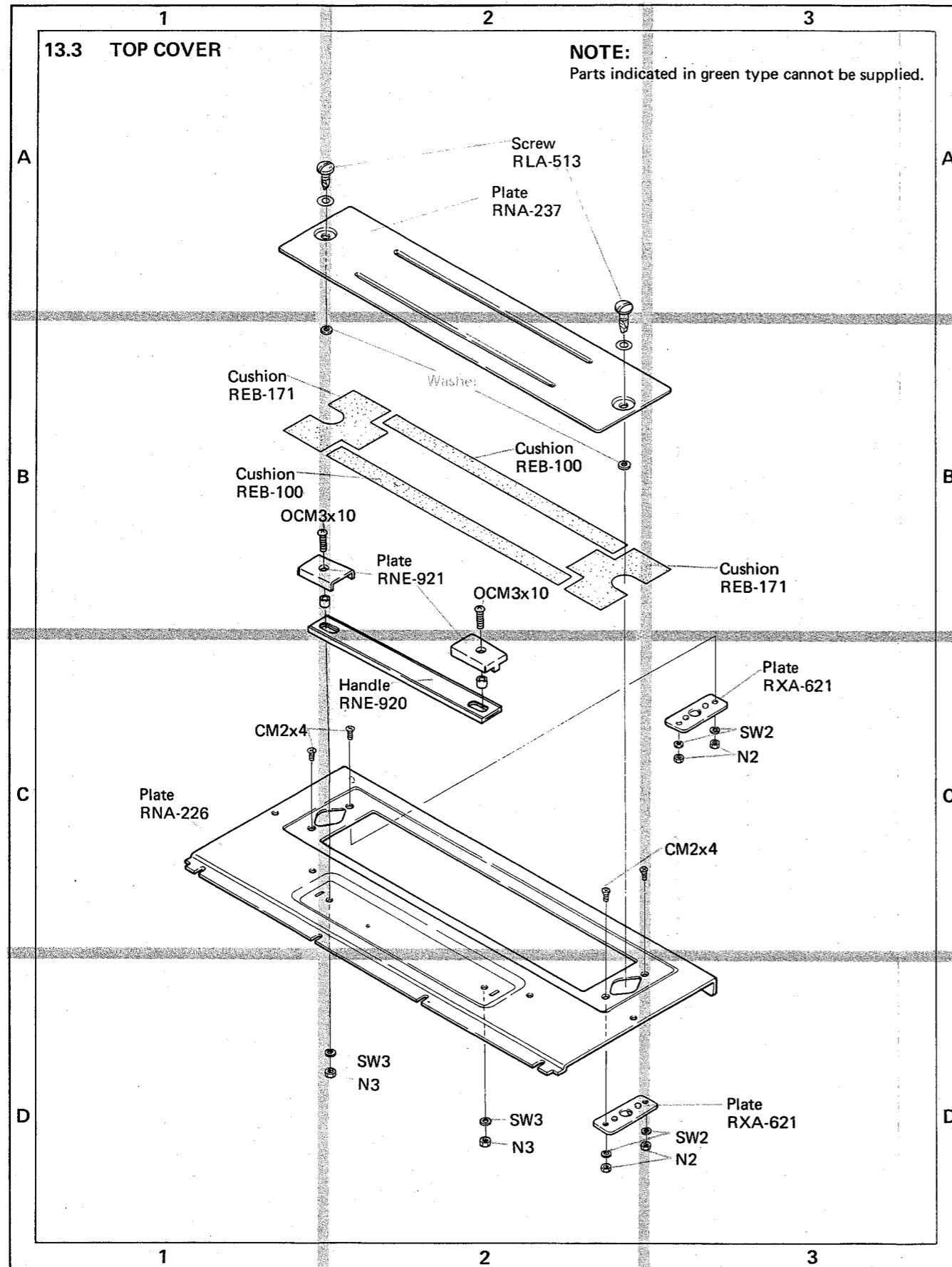

13.6 REAR PANEL

NOTE:
Parts indicated in green type cannot be supplied.

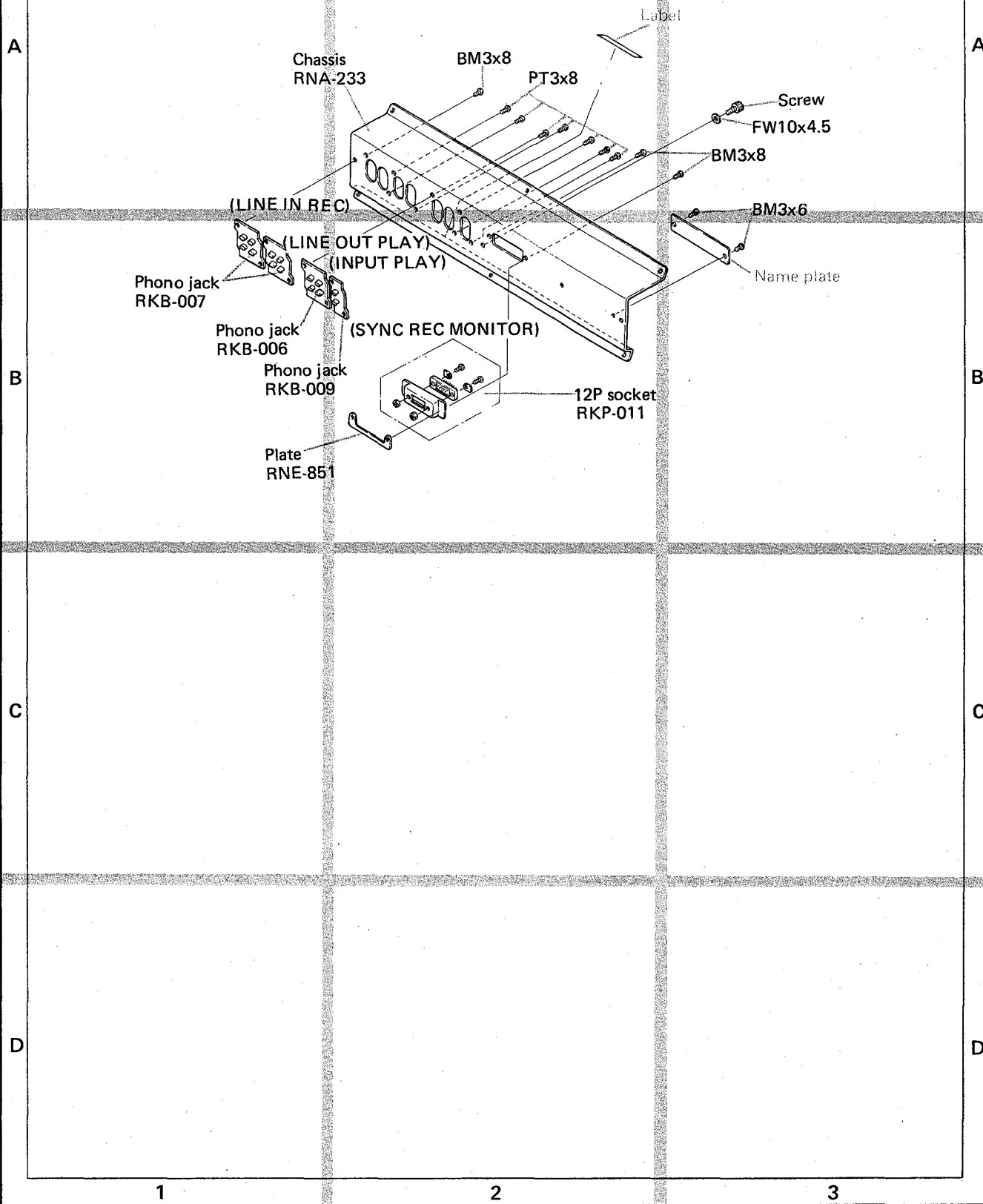

13.7 TAU-11 PACKING

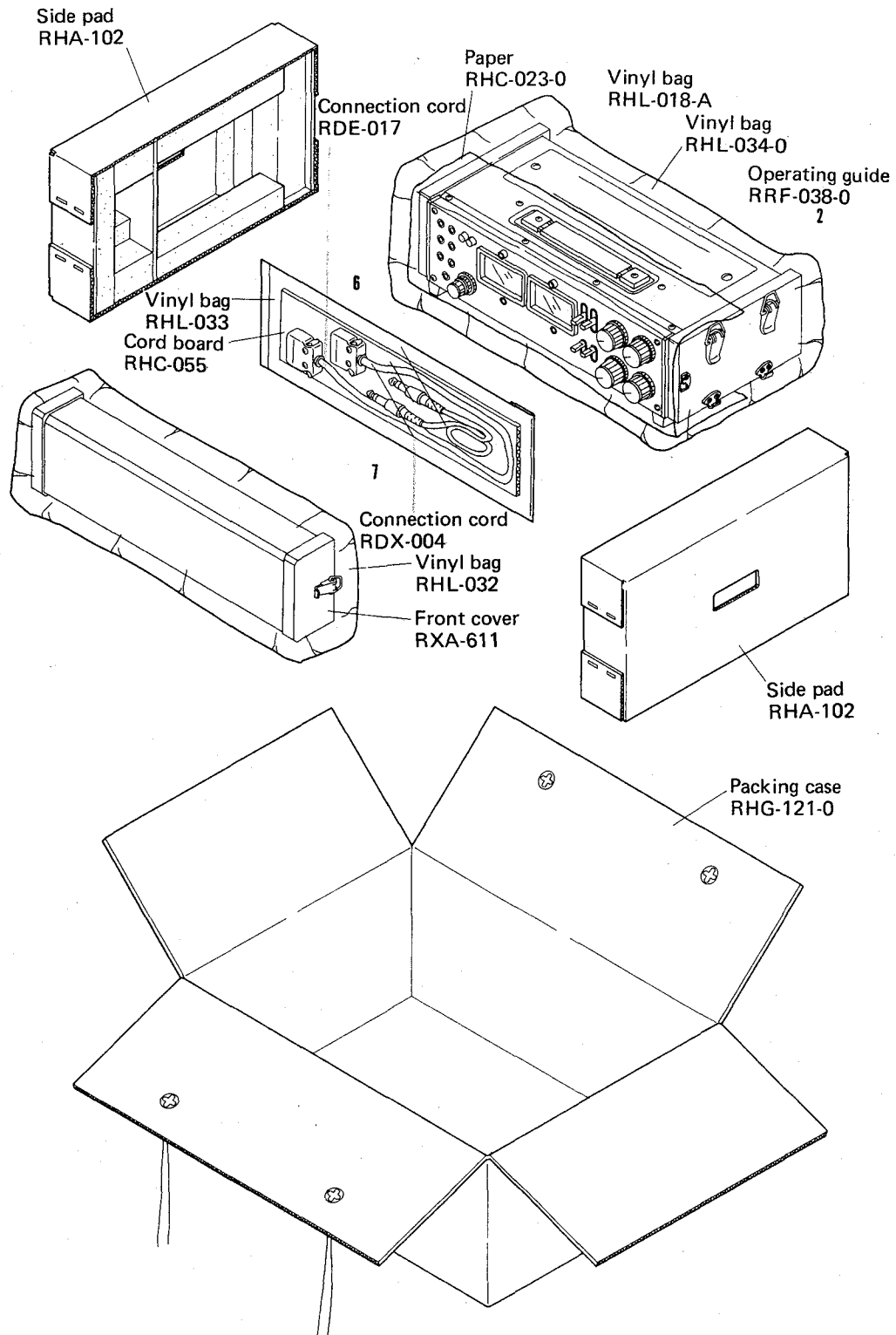

14. JT-211 EXPLODED VIEW

NOTE:
Parts indicated in green type cannot be supplied.

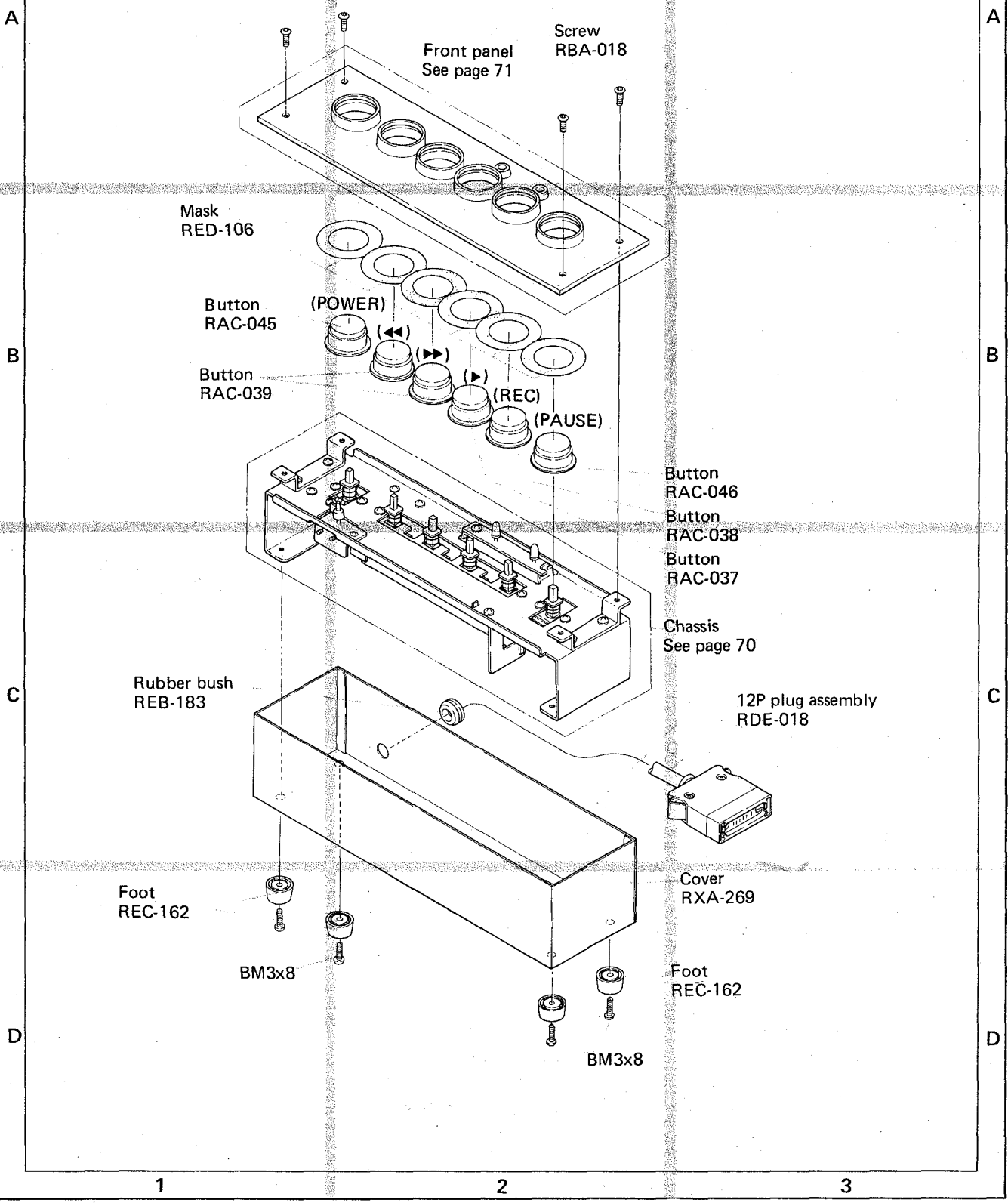

14.1 CHASSIS

NOTE:
Parts indicated in green type cannot be supplied.

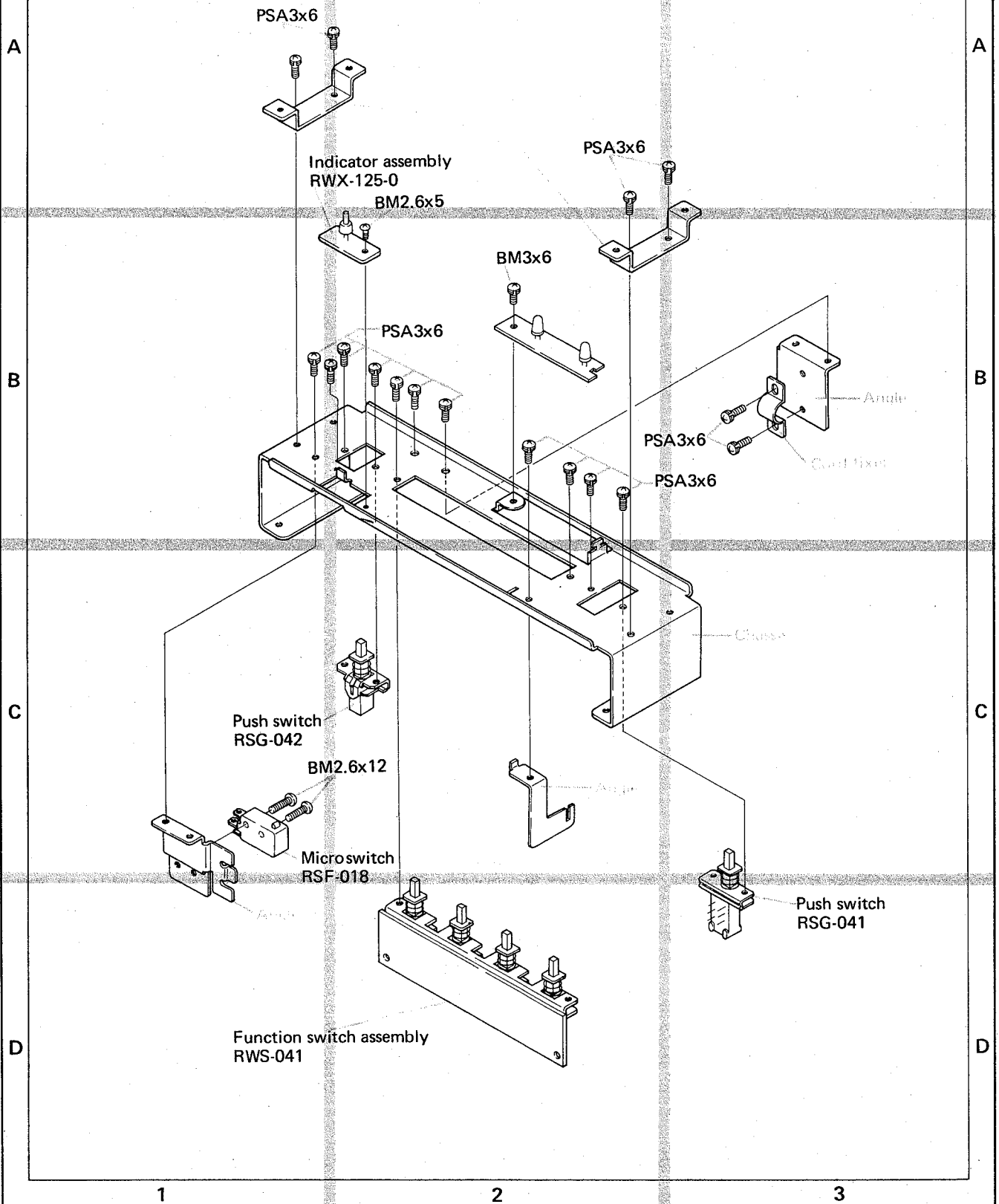

14.2 FRONT PANEL

NOTE:
Parts indicated in green type cannot be supplied.

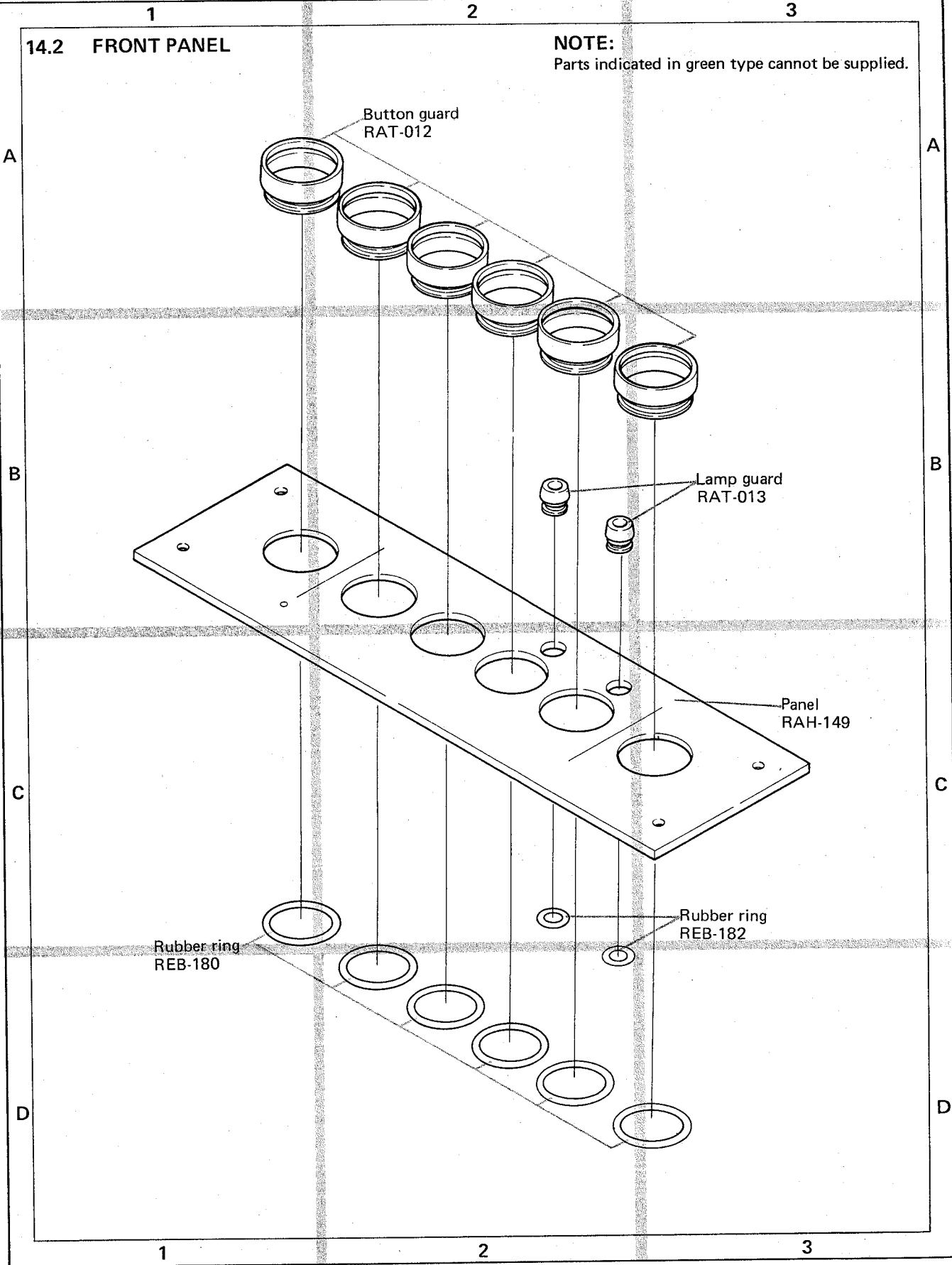

14.3 JT-211 PACKING

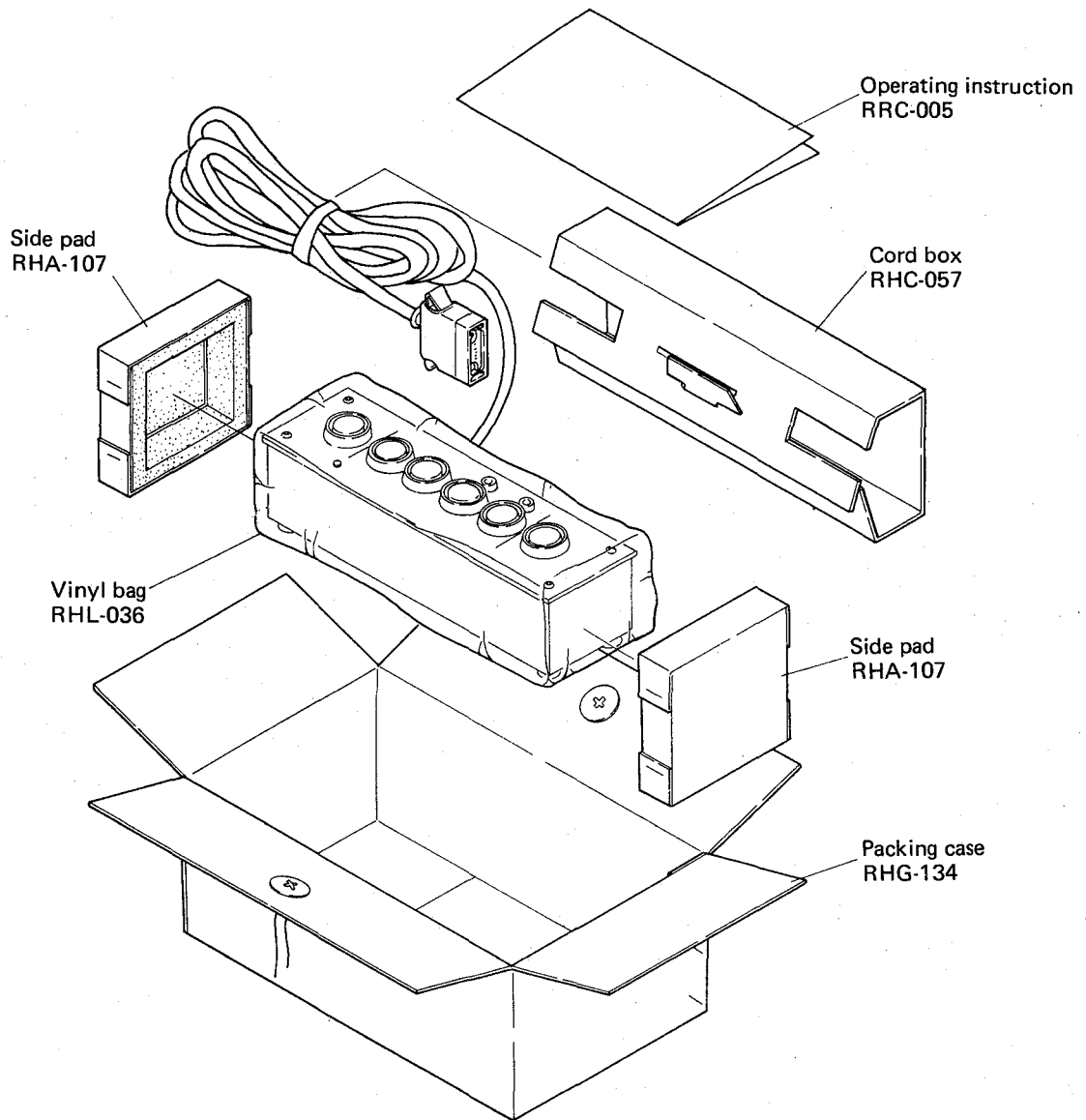

15. JT-2022T(JT-2044T) EXPLODED VIEW

NOTE:
Parts indicated in green type cannot be supplied.

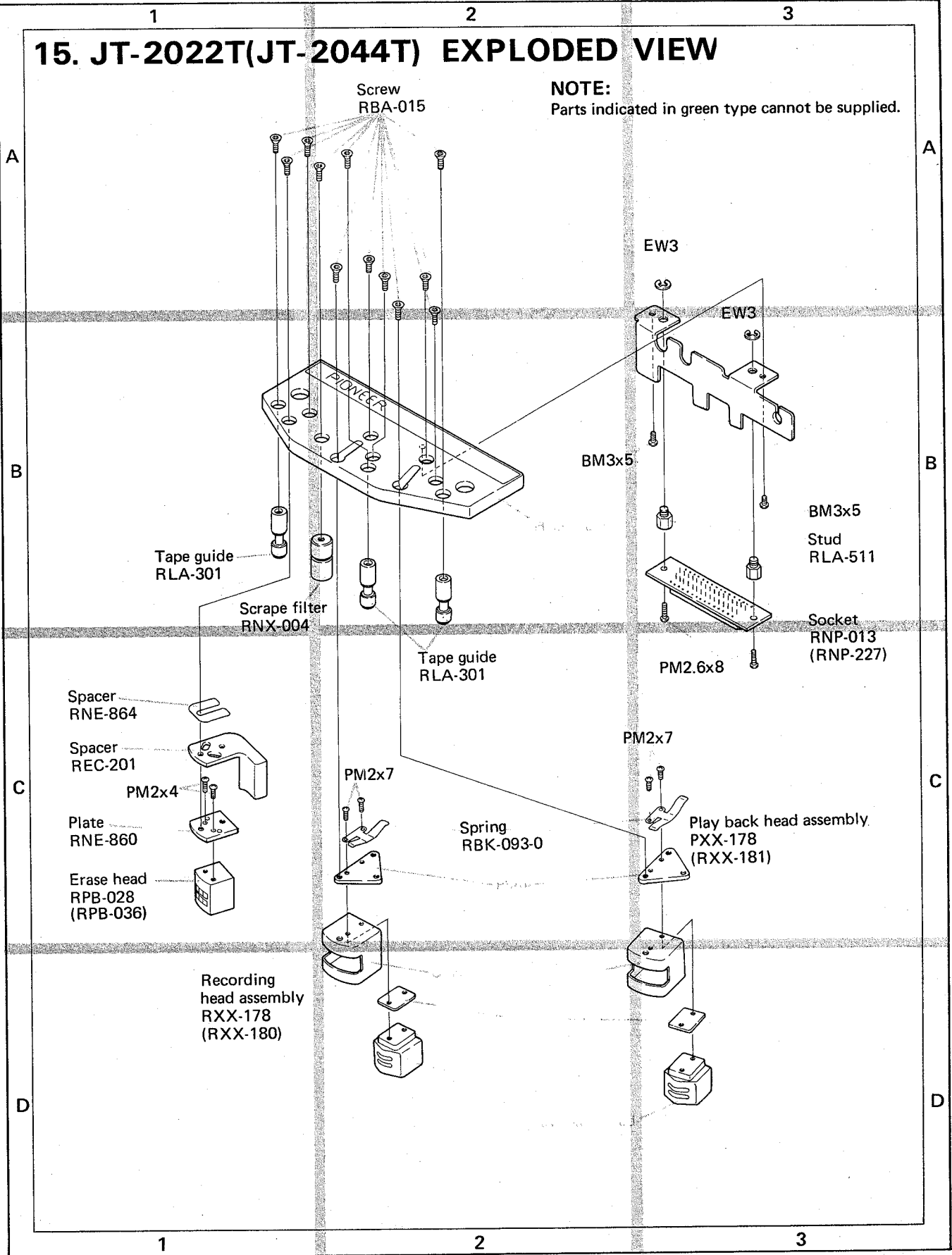

15.1 JT-2022T (JT-2044T) PACKING

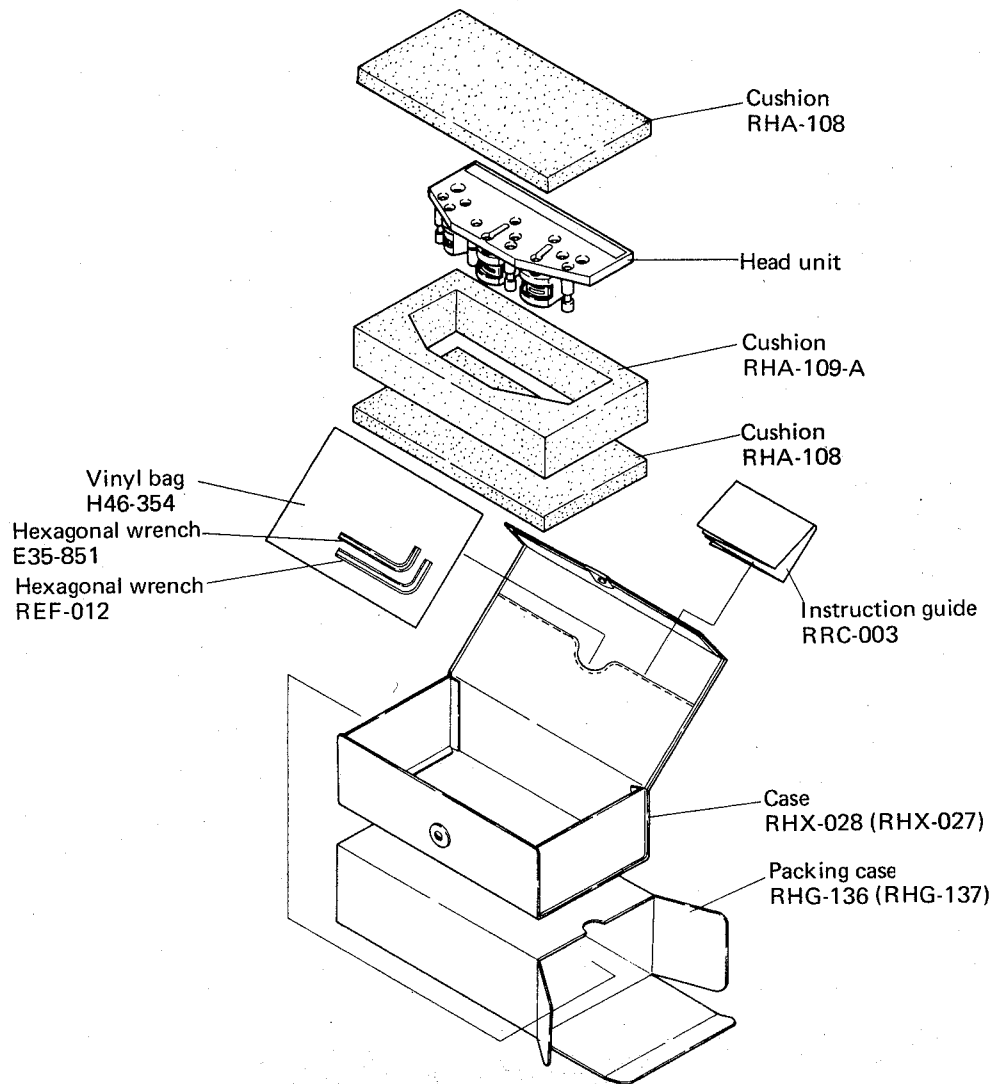

16.3 MISCELLANEOUS PARTS

SEMICONDUCTORS

Symbol	Description	Part No.
D1	Diode	W06B
D2	Diode	W06B
D3	Diode	W06B

SWITCHES

Symbol	Description	Part No.
S1	Microswitch (STOP)	RSF-018
S2	Lever switch (PAUSE)	RSK-028
S4	Slide switch (REMOTE)	RSH-018
S1001-1	Microswitch (SHUT OFF)	RSF-013
S1001-2	Microswitch (SHUT OFF) TV type	RSF-016

RESISTORS

Symbol	Description	Part No.
R1	Wire wound 2.2k 30W	RCN-025
R2	Wire wound 350 30W	RCN-024
R3	Carbon film 10k	RD½PS 103J
R4	Carbon film 1.8k	RD½PS 182J

CAPACITORS

Symbol	Description	Part No.
C1	Electrolytic 1000 80V	RCH-025
C2	MP 0.5+2 250V	RCL-016
C3	MP 0.5+4 250V	RCL-010
C4	MP 0.5+4 250V	RCL-010
C5	Ceramic 0.01 1.4kV	C43-003

SOLENOIDS

Symbol	Description	Part No.
SL1	Brake solenoid	RXP-020
SL2	Brake solenoid	RXP-020
SL3	Pinch solenoid	RXP-011

OTHERS

Symbol	Description	Part No.
	Control assembly	RWG-050
	REC/PB amplifier assembly	RWF-044
	Power supply & O.S.C. assembly	RWR-031
	Syncro amplifier assembly	RWF-052
	Power SW assembly	RWS-033
	Test O.S.C. assembly	RWA-024
	Function switch assembly	RWS-040
	Selector switch assembly	RWX-121

NOTE:

- Capacitors: in μF unless otherwise noted p:pF
- Resistors: in Ω , $\frac{1}{4}W$ unless otherwise noted k:k Ω , M:M Ω

Symbol	Description	Part No.
	Indicator A assembly	RWX-094
	Indicator B assembly	RWX-095
	Shut off switch assembly	RWX-047
	Motor fuse assembly	RWX-048
	Capstan motor	RXM-020
	Take-up motor	RXM-015
	Supply motor	RXM-015
	Power transformer	RTT-084
	Capacitor cover (A) C5	REC-150
	Connector A assembly	RWX-096
	Connector B assembly	RWX-097
	Plug assembly	RWX-093
	12P socket (FRONT)	RKP-011
	12P socket (BACK)	RKP-011
	12P socket (REMO CON)	RKP-012

16.4 CONTROL ASSEMBLY (RWG-050)

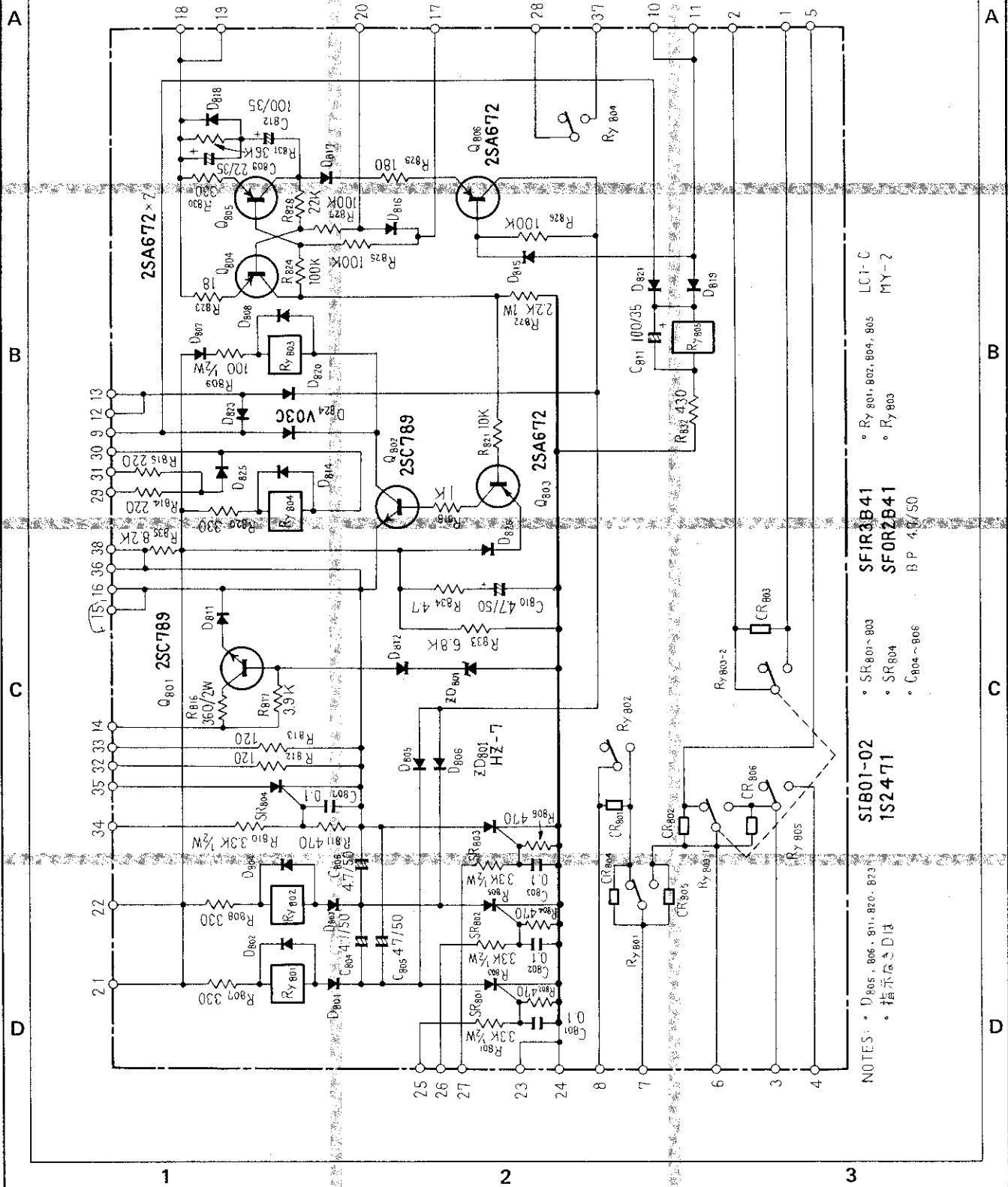

- NOTES: • D805, 806, 807, 808, 809, 810, 811, 812, 813, 814, 815, 816, 817, 818, 819, 820, 821, 822, 823, 824, 825, 826, 827, 828, 829, 830, 831, 832, 833, 834, 835
 • 指示器はDは
- SF801~803 SFIR3B41 LCT-C
 - SF804 SFOR2B41 MY-2
 - C804~806 B.P. 4.7/50
- SIB01-02
 1S2471

16.7 FUNCTION SWITCH ASSEMBLY (RWS-040)

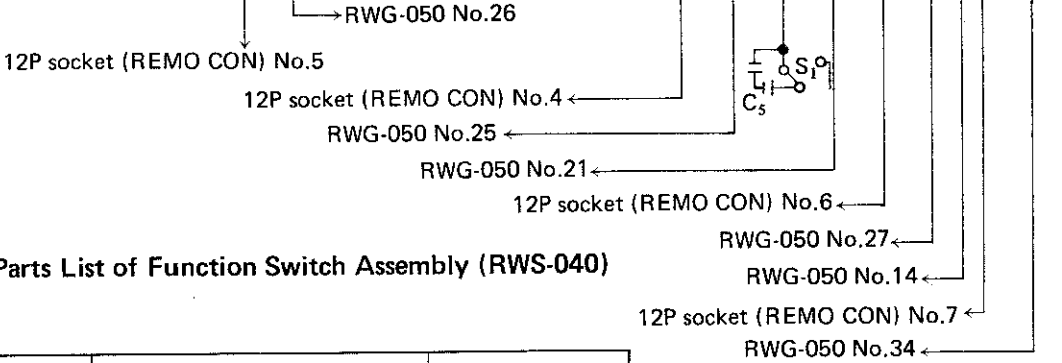
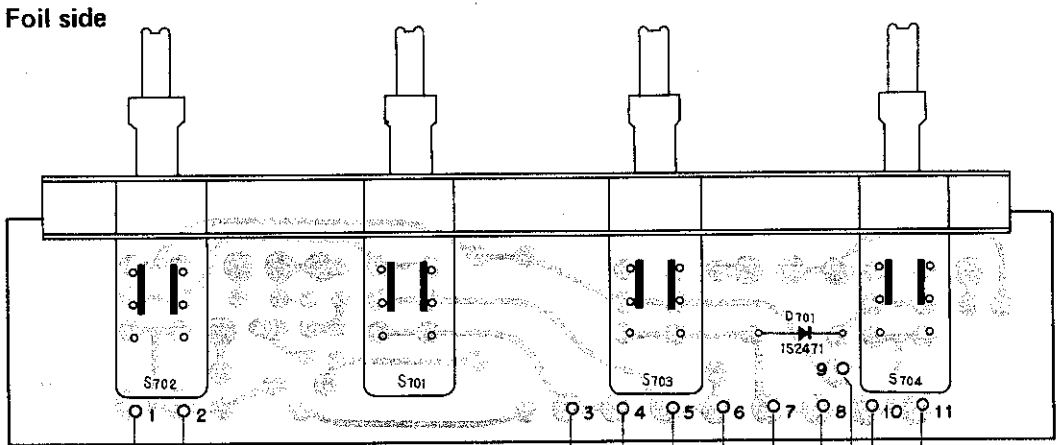
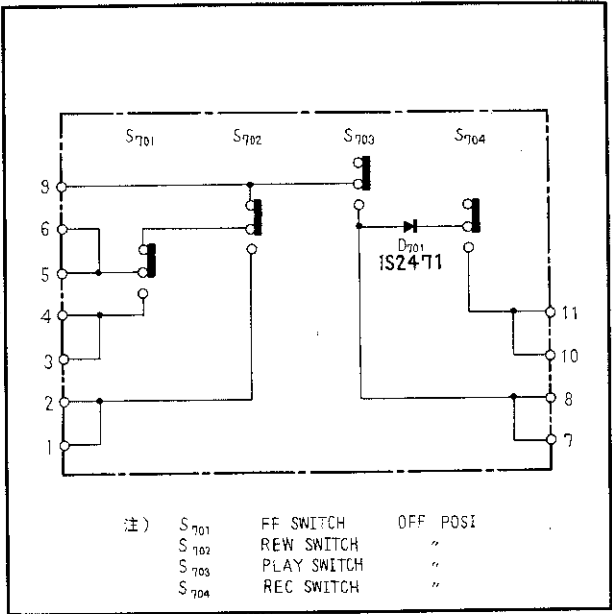

Parts List of Function Switch Assembly (RWS-040)

Symbol	Description	Part No.
D701	Diode Switch	1S2471 RSG-032

16.8 TEST O.S.C. ASSEMBLY (RWA-024)

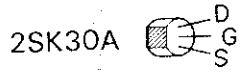
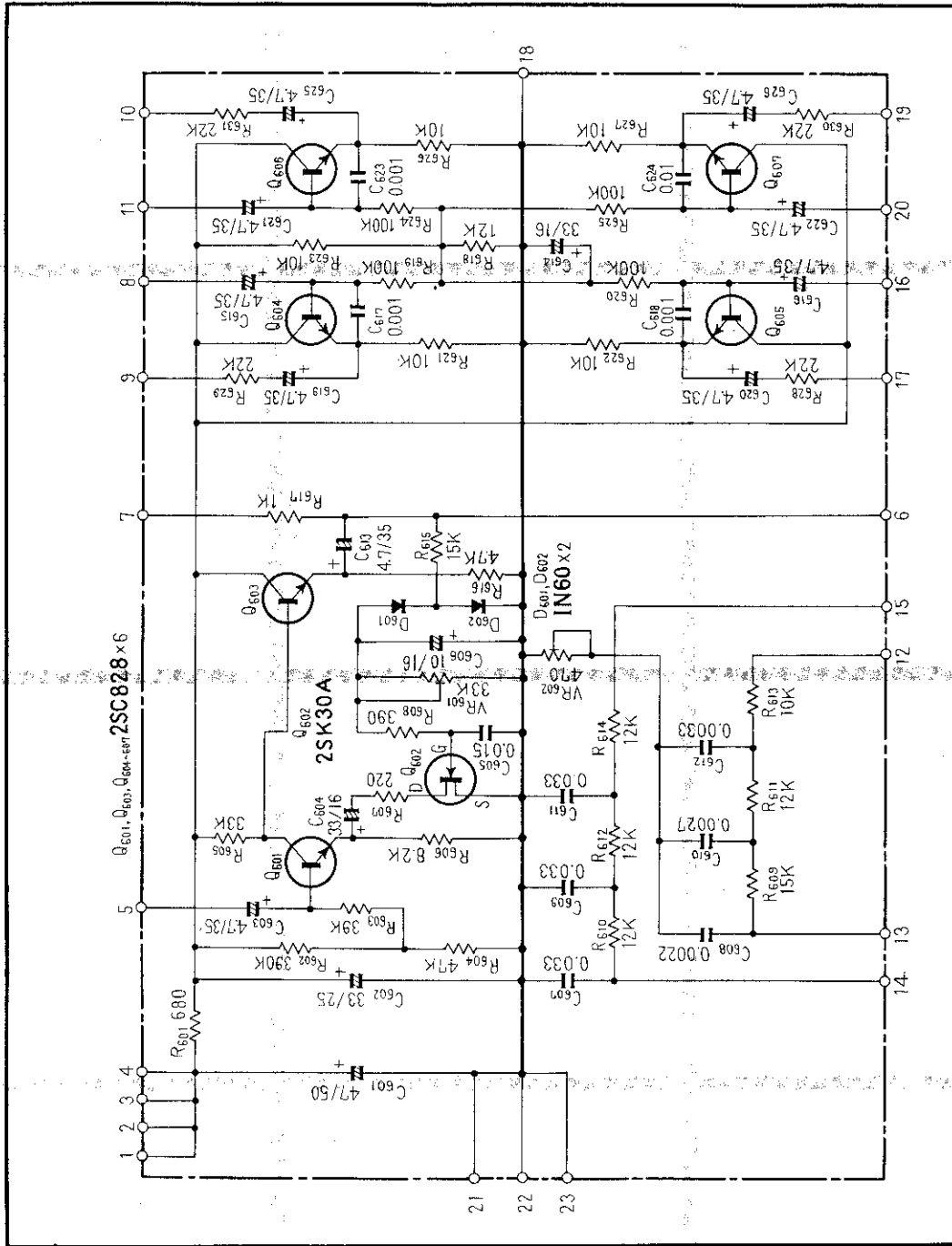

16.11 POWER SWITCH ASSEMBLY (RWS-033)

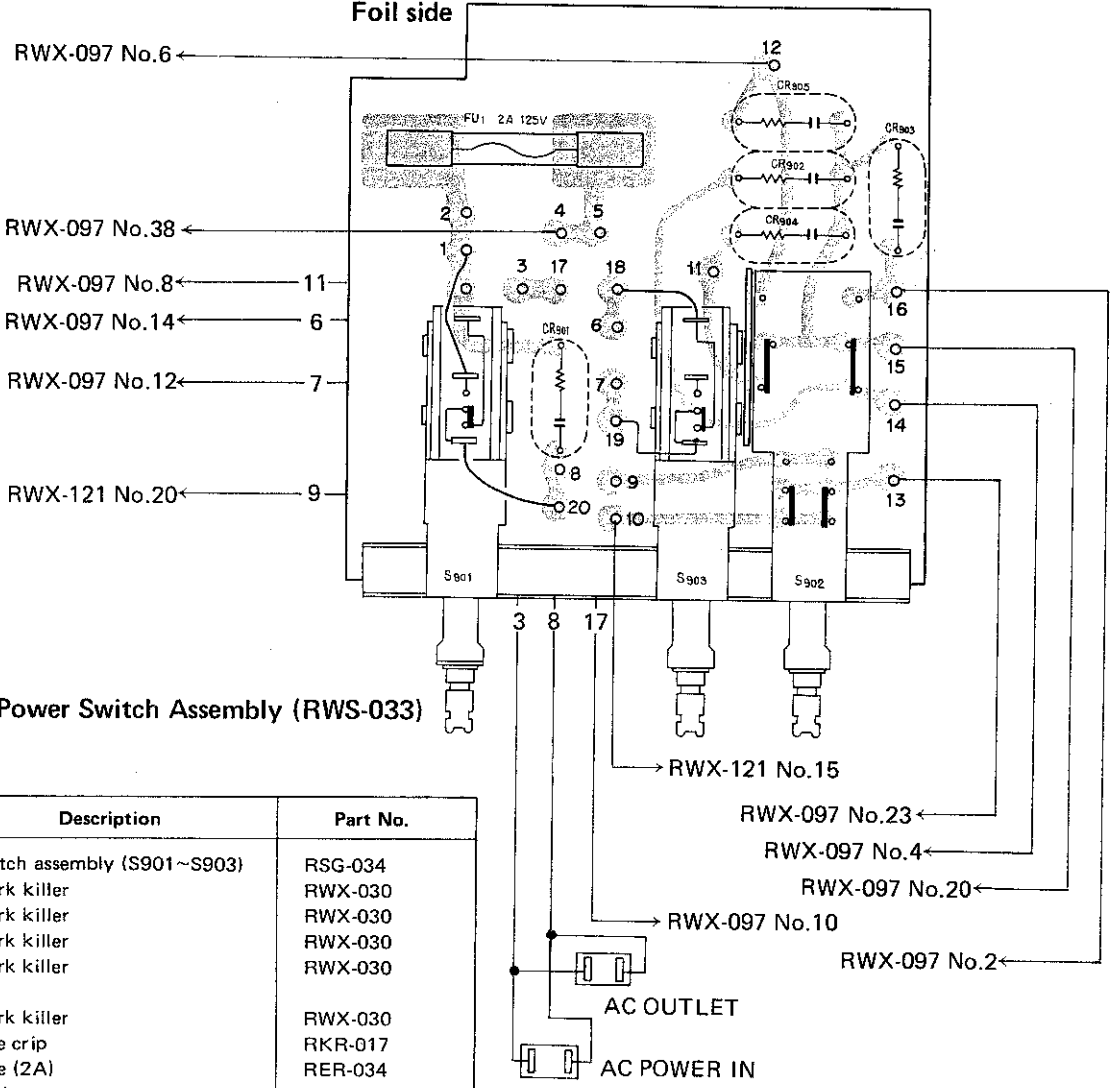
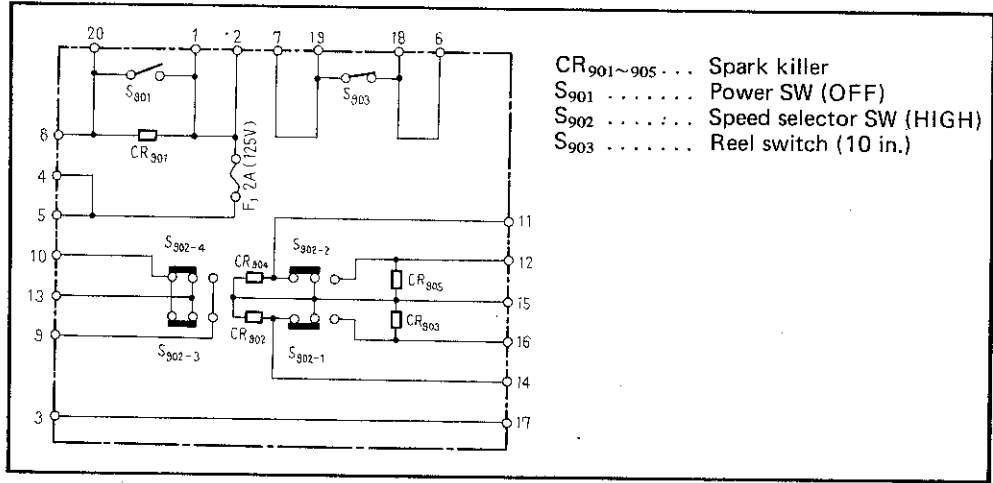

Parts List of Power Switch Assembly (RWS-033)

OTHERS

Symbol	Description	Part No.
	Switch assembly (S901~S903)	RSG-034
CR901	Spark killer	RWX-030
CR902	Spark killer	RWX-030
CR903	Spark killer	RWX-030
CR904	Spark killer	RWX-030
CR905	Spark killer	RWX-030
	Fuse crip	RKR-017
	Fuse (2A)	RER-034
	Insulator	REE-053

16.12 POWER SUPPLY & O.S.C. ASSEMBLY (RWR-031)

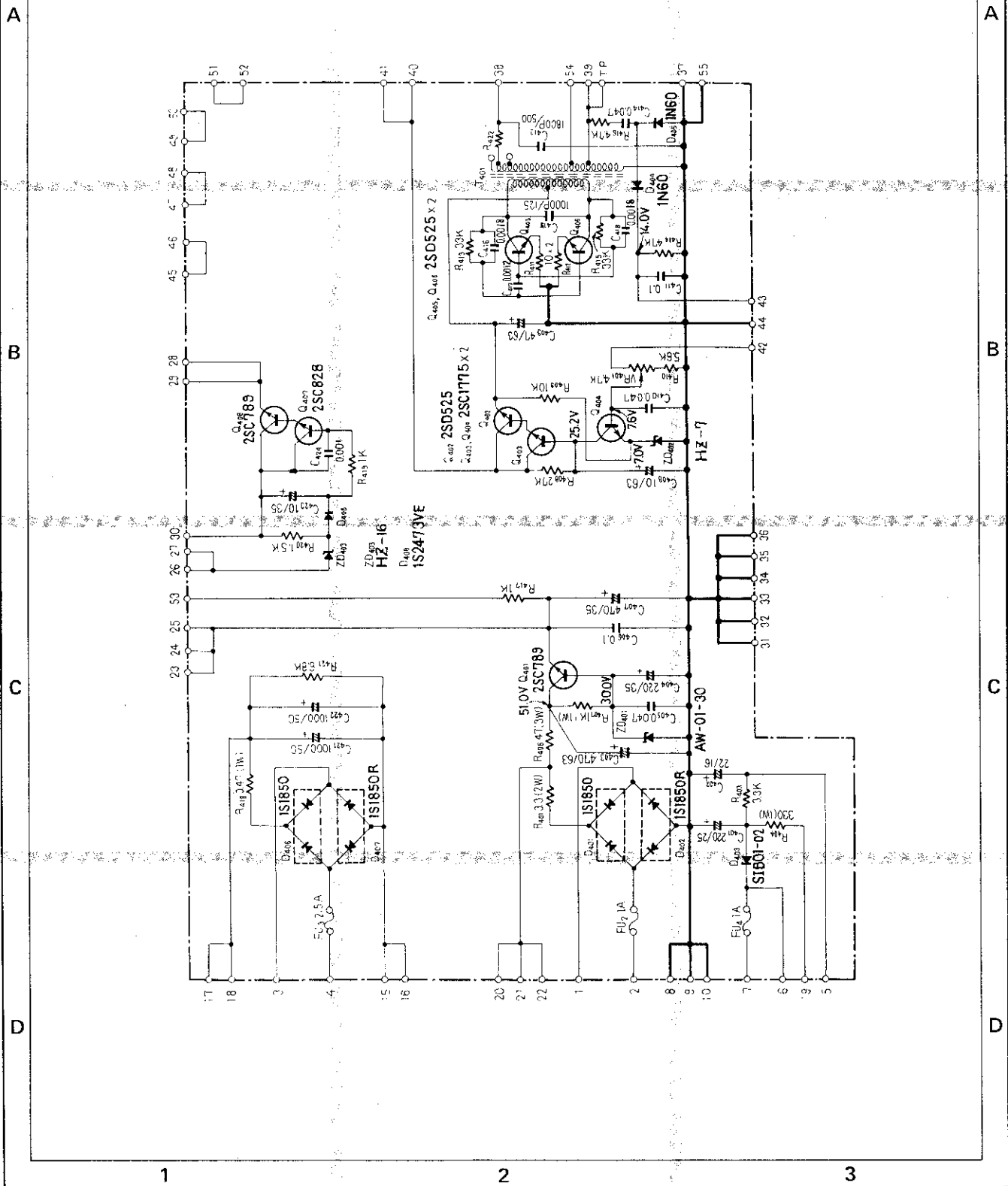

19.4 PINCH PRESSURE

When replacing pinch roller solenoid or pinch roller, confirm pinch pressure by the following steps.

1. With deck vertical, set tension selector switch to 10-in reel position.
2. With POWER and shut off switches ON, set for playback mode.
3. At this time, check that space B in Fig. 10 is 1 mm.
4. If not, loosen 3 screws and adjust by moving pinch solenoid bracket.
5. Install Scotch No. 111 tape (or equivalent) with 10-in metal reel. Operate fast forward until approximately the same amount of tape is on both reels.
6. With tape speed at 19 cm/s, pull pinch roller shaft with tension gauge (Fig. 11) and confirm that tape motion stops in the range of 1.7 kg—2 kg.
7. If tape does not stop in this range, check the following points:
 - Pinch roller pressure spring tightening faulty
 - Pinch roller pressure spring defective
 - Pinch roller contaminated
 - Capstan contaminated

19.5 TAPE GUIDE HEIGHT (TENSION ARM)

Loosen tension arm setscrew and adjust for 6.4 mm dimension shown in Fig. 12.

19.6 TAPE SPEED

Three types of drive pulleys are available for adjusting RTU-11 tape speed. With No. 2 pulley as center value, No. 1 pulley will vary tape speed -0.5% and No. 3 by +0.5%.

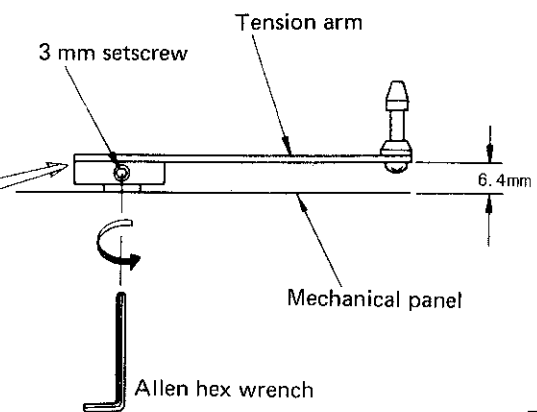
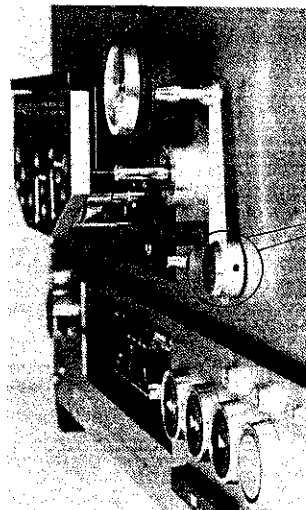
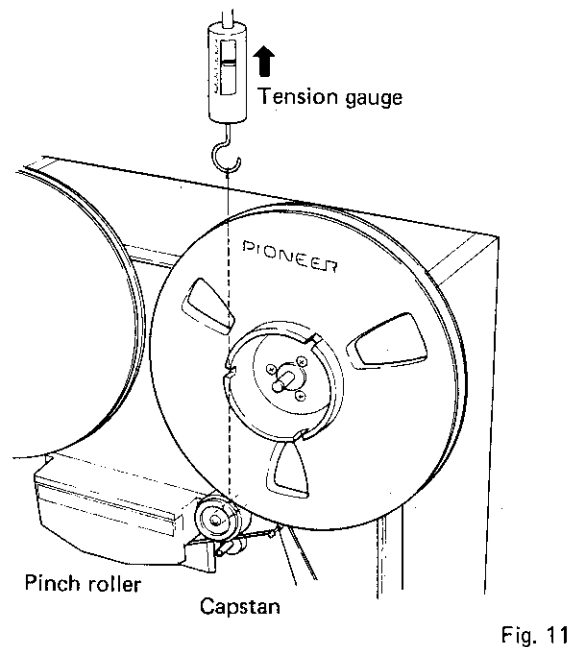
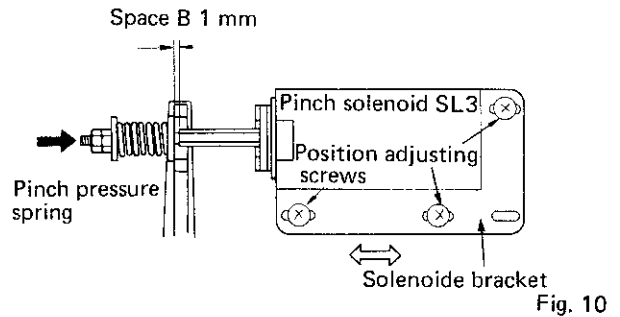

19.7 CUE OPERATION

Perform this adjustment if FF operation or cue lever locking is defective.

1. Observe that cue arm B moves smoothly in cue arm guide slit (Fig. 13, 14), adjust by bending at the point indicated by the arrow in Fig. 13.
2. With deck in stop mode, loosen cue adjusting plate screws (Fig. 15) and adjust for 0 – 0.2 mm spacing A between shifter roller and cue adjusting plate.
3. After completing Step 1 and 2, with cue lever locked by means of lock switch on front panel, confirm 0.5 – 2 mm spacing B between pinch roller and capstan (Fig. 16). If not in this range, defective pinch roller shaft is indicated. Replace pinch roller arm A (Fig. 15) and repeat adjustments.
4. If cue lever lock and release are not smooth, loosen lock bracket screws (Fig. 13) and move lock bracket. Adjust so that lock pin (Fig. 14) moved smoothly in cue arm B lock hole.

(Cue Assembly Diagram)

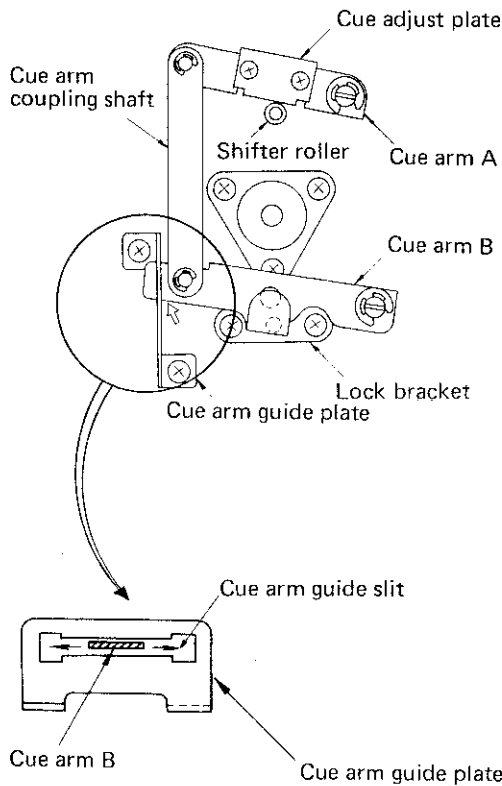

Fig. 13

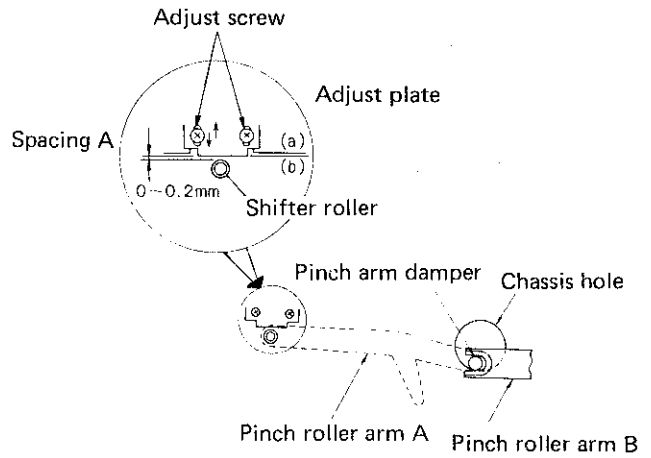

Fig. 15

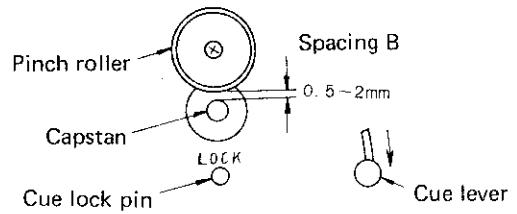

Fig. 16

22. TAU-11 ADJUSTMENT

22.1 ADJUSTMENT CONDITIONS

1. Connect 12 k ohms to OUTPUT REC jacks as load resistance.
2. Connect 47 k ohms to 51 k ohms to LINE OUT PLAY jacks as load resistance.

22.2 ADJUSTMENT STEPS (Photo 7)

1. Apply 1 kHz/-10 dBv input signal to LINE IN REC jacks and set MONITOR switch to SOURCE position.
2. Adjust LINE control for -7 dBv (447mV) indication on VTVM connected to LINE OUT PLAY (L & R) jacks.
3. At this time, adjust for 0dB indication on level meters.

Locations: L-ch: VR101
R-ch: VR102

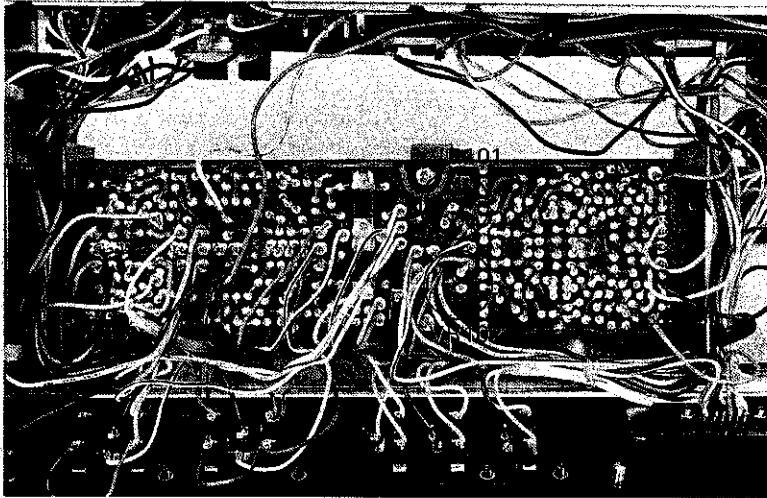

TAU-11 Amplifier assembly (RWF-046)

Photo 7

23. CIRCUIT DESCRIPTION(RTU-11)

Two types of head units (JT-2022T and JT-2044T) are available for the RTU-11. JT-2022T is for 2-track 2-channel, and JT-2044T for 4-track 4-channel. In this description, 2-track 2-channel appears as 2T/2C and 4-track 4-channel as 4T/4C. Control operation and circuit descriptions are covered in this section.

Semiconductor and relay operations with respect to RTU-11 operating modes are indicated in table 1.

Table 1

	STOP	PLAY	REC	FF	REW	PAUSE (PLAY)	Remarks
SR ₈₀₁	—	—	—	ON	—	—	
SR ₈₀₂	—	—	—	—	ON	—	
SR ₈₀₃	—	ON	ON	—	—	ON	
SR ₈₀₄	—	—	ON	—	—	—	
Ry ₈₀₁	—	—	—	ON	—	—	
Ry ₈₀₂	—	—	—	—	ON	—	
Ry ₈₀₃	—	ON	ON	—	—	—	
Ry ₈₀₄	—	—	ON	—	—	—	
Ry ₈₀₅	ON	—	—	—	—	—	
D ₅	—	ON	ON	—	—	—	
D ₆	—	—	ON	—	—	—	
Q ₈₀₁	ON	ON	ON	—	—	ON	
Q ₈₀₂	—	ON	ON	—	—	—	
Q ₈₀₃	—	ON	ON	—	—	—	
Q ₈₀₄	—	—	—	ON	ON	ON	
Q ₈₀₅	ON	ON	ON	—	—	ON	
Q ₈₀₆	—	—	—	ON	ON	—	
Q ₄₀₇	ON	ON	ON	ON	ON	ON	
Q ₄₀₈	ON	ON	ON	ON	ON	ON	
SL ₁	—	ON	ON	ON	ON	—	
SL ₂	—	ON	ON	ON	ON	—	
SL ₃	—	ON	ON	—	—	—	

23.13 2T-4T AUTOMATIC SELECTOR CIRCUIT

Two types of head units, JT-2044T (4T/4C) and JT-2022T (2T/2C), are available for the RTU-11. By simply plugging in the appropriate head unit, connections become automatically switched for 4T/4C or 2T/2C.

JT-2044T:

JT-2044T connects terminals J-K, turning on relay Ry301. Ry301-1 and Ry301-2 contacts are then switched to 4T/4C and back (ch-2 and ch-4) can be operated. Normal setting is at 2T/2C.

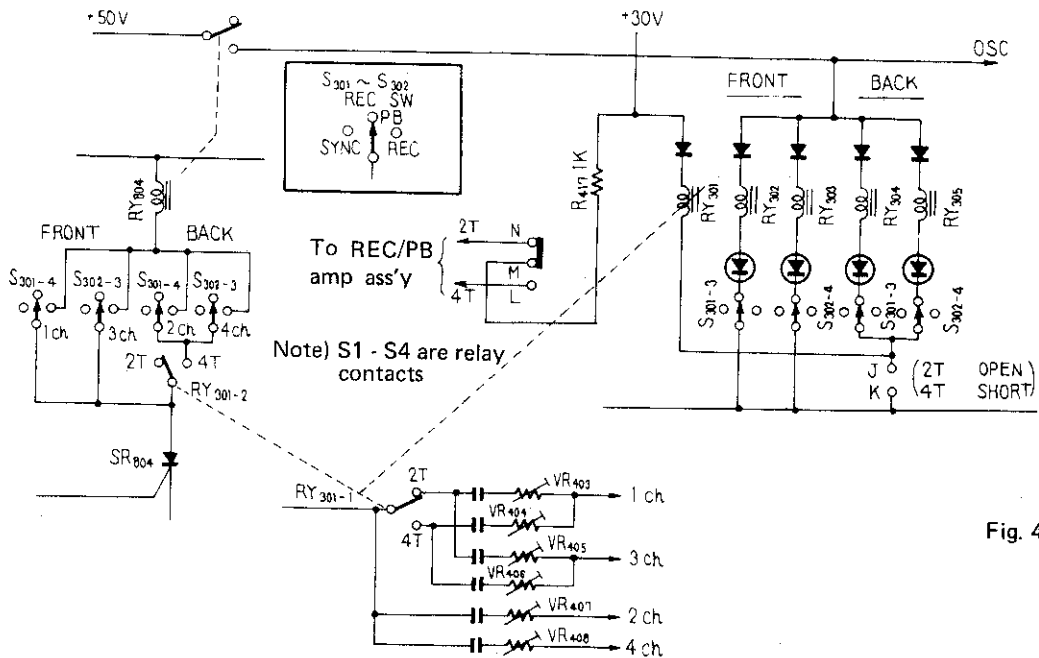

Fig. 42

23.14 ERASE HEAD DUMMY

The erase head is connected to the bias oscillator circuit. In order to provide the same circuit load conditions with either head unit (JT-2044T or JT-2022T), dummy coils are provided.

JT-2044T:

Dummy coils must comply with complex matching requirements between channels of 4-track 4-channel erase head (EH). L305 and L306 thus employ bifilar windings. L305 is EH1 and EH3 (front) dummy coil, consisting of L305-1 for EH1 (ch-1) and L305-2 for EH3 (ch-3).

JT-2022T:

Since EH2 and EH4 erase heads are absent in the case of 2-track 2-channel, L306 is always connected as the dummy coil.

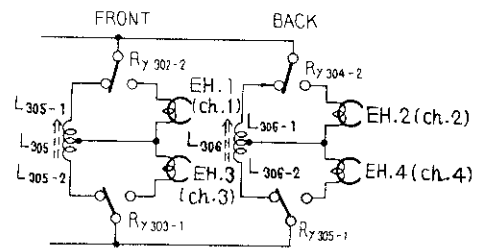













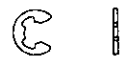

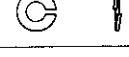

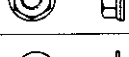

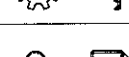



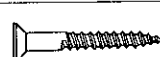



Fig. 43

24. NOMENCLATURE OF SCREWS, WASHERS AND NUTS

The following symbols stand for screws, washers and nuts as shown in exploded view.

Symbol	Description	Shape
RT	Brazier head tapping screw	
PT	Pan head tapping screw	
BT	Binding head tapping screw	
CT	Countersunk head tapping screw	
TT	Truss head tapping screw	
OCT	Oval countersunk head tapping screw	
PM	Pan head machine screw	
CM	Countersunk head machine screw	
OCM	Oval countersunk head machine screw	
TM	Truss head machine screw	
BM	Binding head machine screw	
PSA	Pan head screw with spring lock washer	
PSB	Pan head screw with spring lock washer and flat washer	
PSF	Pan head screw with flat washer	

Symbol	Description	Shape
EW	E type washer	
FW	Flat washer	
SW	Spring lock washer	
N	Nut	
WN	Washer faced nut	
ITW	Internal toothed lock washer	
OTW	Outernal toothed lock washer	
SC	Slotted set screw (Cone point)	
SF	Slotted set screw (Flat point)	
HS	Hexagon socket headless set screw	
OCW	Oval countersunk head wood screw	
CW	Countersunk head wood screw	
RW	Round head wood screw	

EXAMPLE

PM 3x8
 length in mm (l)
 diameter in mm (d)
 Symbol

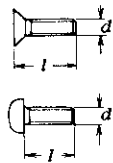

FW 9φ x 1^t
 thickness in mm (t)
 diameter in mm (d)
 Symbol

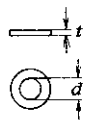

16.11 POWER SWITCH ASSEMBLY (RWS-033)

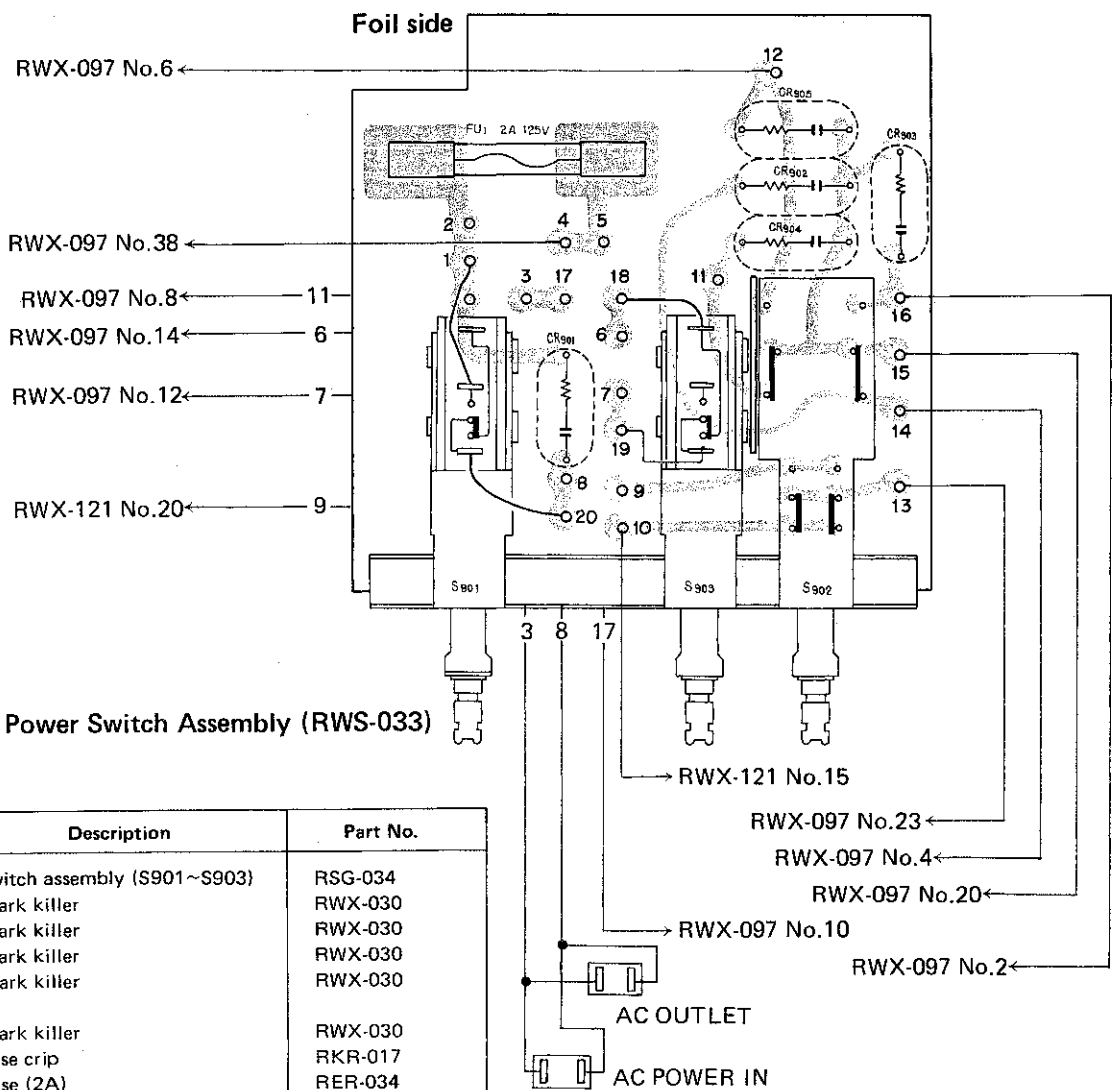
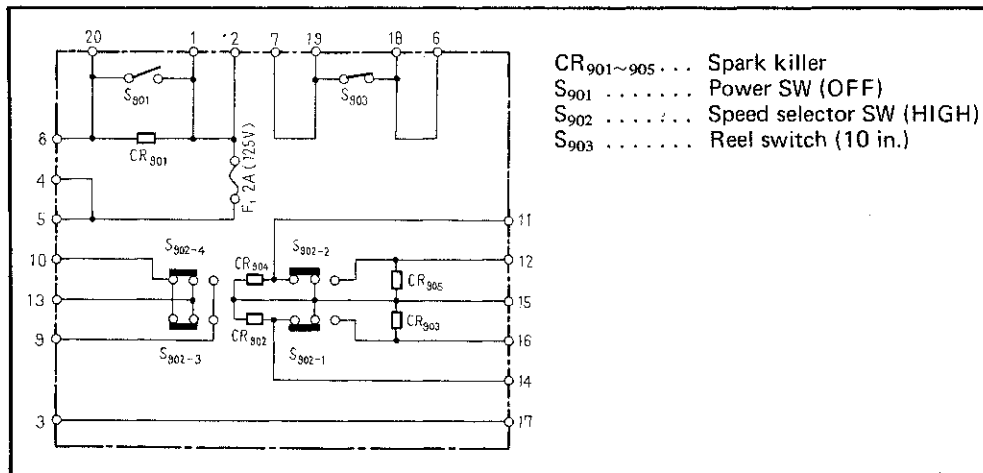

Parts List of Power Switch Assembly (RWS-033)

OTHERS

Symbol	Description	Part No.
	Switch assembly (S901~S903)	RSG-034
CR901	Spark killer	RWX-030
CR902	Spark killer	RWX-030
CR903	Spark killer	RWX-030
CR904	Spark killer	RWX-030
CR905	Spark killer	RWX-030
	Fuse crip	RKR-017
	Fuse (2A)	RER-034
	Insulator	REE-053

16.12 POWER SUPPLY & O.S.C. ASSEMBLY (RWR-031)

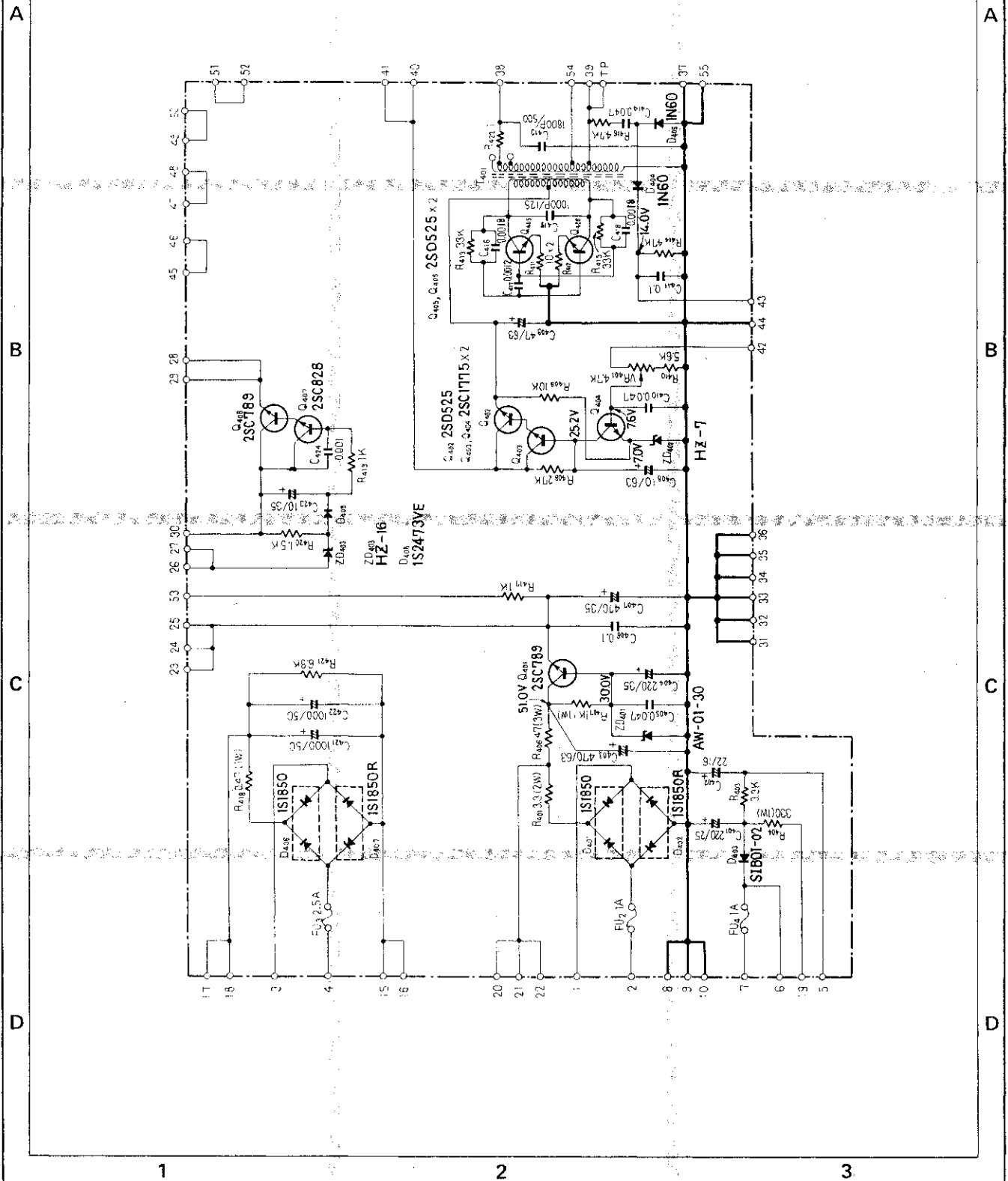

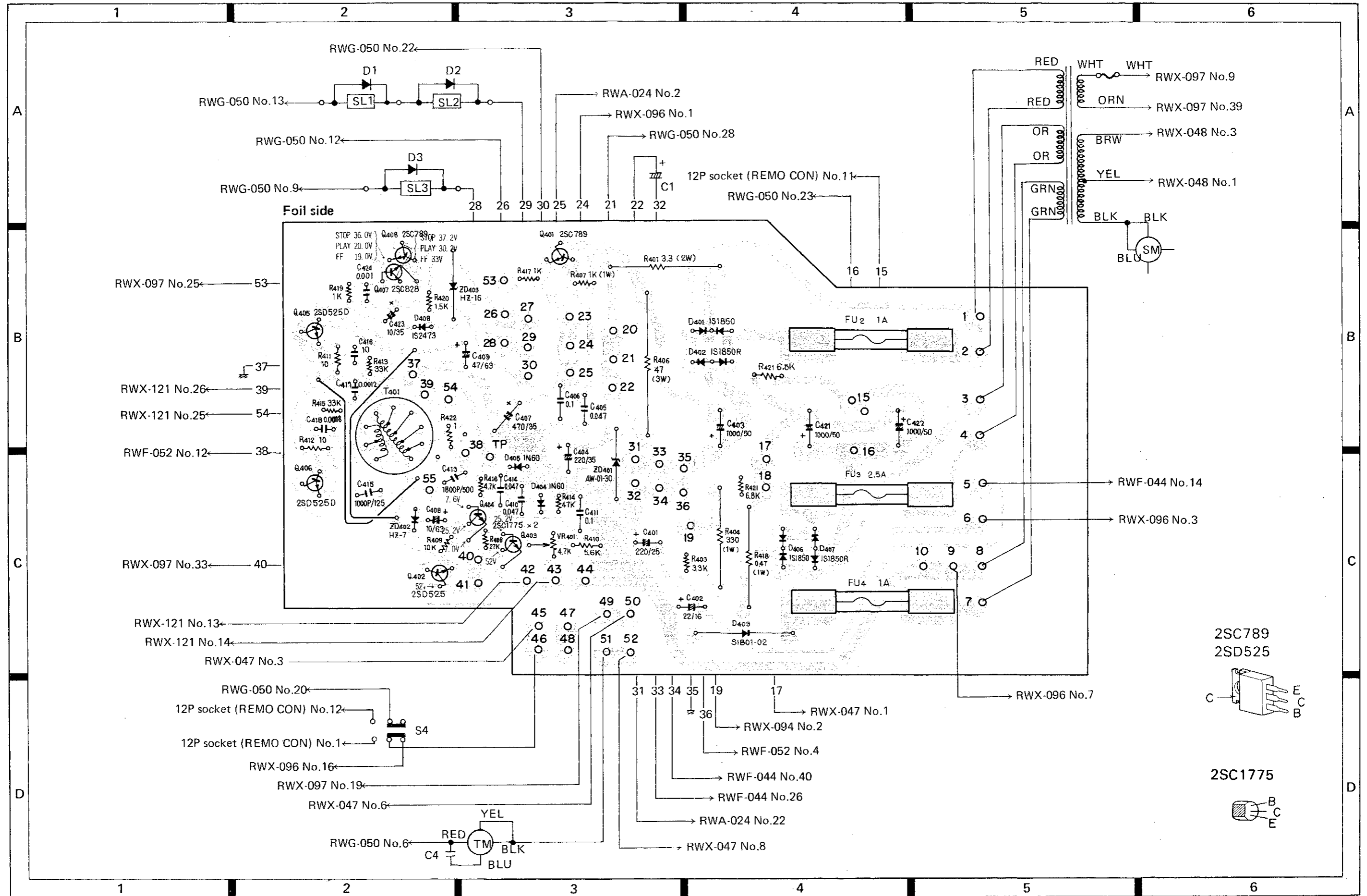

Parts List of Power Supply & O.S.C. Assembly (RWR-031)

SEMICONDUCTORS

Symbol	Description	Part No.
Q401	Transistor	2SC789-0
Q402	Transistor	2SD525-0
Q403	Transistor	2SC1775-E
Q404	Transistor	2SC1775-E
Q405	Transistor	2SD525-0
Q406	Transistor	2SD525-0
Q407	Transistor	2SC828-R
Q408	Transistor	2SC789-0
D401	Diode	1S1850
D402	Diode	1S1850R
D403	Diode	SIB01-02
D404	Diode	1N60
D405	Diode	1N60
D406	Diode	1S1850
D407	Diode	1S1850R
D408	Diode	1S2473VE
ZD401	Zener diode	AW-01-30
ZD402	Zener diode	HZ7-B
ZD403	Zener diode	HZ16

CAPACITORS

Symbol	Description	Part No.
C401	Electrolytic 220 25V	CEA 221P 25
C402	Electrolytic 22 16V	CEA 220P 16
C404	Electrolytic 220 35V	CEA 221P 35
C405	Mylar 0.047 50V	CQMA 473K 50
C406	Mylar 0.1 50V	CQMA 104K 50
C407	Electrolytic 470 35V	CEA 471P 35
C408	Electrolytic 10 63V	CEA 100P 63
C409	Electrolytic 47 63V	CEA 470P 63
C410	Mylar 0.047 50V	CQMA 473K 50
C411	Mylar 0.1 50V	CQMA 104K 50
C413	Polystyrene 1800p 500V	CQSA 182J 500
C414	Mylar 0.047 50V	CQMA 473K 50
C415	Polystyrene 1000p 125V	CQSA 102J 125
C416	Mylar 0.0018 50V	CQMA 182K 50
C417	Mylar 0.0012 50V	CQMA 122K 50
C418	Mylar 0.0018 50V	CQMA 182K 50
C421	Electrolytic 1000 50V	CEA 102P 50
C422	Electrolytic 1000 50V	CEA 102P 50
C423	Electrolytic 10 35V	CEA 100P 35
C424	Mylar 0.001 50V	CQMA 102K 50
C403	Electrolytic 470 63V	CEA 471P 63

RESISTORS

Symbol	Description	Part No.
VR401	Semi-fixed 4.7k-B	C92-051
R401	Metal film 3.3 2W	RN2PSF 3R3K
R403	Carbon film 3.3k	RD%VS 332J
R404	Metal oxide 330 1W	RS1P 331J
R406	Metal oxide 47 3W	RS3PSF 470J
R407	Metal oxide 1k 1W	RS1P 102J
R408	Carbon film 27k	RD%VS 273J
R409	Carbon film 10k	RD%VS 103J
R410	Carbon film 5.2k	RD%VS 562J
R411	Carbon film 10	RD%VS 100J
R412	Carbon film 10	RD%VS 100J
R413	Carbon film 33k	RD%VS 333J
R414	Carbon film 47k	RD%VS 473J
R415	Carbon film 33k	RD%VS 333J
R416	Carbon film 4.7k	RD%VS 472J
R417	Carbon film 1k	RD%VS 102J
R418	Metal film 0.47 1W	RN1PSF R47K
R419	Carbon film 1k	RD%VS 102J
R420	Carbon film 1.5k	RD%VS 152J
R421	Carbon film 6.8k	RD%VS 682J
R422	Carbon film 1	RD%VS 010J

OTHERS

Symbol	Description	Part No.
T401	Spacer	REE-051
	Washer	REE-044
	O.S.C transformer	RTD-011
	Fuse clip	RKR-017
	Fuse 1A	REK-033
	Fuse 2.5A	REK-046

16.13 SELECTOR SWITCH ASSEMBLY (RWX-121)

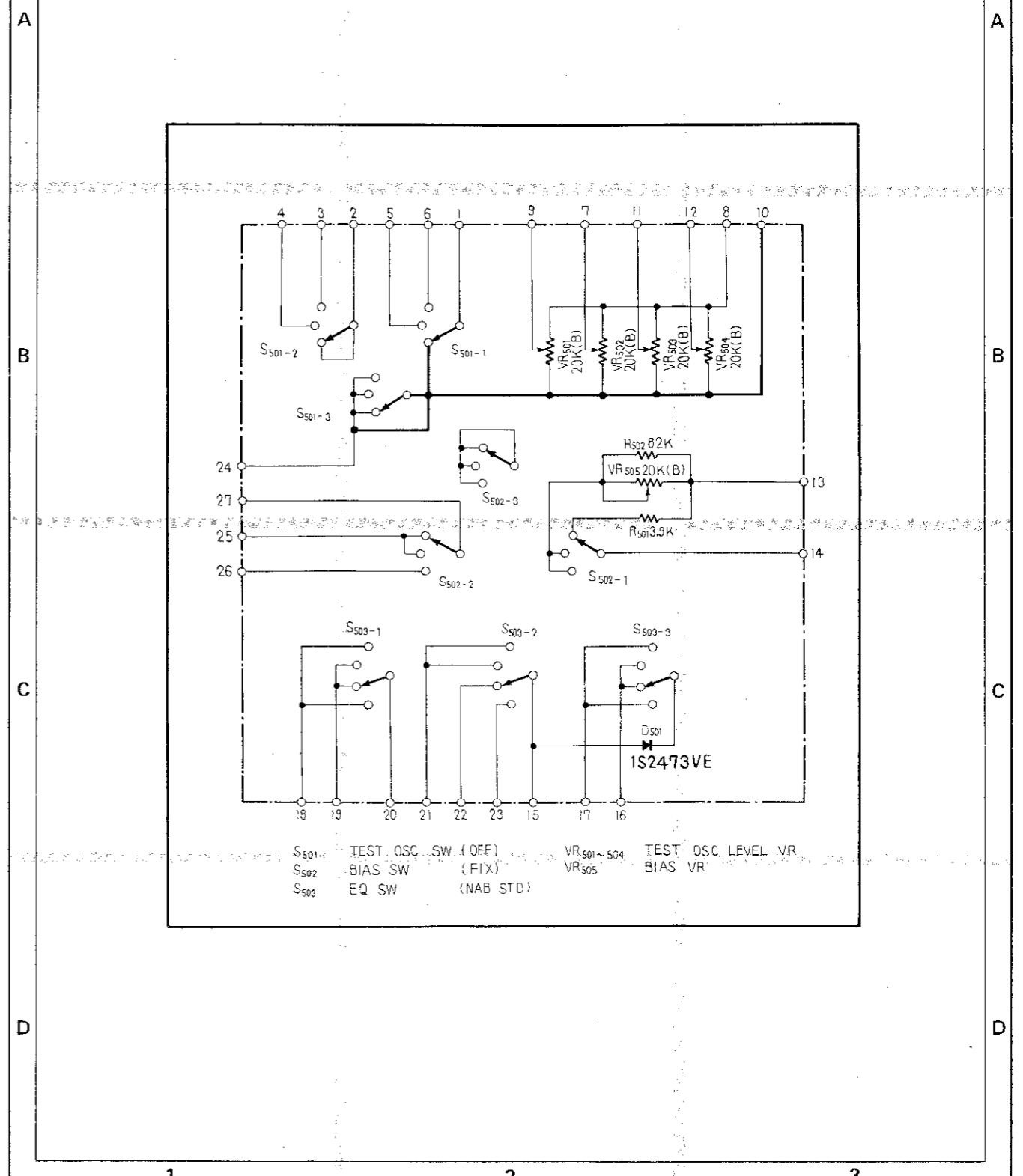

16. RTU-11 SCHEMATIC DIAGRAMS, P.C. BOARD PATTERNS AND PARTS LIST

16.1 SCHEMATIC DIAGRAM

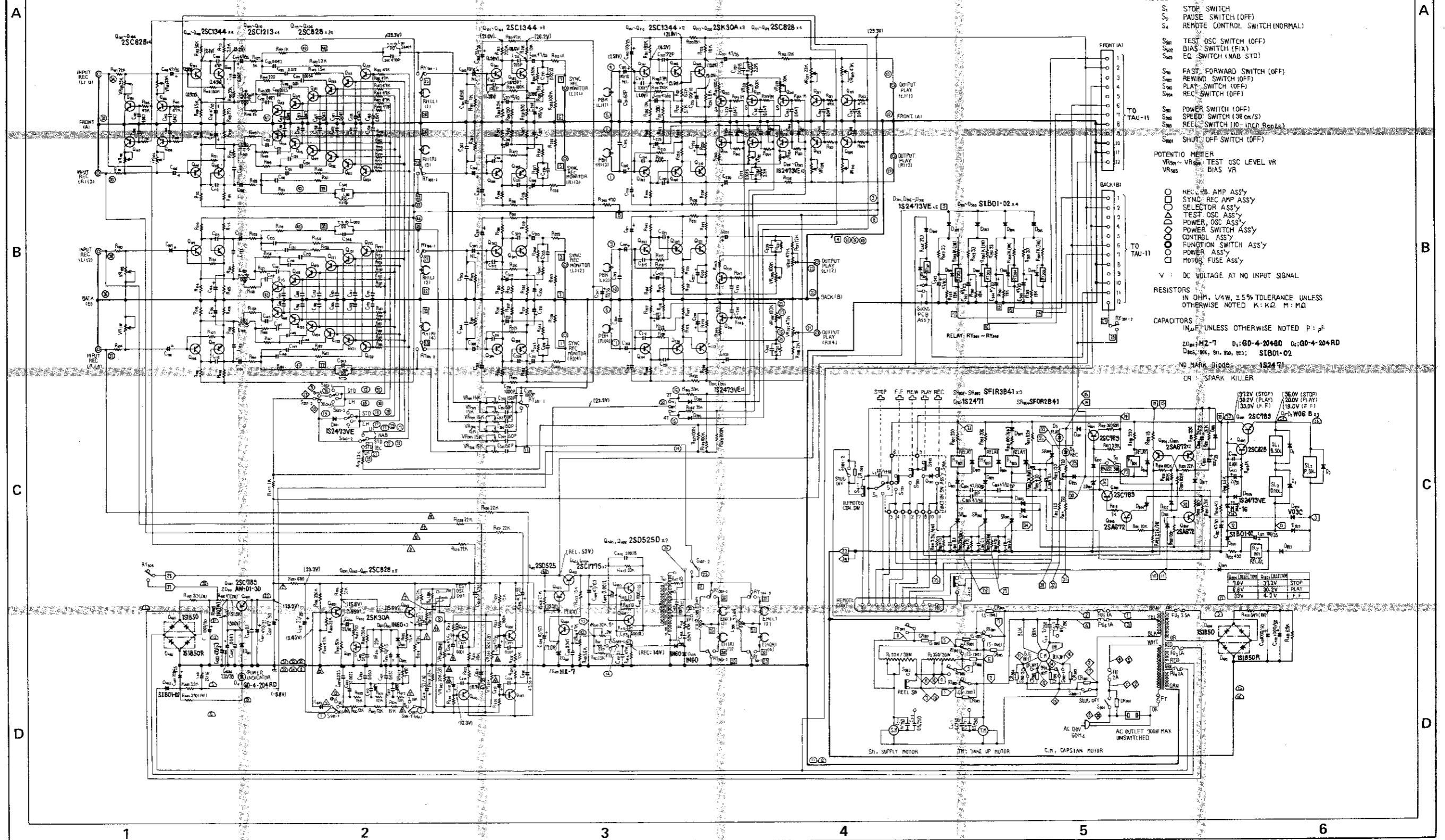

NOTES:

- S1 STOP SWITCH
- S2 PAUSE SWITCH (OFF)
- S3 REMOTE CONTROL SWITCH (NORMAL)
- S4 TEST OSC SWITCH (OFF)
- S5 BIAS SWITCH (FIX)
- S6 EQ SWITCH (NAB STD)
- S7 FAST FORWARD SWITCH (OFF)
- S8 REWIND SWITCH (OFF)
- S9 PLAY SWITCH (OFF)
- S10 REC SWITCH (OFF)
- S11 POWER SWITCH (OFF)
- S12 SPEED SWITCH (38 CM/3)
- S13 REEL SWITCH (10-INCH REELS)
- S14 SHUT OFF SWITCH (OFF)

POTENTIOMETER

- VR500 TEST OSC LEVEL VR
- VR600 BIAS VR

○ HELD IN AMP ASSY
○ SYNC REC AMP ASSY
○ SELECTOR ASSY
○ TEST OSC ASSY
○ POWER OSC ASSY
○ POWER SWITCH ASSY
○ CONTROL ASSY
○ FUNCTION SWITCH ASSY
○ POWER ASSY
○ MOTOR FUSE ASSY

V : DC VOLTAGE AT NO INPUT SIGNAL

RESISTORS
IN OHM, 1/4W, ±5% TOLERANCE UNLESS OTHERWISE NOTED K: KΩ M: MΩ

CAPACITORS
IN μF UNLESS OTHERWISE NOTED P: pF

ZD001 MZ-7 D1: GD-4-20480 D2: GD-4-20480
D005, 006, 007, 008, 009; S1601-02
NO MARK Diodes: 1S2471
CR SPARK KILLER

120V (STOP)	35.0V (STOP)
30.2V (PLAY)	30.0V (PLAY)
33.0V (F.F)	18.0V (F.F)
120V (STOP)	35.0V (STOP)
30.2V (PLAY)	30.0V (PLAY)
33.0V (F.F)	18.0V (F.F)

16.2 CONNECTION DIAGRAM

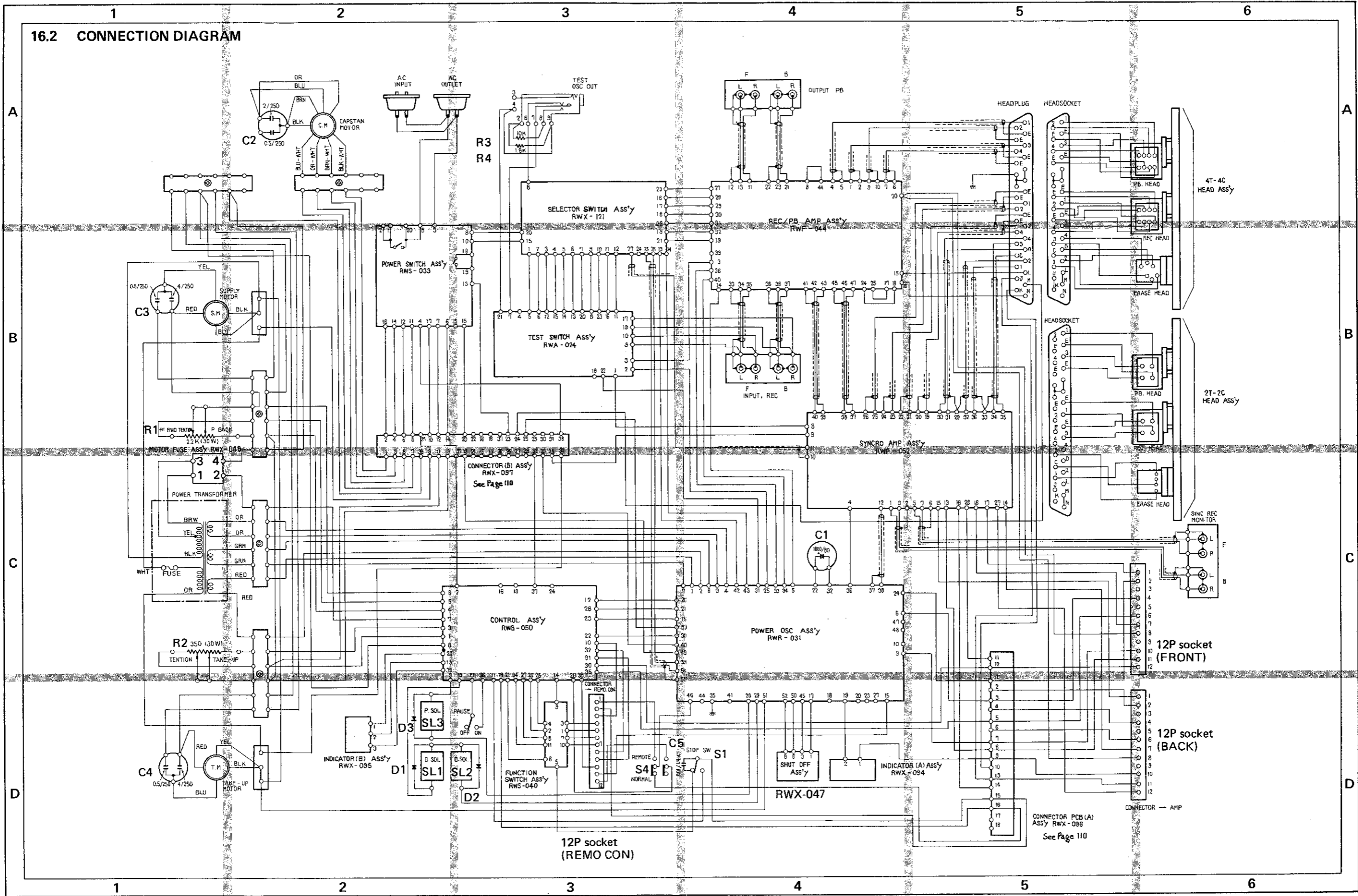

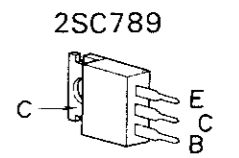
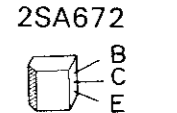
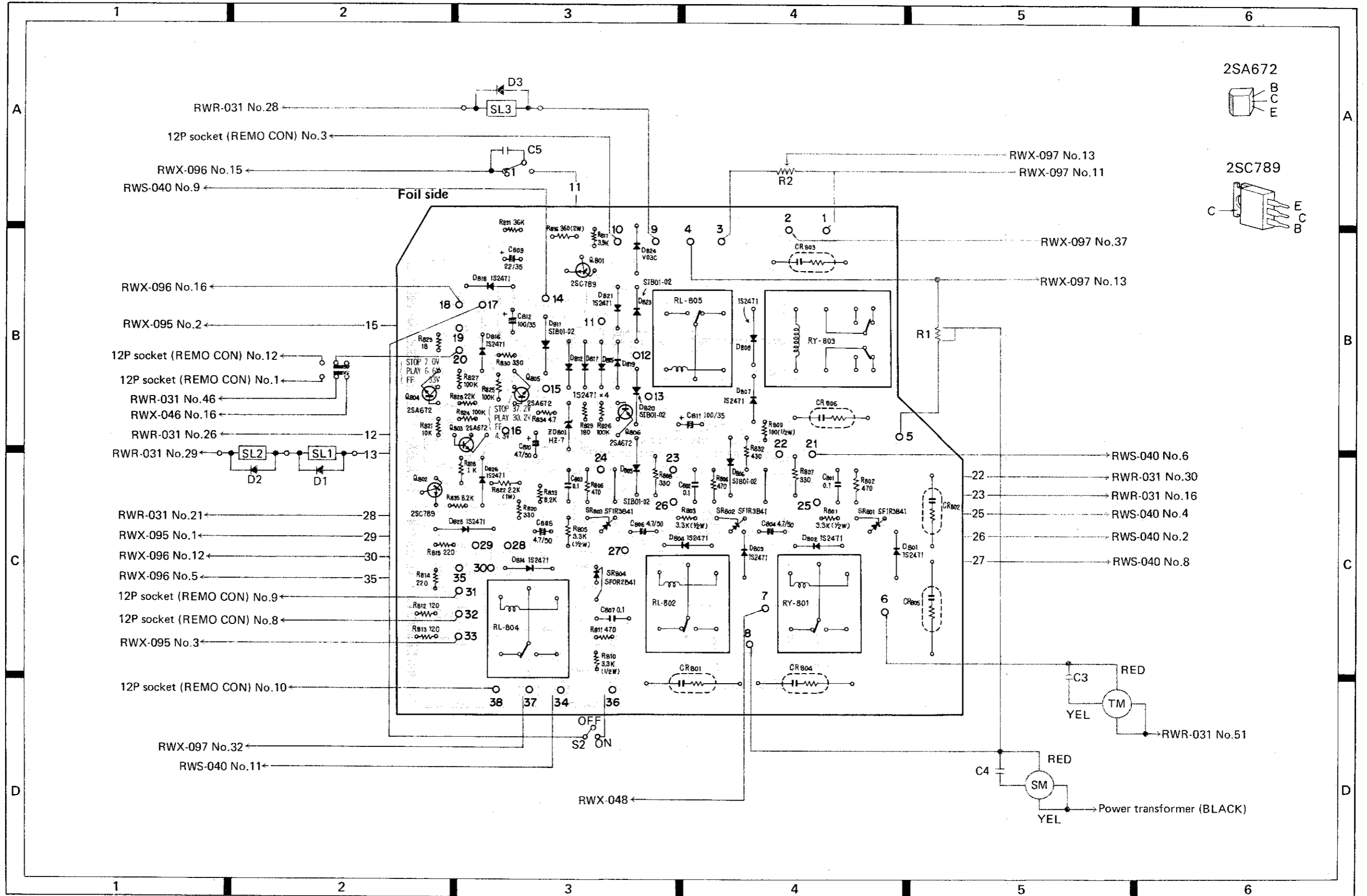

Parts List of Control Assembly (RWG-050)

SEMICONDUCTORS

Symbol	Description	Part No.
Q801	Transistor	2SC789-O (or Y)
Q802	Transistor	2SC789-O (or Y)
Q803	Transistor	2SA672-B
Q804	Transistor	2SA672-B
Q805	Transistor	2SA672-B
Q806	Transistor	2SA672-B
D801	Diode	1S2471
D802	Diode	1S2471
D803	Diode	1S2471
D804	Diode	1S2471
D805	Diode	SIB-01-02
D806	Diode	SIB-01-02
D807	Diode	1S2471
D808	Diode	1S2471
D811	Diode	SIB-01-02
D812	Diode	1S2471
D813	Diode	HZ-7 B
D814	Diode	1S2471
D815	Diode	1S2471
D816	Diode	1S2471
D817	Diode	1S2471
D818	Diode	1S2471
D819	Diode	1S2471
D820	Diode	SIB-01-02
D821	Diode	1S2471
D823	Diode	SIB-01-02
D824	Diode	V03 C
D825	Diode	1S2471
D826	Diode	1S2471

OTHERS

Symbol	Description	Part No.
RY801	Relay	RSR-011
RY802	Relay	RSR-011
RY803	Relay	RSR-016
RY804	Relay	RSR-011
RY805	Relay	RSR-011
SR801	Thyristor	SF1R3B41
SR802	Thyristor	SF1R3B41
SR803	Thyristor	SF1R3B41
SR804	Thyristor	SF0R2B41
CR801	Spark killer	RWX-106
CR802	Spark killer	RWX-105
CR803	Spark killer	RWX-105
CR804	Spark killer	RWX-106
CR805	Spark killer	RWX-106
CR806	Spark killer	RWX-105

RESISTORS

Symbol	Description	Part No.
R801	Carbon film 3.3k 1/4W	RD1/4VS 332J
R802	Carbon film 470	RD1/4VS 471J
R803	Carbon film 3.3k 1/4W	RD1/4VS 332J
R804	Carbon film 470	RD1/4VS 471J
R805	Carbon film 3.3k 1/4W	RD1/4VS 332J
R806	Carbon film 470	RD1/4VS 471J
R807	Carbon film 330	RD1/4PSF 331J
R808	Carbon film 330	RD1/4PSF 331J
R809	Carbon film 100 1/4W	RD1/4PSF 101J
R810	Carbon film 3.3k 1/4W	RD1/4VS 332J
R811	Carbon film 470	RD1/4VS 471J
R812	Carbon film 120	RD1/4VS 121J
R813	Carbon film 120	RD1/4VS 121J
R814	Carbon film 220	RD1/4VS 221J
R815	Carbon film 220	RD1/4VS 221J
R816	Metal oxide 360 2W	RS2P 361J
R817	Carbon film 3.9k	RD1/4VS 392J
R818	Carbon film 1.0k	RD1/4VS 102J
R820	Carbon film 330	RD1/4PSF 331J
R821	Carbon film 10k	RD1/4VS 103J
R822	Metal oxide 2.2k 1W	RS1P 222J
R823	Carbon film 18	RD1/4VS 180J
R824	Carbon film 100k	RD1/4VS 104J
R825	Carbon film 100k	RD1/4VS 104J
R826	Carbon film 100k	RD1/4VS 104J
R827	Carbon film 100k	RD1/4VS 104J
R828	Carbon film 22k	RD1/4VS 223J
R829	Carbon film 180	RD1/4PSF 181J
R830	Carbon film 330	RD1/4PSF 331J
R831	Carbon film 36k	RD1/4VS 363J
R832	Carbon film 430	RD1/4PSF 431J
R833	Carbon film 8.2k	RD1/4VS 822J
R834	Carbon film 4.7k	RD1/4VS 472J
R835	Carbon film 8.2k	RD1/4VS 822J

CAPACITORS

Symbol	Description	Part No.
C801	Mylar 0.1 50V	CQMA 104K 50
C802	Mylar 0.1 50V	CQMA 104K 50
C803	Mylar 0.1 50V	CQMA 104K 50
C804	Bi-polar 4.7 50V	RCH-026
C805	Bi-polar 4.7 50V	RCH-026
C806	Bi-polar 4.7 50V	RCH-026
C807	Mylar 0.1 50V	CQMA 104K 50
C809	Electrolytic 22 35V	CEA 220P 35
C810	Electrolytic 4.7 50V	CEA 4R7P 50
C811	Electrolytic 100 35V	CEA 101P 35
C812	Electrolytic 100 35V	CEA 101P 35

16.5 INDICATOR (A) ASSEMBLY (RWX-094)

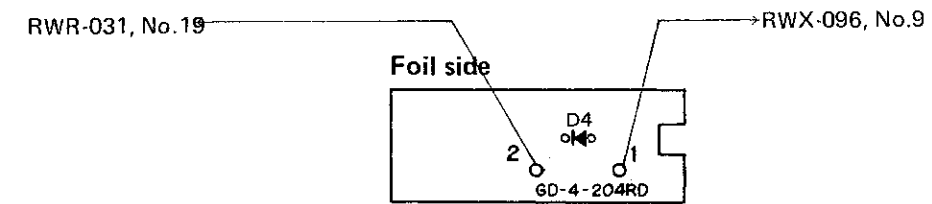

Parts List of Indicator (A) Assembly (RWX-094)

Symbol	Description	Part No.
D4	Light emitting diode	GD-4-204RD

16.6 INDICATOR (B) ASSEMBLY (RWX-095)

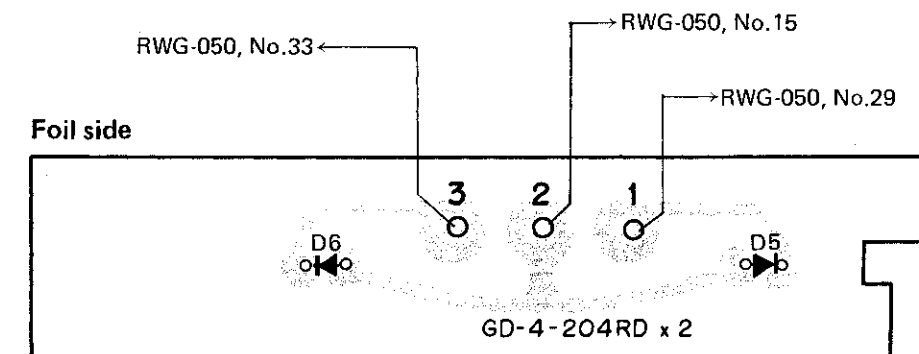

Parts List of Indicator (B) Assembly (RWX-095)

Symbol	Description	Part No.
D5	Light emitting diode	GD-4-204RD
D6	Light emitting diode	GD-4-204GD

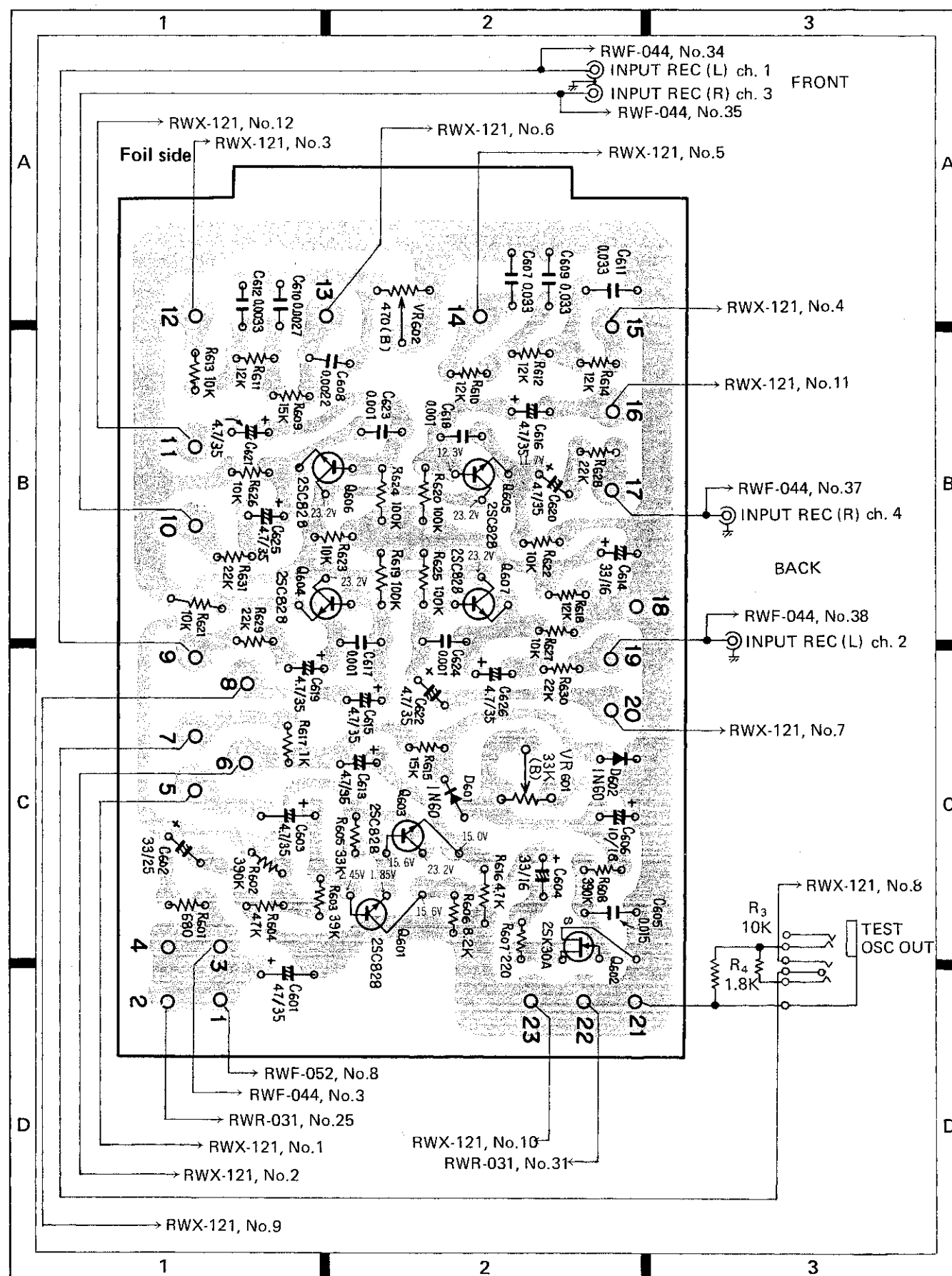

Parts List of Test O.S.C. Assembly (RWA-024)

SEMICONDUCTORS

Symbol	Description	Part No.
Q601	Transistor	2SC828-R (or S)
Q602	Transistor	2SK30A-Y
Q603	Transistor	2SC828-R (or S)
Q604	Transistor	2SC828-R (or S)
Q605	Transistor	2SC828-R (or S)
Q606	Transistor	2SC828-R (or S)
Q607	Transistor	2SC828-R (or S)
D601	Diode	1N60
D602	Diode	1N60

CAPACITORS

Symbol	Description	Part No.
C601	Electrolytic 47 50V	CEA 470P 50
C602	Electrolytic 33 25V	CEA 330P 25
C603	Electrolytic 4.7 35V	CEA 4R7P 35
C604	Electrolytic 33 16V	CEA 330P 16
C605	Mylar 0.015 50V	CQMA 153K 50
C606	Electrolytic 10 16V	CEA 100P 16
C607	Mylar 0.033 50V	CQMA 333K 50
C608	Mylar 0.0022 50V	CQMA 222K 50
C609	Mylar 0.033 50V	CQMA 333K 50
C610	Mylar 0.0027 50V	CQMA 272K 50
C611	Mylar 0.033 50V	CQMA 333K 50
C612	Mylar 0.0033 50V	CQMA 332K 50
C613	Electrolytic 4.7 35V	CEA 4R7P 35
C614	Electrolytic 33 16V	CEA 330P 16
C615	Electrolytic 4.7 35V	CEA 4R7P 35
C616	Electrolytic 4.7 35V	CEA 4R7P 35
C617	Mylar 0.001 50V	CQMA 102K 50
C618	Mylar 0.001 50V	CQMA 102K 50
C619	Electrolytic 4.7 35V	CEA 4R7P 35
C620	Electrolytic 4.7 35V	CEA 4R7P 35
C621	Electrolytic 4.7 35V	CEA 4R7P 35
C622	Electrolytic 4.7 35V	CEA 4R7P 35
C623	Mylar 0.001 50V	CQMA 102K 50
C624	Mylar 0.001 50V	CQMA 102K 50
C625	Electrolytic 4.7 35V	CEA 4R7P 35
C626	Electrolytic 4.7 35V	CEA 4R7P 35

RESISTORS

Symbol	Description	Part No.
VR601	Semi-fixed	C81-426
VR602	Semi-fixed	C81-422
R601	Carbon film 680	RD%VS 681J
R602	Carbon film 390k	RD%VS 394J
R603	Carbon film 39k	RD%VS 393J
R604	Carbon film 47k	RD%VS 473J
R605	Carbon film 33k	RD%VS 333J
R606	Carbon film 8.2k	RD%VS 822J
R607	Carbon film 220	RD%VS 221J
R608	Carbon film 390k	RD%VS 394J
R609	Carbon film 15k	RD%VS 153J
R610	Carbon film 12k	RD%VS 123J
R611	Carbon film 12k	RD%VS 123J
R612	Carbon film 12k	RD%VS 123J
R613	Carbon film 10k	RD%VS 103J
R614	Carbon film 12k	RD%VS 123J
R615	Carbon film 15k	RD%VS 153J
R616	Carbon film 4.7k	RD%VS 472J
R617	Carbon film 1k	RD%VS 102J
R618	Carbon film 12k	RD%VS 123J
R619	Carbon film 100k	RD%VS 104J
R620	Carbon film 100k	RD%VS 104J
R621	Carbon film 10k	RD%VS 103J
R622	Carbon film 10k	RD%VS 103J
R623	Carbon film 10k	RD%VS 103J
R624	Carbon film 100k	RD%VS 104J
R625	Carbon film 100k	RD%VS 104J
R626	Carbon film 10k	RD%VS 103J
R627	Carbon film 10k	RD%VS 103J
R628	Carbon film 22k	RD%VS 223J
R629	Carbon film 22k	RD%VS 223J
R630	Carbon film 22k	RD%VS 223J
R631	Carbon film 22k	RD%VS 223J

16.9 REC/PB AMPLIFIER ASSEMBLY (RWF-044)

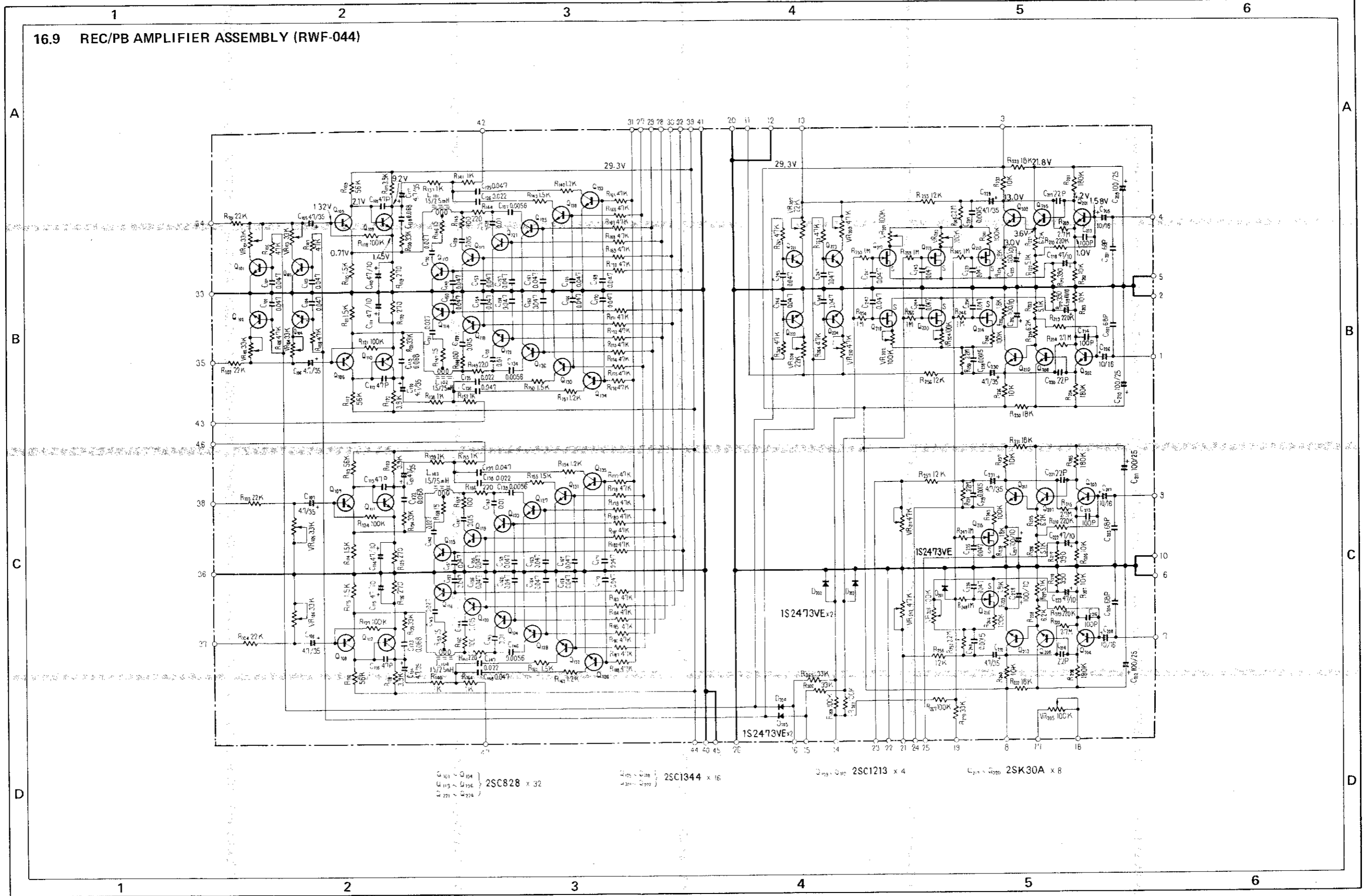

Q₁₀₁ - Q₁₀₄ } 2SC828 x 4
 C₁₁₅ - C₁₁₆ }
 C₁₁₇ - C₁₁₈ }
 C₁₁₉ - C₁₂₀ }

Q₁₀₅ - Q₁₀₈ } 2SC1344 x 4
 Q₁₀₉ - Q₁₁₂ }

Q₁₁₃ - Q₁₁₆ } 2SC1213 x 4

C₁₂₁ - C₁₂₀ } 2SK30A x 8

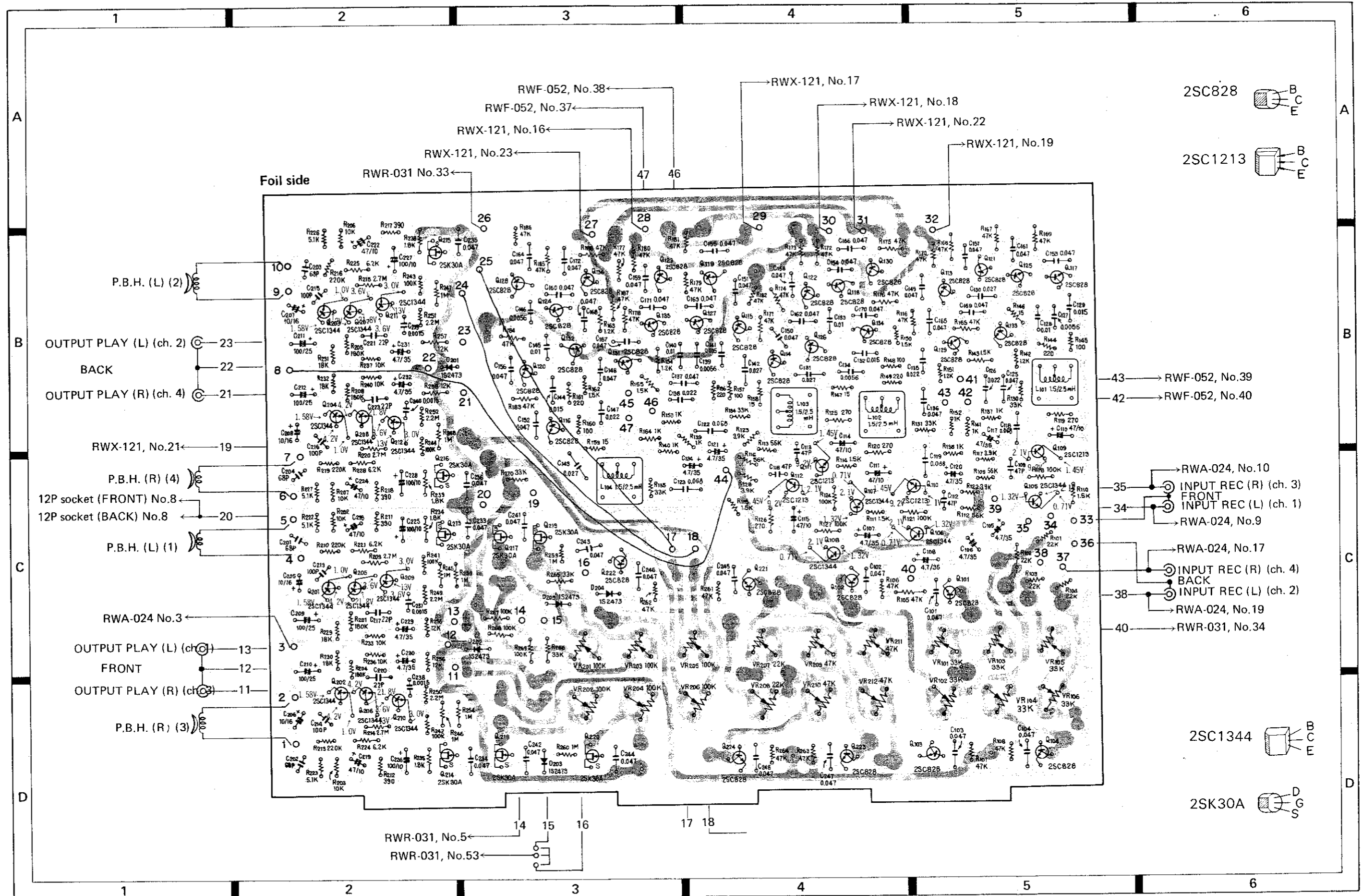

2SC828

2SC1213

2SC1344

2SK30A

Parts List of REC/PB Amplifier Assembly (RWF-044)

SEMICONDUCTORS

Symbol	Description	Part No.
Q101	Transistor	2SC828-R
Q102	Transistor	2SC828-R
Q103	Transistor	2SC828-R
Q104	Transistor	2SC828-R
Q105	Transistor	2SC1344-D
Q106	Transistor	2SC1344-D
Q107	Transistor	2SC1344-D
Q108	Transistor	2SC1344-D
Q109	Transistor	2SC1213-B
Q110	Transistor	2SC1213-B
Q111	Transistor	2SC1213-B
Q112	Transistor	2SC1213-B
Q113	Transistor	2SC828-R
Q114	Transistor	2SC828-R
Q115	Transistor	2SC828-R
Q116	Transistor	2SC828-R
Q117	Transistor	2SC828-R
Q118	Transistor	2SC828-R
Q119	Transistor	2SC828-R
Q120	Transistor	2SC828-R
Q121	Transistor	2SC828-R
Q122	Transistor	2SC828-R
Q123	Transistor	2SC828-R
Q124	Transistor	2SC828-R
Q125	Transistor	2SC828-R
Q126	Transistor	2SC828-R
Q127	Transistor	2SC828-R
Q128	Transistor	2SC828-R
Q129	Transistor	2SC828-R
Q130	Transistor	2SC828-R
Q131	Transistor	2SC828-R
Q132	Transistor	2SC828-R
Q133	Transistor	2SC828-R
Q134	Transistor	2SC828-R
Q135	Transistor	2SC828-R
Q136	Transistor	2SC828-R
Q201	Transistor	2SC1344-D
Q202	Transistor	2SC1344-D
Q203	Transistor	2SC1344-D
Q204	Transistor	2SC1344-D
Q205	Transistor	2SC1344-D
Q206	Transistor	2SC1344-D
Q207	Transistor	2SC1344-D
Q208	Transistor	2SC1344-D
Q209	Transistor	2SC1344-D
Q210	Transistor	2SC1344-D
Q211	Transistor	2SC1344-D
Q212	Transistor	2SC1344-D

Symbol	Description	Part No.
Q213	FET	2SK30A-Y
Q214	FET	2SK30A-Y
Q215	FET	2SK30A-Y
Q216	FET	2SK30A-Y
Q217	FET	2SK30A-Y
Q218	FET	2SK30A-Y
Q219	FET	2SK30A-Y
Q220	FET	2SK30A-Y
Q221	Transistor	2SC828-R
Q222	Transistor	2SC828-R
Q223	Transistor	2SC828-R
Q224	Transistor	2SC828-R
D201	Diode	1S2473VE
D202	Diode	1S2473VE
D203	Diode	1S2473VE
D204	Diode	1S2473VE
D205	Diode	1S2473VE

COIL

Symbol	Description	Part No.
L101	Peaking coil	RTF-014
L102	Peaking coil	RTF-014
L103	Peaking coil	RTF-014
L104	Peaking coil	RTF-014

RESISTORS

Symbol	Description	Part No.
VR101	Semi-fixed 33k-B	RCP-025
VR102	Semi-fixed 33k-B	RCP-025
VR103	Semi-fixed 33k-B	RCP-025
VR104	Semi-fixed 33k-B	RCP-025
VR105	Semi-fixed 33k-B	RCP-025
VR106	Semi-fixed 33k-B	RCP-025
VR201	Semi-fixed 100k-B	RCP-027
VR202	Semi-fixed 100k-B	RCP-027
VR203	Semi-fixed 100k-B	RCP-027
VR204	Semi-fixed 100k-B	RCP-027
VR205	Semi-fixed 100k-B	RCP-027
VR206	Semi-fixed 100k-B	RCP-027
VR207	Semi-fixed 22k-B	RCP-024
VR208	Semi-fixed 22k-B	RCP-024
VR209	Semi-fixed 47k-B	RCP-026
VR210	Semi-fixed 47k-B	RCP-026
VR211	Semi-fixed 47k-B	RCP-026
VR212	Semi-fixed 47k-B	RCP-026

Symbol	Description	Part No.
R101	Carbon film 22k	RD%VS 223J
R102	Carbon film 22k	RD%VS 223J
R103	Carbon film 22k	RD%VS 223J
R104	Carbon film 22k	RD%VS 223J
R105	Carbon film 47k	RD%VS 473J
R106	Carbon film 47k	RD%VS 473J
R107	Carbon film 47k	RD%VS 473J
R108	Carbon film 47k	RD%VS 473J
R109	Carbon film 56k	RD%VS 563J
R110	Carbon film 1.5k	RD%VS 152J
R111	Carbon film 1.5k	RD%VS 152J
R112	Carbon film 56k	RD%VS 563J
R113	Carbon film 56k	RD%VS 563J
R114	Carbon film 1.5k	RD%VS 152J
R115	Carbon film 1.5k	RD%VS 152J
R116	Carbon film 56k	RD%VS 563J
R117	Carbon film 3.9k	RD%VS 392J
R118	Carbon film 100k	RD%VS 104J
R119	Carbon film 270	RD%VS 271J
R120	Carbon film 270	RD%VS 271J
R121	Carbon film 100k	RD%VS 104J
R122	Carbon film 3.9k	RD%VS 392J
R123	Carbon film 3.9k	RD%VS 392J
R124	Carbon film 100k	RD%VS 104J
R125	Carbon film 270	RD%VS 271J
R126	Carbon film 270	RD%VS 271J
R127	Carbon film 100k	RD%VS 104J
R128	Carbon film 3.9k	RD%VS 392J
R129	RD%VS 105J
R130	Carbon film 33k	RD%VS 333J
R131	Carbon film 33k	RD%VS 333J
R132	RD%VS 105J
R133	RD%VS 105J
R134	Carbon film 33k	RD%VS 333J
R135	Carbon film 33k	RD%VS 333J
R136	RD%VS 105J
R137	Carbon film 1k	RD%VS 102J
R138	Carbon film 1k	RD%VS 102J
R139	Carbon film 1k	RD%VS 102J
R140	Carbon film 1k	RD%VS 102J
R141	Carbon film 1k	RD%VS 102J
R142	Carbon film 1.2k	RD%VS 122J
R143	Carbon film 1.5k	RD%VS 152J
R144	Carbon film 220	RD%VS 221J
R145	Carbon film 100	RD%VS 101J
R146	Carbon film 15	RD%VS 150J
R147	Carbon film 15	RD%VS 150J
R148	Carbon film 100	RD%VS 101J
R149	Carbon film 220	RD%VS 221J
R150	Carbon film 1.5k	RD%VS 152J

Symbol	Description	Part No.
R151	Carbon film 1.2k	RD%VS 122J
R152	Carbon film 1k	RD%VS 102J
R153	Carbon film 1k	RD%VS 102J
R154	Carbon film 1.2k	RD%VS 122J
R155	Carbon film 1.5k	RD%VS 152J
R156	Carbon film 220	RD%VS 221J
R157	Carbon film 100	RD%VS 101J
R158	Carbon film 15	RD%VS 150J
R159	Carbon film 15	RD%VS 150J
R160	Carbon film 100	RD%VS 101J
R161	Carbon film 220	RD%VS 221J
R162	Carbon film 1.5k	RD%VS 152J
R163	Carbon film 1.2k	RD%VS 122J
R164	Carbon film 1k	RD%VS 102J
R165	Carbon film 47k	RD%VS 473J
R166	Carbon film 47k	RD%VS 473J
R167	Carbon film 47k	RD%VS 473J
R168	Carbon film 47k	RD%VS 473J
R169	Carbon film 47k	RD%VS 473J
R170	Carbon film 47k	RD%VS 473J
R171	Carbon film 47k	RD%VS 473J
R172	Carbon film 47k	RD%VS 473J
R173	Carbon film 47k	RD%VS 473J
R174	Carbon film 47k	RD%VS 473J
R175	Carbon film 47k	RD%VS 473J
R176	Carbon film 47k	RD%VS 473J
R177	Carbon film 47k	RD%VS 473J
R178	Carbon film 47k	RD%VS 473J
R179	Carbon film 47k	RD%VS 473J
R180	Carbon film 47k	RD%VS 473J
R181	Carbon film 47k	RD%VS 473J
R182	Carbon film 47k	RD%VS 473J
R183	Carbon film 47k	RD%VS 473J
R184	Carbon film 47k	RD%VS 473J
R185	Carbon film 47k	RD%VS 473J
R186	Carbon film 47k	RD%VS 473J
R187	Carbon film 47k	RD%VS 473J
R188	Carbon film 47k	RD%VS 473J
R201	Carbon film 180k	RD%VS 184J
R202	Carbon film 10k	RD%VS 103J
R203	Carbon film 10k	RD%VS 103J
R204	Carbon film 180k	RD%VS 184J
R205	Carbon film 180k	RD%VS 184J
R206	Carbon film 10k	RD%VS 103J
R207	Carbon film 10k	RD%VS 103J
R208	Carbon film 180k	RD%VS 103J
R209	Carbon film 2.7M	RD%VS 275J
R210	Carbon film 220k	RD%VS 224J
R211	Carbon film 390	RD%VS 391J
R212	Carbon film 390	RD%VS 391J

Symbol	Description	Part No.
R213	Carbon film 220k	RD%VS 224J
R214	Carbon film 2.7M	RD%VS 275J
R215	Carbon film 2.7M	RD%VS 275J
R216	Carbon film 220k	RD%VS 224J
R217	Carbon film 390	RD%VS 391J
R218	Carbon film 390	RD%VS 391J
R219	Carbon film 220k	RD%VS 224J
R220	Carbon film 2.7M	RD%VS 275J
R221	Carbon film 6.2k	RD%VS 622J
R222	Carbon film 5.1k	RD%VS 512J
R223	Carbon film 5.1k	RD%VS 512J
R224	Carbon film 6.2k	RD%VS 622J
R225	Carbon film 6.2k	RD%VS 622J
R226	Carbon film 5.1k	RD%VS 512J
R227	Carbon film 5.1k	RD%VS 512J
R228	Carbon film 6.2k	RD%VS 622J
R229	Carbon film 18k	RD%VS 183J
R230	Carbon film 18k	RD%VS 183J
R231	Carbon film 18k	RD%VS 183J
R232	Carbon film 18k	RD%VS 183J
R233	Carbon film 10k	RD%VS 103J
R234	Carbon film 1.8k	RD%VS 182J
R235	Carbon film 1.8k	RD%VS 182J
R236	Carbon film 10k	RD%VS 103J
R237	Carbon film 10k	RD%VS 103J
R238	Carbon film 1.8k	RD%VS 182J
R239	Carbon film 1.8k	RD%VS 182J
R240	Carbon film 10k	RD%VS 103J
R241	Carbon film 100k	RD%VS 104J
R242	Carbon film 100k	RD%VS 104J
R243	Carbon film 100k	RD%VS 104J
R244	Carbon film 100k	RD%VS 104J
R245	Carbon film 1M	RD%VS 105J
R246	Carbon film 1M	RD%VS 105J
R247	Carbon film 1M	RD%VS 105J
R248	Carbon film 1M	RD%VS 105J
R249	Carbon film 2.2M	RD%VS 225J
R250	Carbon film 2.2M	RD%VS 225J
R251	Carbon film 2.2M	RD%VS 225J
R252	Carbon film 2.2M	RD%VS 225J
R253	Carbon film 1M	RD%VS 105J
R254	Carbon film 1M	RD%VS 105J
R255	Carbon film 12k	RD%VS 123J
R256	Carbon film 12k	RD%VS 123J
R257	Carbon film 12k	RD%VS 123J
R258	Carbon film 12k	RD%VS 123J
R259	Carbon film 1M	RD%VS 105J
R260	Carbon film 1M	RD%VS 105J
R261	Carbon film 47k	RD%VS 473J
R262	Carbon film 47k	RD%VS 473J

Symbol	Description	Part No.
R263	Carbon film 47k	RD%VS 473J
R264	Carbon film 47k	RD%VS 473J
R265	Carbon film 33k	RD%VS 333J
R266	Carbon film 33k	RD%VS 333J
R267	Carbon film 100k	RD%VS 104J
R268	Carbon film 100k	RD%VS 104J
R269	Carbon film 100k	RD%VS 104J
R270	Carbon film 33k	RD%VS 333J

CAPACITORS

Symbol	Description	Part No.
C101	Mylar 0.047 50V	CQMA 473K 50
C102	Mylar 0.047 50V	CQMA 473K 50
C103	Mylar 0.047 50V	CQMA 473K 50
C104	Mylar 0.047 50V	CQMA 473K 50
C105	Electrolytic 4.7 35V	CEA 4R7P 35
C106	Electrolytic 4.7 35V	CEA 4R7P 35
C107	Electrolytic 4.7 35V	CEA 4R7P 35
C108	Electrolytic 4.7 35V	CEA 4R7P 35
C109	Polystyrene 47p 50V	RCE-012
C110	Electrolytic 47 10V	CEA 470P 10
C111	Electrolytic 47 10V	CEA 470P 10
C112	Polystyrene 47p 50V	RCE-012
C113	Polystyrene 47p 50V	RCE-012
C114	Electrolytic 47 10V	CEA 470P 10
C115	Electrolytic 47 10V	CEA 470P 10
C116	Polystyrene 47p 50V	RCE-012
C117	Electrolytic 4.7 35V	CEA 4R7P 35
C118	Mylar 0.068 50V	CQMA 683K 50
C119	Mylar 0.068 50V	CQMA 683K 50
C120	Electrolytic 4.7 35V	CEA 4R7P 35
C121	Electrolytic 4.7 35V	CEA 4R7P 35
C122	Mylar 0.068 50V	CQMA 683K 50
C123	Mylar 0.068 50V	CQMA 683K 50
C124	Electrolytic 4.7 35V	CEA 4R7P 35
C125	Mylar 0.047 50V	CQMA 473K 50
C126	Mylar 0.022 50V	CQMA 223K 50
C127	Mylar 0.0056 50V	CQMA 562K 50
C128	Mylar 0.01 50V	CQMA 103K 50
C129	Mylar 0.015 50V	CQMA 153K 50
C130	Mylar 0.027 50V	CQMA 273K 50
C131	Mylar 0.027 50V	CQMA 273K 50
C132	Mylar 0.015 50V	CQMA 153K 50
C133	Mylar 0.01 50V	CQMA 103K 50
C134	Mylar 0.0056 50V	CQMA 562K 50
C135	Mylar 0.022 50V	CQMA 223K 50
C136	Mylar 0.047 50V	CQMA 473K 50
C137	Mylar 0.047 50V	CQMA 473K 50
C138	Mylar 0.022 50V	CQMA 223K 50
C139	Mylar 0.0056 50V	CQMA 562K 50

Symbol	Description	Part No.
C140	Mylar 0.01 50V	CQMA 103K 50
C141	Mylar 0.015 50V	CQMA 153K 50
C142	Mylar 0.027 50V	CQMA 273K 50
C143	Mylar 0.027 50V	CQMA 273K 50
C144	Mylar 0.015 50V	CQMA 153K 50
C145	Mylar 0.01 50V	CQMA 103K 50
C146	Mylar 0.0056 50V	CQMA 562K 50
C147	Mylar 0.022 50V	CQMA 223K 50
C148	Mylar 0.047 50V	CQMA 473K 50
C149	Mylar 0.047 50V	CQMA 473K 50
C150	Mylar 0.047 50V	CQMA 473K 50
C151	Mylar 0.047 50V	CQMA 473K 50
C152	Mylar 0.047 50V	CQMA 473K 50
C153	Mylar 0.047 50V	CQMA 473K 50
C154	Mylar 0.047 50V	CQMA 473K 50
C155	Mylar 0.047 50V	CQMA 473K 50
C156	Mylar 0.047 50V	CQMA 473K 50
C157	Mylar 0.047 50V	CQMA 473K 50
C158	Mylar 0.047 50V	CQMA 473K 50
C159	Mylar 0.047 50V	CQMA 473K 50
C160	Mylar 0.047 50V	CQMA 473K 50
C161	Mylar 0.047 50V	CQMA 473K 50
C162	Mylar 0.047 50V	CQMA 473K 50
C163	Mylar 0.047 50V	CQMA 473K 50
C164	Mylar 0.047 50V	CQMA 473K 50
C165	Mylar 0.047 50V	CQMA 473K 50
C166	Mylar 0.047 50V	CQMA 473K 50
C167	Mylar 0.047 50V	CQMA 473K 50
C168	Mylar 0.047 50V	CQMA 473K 50
C169	Mylar 0.047 50V	CQMA 473K 50
C170	Mylar 0.047 50V	CQMA 473K 50
C171	Mylar 0.047 50V	CQMA 473K 50
C172	Mylar 0.047 50V	CQMA 473K 50
C201	Polystyrene 68p 50V	RCE-023
C202	Polystyrene 68p 50V	RCE-023
C203	Polystyrene 68p 50V	RCE-023
C204	Polystyrene 68p 50V	RCE-023
C205	Electrolytic 10 16V	RCH-018
C206	Electrolytic 10 16V	RCH-018
C207	Electrolytic 10 16V	RCH-018
C208	Electrolytic 10 16V	RCH-018
C209	Electrolytic 100 25V	CEA 101P 25
C210	Electrolytic 100 25V	CEA 101P 25
C211	Electrolytic 100 25V	CEA 101P 25
C212	Electrolytic 100 25V	CEA 101P 25
C213	Polystyrene 100p 50V	RCE-003
C214	Polystyrene 100p 50V	RCE-003
C215	Polystyrene 100p 50V	RCE-003
C216	Polystyrene 100p 50V	RCE-003
C217	Polystyrene 22p 50V	RCE-019

Symbol	Description	Part No.
C218	Electrolytic 47 10V	CEA 470P 10
C219	Electrolytic 47 10V	CEA 470P 10
C220	Polystyrene 22p 50V	RCE-019
C221	Polystyrene 22p 50V	RCE-019
C222	Electrolytic 47 10V	CEA 470P 10
C223	Electrolytic 47 10V	CEA 470P 10
C224	Polystyrene 22p 50V	RCE-019
C225	Electrolytic 100 10V	CEA 101P 10
C226	Electrolytic 100 10V	CEA 101P 10
C227	Electrolytic 100 10V	CEA 101P 10
C228	Electrolytic 100 10V	CEA 101P 10
C229	Electrolytic 4.7 35V	CEA 4R7P 35
C230	Electrolytic 4.7 35V	CEA 4R7P 35
C231	Electrolytic 4.7 35V	CEA 4R7P 35
C232	Electrolytic 4.7 35V	CEA 4R7P 35
C233	Mylar 0.047 50V	CQMA 473K 50
C234	Mylar 0.047 50V	CQMA 473K 50
C235	Mylar 0.047 50V	CQMA 473K 50
C236	Mylar 0.047 50V	CQMA 473K 50
C237	Mylar 0.0015 50V	CQMA 152K 50
C238	Mylar 0.0015 50V	CQMA 152K 50
C239	Mylar 0.0015 50V	CQMA 152K 50
C240	Mylar 0.0015 50V	CQMA 152K 50
C241	Mylar 0.047 50V	CQMA 473K 50
C242	Mylar 0.047 50V	CQMA 473K 50
C243	Mylar 0.047 50V	CQMA 473K 50
C244	Mylar 0.047 50V	CQMA 473K 50
C245	Mylar 0.047 50V	CQMA 473K 50
C246	Mylar 0.047 50V	CQMA 473K 50
C247	Mylar 0.047 50V	CQMA 473K 50
C248	Mylar 0.047 50V	CQMA 473K 50

16.10 SYNCRO AMPLIFIER ASSEMBLY (RWF-052)

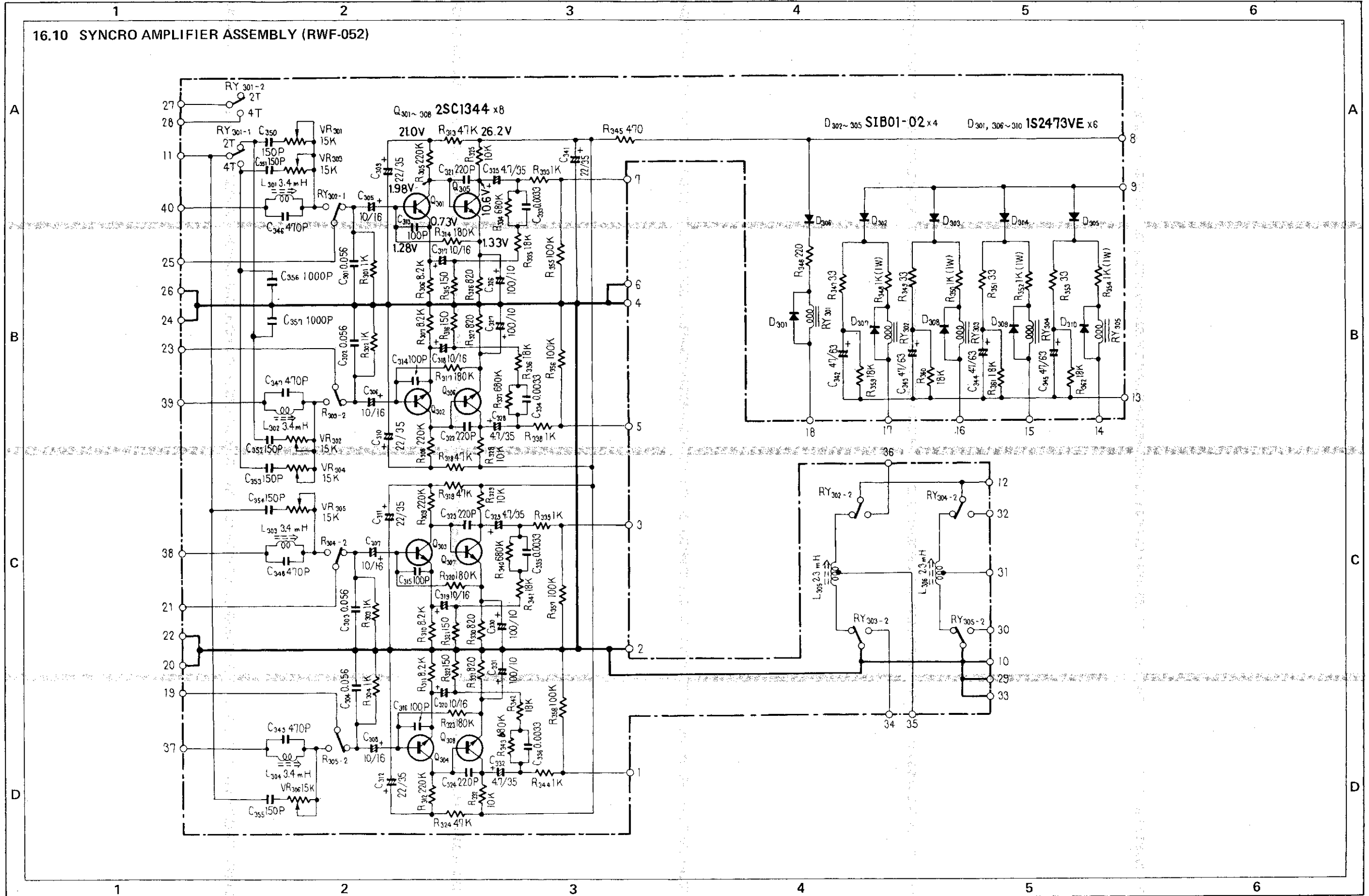

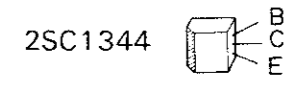
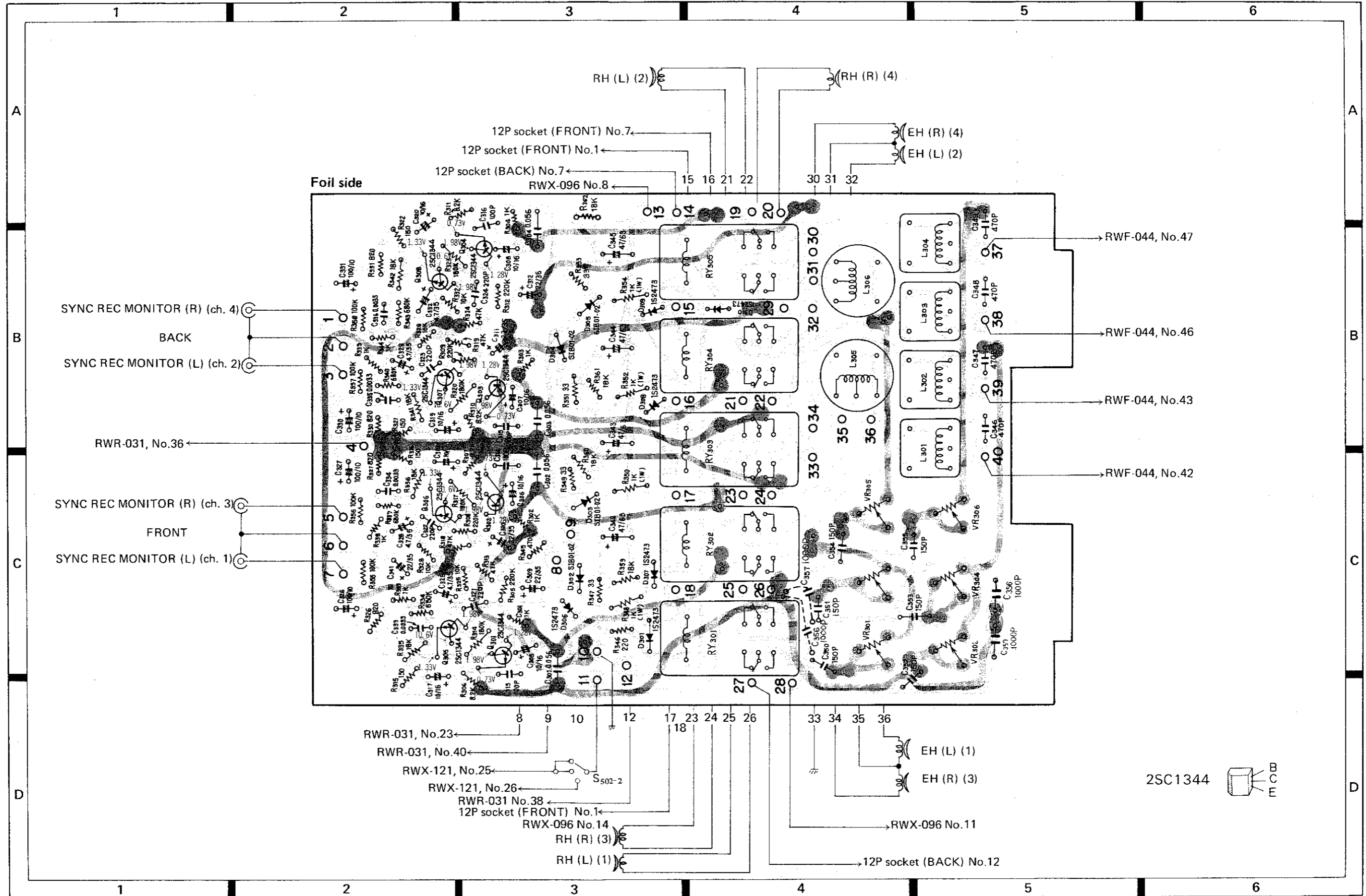

Parts List of Syncro Amplifier Assembly (RWF-052)

SEMICONDUCTOR

Symbol	Description	Part No.
Q301	Transistor	2SC1344-D
Q302	Transistor	2SC1344-D
Q303	Transistor	2SC1344-D
Q304	Transistor	2SC1344-D
Q305	Transistor	2SC1344-D
Q306	Transistor	2SC1344-D
Q307	Transistor	2SC1344-D
Q308	Transistor	2SC1344-D
D301	Diode	1S2473VE
D302	Diode	SIB01-02
D303	Diode	SIB01-02
D304	Diode	SIB01-02
D305	Diode	SIB01-02
D306	Diode	1S2473VE
D307	Diode	1S2473VE
D308	Diode	1S2473VE
D309	Diode	1S2473VE
D310	Diode	1S2473VE

RESISTORS

Symbol	Description	Part No.
R301	Carbon film 1k	RD%VS 102J
R302	Carbon film 1k	RD%VS 102J
R303	Carbon film 1k	RD%VS 102J
R304	Carbon film 1k	RD%VS 102J
R305	Carbon film 220k	RD%VS 224J
R306	Carbon film 8.2k	RD%VS 822J
R307	Carbon film 8.2k	RD%VS 822J
R308	Carbon film 220k	RD%VS 224J
R309	Carbon film 220k	RD%VS 224J
R310	Carbon film 8.2k	RD%VS 822J
R311	Carbon film 8.2k	RD%VS 822J
R312	Carbon film 220k	RD%VS 224J
R313	Carbon film 47k	RD%VS 473J
R314	Carbon film 180k	RD%VS 184J
R315	Carbon film 150	RD%VS 151J
R316	Carbon film 150	RD%VS 151J
R317	Carbon film 180k	RD%VS 184J
R318	Carbon film 47k	RD%VS 473J
R319	Carbon film 47k	RD%VS 473J
R320	Carbon film 180k	RD%VS 184J
R321	Carbon film 150	RD%VS 151J
R322	Carbon film 150	RD%VS 151J
R323	Carbon film 180k	RD%VS 184J
R324	Carbon film 47k	RD%VS 473J
R325	Carbon film 10k	RD%VS 103J

Symbol	Description	Part No.
R326	Carbon film 820	RD%VS 821J
R327	Carbon film 820	RD%VS 821J
R328	Carbon film 10k	RD%VS 103J
R329	Carbon film 10k	RD%VS 103J
R330	Carbon film 820	RD%VS 821J
R331	Carbon film 820	RD%VS 821J
R332	Carbon film 10k	RD%VS 103J
R333	Carbon film 1k	RD%VS 102J
R334	Carbon film 680k	RD%VS 684J
R335	Carbon film 18k	RD%VS 183J
R336	Carbon film 18k	RD%VS 183J
R337	Carbon film 680k	RD%VS 684J
R338	Carbon film 1k	RD%VS 102J
R339	Carbon film 1k	RD%VS 102J
R340	Carbon film 680k	RD%VS 684J
R341	Carbon film 18k	RD%VS 183J
R342	Carbon film 18k	RD%VS 183J
R343	Carbon film 680k	RD%VS 684J
R344	Carbon film 1k	RD%VS 102J
R345	Carbon film 470	RD%VS 471J
R346	Carbon film 220	RD%VS 221J
R347	Carbon film 33	RD%VS 330J
R348	Metal oxide 1k 1W	RS1P 102J
R349	Carbon film 33	RD%VS 330J
R350	Metal oxide 1k 1W	RS1P 102J
R351	Carbon film 33	RD%VS 330J
R352	Metal oxide 1k 1W	RS1P 102J
R353	Carbon film 33	RD%VS 330J
R354	Metal oxide 1k 1W	RS1P 102J
R355	Carbon film 100k	RD%VS 104J
R356	Carbon film 100k	RD%VS 104J
R357	Carbon film 100k	RD%VS 104J
R358	Carbon film 100k	RD%VS 104J
R359	Carbon film 18k	RD%VS 183J
R360	Carbon film 18k	RD%VS 183J
R361	Carbon film 18k	RD%VS 183J
R362	Carbon film 18k	RD%VS 183J
VR301	Semi-fixed 15k-B	RCP-023
VR302	Semi-fixed 15k-B	RCP-023
VR303	Semi-fixed 15k-B	RCP-023
VR304	Semi-fixed 15k-B	RCP-023
VR305	Semi-fixed 15k-B	RCP-023
VR306	Semi-fixed 15k-B	RCP-023

CAPACITORS

Symbol	Description	Part No.
C301	Mylar 0.056 50V	CQMA 563K 50
C302	Mylar 0.056 50V	CQMA 563K 50
C303	Mylar 0.056 50V	CQMA 563K 50
C304	Mylar 0.056 50V	CQMA 563K 50
C305	Electrolytic 10 16V	RCH-018
C306	Electrolytic 10 16V	RCH-018
C307	Electrolytic 10 16V	RCH-018
C308	Electrolytic 10 16V	RCH-018
C309	Electrolytic 22 35V	CEA 220P 35
C310	Electrolytic 22 35V	CEA 220P 35
C311	Electrolytic 22 35V	CEA 220P 35
C312	Electrolytic 22 35V	CEA 220P 35
C313	Polystyrene 100p 50V	RCE-003
C314	Polystyrene 100p 50V	RCE-003
C315	Polystyrene 100p 50V	RCE-003
C316	Polystyrene 100p 50V	RCE-003
C317	Electrolytic 10 16V	CEA 100P 16
C318	Electrolytic 10 16V	CEA 100P 16
C319	Electrolytic 10 16V	CEA 100P 16
C320	Electrolytic 10 16V	CEA 100P 16
C321	Polystyrene 220p 50V	RCE-006
C322	Polystyrene 220p 50V	RCE-006
C323	Polystyrene 220p 50V	RCE-006
C324	Polystyrene 220p 50V	RCE-006
C325	Electrolytic 4.7 35V	CEA 4R7P 35
C326	Electrolytic 100 10V	CEA 101P 10
C327	Electrolytic 100 10V	CEA 101P 10
C328	Electrolytic 4.7 35V	CEA 4R7P 35
C329	Electrolytic 4.7 35V	CEA 4R7P 35
C330	Electrolytic 100 10V	CEA 101P 10
C331	Electrolytic 100 10V	CEA 101P 10
C332	Electrolytic 4.7 35V	CEA 4R7P 35
C333	Mylar 0.0033 50V	CQMA 332K 50
C334	Mylar 0.0033 50V	CQMA 332K 50
C335	Mylar 0.0033 50V	CQMA 332K 50
C336	Mylar 0.0033 50V	CQMA 332K 50
C341	Electrolytic 22 35V	CEA 220P 35
C342	Electrolytic 47 63V	CEA 470P 63
C343	Electrolytic 47 63V	CEA 470P 63
C344	Electrolytic 47 63V	CEA 470P 63
C345	Electrolytic 47 63V	CEA 470P 63
C346	Polystyrene 470p 50V	RCE-014
C347	Polystyrene 470p 50V	RCE-014
C348	Polystyrene 470p 50V	RCE-014
C349	Polystyrene 470p 50V	RCE-014
C350	Polystyrene 150p 50V	RCE-007
C351	Polystyrene 150p 50V	RCE-007
C352	Polystyrene 150p 50V	RCE-007
C353	Polystyrene 150p 50V	RCE-007
C354	Polystyrene 150p 50V	RCE-007
C355	Polystyrene 150p 50V	RCE-007
C356	Polystyrene 1000p 50V	RCE-011
C357	Polystyrene 1000p 50V	RCE-011

OTHERS

Symbol	Description	Part No.
RY301	Relay	RSR-019
RY302	Relay	RSR-019
RY303	Relay	RSR-019
RY304	Relay	RSR-019
RY305	Relay	RSR-019
L301	Trap coil	RTF-013
L302	Trap coil	RTF-013
L303	Trap coil	RTF-013
L304	Trap coil	RTF-013
L305	Dummy coil	RTD-009
L306	Dummy coil	RTD-009

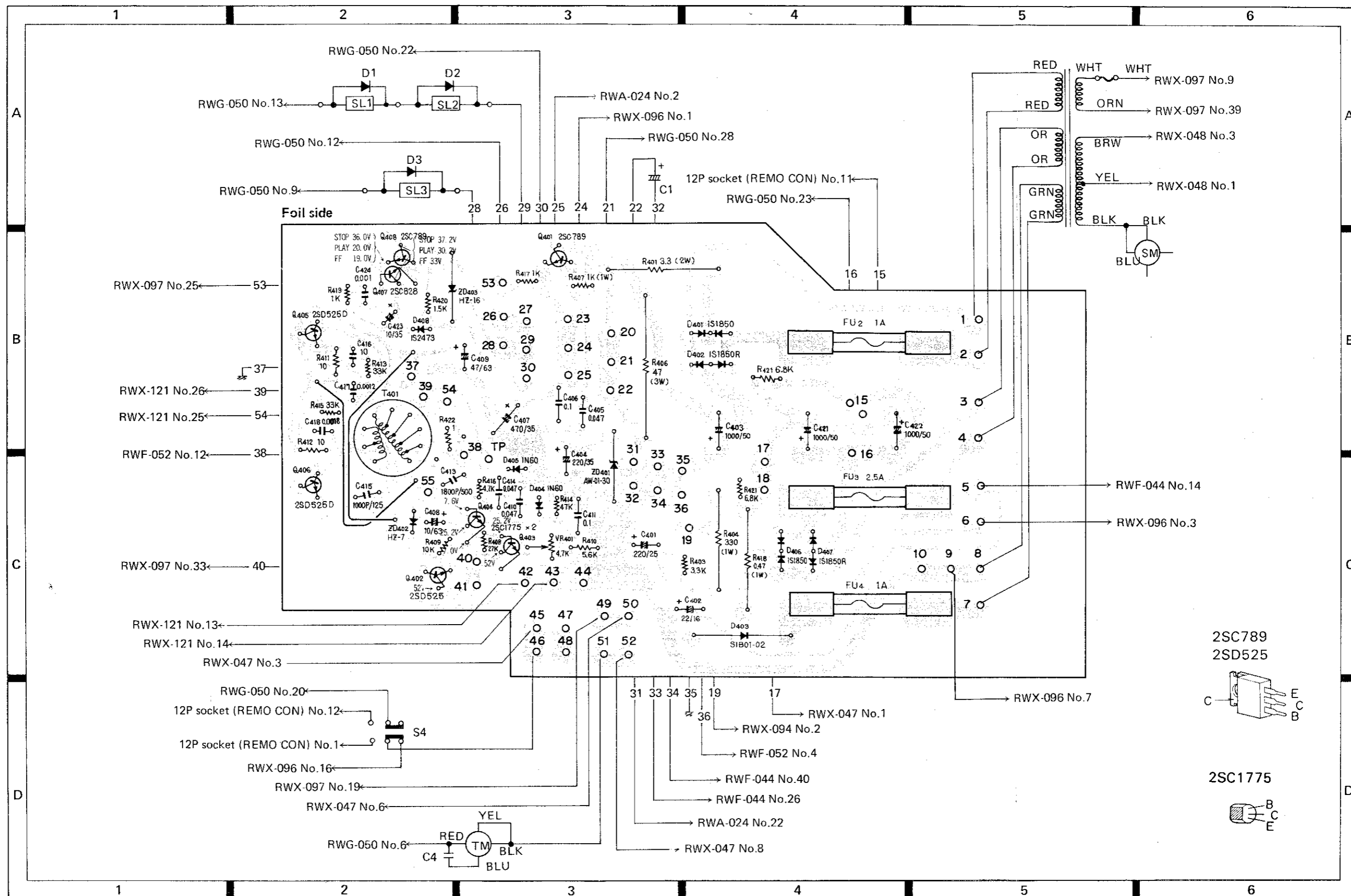

Parts List of Power Supply & O.S.C. Assembly (RWR-031)

SEMICONDUCTORS

Symbol	Description	Part No.
Q401	Transistor	2SC789-0
Q402	Transistor	2SD525-0
Q403	Transistor	2SC1775-E
Q404	Transistor	2SC1775-E
Q405	Transistor	2SD525-0
Q406	Transistor	2SD525-0
Q407	Transistor	2SC828-R
Q408	Transistor	2SC789-0
D401	Diode	1S1850
D402	Diode	1S1850R
D403	Diode	S1B01-02
D404	Diode	1N60
D405	Diode	1N60
D406	Diode	1S1850
D407	Diode	1S1850R
D408	Diode	1S2473VE
ZD401	Zener diode	AW-01-30
ZD402	Zener diode	HZ7-B
ZD403	Zener diode	HZ16

CAPACITORS

Symbol	Description	Part No.
C401	Electrolytic 220 25V	CEA 221P 25
C402	Electrolytic 22 16V	CEA 220P 16
C404	Electrolytic 220 35V	CEA 221P 35
C405	Mylar 0.047 50V	CQMA 473K 50
C406	Mylar 0.1 50V	CQMA 104K 50
C407	Electrolytic 470 35V	CEA 471P 35
C408	Electrolytic 10 63V	CEA 100P 63
C409	Electrolytic 47 63V	CEA 470P 63
C410	Mylar 0.047 50V	CQMA 473K 50
C411	Mylar 0.1 50V	CQMA 104K 50
C413	Polystyrene 1800p 500V	CQSA 182J 500
C414	Mylar 0.047 50V	CQMA 473K 50
C415	Polystyrene 1000p 125V	CQSA 102J 125
C416	Mylar 0.0018 50V	CQMA 182K 50
C417	Mylar 0.0012 50V	CQMA 122K 50
C418	Mylar 0.0018 50V	CQMA 182K 50
C421	Electrolytic 1000 50V	CEA 102P 50
C422	Electrolytic 1000 50V	CEA 102P 50
C423	Electrolytic 10 35V	CEA 100P 35
C424	Mylar 0.001 50V	CQMA 102K 50
C403	Electrolytic 470 63V	CEA 471P 63

RESISTORS

Symbol	Description	Part No.
VR401	Semi-fixed 4.7k-B	C92-051
R401	Metal film 3.3 2W	RN2PSF 3R3K
R403	Carbon film 3.3k	RD%VS 332J
R404	Metal oxide 330 1W	RS1P 331J
R406	Metal oxide 47 3W	RS3PSF 470J
R407	Metal oxide 1k 1W	RS1P 102J
R408	Carbon film 27k	RD%VS 273J
R409	Carbon film 10k	RD%VS 103J
R410	Carbon film 5.2k	RD%VS 562J
R411	Carbon film 10	RD%VS 100J
R412	Carbon film 10	RD%VS 100J
R413	Carbon film 33k	RD%VS 333J
R414	Carbon film 47k	RD%VS 473J
R415	Carbon film 33k	RD%VS 333J
R416	Carbon film 4.7k	RD%VS 472J
R417	Carbon film 1k	RD%VS 102J
R418	Metal film 0.47 1W	RN1PSF R47K
R419	Carbon film 1k	RD%VS 102J
R420	Carbon film 1.5k	RD%VS 152J
R421	Carbon film 6.8k	RD%VS 682J
R422	Carbon film 1	RD%VS 010J

OTHERS

Symbol	Description	Part No.
T401	Spacer	REE-051
	Washer	REE-044
	O.S.C transformer	RTD-011
	Fuse clip	RKR-017
	Fuse 1A	REK-033
	Fuse 2.5A	REK-046

16.13 SELECTOR SWITCH ASSEMBLY (RWX-121)

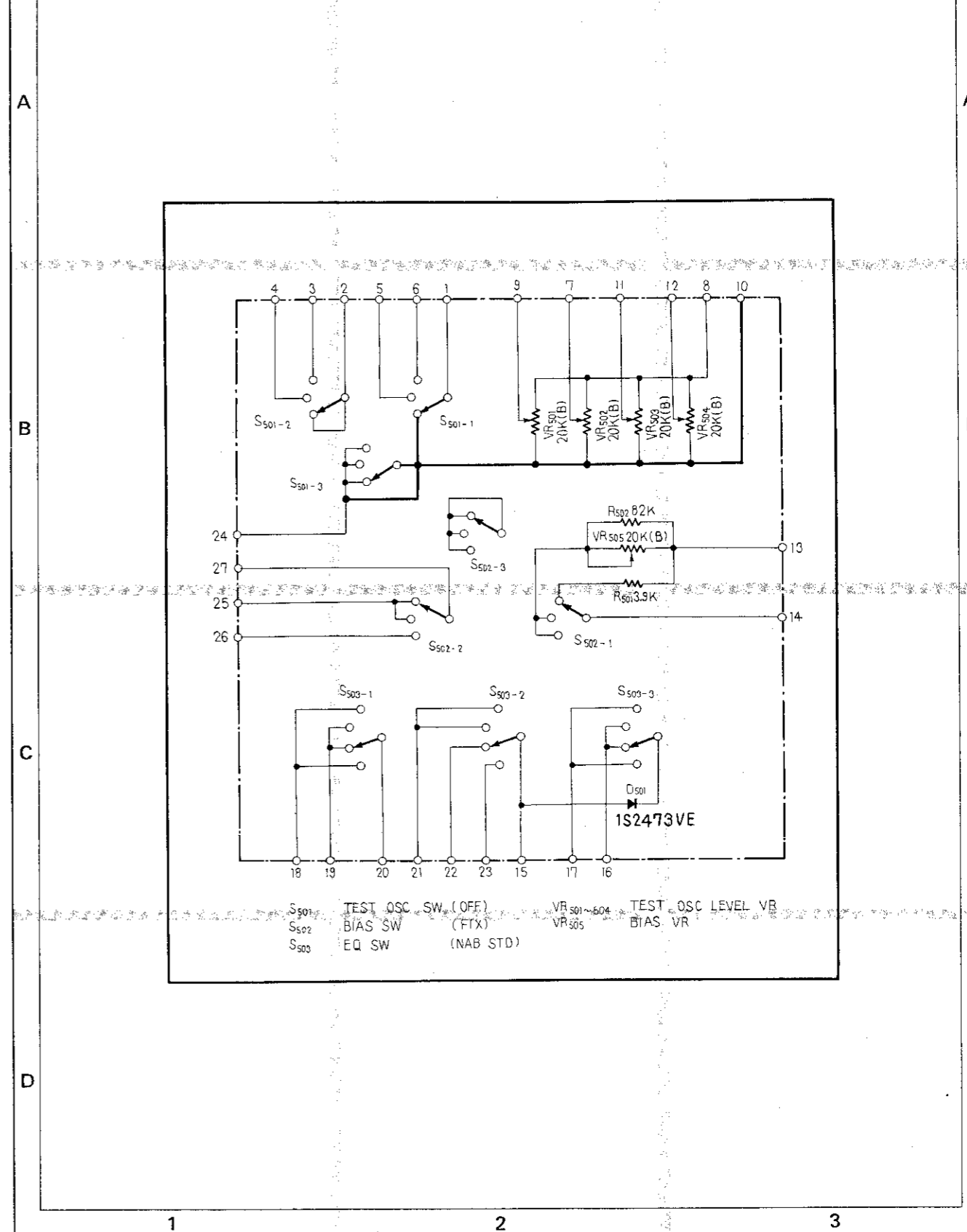

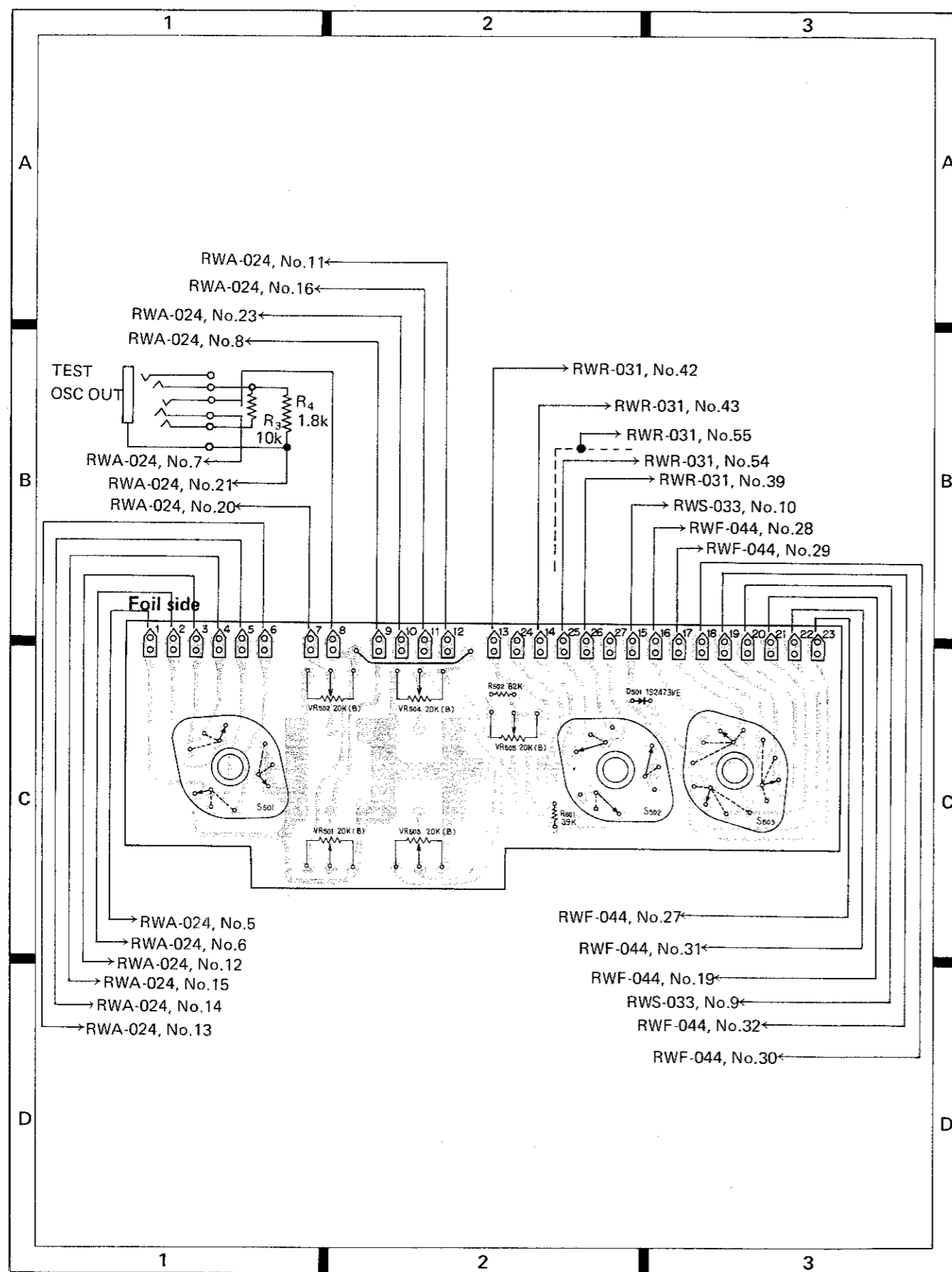

Parts List of Selector Switch Assembly (RWX-121)

SEMICONDUCTORS

Symbol	Description	Part No.
D501	Diode	1S2473VE

OTHERS

Symbol	Description	Part No.
S501	Selector switch (TEST O.S.C)	RSB-012
S502	Selector switch (BIAS)	RSB-012
S503	Selector switch (EQ)	RSB-014
	Sub chassis	RNA-265

RESISTORS

Symbol	Description	Part No.
R501	Carbon film 3.9k	RD½VS 392J
R502	Carbon film 82k	RD½VS 823J
VR501	Variable resistor 20k-B	RCS-009
VR502	Variable resistor 20k-B	RCS-009
VR503	Variable resistor 20k-B	RCS-009
VR504	Variable resistor 20k-B	RCS-009
VR505	Variable resistor 20k-B	RCS-009

CONNECTOR ASSEMBLY A (RWX-096)

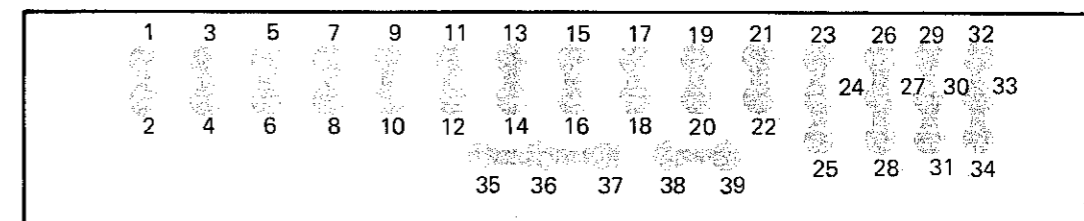

CONNECTOR ASSEMBLY B (RWX-097)

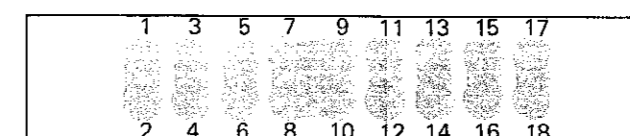

17. TAU-11 SCHEMATIC DIAGRAMS, P.C. BOARD PATTERNS AND PARTS LIST

17.1 SCHEMATIC DIAGRAM

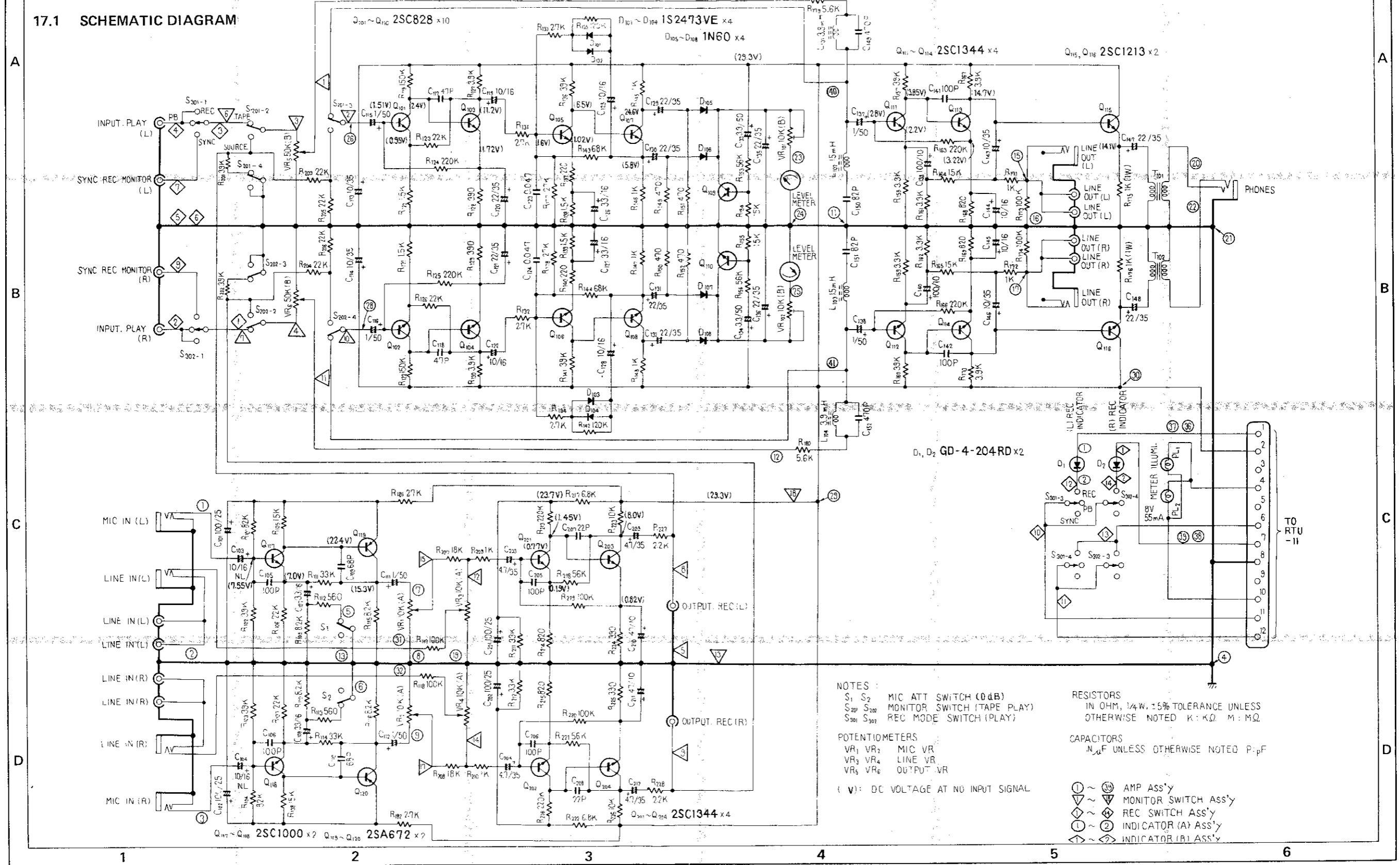

NOTES:
 S₁ S₂ MIC ATT SWITCH (0dB)
 S₂₀₁ S₂₀₂ MONITOR SWITCH (TAPE PLAY)
 S₃₀₁ S₃₀₂ REC MODE SWITCH (PLAY)

POTENTIOMETERS:
 VR₁ VR₂ MIC VR
 VR₃ VR₄ LINE VR
 VR₅ VR₆ OUTPUT VR

(V): DC VOLTAGE AT NO INPUT SIGNAL

RESISTORS
 IN OHM, 1/4W, 5% TOLERANCE UNLESS
 OTHERWISE NOTED K: KΩ M: MΩ

CAPACITORS
 nF UNLESS OTHERWISE NOTED p.pF

① ~ ③④ AMP Ass'y
 ⬇ ~ ⬆ MONITOR SWITCH Ass'y
 ⬇ ~ ⬆ REC SWITCH Ass'y
 Ⓛ ~ Ⓜ INDICATOR (A) Ass'y
 Ⓜ ~ Ⓜ INDICATOR (B) Ass'y

17.2 CONNECTION DIAGRAM

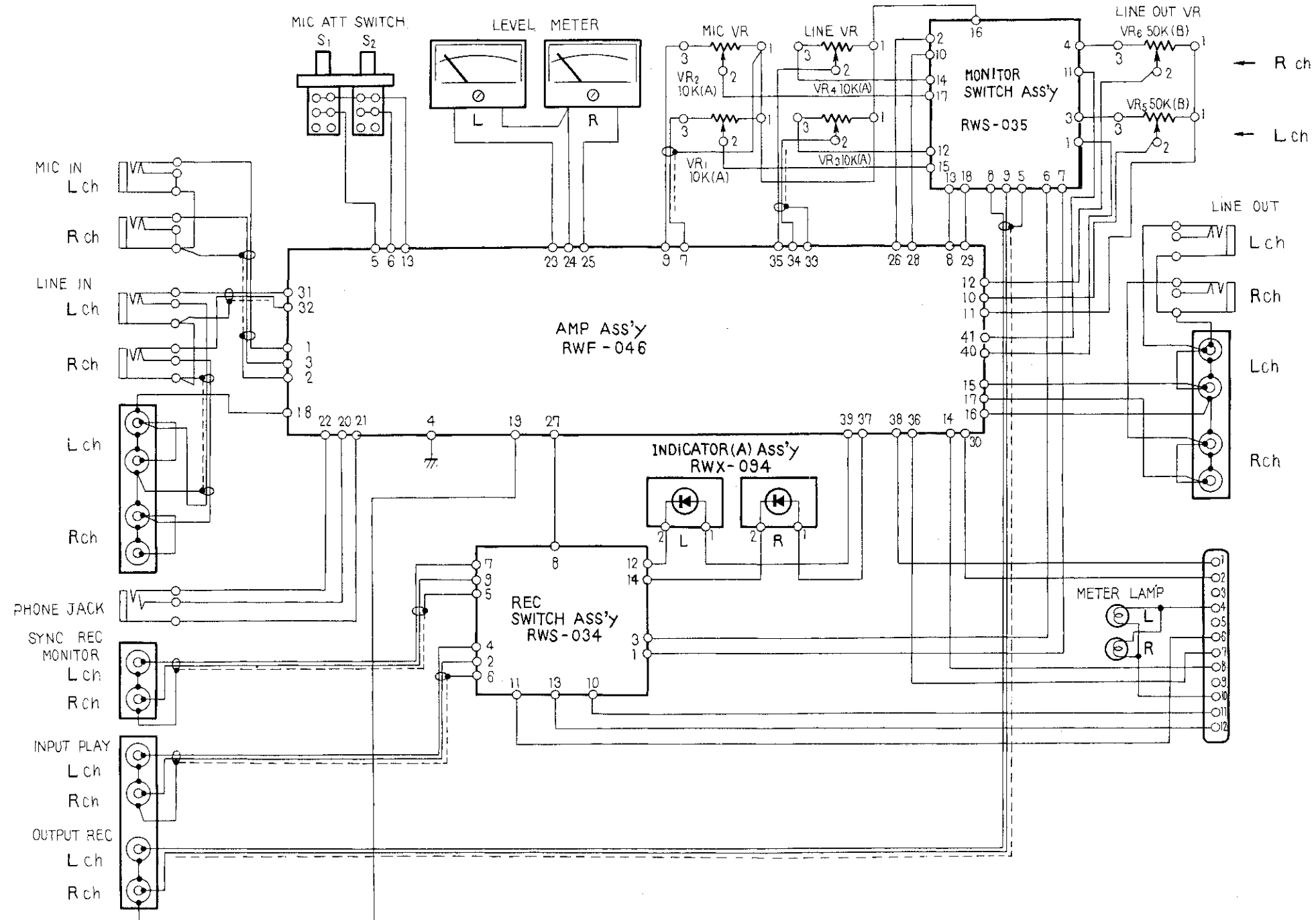

17.3 MISCELLANEOUS PARTS

Symbol	Description	Part No.
VR1	Variable resistor 10k-A (MIC VR)	RCV-024
VR2	Variable resistor 10k-A (MIC VR)	RCV-024
VR3	Variable resistor 10k-A (LINE VR)	RCV-024
VR4	Variable resistor 10k-A (LINE VR)	RCV-024
VR5	Variable resistor 50k-B (LINE OUT)	RCV-023
VR6	Variable resistor 50k-B (LINE OUT)	RCV-023
S1	Push switch (MIC ATT)	RSG-033
S2	Push switch (MIC ATT)	RSG-033
	Level meter	RAW-035
	REC switch assembly	RWS-034
	Amplifier assembly	RWF-046
	Monitor switch assembly	RWS-035
	Indicator assembly	RWX-094

17.4 REC SWITCH ASSEMBLY (RWS-034)

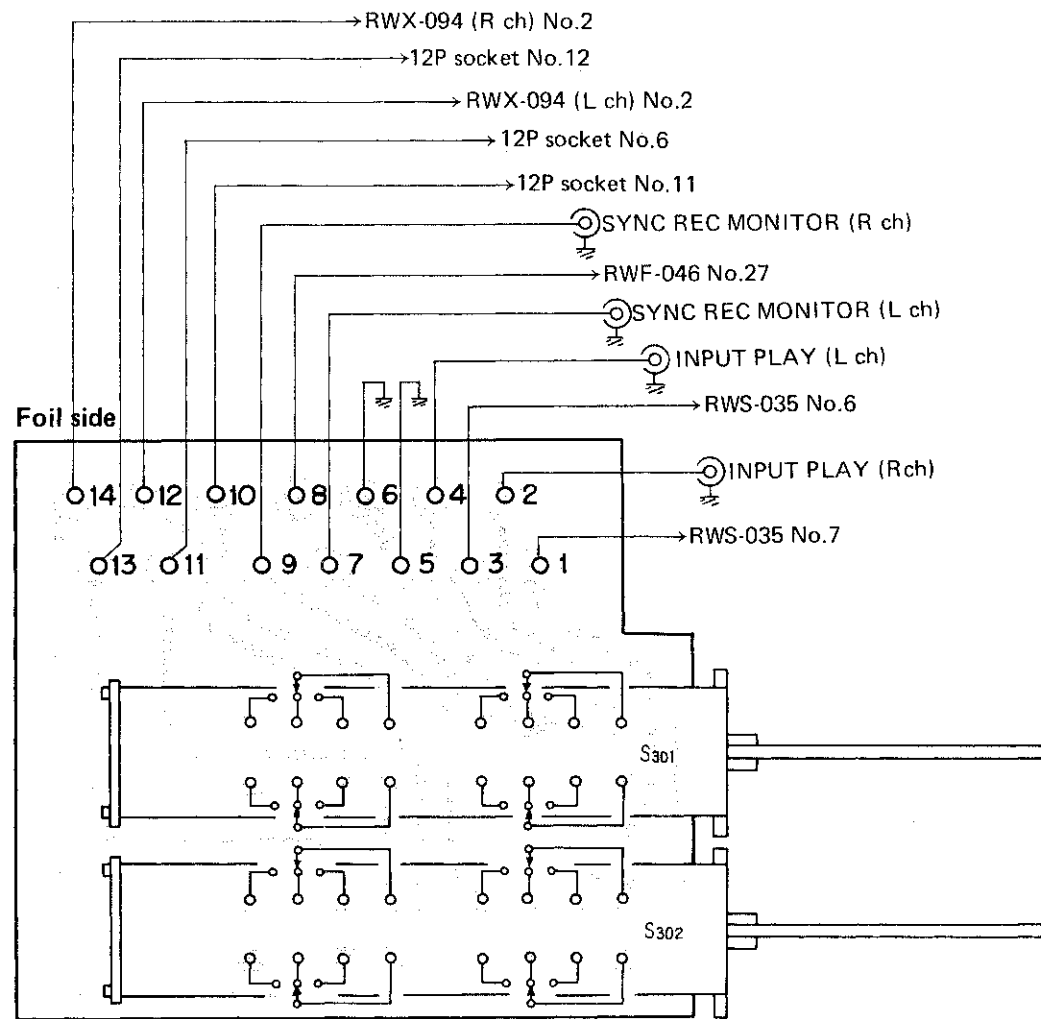

Parts List of REC Switch Assembly (RWS-034)

Symbol	Description	Part No.
	Switch (REC, MODE)	RSK-029

17.5 AMPLIFIER ASSEMBLY (RWF-046)

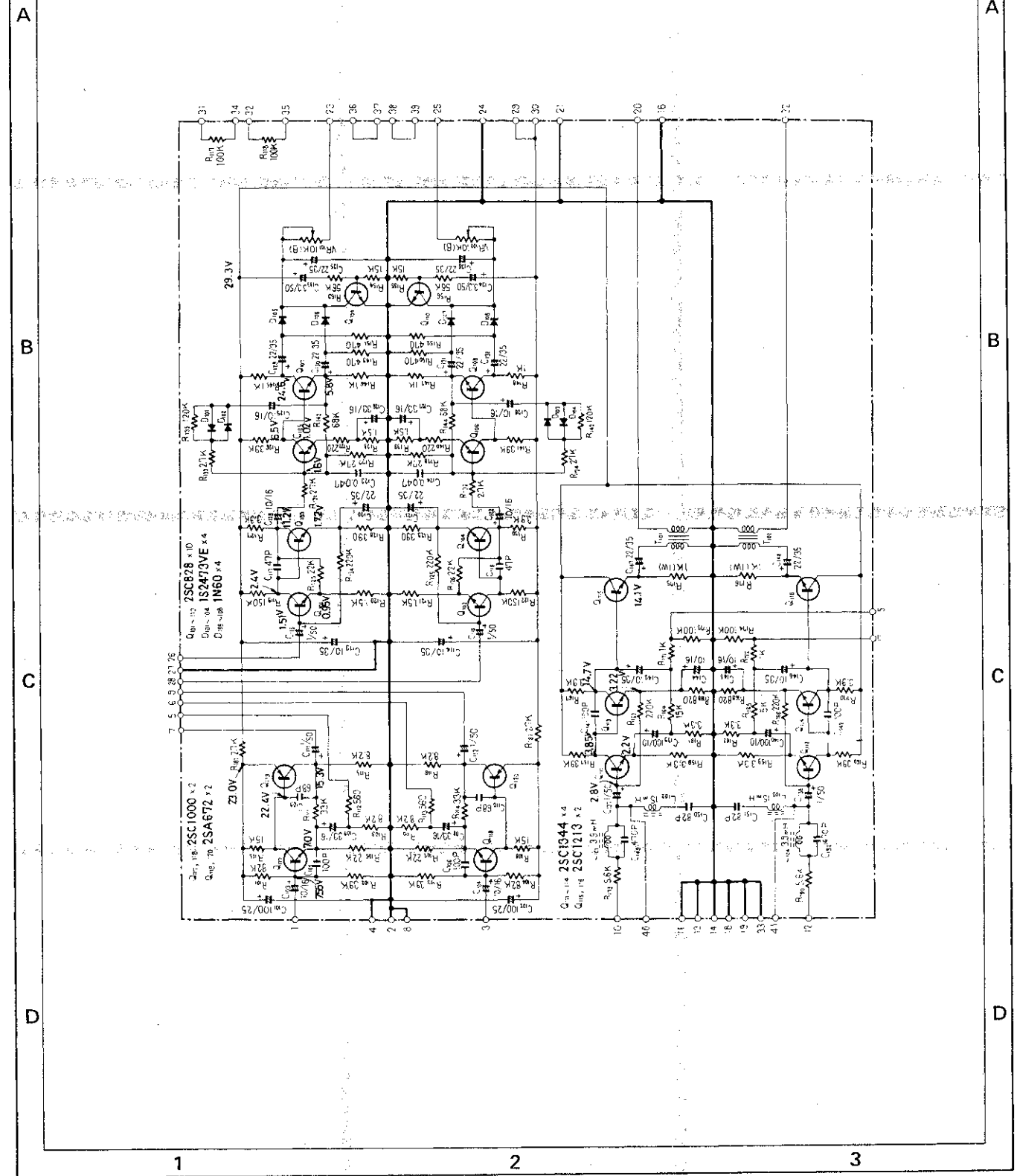

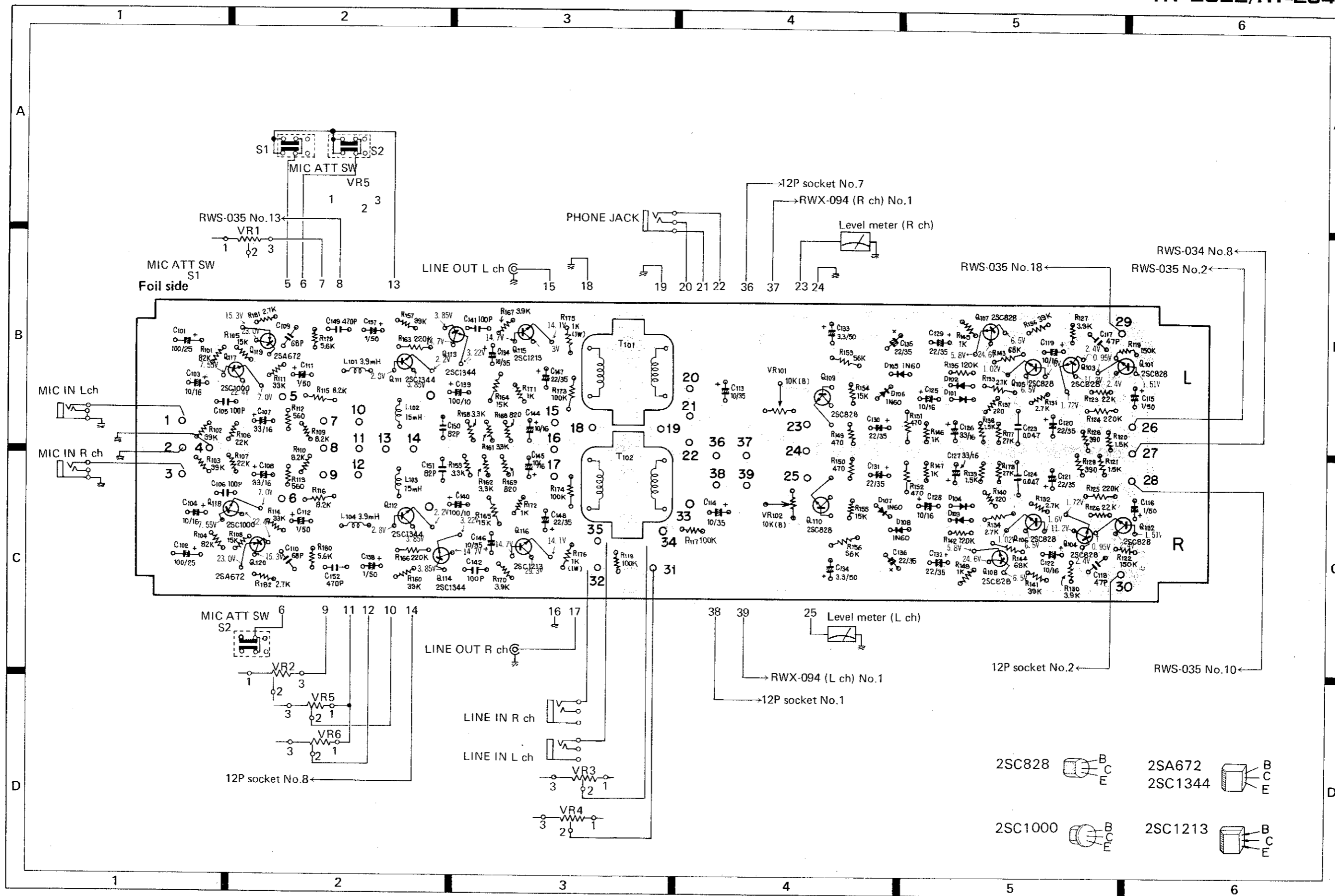

Parts List of Amplifier Assembly (RWF-046)

SEMICONDUCTORS

Symbol	Description	Part No.
Q101	Transistor	2SC828-R
Q102	Transistor	2SC828-R
Q103	Transistor	2SC828-R
Q104	Transistor	2SC828-R
Q105	Transistor	2SC828-R
Q106	Transistor	2SC828-R
Q107	Transistor	2SC828-R
Q108	Transistor	2SC828-R
Q109	Transistor	2SC828-R
Q110	Transistor	2SC828-R
Q111	Transistor	2SC1344-D
Q112	Transistor	2SC1344-D
Q113	Transistor	2SC1344-D
Q114	Transistor	2SC1344-D
Q115	Transistor	2SC1213-B
Q116	Transistor	2SC1213-B
Q117	Transistor	2SC1000-GR
Q118	Transistor	2SC1000-GR
Q119	Transistor	2SA672-B
Q120	Transistor	2SA672-B
D101	Diode	1S2473VE
D102	Diode	1S2473VE
D103	Diode	1S2473VE
D104	Diode	1S2473VE
D105	Diode	1N60
D106	Diode	1N60
D107	Diode	1N60
D108	Diode	1N60

RESISTOR

Symbol	Description	Part No.
VR101	Semi-fixed 10k-B	C92-049
VR102	Semi-fixed 10k-B	C92-049
R101	Carbon film 82k	RD%VS 823J
R102	Carbon film 39k	RD%VS 393J
R103	Carbon film 39k	RD%VS 393J
R104	Carbon film 82k	RD%VS 823J
R105	Carbon film 15k	RD%VS 153J
R106	Carbon film 22k	RD%VS 223J
R107	Carbon film 22k	RD%VS 223J
R108	Carbon film 15k	RD%VS 153J
R109	Carbon film 8.2k	RD%VS 822J
R110	Carbon film 8.2k	RD%VS 822J
R111	Carbon film 33k	RD%VS 333J
R112	Carbon film 560	RD%VS 561J
R113	Carbon film 560	RD%VS 561J

Symbol	Description	Part No.
R114	Carbon film 33k	RD%VS 333J
R115	Carbon film 8.2k	RD%VS 822J
R116	Carbon film 8.2k	RD%VS 822J
R117	Carbon film 100k	RD%VS 104J
R118	Carbon film 100k	RD%VS 104J
R119	Carbon film 150k	RD%VS 154J
R120	Carbon film 1.5k	RD%VS 152J
R121	Carbon film 1.5k	RD%VS 152J
R122	Carbon film 150k	RD%VS 154J
R123	Carbon film 22k	RD%VS 223J
R124	Carbon film 220k	RD%VS 224J
R125	Carbon film 220k	RD%VS 224J
R126	Carbon film 22k	RD%VS 223J
R127	Carbon film 3.9k	RD%VS 392J
R128	Carbon film 390	RD%VS 391J
R129	Carbon film 390	RD%VS 391J
R130	Carbon film 3.9k	RD%VS 392J
R131	Carbon film 2.7k	RD%VS 272J
R132	Carbon film 2.7k	RD%VS 272J
R133	Carbon film 2.7k	RD%VS 272J
R134	Carbon film 2.7k	RD%VS 272J
R135	Carbon film 120k	RD%VS 124J
R136	Carbon film 39k	RD%VS 393J
R137	Carbon film 220	RD%VS 221J
R138	Carbon film 1.5k	RD%VS 152J
R139	Carbon film 1.5k	RD%VS 152J
R140	Carbon film 220	RD%VS 221J
R141	Carbon film 39k	RD%VS 393J
R142	Carbon film 120k	RD%VS 124J
R143	Carbon film 68k	RD%VS 683J
R144	Carbon film 68k	RD%VS 683J
R145	Carbon film 1.0k	RD%VS 102J
R146	Carbon film 1.0k	RD%VS 102J
R147	Carbon film 1.0k	RD%VS 102J
R148	Carbon film 1.0k	RD%VS 102J
R149	Carbon film 470	RD%VS 471J
R150	Carbon film 470	RD%VS 471J
R151	Carbon film 470	RD%VS 471J
R152	Carbon film 470	RD%VS 471J
R153	Carbon film 56k	RD%VS 563J
R154	Carbon film 15k	RD%VS 153J
R155	Carbon film 15k	RD%VS 153J
R156	Carbon film 56k	RD%VS 563J
R157	Carbon film 39k	RD%VS 393J
R158	Carbon film 3.3k	RD%VS 332J
R159	Carbon film 3.3k	RD%VS 332J
R160	Carbon film 39k	RD%VS 393J

Symbol	Description	Part No.
R161	Carbon film 3.3k	RD%VS 332J
R162	Carbon film 3.3k	RD%VS 332J
R163	Carbon film 220k	RD%VS 224J
R164	Carbon film 15k	RD%VS 153J
R165	Carbon film 15k	RD%VS 153J
R166	Carbon film 220k	RD%VS 224J
R167	Carbon film 3.9k	RD%VS 392J
R168	Carbon film 820	RD%VS 821J
R169	Carbon film 820	RD%VS 821J
R170	Carbon film 3.9k	RD%VS 392J
R171	Carbon film 1.0k	RD%VS 102J
R172	Carbon film 1.0k	RD%VS 102J
R173	Carbon film 100k	RD%VS 104J
R174	Carbon film 100k	RD%VS 104J
R175	Metal oxide 1k 1W	RS1P 102J
R176	Metal oxide 1k 1W	RS1P 102J
R177	Carbon film 27k	RD%VS 273J
R178	Carbon film 27k	RD%VS 273J
R179	Carbon film 5.6k	RD%VS 562J
R180	Carbon film 5.6k	RD%VS 562J
R181	Carbon film 2.7k	RD%VS 272J
R182	Carbon film 2.7k	RD%VS 272J

CAPACITOR

Symbol	Description	Part No.
C101	Electrolytic 100 25V	CEA 101P 25
C102	Electrolytic 100 25V	CEA 101P 25
C103	Electrolytic 10 16V	RCH-018
C104	Electrolytic 10 16V	RCH-018
C105	Polystyrene 100p 50V	RCE-003
C106	Polystyrene 100p 50V	RCE-003
C107	Electrolytic 33 16V	CEA 330P 16
C108	Electrolytic 33 16V	CEA 330P 16
C109	Polystyrene 68p 50V	RCE-023
C110	Polystyrene 68p 50V	RCE-023
C111	Electrolytic 1 50V	CEA 010P 50
C112	Electrolytic 1 50V	CEA 010P 50
C113	Electrolytic 10 35V	CEA 100P 35
C114	Electrolytic 10 35V	CEA 100P 35
C115	Electrolytic 1 50V	CEA 010P 50
C116	Electrolytic 1 50V	CEA 010P 50
C117	Polystyrene 47p 50V	RCE-012
C118	Polystyrene 47p 50V	RCE-012
C119	Electrolytic 10 16V	CEA 100P 16
C120	Electrolytic 22 35V	CEA 220P 35
C121	Electrolytic 22 35V	CEA 220P 35
C122	Electrolytic 10 16V	CEA 100P 16
C123	Mylar 0.047 50V	CQMA 473K 50
C124	Mylar 0.047 50V	CQMA 473K 50
C125	Electrolytic 10 16V	CEA 100P 16

Symbol	Description	Part No.
C126	Electrolytic 33 16V	CEA 330P 16
C127	Electrolytic 33 16V	CEA 330P 16
C128	Electrolytic 10 16V	CEA 100P 16
C129	Electrolytic 22 35V	CEA 220P 35
C130	Electrolytic 22 35V	CEA 220P 35
C131	Electrolytic 22 35V	CEA 220P 35
C132	Electrolytic 22 35V	CEA 220P 35
C133	Electrolytic 3.3 50V	CEA 3R3P 50
C134	Electrolytic 3.3 50V	CEA 3R3P 50
C135	Electrolytic 22 35V	CEA 220P 35
C136	Electrolytic 22 35V	CEA 220P 35
C137	Electrolytic 1 50V	CEA 010P 50
C138	Electrolytic 1 50V	CEA 010P 50
C139	Electrolytic 100 10V	CEA 101P 10
C140	Electrolytic 100 10V	CEA 101P 10
C141	Polystyrene 100p 50V	RCE-003
C142	Polystyrene 100p 50V	RCE-003
C144	Electrolytic 10 16V	CEA 100P 16
C145	Electrolytic 10 16V	CEA 100P 16
C146	Electrolytic 10 35V	CEA 100P 35
C147	Electrolytic 22 35V	CEA 220P 35
C148	Electrolytic 22 35V	CEA 220P 35
C149	Polystyrene 470p 50V	RCE-014
C150	Polystyrene 82p 50V	RCE-024
C151	Polystyrene 82p 50V	RCE-024
C152	Polystyrene 470p 50V	RCE-014
C143	Electrolytic 10 35V	CEA 100P 35

OTHERS

Symbol	Description	Part No.
T101	Matching transformer	RTV-005
T102	Matching transformer	RTV-005
L101	Trap coil	RTF-015
L102	Trap coil	RTF-016
L103	Trap coil	RTF-016
L104	Trap coil	RTF-015

17.6 MONITOR SWITCH ASSEMBLY (RWS-035)

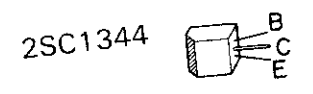
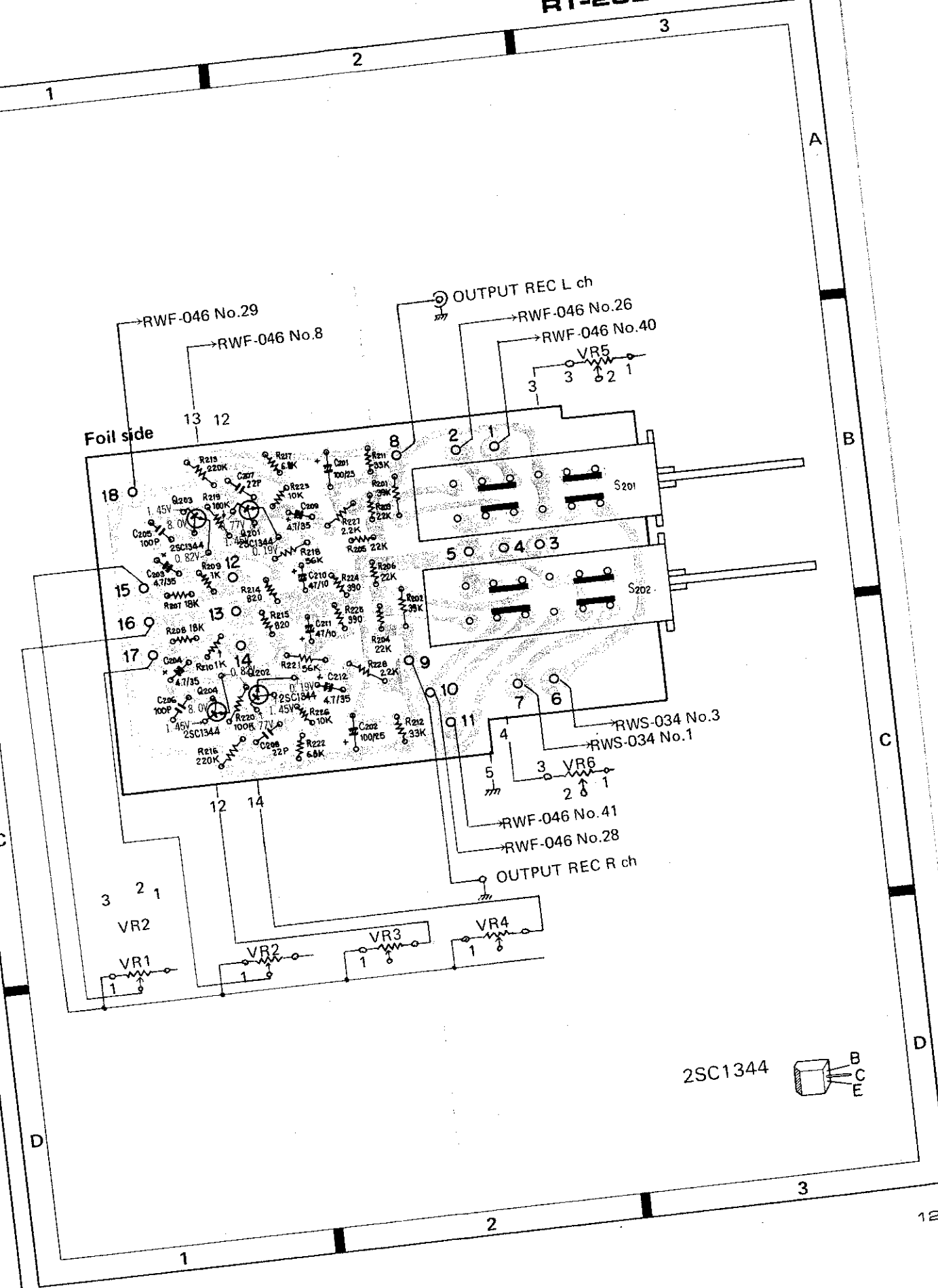
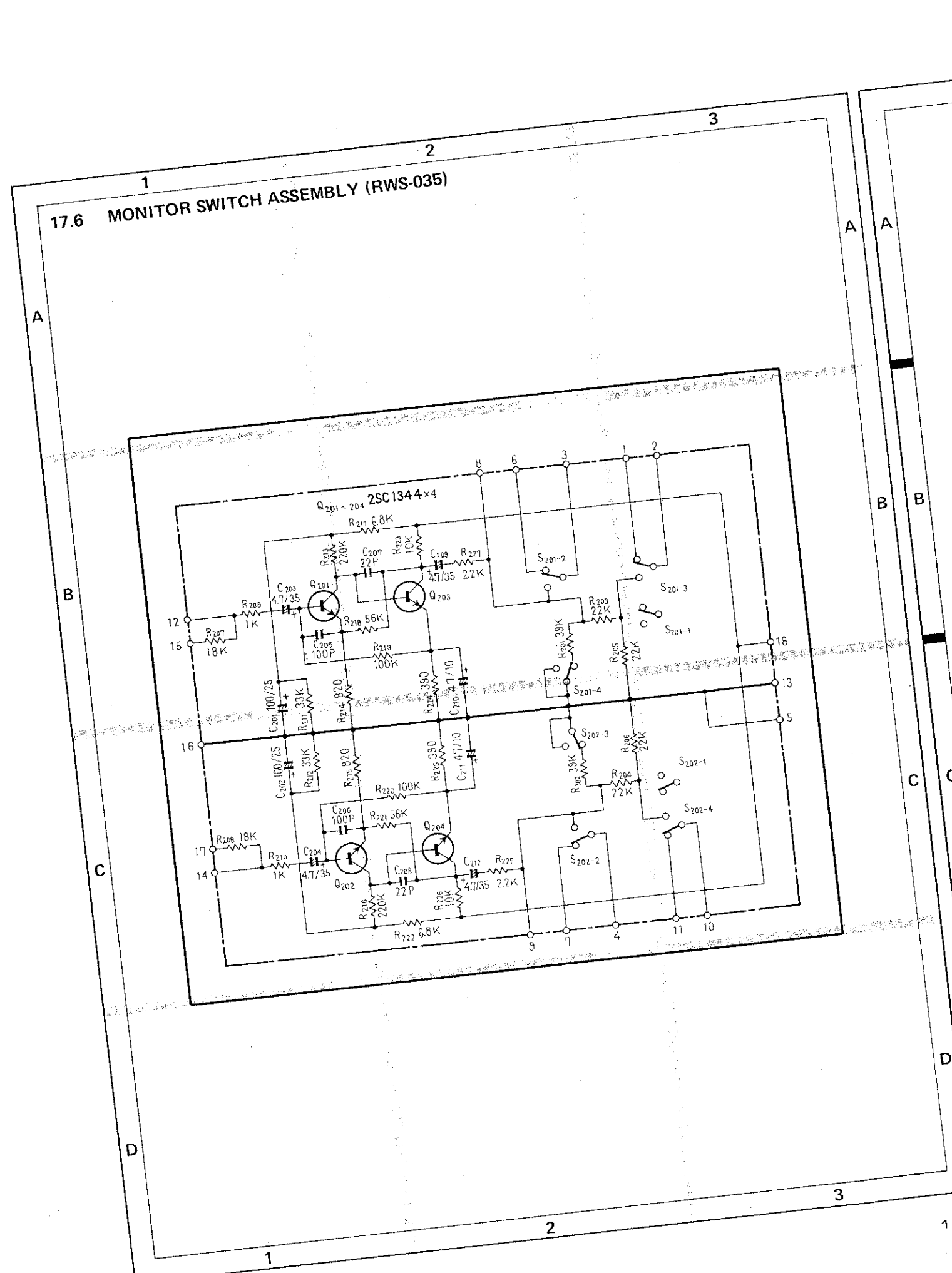

Parts List of Monitor Switch Assembly (RWS-035)

SEMICONDUCTORS

Symbol	Description	Part No.
Q201	Transistor	2SC1344-D
Q202	Transistor	2SC1344-D
Q203	Transistor	2SC1344-D
Q204	Transistor	2SC1344-D

Symbol	Description	Part No.
C209	Electrolytic 4.7 35V	CEA 4R7P 35
C210	Electrolytic 47 10V	CEA 470P 10
C211	Electrolytic 47 10V	CEA 470P 10
C212	Electrolytic 4.7 35V	CEA 4R7P 35

RESISTORS

Symbol	Description	Part No.
R201	Carbon film 39k	RD%VS 393J
R202	Carbon film 39k	RD%VS 393J
R203	Carbon film 22k	RD%VS 223J
R204	Carbon film 22k	RD%VS 223J
R205	Carbon film 22k	RD%VS 223J
R206	Carbon film 22k	RD%VS 223J
R207	Carbon film 18k	RD%VS 183J
R208	Carbon film 18k	RD%VS 183J
R209	Carbon film 1k	RD%VS 102J
R210	Carbon film 1k	RD%VS 102J
R211	Carbon film 33k	RD%VS 333J
R212	Carbon film 33k	RD%VS 333J
R213	Carbon film 220k	RD%VS 224J
R214	Carbon film 820	RD%VS 821J
R215	Carbon film 820	RD%VS 821J
R216	Carbon film 220k	RD%VS 224J
R217	Carbon film 6.8k	RD%VS 682J
R218	Carbon film 56k	RD%VS 563J
R219	Carbon film 100k	RD%VS 104J
R220	Carbon film 100k	RD%VS 104J
R221	Carbon film 56k	RD%VS 563J
R222	Carbon film 6.8k	RD%VS 682J
R223	Carbon film 10k	RD%VS 103J
R224	Carbon film 390	RD%VS 391J
R225	Carbon film 390	RD%VS 391J
R226	Carbon film 10k	RD%VS 103J
R227	Carbon film 2.2k	RD%VS 222J
R228	Carbon film 2.2k	RD%VS 222J

OTHERS

Symbol	Description	Part No.
	Switch (MONITOR)	RSK-030

CAPACITORS

Symbol	Description	Part No.
C201	Electrolytic 100 25V	CEA 101P 25
C202	Electrolytic 100 25V	CEA 101P 25
C203	Electrolytic 4.7 35V	CEA 4R7P 35
C204	Electrolytic 4.7 35V	CEA 4R7P 35
C205	Polystyrene 100p 50V	RCE-003
C206	Polystyrene 100p 50V	RCE-003
C207	Polystyrene 22p 50V	RCE-019
C208	Polystyrene 22p 50V	RCE-019

17.7 INDICATOR (A) ASSEMBLY (RWX-094)

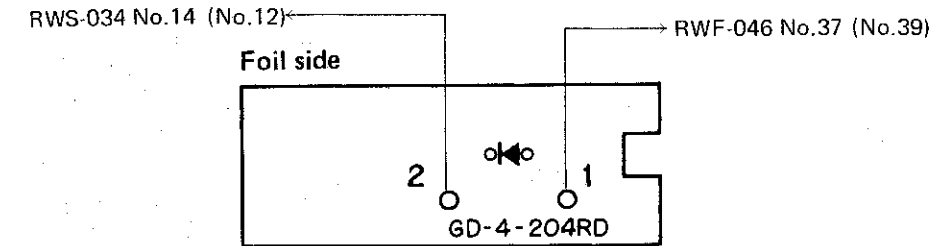

Parts List of Indicator (A) Assembly (RWX-094)

Symbol	Description	Part No.
	Light emitting diode	GD-4-204RD

18. JT-211 SCHEMATIC DIAGRAMS, P.C. BOARD PATTERNS AND PARTS LIST

18.1 SCHEMATIC DIAGRAM

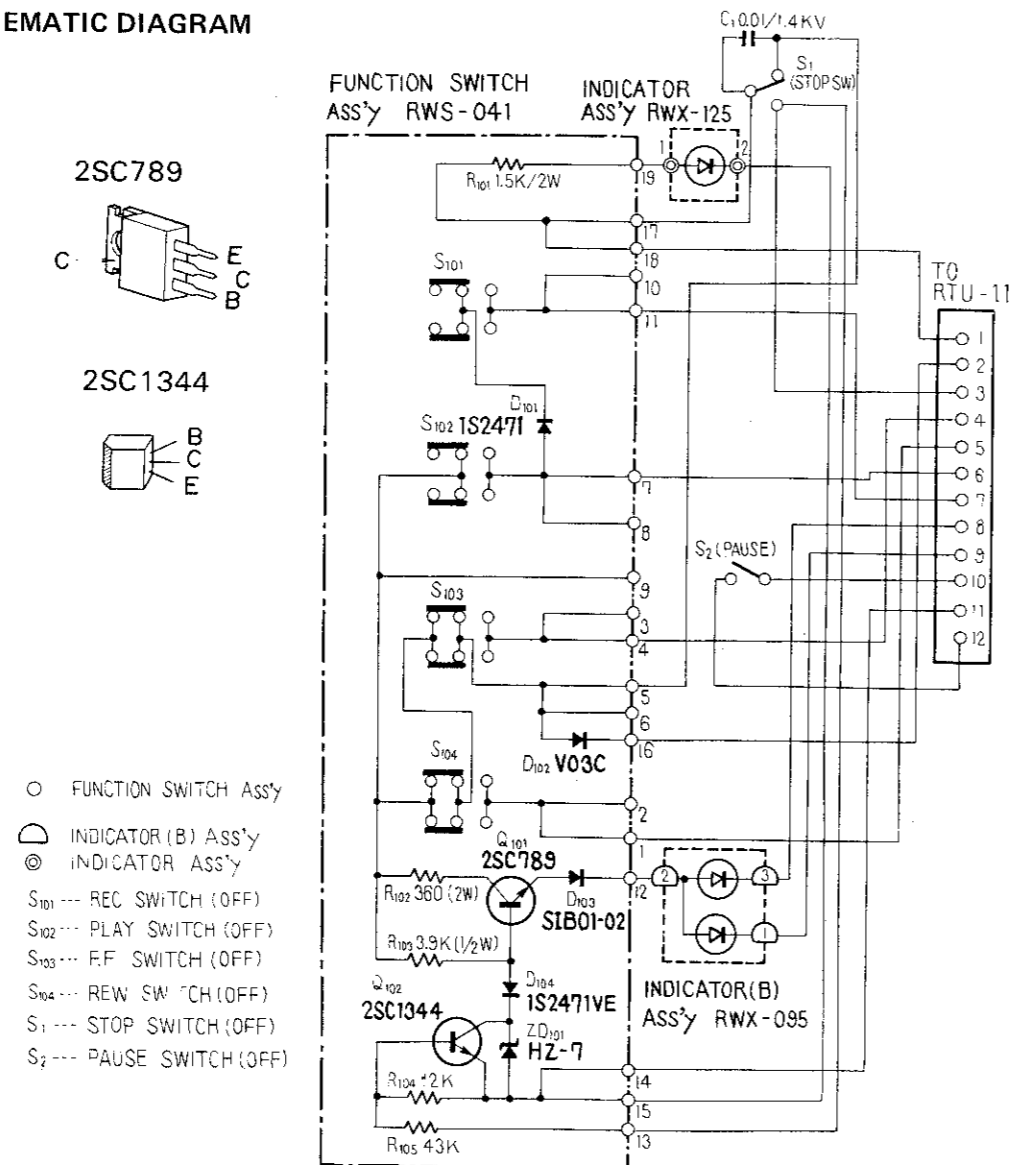

18.2 MISCELLANEOUS PARTS

Symbol	Description	Part No.
	Function switch assembly	RWS-041
	Indicator assembly	RWX-125
	Indicator B assembly	RWX-095
	Wire crip	RNE-941
	Capacitor cover (A) C1	REC-150
	C1 Ceramic 0.01 1.4kV	C43-003
	S1 Microswitch (STOP)	RSF-018
	S2 Microswitch (PAUSE)	RSF-018

18.3 FUNCTION SWITCH ASSEMBLY (RWS-041)

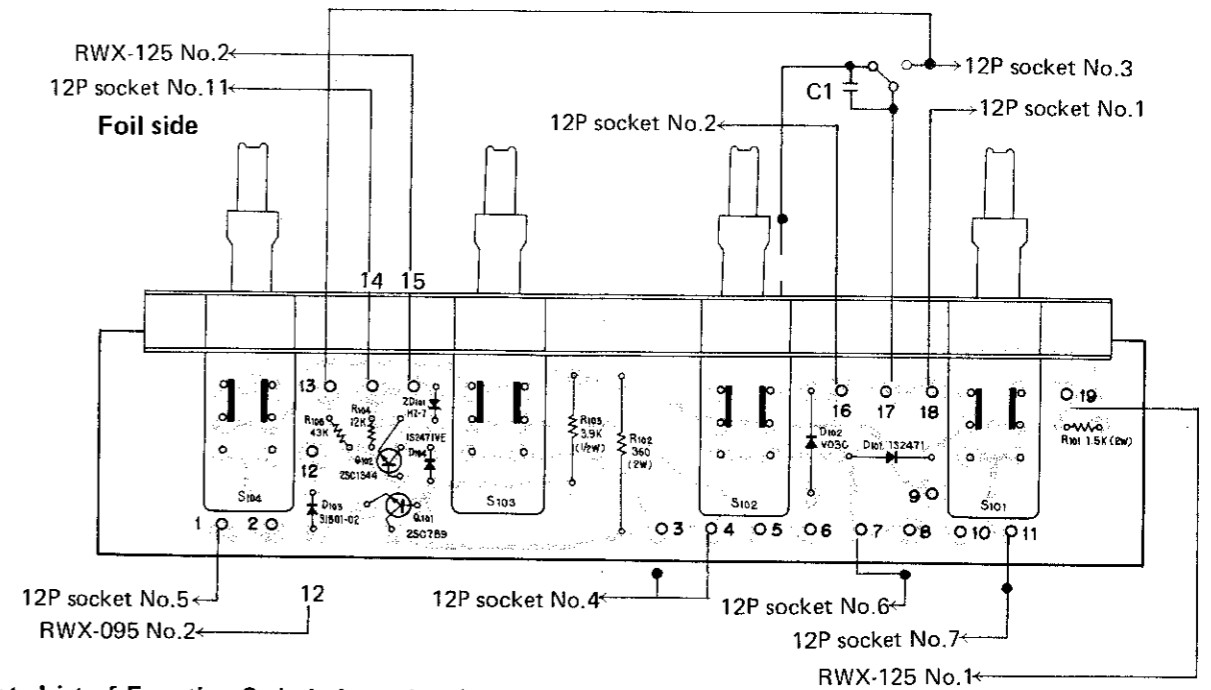

Parts List of Function Switch Assembly (RWS-041)

SEMICONDUCTORS

Symbol	Description	Part No.
D101	Diode	1S2471
D102	Diode	V03C
D103	Diode	S1B01-02
D104	Diode	1S2471VE
ZD101	Zener diode	HZ7-B
Q101	Transistor	2SC789-0
Q102	Transistor	2SC1344-D

RESISTORS

Symbol	Description	Part No.
R101	Metal oxide 1.5k 2W	RS2P 152J
R102	Metal oxide 360 2W	RS2P 361J
R103	Carbon film 3.9k 1/2W	RD1/2PS 392J
R104	Carbon film 12k	RD1/2VS 123J
R105	Carbon film 43k	RD1/2VS 433J

18.4 INDICATOR (B) ASSEMBLY (RWX-095)

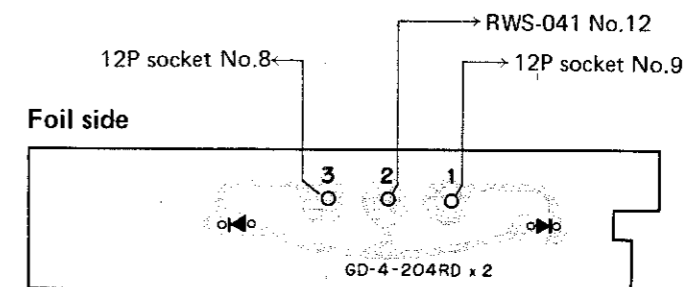

Parts List of Indicator (B) Assembly (RWX-095)

Symbol	Description	Part No.
	Light emitting diode	GD-4-204RD
	Light emitting diode	GD-4-204GD

19. MECHANICAL ADJUSTMENTS

- Be sure to perform adjustments in specified operating modes (horizontal or vertical).

19.1 REEL HUB HEIGHT (Fig. 6)

This adjustment is required when reel hub height is unsuitable, or after replacing supply or take-up motor. Perform with side panels removed. Steps are the same for both supply and take-up reel hubs.

1. Set tape deck for horizontal operation.
2. Check for secure mounting of mechanical panel and chassis.
3. Loosen Allen set screws and adjust for 2 mm spacing between panel and reel hub.
4. After adjusting, tighten screw firmly (to more than 10 kg.cm torque).

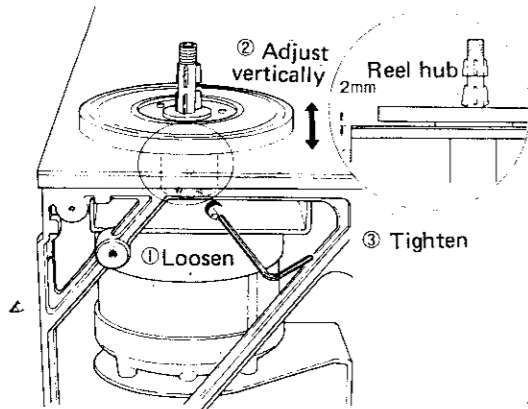

Fig. 6

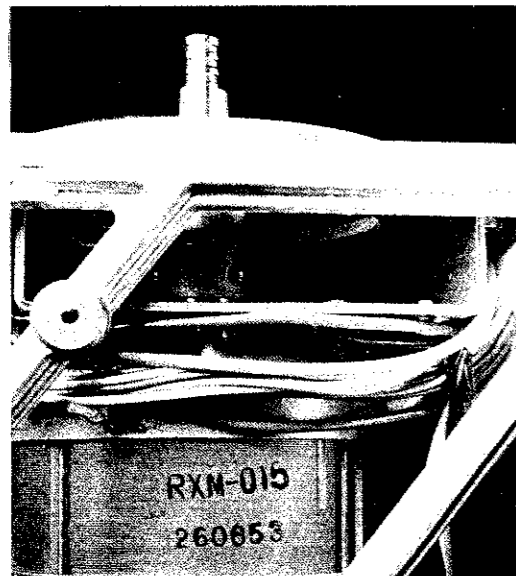

Photo 1

19.2 BRAKE

This adjustment is required when tape slackens while breaking, or when solenoids or motors are replaced. Set deck for vertical operation and check the following points before adjusting.

1. When solenoid is not pulled in (brake applied) dimension A in photo 3 is 4 mm.
2. Press solenoid shaft to release brake and confirm that motor can be turned smoothly by hand.

• Adjustment Steps (Figs. 7 & 8)

1. In order to standardize test conditions, operate reel hub to be tested at fast forward (or rewind) for about 2 seconds, then press the STOP button to stop rotation.
2. Install 7-in. reel wound with string in counter-clockwise direction for supply hub or clockwise direction for the take-up hub for fast forward.
3. With tension gauge pull perpendicularly in direction B for supply hub or C for left hub and read value when reel hub starts turning.
4. Adjust brake spring anchor point so that tension gauge reads 300 to 450 g (torque = 900–1350 g.cm). Lower brake torque is desirable, provided that the following Post Adjustment Checks are satisfied.
5. If specified value is not obtained by changing spring anchor point in adjusting hole, check the following points.

- Brake drum contamination
- Brake felt contamination
- Brake guide out of position
- Brake drum operation not smooth

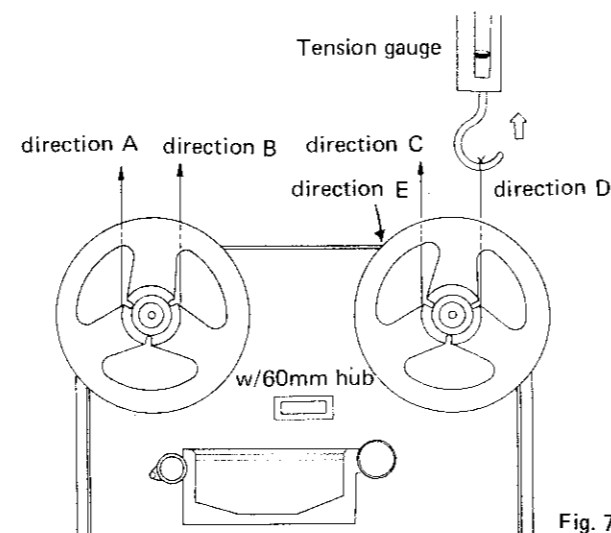

Fig. 7

6. Confirm that values obtained when tension gauge is pulled in direction D (A) and direction B (C) have the following relationship.

$$\begin{aligned} & \text{B (C) Direction} \\ & \text{D (A) Direction} = 2.3 \text{ to } 3.7 \end{aligned}$$

• Post Adjustment Checks

1. Install 10-in. tape reel on the supply reel hub.
2. Operate fast forward (or rewind) and when tape diameter on take-up reel becomes 10 to 40 mm larger than that on the supply reel, press the PLAY button. Confirm that tape comes to a full stop before playback begins.
3. If this is not fulfilled, readjust.

NOTE:

Step 2 condition may not be obtained if capacitance of C809 and C812 is insufficient.

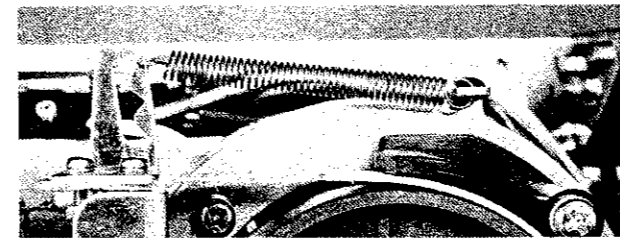

Photo 2

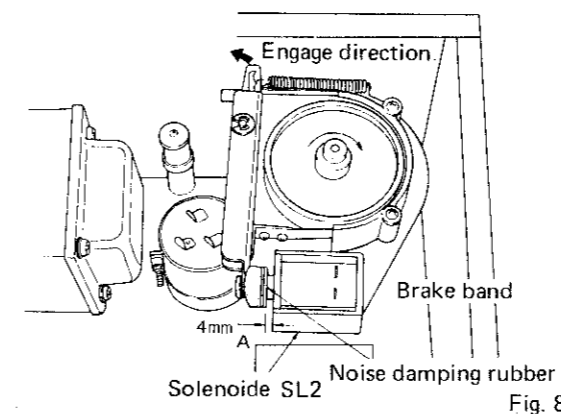

Fig. 8

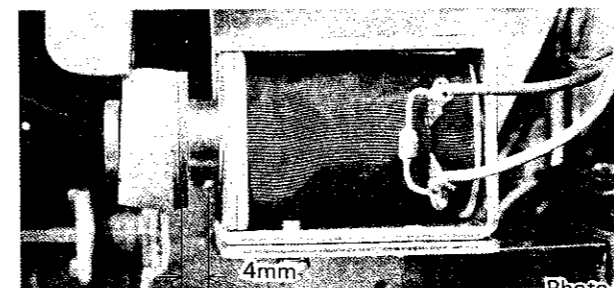

Photo 3

19.3 TAKE-UP TORQUE AND BACK TENSION

• Back Tension Torque During Playback

1. Set tension selector switch to 10-in. reel position (switch not depressed).
2. With tape deck vertical, perform 19 cm/s playback and measure back tension of supply reel hub (pull in direction B of Fig. 7).

NOTE:

Shut off switch must be vertical in order to activate playback.

3. So that this value becomes 93 – 110g (280 – 330 g.cm), adjust slider of R1 2.2k ohms (R1-2). Refer to Fig. 9.
4. Set tension selector switch to 7-in reel position (switch depressed) and measure back tension as in Step 2.
5. So that this value becomes 63 – 77 g (190 – 230 g.cm), adjust slider of R2 350 ohms (R2-1).
6. After adjusting resistors, tighten slider screws firmly.

• Take-Up Torque During Playback

1. Set tension selector switch to 10-in reel position.
2. With deck in vertical position, perform 19cm/s playback and measure take-up reel torque (transmitted during take-up in direction E of Fig. 7).
3. So that this value becomes 190 – 210 g (570 – 630 g.cm) adjust slider of R2 350 ohms (R2-2) (Fig. 9).

• Fast Forward Back Tension Torque

1. With deck vertical, measure supply reel back tension (direction B of Fig. 7) during fast forward.
2. So that this value becomes 35 – 45 g (105 – 135 g.cm) adjust slider of R1 2.2 k ohms (R 1-1) (Fig. 9).

NOTE:

Since rewind back tension also employs R1, it becomes automatically set when FF back tension adjustment has been completed.

FF back tension adjust (R1-1)

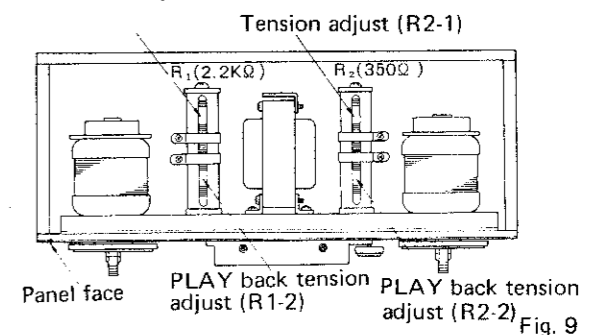

Fig. 9

20. HEAD ADJUSTMENTS(JT-2022T & JT-2044T)

20.1 COARSE ADJUSTMENTS

Run tape and turn adjusting screws to adjust each head as indicated in Fig. 17, 18.

Head	Adjusting Locations				
Playback	1	2	3	4	5
Record	6	7	8	9	10
Erase	11	12	13	14	

Screws 4-5, 9-10, 13-14 are for fine adjustments.

20.2 HEIGHT ADJUSTMENTS

Adjust each head core end and tape space to dimensions indicated in Fig. 20. Numbers in parentheses indicate JT-2044T

Head	Adjustment Locations		
Playback	1	2	3
Record	6	7	8
Erase	13	14	(see note 1)

NOTE 1:

If erase head height cannot be adjusted to Fig. 19 dimensions, loosen screws 13 and 14 and employ spacer to adjust.

- Spacer A: 0.1t (Part No. RNE-863)
- Spacer B: 0.2t (Part No. RNE-864)
- Spacer C: 0.3t (Part No. RNE-865)

20.3 TILT ADJUSTMENTS (RECORD & PLAY HEADS)

Adjust for parallelism between tape guide (at 90° angle with respect to head base) and head surface (Fig. 21).

Play	1	2	3
Record	6	7	8

20.4 AZIMUTH ADJUSTMENTS (RECORD & PLAY HEADS)

Adjust for 90° between tape head gap and tape (Fig. 22).

Playback	3
Record	8

20.5 HEAD FINE ADJUSTMENTS (JT-2022T & JT-2044T)

Connect VTVM to OUTPUT PLAY jacks (39k ohms load) and play test tape STD-154.

20.6 PLAYBACK HEAD

Play 15 kHz of STD-154 and adjust screw 3 for maximum output from all channels.

20.7 RECORD HEAD

- Insert 12P dummy plug into connector.
- Apply 15 kHz/-20dB signal to INPUT REC jacks and set for recording mode.
- Record on test tape STD-502 and adjust screw 8 for maximum output from all channels at OUTPUT PLAY jacks.

NOTE:

If playback level varies (at OUTPUT PLAY jacks), re-adjust heads left-right inclination.

Adjust locations

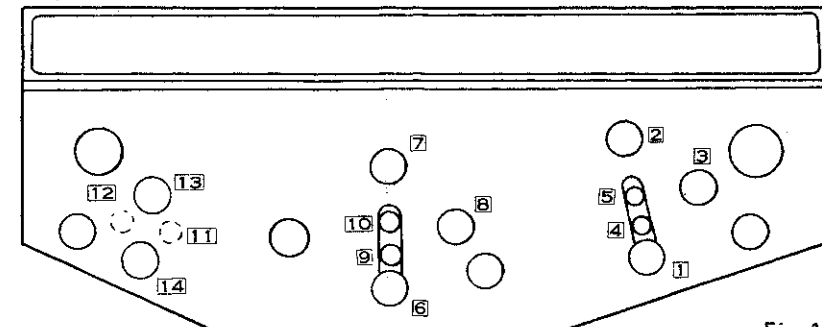

Fig. 17

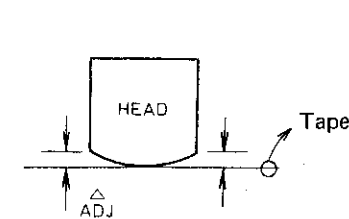

Fig. 18

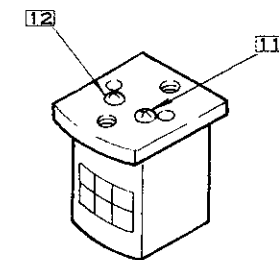

Fig. 19

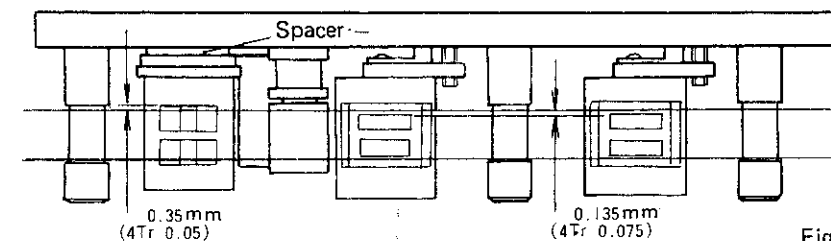

Fig. 20



Photo 5

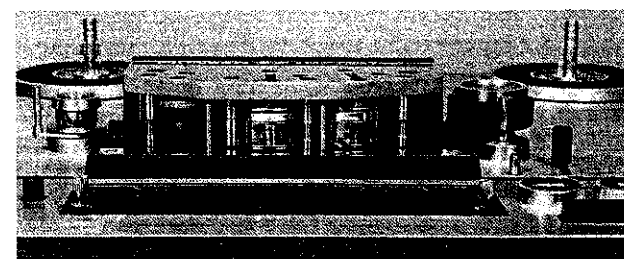

Photo 6

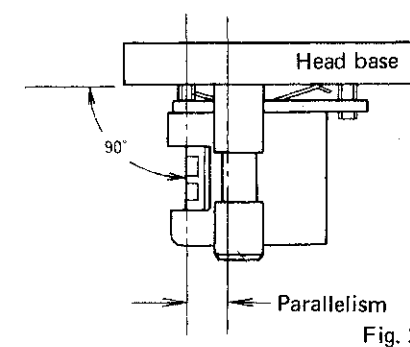

Fig. 21

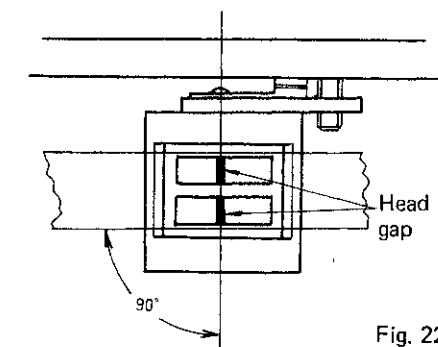

Fig. 22

21. ELECTRICAL ADJUSTMENTS

Electrical adjustments consist of 11 steps (21.1 to 21.11) and with the exception of 22 TAU-11 Adjustments, all pertain to RTU-11.

Adjustment Conditions of RTU-11

1. EQ switch at NAB-LH position
2. Tape speed of 19 cm/s
3. Playback test tape is STD-154
4. Recording test tape is STD-502
5. OUTPUT PLAY jack load is 39 k ohms
6. Two dummy plugs are required for recording mode.
7. Refer to Disassembly on page 18 and remove back cover and side panels.

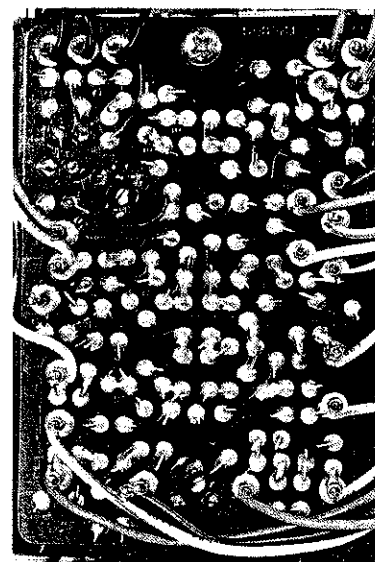

Test OSC Ass'y (RWA-024)

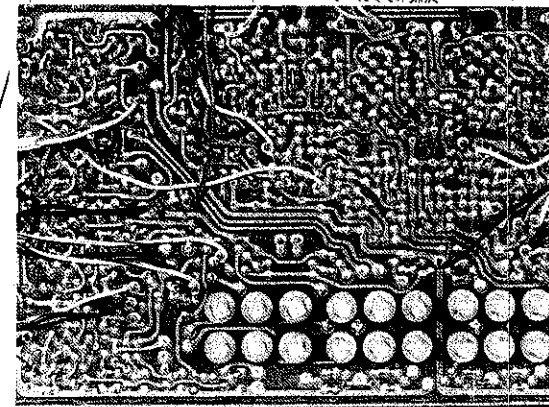
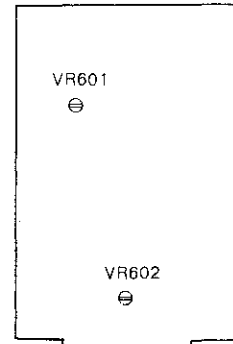

REC/PB Amp Ass'y (RWF-044)

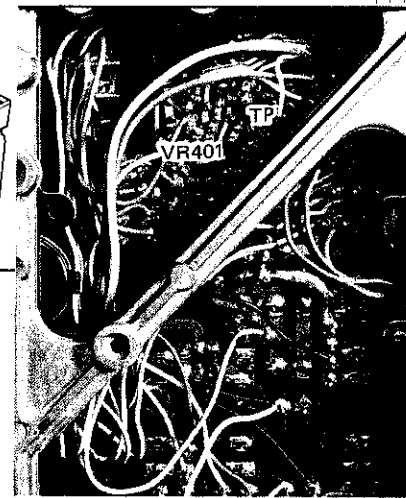
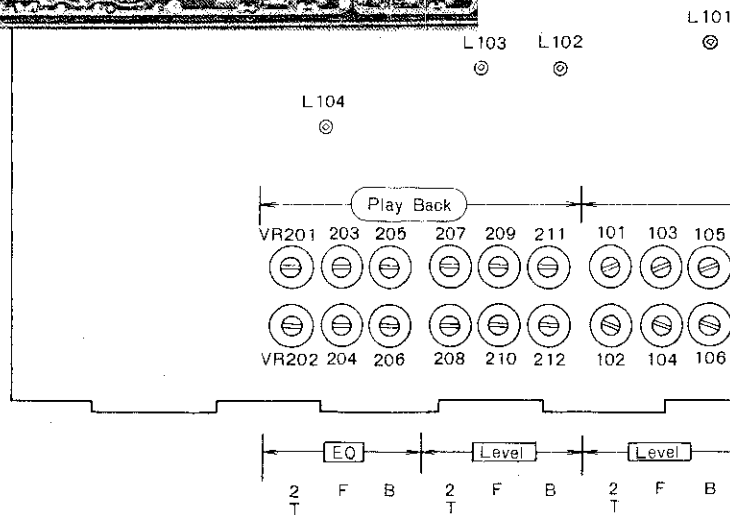

Power Supply & O.S.C. Ass'y (RWR-031)

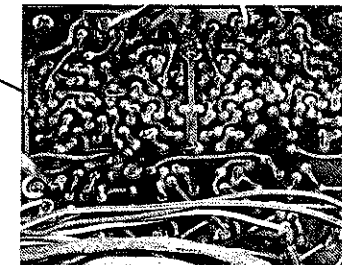
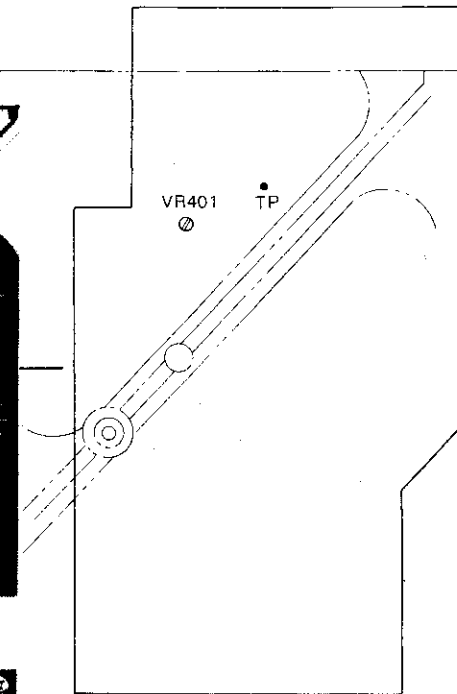

Sync Amp Ass'y (RWF-052)

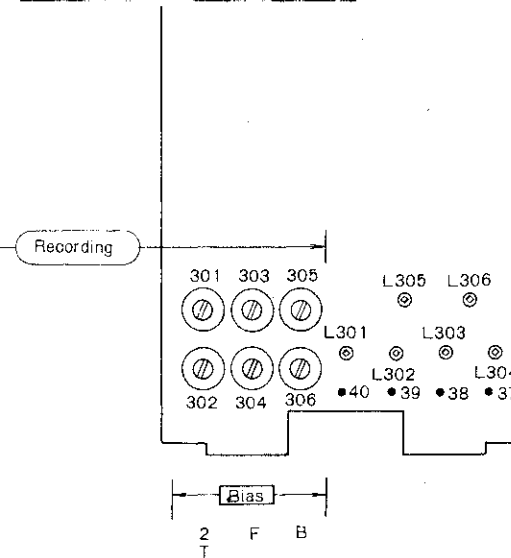

21.1 PLAYBACK LEVEL (Fig. 23)

Play 700 Hz/0dB of test tape STD-154 and adjust for -20 dBv (100 mV) output on each channel at OUTPUT PLAY jacks (39 k ohms load).

		Head unit		JT-2022T	JT-2044T
Channel	L	ch. 1		VR ₂₀₇	VR ₂₀₉
		FRONT	R	ch. 3	
BACK	L		ch. 2		
	R	ch. 4			VR ₂₁₂

21.2 PLAYBACK EQUALIZATION (Fig. 23)

1. Play 700 Hz/0dB and 10 kHz/-10dB of test tape STD-154.
2. Adjust so that output of each channel at OUTPUT PLAY jacks (39 k ohms load) becomes as follows:
3. As this adjustment affects that of 21.1, repeat steps 21.1 and 21.2 several times to obtain correct level setting.

700Hz/0dB playback -20 dBv (100mV) ±0.5dB
(94.4 ~ 106mV)
10kHz/-10dB playback -30 dBv (31.6mV) ±0.5dB
(29 ~ 34mV)

		Head unit		JT-2022T	JT-2044T
Channel	L	ch. 1		VR ₂₀₁	VR ₂₀₃
		FRONT	R	ch. 3	
BACK	L		ch. 2		
	R	ch. 4			VR ₂₀₆

21.3 OSCILLATION STRENGTH (Fig. 24)

1. Set BIAS switch to FIX position.
2. Install JT-2044T head unit.
3. Connect VTVM between TP and ground on power supply & O.S.C ass'y (RWR-031).
4. With 4 channels simultaneously in record mode, adjust VR401 for 20V at TP on power supply & O.S.C ass'y.

21.4 ERASE HEAD DUMMY

21.4.1 Employing Frequency Counter (Fig. 25-A)

1. Connect frequency counter between TP on power supply & O.S.C ass'y (RWR-031) and ground.
2. With 4 channels simultaneously in recording mode, note oscillation frequency.
3. Adjust so that frequencies during front (ch-1 & ch-3) only recording, and back (ch-2 & ch-4) only recording are the same as the 4 channel recording mode. Adjustment points are given below.

L305: Oscillation frequency during back only recording adjustment point.

L306: Oscillation frequency during front only recording adjustment point.

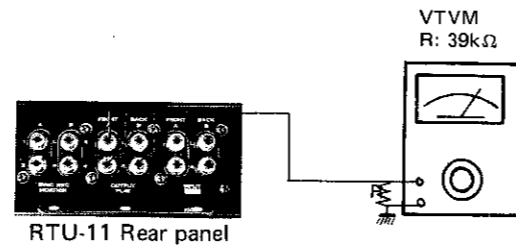

Fig. 23

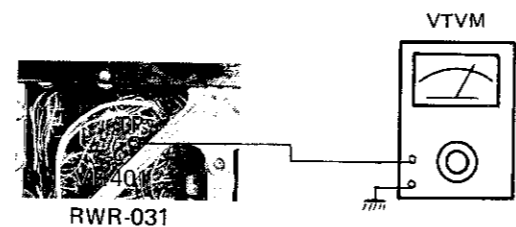

Fig. 24

21.4.2 Without Frequency Counter (Fig. 25-B)

Employ dual trace oscilloscope.

1. Connect ch-1 of oscilloscope between TP on power supply & O.S.C ass'y (RWR-031) and ground.
2. Connect signal from external oscillator (such as signal generator) to ch-2 of oscilloscope.
3. With 4 channels simultaneously in recording mode, observe oscilloscope ch-1 waveform (frequency).
4. Adjust external oscillator so that ch-2 waveform (frequency) is the same as ch-1. See note 2.
5. Select front (ch-1 & ch-3) only and back (ch-2 & ch-4) only recording modes of RTU-11. Adjust so that oscilloscope ch-1 waveform (frequency) becomes the same as the oscilloscope waveform (frequency) during both front and back recording modes.

L305: Oscillation frequency during back only recording adjustment point.

L306: Oscillation frequency during front only recording adjustment point.

NOTE 2:
Oscillation frequency is approximately 125 kHz.

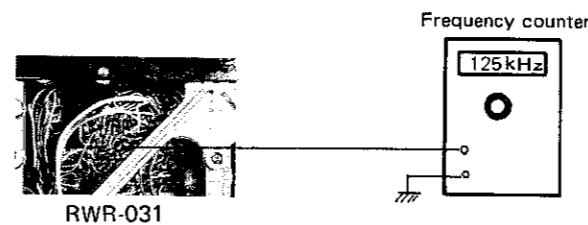

Fig. 25-A

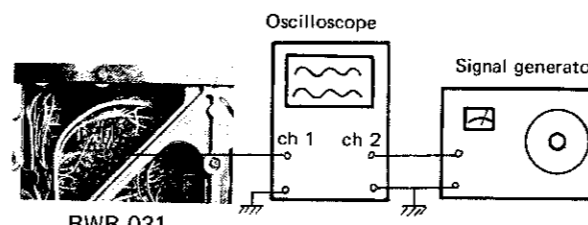

Fig. 25-B

21.5 BIAS TRAP (Fig. 26)

1. Set for 4 channel simultaneous recording mode.
2. Connect oscilloscope to terminal 37 (38, 39, 40) on sync amp ass'y (RWF-052) and adjust for minimum bias leakage (smallest waveform).

			Test terminal	Adjustment location
FRONT	L	ch. 1	37	L ₃₀₄
	R	ch. 3	38	L ₃₀₃
BACK	L	ch. 2	39	L ₃₀₂
	R	ch. 4	40	L ₃₀₁

Set to less than 1Vp-p

21.6 BIAS VOLTAGE VARIABLE RANGE (Fig. 28)

1. Set for 4 channel simultaneous recording mode.
2. Set BIAS switch to LOW or HIGH position.
3. Connect VTVM between TP on power supply & O.S.C ass'y (RWR-031) and ground.
4. When BIAS control is turned from MIN to MAX, confirm that VTVM indication varies in the range of 18.5V to more than 25V.

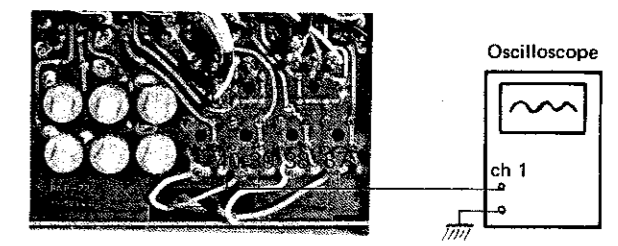

Fig. 26

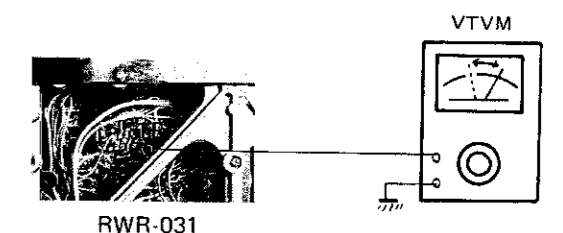

Fig. 27

21.7 RECORDING BIAS (Fig. 29)

1. Set for 4 (2) channel simultaneous recording mode.
2. Set BIAS switch to FIX position.
3. Apply 1 kHz/- 20 dBv (100mV) signal to INPUT REC jacks and run tape.
4. Adjust so that after passing peak, each channel output at OUTPUT PLAY jacks (39 k ohms load) becomes -0.3dB, as shown in Fig. 28.

NOTE:
Since VR301 & VR302 and VR303 - VR306 interact, repeat adjustments several times to obtain correct setting.

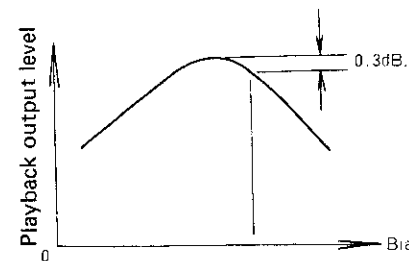
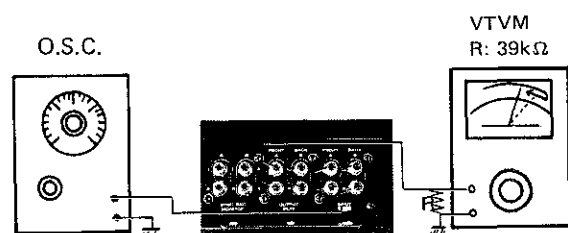

Fig. 28

Channel		Head unit	JT-2022T	JT-2044T
FORWARD	L	ch. 1	VR ₃₀₁	VR ₃₀₃
	R	ch. 3	VR ₃₀₂	VR ₃₀₄
BACK	L	ch. 2		VR ₃₀₅
	R	ch. 4		VR ₃₀₆



RTU-11 Rear panel

Fig. 29

21.8 RECORDING LEVEL (Fig. 30)

1. After completing Bias Adjustment (21.7), apply 1 kHz/- 20dB signal to each INPUT REC jack and perform simultaneous recording and playback.
2. Adjust for - 20 dBv (100mV) output on each channel at the OUTPUT PLAY jacks (39 k ohms load) by using the adjustment points listed figure below.

Channel		Head unit	JT-2022T	JT-2044T
FORWARD	L	ch. 1	VR ₁₀₁	VR ₁₀₃
	R	ch. 3	VR ₁₀₂	VR ₁₀₄
BACK	L	ch. 2		VR ₁₀₅
	R	ch. 4		VR ₁₀₆

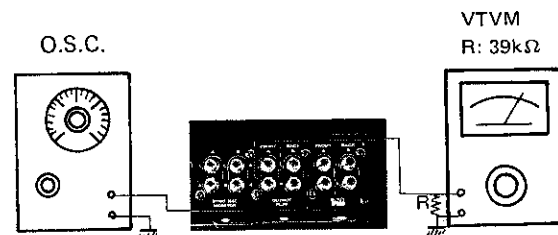

RTU-11 Rear panel

Fig. 30

21.9 OVERALL FREQUENCY RESPONSE CHECK (Fig. 32)

1. Set BIAS switch to FIX position.
2. Apply 1 kHz/- 40 dBv (10mV) and 15 kHz/- 40 dBv (10mV) signals to INPUT REC jacks of each channel and record each signal for several seconds (use tape STD-502 for recording).
*See note
3. Rewind and play back tape.
4. Confirm that 15 kHz playback level is within the range of ±2dB with respect to 1 kHz playback level for each channel at the OUTPUT PLAY jacks (39 k ohms internal load).
5. If not within this range, repeat 21.7 Recording Bias and 21.8 Recording Level adjustments. In this case, be sure to maintain bias in the range -0.3dB ± 0.2dB.
6. If after repeating steps 21.7 and 21.8, difference between the two frequency levels exceeds ±2dB, readjustment of head azimuth, recording equalization, etc. will be necessary.

NOTE:
When performed simultaneous recording and playback, correct output level cannot be obtained due to bias leakage. Be sure to perform in the sequence record - rewind - playback.

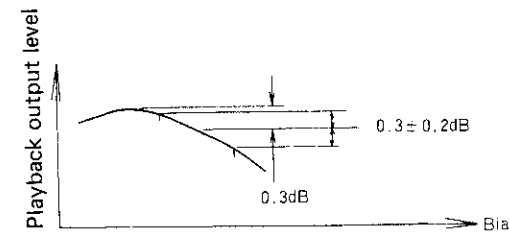
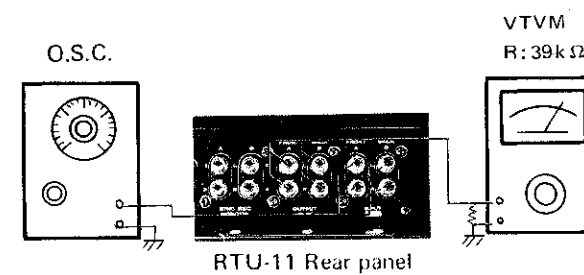

Fig. 31

Peaking frequencies (for reference):

Tape type	Tape speed	19cm	38cm
STD		25kHz	32kHz
LH		26kHz	42kHz



RTU-11 Rear panel

Fig. 32

21.10 TEST OSCILLATOR OUTPUT VOLTAGE

Set TEST OSC switch to 1 kHz position and adjust for -10 dBv (316mV) output at OSC OUT jack (standard plug). Load resistance at this time is 47k ohms to 51k ohms.

Location: VR601 on test osc ass'y (RWA-024)

21.11 TEST OSC 1 kHz/10 kHz LEVEL DIFFERENCE

Set TEST OSC switch to 10 kHz and adjust for same output (-10 dBv/316mV) as for 1 kHz.

Location: VR602 on test osc ass'y (RWA-024)
Load resistance is also 47 k ohms to 51 k ohms.

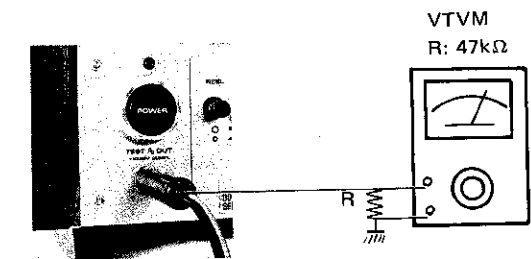

Fig. 33

23.1 POWER SUPPLY ON

With tape installed and POWER switch (S901) set to ON, and since the shut-off switch (S1001) is also ON, voltage (100V) will be supplied to capstan motor (CM) causing it to rotate. From rectifiers (D406 & D407) in the power transformer secondary, +B1 is applied to Q408 by the route S1001-2 - S4-1 - S1. +B2 from Q408 emitter then flows by the route SL3 - D821 - Ry805 - R832, caus-

ing Ry805 to operate. Even though current flows in Ry805 via SL3, SL3 does not operate at this time. This is because Ry805 itself becomes SL3 load and the current amount is low at approximately 15 mA. SL3 operating current is approximately 400 mA. Ry805 operation shorts R2-2 to regulate take-up motor (TM) torque when play operation starts. Also, C811 in parallel with Ry805 becomes

charged. In such repetitive operations as pressing the STOP BUTTON, the PLAY button, and again the STOP button, C811 charging route becomes S1 - D819 - C811 - R832. Since STOP-PLAY repetition can be instantaneous, in order to always provide proper torque during play, it is necessary to charge C811 by this route as the STOP button is pressed.

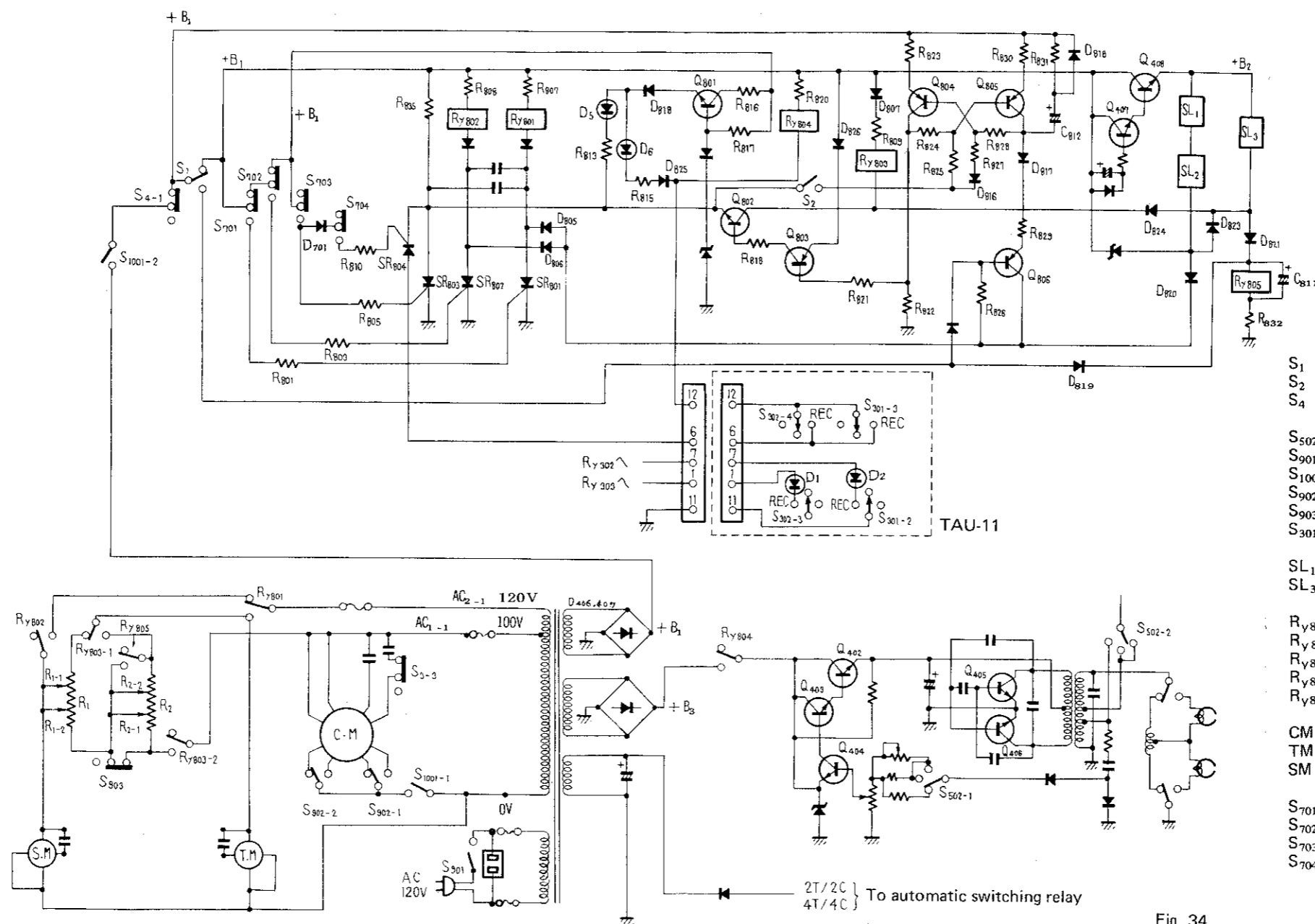

- S₁ STOP SWITCH
- S₂ PAUSE SWITCH (OFF)
- S₄ REMOTE CONTROL SWITCH (NORMAL)

- S₅₀₂ BIAS SWITCH (FIX)
- S₉₀₁ POWER SWITCH
- S₁₀₀₁ SHUT OFF SWITCH
- S₉₀₂ SPEED SWITCH (38 cm/sec)
- S₉₀₃ REEL SWITCH (10 in)
- S₃₀₁ REC MODE SWITCH

- SL₁, SL₂ BLAKE SOLENOID
- SL₃ PINCH SOLENOID

- Ry₈₀₁ FF relay
- Ry₈₀₂ REW relay
- Ry₈₀₃ PLAY (REC) relay
- Ry₈₀₄ REC relay
- Ry₈₀₅ Torque relay

- CM Capstan motor
- TM Take up motor
- SM Supply motor

- S₇₀₁ FF SWITCH
- S₇₀₂ REW SWITCH
- S₇₀₃ PLAY SWITCH
- S₇₀₄ REC SWITCH

Fig. 34

23.2 PLAY OPERATION

Pressing the PLAY button (S703) applies +B1 to SR803 gate by the route S1 - S702 - S703 - R805, switching SR803 ON. +B1 from S1 then flows in the route D807 - R809 - Ry803 - Q802 - SR803, holding PLAY relay Ry803. Play operation begins at this time.

With SR803 ON, Q802 emitter* approaches ground potential. +B2 flows in the route SL3 - D824 - Q802 - SR803. SL3 operates and pinch roller contacts the capstan.

* Since Q804 is OFF, Q803 is forward biased ON by the path R821 - R822. +B2 is then applied as forward bias to Q802 by the route D826 - Q803 - R818. (Fig. 34. See page 142.)

As SL3 operates, some Ry805 current flows in the route D824 - Q802 - R803, and the current through Ry805 resets after being held for approximately 1 second by the charge on C811.

Take-up reel motor (TM) starts to rotate with Ry803 operation, since AC current AC1-1 flows in the route Ry803-2 - S903 - Ry805-(R2-2) - Ry803-1 (see note 1). In the same manner, AC current AC1-1 is applied in the route Ry803-2 - S903 - R1-2 to operate the supply reel motor (SM). Brake release of TM and SM is performed by brake solenoid operation with +B2 flowing in the route SL1 - SL2 - D823 - D824 - Q802 - SR803. The PLAY lamp (D5) lights from +B1 in the route S702 - R816 - Q801 - D811 - D5 - R813 - SR803.

NOTE 1:

SINCE Ry805 resets upon completion of C811 discharge, R2-2 is shorted for only about 1 second when TM drive starts. Afterwards, current is supplied via R2-2.

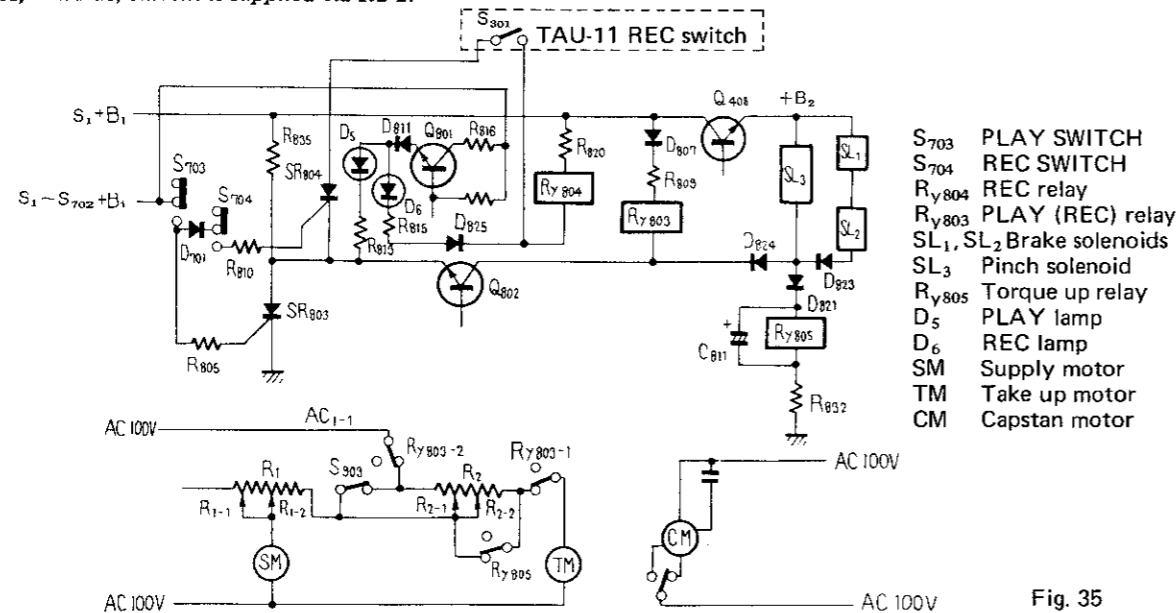

Fig. 35

23.3 RECORDING OPERATION

Recording starts when PLAY (S703) and REC (S704) buttons are pressed simultaneously. With buttons pressed, +B1 is applied to SR804 gate in the route S1 - S701 - S702 - S703 - D701 - S704 - R810 and SR804 gates ON. Thus, +B1 flows through R820 - Ry804 - S301 (S302 - SR804 - SR803 to hold REC relay Ry804 (see note 2). Ry804 is energized and sends to the oscillator circuit initiating the recording mode. Pinch roller operation is the same as that described for play operation. (Fig. 34. See page 142)

*NOTE 2:

S301 and S302 operate with TAU-11 REC switch. Setting REC switch to REC position completes current path through Ry804. D1, D2, (TAU-11) light to indicate recording mode. Recording mode is not obtained if switches are in positions other than REC, even when PLAY and REC buttons are pressed.

23.4 FF OPERATION

When the FF button (S701) is pressed, +B1 in the route S1 - S701 - R801 turns ON SR801 gate. +B1 then flows in the path R807 - Ry801 - D801 - SR801 to hold Ry801. AC2-1 (120V) flows from Ry801 contacts to TM, which starts to rotate at high speed. To supply back tension during this time, AC2-1 follows the route Ry801 (contacts) - Ry803-1 - R1-1 - SM to operate the supply reel motor. TM and SM brake solenoids are released by +B2 in the route SL1 - SL2 - D820 - D805 - SR801.

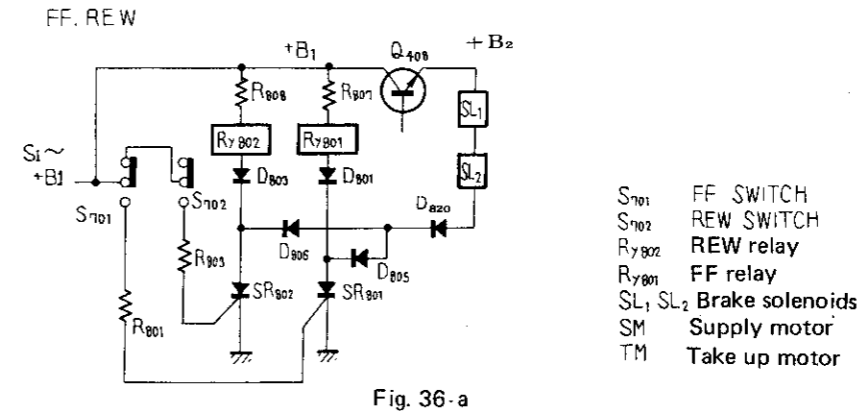

Fig. 36-a

- S701 FF SWITCH
- S702 REW SWITCH
- Ry802 REW relay
- Ry801 FF relay
- SL1, SL2 Brake solenoids
- SM Supply motor
- TM Take up motor

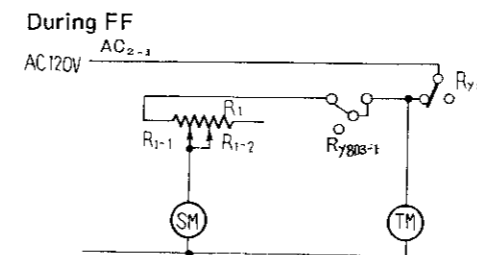

Fig. 36-b

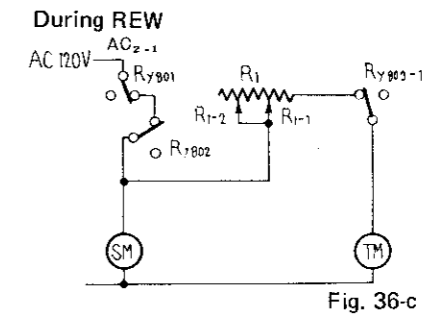

Fig. 36-c

23.5 REW OPERATION

SR802 gates ON when the REW button (S702) is pressed and +B1 applied to its gate by the route S1 - S701 - S702 - R803 - SR802. +B1 then flows in the route R808 - Ry802 - D803 - SR802 to hold Ry802. Ry802 contacts close and AC2-1 (120V) is supplied directly to SM through contacts of Ry801 and Ry802, causing high speed rotation. AC2-1 is applied to TM for back tension through the path Ry801 - Ry802 - R1-1 - R1-1 - Ry803-1 - RM. TM and SM brake solenoids are released by +B2 through the path SL1 - SL2 - D820 - D806 - SR802.

23.6 TIMING OPERATION

In order to protect tape when switching directly from FF or REW to PLAY (REC), a fixed time lag is provided during which the tape stops. Transistor states during FF are:

ON: Q407, Q408, Q804, Q806
OFF: Q802, Q803, Q805

1. During FF, Q806 is biased through R826 — D805 — SR801 and it switches ON.
2. Q804 switches ON due to bias through R828 — D817 — R829 — Q806.
3. With Q804 ON, the bases of Q803 and Q805, connected to Q804 collector through R821 and R824, become reverse biased, switching them OFF.
4. Q802 loses bias with Q803 OFF and it also turns OFF.
5. C812 (timing capacitor) is charged from +B1 through the path R831 — C812 — D817 — R829 — Q806 — SR801.
6. When PLAY (REC) is switched directly at this point, +B1 becomes applied to SR803, switching it ON (see Play Operation). The two current routes maintaining SR803 in the ON state are +B1 — R835 — SR803 and +B1 — R816 — Q801 — D818 — D5 — R813 (see Fig. 34 on page 142).
7. When SR803 turns on, SR801 is cut off by operation of C805 (bipolar capacitor).
8. Q806 becomes OFF since its bias is absent with SR801 OFF. However, Q804 ON state continues through bias from C812 charge via R828.
9. C812 discharge continues through the route D818 — R823 — Q804 — R828 and as Q804 base current gradually declines, its internal resistance increases. For this reason, the potential difference between collector and emitter of Q804 becomes large. The reverse biased Q803 and Q805 then become forward biased and switch ON.
10. When Q805 turns ON, C812 is rapidly discharged through the path D818 — R830 — Q805 and Q804 becomes OFF.
11. With Q803 ON, Q802 is switched ON by +B1 applied to its base through the route D826 — Q803 — R818.
12. With Q802 ON, +B2 is applied to the pinch solenoid SL3 through the route D824 — Q802 — SR803 and to the brake solenoids SL1 and SL2 through the route D823 — D824 — Q802 — SR803. The solenoids operate to start PLAY (REC) operation.
13. When the PLAY button is suddenly pressed during FF (REW) operation, the time required for play to begin (6 — 7 seconds) is determined by C812 discharge time.

23.7 PAUSE OPERATION

Q804 and Q806 are OFF during PLAY (REC), while Q802, Q803 and Q805 are ON. When PAUSE switch (S2) is set to ON, Q804 becomes ON by forward bias through the route R827 — D816 — S2 — SR803. This reverse biases the base of Q803 to switch it OFF; Q802 also becomes OFF. At this point solenoids SL1 — SL3 and relay Ry803 reset to obtain pause mode. Current flow through the two routes of +B1 — R805 and +B1 — R816 — Q801 — D811 — D5 — R813 (Fig. 34 on page 142) maintains SR803 in the ON state. When the PAUSE switch is set to OFF, Q804 turns OFF due to reverse bias, while Q803 and Q802 become ON to resume tape motion.

23.8 REDUCED SWITCHING TIME THROUGH PAUSE SWITCH OPERATION

The time lag when switching directly from FF (REW) to PLAY (REC) can be shortened by operating the PAUSE switch. This operating method is as follows:

FF (REW) (tape at high speed) → PAUSE switch ON → PLAY (REC) button ON (tape stops) → PAUSE switch OFF (tape motion begins)

The principle of this, as described in Timing Operation, is that during FF (REW) Q804 is ON and Q805 OFF and C812 charges. When FF (REW) operation is stopped, C812 becomes slowly discharged through Q804, then Q805 is switched ON. By rapidly discharging C812, PLAY (REC) operation can be begun immediately. This rapid discharge is provided by the PAUSE switch. The actual circuit operation with respect to the above sequence is as follows:

1. Q804, Q806 and SR801 are ON during FF (REW), while Q802, Q803, Q805 and SR803 are OFF.
2. When PAUSE switch (S2) is set ON and since SR803 is OFF, tape high speed motion continues.
3. SR803 turns ON when the PLAY (REC) button is pressed. SR801 is turned OFF by C805 and tape motion stops.
4. Since PAUSE switch (S2) is already ON, Q805 base is forward biased and it becomes ON.
5. As Q805 is ON, C812 timing capacitor is rapidly discharged.
6. Tape running is attained by setting PAUSE switch (S2) to OFF.

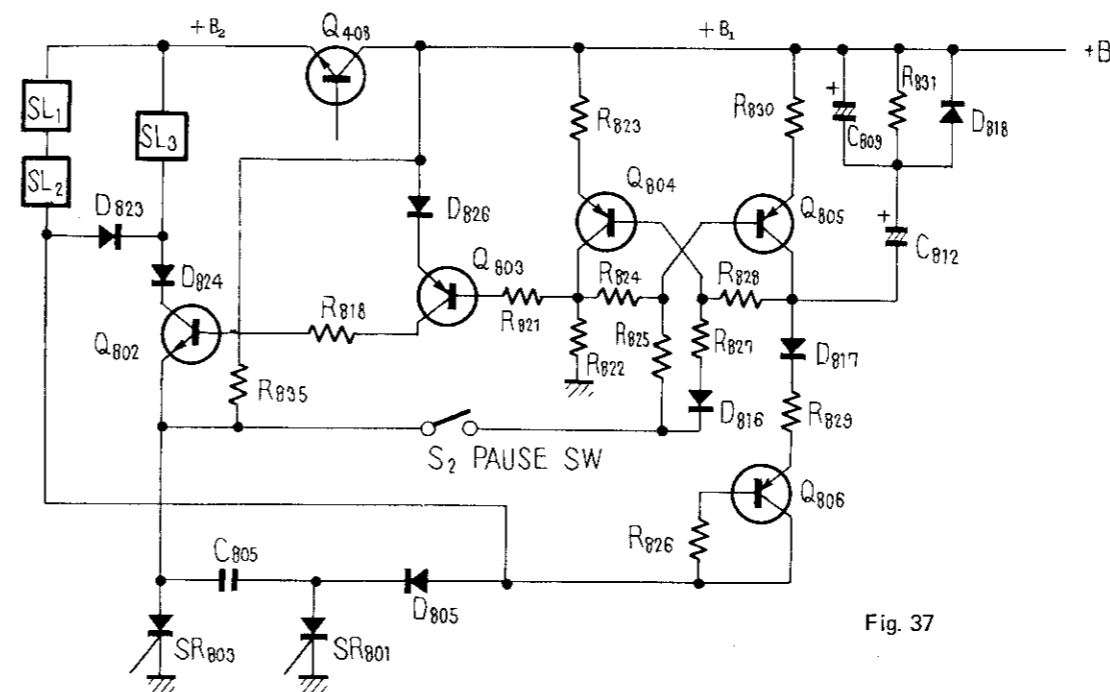

Fig. 37

23.9 PLAYBACK EQUALIZATION AMPLIFIER

This is a 3-stage direct coupled amplifier, containing a feedback circuit from Q209 collector to Q201 emitter. Equalization differs according to head unit (JT-2022T or JT-2044T). At 2T/2C FET Q217 turns ON, while Q219 turns ON at 4T/4C to change the feedback path. Since Q213 is connected in parallel with Q219 and Q217, NAB/IEC selection can be performed with both 2T/2C and 4T/4C. Output level switching is performed by Q221 (2T/2C) and Q223 (4T/4C). Q217, Q219, Q221 and Q223 are automatically switched by simply plugging in the head unit.

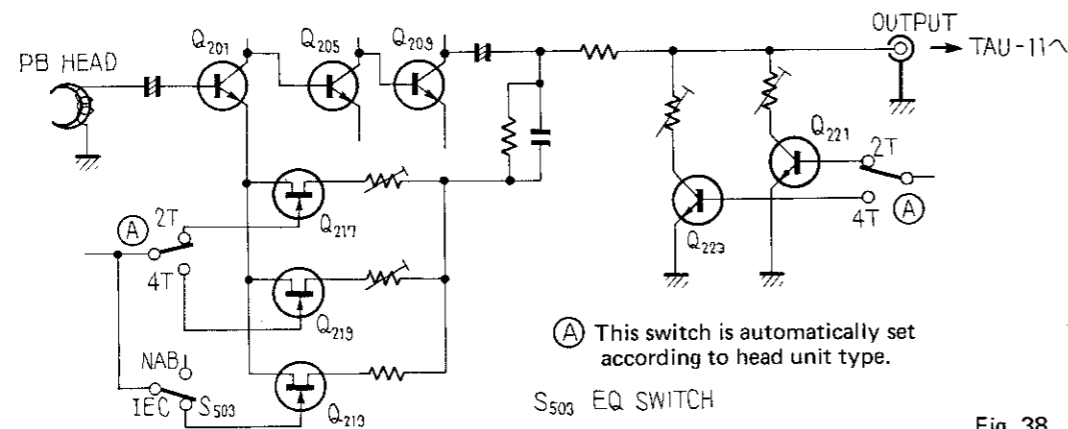

Fig. 38

23.10 RECORDING EQUALIZATION AMPLIFIER

In this 2-stage direct coupled amplifier, low frequencies are equalized by CR feedback, and high frequencies by LC. Input level is automatically set by simply plugging in the head unit (Q101 for 2T/2C and Q103 for 4T/4C).

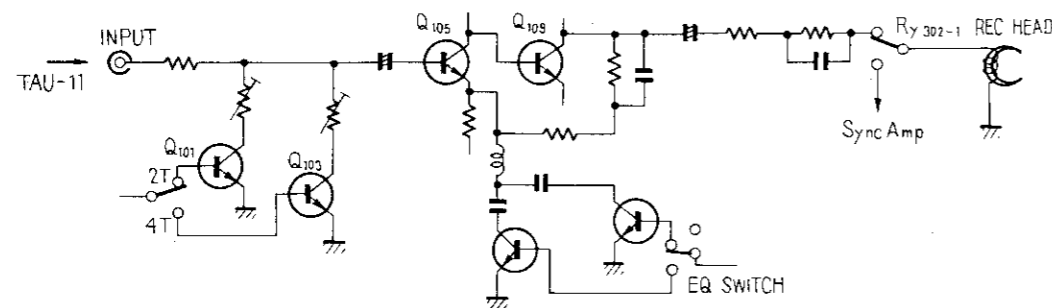

Fig. 39

23.11 TEST OSCILLATOR CIRCUIT

The built-in test oscillator circuit in the RTU-11 is a CR phase shift oscillator. The amplifier composed of Q601 and Q603. Since Q603 is an emitter-follower, Q601 input and Q603 output are in opposite phase. 3-stage CR elements are inserted as a feedback circuit between these two transistors to determine the oscillation frequency. The oscillation voltage produced at this point is rectified to a

negative voltage by D601 and C606, and applied to Q602 (FET) gate. As the oscillation voltage increases, Q602 internal impedance increases, decreasing the gain of Q601 and maintaining the oscillation voltage at a fixed level. 1 kHz and 10 kHz selection is performed by a switch which changes the CR constant.

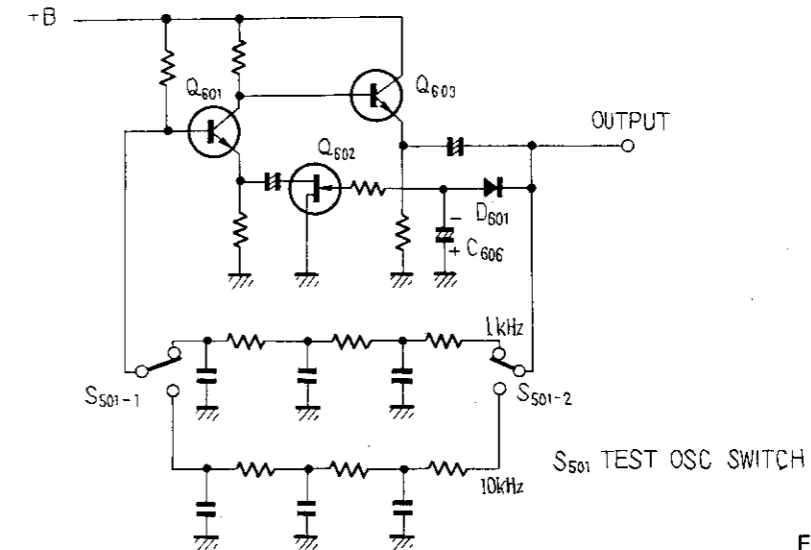
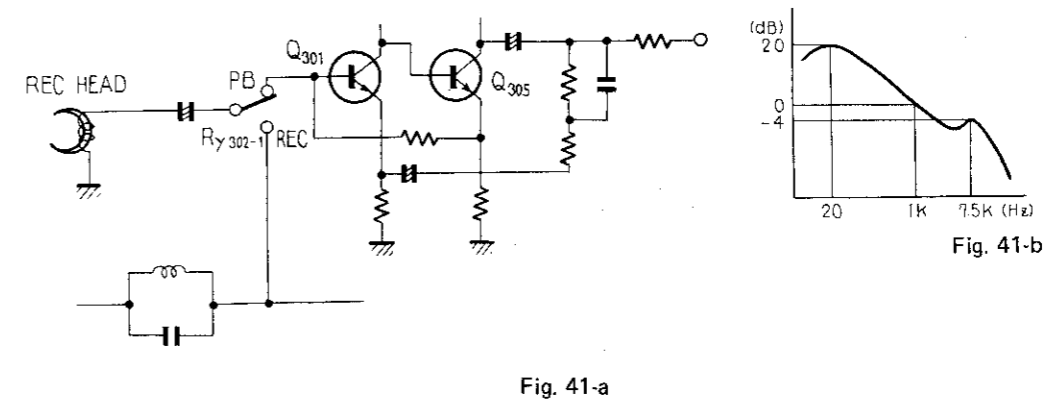

Fig. 40

23.12 SYNC AMP CIRCUIT

The recording signal is played back (synchronizer) by the record head (RH) to perform synchronized recording. A special amplifier (sync amp) matching RH characteristics then becomes necessary. As shown in the Fig. 41-a. RH is connected to the bias oscillator during recording and at other times it is connected to the sync amp circuit. The sync amp is a 2-stage direct coupled circuit with response as shown in the graph. Fig. 41-b



SYSTEM TAPE DECK

RT-2022/RT-2044

TRANSPORT UNIT RTU-11/2T, RTU-11/QT

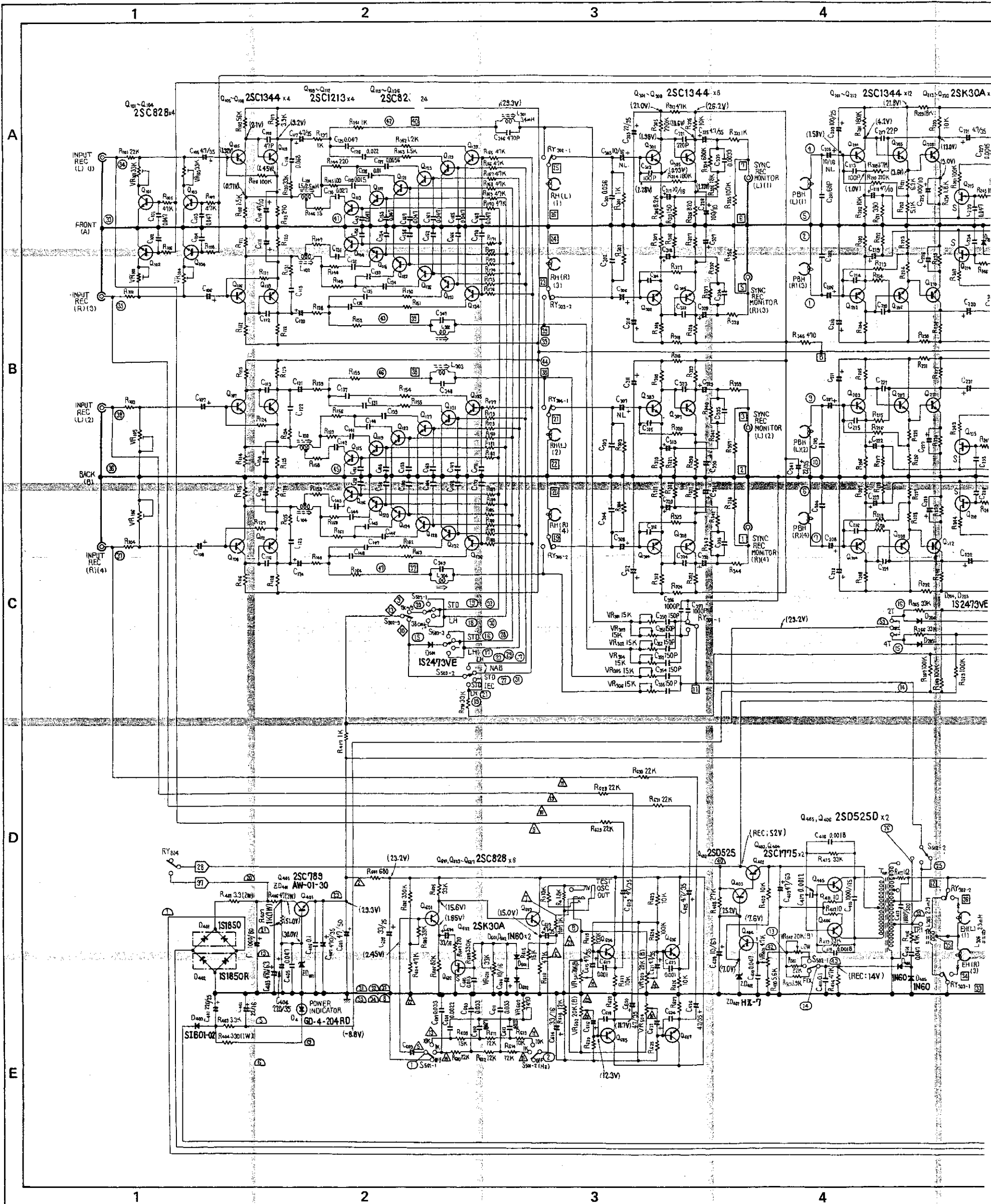

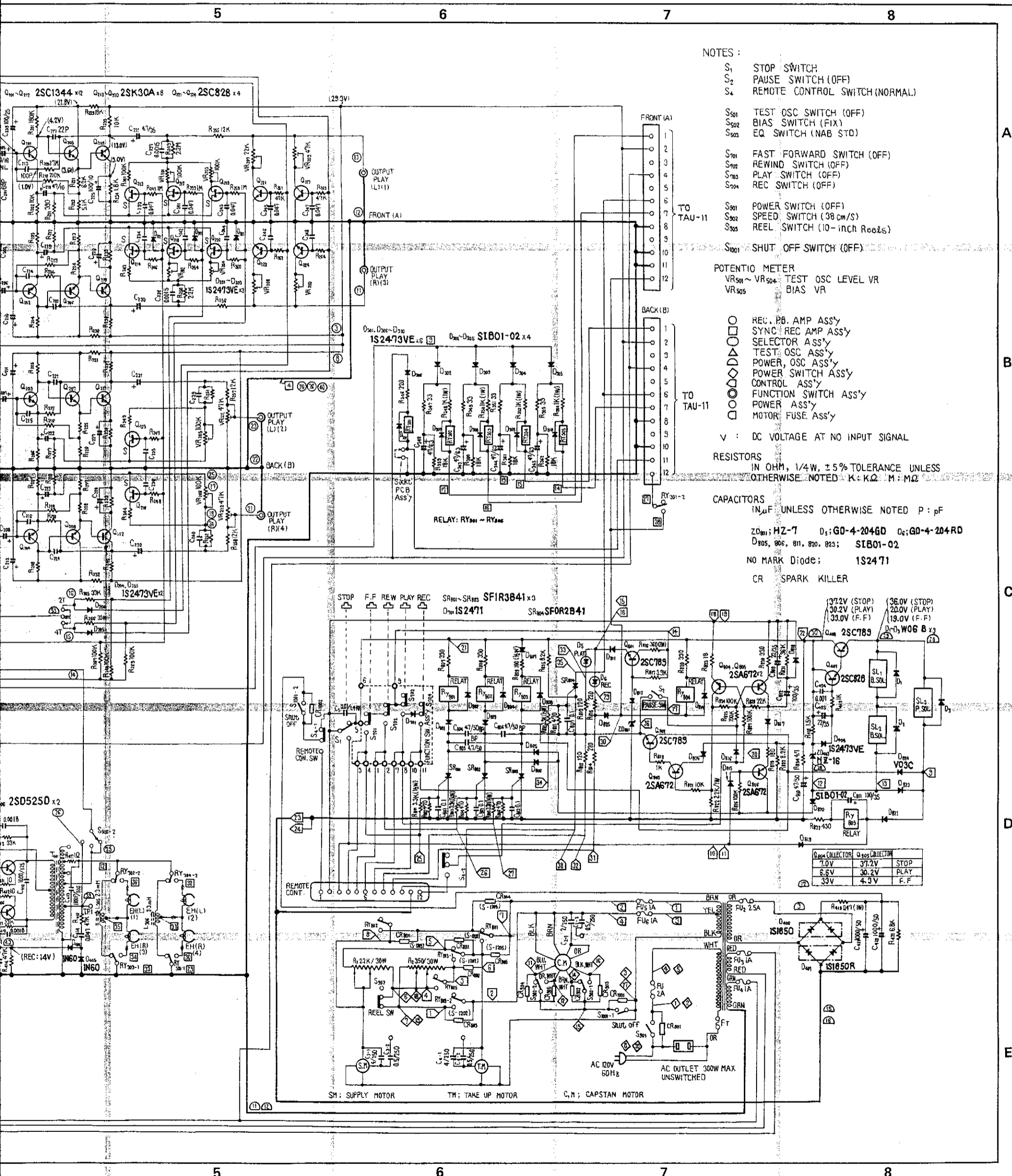

NOTES :

- S₁ STOP SWITCH
- S₂ PAUSE SWITCH (OFF)
- S₃ REMOTE CONTROL SWITCH (NORMAL)

- S₅₀₁ TEST OSC SWITCH (OFF)
- S₅₀₂ BIAS SWITCH (FIX)
- S₅₀₃ EQ SWITCH (NAB STD)
- S₇₀₁ FAST FORWARD SWITCH (OFF)
- S₇₀₂ REWIND SWITCH (OFF)
- S₇₀₃ PLAY SWITCH (OFF)
- S₇₀₄ REC SWITCH (OFF)

- S₉₀₁ POWER SWITCH (OFF)
- S₉₀₂ SPEED SWITCH (38 cm/S)
- S₉₀₃ REEL SWITCH (10-inch Reels)
- S₉₀₄ SHUT OFF SWITCH (OFF)

POTENTIO METER
 VR₅₀₁ ~ VR₅₀₄ TEST OSC LEVEL VR
 VR₅₀₅ BIAS VR

- REC. PB. AMP ASS'Y
- SYNC. REC. AMP ASS'Y
- ◇ SELECTOR ASS'Y
- △ TEST OSC ASS'Y
- ▽ POWER OSC ASS'Y
- ◇ POWER SWITCH ASS'Y
- CONTROL ASS'Y
- FUNCTION SWITCH ASS'Y
- POWER ASS'Y
- MOTOR FUSE ASS'Y

V : DC VOLTAGE AT NO INPUT SIGNAL

RESISTORS
 IN OHM, 1/4W, ±5% TOLERANCE UNLESS
 OTHERWISE NOTED K: KΩ M: MΩ

CAPACITORS
 IN μF UNLESS OTHERWISE NOTED P: pF

ZD₉₀₁: HZ-7 D₅: GD-4-2046D D₆: GD-4-204RD
 D₉₀₅, 906, 911, 920, 923; SIB01-02

NO MARK Diode: 1S2471

CR SPARK KILLER

Collector	Q ₉₀₅ Collector	STOP
7.0V	37.2V	20.0V (PLAY)
6.6V	30.2V (PLAY)	19.0V (F.F)
3.3V	4.3V	F.F

SM: SUPPLY MOTOR TM: TAKE UP MOTOR C.M.: CAPSTAN MOTOR

SYSTEM TAPE DECK

RT-2022/RT-2044 KU

AMPLIFIER UNIT TAU-11

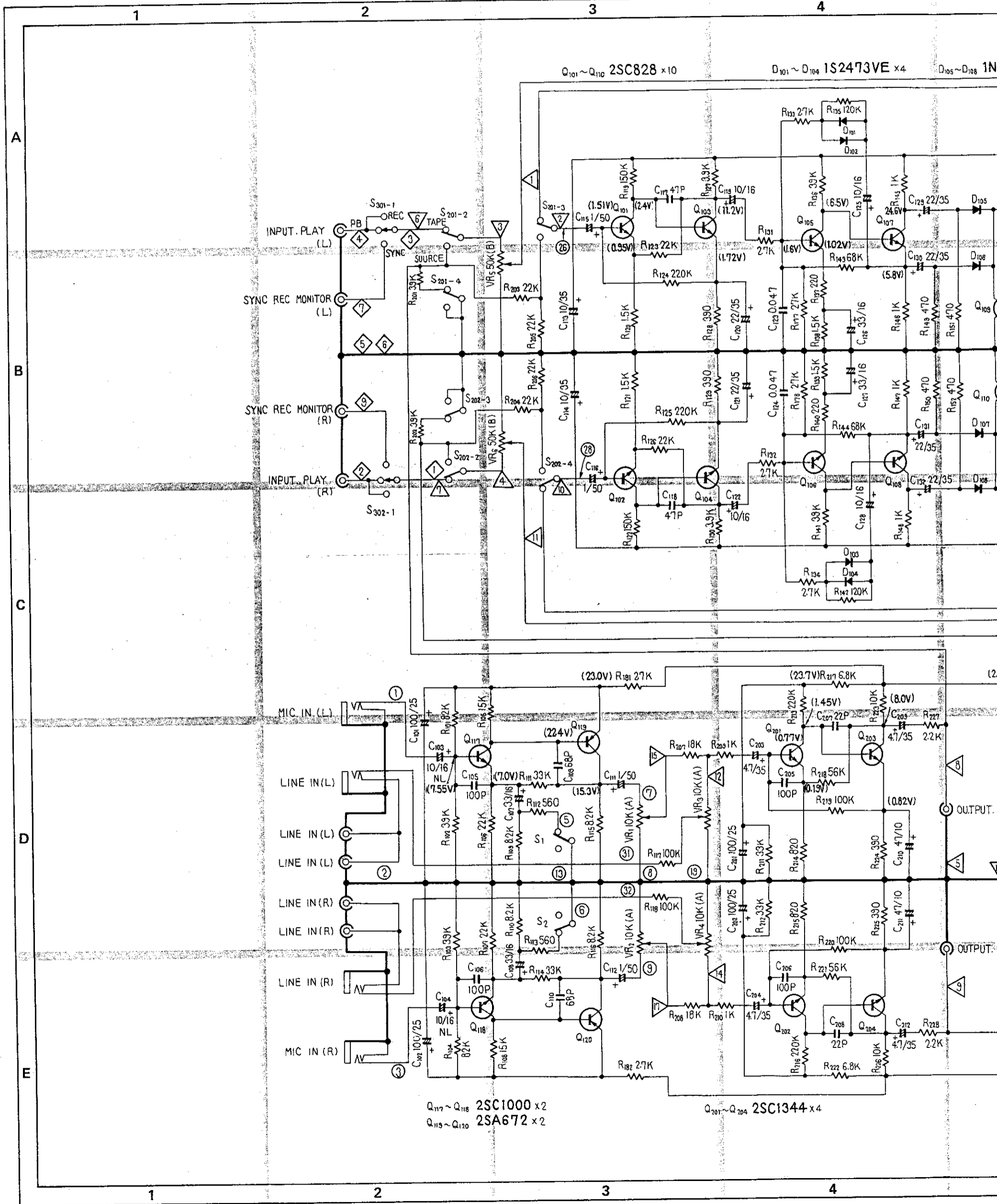

44 KU

