

<R42-345-0>

SERVICE MANUAL

STEREO TAPE DECK

RT-1020L
F

<73D02F31F>

 **PIONEER®**

CONTENTS

1.	SPECIFICATIONS	3
2.	PARTS IDENTIFICATION	5
3.	CIRCUIT DESCRIPTION	
3.1	Playback Circuit	9
3.2	Recording Circuit	9
3.3	Oscillator Circuit	10
3.4	Control Circuit	11
3.5	Operation Buttons Reset Circuit	12
3.6	Tape Speed Switching	12
3.7	Pause Circuit	12
4.	DISASSEMBLY	
4.1	Back Covers	13
4.2	Side boards	13
4.3	Amplifier Panel	14
4.4	Mechanical Panel	14
5.	TROUBLE SHOOTING	
5.1	Transport Mechanism and Control System (1)	15
5.2	Transport Mechanism and Control System (2)	16
5.3	Electronic Circuit Trouble	18
6.	MECHANICAL ADJUSTMENTS	
6.1	Reel Base Height Adjustment	21
6.2	Brake Adjustment	21
6.3	Take-up and Back Tension Torque Adjustment	22
6.4	Pinch Roller Pressure Adjustment	23
7.	TAPE HEAD ADJUSTMENTS	
7.1	Coarse Adjustment	24
7.2	P.B. Head Adjustment	24
7.3	REC. Head Adjustment	24
8.	CIRCUIT ADJUSTMENTS	
8.1	Playback Sensitivity Adjustment	25
8.2	Playback Equalizer Adjustment	25
8.3	Playback Frequency Response Confirmation	25
8.4	Bias Oscillator Amplitude Adjustment	26
8.5	Bias-trap Adjustment	26
8.6	Recording Bias Adjustment	26
8.7	Erase Head Dummy Adjustment	26
8.8	Level Meter Calibration	26
8.9	Recording Sensitivity Adjustment	26
8.10	REC. and P.B. Frequency Response Adjustment	27

9.	SELECTION OF LINE FREQUENCY AND VOLTAGE	
9.1	Selection of Line Frequency.....	28
9.2	Switching Line Voltage Setting and Fuse.....	28
10.	SCHEMATIC DIAGRAMS, P.C. BOARD PATTERNS AND PARTS LISTS	
10. 1	Connection Diagram (Amplifier)	29
10. 2	Schematic Diagram (Amplifier)	31
10. 3	Connection Diagram (Control)	33
10. 4	Schematic Diagram (Control)	33
10. 5	Electric Parts	34
10. 6	P.B. Amplifier Assembly (RWF-014)	35
10. 7	REC. Amplifier Assembly (RWF-015)	40
10. 8	Control Assembly (RWG-040)	46
10. 9	Switch Circuit Assembly (RWS-011)	50
10.10	EQ. Switch Circuit Assembly (RWS-013)	55
10.11	OSC. Assembly (RWA-008)	57
10.12	Fuse P.C. Board (RWX-036)	61
10.13	REC. Lamp P.C. Board (RWX-033)	61
10.14	VR Assembly (RWX-040)	62
10.15	Shut-off Switch P.C. Board (RWX-038)	62
11.	EXPLODED VIEWS AND PARTS LISTS	
11.1	Panel and Back Cover	63
11.2	Mechanism (Drive Motor, Head)	67
11.3	Mechanism (Amplifier Assembly)	71
11.4	Mechanism (Reel Motor)	74
11.5	Packing	77
12.	LEVEL DIAGRAMS	80

1. SPECIFICATIONS

Operation	3-motor, 3-head system, 4-track 2-channel recording, 4-track 4-channel playback operations
Heads	4-track 4-channel playback head x 1 4-track 2-channel recording head x 1 4-track 2-channel erase head x 1
Motors	For reel; 6-pole inner rotor induction motor x 2 For capstan; 4/8-pole hysteresis synchronous motor x 1
Tape speeds	7 1/2 ips (19cm/s), 3 3/4 ips (9.5cm/s)
High speed wind times	10-in. reel; 110 sec at 740m (2400 feet) tape 7-in. reel; 90 sec at 370m (1200 feet) tape
Wow and flutter	7 1/2 ips; 0.08% WRMS (0.10% RMS) 3 3/4 ips; 0.10% WRMS (0.13% RMS)
Signal to noise ratio	More than 55 dB
Distortion	Less than 1%
Frequency response	7 1/2 ips; 40Hz to 20,000Hz \pm 3 dB 3 3/4 ips; 40Hz to 12,000Hz \pm 3 dB
Crosstalk	More than 60 dB
Stereo channel separation	More than 50 dB
Erase ratio	More than 60 dB
Recording bias frequency	125 kHz
Inputs	Microphone; 0.25mV to 80mV/20k Ω (1mV reference) Line input; 50mV to 25V/100k Ω (316mV reference) DIN; 15mV to 1.5V/1.5k Ω Line; 316mV/50k Ω load with output level control at max. Output impedance; 3.3k Ω DIN; 316mV/50k Ω load with output level control at max. Output impedance; 3.3k Ω Headphone; 40mV/8 Ω with output level control at max. Load impedance; 4 to 16 Ω
Outputs	3-position bias selector 2-position recording equalizer selector Pause lever (lock type) 4-digit tape counter Tape monitor switches (L ch. and R ch.) 4-channel front/rear select switch; for LEVEL METER and HEADPHONE Mic recording level control Line recording level control Output level control

Power requirements	AC. 110V, 120V, 130V, 220V and 240V (switchable) 50Hz or 60Hz
Power consumption	115W
Dimensions	440(W) x 431(H) x 227(D)mm (including feet and reel shafts) 17-5/16(W) x 17(H) x 8-15/16(D) in. Without package; 21kg (46 lb 3 oz) With package; 26kg (57 lb 3 oz)
Weight	10-in. metal reel (Pioneer PR-100) 1 10-in. reel adaptors (Pioneer PP-220) 2 Reel adjusting sheets 2 Connection cords 3 Splicing tape 1 Cleaning kit 1 Cleaning ribbon 1 AC power cord 1 Fuse (2A) 1 Operating instructions 1
Furnished parts	

NOTE: Specifications and the design subject to possible modification without notice due to improvements.



2. PARTS IDENTIFICATION

PAUSE SWITCH

For short interruptions of tape travel. In position ON, the tape is stopped while the unit remains in its previous—recording or playback—mode. At OFF, the tape resumes travel at normal speed. Note, however, that the PAUSE switch does not function during fast forward or rewind.

POWER SWITCH

Push this button to turn the unit ON, push it again and release it to turn the power OFF.

REEL SIZE SWITCH

Changes tape tension in accordance with reel size. For 7-inch (17cm) or smaller reels, push the button in. When using 10-inch (26cm) reels, release the button.
IMPORTANT!
ALWAYS USE TWO REELS OF THE SAME SIZE.

TAPE SPEED SELECTOR

Pushbutton depressed: LO (low) tape speed.
Pushbutton released: HI (high) tape speed.
To switch from LO to HI, push the button lightly — it will return to released position.
HI: 7-1/2 ips (19cm/s)
LO: 3-3/4 ips (9.5cm/s)

MIC RECORDING LEVEL CONTROL

Controls the recording level of live microphone recordings. Clockwise rotation increases the recording level. This control also governs the recording level when a recording is made through the REC./P.B. connector (DIN-type) on the rear panel.

LEVEL METERS

Indicate the recording and playback signal levels.

LINE RECORDING LEVEL CONTROL

Controls the recording level that the signal is fed into the INPUT (REC) jacks on the rear panel. Clockwise rotation increases the recording level.

NOTE:

The MIC and LINE recording level controls both consist of a pair of friction-coupled knobs; the inner knob controls the left channel, the outer ring, the right channel. Usually, knob and ring rotate together, but you can rotate one while holding the other in place with your other hand.

OUTPUT LEVEL CONTROL

Controls the output level that recorded tape is played back. This is a friction-coupled type consisting of the inner and outer knobs.

INNER KNOB: FRONT (CH.1, CH.3)
REAR (CH.2, CH.4)

OUTER KNOB: Usually, knob and ring rotate together, but you can rotate one while holding the other in place with your other hand.

TAPE COUNTER

Before starting a recording, reset the TAPE COUNTER to "0000" by depressing the reset button. Use of the TAPE COUNTER will make it easy to locate the starting point of a recording.

RECORDING INDICATORS

REC-L: Red light emitting diode lights up when the left channel is in recording mode.
REC-R: Lights up when the right channel is in recording mode.

For stereo recordings, confirm that both indicators are lighted.

MIC INPUT JACKS

Two microphones for stereo recording can be connected here. Low-impedance (600Ω) as well as high-impedance (10kΩ to 50kΩ) can be used, but the cables must have standard 6φmm plugs.

TENSION ARM

Regulates tape tension, but also functions as an automatic shut-off sensor. If the tape is slack, breaks or runs out, the automatic shut-off mechanism stops the tape transport and returns all function buttons to neutral position.

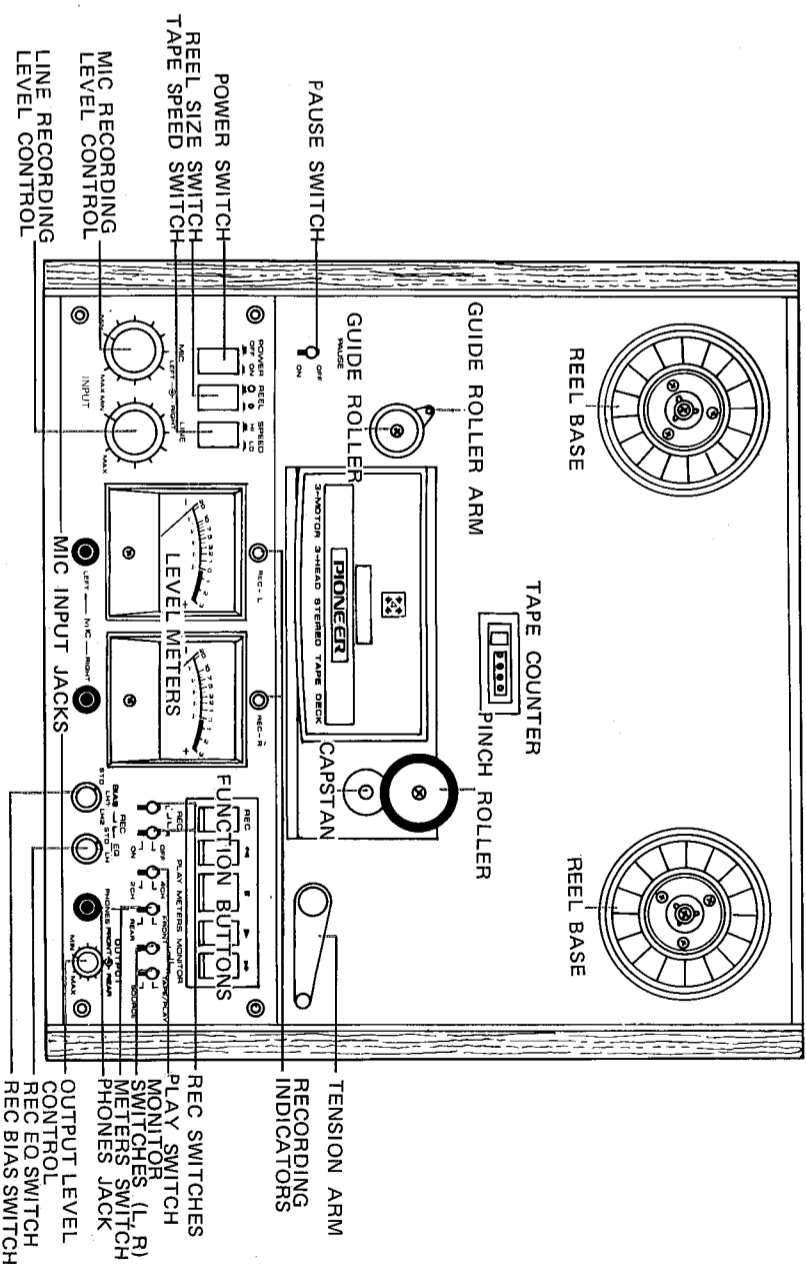

FUNCTION BUTTONS

- **STOP:** Stops tape travel from any mode, returns unit to neutral position.
- ▶ **PLAY:** Makes tape travel at selected speed. For playback, push this button. For recording, push this and the REC button.
- ▶ **FAST FORWARD:** Makes tape travel at high speed from left to right.
- ▶ **REWIND:** Makes tape travel at high speed from right to left.
- REC: Activates recording circuits. To start a recording, hold this button down while pushing the PLAY button.

NOTE:

Unlike inconvenience of some kinds of tape machines on the market, this model helps you switch from one mode of operation to another without pushing the STOP button. That is, there is no need to push the STOP button when switching from either FAST-FORWARD or REWIND mode to another, for instance, you can switch directly to PLAY. Note, however, that such switching operation always stops

REC EQ SWITCH

Selects the recording equalization characteristics in accordance with the type of tape to be used.

STD: For recording on normal, conventional tape.

LH: For recording on low-noise high-output tape.

This switch has no function in playback.

REC BIAS SWITCH

Selects the proper bias current in accordance with the type of tape to be used.

STD: For recording on normal tape. Smallest bias current.

LH 1, LH2: For recording on low-noise high-output tape.

LH 2 gives the strongest bias current.

This switch has no function in playback.

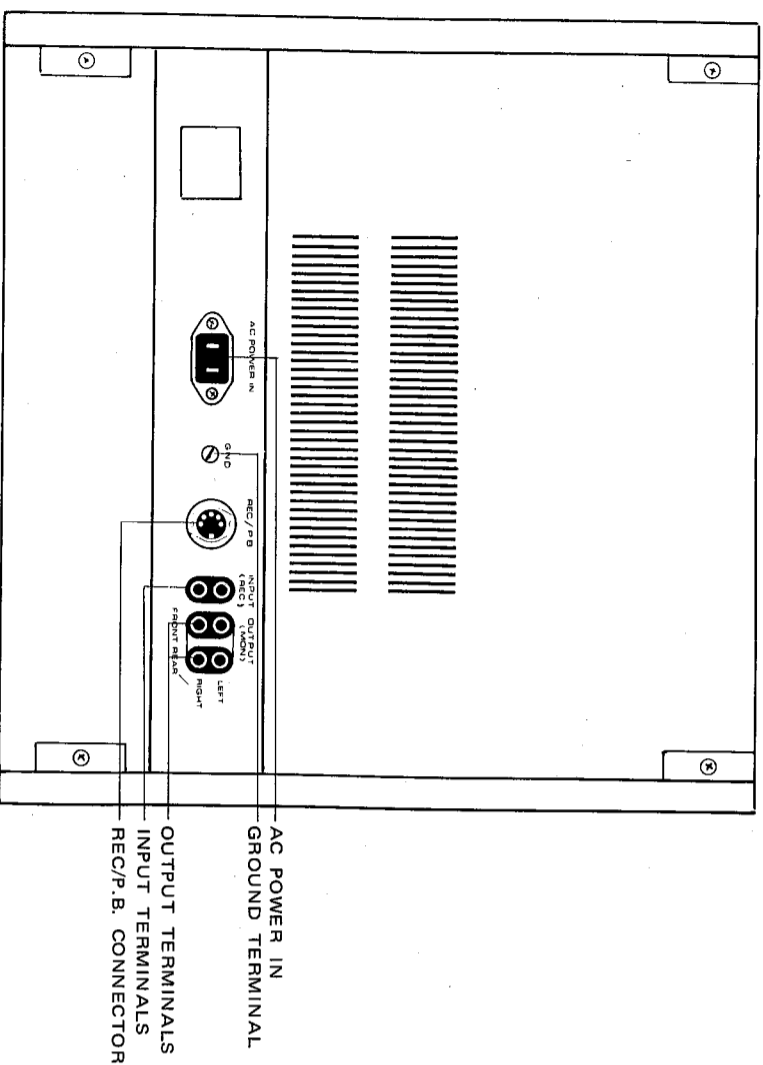

the tape travel once, momentarily. A few seconds more, and it will soon run at normal speed.

Of a variety of magnetic tapes available on the market, thin tape in thickness, used for long hours of continuous playing, must be taken of care not to change the PLAY or STOP mode directly from the FAST-FORWARD mode, for example.

Push the PLAY or STOP button only when reel rotation becomes slow shortly after switching the REWIND mode from the FAST-FORWARD mode or vice versa.

REC SWITCHES (L, R)

To make a recording, one or both of these switches must be set at ON.

L: Recording on left channel

R: Recording on right channel

For stereophonic recordings, set both switches at ON.

PLAY SWITCH

Selects 4-channel or 2-channel playback mode.

4 CH: Playback of 4-channel recorded tapes

2 CH: Playback of 2-channel recorded tapes

METERS SWITCH

Selects the channels to be displayed by the level meters (and supplied to the headphones jack) when playing 4-channel recorded tapes.

FRONT: Front channels (CH. 1 = left, CH. 3 = right)

supplied to level meters and headphones.

REAR: Rear channels (CH. 2 = left, CH. 4 = right)

supplied to level meters and headphones.

MONITOR SWITCHES (L, R)

A recording in progress can be monitored (via speakers or headphones) in either of two ways — the original SOURCE sound, or the recorded TAPE sound as picked up by the playback head. By switching back and forth between positions SOURCE and TAPE/PLAY, you can compare the original sound quality with that of the recording and take corrective action if necessary.

The left switch controls the left channel, the right switch, the right channel.

PHONES JACK

Stereo headphones can be connected here for monitoring or private listening. The METERS switch selects the channels that you hear through the headphones.

AC POWER IN

Connect the AC power cord here.

GROUND TERMINAL (GND)

Grounding is not necessarily required, but in the case of hum or externally induced noise, the GND terminal on the amplifier, or directly to earth.

REC./P.B. CONNECTOR

A combined input and output, for 2-channel operation only. If your stereo amplifier has an identical REC./P.B. connector, you can establish all recording (INPUT), and playback (OUTPUT) connections with a single DIN cable (optional) available from your Pioneer dealer. Note that if connection is made to the REC./P.B. connector, the recording level must be controlled with the MIC recording level controls.

INPUT (REC) TERMINALS

For recording, connect these inputs to the TAPE REC or similar outputs of your stereo amplifier by means of the supplied phono cables. Be sure to connect left channel to LEFT, right to RIGHT.

OUTPUT (MON) TERMINALS

For playback, connect these outputs to the TAPE MONITOR, TAPE PLAYBACK or similar inputs on stereo or 4-channel amplifier.

With a 4-channel amplifier:

FRONT LEFT to FRONT LEFT (CH. 1) of amplifier

FRONT RIGHT to FRONT RIGHT (CH. 3) of amplifier

REAR LEFT to REAR LEFT (CH. 2) of amplifier

REAR RIGHT to REAR RIGHT (CH. 4) of amplifier

With a 2-channel amplifier:

3. CIRCUIT DESCRIPTION

The RT-1020L tape deck contains both 4-channel playback and 2-channel recording and playback. It employs four playback circuits, two recording circuits and one oscillator circuit. The left-channel front unit major circuitry is shown in Fig. 1.

3.1 PLAYBACK CIRCUIT (Fig. 1)

1. The signal received by the playback head is amplified via the three-stage direct coupled amplifier consisting of Q201, Q205 and Q209.
2. The playback signal flat frequency response is obtained by negative feedback from the Q209 collector to the Q201 emitter through the equalizer elements (R241, C229, VR201, R245 and Q213). Playback characteristics can be adjusted to two different tape speeds by utilizing the internal resistance of FET (Q213) which varies according to gate voltage (0.6V for 7-1/2 ips, -10V for 3-3/4 ips). The signal from Q209 is fed to the Q301 via VR5 and VR9.
3. The Q301 works as the emitter follower and the playback output is provided at the LINE OUTPUT terminals.
4. The signal from VR9 is fed to the IC301 through the METERS switch (S4 . . . FRONT/REAR switch) and this provides the HEADPHONE output, indicated on the level meter.

3.2 RECORDING CIRCUIT (Fig. 2)

1. The input signal from the MIC input jack is amplified via C103 by the two-stage direct coupled amplifier consisting of Q101 and Q103.

2. The output from Q103 is fed to Q105 after the MIC recording level control (VR1) is established. Then the input signal from the INPUT terminal (LINE) is fed to the Q105 through the LINE recording level control (VR3). When mixing recording with MIC and LINE, therefore, levels can be adjusted independently.

3. The signal amplified by Q105 and Q107 is fed to the Q109 base via VR101.
4. In Q109, Q111, the signal is amplified, supplying the signal current which is required at the recording head.

In addition, the negative feedback from the Q111 collector is fed to the Q109 emitter through the equalizer for the low sound range via R153, C131, R155 (approx. +4dB at 20Hz).

5. In the high sound range, where compensation is made according to tape speeds, a switching circuit using diodes is employed.

Assuming that LH tape is used at the speed of 7-1/2 ips (19cm/s), D101 and D103 are biased plus into causing to flow current, and the series resonance circuit using L101 and C141 are activated.

6. The signal from the Q111 is fed to the recording head through L401 and C401. These are tuned in the oscillator frequency to prevent bias leakage through Q111, Q109 circuit.
7. When operating the REC switches (S7 and S8), i.e., the stereo recording, the +B voltage is fed to the oscillator circuit and the current flows to the light-emitting diodes (D001, D002) through relays simultaneously and recording is indicated (Fig. 3).

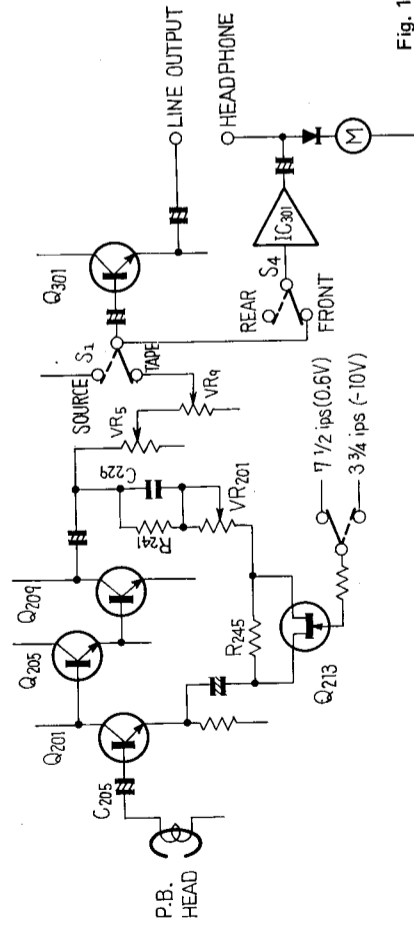

Fig. 1

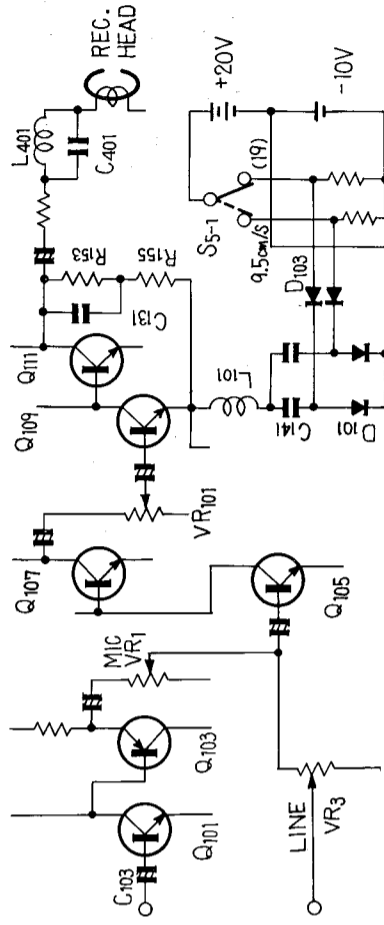

Fig. 2

3.3 OSCILLATOR CIRCUIT (Fig. 3)

1. When the voltage, approx. 39V, is supplied to Q401 and Q402, the oscillation is activated by the positive feedback through the oscillator transformer (T401).
2. The oscillator output is supplied to recording head and erase head through the T401 secondary winding.
3. Part of the oscillator output is extracted through R410 and C411, and rectified by D401 and D402 to feed the VR405. The DC voltage from the VR405 is fed to the Q404 base.
4. The +B power is supplied to Q401 and Q402 through the Q403 emitter.
5. The DC voltage at the Q404 base controls the +B voltage supplies oscillator circuit with regulator Q403. In this way oscillator output is regulated constantly.
6. The switch S9 functions for a variety of recording tape bias currents, and the switch S5-4 for tape speeds.

3.4 CONTROL CIRCUIT (Fig. 4)

The control circuit employs three relays whose functions are as follows:

RL601 functions during fast forward and rewind.

When operating the fast forward or rewind, the current flows through R606 ~ D603 ~ FR601 ~ RL601 ~ S17-2, (S16-2) and operates the relay.

RL602 functions during recording or playback.

When operating the recording or playback, the current flows through FR602 ~ RL602 ~ relay contact RL601 ~ S20 ~ S18-1 ~ S16-2 ~ S17-2.

When POWER switch S12 and shut-off switch S15 are ON, the current flows through D605 ~ R603 ~ RL603 ~ S18-1 ~ S16-2.

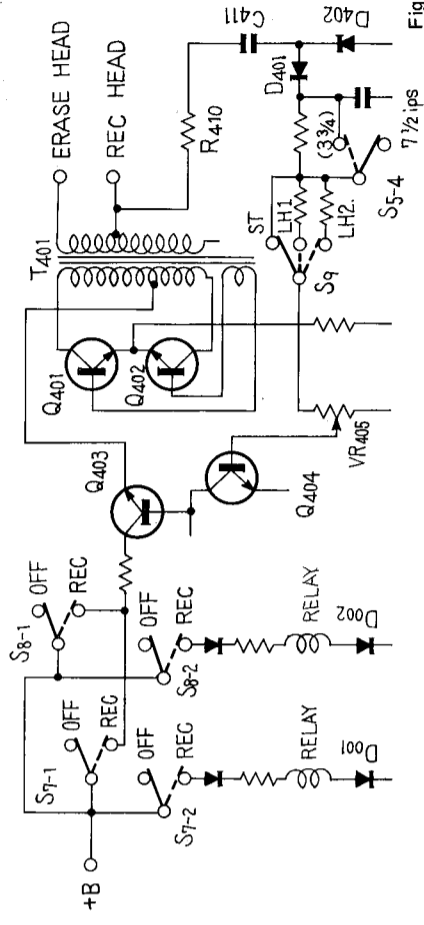

Fig. 3

● Solenoid Voltage Control Circuit

When operating the tape deck (in playback, recording, fast forward and rewind), the solenoid starting current is increased so that the attracting force can be raised and then reduced to protect the solenoid from overheating after the operation.

1. When S12 and S15 are ON, voltage is generated between A and B at the power transformer secondary winding.
2. If the deck is in the playback mode (S18 at PLAY), the AC voltage of the secondary winding is rectified and the charging current (Q602 base current) flows into C612 to make the Q602 in conduction.
3. The Q602 emitter current is identical with the Q1 base current to make the Q1 in conduction.

In this way, the brake solenoids (SL2, SL1) are operated by current flowing through it ~ D608 ~ relay contact RL601 ~ S20 ~ S18-1 ~ S16-2 ~ S17-2. The pinch roller solenoid (SL3) is operated simultaneously.

4. When the C612 is charged, the bias potential of Q602 is stabilized and turned back to its normal condition by R604 and zener diode (ZD601).
5. When operating the tape deck in the fast forward or rewind mode, the pinch roller solenoid does not work, since the S18-1 is out of PLAY. The D608, however, works as the reverse current protection diode.

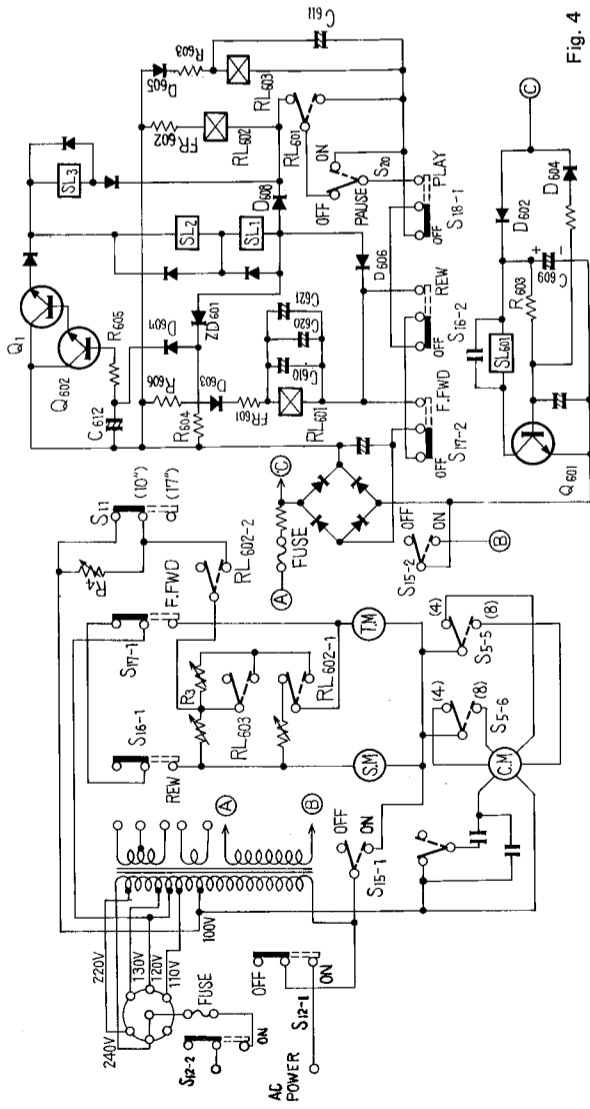

Fig. 4

● Take-up Torque Switching Control Circuit at Playback

In order to prevent tape slacking or hunting when the STOP mode is turned to playback, the take-up torque is at first reinforced, then allowed to adjust automatically.

1. While in the STOP mode, the RL603 relay is operating. Also, the relay contact (RL603) short-circuits both ends of R3.
2. While in the playback mode, the S18-1 is on PLAY and current to the RL603 is shut off. The relay, however, continues for a short time to be activated by the electric charge remaining in C611.

● Protection Circuit at Playback Immediately after Fast Forward (Rewind)

When operating the playback immediately after fast forward or rewind operation, the solenoid will not function for a certain period in order to protect the tape.

1. The RL601 operates in fast forward or rewind mode.
2. The playback mode turns S16-2 or S17-2 to the OFF position, thus shutting off the current now flowing in the relay. However, the relay remains activated for a short time by the discharging action of C620, C621. Relay contact RL601 is shown in Fig. 4 at the dotted line.
3. Since the RL601 is operating, the relay RL602 does not function.
4. When the RL601 is released, the current flows through FR602 ~ RL602 ~ relay contact RL601 ~ S20 ~ S18-1 ~ S16-2 ~ S17-2 and operates the RL602.

3.5 OPERATION BUTTONS RESET CIRCUIT (Fig. 4)

When tape is taken up or broken, the shut-off switch S15 is opened to reset the buttons.

1. The AC voltage is generated at A, B and C of the power transformer secondary winding when the power switches S12 and S15 are ON.
2. This voltage potential biases the Q601 base minus through D604, making the Q602 OFF.
3. Assuming that the S12 or the S15 is OFF, the AC voltage becomes zero and the minus bias from the D604 is shut off. For this reason, the discharging current from C609 is fed to the Q601 through R603, so that the Q601 is ON. The Q601, ON, activates the reset solenoid (SL601) to reset all buttons.
4. After the C609 is discharged, the Q601 is then OFF, and the SL601 is released.

3.6 TAPE SPEED SWITCHING (Fig. 4)

Tape speed is switched by alternating the number of poles in the motor with the SPEED switch S5.

- 7-1/2 ips (19cm/s) 4 poles
- 3-3/4 ips (9.5cm/s) 8 poles

4. DISASSEMBLY

4.1 BACK COVERS (Fig. 5)

1. Take out screws 1 ~ 7 and remove the back cover (A). This exposes the internal mechanism and permits examination.
2. Take out screws 8 ~ 13 and remove back cover (B). The amplifiers can then be adjusted.

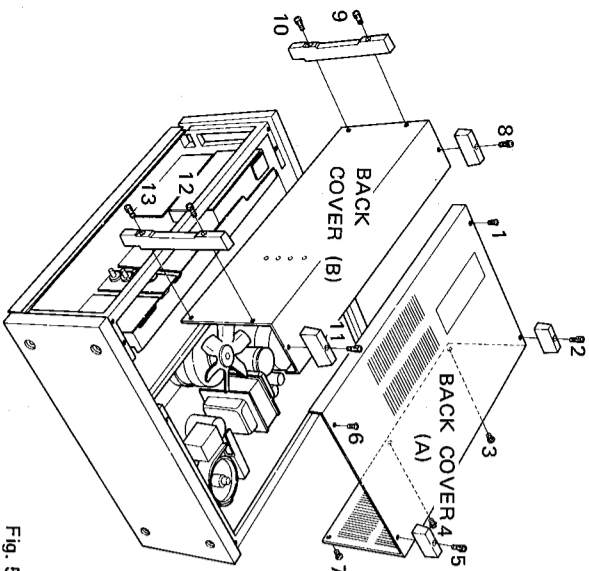

Fig. 5

4.2 SIDE BOARDS (Fig. 6)

Take out screws 1 ~ 8 and remove the side boards.

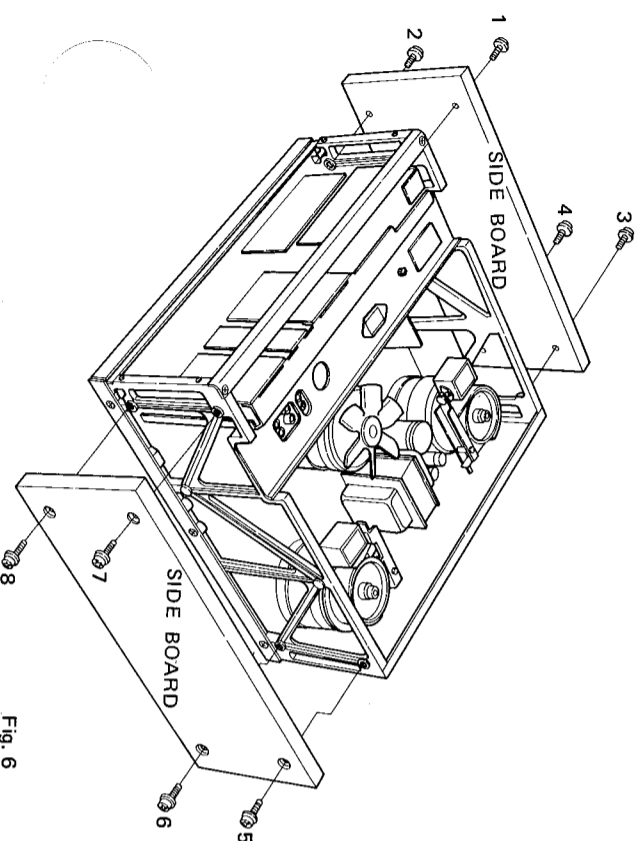

Fig. 6

4.3 AMPLIFIER PANEL (Fig. 7)

1. Remove all knobs.
2. Take out screws 1 ~ 4 and remove the amplifier panel. The level meters can then be replaced.

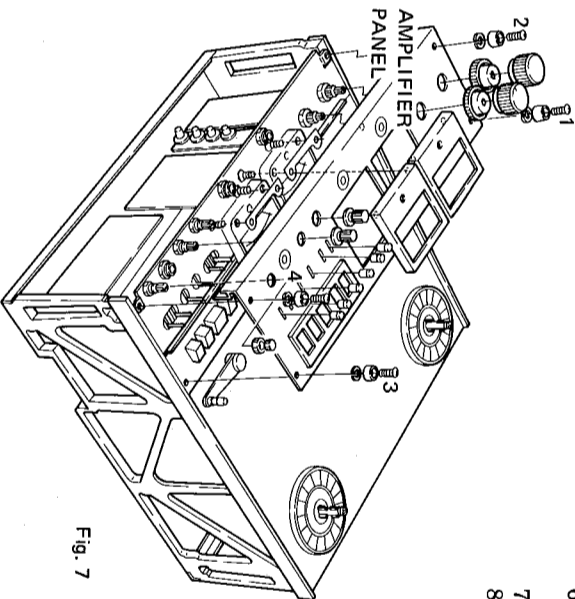

Fig. 7

4.4 MECHANICAL PANEL (Fig. 8)

1. Take out screws 1 ~ 2 and remove the head housing.
2. Take out screw 3 and remove pinch roller.
3. Take out screws 4 ~ 6 and remove head escutcheon by turning cap.
4. Take out screws 7 ~ 12 and remove the reel base.
5. Take out screws 13 ~ 15 and remove the guide roller.
6. Take out screw 16 and remove the tension arm.
7. Remove the PAUSE knob.
8. Take out screws 17 ~ 22 and remove the mechanical panel by lifting out the aluminum sashes.

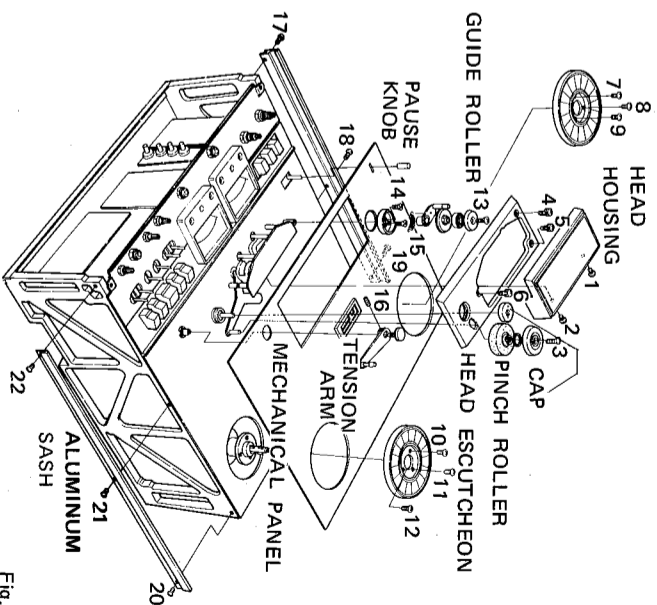

Fig. 8

5. TROUBLE SHOOTING

5.1 TRANSPORT MECHANISM AND CONTROL SYSTEM (1).

"Reel motor" refers to the take-up and supply motors. For further explanation, see section 5.2, Nos. 1 ~ 5.

● Power supply and lamps.

Lack of Power ON. ————— See 5.2.1 "Power and lamps."

Lamp does not light. ————— See 5.2.1 "Power and lamps."

Control system does not function. ———— Burned-out fuse (F 5). ————— Replace.
 ———— Defective shut-off switch. ————— Replace.

● Playback function.

Take-up too weak or too strong. ———— Improperly positioned REEL size switch. ———— Correct position to match reel size.

————— Trouble in reel motors. ————— See 5.2.2 "Reel motors."

Insufficient tape speed. ———— Pinch roller slipping. ————— See 5.2.3 "Pinch roller."

————— Poor pinch roller pressure. ————— See 5.2.3 "Pinch roller."

————— Excessive back tension. ————— Re-adjust. See section 6.3.

————— Poor capstan motor torque. ————— See 5.2.4 "Capstan motor."

Defective tape speed switching. ———— Defective switch (S 5). ————— Replace.

Wow and flutter. ———— Dust on pinch roller and capstan. ————— Clean with absolute alcohol.

————— Defective pinch roller. ————— See 5.2.3 "Pinch roller."

————— Poor pinch roller pressure. ————— See 5.2.3 "Pinch roller."

————— Excessive friction or sticking of flywheel bearing. ————— Lubricate, clean or replace where necessary.

————— Excessive back tension. ————— Re-adjust. See section 6.3.

————— Trouble in capstan motor. ————— See 5.2.4 "Capstan motor."

(Take-up side)
 Tape slackens at start of tape travel. ———— Abnormal take-up torque. ————— See 5.2.2 "Reel motor."

————— Relay RL603 released earlier. ———— Replace capacitor (C 611).

————— Poor back tension. ————— See 5.2.2 "Reel motor."

(Supply side)

Tape squeals. ———— Soiled tape guide. ————— Clean with absolute alcohol.

————— Damaged tape. ————— Replace.

2. Reel motors Check to make sure line frequency switch is in proper position.

No voltage to motor. — Defective shut-off switch contact. — Replace.

OK

Motor failure despite
apparent voltage. — Defective phase capacitor. — Replace.
— Stuck motor shaft. — Replace the motor.
— Defective motor coil. — Replace the motor.
— Brake does not clearance. — Re-adjust. See section 6.2.

Defective take-up at
playback mode. — Defective wire wound resistor — Replace.
(R 3 or R 4).
— Defective relay contact or — Replace
relay (RL 602).
— Imperfect FUNCTION — Replace.
button contact.

No back tension — Defective wire wound resistor — Replace.
in playback mode. (R 2).

Defective fast forward. — Excessive back tension. — Re-adjust. See section 6.3.
— FUNCTION button contact — Replace.
failure.

Defective rewind. — Excessive back tension. — Re-adjust. See section 6.3.
— Poor FUNCTION button — Replace.
contact.

No back tension in — Defective wire wound resistor — Replace.
fast forward mode. (R 1).

3. Pinch roller Also check solenoid (SL 3).

Revolving sound squeaks. — Stuck bearing. — Clean and lubricate.

Dull rotation. — Stuck bearing excessive — Clean or replace bearing, then
friction. lubricate.

Pinch roller slipping. — Dirty pinch roller. — Clean with absolute alcohol.

Defective solenoid — Defective transistors (Q1, Q602). — Replace.
function. — Defective diode (D609). — Replace.

OK

Insufficient attracting — Imperfect solenoid installation. — Re-adjust. See section 6.4.
force. — Defective control circuit. — Check circuit and make necessary
repairs.

4. Capstan motor Check to see that line frequency switch is properly positioned.

No voltage to motor. — Defective shut-off switch contact. — Replace.

OK

Motor does not rotate. — Defective phase capacitor. — Replace.
— Motor shaft friction. — Lubricate.
— Stuck motor shaft. — Replace the motor.
— Defective motor coil. — Replace the motor.

OK

Insufficient torque. — Defective phase capacitor. — Replace.

5. Brake Also check brake solenoids (SL1, SL2).

Brake mechanism does not function. — Defective transistors (Q1, Q602). — Replace.
— Defective diode (D609). — Replace.

OK

Insufficient brake solenoid attracting force. — Improper solenoid installation. — Re-adjust.
— Defective control circuit. — Check circuit and make necessary repairs.

OK

Brake release failure. — Improper adjustment. — Re-adjust. See section 6.2.

Improper brake friction. — Dusty or soiled brake drum. — Clean with absolute alcohol.

6. Function button.

Button fails to snap back. — Stuck button. — Repair.
— Switch contact welded. — Replace switch.
— Switch lock plate caught. — Replace switch.

Button fails to snap back at shut-off or power OFF. — Defective capacitor (C609). — Replace.
— Defective reset solenoid (SL601). — Replace.
— Reset plate caught. — Replace.

5.3 ELECTRONIC CIRCUIT TROUBLE

● No playback sound.

Connection cord check. — Defective connection cord — Reconnect.
contact.

OK

— Defective playback head. — Replace.

Power supply circuit check. — Repair or replace.

OK

— Defective P.B. amplifier circuit. — Repair or replace.

— Loose connection of internal connection cord. — Repair.

● **Insufficient sound.**

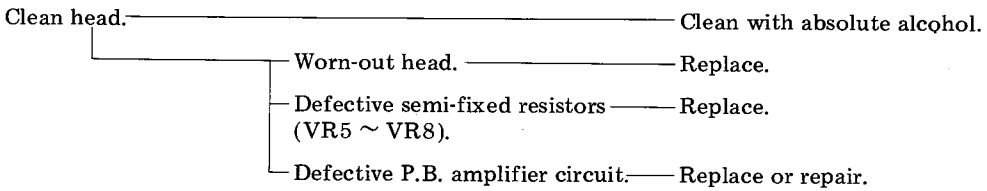

● **Sound distortion.**

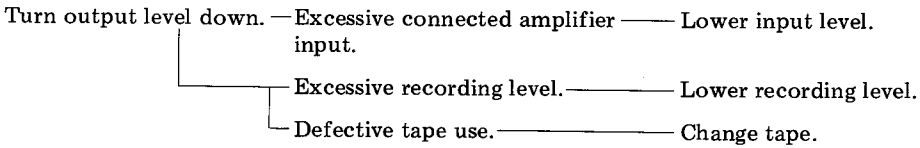

● **Poor treble.**

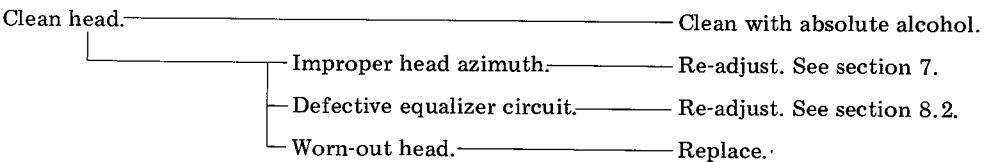

● **Poor bass.**

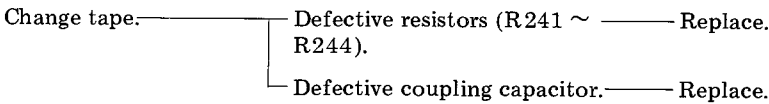

● **Sound drop-out.**

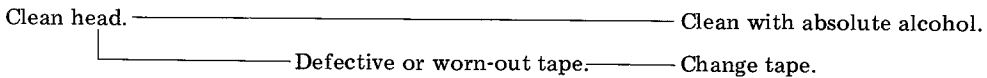

● **Excessive or occasional noise.**

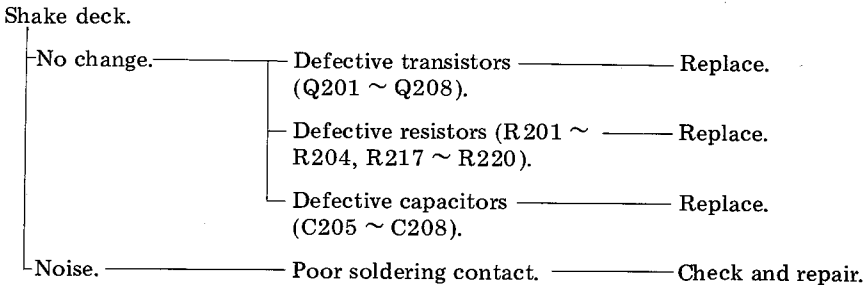

6. MECHANICAL ADJUSTMENTS

For items 6.1 ~ 6.4 adjustments, never fail to place the tape deck in specified positions (6.1: horizontal, 6.2 ~ 6.4: vertical), otherwise, correct measuring value would not be obtained. With these things in mind, proceed as follows:

6.1 REEL BASE HEIGHT ADJUSTMENT

In the case of incorrect reel base height, or replacement of supply motor or take-up motor, sideboards are removed and reel base height must be adjusted.

1. Place the tape deck in a horizontal position and check to make sure the panel and chassis of the transport mechanism are firmly attached.
2. Loosen screw to allow a clearance of 2mm between the panel and reel base as in Fig. 9.
3. Adjust supply and take-up reel bases as above.

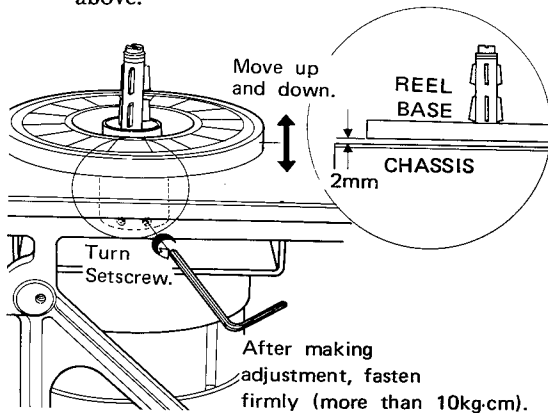

Fig. 9

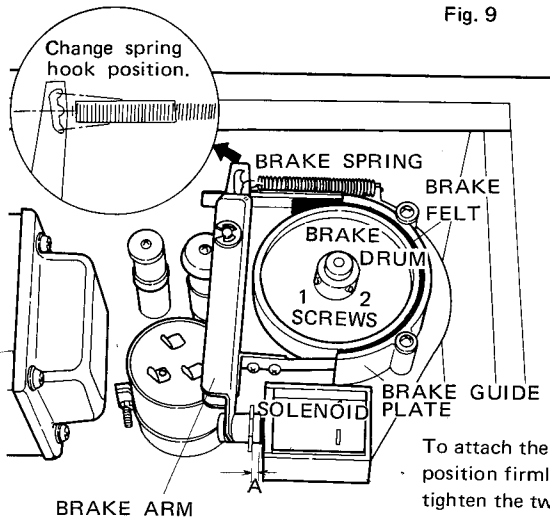

Fig. 10

6.2 BRAKE ADJUSTMENT

Required when tape slackens or when solenoid or motor is replaced.

First, place the tape deck in a vertical position and check the following:

- Is A in Fig.10 4mm when the solenoid is not operating?
- Can you rotate the motor smoothly with your hand while pressing the solenoid shaft?

● Adjustment (Figs. 10, 11)

For adjusting the take-up reel, fast-forward it for about 2sec. once to minimize unstableness in measuring values, then push the STOP button to cause reel revolution to halt.

Should the reel be rotated before measuring, differences in measuring values would result. For adjusting the Supply reel, rewind it once, then make the adjustment.

These adjustments are made in (A) ~ (D) arrow-indicated directions.

With these things in mind, proceed as follows:

1. Load the 7-inch reel, fixing the string on the reel base.
2. Pull tension gauge to measure brake friction, pulling in B (C) direction until reel turns.
3. Adjust the brake spring hook position so that the gauge reads 300 ~ 450g (900 ~ 1350g-cm).
4. When the above adjustments fail to bring the desired results, check the following points:
 - Soiled brake drum
 - Soiled brake felt
 - Faulty brake guide plate
 - Unstable brake arm
5. Measure brake friction by pulling tension gauge in D (A) direction. Then, check ratio of brake friction to measured value of step 3. It should be 2.3:1 ~ 3.7:1.

NOTE:

When the value in B (C) direction indicates 400g, the value in D (A) direction is optimum at a range of 174 ~ 108g.

● **Confirmation After Adjustment**

1. When the prior adjustment is over, lower 10% power source voltage (down to 216V in 240V area, for example) in order to check up on fast-forward or rewind operation with the help of a 10-inch metal reel (long tape 150%).
2. While transporting the tape reels at high speed, push the PLAY button when the tape volume being now taken up in the take-up reel becomes increased more than that of the supply reel — when you see the taken-up volume show about $10 \sim 40\phi$.
3. Confirm that the tape speed runs normal after it stops completely.
4. If the specified condition in step 3 is found unsatisfactory, try to satisfy step 3 repeatedly even though a tension gauge does not read less than 300g.cm.

NOTE: C610 and C620 short of capacitance make condition in step 3 unsatisfactory.

6.3 TAKE-UP AND BACK TENSION TORQUE ADJUSTMENT

● **Back Tension Torque at Playback (Figs. 11, 12)**

1. Set REEL size switch at 10-inch reel position.
2. Set tape deck in vertical position in playback mode at 7-1/2 ips (19cm/s). Measure back tension of supply reel base by pulling tension gauge in B direction as shown in Fig. 11.

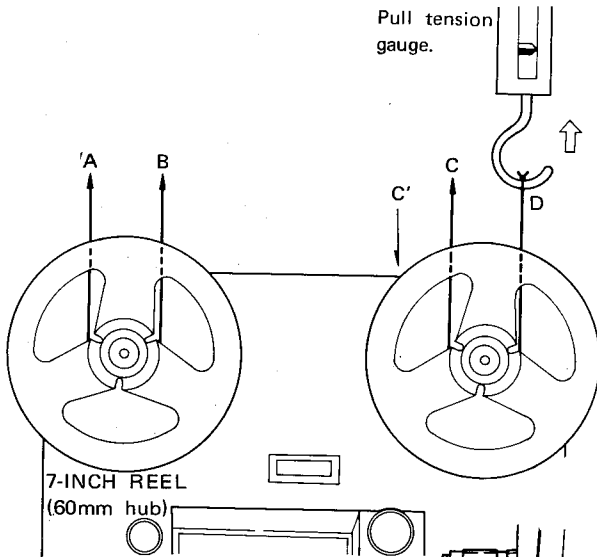

Fig. 11

3. Adjust slider (R_2 500 Ω) so that the gauge reads 93 ~ 110g (280 ~ 330g.cm) (Fig. 12).
4. Set REEL size switch at 7-inch reel position. Measure back tension as mentioned in step 2.
5. Adjust slider (R_4 100 Ω) so that the gauge reads 63 ~ 77g (190 ~ 230g.cm).
6. After adjustment, the slider screw must be firmly clamped.

● **Take-up Torque at Playback (Figs. 11, 12)**

1. Set REEL size switch at 10-inch reel position.
2. Set tape deck in vertical position and in playback mode at 7-1/2 ips (19cm/s). Measure take-up torque of take-up reel base (While moving tension gauge slowly in C' direction as shown in Fig.11, read value of the gauge.)
3. Adjust slider (R_3 300 Ω) so that the gauge reads 190 ~ 210g (570 ~ 630g.cm).

● **Back Tension Torque at Fast Forward (Figs. 11, 12)**

1. Set tape deck in vertical position in fast forward mode. Measure back tension of supply reel base (pull in B direction as shown in Fig. 11).
2. Adjust the slider (R_1 2k Ω) so that the gauge reads 35 ~ 45g (105 ~ 135g.cm).

NOTE:

When back tension of fast forward is adjusted, back tension of rewind is determined automatically, since the resistor R_1 is used for both functions.

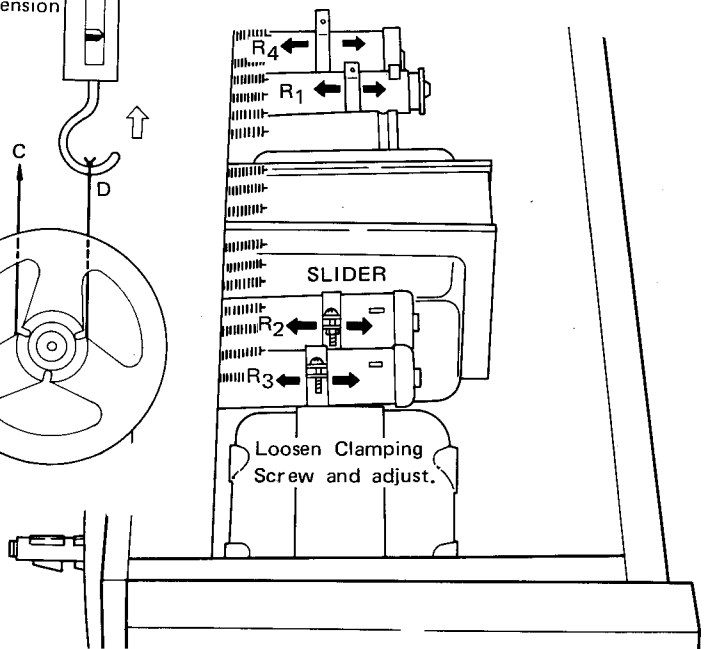

Fig. 12

6.4 PINCH ROLLER PRESSURE ADJUSTMENT (Figs. 13, 14)

When replacing pinch roller solenoid or pinch roller, check pressure of capstan as follows:

1. Set tape deck in vertical position with REEL size switch at 10-inch reel position.
2. Turn POWER switch and shut-off switch ON.
Set deck in playback mode.
3. Make sure that the gap B shown in Fig. 13 is 1mm.
4. If the value is not correct, loosen the three bracket-held screws and adjust position of pinch roller solenoid.
5. Load Scotch No. 111, 10-inch metal reel (or similar product). Run tape fast forward until amount on take-up reel matches that on supply reel.
6. Play tape at constant speed (7-1/2 ips) hook tension gauge as in Fig. 14, then pull the gauge, and confirm the value when travel is stopped in 1.7kg ~ 2kg range.
7. When tape traveling is not stopped with in 1.7kg ~ 2kg, check the following:
 - Loosen pressure spring fastening
 - Defective pinch pressure spring
 - Soiled pinch roller
 - Soiled capstan

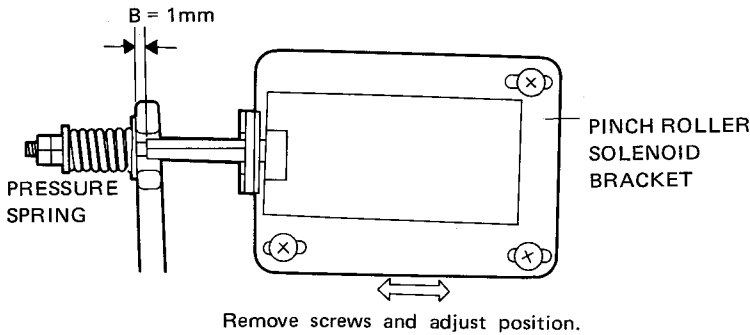

Fig. 13

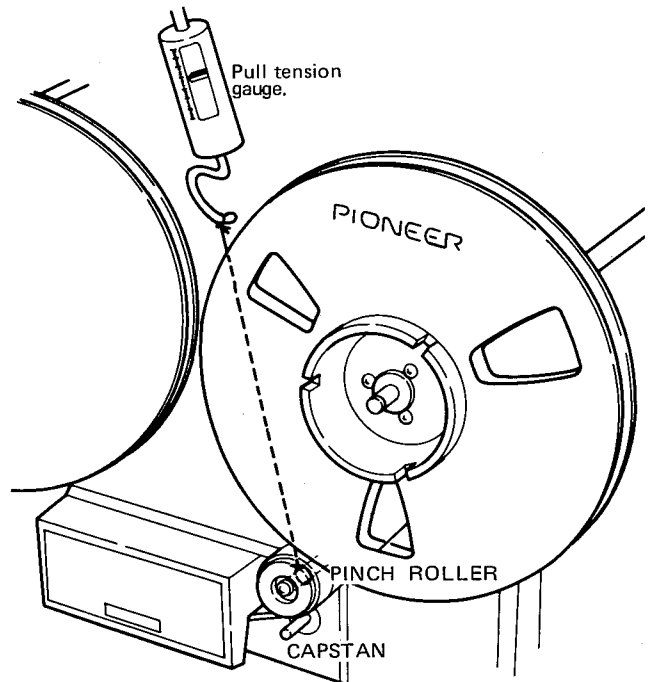

Fig. 14

7. TAPE HEAD ADJUSTMENTS

7.1 COARSE ADJUSTMENTS (Figs. 15, 16)

● Height

Adjust screws to proper relation dimension between tape and heads as shown in Fig. 15.

P.B. Head screws 1, 2, 3

REC Head screws 6, 7, 8

ERASE Head . . Use spacer.

When adjusting the erase head, make sure contact with the tape surface is flat.

● Tilt Angle

Adjust the following screws so that the head and tape touch evenly and flatly when tape is traveling.

P.B. Head screw 1

REC Head screw 6

● Azimuth

Adjust the following screws so that the head gap and tape surface are touching vertically.

P.B. Head screw 3

REC Head screw 8

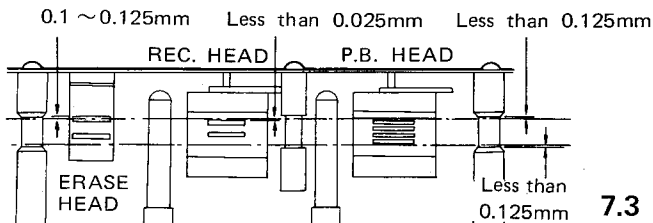

Fig. 15

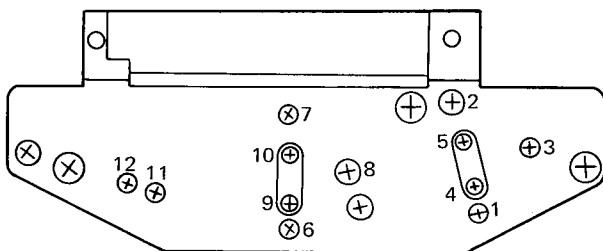

Fig. 16

7.2 P.B. HEAD ADJUSTMENT (Fig. 16)

1. Play the fifth band (15kHz, -10dB full track) of test tape at 7-1/2 ips (19cm/s).
2. Adjust the screw 3 for the maximum output level.
A little output level difference between L- and R-channel is allowed in this adjustment.
3. During step 1, check to make sure the output level does not change, by pressing the tape slightly with your fingertip while it travels.
4. If the output levels change from step 3, screws 4 and 5 and adjust the head position by slightly moving it horizontally.

7.3 REC. HEAD ADJUSTMENT (Fig. 16)

1. Supply input signal of 500Hz, -10dBv (316mV) to the INPUT terminals. Load tape, then record above signal.
2. During recording, check playback level with MONITOR switch set to TAPE position.
3. Adjust the screws 6, 7 and 8 for the maximum playback level.
4. Set frequency to 15kHz and check playback output as above.
Adjust screw 8 slightly for the maximum playback level.
5. During step 4, check to make sure that the output level does not vary, by pressing the tape slightly with your fingertip while it travels.
6. If output levels differ greatly, loosen the screws 9, 10 and adjust the head position by slightly moving the head horizontally.

8. CIRCUIT ADJUSTMENTS

The following measuring instruments are required for circuit adjustments:

- MILLI VOLTMETER
 - AUDIO OSCILLATOR
 - OSCILLOSCOPE
 - ATTENUATOR
 - FREQUENCY MEASURING INSTRUMENT (FREQUENCY COUNTER)
 - AC VOLTMETER (With probe)
- Controls are the tape deck as follows unless otherwise specified:
- Tape speed 7-1/2 ips (19cm/s)
 - REEL size switch 7-inch reel
 - REC BIAS switch STD
 - REC EQ switch STD
 - METER switch FRONT
 - REC switch STEREO
 - OUTPUT level MAX

Reference voltage level for measurements 50kΩ resistor to the LINE OUTPUT terminals.

8.1 PLAYBACK SENSITIVITY ADJUSTMENT (Fig. 17)

1. Connect milli voltmeter to LINE OUTPUT terminal.
2. Play back the third band (700Hz, 0dB full track) of test tape.
3. Adjust the following semi-fixed resistors so that the voltmeter reads -10dBv (316mV).
 VR5 FRONT L ch.
 VR6 FRONT R ch.
 VR7 REAR L ch.
 VR8 REAR R ch.

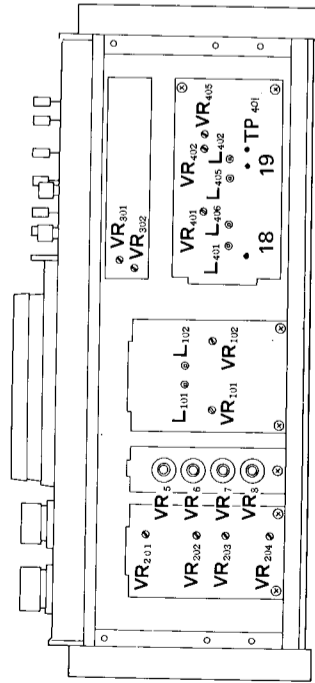

Fig. 17

8.2 PLAYBACK EQUALIZER ADJUSTMENT (Figs. 17, 18)

1. Connect milli voltmeter to LINE OUTPUT terminal.
2. Play back the second band (10kHz, -10dB full track) of test tape.
3. Adjust the following semi-fixed resistors so that the voltmeter reads -20dBv (100mV).
 VR201 FRONT L ch.
 VR202 FRONT R ch.
 VR203 REAR L ch.
 VR204 REAR R ch.
4. "PLAYBACK SENSITIVITY ADJUSTMENT" and "PLAYBACK EQUALIZER ADJUSTMENT" have related functions. Repeat these adjustments as several times as necessary.

8.3 PLAYBACK FREQUENCY RESPONSE CONFIRMATION

After the "PLAYBACK EQUALIZER ADJUSTMENT" is completed, playback the fifth band (15kHz) to the eleventh band (50 Hz) of the test tape. Check the output response to make sure that it is made in the proper sequence following playback frequency response as shown in Fig. 18.

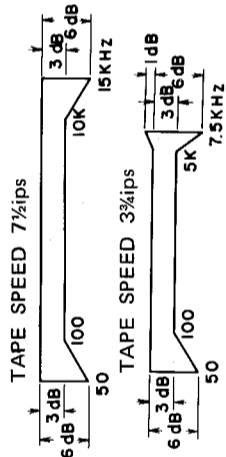

Fig. 18

8.4 BIAS OSCILLATOR AMPLITUDE ADJUSTMENT (Fig. 17)

1. Connect AC voltmeter with probe to the test point (TP401) of OSC circuit P.C. board and ground.
2. Without loading tape, set tape deck in recording mode.
3. Adjust the VR405 so that the oscillator voltage reads 22V.

NOTE:
 Since the oscillator frequency is high (125kHz), handle the probe or connections carefully to avoid measurement errors.

8.5 BIAS-TRAP ADJUSTMENT (Fig. 17)

1. Connect oscilloscope to terminals 18 and 19 at OSC circuit P.C. board and ground.
2. Without loading tape, set the tape deck in recording mode.
3. Adjust the L401 (L ch.) and L402 (R ch.) for the minimum amplitude on the oscilloscope (less than 1V p-p).

8.6 RECORDING BIAS ADJUSTMENT (Fig. 17)

1. Connect milli voltmeter to LINE OUTPUT terminal. Apply the 1kHz, -10dBv (316mV) signal to INPUT terminal.
2. Record the signal on Scotch No. 111 tape and playback simultaneously.
3. Control the LINE recording level control to obtain the output level of -10dBv at OUTPUT terminal.
4. Allow tape to travel for approx. 30 seconds.
5. Adjust the semi-fixed resistors, VR401 (L ch.) and VR402 (R ch.) by rotating clockwise so that the playback level becomes 0.5dB down through the maximum value.
6. Repeat the adjustment in step 3 several times for both L- and R-channels.
7. After the step 3 adjustment is completed, set the recording bias to LH1 and LH2 in order.
8. Adjust the recording bias according to the procedure mentioned in step 1.
9. Assuming the value of step 3 (0.5dB down) to 0dB, confirm that the value at LH1 is 0.9 - 0.3 + 0.9 dB down and the value at LH2 is 2.2 - 0.4 dB down.

8.7 ERASE HEAD DUMMY ADJUSTMENT (Fig. 17)

1. Connect frequency counter to the test point (TP401) at OSC circuit P.C. board and the ground.
2. Set tape deck in L- and R- monophonic recording mode without loading tape. Adjust the L405 (R ch.) and L406 (L ch.) for oscillator frequency to obtain the identical value within stereo recording range.

8.8 LEVEL METER CALIBRATION (Fig. 17)

1. Connect milli voltmeter to LINE OUTPUT terminal.
2. Apply the 1kHz, -10dBv (316mV) input signal to INPUT terminal and turn MONITOR switch to SOURCE.
3. Control the LINE recording level control for the LINE output to obtain -10dBv (316mV).
4. Adjust the VR301 (L ch.) and VR302 (R ch.) so that the level meter indicates "0."

8.9 RECORDING SENSITIVITY ADJUSTMENT (Fig. 17)

1. Connect milli voltmeter to LINE OUTPUT terminal.
2. Apply the 1kHz, -10dBv (316mV) input signal to INPUT terminal. Record it on Scotch No. 111 tape and play back simultaneously.
3. Turn MONITOR switch to SOURCE. Control the LINE recording level control for the LINE output to obtain -10dBv (316mV).
4. Turn MONITOR switch to TAPE. Adjust the VR101 (L ch.) and VR102 (R ch.) for the LINE output to obtain the same value as in step 3.
5. Check to make sure that the recording level at L- and R- monophonic recording is within ±0.3dB as compared to stereo recording.

8.10 REC. AND P.B. FREQUENCY RESPONSE ADJUSTMENT (Figs. 17, 19)

To be made after "RECORDING BIAS ADJUSTMENT."

1. Connect milli voltmeter to LINE OUTPUT terminal.
Apply the 1kHz, -10dBv (316mV) input signal to INPUT terminal, recording on Scotch No. 111 tape and playing back simultaneously.
2. Control the LINE recording level control for the output level to obtain -10dBv (316mV).
3. Keeping the LINE recording level control, attenuate the input level down to 20dB with attenuator to record the 1kHz and 15kHz and to play back simultaneously. The output level in step 3 must fall within the specified response range as shown in Fig. 19.
4. Adjust the L101 (L ch.) and L102 (R ch.) so that the level difference of 15kHz against 1kHz is made within ± 1 dB compared to the deviation between 1kHz and 15kHz at the "PLAYBACK FREQUENCY RESPONSE CONFIRMATION" step.
If the level deviation is greater than ± 3 dB, readjust after "HEAD AZIMUTH ADJUSTMENT."
5. Apply following input signals as 50, 100, 250, 2.5k, 5k, 10k, 15k and 20kHz. Check to make sure the output levels are made within the specified response ranges as shown in Fig. 19 at simultaneous recording and playback.

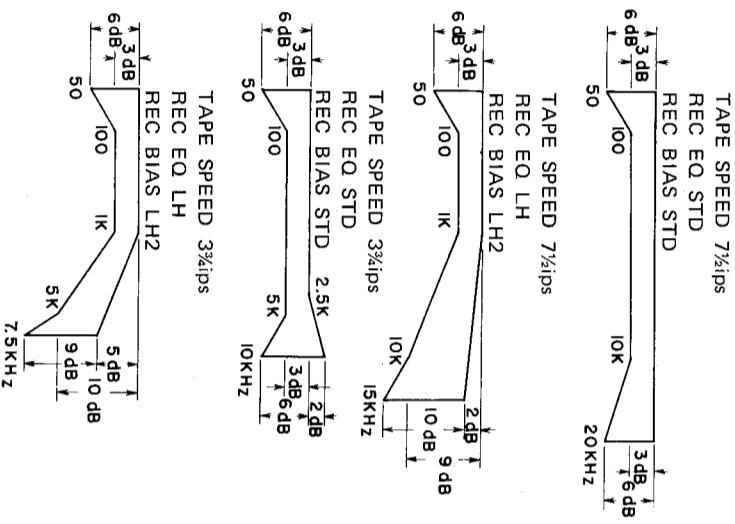

Fig. 19

9. SELECTION OF LINE FREQUENCY AND VOLTAGE

9.1 SELECTION OF LINE FREQUENCY (Figs. 20, 21)

1. Make sure power is OFF.
2. Remove back cover (A).
3. 50Hz to 60Hz:
 - Set drive belt on smaller diameter motor pulley.
 - Set switches to 60Hz.
4. 60Hz to 50Hz:
 - Set drive belt on larger diameter motor pulley.
 - Set switches to 50Hz.
5. When drive belt is set, make sure that the belt remains in its proper position as the flywheel is rotated by hand several times.
6. Clean any spots of oil that appear on the drive belt or flywheel with absolute alcohol.

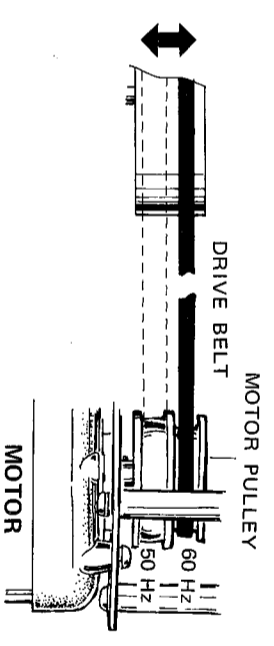

Fig. 20

9.2 SWITCHING LINE VOLTAGE SETTING AND FUSE (Figs. 21, 22)

1. Make sure power is OFF.
2. Remove back cover (A), then LINE VOLTAGE SELECTOR switch is easily accessible.
3. To remove fuse, turn fuse cap.
4. Remove fuse plug from unit.
5. Put fuse plug back so as to see proper line voltage marking through cut in edge of plug.
6. 1-ampere fuse: used in either 220V or 240V area.
2-ampere fuse: used in 110V, 120V, or 130V area.

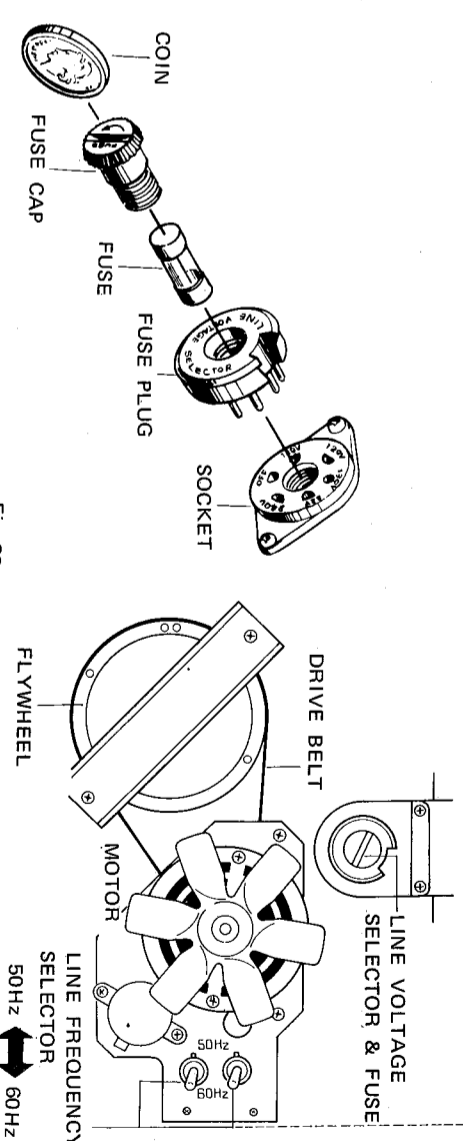

Fig. 21

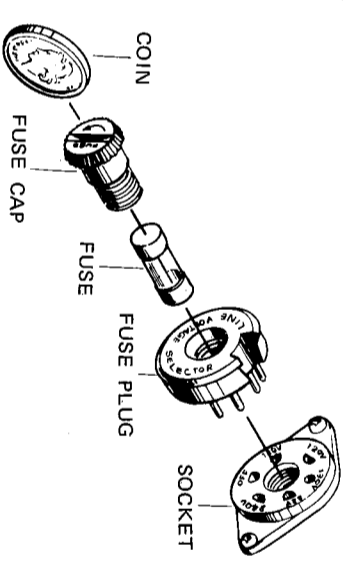
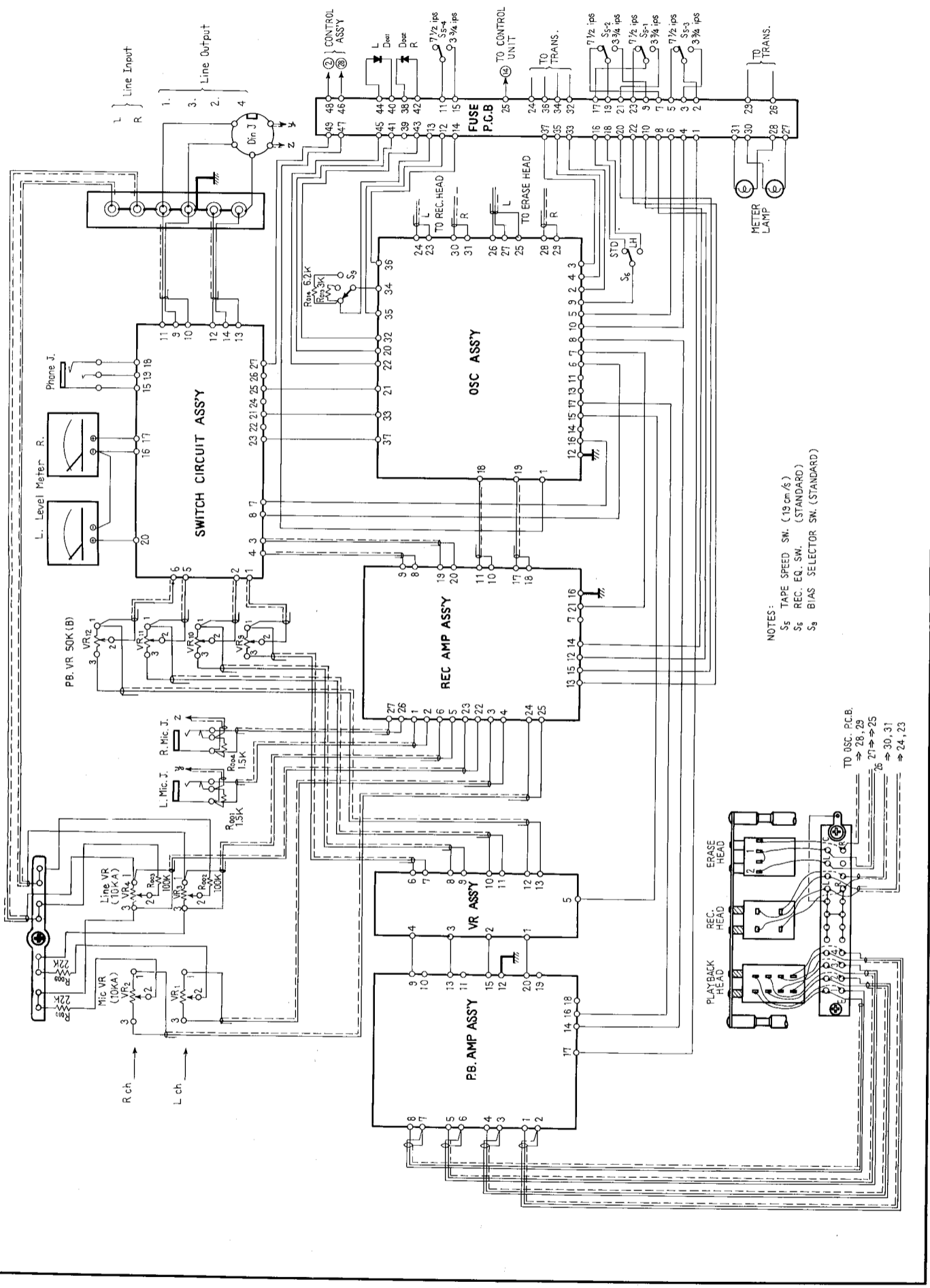

Fig. 22

10. SCHEMATIC DIAGRAMS, P.C. BOARD PATTERNS AND PARTS LISTS

10. 1 CONNECTION DIAGRAM (AMPLIFIER)

RT-1020L



NOTES:
 S5 TAPE SPEED SW. (19 cm/s)
 S5 REC. EQ. SW. (STANDARD)
 S5 BIAS SELECTOR SW. (STANDARD)

TO OSC. P.C.B.
 → 28, 29
 → 27 → 25
 → 30, 31
 → 24, 23

10. 3 CONNECTION DIAGRAM (CONTROL)

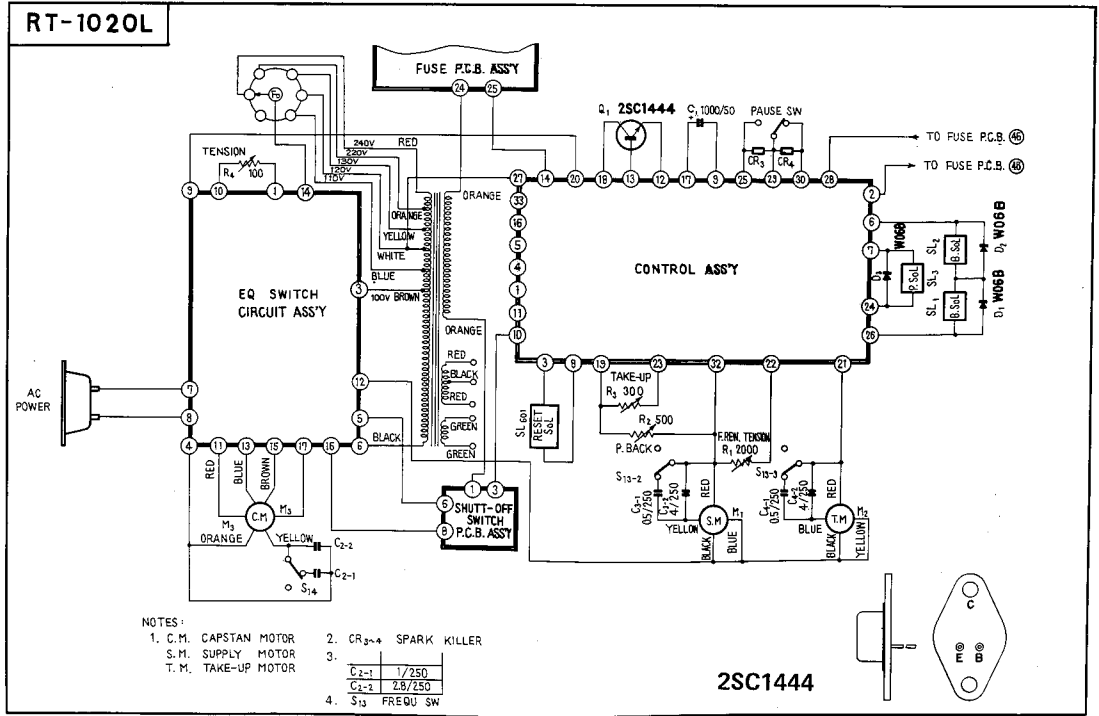

10. 4 SCHEMATIC DIAGRAM (CONTROL)

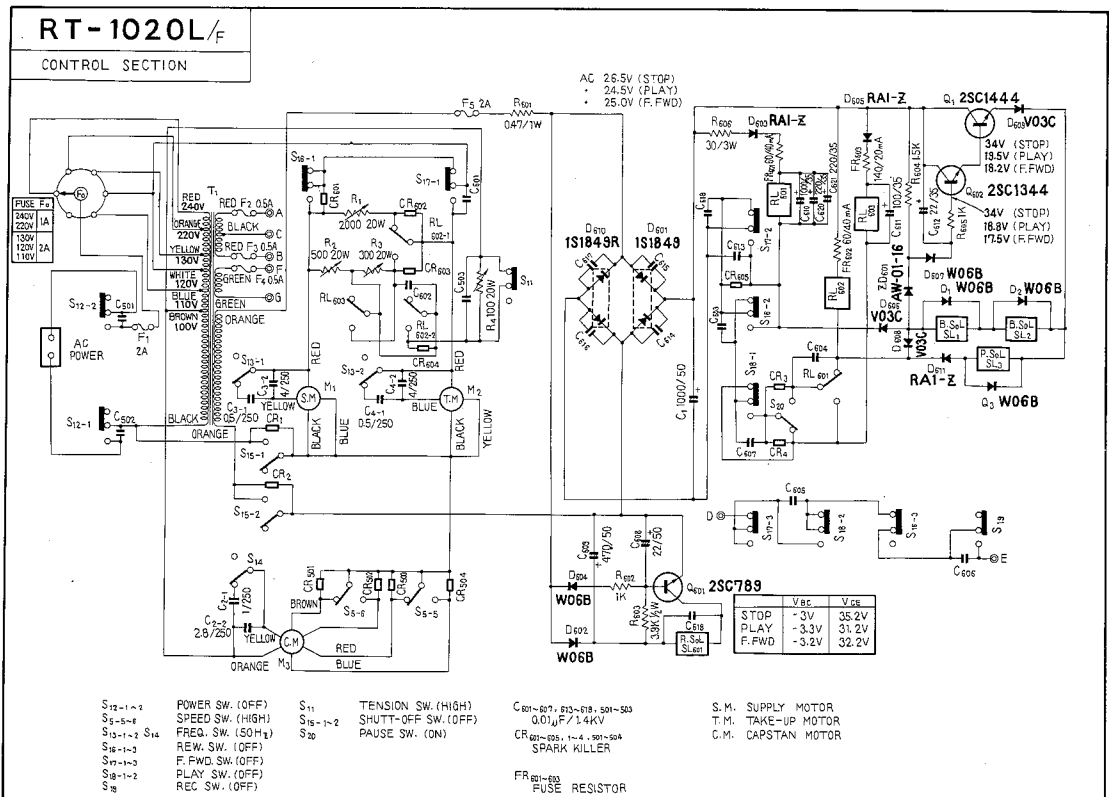

10. 5 ELECTRIC PARTS

Symbol	Description	Part No.
	Head P. C. board assembly	RWX-035-O
	Control assembly	RWG-034-O
	E Q switch circuit assembly	RWS-013-A
	REC lamp P. C. board assembly	RWX-033-O
	P. B. amplifier assembly	RWF-014-O
	REC amplifier assembly	RWF-015-O
	SW circuit assembly	RWS-011-A
	VR assembly	RWX-040-O
	OSC assembly	RWA-008-A
	Fuse P. C. board assembly	RWX-036-A
	Shut-off switch P. C. board assembly	RWX-038-O
C.M.	Capstan motor	RXM-012-O
S.M, T.M	Reel motor	RXM-015-O
SL1, SL2	Brake solenoid	RXP-012-A
SL3	Pinch solenoid	RXP-011-C
SL601	Reset solenoid	RXP-013-B
T1	Power transformer	RTT-039-A
	Erase head	RPB-020-O
	Recording head	RPB-021-A
	Playback head	RPB-022-O
C1	Electrolytic capacitor 1,000 μ F 50V	RCH-010-O
C2	MP capacitor (A) 1 + 2.8 μ F 250V	RCL-013-O
C3, C4	Phase capacitor 0.5 + 4 μ F 250V	RCL-010-O
CR3, CR4	Spark killer	RWX-030-O
S13, S14	Frequency switch	RSL-004-O
S15	Microswitch (SHUT-OFF)	RSF-007-O
S20	Lever switch (PAUSE)	RSK-021-B
	Line voltage selector switch (fuse holder)	AKR-001-O
	1A fuse	E21-004-A
D1	Diode W06B	
D2	Diode W06B	
D3	Diode W06B	
Q1	Transistor 2SC1444-O or Y	
R1	Wire wound resistor (D) 2k Ω 20W	RCN-014-O
R2	Wire wound resistor (C) 500 Ω 20W	RCN-012-O
R3	Wire wound resistor (B) 300 Ω 20W	RCN-011-O
R4	Wire wound resistor (A) 100 Ω 20W	RCN-010-O
R001	Carbon film resistor 1.5k Ω ¼W	RD¼PS 152J
R002	Carbon film resistor 100k Ω ¼W	RD¼PS 104J
R003	Carbon film resistor 100k Ω ¼W	RD¼PS 104J
R004	Carbon film resistor 1.5k Ω ¼W	RD¼PS 152J
R009	Carbon film resistor 22k Ω ¼W	RD¼PS 223J
R010	Carbon film resistor 22k Ω ¼W	RD¼PS 223J
R013	Carbon film resistor 3k Ω ¼W	RD¼PS 302J
R014	Carbon film resistor 6.2k Ω ¼W	RD¼PS 622J
VR1, VR2	REC level 10k Ω -A	RCV-010-A
	P. B. level 50k Ω -B	RCV-011-O
S6	EQ switch	RSB-009-O
S9	Bias switch	RSB-008-O

10. 6 P.B. AMPLIFIER ASSEMBLY (RWF-014)

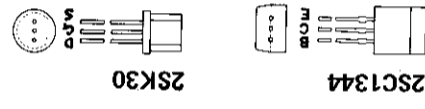
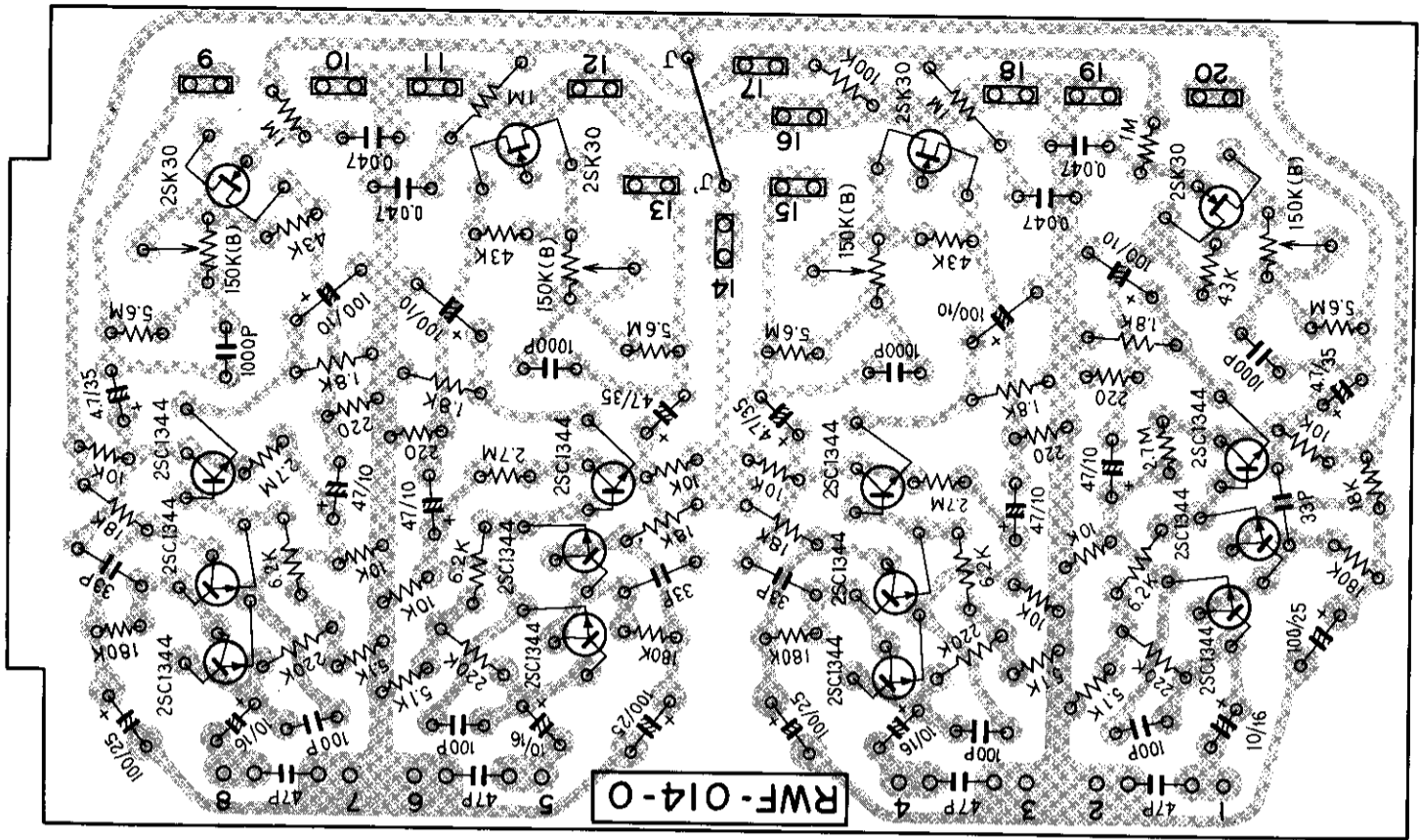
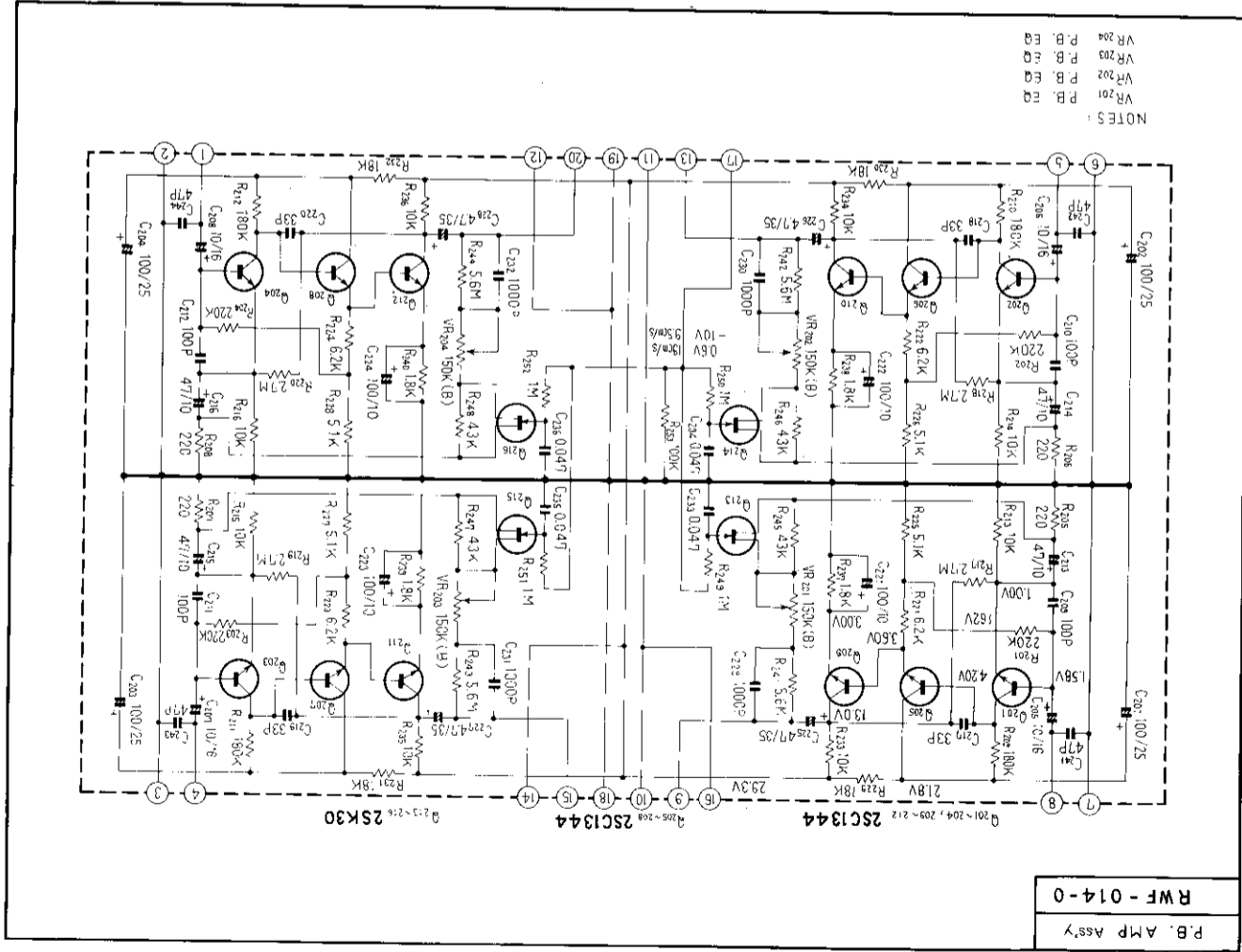

Parts Lists of P. B. Amplifier Assembly

CAPACITORS

CAPACITORS: IN μ F UNLESS OTHERWISE NOTED p: pF
RESISTORS: IN Ω , $\frac{1}{2}$ W UNLESS OTHERWISE NOTED K: K Ω , M: M Ω

Symbol	Description	Part No.	
C201	Electrolytic 100	CEA 101P 25	
C202	Electrolytic 100	CEA 101P 25	
C203	Electrolytic 100	CEA 101P 25	
C204	Electrolytic 100	CEA 101P 25	
C205	Electrolytic 10	CSZA 100M 16	tantalum
C206	Electrolytic 10	CSZA 100M 16	tantalum
C207	Electrolytic 10	CSZA 100M 16	tantalum
C208	Electrolytic 10	CSZA 100M 16	tantalum
C209	Electrolytic 100p	RCE-003-O	
C210	Electrolytic 100p	RCE-003-O	
C211	Electrolytic 100p	RCE-003-O	
C212	Electrolytic 100p	RCE-003-O	
C213	Electrolytic 47	CEA 470P 10	
C214	Electrolytic 47	CEA 470P 10	
C215	Electrolytic 47	CEA 470P 10	
C216	Electrolytic 47	CEA 470P 10	
C217	Electrolytic 33p	RCE-016-O	
C218	Electrolytic 33p	RCE-016-O	
C219	Electrolytic 33p	RCE-016-O	
C220	Electrolytic 33p	RCE-016-O	
C221	Electrolytic 100	CEA 101P 10	
C222	Electrolytic 100	CEA 101P 10	
C223	Electrolytic 100	CEA 101P 10	
C224	Electrolytic 100	CEA 101P 10	
C225	Electrolytic 4.7	CEA 4R7P 35	
C226	Electrolytic 4.7	CEA 4R7P 35	
C227	Electrolytic 4.7	CEA 4R7P 35	
C228	Electrolytic 4.7	CEA 4R7P 35	
C229	Electrolytic 0.001	RCE-011-O	
C230	Electrolytic 0.001	RCE-011-O	
C231	Electrolytic 0.001	RCE-011-O	
C232	Electrolytic 0.001	RCE-011-O	
C233	MyIar 0.047	COMA 473K 50	
C234	MyIar 0.047	COMA 473K 50	
C235	MyIar 0.047	COMA 473K 50	
C236	MyIar 0.047	COMA 473K 50	
C237			
C238			
C239			
C240			
C241	StyroI 47p	RCE-012-O	
C242	StyroI 47p	RCE-012-O	
C243	StyroI 47p	RCE-012-O	
C244	StyroI 47p	RCE-012-O	
C245			

RESISTORS, POTENTIOMETERS

Symbol	Description	Part No.	
R201	Carbon film 220k	RD $\frac{1}{2}$ VS 224J	
R202	Carbon film 220k	RD $\frac{1}{2}$ VS 224J	
R203	Carbon film 220k	RD $\frac{1}{2}$ VS 224J	
R204	Carbon film 220k	RD $\frac{1}{2}$ VS 224J	
R205	Carbon film 220	RD $\frac{1}{2}$ VS 221J	
R206	Carbon film 220	RD $\frac{1}{2}$ VS 221J	
R207	Carbon film 220	RD $\frac{1}{2}$ VS 221J	
R208	Carbon film 220	RD $\frac{1}{2}$ VS 221J	
R209	Carbon film 180k	RD $\frac{1}{2}$ VS 184J	
R210	Carbon film 180k	RD $\frac{1}{2}$ VS 184J	
R211	Carbon film 180k	RD $\frac{1}{2}$ VS 184J	
R212	Carbon film 180k	RD $\frac{1}{2}$ VS 184J	
R213	Carbon film 10k	RD $\frac{1}{2}$ VS 103J	
R214	Carbon film 10k	RD $\frac{1}{2}$ VS 103J	
R215	Carbon film 10k	RD $\frac{1}{2}$ VS 103J	
R216	Carbon film 10k	RD $\frac{1}{2}$ VS 103J	
R217	Carbon film 2.7M	RD $\frac{1}{2}$ PS 275J	
R218	Carbon film 2.7M	RD $\frac{1}{2}$ PS 275J	
R219	Carbon film 2.7M	RD $\frac{1}{2}$ PS 275J	
R220	Carbon film 2.7M	RD $\frac{1}{2}$ PS 275J	
R221	Carbon film 6.2k	RD $\frac{1}{2}$ VS 622J	
R222	Carbon film 6.2k	RD $\frac{1}{2}$ VS 622J	
R223	Carbon film 6.2k	RD $\frac{1}{2}$ VS 622J	
R224	Carbon film 6.2k	RD $\frac{1}{2}$ VS 622J	
R225	Carbon film 5.1k	RD $\frac{1}{2}$ VS 512J	
R226	Carbon film 5.1k	RD $\frac{1}{2}$ VS 512J	
R227	Carbon film 5.1k	RD $\frac{1}{2}$ VS 512J	
R228	Carbon film 5.1k	RD $\frac{1}{2}$ VS 512J	
R229	Carbon film 18k	RD $\frac{1}{2}$ VS 183J	
R230	Carbon film 18k	RD $\frac{1}{2}$ VS 183J	
R231	Carbon film 18k	RD $\frac{1}{2}$ VS 183J	
R232	Carbon film 18k	RD $\frac{1}{2}$ VS 183J	
R233	Carbon film 10k	RD $\frac{1}{2}$ VS 103J	
R234	Carbon film 10k	RD $\frac{1}{2}$ VS 103J	
R235	Carbon film 10k	RD $\frac{1}{2}$ VS 103J	
R236	Carbon film 10k	RD $\frac{1}{2}$ VS 103J	
R237	Carbon film 1.8k	RD $\frac{1}{2}$ VS 182J	
R238	Carbon film 1.8k	RD $\frac{1}{2}$ VS 182J	
R239	Carbon film 1.8k	RD $\frac{1}{2}$ VS 182J	
R240	Carbon film 1.8k	RD $\frac{1}{2}$ VS 182J	
R241	Carbon film 5.6M	RD $\frac{1}{2}$ PS 565J	
R242	Carbon film 5.6M	RD $\frac{1}{2}$ PS 565J	
R243	Carbon film 5.6M	RD $\frac{1}{2}$ PS 565J	
R244	Carbon film 5.6M	RD $\frac{1}{2}$ PS 565J	
R245	Carbon film 43k	RD $\frac{1}{2}$ VS 433J	
R246	Carbon film 43k	RD $\frac{1}{2}$ VS 433J	
R247	Carbon film 43k	RD $\frac{1}{2}$ VS 433J	
R248	Carbon film 43k	RD $\frac{1}{2}$ VS 433J	
R249	Carbon film 1M	RD $\frac{1}{2}$ VS 105J	
R250	Carbon film 1M	RD $\frac{1}{2}$ VS 105J	

Symbol	Description	Part No.
R251	Carbon film 1M	RD¼VS 105J
R252	Carbon film 1M	RD¼VS 105J
R253	Carbon film 100k	RD¼VS 104J
VR201	Semi-fixed 150k-B	C92-860-O
VR202	Semi-fixed 150k-B	C92-860-O
VR203	Semi-fixed 150k-B	C92-860-O
VR204	Semi-fixed 150k-B	C92-860-O

SEMICONDUCTORS

Symbol	Description	Part No.
Q201	Transistor 2SC1344-E or D	
Q202	Transistor 2SC1344-E or D	
Q203	Transistor 2SC1344-E or D	
Q204	Transistor 2SC1344-E or D	
Q205	Transistor 2SC1344-D or E	
Q206	Transistor 2SC1344-D or E	
Q207	Transistor 2SC1344-D or E	
Q208	Transistor 2SC1344-D or E	
Q209	Transistor 2SC1344-E or D	
Q210	Transistor 2SC1344-E or D	
Q211	Transistor 2SC1344-E or D	
Q212	Transistor 2SC1344-E or D	
Q213	FET 2SK30-Y or O	
Q214	FET 2SK30-Y or O	
Q215	FET 2SK30-Y or O	
Q216	FET 2SK30-Y or O	

10. 7 REC. AMPLIFIER ASSEMBLY (RWF-015)

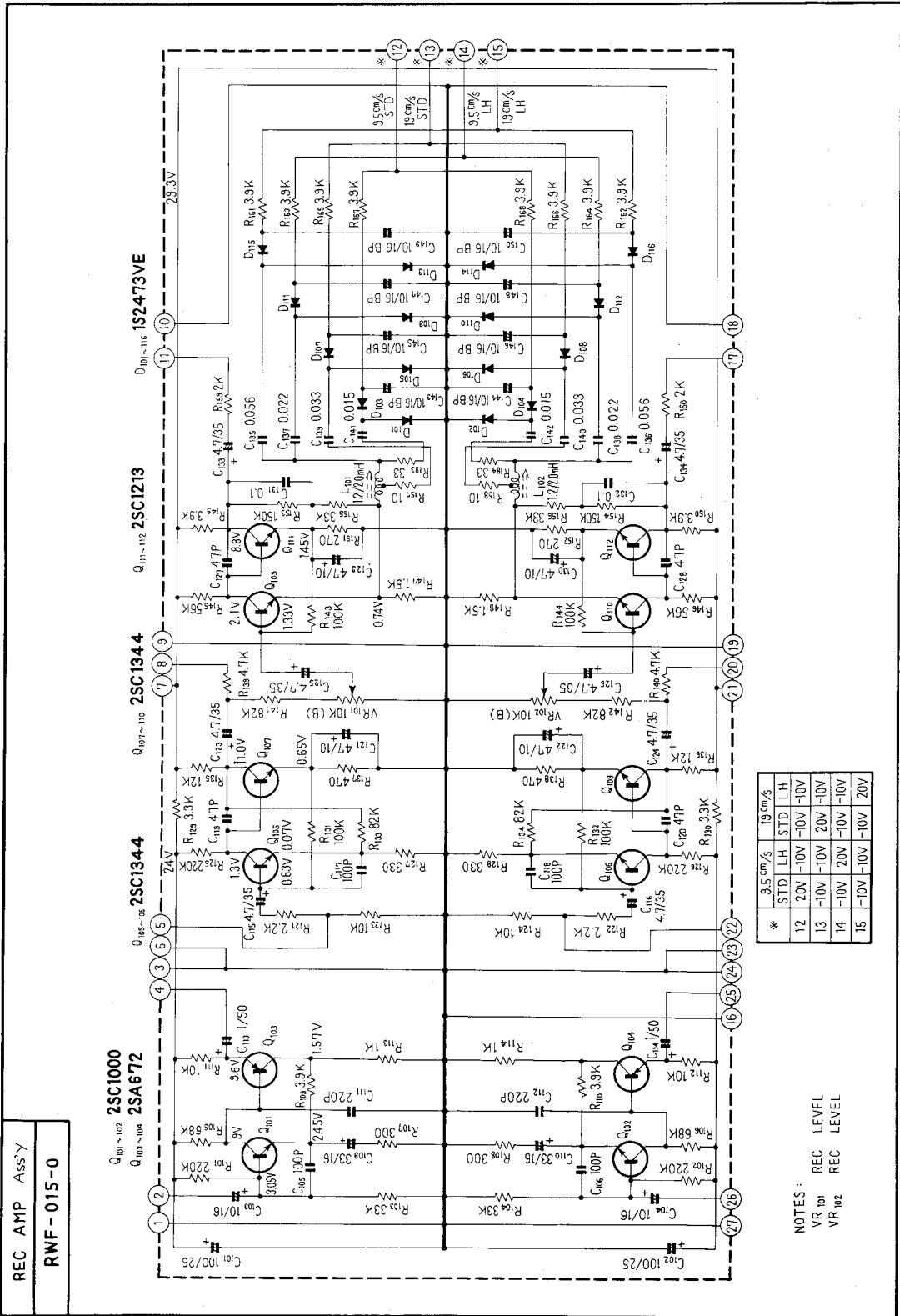

*	9.5cm/6	19cm/6
12	20V LH STD	10V LH
13	-10V -10V	20V -10V
14	-10V 20V	-10V -10V
15	-10V -10V	20V

NOTES:
VR₁₀₁ REC LEVEL
VR₁₀₂ REC LEVEL

Parts Lists of REC. Amplifier Assembly

CAPACITORS

Symbol	Description	Part No.	
C101	Electrolytic 100 25V	CEA 101P 25	Tantalum Tantalum
C102	Electrolytic 100 25V	CEA 101P 25	
C103	Electrolytic 10 16V	CSZA 100M 16	
C104	Electrolytic 10 16V	CSZA 100M 16	
C105	Styrol 100p 50V	RCE-003-O	
C106	Styrol 100p 50V	RCE-003-O	
C107			
C108			
C109	Electrolytic 33 16V	CEA 330P 16	
C110	Electrolytic 33 16V	CEA 330P 16	
C111	Styrol 220p 50V	RCE-006-O	
C112	Styrol 220p 50V	RCE-006-O	
C113	Electrolytic 1 50V	CEA 010P 50	
C114	Electrolytic 1 50V	CEA 010P 50	
C115	Electrolytic 4.7 35V	CEA 4R7P 35	
C116	Electrolytic 4.7 35V	CEA 4R7P 35	
C117	Styrol 100p 50V	RCE-003-O	
C118	Styrol 100p 50V	RCE-003-O	
C119	Styrol 47p 50V	RCE-012-O	
C120	Styrol 47p 50V	RCE-012-O	
C121	Electrolytic 47 10V	CEA 470P 10	
C122	Electrolytic 47 10V	CEA 470P 10	
C123	Electrolytic 4.7 35V	CEA 4R7P 35	
C124	Electrolytic 4.7 35V	CEA 4R7P 35	
C125	Electrolytic 4.7 35V	CEA 4R7P 35	
C126	Electrolytic 4.7 35V	CEA 4R7P 35	
C127	Styrol 47p 50V	RCE-012-O	
C128	Styrol 47p 50V	RCE-012-O	
C129	Electrolytic 47 10V	CEA 470P 10	
C130	Electrolytic 47 10V	CEA 470P 10	
C131	Mylar 0.1 50V	CQMA 104K 50	
C132	Mylar 0.1 50V	CQMA 104K50	
C133	Electrolytic 4.7 35V	CEA 4R7P 35	
C134	Electrolytic 4.7 35V	CEA 4R7P 35	
C135	Mylar 0.056 50V	CQMA 563K 50	
C136	Mylar 0.056 50V	CQMA 563K 50	
C137	Mylar 0.022 50V	CQMA 223K 50	
C138	Mylar 0.022 50V	CQMA 223K 50	
C139	Mylar 0.033 50V	CQMA 333K 50	
C140	Mylar 0.033 50V	CQMA 333K 50	
C141	Mylar 0.015 50V	CQMA 153K 50	
C142	Mylar 0.015 50V	CQMA 153K 50	
C143	Electrolytic 10 16V	RCH-011-O	Bi-polar
C144	Electrolytic 10 16V	RCH-011-O	Bi-polar
C145	Electrolytic 10 16V	RCH-011-O	Bi-polar

Symbol	Description	Part No.	
C146	Electrolytic 10 16V	RCH-011-O	Bi-polar
C147	Electrolytic 10 16V	RCH-011-O	Bi-polar
C148	Electrolytic 10 16V	RCH-011-O	Bi-polar
C149	Electrolytic 10 16V	RCH-011-O	Bi-polar
C150	Electrolytic 10 16V	RCH-011-O	Bi-polar

RESISTORS

Symbol	Description	Part No.	
R101	Carbon film 220k	RD $\frac{1}{2}$ VS 224J	
R102	Carbon film 220k	RD $\frac{1}{2}$ VS 224J	
R103	Carbon film 33k	RD $\frac{1}{2}$ VS 333J	
R104	Carbon film 33k	RD $\frac{1}{2}$ VS 333J	
R105	Carbon film 68k	RD $\frac{1}{2}$ VS 683J	
R106	Carbon film 68k	RD $\frac{1}{2}$ VS 683J	
R107	Carbon film 300	RD $\frac{1}{2}$ VS 301J	
R108	Carbon film 300	RD $\frac{1}{2}$ VS 301J	
R109	Carbon film 3.9k	RD $\frac{1}{2}$ VS 392J	
R110	Carbon film 3.9k	RD $\frac{1}{2}$ VS 392J	
R111	Carbon film 10k	RD $\frac{1}{2}$ VS 103J	
R112	Carbon film 10k	RD $\frac{1}{2}$ VS 103J	
R113	Carbon film 1k	RD $\frac{1}{2}$ VS 102J	
R114	Carbon film 1k	RD $\frac{1}{2}$ VS 102J	
R115			
R121	Carbon film 2.2k	RD $\frac{1}{2}$ VS 222J	
R122	Carbon film 2.2k	RD $\frac{1}{2}$ VS 222J	
R123	Carbon film 10k	RD $\frac{1}{2}$ VS 103J	
R124	Carbon film 10k	RD $\frac{1}{2}$ VS 103J	
R125	Carbon film 220k	RD $\frac{1}{2}$ VS 224J	
R126	Carbon film 220k	RD $\frac{1}{2}$ VS 224J	
R127	Carbon film 330	RD $\frac{1}{2}$ VS 331J	
R128	Carbon film 330	RD $\frac{1}{2}$ VS 331J	
R129	Carbon film 3.3k	RD $\frac{1}{2}$ VS 332J	
R130	Carbon film 3.3k	RD $\frac{1}{2}$ VS 332J	
R131	Carbon film 100k	RD $\frac{1}{2}$ VS 104J	
R132	Carbon film 100k	RD $\frac{1}{2}$ VS 104J	
R133	Carbon film 82k	RD $\frac{1}{2}$ VS 823J	
R134	Carbon film 82k	RD $\frac{1}{2}$ VS 823J	
R135	Carbon film 12k	RD $\frac{1}{2}$ VS 123J	
R136	Carbon film 12k	RD $\frac{1}{2}$ VS 123J	
R137	Carbon film 470	RD $\frac{1}{2}$ VS 471J	
R138	Carbon film 470	RD $\frac{1}{2}$ VS 471J	
R139	Carbon film 4.7k	RD $\frac{1}{2}$ VS 472J	
R140	Carbon film 4.7k	RD $\frac{1}{2}$ VS 472J	
R141	Carbon film 82k	RD $\frac{1}{2}$ VS 823J	
R142	Carbon film 82k	RD $\frac{1}{2}$ VS 823J	
R143	Carbon film 100k	RD $\frac{1}{2}$ VS 104J	
R144	Carbon film 100k	RD $\frac{1}{2}$ VS 104J	
R145	Carbon film 56k	RD $\frac{1}{2}$ VS 563J	

Symbol	Description	Part No.
R146	Carbon film 56k	RD¼VS 563J
R147	Carbon film 1.5k	RD¼VS 152J
R148	Carbon film 1.5k	RD¼VS 152J
R149	Carbon film 3.9k	RD¼VS 392J
R150	Carbon film 3.9k	RD¼VS 392J
R151	Carbon film 270	RD¼VS 271J
R152	Carbon film 270	RD¼VS 271J
R153	Carbon film 150k	RD¼VS 154J
R154	Carbon film 150k	RD¼VS 154J
R155	Carbon film 33k	RD¼VS 333J
R156	Carbon film 33k	RD¼VS 333J
R157	Carbon film 10	RD¼VS 100J
R158	Carbon film 10	RD¼VS 100J
R159	Carbon film 2k	RD¼VS 202J
R160	Carbon film 2k	RD¼VS 202J
R161	Carbon film 3.9k	RD¼VS 392J
R162	Carbon film 3.9k	RD¼VS 392J
R163	Carbon film 3.9k	RD¼VS 392J
R164	Carbon film 3.9k	RD¼VS 392J
R165	Carbon film 3.9k	RD¼VS 392J
R166	Carbon film 3.9k	RD¼VS 392J
R167	Carbon film 3.9k	RD¼VS 392J
R168	Carbon film 3.9k	RD¼VS 392J
R183	Carbon film 33	RD¼VS 330J
R184	Carbon film 33	RD¼VS 330J

SEMICONDUCTORS

Symbol	Description	Part No.
Q101	Transistor 2SC1000-GR or BL	
Q102	Transistor 2SC1000-GR or BL	
Q103	Transistor 2SA672-B or C	
Q104	Transistor 2SA672-B or C	
Q105	Transistor 2SC1344-E or D	
Q106	Transistor 2SC1344-E or D	
Q107	Transistor 2SC1344-D or E	
Q108	Transistor 2SC1344-D or E	
Q109	Transistor 2SC1344-D or E	
Q110	Transistor 2SC1344-D or E	
Q111	Transistor 2SC1213-B or C	
Q112	Transistor 2SC1213-B or C	
D101	Diode 1S2473VE	
D102	Diode 1S2473VE	
D103	Diode 1S2473VE	
D104	Diode 1S2473VE	
D105	Diode 1S2473VE	
D106	Diode 1S2473VE	
D107	Diode 1S2473VE	
D108	Diode 1S2473VE	
D109	Diode 1S2473VE	
D110	Diode 1S2473VE	

Symbol	Description	Part No.
D111	Diode 1S2473VE	
D112	Diode 1S2473VE	
D113	Diode 1S2473VE	
D114	Diode 1S2473VE	
D115	Diode 1S2473VE	
D116	Diode 1S2473VE	

COILS AND POTENTIOMETERS

Symbol	Description	Part No.
L101	Peaking coil	RTF-007-O
L102	Peaking coil	RTF-007-O
VR101	Semi-fixed 10k-B	C92-049-O
VR102	Semi-fixed 10k-B	C92-049-O

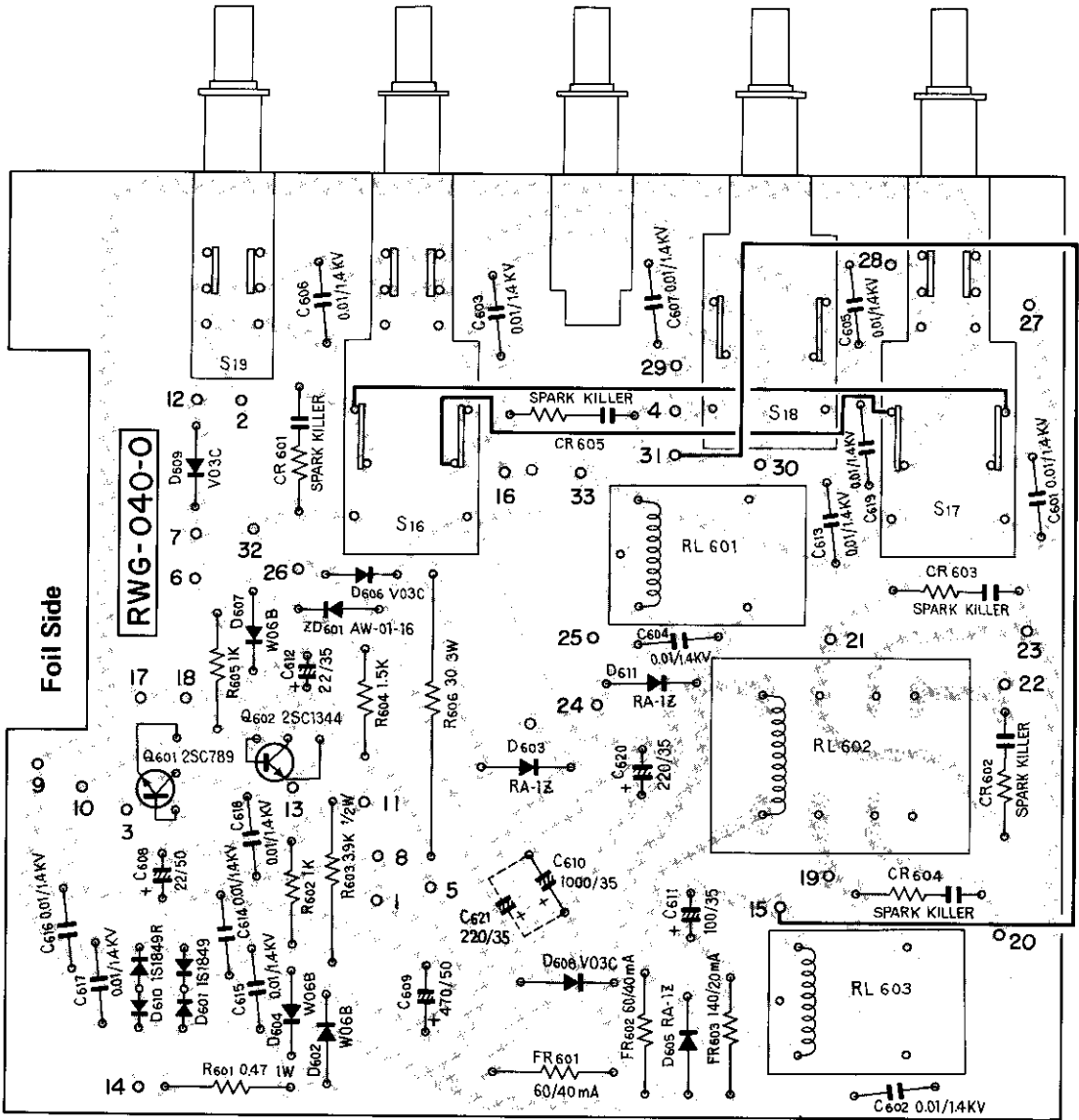

2SC789

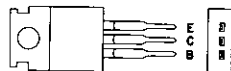

2SC1344



Parts Lists of Control Assembly

CAPACITORS

Symbol	Description			Part No.
C601	Ceramic	0.01	DC 1.4kV	C43-003-O
C602	Ceramic	0.01	DC 1.4kV	C43-003-O
C603	Ceramic	0.01	DC 1.4kV	C43-003-O
C604	Ceramic	0.01	DC 1.4kV	C43-003-O
C605	Ceramic	0.01	DC 1.4kV	C43-003-O
C606	Ceramic	0.01	DC 1.4kV	C43-003-O
C607	Ceramic	0.01	DC 1.4kV	C43-003-O
C608	Electrolytic	22	50V	CEA 220P 50
C609	Electrolytic	470	50V	CEA 471P 50
C610	Electrolytic	1000	35V	CEA 102P 35
C611	Electrolytic	100	35V	CEA 101P 35
C612	Electrolytic	22	35V	CEA 220P 35
C613	Ceramic	0.01	DC 1.4kV	C43-003-O
C614	Ceramic	0.01	DC 1.4kV	C43-003-O
C615	Ceramic	0.01	DC 1.4kV	C43-003-O
C616	Ceramic	0.01	DC 1.4kV	C43-003-O
C617	Ceramic	0.01	DC 1.4kV	C43-003-O
C618	Ceramic	0.01	DC 1.4kV	C43-003-O
C619	Ceramic	0.01	DC 1.4kV	C43-003-O
C620	Electrolytic	220	35V	CEA 221P 35
C621	Electrolytic	220	35V	CEA 221P 35

RESISTORS

Symbol	Description			Part No.
R601	Wire wound	0.47	1W	PT1P R47K
R602	Carbon film	1k		RD½PS 102J
R603	Carbon film	3.9k	½W	RD½PW 392J
R604	Carbon film	1.5k		RD½PS 152J
R605	Carbon film	1k		RD½PS 102J
R606	Metal oxide	30	3W	RS3P 300J

SEMICONDUCTORS

Symbol	Description	Part No.
Q601	Transistor	2SC789-O or Y
Q602	Transistor	2SC1344-D or E
D601	Diode	1S1849
D602	Diode	W06B
D603	Diode	RA1-Z
D604	Diode	W06B
D605	Diode	RA1-Z
D606	Diode	V03C
D607	Diode	W06B
D608	Diode	V03C
D609	Diode	V03C
D610	Diode	1S1849R
D611	Diode	RA1-Z
ZD601	Zener diode	AW01-16

OTHERS

Symbol	Description	Part No.
CR601	Spark Killer	RWX-030-O
CR602	Spark Killer	RWX-030-O
CR603	Spark Killer	RWX-030-O
CR604	Spark Killer	RWX-030-O
CR605	Spark Killer	RWX-030-O
FR601	Metal film fuse resistor 60 Ω /40mA	REK-012-A
FR602	Metal film fuse resistor 60 Ω /40mA	REK-012-A
FR603	Metal film fuse resistor 140 Ω /20mA	REK-013-A
S16	Switch (REW)	RSG-013-A
S17	Switch (F. FWD)	RSG-013-A
S18	Switch (PLAY)	RSG-013-A
S19	Switch (REC)	RSG-013-A
RL601	Timing relay	RSR-015-A
RL602	Relay	RSR-016-O
RL603	Timing relay	RSR-015-A
	Capacitor sleeve (A)	REL-150-O

10. 9 SWITCH CIRCUIT ASSEMBLY (RWS-011)

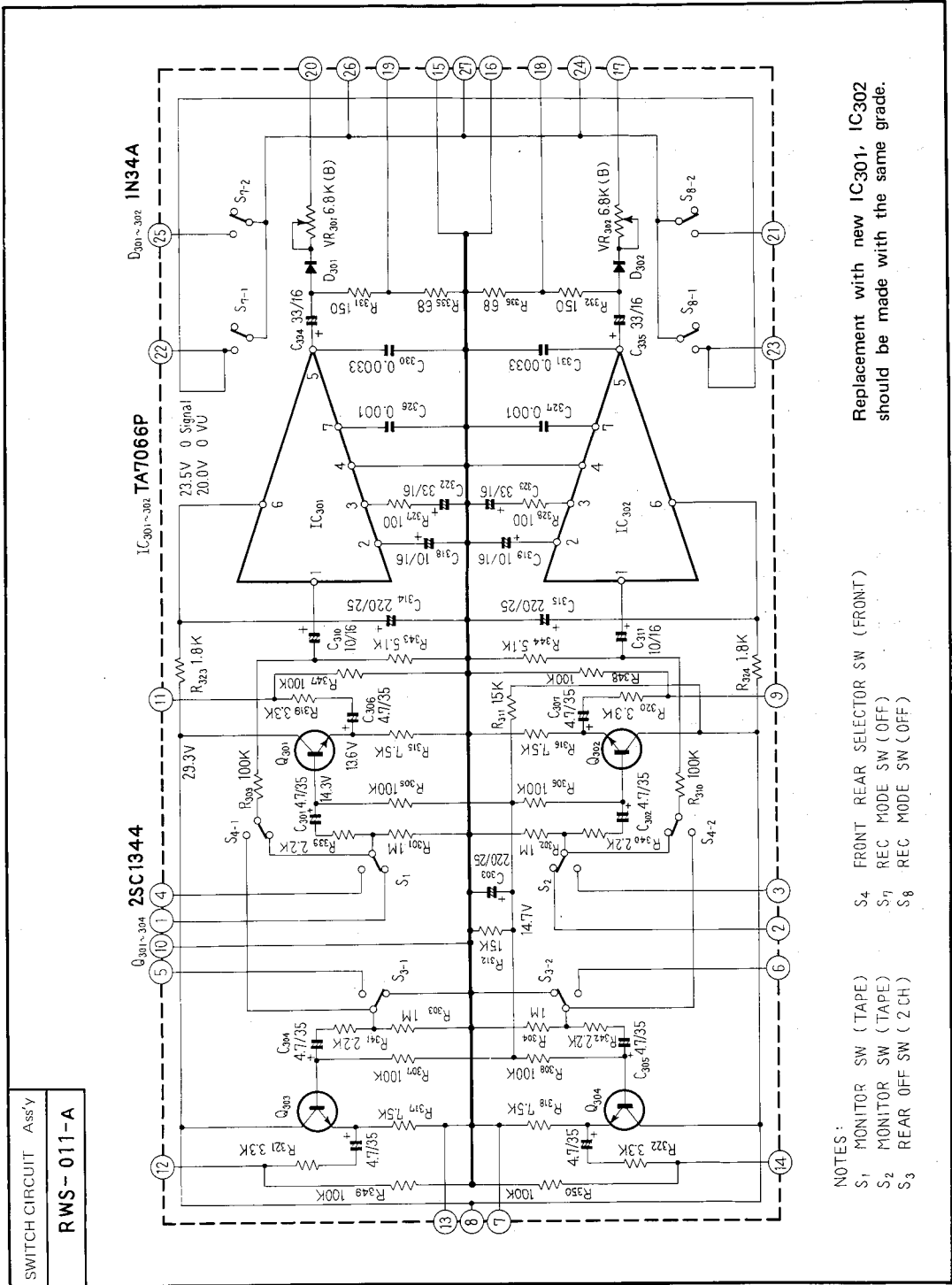

NOTES:

- S1 MONITOR SW (TAPE)
- S2 MONITOR SW (TAPE)
- S3 REAR OFF SW (2 CH)
- S4 FRONT REAR SELECTOR SW (FRONT)
- S7 REC MODE SW (OFF)
- S8 REC MODE SW (OFF)

Replacement with new IC301, IC302 should be made with the same grade.

Parts Lists of Switch Circuit Assembly

CAPACITORS

Symbol	Description			Part No.
C301	Electrolytic	4.7	35V	CEA 4R7P 35
C302	Electrolytic	4.7	35V	CEA 4R7P 35
C303	Electrolytic	220	25V	CEA 221P 25
C304	Electrolytic	4.7	35V	CEA 4R7P 35
C305	Electrolytic	4.7	35V	CEA 4R7P 35
C306	Electrolytic	4.7	35V	CEA 4R7P 35
C307	Electrolytic	4.7	35V	CEA 4R7P 35
C308	Electrolytic	4.7	35V	CEA 4R7P 35
C309	Electrolytic	4.7	35V	CEA 4R7P 35
C310	Electrolytic	10	16V	CEA 100P 16
C311	Electrolytic	10	16V	CEA 100P 16
C312				
C313				
C314	Electrolytic	220	25V	CEA 221P 25
C315	Electrolytic	220	25V	CEA 221P 25
C316				
C317				
C318	Electrolytic	10	16V	CEA 100P 16
C319	Electrolytic	10	16V	CEA 100P 16
C320				
C321				
C322	Electrolytic	33	16V	CEA 330P 16
C323	Electrolytic	33	16V	CEA 330P 16
C324				
C325				
C326	Mylar	0.001	50V	CQMA102K 50
C327	Mylar	0.001	50V	CQMA102K 50
C328				
C329				
C330	Mylar	0.0033	50V	CQMA332K 50
C331	Mylar	0.0033	50V	CQMA332K 50
C332				
C333				
C334	Electrolytic	33	16V	CEA 330P 16
C335	Electrolytic	33	16V	CEA 330P 16

RESISTORS

Symbol	Description		Part No.
R301	Carbon film	1M	RD $\frac{1}{4}$ VS 105J
R302	Carbon film	1M	RD $\frac{1}{4}$ VS 105J
R303	Carbon film	1M	RD $\frac{1}{4}$ VS 105J
R304	Carbon film	1M	RD $\frac{1}{4}$ VS 105J
R305	Carbon film	100k	RD $\frac{1}{4}$ VS 104J

Symbol	Description	Part No.
R306	Carbon film 100k	RD½VS 104J
R307	Carbon film 100k	RD½VS 104J
R308	Carbon film 100k	RD½VS 104J
R309	Carbon film 100k	RD½VS 104J
R310	Carbon film 100k	RD½VS 104J
R311	Carbon film 15k	RD½VS 153J
R312	Carbon film 15k	RD½VS 153J
R313		
R314		
R315	Carbon film 7.5k	RD½VS 752J
R316	Carbon film 7.5k	RD½VS 752J
R317	Carbon film 7.5k	RD½VS 752J
R318	Carbon film 7.5k	RD½VS 752J
R319	Carbon film 3.3k	RD½VS 332J
R320	Carbon film 3.3k	RD½VS 332J
R321	Carbon film 3.3k	RD½VS 332J
R322	Carbon film 3.3k	RD½VS 332J
R323	Carbon film 1.8k	RD½VS 182J
R324	Carbon film 1.8k	RD½VS 182J
R325		
R326		
R327	Carbon film 100	RD½VS 101J
R328	Carbon film 100	RD½VS 101J
R329		
R330		
R331	Carbon film 150	RD½VS 151J
R332	Carbon film 150	RD½VS 151J
R333		
R334		
R335	Carbon film 68	RD½VS 680J
R336	Carbon film 68	RD½VS 680J
R337		
R338		
R339	Carbon film 2.2k	RD½VS 222J
R340	Carbon film 2.2k	RD½VS 222J
R341	Carbon film 2.2k	RD½VS 222J
R342	Carbon film 2.2k	RD½VS 222J
R343	Carbon film 5.1k	RD½VS 512J
R344	Carbon film 5.1k	RD½VS 512J
R345		
R346		
R347	Carbon film 100K	RD½VS 104J
R348	Carbon film 100K	RD½VS 104J
R349	Carbon film 100K	RD½VS 104J
R350	Carbon film 100K	RD½VS 104J

SEMICONDUCTORS

Symbol	Description	Part No.
Q301	Transistor 2SC1344-D or E	
Q302	Transistor 2SC1344-D or E	
Q303	Transistor 2SC1344-D or E	
Q304	Transistor 2SC1344-D or E	
D301	Diode 1N34A	
D302	Diode 1N34A	
IC301	IC TA7066P-B or A	RYY-002-O
IC302	IC TA7066P-B or A	RYY-002-O

OTHERS

Symbol	Description	Part No.
VR301	Semi-fixed 6.8k-B	RCP-001-O
VR302	Semi-fixed 6.8k-B	RCP-001-O
S1	Lever switch	RSK-018-O
S2	Lever switch	RSK-018-O
S3	Lever switch	RSK-018-O
S4	Lever switch	RSK-018-O
S7	Lever switch	RSK-018-O
S8	Lever switch	RSK-018-O

10.10 EQ. SWITCH CIRCUIT ASSEMBLY (RWS-013)

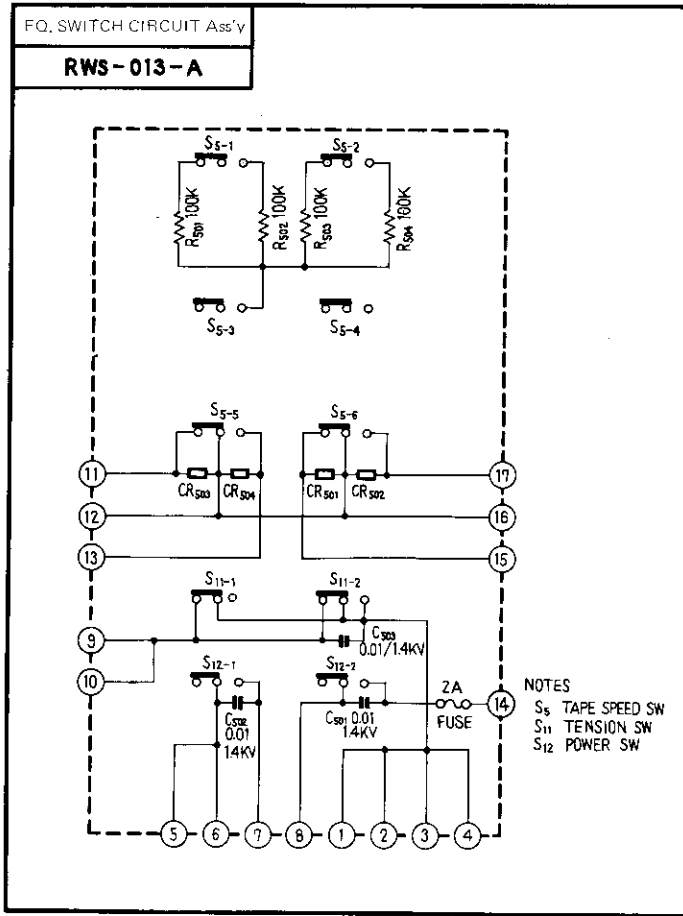

Foil Side

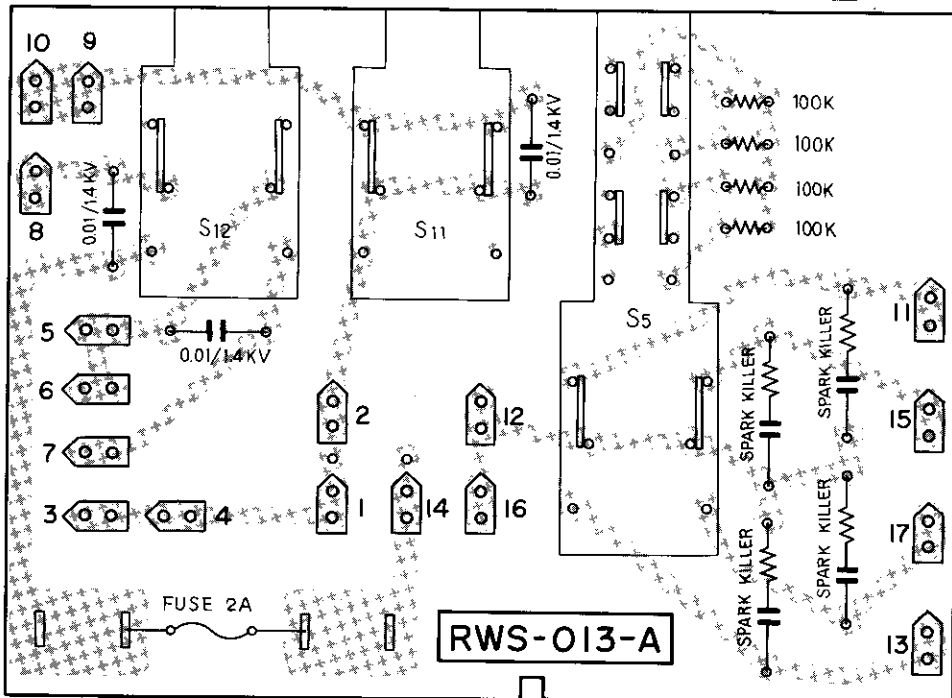

Parts Lists of EQ Switch Circuit Assembly

CAPACITORS

Symbol	Description	Part No.
C501	Ceramic 0.01 DC1.4kV	C43-003-O
C502	Ceramic 0.01 DC1.4kV	C43-003-O
C503	Ceramic 0.01 DC1.4kV	C43-003-O

RESISTORS

Symbol	Description	Part No.
R501	Carbon film 100k	RD½VS 104J
R502	Carbon film 100k	RD½VS 104J
R503	Carbon film 100k	RD½VS 104J
R504	Carbon film 100k	RD½VS 104J

OTHERS

Symbol	Description	Part No.
CR501	Spark Killer	RWX-030-O
CR502	Spark Killer	RWX-030-O
CR503	Spark Killer	RWX-030-O
CR504	Spark Killer	RWX-030-O
	Push switch	RSG-014-O
	Fuse (2A)	E21-005-A
	Capacitor sleeve (A)	REC-150-O

10.11 OSC. ASSEMBLY (RWA-008)

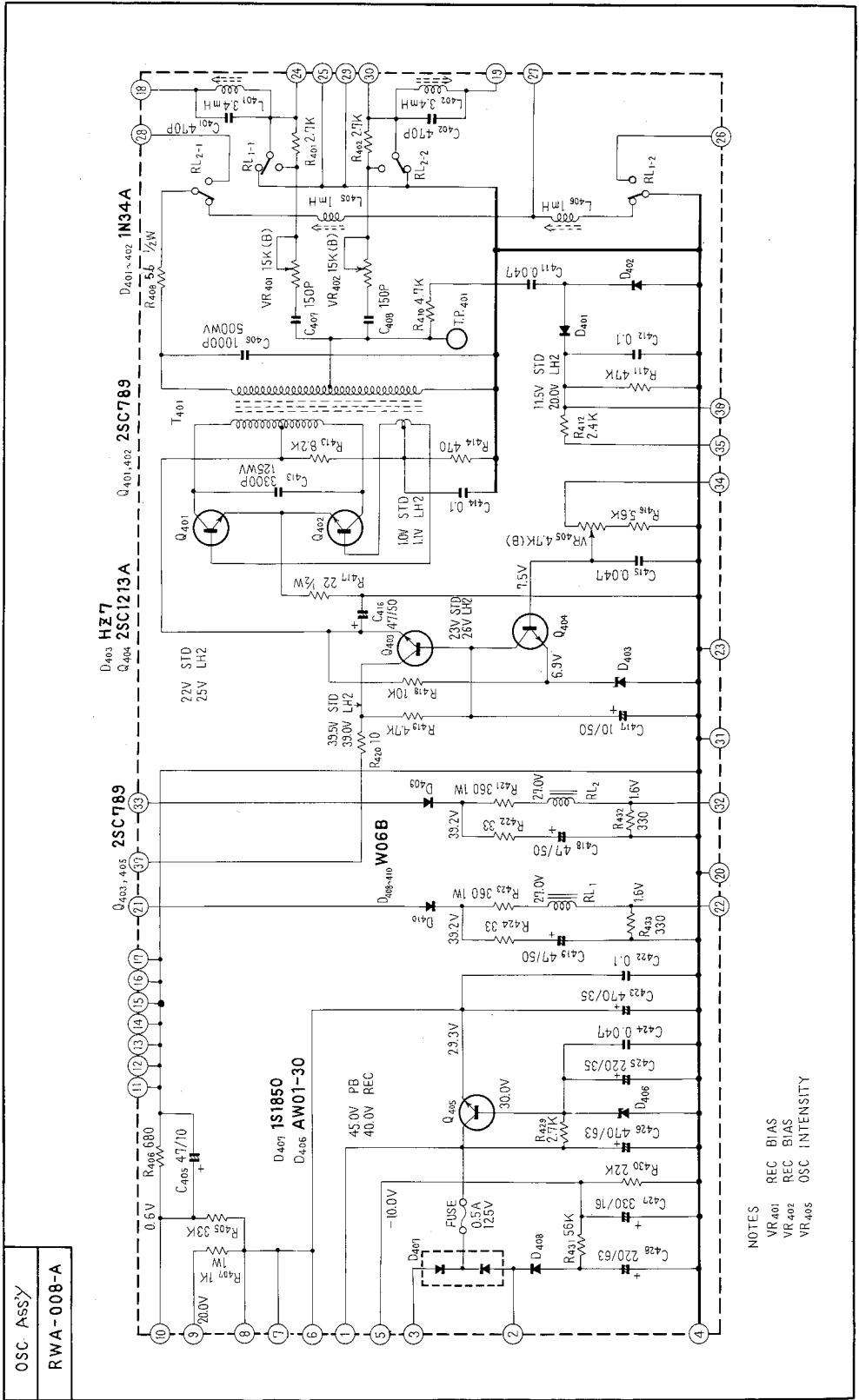

Parts Lists of OSC. Assembly

CAPACITORS

Symbol	Description			Part No.
C401	Styrol	470p	50V	RCE-014-O
C402	Styrol	470p	50V	RCE-014-O
C403				
C404				
C405	Electrolytic	47	10V	CEA 470P 10
C406	Styrol	0.001	500V	CQSA 102J 500
C407	Styrol	150p	50V	RCE-007-O
C408	Styrol	150p	50V	RCE-007-O
C409				
C410				
C411	Mylar	0.047	50V	CQMA 473K 50
C412	Mylar	0.1	50V	CQMA 104K 50
C413	Styrol	0.0033	125V	CQSA 332J 125
C414	Mylar	0.1	50V	CQMA 104K 50
C415	Mylar	0.047	50V	CQMA 473K 50
C416	Electrolytic	47	50V	CEA 470P 50
C417	Electrolytic	10	50V	CEA 100P 50
C418	Electrolytic	47	50V	CEA 470P 50
C419	Electrolytic	47	50V	CEA 470P 50
C420				
C421				
C422	Mylar	0.1	50V	CQMA 104K 50
C423	Electrolytic	470	35V	CEA 471P 35
C424	Mylar	0.047	50V	CQMA 473K 50
C425	Electrolytic	220	35V	CEA 221P 35
C426	Electrolytic	470	63V	CEA 471P 63
C427	Electrolytic	330	16V	CEA 331P 16
C428	Electrolytic	220	63V	CEA 221P 63

OTHERS

Symbol	Description		Part No.
RL-1	Relay		RSR-012-O
RL-2	Relay		RSR-012-O
L401	Trap coil		RTF-006-O
L402	Trap coil		RTF-006-O
L405	Dummy coil		RTD-008-O
L406	Dummy coil		RTD-008-O
T401	Osc coil		RTD-007-O
VR401	Semi-fixed	15k-B	RCP-006-O
VR402	Semi-fixed	15k-B	RCP-006-O
VR405	Semi-fixed	4.7k-B	C92-051-O
	Fuse (0.5A)		E21-007-O

RESISTORS AND SEMICONDUCTORS

Symbol	Description	Part No.
R401	Carbon film 2.7k	RD $\frac{1}{4}$ VS 272J
R402	Carbon film 2.7k	RD $\frac{1}{4}$ VS 272J
R403		
R404		
R405	Carbon film 33k	RD $\frac{1}{4}$ VS 333J
R406	Carbon film 680	RD $\frac{1}{4}$ VS 681J
R407	Carbon film 1k 1W	RD1PW 102J
R408	Carbon film 5.6 $\frac{1}{2}$ W	RD $\frac{1}{2}$ PW 5R6J
R409		
R410	Carbon film 4.7k	RD $\frac{1}{4}$ VS 472J
R411	Carbon film 47k	RD $\frac{1}{4}$ VS 473J
R412	Carbon film 2.4k	RD $\frac{1}{4}$ VS 242J
R413	Carbon film 8.2k	RD $\frac{1}{4}$ VS 822J
R414	Carbon film 470	RD $\frac{1}{4}$ VS 471J
R415		
R416	Carbon film 5.6k	RD $\frac{1}{4}$ VS 562J
R417	Carbon film 22 $\frac{1}{2}$ W	RD $\frac{1}{2}$ PW 220J
R418	Carbon film 10k	RD $\frac{1}{4}$ VS 103J
R419	Carbon film 4.7k	RD $\frac{1}{4}$ VS 472J
R420	Carbon film 10	RD $\frac{1}{4}$ VS 100J
R421	Carbon film 360 1W	RD1PW 361J
R422	Carbon film 33	RD $\frac{1}{4}$ VS 330J
R423	Carbon film 360 1W	RD1PW 361J
R424	Carbon film 33	RD $\frac{1}{4}$ VS 330J
R425		
R426		
R427		
R428		
R429	Carbon film 2.7k	RD $\frac{1}{4}$ VS 272J
R430	Carbon film 22k	RD $\frac{1}{4}$ VS 223J
R431	Carbon film 56k	RD $\frac{1}{4}$ VS 563J
R432	Carbon film 330	RD $\frac{1}{4}$ VS 331J
R433	Carbon film 330	RD $\frac{1}{4}$ VS 331J
Q401	Transistor 2SC789-O	
Q402	Transistor 2SC789-O	
Q403	Transistor 2SC789-O or Y	
Q404	Transistor 2SC1213A-B or C	
Q405	Transistor 2SC789-O or Y	
D401	Diode 1N34A	
D402	Diode 1N34A	
D403	Zener Diode HZ-7 B	
D404		
D405		
D406	Zener diode AW01-30	
D407	Diode 1S1850	
D408	Diode W06B	
D409	Diode W06B	
D410	Diode W06B	

10.12 FUSE P.C. BOARD ASSEMBLY (RWX-036)

Foil Side

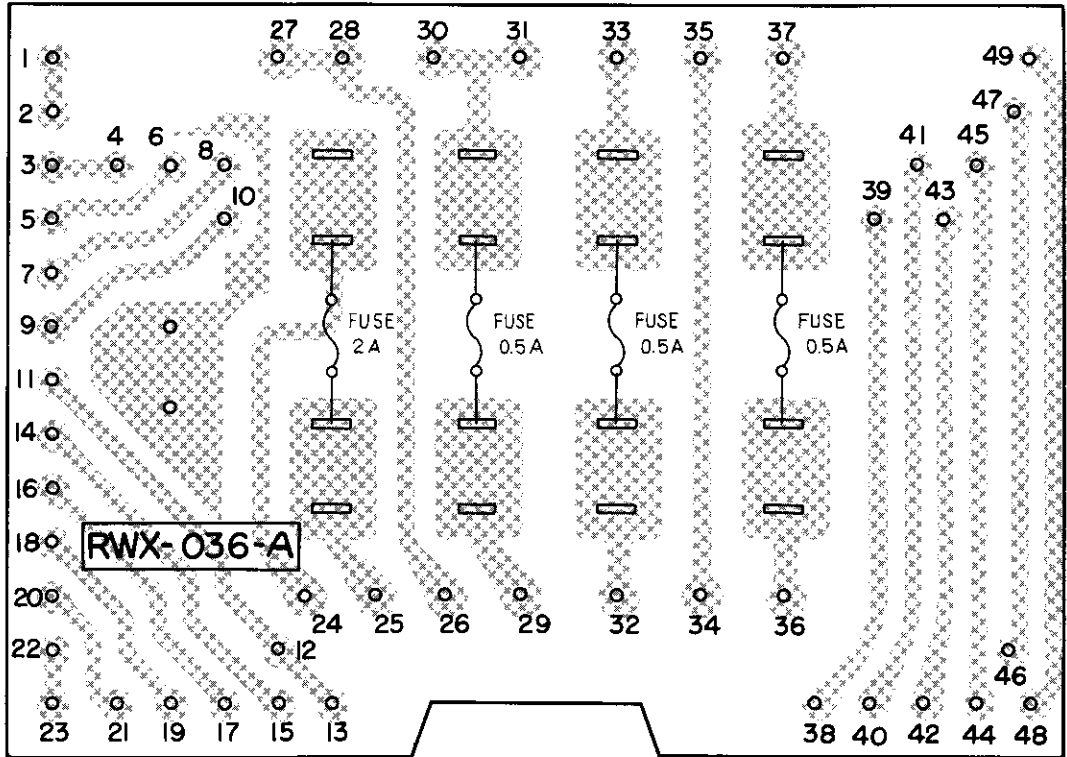

Symbol	Description	Part No.	
	0.5A Fuse	E21-007-O	
	2A Fuse	E21-005-A	

10.13 REC. LAMP P.C. BOARD ASSEMBLY (RWX-033)

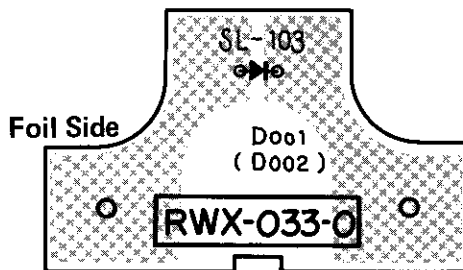

Symbol	Description	Part No.	
	Light-emitting diode	SL-103	

10.14 VR ASSEMBLY (RWX-040)

Foil Side

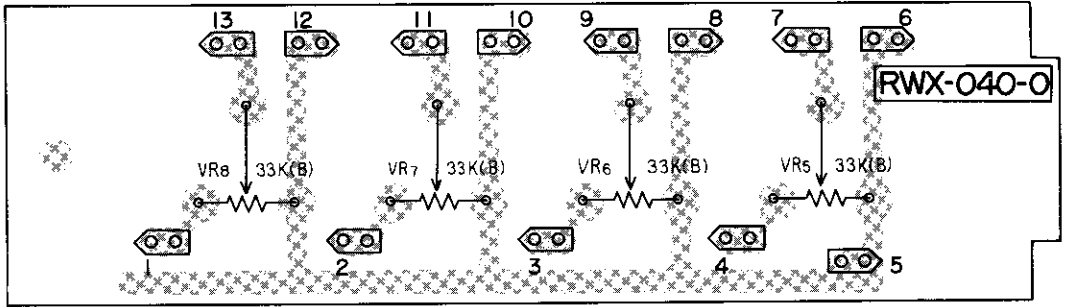

Symbol	Description	Part No.	
VR5	Semi-fixed 33k-B	RCP-016-0	
VR6	Semi-fixed 33k-B	RCP-016-0	
VR7	Semi-fixed 33k-B	RCP-016-0	
VR8	Semi-fixed 33k-B	RCP-016-0	

10.15 SHUT-OFF SWITCH P.C. BOARD ASSEMBLY (RWX-038)

Foil Side

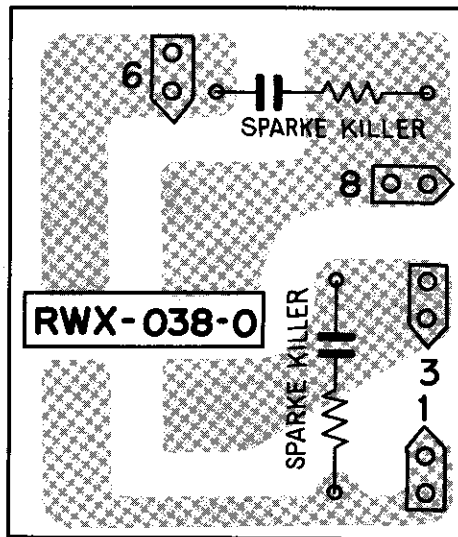

Symbol	Description	Part No.	
	Spark killer	RWX-030-0	

11. EXPLODED VIEWS AND PARTS LISTS

The following symbols stand for screws, nuts, washers, etc. as shown in EXPLODED VIEWS on pp. 65 ~ 76.

P	: Pan head screw	T	: Tapping screw
B	: Binding head screw	E	: Retaining washer E-type
C	: Countersunk head screw	SW	: Spring washer
TS	: Truss head screw	N	: Hexagonal nut
PS	: Pan head sems screw	OC	: Oval countersunk head screw
S	: Setscrew		

11. 1 PANEL AND BACK COVER

NOTICE: Any parts asterisked (*) are subject to being not supplied.

Key No.	Description	Part No.	
1	Roller cover (A)	RAH-092-O	
2	Ball bearing	RNX-003-O	
3	Roller cover (B)	RAH-093-O	
4	Roller arm guide	RLA-317-O	
5	Roller arm assembly	RXA-311-A	
6	Spring (roller arm)	RBH-148-A	
7	Washer 6φ BN 1	B22-426-O	
8	Roller arm damper	RED-060-B	
9	Roller guide assembly	RXX-109-O	Including 8
10	Washer 6φ BN 1	B22-426-O	
11	Meter Escutcheon	RAP-043-A	
12	Shading washer	REB-091-O	
13	Head cover (L) assembly	RXX-128-O	
14	Center base	RAX-008-B	
15	Cap (pinch roller)	RAT-002-A	
16	Felt (pinch roller)	RED-053-O	
17	Washer 6φ BN 1	B22-426-O	
18	Pinch roller assembly	RXA-309-O	
19	Washer 6φ BN1	B22-426-O	
20	Cap (bearing)	RAT-003-O	
21	Reel base assembly	RXA-400-O	
22	Spin screw	RAH-079-A	
23	Tension arm assembly	RXA-310-C	
24	Tape guide (C)	RLA-309-A	
25	Lever switch knob (B) assembly	RAA-062-B	
26	Frame (A)	RAP-035-O	
27	Mech. panel assembly	RXX-115-O	
28	Sash (B)	RAP-036-B	
29	Side board	RMS-021-O	
30	Special screw M4 x 26	ABA-011-O	
31	Amp. panel (L) assembly	RXX-129-O	Including 11, 34, 40.
32	Lever switch knob (A) Assembly	RAA-060-D	
33	Knob (REC BIAS, REC EQ)	RAA-063-O	
34	Escutcheon (jack)	REC-115-A	
35	Double knob inner (REC LEVEL)	RAA-065-A	

NOTICE: Any parts asterisked (*) are subject to being not supplied.

Key. No	Description	Part No.	
36	Double knob outer (REC LEVEL)	RAA-066-B	
37	Rosette washer	RAP-041-O	
38	Nylon washer	RBF-007-O	
39	Button guard	REC-145-B	
40	Meter clamper	RNC-073-O	
41	Special screw M4 x 26	ABA-011-O	
42	Side board	RMS-021-O	
43	Sash (B)	RAP-036-B	
44*	Cover cushion (A)	REB-099-O	
45	Back cover (L) assembly	RXX-124-O	Including 44, 51, 55.
46*	Cover cushion (B)	REB-100-O	
47	Rubber grommet	REB-094-O	
48	Back cover (B) assembly	RXX-113-O	including 46, 47, 52.
49	Foot (A)	REC-116-A	
50	Foot (B)	REC-119-A	
51*	Label (mechanism adj.)	RRH-001-O	
52*	Label (amp. adj.)	RRH-002-O	
53	Double knob inner (FRONT OUTPUT)	RAA-070-O	
54	Double knob outer (REAR OUTPUT)	RAA-071-O	
55*	Label (voltage selector)	RRW-016-O	

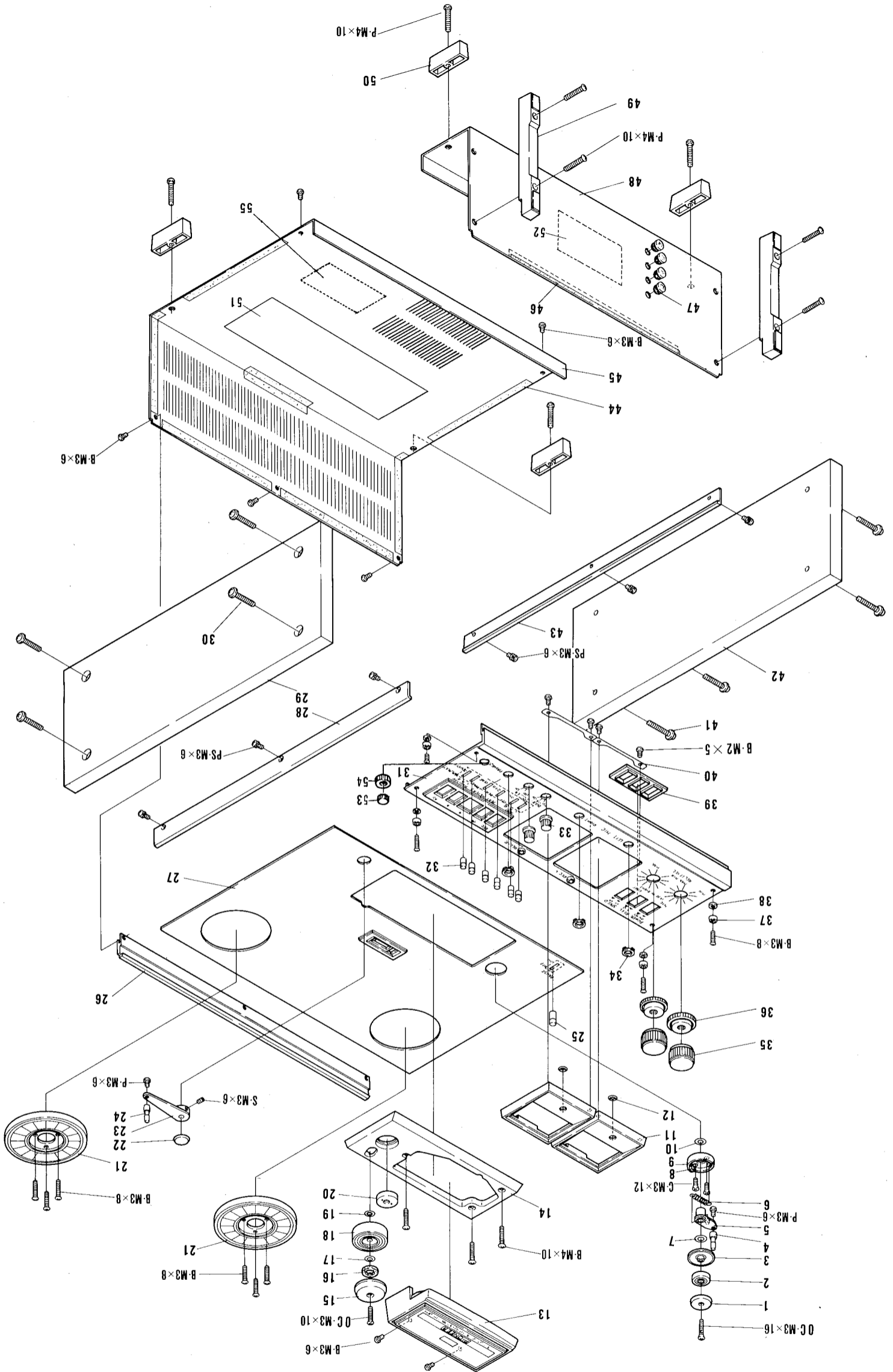

NOTICE: Any parts asterisked (*) are subject to being not supplied.

Key No.	Description	Part No.
1*	Head base	RNE-415-D
2	Tape guide (A)	RLA-300-A
3	Head P.C. board assembly	RWX-035-O
4	E.H. adj. spacer (B)	REF-005-O
5	Spacer (erase head)	REC-122-A
6	Erase head	RPB-020-O
7	Head adj. spring	RBK-060-B
8*	Head mounting metal	RNK-391-O
9*	Shield case (B)	RNA-096-A
10	Recording head	RPB-021-A
11*	Solder lug 3φ	
12	Tape guide (B)	RLA-301-O
13*	Shield case (A)	RNA-095-A
14	Playback head	RPB-022-O
15	Tape guide (A)	RLA-300-A
16	Washer 6φ BN 1	B22-426-O
17	Pinch arm (A) assembly	RXA-399-O
18	Washer 6φ BN 1	B22-426-O
19*	Pinch arm shaft	RLA-307-O
20	Pinch arm damper	REB-078-O
21*	Shifter roller	RLP-004-O
22*	Mechanism chassis	RNB-030-F
23*	Cord fixer (B)	RNE-513-O
24*	Shield plate	RNE-403-C
25*	Hex. pole (head assembly)	RLA-311-O
26*	Switch mounting plate	RNE-393-O
27	Lever switch	RSK-021-B
28*	Solenoid bracket	RNE-386-B
29	Pinch solenoid	RXP-011-C
30*	Rubber washer	RNE-392-O
31	Felt	RED-054-A
32*	Solenoid shaft	RLA-305-B
33	Stepped washer	RLA-304-A
34	Pinch pressure spring	RBH-146-O
35	Stepped washer	RLA-304-A
36*	Hex. pole (motor)	RLA-296-A
37*	Roller arm shaft	RLA-302-O
38*	Roller bracket	RNE-389-B
39	Shifter damper	REB-109-O
40	Shifter pole	RLA-298-O
41*	Shifter arm	RNG-053-O
42*	Spring hook	RNE-406-O
43	Shifter spring	RBH-169-O
44*	Vinyl tube	
45*	Shifter arm shaft	RLA-297-O
46	Washer 6φ BN 1	B22-426-O
47*	Flywheel shaft (B)	RLA-295-A
48*	Flywheel shaft (A)	RLA-294-A
49	Washer 6φ BN 1	B22-426-O
50	Transistor 2SC1444-O or Y	

Key No.	Description	Part No.
51	Insulate bushing	REE-043-O
52*	Heat sink	RNE-407-E
53	Insulate bushing	REE-042-O
54*	Solder lug	
55*	Tension arm bracket assembly	RXA-382-A
56	Tension arm damper	REB-103-A
57*	Tension arm shaft	RLA-308-O
58*	Tension arm cam assembly	RXA-360-A
59	Tension arm spring	RBH-149-A
60	Shut-off switch P.C. board assembly	RWX-038-O
61	Microswitch (shut-off switch)	RSF-007-O
62	Counter	RAW-017-O
63*	Counter bracket	RNE-394-O
64	Backward spring	RBH-170-O
65*	Pinch arm shaft	RLA-307-O
66*	Pinch arm (B)	RNG-031-A
67	Washer 6φ BN 1	B22-426-O
68	Rubber washer (A)	REB-052-O
69	Felt	RED-069-O
70	Capstan bearing assembly	RXA-307-O
71	Washer 6φ BN 2	B22-425-O
72	Flywheel assembly	RXX-105-O
73	Flywheel belt	N28-417-O
74	Nylon ball	N23-608-A
75*	Flywheel bracket	RNE-475-O
76	Snap switch (frequency change switch)	RSL-004-O
77	Terminal strip 6P	RKC-013-O
78*	Terminal strip mounting metal	RNE-479-O
79*	Motor chassis	RNE-474-B
80	MP capacitor (A) 2.8 + 1μF 250V	RCL-013-O
81	Drive pulley	RLA-346-O
82	Capstan motor	RXM-012-O
83	Motor fan (A)	RNC-072-O
84	Washer 6φ BN 1	B22-426-O
①	Playback head assembly	RXX-107-O
②	Recording head assembly	RXX-108-O
③	Pinch solenoid assembly	RXX-106-O

Note 2

NOTE 1:
There are three different kinds in thickness of erase head-adjustable spacer as follows:

- REF-004-O E.H. adj. spacer (A) t = 0.1 mm
- REF-005-O E.H. adj. spacer (B) t = 0.2 mm
- REF-006-O E.H. adj. spacer (C) t = 0.3 mm

NOTE 2:
Tape speed-adjustable drive pulley is available in three different kinds as follows:

- RLA-345-O slightly small drive pulley in diam.
- RLA-346-O standard-size drive pulley in diam. (standard speeds)
- RLA-347-O slightly large drive pulley in diam.

NOTICE: Any parts asterisked (*) are subject to being not supplied.

Key No.	Description	Part No.
1	Level meter	RAW-018-O
2*	P. C. board holder	RNE-537-A
3	REC lamp P.C. board assembly	RWX-033-O
4*	Control chassis	RNB-032-C
5	Buffer felt	RED-052-O
6	Knob (POWER, REEL, SPEED)	RAC-004-A
7	EQ switch circuit assembly	RWS-013-A
8*	Cord fixer (B)	RNE-513-O
9	Insulate washer	E34-004-O
10	Electrolytic capacitor 1,000 μ F 35V	RCH-010-O
11	Fuse P. C. board assembly	RWX-036-A
12*	Function button shaft	RLA-310-A
13	Button spring assembly	RXA-316-A
14*	Button frame	RNE-409-A
15*	Button spacer (B)	RLP-003-A
16	Function button (REC)	RAC-003-B
17	Function button (REW)	RAC-002-A
18	Function button (STOP)	RAC-001-A
19	Function button (PLAY)	RAC-002-A
20	Function button (FAST)	RAC-002-A
21*	Button spacer (A)	RLP-002-O
22*	Function switch bracket	RNE-412-A
23*	Release plate	RNE-404-B
24	Release spring	RBH-152-O
25	Reset solenoid	RXP-013-O
26	Control assembly	RWG-040-O
27	AC socket	RKP-003-A
28*	Amp chassis	RNB-043-O
29	REC level volume 10k Ω -A	RCV-010-A
30	Terminal strip 4P	AKC-013-O
31	Insulate washer	E32-045-O
32	MIC jack	K72-024-O
33	BIAS switch	RSB-008-O
34	EQ switch	RSB-009-O
35	Headphone jack (A)	RKN-002-A
36	P. B. amplifier assembly	RWF-014-O
37	VR assembly	RWX-040-O
38	REC amplifier assembly	RWF-015-O
39	SW circuit assembly	RWS-011-A
40	OSC assembly	RWA-008-A
41*	Shield cover	RNE-543-O
42	6P pin jack (INPUT/OUTPUT)	AKB-008-O
43*	Pin jack mounting bracket	RNE-413-B
44	DIN socket	K93-003-B
45*	Rear panel	RNA-098-C
46	Screw (GND)	B11-012-A
47*	Model plate	RAL-092-O
48	P. B. level volume 50k Ω -B	RCV-011-O

11. 4 MECHANISM (REEL MOTOR)

NOTICE: Any parts asterisked (*) are subject to being not supplied.

Key No.	Description	Part No.
1*	Chassis frame	RNG-036-C
2	Molded terminal T-type 3P	K15-402-O
3	Special spring washer 3φ	
4*	Terminal mounting plate	RNE-478-O
5	Terminal strip 6P	RKC-013-O
6	Special spring washer 3φ	
7	Molded terminal T-type 3P	K15-402-O
8*	Reel chassis	RNB-042-O
9*	Cord fixer (B)	RNE-513-O
10	Bushing	B23-405-A
11	Wire wound resistor (A) 100Ω 20W	RCN-010-O
12	Special spring washer 3φ	
13	Wire wound resistor (D) 2kΩ 20W	RCN-014-O
14	Phase capacitor 0.5+4μF 250V	RCL-010-O
15	Power transformer	RTT-039-A
16	Reel base screw	RLA-321-O
17	Reel base spring	RBH-162-O
18	Reel feather shaft	RNG-051-O
19	Reel base	RNG-055-O
20	Counter belt	REB-077-O
21	Reel motor	RXM-015-O
22*	Brake plate (R) assembly	RXA-314-A
23	Brake arm damper	REB-098-O
24	Brake solenoid	RXP-012-A
25*	Brake guide	RNK-111-B
26	Brake band assembly	RXX-111-O
27	Brake dram assembly	RXX-110-O
28*	Brake arm (R)	RNE-400-B
29	Brake spring	RBH-173-O
30*	Vinyl tube	
31	Plate	RNE-401-O
32	Wire wound resistor (C) 500Ω 20W	RCN-012-O
33	Wire wound resistor (B) 300Ω 20W	RCN-011-O
34*	Brake plate (L) assembly	RXA-313-A
35*	Brake arm (L)	RNE-399-B
36*	Stiffen angle	RNC-068-O
37	Washer 6φ BN 1	B22-426-O
38*	Switch mounting plate	RNE-554-O
39	Line voltage selector switch (fuse holder)	AKR-001-O

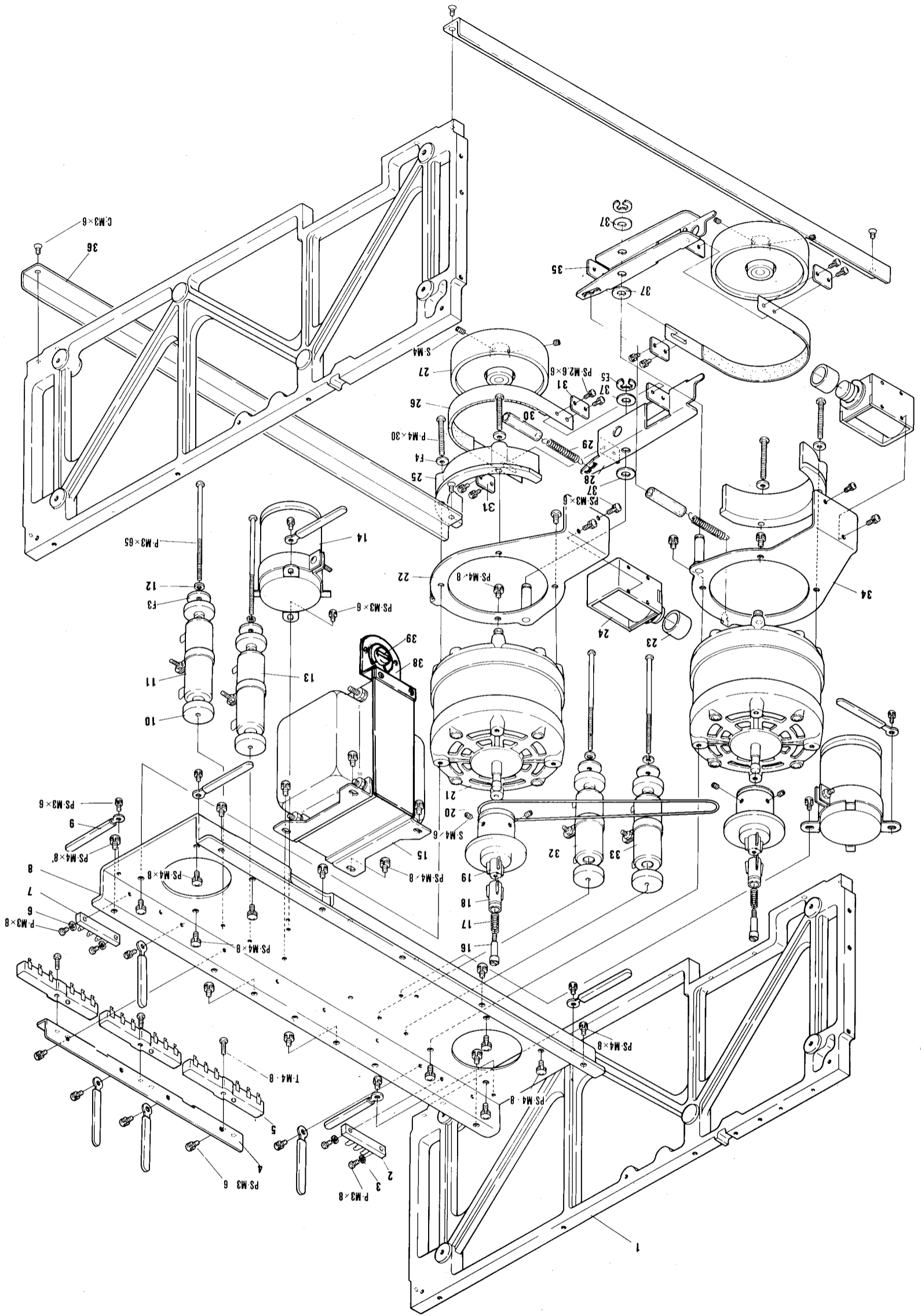

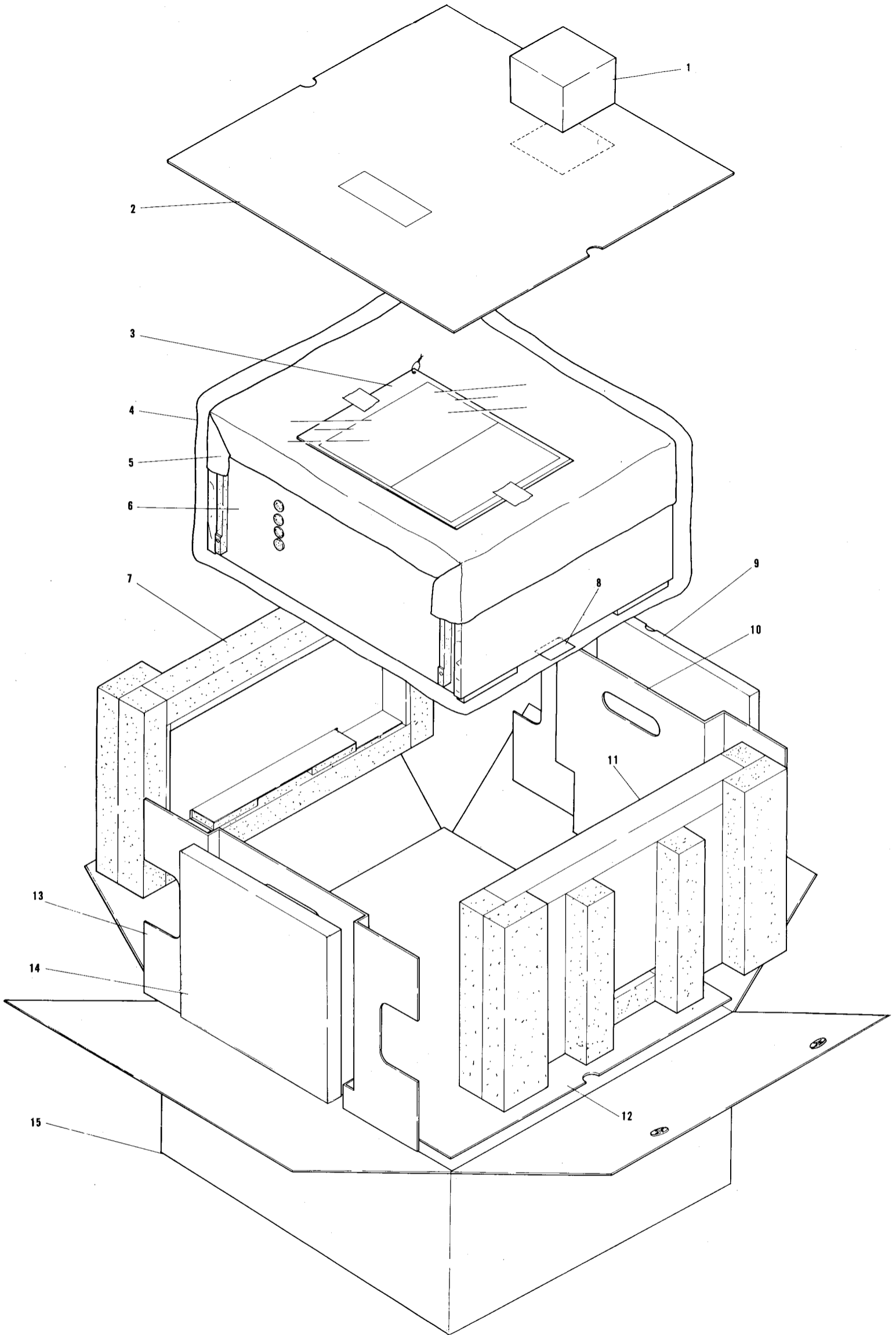

NOTICE: Any parts asterisked (*) are subject to being not supplied.

Key No.	Description	Part No.	
1*	Buffer block	RHA-049-O	
2*	Cardboard	RHA-045-B	
3	Operating instructions	RRB-021-O	
4	Vinyl bag	RHL-007-O	
5*	Styrene paper	RHC-023-O	
6*	RT-1020L		
7*	Cushion (L)	RHA-043-C	
8*	Silica gel	H46-856-O	
9*	Empty reel (RP-100)		
10*	Frame for accessory reel	RHA-046-A	
11*	Cushion (R)	RHA-042-C	
12*	Cardboard	RHA-045-B	
13*	Frame for accessory box	RHA-047-B	
14	Accessory box	RHX-019-O	
15*	Packing case	RHA-044-A	
	Packing case assembly	RHK-102-O	Including 1, 2, 7, 10, 11, 12, 13, 15.
	Connection cord	D53-851-O	
	Power cord	RDG-003-O	
	Head cleaning ribbon	E33-856-O	
	Splicing tape	P45-851-O	
	Head cleaning kit	REA-005-O	
	*10" reel adaptor (PP-220)		

12. LEVEL DIAGRAMS

