

4-CHANNEL STEREO RECEIVER
QX-949A
F, KCU

<ART-140-0>

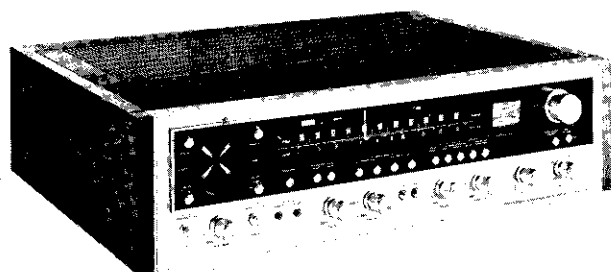

 **PIONEER®**

CONTENTS

1.	SPECIFICATIONS	3
2.	FRONT PANEL FACILITIES	5
3.	CONNECTION DIAGRAM	9
4.	BLOCK DIAGRAM	11
5.	LEVEL DIAGRAM	13
6.	CIRCUIT DESCRIPTIONS	
6.1	FM Tuner Section	14
6.2	AM Tuner Section	14
6.3	CD-4 Demodulator Section	16
6.4	SQ Full Logic/RM Decoder Section	20
6.5	Control Amplifier	23
6.6	Power Amplifier Section	24
6.7	Protection Circuit	24
7.	DISASSEMBLY	
7.1	Wooden Cabinet	26
7.2	Bottom Plate	26
7.3	Front Panel	27
8.	ADJUSTMENTS	
8.1	AM Section	28
8.2	FM Section	29
8.3	FM MPX Section	30
8.4	Power Amplifier Section	31
9.	DIAL CORD STRINGING	32
10.	PARTS LOCATIONS	
10.1	Front View 1	33
10.2	Front View 2	35
10.3	Top View	37
10.4	Bottom View	39
10.5	Rear View	41
11.	EXPLODED VIEWS	43
12.	PACKING	52
13.	SCHMATIC DIAGRAMS, P.C. BOARD PATTERNS AND PARTS LISTS	
13.1	Schematic Diagrams and Miscellaneous Parts	53
13.2	Tuner Assembly (AWE-041)	61

13.3	Headphone Jack Assembly (AWX-054)	67
13.4	Power Supply Circuit B Assembly (AWR-039)	68
13.5	CD-4 Assembly (AWM-076)	69
13.6	SQ/RM Decoder Assembly (AWM-077)	77
13.7	Protection Circuit Assembly (AWM-079)	83
13.8	Control Amplifier Assembly (AWG-023)	86
13.9	Power Supply Circuit A Assembly (AWR-080)	91
13.10	Switch Circuit Assembly (AWS-048)	94
13.11	Power Amplifier Assembly (AWH-027)	98
14.	PARTS LIST OF EXPLODED VIEWS	102

NOTE:

THE MODEL QX-949A COMES IN TWO VERSIONS DISTINGUISHED AS FOLLOWS:

Round label on rear panel	Voltage	Type
F	110V, 120V, 130V, 220V, and 240V (switchable)	General export model
KCU	120V only	UL (U.S.A.) and CSA (Canada) approved

1. SPECIFICATIONS

Semiconductors

FETs	12	Transistors	85
ICs	11	Diodes	63

Amplifier Section

Continuous Power Output from 20 Hertz to 20,000 (4 channels driven)	40 watts per channel (8ohms) 50 watts per channel (4ohms)
Continuous Power Output from 20 Hertz to 20,000 Hertz (2 CHANNEL POWER BOOSTING SWITCH set at "2 CH") (2 channels driven)	60 watts per channel (8ohms) 75 watts per channel (4ohms)
Continuous Power Output at 1,000 Hertz (4-channels driven)	44 watts per channel (8ohms) 58 watts per channel (4ohms)
Continuous Power Output at 1,000 Hertz (2 CHANNEL POWER BOOSTING SWITCH set at "2 CH") (2 channels driven)	65 watts per channel (8ohms) 85 watts per channel (4ohms)
Circuitry	Direct Coupled Complementary OCL
Total Harmonic Distortion (20 Hertz to 20,000 Hertz) (Continuous Rated Power Output)	No more than 0.3%
(1 watt per channel Power Output, 8 ohms)	No more than 0.05%
Intermodulation Distortion (Continuous Rated Power Output)	No more than 0.3%
(1 watt per channel Power Output, 8 ohms)	No more than 0.05%
Output, Speaker	FRONT: A, B, A+B REAR: A, B, A+B
Headphones	FRONT & REAR Low impedance
Damping Factor (1,000 Hertz, 8ohms)	35
Input Sensitivity/Impedance	
PHONO 1	2.5mV/50kohms
PHONO 2	2.5mV/50kohms
PHONO Overload Level (rms)	100mV
AUX	150mV/100kohms
TAPE MONITOR (2CH, 4CH)	150mV/100kohms
Output Level	
TAPE REC (2CH, 4CH)	150mV
Frequency Response	
PHONO (RIAA equalization)	30 Hertz—15,000 Hertz ± 1 dB
AUX, TAPE PB	7 Hertz—25,000 Hertz ± 1.5 dB

Tone Control	
BASS	± 10 dB (100 Hertz)
TREBLE	± 10 dB (10,000 Hertz)
Loudness Contour	
(Volume control set at -40dB position)	+6dB (100 Hertz) +3dB (10,000 Hertz)
Hum & Noise (IHF, Short-circuited, A Network)	
PHONO	70dB
AUX, TAPE PB	90dB
Filter	
LOW	50 Hertz (6dB/oct.)
HIGH	10,000 Hertz (6dB/oct.)

CD-4 Demodulator Section

Input Sensitivity	2.5mV (1—5mV adjustable)
Input Impedance	100k Ω
Harmonic Distortion	0.15%
Signal-to-Noise Ratio (IHF, A Network)	More than 70dB
Separation (STD Test Signal at 1kHz)	
Left ~ Right	50dB
Front ~ Rear	30dB

FM Tuner Section

Circuitry	2 MOS FETs, 1-stage RF Amplifier, 4-ganged Tuning Capacitor, 6-stage Limiter
Usable Sensitivity (IHF)	1.8 μ V
Capture Ratio (IHF)	1dB
Selectivity (IHF)	80dB
Signal-to-Noise Ratio	70dB
Image Rejection (98MHz)	85dB
IF Rejection (98MHz)	100dB
Spurious Rejection	100dB
AM Suppression	55dB
Harmonic Distortion	
Mono	0.2%
Stereo	0.4%
Frequency Response	20Hz—15kHz $^{+0.2}_{-2.0}$ dB 50Hz—10kHz $^{+0.2}_{-0.3}$ dB
Stereo Separation	
1kHz	40dB
50Hz~10kHz	30dB
Sub-carrier Suppression	65dB
Antenna Input	300 Ω Balanced, 75 Ω Unbalanced
Muting	ON-OFF
MPX Noise Filter	ON-OFF

AM Section

Circuitry	1 Stage RF Amplifier, 3-ganged Tuning Capacitor
Sensitivity	
(IHF, Ferrite Antenna)	300 μ V/m
(IHF, Ext. Antenna)	15 μ V
Selectivity	40dB
Signal-to-Noise Ratio	50dB
Image Rejection	65dB
IF Rejection	85dB
Antenna	Built-in Ferrite Loopstick Antenna

Miscellaneous

Built-in CD-4 Demodulator, Regular Matrix Decoder, SQ Full Logic Decoder	
Power Requirements	AC 120V 60 Hertz or 110V, 120V, 130V, 220V and 240V (Switchable) 50/60 Hertz
Power Consumption	
KCU type	400W (450VA) (UL, CSA approved model)
F type	530W (General export model)
AC Outlets	Unswitched 2, Switched 1
Dimensions	550(W) x 160(H) x 440(D)mm 22-1/16 x 6-5/16 x 17-5/16 in.
Weight: Without Package	22.4kg, 49 lb 5oz
With Package	27.2kg, 59 lb 14oz
Furnished Parts	
FM T-type Dipole Antenna	1
CD-4 Test Record (PQX-1014)	1
FUSE 6A	1
FUSE 3A	1 (5-line voltage model)
Operating Instructions	1

NOTE:

Specifications and the design subject to possible modification without notice due to improvements.

2. FRONT PANEL FACILITIES

POWER SWITCH

Push button switch for turning on AC power. Also activates switched AC outlets on the rear panel. Depress once for power ON; press again for power OFF.

BALANCE CONTROLS

Individual balance controls for each of the four stereo channels.

4-CHANNEL LEVEL INDICATOR

All channels simultaneously displayed; relative intensity easily compared and adjusted.

VOLUME CONTROL

Control for adjusting sound volume. When rotated clockwise, 4-channel speaker sound increases.

CD-4 SEPARATION CONTROLS

Controls for adjusting front and rear separation when playing CD-4 records using a CD-4 cartridge.

Please refer to page 16 section on CD-4 channel separation adjustment procedures for detailed information. After adjustment, 2-channel records and matrix 4-channel records can also be played at the same setting.

When playing records employing a conventional 2-channel cartridge, set these controls (left & right) to center position.

LEFT Control: Front left (CH 1) and rear left (CH 2) separation adjustment.

RIGHT Control: Front right (CH 3) and rear right (CH 4) separation adjustment.

Be sure to readjust when replacing cartridge or stylus.

NOTE:

These SEPARATION CONTROLS are effective only when playing CD-4 record. When playing the other records, set MODE switch according to record type.

PHONES JACKS (FRONT & REAR)

Accept stereo headphone jacks

Front left and right (CH 1 & CH 3) can be heard when using FRONT jack.

Rear left and right (CH 2 & CH 4) can be heard when using REAR jack.

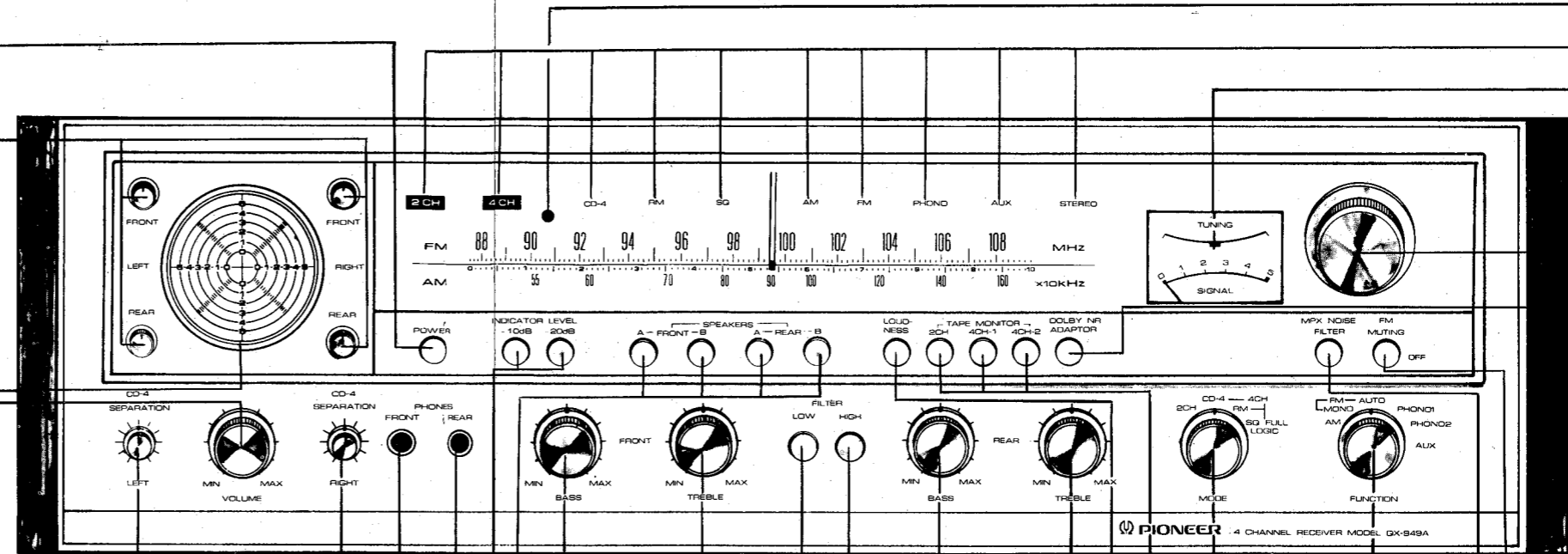

INDICATOR LEVEL BUTTONS

Step attenuator switches convenient for reading of the 4-Channel Level Indicator. If both buttons are depressed, their values are added.

Both positions	Attenuation
Both undepressed	0dB
-10dB only depressed	-10dB
-20dB only depressed	-20dB
Both depressed	-30dB

SPEAKER SWITCHES

Up to four pairs of speakers can be connected and switched on and off (in pairs) with the SPEAKERS SWITCH buttons.

Button depressed: respective pair of speakers in operation.

Button released: respective pair of speakers off.

By depressing all four buttons 2 sets of four-channel speaker systems can be used simultaneously (in different rooms, etc.).

BASS & TREBLE CONTROLS

Separate controls are provided for front and rear bass and treble.

FILTER BUTTON

LOW: Use this filter to cut out low-frequency noise (hum, rumble).

HIGH: Use this filter to cut out high-frequency noise (hiss).

LOUDNESS BUTTON

Depress when listening at low volume levels for proper sound balance relative to human ear sensitivity.

TAPE MONITOR BUTTONS (2CH, 4CH-1, 4CH-2)

These buttons are set to ON for checking the recording conditions or for playback with tape decks.

2CH: This button is set to ON for monitoring a recording in progress or for playback with a 2-channel tape deck connected to the 2CH TAPE PB and REC terminals.

4CH-1: This button is set to ON for monitoring a recording in progress or for playback with a 4-channel tape deck connected to the 4CH-1 TAPE PB and REC terminals.

4CH-2: This button is set to ON for monitoring a recording in progress or for playback with a 4-channel tape deck connected to the 4CH-2 TAPE PB and REC terminals.

NOTE:

For record/playback or listening to broadcasts, leave these buttons set to the OFF position. With the button set to ON no sound will be heard.

MODE SWITCH

Selector switch for 2-channel and each type of four channel reproduction method.

2CH: During 2-channel stereo reproduction (sound does not emerge from rear speakers.)

4CH: CD-4; For reproduction of discrete 4-channel tape, cartridge tape, or CD-4 records. 2-channel source can also be played in this position. At this time the same sounds are obtained from the rear left and right speakers as from the front left and right speakers (CH2 - CH1; CH4 - CH3).

RM; During 4-channel reproduction of Regular Matrix (RM) records and FM broadcasts. The matrix effect can also be obtained with a 2-channel program source.

SQ FULL LOGIC; For 4-channel reproduction of SQ system LOGIC; records and FM broadcasts. The matrix effect can also be obtained with a 2-channel program source.

NOTE:

Sound will not be heard from the rear speakers (CH 2 & CH 4) at any setting of the Mode switch when the 2 CH Power Boosting switch on the rear panel of the QX-949A has been set to 2 CH.

**CD-4 INDICATOR LAMP**

This lights to indicate that CD-4 record is being played (only when the MODE switch is set at 4CH CD-4).

MODE & FUNCTION INDICATORS

Separately lighted indicators provide one-glance recognition of the QX-949A operating mode and function. Left to right: 2CH, 4CH, CD-4, RM, SQ, AM, FM, PHONO, AUX, STEREO (FM stereo indicator)

**TUNING/SIGNAL METER**

When selecting an AM broadcast, tune so that the dial pointer of the lower meter deflects as far to the right as possible. For an FM broadcast, use the lower meter in the same way. Precise FM tuning is also possible by adjusting so that the dial pointer of the upper meter is centered.

**TUNING KNOB**

Rotate to tune in AM or FM broadcasts.

**DOLBY NR ADAPTOR BUTTON**

Used when employing separately sold Dolby NR Adaptor. Set to ON (depressed) for listening to FM Dolby broadcasts, playing Dolby encoded tape, or monitoring Dolby recording via the adaptor.

**FM MUTING BUTTON**

Circuit for eliminating inter-station noise and weak interfering stations when tuning FM broadcast. Up position is ON; depress button (OFF) when weak station reception is desired.

**MPX NOISE FILTER BUTTON**

Push this button to ON to eliminate high-frequency noise during FM stereo reception.

**FUNCTION SWITCH**

Switch for selecting program source for playing.

AM: When listening to AM broadcasts

FM MONO: When listening to FM monophonic broadcasts

FM AUTO: Select when listening to FM stereo broadcasts. During FM monophonic broadcasts, automatically receives monophonic signals. Stereo indicator lights during FM stereo broadcasts.

PHONO 1: When playing records on turntable connected to the PHONO 1 terminals.

PHONO 2: Same as above for PHONO 2 terminals.

AUX: When playing component connected to the AUX terminals.

ABOUT 2CH POWER BOOSTING SWITCH

To increase available power when using the QX-949A for 2-channel reproduction, a convenient power select feature is incorporated. The covered compartment on the rear panel houses a reversible connector panel. When added power is desired during 2-channel operation turn off set power. Open the cover, remove the connector panel and rotate it 180°, then re-insert it and close the cover. Be sure to reverse the connector again before returning to 4-channel operation.

These illustrations show how the boosting switch is employed.

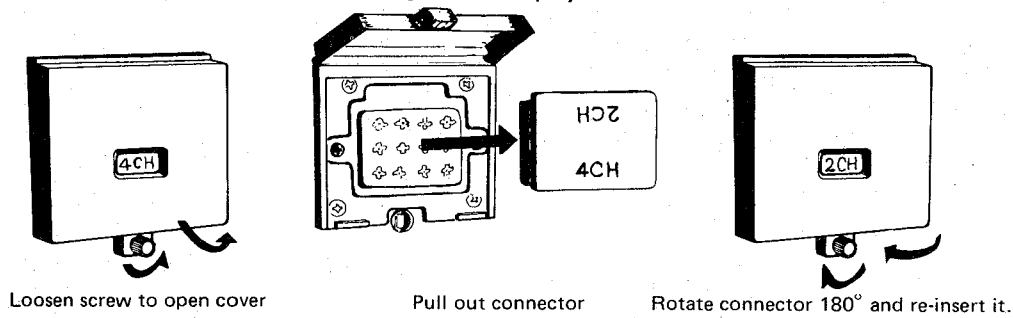

CHANGING LINE VOLTAGE SETTING AND FUSE (F MODEL)

To remove the fuse, unscrew the fuse cap located in the center of the line voltage selector and withdraw it, together with the fuse. Next, pull the line voltage selector plug out of its socket, rotate it until the cutaway aligns with the appropriate line voltage marked on the back of the unit, then push it back into its socket. It is important to check the rating of the fuse; a 3A fuse should be used with either 220V or 240V, while a 6A fuse should be used for 110V, 120V, or 130V operation. If the fuse rating is correct, reinsert it and screw in the fuse cap.

No selector plug is provided for "KCU" type (120V only model).

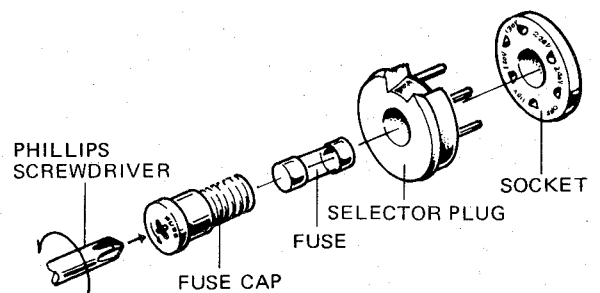

3. CONNECTION DIAGRAM

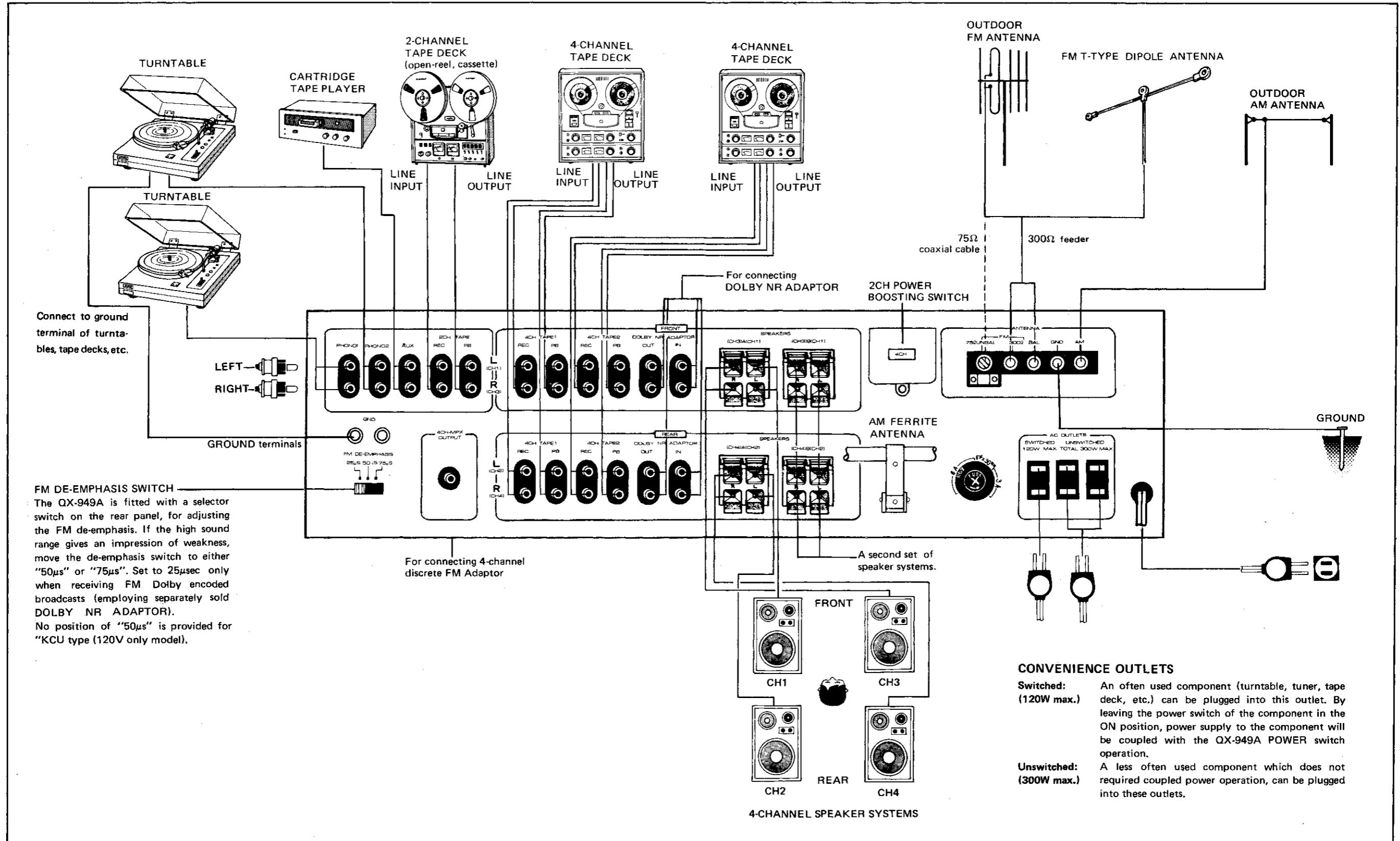

4. BLOCK DIAGRAM

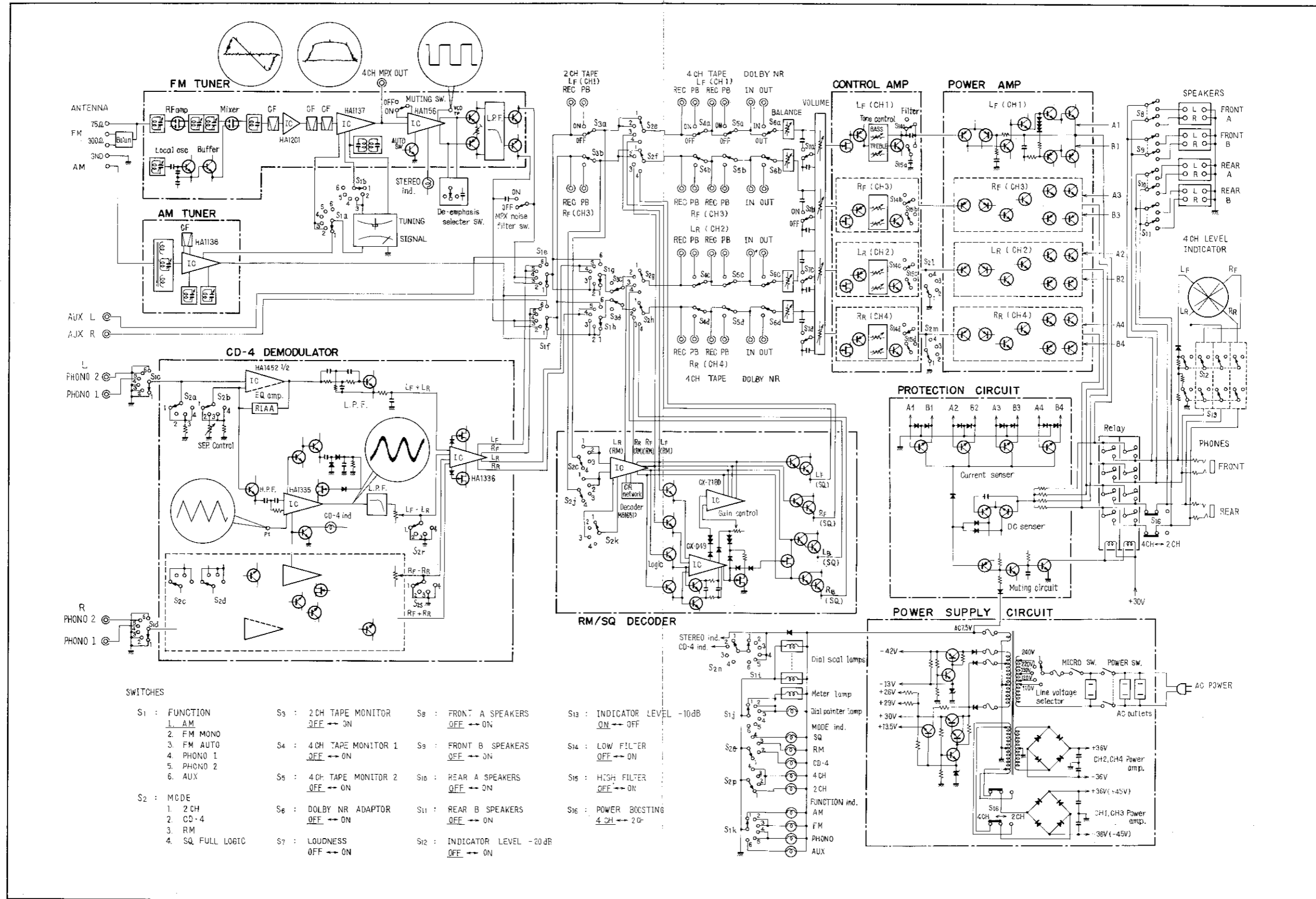

5. LEVEL DIAGRAM

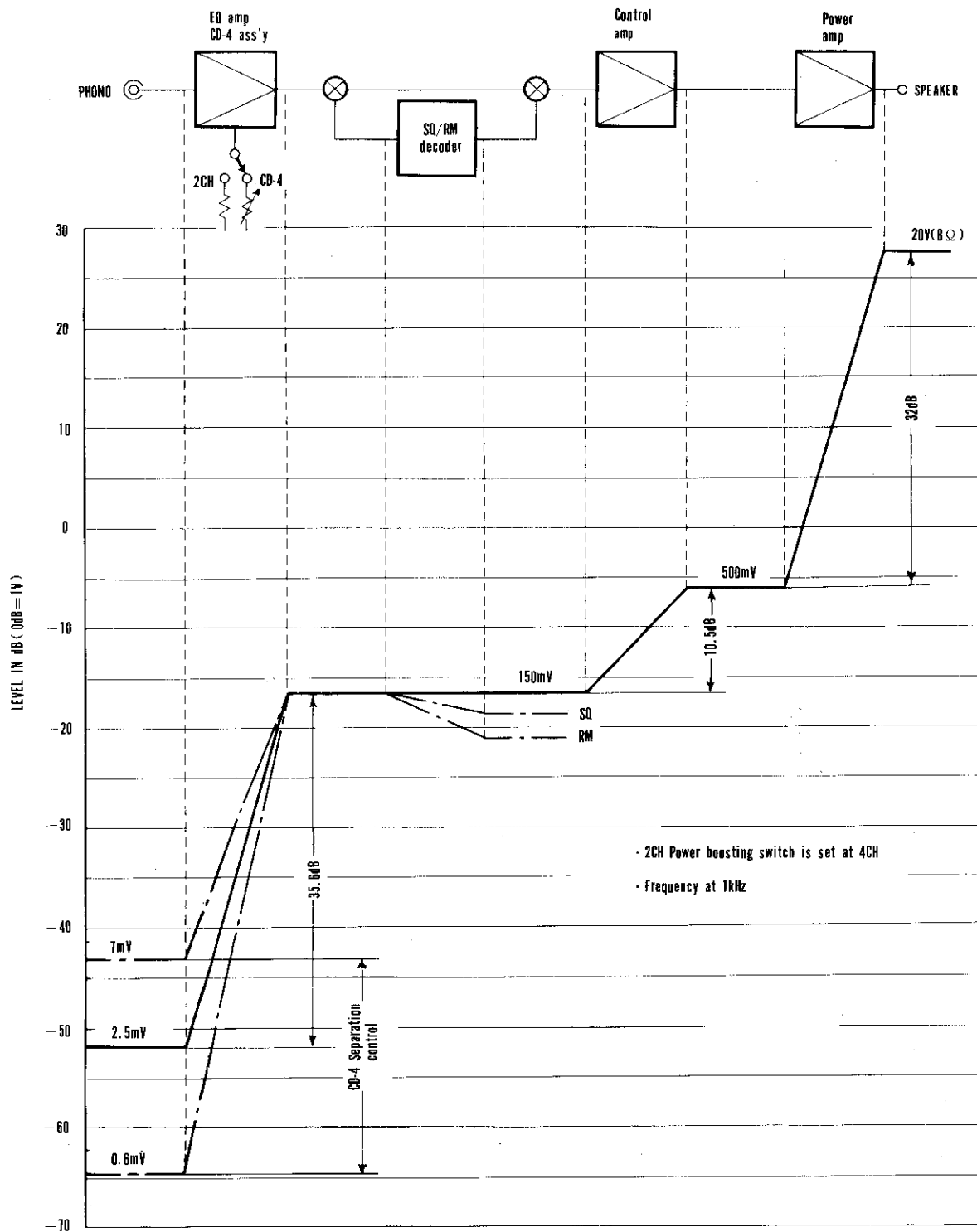

6. CIRCUIT DESCRIPTIONS

6.1 FM TUNER SECTION

Front End

This consists of a 4-gang variable capacitor tuning circuit, dual-gate MOS FET RF amplifier and mixer, and local oscillator with buffer. By employing a grounded gate-2 of the dual-gate MOS FET, the circuit becomes equivalent to a cascade amplifier, providing large gain with stable operation in the RF amplifier.

In the mixer stage, the signal is applied from the local oscillator to gate-2. This method allows input power from the local oscillator to be minimized and features low mutual interference. A variation of a Clapp circuit forms the local oscillator and by inserting a buffer amplifier between it and the mixer, the oscillator load is reduced and waveform distortion suppressed. The oscillation frequency drawing effect is also eliminated, to provide extremely stable operation even with strong inputs.

IF Amplifier and Detector

These are composed of three dual-element ceramic filters and two integrated circuits. The first stage IC (HA1201) incorporates a current limiter, while the second stage IC (HA1137) is shown in Fig. 2. When pin 12 of HA1137 is at more than $\pm 70\text{kHz}$ detuning and with an extremely low input level,

a DC voltage is produced. By setting the FM Muting switch to ON, pin 12 is connected to pin 5, and the analog switch in HA1137 is operated ON-OFF to perform muting.

Multiplex Decoder

Demodulation is performed by switching detection with the circuit contained in the IC (HA1156), depicted in Fig. 3. A phase locked loop (PLL) produces a 38kHz square wave synchronized to the pilot signal. The two gates are alternately switched ON-OFF by this signal to derive the L and R channels from the composite signal. By detecting the pilot signal level, the switching signal from PLL to demodulator is operated ON-OFF. The STEREO indicator lights at the same time.

6.2 AM TUNER SECTION

This consists of a 3-gang variable capacitor tuning circuit, a dual element ceramic filter and an IC (HA1138). The IC (Fig. 4) contains an RF stage and two IF amplifier stages.

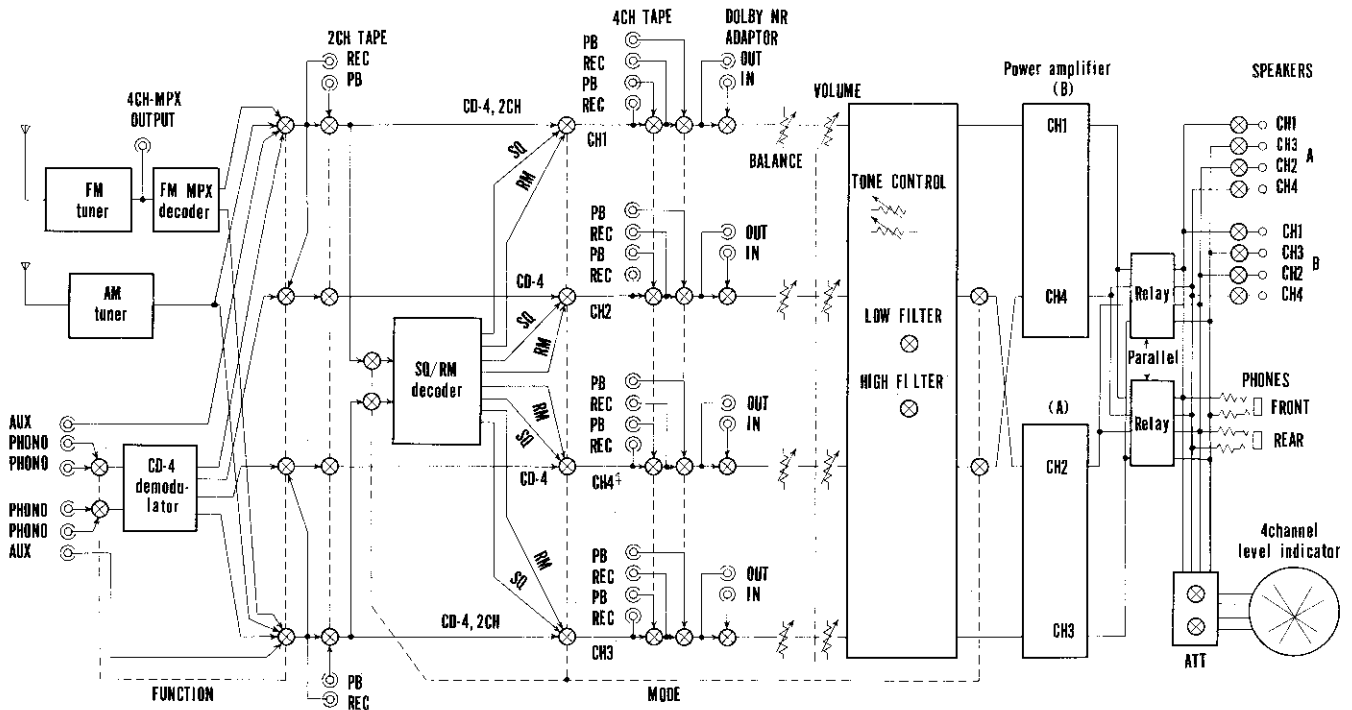
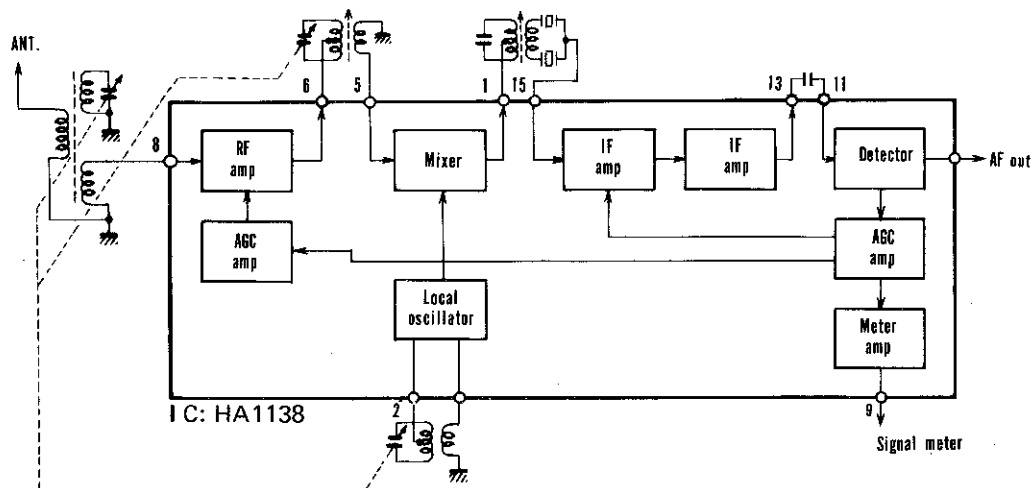
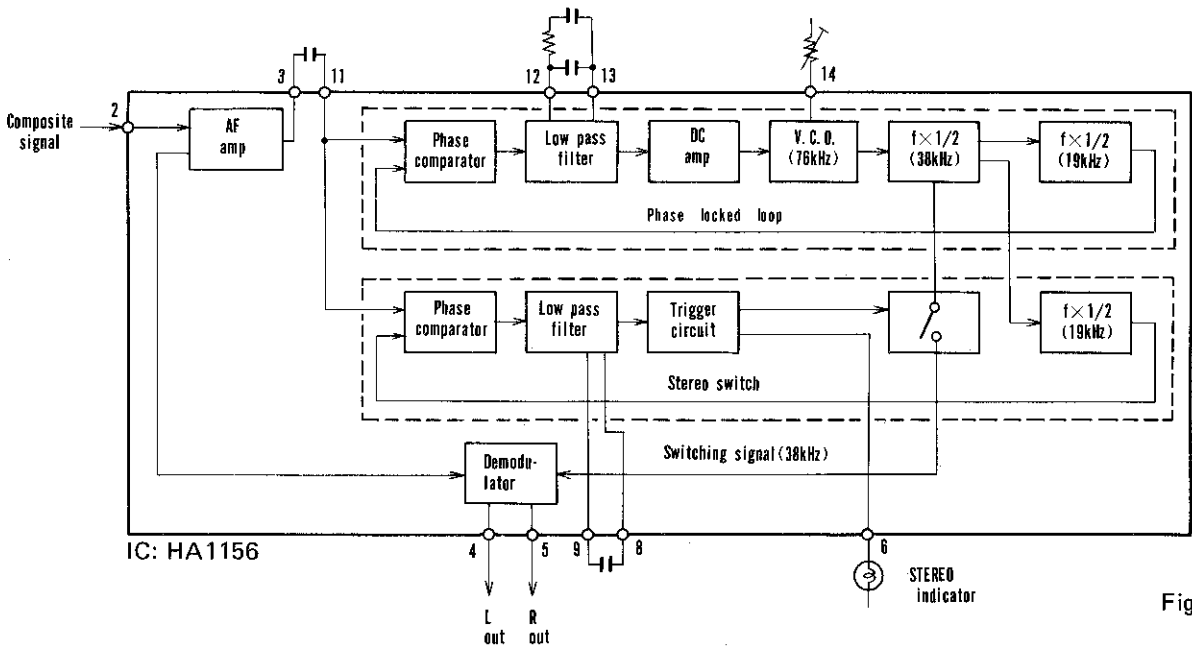
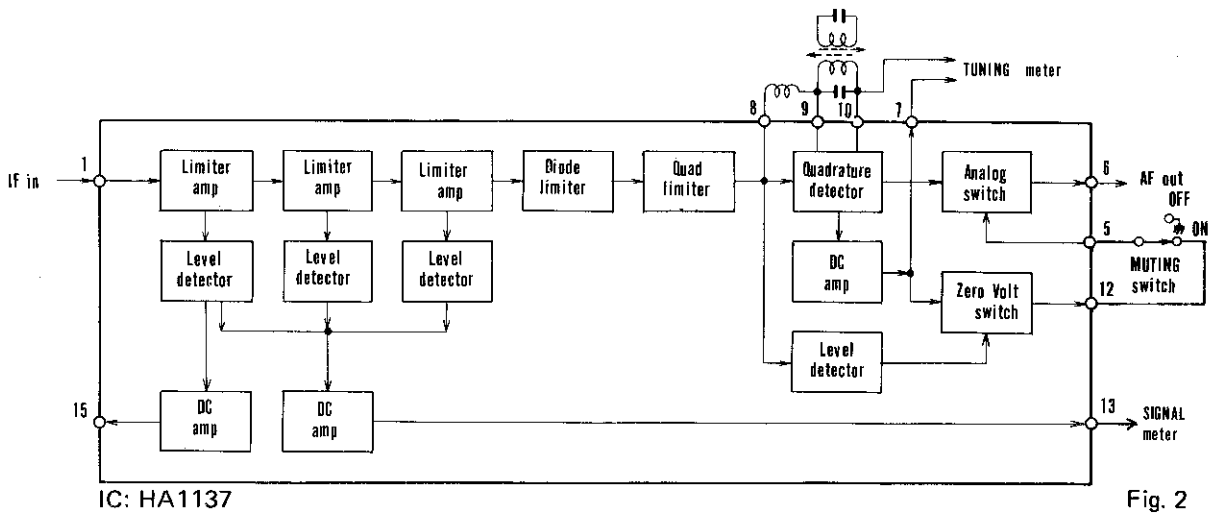

Fig. 1



6.3 CD-4 DEMODULATOR SECTION

Fig. 5 illustrates the composition of this section.

Sum Signal System

IC HA1452 is an orthodox 2-channel equalizer amplifier. In CD-4 operation, a variable resistor is inserted in the NFB circuit to provide separation control by varying the main signal (sum signal) gain. Although the final objective of the CD-4 demodulator is to matrix the sum and difference

signals, as the difference signal is demodulated from a frequency modulated 30kHz carrier (sub signal), and the sum signal varies according to the cartridge output level (though indirectly related), level matching becomes necessary.

In other than the CD-4 mode, a fixed resistor replaces of the variable resistor to provide a fixed gain (35.6dB at 1kHz) equalizer amplifier. The inclusion of a balanced power supply with this circuit maintains input and output point potentials at 0V, preventing click noises when switches are operated. The 100kΩ impedance of this circuit is changed to 50kΩ by inserting two 100kΩ resistors in parallel during other than CD-4 operation.

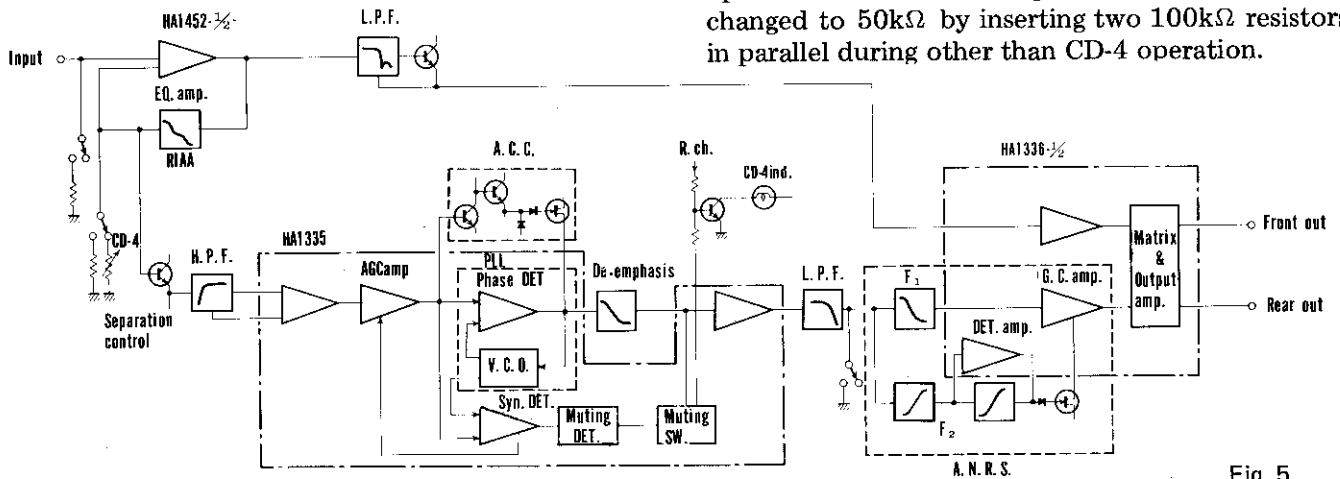

Fig. 5

RECORDING AND PLAYBACK OF CD-4 DISCS

The CD-4 disc is a recent development. Being a "Discrete" 4-channel medium, it features excellent channel separation when played over suitable 4-channel equipment, but can also be played as a conventional 2-channel stereo record.

Fig. 6 shows the configuration of signals present in a CD-4 record.

Each of the two sub-signals occupies a frequency modulated supersonic carrier with a center frequency of 30kHz.

The sub-signal conveys the "Front-Rear" difference information.

The main signals are recorded as a conventional

stereo record, occupying the 30Hz ~ 15kHz audio band and conveying the "Front+Rear" sum information.

From these sum and difference signals, the original 4 channel signals are retrieved in a series of algebraic operations performed in the demodulator:

$$\begin{aligned} (L_f + L_r) + (L_f - L_r) &= 2L_f \\ (L_f + L_r) - (L_f - L_r) &= 2L_r \\ (R_f + R_r) + (R_f - R_r) &= 2R_f \\ (R_f + R_r) - (R_f - R_r) &= 2R_r \end{aligned}$$

where "R" stands for Right, "L" for Left, "f" for front, "r" for rear.

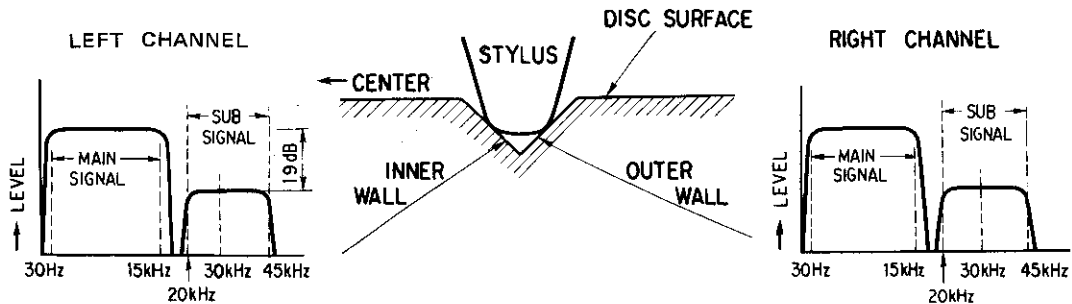

Fig. 6

The equalizer amplifier output goes through a low pass filter (LPF) to remove the sub signal (30kHz FM signal). This LPF is an active filter whose frequency response is shown in Fig. 7.

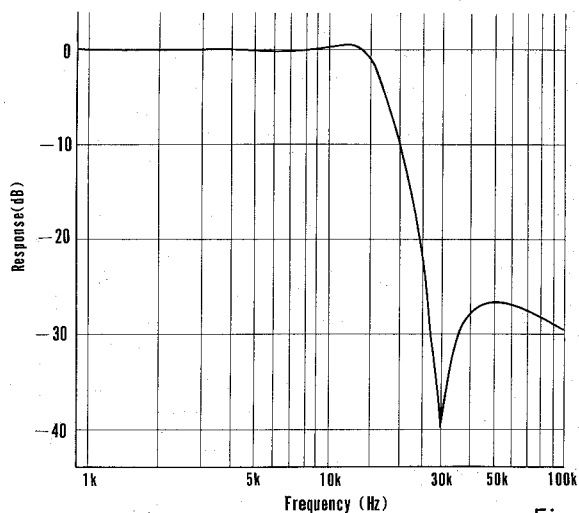

Fig. 7

Difference Signal System

The sub signal is taken from the equalizer amplifier NFB circuit. As it does not pass through the RIAA playback standard equalizer, it possesses a flat frequency response. After passing through a high pass filter ($f_c = 27\text{kHz}$, 12dB/oct.), the sub signal enters IC HA1335.

This IC contains a phase locked loop (PLL) FM demodulator circuit, an automatic gain control (AGC) circuit to stabilize the PLL input signal, a muting circuit to cut the demodulated output in the absence of an input signal, and a demodulated signal amplifier. In addition to the IC, a de-emphasis circuit, automatic capture range control (ACC) circuit, LPF, HPF, indicator lamp drive, and other circuits are used to demodulate the difference signal from the sub signal.

***AGC Amplifier**

Fig. 8 shows the AGC amplifier principle. In this circuit, e_1 is the input signal voltage, e_2 the output signal voltage, V_r the reference voltage, and V_b the control voltage.

If V_b is much greater than V_r , I_3 becomes approximately equal to I_2 and $e_2 \cong 0$. Conversely, if V_b is much less than V_r , I_3 becomes approximately equal to I_1 and e_2 reaches a maximum (determined by the maximum gain of the AGC amplifier). The amplifier gain can therefore be controlled by V_b in this manner, V_b being obtained from a synchronous detector.

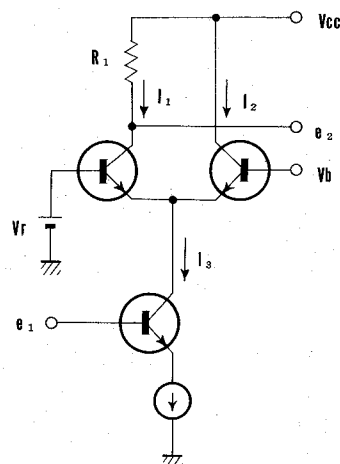

Fig. 8

***FM Demodulator**

The block diagram of the PLL FM demodulator circuit is depicted in Fig. 9. This circuit consists of a voltage control oscillator (VCO), phase comparator (PC), DC amplifier (A) and low pass filter (LPF), with a type of NFB loop following the input signal. The VCO oscillates at a controlled frequency according to the LPF output voltage. A voltage proportional to the phase difference between the input signal and VCO oscillation output is generated in the PC. By using this voltage to control the VCO oscillation, the oscillation becomes locked to the input signal phase.

If the input signal is frequency modulated, the control signal obtained from the LPF becomes the FM demodulated output. With an excessively large frequency deviation of the input signal, which the PLL circuit cannot follow, the lock becomes disengaged. The frequency range in which locking can be performed is termed the lock range.

Locking also becomes impossible when the VCO free running frequency (oscillating frequency without an input signal) and input signal frequency are excessively separated. The frequency range in which locking can be performed is termed the capture range. The locking and capture ranges are determined by the PLL loop gain and LPF constant.

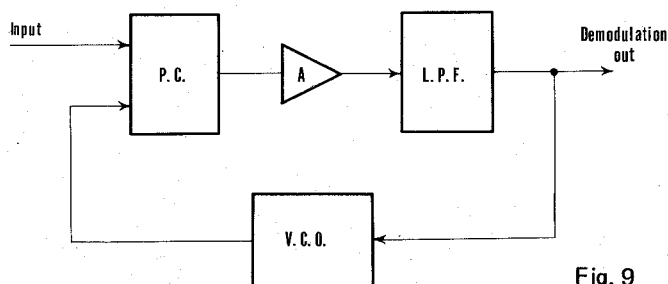

Fig. 9

*Synchronous Detector

The PLL produces a signal in phase with the input signal. By employing this to switch the input signal, full-wave rectification and a DC voltage proportional to the input signal oscillation are obtained. The same in-phase frequencies are required at this time. The frequencies become the same if the PLL is locked, they then become in-phase by shifting the VCO output phase by 90° .

A DC voltage rise proportional to the input level is obtained as AGC from this circuit, together with muting in the form of a DC voltage drop inversely proportional to the input level.

*Muting Circuit

The muting circuit is shown in Fig. 10. Q1 and Q2 form a Schmidt trigger. Q5 is inserted between the difference signal demodulator circuit signal line and ground. The collector of Q4 is connected to the CD-4 indicator circuit and its potential employed to determine whether or not the CD-4 demodulator circuit operates. The synchronous detector provides the input to this circuit.

DC voltage is supplied to the muting circuit from the synchronous detector when the sub signal is absent. Q1 then switches ON, Q2 OFF, and Q3, Q4 & Q5 ON. The difference signal demodulator circuit line is thus shorted to ground and Q4 collector potential reduced.

When a CD-4 record is played and the sub signal is applied to the synchronous detector, the input DC voltage of the muting circuit declines in inverse proportion to the sub signal level. If the sub signal is above a certain level, the Q1 & Q2 Schmidt trigger circuit reverses: Q1 switches OFF, Q2 ON, and Q3, Q4 and Q5 OFF. This removes the short to ground of the difference signal demodulator circuit output line and Q4 collector voltage increases.

*CD-4 Indicator Circuit

Q6 in Fig. 10 is the lamp drive transistor. With a high Q4 collector voltage (during CD-4 play), Q6 is switched ON and the CD-4 indicator lamp lights. This lighting operation is synchronized to the previously described muting circuit operation (in practice, it is slightly delayed). The lamp lights if either the right or left channel gate is open, and extinguishes when both gates are closed.

*ACC (Automatic Capture Range Control)

The PLL does not lock to frequencies out of the capture range and cannot follow frequency variations exceeding the lock range. Automatic control of the PLL capture range is provided by the ACC. It also functions to suppress noise and prevent misoperation with sources other than CD-4.

Peak values associated with amplitude variations in the PLL input sub signal, transients with which AGC is ineffective, noise, main signal interference with the sub signal (sub signal modulated by the main signal) and other causes are converted into a DC voltage. By using this voltage to regulate the equivalent internal resistance of the FET in the PLL load circuit, the PLL capture range (lock range) can be automatically controlled.

There is no PLL detector output with respect to sub signal AM components. However, if the sub signal is AM modulated by noise or the main signal, this can also be considered as phase modulation. This effect is minimized since amplification of the sub signal AM component narrows the PLL lock range (playback bandwidth becomes narrow).

AGC amplifier gain is maximum with no input signal. If some sort of input becomes available at this time, a large output can be temporarily obtained (until the AGC takes effect). For this reason,

the PLL capture range is narrowed by the ACC and remains completely unlocked with an input other than the sub signal. The PLL locks with a sub signal input and when the AGC takes effect, the PLL lock range becomes widened by the ACC.

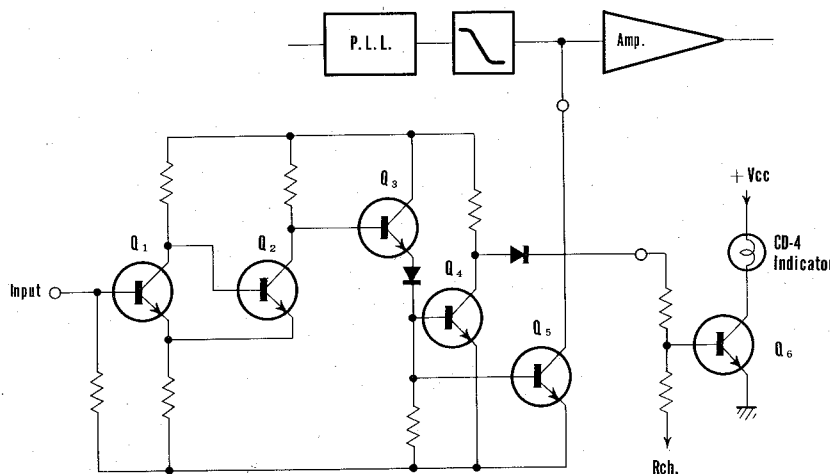

Fig. 10

***ANRS (Automatic Noise Reduction System)**

The ANRS is employed in the difference signal system for CD-4 records in order to improve SN ratio and reduce crosstalk distortion from the cartridge. It is not used in the sum signal system in order to preserve compatibility with 2-channel stereo records.

The ANRS consists of a mutually reciprocal compressor and expander compose the ANRS (Fig. 11). In CD-4 application, compression and expansion are performed in the area of 700Hz and above 2kHz. Fig. 12 shows the ANRS composition used in this set.

Although expansion is normally performed separately for middle and high frequencies, it is not divided in this set (in practice, this poses no difficulty). Filter F1 possesses ANRS expansion properties when compensation is maximum. F2 is a middle and high frequency bandpass filter (bands at which ANRS is employed). The output of this section is amplified and rectified, then used to control the equivalent internal resistance of the FET.

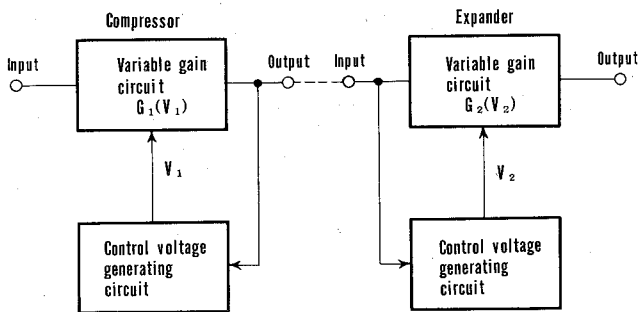

Fig. 11

This FET regulates the NFB in the gain control amplifier (GCA). Its equivalent internal resistance declines with a middle and high frequency input to the circuit, decreasing NFB to the GCA and increasing GCA gain. As these frequencies increase further, the resistance continues to decline and eventually saturates. At this point, the F1 frequency response is cancelled by GCA frequency response, resulting in a flat response in the ANRS expander circuit. In this manner, the GCA compensates F1 frequency response according to the input level.

Consequently, the ANRS frequency response becomes flat above a certain level and when middle and high frequency levels decline, it approaches the frequency response of F1. Below a certain level, the response of F1 is attained. Applying ANRS reduces noise level by an average of 8dB. Also, if 15dB separation is available in the cartridge, crosstalk distortion becomes negligible.

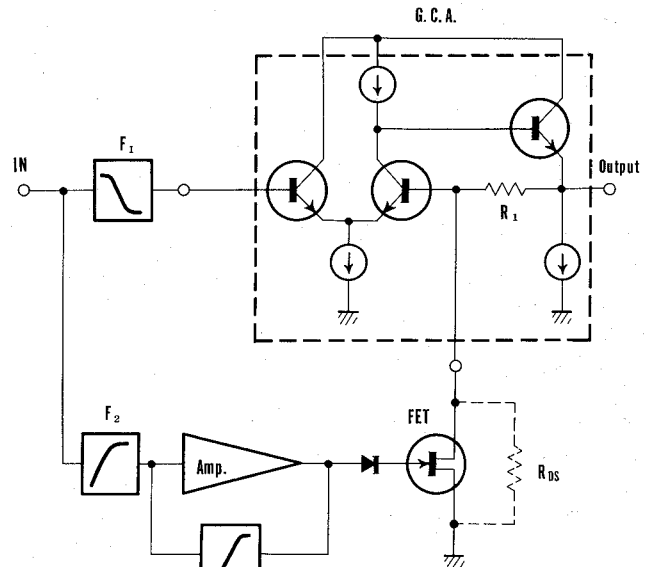

Fig. 12

***Matrix Section**

Matrixing (adding or subtracting) the front and rear sum signals of the main signal system, and the front and rear difference signals of the sub signal system, the front and rear signals are derived.

$$\begin{aligned}
 M &= F + R \\
 S &= F - R \\
 M + S &= (F + R) + (F - R) = 2F \\
 M - S &= (F + R) - (F - R) = 2R
 \end{aligned}$$

6.4 SQ FULL LOGIC/RM DECODER SECTION

SQ System

The Matrix four channel system utilizes 2-channel media (tape, records, broadcasts, etc.) to transmit 4 or more channel signals. Four channel playback systems employ matrixing 4-2-4 (n-2-4) to convert 2-channel into 4-channel. The main systems currently available for this purpose are RM (Regular Matrix) and SQ (Stereo Quad).

With the RM system, if the only sound source is LF (left front), -3dB crosstalk occurs in the RF (right front) and LB (left back). In the SQ system however, -3dB occurs in LB and RB (right back). RM and SQ are therefore not compatible.

Fig. 13 shows the basic SQ decoder construction and signal vectors. LT and RT are combined in LB and RB, while LF' and RF' are taken directly from LT and RT. LB' and RB' are obtained from LT and RT by phase shifting and blending. But LB' and RB' contain respective LF, RF other than necessary components. Left and right separation remains good since LF' does not combine with RF, and RF' does not combine with LF.

If the sound source is CF (center front) or CB (center back), front to rear separation cannot be obtained since LF', RF', LB' and RB' all become the same volume. The logic circuit is provided for improve this effect.

With CF crosstalk to LB and RB is at out of and since with CB crosstalk to LF and RF is also at out of, only these anti-phase components are cancelled. This is termed front-back logic. The objective of full logic is to deal not only with CF and CB sound sources, but also with various other directions.

Front-back logic performs CF and CB detection, while wave matching logic performs LF, RF, LB and RB detection. The combined detector signal passes through a time constant circuit and is applied to the gain control circuit, where gain is controlled in order to adequately reduce the crosstalk level.

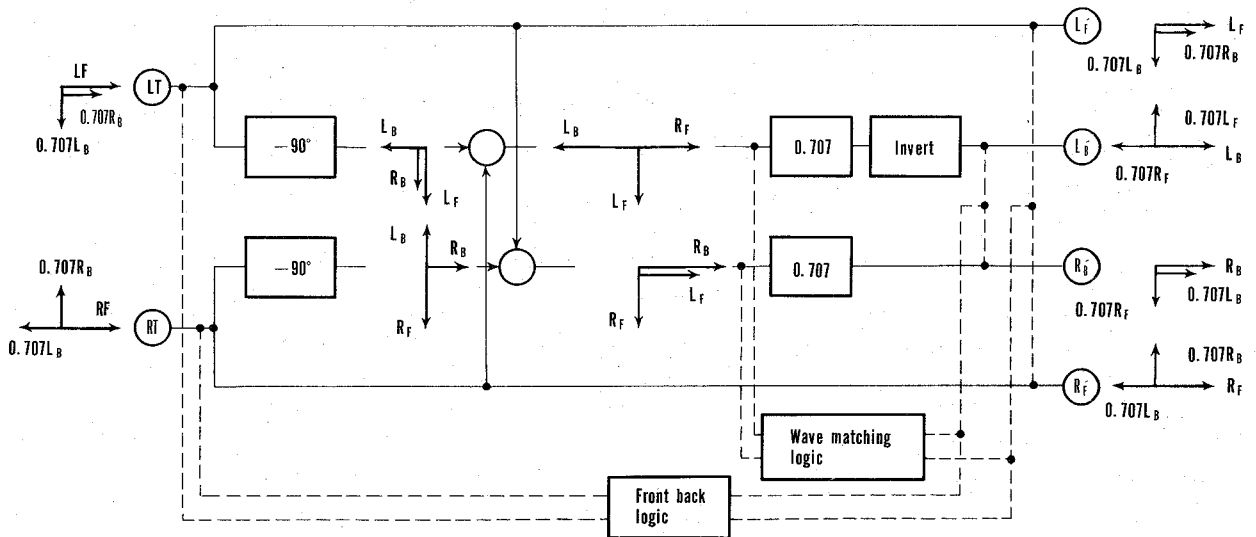

Fig. 13

Circuit Composition

Three ICs are employed, as shown in Fig. 15. M51651P is an SQ basic decoder and can function as an SQ decoder without independent logic. Although a phase shift network is not included, by a CR network, this IC perform to shift the phase 90° with cover wide range. A selector switch also permits the IC to be used as an RM decoder. During RM, a blend resistor is added at the front, while the rear is blended internally by the IC and taken from separate terminals.

CX-049 is a high density full logic IC incorporating both wave matching and front back logic. CX-718D is a gain control IC and contains four MOS FETs to form a variable resistance voltage control circuit. Since these MOS FETs are P channel enhancement types, equivalent internal resistance becomes infinite when gate voltage is zero. By applying a negative voltage to the gate (Fig. 14), the equivalent internal resistance can be varied from infinity to several hundred ohms.

2SK40V (FET) is employed for back blending. With a CF sound source, it functions to cancel the mutually opposite crosstalk phase to LB and RB. This is an N channel depletion type junction FET and when the gate voltage is zero, the channel is already established. LB and RB become normally blended for this reason, and the gate becomes open only in the case of a single signal from LB or RB.

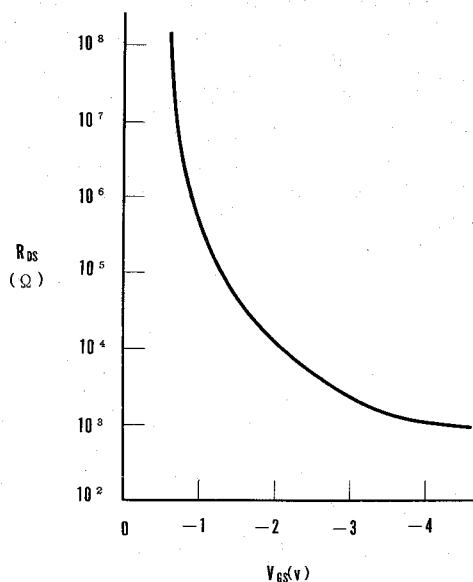

Fig. 14

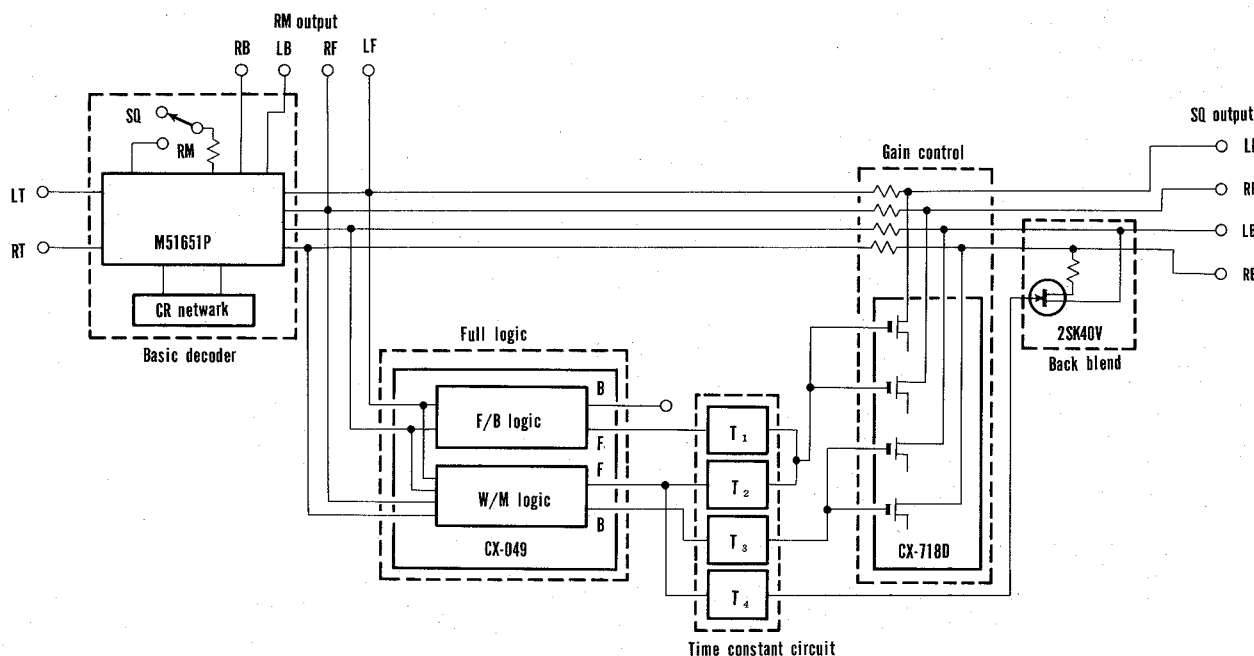

Fig. 15

Operating Description

The input signal (LT & RT) enters the SQ basic decoder (M51651P), where 4-channel signals LF, RF, LB and RB are obtained by the SQ decode matrix, then these signals enter the gain control, back blend and logic circuits. The front-back logic produces a positive voltage with a CF sound source, and a negative one with a CB source. This voltage passes through the time constant circuit and is applied to the gates of the MOS FETs for LF and RF gain control.

As these FETs are P channel enhancement types, their equivalent internal resistance decreases only when a negative voltage is applied. Front (LF & RF) output signal levels are attenuated with a CB sound source.

For rear control, wave matching logic produces a negative voltage with respect to a front single signal (LF or RF) and a positive voltage with respect to a rear single signal (LB or RB). Front control is also performed by producing the reverse polarity of these voltages.

The rear control voltage passes through the time constant circuit and is applied to the gates of MOS FETs for LB and RB gain control. The front control voltage passes through the time constant circuit and is applied to the gates of the junction FET for back blend and the MOS FETs for LF and LB gain control. As the junction FET is an N channel depletion type, LB and RB are normally blended, but the device becomes open when a negative voltage is applied.

The detector outputs of the full logic IC (CX-049) with respect to sound source are as shown in the following table.

		LF	RF	LB	RB	CF	CB	Gain control*
F/B logic	F	0	0	0	0	+	-	LF, RF
	B	0	0	0	0	-	+	**
W/M logic	F	+	+	-	-	0	0	LF, RF***
	B	-	-	+	+	0	0	LB, RB

*Gain control operates (attenuates) with (-) detecting mode.

**Front back logic output B is not employed.

***Back blend is not performed only when wave matching logic output F mode is (-).

CAUTION

The gain control IC (CX-718D) is an MOS (metal oxide semiconductor) type and subject to dielectric breakdown from static electricity. Note the following precaution when handling.

*Do not remove the aluminum cap from the IC until it has been installed in the circuit. First solder the IC to the circuit board, then remove the aluminum cap.

6.5 CONTROL AMPLIFIER CIRCUIT

The control amplifier circuit of the QX-949A is the NFB type, using a FET (field effect transistor) in the first stage.

The FET amplifier being a controllable voltage type, which holds the input impedance constant, even if the level of the NFB changes, and has additional advantage as a coupled circuit, as the input impedance can be raised.

Low Frequency Control

The low frequency control circuit is shown in Fig. 16, and the equivalent circuit, when boosting low frequency, is shown in Fig. 17.

As the parallel impedance of VR1 and C29, in Fig. 17, is high at low frequency, the volume of the NFB decreases and the gain in the low frequency range increases.

The equivalent circuit, when cutting out low frequencies, is shown in Fig. 18. In this case, the input signal is applied to Q9, through the parallel impedance of VR1 and C33, which is high in the low frequency range and suppresses the lower frequency signals.

High Frequency Control

The high frequency control circuit is shown in Fig. 19, and the equivalent circuit, when boosting high frequencies, is shown in Fig. 20.

In this circuit, the input signal is applied to Q9 through the parallel impedance circuit. This impedance is small in the high frequency range and produces a signal with an enhanced high range. Fig. 21 shows the equivalent circuit when cutting out high frequencies. As the impedance of R53, R41 and C41 of the circuit becomes small, the level of the NFB increases and the gain of the circuit decreases.

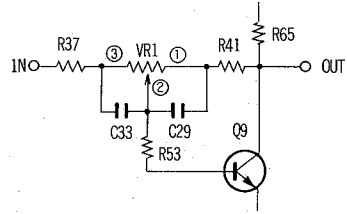

Fig. 16

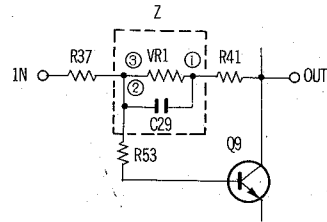

Fig. 17

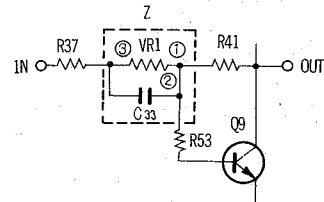

Fig. 18

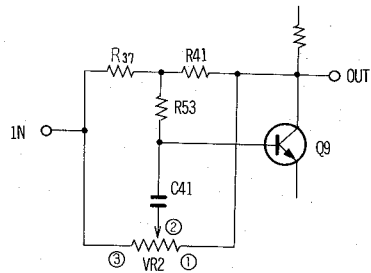

Fig. 19

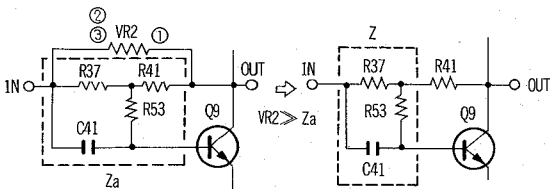

Fig. 20

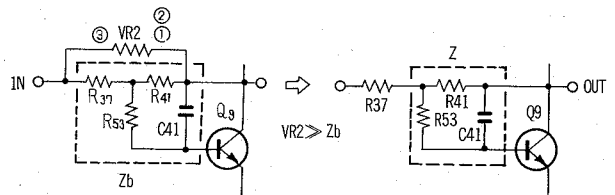

Fig. 21

6.6 POWER AMPLIFIER SECTION

This unit possesses four power amplifiers. The circuitry employs a balanced power supply and consists of direct-coupled Darlington connection pure complementary OCL amplifiers. By applying 100% DC NFB from the output stage center point to the first stage differential amplifier, circuit DC gain becomes 0dB. Since the center point potential is determined by the first stage base potential, temperature compensating and fine adjustment circuits are included in the first stage base bias circuit to maintain the center point potential at 0V.

2-channel Power Boosting Circuit

The power supply can be boosted when using this unit as a 2-channel stereo amplifier (using only ch1 and ch3, and with the MODE switch set to 2CH). Power transistors of channels 1 and 3 are of higher rating than those of channels 2 and 4. Their supply voltage can be raised during 2-channel operation to provide increased power to each channel.

Power boosting is available by turning over the rear panel plug. This raises the power transformer secondary winding taps and opens CH2 and CH4 power amplifier output circuits.

For safety reasons, a microswitch in the power transformer primary side cuts off the power supply when the selector plug cover is opened.

6.7 PROTECTION CIRCUIT

This protection circuit functions to protect the speakers from damage due to short-circuit of the load, etc., and performs a muting operation to cut noise and distortion which occur when switching the power on and off.

The circuit is shown in Fig. 22, and consists of a bridge type over-current and overload detector, a differential amplifier DC voltage detector, and a power switch on/off detector section.

Relay Driving Circuit

Q7 – Q9, in Fig. 22, comprise the relay driving circuit.

In the normal condition reverse bias is applied to the base of Q7, and Q7 is in a cutout condition. When one of the above mentioned detection circuits goes on, current flows through R28, the base potential falls and Q7 is turned on. Consequently Q8 comes on and Q9 goes off. When Q9 goes off, the current of the relay circuit is cut, to release the switch of the output circuit.

When the power switch is turned on, a delay operation occurs in this circuit. R33, R34 and C7, in the base circuit of Q9, are the time constant elements which determine the delay time. When the power switch is switched on, C7 charges to a potential of +30 volts through R33 and R34, and Q9 is kept in the OFF condition during this time. When the power source is switched off the muting operation of Q8 prevents shock noise. In the normal condition, the potentials of +30 volts and -5.1 volts are applied to Q8 through R31 and R32. The resultant potential at the base of Q8 is -1 volt in the cutout condition. When the power supply is turned off, the potential of -5.1 volts disappears immediately, due to the small time constant of the power circuit. Thus a positive base potential remains, switching Q8 on, which in turn switches off Q9 and hence the relay.

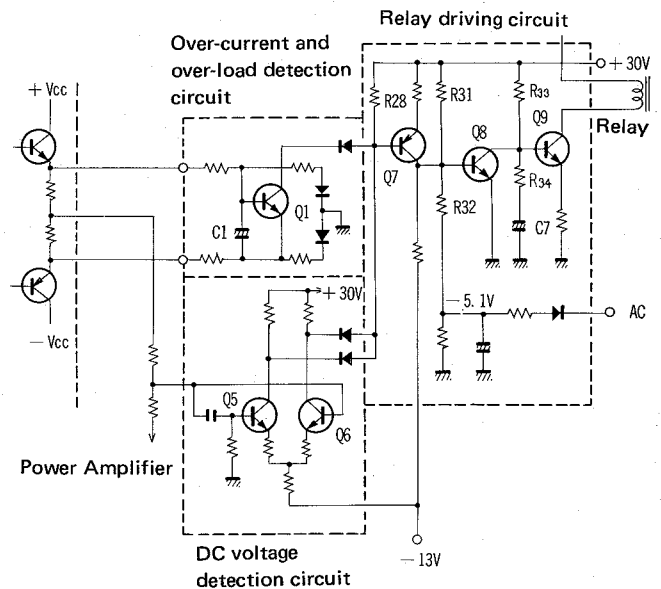

Fig. 22

Over-current and Overload Detection

The equivalent circuit of this detector section is shown in Fig. 23, and Fig. 24 shows the equivalent circuit at the time of a positive half cycle. When this equivalent circuit is overloaded, the balance of the bridge, formed by RE1, R1, R9 and RL, is disturbed, and a potential is produced between b and a in such a direction that Q1 is turned on. When Q1 is turned on, the collector current increases, the relay driving circuit functions and the relay switch of the output circuit is turned off. After the cause of the overload is removed, the bias of Q1 is reduced and the relay switch turns on to automatically restore normal operation, Fig. 25 shows the equivalent circuit at the time of a negative half cycle. In this circuit a potential is produced between b and e as above, and Q1 is turned on.

Detection of DC Voltage

This is a differential amplifier consisting of Q5 and Q6, as shown in Fig. 26. The bases of Q5 and Q6 are connected to the junction-points of the power amplifiers. When the DC balance of the power stage is lost for some reason, a potential difference is produced in the input signal to the differential amplifier, and the collector currents of Q5 and Q6 are put out of balance. Thus, the relay driving circuit functions, and the relay switch is turned off.

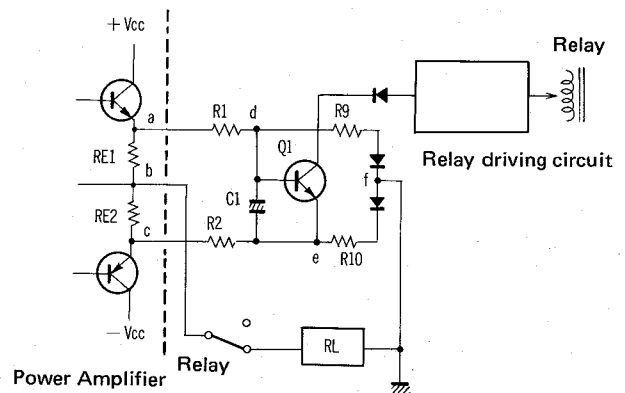

Fig. 23

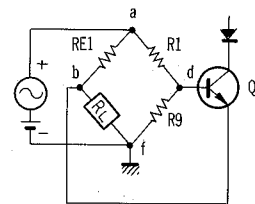

Fig. 24

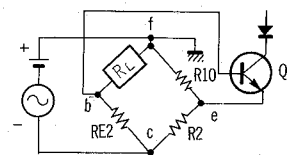

Fig. 25

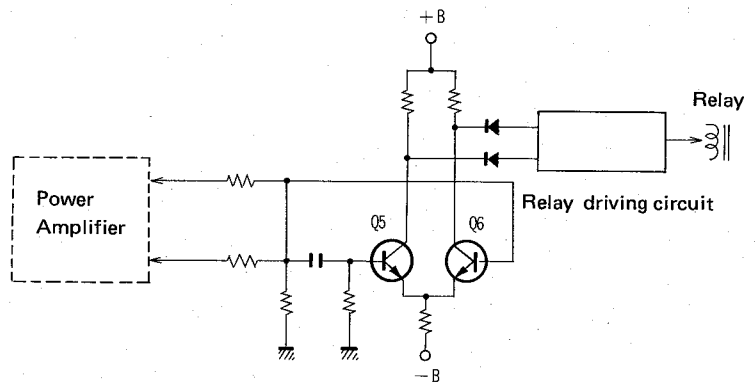
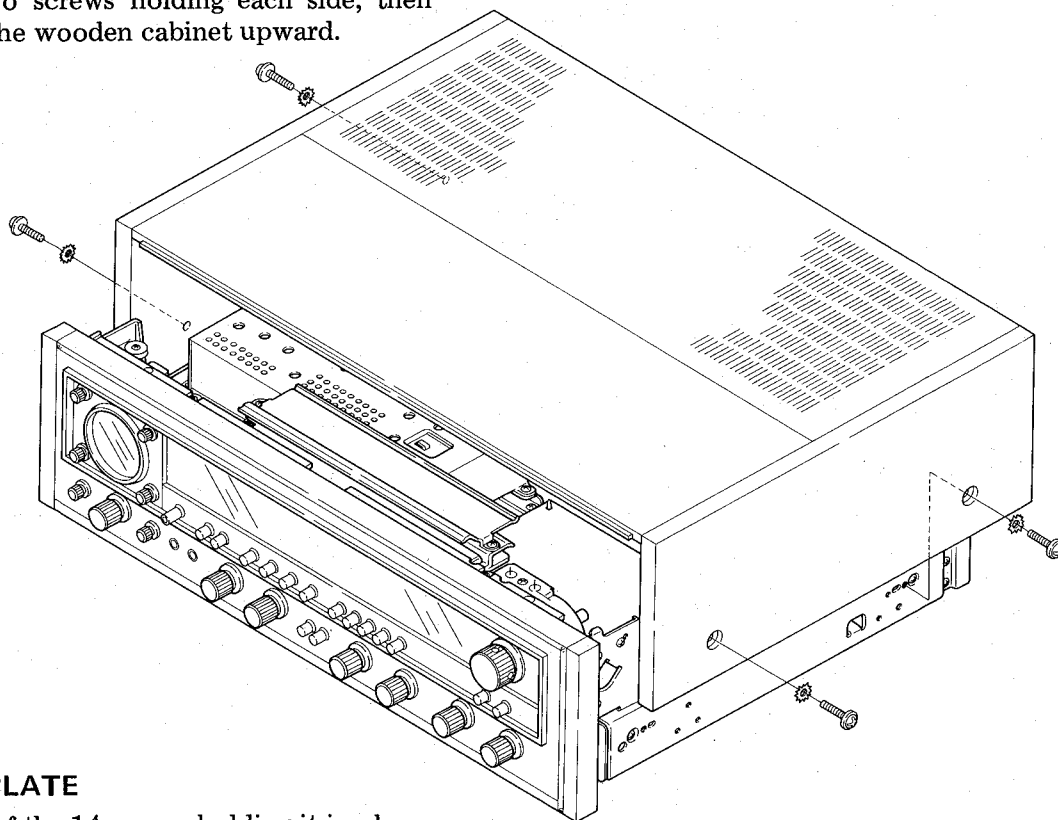

Fig. 26

7. DISASSEMBLY

7.1 WOODEN CABINET

Unscrew the two screws holding each side, then lift the back of the wooden cabinet upward.



7.2 BOTTOM PLATE

Unscrew a total of the 14 screws holding it in place.

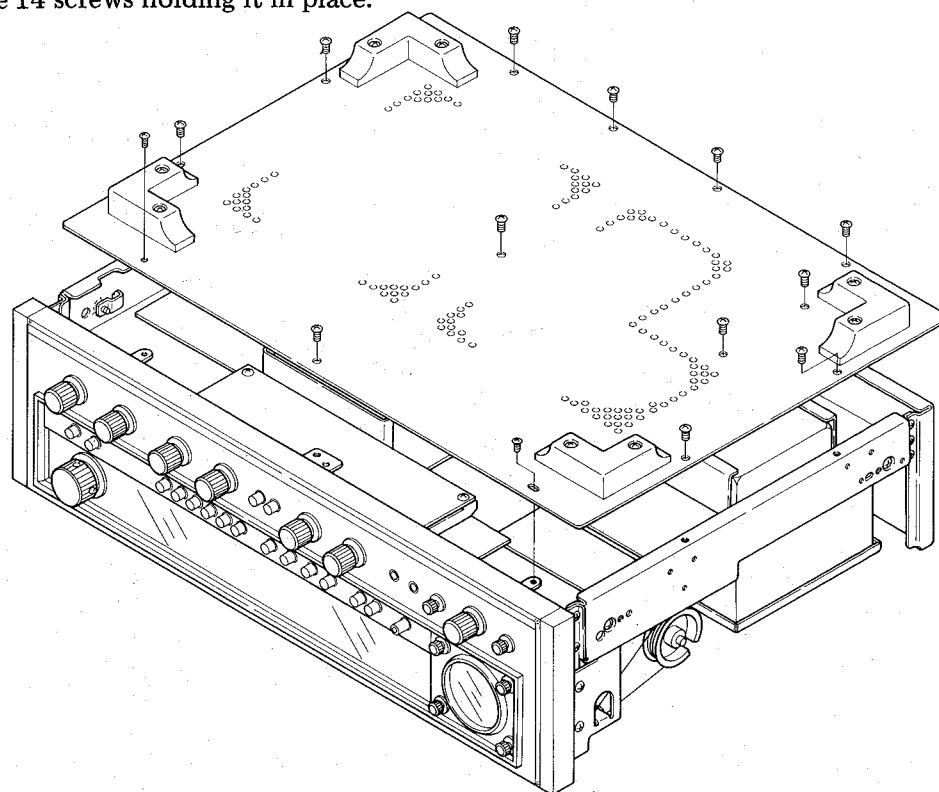

7.3 FRONT PANEL

Pull off knobs. For TUNING knob, loosen the setscrews with a hexagonal wrench before removing it. Unscrew the two screws in the upper edge of the front panel, and the three nuts from the shafts. Then pull the panel gently forward.

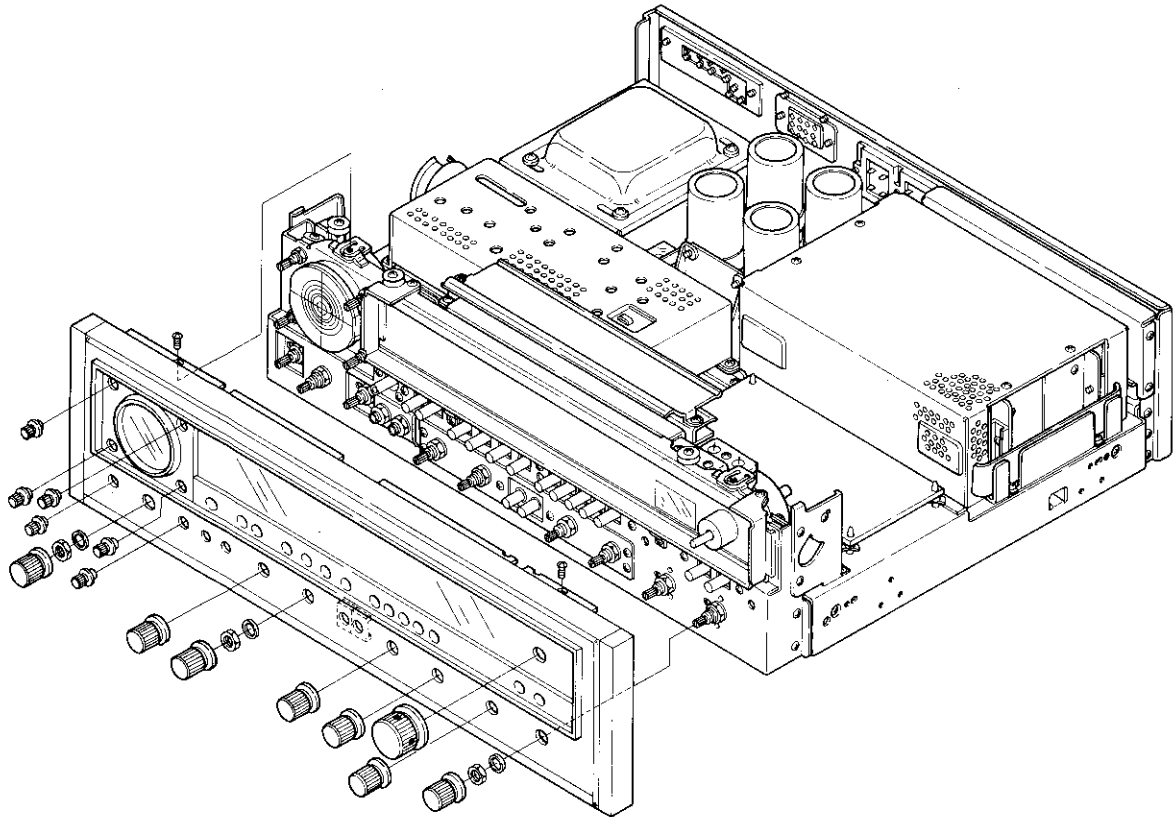

8. ADJUSTMENTS

*Do not attempt to adjust the CD-4 assembly or RM/SQ assembly. These adjustments require special test equipment, including a CD-4 signal generator, SQ encoder and other apparatus.

Required Measuring Instruments

- FM signal generator
- MPX signal generator
- AM signal generator
- Millivolt meter
- Distortion meter

8.1 AM SECTION

1. Set AM signal generator at 400Hz 30% modulation. Connect to AM antenna terminal via 1k-ohm resistor.
2. Connect oscilloscope and voltmeter in parallel to unit's TAPE REC terminals.
3. Tune signal generator and unit to 600kHz. Set signal generator output level at approx. 30dB.
4. Adjust T8 and T7 on tuner assembly and core of ferrite bar antenna for maximum output level reading.
5. Now tune unit and signal generator to 1,400kHz.
6. Adjust TC5, TC6 and TC7 on tuner assembly for maximum output level reading.
7. Repeat steps 3 thru 6 several times to obtain maximum readings at both frequencies.

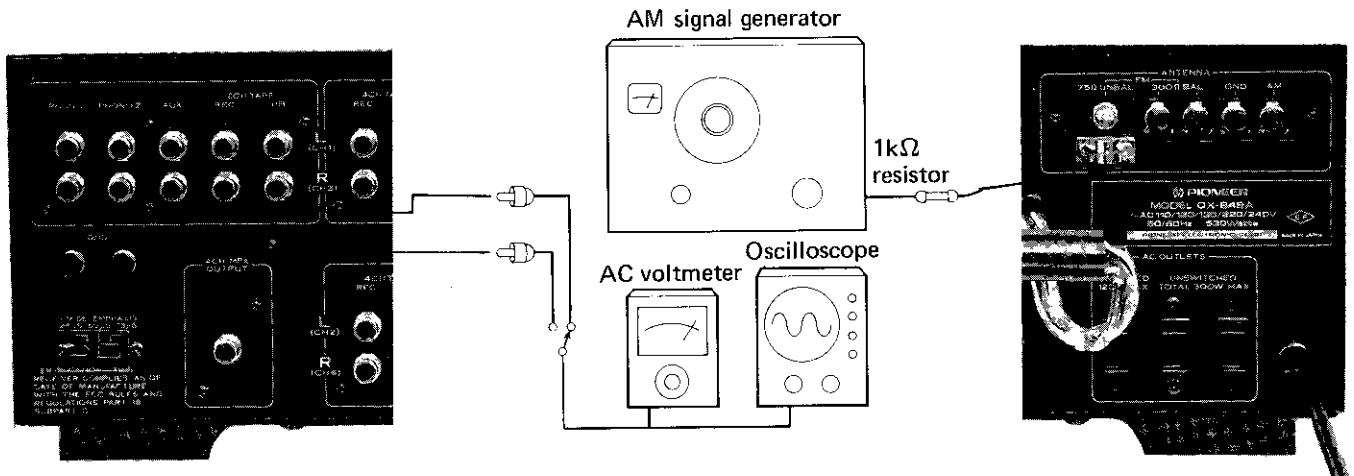
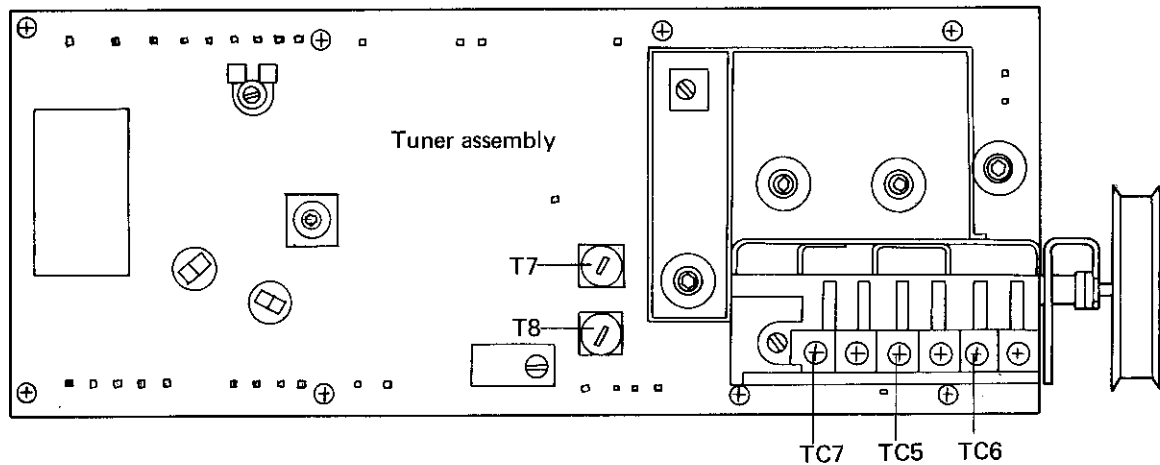

8.2 FM SECTION

1. Set the FM signal generator for 400Hz modulation at 100%.
Connect generator output to the FM antenna terminals through a 300Ω balanced dummy antenna.
2. Connect the oscilloscope, voltmeter, and distortion meter in parallel across TAPE REC jack.
3. Set the signal generator output level to 8~10dB.
Set the signal generator and set dials to 90MHz.
4. Adjust cores of T4 (tuner assembly) and T1, T2, and T3 to obtain peak output.
5. Set signal generator and set dials to 106MHz.
6. Adjust TC4 (tuner assembly) and TC1, TC2, and TC3 to obtain peak output.
7. Repeat steps (3) through (6) several times, to obtain optimum tracking.
8. Set the frequency to 90MHz and adjust the T5 core of the tuner assembly to obtain peak output.
9. Detune the set so that noise only is received. Adjust the primary (bottom) core of T6 so that the tuning meter pointer indicates the center position.
10. Set signal generator and set dials to 98MHz. Set signal generator output level to 60dB. Carefully tune the set to this frequency as indicated by the tuning meter.
11. Adjust the secondary (top) core of T6 (tuner assembly) for minimum distortion.

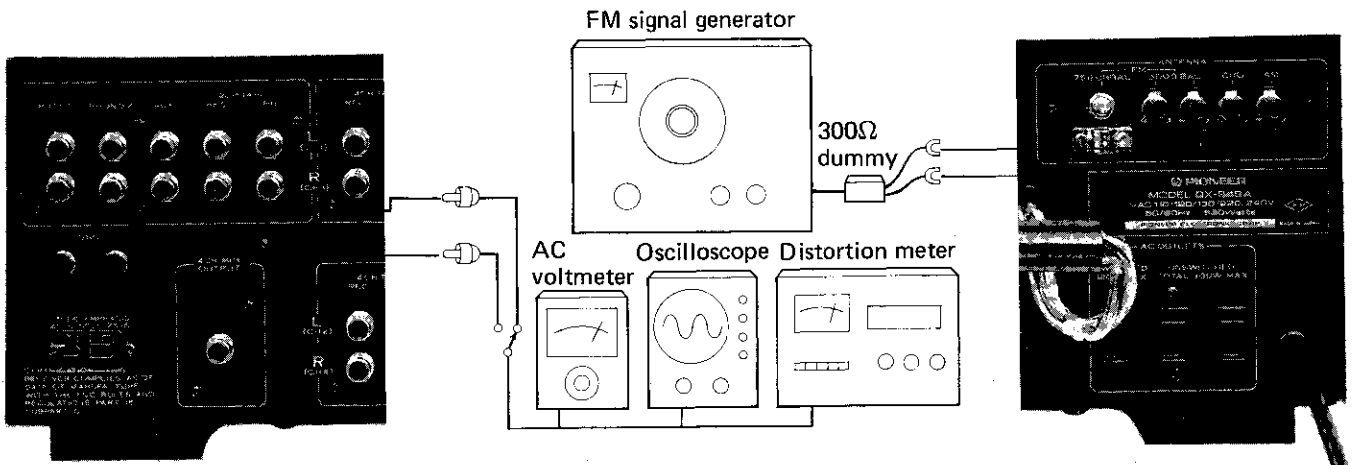
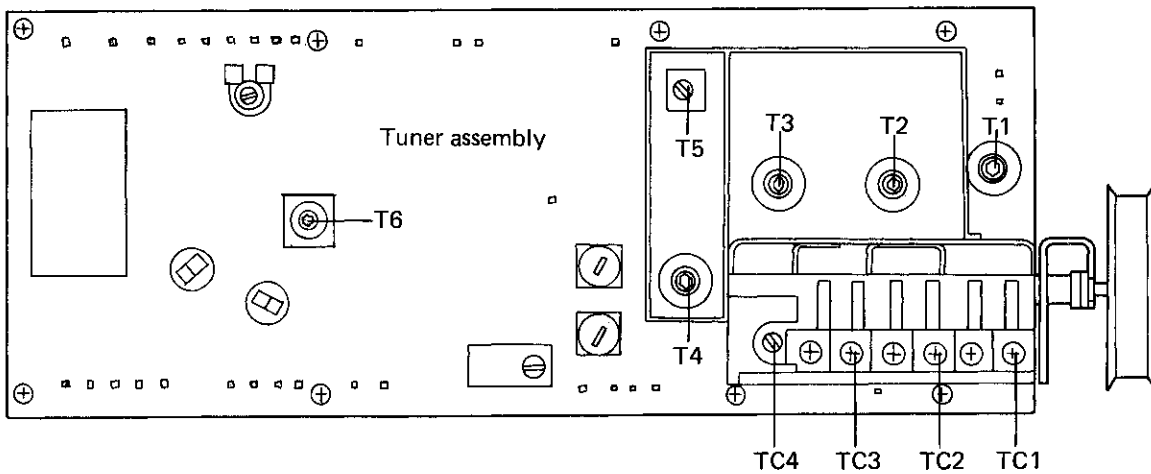

8.3 FM MPX SECTION

1. Set FM signal generator at external modulation. Connect to unit's FM antenna terminals via 300-ohm balanced dummy antenna. Set FM SG output to 60dB.
2. Adjust MPX signal generator to obtain main signal modulation of 1kHz, 67.5kHz frequency deviation. Connect to FM SG's external modulator terminals.

3. Connect the oscilloscope horizontal inputs to MPX SG's PILOT OUT terminals and Vertical inputs to No. 18 terminal of tuner assembly.
4. Tune unit and FM SG to 98MHz.
5. Produce a Lissajous pattern on oscilloscope and adjust VR1 to make the pattern still.
6. Then set signal generator for modulation of L (later R) and pilot. Adjust VR2 to obtain maximum channel separation.

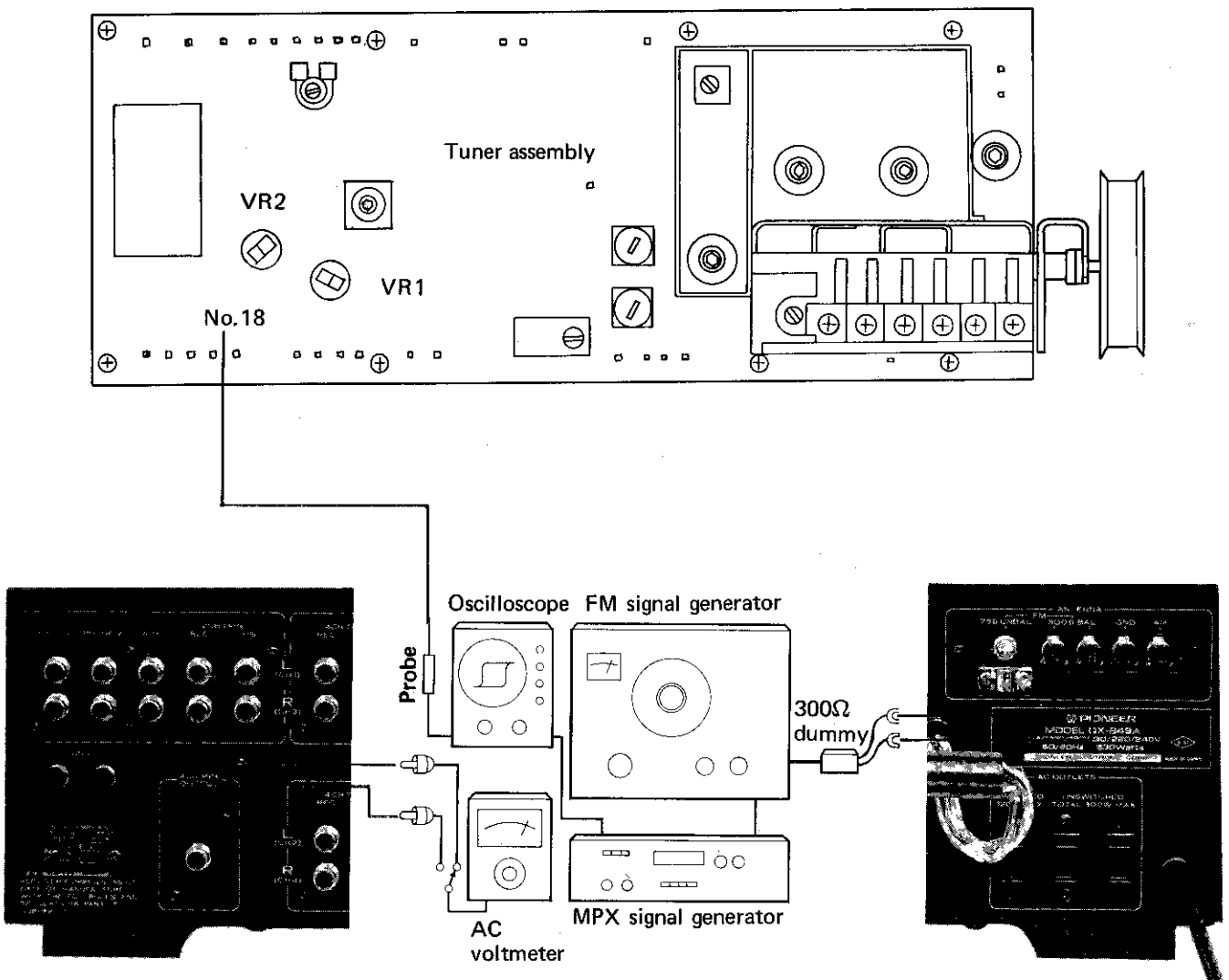

8.4 POWER AMPLIFIER SECTION

1. Do not connect load to speaker terminals. VOLUME Control set at minimum.
2. Set power boosting switch to 4CH position. Then energize unit.
3. For first approximately six seconds, the relay remains open, keeping the unit muted. Confirm that all voltages are as indicated in the circuit diagram on page 98.
4. If voltages are greatly different from rated values, shut off power immediately. Check suspicious areas, especially power supply unit.
5. If the relay opens immediately after the power

- amplifier has been come into operation, a defect in the output transistors can be suspected. Check the output stage.
6. After approx. 10~20 minutes of warming-up time, adjust VR3 so that the voltage across terminals 1 and 2 of the power amplifier assembly becomes 20mV.
7. In the same way, adjust VR4 to obtain 20mV voltage readings across the terminals 25 and 26.
8. Next, connect voltmeter between terminal 5 and ground. Adjust VR1 to obtain 0V reading.
9. In the same way, adjust VR2 to obtain zero readings between terminal 23 and ground.

Bottom View

Top View

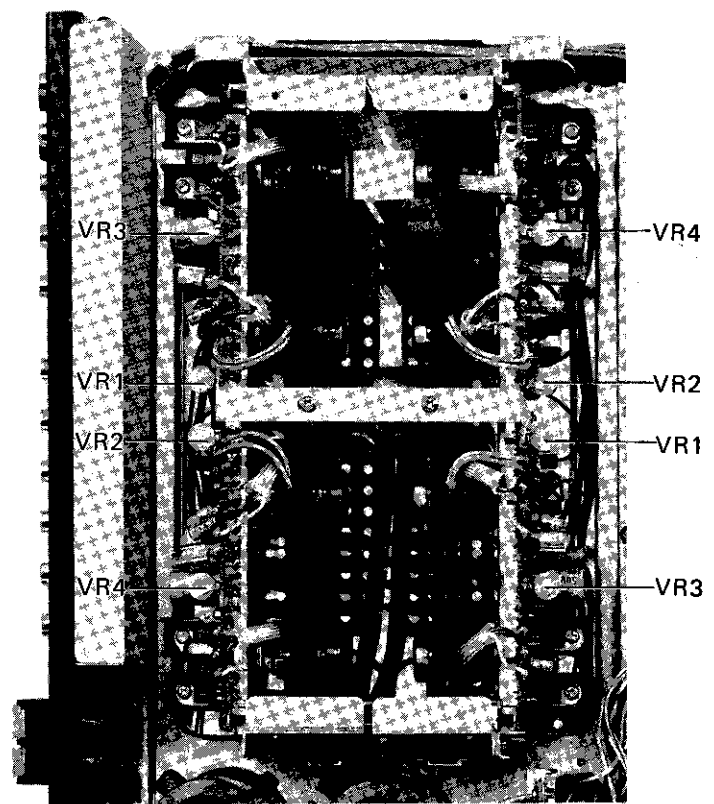
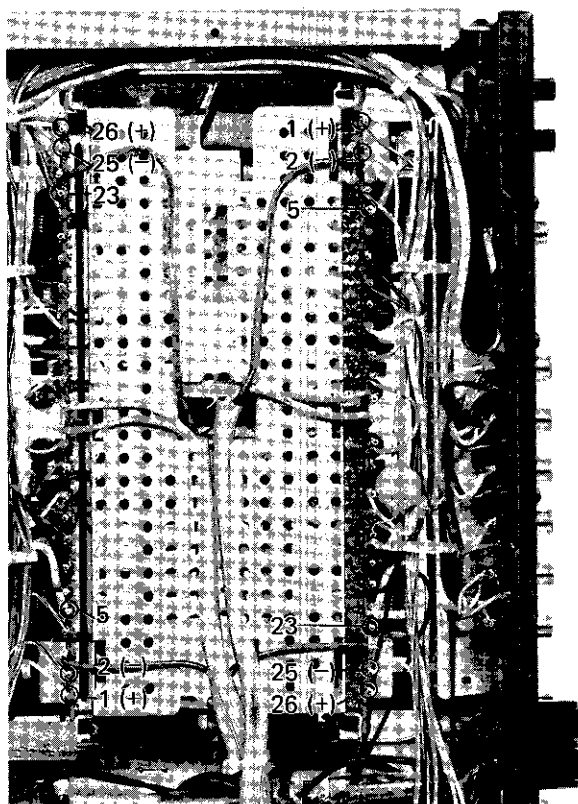

9. DIAL CORD STRINGING

1. Turn the tuning capacitor so that its plates protrude as much as possible.
2. Tie one end of the string to the spring on the Tuning drum (attached to the tuning capacitor).
3. Lead the string around pulleys A, B, C, D and E, then wind it 3 turns around the tuning shaft.
4. Lead the string around pulleys F and G, then wind it 2 turns around the Tuning drum.
5. Now tie the other end of the string to the spring on the Tuning drum. Turn the tuning shaft and check for proper function. Then trim the ends of the string.
6. Turn the tuning shaft until the plates of the variable are all the way in. Move the pointer to the left-end starting point on the dial and fasten it to the string in that position.

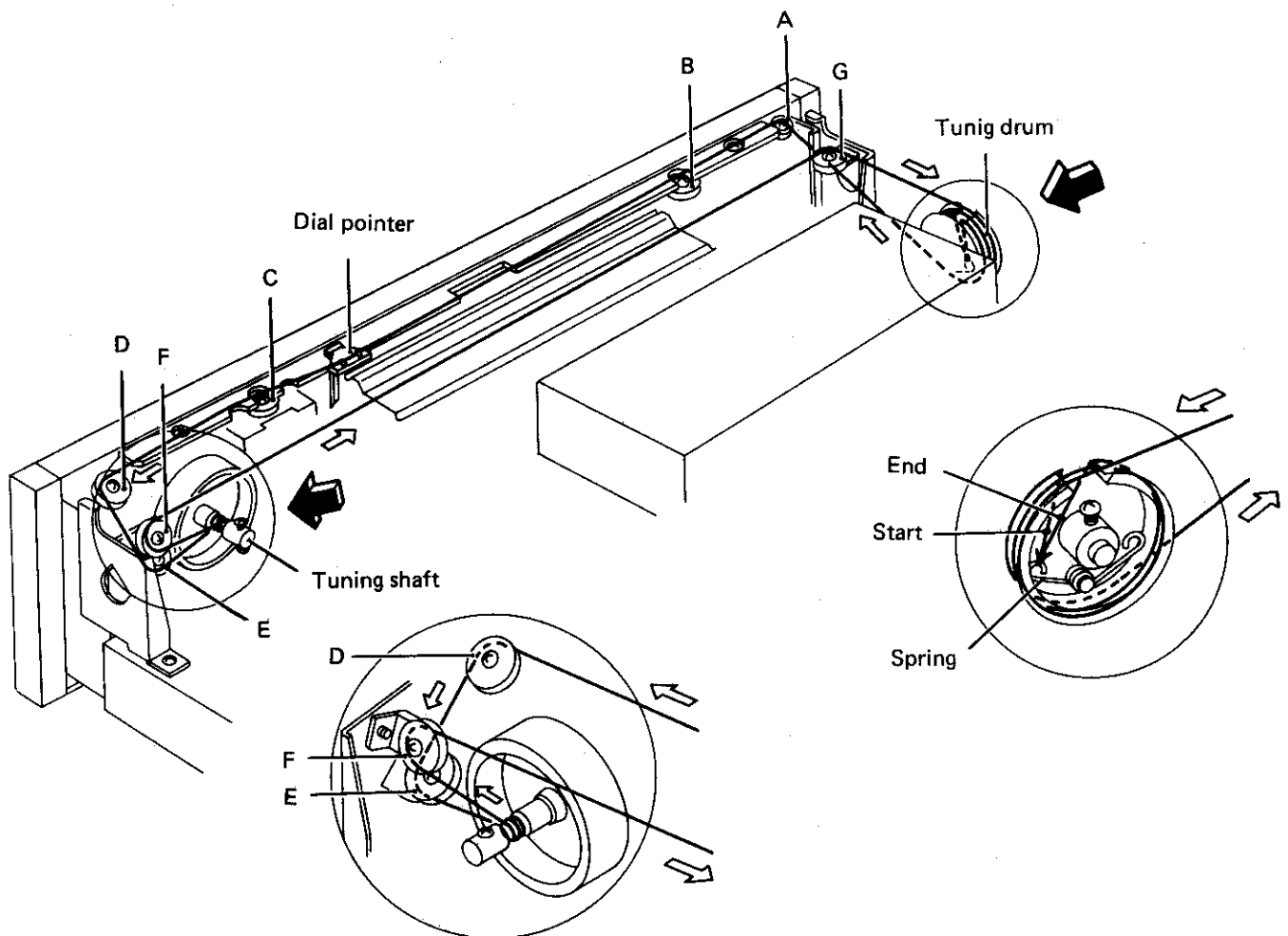

10. PARTS LOCATIONS

10.1 FRONT VIEW 1

Knob (INDICATOR LEVEL -20dB)
AAD-108

Knob (SPEAKERS FRONT B)
AAD-108

Knob (SPEAKERS REAR A)
AAD-108

Knob (TAPE MONITOR 2CH)
AAD-108

Knob (INDICATOR LEVEL -10dB)
AAD-108

Knob (SPEAKERS FRONT A)
AAD-108

Knob (SPEAKERS REAR B)
AAD-108

Knob (TAPE MONITOR 4CH-1)
AAD-108

Knob (POWER)
AAD-055

Knob (LOUDNESS)
AAD-108

Knob (TAPE MONITOR 4CH-2)
AAD-108

Knob (RIGHT REAR)
AAB-079

Knob (DOLBY NR ADAPTOR)
AAD-108

Knob (RIGHT FRONT)
AAB-079

Front panel assembly
ANB-318

Knob (LEFT FRONT)
AAB-079

Knob (TUNING)
AAA-023

Knob (LEFT REAR)
AAB-079

Knob (FM MUTING)
AAD-108

Knob (CD-4 SEPARATION LEFT)
AAB-080

Knob (MPX NOISE FILTER)
AAD-108

Knob (VOLUME)
AAB-065

Knob (FUNCTION)
AAB-065

Knob (CD-4 SEPARATION RIGHT)
AAB-080

Knob (MODE)
AAB-065

Phone jack (PHONES FRONT)
AKN-002

Knob (FRONT BASS)
AAB-065

Knob (HIGH FILTER)
AAD-108

Knob (REAR TREBLE)
AAB-065

Phone jack (PHONES REAR)
AKN-002

Knob (FRONT TREBLE)
AAB-065

Knob (LOW FILTER)
AAD-108

Knob (REAR BASS)
AAB-065

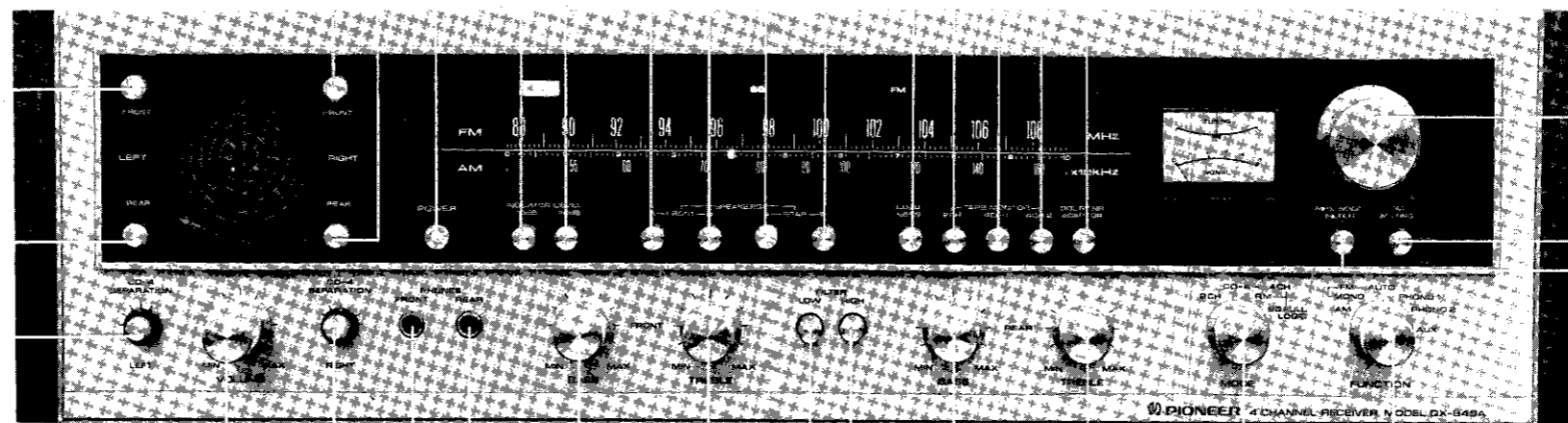

10.2 FRONT VIEW 2 (with Panel Removed)

Variable resistor 250k-B2
(RIGHT REAR)
ACT-009

Variable resistor 250k-B2
(RIGHT FRONT)
ACT-009

Variable resistor 250k-B2
(LEFT FRONT)
ACT-009

4-channel level indicator
AAW-021

Variable resistor 250k-B2
(LEFT REAR)
ACT-009

Variable resistor 3k-B
(CD-4 SEPARATION LEFT)
ACV-017

Variable resistor 250k-B1, 4-gang
(VOLUME)
ACV-311

Variable resistor 3k-B
(CD-4 SEPARATION RIGHT)
ACV-017

Phone jack (PHONES FRONT)
AKN-002

Phone jack (PHONES REAR)
AKN-002

Variable resistor 100k-B, dual
(FRONT BASS)
ACV-110

Variable resistor 100k-B, dual
(FRONT TREBLE)
ACV-110

Push switch (POWER)
ASG-070 (for "F" type)
ASG-043 (for "KCU" type)

Push switch
(INDICATOR LEVEL -10dB, -20dB)
ASG-047

Dial pointer assembly
AAF-036

Push switch
(SPEAKERS FRONT A, B,
SPEAKERS REAR A, B)
ASG-046

Push switch
(TAPE MONITOR 2CH, 4CH-1, 4CH-2,
DOLBY NR ADAPTOR, LOUDNESS)
ASG-049

Twin meter (TUNING/SIGNAL)
AAW-042

Tuning shaft assembly
AXA-039

Dial scale plate
AAG-063

Push switch
(FM MUTING, MPX NOISE FILTER)
ASG-050

Rotary switch (FUNCTION)
ASB-048

Rotary switch (MODE)
ASC-066

Variable resistor 100k-B, dual
(REAR TREBLE)
ACV-110

Variable resistor 100k-B, dual
(REAR BASS)
ACV-110

Push switch (HIGH FILTER)
ASG-019

Push switch (LOW FILTER)
ASG-019

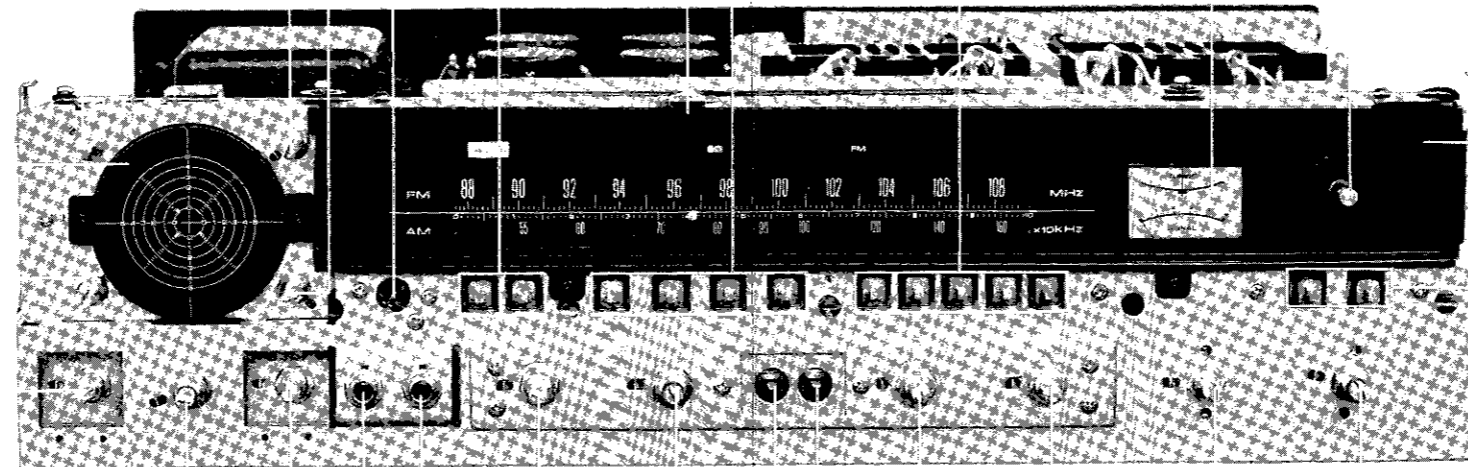

10.3 TOP VIEW

Electrolytic capacitor 10,000μF 50V (C8)
ACH-029

Electrolytic capacitor 10,000μF 50V (C6)
ACH-029

Electrolytic capacitor 10,000μF 50V (C7)
ACH-029

Electrolytic capacitor 10,000μF 50V (C9)
ACH-029

Ferrite balun
T22-025

Micro switch (S7)
ASF-001

Power transformer
ATT-222 (for "F" type)
ATT-221 (for "KCU" type)

Relay
ASR-007

Power supply circuit B assembly
AWR-039

Tuning drum assembly
AXA-015

Tuner assembly
AWE-041

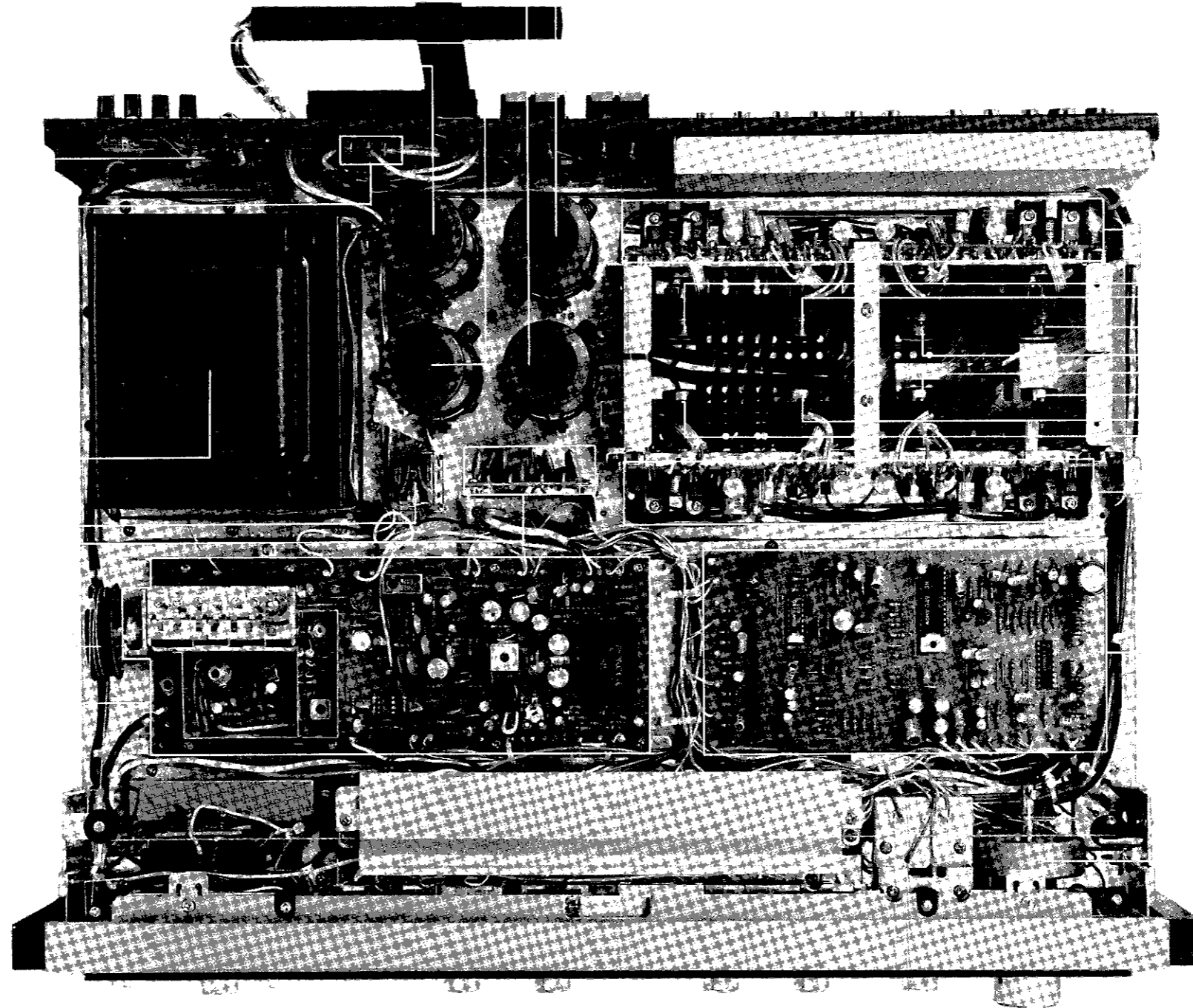

Power amplifier assembly (for CH1, CH4)
AWH-027

Transistor (Q16)
2SA679-R or Y (2SA747-R, O or Y)

Transistor (Q14)
2SC1079-R or Y (2SC1116-R, O or Y)

Transistor (Q15)
2SB530-R or O (2SA745-R, O or Y)

Transistor (Q13)
2SD370-R or O (2SC1403-R, O or Y)

Transistor (Q14)
2SC1079-R or Y (2SC1116-R, O or Y)

Transistor (Q16)
2SA679-R or Y (2SC1116-R, O or Y)

Transistor (Q13)
2SD370-R or O (2SA747-R, O or Y)

Transistor (Q15)
2SB530-R or O (2SA745-R, O or Y)

Power amplifier assembly (for CH2, CH3)
AWH-027

SQ/RM decoder assembly
AWM-077

Tuning shaft assembly
AXA-039

10.4 BOTTOM VIEW

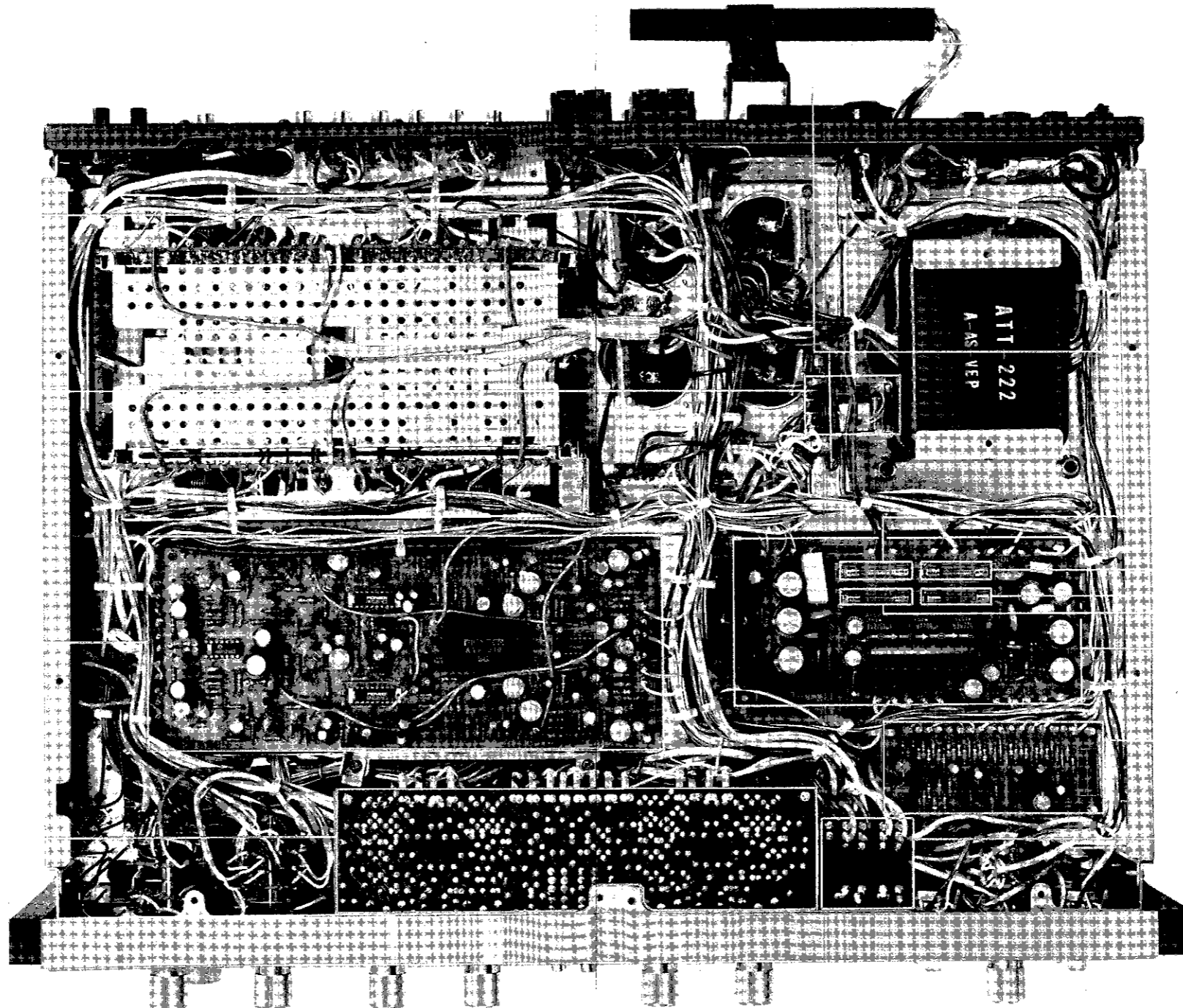

Ceramic capacitor 0.01 μ F 250V (C13)
ACG-001

Relay
ASR-007

CD-4 assembly
AWM-076

Control amplifier assembly
AWG-023

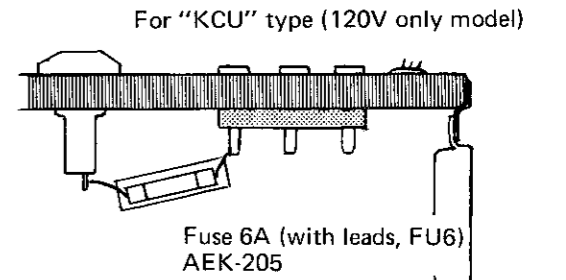

No fuse (FU6) is provided for "F" type

Fuse 1A (FU4)
AEK-106

Fuse 3A (FU1)
AEK-101

Fuse 1A (FU2)
AEK-106

Fuse 1A (FU3)
AEK-106

Power supply circuit A assembly
AWR-080

Protection circuit assembly
AWM-079

Headphone jack assembly
AWX-054

10.5 REAR VIEW

Speaker output terminal-A
AKE-018

Phono jack (6 jacks)
AKB-018

Phono jack (6 jacks)
AKB-017

Phono jack (6 jacks)
AKB-017

Phono jack (4 jacks)
AKB-015

Binding post for ground
AKE-012

Binding post for ground
AKE-012

Slide switch (S3)
ASH-013 (for "F" type)
ASH-008 (for "KCU" type)
No position of "50μs" is provided
for "KCU" type.

Phono jack (1 jack)
AKB-019

Phono jack (6 jacks)
AKB-017

Phono jack (6 jacks)
AKB-018

Speaker output terminal
AKE-010

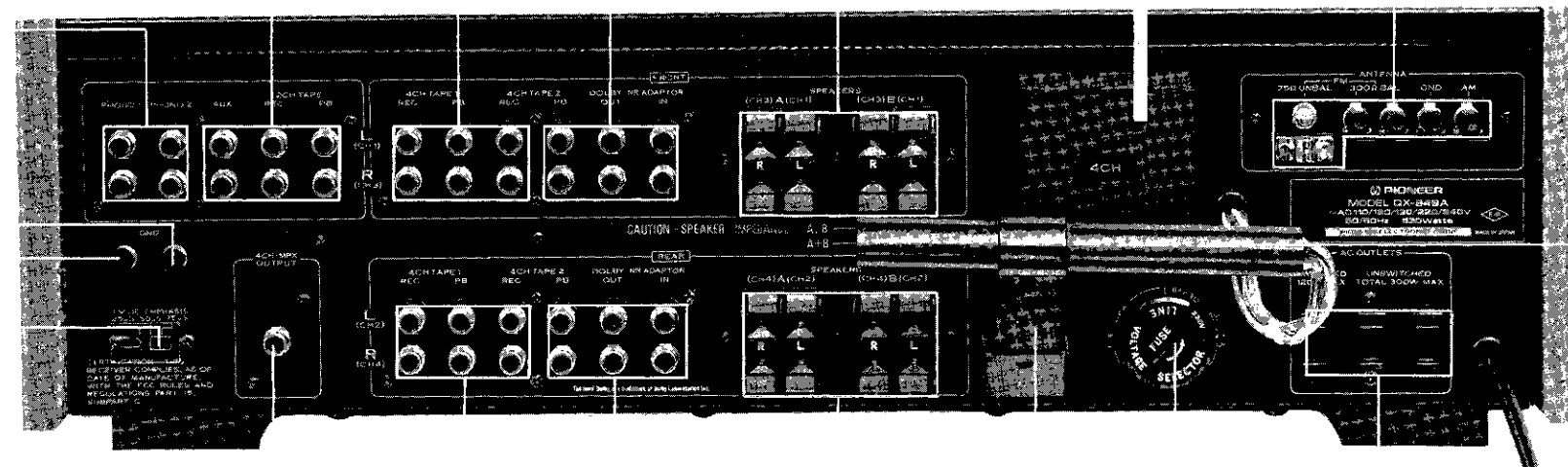
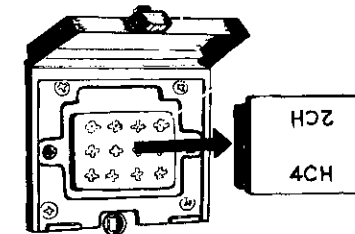

Switch cover assembly
AEC-110

Multi-socket (power boosting switch)
AKP-006

Multi-plug (power boosting switch)
AKM-006

Antenna terminal board
AKA-004

Ferrite bar-antenna
ATB-042

AC socket
AKP-005

Fuse holder
AKR-026 (for "KCU" type)
AKR-027 (with line voltage selector,
for "F" type)

Antenna holder assembly
AXB-001

11. EXPLODED VIEWS

NOTE:
Parts indicated in green type cannot be supplied.

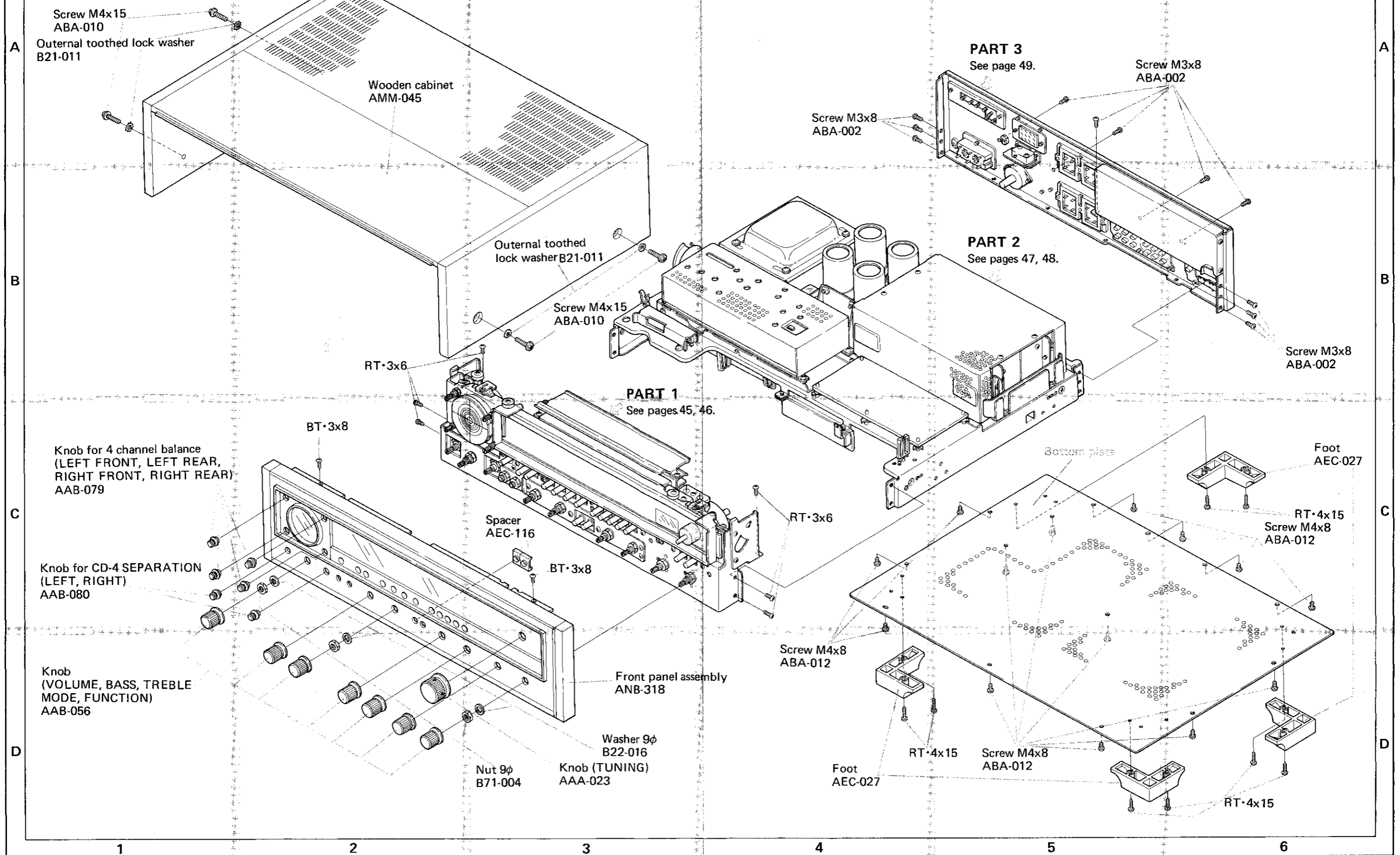

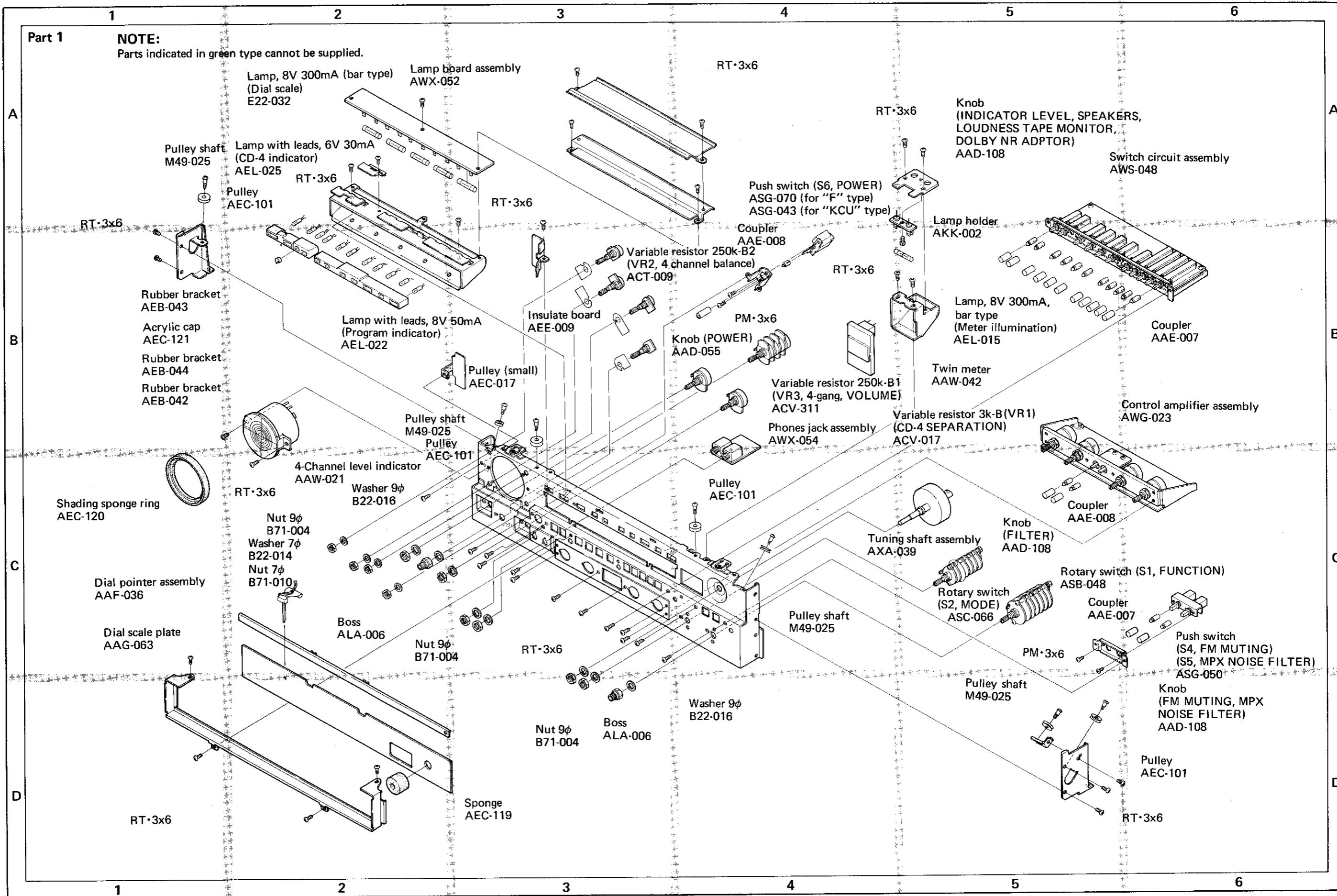

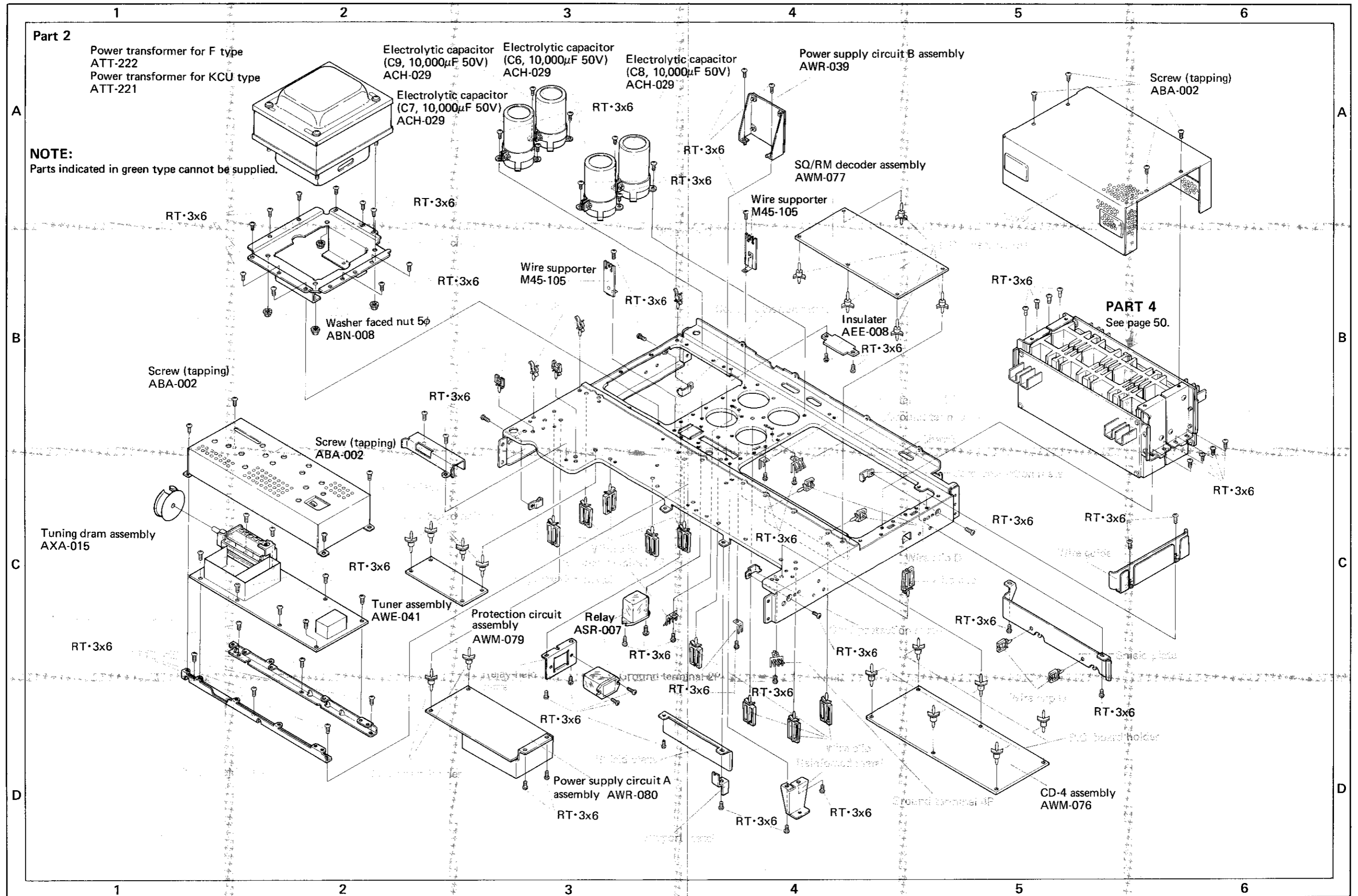

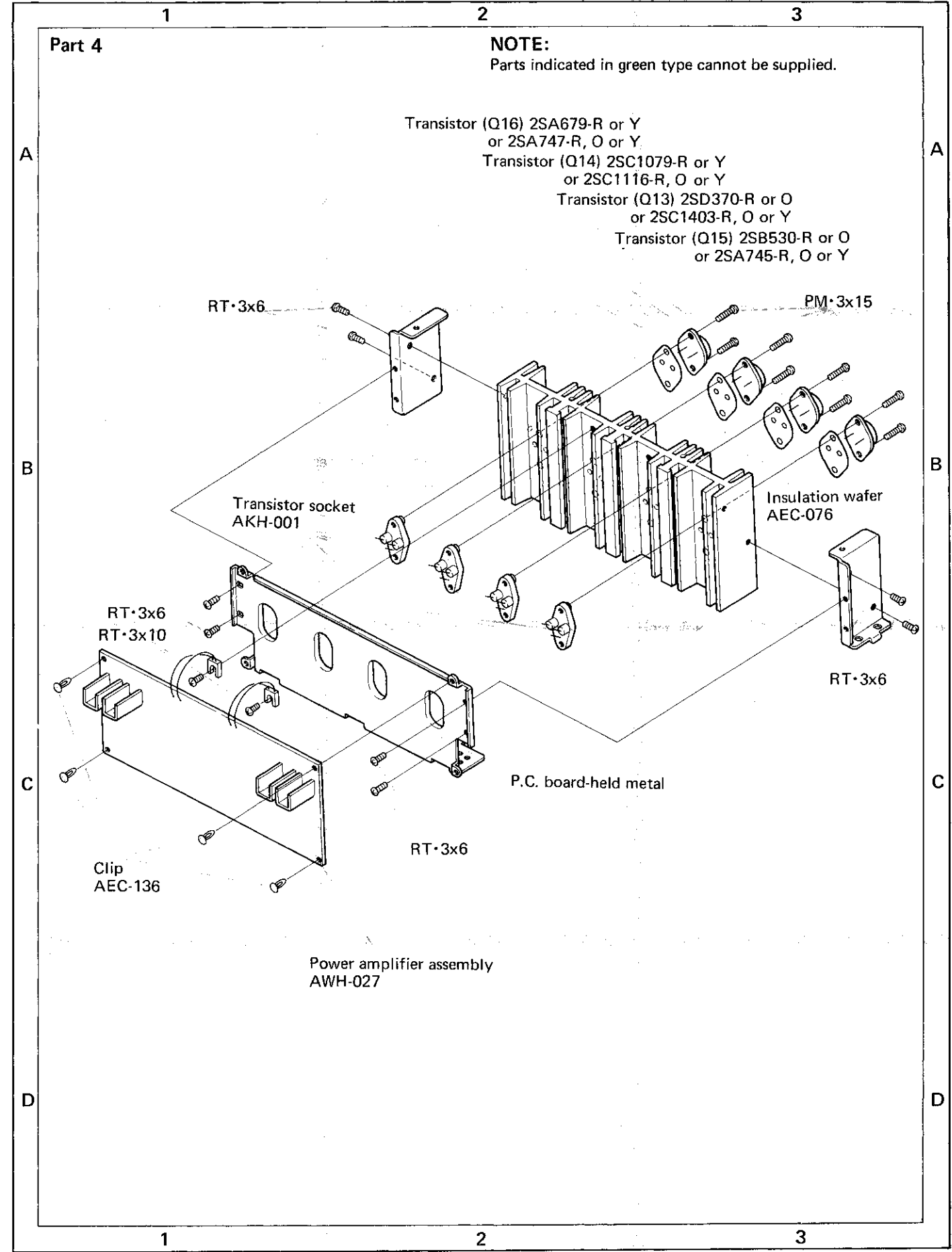
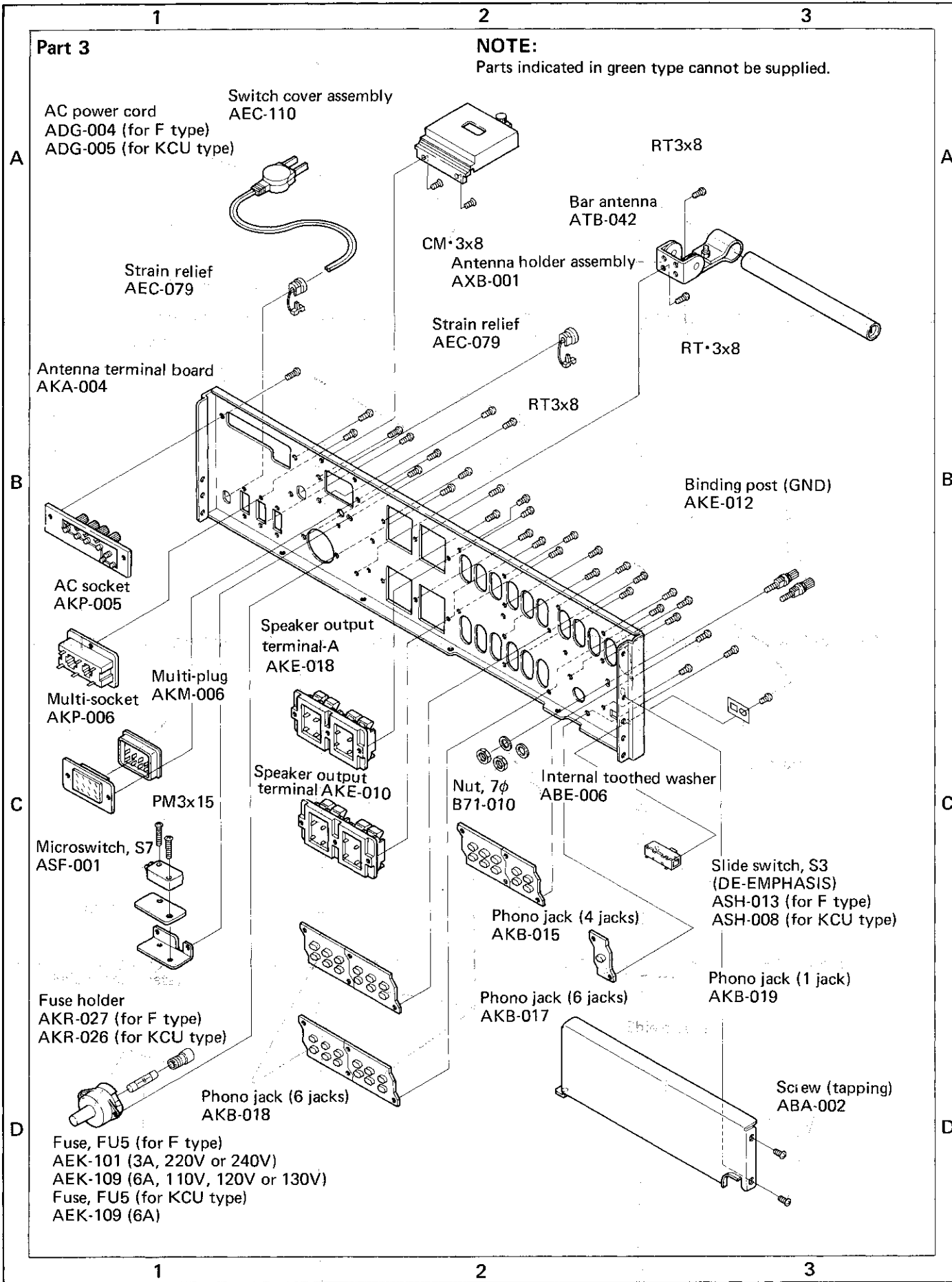



























NOMENCLATURE OF SCREWS, WASHERS AND NUTS

The following symbols stand for screws, washers and nuts as shown in exploded view.

Symbol	Description	Shape	Symbol	Description	Shape
RT	Brazier head tapping screw		EW	E type washer	
PT	Pan head tapping screw		FW	Flat washer	
BT	Binding head tapping screw		SW	Spring lock washer	
CT	Countersunk head tapping screw		N	Nut	
TT	Truss head tapping screw		WN	Washer faced nut	
OCT	Oval countersunk head tapping screw		ITW	Internal toothed lock washer	
PM	Pan head machine screw		OTW	Outernal toothed lock washer	
CM	Countersunk head machine screw		SC	Slotted set screw (Cone point)	
OCM	Oval countersunk head machine screw		SF	Slotted set screw (Flat point)	
TM	Truss head machine screw		HS	Hexagon socket headless set screw	
BM	Binding head machine screw		OCW	Oval countersunk head wood screw	
PSA	Pan head screw with spring lock washer		CW	Countersunk head wood screw	
PSB	Pan head screw with spring lock washer and flat washer		RW	Round head wood screw	
PSF	Pan head screw with flat washer				

EXAMPLE

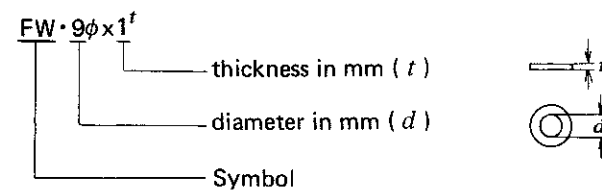
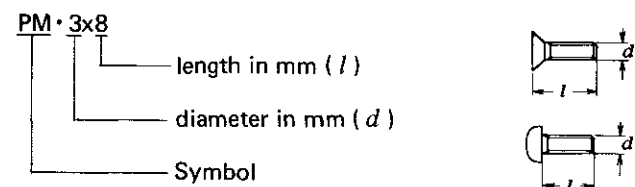

12. PACKING

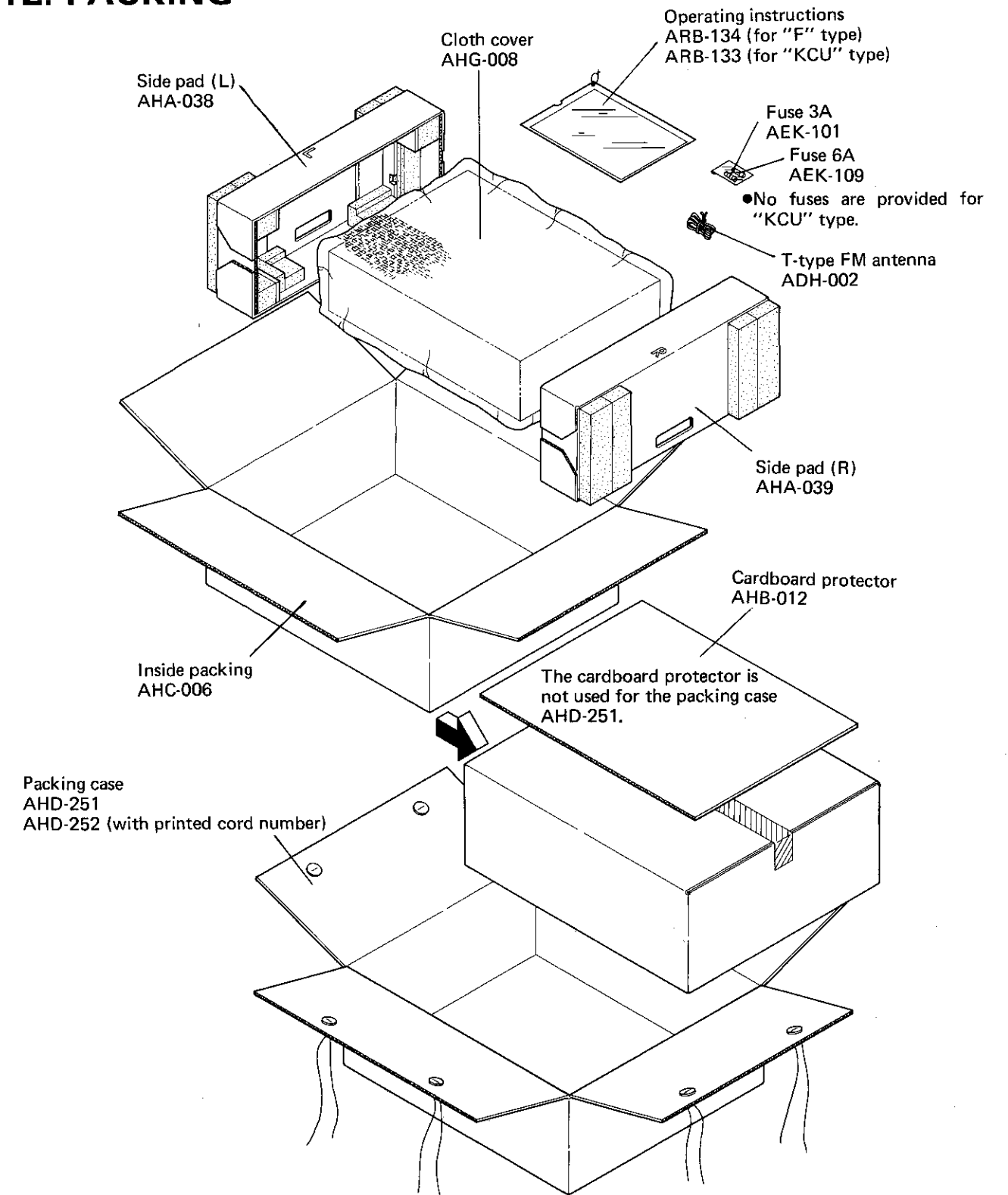

13. SCHEMATIC DIAGRAMS, P.C. BOARD PATTERNS AND PARTS LISTS

13.1 SCHEMATIC DIAGRAMS AND MISCELLANEOUS PARTS For "F" type (5 line voltage model)

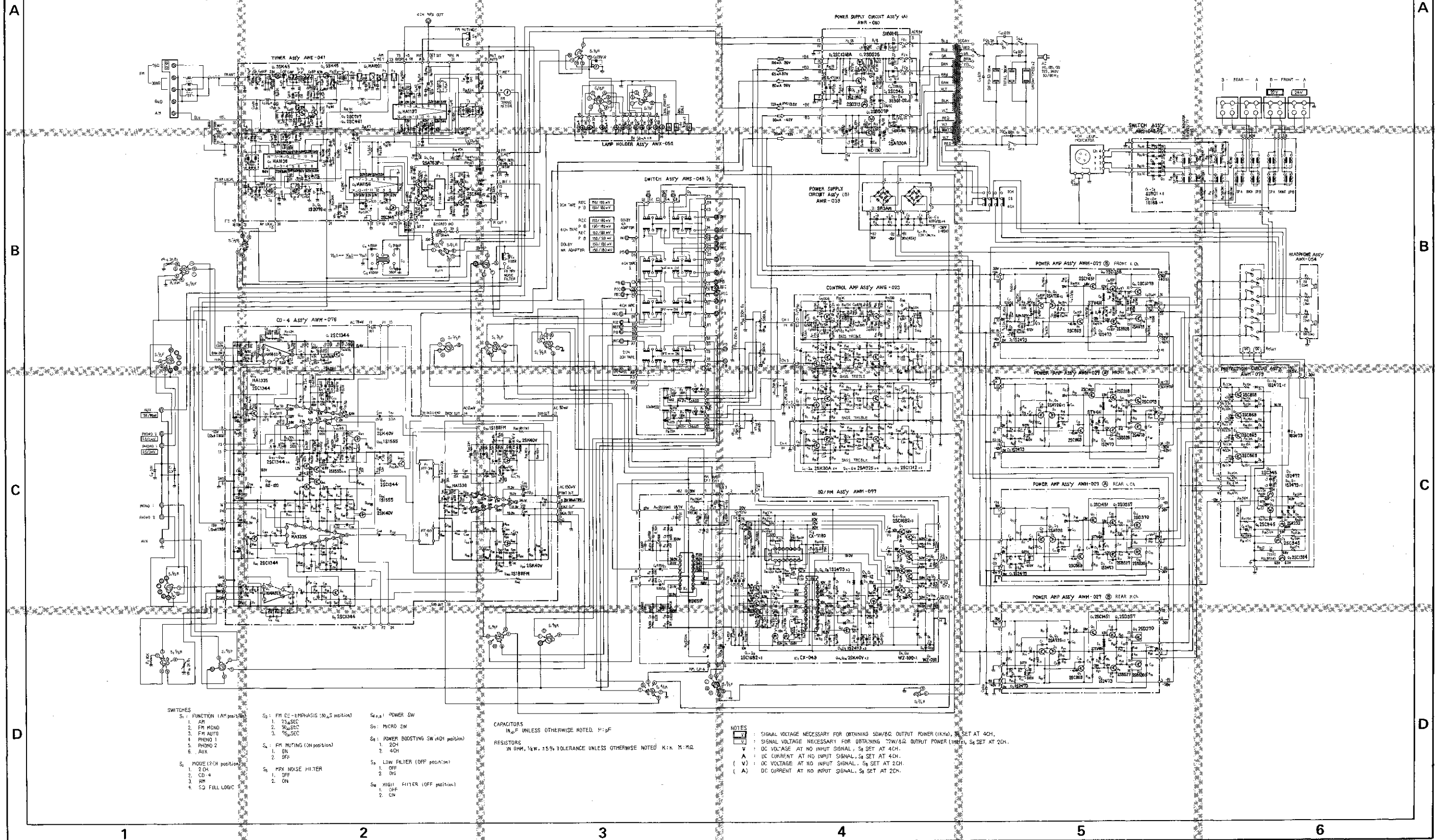

- SWITCHES**
- S₁ - FUNCTION (A-W position)
 - 1. AM
 - 2. FM MONO
 - 3. FM AUTO
 - 4. PHONO 1
 - 5. PHONO 2
 - 6. AUX
 - S₂ - MODE (2CH position)
 - 1. 2 CH
 - 2. CD-4
 - 3. RM
 - 4. S2 FULL LOGIC
 - S₃ - FM DE-EMPHASIS (00.5 position)
 - 1. 25 SEC
 - 2. 30 SEC
 - 3. 75 SEC
 - S₄ - FM MUTING (ON position)
 - 1. ON
 - 2. OFF
 - S₅ - FM NOISE FILTER
 - 1. OFF
 - 2. ON
 - S₆ - POWER SW
 - 1. ON
 - 2. OFF
 - S₇ - MICRO SW
 - 1. ON
 - 2. OFF
 - S₈ - POWER BOOSTING SW (401 position)
 - 1. 2CH
 - 2. 4CH
 - S₉ - LOW FILTER (OFF position)
 - 1. OFF
 - 2. ON
 - S₁₀ - HIGH FILTER (OFF position)
 - 1. OFF
 - 2. ON

CAPACITORS
IN μF UNLESS OTHERWISE NOTED. P: pF

RESISTORS
IN OHM, 1/4W, 5% TOLERANCE UNLESS OTHERWISE NOTED. K: K, M: MΩ

NOTES

- (V) : SIGNAL VOLTAGE NECESSARY FOR OBTAINING 50W/50C OUTPUT POWER (1KHz), S₈ SET AT 4CH.
- (A) : SIGNAL VOLTAGE NECESSARY FOR OBTAINING 12W/6Q OUTPUT POWER (1KHz), S₈ SET AT 2CH.
- (V) : DC VOLTAGE AT NO INPUT SIGNAL, S₈ SET AT 4CH.
- (A) : DC CURRENT AT NO INPUT SIGNAL, S₈ SET AT 4CH.
- (V) : DC VOLTAGE AT NO INPUT SIGNAL, S₈ SET AT 2CH.
- (A) : DC CURRENT AT NO INPUT SIGNAL, S₈ SET AT 2CH.

For "KCU" type (120V model)

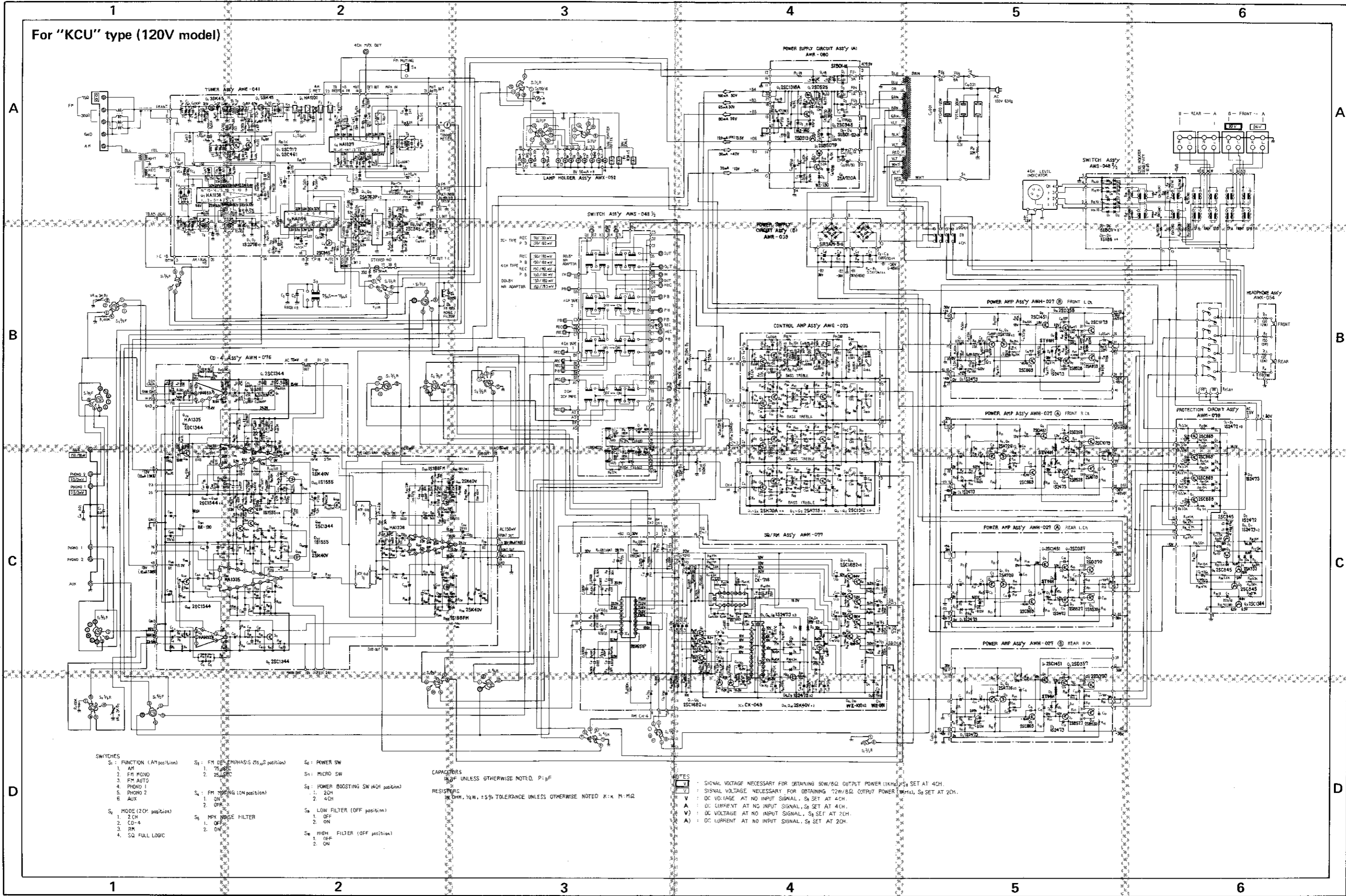

- SWITCHES**
- S₁: FUNCTION (A position)
 - 1. AM
 - 2. FM PHONO
 - 3. FM AUTO
 - 4. PHONO 1
 - 5. PHONO 2
 - 6. AUX
 - S₂: MODE (2CH position)
 - 1. 2CH
 - 2. CD-4
 - 3. RM
 - 4. SQ FULL LOGIC
 - S₃: FM DE-EMPHASIS (0.5 position)
 - 1. 75dB
 - 2. 25dB
 - S₄: FM SQUELCH (ON position)
 - 1. ON
 - 2. OFF
 - S₅: MPX NOISE FILTER
 - 1. OFF
 - 2. ON
 - S₆: POWER SW
 - 1. MICRO SW
 - 2. POWER BOOSTING SW (4CH position)
 - 1. 2CH
 - 2. 4CH
 - 3. LOW FILTER (OFF position)
 - 1. OFF
 - 2. ON
 - 4. HIGH FILTER (OFF position)
 - 1. OFF
 - 2. ON

CAPACITORS
 IN UNLESS OTHERWISE NOTED. P: pF

RESISTORS
 IN OHM, 1/4W, ±5% TOLERANCE UNLESS OTHERWISE NOTED. K:k M:M Ω:Ω

NOTES

- : SIGNAL VOLTAGE NECESSARY FOR OBTAINING 50W/8Ω OUTPUT POWER (1kHz); S₂ SET AT 4CH.
- ▤: SIGNAL VOLTAGE NECESSARY FOR OBTAINING 72W/8Ω OUTPUT POWER (1kHz); S₂ SET AT 2CH.
- V: DC VOLTAGE AT NO INPUT SIGNAL; S₂ SET AT 4CH.
- A: DC CURRENT AT NO INPUT SIGNAL; S₂ SET AT 4CH.
- ∇: DC VOLTAGE AT NO INPUT SIGNAL; S₂ SET AT 2CH.
- ∧: DC CURRENT AT NO INPUT SIGNAL; S₂ SET AT 2CH.

HA1137 (FM IF IC)

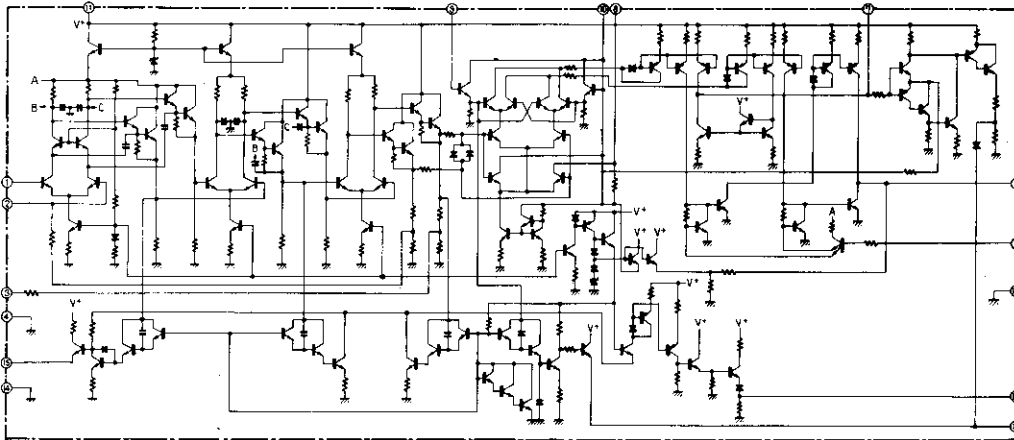

HA1138 (AM IC)

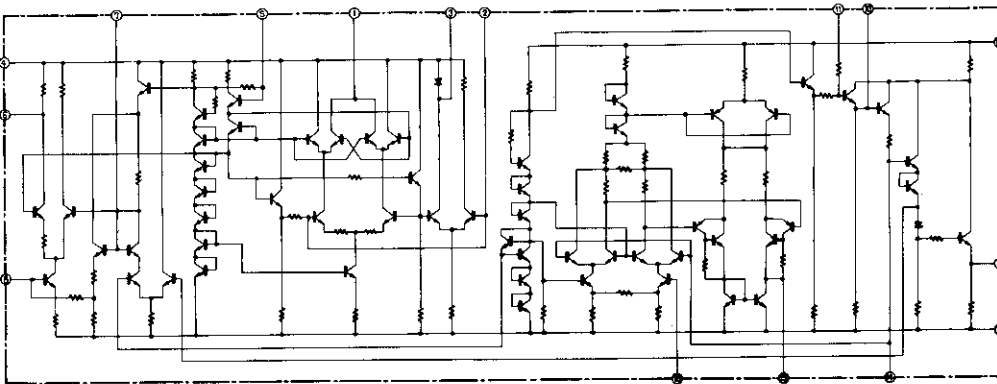

HA1156 (FM MPX IC)

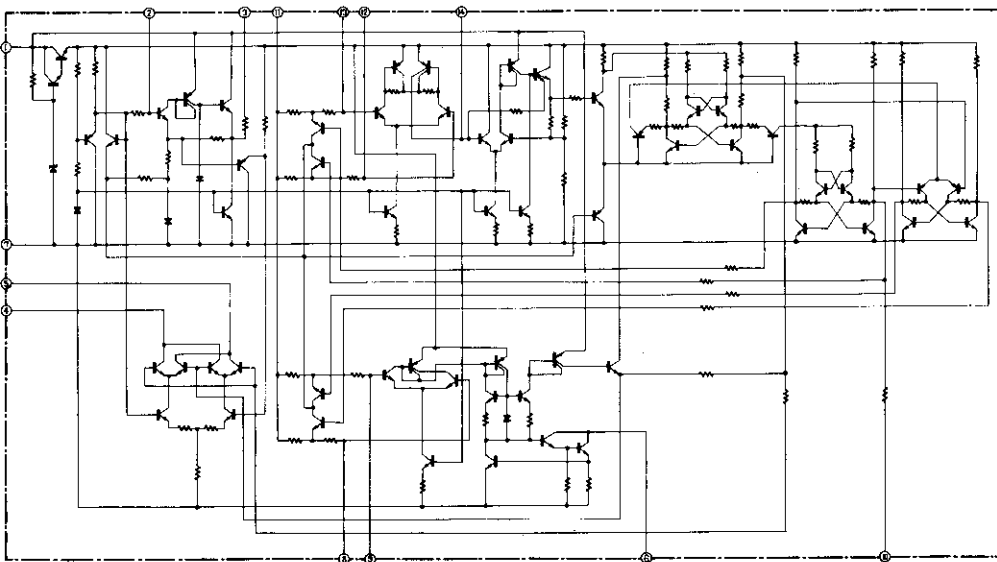

HA1452(EQ AMP IC)

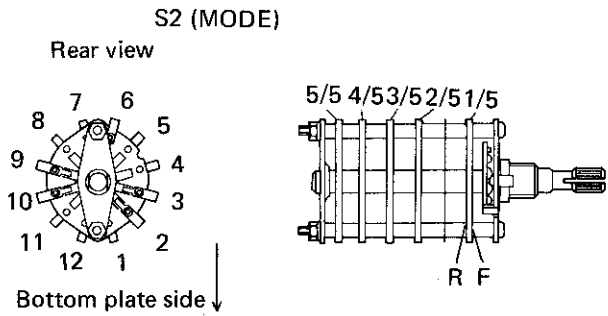
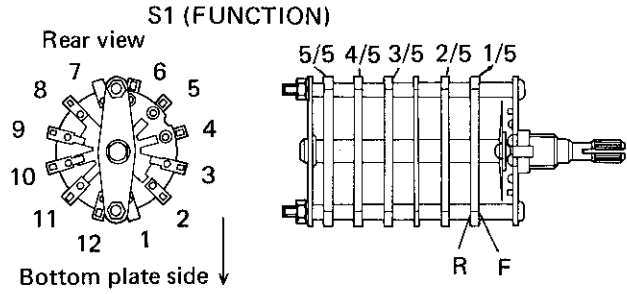
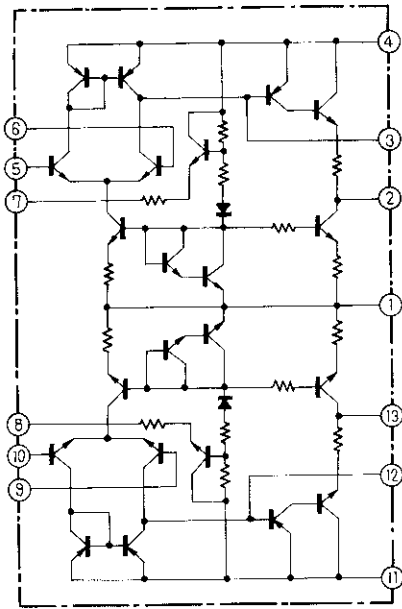

HA1335

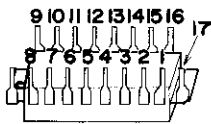

CX-718D

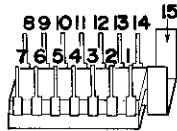

M51651P

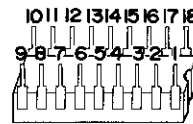

CX-049

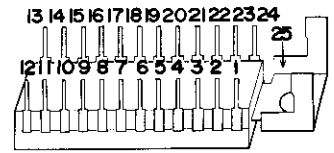

HA1137

HA1136

HA1336

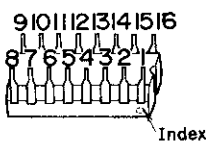

HA1156

HA1452

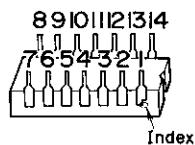

HA1201

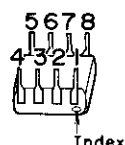

3SK45

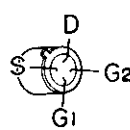

2SK40V

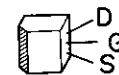

2SK30A



2SA725

2SA726

2SC869

2SC1312



2SC461

2SC717

2SC1344

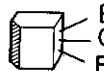

2SB507

2SD313

2SD525

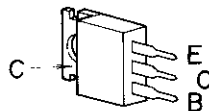

2SA720A

2SA733

2SA763P

2SC945

2SC1318A

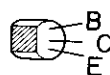

2SA679

2SB530

2SC1079

2SD370

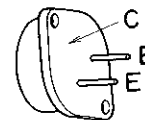

2SB527

2SB528

2SD357

2SD358

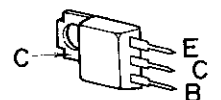

2SC1682

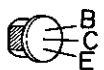

2SC1451

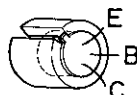

2SC1384

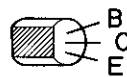

Miscellaneous Parts for "F" type

CAPACITORS

Symbol	Description	Part No.
C1	Ceramic 0.01 50V	CKDYF 103Z 50
C2	Mylar 0.0091 50V	CQMA 912J 50
C3	Mylar 0.0091 50V	CQMA 912J 50
C4	Ceramic 0.0056 50V	CKDYB 562K 50
C5	Electrolytic 220 16V	CEA 221P 16
C6	Electrolytic 10,000 50V	ACH-029
C7	Electrolytic 10,000 50V	ACH-029
C8	Electrolytic 10,000 50V	ACH-029
C9	Electrolytic 10,000 50V	ACH-029
C10	Ceramic 0.01 250V	ACG-001
C11	Ceramic 0.01 250V	ACG-001
C12	Ceramic 0.01 250V	ACG-001
C13	Ceramic 0.01 250V	ACG-001
C14	Mylar 0.0047 50V	CQMA 472J 50
C15	Mylar 0.0047 50V	CQMA 472J 50
C16	Ceramic 0.01 50V	CKDYF 103Z 50
C17	Ceramic 0.01 250V	ACG-001

RESISTORS

Symbol	Description	Part No.
R1	Carbon film 100k	RD½PS 104J
R2	Carbon film 100k	RD½PS 104J
R3	Carbon film 1M	RD½PS 105J
R4	Metal oxide 3.3k 3W	RS3P 332K
R5	Metal oxide 3.3k 3W	RS3P 332K
R6	Metal oxide 3.3k 3W	RS3P 332K
R7	Metal oxide 3.3k 3W	RS3P 332K
VR1a	Variable resistor 3k-B (CD-4 SEPARATION LEFT)	ACV-017
VR1b	Variable resistor 3k-B (CD-4 SEPARATION RIGHT)	ACV-017
VR2a	Variable resistor 250k-B2 (FRONT L level)	ACT-009
VR2b	Variable resistor 250k-B2 (REAR R level)	ACT-009
VR2c	Variable resistor 250k-B2 (FRONT L level)	ACT-009
VR2d	Variable resistor 250k-B2 (REAR R level)	ACT-009
VR3	Variable resistor 250k-B1, 4-gang (VOLUME)	ACV-311

NOTE:

- Capacitors: in μF unless otherwise noted p:pF
- Resistors: in Ω , $\frac{1}{4}W$ unless otherwise noted k:k Ω , M:M Ω

POWER TRANSISTORS (for Power amplifier)

Symbol	Description	Part No.
Q13		2SD370-R
Q14		(2SC1403-R)
Q15		2SC1079-R
Q16		(2SC1116-R)
		2SB530-R
		(2SA745-R)
		2SA679-R
		(2SA747-R)

LAMPS

Symbol	Description	Part No.
	Lamp 8V, 300mA, bar type (Dial illumination)	E22-032
	Lamp 8V, 300mA, bar type (Meter illumination)	AEL-015
	Lamp 6V, 30mA, with leads (CD-4 indicator)	AEL-025
	Lamp 8V 50mA, with leads (Program indicator)	AEL-022

FUSES

Symbol	Description	Part No.
FU1	Fuse 3A (lamp circuit)	AEK-101
FU2	Fuse 1A (secondary)	AEK-106
FU3	Fuse 1A (secondary)	AEK-106
FU4	Fuse 1A (secondary)	AEK-106
FU5	Fuse 3A (220V, 240V, primary) or 6A (110V, 120V, 130V, primary)	AEK-101

SWITCHES

Symbol	Description	Part No.
S1	Rotary switch (FUNCTION)	ASB-048
S2	Rotary switch (MODE)	ASC-066
S3	Slide switch (DE-EMPHASIS)	ASH-013
S4, S5	Push switch (FM MUTING, MPX NOISE FILTER)	ASG-050
S6	Push switch (POWER)	ASG-070
S7	Micro switch (Switch cover)	ASF-001

Miscellaneous Parts for "KCU" type

CAPACITORS

Symbol	Description	Part No.
C1	Ceramic 0.01 50V	CKDYF103Z 50
C2	Mylar 0.0091 50V	CQMA 912J 50
C3	Mylar 0.0091 50V	CQMA 912J 50
C4	Ceramic 0.0056 50V	CKDYB 562K 50
C5	Electrolytic 220 16V	CEA 221P 16
C6	Electrolytic 10,000 50V	ACH-029
C7	Electrolytic 10,000 50V	ACH-029
C8	Electrolytic 10,000 50V	ACH-029
C9	Electrolytic 10,000 50V	ACH-029
C10	Ceramic 0.01 150V	ACG-003
C11	Ceramic 0.01 150V	ACG-003
C12	Ceramic 0.01 150V	ACG-003
C13	Ceramic 0.01 250V	ACG-001
C14	Ceramic 0.01 50V	CKDYF 103Z 50

RESISTORS

Symbol	Description	Part No.
R1	Carbon film 100k	RD½PS 104J
R2	Carbon film 100k	RD½PS 104J
R3	Carbon film 1M	RD½PS 105J
R4	Metal oxide 3.3k 3W	RS3P 332K
R5	Metal oxide 3.3k 3W	RS3P 332K
R6	Metal oxide 3.3k 3W	RS3P 332K
R7	Metal oxide 3.3k 3W	RS3P 332K
R8	Carbon film 2.2M ½W	RD½PS 225J
VR1a	Variable resistor 3k-B (CD-4 SEPARATION LEFT)	ACV-017
VR1b	Variable resistor 3k-B (CD-4 SEPARATION RIGHT)	ACV-017
VR2a	Variable resistor 250k-B2 (FRONT L level)	ACT-009
VR2b	Variable resistor 250k-B2 (REAR R level)	ACT-009
VR2c	Variable resistor 250k-B2 (FRONT L level)	ACT-009
VR2d	Variable resistor 250k-B2 (REAR R level)	ACT-009
VR3	Variable resistor 250k-B1 4-gang (VOLUME)	ACV-311

POWER TRANSISTORS (for Power amplifier)

Symbol	Description	Part No.
Q13		2SD370-R
Q14		(2SC1403-R)
Q15		2SC1079-R
Q16		(2SC1116-R)
		2SB530-R
		(2SA745-R)
		2SA679-R
		(2SA747-R)

LAMPS

Symbol	Description	Part No.
	Lamp 8V, 300mA, bar type (Dial illumination)	E22-032
	Lamp 8V, 300mA, bar type (Meter illumination)	AEL-015
	Lamp 6V, 30mA, with leads (CD-4 indicator)	AEL-025
	Lamp 8V, 50mA, with leads (Program indicator)	AEL-022

FUSES

Symbol	Description	Part No.
FU1	Fuse 3A (lamp circuit)	AEK-101
FU2	Fuse 1A (secondary)	AEK-106
FU3	Fuse 1A (secondary)	AEK-106
FU4	Fuse 1A (secondary)	AEK-106
FU5	Fuse 6A (primary)	AEK-109
FU6	Fuse 6A (primary, with leads)	AEK-205

SWITCHES

Symbol	Description	Part No.
S1	Rotary switch (FUNCTION)	ASB-048
S2	Rotary switch (MODE)	ASC-066
S3	Slide switch (DE-EMPHASIS)	ASH-008
S4, S5	Push switch (FM MUTING, MPX NOISE FILTER)	ASG-050
S6	Push switch (POWER)	ASG-043
S7	Micro switch (Switch cover)	ASF-001

13.2 TUNER ASSEMBLY (AWE-041)

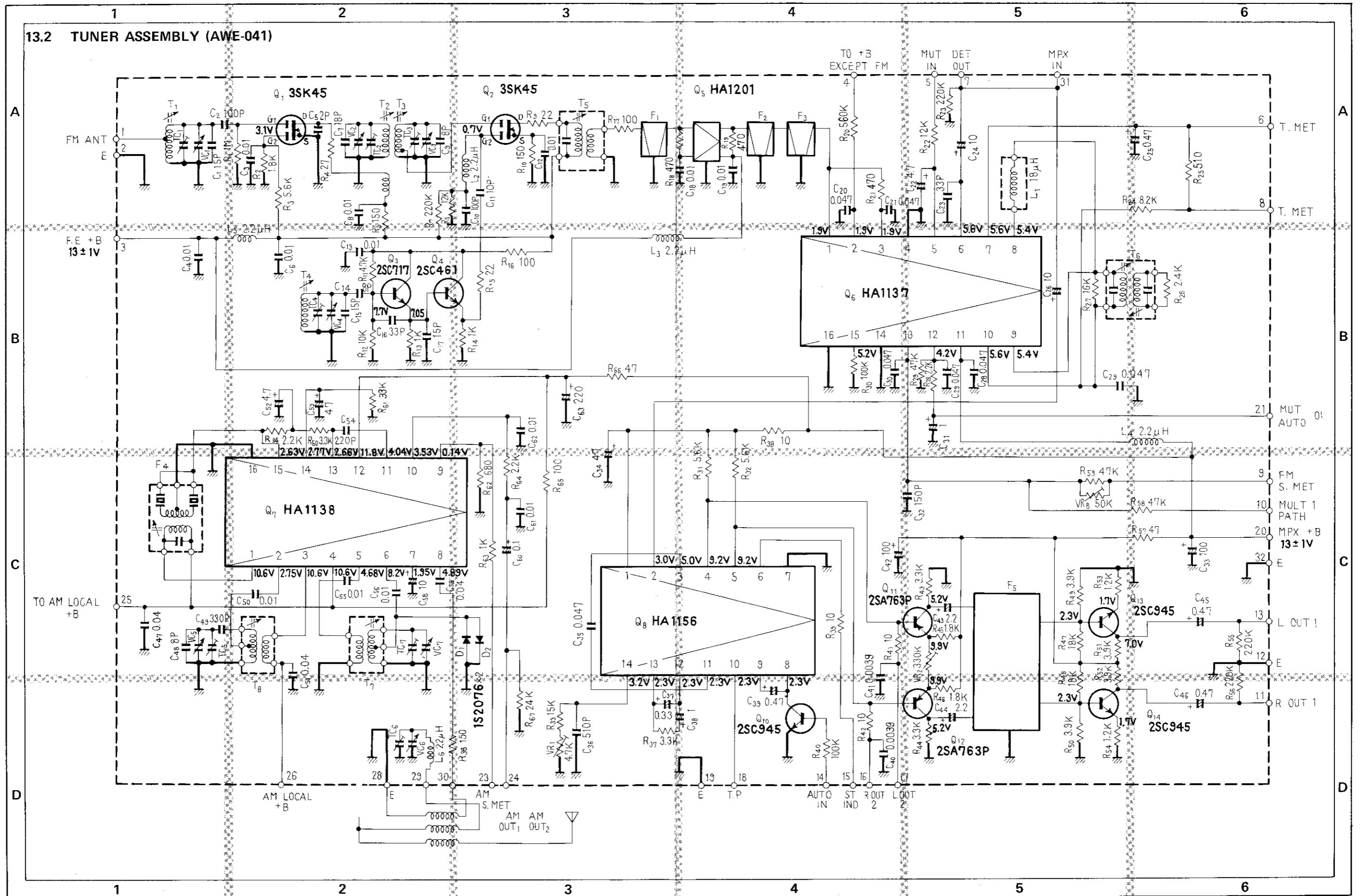

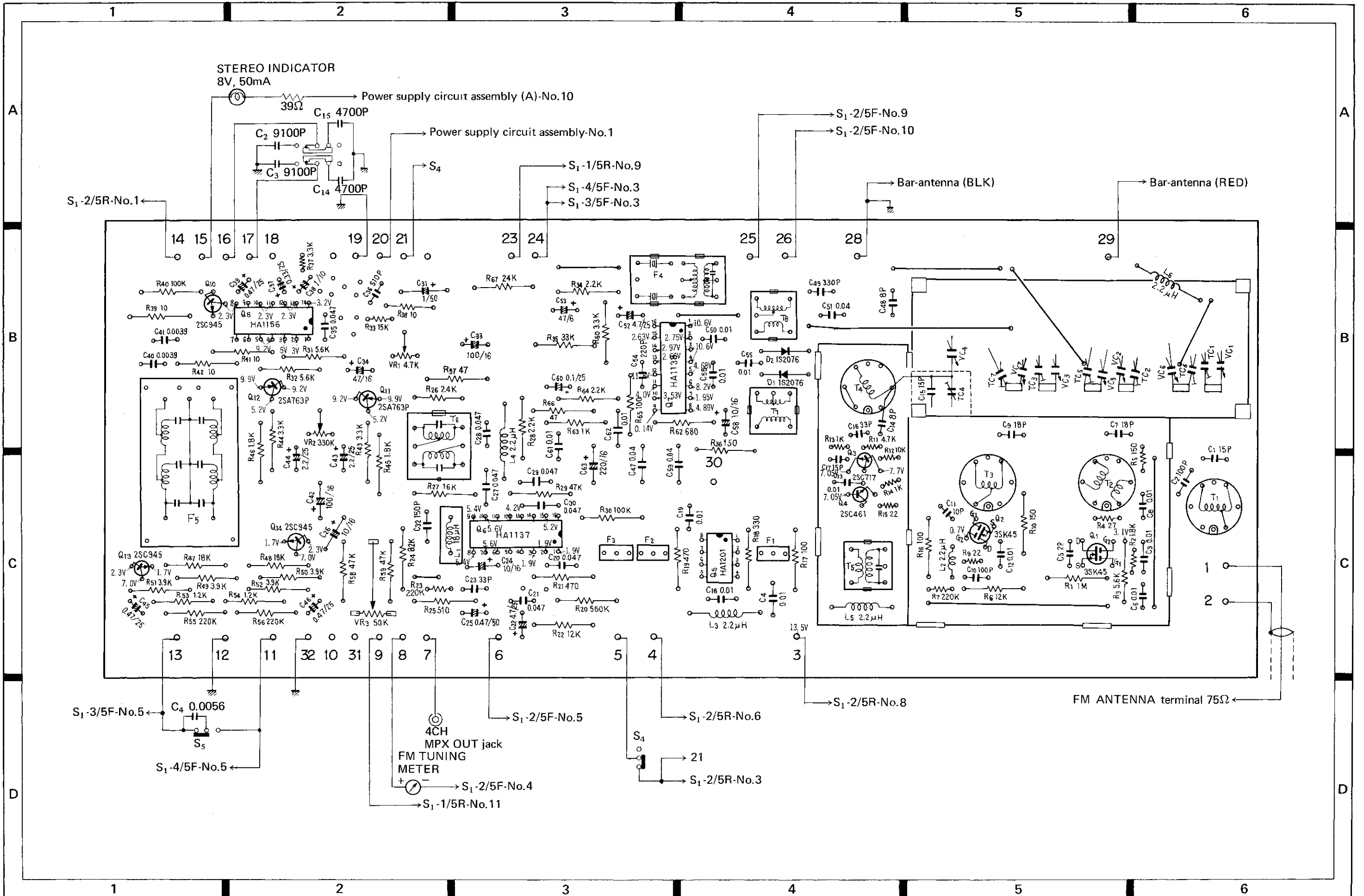

Parts List of Tuner Assembly (AWE-041)

CAPACITORS

Symbol	Description	Part No.
C1	Ceramic 15p 50V	CCDSH 150K 50
C2	Ceramic 100p 50V	CCDSL 101K 50
C3	Ceramic 0.01 50V	CKDYF 103Z 50
C4	Ceramic 0.01 50V	CKDYF 103Z 50
C5	Ceramic 2p 50V	CCDSL 020C 50
C6	Ceramic 0.01 50V	CKDYF 103Z 50
C7	Ceramic 18p 50V	CCDSH 180K 50
C8	Ceramic 0.01 50V	CKDYF 103Z 50
C9	Ceramic 18p 50V	CCDSH 180K 50
C10	Ceramic 100p 50V	CCDSL 101K 50
C11	Ceramic 10p 50V	CCDSL 100F 50
C12	Ceramic 0.01 50V	CKDYF 103Z 50
C13	Ceramic 0.01 50V	CKDYB 103K 50
C14	Ceramic 8p 50V	CCDLH 080F 50
C15	Ceramic 15p 50V	CCDLH 150K 50
C16	Ceramic 33p 50V	CCDCH 330K 50
C17	Ceramic 15p 50V	CCDCH 150K 50
C18	Ceramic 0.01 50V	CKDYF 103Z 50
C19	Ceramic 0.01 50V	CKDYF 103Z 50
C20	Ceramic 0.047 25V	CKDBC 473Z 25
C21	Ceramic 0.047 25V	CKDBC 473Z 25
C22	Electrolytic 4.7 25V	CEA 4R7P 25
C23	Ceramic 33p 50V	CCDSL 330K 50
C24	Electrolytic 10 16V	CEA 100P 16
C25	Electrolytic 0.47 50V	CEA R47P 50
C26	Electrolytic 10 16V	CEA 100P 16
C27	Ceramic 0.047 25V	CKDBC 473Z 25
C28	Ceramic 0.047 25V	CKDBC 473Z 25
C29	Ceramic 0.047 25V	CKDBC 473Z 25
C30	Ceramic 0.047 25V	CKDBC 473Z 25
C31	Electrolytic 1 50V	CEA 010P 50
C32	Ceramic 150p 50V	CCDSL 151K 50
C33	Electrolytic 100 16V	CEA 101P 16
C34	Electrolytic 47 16V	CEA 470P 16
C35	Mylar 0.047 50V	CQMA 473K 50
C36	Styrol 510P 50V	CQSH 511J 50
C37	Electrolytic 0.33 25V	CSSA R33M 25
C38	Electrolytic 1 10V	CSSA 010M 10
C39	Electrolytic 0.47 25V	CSSA R47M 25
C40	Ceramic 0.0039 50V	CKDYA 392J 50
C41	Ceramic 0.0039 50V	CKDYA 392J 50
C42	Electrolytic 100 16V	CEA 101P 16
C43	Electrolytic 2.2 25V	CEA 2R2P 25
C44	Electrolytic 2.2 25V	CEA 2R2P 25
C45	Electrolytic 0.47 25V	CSSA R47M 25
C46	Electrolytic 0.47 25V	CSSA R47M 25
C47	Ceramic 0.04 50V	CKDYF 403Z 50
C48	Ceramic 8p 50V	CCDXL 080F 50

Symbol	Description	Part No.
C49	Styrol 330p 50V	CQSA 331J 50
C50	Mylar 0.01 50V	CQMA 103K 50
C51	Ceramic 0.04 50V	CKDYF 403Z 50
C52	Electrolytic 4.7 25V	CEA 4R7P 25
C53	Electrolytic 47 6V	CEA 470P 6
C54	Ceramic 220p 50V	CCDSL 221K 50
C55	Ceramic 0.01 50V	CKDYF 103Z 50
C56	Ceramic 0.01 50V	CKDYF 103Z 50
C57	Vacancy
C58	Electrolytic 10 16V	CEA 100P 16
C59	Electrolytic 0.04 50V	CKDYF 403Z 50
C60	Electrolytic 0.1 25V	CSSA 0R1M 25
C61	Ceramic 0.01 50V	CKDYB 103K 50
C62	Ceramic 0.01 50V	CKDYB 103K 50
C63	Electrolytic 220 16V	CEA 221P 16
VC	Tuning capacitor	ACK-006-A
TC4	Ceramic trimmer	C43-007-A

RESISTORS

Symbol	Description	Part No.
R1	Carbon film 1M	RD%PS 105J
R2	Carbon film 1.8k	RD%VS 182J
R3	Carbon film 5.6k	RD%PS 562J
R4	Carbon film 27	RD%VS 270J
R5	Carbon film 150	RD%VS 151J
R6	Carbon film 12k	RD%PS 123J
R7	Carbon film 220k	RD%VS 224J
R8	Vacancy
R9	Carbon film 22	RD%VS 220J
R10	Carbon film 150	RD%PS 151J
R11	Carbon film 4.7k	RD%VS 472J
R12	Carbon film 10k	RD%VS 103J
R13	Carbon film 1k	RD%VS 102J
R14	Carbon film 1k	RD%VS 102J
R15	Carbon film 22	RD%VS 220J
R16	Carbon film 100	RD%PS 101J
R17	Carbon film 100	RD%PS 101J
R18	Carbon film 470	RD%PS 471J
R19	Carbon film 470	RD%PS 471J
R20	Carbon film 560k	RD%PS 564J
R21	Carbon film 470	RD%PS 471J
R22	Carbon film 12k	RD%PS 123J
R23	Carbon film 220k	RD%VS 224J
R24	Carbon film 8.2k	RD%PS 822J
R25	Carbon film 510	RD%PS 511J
R26	Carbon film 2.4k	RD%VS 242J
R27	Carbon film 16k	RD%PS 163J
R28	Carbon film 2.2k	RD%PS 222J
R29	Carbon film 47k	RD%PS 473J
R30	Carbon film 100k	RD%PS 104J

Symbol	Description	Part No.
R31	Carbon film 5.6k	RD%PS 562J
R32	Carbon film 5.6k	RD%PS 562J
R33	Carbon film 15k	RD%VS 153J
R34	Carbon film 2.2k	RD%PS 222J
R35	Carbon film 33k	RD%PS 333J
R36	Carbon film 150	RD%PS 151J
R37	Carbon film 3.3k	RD%VS 332J
R38	Carbon film 10	RD%VS 100J
R39	Carbon film 10	RD%PS 100J
R40	Carbon film 100k	RD%PS 104J
R41	Carbon film 10	RD%PS 100J
R42	Carbon film 10	RD%PS 100J
R43	Carbon film 3.3k	RD%PS 332J
R44	Carbon film 3.3k	RD%PS 332J
R45	Carbon film 1.8k	RD%PS 182J
R46	Carbon film 1.8k	RD%PS 182J
R47	Carbon film 18k	RD%PS 183J
R48	Carbon film 18k	RD%PS 183J
R49	Carbon film 3.9k	RD%PS 392J
R50	Carbon film 3.9k	RD%PS 392J
R51	Carbon film 3.9k	RD%PS 392J
R52	Carbon film 3.9k	RD%PS 392J
R53	Carbon film 1.2k	RD%PS 122J
R54	Carbon film 1.2k	RD%PS 122J
R55	Carbon film 220k	RD%PS 224J
R56	Carbon film 220k	RD%PS 224J
R57	Carbon film 47	RD%PS 470J
R58	Carbon film 47k	RD%PS 473J
R59	Carbon film 47k	RD%PS 473J
R60	Carbon film 3.3k	RD%PS 332J
R61	Vacancy
R62	Carbon film 680	RD%PS 681J
R63	Carbon film 1k	RD%PS 102J
R64	Carbon film 2.2k	RD%PS 222J
R65	Carbon film 100	RD%PS 101J
R66	Carbon film 47	RD%PS 470J
R67	Carbon film 24k	RD%PS 243J
VR1	Variable (semi-fixed) 4.7k-B	C92-051-0
VR2	Variable (semi-fixed) 330k-B	ACP-042-0
VR3	Variable (semi-fixed) 50k-B	ACP-043-0

SEMICONDUCTORS

Symbol	Description	Part No.
Q1	FET	3SK45-B
Q2	FET	3SK45-B
Q3	Transistor	2SC717

Symbol	Description	Part No.
Q4	Transistor	2SC461-B
Q5	IC	HA1201
Q6	IC	HA1137
Q7	IC	HA1138
Q8	IC	HA1156
Q10	Transistor	2SC945-Q, R or S
Q11	Transistor	2SA763P-6 or 5 (2SA725-F or G)
Q12	Transistor	2SA763P-6 or 5 (2SA725-F or G)
Q13	Transistor	2SC945-Q, R or S
Q14	Transistor	2SC945-Q, R or S
D1	Diode	1S2076
D2	Diode	1S2076

COILS, TRANSFORMERS, AND FILTERS.

Symbol	Description	Part No.
T1	FM antenna coil	ATC-021
T2	FM RF coil	ATC-015
T3	FM RF coil	ATC-016
T4	FM osc coil	ATC-022
T5	FM IF transformer	ATE-008
T6	FM DET transformer	T73-035
T7	AM RF coil	ATB-014
T8	AM osc coil	ATB-013
F1	FM ceramic filter	ATF-013
F2	FM ceramic filter	ATF-013
F3	FM ceramic filter	ATF-013
F4	AM ceramic filter	ATF-009
F5	LOW Pass filter	ATF-019
L1	RF choke coil 18μH	ATH-007
L2	RF choke coil 2.2μH	T24-028
L3	RF choke coil 2.2μH	T24-028
L4	RF choke coil 2.2μH	T24-028
L5	RF choke coil 2.2μH	T24-028
L6	RF choke coil 2.2μH	T24-028

13.3 HEADPHONE JACK ASSEMBLY (AWX-054)

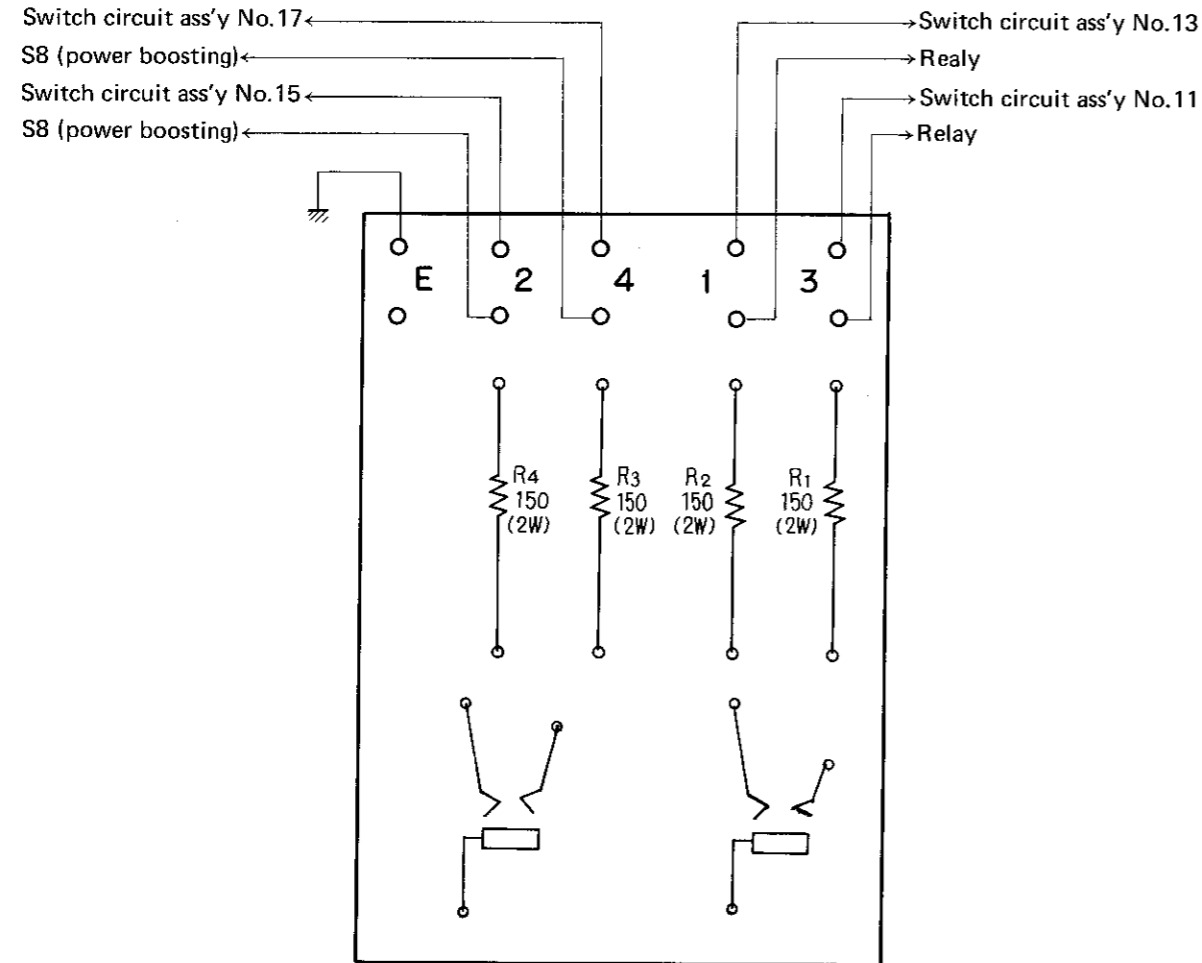

Parts List of Headphone Jack Assembly (AWX-054)

RESISTORS

Symbol	Description	Part No.
R1	Metal oxide 150 2W	RS2P 151K
R2	Metal oxide 150 2W	RS2P 151K
R3	Metal oxide 150 2W	RS2P 151K
R4	Metal oxide 150 2W	RS2P 151K

OTHERS

Symbol	Description	Part No.
	Phone jack (FRONT)	AKN-002
	Phone jack (REAR)	AKN-002

13.4 POWER SUPPLY CIRCUIT B ASSEMBLY (AWR-039)

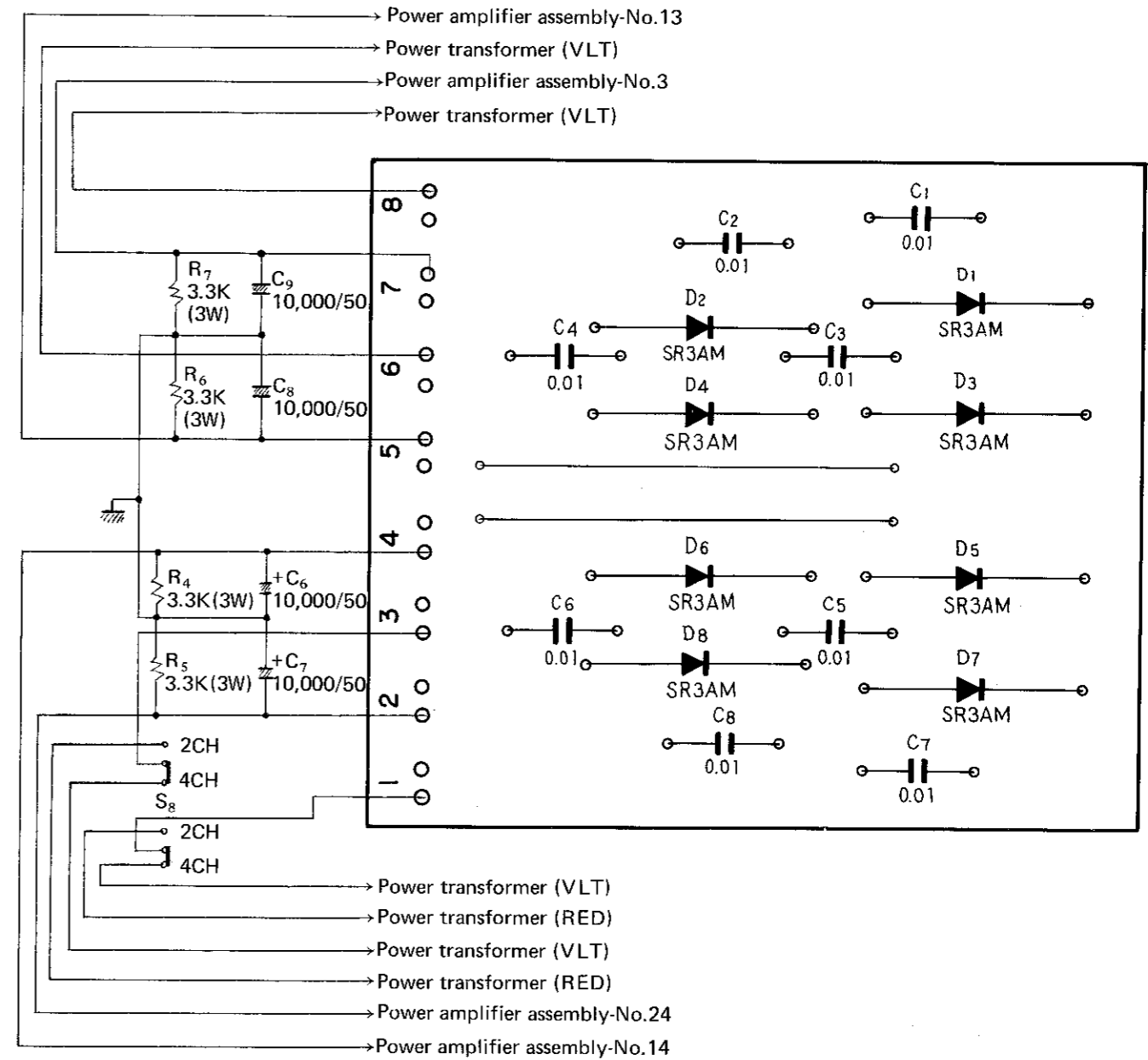

Parts List of Power Supply Circuit B Assembly (AWR-039)

CAPACITORS

Symbol	Description	Part No.
C1	Ceramic 0.01 150V	ACG-004
C2	Ceramic 0.01 150V	ACG-004
C3	Ceramic 0.01 150V	ACG-004
C4	Ceramic 0.01 150V	ACG-004
C5	Ceramic 0.01 150V	ACG-004
C6	Ceramic 0.01 150V	ACG-004
C7	Ceramic 0.01 150V	ACG-004
C8	Ceramic 0.01 150V	ACG-004

SEMICONDUCTORS

Symbol	Description	Part No.
D1	Diode	SR3AM-4
D2	Diode	SR3AM-4
D3	Diode	SR3AM-4
D4	Diode	SR3AM-4
D5	Diode	SR3AM-4
D6	Diode	SR3AM-4
D7	Diode	SR3AM-4
D8	Diode	SR3AM-4

13.5 CD-4 ASSEMBLY (AWM-076)

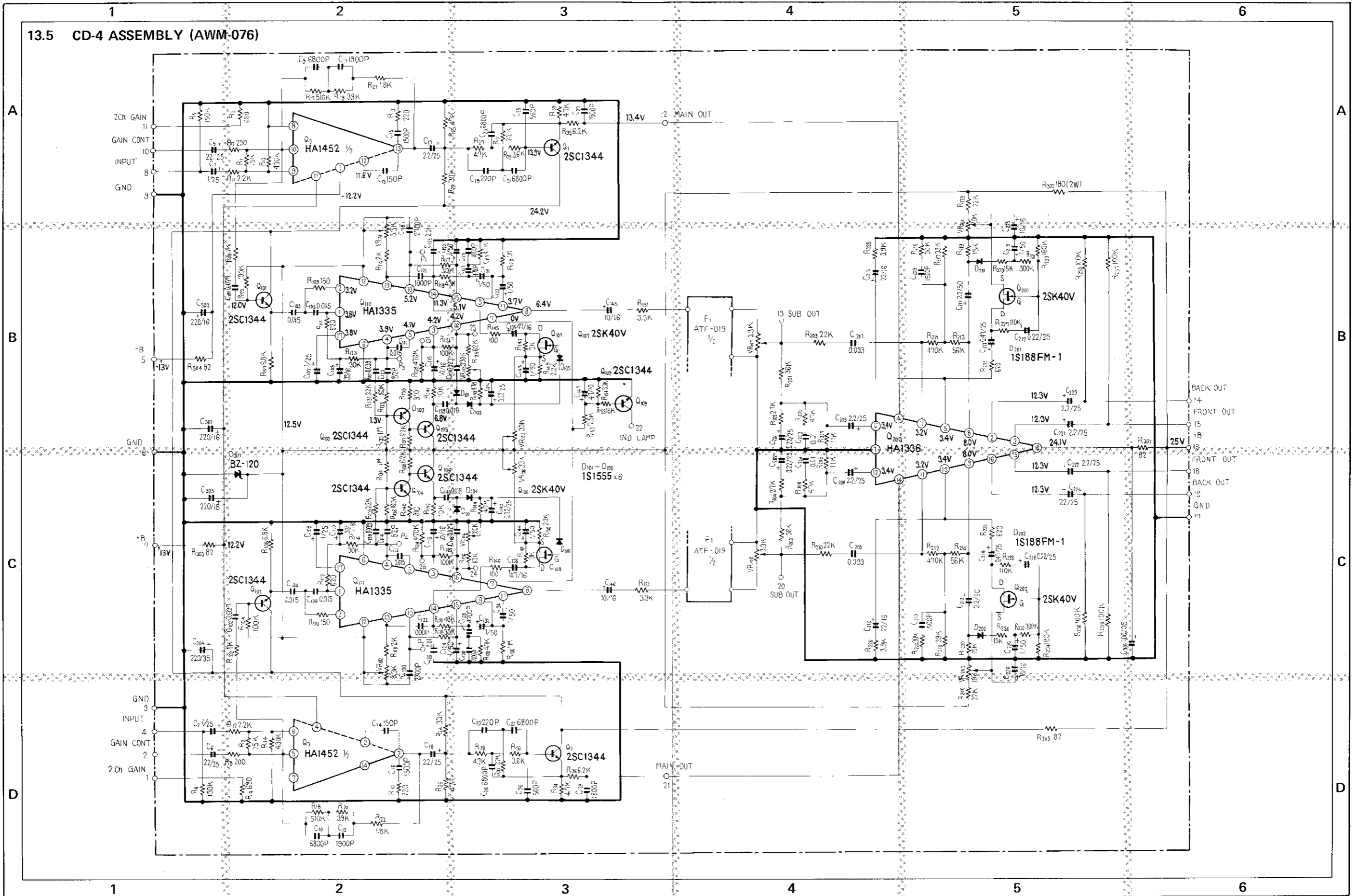

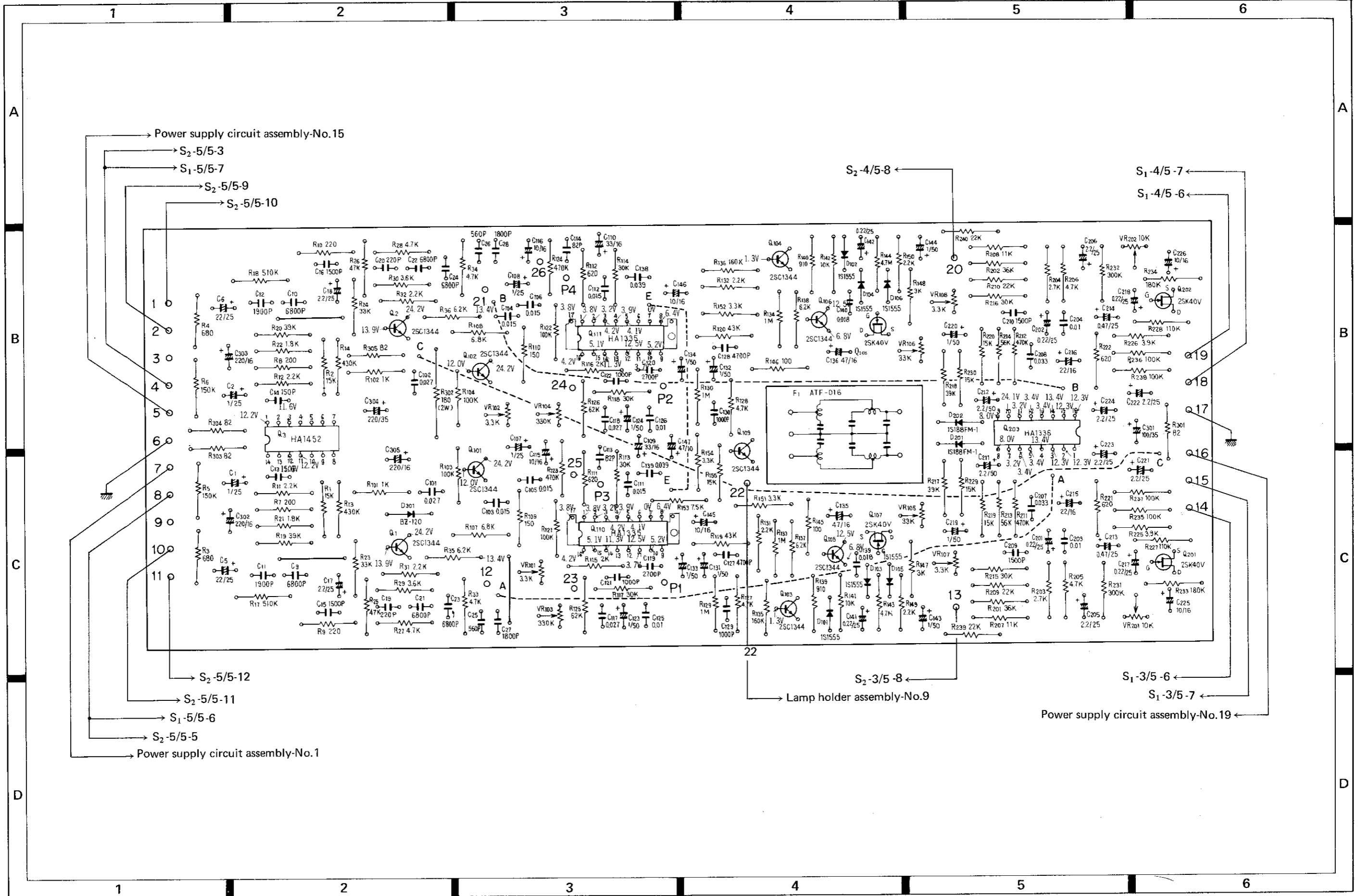

Parts List of CD-4 Assembly (AWM-076)

CAPACITORS

Symbol	Description	Part No.
C1	Electrolytic 1 25V	CSSA 010M 25
C2	Electrolytic 1 25V	CSSA 010M 25
C3	Vacancy
C4	Vacancy
C5	Electrolytic 22 25V	CEANL 220P 25
C6	Electrolytic 22 25V	CEANL 220P 25
C7	Vacancy
C8	Vacancy
C9	Styrol 6800p 50V	CQSA 682G 50
C10	Styrol 6800p 50V	CQSA 682G 50
C11	Styrol 1900p 50V	CQSA 192G 50
C12	Styrol 1900p 50V	CQSA 192G 50
C13	Ceramic 150p 50V	CCDSL 151K 50
C14	Ceramic 150p 50V	CCDSL 151K 50
C15	Mylar 0.0015 50V	CQMA 152K 50
C16	Mylar 0.0015 50V	CQMA 152K 50
C17	Electrolytic 2.2 25V	CSSA 2R2M 25
C18	Electrolytic 2.2 25V	CSSA 2R2M 25
C19	Styrol 220p 50V	CQSA 221J 50
C20	Styrol 220p 50V	CQSA 221J 50
C21	Mylar 0.0068 50V	CQMA 682J 50
C22	Mylar 0.0068 50V	CQMA 682J 50
C23	Mylar 0.0068 50V	CQMA 682J 50
C24	Mylar 0.0068 50V	CQMA 682J 50
C25	Ceramic 560p 50V	CKDYB 561K 50
C26	Ceramic 560p 50V	CKDYB 561K 50
C27	Mylar 0.0018 50V	CQMA 182K 50
C28	Mylar 0.0018 50V	CQMA 182K 50
C101	Mylar 0.027 50V	CQMA 273K 50
C102	Mylar 0.027 50V	CQMA 273K 50
C103	Mylar 0.015 50V	CQMA 153K 50
C104	Mylar 0.015 50V	CQMA 153K 50
C105	Mylar 0.015 50V	CQMA 153K 50
C106	Mylar 0.015 50V	CQMA 153K 50
C107	Electrolytic 1 25V	CSSA 010M 25
C108	Electrolytic 1 25V	CSSA 010M 25
C109	Electrolytic 33 16V	CEA 330P 16
C110	Electrolytic 33 16V	CEA 330P 16
C111	Mylar 0.015 50V	CQMA 153K 50
C112	Mylar 0.015 50V	CQMA 153K 50
C113	Ceramic 82p 50V	CCDSL 820K 50
C114	Ceramic 82p 50V	CCDSL 820K 50
C115	Electrolytic 10 16V	CEA 100P 16
C116	Electrolytic 10 16V	CEA 100P 16
C117	Mylar 0.027 50V	CQMA 273K 50
C118	Mylar 0.027 50V	CQMA 273K 50
C119	Mylar 0.0027 50V	CQMA 272K 50
C120	Mylar 0.0027 50V	CQMA 272K 50

Symbol	Description	Part No.
C121	Mylar 0.001 50V	CQMA 102K 50
C122	Mylar 0.001 50V	CQMA 102K 50
C123	Electrolytic 1 50V	CEA 010P 50
C124	Electrolytic 1 50V	CEA 010P 50
C125	Mylar 0.01 50V	CQMA 103K 50
C126	Mylar 0.01 50V	CQMA 103K 50
C127	Mylar 0.0047 50V	CQMA 472K 50
C128	Mylar 0.0047 50V	CQMA 472K 50
C129	Mylar 0.001 50V	CQMA 102K 50
C130	Mylar 0.001 50V	CQMA 102K 50
C131	Electrolytic 1 50V	CEA 010P 50
C132	Electrolytic 1 50V	CEA 010P 50
C133	Electrolytic 1 50V	CEA 010P 50
C134	Electrolytic 1 50V	CEA 010P 50
C135	Electrolytic 47 16V	CEA 470P 16
C136	Electrolytic 47 16V	CEA 470P 16
C137	Mylar 0.039 50V	CQMA 393K 50
C138	Mylar 0.039 50V	CQMA 393K 50
C139	Mylar 0.018 50V	CQMA 183K 50
C140	Mylar 0.018 50V	CQMA 183K 50
C141	Electrolytic 0.22 25V	CSSA R22M 25
C142	Electrolytic 0.22 25V	CSSA R22M 25
C143	Electrolytic 1 50V	CEA 010 50
C144	Electrolytic 1 50V	CEA 010 50
C145	Electrolytic 10 16V	CEA 100P 16
C146	Electrolytic 10 16V	CEA 100P 16
C147	Electrolytic 47 10V	CEA 470P 10
C201	Electrolytic 0.22 25V	CSSA R22M 25
C202	Electrolytic 0.22 25V	CSSA R22M 25
C203	Mylar 0.01 50V	CQMA 103K 50
C204	Mylar 0.01 50V	CQMA 103K 50
C205	Electrolytic 2.2 25V	CSSA 2R2M 25
C206	Electrolytic 2.2 25V	CSSA 2R2M 25
C207	Mylar 0.033 50V	CQMA 333K 50
C208	Mylar 0.033 50V	CQMA 333K 50
C209	Mylar 0.0015 50V	CQMA 152K 50
C210	Mylar 0.0015 50V	CQMA 152K 50
C211	Electrolytic 2.2 50V	CEA 2R2P 50
C212	Electrolytic 2.2 50V	CEA 2R2P 50
C213	Electrolytic 0.47 25V	CSSA R47M 25
C214	Electrolytic 0.47 25V	CSSA R47M 25
C215	Electrolytic 22 16V	CEA 220P 16
C216	Electrolytic 22 16V	CEA 220P 16
C217	Electrolytic 0.22 25V	CSSA R22M 25
C218	Electrolytic 0.22 25V	CSSA R22M 25
C219	Electrolytic 1 50V	CSSA 010P 50
C220	Electrolytic 1 50V	CSSA 010P 50
C221	Electrolytic 2.2 25V	CSSA 2R2M 25
C222	Electrolytic 2.2 25V	CSSA 2R2M 25

Symbol	Description	Part No.
C223	Electrolytic 2.2 25V	CSSA 2R2M 25
C224	Electrolytic 2.2 25V	CSSA 2R2M 25
C225	Electrolytic 10 16V	CEA 100P 16
C226	Electrolytic 10 16V	CEA 100P 16
C301	Electrolytic 100 35V	CEA 101P 35
C302	Electrolytic 220 16V	CEA 221P 16
C303	Electrolytic 220 16V	CEA 221P 16
C304	Electrolytic 220 35V	CEA 221P 35
C305	Electrolytic 220 16V	CEA 221P 16

RESISTORS

Symbol	Description	Part No.
R1	Carbon film 15k	RD%PS 153J
R2	Carbon film 15k	RD%PS 153J
R3	Carbon film 680	RD%PS 681J
R4	Carbon film 680	RD%PS 681J
R5	Carbon film 150k	RD%PS 154J
R6	Carbon film 150k	RD%PS 154J
R7	Carbon film 200	RD%PS 201J
R8	Carbon film 200	RD%PS 201J
R9	Carbon film 220	RD%PS 221J
R10	Carbon film 220	RD%PS 221J
R11	Carbon film 2.2k	RD%PS 222J
R12	Carbon film 2.2k	RD%PS 222J
R13	Carbon film 430k	RD%PS 434J
R14	Carbon film 430k	RD%PS 434J
R15	Vacancy
R16	Vacancy
R17	Carbon film 510k	RD%PS 514J
R18	Carbon film 510k	RD%PS 514J
R19	Carbon film 39k	RD%PS 393J
R20	Carbon film 39k	RD%PS 393J
R21	Carbon film 1.8k	RD%PS 182J
R22	Carbon film 1.8k	RD%PS 182J
R23	Carbon film 33k	RD%PS 333J
R24	Carbon film 33k	RD%PS 333J
R25	Carbon film 47k	RD%PS 473J
R26	Carbon film 47k	RD%PS 473J
R27	Carbon film 4.7k	RD%PS 472J
R28	Carbon film 4.7k	RD%PS 472J
R29	Carbon film 3.6k	RD%PS 362J
R30	Carbon film 3.6k	RD%PS 362J
R31	Carbon film 2.2k	RD%PS 222J
R32	Carbon film 2.2k	RD%PS 222J
R33	Carbon film 4.7k	RD%PS 472J
R34	Carbon film 4.7k	RD%PS 472J
R35	Carbon film 6.2k	RD%PS 622J
R36	Carbon film 6.2k	RD%PS 622J
R101	Carbon film 1k	RD%PS 102J
R102	Carbon film 1k	RD%PS 102J

Symbol	Description	Part No.
R103	Carbon film 100k	RD%PS 104J
R104	Carbon film 100k	RD%PS 104J
R105	Vacancy
R106	Vacancy
R107	Carbon film 6.8k	RD%PS 682J
R108	Carbon film 6.8k	RD%PS 682J
R109	Carbon film 150	RD%PS 151J
R110	Carbon film 150	RD%PS 151J
R111	Carbon film 620	RD%PS 621J
R112	Carbon film 620	RD%PS 621J
R113	Carbon film 30k	RD%PS 303J
R114	Carbon film 30k	RD%PS 303J
R115	Carbon film 2k	RD%PS 202J
R116	Carbon film 2k	RD%PS 202J
R117	Carbon film 30k	RD%PS 303J
R118	Carbon film 30k	RD%PS 303J
R119	Carbon film 43k	RD%PS 433J
R120	Carbon film 43k	RD%PS 433J
R121	Carbon film 100k	RD%PS 104J
R122	Carbon film 100k	RD%PS 104J
R123	Carbon film 470k	RD%PS 474J
R124	Carbon film 470k	RD%PS 474J
R125	Carbon film 62k	RD%PS 623J
R126	Carbon film 62k	RD%PS 623J
R127	Carbon film 4.7k	RD%PS 472J
R128	Carbon film 4.7k	RD%PS 472J
R129	Carbon film 1M	RD%PS 105J
R130	Carbon film 1M	RD%PS 105J
R131	Carbon film 2.2k	RD%PS 222J
R132	Carbon film 2.2k	RD%PS 222J
R133	Carbon film 1M	RD%PS 105J
R134	Carbon film 1M	RD%PS 105J
R135	Carbon film 160k	RD%PS 164J
R136	Carbon film 160k	RD%PS 164J
R137	Carbon film 6.2k	RD%PS 622J
R138	Carbon film 6.2k	RD%PS 622J
R139	Carbon film 910	RD%PS 911J
R140	Carbon film 910	RD%PS 911J
R141	Carbon film 10k	RD%PS 103J
R142	Carbon film 10k	RD%PS 103J
R143	Carbon film 4.7M	RD%PS 475J
R144	Carbon film 4.7M	RD%PS 475J
R145	Carbon film 100	RD%PS 101J
R146	Carbon film 100	RD%PS 101J
R147	Carbon film 3k	RD%PS 302J
R148	Carbon film 3k	RD%PS 302J
R149	Carbon film 2.2k	RD%PS 222J
R150	Carbon film 2.2k	RD%PS 222J
R151	Carbon film 3.3k	RD%PS 332J
R152	Carbon film 3.3k	RD%PS 332J
R153	Carbon film 7.5k	RD%PS 752J
R154	Carbon film 3.3k	RD%PS 332J

Symbol	Description	Part No.
R155	Carbon film 15k	RD%PS 153J
R201	Carbon film 36k	RD%PS 363J
R202	Carbon film 36k	RD%PS 363J
R203	Carbon film 2.7k	RD%PS 272J
R204	Carbon film 2.7k	RD%PS 272J
R205	Carbon film 4.7k	RD%PS 472J
R206	Carbon film 4.7k	RD%PS 472J
R207	Carbon film 11k	RD%PS 113J
R208	Carbon film 11k	RD%PS 113J
R209	Carbon film 22k	RD%PS 223J
R210	Carbon film 22k	RD%PS 223J
R211	Carbon film 470k	RD%PS 474J
R212	Carbon film 470k	RD%PS 474J
R213	Carbon film 56k	RD%PS 563J
R214	Carbon film 56k	RD%PS 563J
R215	Carbon film 30k	RD%PS 303J
R216	Carbon film 30k	RD%PS 303J
R217	Carbon film 39k	RD%PS 393J
R218	Carbon film 39k	RD%PS 393J
R219	Carbon film 15k	RD%PS 153J
R220	Carbon film 15k	RD%PS 153J
R221	Carbon film 620	RD%PS 621J
R222	Carbon film 620	RD%PS 621J
R223	Vacancy
R224	Vacancy
R225	Carbon film 3.9k	RD%PS 392J
R226	Carbon film 3.9k	RD%PS 392J
R227	Carbon film 110k	RD%PS 114J
R228	Carbon film 110k	RD%PS 114J
R229	Carbon film 15k	RD%PS 153J
R230	Carbon film 15k	RD%PS 153J
R231	Carbon film 300k	RD%PS 304J
R232	Carbon film 300k	RD%PS 304J
R233	Carbon film 180k	RD%PS 184J
R234	Carbon film 180k	RD%PS 184J
R235	Carbon film 100k	RD%PS 104J
R236	Carbon film 100k	RD%PS 104J
R237	Carbon film 100k	RD%PS 104J
R238	Carbon film 100k	RD%PS 104J
R239	Carbon film 22k	RD%PS 223J
R240	Carbon film 22k	RD%PS 223J
R301	Carbon film 82	RD%PS 820J
R302	Metal oxide 180 2W	RS2P 181J
R303	Carbon film 82	RD%PS 820J
R304	Carbon film 82	RD%PS 820J
R305	Carbon film 82	RD%PS 820J
VR101	Variable (semi-fixed) 3.3k-B	ACP-047
VR102	Variable (semi-fixed) 3.3k-B	ACP-047
VR103	Variable (semi-fixed) 330k-B	ACP-042
VR104	Variable (semi-fixed) 330k-B	ACP-042
VR105	Variable (semi-fixed) 33k-B	ACP-025

Symbol	Description	Part No.
VR106	Variable (semi-fixed) 33k-B	ACP-025
VR107	Variable (semi-fixed) 3.3k-B	ACP-028
VR108	Variable (semi-fixed) 3.3k-B	ACP-028
VR201	Variable (semi-fixed) 10k-B	C92-049
VR202	Variable (semi-fixed) 10k-B	C92-049

SEMICONDUCTORS

Symbol	Description	Part No.
Q1	Transistor	2SC1344-E or F (2SC1312-G or H)
Q2	Transistor	2SC1344-E or F (2SC1312-G or H)
Q3	IC	HA1452
Q101	Transistor	2SC1344-E or F (2SC1312-G or H)
Q102	Transistor	2SC1344-G or F (2SC1312-G or H)
Q103	Transistor	2SC1344-E or F (2SC1312-G or H)
Q104	Transistor	2SC1344-E or F (2SC1312-G or H)
Q105	Transistor	2SC1344-E or F (2SC1312-G or H)
Q106	Transistor	2SC1344-E or F (2SC1312-G or H)
Q107	FET	2SK40V-2 or 3 (2SK30AP-2 or 3)
Q108	FET	2SK40V-2 or 3 (2SK30AP-2 or 3)
Q109	Transistor	2SC1344-E or F (2SC1312-G or H)
Q110	IC	HA1335
Q111	IC	HA1335
Q201	FET	2SK40V-2 or 3 (2SK30AP-2 or 3)
Q202	FET	2SK40V-2 or 3 (2SK30AP-2 or 3)
Q203	IC	HA1336
D101	Diode	1S1555 (1S2473)
D102	Diode	1S1555 (1S2473)
D103	Diode	1S1555 (1S2473)
D104	Diode	1S1555 (1S2473)
D105	Diode	1S1555 (1S2473)
D106	Diode	1S1555 (1S2473)

Symbol	Description	Part No.
D201	Diode	1S188FM-1
D202	Diode	1S188FM-1
D301	Zener diode	BZ-120

13.6 SQ/RM DECODER ASSEMBLY (AWM-077)

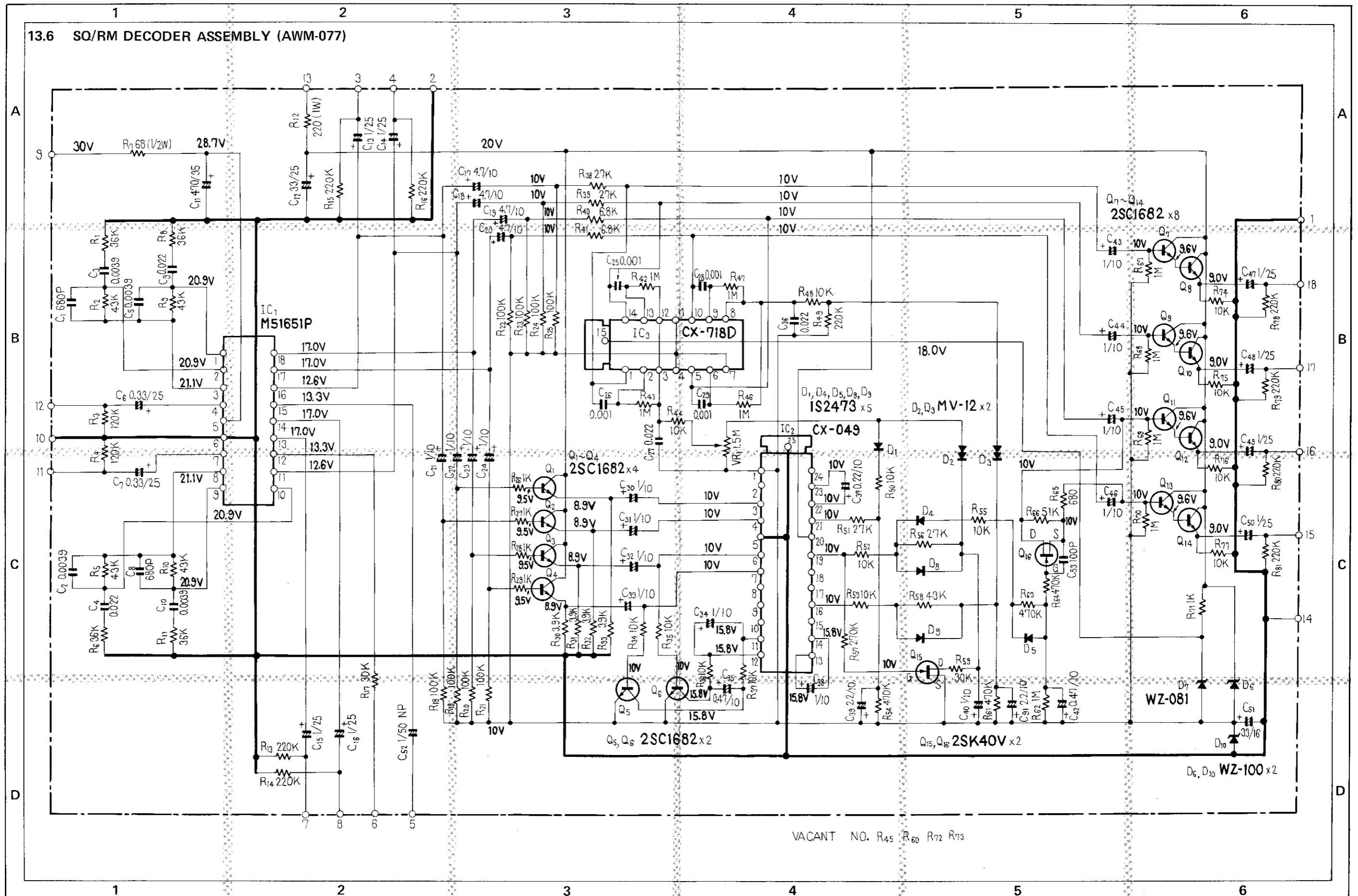

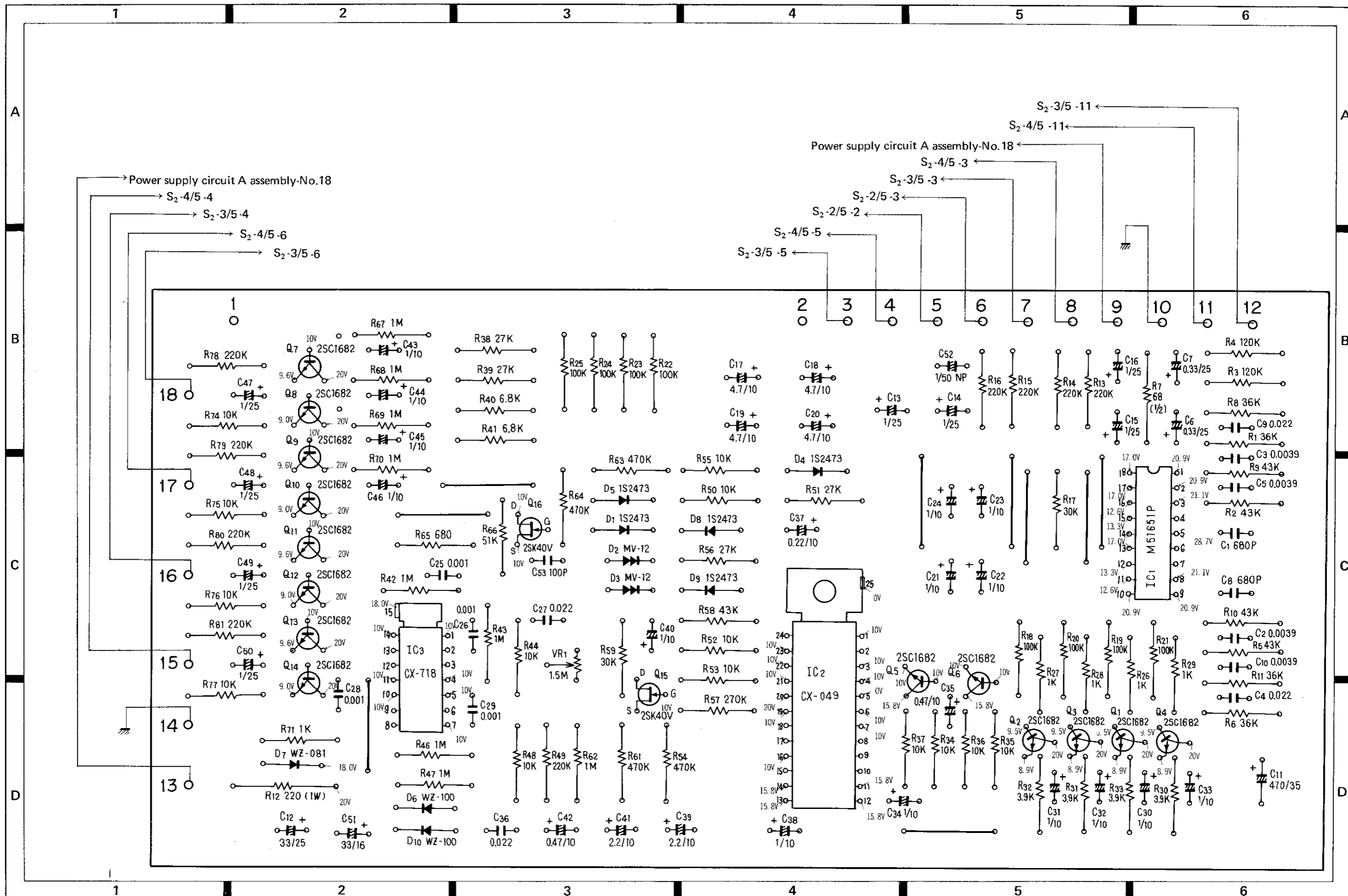

Parts List of SQ/RM Decoder Assembly (AWM-077)

CAPACITORS

Symbol	Description	Part No.
C1	Styrol 680p 50V	CQSA 681J 50
C2	Mylar 0.0039 50V	CQMA 392J 50
C3	Mylar 0.0039 50V	CQMA 392J 50
C4	Mylar 0.022 50V	CQMA 223J 50
C5	Mylar 0.0039 50V	CQMA 392J 50
C6	Electrolytic 0.33 25V	CSSA R33M 25
C7	Electrolytic 0.33 25V	CSSA R33M 25
C8	Styrol 680p 50V	CQSA 681J 50
C9	Mylar 0.022 50V	CQMA 223J 50
C10	Mylar 0.0039 50V	CQMA 392J 50
C11	Electrolytic 470 35V	CEA 471P 35
C12	Electrolytic 33 25V	CEA 330P 25
C13	Electrolytic 1 25V	CSSA 010M 25
C14	Electrolytic 1 25V	CSSA 010M 25
C15	Electrolytic 1 25V	CSSA 010M 25
C16	Electrolytic 1 25V	CSSA 010M 25
C17	Electrolytic 4.7 10V	CSSA 4R7M 10
C18	Electrolytic 4.7 10V	CSSA 4R7M 10
C19	Electrolytic 4.7 10V	CSSA 4R7M 10
C20	Electrolytic 4.7 10V	CSSA 4R7M 10
C21	Electrolytic 1 10V	CSSA 010M 10
C22	Electrolytic 1 10V	CSSA 010M 10
C23	Electrolytic 1 10V	CSSA 010M 10
C24	Electrolytic 1 10V	CSSA 010M 10
C25	Mylar 0.001 50V	CQMA 102J 50
C26	Mylar 0.001 50V	CQMA 102J 50
C27	Mylar 0.022 50V	CQMA 223J 50
C28	Mylar 0.001 50V	CQMA 102J 50
C29	Mylar 0.001 50V	CQMA 102J 50
C30	Electrolytic 1 10V	CSSA 010M 10
C31	Electrolytic 1 10V	CSSA 010M 10
C32	Electrolytic 1 10V	CSSA 010M 10
C33	Electrolytic 1 10V	CSSA 010M 10
C34	Electrolytic 1 10V	CSSA 010M 10
C35	Electrolytic 0.47 10V	CSSA R47M 10
C36	Mylar 0.022 50V	CQMA 223J 50
C37	Electrolytic 0.22 10V	CSSA R22M 10
C38	Electrolytic 1 10V	CSSA 010M 10
C39	Electrolytic 2.2 10V	CSSA 2R2M 10
C40	Electrolytic 1 10V	CSSA 010M 10
C41	Electrolytic 2.2 10V	CSSA 2R2M 10
C42	Electrolytic 0.47 10V	CSSA R47M 10
C43	Electrolytic 1 10V	CSSA 010M 10
C44	Electrolytic 1 10V	CSSA 010M 10
C45	Electrolytic 1 10V	CSSA 010M 10
C46	Electrolytic 1 10V	CSSA 010M 10
C47	Electrolytic 1 25V	CSSA 010M 25
C48	Electrolytic 1 25V	CSSA 010M 25

Symbol	Description	Part No.
C49	Electrolytic 1 25V	CSSA 010M 25
C50	Electrolytic 1 25V	CSSA 010M 25
C51	Electrolytic 33 16V	CEA 330P 16
C52	Electrolytic (N.P.) 1 50V	ACH-305
C53	Ceramic 100p 50V	CCDSL 101K 50

RESISTORS

Symbol	Description	Part No.
R1	Carbon film 36k	RD%PS 363J
R2	Carbon film 43k	RD%PS 433J
R3	Carbon film 120k	RD%PS 124J
R4	Carbon film 120k	RD%PS 124J
R5	Carbon film 43k	RD%PS 433J
R6	Carbon film 36k	RD%PS 363J
R7	Carbon film 68 1/2W	RD%PS 680J
R8	Carbon film 36k	RD%PS 363J
R9	Carbon film 43k	RD%PS 433J
R10	Carbon film 43k	RD%PS 433J
R11	Carbon film 36k	RD%PS 363J
R12	Metal oxide 220 1W	RS1P 221J
R13	Carbon film 220k	RD%PS 224J
R14	Carbon film 220k	RD%PS 224J
R15	Carbon film 220k	RD%PS 224J
R16	Carbon film 220k	RD%PS 224J
R17	Carbon film 30k	RD%PS 303J
R18	Carbon film 100k	RD%PS 104J
R19	Carbon film 100k	RD%PS 104J
R20	Carbon film 100k	RD%PS 104J
R21	Carbon film 100k	RD%PS 104J
R22	Carbon film 100k	RD%PS 104J
R23	Carbon film 100k	RD%PS 104J
R24	Carbon film 100k	RD%PS 104J
R25	Carbon film 100k	RD%PS 104J
R26	Carbon film 1k	RD%PS 102J
R27	Carbon film 1k	RD%PS 102J
R28	Carbon film 1k	RD%PS 102J
R29	Carbon film 1k	RD%PS 102J
R30	Carbon film 3.9k	RD%PS 392J
R31	Carbon film 3.9k	RD%PS 392J
R32	Carbon film 3.9k	RD%PS 392J
R33	Carbon film 3.9k	RD%PS 392J
R34	Carbon film 10k	RD%PS 103J
R35	Carbon film 10k	RD%PS 103J
R36	Carbon film 10k	RD%PS 103J
R37	Carbon film 10k	RD%PS 103J
R38	Carbon film 27k	RD%PS 273J
R39	Carbon film 27k	RD%PS 273J
R40	Carbon film 6.8k	RD%PS 682J

Symbol	Description	Part No.
R41	Carbon film 6.8k	RD%PS 682J
R42	Carbon film 1M	RD%PS 105J
R43	Carbon film 1M	RD%PS 105J
R44	Carbon film 10k	RD%PS 103J
R45	Vacancy
R46	Carbon film 1M	RD%PS 105J
R47	Carbon film 1M	RD%PS 105J
R48	Carbon film 10k	RD%PS 103J
R49	Carbon film 220k	RD%PS 224J
R50	Carbon film 10k	RD%PS 103J
R51	Carbon film 27k	RD%PS 273J
R52	Carbon film 10k	RD%PS 103J
R53	Carbon film 10k	RD%PS 103J
R54	Carbon film 470k	RD%PS 474J
R55	Carbon film 10k	RD%PS 103J
R56	Carbon film 27k	RD%PS 273J
R57	Carbon film 270k	RD%PS 274J
R58	Carbon film 43k	RD%PS 433J
R59	Carbon film 30k	RD%PS 303J
R60	Vacancy
R61	Carbon film 470k	RD%PS 474J
R62	Carbon film 1M	RD%PS 105J
R63	Carbon film 470k	RD%PS 474J
R64	Carbon film 470k	RD%PS 474J
R65	Carbon film 680	RD%PS 681J
R66	Carbon film 51k	RD%PS 513J
R67	Carbon film 1M	RD%PS 105J
R68	Carbon film 1M	RD%PS 105J
R69	Carbon film 1M	RD%PS 105J
R70	Carbon film 1M	RD%PS 105J
R71	Carbon film 1k	RD%PS 102J
R74	Carbon film 10k	RD%PS 103J
R75	Carbon film 10k	RD%PS 103J
R76	Carbon film 10k	RD%PS 103J
R77	Carbon film 10k	RD%PS 103J
R78	Carbon film 220k	RD%PS 224J
R79	Carbon film 220k	RD%PS 224J
R80	Carbon film 220k	RD%PS 224J
R81	Carbon film 220k	RD%PS 224J
VR1	Variable (semi-fixed) 1.5M-B	ACP-048

Symbol	Description	Part No.
Q3	Transistor	2SC1682-V or BL (2SC1312-G or H)
Q4	Transistor	2SC1682-V or BL (2SC1312-G or H)
Q5	Transistor	2SC1682-V or BL (2SC1312-G or H)
Q6	Transistor	2SC1682-V or BL (2SC1312-G or H)
Q7	Transistor	2SC1682-V or BL (2SC1312-G or H)
Q8	Transistor	2SC1682-V or BL (2SC1312-G or H)
Q9	Transistor	2SC1682-V or BL (2SC1312-G or H)
Q10	Transistor	2SC1682-V or BL (2SC1312-G or H)
Q11	Transistor	2SC1682-V or BL (2SC1312-G or H)
Q12	Transistor	2SC1682-V or BL (2SC1312-G or H)
Q13	Transistor	2SC1682-V or BL (2SC1312-G or H)
Q14	Transistor	2SC1682-V or BL (2SC1312-G or H)
Q15	FET	2SK40V-2 or 3 (2SK30AP-2 or 3)
Q16	FET	2SK40V-2 or 3 (2SK30AP-2 or 3)
D1	Diode	1S2473
D2	Varistor	MV-12
D3	Varistor	MV-12
D4	Diode	1S2473
D5	Diode	1S2473
D6	Zener diode	WZ-100
D7	Zener diode	WZ-081
D8	Diode	1S2473
D9	Diode	1S2473
D10	Zener diode	WZ-100

SEMICONDUCTORS

Symbol	Description	Part No.
IC1	IC	M51651P
IC2	IC	CX-049
IC3	IC	CX-718D
Q1	Transistor	2SC1682-V or BL (2SC1312-G or H)
Q2	Transistor	2SC1682-V or BL (2SC1312-G or H)

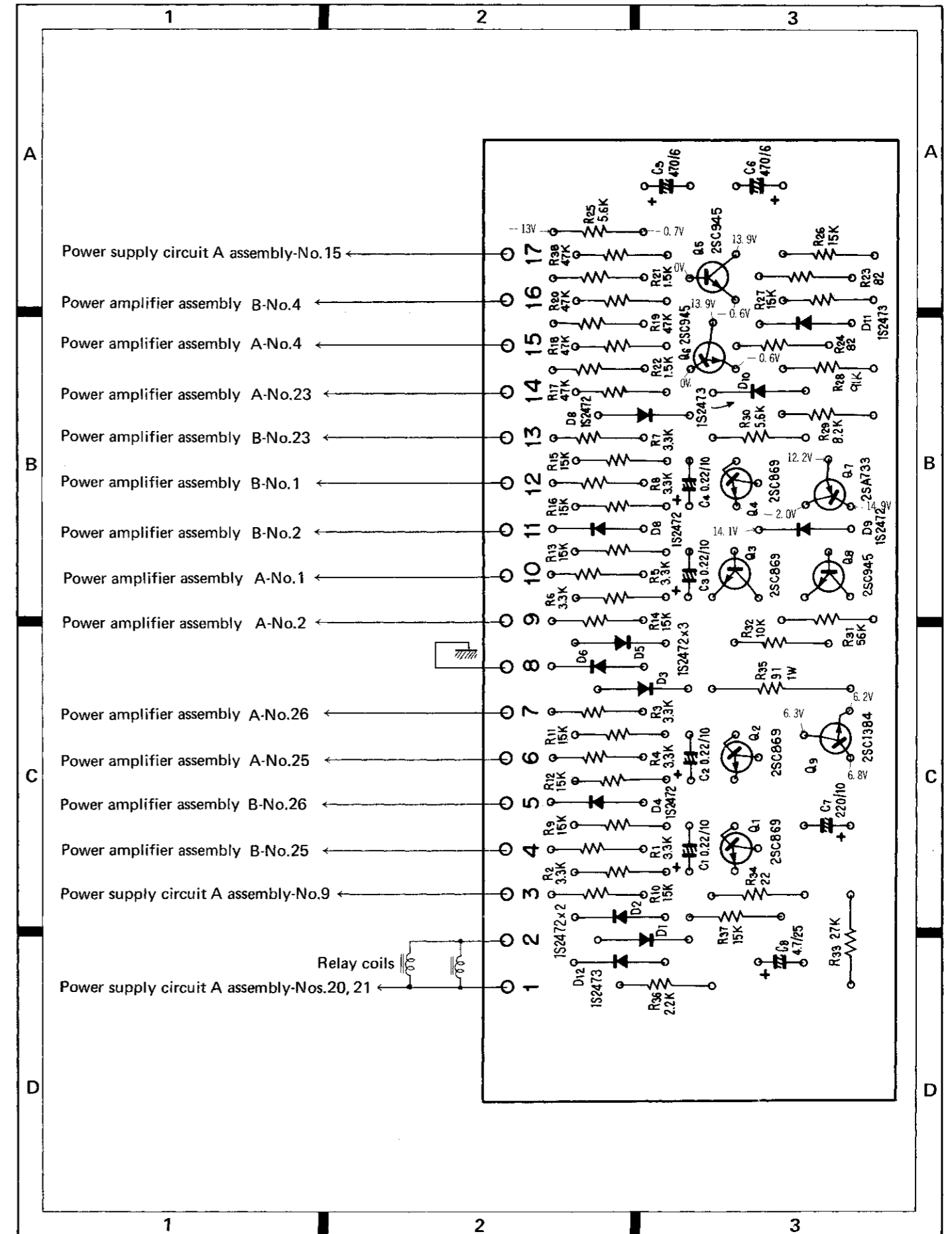
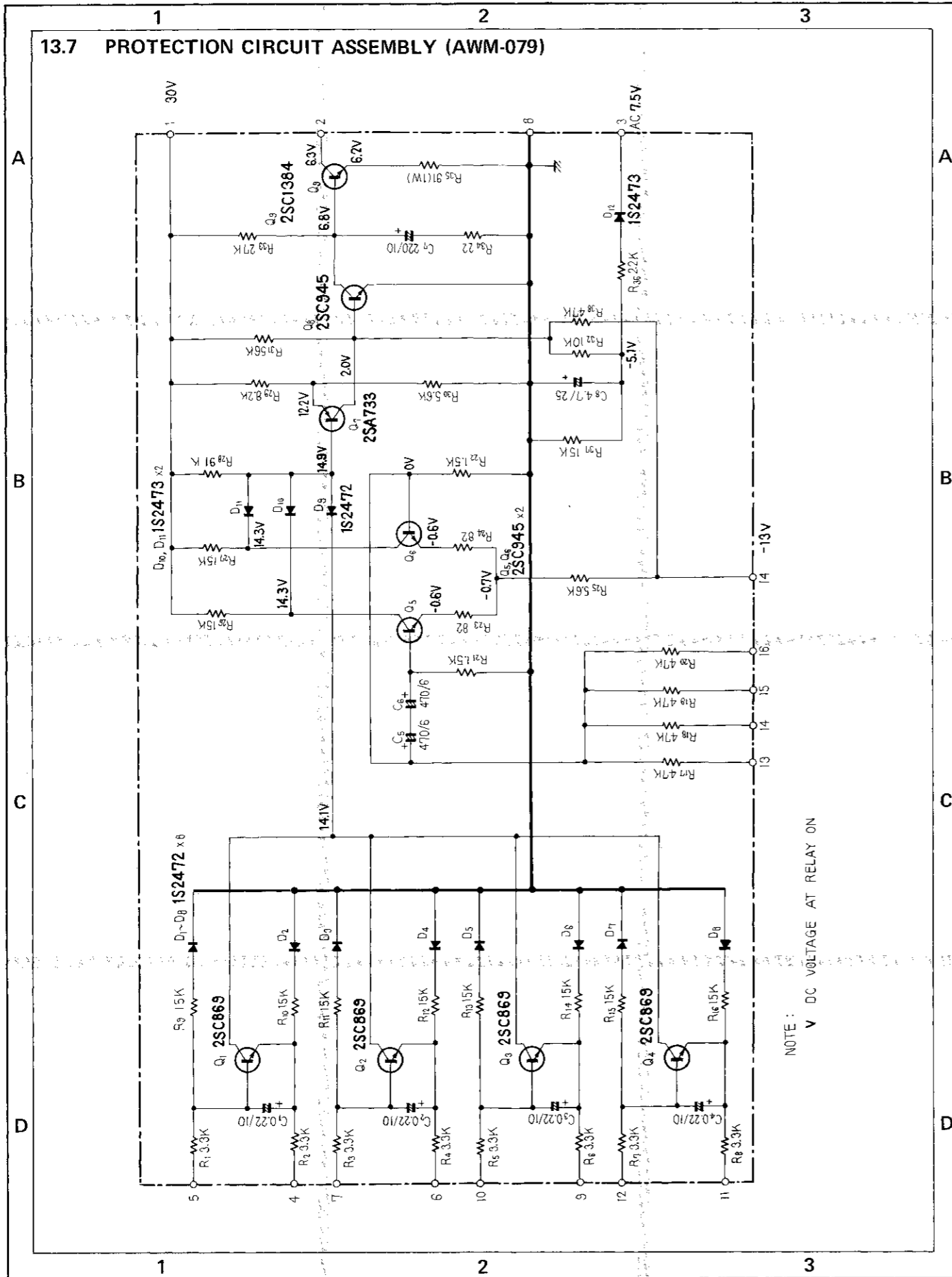

Parts List of Protection Circuit Assembly (AWM-079)

CAPACITORS

Symbol	Description	Part No.
C1	Electrolytic 0.22 10V	CSSA R22M 10
C2	Electrolytic 0.22 10V	CSSA R22M 10
C3	Electrolytic 0.22 10V	CSSA R22M 10
C4	Electrolytic 0.22 10V	CSSA R22M 10
C5	Electrolytic 470 6V	CEA 471P 6
C6	Electrolytic 470 6V	CEA 471P 6
C7	Electrolytic 220 10V	CEA 221P 10
C8	Electrolytic 4.7 25V	CEA 4R7P 25

RESISTORS

Symbol	Description	Part No.
R1	Carbon film 3.3k	RD4PM 332J
R2	Carbon film 3.3k	RD4PM 332J
R3	Carbon film 3.3k	RD4PM 332J
R4	Carbon film 3.3k	RD4PM 332J
R5	Carbon film 3.3k	RD4PM 332J
R6	Carbon film 3.3k	RD4PM 332J
R7	Carbon film 3.3k	RD4PM 332J
R8	Carbon film 3.3k	RD4PM 332J
R9	Carbon film 15k	RD4PM 153J
R10	Carbon film 15k	RD4PM 153J
R11	Carbon film 15k	RD4PM 153J
R12	Carbon film 15k	RD4PM 153J
R13	Carbon film 15k	RD4PM 153J
R14	Carbon film 15k	RD4PM 153J
R15	Carbon film 15k	RD4PM 153J
R16	Carbon film 15k	RD4PM 153J
R17	Carbon film 47k	RD4PM 473J
R18	Carbon film 47k	RD4PM 473J
R19	Carbon film 47k	RD4PM 473J
R20	Carbon film 47k	RD4PM 473J
R21	Carbon film 1.5k	RD4PM 152J
R22	Carbon film 1.5k	RD4PM 152J
R23	Carbon film 82	RD4PM 820J
R24	Carbon film 82	RD4PM 820J
R25	Carbon film 5.6k	RD4PM 562J
R26	Carbon film 15k	RD4PM 153J
R27	Carbon film 15k	RD4PM 153J
R28	Carbon film 91k	RD4PM 913J
R29	Carbon film 8.2k	RD4PM 822J
R30	Carbon film 5.6k	RD4PM 562J
R31	Carbon film 56k	RD4PM 563J
R32	Carbon film 10k	RD4PM 103J
R33	Carbon film 27k	RD4PM 273J
R34	Carbon film 22	RD4PM 220J
R35	Metal oxide 91 1W	RS1P 910J

Symbol	Description	Part No.
R36	Carbon film 2.2k	RD4PM 222J
R37	Carbon film 15k	RD4PM 153J
R38	Carbon film 47k	RD4PM 473J

SEMICONDUCTORS

Symbol	Description	Part No.
Q1	Transistor	2SC869-C, B or D (2SC1515K)
Q2	Transistor	2SC869-C, B or D (2SC1515K)
Q3	Transistor	2SC869-C, B or D (2SC1515K)
Q4	Transistor	2SC869-C, B or D (2SC1515K)
Q5	Transistor	2SC945-R or Q
Q6	Transistor	2SC945-R or Q
Q7	Transistor	2SA733-R or Q
Q8	Transistor	2SC945-R or Q
Q9	Transistor	2SC1384-Q or R
D1	Diode	1S2472
D2	Diode	1S2472
D3	Diode	1S2472
D4	Diode	1S2472
D5	Diode	1S2472
D6	Diode	1S2472
D7	Diode	1S2472
D8	Diode	1S2472
D9	Diode	1S2472
D10	Diode	1S2473
D11	Diode	1S2473
D12	Diode	1S2473

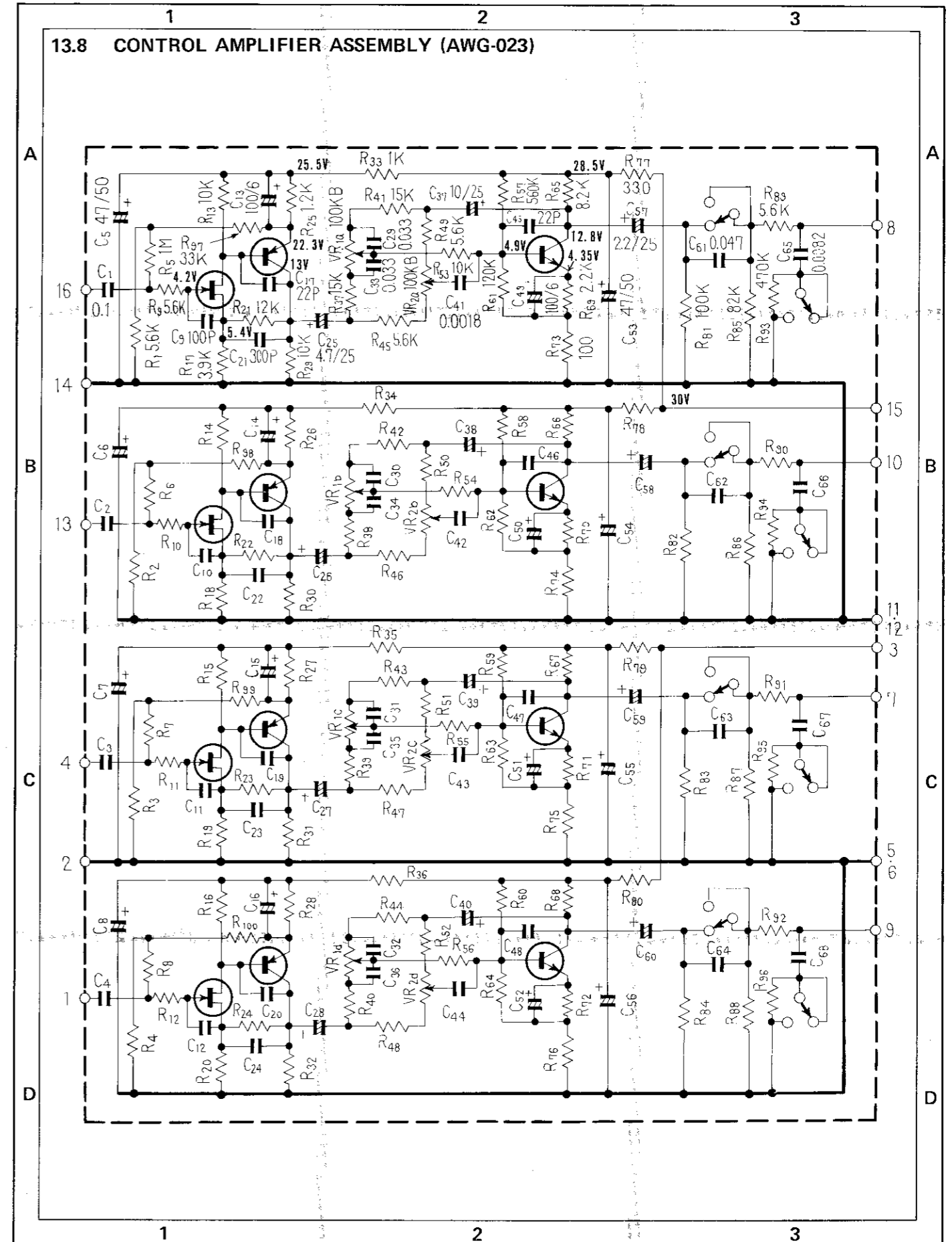

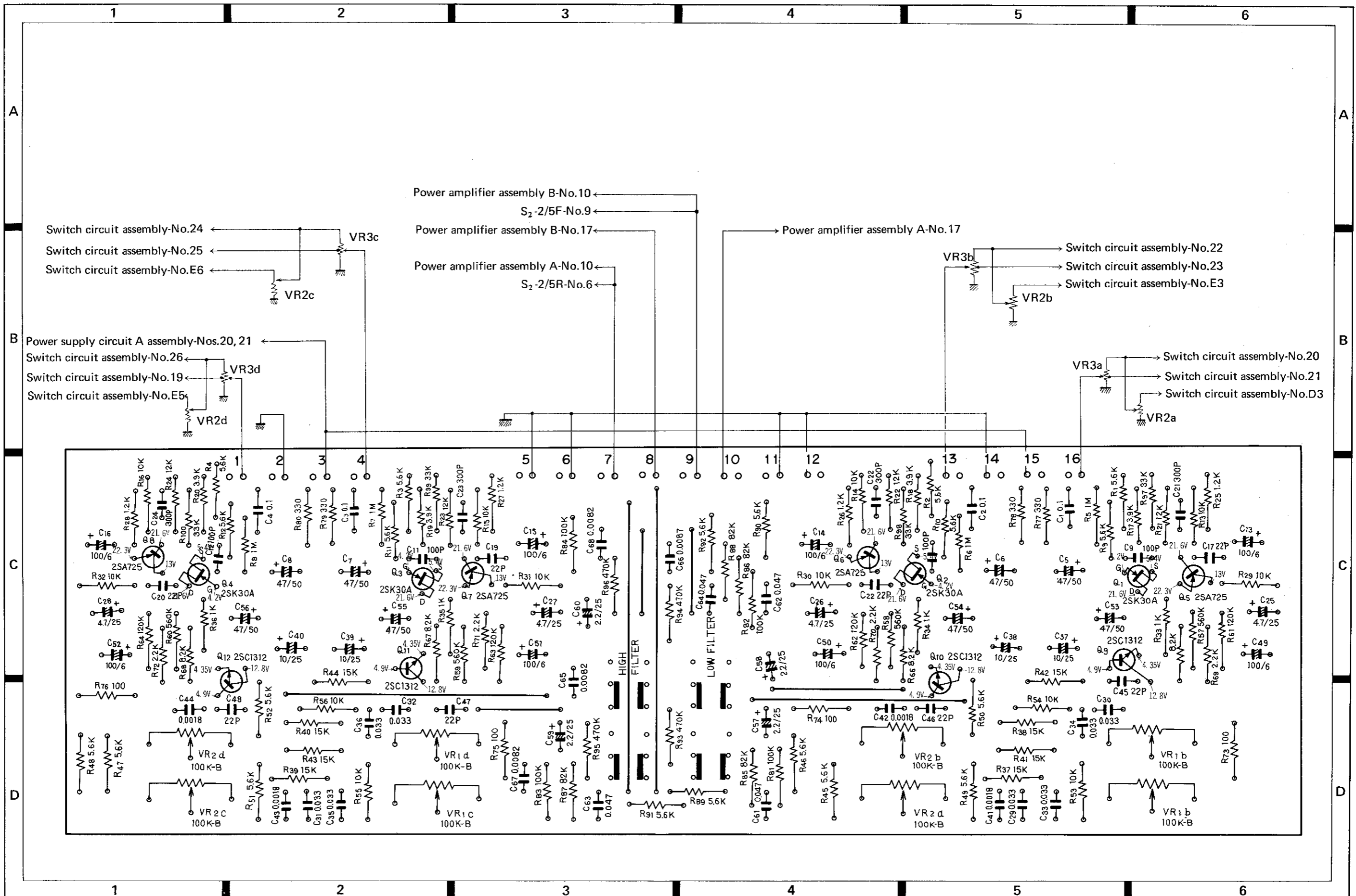

Parts List of Control Amplifier Assembly (AWG-023)

CAPACITORS

Symbol	Description			Part No.
C1	Mylar	0.1	50V	CQMA 104K 50
C2	Mylar	0.1	50V	CQMA 104K 50
C3	Mylar	0.1	50V	CQMA 104K 50
C4	Mylar	0.1	50V	CQMA 104K 50
C5	Electrolytic	47	50V	CEA 470P 50
C6	Electrolytic	47	50V	CEA 470P 50
C7	Electrolytic	47	50V	CEA 470P 50
C8	Electrolytic	47	50V	CEA 470P 50
C9	Ceramic	100p	50V	CCDSL 101K 50
C10	Ceramic	100p	50V	CCDSL 101K 50
C11	Ceramic	100p	50V	CCDSL 101K 50
C12	Ceramic	100p	50V	CCDSL 101K 50
C13	Electrolytic	100	6V	ACH-311-0
C14	Electrolytic	100	6V	ACH-311-0
C15	Electrolytic	100	6V	ACH-311-0
C16	Electrolytic	100	6V	ACH-311-0
C17	Ceramic	22p	50V	CCDSL 220K 50
C18	Ceramic	22p	50V	CCDSL 220K 50
C19	Ceramic	22p	50V	CCDSL 220K 50
C20	Ceramic	22p	50V	CCDSL 220K 50
C21	Ceramic	300p	50V	CKDYB 301K 50
C22	Ceramic	300p	50V	CKDYB 301K 50
C23	Ceramic	300p	50V	CKDYB 301K 50
C24	Ceramic	300p	50V	CKDYB 301K 50
C25	Electrolytic	4.7	25V	CSZA 4R7P 25
C26	Electrolytic	4.7	25V	CSZA 4R7P 25
C27	Electrolytic	4.7	25V	CSZA 4R7P 25
C28	Electrolytic	4.7	25V	CSZA 4R7P 25
C29	Mylar	0.033	50V	CQMA 333K 50
C30	Mylar	0.033	50V	CQMA 333K 50
C31	Mylar	0.033	50V	CQMA 333K 50
C32	Mylar	0.033	50V	CQMA 333K 50
C33	Mylar	0.033	50V	CQMA 333K 50
C34	Mylar	0.033	50V	CQMA 333K 50
C35	Mylar	0.033	50V	CQMA 333K 50
C36	Mylar	0.033	50V	CQMA 333K 50
C37	Electrolytic	10	25V	CEA 100P 25
C38	Electrolytic	10	25V	CEA 100P 25
C39	Electrolytic	10	25V	CEA 100P 25
C40	Electrolytic	10	25V	CEA 100P 25
C41	Mylar	0.0018	50V	CQMA 182K 50
C42	Mylar	0.0018	50V	CQMA 182K 50
C43	Mylar	0.0018	50V	CQMA 182K 50
C44	Mylar	0.0018	50V	CQMA 182K 50
C45	Ceramic	22p	50V	CCDSL 220K 50

Symbol	Description			Part No.
C46	Ceramic	22p	50V	CCDSL 220K 50
C47	Ceramic	22p	50V	CCDSL 220K 50
C48	Ceramic	22p	50V	CCDSL 220K 50
C49	Electrolytic	100	6V	CEA 101P 6
C50	Electrolytic	100	6V	CEA 101P 6
C51	Electrolytic	100	6V	CEA 101P 6
C52	Electrolytic	100	6V	CEA 101P 6
C53	Electrolytic	47	50V	CEA 470P 50
C54	Electrolytic	47	50V	CEA 470P 50
C55	Electrolytic	47	50V	CEA 470P 50
C56	Electrolytic	47	50V	CEA 470P 50
C57	Electrolytic	2.2	25V	CSZA 2R2P 25
C58	Electrolytic	2.2	25V	CSZA 2R2P 25
C59	Electrolytic	2.2	25V	CSZA 2R2P 25
C60	Electrolytic	2.2	25V	CSZA 2R2P 25
C61	Mylar	0.047	50V	CQMA 473K 50
C62	Mylar	0.047	50V	CQMA 473K 50
C63	Mylar	0.047	50V	CQMA 473K 50
C64	Mylar	0.047	50V	CQMA 473K 50
C65	Mylar	0.0082	50V	CQMA 822K 50
C66	Mylar	0.0082	50V	CQMA 822K 50
C67	Mylar	0.0082	50V	CQMA 822K 50
C68	Mylar	0.0082	50V	CQMA 822K 50

SWITCHES

Symbol	Description	Part No.
S1	Push switch (LOW FILTER)	ASG-019
S2	Push switch (HIGH FILTER)	ASG-019

RESISTORS

Symbol	Description			Part No.
R1	Carbon film	5.6k		RD%PM 562J
R2	Carbon film	5.6k		RD%PM 562J
R3	Carbon film	5.6k		RD%PM 562J
R4	Carbon film	5.6k		RD%PM 562J
R5	Carbon film	1M		RD%PM 105J
R6	Carbon film	1M		RD%PM 105J
R7	Carbon film	1M		RD%PM 105J
R8	Carbon film	1M		RD%PM 105J
R9	Carbon film	5.6k		RD%PM 562J
R10	Carbon film	5.6k		RD%PM 562J
R11	Carbon film	5.6k		RD%PM 562J
R12	Carbon film	5.6k		RD%PM 562J
R13	Carbon film	10k		RD%PS 103J
R14	Carbon film	10k		RD%PS 103J
R15	Carbon film	10k		RD%PS 103J
R16	Carbon film	10k		RD%PS 103J
R17	Carbon film	3.9k		RD%PM 392J
R18	Carbon film	3.9k		RD%PM 392J
R19	Carbon film	3.9k		RD%PM 392J
R20	Carbon film	3.9k		RD%PM 392J

Symbol	Description			Part No.
R21	Carbon film	12k		RD%PS 123J
R22	Carbon film	12k		RD%PS 123J
R23	Carbon film	12k		RD%PS 123J
R24	Carbon film	12k		RD%PS 123J
R25	Carbon film	1.2k		RD%PM 122J
R26	Carbon film	1.2k		RD%PM 122J
R27	Carbon film	1.2k		RD%PM 122J
R28	Carbon film	1.2k		RD%PM 122J
R29	Carbon film	10k		RD%PM 103J
R30	Carbon film	10k		RD%PM 103J
R31	Carbon film	10k		RD%PM 103J
R32	Carbon film	10k		RD%PM 103J
R33	Carbon film	1k		RD%PM 102J
R34	Carbon film	1k		RD%PM 102J
R35	Carbon film	1k		RD%PM 102J
R36	Carbon film	1k		RD%PM 102J
R37	Carbon film	15k		RD%PM 153J
R38	Carbon film	15k		RD%PM 153J
R39	Carbon film	15k		RD%PM 153J
R40	Carbon film	15k		RD%PM 153J
R41	Carbon film	15k		RD%PM 153J
R42	Carbon film	15k		RD%PM 153J
R43	Carbon film	15k		RD%PM 153J
R44	Carbon film	15k		RD%PM 153J
R45	Carbon film	5.6k		RD%PM 562J
R46	Carbon film	5.6k		RD%PM 562J
R47	Carbon film	5.6k		RD%PM 562J
R48	Carbon film	5.6k		RD%PM 562J
R49	Carbon film	5.6k		RD%PM 562J
R50	Carbon film	5.6k		RD%PM 562J
R51	Carbon film	5.6k		RD%PM 562J
R52	Carbon film	5.6k		RD%PM 562J
R53	Carbon film	10k		RD%PM 103J
R54	Carbon film	10k		RD%PM 103J
R55	Carbon film	10k		RD%PM 103J
R56	Carbon film	10k		RD%PM 103J
R57	Carbon film	560k		RD%PS 564JNL
R58	Carbon film	560k		RD%PS 564JNL
R59	Carbon film	560k		RD%PS 564JNL
R60	Carbon film	560k		RD%PS 564JNL
R61	Carbon film	120k		RD%PS 124JNL
R62	Carbon film	120k		RD%PS 124JNL
R63	Carbon film	120k		RD%PS 124JNL
R64	Carbon film	120k		RD%PS 124JNL
R65	Carbon film	8.2k		RD%PM 822J
R66	Carbon film	8.2k		RD%PM 822J
R67	Carbon film	8.2k		RD%PM 822J
R68	Carbon film	8.2k		RD%PM 822J
R69	Carbon film	2.2k		RD%PM 222J
R70	Carbon film	2.2k		RD%PM 222J

Symbol	Description			Part No.
R71	Carbon film	2.2k		RD%PM 222J
R72	Carbon film	2.2k		RD%PM 222J
R73	Carbon film	100		RD%PM 101J
R74	Carbon film	100		RD%PM 101J
R75	Carbon film	100		RD%PM 101J
R76	Carbon film	100		RD%PM 101J
R77	Carbon film	330		RD%PM 331J
R78	Carbon film	330		RD%PM 331J
R79	Carbon film	330		RD%PM 331J
R80	Carbon film	330		RD%PM 331J
R81	Carbon film	100k		RD%PM 104J
R82	Carbon film	100k		RD%PM 104J
R83	Carbon film	100k		RD%PM 104J
R84	Carbon film	100k		RD%PM 104J
R85	Carbon film	82k		RD%PM 823J
R86	Carbon film	82k		RD%PM 823J
R87	Carbon film	82k		RD%PM 823J
R88	Carbon film	82k		RD%PM 823J
R89	Carbon film	5.6k		RD%PM 562J
R90	Carbon film	5.6k		RD%PM 562J
R91	Carbon film	5.6k		RD%PM 562J
R92	Carbon film	5.6k		RD%PM 562J
R93	Carbon film	470k		RD%PM 474J
R94	Carbon film	470k		RD%PM 474J
R95	Carbon film	470k		RD%PM 474J
R96	Carbon film	470k		RD%PM 474J
R97	Carbon film	33k		RD%PM 333J
R98	Carbon film	33k		RD%PM 333J
R99	Carbon film	33k		RD%PM 333J
R100	Carbon film	33k		RD%PM 333J
VR1	Variable resistor dual 100k-B			ACV-110-0
VR2	Variable resistor dual 100k-B			ACV-110-0
VR3	Variable resistor dual 100k-B			ACV-110-0
VR4	Variable resistor dual 100k-B			ACV-110-0

SEMICONDUCTORS

Symbol	Description	Part No.
Q1	FET	2SK30A-Y or GR
Q2	FET	2SK30A-Y or GR
Q3	FET	2SK30A-Y or GR
Q4	FET	2SK30A-Y or GR
Q5	Transistor	2SA725-F or G
Q6	Transistor	2SA725-F or G
Q7	Transistor	2SA725-F or G
Q8	Transistor	2SA725-F or G
Q9	Transistor	2SC1312-F or G
Q10	Transistor	2SC1312-F or G
Q11	Transistor	2SC1312-F or G
Q12	Transistor	2SC1312-F or G

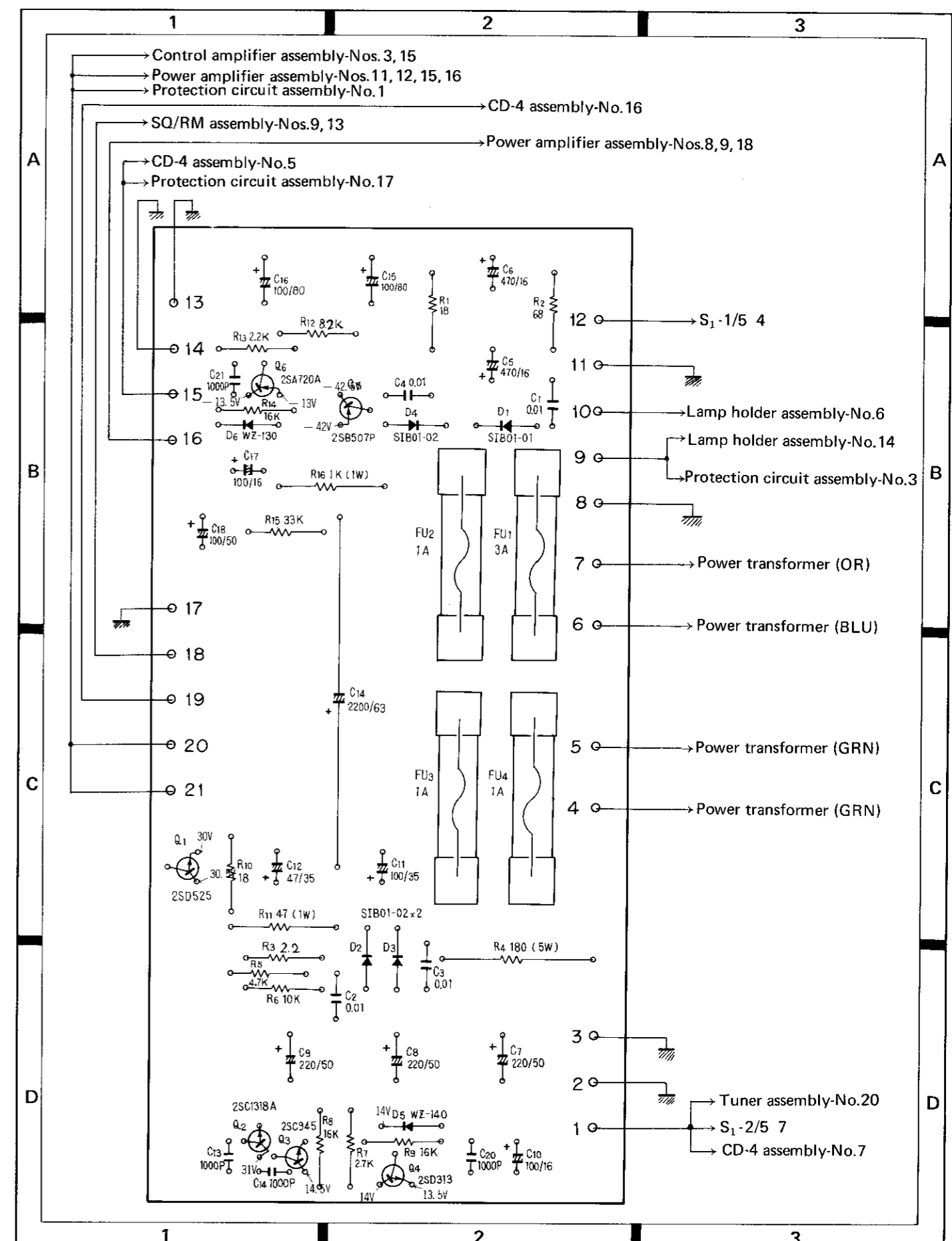
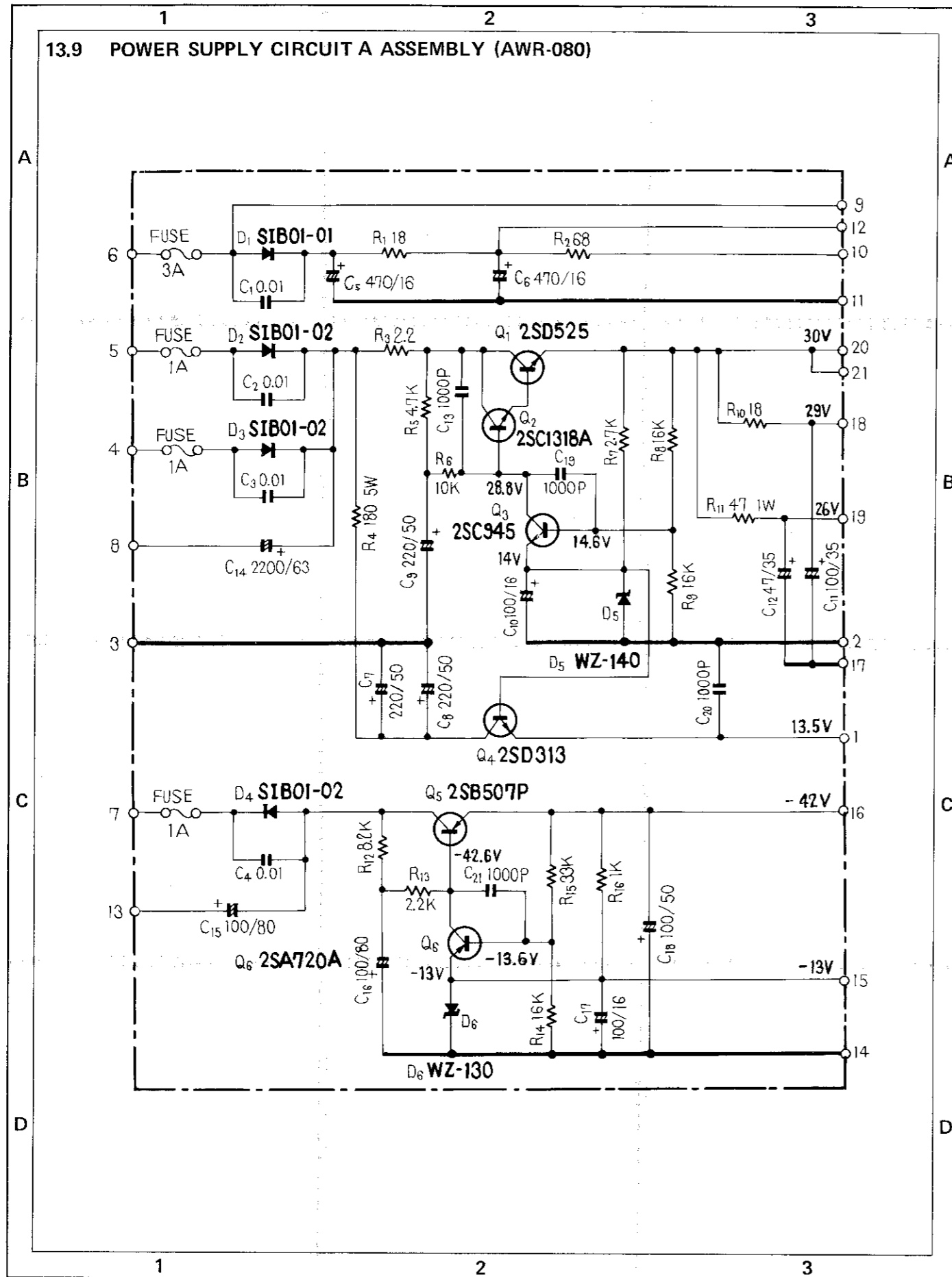

Parts List of Power Supply Circuit A Assembly (AWR-080)

CAPACITORS

Symbol	Description	Part No.
C1	Ceramic 0.01 150V	ACG-004
C2	Ceramic 0.01 150V	ACG-004
C3	Ceramic 0.01 150V	ACG-004
C4	Ceramic 0.01 150V	ACG-004
C5	Electrolytic 470 16V	CEA 471P 16
C6	Electrolytic 470 16V	CEA 471P 16
C7	Electrolytic 220 50V	CEA 221P 50
C8	Electrolytic 220 50V	CEA 221P 50
C9	Electrolytic 220 50V	CEA 221P 50
C10	Electrolytic 100 16V	CEA 101P 16
C11	Electrolytic 100 35V	CEA 101P 35
C12	Electrolytic 47 35V	CEA 470P 35
C13	Ceramic 0.01 50V	CKDYF 103Z 50
C14	Electrolytic 2,200 63V	CEB 222P 63
C15	Electrolytic 100 80V	CEA 101P 80
C16	Electrolytic 100 80V	CEA 101P 80
C17	Electrolytic 100 16V	CEA 101P 16
C18	Electrolytic 100 50V	CEA 101P 50
C19	Ceramic 0.01 50V	CKDYF 103Z 50
C20	Ceramic 0.01 50V	CKDYF 103Z 50
C21	Ceramic 0.01 50V	CKDYF 103Z 50

SEMICONDUCTORS

Symbol	Description	Part No.
Q1	Transistor	2SD525-O or R
Q2	Transistor	2SC1318A-Q or R
Q3	Transistor	2SC945-R or Q
Q4	Transistor	2SD313-E or D
Q5	Transistor	2SB507P-E or D
Q6	Transistor	2SA720A-Q or R
D1	Diode	SIB01-01 (1S1885)
D2	Diode	SIB01-02 (1S1886)
D3	Diode	SIB01-02 (1S1886)
D4	Diode	SIB01-02 (1S1886)
D5	Zener diode	WZ-140
D6	Zener diode	WZ-130

OTHERS

Symbol	Description	Part No.
	Tr socket	AKH-002
	Insulator wafer	AEC-043
	Fuse clip	AKR-013

RESISTORS

Symbol	Description	Part No.
R1	Carbon film 18	RD¼PS 180J
R2	Carbon film 68	RD¼PS 680J
R3	Carbon film 2.2	RD¼PS 2R2J
R4	Wire wound 180 5W	RT5B 181K
R5	Carbon film 4.7k	RD¼PS 472J
R6	Carbon film 10k	RD¼PS 103J
R7	Carbon film 2.7k	RD¼PS 272J
R8	Carbon film 16k	RD¼PS 163J
R9	Carbon film 16k	RD¼PS 163J
R10	Carbon film 18	RD¼PS 180J
R11	Metal oxide 47 1W	RS1P 470J
R12	Carbon film 8.2k	RD¼PS 822J
R13	Carbon film 2.2k	RD¼PS 222J
R14	Carbon film 16k	RD¼PS 163J
R15	Carbon film 33k	RD¼PS 333J
R16	Metal oxide 1k 1W	RS1P 102J

13.10 SWITCH CIRCUIT ASSEMBLY (AWS-048)

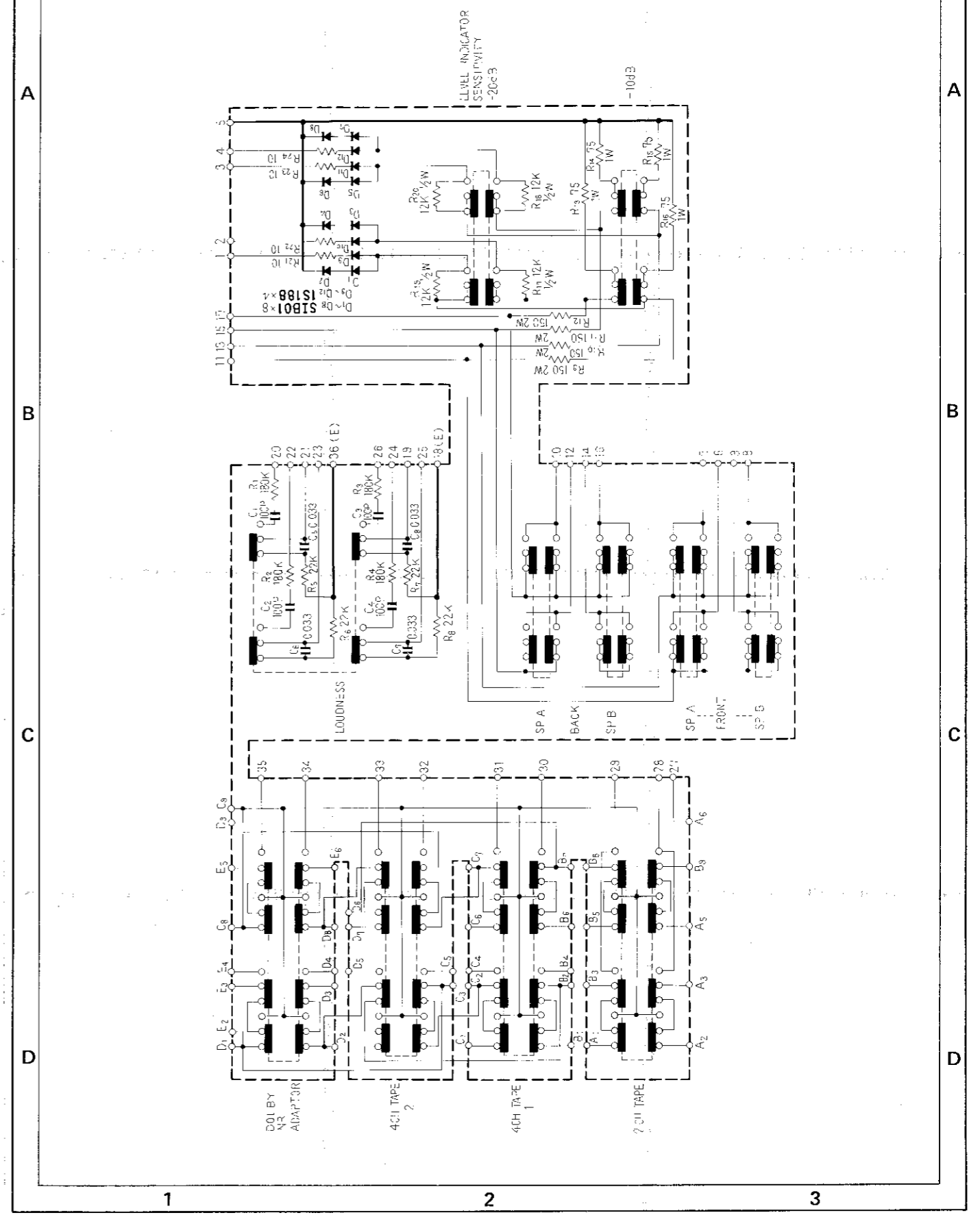

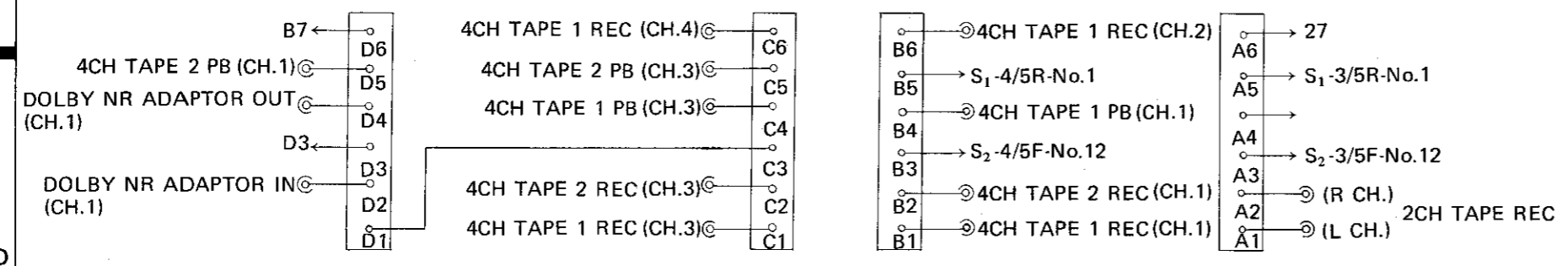
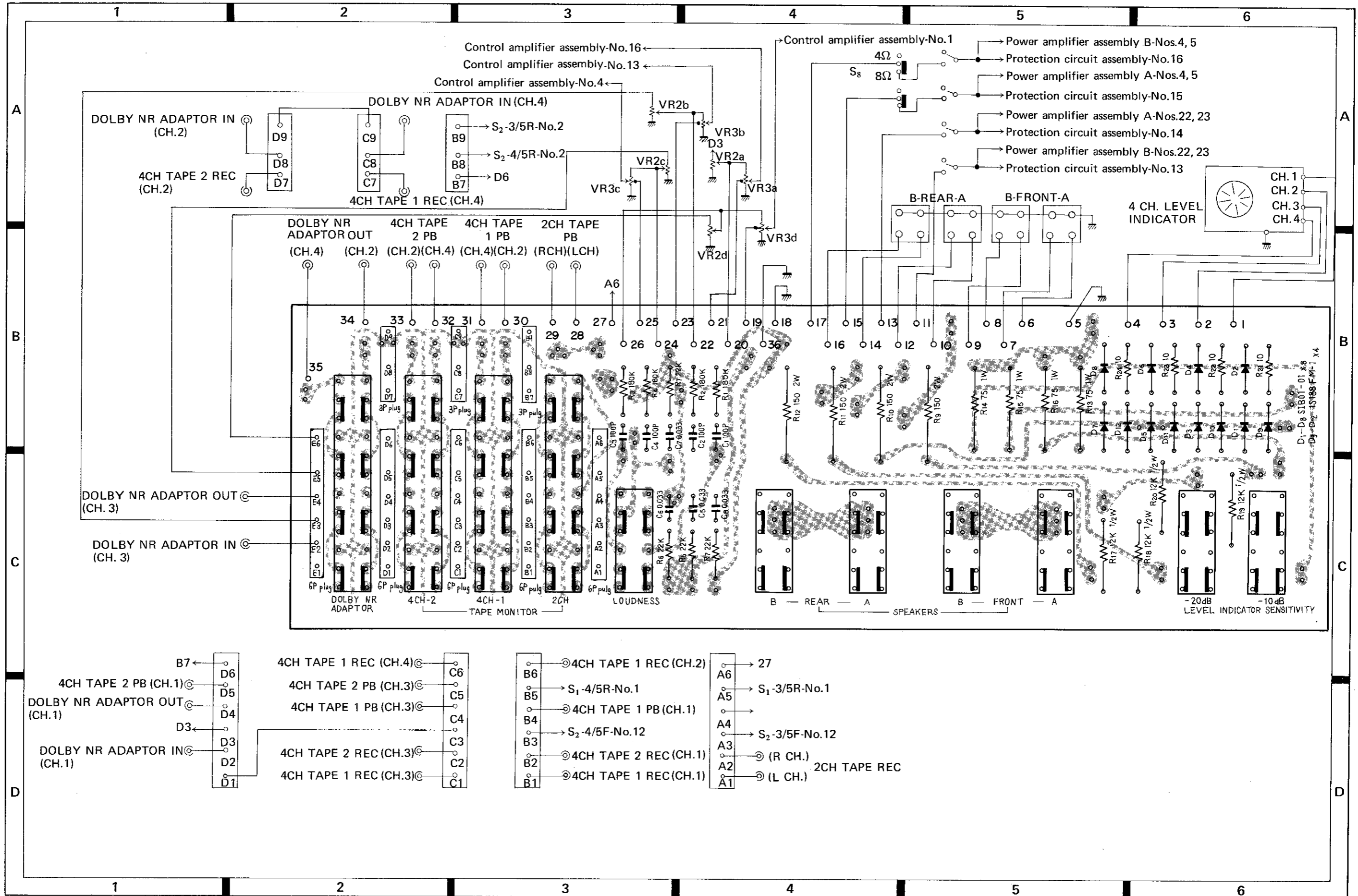

Parts List of Switch Circuit Assembly (AWS-048)

CAPACITORS

Symbol	Description	Part No.
C1	Ceramic 100p 50V	CKDSL 101K 50
C2	Ceramic 100p 50V	CKDSL 101K 50
C3	Ceramic 100p 50V	CKDSL 101K 50
C4	Ceramic 100p 50V	CKDSL 101K 50
C5	Mylar 0.033 50V	CQMA 333K 50
C6	Mylar 0.033 50V	CQMA 333K 50
C7	Mylar 0.033 50V	CQMA 333K 50
C8	Mylar 0.033 50V	CQMA 333K 50

RESISTORS

Symbol	Description	Part No.
R1	Carbon film 180k	RD%PM 184J
R2	Carbon film 180k	RD%PM 184J
R3	Carbon film 180k	RD%PM 184J
R4	Carbon film 180k	RD%PM 184J
R5	Carbon film 22k	RD%PM 223J
R6	Carbon film 22k	RD%PM 223J
R7	Carbon film 22k	RD%PM 223J
R8	Carbon film 22k	RD%PM 223J
R9	Metal oxide 150 2W	RS2P 151K
R10	Metal oxide 150 2W	RS2P 151K
R11	Metal oxide 150 2W	RS2P 151K
R12	Metal oxide 150 2W	RS2P 151K
R13	Metal oxide 75 1W	RS1P 750K
R14	Metal oxide 75 1W	RS1P 750K
R15	Metal oxide 75 1W	RS1P 750K
R16	Metal oxide 75 1W	RS1P 750K
R17	Carbon film 12k 1/2W	RD%PS 123J
R18	Carbon film 12k 1/2W	RD%PS 123J
R19	Carbon film 12k 1/2W	RD%PS 123J
R20	Carbon film 12k 1/2W	RD%PS 123J
R21	Carbon film 10	RD%PM 100J
R22	Carbon film 10	RD%PM 100J
R23	Carbon film 10	RD%PM 100J
R24	Carbon film 10	RD%PM 100J

SEMICONDUCTORS

Symbol	Description	Part No.
D1	Diode	SIB01-01
D2	Diode	SIB01-01
D3	Diode	SIB01-01
D4	Diode	SIB01-01
D5	Diode	SIB01-01
D6	Diode	SIB01-01
D7	Diode	SIB01-01
D8	Diode	SIB01-01
D9	Diode	1S188 FM-1
D10	Diode	1S188 FM-1
D11	Diode	1S188 FM-1
D12	Diode	1S188 FM-1

SWITCHES

Symbol	Description	Part No.
	Push switch (TAPE MONITOR, DOLBY NR ADP, LOUDNESS)	ASG-049
	Push switch (LEVEL INDICATOR SENSITIVITY)	ASG-047
	Push switch (SPEAKERS)	ASG-046

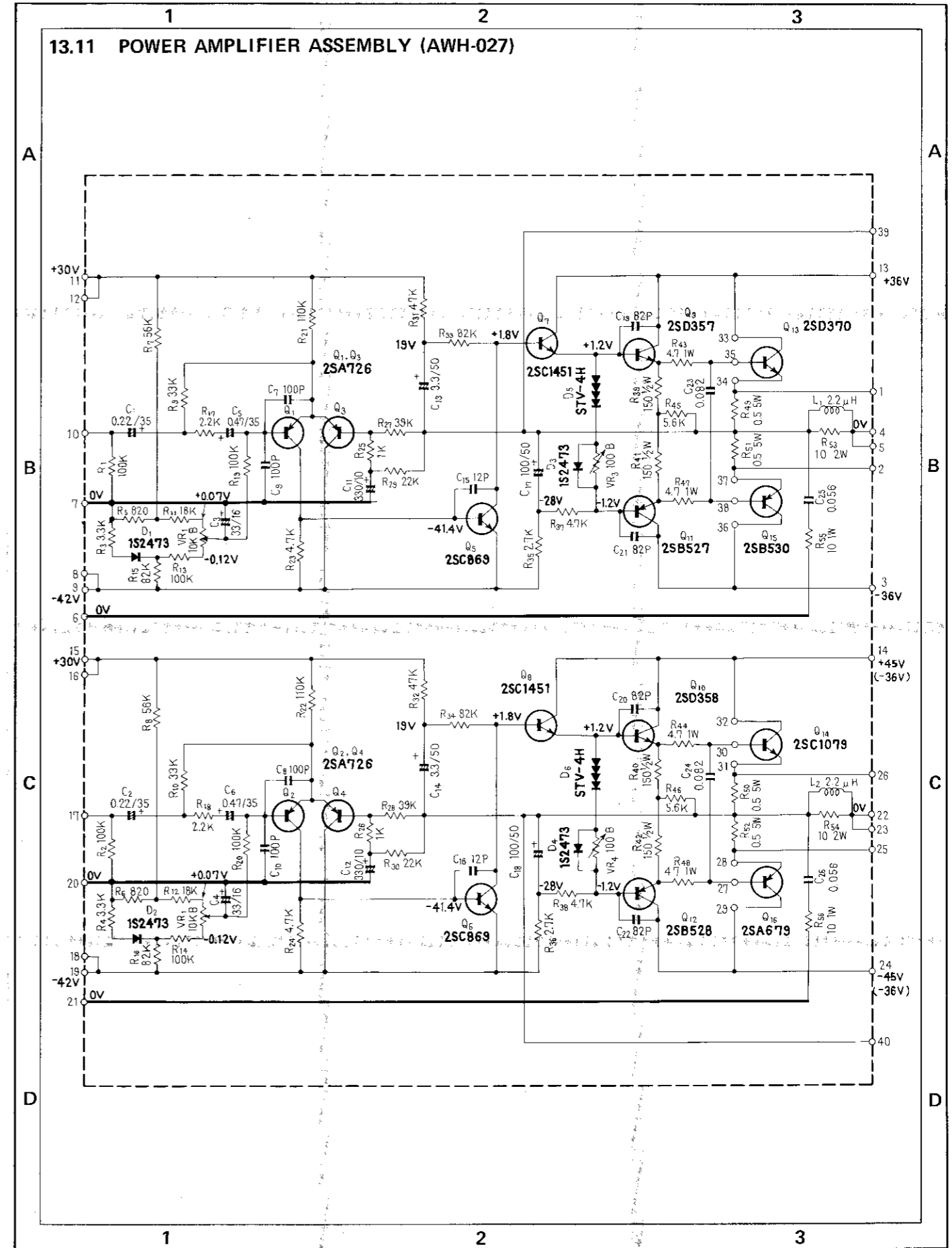

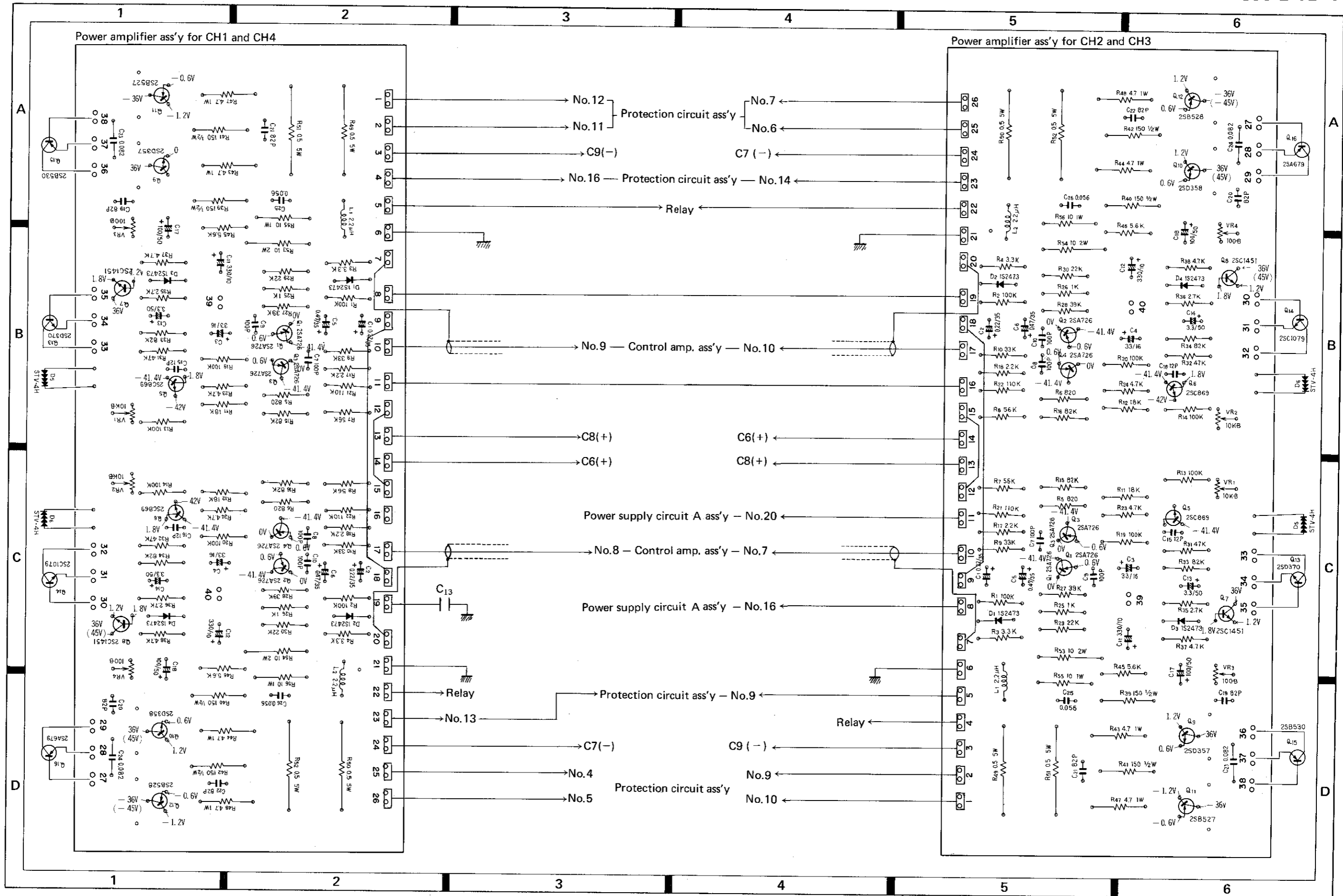

Parts List of Power Amplifier Assembly (AWH-027)

CAPACITORS

Symbol	Description	Part No.
C1	Electrolytic 0.22 35V	CSZA R22M 35
C2	Electrolytic 0.22 35V	CSZA R22M 35
C3	Electrolytic 33 16V	CEA 330P 16
C4	Electrolytic 33 16V	CEA 330P 16
C5	Electrolytic 0.47 35V	CSZA R47M 35
C6	Electrolytic 0.47 35V	CSZA R47M 35
C7	Ceramic 100p 50V	CCDSL 101K 50
C8	Ceramic 100p 50V	CCDSL 101K 50
C9	Ceramic 100p 50V	CCDSL 101K 50
C10	Ceramic 100p 50V	CCDSL 101K 50
C11	Electrolytic 330 10V	CEA 331P 10
C12	Electrolytic 330 10V	CEA 331P 10
C13	Electrolytic 3.3 50V	CEA 3R3P 50
C14	Electrolytic 3.3 50V	CEA 3R3P 50
C15	Ceramic 12p 50V	CCDSL 120K 50
C16	Ceramic 12p 50V	CCDSL 120K 50
C17	Electrolytic 100 50V	CEA 101P 50
C18	Electrolytic 100 50V	CEA 101P 50
C19	Ceramic 82p 50V	CCDSL 820K 50
C20	Ceramic 82p 50V	CCDSL 820K 50
C21	Ceramic 82p 50V	CCDSL 820K 50
C22	Ceramic 82p 50V	CCDSL 820K 50
C23	Mylar 0.082 50V	CQMA 823M 50
C24	Mylar 0.082 50V	CQMA 823M 50
C25	Mylar 0.056 50V	CQMA 563M 50
C26	Mylar 0.056 50V	CQMA 563M 50

RESISTORS AND POTENTIOMETERS

Symbol	Description	Part No.
R1	Carbon film 100k	RD½PS 104J
R2	Carbon film 100k	RD½PS 104J
R3	Carbon film 3.3k	RD½PS 332J
R4	Carbon film 3.3k	RD½PS 332J
R5	Carbon film 820	RD½PS 821J
R6	Carbon film 820	RD½PS 821J
R7	Carbon film 56k	RD½PS 563J
R8	Carbon film 56k	RD½PS 563J
R9	Carbon film 33k	RD½PS 333J
R10	Carbon film 33k	RD½PS 333J
R11	Carbon film 18k	RD½PS 183J
R12	Carbon film 18k	RD½PS 183J
R13	Carbon film 100k	RD½PS 104J
R14	Carbon film 100k	RD½PS 104J
R15	Carbon film 82k	RD½PS 823J

Symbol	Description	Part No.
R16	Carbon film 82k	RD½PS 823J
R17	Carbon film 2.2k	RD½PS 222J
R18	Carbon film 2.2k	RD½PS 222J
R19	Carbon film 100k	RD½PS 104J
R20	Carbon film 100k	RD½PS 104J
R21	Carbon film 110k	RD½PS 114J
R22	Carbon film 110k	RD½PS 114J
R23	Carbon film 4.7k	RD½PS 472J
R24	Carbon film 4.7k	RD½PS 472J
R25	Carbon film 1k	RD½PS 102J
R26	Carbon film 1k	RD½PS 102J
R27	Carbon film 39k	RD½PS 393J
R28	Carbon film 39k	RD½PS 393J
R29	Carbon film 22k	RD½PS 223J
R30	Carbon film 22k	RD½PS 223J
R31	Carbon film 47k	RD½PS 473J
R32	Carbon film 47k	RD½PS 473J
R33	Carbon film 82k	RD½PS 823J
R34	Carbon film 82k	RD½PS 823J
R35	Carbon film 2.7k	RD½PS 272J
R36	Carbon film 2.7k	RD½PS 272J
R37	Carbon film 4.7k	RD½PS 472J
R38	Carbon film 4.7k	RD½PS 472J
R39	Carbon film 150 ½W	RD½PS 151J
R40	Carbon film 150 ½W	RD½PS 151J
R41	Carbon film 150 ½W	RD½PS 151J
R42	Carbon film 150 ½W	RD½PS 151J
R43	Metal film 4.7 1W	RN1H 4R7K
R44	Metal film 4.7 1W	RN1H 4R7K
R45	Carbon film 5.6k	RD½PS 562J
R46	Carbon film 5.6k	RD½PS 562J
R47	Metal film 4.7 1W	RN1H 4R7K
R48	Metal film 4.7 1W	RN1H 4R7K
R49	Wire wound 0.5 5W	RT5B 0R5K
R50	Wire wound 0.5 5W	RT5B 0R5K
R51	Wire wound 0.5 5W	RT5B 0R5K
R52	Wire wound 0.5 5W	RT5B 0R5K
R53	Metal oxide 10 2W	RS2P 100J
R54	Metal oxide 10 2W	RS2P 100J
R55	Metal oxide 10 1W	RS1P 100J
R56	Metal oxide 10 1W	RS1P 100J
VR1	Variable resistor (Semi-fixed) 10k-B	ACP-029
VR2	Variable resistor (Semi-fixed) 10k-B	ACP-029
VR3	Variable resistor (Semi-fixed) 100-B	ACP-019
VR4	Variable resistor (Semi-fixed) 100-B	ACP-019

SEMICONDUCTORS

Symbol	Description	Part No.
Q1	Transistor	2SA726-G or F (2SA763F-6 or 5)
Q2	Transistor	2SA726-G or F (2SA763F-6 or 5)
Q3	Transistor	2SA726-G or F (2SA763F-6 or 5)
Q4	Transistor	2SA726-G or F (2SA763F-6 or 5)
Q5	Transistor	2SC869-C or D
Q6	Transistor	2SC869-C or D
Q7	Transistor	2SC1451-V or B
Q8	Transistor	2SC1451-V or B
Q9	Transistor	2SD357-C or D
Q10	Transistor	2SD358-C or D
Q11	Transistor	2SB527-C or D
Q12	Transistor	2SB528-C or D
D1	Diode	1S2473
D2	Diode	1S2473
D3	Diode	1S2473
D4	Diode	1S2473
D5	Varistor	STV-4
D6	Varistor	STV-4

OTHER

Symbol	Description	Part No.
L1	AF Choke coil	T63-009
L2	AF Choke coil	T63-009

14. PARTS LIST OF EXPLODED VIEWS

Parts No.	Parts Name
AAA-023	Knob
AAB-056	Knob
AAB-065	Knob
AAB-079	Knob
AAB-080	Knob
AAD-055	Knob
AAD-108	Knob
AAE-007	Coupler
AAE-008	Coupler
AAF-036	Dial Pointer Ass.
AAG-063	Dial Scale Plate
AAW-021	4-CH Level Indicator
AAW-042	Twin Meter
ABA-002	Screw M3x8
ABA-010	Screw M4x15
ABA-012	Screw M4x8
ABE-006	Washer
ABN-008	Washer Faced Nut 5mm
ACG-001	Ceramic Capacitor
ACH-029	Ele. Capacitor
ACT-009	Variable Resistor
ACV-017	Variable Resistor
ACV-110	Variable Resistor
ACV-311	Variable Resistor
ADG-004	AC Power Cord (QX-949A/F)
ADG-005	AC Power Cord (QX-949A/KCU)
AEB-042	Rubber Bracket
AEB-043	Rubber Bracket
AEB-044	Rubber Bracket
AEC-017	Pulley
AEC-027	Foot
AEC-076	Insulation Wafer
AEC-079	Strain Relief
AEC-101	Pulley
AEC-110	Switch Cover Ass.
AEC-116	Spacer
AEC-119	Sponge
AEC-120	Shading Sponge Ring
AEC-121	Acrylic Cap
AEC-136	Clip
AEE-008	Insulator
AEE-009	Insulate Board
AEK-101	Fuse 3A
AEK-106	Fuse 1A
AEK-109	Fuse 6A
AEK-205	Fuse 6A (QX-949A/KCU)
AEL-015	Lamp 8V 300mA
AEL-022	Lamp 8V 50mA
AEL-025	Lamp 6V 30mA

Parts No.	Parts Name
AKA-004	Ant. Terminal Board
AKB-015	Phono Jack 4P
AKB-017	Phono Jack 6P
AKB-018	Phono Jack 6P
AKB-019	Phono Jack 1P
AKE-010	Sp. Output Terminal
AKE-012	Binding Post (for Ground)
AKE-018	Sp. Output Terminal-A
AKH-001	Transistor Socket
AKK-002	Lamp Holder
AKM-006	Multi Plug
AKN-002	Phone Jack
AKP-005	AC Socket
AKP-006	Multi Socket
AKR-026	Fuse Holder (QX-949A/KCU)
AKR-027	Fuse Holder (QX-949A/F)
ALA-006	Boss
AMM-045	Wooden Cabinet
ANB-318	Front Panel Ass.
ASB-048	Rotary Switch
ASC-066	Rotary Switch
ASF-001	Micro Switch
ASG-019	Push Switch
ASG-043	Push Switch (QX-949A/KCU)
ASG-046	Push Switch
ASG-047	Push Switch
ASG-049	Push Switch
ASG-050	Push Switch
ASG-070	Push Switch (QX-949A/F)
ASH-008	Slide Switch (QX-949A/KCU)
ASH-013	Slide Switch (QX-949A/F)
ASR-007	Relay
ATB-042	Ferrite Bar-Antenna
ATT-221	Power Transformer (QX-949A/KCU)
ATT-222	Power Transformer (QX-949A/F)
AWE-041	Tuner Ass.
AWG-023	Control Amplifier Ass.
AWH-027	Power Amplifier Ass.
AWM-076	CD-4 Ass.
AWM-077	SQ/RM Decoder Ass.
AWM-079	Protection Ass.
AWR-039	Power Supply (B) Ass.
AWR-080	Power Supply (A) Ass.
AWS-048	Switch Ass.
AWX-052	Lamp Board Ass.
AWX-054	Headphone Jack Ass.
AXA-015	Tuning Drum Ass.
AXA-039	Tuning Shaft Ass.
AXB-001	Antenna Holder Ass.
B21-011	Washer (Outernal Toothed Lock)

Parts No.	Parts Name
B22-016	Washer 9mm
B71-004	Nut 9mm
B71-010	Nut 7mm
E22-032	Lamp 8V 300mA
M45-105	Wire Supporter
M49-025	Pulley Shaft
T22-025	Ferrite Balun
2SA679	Transistor
2SB530	Transistor
2SC1079	Transistor
2SD370	Transistor

4-CHANNEL STEREO RECEIVER

QX-949A F

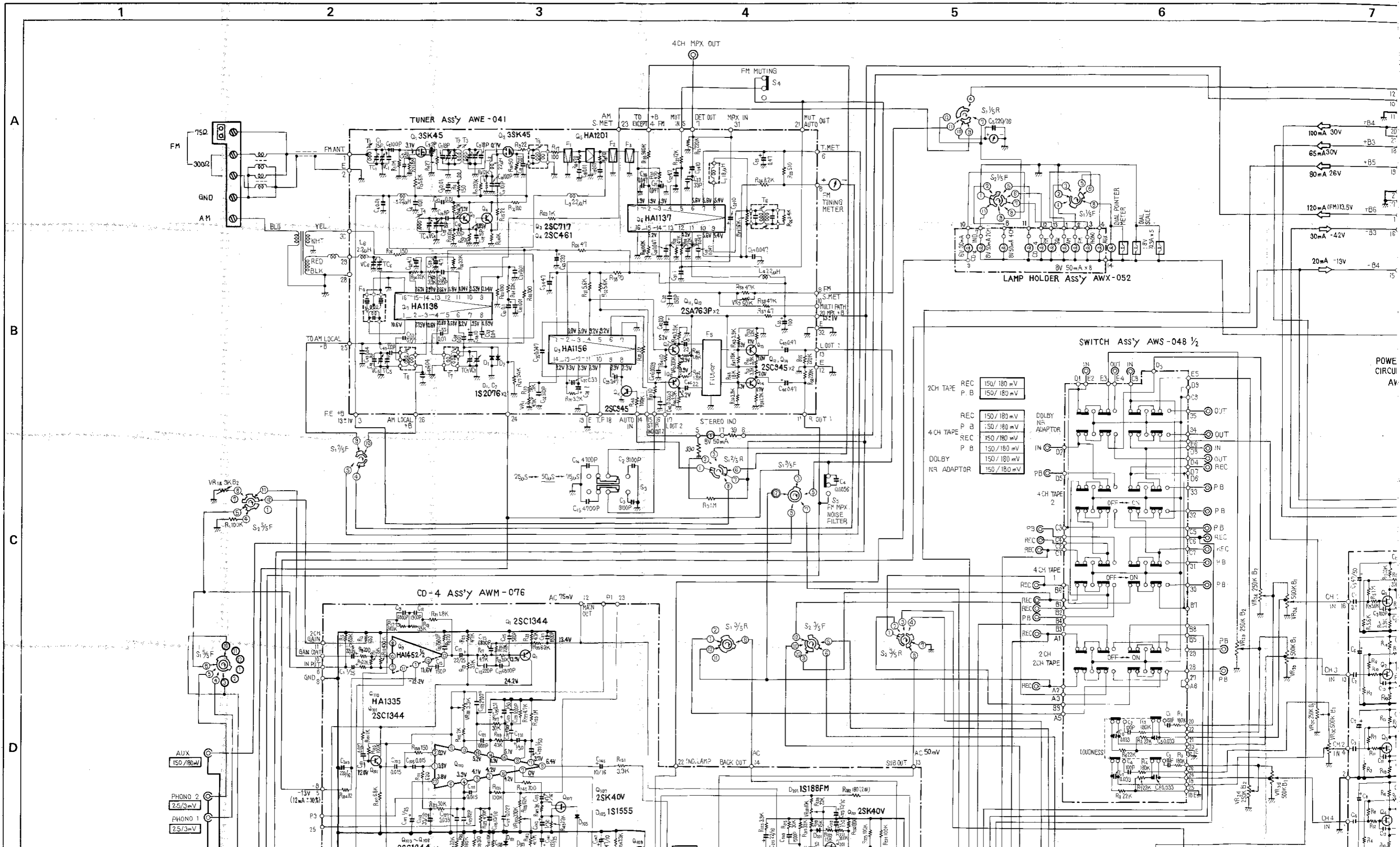

POWER SUPPLY CIRCUIT Ass'y (A)
AWR - 080

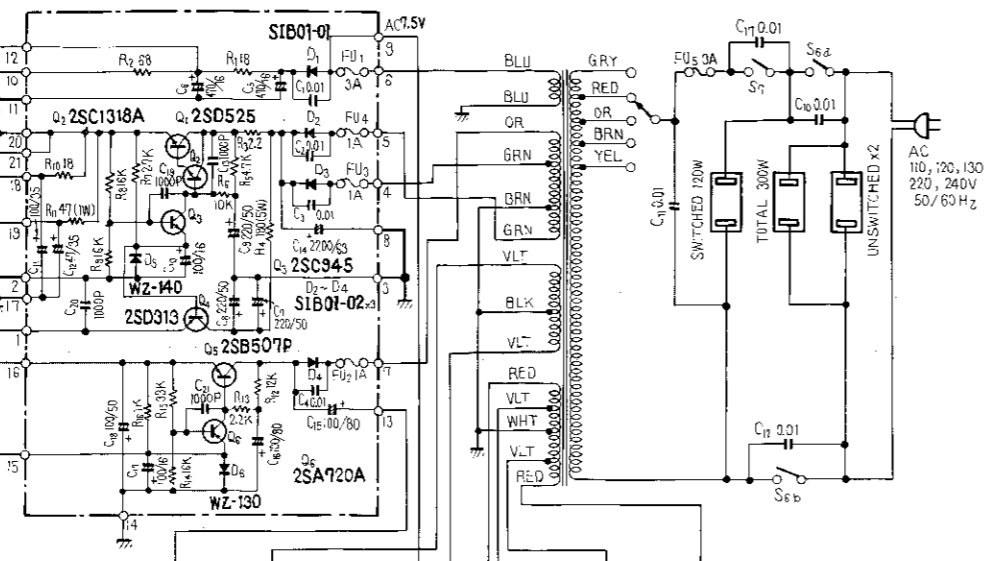

POWER SUPPLY CIRCUIT Ass'y (B)
AWR - 039

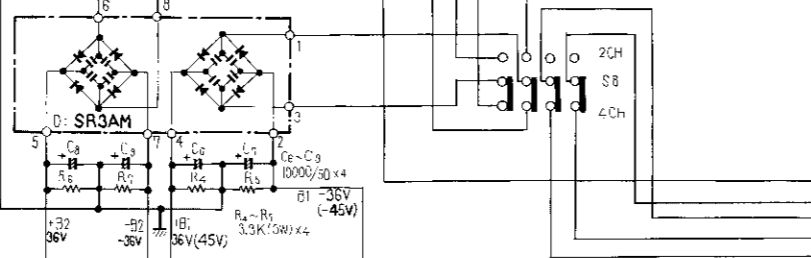

CONTROL AMP ASS'y AWG - 023

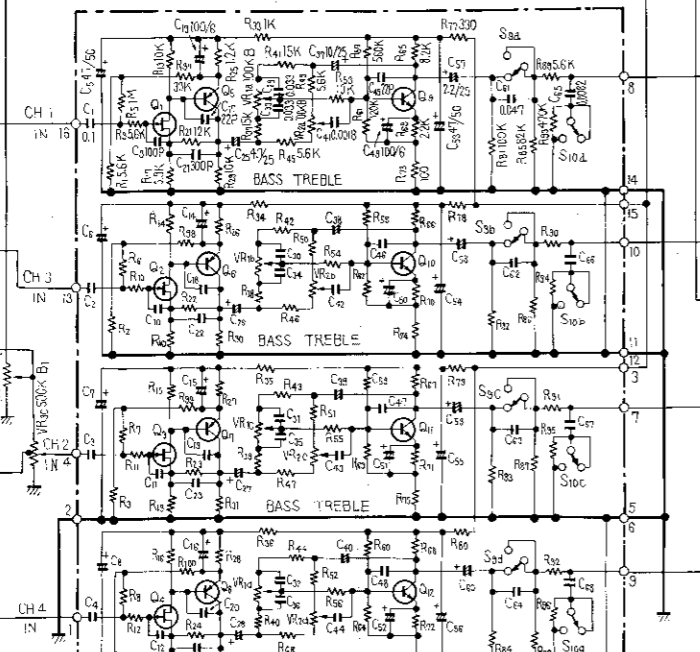

POWER AMP Ass'y AWH-027 (B) FRONT L Ch

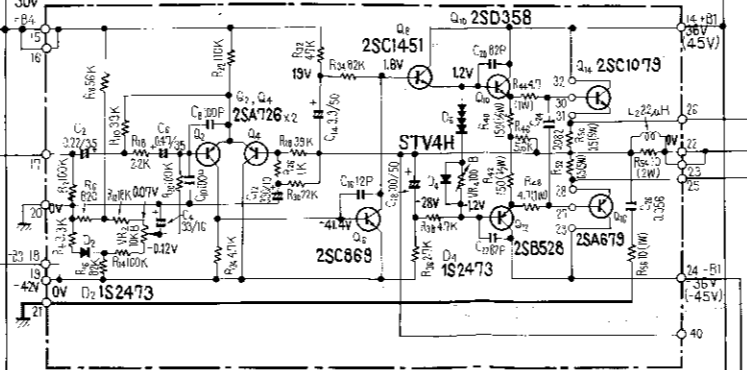

POWER AMP Ass'y AWH-027 (A) FRONT R Ch

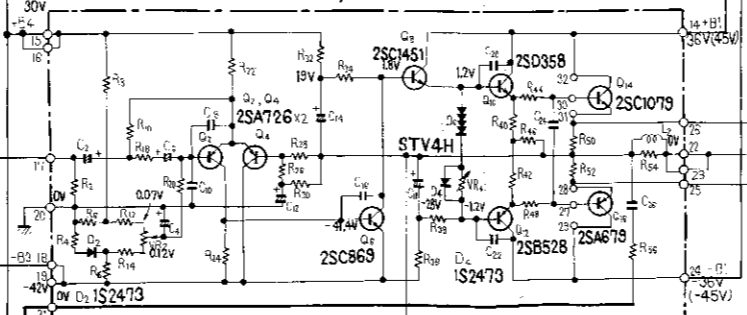

SWITCH ASS'y
AWS-048 1/2

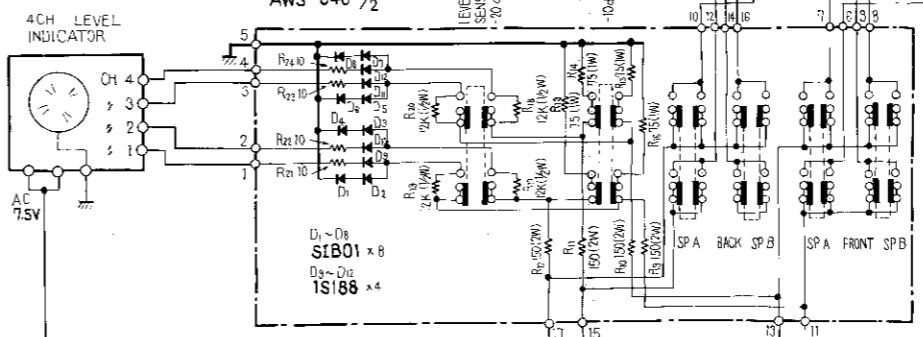

HEADPHONE Ass'y
AWX-054

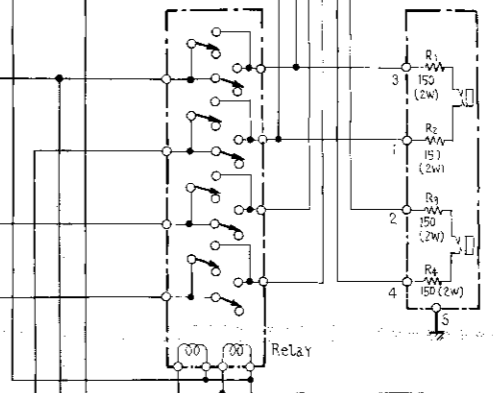

PROTECTION CIRCUIT ASS'y
AWM-079

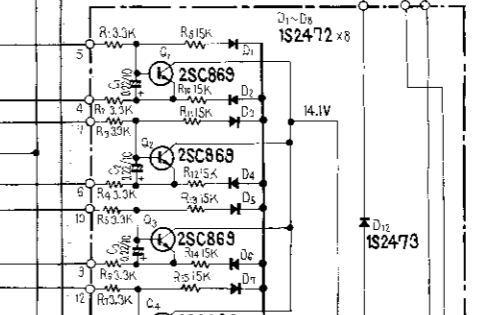

A
B
C
D

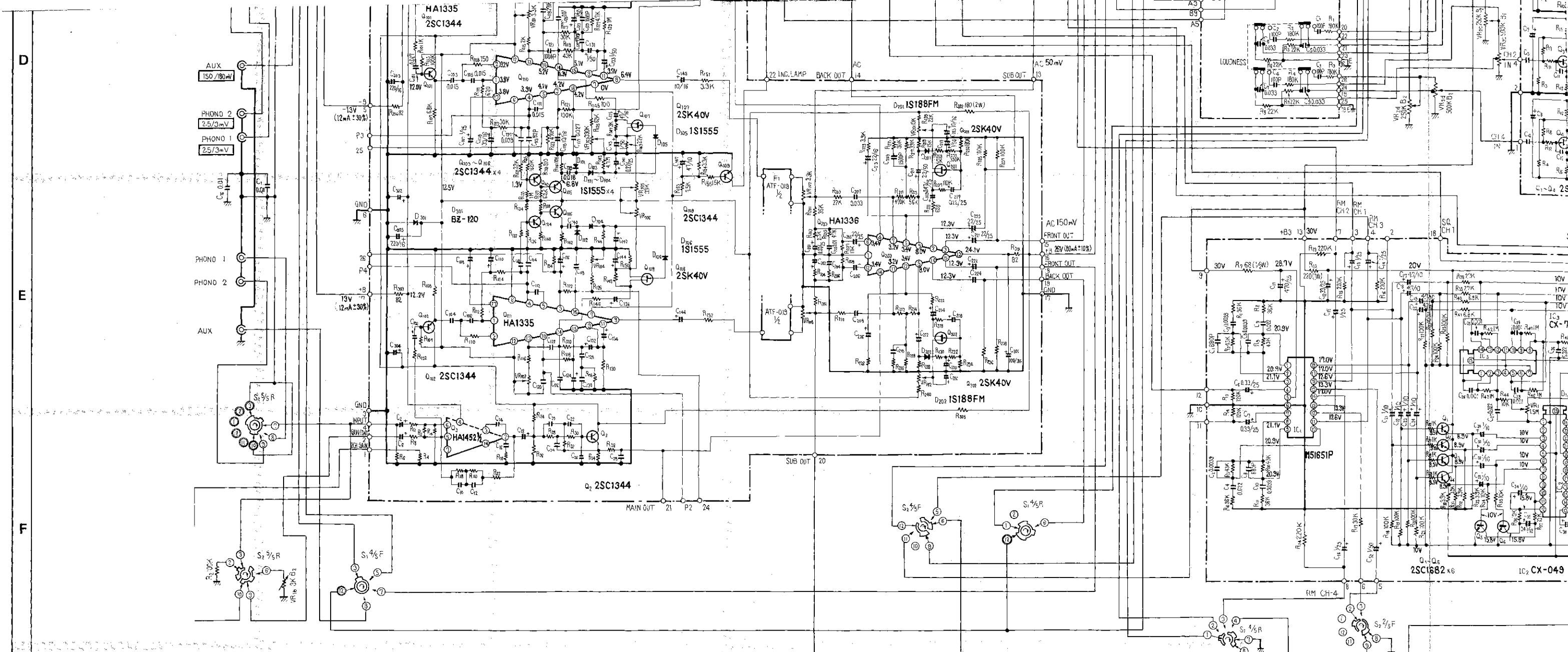

SWITCHES

- | | | |
|---|---|--|
| <p>S₁ : FUNCTION (AM position)</p> <ol style="list-style-type: none"> 1. AM 2. FM MONO 3. FM AUTO 4. PHONO 1 5. PHONO 2 6. AUX <p>S₂ MODE (2CH position)</p> <ol style="list-style-type: none"> 1. 2CH 2. CD-4 3. RM 4. SQ FULL LOGIC | <p>S₃ : FM DE-EMPHASIS (50μS position)</p> <ol style="list-style-type: none"> 1. 25μSEC 2. 50μSEC 3. 75μSEC <p>S₄ : FM MUTING (ON position)</p> <ol style="list-style-type: none"> 1. ON 2. OFF <p>S₅ MPX NOISE FILTER</p> <ol style="list-style-type: none"> 1. OFF 2. ON | <p>S_{6 a, b} : POWER SW</p> <p>S₇ : MICRO SW</p> <p>S₈ : POWER BOOSTING SW (4CH position)</p> <ol style="list-style-type: none"> 1. 2CH 2. 4CH <p>S₉ LOW FILTER (OFF position)</p> <ol style="list-style-type: none"> 1. OFF 2. ON <p>S₁₀ HIGH FILTER (OFF position)</p> <ol style="list-style-type: none"> 1. OFF 2. ON |
|---|---|--|

CAPACITORS

IN μ F UNLESS OTHERWISE NOTED. P: pF

RESISTORS

IN OHM, $\frac{1}{4}$ W, $\pm 5\%$ TOLERANCE UNLESS OTHERWISE NOTED K:K M:M Ω

NOTES

- \square V : SIGNAL VOLTAGE NECESSARY
- \square V : SIGNAL VOLTAGE NECESSARY
- V : DC VOLTAGE AT NO INPUT
- (V) : DC VOLTAGE AT NO INPUT
- (A) : DC CURRENT AT NO INPUT

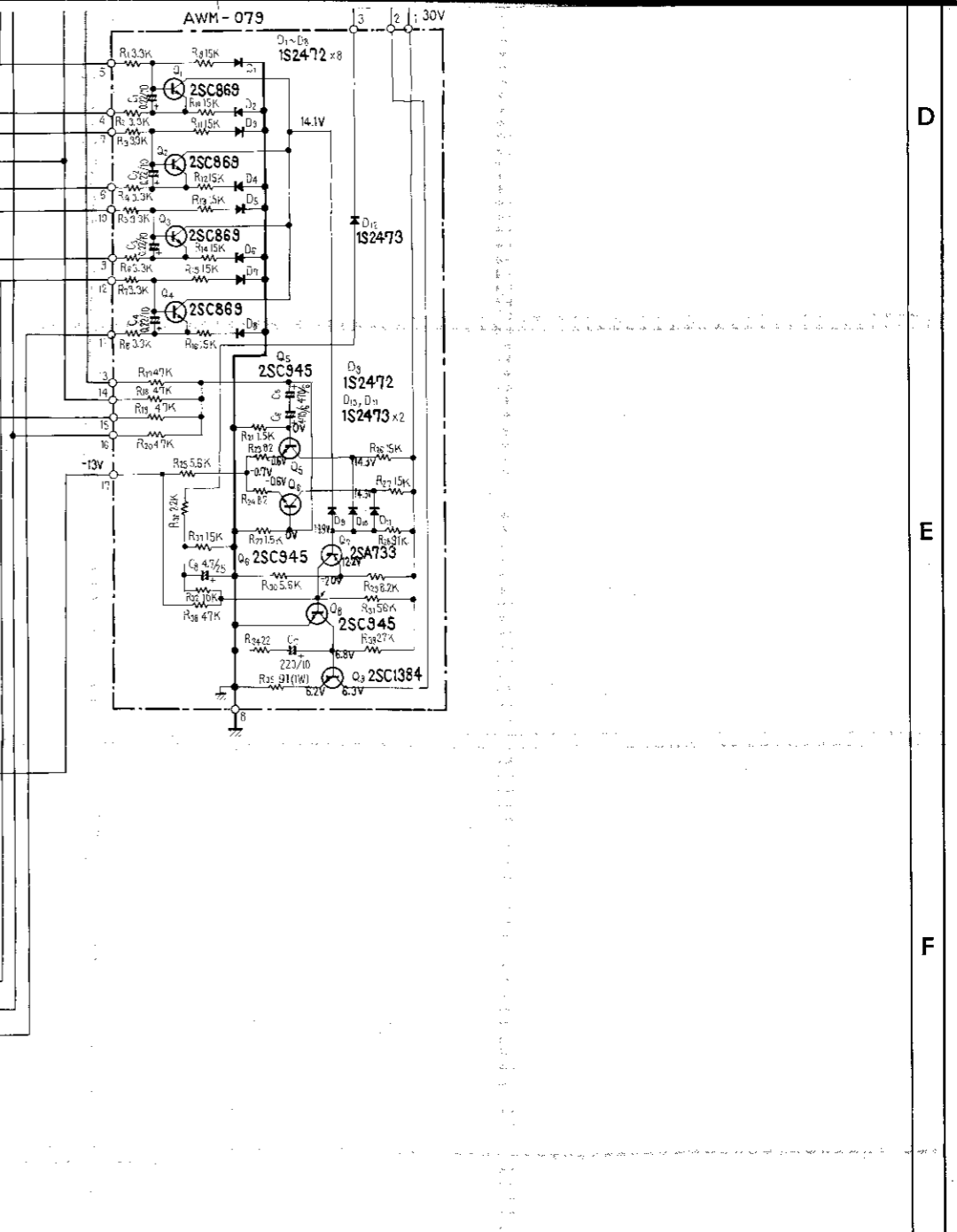
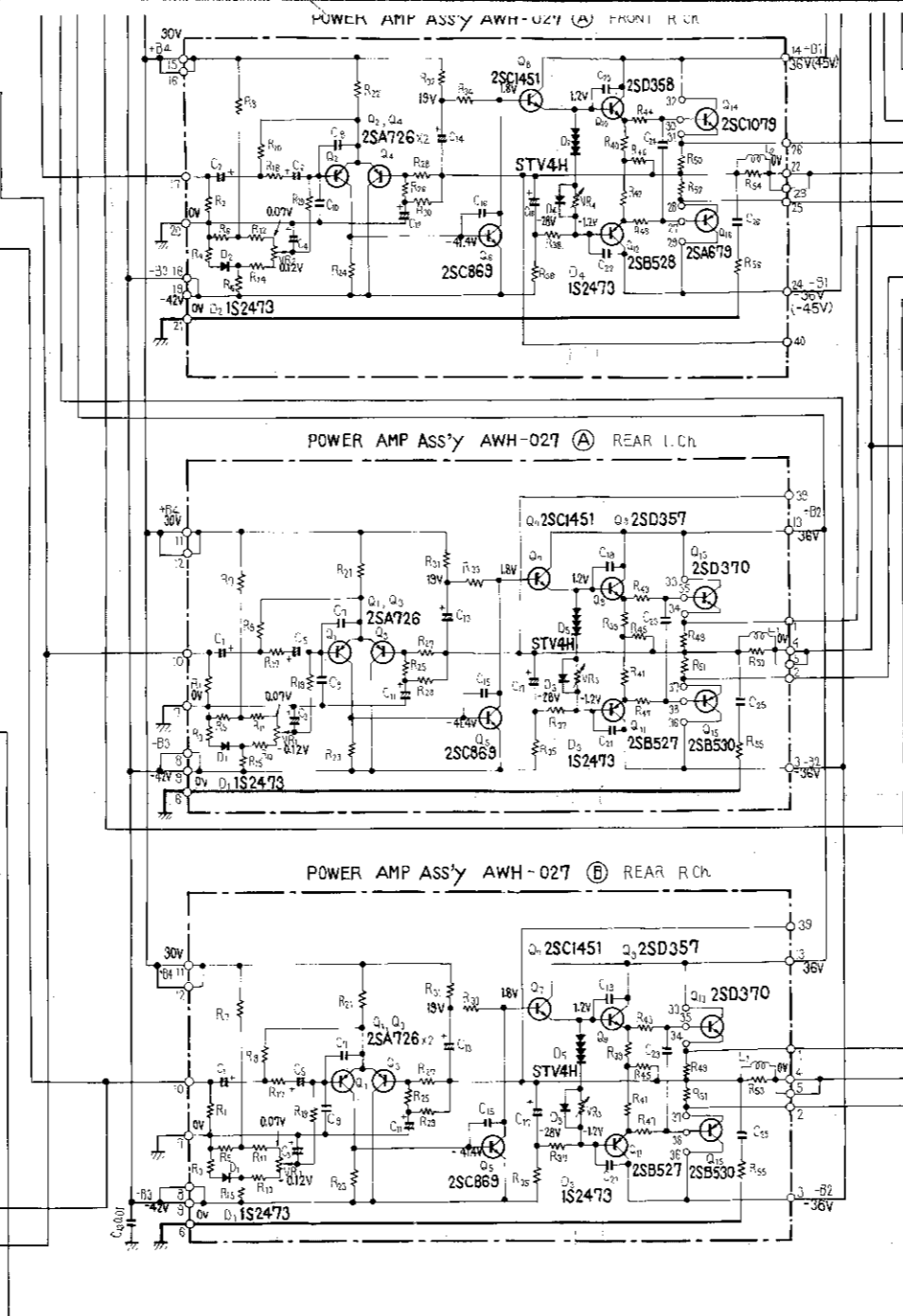
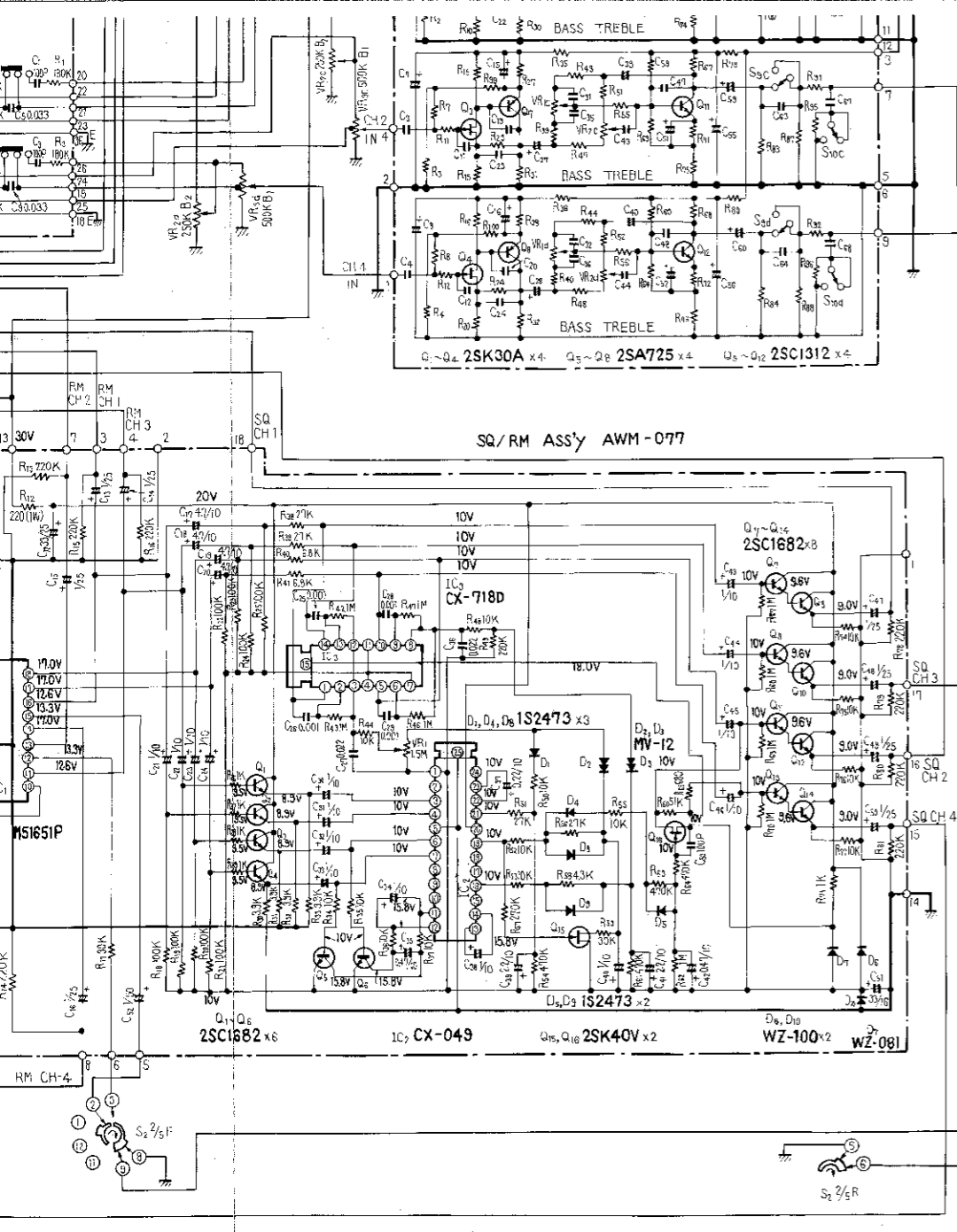

- NOTES
- V : SIGNAL VOLTAGE NECESSARY FOR OBTAINING 50W/8Ω OUTPUT POWER (1KHz), S_8 SET AT 4CH.
 - V : SIGNAL VOLTAGE NECESSARY FOR OBTAINING 72W/8Ω OUTPUT POWER (1KHz), S_8 SET AT 2CH.
 - V : DC VOLTAGE AT NO INPUT SIGNAL, S_8 SET AT 4CH.
 - A : DC CURRENT AT NO INPUT SIGNAL, S_8 SET AT 4CH.
 - (V) : DC VOLTAGE AT NO INPUT SIGNAL, S_8 SET AT 2CH.
 - (A) : DC CURRENT AT NO INPUT SIGNAL, S_8 SET AT 2CH.

MΩ

6

7

8

9

10

11

12

D
E
F
G

4-CHANNEL STEREO RECEIVER

QX-949A KCU

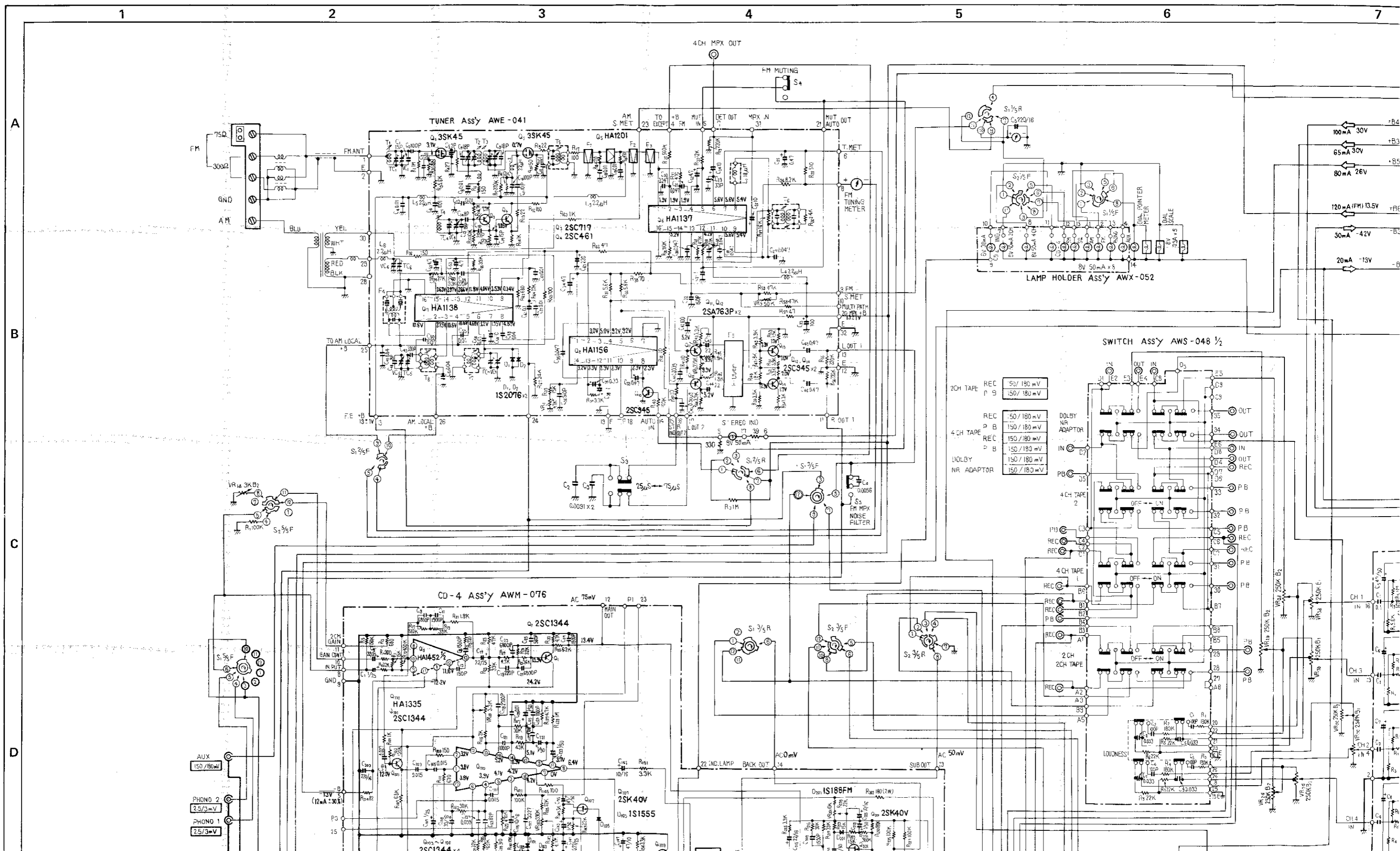

POWER SUPPLY CIRCUIT ASS'y (A)
AWR - 080

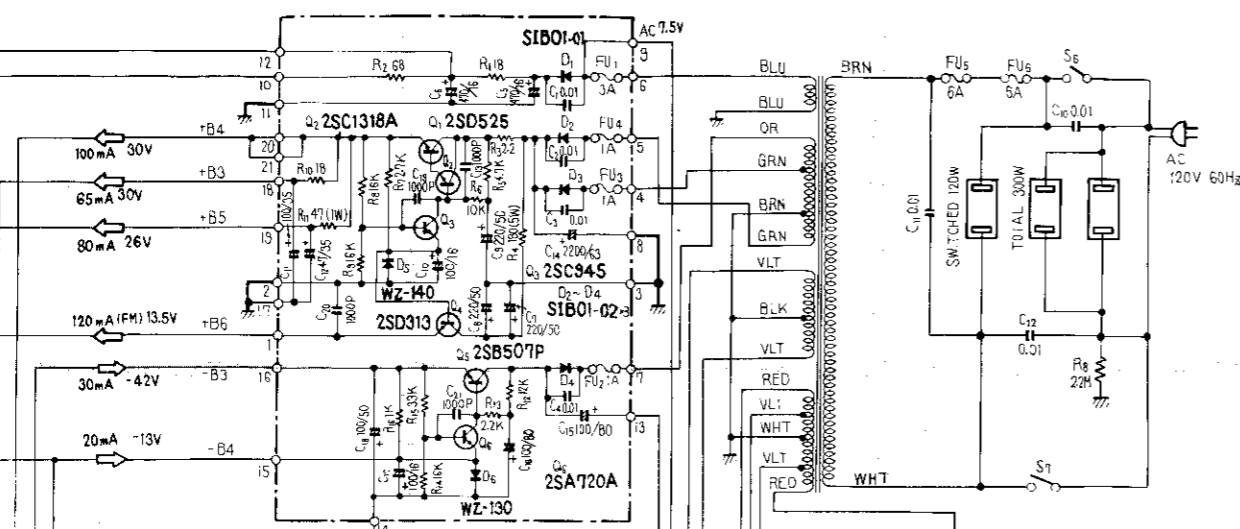

POWER SUPPLY CIRCUIT ASS'y (B)
AWR - 039

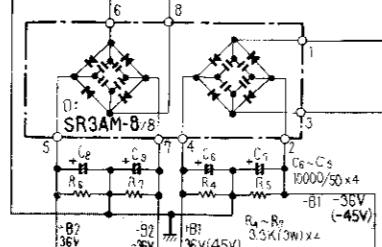

CONTROL AMP ASS'y AWG - 023

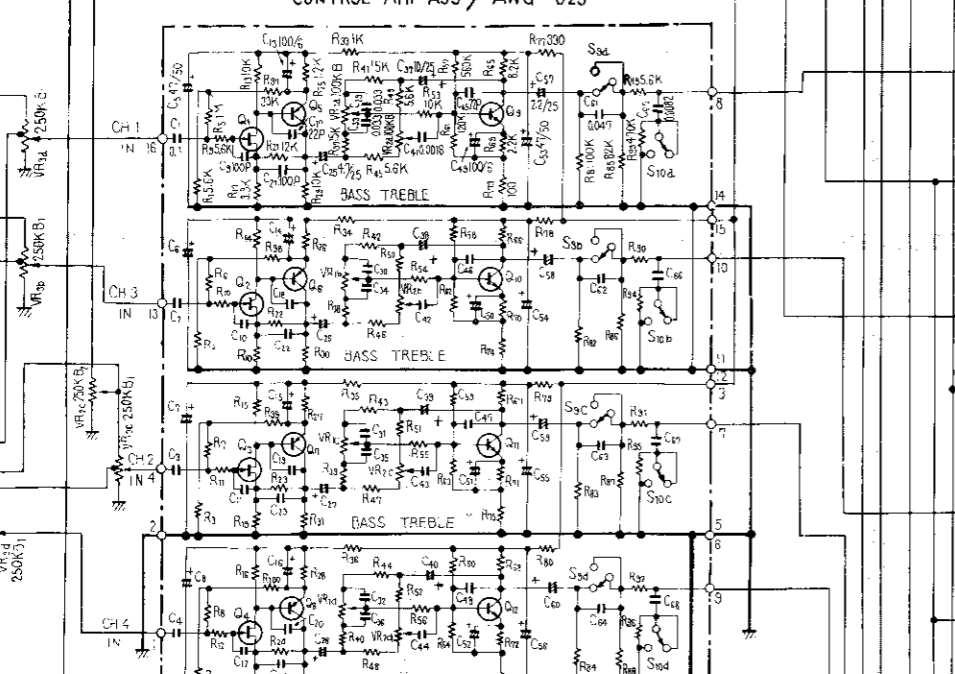

POWER AMP ASS'y AWH - 027 (B) FRONT L CH

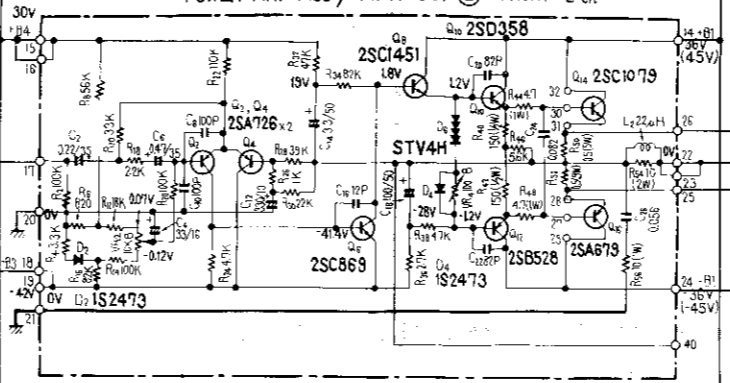

POWER AMP ASS'y AWH - 027 (A) FRONT R CH

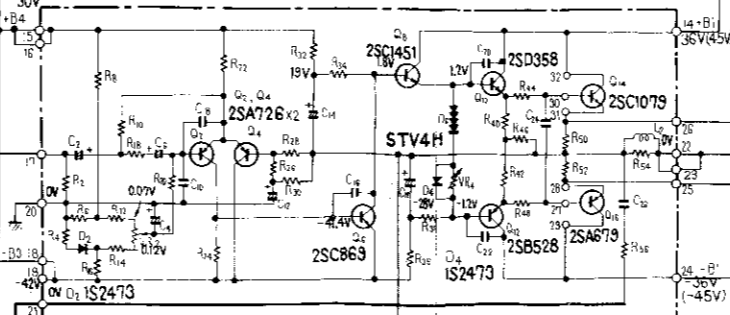

PROTECTION CIRCUIT ASS'y
AWM - 079

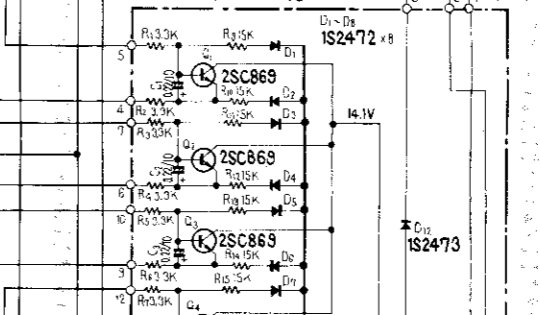

HEADPHONE ASS'y
AWX - 054

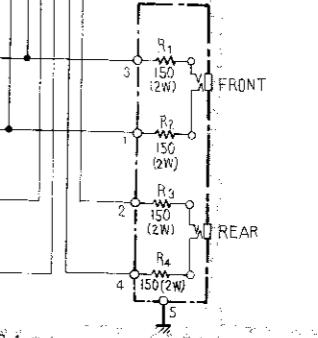

SWITCH ASS'y
AWS - 048 1/2

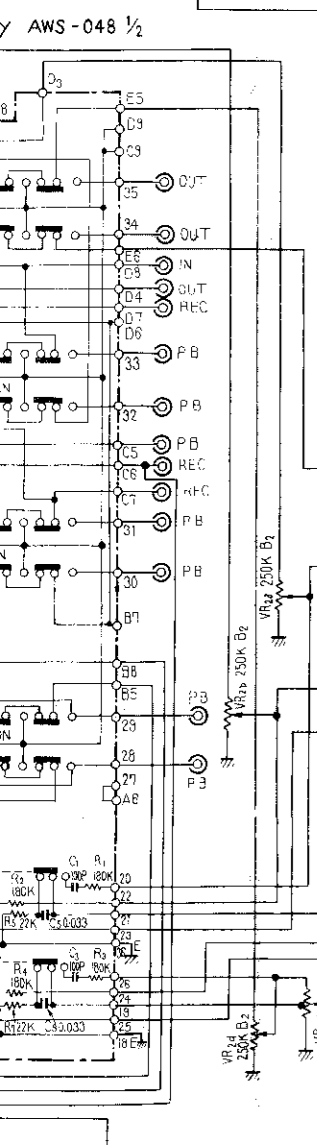
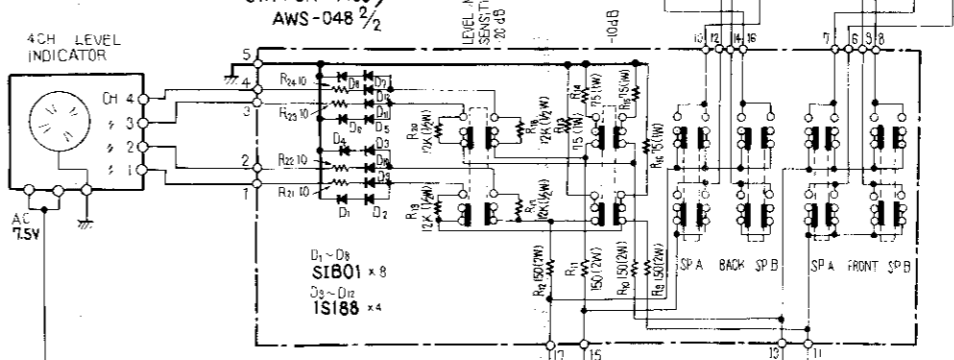

A
B
C
D

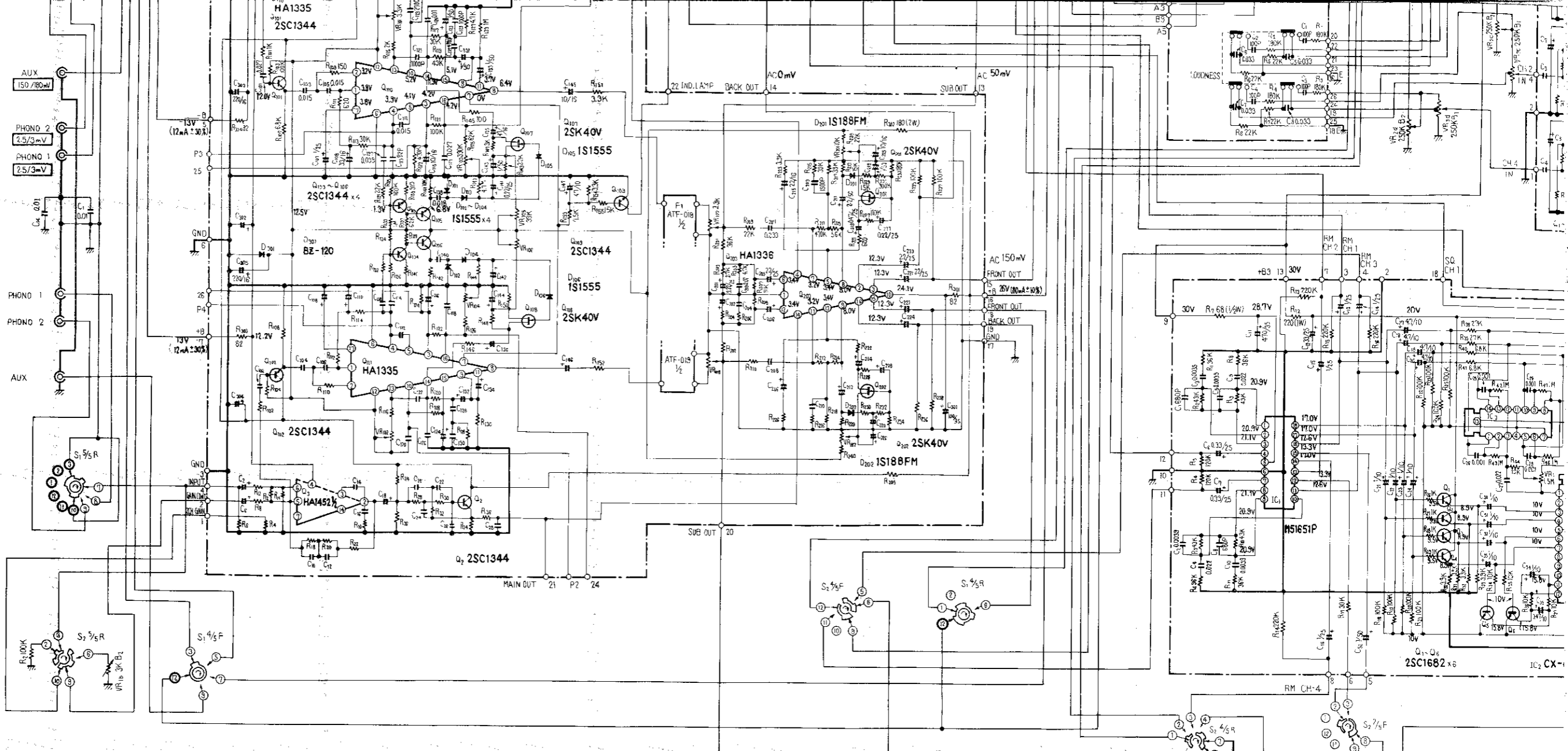

SWITCHES

- S₁: FUNCTION (AM position)
 1. AM
 2. FM MONO
 3. FM AUTO
 4. PHONO 1
 5. PHONO 2
 6. AUX

- S₂: MODE (2CH position)
 1. 2CH
 2. CD-4
 3. RM
 4. SQ FULL LOGIC

- S₃: FM DE-EMPHASIS (75 μ S position)
 1. 75 μ SEC
 2. 25 μ SEC

- S₄: FM MUTING (ON position)
 1. ON
 2. OFF

- S₅: MPX NOISE FILTER
 1. OFF
 2. ON

- S₆: POWER SW

- S₇: MICRO SW

- S₈: POWER BOOSTING SW (4CH position)
 1. 2CH
 2. 4CH

- S₉: LOW FILTER (OFF position)
 1. OFF
 2. ON

- S₁₀: HIGH FILTER (OFF position)
 1. OFF
 2. ON

CAPACITORS

IN μ F UNLESS OTHERWISE NOTED. P: pF

RESISTORS

IN OHM, 1/4W, $\pm 5\%$ TOLERANCE UNLESS OTHERWISE NOTED K:k M:M Ω

NOTES

- \square V : SIGNAL VOLTAGE NEAR
- \square V : SIGNAL VOLTAGE NEAR
- V : DC VOLTAGE AT N
- A : DC CURRENT AT N
- (V) : DC VOLTAGE AT N
- (A) : DC CURRENT AT N

1

2

3

4

5

6

7

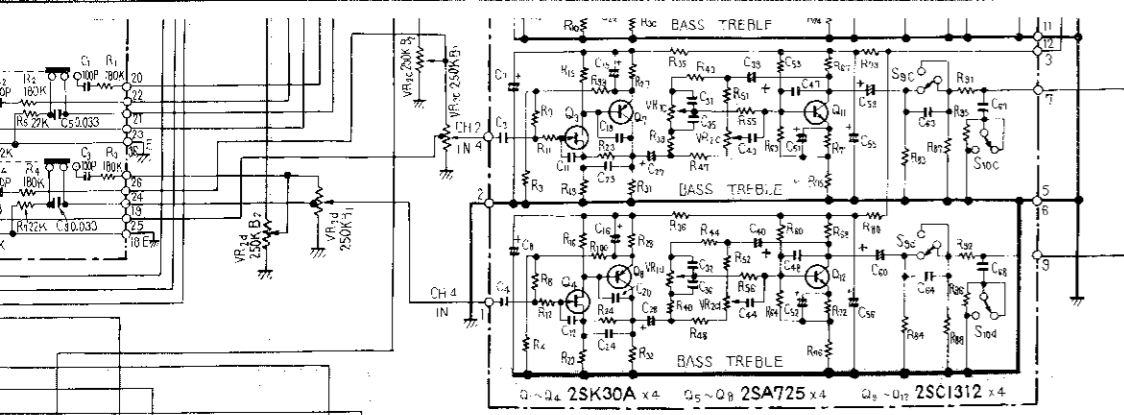

SQ/RM Ass'y AWM-077

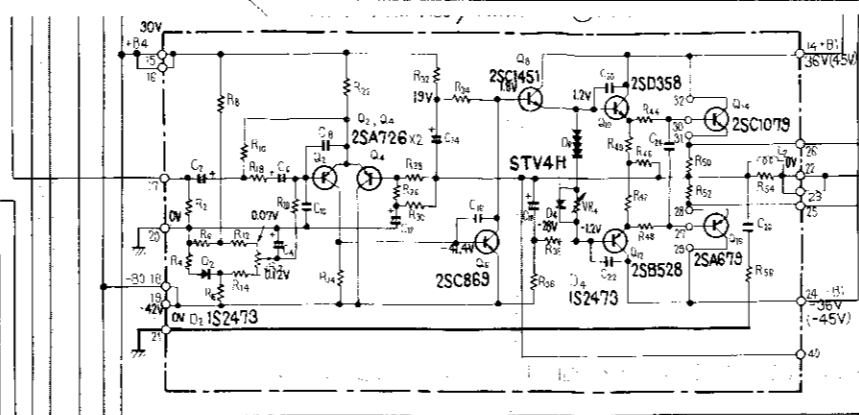
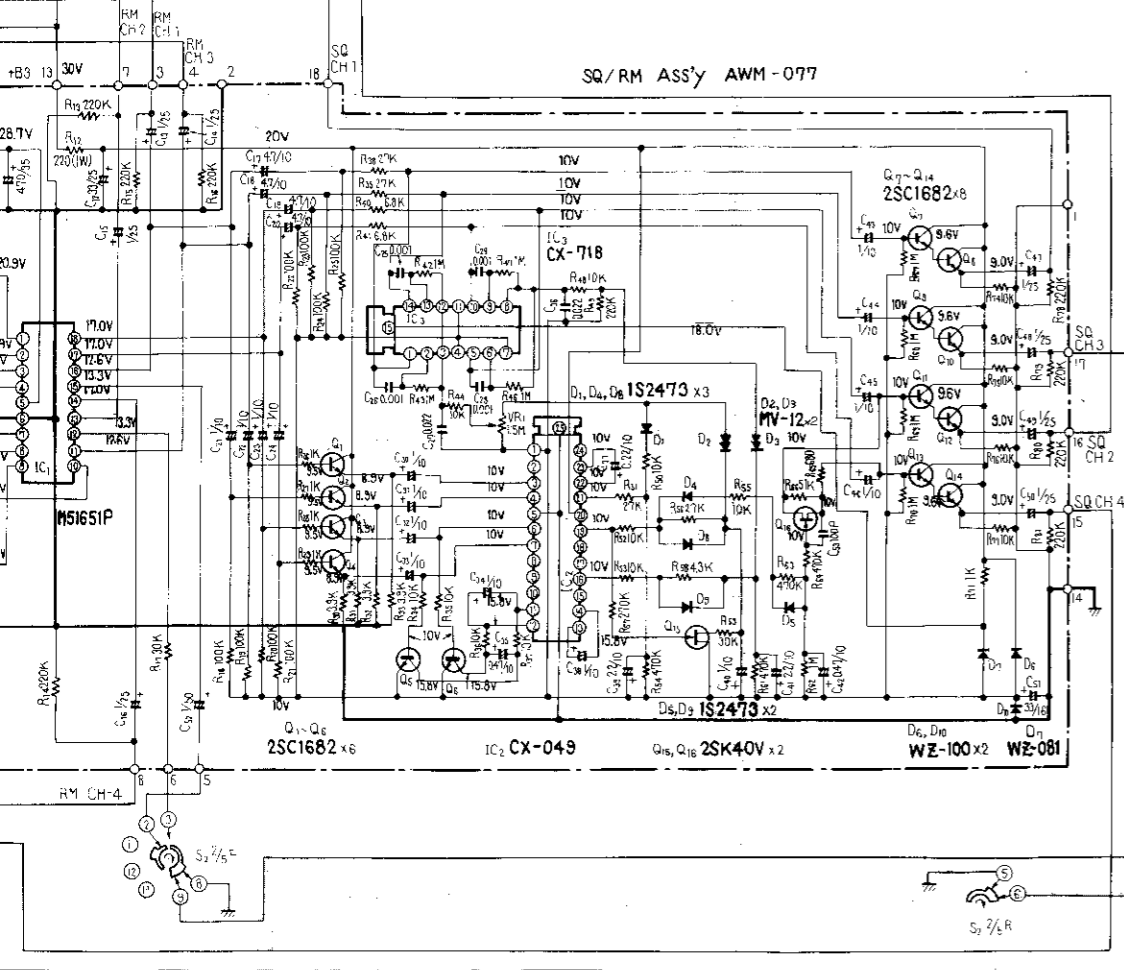

POWER AMP ASSY AWH-027 (A) REAR L Ch

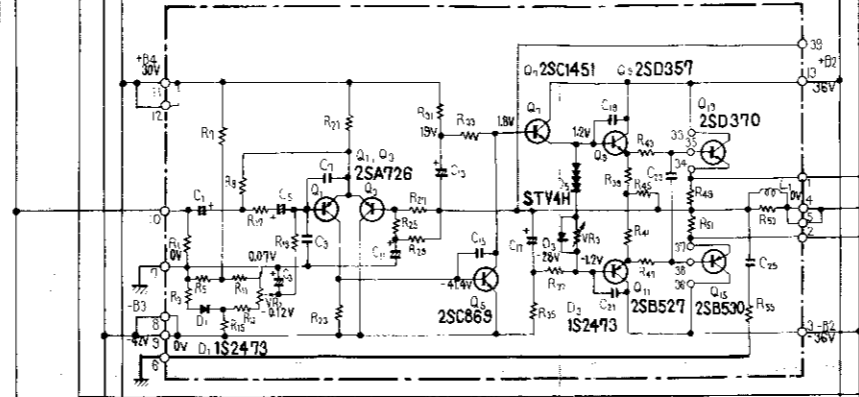

POWER AMP ASSY AWH-027 (B) REAR R Ch

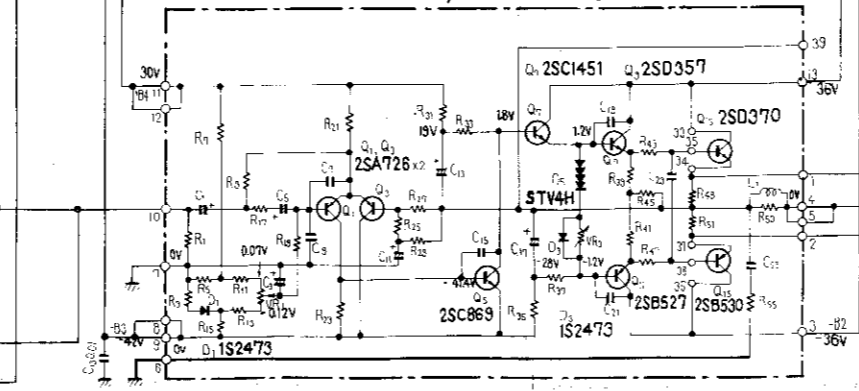

POWER AMP ASSY AWH-027 (A) REAR L Ch

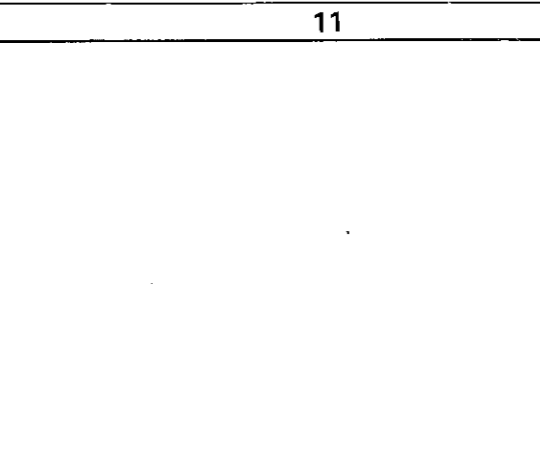
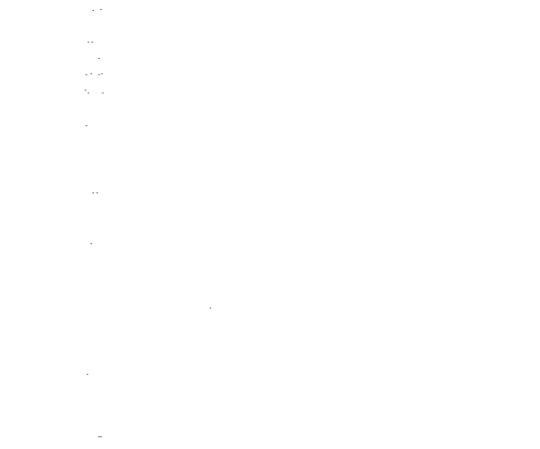
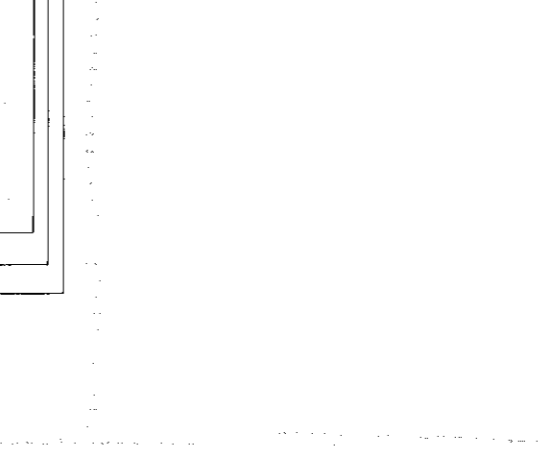
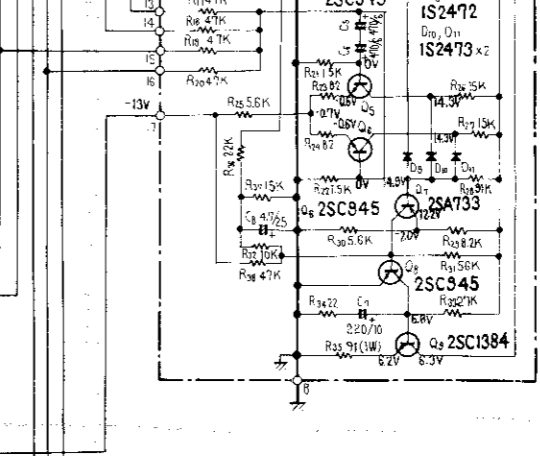
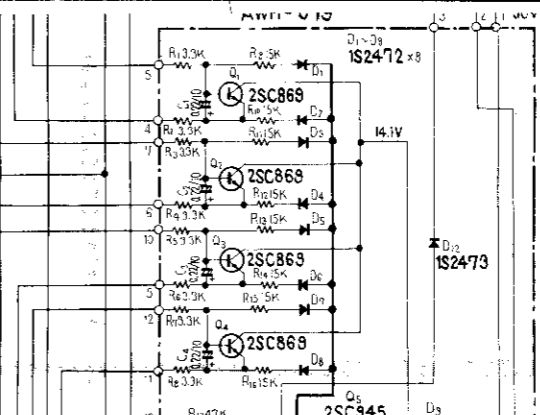

NOTES

- V : SIGNAL VOLTAGE NECESSARY FOR OBTAINING 50W/8Ω OUTPUT POWER (1KHz), S₈ SET AT 4CH.
- V : SIGNAL VOLTAGE NECESSARY FOR OBTAINING 12W/8Ω OUTPUT POWER (1KHz), S₈ SET AT 2CH.
- V : DC VOLTAGE AT NO INPUT SIGNAL, S₈ SET AT 4CH.
- A : DC CURRENT AT NO INPUT SIGNAL, S₈ SET AT 4CH.
- (V) : DC VOLTAGE AT NO INPUT SIGNAL, S₈ SET AT 2CH.
- (A) : DC CURRENT AT NO INPUT SIGNAL, S₈ SET AT 2CH.

M: MΩ