

STEREO AMPLIFIER

SA-9500II

SERVICE MANUAL



MODEL SA-9500II COMES IN FOUR VERSIONS DISTINGUISHED AS FOLLOWS:

Type	Voltage	Remarks
KU	120V only	UL (U.S.A.) approved
KC	120V only	CSA (Canada) approved
HG	220V and 240V (Switchable)	SEMKO (Sweden), NEMKO (Norway), DEMKO (Denmark) and EI (Finland) approved
S	110V, 120V, 220V and 240V (Switchable)	General export model

This service manual is applicable to the KU-type. When repairing the KC-type, HG-type, S-type, please see the additional service manual.

CONTENTS

1.	SPECIFICATIONS	5
2.	CONNECTION DIAGRAM	6
3.	FRONT PANEL FACILITIES	7
4.	BLOCK DIAGRAM	9
5.	CIRCUIT DESCRIPTIONS	
5.1	Equalizer Amplifier	11
5.2	Tone Controls	11
5.3	Power Amplifier	12
5.4	Protection Circuit	13
5.5	Power Supply Circuit	14
6.	LEVEL DIAGRAM	15
7.	DISASSEMBLY	16
8.	PARTS LOCATION	
8.1	Front Panel View	18
8.2	Front View with Panel Removed	19
8.3	Top View	20
8.4	Bottom View	21
8.5	Rear View	22
9.	ADJUSTMENT	23
10.	EXPLODED VIEWS	24
11.	SCHEMATIC DIAGRAMS, P.C. BOARD PATTERNS AND PARTS LIST	
11.1	Miscellanea	32
11.2	Schematic Diagram	33

11.3	Switch Assembly (AWS-109)	35
11.4	Phono Jack Assembly (AWX-107)	41
11.5	Equalizer Amplifier Assembly (AWF-024)	42
11.6	Switch Assembly (AWS-102)	45
11.7	Control Amplifier Assembly (AWG-045)	46
11.8	Power Amplifier Assembly (AWH-052)	50
12.	PACKING	53

1. SPECIFICATIONS

Semiconductor

Transistors	55
Diodes	33

Power Amplifier Section

Circuitry 2-stage differential amplifier Parallel
PP direct-coupled OCL.

Continuous Power Output from 20 Hertz to 20,000 Hertz
(Both channels driven) . . 80 watts per channel (8 ohms)
100 watts per channel (4 ohms)

Total Harmonic Distortion at 20Hertz to 20,000Hertz
Continuous rated power output 0.05%
40watts per channel power output, 8ohms 0.01%
1 watt per channel power output, 8ohms 0.01%

Intermodulation Distortion
Continuous rated power output 0.05%
40watts per channel power output, 8ohms 0.01%
1 watt per channel power output, 8ohms 0.01%

Frequency Response 5Hertz to 100,000Hertz ± 1 dB

Input (Sensitivity/Impedance)
POWER AMP IN 1V/50kohms

Output Speaker: A, B, A + B

Headphone: Low impedance

Damping Factor (20Hertz to 20,000Hertz, 8ohms) . . . 30

Hum and Noise (IHF, short-circuited, A network) . . 110dB

Preamplifier Section

Circuitry

Equalizer amplifier: 1st stage differential amplifier 3-
stage direct-coupled A class SEPP.

Control amplifier: 1st stage differential amplifier 2-
stage direct-coupled, NFB type.

Input (Sensitivity/Impedance)

PHONO 1 2.5mV/10, 25, 50, 100kohms

PHONO 2 2.5mV/10, 25, 50, 100kohms

CARTRIDGE LOAD Both PHONO 1 and 2,
100, 200, 300, 400pF

TUNER 150mV/50kohms

AUX 150mV/50kohms

TAPE PLAY 1 150mV/50kohms

TAPE PLAY 2 150mV/50kohms

PHONO Overload Level (T.H.D. : 0.05%)

PHONO 1 300mV (1kHz)

PHONO 2 300mV (1kHz)

Output (Level/Impedance)

TAPE REC 1 150mV

TAPE REC 2 150mV

PRE OUT 1V/2kohms, 10V/2kohms (Max.)

Total Harmonic Distortion
(20Hz to 20,000Hz) 0.01%

Frequency Response
PHONO (RIAA Equalization) 20Hz to 20,000Hz
 ± 0.2 dB

TUNER, AUX, TAPE PLAY 5Hz to 50,000Hz
 ± 1 dB

Tone Control (2dB step)

BASS MAIN ± 8 dB (100Hz)
SUB ± 6 dB (50Hz)

TREBLE MAIN ± 8 dB (10kHz)
SUB ± 6 dB (20kHz)

Filter

LOW 15Hz (6dB/oct.)

HIGH 8kHz (6dB/oct.)

Loudness Contour

(Volume control set at -40 dB position) : $+6$ dB (100Hz)
 $+3$ dB (10kHz)

Hum and Noise

(IHF, short-circuited, A network)

PHONO 75dB

TUNER, AUX, TAPE PLAY 95dB

Muting 0, -20 dB

Miscellaneous

Power Requirements 120V 60Hz only.

Power Consumption 230watts (UL)
490VA (CSA), 560watts (Max.)

Dimensions 420(W) x 150 (H) x 376 (D) mm
16-9/16 x 5-7/8 x 14-13/16 in

Weight Without Package: 16kg (35lb 4oz)
With Package: 17.9kg (39lb 7oz)

Furnished Parts

Operating Instructions 1

Connection Cord with Pin Plugs 1

Hex. Wrench (Used for fastening Volume Knob) 1

NOTE:

Specifications and the design subject to possible modification without notice due to improvements.

2. CONNECTION DIAGRAM

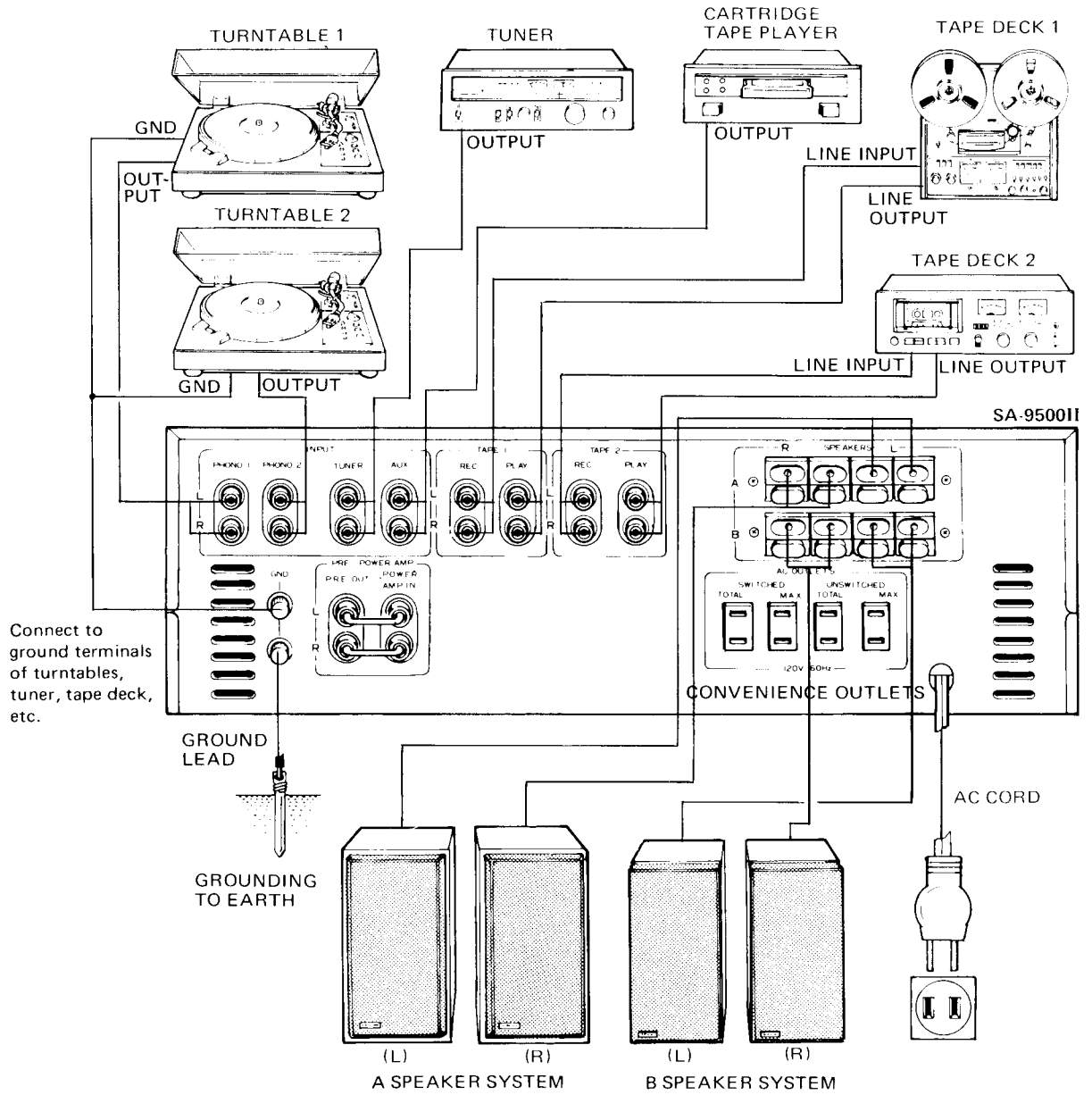

3. FRONT PANEL FACILITIES

POWER SWITCH

Set to ON position to energize SA-9500II. After setting to ON, there is a brief delay before sound is obtained. This is due to the operation of the muting circuit which prevents noise when the POWER is switched. This function does not indicate difficulty and normal operating condition is attained in a few seconds. The POWER switch also controls the rear panel SWITCHED convenience outlets.

TONE SWITCH

In the ON position, tone adjustments can be performed with the BASS and TREBLE twin controls. When set to the upper (OFF) position, the tone control circuits are disengaged and frequency response is flat. This function is convenient for checking phono cartridge and speaker tone quality and listening room acoustics.

BASS TWIN CONTROLS

Controls for adjusting low frequency tones.
 100Hz: Adjusts frequencies below 400Hz. With respect to 100Hz, adjustment range is $\pm 8\text{dB}$.
 50Hz: Provides additional adjustment to the 100Hz control for the band below 200Hz. Adjustment range with respect to 50Hz is $\pm 6\text{dB}$.

PHONES JACK

When listening with stereo headphones, connect them to this jack.

NOTE:

Set **SPEAKERS** switch to OFF when listening only with headphones.

SPEAKERS SWITCH

Selects speaker system operation.

- OFF: Sound not obtained from speakers (when using headphones).
- A: Sound obtained from speakers connected to A speaker terminals.
- B: Sound obtained from speakers connected to B speakers terminals.
- A + B: Sound obtained from speakers connected to both A and B speaker terminals.

NOTE:

When listening with headphones or to temporarily interrupt the speaker sound, set switch to OFF or to an unused speaker position.

TREBLE TWIN CONTROLS

Controls for adjusting high frequency tones.
 10kHz: Adjusts frequencies above 2.5kHz. With respect to 10kHz, adjustment range is $\pm 8\text{dB}$.
 20kHz: Provides additional adjustment to the 10kHz control for the band above 5kHz. Adjustment range with respect to 20kHz is $\pm 6\text{dB}$.

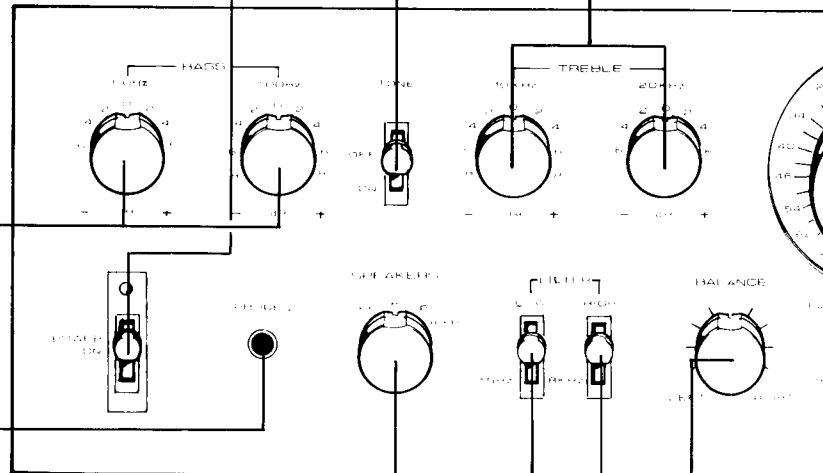

LOW FILTER SWITCH

Set to 15Hz position in the event that turntable rumble, recording cutting noise or other low frequency noise becomes objectionable. Attenuation in the frequency band below 15Hz is 6dB/octave.

HIGH FILTER SWITCH

Set to 8kHz position if record scratch noise or other high frequency noise becomes objectionable. Attenuation in the frequency band above 8kHz is 6dB/octave.

BALANCE CONTROL

Control for adjusting stereo balance between left and right speaker systems or headphones. Turn clockwise from center to increase right (R) channel volume and counter-clockwise from center to increase left (L) channel volume in order to obtain a balance.

VOL
Ad
att
arb
bin
wic

CAR
Sel
acc
car

MUTI
Switc
contro
volum
the r
contro

LOUD
When
enhan
human
switc

es.
With respect
B.
to the 10kHz
Adjustment
dB.

table rumble,
quency noise
ne frequency

or other high
attenuation in
ve.

left and right
clockwise from
and counter-
channel volume

VOLUME CONTROL

Adjusts speaker and headphone volume. Scale indicates attenuation in dB with maximum volume assigned an arbitrary value of 0dB. Control can also be used in combination with the MUTING switch to provide a finer and wider range of adjustment.

CARTRIDGE LOAD SWITCHES

Select phono input circuit resistance and capacitance according to the specifications for the employed phono cartridge.

FUNCTION SWITCH

Selects desired playback program source.

- PHONO 2: To play records on a turntable connected to the PHONO 2 jacks.
- PHONO 1: To play records on a turntable connected to the PHONO 1 jacks.
- TUNER: To listen to broadcasts with a tuner connected to the TUNER jacks.
- AUX: To play a component connected to the AUX jacks.

TAPE MONITOR SWITCH

Employ for tape playback or to monitor a recording in progress.

- 1: Playback or monitoring of a tape deck connected to the TAPE 1 jacks.
- SOURCE: Be sure to set to this position when not using the tape deck for playback.
- 2: Playback or monitoring of a tape deck connected to the TAPE 2 jacks.

NOTE:

When listening to records or broadcasts, be sure to set this switch to SOURCE. Sound will not be obtained from speakers if set to 1 or 2.

TAPE DUPLICATE SWITCH

Employ when using two tape decks for duplication or editing. Be sure to set to the OFF position at other times.

- 1 → 2: Duplication of tape from TAPE 1 (playback mode) to TAPE 2 (recording mode).
- OFF: Set to this position when not using the duplication feature (this includes simultaneous recording with two tape decks and tape playback).
- 2 → 1: Duplication of tape from TAPE 2 (playback mode) to TAPE 1 (recording mode).

MODE SWITCH

- REV: Reverses left and right channel stereo signals and reproduces them stereophonically.
- STEREO: Set to this position for normal stereo reproduction.
- L + R: Mixes left and right channel signals and reproduces them monophonically.
- L: Left channel signal is reproduced monophonically from both speakers.
- R: Right channel signal is reproduced monophonically from both speakers.

MUTING SWITCH

Switch for reducing volume by 20dB from the VOLUME control setting. Convenient for temporarily reducing the volume when changing records or tapes, since it eliminates the need for continually readjusting the VOLUME control.

LOUDNESS SWITCH

When listening at low volume settings, set switch to ON to enhance low and high frequencies. The response of the human ear to sound differs according to loudness. This switch compensates for this effect at low volumes.

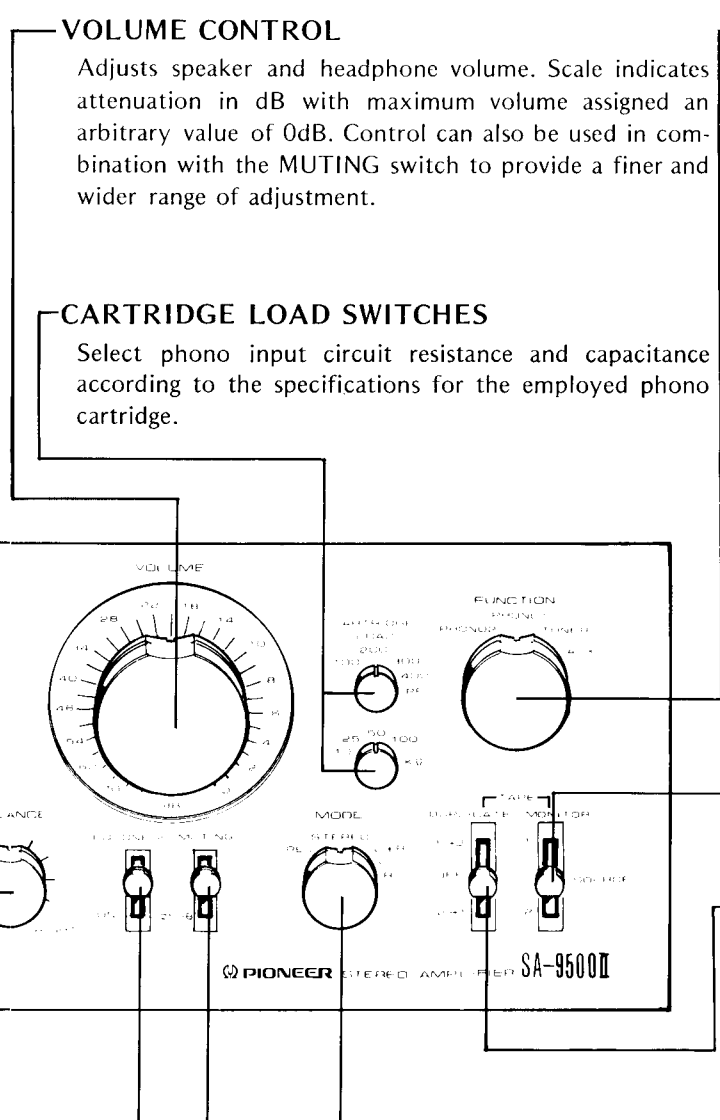

PIONEER STEREO AMPLIFIER SA-9500II

4. BLOCK DIAGRAM

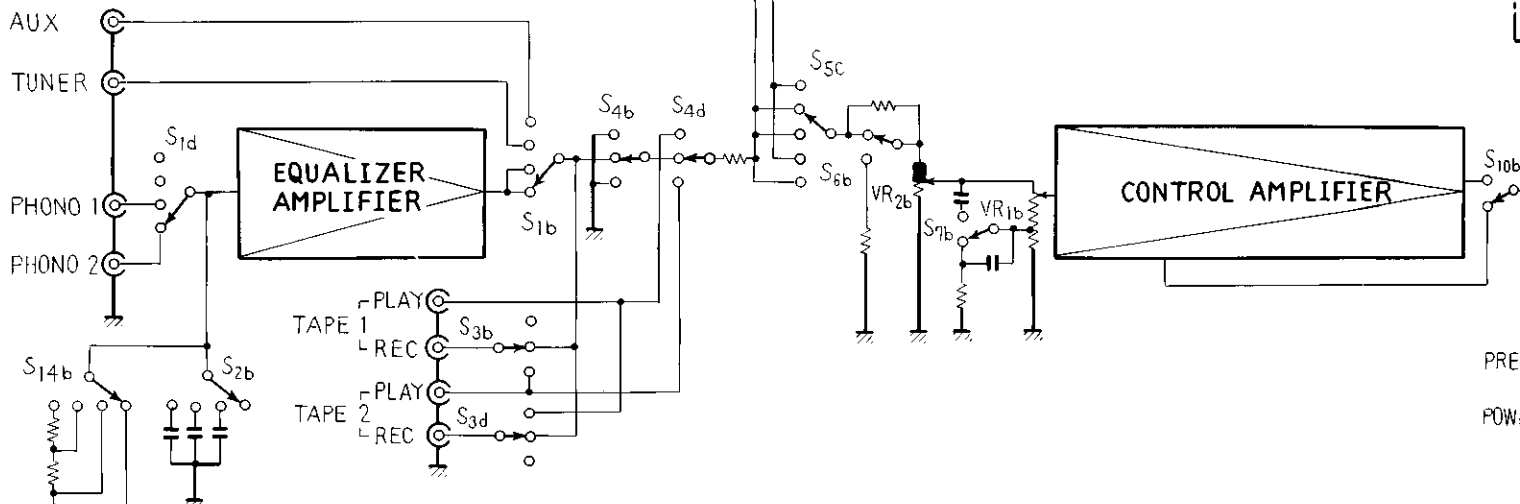
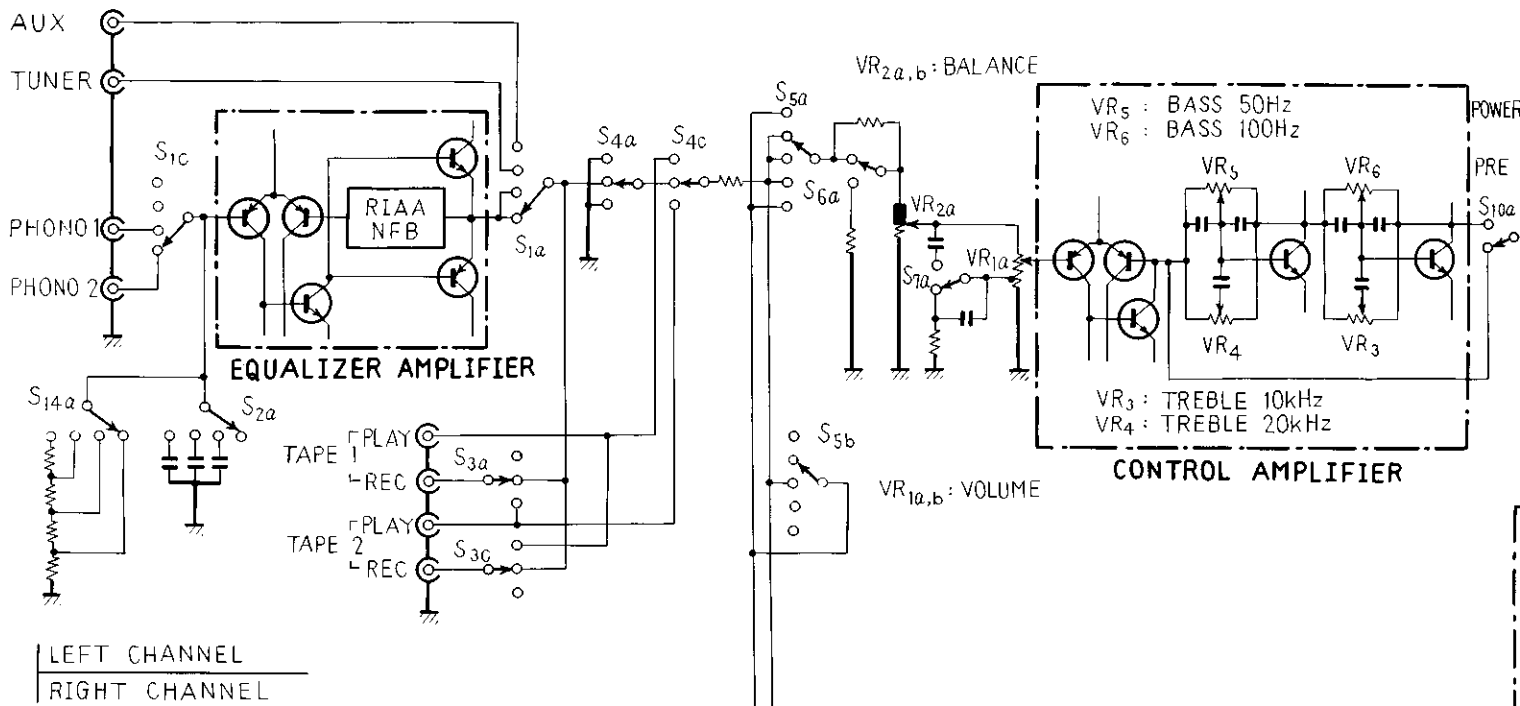

SWITCHES:

- S_{1a~d} : FUNCTION
 1. PHONO 2 2. PHONO 1
 3. TUNER 4. AUX
- S_{2a,b} : C SELECTOR
 1. 100pF 2. 200pF
 3. 300pF 4. 400pF
- S_{3a~d} : DUPLICATE
 1. 1 → 2 2. OFF
 3. 2 → 1

- S_{4a~d} : TAPE MONITOR
 1. TAPE 1 2. OFF
 3. TAPE 2
- S_{5a~c} : MODE
 1. REV. 2. STEREO
 3. L+R 4. L 5. R
- S_{6a,b} : MUTING OFF - -20dB
- S_{7a,b} : LOUDNESS OFF - ON
- S_{8a,b} : HIGH FILTER OFF - 8kHz
- S_{9a,b} : LOW FILTER OFF - 15Hz

- S_{10a,b} : TONE OFF - ON
- S_{11a~d} : SPEAKER
 1. OFF 2. A 3. B
 4. A+B
- S₁₂ : RELAY
- S₁₃ : POWER OFF - ON
- S_{14a,b} : R SELECTOR
 1. 10kΩ 2. 25kΩ
 3. 50kΩ 4. 100kΩ

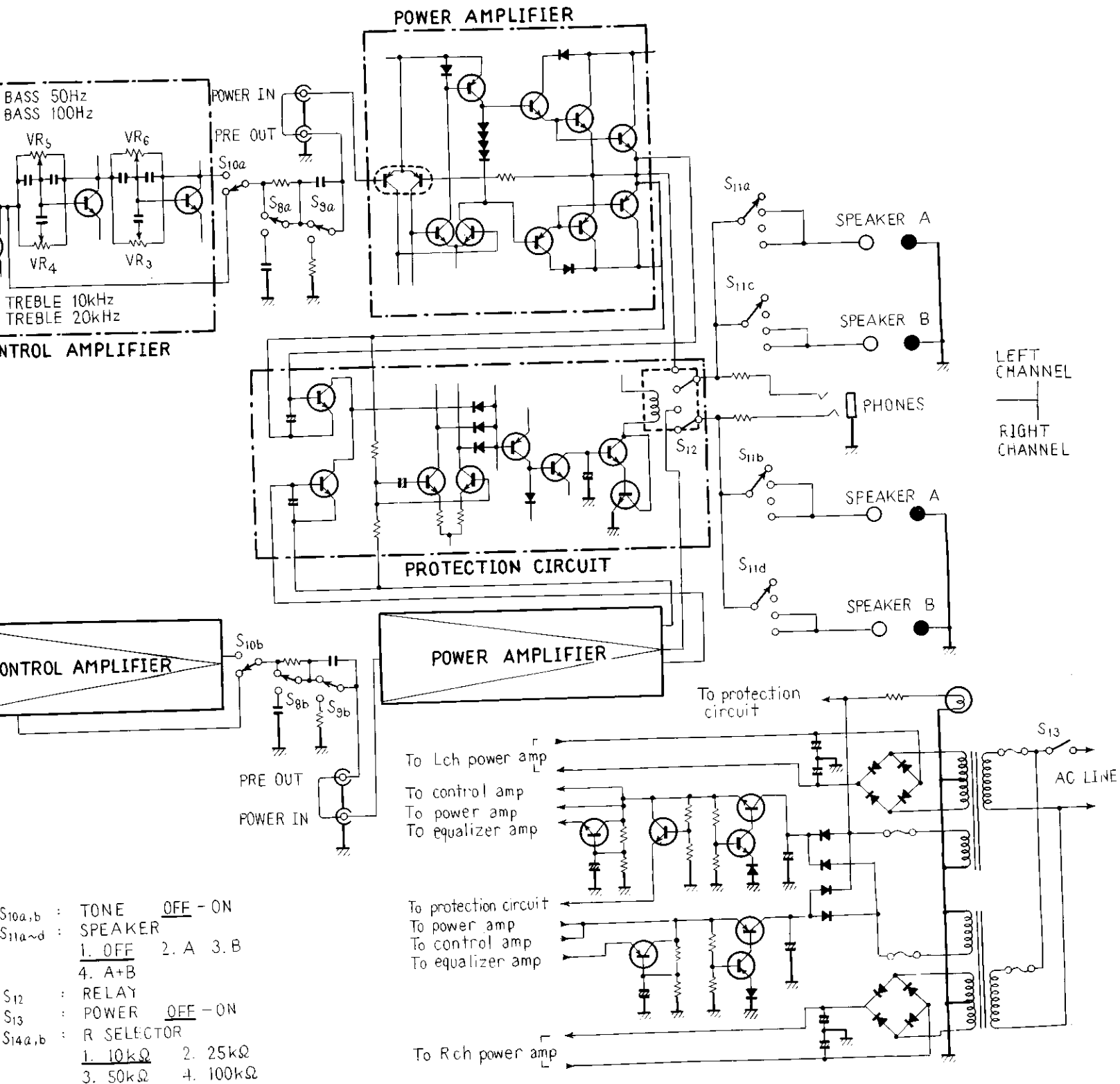

- S_{10a,b} : TONE OFF - ON
- S_{11a~d} : SPEAKER
 - 1. OFF 2. A 3. B
 - 4. A+B
- S₁₂ : RELAY
- S₁₃ : POWER OFF - ON
- S_{14a,b} : R SELECTOR
 - 1. 10kΩ 2. 25kΩ
 - 3. 50kΩ 4. 100kΩ

5. CIRCUIT DESCRIPTIONS

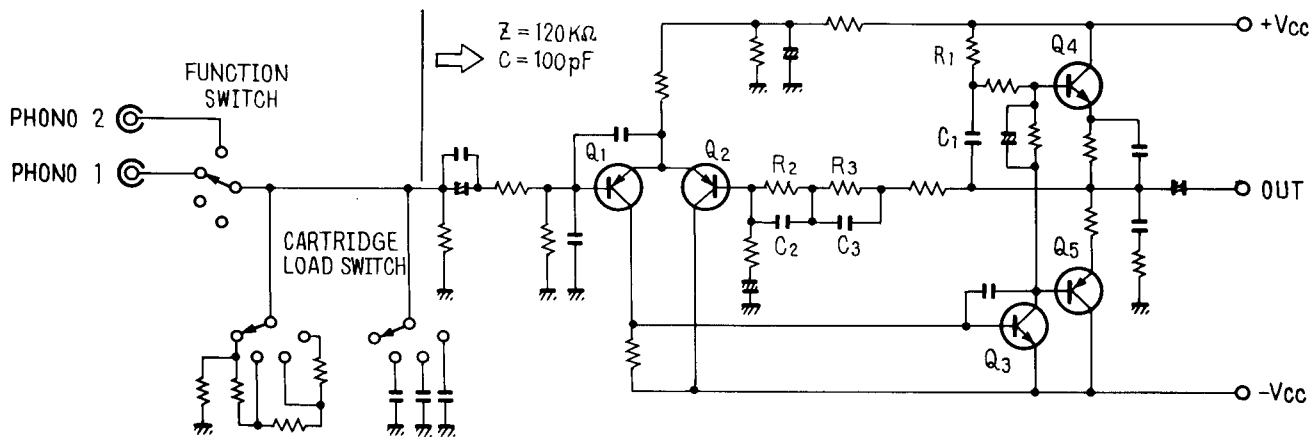

Fig. 1. Schematic diagram for equalizer amplifier

5.1 EQUALIZER AMPLIFIER

The circuit diagram for the equalizer amplifier is shown in Fig. 1. The two separate phono inputs are selected by the FUNCTION selector on the front panel. The input resistance and input capacitance can both be adjusted to 4 different levels ($R=10k\Omega$, $25k\Omega$, $50k\Omega$ and $100k\Omega$, $C=100pF$, $200pF$, $300pF$ and $400pF$) by means of the CARTRIDGE LOAD control knobs (R and C) which switches in and out, additional resistors and capacitors in parallel with the input terminal. Hence, optimum load conditions for different phono cartridges can be adjusted, as well as modifying the cartridge's frequency response in the high frequency range and thus producing variations in its characteristics.

The first stage of the equalizer amplifier (Q_1 & Q_2) is a differential amplifier using PNP transistors. The next stage (Q_3) is a bootstrap circuit employing C_1 , R_1 to provide high voltage gain. The output stage (Q_4 & Q_5) is a complementary-symmetrical SEPP circuit, whose high voltage utility factor results in a high output voltage. This gives the equalizer amplifier a very wide dynamic range, and a considerable overload input level of $300mV$ (RMS at $1kHz$) with no more than 0.05% distortion.

The equalizer elements (C_2 , C_3 , R_2 and R_3) consist of polypropylene film capacitors (tolerance $\pm 2\%$) and metal film resistors (tolerance $\pm 1\%$). Phono equalizer RIAA deviation has been reduced to less than $\pm 0.2dB$ ($20Hz \sim 20kHz$).

5.2 TONE CONTROLS

The SA-9500 II features two sets of tone controls (Twin Tone Controls) with different turnover frequencies for bass and treble. And each of these controls may be used independently.

Incoming signals are amplified to the required level by the 2 stage amplifier which uses a differential amplifier at first stage. Two tone control circuits (C-B feedback NFB type) are connected together in series. The second stage is the normal tone control (MAIN), while the other is a secondary tone control at a different turnover frequency (SUB). On the TREBLE side, this (SUB) turnover frequency is higher than the MAIN, while on the BASS side, it is lower.

The basic principles of the NFB type tone control circuit are outlined in Fig. 2.

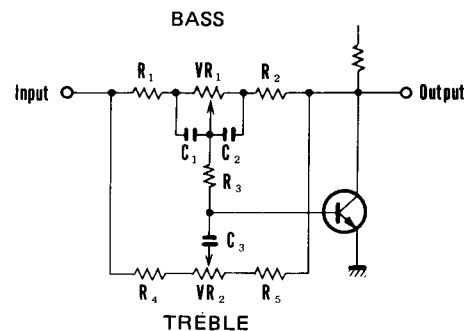

Fig. 2. Basic circuitry of NFB type tone control circuit

Midrange Operation

The C_1 and C_2 reactances are considerably smaller than VR_1 at frequencies above midrange, effectively shorting VR_1 . At frequencies below midrange, C_3 reactance becomes large and in effect, opens the circuit. Consequently, the circuit becomes equivalent to that shown in Fig. 3 with respect to the midrange. In this figure, the circuit parameters are not changed by any change in position of the VR_1 and VR_2 sliders. The NFB amount is therefore fixed and the circuit gain is also fixed without regard to VR_1 and VR_2 slider positions.

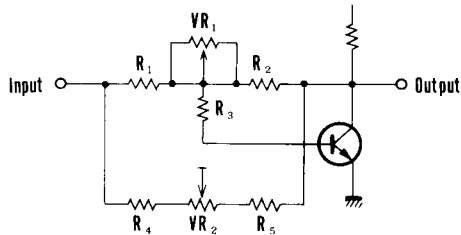

Fig. 3. Midrange operation of NFB type tone control circuit

Low Frequency Operation

The reactance of C_1 and C_2 increases at low frequency to form a circuit as shown in Fig. 4. This reactance increases in proportion to the frequency declines. Also, the NFB amount varies greatly according to VR_1 slider position. The circuit gain at low frequencies can therefore be varied by VR_1 .

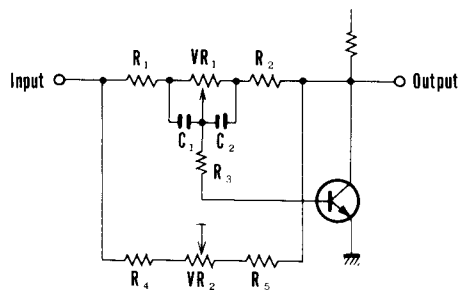

Fig. 4. Low frequency operation of NFB type tone control circuit

High Frequency Operation

The considerably smaller reactance of C_1 and C_2 at high frequency in comparison with VR_1 effectively shorts VR_1 to form an equivalent circuit such as that shown in Fig. 5. C_3 reactance decreases in the same degree that the frequency increases and the NFB amount is now mainly controlled by the VR_2 slider position. Consequently, the gain at high frequencies can be varied by VR_2 .

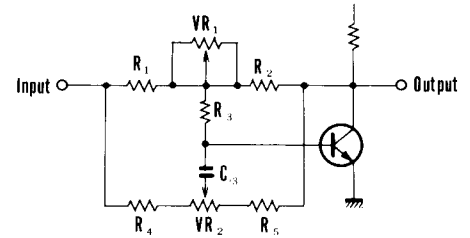

Fig. 5. High frequency operation of NFB type tone control circuit

Tone Defeat Circuit

By setting the TONE switch to OFF, the above described tone control circuit becomes bypassed.

5.3 POWER AMPLIFIER

The circuit diagram for the power amplifier section is shown in Fig. 6.

The input stage (Q_1) constitutes a differential amplifier, employing a dual transistor (a 2-in-1 transistor "package" possessing the functions of 2 separate transistors). The second stage (Q_2, Q_3) is also a differential amplifier, but with the inclusion of a current mirror (D_1, Q_4). Since the Q_4 base-emitter junction corresponds to a diode, the potential on the anode of D_1 and the emitter of Q_4 will be the same. Consequently, the potential drops across R_1 and R_2 will also be equal. So if the resistance of these 2 resistors is the same, the same current will flow through both sections. And if the h_{FE} of the transistor is sufficiently large, the base current can be neglected. That is, the Q_2 collector current and the Q_4 collector current will be the same. Since Q_2 and Q_3 operate out of phase with each other, Q_3 and Q_4 will operate as a push-pull amplifier. The bias voltage for the power stage is supplied by the potential difference produced across the VR_1-D_2 , where VR_1 is the variable resistor used to set this potential difference. D_2 is a varistor which compensates for thermal differences. The power stage (Q_5-Q_{10}) includes a 2-stage Darlington connection, with the final stage (Q_7-Q_{10}) forming two complementary symmetrical parallel circuits. The output mid-point is maintained at 0V by a balanced plus and minus power supply and a 100% DC NFB circuit.

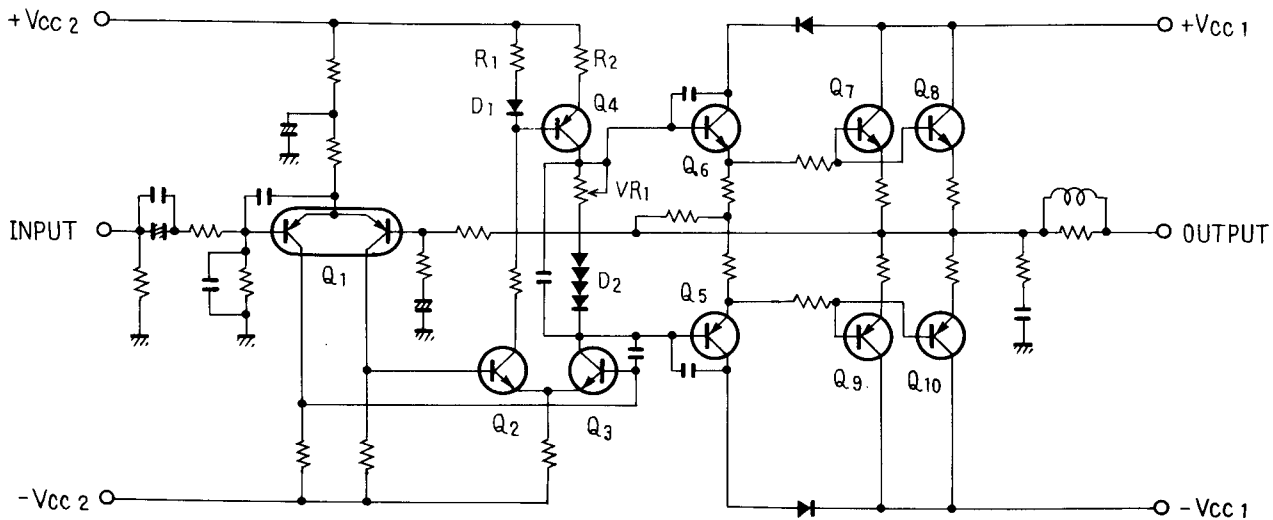

Fig. 6. Schematic diagram for power amplifier

5.4 PROTECTION CIRCUIT

This circuit protects the power transistors in case of overload, the speakers in case of power amplifier malfunction, and also performs a muting function when the power supply is turned ON or OFF. The protection circuit is composed of three sections (Fig. 7).

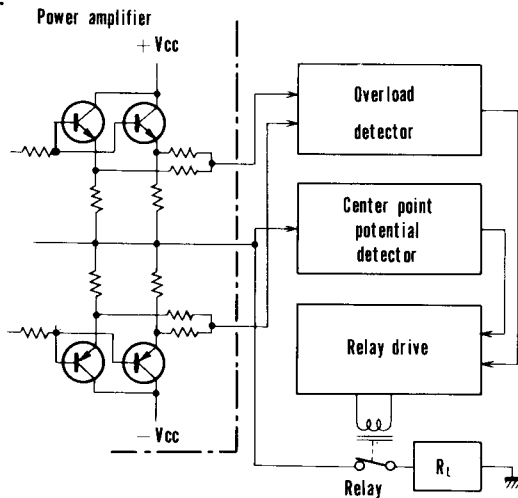

Fig. 7. Block diagram of protection circuit

The collector current of Q₈ then flows through the relay coil, operating the relay to turn on the power amplifier output circuit. The reverse bias of Q₆ base from D₆ & R₁₉ disappears when the power supply is set from ON to OFF. Q₆ remains ON however, due to the residual power supply voltage. C₄ very rapidly discharges, Q₇ base potential drops and Q₇ & Q₈ turn OFF. The relay releases and the power amplifier output circuit turns OFF.

Note:

Q₅ is normally OFF due to base bias and does not participate in the muting operation.

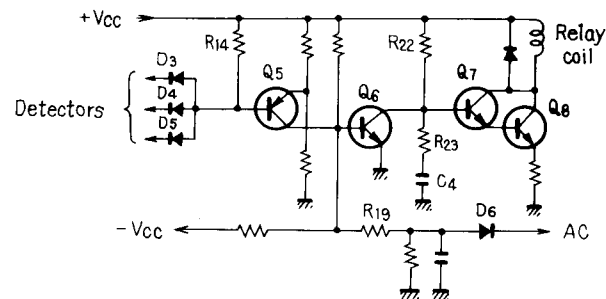

Fig. 8. Schematic diagram of relay driver circuit

1. Relay Driver Circuit (Fig. 8)

The relay which connects the output circuits is driven by this circuit. It also performs a muting function to prevent unpleasant noise during ON-OFF operation of the power supply as well as opening the output circuit on command from the detector circuits.

Muting Operation

When the power supply is turned ON, Q₆ base is reverse biased through D₆ and R₁₉, turning Q₆ OFF. Q₇ base potential rises as C₄ charges through R₂₂ & R₂₃, and Q₇ & Q₈ turn ON several seconds later.

Operation by Detector Circuit Command

Command from the detector circuits pass through one of D₃, D₄ or D₅ and are applied in the form of a current flow. Q₅ is normally reverse biased through R₁₄, but when a large current flows through one of these diodes, Q₅ base potential declines according to the voltage drop at R₁₄. Q₅ then turns ON, Q₆ base potential rises and Q₆ turns ON. C₄ rapidly discharges and Q₇ base potential drops, turning Q₇ & Q₈ OFF. The relay releases and the power amplifier output circuit becomes cut off.

6. LEVEL DIAGRAM

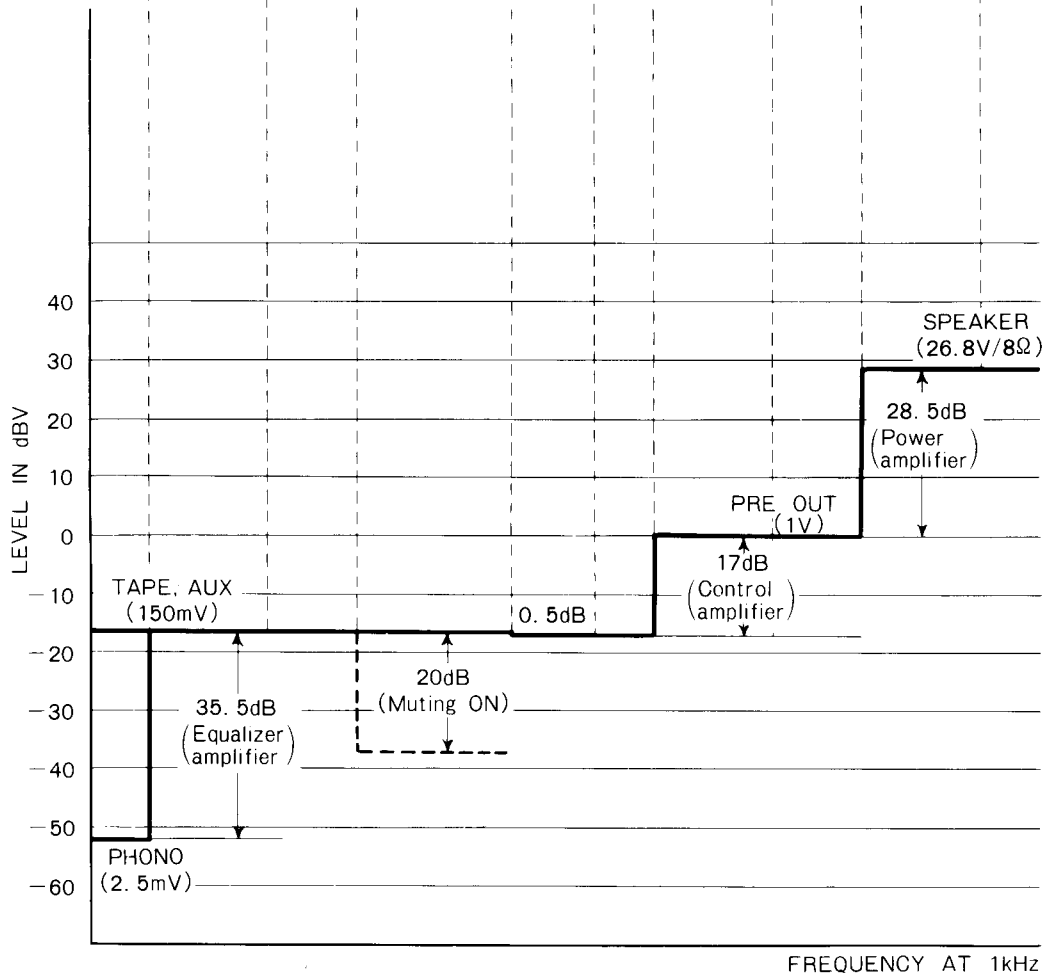
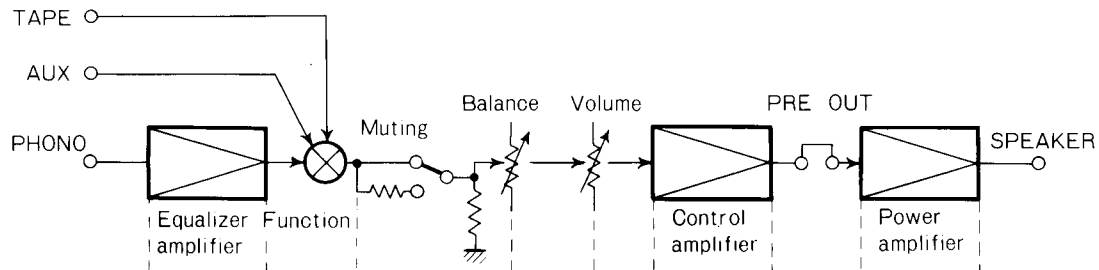

7. DISASSEMBLY

Top Cover
Remove the four screws (A).

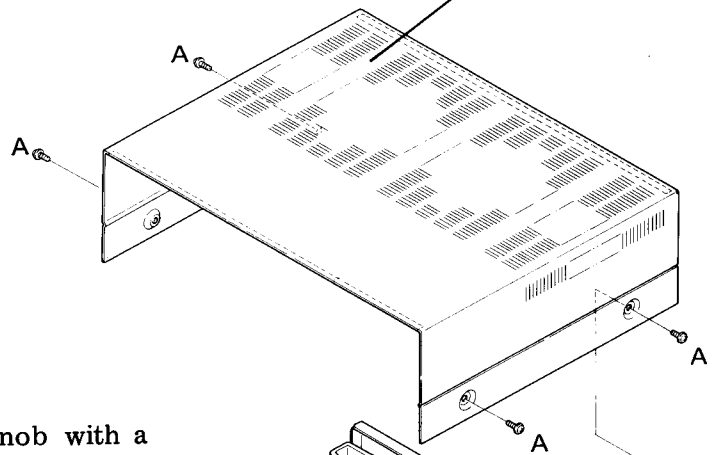

Front Panel
Loosen the setscrews of VOLUME knob with a hexagonal wrench. Remove all the knobs by pulling. Remove the four nuts (B).

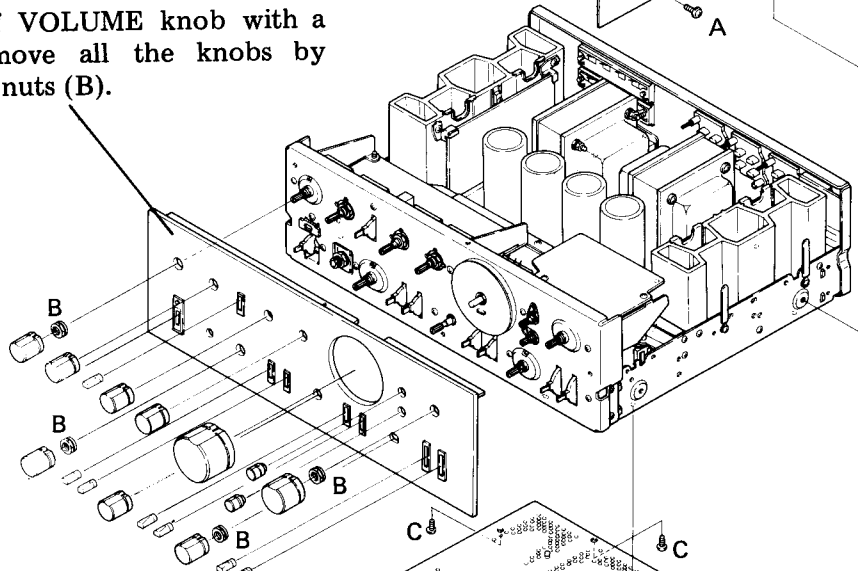

Bottom Plate
Remove the ten screws (C).

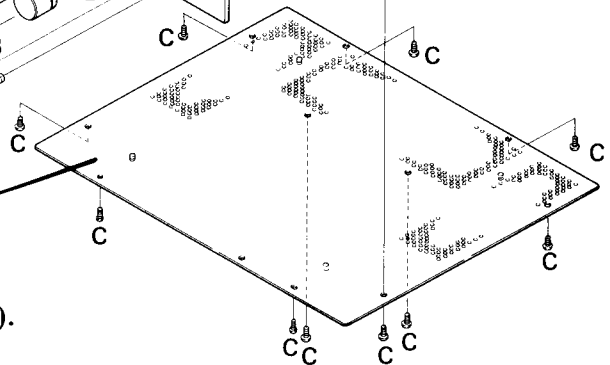

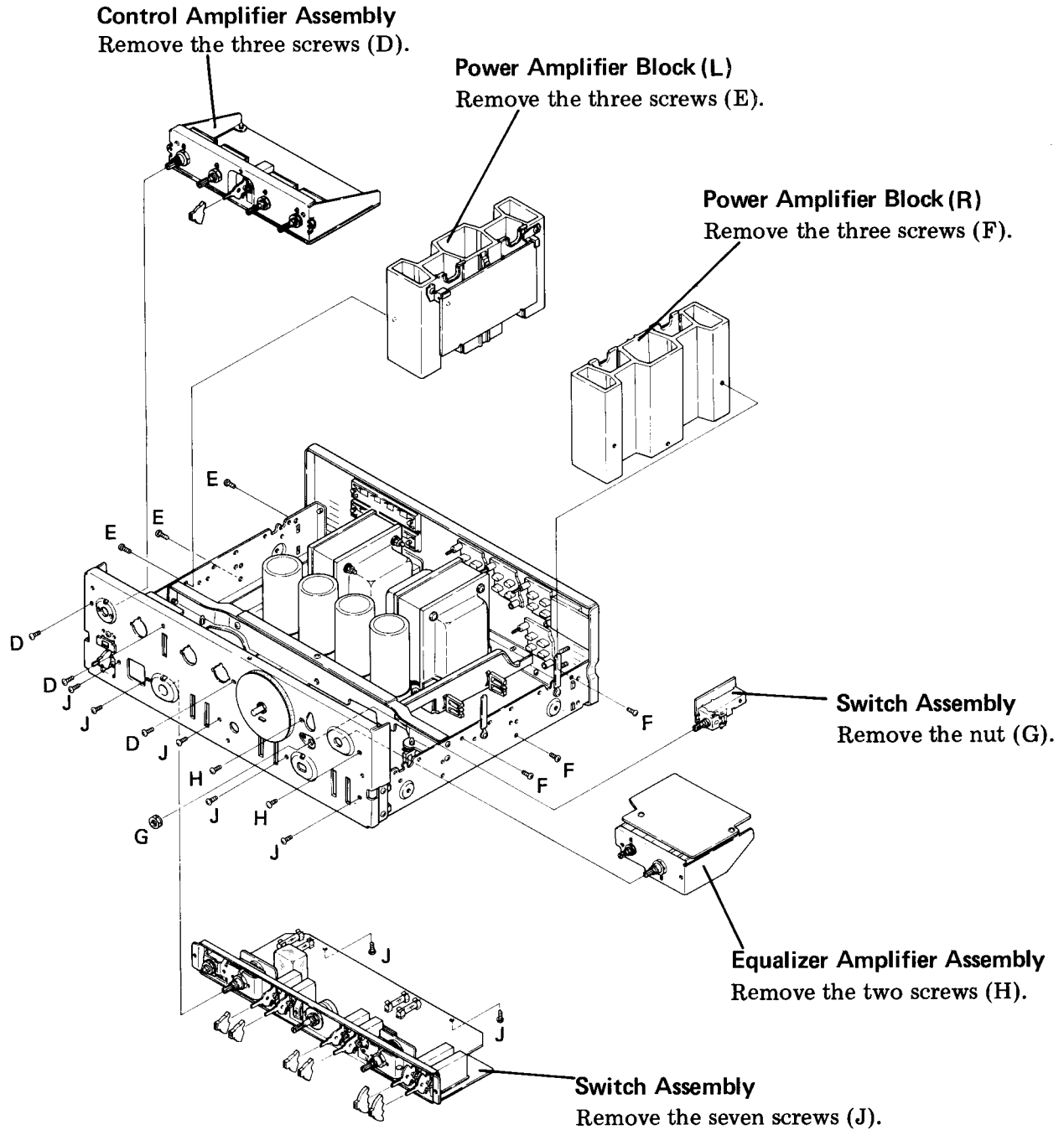

8. PARTS LOCATION

8.1 FRONT PANEL VIEW

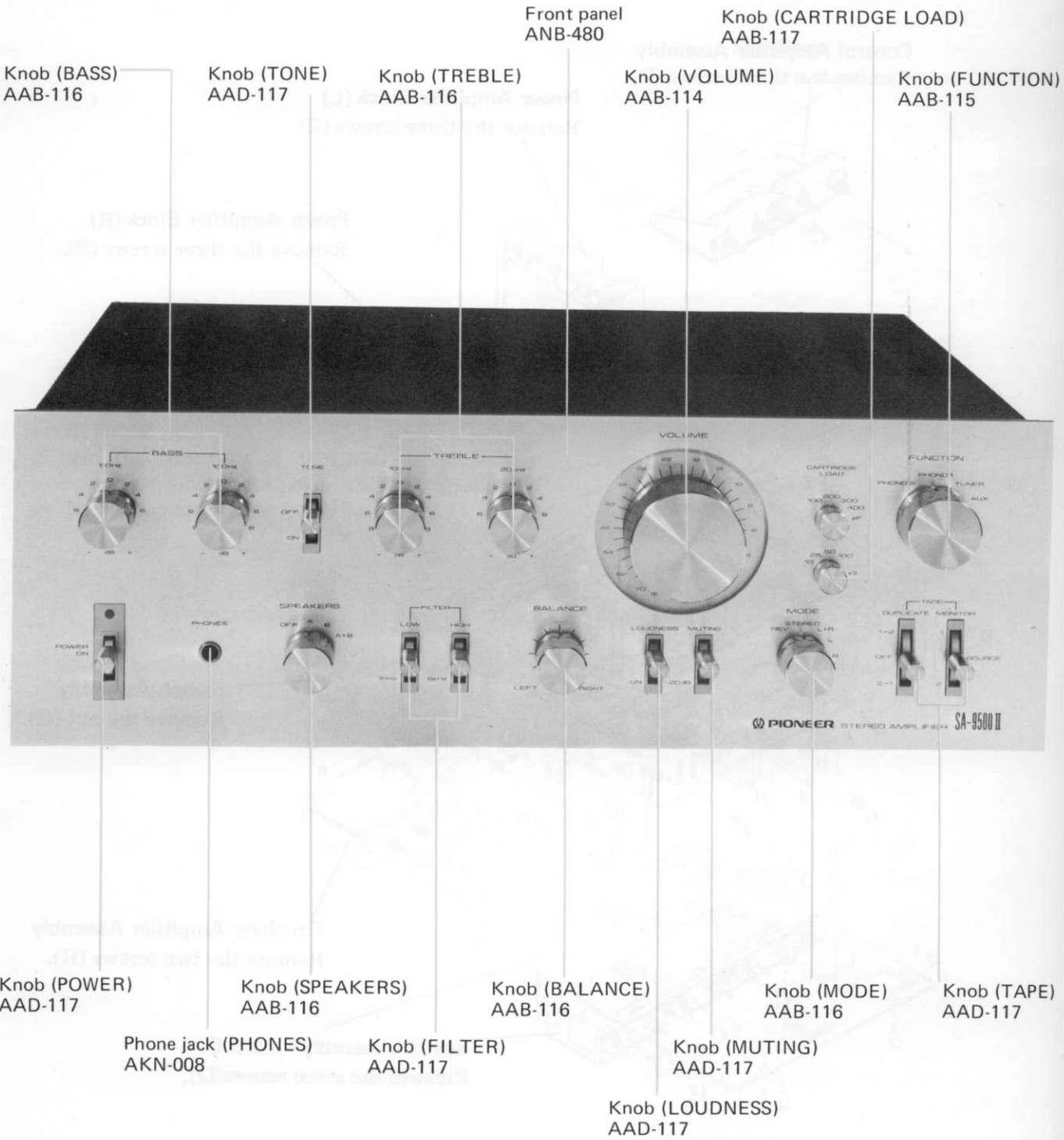

8.2 FRONT VIEW WITH PANEL REMOVED

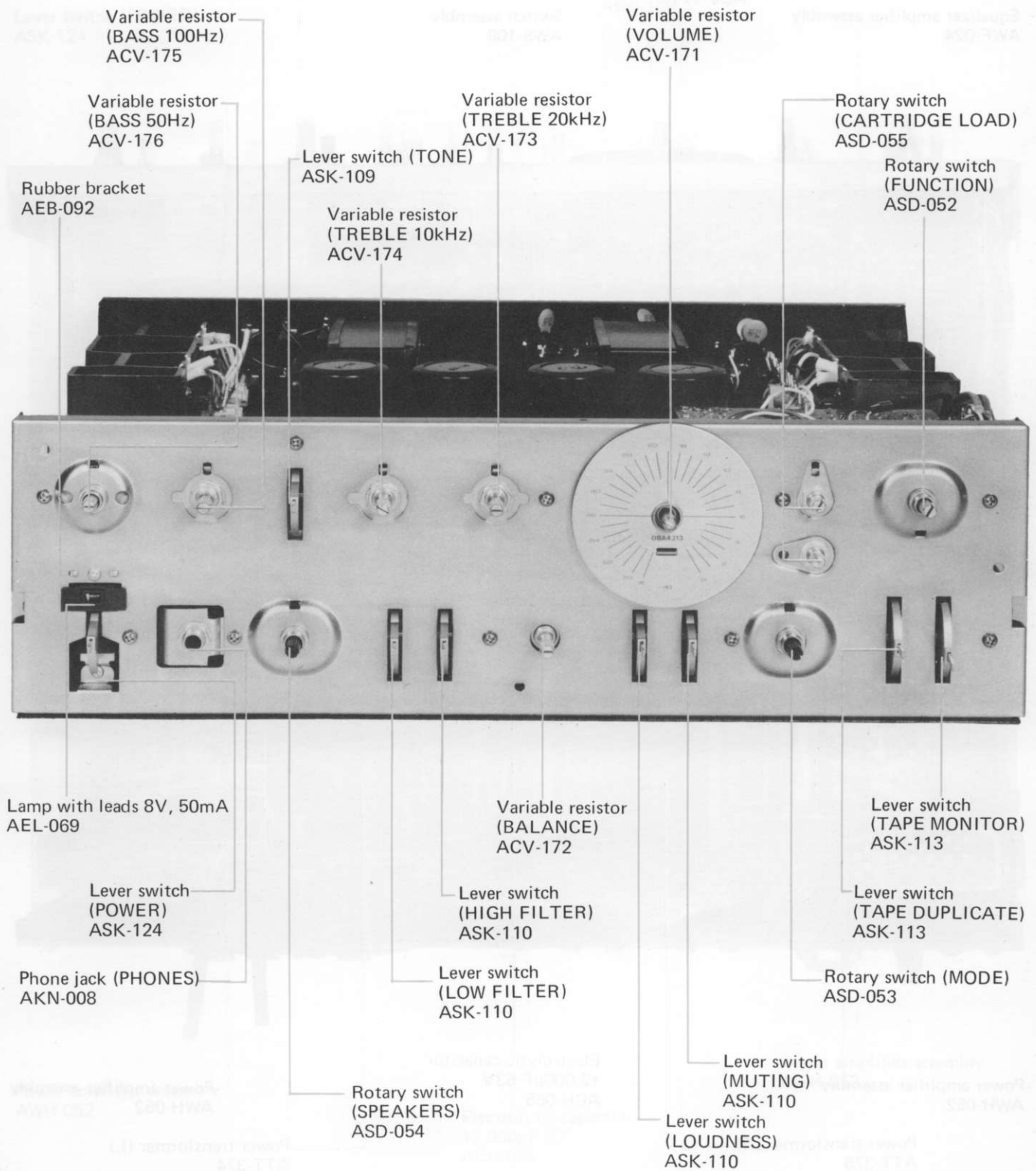

8.3 TOP VIEW

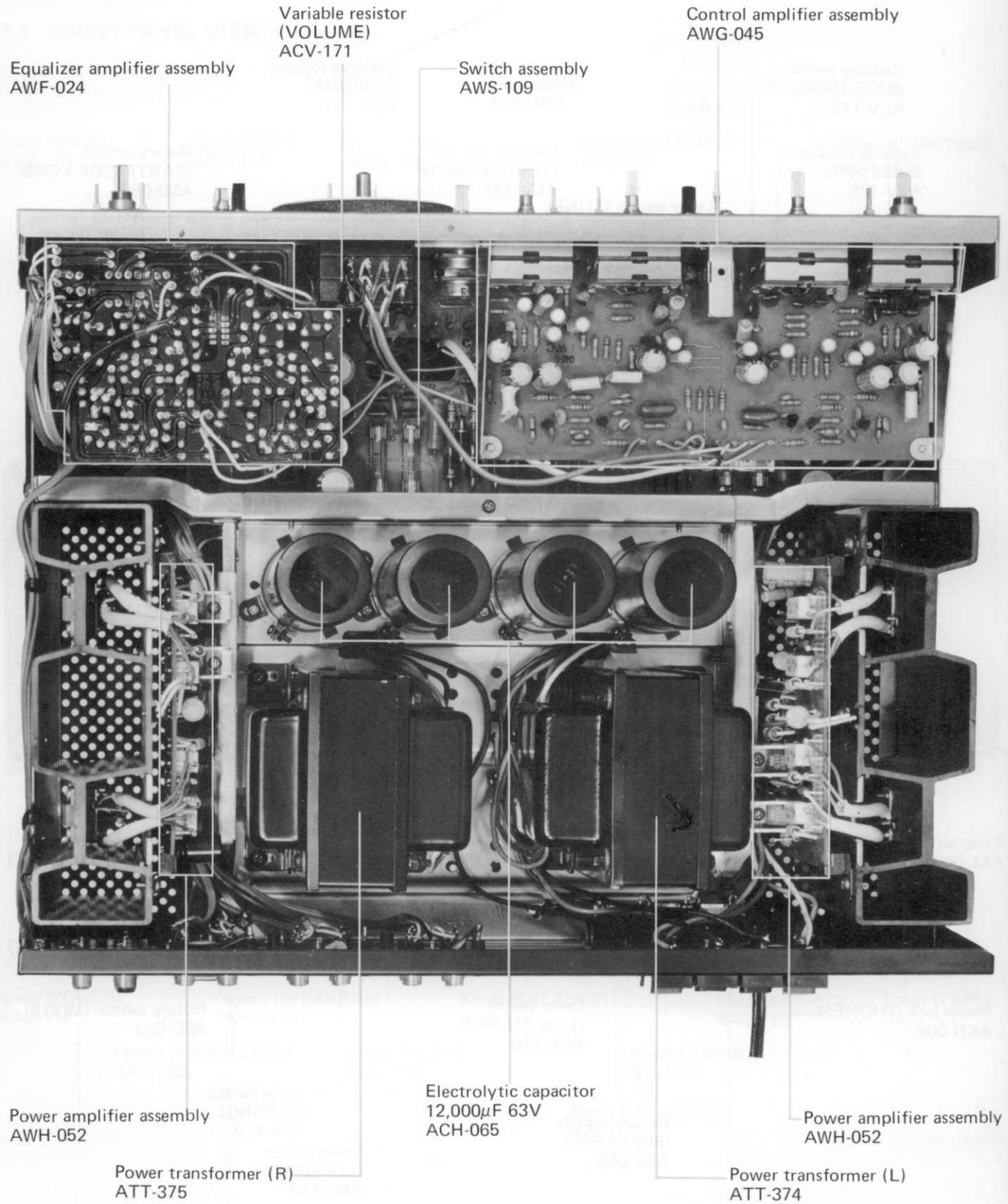

8.4 BOTTOM VIEW

Lever switch (POWER)
ASK-124

Switch assembly
AWS-109

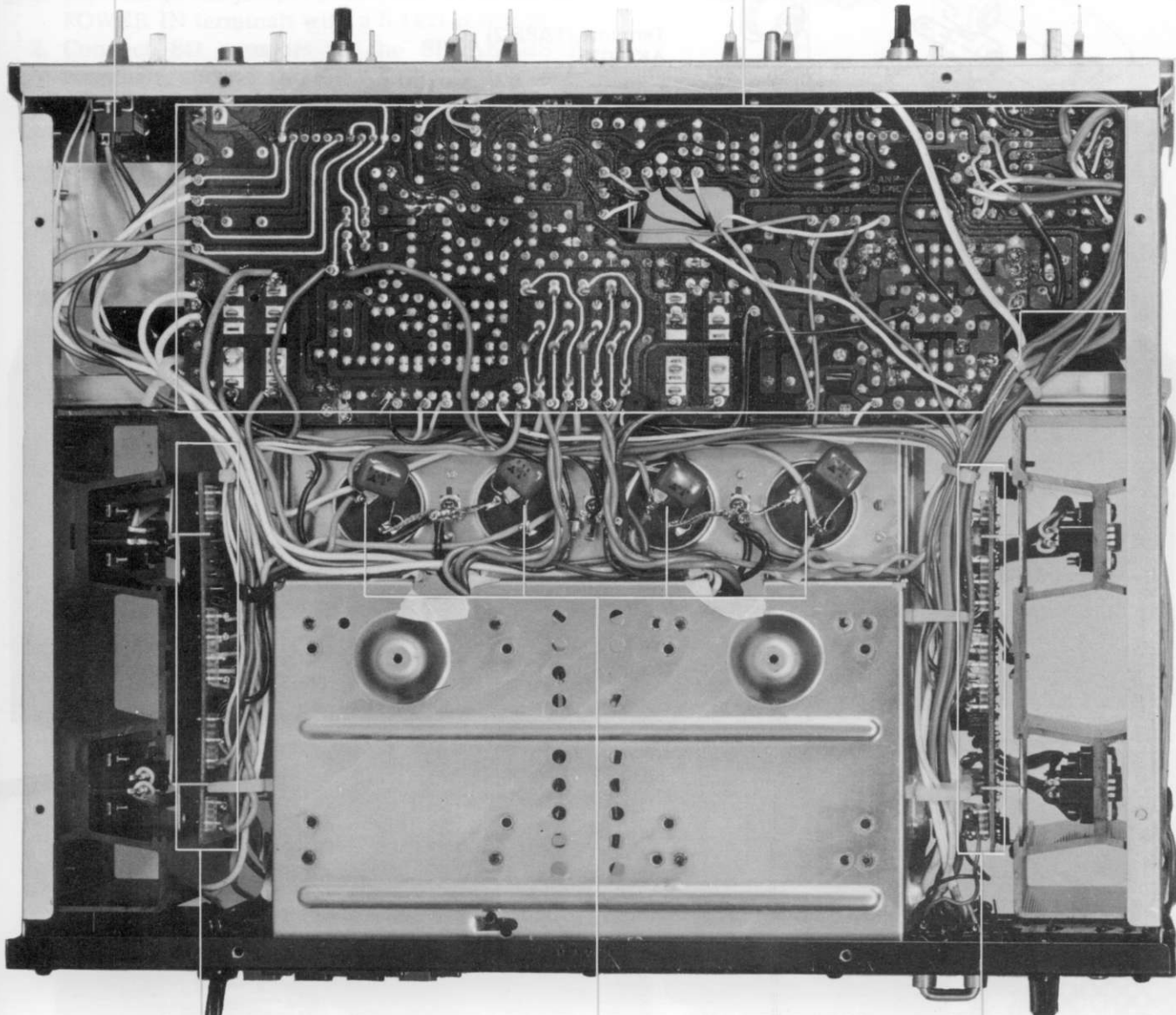

Power amplifier assembly
AWH-052

Electrolytic capacitor
12,000 μ F 63V
ACH-065

Power amplifier assembly
AWH-052

8.5 REAR VIEW

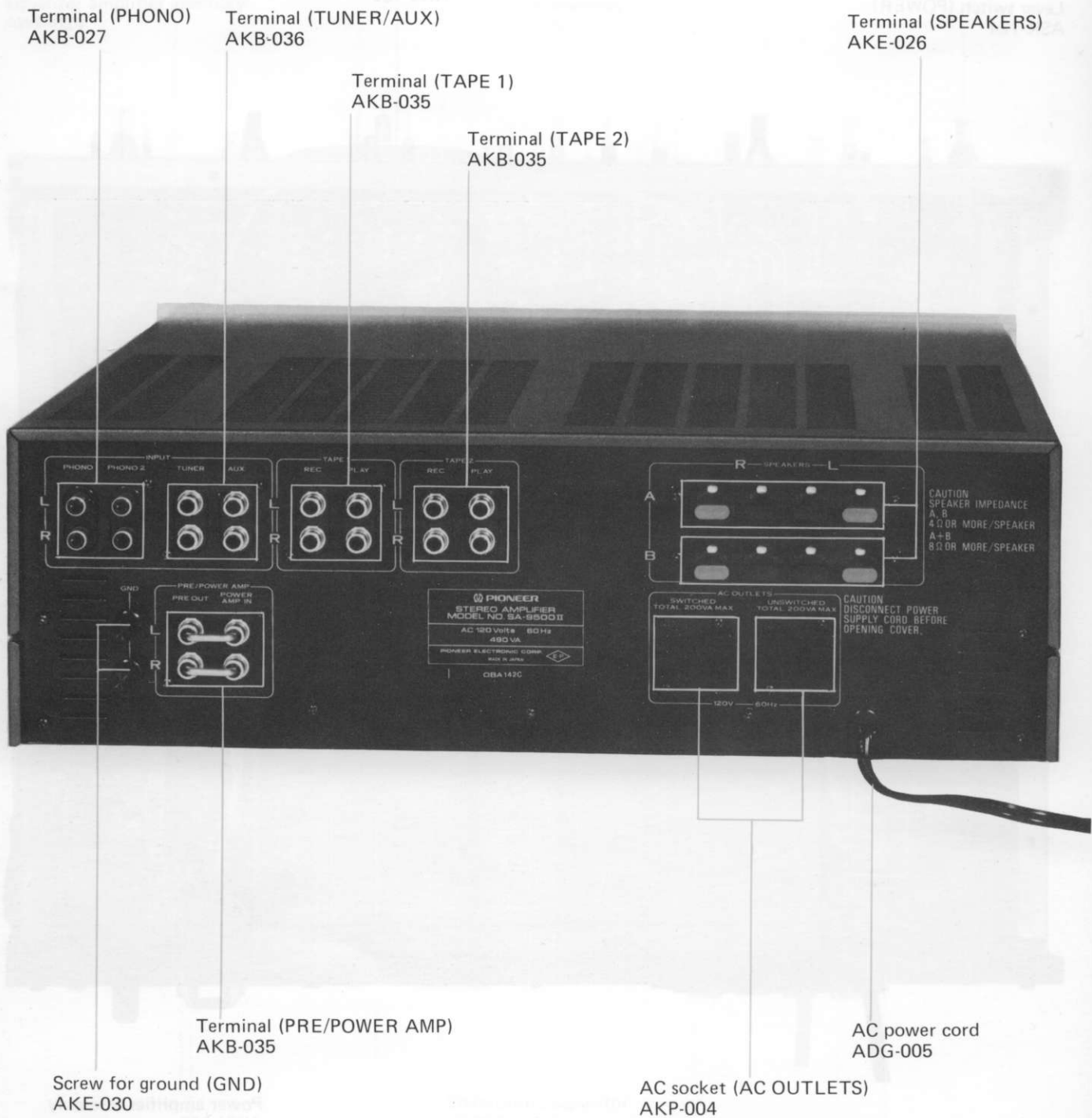

9. ADJUSTMENT

The SA-9500 II amplifier employs the same type of power amplifier assembly in both left and right channels. Any adjustment will thus have to be identical in both channels, and is limited to adjustments of the idler current.



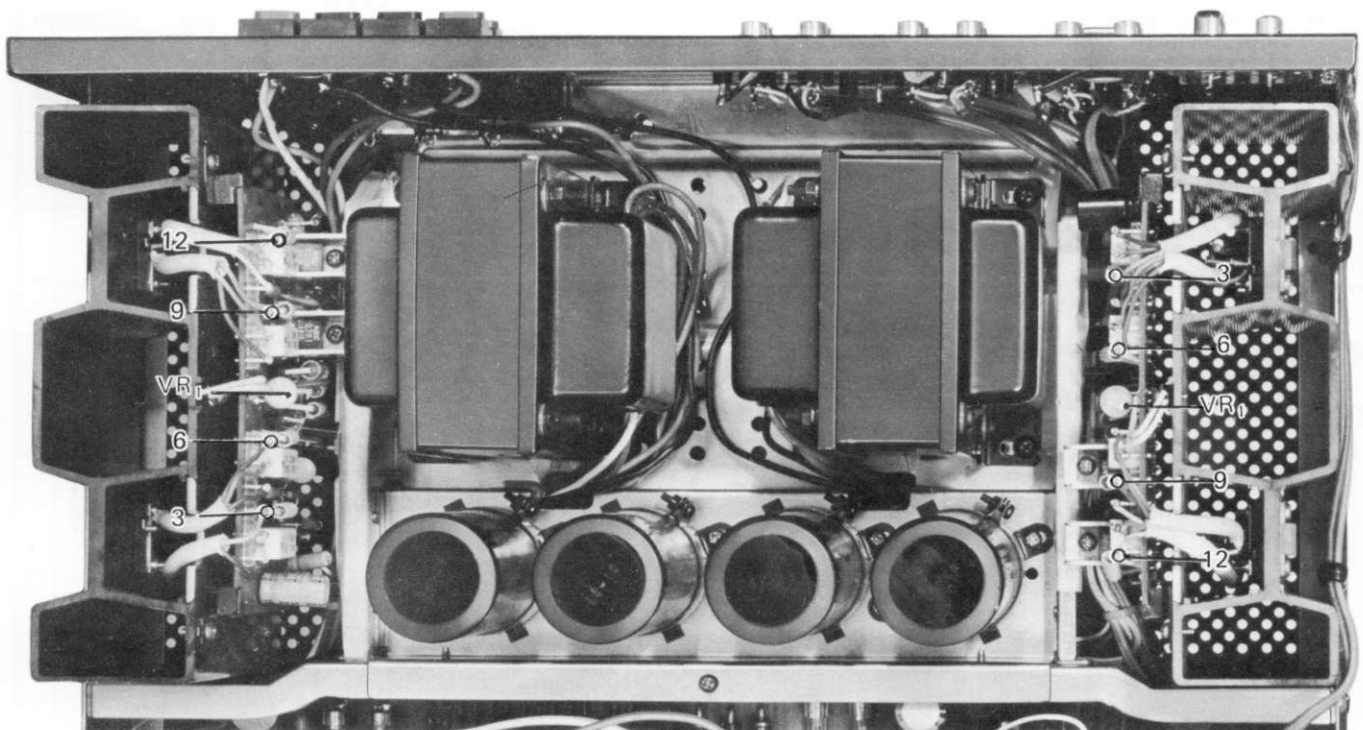
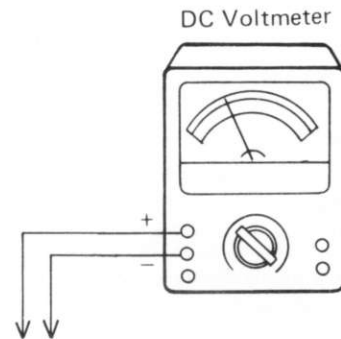
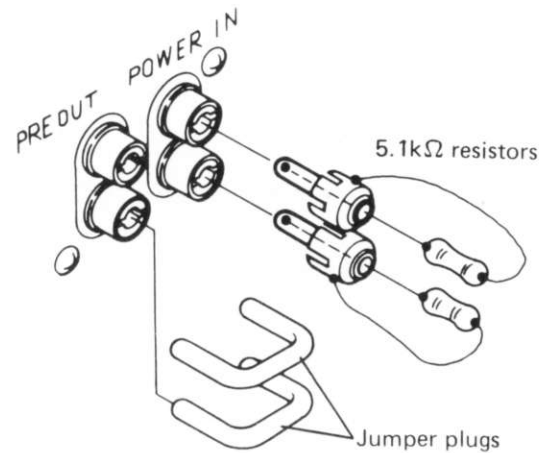











1. Disconnect the jumper plugs, and terminate the POWER IN terminals with a $5.1k\Omega$ resistors.
2. Connect 8Ω resistors to the SPEAKERS A terminals, and set the SPEAKERS switch to A.
3. Turn VR_1 in fully a counter-clockwise.
4. Turn the POWER switch ON, and then readjust VR_1 so that the voltage between terminals No. 3 (+) and No. 9 (-) reads 30mV.
5. Now check that the voltage between terminals No. 6 (+) and No. 12 (-) reads $30mV \pm 10mV$ (in order to check the current distribution, since the final stages are in parallel).
6. Leave the amplifier ON for about 30 minutes, then repeat steps 4 and 5.
7. Finally, apply an actual signal, and check for no crossover distortion.











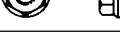
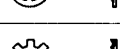
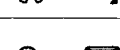

10. EXPLODED VIEWS

NOMENCLATURE OF SCREWS, WASHERS, AND NUTS

The following symbols stand for screws, washers and nuts as shown in exploded view.

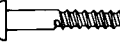
Symbol	Description	Shape
RT	Brazier head tapping screw	
PT	Pan head tapping screw	
BT	Binding head tapping screw	
CT	Countersunk head tapping screw	
TT	Truss head tapping screw	
OCT	Oval countersunk head tapping screw	
PM	Pan head machine screw	
CM	Countersunk head machine screw	
OCM	Oval countersunk head machine screw	
TM	Truss head machine screw	
BM	Binding head machine screw	
PSA	Pan head screw with spring lock washer	
PSB	Pan head screw with spring lock washer and flat washer	
PSF	Pan head screw with flat washer	

Symbol	Description	Shape
EW	E type washer	
FW	Flat washer	
SW	Spring lock washer	
N	Nut	
WN	Washer faced nut	
ITW	Internal toothed lock washer	
OTW	Outernal toothed lock washer	
SC	Slotted set screw (Cone point)	
SF	Slotted set screw (Flat point)	
HS	Hexagon socket headless set screw	
OCW	Oval countersunk head wood screw	
CW	Countersunk head wood screw	
RW	Round head wood screw	

EXAMPLE

PM · 3x8
 length in mm (l)
 diameter in mm (d)
 Symbol

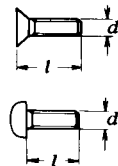

FW · 9φ x 1^t
 thickness in mm (t)
 diameter in mm (d)
 Symbol

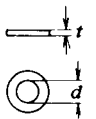

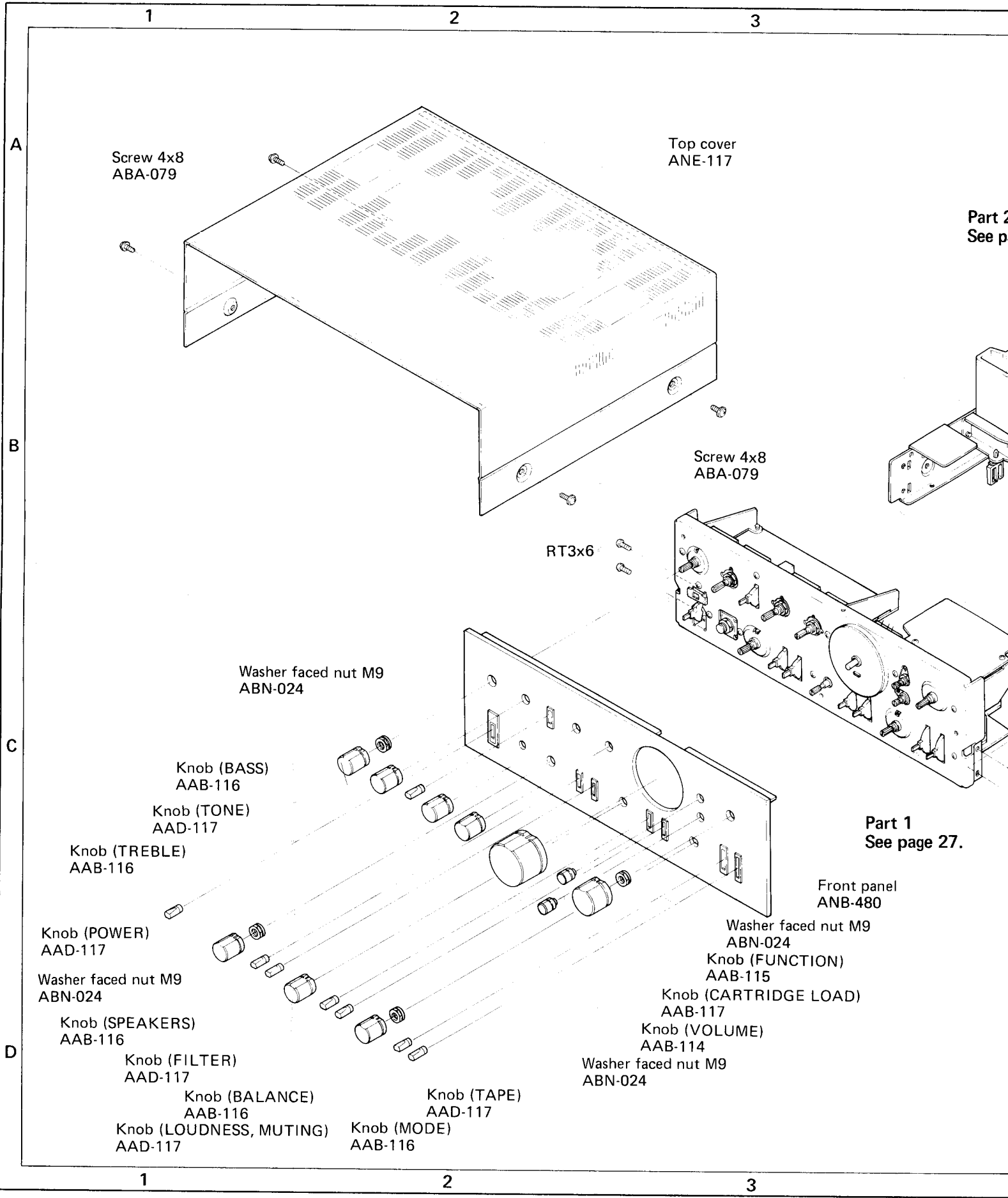

Part 2
See p

Part 1
See page 27.

4

5

6

NOTE:
Parts indicated in green type cannot be supplied.

Part 3
See page 29.

Screw 3x8
ABA-002

Part 2
See page 28.

A

B

C

D

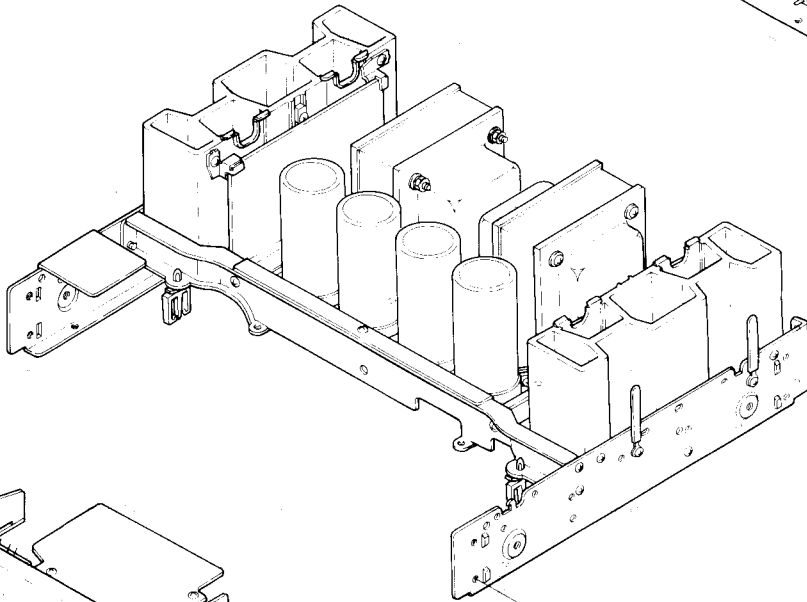

Screw 4x8
ABA-012

Part 1
See page 27.

RT3x6

Front panel
ANB-480
Nut M9

Screw 4x8
ABA-012

Screw 4x8
ABA-012

(ION)
(LOAD)

Foot
AEC-178

Foot
AEC-178

RT4x16
Foot
AEC-178

RT4x16

Screw 4x8
ABA-012
Foot
AEC-178

RT4x16

RT4x16

4

5

6

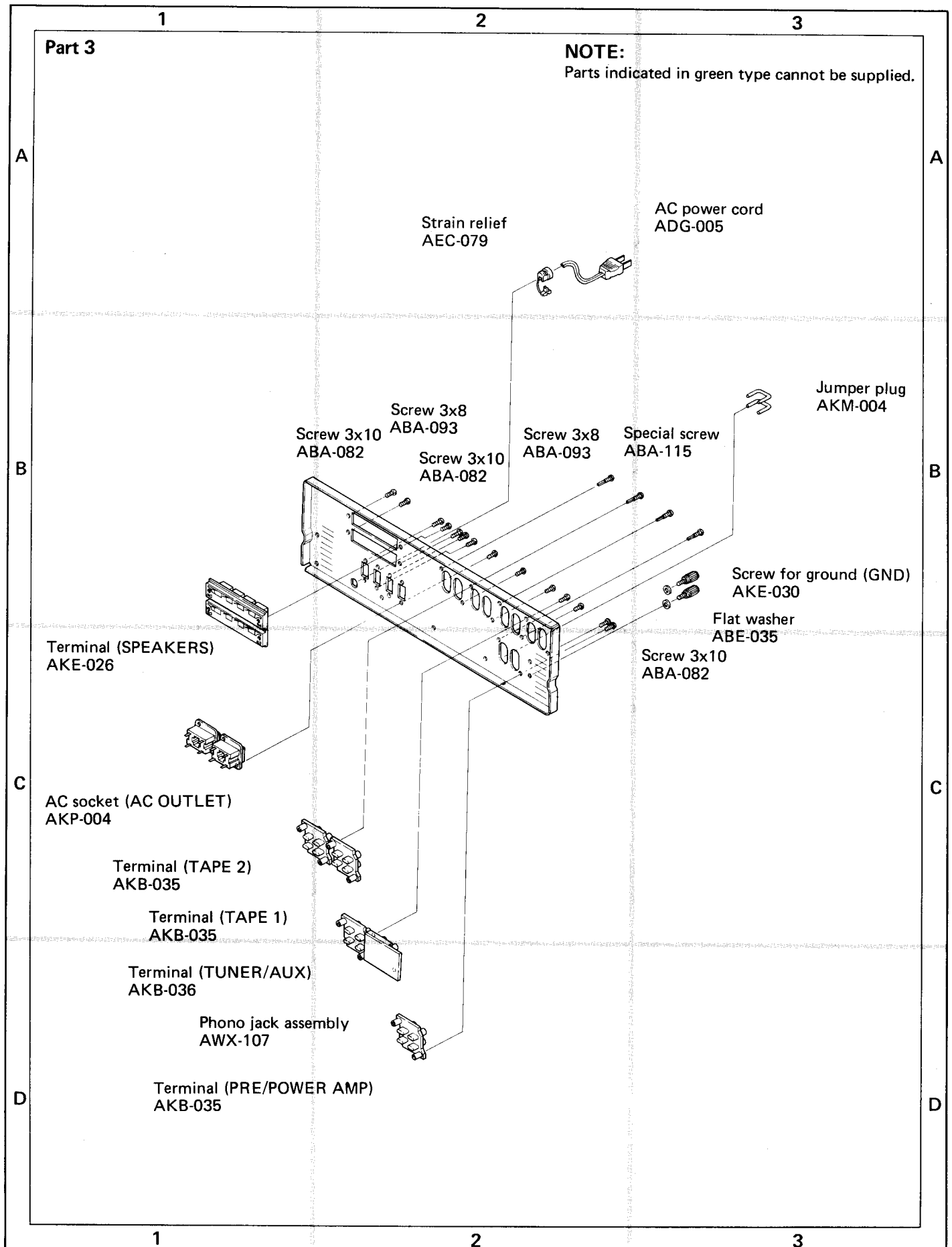

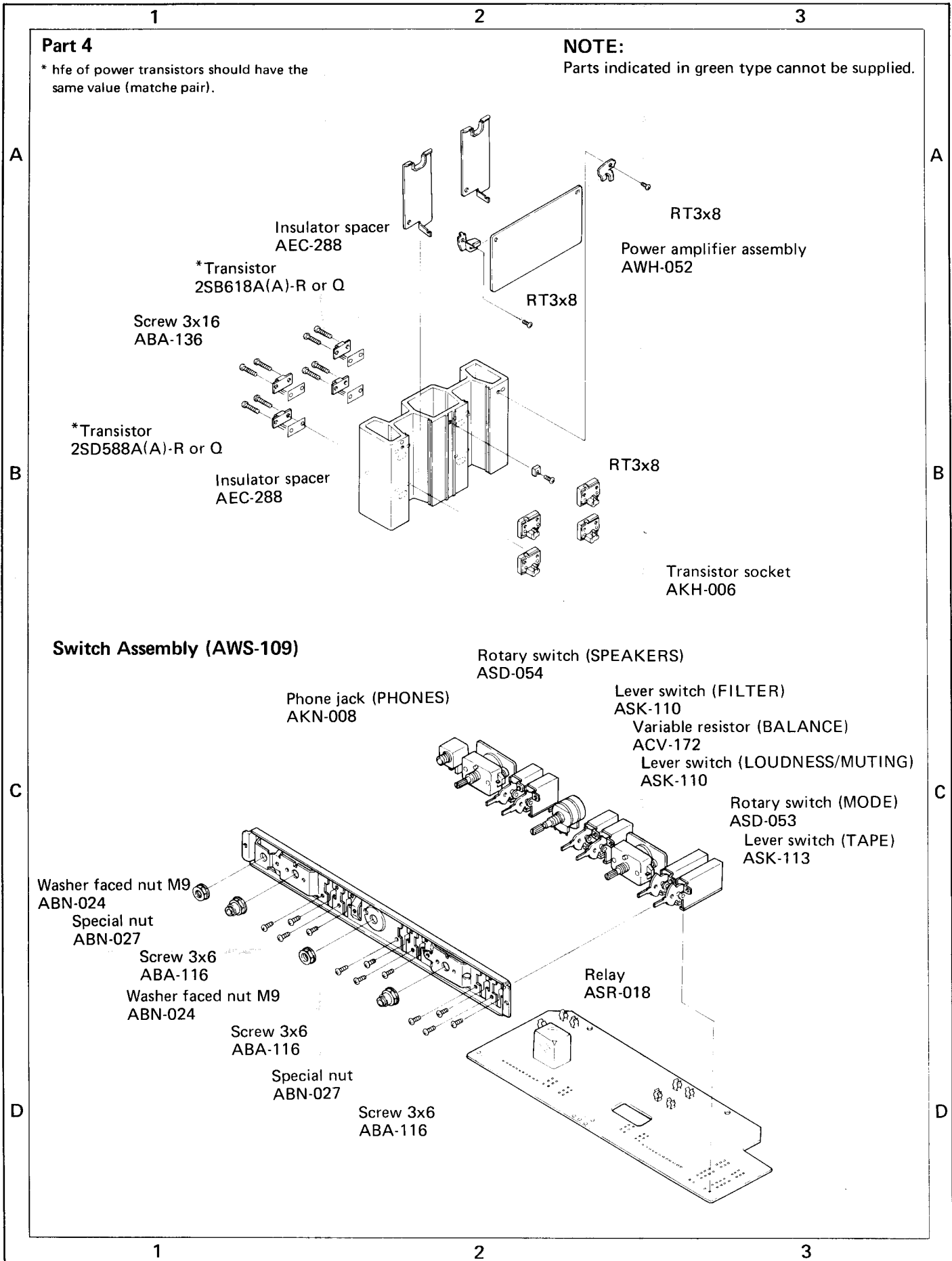

1

2

3

NOTE:
Parts indicated in green type cannot be supplied.

Control Amplifier Assembly (AWG-045)

Variable resistor (BASS 50Hz)
ACV-176

Variable resistor (BASS 100Hz)
ACV-175

Lever switch (TONE)
ASK-109

Variable resistor (TREBLE 10kHz)
ACV-174

Variable resistor (TREBLE 20kHz)
ACV-173

Screw 3x6
ABA-116

Special nut
ABN-027

Washer faced nut M9
ABN-024

RT3x6

Equalizer Amplifier Assembly (AWF-024)

RT3x6

Switch Assembly (AWS-102)

Rotary switch (CARTRIDGE LOAD C)
ASD-055

Washer faced nut M7
ABN-031

Rotary switch
(CARTRIDGE LOAD R)
ASD-055

Rotary switch (FUNCTION)
ASD-052

Special nut
ABN-027

1

2

3

11. SCHEMATIC DIAGRAMS, P. C. BOARD PATTERNS AND PARTS LIST

11.1 MISCELLANEA

Miscellaneous Parts

NOTE:

- Capacitors: in μF unless otherwise noted $p:pF$
- Resistors: in Ω , $\frac{1}{4}W$ unless otherwise noted $k:k\Omega$, $M:M\Omega$

SEMICONDUCTORS

Symbol	Description	Part No.
Q1	Transistor	2SD588A/A/-R or Q
Q2	Transistor	2SD588A/A/-R or Q
Q3	Transistor	2SB618A/A/-R or Q
Q4	Transistor	2SB618A/A/-R or Q
Q5	Transistor	2SD588A/A/-R or Q
Q6	Transistor	2SD588A/A/-R or Q
Q7	Transistor	2SB618A/A/-R or Q
Q8	Transistor	2SB618A/A/-R or Q

LAMP, FUSES

Symbol	Description	Part No.
PL1	Lamp with leads 8V, 50mA	AEL-069
FU1	Fuse 4A	AEK-100
FU2	Fuse 4A	AEK-100
FU3	Fuse 0.8A	AEK-111
FU4	Fuse 0.8A	AEK-111

SWITCH

Symbol	Description	Part No.
S13	Lever switch (POWER)	ASK-124

TRANSFORMERS

Symbol	Description	Part No.
T1	Power transformer (L)	ATT-374
T2	Power transformer (R)	ATT-375

RESISTOR

Symbol	Description	Part No.
VR1	Variable resistor 100k 32-step (VOLUME)	ACV-171

CAPACITORS

Symbol	Description	Part No.
C1	Ceramic 0.047 50V	CKDYF 473Z 50
C2	Ceramic 0.047 50V	CKDYF 473Z 50
C3	Ceramic 0.047 50V	CKDYF 473Z 50
C4	Ceramic 0.047 50V	CKDYF 473Z 50
C5	Ceramic 0.047 50V	CKDYF 473Z 50
C6	Electrolytic 12,000 63V	ACH-065
C7	Electrolytic 12,000 63V	ACH-065
C8	Electrolytic 12,000 63V	ACH-065
C9	Electrolytic 12,000 63V	ACH-065
C10	Ceramic 0.01 250V	ACG-001

External Appearance of Transistor

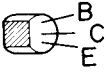
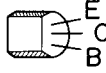
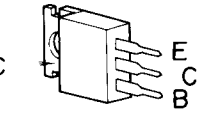
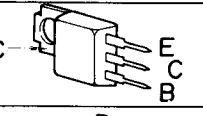
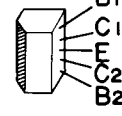
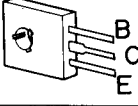
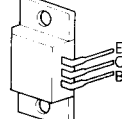
Type	Fig.
2SA733 2SA640 2SA720 2SA750 2SC945A 2SC1318 2SC1400	
2SA906 2SC869	
2SB536 2SB596 2SD381 2SD526	
2SD356	
2SA798	
2SA898 2SC1903	
2SB618 A(A) 2SD588A(A)	

11.2 SCHEMATIC DIAGRAM

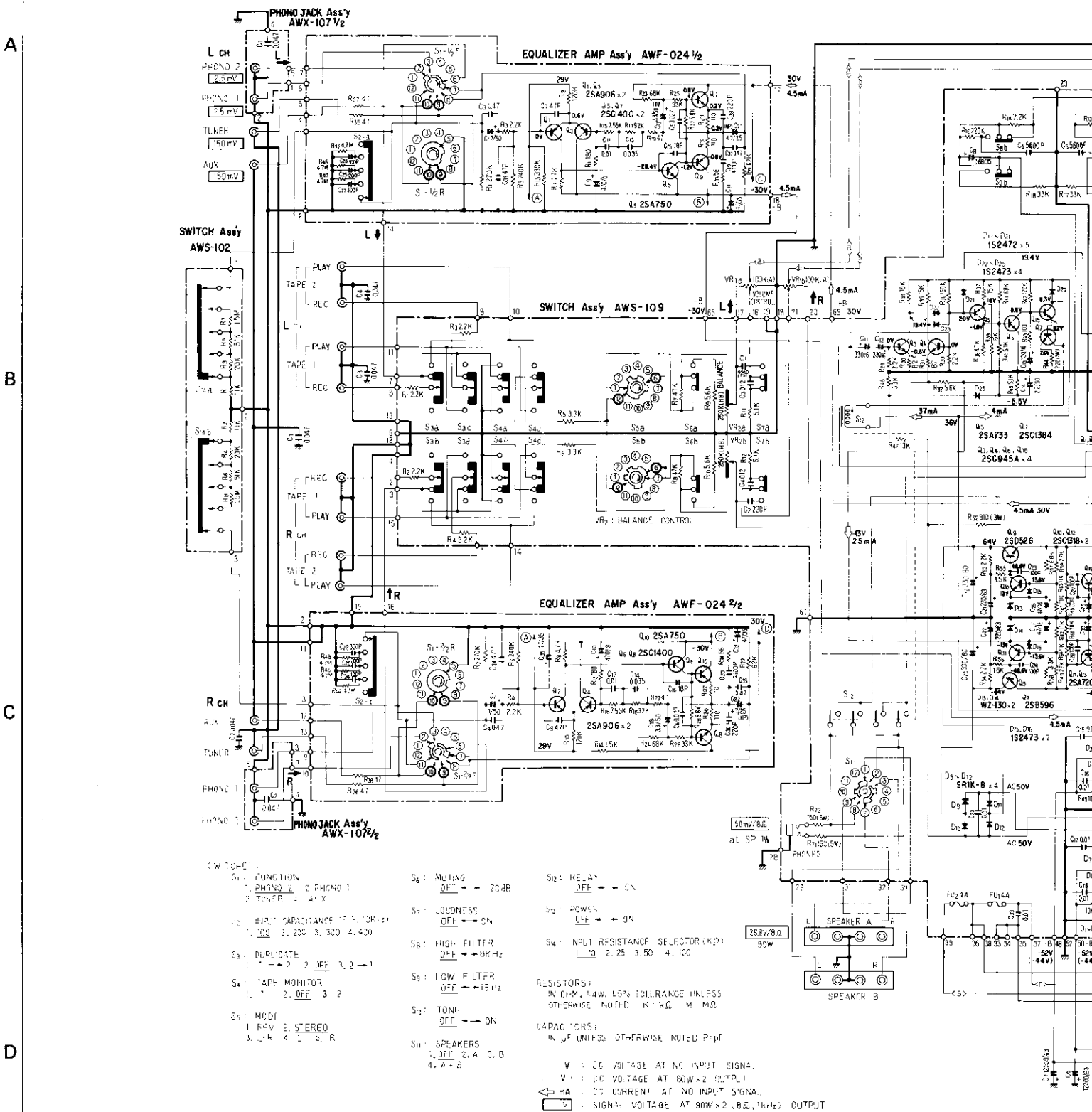

- SWITCHES:**
- S₁: FUNCTION
1. PHONO 2. PHONO 1
3. TUNER 4. AUX
 - S₂: INPUT CAPACITANCE (TAP) OFF
1. 100 2. 230 3. 300 4. 400
 - S₃: DUPLICATE
1. OFF 2. OFF 3. 2 → 1
 - S₄: TAPE MONITOR
1. ON 2. OFF 3. 2
 - S₅: MODE
1. REV 2. STEREO
3. L-R 4. L-R
 - S₆: Muting
OFF → ON
 - S₇: LOUDNESS
OFF → ON
 - S₈: HIGH FILTER
OFF → ON
 - S₉: LOW FILTER
OFF → ON
 - S₁₀: TONE
OFF → ON
 - S₁₁: SPEAKERS
1. OFF 2. A 3. B
4. A-B

- S₁₂: RELAY
OFF → ON
- S₁₃: POWER
OFF → ON
- S₁₄: INPUT RESISTANCE SELECTOR (KΩ)
1. 10 2. 2.5 3. 50 4. 100

RESISTORS:
IN OHMS, 1/4W, 5% TOLERANCE UNLESS OTHERWISE NOTED. K = KΩ, M = MΩ.

CAPACITORS:
IN μF UNLESS OTHERWISE NOTED. P = pF

V : DC VOLTAGE AT NO INPUT SIGNAL.
V : DC VOLTAGE AT 80W x 2 OUTPUT.
mA : DC CURRENT AT NO INPUT SIGNAL.
V : SIGNAL VOLTAGE AT 80W x 2, 80, 1kHz OUTPUT

4

5

6

NOTE:

The indicated semiconductors are representative ones only. Other alternative semiconductors may be used and are listed in the parts lists.

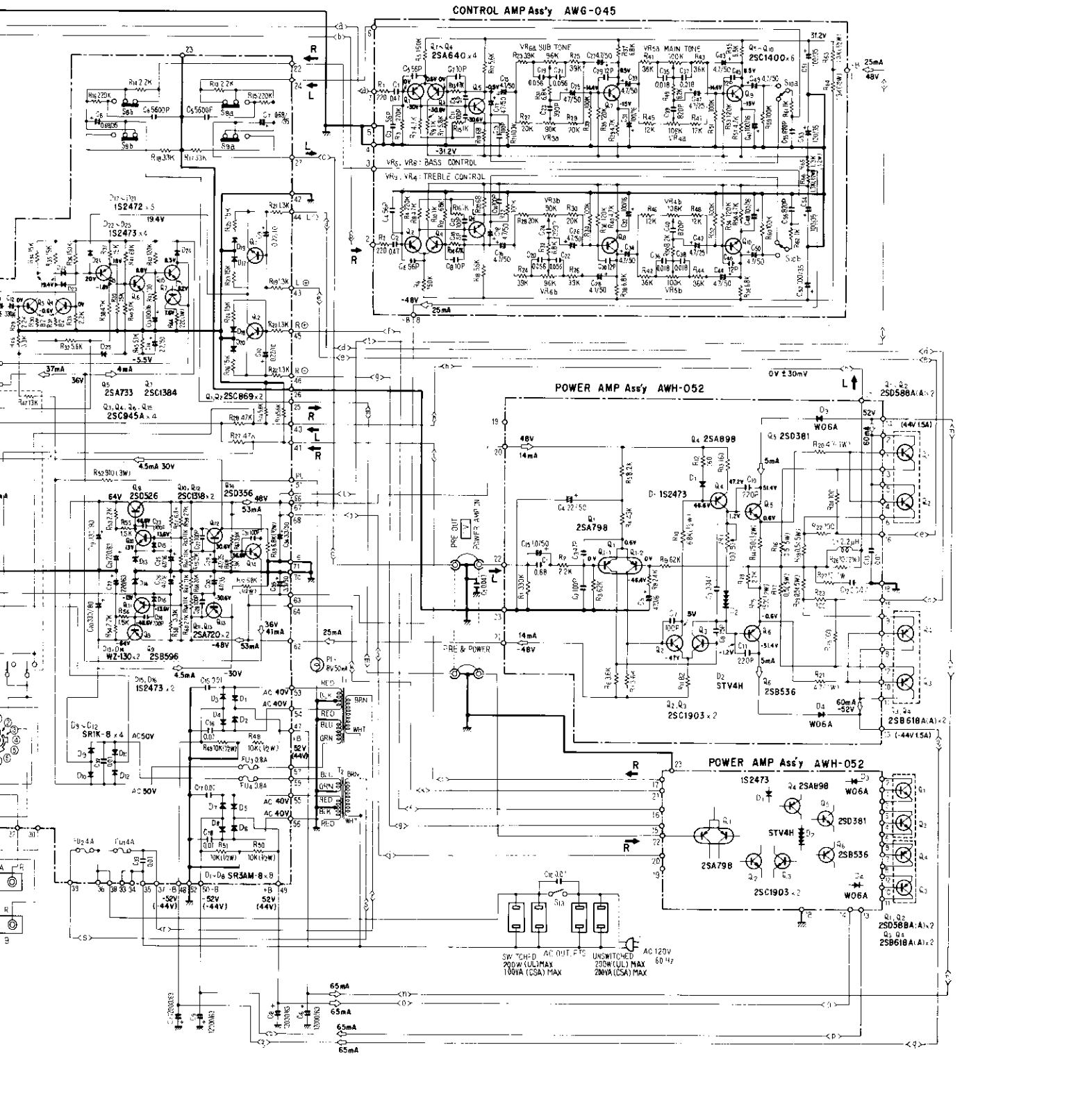

11.3 SWITCH ASSEMBLY (AWS-109)

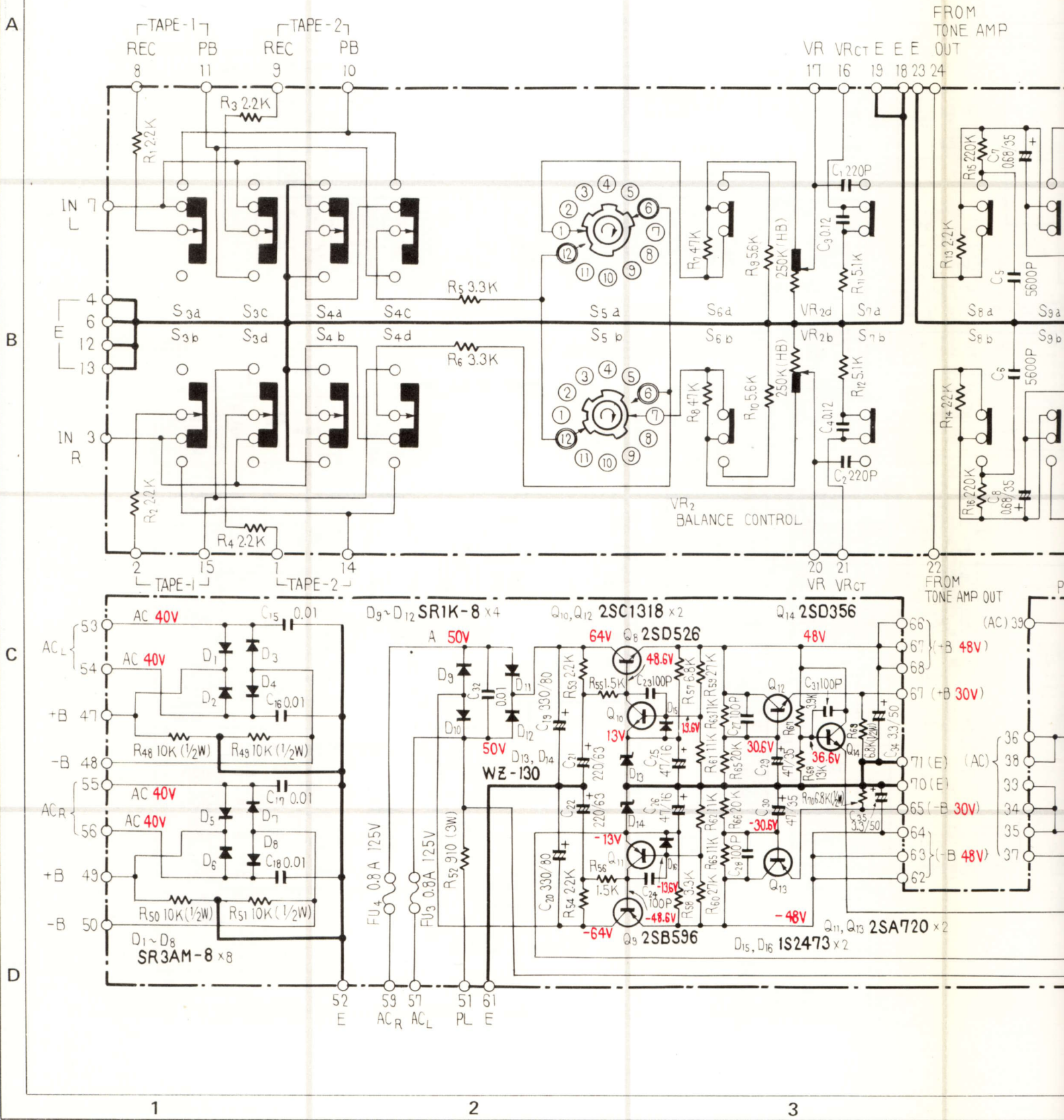

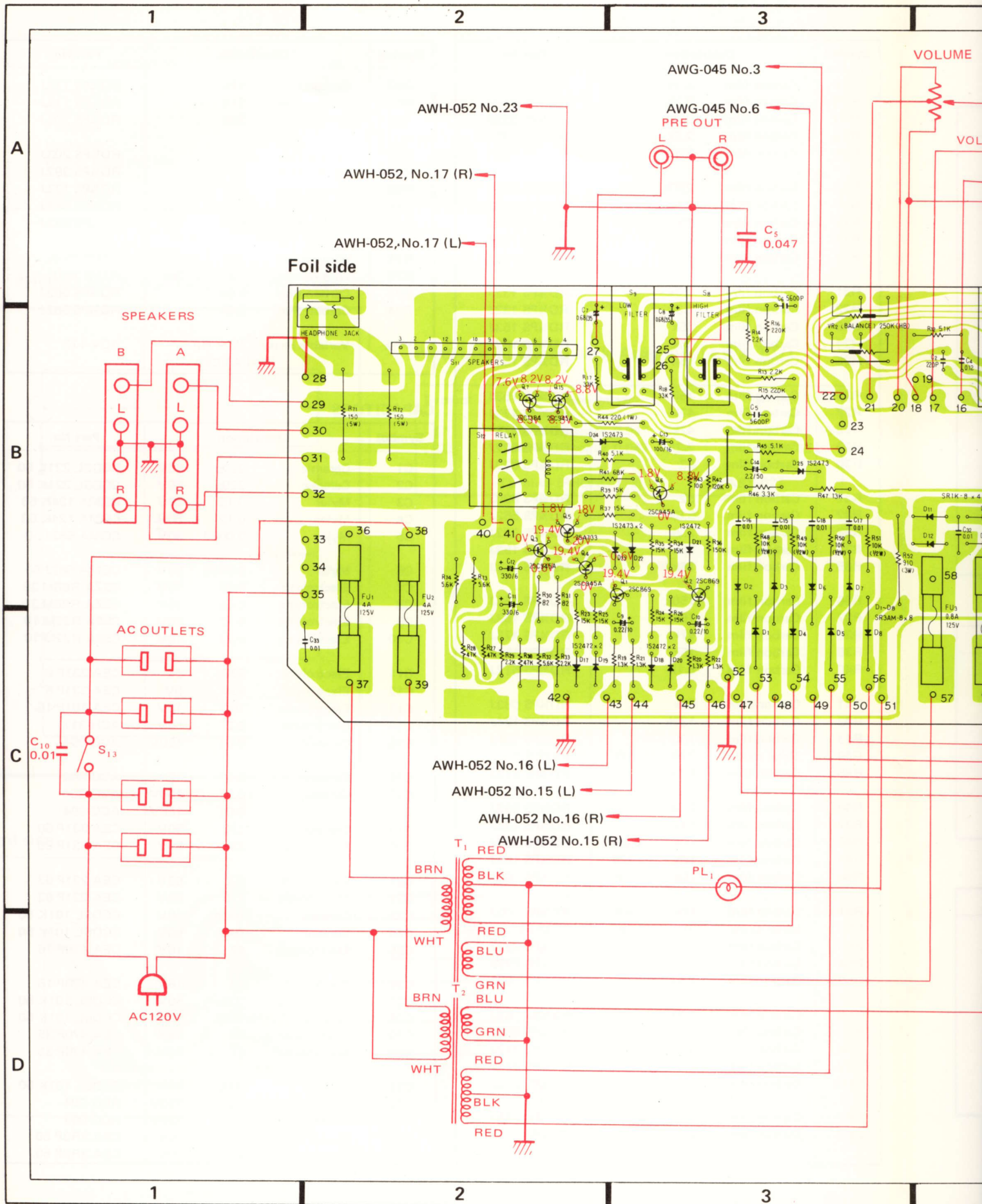

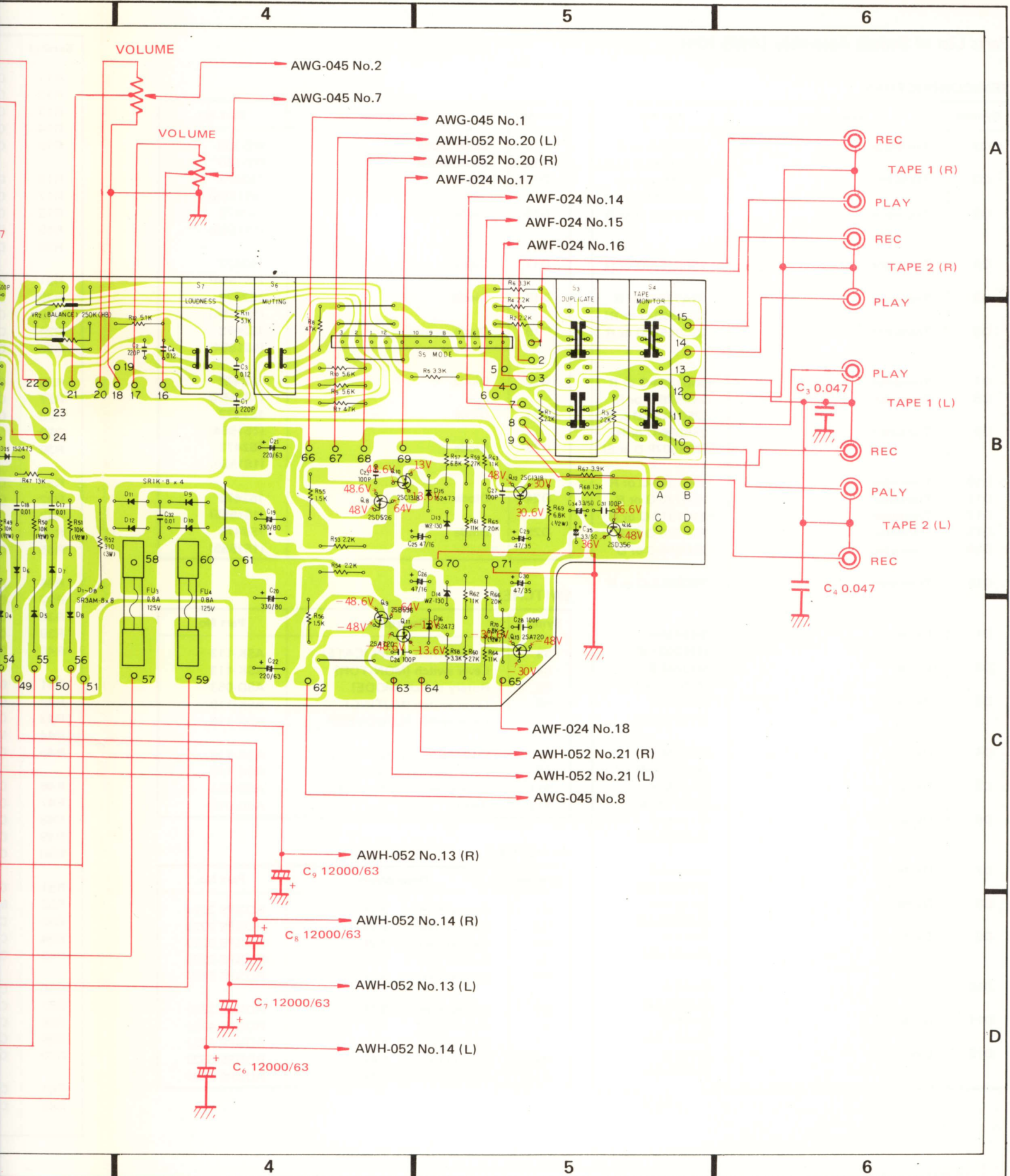

A

B

C

D

4

5

6

4

5

6

Parts List of Switch Assembly (AWS-109)

SEMICONDUCTORS

Symbol	Description	Part No.
Q1	Transistor	2SC869-C or D (2SC1649-C or R)
Q2	Transistor	2SC869-C or D (2SC1649-Q or R)
Q3	Transistor	2SC945A-Q or R
Q4	Transistor	2SC945A-Q or R
Q5	Transistor	2SA733-Q or R (2SA823-Q or R)
Q6	Transistor	2SC945A-Q or R
Q7	Transistor	2SC1384-Q or R
Q8	Transistor	2SD526-O or R (2SD313P-D or E)
Q9	Transistor	2SB596-O or R (2SB507P-D or E)
Q10	Transistor	2SC1318-Q or R
Q11	Transistor	2SA720-Q or R
Q12	Transistor	2SC1318-Q or R
Q13	Transistor	2SA720-Q or R
Q14	Transistor	2SD356-C or D
Q15	Transistor	2SC945A-Q or R
D1	Diode	SR3AM-8 (ERD03-04)
D2	Diode	SR3AM-8 (ERD03-04)
D3	Diode	SR3AM-8 (ERD03-04)
D4	Diode	SR3AM-8 (ERD03-04)
D5	Diode	SR3AM-8 (ERD03-04)
D6	Diode	SR3AM-8 (ERD03-04)
D7	Diode	SR3AM-8 (ERD03-04)
D8	Diode	SR3AM-8 (ERD03-04)
D9	Diode	SR1K-8 (SIB01-04)
D10	Diode	SR1K-8 (SIB01-04)
D11	Diode	SR1K-8 (SIB01-04)
D12	Diode	SR1K-8 (SIB01-04)

Symbol	Description	Part No.
D13	Zener diode	WZ-130
D14	Zener diode	WZ-130
D15	Diode	1S2473 (1S1555)
D16	Diode	1S2473 (1S1555)
D17	Diode	1S2472 (1S1554)
D18	Diode	1S2472 (1S1554)
D19	Diode	1S2472 (1S1554)
D20	Diode	1S2472 (1S1554)
D21	Diode	1S2472 (1S1554)
D23	Diode	1S2473 (1S1555)
D24	Diode	1S2473 (1S1555)
D25	Diode	1S2473 (1S1555)

SWITCHES

Symbol	Description	Part No.
S3	Lever switch (DUPLICATE)	ASK-113
S4	Lever switch (MONITOR)	ASK-113
S5	Rotary switch (MODE)	ASD-053
S6	Lever switch (MUTING)	ASK-110
S7	Lever switch (LOUDNESS)	ASK-110
S8	Lever switch (HIGH FILTER)	ASK-110
S9	Lever switch (LOW FILTER)	ASK-110
S11	Rotary switch (SPEAKERS)	ASD-054
S12	Relay	ASR-018

RESISTORS

Symbol	Description	Part No.
R1	Carbon film 2.2k	RD¼PS 222J
R2	Carbon film 2.2k	RD¼PS 222J
R3	Carbon film 2.2k	RD¼PS 222J
R4	Carbon film 2.2k	RD¼PS 222J
R5	Carbon film 3.3k	RD¼PS 332J
R6	Carbon film 3.3k	RD¼PS 332J
R7	Carbon film 47k	RD¼PS 473J
R8	Carbon film 47k	RD¼PS 473J
R9	Carbon film 5.6k	RD¼PS 562J
R10	Carbon film 5.6k	RD¼PS 562J

Symbol	Description	Part No.
R11	Carbon film 5.1k	RD½PS 512J
R12	Carbon film 5.1k	RD½PS 512J
R13	Carbon film 2.2k	RD½PS 222J
R14	Carbon film 2.2k	RD½PS 222J
R15	Carbon film 220k	RD½PS 224J
R16	Carbon film 220k	RD½PS 224J
R17	Carbon film 33k	RD½PS 333J
R18	Carbon film 33k	RD½PS 333J
R19	Carbon film 1.3k	RD½PS 132J
R20	Carbon film 1.3k	RD½PS 132J
R21	Carbon film 1.3k	RD½PS 132J
R22	Carbon film 1.3k	RD½PS 132J
R23	Carbon film 15k	RD½PS 153J
R24	Carbon film 15k	RD½PS 153J
R25	Carbon film 15k	RD½PS 153J
R26	Carbon film 15k	RD½PS 153J
R27	Carbon film 47k	RD½PS 473J
R28	Carbon film 47k	RD½PS 473J
R29	Carbon film 2.2k	RD½PS 222J
R30	Carbon film 82	RD½PS 820J
R31	Carbon film 82	RD½PS 820J
R32	Carbon film 5.6k	RD½PS 562J
R33	Carbon film 2.2k	RD½PS 222J
R34	Carbon film 15k	RD½PS 153J
R35	Carbon film 15k	RD½PS 153J
R36	Carbon film 150k	RD½PS 154J
R37	Carbon film 15k	RD½PS 153J
R38	Carbon film 47k	RD½PS 473J
R39	Carbon film 15k	RD½PS 153J
R40	Carbon film 5.1k	RD½PS 512J
R41	Carbon film 68k	RD½PS 683J
R42	Carbon film 120k	RD½PS 124J
R43	Carbon film 100	RD½PS 101J
R44	Metal oxide 220 1W	RS1P 221J
R45	Carbon film 5.1k	RD½PS 512J
R46	Carbon film 3.3k	RD½PS 332J
R47	Carbon film 13k	RD½PS 133J
R48	Carbon film 10k ½W	RD½PS 103J
R49	Carbon film 10k ½W	RD½PS 103J
R50	Carbon film 10k ½W	RD½PS 103J
R51	Carbon film 10k ½W	RD½PS 103J
R52	Metal oxide 910 3W	RS3P 911J
R53	Carbon film 2.2k	RD½PS 222J
R54	Carbon film 2.2k	RD½PS 222J
R55	Carbon film 1.5k	RD½PS 152J
R56	Carbon film 1.5k	RD½PS 152J
R57	Carbon film 6.8k	RD½PS 682J
R58	Carbon film 3.3k	RD½PS 332J
R59	Carbon film 27k	RD½PS 273J
R60	Carbon film 27k	RD½PS 273J
R61	Carbon film 11k	RD½PS 113J
R62	Carbon film 11k	RD½PS 113J

Symbol	Description	Part No.
R63	Carbon film 11k	RD½PS 113J
R64	Carbon film 11k	RD½PS 113J
R65	Carbon film 20k	RD½PS 203J
R66	Carbon film 20k	RD½PS 203J
R67	Carbon film 3.9k	RD½PS 392J
R68	Carbon film 13k	RD½PS 133J
R69	Carbon film 6.8k ½W	RD½PS 682J
R70	Carbon film 6.8k ½W	RD½PS 682J
R71	Wire wound 150 5W	RT5B 151K
R72	Wire wound 150 5W	RT5B 151K
R73	Carbon film 5.6k	RD½PS 562J
R74	Carbon film 5.6k	RD½PS 562J
VR2	Variable resistor 250k-HB (BALANCE)	ACV-172

CAPACITORS

Symbol	Description	Part No.
C1	Ceramic 220p 50V	CCDSL 221K 50
C2	Ceramic 220p 50V	CCDSL 221K 50
C3	Mylar 0.12 50V	CQMA 124K 50
C4	Mylar 0.12 50V	CQMA 124K 50
C5	Mylar 0.0056 50V	CQMA 562J 50
C6	Mylar 0.0056 50V	CQMA 562J 50
C7	Electrolytic 0.68 35V	CSZA R68M 35
C8	Electrolytic 0.68 35V	CSZA R68M 35
C9	Electrolytic 0.22 10V	CSSA R22M 10
C10	Electrolytic 0.22 10V	CSSA R22M 10
C11	Electrolytic 330 6V	CEA 331P 6
C12	Electrolytic 330 6V	CEA 331P 6
C13	Electrolytic 100 16V	CEA 101P 16
C14	Electrolytic 2.2 50V	ACH-317
C15	Ceramic 0.01 150V	ACG-004
C16	Ceramic 0.01 150V	ACG-004
C17	Ceramic 0.01 150V	ACG-004
C18	Ceramic 0.01 150V	ACG-004
C19	Electrolytic 330 80V	CEA 331P 80
C20	Electrolytic 330 80V	CEA 331P 80
C21	Electrolytic 220 63V	CEA 221P 63
C22	Electrolytic 220 63V	CEA 221P 63
C23	Ceramic 100p 50V	CCDSL 101K 50
C24	Ceramic 100p 50V	CCDSL 101K 50
C25	Electrolytic 47 16V	CEA 470P 16
C26	Electrolytic 47 16V	CEA 470P 16
C27	Ceramic 100p 50V	CCDSL 101K 50
C28	Ceramic 100p 50V	CCDSL 101K 50
C29	Electrolytic 47 35V	CEA 470P 35
C30	Electrolytic 47 35V	CEA 470P 35
C31	Ceramic 100p 50V	CCDSL 101K 50
C32	Ceramic 0.01 150V	ACG-004
C33	Ceramic 0.01 125V	ACG-003
C34	Electrolytic 3.3 50V	CEA 3R3P 50
C35	Electrolytic 3.3 50V	CEA 3R3P 50

OTHERS

Symbol	Description	Part No.
	Phone jack (PHONES)	AKN-008
	Fuse clip	AKR-030
	Fuse clip	AKR-013
	Heat sink	ANH-117
	Washer faced nut M9	ABN-024
	Special nut	ABN-027

11.4 PHONO JACK ASSEMBLY (AWX-107)

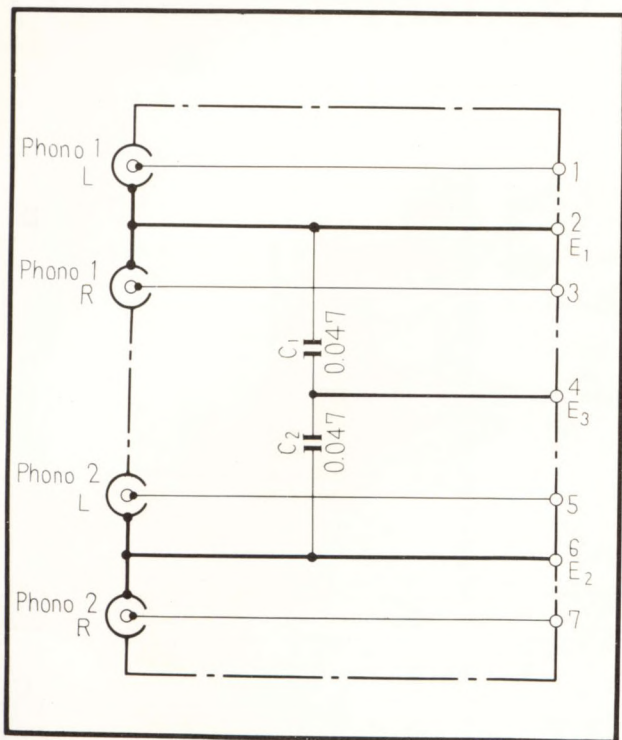

Parts List of Phono Jack Assembly (AWX-107)

Symbol	Description	Part No.
C1	Ceramic capacitor 0.047 50V	CKDYF 473Z 50
C2	Ceramic capacitor 0.047 50V	CKDYF 473Z 50
	Terminal (PHONO 1, 2)	AKB-027

Foil side

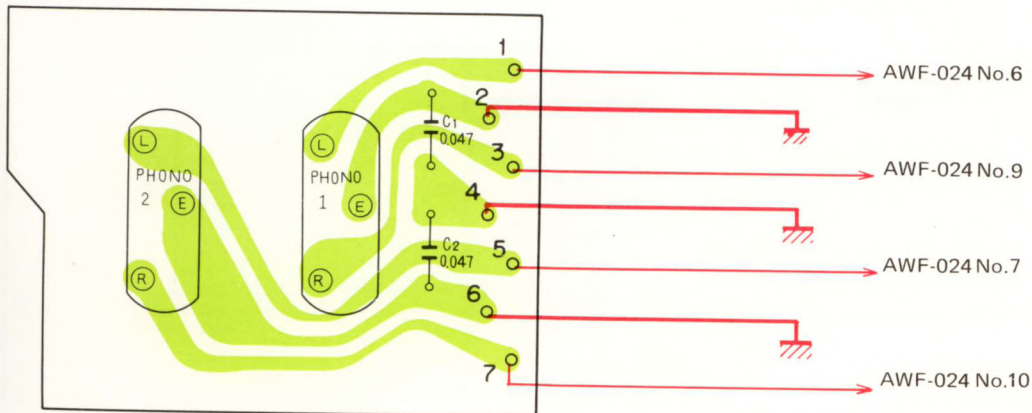

11.5 EQUALIZER AMPLIFIER ASSEMBLY (AWF-024)

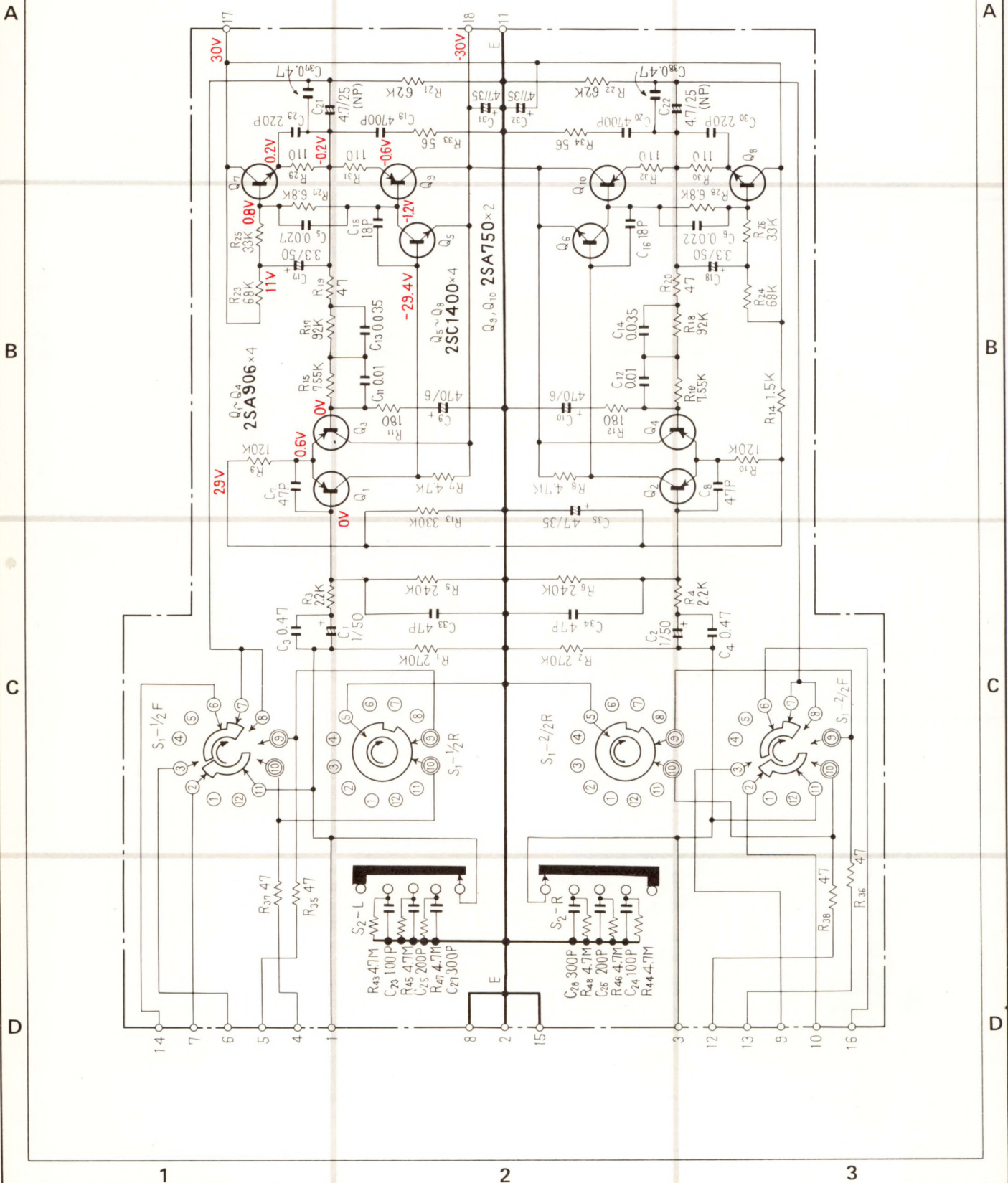

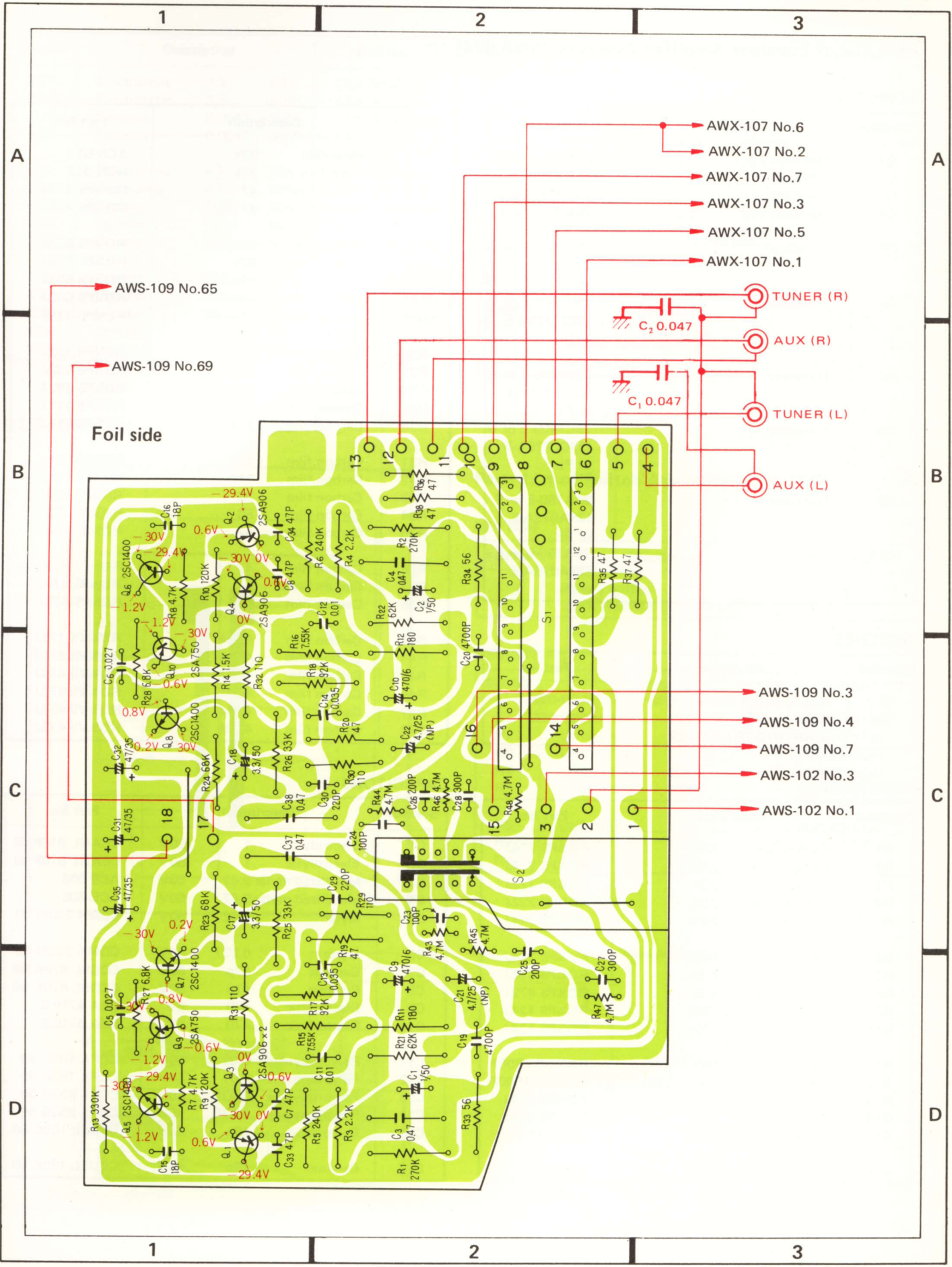

Parts List of Equalizer Amplifier Assembly (AWF-024)

SEMICONDUCTORS

Symbol	Description	Part No.
Q1	Transistor	2SA906-G or F
Q2	Transistor	2SA906-G or F
Q3	Transistor	2SA906-G or F
Q4	Transistor	2SA906-G or F
Q5	Transistor	2SC1400-E or U (2SC1775A-E or F)
Q6	Transistor	2SC1400-E or U (2SC1775A-E or F)
Q7	Transistor	2SC1400-E or U (2SC1775A-E or F)
Q8	Transistor	2SC1400-E or U (2SC1775A-E or F)
Q9	Transistor	2SA750-E or F (2SA872A-E or F)
Q10	Transistor	2SA750-E or F (2SA872A-E or F)

Symbol	Description	Part No.
R17	Metal film 92k	ACN-012
R18	Metal film 92k	ACN-012
R19	Carbon film 47	RD¼PS 470J
R20	Carbon film 47	RD¼PS 470J
R21	Carbon film 62k	RD¼PS 623J
R22	Carbon film 62k	RD¼PS 623J
R23	Carbon film 68k	RD¼PS 683J
R24	Carbon film 68k	RD¼PS 683J
R25	Carbon film 33k	RD¼PS 333J
R26	Carbon film 33k	RD¼PS 333J
R27	Carbon film 6.8k	RD¼PS 682J
R28	Carbon film 6.8k	RD¼PS 682J
R29	Carbon film 110	RD¼PS 111J
R30	Carbon film 110	RD¼PS 111J
R31	Carbon film 110	RD¼PS 111J
R32	Carbon film 110	RD¼PS 111J
R33	Carbon film 56	RD¼PS 560J
R34	Carbon film 56	RD¼PS 560J
R35	Carbon film 47	RD¼PS 470J
R36	Carbon film 47	RD¼PS 470J
R37	Carbon film 47	RD¼PS 470J
R38	Carbon film 47	RD¼PS 470J
R43	Carbon film 4.7M	RD¼VS 475J
R44	Carbon film 4.7M	RD¼VS 475J
R45	Carbon film 4.7M	RD¼VS 475J
R46	Carbon film 4.7M	RD¼VS 475J
R47	Carbon film 4.7M	RD¼VS 475J
R48	Carbon film 4.7M	RD¼VS 475J

SWITCHES

Symbol	Description	Part No.
S1	Rotary switch (FUNCTION)	ASD-052
S2	Rotary switch (CARTRIDGE LOAD C)	ASD-055

RESISTORS

Symbol	Description	Part No.
R1	Carbon film 270k	RD¼PS 274J
R2	Carbon film 270k	RD¼PS 274J
R3	Carbon film 2.2k	RD¼PS 222J
R4	Carbon film 2.2k	RD¼PS 222J
R5	Carbon film 240k	RD¼PS 244J
R6	Carbon film 240k	RD¼PS 244J
R7	Carbon film 4.7k	RD¼PS 472J
R8	Carbon film 4.7k	RD¼PS 472J
R9	Carbon film 120k	RD¼PS 124J
R10	Carbon film 120k	RD¼PS 124J
R11	Metal film 180 ½W	RN¼SQ 1800F
R12	Metal film 180 ½W	RN¼SQ 1800F
R13	Carbon film 330k	RD¼PS 334J
R14	Carbon film 1.5k	RD¼PS 152J
R15	Metal film 7.55k	ACN-011
R16	Metal film 7.55k	ACN-011

CAPACITORS

Symbol	Description	Part No.
C1	Electrolytic 1 50V	CEANL 010P 50
C2	Electrolytic 1 50V	CEANL 010P 50
C3	Metallized mylar 0.47 50V	ACE-006
C4	Metallized mylar 0.47 50V	ACE-006
C5	Mylar 0.027 50V	CQMA 273M 50
C6	Mylar 0.027 50V	CQMA 273M 50
C7	Ceramic 47p 50V	CCDSL 470K 50
C8	Ceramic 47p 50V	CCDSL 470K 50
C9	Electrolytic 470 6V	CEA 471P 6
C10	Electrolytic 470 6V	CEA 471P 6
C11	Polypropylene 0.01 50V	CQPA 103G 50
C12	Polypropylene 0.01 50V	CQPA 103G 50
C13	Polypropylene 0.035 50V	CQPA 353G 50
C14	Polypropylene 0.035 50V	CQPA 353G 50
C15	Ceramic 18p 50V	CCDSL 180K 50
C16	Ceramic 18p 50V	CCDSL 180K 50

Symbol	Description			Part No.
C17	Electrolytic	3.3	50V	CEA 3R3P 50
C18	Electrolytic	3.3	50V	CEA 3R3P 50
C19	Ceramic	0.0047	50V	CKDYB 472K 50
C20	Ceramic	0.0047	50V	CKDYB 472K 50
C21	Electrolytic	4.7	25V	ACH-318
C22	Electrolytic	4.7	25V	ACH-318
C23	Ceramic	100p	50V	CCDSL 101K 50
C24	Ceramic	100p	50V	CCDSL 101K 50
C25	Ceramic	200p	50V	CCDSL 201K 50
C26	Ceramic	200p	50V	CCDSL 201K 50
C27	Ceramic	300p	50V	CKDYB 301K 50
C28	Ceramic	300p	50V	CKDYB 301K 50
C29	Ceramic	220p	50V	CCDSL 221K 50
C30	Ceramic	220p	50V	CCDSL 221K 50

Symbol	Description			Part No.
C31	Electrolytic	47	35V	CEA 470P 35
C32	Electrolytic	47	35V	CEA 470P 35
C33	Ceramic	47p	50V	CCDSL 470K 50
C34	Ceramic	47p	50V	CCDSL 470K 50
C35	Electrolytic	47	35V	CEA 470P 35
C36				
C37	Metallized mylar 0.47	50V		ACE-006
C38	Metallized mylar 0.47	50V		ACE-006

OTHERS

Symbol	Description	Part No.
	Washer faced nut M7	ABN-031
	Special nut	ABN-027

11.6 SWITCH ASSEMBLY (AWS-102)

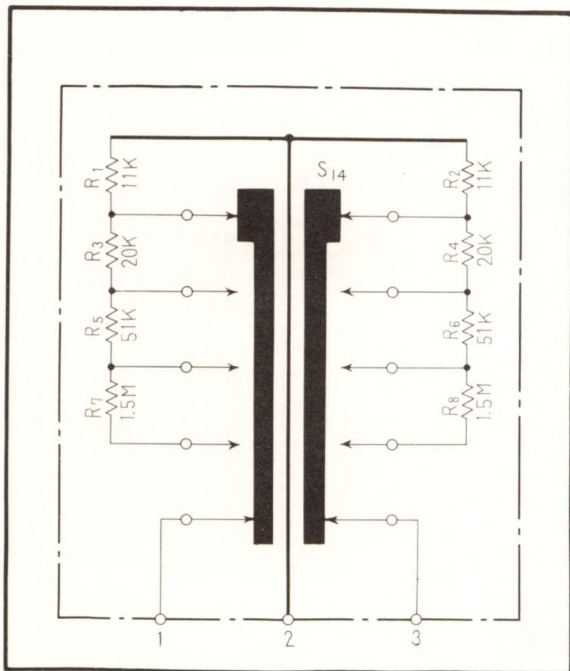

Parts List of Switch Assembly (AWS-102)

SWITCH

Symbol	Description	Part No.
S14	Rotary switch (CARTRIDGE LOAD R)	ASD-055

RESISTORS

Symbol	Description		Part No.
R1	Carbon film	11k	RD¼PS 113J
R2	Carbon film	11k	RD¼PS 113J
R3	Carbon film	20k	RD¼PS 203J
R4	Carbon film	20k	RD¼PS 203J
R5	Carbon film	51k	RD¼PS 513J
R6	Carbon film	51k	RD¼PS 513J
R7	Carbon film	1.5M	RD¼PS 155J
R8	Carbon film	1.5M	RD¼PS 155J

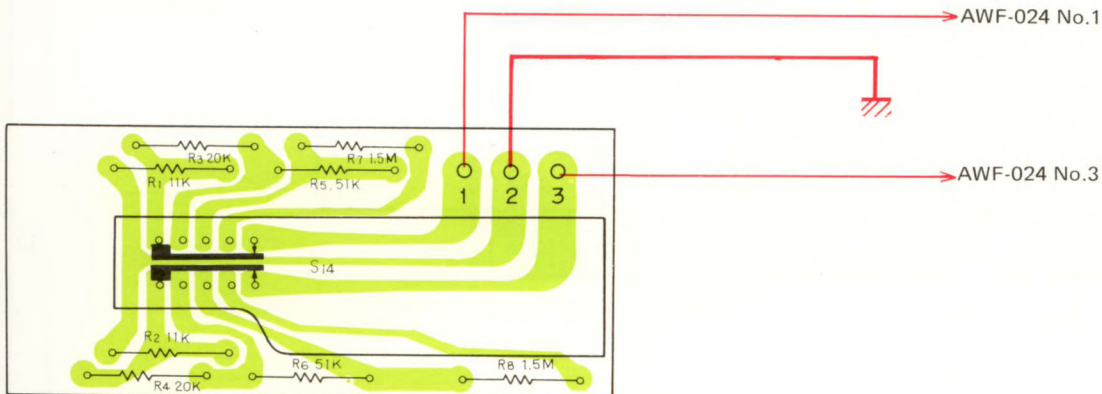

11.7 CONTROL AMPLIFIER ASSEMBLY (AWG-045)

A

B

C

D

1

2

3

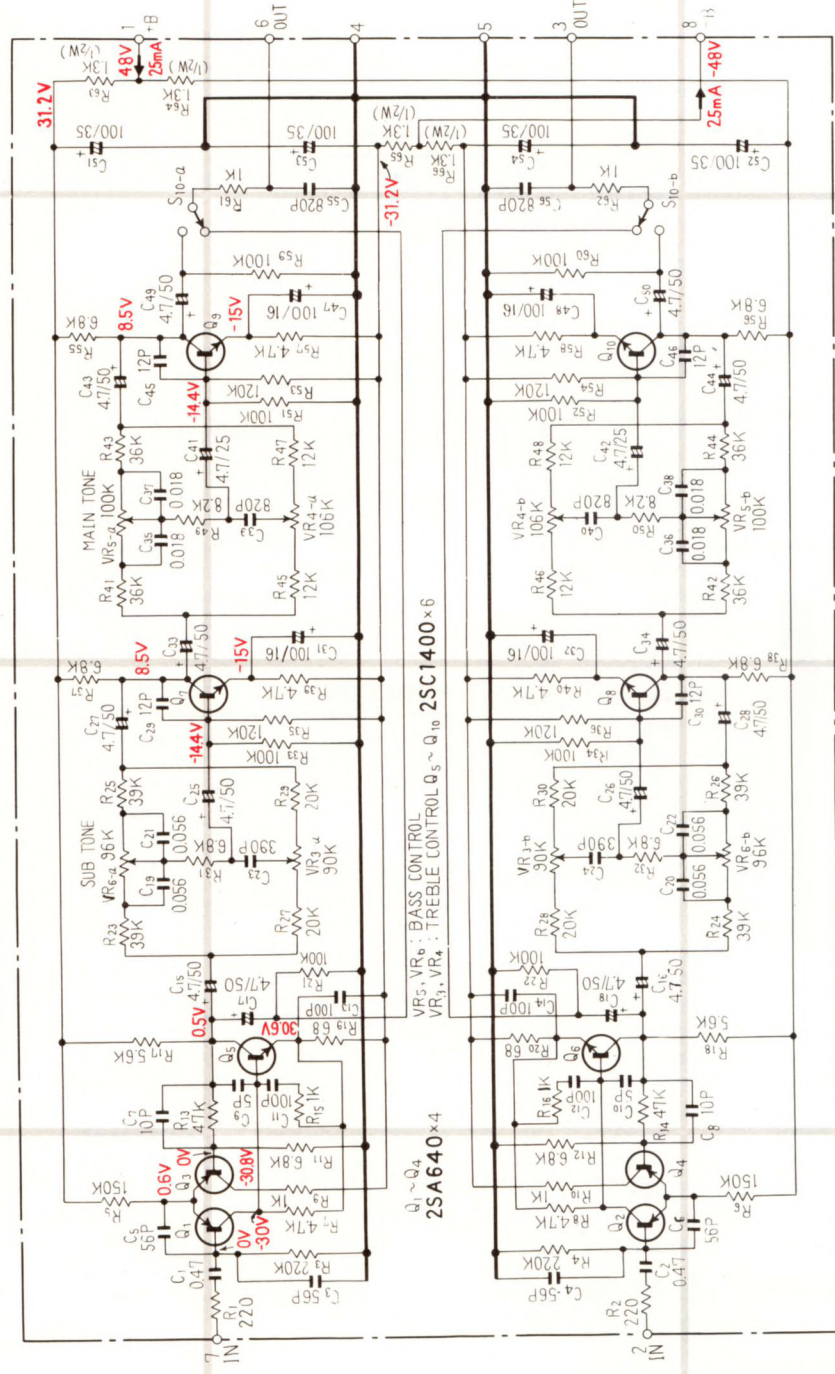

A

B

C

D

1

2

3

Foil side

A

A

B

B

C

C

D

D

AWS-109 No.62

AWS-109 No.24

AWS-109 No.17

AWS-109 No.16

AWS-109 No.18

AWS-109 No.21

AWS-109 No.20

AWS-109 No.22

AWS-109 No.66

VOLUME

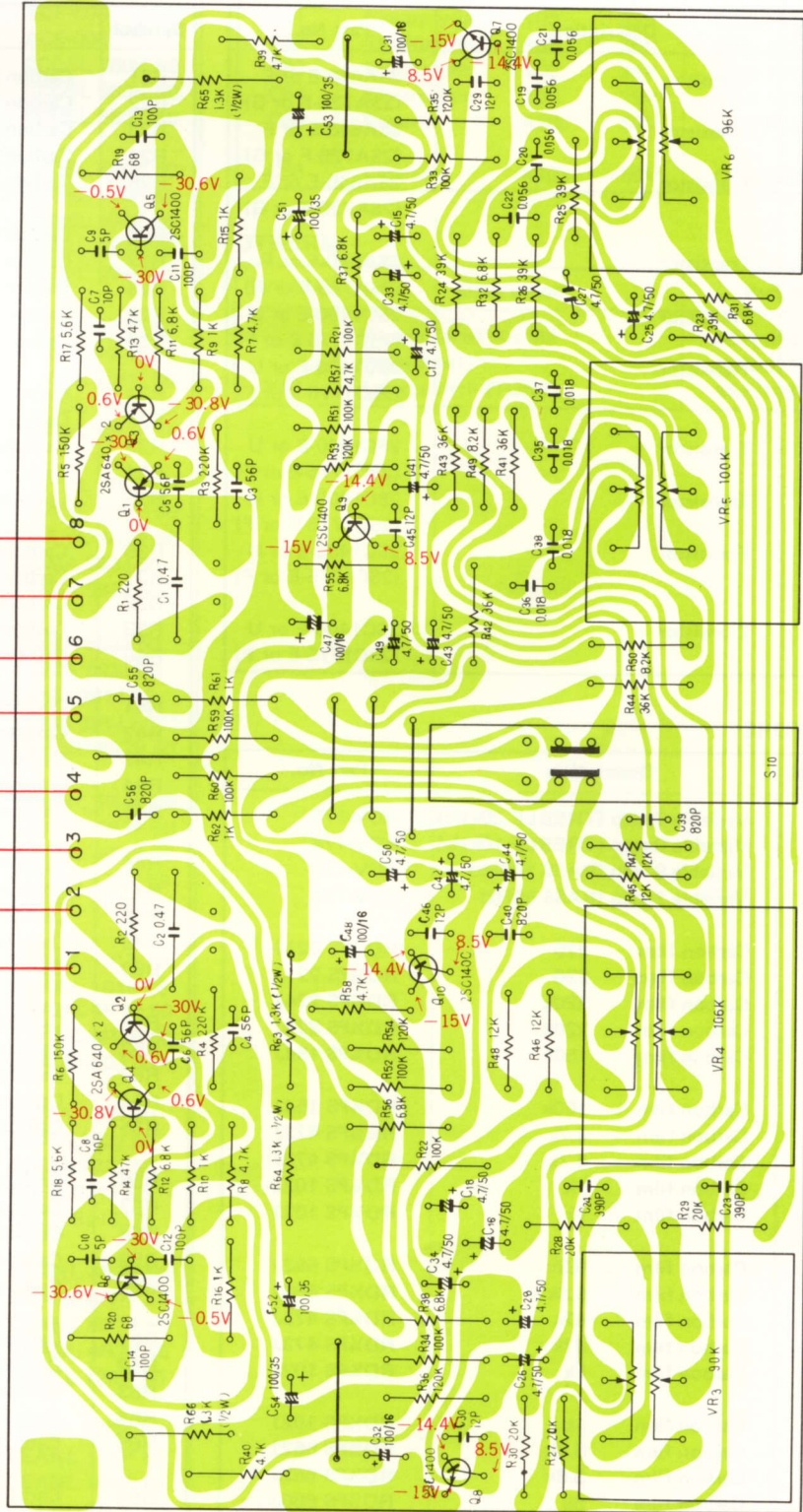

1

2

3

Parts List of Control Amplifier Assembly (AWG-045)

SEMICONDUCTORS

Symbol	Description	Part No.
Q1	Transistor	2SA640-E or F (2SA726-F or G)
Q2	Transistor	2SA640-E or F (2SA726-F or G)
Q3	Transistor	2SA640-E or F (2SA726-F or G)
Q4	Transistor	2SA640-E or F (2SA726-F or G)
Q5	Transistor	2SC1400-E or U (2SC1775-E or F)
Q6	Transistor	2SC1400-E or U (2SC1775-E or F)
Q7	Transistor	2SC1400-E or U (2SC1775-E or F)
Q8	Transistor	2SC1400-E or U (2SC1775-E or F)
Q9	Transistor	2SC1400-E or U (2SC1775-E or F)
Q10	Transistor	2SC1400-E or U (2SC1775-E or F)

Symbol	Description	Part No.
R21	Carbon film 100k	RD¼PS 104J
R22	Carbon film 100k	RD¼PS 104J
R23	Carbon film 39k	RD¼PS 393J
R24	Carbon film 39k	RD¼PS 393J
R25	Carbon film 39k	RD¼PS 393J
R26	Carbon film 39k	RD¼PS 393J
R27	Carbon film 20k	RD¼PS 203J
R28	Carbon film 20k	RD¼PS 203J
R29	Carbon film 20k	RD¼PS 203J
R30	Carbon film 20k	RD¼PS 203J
R31	Carbon film 6.8k	RD¼PS 682J
R32	Carbon film 6.8k	RD¼PS 682J
R33	Carbon film 100k	RD¼PS 104J NL
R34	Carbon film 100k	RD¼PS 104J NL
R35	Carbon film 120k	RD¼PS 124J NL
R36	Carbon film 120k	RD¼PS 124J NL
R37	Carbon film 6.8k	RD¼PS 682J
R38	Carbon film 6.8k	RD¼PS 682J
R39	Carbon film 4.7k	RD¼PS 472J
R40	Carbon film 4.7k	RD¼PS 472J
R41	Carbon film 36k	RD¼PS 363J
R42	Carbon film 36k	RD¼PS 363J
R43	Carbon film 36k	RD¼PS 363J
R44	Carbon film 36k	RD¼PS 363J
R45	Carbon film 12k	RD¼PS 123J
R46	Carbon film 12k	RD¼PS 123J
R47	Carbon film 12k	RD¼PS 123J
R48	Carbon film 12k	RD¼PS 123J
R49	Carbon film 8.2k	RD¼PS 822J
R50	Carbon film 8.2k	RD¼PS 822J
R51	Carbon film 100k	RD¼PS 104J NL
R52	Carbon film 100k	RD¼PS 104J NL
R53	Carbon film 120k	RD¼PS 124J NL
R54	Carbon film 120k	RD¼PS 124J NL
R55	Carbon film 6.8k	RD¼PS 682J
R56	Carbon film 6.8k	RD¼PS 682J
R57	Carbon film 4.7k	RD¼PS 472J
R58	Carbon film 4.7k	RD¼PS 472J
R59	Carbon film 100k	RD¼PS 104J
R60	Carbon film 100k	RD¼PS 104J
R61	Carbon film 1k	RD¼PS 102J
R62	Carbon film 1k	RD¼PS 102J
R63	Carbon film 1.3k ½W	RD½PS 132J
R64	Carbon film 1.3k ½W	RD½PS 132J
R65	Carbon film 1.3k ½W	RD½PS 132J
R66	Carbon film 1.3k ½W	RD½PS 132J

RESISTORS

Symbol	Description	Part No.
VR3	Variable 7-step (TREBLE 20kHz)	ACV-173
VR4	Variable 9-step (TREBLE 10kHz)	ACV-174
VR5	Variable 9-step (BASS 100Hz)	ACV-175
VR6	Variable 7-step (BASS 50Hz)	ACV-176
R1	Carbon film 220	RD¼PS 221J
R2	Carbon film 220	RD¼PS 221J
R3	Carbon film 220k	RD¼PS 224J
R4	Carbon film 220k	RD¼PS 224J
R5	Carbon film 150k	RD¼PS 154J
R6	Carbon film 150k	RD¼PS 154J
R7	Carbon film 4.7k	RD¼PS 472J
R8	Carbon film 4.7k	RD¼PS 472J
R9	Carbon film 1k	RD¼PS 102J
R10	Carbon film 1k	RD¼PS 102J
R11	Carbon film 6.8k	RD¼PS 682J
R12	Carbon film 6.8k	RD¼PS 682J
R13	Carbon film 47k	RD¼PS 473J
R14	Carbon film 47k	RD¼PS 473J
R15	Carbon film 1k	RD¼PS 102J
R16	Carbon film 1k	RD¼PS 102J
R17	Carbon film 5.6k	RD¼PS 562J
R18	Carbon film 5.6k	RD¼PS 562J
R19	Carbon film 68	RD¼PS 680J
R20	Carbon film 68	RD¼PS 680J

CAPACITORS

Symbol	Description		Part No.
C1	Metallized mylar	0.47 50V	ACE-006
C2	Metallized mylar	0.47 50V	ACE-006
C3	Ceramic	56p 50V	CCDSL 560K 50
C4	Ceramic	56p 50V	CCDSL 560K 50
C5	Ceramic	56p 50V	CCDSL 560K 50
C6	Ceramic	56p 50V	CCDSL 560K 50
C7	Ceramic	10p 50V	CCDSL 100F 50
C8	Ceramic	10p 50V	CCDSL 100F 50
C9	Ceramic	5p 50V	CCDSL 050D 50
C10	Ceramic	5p 50V	CCDSL 050D 50
C11	Ceramic	100p 50V	CCDSL 101K 50
C12	Ceramic	100p 50V	CCDSL 101K 50
C13	Ceramic	100p 50V	CCDSL 101K 50
C14	Ceramic	100p 50V	CCDSL 101K 50
C15	Electrolytic	4.7 50V	CEANL 4R7P 50
C16	Electrolytic	4.7 50V	CEANL 4R7P 50
C17	Electrolytic	4.7 50V	CEANL 4R7P 50
C18	Electrolytic	4.7 50V	CEANL 4R7P 50
C19	Mylar	0.056 50V	CQMA 563J 50
C20	Mylar	0.056 50V	CQMA 563J 50
C21	Mylar	0.056 50V	CQMA 563J 50
C22	Mylar	0.056 50V	CQMA 563J 50
C23	Polystyrene	390p 50V	CQSA 391J 50
C24	Polystyrene	390p 50V	CQSA 391J 50
C25	Electrolytic	4.7 50V	CEANL 4R7P 50
C26	Electrolytic	4.7 50V	CEANL 4R7P 50
C27	Electrolytic	4.7 50V	CEANL 4R7P 50
C28	Electrolytic	4.7 50V	CEANL 4R7P 50
C29	Ceramic	12p 50V	CCDSL 120K 50
C30	Ceramic	12p 50V	CCDSL 120K 50
C31	Electrolytic	100 16V	CEANL 101P 16
C32	Electrolytic	100 16V	CEANL 101P 16
C33	Electrolytic	4.7 50V	CEANL 4R7P 50
C34	Electrolytic	4.7 50V	CEANL 4R7P 50
C35	Mylar	0.018 50V	CQMA 183J 50
C36	Mylar	0.018 50V	CQMA 183J 50
C37	Mylar	0.018 50V	CQMA 183J 50
C38	Mylar	0.018 50V	CQMA 183J 50
C39	Polystyrene	820p 50V	CQSA 821J 50
C40	Polystyrene	820p 50V	CQSA 821J 50
C41	Electrolytic	4.7 50V	CEANL 4R7P 50
C42	Electrolytic	4.7 50V	CEANL 4R7P 50
C43	Electrolytic	4.7 50V	CEANL 4R7P 50
C44	Electrolytic	4.7 50V	CEANL 4R7P 50
C45	Ceramic	12p 50V	CCDSL 120K 50
C46	Ceramic	12p 50V	CCDSL 120K 50
C47	Electrolytic	100 16V	CEANL 101P 16
C48	Electrolytic	100 16V	CEANL 101P 16
C49	Electrolytic	4.7 50V	CEANL 4R7P 50
C50	Electrolytic	4.7 50V	CEANL 4R7P 50

Symbol	Description		Part No.
C51	Electrolytic	100 35V	CEA 101P 35
C52	Electrolytic	100 35V	CEA 101P 35
C53	Electrolytic	100 35V	CEA 101P 35
C54	Electrolytic	100 35V	CEA 101P 35
C55	Ceramic	820p 50V	CKDYB 821K 50
C56	Ceramic	820p 50V	CKDYB 821K 50

OTHERS

Symbol	Description	Part No.
S10	Washer faced nut M9	ABN-024
	Special nut	ABN-027
	Lever switch (TONE)	ASK-109

11.8 POWER AMPLIFIER ASSEMBLY (AWH-052)

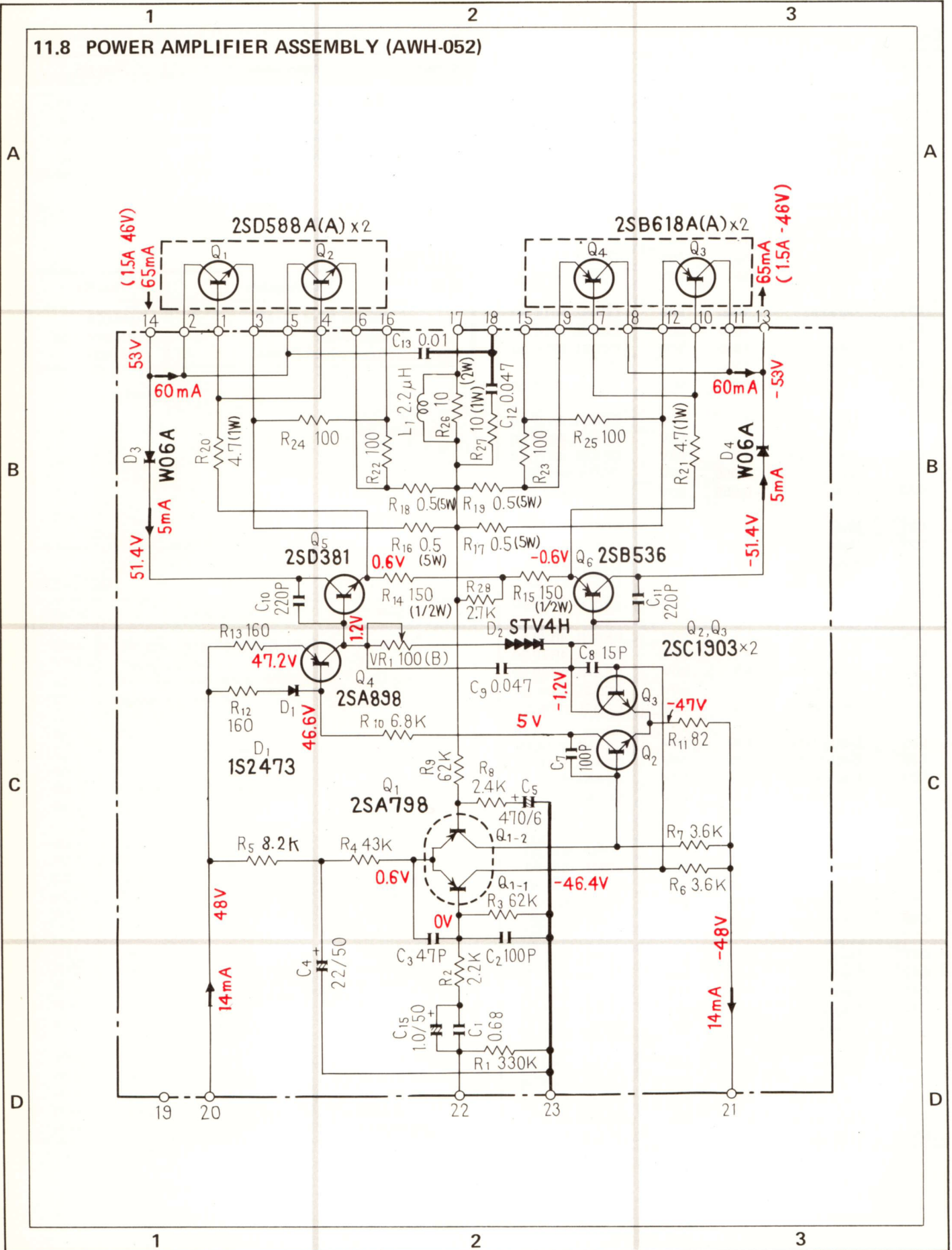

Parts List of Power Amplifier (AWH-052)

SEMICONDUCTORS

Symbol	Description	Part No.
Q1	Transistor	2SA798-G or F
Q2	Transistor	2SC1903-V or B (2SC1885-S or R)
Q3	Transistor	2SC1903-V or B (2SC1885-S or R)
Q4	Transistor	2SA898-V or B (2SA912-S or R)
Q5	Transistor	2SD381-L or M
Q6	Transistor	2SB536-L or M
D1	Diode	1S2473 (1S1555)
D2	Varistor	STV-4H
D3	Diode	W06A (1S1885)
D4	Diode	W06A (1S1885)

CAPACITORS

Symbol	Description	Part No.
C1	Metallized mylar 0.68 100V	ACE-010
C2	Ceramic 100p 50V	CCDSL 101K 50
C3	Ceramic 47p 50V	CCDSL 470K 50
C4	Electrolytic 22 50V	CEA 220P 50
C5	Electrolytic 470 6V	CEA 471P 6
C7	Ceramic 100p 500V	CCDSL 101K 500
C8	Ceramic 15p 50V	CCDSL 150K 50
C9	Ceramic 0.047 50V	CKDYF 473Z 50
C10	Ceramic 220p 500V	CCDSL 221K 500
C11	Ceramic 220p 500V	CCDSL 221K 500
C12	Ceramic 0.047 150V	ACG-009
C13	Ceramic 0.01 150V	ACG-001
C15	Electrolytic 1 50V	CEANL 010P 50

OTHER

Symbol	Description	Part No.
L1	AF choke coil 2.2μH	T63-009

RESISTORS

Symbol	Description	Part No.
R1	Carbon film 330k	RD½PS 334J
R2	Carbon film 2.2k	RD½PS 222J
R3	Carbon film 62k	RD½PS 623J
R4	Carbon film 43k	RD½PS 433J
R5	Carbon film 8.2k	RD½PS 822J
R6	Carbon film 3.6k	RD½PS 362J
R7	Carbon film 3.6k	RD½PS 362J
R8	Carbon film 2.4k	RD½PS 242J
R9	Carbon film 62k	RD½PS 623J
R10	Carbon film 6.8k ½W	RD½PS 682J
R11	Carbon film 82	RD½PS 820J
R12	Carbon film 160	RD½PSF 161J
R13	Carbon film 160	RD½PSF 161J
R14	Carbon film 150 ½W	RD½PSF 151J
R15	Carbon film 150 ½W	RD½PSF 151J
R16	Wire wound 0.5 5W	RT5B 0R5K
R17	Wire wound 0.5 5W	RT5B 0R5K
R18	Wire wound 0.5 5W	RT5B 0R5K
R19	Wire wound 0.5 5W	RT5B 0R5K
R20	Metal film 4.7 1W	RN1H 4R7K
R21	Metal film 4.7 1W	RN1H 4R7K
R22	Carbon film 100	RD½PS 101J
R23	Carbon film 100	RD½PS 101J
R24	Carbon film 100	RD½PS 101J
R25	Carbon film 100	RD½PS 101J
R26	Metal oxide 10 2W	RS2P 100J
R27	Metal oxide 10 1W	RS1P 100J
R28	Carbon film 2.7k	RD½PS 272J
VR1	Semi-fixed 100-B	ACP-019

12. PACKING

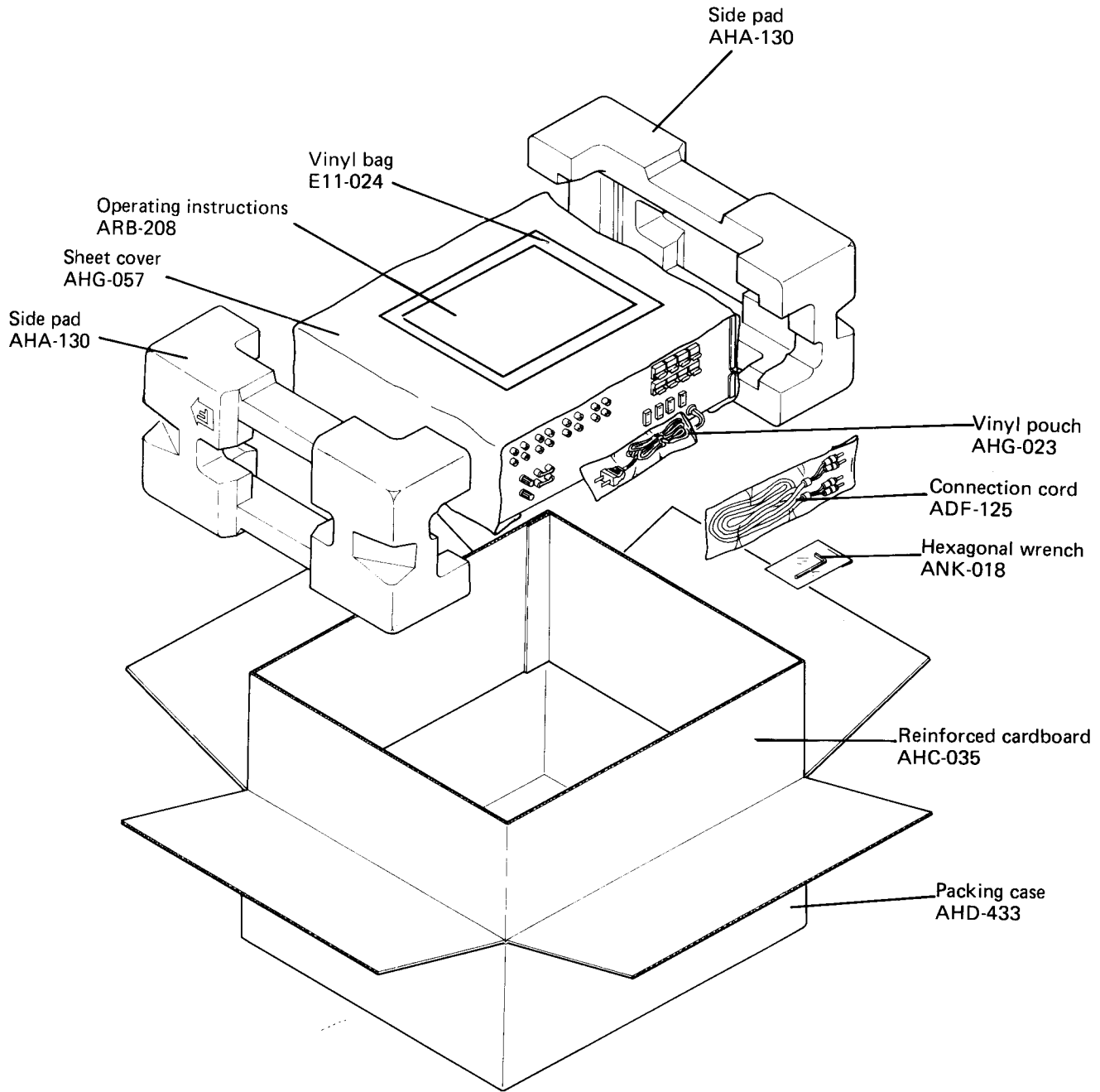

PIONEER ELECTRONIC CORPORATION

4-1, Meguro 1-Chome, Meguro-ku, Tokyo 153, Japan

U.S. PIONEER ELECTRONICS CORPORATION
75 Oxford Drive, Moonachie, New Jersey 07074, U.S.A.

PIONEER ELECTRONIC (EUROPE) N.V.

Luithagen-Haven 9, 2030 Antwerp, Belgium

PIONEER ELECTRONICS AUSTRALIA PTY. LTD.

178-184 Boundary Road, Braeside, Victoria 3195, Australia