

SERVICE MANUAL

AM/FM STEREO TUNER

TX-9500

FV

NOTE:

MODEL TX-9500 COMES IN TWO VERSIONS DISTINGUISHED AS FOLLOWS:

Round label on rear panel	Voltage	Type
FV	110V, 120V, 130V, 220V and 240V (Switchable)	General export model
KCU	120V only	CSA (Canada) and UL (U.S.A.) approved

- If you want to see KCU type not described in this manual, you are requested to refer to the service manual furnished with KCU type (ART-106-0).

CONTENTS

1. SPECIFICATIONS	3
2. FRONT PANEL FACILITIES	5
3. CONNECTION DIAGRAM	7
4. DISASSEMBLY	8
5. PARTS LOCATION	9
6. BLOCK DIAGRAM	11
7. CIRCUIT DESCRIPTION	13
8. ADJUSTMENTS	
8.1 Adjustment of FM Section	17
8.2 Adjustment of AM Section	20
8.3 Adjustment of Audio Frequency Oscillator	22
9. DIAL CORD STRINGING	23
10. PACKING	24
11. EXPLODED VIEW AND PARTS LIST	25
12. SCHEMATIC DIAGRAMS, P.C. BOARD PATTERNS AND PARTS LISTS	
12.1 Circuit Diagram	29
12.2 Electro-Parts	33
12.3 FM Front End (AWB-023)	33
12.4 Power Supply Circuit Assembly (AWR-076)	34
12.5 AF Oscillator Assembly (AWK-040)	38
12.6 AM-FM IF Assembly (AWE-055)	43
12.7 MPX Assembly (AWD-007)	53

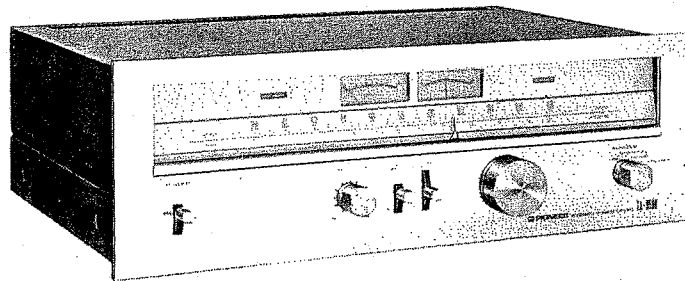

1. SPECIFICATIONS

Semiconductor

FET(s)	3
IC(s)	11
Transistors	34
Diodes	23

FM Section

Circuitry 3 MOS FETs, 2-stage RF Amplifier 5-gang Variable Capacitor, 8-stage Limiter, PLL MPX Circuit.

Sensitivity

IHF	1.5 μ V
50dB Quieting	2.5 μ V (mono), 35 μ V (stereo)
Signal-to-Noise Ratio	80dB (mono), 75dB (stereo)
Total Harmonic Distortion	
100Hz	0.15% (mono), 0.2% (stereo)
1kHz	0.15% (mono), 0.2% (stereo)
10kHz	0.15% (mono), 0.5% (stereo)

Capture Ratio 1.0dB

Selectivity \pm 400kHz 85dB
 \pm 300kHz 55dB

Frequency Response 50Hz ~ 10kHz $\begin{matrix} +0.2 \\ -0.5 \end{matrix}$ dB
 20Hz ~ 15kHz $\begin{matrix} +0.2 \\ -1.5 \end{matrix}$ dB

Separation

1kHz	40dB
50Hz ~ 10kHz	35dB
Image Rejection	110dB
IF Rejection	110dB
Spurious Rejection	110dB
AM Suppression	55dB
Sub Carrier Suppression	65dB
Muting Threshold	5 μ V/22 μ V
Stereo Threshold	5 μ V
De-emphasis	25 μ s/50 μ s/75 μ s switchable

AM Section

Circuitry 1-stage RF Amplifier, 3-gang Variable Capacitor.

Sensitivity

(IHF, Ferrite antenna)	300 μ V/m
(IHF, Ext. antenna)	15 μ V

Selectivity 40dB

Signal-to-Noise Ratio 50dB

Image Rejection 65dB

IF Rejection 85dB

Audio Section

Output Level/Impedance

FIXED	650mV/5k Ω
VARIABLE	70mV ~ 2V/3.5k Ω
4CH MPX	400mV/2.5k Ω

Miscellaneous

Power Requirements AC 110V, 120V, 130V, 220V, and 240V (Switchable) 50/60Hz

Power Consumption 23W

Dimensions 420(W) x 150(H) x 365(D)mm
 16-9/16 x 5-7/8 x 14-3/8 in.

Weight: Without Package 9.1kg (20 lb 1 oz)

With Package 10.6kg (23 lb 5 oz)

Furnished Parts

FM T-type Antenna	1
Connection Cord with Pin Plugs	1
Operating Instructions	1
Hexagonal wrench	1
Fuse 1A	1
Fuse 0.5A	1

NOTE:

Specifications and the design subject to possible modification without notice due to improvements.

2. FRONT PANEL FACILITIES

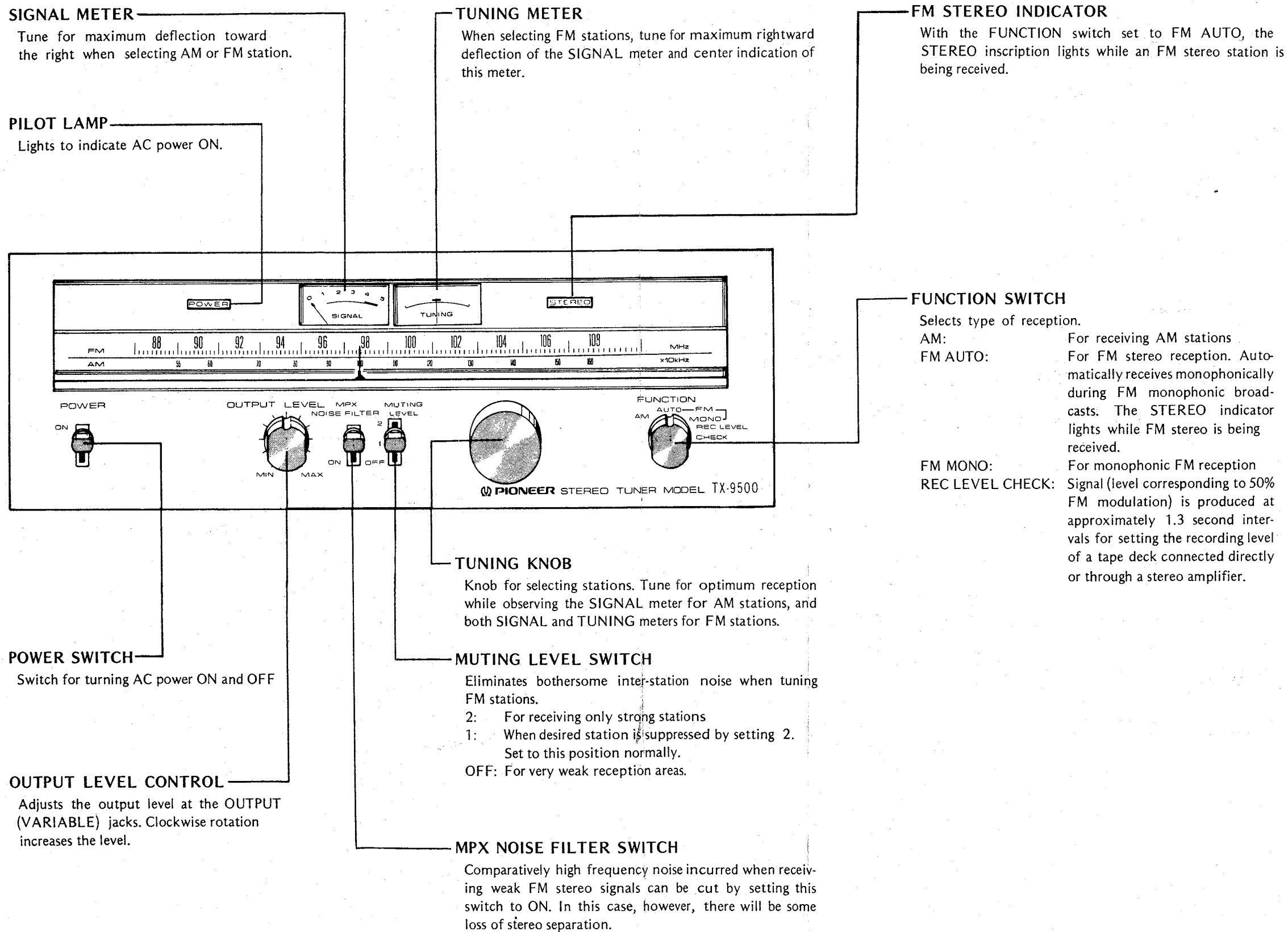

3. CONNECTION DIAGRAM

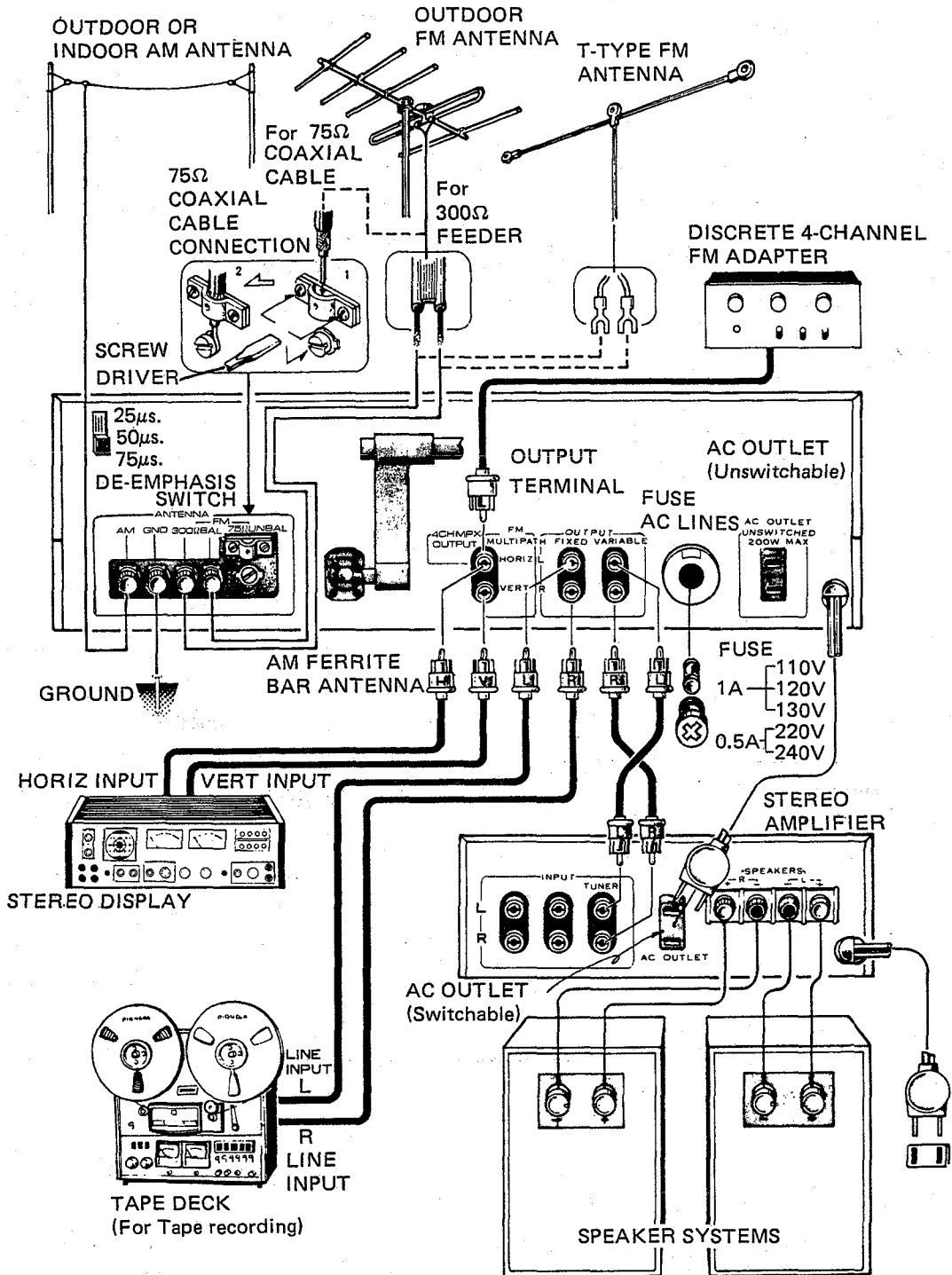

4. DISASSEMBLY

Bonnet Case

Unscrew the four screws (① ~ ④). Lift up the Bonnet case.

Bottom Plate

Unscrew the seven screws (⑬ ~ ⑰). Take off the bottom plate.

Front Panel

Remove all front panel knobs. For TUNING knob, loosen the setscrew with a hexagonal wrench before removing it. Unscrew the five screws (⑧ ~ ⑫). Remove the TUNING shaft nut and washer. The front panel is ready for removal.

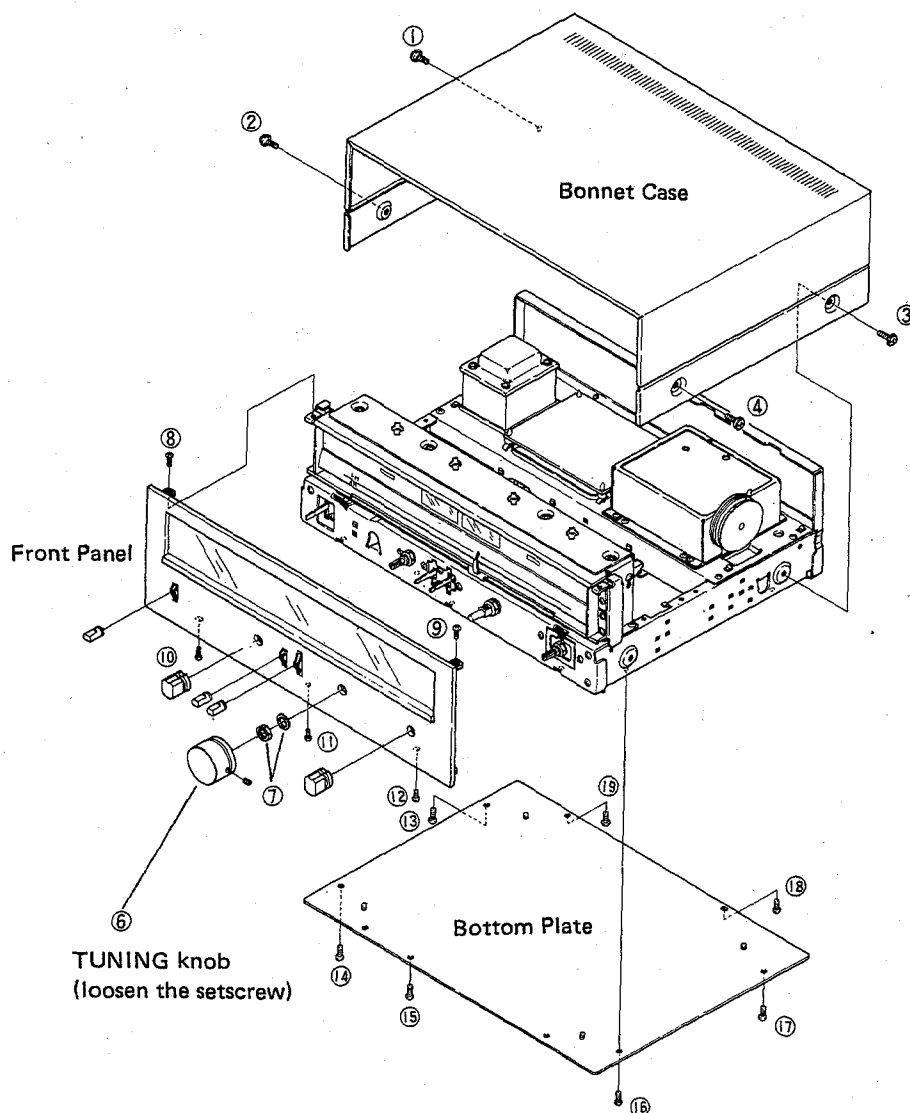

5. PARTS LOCATION

Top View

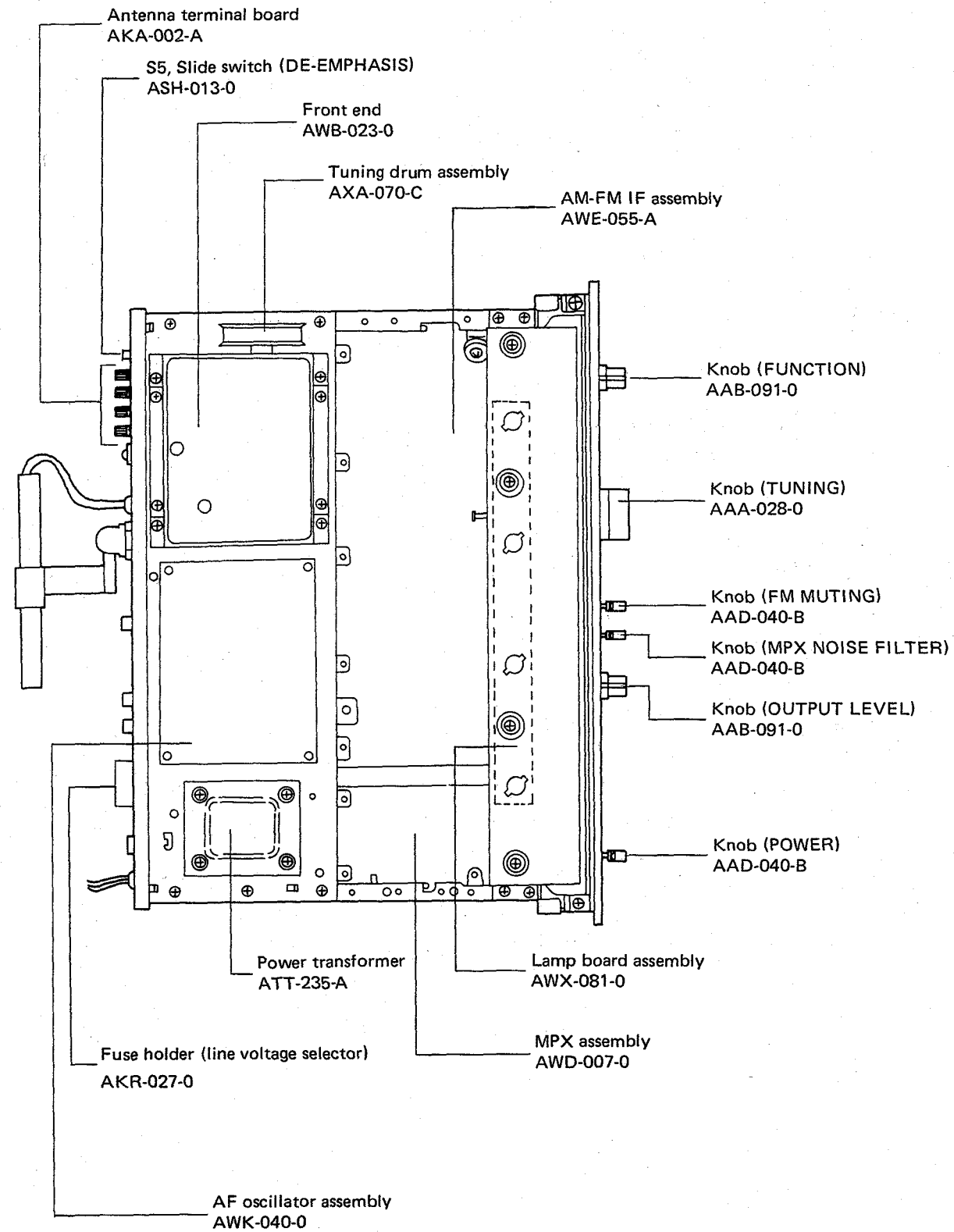

Bottom View

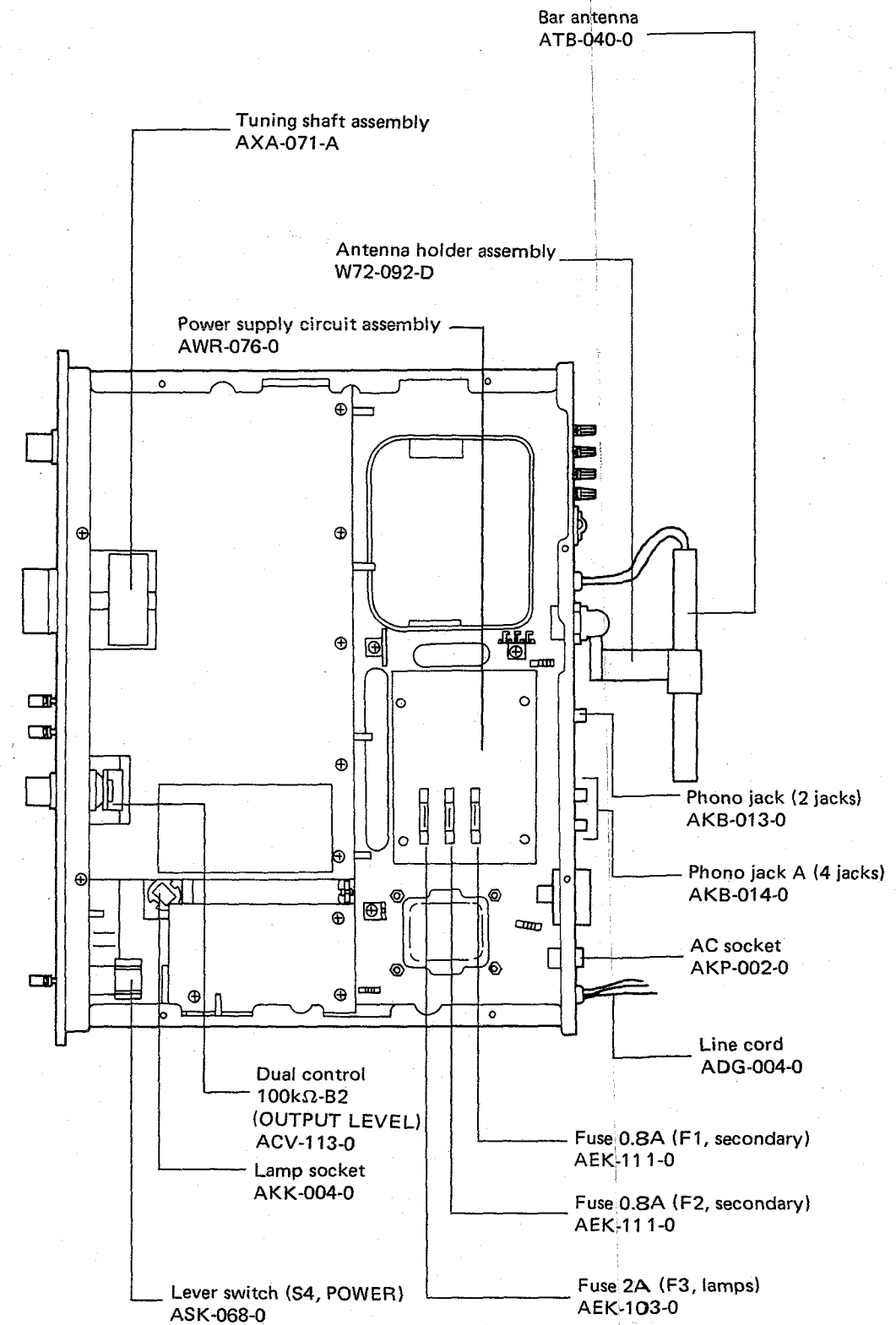

6. BLOCK DIAGRAM

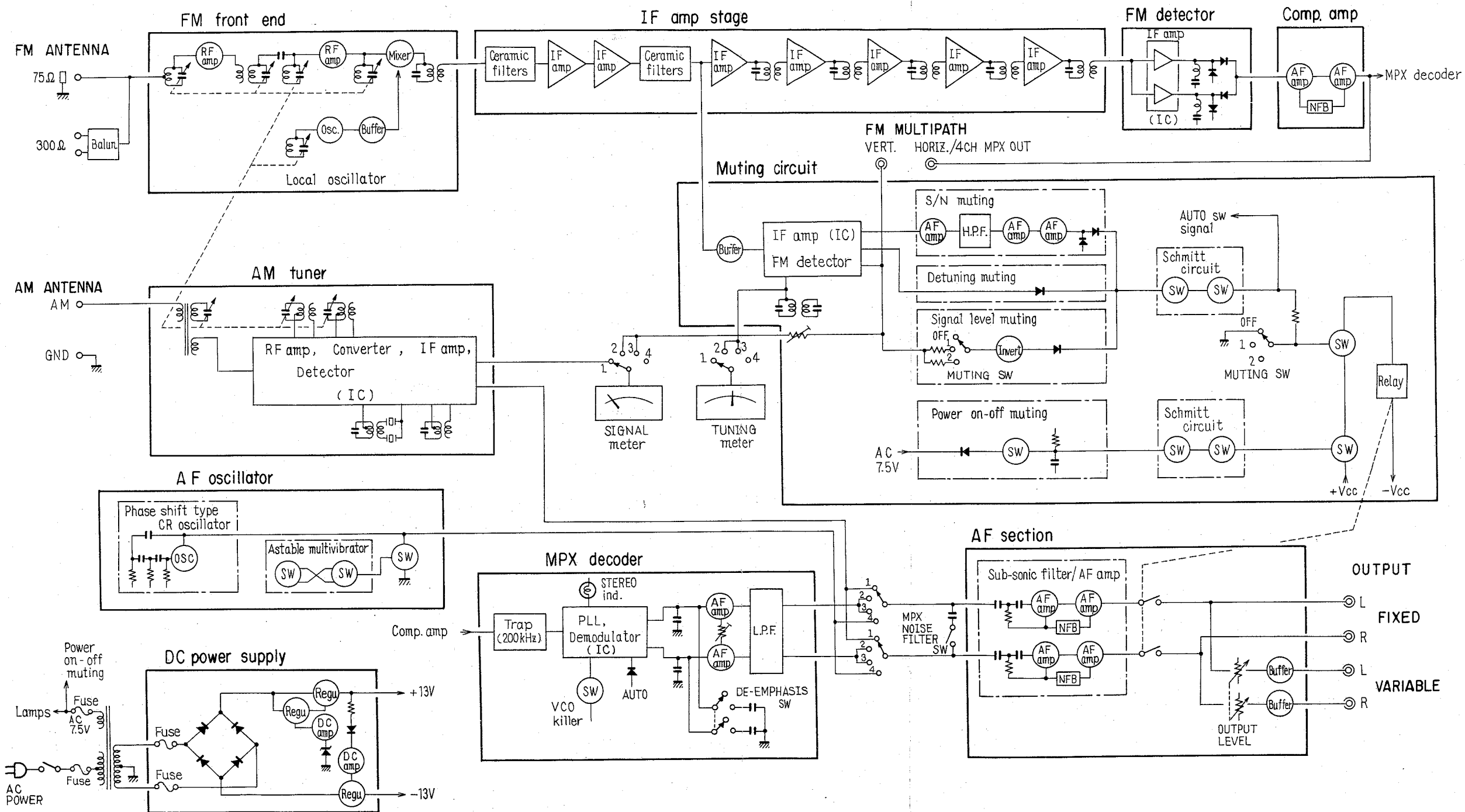

7. CIRCUIT DESCRIPTION

FM Front End

This comprises a tuning circuit with a 5-gang variable capacitor, a two-stage RF amplifier and a local oscillator with buffer.

• RF amplifier

This uses a dual-gate MOS field effect transistor and is equivalent to a cascode amplifier with two ordinary MOS FETs due to the employed circuitry that the FET's gate-2 is grounded. This has resulted in a stable RF amplification with large gain.

• Mixer

A dual-gate MOS FET is used in such a manner that the RF amplifier's output, coming to the gate-1, is mixed with the signal from the local oscillator applied to the gate-2.

This method has advantages that no big power signal from the local oscillator is needed and there is a least mutual interference even when the input level is very high.

• Local oscillator

This is a variation of the Clapp circuit. A buffer amplifier is provided between the mixer and local oscillator to ease its load so that the distortion of the oscillator's output is kept minimum and, at the same time, to protect the local oscillator from being affected by the mixer.

FM IF Amplifier

This comprises 7 monolithic integrated circuits (ICs), 4 dual element ceramic filters and 5 single-tuned intermediate frequency transformers (IFTs) and has a wide frequency response as well as a satisfactory limiter characteristics.

FM Detector (Figs. 1, 2, 3)

This is a newly-developed delay-type ultra wide-band linear phase detector. The linearity of detection extends up to about $\pm 3\text{MHz}$ while it has superb differential characteristics. However, the limiter must be effectively provided in the IF stage because this circuit has no facility of amplitude suppression.

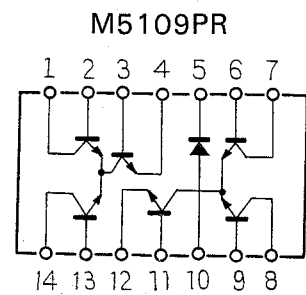

Fig. 1

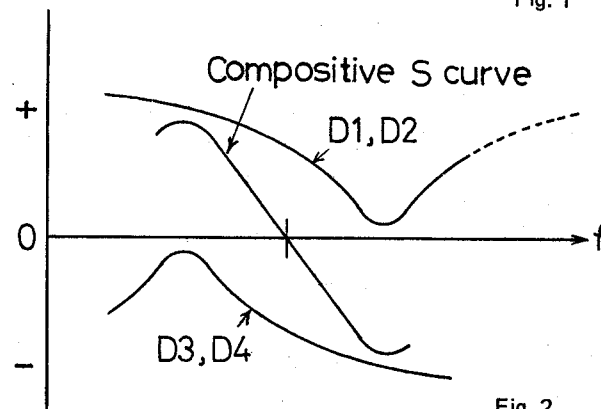

Fig. 2

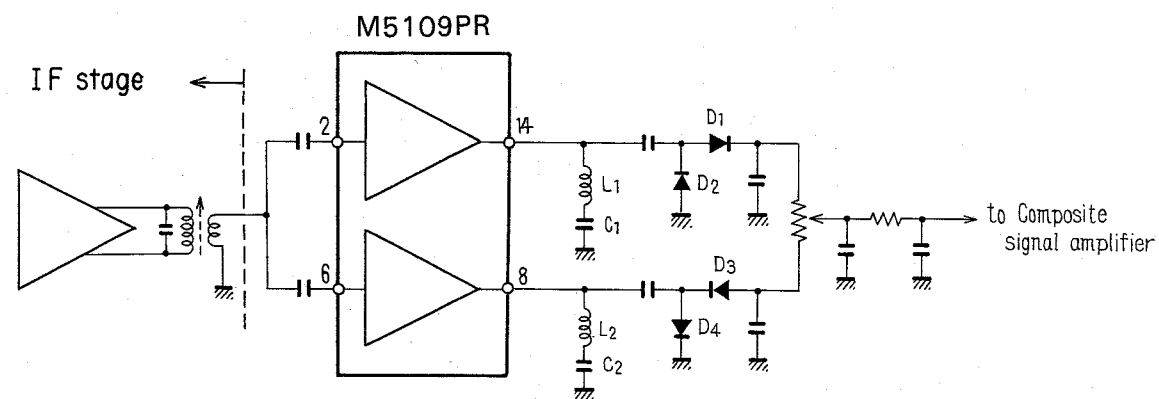

Fig. 3

The M5109PR is an IC in which two pairs of differential amplifiers are incorporated (Fig. 1). The load of each differential amplifier is a series resonance circuit. The frequency deviation of the modulated signal from the intermediate frequency (10.7MHz) is converted to amplitude-modulated wave, making use of a characteristic slope of each resonance circuit, which is symmetrically detected into two components and finally composed into one (Fig. 2).

MPX Decoder (Fig. 4)

This is of the phase locked loop (PLL) circuit which is integrated into an IC (HA1156).

AM Tuner (Fig. 5)

This consists of an IC (HA1138) which performs single-stage RF and double-stage IF amplifications.

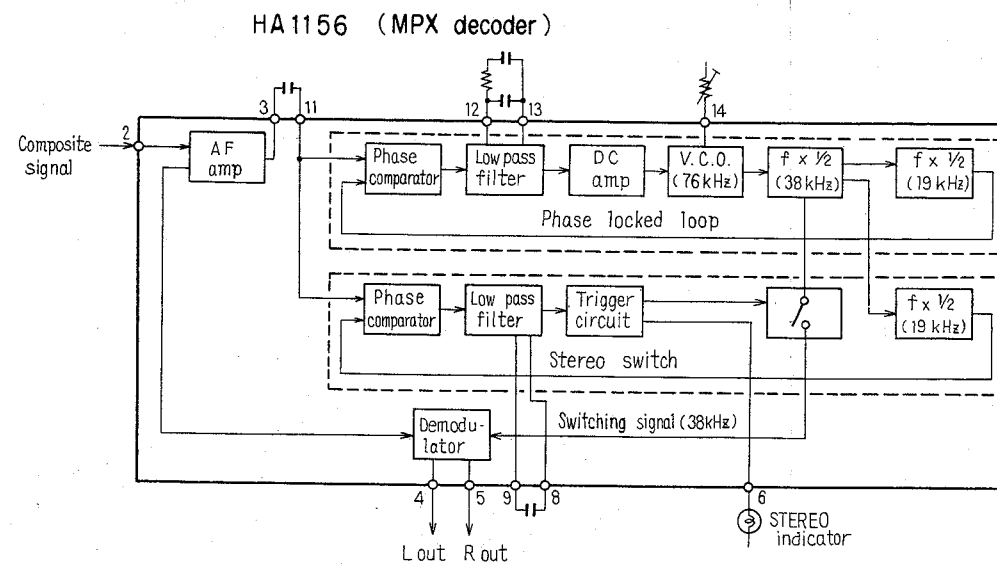

Fig. 4

*Voltage Control Oscillator (VCO)

This is an oscillator of which oscillation frequency can be controlled by the input voltage. The free-running frequency, which is the natural frequency when there are no input signals, is adjusted to 76kHz.

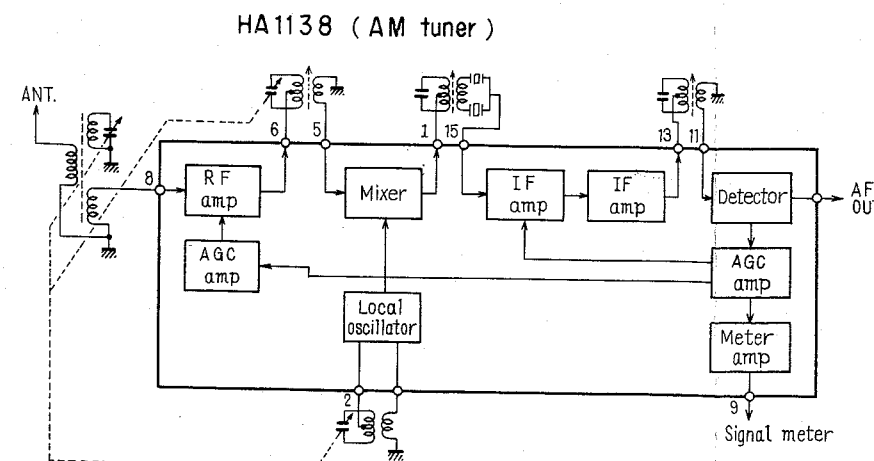

Fig. 5

Muting Circuit (Fig. 6)

The TX-9500 is provided with the IF amplifier and detector exclusively used for the FM muting, which are integrated into an IC (HA1137).

• S/N Muting

This starts functioning, when the signal-to-noise ratio has deteriorated.

The components of 100kHz and over of the detected signal (pin 6 of HA1137), being taken as noise signals, are amplified (Q1~Q3) and rectified (D1 and D2) before being applied to the Schmitt circuit to make the muting relay operate (off).

• Input level muting

This operates when the level of input signal is too low.

The operation level of this muting can be switched over two levels with the front panel MUTING switch. DC voltages, which develop at pin 13 of the HA1137 and are almost proportional to the levels of antenna input signals,

are inverted at Q4 (i.e. in inverse proportion) and applied to the Schmitt circuit (Q5 and Q6) to make the muting relay (RL1) operate (off).

• Detuning muting

This operates when the tuner has been detuned. A DC voltage, which is available at pin 12 of the HA1137 when the tuner has been detuned by about 70kHz, is sent to the Schmitt circuit to make the muting relay (RL1) operate (off).

• Power switch muting

This operates to keep click noises low when turning on and off the power.

When 7.5V AC voltage is supplied with the power turned on, the collector potential of Q9 which has just been switched off rises as C1 becomes more and more charged until the Schmitt circuit is reversed to make the muting relay (RL1) operate (on). When turning off the power has stopped supplying 7.5V AC voltage,

the base potential of Q9 rises temporarily. It will switch on Q9 and the electricity stored in C1 will discharge instantaneously resulting in reversal of the Schmitt circuit, which causes the muting relay to operate (off).

AF Oscillator

This is a phase shift type CR oscillator which supplies the REC LEVEL CHECK signal by generating 440Hz sine waves and switching them at 1.3 second intervals with an astable multivibrator.

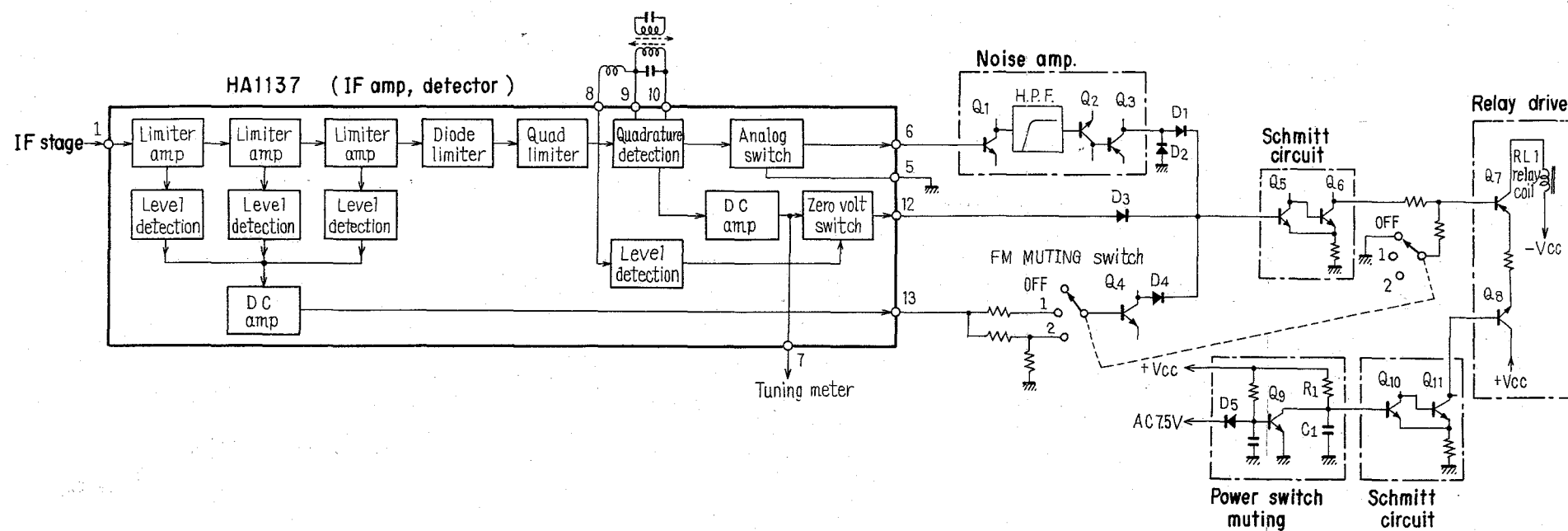

Fig. 6

8. ADJUSTMENTS

Before starting adjustment, make sure that the dial pointer indicates the left hand end of the frequency scale (the lowest frequency position) when the tuning knob is turned fully counter-clockwise.

8.1 ADJUSTMENT OF FM SECTION

Caution:

Do not touch the IF transformers (T1 ~ T5) in the AM-FM IF assembly.

FM front end

Switch positions:

FUNCTION switch: FM MONO

MPX NOISE FILTER switch: OFF

FM MUTING switch: OFF

Connection of instruments:

FM signal generator (FM SG): Connect to the FM ANTENNA terminals through a 300-ohm dummy antenna.

AC voltmeter (with the maximum indication of about 1V): Connect to the FIXED L terminal.

Adjustment

1. Position the dial pointer of the TX-9500 at 90MHz.
2. Set the FM SG's output to 90MHz, 10dB with 100% modulation by 400Hz.
3. Adjust T5 so that the AC voltmeter reads a maximum.
4. Reset the TX-9500's dial pointer and the FM SG's output frequency to 106MHz (leaving the output level and degree of modulation as it is).
5. Adjust TC5 so that the AC voltmeter reads a maximum.
6. Reset the TX-9500's dial pointer and the FM SG's output frequency to 90MHz (leaving the output level and degree of modulation as it is).
7. Adjust T1, T2, T3 and T4 so that the AC voltmeter reads a maximum.
8. Reset the TX-9500's dial pointer and the FM SG's output frequency to 106MHz (leaving the output level and degree of modulation as it is).
9. Adjust TC1, TC2, TC3 and TC4 so that the AC voltmeter reads a maximum.
10. Repeat 1 to 9 until the AC voltmeter reads almost the same indications for 90MHz and 106MHz.
11. Resetting the FM SG's output level to 10dB, adjust T6 so that the AC voltmeter reads a maximum.

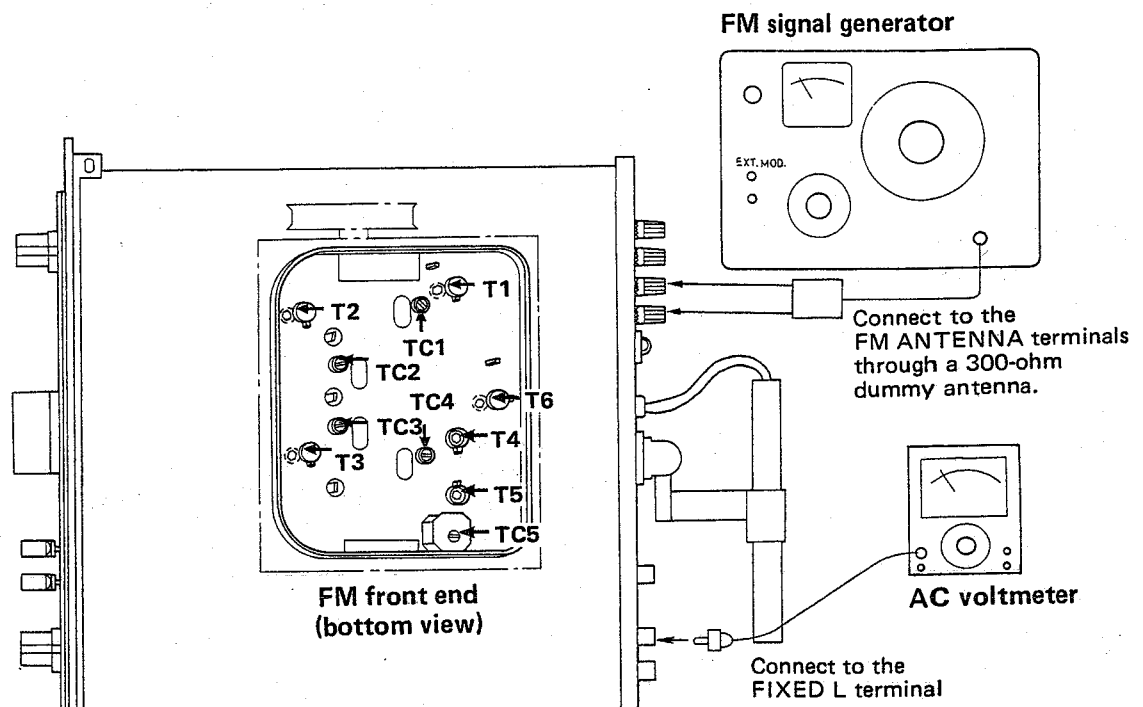

Fig. 7

Muting circuit

Switch positions:

FUNCTION switch: FM MONO

MPX NOISE FILTER switch: OFF

MUTING switch: OFF

Connection of instruments:

FM signal generator (FM SG): Connect to the FM ANTENNA terminals through a 300-ohm dummy antenna.

AC voltmeter (with the maximum indication of about 1V): Connect to the FIXED L terminal.

Distortion meter: Connect to terminal No.12 of the AM-FM IF assembly.

Adjustment

1. Turn VR1 fully counterclockwise.
2. Setting the TX-9500 to a condition, by reducing the FM SG's output level (less than -6dB) or detuning the TX-9500, such that it is receiving no input signals, adjust the primary (lower) core of T6 so that the TUNING meter points to the center of the scale.
3. Resetting the FM SG's output level to 60dB, adjust the secondary (upper) core of T6 so that distortion becomes minimum.
4. Set the FM SG's output to 98MHz, 20dB with 100% modulation by 400Hz.
5. Tune the TX-9500 to 98MHz (Make a fine tuning looking at the TUNING meter).
6. Set the MUTING switch at "1."
7. Turn VR1 clockwise slowly and stop it just when the AC voltmeter abruptly indicates 0V.
8. Reset the MUTING switch "OFF".
9. Setting the TX-9500 to a condition, by reducing the FM SG's output level (less than -6dB), such that it is receiving no input signals, adjust the primary (lower) core of T6 so that the TUNING meter points to the center of the scale.
10. Repeat 8 to 9 for several times.
11. Resetting the FM SG's output level to 100dB, adjust VR2 so that the SIGNAL meter points to "5."

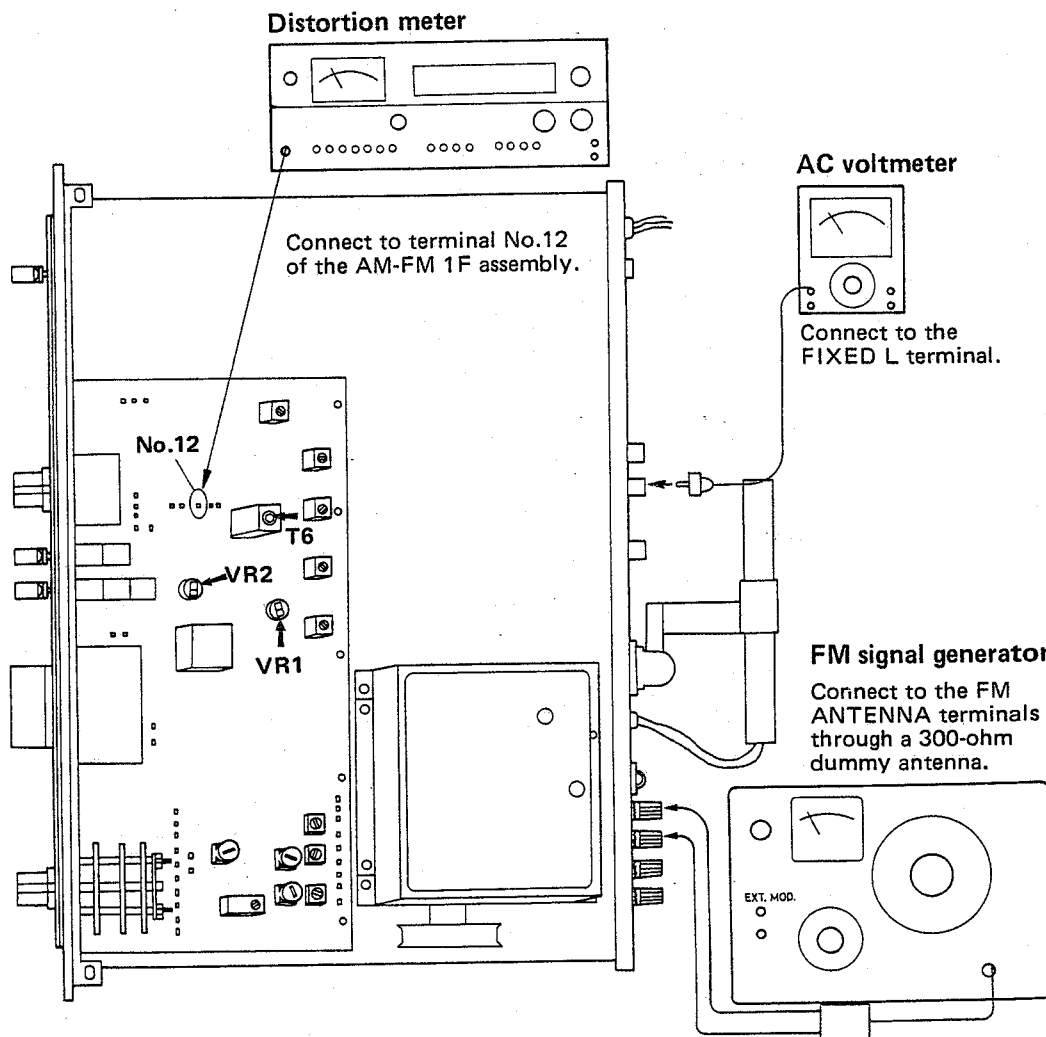

Fig. 8

FM MPX circuit

Switch positions:

FUNCTION switch: FM AUTO
 MPX NOISE FILTER: switch: OFF
 MUTING switch: OFF

Connection of instruments:

FM signal generator (FM SG): Connect to the FM ANTENNA terminals through a 300-ohm dummy antenna.

MPX signal generator (MPX SG): Connect to the "external modulation" terminals of FM SG.

AC voltmeter: Connect to the FIXED L terminal.

Oscilloscope: Connect the horizontal and vertical input terminals respectively to the MPX SG's PILOT OUT terminal and No.11 terminal of the MPX assembly through a probe.

Adjustment

1. Set the FM SG's output to 98MHz, 60dB with 0% modulation.
2. Tune the TX-9500 to 98MHz. (Make a fine tuning looking at the TUNING meter.)
3. Adjust VR1 so that the Lissajous' figure developed on the oscilloscope screen becomes stationary.
4. Reset the FM SG's output to 98MHz, 60dB with external modulation and make the MPX SG generate the pilot and R channel signals.
5. Adjust VR2 so that the AC voltmeter reads minimum.

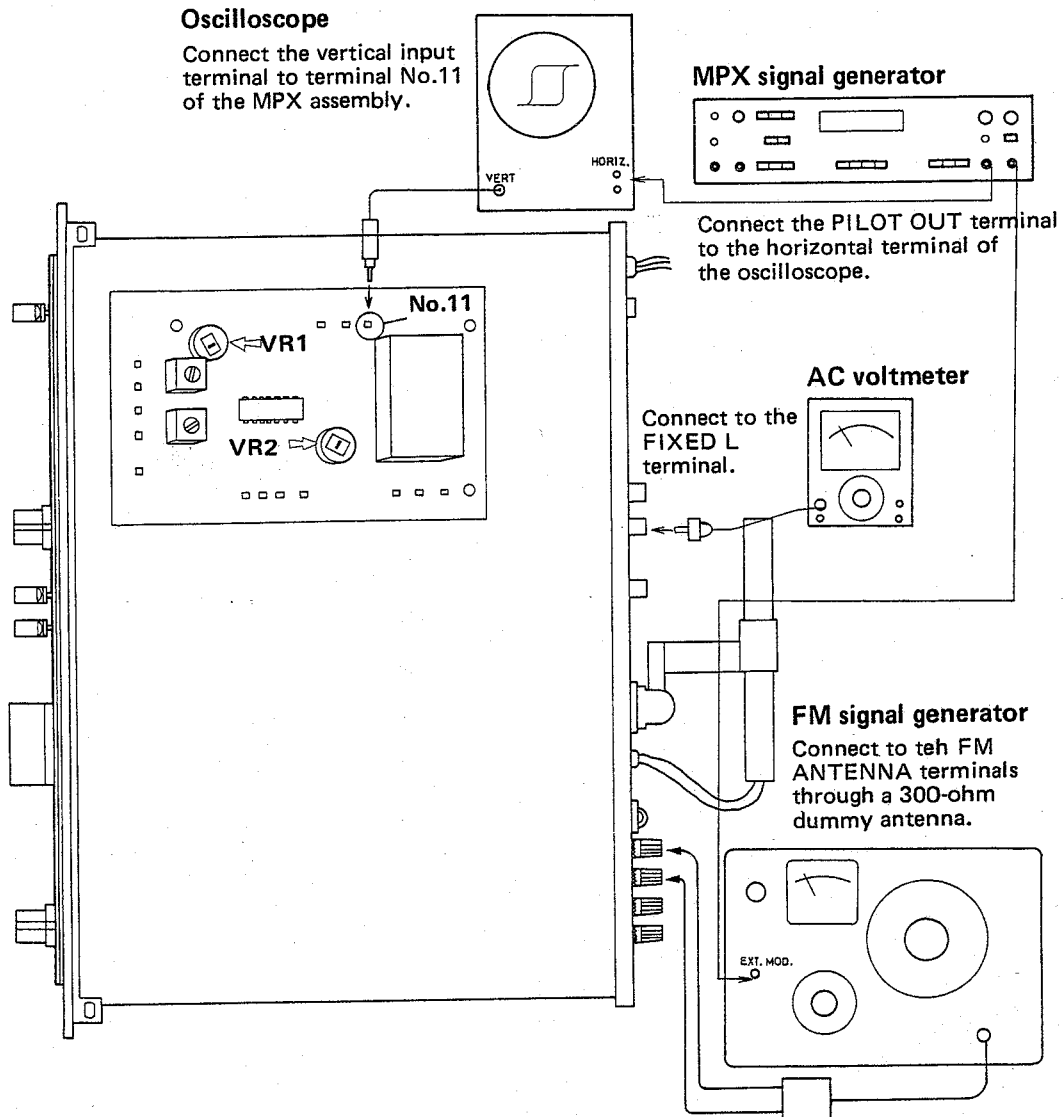

Fig. 9

8.2 ADJUSTMENT OF AM SECTION

Adjustment of IFT

Switch positions:

FUNCTION switch: AM

Connection of instruments:

Sweep generator (400kHz ~ 500kHz): Connect the output terminal to No.2 terminal of the AM-FM IF assembly.

Oscilloscope: Connect the vertical and horizontal input terminals respectively to the TX-9500's FIXED L terminal and the sweep generator's time axis output terminal.

Adjustment

1. Set the sweep generator output level to 80dB.
2. Adjust F5 and T9 so that the figure developed on the oscilloscope becomes laterally symmetrical with the axis of symmetry at 455kHz and it has a maximum amplitude as well.

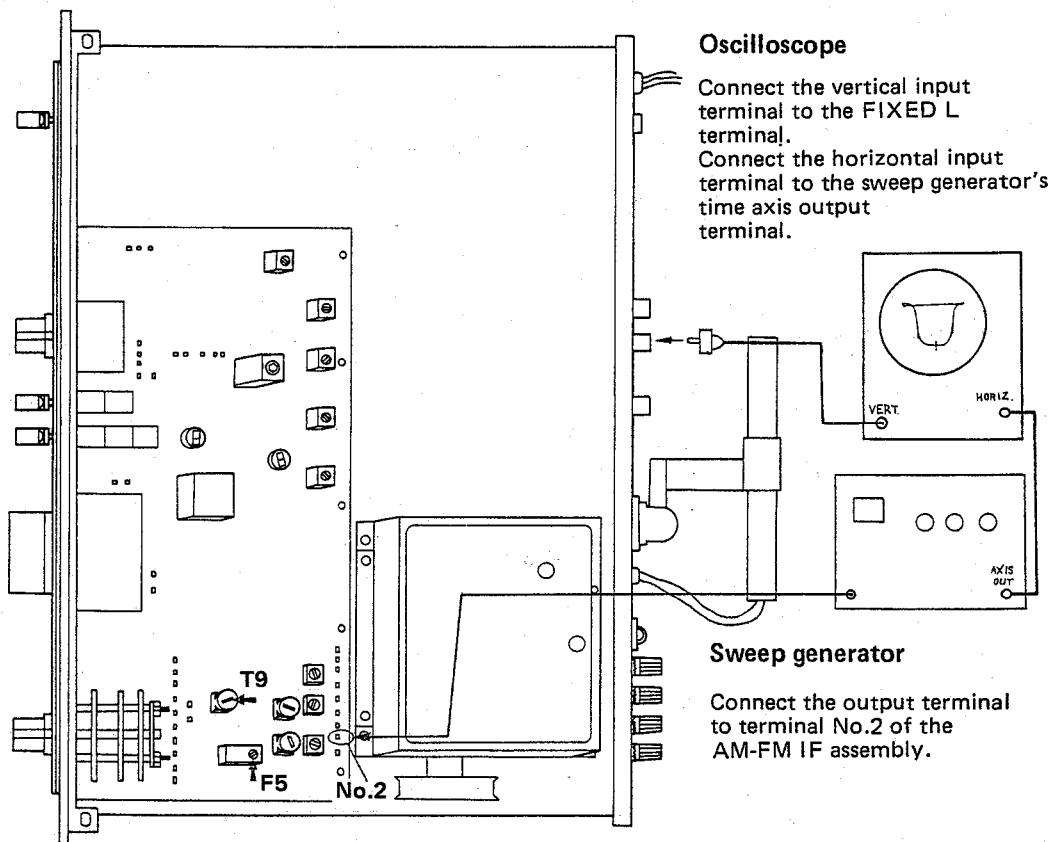

Fig. 10

• Tracking adjustment

Switch position:

FUNCTION switch: AM

Connection of instruments:

AM signal generator (AM SG): Connect to the AM ANTENNA terminals through a 1k-ohm resistor.

AC voltmeter: Connect to the FIXED L terminal.

Adjustment

1. Position the TX-9500's dial pointer at 600kHz.
2. Set the AM SG's output to 600kHz, 30dB with 30% modulation by 400Hz.

3. Adjust the cores of T8, T7 and the bar antenna so that the AC voltmeter reads maximum.
4. Reset the TX-9500's dial pointer and the AM SG's output frequency to 1,400kHz (leaving the output level and degree of modulation as it is set).
5. Adjust TC1, TC2 and TC3 so that the AC voltmeter reads maximum.
6. Repeat 1 to 5 until the AC voltmeter reads almost the same indications for 600kHz and 1,400kHz.

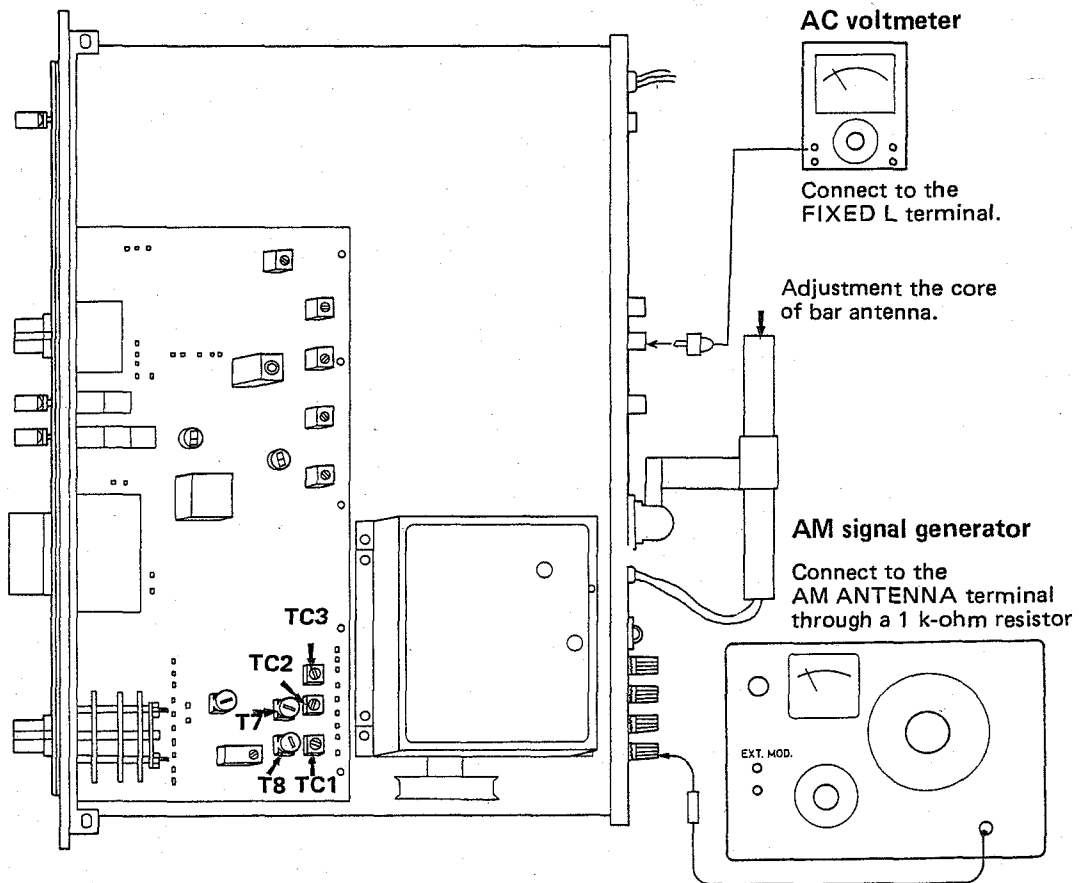

Fig. 11

8.3 ADJUSTMENT OF AUDIO FREQUENCY OSCILLATOR

Switch position:

FUNCTION switch: REC LEVEL CHECK

Connection of instrument:

AC voltmeter: Connect to the FIXED L terminal.

1. Make sure that the AC voltmeter deflects intermittently.
2. Adjust VR1 so that the AC voltmeter reads half of the rated output.*

*The output level of audio signal when the TX-9500 is receiving FM signals of 60dB with 100% 400Hz modulation.

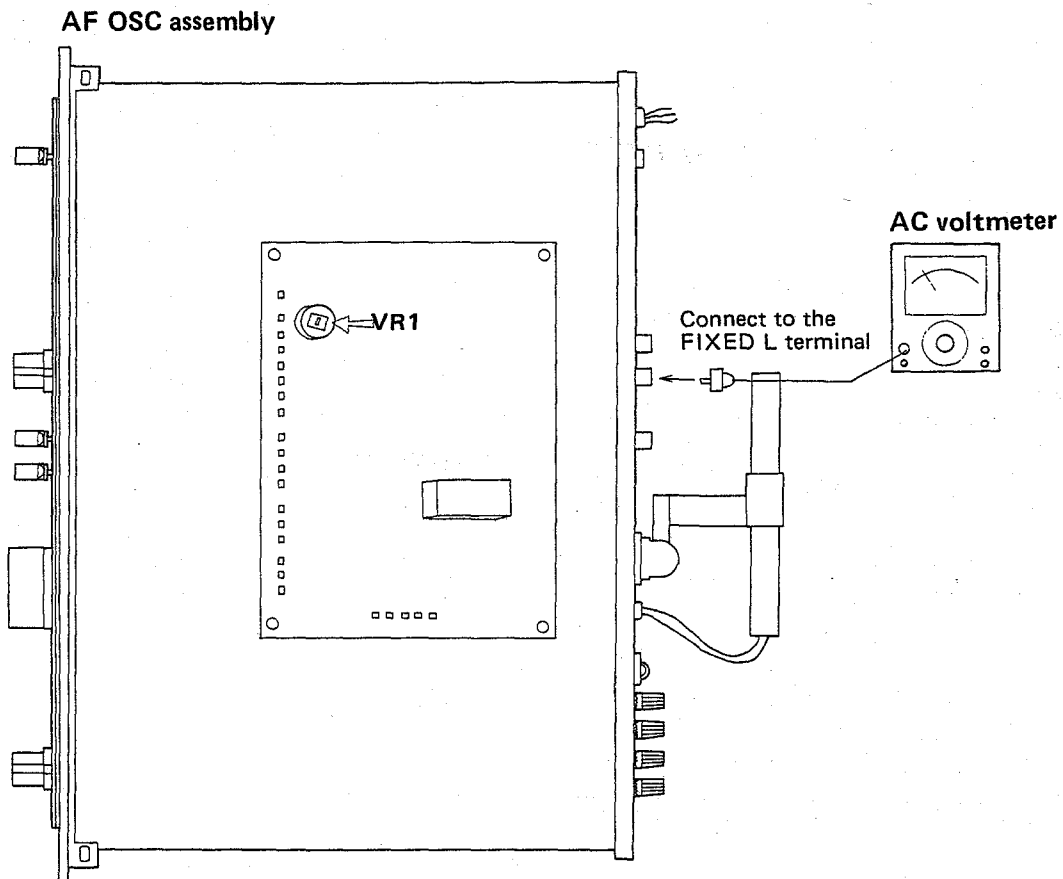
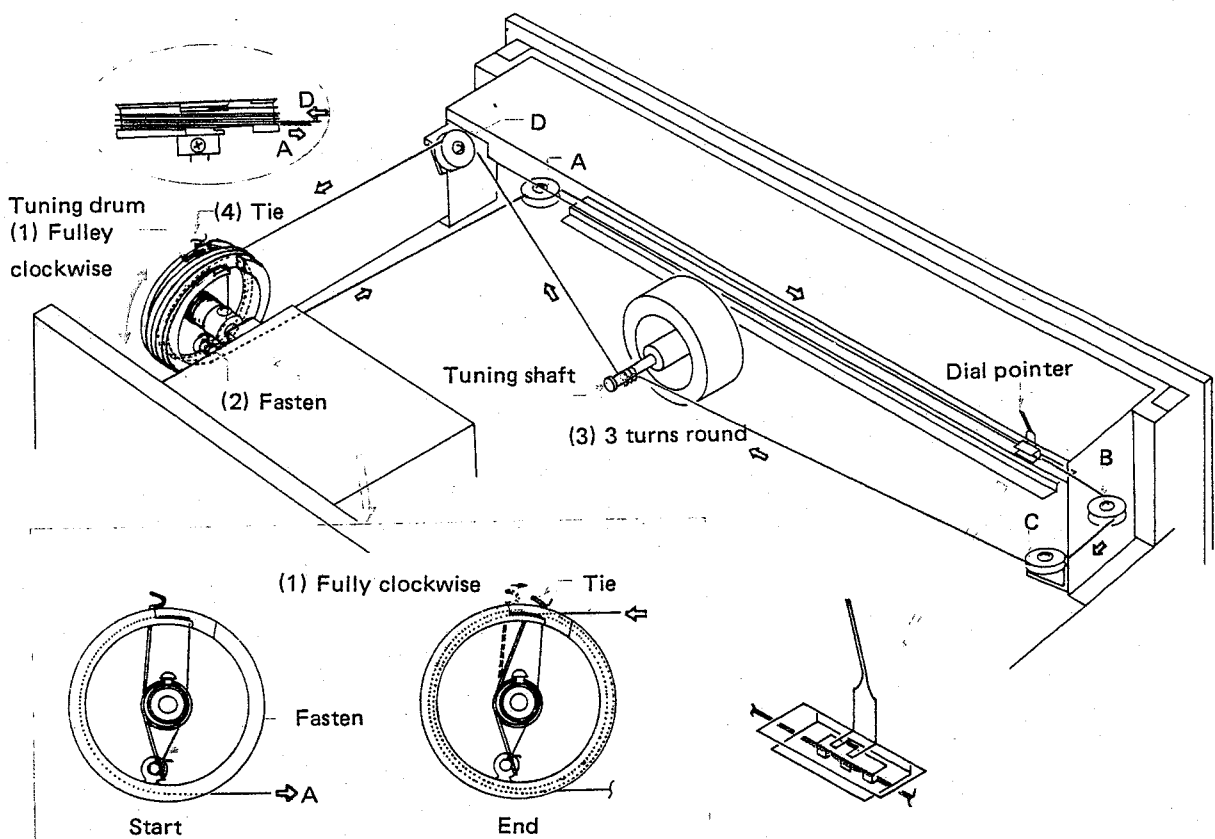

Fig. 12

9. DIAL CORD STRINGING

1. Set the tuning capacitor to maximum capacitance, fully clockwise.
2. Fasten one end of the cord to the protrusion on the tuning drum and lead it round pulleys A, B and C.
3. Wind the cord 3 turns round the tuning shaft and run it round pulley D.
4. Wind the cord 2 turns round the dial pulley and tie the end to the spring while tensioning the spring slightly.
5. Confirm that dial stringing moves smoothly. If so, cut the unnecessary portion of string.
6. Turn the tuning knob fully counterclockwise and fix the dial pointer to string so that it indicates low end on the dial scale.



10. PACKING

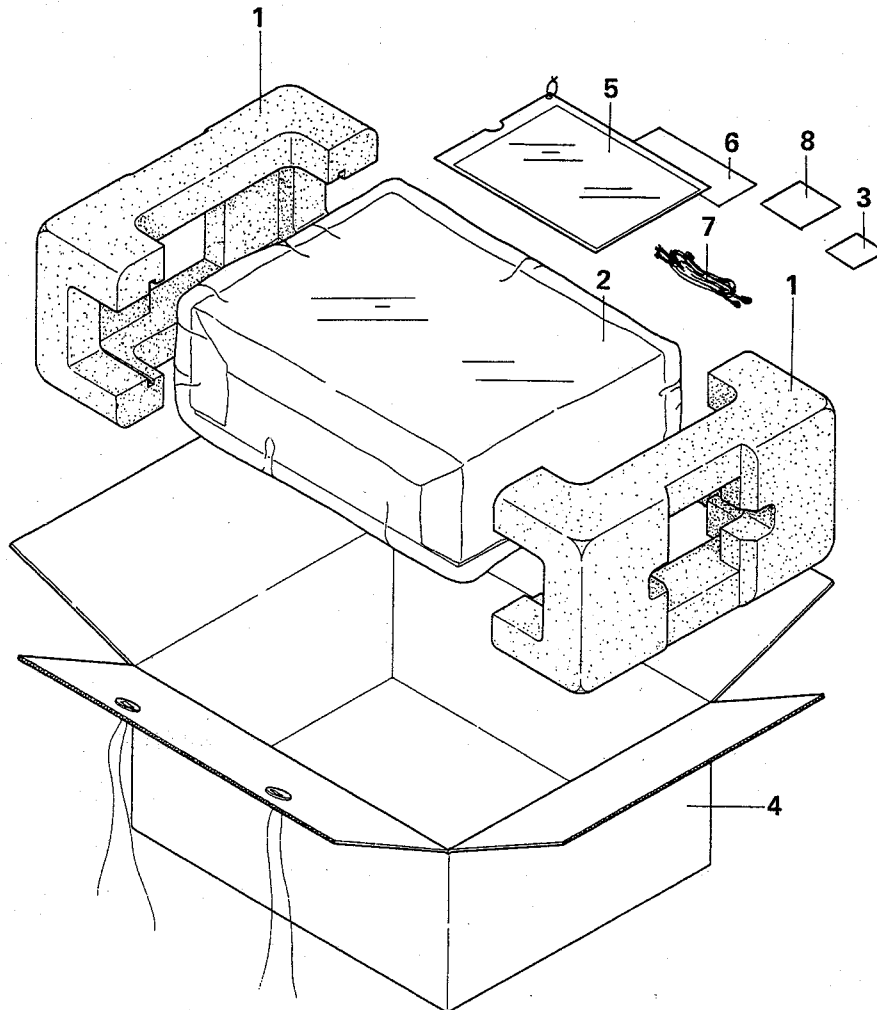

Parts List

Key No.	Description	Part No.
1	Side pad	AHA-081-0
2	Sheet	AHG-026-B
3	Hexagonal wrench	ANK-018-0
4	Packing case	AHD-249-0
5	Operating instructions (English) Operating instructions (German/French)	ARB-148-0 ARD-082-0
6	Connection cord with pin plugs	ADE-005-0
7	FM T-type antenna	ADH-002-0
8	Fuse 1A Fuse 0.5A	AEK-106-0 AEK-107-0

11. EXPLODED VIEW AND PARTS LIST

NOTE

Parts number is subject to change for the purpose of improvement with notice of a service bulletin.

Service bulletin will be furnished whenever necessary and you are requested to amend parts number in this manual according to the instructions.

Parts List of Exploded View

NOTICE: Any parts asterisked (*) are subject to being not supplied.

Key No.	Description	Part No.
1*	Lamp board mount plate	ANH-250-A
2*	Acrylic board clip	AEC-036-A
3*	Acrylic board	AEC-192-B
4	Pulley shaft	M49-025-E
5	Pulley	AEC-101-0
6*	Pulley-held metal	ANG-115-0
7	Dial panel assembly	AAG-089-A
8*	Side screen (L)	AAH-020-0
9*	Dial pointer guide plate	ANK-077-0
10	Dial pointer	AAF-040-0
11*	Nylon sheet	AEC-191-0
12*	Side screen (R)	AAH-021-0
13	Rubber bracket	AEB-068-0
14	Lamp 6V, 30mA (with leads)	AEL-025-0
15	Double meter (SIGNAL/TUNING)	AAW-040-0
16*	Hold plate	ABK-003-0
17	Power transformer	ATT-235-A
18*	PC board spacer	AEB-019-0
19*	Dial stay	AND-084-A
20*	Pulley-held metal	ANG-014-A
21	AF oscillator assembly	AWK-040-0
22	Lamp socket (wedge type)	AKK-004-0
23	Lamp 8V, 300mA (wedge type)	AEL-029-0
24	Lamp board assembly	AWX-081-0
25	Front end	AWB-023-0
26	Collar head tapping screw 4x8	ABA-079-A
27	Dial drum assembly	AXA-070-C
28	Strain relief	AEC-079-0
29	Line cord	ADG-004-0
30	Bonnet	ANE-079-0
31	Bar-antenna	ATB-040-0
32	Antenna holder assembly	W72-092-D
33	Tapping screw M3x8	ABA-002-0
34*	Rear panel	ANC-188-0
35	AC socket	AKP-002-0
36*	Socket mount plate	M49-127-0
37*	Wire clip (B)	AEC-005-0
38	Phono jack A (4 jacks)	AKB-014-0
39	Phono jack (2 jacks)	AKB-013-0
40	Antenna terminal board	AKA-002-A

Continued on the Next Page

NOTICE: Any parts asterisked (*) are subject to being not supplied.

Key No.	Description	Part No.	
41	Ferrite balun	T22-025-A	
42*	Center frame	ANA-083-C	
43*	Side frame	ANF-303-0	
44	Ground terminal 4P	K13-047-0	
45*	Wire clip (S)	AEC-037-0	
46	Ground terminal 2P	K13-048-0	
47*	Wire supporter	AEC-151-B	
48	Lever switch (S4, POWER)	ASK-068-0	
49	Dual control 100k Ω -B2 (OUTPUT)	ACV-113-0	
50	Tuning shaft assembly	AXA-071-A	
51*	Front frame	ANA-082-0	
52	Flat washer 9 ϕ	B22-016-0	
53	Hex. nut 9 ϕ	B71-004-0	
54	Flat washer 11 ϕ	B22-017-0	
55	Hex. nut 11 ϕ	B71-005-0	
56	Front panel assembly	ANB-313-A	
57	Knob (POWER, MPX NOISE FILTER, FM MUTING)	AAD-040-B	
58	Knob (OUTPUT LEVEL, FUNCTION)	AAB-091-0	
59	Knob (TUNING)	AAA-028-0	
60	MPX assembly	AWD-007-0	
61	Collar head tapping screw M3x8	ABA-078-A	
62	Fuse 2A (F3, lamps)	AEK-103-0	
63	Fuse 0.5A (F4, primary)	AEK-107-0	
64	Power supply circuit assembly	AWR-076-0	
65	AM-FM IF assembly	AWE-055-A	
66	Foot	AEC-178-0	
67*	Bottom plate	ANE-078-C	
68	Tapping screw 4x8	ABA-012-0	
69	Fuse 0.8A (F1, F2 secondary)	AEK-111-0	
70	Round head screw M3x10	ABA-003-0	
71	Pan head screw M3x6 (pit-shaped)	B11-037-0	attach 27
72	Set screw M3x4	attach 59
73	Slide switch (S5, DE-EMPHASIS)	ASH-013-A	
74*	Lock plate	AEC-199-0	
75	Fuse holder (line voltage selector)	AKR-027-0	

The following symbols stand for screws as shown in the exploded view.

TC: Brazier head tapping screw

TB: Brazier head tapping screw (large pitch)

BM: Binding head screw

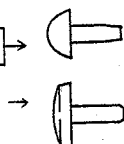

Exploded View

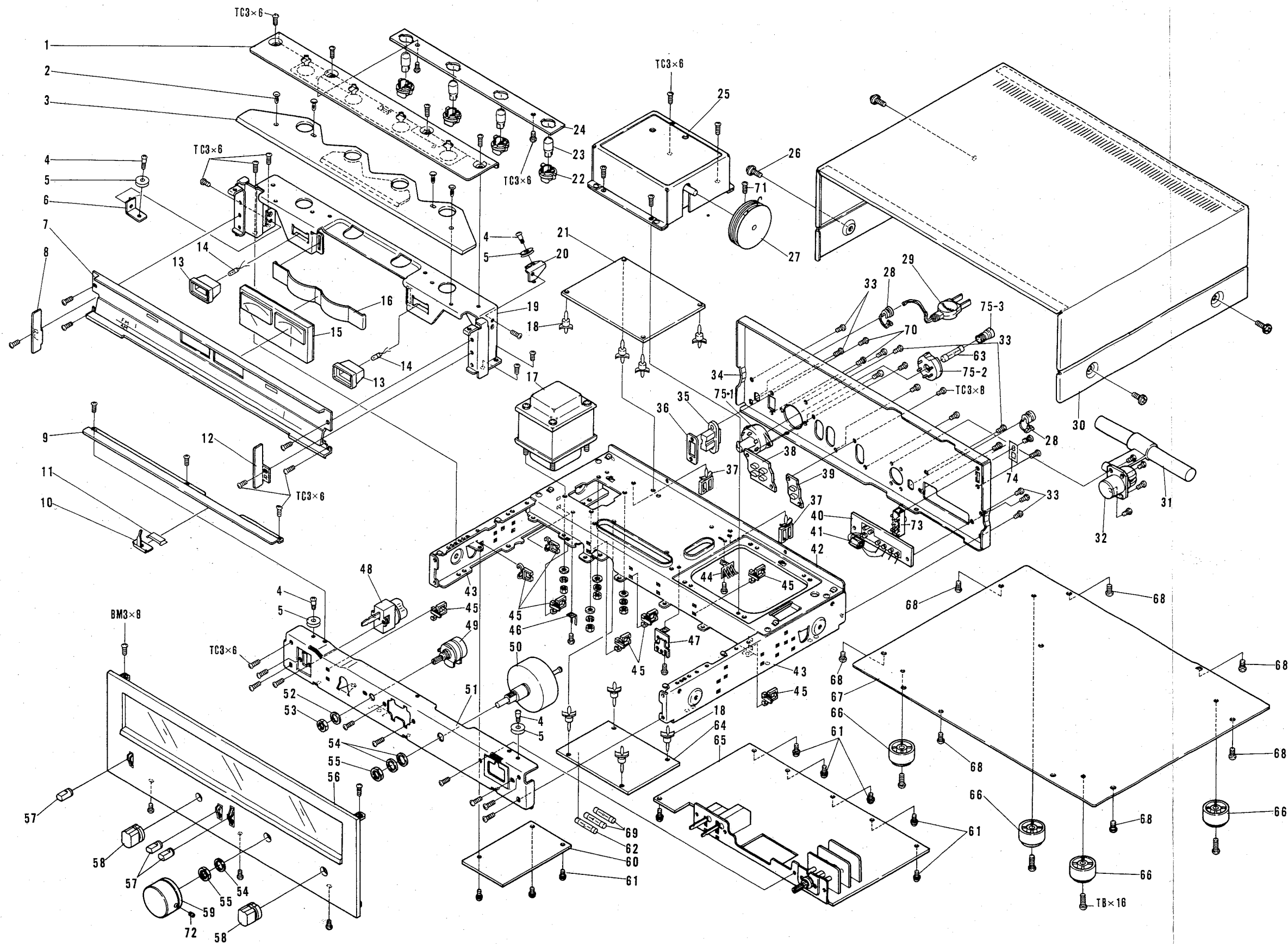

12. SCHEMATIC DIAGRAMS, PCB PATTERNS AND PARTS LISTS

12.1 CIRCUIT DIAGRAM

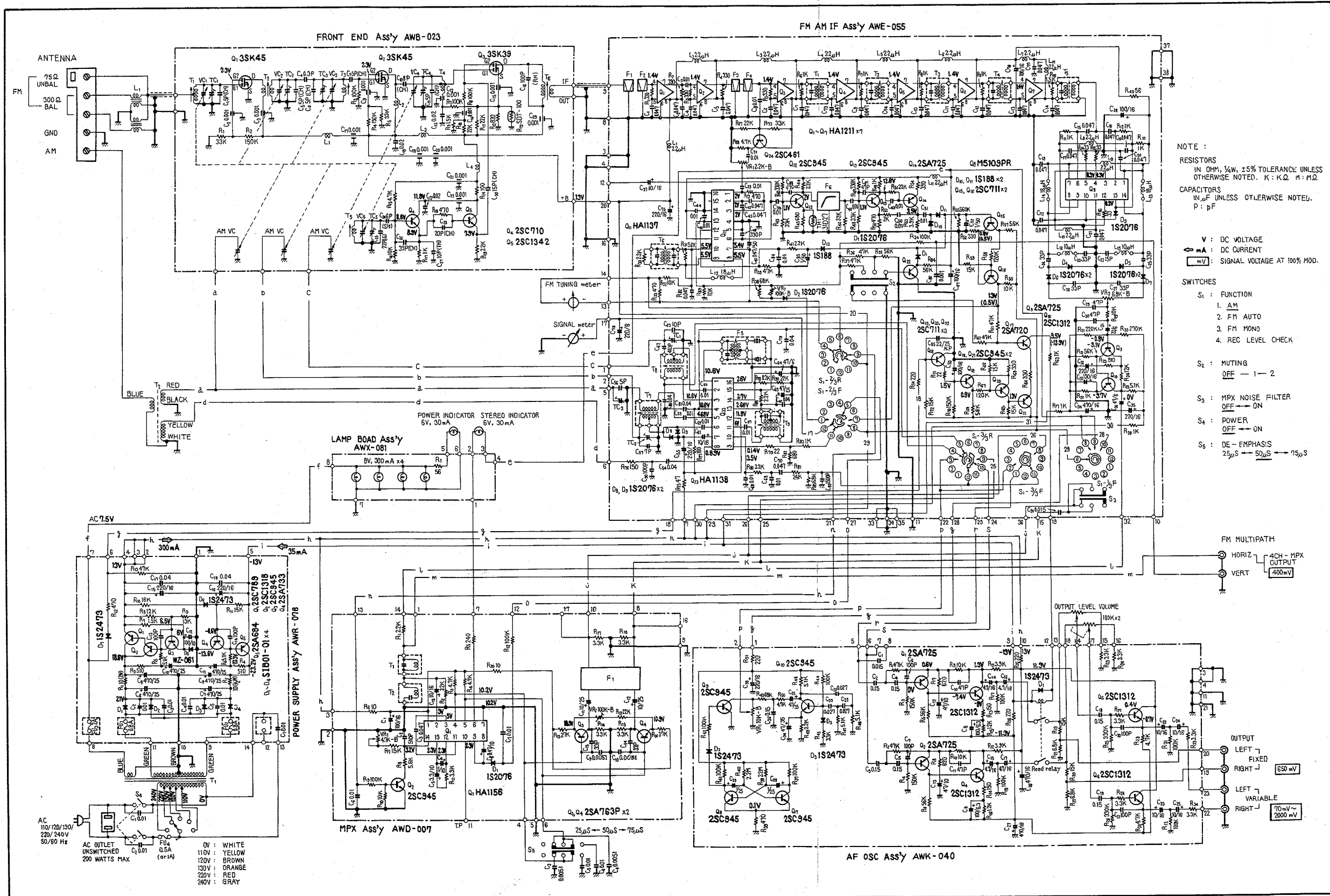

HA1137 (FM IF IC)

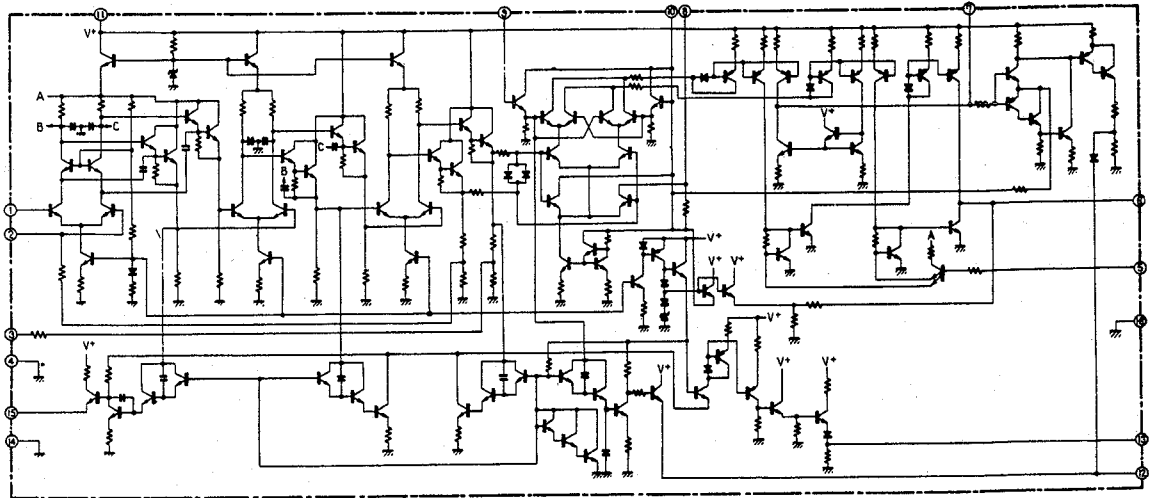

HA1138 (AM IC)

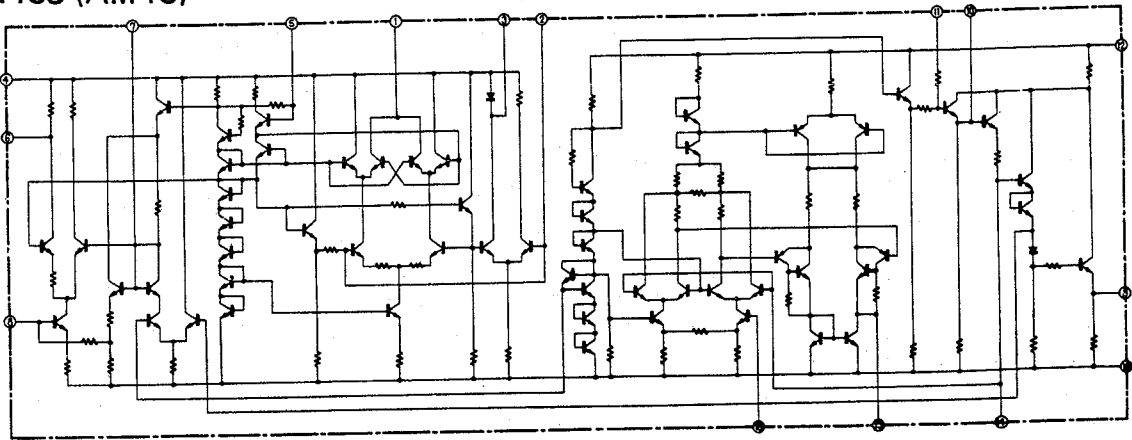

HA1156 (FM MPX IC)

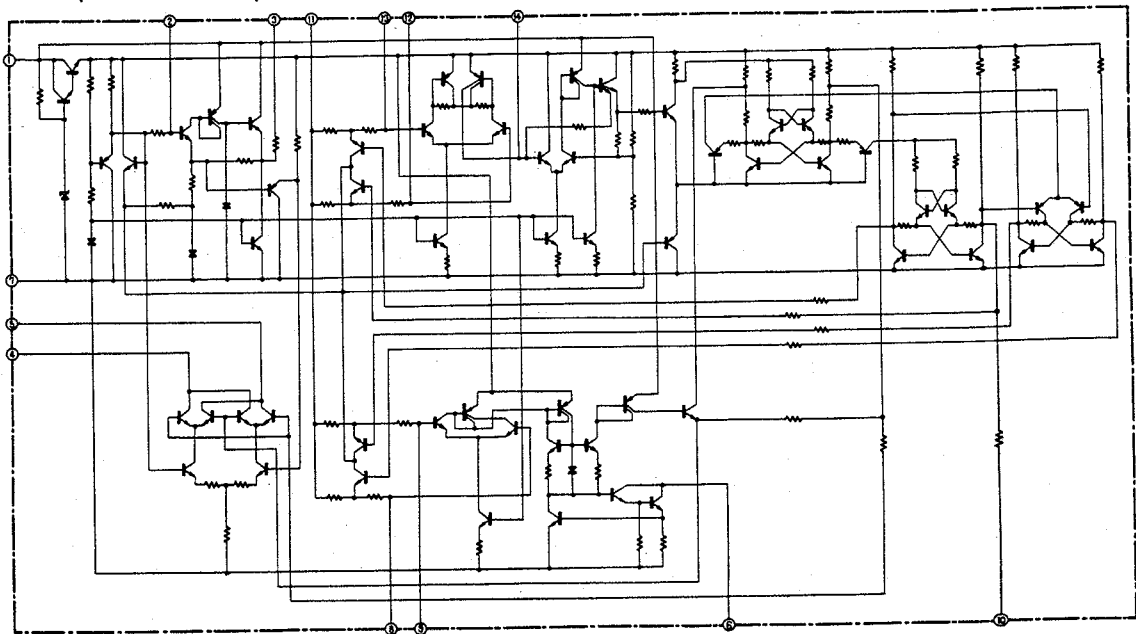

M5109P

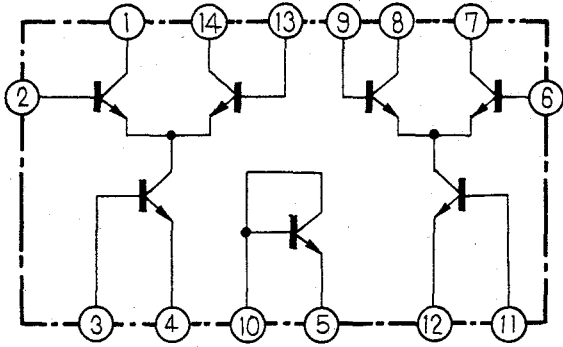

HA1211

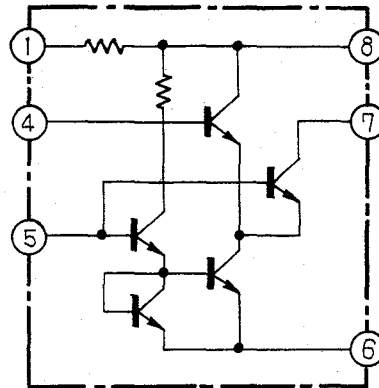

HA1138
HA1137

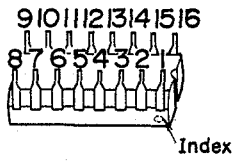

HA1156
M5109PR

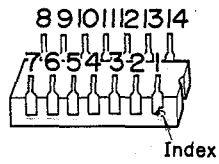

HA1211

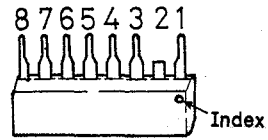

12.2 ELECTRO-PARTS

- CAPACITORS: IN μF UNLESS OTHERWISE NOTED p: pF
- RESISTORS: IN Ω , $\frac{1}{4}\text{W}$ UNLESS OTHERWISE NOTED k: k Ω , M: M Ω

Symbol	Description	Part No.	
C1	Ceramic capacitor 0.01 250V	ACG-001-0	110,120or130V 220 or 240V
C2	Ceramic capacitor 0.01 250V	ACG-001-0	
C3	Mylar capacitor 0.0051 50V	CQMA 512J 50	
C4	Mylar capacitor 0.0051 50V	CQMA 512J 50	
C5	Mylar capacitor 0.01 50V	CQMA 103J 50	
C6	Mylar capacitor 0.01 50V	CQMA 103J 50	
FU1	Fuse 0.8A (secondary)	AEK-111-0	
FU2	Fuse 0.8A (secondary)	AEK-111-0	
FU3	Fuse 2A (lamps)	AEK-103-0	
FU4	Fuse 0.5A (primary) Fuse 1A (primary)	AEK-107-0 AEK-106-0	
T1	Power transformer	ATT-235-A	
T2	Bar-antenna	ATB-040-0	
L1	Ferrite balun	T22-025-A	
S4	Lever switch (POWER)	ASK-068-0	
S5	Slide switch (DE-EMPHASIS)	ASH-013-0	

12.3 FM FRONT END (AWB-023-0)

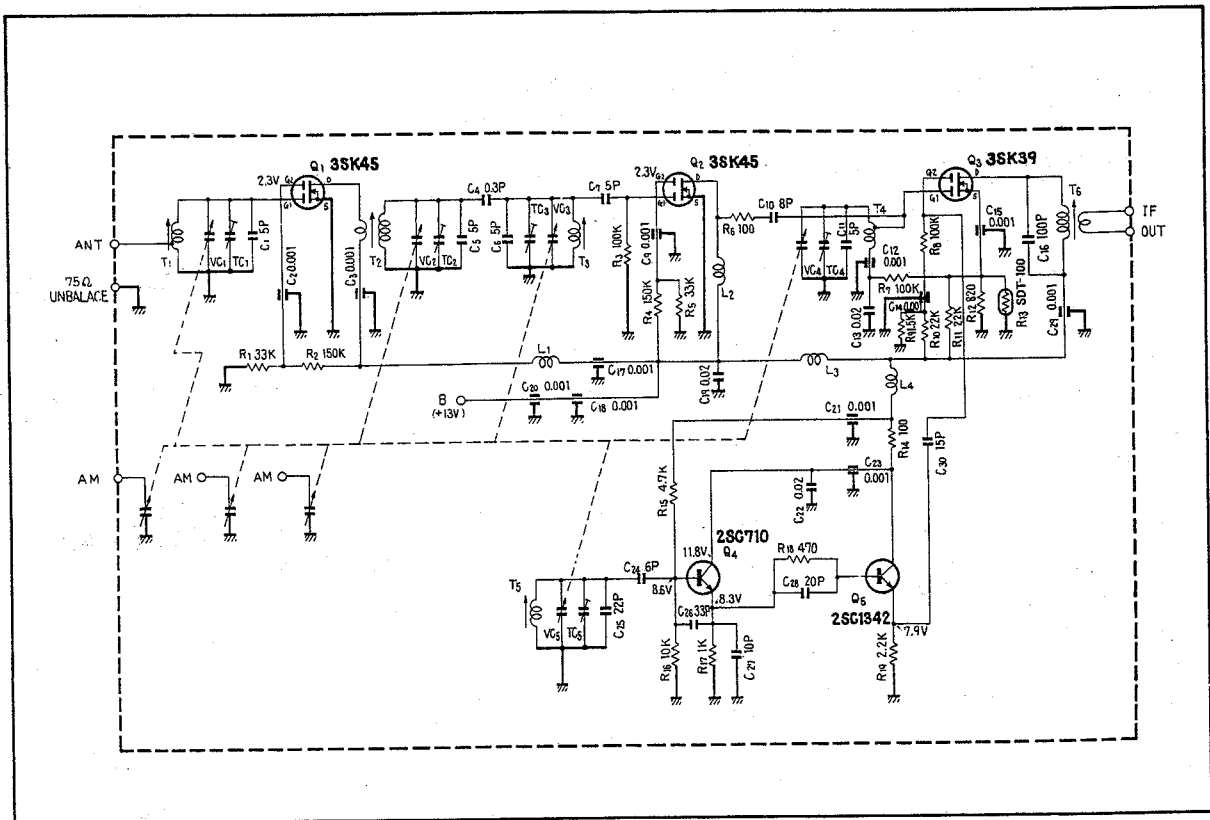

12.4 POWER SUPPLY CIRCUIT ASSEMBLY (AWR-076-0)

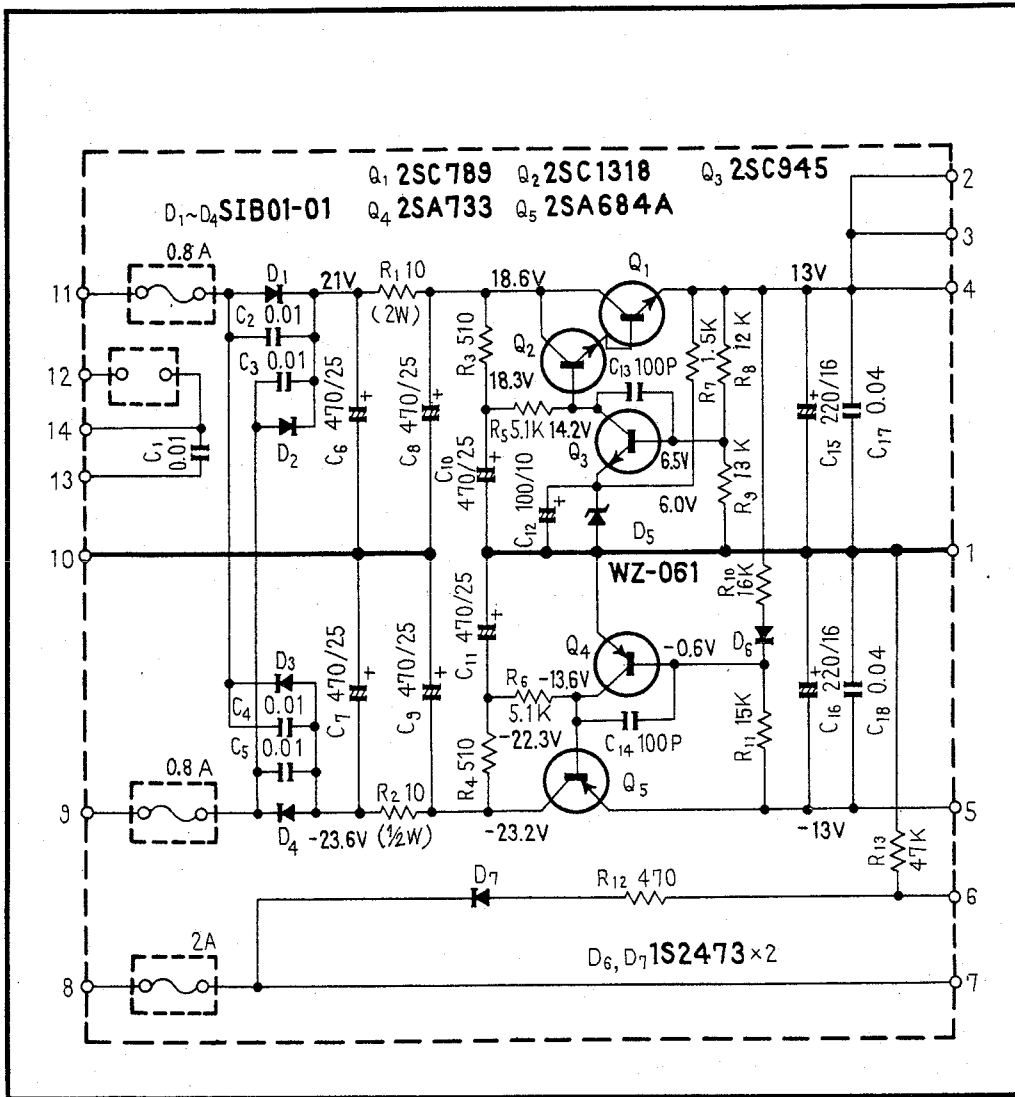

2SA733
2SC945
2SC1318

2SA684A

2SC789

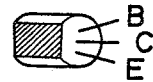
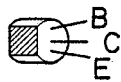
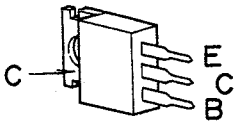

Parts List of Power Supply Circuit Assembly (AWR-076-0)

CAPACITORS

Symbol	Description	Part No.
C1	Ceramic 0.01 AC 250V	ACG-001-0
C2	Ceramic 0.01 AC150V	ACG-004-0
C3	Ceramic 0.01 AC150V	ACG-004-0
C4	Ceramic 0.01 AC150V	ACG-004-0
C5	Ceramic 0.01 AC150V	ACG-004-0
C6	Electrolytic 470 25V	CEA 471P 25
C7	Electrolytic 470 25V	CEA 471P 25
C8	Electrolytic 470 25V	CEA 471P 25
C9	Electrolytic 470 25V	CEA 471P 25
C10	Electrolytic 470 25V	CEA 471P 25
C11	Electrolytic 470 25V	CEA 471P 25
C12	Electrolytic 100 10V	CEA 101P 10
C13	Ceramic 100p 50V	CCDSL 101K 50
C14	Ceramic 100p 50V	CCDSL 101K 50
C15	Electrolytic 220 16V	CEA 221P 16
C16	Electrolytic 220 16V	CEA 221P 16
C17	Ceramic 0.04 50V	CKDYF 403Z 50
C18	Ceramic 0.04 50V	CKDYF 403Z 50

RESISTORS

Symbol	Description	Part No.
R1	Metal Oxide film 10 2W	RS2P 100K
R2	Carbon film 10 ½W	RD½PSF 100J
R3	Carbon film 510	RD¼PS 511J
R4	Carbon film 510	RD¼PS 511J
R5	Carbon film 5.1k	RD¼PS 512J
R6	Carbon film 5.1k	RD¼PS 512J
R7	Carbon film 1.5k	RD¼PS 152J
R8	Carbon film 12k	RD¼PS 123J
R9	Carbon film 13k	RD¼PS 133J
R10	Carbon film 16k	RD¼PS 163J
R11	Carbon film 15k	RD¼PS 153J
R12	Carbon film 470	RD¼PS 471J
R13	Carbon film 47k	RD¼PS 473J

SEMICONDUCTORS

Symbol	Description	Part No.
Q1	Transistor 2SC789-O or R (2SD313-D or E)	
Q2	Transistor 2SC1318-Q or R	
Q3	Transistor 2SC945-Q or R (2SC1647-P or Q)	
Q4	Transistor 2SA733-Q or R (2SA823-P or Q)	
Q5	Transistor 2SA684A-R or Q	
D1	Diode S1B01-01(1S1885)	
D2	Diode S1B01-01(1S1885)	

Symbol	Description	Part No.
D3	Diode SIB01-01(1S1885)	
D4	Diode SIB01-01(1S1885)	
D5	Zener diode WZ-061	
D6	Diode 1S2473(1S1555)	
D7	Diode 1S2473(1S1555)	

OTHERS

Symbol	Description	Part No.
	Fuse clip	AKR-013-0
	Heat sink	ANH-135-A

2SC945
2SA725
2SC1312

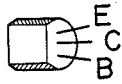
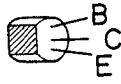

Foil Side

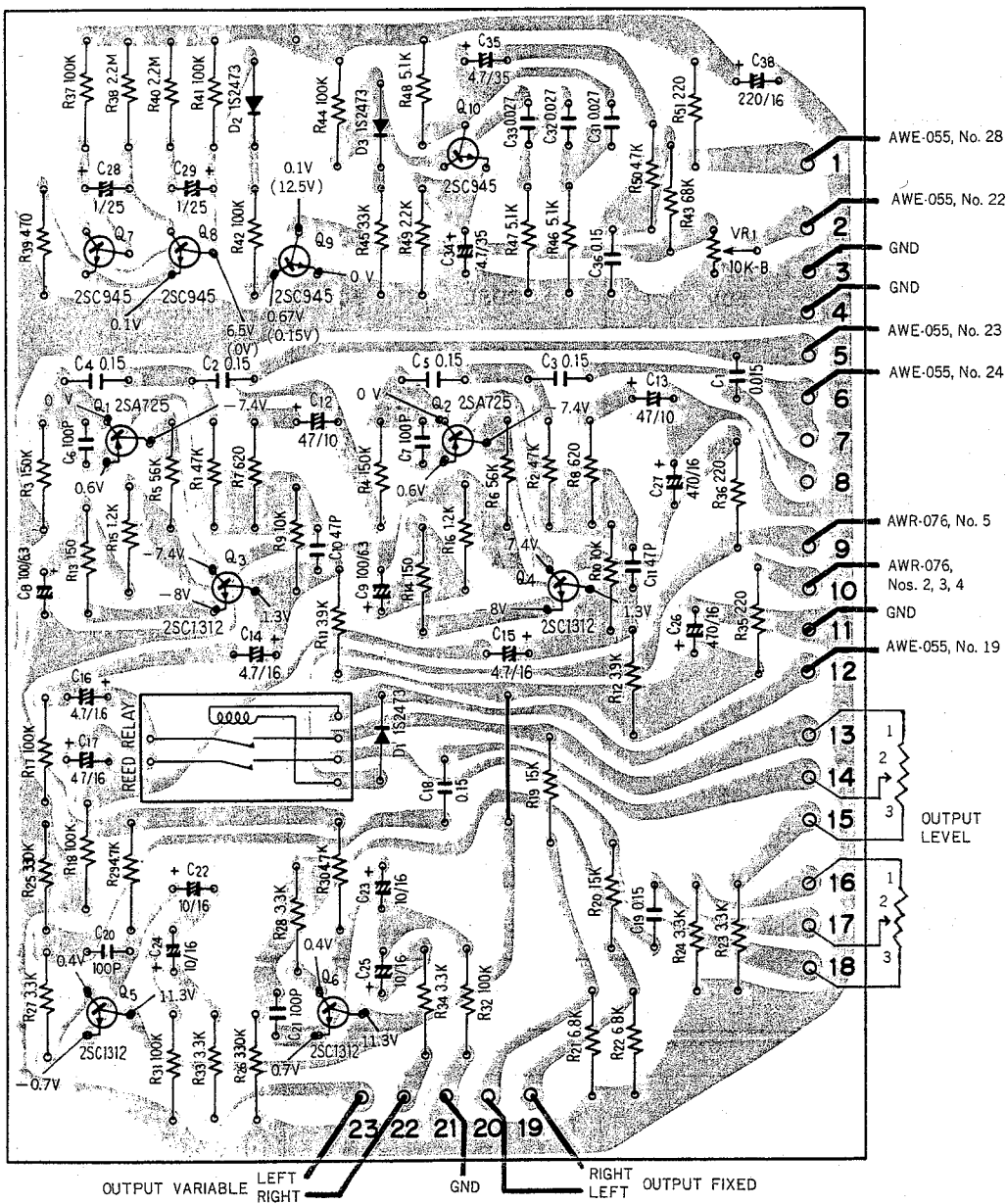

Parts List of Oscillator Assembly (AWK-040-0)

CAPACITORS

Symbol	Description			Part No.	
C1	Mylar	0.015	50V	CQMA	153J 50
C2	Mylar	0.15	50V	CQMA	154J 50
C3	Mylar	0.15	50V	CQMA	154J 50
C4	Mylar	0.15	50V	CQMA	154J 50
C5	Mylar	0.15	50V	CQMA	154J 50
C6	Ceramic	100p	50V	CCDSL	101K 50
C7	Ceramic	100p	50V	CCDSL	101P 50
C8	Electrolytic	100	6V	CEA	101P 6
C9	Electrolytic	100	6V	CEA	101P 6
C10	Ceramic	47p	50V	CCDSL	470K 50
C11	Ceramic	47p	50V	CCDSL	470K 50
C12	Electrolytic	47	10V	CEA	470P 10
C13	Electrolytic	47	10V	CEA	470P 10
C14	Electrolytic	4.7	16V	CSZA	4R7M 16
C15	Electrolytic	4.7	16V	CSZA	4R7M 16
C16	Electrolytic	4.7	16V	CSZA	4R7M 16
C17	Electrolytic	4.7	16V	CSZA	4R7M 16
C18	Mylar	0.15	50V	CQMA	154J 50
C19	Mylar	0.15	50V	CQMA	154J 50
C20	Ceramic	100p	50V	CCDSL	101K 50
C21	Ceramic	100p	50V	CCDSL	101K 50
C22	Electrolytic	10	16V	CSZA	100M 16
C23	Electrolytic	10	16V	CSZA	100M 16
C24	Electrolytic	10	16V	CSZA	100M 16
C25	Electrolytic	10	16V	CSZA	100M 16
C26	Electrolytic	470	16V	CEA	471P 16
C27	Electrolytic	470	16V	CEA	471P 16
C28	Electrolytic	1	25V	CSSA	010M 25
C29	Electrolytic	1	25V	CSSA	010M 25
C30				
C31	Mylar	0.027	50V	CQMA	273J 50
C32	Mylar	0.027	50V	CQMA	273J 50
C33	Mylar	0.027	50V	CQMA	273J 50
C34	Electrolytic	4.7	35V	CEA	4R7P 35
C35	Electrolytic	4.7	35V	CEA	4R7P 35
C36	Mylar	0.15	50V	CQMA	154J 50
C37				
C38	Electrolytic	220	16V	CEA	221P 16

RESISTORS

Symbol	Description		Part No.	
R1	Carbon film	47k	RD $\frac{1}{4}$ PS	473J
R2	Carbon film	47k	RD $\frac{1}{4}$ PS	473J
R3	Carbon film	150k	RD $\frac{1}{4}$ PS	154J
R4	Carbon film	150k	RD $\frac{1}{4}$ PS	154J
R5	Carbon film	56k	RD $\frac{1}{4}$ PS	563J
R6	Carbon film	56k	RD $\frac{1}{4}$ PS	563J

Symbol	Description	Part No.
R7	Carbon film 620	RD¼PS 621J
R8	Carbon film 620	RD¼PS 621J
R9	Carbon film 10k	RD¼PS 103J
R10	Carbon film 10k	RD¼PS 103J
R11	Carbon film 3.9k	RD¼PS 392J
R12	Carbon film 3.9k	RD¼PS 392J
R13	Carbon film 150	RD¼PS 151J
R14	Carbon film 150	RD¼PS 151J
R15	Carbon film 1.2k	RD¼PS 122J
R16	Carbon film 1.2k	RD¼PS 122J
R17	Carbon film 100k	RD¼PS 104J
R18	Carbon film 100k	RD¼PS 104J
R19	Carbon film 15k	RD¼PS 153J
R20	Carbon film 15k	RD¼PS 153J
R21	Carbon film 6.8k	RD¼PS 682J
R22	Carbon film 6.8k	RD¼PS 682J
R23	Carbon film 3.3k	RD¼PS 332J
R24	Carbon film 3.3k	RD¼PS 332J
R25	Carbon film 330k	RD¼PS 334J
R26	Carbon film 330k	RD¼PS 334J
R27	Carbon film 3.3k	RD¼PS 332J
R28	Carbon film 3.3k	RD¼PS 332J
R29	Carbon film 4.7k	RD¼PS 472J
R30	Carbon film 4.7k	RD¼PS 472J
R31	Carbon film 100k	RD¼PS 104J
R32	Carbon film 100k	RD¼PS 104J
R33	Carbon film 3.3k	RD¼PS 332J
R34	Carbon film 3.3k	RD¼PS 332J
R35	Carbon film 220	RD¼PS 221J
R36	Carbon film 220	RD¼PS 221J
R37	Carbon film 100k	RD¼PS 104J
R38	Carbon film 2.2M	RD¼PS 225J
R39	Carbon film 470	RD¼PS 471J
R40	Carbon film 2.2M	RD¼PS 225J
R41	Carbon film 100k	RD¼PS 104J
R42	Carbon film 100k	RD¼PS 104J
R43	Carbon film 68k	RD¼PS 683J
R44	Carbon film 100k	RD¼PS 104J
R45	Carbon film 33k	RD¼PS 333J
R46	Carbon film 5.1k	RD¼PS 512J
R47	Carbon film 5.1k	RD¼PS 512J
R48	Carbon film 5.1k	RD¼PS 512J
R49	Carbon film 2.2k	RD¼PS 222J
R50	Carbon film 4.7k	RD¼PS 472J
R51	Carbon film 220	RD¼PS 221J
VR1	Semi-fixed 10k-B	C92-049-0

SEMICONDUCTORS

Symbol	Description	Part No.
Q1	Transistor 2SA725-F or G (2SA763P-5 or 6)	
Q2	Transistor 2SA725-F or G (2SA763P-5 or 6)	
Q3	Transistor 2SC1312-G, F or H (2SC1344-D, E or F)	
Q4	Transistor 2SC1312-G, F or H (2SC1344-D, E or F)	
Q5	Transistor 2SC1312-G, F or H (2SC1344-D, E or F)	
Q6	Transistor 2SC1312-G, F or H (2SC1344-D, E or F)	
Q7	Transistor 2SC945-Q or R	
Q8	Transistor 2SC945-Q or R	
Q9	Transistor 2SC945-Q or R	
Q10	Transistor 2SC945-Q or P	
D1	Diode 1S2473 (1S1555)	
D2	Diode 1S2473 (1S1555)	
D3	Diode 1S2473 (1S1555)	

OTHER

Symbol	Description	Part No.
S1	Reed relay	ASR-005-C

12.6 AM-FM IF ASSEMBLY (AWE-055-A)

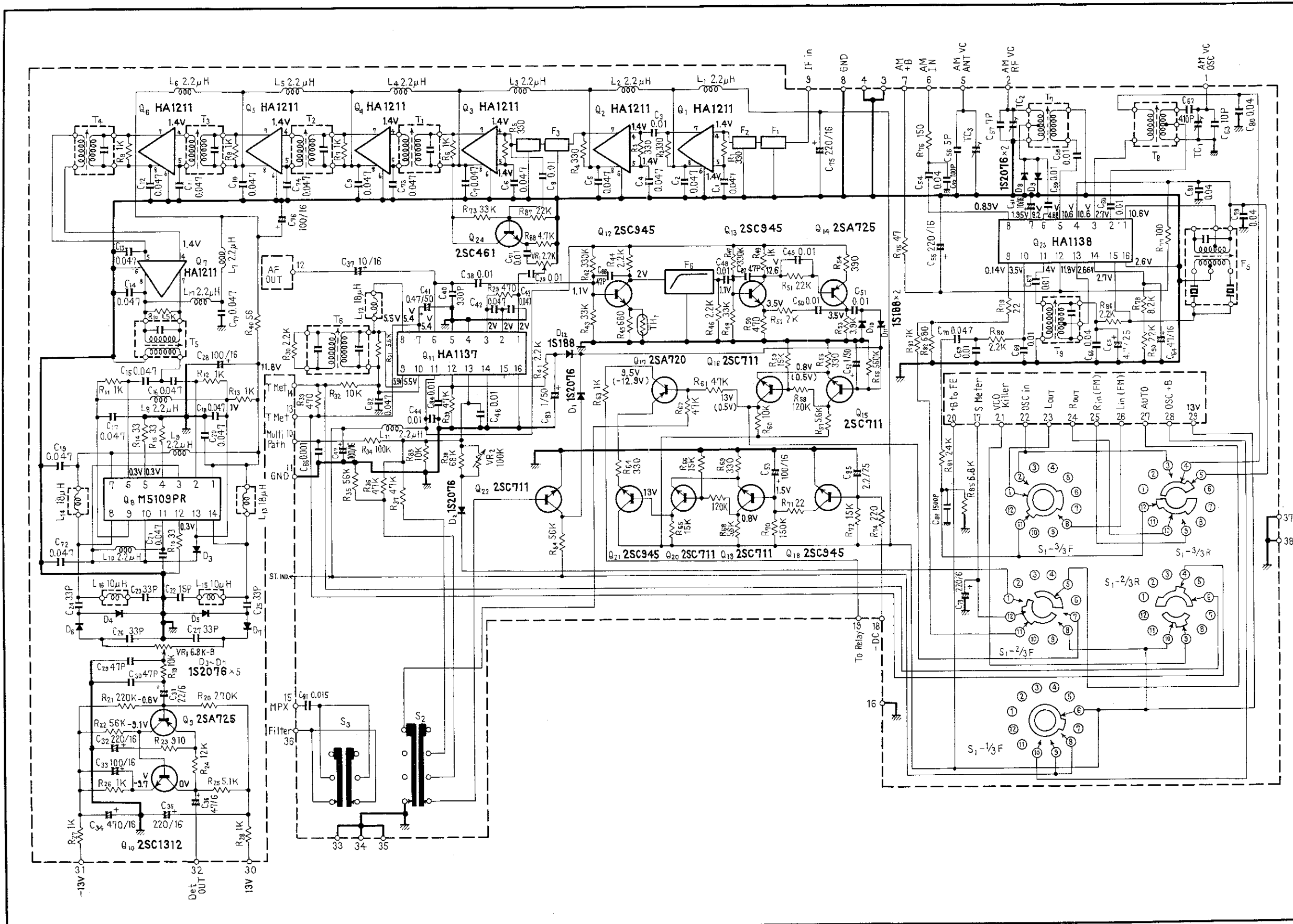

Foil Side

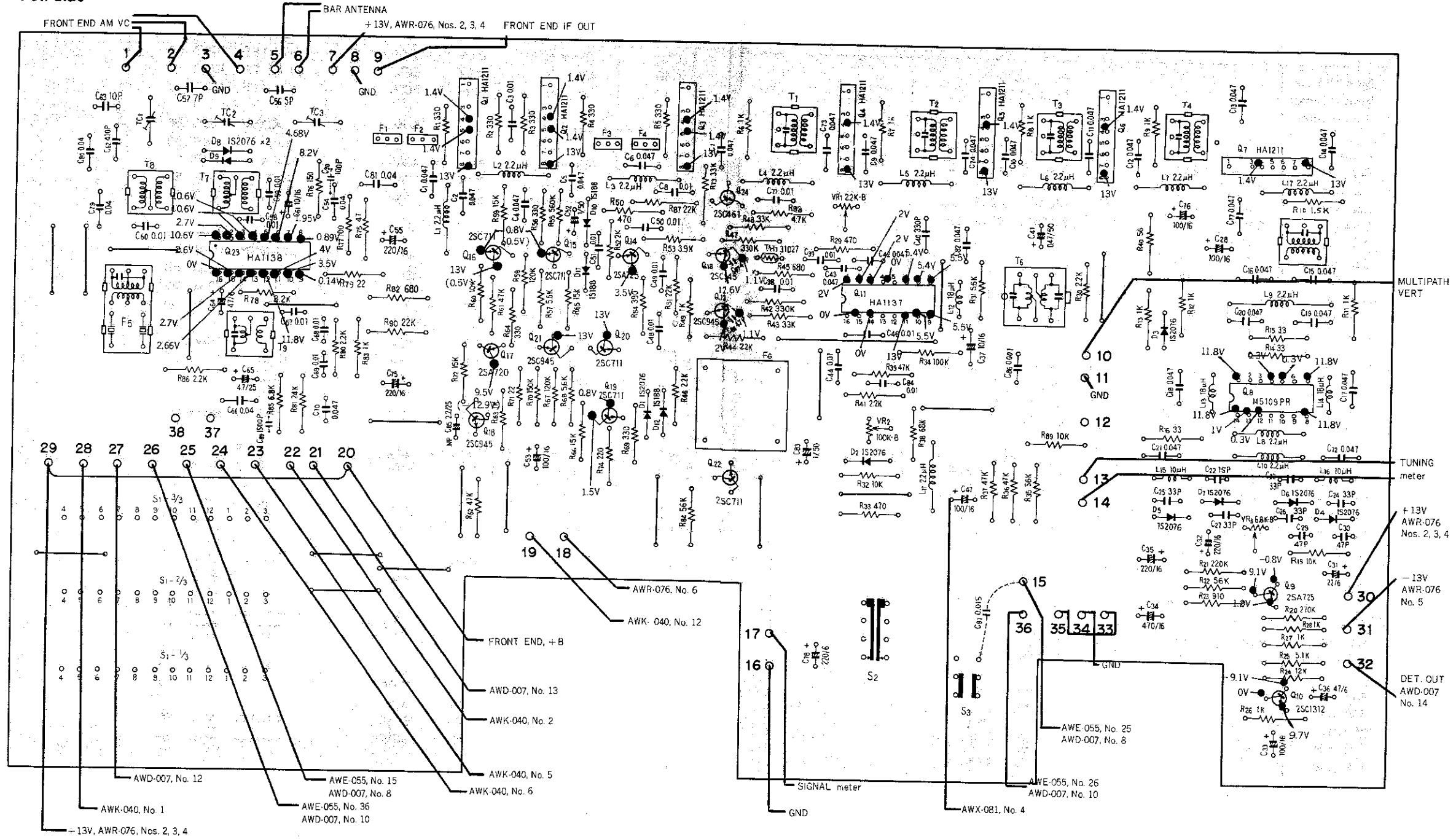

2SA720
2SC945

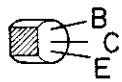

2SA725
2SC1312
2SC711



2SC461

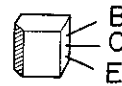

HA1137
HA1138

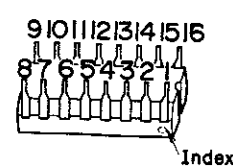

HA1211

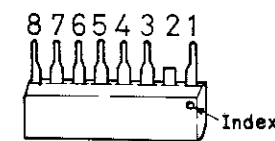

M5109PR

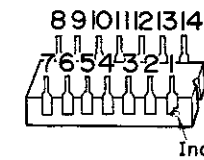

Parts List of AM-FM IF Assembly (AWE-055-A)

CAPACITORS

Symbol	Description	Part No.
TC1	Film trimmer	ACM-002-0
TC2	Film trimmer	ACM-002-0
TC3	Film trimmer	ACM-002-0
C1	Ceramic 0.047 25V	CKDBC 473Z 25
C2	Ceramic 0.047 25V	CKDBC 473Z 25
C3	Ceramic 0.01 50V	CKDYF 103Z 50
C4	Ceramic 0.047 25V	CKDBC 473Z 25
C5	Ceramic 0.047 25V	CKDBC 473Z 25
C6	Ceramic 0.047 25V	CKDBC 473Z 25
C7	Ceramic 0.047 25V	CKDBC 473Z 25
C8	Ceramic 0.01 50V	CKDYF 103Z 50
C9	Ceramic 0.047 25V	CKDBC 473Z 25
C10	Ceramic 0.047 25V	CKDBC 473Z 25
C11	Ceramic 0.047 25V	CKDBC 473Z 25
C12	Ceramic 0.047 25V	CKDBC 473Z 25
C13	Ceramic 0.047 25V	CKDBC 473Z 25
C14	Ceramic 0.047 25V	CKDBC 473Z 25
C15	Ceramic 0.047 25V	CKDBC 473Z 25
C16	Ceramic 0.047 25V	CKDBC 473Z 25
C17	Ceramic 0.047 25V	CKDBC 473Z 25
C18	Ceramic 0.047 25V	CKDBC 473Z 25
C19	Ceramic 0.047 25V	CKDBC 473Z 25
C20	Ceramic 0.047 25V	CKDBC 473Z 25
C21	Ceramic 0.047 25V	CKDBC 473Z 25
C22	Ceramic 15p 50V	CCDCH 150J 50
C23	Ceramic 33p 50V	CCDCH 330J 50
C24	Ceramic 33p 50V	CCDSL 330K 50
C25	Ceramic 33p 50V	CCDSL 330K 50
C26	Ceramic 33p 50V	CCDSL 330K 50
C27	Ceramic 33p 50V	CCDSL 330K 50
C28	Electrolytic 100 16V	CEA 101P 16
C29	Ceramic 47p 50V	CCDSL 470K 50
C30	Ceramic 47p 50V	CCOSL 470K 50
C31	Electrolytic 22 6V	CSZA 220M 6
C32	Electrolytic 220 16V	CEA 221P 16
C33	Electrolytic 100 16V	CEA 101P 16
C34	Electrolytic 470 16V	CEA 471P 16
C35	Electrolytic 220 16V	CEA 221P 16
C36	Electrolytic 47 6V	CSZA 470M 6
C37	Electrolytic 10 16V	CEA 100P 16
C38	Ceramic 0.01 50V	CKDYF 103Z 50
C39	Ceramic 0.01 50V	CKDYF 103Z 50
C40	Ceramic 330p 50V	CKDYB 331K 50
C41	Electrolytic 0.47 50V	CEA R47P 50
C42	Ceramic 0.047 25V	CKDBC 473Z 25
C43	Ceramic 0.047 25V	CKDBC 473Z 25
C44	Ceramic 0.01 50V	CKDYF 103Z 50
C45	

Symbol	Description	Part No.
C46	Ceramic 0.01 50V	CKDYF 103Z 50
C47	Electrolytic 100 16V	CEA 101P 16
C48	Ceramic 0.01 50V	CKDYF 103Z 50
C49	Ceramic 0.01 50V	CKDYF 103Z 50
C50	Ceramic 0.01 50V	CKDYF 103Z 50
C51	Ceramic 0.01 50V	CKDYF 103Z 50
C52	Electrolytic 1 50V	CEA 010P 50
C53	Electrolytic 100 16V	CEA 101P 16
C54	Ceramic 0.04 50V	CKDYF 403Z 50
C55	Electrolytic 220 16V	CEA 221P 16
C56	Ceramic 5p 50V	CCDSH 050D 50
C57	Ceramic 7p 50V	CCDSH 070F 50
C58	Ceramic 0.01 50V	CKDYF 103Z 50
C59	Ceramic 0.01 50V	CKDYF 103Z 50
C60	Mylar 0.01 50V	CQMA 103K 50
C61	Electrolytic 10 16V	CEA 100P 16
C62	Styrol 410p 50V	CQSA 411J 50
C63	Ceramic 10p 50V	CCDWK 100F 50
C64	Electrolytic 47 6V	CEA 470P 6
C65	Electrolytic 4.7 25V	CEA 4R7P 25
C66	Ceramic 0.04 50V	CKDYF 403Z 50
C67	Ceramic 0.01 50V	CKDYF 103Z 50
C68	Mylar 0.01 50V	CQMA 103K 50
C69	Mylar 0.01 50V	CQMA 103K 50
C70	Mylar 0.047 50V	CQMA 473K 50
C71	Ceramic 0.01 50V	CKDYF 103Z 50
C72	Ceramic 0.047 25V	CKDBC 473Z 25
C73	Ceramic 0.047 25V	CKDBC 473Z 25
C74	Ceramic 0.047 25V	CKDBC 473Z 25
C75	Electrolytic 220 16V	CEA 221P 16
C76	Electrolytic 100 16V	CEA 101P 16
C77	Ceramic 0.047 25V	CKDBC 473Z 25
C78	Electrolytic 220 6V	CEA 221P 6
C79	Ceramic 0.04 50V	CKDYF 403Z 50
C80	Ceramic 0.04 50V	CKDYF 403Z 50
C81	Ceramic 0.04 50V	CKDYF 403Z 50
C82	Ceramic 0.047 25V	CKDBC 473Z 25
C83	Electrolytic 1 50V	CEA 010P 50
C84	Ceramic 0.01 50V	CKDYF 103Z 50
C85	Electrolytic 2.2 25V	CEA 2R2M 25NP
C86	Ceramic 0.001 50V	CKDYF 102Z 50
C87	Ceramic 47p 50V	CCDSL 470K 50
C88	Ceramic 47p 50V	CCDSL 470K 50
C89	Ceramic 1500p 50V	CKDYB 152K 50
C90	Ceramic 100p 50V	CCDSL 101K 50
C91	Mylar 0.015 50V	CQMA 153J 50

RESISTORS

Symbol	Description	Part No.
R1	Carbon film 330	RD¼PS 331J
R2	Carbon film 330	RD¼PS 331J
R3	Carbon film 330	RD¼PS 331J
R4	Carbon film 330	RD¼PS 331J
R5	Carbon film 330	RD¼PS 331J
R6	Carbon film 1k	RD¼PS 102J
R7	Carbon film 1k	RD¼PS 102J
R8	Carbon film 1k	RD¼PS 102J
R9	Carbon film 1k	RD¼PS 102J
R10	Carbon film 1.5k	RD¼PS 152J
R11	Carbon film 1k	RD¼PS 102J
R12	Carbon film 1k	RD¼PS 102J
R13	Carbon film 1k	RD¼PS 102J
R14	Carbon film 33	RD¼PS 330J
R15	Carbon film 33	RD¼PS 330J
R16	Carbon film 33	RD¼PS 330J
R17	
R18	
R19	Carbon film 10k	RD¼PS 103J
R20	Carbon film 270k	RD¼PS 274J
R21	Carbon film 220k	RD¼PS 224J
R22	Carbon film 56k	RD¼PS 563J
R23	Carbon film 910	RD¼PS 911J
R24	Carbon film 12k	RD¼PS 123J
R25	Carbon film 5.1k	RD¼PS 512J
R26	Carbon film 1k	RD¼PS 102J
R27	Carbon film 1k	RD¼PS 102J
R28	Carbon film 1k	RD¼PS 102J
R29	Carbon film 470	RD¼PS 471J
R30	Carbon film 2.2k	RD¼PS 222J
R31	Carbon film 5.6k	RD¼PS 562J
R32	Carbon film 10k	RD¼PS 103J
R33	Carbon film 470	RD¼PS 471J
R34	Carbon film 100k	RD¼PS 104J
R35	Carbon film 56k	RD¼PS 563J
R36	Carbon film 47k	RD¼PS 473J
R37	Carbon film 47k	RD¼PS 473J
R38	Carbon film 68k	RD¼PS 683J
R39	Carbon film 47k	RD¼PS 473J
R40	Carbon film 56	RD¼PS 560J
R41	Carbon film 2.2k	RD¼PS 222J
R42	Carbon film 330k	RD¼PS 334J
R43	Carbon film 33k	RD¼PS 333J
R44	Carbon film 2.2k	RD¼PS 222J
R45	Carbon film 680	RD¼PS 681J
R46	Carbon film 2.2k	RD¼PS 222J
R47	Carbon film 330k	RD¼PS 334J
R48	Carbon film 33k	RD¼PS 333J
R49	Carbon film 1k	RD¼PS 102J
R50	Carbon film 470	RD¼PS 471J

Symbol	Description	Part No.
R51	Carbon film 22k	RD¼PS 223J
R52	Carbon film 2k	RD¼PS 202J
R53	Carbon film 3.9k	RD¼PS 392J
R54	Carbon film 390	RD¼PS 391J
R55	Carbon film 560k	RD¼PS 564J
R56	Carbon film 330	RD¼PS 331J
R57	Carbon film 5.6k	RD¼PS 562J
R58	Carbon film 120k	RD¼PS 124J
R59	Carbon film 15k	RD¼PS 153J
R60	Carbon film 10k	RD¼PS 103J
R61	Carbon film 47k	RD¼PS 473J
R62	Carbon film 47k	RD¼PS 473J
R63	Carbon film 1k	RD¼PS 102J
R64	Carbon film 330	RD¼PS 331J
R65	Carbon film 15k	RD¼PS 153J
R66	Carbon film 15k	RD¼PS 153J
R67	Carbon film 120k	RD¼PS 124J
R68	Carbon film 56k	RD¼PS 562J
R69	Carbon film 330	RD¼PS 331J
R70	Carbon film 150k	RD¼PS 154J
R71	Carbon film 22	RD¼PS 220J
R72	Carbon film 15k	RD¼PS 153J
R73	Carbon film 33k	RD¼PS 333J
R74	Carbon film 220	RD¼PS 221J
R75	Carbon film 47	RD¼PS 470J
R76	Carbon film 150	RD¼PS 151J
R77	Carbon film 100	RD¼PS 101J
R78	Carbon film 8.2k	RD¼PS 822J
R79	Carbon film 22	RD¼PS 220J
R80	Carbon film 2.2k	RD¼PS 222J
R81	Carbon film 24k	RD¼PS 243J
R82	Carbon film 680	RD¼PS 681J
R83	Carbon film 1k	RD¼PS 102J
R84	Carbon film 56k	RD¼PS 563J
R85	Carbon film 6.8k	RD¼PS 682J
R86	Carbon film 2.2k	RD¼PS 222J
R87	Carbon film 22k	RD¼PS 223J
R88	Carbon film 4.7k	RD¼PS 472J
R89	Carbon film 10k	RD¼PS 103J
R90	Carbon film 22k	RD¼PS 223J
VR1	Semi-fixed 2.2k-B	ACP-001-0
VR2	Semi-fixed 100k-B	C92-047-0
VR3	Semi-fixed 6.8k-B	ACP-023-0

SEMICONDUCTORS

Symbol	Description	Part No.
Q1	IC HA 1211	
Q2	IC HA 1211	
Q3	IC HA 1211	
Q4	IC HA 1211	
Q5	IC HA 1211	
Q6	IC HA 1211	
Q7	IC HA 1211	
Q8	IC M5109PR	
Q9	Transistor 2SA725-G, F or H (2SA763P-5 or 6)	
Q10	Transistor 2SC1312-G, F or H	
Q11	IC HA 1137	
Q12	Transistor 2SC945-Q or R	
Q13	Transistor 2SC945-Q or R	
Q14	Transistor 2SA725-G, F or H (2SA763P-5 or 6)	
Q15	Transistor 2SC711-F or G (2SC945-Q or R)	
Q16	Transistor 2SC711-F or G (2SC945-Q or R)	
Q17	Transistor 2SA720-R or S	
Q18	Transistor 2SC945-Q or R	
Q19	Transistor 2SC711-F or G (2SC945-Q or R)	
Q20	Transistor 2SC711-F or G (2SC945-Q or R)	
Q21	Transistor 2SC945-Q or R	
Q22	Transistor 2SC711-F or G (2SC945-Q or R)	
Q23	IC HA 1138	
Q24	Transistor 2SC461-B, A or C	
D1	Diode 1S2076	
D2	Diode 1S2076	
D3	Diode 1S2076	
D4	Diode 1S2076	
D5	Diode 1S2076	
D6	Diode 1S2076	
D7	Diode 1S2076	
D8	Diode 1S2076	
D9	Diode 1S2076	
D10	Diode 1S188FM-1	
D11	Diode 1S188FM-1	
D12	Diode 1S188FM-1	
TH1	Thermistor 31D27	

COILS, TRANSFORMERS

Symbol	Description	Part No.
T1	FM matching transformer	ATE-008-0
T2	FM IF transformer	ATE-023-0
T3	FM IF transformer	ATE-023-0
T4	FM IF transformer	ATE-023-0
T5	FM IF transformer	ATE-023-0
T6	FM IF transformer	T73-035-A
T7	AM RF coil	ATB-020-C
T8	AM OSC coil	ATB-019-0
T9	AM IF transformer	ATE-012-0
L1	RF choke coil 2.2μH	T24-028-A
L2	RF choke coil 2.2μH	T24-028-A
L3	RF choke coil 2.2μH	T24-028-A
L4	RF choke coil 2.2μH	T24-028-A
L5	RF choke coil 2.2μH	T24-028-A
L6	RF choke coil 2.2μH	T24-028-A
L7	RF choke coil 2.2μH	T24-028-A
L8	RF choke coil 2.2μH	T24-028-A
L9	RF choke coil 2.2μH	T24-028-A
L10	RF choke coil 2.2μH	T24-028-A
L11	RF choke coil 2.2μH	T24-028-A
L12	RF choke coil 18μH	ATH-007-0
L13	RF choke coil 18μH	ATH-007-0
L14	RF choke coil 18μH	ATH-007-0
L15	RF choke coil 10μH	ATH-010-B
L16	RF choke coil 10μH	ATH-010-B
L17	RF choke coil 2.2μH	T24-028-0
F1	FM ceramic filter	ATF-018-0
F2	FM ceramic filter	ATF-018-0
F3	FM ceramic filter	ATF-018-0
F4	FM ceramic filter	ATF-018-0
F5	AM ceramic filter	ATF-009-0
F6	High pass filter	ATF-014-0

OTHERS

Symbol	Description	Part No.
S1	Rotary switch (FUNCTION)	ASD-037-A
S2	Lever switch (MPX NOISE FILTER)	ASK-087-B
S3	Lever switch (FM MUTING)	ASK-090-A
	Washer (9φ)	B22-016-0
	Nut (9φ)	B71-004-0

12.7 MPX ASSEMBLY (AWD-007-0)

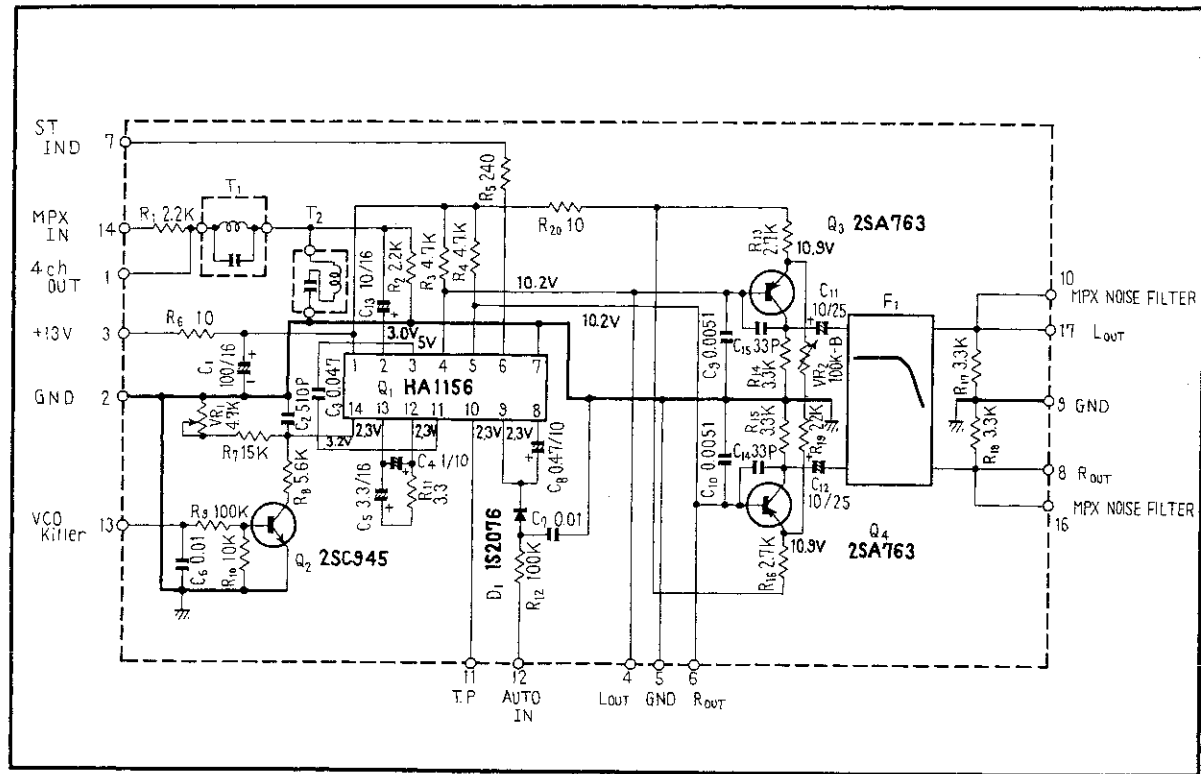

HA1156

2SC945

2SA763P

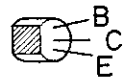
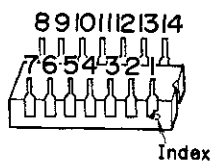

Parts List of MPX Assembly (AWD-007-0)

CAPACITORS

Symbol	Description	Part No.
C1	Electrolytic 100 16V	CEA 101P 16
C2	Styrol 510p 50V	CQSH 511J 50
C3	Mylar 0.047 50V	CQMA 473K 50
C4	Electrolytic 1 10V	CSSA 010M 10
C5	Electrolytic 3.3 10V	CSSA 3R3M 10
C6	Ceramic 0.01 50V	CKDYF 103Z 50
C7	Ceramic 0.01 50V	CKDYF 103Z 50
C8	Electrolytic 0.47 10V	CSSA R47M 10
C9	Mylar 0.0051 50V	CQMA 512J 50
C10	Mylar 0.0051 50V	CQMA 512J 50
C11	Electrolytic 10 25V	CEANL 100P 25
C12	Electrolytic 10 25V	CEANL 100P 25
C13	Electrolytic 10 16V	CEA 100P 16
C14	Ceramic 33p 50V	CCDSL 330K 50
C15	Ceramic 33p 50V	CCDSL 330K 50

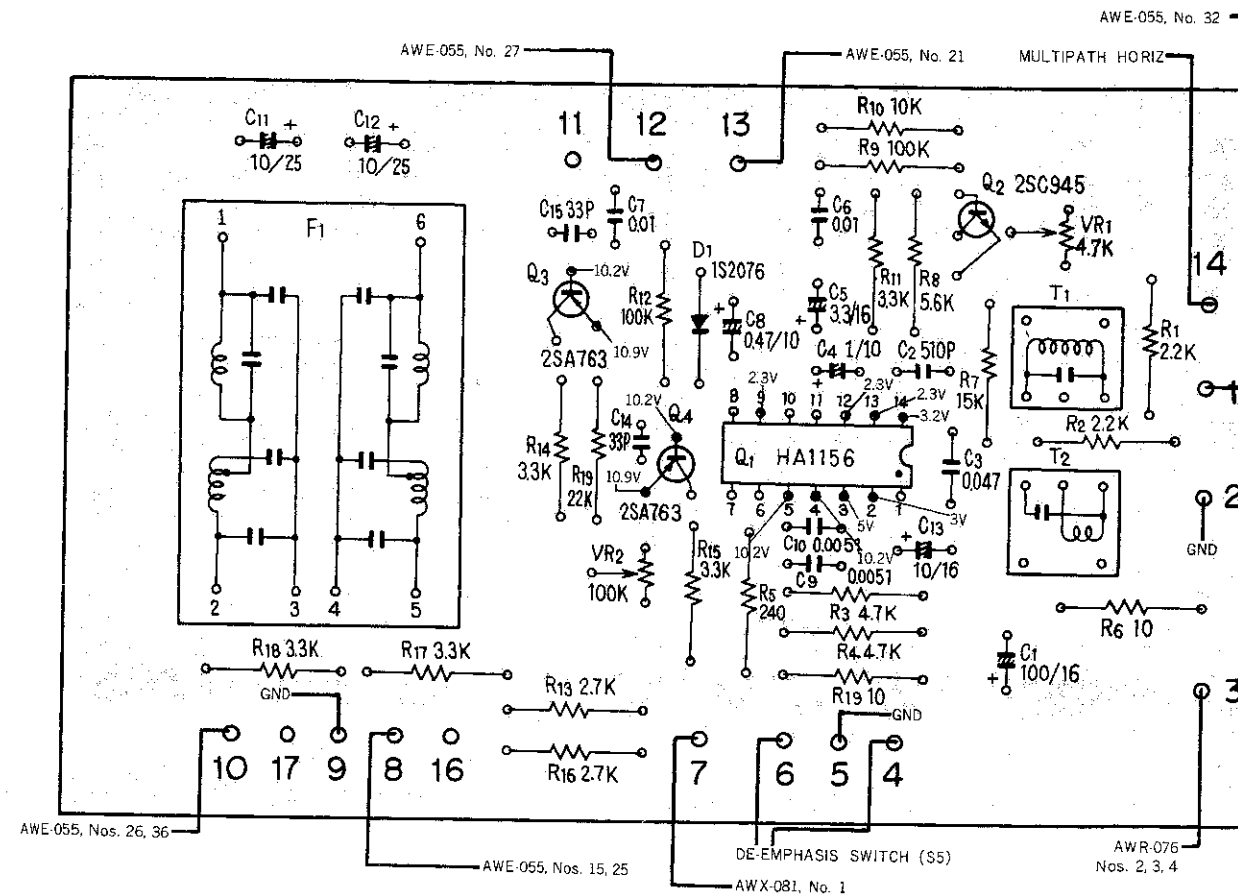

RESISTORS

Symbol	Description	Part No.
R1	Carbon film 2.2k	RD¼PS 222J
R2	Carbon film 2.2k	RD¼PS 222J
R3	Carbon film 4.7k	RD¼PS 472J
R4	Carbon film 4.7k	RD¼PS 472J
R5	Carbon film 240	RD¼PS 241J
R6	Carbon film 10	RD¼PS 100J
R7	Carbon film 15k	RD¼PS 153J
R8	Carbon film 5.6k	RD¼PS 562J
R9	Carbon film 100k	RD¼PS 104J
R10	Carbon film 10k	RD¼PS 103J

FRONT END Ass'y AWB-023

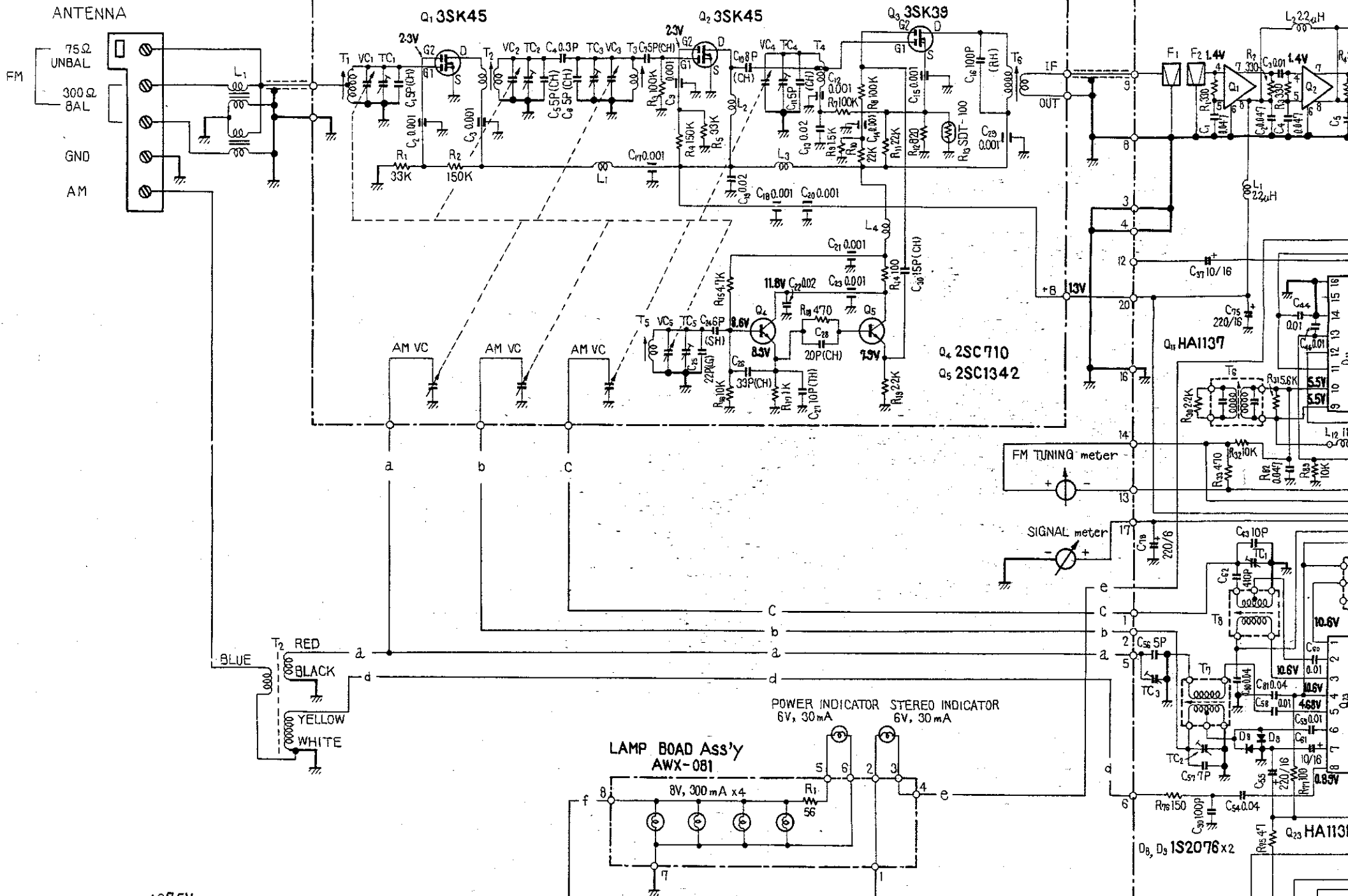

LAMP BOAD Ass'y AWX-081

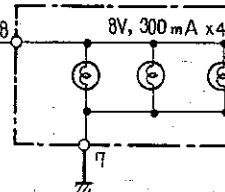

POWER SUPPLY Ass'y AWR-078

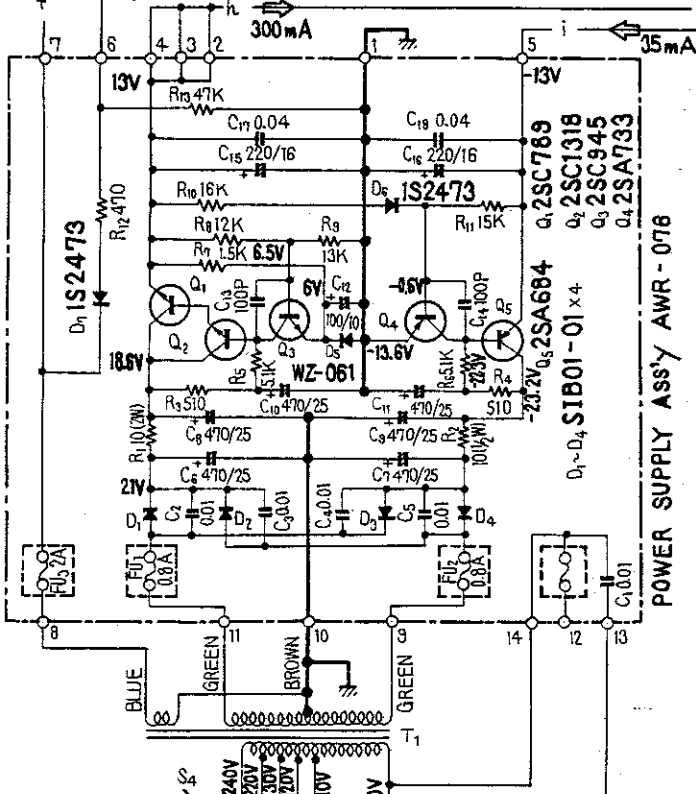

MPX Ass'y AWD-007

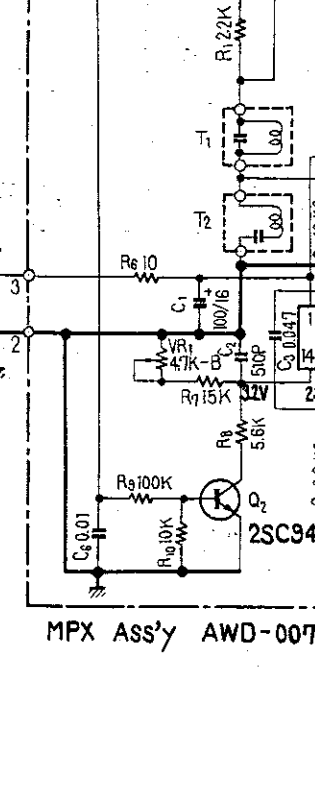

AC 110/120/130/220/240V
50/60 Hz

AC OUTLET
UNSWITCHED
200 WATTS MAX

FU4 0.5A

0V : WHITE
110V : YELLOW
120V : BROWN
130V : ORANGE
220V : RED
240V : GRAY

FM AM IF ASS'Y AWE-055

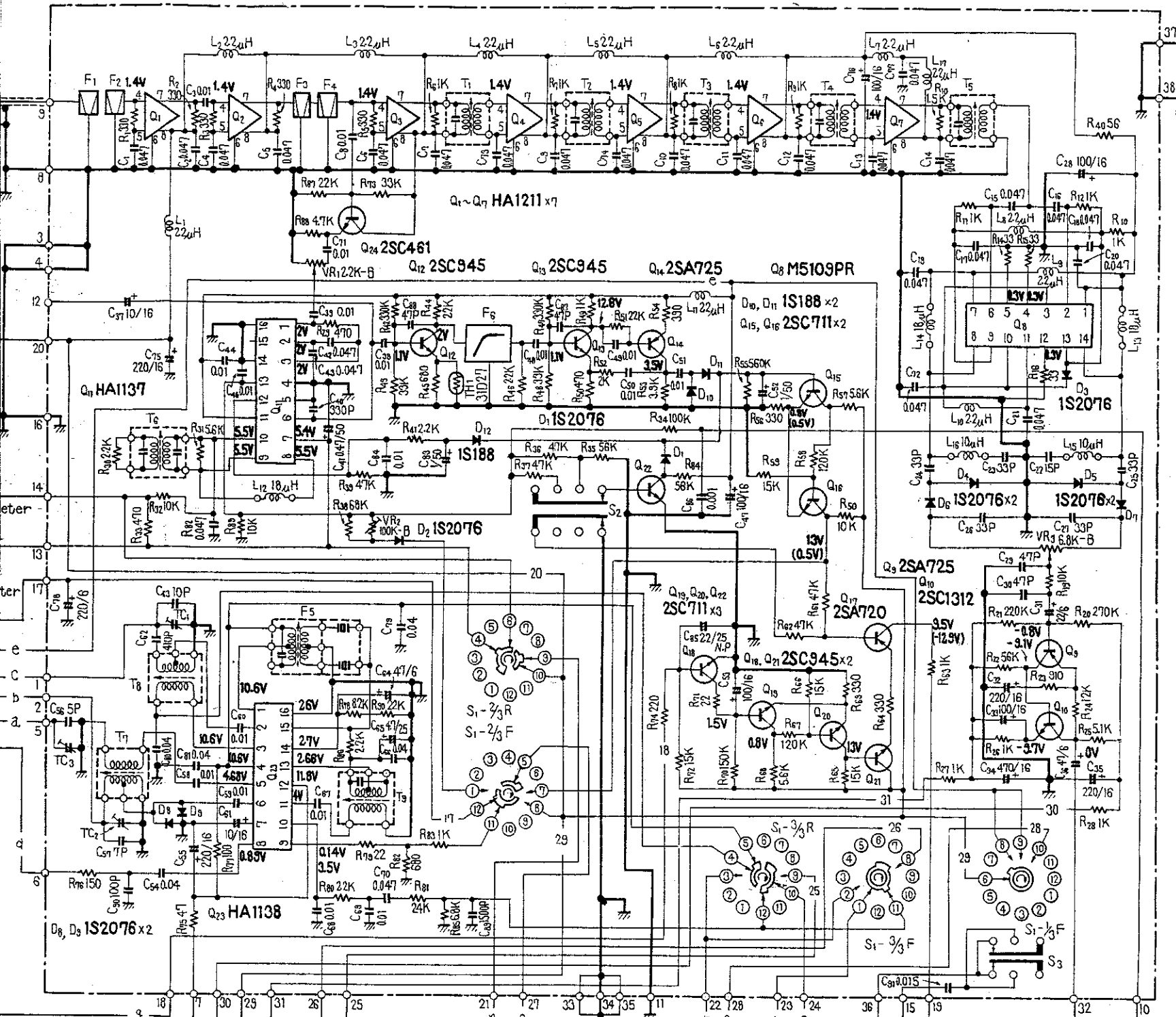

RESISTORS
IN OHM, 1/4W, ±5% TOLERANCE UNLESS OTHERWISE NOTED. K: KΩ M: MΩ

CAPACITORS
IN μF UNLESS OTHERWISE NOTED.
P: pF

V : DC VOLTAGE
mA : DC CURRENT
mV : SIGNAL VOLTAGE AT 100% MOD.

- SWITCHES
- S₁ : FUNCTION
 - 1. AM
 - 2. FM AUTO
 - 3. FM MONO
 - 4. REC LEVEL CHECK
 - S₂ : MUTING
OFF — 1 — 2
 - S₃ : MPX NOISE FILTER
OFF → ON
 - S₄ : POWER
OFF → ON
 - S₅ : DE-EMPHASIS
25μS → 50μS → 75μS

FM MULTIPATH
HORIZ → 4CH-MPX OUTPUT
VERT → 400mV

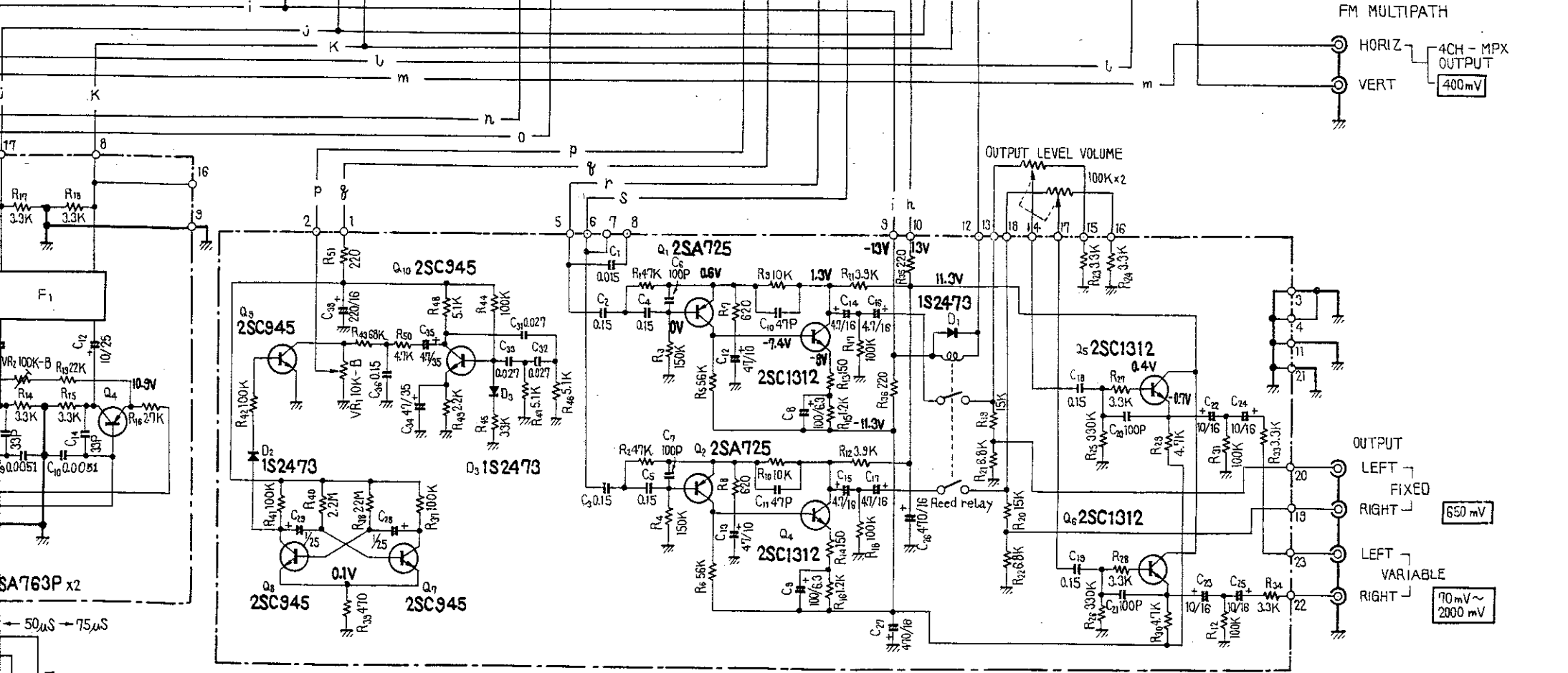

AF OSC ASS'Y AWK-040

OUTPUT LEVEL VOLUME
100K × 2

OUTPUT
LEFT → FIXED
RIGHT → 650 mV

LEFT → VARIABLE
RIGHT → 70 mV ~ 2000 mV

Symbol	Description	Part No.
R11	Carbon film 3.3k	RD¼PS 332J
R12	Carbon film 100k	RD¼PS 104J
R13	Carbon film 2.7k	RD¼PS 272J
R14	Carbon film 3.3k	RD¼PS 332J
R15	Carbon film 3.3k	RD¼PS 332J
R16	Carbon film 2.7k	RD¼PS 272J
R17	Carbon film 3.3k	RD¼PS 332J
R18	Carbon film 3.3k	RD¼PS 332J
R19	Carbon film 22k	RD¼PS 223J
R20	Carbon film 10	RD¼PS 100J
VR1	Semi-fixed 4.7k-B	C92-051-0
VR2	Semi-fixed 100-B	C92-047-0

SEMICONDUCTORS

Symbol	Description	Part No.
Q1	IC HA1156	
Q2	Transistor 2SC945-Q, R or S	
Q3	Transistor 2SA763P-5 or 6 (2SA725-F or G)	
Q4	Transistor 2SA763P-5 or 6 (2SA725-F or G)	
D1	Diode 1S2076	

FILTERS

Symbol	Description	Part No.
T1	Anti-birdy filter	ATF-023-0
T2	Anti-birdy filter	ATF-024-0
F1	Low pass filter	ATF-016-0 (ATF-019-0) (ATF-028-0)