

TF 2304

TF 2304

**FM/AM Modulation
Meter**

INSTRUCTION MANUAL

mi

MARCONI INSTRUMENTS

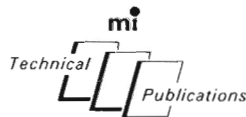
Instruction Manual
No. H 52304-900S
for
FM/AM Modulation Meter
TF 2304

Code: 52304-900S

RADIO FREQUENCY INTERFERENCE

This equipment conforms with the requirements of EEC Directive 76/889 as to limits of r.f. interference.

H 54881-030D:C1



©
1975

MARCONI INSTRUMENTS LIMITED
ST. ALBANS HERTFORDSHIRE ENGLAND



Contents

Chapter 1 GENERAL INFORMATION

1.1	Introduction	3
1.2	Data summary	4
1.3	Accessories	5
1.4	Response curves	8

Chapter 2 OPERATION

2.1	Installation	9
2.2	Power	9
2.2.1	AC mains connections	9
2.2.2	Battery installation	9
2.2.3	Switching on	11
2.2.4	TF 2304 battery characteristics	11
2.3	Controls	12
2.4	Sequence of operation	13
2.5	Operation in the presence of interfering signals	14
2.6	Using accessories to couple TF 2304 to a transmitter	14
2.6.1	20 dB, 20 W Attenuator (54431-021B)	15
2.6.2	Signal Sniffer (54452-011F)	15
2.7	Output sockets	17

Chapter 3 TECHNICAL DESCRIPTION

3.1	Introduction	18
3.2	Circuit summary	18
3.3	RF input	18
3.4	Local oscillator	19
3.5	Automatic tuning	19
3.6	Mixer	19
3.7	IF amplifier	20
3.8	FM circuit	20

3.9	Automatic frequency control	21
3.10	AM circuit	22
3.11	Level control and indication	22
3.12	AF amplifiers	22
3.13	De-emphasis	22
3.14	Peak detector	23
3.15	Power supply	23

Chapter 4 MAINTENANCE

4.1	Introduction	26
4.2	Access and layout	26
4.3	Performance checks	28
4.3.1	Test equipment required	28
4.3.2	Initial checks	28
4.3.3	Level check	29
4.3.4	Range calibration	29
4.3.5	Noise	30
4.3.6	Distortion	30
4.3.7	AM rejection	31

Chapter 5 REPAIR

5.1	General	32
5.2	RF input attenuator	32
5.3	Fault location procedures	32
5.3.1	Introduction	32
5.3.2	Test equipment required	33
5.3.3	Stage-by-stage checks	33
5.3.4	Sweep and a. f. c. system	36
5.3.5	Noise fault location	39

Chapter 6 REPLACEABLE PARTS

Introduction and ordering	41
---------------------------	-----	-----	-----	----

Chapter 7 CIRCUIT DIAGRAMS

Circuit notes	48
Fig. 7.1	Block diagram	49
7.2	Power supply and circuit interconnections	51
7.3	Input circuits	53
7.4	FM and a. m. circuits	55
7.5	Measuring circuits	57

1.1 INTRODUCTION

FM/AM Modulation Meter type TF 2304 has been designed primarily for the servicing and production line testing of mobile radio transmitters. It covers the frequency bands most commonly used for fixed and mobile communications and particular attention has been paid to the provision of facilities and accessories required for the field testing of mobile equipment.

The instrument incorporates automatic tuning over the carrier frequency range of 9 to 12.5 MHz and 18 to 1000 MHz and also provides automatic level control provided the input signal to the instrument is within specified limits. Panel lamps are provided to indicate when the r.f. input level is too high or too low. With a suitable input the TF 2304 automatically locks to the carrier signal, the level is automatically set, the meter settles, and a reading can be taken in about five seconds.

Measurements can be made, on f.m. transmitters, of both positive and negative deviations at modulation frequencies of 50 Hz to 9 kHz. Eight

selectable ranges between 1.5 kHz f.s.d. and 150 kHz f.s.d. are provided.

On a.m. transmitters depth measurements up to 95% at modulation frequencies between 50 Hz and 9 kHz can be made at carrier frequencies up to 400 MHz. Peak or trough indication can be selected by a switch.

Although measurements are normally made by means of meter readout, i.f. and demodulated outputs are available at the front panel for examination or analysis. A switched de-emphasis facility is provided for the demodulated output to restore a modulation signal that has had pre-emphasis applied.

The instrument can operate from an a.c. mains supply or from an optional rechargeable nickel cadmium battery pack mounted inside the instrument case. The instrument can be operated from the battery pack all day (the continuous operational life of the battery pack is about 8 hours) then charged up overnight using the built-in charger.



Fig. 1.1 FM/AM Modulation Meter type TF 2304

1.2 DATA SUMMARY

TUNING

Carrier frequency range : 9 to 12.5 MHz and 18 to 1000 MHz with automatic tuning
Max. reading time : 5 s (approx.).

RF INPUT

Sensitivity : Better than 50 mV up to 600 MHz,
Better than 100 mV up to 1000 MHz.
Maximum working input : 1 V r.m.s. extended to 7 V r.m.s. by switchable 20 dB nominal pad.
Maximum safe input : 1 W (7 V into 50 Ω) continuous.
RF level control : Automatic. Panel indicators lit when input level outside high or low limits of range.
Input impedance : 50 Ω nominal.

FM MEASUREMENT

Deviation ranges : Three ranges plus switched x2 and x10 factors giving full-scale indications of : 1.5, 5 and 15 kHz; 3, 10 and 30 kHz; and 15, 50 and 150 kHz. Positive or negative deviation indication selected by switch.
Deviation accuracy : $\pm 3\%$ of f.s.d. at 1 kHz modulation frequency.
Modulation frequency range : Over the range 50 Hz to 9 kHz deviation measurements are within ± 0.5 dB with respect to 1 kHz.
Inherent noise : Deviation due to noise is better than 40 Hz at 150 MHz with 100 mV input in a 3 dB bandwidth of 15 kHz. Equivalent to -42 dB relative to a 5 kHz deviation signal.
AM rejection : Additional deviation error is at least 26 dB below the reading for 5 kHz deviation when a.m. depth is 30% at 1 kHz modulation frequency. Normally better than 36 dB.

AM MEASUREMENT

Modulation depth range : Full-scale indication 10%, 30% and 100% (usable up to 95%). Peak (+) or trough (-) indication selected by a switch.
Depth accuracy : Up to a carrier frequency of 400 MHz and at 1 kHz modulation frequency, $\pm 3\%$ of f.s.d. on 30% range and on 100% range (up to 80% modulation depth).
Modulation frequency range : Over the range 50 Hz to 9 kHz, modulation depth measurements are within ± 0.5 dB with respect to 1 kHz.
Noise : Better than 50 dB down on 100% modulation depth in a nominal 3 dB, 10 Hz to 15 kHz bandwidth at 100 mV input level

IF OUTPUT

Frequency : 400 kHz (nominal).
 Level : 100 mV nominal e.m.f. from 1 k Ω nominal source

AF OUTPUT

Level : 1 mW nominal into 600 Ω with meter at f.s.d. (775 mV into 600 Ω).
 Distortion : Less than 1% for a.m. depths up to 80%.
 Less than 1% (normally 0.5%) for f.m. up to 150 kHz deviation.
 De-emphasis : Switchable 0 or 750 μ s. Output falls at nominal 6 dB/octave from 300 Hz.

POWER REQUIREMENTS

AC mains operation : Any a.c. voltage within the limits : 190 V to 264 V or 95 V to 130 V at any frequency between 45 and 500 Hz.
 Power consumption, 6 VA approximately.
 Battery operation : Rechargeable 21 V internal battery (54463-011D) can be fitted.
 Operation time, 8 hours nominal.
 Battery monitoring facility provided.

DIMENSIONS AND WEIGHT

Dimensions :	Height	Width	Depth
	100 mm (3.9 in)	206 mm (8.1 in)	305 mm (12 in)
Weight :	Without battery, 2.7 kg (6 lb). With battery, 3.6 kg (8 lb).		

1.3 ACCESSORIESSupplied

Mains Lead 43129-003.

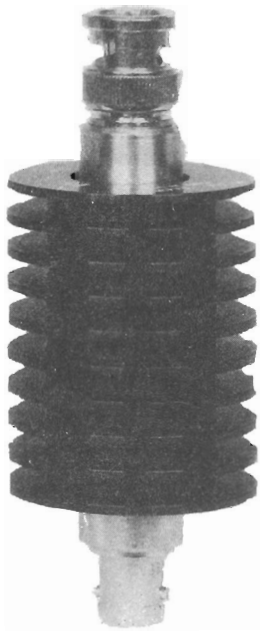
Optional

A range of accessories is available; the remainder of this section gives details of this range.

SIGNAL SNIFFER, 54452-011F

T connector for insertion between transmitter and load with pick-up to give a small signal from the T branch to TF 2304.

Attenuation : Dependent upon frequency. Approximate range is 50 dB at 25 MHz reducing to 24 dB at 500 MHz and to 18 dB at 1000 MHz when terminated by 50 Ω .
 Dimensions : 66 mm x 66 mm x 15 mm (2.6 in x 2.6 in x 0.6 in).



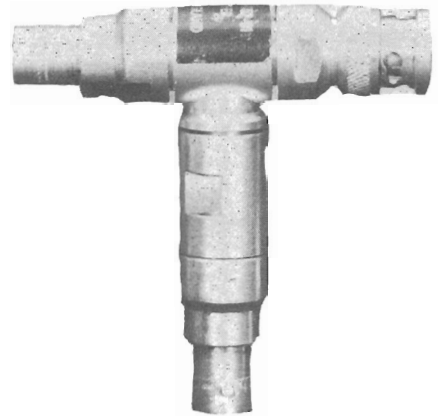
Attenuator
20 W, 50 Ω 20 dB
(54431-021B)



Termination
12 W, 50 Ω
(54422-011A)



RF fuse unit
TM 9884, 50 Ω
(43281-007C)



Signal Sniffer
(54452-011F)

Fig. 1.2
TF 2304 input
accessories

WARNING

- 54431-021B 20 W, 50 Ω, 20 dB ATTENUATOR
- 54422-011A 12 W, 50 Ω TERMINATION

Beryllia is used in the internal construction of these accessories. This material when in the form of fine dust or vapour and inhaled into the lungs can cause a respiratory disease. Because of this hazard, you are strongly advised not to open the accessory. If a fault is suspected the accessory must be returned for repair to Marconi Instruments Service Division, or disposed of in such a manner that no health hazard will result.

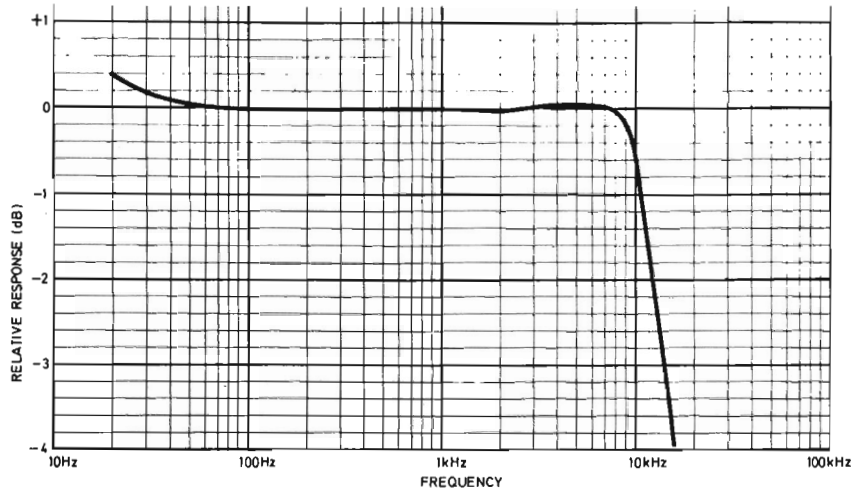
20 W, 50 Ω, 20 dB ATTENUATOR, 54431-021B

Attenuator for use with signal sniffer where additional attenuation and/or termination is required with transmitters up to 30 W.

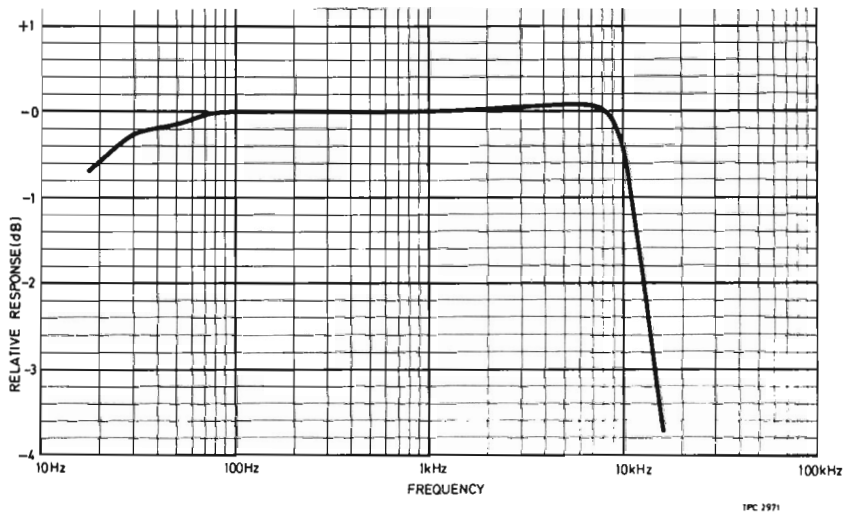
- Attenuation : 20 dB nominal.
- Frequency range : DC to 1 GHz.
- Impedance : 50 Ω nominal.
- Rating : 20 W continuous. 30 W for up to 5 minutes with off periods of at least 5 minutes.
- Connectors : 50 Ω, BNC plug to BNC socket.
- Dimensions : 66.4 mm long x 38 mm dia. nominal (2.625 in x 1.5 in nominal).

1.4 RESPONSE CURVES

Fig. 1.3 gives representative a.m. and f.m. demodulated frequency response curves for an instrument with de-emphasis off.



(a) AM on 100% range



(b) FM on 5 kHz range

Fig. 1.3 Representative frequency response curves

2.1 INSTALLATION

Unpack the instrument and any accessories ordered and check the goods received against the packing note. Sect. 1.3 lists the accessories supplied with the instrument and optional accessories available.

2.2 POWER

The TF 2304 modulation meter derives its power from either of two sources : the a.c. mains or rechargeable batteries. Facilities are provided for the meter to recharge its battery from the mains, but the battery can be removed and charged externally.

2.2.1 AC mains connections

The mains lead supplied must be fitted with a mains plug by the user. The colour coding is as follows :

Connection	Colour	Sleeve
Line	Brown	
Neutral	Blue	N
Earth	Yellow/green	⏚

Before connecting to the mains supply, check the fuses and mains voltage setting. For mains voltages around 230 V, a 50 mA fuse is fitted; for 110 V this must be changed to 100 mA. To change the mains voltage setting reverse the L-shaped plate on the rear panel, switching the slide switch to the other position.

2.2.2 Battery installation

NOTE. The battery pack is normally supplied in the discharged state and must be charged before the TF 2304 can be powered by it. The battery can be charged externally or by using the TF 2304's internal charging circuits.

The battery pack accessory (54463-011D) consists of sealed nickel cadmium rechargeable cells.

It is located, when fitted, in an internal push fit container along the top right-hand side of the instrument when viewed from the front. The battery fuse is fitted with the battery and should be removed whenever the battery is removed. The battery is fitted by swivelling the r.f. board assembly, which includes the battery retaining brackets, to a vertical position as illustrated in Fig. 2.1, sliding the battery into place, connecting it up, and returning the r.f. board assembly to the horizontal. The following procedure details the steps to be taken to accomplish this.

In this procedure all positional references are as seen from the front with the instrument the correct way up. Also, reference should be made to Fig. 2.1 which is a diagram indicating the various screw positions.

- (1) Remove the outer case by removing the two retaining screws at the rear, standing the instrument on its front panel and sliding the outer case off.
 - (2) Remove the two main function board retaining screws. The heads of these are located underneath and are the only two screw heads on the right-hand side.
 - (3) Loosen, but do not remove, the two pivot screws. The left-hand pivot screw is nearer the top of the left side and nearest to the front. The right-hand pivot screw is near the top of the right side and nearest the front.
 - (4) Remove the four r.f. board assembly retaining screws. These are located as follows :
 - (i) Under the right-hand pivot screw.
 - (ii) and (iii) on the right-hand side at the rear. The two screws nearest the front. Do not move the two back panel retaining screws which are nearest to the rear.
 - (iv) On the left-hand side. The single screw at the rear but nearest to the front.
- Do not move the two back panel retaining screws which are nearest to the rear or the single front panel retaining screw under the left-hand pivot screw.

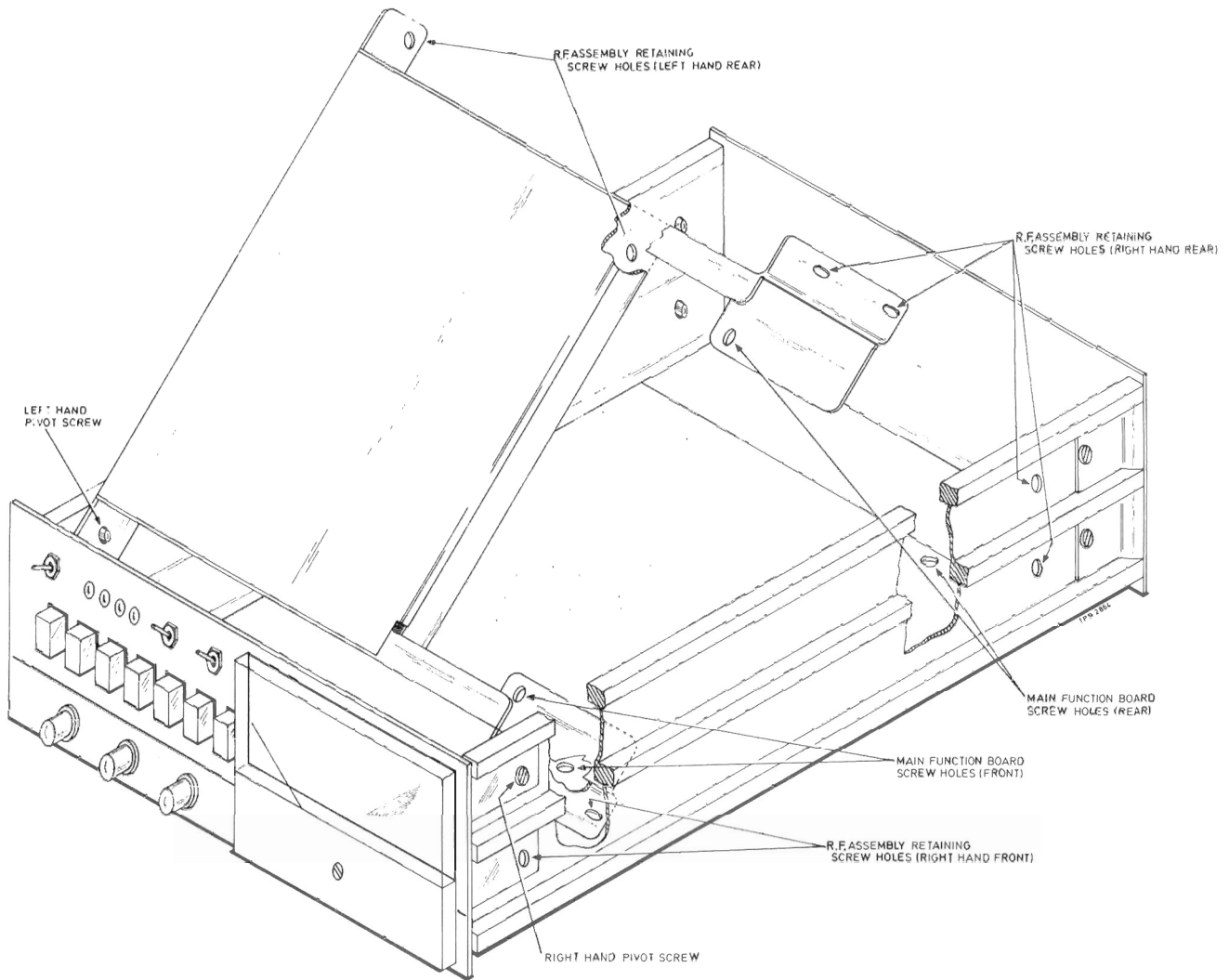


Fig. 2.1 Battery installation

(5) Lift the rear of the r.f. board assembly free of the instrument and into a vertical position, pivoting the assembly about the two pivot screws at the front.

(6) Ensure that the rubber padding on the lower battery retaining bracket is clear of the right-hand side and slide the battery in (see Fig. 2.1) with the connector at the bottom.

(7) Ensure that the SUPPLY switch is at OFF. Mate the free battery connector to the fixed battery connector.

(8) Insert a 1 A fuse (supplied initially in a plastic bag tied to the fixed battery connector) into the fuse holder behind the fixed battery connector.

(9) Depress the BATTERY VOLTAGE switch. If the battery has sufficient charge to operate the instrument it will register a reading in the black BATT arc on the meter. If there is insufficient charge then continue at step 11 below and then charge the battery as indicated in Sect. 2.2.3. Clear the BATTERY VOLTAGE switch by pressing any one of the RANGE switches.

(10) If the battery has sufficient charge switch the SUPPLY switch to ON and check that the ON and LOW LEVEL indicators light. There is an error condition if they do not. Switch the SUPPLY switch to OFF.

(11) Re-assemble the instrument in reverse order to steps (1) to (5).

Table 2.1 Power indications

SUPPLY switch setting	Power source		Indicator	
	AC Mains	Battery	~ (Red)	ON (Yellow)
OFF	-	-	OFF	OFF
ON	YES	NO	LIT	LIT
	YES	YES	LIT	LIT
	NO	YES	OFF	LIT
CHARGE	YES	YES	LIT	OFF

2.2.3 Switching on

With the appropriate power source connections made switch the SUPPLY switch to ON. Table 2.1 shows which indicators should light.

If the correct indicators light and, in the case of battery only operation, the battery is sufficiently charged then the instrument is ready for use.

If the battery needs to be charged the instrument should be connected to the mains and the SUPPLY switch set to CHARGE. This extinguishes the ON indicator as shown in Table 2.1. The battery should be left on charge for as long as necessary - see Sect. 2.2.4.

NOTE. When the instrument operates from the a.c. mains with the SUPPLY switch in the ON position a trickle charge is applied to the battery, if fitted.

If the SUPPLY switch is left in the ON position and the a.c. mains supply removed the instrument will continue to operate using the battery, if fitted.

2.2.4 TF 2304 battery characteristics

If a battery is stored for periods in excess of one month it should be stored in the discharged condition to preserve its cell life. Batteries in a discharged state can be charged either by the TF 2304's internal charging network or by removing the battery and quick-charging from an external source at a rate up to 1.2 A. The quick-charging should be carefully controlled and the high rate terminated when about 85% of the charge has been

replaced or if the temperature rise exceeds 10°C. The charging may then be completed at 120 mA.

NOTE. Verification of charge state is a difficult procedure - refer to battery manufacturer for details.

The battery charging system of the TF 2304 modulation meter utilizes the unregulated d.c. produced from the a.c. power supply, and hence the charging current varies with the line voltage. If the line voltage is around its mid-value a battery discharged to voltage regulator drop-out (17.5 V) will be fully charged in about 13 hours. This time will be increased or decreased if the line voltage is lower or higher. If the line voltage is persistently low, then it should be transformed up to 230 V to avoid an excessive charging time. At the charging rate employed by the TF 2304 no damage should occur if the charging is continued beyond the fully charged condition. The manufacturer's data gives more detailed information.

A fully charged battery will give about 8 hours of use by the TF 2304 before it requires re-charging. As the end of this charge period approaches it is most important to frequently check that the battery voltage is not below the voltage limit (bottom of black arc on meter) since there is no other indication and errors in measurement will occur if the instrument is operated with battery volts below the limit. The battery voltage is monitored on load by pressing the BATTERY VOLTAGE switch which connects the meter across the battery. If the meter reads within the black BATT arc then the battery is sufficiently charged for correct operation. Selection of a deviation or modulation depth range cancels the BATTERY VOLTAGE switch.

7 FM/AM double action push button switch. When IN the red ranges of the meter are applicable and a.m. depth measurements can be made. When OUT the black ranges of the meter (except BATT) are applicable and f.m. frequency deviation measurements can be made.

8 +/- double action push button switch. For f.m. causes the meter to read peak frequency deviation above (OUT) or below (IN) the carrier. For a.m. causes the meter to read the amplitude of the peak (OUT) or trough (IN) of the modulating waveform.

9 RANGE push button switches. Three inter-locked switches which determine the full-scale range for the function to be measured by the meter as determined by the FM/AM switch. The required range is selected by depressing the appropriate push button.

If the FM/AM switch is IN then the ranges available for a.m. modulation depth are 10%, 30% or 100%.

If the FM/AM switch is OUT then the basic ranges available for f.m. deviation measurements are 1.5, 5 or 15 kHz. These ranges are affected by the DEVIATION multiplier switch (see (10)).

10 DEVIATION switch. Three position toggle. Modifies the selected meter range when measuring f.m. deviation. Modification factors are x1, x2 and x10.

11 IF OUTPUT BNC socket. Provides 400 kHz i.f. signal.

12 METER. Calibrated scales : Black for f.m. frequency deviation measurements and red for a.m. modulation depth measurements. In addition an unscaled battery voltage indication is given.

13 BATTERY VOLTAGE push button switch. Depressing this switch causes the meter to indicate the state of charge of the battery. Interlocked with the RANGE switches; pressing any one clears the BATTERY VOLTAGE switch.

14 AF OUTPUT BNC socket. Provides de-modulated output for connection to extra sensitive meter, wave analyser etc.

15 DE-EMPHASIS 750 μ s. Two position toggle switch. When the switch is 'up', de-emphasis at 6 dB/octave is applied to the demodulated signal at the AF OUTPUT socket. Does not affect meter readout.

The following controls and connections are on the rear panel.

Supply plug - accepts Mains Lead type TM 7052.

230V/115 V selector - set for required voltage.

Mains fuse - 50 mA for 230 V, 100 mA for 115 V.

2.4 SEQUENCE OF OPERATION

Before commencing measurements check the mechanical zero of the meter and adjust, if necessary, by means of the screw.

(1) Set SUPPLY switch to ON. Check that ON and LOW LEVEL indicators are lit. (Other power checks are given in Sect. 2.2).

(2) Select AM or FM as required.

(3) Select + (for positive deviation or a.m. peak) or - (for negative deviation or a.m. trough).

(4) Select appropriate range by depressing one of the three RANGE push buttons. For f.m. deviation measurements a DEVIATION multiplier factor must also be selected. Table 2.2 details the eight deviation ranges that can be attained using these switches.

Table 2.2 FM deviation range

Deviation range required	RANGE switch setting (kHz)	DEVIATION multiplier switch setting
1.5 kHz	1.5	x1
3 kHz	1.5	x2
5 kHz	5	x1
10 kHz	5	x2
15 kHz	{ 1.5	x10
	{ 15	x1
30 kHz	15	x2
50 kHz	5	x10
150 kHz	15	x10

- (5) Select DE-EMPHASIS if required.
- (6) Connect r.f. input signal of between 18 and 1000 MHz maximum level as stated on front panel. See Sects. 2.5 and 2.6 for detailed information on input connections.
- (7) Adjust input level if HIGH or LOW LEVEL indicators are lit, using 20 dB switched attenuator if required, until both LEVEL indicators are off.
- (8) Modulate source at a modulation frequency up to 9 kHz.
- (9) Read deviation (black scales) or a.m. depth (red scales) from meter.
- (10) After use switch SUPPLY switch to OFF. If a battery has been used refer to Sect. 2.2 for details of charging and battery monitoring.

2.5 OPERATION IN THE PRESENCE OF INTERFERING SIGNALS

A modulation meter with automatic tuning searches for and tunes to any signal of the correct level within its tuning range. It would therefore appear that compared to a manually tuned instrument there is a much greater risk of tuning to an interfering signal when the instrument is used in the presence of such a signal. The advantage of the manually tuned instrument is more apparent than real however, especially if the two frequencies are close together, since the frequency calibration accuracy of a manual tuned instrument is usually not better than a few % of indicated frequency. Thus at 470 MHz an accuracy of $\pm 3\%$ will give a possible tuning range of 28.2 MHz which may embrace many possible interfering frequencies around the wanted frequency, as well as other bands of frequencies covered by the various oscillator harmonics.

The TF 2304 modulation meter incorporates screening for those parts of its circuits which could be affected by interfering signals, and in addition incorporates filtering in the a.c. power input. Thus the TF 2304 will operate satisfactorily in any interference environment suitable for a manually tuned modulation meter. Where there is a possibility that the instrument may be affected by an interfering signal certain precautions, described in the next paragraph, should be observed to minimize the risk.

Coupling the signal to the modulation meter by means of an aerial or pick-up loop is always a bad method and should only be used as a last resort as it clearly invites coupling of unwanted signals, and also variable reflections from people in the vicinity may overload the instrument. The wanted signal should be coupled to the modulation meter as described in Sect. 2.6 by a coaxial attenuator system, or by feeding the signal to a coaxial load (which may be a power meter) and picking off a small signal with a signal sniffer. These procedures will normally ensure that interfering signals are below the level at which they will affect the instrument. It may be, however, that the interfering signal is picked up via the source if that is not well screened (e.g. a transmitter being serviced with its screening removed). In this case, since the dynamic range of the modulation meter is a nominal 26 dB, any interfering signals which are more than 26 dB below the wanted signal cannot affect the tuning. This applies even if the wanted signal is just below the 'high' level. If the wanted signal is attenuated down to a level where it is near the minimum operating level then the instrument will not tune to the interfering signal even if it is only a few dB below the wanted signal.

In all cases, if there is any doubt that the signal to which the instrument is tuned is the wanted signal, it should be identified by modulating the source and checking that the modulation meter responds correctly.

2.6 COUPLING TF 2304 TO A TRANSMITTER

If the power source is less than 1 W the input signal can be fed directly to the TF 2304 (subject to the limitations detailed in Sect. 2.5). In this case the power levels at which measurements can be made depend upon the setting of the 0/20 dB switch. Table 2.3 gives details of the signal levels which can be connected directly to the RF INPUT socket of the TF 2304 and from which measurements can be made.

Table 2.3 Input power levels to TF 2304*

Frequency range (MHz)	RF input power to TF 2304			
	20 dB pad OUT		20 dB pad IN	
	Min	Max	Min	Max
25 - 600	<0.05 mW	20 mW	5 mW	1 W
600 - 1000	<0.2 mW	20 mW	20 mW	1 W
* Maximum safe continuous input is 1 W				

If the power level is above 1 W the input must be attenuated before it is coupled to the modulation meter. There are two main methods of doing this, illustrated in Fig. 2.3 using the accessories described in Sect. 1.3. Fig. 2.4 is a chart giving maximum and minimum power levels which can be accepted by the various configurations of the TF 2304 and its accessories over the instrument's frequency range. On this chart steps are shown in the minimum power levels at 600 MHz; these steps are drawn to the specification limit but in practice there will not be a sudden transition in sensitivity at this frequency.

As an example of the use of Fig. 2.4, consider a typical mobile transmitter with an output at 170 MHz of 8 W. Placing these co-ordinates on the chart shows that the signal can be monitored either

(a) by the TF 2304 with its internal 20 dB pad switched IN and the external 20 dB, 20 W attenuator accessory fitted or

(b) by the TF 2304 with its internal 20 dB pad switched OUT and the signal sniffer accessory fitted.

In all the configurations mentioned in this section the RF Fuse Unit accessory TM 9884 can be connected in the line to the modulation meter, immediately before the input socket. However, use of this accessory may slightly modify signal levels to the instrument, especially at the high frequencies.

2.6.1 20 dB, 20 W Attenuator (54431-021B)

The 20 dB, 20 W attenuator is used as shown in Fig. 2.3(a). This attenuator can be used at power levels up to 30 W provided that it is not 'on' for longer than 5 minutes and that at least 5 minutes are allowed between each 'on' period. For levels of 20 W or less the power can be on continuously.

CAUTION When the attenuator is used at the higher input power levels it becomes very hot and care should be exerted to avoid burns.

With the modulation meter's internal 20 dB pad switched IN the power levels which can be handled are :

- 0.5 W to 30 W up to 600 MHz
- 2.0 W to 30 W up to 1000 MHz.

It would seem from these figures that there is a gap in the level handling range between 1 W and 2 W at frequencies above 600 MHz (at this frequency the maximum input level of the TF 2304 without an external attenuator is 1 W whilst the specification minimum for the attenuator is 2 W). This apparent gap is covered by switching the TF 2304's internal 20 dB pad OUT. This effectively fills the gap since the external attenuator does not have a sensitivity step at 600 MHz.

If the ambient temperature rises above 35°C it is advisable to limit the maximum power to 25 W intermittent, or 15 W continuous.

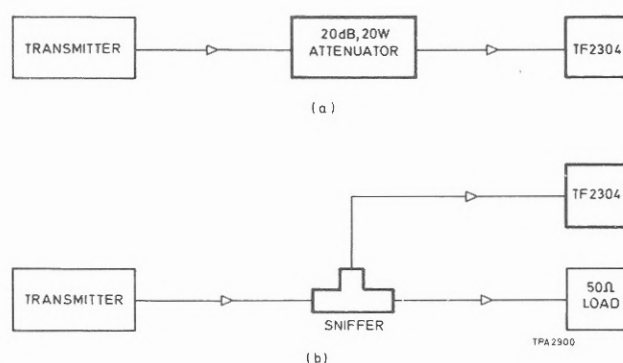
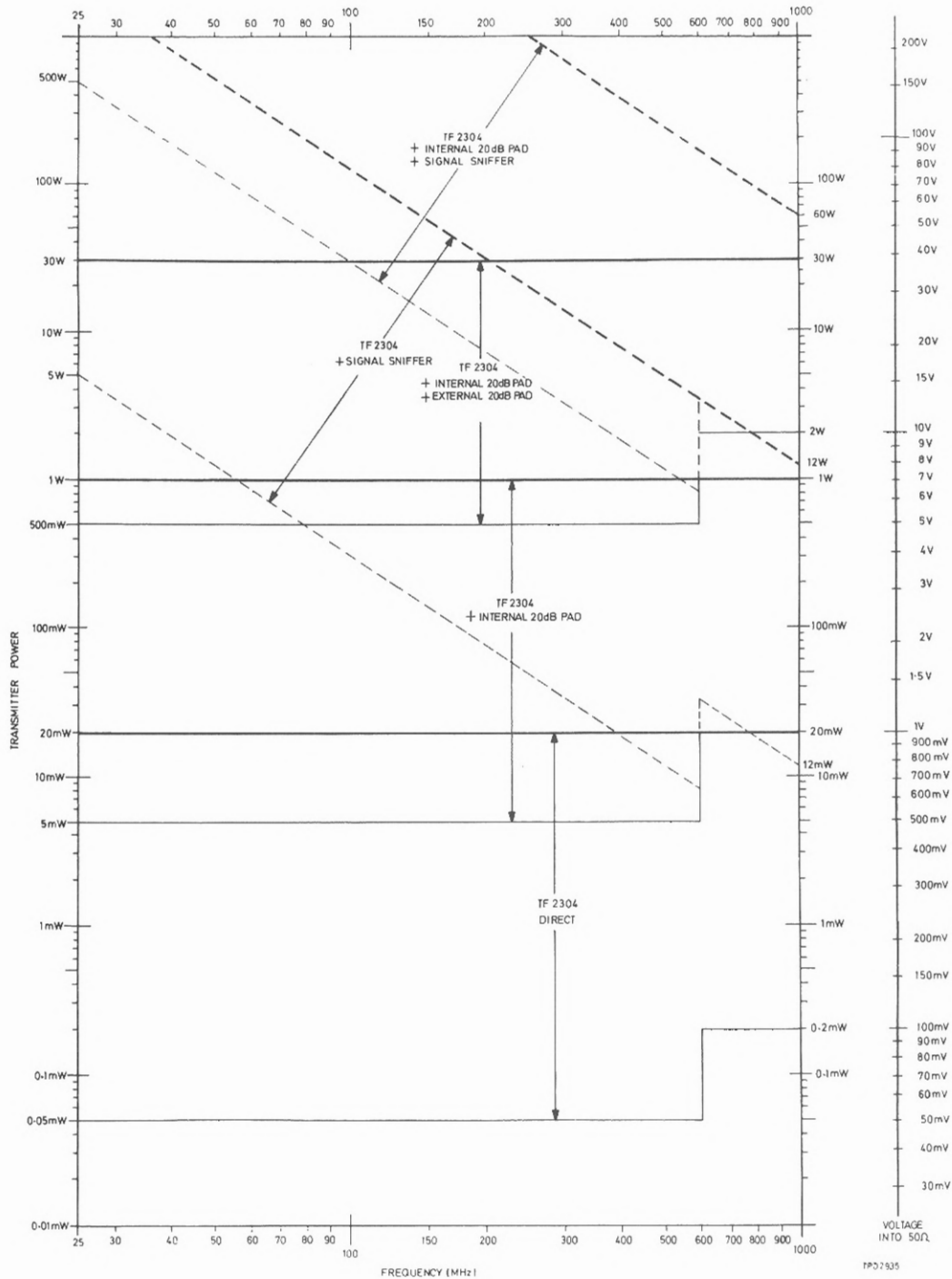


Fig. 2.3 Use of accessories

2.6.2 Signal Sniffer (54452-011F)

A second method of connecting a high power level, by use of the signal sniffer accessory, is shown in Fig. 2.3(b). In this figure the 50 Ω load is often a power meter but the 12 W, 50 Ω Termination accessory (54422-011A) may be used for power levels up to 12 W. For higher power levels the 20 dB, 20 W accessory can be used as a load, preferably terminated by the 12 W, 50 Ω termination accessory.

The signal sniffer is frequency sensitive and reference should be made to Fig. 2.4 to determine whether or not a transmitter output can be coupled to the TF 2304 via the signal sniffer. In this figure the power bands over which the sniffer is effective are indicated by the dotted diagonal lines. The chart is drawn for powers up to 1 kW but it must be emphasized that maximum power is determined by the power handling capacity of the BNC connector and the power which the load can absorb.



- NOTES. 1. Horizontal lines are TF 2304 & 20 dB pad ranges.
Diagonal lines are TF 2304 & signal sniffer ranges.
2. The step in the minimum line of each range is drawn to the TF 2304 specification limit, and in practice there will not be a sudden transition at this frequency.
3. The 30 W rating shown for the external 20 dB attenuator is for intermittent applications only (see text).
4. The power rating of the signal sniffer is limited by its input connector.

Fig. 2.4 Input power/accessory chart

2.7 OUTPUT SOCKETS

The IF OUTPUT socket provides a 400 kHz i.f. output of 100 mV r.m.s. nominal from a 1 kΩ source. This signal can be used to view the a.m. envelope on an oscilloscope.

The AF OUTPUT socket provides the de-modulated signal which can be measured by a sensitive voltmeter or wave analyser for low deviation and low modulation depths. The output level is approximately 775 mV into 600 Ω with the meter at f.s.d. The socket is fed by an independent buffer stage and therefore the meter is unaffected by the load connected.

CAUTION Application of d.c. to this socket may cause damage to the associated electrolytic coupling capacitor.

2.8 NOISE MEASUREMENTS

By connecting an external meter to the OUTPUT socket, noise measurements limited only by the noise level generated within the instrument can be made. The internal meter, being peak reading, is not suitable for measuring noise and, ideally, an r.m.s. responding meter should be used. However, sufficiently accurate results are usually obtained with an average reading meter by applying the appropriate correction factor.

The curve given in Fig. 2.5 shows typical noise levels produced by the internal oscillator over the r.f. range of the instrument.

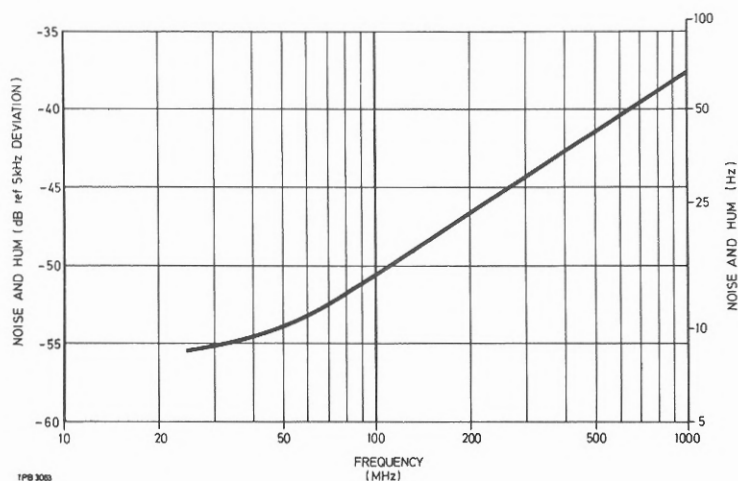


Fig. 2.5 Typical modulation meter noise levels

3.1 INTRODUCTION

FM/AM Modulation Meter TF 2304 is basically a heterodyne f.m./a.m. receiver with discriminator and a.m. detector and a peak reading voltmeter to measure the demodulated signal.

The circuit is summarized in Sect. 3.2 and detailed in Sects. 3.3 to 3.15. These sections should be read in conjunction with the block diagram Fig. 7.1 and the circuit diagrams Figs. 7.2 to 7.5.

3.2 CIRCUIT SUMMARY

The signal to the RF INPUT socket is passed through a fixed 20 dB attenuator and a switched (0 - 20 dB) attenuator and the level at this point checked by the high level indicating circuits. If the input level is too high an indicator is lit. The output of the attenuator is fed to a mixer where it is heterodyned with the output from a local oscillator.

The oscillator is swept over a range of frequencies by the output of a ramp generator. During the sweep the oscillator frequency, or one of its harmonics, approaches the signal frequency and when separated by the chosen i.f. a signal in the i.f. band is produced in the mixer. The detection of this signal causes the sweep to be halted and automatic frequency control then keeps the oscillator in tune.

The output of the mixer is fed to an i.f. amplifier. The resultant i.f. signal is taken to the IF OUTPUT socket, to a limiter for f.m. measurements, and to an a.m. detector for a.m. measurements.

The limiter is followed by a discriminator. The d.c. component of the discriminator output is proportional to the intermediate frequency and is used for automatic frequency control. The amplitude of the a.c. component of the output is propor-

tional to deviation and hence, after being inverted to provide correspondence with the front panel +/- switch, this signal is routed via the DEVIATION multiplier and FM/AM switches to the measurement circuits.

The d.c. component of the a.m. detector output is proportional to mean carrier envelope level and is used to inhibit the ramp generator for the frequency sweep. It is also used to indicate whether the level is too low in which case an indicator is lit, and to maintain level control. The a.c. component of the detector output is proportional to modulation depth and accordingly is routed via the FM/AM switch to the measurement circuits.

The output obtained from the f.m. discriminator or from the a.m. detector (as determined by the FM/AM switch) is input to an a.f. amplifier which incorporates the range switches in its output. The range corrected signal is then passed through a second amplifier stage to the peak detector, and also through a buffer to the AF OUTPUT socket.

The peak detector is effectively a diode and capacitor with the +/- switch reversing the signal and earth connections to them. The +/- switch allows a.m. peak or trough and f.m. positive and negative measurements to be made on the meter. Note that due to the sense of the automatic frequency control the + and - deviation are correct.

3.3 RF INPUT

The attenuation of the r.f. input is provided by a resistive 20 dB pad located behind the RF INPUT socket and connected to a switched 0 or 20 dB attenuator mounted on the switch board. The common of the 0 - 20 dB switch which controls this attenuator is taken to the r.f. board where it is coupled to the mixer (Sect. 3.6) and also to the high level detector circuit (Sect. 3.11).

3.4 LOCAL OSCILLATOR

The local oscillator, mounted on the r.f. board, is a varactor tuned f.e.t. oscillator working in the approximate range 8.5 to 13 MHz. This oscillator feeds a step recovery diode pulse generator which produces a 'comb' of harmonics to above 1 GHz.

Oscillator

The oscillator is a Hartley oscillator variant using an f.e.t. and varactor diode as illustrated in Fig. 3.1.

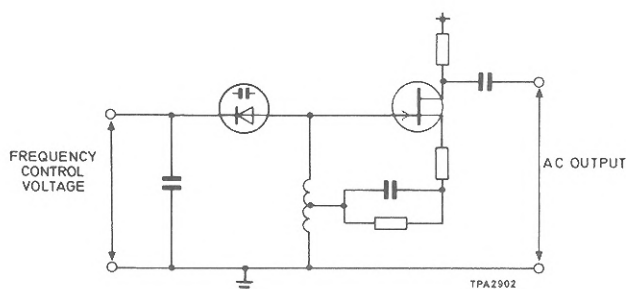


Fig. 3.1 Oscillator circuit

To obtain as large a capacitance as possible, hence lowest possible noise, several varactor diodes are used. The varactor diode bias voltage which determines the working frequency of the oscillator is controlled by the automatic tuning circuits (Sect. 3.5).

The output of the oscillator is taken to a buffer stage formed by TR2 feeding the push-pull pair TR3 and TR4 which in turn drive the pulse generator circuit.

Pulse generator

The pulse generator is a step recovery diode, D7, with a small forward bias applied by R11 and R12. The standing bias is adjusted so that the a.c. voltage from the oscillator buffer turns the diode off once per cycle and a sharp current edge is generated. Since this edge is not loaded heavily a voltage edge is produced and fed to the mixer.

3.5 AUTOMATIC TUNING

Varying the varactor diode bias voltage alters the output frequency of the local oscillator. Therefore for automatic control there are two requirements :

1. To apply a relatively large voltage swing to the oscillator to sweep it across its range for search purposes.
2. Having found a signal, to apply relatively small voltage changes to the oscillator for automatic frequency control.

Both of these requirements are met by using the integrator formed by IC2 and TR6 and applying a constant reference voltage of approximately +7 V to pin 2 of IC2.

To achieve 1 above a voltage of approximately +14 V is applied to D10 causing a steady current to flow in R45 and hence producing a falling ramp voltage at the output of the integrator. When this output voltage falls to approximately +3 V the base current of TR10 will have decreased sufficiently to cause TR8 to turn on and set the monostable formed by TR7 and TR9. While the monostable is in this state R46 and D11 cause the voltage at pin 3 of IC2 to drop below that at pin 2 - the reference - and the output voltage of the integrator returns to approximately +14 V. When the monostable returns to its stable state the downward ramp at the integrator output starts again.

This sweep process continues until an i.f. of sufficient level is produced from the mixer. This causes the voltage on D10 to drop sharply to a fraction of a volt and the ramp stops abruptly. Frequency control is now taken over by the voltage applied to R44, which is derived from the f.m. discriminator (Sect. 3.8), with respect to the reference voltage applied to pin 2 of IC2. The voltage from the discriminator is the d.c. component of the output and as this is proportional to the i.f. it adjusts the oscillator frequency to maintain the correct i.f.

3.6 MIXER

The sharp voltage edge produced by the pulse generator (Sect. 3.4) across D7 is differentiated by C9 and the reflected load of R13 and R14 through the balun T1. The resultant pulse, which is positive-going on R13 and negative-going on R14,

causes D8 and D9 to conduct for less than 1 ns at the repetition rate of the local oscillator frequency. The reverse bias applied to these diodes by R15 - R18 causes a small increase in maximum signal handling.

The i.f. output from the mixer is generated at the junction of R15 and R16. The source follower TR5 is used to reduce the impedance at this point before the i.f. is fed to the i.f. amplifier.

3.7 IF AMPLIFIER

The main purpose of the i.f. amplifier is to allow automatic level control on the i.f. signal and to filter out signals not in the wanted pass band. The amplifier utilizes a 5 transistor array integrated circuit (IC1) and is effectively in two sections : a gain controlled section and a filter/output section.

The i.f. signal from the mixer is applied to the base of IC1b4. This forms a simple amplifier with a feedback resistor in its emitter to minimize distortion and with its collector loaded by the emitters of the matched pair IC1a4. The d.c. bias of one of this pair is adjusted, at pin 2, by the automatic level control voltage output from IC3 (ALC LEVEL - Sect. 3.11). Varying this bias varies the a.c. and d.c. current in pin 5 of IC1 and hence produces a variable gain at the output to the filter section.

The i.f. filter must attenuate signals above the pass band very sharply to prevent wrong triggering of the discriminator. This can happen at frequencies at which the discriminator pulse approaches or exceeds 100% mark/space ratio when the discriminator will operate in a 'divide-by-two' mode. The filter, therefore, has an attenuation slope such that the output level from the limiter falls below the triggering level of the discriminator before the 'divide-by-two' frequency is reached : this frequency is 1.5 MHz. The characteristic of the low-pass i.f. filter is flat from d.c. to the cut-off frequency and cuts off sharply at higher frequencies.

The filter used consists of two π section filters with a cut-off frequency of approximately 800 kHz.

The filter is followed by a d.c. coupled pair of transistors, IC1c4 and IC1d4, which amplify the signal up to approximately 60 mV. C22 and C26 reduce local oscillator pick-up and amplification at this point and improve stability.

The gain controlled and filtered i.f. signal is taken (IF) from the RF board to the Main Function board where it is distributed to the limiter (Sect. 3.8) and the a.m. detector (Sect. 3.10). In addition the i.f. is fed to the buffer amplifier TR6, on the Main Function board, which provides the IF OUTPUT.

3.8 FM CIRCUIT

Limiter and discriminator

The actions of the limiter and discriminator are illustrated by the waveforms shown in Fig. 3.2.

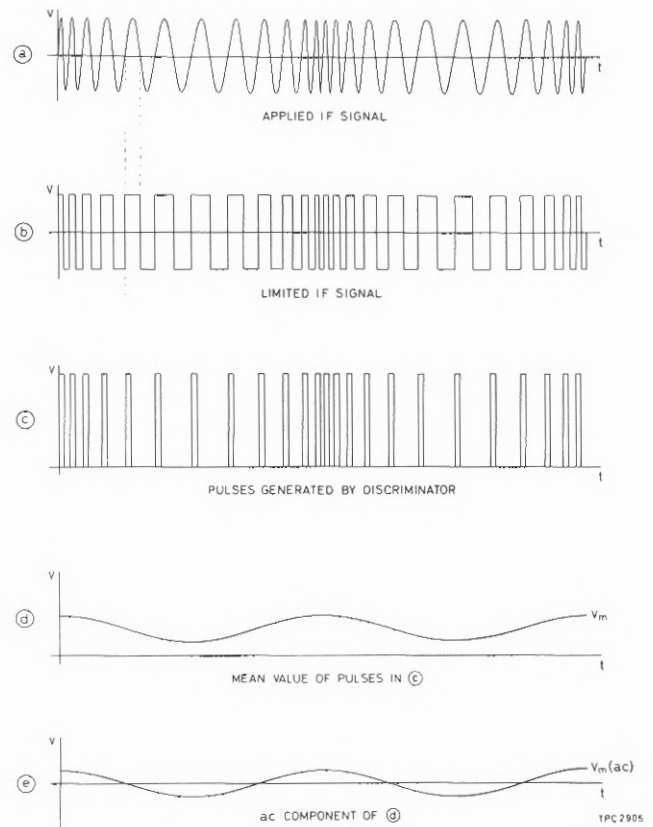


Fig. 3.2 FM demodulation

To provide good a.m. rejection when measuring deviation the limiter must eliminate all amplitude changes and produce a rectangular waveform (Fig. 3.2b). This limited i.f. signal triggers the pulse counter type of discriminator. A monostable pulse generator produces a pulse of fixed width and amplitude every time the i.f. signal passes through zero in the positive-going sense (Figs. 3.2b and c). V_m , the mean amplitude of these pulses varies with the p.r.f. of the input signal so, when f.m. is present, V_m varies directly with deviation frequency (Figs. 3.2c and d).

IF limiting amplifier IC3 provides high gain (60 dB) and has good limiting characteristics so that any a.m. on the input signal does not produce spurious f.m. The integrated circuit used for limiting does in fact include an f.m. detector but only the three-stage amplifier is used.

A rectangular waveform (Fig. 3.2b) with a standing d.c. level is provided by the limiter and is fed via the buffer TR5 to the discriminator. The 5 V power rail for both buffer and discriminator is derived via the ON l.e.d., a 4.7 V Zener diode (D1), and regulating transistor TR4. The base voltage of TR4 is temperature compensated by D2 to cancel the change in base emitter voltage with temperature.

The discriminator IC4 is a t.t.l. monostable. Pin 5 is a positive edge Schmitt trigger input and triggers the one shot when pin 5 goes high and both NAND inputs (pins 3 and 4) are low. The output of the monostable pulse generator (from pin 6) is a positive-going pulse of amplitude at least 2 V.

This pulse train has a repetition rate, which is equal to the signal frequency from the i.f. amplifier, and a pulse duration of 700 ns, determined by C10, R18. At 400 kHz the mark/space ratio is 2:5 but the discriminator can operate well above 400 kHz i.e. with mark/space increasing. However, if the repetition rate approaches 1.4 MHz the discriminator will operate in a 'divide-by-two' mode and the slope of the output voltage versus frequency will be halved.

AF filter and amplifier

The pulse train obtained from IC4 is clamped at +7 V by the voltage divider R20 - R22 and fed to IC5 and then to IC6. IC5 is a second order active

a.f. filter providing a cut-off of 12 dB/octave above 15 kHz. IC6 provides 20 dB of gain and inverts the signal to make peak a.m. and positive deviation correspond on the front panel switches. The output from IC6 is fed via the DEVIATION multiplier switch to the FM/AM switch (Sect. 3.12)

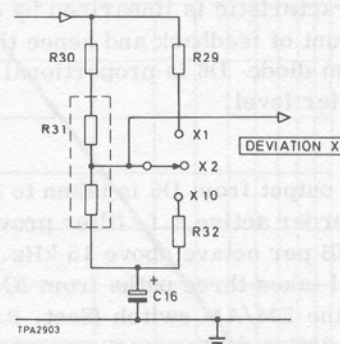


Fig. 3.3 Operation of DEVIATION switch

The wiper of the DEVIATION multiplier switch is connected directly to the FM/AM switch, and to IC6 through a voltage divider formed by R30 and R31. The effect of the switch (see Fig. 3.3) is to change the voltage ratio of the divider by switching extra resistors in parallel with the arms of the divider, as required. Table 2.2 gives details of the various deviation measurement ranges available when the DEVIATION multiplier switch is used in conjunction with the range switches.

3.9 AUTOMATIC FREQUENCY CONTROL

The voltage divider R20 - R22 which clamps the output of IC4 (the discriminator) also provides the reference voltage of approximately +7 V for automatic tuning (AFC REF - Sect. 3.5). The d.c. component of the filtered signal at the output of IC5 is fed to the automatic tuner as AFC. This voltage is applied to the tuner's integrator in place of the sweep voltage and hence controls the output of the integrator. The local oscillator is now controlled by the discriminator. As the AFC voltage is proportional to frequency and is of the correct sense when the oscillator frequency is above the signal frequency, it adjusts the oscillator frequency to maintain the correct i.f. and functions as an automatic frequency control system.

3.10 AM CIRCUIT

The a.m. circuit comprises an a.m. detector, an a.f. filter and a frequency sweep control circuit.

The a.m. detector uses a diode in the feedback loop of an operational amplifier (IC7). The diode characteristic is linearized by employing a large amount of feedback and hence the rectified output from diode D6 is proportional to the modulated carrier level.

The output from D6 is taken to IC8 which is a second order active a.f. filter providing a cut-off of 12 dB per octave above 15 kHz. The filtered a.f. signal takes three paths from IC8: it is connected to the FM/AM switch (Sect. 3.12) for ultimate modulation depth measurements, to the level control circuit (ALC - Sect. 3.10) and to the frequency sweep control circuit.

When the presence of a suitable signal is first detected it is necessary to halt the frequency sweep (Sect. 3.5). This is achieved by taking the output of the a.f. filter, IC8, to the Schmitt trigger IC9 which controls the transistor switch TR7. When no signal is present then the switch is off and approximately +14 V are applied to the tuner. When the a.m. detector produces an output TR7 conducts and the voltage to the tuner drops to a fraction of a volt thus halting the sweep. IC9 includes a small amount of hysteresis so that once a signal is 'locked' a reduction in signal level is required to unlock the local oscillator.

3.11 LEVEL CONTROL AND INDICATION

The output of the a.m. detector and filter IC8 (ALC) on the main function board is taken to pin 3 of integrator IC3 on the r.f. board. A reference voltage (ALC REF) derived from a potential divider on the main function board is applied to pin 2 of IC3. The output of the integrator is proportional to mean carrier envelope level (since it is derived from the d.c. component of the a.m. detector output) and is applied to the base of IC1a4 in the i.f. amplifier (Sect. 3.7) for automatic level control. This signal is also returned to the main function board as ALC LEVEL.

The low level detector (on the main function board) senses the potential on the ALC LEVEL

line by using IC1 as a comparator. When there is a low i.f. signal or none the output of IC1 is high turning on TR1 and lighting the LOW LEVEL l.e.d.

The high level indicator signal is obtained from a Schottky diode (D14) detector at the input to the mixer on the r.f. board and is brought onto the main function board as RF LEVEL and connected to pin 3 of IC2. When the r.f. signal is high, compared to the reference RF REF, the output of IC2 is high and TR2 and TR3 are turned on. TR2 turns off the LOW LEVEL l.e.d.; TR3 lights the HIGH LEVEL l.e.d.

When the i.f. signal is correct both lamps are extinguished and the supply for the discriminator flows through D1.

3.12 AF AMPLIFIERS

The wiper of the FM/AM switch connects either the f.m. circuit or the a.m. circuit output to the a.f. amplifiers. These prepare the signal for presentation to the measuring circuit.

The FM/AM switch wiper is connected to IC11 which is an a.f. amplifier incorporating an active filter with a 3 dB point at about 15 kHz. The output of this amplifier is passed, via a potentiometer system (R71 - R75) controlled by the range switches, to another stage of amplification, IC10, which blocks out any d.c. component. The output of IC10 takes two paths: to the peak detector (Sect. 3.14) and, via the buffer stage TR8, to the AF OUTPUT socket. The buffer stage provides a nominal 600 Ω output.

3.13 DE-EMPHASIS

The DE-EMPHASIS switch is used to switch a 750 μ s de-emphasis circuit in or out of the output circuit and hence serves to restore a modulation signal that has had pre-emphasis applied. The de-emphasis is introduced in the buffer audio amplifier (before AF OUTPUT) and does not affect the meter circuit.

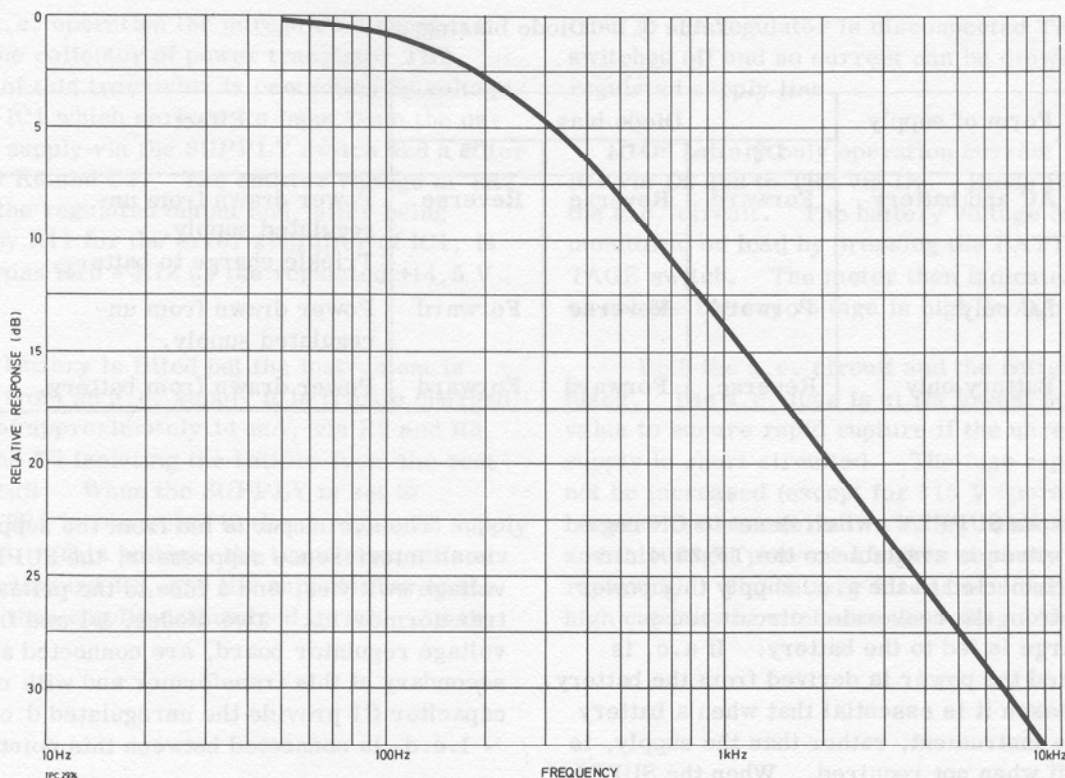


Fig. 3.4 Idealized 750 μ s de-emphasis response

The switch functions by shorting the inner and screen of a coaxial cable. The screen is earthed and the inner connected to C35. Fig. 3.4 is an idealized response curve for a 750 μ s de-emphasis circuit.

NOTE . DC output terminals are not provided as the meter scale calibration is non-linear. The AF OUTPUT socket gives an a.f. output proportional to the modulation and can be used with an external peak voltmeter.

3.14 PEAK DETECTOR

The peak detector is a diode/capacitor peak rectifier circuit mounted on the switch board. The signal to be measured is fed through the +/- switch to the rectifier circuit. The capacitor, C1, is charged via the diode, D1, to the peak voltage of the a.f. waveform and is then discharged through the meter and a series resistor. To allow positive or negative peak amplitudes to be measured the signal and earth connections to the detector can be reversed, as necessary, by the +/- switch.

The meter is connected across the wiper of the BATTERY VOLTAGE switch. When the switch is depressed the meter measures only battery voltage and the ranges are cancelled. However, pressing one of the RANGE switches returns the BATTERY VOLTAGE switch to the 'Out' position and peak measurements can be made.

3.15 POWER SUPPLY

The TF 2304 derives its power either from the a.c. mains supply or from an optional internal battery. The a.c. supply is converted to a regulated +14.5 V d.c. by an internal circuit and is then routed to the main instrument circuits. In addition this circuit incorporates facilities for charging the battery, if one is fitted. The conversion circuit is illustrated in Fig. 7.2 which also illustrates the power connections to the boards. It consists of a transformer, a full-wave rectifier, a charging circuit and a voltage regulator. The battery is an accessory and is detailed in Sect. 1.3.

Switch SB, on the rear panel, selects the transformer taps for 115 V or 230 V a.c. voltage. The SUPPLY switch controls the mode of operation of the conversion circuit.

Table 3.1 Diode biasing

Form of supply	Diode bias			Effect
	D3	D4	D5	
AC and battery	Forward	Reverse	Reverse	Power drawn from unregulated supply. Trickle charge to battery.
AC only	Forward	Reverse	Forward	Power drawn from unregulated supply.
Battery only	Reverse	Forward	Forward	Power drawn from battery.

When the SUPPLY switch is set to ON regulated d.c. power is available to the TF 2304 circuits. If connected to the a.c. supply this power is derived from the conversion circuit and a trickle charge is fed to the battery. If a.c. is not connected the power is derived from the battery. For this reason it is essential that when a battery is fitted the instrument, rather than the supply, is switched off when not required. When the SUPPLY switch is set to charge a supply current of approximately 130 mA (from a 230 V source) is applied to the battery and there is no power connection to the instrument circuits. When set to OFF all the power circuits are open circuit and no power is available.

When power is drawn from the a.c. supply the ~ l.e.d. is lit. When regulated d.c. power is being drawn the ON l.e.d. is lit. Table 2.1 illustrates the significance of the various combinations of these two indicators.

The a.c. input is fed from the supply plug via an interference suppressor, the SUPPLY and voltage switches, and a fuse to the primary of transformer T1. Two diodes, D1 and D2 on the voltage regulator board, are connected across the secondary of this transformer and with reservoir capacitor C1 provide the unregulated d.c. The ~ l.e.d. is connected between this point and 0 V.

The inter-relationship of the two forms of power (i.e. battery or rectified a.c.) is controlled by diodes as illustrated in Fig. 3.5. The biasing of these diodes, under particular circumstance, is detailed in Table 3.1 which also includes the result.

NOTE . This table assumes that the SUPPLY switch is set to ON. If it is set to CHARGE the diode biasing will be the same. Only the effect will change.

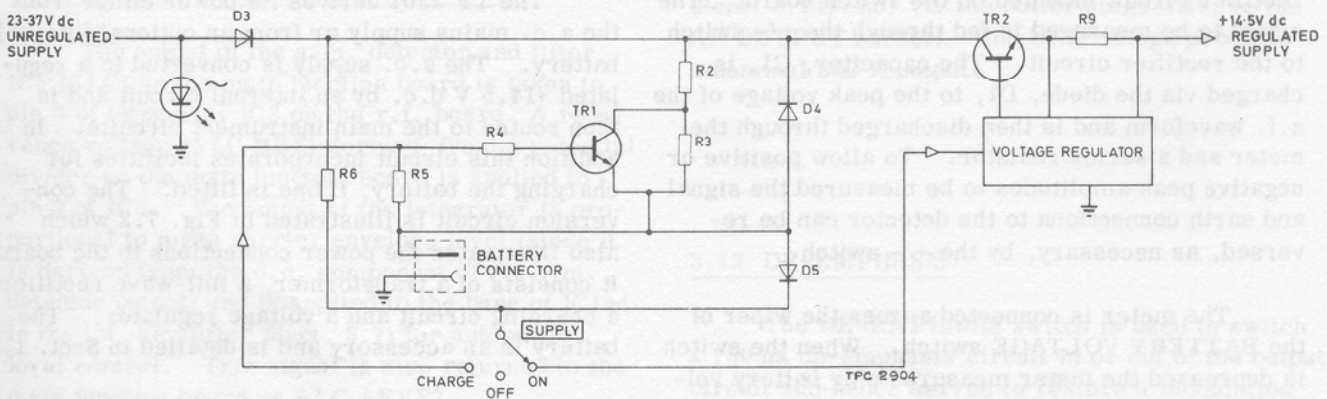


Fig. 3.5 DC power circuit schematic

In a.c. operation the unregulated supply is taken to the collector of power transistor TR2. The base of this transistor is controlled by voltage regulator IC1 which derives its input from the unregulated supply via the SUPPLY switch and a filter formed by R6 and C2. The emitter voltage of TR2 provides the regulated output and, after being sampled by R11 for the error amplifier of IC1, is output across R10 - R12 as the regulated +14.5 V supply.

If a battery is fitted but the instrument is being run from an a.c. supply it is trickle charged, at a rate of approximately 14 mA, via R2 and R3, with D4 and D5 isolating the battery from the rest of the circuit. When the SUPPLY is set to CHARGE TR1 is connected to the unregulated supply through R6. This bottoms the transistor, effectively shorting out R3, and the current flow to the battery is then chiefly determined by R2. As the

input to the regulator is disconnected TR2 is switched off and no current can be drawn from the regulated supply line.

On battery only operation current is fed to IC1 via D5 and to TR2 via D4. Diode D3 isolates the a.c. circuit. The battery voltage can be monitored on load by pressing the BATTERY VOLTAGE switch. The meter then indicates whether or not the battery voltage is high enough for use.

Both the a.c. circuit and the battery line are fused. The a.c. fuse is at its lowest possible value to ensure rapid rupture if the unregulated d.c. supply is short circuited. The fuse capacity should not be increased (except for 115 V operation) because the transformer winding resistance is high and this might prevent a higher capacity fuse from rupturing. The battery fuse is of a deliberately high capacity to minimize the voltage drop across it.



4.1 INTRODUCTION

This section contains information for keeping the equipment in good working order and for checking its overall performance.

CAUTION

This instrument uses integrated circuits and discrete semiconductor devices which, although having inherent long term reliability and mechanical ruggedness, are susceptible to damage by overloading, reversed polarity and excessive heat or radiation. Avoid hazards such as : reversal of batteries, prolonged soldering, strong r.f. fields or other forms of radiation, use of insulation testers, or accidentally applied short circuits. Even the leakage current from an unearthened soldering iron could cause trouble. Before shorting or breaking any circuit, refer to the circuit diagrams to establish the effect on bias arrangements of the transistors.

Main voltage setting, battery installation and battery charging are all dealt with in Chapter 2.

4.2 ACCESS AND LAYOUT

Chapter 2 - Section 2.2 battery installation - describes, in detail, how the r.f. board assembly is pivoted into a vertical position. This position gives access to most components on the main function board and allows signal monitoring on the switch and voltage regulator boards, as well as the front panel controls and indicators.

Access to the r.f. board is achieved by removing the four countersunk screws on the top of the r.f. board assembly and removing the assembly cover. Inspection of the assembly shows several screws holding the board in plus two screws in the sides near the pivot point. To obtain access to every point on the r.f. board without removing the board the following procedure should be followed :

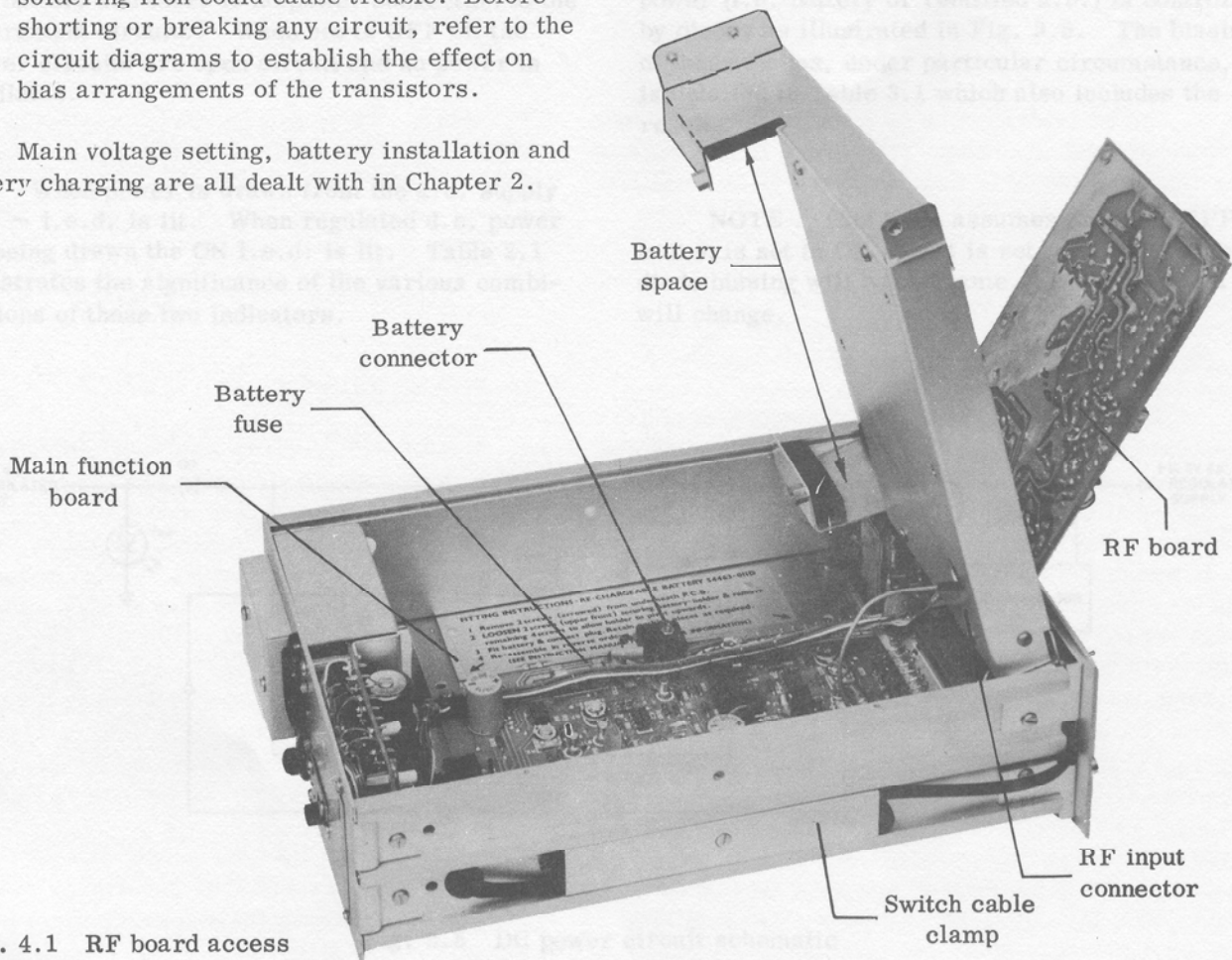


Fig. 4.1 RF board access

- (1) Loosen but do NOT remove the two screws in the assembly sides.
 - (2) Remove the screws holding the board in EXCEPT for the two screws along the pivoting edge of the board - these should only be touched if the complete board is to be removed.
 - (3) Disconnect the IF connector from underneath.
 - (4) Lift the board edge furthest from the pivot point and position the board in the most convenient position for access. This position can be fixed, if necessary, by tightening the side screws.
- The position achieved by this procedure is illustrated in Fig. 4.1 and in it every component, except the mains wiring and r.f. input attenuator can be monitored and the majority changed as necessary.
- Certain components on the main function board are partially concealed by the switchboard. Access to these and to the underside of the switchboard is achieved as follows :
- (1) Remove the remaining screws fixing the front panel to the side rails. This will also free the r.f. board assembly from the main unit.
 - (2) Slacken the four main function board clamping screws; two in the underside of each side rail.
 - (3) Remove the switch cable clamp (see Fig. 4.1) by removing the central fixing screw and slide the main function board and front panel assembly forward.
 - (4) Remove the screws underneath which hold the front panel to the main function board.
 - (5) Bend the front panel upwards on the connecting wires between the switchboard and main function board.

The instrument is designed to allow further dis-assembly, as illustrated in Fig. 4.2, by undoing the remaining fixing screws. In this condition the various boards can be connected up to allow operation independent of the instrument chassis.

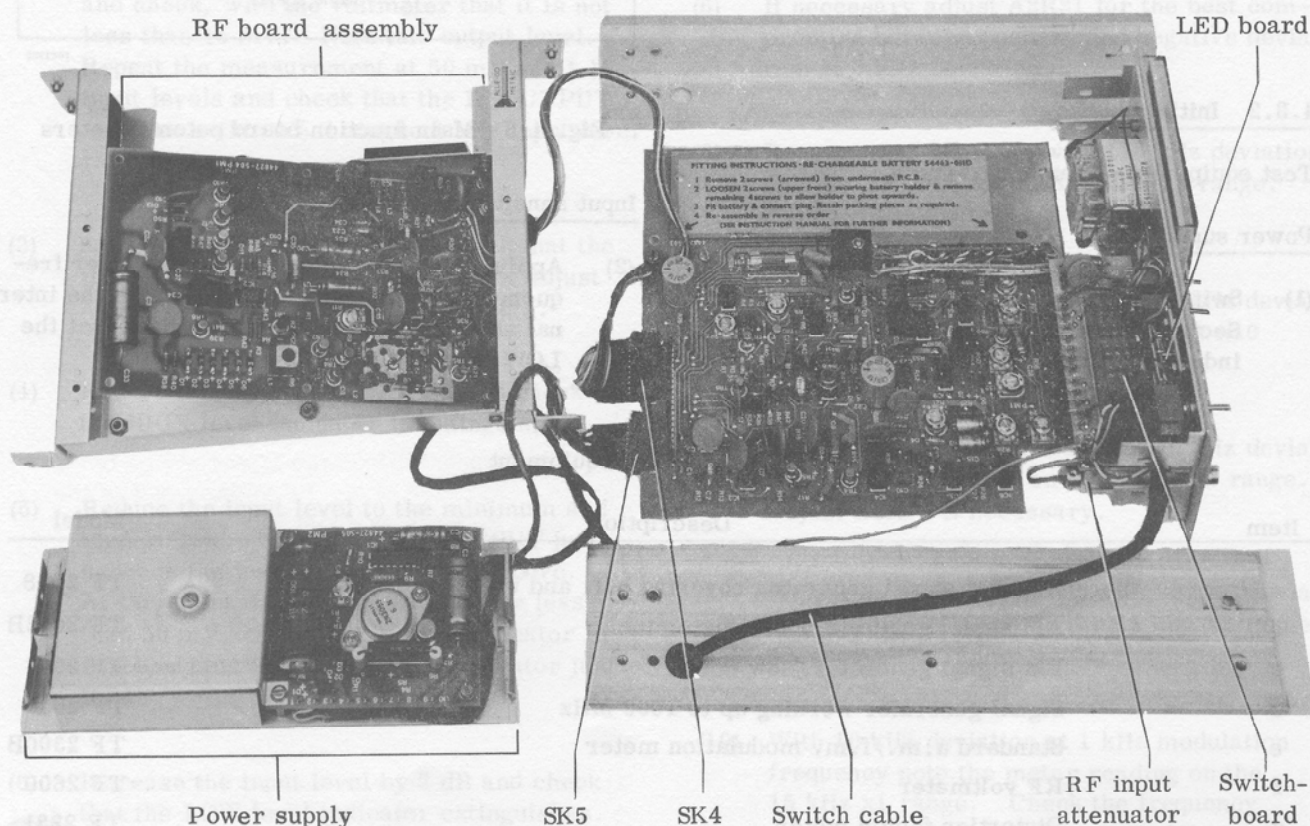


Fig. 4.2 TF 2304 - dismantled

4.3 PERFORMANCE CHECKS

The tests in this section may be used as a routine maintenance procedure to verify the main performance parameters of the instrument. The tests can be completed without removing the case except where some internal readjustment is indicated. Fig. 4.3 illustrates the positions of the various potentiometers on the main function board. Tests can be done at any convenient frequency within the carrier range of the modulation meter provided that this frequency is also within the range of the test equipment.

Many of the methods used in this section are simplified and of restricted range compared with those which would be needed to demonstrate complete compliance with the specification. They should be regarded only as providing a check procedure, for use during routine maintenance, to determine whether or not repair is needed.

4.3.1 Test equipment required

See Table 4.1

4.3.2 Initial checks

Test equipment : items a, d and h.

Power supply

- (1) Switch the instrument ON as described in Sect. 2.2.3 and check that the appropriate indicators light.

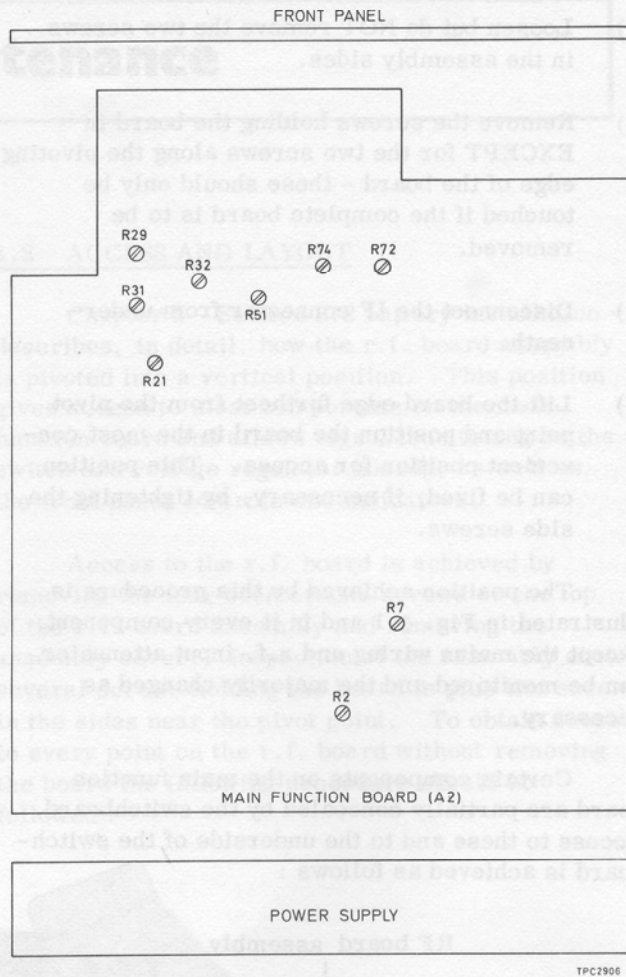


Fig. 4.3 Main function board potentiometers

Input sensitivity

- (2) Apply 50 mV at an intermediate carrier frequency between 25 and 600 MHz with the internal attenuator set to 0 dB and check that the LOW level indicator is extinguished.

Table 4.1 Test equipment

Item	Description	Model
a	AM/FM signal generator covering h.f. and v.h.f. mobile bands	TF 2008
b	AM signal generator, low distortion	TF 2002B
c	FM signal generator, low noise	TF 2011 and TF 2012
d	Signal generator working up to 1000 MHz	TF 2006
e	Standard a.m./f.m. modulation meter	TF 2300B
f	RF voltmeter	TF 2600
g	Distortion factor meter	TF 2331
h	General purpose oscilloscope	
j	1 kΩ resistor	

- (3) Repeat step (2) at a frequency between 600 and 1000 MHz with the input level set to 100 mV. Check that the LOW level indicator is extinguished.

IF frequency

- (4) Monitor the IF OUTPUT with the oscilloscope and, if necessary, adjust the output to approximately 400 kHz ($2.5 \pm 0.5 \mu\text{s}$ period) with A2R21.
- (5) Remove the test equipment.

4.3.3 Level check

Test equipment : items b, f and j.

- (1) Connect the signal generator with its output at under 1 V to the RF INPUT of the TF 2304. Set the TF 2304 internal attenuator to 0 dB.
- (2) Connect a 1 k Ω load across the IF OUTPUT and check, with the voltmeter that it is not less than 45 mV. Note this output level. Repeat the measurement at 50 mV and 1 V input levels and check that the IF OUTPUT remains within 1% throughout this input level range.
- (3) Set the input level to 1 V and check that the HIGH level indicator lights. If not adjust A2R7 so that the indicator just lights.
- (4) Reduce the input level by 2 dB and check that the HIGH level indicator is extinguished.
- (5) Reduce the input level to the minimum and then increase it until the IF OUTPUT just exceeds the level recorded in (2) above. At this point the input level must be less than 50 mV and the LOW level indicator lit. If not adjust A2R2 so that the indicator just lights.
- (6) Increase the input level by 2 dB and check that the LOW level indicator extinguishes.
- (7) Disconnect the test equipment.

4.3.4 Range calibration

Test equipment : items b and c.

FM calibration

- (1) Connect the signal generator to the RF INPUT of the TF 2300B. Set the generator for 3 kHz deviation, 1 kHz modulation frequency at a carrier frequency below 200 MHz.

- (2) Disconnect the signal from the TF 2300B and connect it to the TF 2304.

NOTE . Do not connect the TF 2300B and TF 2304 in parallel.

- (3) Set the TF 2304 to : 0 dB, FM, positive deviation, with a range setting of 1.5 kHz and the DEVIATION multiplier set to x2 i.e. (1.5 kHz x 2). Check that the TF 2304 reads 3 kHz deviation.
- (4) Set the TF 2304 to read negative deviation and check that it reads within 1% of the positive reading.
- (5) If necessary adjust A2R31 for the best compromise between positive and negative deviation at 3 kHz deviation.
- (6) Repeat steps (1) to (4) with 1.5 kHz deviation and the TF 2304 on the 1.5 kHz x1 range. Adjust A2R29 if necessary.
- (7) Repeat steps (1) to (4) but with 15 kHz deviation and the TF 2304 on the 1.5 kHz x10 range. Adjust A2R32 if necessary.
- (8) Repeat steps (1) to (4) but with 10 kHz deviation and the TF 2304 on the 5 kHz x2 range. Adjust A2R72 if necessary.
- (9) Repeat steps (1) to (4) but with 30 kHz deviation and the TF 2304 on the 15 kHz x2 range. Adjust A2R74 if necessary.
- (10) With 10 kHz deviation at 1 kHz modulation frequency note the meter reading on the 15 kHz x1 range. Check the frequency response at 50 Hz, 7 kHz and 9 kHz modulation frequencies - reading should be within 0.5 dB of the 1 kHz reading.

AM calibration

- (11) Set the signal generator to a carrier frequency below 400 MHz with 100 mV r.f. signal, 1 kHz modulation frequency, 80% depth, and connect it to the TF 2300B.
- (12) Set the signal generator so that its modulation depth is exactly 80% as measured on the TF 2300B.
- (13) Set the TF 2304 to measure modulation depth (Peak) on the 100% range and connect it to the signal generator in place of the TF 2300B.

NOTE . Do not connect the TF 2300B and TF 2304 in parallel.

- (14) The meter should read 80%. Switch to trough measurement and check that the two measurements are within 1%. If necessary adjust A2R51 for the best compromise at 80% modulation depth.
- (15) Check the frequency response at 50 Hz, 7 kHz and 9 kHz modulation frequency. Readings should be within 0.5 dB of the 1 kHz reading.
- (16) Disconnect measuring equipment.

4.3.5 Noise

Test equipment : items a, c and g.

NOTE . All noise measurements must be carried out with the instrument in its case.

AF output

- (1) Set the signal generator to 100 mV r.f. signal, 5 kHz deviation at 1 kHz modulating frequency. Connect it to the RF INPUT of the TF 2304, which should indicate f.s.d. on the 5 kHz x 1 f.m. deviation range.
- (2) Connect the distortion factor meter, set to VOLTMETER, 600 Ω to the AF OUTPUT of TF 2304. Check that the output is 0 dBm \pm 2 dB.
- (3) Disconnect the signal generator.

FM noise

- (4) Set the low noise signal generator (TF 2012) to 500 MHz carrier, 100 mV r.f. signal and connect it to the RF INPUT of the TF 2304. Check that the distortion factor meter reading is more than 34 dB down on the AF OUTPUT level recorded in (2) above. Disconnect the low noise signal generator. Repeat at 150 MHz using a TF 2011; the noise should be more than 42 down.

NOTE. At higher frequencies the f.m. noise will, in general, vary by 6 dB/octave. For example at 250 MHz and 1000 MHz the f.m. noise should be better than 40 dB and 28 dB respectively.

AM noise

- (5) Set the signal generator to 100 mV r.f. signal and connect it to the RF INPUT of the TF 2304. With the TF 2304 on the 100% AM range, check that the distortion factor reading is more than 50 dB down on the AF OUTPUT level recorded in (2) above.
- (6) Disconnect the test equipment.

4.3.6 Distortion

Test equipment : items a and g.

FM distortion

- (1) Set the signal generator for 150 kHz deviation at 1 kHz modulation and connect it with an input level of 100 mV to the RF INPUT of the TF 2304. Set the TF 2304 to measure deviation in the 15 x 10 kHz range.
- (2) Connect the distortion factor meter to the AF OUTPUT of the TF 2304, set it to the SET REF LEVEL and adjust to 0 dB.
- (3) Switch the meter to REJECT FUNDAMENTAL and check that distortion on the output is less than 1% (40 dB down).

AM distortion

- (4) Set the signal generator to 1 kHz modulation with 80% modulation depth. Set the TF 2304 to measure modulation depth in the 100% range. Set the distortion factor meter to SET REFERENCE LEVEL and adjust to 0 dB.

5.1 GENERAL

As the TF 2304 is, to a certain extent, a 'closed loop' device it is difficult to give detailed repair information without knowing the nature of the fault. Sect. 5.3 gives fault finding procedures which when used in conjunction with the annotated circuit diagrams should enable the general area of the fault to be determined. In addition the maintenance procedures detailed in Chapter 4 allow systematic calibration to be carried out and should show up any faulty areas.

If any difficulty is experienced, please write to or 'phone the Marconi Instruments Service Division (see address on back cover), or nearest representative, quoting the type and serial number on the data plate at the rear of the instrument. If the instrument is being returned for repair, please indicate clearly the nature of the fault or the work you require to be done.

5.2 RF INPUT ATTENUATOR

The r.f. input attenuator is outside the closed loop mentioned in Sect. 5.1. Its position in the instrument is shown on Fig. 4.2 and its circuit details are given on Fig. 7.3.

At the RF INPUT socket the input impedance is 50Ω , the input resistors R1 - R4 providing a terminating resistance. Inputs up to 1 W will not cause damage but a large overload may. Fig. 5.1 is a drawing illustrating the dismantling of the r.f. input attenuator using the following procedure :

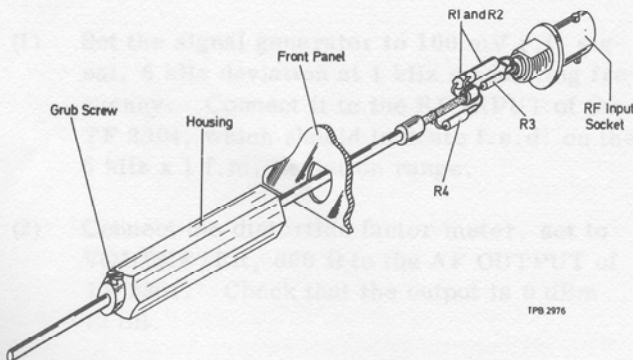


Fig. 5.1 Attenuator assembly

- (1) Loosen the grub screw at the end of the attenuator housing furthest from the front panel.
- (2) Unscrew the attenuator housing. Use a $\frac{1}{2}$ in AF spanner on the body of the housing at the front panel. The RF INPUT socket is retained by a 'D' shaped hole in the front panel.
- (3) Draw the RF INPUT socket forward, away from the front panel. This will bring the resistors and cable end into a position in front of the front panel where they can be investigated.

NOTE . If an attenuator component is faulty its replacement MUST occupy the same physical position within the attenuator assembly.

5.3 FAULT LOCATION PROCEDURES

5.3.1 Introduction

Before attempting to locate a fault its symptoms should be carefully assessed since correct interpretation of the evidence will usually enable the faulty circuit area to be determined. For instance, if the instrument locks on to a modulated carrier of the correct level but there is no indication of modulation on the meter, the fault will probably be in the l.f. section of the circuit. Further checks with a.m. and f.m. signals may further narrow the fault, also checks on the presence or absence of an a.f. output may indicate that the trouble is in the peak voltmeter circuit. Faults in the l.f. section will usually yield to conventional signal tracing procedures. Similarly power supply faults usually produce incorrect voltages in the power unit circuits and faults may be found by conventional test methods.

The two types of fault which can cause most difficulty are : failure to lock onto a carrier of the correct level in the correct frequency range, and faults which produce excessive f.m. noise.

Failure to lock onto a carrier will tend to produce confusing symptoms since the correct operation of the circuit depends on several feedback circuits which are inter-dependent and a fault in any one of these circuits may result in the others appearing to function incorrectly.

The remainder of this chapter describes procedures which enable each part of the circuit to be tested independently. It must be emphasized that these procedures are intended as a general guide rather than a complete and comprehensive procedure and it may be possible to take short cuts or to extend and improve them in particular circumstances.

As a preliminary, check that the signal being fed to the instrument is within the correct level and frequency range. A carrier frequency at the low end of the range and at maximum level is recommended for initial fault finding, as this will permit signal tracing with an oscilloscope. Also check that the controls are correctly set.

As a first step, with the carrier signal connected to the instrument, check the i.f. output on an oscilloscope. If a periodic burst of i.f. signal at a repetition rate of approximately once per second can be detected, it indicates that the instrument's local oscillator is functioning, the oscillator is being swept, and the mixer and i.f. circuits are functioning. This may enable some of the steps in the following sections to be omitted. In these steps it is assumed that if the indicated result is not obtained, there is a fault in that part of the circuit and that it will be located and cleared before proceeding to the next step.

The steps in Sects. 5.3.3 and 5.3.4 have been arranged into table form for convenience. The structure of these tables are as follows :

Column 1 - Step number.

Column 2 - Fig. ref. - Circuit diagram number with reference number, drawn on that diagram, of the point to be monitored.

Column 3 - Cct. ref. - Board involved (A1 = RF board; A2 = Main Function board) followed by specific component location.

Column 4 - Equipment involved as given by Table 5.1.

Column 5 - Action - This column may be blank if no adjustment, other than changing the monitoring connections, is required.

Column 6 - Expected result.

5.3.2 Test equipment required

See Table 5.1

5.3.3 Stage-by-stage checks

Initial conditions

For the steps given in Table 5.2 connect a low noise variable voltage regulated power supply between chassis and the positive end of any of the diodes D1 - D6 on the RF board ((1) on Fig. 7.3). The positive terminal of the supply should be connected to the diodes to take control of the oscillator and disable the sweep and a.f.c. inputs.

Table 5.1 Test equipment

Item	Description	Model
a	AM/FM signal generator covering h.f. and v.h.f. mobile bands	TF 2008
b	FM signal generator, low noise	TF 2012
c	General purpose oscilloscope fitted with a x10 probe	
d	Low noise variable voltage (+2.5 to +12.5 V) power supply	
e	Variable voltage, low impedance power supply	
f	RF millivoltmeter	
g	20 000 Ω/volt d.c. voltmeter	

Table 5.2 Stage-by-stage checks










Step	Monitor point			Action	Result
	Fig. ref.	Cct. ref.	Eqpt.		
1	7.3 (2)	A1R2/C5	c, d	Set PSU to +2.5	 → 250mV at 9MHz (approx.)
				Set PSU to +12.5	 → 500mV at 14.5MHz (approx.)
2	7.3 (3)	A1R7/C6	c	As step 1	 → 6 to 8V (approx.)
3	7.3 (4)	A1C8/R12	c	As step 1	 → 5.5 to 8V (approx.)
4	7.3 (5)	A1C9/D7	c	As step 1	As step 3
5(a)	7.3 (6)	A1R14/C11	c	As step 1	 → 750mV to 1.25V
(b)	7.3 (6)	A1R13/C12	c	As step 1	Similar to above but inverted and slightly lower amplitude.
6	7.3 (7)	A1R21/C14	a, c	Set signal generator to convenient frequency and level within TF 2304 input range. Tune TF 2304 oscillator by means of variable d.c. volts on diodes D1 - D6, to produce an i.f.	 Check for i.f. signal 100mV approx. for 1V p-p input
7	7.3 (8)	A1R31/C19	c		 → 18mV, i.f.
<p>If the i.f. level is not correct, check the voltage at the junction of A1R24/R28 (7.3 (9)). This should be approximately +4V; if it is not then there is probably a fault on the a.l.c. system. In this case the voltage at the junction of A1R26/R28 (7.3 (10)) must be corrected to allow testing to proceed. This can be done by clamping it either with another variable voltage low impedance source (e in Table 5.1) or by temporarily connecting resistors of appropriate value between this point and the appropriate power rail. The clamping voltage should be adjusted until the signal at A1R31/C19 (7.3 (8)) is about 18mV p-p.</p>					
8	7.3 (11)	A1 Tag 9	c		 → 300mV i.f.
	7.4 (11)	A2 Tag 9	c		

Table 5.2 continued

Step	Monitor point			Action	Result
	Fig. ref.	Cct. ref.	Eqpt.		
9	7.4 (12)	A2 D6+	a, c, g	Use probe to check i.f. and then connect the voltmeter and check the d.c. level with and without a signal input to the instrument.	 $\rightarrow 1.3V$ i.f. d.c. level no input $\approx 5.5V$ d.c. level with input $\approx 6.5V$
10	7.4 (13)	A2 SK4 pin 6	a, g	Check d.c. levels are similar to step 9.	
11	7.4 (14)	A2 SK4 pin 5	a, g	Check d.c. level with and without signal input.	d.c. level, no input $\approx 6V$ d.c. level, with input $\approx 6.4V$
12	7.4 (15)	A1 Tag 5/ R52	a, g	Check d.c. levels are the same as in step 11.	
13	7.4 (16)	A1 Tag 6/ R53	a, g	Check d.c. levels are the same as in step 10.	
14	7.3 (17) 7.4 (17)	A1R24/C38	a, g	Check d.c. level with and without a signal input	d.c. level, no input $\approx +2V$ d.c. level, with input $\approx +5.5V$
15	Step 14 completes the checks on the a.l.c. system and, provided the cause of incorrect voltages has been located and cleared, the voltage at the A1R24/R28 junction (7.3 (9)) should now be correct and any correction voltages applied at step 7 can be removed.				
	7.3 (9)	A1R28/24	a, g	Check d.c. level with and without a signal input	d.c. level, no input $\approx 3.8V$ d.c. level, with input $\approx 4.5V$
16	7.3 (8)	A1R31/C19	a, f	Set signal generator to deliver a 50mV carrier signal to the TF 2304 and note the millivoltmeter reading. Repeat at input signal level of 1.0V.	The change in the millivoltmeter reading should not exceed $\pm 1\%$.

5.3.4 Sweep and a.f.c. system

Initial conditions

For the steps listed in Table 5.3 below it is assumed that the oscillator is being controlled by a variable d.c. voltage source (d in Table 5.1) connected to D1 - D6 on the r.f. board (see Sect. 5.3.3). Also that where necessary the checks in Table 5.2 have been carried out so that with a carrier input to the instrument, an i.f. signal is obtained at the i.f. output, tag 9 on the r.f. board (7.4 (11)).

Table 5.3 Sweep and a.f.c. system checks



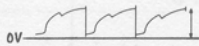
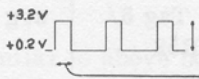
Step	Monitor point			Action	Result
	Fig. ref.	Cct. ref.	Eqpt.		
1	7.4 (18)	A2C1/R12	c		 220mV i.f.
2	7.4 (19)	A2C7/R16	c		 1.75V approx.
3	7.4 (20)	A2 TR5c	c		 4.5V approx.
4	7.4 (21)	A2C11/R19	c a, g	Check the change in d.c. level at this point when the carrier input signal is removed.	 700 ns Level change \approx 0.6V d.c. Exact value depends on i.f. which is under manual control.
5	7.4 (22)	A2C11/R23	a, g	Check the change in d.c. level as in step 4.	Level change as step 4 but initial d.c. level \approx 7.0V.
6	7.4 (23)	A2R25/R26	a, g	As step 5. Check that the d.c. level also appears at SK4 pin 4.	Level change as step 5.
7	7.4 (24)	A2 SK4 pin 3	g		d.c. level \approx +7.5V. (Exact value depends on setting of A2R21, which was set up, when the instrument was functioning correctly, to produce an i.f. nominally of 400kHz.)

Table 5.3 continued

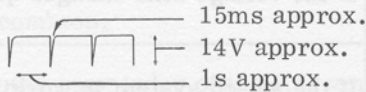
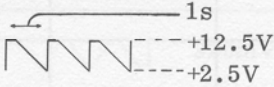
Step	Monitor point			Action	Result
	Fig. ref.	Cct. ref.	Eqpt.		
8	7.4 (25) 7.3 (25)	A2 SK4 pin 8	a, g	Measure d.c. level with and without a carrier signal input.	d.c. level, no carrier $\approx +13.2V$. d.c. level, with carrier $\approx +0.2V$.
9	7.3 (26)	A1R43	g		On tag 3 side of R43 d.c. level should be the same as in step 7 and should be similar on the IC2 side.
10	7.3 (27)	A1 tag 4/ R44	g		As step 6.
11	7.3 (28)	A1R45/D10	a, g	Set voltmeter to 25V range and check d.c. levels with and without a carrier signal input.	d.c. level, no carrier $\approx +12.5V$. d.c. level, with carrier $\approx +1.5V$.
12	7.3 (29)	A1R46/D11	a, g	As step 11.	d.c. level, no carrier $\approx +7.5V$. d.c. level, with carrier $\approx +1.5V$.
13	7.3 (30)	A1 TR7c	c		 <p>15ms approx. 14V approx. 1s approx.</p> <p>If the waveform specified is not present it will be because either the sweep system is not functioning or the monostable TR7 - TR10 is faulty. Steps 14 to 17 test for these conditions and should be ignored if a correct response is obtained at the collector of TR7. Fig. 5.2 illustrates the correct waveforms for these sections during sweep conditions.</p>
14	7.3 (31)	A1 TR10b	c	Check that a sufficient voltage is present to switch TR10 on. If not connect it to a source of +1 or 2V via a 22k resistor (g and h in Table 5.1).	

Table 5.3 continued

Step	Monitor point			Action	Result
	Fig. ref.	Cct. ref.	Eqpt.		
15	7.3 (30)	A1 TR7c	g	Check voltage then earth base of TR10 and repeat. Remove earth link.	TR7c with TR10b unearthed $\approx +12V$. TR7c with TR10b earthed $\approx +0.2V$.
16	7.3 (32)	A1 TR6c	a, c	Check waveform with and without a carrier signal input.	<p>With no carrier input :</p>  <p>With a carrier input a steady d.c. voltage between +2.5 and +12.5V should register. If the d.c. clamping voltage on D1 - D6 is slightly varied, this d.c. voltage should slowly change.</p>
<p>If the sweep voltage is present then the sweep system should be working correctly and step 13 can be retried.</p>					
17	<p>If the sweep voltage is not present at TR6 collector and all the input voltages are correct on R43, R44, R45 and R46, disconnect SK4 and measure the value of these resistors. If the values are correct, connect a low impedance variable voltage source (e in Table 5.1) to the junction of R44/R45/R46. (Fig. 7.3 (33)). Vary this voltage either side of the reference voltage on R43 (AFC REF). Monitor the voltage at the collector of TR6. This should swing quickly between +2.5V and +13.5V approximately. Repeat this procedure with 2.2MΩ in the variable voltage line. If the voltage still changes quickly then C34 may be open circuit.</p>				
18	<p>If the sweep system is working correctly remove the clamping voltage on D1 - D6 and check that the instrument now functions correctly and will lock on to an input signal.</p> <p>If the locking operation is correct, but the HIGH and LOW indicator lamps do not operate correctly, check that the adjustment of A2R2 and A2R7 (see Sect. 4.3.3) is correct.</p> <p>NOTE : The lamp trigger circuits are conventional d.c. amplifiers, the LOW lamp being triggered from the a.l.c. control line voltage and the HIGH lamp from a peak rectifier circuit connected to the carrier signal input. Both of these lamps are in series with the ON lamp so that if this is open circuit they will all fail. Also the HIGH lamp circuit overrides the LOW lamp circuit to avoid a possible condition in which they would both be on.</p>				

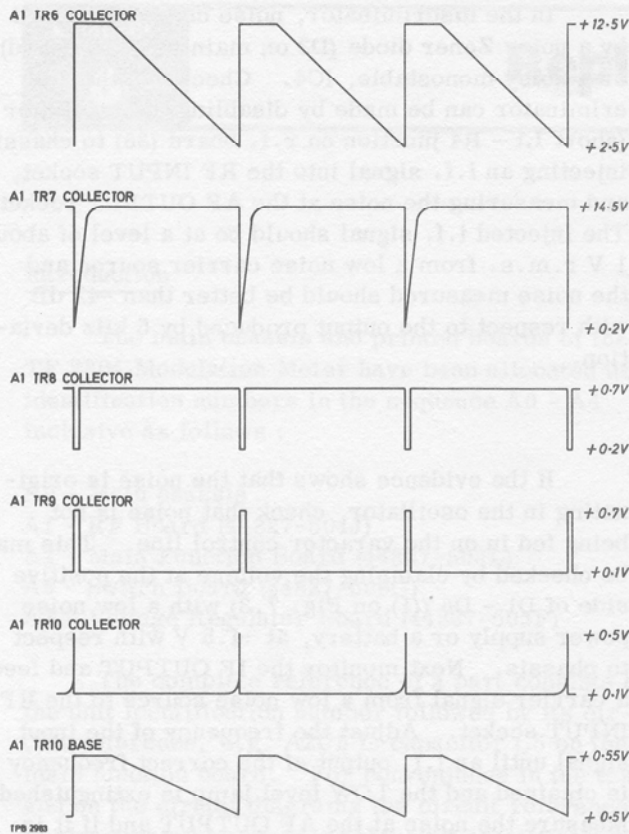


Fig. 5.2 Sweep and monostable waveforms during sweeping conditions

5.3.5 Noise fault location

General

When a noise fault occurs it is first necessary to establish in which area of the circuit the noise is being generated. The most probable being the power supply, the l.f. amplifiers, the oscillator, or the discriminator. Always examine the noise at the AF OUTPUT socket with an oscilloscope as this may indicate whether it is a power supply fault, outside interference, or a component noise. Thus if the noise is predominantly at the power supply frequency it may be due to pick-up from the magnetic field of a poor transformer in an adjacent piece of equipment. If the noise is at a frequency double that of the power frequency then the voltage regulator in the power supply may be faulty.

Almost any component in the circuit can generate noise, if it is not functioning correctly.

However, once the faulty area has been located it will usually contain certain components which are more prone to noise faults than others (e.g. active components tend to be more noisy than passive components). These components should be changed first. If this fails to clear the trouble then a painstaking component-by-component substitution procedure may have to be undertaken.

Power supply

The most common cause of power supply noise is noise generated in the Zener reference diode in the regulator IC.

If a known good power supply is available it can be substituted for the suspect supply unit at SK5. Alternatively, a battery may be substituted but in this case to isolate the regulator SK5 must be disconnected and the battery connected directly to the +14.5 V line rather than to the internal battery connector.

LF amplifier

When a noise fault occurs in the l.f. amplifier it is necessary to carry out a systematic investigation to isolate the circuit section in which the trouble originates. First establish whether the noise is present on both a.m. and f.m. functions. If the fault is not present on one or the other it will also eliminate that part of the l.f. amplifier circuit which is common.

Next check the remainder of the l.f. amplifier which is used only on the faulty function. Test signals can be injected as described in 1 and 2 below but a blocking capacitor must always be used.

1. For the f.m. function a test signal can be injected at the junction of R23 and R24 (34) on the main function board. The signal should be about 1 kHz at a level of 7 mV r.m.s., and the TF 2304 should be set to FM 5 kHz range. If it is decided to inject a signal at C11, then the capacitor should be disconnected from IC4 owing to the latter's low output impedance.
2. For the a.m. function a test signal at a level of about 100 mV r.m.s. can be injected at the junction of R48 and R49 (35) on the main function board. The TF 2304 should be set to AM 30% range.

AM noise

AM noise is not a very common problem and the majority of circuits which may produce a.m. noise are common to the f.m. function. In general f.m. noise is more likely to arise than a.m. noise, however the procedure for tracing f.m. noise which follows can, to a large extent, be applied to tracing a.m. noise.

FM noise

FM noise is most often produced in the local oscillator or discriminator circuits.

Local oscillator noise is produced when some noise source modulates the oscillator. This noise source may be the power supply which should be eliminated as previously described. If noise is being generated in the oscillator the magnitude of the noise will tend to increase as the signal carrier frequency is increased. The increase will be about 6 dB per octave from 100 MHz upwards but as the fundamental frequency of the oscillator may change this increase rate may not be followed exactly. As discriminator noise tends to be constant a few checks at carrier frequencies, each of which is double the previous frequency should enable oscillator noise to be distinguished from discriminator noise, but be sure that noise in the test source remains constant.

In the discriminator, noise can be produced by a noisy Zener diode (D3 on main function board) or a noisy monostable, IC4. Checks on the discriminator can be made by disabling the oscillator (short L1 - R4 junction on r.f. board (36) to chassis), injecting an i.f. signal into the RF INPUT socket, and measuring the noise at the AF OUTPUT socket. The injected i.f. signal should be at a level of about 1 V r.m.s. from a low noise carrier source and the noise measured should be better than -42 dB with respect to the output produced by 5 kHz deviation.

If the evidence shows that the noise is originating in the oscillator, check that noise is not being fed in on the varactor control line. This may be checked by clamping the voltage at the positive side of D1 - D6 ((1) on Fig. 7.3) with a low noise power supply or a battery, at +4.5 V with respect to chassis. Next monitor the IF OUTPUT and feed a carrier signal from a low noise source to the RF INPUT socket. Adjust the frequency of the input signal until an i.f. output of the correct frequency is obtained and the LOW level lamp is extinguished. Measure the noise at the AF OUTPUT and if it is now at its normal level then the noise is being fed in on the control line. In this event check components in the a.f.c. loop especially C3, C32 and R38 on the r.f. board. Also check R44, IC2 and TR6.

Introduction

The main chassis and printed boards of the TF 2304 Modulation Meter have been allocated unit identification numbers in the sequence A0 - A4 inclusive as follows :

- A0 - Main chassis
- A1 - RF Board (44827-504J)
- A2 - Main Function Board (44827-503L)
- A3 - Switch Board (44827-506G)
- A4 - Voltage Regulator Board (44827-505F)

The complete reference of a part consists of the unit identification number followed by its circuit reference, e.g. A2C5 is capacitor C5 on the main function board. For convenience in the text and on the circuit diagrams the circuit reference is abbreviated by dropping this unit identification prefix, however when ordering spare parts or in any other correspondence the prefix must be quoted

This chapter lists the components of each unit in alpha-numerical order of the complete circuit reference. The following abbreviations are used :-

- C : capacitor
- Carb : carbon
- Cer : ceramic
- D : semiconductor diode
- Elec : electrolytic
- FS : fuse
- IC : integrated circuit
- L : inductor
- LP : lamp
- M : meter
- Met : metal
- Ox : oxide
- PL : plug
- Plas : plastic
- R : resistor
- S : switch
- SK : socket
- T : transformer
- Var : variable
- TR : transistor
- W : watts rating at 70°C
- WW : wirewound

Ordering

When ordering replacements, address the order to our Service Division (address on rear cover) or nearest agent and specify the following for each component required.

- (1) Type* and serial number of instrument
- (2) Complete circuit reference
- (3) Description
- (4) MI code

* as given on the serial number label at the rear of the instrument; if this is superseded by a model number label, quote the model number instead of the type number.

If a part is not listed, state its function, location and description when ordering.

One or more of the parts fitted to the instrument may differ from those listed in this chapter for any of the following reasons.

- (a) Components indicated by † have their value selected during test to achieve particular performance limits.
- (b) Owing to supply difficulties components may be substituted by others of different type or value provided that the overall performance of the instrument is maintained.
- (c) As part of a policy of continuous development, components may be changed in value or type to obtain detail improvements in performance.

Whenever there is such a difference between the component fitted and the one listed, always use a replacement the same type and value as found in the instrument.

Circuit reference	Description	M.I. code
<u>A0 - Main assembly including Power Unit</u>		
When ordering, prefix circuit reference with A0.		
C1	Cer 0.001 μ F 20% 4000V	26383-437G
C2	Cer 0.001 μ F 20% 4000V	26383-437G
FS1	50mA fuse link for 230V	23411-051S
	100mA fuse link for 115V	23411-052W
L1	100 μ H	23642-561W
L2	100 μ H	23642-561W
LP1	Solid state lamp (red)	28624-105D
LP2	Solid state lamp (red)	28624-105D
LP3	Solid state lamp (yellow)	28624-106T
LP4	Solid state lamp (red)	28624-105D
M1	Meter	44559-012H
PL1	Plug fixed CEE22	23423-159P
PL3	Miniature r.f. plug, right angle	23444-338F
R1	Met ox 120 Ω 2% $\frac{1}{2}$ W	24573-051R
R2	Met ox 120 Ω 2% $\frac{1}{2}$ W	24573-051R
R3	Met film 247 Ω 1% $\frac{1}{4}$ W	24762-631R
R4	Met film 61.1 Ω 1% $\frac{1}{4}$ W	24762-571U
R5	Met film 22 Ω 2% $\frac{1}{4}$ W	24773-233M
SA	SUPPLY	23462-264G
SB	AC input selector	23467-155G
SK	DE-EMPHASIS	23462-252Z
SL	DEVIATION multiplier	23462-257N
SK4	12-way edge connector	23435-092D
SK5	9-way edge connector	23435-093T
SK6	RF INPUT socket, BNC	23443-443K

Circuit reference	Description	M.I. code
SK7	IF OUTPUT socket, BNC	23443-443K
SK8	AF OUTPUT socket, BNC	23443-443K
T1	Transformer assembly	43490-026D

A1 - RF board

When ordering, prefix circuit reference with A1.

Complete board 44827-943U

C1	Elec 100 μ F +100-20% 25V	26415-813U
C2	Cer 0.1 μ F +50-25% 30V	26383-031S
C3	Tant 4.7 μ F 20% 85V	26486-219P
C4	Cer 0.001 μ F +80-20% 500V	26383-242P
C5	Cer 0.001 μ F +80-20% 500V	26383-242P
C6	Cer 0.001 μ F +80-20% 500V	26383-242P
C7	Cer 0.001 μ F +80-20% 500V	26383-242P
C8	Cer 0.001 μ F +80-20% 500V	26383-242P
C9	Cer 10pF 5% 50V	26343-465H
C10	Cer 0.1 μ F +50-25% 30V	26383-031S
C11	Cer 12pF 5% 50V	26343-466E
C12	Cer 12pF 5% 50V	26343-466E
C13	Cer 0.001 μ F +80-20% 500V	26383-242P
C14	Cer 0.001 μ F +80-20% 500V	26383-242P
C15	Cer 0.1 μ F +50-25% 30V	26383-031S
C16	Cer 0.1 μ F +50-25% 30V	26383-031S
C17	Cer 0.1 μ F +50-25% 30V	26383-031S
C18	Cer 0.1 μ F +50-25% 30V	26383-031S
C19	Cer 0.1 μ F +50-25% 30V	26383-031S
C20	Elec 100 μ F +100-20% 25V	26415-813U
C21	Cer 0.1 μ F +50-25% 30V	26383-031S
C22	Cer 15pF 5% 50V	26343-467U
C23	Plas 180pF 2% 180V	26516-303Z
C24	Plas 390pF 2% 125V	26516-387T
C25	Plas 180pF 2% 350V	26516-306U
C26	Cer 0.001 μ F +80-20% 500V	26383-242P
C27	Cer 0.001 μ F +80-20% 500V	26383-242P
C28	Cer 0.001 μ F +80-20% 500V	26383-242P

For symbols and abbreviations see introduction to this chapter

Circuit reference	Description	M.I. code	Circuit reference	Description	M.I. code
C29	Cer 0.001 μ F +80-20% 500V	26383-242P	IC3	μ A741C	28461-304T
C30	Cer 0.001 μ F +80-20% 500V	26383-242P			
C31	Cer 0.0012 μ F 10% 63V	26383-592K	L1	Inductor	44290-438K
C32	Cer 0.1 μ F +50-25% 30V	26383-031S	L2	Inductor	34900-242V
C33	Elec 1000 μ F +100-20% 25V	26415-825W	L3	330 μ H	23642-564P
C34	Plas 1.0 μ F 10% 100V	26582-217U	L4	330 μ H	23642-564P
C35	Elec 22 μ F +100-20% 25V	26415-805K			
C36	Cer 0.1 μ F +50-25% 30V	26383-031S	R1	Var cermet 47k Ω 10% $\frac{1}{2}$ W	25711-506S
C37	Plas 0.22 μ F 10% 100V	26582-226G	R2	Met film 330 Ω 2% $\frac{1}{4}$ W	24773-261D
C38	Plas 1.0 μ F 10% 100V	26582-217U	R3	Met film 1.5k Ω 2% $\frac{1}{4}$ W	24773-277U
C39	Plas 1.0 μ F 10% 100V	26582-217U	R4	Met film 3.3k Ω 2% $\frac{1}{2}$ W	24773-285F
C40	Cer 0.1 μ F +50-25% 30V	26383-031S	R5	Met film 4.7k Ω 2% $\frac{1}{4}$ W	24773-289W
C41	Plas 0.68 μ F 10% 63V	26582-412M	R6	Met film 1.0k Ω 2% $\frac{1}{4}$ W	24773-273A
			R7	Met film 1.0k Ω 2% $\frac{1}{4}$ W	24773-273A
D1	BB105	28381-096S	R8	Met film 330 Ω 2% $\frac{1}{4}$ W	24773-261D
D2	BB105	28381-096S	R9	Met film 4.7k Ω 2% $\frac{1}{4}$ W	24773-289W
D3	BB105	28381-096S	R10	Met film 4.7k Ω 2% $\frac{1}{4}$ W	24773-289W
D4	BB105	28381-096S	R11	Var cermet 100k Ω 10% $\frac{1}{2}$ W	25711-550M
D5	BB105	28381-096S	R12	Met film 470 Ω 2% $\frac{1}{4}$ W	24773-265M
D6	BB105	28381-096S	R13	Met film 150 Ω 2% $\frac{1}{4}$ W	24773-253F
D7	HP5082-0180	28383-998P	R14	Met film 150 Ω 2% $\frac{1}{4}$ W	24773-253F
D8	MBD102	28349-004A	R15	Met film 47k Ω 2% $\frac{1}{4}$ W	24773-313H
D9	MBD102	28349-004A	R16	Met film 47k Ω 2% $\frac{1}{4}$ W	24773-313H
D10	1N4148	28336-676J	R17	Met film 47k Ω 2% $\frac{1}{4}$ W	24773-313H
D11	1N4148	28336-676J	R18	Met film 47k Ω 2% $\frac{1}{4}$ W	24773-313H
D12	1N4148	28336-676J	R19	Met film 47k Ω 2% $\frac{1}{4}$ W	24773-313H
D13	Z5B4.7	28371-373V	R20	Met film 5.1k Ω 2% $\frac{1}{4}$ W	24773-290V
D14	MBD102	28349-004A	R21	Met film 3.9k Ω 2% $\frac{1}{4}$ W	24773-287V
D15	BZY88C13	28372-213U	R22	Met film 5.1k Ω 2% $\frac{1}{4}$ W	24773-290V
D16	1N4148	28336-676J	R23	Met film 51 Ω 2% $\frac{1}{4}$ W	24773-242Z
D17	1N4148	28336-676J	R24	Met film 56k Ω 2% $\frac{1}{4}$ W	24773-315U
D18	1N4148	28336-676J	R25	Met film 11k Ω 2% $\frac{1}{4}$ W	24773-298C
D19	1N4148	28336-676J	R26	Met film 3.3k Ω 2% $\frac{1}{4}$ W	24773-285F
IC1	CA3046	28461-901A	R27	Met film 1.8k Ω 2% $\frac{1}{4}$ W	24773-279N
IC2	μ A741C	28461-304T	R28	Met film 11k Ω 2% $\frac{1}{4}$ W	24773-298C
			R29	Met film 43 Ω 2% $\frac{1}{4}$ W	24773-240K

For symbols and abbreviations see introduction to this chapter

Circuit reference	Description	M.I. code	Circuit reference	Description	M.I. code
R30	Met film 430Ω 2% ¼W	24773-264X	R67	Var cermet 470kΩ 10% ½W	25711-552R
R31	Met film 2.0kΩ 2% ¼W	24773-280U	SK2	Miniature r.f. socket	23444-334Y
R32	Met film 220Ω 2% ¼W	24773-257W	T1	Transformer	43590-023M
R33	Met film 12kΩ 2% ¼W	24773-299R	TR1	BF244B	28459-036J
R34	Met film 39kΩ 2% ¼W	24773-311A	TR2	BSX20	28452-197H
R35	Met film 2.0kΩ 2% ¼W	24773-280U	TR3	BSX20	28452-197H
R36	Met film 10kΩ 2% ¼W	24773-297M	TR4	BCY71	28435-235L
R37	Met film 10kΩ 2% ¼W	24773-297M	TR5	BF244B	28459-036J
R38	Met film 680Ω 2% ¼W	24773-269K	TR6	BCY71	28435-235L
R39	Met film 1.0kΩ 2% ¼W	24773-273A	TR7	BC108	28452-787N
R40	Met film 3.3kΩ 2% ¼W	24773-285F	TR8	BC108	28452-787N
R41	Met film 6.8kΩ 2% ¼W	24773-293D	TR9	BC108	28452-787N
R42	Met film 51Ω 2% ¼W	24773-242Z	TR10	BC108	28452-787N
R43	Met film 10kΩ 2% ¼W	24773-297M	TR11	BCY71	28435-235L
R44	Carb 2.2MΩ 10% 1/8W	24321-877J	TR12	BC109	28452-777K
R45	Carb 390kΩ 5% 1/8W	24311-935B	TR13	BC108	28452-787N
R46	Met film 6.8kΩ 2% ¼W	24773-293D	TR14	BC109	28452-777K
R47	Met film 100kΩ 2% ¼W	24773-321L	TR15	BC108	28452-787N
R48	Met film 100kΩ 2% ¼W	24773-321L	TR16	BC109	28452-777K
R49	Met film 100kΩ 2% ¼W	24773-321L			
R50	Met film 100kΩ 2% ¼W	24773-321L			
R51	Met film 100kΩ 2% ¼W	24773-321L			
R52	Met film 200kΩ 2% ¼W	24773-328D			
R53	Met film 200kΩ 2% ¼W	24773-328D			
R54	Met film 2.2kΩ 2% ¼W	24773-281Y			
R55	Met film 150kΩ 2% ¼W	24773-325V			
R56	Met film 100kΩ 2% ¼W	24773-321L			
R57	Met film 3.9kΩ 2% ¼W	24773-287V			
R58	Carb 1MΩ 5% 1/8W	24311-945Y			
R59	Met film 100kΩ 2% ¼W	24773-321L			
R60	Met film 100kΩ 2% ¼W	24773-321L			
R61	Met film 100kΩ 2% ¼W	24773-321L			
R62	Met film 100kΩ 2% ¼W	24773-321L			
R63	Met film 12kΩ 2% ¼W	24773-299R			
R64	Met film 100kΩ 2% ¼W	24773-321L			
R65	Met film 12kΩ 2% ¼W	24773-299R			
R66	Met film 150kΩ 2% ¼W	24773-325V			

A2 - Main function board

When ordering, prefix circuit reference with A2.

	Complete board	44827-503L
C1	Cer 0.001μF +80-20% 500V	26383-242P
C2	Plas 470pF 2% 350V	26516-408U
C3	Cer 0.1μF +50-25% 30V	26383-031S
C4	Cer 0.1μF +50-25% 30V	26383-031S
C5	Cer 0.1μF +50-25% 30V	26383-031S
C6	Cer 0.1μF +50-25% 30V	26383-031S
C7	Cer 0.001μF +80-20% 500V	26383-242P
C8	Elec 22μF +100-20% 25V	26415-805K
C9	Cer 0.1μF +50-25% 30V	26383-031S
C10	Cer 22pF ±0.25pF 750V	26324-715T
C11	Cer 0.1μF +50-25% 30V	26383-031S

For symbols and abbreviations see introduction to this chapter

Circuit reference	Description	M.I. code	Circuit reference	Description	M.I. code
C12	Plas 560pF 2% 350V	26516-428M	D3	Z5B5.6	28371-434Y
C13	Plas 270pF 2% 350V	26516-351V	D4	1N4148	28336-676J
C14	Cer 0.1 μ F +50-25% 30V	26383-031S	D5	1N4148	28336-676J
C15	Elec 22 μ F +100-20% 25V	26415-805K	D6	1N4148	28336-676J
C16	Elec 47 μ F +100-20% 10V	26415-809E	D7	1N4148	28336-676J
C17	Cer 0.1 μ F +50-25% 30V	26383-031S	D8	Z5B6.8	28371-553P
C18	Cer 0.001 μ F +80-20% 500V	26383-242P			
C19	Cer 0.1 μ F +50-25% 30V	26383-031S	FS1	1A fuse link, time lag	23411-058C
C20	Plas 0.0039 μ F 2% 125V	26516-628D			
C21	Elec 22 μ F +100-20% 25V	26415-805K	IC1	μ A741C	28461-304T
C22	Cer 68pF 2% 50V	26343-475F	IC2	μ A741C	28461-304T
C23	Cer 0.1 μ F +50-25% 30V	26383-031S	IC3	ULN2111A	28461-903H
C24	Elec 470 μ F +100-20% 16V	26423-262J	IC4	SN74121N	28468-402S
C25	Cer 330pF 2% 50V	26343-483D	IC5	μ A741C	28461-304T
C26	Plas 560pF 2% 350V	26516-428M	IC6	μ A741C	28461-304T
C27	Plas 270pF 2% 350V	26516-351V	IC7	μ A702C	28461-308C
C28	Elec 47 μ F +100-20% 10V	26415-809E	IC8	μ A741C	28461-304T
C29	Plas 0.68 μ F 10% 63V	26582-412M	IC9	μ A741C	28461-304T
C30	Cer 0.001 μ F +80-20% 500V	26383-242P	IC10	μ A741C	28461-304T
C31	Elec 100 μ F +100-20% 25V	26415-813U	IC11	μ A741C	28461-304T
C32	Cer 100pF 2% 50V	26343-477V			
C33	Cer 100pF 2% 50V	26343-477V	PL1	Battery connector	23423-105A
C34	Elec 22 μ F +100-20% 25V	26415-805K			
C35	Plas 0.047 μ F 10% 250V	26582-206C	R1	Met film 22k Ω 2% $\frac{1}{4}$ W	24773-305R
C36	Elec 22 μ F +100-20% 25V	26415-805K	R2	Var cermet 4.7k Ω 10% $\frac{1}{2}$ W	25711-542W
C37	Elec 22 μ F +100-20% 25V	26415-805K	R3	Met film 4.7k Ω 2% $\frac{1}{4}$ W	24773-289W
C38	Plas 1 μ F 10% 100V	26582-217U	R4	Met film 150k Ω 2% $\frac{1}{4}$ W	24773-325V
C39	Plas 0.001 μ F 2% 350V	26516-484G	R5	Met film 100 Ω 2% $\frac{1}{4}$ W	24773-249J
C40	Elec 47 μ F +100-20% 10V	26415-809E	R6	Met film 15k Ω 2% $\frac{1}{4}$ W	24773-301P
C41	Plas 680pF 2% 350V	26516-446L	R7	Var cermet 470 Ω 10% $\frac{1}{2}$ W	25711-541S
C42	Elec 47 μ F +100-20% 10V	26415-809E	R8	Met film 15k Ω 2% $\frac{1}{4}$ W	24773-301P
C43	Elec 470 μ F +100-20% 16V	26423-262J	R9	Met film 150k Ω 2% $\frac{1}{4}$ W	24773-325V
C44	Cer 180pF 2% 50V	26343-480V	R10	Met film 150k Ω 2% $\frac{1}{4}$ W	24773-325V
			R11	Met film 100 Ω 2% $\frac{1}{4}$ W	24773-249J
			R12	Met film 1.3k Ω 2% $\frac{1}{4}$ W	24773-276E
D1	Z5B4.7	28371-373V	R13	Met film 330 Ω 2% $\frac{1}{4}$ W	24773-261D
D2	1N4148	28336-676J	R14	Met film 100 Ω 2% $\frac{1}{4}$ W	24773-249S

For symbols and abbreviations see introduction to this chapter

Circuit reference	Description	M.I. code	Circuit reference	Description	M.I. code
R15	Met film 8.2k Ω 2% $\frac{1}{4}$ W	24773-295P	R52	Met film 1.0k Ω 2% $\frac{1}{4}$ W	24773-273A
R16	Met film 1.0k Ω 2% $\frac{1}{4}$ W	24773-273A	R53	Met film 100k Ω 2% $\frac{1}{4}$ W	24773-321L
R17	Met film 18k Ω 2% $\frac{1}{4}$ W	24773-303M	R54	Met film 9.1k Ω 2% $\frac{1}{4}$ W	24773-296X
R18	Met film 39k Ω 2% $\frac{1}{4}$ W	24773-311A	R55	Carb 680k Ω 5% 1/8W	24311-941Z
R19	Met film 510 Ω 2% $\frac{1}{4}$ W	24773-266C	R56	Met film 33k Ω 2% $\frac{1}{4}$ W	24773-309Z
R20	Met film 5.1k Ω 2% $\frac{1}{4}$ W	24773-290V	R57	Met film 560 Ω 2% $\frac{1}{4}$ W	24773-267R
R21	Var cermet 1.0k Ω 10% $\frac{1}{2}$ W	25711-544T	R58	Met film 100k Ω 2% $\frac{1}{4}$ W	24773-321L
R22	Met film 5.1k Ω 2% $\frac{1}{4}$ W	24773-290V	R59	Met film 1.0k Ω 2% $\frac{1}{4}$ W	24773-273A
R23	Met film 22k Ω 2% $\frac{1}{4}$ W	24773-305R	R60	Met film 27k Ω 2% $\frac{1}{4}$ W	24773-307K
R24	Met film 22k Ω 2% $\frac{1}{4}$ W	24773-305R	R61	Met film 39k Ω 2% $\frac{1}{4}$ W	24773-311A
R25	Met film 8.2k Ω 2% $\frac{1}{4}$ W	24773-295P	R62	Met film 100k Ω 2% $\frac{1}{4}$ W	24773-321L
R26	Met film 10k Ω 2% $\frac{1}{4}$ W	24773-297M	R63	Met film 2.0k Ω 2% $\frac{1}{4}$ W	24773-280U
R27	Met film 10k Ω 2% $\frac{1}{4}$ W	24773-297M	R64	Met film 6.8k Ω 2% $\frac{1}{4}$ W	24773-293D
R28	Met film 100k Ω 2% $\frac{1}{4}$ W	24773-321L	R65	Met film 200k Ω 2% $\frac{1}{4}$ W	24773-328D
R29	Var cermet 10k Ω 10% $\frac{1}{2}$ W	25711-543D	R66	Met film 240k Ω 2% $\frac{1}{4}$ W	24773-330W
R30	Met film 4.7k Ω 2% $\frac{1}{4}$ W	24773-289W	R67	Met film 6.8k Ω 2% $\frac{1}{4}$ W	24773-293D
R31	Var cermet 4.7k Ω 10% $\frac{1}{2}$ W	25711-542W	R68	Met film 6.8k Ω 2% $\frac{1}{4}$ W	24773-293D
R32	Var cermet 1.0k Ω 10% $\frac{1}{2}$ W	25711-544T	R69	Met film 680 Ω 2% $\frac{1}{4}$ W	24773-269K
R33	Met film 220k Ω 2% $\frac{1}{4}$ W	24773-329T	R70	Met film 10k Ω 2% $\frac{1}{4}$ W	24773-297M
R34	Met film 1.0k Ω 2% $\frac{1}{4}$ W	24773-273A	R71	Met film 18k Ω 2% $\frac{1}{4}$ W	24773-303M
R35	Met film 510 Ω 2% $\frac{1}{4}$ W	24773-265M	R72	Var cermet 4.7k Ω 10% $\frac{1}{2}$ W	25711-542W
R36	Met film 15k Ω 2% $\frac{1}{4}$ W	24773-301P	R73	Met film 4.3k Ω 2% $\frac{1}{4}$ W	24773-288S
R37	Met film 3.9k Ω 2% $\frac{1}{4}$ W	24773-287V	R74	Var cermet 1.0k Ω 10% $\frac{1}{2}$ W	25711-544T
R38	Met film 6.8k Ω 2% $\frac{1}{4}$ W	24773-293D	R75	Met film 2.7k Ω 2% $\frac{1}{4}$ W	24773-283L
R39	Met film 100 Ω 2% $\frac{1}{4}$ W	24773-249J	R76	Met film 10 Ω 2% $\frac{1}{4}$ W	24773-225W
R40	Met film 300 Ω 2% $\frac{1}{4}$ W	24773-260W	R77	Met film 1k Ω 2% $\frac{1}{4}$ W	24773-273A
R41	Met film 6.8k Ω 2% $\frac{1}{4}$ W	24773-293D	R78	Met film 51k Ω 2% $\frac{1}{4}$ W	24773-314E
R42	Met film 2.2k Ω 2% $\frac{1}{4}$ W	24773-281Y			
R43	Met film 51 Ω 2% $\frac{1}{4}$ W	24773-242Z			
R44	Met film 2.2k Ω 2% $\frac{1}{4}$ W	24773-281Y	TR1	BC108	28452-787N
R45	Met film 20k Ω 2% $\frac{1}{4}$ W	24773-304C	TR2	BC108	28452-787N
R46	Met film 20k Ω 2% $\frac{1}{4}$ W	24773-304C	TR3	BC108	28452-787N
R47	Met film 1.0k Ω 2% $\frac{1}{4}$ W	24773-273A	TR4	BC108	28452-787N
R48	Met film 22k Ω 2% $\frac{1}{4}$ W	24773-305R	TR5	BC108	28452-787N
R49	Met film 22k Ω 2% $\frac{1}{4}$ W	24773-305R	TR6	BC108	28452-787N
R50	Met film 4.7k Ω 2% $\frac{1}{4}$ W	24773-289W	TR7	BC108	28452-787N
R51	Var cermet 4.7k Ω 10% $\frac{1}{2}$ W	25711-542W	TR8	BC108	28452-787N

For symbols and abbreviations see introduction to this chapter

Circuit reference	Description	M.I. code	Circuit reference	Description	M.I. code
<u>A3 - Switch board</u>			C3	Elec 220 μ F +100-20% 10V	26415-817J
When ordering, prefix circuit reference with A3.			C4	Plas 510pF 2% 125V	26516-416F
	Complete board	44827-506G	D1	1N4004	28357-028K
C1	Elec 47 μ F +100-20% 10V	26415-809E	D2	1N4004	28357-028K
C2	Cer 0.1 μ F +50-25% 30V	26383-031S	D3	1N4004	28357-028K
C3	Cer 0.1 μ F +50-25% 30V	26383-031S	D4	1N4004	28357-028K
			D5	1N4004	28357-028K
D1	CG85H	28321-201E	IC1	μ A723	28461-706F
R1	Met film 61.1 Ω 1% $\frac{1}{4}$ W	24762-571U	R1	Met ox 3.3k Ω 2% $\frac{1}{2}$ W	24573-085K
R2	Met film 247 Ω 1% $\frac{1}{4}$ W	24762-631R	R2	WW 82 Ω 5% 3W	25125-046E
R3	Met film 61.1 Ω 1% $\frac{1}{4}$ W	24762-571U	R3	Met ox 820 Ω 2% $\frac{1}{2}$ W	24573-071V
R4	Met film 13k Ω 2% $\frac{1}{4}$ W	24773-300T	R4	Met film 1k Ω 2% $\frac{1}{4}$ W	24773-273A
R5	Met film 20k Ω 2% $\frac{1}{4}$ W	24773-304C	R5	Met film 10k Ω 2% $\frac{1}{4}$ W	24773-297M
SC	0/20 dB switch	Assembled 44338-039R	R6	Met film 820 Ω 2% $\frac{1}{4}$ W	24773-271B
SD	FM/AM switch		R7	Met film 6.2k Ω 2% $\frac{1}{4}$ W	24773-292W
SE	+/- switch		R8	Met film 12k Ω 2% $\frac{1}{4}$ W	24773-299R
SF	1.5 kHz range switch		R9	Met ox 2.2 Ω 10% 3/8W	24582-560L
SG	5 kHz/30% range switch		R10	Met film 12k Ω 2% $\frac{1}{4}$ W	24773-299R
SH	15 kHz/100% range switch		R11	Var cermet 2.2k Ω 10% $\frac{1}{2}$ W	25711-547M
SJ	BATT VOLTS switch		R12	Met film 4.7k Ω 2% $\frac{1}{4}$ W	24773-289W
<u>A4 - Voltage regulator board</u>			TR1	BFY51	28455-827T
When ordering, prefix circuit reference with A4.			TR2	2N3055	28456-567W
	Complete board	44827-505F	<u>Miscellaneous parts</u>		
C1	Elec 470 μ F +100-20% 63V	26415-842Z	DC fuse holder		23416-151D
C2	Elec 220 μ F +100-20% 63V	26415-820J	AC fuse holder		23416-191C

For symbols and abbreviations see introduction to this chapter

Circuit notes

1. ARRANGEMENT

The block diagram, Fig. 7.1, illustrates the interconnection between the circuits which make up the TF 2304 and shows which of the circuit diagrams, Figs. 7.3 to 7.5, give further details. Fig. 7.2 is a diagram of the inter-unit connections and, for convenience, contains the power supply circuit diagram.

2. COMPONENT VALUES

Resistors : No suffix = ohms, k = kilohms, M = megohms.

Capacitors : No suffix = microfarads, p = picofarads.

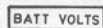
Inductors : No suffix = henries, m = millihenries, μ = microhenries.

† : value selected during test, nominal value shown.

3. VOLTAGES

Printed in italics. Voltages are d.c. and relative to chassis unless otherwise indicated. Measured with a 20 k Ω /V meter.

4. SYMBOLS



Panel marking.



Interconnection to another diagram.

5. SWITCHES



Slider switch representation in circuit diagrams. All are drawn in 'OUT' position. In this example switch is in + position and must be depressed to be in the - position. If only one position is indicated e.g. $\boxed{5 \text{ kHz}/30\%}$ ← a non-effective 'OUT' position is assumed. In this case the push button must be depressed (as indicated by the arrow) to set the instrument to the 5 kHz deviation or 30% modulation depth range.

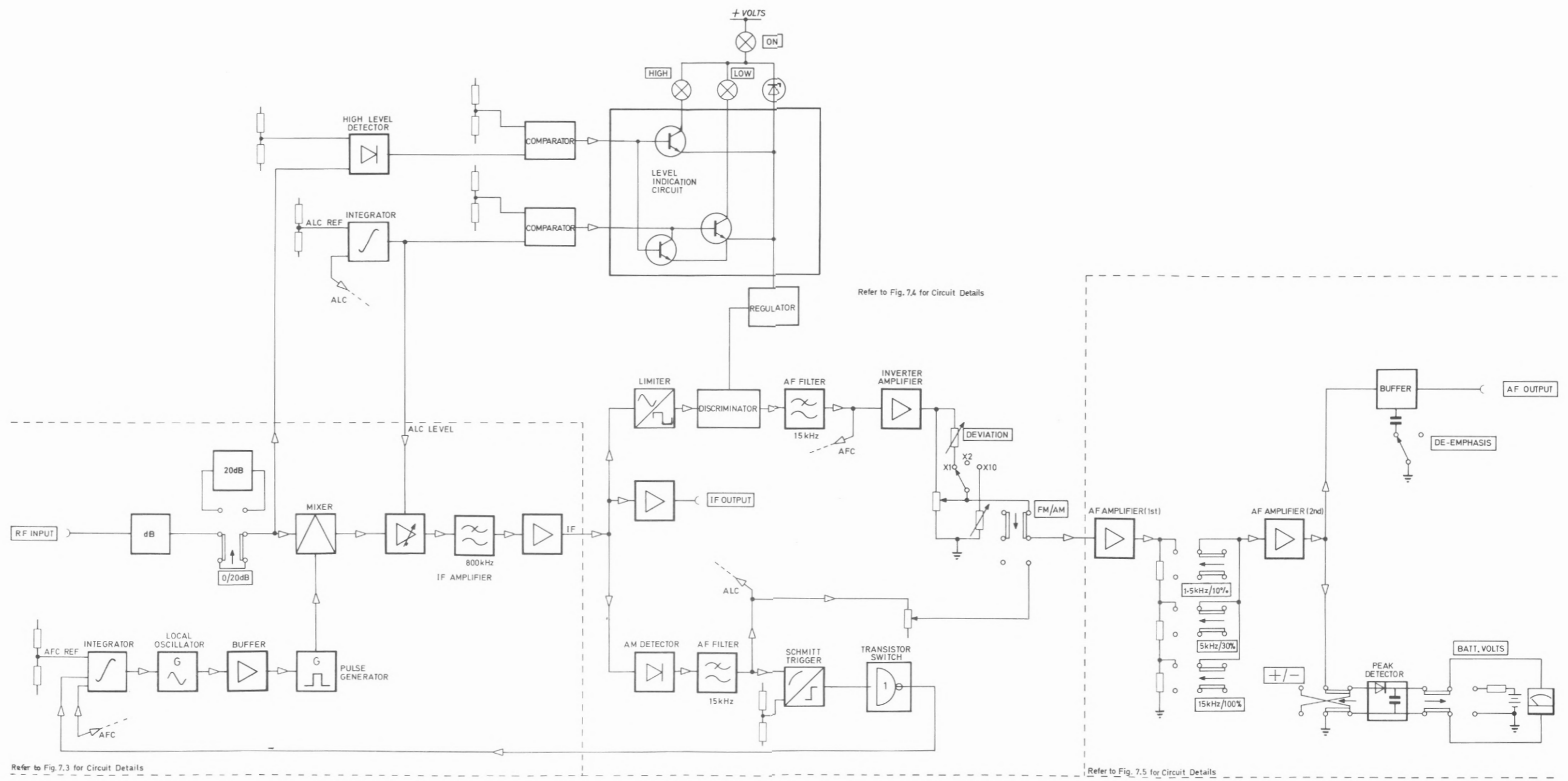
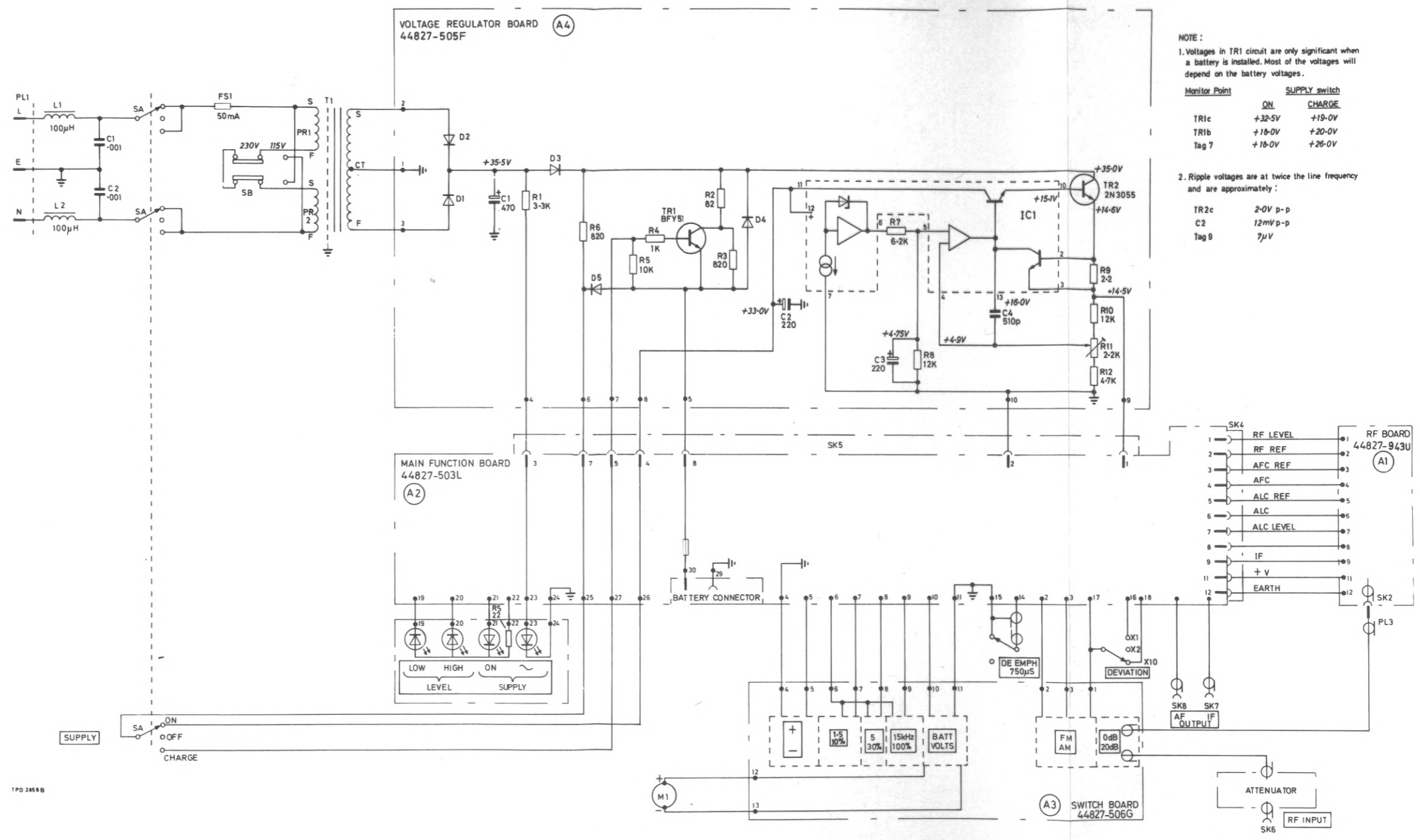


Fig. 7.1 Block diagram



NOTE:

1. Voltages in TR1 circuit are only significant when a battery is installed. Most of the voltages will depend on the battery voltages.

Monitor Point	SUPPLY switch	
	ON	CHARGE
TR1c	+32.5V	+19.0V
TR1b	+18.0V	+20.0V
Tag 7	+18.0V	+26.0V

2. Ripple voltages are at twice the line frequency and are approximately:

TR2c	2.0V p-p
C2	12mV p-p
Tag 9	7μV

Fig. 7.2 Power supply and circuit interconnections

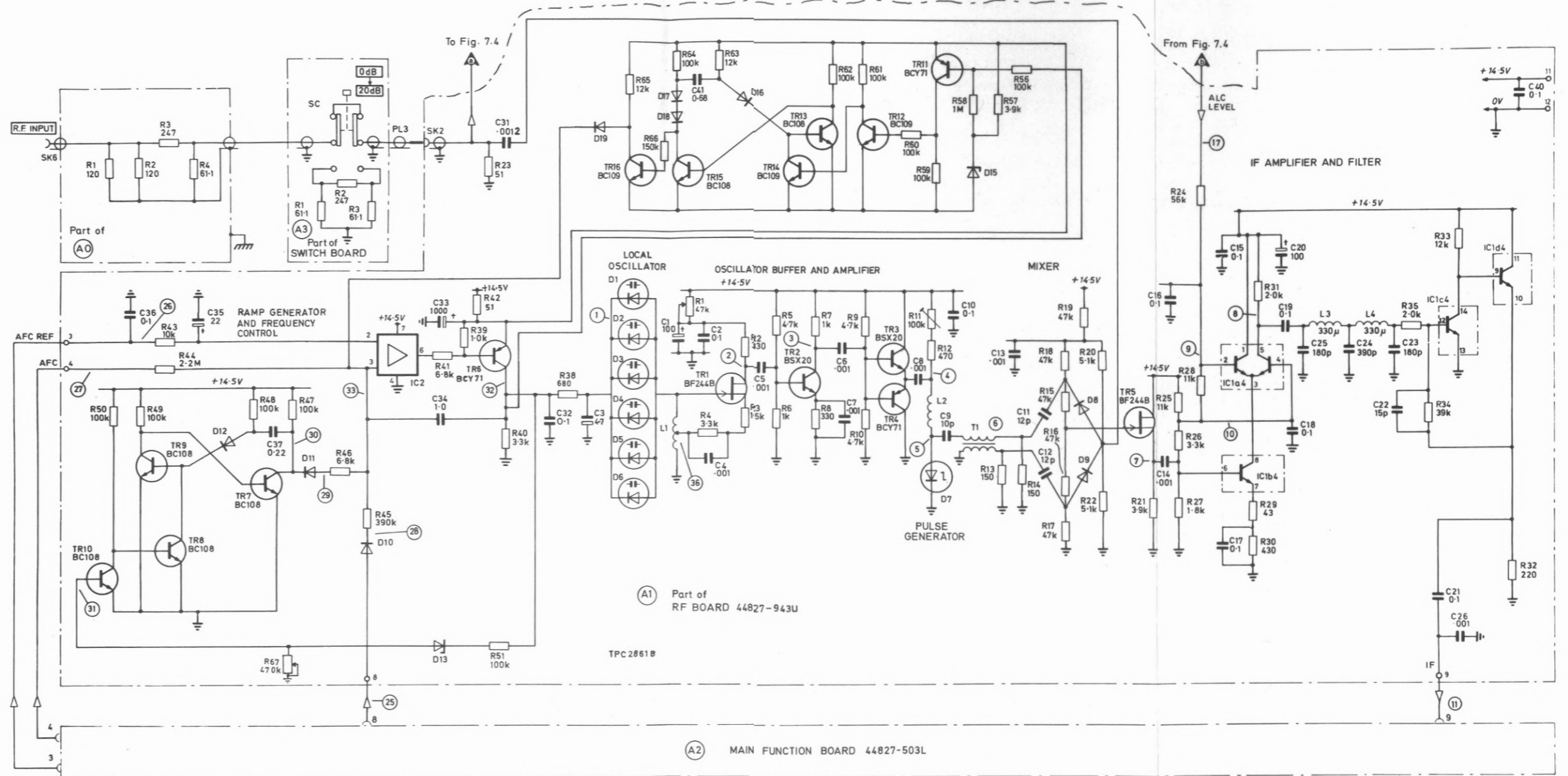


Fig. 7.3 Input circuits

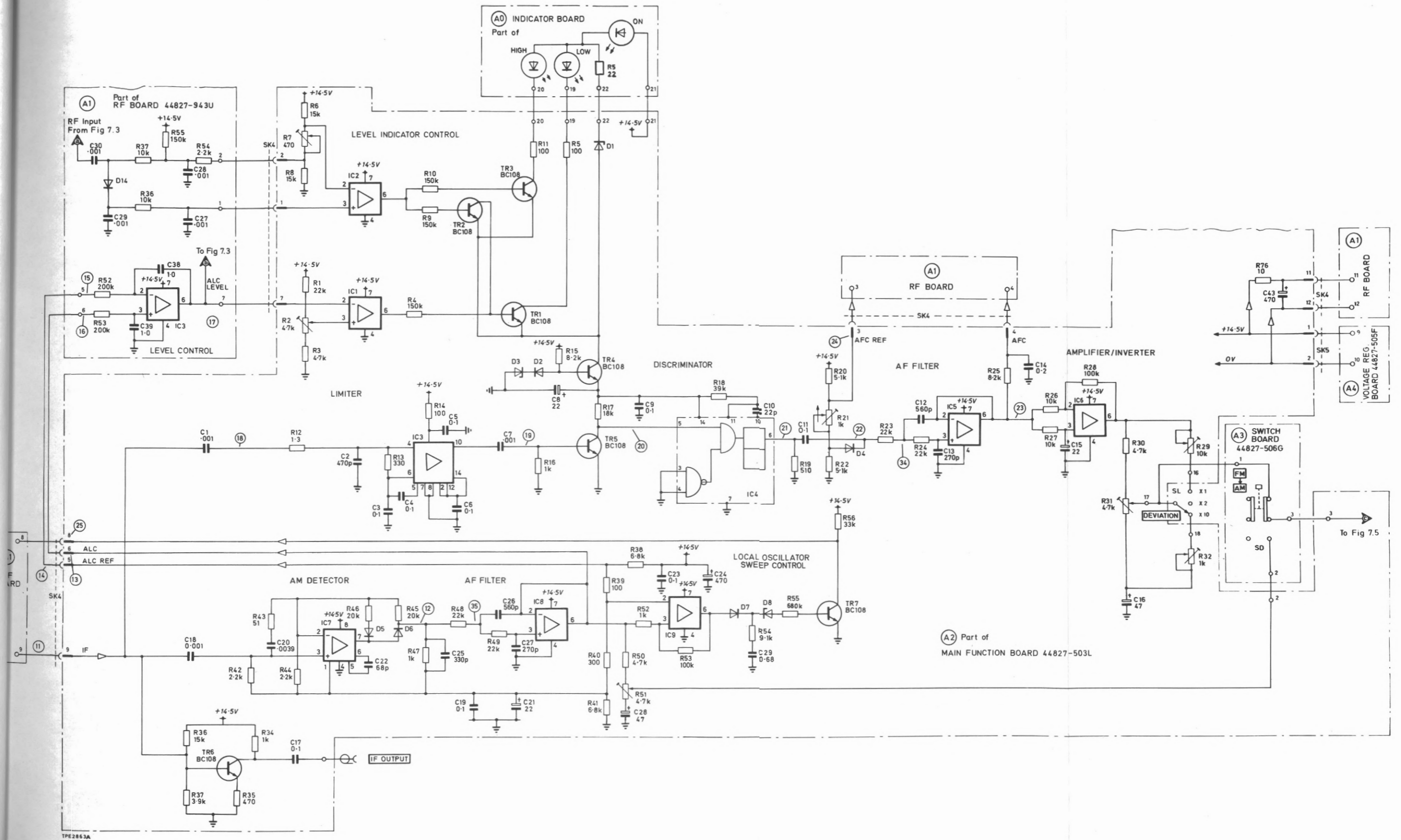


Fig. 7.4 FM and a.m. circuits

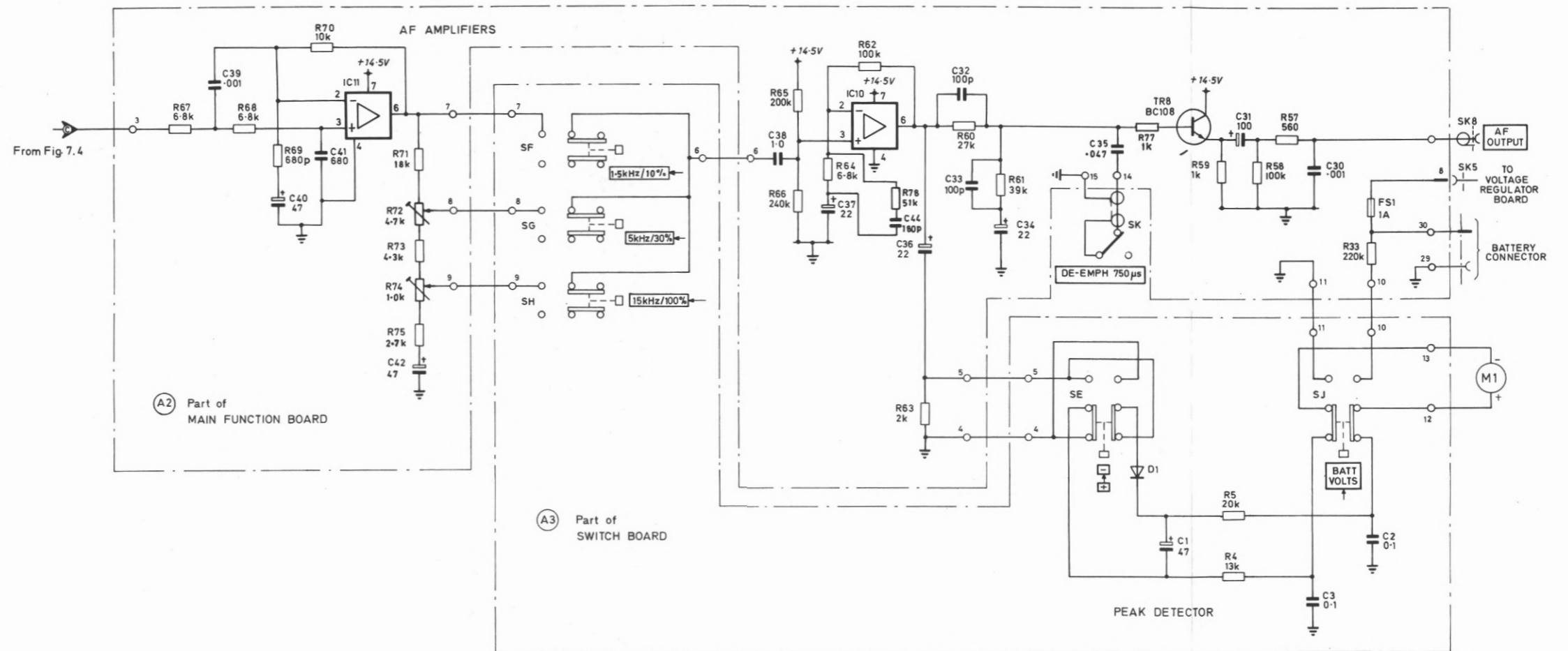


Fig. 7.5 Measuring circuits