

AKAI SERVICE MANUAL

AP-B110/C

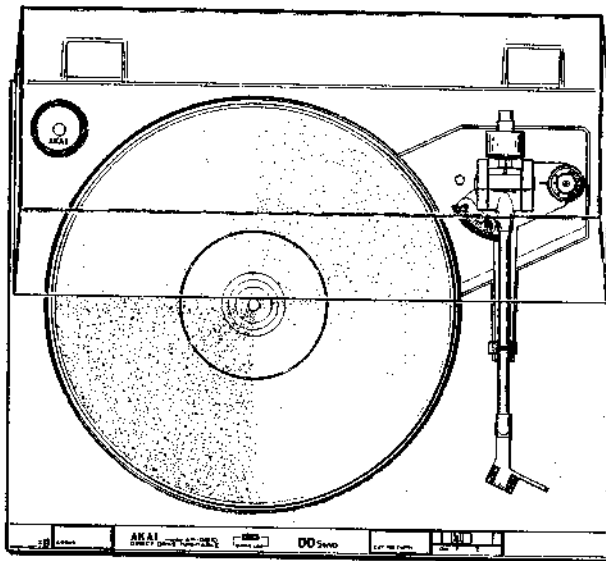
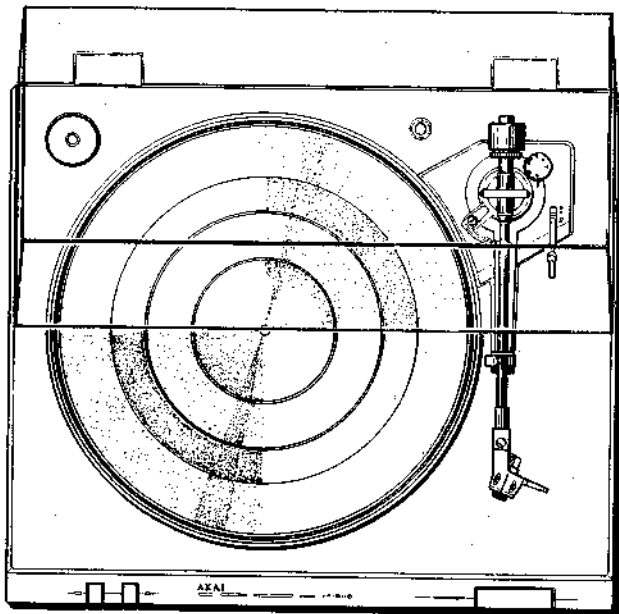

AUTO-RETURN TURN TABLE

MODEL **AP-B110/C**

DIRECT DRIVE TURN TABLE

MODEL **AP-D210/C**

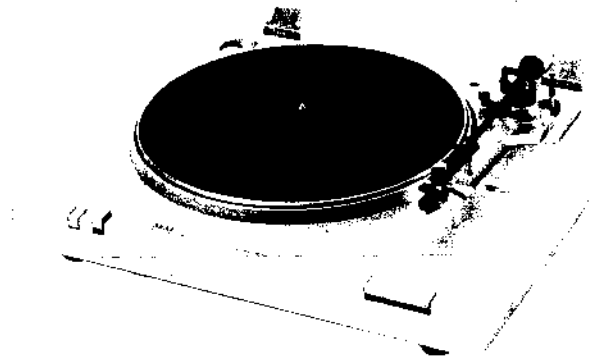

AP-B110/C

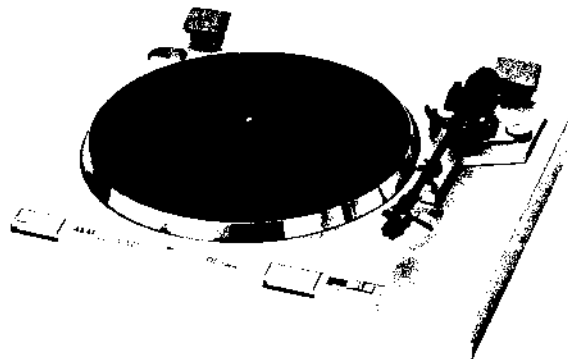

AP-D210/C

AUTO-RETURN TURN TABLE
MODEL AP-B110/C
DIRECT DRIVE TURN TABLE
MODEL AP-D210/C

THIS MANUAL IS APPLICABLE TO BOTH SILVER AND BLACK PANEL MODELS

SECTION 1	MODEL AP-B110/C SERVICE MANUAL	3
SECTION 2	MODEL AP-D210/C SERVICE MANUAL	13
SECTION 3	PARTS LIST	29
SECTION 4	SCHEMATIC DIAGRAM	38

SAFETY INSTRUCTIONS

SAFETY CHECK AFTER SERVICING

Confirm the specified insulation resistance between power cord plug prongs and externally exposed parts of the set is greater than 10 Mohms, but for equipment with external antenna terminals (tuner, receiver, etc.) and is intended for **C** or **A**, specified insulation resistance should be more than 2.2 Mohms (ground terminals, microphone jacks, headphone jacks, line-in-out jacks etc.)

PRECAUTIONS DURING SERVICING

1. Parts identified by the **A** symbol parts are critical for safety.
Replace only with parts number specified.
2. In addition to safety, other parts and assemblies are specified for conformance with such regulations as those applying to spurious radiation. These must also be replaced only with specified replacements.
Examples: RF converters, tuner units, antenna selector switches, RF cables, noise blocking capacitors, noise blocking filters, etc.
3. Use specified internal wiring. Note especially:
 - 1) Wires covered with PVC tubing
 - 2) Double insulated wires
 - 3) High voltage leads
4. Use specified insulating materials for hazardous live parts. Note especially:
 - 1) Insulation Tape
 - 2) PVC tubing
 - 3) Spacers (Insulating Barriers)
 - 4) Insulation sheets for transistors
5. When replacing AC primary side components (transformers, power cords, noise blocking capacitors, etc.), wrap ends of wires securely about the terminals before soldering.

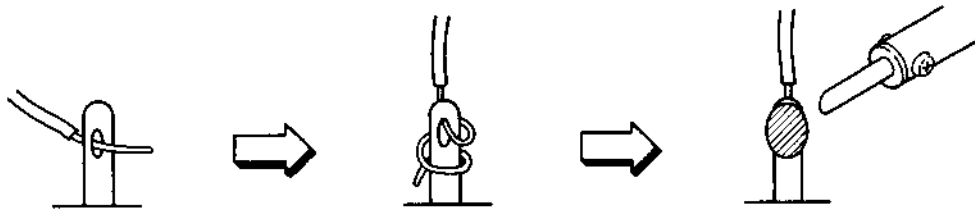

6. Observe that wires do not contact heat producing parts (heatsinks, oxide metal film resistors, fusible resistors, etc.).
7. Check that replaced wires do not contact sharp edged or pointed parts.
8. Also check areas surrounding repaired locations.
9. Use care that foreign objects (screws, solder droplets, etc.) do not remain inside the set.

SECTION 1

SERVICE MANUAL

MODEL AP-B110/C

TABLE OF CONTENTS

I. SPECIFICATIONS	4
II. DISMANTLING OF UNIT	5
III. CONTROLS	6
IV. PRINCIPAL PARTS LOCATION	7
V. VOLTAGE AND CYCLE CONVERSION	8
1. VOLTAGE CONVERSION	8
2. CYCLE CONVERSION AND MOTOR PULLEY HEIGHT ADJUSTMENT	8
VI. ORDINARY ADJUSTMENT	9
1. STYLUS PRESSURE ADJUSTMENT	9
2. OVERHANG ADJUSTMENT	10
3. TONE ARM LIFTER HEIGHT ADJUSTMENT	10
VII. MECHANISM ADJUSTMENT	11
1. SPINDLE GEAR POSITION ADJUSTMENT	11
2. AUTO RETURN ADJUSTMENT	11

For basic adjustments, measuring methods, and operating principles, refer to GENERAL TECHNICAL MANUAL.

I . SPECIFICATIONS

TURNTABLE	Aluminum alloy diecast
DRIVE SYSTEM & MECHANISM	Belt Drive, Semi-automatic
MOTOR	4-pole Synchronous Motor
SPEED	33-1/3, 45 rpm
WOW AND FLUTTER	0.05% (WRMS)
RUMBLE	65 dB (DIN B)
TOPE ARM	Static balanced type with inside force canceller
EFFECTIVE ARM LENGTH	215 mm
STYLUS PRESSURE ADJUSTMENT RANGE	0 to 2.5 grams
APPLICABLE CARTRIDGE WEIGHT	5 to 9 grams
ARM LIFTER	Oil Damped
OVERHANG	15 mm
SHELL WEIGHT	2.7 grams
CARTRIDGE	VM (Dual Magnet) type (Model AP-B110 does not include cartridge.)
OUTPUT VOLTAGE	5 mV (DIN)
CHANNEL SEPARATION	More than 20 dB (DIN)
OPTIMAL STYLUS PRESSURE	2 grams
POWER REQUIREMENTS	120V, 60 Hz for USA and Canada 220V, 50 Hz for Europe except UK 240V, 50 Hz for UK and Australia 110-120V/220-240V, 50/60 Hz switchable for other countries
POWER CONSUMPTION	U/T, CSA, AAL 10W CEE, VDE 7.5W SAA, UK 9W
DIMENSIONS	440 (W) x 132 (H) x 383 (D) mm (17.3 x 5.2 x 15.1 x inches)
WEIGHT	4.2 kg (9.3 lbs)

* For improvement purposes, specifications and design are subject to change without notice.

II. DISMANTLING OF UNIT

AP-B110/C

In case of trouble, etc. necessitating dismantling, please dismantle in the order shown in the photographs. Reassemble in reverse order.

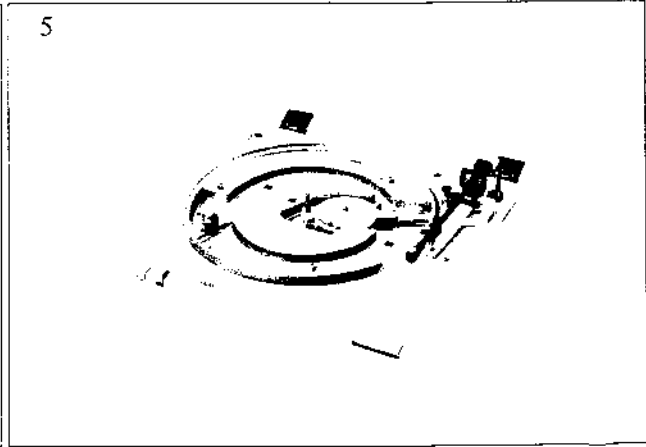
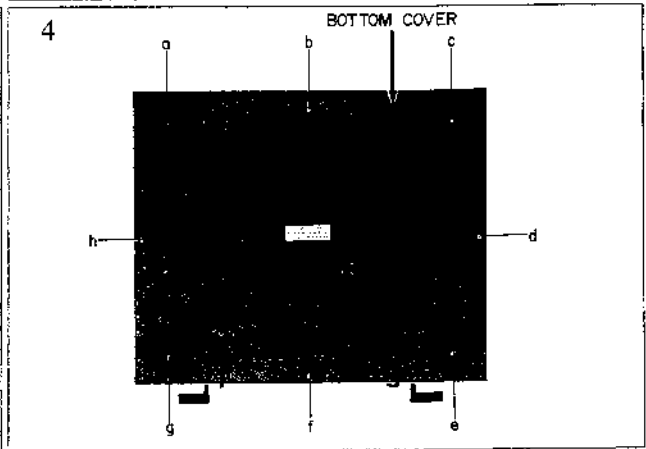
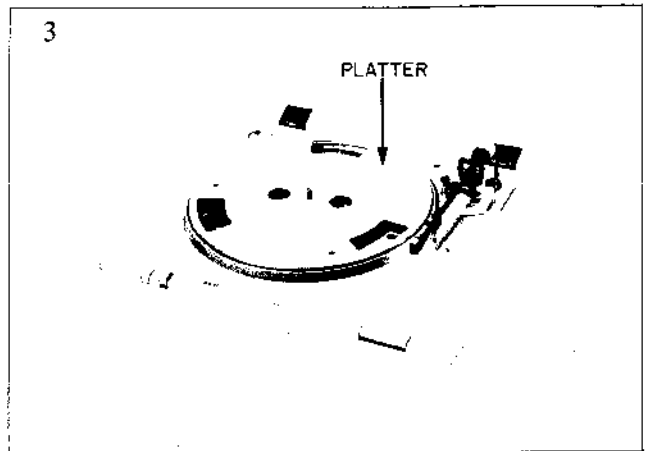
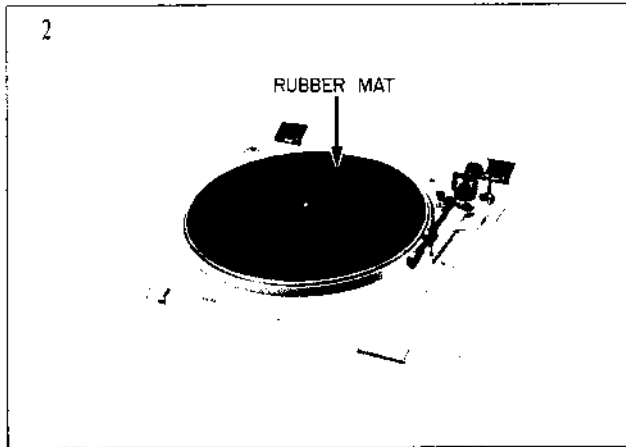
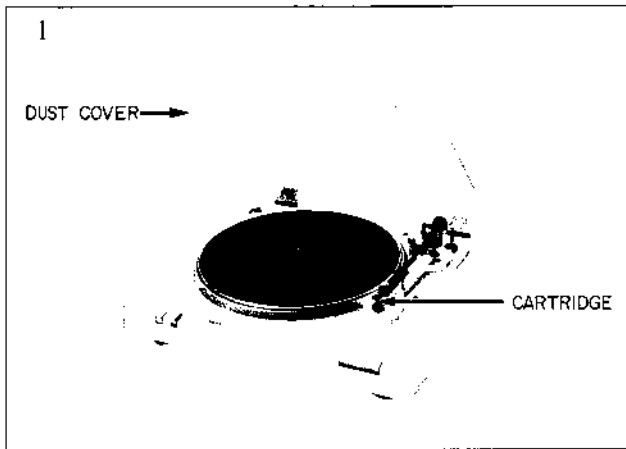

III. CONTROLS

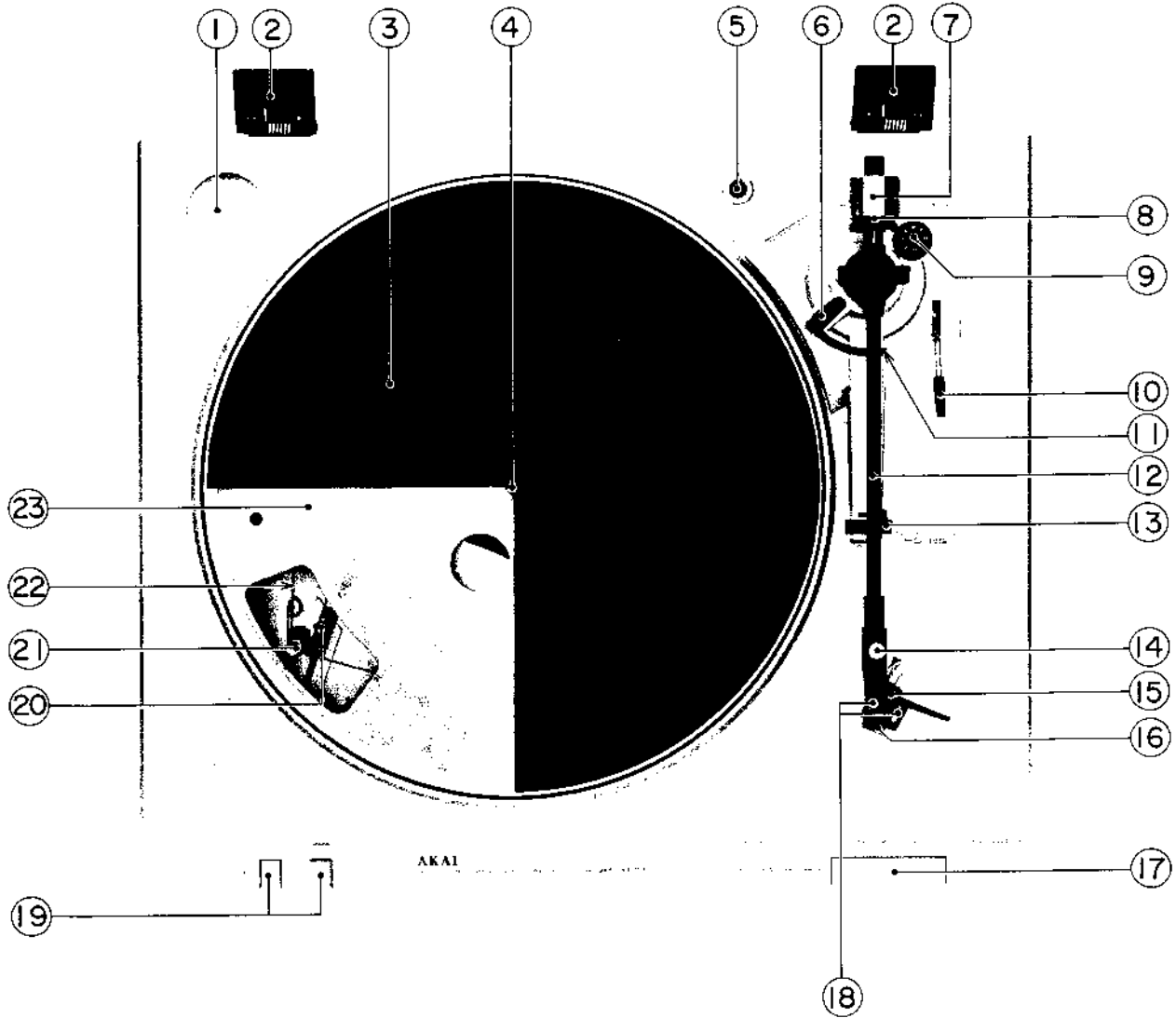

Fig. 1 Controls

- | | |
|--|--|
| 1. 45 rpm ADAPTER HOLDER | 13. TONE ARM REST |
| 2. HINGE | 14. HEAD SHELL RE-SETTING SCREW |
| 3. RUBBER MAT | 15. HEAD SHELL |
| 4. SPINDLE | 16. CARTRIDGE (CARTRIDGE NOT INCLUDED WITH AP-110) |
| 5. CARTRIDGE SHELL HOLDER | 17. CUT/RETURN SWITCH |
| 6. TONE ARM LIFTER HEIGHT ADJUSTMENT SCREW | 18. CARTRIDGE RE-SETTING SCREWS |
| 7. MAIN WEIGHT | 19. SPEED SELECTOR |
| 8. STYLUS PRESSURE SCALE RING | 20. DRIVE BELT GUIDE |
| 9. ANTISKATING ADJUSTER | 21. CAPSTAN |
| 10. CUEING LEVER (▲ TO LIFT, ▼ TO LOWER) | 22. DRIVE BELT |
| 11. TONE ARM LIFTER | 23. TURNTABLE PLATTER |
| 12. TONE ARM | |

* Hinges and dust cover not included with DL type turntable.

IV. PRINCIPAL PARTS LOCATION

AP-B110/C

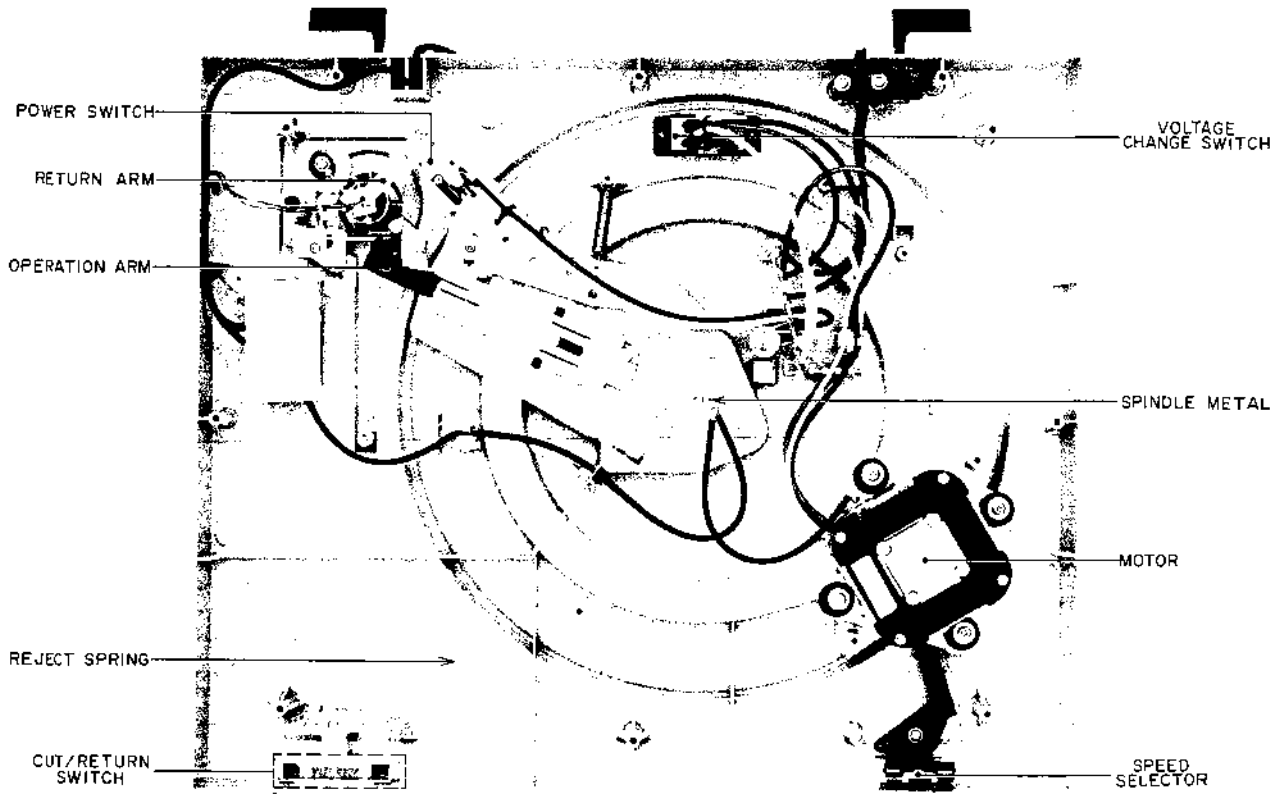

Fig. 2 Principal Parts Location (Bottom View)

V. VOLTAGE AND CYCLE CONVERSION

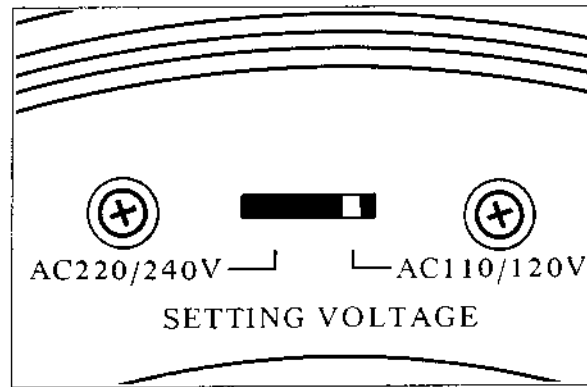

Fig. 3 Voltage Conversion

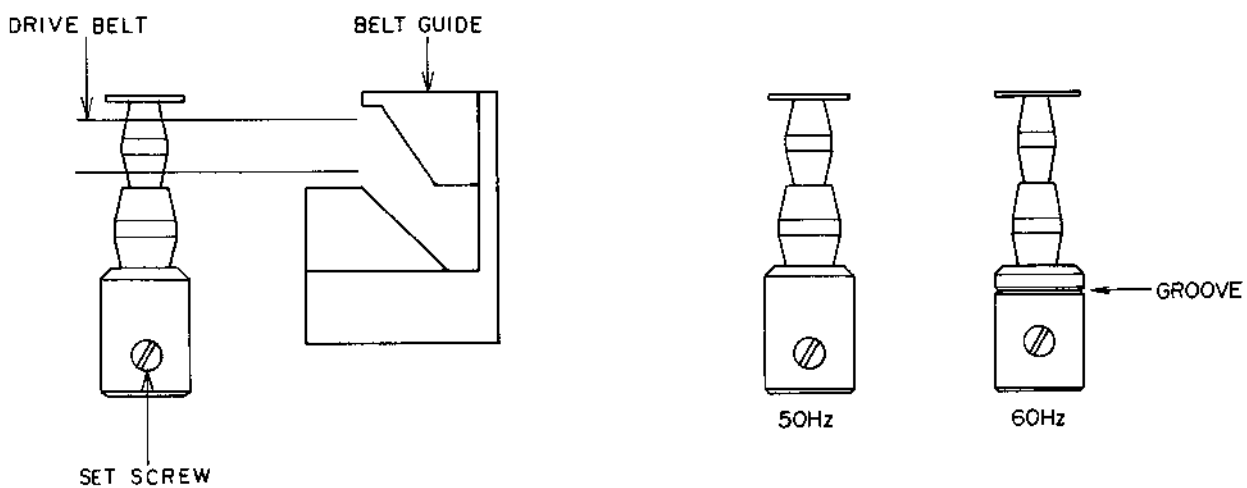

Fig. 4 Cycle Conversion and Motor Pulley Height Adjustment

1. VOLTAGE CONVERSION (Refer to Fig. 3)

Models for Canada, USA, Europe, UK and Australia are not equipped with this facility. Each unit is pre-set at the factory depending on its destination, but some units can be converted to 110-120V or to 220-240V as required.

If voltage change is necessary, this can be accomplished as follows.

1. Disconnect the Power Cord.
2. Remove the turntable platter.
3. Change the alternate capstan according to the power source frequency for your area.
4. Switch the voltage conversion switch so that it indicates the correct voltage for your area.

2. CYCLE CONVERSION AND MOTOR PULLEY HEIGHT ADJUSTMENT

(Refer to Fig. 4)

- 1) Loosen the Set Screw and change the Motor Pulley to match the frequency (50 Hz or 60 Hz).
Motor Pulley (With Groove) : 60 Hz.
Motor Pulley (With Out Groove) : 50 Hz.
- 2) Set the Speed Selector to "33".
- 3) Turn the Platter and adjust the height of Motor Pulley by Set Screw so that the Drive Belt is revolving smoothly through the center of the Belt Guide.
- 4) Set the Speed Selector to "45" and confirm that the Drive Belt is revolving smoothly through the center of the Belt Guide.

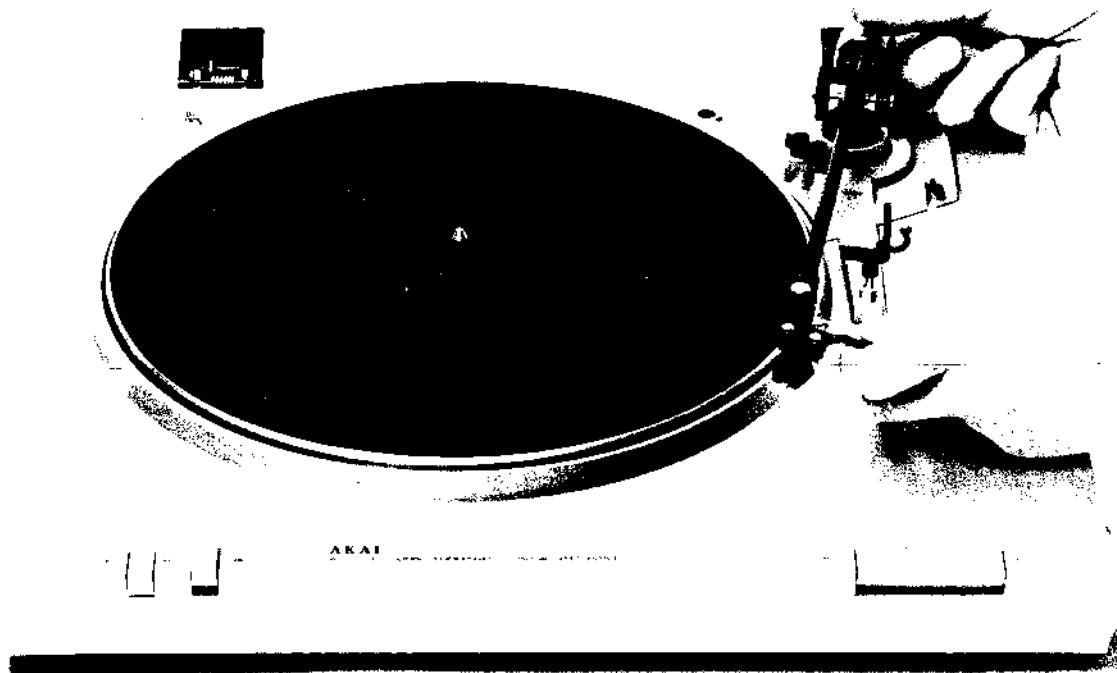

Fig. 5 Stylus Pressure Adjustment

1. STYLUS PRESSURE ADJUSTMENT

(Refer to Fig. 5)

1. Connect the Power Cord.
2. Turn the ANTISKATING Adjuster to 0.
3. Set the Cueing lever to ▼.
4. Unlock the Tone Arm and bring it towards the Platter.
 - * Remove the Stylus Guard being careful not to damage the Stylus.
5. With the Tone Arm held midway between the Tone Arm Rest and the rim of the Platter, adjust the Main Weight until the Tone Arm is in perfect horizontal balance.
6. Without moving the Main Weight, rotate the Stylus Pressure Scale Ring only to match the "0" mark with the mark on the weight shaft.
7. Lock the Tone Arm in place and rotate the Main Weight counterclockwise, as viewed from the front (the Stylus Pressure Scale Ring will move with it), until the desired Stylus Pressure Scale indication is at the mark on the shaft.

The range of adjustment is from 0 to 3 grams.

- * For AP-B110C only: The recommended Stylus Pressure for the cartridge supplied, PC-85, is 2 grams.
8. Set the ANTISKATING adjuster to the corresponding Stylus Pressure.

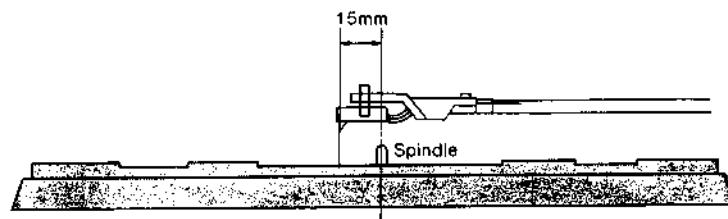

Fig. 6 Overhang Adjustment

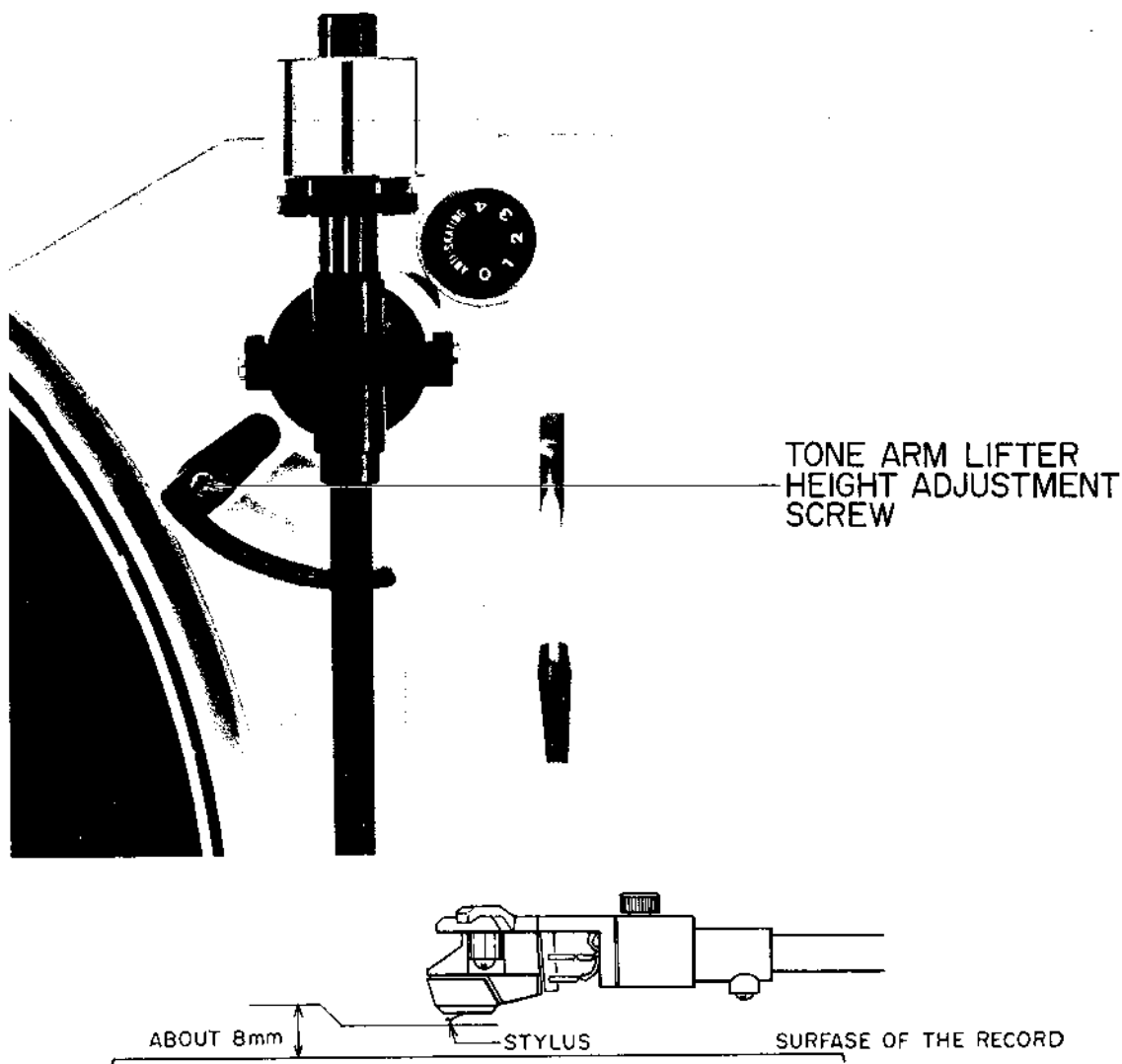

Fig. 7 Tone Arm Lifter Height Adjustment

2. OVERHANG ADJUSTMENT (Refer to Fig. 6)

The distance between the turntable Spindle and the Stylus when the Tone Arm is centered over the Platter is known as the overhang.

Different cartridges require different overhang adjustments.

1. Disconnect the Power Cord.
2. Center the Tone Arm over the Platter.
3. Adjust the cartridge position in the shell so that the Stylus position is 15 mm from the Spindle.

* The cartridge position can be adjusted by resetting the screws in the shell.

3. TONE ARM LIFTER HEIGHT

ADJUSTMENT (Refer to Fig. 7)

With the Tone Arm in the up-position, the Stylus should be 8 mm above the surface of the record. If it is not, increase the height by adjusting the Tone Arm Lifter Height Adjustment Screw.

Clockwise: Down

Counterclockwise: Up

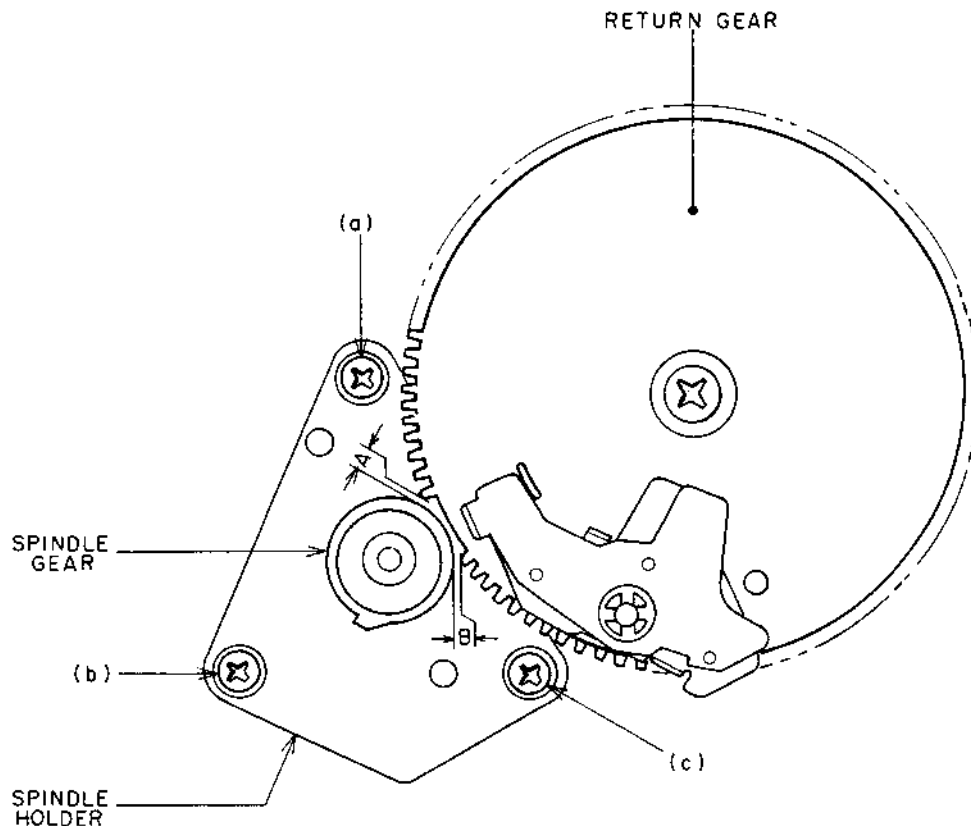

Fig. 8 Spindle Gear Position Adjustment

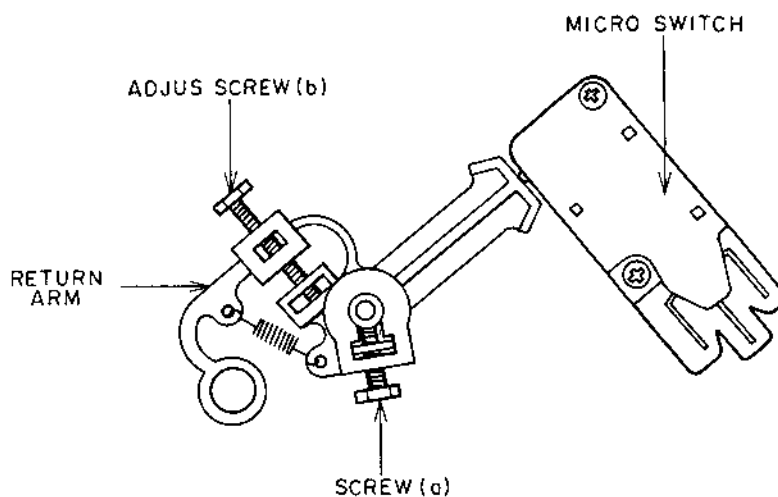

Fig. 9 Auto Return Adjustment

1. SPINDLE GEAR POSITION ADJUSTMENT (Refer to Fig. 8)

With the motor free, confirm that the gaps A and B between the spindle gear and Return Gear are equal. If not, loosen screw (a), (b), (c), move the Spindle Holder than tight again.

2. AUTO RETURN ADJUSTMENT (Refer to Fig. 9)

- 1) Connect the Power Cord.
- 2) Move the Tone Arm and turn on the power.
- 3) Set the Arm in the down "▼" condition.
- 4) With your fingers, slowly move the Tone Arm towards the center of the platter and set the adjust screw (b) so that return operation begins between $110\phi \sim 129\phi$ from the center spindle.

SECTION 2

SERVICE MANUAL

MODEL AP-D210/C

TABLE OF CONTENTS

I.	SPECIFICATIONS	14
II.	DISMANTLING OF UNIT	15
III.	CONTROLS	16
IV.	PRINCIPAL PARTS LOCATION	17
V.	VOLTAGE AND CYCLE CONVERSION	18
	1. VOLTAGE CONVERSION	18
	2. CYCLE CONVERSION	18
VI.	MECHANICAL ADJUSTMENT	19
	1. STYLUS PRESSURE ADJUSTMENT	19
	2. OVERHANG ADJUSTMENT	20
	3. TONE ARM LIFTER HEIGHT ADJUSTMENT	21
	4. AUTO-RETURN ADJUSTMENT	21
VII.	ELECTRICAL ADJUSTMENT	22
	1. SPEED ADJUSTMENT	22
	2. RETURN SENSOR SENSITIVITY ADJUSTMENT	22
VIII.	CLASSIFICATION OF VARIOUS P.C BOARDS	23
	1. P.C BOARD TITLES AND IDENTIFICATION NUMBERS	23
	2. COMPOSITION OF VARIOUS P.C BOARDS	24

For basic adjustments, measuring methods, and operating principles, refer to GENERAL TECHNICAL MANUAL.

I. SPECIFICATIONS

TURNTABLE	Aluminum alloy diecast
DRIVE SYSTEM & MECHANISM	Direct Drive, Auto-Return
MOTOR	DC Servo Motor
SPEED	33-1/3 rpm, 45 rpm
SPEED DEVIATION	± 0.5%
WOW AND FLUTTER	0.045% (DIN) 0.03% (JIS)
RUMBLE	48 dB (DIN A) 73 dB (DIN B)
TONE ARM	Static Balanced Type
EFFECTIVE ARM LENGTH	220 mm
STYLUS PRESSURE ADJUSTMENT RANGE	0 to 2.5 grams
APPLICABLE CARTRIDGE WEIGHT	3 to 8 grams
ARM LIFTER	Oil damped
OVERHANG	17.5 mm
OFFSET ANGLE	24°
CARTRIDGE	VM (Dual Magnet) Type (Model AP-D210 does not include cartridge.)
OPTIMAL STYLUS PRESSURE	2.0 grams
OUTPUT VOLTAGE	5 mV (DIN)
CHANNEL SEPARATION	20 dB
FREQUENCY RESPONSE	20 to 20,000 Hz
CARTRIDGE LOAD IMPEDANCE	47 kohms
STATIC VERTICAL COMPLIANCE	16×10^{-6} cm/dyne
STATIC HORIZONTAL COMPLIANCE	12.5×10^{-6} cm/dyne
DYNAMIC VERTICAL COMPLIANCE	4.5×10^{-6} cm/dyne
DYNAMIC HORIZONTAL COMPLIANCE	4.5×10^{-6} cm/dyne
POWER REQUIREMENTS	100V, 50/60 Hz for Japan 120V, 60 Hz for USA and Canada 220V, 50 Hz for Europe except UK 240V, 50 Hz for UK and Australia 110-120V/220-240V, 50/60Hz switchable for other countries
POWER CONSUMPTION	5W (U, J, C, A)
DIMENSIONS	440 (W) x 96 (H) x 359 (D) mm (17.3 x 3.8 x 14.1 inches)
WEIGHT	5.0 kg (11 lbs)

* For improvement purposes, specifications and design are subject to change without notice.

II. DISMANTLING OF UNIT

AP-D210/C

In case of trouble, etc. necessitating dismantling, please dismantle in the order shown in the photographs. Reassemble in reverse order.

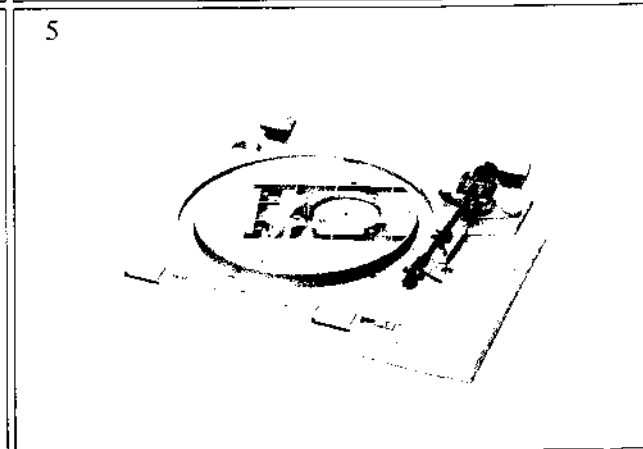
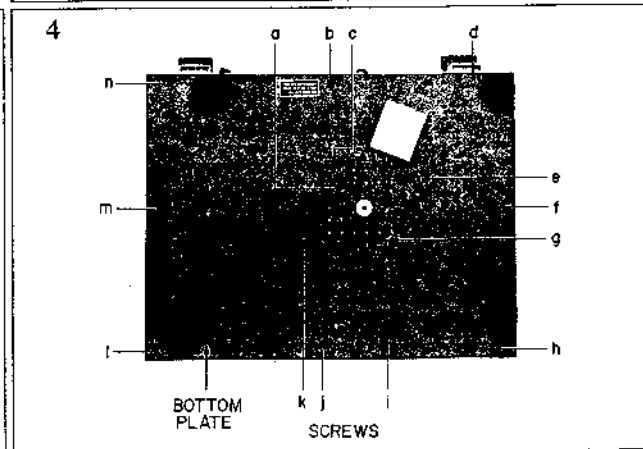
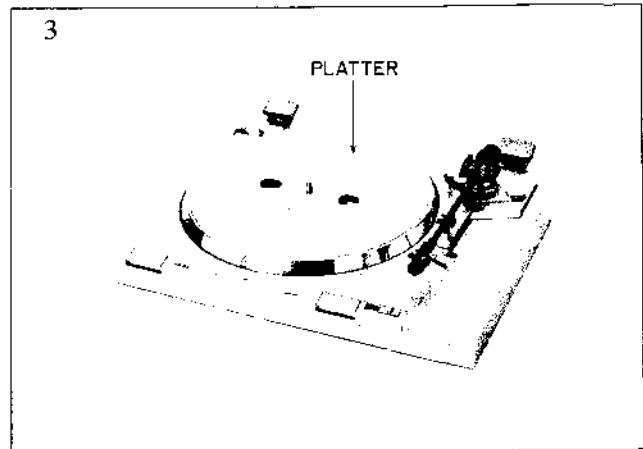
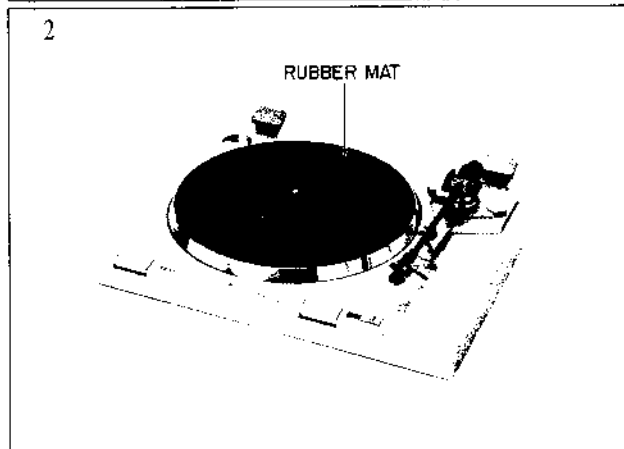
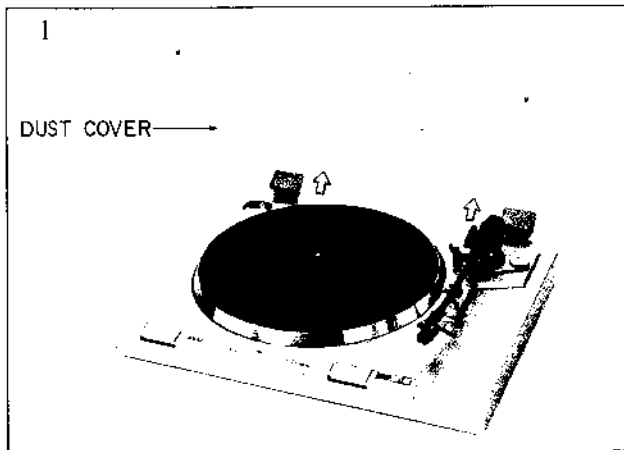

III. CONTROLS

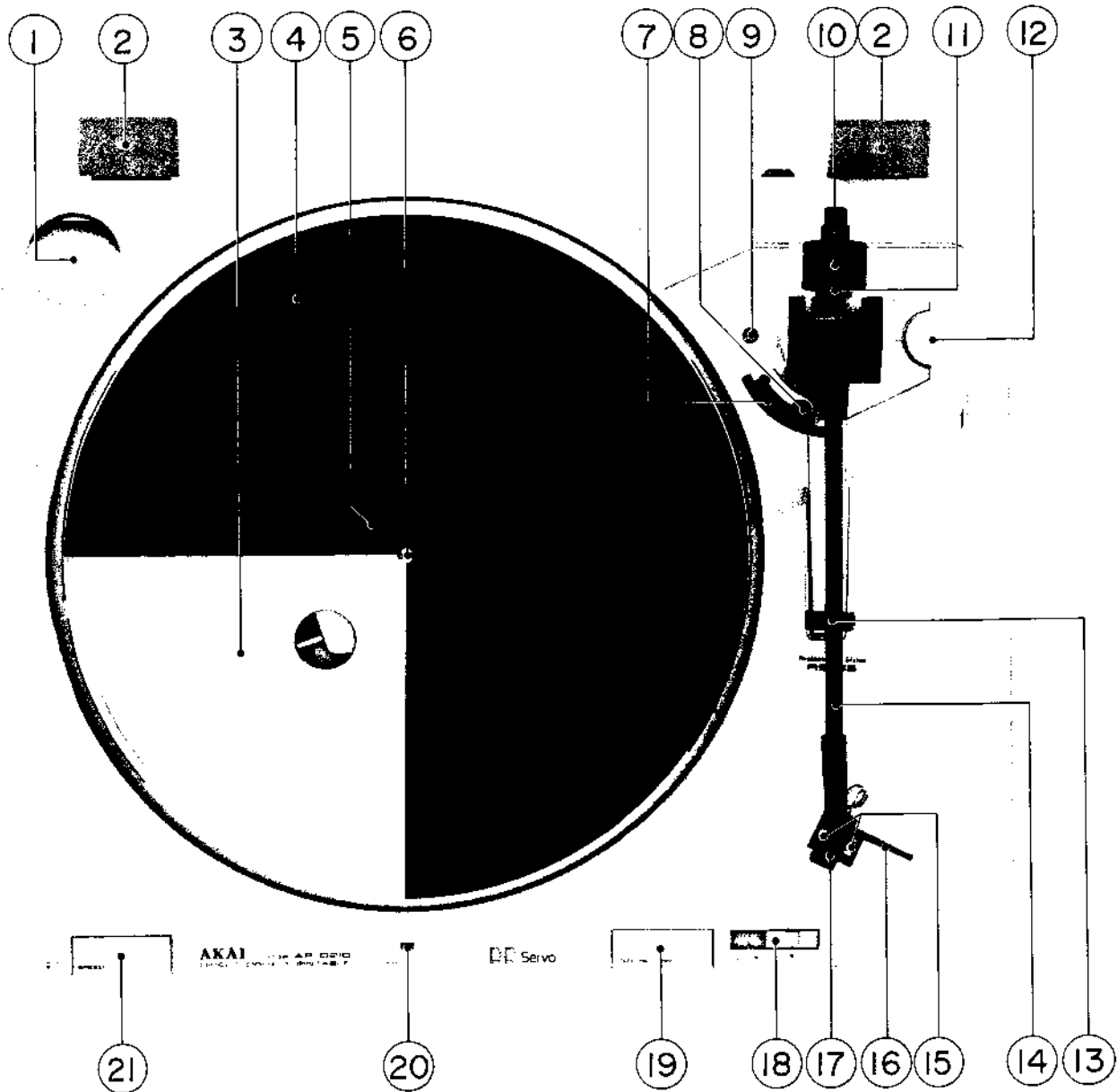

Fig. 1 Controls

- | | | | |
|-----|---|-----|--|
| 1. | 45 rpm ADAPTER HOLDER | 12. | ANTISKATING ADJUSTER |
| 2. | HINGE | 13. | TONE ARM REST AND CLAMP |
| 3. | PLATTER | 14. | TONE ARM |
| 4. | RUBBER MAT | 15. | CARTRIDGE RE-SETTING SCREWS |
| 5. | GROOVE FOR OVERHANG ADJUSTMENT | 16. | HEAD SHELL |
| 6. | SPINDLE | 17. | CARTRIDGE (AP-D210C ONLY) |
| 7. | TONE ARM LIFTER | 18. | CUEING (CUE) LEVER (▼ TO LIFT, ▼ TO LOWER) |
| 8. | TONE ARM LIFTER HEIGHT ADJUSTMENT SCREW | 19. | CUT/RETURN SWITCH |
| 9. | AUTO-RETURN ADJUSTMENT SCREW | 20. | SERVO LOCK INDICATOR |
| 10. | MAIN WEIGHT | 21. | SPEED SELECTOR |
| 11. | STYLUS PRESSURE SCALE RING | | |

IV. PRINCIPAL PARTS LOCATION

AP-D210/C

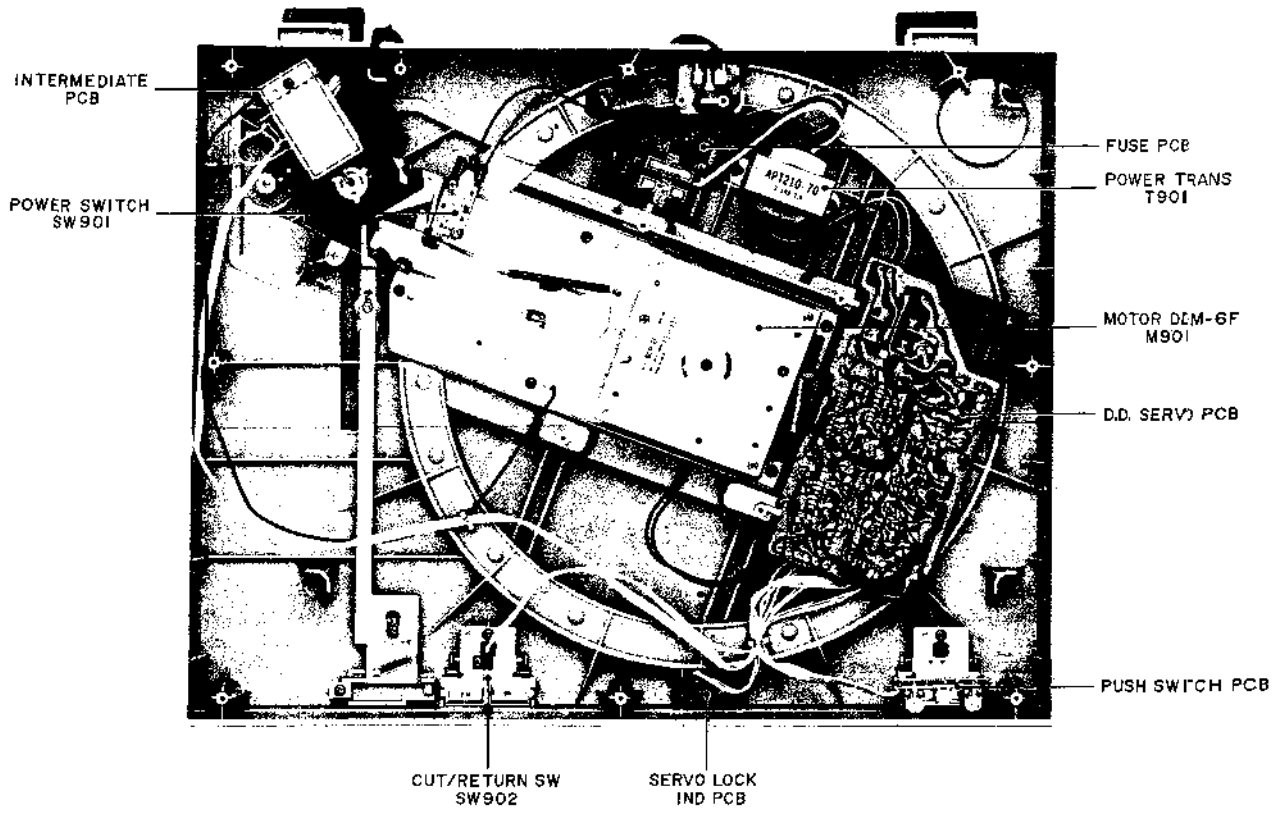
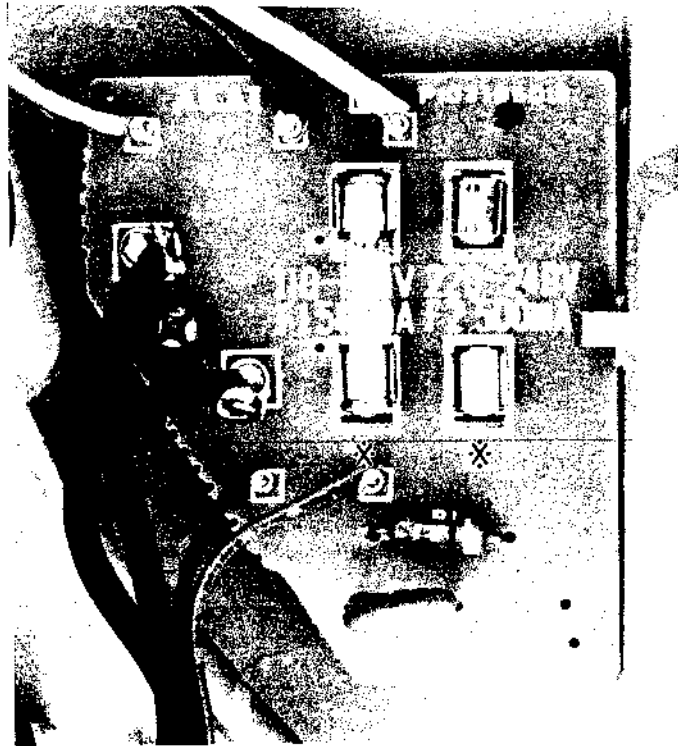

Fig. 2 Principal Parts Location (Bottom View)

V. VOLTAGE AND CYCLE CONVERSION



※	F1	F2
110V,120V AREA	500mA 250V	OPEN
220V,240V AREA	OPEN	500mA 250V

Fig. 3 Voltage Conversion (U Model Only)

1. VOLTAGE CONVERSION

Models for Canada, USA, Europe, UK and Australia are not equipped with this facility.

Each unit is preset at the factory depending on its destination, but some units can be converted to 110-120V or to 220-240V as required.

If voltage change is necessary, this can be accomplished as follows:

1. Disconnect the power cord.
2. Remove the bottom cover.
3. Remove the existing Line Voltage Fuse and insert the required Line Voltage Fuse in the proper fuse holder according to the printed instructions.

2. CYCLE CONVERSION

With DC servo motor, cycle conversion is not necessary.

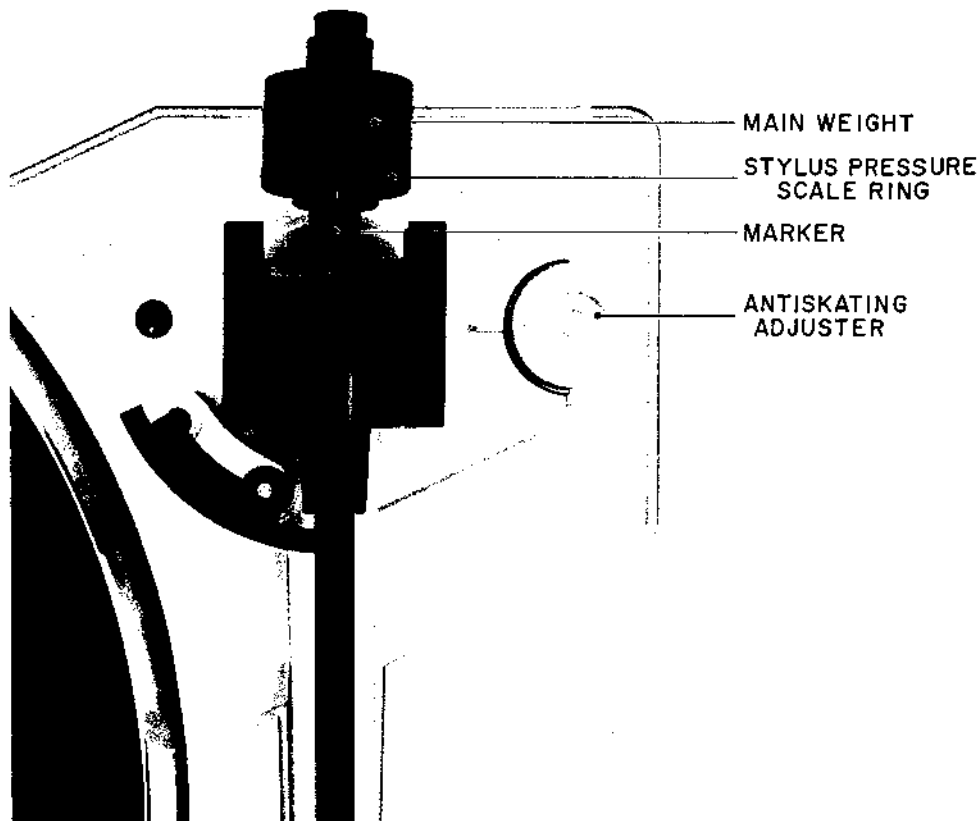
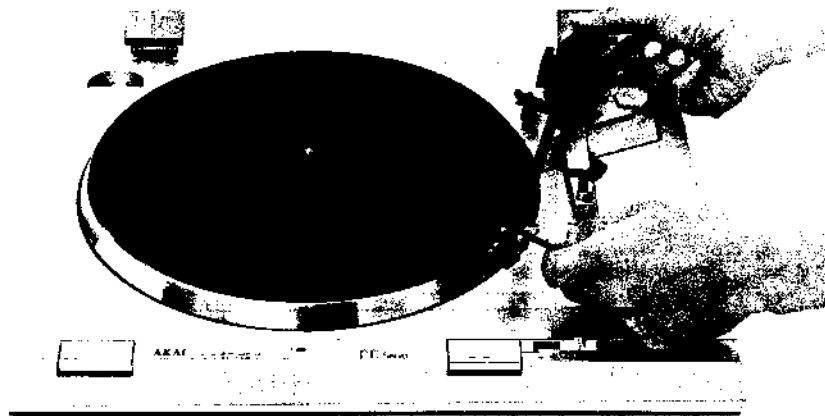

Fig. 4 Stylus Pressure Adjustment

1. STYLUS PRESSURE ADJUSTMENT

(Refer to Fig. 4)

1. Disconnect the Power Cord.
2. Set the ANTISKATING Adjuster to 0.
3. Unlock the Tone Arm and bring it towards the Platter.
 - * Remove the Stylus Guard being careful not to damage the stylus.
4. With the Tone Arm held midway between the Tone Arm Rest and the rim of the Platter, adjust the Main Weight until the Tone Arm is in perfect horizontal balance.
5. Without moving the Main Weight, rotate the Stylus Pressure Scale Ring only to match the "0"

- mark with the mark on the weight shaft.
6. Return the Tone Arm to the Tone Arm Rest.
7. Lock the Tone Arm in place and rotate the Main Weight counterclockwise, as viewed from the front (the Stylus Pressure Scale Ring will move with it), until the desired Stylus Pressure Scale indication is at the mark on the shaft.
 - The range of adjustment is from 0 to 2.5 grams.
 - * For AP-D210C only: The recommended stylus pressure for the cartridge supplied, PC-85, is 2 grams.
8. Set the ANTISKATING adjuster to the corresponding stylus pressure.

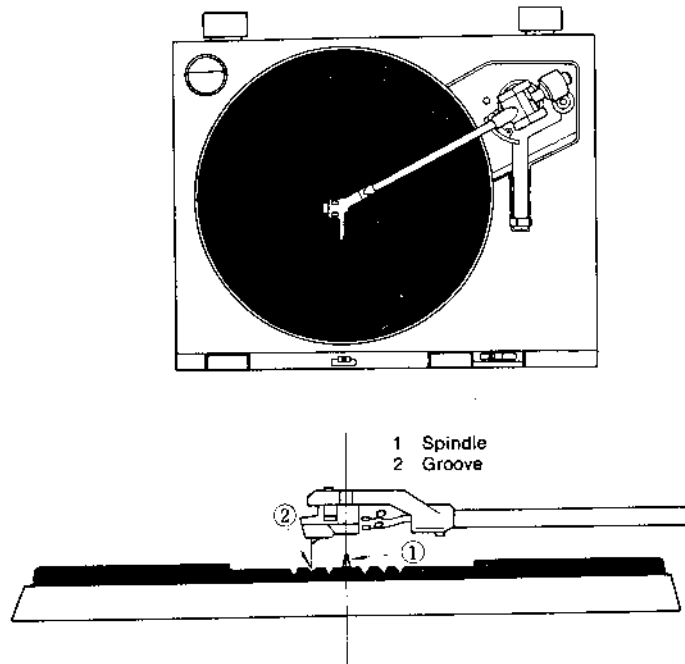

Fig. 5 Overhang Adjustment

2. OVERHANG ADJUSTMENT

(Refer to Fig. 5)

The distance between the Spindle and the Stylus when the Tone Arm is centered over the Platter is known as the overhang.

Different cartridges require different overhang adjustments.

For your convenience, the Rubber Mat has indicator grooves at the center to facilitate overhang adjustment.

1. Disconnect the Power Cord.
2. Center the Tone Arm over the Platter.
3. Adjust the cartridge so that the Stylus position is even with the Groove for Overhang Adjustment (middle groove ring).

* The cartridge position can be adjusted by resetting the Cartridge Re-setting Screws in the shell.

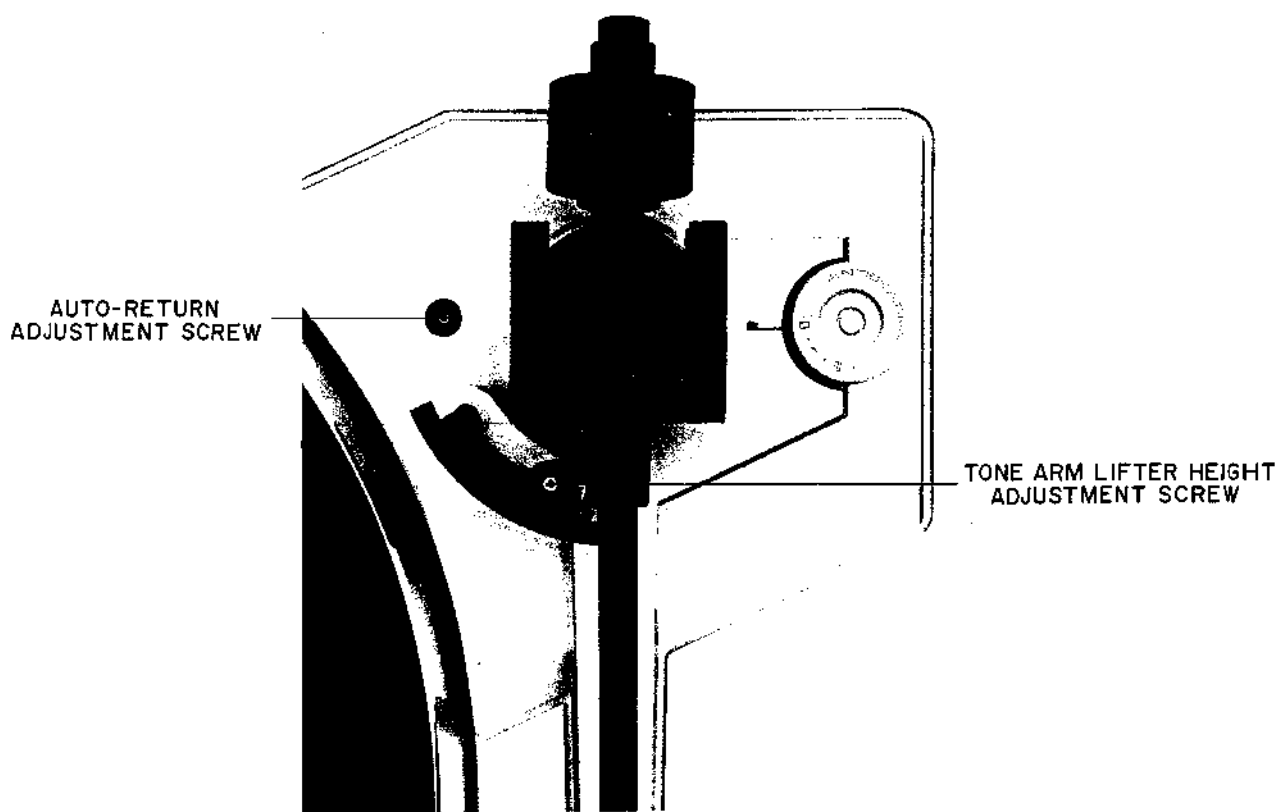

Fig. 6 Tone Arm Lifter Height Adjustment & Auto-Return Adjustment

3. TONE ARM LIFTER HEIGHT

ADJUSTMENT (Refer to Fig. 6)

With the Tone Arm in the up-position, the Stylus should be 3 to 6 mm above the surface of the record. If it is not, increase the height by adjusting the Tone Arm Lifter Height Adjustment Screw.

Clockwise: Down

Counterclockwise: Up

4. AUTO-RETURN ADJUSTMENT

(Refer to Fig. 6)

If the Tone Arm does not return automatically to the Tone Arm Rest at the end of the playback, or does so during playback:

1. Leave the Power Cord connected.
2. Adjust the Auto-Return Adjustment Screw.
 Turn clockwise: If the Tone Arm returns before the end of record.
 Turn counterclockwise: If the Tone Arm does not return at the end of record.

* Do not turn the Screw counterclockwise too much.

NOTE:

Akai recommends that a record be placed on the Platter and auto-return operation be carried out after each adjustment to confirm that the adjustment is successful.

VII. ELECTRICAL ADJUSTMENT

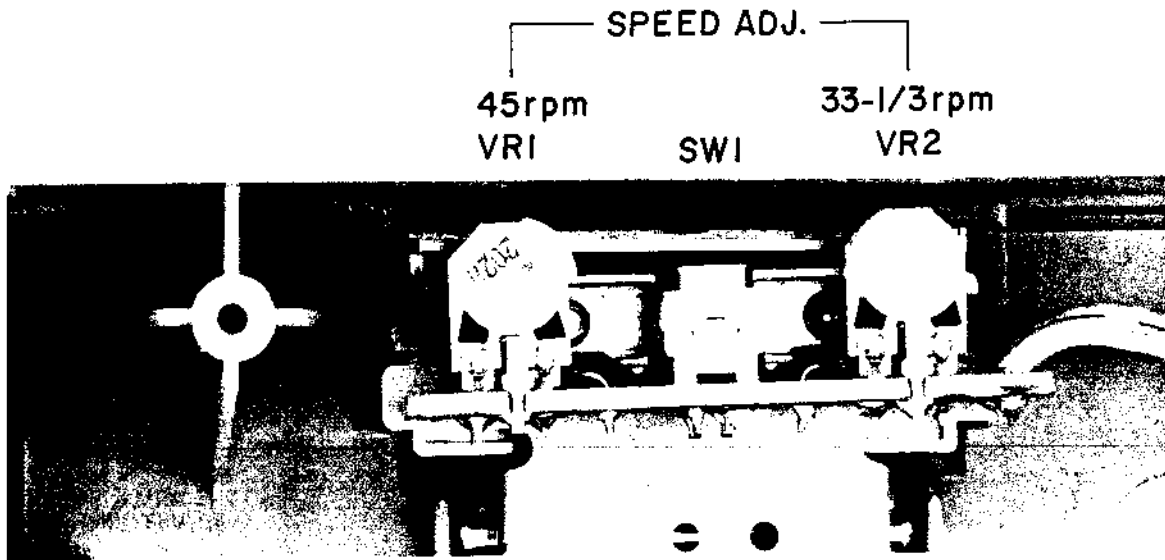

Fig. 7 Push Switch PCB

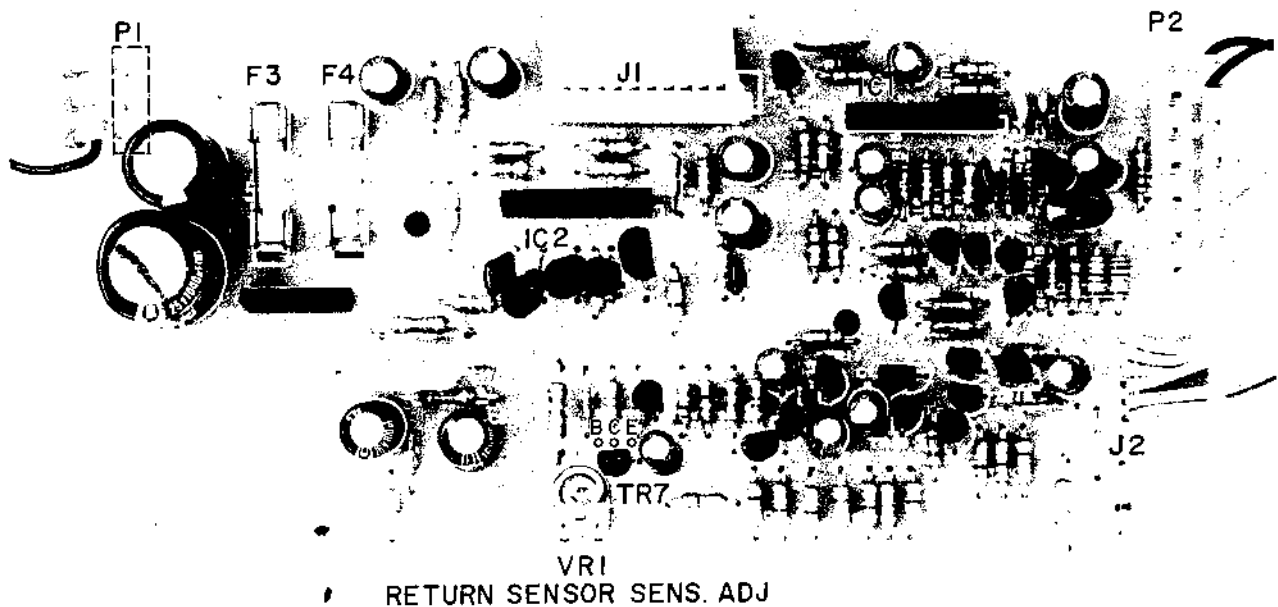

Fig. 8 D.D. Servo PCB

1. SPEED ADJUSTMENT (Refer to Fig. 7)

- 1) Set the Speed Selector to 33-1/3 rpm.
- 2) Playback the Test Record (33-1/3 rpm, 1,000 Hz).
- 3) Adjust VR2 (2 k Ω) so that the speed is 1,000 \pm 5 Hz.
- 4) Set the Speed Selector to 45 rpm.
- 5) Playback the Test Record (45 rpm, 1,000 Hz).
- 6) Adjust VR1 (2 k Ω) so that the speed is 1,000 \pm 5 Hz.

2. RETURN SENSOR SENSITIVITY ADJUSTMENT (Refer to Fig. 8)

- 1) Move the Tone Arm and turn on the power.
- 2) Connect the DC Voltmeter to Base of TR7.
- 3) Adjust VR1 (5 k Ω) so that the Base Voltage of TR7 is 2 \pm 1V.

VIII. CLASSIFICATION OF VARIOUS P.C BOARDS

1. P.C BOARD TITLES AND IDENTIFICATION NUMBERS

P.C Board Title	P.C Board Number	* Notes
D.D. Servo P.C Board	P1021B501A	U
"	P1021B502A	C, A
"	P1021B503A	E, V, H, S
"	P1021B504A	B
"	P1021B505A	J
Fuse P.C Board	P1021B501B	U
"	P1021B502B	C, A
"	P1021B503B	E, V, H, S
"	P1021B504B	B
"	P1021B505B	J
Push Switch P.C Board	P1021B501C	U
"	P1021B502C	C, A
"	P1021B503C	E, V, H, S
"	P1021B504C	B
"	P1021B505C	J
Servo Lock LED P.C Board	P1021B501D	
Sensor P.C Board	P1021B501E	
CDS P.C Board	P1021B501F	
Intermediate P.C Board	P1021B501G	

*Notes

Symbol For Distination

U: Universal Area
C: Canada
S: Australia

A: America
E: Europe
V: Germany

B: UK
J: Japan
H: Hungary

2. COMPOSITION OF VARIOUS P.C BOARDS

- 1) D.D. SERVO P.C BOARD P1021B501A, P1021B502A, P1021B503A, P1021B504A, P1021B505A PUSH SWITCH P.C BOARD P1021B501C, P1021B502C, P1021B503C, P1021B504C, P1021B505C, SERVO LOCK LED P.C BOARD P1021B501D, SENSOR P.C BOARD P1021B501E, CDS P.C BOARD P1021B501F

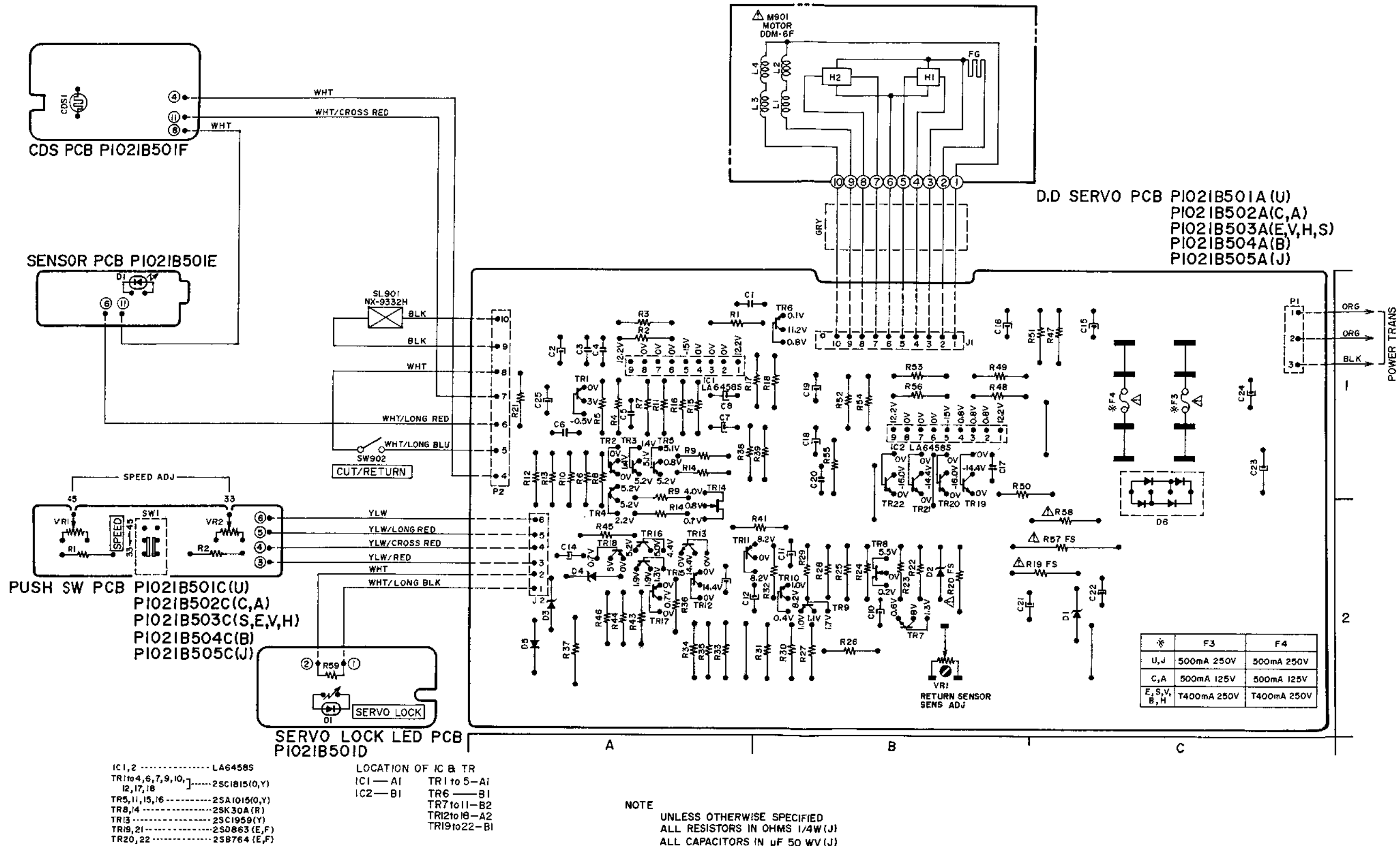

2) INTERMEDIATE P.C BOARD P1021B501G

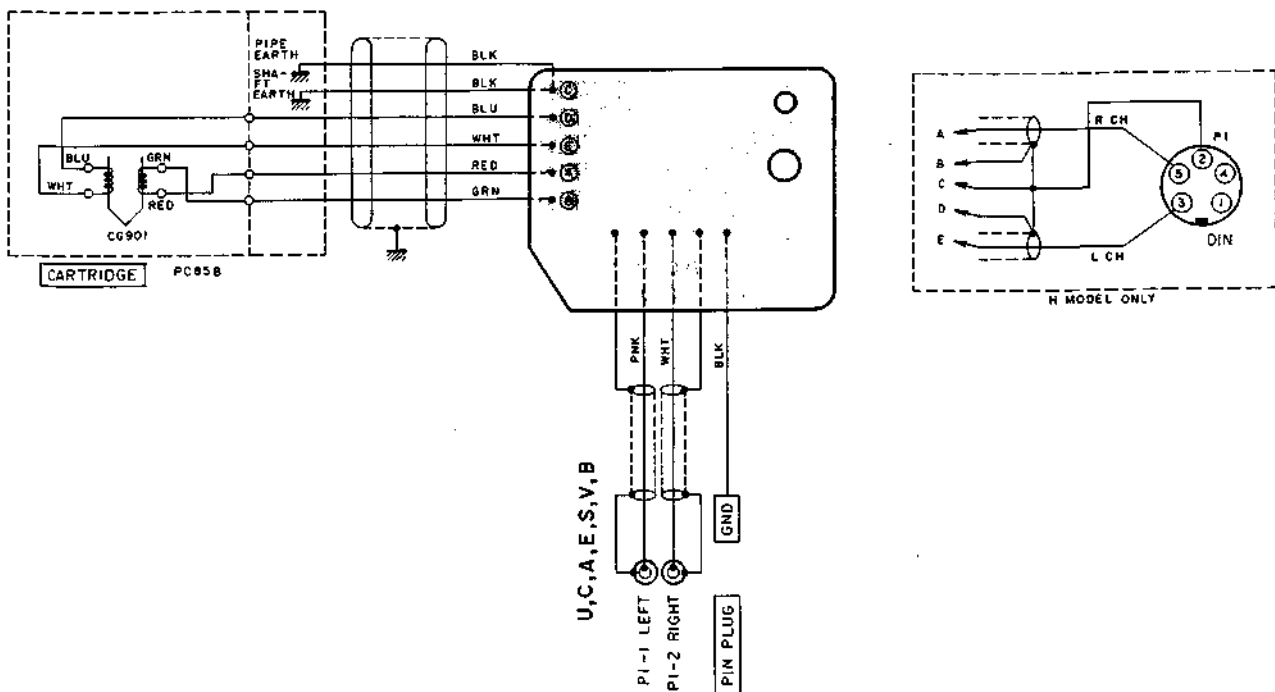

3) FUSE P.C BOARD (U) P1021B501C

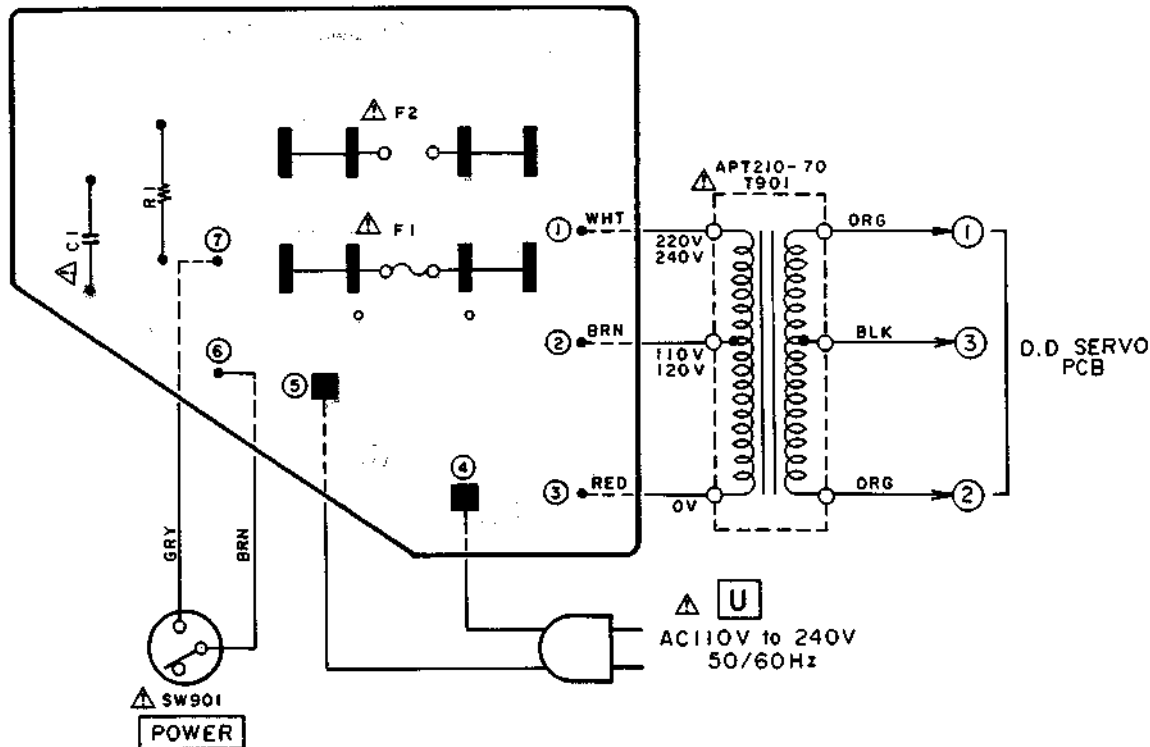

*	110V/120V	220V/240V
F1	500mA 250V	OPEN
F2	OPEN	500mA 250V

WARNING: Δ INDICATES SAFETY CRITICAL COMPONENTS. FOR CONTINUED SAFETY, REPLACE SAFETY CRITICAL COMPONENTS ONLY WITH MANUFACTURER'S RECOMMENDED PARTS.
 AVERTISSEMENT: Δ IL INDIQU LES COMPOSANTS CRITIQUES DE SÛRETÉ. POUR MAINTENIR LE DEGRÉ DE SÛRETÉ DE L'APPAREIL, NE REMPLACER LES COMPOSANTS DONT LE FONCTIONNEMENT EST CRITIQUE POUR LA SÛRETÉ QUE PAR DES PIÈCES RECOMMANDÉES PAR LE FABRICANT.

4) FUSE P.C BOARD (C,A) P1021B502C

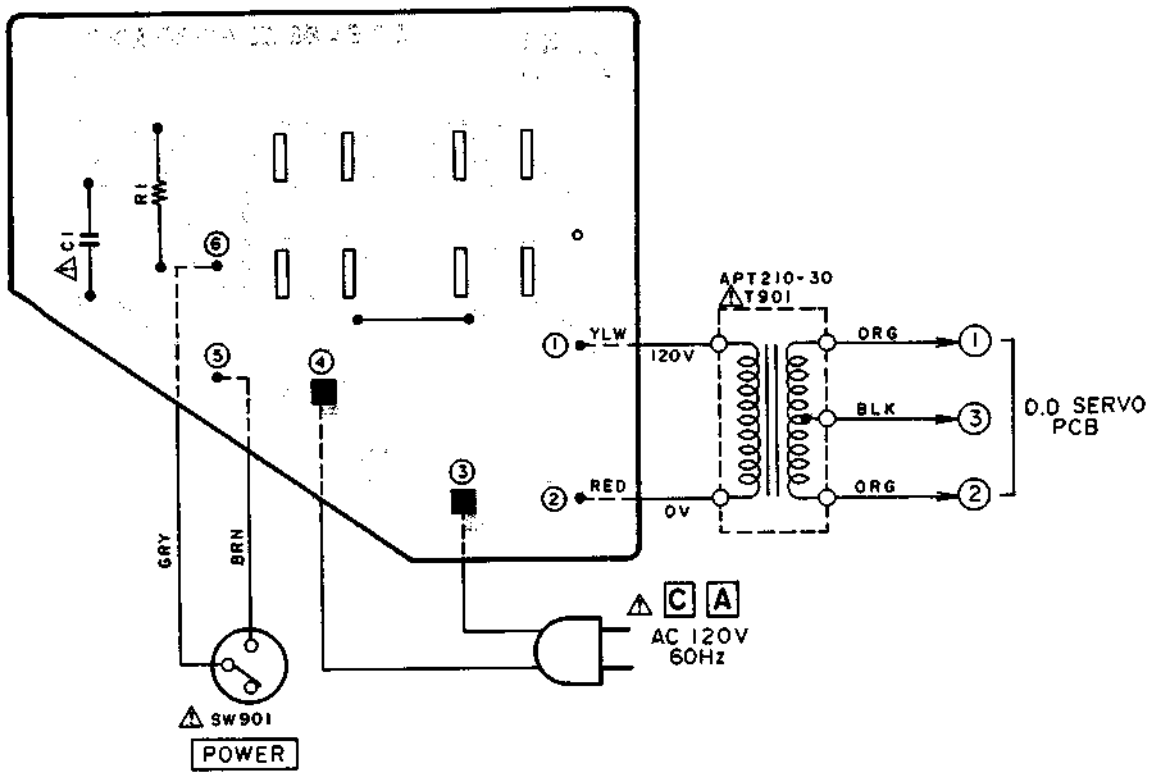

5) FUSE P.C BOARD (E,V,H,S) P1021B503C

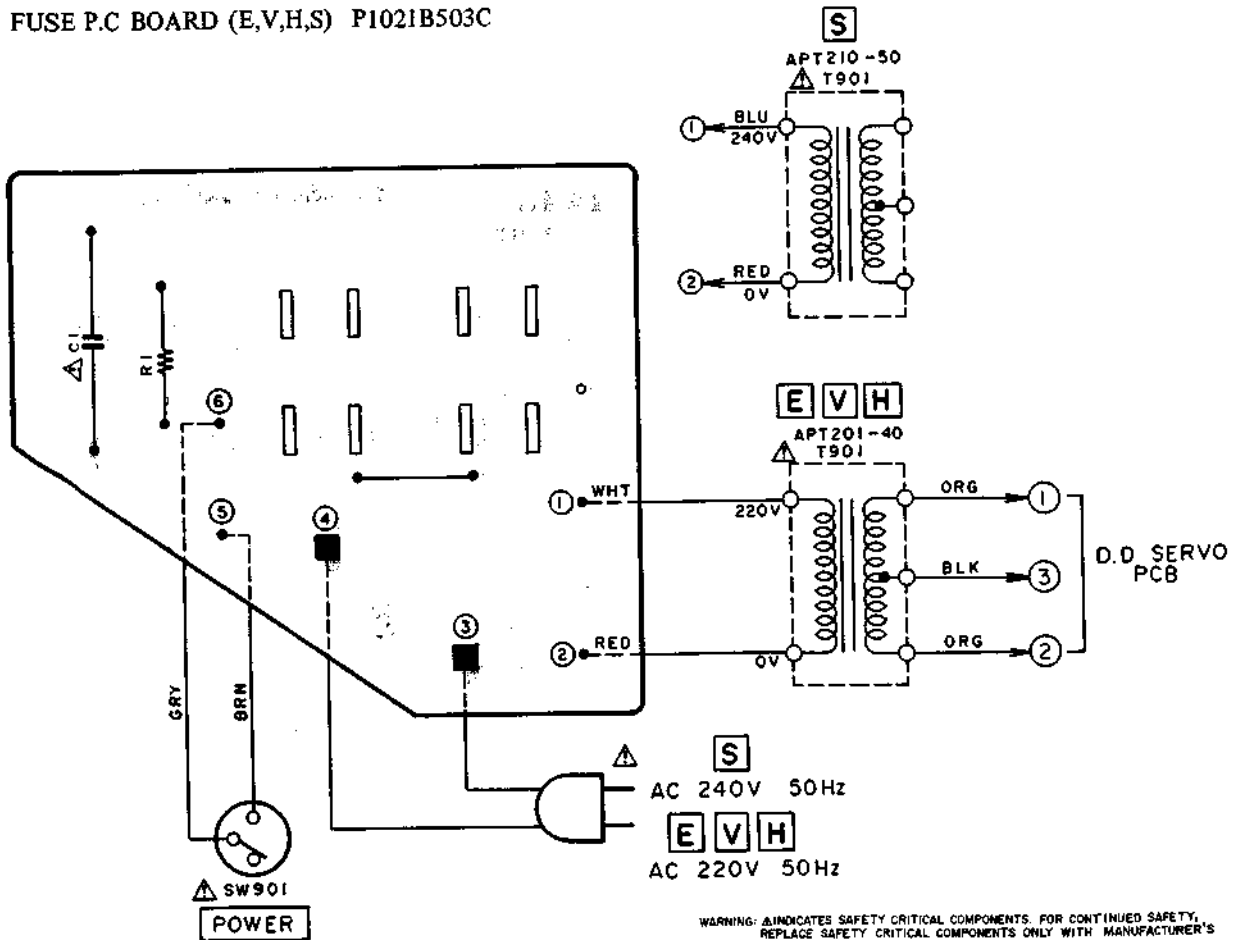

WARNING: ⚠ INDICATES SAFETY CRITICAL COMPONENTS. FOR CONTINUED SAFETY, REPLACE SAFETY CRITICAL COMPONENTS ONLY WITH MANUFACTURER'S RECOMMENDED PARTS.
 AVERTISSEMENT: ⚠ IL INDIQUE LES COMPOSANTS CRITIQUES DE SÛRETÉ. POUR MAINTENIR LE DEGRÉ DE SÛRETÉ DE L'APPAREIL, NE REMPLACER LES COMPOSANTS DONT LE FONCTIONNEMENT EST CRITIQUE POUR LA SÛRETÉ QUE PAR DES PIÈCES RECOMMANDÉES PAR LE FABRICANT.

6) FUSE P.C BOARD (B) P1021B504C

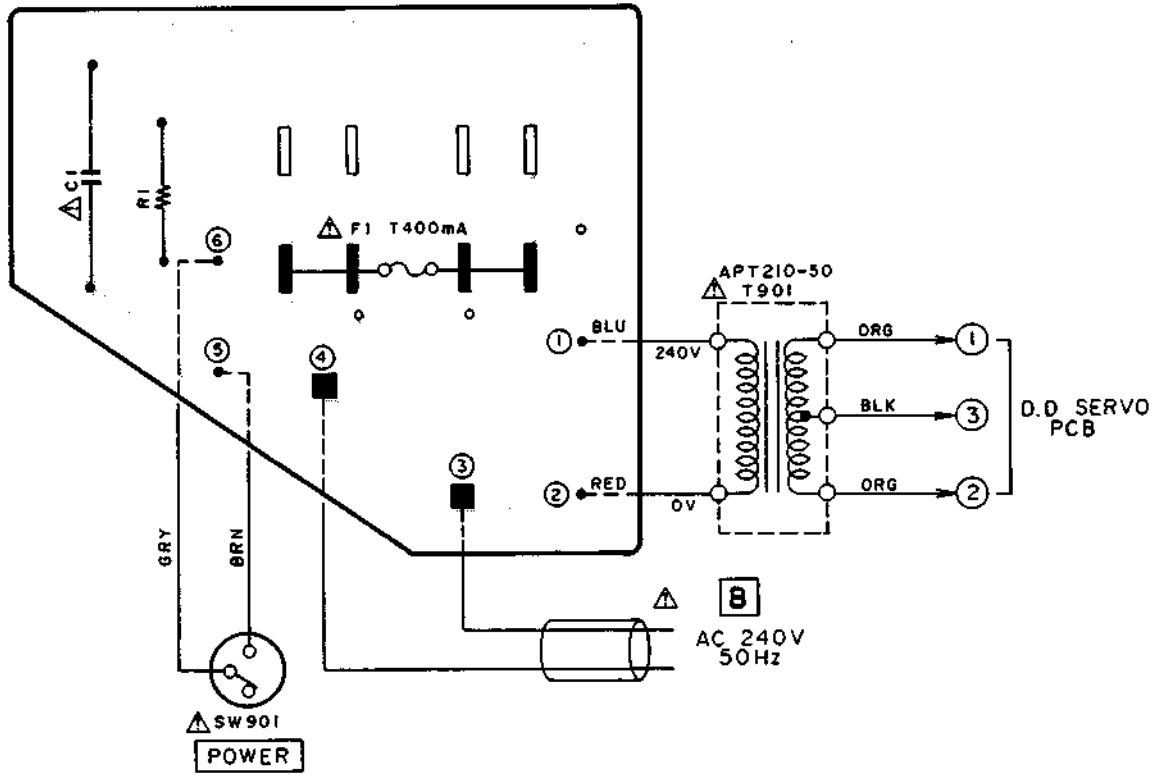

7) FUSE P.C BOARD (J) P1021B505C

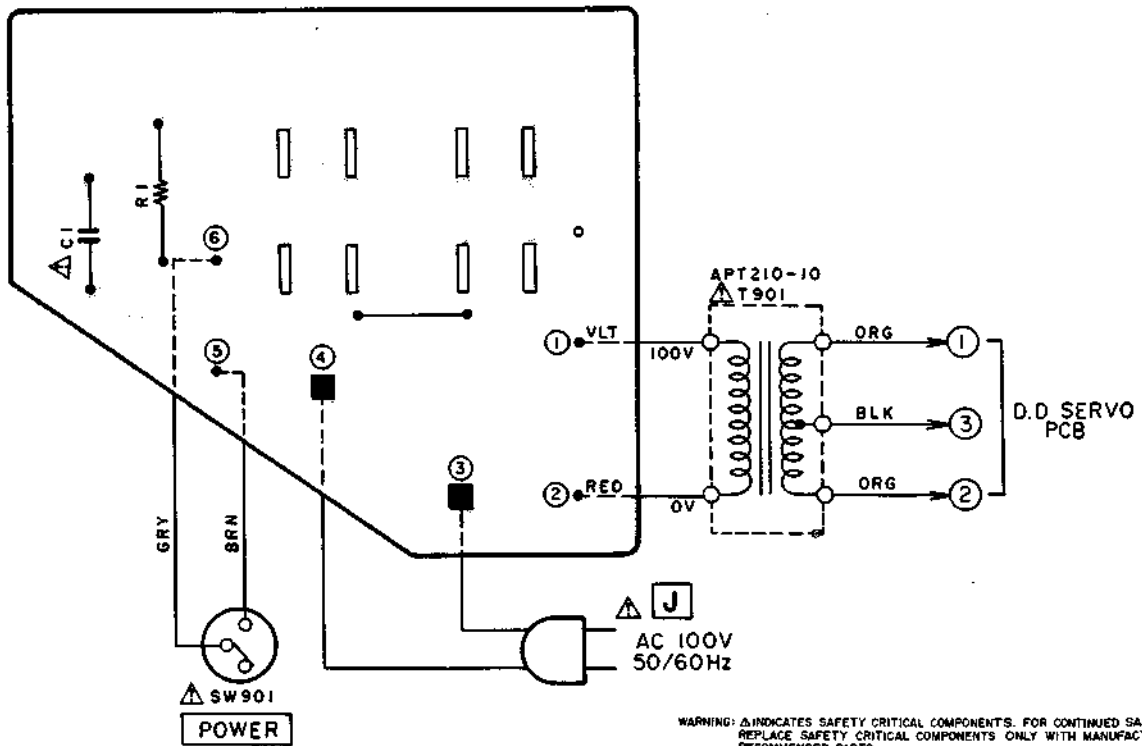

WARNING: Δ INDICATES SAFETY CRITICAL COMPONENTS. FOR CONTINUED SAFETY, REPLACE SAFETY CRITICAL COMPONENTS ONLY WITH MANUFACTURER'S RECOMMENDED PARTS.
 AVERTISSEMENT: Δ IL INDIQUE LES COMPOSANTS CRITIQUES DE SÛRETÉ. POUR MAINTENIR LE DEGRÉ DE SÛRETÉ DE L'APPAREIL, NE REMPLACER LES COMPOSANTS DONT LE FONCTIONNEMENT EST CRITIQUE POUR LA SÛRETÉ QUE PAR DES PIÈCES RECOMMANDÉES PAR LE FABRICANT.

SECTION 3

PARTS LIST

TABLE OF CONTENTS

I. MODEL AP-B110/C	31
1. RECOMMENDED SPARE PARTS	31
2. FINAL ASSEMBLY BLOCK	32
II. MODEL AP-D210/C	34
1. RECOMMENDED SPARE PARTS	34
2. D.D. SERVO P.C BOARD BLOCK	34
3. ASSEMBLY BLOCK	35
4. FINAL ASSEMBLY BLOCK	36
INDEX	37

Resistor and Capacitor which is not listed in this parts list, please refer to
COMMON LIST FOR SERVICE PARTS.

HOW TO USE THIS PARTS LIST

1. This parts list is compiled by various individual blocks based on assembly process.
2. When ordering parts, please describe parts number, serial number, and model number in detail.
3. How to read list.

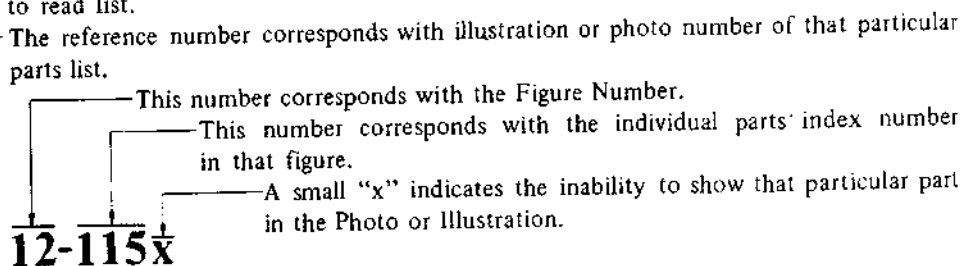

Ref. No.	Parts No.	Description
FLYWHEEL BLOCK #13		
12-115x	800425	Flywheel Block Assy. Comp.
12-116	244506	Flywheel Only
12-117x	244754	Felt, Flywheel
12-118	251324	Main Metal Case
12-119	253080	Main Metal

4. The symbol numbers shown on the P.C. Board list can be matched with the Composite Views of components of the Schematic Diagram or Service Manual.
5. The indications of Resistors and Capacitors in the photos of P.C. Board are being eliminated.
6. The shape of the parts and parts name, etc. can be confirmed by comparing them with the parts shown on the Electrical Parts Table of P.C. Board.
7. Both the kind of part and installation position can be determined by the Parts Number. To determine where a parts number is listed, utilize Parts Index at end of Parts List.
It is necessary first of all to find the Parts Number. This can be accomplished by using the Reference Number listed at right of parts number in the Parts Index. (meaning of ref. no. outlined in Item 3 above).
8. Utilize separate "Price List for Parts" to determine unit price. The most simple method of finding parts Price is to utilize the reference number.

CAUTION:

1. When placing an order for parts, be sure to list the parts no. model no., and description. There are instances in which if any of this information is omitted, parts cannot be shipped or the wrong parts will be delivered.
2. Please be careful not to make a mistake in the parts no. If the parts no. is in error, a part different from the one ordered may be delivered.
3. Because parts number and parts unit supply in the Preliminary Service Manual (Basic Parts List) may be partially changed, please use this parts list for all future reference.

WARNING: Δ INDICATES SAFETY CRITICAL COMPONENTS. FOR CONTINUED SAFETY, REPLACE SAFETY CRITICAL COMPONENTS ONLY WITH MANUFACTURER'S RECOMMENDED PARTS.

AVERTISSEMENT: Δ IL INDIQUE LES COMPOSANTS CRITIQUES DE SURETE. POUR MAINTENIR LE DEGRE DE SECURITE DE L'APPAREIL NE REMPLACER LES COMPOSANTS DONT LE FONCTIONNEMENT EST CRITIQUE POUR LA SECURITE QUE PAR DES PIECES RECOMMANDEES PAR LE FABRICANT.

I. MODEL AP-B110/C

1. RECOMMENDED SPARE PARTS

Because, if the parts listed below are on hand, almost any repair can be accomplished, we suggest that you stock these Recommended Spare Parts Items.

REF. NO.	PARTS NO.	DESCRIPTION
1-1	BM706466	△ MOTOR BLK IM-S275-12BUC11 (A,C)
1-2	BM706489	△ MOTOR BLK IM-S275-12C15 (E,B,S,V)
1-3	BM706490	△ MOTOR BLK IM-S275-12D15 (U)
1-4	EF706494	△ FUSE T 63MA (B)
1-5	EJ706493	△ HOLDER FUSE (B)
1-6	ER706465	△ SPARK KILLER
1-7	ES706464	△ SW MICRO
1-8	ES706492	△ SW VOLT CHANGE (U)
1-9	EW707626	△ AC CORD (U,C,A)
1-10	EW707627	△ AC CORD (E)
1-11	EW707628	△ AC CORD (B)
1-12	EW707629	△ AC CORD (S)
1-13	MB706483	BELT
1-14	MR706491	PULLEY (50Hz)
1-15	MR706469	PULLEY (60Hz)
1-16	TP706456	R GEAR PART
1-17	TP706471	TONE ARM BLK
1-18	TP706453	TT SHAFT PART

FINAL ASSEMBLY BLOCK

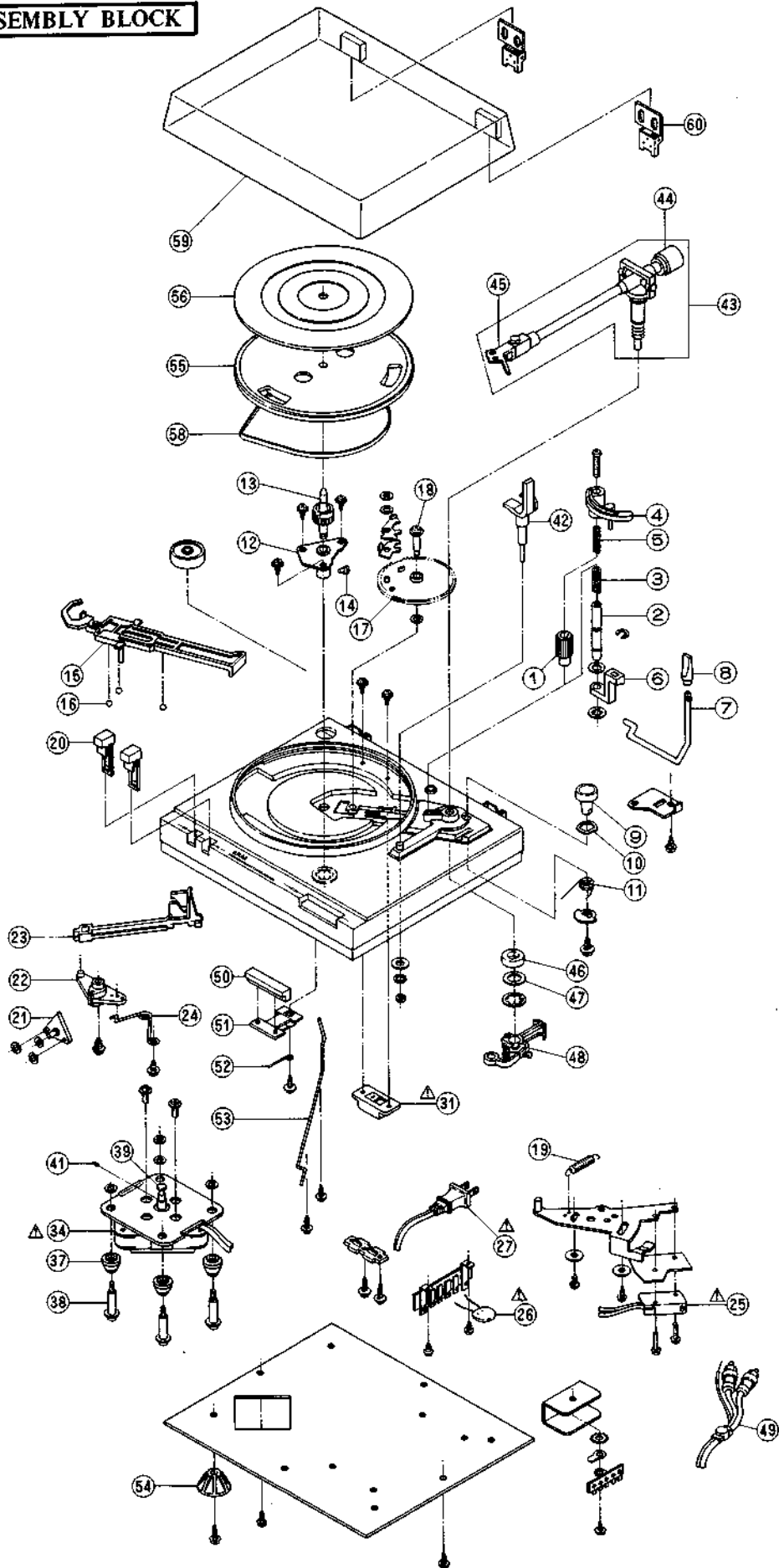

2. FINAL ASSEMBLY BLOCK

REF. NO.	PARTS NO.	DESCRIPTION
2-1	TP706441	BASE ELEVATION
2-2	TP706442	SHAFT ELEVATION
2-3	ZG706503	SP ELEVATION
2-4	TP706444	PLATE ELEVATION
2-5	ZG706445	SP
2-6	TP706446	ARM CUEING
2-7	TP706447	LEVER CUEING
2-8	SK706448	KNOB CUE
2-9	SK706449	KNOB IFC
2-10	ZW706450	W SP D6
2-11	ZG706451	SP IFC
2-12	TP706452	TT BEARING PART
2-13	TP706453	TT SHAFT PART
2-14	ZW706454	PIN
2-15	TP706455	ARM OPERATION
2-16	MV269965	BALL 400STL
2-17	TP706456	R GEAR PART
2-18	ZS706457	SPL SCREW
2-19	ZG706458	SP
2-20	SB706459	BUTTON PART
2-21	TP706460	ARM CHANGE
2-22	TP706461	CAM CHANGE
2-23	MB706462	GUIDE BELT
2-24	ZG706463	SP TORSION
2-25	ES706464	△ SW MICRO
2-26	ER706465	△ SPARK KILLER
2-27	EW707626	△ AC CORD (U,C,A)
2-28x	EW707627	△ AC CORD (E)
2-29x	EW707628	△ AC CORD (B)
2-30x	EW707629	△ AC CORD (S)
2-31	ES706492	△ SW VOLT CHANGE (U)
2-32x	EJ706493	△ HOLDER FUSE(B)
2-33x	EF706494	△ FUSE T 63MA (B)
2-34	BM706490	△ MOTOR BLK IM-S275-12D15 (U)
2-35x	BM706466	△ MOTOR BLK IM-S275-12BUC11 (A,C)
2-36x	BM706489	△ MOTOR BLK IM-S275-12C15 (E,B,S,V)
2-37	TP706467	RUBBER BUSH
2-38	ZS706468	SPL SCREW
2-39	MR706491	PULLEY (50Hz)
2-40x	MR706469	PULLEY (60Hz)
2-41	ZS499454	6 SET26x030SCM PKR HP
2-42	TP706470	ARM REST PART
2-43	TP706471	tone ARM BLK
2-44	TP706486	WEIGHT MAIN
2-45	TP706488	SHELL CARTRIDGE
2-46	ZW706472	WASHER RUBBER
2-47	ZW706473	WASHER RUBBER
2-48	TP706474	ARM DRIVER
2-49	EW325489	CORD P-54-075 2P AUDIO
2-50	SB706475	BUTTON REJECT
2-51	TP706477	ARM REJECT
2-52	ZG706478	SP BUTTON
2-53	ZG706479	SP REJECT
2-54	TP706480	INSULATOR
2-55	TP706481	PLATTER
2-56	TP707625	TABLE SHEET (EXCEPT A)
2-57x	TP706482	TABLE SHEET (A)
2-58	MB706483	BELT
2-59	BC706484	DUST COVER
2-60	TP706485	HINGE

II. MODEL AP-D210/C

1. RECOMMENDED SPARE PARTS

Because, if the parts listed below are on hand, almost any repair can be accomplished, we suggest that you stock these Recommended Spare Parts Items.

REF. NO.	PARTS NO.	DESCRIPTION
1-1	BMP1021A060A	△ MOTOR BLK AP-D210
1-2	BT336788	△ TRANS POWER APT210-10 (J)
1-3	BT336790	△ TRANS POWER APT210-30 (C,A)
1-4	BT336791	△ TRANS POWER APT210-40 (E,V,H)
1-5	BT336815	△ TRANS POWER APT210-50 (B,S)
1-6	BT336789	△ TRANS POWER APT210-70 (U)
1-7	ED322773	D LED SLP-255D-01 GRN
1-8	ED325341	D LED TLR-103 RED
1-9	ED321115	D SILICON H 1S1588LB-5 F-10
1-10	ED322238	D SILICON 1B4B41 100/1.0A
1-11	ED336823	D ZENER H 05Z4.7 X
1-12	ED324194	D ZENER H 05Z5.1 X
1-13	ED323535	D ZENER H 05Z8.2 X
1-14	EF300599	△ FUSE FST3100 T 250V 0.40A (E,V,B,S,H)
1-15	EF327103	△ FUSE TSC A 250V 0.50A (U,J)
1-16	EF309390	△ FUSE TSC 125V 0.50A (A,C)
1-17	EI336761	IC LA6458S
1-18	EP336821	△ SOLENOID NX-9332H (SL901)
1-19	ES325488	△ SW MICRO K1 UCE (SW901)
1-20	ES336814	SW LEAF MSW-1150NBK 01-1 NO (SW902)
1-21	ES307576	SW PUSH SUJ12 2-02-02N
1-22	ET336819	CDS MKY-76C348/A.K
1-23	ET336816	TR FET 2SK30A R
1-24	ET318237	TR 2SB764 E,F
1-25	ET306705	TR 2SC1815 O,Y
1-26	ET325482	TR 2SC1959 Y
1-27	ET316643	TR 2SC536K-NP F,G
1-28	ET318239	TR 2SD863 E,F
1-29	EV315412	R S-FIX H D8 3P 502
1-30	EV336817	R S-FIX V TM8KH1-1S 3P 0.50W 202
1-31	TPP1021A070A	GEAR MAIN BLK AP-D210
1-32	TP336839	TONE ARM W/SHELL ARM-210

2. D.D. SERVO P.C BOARD BLOCK

REF. NO.	PARTS NO.	DESCRIPTION
2-1	BAP1021A140A	PC DD SERVO BLK AP-D210(A)
2-2	BAP1021A140B	PC DD SERVO BLK AP-D210(E) (E,V,S)
2-3	BAP1021A140C	PC DD SERVO BLK AP-D210-C(U)
2-4	BAP1021A140D	PC DD SERVO BLK AP-D210-C(J)
2-5	BAP1021A140E	PC DD SERVO BLK AP-D210-C(B)
2-6	BAP1021A140F	PC DD SERVO BLK AP-D210-C(C)
2-7	BAP1021A140G	PC DD SERVO BLK AP-D210CH(Y)(H)

D.D. SERVO P.C BOARD BLOCK

2-IC1,2	EI336761	IC LA6458S
2-TR1to4	ET306705	TR 2SC1815 O,Y
2-TR5	ET325501	TR 2SA1015 O,Y
2-TR6,7	ET306705	TR 2SC1815 O,Y
2-TR8	ET336816	TR FET 2SK30A R
2-TR9,10	ET316643	TR 2SC536K-NP F,G
2-TR11	ET325501	TR 2SA1015 O,Y
2-TR12	ET306705	TR 2SC1815 O,Y
2-TR13	ET325482	△ TR 2SC1959 Y
2-TR14	ET336816	TR FET 2SK30A R
2-TR15,16	ET325501	TR 2SA1015 O,Y
2-TR17,18	ET306705	TR 2SC1815 O,Y
2-TR19	ET318239	△ TR 2SD863 E,F
2-TR20	ET318237	△ TR 2SB764 E,F
2-TR21	ET318239	△ TR 2SD863 E,F
2-TR22	ET318237	△ TR 2SB764 E,F
2-D1	ED324194	D ZENER H 05Z5.1 X
2-D2	ED323535	D ZENER H 05Z8.2 X
2-D3	ED324194	D ZENER H 05Z5.1 X
2-D4	ED336823	D ZENER H 05Z4.7 X
2-D5	ED321115	D SILICON H 1S1588LB-5 F10
2-D6	ED322238	△ D SILICON 1B4B41 100/1.0A
2-VR1	EV315412	R S-FIX H D8 3P 502
2-R8	ER336820	R MF H F10 1/4W 4703F
2-R12	ER318319	R MF H F10 1/4W 1002F
2-R13	ER318317	R MF H F10 1/4W 8201F
2-R19	ER308849	△ R CB H SNP FS RD 1/4W 221J
2-R20	ER308873	△ R CB H SNP FS RD 1/4W 151J
2-R37	ER308849	△ R CB H SNP FS RD 1/4W 221J
2-R57	ER304256	△ R OMF H 2W 560J
2-R58	ER308849	△ R CB H SNP FS RD 1/4W 221J
2-F3,4	EF309390	△ FUSE TSC 125V 0.50A (C,A)
2-F3,4	EF300599	△ FUSE FST3100 T 250V 0.40A (E,V,B,S,H)
2-F3,4	EF327103	△ FUSE TSC A 250V 0.50A (U,J)

PUSH SWITCH P.C BOARD BLOCK

2-SW1	ES307576	SW PUSH SUJ12 2-02-02N
2-VR1,2	EV336817	R S-FIX V TM8KH1-1S 3P 0.5W 202
2-R1	ER318318	R MF H F10 1/4W 9101F
2-R2	ER318337	R MF H F10 1/4W 6801F

FUSE P.C BOARD BLOCK

2-F1,2	EF327103	△ FUSE TSC A 250V 0.50A (U)
2-F1	EF300599	△ FUSE FST3100 T 250V 0.40A (U)
2-C1	EC314688	△ C CE V FZ 103P 125AC (C,A)
2-C1	EC330308	△ C MMY V ECQUF 103M 250AC (E,V,B,S,H)
2-C1	EC320548	△ C CE V F 103Z 250AC (U,J)

SERVO LOCK LED P.C BOARD BLOCK

2-D1	ED322773	D LED SLP-255D-01 GRN
------	----------	-----------------------

SENSOR P.C BOARD BLOCK

2-D1	ED325341	D LED TLR-103 RED
------	----------	-------------------

CDS P.C BOARD BLOCK

2-CDS1	ET336819	CDS MKY-76C348/A.K
--------	----------	--------------------

INTERMEDIATE P.C BOARD BLOCK

2-P1	EW325489	CORD P-54-075 2P AUDIO
2-P1	EW325492	CORD 2P AUDIO
2-P1	EW321078	CORD TH-54-154 5P AUDIO

ASSEMBLY BLOCK

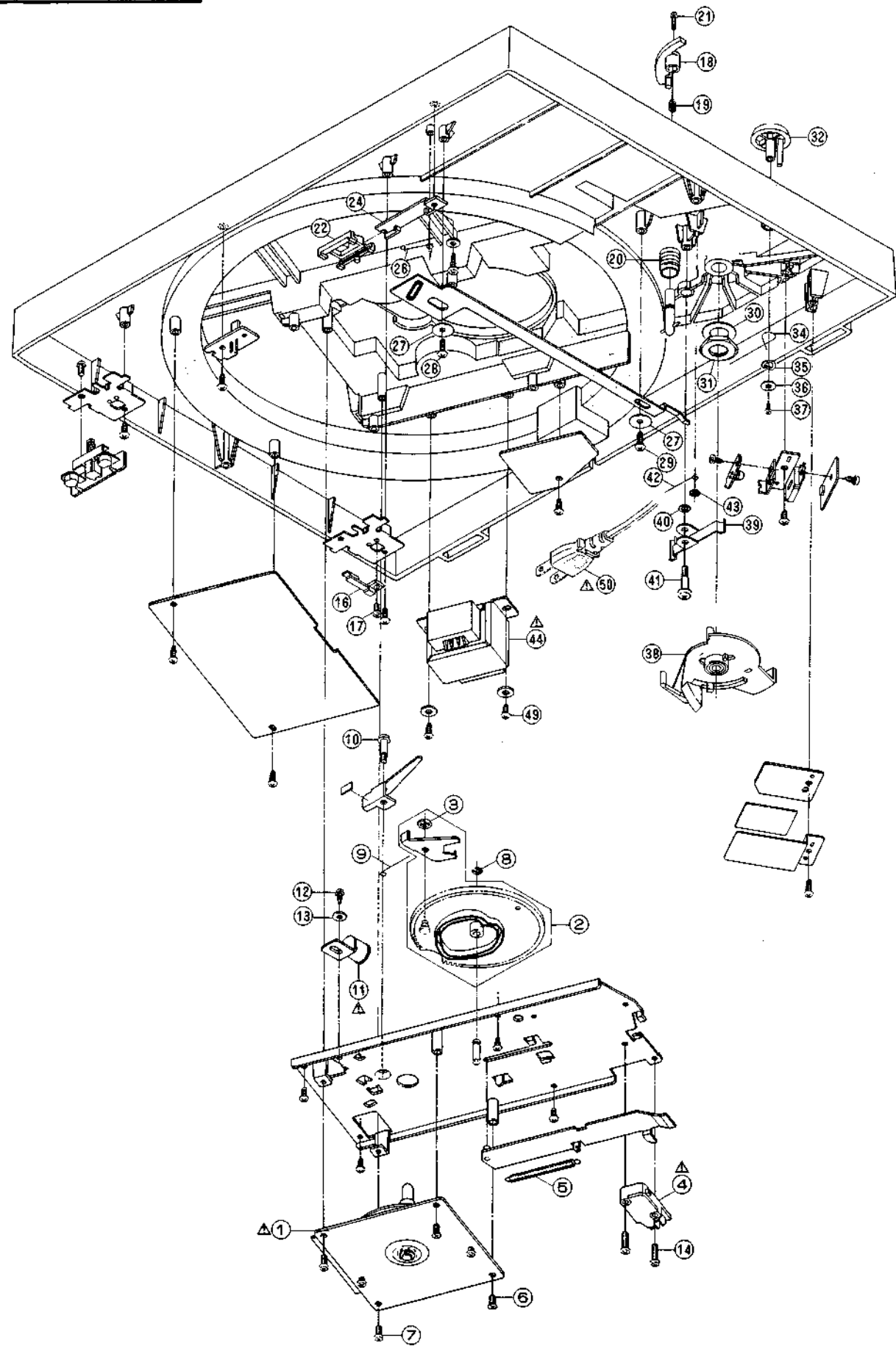

3. ASSEMBLY BLOCK

REF. NO.	PARTS NO.	DESCRIPTION
MOTOR BLOCK		
3-1	BMP1021A060A	△ MOTOR BLK AP-D210
GEAR MAIN BLOCK		
3-2	TPP1021A070A	GEAR MAIN BLK AP-D210
3-3	ZW653163	RING CS280STL PKR
SW MICRO BLOCK		
3-4	ES325488	△ SW MICRO K1 UCE (SW901)
CHASSIS MAIN BLOCK		
3-5	ZG313008	SP T1-4.0/0.4-50.0 T1-121
3-6	ZS414033	CTS30x08STL CMT
3-7	ZS666336	T2PAN30x08STL CMT
3-8	ZW270101	RING E300SUP CMT
3-9	ZG332558	SP TORSION REJECT
3-10	MS302757	STOPPER SHAFT
3-11	EP336821	△ SOLENOID NX-9332H
3-12	ZS325495	T2BR30x06STL CMT
3-13	ZW261382	PW31x080x030STL
3-14	ZS419670	PAN30x12STL CMT
3-15x	ZS302778	PAN30x15PCN
SW LEAF BLOCK		
3-16	ES336814	SW LEAF MSW-1150NBK 01-1 NO
3-17	ZS468101	T2PAN26x06STL CMT
ASSEMBLY BLOCK		
3-18	TPB332568	ARM ELEVATION PART
3-19	ZG332548	SP PUSH (A)
3-20	ZG325402	ELEVATION SPRING
3-21	ZS572804	PAN20x10STL NI3
3-22	SK332583A	KNOB ELEVATION
3-23x	SK332583B	KNOB ELEVATION-P
3-24	TP332584A	GUIDE KNOB
3-25x	TP332584B	GUIDE KNOB-P
3-26	ZG332549	SP TORSION STOPPER
3-27	ZW324147	PW31x130x100NYL
3-28	ZS323993	PT BR30x10STL CMT
3-29	ZS609131	T2PAN30x12STL CMT
3-30	ZW336398	PW130x200x050STL CMT
3-31	ZW325521	N120x170x30STL CMT P100
3-32	SK332551A	KNOB CANCELLER
3-33x	SK332551B	KNOB CANCELLER-P
3-34	ZG332552A	SP TORSION CANCELLER (A)
3-35	ZW315478	WAVE WASHER D5 SUS
3-36	ZW429120	PW23x090x050STL CMT
3-37	ZS669104	T2PAN13x06STL CMT
3-38	TPP1021A090A	LEVER PU BLK AP-D210
3-39	TP332559	LEVER BRAKE
3-40	ZW-616004	PW31x080x100STL CMT
3-41	ZS325426	TAPPING ROLLER SCREW
3-42	ZG332558	SP TORSION REJECT
3-43	ZW340648	RING CS190STL PKR
3-44	BT336789	△ TRANS POWER APT210-70 (U)
3-45x	BT336788	△ TRANS POWER APT210-10 (J)
3-46x	BT336790	△ TRANS POWER APT210-30 (C,A)
3-47x	BT336791	△ TRANS POWER APT210-40 (E,V,H)
3-48x	BT336815	△ TRANS POWER APT210-50 (B,S)
3-49	ZS310984	PT BR30x08STL CMT
3-50	EW306428	△ AC CORD 2 CORES KP-205A, VFF J (U)
3-51x	EW306427	△ AC CORD 2 CORES KP-211, VFF J (J)
3-52x	EW305691	△ AC CORD 2 CORES KP-8,SPT-1 UC (C,A)
3-53x	EW313882	△ AC CORD 2 CORES KP-419C,LTCE-2F E (E,V,H)
3-54x	EW313884	△ AC CORD 2 CORES GTBS-2F 24/0.20x2 B (B)
3-55x	EW201515	△ AC CORD 2 CORES KP-560,LTSA-2F S (S)

FINAL ASSEMBLY BLOCK

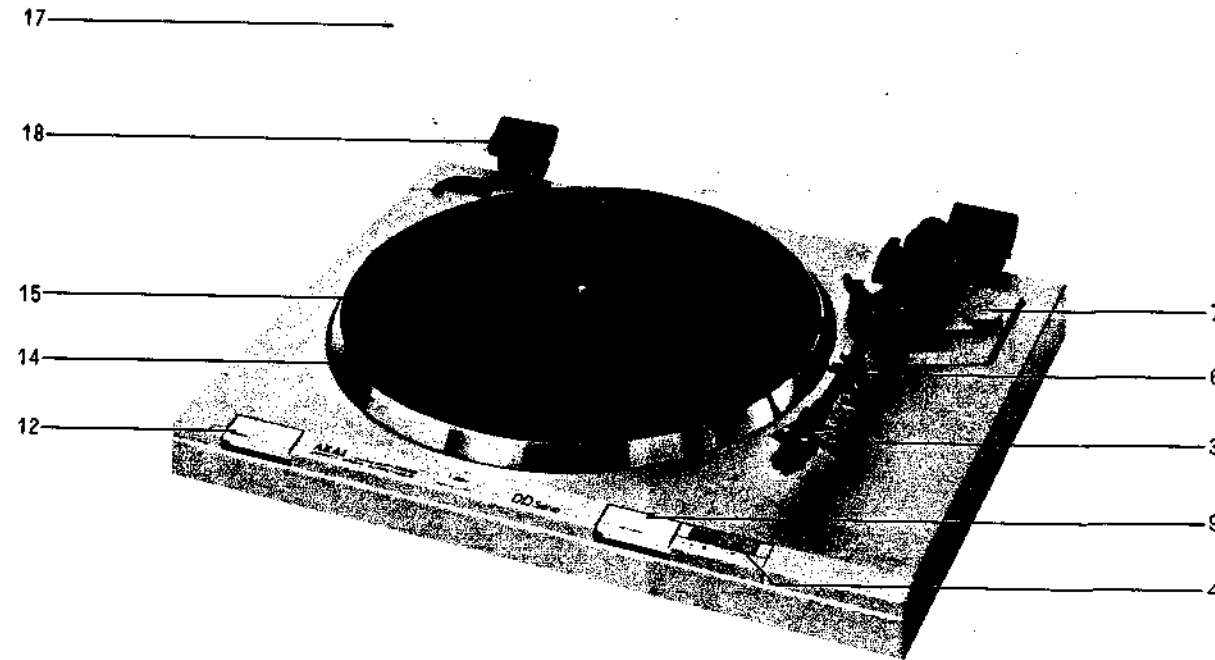

4. FINAL ASSEMBLY BLOCK

REF. NO.	PARTS NO.	DESCRIPTION
COVER BOTTOM BLOCK		
4-1x	SP332564	COVER BOTTOM
4-2x	TP332577	INSULATOR
TONE ARM BLOCK		
4-3	TP336839	TONE ARM W/SHELL ARM-210
FINAL ASSEMBLY BLOCK		
4-4	SK332583A	KNOB ELEVATION
4-5x	SK332583B	KNOB ELEVATION-P
4-6	TPB332571	CLAMPER ARM PART
4-7	SK332551A	KNOB CANCELLER
4-8x	SK332551B	KNOB CANCELLER-P
4-9	SK332560C	KNOB SW (B)
4-10x	SK332560D	KNOB SW (B)-P
4-11x	ZG325402	ELEVATION SPRING
4-12	SK332560A	KNOB SW (A)
4-13x	SK332560B	KNOB SW (A)-P
4-14	TPB332578	PLATTER PART
4-15	TP332566A	TABLE SHEET (A)
4-16x	TP332566B	TABLE SHEET (B)
4-17	TPB332582	DUST COVER PART
4-18	TP336361	AUTO HINGE OH-5
4-19x	TP336362	AUTO HINGE OH-5-BL

INDEX

I. MODEL AP-B110/C

PARTS NO.	REF. NO.	PARTS NO.	REF. NO.	PARTS NO.	REF. NO.	PARTS NO.	REF. NO.	PARTS NO.	REF. NO.
BC706484	2-59	TP706455	2-15						
BM706466	2-35x	TP706456	2-17						
BM706489	2-36x	TP706460	2-21						
BM706490	2-34	TP706461	2-22						
EF706494	2-33x	TP706467	2-37						
EJ706493	2-32x	TP706470	2-42						
ER706465	2-26	TP706471	2-43						
ES706464	2-25	TP706474	2-48						
ES706492	2-31	TP706477	2-51						
EW325489	2-49	TP706480	2-54						
EW707626	2-27	TP706481	2-55						
EW707627	2-28x	TP706482	2-57x						
EW707628	2-29x	TP706485	2-60						
EW707629	2-30x	TP706486	2-44						
MB706462	2-23	TP706488	2-45						
MB706483	2-58	TP707625	2-56						
MR706469	2-40x	ZG706445	2-5						
MR706491	2-39	ZG706451	2-11						
MV269965	2-16	ZG706458	2-19						
SB706459	2-20	ZG706463	2-24						
SB706475	2-50	ZG706478	2-52						
SK706448	2-8	ZG706479	2-53						
SK706449	2-9	ZG706503	2-3						
TP706441	2-1	ZS499454	2-41						
TP706442	2-2	ZS706457	2-18						
TP706444	2-4	ZS706468	2-38						
TP706446	2-6	ZW706450	2-10						
TP706447	2-7	ZW706454	2-14						
TP706452	2-12	ZW706472	2-46						
TP706453	2-13	ZW706473	2-47						

2. MODEL AP-D210/C

PARTS NO.	REF. NO.	PARTS NO.	REF. NO.	PARTS NO.	REF. NO.	PARTS NO.	REF. NO.	PARTS NO.	REF. NO.
BAF1021A140A	2-1	ER336820	2-R8	SK332583A	3-22	ZW261382	3-13		
BAF1021A140B	2-2	ES307576	2-SW1	SK332583A	4-4	ZW270101	3-8		
BAF1021A140C	2-3	ES325488	3-4	SK332583B	3-23x	ZW315478	3-35		
BAF1021A140D	2-4	ES336814	3-16	SK332583B	4-5x	ZW324147	3-27		
BAF1021A140E	2-5	ET306705	2-TR1to4	SP332564	4-1x	ZW325521	3-31		
BAF1021A140F	2-6	ET306705	2-TR6, 7	TPB332568	3-18	ZW336398	3-30		
BAF1021A140G	2-7	ET306705	2-TR12	TPB332571	4-6	ZW340648	3-43		
BMP1021A060A	3-1	ET306705	2-TR17,18	TPB332578	4-14	ZW429120	3-36		
BT336788	3-45x	ET316643	2-TR9, 10	TPB332582	4-17	ZW616004	3-40		
BT336789	3-44	ET318237	2-TR20	TPP1021A070A	3-2	ZW653163	3-3		
BT336790	3-46x	ET318237	2-TR22	TPP1021A090A	3-38				
BT336791	3-47x	ET318239	2-TR19	TP332559	3-39				
BT336815	3-48x	ET318239	2-TR21	TP332566A	4-15				
EC314688	2-C1	ET325482	2-TR13	TP332566B	4-16x				
EC320548	2-C1	ET325501	2-TR5	TP332577	4-2x				
EC330308	2-C1	ET325501	2-TR11	TP332584A	3-24				
ED321115	2-D5	ET325501	2-TR15,16	TP332584B	3-25x				
ED322238	2-D6	ET336816	2-TR8	TP336361	4-18				
ED322773	2-D1	ET336816	2-TR14	TP336362	4-19x				
ED323535	2-D2	ET336819	2-CDS1	TP336839	4-3				
ED324194	2-D1	EV315412	2-VR1	ZG313008	3-5				
ED324194	2-D3	EV336817	2-VR1, 2	ZG325402	3-20				
ED325341	2-D1	EW201515	3-55x	ZG325402	4-11x				
ED336823	2-D4	EW305691	3-52x	ZG332548	3-19				
EF300599	2-F3, 4	EW306427	3-51x	ZG332549	3-26				
EF300599	2-F1	EW306428	3-50	ZG332552A	3-34				
EF309390	2-F3, 4	EW313882	3-53x	ZG332558	3-9				
EF327103	2-F3, 4	EW313884	3-54x	ZG332558	3-42				
EF327103	2-F1, 2	EW321078	2-P1	ZS302778	3-15x				
EI336761	2-IC1, 2	EW325489	2-P1	ZS310984	3-49				
EP336821	3-11	EW325492	2-P1	ZS323993	3-28				
ER304256	2-R57	MS302757	3-10	ZS325426	3-41				
ER308849	2-R19	SK332551A	3-32	ZS325495	3-12				
ER308849	2-R37	SK332551A	4-7	ZS414033	3-6				
ER308849	2-R58	SK332551B	3-33x	ZS419670	3-14				
ER308873	2-R20	SK332551B	4-8x	ZS468101	3-17				
ER318317	2-R13	SK332560A	4-12	ZS572804	3-21				
ER318318	2-R1	SK332560B	4-13x	ZS609131	3-29				
ER318319	2-R12	SK332560C	4-9	ZS666336	3-7				
ER318337	2-R2	SK332560D	4-10x	ZS669104	3-37				

SECTION 4

SCHEMATIC DIAGRAM

1. SCHEMATIC DIAGRAM OF ICs
2. AP-B110/C NO. 1622450A SCHEMATIC DIAGRAM
3. AP-D210/C NO. 1622448A SCHEMATIC DIAGRAM

LA6458S

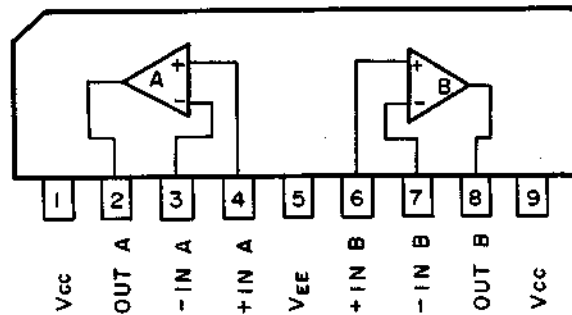

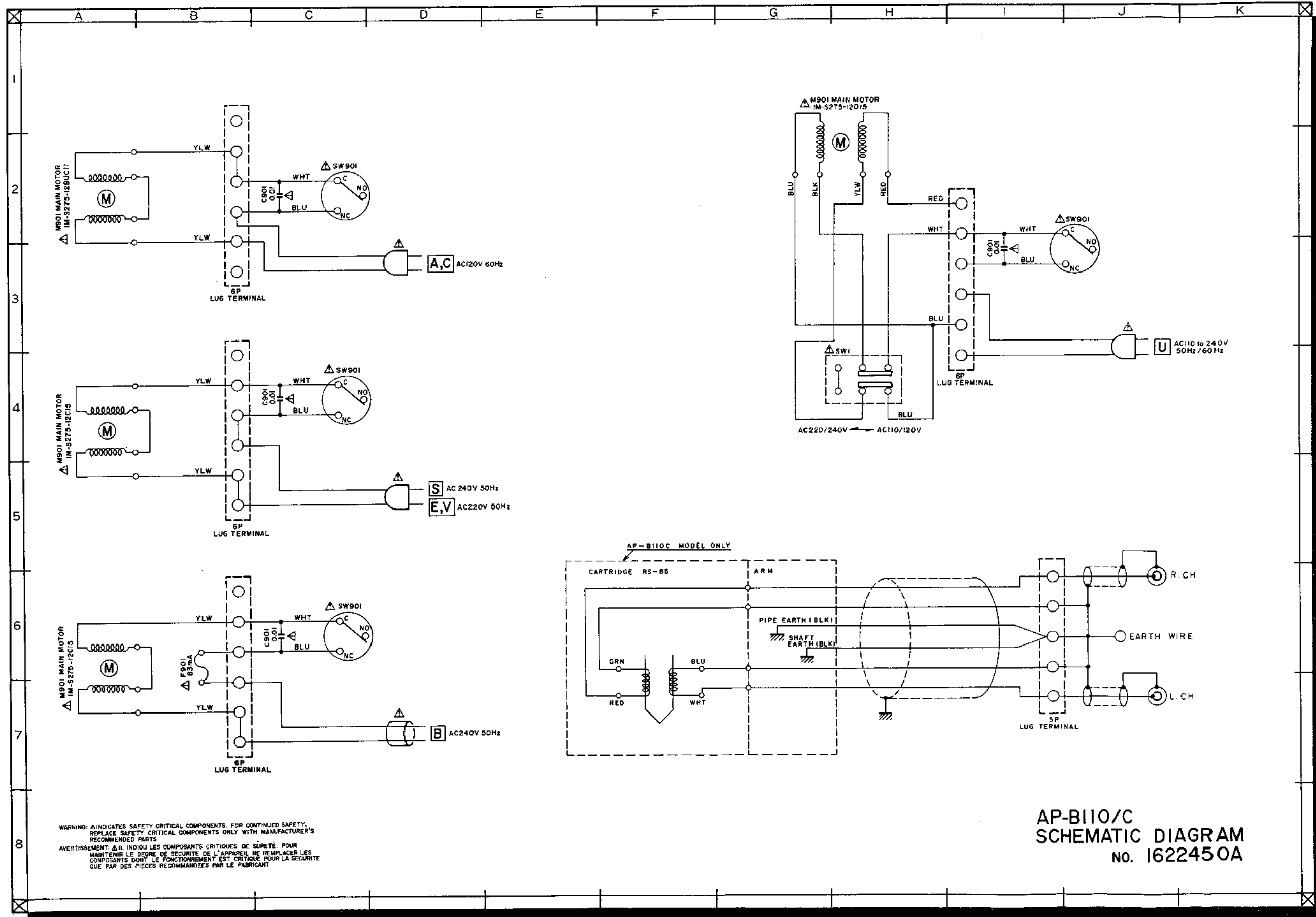

WARNING: Δ INDICATES SAFETY CRITICAL COMPONENTS. FOR CONTINUED SAFETY, REPLACE SAFETY CRITICAL COMPONENTS ONLY WITH MANUFACTURER'S RECOMMENDED PARTS.
 AVERTISSEMENT: Δ IL INDIQUÉ LES COMPOSANTS CRITIQUES DE SÛRETÉ. POUR MAINTENIR LE DEGRÉ DE SÛRETÉ DE L'APPAREIL, NE REMPLACER LES COMPOSANTS DONT LE FONCTIONNEMENT EST CRITIQUE POUR LA SÛRETÉ QUE PAR DES PIÈCES RECOMMANDÉES PAR LE FABRICANT.

AP-B110/C
 SCHEMATIC DIAGRAM
 No. 162245 0A

AP-D210/C

PUSH SWITCH PCB
 U-----PI021B501C
 C,A-----PI021B502C
 S,E,V,HUNGARY-----PI021B503C
 B-----PI021B504C
 J-----PI021B505C

SENSOR PCB
 PI021B501E

CDS PCB
 PI021B501F

SERVO LOCK LED PCB
 PI021B501D

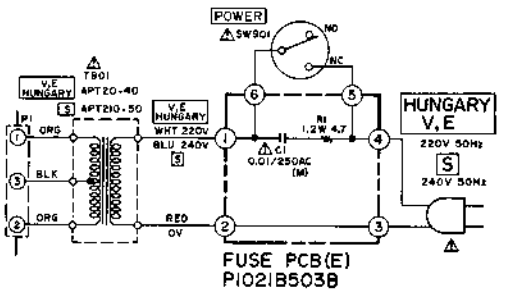
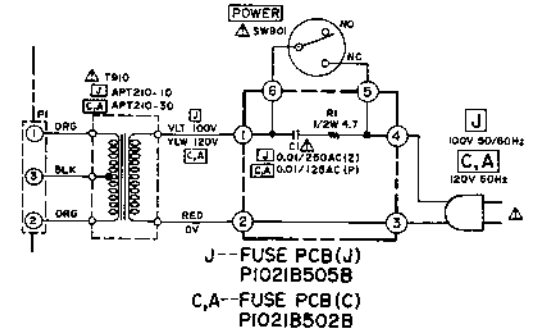
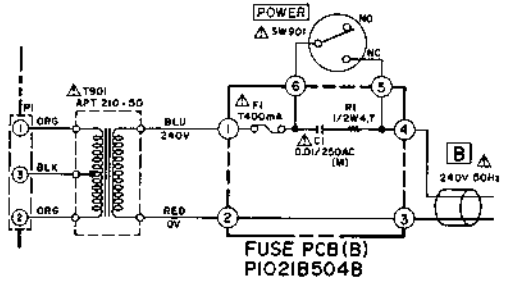
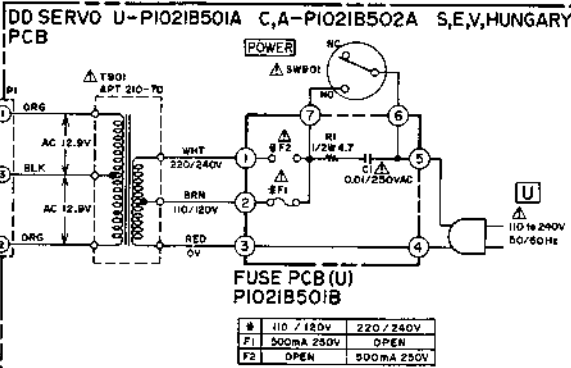
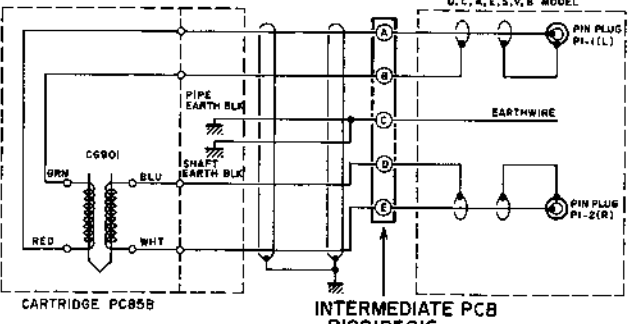
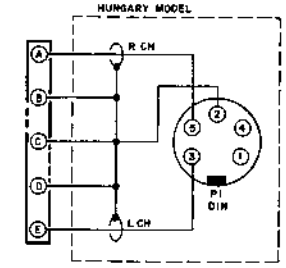
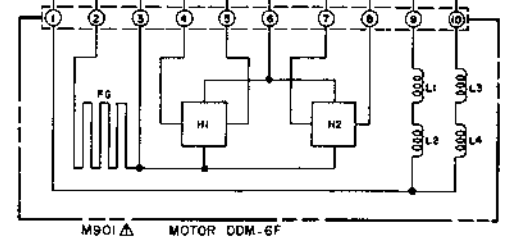
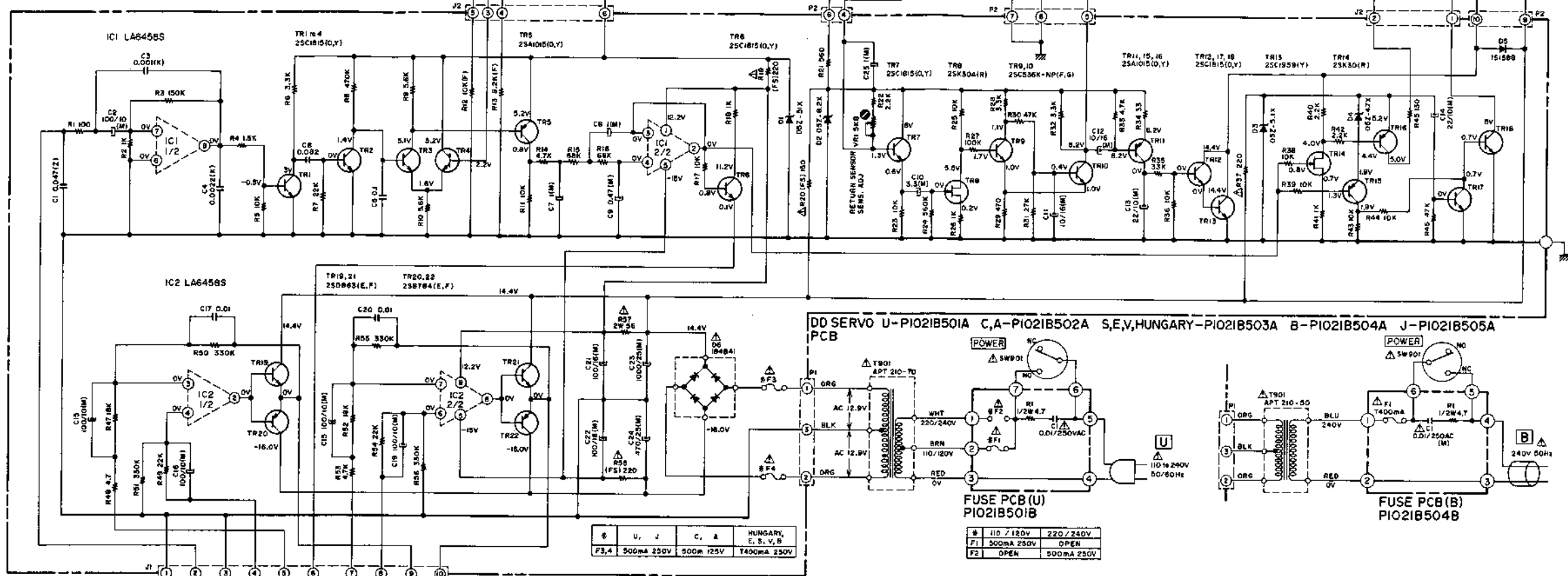

F3,4	500mA 250V	500mA 125V	T400mA 250V
------	------------	------------	-------------

F1	110 / 120V	220 / 240V
F2	500mA 250V	OPEN
F2	OPEN	500mA 250V



NOTE
 UNLESS OTHERWISE SPECIFIED
 ALL RESISTORS IN OHMS (1/4W(J))
 ALL CAPACITORS IN pF 50 WV(J)
 (FS) - FAIL SAFE RESISTORS

WARNING: Δ INDICATES SAFETY CRITICAL COMPONENTS. FOR CONTINUED SAFETY, REPLACE SAFETY CRITICAL COMPONENTS ONLY WITH MANUFACTURER'S RECOMMENDED PARTS.
 AVERTISSEMENT: Δ IL INDIQUE LES COMPOSANTS CRITIQUES DE SÛRETÉ. POUR MAINTENIR LE DEGRÉ DE SÛRETÉ DE L'APPAREIL, NE REMPLACER LES COMPOSANTS DONT LE FONCTIONNEMENT EST CRITIQUE POUR LA SÛRETÉ QUE PAR DES PIÈCES RECOMMANDÉES PAR LE FABRICANT.

AP-D210/C
 SCHEMATIC DIAGRAM
 NO. 1622448A