



# Service Manual

LIQUID CRYSTAL DISPLAY TELEVISION



**LT-3280 (LT-3280D)**  
**LT-3780 (LT-3780D)**

The LT-3280 includes the LT-3280D, monitor and HD-4001, receiver/controller. The LT-3780 includes the LT-3780D, monitor and HD-4001, receiver/controller. This manual covers the LT-3280D and LT-3780D, monitors. For the receiver/controller, see the HD-4001 Service Manual.

**CAUTION:**

Before servicing this chassis, it is important that the service person read the "SAFETY PRECAUTIONS" and "PRODUCT SAFETY NOTICE" contained in this manual.

## SPECIFICATIONS

- **Power** : AC 120V, 60Hz  
[LT-3280D] 200W  
[LT-3780D] 300W  
Standby <5W
- **LCD Panel** : Size/Resolution -  
[LT-3280D] 32" diagonal, 16:9 / 1366x768  
[LT-3780D] 37" diagonal, 16:9 / 1920x1080  
: Pixel Pitch -  
[LT-3280D] 0.519mm x 0.173mm x RGB  
[LT-3780D] 0.4275mm x 0.1425mm x RGB
- **Input Jacks** : MonitorLink™ Audio/Video - HDMI™  
: MonitorLink™ Control - RS-232C  
: PC Video - VGA /Mini D-sub 15 pin  
: PC Audio - 3.5mm Mini-Jack
- **Speakers** : 2 Way Bass Reflex Left & Right (2 X 5W)

• **Cabinet Dimensions / Weight**

LT-3280D

With Stand:	Height	Width	Depth	Weight
	25.4"	32.4"	12.8"	68.0 lbs

W/O Stand:	Height	Width	Depth	Weight
	22.9"	32.4"	5.0"	44.3 lbs

LT-3780D

With Stand:	Height	Width	Depth	Weight
	28.5"	37.3"	12.8"	80.0 lbs

W/O Stand:	Height	Width	Depth	Weight
	26.0"	37.3"	5.3"	57.3 lbs

- Weight and dimensions shown are approximate.
- Design specifications are subject to change without notice.
- HDMI™ is a trademark of HDMI Licensing, LLC

**MITSUBISHI DIGITAL ELECTRONICS AMERICA, INC.**

9351 Jeronimo Road, Irvine, CA 92618-1904  
Copyright © 2005 Mitsubishi Digital Electronics America, Inc.  
All Rights Reserved



**CONTENTS**

**PRODUCT SAFETY NOTICE & SAFETY PRECAUTIONS** ..... 5

**DISASSEMBLY**

    Disassembly & Panel Replacement ..... 7

    LT-3280 Wire Dressing ..... 23

    LT-3780 Wire Dressing ..... 24

**ELECTRICAL ADJUSTMENTS**

    Initial Setup ..... 25

**CIRCUIT EXPLANATIONS & BLOCK DIAGRAMS**

    Circuit Explanations ..... 27

    Block Diagrams ..... 32

**TROUBLESHOOTING**

    Power Troubleshooting ..... 35

    Video Troubleshooting ..... 38

    Audio Troubleshooting ..... 40

    Remote Control Troubleshooting ..... 42

    Front Switch Troubleshooting ..... 43

**REPLACEMENT PARTS**

    LT-3280 Replacement Parts List ..... 44

    LT-3780 Replacement Parts List ..... 45

**SCHEMATICS**



## PRODUCT SAFETY NOTICE

Many electrical and mechanical parts in television receivers have special safety related characteristics. These characteristics are often not evident from visual inspection nor can the protection afforded by them necessarily be obtained by using replacement components rated for higher voltage, wattage, etc.

Replacement parts which have special safety characteristics are identified in this service manual.

**The replacement for any safety part should be identical in value and characteristics.**

## SAFETY PRECAUTIONS

**NOTICE:** Observe all cautions and safety related notes located inside the receiver cabinet and on the receiver chassis.

**WARNING:**

1. Operation of this receiver outside the cabinet or with the cover removed presents a shock hazard from the receiver's power supplies. Work on the receiver should not be attempted by anyone who is not thoroughly familiar with the precautions necessary when working on high voltage equipment.
2. Do not install, remove or handle the LCD panel in any manner unless shatterproof goggles are worn. People not so equipped should be kept away while the panel is being handled. Keep the panel away from the body while handling.
3. When service is required, observe the original lead dress. Where a short-circuit has occurred, replace those components that indicate evidence of overheating.

**Leakage current check**

Before returning the receiver to the customer, leakage current should be measured using following methods.

**1. Cold Check**

With the alternating current (AC) plug removed from the AC source, place a jumper across the two AC plug prongs. Connect one lead of an ohm meter to the AC plug and touch the other lead to each exposed metal part (i.e. antennas, handle bracket, metal cabinet, screw heads, metal overlay, control shafts, etc.), particularly any exposed metal part that has a return path to the chassis. The resistance of the exposed metal parts having a return path to the chassis **should be a minimum of 1Meg Ohm**. Any resistance below this value indicates an abnormal condition and requires corrective action.

**2. Hot Check ...Use the circuit shown below to perform the hot check test.**

1. Keep switch S1 open and connect the receiver to the measuring circuit. Immediately after connection, and with the switching devices of the receiver in their operating positions, measure the leakage current for both positions of switch S2.
2. Close switch S1, energizing the receiver. Immediately after closing switch S1, and with the switching devices of the receiver in their operating positions, measure the leakage current for both positions of switch S2. Repeat the current measurements of items 1 and 2 after the receiver has reached thermal stabilization. **The leakage current must not exceed 0.5 milliampere (mA).**

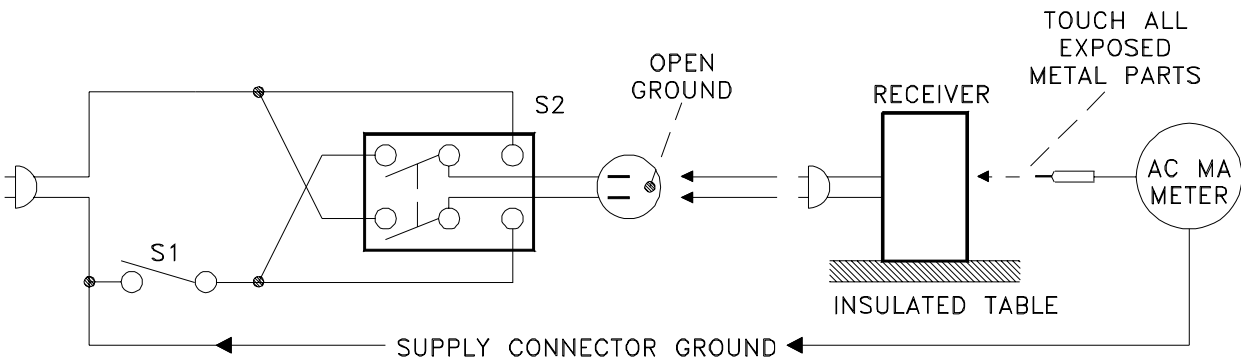



## DISASSEMBLY & PANEL REPLACEMENT PROCEDURE

1. REMOVE AV1, AV2, DTV & STAND COVERS.

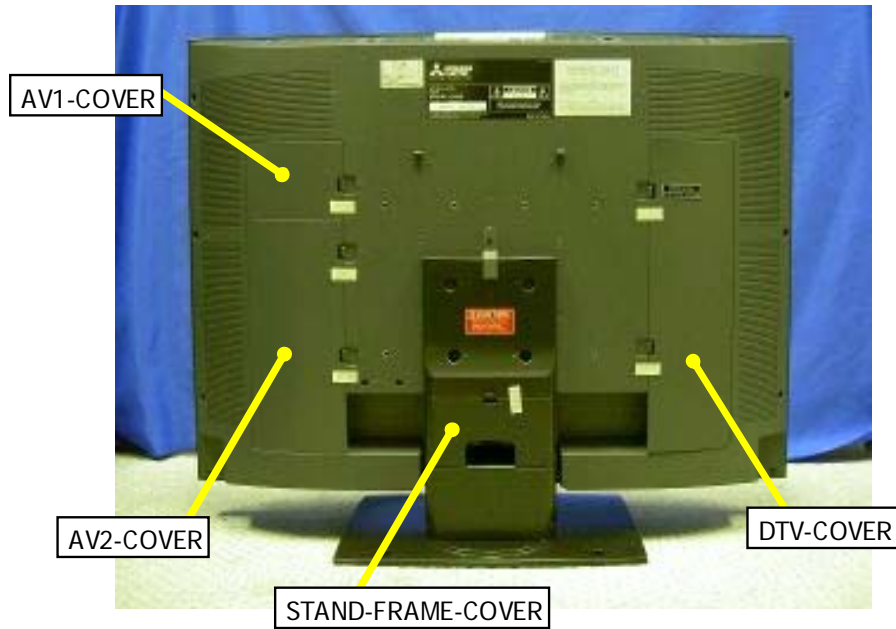

2. PLACE SET FACE DOWN ON A SOFT CUSHION, WITH THE STAND HANGING OVER THE EDGE OF THE TABLE.
3. REMOVE STAND-KIT.

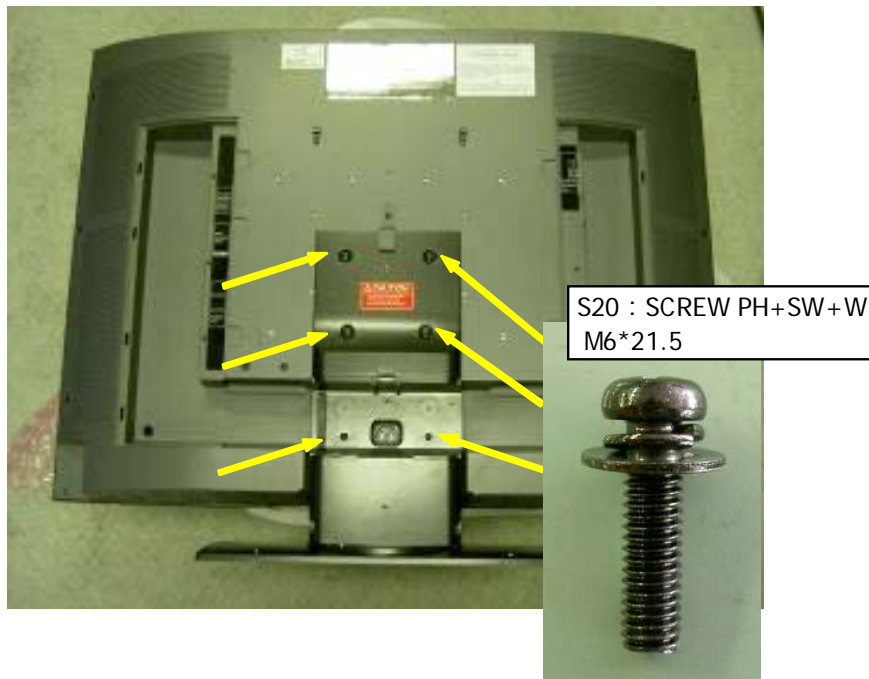

4. REMOVE BACK COVER KIT.

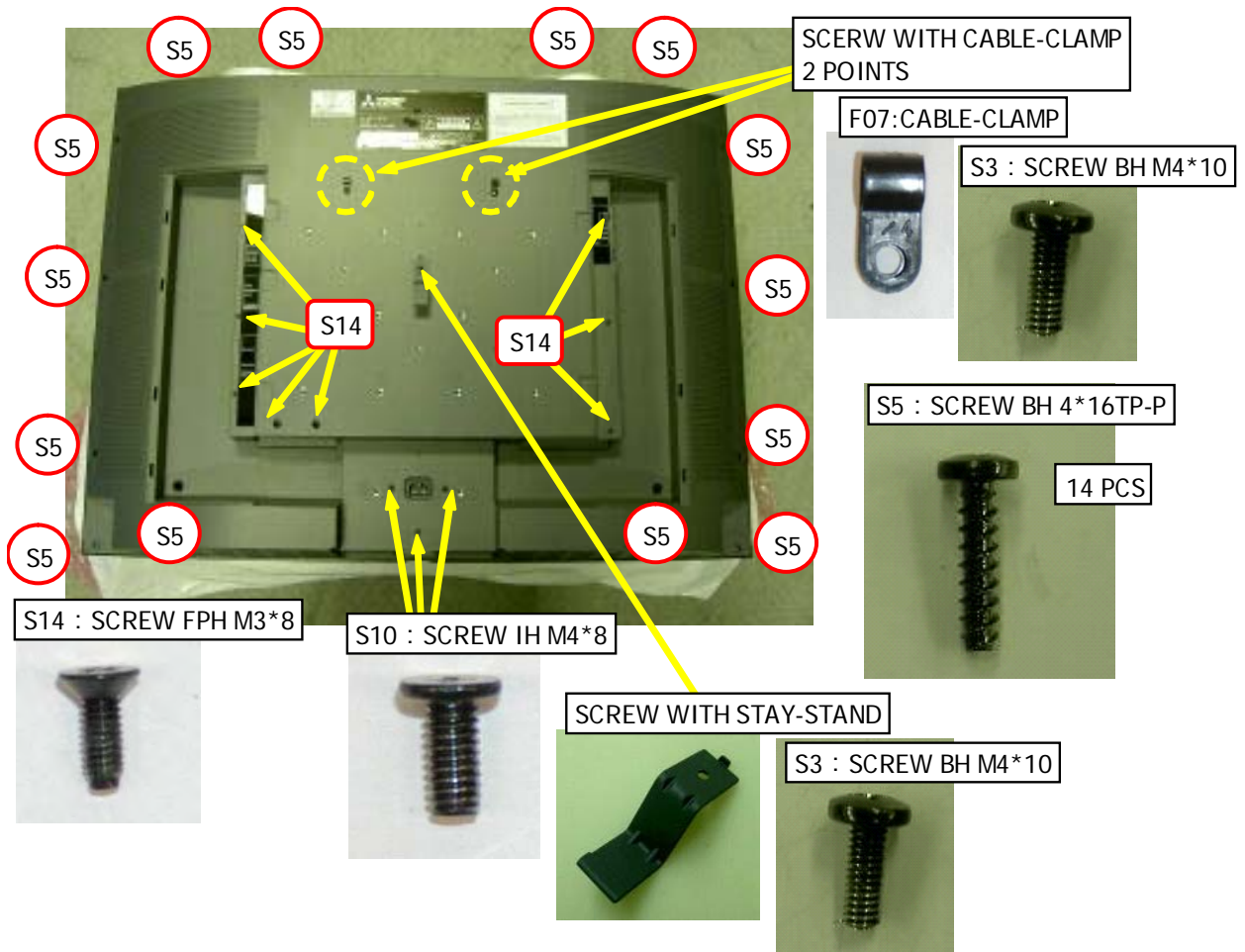



5. REMOVE WALL MOUNT BRACKET

S9 : SCREW PHW M3\*6

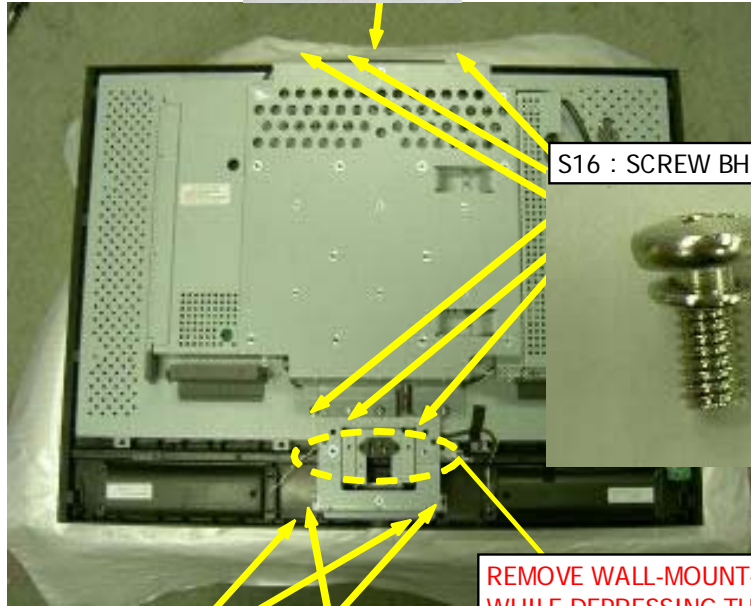

S16 : SCREW BH+SW M6\*12



REMOVE WALL-MOUNT-BKT,  
WHILE DEPRESSING THE HANGING  
PART OF POWER-BKT BELOW.

LT-3780D  
S5 : SCREW BH 4\*16TP-P



LT-3280D  
S8 : SCREW BH 4\*12TP-P

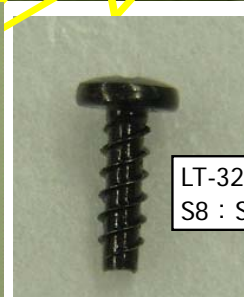

6. REMOVE SHIELD-POWER-SUB & SHIELD-CASEMAIN.

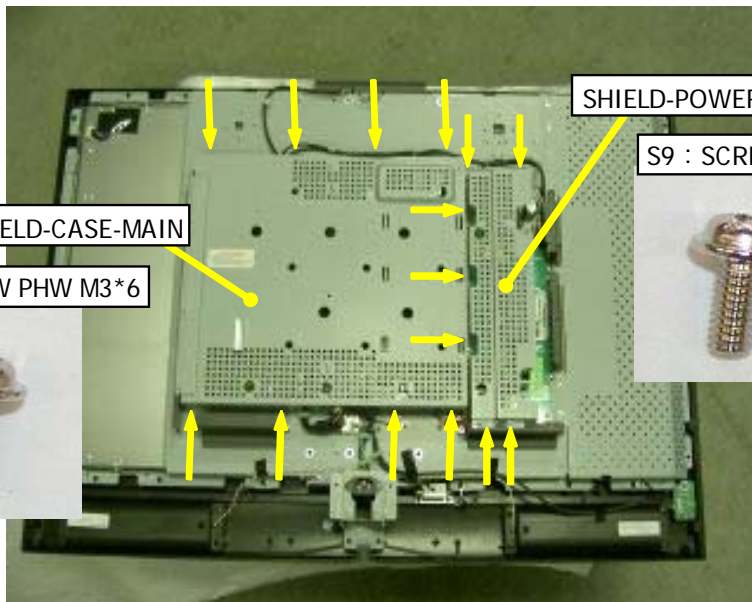

SHIELD-POWER-SUB

S9 : SCREW PHW M3\*6



SHIELD-CASE-MAIN

S9 : SCREW PHW M3\*6



7A. (LT-3280D)

(NOT NECESSARY FOR PANEL REPLACEMENT)

REMOVE:

- a. PLATE-MAIN-SIDE
- b. SERVICE-KIT
- c. PLATE-MAIN-BOTTOM
- d. PLATE-POWER-BOTTOM

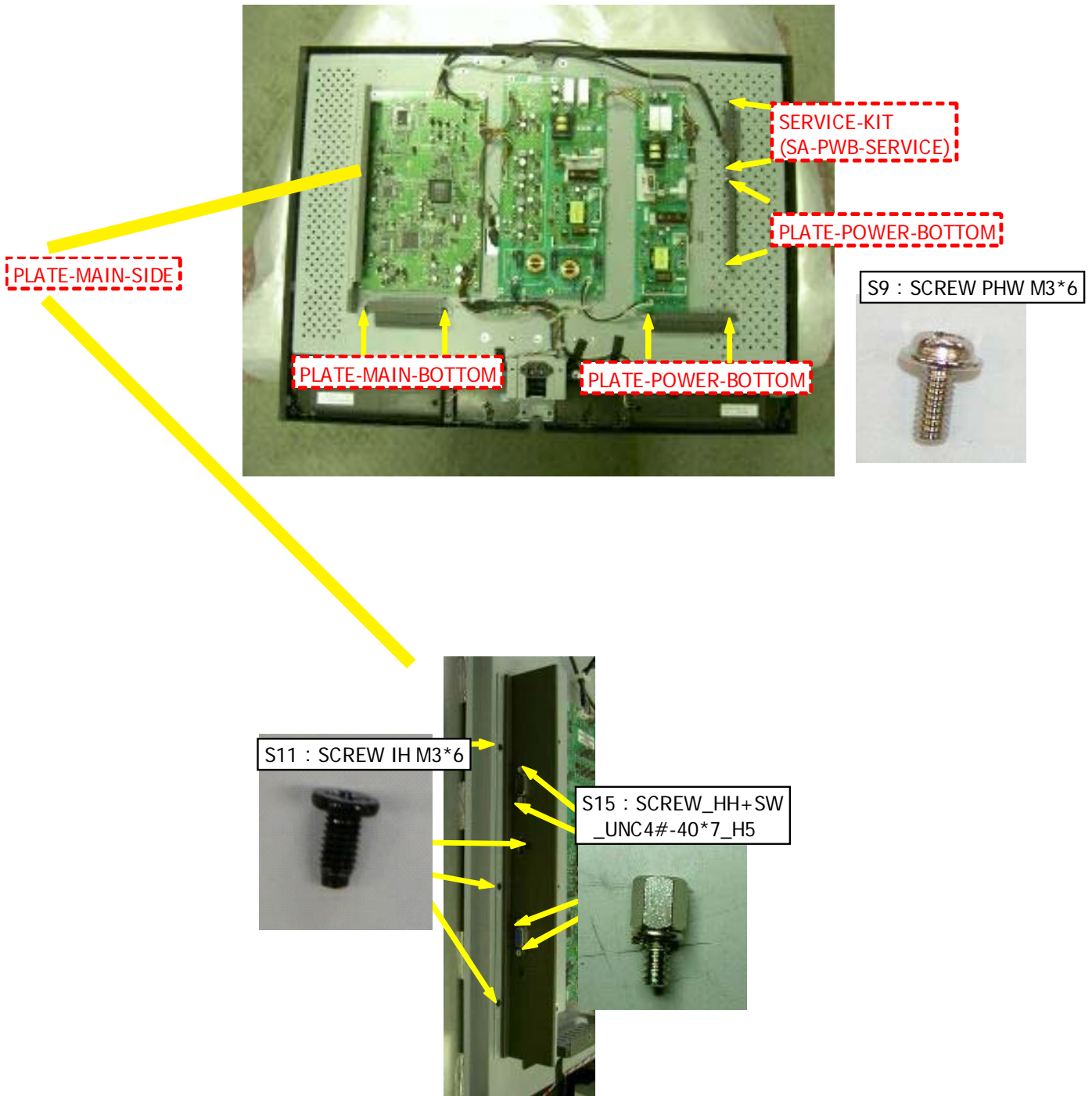

- 7B. (LT-3780D) REMOVE:
  - a. PLATE-MAIN-SIDE
  - b. SERVICE-KIT
  - c. PLATE-MAIN-BOTTOM
  - d. (NOT NECESSARY FOR PANEL REPLACEMENT)  
PLATE-POWER-BOTTOM

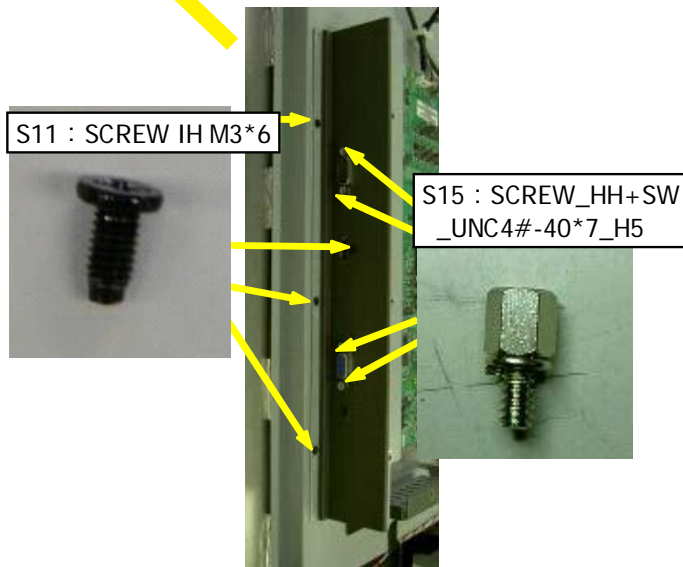
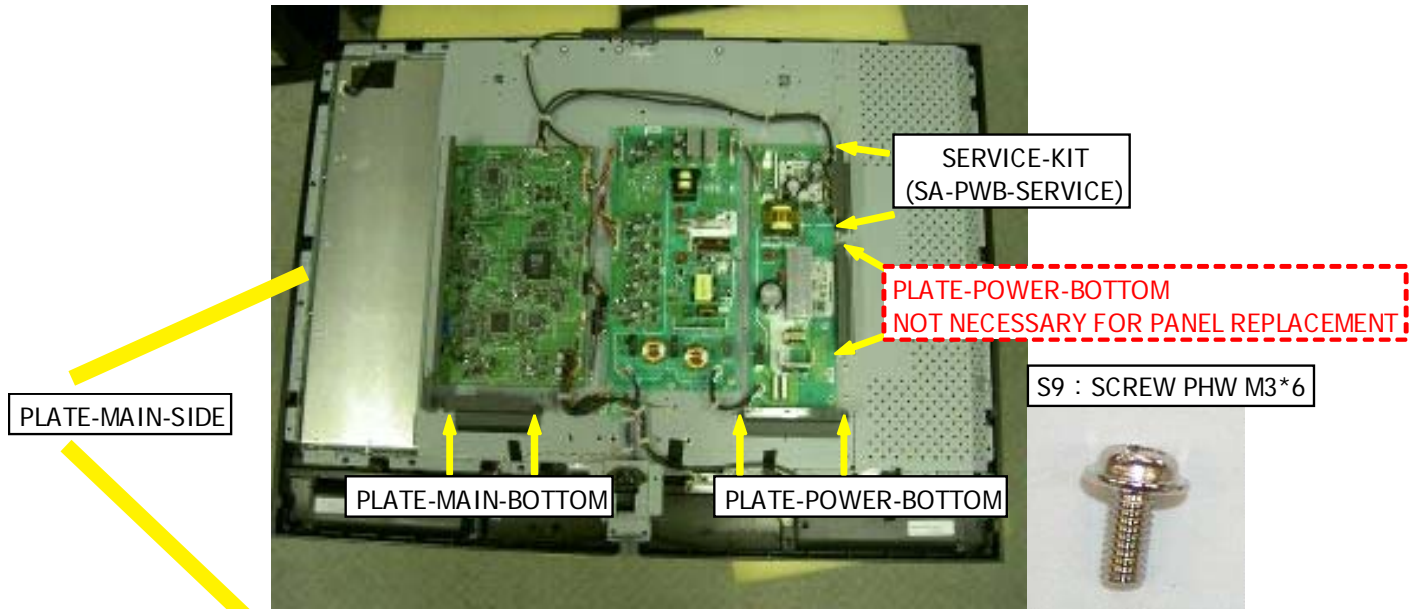

8. (LT-3780D ONLY) REMOVE SHIELD-INVERTER

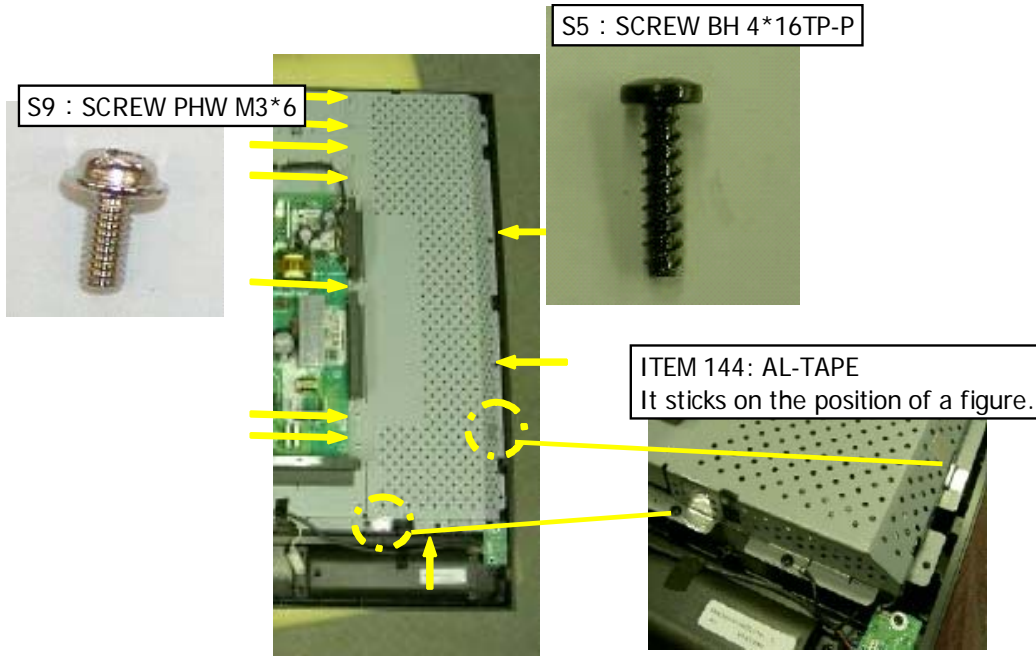

9. REMOVE FUNCTION-KEY-KIT



S6 : SCREW BH 3\*12 TP-P



10. REMOVE IR-KIT

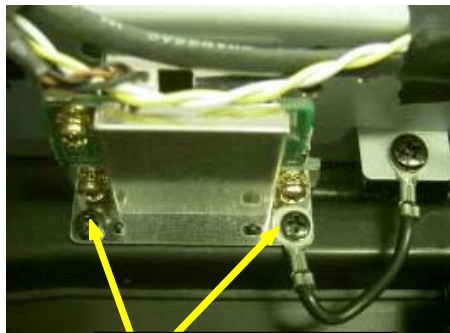

S4 : SCREW BH 3\*8 TP-P



11. REMOVE SA-PWB-LED

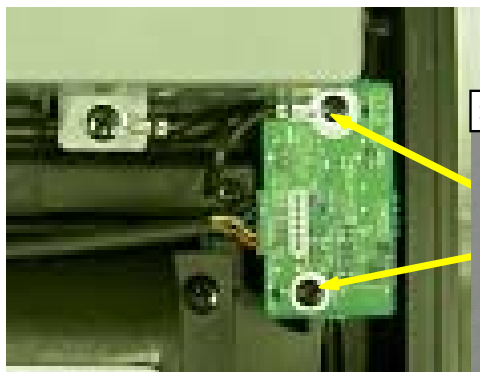

S4 : SCREW BH 3\*8 TP-P





12. REMOVE POWER-KIT & SPEAKER CONNECTOR

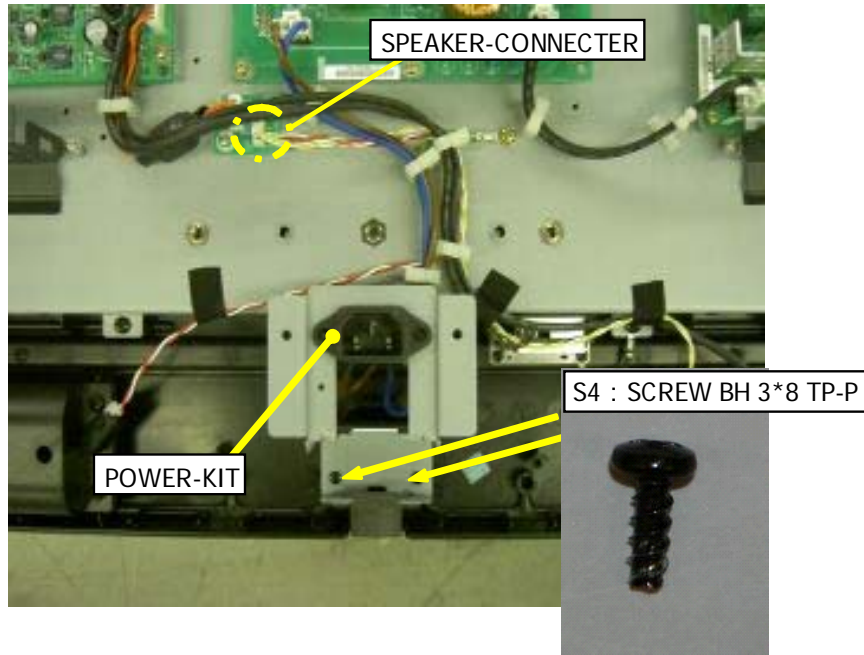

13A. (LT-3280D)

(NOT NECESSARY FOR PANEL REPLACEMENT)

REMOVE:

- a. A-PWB-MAIN 2
- b. SA-PWB-POWER
- c. A-PWB-POWER-SUB2

S17 : SCREW PH+SW+TW M3\*6

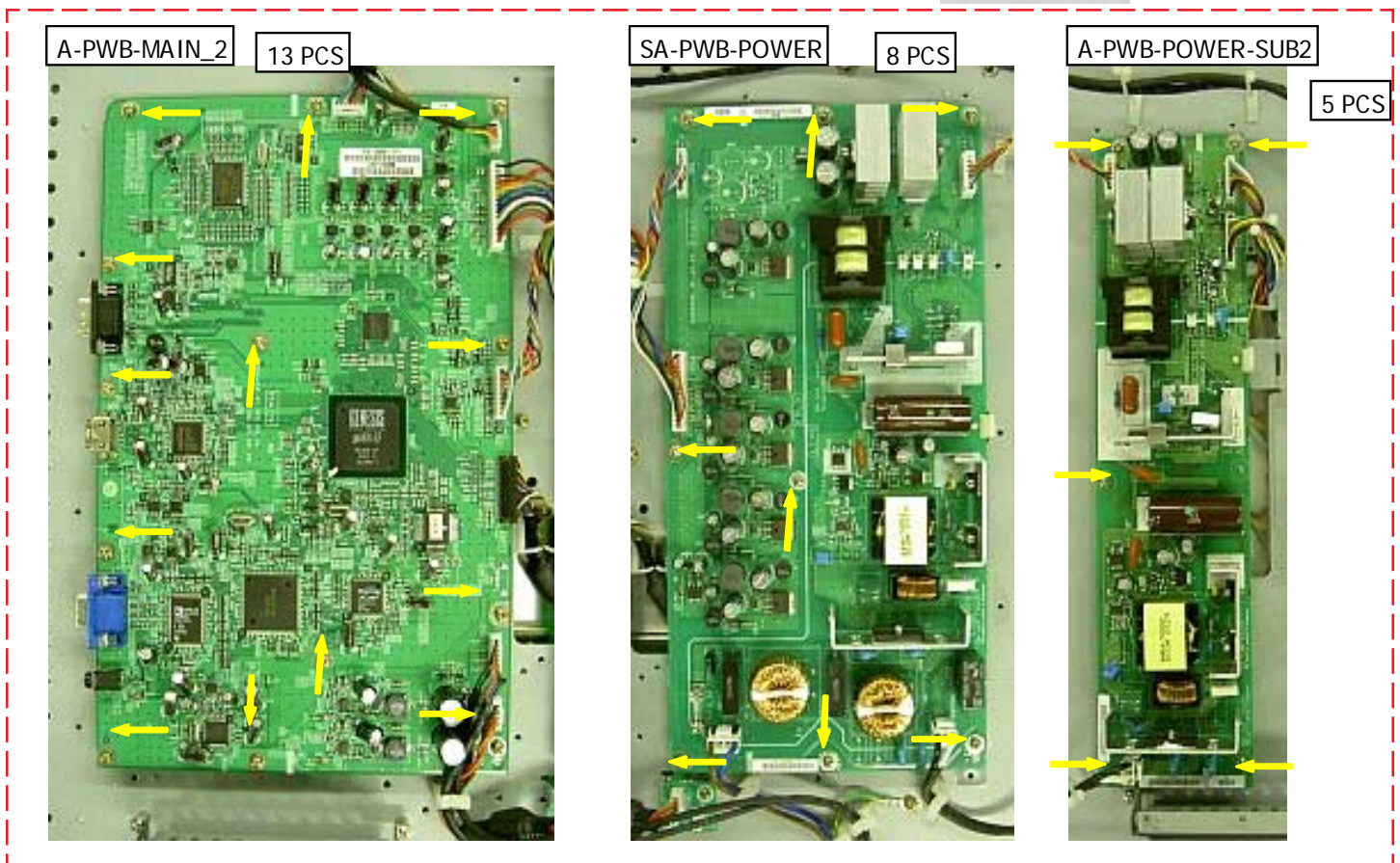

13B. (LT-3780D)

REMOVE:

a. A-PWB-MAIN 2

b. SA-PWB-POWER (NOT NECESSARY FOR PANEL REPLACEMENT)

c. A-PWB-POWER-SUB2

S17 : SCREW PH+SW+TW M3\*6



A-PWB-MAIN\_1

13 PCS

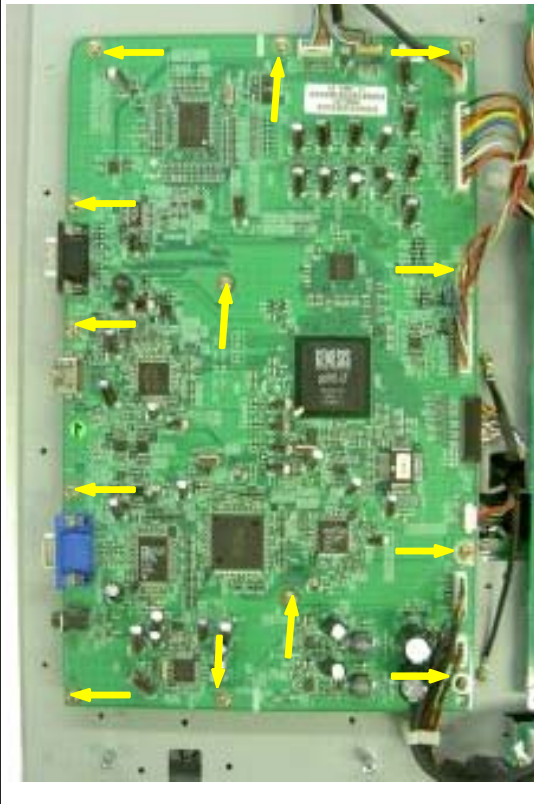

SA-PWB-POWER  
NOT NECESSARY FOR PANEL  
REPLACEMENT

8 PCS

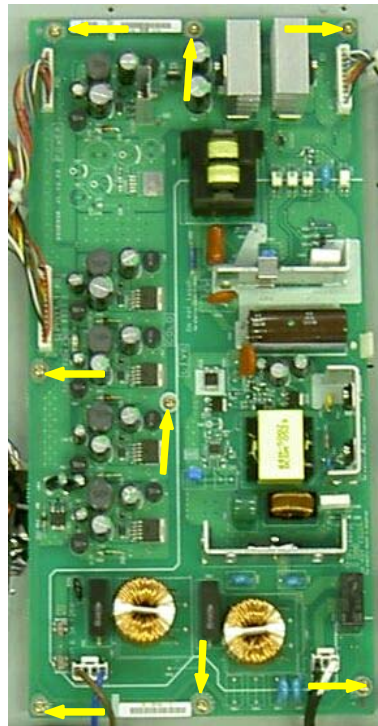

A-PWB-POWER-SUB1

7 PCS

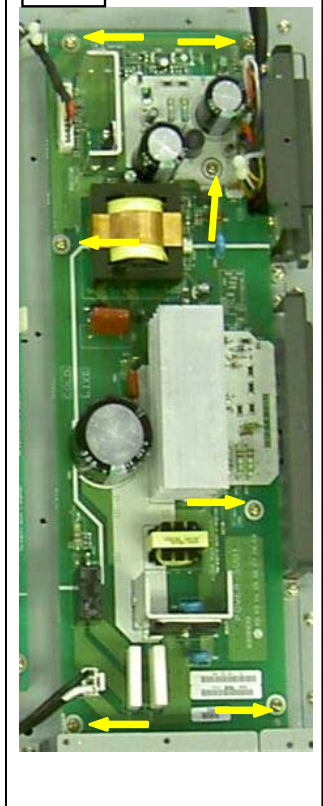



14. (LT-3780D) REMOVE PANEL\_BKT

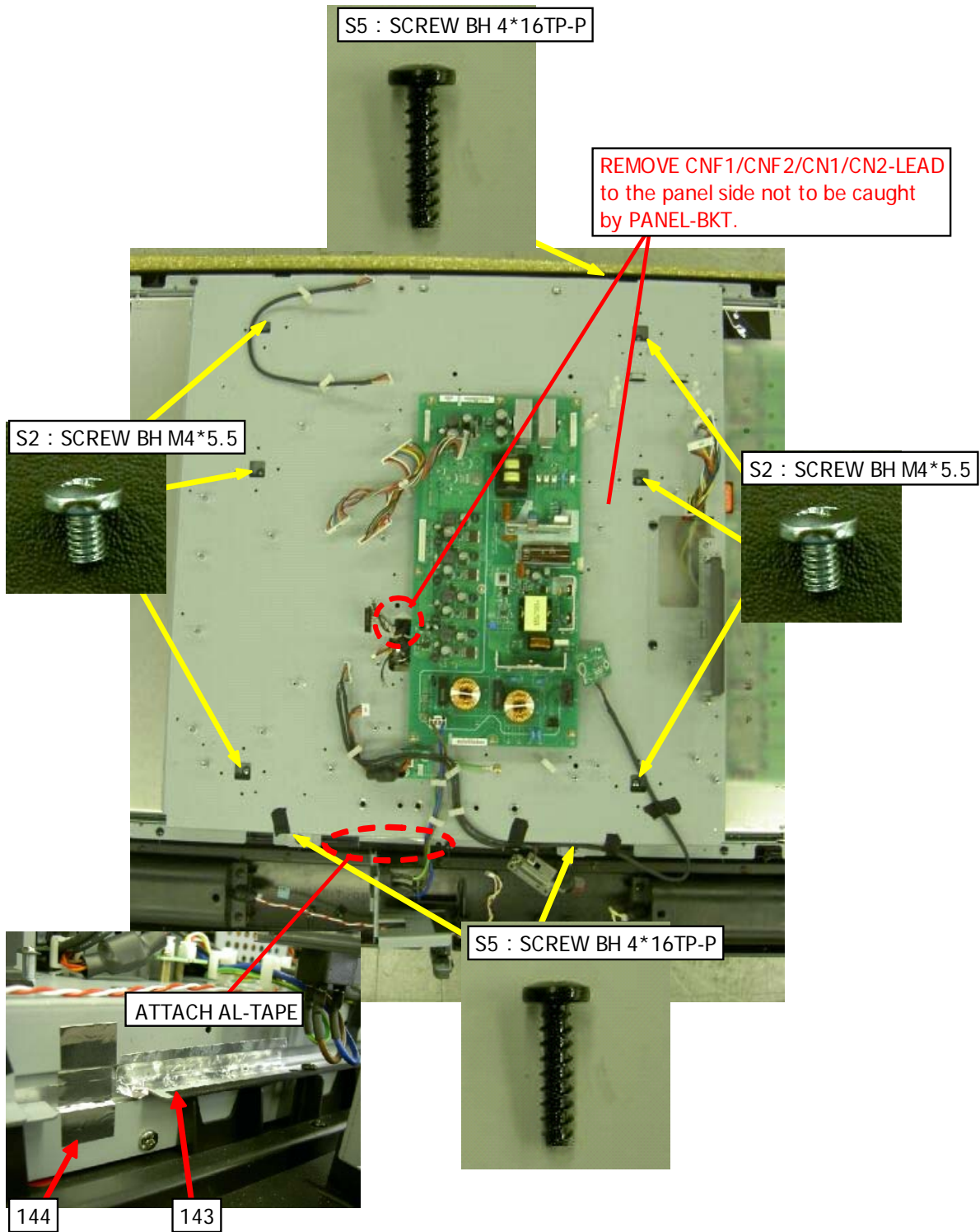



15A. (LT-3280D) REMOVE FRONT-KIT & SPEAKER

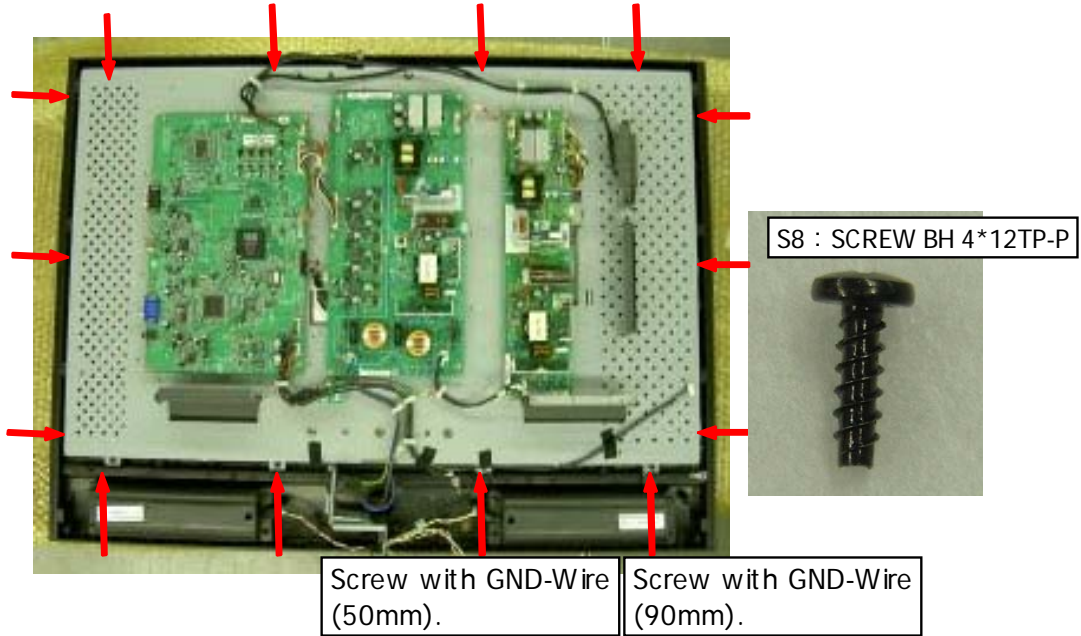

15B. (LT-3780D) REMOVE FRONT-KIT & SPEAKER

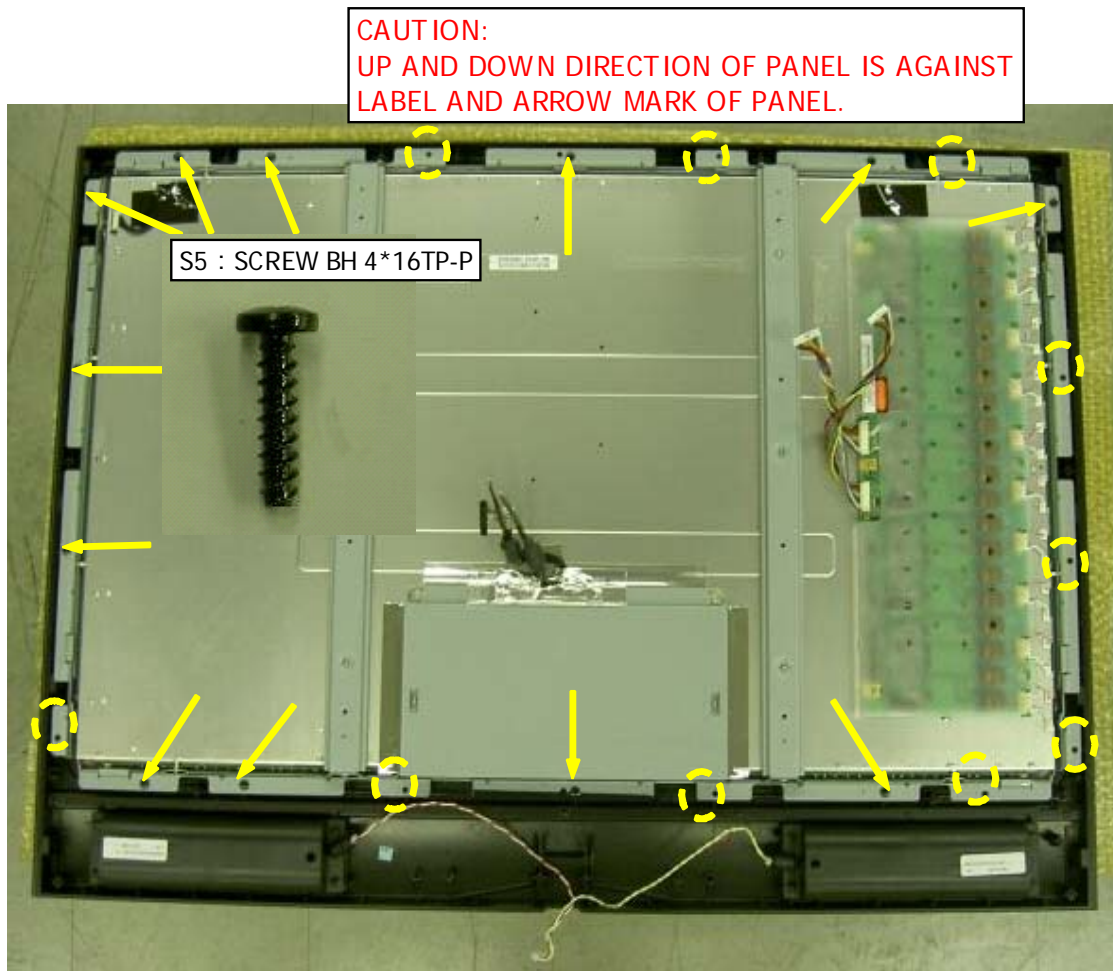

16. (LT-3280D) REMOVE PANEL\_BKT



REMOVE CNF1/CN1/CN2-LEAD first and push in under PANEL-BKT for easy removal.

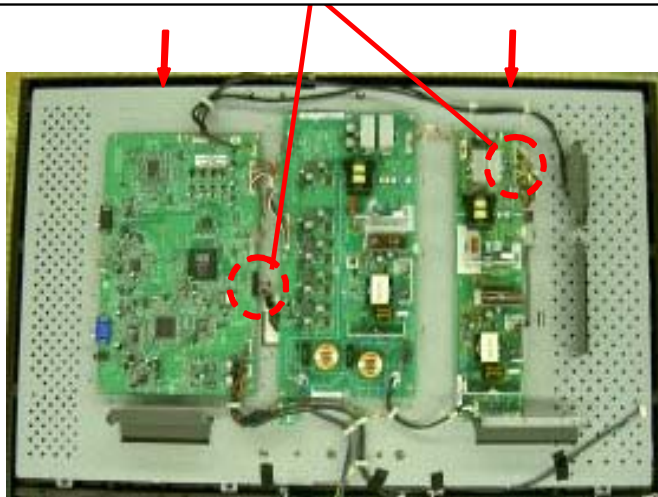

CAUTION:  
UP AND DOWN DIRECTION OF  
PANEL IS AGAINST LABEL AND  
ARROW MARK OF PANEL.



Top & Bottom is same.  
4 PCS (2x2)

S2 : SCREW BH M4\*5.5



17. (LT-3280D)  
FOR RE-ASSEMBLY AFTER PANEL REPLACEMENT,  
REVERSE THE DISASSEMBLY PROCEDURE.  
CONTINUE FOR LT-3780D PANEL REPLACEMENT AND  
FURTHER DISASSEMBLY INSTRUCTIONS.

18. (LT-3780D) REMOVE SUPPORT-PANEL-BKT-RIGHT, LEFT, TOP, BOTTOM

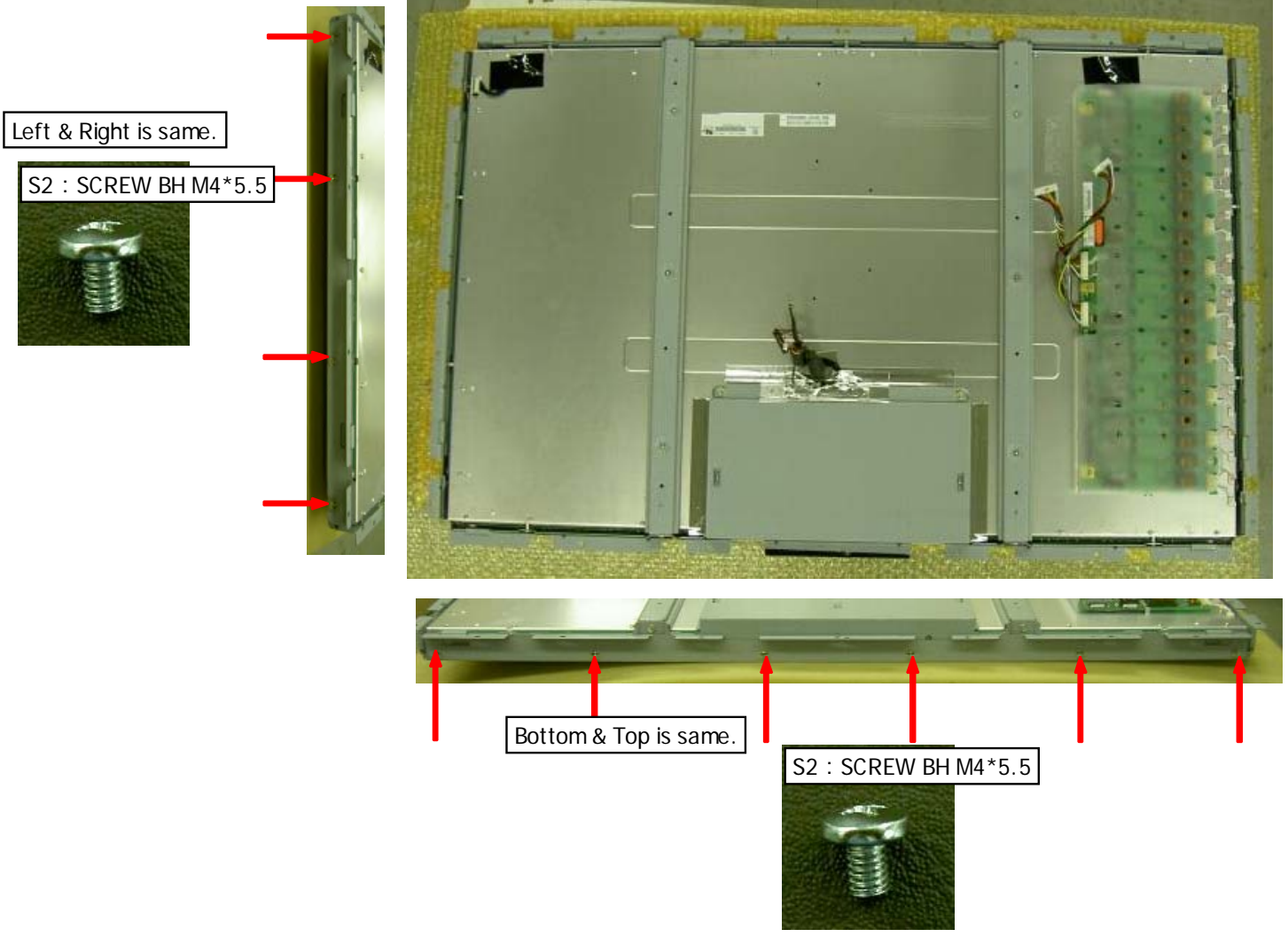

19. (LT-3780D) ATTACH AL-TAPE AT DRIVE-UNIT OF PANEL

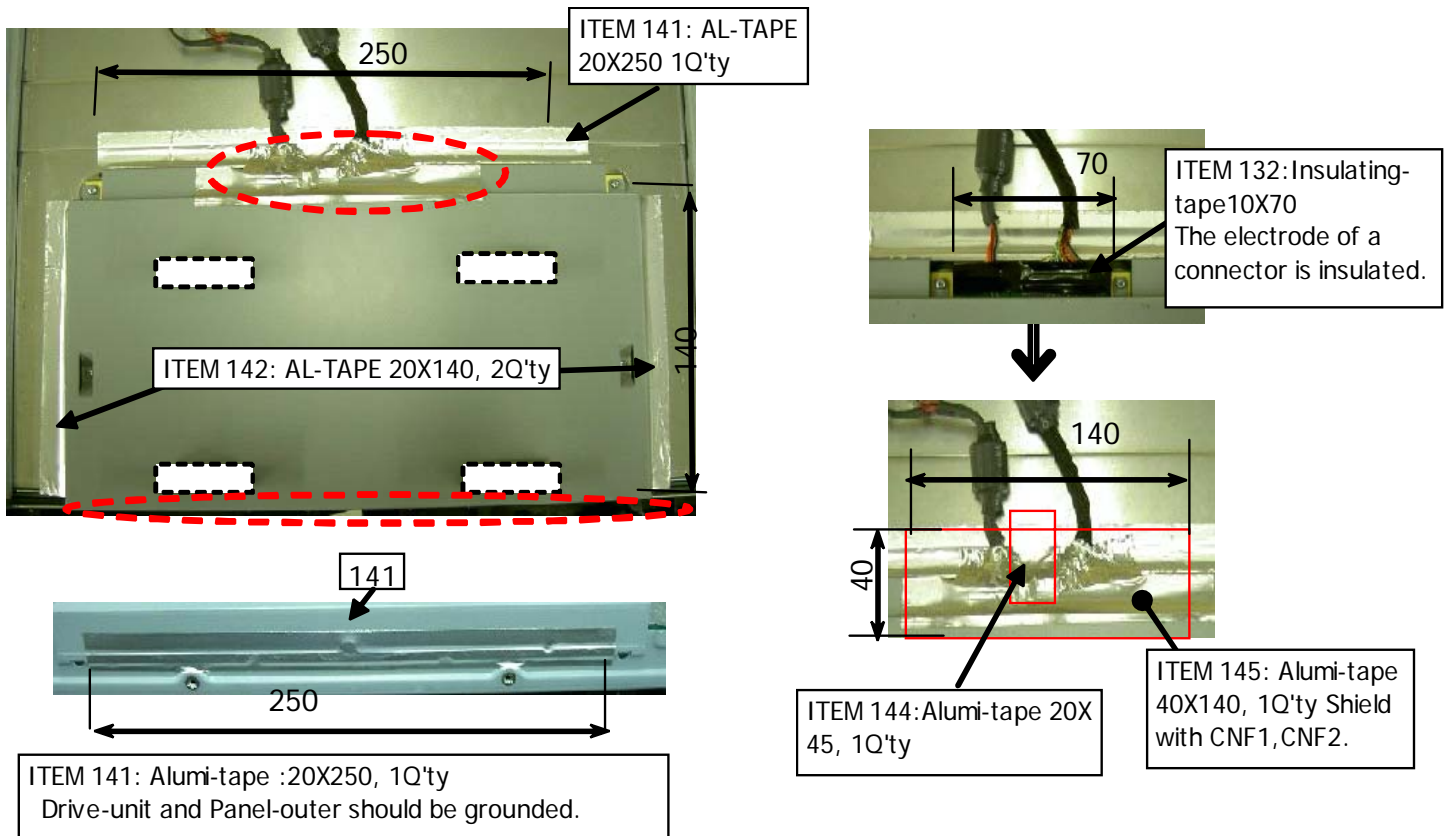

20. (LT-3780D)  
FOR RE-ASSEMBLY AFTER PANEL REPLACEMENT,  
REVERSE THE DISASSEMBLY PROCEDURE.  
CONTINUE FOR FURTHER DISASSEMBLY INSTRUCTIONS  
FOR BOTH LT-3280D & LT-3780D.



20. REMOVE FUNCTION-KEY-KIT

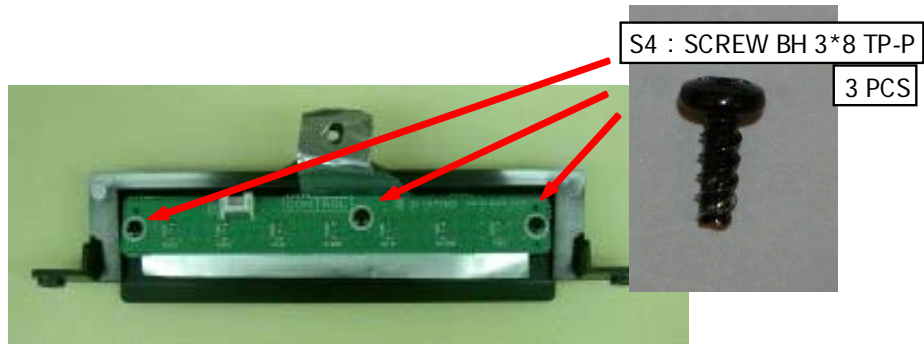

21. REMOVE IR-KIT

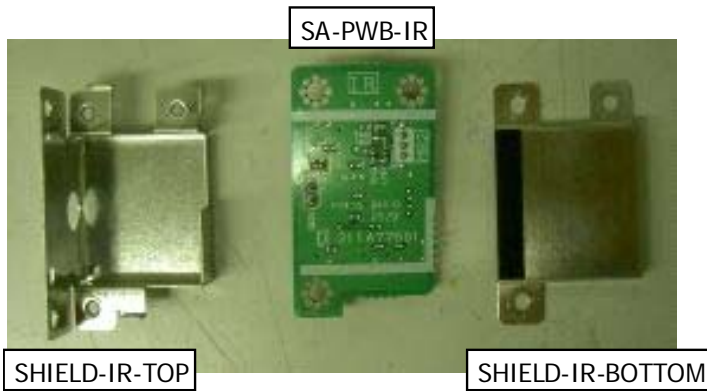
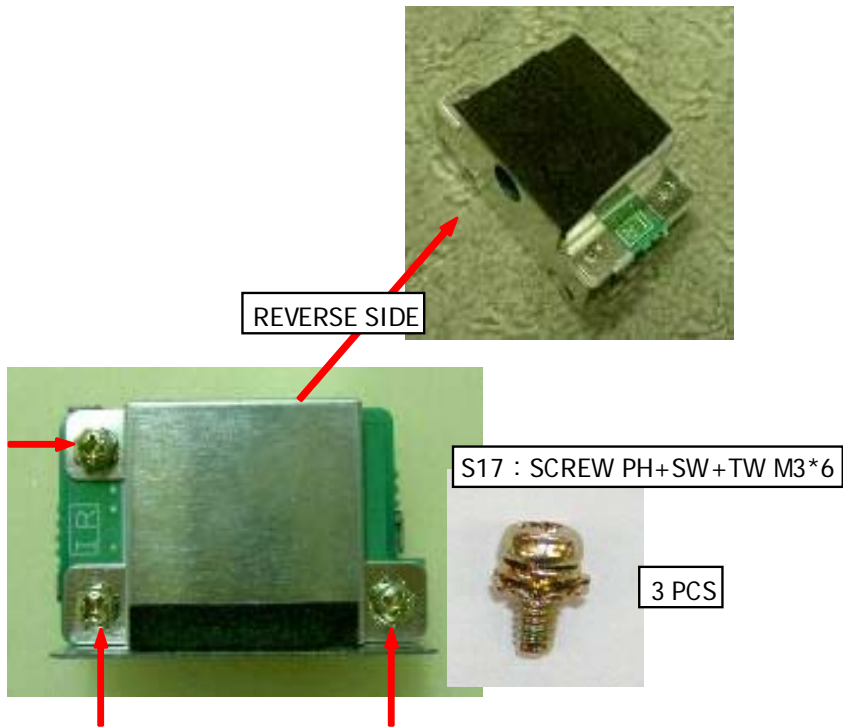

22. REMOVE SERVICE-KIT

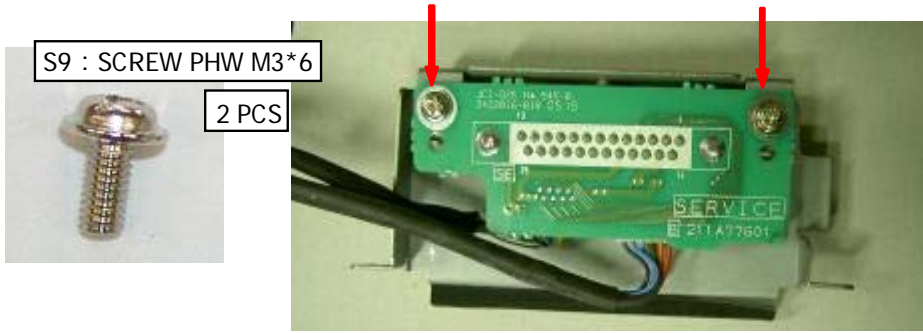

After the projection at the right of COVER is inserted in the hole of PLATE, screw LEFT SIDE.

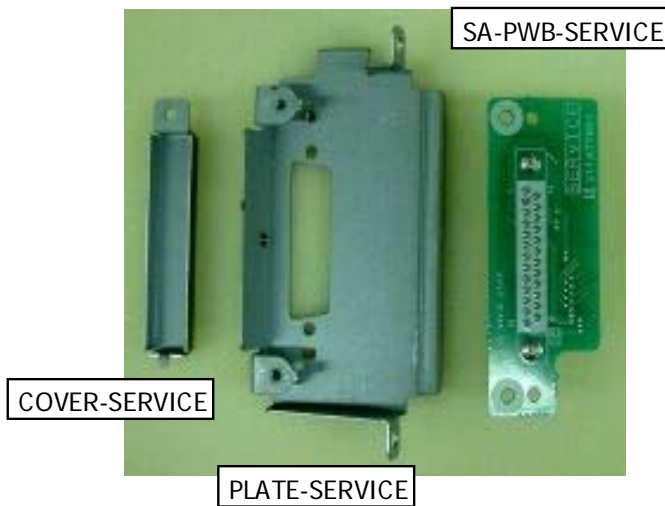
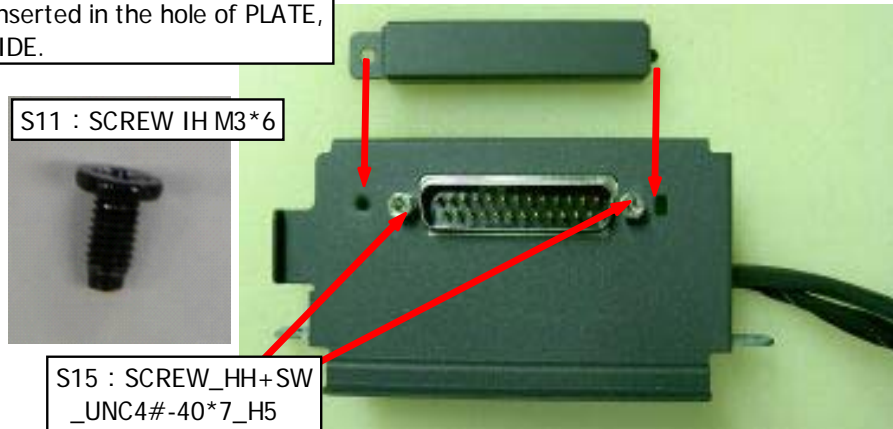



WIRING LAYOUT: LT-3280DD

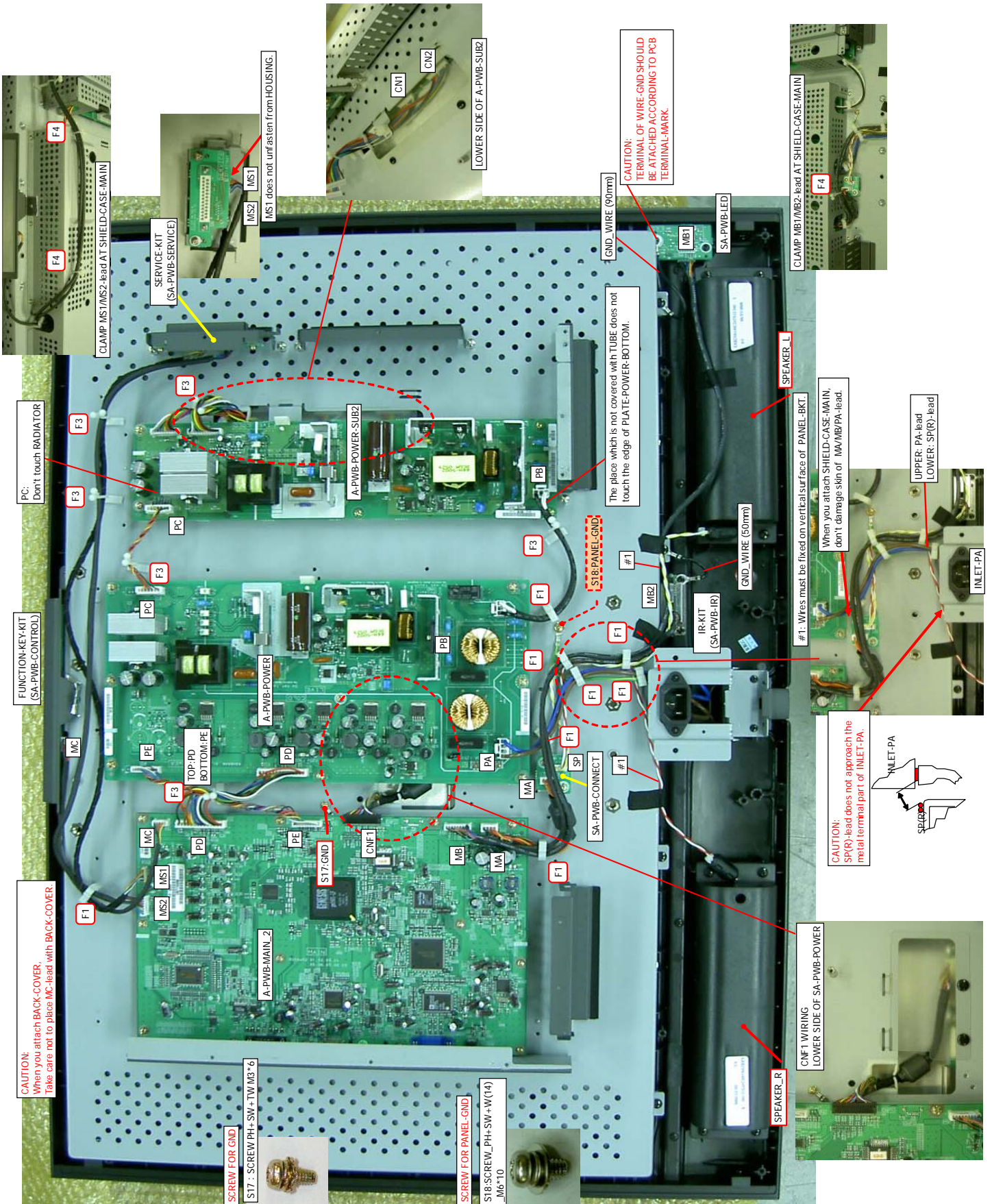







## Initial Setup

### A. Option Menu Setup

Follow the steps below for the initial set-up:

1. Disconnect the HD-4001.
2. Place the Remote control in the "TV" layer.
3. Select the "MENU" display by pressing the "TV MENU" button once.
4. Press the number buttons "2", "0", "7", "0" in sequence to select the "OPTION MENU" display.
5. Press the "ADJUST▲▼" buttons to select "INITIALIZE."
6. Press "ENTER."

<MENU><2-0-7-0>

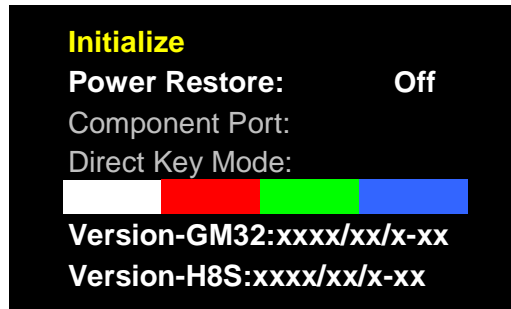

**NOTE:** At this time all Menu and Audio/Video user setting are set to the defaults shown in the chart below.

### B. Default Settings

Menu	Items	Default Setting	
Volume		10	
INPUT		MonitorLink™ A/V input	
FORMAT(PC)		Full	
FORMAT (MonitorLink™ A/V input)		Stretch	
Setup	INPUT ASSIGNMENT	PC	
		HDMI	
	Language	English	
	Front Button Lock	Off	
Audio/Video	Audio Setting	Bass	31
		Treble	31
		Balance	31
		Surround	Off
		Level Sound	Off
	Video Setting	Contrast	31
		Brightness	31
		Sharpness	31
		Color	31
		Tint	31
		Color Temp	High
		Video Noise	N/A
	Back Light	63	
	Black Enhancement		On
TV Speakers		On	

ADVANCED FEATURES	Perfect Color	Magenta	31
		Red	31
		Yellow	31
		Green	31
		Cyan	31
		Blue	31
	Color View	Magenta	31
		Red	31
		Yellow	31
		Green	31
		Cyan	31
		Blue	31
	PC Power Save		Off
	Video Mute		On

## Circuit explanation

### 1. Video circuits

It explains the video circuits of LT-3780,LT-3280(Model name of display side only : LT-3780D,LT-3280D). It corresponds to various inputs (PC, Monitor Link™ A/V Input).

It explains the composition and its function of an video circuit.

(Refer to an attached “Video block diagram of LT-3780D,LT-3280D”, regarding as the flow of video signal.)

#### 1-1. Video input circuit of PC

In PC input, it is inputted into IC400 of the signal processing IC via Following IC

(A) IC203 : Analog-to-digital conversion IC (AD9888KSZ-170 : Analog devices)

The video signal (R, G, B) of PC input is changed into a digital signal (8 bits each) from an analog signal. Moreover, by this IC, it has the function below besides digital conversion.

- Contrast adjustment for PC
- brightness adjustment for PC

This IC is controlled by register control of IC203 via **3.3V IIC-bus** to MPU(IC700)

(B) IC201 : Invert IC with the Schmidt trigger (74LCX14 : Fairchild)

It is IC which inputs the horizontal sync signal and vertical sync signal of PC input.

Since there are what has a bad rising and falling characteristic and what has low amplitude in the sync signal outputted from PC, it is necessary to modify the waveform.

It corresponds to the above-mentioned waveform as follows by this IC.

- a bad rising and falling characteristic. : Rise-time and fall-time is carried out early.
- a waveform is noisy : It prevents that the mistaken pulse occurs by the Schmidt circuit.
- Low Amplitude : If voltage threshold is satisfied, high level will output in 3.3V.

Since 74LCX14 is a invert circuit, if its gate pass twice and it has united polarity.

(C) IC200 : 1K-bit EEPROM (24LC21ATI : Microchip)

This is the IC for EDID of PC.

This IC has important information about PC input such as product code, serial number, video specification, proposed timing, color information etc.

(D)IC202 : AND-circuit IC (SN74LVC08APWR : Texas Instruments)

This IC is to disable the H, V sync signal line connected to IC which power supply is dropped while stand-by. It can operate correctly by using this.

This is controlled by ENABLE signal from MPU(IC700) ( L : disable)

(E)IC204 : D Flop-Flop IC(TC74VCX74FT : TOSHIBA)

The role of this IC is to synchronize H sync signal and V sync signal.

For output signal of IC203, H sync is synchronized by dot-clock from IC203, but V sync is not Synchronized by H sync. This IC uses to be operated without miss-operation.

(F)IC2A0 : Color conversion IC(M66471FP : Mitsubishi)

This IC uses to perform Color conversion function such as PerfectColor, Colorview.

(G)IC2A1 : TMDS-Transmitter IC(SII160CTG100 : SiliconImage)

This IC uses to convert signal's specification from TTL to TMDS (differential signal).

Since the input port of latter IC (IC400: Signal processor ) could use only the TMDS input, this input specification was united by this IC.

1-2. Video input circuit of Monitor Link™ A/V Input

In Monitor Link™ A/V Input, it is inputted into IC400 of the signal processing IC via Following IC.

(H)IC500 : HDMI-Receiver IC ((SII9993CTG100 : SiliconImage)

This IC uses to receive and correspond the differential signal. This IC corresponds not only HDMI input but also DVI input(TMDS interface) . Supported timing of this input is 480P/1080i/720P.

The output format of this IC is YCbCr4:4:4, not RGB.

(I) IC501 : 2K-bit EEPROM (24LC22ATI : Microchip)

This is the IC for E-EDID of Monitor Link™ A/V Input.

This IC has important information about Monitor Link™ A/V Input such as audio, speaker, Identification code, in addition to product code, serial number, video specification, proposed timing, color information.

1-3. Signal processor circuit

(J)IC400 : Signal processor IC ( gm1601-LF-CF : Genesis)

By this IC, it has the function below.

- Scaling for all inputs.
- PIP/POP/PAP control for all inputs
- Auto setup for PC
- Frequency measurement / distinction for all inputs
- Color space conversion (YPbPr → RGB )
- Motion Adaptive De-Interlacer.(480i/1080i)
- Color / tint control the input signal except PC input.
- 3 dimension Noise reduction.
- Adaptive Film Mode (24Hz → 30Hz)
- Gamma correction
- Contrast and brightness adjustment for COMPONENT
- OSD mixing

This IC is controlled by register control of IC 400 via 5-lines serial communication.

The output format of this IC is LVDS data stream (differential signals).

In 28 bits, 24-bits digital video signal and horizontal sync signal, vertical sync signal, and an enable signal and a clock signal for LCD panel are pointed out.

A phase-locked transmit clock is transmitted in parallel with the data streams over a fifth LVDS link. And this output is sent to LCD panel through CNF1.

(K)IC405 : 4M bit Flash Memory(PM39LV040-70JCE : PMC)

This IC is installed the firmware of IC400(gm1601), helps that IC400(gm1601) serves as another MPU. (This model operates by 2 MPU)

(L)IC403 : 128M-bit DDR SDRAM

( HY5DU283222AFP-36, HY5DU283222AF-36 : HYNIX• ANT5DS4M32EG-5 32809BPT : NANYA)

This IC is used as external frame buffer of IC400(gm1601), provides the storage required for the frame rate conversion process and integrated OSD.

**2. Audio circuits**

It explains the audio circuits and speaker system of LT-3780,LT-3280.  
Our design spec is as follows.

- Power outputs : Total 10W(5W\*2(L,R))
- Impedance : 8+/-1.2 ohms
- Compact sound 2 way bass reflex speaker box.

(Refer to an attached “Audio block diagram of LT-3780, LT-3280”, regarding as the flow of audio signal.)

2-1. Audio process circuits

(M)IC301 : Audio processor IC (MSP3440G : Micronas)

This models are used the MSP3440G as the audio processor.

This IC's functions are as follows.

- Volume control
- Tone control
- Surround
- L/R mixing
- Audio line output

This model has some sound effect features on user menu, Bass, Treble, Balance, Surround, Level Sound.

Audio adjustment of those in this model is performed by this IC.

2-2. Audio amplifiers circuits

(N)IC370, IC380 : Single Ended Audio Amplifier IC (MP7720DS-Z : MPS)

This model apply digital Audio Amplifier in order to decrease power consumption.

This amplifier voltage is 14V and SAMPVCC(for Sub Woofer)).

2-5. Speakers

No.	ITEM	SPECIFICATION
1	Nominal	8 ohms +/- 1.2%
2	Lowest Resonance	180 +/- 36Hz
3	Effective / Rated Frequency Range	F0~20KHz OUT PUT SPL-10dB
4	Rated Input	10W
5	Maximum Input	15W

### 3. Power circuit

For power supply of LT-3280D and LT-3780D, there are the power supply of “always on” and “ON/OFF” with a control signal.(Refer to BLOCK POWER.pdf)

PCB	Power source signal	Voltage [V]	“always on” or “ON/OFF”	Control signal	Output IC	Note
POWER-SUB1	120V	120V	ON/OFF	Psave1		For inverter. Only 37”
POWER-SUB2	24V	24	ON/OFF	Psave1		For inverter. Only 32”
POWER	24V	24	<b>always on</b>	-		For MAIN
	18V	18	ON/OFF	Psave4	IC9B5	Only 37”
	P5V	5	ON/OFF	Psave4	IC9B6	Only 32”
	S8V	8	<b>always on</b>	-	IC9B4	
	S5V	5	<b>always on</b>	-	IC9B7	
	S3.3V	3.3	<b>always on</b>	-	IC830	
	AMPVC C	17	ON/OFF	Psave3	IC9B3	
	4.5V	4.5	ON/OFF	Psave2	IC9B2	
MAIN	A3.3V	3.3	ON/OFF	Psave2	IC9000	
	D3.3V	3.3	ON/OFF	Psave2	IC9010	
	AD3.3V	3.3	ON/OFF	Psave2	IC9020	
	D2.5V	2.5	ON/OFF	Psave2.5	IC9030	
	A1.8V	1.8	ON/OFF	Psave2.5	IC9040	

(O)IC9A1, IC901(Only 32”) :

Power supply control IC(power factor correction) (FA5500/FA5501 : FUJI)

This IC are control IC for a power factor correction converter using critical conduction mode of operation. This IC performs a power factor correction by conversion the current waveform from triangle waveform to sine waveform. This IC and circuit is the same as LT-4260.

(P)IC9A2, IC902(Only 32”) : Power supply voltage control IC (F9222 : FUJI)

This IC controls the power supply voltage by switching about 75KHz.

This IC has MOSFET inside IC, keep switching on and off, and controls its duty to be stable output voltage. . This IC and circuit is the same as LT-4260.

(Q)IC920(Only 37”) : Power supply voltage control IC (STR-G9628 : SANKEN)

This IC controls the power supply voltage by switching above 50kHz.

This IC has MOSFET inside IC, keep switching on and off, and controls its frequency to be stable output voltage. And the duty is determined by input AC power voltage.

**4. Protection Circuit**

LT-3280D and LT-3780D has two protection circuits and some fuses.  
 If the protection circuits work, The LCD turns to stand-by mode.  
 The protection operation can be confirmed by the blinking of the blue power LED.  
 And the content can be confirmed by the number of blinking within one cycle.  
 The following table shows the content of the operation.  
 Protection Circuit:

Name	Number of blinks	Fault Location	Cause	Remark
Short1	1	POWER-SUB1 or Panel	Excessive current on the 120V line.	Only LT-3780D
		POWER-SUB2 or Panel	The 24V line on the POWER-SUB2 is low.	Only LT-3280D
Short2	2	POWER or MAIN or Panel (Only 18V or P5V)	The voltage on any of the following output lines is low.  18V  P5V AMPVCC ( 17V ) 4.5V A3.3V D3.3V AD3.3V D2.5V A1.8V	Check the fuses on POWER board.  (F9G2,F9G3, F9G5~F9G8)

Fuses:

Part No.	Rated Value	PCB	Remark
F9A1	6.3A	POWER	AC line
F9G2	500mA		S8V line ,S8V line for S5V
F9G3	1A		24V line for S8V and S5V.
F9G4	500mA		24V line for S3.3V and D1.8V.
F9G5	1.6A		24V line for AMP VCC.
F9G6	4A		24V line for 18V.
F9G7	1A		24V line for P5V.
F9G8	500mA		24V line for 4.5V.
F9I0	1A	POWER-SUB1	IC920 is broken.

LT-3780/LT-3280 BLOCK-DIAGRAM

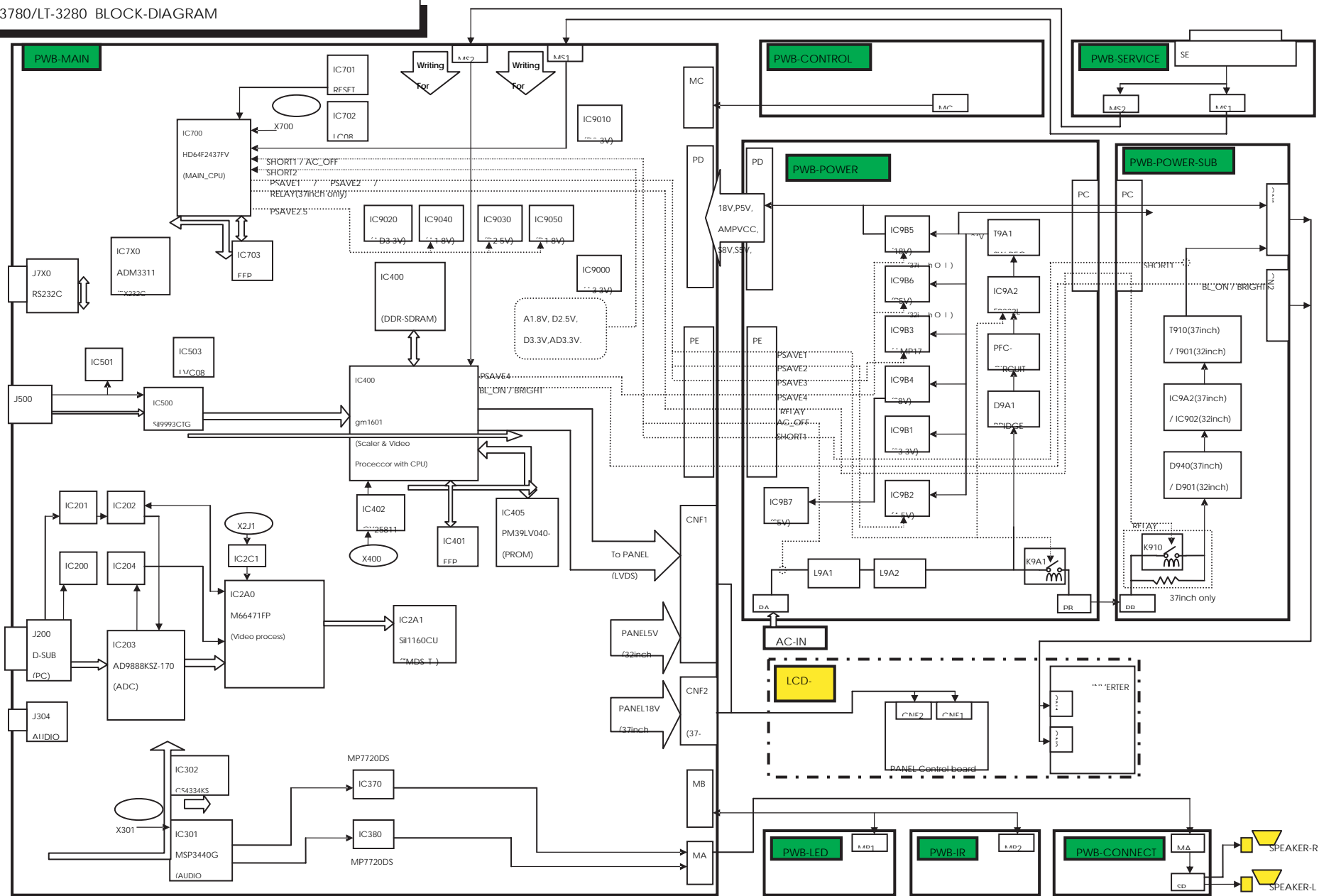



# LT-3780/LT-3280 VIDEO BLOCK-DIAGRAM

- Analog signal ➔
- Digital signal ➔
- Differential signal (TMDS) ➔
- Differential signal (LVDS) ➔

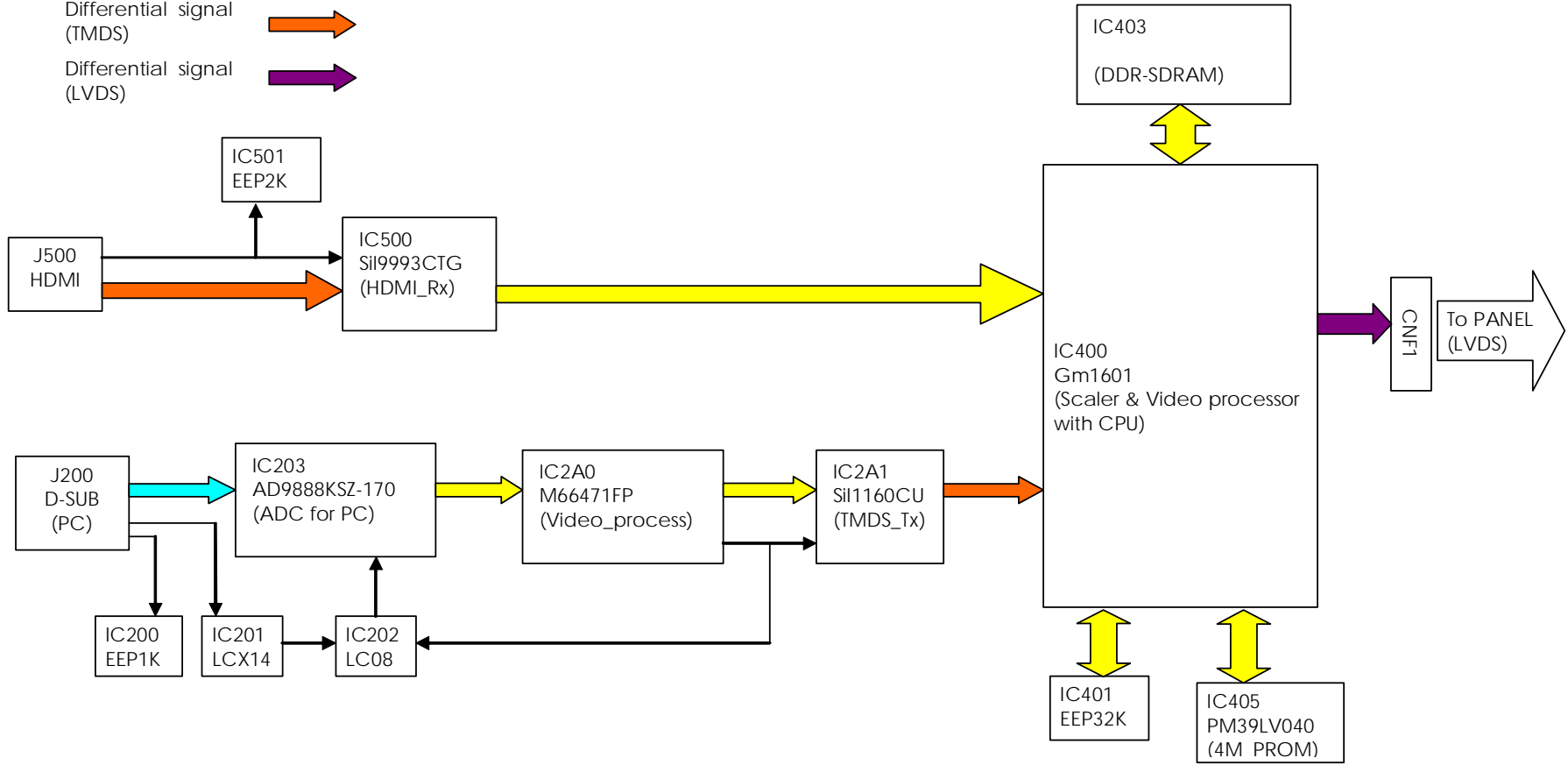

AUDIO CIRCUIT BLOCK-DIAGRAM for LT-3780/LT-3280

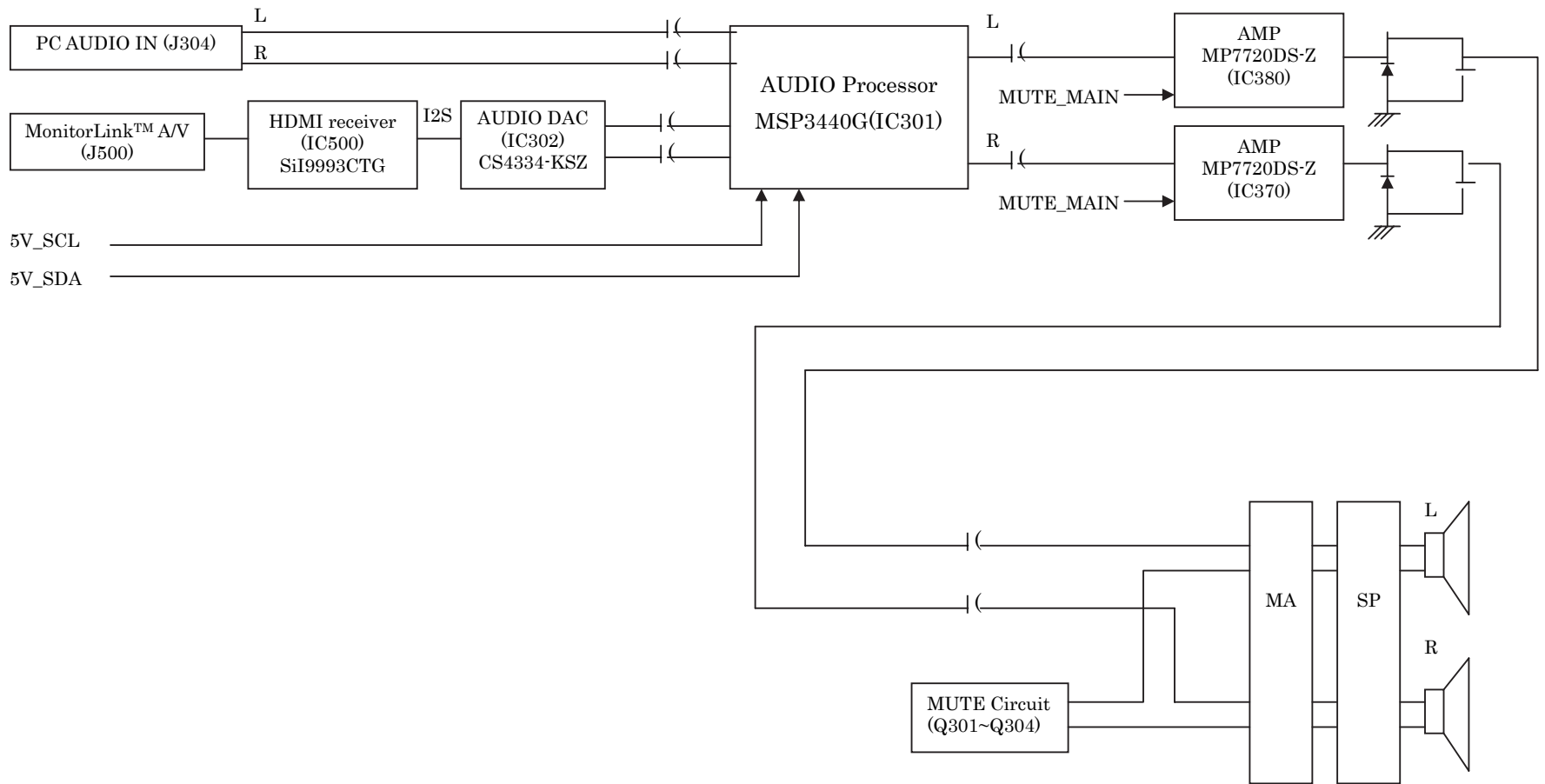

# Troubleshooting

## 1. Power failure

(1)POWER is turned off.

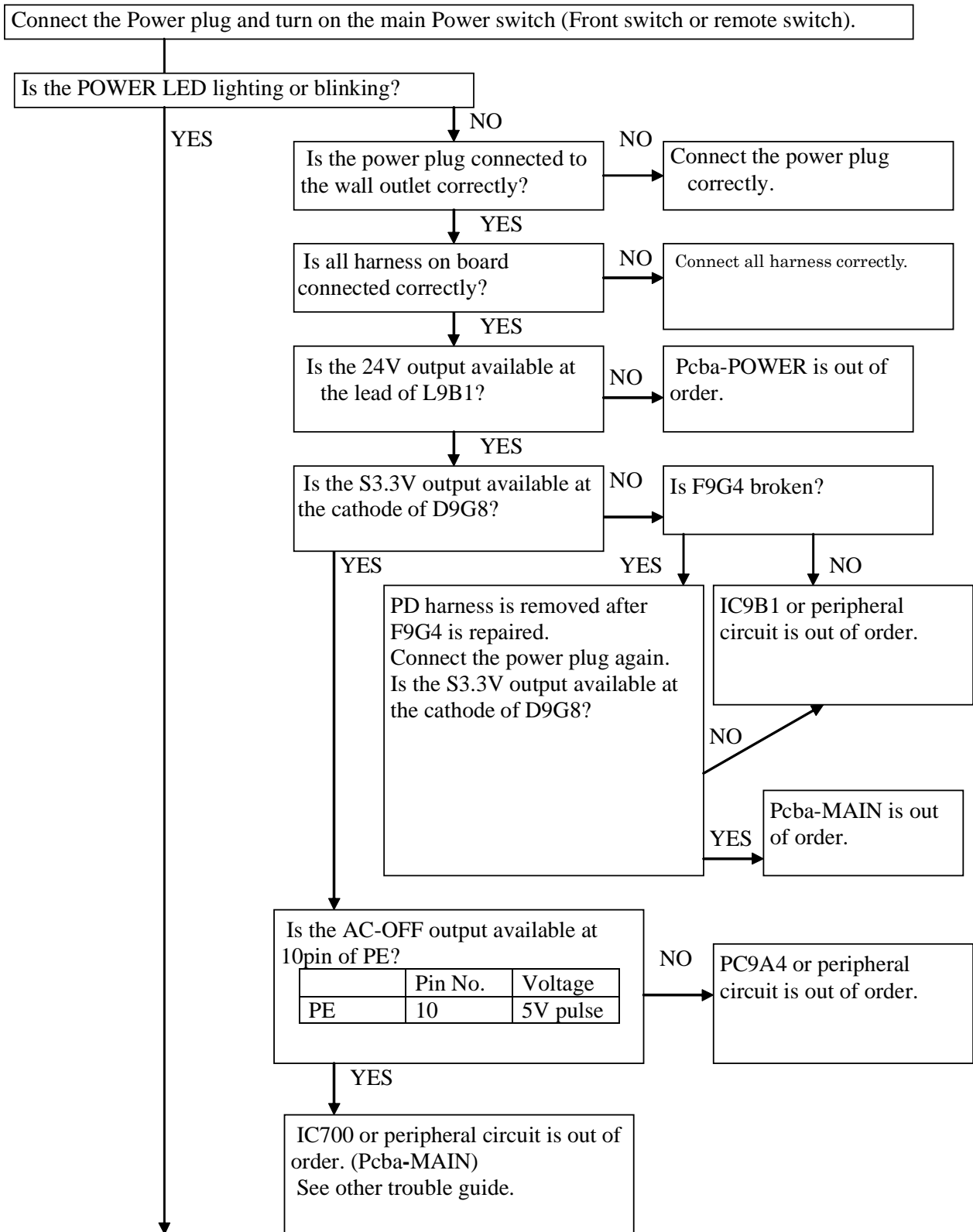

Skip to

(A):In case of the POWER-LED blinking, (B): In case of the POWER-LED lighting.

(A) In case of the POWER-LED blinking.

**☆Short1 mode: The POWER-LED blinking is 1 time within a cycle.**

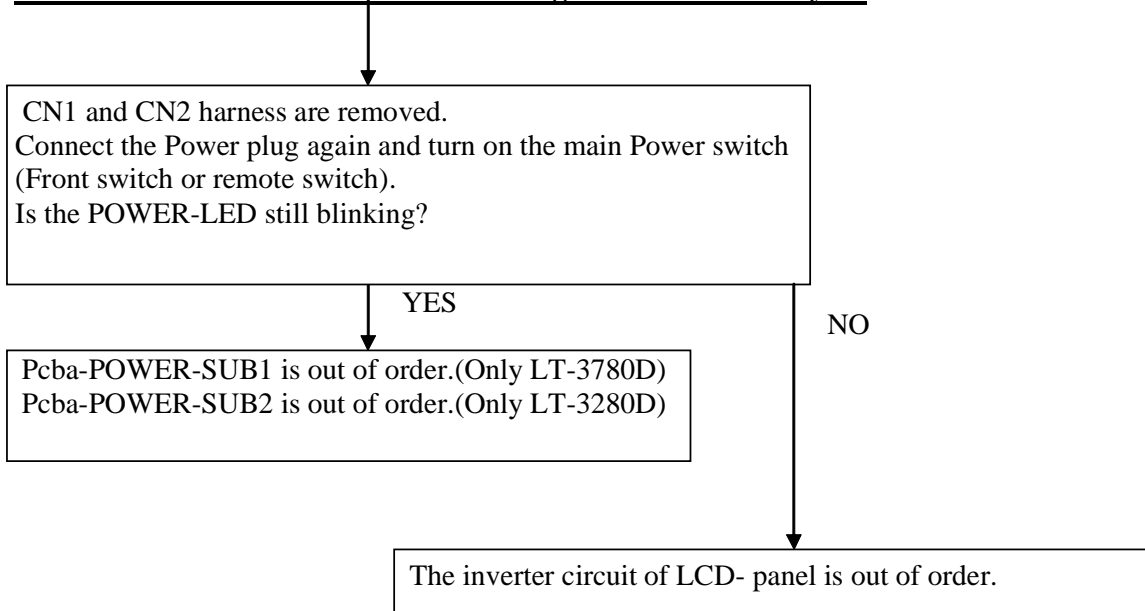

**☆Short2 mode: The POWER-LED blinking is 2 times within a cycle.**

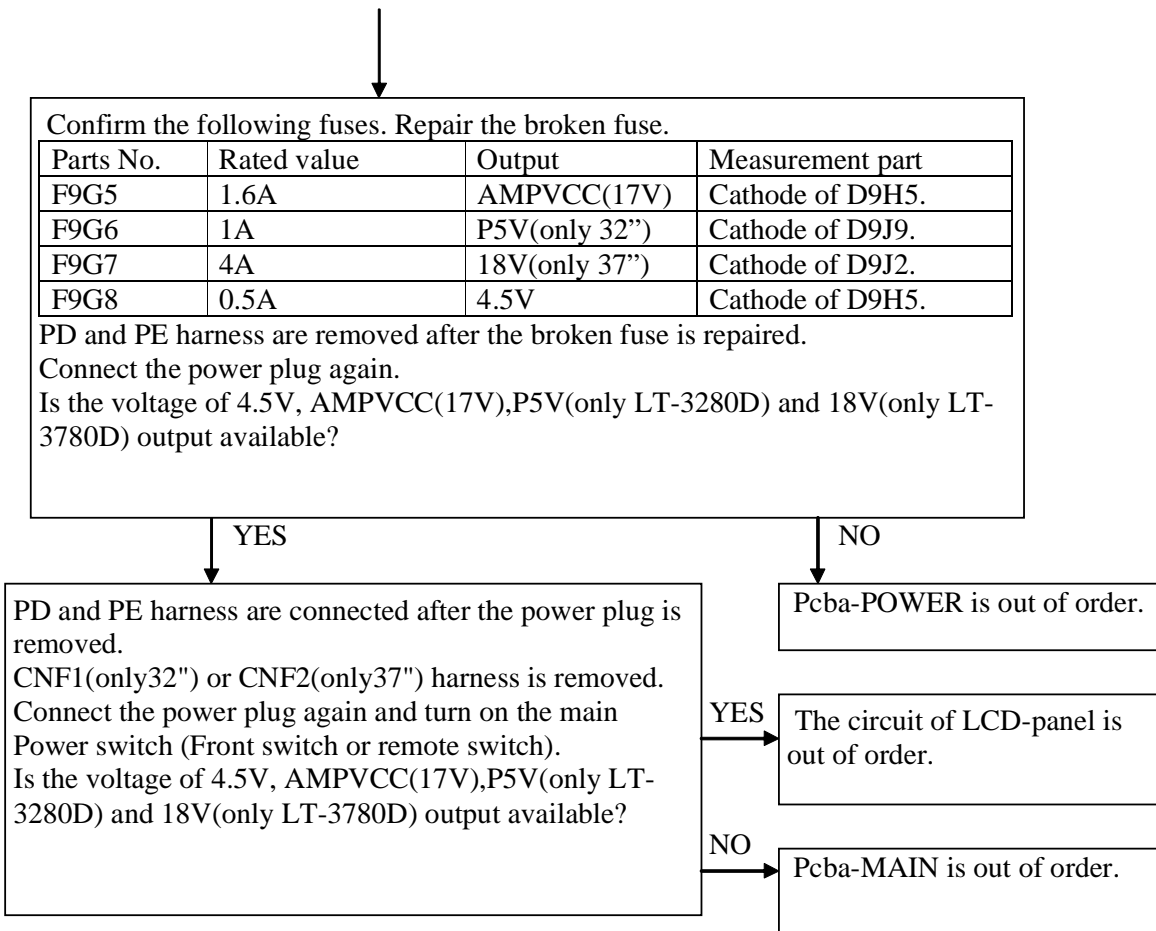

(B) In case of the POWER-LED lighting

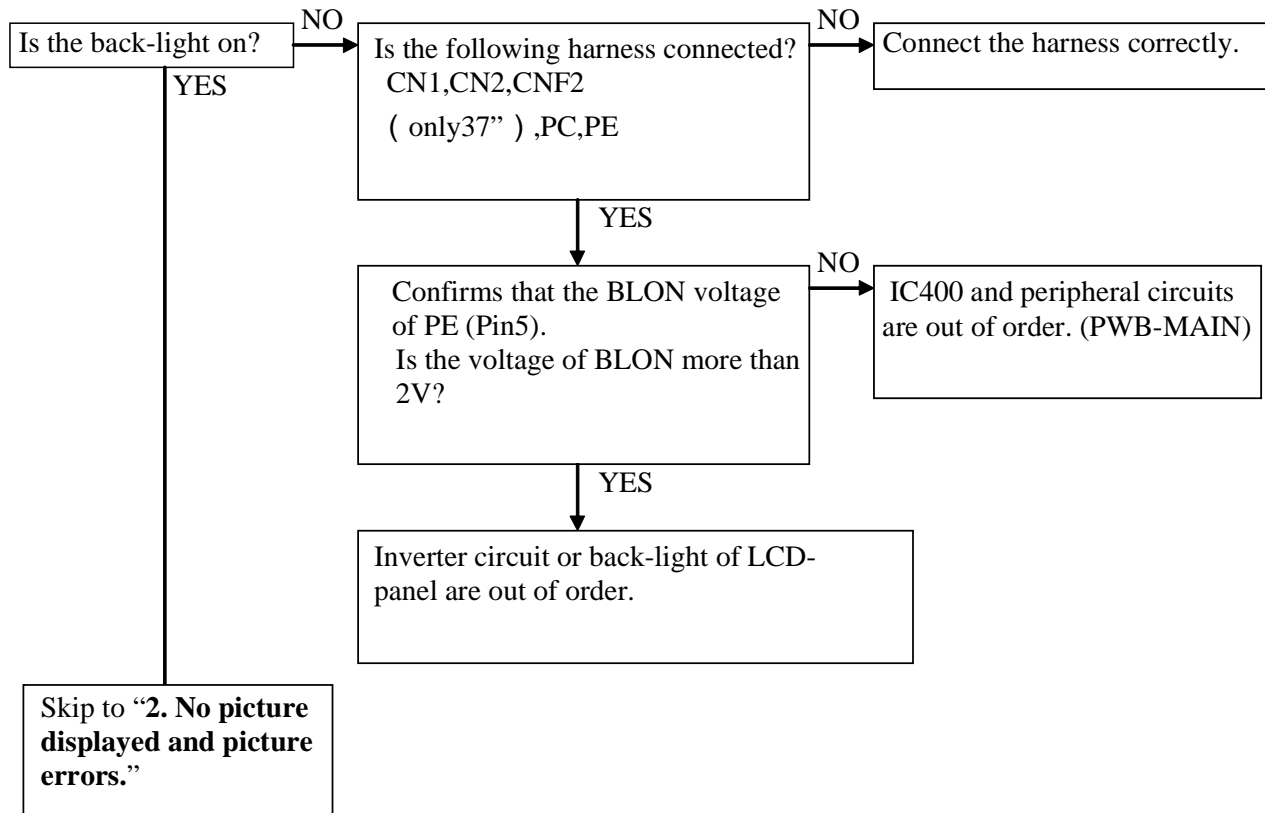

**2. No picture displayed and picture errors.**

Note ) It applies when there is no screen display or an unusual screen is outputted, although 24V(Voltage between pin4(GND) and pin6(24V) of Connector-PC) from PWB-POWER is outputted normally and the back light is turned on.

\*Input source changes in following order with DEVICE UP button of remote control or DEVICE button of front switch.

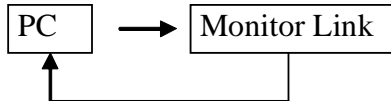

**2-1. No picture displayed and picture errors of all input.**

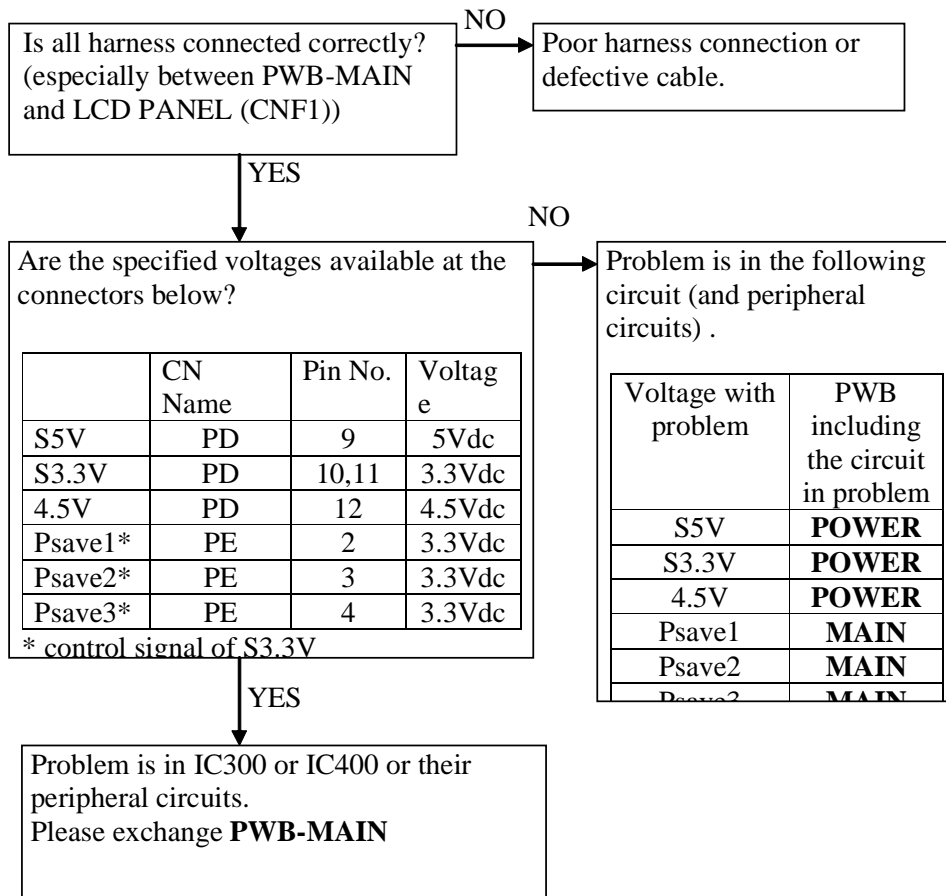

\*When it cannot still fix, it may have a problem with LCD-Module.

2-2. No picture displayed and picture errors of PC signal only.

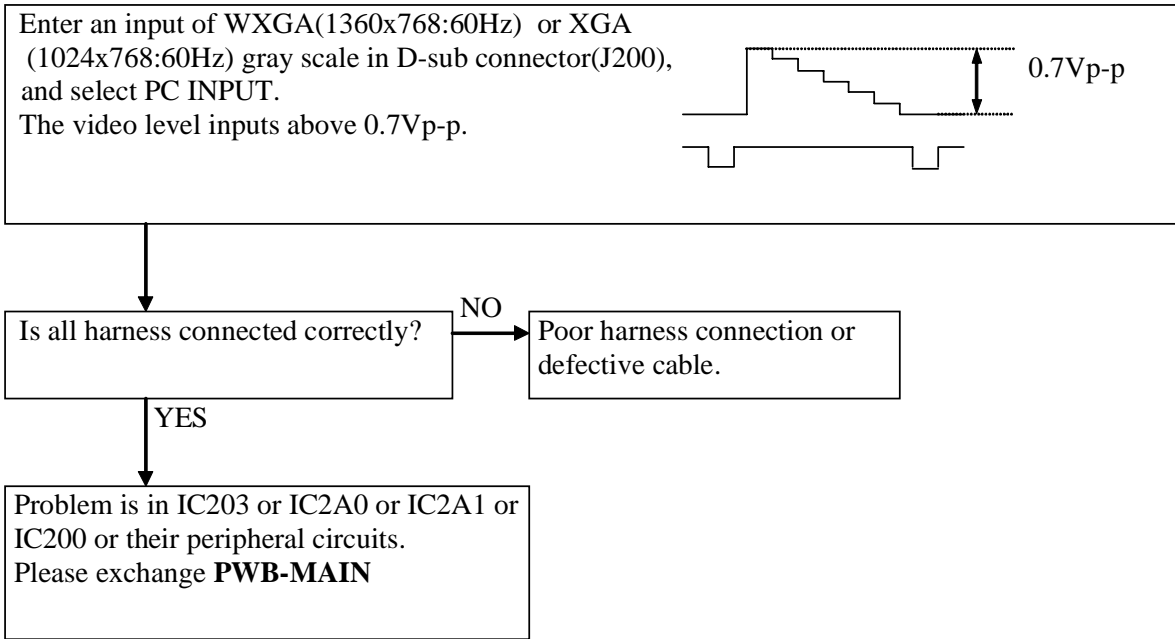

2-3. No picture displayed and picture errors of HDMI signal only.

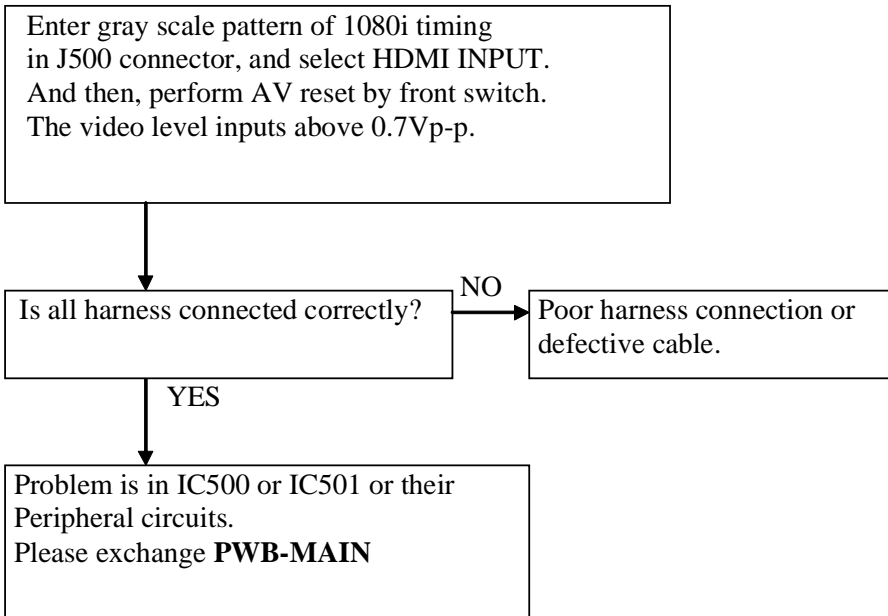

3. No audio output generated.

3-1. No all audio output generated.

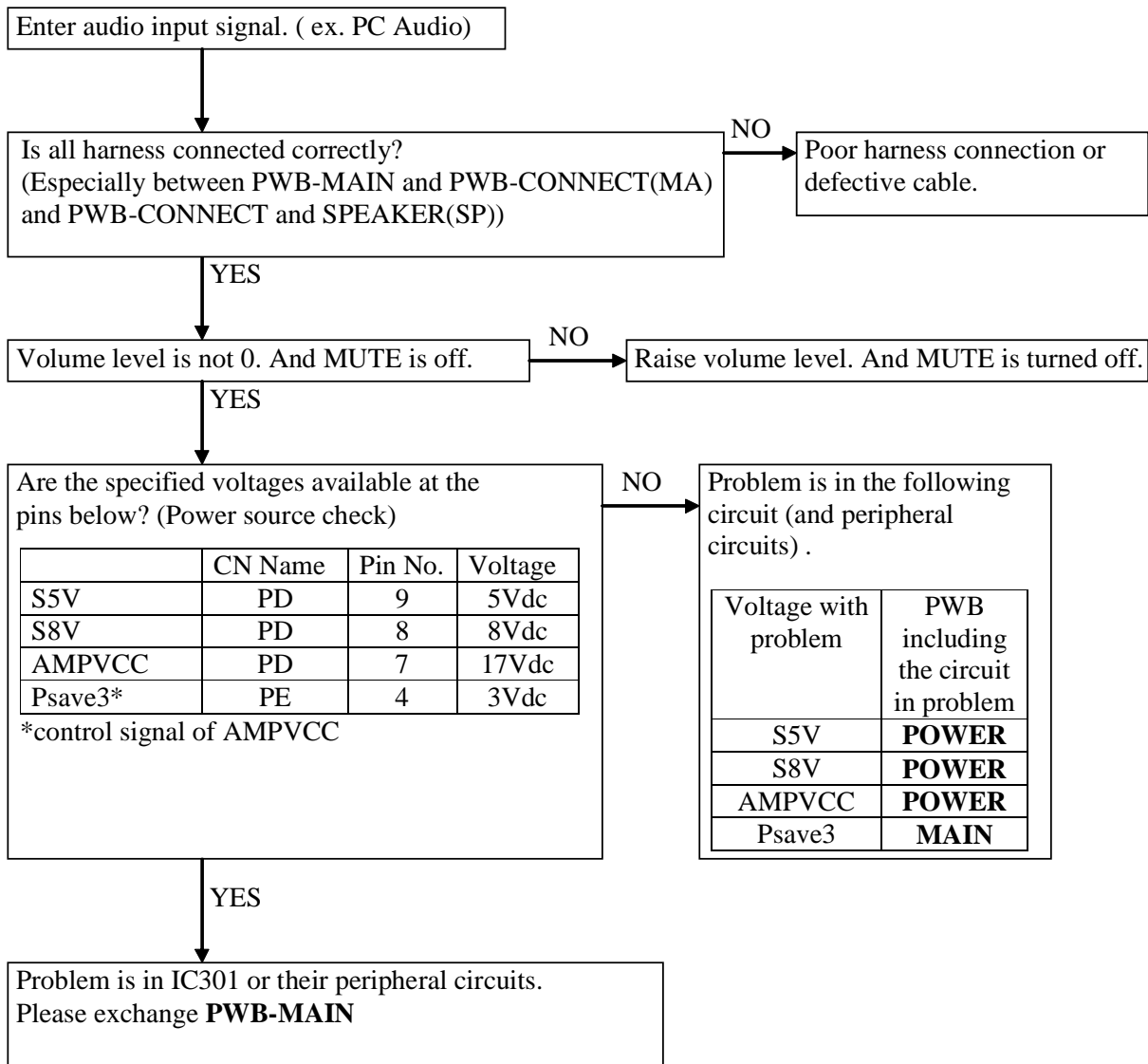

\*When it cannot still fix, it may have a problem with **SPEAKER**.



**3-2. No each(L or R) of audio output generated.**

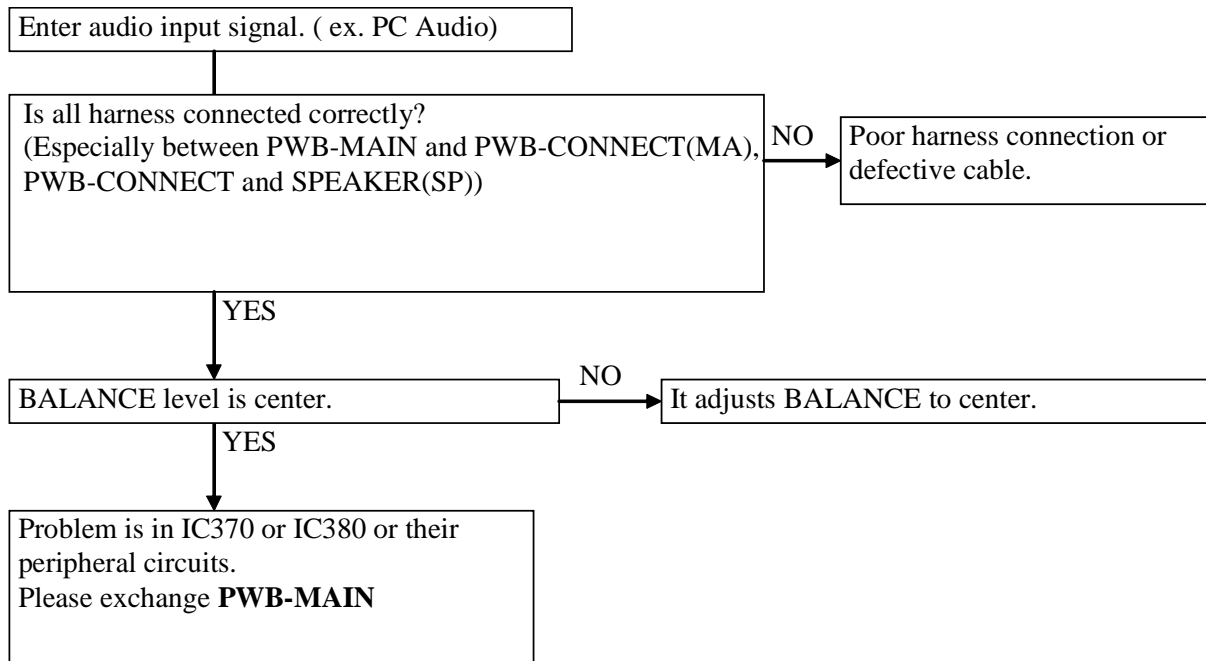

**3-3. No HDMI audio output generated.**

In case of no HDMI audio output generates, problem is in IC500 or IC302 or their peripheral Circuits.  
Please exchange **PWB-MAIN**.

**3-4. No PC audio output generated.**

In case of no PC audio output generates, problem is in J304 or their peripheral circuits.  
Please exchange **PWB-MAIN**.

**3-5. When you turn up volume(over 50), there is noise from speaker.**

Please exchange the parts of **PWB-MAIN** as below.

C37A and C38A : from 220 $\mu$ F to 470 $\mu$ F

C371 and C381 : from 0.47 $\mu$ F to 0.1 $\mu$ F

If PWB-CONNECT number is “211A77601”, please exchange this PWB-CONNECT to the PWB-CONNECT that number is “211A84201”.

4. Other faults

Notes) It considers the case where there are problems except 1, 2, 3.

4-1. Remote control is not effective.

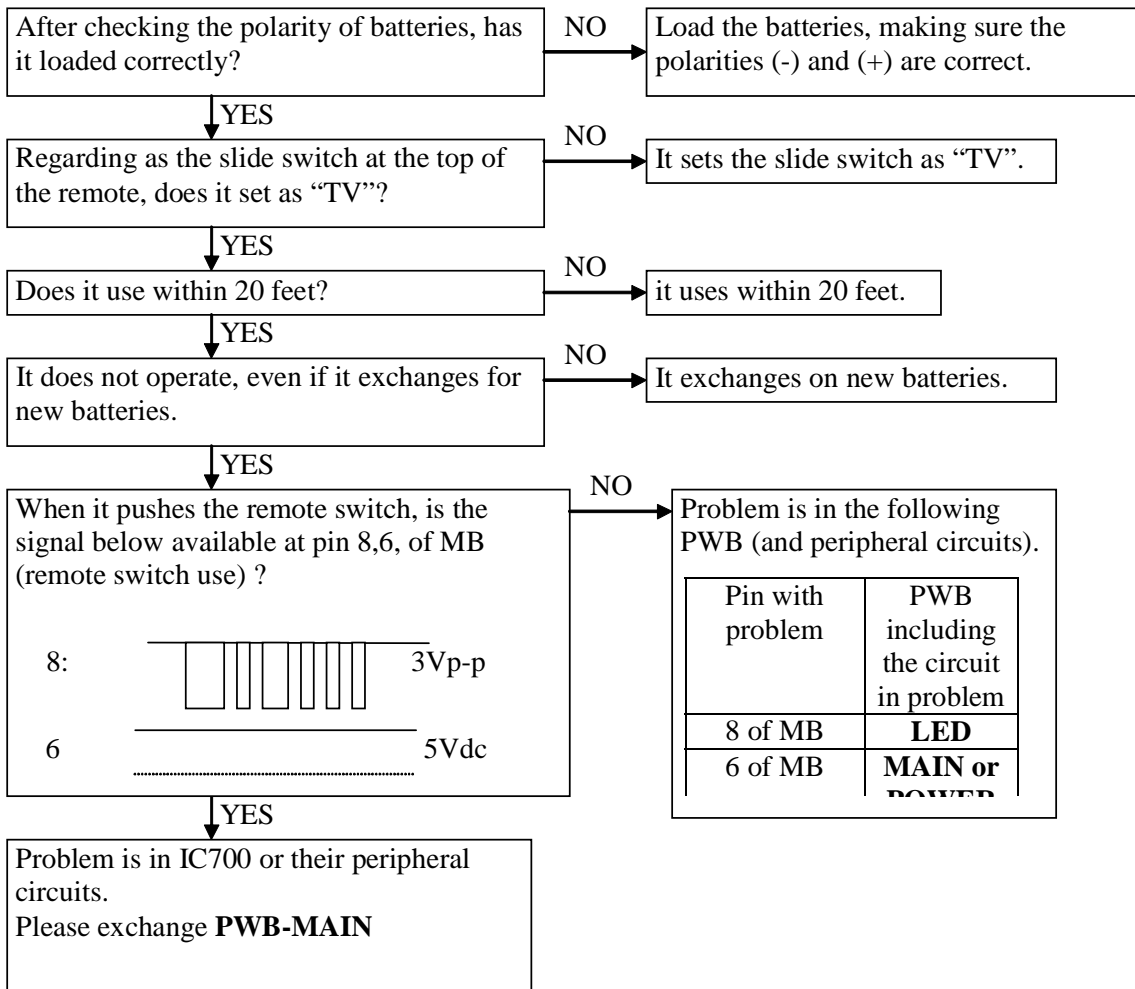

4-2. Button switch is not effective.

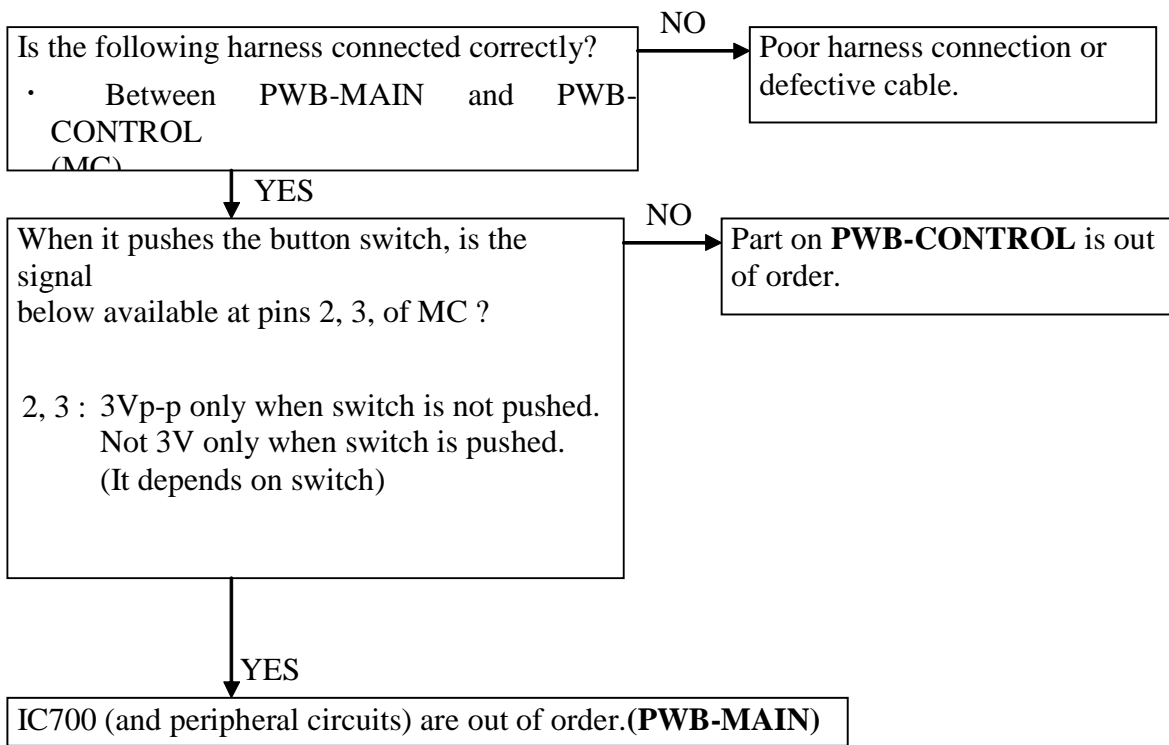

**LT-3280 Parts List**

<b>Part Number</b>	<b>Description</b>
260-320006-011	BAR-BEZEL FRONT
200-320039-0101	BEZEL-FRONT
250-320026-011	BRACKET-PANEL
250-320025-011	BRACKET-POWER
250-000034-011	BRACKET-STAND BASE
250-000033-011	BRACKET-STAND FRAME
250-320003-011	BRACKET-WALL MOUNT
200-370016-0101	BUTTON-POWER
240-000008-011	CABLE-FLAT CLIP
170-021803-101	CORD-POWER
200-320044-0101	COVER-AV1
200-320045-0101	COVER-AV2
200-320043-0101	COVER-BACK
200-320046-0101	COVER-DTV
250-370006-011	HINGE-ASSY
I/B LT3280	I/B LT3280/LT3780
180-320001-101	LCD (MODULE 1920*1080) 32" (T/A REQ)
PSM-2048	MOUNT-WALL
200-320042-0101	PANEL-FUNCTION KEY
200-320040-0101	PANEL-LEFT
200-320041-0101	PANEL-RIGHT
210-320004-011	PLATE-PC
510-322010-021	PWB-CONNECT (LT-3280/LT-3780)
510-322011-011	PWB-CONTROL (LT-3280/LT-3780)
510-322008-011	PWB-IR (LT-3280/LT-3780)
510-322009-011	PWB-LED (LT-3280/LT-3780)
510-322007-011	PWB-MAIN (LT-3280) (T/A REQ)
185-015001-101	PWB-P SUB2 (AC/DC 150 W)(LT3280) T/A REQ
185-023002-101	PWB-POWER SUPPLY(230W)(LT3280) T/A REQ
510-322012-011	PWB-SERVICE BOARD (LT-3280/LT-3780)
I/QR LT3280	QUICK REFERENCE LT3280/LT3780
290P118020	REMOTE
154-080801-101	SPEAKER 10W 8R (2 EA)
200-370021-0101	STAND-BASE PLASTIC
220-000004-011	STAND-BASE RUBBER (6 pcs/PKG)
200-370018-0101	STAND-FRAME COVER
200-370019-0101	STAND-FRAME PLASTIC COVER
200-370020-0101	STAND-FRONT PLATE
250-000036-011	STAND-STAY
220-320001-011	STAND-SUPPORT RUBBER

**LT-3780 Parts List**

<b>Part Number</b>	<b>Description</b>
260-370002-011	BAR-BEZEL FRONT
200-370009-0101	BEZEL-FRONT
250-370001-011	BRACKET-PANEL SUPPORT RL (37")
250-370002-011	BRACKET-PANEL SUPPORT TB (37")
250-000034-011	BRACKET-STAND BASE
250-000033-011	BRACKET-STAND FRAME
250-370004-011	BRACKET-WALL MOUNT
200-370016-0101	BUTTON-POWER
170-021803-101	CORD-POWER
200-370022-0101	COVER-AV1
250-370006-011	HINGE-ASSY
I/B LT3780	I/B LT3280/LT3780
543-370001-001	KIT-COVER BACK LT-3780
180-370001-201	LCD (MODULE 1920*1080) 37" (T/A REQ)
PSM-2048	MOUNT-WALL
200-370015-0101	PANEL-FUNCTION KEY
200-370010-0101	PANEL-SIDE LEFT
200-370011-0101	PANEL-SIDE RIGHT
210-370002-011	PLATE-PC
510-322010-021	PWB-CONNECT (LT-3280/LT-3780)
510-322011-011	PWB-CONTROL (LT-3280/LT-3780)
510-322008-011	PWB-IR (LT-3280/LT-3780)
510-322009-011	PWB-LED (LT-3280/LT-3780)
510-372001-011	PWB-MAIN (LT-3780) (T/A REQ)
185-021001-101	PWB-P SUB1 (210W) (LT3780) T/A REQ
185-023003-101	PWB-POWER-SUPPLY(230W)(LT3780) T/A REQ
510-322012-011	PWB-SERVICE BOARD (LT-3280/LT-3780)
I/QR LT3780	QUICK REFERENCE LT3280/LT3780
154-080801-101	SPEAKER 10W 8R (2 EA)
200-370021-0101	STAND-BASE PLASTIC
220-000004-011	STAND-BASE RUBBER (6 pcs/PKG)
200-370018-0101	STAND-FRAME COVER
200-370019-0101	STAND-FRAME PLASTIC COVER
200-370020-0101	STAND-FRONT PLATE
250-000036-011	STAND-STAY





32inch (LT-3280D)

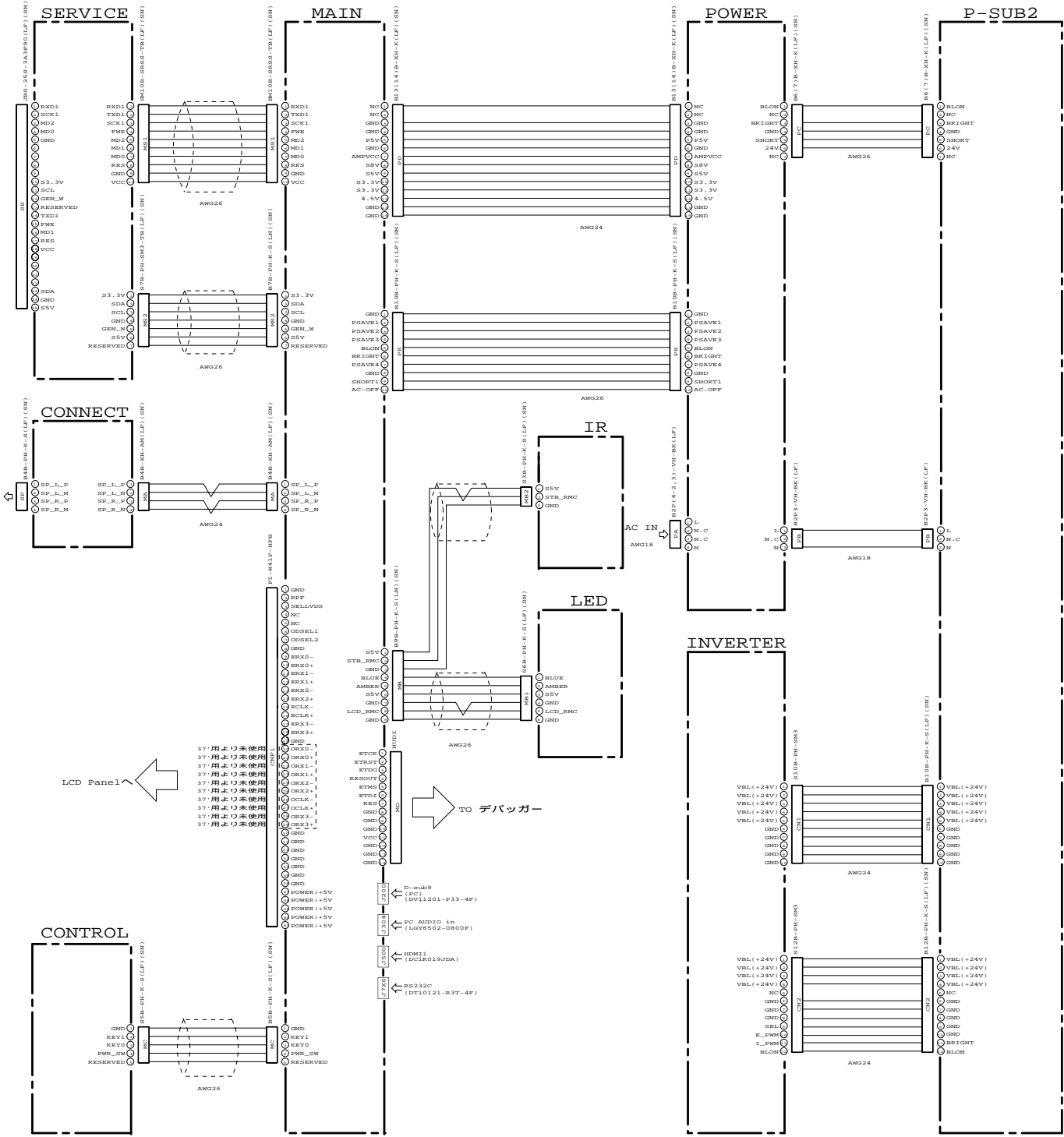

37inch (LT-3780D)

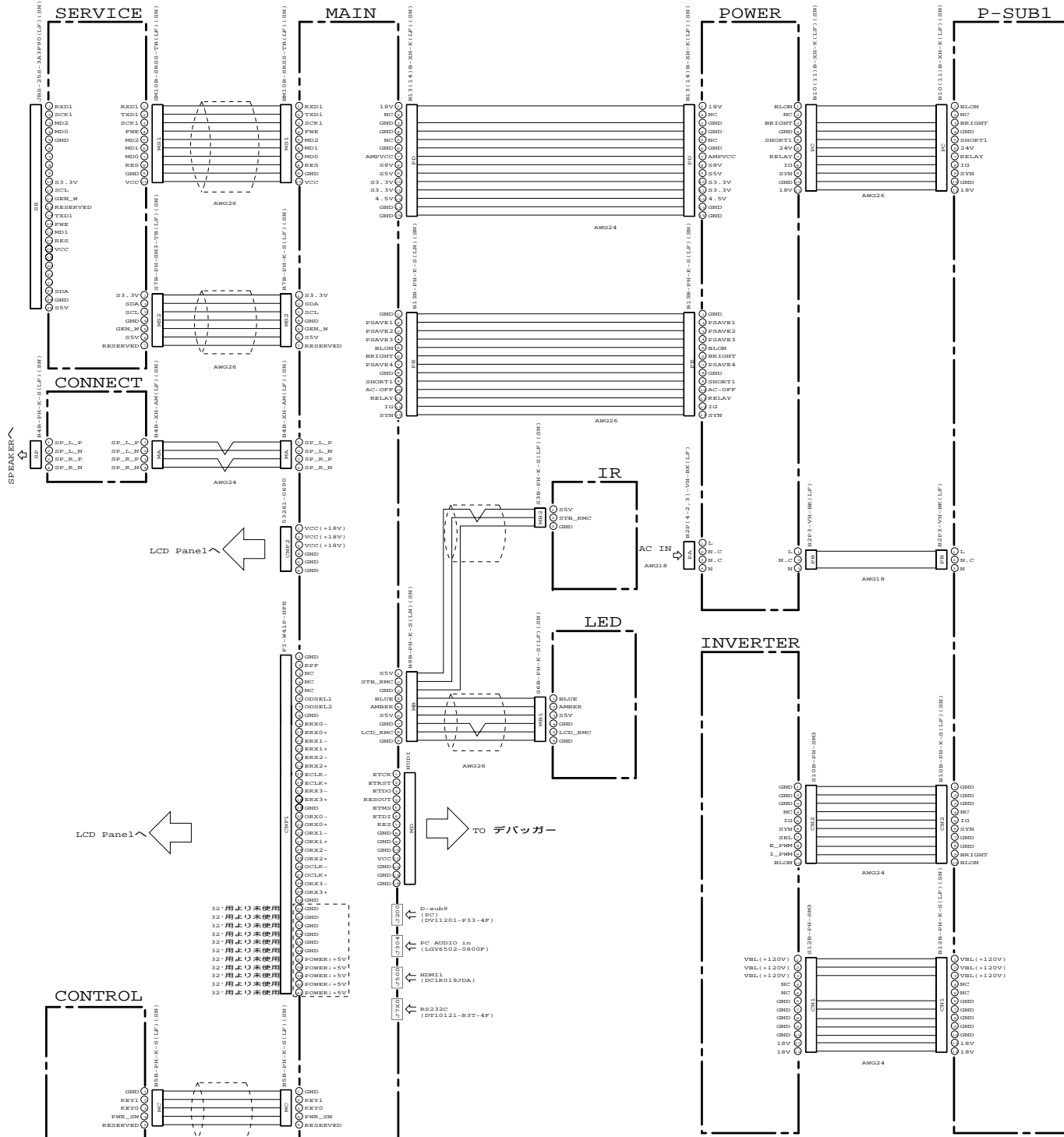

2		LT-3780D		
1		LT-3280D		

CHANGE

出図先	規格	MATERIAL AND DIMENSIONS	(NE)	DATE	5	TITLE OF DRAWING			24
第3角法	3RD ANGLE PROJECTION	DIM IN UNIT	寸法 SCALE	作成日付 DATE	2005.7.11	SCHEMATIC-DIAGRAM (1/14)			25 26 27 28 29 30 31
MITSUBISHI ELECTRIC CORPORATION		図名		880A647					
作成 DRAWN	確認 CHECKED	設計 DESIGNED	审核 REVIEWED						
CAD		中井							

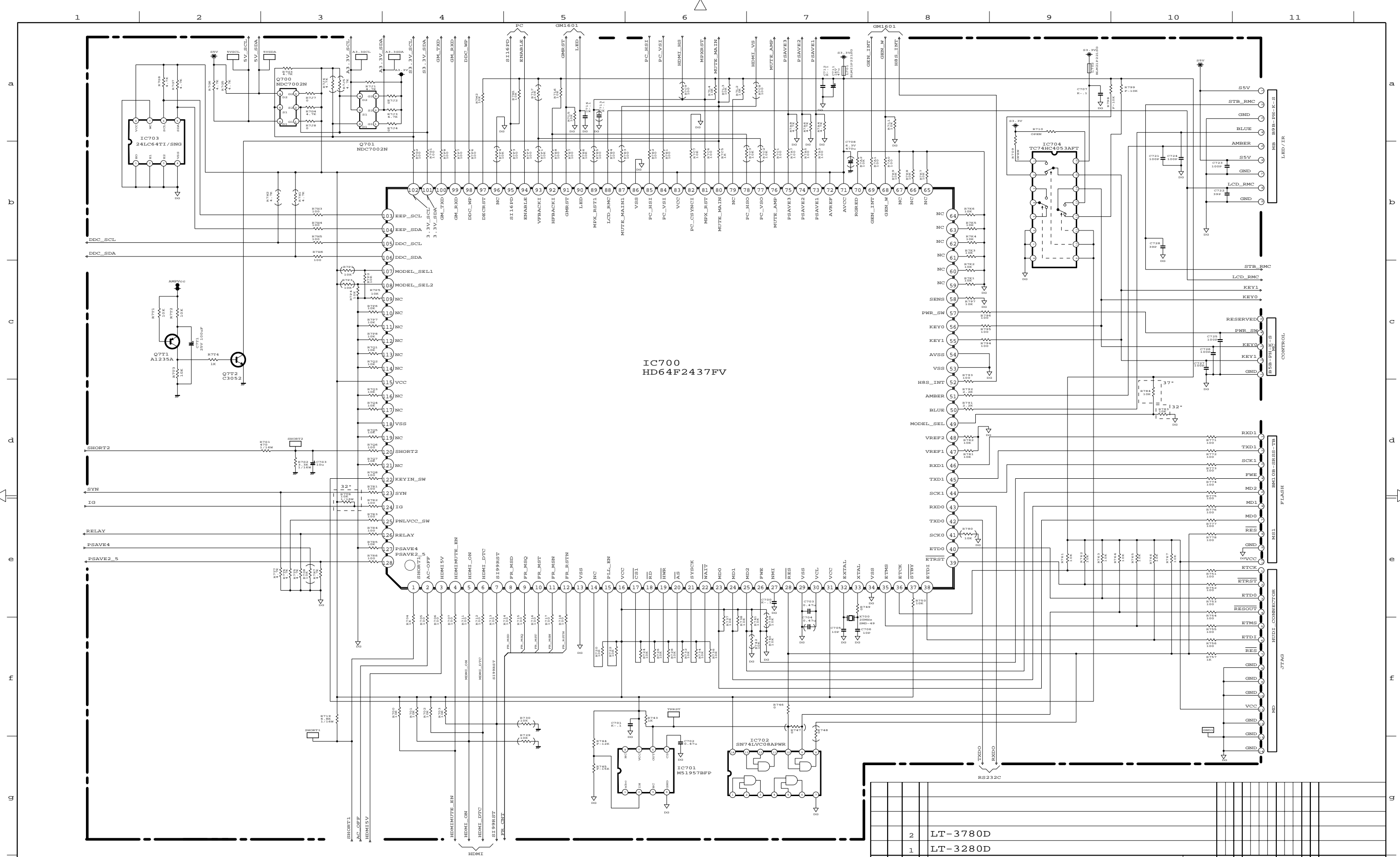

2	LT-3780D
1	LT-3280D

改定 CHANGE	出図先		第3角法		3RD ANGLE PROJECTION	DIM IN mm	尺度 SCALE NTS	作成日付 DATE 2005.7.11	MATERIAL AND DIMENSIONS		(MI) MARK	UNIT CODE	摘要 REMARK				
	作成 DRAWN CAD		检查 CHECKED 本間		设计 DESIGNED 千原		校核 APPROVED 石畑		5 ~ uCON (MAIN) SCHEMATIC-DIAGRAM (2/14)		25	26	27	28	29	30	31
	880A647																
	MITSUBISHI ELECTRIC CORPORATION																

DIRECTORY: WORK/KYOTO/FPD/MDEA05/LCD\_DISPLAY\_SIDE/PWB\_MAIN



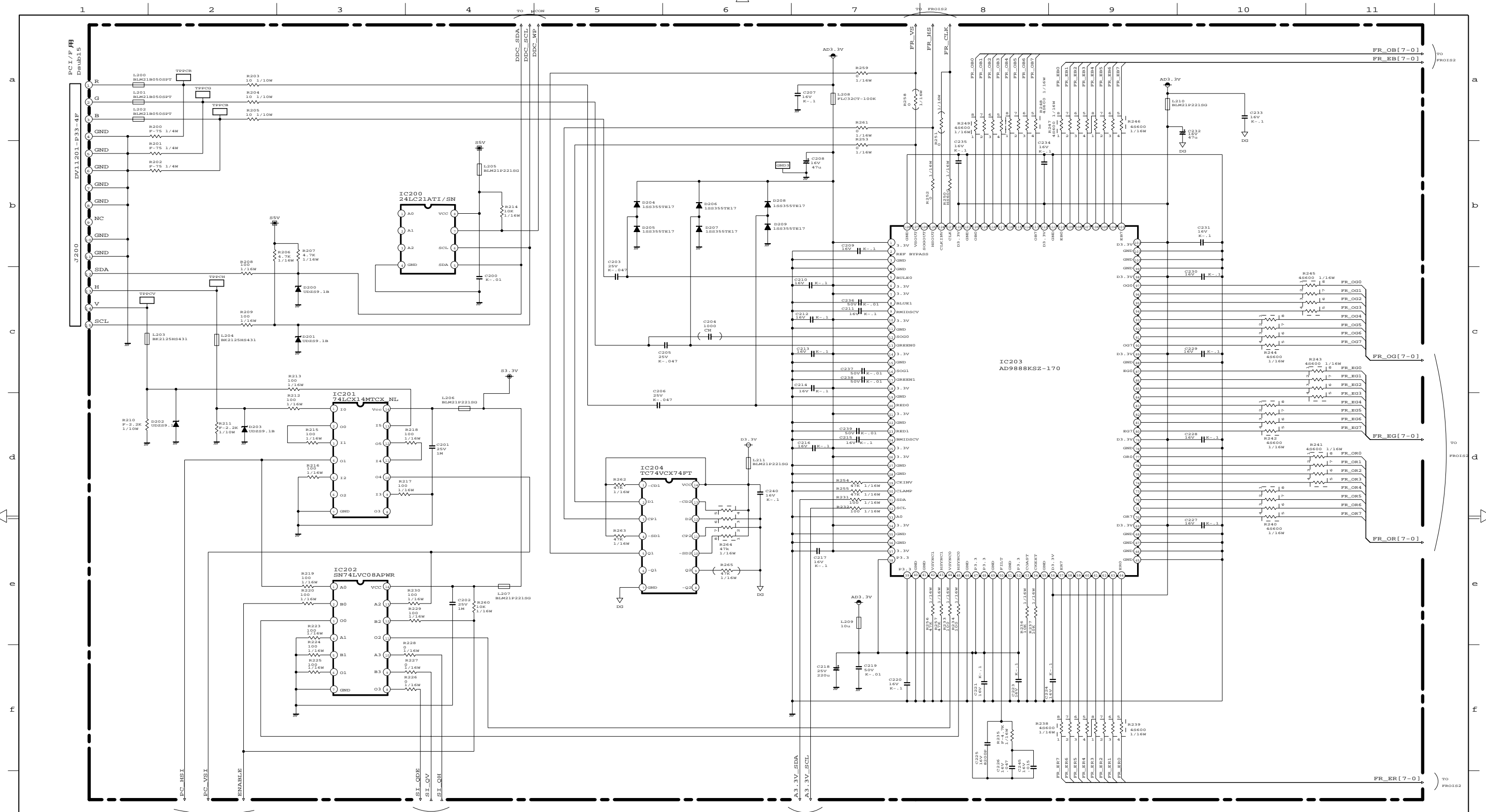

2	LT-3780D
1	LT-3280D

改定 CHANGE

* 出図先		MATERIAL AND DIMENSIONS		(MI) MARK	UNIT CODE	5 ~ TITLE OF DRAWING		~ 24				
第3角法	3RD ANGLE PROJECTION	DIM IN mm	尺度 SCALE NTS	作成日付 DATE 2005.7.11	図名	AD (MAIN)	SCHEMATIC-DIAGRAM (4/14)					
<b>MITSUBISHI ELECTRIC CORPORATION</b>						25	26	27	28	29	30	31
作成 DRAWN	検査 CHECKED	設計 DESIGNED	校核 APPROVED		880A647							
CAD	本間	千原	石畑									



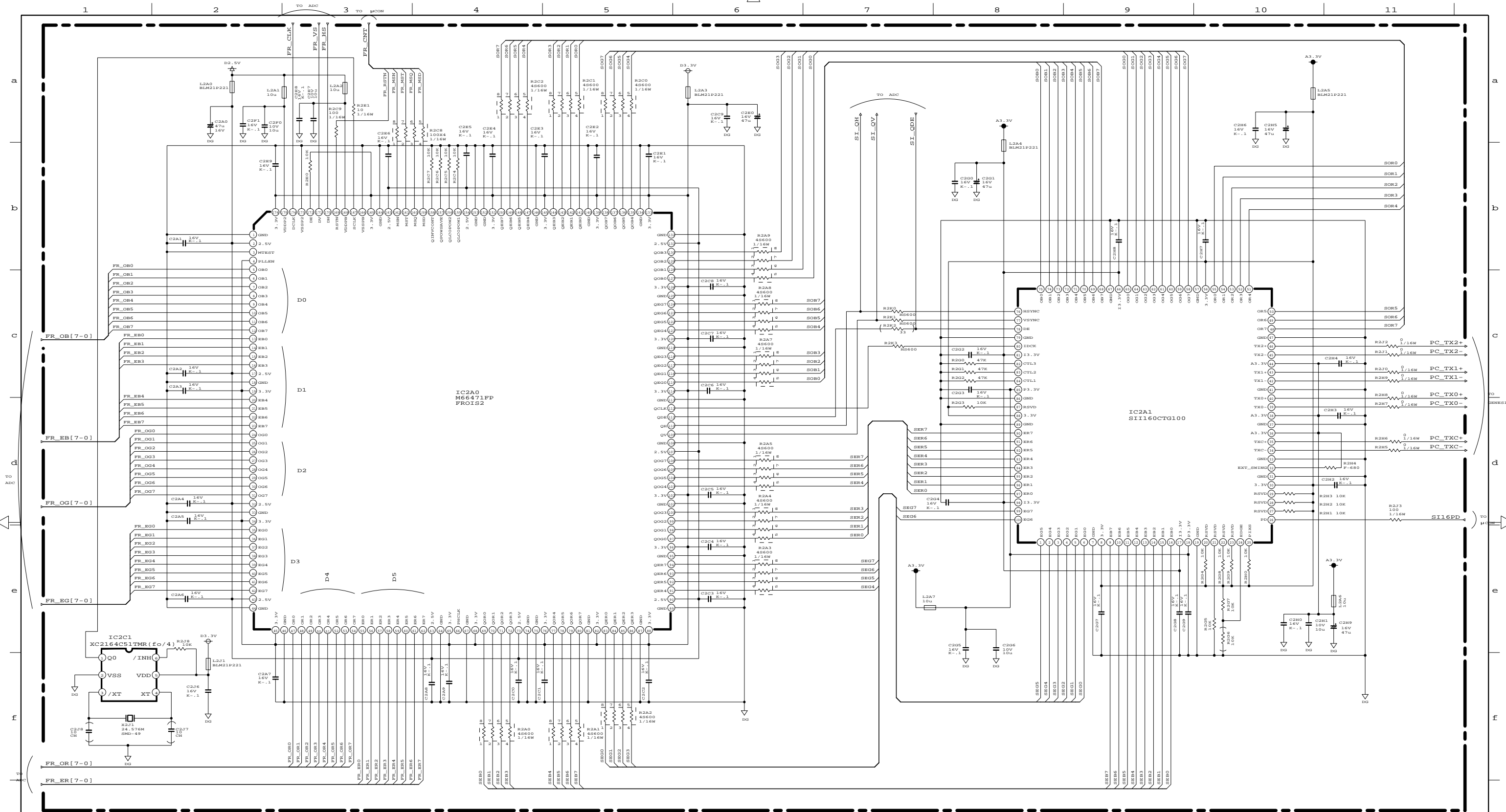

2	LT-3780D
1	LT-3280D

改定 CHANGE

* 出図先		MATERIAL AND DIMENSIONS		(MI) MARK	UNIT CODE	TITLE OF DRAWING		REMARK	
第3角法	3RD ANGLE PROJECTION	DIM IN mm	尺度 SCALE	作成日付 DATE	2005.7.11	FROIS2 (MAIN) SCHEMATIC-DIAGRAM (5/14)		24	
MITSUBISHI ELECTRIC CORPORATION						25 26 27 28 29 30 31			
作成 DRAWN	審査 CHECKED	設計 DESIGNED	校核 APPROVED	880A647					
CAD	本間	千原	石畑						

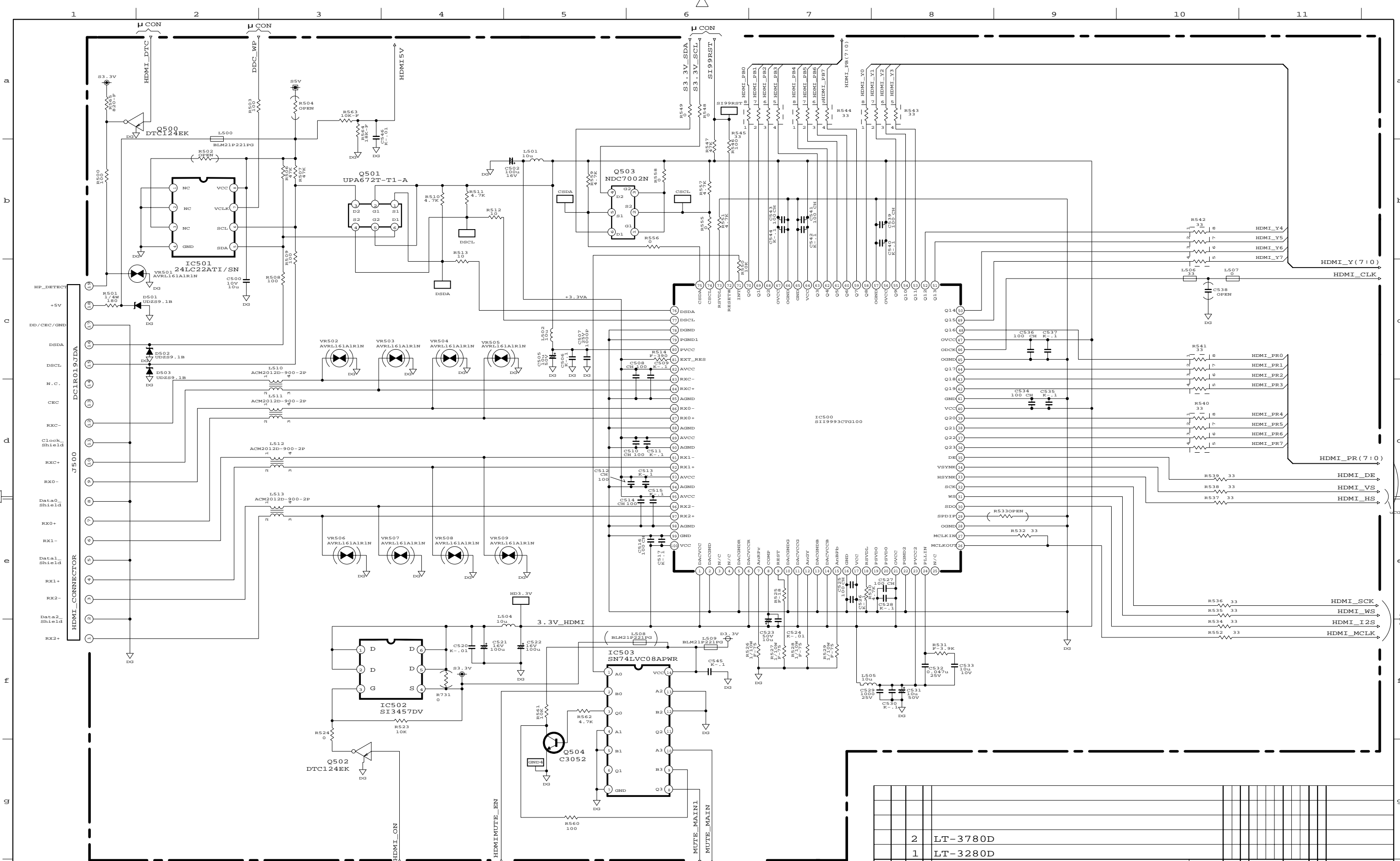

2	LT-3780D	改訂 制図 部品 注記 材料 検査 出荷 検査 部品 注記	規格 部品 注記 材料 検査 出荷 検査 部品 注記	MATERIAL AND DIMENSIONS (M) UNIT CODE 5 ~ TITLE OF DRAWING HDMI (MAIN) SCHEMATIC-DIAGRAM (6/14)	摘要 REMARK 24
1	LT-3280D				

改定	MITSUBISHI ELECTRIC CORPORATION				880A647						
	第3角法 3RD ANGLE PROJECTION				DIM IN	尺度 SCALE	作成日付 DATE 2005.7.11		5 ~ TITLE OF DRAWING HDMI (MAIN) SCHEMATIC-DIAGRAM (6/14)		~ 24
	作成 DRAWN		検査 CHECKED		設計 DESIGNED		確認 APPROVED				25 26 27 28 29 30 31
CAD		本間		千原		石畑					

IC400  
gm1601-LF-CF

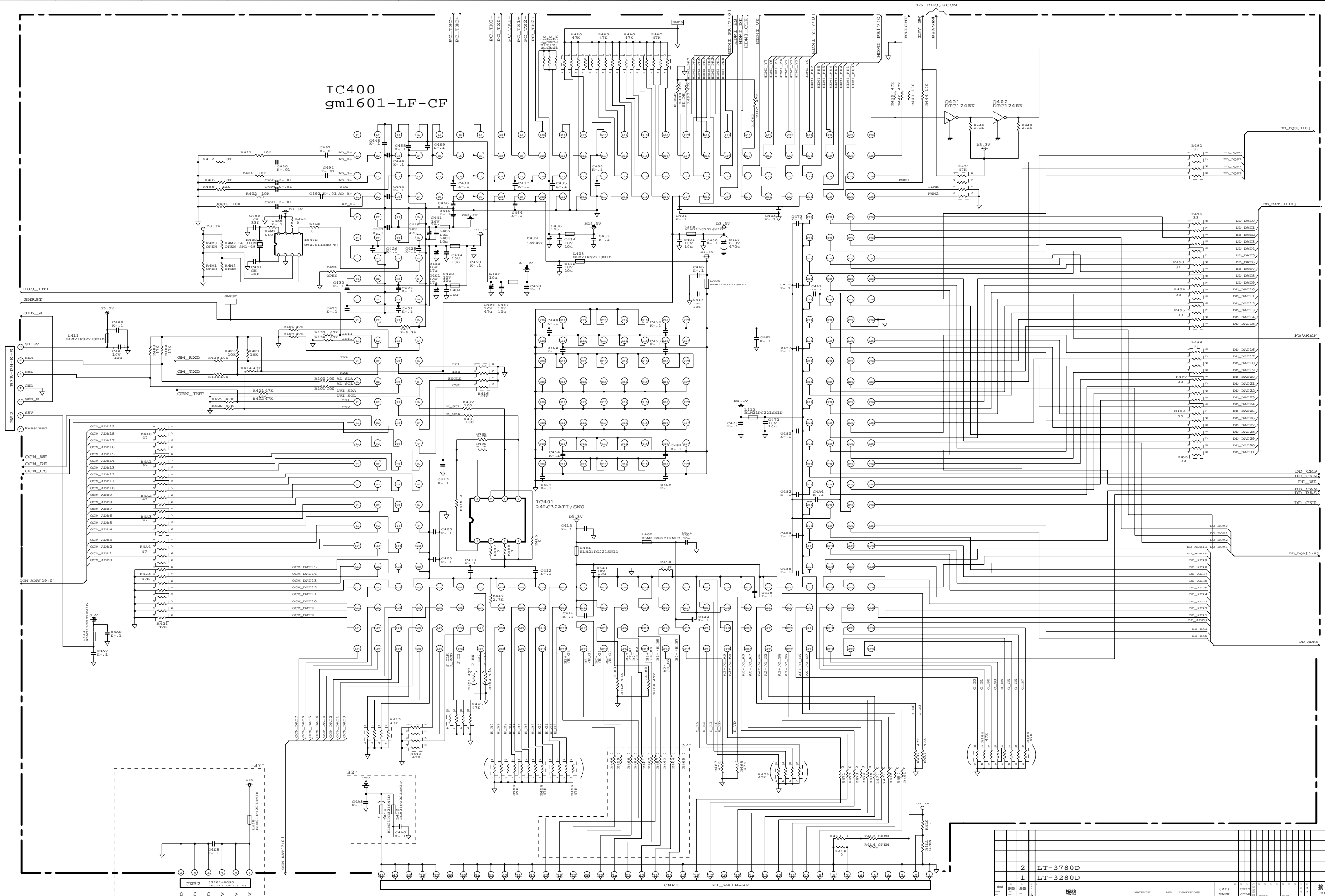

2	LT-3780D
1	LT-3280D

DATE	2005.7.11
SCALE	1:1
DESIGNER	本間 千原 石畑
CHECKED	
APPROVED	

880A647

CHANGE

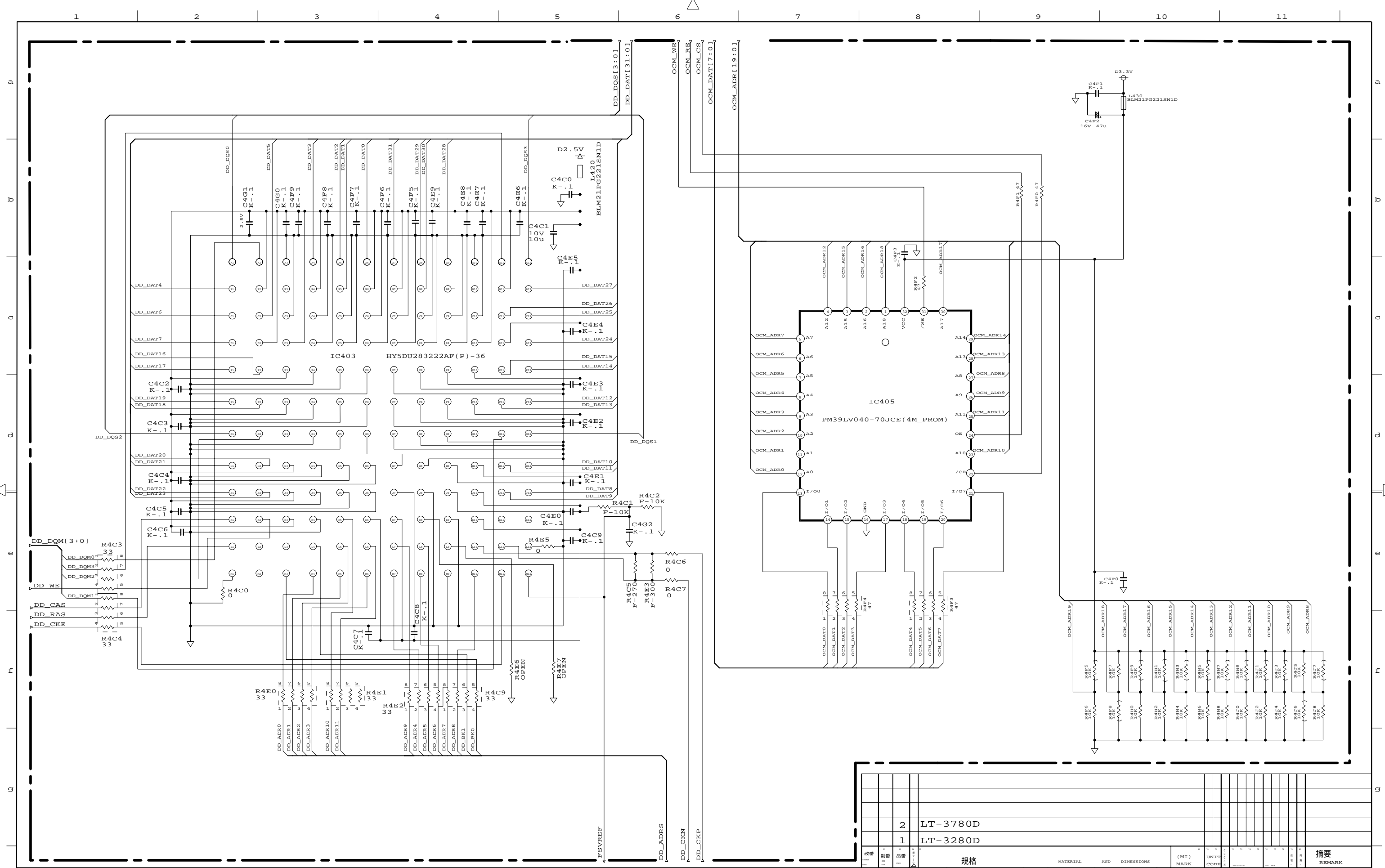

2	LT-3780D
1	LT-3280D

改定 CHANGE	出図先		MATERIAL AND DIMENSIONS		(M)	UNIT		REMARK	
	第3角法	3RD ANGLE PROJECTION	DIM IN mm	尺度 SCALE NTS	作成日付 DATE	2005.7.11	5 ~ TITLE OF DRAWING ~ 24		摘要
	GM-MEMORY (MAIN)		SCHEMATIC-DIAGRAM (8/14)		25 26 27 28 29 30 31				
	MITSUBISHI ELECTRIC CORPORATION				作成 DRAWN		検査 CHECKED	設計 DESIGNED	検印 APPROVED
CAD		本間	千原	石畑					

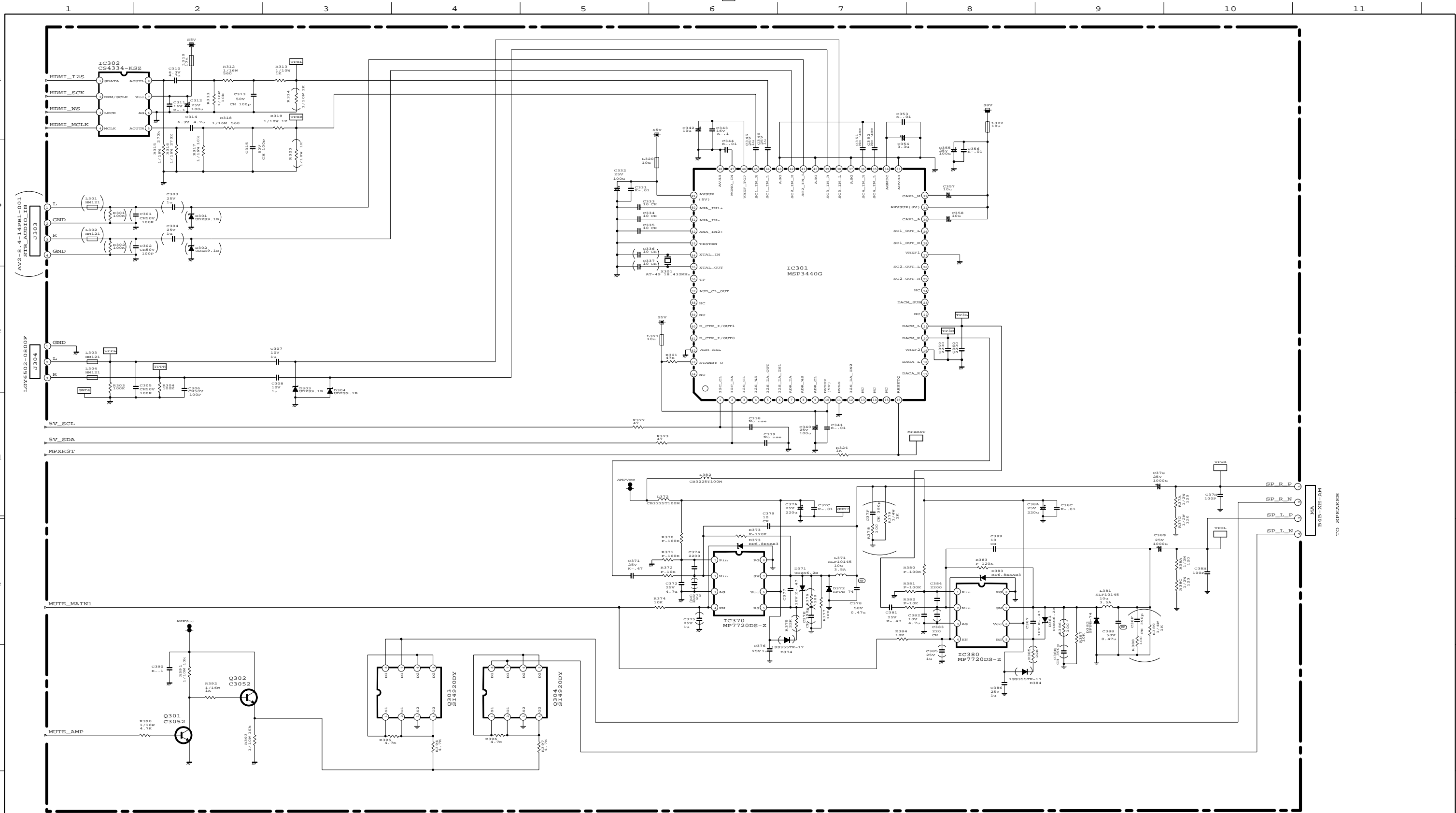

2	LT-3780D
1	LT-3280D

改定 CHANGE

規格		MATERIAL AND DIMENSIONS		(MI) MARK	UNIT CODE	摘要					
出図先	第3角法 3RD ANGLE PROJECTION	DIM IN mm	尺度 SCALE	作成日付 DATE	5 ~	TITLE OF DRAWING					
			NTS	2005・7・11	名	AUDIO (MAIN)					
作成 DRAWN		検査 CHECKED	設計 DESIGNED	核議 APPROVED	SCHEMATIC-DIAGRAM ( 9 / 14 )						
CAD	本間	千原	石畑		25	26	27	28	29	30	31
				880A647							

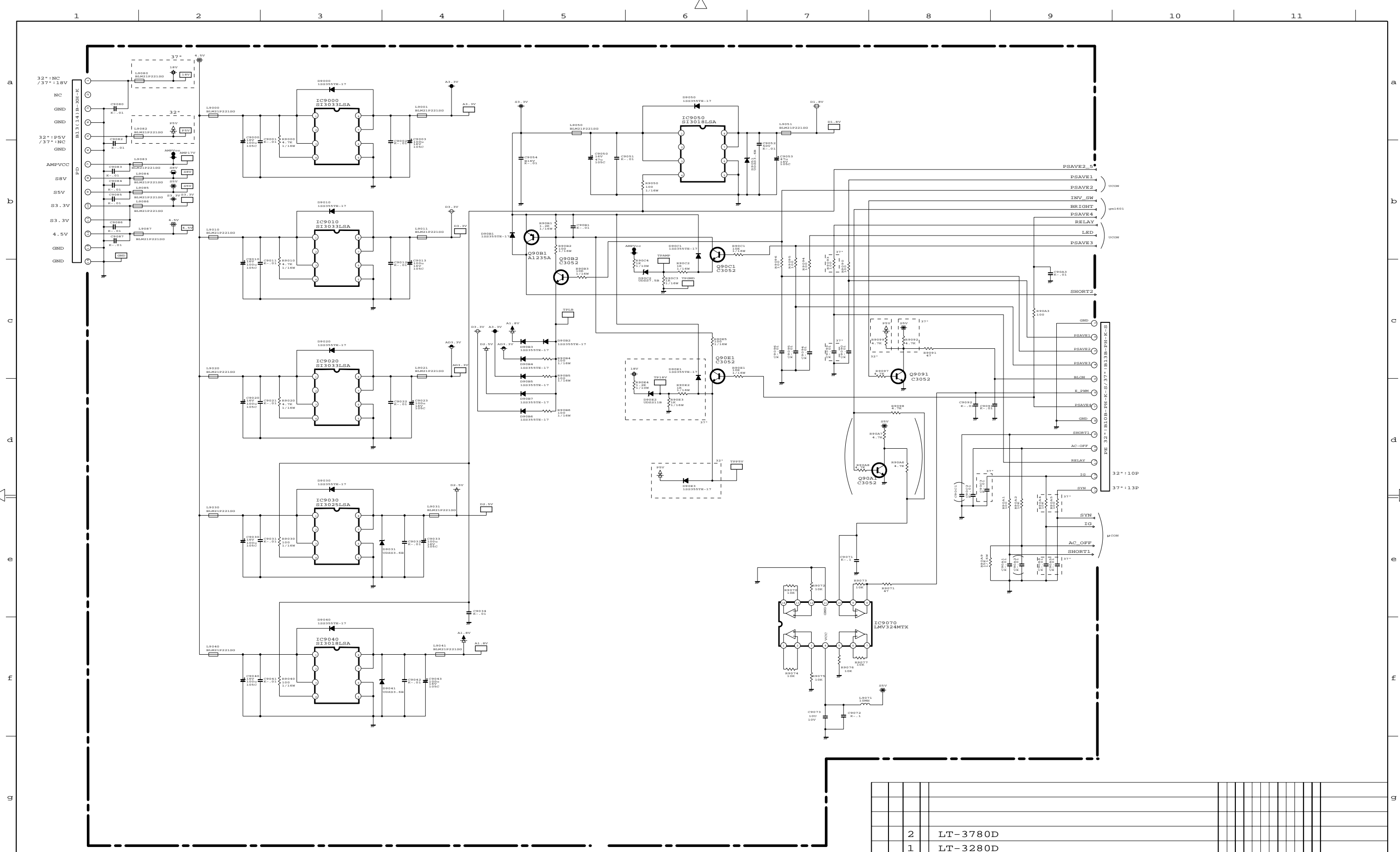

2	LT-3780D
1	LT-3280D

改定 CHANGE	規格		MATERIAL AND DIMENSIONS		(MI) MARK	UNIT CODE	摘要			
	出図先	第3角法 3RD ANGLE PROJECTION	DIM IN mm	尺度 SCALE NTS	作成日付 DATE	5 ~	TITLE OF DRAWING (10/14)			
					2005.7.11	REG(MAIN) SCHEMATIC-DIAGRAM				
	MITSUBISHI ELECTRIC CORPORATION				25 26 27 28 29 30 31					
作成 DRAWN	検査 CHECKED	設計 DESIGNED	検査 APPROVED	880A647						
CAD	本間	千原	石畑							



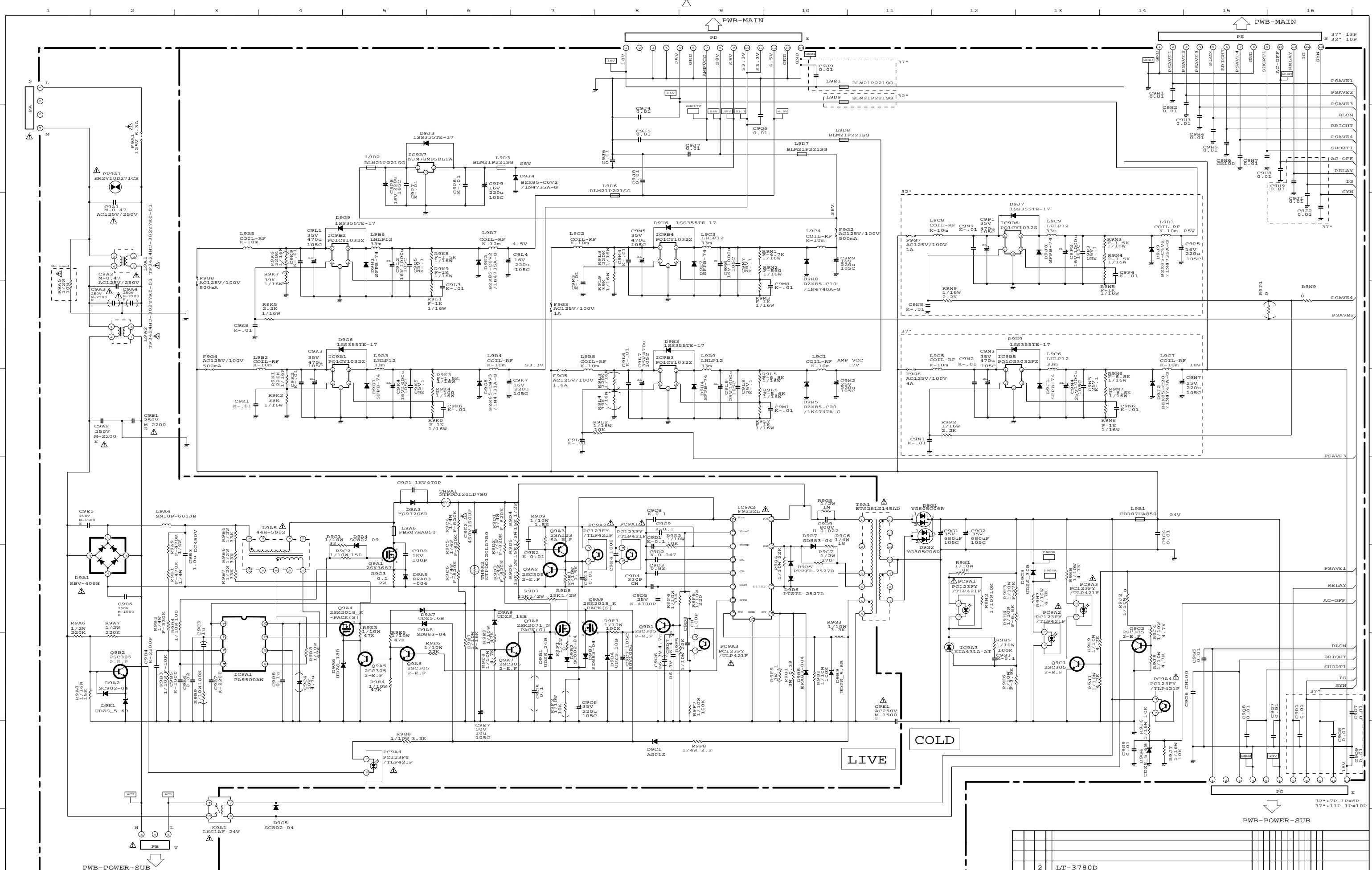

2	LT-3780D
1	LT-3280D

変更 内容 理由 日付 担当者	規格	材料表	寸法	スケール	作成日付	DATE	5	TITLE OF DRAWING	~ 24
	3角法 第三角法 DIM IN mm MTS 2005・7・11	図名 MITSUBISHI ELECTRIC CORPORATION POWER SCHEMATIC-DIAGRAM (11/14)	図 25 26 27 28 29 30 31	880A647	描 要 REMARK				
	作成 確認 設計 承認 CAD 本間 栗秋 石畑	図 25 26 27 28 29 30 31	880A647	25 26 27 28 29 30 31					

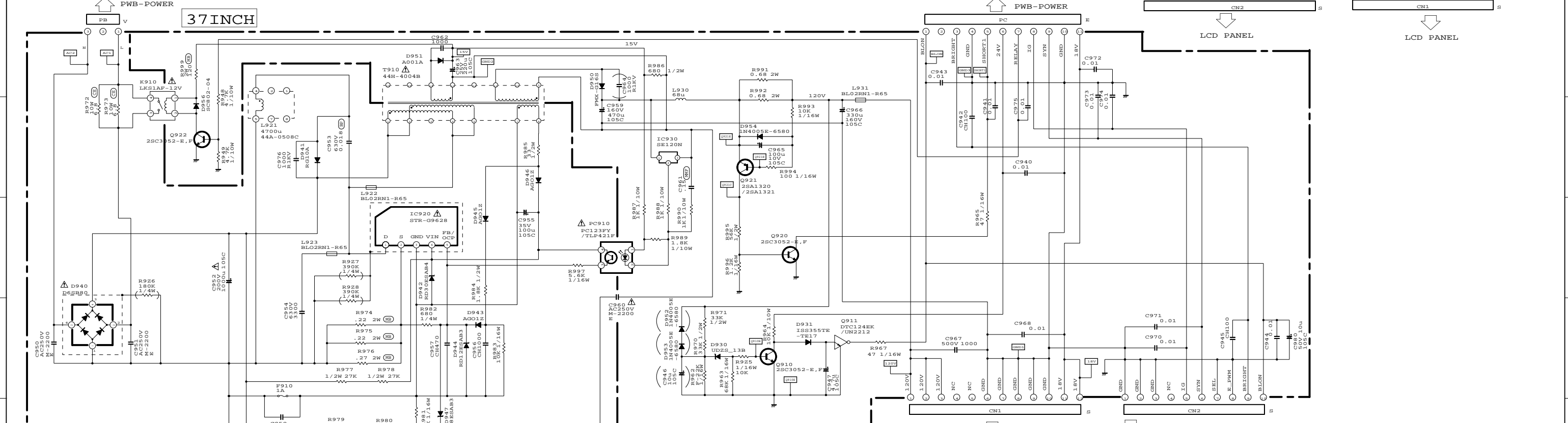
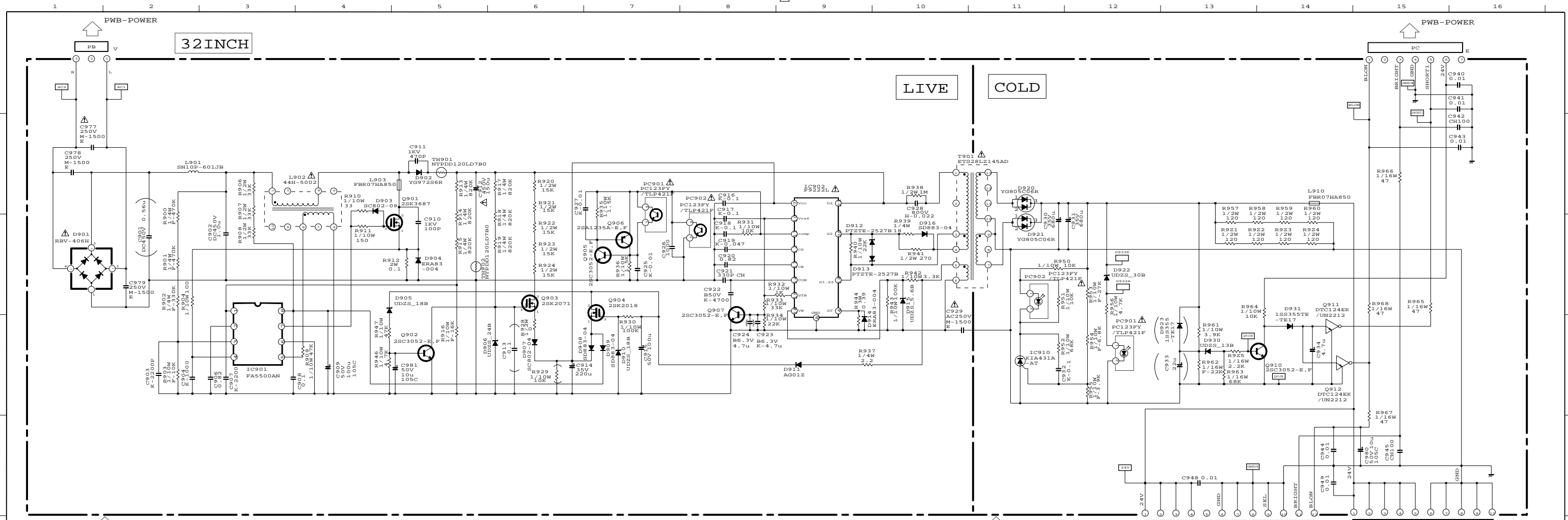

2	LT-3780D
1	LT-3280D

図名 <b>MITSUBISHI ELECTRIC CORPORATION</b>	規格 LT-3780D LT-3280D	図番 25 26 27 28 29 30 31	図名 <b>POWER-SUB SCHEMATIC-DIAGRAM (12/14)</b>	図番 <b>880A647</b>	
	出図先 本間 栗秋 石畑	3RD SCALE DIM IN MM DATE 2005.7.11	作成日付 DATE 2005.7.11	5 ~ TITLE OF DRAWING POWER-SUB SCHEMATIC-DIAGRAM (12/14)	備考 880A647
	作成 本間 栗秋 石畑	確認 本間 栗秋 石畑	承認 本間 栗秋 石畑	承認 本間 栗秋 石畑	承認 本間 栗秋 石畑

# IR

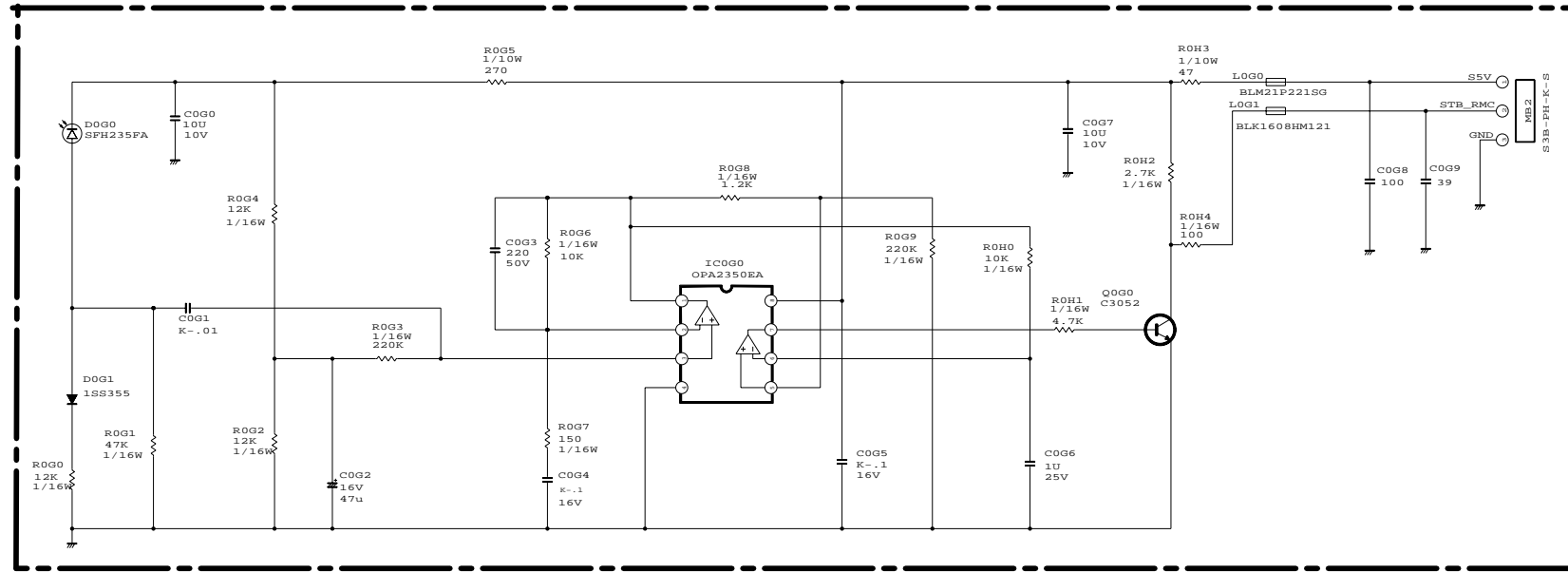

# SERVICE

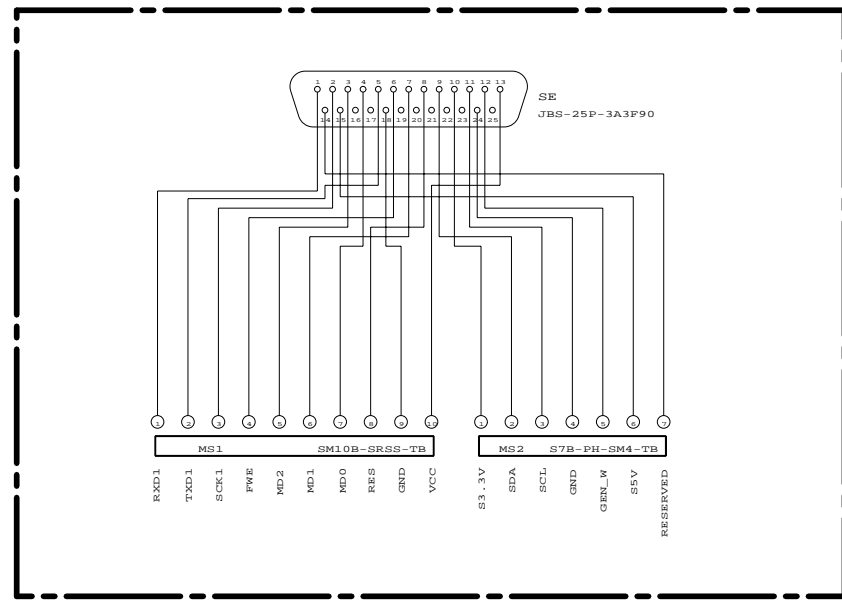

# LED

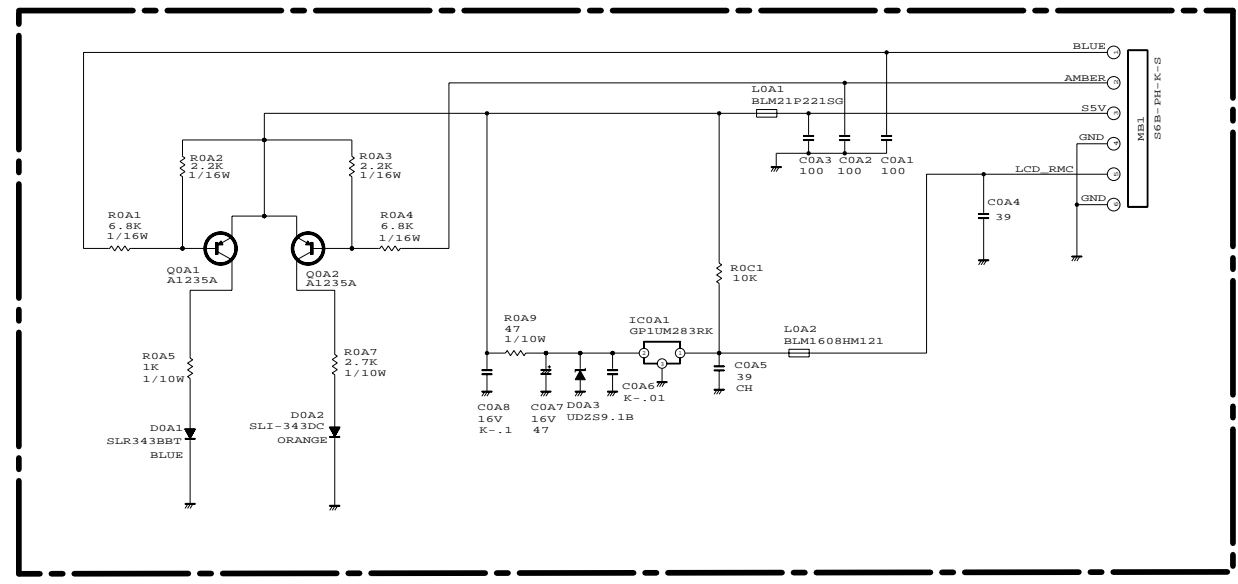

# CONTROL

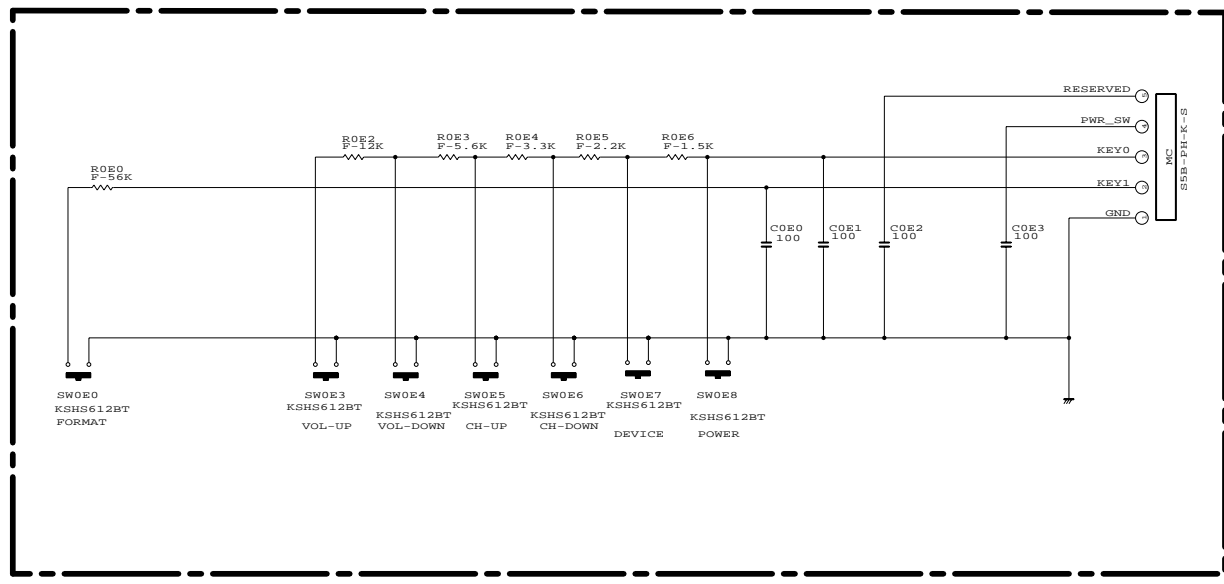

# CONNECT

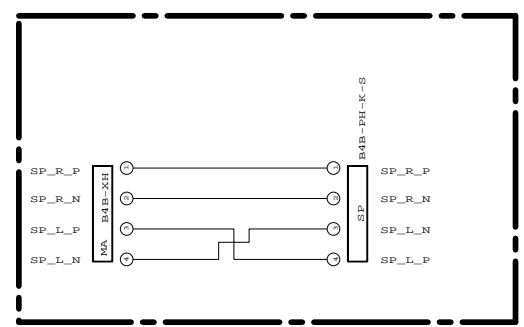

# EDID

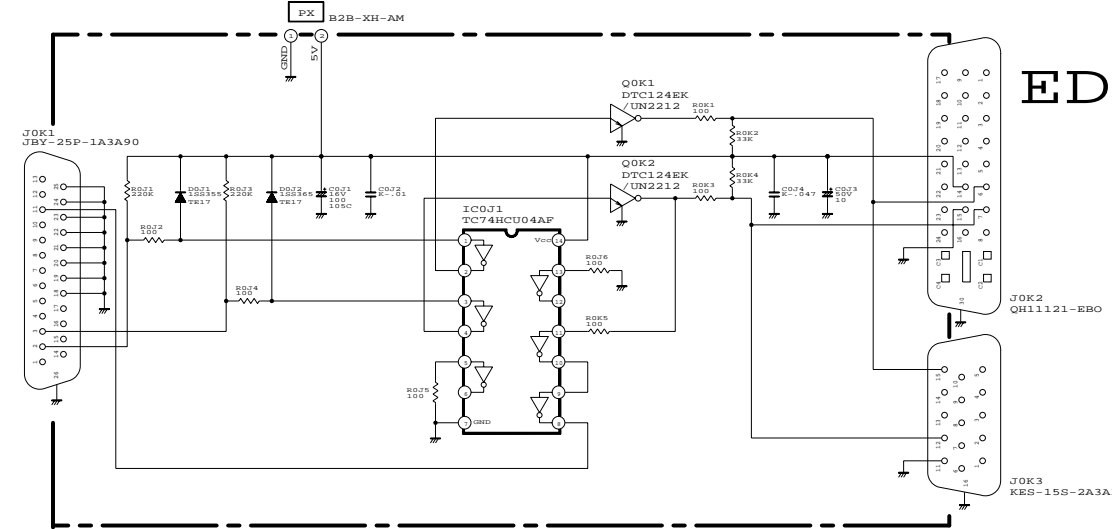

2	LT-3780D				
1	LT-3280D				

改定 CHANGE

規格		MATERIAL AND DIMENSIONS		(MI) MARK	UNIT CODE	摘要
出図先	第3角法 3RD ANGLE PROJECTION	DIM IN mm	尺度 SCALE NTS	作成日付 DATE 2005.7.11	5	TITLE OF DRAWING CONTROL IR LED SCHEMATIC-DIAGRAM (13/14)
MITSUBISHI ELECTRIC CORPORATION				25 26 27 28 29 30 31		
作成 DRAWN	検査 CHECKED	設計 DESIGNED	検査 APPROVED	880A647		
CAD	本間	栗秋	石畑			

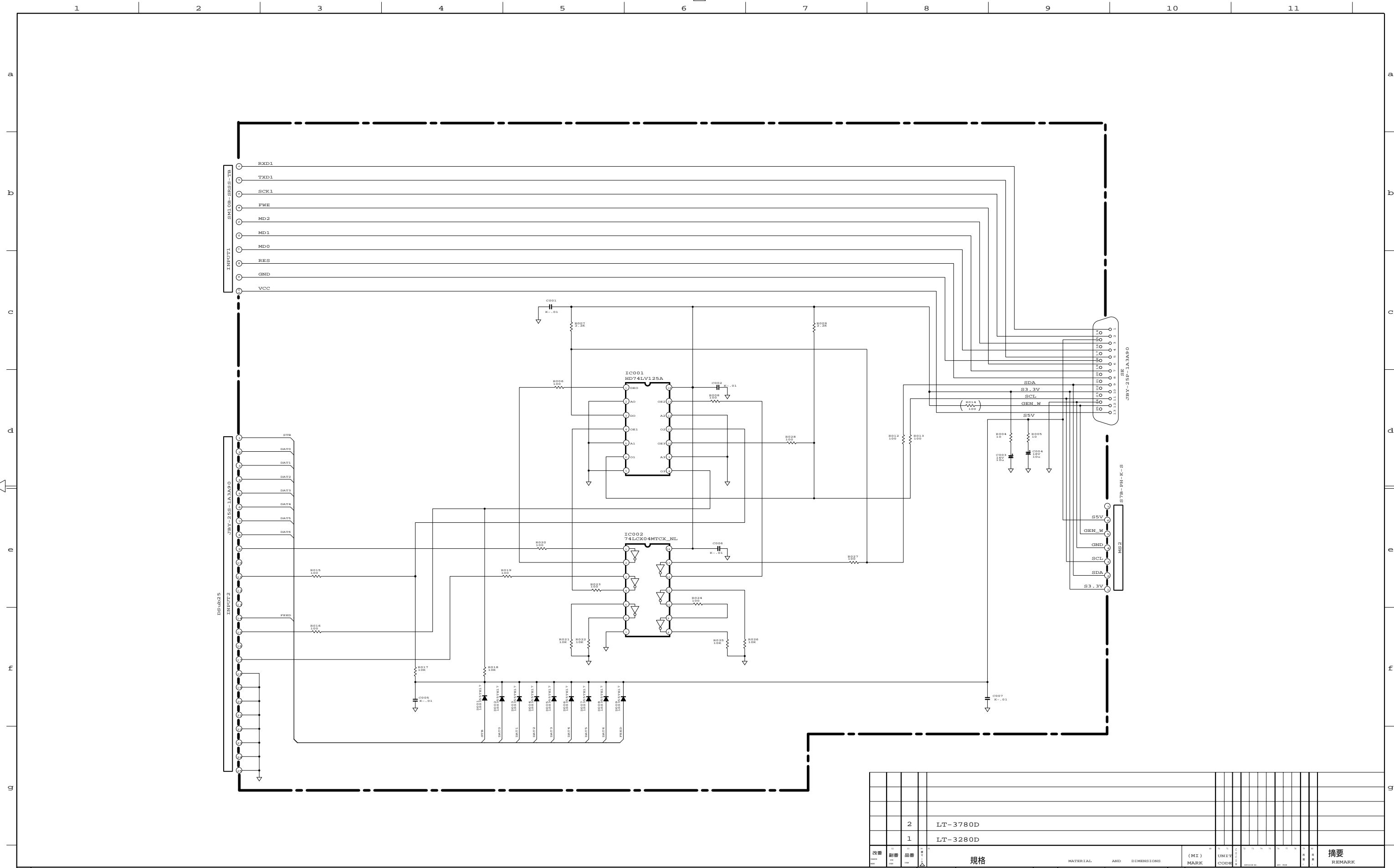

2	LT-3780D			
1	LT-3280D			
改訂	副標準	品番	規格	MATERIAL AND DIMENSIONS
				(MI) UNIT CODE
				摘要 REMARK

出図先		第3角法 3RD ANGLE PROJECTION		DIM IN mm	尺度 SCALE	作成日付 DATE	2005. 7. 11	TITLE OF DRAWING 5 ~ 24						
MITSUBISHI ELECTRIC CORPORATION							JIG SCHEMATIC-DIAGRAM (14/14)							
作成 DRAWN	検査 CHECKED	設計 DESIGNED	検閲 APPROVED			25	26	27	28	29	30	31		
CAD	本間	栗秋	石畑	880A647										

改定 CHANGE