

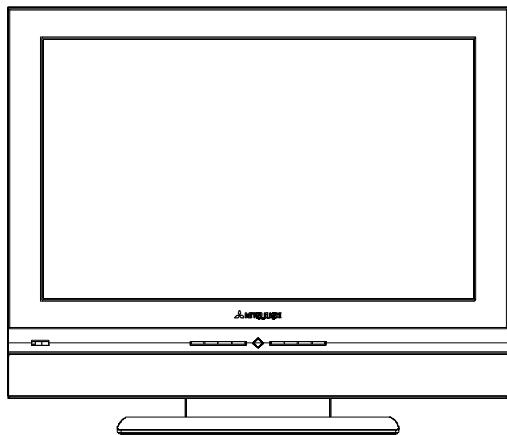

Service Manual

LIQUID CRYSTAL DISPLAY TELEVISION



LT-2220
 LT-2240
 LT-3020
 LT-3040
 LT-3050

CAUTION:

Before servicing this chassis, it is important that the service person read the "SAFETY PRECAUTIONS" and "PRODUCT SAFETY NOTICE" contained in this manual.

SPECIFICATIONS

- **Power** : [LT-2220, LT-2240] AC ADAPTOR
 In - AC 120V, 60Hz; Out - 20VDC 6.0A
 : [LT-3020, LT-3040, LT-3050] 120V, 60Hz, 2.2A
- **LCD Panel** : Resolution - 1280X768
 : Pixel Pitch - [LT-2220, LT-2240] 0.375mm
 [LT-3020, LT-3040, LT-3050] 0.5025mm
- **Analog Inputs** : VHF/UHF 75Ω unbalanced
 : Two A/V Inputs (Composite or S-Video)
 L-R Audio
 : Two Component Video Inputs (480i/480p/
 720p/1080i) L-R Audio
 : PC Input - 60Hz (VGA, S-VGA, XGA, W-XGA)
 : PC Audio - 3.5mm Mini-Jack
- **Digital Input** : MonitorLink™/DVI (Video Sources Only)
 L-R Audio (Analog)
 : MonitorLink™ Control/RS-232C
- **Audio Outputs** : L-R Audio Output (Fixed/Variable)
 : Headphone Jack (Variable) 3.5mm
- **Tuning** : NTSC 181Channel Analog Cable
- **Frequency Range** : VHF 54 ~ 470MHz
 UHF 470 ~ 806MHz
- **Speakers** : [LT-2220, LT-2240]
 Left & Right (2 X 2.3W) Sub (3.4W)
 : [LT-3020, LT-3040, LT-3050]
 Left & Right (2 X 3.5W) Sub (6W)
- **Weight / Cabinet Dimensions**

With Stand:	Height	Width	Depth	Weight
[LT-22XX]	20-1/4"	22-3/4"	11-7/8"	36.6 lbs
[LT-30XX]	25-3/8"	29-3/4"	11-7/8"	54.3 lbs

W/O Stand:	Height	Width	Depth	Weight
[LT-22XX]	18-5/8"	22-3/4"	4"	19.8 lbs
[LT-30XX]	23-1/4"	29-3/4"	5"	37.5 lbs

- Weight and dimensions shown are approximate.
- Design specifications are subject to change without notice.

MITSUBISHI DIGITAL ELECTRONICS AMERICA, INC.

9351 Jeronimo Road, Irvine, CA 92618-1904

Copyright © 2004 Mitsubishi Digital Electronics America, Inc.

All Rights Reserved

CONTENTS

INTRODUCTION	5
PRODUCT SAFETY NOTICE	5
SAFETY PRECAUTIONS	5
DISASSEMBLY	
LT-22XX	7
LT-30XX	13
ELECTRICAL ADJUSTMENTS	
Initial Setup	21
CIRCUIT EXPLANATIONS & BLOCK DIAGRAMS	
Circuit Explanations	23
Block Diagrams	29
TEST POINT LOCATIONS AND DESCRIPTIONS	
PWB-SET Test Point Locations and Description	33
PWB-MAIN Test Point Locations and Description	35
TROUBLESHOOTING	
LT-22XX Power Troubleshooting	37
LT-30XX Power Troubleshooting	39
Video Troubleshooting	41
Audio Troubleshooting	51
Remote Control & Front Switch Troubleshooting	53
REPLACEMENT PARTS	
Replacement Parts List	55
INTERCONNECT WIRING DIAGRAM	

PRODUCT SAFETY NOTICE

Many electrical and mechanical parts in television receivers have special safety related characteristics. These characteristics are often not evident from visual inspection nor can the protection afforded by them necessarily be obtained by using replacement components rated for higher voltage, wattage, etc.

Replacement parts which have special safety characteristics are identified in this service manual.

The replacement for any safety part should be identical in value and characteristics.

SAFETY PRECAUTIONS

NOTICE: Observe all cautions and safety related notes located inside the receiver cabinet and on the receiver chassis.

WARNING:

1. Operation of this receiver outside the cabinet or with the cover removed presents a shock hazard from the receiver's power supplies. Work on the receiver should not be attempted by anyone who is not thoroughly familiar with the precautions necessary when working on high voltage equipment.
2. Do not install, remove or handle the LCD panel in any manner unless shatterproof goggles are worn. People not so equipped should be kept away while the panel is being handled. Keep the panel away from the body while handling.
3. When service is required, observe the original lead dress. Where a short-circuit has occurred, replace those components that indicate evidence of overheating.

Leakage current check

Before returning the receiver to the customer, leakage current should be measured using following methods.

1. Cold Check

With the alternating current (AC) plug removed from the AC source, place a jumper across the two AC plug prongs. Connect one lead of an ohm meter to the AC plug and touch the other lead to each exposed metal part (i.e. antennas, handle bracket, metal cabinet, screw heads, metal overlay, control shafts, etc.), particularly any exposed metal part that has a return path to the chassis. The resistance of the exposed metal parts having a return path to the chassis **should be a minimum of 1Mega Ohm**. Any resistance below this value indicates an abnormal condition and requires corrective action.

2. Hot Check ...Use the circuit shown below to perform the hot check test.

1. Keep switch S1 open and connect the receiver to the measuring circuit. Immediately after connection, and with the switching devices of the receiver in their operating positions, measure the leakage current for both positions of switch S2.
2. Close switch S1, energizing the receiver. Immediately after closing switch S1, and with the switching devices of the receiver in their operating positions, measure the leakage current for both positions of switch S2. Repeat the current measurements of items 1 and 2 after the receiver has reached thermal stabilization. **The leakage current must not exceed 0.5 milliamper (mA).**

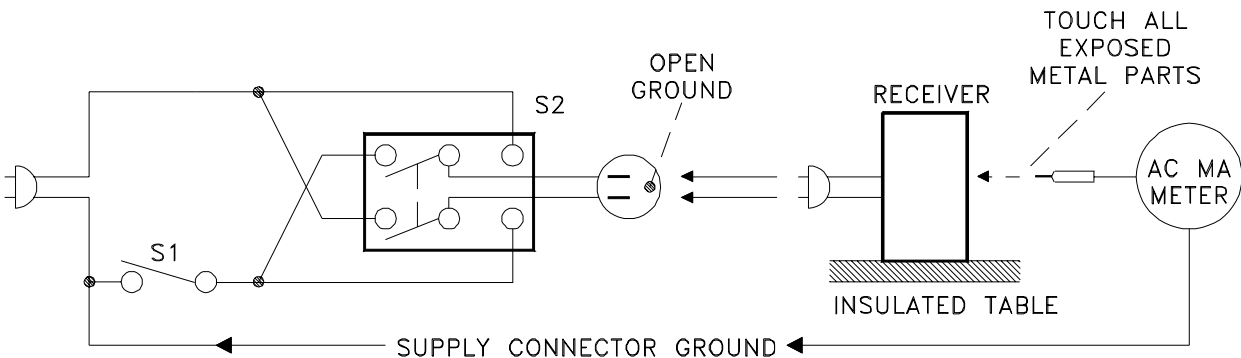

DISASSEMBLY PROCEDURE (LT-22XX)

Remove the screws and components in the quantities indicated.
Reassemble in reverse order.

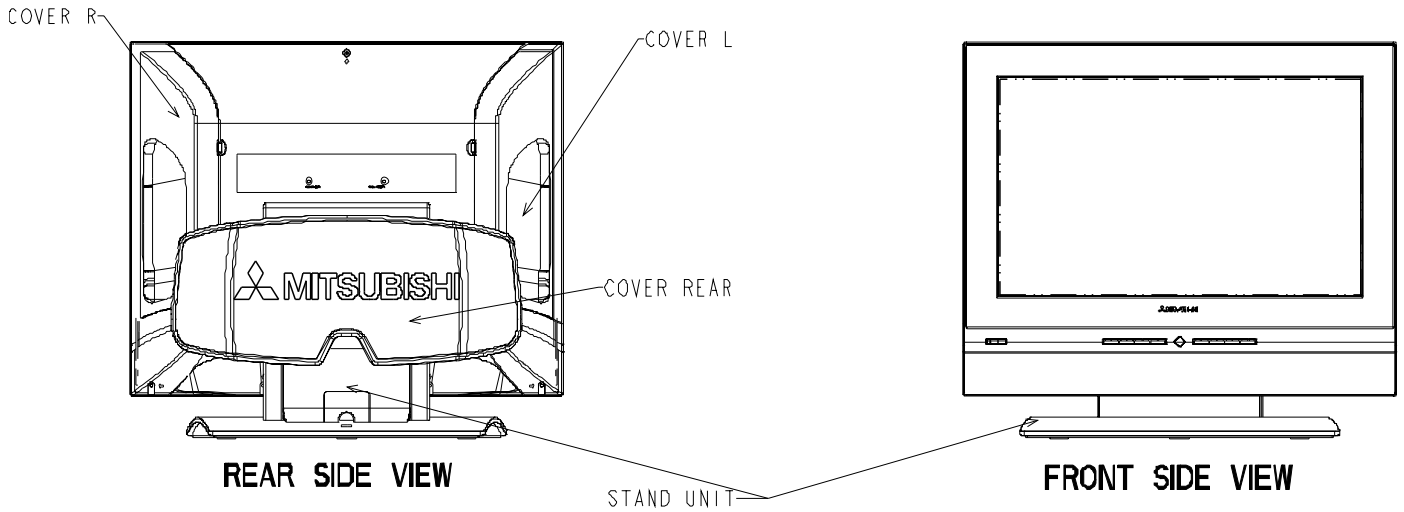

1. COVER, REAR

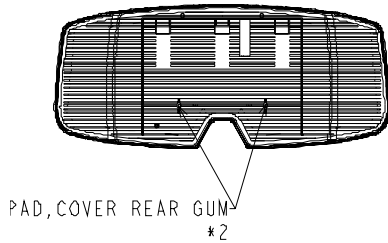

2. STAND UNIT

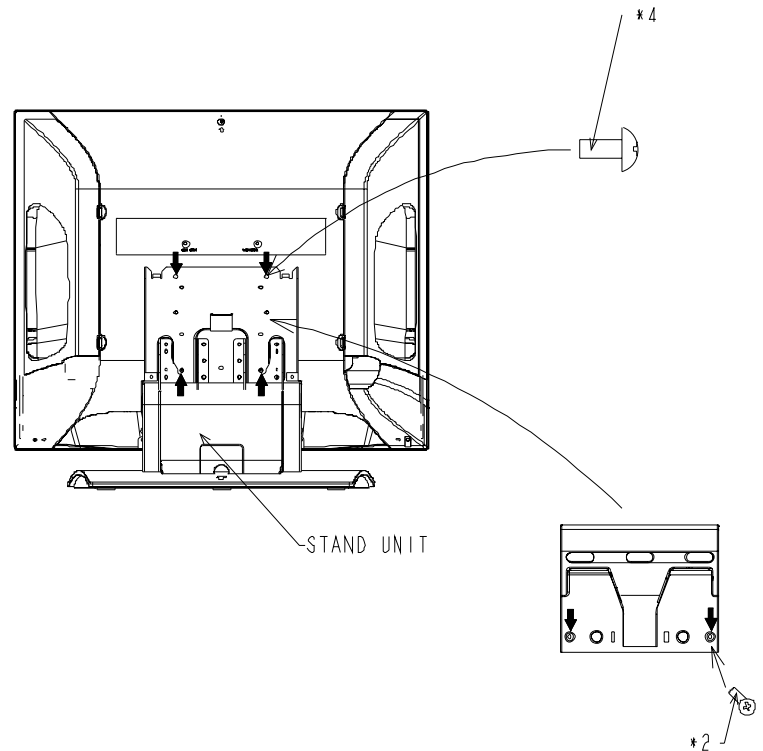

DISASSEMBLY PROCEDURE (LT-22XX) CONTINUED

3. BACK UNIT

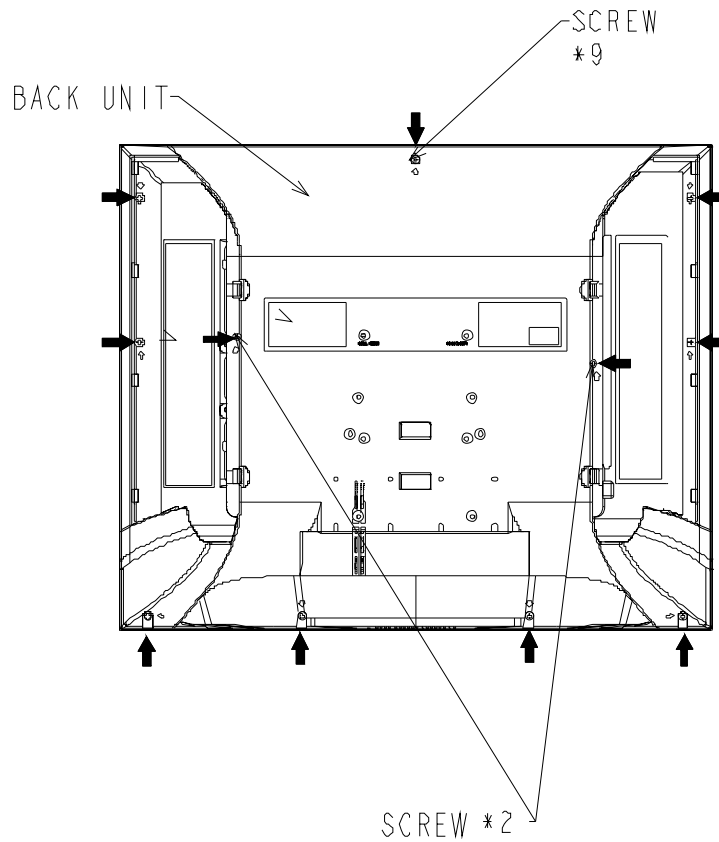

4. BACK COVER

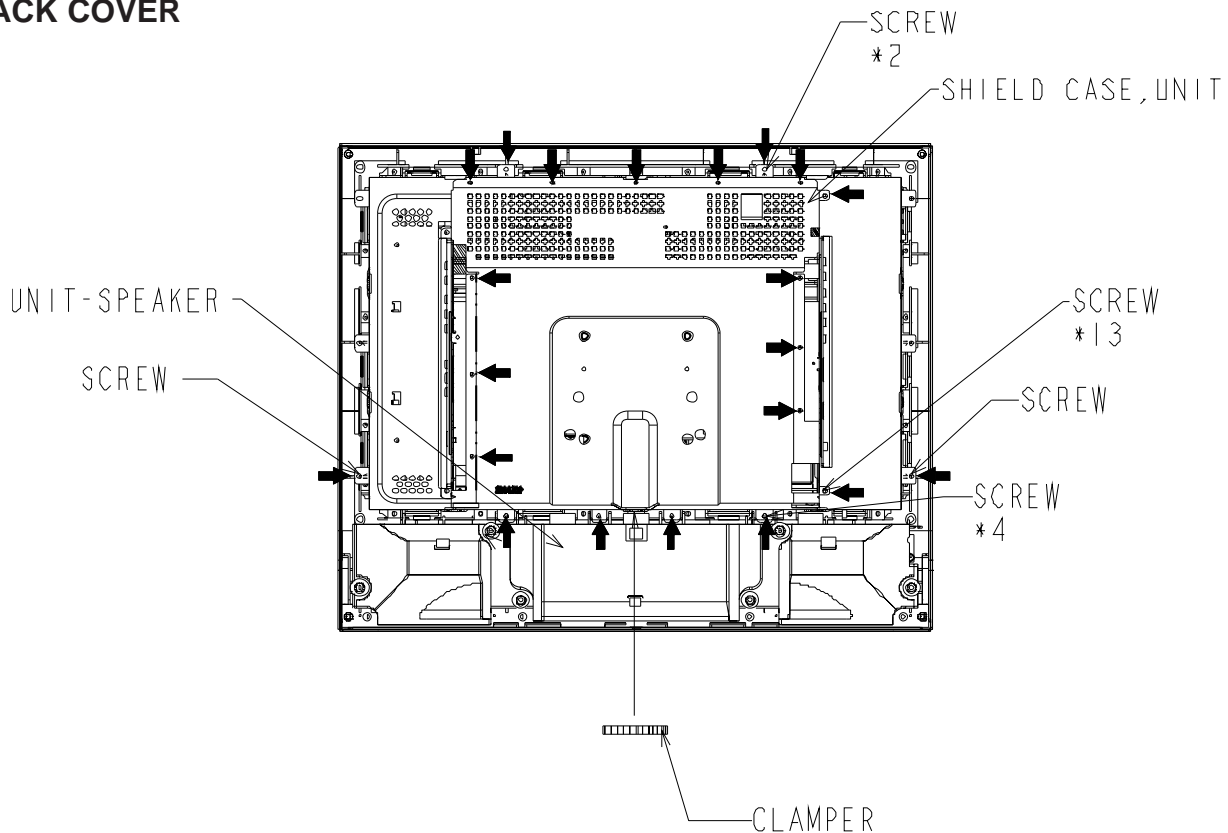

DISASSEMBLY PROCEDURE (LT-22XX0) CONTINUED

5. PWB-SET

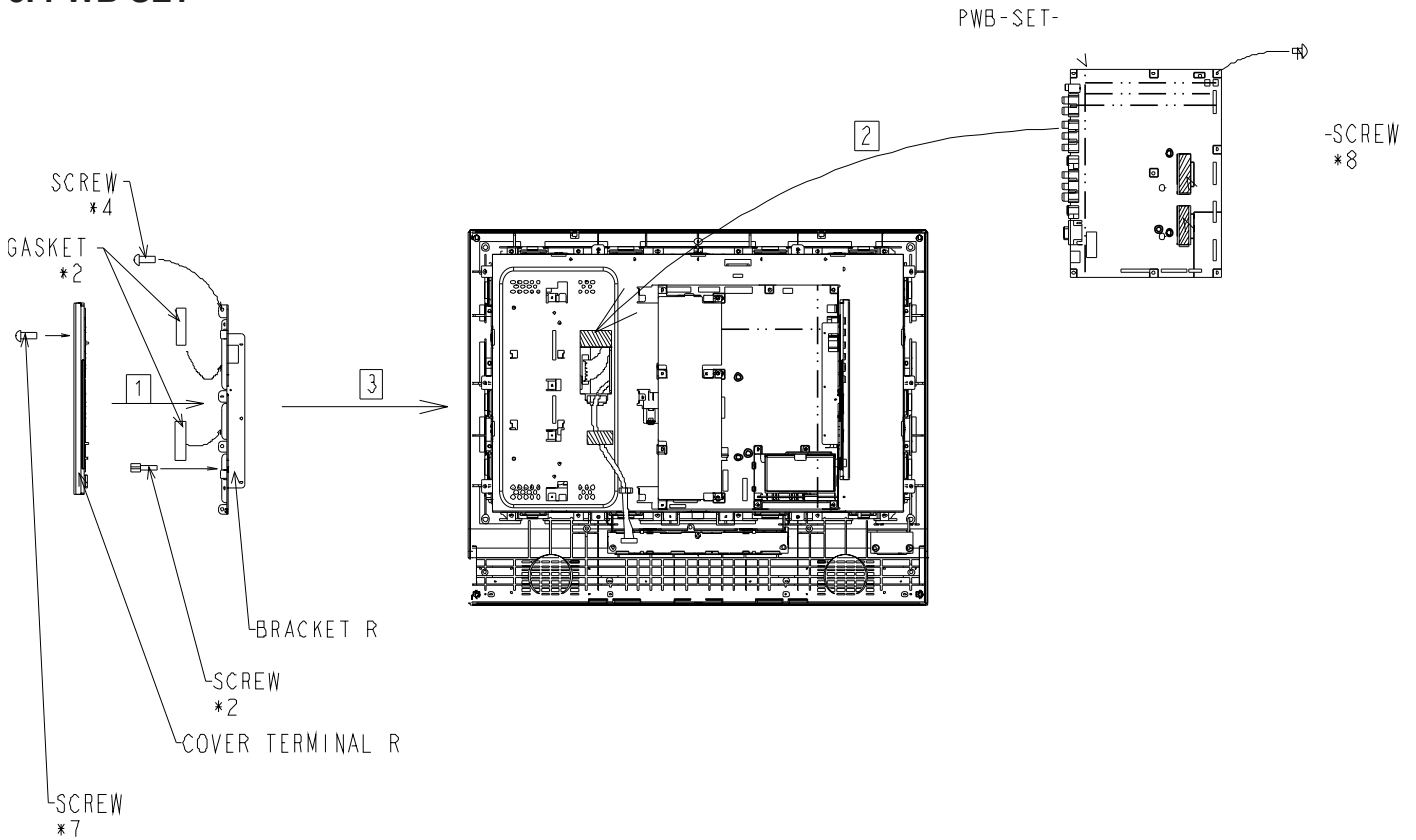

6. PWB-MAIN

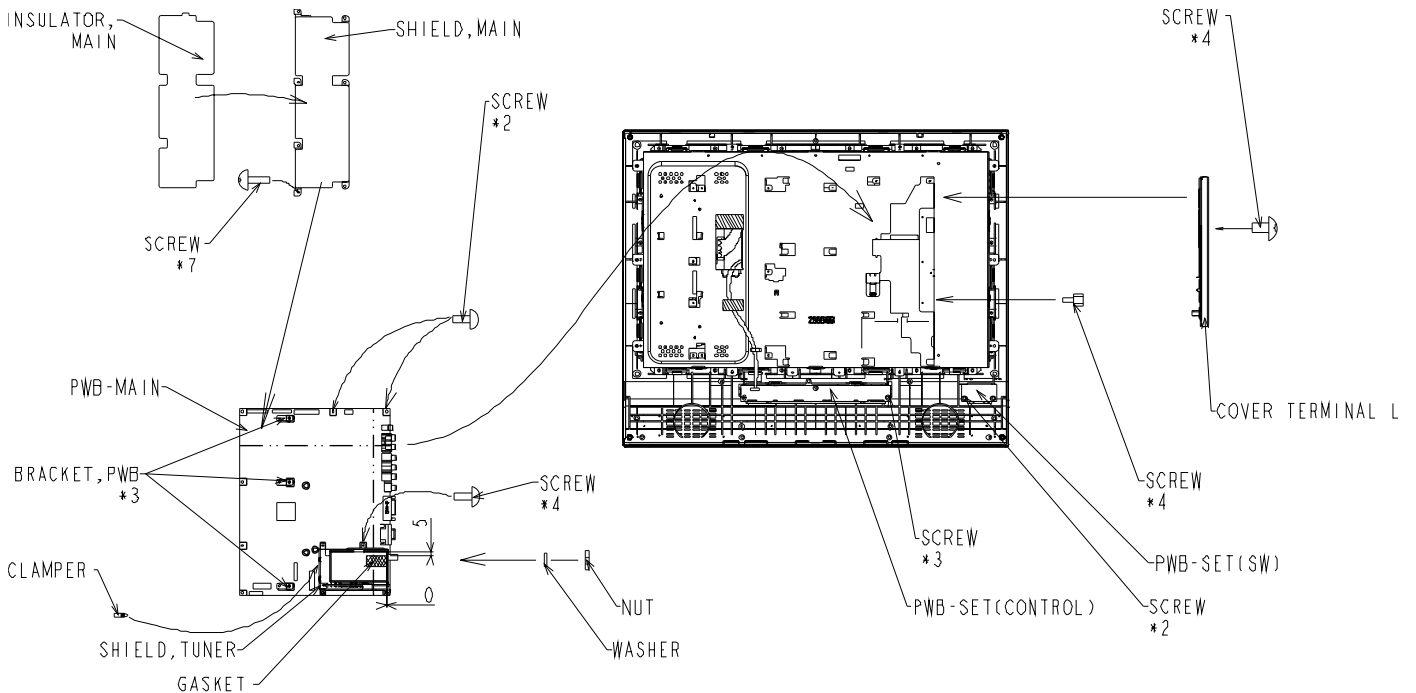

DISASSEMBLY PROCEDURE (LT-22XX) CONTINUED

7. CHASSIS BASE

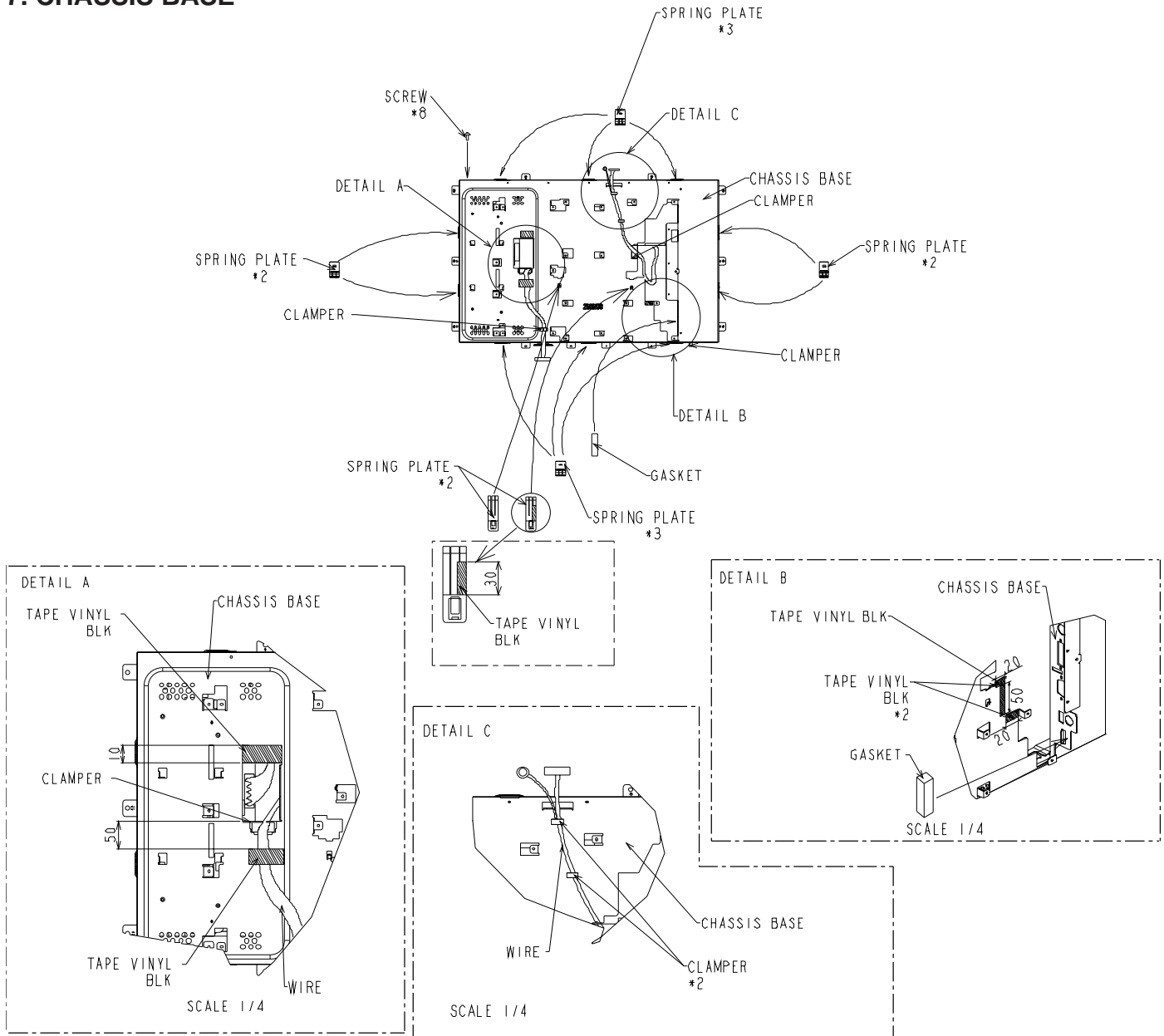

DISASSEMBLY PROCEDURE (LT-22XX) CONTINUED

8. LCD

9. PANEL

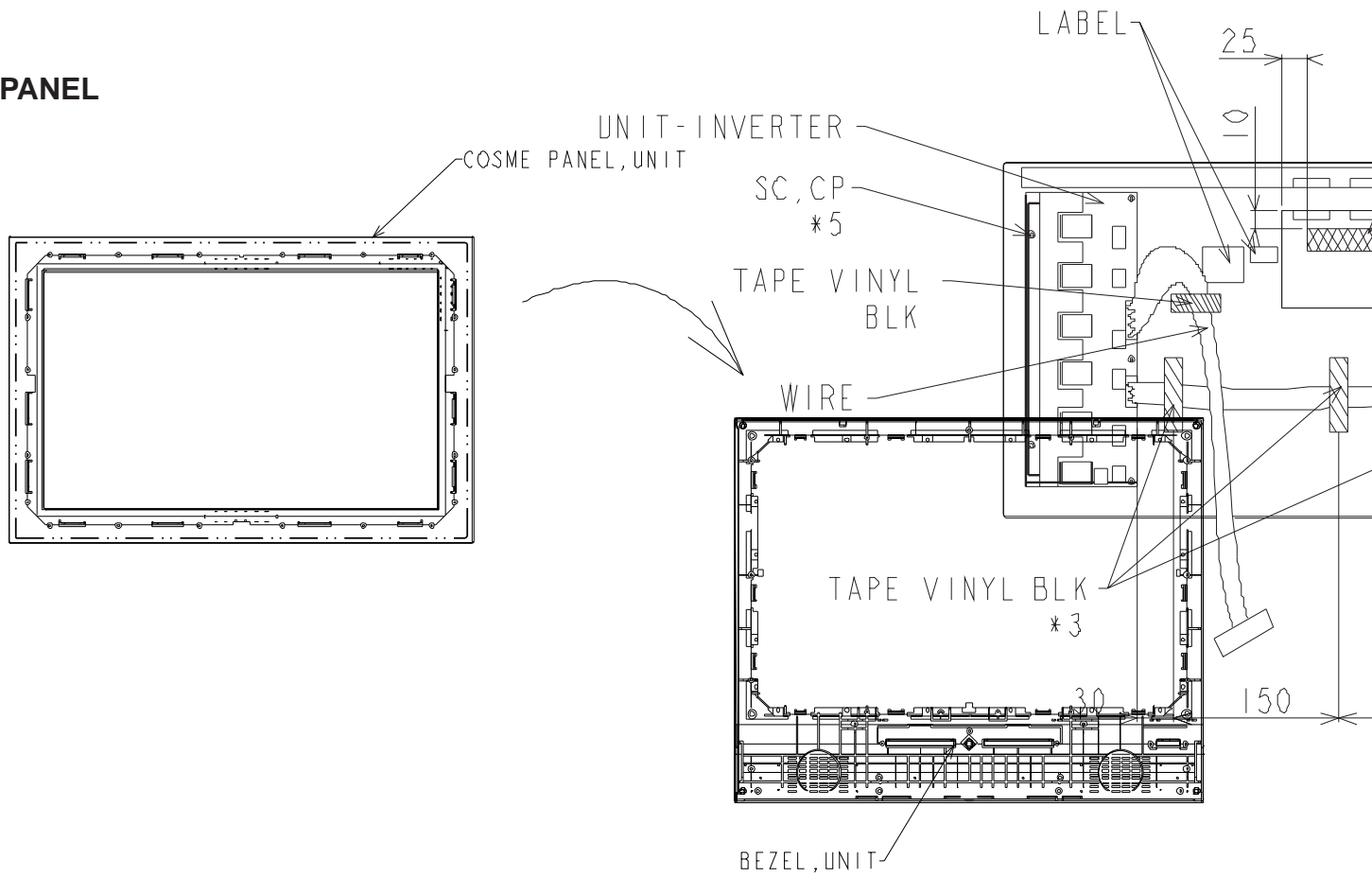

DISASSEMBLY PROCEDURE (LT-22XX) CONTINUED

WIRING HARNESS LOCATIONS

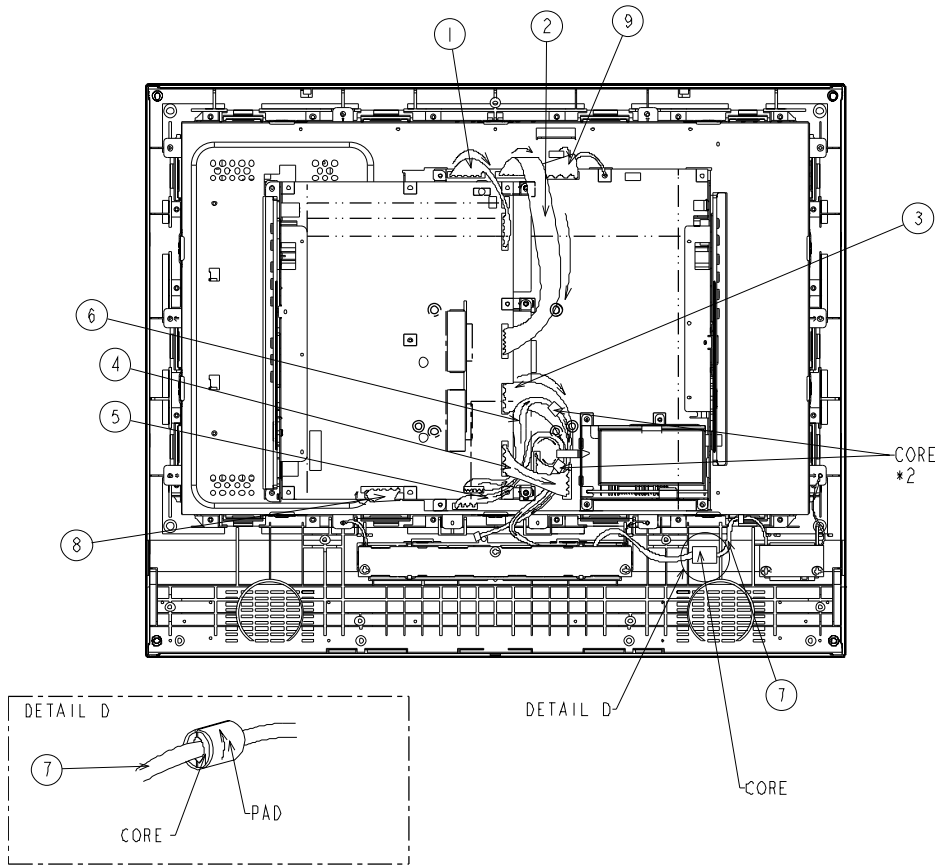

SYMBOL	PARTS NAME
1	WIRE CC14P 1007#24L110
2	WIRE CC13P 1007#24L170
3	WIRE CC12P 1691+1007L115
4	WIRE CC10P 1007#22L80
5	WIRE CC9P 1007#24L290
6	WIRE CC6P 1007#24L250
7	WIRE CC4P 1007#24L180
8	WIRE C16C15P 1007#24L350
9	WIRE C31C30P 1516#30LVD^

DISASSEMBLY PROCEDURE (LT-30XX)

Remove the screws and components in the quantities indicated.
Reassemble in reverse order.

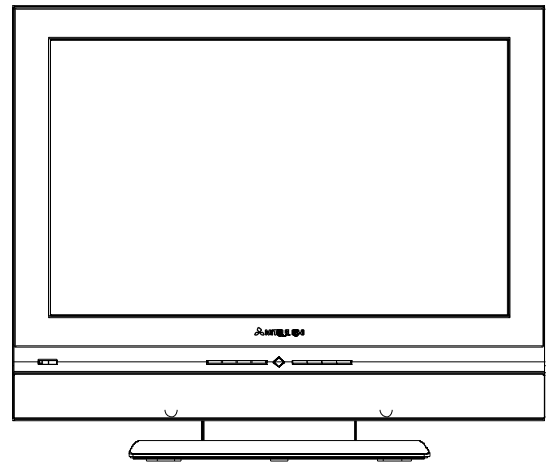
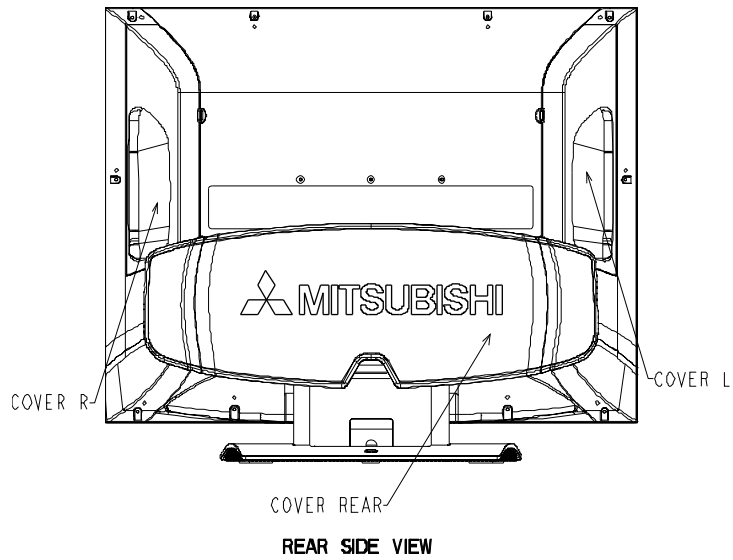

1. COVER, REAR

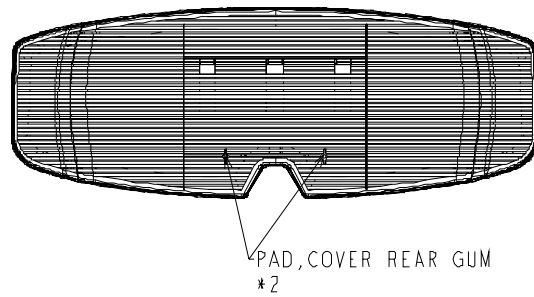

DISASSEMBLY PROCEDURE (LT-30XX) CONTINUED

2. STAND UNIT

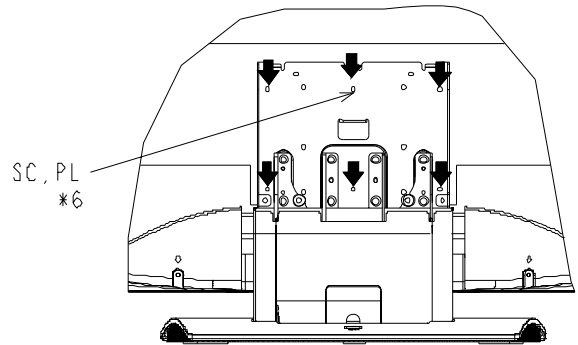
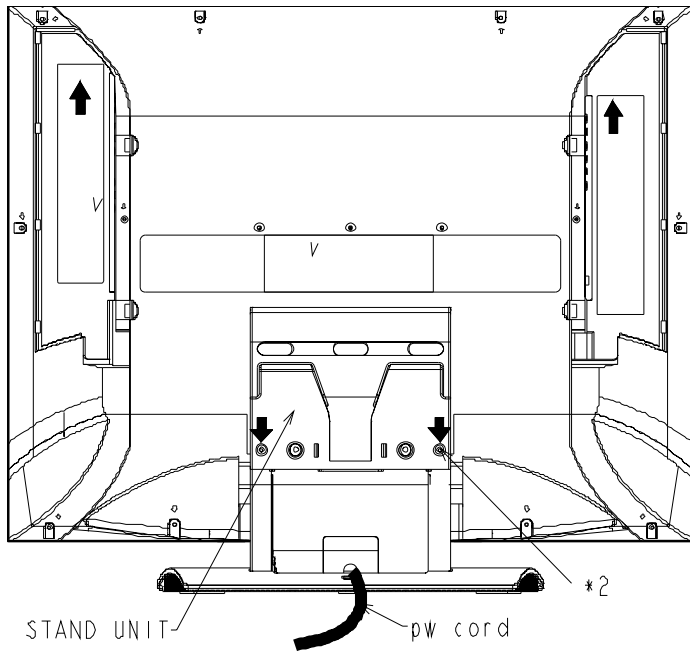

3. BACK COVER

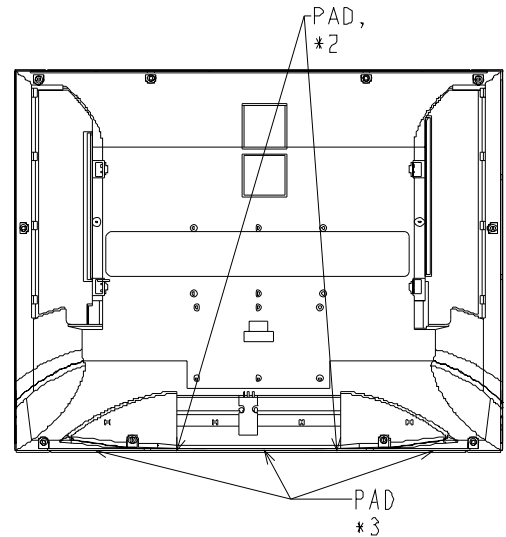
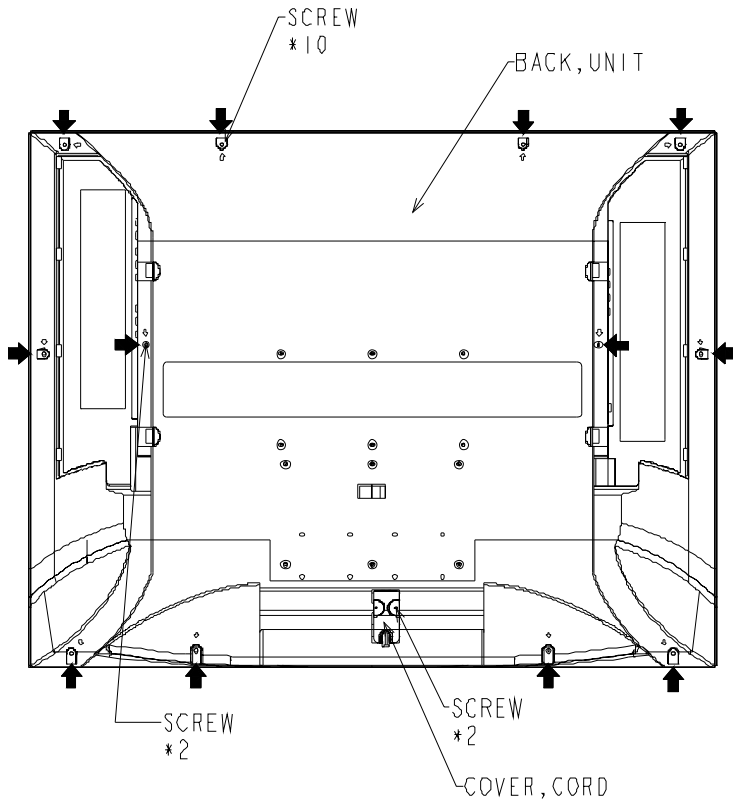

DISASSEMBLY PROCEDURE (LT-30XX) CONTINUED

4. UNIT SPEAKER

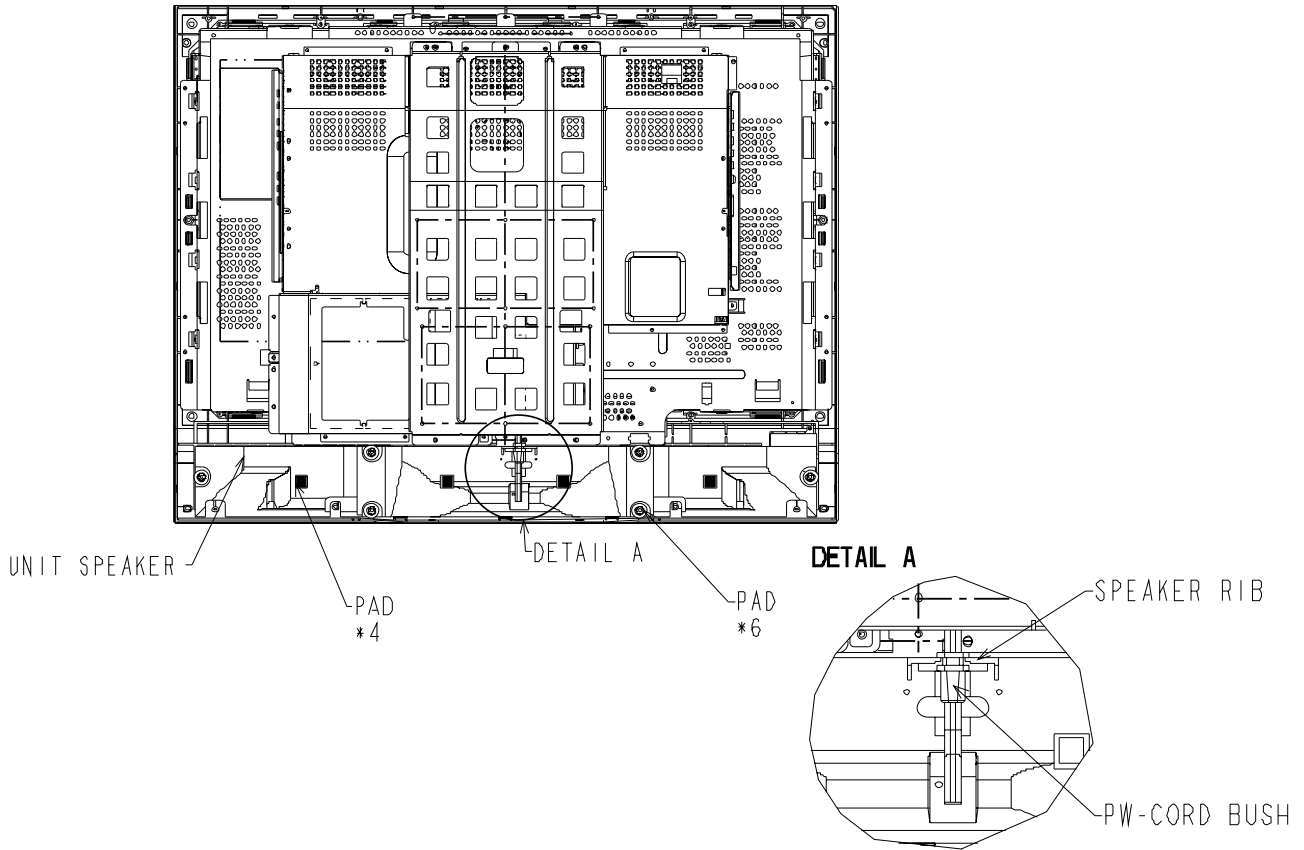

5. BRACKET, VESA

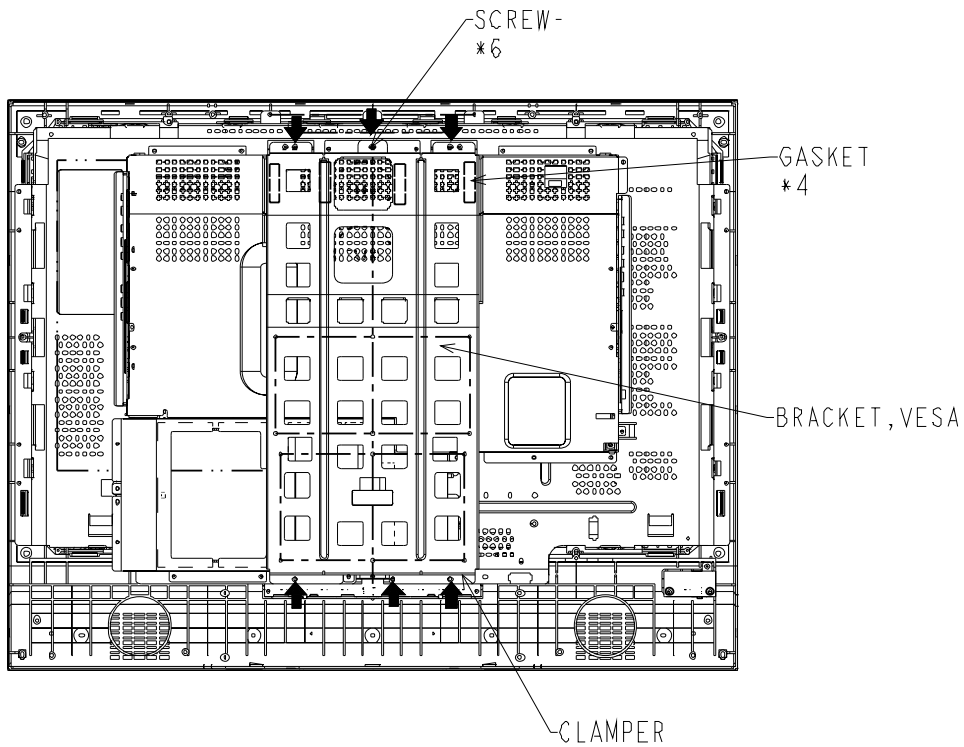

DISASSEMBLY PROCEDURE (LT-30XX) CONTINUED

6. SHIELD, POWER & SHIELD, CASE

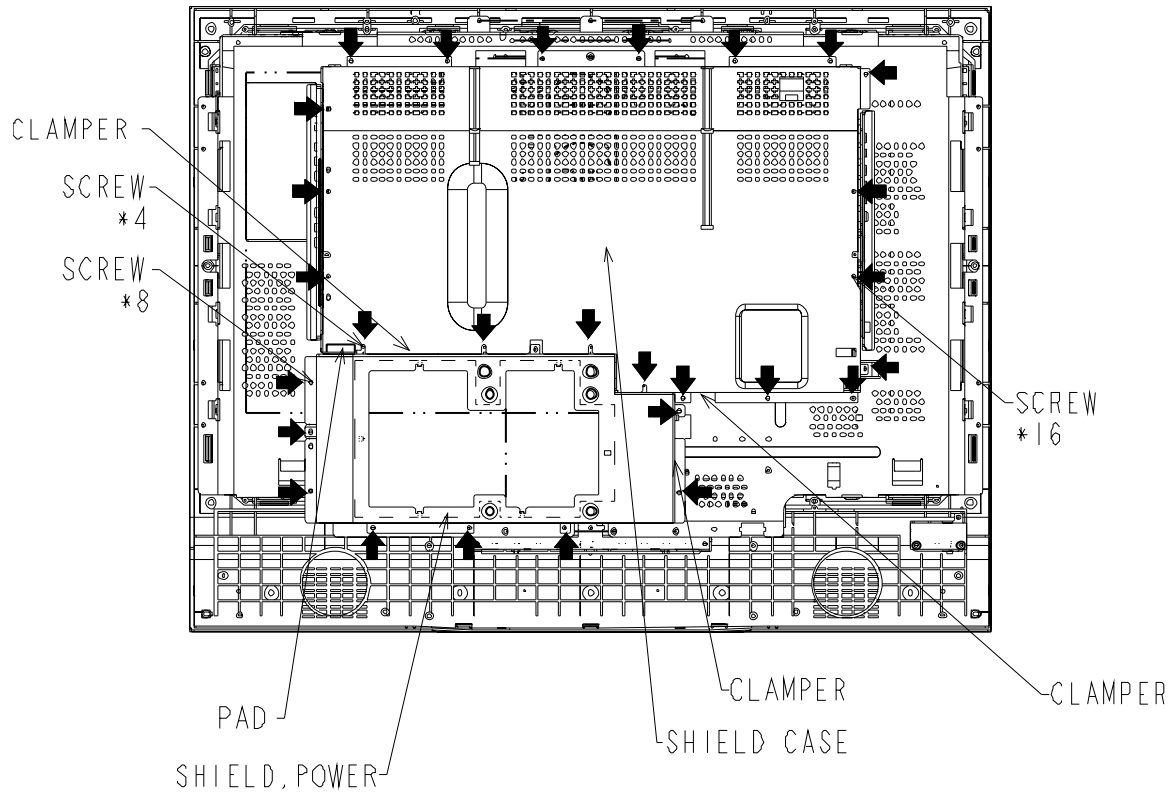

7. COVER, TERMINAL, LEFT & RIGHT

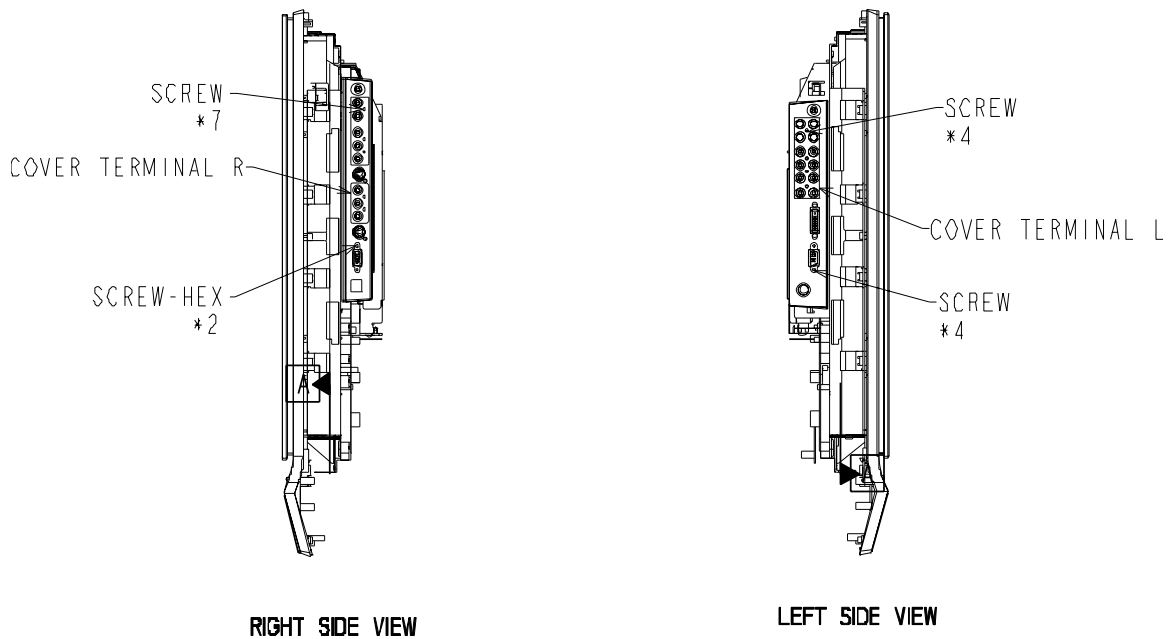

DISASSEMBLY PROCEDURE (LT-30XX) CONTINUED

8. ASSY-PWB-MAIN/ASSY-PWB-SET/UNIT-POWER

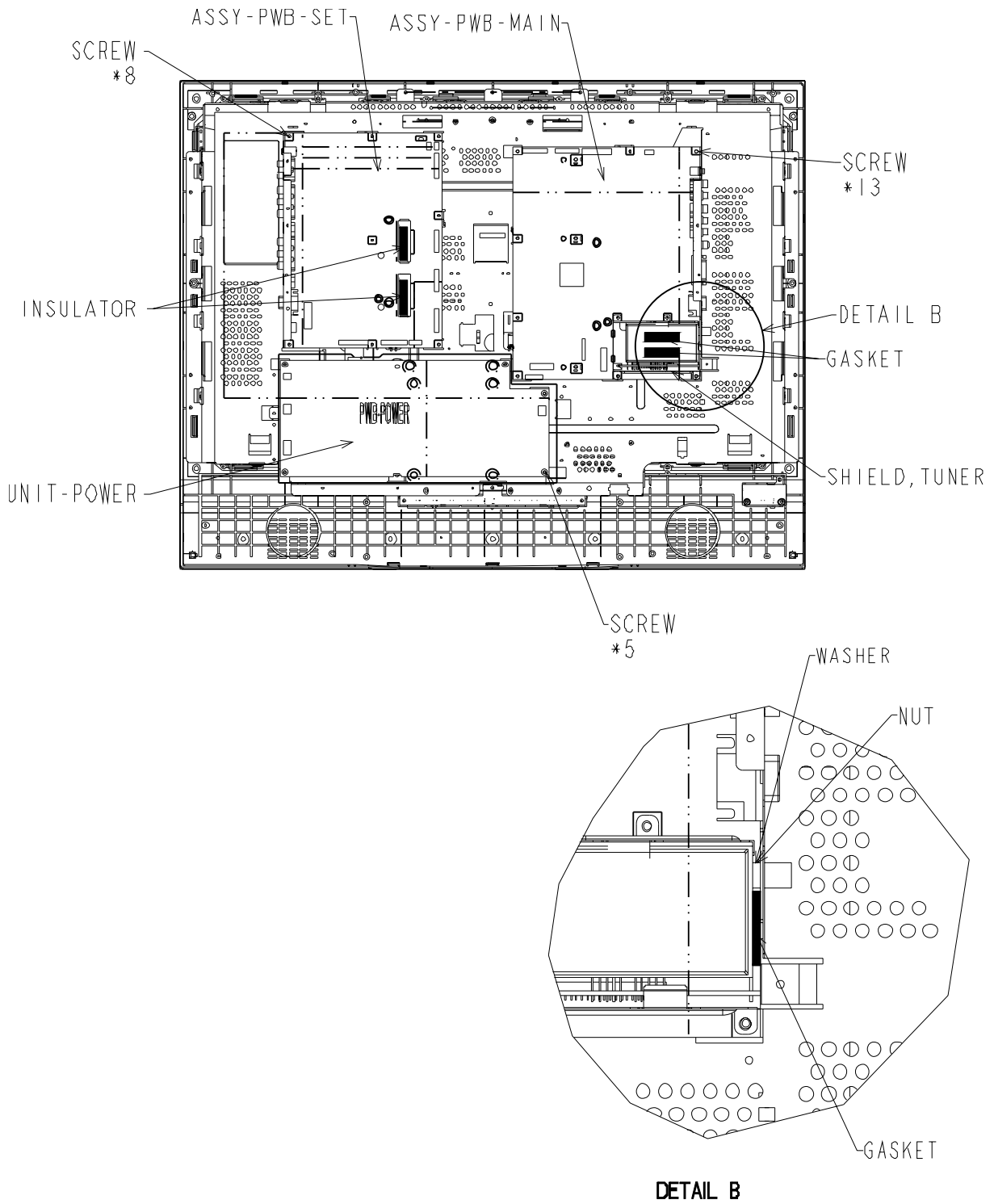

DISASSEMBLY PROCEDURE (LT-30XX) CONTINUED

9. CHASSIS, REAR

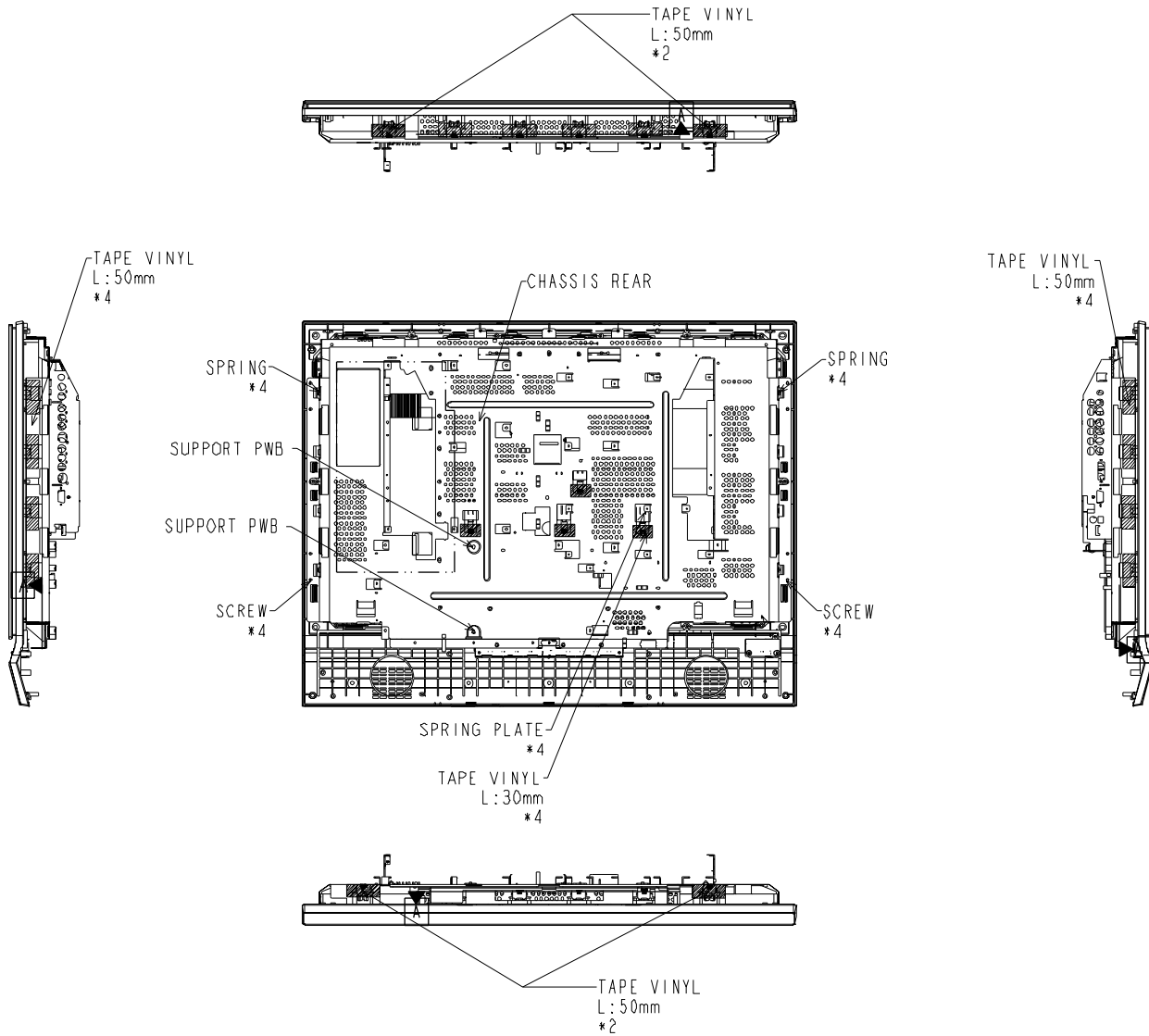

DISASSEMBLY PROCEDURE (LT-30XX) CONTINUED

10. BRACKET T/B/LCD PANEL

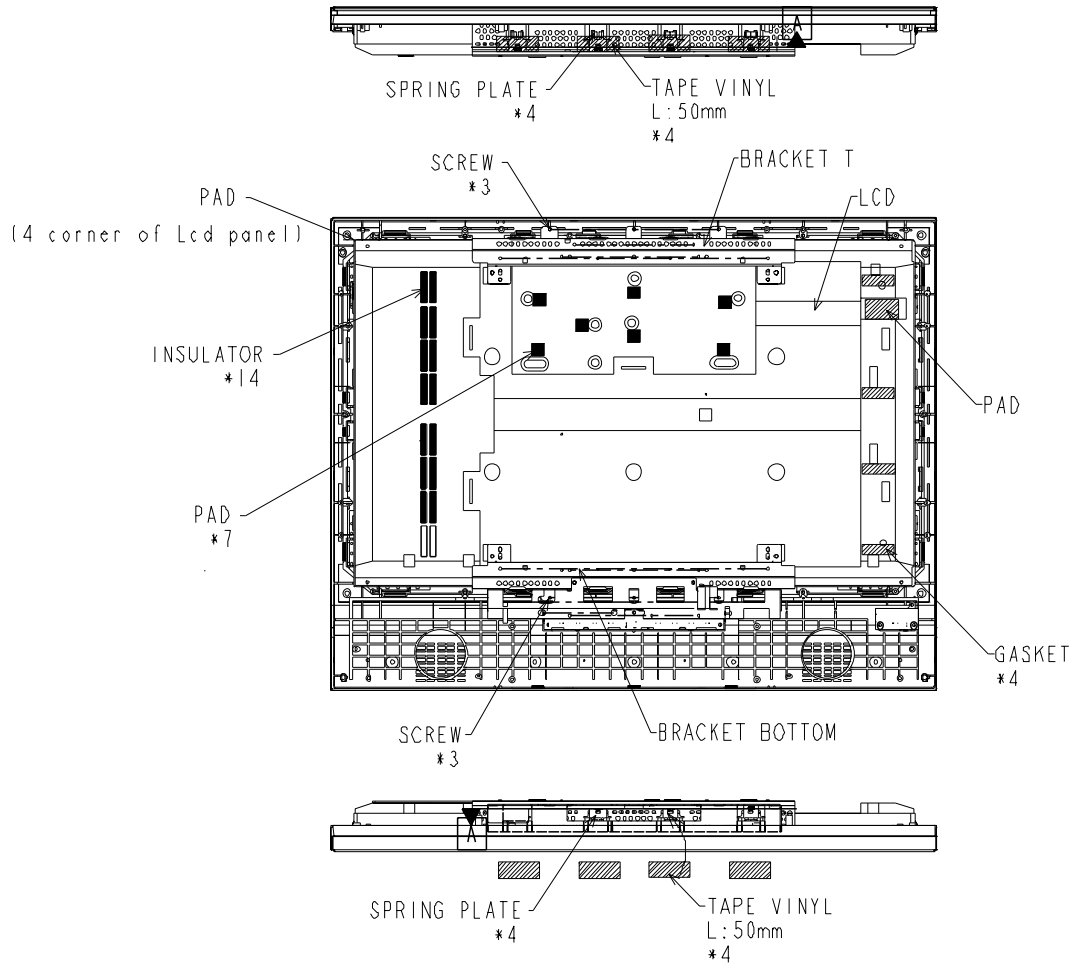

11. BEZEL

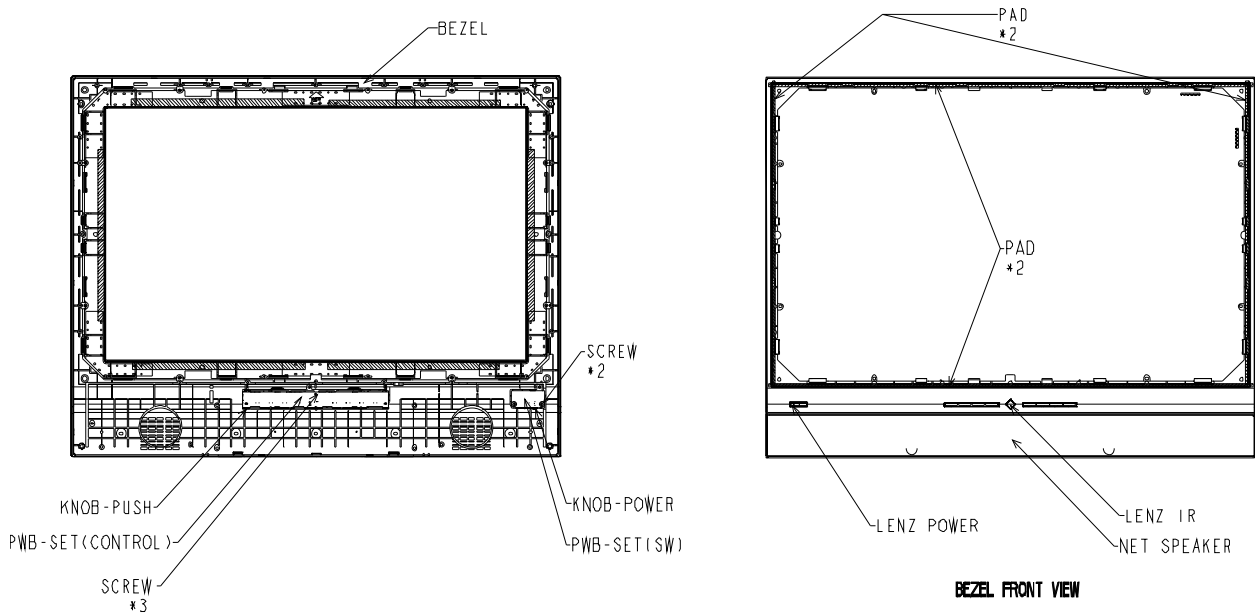

DISASSEMBLY PROCEDURE (LT-30XX) CONTINUED

WIRING HARNESS LOCATIONS

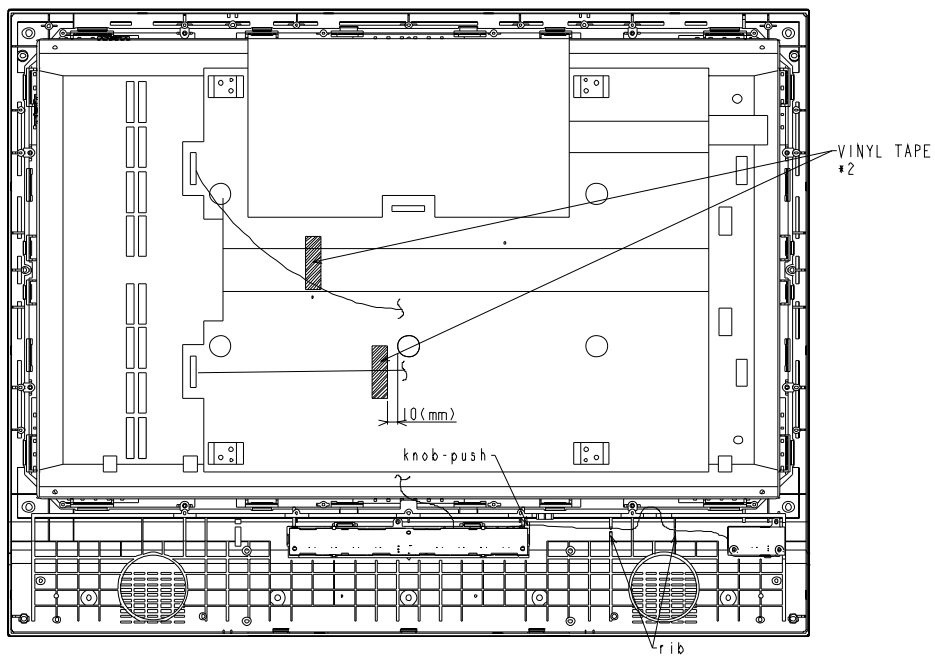
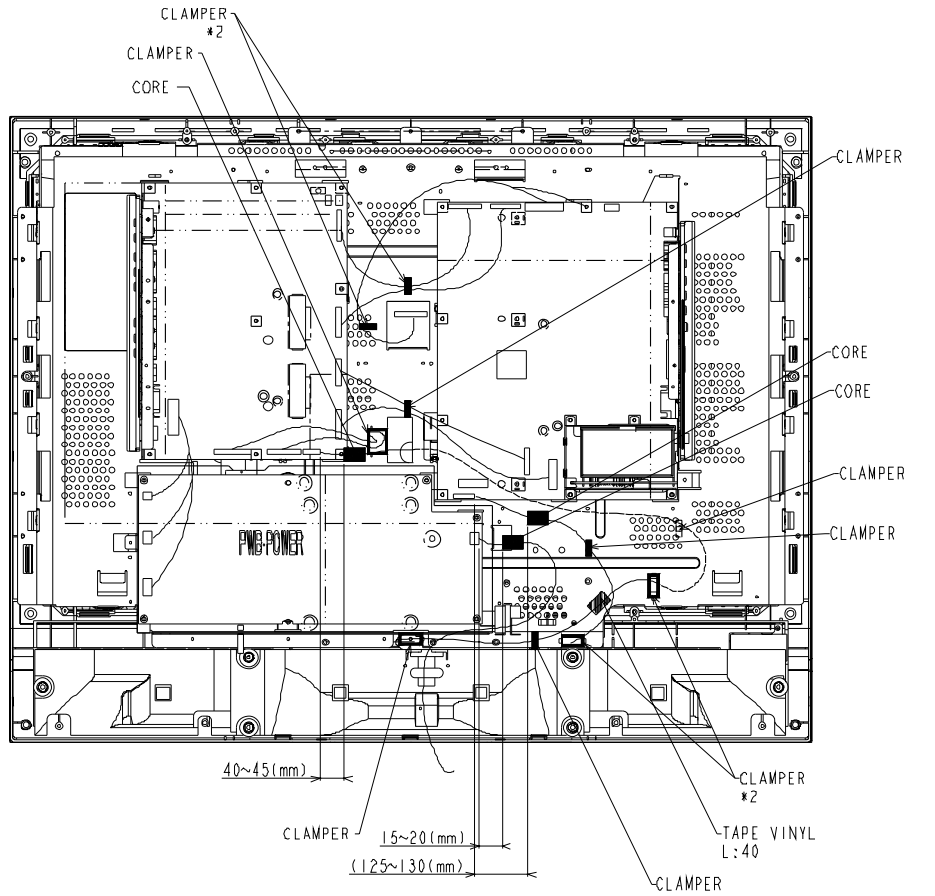

Initial Setup

A. Option Menu Setup

Follow the steps below for the initial set-up:

1. Select the "MENU" display by pressing the "MENU" button once.
2. Press the number buttons "2", "0", "7", "0" in sequence to select the "OPTION MENU" display.
3. Press the "ADJUST▲▼" buttons to select "INITIAL."
4. Press "ENTER."

MENU-2-0-7-0

OPTION MENU	
Initial	
Power Restore	:OFF
DTV Port	:Auto
Direct Key Mode	:OFF

NOTE: At this time channel 3 is automatically selected and all Menu and Audio/Video user setting are set to the defaults shown in the chart below.

B. Default Settings

MAIN MENU DEFAULT SETTINGS

SETUP	V-CHIP LOCK By Time	AUDIO/VIDEO
Memorize channels \ANT-A - Air	V-Chip Start Time 12:00AM	TV Speakers (Internal) On
Language (idioma) English	V-Chip Stop Time 12:00AM	Audio Output Variable
Front Button Lock Off	Lock by Time Off	AUDIO SETTINGS
CLOCK	Lock Time N/A	Bass 31
Clock Setting Manual	Unlock Time N/A	Treble 31
Clock Time -- : -- --	ADVANCED FEATURES	Balance 31
Set Day Sunday	Video Mute On	Sub-Woofer Level 31
CAPTIONS	Black Enhancement On	Surround Off
Closed Captions On if Mute	PC Power Save On	TV Listen To Stereo
CC Background Gray	TIMER	Level Sound Off
CHANNEL EDIT	Timer Off	VIDEO SETTINGS
Antenna ANT-A	Set Time -- : -- --	Contrast 31
Channel 3	Set Day Sunday	Brightness 31
Memory Deleted	COLOR BALANCE	Sharpness 31
Name N/A	Auto Color Correction Off	Color 31
SQV N/A	MANUAL COLOR ADJUST	Tint 31
V-CHIP-LOCK	Magenta 31	Color Temp High
V-Chip Off	Red 31	Video Noise Standard
TV Rating TV-PG	Yellow 31	Film Mode (Auto) On
FV- Fantasy Violence Allow	Green 31	Back Light 63
D-Sexual Dialog Allow	Cyan 31	PC/DVI H-Position 31
L-Adult Language Allow	Blue 31	PC/DVI V-Position 31
S-Sexual Situations Allow		PC Video Clock 31
V-Violence Allow		PC Fine Detail 31
Programs Not Rated Allow		PC H-Resolution 31
Movie Rating PG		PC V-Resolution 31

Circuit Explanations

1. Video circuits

This section explains the video circuitry of models LT-2220/LT3020. Both models have almost the same circuits. The explanation corresponds to the various inputs (PC, TV, VIDEO, Component, DVI).

The HD input has realized high definition with the resolution of WXGA.

(Refer to the LT-2220 / LT-3020 Video block diagram, for the flow of video signals.)

1-1. Video input circuit

1-1-1. PC Input video circuit

For PC input, video is inputted into IC400 of the signal processing IC via the following IC's.

(A) IC2A3 : Analog-to-digital conversion IC (AD9883AKST-110 : Analog devices)

The video signal (R, G, B) of PC input is changed into a digital signal (8 bits each) from an analog signal. Besides digital conversion, this IC has the functions below:

- Contrast adjustment for PC
- brightness adjustment for PC

This IC is controlled by register control of IC 2A3 via **3.3V IIC-bus**.

(B) IC2A2 : Inverting IC with Schmidt trigger (74LCX14 : Fairchild)

Input IC for Horizontal and Vertical sync signals from the PC input.

In case of noise on the leading and trailing edges or low amplitude of the sync signals outputted from a PC, it is necessary to modify the waveform.

Improper waveforms are corrected by this IC in the following manner.

- Noise on the leading/trailing edge : Rise-time and fall-time is carried out early.
- Waveform is noisy : False triggering prevented by the Schmidt circuit.
- Low Amplitude : If voltage threshold is satisfied, it will output at 3.3V.

Since the IC is an inverter, it will let it pass twice and has united polarity.

1-1-2. Component and DVI Input circuit.

For Component and DVI inputs, video is inputted into IC400, signal processing IC, via the following IC's.

(C)IC204 : Analog-switch IC (BA7657 : Rohm)

In this IC, one of the 2 component signal inputs (Y, Cb, Cr) is chosen by the select signal. Select signal CTL is controlled by the MCU.

(D)IC2J1 : TMDS receiver IC with HDCP (Sii907B : SiliconImage)

In this IC, the input signal is processed based on EIA-861A. Inputs from a TMDS-Interface are converted into a RGB analog signal. HDCP and HDTV resolutions are supported.

When no DVI signal is input, it changes to standby mode automatically and power consumption is lowered. The LCD panel specification is for input signals whose vertical sync signal is 60Hz. The outputs of this IC include separate horizontal and vertical sync signals.

(E)IC201 : Analog-switch IC with LPF (SM5301A : NPC)

In this IC, the component signal (Y, Cb, Cr) from IC204 or DVI signal (R,G,B) from IC2J1 is chosen by the select signal and outputted.

Select signal MUXSEL is controlled by the MCU.

(F) IC202 : Sync separate IC (LM1881M : National Semiconductor)

Used for Component input.

This IC separates the composite H and V sync signal from the composite video signal

The composite sync signal is sent to IC203 (Sync select IC).

(G) IC203 : Sync select IC (HD74LV157: Hitachi)

In this IC, the composite sync signal from IC202(for component) or Separate sync signal from IC2J1(for DVI) is chosen by the select signal and outputted.

Select signal MUXSEL is controlled by the MCU.

The output from this IC is sent to IC400 (Signal processor IC) in order to remove the vertical sync signal and output the separated horizontal sync signal. The horizontal sync signal is then routed to IC205 (Analog-to-digital conversion IC).

(H) IC205 : Analog-to-digital conversion IC (AD9883AKST-110 : Analog devices)

The Component video (YCbCr / RGB) or DVI input is converted into a digital signal (8 bits each) from an analog signal. Besides digital conversion this IC performs the following:

- Contrast adjustment for Component or DVI
- brightness adjustment for Component or DVI

This IC is controlled by register control of IC 205 via **3.3V IIC-bus**.

This IC's output is sent to IC500.

(I) IC500 : Interlace-to-Progressive conversion IC (gm6015 : Genesis)

This IC performs the following functions to all input signals except the PC input.

- Motion adaptive De-interlacer for SD (480i) signals.
- Scaling
- PIP / POP control for AV input combinations.
- Color / tint control
- 3 dimension Noise reduction.
- Adaptive Film mode
- Sync Separation for Composite sync.(for component only)

A format change to the input signal is also made by this IC.

Control is performed in 5-line serial communication from the MCU.

1-1-3. VIDEO and TV input circuitry

For VIDEO and TV inputs, the signal is applied to IC400, signal processing IC, via the following ICs.

(J)IC701 : Analog-switch IC (CXA2089 : SONY)

In this IC, the composite signal (CVBS) from video1/2 input or composite signal (S-video) from video1/2 input is chosen by register control of IC 701 via **5V IIC-bus**.

(K)IC702 : Buffer IC with LPF (MM1566AF : Mitsumi)

IC701 reduces the high frequency noise ingredient of the video signal.

(L)IC100 : Analog-switch IC (CXA2069 : SONY)

In this IC, the composite signal (CVBS / S-video) from the video1/2 inputs or the composite signal (CVBS) from the TV input is selected by register control of IC 100 via **5V IIC-bus**.

It is also selected and sent to IC300 for CCD use.

(M)IC601 : Digital decoder IC with 3D Y/C separation (uPC64011 : NEC)

This IC converts the analog video signal (S-VIDEO/CVBS) from IC100 into a digital signal.

Besides digital conversion this IC also has the following functions.

- 3 dimension Y/C separation for CVBS
- Contrast adjustment.
- Brightness adjustment.
- FIELD signal generation.
- PLL (Phase-Locked Loop) : referential clock generation.
- Sync signal generation

This IC is controlled by register control of IC 601 via **3.3V IIC-bus**.

This IC's output is sent to IC400.

(The output format is YPbPr and WXGA. Thw Vertical frequency is 60Hz.)

1-2. Signal processor circuit

(N)IC400 : Signal processor IC (M66473FP : Mitsubishi)

This IC has the functions below.

- Scaling for PC
- PIP/POP control for PC and AV combination
- Picture enhancement
- Auto setup for PC
- Colorsync function
- Frequency measurement / distinction
- Sync separation for component CS
- Color space conversion (YPbPr → RGB)
- Gamma correction

This IC is controlled by register control of IC 400 via 5-lines serial communication.

This IC's output is sent to IC4A0.

(The output format is RGB and WXGA, and Vertical frequency is 60Hz.)

(O)IC4A0 : OSD mixing IC (M66617FP : Mitsubishi)

This IC combines the picture signal outputted from IC400, the OSD signal outputted from the MCU and the signal detected by CCD.

V-CHIP function is also controlled by this IC.

This IC is controlled by register control of IC 4A0 via serial communication.

The IC's output is sent to IC4A1.

1-3. Output signal circuit

(P)IC4A1 : LVDS transmitter IC (THC63LVDM83R : Thine)

This IC converts 28bits of TTL/CMOS data into LVDS data stream.

In 28 bits, 24-bits digital video signal, horizontal sync signal, vertical sync signal, an enable signal and a clock signal for the LCD panel are included.

A phase-locked transmit clock is transmitted in parallel with the data streams over a fifth LVDS link.

This IC's output is sent to the LCD panel.

2. Audio circuits

The audio circuits and speaker system of LT-22XX/LT30XX basically have the same circuits, except the Vcc applied to the audio amplifier is different.

The specifications are as follows.

- High Power (LT-22XX : 8W ,LT-30XX: 12W)
- 2.1ch Sub woofer speaker system
- Impedance : 8 +/-1.2 ohms (LT-22XX / LT-30XX)
- Compact and high performance sound enclosure box.
- Minimization of vibration noise

Refer to the LT-22XX / LT-30XX Audio block diagram.

2-1 Audio input mixing circuits

The audio input block consist of 2 AV-SW, IC701(CXA2089) on SUB-PWB and IC100(CXA2069) on MAIN-PWB. Audio inputs for VIDEO1 and VIDEO2 are connected to IC701. Other external audio Inputs (Component1/2 and DVI and PC) are connected to IC100. Their output is connected to IC710 (Audio Processor : MSP3440G) of Scart1 / Scart2 input port.

TV broadcasting audio(SIF) is also connected to IC710's IF Input port. Input sources are selected by register control of IC 701/IC100/IC710 via **5V IIC-bus**.

2-2 Audio processor IC

MSP3440G is used as the main audio processor.

This IC's functions are as follows.

- De modulator (SAP/Stereo)
- Sub-woofer output
- Volume control
- Tone control
- Surround
- L/R mixing
- Audio line output

Both models have the following audio controls on the users menu: Bass, Treble, Balance, Surround, Listen to, Level Sound, Sub Woofer, Audio Out Fixed/Variable.

Audio adjustment of all controls except volume is performed by this IC.

(Refer to the "Owner's guide" for a full explanation of each control.)

2-3 Audio amplifiers and speakers

These models use 2pcs of 2-CH BTL type audio amplifier AN7522.

One piece is for main audio, and one more piece is for the sub-woofer.

Amplifier +B voltage and the input circuits are slightly different by model. (Refer to table 1).

Table 1: Amp supply voltage(+B)

	LT-22XX	LT-30XX
AMPVCC(for main)	7.5V	9V
SAMPVCC(for Sub Woofer)	9V	12V

Volume control is controlled by fading Volume1 /Volume2 DC signal to the amplifier Pin(#9).

Although the audio signals outputted from amplifier is sent to the SPEAKER, between the amplifier and SPEAKER is a headphone terminal. If a headphone is connected, the audio signal to SPEAKER will be interrupted and the audio signal will be sent to the headphone terminal.

3. Power circuit

Refer the LT-2220 / LT-3020 Power circuit block for the following.

The LT-2220 power supply is supplied from an AC adapter.

The LT-3020 power supply is supplied from a power supply board.

The LT-2220 has one connector for the inverter connection, the LT-3020 has two connectors.

Except for that, the circuit composition of the power supply is almost the same.

There are power supplies that are “always on” and “ON/OFF” with a control signal, as follows.

Power source signal	Voltage [V]	“always on” or “ON/OFF”	Control signal	Note
20V	20	always on	-	“22 only
24V	24	ON/OFF	ON_24V	“30 only
8.5V	8.5	always on	-	“30 only
A12V	12	ON/OFF	Psave2	
A9V	9	ON/OFF	Psave2	
A8V	8	always on	-	
AMPVCC	“30 : 9 “22 :7.5	ON/OFF	Psave3	
SAMPVCC	“30 : 12 “22 :9	ON/OFF	Psave3	
S5V	5	always on	-	
SW5V	5	ON/OFF	Psave1	
A30V	30	ON/OFF	Psave1	
S3.3V	3.3	always on	-	
4.5V	4.5	always on	-	
D3.3V	3.3	ON/OFF	Psave1	
A3.3V	3.3	ON/OFF	Psave1	
AD3.3V	3.3	always on	-	
D1.9V	1.9	ON/OFF	Psave1	
D2.5V	2.5	ON/OFF	Psave1	
1.5V	1.5	ON/OFF	Psave1	

BLOCK DIAGRAM of LT-22XX/LT-30XX(except Power)

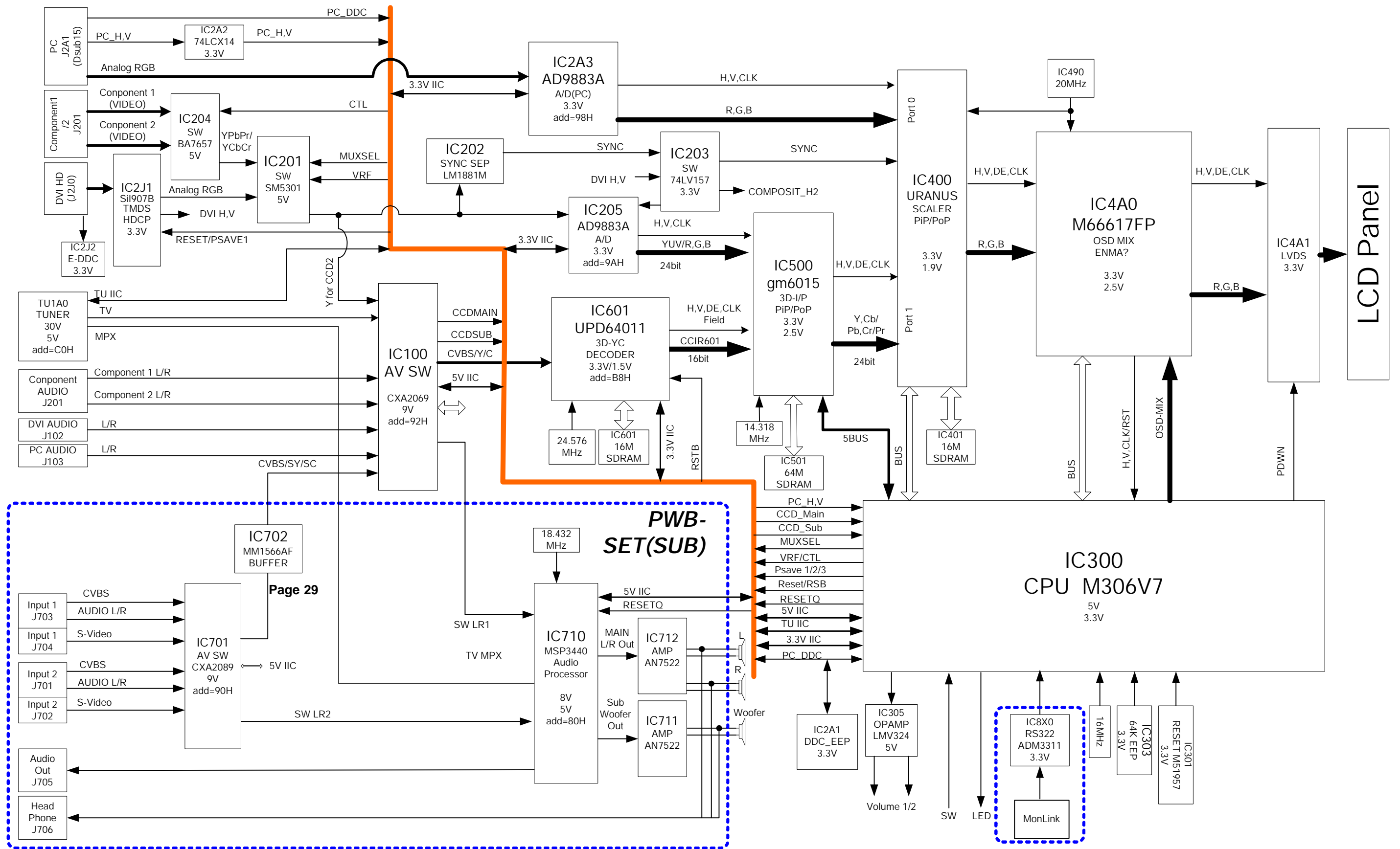

MODELS: LT-2220 / LT-2240 / LT-3020 / LT-3040 / LT-3050

POWER CIRCUIT BLOCK DIAGRAM FOR LT-22XX / LT30XX

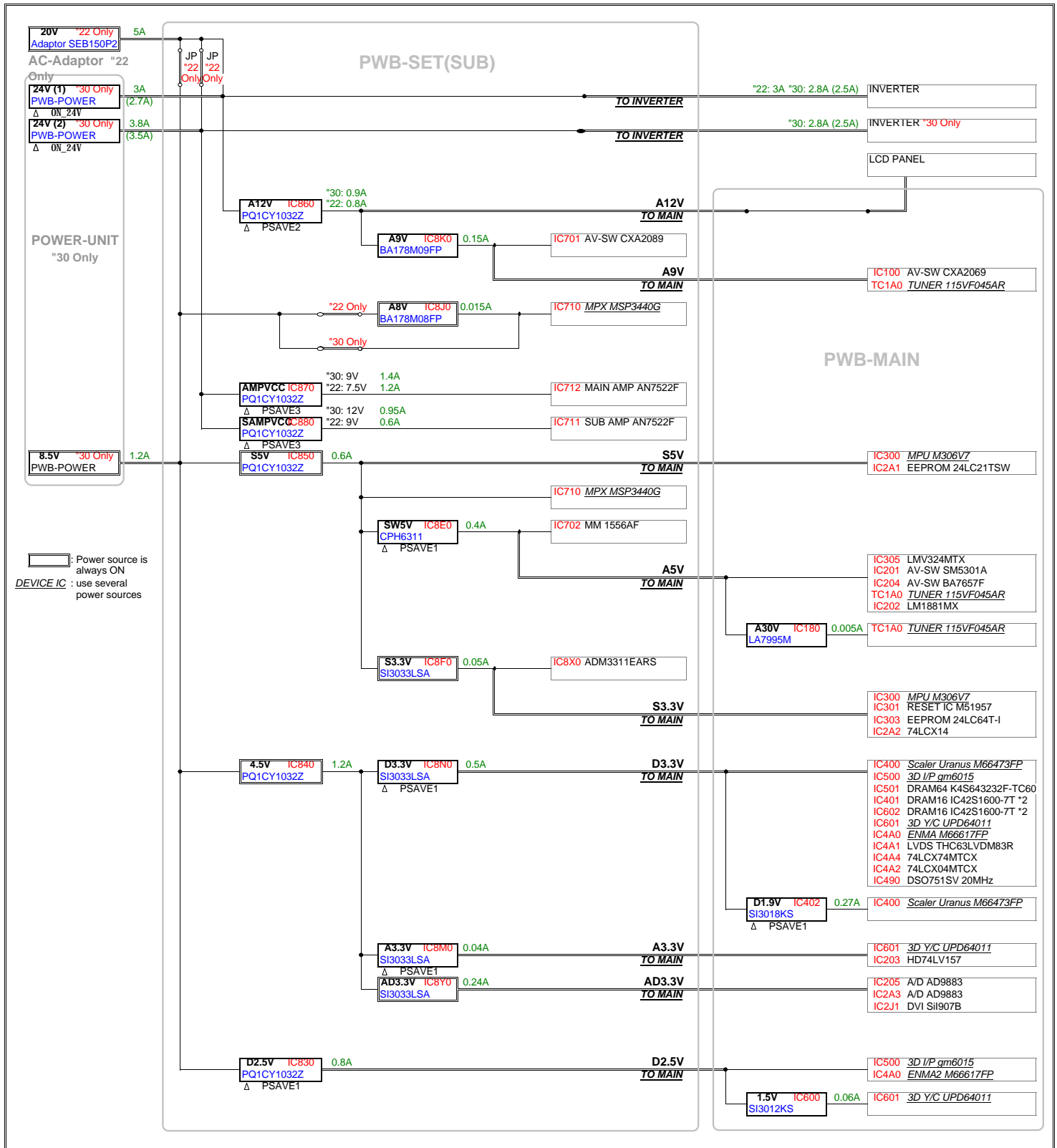

PC & Video BLOCK DIAGRAM for LT-22XX/LT-30XX

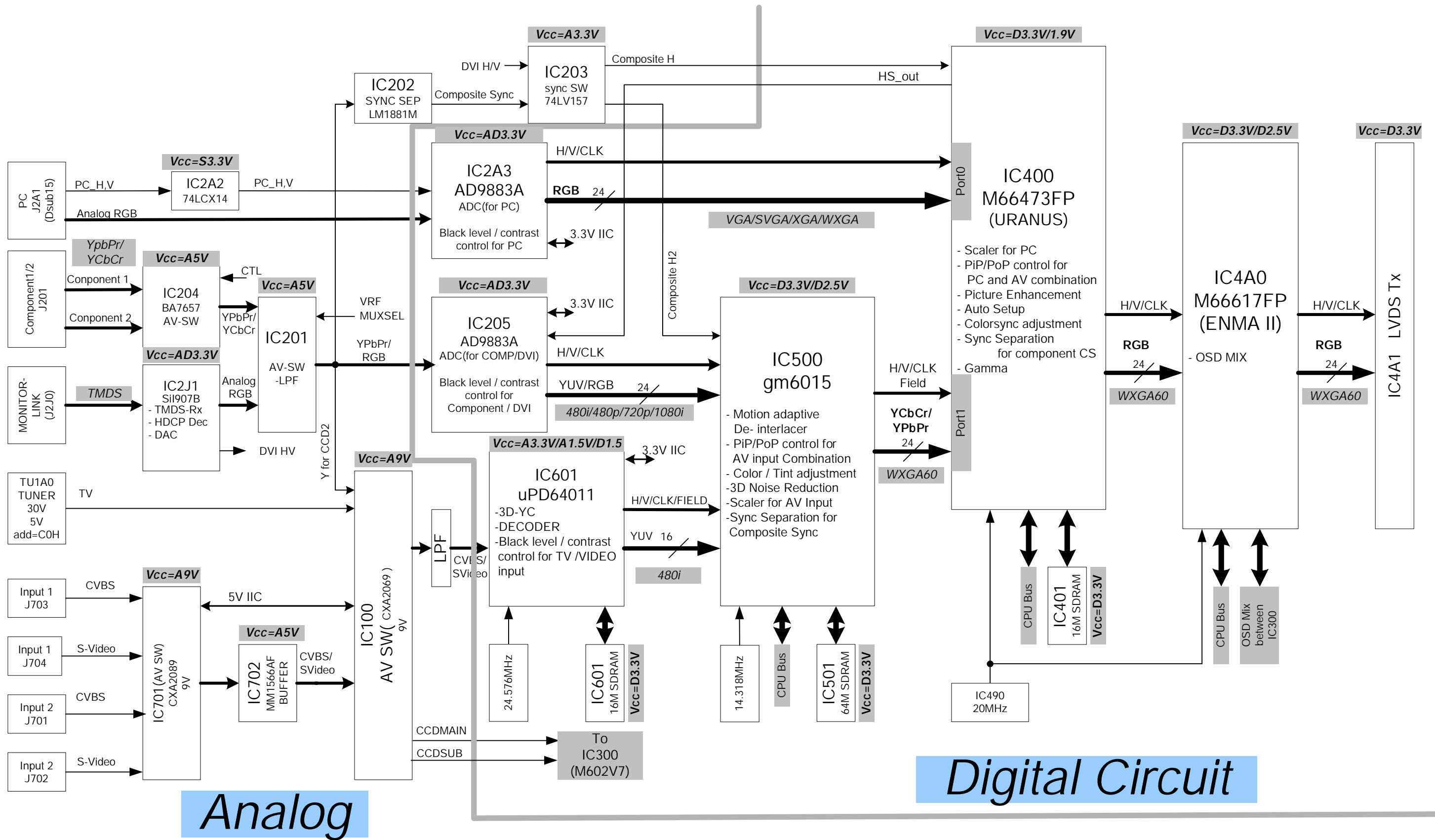

AUDIO Block Diagram for LT-22XX/LT-30XX

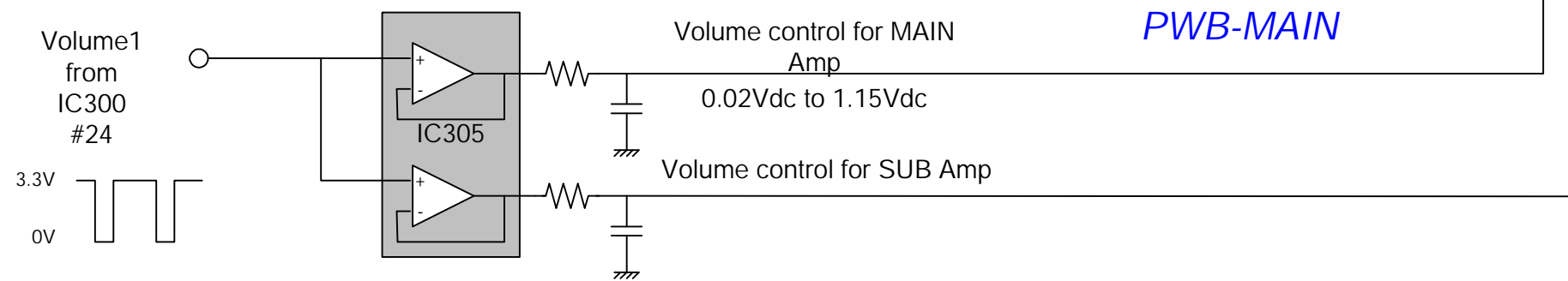
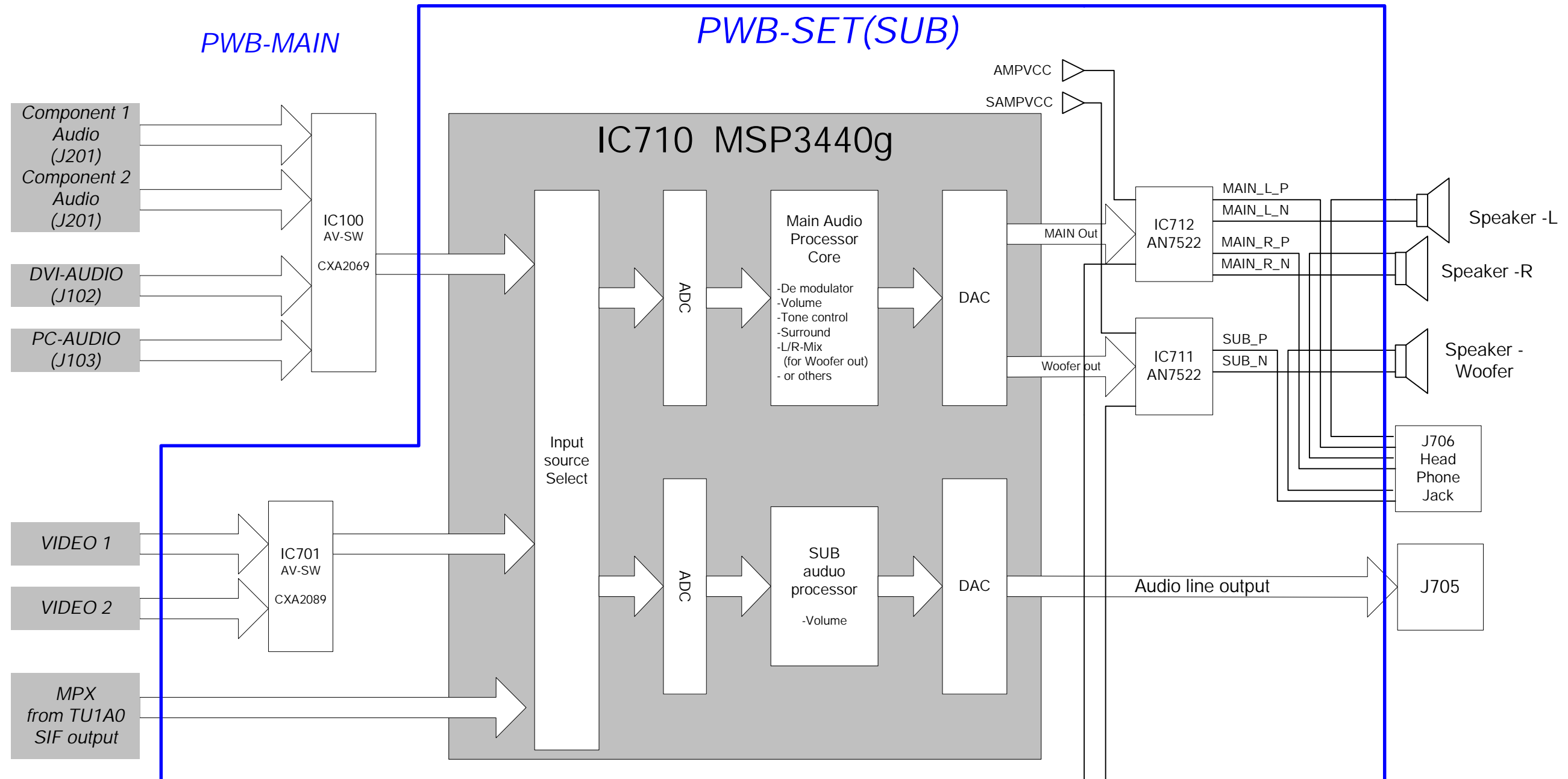

Table: Supplied voltage to Amp +B

	LT-2220	LT-3020
AMPVCC	7.5V	9V
SAMPVCC	9V	12V

TEST POINT LOCATIONS AND DESCRIPTIONS

Test points, locations and descriptions are shown below.

(1) PWB-SET (SUB)

	Test Point	Location	Description	Note
1	Pin1 of J800	J801(Fuse-clip)	20Vdc from AC-ADAPTOR	22inches only
2	F800	J802(Fuse-clip)	20Vdc behind the fuse F800	22inches only
3	INV-SW	Pin12 of J821	Used to control inverter ON/OFF. (0V : OFF , 5Vdc : ON)	
4	BRIGHT	Pin14 of J821	Used for brightness control of inverter. (PWM control) (Max : 5Vdc, Min : thin pulse)	
5	24V	Pin4, 6 of J810	24Vdc from Power-unit.	30inches only
6	8.5V	Pin2 of J810	8.5Vdc from Power-unit.	30inches only
7	IN_24V	Pin8 of J810	3.3Vdc. Used for ON/OFF control of the power supply from the POWER-UNIT.	30inches only
8	Psave1	Pin5 of J712	ON/OFF control signal of D3.3V, A3.3A. (0V : OFF , 3.3Vdc : ON)	
9	A8V	(+) of C733	8Vdc. Used to supply power to IC710.	
10	AMPVCC	Pin1 of IC711	7~9Vdc. Used to supply power to IC711.	
11	SAMPVCC	Pin1 of IC712	8~12Vdc. Used to supply power to IC712.	
12	Psave2	Pin6 of J712	ON/OFF control signal of A9V, A8V A5A. (0V : OFF , 3.3Vdc : ON)	
13	Psave3	Pin7 of J712	ON/OFF control signal of AMPVCC, SAMPVCC. (0V : OFF , 3.3Vdc : ON)	
14	MPX	Pin8 of J710	Analog video signal from TV input. Voltage level is 1.0Vp-p (Typical)	
15	SW_L	Pin10 of J710	Audio L signal for PC or Monitorlink or Component input.	
16	SW_R	Pin12 of J710	Audio R signal for PC or Monitorlink or Component input.	
17	5V_SDA	5 of J711	Serial port data I/O for IC of 5V power supply.	
18	5V_SCL	6 of J711	Serial port data clock for IC of 5V power supply.	
19	MPX_RST	Pin10 of J711	Reset signal of IC710. (0V : reset)	
20	F880	F880	7~9Vdc. Power supply fuse for IC711.	
21	F870	F870	8~12Vdc. Power supply fuse for IC712.	

PWB- SET(SUB)

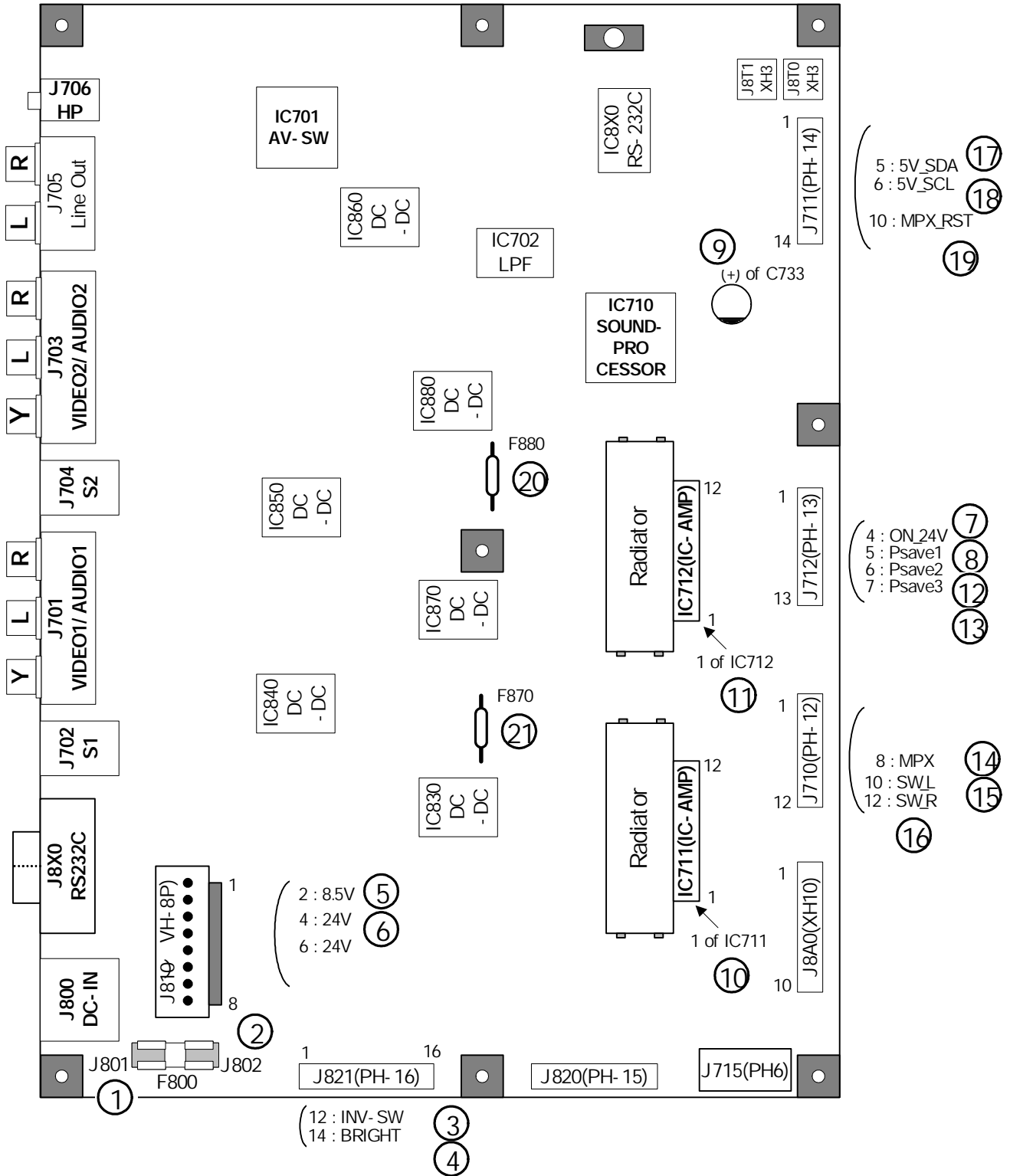

(2) PWB-MAIN

	Test Point	Location	Description	Note
1	S5V	Pin12 of J303	5Vdc(always on). Power supply voltage for MCU, etc.	
2	S3.3V	Pin13 of J303	3.3Vdc(always on). Power supply voltage for MCU, etc.	
3	D3.3V	Pin7 of J190	3.3Vdc. Power supply for IC300, IC4A0, IC4A1 etc.	
4	A5V	Pin1 of J190	5Vdc. Power supply for IC204, IC201 etc.	
5	A3.3V	Pin5 of J190	3.3Vdc. Power supply for IC203, etc.	
6	D2.5V	Pin8 of J190	2.5Vdc. Power supply for IC500.	
7	AD3.3V	Pin6 of J190	3.3Vdc. Power supply for IC2A3, IC205, IC2J1, etc.	
8	D1.9V	L400	1.9Vdc. Power supply for IC500.	
9	Digital_G7	14 of IC4A1	3.3Vdc. MSB of green digital video signal to LCD panel.	
10	QHS -27 of IC4A1	R4H6	Horizontal sync signal to LCD panel	
11	QVS -28 of IC4A1	R4H5	Vertical sync signal to LCD panel	
12	QCLK -31 of IC4A1	R4H3	Clock signal to LCD panel	
13	QDE -30 of IC4A1	R4H4	Data_Enable signal to LCD panel	
14	A9V	10 of J190	9Vdc. Power supply for IC100.	
15	30V	Pin7 of IC180	30Vdc. Power supply for TU1A0.	
16	A1.5V, D1.5V	Pin3 of IC600	1.5Vdc. Power supply for IC601.	
17	TU_SDA	Pin31 of IC300	Serial port data I/O for TU1A0.	
18	TU_SCL	Pin28 of IC300	Serial port data clock forTU1A0.	
19	S3.3V(RMC)	Pin1 of J301	3.3Vdc(always on). Power supply for IR receiver and front switches, etc.	
20	RMC	Pin2 of J301	Data signal from IR receiver. This data is sent to MCU.	
21	KEY1	Pin4 of J301	Data signal from front switch. This data is sent to MCU.	
22	KEY2	Pin5 of J301	Data signal from front switch. This data is sent to MCU.	
23	V_OUT	Pin2 of J110	Analog video signal from VIDEO 1&2 inputs. (Composite video)	
24	SY_OUT	Pin4 of J110	Analog video signal from VIDEO 1&2 inputs. (S-video)	

PWB-MAIN

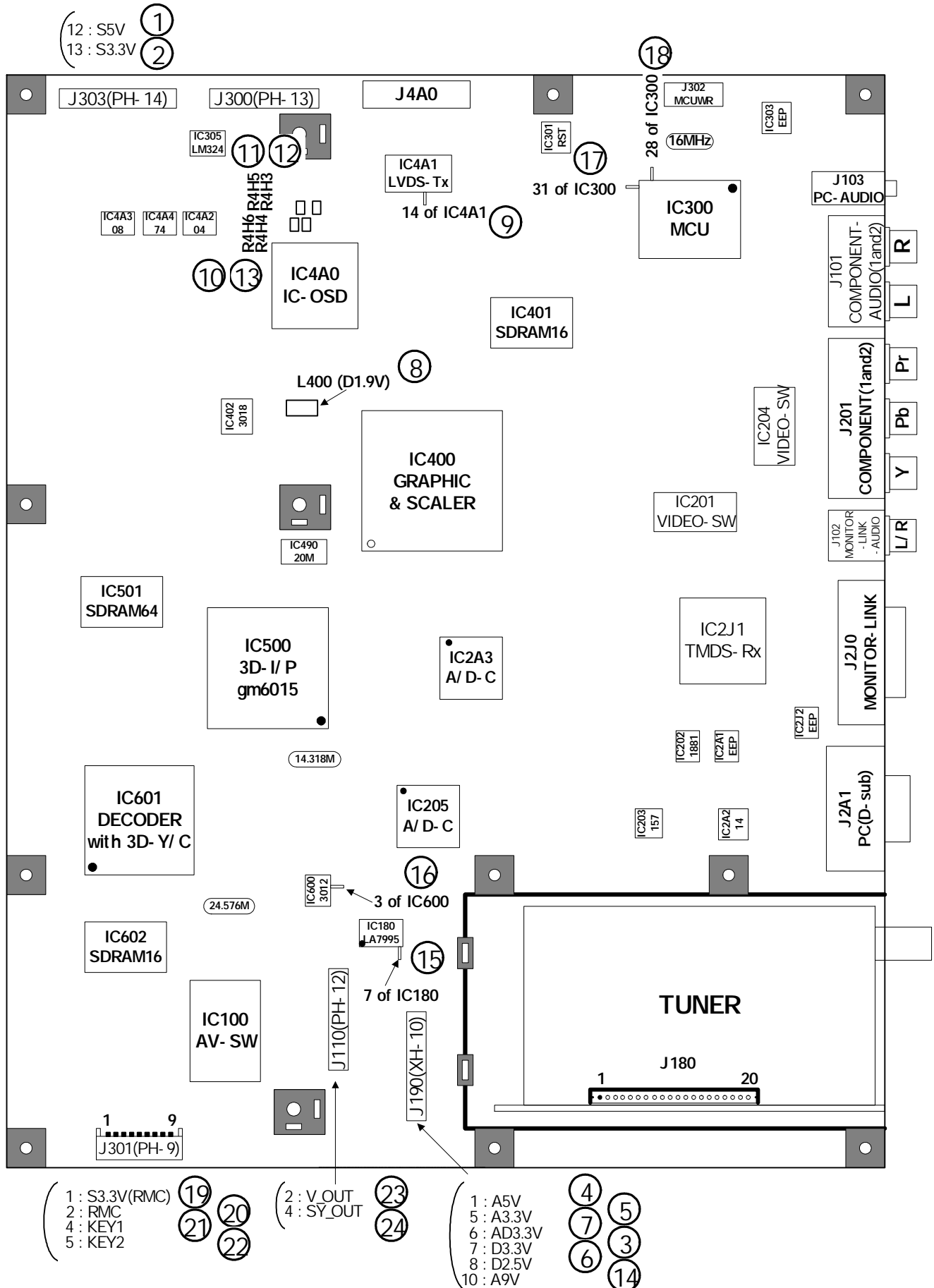

1. Power failure

1.1 In case of LT-22XX

(1)POWER is turned off.

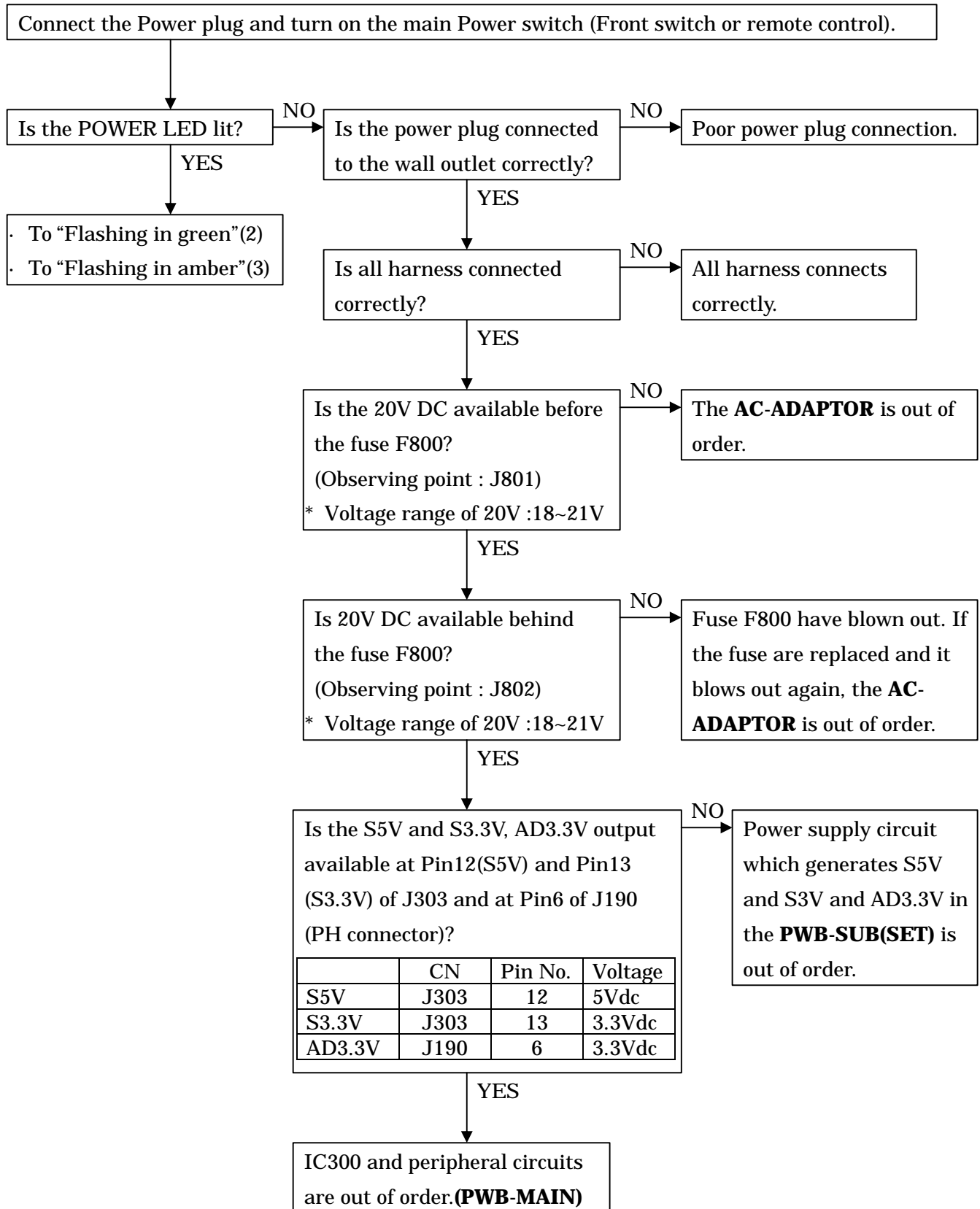

(2)Flashing in green.

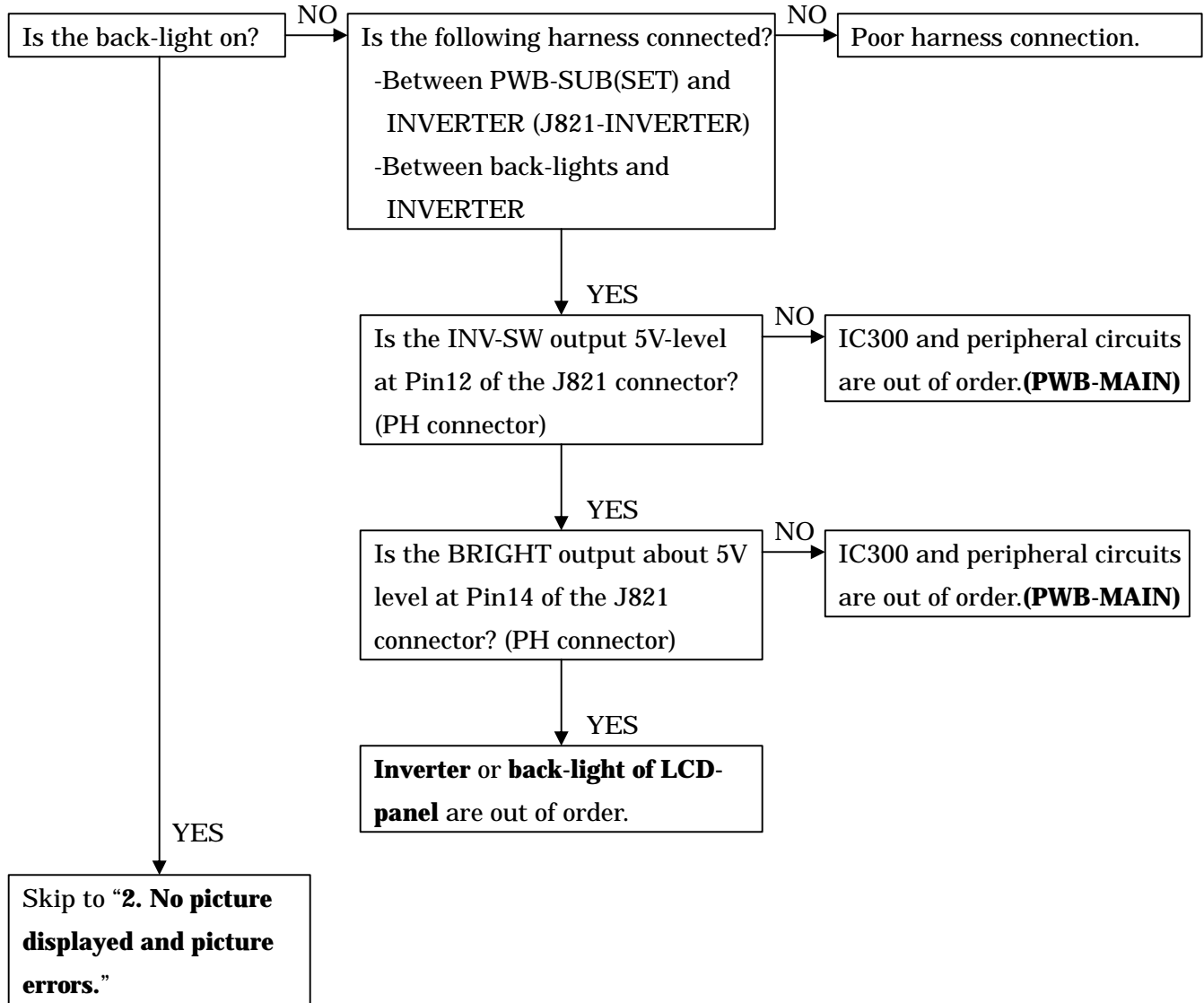

(3)Flashing in Amber.

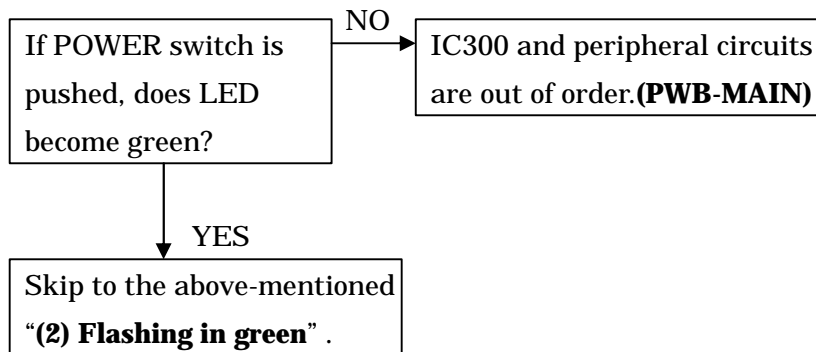

1.2 In case of LT-30XX

(1) POWER is turned off.

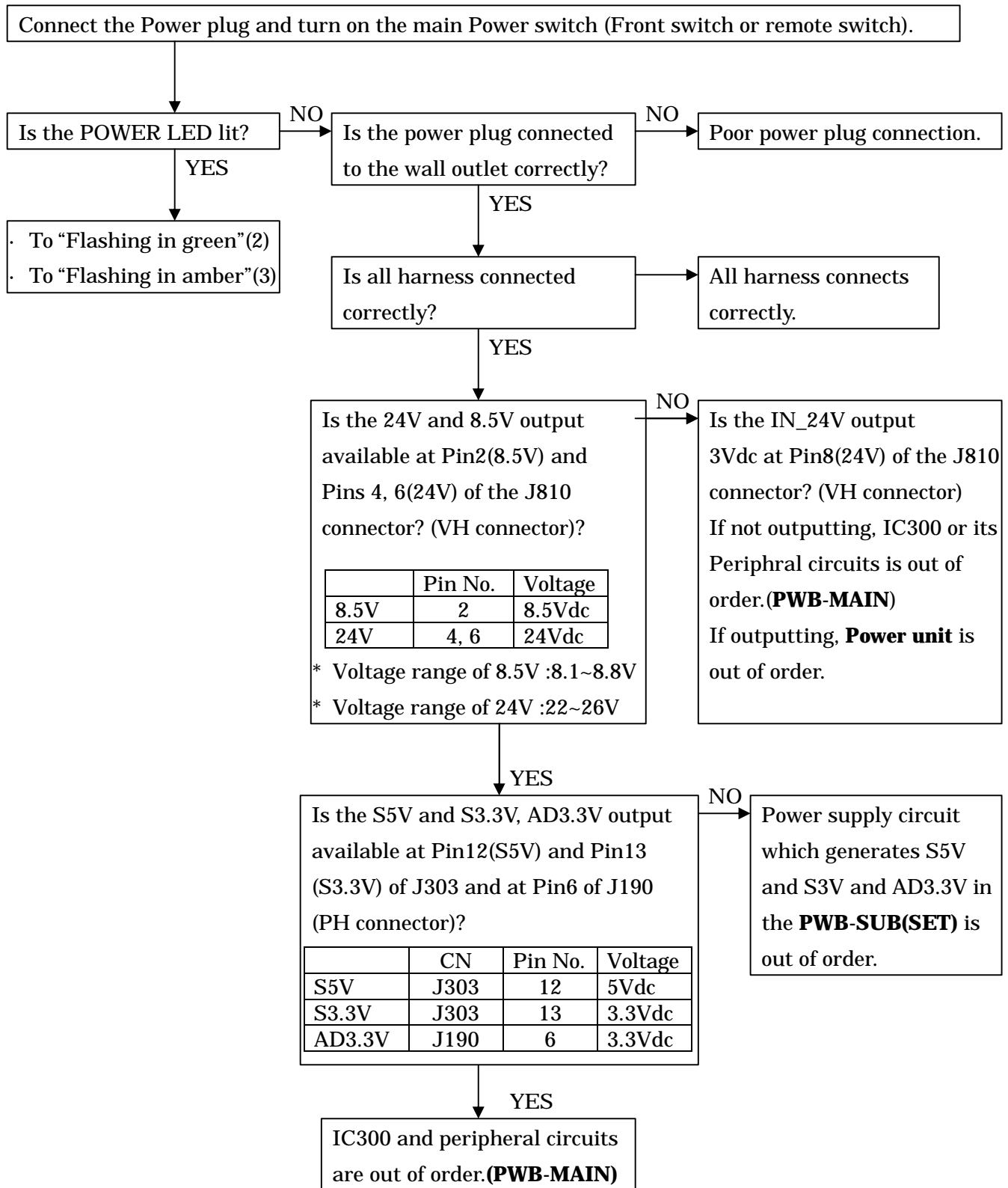

(2)Flashing in green.

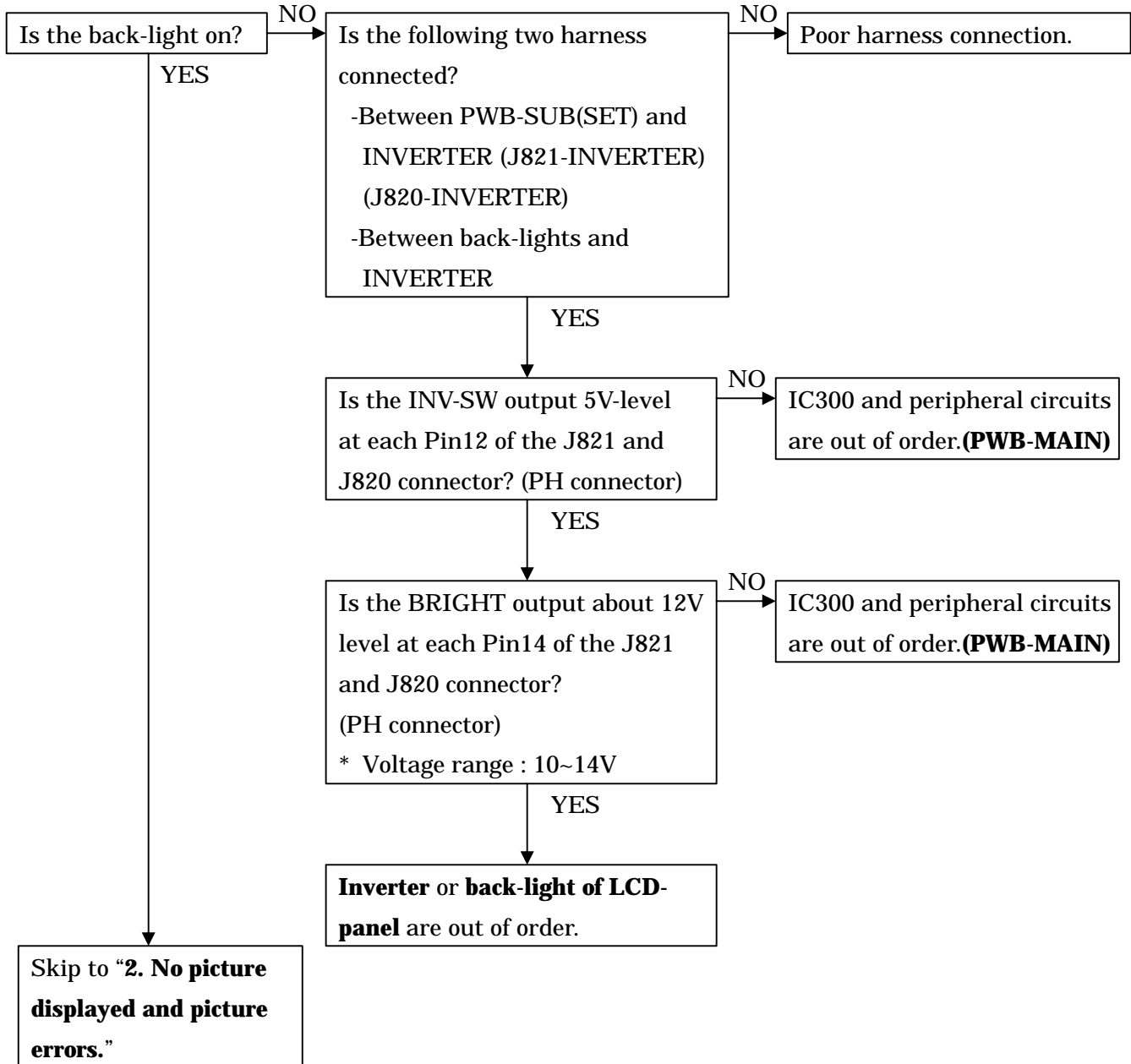

(3)Flashing in Amber.

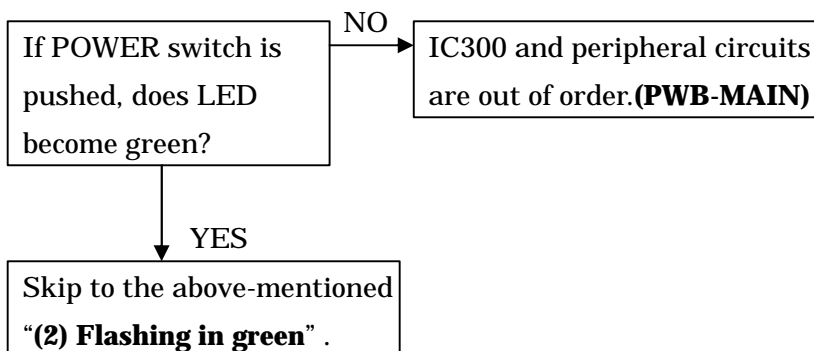

2. No picture displayed and picture errors (It applies both LT-30XX and LT-22XX)

Note) It applies when there is no screen display or an unusual screen is outputted, although power supply is turned on and the back light is turned on.

Before checking, perform the initial setup. (Input before the initial setup is channel 3 of TV.)

* Input source changes in following order with DEVICE UP button of remote control or DEVICE button of front switch.

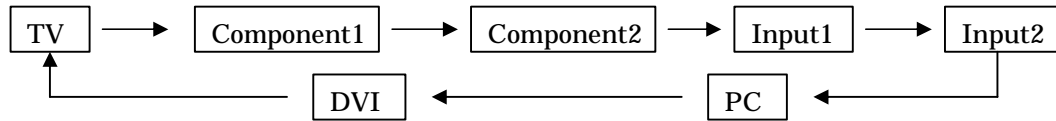

2-1. No picture displayed and picture errors of PC signal.

Enter an input of WXGA(60Hz) gray scale in D-sub connector(J2A1), and select PC INPUT. (Push the device UP button 5 times.)
 And then, perform AV reset by front switch.
 The video level inputs above 0.7Vp-p.

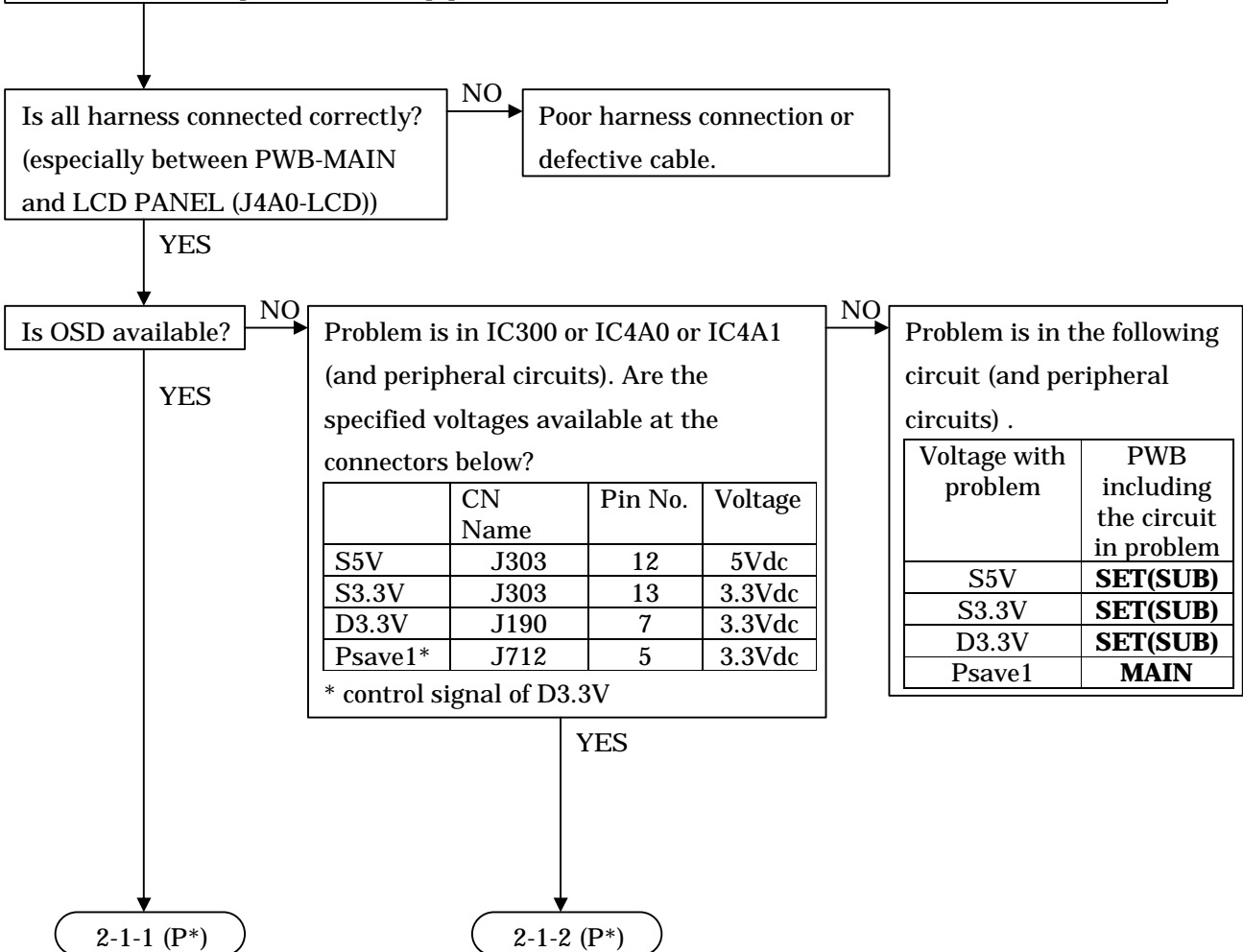

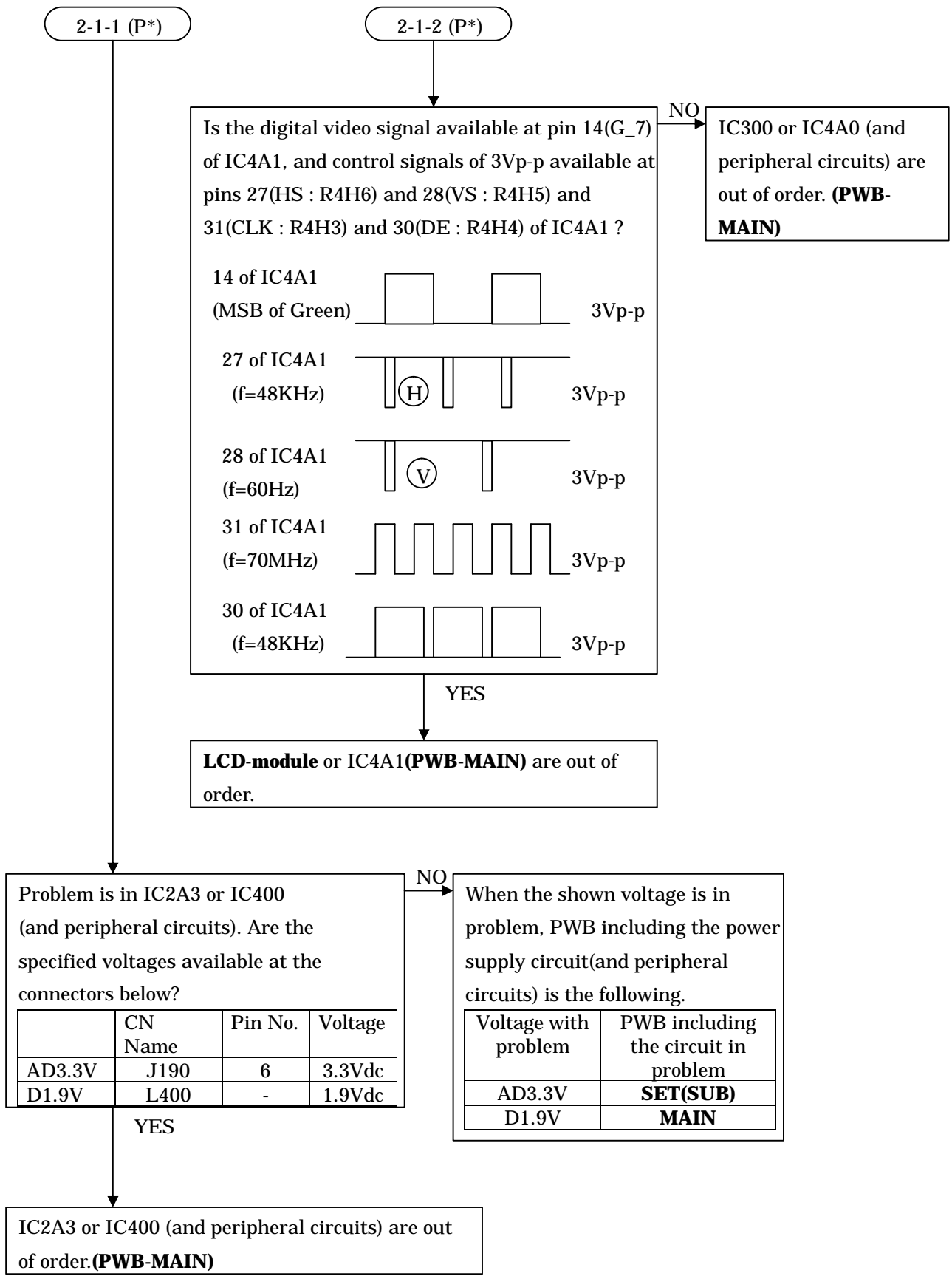

2-2. No picture displayed and picture errors of Component signal.

Enter an input of D1(480i) gray scale in J201 connector, and select COMPONENT1 (or2) INPUT. (Push the device UP button once.: twice in the case of COMPONENT2)
And then, perform AV reset by front switch.
The video level inputs about 1.0Vp-p.

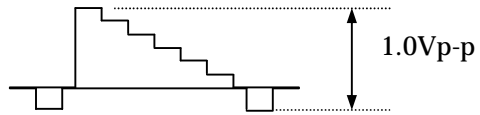

Is all harness connected correctly? (especially between PWB-MAIN and LCD PANEL (J4A0-LCD))

NO → Poor harness connection or defective cable.

YES

Is OSD available?

NO → Problem is in IC300 or IC4A0 or IC4A1 (and peripheral circuits). Are the specified voltages available at the connectors below?

	CN Name	Pin No.	Voltage
S5V	J303	12	5Vdc
S3.3V	J303	13	3.3Vdc
D3.3V	J190	7	3.3Vdc
Psave1*	J712	5	3.3Vdc

*control signal of D3.3V

Problem is in the following circuit (and peripheral circuits) .

Voltage with problem	PWB including the circuit in problem
S5V	SET(SUB)
S3.3V	SET(SUB)
D3.3V	SET(SUB)
Psave1	MAIN

YES

YES

Is the digital video signal available at pin 14(G_7) of IC4A1, and control signals of 3Vp-p available at pins 27(HS : R4H6) and 28(VS : R4H5) and 31(CLK : R4H3) and 30(DE : R4H4) of IC4A1 ?

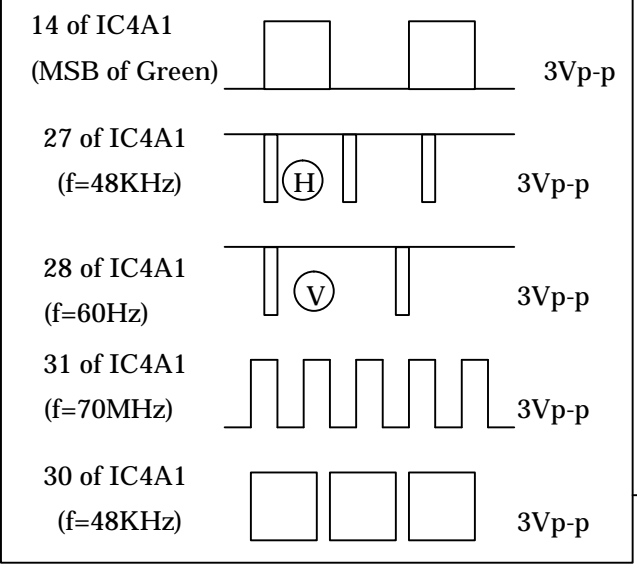

NO → IC300 or IC4A0 (and peripheral circuits) are out of order. **(PWB-MAIN)**

YES → **LCD-module** or IC4A1 **(PWB-MAIN)** are out of order.

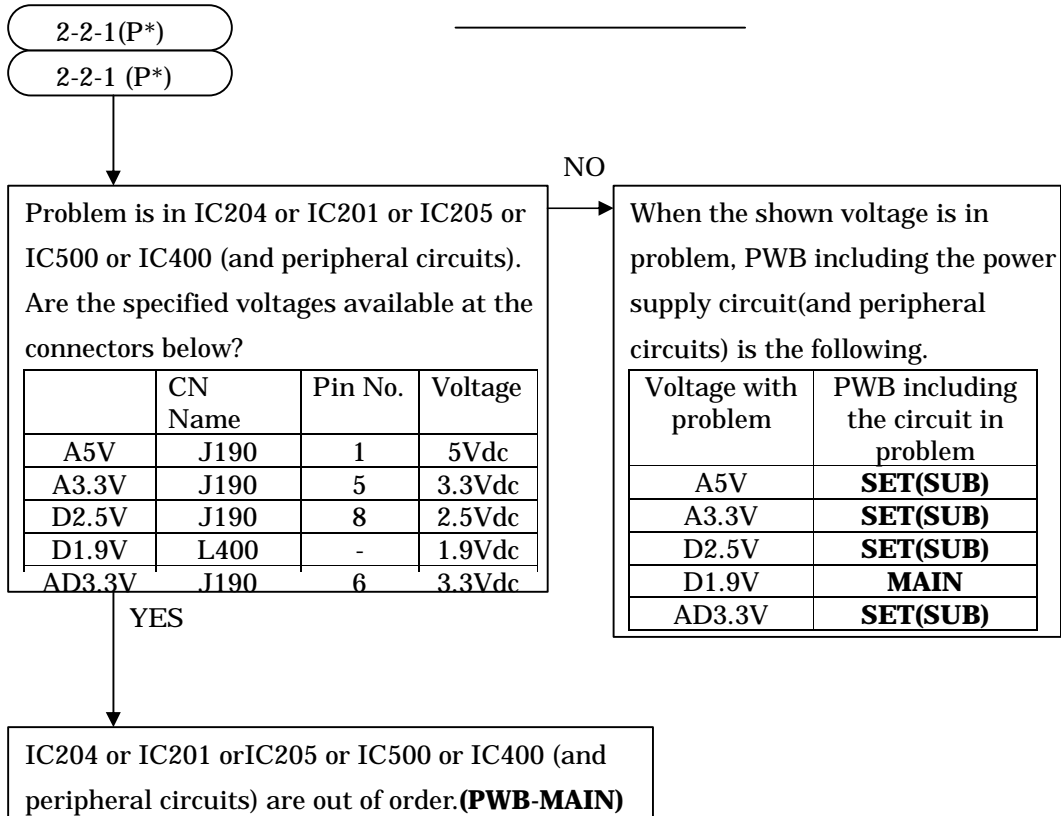

2-3. No picture displayed and picture errors of DVI signal.

Enter an input of D2(480p) gray scale in J2J0 connector, and select DVI INPUT.
 (Push the device UP button 6 times)
 And then, perform AV reset by front switch.
 The video level inputs above 0.7Vp-p.

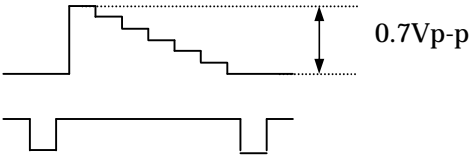

Is all harness connected correctly?
 (especially between PWB-MAIN and LCD PANEL (J4A0-LCD))

NO → Poor harness connection or defective cable.

Is OSD available?

YES → YES

NO → Problem is in IC300 or IC4A0 or IC4A1 (and peripheral circuits). Are the specified voltages available at the connectors below?

	CN Name	Pin No.	Voltage
S5V	J303	12	5Vdc
S3.3V	J303	13	3.3Vdc
D3.3V	J190	7	3.3Vdc
Psave1*	J712	5	3.3Vdc

*control signal of D3.3V

NO → Problem is in the following circuit (and peripheral circuits).

Voltage with problem	PWB including the circuit in problem
S5V	SET(SUB)
S3.3V	SET(SUB)
D3.3V	SET(SUB)
Psave1	MAIN

Is the digital video signal available at pin 14(G_7) of IC4A1, and control signals of 3Vp-p available at pins 27(HS : R4H6) and 28(VS : R4H5) and 31(CLK : R4H3) and 30(DE : R4H4) of IC4A1 ?

14 of IC4A1 (MSB of Green)  3Vp-p

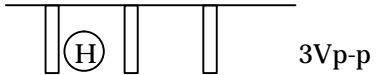
27 of IC4A1 (f=48KHz)  3Vp-p

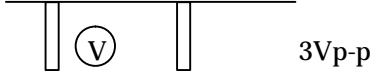
28 of IC4A1 (f=60Hz)  3Vp-p

31 of IC4A1 (f=70MHz)  3Vp-p

30 of IC4A1  3Vp-p

NO → IC300 or IC4A0 (and peripheral circuits) are out of order. (**PWB-MAIN**)

YES → **LCD-module** or IC4A1 (**PWB-MAIN**) are out of order.

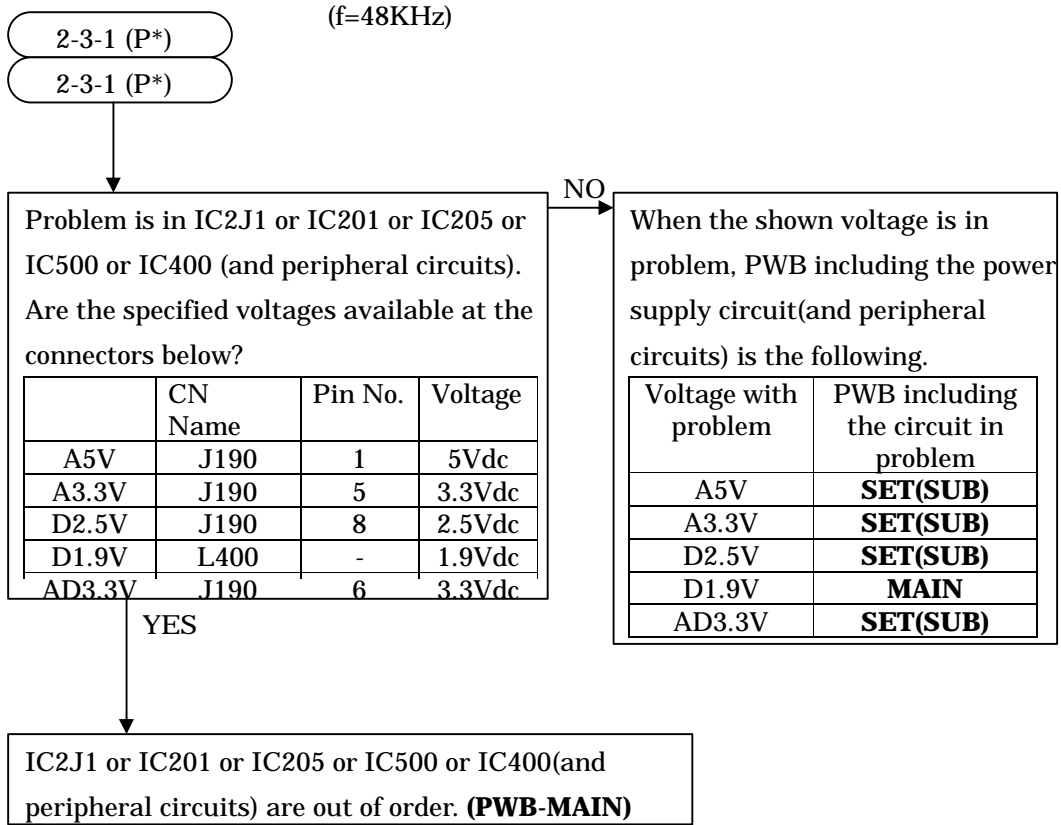

2-4. No picture displayed and picture errors of VIDEO signal.

Enter an input of NTSC gray scale in J2J0 connector, and select VIDEO1 (or 2) INPUT.
 (Push the device UP button 3 times :
 4 times in case of VIDEO2)
 And then, perform AV reset by front switch.
 The video level inputs about 1.0Vp-p.

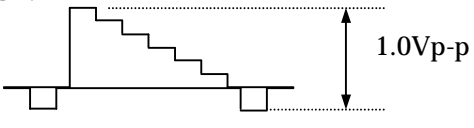

Is all harness connected correctly?
 (especially between PWB-MAIN
 and LCD PANEL (J4A0-LCD))

NO → Poor harness connection or defective cable.

Is OSD available?

YES

NO → Problem is in IC300 or IC4A0 or IC4A1 (and peripheral circuits). Are the specified voltages available at the connectors below?

	CN Name	Pin No.	Voltage
S5V	J303	12	5Vdc
S3.3V	J303	13	3.3Vdc
D3.3V	J190	7	3.3Vdc
Psave1*	J712	5	3.3Vdc

*control signal of D3.3V

NO → Problem is in the following circuit (and peripheral circuits) .

Voltage with problem	PWB including the circuit in problem
S5V	SET(SUB)
S3.3V	SET(SUB)
D3.3V	SET(SUB)
Psave1	MAIN

YES

YES → Is the digital video signal available at pin 14(G_7) of IC4A1, and control signals of 3Vp-p available at pins 27(HS : R4H6) and 28(VS : R4H5) and 31(CLK : R4H3) and 30(DE : R4H4) of IC4A1 ?

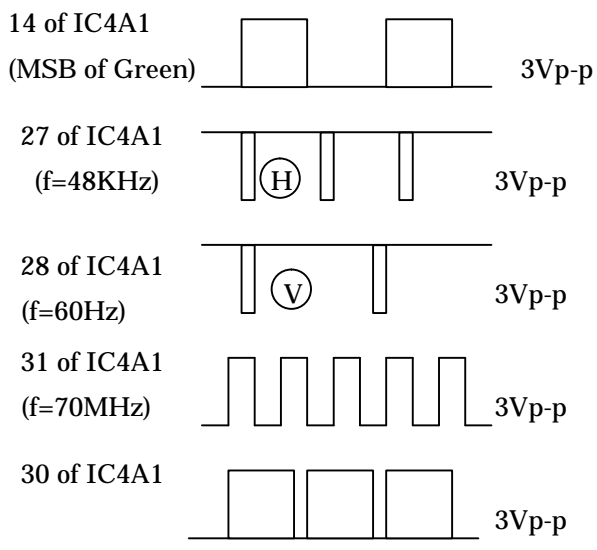

IC300 or IC4A0 (and peripheral circuits) are out of order. **(PWB-MAIN)**

YES → **LCD-module** or IC4A1 **(PWB-MAIN)** are out of order.

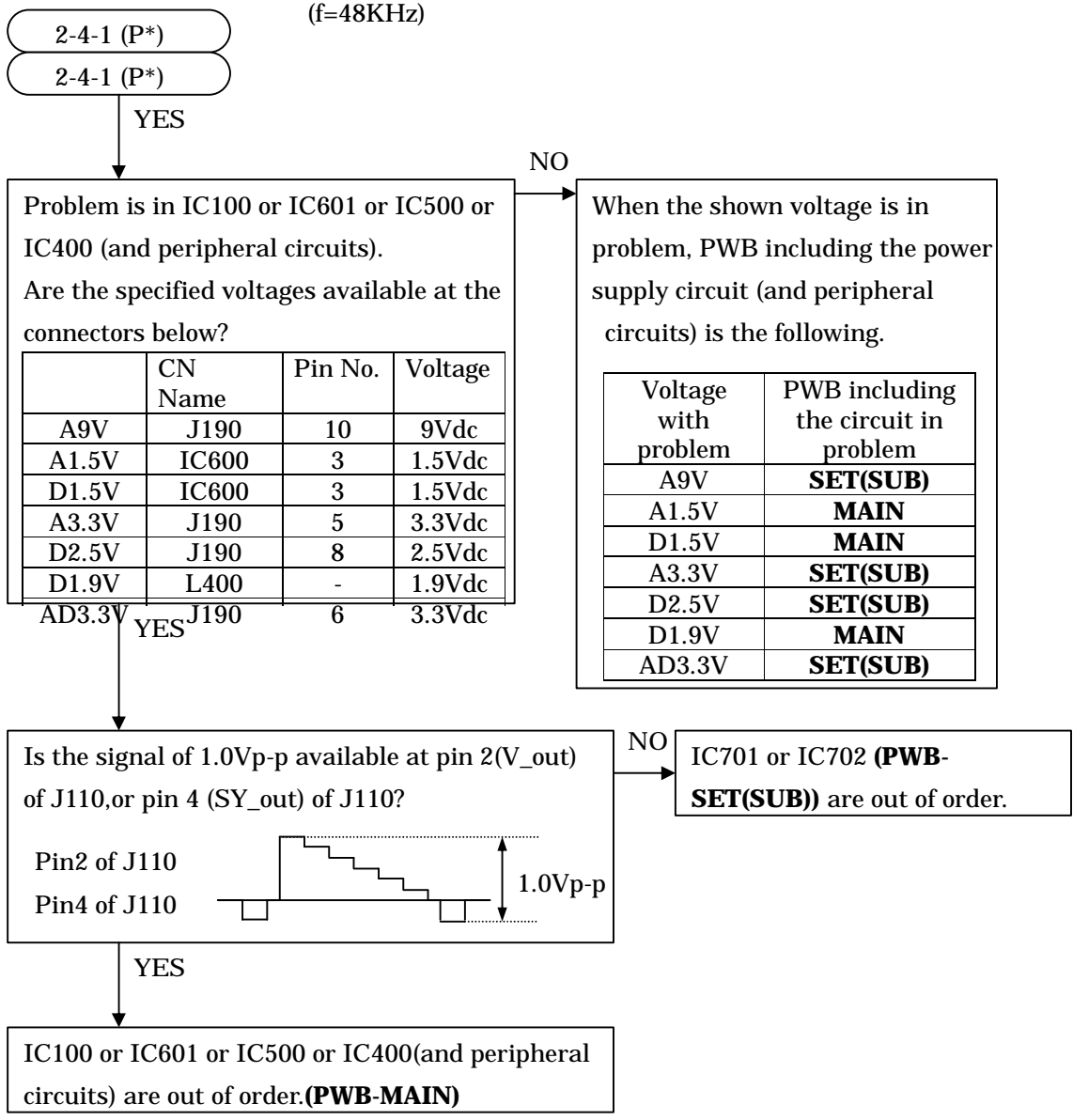

2-5. No picture displayed and picture errors of TV signal.

Enter an input of NTSC gray scale in TU1A0 (TUNER), and select TV INPUT. (It may not push the device button after initial setup. Adjust the channel of TV with the channel of a signal source.) And then, perform AV reset by front switch.

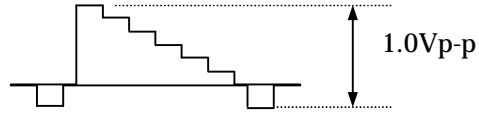

Is all harness connected correctly? (especially between PWB-MAIN and LCD PANEL (J4A0-LCD))

NO → Poor harness connection or defective cable.

YES → Is OSD available?

NO → Problem is in IC300 or IC4A0 or IC4A1 (and peripheral circuits). Are the specified voltages available at the connectors below?

	CN Name	Pin No.	Voltage
S5V	J303	12	5Vdc
S3.3V	J303	13	3.3Vdc
D3.3V	J190	7	3.3Vdc
Psave1*	J712	5	3.3Vdc

NO → Problem is in the following circuit (and peripheral circuits) .

Voltage with problem	PWB including the circuit in problem
S5V	SET(SUB)
S3.3V	SET(SUB)
D3.3V	SET(SUB)
Psave1	MAIN

YES →

YES → Is the digital video signal available at pin 14(G_7) of IC4A1, and control signals of 3Vp-p available at pins 27(HS : R4H6) and 28(VS : R4H5) and 31(CLK : R4H3) and 30(DE : R4H4) of IC4A1 ?

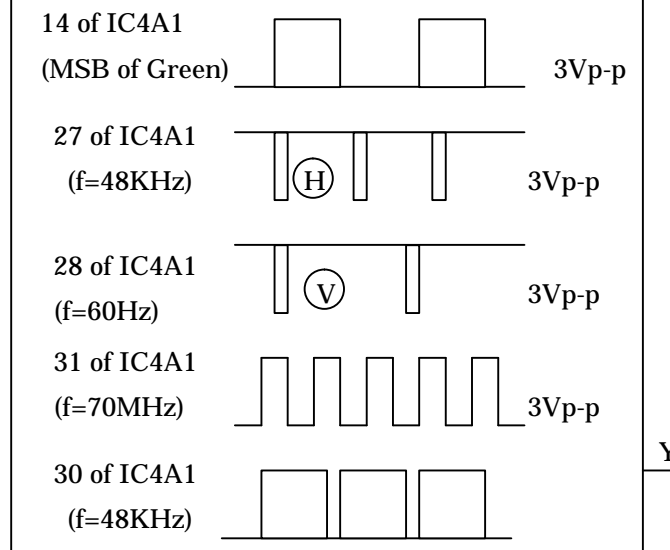

IC300 or IC4A0 (and peripheral circuits) are out of order. (PWB-MAIN)

YES → LCD-module or IC4A1 (PWB-MAIN) are out of order.

3Vp-p

2-5-1 (P*)
2-5-1 (P*)

Problem is in IC100 or IC601 or IC500 or IC400 (and peripheral circuits).
Are the specified voltages available at the connectors below?

	CN Name	Pin No.	Voltage
30V	IC180	7	30Vdc
A9V	J190	10	9Vdc
A1.5V	IC600	3	1.5Vdc
D1.5V	IC600	3	1.5Vdc
A3.3V	J190	5	3.3Vdc
D2.5V	J190	8	2.5Vdc
D1.9V	L400	-	1.9Vdc
AD3.3V	J190	6	3.3Vdc

NO

When the shown voltage is in problem, PWB including the power supply circuit (and peripheral circuits) is the following.

Voltage with problem	PWB including the circuit in problem
30V	MAIN
A9V	SET(SUB)
A1.5V	MAIN
D1.5V	MAIN
A3.3V	SET(SUB)
D2.5V	SET(SUB)
D1.9V	MAIN
AD3.3V	SET(SUB)

YES

TU1A0 or IC100 or IC601 or IC500 or IC400 (and peripheral circuits) are out of order. **(PWB-MAIN)**

3. No audio output generated.(It applies both LT-30XX and LT-22XX)

Notes) This model is enabled to set up an audio input terminal for each video input terminal. No audio output is available unless the input terminal of displayed pictures (example:VIDEO1) coincides with that of audio (example:PC). Therefore, analysis for troubleshooting should be carried out after the displayed video input terminal (example:VIDEO1) has been made to coincide with the input terminal according to the instruction manual.

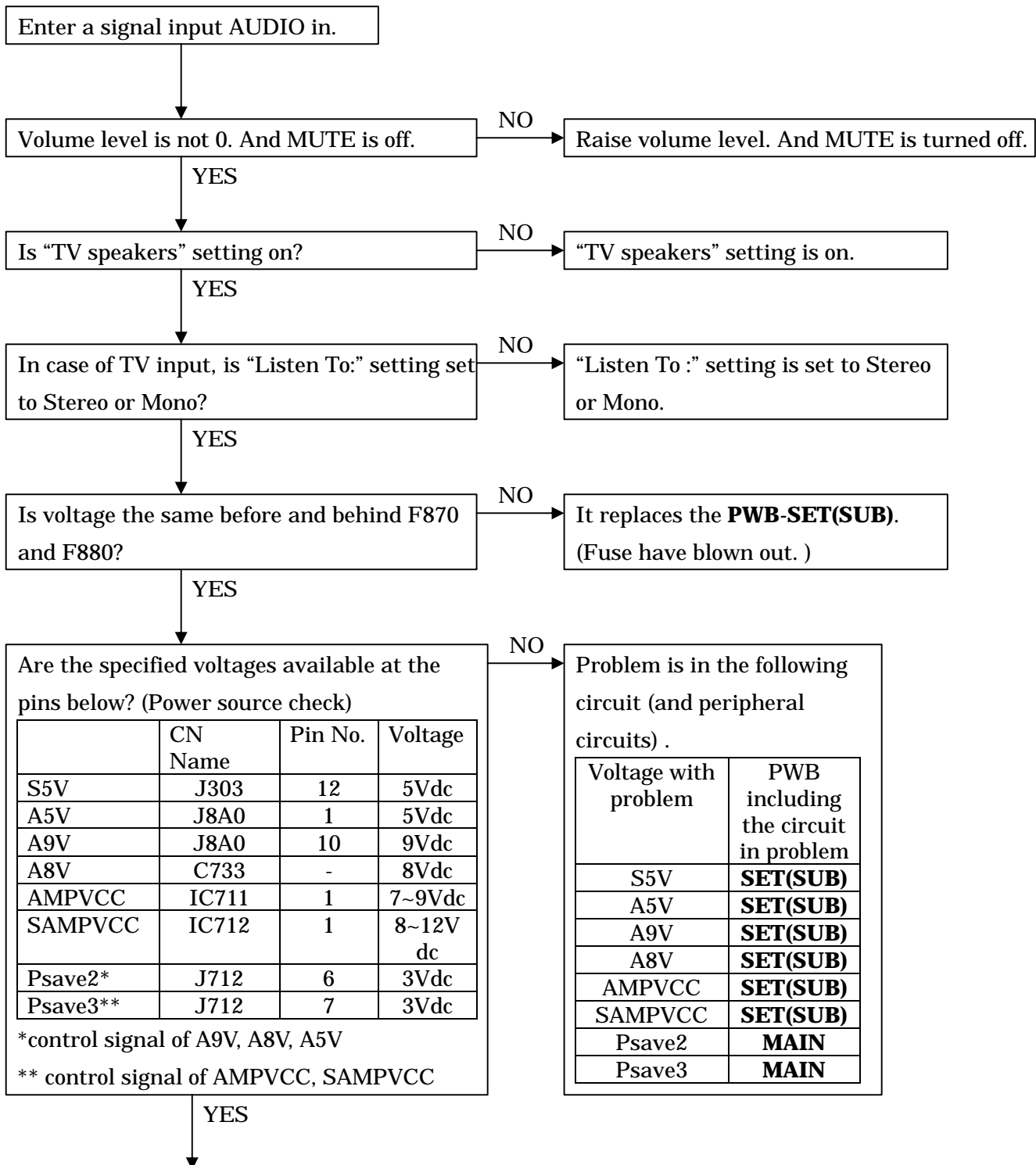

3-A (P*)

3-A (P*)

YES

Is the signal below available at pins 5, 6 of J711 (control signals of IC701 and IC710 and IC100) and 10 of J711 (control signals of IC710) and 28, 31 of IC300 (control signals of TU1A0) ?

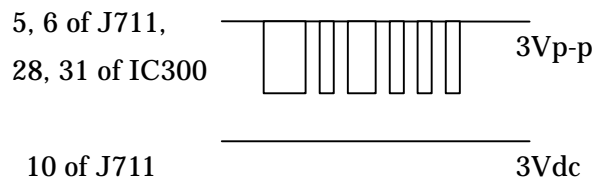

NO

IC300 (and peripheral circuits) are out of order. **(PWB-MAIN)**

YES

Is sound signal outputted correctly at the pins 10, 12, 8 of J710 connector?
? It checks that a certain signal is outputting in the voltage range of 1V.

NO

IC100 (and peripheral circuits) are out of order. **(PWB- SET(SUB))**

YES

IC701 and IC710 and IC711 and IC712 (and peripheral circuits) are out of order. **(PWB-MAIN)**

4. Other faults.(It applies both LT-30XX and LT-22XX)

Notes) It considers the case where there are problems except 1, 2, 3.

4-1. Remote control is not effective.

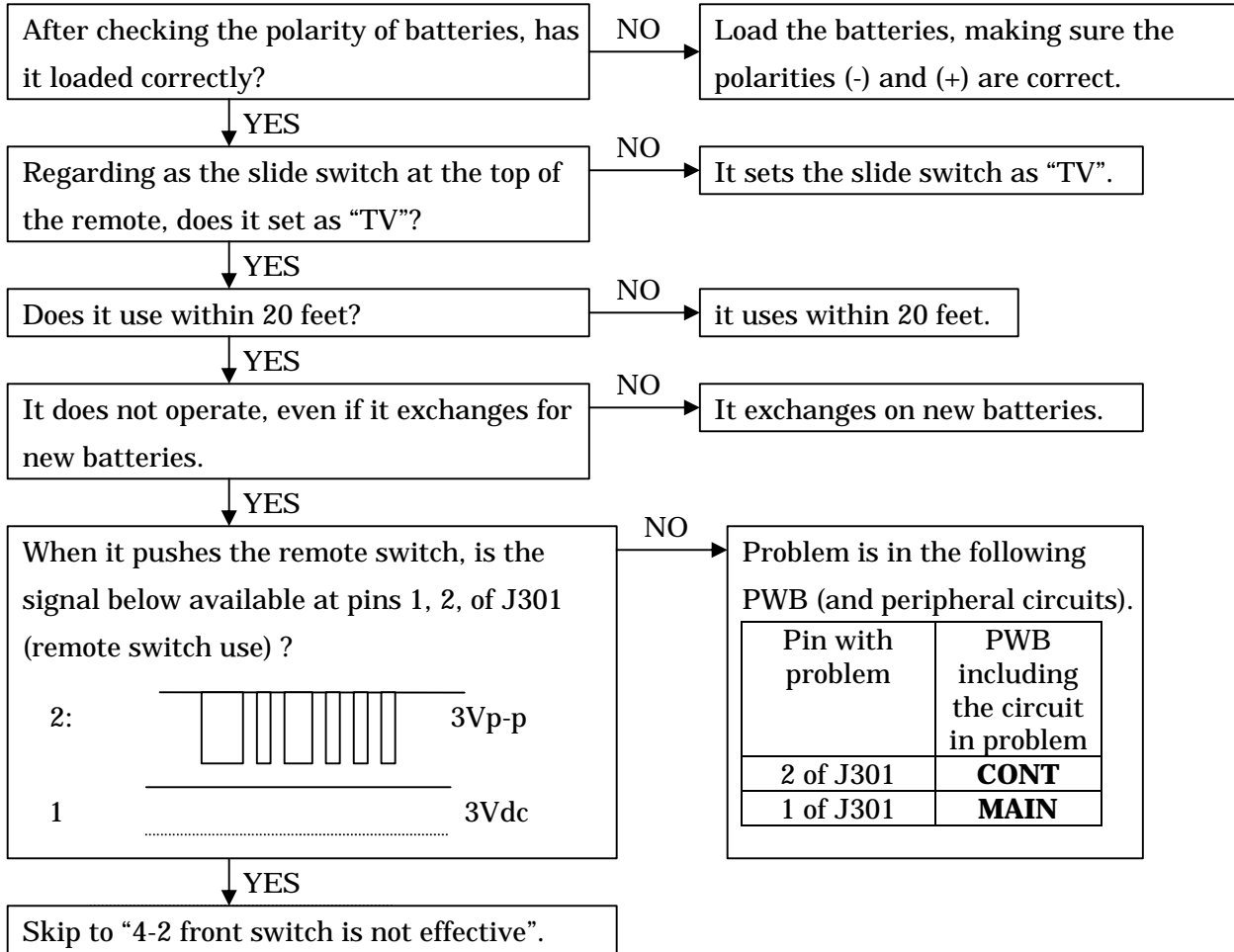

4-2. Front switch is not effective.

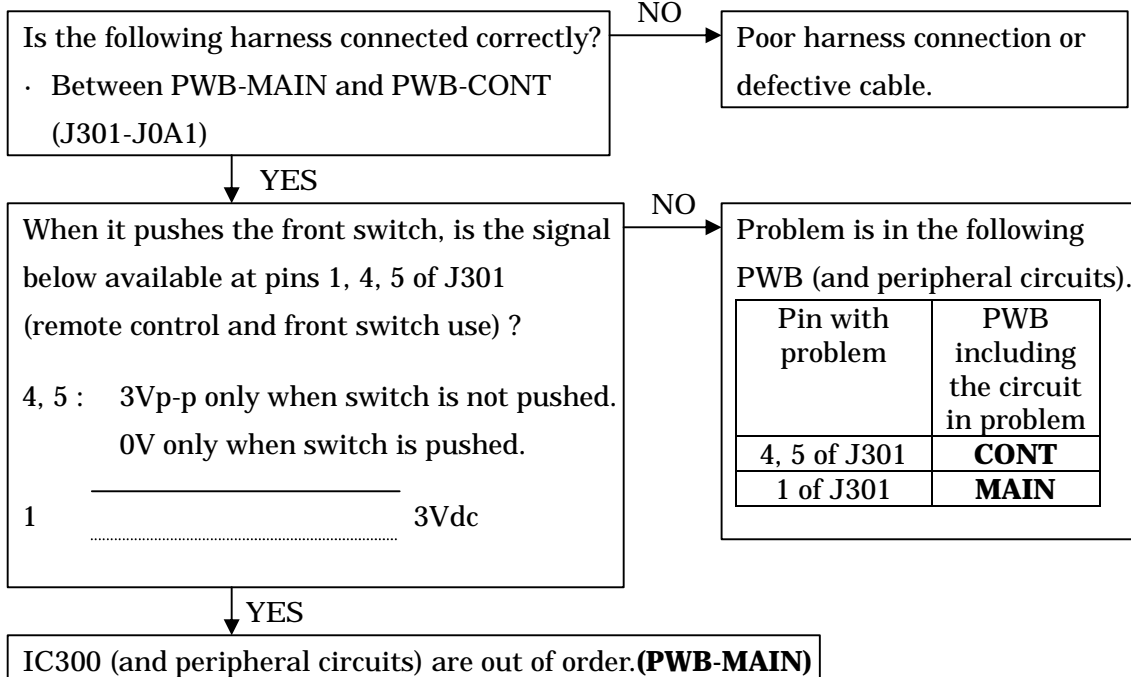

MODELS: LT-2220 / LT-2240 / LT-3020 / LT-3040 / LT-3050

LT-2220 PARTS LIST

Part Number	Description
7A930032	AC-ADAPTER (SEB150P2-20.0B)
25327981	BACK-UNIT (CABINET-BACK LT2220/2240)
08LA10AE	BEZEL (INCLUDES INNER BEZEL & PLATE)
25327921	BEZEL-INNER (LC-T2220)
25327971	BEZEL-UNIT (LC-T2220 GRY)
7A081023	CORD-POWER (1.9M 2P BLK)
25435861	COVER-LEFT
25435911	COVER-REAR (CLEAR)
25435851	COVER-RIGHT
25435881	COVER-TERMINAL LEFT
25435871	COVER-TERMINAL RIGHT
3A684043	LCD (AA220TA01) T/A REQUIRED
3A681009	LED (SML78420C)
PWB-CONTROL LT2220	PWB-CONTROL/LED T/A REQUIRED
8BL61M12	PWB-MAIN (LT-2220) T/A REQUIRED
PWB-SUB LT2220	PWB-SUB T/A REQUIRED
PWB-TUNER LT2220	PWB-TUNER T/A REQUIRED
7A930037	REMOTE(EUR7616Z20/Z2A)
3A290003	REMOTE-RECEIVER (GP1UD263XK)
7A930033	SPEAKER-UNIT(ST-220-1)
25261691	STAND-UNIT (GREY)
7A930029	TUNER (115V VF045AR)
7A930030	UNIT-INVERTER (J191007.00)

LT-2240 PARTS LIST

Part Number	Description
7A930032	AC-ADAPTER (SEB150P2-20.0B)
25327981	BACK-UNIT (CABINET-BACK LT2220/2240)
08LA10AE	BEZEL (INCLUDES INNER BEZEL & PLATE)
25327973	BEZEL-UNIT (LC-T2240 GRY)
79PQ6640	CORD-POWER (1.9M 2P BLK)
25435861	COVER-LEFT
25435911	COVER-REAR (CLEAR)
25435851	COVER-RIGHT
25435881	COVER-TERMINAL LEFT
25435871	COVER-TERMINAL RIGHT
3A684064	LCD (LC56XWC8V-02) T/A REQ
3A681009	LED (SML78420C)
PWB-CONTROL LT2240	PWB-CONTROL/LED T/A REQUIRED
8BL63M15	PWB-MAIN (LT-2240) T/A REQUIRED
PWB-SUB LT2240	PWB-SUB T/A REQUIRED
PWB-TUNER LT2240	PWB-TUNER
79PQ6596	REMOTE
3A290003	REMOTE-RECEIVER (GP1UD263XK)
7A930033	SPEAKER-UNIT(ST-220-1)
25261691	STAND-UNIT (GREY)
7A930029	TUNER (115V VF045AR)
79PQ6630	UNIT-INVERTER (J191007.01)

LT-3020 PARTS LIST

Part Number	Description
25327961	BACK-UNIT
08LB10AE	BEZEL (INCLUDES INNER BEZEL & PLATE)
25327891	BEZEL-INNER (LC-T3020)
7A081022	CORD-POWER (2.0M 2P BLK)
25435841	COVER-CORD
25435861	COVER-LEFT
25435831	COVER-REAR
25435851	COVER-RIGHT
25435881	COVER-TERMINAL LEFT
25435871	COVER-TERMINAL RIGHT
25327951	FRONT-CABINET (W/BUTTONS LT-3020)
3A684029-M	LCD (LC300W01 A3 LGPL) T/A REQ
3A681009	LED (SML78420C)
25620101	PLATE (COSMETIC LC-T3020)
7A930031	POWER-UNIT (HS210N2J)(T/A REQ)
PWB-CONTROL LT3020	PWB-CONTROL/LED T/A REQUIRED
8BL71M12	PWB-MAIN (LT-3020) T/A REQUIRED
PWB-SUB LT3020	PWB-SUB T/A REQUIRED
PWB-TUNER LT3020	PWB-TUNER T/A REQUIRED
7A930037	REMOTE(EUR7616Z20/Z2A)
3A290003	REMOTE-RECEIVER (GP1UD263XK)
7A930034	SPEAKER-UNIT(ST-300-1)
25261681	STAND-UNIT (GREY)
7A930029	TUNER (115V VF045AR)

LT-3040 PARTS LIST

Part Number	Description
25327961	BACK-UNIT
08LB10AE	BEZEL (INCLUDES INNER BEZEL & PLATE)
25327952	BEZEL-UNIT
7A392043	CABLE-ANT(BLACK RF-RF)
79PQ6612	CORD-POWER(2.0M 2P BLK)
25435841	COVER-CORD
25435861	COVER-LEFT
25435831	COVER-REAR
25435851	COVER-RIGHT
25435881	COVER-TERMINAL LEFT
25435921	COVER-TERMINAL RIGHT
3A684029-M	LCD (LC300W01 A3 LGPL) T/A REQ
3A681009	LED (SML78420C)
7A930031	POWER-UNIT (HS210N2J)(T/A REQ)
PWB-CONTROL LT3040	PWB-CONTROL/LED T/A REQUIRED
8BL73M15	PWB-MAIN (LT-3040) T/A REQUIRED
PWB-SUB LT3040	PWB-SUB T/A REQUIRED
PWB-TUNER LT3040	PWB-TUNER T/A REQUIRED
79PQ6596	REMOTE
3A290003	REMOTE-RECEIVER (GP1UD263XK)
7A930034	SPEAKER-UNIT(ST-300-1)
25261681	STAND-UNIT (GREY)
7A930029	TUNER (115V VF045AR)

LT-3050 PARTS LIST

Part Number	Description
08LB20AE	BEZEL (INCLUDES INNER BEZEL & PLATE)
3A684029-M	LCD (LC300W01 A3 LGPL) T/A REQ
8BL72M15	PWB-MAIN (LT-3050) T/A REQUIRED
25327961	BACK-UNIT
25327952	BEZEL-UNIT
7A392043	CABLE-ANT(BLACK RF-RF)
79PQ6612	CORD-POWER(2.0M 2P BLK)
25435841	COVER-CORD
25435861	COVER-LEFT
25435831	COVER-REAR
25435851	COVER-RIGHT
25435881	COVER-TERMINAL LEFT
25435921	COVER-TERMINAL RIGHT
3A681009	LED (SML78420C)
7A930031	POWER-UNIT (HS210N2J)(T/A REQ)
PWB-CONTROL LT3050	PWB-CONTROL/LED T/A REQUIRED
PWB-SUB LT3050	PWB-SUB T/A REQUIRED
PWB-TUNER LT3050	PWB-TUNER T/A REQUIRED
79PQ6618	REMOTE
3A290003	REMOTE-RECEIVER (GP1UD263XK)
7A930034	SPEAKER-UNIT(ST-300-1)
25261681	STAND-UNIT (GREY)
7A930029	TUNER (115V VF045AR)

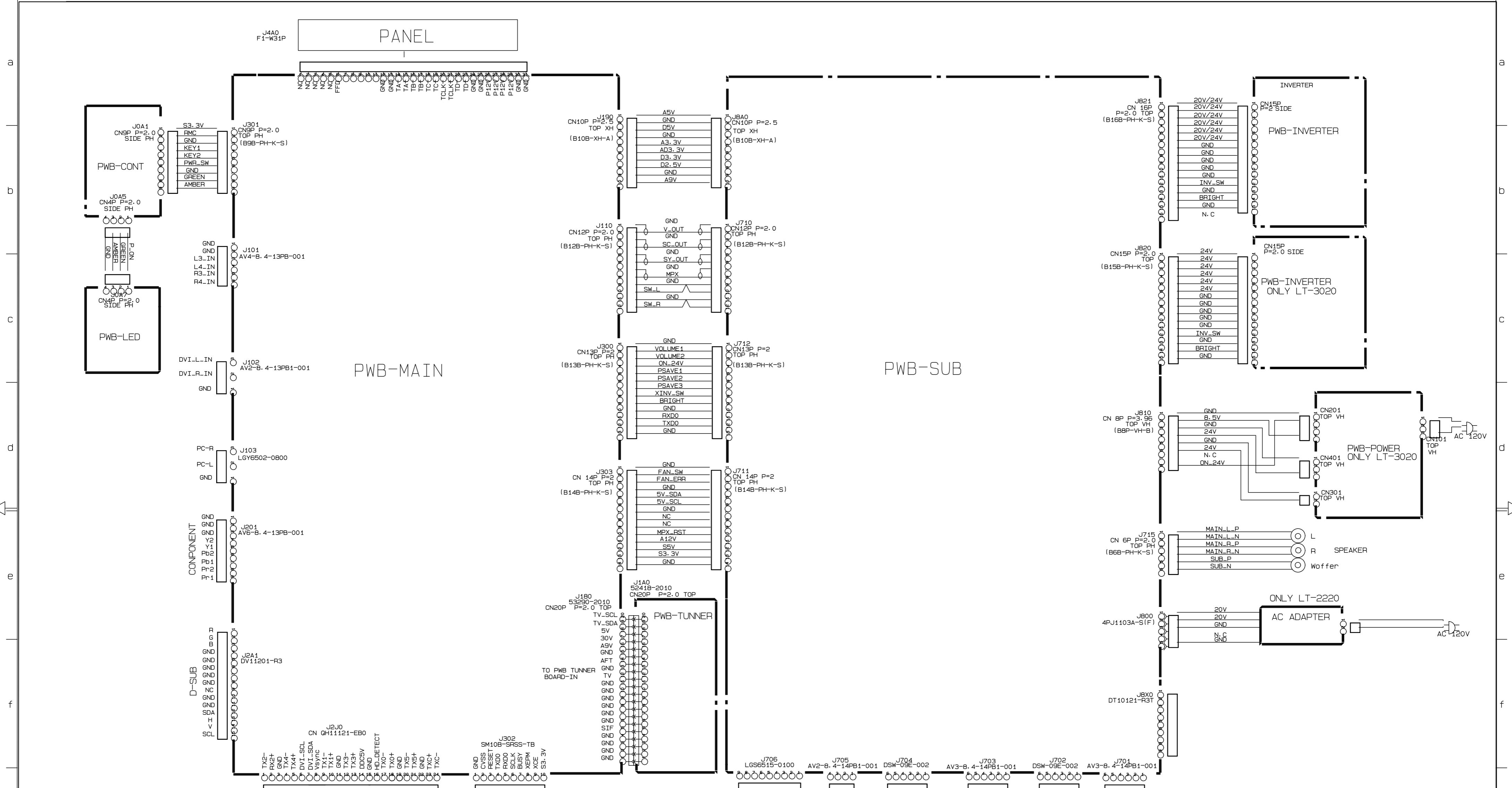

NO.	REV.	DESCRIPTION	DATE
2		LT-30	
1		LT-22	

改定 CHANGE MARK	制 MARK	品番 ITEM	規格		MATERIAL AND DIMENSIONS	(MI) UNIT CODE	UNIT	REVISION NO.	APP. FROM	REMARK
								5 ~		摘

第 3 角法 3RD ANGLE PROJECTION DIM IN mm 大 尺 度 SCALE 作成日 DATE 2003.4.14

名 SCHEMATIC-DIAGRAM (1/)

25 26 27 28 29 30 31

MP

作成 照査 設計 検定

DRAWN CHECKED DESIGNED APPROVED

改定 CHANGE