

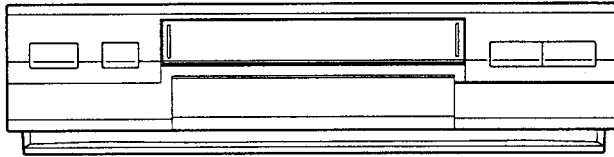

Service Manual

VIDEO CASSETTE RECORDER



HS-M10

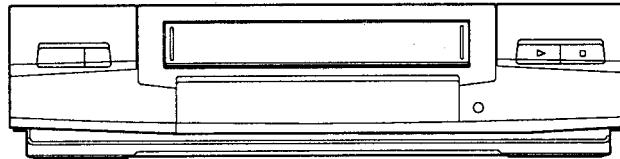

HS-M20

VHS
PAL

MODEL

HS-M10V(B)
HS-M20V(B)
HS-M20V(G)
HS-M20V(IR)

Only cassettes marked VHS can be used with this video cassette recorder.

SPECIFICATION

Tape Format	: VHS 1/2" high-density video cassette tape	Video Input	: 0.75 to 1.5Vp-p, 75Ω unbalanced EURO AV socket
Power Source	: AC 230V ; 50Hz	Audio Input	Line : -8dBs, 50kΩ unbalanced EURO AV socket
Power Consumption	: Approx. 29W	Video Output	: 1.0Vp-p, 75Ω unbalanced EURO AV socket
Television System	: 625lines, 50fields System CCIR I PAL [B,IR] System CCIR B&G PAL [G]	Audio Output	: -6dBs, 1kΩ unbalanced EURO AV socket
Video Recording System	: Azimuth helical scanning system	TV Tuner	VHF : 47~89MHz, 104~470MHz [G] 44~89MHz, 104~300MHz [IR] UHF : 470~870MHz
Luminance	: Frequency modulation recording	Operating Temperature	: 5°C to 40°C
Colour Signal	: Low frequency conversion subcarrier phase shift recording	RF Channel Output	: Set to Channel 38 [IR]/ Channel 36 [B,G], (Channel 32~40 selectable)
Linear Audio Track	: 1 track	Weight	: Approx. 5.0kg
Tape Speed	: 23.39mm/sec(PAL SP mode) 11.70mm/sec(PAL LP mode) [M10V(B)/M20V(B)/M20V(IR)]	Dimensions	: 380(W)×94(H)×326(D)mm
Record/Playback Time	: 240min. with E-240 cassette (PAL SP mode) 480min. with E-240 cassette (PAL LP mode) [M10V(B)/M20V(B)/M20V(IR)]	Timer	: 8 programmes for any channels in one month/every day/every week day 24 hour digital synchronized with oscillator frequency.
Heads:Video	: 2 rotary heads	Channel Selection	: 100 position Up/Down + EXT
Audio/Control	: 1 stationary head	Deck	: J Deck
Erase	: 1 full track head		

●Weight and dimensions shown are approximate.

●Design and specifications are subject to change without notice.

CONTENTS

DISASSEMBLY	1
HOW TO EXECUTE CIRCUIT BOARD SERVICE	3
MECHANICAL ADJUSTMENT TOOLS	7
ELECTRICAL ADJUSTMENT TOOLS	8
HOW TO INITIALIZE E²PROM	9
PROVIDING DUMMY SIGNAL FOR SERVICE	
POSITION [B] AND [C]	9
SERVICE POSITION	10
ELECTRICAL ADJUSTMENTS	11
Servo Circuit Adjustment	13
Y/C signal Circuit Adjustments	13
Audio Circuit Adjustments	16
Timer Circuit Adjustments	17
MECHANICAL ADJUSTMENT AND	
REPLACEMENT	18
1. Cleaning of Deck	18
1-1 Video Head	18
1-2 Tape Transport	18
1-3 Reel Disk Drive System	18
2. Replacement of Major Parts	19
2-1 Cassette Housing	19
2-2 Sense Gear, Driver Gear, Takeup Arm, and Arm Spring(TU)	20
2-3 Door Arm	22
2-4 Gear S and Gear T	22
2-5 Wheel Gear	23
2-6 Supply Arm and Arm Spring(SP)	23
2-7 Jut	26
2-8 PCB-HEAD-AMP	26
2-9 Brush	27
2-10 Drum Assembly	27
2-11 Upper Drum and Drum Motor	29
2-12 Safety Spring and Safety Lever	30
2-13 Safety Arm	31
2-14 Sub Brake(SP) and Sub Spring(SP)	31
2-15 Main Brake(SP) and Main Spring(SP)	32
2-16 Sub Off Lever, Sub Brake(TU), and Sub Spring(TU)	33
2-17 Main Brake(TU) and Main Brake Spring J(SP)	34
2-18 ID Swing Lever, Revolution Lever, and Revolution Spring	34
2-19 Tension Arm, Tension Brake Belt, and Tension Spring	35
2-20 Takeup Reel Disk and Gear R (Takeup side)	37
2-21 Supply Reel Disk	38
2-22 Gear R(supply side)	39
2-23 Main Brake Release Lever	40
2-24 Pinch Cam Cap, Pinch Roller Arm Assem- bly, Pinch Roller Cam, Takeup Guide Gear, Gear Pinch, Takeup Guide Arm, and Takeup Guide Spring	41
2-25 Pinch Roller, Roller Cap, Pinch Spring, and Pinch Cam Spring	43
2-26 Mode Switch	44
2-27 FE Head	45
2-28 Reel Belt and Belt Pulley	45
2-29 Loading Motor Assembly, Pulley Worm J, Loading Motor Belt, and Gear A	46
2-30 Main Gear J	47
2-31 Gear Joint J	48
2-32 Capstan Brake and Capstan Brake Spring	49
2-33 Plate J, Roller B, and Cam Plate B	50
2-34 Cam Gear R Change Lever, and Tension Off Lever	51
2-35 Reel Idler Assembly	52
2-36 Cam Plate C and Cam Spring C	53
2-37 Loading Arm(SP, TU)	54
2-38 Capstan Motor and Lead Card	55
2-39 A/C Head Assembly	56
2-40 A/C Head	57
2-41 Supply & Takeup Guide Rollers	58
2-42 Cleaning Roller, Cleaning Arm, Cleaning Lever, and Cleaning Spring	59
2-43 Supply & Takeup Tape Guide Assemblies	60
2-44 Drum base spring	61

CONTENTS

3. Interchangeability Adjustment of Mechanism	62
3-1 Adjustment of Back-Tension and Tension Pole Position	62
3-2 Check and Adjustment of FM Envelope	63
3-2-1 Guide Roller Adjustment	63
3-2-2 Adjustment of Supply Guide Roller Height ..	63
3-2-3 Adjustment of Takeup Guide Roller Height ...	63
3-2-4 Coarse Adjustment of Phase	64
3-2-5 Check of FM Waveform Flatness	64
3-2-6 Check 1:Tape Running Condition on Guide Rollers	65
3-2-7 Replacement of Tape Guides	65
3-2-8 Check 2:Tape Running Condition on Guide Rollers	65
3-3 Adjustment of A/C Head	66
3-3-1 Adjustment of A/C-Head Slant	66
3-3-2 Adjustment of A/C-Head Azimuth and Height	66
3-4 Adjustment of Phase	67
3-5 Adjustment of Takeup Guide Arm Height	68
4. Servicing Tape Jamming during the Loading Mode.....	69
(1) If the tape guides do not move (the pulley worm J does not turn);	69
(2) If the tape guides move (the pulley worm J turns);	72

SPECIFICATION OF VPS RECORDING

SYSTEM	73
GLOSSARY OF ABBREVIATIONS	74
CHIP PARTS REPLACEMENT	75
Parts List.....	76
1. CABINET ASSEMBLY	76
2. PACKING PARTS	78
3. ELECTRICAL PARTS	80
4. DECK ASSEMBLY	

DISASSEMBLY

Note: Any screw can be used between 669D448030 securing the boss of the molded parts(silver) and 669D220030 (preferred part) for replacement because they are compatible with each other in service.

1. Removal of Top Cover

- ① Remove the two Top Cover fastening screws (a) and (b) shown in Fig. 1 and remove the Top Cover in the direction shown by the arrows.

2. Removal of Front Panel

- ① Remove the Top Cover referring to Para. 1 of the DISASSEMBLY.
- ② Unfasten seven catches (c~i), two on the top, two on the side, and three on the bottom, and remove the Front Panel in the direction shown by the arrows.

3. Removal of Bottom Cover

- ① Remove five fastening screws (a~e) shown in Fig. 2.
- ② Push the two inside hooks (f and g), holding the Bottom Cover and slide the Bottom Cover toward the rear to remove it.

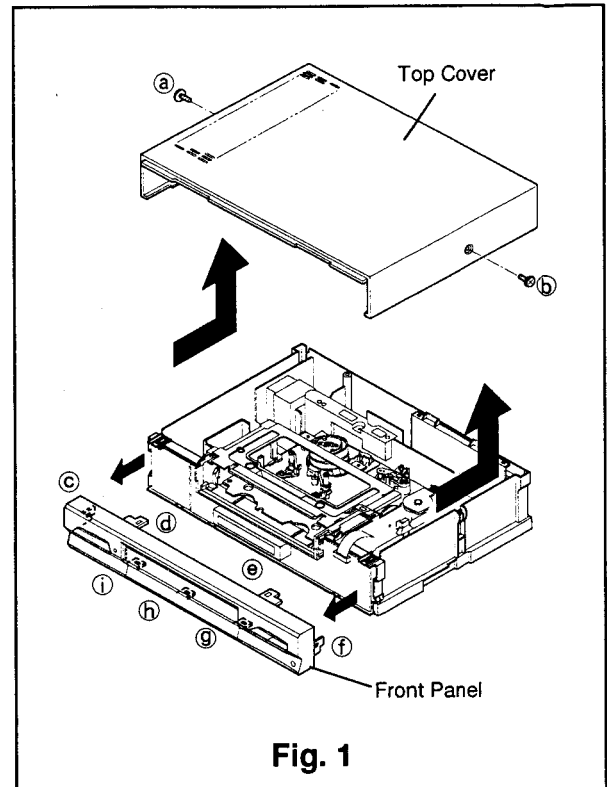

Fig. 1

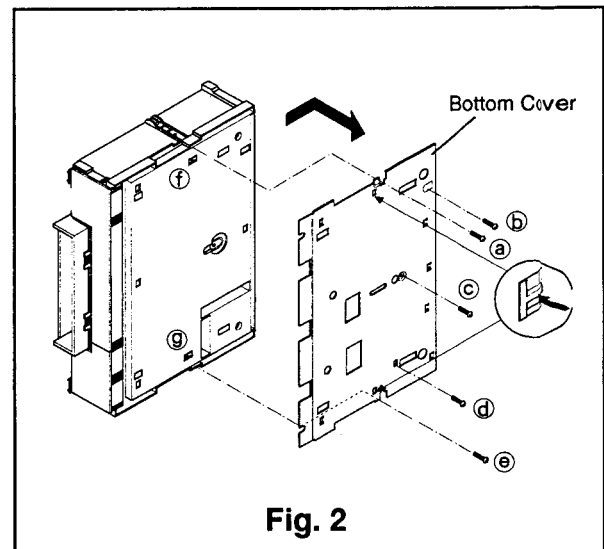
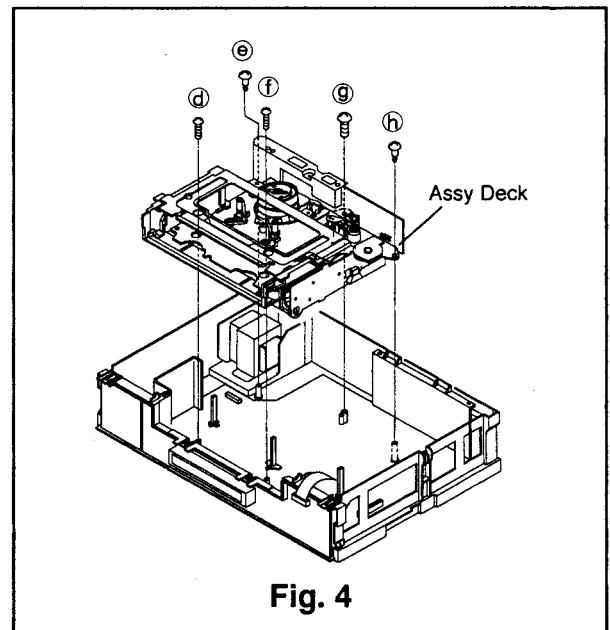
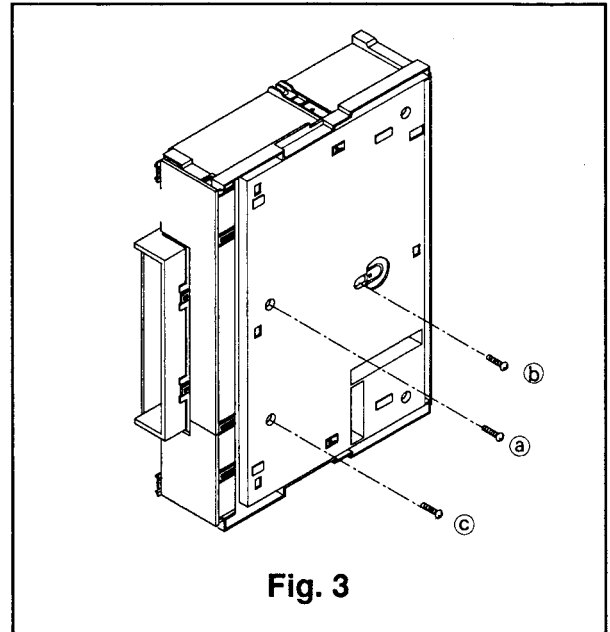

Fig. 2

4. Removal of Assy Deck

- ① Remove the Top Cover referring to Para. 1 of the DISASSEMBLY.
- ② Remove the three fastening screws (a), (b) and (c) on the bottom of the set shown in Fig. 3.
- ③ Remove the five screws (d)~(h) holding the Assy Deck, shown in Fig.4, and disconnect the connectors **ML**, **MM** and **ME**.
- ④ Slowly raise slowly the Assy Deck upward to remove it.



5. Removal of Barrier

- ① Pull the part (a) of the barrier and remove it, as shown in Fig. 5.
- * **Caution in installation.**
Insert a convex part of the barrier into a slit that is side of Assy Deck. And put the other of the barrier in at the inside of the partition.

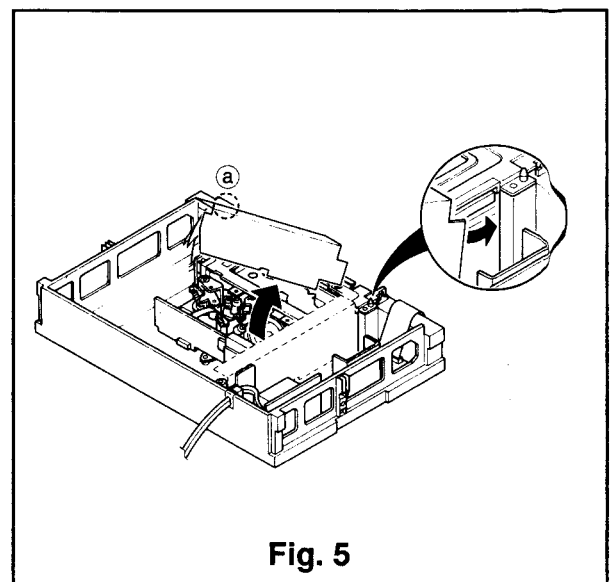

HOW TO EXECUTE CIRCUIT BOARD SERVICE

CAUTION: BEFORE ATTEMPTING TO REMOVE OR REPAIR ANY PCB, UNPLUG THE POWER CORD FROM THE A.C. SOURCE.

LOCATION OF PRINT CIRCUIT BOARDS

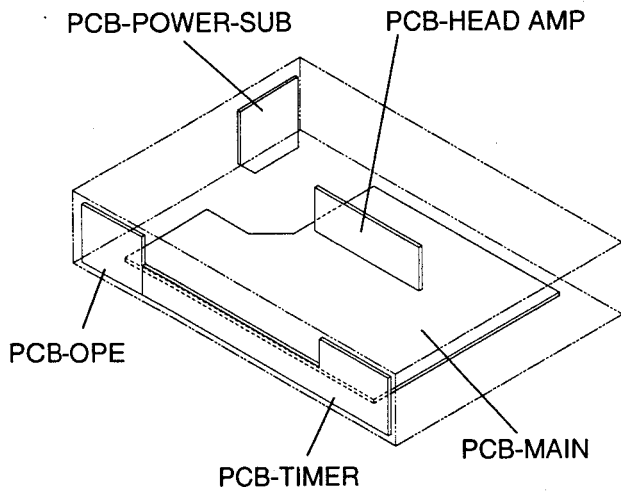

Fig. 6A
[HS-M10V(B)/M20V(IR)]

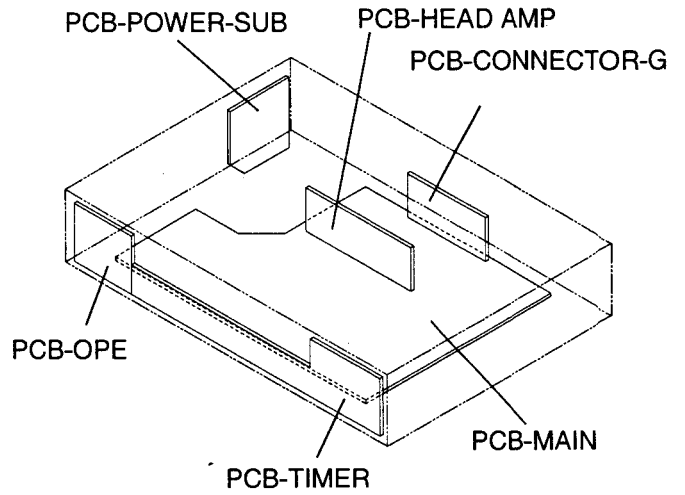

Fig. 6B
[HS-M20V(G)]

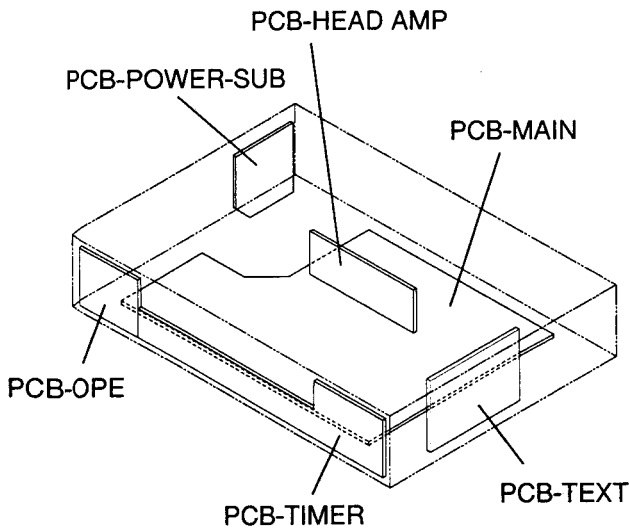

Fig. 6C
[HS-M20V(B)]

Note:

- Take caution when removing flat cables to prevent any contact problem.
- Connect and disconnect the flat cables at right angles with the connector and make sure that it is completely secured.
- After servicing the PCB, restore the flat cable and leads to their former state.

1. PCB-MAIN

- ① Remove the Top Cover referring to Para. 1 of the DISASSEMBLY. Servicing on the components side is partially possible.
- ② Remove the Front Panel referring to Para. 2 of the DISASSEMBLY, and remove eight fastening screws referred to ②, ③ in Para. 4 of the DISASSEMBLY. (Do not disconnect the connector **ML**.)
- ③ Raise the front side of the Assy Deck upward as shown in Fig. 7 and support it with a screw driver, etc. Servicing on the components side is now possible.
- ④ If necessary, remove the Assy Deck refer to Para. 4 of the DISASSEMBLY. Remove one fastening screw (a) on the bottom and two fastening screws (b and c) on the Antenna Terminal Board shown in Fig. 8 and raise the PCB-MAIN upward to remove it.

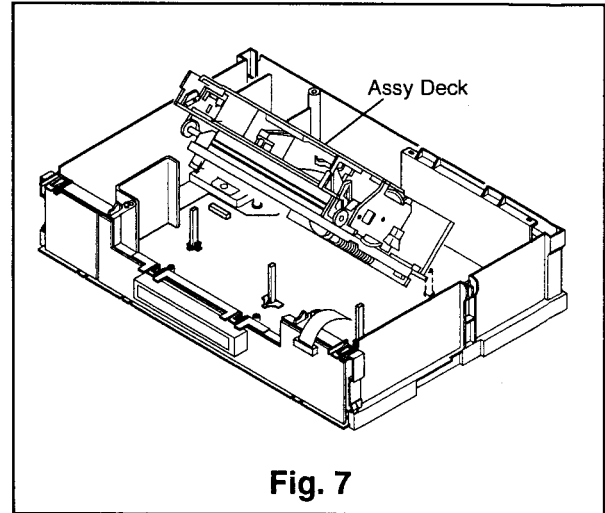

Fig. 7

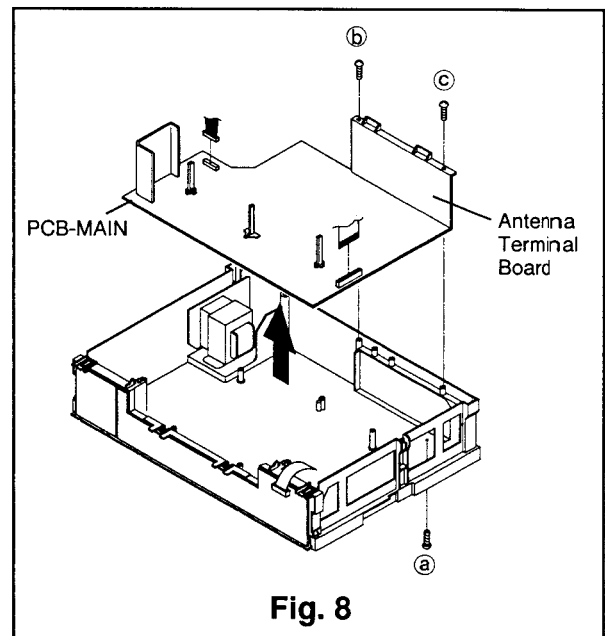

Fig. 8

2. PCB-TIMER/OPE

- ① Remove the Top Cover referring to Para. 1 of the DISASSEMBLY.
- ② Remove the Front Panel, refer to Para. 2 of the DISASSEMBLY.
- ③ Remove six catches (a~f) shown in Fig. 9 to remove the PCB-TIMER/OPE.

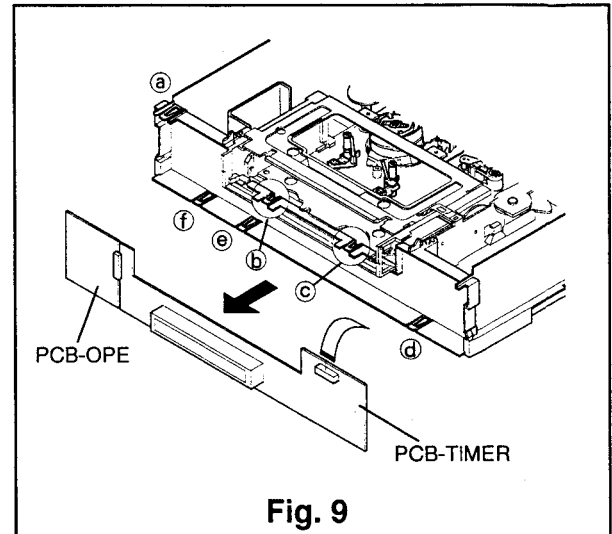

Fig. 9

3. PCB-HEAD AMP

- ① Remove the Top Cover referring to Para. 1 of the DISASSEMBLY. Servicing on the copper side is possible.
- ② If necessary, remove the Assy Deck, refer to Para. 4 of the DISASSEMBLY. Raise the SHIELD-PLATE - HAK upward to remove it. Disconnect three terminals (a,b and c), remove three fastening screws (d,e and f) shown in Fig. 10 and disconnect the connectors of Head FE, A/C Head, and Motor CP to remove the PCB-HEAD AMP.

Note: For HS-M20V(G)

Remove three screws (g,h and i) shown in Fig.10 and raise the shield-drum upward to remove it.

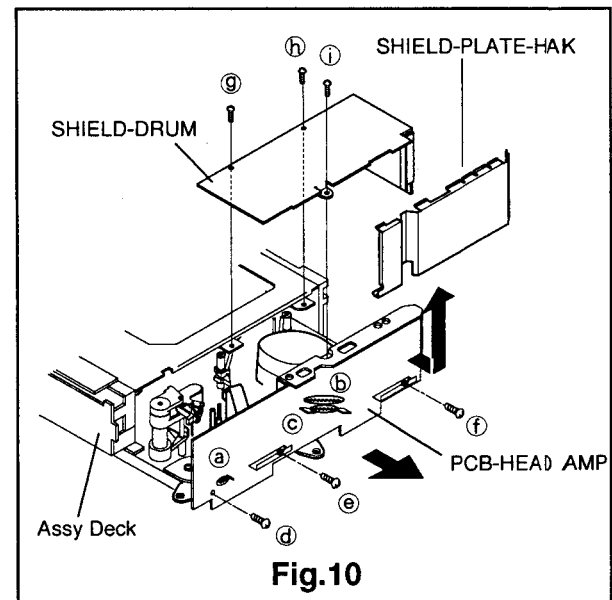

Fig.10

4. PCB-POWER-SUB

- ① Remove the Top Cover referring to Para. 1 of the DISASSEMBLY.
- ② Remove one fastening screw (a) on the bottom shown in Fig. 11 and two screws (b and c:669D221O40) holding the transformer, and raise the PCB-POWER-SUB to remove it.

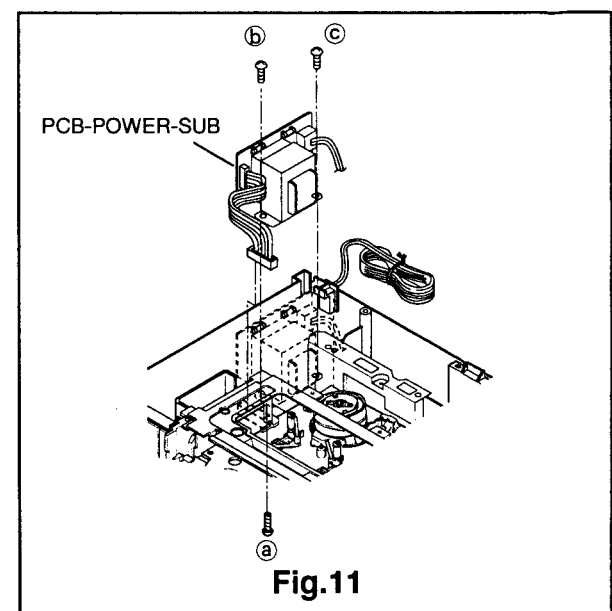

Fig.11

5. PCB-CONNECTOR-G

- ① Remove the Top Cover referring to Para. 1 of the DISASSEMBLY.
(Servicing for the solder side of PCB-CONNECTOR-G is available.)
- ② If it is necessary to remove the PCB-CONNECTOR-G, comply with the following steps.
 - (1) Remove the PCB-MAIN referring to the preceding paragraph.
 - (2) Remove four screws (a), (b), (c) and (d), unfasten five catches (e)~(i) on the Antenna Terminal Board as shown in Fig.12, and remove the Antenna Terminal Board.
 - (3) Raise the PCB-CONNECTOR-G upward to remove it.

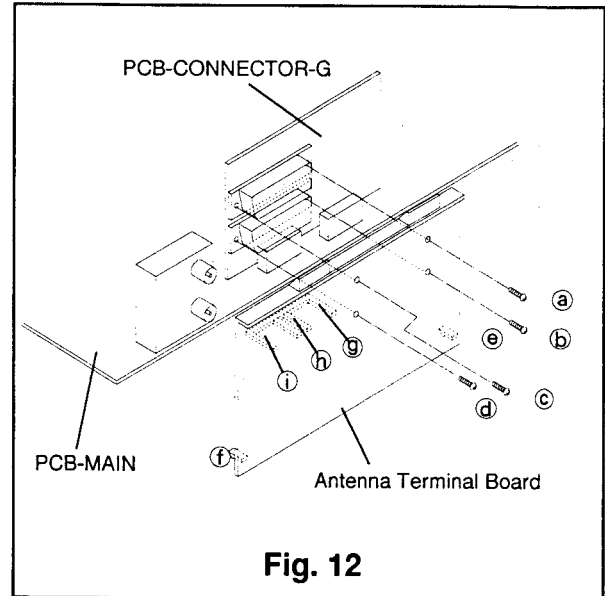

Fig. 12

6. PCB-TEXT

- ① If it is necessary to remove the PCB-TEXT, comply with the following steps.
 - (1) Remove a screw (a) and unfasten two snaps (b) and (c) as shown in Fig. 13.
 - (2) Disconnect the connector (EP) and raise the PCB-TEXT upward to remove it.

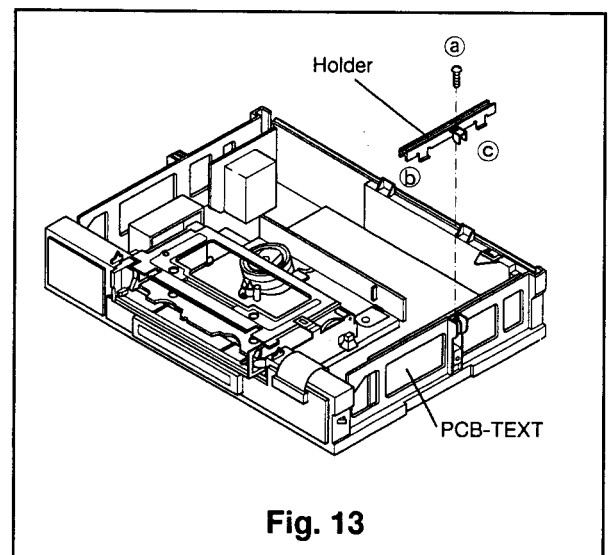
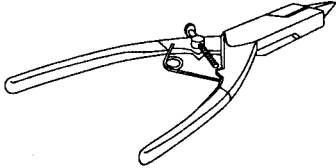
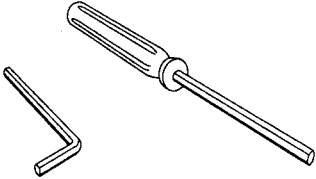
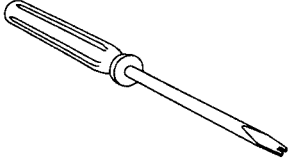
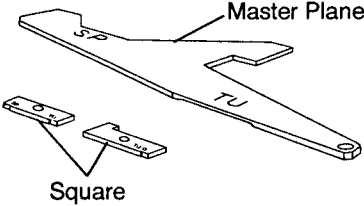
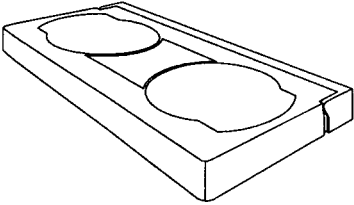

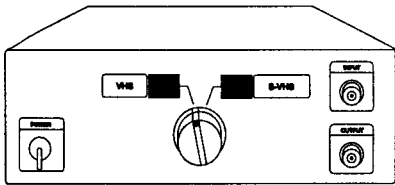
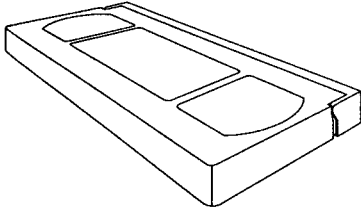

Fig. 13

MECHANICAL ADJUSTMENT TOOLS

	PURPOSE	METHOD
Grip ring fixer (859C347O50) 	A tool for preventing the grip ring from opening excessively.	Opening the grip ring with the tips of this tool, install the grip ring on to the shaft.
Hex Keys(1.5mm)  (859C259O20) (859C259O50)	The hex keys are used for tightening or removing hexagonal socket head screws which fasten the guide rollers.	Insert the given size(1.5mm) hexagonal socket and turn.
Adjustment Driver (859C259O80) 	For adjustment of guide rollers.	Carefully insert and adjust guide rollers.
Height adjusting Jig • Master Plane (859C342O20) • Square (859C341O70) 	The master plane and the square are used for measuring height and perpendicularity of the reel disk and Takeup guide arm.	The gauge is applied to the part being measured.
Back Tension Gauge (859C345O80) 	The back tension gauge is used for measuring the tension of the tape on the supply side.	Load this gauge in the cassette housing and run in the play mode. Read the gauge indicator.
Cotton gloves	For changing, cleaning and handling of drum, heads and guides.	Use when handling all parts in the tape path.
Grease PG641 (859D055O30) G (859D055O50)	Lubrication of various parts.	To be applied as specified.

ELECTRICAL ADJUSTMENT TOOLS

	PURPOSE	METHOD
<p>Adjustment Driver (859C338O00)</p> <p>767-M</p> 	<p>The adjustment driver is intended to adjust variable resistors, trimmers, transformers etc.in the circuitry.</p>	<p>Select a tip suitable for the particular head of the component concerned and adjust.</p>
<p>Carrier Checker (859C346O50)</p> 	<p>Used for the adjustment or inspection of the carrier set deviation.</p>	<p>Use in conjunction with the oscilloscope. For detail refer to the service manual.</p>
<p>Alignment Tape</p> <p>(PS-2 :859C339O10)</p> <p>(PM6KH3 :859C339O30)</p> <p>(PM6KE2 35 :859C568O90)</p> <p>(PMX :859C568O70)</p> 	<p>Standard signals(VHS Standard) are recorded on the alignment tape and reproduced when required in the adjustment of Y/C circuit, audio circuit and interchangeability alignment.</p>	<p>Install and run in the play mode, the same as for an ordinary tape.</p>
<p>Record Current Adjustment Jig (859C347O80)</p>	<p>For Y/C Recording Level.</p>	<p>For Y/C Recording Level adjustment.</p>

HOW TO INITIALIZE E²PROM

E²PROM is initialized before shipping, so E²PROM must be initialized when replaced.

Initialize E²PROM following the step below.

1. Set the VCR to "Set the clock" mode.
2. Push COUNTOR RESET button on the remote hand unit for 8 seconds.

PROVIDING DUMMY SIGNAL FOR SERVICE POSITIONS [B] AND [C]

Refer to page 10 for Service Position Information.

■ Function check for PB, REC, FF and REW Mode

- Cover the Start and End Sensors with an Infra-red opaque material e.g. black vinyl tape etc..
- The reel sensor must provide input "rotating" signals to the microprocessor. To provide a dummy reel rotating signal, connect TP2H(Drum FF) to TP5J8 on PCB-MAIN.

NOTE:

- 1) Because the Start and End sensors are disabled there will be a risk of END of TAPE damage in REW and FF Modes.
- 2) When TAPE EJECT is necessary, disconnect the mains supply and reinstall the DECK ASSY to the Service Position [A], restore power then EJECT the tape.

■ Record Protection Method

- To protect TEST TAPE(s) from accidental Record (erasure) during testing, connect TP5B (STBY 5V) to TP5K4 on PCB-MAIN .

PCB-MAIN(Component side)

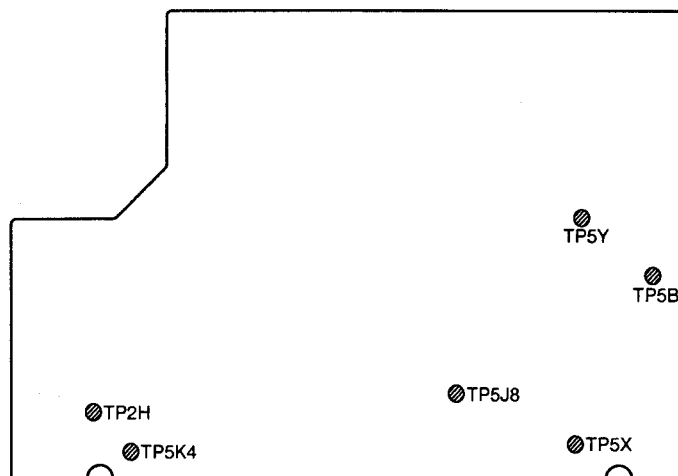

When replacing parts or performing service adjustments, place the unit in the service positions shown below. Refer to page 9 for additional information about Service Positions.

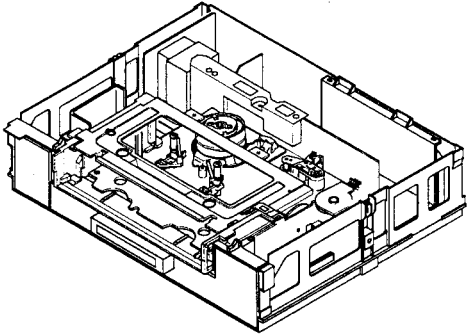
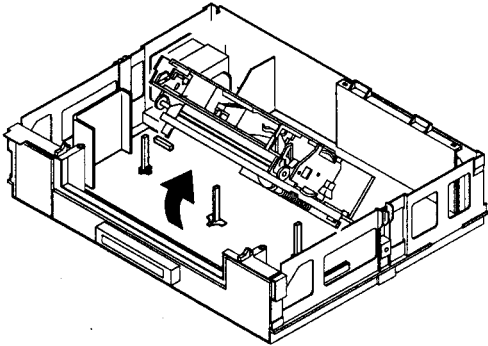
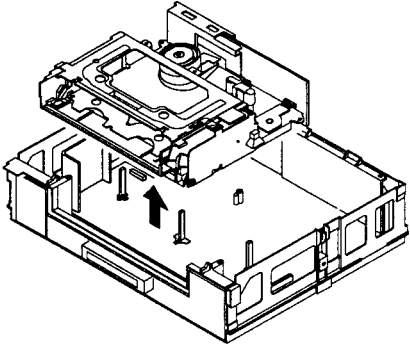
Service Position	Service Item
<p>(A)</p> 	<ul style="list-style-type: none"> • Remove the top cover and the front panel. (1) Worn parts on the deck(upper drum, pinch roller assembly, A/C head, and FE head) can be replaced. (2) Checks at test points may be made to isolate a problem to a specific circuit.
<p>(B)</p> 	<ul style="list-style-type: none"> • Remove the screw holding the deck, raise the front side of the deck upward, and hold it with a screw driver etc. (1) Worn parts on the deck(reel belt, idler assembly, and capstan motor) can be replaced. (2) The performance of the deck can be checked. • The REC safety switch does not operate in position(B). • Set the deck to service position (A) and load the cassette tape. Then turn the power off and set the deck to service position (B). Cover the start and end sensors and short-circuit test points TP2H to TP5J8. Turn the power on and play the tape. (Do not use the start or end portion of the tape.) • If it is necessary to eject the tape, turn the power off and set the deck to the service position (A). Turn the power on again and eject the tape.
<p>(C)</p> 	<ul style="list-style-type: none"> • Remove the screw holding the deck to disconnect the deck from the connector. (1) Parts on the deck(drum assembly, PCB-HEAD-AMP, loading belt etc.) can be replaced. (2) The EE picture can be displayed by short-circuiting TP5X to TP5Y. (Short-circuit before turning the power on.) (Playback and recording operation can not be checked.)

Electrical Adjustments

Perform only the alignments required. If proper equipment is not available, do not attempt an alignment.

■ Measuring equipment and Jigs

- Oscilloscope (Unless otherwise specified in particular, use it at 10:1 probes.)
- Signal generator
- Frequency counter
- Audio tester
- Direct current voltmeter
- Electrical tools

■ Test Signal

1). Monoscope signal

When you have no monoscope signal source for adjustment, connect the unit to a VCR and play an alignment tape (Monoscope).

2). Colour bar signal

In this manual, unless otherwise specified in particular, use colour bar signal in specifications below.

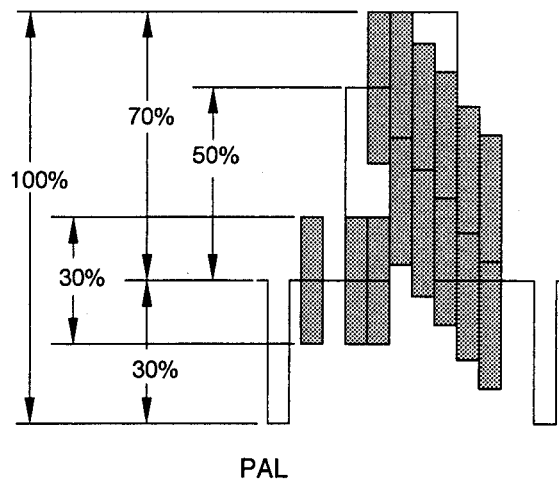

Split-Field colour bar (with 100% window)

LOCATIONS

PCB-MAIN(Component side)

REAR

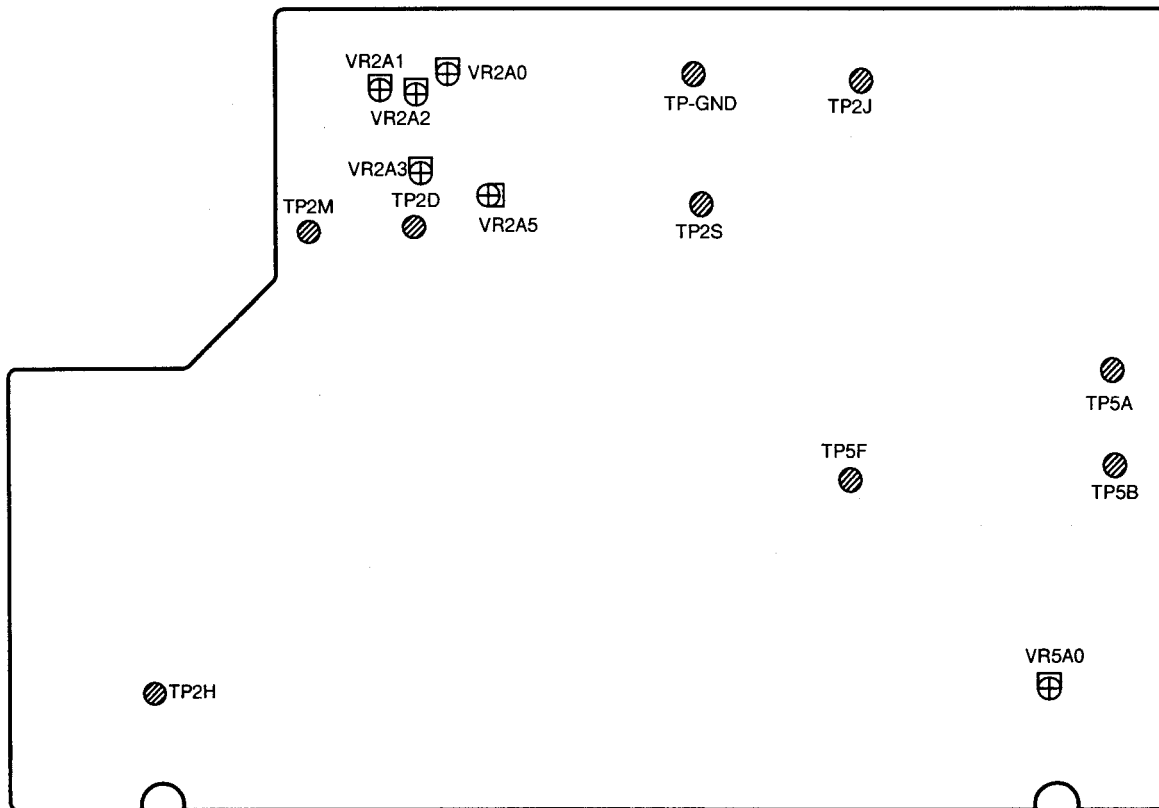

PCB-HEAD AMP(Component side)

TOP

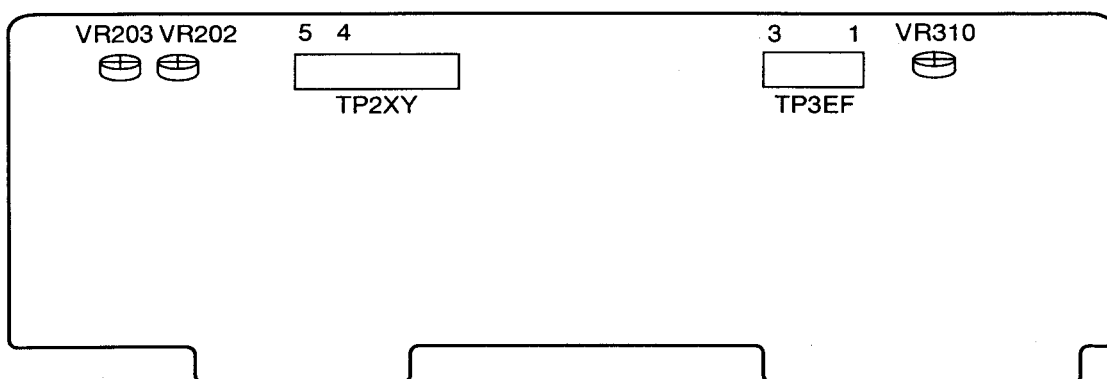

[Servo circuit] 1. Playback Switching Point		Adjustment purpose Video switch over timing during playback.	
		Symptom when incorrectly adjusted Switching noise or jitter in the playback picture.	
Measuring instrument and condition		VCR set up condition	
Oscilloscope		Input signal	—
Test point	TP2J	Using tape	Alignment tape (PS2, stair step)
EXT trigger	TP2H	VCR condition	Playback
Measurement range	DIV 20mV TIM 50 μ s	Using Jig	—

1. Play back an alignment tape(PS2, stair step).
2. Short-circuit TP5A and TP5B. Confirm that the "DTR" displayed in Fluorescent Display flashes fast.
3. Set the oscilloscope's slope to (-).
4. Observe the waveform at TP2J.
5. Adjust VR5A0 so that the trigger point is located at $6.5 \pm 1.0H$ before the vertical synchronizing signal.

PCB-MAIN (Component side)

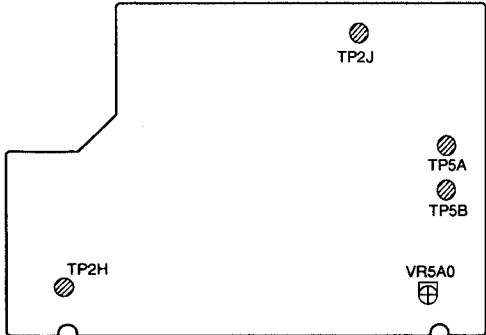
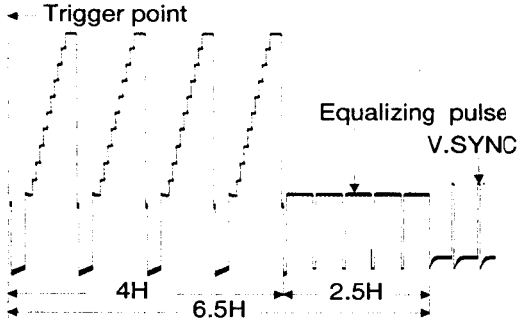
[Y/C signal circuit] 2. EE Output Level		Adjustment purpose Output level of signal at STOP mode.	
		Symptom when incorrectly adjusted Too bright or too dark image: incorrect colour.	
Measuring instrument and condition		VCR set up condition	
Oscilloscope		Input signal	RF signal (PAL colour bar)
Test point	TP2J	Using tape	—
EXT trigger	—	VCR condition	STOP
Measurement range	DIV 20mV TIM 10 μ s	Using Jig	—

1. Supply an RF signal(PAL colour bar).
2. Be certain that nothing is connected to the VIDEO OUT terminal.
3. Observe the waveform at TP2J.
4. Adjust VR2A0 so that the amplitude of the waveform is 1.0Vp-p.

PCB-MAIN (Component side)

[Y/C signal circuit] 3.Clamp		Adjustment purpose Set the level of video signal.	
		Symptom when incorrectly adjusted Blurred image, white streaking black streaking.	
Measuring instrument and condition		VCR set up condition	
Oscilloscope		Input signal	RF signal (PAL colour bar)
Test point	TP2D	Using tape	—
EXT trigger	—	VCR condition	STOP
Measurement range	DIV 10mV TIM 10 μ s	Using Jig	—

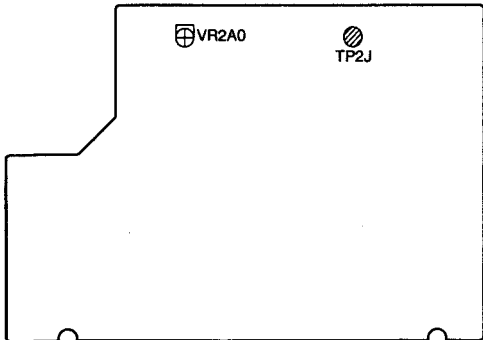
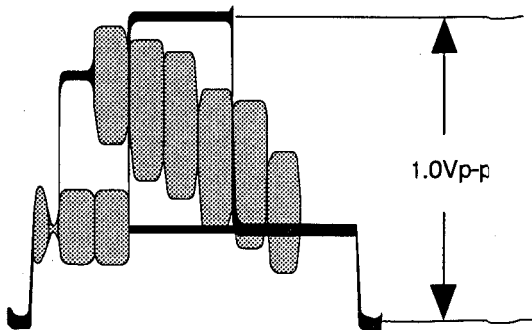
PCB-MAIN (Component side)



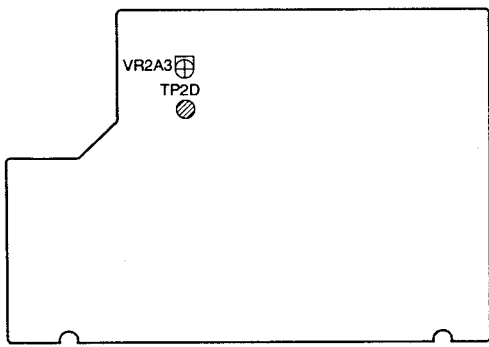

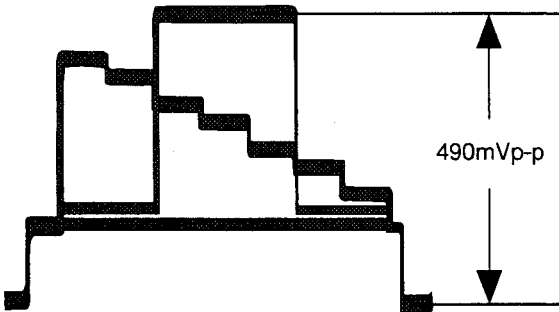
490mVp-p

[Y/C signal circuit] 4.Carrier set, Deviation		Adjustment purpose Set the FM carrier frequency and frequency deviation.	
		Symptom when incorrectly adjusted Too bright or too dark image: colour signal is to reproduced incorrectly. Horizontal noise or out of sync.	
Measuring instrument and condition		VCR set up condition	
Oscilloscope(Probe 1:1)		Input signal	RF signal (PAL colour bar)
Test point	TP2M	Using tape	—
EXT trigger	TP2S	VCR condition	STOP
Measurement range	DIV 0.2V TIM 10 μ s	Using Jig	Carrier checker

PCB-MAIN (Component side)

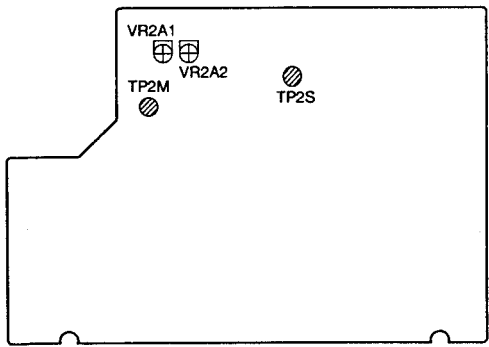

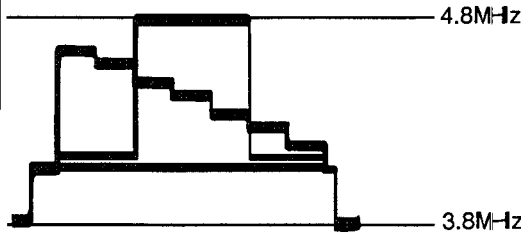

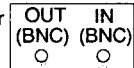

4.8MHz
3.8MHz

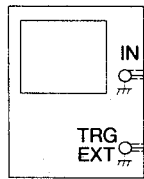

Carrier Checker



Oscilloscope



VCR (PCB-MAIN)

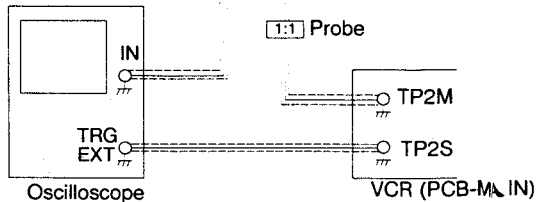

1:1 Probe

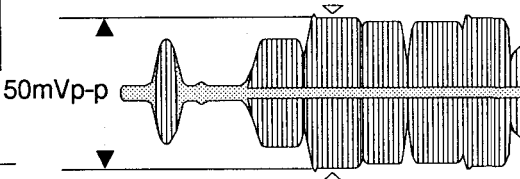
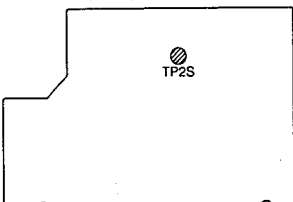
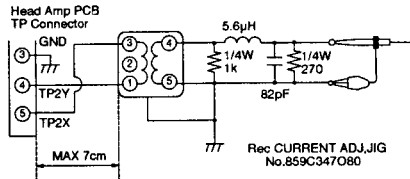
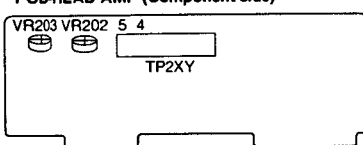
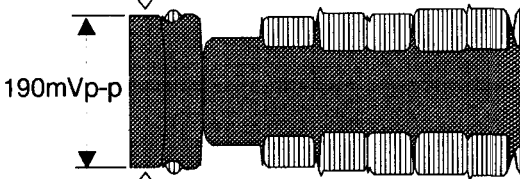
[Y/C signal circuit] 5.Y/C Recording Level (HS-M10V(B),M20V(B) M20V(IR)only)		Adjustment purpose Set the record level of the video and chroma signals.	
		Symptom when incorrectly adjusted Low luminance signal S/N ratio, beats, colour bounding or flicker.	
Measuring instrument and condition Oscilloscope(Probe 1:1)		VCR set up condition Input signal RF signal (PAL colour bar)	
Test point TP2XY pin ④, pin ⑤	Using tape A blank tape	1. Supply an RF signal(PAL colour bar). 2. Set a VCR to SP REC mode. 3. Observe the waveform at TP2XY pin ④ and pin ⑤ using the REC CURRENT ADJ. JIG.	
EXT trigger TP2S	VCR condition SP REC	4. Turn VR203 fully counter clockwise as seen from top side. 5. Adjust VR202 so that the amplitude of cyan is 50mVp-p.	
Measurement range DIV 10mV TIM 10 μs	Using Jig REC CURRENT ADJ. JIG		
PCB-MAIN (Component side) 		Head Amp PCB TP Connector 	
PCB-HEAD AMP (Component side) 		6. Set the oscilloscope's probe to 10:1. 7. Set an oscilloscope's volt range to 5mV/div. 8. Adjust VR203 so that the amplitude of horizontal sync is 190mVp-p.	
			

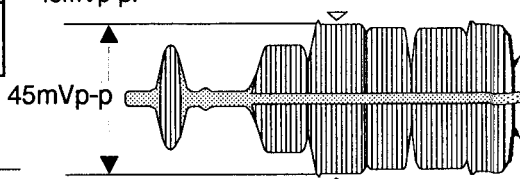
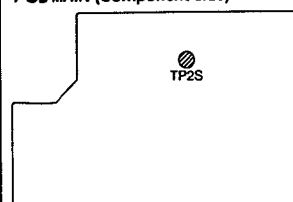
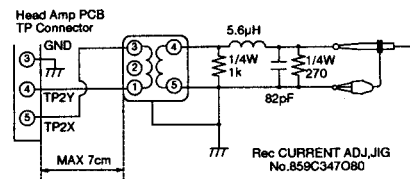
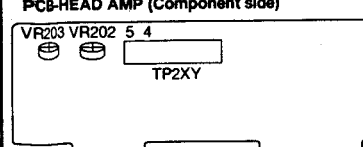
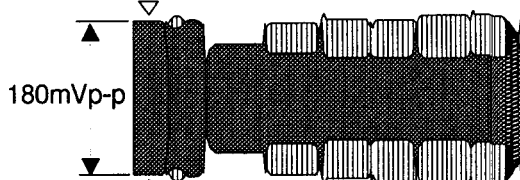
[Y/C signal circuit] 5.Y/C Recording Level (HS-M20V(G)only)		Adjustment purpose Set the record level of the video and chroma signals.	
		Symptom when incorrectly adjusted Low luminance signal S/N ratio, beats, colour bounding or flicker.	
Measuring instrument and condition Oscilloscope(Probe 1:1)		VCR set up condition Input signal RF signal (PAL colour bar)	
Test point TP2XY pin ④, pin ⑤	Using tape A blank tape	1. Supply an RF signal(PAL colour bar). 2. Set a VCR to LP REC mode. 3. Observe the waveform at TP2XY pin ④ and pin ⑤ using the REC CURRENT ADJ. JIG.	
EXT trigger TP2S	VCR condition LP REC	4. Turn VR203 fully counter clockwise as seen from top side. 5. Adjust VR202 so that the amplitude of cyan is 45mVp-p.	
Measurement range DIV 10mV TIM 10 μs	Using Jig REC CURRENT ADJ. JIG		
PCB-MAIN (Component side) 		Head Amp PCB TP Connector 	
PCB-HEAD AMP (Component side) 		6. Set the oscilloscope's probe to 10:1. 7. Set an oscilloscope's volt range to 5mV/div. 8. Adjust VR203 so that the amplitude of horizontal sync is 180mVp-p.	
			

[Y/C signal circuit] 6. Playback Video Output Level	Adjustment purpose Video output level during playback.
	Symptom when incorrectly adjusted Colour signal is not correctly reproduced.

Measuring instrument and condition		VCR set up condition	
Oscilloscope		Input signal	—
Test point	TP2J	Using tape	Alignment tape (PS2, colour bar)
EXT trigger	—	VCR condition	Playback
Measurement range	DIV 20mV TIM 10 μ s	Using Jig	—

1. Be certain that nothing is connected to be a VIDEO OUT terminal.
2. Play back an alignment tape(PS2, colour bar).
3. Observe the waveform at TP2J.
4. Adjust VR2A5 so that the amplitude of the waveform is 1.0Vp-p.

PCB-MAIN (Component side)

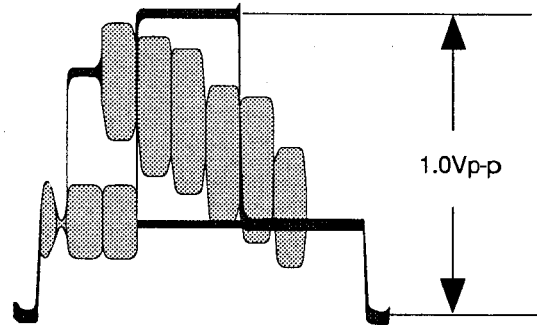
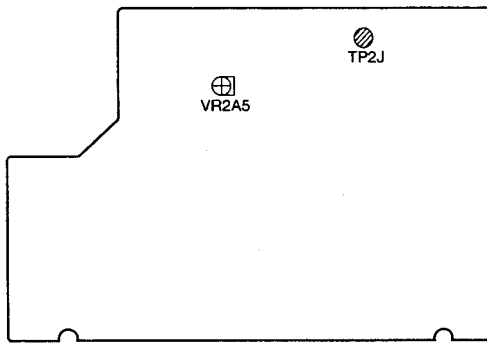

[Audio circuit] 7. Audio Bias Level	Adjustment purpose Audio bias level during recording.
	Symptom when incorrectly adjusted Poor audio high frequency response or distortion.

Measuring instrument and condition		VCR set up condition	
Audio tester		Input signal	—
Test point	TP3EF pin ①, pin ③	Using tape	A blank tape
EXT trigger	—	VCR condition	SP REC
Measurement range	—	Using Jig	High pass filter

1. Supply no signal.
2. Short-circuit EURO AV socket pin ② (AUDIO IN) and pin ④ (GND) using an electrolytic capacitor (16V or more 10 μ F).
3. Set the VCR to SP REC mode.
4. Observe the audio level at TP3EF pin ① and pin ③ with an Audio Tester using a high pass filter.
5. Confirm that the monitor TV etc. does not affect the indication of the audio tester and then adjust VR310 so that the level is 2.6mVr.m.s.

Note 1:

Be careful that the audio tester housing does not touch the VCR chassis.

Note 2:

Never set the VCR to Play mode with the audio tester connected.
(The audio amplifier will be over loaded.)

PCB-HEAD AMP (Component side)

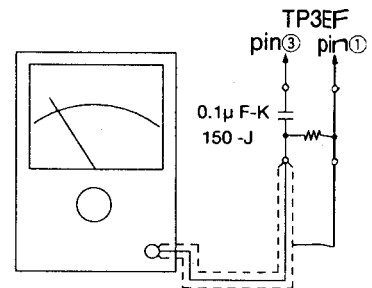
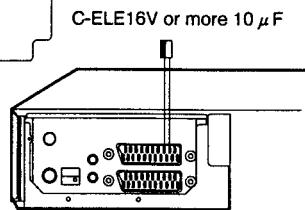
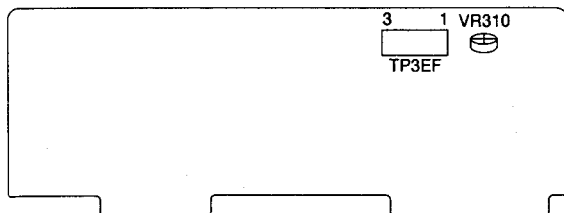

【 Timer circuit 】 8. Clock Frequency Correction	Adjustment purpose Accuracy of clock.
	Symptom when incorrectly adjusted Poor clock accuracy.

Measuring instrument and condition		VCR set up condition	
Frequency Counter		Input signal	---
Test point	TP5F	Using tape	---
EXT trigger	---	VCR condition	Power off
Measurement range	---	Using Jig	---

1. Short-circuit TP5A to TP5B.
2. Observe the frequency at TP5F.
3. Be certain that the frequency is between 262.1000 ~ 262.1882kHz.
4. Use the number buttons on the remote hand unit to enter the last three digits of the frequency counter reading (262.1**a****b****c**kHz). Enter the digits in **a****b****c** sequence.
5. Push the REC button on a remote hand unit.
6. Open circuit TP5A and TP5B.

PCB-MAIN (Component side)

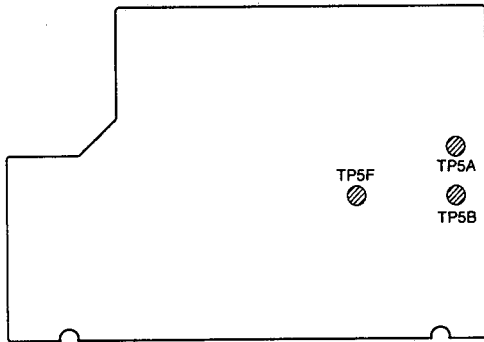

MECHANICAL ADJUSTMENT AND REPLACEMENT

1. Cleaning of Deck

The following parts require cleaning whenever serviced to maintain satisfactory performance.

1-1 Video Head

A. Clean the video heads by the following method. Dust and other foreign objects on the video heads disturbs the normal playback picture:

Dampen a video head cleaning cloth with alcohol. Hold the cloth against the drum and turn the drum slowly counterclockwise to clean.

NOTE:

Do not directly touch the head attached to the upper drum. The head is very hard but brittle to impact, especially in the vertical direction.

Do not apply force in the vertical direction.

B. Allow residual alcohol to dry thoroughly before running tape. Otherwise, the liquid may stick to and damage the tape.

1-2 Tape Transport (Refer to Fig. 1-1.)

Clean the following parts of the tape transport.

1. Tension arm
2. Supply guide pole
3. FE head
4. Supply slant pole
5. Upper and lower drum

6. Takeup slant pole
7. A/C head
8. Takeup guide pole
9. Capstan shaft
10. Takeup guide arm

A. Clean the tape transport using gauze dampened with alcohol, except the supply guide roller and takeup guide roller. If Guide rollers and pinch roller are stained with dust, clean them with dry gauze or replace them with new parts.

B. Allow residual alcohol to dry thoroughly before running a tape. Otherwise the liquid may stick to and damage the tape.

1-3 Reel Disk Drive System

Clean the reel disk braking surfaces and the reel belt.

A. Clean the reel disk braking surfaces with gauze dampened with alcohol.

- After the alcohol dries completely, perform "Adjustment of Back Tension and Tension Position" (Item 3-1).

B. If the Reel belt is stained with dust, clean it with dry gauze or exchange it for a new part.

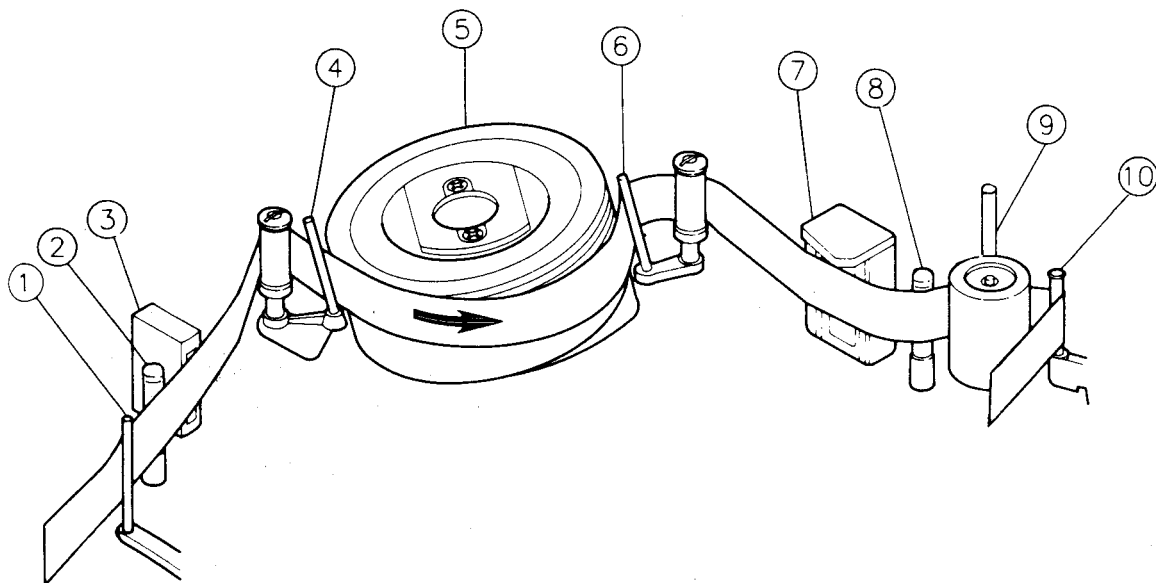

Fig. 1-1

2. Replacement of Major Parts

2-1 Cassette Housing

(Removal)

- ① Set the VCR to the eject mode.
- ② Remove the top cover and the front panel.
- ③ Unfasten the clamp holding the lead of the loading motor, which is attached to the side plate of the cassette housing. Unscrew the two cassette housing fastening screws (a) and (b). Slowly raise the cassette housing in the direction shown by the arrow. (Refer to Fig. 2-1-1.)

(Installation)

- ① Make sure that the holes (matching mark M) on the body and cogwheel of the mode switch align with each other as shown in Fig. 2-1-2. At the same time confirm that the hole of the gear pinch aligns with the matching marks of the gear joint J and the ∇ mark on the mode switch cogwheel, refer to Fig. 2-19-5. This indicates the J deck is in the EJECT mode.
- ② If the deck is not completely set to the eject mode, turn part A of the pulley worm J by hand to set the eject mode. (Refer to Fig. 2-1-4)
Turn in the direction a for loading
Turn in the direction b for unloading
- ③ Slowly lower the cassette housing onto the main plate of the deck.
- ④ Make sure the record safety lever enters between the insert guide of the cassette housing and the shaft as shown in Fig. 2-1-3. Align the four points (c), (d), (e) and (f), located on the bottom of the housing with the matching holes in the deck. Secure the cassette housing on the deck with the two screws (a) and (b). (Refer to Fig. 2-1-1.)

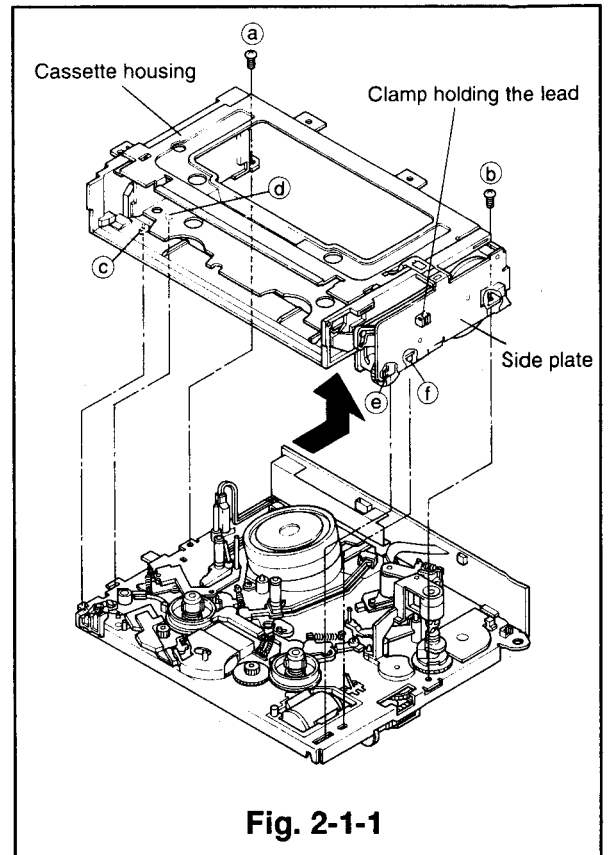

Fig. 2-1-1

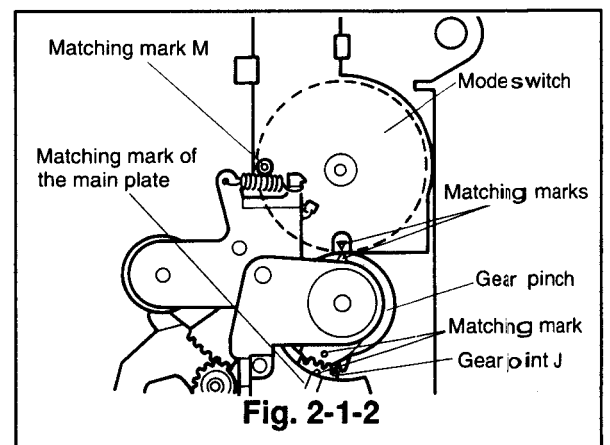

Fig. 2-1-2

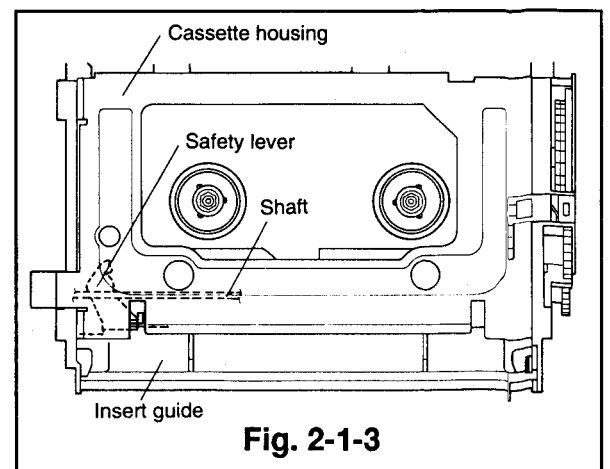

Fig. 2-1-3

2-2 Sense Gear, Drive Gear, Takeup Arm, and Arm Spring(TU)

(Removal)

- ① Remove the cassette housing. (Refer to Para. 2-1 for the removal method.)
- ② Unfasten the four catches (a, b, c and d) as shown in Fig. 2-2-1 and remove the side plate.
- ③ Remove the sense gear.
- ④ Pull the lock levers on both the supply and takeup side, shown in Fig. 2-6-1, in the direction shown by the arrow to shift the bottom plate to the position shown in Fig. 2-6-2.
- ⑤ Remove the takeup arm.
- ⑥ Turn and pull the drive gear in the direction shown by the arrow to remove it from the sense gear as shown in Fig. 2-2-3.
- ⑦ Remove the arm spring(TU) from the takeup arm as shown in Fig. 2-2-4.

(Installation)

- ① Apply the grease(G)[859D055050] to the area of the new takeup arm shown in Fig. 2-2-2 and 2-2-4.
- ② Apply the grease(G)[859D055050] to the area shown in Fig. 2-2-5 of the new sense gear.
- ③ Place the clip spring onto the drive gear hooking one end under the catch as shown in Fig. 2-2-5. Install the sense gear unto the drive gear so that hole A aligns with hole B. Hold the sense gear while turning the drive gear clockwise, in so doing engage the other end of the clip spring with the catch of the sense gear. The projection A of the sense gear must enter the hole B of the drive gear.
- ④ Ensure the spring action is effective by holding the sense gear and turning the drive gear slightly clockwise, observing whether the drive gear returns when released.

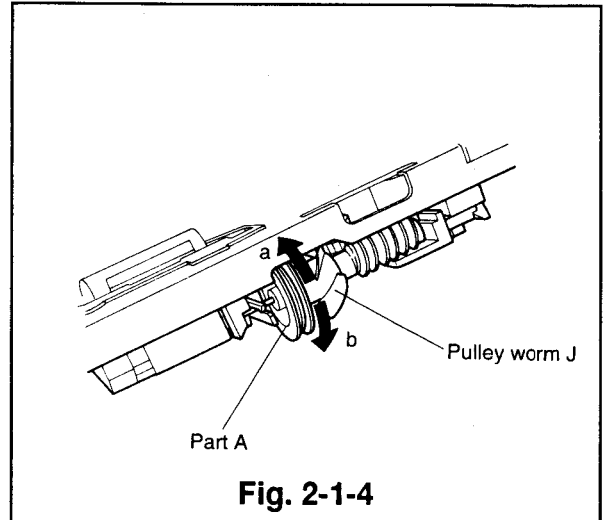

Fig. 2-1-4

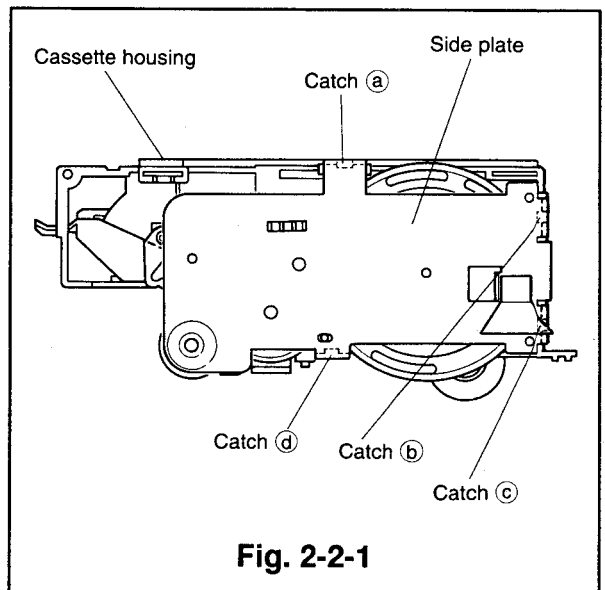

Fig. 2-2-1

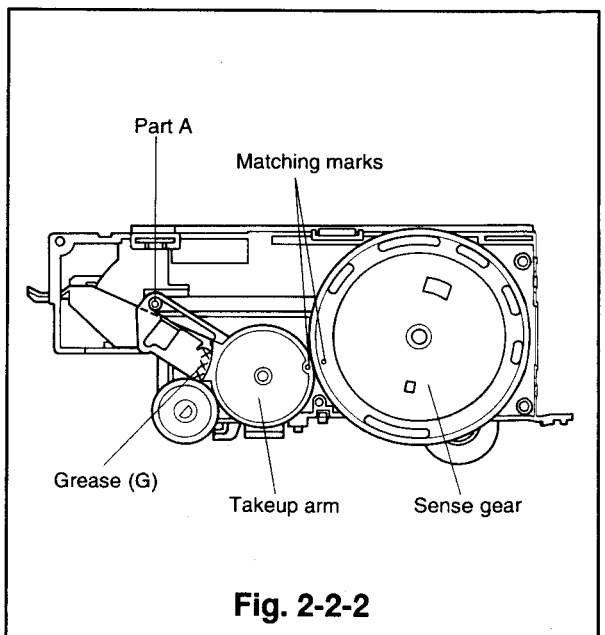

Fig. 2-2-2

- ⑤ Install the takeup arm so that the shaft attached to the bottom plate enters between the takeup arm and takeup spring after the bottom plate has been moved as shown in Fig. 2-6-2.

Note: Install the takeup arm so that the engaging point between the supply arm and the gear-S and that between the takeup arm and the gear-T are symmetrical as shown in Fig. 2-4-1.

- ⑥ Shift the bottom plate back to the eject position and install the sense gear so that the matching marks of the sense gear and the takeup arm align to each other as shown in Fig. 2-2-2.
- ⑦ Install the side plate.
- ⑧ Install the cassette housing. (Refer to Para. 2-1 for the installation method.)

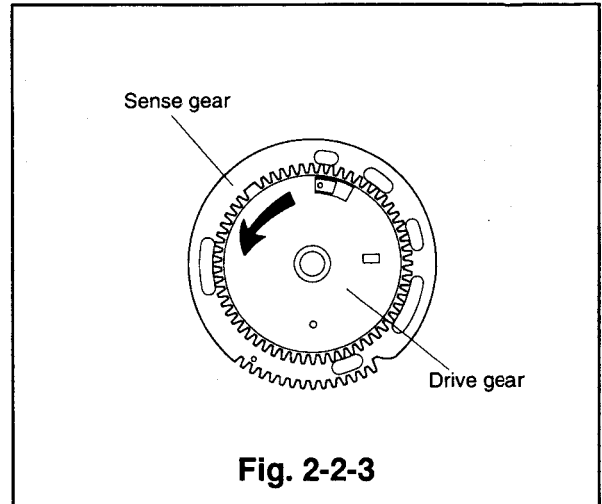

Fig. 2-2-3

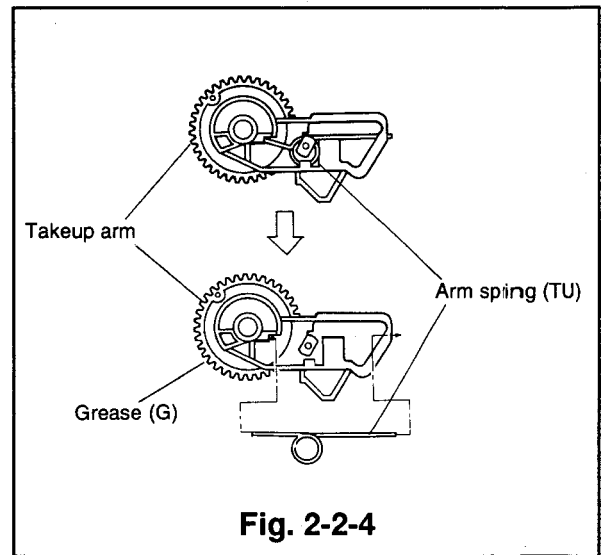

Fig. 2-2-4

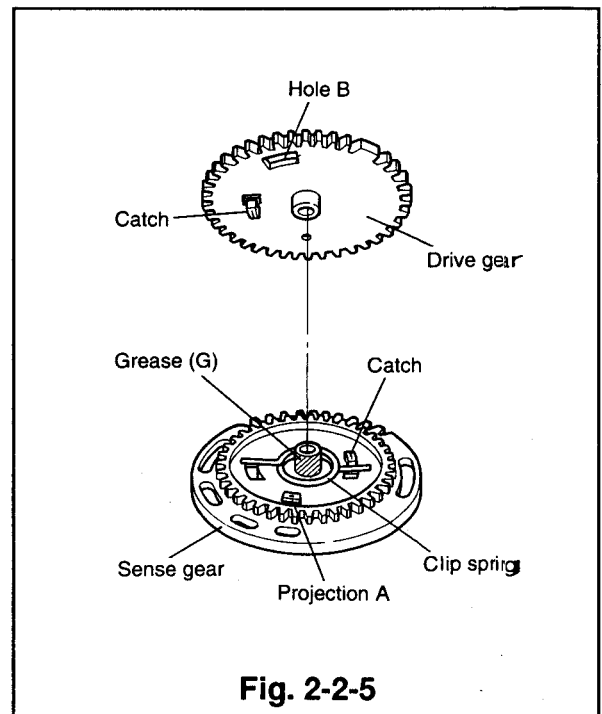

Fig. 2-2-5

2-3 Door Arm

(Removal)

- ① Remove the cassette housing. (Refer to Para. 2-1 for the removal method.)
- ② Remove the side plate, sense gear, and takeup arm. (Refer to Para. 2-2 for the removal method.)
- ③ Unfasten the catch shown in Fig. 2-3-1 to remove the door arm. (The simple way is to pull the door arm at the same time as unfastening the catch.)

(Installation)

- ① Fix the door arm to the shaft A shown in Fig. 2-3-1 and secure it with the catch so that the parts A and B are inside of the cassette housing as shown in Fig. 2-3-2.
- ② Install the takeup arm, the sense gear, and the side plate. (Refer to Para. 2-2 for the installation method.)
- ③ Install the cassette housing. (Refer to Para. 2-1 for the installation method.)

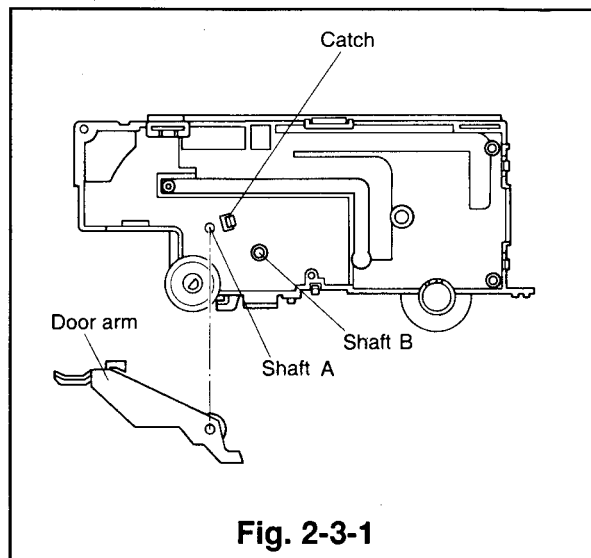

Fig. 2-3-1

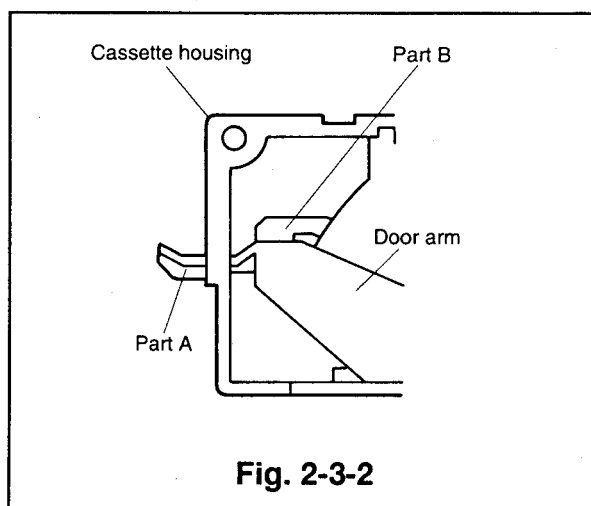

Fig. 2-3-2

2-4 Gear S and Gear T

(Removal)

- ① Follow the removal method in Items ① to ⑤ of Para. 2-2.
- ② Unfasten the catch fastening the gear T from the inside of the cassette housing to remove the FL shaft to which the gear S and T are attached. (Refer to Fig. 2-4-2)
- ③ Pull out the gear S and T from the FL shaft.

(Installation)

- ① Fix the gear S and T to the FL shaft.
- ② Install the FL shaft, first at the end attached to the gear T and then at the end to the gear S.
- ③ Follow the installation method in Item ⑤ to ⑧ in Para. 2-2.

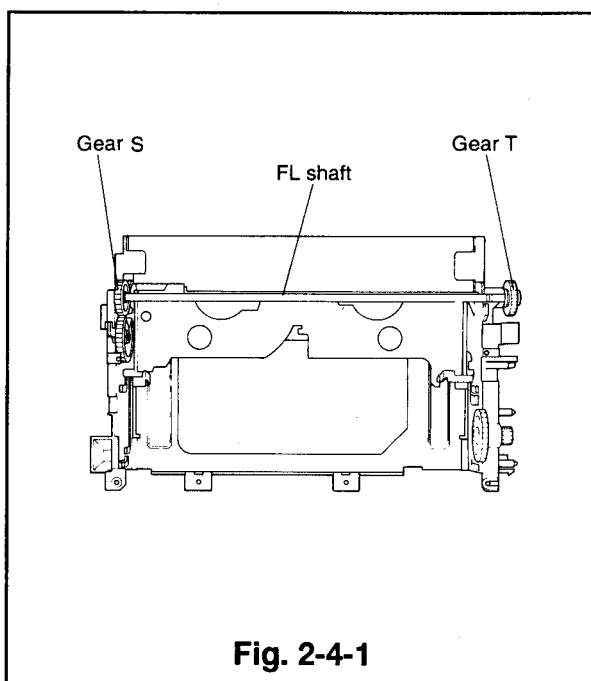

Fig. 2-4-1

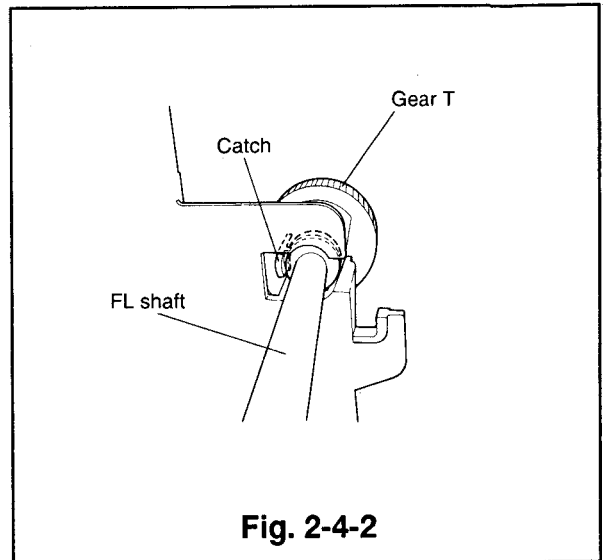

Fig. 2-4-2

2-5 Wheel Gear

(Removal)

- ① Remove the cassette housing. (Refer to Para. 2-1 for the removal method.)
- ② Remove the side plate and sense gear. (Refer to Para. 2-2 for the removal method.)
- ③ Unfasten the catch shown in Fig. 2-5-1 to remove the wheel gear.

(Installation)

- ① Install the wheel gear on the position shown in Fig. 2-5-1 from the inside of the cassette housing.
- ② Install the sense gear and side plate. (Refer to Para. 2-2 for the installation method.)
- ③ Install the cassette housing. (Refer to Para. 2-1 for the installation method.)

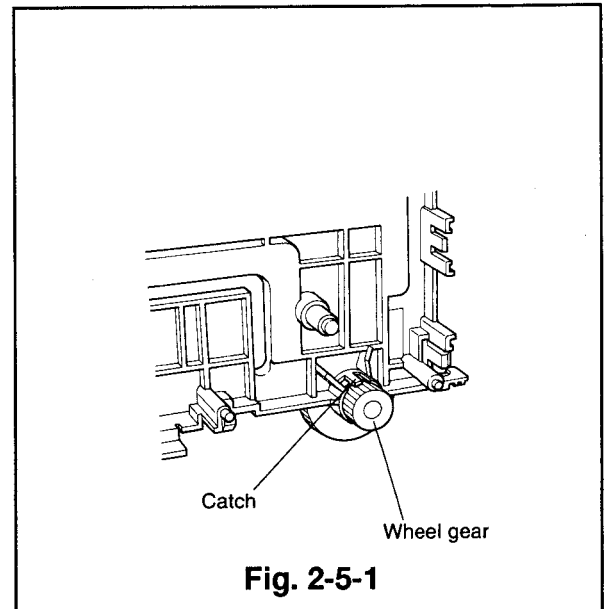

Fig. 2-5-1

2-6 Supply Arm and Arm Spring(SP)

(Removal)

- ① Remove the cassette housing. (Refer to Para. 2-1 for the removal method.)
- ② Remove the side plate. (Refer to Item ② of Para. 2-2 for the removal method.)
- ③ Remove the sense gear. (Refer to Item ③ of Para. 2-2 for the removal method.)
- ④ Pull the lock levers on both the supply and takeup side, shown in Fig. 2-6-1, in the direction shown by the arrow to shift the bottom plate to the position shown in Fig. 2-6-2.
- ⑤ Remove the takeup arm. (Refer to Item ⑤ of Para. 2-2 for the removal method.)
- ⑥ Pull part A, fixed to the supply arm, in the direction shown by the arrow to remove the bottom plate. (Refer to Fig. 2-6-3.)

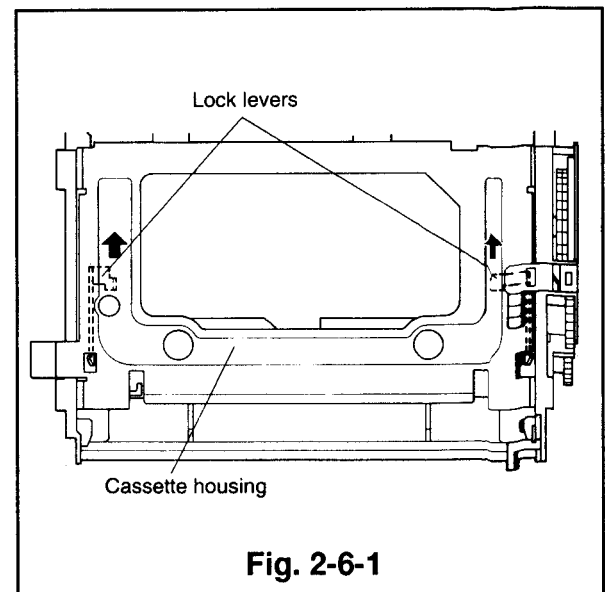

Fig. 2-6-1

- ⑦ Turn the supply arm in the direction shown by the arrow to shift part B, shown in Fig. 2-6-4, so that it aligns with the catch. Unfasten the catch to remove the supply arm.
- ⑧ Detach the arm spring from the supply arm as shown in Fig. 2-6-5.

(Installation)

- ① Attach the arm spring to the supply arm as shown in Fig. 2-6-5.
- ② Install the supply arm in the position shown in Fig. 2-6-4. (Align the catch with the part B of the supply arm.)
- ③ Insert the bottom plate so that the part A of it enters between the supply arm and the supply spring as shown in Fig. 2-6-3. Then install the bottom plate so that part C of it in the right position as shown in Fig. 2-6-6.
- ④ Follow the installation method in Item ⑤ to ⑧ in Para. 2-2.

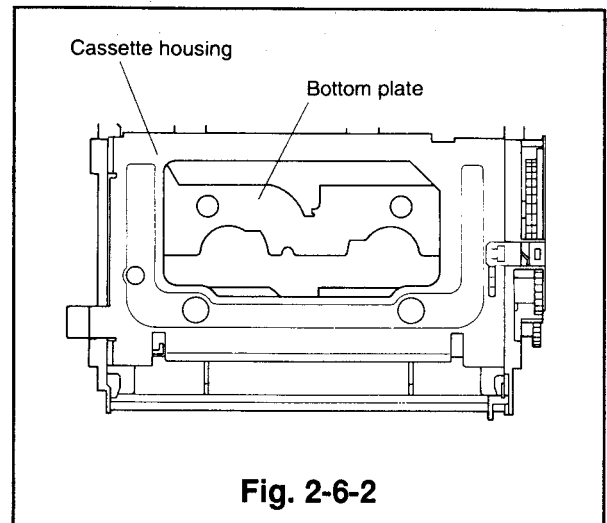

Fig. 2-6-2

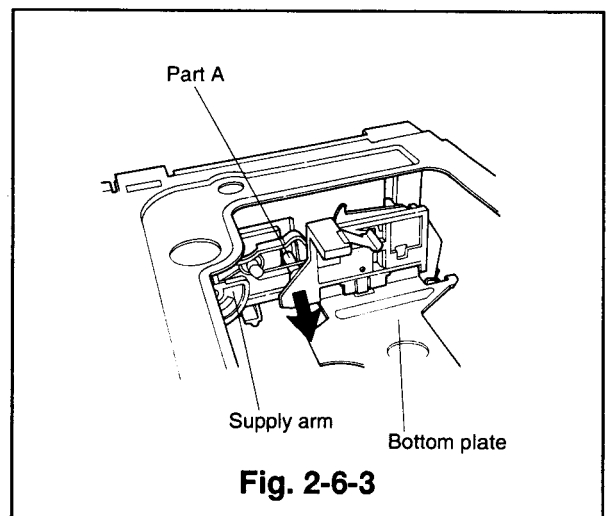

Fig. 2-6-3

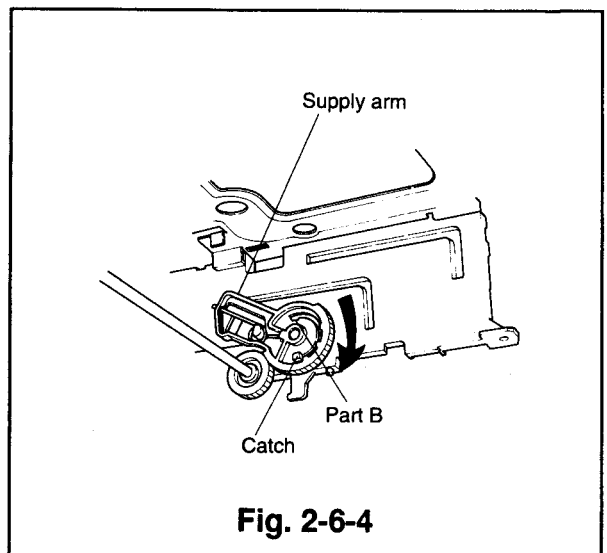

Fig. 2-6-4

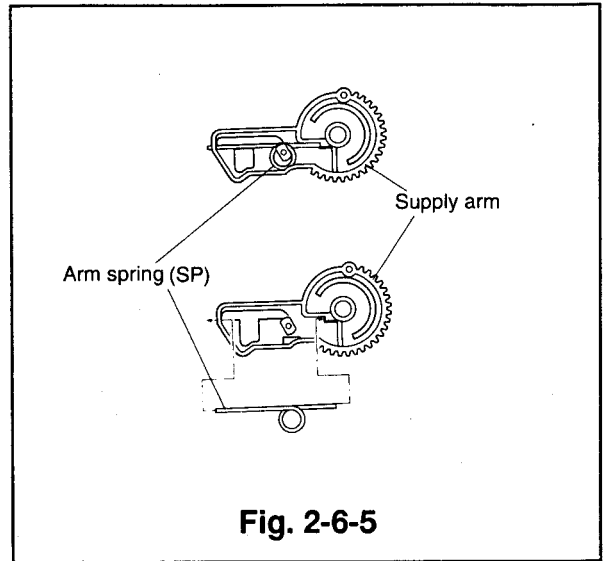

Fig. 2-6-5

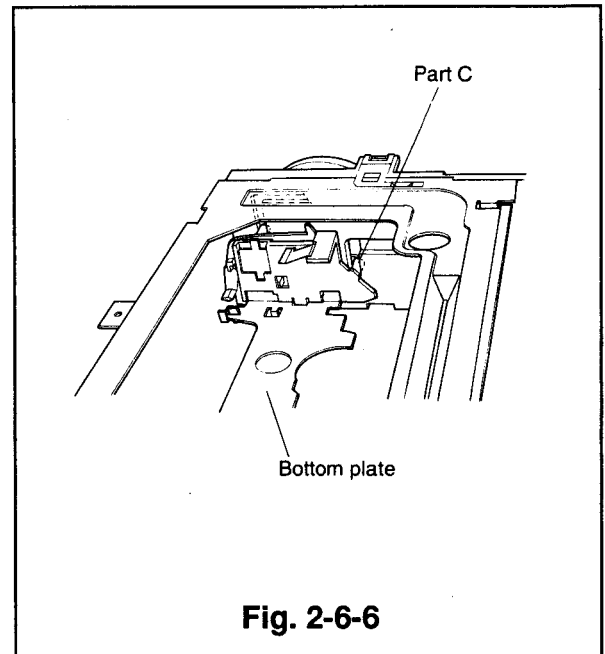

Fig. 2-6-6

2-7 Jut

(Removal)

- ① Follow the removal method in Items ① to ⑥ of Para. 2-6.
- ② Unfasten the four catches (a, b, c and d) shown in Fig. 2-7-1 to remove the jut and the jut spring.

(Installation)

- ① Install the jut and the jut spring as shown in Fig. 2-7-1. (Insert the jut spring into the part A of the jut before installing the jut. Hook one end of the jut spring with the outside of the catch (a) and the other end with part B of the jut.)
- ② Install the bottom plate according to the installation method in ③ of Para. 2-6.
- ③ Follow the installation method in Item ⑤ to ⑧ in Para. 2-2.

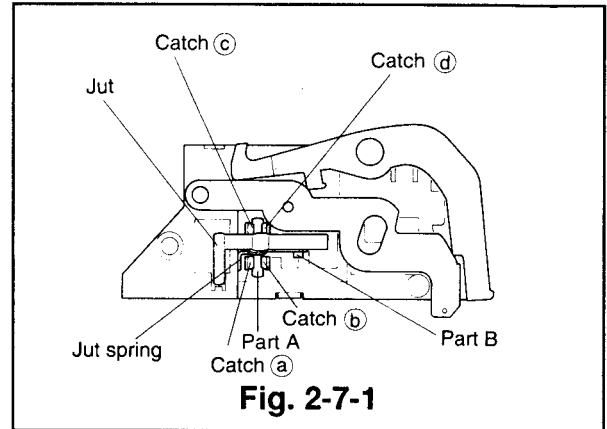

Fig. 2-7-1

2-8 PCB-HEAD-AMP

(Removal)

- ① Unfasten the hook and raise the head amp shield cover shown in Fig. 2-8-1 to remove it.
- ② Unsolder the terminals of the mode switch, the drum motor, and the rotary transformer shown in Fig. 2-8-1.
- ③ Lift the stopper of the A/C head assembly in Fig. 2-8-4 slightly upward and disconnect the lead connector (bare wire), connecting the PCB-HEAD-AMP and the PCB-A/C-HEAD.
- ④ Disconnect the lead connector (point A), connected to the FE head. (Refer to Fig. 2-8-2.)
- ⑤ Reverse the deck and disconnect the lead card, connecting the PCB of the capstan motor and the PCB-HEAD-AMP. (Refer to Fig. 2-8-3.)
- ⑥ Remove the three screws (a, b and c) and slowly pull the PCB-HEAD-AMP in the direction shown by the arrows. (Refer to Fig. 2-8-1.)

(Installation)

- ① Insert the terminals of the mode switch, the drum motor, and the rotary transformer, and the boss, adjacent to the mode switch, in the matching holes on the PCB-HEAD-AMP and secure the PCB-HEAD-AMP with the three screws (a, b and c) in the order, b → c → a. (Refer to Fig. 2-8-1)
- ② Solder the pins mentioned in Item ①.
- ③ Reverse the deck and reconnect the lead card connecting the PCB of the capstan motor and the PCB-HEAD-AMP (Refer to Fig. 2-8-3.) Take care not to fit lead card upside down.
- ④ Connect the lead connector, connected to the FE head, to the point A. (Refer to Fig. 2-8-2.)
- ⑤ Shift part B of the bare wire lead extended from the head amp slightly downward, lower the stopper, and connect it to the connector on the PCB-A/C-HEAD. (Refer to Fig. 2-8-4)

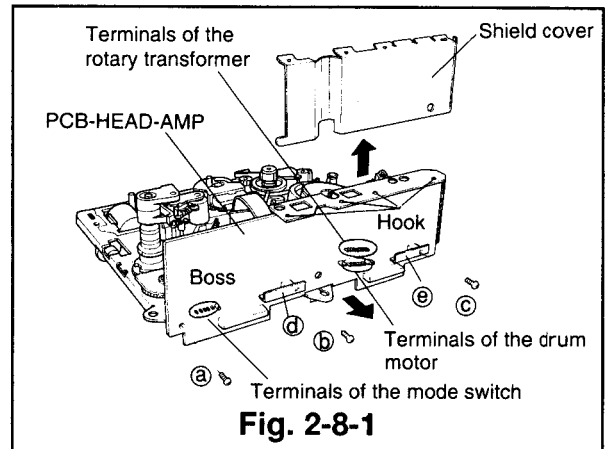

Fig. 2-8-1

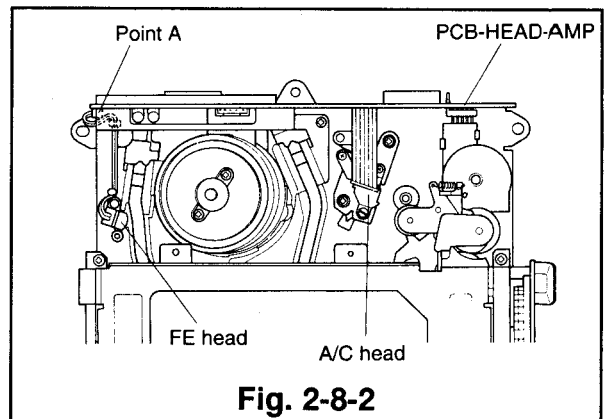

Fig. 2-8-2

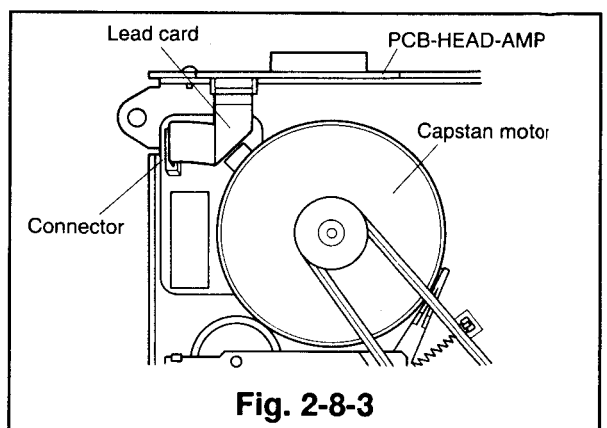
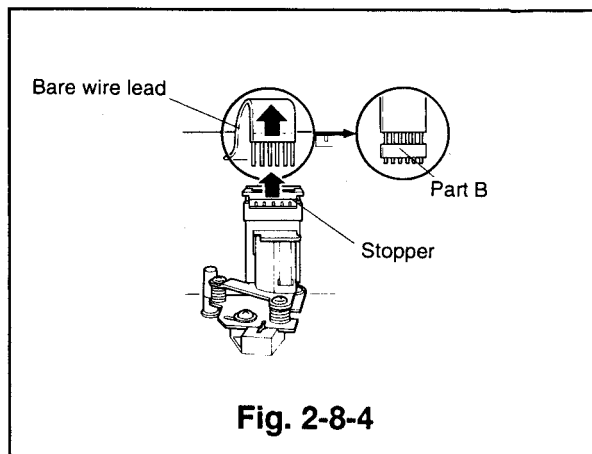

Fig. 2-8-3



2-9 Brush (Refer to the Fig.2-9-1.)

(Removal)

- ① Reverse the deck and remove the three screws (a), (b) and (c) to remove the brush.

(Installation)

- ① Attach the brush on the position shown in Fig. 2-9-1 and secure it with the screws (a) and (b). Tighten screw (c).

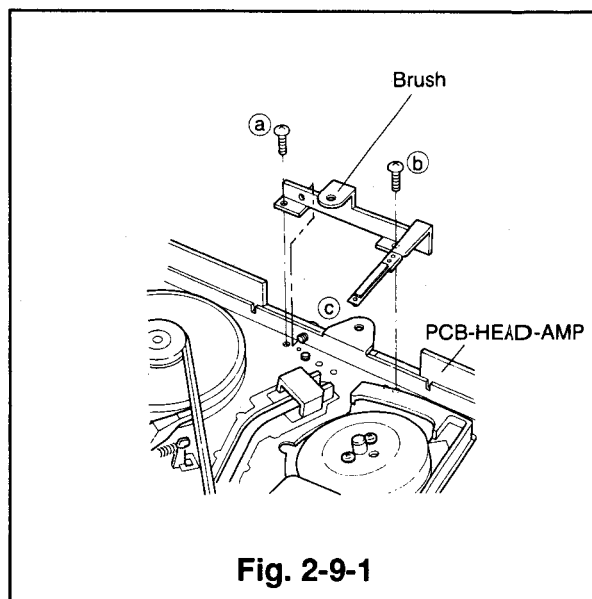

2-10 Drum Assembly

Note: When removing and installing the drum assembly, do not touch the tape running surface with your hands.

Note: Take care not to bend the PCB-HEAD-AMP.

(Removal)

- ① Remove the cassette housing. (Refer to Para. 2-1 for the removal method.)
- ② Remove the PCB-HEAD-AMP. (Refer to Para. 2-8 for the removal method.)
- ③ Unscrew the three screws (a), (b) and (c) on the reverse side of the deck and remove the drum assembly. (Refer to Fig. 2-10-1.)
- ④ Slowly raise the drum assembly upward, take care not to touch other parts around it. (Do not touch the tape running surface of the drum with your hand.)

Note: During removal, support the drum assembly when it is not secured by fastening screws.

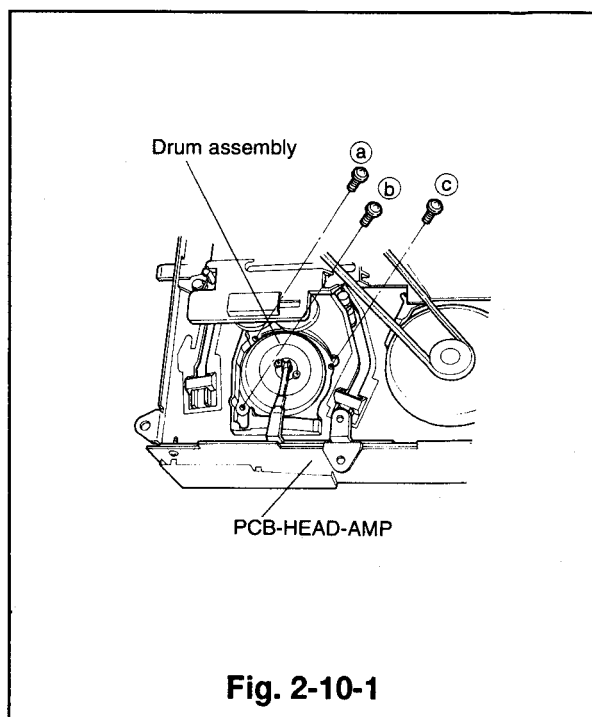

(Installation)

- ① Carefully place the new drum assembly on the main plate of the deck, take care not to touch other parts.
- ② Holding the drum assembly, reverse the deck and secure the drum assembly with the three screws (a), (b) and (c). (Tighten the screws in the order a → b → c and finally tighten again a.) (Refer to Fig. 2-10-1.)
- ③ Install the PCB-HEAD-AMP. (Refer to Para. 2-8 for the installation method.)
- ④ Install the cassette housing. (Refer to Para. 2-1 for the installation method.)

[Another Method]

(Removal)

- ① Remove the cassette housing. (Refer to Para. 2-1 for the removal method.)
- ② Unsolder the soldered pins on the terminal of the drum assembly and the terminal of the rotary transformer. (Refer to Fig. 2-10-2)
- ③ Unscrew the three screws (a), (b) and (c) on the reverse side of the deck and remove the drum assembly. (Refer to Fig. 2-10-1.)
- ④ Slightly raise the drum assembly in the opposite direction of the pins. Remove the pins of the drum assembly and of the rotary transformer from the PCB-HEAD-AMP. Slowly remove the drum assembly, take care not to touch other parts around it.

(Installation)

- ① Carefully place the drum assembly on the main plate, take care not to touch the other parts around it. The pins of the drum assembly and the rotary transformer must enter the holes of the PCB-HEAD-AMP.
- ② Secure the drum assembly with the three screws (a), (b) and (c) on the reverse side of the deck. (Tighten the screws in the order a → b → c and finally tighten a again.) (Refer to Fig. 2-10-1.)
- ③ Solder the pins of the drum assembly and the rotary transformer. (Refer to Fig. 2-10-2.)
- ④ Install the cassette housing. (Refer to Para. 2-1 for the installation method.)

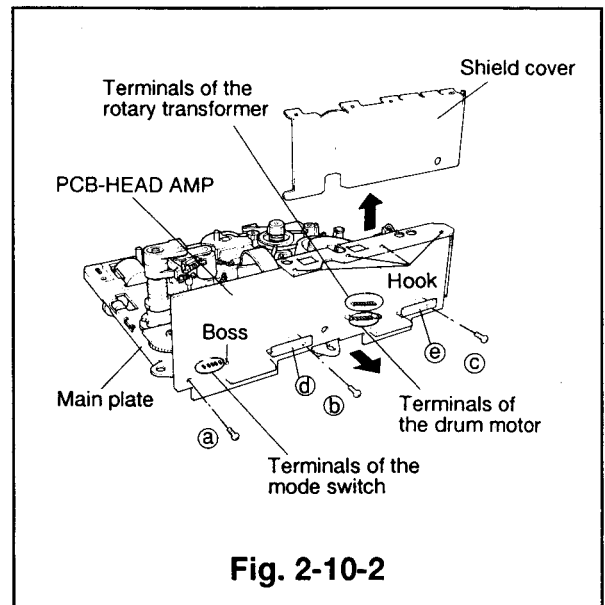

Fig. 2-10-2

2-11 Upper Drum and Drum Motor

Note: When only the upper drum is to be replaced, follow the procedure of Items ①~④ of the removal method and ②~④ of the installation method.

(Removal)

- ① Remove the drum assembly. (Refer to Para. 2-10 for the removal method.)
- ② Unsolder the terminals of each head on the upper drum.
- ③ Remove the screws holding the upper drum shown in Fig. 2-11-1.
- ④ Remove the upper drum slowly and carefully.
- ⑤ Remove the screws(Ⓐ and Ⓑ) shown in Fig. 2-11-1 to remove the rotor case and damper. Remove the screws(Ⓒ,Ⓓ and Ⓔ) to remove the drum motor.

(Installation)

Note: Handle the upper drum carefully as the video heads are fragile.

- ① Attach the rotary transformer and the drum motor so that the terminals of both face in the same direction, and secure them with the screws(Ⓒ,Ⓓ and Ⓔ). Secure the rotor case with the screws(Ⓐ and Ⓑ).
- ② Position the white painted (shaded) area of the upper drum so that the area is -90° apart from the hole of the lower drum shaft. Insert the upper drum. Take care not to touch the head terminals. [Fig. 2-11-2]
- ③ Secure the upper drum with the two fastening screws. (Tighten the screws alternately.)
- ④ Solder the terminals of each head.

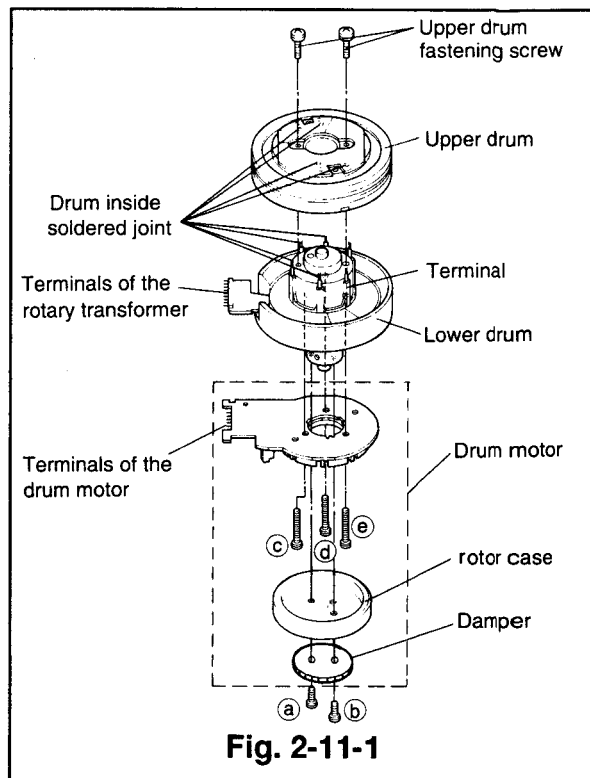

Fig. 2-11-1

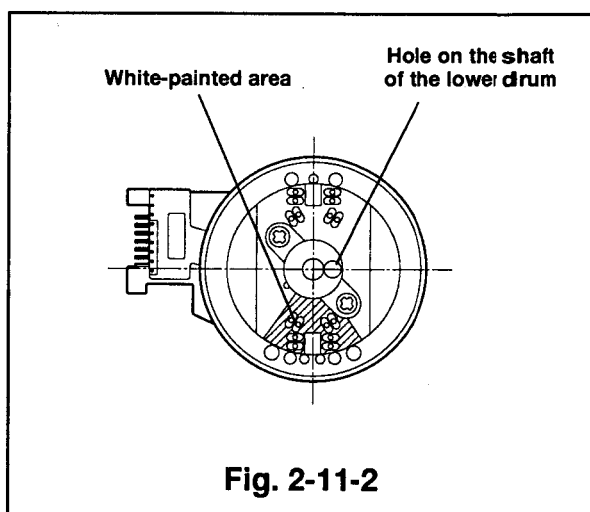

Fig. 2-11-2

2-12 Safety Spring and Safety Lever

(Removal)

- ① Remove the cassette housing. (Refer to Para. 2-1 for the removal method.)
- ② Unhook the safety spring with a tweezers.
- ③ Turn the safety lever clockwise and remove by raising it upward as shown in Fig. 2-12-2.

(Installation)

- ① Install the safety lever so that part A aligns with the hole on the main plate, shown in Fig. 2-12-1, and part B with the hole of the safety arm on the reverse side of the deck.
- ② Fix the safety spring to the shaft of the safety lever and hook it as shown in Fig. 2-12-3.
- ③ Install the cassette housing. (Refer to Para. 2-1 for the installation method.)

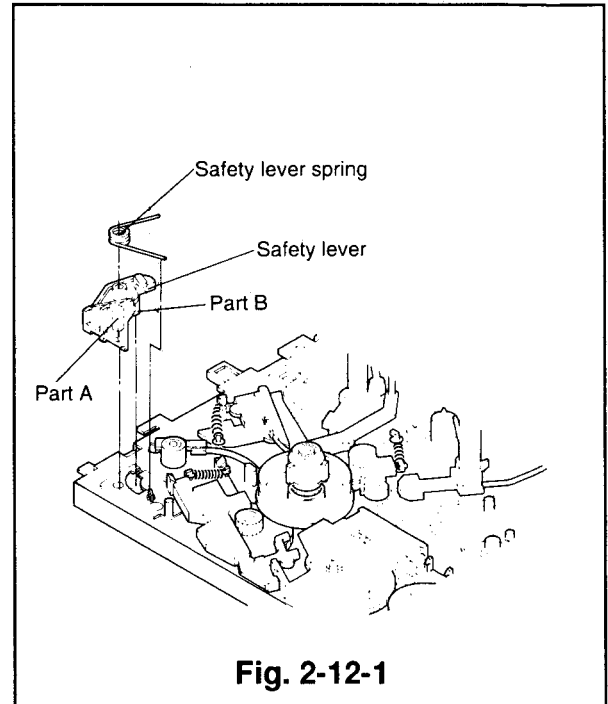

Fig. 2-12-1

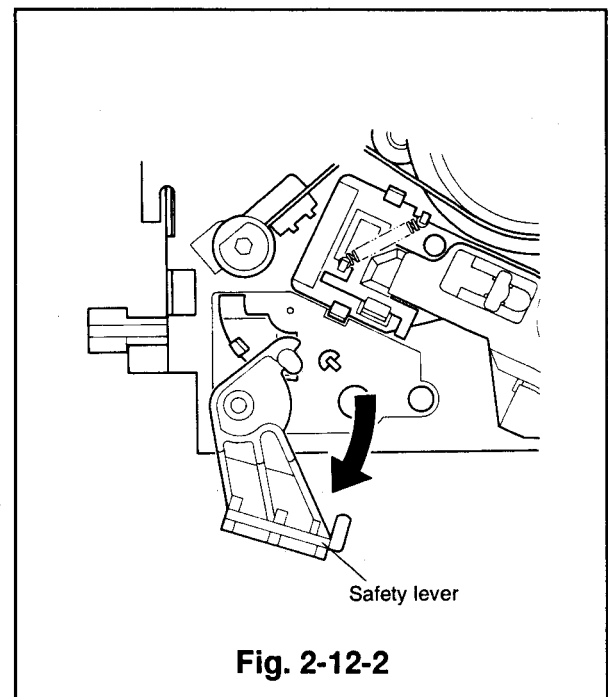

Fig. 2-12-2

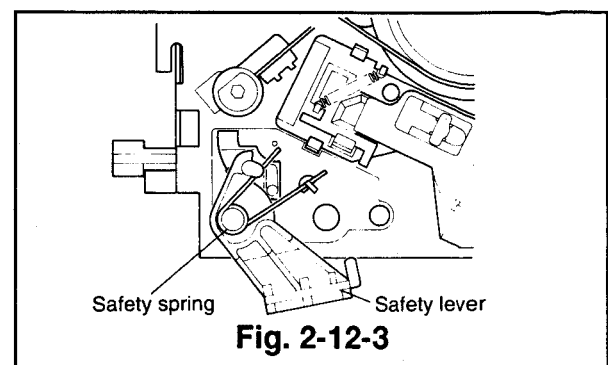

Fig. 2-12-3

2-13 Safety Arm

(Removal)

- ① Remove the cassette housing. (Refer to Para. 2-1 for the removal method.)
- ② Remove the safety spring and the safety lever. (Refer to Para. 2-12 for the removal method.)
- ③ Unfasten the catch to remove the safety arm. (Refer to Fig. 2-13-1).

(Installation)

- ① Reverse the deck and fix the safety arm to the shaft of the main plate so that its catch is within the range shown in Fig. 2-13-2.
- ② Install the safety spring and the safety lever. (Refer to Para. 2-12 for the installation method.)
- ③ Install the cassette housing. (Refer to Para. 2-1 for the installation method.)

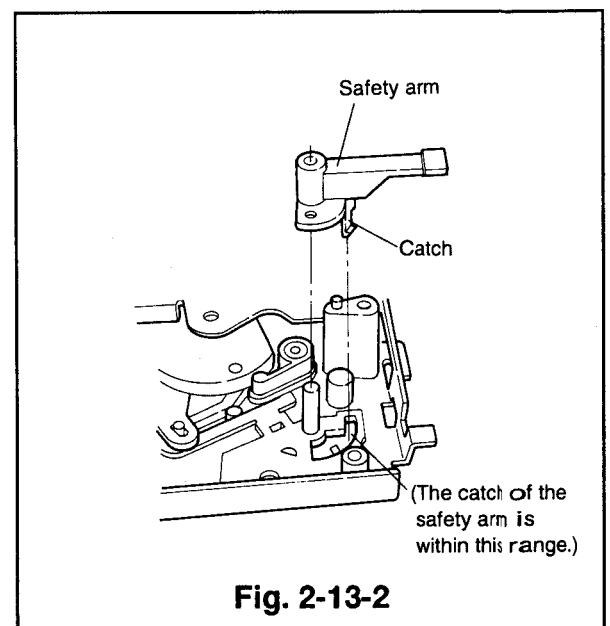
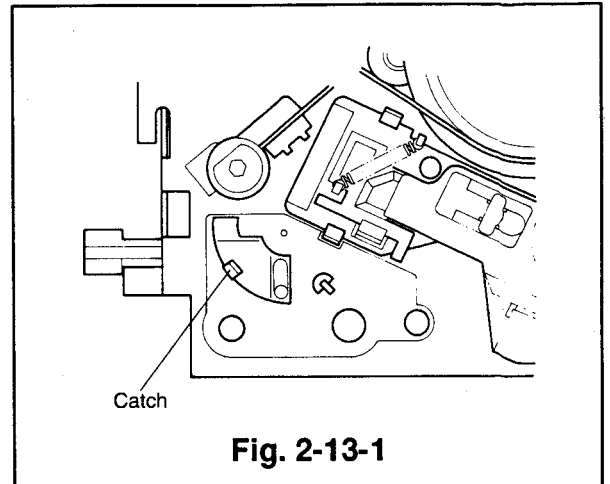

2-14 Sub Brake(SP) and Sub Spring(SP)

(Removal)

- ① Remove the cassette housing. (Refer to Para. 2-1 for the removal method.)
- ② Detach the sub spring(SP).
- ③ Reverse the deck and unfasten the catch with a small screw driver, etc., to remove the sub brake(SP) as shown in Fig. 2-14-2.

(Installation)

- ① Install the sub brake(SP) with care not to score the tension brake belt(without loosening of the tension brake belt).(Refer to Fig. 2-14-1)
- ② Attach the sub spring(SP).
- ③ Install the cassette housing.(Refer to Para. 2-1 for the installation method.)

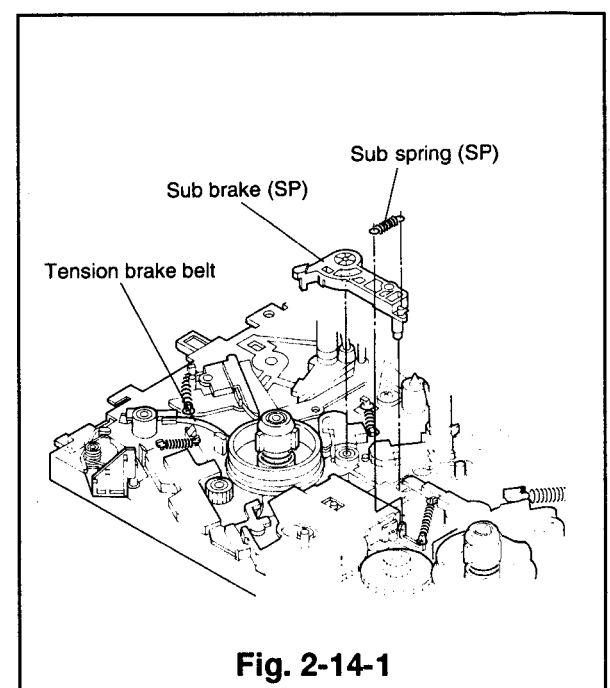

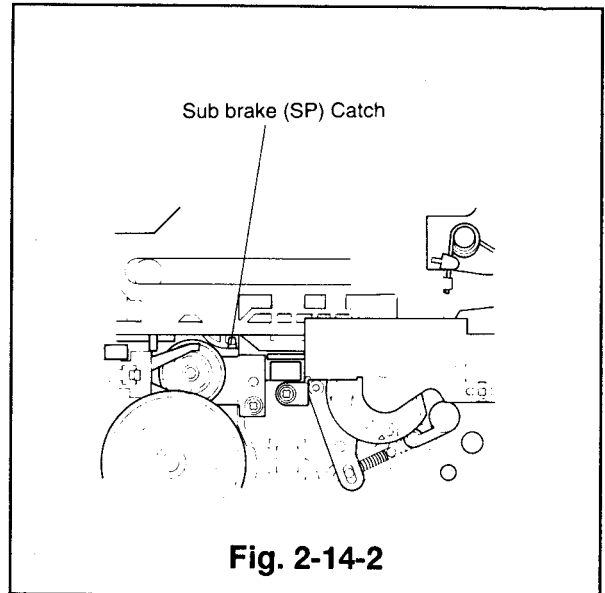

2-15 Main Brake (SP) and Main Brake Spring J(SP) (Refer to Fig. 2-15-1.)

(Removal)

- ① Remove the cassette housing. (Refer to Para. 2-1 for the removal method.)
- ② Remove the sub brake(SP) and the sub spring(SP). (Refer to Para. 2-14 for the removal method.)
- ③ Unhook the main brake spring J(SP).
- ④ Raise the main brake(SP) upward to remove it.

(Installation)

- ① Install the main brake(SP) on the main plate and attach the main brake spring J(SP).
- ② Install the sub brake(SP) and the sub spring(SP). (Refer to Para. 2-14 for the installation method.)
- ③ Install the cassette housing. (Refer to Para. 2-1 for the installation method.)

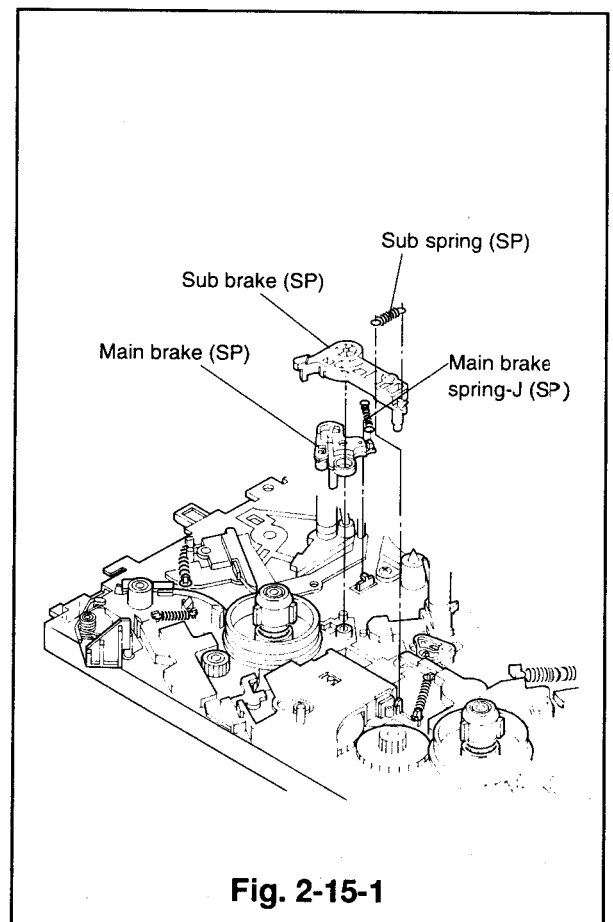

2-16 Sub Off Lever, Sub Brake(TU), and Sub Spring(TU)

(Removal)

- ① Remove the cassette housing. (Refer to Para. 2-1 for the removal method.)
- ② Remove the sub brake(SP) and the sub spring(SP). (Refer to Para. 2-14 for the removal method.)
- ③ Unfasten the catch with a small screw driver, etc., and raise the sub off lever upward to remove it. (Refer to Fig. 2-16-2)
- ④ Remove the sub spring(TU). (Refer to Fig. 2-16-1.)
- ⑤ Unfasten the catch with a small screw driver, etc., and raise the sub brake(TU) upward to remove it as shown in Fig. 2-16-2.

(Installation)

- ① Apply the grease(PG-641)[859D055O30] to the area shown in Fig. 2-16-3.
- ② Install the sub brake(TU) on the main plate.
- ③ Install the sub off lever so that the hole A aligns with the boss of the sub brake(TU) as shown in Fig. 2-16-1.
- ④ Install the sub spring(TU).
- ⑤ Install the sub brake(SP) and the sub spring(SP). (Refer to Para. 2-14 for the installation method.)
- ⑥ Install the cassette housing. (Refer to Para. 2-1 for the installation method.)

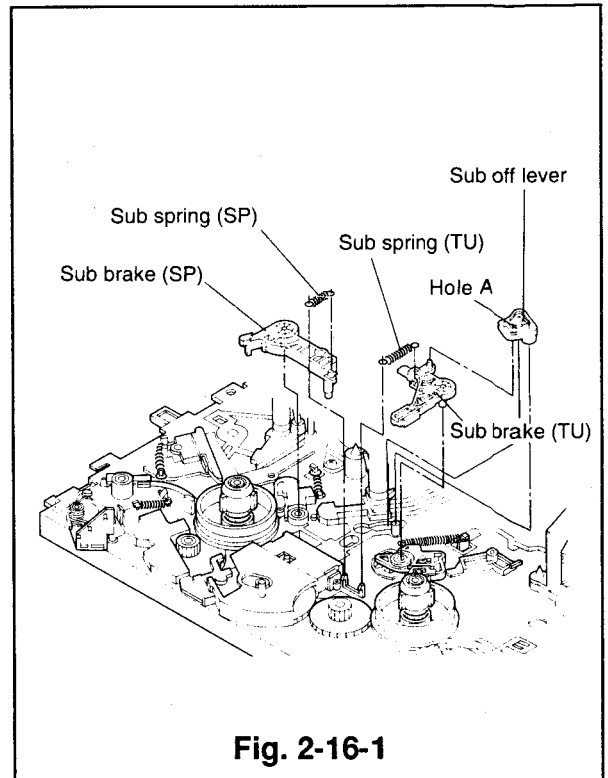

Fig. 2-16-1

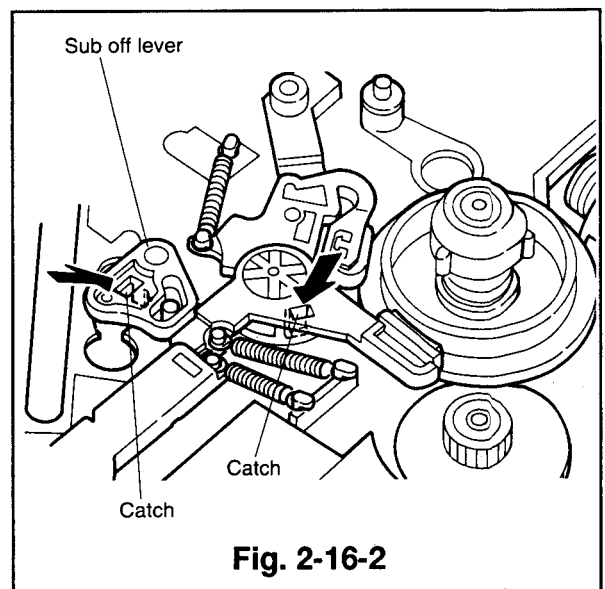

Fig. 2-16-2

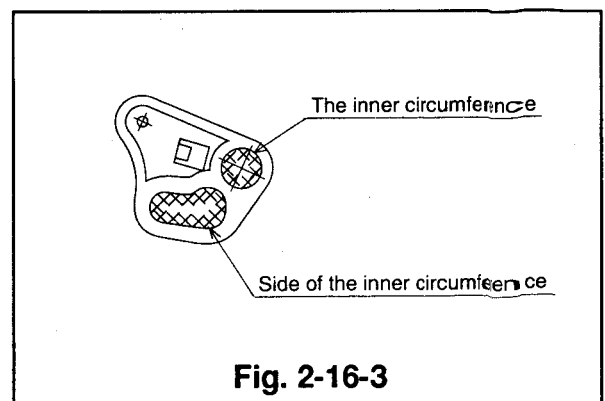

Fig. 2-16-3

2-17 Main Brake(TU) and Main Brake Spring J(TU)

(Removal)

- ① Remove the cassette housing. (Refer to Para. 2-1 for the removal method.)
- ② Remove the sub brake(SP) and the sub spring(SP). (Refer to Para. 2-14 for the removal method.)
- ③ Remove the sub off lever, the sub brake(TU), and the sub spring(TU). (Refer to Para. 2-16 for the removal method.)
- ④ Remove the main brake spring J(TU) and raise the main brake(TU) upward to remove it. (Refer to Fig. 2-17-1.)

(Installation)

- ① Install the main brake(TU) on the main plate assembly so that the coupling portion with the main brake release lever is as shown in Fig. 2-17-2.
- ② Install the main brake spring J(TU).
- ③ Install the sub brake(TU), the sub off lever, and the sub spring(TU). (Refer to Para. 2-16 for the installation method.)
- ④ Install the sub brake(SP) and the sub spring(SP). (Refer to Para. 2-14 for the installation method.)
- ⑤ Install the cassette housing. (Refer to Para. 2-1 for the installation method.)

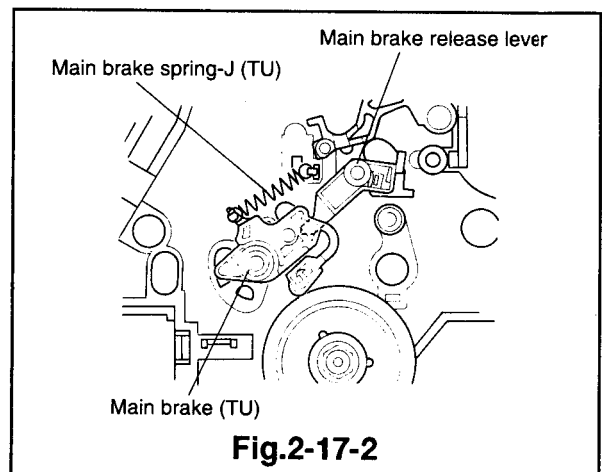
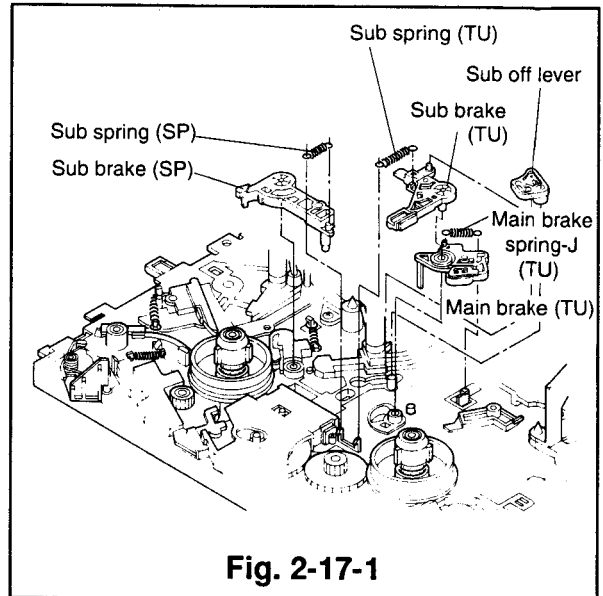

2-18 ID Swing Lever, Revolution Lever, and Revolution Spring

(Removal)

- ① Remove the cassette housing. (Refer to Para. 2-1 for the removal method.)
- ② Reverse the deck and remove the grip ring attached to the shaft G of the charge assembly.
- ③ Unfasten the two catches(A, B) to remove the charge assembly.
- ④ Remove the revolution spring with a tweezers.
- ⑤ Slide the revolution lever in the direction shown by the arrow and unfasten it from the catch C of the ID swing lever. (Refer to Fig. 2-18-1)
- ⑥ Detach the charge spring from the ID swing lever.

(Installation)

- ① Apply the grease(PG-641)[859D055O30] to the areas shown in Fig. 2-18-2 of the new revolution lever and the ID swing lever.

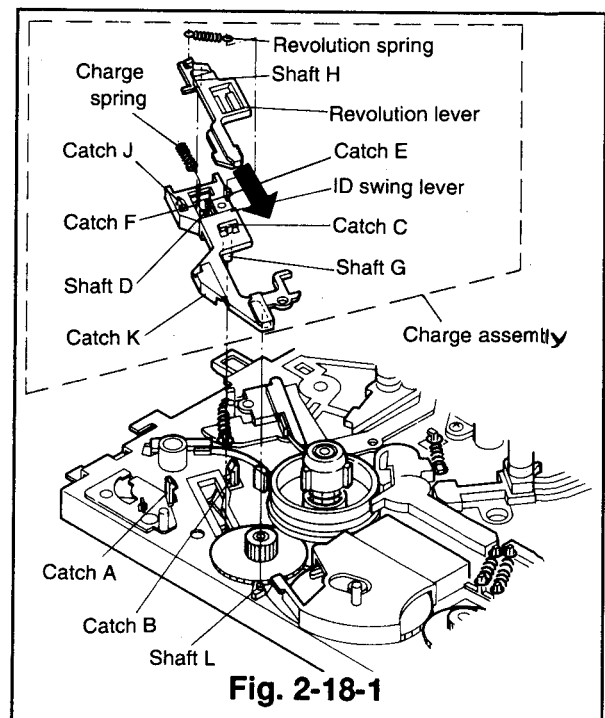

- ② Fix the charge spring to shaft D of the ID swing lever and compress it to hook its ends with the catches E and F. (Refer to Fig. 2-18-1)

Note: The charge spring should be installed in the directions shown below.

(Longitudinal Direction)

The bent tip is attached on the shaft D.

(Traverse Direction)

The wider semicircle is on the left as shown in Fig. 2-18-1.

- ③ Align the shaft H of the revolution lever with the position shown in Fig. 2-18-1. Insert catch C of the ID swing lever into the hole of the revolution lever, pushing the charge spring with a revolution lever in the direction shown by the arrow. At the same time, hook the ends of the revolution lever with the catches J and K.
- ④ Attach the revolution spring with a tweezers.
- ⑤ Install the charge assembly so that shaft G enters into the oval hole of the charge lever on the reverse side of the deck and the groove of the charge assembly fits the shaft as shown in Fig. 2-18-1. Secure the charge assembly with the catch A and B.
- ⑥ Reverse the deck and fix the new grip ring to the shaft G of the charge assembly.
- ⑦ Install the cassette housing. (Refer to Para. 2-1 for the installation method.)

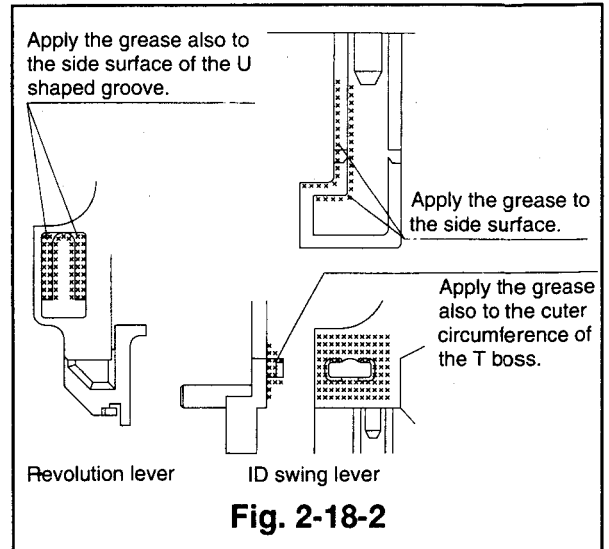

Fig. 2-18-2

2-19 Tension Arm, Tension Brake Belt, and Tension Spring

Note: During removal and installation, take care not to change the shape of the tension brake belt.

(Removal)

- ① Remove the cassette housing. (Refer to Para. 2-1 for removal method.)
- ② Supply a voltage (approximately 5V DC plus voltage on the red wire) to the loading motor and slide the tape guide assembly completely to the loaded position, to set it to the loaded position.
- ③ Remove the sub brake (SP) and the sub spring (SP). (Refer to Para. 2-14 for the removal method.)
- ④ Unfasten the catch of the part A on the tension brake belt and raise the part A to unfasten the tension brake belt from the supply reel disk. (Refer to Fig. 2-19-1)
- ⑤ Remove the tension spring, unfasten the catch shown in Fig. 2-19-2, and raise the tension arm upward to remove it.
- ⑥ Reverse the tension arm, unfasten the catch with a tweezers as shown in Fig. 2-19-3 to remove the tension brake belt.

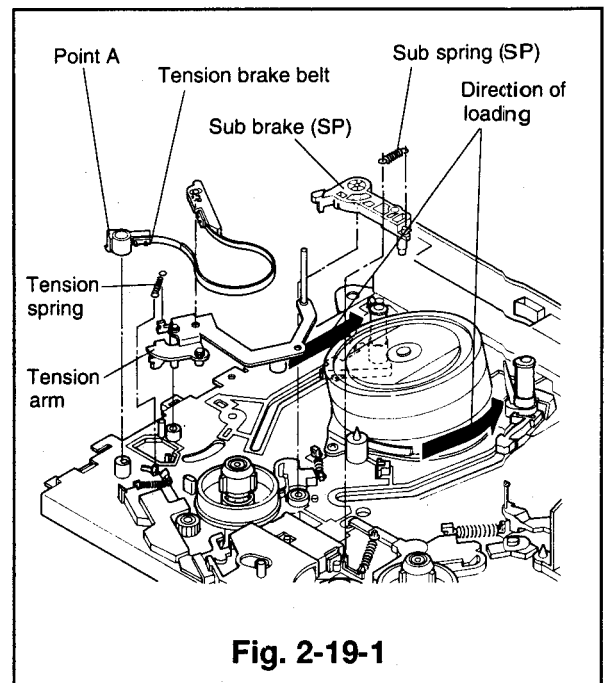

Fig. 2-19-1

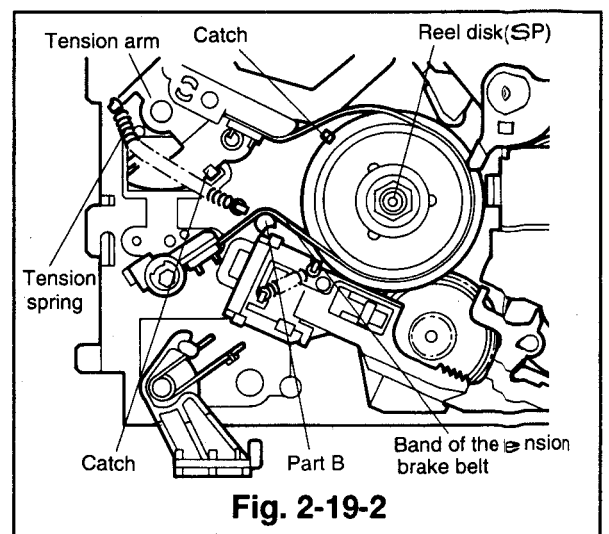

Fig. 2-19-2

(Installation)

- ① Insert the catch in the position of the tension arm as shown in Fig. 2-19-3 to fasten the tension brake belt on the tension arm. (Take care not to let projection C, next to the catch of the tension brake belt touch the tension arm.)
- ② Install the tension arm, where the tension brake belt is fastened, on the main plate.
- ③ Fasten the tension brake belt around the supply reel disk. (The band of the tension brake belt must pass the outside of the catch shown in Fig. 2-19-2 and inside of the part B.)
- ④ Attach the tension spring.
- ⑤ Install the sub brake(SP) and sub spring(SP). (Refer to Para. 2-14 for the installation method.)
- ⑥ Supply voltage(approximately 5V), reversing the polarity used in ② of the Removal method, to set the motor to the unloaded position.
- ⑦ Make sure that the holes (matching mark M) on the body and cogwheel of the mode switch align with each other as shown in Fig. 2-19-4. At the same time confirm that the hole of the gear pinch aligns with the matching marks of the gear joint J and the ∇ mark on the mode switch cogwheel, refer to Fig. 2-19-5. This indicates the J deck is in the EJECT mode.
- ⑧ If the deck is not completely set to the eject mode, turn part D of the pulley worm J by hand to set the eject mode.

Turn in the direction a for loading

Turn in the direction b for unloading

(Refer to Fig. 2-19-6)

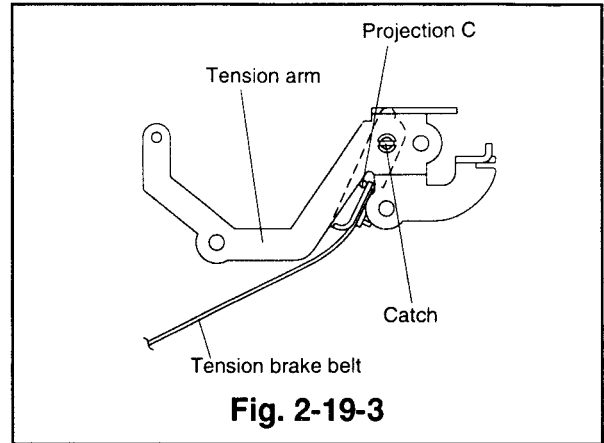

Fig. 2-19-3

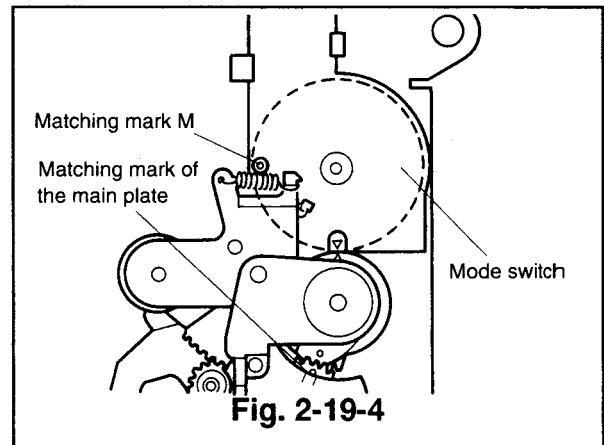

Fig. 2-19-4

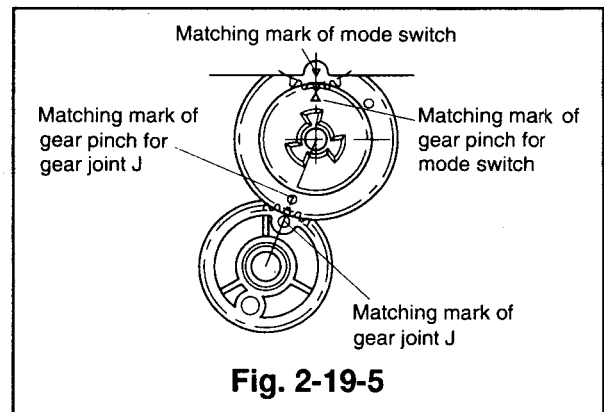

Fig. 2-19-5

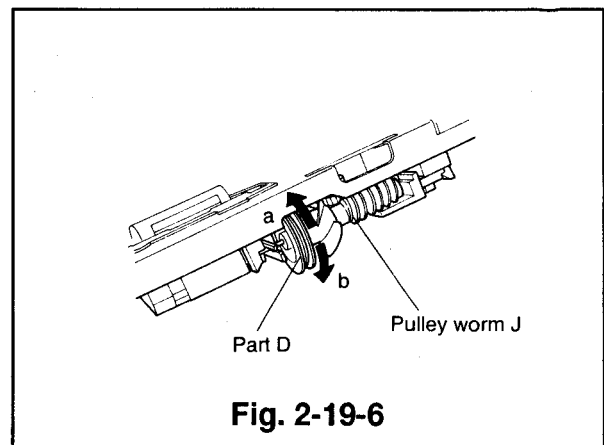

Fig. 2-19-6

2-20 Takeup Reel Disk and Gear R(takeup side)

(Removal)

- ① Remove the cassette housing. (Refer to Para. 2-1 for the removal method.)
- ② Remove the sub brake(SP) and the sub spring(SP). (Refer to Para. 2-14 for the removal method.)
- ③ Remove the sub off lever, the sub brake(TU), and the sub spring(TU). (Refer to Para. 2-16 for the removal method.)
- ④ Unfasten the catch shown in Fig. 2-20-1 and raise the takeup reel disk upward to remove it from the shaft.
- ⑤ Raise the gear R(takeup side) upward to remove it from the shaft. (Refer to Fig. 2-20-2.)

(Installation)

- ① Install the gear R(takeup side) on the shaft. (Refer to Fig. 2-20-2.)
- ② Install the takeup reel disk on the shaft.(Refer to Fig. 2-20-2)
- ③ Install the height adjusting jig [master plane](used for F deck: Part No.859C342020) in the specified position. (Insert the jig into hole A, shown in Fig. 2-20-3, so that the jig sets on part B and the end of part C. Take care that the jig does not touch the supply and takeup reel disks.)
- ④ Place the height adjusting jig [square](used for E deck: Part No.859C341070) on the jig installed in Item ③ as shown in Fig. 2-20-4. Make sure that the height is correct (between A and B).
- ⑤ Adjust the height of the supply reel disk by varying the number of the washers (Part No.552C017020) under the disk.
 - A) If it is high, remove washer(s).
 - B) If it is low, add washer(s).
- ⑥ Install the sub brake(TU), the sub off lever, and the sub spring(TU). (Refer to Para. 2-16 for the installation method.)
- ⑦ Install the sub brake(SP) and the sub spring(SP). (Refer to Para. 2-14 for the installation method.)
- ⑧ Install the cassette housing. (Refer to Para. 2-1 for the installation method.)

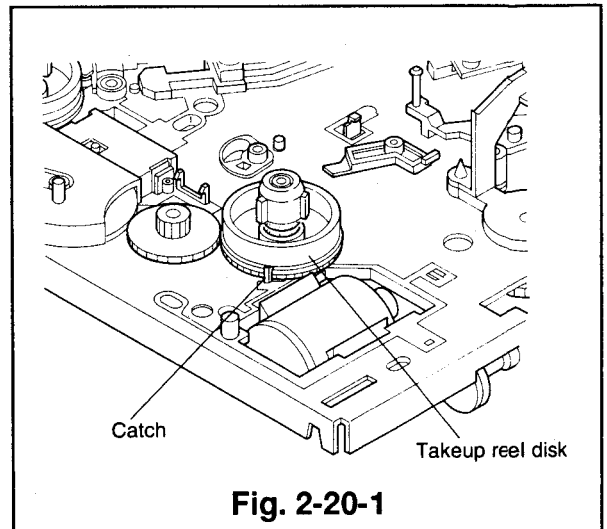

Fig. 2-20-1

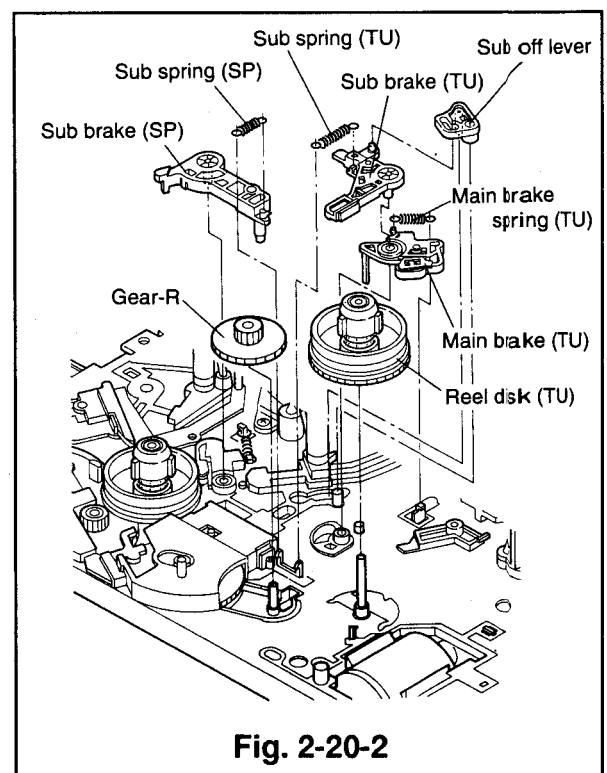

Fig. 2-20-2

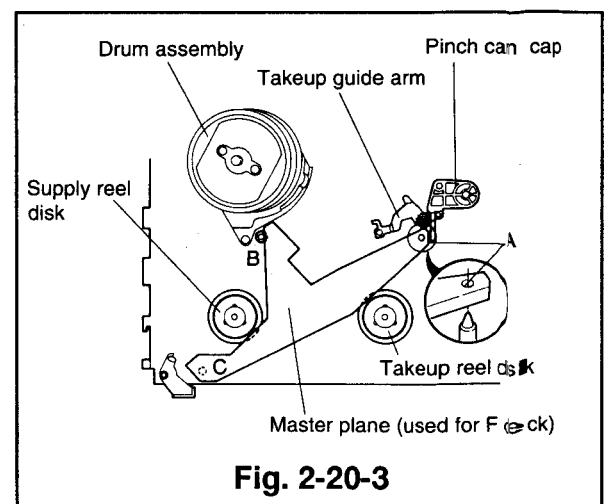

Fig. 2-20-3

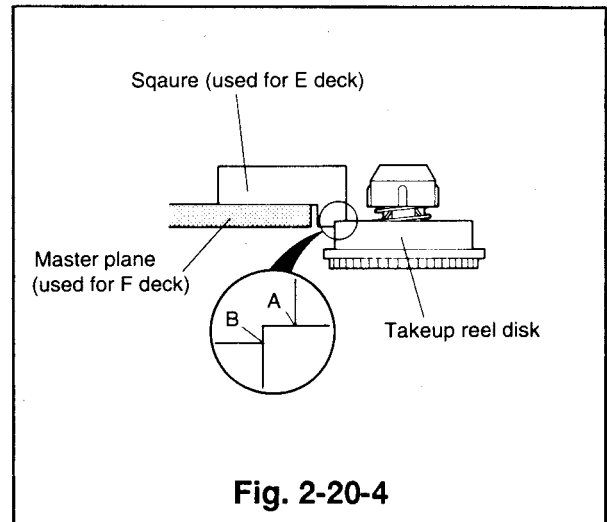

Fig. 2-20-4

2-21 Supply Reel Disk

(Removal)

- ① Remove the cassette housing. (Refer to Para. 2-1 for the removal method.)
- ② Remove the sub brake(SP) and the sub spring(SP). (Refer to Para. 2-14 for the removal method.)
- ③ Raise the part B of the tension brake belt upward to unfasten the belt from the supply reel disk as shown in Fig. 2-21-2. (Refer to Para. 2-19 for the removal method.)
- ④ Unfasten the catch shown in Fig. 2-21-1 and raise the supply reel disk upward to remove it from the shaft.

(Installation)

- ① Install the supply reel disk on the shaft.
- ② Install the height adjusting jig [master plane](used for F deck: Part No.859C342020) in the specified position. (Insert the jig into the hole A shown in Fig. 2-20-3 so that the jig sets on part B and the end of part C. Take care that the jig does not touch the supply and takeup reel disks.)
- ③ Place the height adjusting jig [square](used for E deck: Part No.859C341070) on the jig, previously installed placed in Item ④, as shown in Fig. 2-21-3. Make sure that the height is correct (between A and B).
- ④ Adjust the height of the supply reel disk by varying the number of the washers(Part No.552C017O20) under the disk.
 - A) If it is high, remove washer(s).
 - B) If it is low, add washer(s).

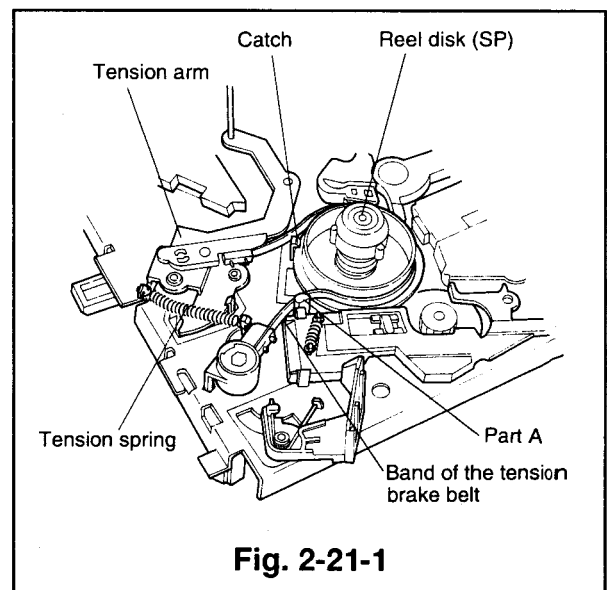

Fig. 2-21-1

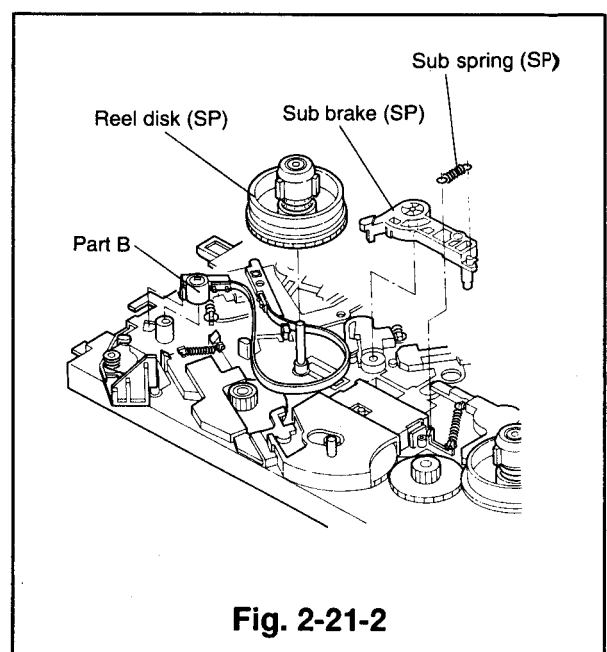

Fig. 2-21-2

- ⑤ Fasten the tension brake belt round on the supply reel disk, taking care not to score the belt and route part B of the tension brake belt as shown in Fig. 2-21-2. (Refer to Para. 2-19 for the installation method.) (The band of the tension brake belt must pass outside of the catch shown in Fig. 2-21-1 and inside of the part A.)
- ⑥ Install the sub brake(SP) and the sub spring(SP). (Refer to Para. 2-14 for the installation method.)
- ⑦ Install the cassette housing. (Refer to Para. 2-1 for the installation method.)

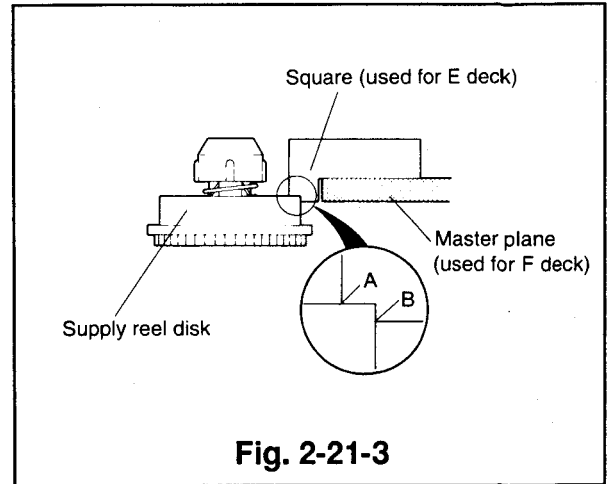

Fig. 2-21-3

2-22 Gear R(supply side) (Refer to Fig. 2-22-1.)

(Removal)

- ① Remove the cassette housing. (Refer to Para. 2-1 for the removal method.)
- ② Remove the sub brake(SP) and the sub spring(SP). (Refer to Para. 2-14 for the removal method.)
- ③ Unfasten the tension brake belt from the supply reel disk and remove the supply reel disk. (Refer to Para. 2-21 for the removal method.)
- ④ Remove the charge assembly. (Refer to item ② of Removal in Para. 2-18 for the removal method.)
- ⑤ Raise the gear R(SP) upward to remove it from the shaft.

(Installation)

- ① Install the gear R(SP) on the shaft.
- ② Install the supply reel disk. (Refer to Para. 2-21 for the installation method.)
- ③ Install sub brake(SP) and sub spring(SP). (Refer to Para. 2-14 for the installation method.)
- ④ Install the charge assembly. (Refer to Item ⑤ of Para. 2-18 for the installation method.)
- ⑤ Install the cassette housing. (Refer to Para. 2-1 for the installation method.)

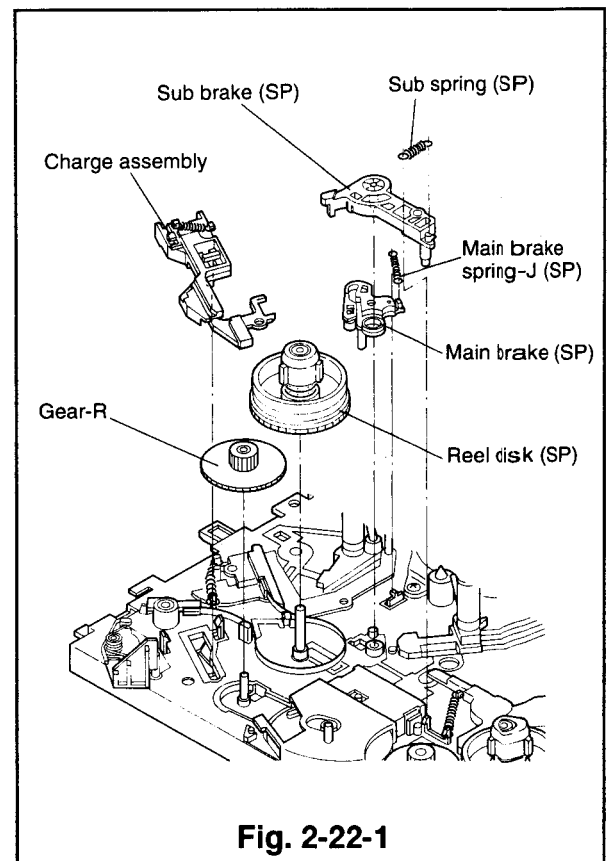

Fig. 2-22-1

2-23 Main Brake Release Lever

(Refer to Fig. 2-23-1.)

(Removal)

- ① Remove the cassette housing. (Refer to Para. 2-1 for the removal method.)
- ② Remove the sub brake(SP), and the sub spring(SP). (Refer to Para. 2-14 for the removal method.)
- ③ Remove the sub off lever, the sub brake(TU), and the sub spring(SP). (Refer to Para. 2-16 for the removal method.)
- ④ Remove the main brake(TU) and the main brake spring J(TU). (Refer to Para. 2-17 for the removal method.)
- ⑤ Shift catch A of the main brake release lever, and push catch B at the same time, in the direction shown by each arrow. Unfasten catch B from the main plate to remove the main brake release lever. (Refer to Fig. 2-23-2).

(Installation)

- ① Install the main brake release lever so that the shaft enters the inside groove shown in Fig. 2-23-3 of the main gear J.
- ② Install the main brake(TU) and the main brake spring J(TU). (Refer to Para. 2-17 for the installation method.)
- ③ Install the sub brake(TU), the sub off lever, and the sub spring(TU). (Refer to Para. 2-16 for the installation method.)
- ④ Install the sub brake(SP) and the sub spring(SP). (Refer to Para. 2-14 for the installation method.)
- ⑤ Install the cassette housing. (Refer to Para. 2-1 for the installation method.)

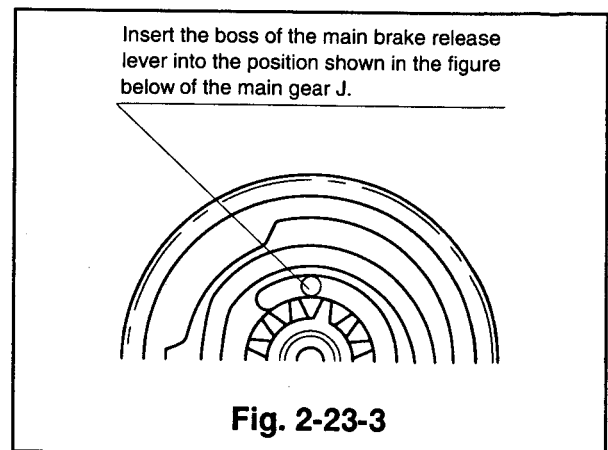
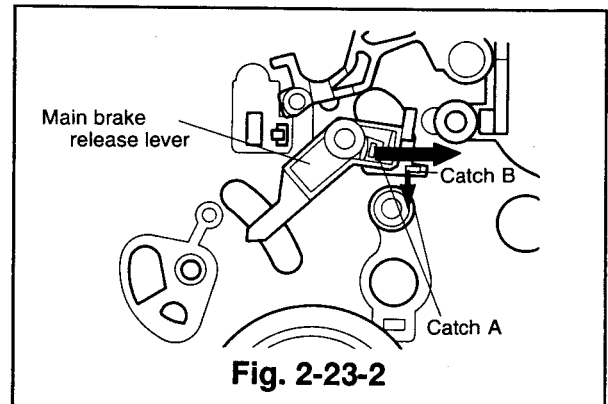
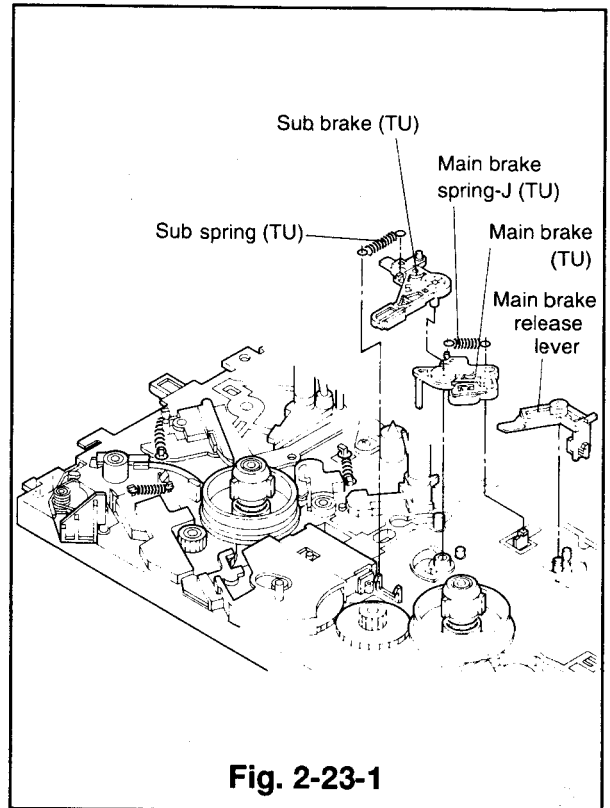

2-24 Pinch Cam Cap, Pinch Roller Arm Assembly, Pinch Cam, Takeup Guide Gear, Gear Pinch, Takeup Guide Arm, and Takeup Guide Spring

(Removal)

- ① Unfasten the catch shown in Fig. 2-24-1 and raise the pinch cam cap upward to remove it.
- ② Raise the pinch roller arm assembly upward to remove it.
- ③ Raise the pinch cam and the takeup guide gear upward to remove them from the shaft.
- ④ Unfasten the two catches holding the mode switch and remove the gear pinch from the shaft, lift the mode switch only high enough to remove the gear pinch. (Take care not to break the pins of the mode switch.)
- ⑤ Remove the nut at the top of the takeup guide arm with a (5.5mm) box screw driver.
- ⑥ Raise the takeup guide arm upward to remove it.
- ⑦ Remove the takeup guide spring.

(Installation)

- ① Hook one end of the takeup guide spring with the takeup guide arm, fix the takeup guide spring to the shaft.
- ② Apply grease(PG-641)[859D055O30] around the top of the new takeup guide arm (the surface which touches with the nut). Fix the takeup guide arm to the shaft, and secure it with the nut. (Set the takeup guide arm to the height shown in Fig. 2-24-2 temporarily.)
- ③ Lift the mode switch, only high enough to install the gear pinch and place the gear pinch under the mode switch. Fix the mode switch to the shaft so that the matching marks of the gear pinch align with those of the gear joint J and the mode switch as shown in Fig. 2-24-3.
- ④ Install the takeup guide gear so that the first cog of the takeup guide arm aligns with the matching mark on the takeup guide gear as shown in Fig. 2-24-4.
- ⑤ Apply grease(G)[859D055O50] to the area shown in Fig. 2-24-5 of the new pinch cam.
- ⑥ Turn the takeup guide arm clockwise while inserting the pinch cam into the gear pinch. Install the pinch cam so that it aligns with the triple catch. (Excessive rotation of the takeup guide arm will keep it from returning, since the takeup guide gear is caught on the pinch roller cam.)
- ⑦ Apply the grease (PG-641)[859D055O30] to the new pinch cam cap on the area shown in Fig. 2-24-1.
- ⑧ Install the pinch roller arm assembly and the pinch cam cap.

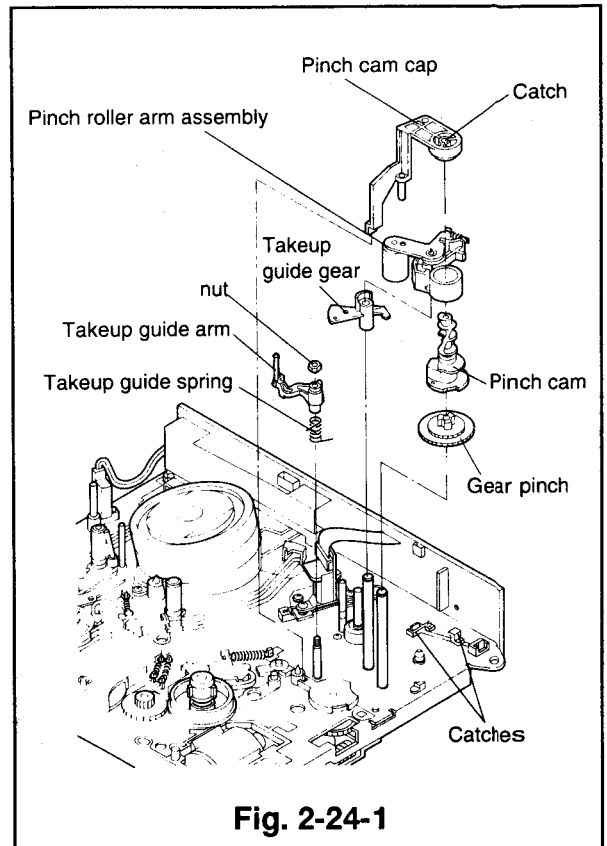

Fig. 2-24-1

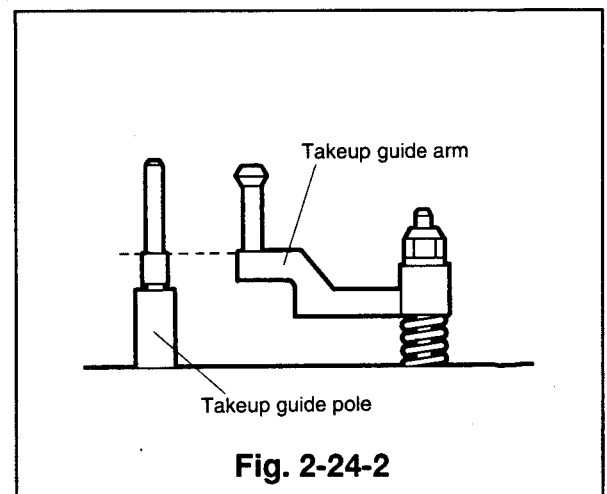

Fig. 2-24-2

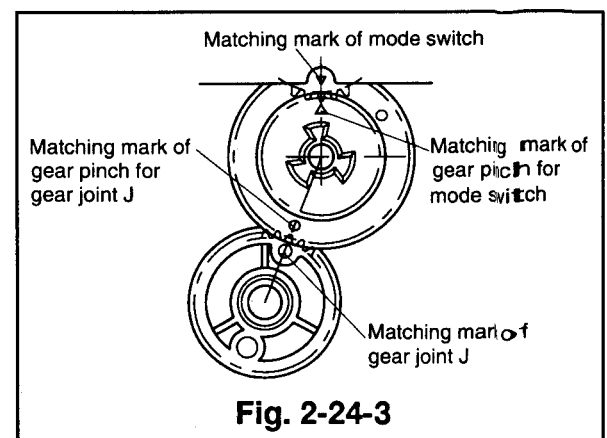
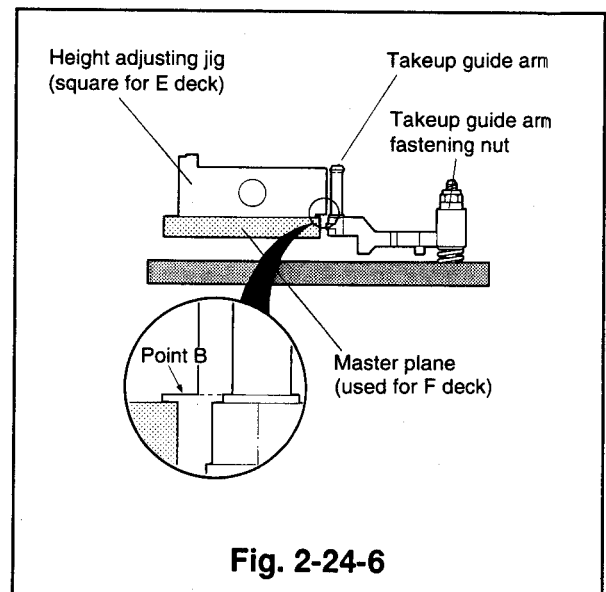
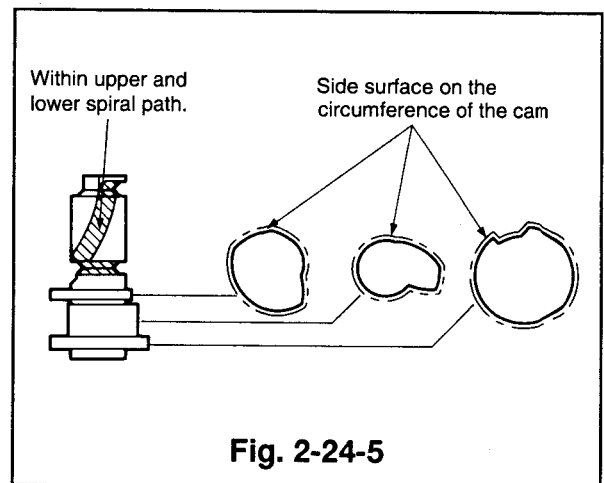
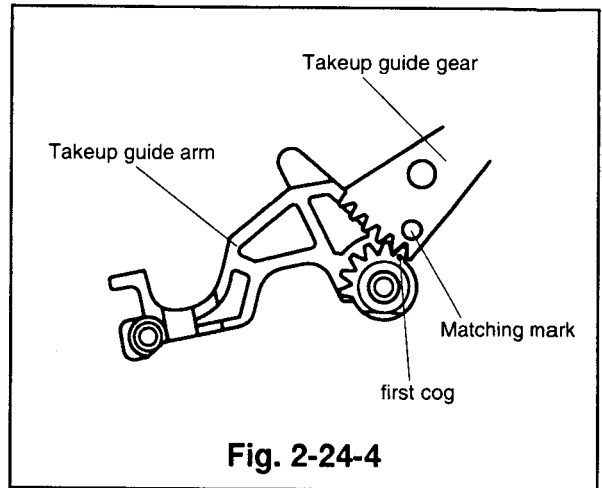

Fig. 2-24-3

[Adjustment of Takeup Guide Arm Height]

Adjust the height of the takeup guide arm according to the following procedure.

- ① Place the height adjusting jig (for the F deck) in the reference position on the main plate (Refer to Fig. 2-20-3). Tighten the takeup guide arm fastening nut so that the lower flange of the takeup guide arm is level with point B of the height adjusting jig (for the E deck). (Refer to Fig. 2-24-6).



2-25 Pinch Roller, Roller Cap, Pinch Spring, and Pinch Cam Spring

Note: During removal and installation, do not expand the pinch spring more than 18mm and the pinch cam spring more than 27mm.

(Removal)

- ① Pry the pinch roller and the roller cap to remove them as shown in Fig. 2-25-1.
- ② Remove the pinch spring and the pinch cam spring.

(Installation)

- ① Install the pinch cam spring and the pinch spring making sure that the pinch arm, the pinch slider, and the pinch lever are composed as shown in Fig. 2-25-2.
- ② Install the pinch roller so that the side, with the widest aluminium bushing, is on the roller cap side. Push the roller cap inside to secure the pinch roller. (Refer to Fig. 2-25-3)

Note: There are two types of pinch rollers as shown in Fig. 2-25-3. Each should be installed in the direction shown below.

(Type A)

The side on which aluminium is wider is attached to the roller cap.

(Type B)

The convex portion is attached to the roller cap.

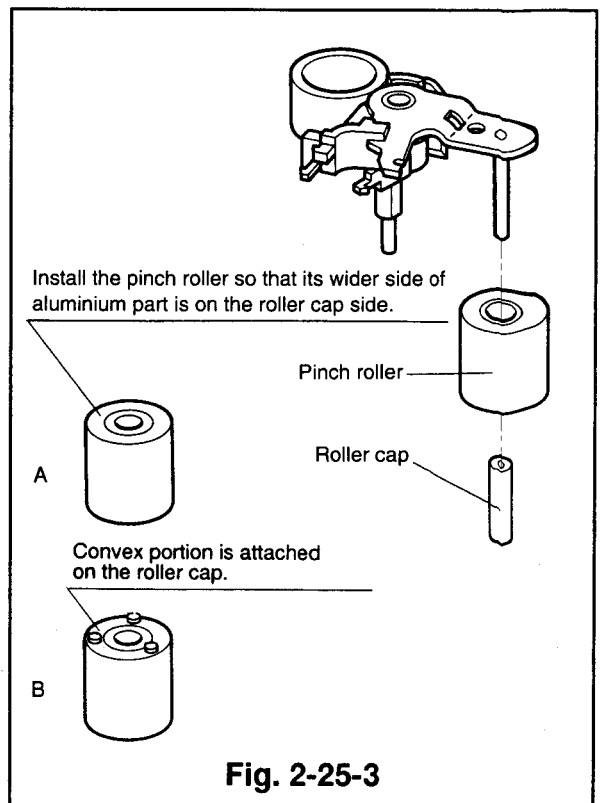
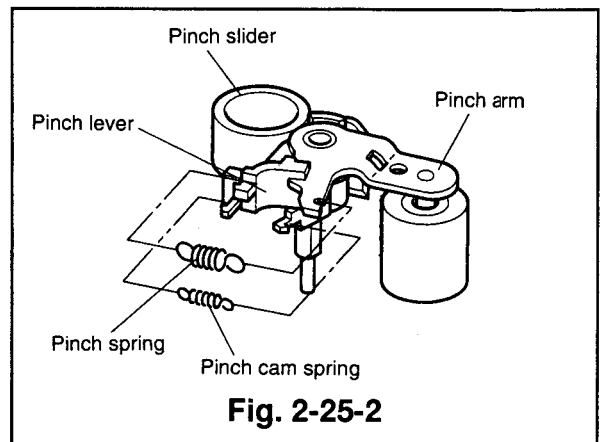
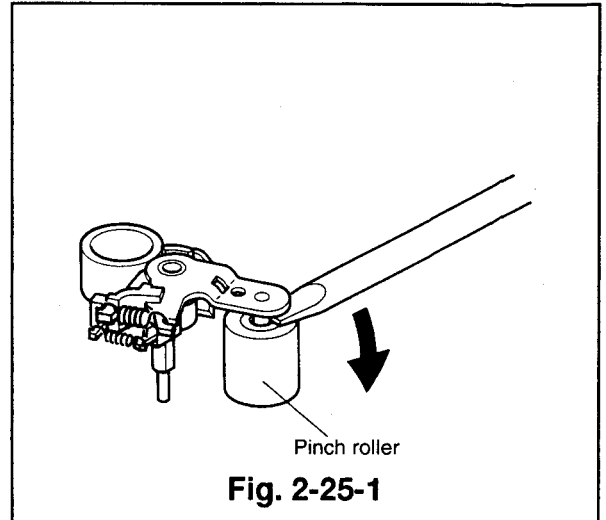

2-26 Mode Switch

(Removal)

- ① Remove the pinch cam cap, the pinch roller arm assembly, the pinch cam, and the takeup guide gear. (Refer to Para. 2-24 for the removal method.)
- ② Unsolder the five soldered terminals connecting the PCB-HEAD-AMP to the mode switch. (Refer to Fig. 2-26-1).
- ③ Unfasten two catches holding the mode switch. (Refer to Fig. 2-26-2.)
- ④ Slowly remove the mode switch, making sure that it is completely unsoldered.

(Installation)

- ① Insert the five pins and the boss of the mode switch shown in Fig. 2-26-1 into the matching holes of the PCB-HEAD-AMP. Place the mode switch on the main plate so that the matching mark of the gear pinch aligns with that of the mode switch and fasten it with the catches as shown in Fig. 2-26-3. (Also make sure that the matching mark of the gear joint aligns with that of the gear pinch.)
- ② Install the takeup guide gear, the pinch cam, the pinch roller arm assembly, and the pinch cam cap. (Refer to Para. 2-24 for the installation method.)

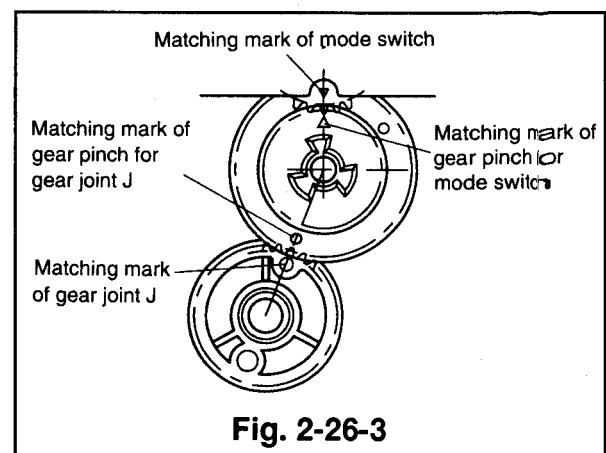
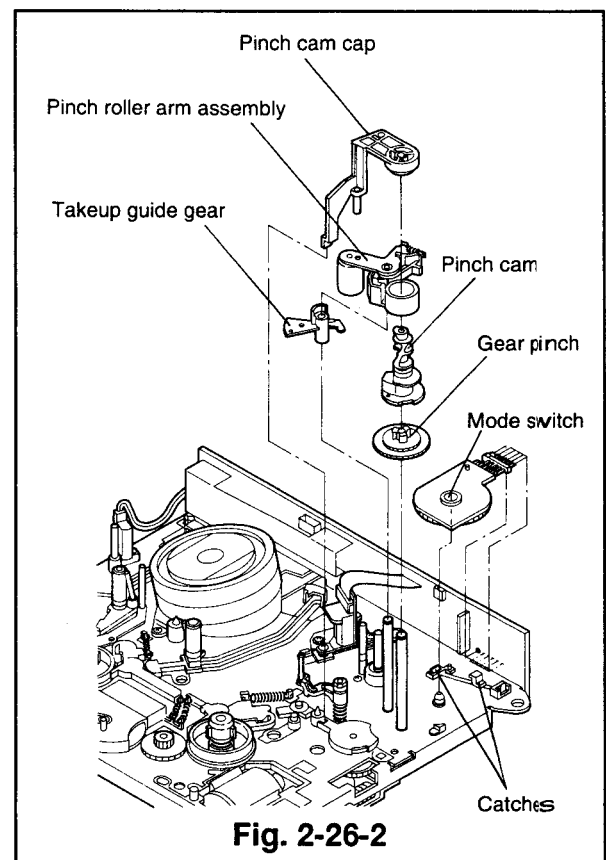
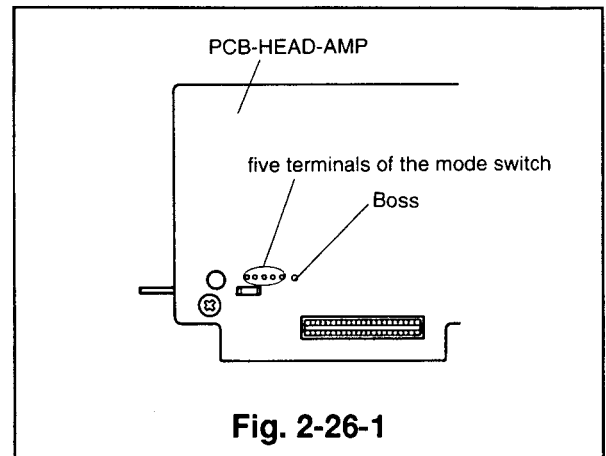

2-27 FE Head (Refer to Fig. 2-27-1.)

(Removal)

- ① Disconnect the lead connector, connected to the FE head.
- ② Remove the screw(Ⓐ) to remove the FE head.

(Installation)

- ① Secure the FE head with the screw(Ⓐ) and connect the lead connector to the FE head. (Route the lead connector, which is fastened with the catch as shown in Fig. 2-27-1, through the hook of the main plate.)

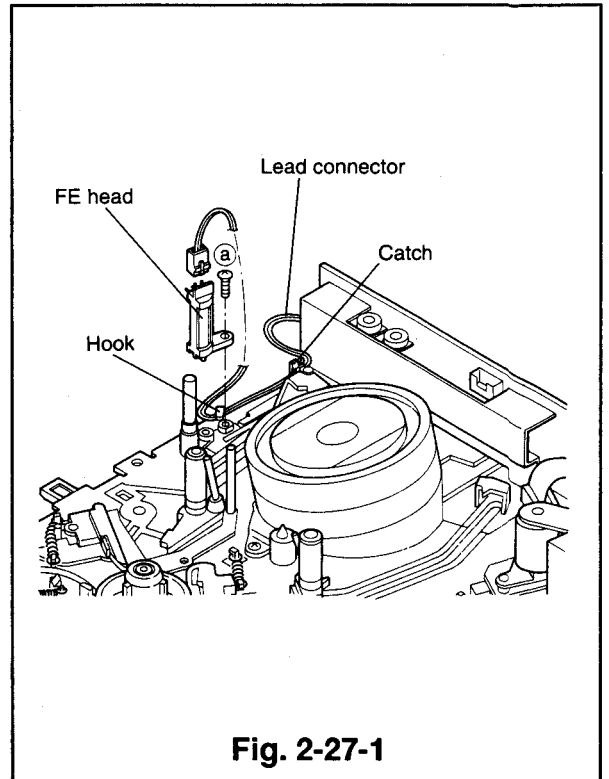

2-28 Reel Belt and Belt Pulley

(Removal)

- ① Unfasten the reel belt from the capstan motor and the belt pulley.
- ② Release the belt pulley as shown in Fig. 2-28-1 and raise the belt pulley upward to remove it.

(Installation)

Note: When installing the reel belt, make sure it is clean and free of grease. (Clean with dry gauze only)

- ① Fasten the belt pulley to the shaft. (When fixing the belt pulley to the shaft of the idler assembly, make sure that the three convex parts of the washer fixed to the shaft enter the matching dents.)
- ② Secure the belt pulley with the new cut washer.
- ③ Install the reel belt on the capstan motor and the belt pulley, taking care that the belt is not twisted.

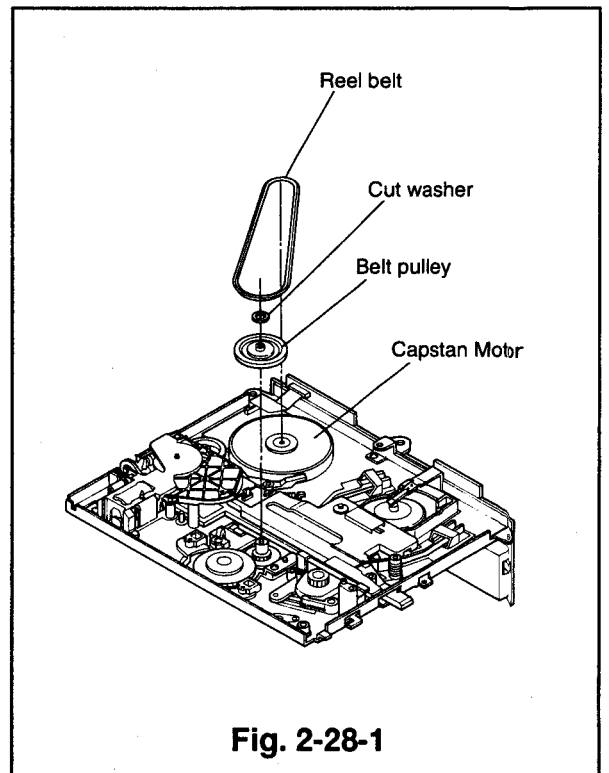

2-29 Loading Motor Assembly, Pulley Worm J, Loading Motor Belt, and Gear A

(Removal)

- ① Unfasten the reel belt. (Refer to Para. 2-28 for the removal method.)
- ② Remove the three screws (a, b and c) as shown in Fig. 2-29-2 and unfasten the three catches to remove the loading motor assembly (which holds the motor holder). (Refer to Fig. 2-29-1)
- ③ Remove the loading motor belt from the motor pulley. (Refer to Fig. 2-29-3.)
- ④ Unfasten the catches holding the motor holder to remove the loading motor assembly. (Refer to Fig. 2-29-3.)
- ⑤ Remove the pulley worm J, first the end attached to the part A shown in Fig. 2-29-3 and then the other end.
- ⑥ Remove the cut washer and unfasten the catch holding Gear A. Remove Gear A.
- ⑦ Pull the motor pulley to remove it from the loading motor.
- ⑧ Disconnect the wires from the loading motor.

(Installation)

- ① Solder the leads to the loading motor. (Red lead wire to the positive terminal and white lead wire to the negative terminal.)
- ② Install the motor pulley on the loading motor so that the space between the loading motor and the outer edge of the motor pulley is 8.5 ± 0.1 mm. (Refer to Fig. 2-29-4)
- ③ Install the loading motor assembly so that the label on it faces part B, shown in Fig. 2-29-3.
- ④ Apply grease (G)[859D055O50] to the areas shown in Fig. 2-29-4 of the new pulley worm J. Install the pulley worm J, first the end attached to the part C shown in Fig. 2-29-3 and then the other end.
- ⑤ Fix the gear A to the shaft of the motor holder J and secure it with new cut washers.
- ⑥ Lift the end attached to the part A shown in Fig. 2-29-3 of the pulley worm J. Fasten the loading motor belt on the pulley worm J and the motor pulley, taking care not to twist the belt.
- ⑦ Install the loading motor assembly (which holds the motor holder) in the position shown in Fig. 2-29-2 and secure it with the three screws (a, b and c).
- ⑧ Install the loading motor belt. (Refer to Para. 2-28 for the installation method.)

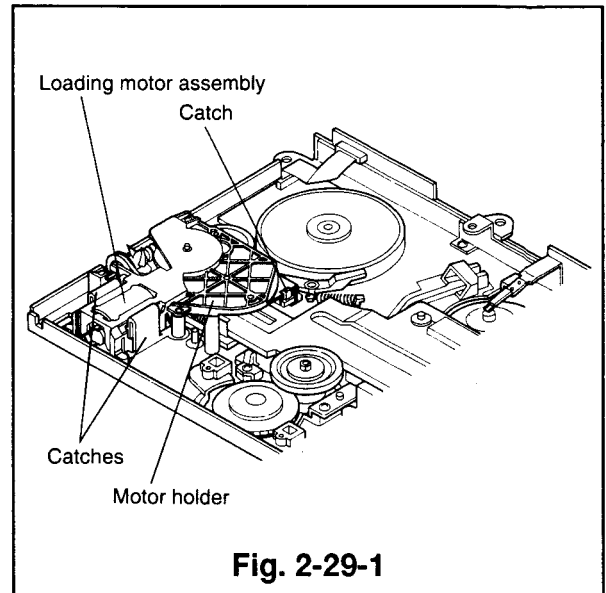

Fig. 2-29-1

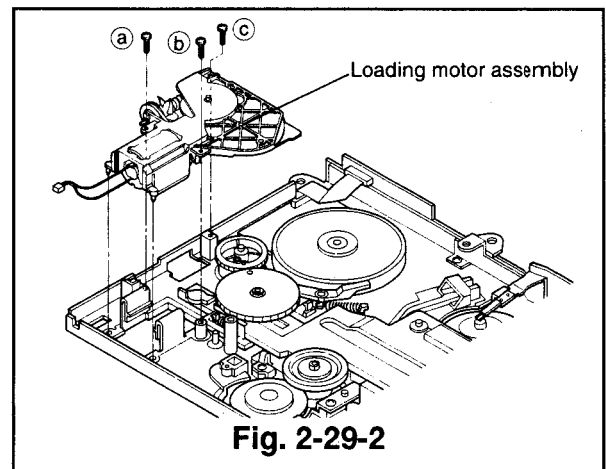

Fig. 2-29-2

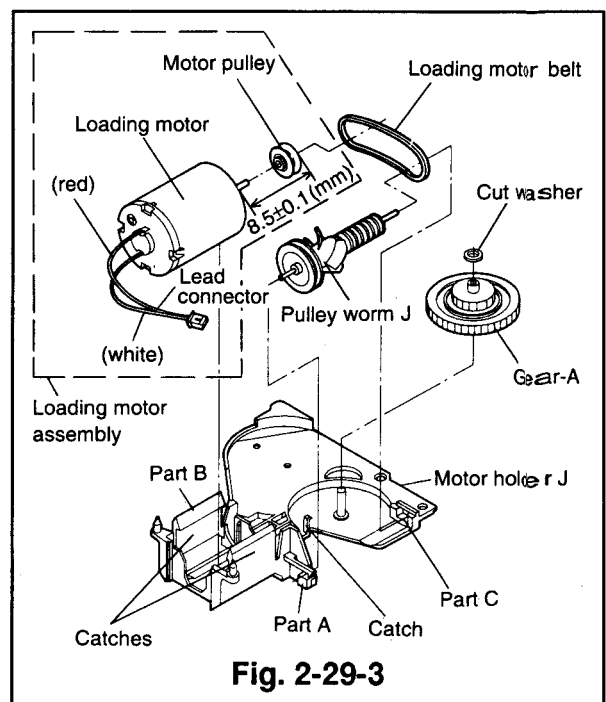

Fig. 2-29-3

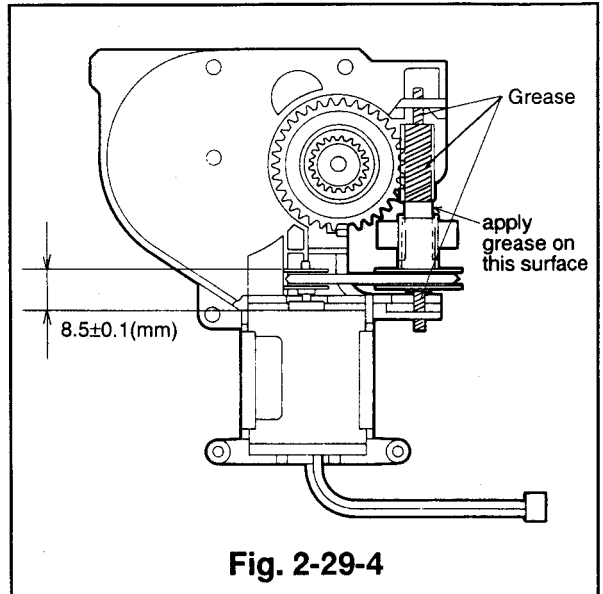

Fig. 2-29-4

2-30 Main Gear J

(Removal)

- ① Remove the reel belt. (Refer to Para. 2-28 for the removal method.)
- ② Remove the loading motor assembly (which holds the motor holder). (Refer to Para. 2-29 for the removal method.)
- ③ Remove the cut washer mounted on the main gear J.
- ④ Raise the main gear J upward to remove it.

(Installation)

- ① Apply grease(G)[859D055O50] to the outside cogs, the groove of the cam and to the inside small cogs of the new main gear J. (Refer to Fig. 2-30-2.)
- ② Make sure that the cam plate B is set to the right side, viewed from the bottom side of the deck. (Eject mode)
- ③ Push the axis of the main brak (TU) in the direction shown by the arrow until the main brake release lever moves freely. Turn the deck the right side up and shift the axis of the main brake release lever in the direction shown by the arrow. Then fix the main gear J to the shaft, with the axis of the main brake release lever held in place. Secure the main plate J with the cut washer. (Refer to Fig. 2-30-3) (Insert the pin of the capstan brake in the outside groove of the main gear J and align the matching marks of gear joint J and the main gear J.)(Refer to Fig. 2-30-4)
- ④ Install the loading motor assembly (which holds the motor holder) and the reel belt. (Refer to Para. 2-28 for the installation method.)

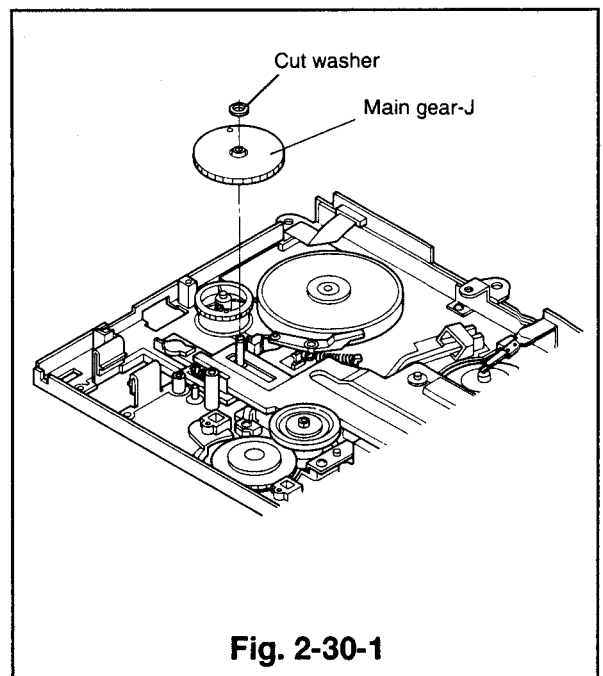

Fig. 2-30-1

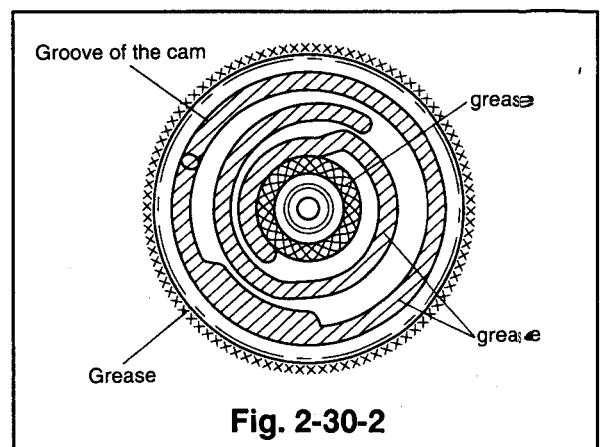
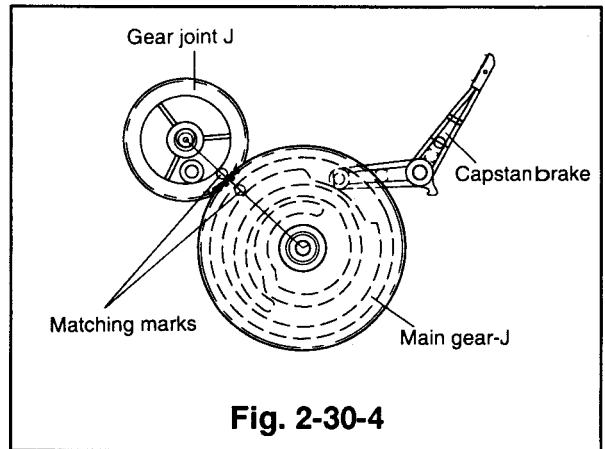
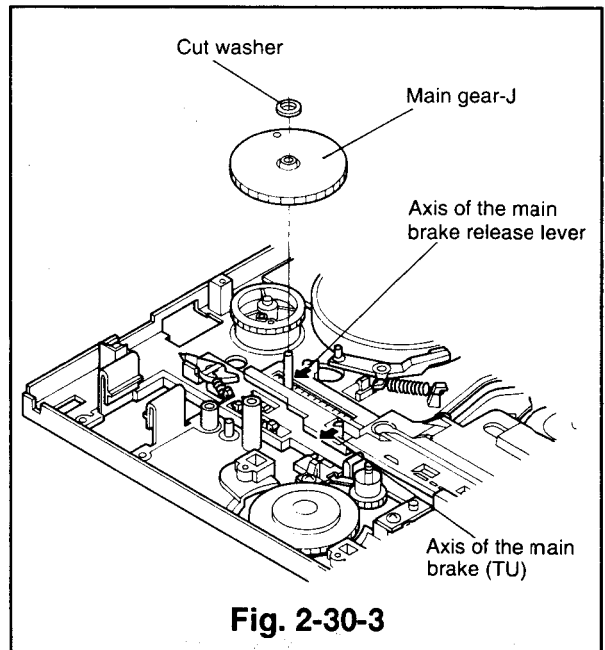

Fig. 2-30-2



2-31 Gear Joint J

(Removal)

- ① Remove the reel belt. (Refer to Para. 2-28 for the removal method.)
- ② Remove the loading motor assembly (which holds the motor holder). (Refer to Para. 2-29 for the removal method.)
- ③ Raise the gear joint J upward to remove it. (Refer to Fig. 2-31-1)

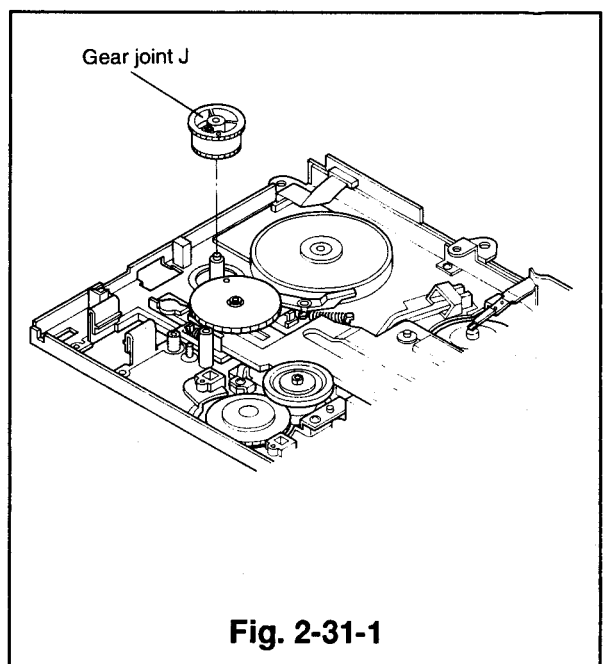

(Installation)

- ① Apply grease (PG-641)[859D055O30] to the new gear joint J on the whole circumference of the small cogwheel as shown in Fig. 2-31-2.
- ② Fix the gear joint J to the shaft so that the matching mark of the gear joint J aligns with that of the main gear as shown in Fig. 2-30-4.
- ③ Turn the deck the right side up, make sure that the matching mark of the gear pinch aligns with that of the gear joint J. (When turning the deck, hold the gear joint J, in place.)(Refer to Fig. 2-31-3)
- ④ Install the loading motor assembly(which holds the motor holder). (Refer to Para. 2-29 for the installation method.)
- ⑤ Install the reel belt. (Refer to Para. 2-28 for the installation method.)

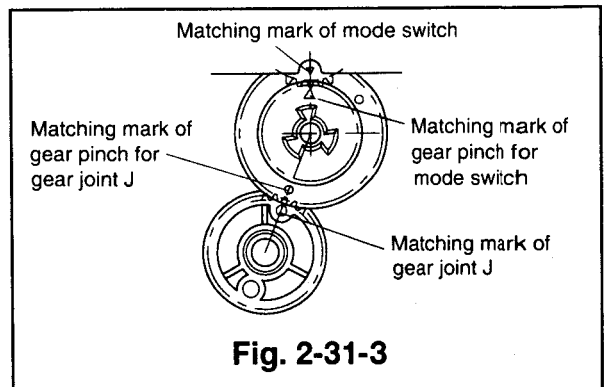
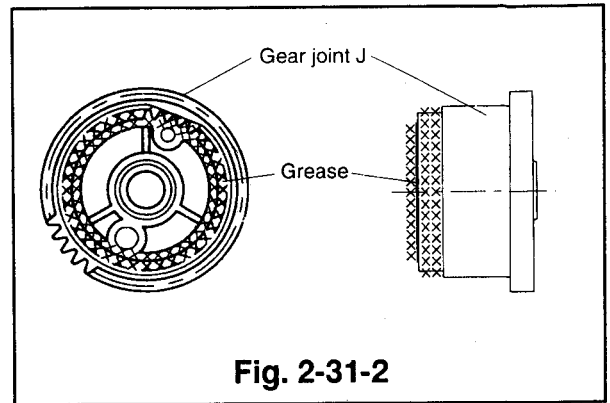

2-32 Capstan Brake and Capstan Brake Spring

(Removal)

- ① Remove the reel belt. (Refer to Para. 2-28 for the removal method.)
- ② Remove the loading motor assembly(which holds the motor holder). (Refer to Para. 2-29 for the removal method.)
- ③ Remove the main gear J. (Refer to Para. 2-30 for the removal method.)
- ④ Raise the capstan brake upward to remove it along with the capstan brake spring. (Refer to Fig. 2-32-1.)

(Installation)

- ① Install the capstan brake and the capstan brake spring.
- ② Install the main gear J. (Refer to Para. 2-30 for the installation method.)
- ③ Install the loading motor assembly(which holds the motor holder). (Refer to Para. 2-29 for the installation method.)
- ④ Fasten the reel belt. (Refer to Para. 2-28 for the installation method.)

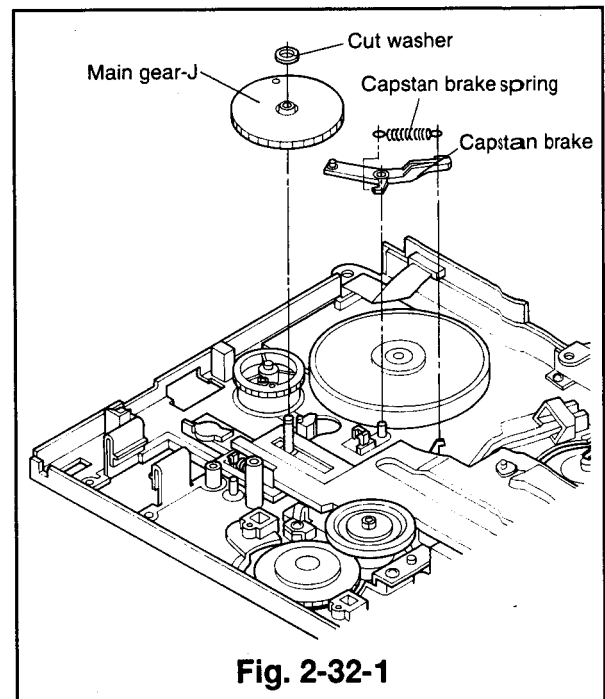

2-33 Plate J, Roller B, and Cam Plate B

(Removal)

- ① Remove the two screws (a) and (b) to remove the plate J. (Fig. 2-33-1)
- ② Take off the cut washer fixed to the shaft of the loading arm (TU) to remove the roller B.
- ③ Remove the reel belt. (Refer to Para. 2-28 for the removal method.)
- ④ Remove the belt pulley. (Refer to Para. 2-28 for the removal method.)
- ⑤ Remove the loading motor assembly (which holds the motor holder). (Refer to Para. 2-29 for the removal method.)
- ⑥ Remove the main gear J. (Refer to Para. 2-30 for the removal method.)
- ⑦ Slide the cam plate B to the left (the direction shown by the arrow) to remove it.

(Installation)

- ① Apply grease (G) [859D055050] to the area shown in Fig. 2-33-2 of the new cam plate B.
- ② Align the loading arms TU and SP so that the matching marks of the cogs align. (Refer to Fig. 2-37-3)
- ③ Passing part A of the cam plate B under cam spring B insert it into the hole on the side of the main plate, as shown by the continuous line. (Refer to Fig. 2-33-1)
- ④ While keeping the rear section of cam plate B raised, align the cam plate B and the cam gear R so that the ○ marks align with each other as shown in Fig. 2-33-3 (Fig. A). Still keeping the rear of cam plate B raised, slide it to the right until the △ marks on cam plate B and cam gear R align, refer Fig. 2-33-3 (Fig. B). From this position lower the rear of the cam plate B unto the already aligned loading gears TU and SP, refer 2 above. Shift the sub off lever and the main brake TU in the directions shown by the arrows to install them. (Refer to Fig. 2-33-1)
- ⑤ Fix the roller B to the shaft of the loading arm (TU) and secure it with the new cut washer.
- ⑥ Install the plate J and secure it with the two screws (a) and (b).
- ⑦ Install the main gear J. (Refer to Para. 2-30 for the installation method.)
- ⑧ Install the loading motor assembly (which holds the motor holder). (Refer to Para. 2-29 for the installation method.)
- ⑨ Install the belt pulley. (Refer to Para. 2-28 for the installation method.)
- ⑩ Fasten the reel belt. (Refer to Para. 2-28 for the installation method.)

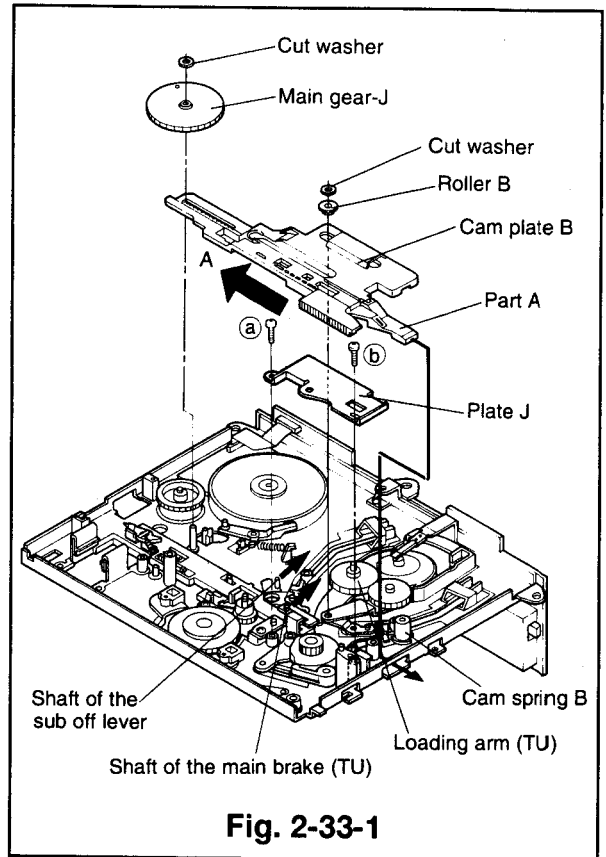

Fig. 2-33-1

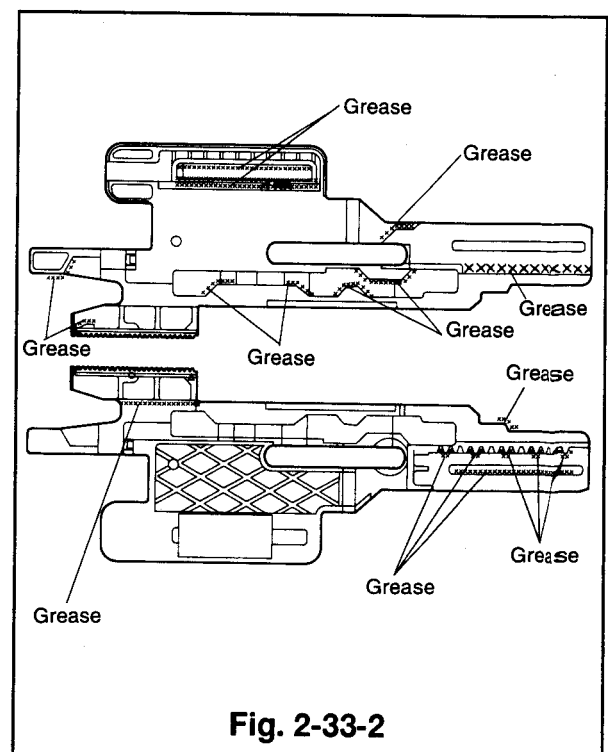

Fig. 2-33-2

2-34 Cam Gear R, Charge Lever, and Tension Off Lever

(Removal)

- ① Remove the cassette housing. (Refer to Para. 2-1 for the installation method.)
- ② Turn the deck the right side up and detach the tension spring. (Refer to Fig. 2-34-4.)
- ③ Remove the charge assembly. (Refer to item ② of Para. 2-18 for the removal method.)
- ④ Remove the reel belt and the pulley belt. (Refer to Para. 2-28 for the removal method.)
- ⑤ Remove the loading motor assembly (which holds the motor holder). (Refer to Para. 2-29 for the removal method.)
- ⑥ Remove the main gear J. (Refer to Para. 2-30 for the removal method.)
- ⑦ Remove the plate J, the roller B, and the cam plate B. (Refer to Para. 2-33 for the removal method.)
- ⑧ Raise the cam gear R upward to remove it. (Refer to Fig. 2-34-1.)
- ⑨ Remove the charge lever. (Refer to Fig. 2-34-1.)
- ⑩ Remove the tension off lever. (Refer to Fig. 2-34-1.)

(Installation)

- ① Let part A pass through part B shown in Fig. 2-34-1 to install the tension off lever.
- ② Fix the charge lever to the shaft.
- ③ Apply grease (PG-641) [859D055O30] to the area shown in Fig. 2-34-2 of the new cam gear R. (The groove and the flank of the outside circumference.)
- ④ Insert the cam gear R so that ○ mark is on the upside, with the charge lever set fully to the right end. Slowly turn the charge lever in the direction shown by the arrow until it enters the groove in the cam gear R. (Refer to Fig. 2-34-3)
- ⑤ Install the cam plate B, the roller B, and the plate J. (Refer to Para. 2-33 for the installation method.)
- ⑥ Install the main gear J. (Refer to Para. 2-30 for the installation method.)
- ⑦ Install the loading motor assembly (which holds the motor holder). (Refer to Para. 2-29 for the installation method.)
- ⑧ Install the belt pulley and the reel belt. (Refer to Para. 2-28 for the installation method.)
- ⑨ Hook the tension spring in the position shown in Fig. 2-34-4.
- ⑩ Install the charge assembly. (Refer to Item ⑤ of Para. 2-18 for the installation method.)
- ⑪ Install the cassette housing. (Refer to Para. 2-1 about the installation method.)

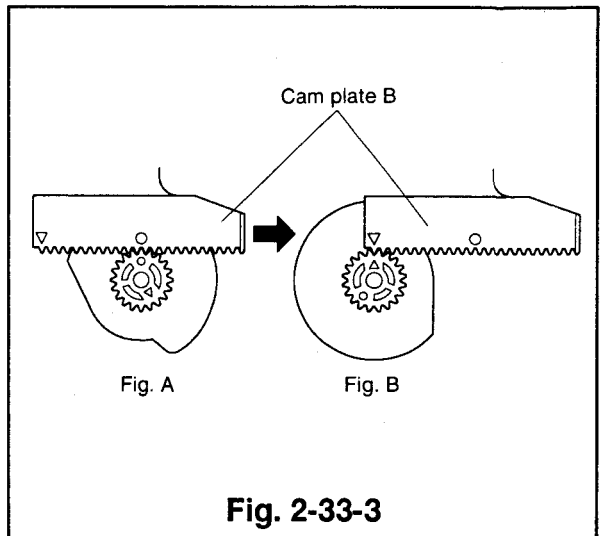

Fig. 2-33-3

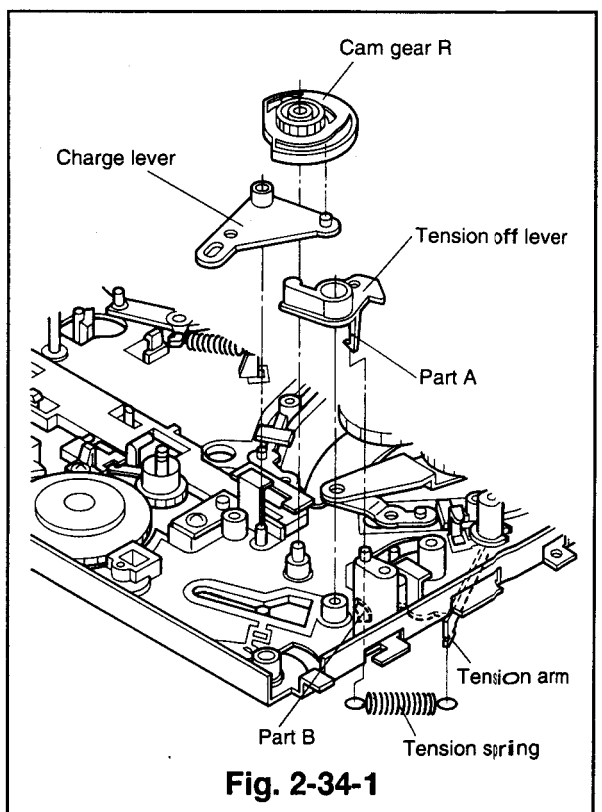

Fig. 2-34-1

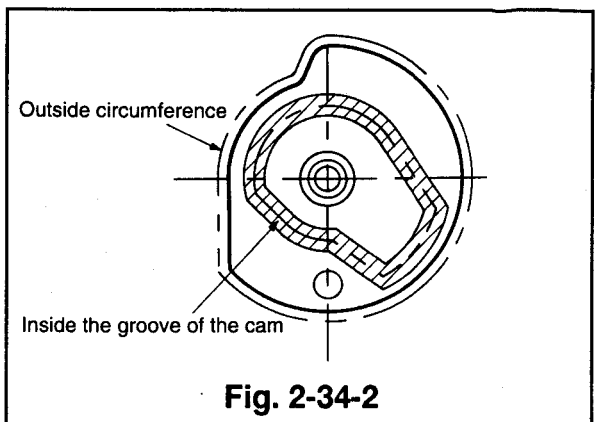
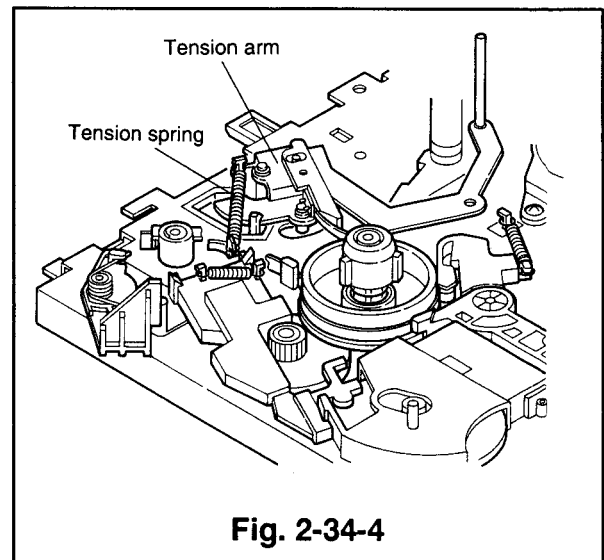
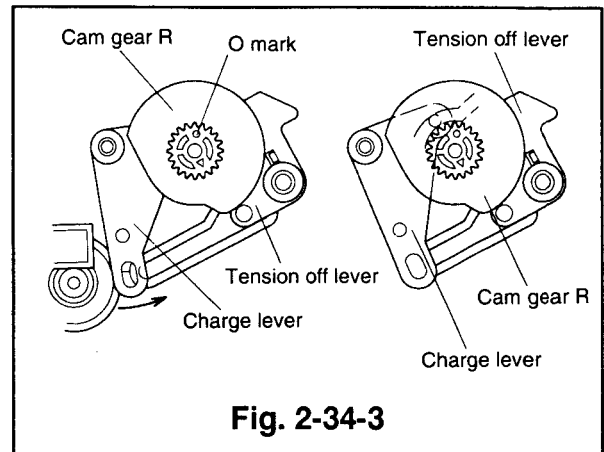

Fig. 2-34-2



2-35 Reel Idler Assembly

(Removal)

- ① Remove the reel belt and the belt pulley. (Refer to Para. 2-28 for the removal method.)
- ② Remove the two screws (a) and (b) holding the reel idler assembly.
- ③ Unfasten the two catches shown in Fig. 2-35-2 and push the reel idler assembly to remove it, with the deck right side up.

(Installation)

- ① Insert the part B of the reel idler assembly under the plate cam B as shown in Fig. 2-35-1 and insure projection A enters the hole on the main plate. Position the reel idler assembly so that its screw holes are aligned and secure it with the two screws (a) and (b). (Fig. 2-35-3 shows its appearance, viewing from the top.)
- ② Install the belt pulley and the reel belt. (Refer to Para. 2-28 for the installation method.)

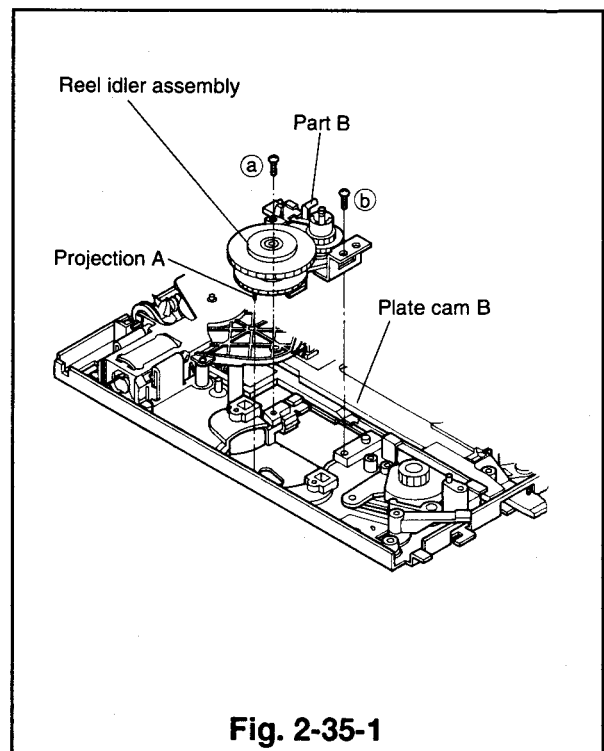

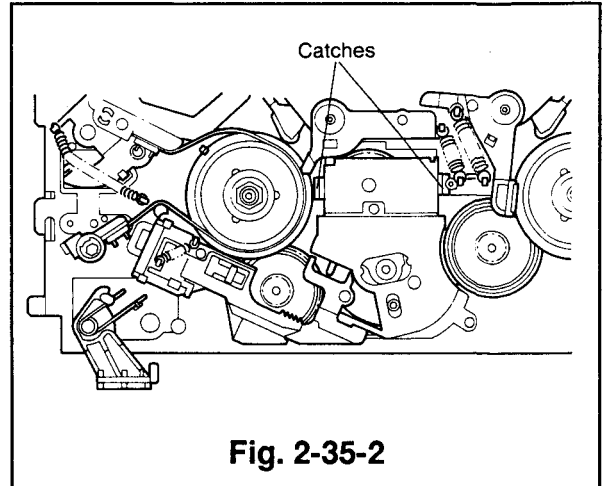

Fig. 2-35-2

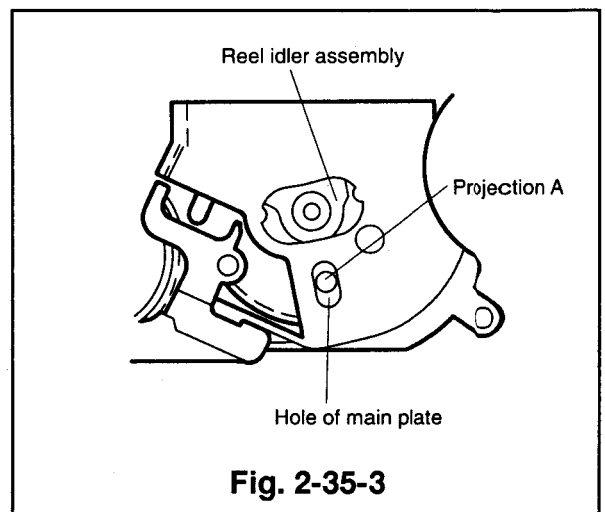

Fig. 2-35-3

**2-36 Cam Plate C and Cam Spring C
(Removal)**

- ① Remove the reel belt and the belt pulley. (Refer to Para. 2-28 for the removal method.)
- ② Remove the reel idler assembly. (Refer to Para. 2-35 for the removal method.)
- ③ Remove the loading motor assembly (which holds the motor holder). (Refer to Para. 2-29 for the removal method.)
- ④ Remove the main gear-J. (Refer to Para. 2-30 for the removal method.)
- ⑤ Remove the plate-J, the roller-B, and the cam plate-B. (Refer to Para. 2-33 for the removal method.)
- ⑥ Remove the cam spring-C. (Refer to Fig. 2-36-1.)
- ⑦ Slide the cam plate-C to the left end.
- ⑧ Unfasten the catch and raise the cam plate-C to remove it. (refer to Fig. 2-36-1.)

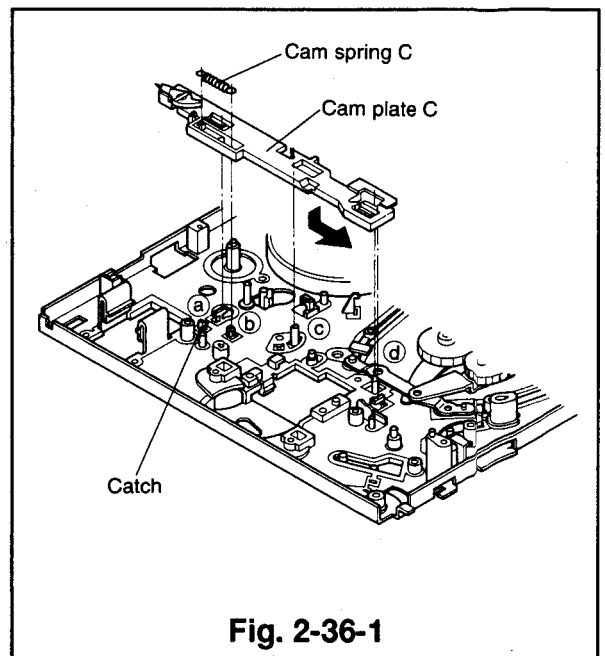

Fig. 2-36-1

(Installation)

- ① Apply grease(PG-641)[859D055O30] to the area shown in Fig. 2-36-2 of the new cam plate-C.
- ② Position the cam plate-C so that the four points(Ⓐ, Ⓑ, Ⓒ and Ⓓ) shown in Fig. 2-36-1 enter into the matching holes and slide it to the right end.
- ③ Install the cam spring-C.
- ④ Install the cam plate-B, the roller-B, and the plate-J. (Refer to Para. 2-33 for the installation method.)
- ⑤ Install the main gear-J. (Refer to Para. 2-30 for the installation method.)
- ⑥ Install the loading motor assembly(which holds the motor holder). (Refer to Para. 2-35 for the installation method.)
- ⑦ Install the reel idler assembly. (Refer to Para. 2-35 for the installation method.)
- ⑧ Install the belt pulley and the reel belt. (Refer to Para. 2-28 for the installation method.)

2-37 Loading Arm(SP, TU)

(Removal)

- ① Remove the reel belt and the belt pulley. (Refer to Para. 2-28 for the removal method.)
- ② Remove the loading motor assembly(which holds the motor holder). (Refer to Para. 2-29 for the removal method.)
- ③ Remove the main gear-J. (Refer to Para. 2-30 for the removal method.)
- ④ Remove the plate-J, the roller-B, and the cam plate-B. (Refer to Para. 2-33 for the removal method.)
- ⑤ Raise the loading arms upward, first SP and then TU, to remove them.(Refer to Fig. 2-37-1)

(Installation)

- ① Move the takeup and supply tape guides to the unloaded position. If the supply tape guide is in the loaded position it will be necessary to shift the tension arm in the direction of the arrow in Fig. 2-37-2 at the same time moving the supply tape guide to the unloading position.
- ② Place the new loading arm(TU) in the position shown in Fig. 2-37-1, then place the loading arm(SP) in the position shown in Fig. 2-37-1 at the same time aligning the marks on the cogs, refer Fig. 2-37-3(shaded area).
- ③ Apply grease(G)[859D055O50] to the area, which touches the cogwheel of the loading arm(TU) when the loading arms(SP and TU) are shifted fully to the loading direction, and grease(G)[859D055O50] to the gear portion which gears with the plate cam B. (Refer to Fig.2-37-4.)

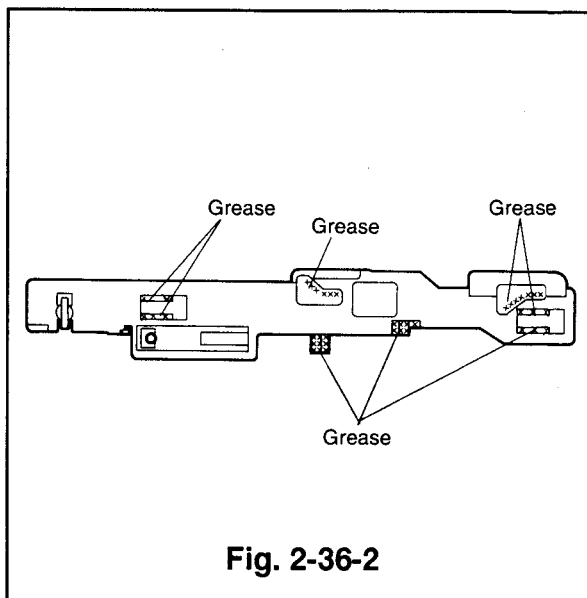

Fig. 2-36-2

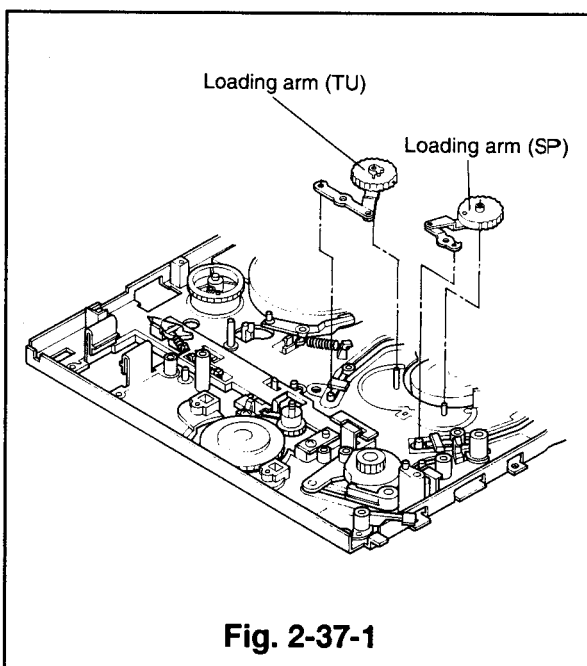

Fig. 2-37-1

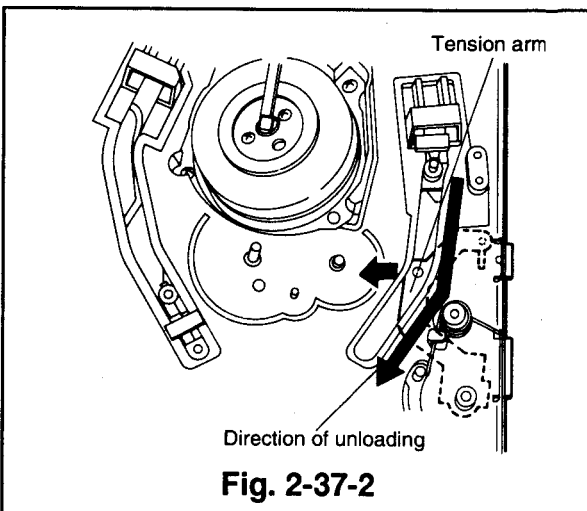

Fig. 2-37-2

- ④ Install the cam plate-B, the roller-B, and the plate-J. (Refer to Para. 2-33 for the installation method.)
- ⑤ Install the main gear-J.(Refer to Para. 2-30 for the installation method)
- ⑥ Install the loading motor assembly (which holds the motor holder). (Refer to Para. 2-29 for the installation method.)
- ⑦ Install the belt pulley and the reel belt. (Refer to Para. 2-28 for the installation method.)

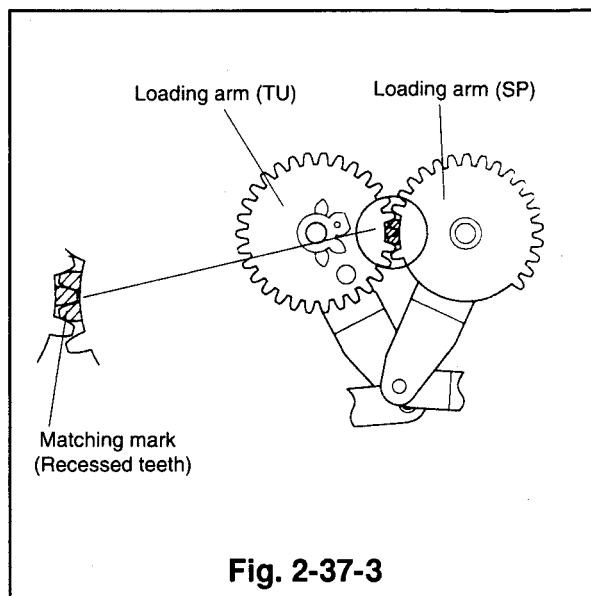

Fig. 2-37-3

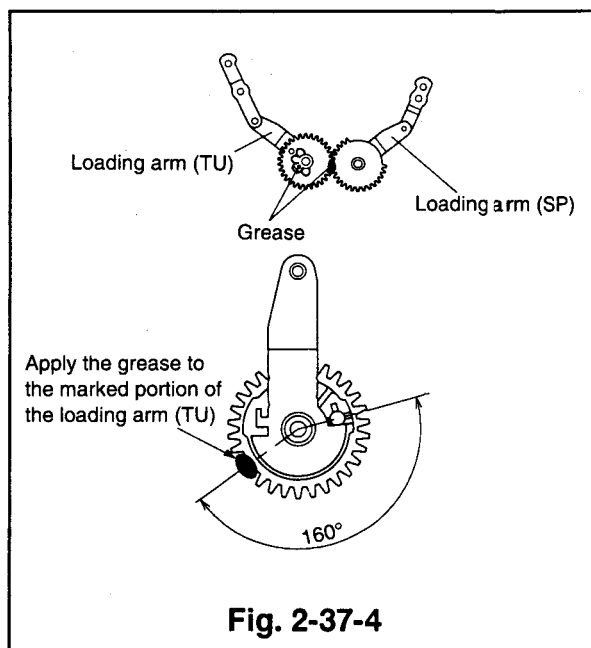

Fig. 2-37-4

2-38 Capstan Motor and Lead Card

Note: During removal and installation of the capstan motor, take care not to touch or score the tape running surface, and insure there is no grease on the outside of the rotor's rim.

(Removal)

- ① Unfasten the reel belt.
- ② Disconnect the lead card, connected to the PCB of the capstan motor and the PCB-HEAD-AMP. (Refer to Fig. 2-38-1.)
- ③ Turn the deck the right side up, remove the three screws shown in Fig. 2-38-2 to remove the capstan motor.

Note: During removal, support the capstan motor assembly when it is not secured by its fastening screws. Take care not to touch other parts.

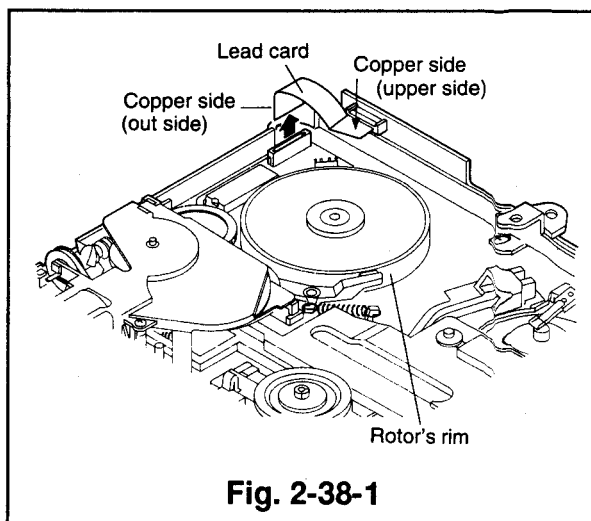
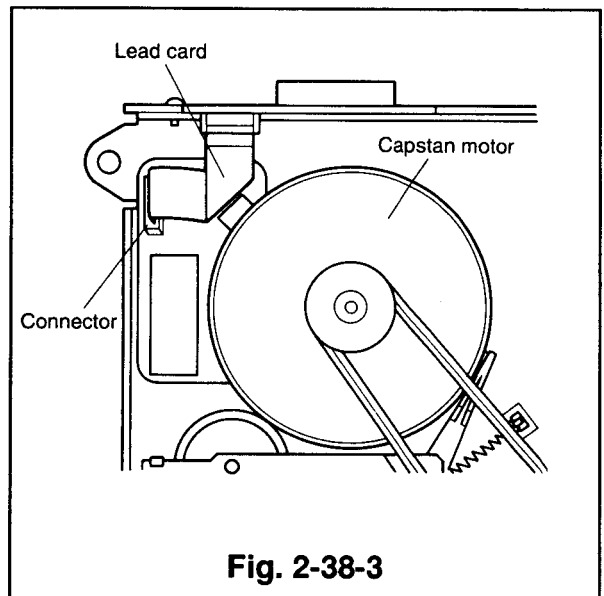
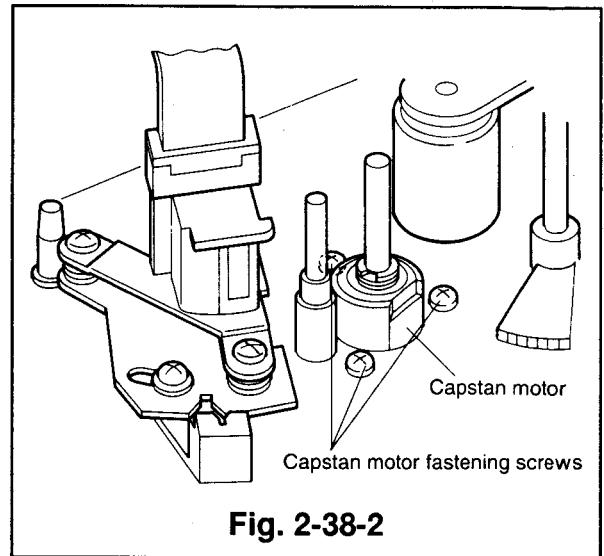

Fig. 2-38-1

(Installation)

- ① Reverse the deck, position the capstan motor so that the capstan brake is on the outside of the capstan motor.
- ② Turn the deck the right side up, secure the capstan motor with the three screws shown in Fig. 2-38-2.
- ③ Bend the new lead card as shown in Fig.2-38-3 and connect it to the connectors of the PCB of the capstan motor and the PCB-HEAD-AMP so that copper side appears as shown in Fig. 2-38-1. Take care not to touch the rotor of the capstan motor.
- ④ Install the reel belt. (Refer to Para. 2-28 for the installation method.)



2-39 A/C Head Assembly

(Removal)

Note: During installation of A/C head assembly, take care not to touch or score the tape running surface.

- ① Lift the stopper shown in Fig. 2-39-1 upward and disconnect the lead connector (bare wire), which is connected to the PCB-A/C-HEAD.
- ② Remove the two screws (a) and (b) holding the A/C head assembly to the main plate, and to remove the A/C head assembly. (Refer to Fig. 2-39-2.)

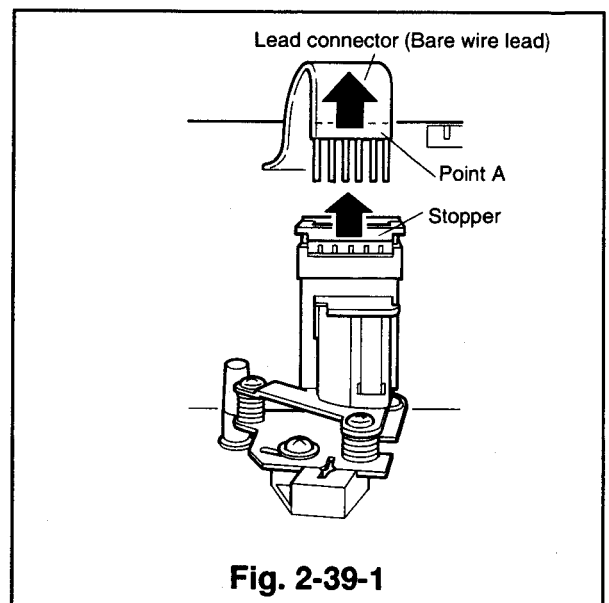

(Installation)

- ① Make sure that the spring(A/C earth spring) is as shown in Fig. 2-39-3.
- ② Place the A/C head assembly in the position shown in Fig. 2-39-2 and secure it with the two screws(Ⓐ and Ⓑ).
- ③ Shift part A downward and lower the stopper. Connect the lead connector to the connector on the PCB-A/C-HEAD as shown in Fig. 2-39-1.

Note: Conduct the A/C head adjustment and the phase adjustment as outlined in Para. 3-3 and 3-4 after the new A/C head is installed.

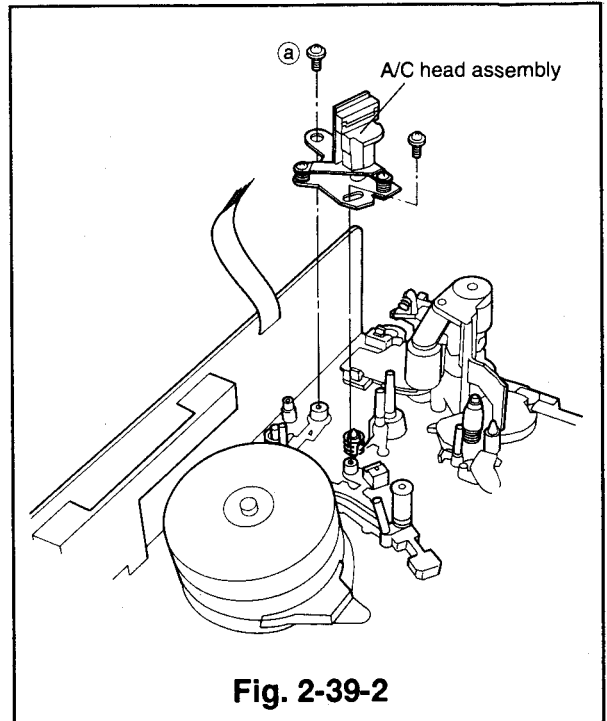

Fig. 2-39-2

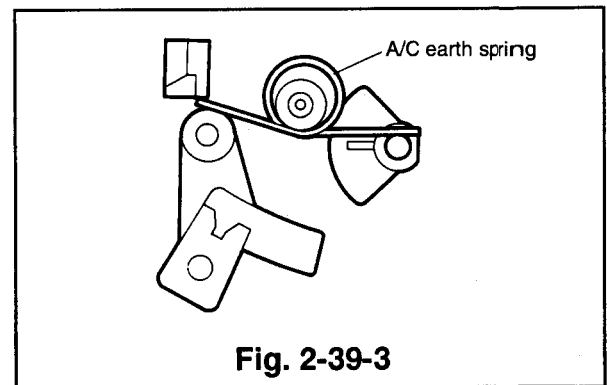

Fig. 2-39-3

2-40 A/C Head

(Removal)

- ① Disconnect the lead connector connected to the PCB-A/C-HEAD. (Refer to Item ① of Para. 2-39 for the removal method.)
- ② Remove the three screws(Ⓐ, Ⓑ and Ⓒ), shown in Fig. 2-40-1 to remove the A/C head.
- ③ Unsolder the PCB-A/C HEAD from the A/C head. (Refer to Fig. 2-40-1.

(Installation)

- ① Install the A/C head with the A/C spring and the three screws(Ⓐ, Ⓑ and Ⓒ) as shown in Fig. 2-40-1.

Note: When installing the A/C head on the A/C plate, the base plate of the A/C head must be parallel to the A/C plate and the spacing between them should be as specified in Fig. 2-40-2.

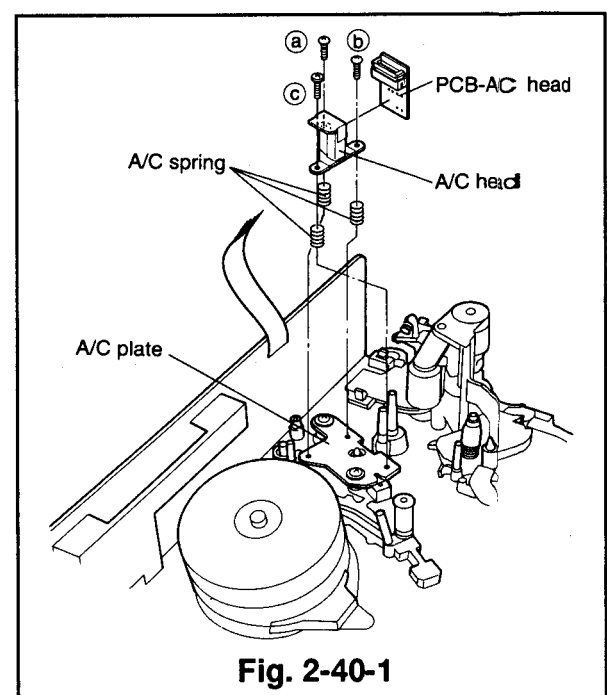
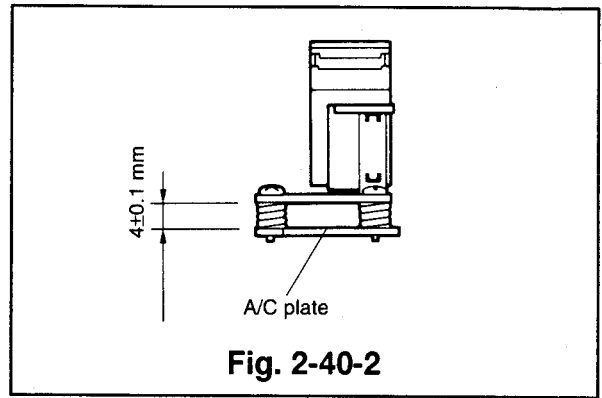

Fig. 2-40-1

- ② Connect the lead connector to the PCB-A/C-HEAD. (Refer to Item ③ of Para. 2-39 for the installation method.)
- ③ Perform the A/C head adjustment as outlined in Para. 3-3 and the phase adjustment as outlined in Para. 3-4.



2-41 Supply & Takeup Guide Rollers

(Removal)

- ① Loosen the set screws with a hexagon key so that the guide rollers rotate freely.
- ② Turn the height adjustment screws at the top of the guide rollers counterclockwise with a height adjustment screwdriver to loosen them. Lift the guide roller upward to remove them from the tape guides. (Refer to Fig. 2-41-1)

(Installation)

- ① Make sure that the rubber rings are fixed to the fastening thread portions of the new guide rollers.
- ② Perform the following steps ③ to ⑤ to seat in the rubber rings.
- ③ Slowly turn the guide rollers clockwise until the rubber rings are firmly seated.
- ④ Turn the guide rollers a further 1/6 of a turn clockwise and then turn them one turn counter-clockwise.
- ⑤ Slowly turn the guide rollers clockwise until they become firmly seated again. Turn the guide rollers a further 1/6 of a turn clockwise.
- ⑥ Secure the guide rollers lightly with the set screws. Perform the mechanism check and adjustment of the FM envelope as outlined in Para. 3-2.

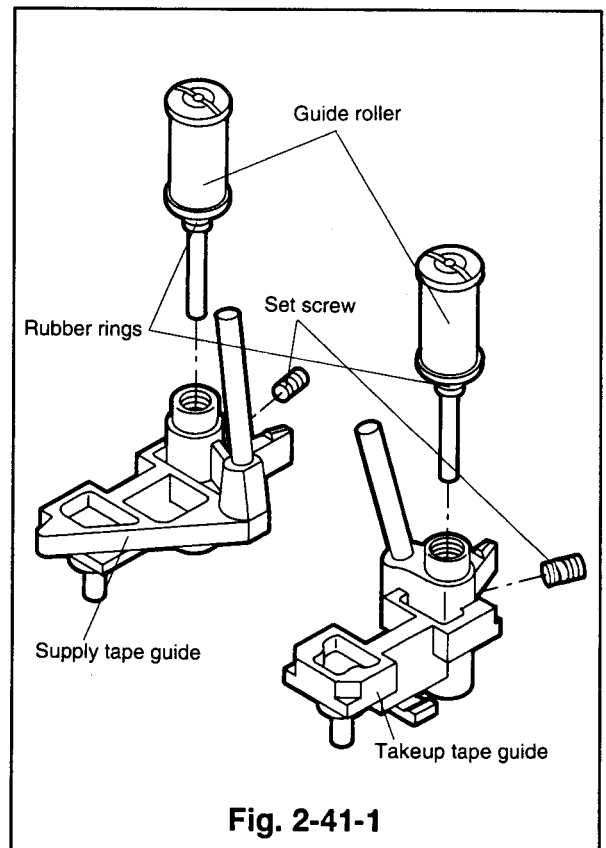

2-42 Cleaning Roller, Cleaning Arm, Cleaning Lever, and Cleaning Spring

(Removal)

- ① Remove the PCB-HEAD-AMP. (Refer to Para. 2-8 for the removal method.)
- ② Unfasten the catch to remove the cleaning roller. (Refer to Fig. 2-42-1)
- ③ Turn part A of the cleaning assembly clockwise as shown in Fig. 2-42-2 to release the catch part B Fig. 2-42-2 and Fig. 2-42-3(c). Release the catch part E and remove the cleaning assembly from the shaft.
- ④ Remove the cleaning spring to detach the cleaning arm and the cleaning lever.

(Installation)

- ① Attach the cleaning arm to the cleaning lever and turn it clockwise as shown in Fig. 2-42-3(c). Make sure that the cleaning arm and the cleaning lever turn without binding.
- ② Hook one end of the cleaning spring with the boss (point C), projecting from the cleaning arm, and the other end to point D of the cleaning lever as shown in Fig. 2-42-3(d).
- ③ Place the cleaning assembly in the position shown in Fig. 2-42-1, and in the direction shown in Fig. 2-42-2(b). Turn the part A, shown in Fig. 2-42-2, counterclockwise to set the part B under the A/C plate of the A/C head assembly. Make sure that the spring hooks with the boss of the main plate shown in Fig. 2-42-2. Shift the part A in the direction shown by the arrow and release to make sure that it returns.
- ④ Insert the cleaning roller into the position shown in Fig. 2-42-1 to install it.

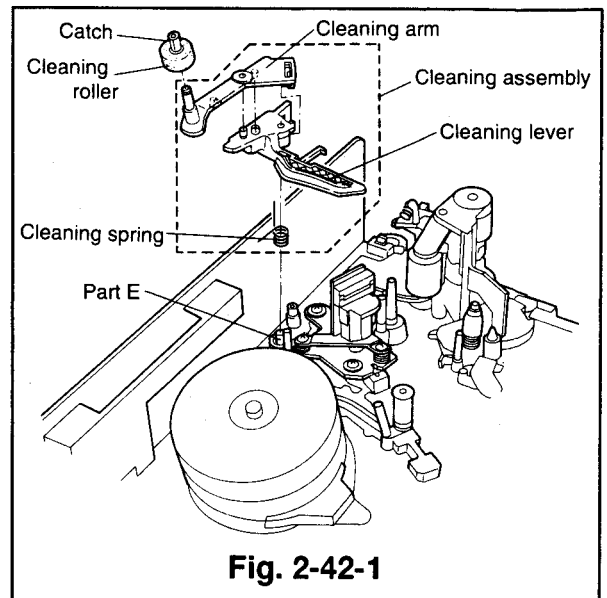

Fig. 2-42-1

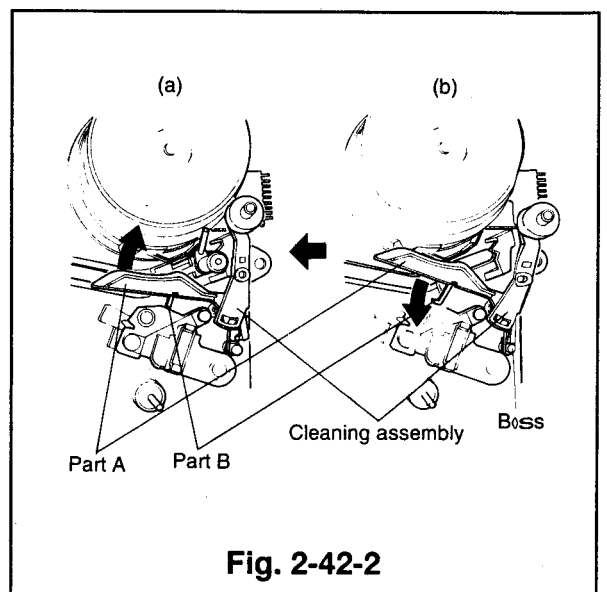

Fig. 2-42-2

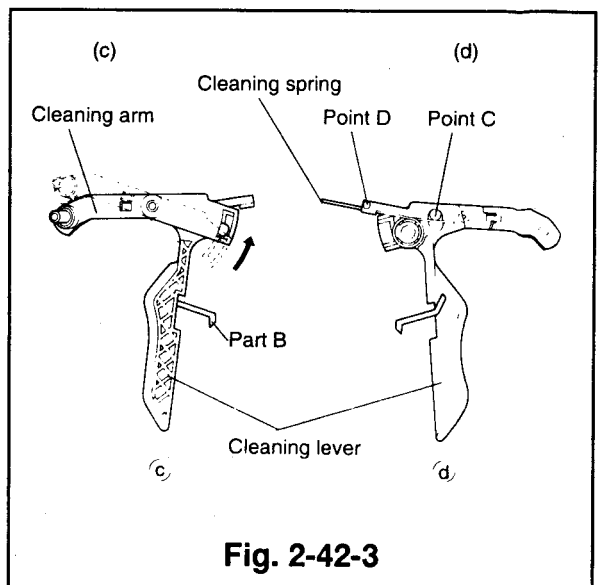

Fig. 2-42-3

2-43 Supply & Takeup Tape Guide Assemblies

(Removal)

- ① Remove the cassette housing. (Refer to Para. 2-1 for the removal method.)
- ② Remove the PCB-HEAD-AMP. (Refer to Para. 2-8 for the removal method.)
- ③ Remove the cleaning assembly. (Refer to item ④ of Para. 2-42 for the removal method.)
- ④ Unscrew the three screws (a, b and c) to remove the drum base together with the drum assembly. (Refer to Fig. 2-43-1.)
- ⑤ Slide the supply and takeup tape guide assemblies to the end of the loaded position by either of the following methods.
 - Supply voltage (approximately 5V plus voltage on the red wire) to the loading motor as in ② of the removal method in Para. 2-19.
 - Turn part A of pulley worm J by hand, in the direction shown by the arrow (a) as shown in Fig. 2-43-3. Raise the supply and takeup tape guide assemblies upward to remove them.

(Installation)

- ① Apply grease (PG-641) [859D055O30] to the area shown in Fig. 2-43-2 of the supply tape guide assembly.
- ② Install the supply and takeup tape guide assemblies so that they respectively enter the holes at the ends of the loading arms (SP and TU) attached to the reverse side of the deck as shown in Fig. 2-43-1.
- ③ Slide the supply and takeup tape guide assemblies to the unloaded position, by either of the following methods so that the upper hole of the mode switch aligns with that of the cogwheel as shown in Fig. 2-43-4.
 - Supply voltage (approximately 5V), reversing the polarity used in ④ of the removal method, to the loading motor as ⑤ of the installation method in Para. 2-19.
 - Turn part A of the pulley worm J by hand, in the direction shown by the arrow (b) as shown in Fig. 2-43-3.
- ④ Make sure that the hole of the gear joint J aligns with the matching mark of the main plate, and the matching mark of the gear pinch with that of the mode switch as shown in Fig. 2-43-5.
- ⑤ Install the drum base on which the drum assembly is attached and secure it with the three screws (a, b and c) as shown in Fig. 2-43-1. (Tighten the screws in the order a → b → c.)
- ⑥ Install the cleaning assembly. (Refer to Item ③ of Para. 2-42 for the installation method.)
- ⑦ Install the PCB-HEAD-AMP. (Refer to Para. 2-8 for the installation method.)
- ⑧ Install the cassette housing. (Refer to Para. 2-1 for the installation method.)

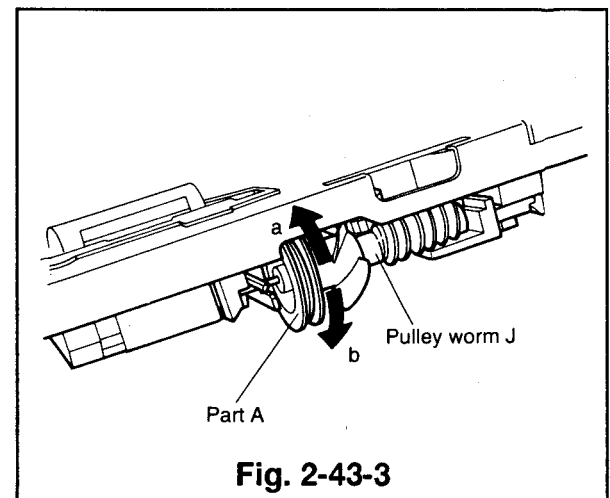
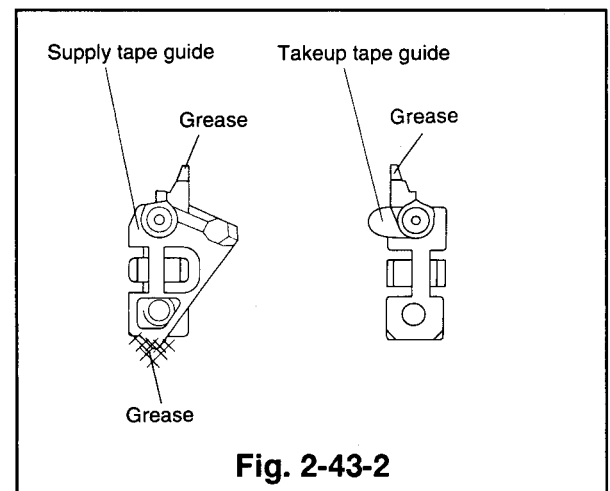
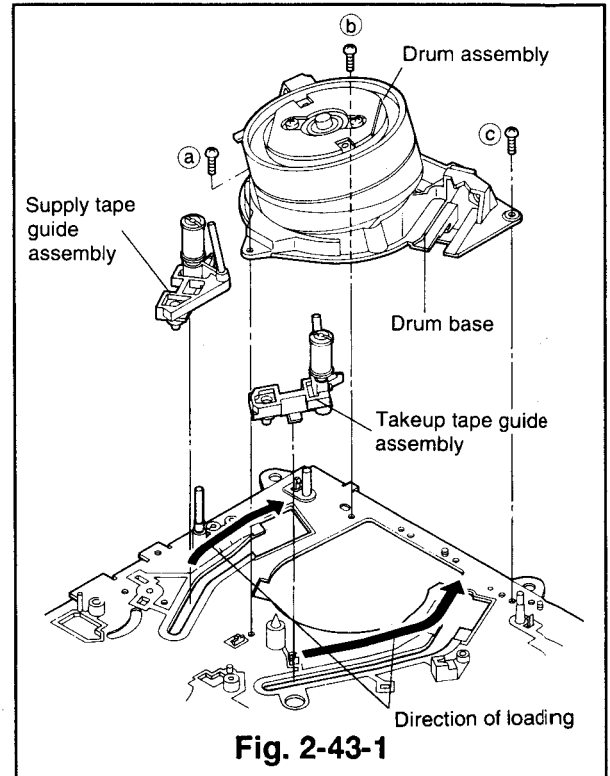

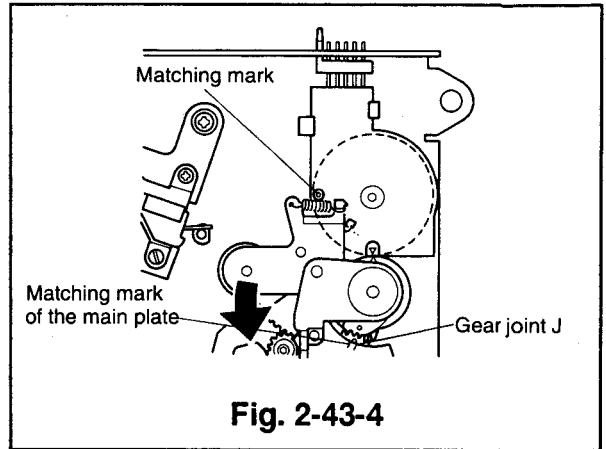

Fig. 2-43-4

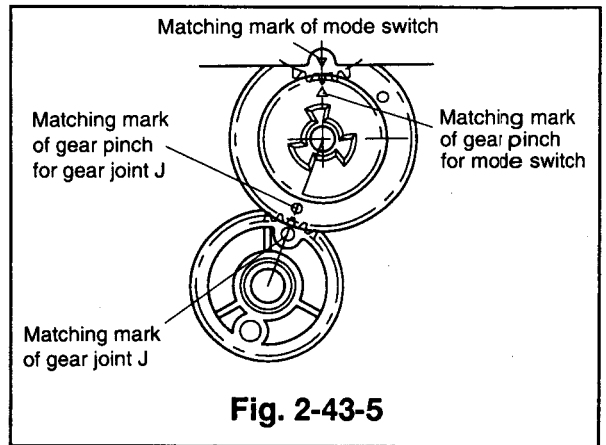

Fig. 2-43-5

2-44 Drum base spring

(Removal)

- ① Remove the drum base spring between the drum base and the drum assembly. (Refer to Fig. 2-44-1.)

Note: If the drum base spring is difficult to remove, remove the drum assembly in advance. (Refer to Para.2-10)

Note: During removal and installation of the drum assembly, do not touch the tape running surface with your hands.

(Installation)

- ① Set the drum base spring in the gap between the drum base and the drum assembly. Make sure that the drum base spring is secure enough not to fall out.
- ② Apply grease(PG-641)[859D055O30] to the area of the drum base spring as shown in Fig. 2-44-1.

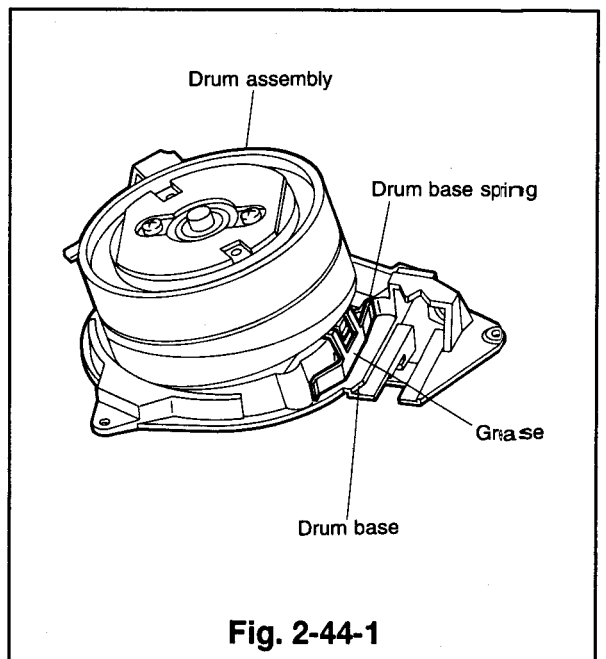

Fig. 2-44-1

3. Interchangeability Adjustment of Mechanism

Note1: Tracking must be preset during the interchangeability adjustment of the mechanism. Digital tracking should be preset by short circuiting TP5A and TP5B on the PCB-MAIN.

Note2: The adjustment is performed in the playback mode, using the stair step signal of an alignment tape, connect an oscilloscope to TP2A and external Trig. From TP2H, unless otherwise specified.

3-1 Adjustment of Back-Tension and Tension Pole Position

Run a blank tape for several minutes to break in the reel disks and the transport before making the adjustment.

- ① Cut out the alignment tape [PM6KH3 : 859C339O30] as shown in Fig. 3-1-2 this allows the boss to be adjusted while playing the tape by inserting the hexagon wrench through the round hole of the cassette housing shown in Fig. 3-1-1. (Take care not to let fragments of the cassette inside the cassette tape.)
- ② Playback an alignment tape which has a cut out.
- ③ Make sure that tip section A of the tension arm is between the divisions "2" and "2.5" on the main plate. (The divisions are numbered from the right to left.)
- ④ If tip section A of the tension arm is on the right of "2", turn the boss clockwise. If A is on the left of "2.5", turn it counter-clockwise.
- ⑤ Insert the back tension measuring jig (Part No. 859C346060) and set the VCR to the playback mode.
- ⑥ When the running of the tape becomes steady, make sure that the reading of the Back Tension Measuring Jig is within 50 ± 6 g-cm.
- ⑦ If the reading is over the specified value, replace the tension spring.
- ⑧ When the running of the tape is steady, check visually to make sure that the runout of the tension pole is 1mm or less.
- ⑨ If the runout is not within the specified value, replace the reel disk.

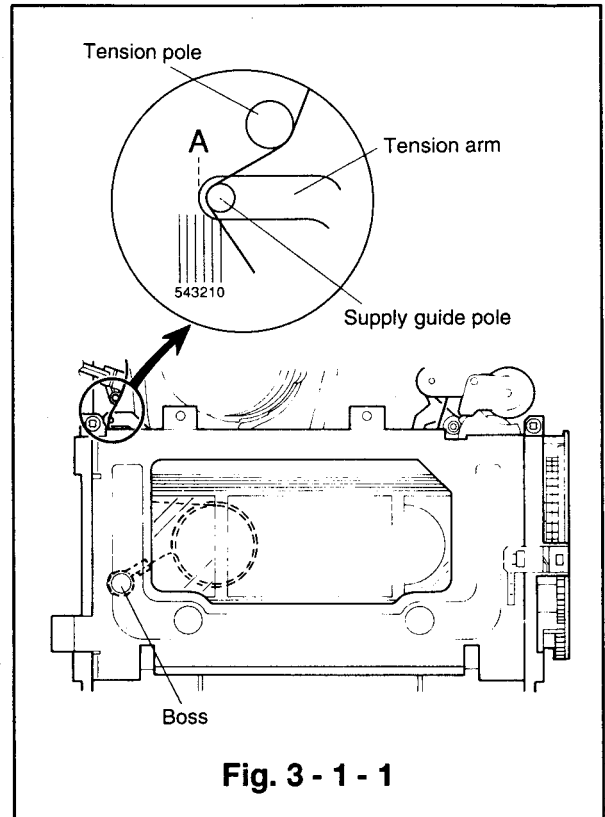

Fig. 3 - 1 - 1

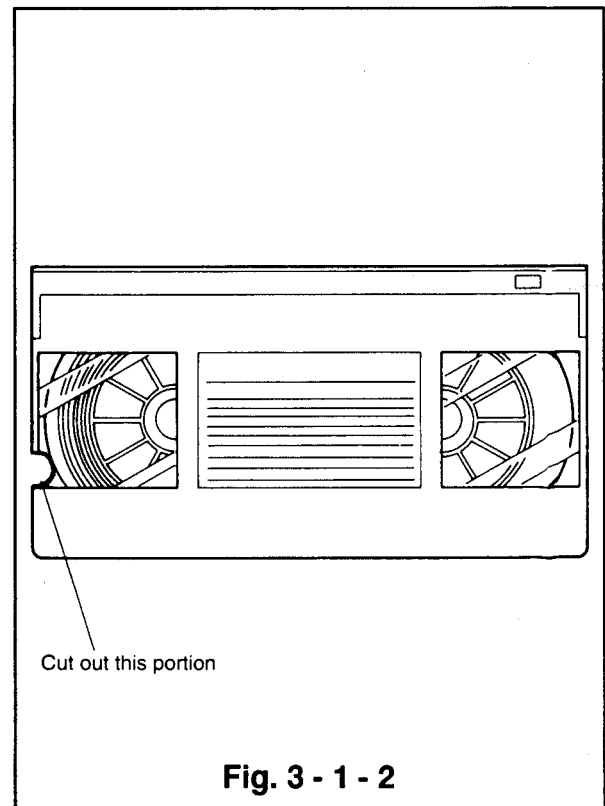

Fig. 3 - 1 - 2

3-2 Check and Adjustment of FM Envelope

3-2-1 Guide Roller Adjustment

- ① Play back the alignment tape.
[PM6KH3 : 859C339O30]
- ② Preset tracking. (Refer to NOTE 1 in Para. 3.)
- ③ Check if the FM waveform is flat like A.
(Refer to Fig. 3-3-2)
- ④ Adjust the height of the supply guide roller if the leading portion (the entry side of the drum) of the FM waveform is not flat, like B or C. (Refer to Fig. 3-3-2) Adjust the height of the takeup guide roller if the trailing portion (the exit side of the drum) is not flat, like D or E.

3-2-2 Adjustment of Supply Guide Roller Height

- ① Loosen the set screw until the supply guide roller is held lightly when rotated.
- ② The supply guide roller may be low if the leading portion (the entry side of the drum) of the FM waveform is like B, and high if like C. Turn the adjusting screw at the top of the roller to adjust the height of it so that the FM waveform is flat like A.
 - Turn the adjusting screw counter-clockwise if the roller is low.
 - Turn the adjusting screw clockwise if the roller is high.
- ③ Coarsely adjust the phase as in Item 3-3-4.

3-2-3 Adjustment of Takeup Guide Roller Height

- ① Loosen the set screw until the takeup guide roller rotates lightly.
- ② The takeup guide roller may be low if the trailing portion (the exit side of the drum) of the FM waveform is like D, and high if like E. Turn the adjusting screw at the top of the roller to adjust the height so that the FM waveform is flat like A.
 - Turn the adjusting screw counter-clockwise if the roller is low.
 - Turn the adjusting screw clockwise if the roller is high.
- ③ Coarsely adjust the phase as in Item 3-2-4.

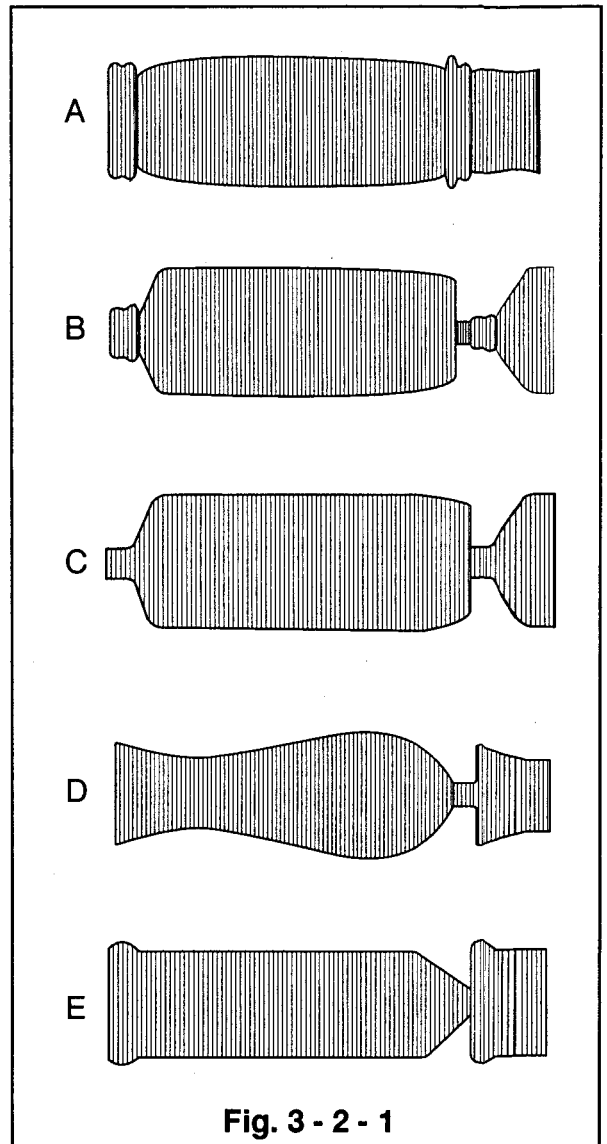

Fig. 3 - 2 - 1

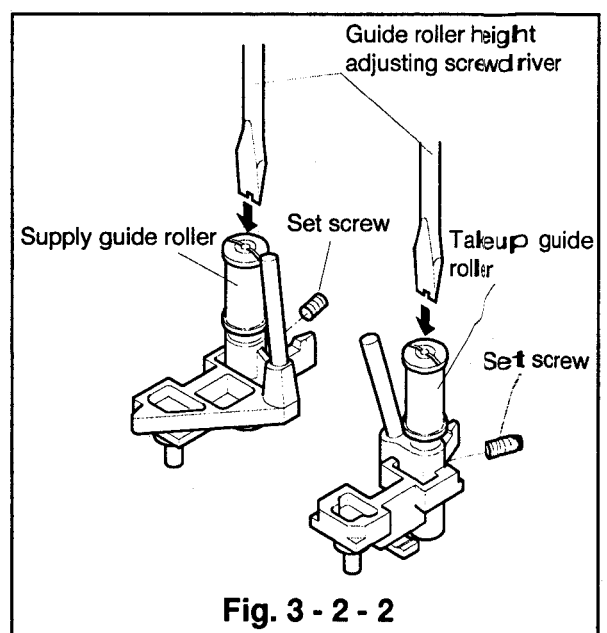

Fig. 3 - 2 - 2

3-2-4 Coarse Adjustment of Phase

- ① Play back the alignment tape.
[PM6KH3 : 859C339O30]
- ② Preset tracking. (Refer to NOTE 1 in Para. 3.)
- ③ Check the FM waveform after checking and adjusting the guide rollers.
- ④ If the amplitude of the FM waveform is narrow like F because of out of phase, adjust it to maximum like G, as shown in Fig. 3-2-4 by the following procedure. Loosen the screw E, insert a screw driver into the groove at the Base A/C and the main plate, and shift the Base A/C right and left.
- ⑤ Tighten the screw E to secure the base-A/C in place.

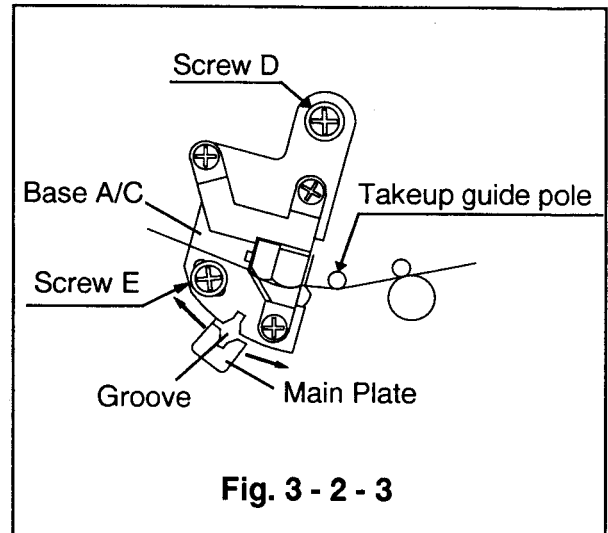

Fig. 3 - 2 - 3

3-2-5 Check of FM Waveform Flatness

- ① Play back the alignment tape.
[PM6KH3 : 859C339O30]

Note: In the following adjustment, follow the next procedure for automatic/manual-selection and adjustment of tracking.

- For the manual tracking adjustment, press an up/down button during reproduction.
 - To change the adjustment mode from manual to automatic in the tracking adjustment, press the up and down buttons at the same time.
- ② In the manual tracking mode, change tracking and make sure the amplitude is changeable while the FM signal remains flat.
 - ③ Adjust tracking so that the amplitude of the FM waveform is maximum. Set the oscilloscope so that the amplitude of the FM waveform is 5 division.
 - ④ Adjust tracking so that the peak value of the FM waveform is 4 divisions. Check if the FM waveform B, C, D, and E are within the specified values shown in Fig. 3-2-5.
 - ⑤ If the waveform is not within the specified value, repeat the procedure for checking and adjustment of FM envelope in Item 3-2 from the beginning.

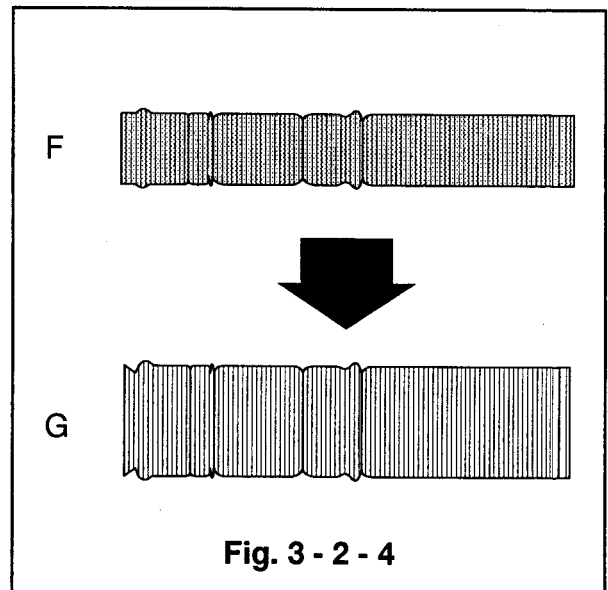

Fig. 3 - 2 - 4

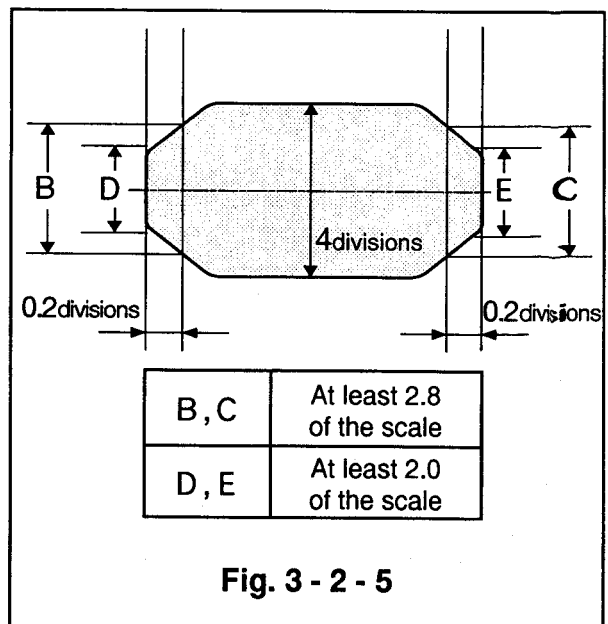

Fig. 3 - 2 - 5

3-2-6 Check 1: Tape Running Condition on Guide Rollers (Refer to Fig. 3-2-6)

- ① Play back the alignment tape.
[PM6KH3 : 859C339O30]
- ② Visually check if there is a space between the tape and the lower flange of the supply guide roller and takeup guide roller.
- ③ If there is no space, replace the tape guide as in Item 3-2-7.
- ④ If the supply tape guide is replaced, check the guide roller as in Item 3-2-1 and if the takeup tape guide is replaced, check the guide roller as in Item 3-2-1 and check the FM waveform flatness in Item 3-2-5.
- ⑤ Load and unload the tape several times alternately check that flatness of the FM waveform does not change.
- ⑥ If flatness changes, check if the A/C arm is loose. If it is not loose, replace the A/C arm and repeat the procedure of coarse adjustment of phase in Item 3-2-4.

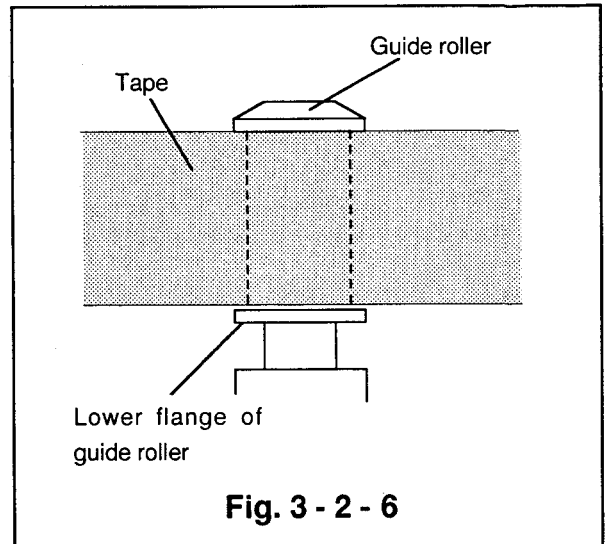

Fig. 3 - 2 - 6

3-2-7 Replacement of Tape Guides

- ① If the current tape guide has no marking, replace it with one with a red mark.
- ② If the current tape guide has a black mark, replace it with one with no mark. If this replacement is not effective, replace the tape guide with one with a red mark.
- ③ If the current tape guide has a red mark, replace it with another one with red mark.

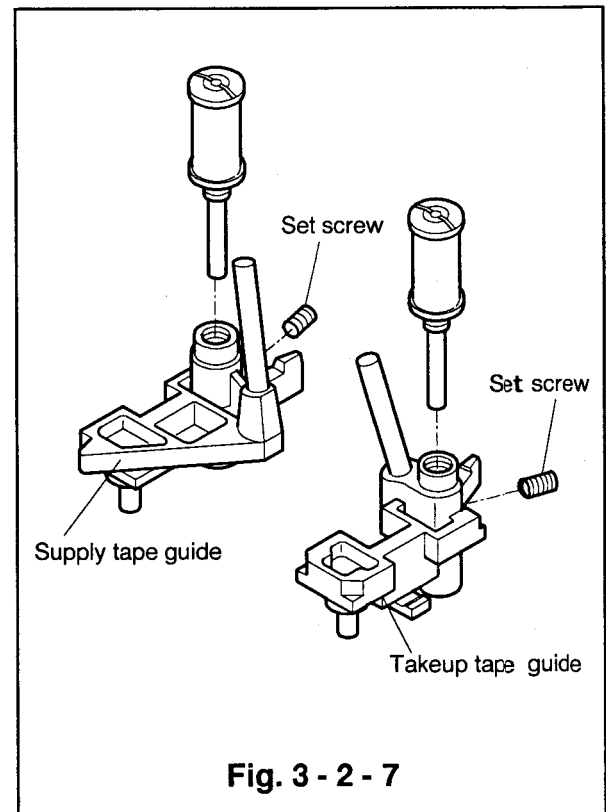

Fig. 3 - 2 - 7

3-2-8 Check 2: Tape Running Condition on Guide Rollers.

- ① Play back the alignment tape.
[PM6KH3 : 859C339O30]
- ② Lightly press and release the top of the supply guide roller and takeup guide roller. Check if the FM waveform is quickly restored to the previous level.
- ③ If the waveform is not quickly restored, replace the tape guide as in Item 3-2-7.
- ④ If the supply tape guide is replaced, check the guide roller as in Item 3-2-1, and if the takeup tape guide is replaced, check the guide roller as in Item 3-2-1 and the check FM waveform flatness as in Item 3-2-5.
- ⑤ If satisfactory, tighten the set screw of the guide roller on the supply side and the takeup side.

Identification of Tape Guide Item Number
(Example; Parts No. 635B059010
Item No. 1)

Item No. 1	No marking
Item No. 2	Marked with black magic marker
Item No. 3	Marked with red magic marker

*The marking point is on the top of the tape guides shown in figure above.

3-3 Adjustment of A/C Head

3-3-1 Adjustment of A/C Head Slant

- ① Playback a blank tape.
- ② Slowly turn the adjusting screw C counter-clockwise to crease the bottom of the tape slightly at the flange portion of the takeup tape guide.
- ③ Return adjusting screw C slowly to remove the crease.
- ④ Slowly turn adjusting screw C counter-clockwise again and stop turning just before the tape is creased.

3-3-2 Adjustment of A/C Head Azimuth and Height

- ① If the height of the CTL head is different from the specified-value in Fig. 3-3-2, adjust the height by the adjusting screw A.
- ② If adjusting screw A is moved, repeat the procedure in Item 3-3-1 to adjust the A/C head Slant.
- ③ Connect the oscilloscope to the audio output terminal and set the VCR to the playback mode.
- ④ Playback the standard tape. [PM6KH3 : 859C339O30]
- ⑤ Turn adjusting screw B to adjust azimuth so that the audio output level is maximum. Set the scope for an amplitude of 5 divisions.
- ⑥ After the adjustment of ⑤, pull out the screw driver and check if the audio output level is 4.6 divisions or more, when the maximum level (audio output) of ⑤ was set for 5 divisions.
- ⑦ If the audio output level is below the specified value, repeat the procedure ①~⑥.
- ⑧ Push the A/C head to the right and left(in the direction of A and A' in Fig. 3-3-1) and the release the A/C head. Check that the audio output level does not change. (Do not push past the point where the audio output level is reduced by 3/4 of its maximum value.)
- ⑨ Set the VCR to the playback mode and check if the change of the audio output level is less than 2dB.
- ⑩ If the change is over 2dB, adjust the A/C head slant again and recheck.
- ⑪ If not satisfactory, replace the takeup tape guide complying with the following procedure and repeat this adjustment.
 - If the original tape guide has no marking, replace it with the one with a black mark.
 - If the original tape guide has a black mark, replace it with one with a black mark.
 - If the original tape guide has a red mark, replace it with the one with a red mark. If this replacement is not effective, replace it with one with a black mark.

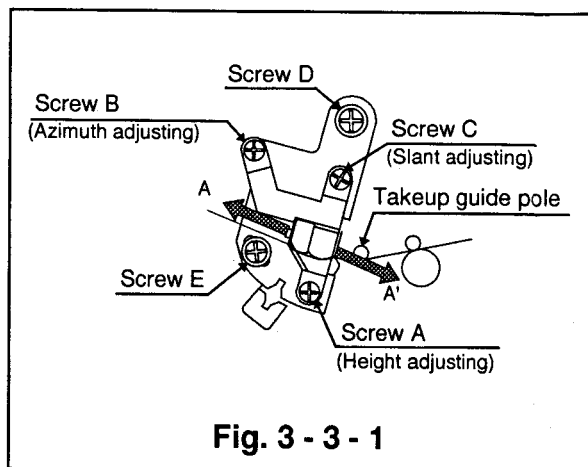

Fig. 3 - 3 - 1

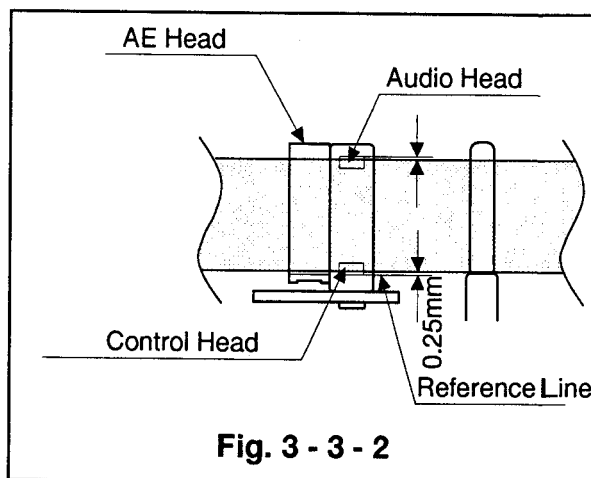

Fig. 3 - 3 - 2

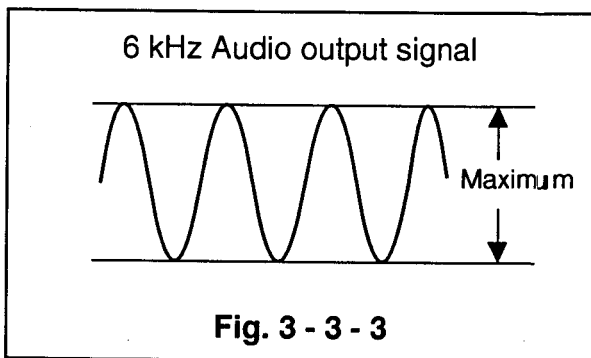

Fig. 3 - 3 - 3

Identification of Tape Guide Item Number
(Example; Parts No. 635B059O10)
Item No. 10

Item No. 1	No marking
Item No. 2	Marked with black magic marker
Item No. 3	Marked with red magic marker

* The marking point is on the tops of the Takeup and Supply tape guides.
(Refer to Fig. 3-2-7)

3-4 Adjustment of Phase

- ① Set the VCR to the playback mode. (Use the alignment tape specified below to perform adjustment ①~④.)

[PM6KE2 : 859C568O90
PM6KH3 : 859C339O30M20V(G) only]

- ② Preset tracking. (Refer to NOTE 1 in Para. 3.)
- ③ Loosen the screw E, insert a screw driver into the gap between the Base A/C and the main plate, and shift the Base A/C right and left to adjust the FM waveform to maximum.
- ④ Tighten the screw E.
- ⑤ Play back the alignment tape. (PMX:859C568O70)
- ⑥ Connect TP2A (the FM waveform output) and the audio output terminal to the oscilloscope, external Trig. to TP2H, and check if the missing portions of the FM waveform and that of the audio waveform are within the specified value (field). (Refer to Fig. 3-4-2.)
- ⑦ If they are not within the specified value, repeat the procedure ③.
- ⑧ Turn the normal tracking control to adjust the FM waveform for maximum and set the oscilloscope so that the waveform is '5' divisions. (Refer to Note in Para. 3-2-5 about tracking adjustment.)
- ⑨ Preset tracking. (Refer to NOTE 1 in Para. 3.)
- ⑩ Check that the FM waveform on the oscilloscope is " 4.8 " or more divisions.
- ⑪ If the FM waveform is below " 4.8 " divisions, perform this adjustment after tracking preset.
- ⑫ Push the A/C head to the right and left (in the direction of A-A' in Fig. 3-4-1) and then release the A/C head. Check that the amplitude of the FM waveform does not change from that before shifting the A/C head.
- ⑬ If the amplitude changes, check if the A/C arm shaft is loose. If it is not loose, replace the A/C arm and repeat the procedure of this adjustment from the beginning, after the adjustment of A/C head in Item 3-3.
- ⑭ Alternately load and unload the tape several times to check that the amplitude of the FM waveform does not change.

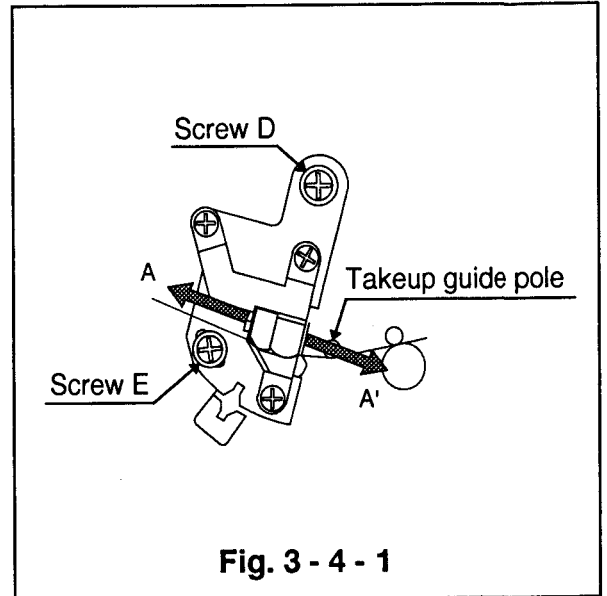

Fig. 3 - 4 - 1

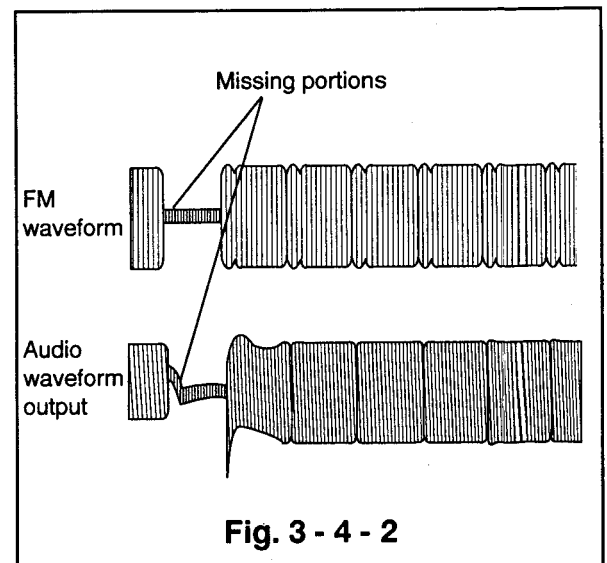

Fig. 3 - 4 - 2

3-5 Adjustment of Takeup Guide Arm Height

- ① Run a final portion of E-240 blank tape in the reverse search mode.
- ② Tighten the adjusting nut of takeup tape guide until the tape is creased at the lower flange of the takeup guide pole. Then slowly return the nut and stop at the point where the crease is removed. (During adjustment, use an uncovered cassette tape or raise the cover so that the adjustment can be performed.)

Note: During adjustment, turn the adjusting nut in the loosening direction. Do not turn the nut more than $\pm 1/2$ turn.

- ③ Eject the cassette tape, set the VCR to the reverse search mode again, and check that the tape is not creased at the upper or lower flange of the takeup tape guide.
- ④ Set the VCR to the playback mode and check that the tape is not creased at the upper or lower flange of the takeup guide pole.
- ⑤ Run the start portion of E-180 blank tape in the forward search mode and check that the tape is not creased at the takeup guide pole.

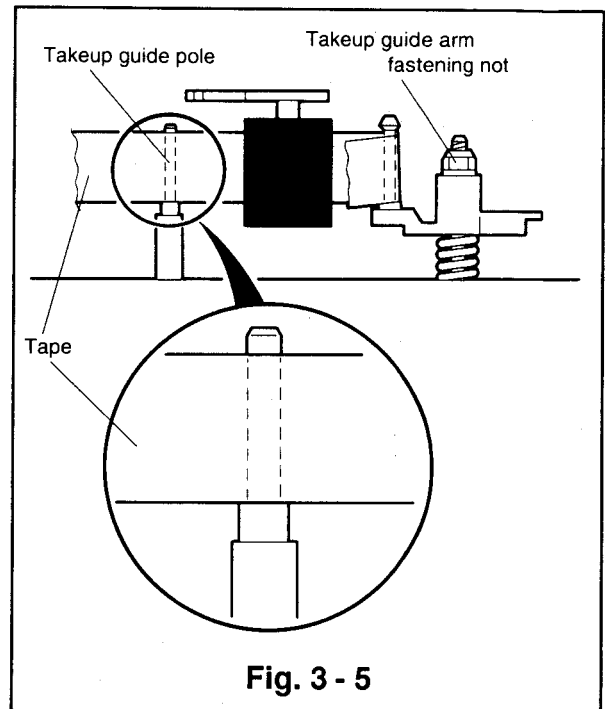

4. Servicing for Tape Jamming during the Loading Mode

- ① Remove the upper cover.
- ② Remove the front unit.
- ③ Remove the bottom panel.
- ④ Reverse the deck and turn the pulley worm J in the direction shown by the arrow in Fig.4-1, observe whether the tape guides move to the unloading position. If they do not, follow the procedure (1). If they do, follow the procedure (2).

(1) If the tape guides do not move (the pulley worm J does not turn);

- ① Unfasten the clamp holding the leads of the loading motor, which are attached to the side plate of the cassette housing. Unscrew screws (a) and (b) holding the cassette housing as shown in Fig. 4-2.
- ② Hold the cassette door with a screw driver to keep it open. (Take care not to allow the screw driver to touch other parts of the tape transport.)

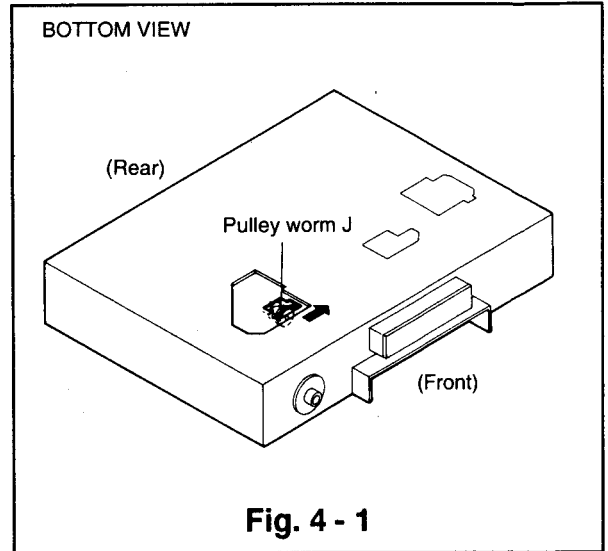

Fig. 4 - 1

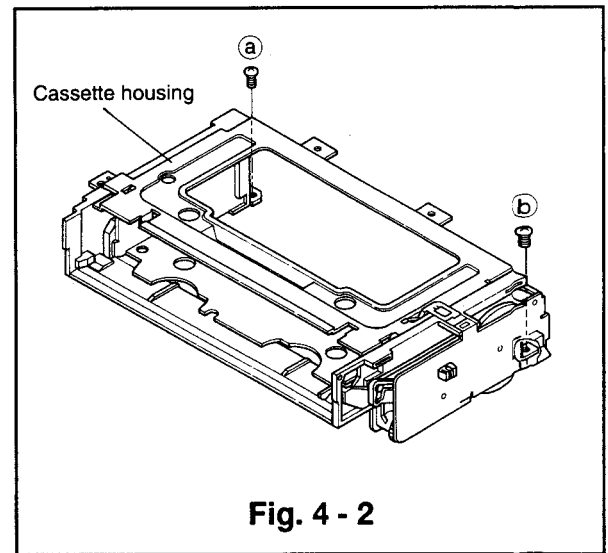

Fig. 4 - 2

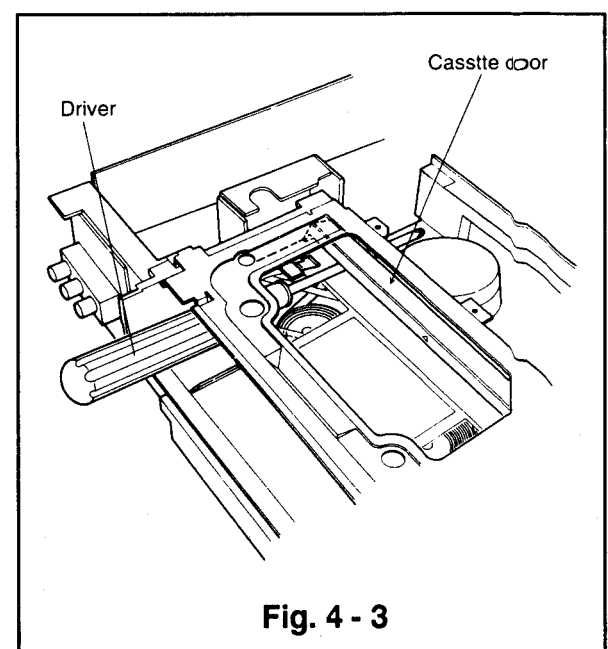

Fig. 4 - 3

- ③ Open the cassette door fully with your hand. Unfasten the catch to remove the pinch roller arm cap as shown in Fig. 4-4. (Refer to Para. 2-24 for the removal method.)
- ④ Push part A of the pinch roller arm assembly, shown in Fig. 4-5, in the direction shown by the arrow to make a space between the pinch roller arm assembly and the tape. Remove it together with the pinch cam taking care not to damage the tape.
- ⑤ Remove the screw driver (refer to Item ②), while holding the cassette door open with your hand. While pushing the tension arm in the direction shown by the arrow in Fig. 4-6 raise the cassette housing upward to remove it from the tape transport as shown in Fig. 4-7. Take care that the grease, which is applied to the main plate, does not adhere to the tape.

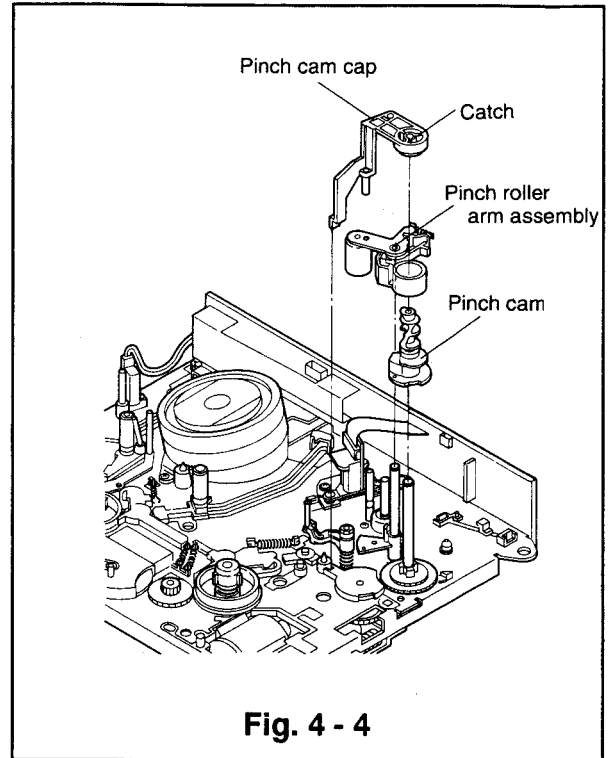

Fig. 4 - 4

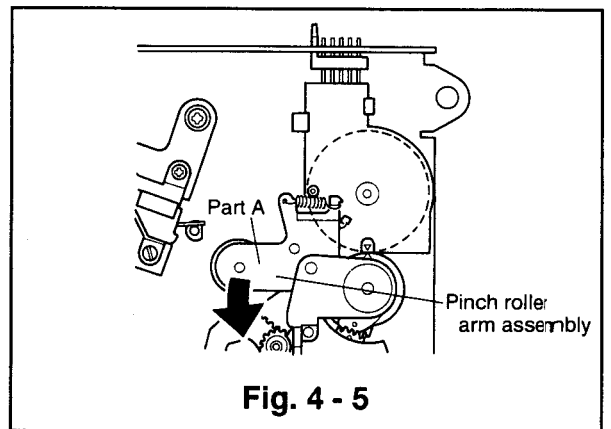

Fig. 4 - 5

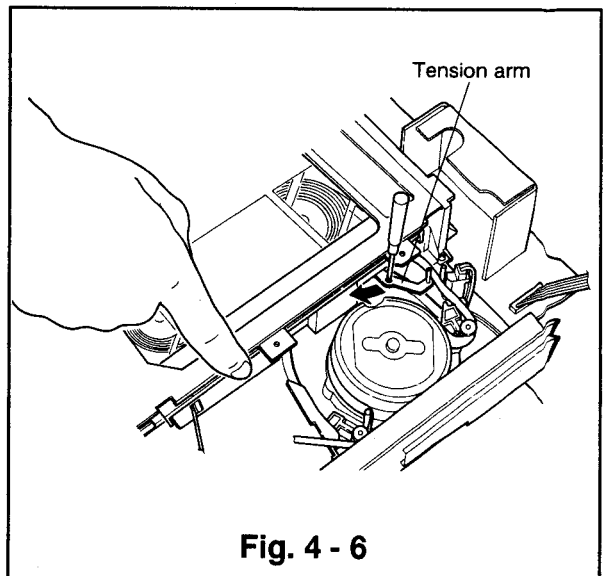
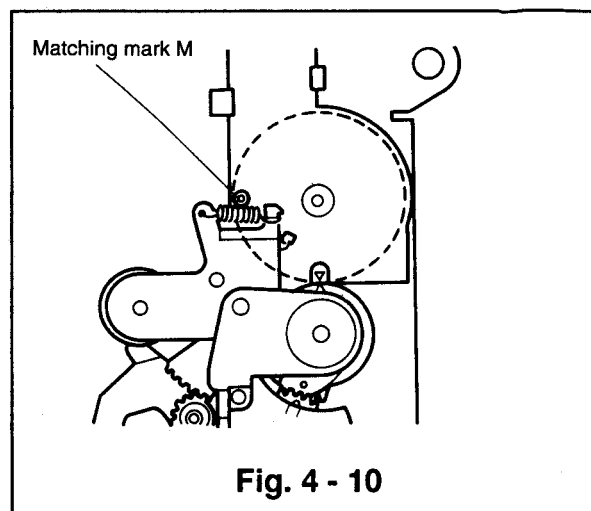
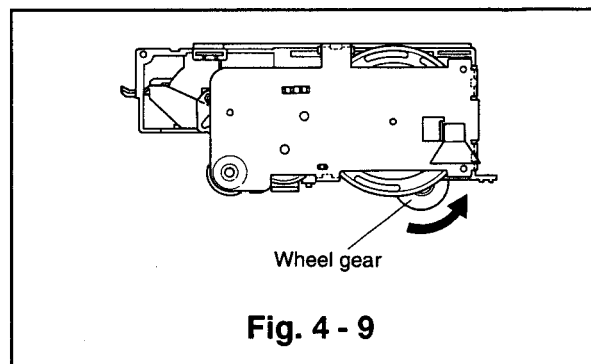
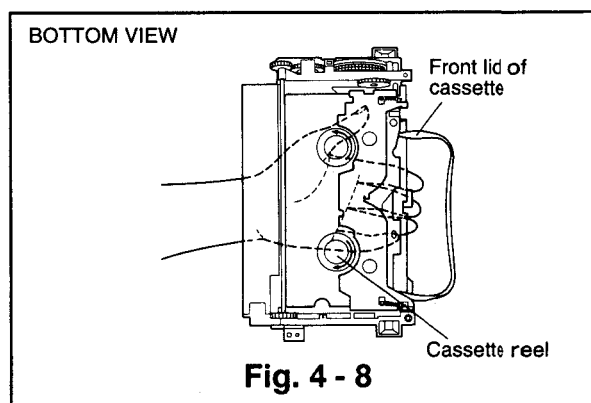
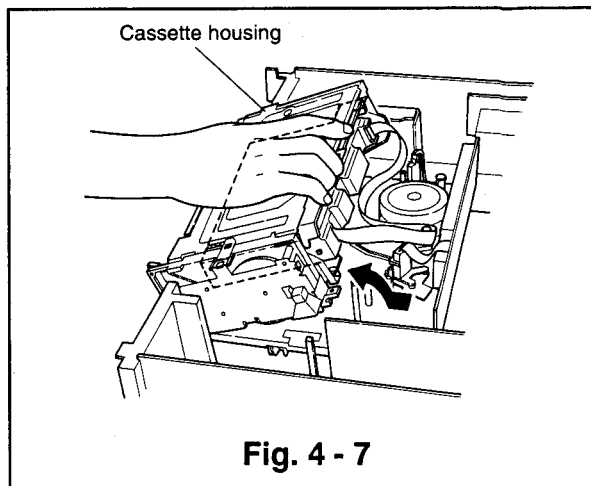

Fig. 4 - 6

- ⑥ Turn the cassette reel of the cassette tape to wind up the tape as shown in Fig. 4-8.
- ⑦ Turn the wheel gear shown in Fig. 4-9 in the direction shown by the arrow to eject the cassette tape.
- ⑧ Reverse the deck and turn the motor pulley J in the direction, shown by the arrow in Fig. 4-1, so that the matching mark M of the mode switch is in the position shown in Fig. 4-10 (the eject position). Make sure that the matching marks of the mode switch and the gear pinch, and those of the gear pinch and the joint gear, respectively, align as shown in Fig. 4-11. Turn the takeup guide arm clockwise to such a degree that takeup guide gear is not in the way of mounting the pinch roller cam to the shaft. Install the pinch roller cam so that its holes align with the triple catch of the gear pinch. (Refer to Para. 2-24 for the installation method.)
- ⑨ Install the pinch roller arm and the pinch roller arm cap.
- ⑩ Install the cassette housing. (Refer to Para. 2-1 for the installation method.)



(2) If the tape guides move (the pulley worm J turns);

- ① Reverse the deck and turn the pulley worm J in the direction shown by the arrow in Fig. 4-1 so that the takeup guide arm moves to the end of the unloading cycle.
- ② Turn the capstan shaft, shown in Fig. 4-12, clockwise to turn the reel so that the tape is wound back into the cassette. (Take care not to scar or stain the capstan shaft. After winding up the tape, clean the capstan shaft with alcohol, refer to Para. 1-2.)
- ③ Turn the pulley worm J as in Item ① so that the matching mark of the mode switch is in the position shown in Fig. 4-10 (the eject position). Eject the cassette tape.

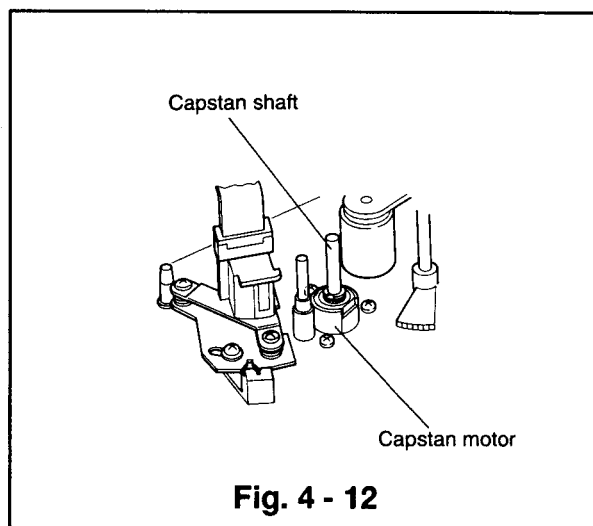
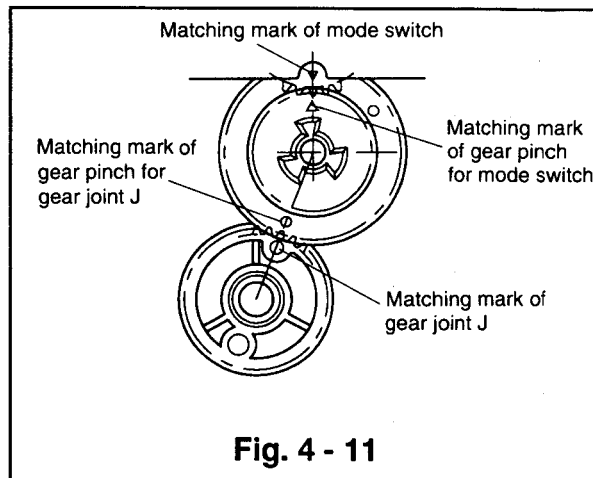

SPECIFICATION OF VPS RECORDING SYSTEM [HS-M20V(G) only]

1. VPS Signal

The VPS signal makes it possible during timer recording of television programs to switch on and off the unit at the correct time by using the preprogrammed recording time. The VPS signal is transmitted in the 16th line of the vertical blanking signal. Refer to Fig. 1. The VPS data signal is shown in Fig. 2. The television stations are responsible for changing of the VPS data. These are included in words 11 to 14.

The normal VPS code includes time data and program data. It is transmitted with the program and recognized by the unit as program identification. A program, which was scheduled for the time from 0:99 to 4:00 and the start of which was changed to the previous day, keeps its original label. If the program is extended, the label is valid until 4:00 of the following day, if the correct sending code is received. The maximum starting time for a delayed program is 4:00 of the following day.

2. Expected VPS time and type of VPS recording

- 2-1 At 20:00 on the day before the starting time the recorder is switched on and enters the expected VPS time. During the expected VPS time the unit is switched to the corresponding channel and waits for the VPS signal.
- 2-2 If a VPS signal, which confirms to the preprogrammed signal, is received, the unit switches into the recording mode.
- 2-3 If no VPS signal or status code is transmitted, the original recording time is used.
- 2-4 If an interruption code is transmitted during the VPS recording, the recording is stopped and the unit switches into the VPS stand-by mode. The recording is started, as soon as the regular VPS code is received again.
- 2-5 If the normal VPS code changes after the programmed timer recording into an unnatural code, the recording is finished.

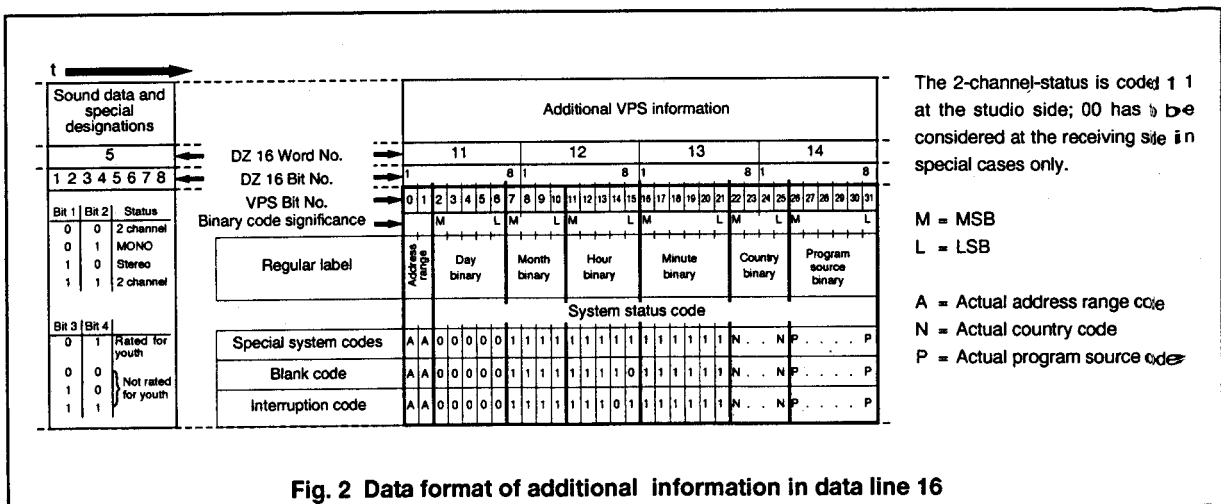
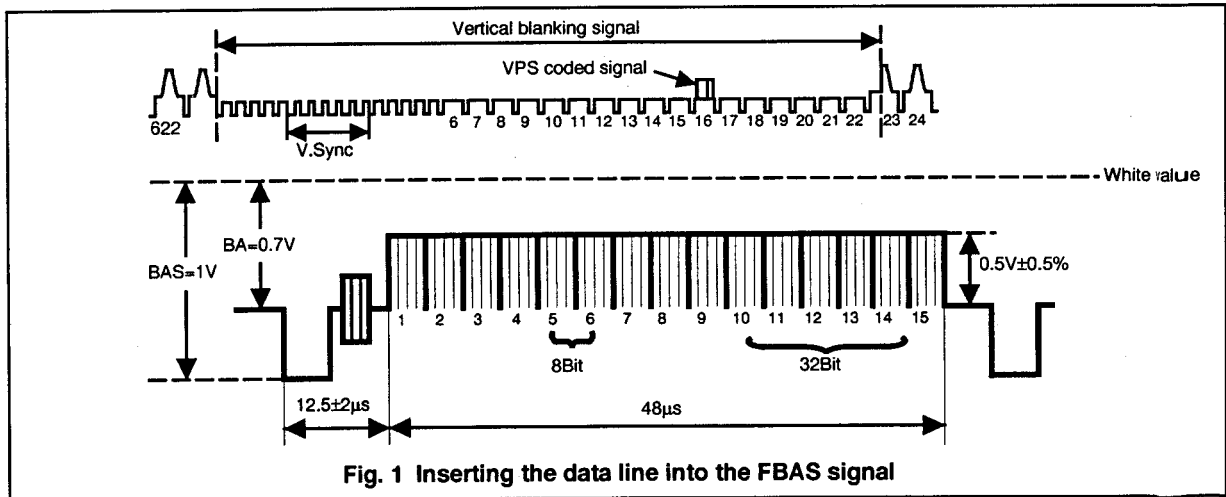

GLOSSARY OF ABBREVIATIONS

A/C	: Audio/Control	LIM	: Limiter
ACC	: Automatic Color Control	LPF	: Low-Pass Filter
A.E	: Audio Erase	LM	: Loading Motor
AFC	: Automatic Frequency Control	MDA	: Motor Drive Amplifier
AFT-D	: Automatic Fine Tuning Door Switch	MC	: Mechanical Control
AGC	: Automatic Gain Control	MIC	: Microphone
AL	: After Load	MOD	: Modulator
AMP	: Amplifier	N	: Not Normal
ANT	: Antenna	OPE	: Operation
A-PB	: Audio-Playback	OSC	: Oscillator
A-REC	: Audio-Recording	O-PWV	: ON/OFF Command from Remote Decoder
ALC	: Automatic Level Control	PB	: Play Back
B-FS	: Brake Forward Search	PG	: Pulse Generator
B-RS	: Brake Reverse Search	P/R-SW	: P.B/REC-SW
BPF	: Band-Pass Filter	PCB	: Printed Circuit Board
B/W	: Black and White	PIC	: Picture Control
BS	: Band SW	P/R	: Play/Record
CASS	: Cassette	PSC	: Pulse swallow control
CP	: Capstan	PWT-SET	: Power TV Set
CP-FG	: Capstan-Frequency Generator	PWV	: ON/OFF Command to B+ Switching Circuit
CP-F/R	: Capstan-Forward/Reverse	REC	: Recording
CP-M	: Capstan-Motor	REF	: Reference
CONV	: Converter	RIS	: Record Inhibit Switch
CTL	: Control	REW	: Rewind
C-LAMP	: Cassette Lamp	REG	: Regulator
C-I LAMP	: Cassette Indicator Lamp	RS	: Reverse Search
CE	: Chip Enable	REC-2	: Record Command for the Fine Editing Circuit
CE	: Not Chip Enable	R-FS	: Reel Drive Forward Search
CK	: Clock	R-P/R	: Reel Drive Play/Record
CL	: Clear	S/AL	: Stop After Load
CNT	: Counter	SL	: Slow
CP R-R	: Capstan Reverse Rotation	SLOK	: Slow OK
CS-1	: Cassette Switch 1	S/P	: Still/Pause
CS-2	: Cassette Switch 2	SS	: Start Sensor
DAL	: Delay-After Loading	SRV-REC	: Servo Record
DEMOD	: Demodulator	SS	: Not Speed Search
DET	: Detector	S-STOP	: Stop Command
DL	: Delay Line	STOK	: Still OK
DL-REV	: During Reverse	STW	: Stop Watch
DL-FWD	: During Forward	SENS	: Sensor
DOC	: Drop Out Compensator	STBY	: Stand By
DL-SL	: During Slow	TM	: Take up Motor
DL-SS	: During Not Speed Search	T-REC	: Timer-Record
DOP	: Drop Out Pulse	T.P	: Test Point
EF	: Emitter Follower	TR	: Transistor
EMPHA	: Emphasis	TU-P	: Tuner-Power
EQ	: Equalizer	UL	: Unload
EE	: Electronic-Electronic	VS	: Voltage Synthesizer
ES	: End Sensor	V.SYNC	: Vertical Sync
FE-H	: Full Erase Head	VCO	: Voltage Controlled Oscillator
FF	: Fast Forward	VXO	: Variable Crystal Oscillator
FG	: Frequency Generator	W/D	: White/Dark
FL-SW	: Front Loading SW	X'OSC	: Crystal Oscillator
FLM	: Front Loading Motor	Y/C	: Luminance/Chrominance
F/R-SW	: FF/Rewind Switch		
F/R	: Forward/Reverse		
FS	: Forward Search		
G	: Ground		
HE	: Hall Element		
H-LED	: Humidity-LED		
H-SENS	: Humidity-Sensor		
HPF	: High-Pass Filter		

CHIP PARTS REPLACEMENT

Some resistors, shorting jumpers (0Ω resistor), ceramic capacitors, transistors and diodes are Chip Parts which are used for certain circuit elements. When replacing these parts, note the following cautions.

Cautions:

- A. Use fine tipped, well insulated soldering pencil (iron) about 30 watts and tweezers.
- B. Melting the solder, remove the Chip Parts carefully not to tear off the copper foil of the printed circuit board.
- C. Discard removed chips; do not reuse them.
- D. Do not apply heat for more than 3 seconds to the new Chip Parts.
- E. Avoid using a rubbing stroke when soldering.
- F. Take care not to scratch when soldering, or damage the Parts.
- G. Supplementary cementing is not required.

1 Removal of Chip Parts

(Resistors, Capacitors, etc.)

- A. Grasp the part with tweezers. Melting the solder at both side alternately, remove the one side of the part with a twisting motion.
- B Melt the solder at the other side and remove the part.

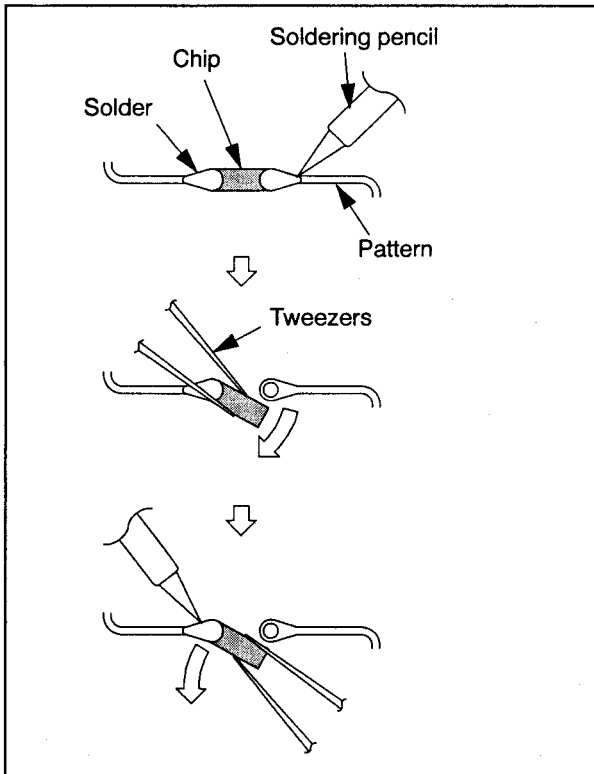

2 Removal of Chip Parts (Transistors)

- A. Melting the solder of one lead, lift the side of that lead upward.
- B. Simultaneously melt the solder of the two remaining leads and lift the part to remove.

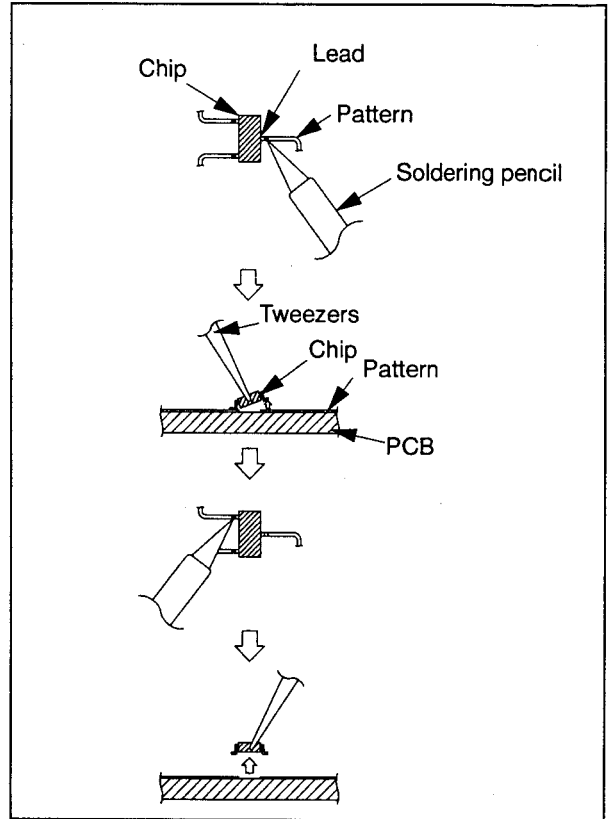

3 Replacement

- A. Pre-solder the contact points of the circuit pattern.
- B. Press the part downward with tweezers and apply the soldering pencil as shown in the figure.

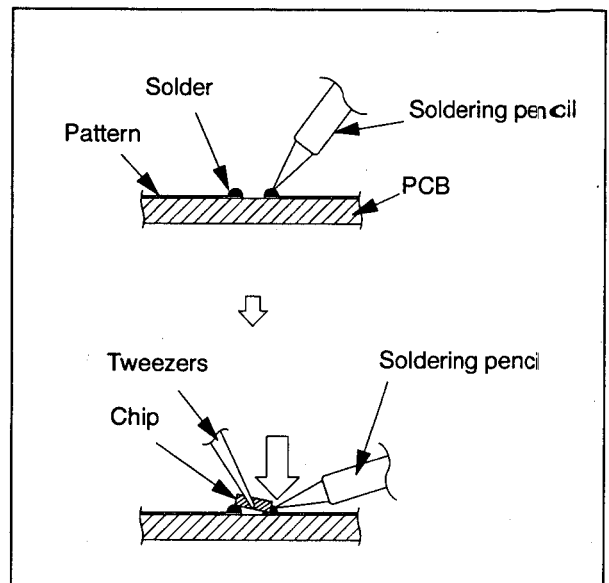

PARTS LIST

1. CABINET ASSEMBLY

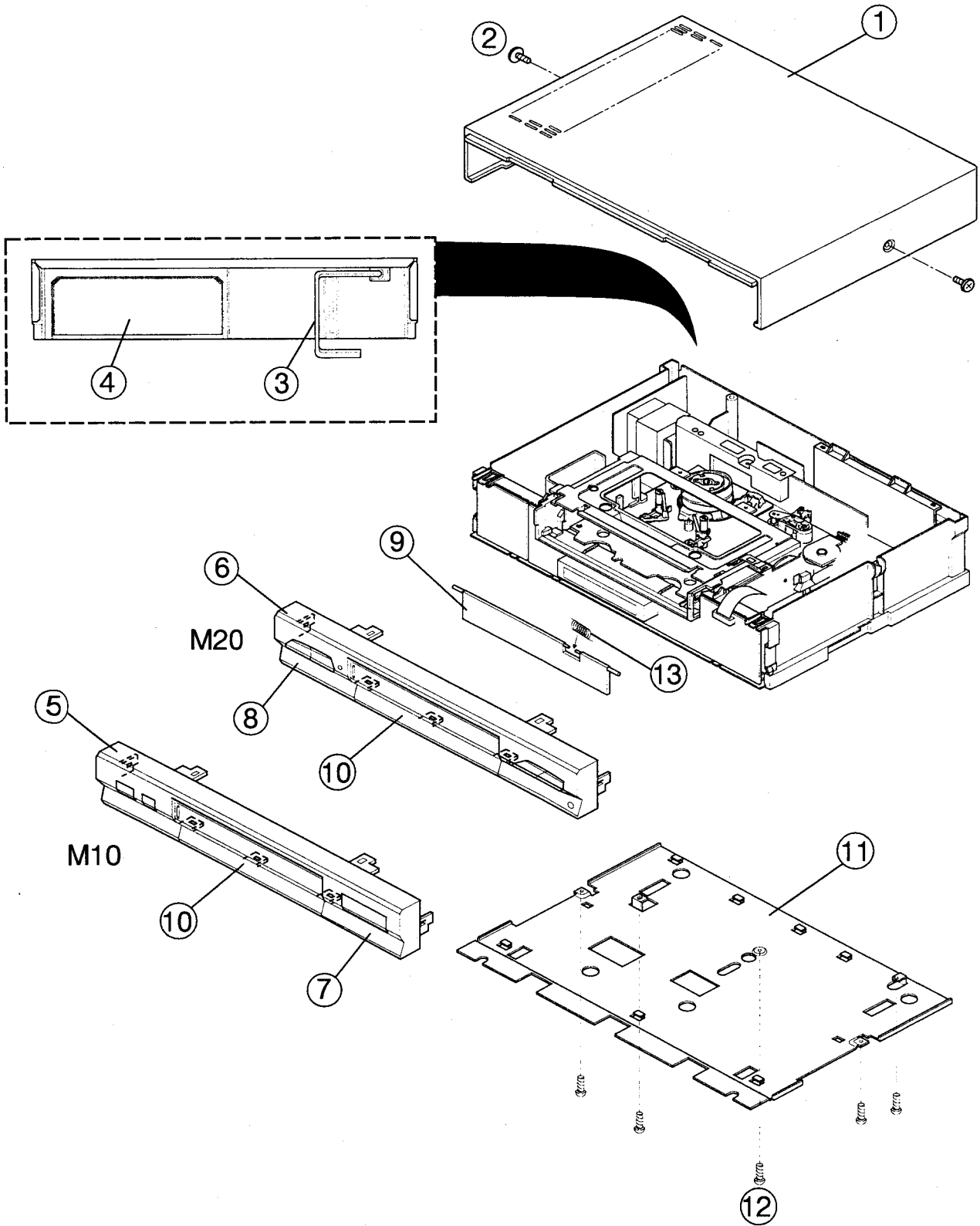

ITEM NO.	PARTS NO.	PARTS NAME	DESCRIPTION
CABINET ASSEMBLY			
1	968C040001	TOP COVER ASSY	
2	669D223080	SCREW	3X10
3	246C149040	AC POWER CORD	[M20VG]
3	246C167010	AC POWER CORD	[M10VB, M20VB, M20V1R]
4	761B257080	ANTENNA COVER	[M20VG]
4	761B257010	ANTENNA COVER	[M10VB, M20VB, M20V1R]
5	968B030010	FRONT UNIT	[M10VB]
6	968B027001	FRONT UNIT	[M20VB]
6	968B027002	FRONT UNIT	[M20V1R]
6	968B027003	FRONT UNIT	[M20VG]
7	752C110090	DOOR PANEL ASSY	[M10VB]
8	752C090010	DOOR PANEL ASSY	[M20VB]
8	752C090020	DOOR PANEL ASSY	[M20V1R]
8	752C111010	DOOR PANEL ASSY	[M20VG]
9	752C091010	CASSETTE DOOR	[M20VB]
9	752C091020	CASSETTE DOOR	[M20V1R]
9	752C095010	CASSETTE DOOR	[M20VG]
9	752C120090	CASSETTE DOOR	[M10VB]
10	702B903010	TIMER PANEL	[M10VB]
10	702B932010	TIMER PANEL	[M20VB, M20VG, M20V1R]
11	590A407010	BOTTOM PANEL	
12	669D220030	SCREW	3X10 46LA005
13	572D385010	SPRING F/L	

2. Packing Parts

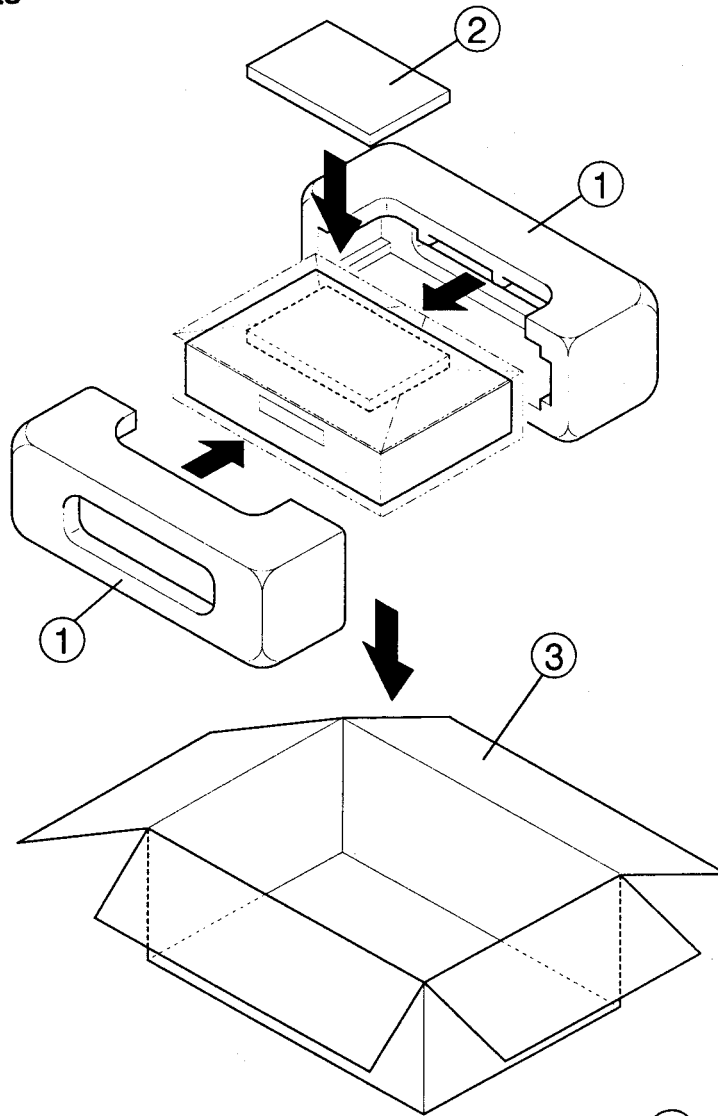

ACCESSORY

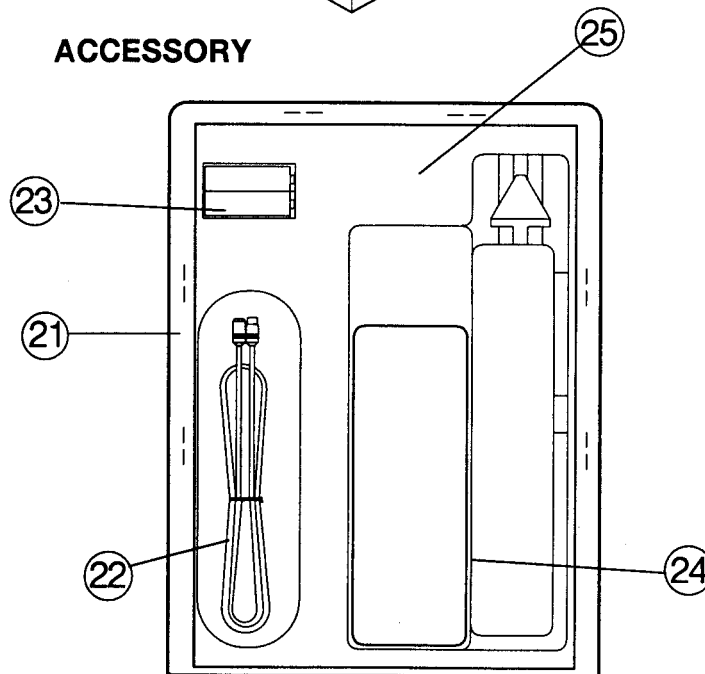

ITEM NO.	PARTS NO.	PARTS NAME	DESCRIPTION
PACKING PARTS			
1	803A351010	PACKING CUSHION	
2	-----	ACCESSORY	
3	802B459010	PACKING CASE	[M20VB]
3	802B459060	PACKING CASE	[M20VG]
3	802B459080	PACKING CASE	[M20VIR]
3	802B482050	PACKING CASE	[M10VB]
ACCESSORY			
21	829B013030	ACCESSORY PACK	[M10VB, M20VB, M20VIR]
21	829B013070	ACCESSORY PACK	[M20VG]
22	242D231030	CABLE	1.5m [M10VB, M20VB, M20VIR]
22	243C120010	CABLE	1.5m [M20VG]
23	-----	BATTERY	
24	939P575020	REMOTE HAND UNIT	[M10VB, M20VB, M20VIR]
24	939P576020	REMOTE HAND UNIT	[M20VG]
25	872C112060	INSTRUCTION BOOK	[M20VB]
25	872C112070	INSTRUCTION BOOK	[M20VIR]
25	872C117000	INSTRUCTION BOOK	[M20VG]
25	872C118000	INSTRUCTION BOOK	[M10VB]

3. ELECTRICAL PARTS

SYMBOL NO.	PARTS NO.	PARTS NAME	DESCRIPTION	SYMBOL NO.	PARTS NO.	PARTS NAME	DESCRIPTION
INTEGRATED CIRCUITS							
○ IC101	270P184010	IC	M52318SP	Q 2C4	260P806010	CHIP TRANSISTOR	DTA124EK [M10VB, M20VB, M20VIR]
IC102	266P192010	IC	LA7910 [M20VG, M20VIR]	Q 2C5	260P807010	CHIP TRANSISTOR	UN2212
IC103	272P654010	IC	M51497L [M20VG]	Q 2C6	260P802020	CHIP TRANSISTOR	2SA1235-F [M20VG]
IC201	272P221010	IC	BA7254S	Q 2C8	260P805030	CHIP TRANSISTOR	2SC3053-D
○ IC2A0	270P195010	IC	LA7346	Q 2D0	260P805030	CHIP TRANSISTOR	2SC3053-D
IC2A1	272P702010	IC	LC8992	Q 2D1	260P807010	CHIP TRANSISTOR	UN2212 [M20VG]
IC2A3	270P067010	IC	BA7645N [M10VB, M20VB, M20VIR]	Q 2D4	260P802020	CHIP TRANSISTOR	2SA1235-F
○ IC2301	270P167020	IC	LA7156-S [M20VG]	Q 2D5	260P805030	CHIP TRANSISTOR	2SC3053-D
IC310	272P234010	IC	LA7295	Q 2D6	260P560040	TRANSISTOR	2SA933S-S [M10VB, M20VG]
IC380	270P046010	IC	BA7644AN [M10VB, M20VB, M20VIR]	Q 2D6	260P255040	TRANSISTOR	2SA950-Y [M20VB, M20VIR]
IC4A0	274P318060	IC	MN67492MSU5	Q 2D7	260P807010	CHIP TRANSISTOR	UN2212
IC4A1	272P079010	IC	NJM2902M	Q 2D9	260P805030	CHIP TRANSISTOR	2SC3053-D
○ IC501	274P573010	IC	M35013-050SP	Q 2E0	260P805030	CHIP TRANSISTOR	2SC3053-D
IC551	270P185010	IC	SAA5233T [M20VG]	Q 2E1	260P562040	TRANSISTOR	2SA952-K
○ IC570	274P315010	IC	LC3517BML-15 [M20VB]	Q 2E3	260P802020	CHIP TRANSISTOR	2SA1235-F
○ IC571	270P216010	IC	SAA5246AGP [M20VB]	Q 2P0	260P802020	CHIP TRANSISTOR	2SA1235-F
○ IC5A0	274P551050	IC	M38185ME-066FP [M10VB, M20VB, M20VIR]	Q 2P1	260P805030	CHIP TRANSISTOR	2SC3053-D
IC5A0	274P551030	IC	M38185ME-053FP [M20VG]	Q 2P2	260P805030	CHIP TRANSISTOR	2SC3053-D
IC5A1	263P593010	IC	CAT35C104P	Q 2P4	260P805030	CHIP TRANSISTOR	2SC3053-D
IC5A2	272P235010	IC	TA7291S	Q 2P5	260P807010	CHIP TRANSISTOR	UN2212 [M10VB, M20VB, M20VIR]
IC5A3	272P204010	IC	LM2904M	Q 2P6	260P806010	CHIP TRANSISTOR	DTA124EK [M10VB, M20VB, M20VIR]
IC5A4	266P010020	IC	μPC574J-K	Q 2P7	260P807010	CHIP TRANSISTOR	UN2212 [M10VB, M20VB, M20VIR]
IC5A5	270P070010	IC	AT93C56-10PC [M20VG]	Q 2U0	260P806010	CHIP TRANSISTOR	DTA124EK [M10VB, M20VB, M20VIR]
IC5A5	263P593010	IC	CAT35C104P [M10VB, M20VB]	Q 2V0	260P802020	CHIP TRANSISTOR	2SA1235-F [M20VB, M20VG]
IC9A0	272P237010	IC	LA6324N	Q 2301	260C676040	TRANSISTOR	2SC3311A-R, S [M20VG]
TRANSISTORS				Q 2304	260P603010	TRANSISTOR	UN4112 [M20VG]
○ Q 101	260P874010	CHIP TRANSISTOR	2SC3082K-P, Q	Q 310	260P629060	TRANSISTOR	2SC3331-S
Q 102	260P560040	TRANSISTOR	2SA933S-S	Q 3A0	260P804020	CHIP TRANSISTOR	2SC3052-F
Q 103	260P805030	CHIP TRANSISTOR	2SC3053-D	Q 3A1	260P804020	CHIP TRANSISTOR	2SC3052-F
Q 106	260P808010	CHIP TRANSISTOR	DTC114EK [M20VG]	Q 4A0	260P804020	CHIP TRANSISTOR	2SC3052-F
Q 107	260P802020	CHIP TRANSISTOR	2SA1235-F [M20VG]	Q 4A2	260P804020	CHIP TRANSISTOR	2SC3052-F
Q 108	260P807010	CHIP TRANSISTOR	UN2212	Q 4A3	260P804030	CHIP TRANSISTOR	2SC3052-G
Q 208	260P802020	CHIP TRANSISTOR	2SA1235-F	Q 4A4	260P802020	CHIP TRANSISTOR	2SA1235-F
Q 211	260P807010	CHIP TRANSISTOR	UN2212	Q 4A7	260P802020	CHIP TRANSISTOR	2SA1235-F
Q 260	260P807010	CHIP TRANSISTOR	UN2212	Q 4A8	260P802020	CHIP TRANSISTOR	2SA1235-F
Q 261	260P807010	CHIP TRANSISTOR	UN2212	Q 501	260P802020	CHIP TRANSISTOR	2SA1235-F
Q 262	260P807010	CHIP TRANSISTOR	UN2212	Q 502	260P807010	CHIP TRANSISTOR	UN2212
Q 2A1	260P805030	CHIP TRANSISTOR	2SC3053-D [M20VG]	Q 503	260P802020	CHIP TRANSISTOR	2SA1235-F
Q 2A2	260P805030	CHIP TRANSISTOR	2SC3053-D [M20VG]	Q 506	260P802020	CHIP TRANSISTOR	2SA1235-F [M20VG]
Q 2B1	260P805030	CHIP TRANSISTOR	2SC3053-D	Q 508	260P804020	CHIP TRANSISTOR	2SC3052-F
Q 2B5	260P807010	CHIP TRANSISTOR	UN2212 [M20VB, M20VG, M20VIR]	Q 5A1	260P802020	CHIP TRANSISTOR	2SA1235-F
Q 2B6	260P805030	CHIP TRANSISTOR	2SC3053-D	Q 5A2	260P802020	CHIP TRANSISTOR	2SA1235-F
Q 2B8	260P805030	CHIP TRANSISTOR	2SC3053-D	Q 5A3	260P804020	CHIP TRANSISTOR	2SC3052-F
Q 2B9	260P805030	CHIP TRANSISTOR	2SC3053-D	Q 5A4	260P802020	CHIP TRANSISTOR	2SA1235-F
Q 2C0	260P805030	CHIP TRANSISTOR	2SC3053-D	Q 5A5	260P805030	CHIP TRANSISTOR	2SC3053-D
Q 2C3	260P806010	CHIP TRANSISTOR	DTA124EK [M10VB, M20VB, M20VIR]	Q 5A6	260P807010	CHIP TRANSISTOR	UN2212
				Q 5A7	260P807010	CHIP TRANSISTOR	UN2212
				Q 5A9	260P806010	CHIP TRANSISTOR	DTA124EK

SYMBOL NO.	PARTS NO.	PARTS NAME	DESCRIPTION	SYMBOL NO.	PARTS NO.	PARTS NAME	DESCRIPTION
Q 580	260P806010	CHIP TRANSISTOR	DTA124EK	D 2307	264P568010	DIODE	1SS252 [M20VG]
Q 581	260P807010	CHIP TRANSISTOR	UN2212	D 2308	264P568010	DIODE	1SS252 [M20VG]
Q 582	260P802020	CHIP TRANSISTOR	2SA1235-F	D 2313	264P568010	DIODE	1SS252 [M20VG]
Q 583	260P802020	CHIP TRANSISTOR	2SA1235-F	D 2315	264P568010	DIODE	1SS252 [M20VG]
Q 585	260P804030	CHIP TRANSISTOR	2SC3052-G	D 3A0	264P568010	DIODE	1SS252
Q 586	260P804030	CHIP TRANSISTOR	2SC3052-G	D 4A0	264P808010	CHIP DIODE	DAN202K
Q 587	260P807010	CHIP TRANSISTOR	UN2212	D 4A1	264P568010	DIODE	1SS252
Q 588	260P806010	CHIP TRANSISTOR	DTA124EK	D 501	264P568010	DIODE	1SS252
Q 589	260P807010	CHIP TRANSISTOR	UN2212	D 5A1	264P807010	DIODE	DA202K HVN21C
Q 5C0	260P804030	CHIP TRANSISTOR	2SC3052-G	D 5A2	264P342070	DIODE	HZ4C2
Q 5C1	260P804020	CHIP TRANSISTOR	2SC3052-F	D 5A4	264P808010	CHIP DIODE	DAN202K
Q 5C2	260P807010	CHIP TRANSISTOR	UN2212	D 5A5	264P808010	CHIP DIODE	DAN202K
Q 5C3	260P804020	CHIP TRANSISTOR	2SC3052-F [M10VB, M20VB, M20V1R]	D 5A6	264P568010	DIODE	1SS252
Q 5E1	268P014030	PHOTO TRANSISTOR	PN205L-(NC). M12	D 5A7	264P568010	DIODE	1SS252
Q 5E2	268P014030	PHOTO TRANSISTOR	PN205L-(NC). M12	D 5A8	264P568010	DIODE	1SS252
Q 5E3	268P059010	PHOTO INTERRUPTER	RPI-244	D 5A9	264P568010	DIODE	1SS252
Q 5E4	268P059010	PHOTO INTERRUPTER	RPI-244	D 5B0	264P808010	CHIP DIODE	DAN202K
Q 9A1	260C628010	TRANSISTOR	2SA1619A-Q	D 5B1	264P585010	LIGHT EMITTING DIODE	LN59L. MI
Q 9A2	260P640040	TRANSISTOR	2SD1762-E	D 5B2	264P568010	DIODE	1SS252
Q 9A3	260P640040	TRANSISTOR	2SD1762-E	D 5B3	264P568010	DIODE	1SS252
Q 9A4	260P640040	TRANSISTOR	2SD1762-E	D 5B4	264P568010	DIODE	1SS252
Q 9A5	260P613010	TRANSISTOR	2SC4208A	D 5B5	264P568010	DIODE	1SS252
Q 9A7	260P560030	TRANSISTOR	2SA933S-R, F	D 5B6	264P568010	DIODE	1SS252
Q 9A8	260P560040	TRANSISTOR	2SA933S-S	D 5B7	264P808010	CHIP DIODE	DAN202K
Q 9A9	260P585030	TRANSISTOR	2SD1682-T, U	D 5V0	264P485050	DIODE	RD7. 5FB1
Q 9B0	260P802020	CHIP TRANSISTOR	2SA1235-F	D 8A1	264P568010	DIODE	1SS252
Q 9B2	260P613010	TRANSISTOR	2SC4208A [M20VG]	D 8A2	264P568010	DIODE	1SS252
DIODES				D 8A3	264P568010	DIODE	1SS252
D 101	264P568010	DIODE	1SS252 [M20VG]	D 8A4	264P568010	DIODE	1SS252 [M20VB, M20V1R]
D 102	264P568010	DIODE	1SS252 [M20VG]	D 8B0	264P568010	DIODE	1SS252
D 2A1	264P807010	DIODE	DA202K HVN21C [M20VG]	D 8B1	264P568010	DIODE	1SS252
D 2A3	264P568010	DIODE	1SS252	D 8B2	264P568010	DIODE	1SS252
D 2A6	264P568010	DIODE	1SS252 [M20VG]	D 8B3	264P568010	DIODE	1SS252
D 2A8	264P568010	DIODE	1SS252	D 8J0	264P568010	DIODE	1SS252 [M20VG]
D 2A9	264P568010	DIODE	1SS252 [M10VB, M20VB, M20V1R]	D 8J1	264P568010	DIODE	1SS252 [M10VB, M20VB, M20V1R]
D 2B0	264P568010	DIODE	1SS252 [M10VB, M20VB, M20V1R]	D 8K0	264P568010	DIODE	1SS252 [M10VB, M20VB]
D 2B1	264P568010	DIODE	1SS252	D 8K1	264P568010	DIODE	1SS252 [M20VG]
D 2B2	264P568010	DIODE	1SS252 [M20VB, M20VG, M20V1R]	D 8K3	264P568010	DIODE	1SS252 [M10VB]
D 2B3	264P568010	DIODE	1SS252 [M20VB, M20VG, M20V1R]	D 8L0	264P568010	DIODE	1SS252 [M10VB, M20VG]
D 2B4	264P808010	CHIP DIODE	DAN202K	D 8L3	264P568010	DIODE	1SS252 [M20VG]
D 2B5	264P568010	DIODE	1SS252 [M10VB, M20VG, M20V1R]	D 9A1	264P101050	DIODE	RM 1B
D 2D0	264P568010	DIODE	1SS252 [M10VB, M20VB, M20V1R]	D 9A2	264P101050	DIODE	RM 1B
D 2301	264P568010	DIODE	1SS252 [M20VG]	D 9A3	264P101050	DIODE	RM 1B
D 2302	264P568010	DIODE	1SS252 [M20VG]	D 9A4	264P101050	DIODE	RM 1B
D 2303	264P568010	DIODE	1SS252 [M20VG]	D 9A5	264P101050	DIODE	RM 1B
D 2305	264P568010	DIODE	1SS252 [M20VG]	D 9A6	264P101050	DIODE	RM 1B
D 2306	264P568010	DIODE	1SS252 [M20VG]	D 9A7	264P101050	DIODE	RM 1B
				D 9A8	264P101050	DIODE	RM 1B
				D 9A9	264P500020	DIODE	EM01Z
				D 9B0	264P500020	DIODE	EM01Z
				D 9B1	264P104040	DIODE	HZ30-2
				D 9B3	264P452030	DIODE	HZ5C3
				D 9C0	264P568010	DIODE	1SS252
				D 9C1	264P568010	DIODE	1SS252
				D 9C2	264P568010	DIODE	1SS252

SYMBOL NO.	PARTS NO.	PARTS NAME	DESCRIPTION	SYMBOL NO.	PARTS NO.	PARTS NAME	DESCRIPTION
D 9C3	264P592010	DIODE	HZ18-2L	L 2B9	321C112050	RF COIL	100 μ H-K
D 9C4	264P500020	DIODE	EM01Z	L 2C0	325C162050	PEAKING COIL	100 μ H-K
D 9C5	264P487080	DIODE	RD12FB2 [M20VG]	L 2C1	325C167010	PEAKING COIL	47 μ H-J
FILTERS				L 2C2	325C166090	PEAKING COIL	33 μ H-J
CF101	296P014030	CERAMIC FILTER	SFE-6.0MHZ [M10VB, M20VB, M20VIR]	L 2C3	325C122050	PEAKING COIL	100 μ H-K
CF101	296P014090	CERAMIC FILTER	SFE-5.5MC2 [M20VG]	L 2G3	325C122000	PEAKING COIL	39 μ H-K [M20VB, M20VG, M20VIR]
CF102	296P024040	CERAMIC TRAP	TPS6.0MB [M10VB, M20VB, M20VIR]	L 2P1	325C166090	PEAKING COIL	33 μ H-J
CF102	296P104010	CERAMIC TRAP	EFC-S3F01W3A [M20VG]	L 2P5	325C166090	PEAKING COIL	33 μ H-J
CF103	299P051050	CERAMIC RESONATOR	CSB500F9 [M20VG]	L 2P6	325C167010	PEAKING COIL	47 μ H-J
CF104	296P143020	CERAMIC RESONATOR	CDSH6.0ME65 [M10VB, M20VB, M20VIR]	L 2301	325C122050	PEAKING COIL	100 μ H-K [M20VG]
CF104	296P143010	CERAMIC RESONATOR	CDSH5.5ME65 [M20VG]	L 2371	325C120010	PEAKING COIL	1.0 μ H-M [M20VG]
SF101	296P141010	SAW FILTER	SAF39.5MVA80Z [M10VB, M20VB, M20VIR]	L 2372	325C120050	PEAKING COIL	2.2 μ H-M/K [M20VG]
SF102	296P134020	SAW FILTER	SAF38.9MV885Z [M20VG]	L 2373	325C121030	PEAKING COIL	10 μ H-K [M20VG]
SF102	296P134010	SAW FILTER	SAF32.9MC70Z [M10VB, M20VB, M20VIR]	L 2374	325C121030	PEAKING COIL	10 μ H-K [M20VG]
SF102	296P134010	SAW FILTER	SAF33.0MC70Z [M20VG]	L 2375	325C120010	PEAKING COIL	1.0 μ H-M [M20VG]
DELAY LINES				L 2376	325C120010	PEAKING COIL	1.0 μ H-M [M20VG]
DL2A0	337P081010	DELAY LINE	CF873	L 2377	325C120010	PEAKING COIL	1.0 μ H-M [M20VG]
COILS				L 2379	325C120050	PEAKING COIL	2.2 μ H-M/K [M20VG]
L 01	325C121030	PEAKING COIL	10 μ H-K	L 2380	325C121030	PEAKING COIL	10 μ H-K [M20VG]
L 101	325C122050	PEAKING COIL	100 μ H-K	L 2381	325C121030	PEAKING COIL	10 μ H-K [M20VG]
L 102	325C165020	PEAKING COIL	1.2 μ H-J	L 2382	325C120010	PEAKING COIL	1.0 μ H-M [M20VG]
L 103	325C170050	PEAKING COIL	2.2 μ H-K SHIELD	L 2383	325C120010	PEAKING COIL	1.0 μ H-M [M20VG]
L 104	325C165040	PEAKING COIL	1.8 μ H-J	L 310	321C113070	RF COIL	1000 μ H-K
L 105	325C121040	PEAKING COIL	12 μ H-K	L 311	321C114080	RF COIL	8200 μ H-J
L 106	323P191010	VIF COIL	292GJS-7145BS	L 312	321C114080	RF COIL	8200 μ H-J
L 107	325C167020	PEAKING COIL	56 μ H-J [M10VB, M20VB, M20VIR]	L 501	325C122050	PEAKING COIL	100 μ H-K
L 107	325C166070	PEAKING COIL	22 μ H-J [M20VG]	L 502	325C146050	CHIP COIL	15 μ H-J
L 108	323P191020	VIF COIL	292GNS-7135BS	L 503	325C262050	PEAKING COIL	100 μ H-K
L 109	325C166020	PEAKING COIL	8.2 μ H-J [M10VB, M20VB, M20VIR]	L 507	325C266080	PEAKING COIL	27 μ H-J [M20VG]
L 109	325C166000	PEAKING COIL	5.6 μ H-J [M20VG]	L 550	325C262050	PEAKING COIL	100 μ H-K [M20VG]
L 201	325C162050	PEAKING COIL	100 μ H-K	L 551	325C110090	PEAKING COIL	4.7 μ H-K [M20VG]
L 206	325C166070	PEAKING COIL	22 μ H-J	L 570	325C262050	PEAKING COIL	100 μ H-K [M20VB]
L 210	325C166070	PEAKING COIL	22 μ H-J	L 571	325C262050	PEAKING COIL	100 μ H-K [M20VB]
L 211	325C166000	PEAKING COIL	5.6 μ H-J	L 572	325C110090	PEAKING COIL	4.7 μ H-K [M20VB]
L 213	325C122050	PEAKING COIL	100 μ H-K	L 5A0	325C262050	PEAKING COIL	100 μ H-K
L 219	325C167040	PEAKING COIL	82 μ H-J	L 5A1	325C266070	PEAKING COIL	22 μ H-J SO
L 220	325C167070	PEAKING COIL	150 μ H-J	L 901	351P038010	LINE FILTER	ELF-18D290CN [M20VG]
L 2A8	325C166060	PEAKING COIL	18 μ H-J	TRANSFORMERS			
L 2A9	325C167080	PEAKING COIL	180 μ H-J	T 310	409P423030	AUDIO BIAS OSC	409P42301/2
L 2B0	325C167030	PEAKING COIL	68 μ H-J	T 901	350P607030	TRANS POWER	
L 2B1	325C166060	PEAKING COIL	18 μ H-J	VARIABLE RESISTORS			
L 2B2	325C168010	PEAKING COIL	330 μ H-J	VR101	127C381010	VR SEMIFIXED	1/5W B50k Ω -M
L 2B4	325C165070	PEAKING COIL	3.3 μ H-J	VR202	127C480040	VR SEMIFIXED	1/5W B1k Ω +25%
L 2B5	325C166020	PEAKING COIL	8.2 μ H-J	VR203	127C480080	VR SEMIFIXED	1/5W B10k Ω +25%
L 2B8	321C112050	RF COIL	100 μ H-K	VR2A0	127C380090	VR SEMIFIXED	1/5W B20k Ω -M
				VR2A1	127C390090	VR SEMIFIXED	1/5W B20k Ω -M
				VR2A2	127C380080	VR SEMIFIXED	1/5W B10k Ω -M
				VR2A3	127C380050	VR SEMIFIXED	1/5W B2k Ω -M
				VR2A5	127C380090	VR SEMIFIXED	1/5W B20k Ω -M
				VR310	127C481020	VR SEMIFIXED	1/5W B100k Ω +25%
				VR5A0	127C381020	VR SEMIFIXED	1/5W B100k Ω -M

SYMBOL NO.	PARTS NO.	PARTS NAME	DESCRIPTION	SYMBOL NO.	PARTS NO.	PARTS NAME	DESCRIPTION
RESISTORS							
R 01	103P403070	CHIP RESISTOR	1/10W 10kΩ-J	R 222	103P402050	CHIP RESISTOR	1/10W 1kΩ-J
R 03	103P404000	CHIP RESISTOR	1/10W 18kΩ-J	R 227	103P402050	CHIP RESISTOR	1/10W 1kΩ-J
R 04	103P401020	CHIP RESISTOR	1/10W 82Ω-J	R 240	103P401090	CHIP RESISTOR	1/10W 330Ω-J
R 06	103P409050	CHIP RESISTOR	1/10W 0Ω	R 243	103P402060	CHIP RESISTOR	1/10W 1.2kΩ-J
R 08	103P403070	CHIP RESISTOR	1/10W 10kΩ-J	R 249	103P401050	CHIP RESISTOR	1/10W 150Ω-J
				R 265	103P473030	CHIP RESISTOR	1/10W 2.2kΩ-F
R 11	103P403070	CHIP RESISTOR	1/10W 10kΩ-J	R 266	103P473030	CHIP RESISTOR	1/10W 2.2kΩ-F
R 12	103P403070	CHIP RESISTOR	1/10W 10kΩ-J [M20VG, M20VIR]	R 267	103P473070	CHIP RESISTOR	1/10W 3.3kΩ-F
R 13	103P403070	CHIP RESISTOR	1/10W 10kΩ-J [M20VG, M20VIR]	R 268	103P473030	CHIP RESISTOR	1/10W 2.2kΩ-F
R 16	103P404000	CHIP RESISTOR	1/10W 18kΩ-J	R 272	103P477050	CHIP RESISTOR	1/10W 120K
R 101	103P403060	CHIP RESISTOR	1/10W 8.2kΩ-J	R 273	103P475070	CHIP RESISTOR	1/10W 22kΩ-F
R 102	103P402050	CHIP RESISTOR	1/10W 1kΩ-J	R 274	103P476070	CHIP RESISTOR	1/10W 56kΩ-F
R 103	103P402030	CHIP RESISTOR	1/10W 680Ω-J	R 277	103P474090	CHIP RESISTOR	1/10W 10kΩ-F
R 104	103P401010	CHIP RESISTOR	1/10W 68Ω-J	R 278	103P474090	CHIP RESISTOR	1/10W 10kΩ-F
R 108	103P477010	CHIP RESISTOR	1/10W 82kΩ-F	R 279	103P474090	CHIP RESISTOR	1/10W 10kΩ-F
R 110	103P476060	CHIP METAL	1/10W 51kΩ-F	R 287	103P401090	CHIP RESISTOR	1/10W 330Ω-J
R 111	103P401030	CHIP RESISTOR	1/10W 100Ω-J	R 288	103P402050	CHIP RESISTOR	1/10W 1kΩ-J
R 112	103P402040	CHIP RESISTOR	1/10W 820Ω-J	R 2A1	103P404010	CHIP RESISTOR	1/10W 22kΩ-J [M20VG]
R 115	103P471090	CHIP RESISTOR	1/10W 560Ω-F	R 2A2	103P404070	CHIP RESISTOR	1/10W 68kΩ-J [M20VG]
R 116	103P404090	CHIP RESISTOR	1/10W 100kΩ-J [M20VB]	R 2A3	103P402070	CHIP RESISTOR	1/10W 1.5kΩ-J [M20VG]
R 116	103P409050	CHIP RESISTOR	1/10W 0Ω [M20VG]	R 2A4	103P401030	CHIP RESISTOR	1/10W 100Ω-J [M20VG]
R 116	103P403020	CHIP RESISTOR	1/10W 3.9kΩ-J [M20VIR]	R 2A5	103P402030	CHIP RESISTOR	1/10W 680Ω-J [M20VG]
R 117	103P402050	CHIP RESISTOR	1/10W 1kΩ-J	R 2A6	103P403010	CHIP RESISTOR	1/10W 3.3kΩ-J [M20VG]
R 118	103P471050	CHIP RESISTOR	1/10W 390Ω-F [M10VB, M20VB]	R 2A7	103P409050	CHIP RESISTOR	1/10W 0Ω [M10VB, M20VB, M20VIR]
R 118	103P470010	CHIP RESISTOR	1/10W 100Ω-F [M20VG]	R 2A8	103P409050	CHIP RESISTOR	1/10W 0Ω
R 118	103P471030	CHIP RESISTOR	1/10W 330Ω-F [M20VIR]	R 2D2	103P402050	CHIP RESISTOR	1/10W 1kΩ-J
R 119	103P401030	CHIP RESISTOR	1/10W 100Ω-J	R 2D3	103P402030	CHIP RESISTOR	1/10W 680Ω-J
R 120	103P402050	CHIP RESISTOR	1/10W 1kΩ-J	R 2D4	103P401060	CHIP RESISTOR	1/10W 180Ω-J [M10VB, M20VB, M20VIR]
R 127	103P402050	CHIP RESISTOR	1/10W 1kΩ-J	R 2D4	103P401030	CHIP RESISTOR	1/10W 100Ω-J [M20VG]
R 129	103P403030	CHIP RESISTOR	1/10W 4.7kΩ-J [M20VG]	R 2E1	103P403000	CHIP RESISTOR	1/10W 2.7kΩ-J [M10VB, M20VB, M20VIR]
R 130	103P405090	CHIP RESISTOR	1/10W 680kΩ-J [M20VG]	R 2E1	103P402070	CHIP RESISTOR	1/10W 1.5kΩ-J [M20VG]
R 131	103P403050	CHIP RESISTOR	1/10W 6.8kΩ-J [M20VG]	R 2E2	103P401080	CHIP RESISTOR	1/10W 270Ω-J [M20VB, M20VIR]
R 132	103P403070	CHIP RESISTOR	1/10W 10kΩ-J [M20VG]	R 2E2	103P401070	CHIP RESISTOR	1/10W 220Ω-J [M20VG]
R 133	103P403040	CHIP RESISTOR	1/10W 5.6kΩ-J [M20VG]	R 2E3	103P402030	CHIP RESISTOR	1/10W 680Ω-J [M10VB, M20VB, M20VIR]
R 134	103P401080	CHIP RESISTOR	1/10W 270Ω-J [M20VG]	R 2E5	103P402020	CHIP RESISTOR	1/10W 560Ω-J
R 135	103P402010	CHIP RESISTOR	1/10W 470Ω-J [M20VG]	R 2E6	103P403030	CHIP RESISTOR	1/10W 1.7kΩ-J
R 136	103P405020	CHIP RESISTOR	1/10W 180kΩ-J [M20VG]	R 2E7	103P403070	CHIP RESISTOR	1/10W 10kΩ-J
R 138	103P409050	CHIP RESISTOR	1/10W 0Ω	R 2E8	103P404040	CHIP RESISTOR	1/10W 39kΩ-J
R 140	103P401030	CHIP RESISTOR	1/10W 100Ω-J	R 2F1	103P402050	CHIP RESISTOR	1/10W 1kΩ-J
R 200	103P409050	CHIP RESISTOR	1/10W 0Ω	R 2F2	103P402050	CHIP RESISTOR	1/10W 1kΩ-J
R 202	103P409050	CHIP RESISTOR	1/10W 0Ω	R 2F3	103P404030	CHIP RESISTOR	1/10W 33kΩ-J
R 204	103P409050	CHIP RESISTOR	1/10W 0Ω	R 2F4	103P403090	CHIP RESISTOR	1/10W 15kΩ-J
R 205	103P409050	CHIP RESISTOR	1/10W 0Ω	R 2F5	103P401070	CHIP RESISTOR	1/10W 220Ω-J [M10VB, M20VB, M20VIR]
R 206	103P402060	CHIP RESISTOR	1/10W 1.2kΩ-J	R 2F5	103P401080	CHIP RESISTOR	1/10W 170Ω-J [M20VG]
R 207	103P402070	CHIP RESISTOR	1/10W 1.5kΩ-J	R 2F6	103P404030	CHIP RESISTOR	1/10W 33kΩ-J
R 208	103P402000	CHIP RESISTOR	1/10W 390Ω-J	R 2F7	103P402020	CHIP RESISTOR	1/10W 560Ω-J
R 209	103P401030	CHIP RESISTOR	1/10W 100Ω-J	R 2F8	103P473080	CHIP RESISTOR	1/10W 1.6kΩ-F
R 210	103P401020	CHIP RESISTOR	1/10W 82Ω-J	R 2G0	103P402060	CHIP RESISTOR	1/10W 1.2kΩ-J
R 212	103P402010	CHIP RESISTOR	1/10W 470Ω-J	R 2G1	103P403020	CHIP RESISTOR	1/10W 1.9kΩ-J
R 216	103P401090	CHIP RESISTOR	1/10W 330Ω-J	R 2G2	103P403000	CHIP RESISTOR	1/10W 1.7kΩ-J
R 217	103P402000	CHIP RESISTOR	1/10W 390Ω-J				

SYMBOL NO.	PARTS NO.	PARTS NAME	DESCRIPTION	SYMBOL NO.	PARTS NO.	PARTS NAME	DESCRIPTION
R 2G3	103P402020	CHIP RESISTOR	1/10W 560Ω-J	R 2U0	103P409050	CHIP RESISTOR	1/10W 0Ω [M20VG]
R 2G4	103P402050	CHIP RESISTOR	1/10W 1kΩ-J	R 2V0	103P401070	CHIP RESISTOR	1/10W 220Ω-J [M20VB, M20VG]
R 2G5	103P401080	CHIP RESISTOR	1/10W 270Ω-J	R 2V1	103P402050	CHIP RESISTOR	1/10W 1kΩ-J [M20VB, M20VG]
R 2G7	103P402050	CHIP RESISTOR	1/10W 1kΩ-J [M10VB, M20VB, M20VIR]	R 311	103P404030	CHIP RESISTOR	1/10W 33kΩ-J
R 2G8	103P406010	CHIP RESISTOR	1/10W 1MΩ-J	R 312	103P401080	CHIP RESISTOR	1/10W 270Ω-J [M10VB, M20VB, M20VIR]
R 2H1	103P402050	CHIP RESISTOR	1/10W 1kΩ-J	R 313	103P401030	CHIP RESISTOR	1/10W 100Ω-J
R 2H3	103P401080	CHIP RESISTOR	1/10W 270Ω-J	R 315	103P403030	CHIP RESISTOR	1/10W 4.7kΩ-J
R 2H4	103P402060	CHIP RESISTOR	1/10W 1.2kΩ-J	R 316	103P406010	CHIP RESISTOR	1/10W 1MΩ-J
R 2H5	103P401030	CHIP RESISTOR	1/10W 100Ω-J	R 317	103P404020	CHIP RESISTOR	1/10W 27kΩ-J
R 2H7	103P409050	CHIP RESISTOR	1/10W 0Ω	R 318	103P403080	CHIP RESISTOR	1/10W 12kΩ-J
R 2J0	103P402060	CHIP RESISTOR	1/10W 1.2kΩ-J	R 319	103P403040	CHIP RESISTOR	1/10W 5.6kΩ-J
R 2J1	103P401080	CHIP RESISTOR	1/10W 270Ω-J	R 320	103P402040	CHIP RESISTOR	1/10W 820Ω-J
R 2J2	103P404030	CHIP RESISTOR	1/10W 33kΩ-J	R 325	103P474080	CHIP RESISTOR	1/10W 9.1K
R 2J3	103P404010	CHIP RESISTOR	1/10W 22kΩ-J	R 326	103P401050	CHIP RESISTOR	1/10W 150Ω-J
R 2J4	103P402090	CHIP RESISTOR	1/10W 2.2kΩ-J	R 327	103P402090	CHIP RESISTOR	1/10W 2.2kΩ-J
R 2J5	103P402050	CHIP RESISTOR	1/10W 1kΩ-J	R 328	103P403070	CHIP RESISTOR	1/10W 10kΩ-J
R 2J6	103P402050	CHIP RESISTOR	1/10W 1kΩ-J	R 330	103P404000	CHIP RESISTOR	1/10W 18kΩ-J
R 2J8	103P402080	CHIP RESISTOR	1/10W 1.8kΩ-J	R 331	103P404020	CHIP RESISTOR	1/10W 27kΩ-J
R 2J9	103P403080	CHIP RESISTOR	1/10W 12kΩ-J	R 332	103P403090	CHIP RESISTOR	1/10W 15kΩ-J
R 2K7	103P470060	CHIP RESISTOR	1/10W 160Ω-F	R 334	103P402050	CHIP RESISTOR	1/10W 1kΩ-J
R 2K8	103P470090	CHIP RESISTOR	1/10W 220Ω-F	R 337	103P401090	CHIP RESISTOR	1/10W 330Ω-J [M10VB, M20VB, M20VIR]
R 2M5	103P403090	CHIP RESISTOR	1/10W 15kΩ-J	R 338	103P473080	CHIP RESISTOR	1/10W 3.6kΩ-F
R 2M6	103P404050	CHIP RESISTOR	1/10W 47kΩ-J	R 339	103P473060	CHIP RESISTOR	1/10W 3kΩ-F
R 2N4	103P401080	CHIP RESISTOR	1/10W 270Ω-J	R 3A0	103P402070	CHIP RESISTOR	1/10W 1.5kΩ-J
R 2N5	103P402050	CHIP RESISTOR	1/10W 1kΩ-J [M20VG]	R 3A1	103P403010	CHIP RESISTOR	1/10W 3.3kΩ-J
R 2N6	103P404010	CHIP RESISTOR	1/10W 22kΩ-J [M20VG]	R 3A2	103P403070	CHIP RESISTOR	1/10W 10kΩ-J
R 2N8	103P401080	CHIP RESISTOR	1/10W 270Ω-J	R 3A3	103P403070	CHIP RESISTOR	1/10W 10kΩ-J
R 2N9	103P404090	CHIP RESISTOR	1/10W 100kΩ-J [M10VB, M20VB, M20VG]	R 3A4	103P403010	CHIP RESISTOR	1/10W 3.3kΩ-J
R 2N9	103P403090	CHIP RESISTOR	1/10W 15kΩ-J[M20VIR]	R 3A5	103P403070	CHIP RESISTOR	1/10W 10kΩ-J
R 2P2	103P402050	CHIP RESISTOR	1/10W 1kΩ-J	R 3A6	103P478020	CHIP RESISTOR	1/10W 240kΩ-F
R 2P3	103P402030	CHIP RESISTOR	1/10W 680Ω-J	R 3B0	103P404050	CHIP RESISTOR	1/10W 47kΩ-J [M10VB, M20VB, M20VIR]
R 2P5	103P403070	CHIP RESISTOR	1/10W 10kΩ-J	R 3B2	103P409050	CHIP RESISTOR	1/10W 0Ω [M10VB, M20VB, M20VIR]
R 2P7	103P403010	CHIP RESISTOR	1/10W 3.3kΩ-J	R 3B2	103P402060	CHIP RESISTOR	1/10W 1.2kΩ-J[M20VG]
R 2R1	103P401080	CHIP RESISTOR	1/10W 270Ω-J	R 3B3	103P403030	CHIP RESISTOR	1/10W 4.7kΩ-J
R 2R2	103P404040	CHIP RESISTOR	1/10W 39kΩ-J [M10VB, M20VB, M20VIR]	R 3B8	103P403010	CHIP RESISTOR	1/10W 3.3kΩ-J [M10VB, M20VB, M20VIR]
R 2R4	103P403010	CHIP RESISTOR	1/10W 3.3kΩ-J	R 4A0	103P404090	CHIP RESISTOR	1/10W 100kΩ-J
R 2R6	103P404010	CHIP RESISTOR	1/10W 22kΩ-J	R 4A5	103P403070	CHIP RESISTOR	1/10W 10kΩ-J
R 2S3	103P401080	CHIP RESISTOR	1/10W 270Ω-J	R 4A9	103P403030	CHIP RESISTOR	1/10W 4.7kΩ-J
R 2S5	103P402020	CHIP RESISTOR	1/10W 560Ω-J	R 4B0	103P402050	CHIP RESISTOR	1/10W 1kΩ-J
R 2T1	103P402070	CHIP RESISTOR	1/10W 1.5kΩ-J	R 4B2	103P404000	CHIP RESISTOR	1/10W 18kΩ-J
R 2T2	103P403070	CHIP RESISTOR	1/10W 10kΩ-J	R 4B4	103P404030	CHIP RESISTOR	1/10W 33kΩ-J
R 2T3	103P403070	CHIP RESISTOR	1/10W 10kΩ-J	R 4B5	103P405050	CHIP RESISTOR	1/10W 330kΩ-J
R 2T4	103P409050	CHIP RESISTOR	1/10W 0Ω [M20VG]	R 4B6	103P404060	CHIP RESISTOR	1/10W 56kΩ-J
R 2T5	103P409050	CHIP RESISTOR	1/10W 0Ω [M20VG]	R 4B7	103P405030	CHIP RESISTOR	1/10W 220kΩ-J
R 2T6	103P402090	CHIP RESISTOR	1/10W 2.2kΩ-J[M20VG]	R 4B8	103P404040	CHIP RESISTOR	1/10W 39kΩ-J
R 2T7	103P473060	CHIP RESISTOR	1/10W 3kΩ-F [M20VG]	R 4B9	103P405010	CHIP RESISTOR	1/10W 150kΩ-J
R 2T8	103P403030	CHIP RESISTOR	1/10W 4.7kΩ-J [M10VB, M20VB, M20VIR]	R 4C0	103P405030	CHIP RESISTOR	1/10W 220kΩ-J
R 2T8	103P403040	CHIP RESISTOR	1/10W 5.6kΩ-J[M20VG]	R 4C1	103P405010	CHIP RESISTOR	1/10W 150kΩ-J
R 2T9	103P403040	CHIP RESISTOR	1/10W 5.6kΩ-J	R 4C3	103P404040	CHIP RESISTOR	1/10W 39kΩ-J
R 2U0	103P402000	CHIP RESISTOR	1/10W 390Ω-J [M10VB, M20VB, M20VIR]	R 4C6	103P405050	CHIP RESISTOR	1/10W 330kΩ-J

SYMBOL NO.	PARTS NO.	PARTS NAME	DESCRIPTION	SYMBOL NO.	PARTS NO.	PARTS NAME	DESCRIPTION
R 4C7	103P404090	CHIP RESISTOR	1/10W 100kΩ-J	R 5B0	103P402050	CHIP RESISTOR	1/10W 1kΩ-J
R 4C8	103P402090	CHIP RESISTOR	1/10W 2.2kΩ-J	R 5B1	103P403070	CHIP RESISTOR	1/10W 10kΩ-J
R 4C9	103P406010	CHIP RESISTOR	1/10W 1MΩ-J	R 5B2	103P403070	CHIP RESISTOR	1/10W 10kΩ-J
R 4D0	103P405000	CHIP RESISTOR	1/10W 120kΩ-J	R 5B3	103P404000	CHIP RESISTOR	1/10W 18kΩ-J
R 4D1	103P402050	CHIP RESISTOR	1/10W 1kΩ-J	R 5B4	103P402050	CHIP RESISTOR	1/10W 1kΩ-J
R 4D2	103P404060	CHIP RESISTOR	1/10W 56kΩ-J	R 5B5	103P402090	CHIP RESISTOR	1/10W 2.2kΩ-J
R 4D3	103P403020	CHIP RESISTOR	1/10W 3.9kΩ-J	R 5B6	103P403060	CHIP RESISTOR	1/10W 8.2kΩ-J
R 4D4	103P405040	CHIP RESISTOR	1/10W 270kΩ-J	R 5B7	103P402090	CHIP RESISTOR	1/10W 2.2kΩ-J
R 4D5	103P405000	CHIP RESISTOR	1/10W 120kΩ-J	R 5B8	103P401030	CHIP RESISTOR	1/10W 100Ω-J [M10VB, M20VB, M20V1R]
R 4D6	103P404000	CHIP RESISTOR	1/10W 18kΩ-J	R 5B8	103P401060	CHIP RESISTOR	1/10W 180Ω-J [M20VG]
R 4D7	103P404010	CHIP RESISTOR	1/10W 22kΩ-J	R 5B9	103P401070	CHIP RESISTOR	1/10W 220Ω-J [M10VB, M20VB]
R 4D8	103P404030	CHIP RESISTOR	1/10W 33kΩ-J	R 5B9	103P401090	CHIP RESISTOR	1/10W 330Ω-J [M20VG]
R 4D9	103P403060	CHIP RESISTOR	1/10W 8.2kΩ-J	R 5B9	103P471020	CHIP RESISTOR	1/10W 300Ω-F[M20V1R]
R 4E1	103P403070	CHIP RESISTOR	1/10W 10kΩ-J	R 5C0	103P404070	CHIP RESISTOR	1/10W 68kΩ-J
R 4E2	103P472070	CHIP RESISTOR	1/10W 1.2kΩ-F	R 5C1	103P403030	CHIP RESISTOR	1/10W 4.7kΩ-J
R 4E3	103P472070	CHIP RESISTOR	1/10W 1.2kΩ-F	R 5C2	103P405070	CHIP RESISTOR	1/10W 470kΩ-J
R 4E6	103P404060	CHIP RESISTOR	1/10W 56kΩ-J	R 5C3	103P403070	CHIP RESISTOR	1/10W 10kΩ-J
R 4E7	103P403030	CHIP RESISTOR	1/10W 4.7kΩ-J	R 5C4	103P403070	CHIP RESISTOR	1/10W 10kΩ-J
R 4E9	103P404020	CHIP RESISTOR	1/10W 27kΩ-J	R 5C5	103P402050	CHIP RESISTOR	1/10W 1kΩ-J
R 4F0	103P404050	CHIP RESISTOR	1/10W 47kΩ-J	R 5C6	103P404090	CHIP RESISTOR	1/10W 100kΩ-J
R 4F1	103P404090	CHIP RESISTOR	1/10W 100kΩ-J	R 5C8	103P401020	CHIP RESISTOR	1/10W 82Ω-J
R 4F2	103P402060	CHIP RESISTOR	1/10W 1.2kΩ-J	R 5D0	103P403070	CHIP RESISTOR	1/10W 10kΩ-J
R 4Z4	103P404090	CHIP RESISTOR	1/10W 100kΩ-J	R 5D2	103P403080	CHIP RESISTOR	1/10W 12kΩ-J
R 503	103P403080	CHIP RESISTOR	1/10W 12kΩ-J	R 5D3	103P404000	CHIP RESISTOR	1/10W 18kΩ-J
R 505	103P402030	CHIP RESISTOR	1/10W 680Ω-J	R 5D4	103P404000	CHIP RESISTOR	1/10W 18kΩ-J
R 506	103P472060	CHIP RESISTOR	1/10W 1.1kΩ-F	R 5D6	103P403070	CHIP RESISTOR	1/10W 10kΩ-J
R 508	103P409050	CHIP RESISTOR	1/10W 0Ω	R 5D8	103P406090	CHIP METAL	1/10W 4.7MΩ-K
R 509	103P403070	CHIP RESISTOR	1/10W 10kΩ-J	R 5E0	103P404050	CHIP RESISTOR	1/10W 47kΩ-J
R 510	103P402030	CHIP RESISTOR	1/10W 680Ω-J	R 5E1	103P478020	CHIP RESISTOR	1/10W 240kΩ-F
R 511	103P403060	CHIP RESISTOR	1/10W 8.2kΩ-J	R 5E2	103P477050	CHIP RESISTOR	1/10W 120K
R 512	103P401090	CHIP RESISTOR	1/10W 330Ω-J	R 5E3	103P476080	CHIP RESISTOR	1/10W 62kΩ-F
R 513	103P401070	CHIP RESISTOR	1/10W 220Ω-J	R 5E4	103P476000	CHIP RESISTOR	1/10W 30kΩ-F
R 520	103P402090	CHIP RESISTOR	1/10W 2.2kΩ-J	R 5E5	103P403070	CHIP RESISTOR	1/10W 10kΩ-J
R 521	103P404030	CHIP RESISTOR	1/10W 33kΩ-J	R 5E6	103P475030	CHIP RESISTOR	1/10W 15kΩ-F
R 527	103P404000	CHIP RESISTOR	1/10W 18kΩ-J	R 5E7	103P476070	CHIP RESISTOR	1/10W 53kΩ-F
R 528	103P403070	CHIP RESISTOR	1/10W 10kΩ-J	R 5E8	103P405030	CHIP RESISTOR	1/10W 220kΩ-J
R 530	103P409050	CHIP RESISTOR	1/10W 0Ω [M10VB, M20VB, M20V1R]	R 5E9	103P406010	CHIP RESISTOR	1/10W 1MΩ-J
R 530	103P402000	CHIP RESISTOR	1/10W 390Ω-J [M20VG]	R 5F0	103P405070	CHIP RESISTOR	1/10W 470kΩ-J
R 532	103P403080	CHIP RESISTOR	1/10W 12kΩ-J [M20VG]	R 5F1	103P403070	CHIP RESISTOR	1/10W 10kΩ-J
R 551	103P404020	CHIP RESISTOR	1/10W 27kΩ-J [M20VG]	R 5F6	103P403020	CHIP RESISTOR	1/10W 3.9kΩ-J
R 552	103P403010	CHIP RESISTOR	1/10W 3.3kΩ-J [M20VG]	R 5F8	103P473090	CHIP RESISTOR	1/10W 3.9kΩ-F
R 553	103P403070	CHIP RESISTOR	1/10W 10kΩ-J [M20VG]	R 5G0	103P404010	CHIP RESISTOR	1/10W 20kΩ-J
R 554	103P403070	CHIP RESISTOR	1/10W 10kΩ-J [M20VG]	R 5G4	103P403070	CHIP RESISTOR	1/10W 10kΩ-J
R 555	103P403070	CHIP RESISTOR	1/10W 10kΩ-J [M20VG]	R 5G5	103P403070	CHIP RESISTOR	1/10W 10kΩ-J
R 556	103P409050	CHIP RESISTOR	1/10W 0Ω [M20VG]	R 5G7	103P404080	CHIP RESISTOR	1/10W 82kΩ-J [M10VB, M20VB, M20V1R]
R 5A0	103P404030	CHIP RESISTOR	1/10W 33kΩ-J	R 5G9	103P403050	CHIP RESISTOR	1/10W 6.8kΩ-J
R 5A1	103P403030	CHIP RESISTOR	1/10W 4.7kΩ-J	R 5H0	103P403050	CHIP RESISTOR	1/10W 6.8kΩ-J
R 5A2	103P403070	CHIP RESISTOR	1/10W 10kΩ-J	R 5H1	103P404090	CHIP RESISTOR	1/10W 100kΩ-J
R 5A3	103P404030	CHIP RESISTOR	1/10W 33kΩ-J	R 5H2	103P406090	CHIP METAL	1/10W 4.7MΩ-K
R 5A5	103P402010	CHIP RESISTOR	1/10W 470Ω-J	R 5H3	103P402050	CHIP RESISTOR	1/10W 1kΩ-J
R 5A6	103P404030	CHIP RESISTOR	1/10W 33kΩ-J	R 5H5	103P403070	CHIP RESISTOR	1/10W 10kΩ-J
R 5A7	103P402030	CHIP RESISTOR	1/10W 680Ω-J	R 5H7	103P404050	CHIP RESISTOR	1/10W 47kΩ-J
R 5A8	103P403070	CHIP RESISTOR	1/10W 10kΩ-J				
R 5A9	103P401070	CHIP RESISTOR	1/10W 220Ω-J				

SYMBOL NO.	PARTS NO.	PARTS NAME	DESCRIPTION	SYMBOL NO.	PARTS NO.	PARTS NAME	DESCRIPTION
R 5H8	103P403070	CHIP RESISTOR	1/10W 10kΩ-J	RJ213	103P409050	CHIP RESISTOR	1/10W 0Ω
R 5J0	103P404090	CHIP RESISTOR	1/10W 100kΩ-J	RJ214	103P409050	CHIP RESISTOR	1/10W 0Ω
R 5J1	103P404060	CHIP RESISTOR	1/10W 56kΩ-J	RJ215	103P409050	CHIP RESISTOR	1/10W 0Ω
			[M10VB, M20VG, M20VIR]				
R 5J1	103P402020	CHIP RESISTOR	1/10W 560Ω-J [M20VB]	RJ216	103P409050	CHIP RESISTOR	1/10W 0Ω
R 5J2	103P403070	CHIP RESISTOR	1/10W 10kΩ-J	RJ217	103P409050	CHIP RESISTOR	1/10W 0Ω
R 5J3	103P403000	CHIP RESISTOR	1/10W 2.7kΩ-J	RJ218	103P409050	CHIP RESISTOR	1/10W 0Ω
R 5J5	103P404040	CHIP RESISTOR	1/10W 39kΩ-J	RJ220	103P409050	CHIP RESISTOR	1/10W 0Ω
R 5J6	103P403070	CHIP RESISTOR	1/10W 10kΩ-J	RJ221	103P409050	CHIP RESISTOR	1/10W 0Ω
R 5J8	103P403080	CHIP RESISTOR	1/10W 12kΩ-J				
			[M10VB, M20VIR]	RJ222	103P409050	CHIP RESISTOR	1/10W 0Ω
R 5K3	103P404030	CHIP RESISTOR	1/10W 33kΩ-J	RJ223	103P409050	CHIP RESISTOR	1/10W 0Ω
			[M10VB, M20VB, M20VG]	RJ224	103P409050	CHIP RESISTOR	1/10W 0Ω
R 5P0	103P403030	CHIP RESISTOR	1/10W 4.7kΩ-J	RJ225	103P409050	CHIP RESISTOR	1/10W 0Ω
R 5X0	103P409050	CHIP RESISTOR	1/10W 0Ω	RJ226	103P409050	CHIP RESISTOR	1/10W 0Ω
			[M20VB, M20VG]	RJ227	103P409050	CHIP RESISTOR	1/10W 0Ω
R 5X1	103P409050	CHIP RESISTOR	1/10W 0Ω	RJ229	103P409050	CHIP RESISTOR	1/10W 0Ω
R 5X2	103P409050	CHIP RESISTOR	1/10W 0Ω [M20VG]	RJ230	103P409050	CHIP RESISTOR	1/10W 0Ω
R 5X6	103P404030	CHIP RESISTOR	1/10W 33kΩ-J	RJ231	103P409050	CHIP RESISTOR	1/10W 0Ω
R 5X7	103P406010	CHIP RESISTOR	1/10W 1MΩ-J	RJ232	103P409050	CHIP RESISTOR	1/10W 0Ω
R 901	109D036040	COMPOSITION	1/2W 8.2MΩ-K	RJ233	103P409050	CHIP RESISTOR	1/10W 0Ω
R 9A3	109P052010	FUSE	1/4W 100Ω-J	RJ401	103P409050	CHIP RESISTOR	1/10W 0Ω
R 9A5	103P403090	CHIP RESISTOR	1/10W 15kΩ-J	RJ402	103P409050	CHIP RESISTOR	1/10W 0Ω
R 9A6	103P476060	CHIP METAL	1/10W 51kΩ-F	RJ403	103P409050	CHIP RESISTOR	1/10W 0Ω
R 9A7	103P476030	CHIP RESISTOR	1/10W 39kΩ-F	RJ404	103P409050	CHIP RESISTOR	1/10W 0Ω
R 9A9	103P475010	CHIP RESISTOR	1/10W 12kΩ-F	RJ501	103P409050	CHIP RESISTOR	1/10W 0Ω
R 9B0	103P475030	CHIP RESISTOR	1/10W 15kΩ-F	RJ502	103P409050	CHIP RESISTOR	1/10W 0Ω
R 9B1	109P052050	FUSE	1/4W 6.8Ω-J	RJ503	103P409050	CHIP RESISTOR	1/10W 0Ω
○ R 9B3	103P405080	CHIP RESISTOR	1/10W 560kΩ-J	RJ504	103P409050	CHIP RESISTOR	1/10W 0Ω
R 9B5	103P404030	CHIP RESISTOR	1/10W 33kΩ-J	RJ505	103P409050	CHIP RESISTOR	1/10W 0Ω
R 9B7	103P398050	FUSE	1/2W 2.7Ω-J				
			[M10VB, M20VB]	RJ506	103P409050	CHIP RESISTOR	1/10W 0Ω
R 9C3	103P403020	CHIP RESISTOR	1/10W 3.9kΩ-J	RJ507	103P409050	CHIP RESISTOR	1/10W 0Ω
RJ 51	103P409050	CHIP RESISTOR	1/10W 0Ω	RJ509	103P409050	CHIP RESISTOR	1/10W 0Ω
RJ 52	103P409050	CHIP RESISTOR	1/10W 0Ω	RJ510	103P409050	CHIP RESISTOR	1/10W 0Ω
RJ 53	103P409050	CHIP RESISTOR	1/10W 0Ω	RJ511	103P409050	CHIP RESISTOR	1/10W 0Ω
RJ 54	103P409050	CHIP RESISTOR	1/10W 0Ω				
RJ 56	103P409050	CHIP RESISTOR	1/10W 0Ω	RJ512	103P409050	CHIP RESISTOR	1/10W 0Ω
RJ101	103P409050	CHIP RESISTOR	1/10W 0Ω	RJ513	103P409050	CHIP RESISTOR	1/10W 0Ω
RJ102	103P409050	CHIP RESISTOR	1/10W 0Ω	RJ514	103P409050	CHIP RESISTOR	1/10W 0Ω
RJ104	103P409050	CHIP RESISTOR	1/10W 0Ω	RJ516	103P409050	CHIP RESISTOR	1/10W 0Ω
RJ105	103P409050	CHIP RESISTOR	1/10W 0Ω	RJ517	103P409050	CHIP RESISTOR	1/10W 0Ω
RJ109	103P409050	CHIP RESISTOR	1/10W 0Ω				
RJ110	103P409050	CHIP RESISTOR	1/10W 0Ω	RJ518	103P409050	CHIP RESISTOR	1/10W 0Ω
RJ201	103P409050	CHIP RESISTOR	1/10W 0Ω	RJ519	103P409050	CHIP RESISTOR	1/10W 0Ω
RJ202	103P409050	CHIP RESISTOR	1/10W 0Ω	RJ521	103P409050	CHIP RESISTOR	1/10W 0Ω
RJ203	103P409050	CHIP RESISTOR	1/10W 0Ω [M20VG]	RJ522	103P409050	CHIP RESISTOR	1/10W 0Ω
RJ204	103P409050	CHIP RESISTOR	1/10W 0Ω	RJ523	103P409050	CHIP RESISTOR	1/10W 0Ω
RJ205	103P409050	CHIP RESISTOR	1/10W 0Ω				
RJ206	103P409050	CHIP RESISTOR	1/10W 0Ω	RJ524	103P409050	CHIP RESISTOR	1/10W 0Ω
RJ207	103P409050	CHIP RESISTOR	1/10W 0Ω	RJ525	103P409050	CHIP RESISTOR	1/10W 0Ω
RJ208	103P409050	CHIP RESISTOR	1/10W 0Ω	RJ526	103P409050	CHIP RESISTOR	1/10W 0Ω
RJ209	103P409050	CHIP RESISTOR	1/10W 0Ω	RJ527	103P409050	CHIP RESISTOR	1/10W 0Ω
RJ210	103P409050	CHIP RESISTOR	1/10W 0Ω	RJ528	103P409050	CHIP RESISTOR	1/10W 0Ω
RJ211	103P409050	CHIP RESISTOR	1/10W 0Ω				
RJ212	103P409050	CHIP RESISTOR	1/10W 0Ω	RJ529	103P409050	CHIP RESISTOR	1/10W 0Ω
				CAPACITORS AND TRIMMERS			
				C 102	141P132010	CHIP CAPACITOR	850V 0.01 μF-K
				C 104	141P132010	CHIP CAPACITOR	850V 0.01 μF-K
				C 105	141P132010	CHIP CAPACITOR	850V 0.01 μF-K
				C 106	154P331010	CHIP CAPACITOR	CH50V 10pF-C

SYMBOL NO.	PARTS NO.	PARTS NAME	DESCRIPTION	SYMBOL NO.	PARTS NO.	PARTS NAME	DESCRIPTION
C 107	141P132010	CHIP CAPACITOR	B50V 0.01 μ F-K	C 2D3	141P132000	CHIP CAPACITOR	B50V 8200pF-K
C 108	141P134020	CHIP CAPACITOR	F50V 0.1 μ F-Z	C 2D4	154P324040	CHIP CAPACITOR	SL50V 220pF-J
C 109	141P132010	CHIP CAPACITOR	B50V 0.01 μ F-K	C 2D5	154P321020	CHIP CAPACITOR	SL50V 10pF-C
C 112	141P132010	CHIP CAPACITOR	B50V 0.01 μ F-K	C 2D7	154P325000	CHIP CAPACITOR	SL50V 390pF-J
C 114	141P132010	CHIP CAPACITOR	B50V 0.01 μ F-K	C 2E0	154P322080	CHIP CAPACITOR	SL50V 47pF-J [M10VB, M20VB, M20V1R]
C 116	154P322040	CHIP CAPACITOR	SL50V 33pF-J [M20VB]	C 2E1	154P322000	CHIP CAPACITOR	SL50V 22pF-J
C 116	154P321080	CHIP CAPACITOR	SL50V 18pF-J [M20VG]	C 2E3	141P132000	CHIP CAPACITOR	B50V 8200pF-K
C 116	141P130090	CHIP CAPACITOR	B50V 1000pF-K [M20V1R]	C 2E4	141P137040	CHIP CAPACITOR	B25V 0.022M
C 117	154P331050	CHIP CAPACITOR	CH50V 15pF-J	C 2F4	141P137080	CHIP CAPACITOR	B25V 0.047M
C 118	141P132010	CHIP CAPACITOR	B50V 0.01 μ F-K	C 2F7	141P139030	CHIP CAPACITOR	B25V 0.1 μ F-K
C 119	154P321060	CHIP CAPACITOR	SL50V 15pF-J [M10VB, M20VB, M20V1R]	C 2G2	154P321080	CHIP CAPACITOR	SL50V 18pF-J [M20VB, M20VG, M20V1R]
C 119	154P322060	CHIP CAPACITOR	SL50V 39pF-J [M20VG]	C 2G5	141P132000	CHIP CAPACITOR	B50V 8200pF-K
C 122	141P133080	CHIP CAPACITOR	F50V 0.01 μ F-Z [M20VG]	C 2G7	141P132000	CHIP CAPACITOR	B50V 8200pF-K
C 124	141P134010	CHIP CAPACITOR	F50V 0.047M [M20VG]	C 2H0	154P322020	CHIP CAPACITOR	SL50V 27pF-J
C 126	141P131020	CHIP CAPACITOR	B50V 1800pF-K [M20VG]	C 2H1	154P322040	CHIP CAPACITOR	SL50V 33pF-J
C 127	154P325080	CHIP CAPACITOR	SL50V 820pF [M20VG]	C 2H2	154P320080	CHIP CAPACITOR	SL50V 6pF-C
C 130	141P130060	CHIP CAPACITOR	B50V 560pF-K	C 2H3	154P322080	CHIP CAPACITOR	SL50V 47pF-J
C 131	141P130060	CHIP CAPACITOR	B50V 560pF-K	C 2H7	141P132000	CHIP CAPACITOR	B50V 8200pF-K
C 132	141P137080	CHIP CAPACITOR	B25V 0.047M	C 2K1	154P324080	CHIP CAPACITOR	SL50V 330pF-J [M10VB, M20VB, M20V1R]
C 207	154P323020	CHIP CAPACITOR	SL50V 68pF-J	C 2P2	154P322060	CHIP CAPACITOR	SL50V 39pF-J
C 209	141P139030	CHIP CAPACITOR	B25V 0.1 μ F-K	C 2P3	154P323020	CHIP CAPACITOR	SL50V 68pF-J
C 210	141P137080	CHIP CAPACITOR	B25V 0.047M	C 2P8	141P132000	CHIP CAPACITOR	B50V 8200pF-K
C 211	141P137080	CHIP CAPACITOR	B25V 0.047M	C 2R0	154P322020	CHIP CAPACITOR	SL50V 27pF-J
C 215	141P132000	CHIP CAPACITOR	B50V 8200pF-K	C 2R1	154P321060	CHIP CAPACITOR	SL50V 15pF-J [M10VB, M20VB, M20V1R]
C 216	141P132000	CHIP CAPACITOR	B50V 8200pF-K	C 2R2	141P137040	CHIP CAPACITOR	B25V 0.022M
C 220	154P322080	CHIP CAPACITOR	SL50V 47pF-J	C 2R3	141P137080	CHIP CAPACITOR	B25V 0.047M
C 221	141P132000	CHIP CAPACITOR	B50V 8200pF-K	C 2R4	154P323060	CHIP CAPACITOR	SL50V 100pF-J
C 227	141P130090	CHIP CAPACITOR	B50V 1000pF-K	C 2R5	141P139030	CHIP CAPACITOR	B25V 0.1 μ F-K
C 231	141P139030	CHIP CAPACITOR	B25V 0.1 μ F-K	C 310	141P133080	CHIP CAPACITOR	F50V 0.01 μ F-Z
C 232	141P136030	CHIP CAPACITOR	F16V 1 μ F-Z	C 311	141P130080	CHIP CAPACITOR	B50V 820pF-K
C 233	141P136030	CHIP CAPACITOR	F16V 1 μ F-Z	C 318	141P131080	CHIP CAPACITOR	B50V 5600pF-K
C 234	154P323000	CHIP CAPACITOR	SL50V 56pF-J	C 328	141P130060	CHIP CAPACITOR	B50V 560pF-K
C 236	154P322080	CHIP CAPACITOR	SL50V 47pF-J	C 331	141P133080	CHIP CAPACITOR	F50V 0.01 μ F-Z
C 237	141P132000	CHIP CAPACITOR	B50V 8200pF-K	C 338	141P136030	CHIP CAPACITOR	F16V 1 μ F-Z
C 238	141P132000	CHIP CAPACITOR	B50V 8200pF-K	C 345	141P130090	CHIP CAPACITOR	B50V 1000pF-K [M20VG]
C 240	141P139030	CHIP CAPACITOR	B25V 0.1 μ F-K	C 3A2	141P138040	CHIP CAPACITOR	B25V 0.15 μ F-K
C 245	154P323000	CHIP CAPACITOR	SL50V 56pF-J [M10VB, M20V1R]	C 3A3	141P138040	CHIP CAPACITOR	B25V 0.15 μ F-K
C 245	154P322080	CHIP CAPACITOR	SL50V 47pF-J [M20VG]	C 3B4	141P132000	CHIP CAPACITOR	B50V 8200pF-K
C 246	141P136030	CHIP CAPACITOR	F16V 1 μ F-Z	C 4A3	141P137070	CHIP CAPACITOR	B25V 0.039 μ F-K
C 249	154P323040	CHIP CAPACITOR	SL50V 82pF-J	C 4A5	141P132000	CHIP CAPACITOR	B50V 8200pF-K
C 255	154P322040	CHIP CAPACITOR	SL50V 33pF-J	C 4A7	154P324020	CHIP CAPACITOR	SL50V 180pF-J
C 256	154P324020	CHIP CAPACITOR	SL50V 180pF-J	C 4A9	141P131060	CHIP CAPACITOR	B50V 3900pF-K
C 275	141P133080	CHIP CAPACITOR	F50V 0.01 μ F-Z [M10VB, M20V1R]	C 4B3	141P133090	CHIP CAPACITOR	F50V 0.022M
C 276	141P130090	CHIP CAPACITOR	B50V 1000pF-K	C 4B4	141P133080	CHIP CAPACITOR	F50V 0.01 μ F-Z
C 2C1	141P132000	CHIP CAPACITOR	B50V 8200pF-K	C 4B6	141P131010	CHIP CAPACITOR	B50V 1500pF
C 2C2	154P322060	CHIP CAPACITOR	SL50V 39pF-J	C 4C1	141P131050	CHIP CAPACITOR	B50V 3300pF-K
C 2C3	154P325000	CHIP CAPACITOR	SL50V 390pF-J	C 4C2	141P139030	CHIP CAPACITOR	B25V 0.1 μ F-K
C 2C4	154P324020	CHIP CAPACITOR	SL50V 180pF-J	C 4C3	141P139010	CHIP CAPACITOR	B25V 0.068 μ F-K
C 2C6	141P132000	CHIP CAPACITOR	B50V 8200pF-K	C 4C4	141P131080	CHIP CAPACITOR	B50V 5600pF-K
C 2C8	154P323080	CHIP CAPACITOR	SL50V 120pF-J	C 4C5	141P131080	CHIP CAPACITOR	B50V 5600pF-K
C 2C9	154P324000	CHIP CAPACITOR	SL50V 150pF-J	C 4C6	141P139000	CHIP CAPACITOR	B25V 0.056 μ F-K
C 2D1	154P322080	CHIP CAPACITOR	SL50V 47pF-J	C 4C9	141P130090	CHIP CAPACITOR	B50V 1000pF-K

SYMBOL NO.	PARTS NO.	PARTS NAME	DESCRIPTION	SYMBOL NO.	PARTS NO.	PARTS NAME	DESCRIPTION
C 4D5	141P130090	CHIP CAPACITOR	B50V 1000pF-K	S 8A3	432P089020	KEY BOARD SWITCH	FF
C 4E0	141P130090	CHIP CAPACITOR	B50V 1000pF-K	S 8A4	432P089040	KEY BOARD SWITCH	AUTO SET UP [M10VB]
C 501	154P330060	CHIP CAPACITOR	CH50V 5pF-C	S 8B1	432P089040	KEY BOARD SWITCH	PLAY
C 502	154P330060	CHIP CAPACITOR	CH50V 5pF-C	S 8B2	432P089040	KEY BOARD SWITCH	EJECT
C 505	154P331090	CHIP CAPACITOR	CH50V 22pF-J	S 8B3	432P089020	KEY BOARD SWITCH	REW
C 507	154P331090	CHIP CAPACITOR	CH50V 22pF-J	S 8C1	432P089020	KEY BOARD SWITCH	REC/OTR
C 510	141P137080	CHIP CAPACITOR	B25V 0.047M	S 8C2	432P089020	KEY BOARD SWITCH	ONE KEY PROGRAM [M10VB]
C 512	141P133080	CHIP CAPACITOR	F50V 0.01 μ F-Z	S 8C2	432P089040	KEY BOARD SWITCH	ONE KEY PROGRAM [M20VB, M20VG, M20V1R]
C 514	141P133080	CHIP CAPACITOR	F50V 0.01 μ F-Z	S 8C3	432P089020	KEY BOARD SWITCH	CH-DOWN [M10VB]
C 525	154P322080	CHIP CAPACITOR	SL50V 47pF-J [M20VG]	S 8C3	432P089040	KEY BOARD SWITCH	CH-DOWN [M20VB, M20VG, M20V1R]
C 551	141P139030	CHIP CAPACITOR	B25V 0.1 μ F-K [M20VG]	S 8D1	432P089020	KEY BOARD SWITCH	PAUSE
C 552	141P139030	CHIP CAPACITOR	B25V 0.1 μ F-K [M20VG]	S 8D2	432P089020	KEY BOARD SWITCH	RENT IP [M10VB]
C 554	141P133080	CHIP CAPACITOR	F50V 0.01 μ F-Z[M20VG]	S 8D2	432P089040	KEY BOARD SWITCH	RENT IP [M20VB, M20VG, M20V1R]
C 555	141P130090	CHIP CAPACITOR	B50V 1000pF-K [M20VG]	S 8D3	432P089020	KEY BOARD SWITCH	CH-UP [M10VB]
C 556	141P139030	CHIP CAPACITOR	B25V 0.1 μ F-K [M20VG]	S 8D3	432P089040	KEY BOARD SWITCH	CH-UP [M20VB, M20VG, M20V1R]
C 557	154P331010	CHIP CAPACITOR	CH50V 10pF-C [M20VG]	MISCELLANEOUS			
C 558	154P331050	CHIP CAPACITOR	CH50V 15pF-J [M20VG]				
C 5A0	189P197020	C-ELE-DOUBLE-LAYER	AC310G473Z5R5				
C 5A3	154P331090	CHIP CAPACITOR	CH50V 22pF-J				
C 5A4	141P133080	CHIP CAPACITOR	F50V 0.01 μ F-Z				
C 5A5	141P133080	CHIP CAPACITOR	F50V 0.01 μ F-Z				
C 5A6	141P130060	CHIP CAPACITOR	B50V 560pF-K				
C 5A7	154P324060	CHIP CAPACITOR	SL50V 270pF-J				
C 5A8	154P333010	CHIP CAPACITOR	CH50V 68pF-J				
C 5B0	141P131090	CHIP CAPACITOR	B50V 6800pF-K				
C 5B3	141P131030	CHIP CAPACITOR	B50V 2200pF-K	CU 01	295P276030	RF CONVERTER	901A [M10VB, M20VB]
C 5B5	141P131010	CHIP CAPACITOR	B50V 1500pF	CU 01	295D059010	RF CONVERTER	[M20VG]
C 5B6	141P132000	CHIP CAPACITOR	B50V 8200pF-K	CU 01	295P276020	RF CONVERTER	725A [M20V1R]
C 5B7	141P132000	CHIP CAPACITOR	B50V 8200pF-K	F 901	283D046080	FUSE	T630MA
C 5D2	141P133080	CHIP CAPACITOR	F50V 0.01 μ F-Z	F 902	283D047050	FUSE	T2.5A
C 5D5	141P135080	CHIP CAPACITOR	F25V 0.1 μ F-Z	F 903	283D047050	FUSE	T2.5A
C 5D6	141P134010	CHIP CAPACITOR	F50V 0.047M	J 2301	451C058020	CONNECTOR	21P [M20VG]
C 5D7	141P133080	CHIP CAPACITOR	F50V 0.01 μ F-Z	J 2302	451C058020	CONNECTOR	21P [M20VG]
C 5D8	141P133080	CHIP CAPACITOR	F50V 0.01 μ F-Z	M 470	288P126010	MOTOR CAPSTAN	F20KB79
C 5E3	141P133090	CHIP CAPACITOR	F50V 0.022M [M10VB, M20VG, M20V1R]	M 570	288P088060	MOTOR DRUM	DC12V 3.3W
C 5E4	141P133090	CHIP CAPACITOR	F50V 0.022M [M10VB, M20VG, M20V1R]	M 571	288D034010	MOTOR LOADING ASSY	[M10VB, M20VB, M20VG]
C 5F0	141P134020	CHIP CAPACITOR	F50V 0.1 μ F-Z	MK TK	243C094080	CARD LEAD	29P L210 (MK-TK)
C 5F1	154P331010	CHIP CAPACITOR	CH50V 10pF-C	MP EP	243C091060	CARD LEAD	9P L=85 (MP-EP) [M20VB]
C 5F2	154P331090	CHIP CAPACITOR	CH50V 22pF-J	P 5A0	286P010010	BUZZER	PKM22EPT-2001
C 5F3	154P331010	CHIP CAPACITOR	CH50V 10pF-C	S 570	439P031010	MODE SELECT SWITCH	(J)
C 5F4	141P134010	CHIP CAPACITOR	F50V 0.047M	T 370	460P060060	A/C HEAD	
C 901	189P153040	C-METAL-P-FILM	AC250V 0.1 μ F-M [M20VG]	T 371	460P153010	FULL ERASE HEAD	
C 902	189P153040	C-METAL-P-FILM	AC250V 0.1 μ F-M [M20VG]	TU 01	295P417010	TUNER	ENV-578E7F1 [M20VG]
C 9A9	141P139030	CHIP CAPACITOR	B25V 0.1 μ F-K	TU 01	295P260040	TUNER	ENV-59890F2 [M20V1R]
C 9C0	141P133080	CHIP CAPACITOR	F50V 0.01 μ F-Z	TU 01	295P194020	TUNER TV	TERB1-044A [M10VB, M20VB]
C 9C1	141P133080	CHIP CAPACITOR	F50V 0.01 μ F-Z	V 8A0	253P105020	TUBE FLUOR	10-MT-56GSK [M10VB]
SWITCHES				V 8A0	253P112020	TUBE FLUOR	10-MT-67GAK [M20VB, M20VG, M20V1R]
S 5A0	439P033010	SWITCH	RIS MPU10101MMB0	X 2A0	285P083010	CRYSTAL RESONATOR	4.43362MHz
S 5A1	432P166010	KEY BOARD SWITCH	RESET	X 501	285P084010	CRYSTAL RESONATOR	17.7345MHz
S 8A1	432P089040	KEY BOARD SWITCH	STOP	X 551	285P166020	CRYSTAL RESONATOR	27MHz [M20VG]
S 8A2	432P089040	KEY BOARD SWITCH	POWER	X 570	285P166010	CRYSTAL RESONATOR	27.000MHz [M20VB]
				X 5A0	285P054030	CRYSTAL RESONATOR	32.8kHz
				X 5A1	285P235010	CRYSTAL RESONATOR	8.3886MHz
				Z 8A0	939P529010	PREAMP UNIT	GP1U783R [M10VB]
				Z 8A0	939P580010	PREAMP UNIT	TFMT 5330 [M20VB, M20VG, M20V1R]

SYMBOL NO.	PARTS NO.	PARTS NAME	DESCRIPTION	SYMBOL NO.	PARTS NO.	PARTS NAME	DESCRIPTION
PRINTED CIRCUIT BOARD ASSY'S							
	928C864001	CONNECTOR-G PCB ASSY	[M20VG]				
	927B800001	HA/AUDIO PCB ASSY	[M10VB, M20VB, M20V1R]				
○	927B800002	HA/AUDIO PCB ASSY	[M20VG]				
○	927B798004	MAIN PCB ASSY	[M10VB]				
○	927B798001	MAIN PCB ASSY	[M20VB]				
○	927B798003	MAIN PCB ASSY	[M20VG]				
○	927B798002	MAIN PCB ASSY	[M20V1R]				
○	928C865001	TEXT PCB ASSY	[M20VB]				
○	927B706015	TIMER PCB ASSY	[M10VB]				
○	927B799001	TIMER PCB ASSY	[M20VB]				
○	927B799003	TIMER PCB ASSY	[M20VG]				
○	927B799002	TIMER PCB ASSY	[M20V1R]				

4.DECK ASSEMBLY
ASSEMBLY DECK-I

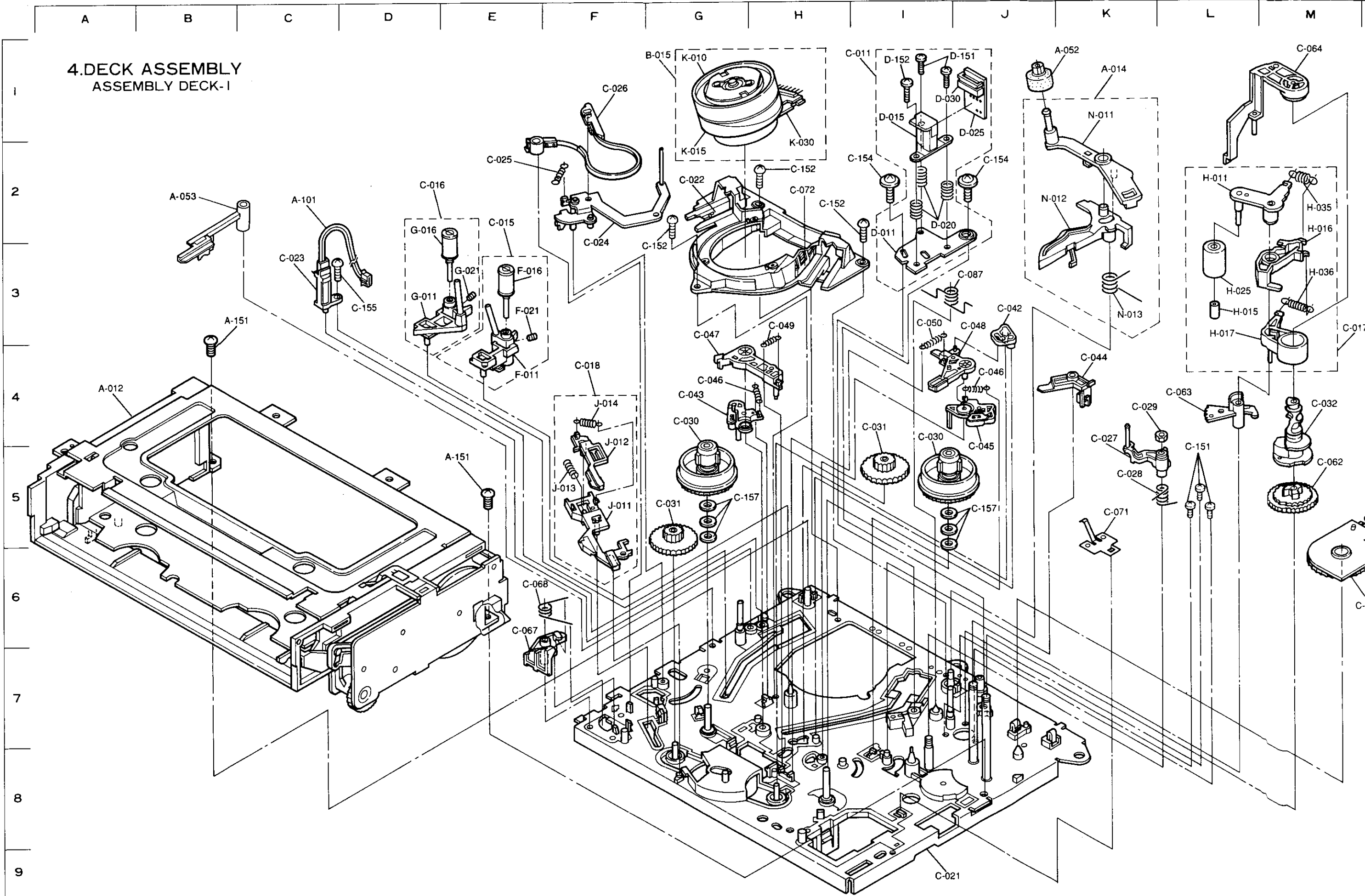

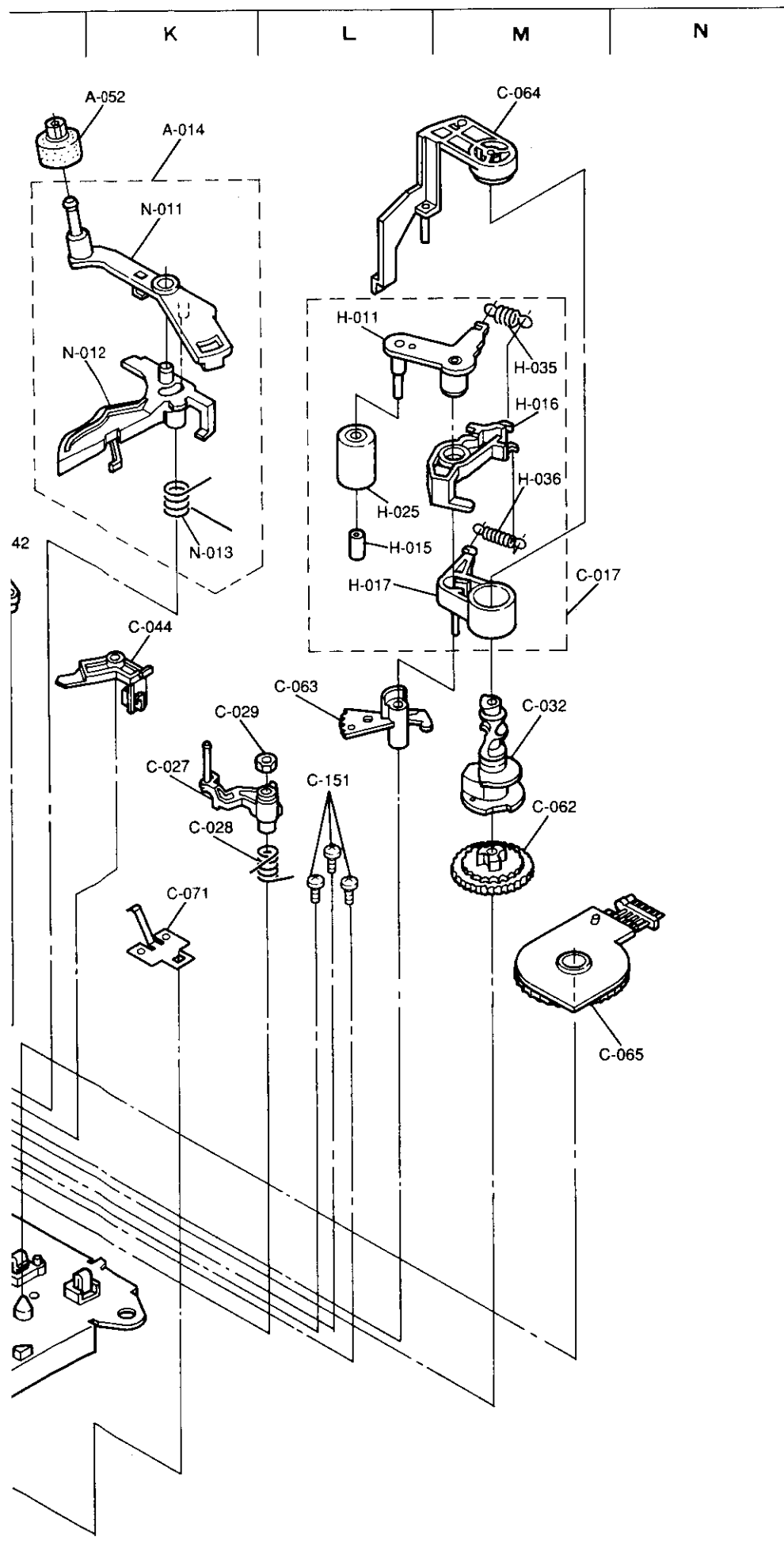

* Settled Service Parts

ITEM	PARTS No.	* ADDRESS	PARTS NAME	DESCRIPTION	Qt.
A-012	948A155001	○ A-4	ASSY-F/L-J	[10VB, 20VB, 20VIR]	01
A-012	948A155002	○ A-4	ASSY-F/L-J	[20VG]	01
A-014	948B349001	○ K-2	ASSY-CLE		01
N-011	641B680010	○ K-2	ARM-CLE		01
N-012	641B681010	○ K-3	LEVER-CLE		01
N-013	572D703010	○ K-3	SPRING-CLE		01
B-015	948B356021	○ G-2	ASSY-DRUM	[10VB, 20VB, 20VIR]	01
B-015	948B356020	○ G-2	ASSY-DRUM	[20VG]	01
K-010	927B802021	○ G-1	ASSY-UPPR-DRUM	[10VB, 20VB, 20VIR]	01
K-010	927B802020	○ G-1	ASSY-UPPR-DRUM	[20VG]	01
K-015	927B803021	○ G-2	ASSY-LOWER-DRUM		01
K-030	288P088060	○ H-2	MOTOR-DRUM	M570	01
C-011	928D104002	○ I-1	ASSY-A/C-HEAD		01
D-011	593C399010	○ I-2	PLATE-A/C		01
D-015	460P060060	○ I-1	HEAD	T370	01
D-020	572D639010	○ I-2	SPRING-A/C		03
D-025	215C730010	○ J-1	PWB-A/C-JA		01
D-030	452C140060	○ J-1	CONNECTOR-PC2M(S)		01
D-151	669D483010	○ I-1	SCREW	M2.6x8	02
D-152	669D485010	○ I-1	SCREW	2.6x8	01
C-015	948D042001	○ E-3	ASSY-TAPE-GUIDE-T		01
C-015	948D042002	○ E-3	ASSY-TAPE-GUIDE-T		01
C-015	948D042003	○ E-3	ASSY-TAPE-GUIDE-T		01
F-011	635B085010	○ E-4	TAPE-GUIDE-T		01
F-011	635B085020	○ E-4	TAPE-GUIDE-T		01
F-011	635B085030	○ E-4	TAPE-GUIDE-T		01
F-016	522D177010	○ E-3	GUIDE-ROLLER		01
F-021	669D197020	○ E-4	SET-SCREW-F	D=M3x0.5 L=4	01
C-016	948D043001	○ D-3	ASSY-TAPE-GUIDE-S		01
C-016	948D043002	○ D-3	ASSY-TAPE-GUIDE-S		01
C-016	948D043003	○ D-3	ASSY-TAPE-GUIDE-S		01
G-011	635B086010	○ D-3	TAPE-GUIDE-S		01
G-011	635B086020	○ D-3	TAPE-GUIDE-S		01
G-011	635B086030	○ D-3	TAPE-GUIDE-S		01
G-016	522D177010	○ D-3	GUIDE-ROLLER		01
G-021	669D197020	○ E-3	SET-SCREW-F	D=M3x0.5 L=4	01
C-017	948D044001	○ M-3	ASSY-ARM-PINCH		01
H-011	593C465010	○ L-2	ARM-PINCH		01
H-015	622D235010	○ L-3	CAP-ROLLER		01
H-016	621C243010	○ M-3	LEVER-PINCH		01
H-017	621C241010	○ M-3	SLIDER-PINCH		01
H-025	522D174010	○ L-3	ROLLER-PINCH		01
H-035	572D314010	○ M-2	SPRING-PINCH		01
H-036	572D714010	○ M-3	SPRING-CAM-PINCH		01
C-018	948C315001	○ F-4	ASSY-CHARGE		01
J-011	641B629010	○ F-6	LEVER-SWING-ID		01
J-012	621C238010	○ F-5	LEVER-REV		01
J-013	572D684010	○ F-5	SPRING-CHARGE		01
J-014	572D624010	○ F-5	SPRING-REV		01
C-021	948A159001	○ I-9	ASSY-MAIN-PLATE		01
C-022	635A038010	○ G-2	DRUM-BASE		01
C-023	460P153010	○ C-3	HEAD-FE	T371	01

* Settled Service Parts

ITEM	PARTS No.	* ADDRESS	PARTS NAME	DESCRIPTION	Qt.
C-024	592B049010	○ F-3	ARM-TENSION		01
C-025	572D627010	○ F-2	SPRING-TENS		01
C-026	641B624020	○ F-2	BELT-TENS-BRAKE		01
C-027	635B084010	○ K-5	ARM-TU-G		01
C-028	572D647010	○ K-5	SPRING-TU-G		01
C-029	674D081020	○ K-5	NUT-NYLON	M3x0.5	01
C-030	522C092010	○ I-5	UNIT-REEL-DISK		02
C-031	621C234010	○ I-5	GEAR-R		02
C-032	641B630010	○ M-4	CAM-PINCH-J		01
C-042	621C315010	○ J-4	LEVER-SUB-OFF		01
C-043	641B635020	○ G-4	BRAKE-MAIN-S		01
C-044	622D219010	○ K-4	LEVER-RELEASE-M/B		01
C-045	641B634020	○ J-4	BRAKE-MAIN-T		01
C-046	572D635010	○ H-4	SPRING-M/B-J		02
C-047	641B633010	○ G-4	BRAKE-SUB-S		01
C-048	641B632020	○ I-4	BRAKE-SUB-T		01
C-049	572D623010	○ H-4	SPRING-SUB-S		01
C-050	572D625010	○ I-4	SPRING-SUB-T		01
C-062	621C240010	○ M-5	GEAR-PINCH		01
C-063	635C098010	○ L-4	GEAR-TU-G		01
C-064	641B628010	○ M-1	CAP-CAM-PINCH		01
C-065	439P031010	○ N-6	SW-MODE-J	S570	01
C-067	641B641010	○ E-7	LEVER-RIS		01
C-068	572D646010	○ E-6	SPRING-RIS		01
C-071	597D102010	○ K-5	PLATE-EB		01
C-072	572D712010	○ H-3	SPRING-DB		01
C-087	572D697010	○ I-3	SPRING-AC-EARTH		01
C-151	669D285040	○ L-5	SCREW-TB-PAN	M2.6x8	03
C-152	669D224020	○ G-3	SCREW-TB	2.6x8	03
C-154	669D476020	○ I-2	J-2 SCREW-TB-SEMS	2.6x8	02
C-155	669D224030	○ D-3	SCREW-TB	2.6x10	01
C-157	552C017030	○ G-5	J-5 WASHER-THRUST	2.5x6x0.13	06
A-052	621C033010	○ J-1	UNIT-CLE-ROLLER		01
A-053	621C344010	○ B-2	LEVER-TG		01
A-101	248B173030	○ C-3	LEAD-CONNECTOR-S		01
A-151	669D224020	○ B-4	E-5 SCREW-TB	2.6x8	02

ASSEMBLY DECK-2

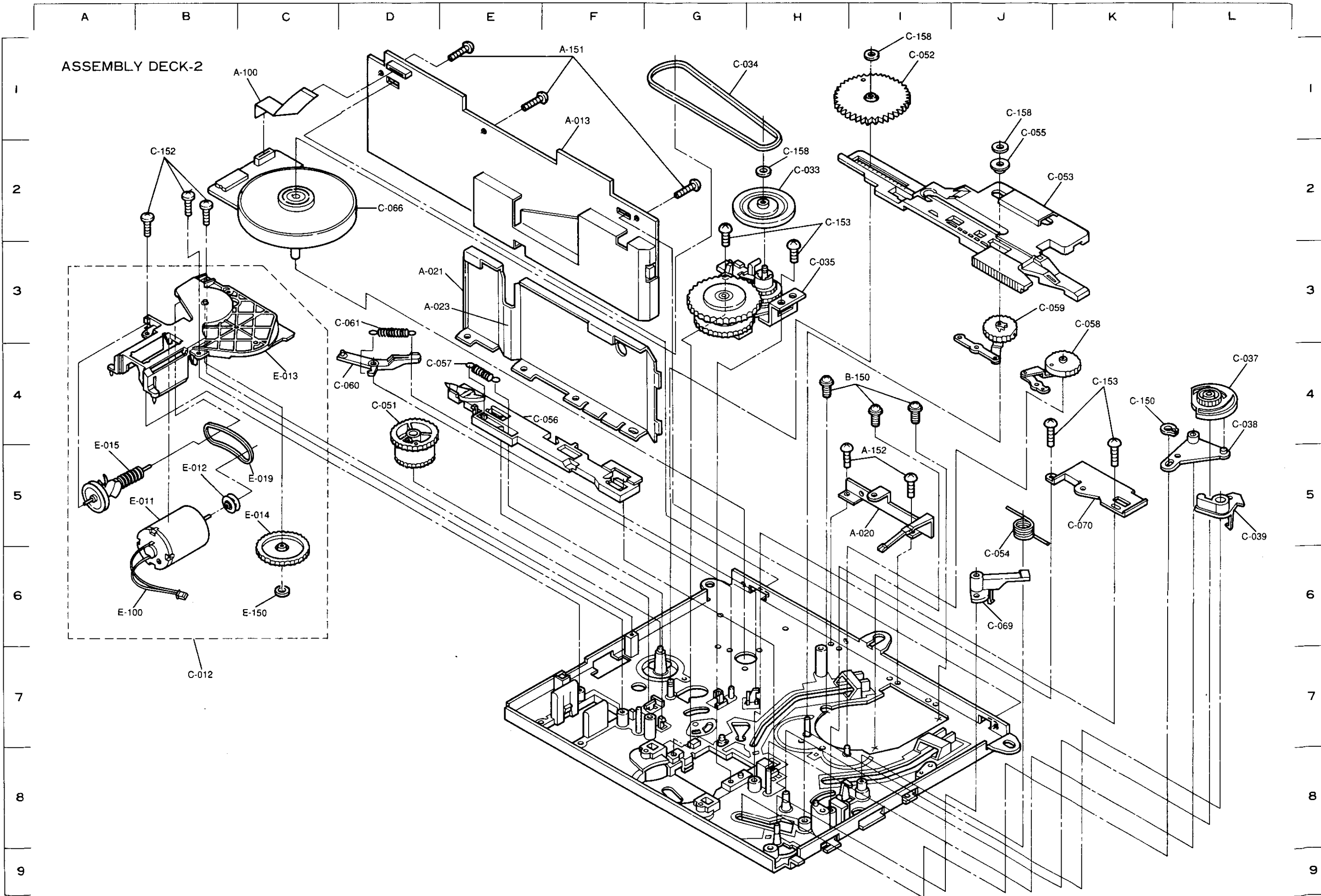

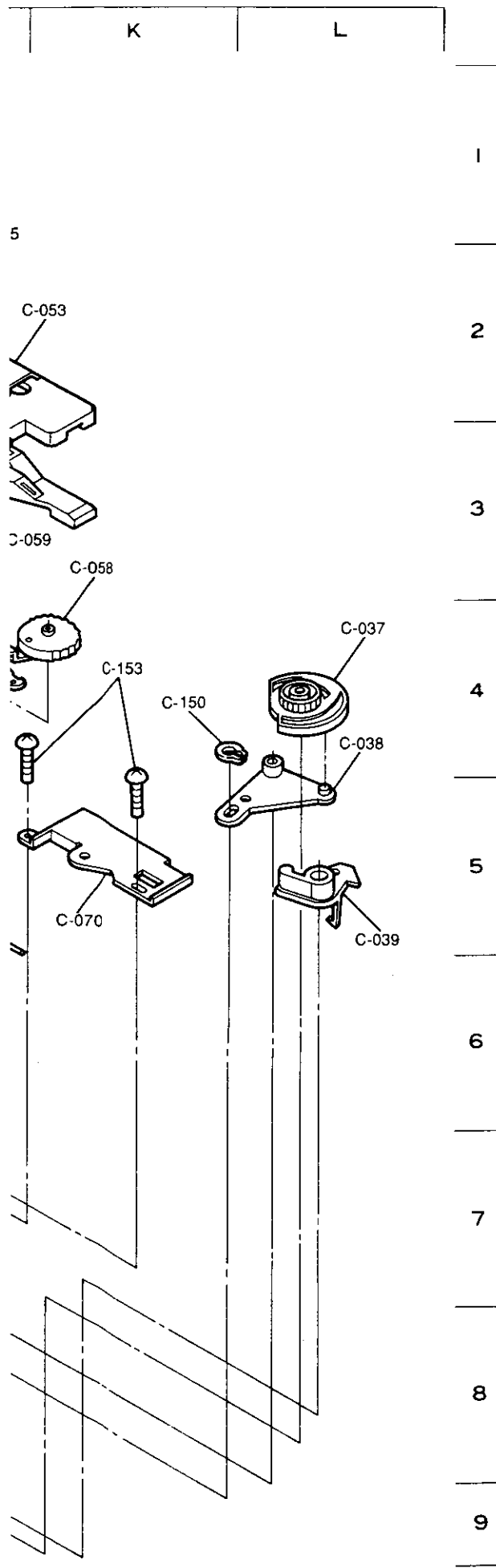

* Settled Service Parts

ITEM	PARTS No.	* ADDRESS	PARTS NAME	DESCRIPTION	Qt.
A-013	928D219001	○ F-2	ASSY-PWB-HA/AUDIO	[10VB, 20VB, 20VIR]	01
A-013	928D219002	○ F-2	ASSY-PWB-HA/AUDIO	[20VG]	01
C-012	928D105001	○ B-7	ASSY-L-MOTOR		01
E-011	288D034010	○ B-5	MOTOR-LOADING		01
E-012	622D220010	○ B-5	PULLEY-MOTOR		01
E-013	641B640010	○ C-4	HOLDER-MOTOR-J		01
E-014	621C258010	○ C-6	GEAR-A		01
E-015	621C259010	○ A-5	PULLEY-WORM-J		01
E-019	521D082010	○ C-5	BELT-LM		01
E-100	248B173020	○ B-6	LEAD-CONNECTOR-S		01
E-150	552C018020	○ C-6	CUT-WASHER	2.5 × 4.7 × 0.5	01
A-020	299C030010	○ I-5	BRUSH		01
A-021	292B204010	○ D-3	SHIELD-PLATE-HAK		01
A-023	223D533010	○ D-3	BARRIER-HA		01
A-100	243C125010	○ C-1	LEAD-CARD		01
A-151	669D224020	○ E-1	SCREW-TB	2.6 × 8	03
		○ G-2			
A-152	669D224010	○ I-5	SCREW-TB	2.6 × 6	02
B-150	669D200020	○ I-4	SCREW-SEMS	M2.6 × 0.45-6	03
C-033	621C254010	○ H-2	PULLEY-BELT		01
C-034	521D081010	○ G-1	BELT-REEL-J		01
C-035	522B057010	○ H-3	UNIT-REEL-IDLER		01
C-037	621C235010	○ L-4	CAM-GEAR-R		01
C-038	622D229010	○ L-5	LEVER-CHARGE		01
C-039	622D223010	○ L-5	LEVER-T-OFF		01
C-051	621C257010	○ D-5	GEAR-JOINT-J		01
C-052	641B637010	○ I-1	MAIN-GEAR-J		01
C-053	641A311010	○ J-2	PLATE-CAM-B		01
C-054	572D640010	○ J-5	SPRING-CAM-B		01
C-055	622D224010	○ J-2	ROLLER-B		01
C-056	641B636010	○ E-4	PLATE-CAM-C		01
C-057	572D636010	○ E-4	SPRING-CAM-C		01
C-058	592B048010	○ K-4	ARM-LOAD-S		01
C-059	592B047010	○ J-4	ARM-LOAD-T		01
C-060	621C261010	○ D-4	BRAKE-CP		01
C-061	572D645010	○ D-3	SPRING-B-CP		01
C-066	288P126010	○ C-2	MOTOR-CP	M470	01
C-069	621C308010	○ J-6	ARM-RIS		01
C-070	593C532010	○ K-5	PLATE-J		01
C-150	685C009010	○ K-4	GRIP-RING		01
C-152	669D224020	○ B-2	SCREW-TB	2.6 × 8	03
C-153	669D224010	○ K-4	SCREW-TB	2.6 × 6	04
		○ G-3			
C-158	552C018010	○ J-2	CUT-WASHER	2.5 × 6.0 × 0.5	03
		○ H-2			

ASSEMBLY DECK-3

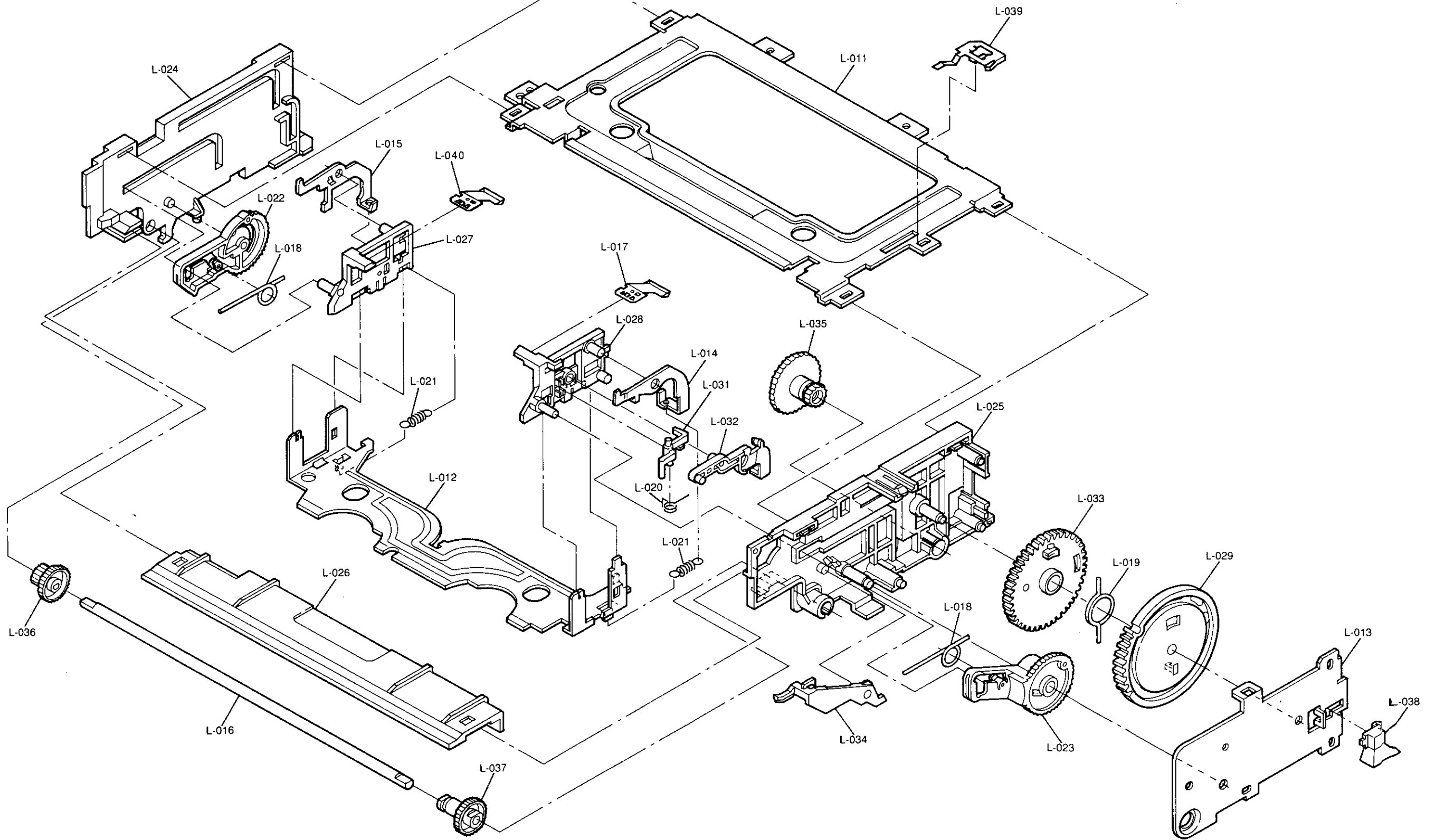

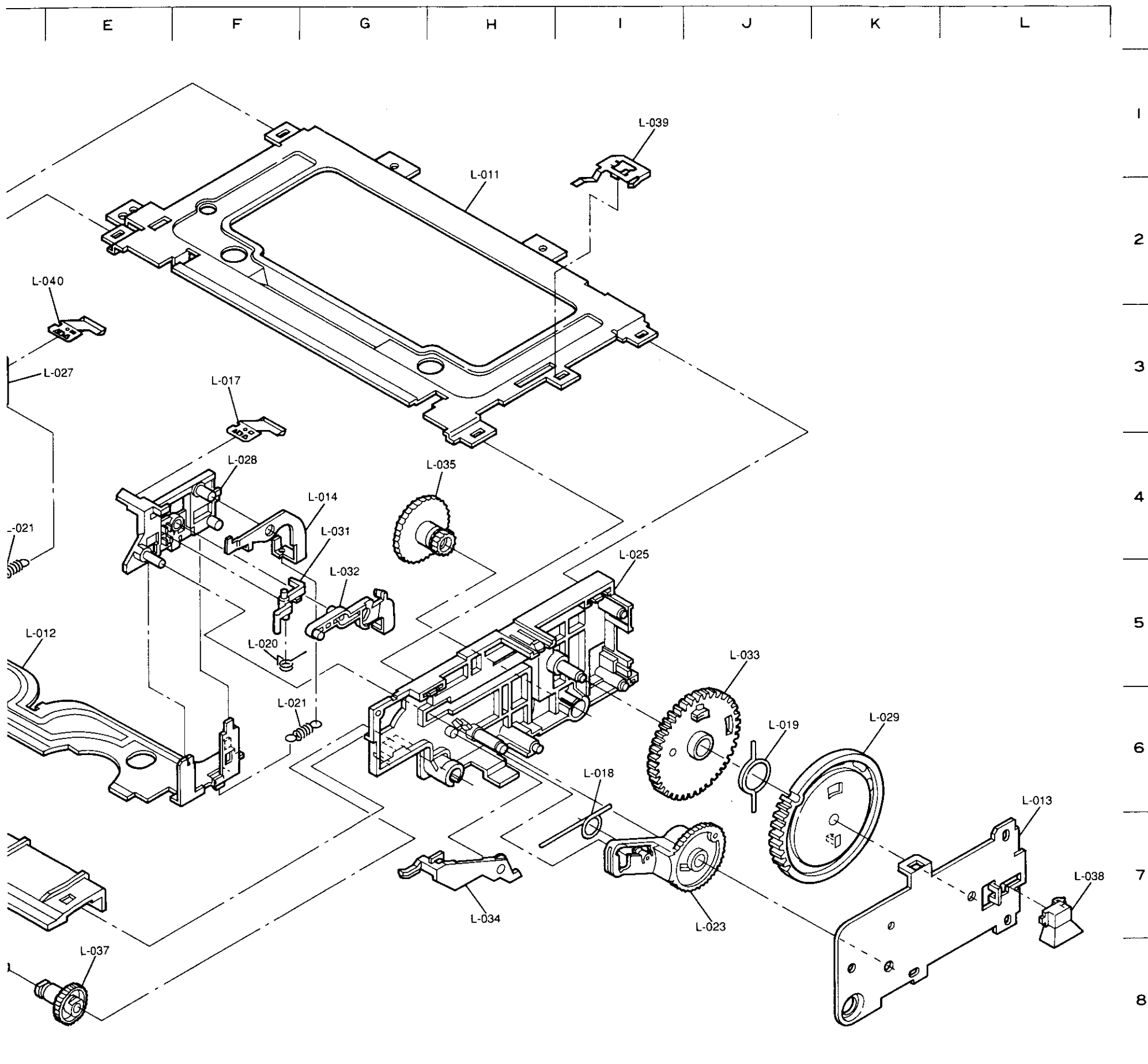

* Settled Service Parts

ITEM	PARTS No.	* ADDRESS	PARTS NAME	DESCRIPTION	Qt.
L-011	592B050010	H-2	PLATE-ROOF	[10VB, 20VB, 20VIR]	01
L-011	592B050020	H-2	PLATE-ROOF	[20VG]	01
L-012	592B051010	D-5	PLATE-BOTTOM		01
L-013	592B079010	L-7	PLATE-SIDE		01
L-014	596D986010	F-4	LEVER-LOCK-T		01
L-015	596D987010	D-3	LEVER-LOCK-S		01
L-016	631D443010	C-7	SHAFT-FL		01
L-017	572D634010	F-4	PLATE-SPR		01
L-018	572D631010	C-4	1-7 SPRING-ARM		02
L-019	572D632010	J-6	SPRING-CHIP		01
L-020	572D633010	F-5	SPRING-JUT		01
L-021	572D630010	D-5	F-6 SPRING-LOCK-T		02
L-022	621C250010	C-3	ARM-SP		01
L-023	641B627010	1-7	ARM-TU		01
L-024	641A313010	B-2	HOLDER-SIDE-SP		01
L-025	641A312010	1-5	HOLDER-SIDE-TU		01
L-026	621C249010	C-6	GUIDE-INSERT		01
L-027	641B626010	D-3	HOLDER-CAS-SP		01
L-028	641B638010	F-4	HOLDER-CAS-TU		01
L-029	641B625010	K-7	GEAR-SENS		01
L-031	622D231010	F-5	JUT-J		01
L-032	621C245010	G-5	OPENER-LID		01
L-033	622D227010	J-6	GEAR-DRIVE		01
L-034	622D230010	H-7	ARM-DOOR		01
L-035	621C252010	G-4	GEAR-WHEEL		01
L-036	622D225010	A-6	GEAR-S		01
L-037	622D226010	E-8	GEAR-T		01
L-038	622D228010	L-7	COVER-SENS		01
L-039	597D085010	1-2	PLATE-EARTH		01
L-040	572D634020	D-3	PLATE-SPR		01

PCB-BLOCK DIAGRAM

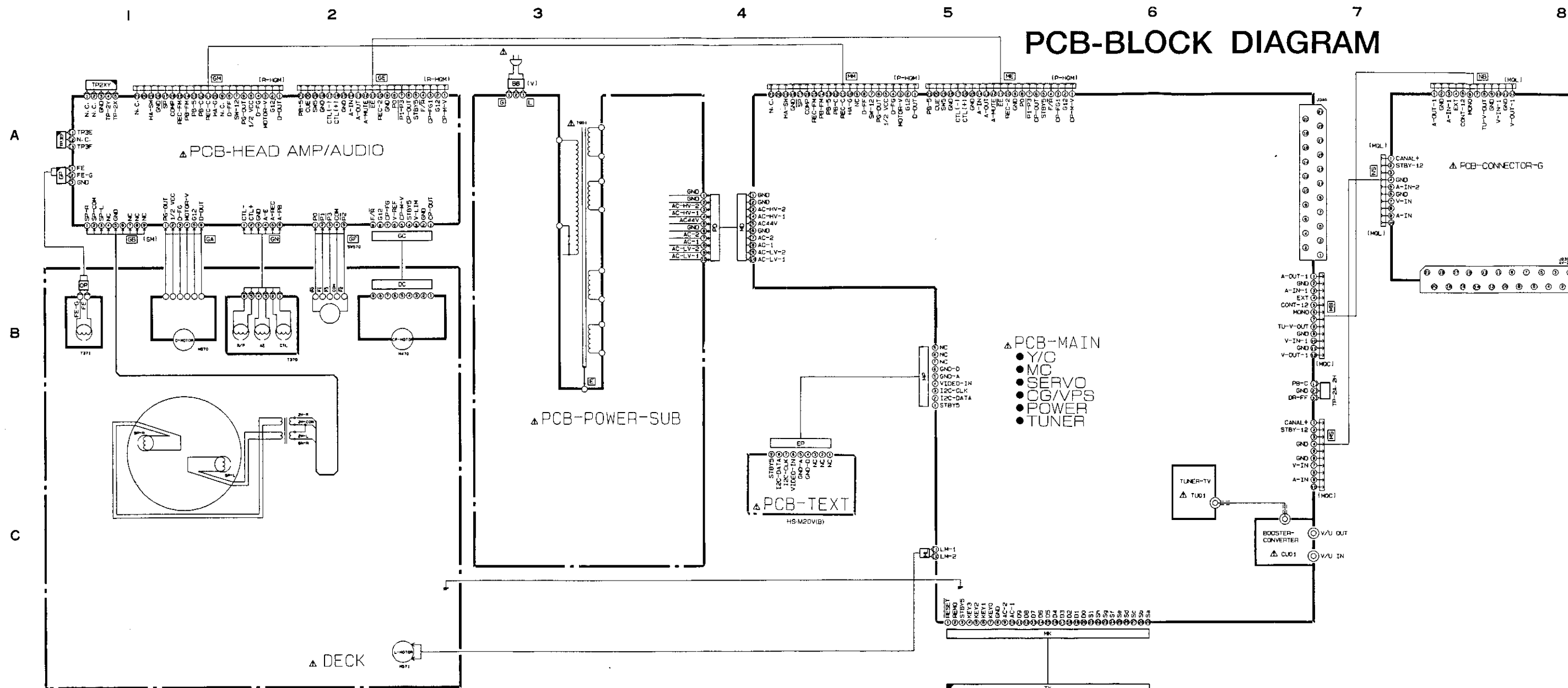

CONTENTS

①	PCB-BLOCK DIAGRAM	⑤	PCB-MAIN (MC)
	PCB-CONNECTOR		PCB-MAIN (SERVO)
③	PCB-TIMER	⑥	PCB-MAIN (CG/VPS)
	PCB-MAIN (TUNER/VIF)		PCB-TEXT
	PCB-HEAD-AMP/AUDIO		PCB-MAIN (POWER)
④	PCB-MAIN (Y/C)	⑦	PATTERN
		⑪	PATTERN TRANSMITTER
		⑫	REMOTE CONTROL

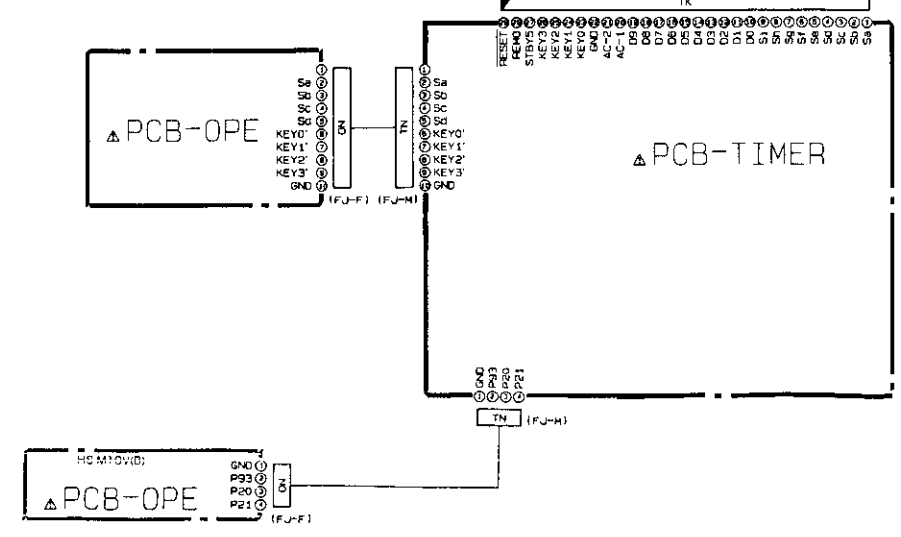

⚠️ SERVICING PRECAUTION

SYMBOLS INDICATE COMPONENTS HAVING SPECIAL CHARACTERISTICS IMPORTANT TO SAFETY AND PERFORMANCE. THEREFORE REPLACEMENT OF ANY SAFETY PARTS SHOULD BE IDENTICAL IN VALUE AND CHARACTERISTICS. DON'T DEGRADE THE SAFETY OF THE VCR THROUGH IMPROPER SERVICING.

HS-M10V(E)
HS-M20V(E)(G)(V)(IR)

PCB-BLOCK DIAGRAM

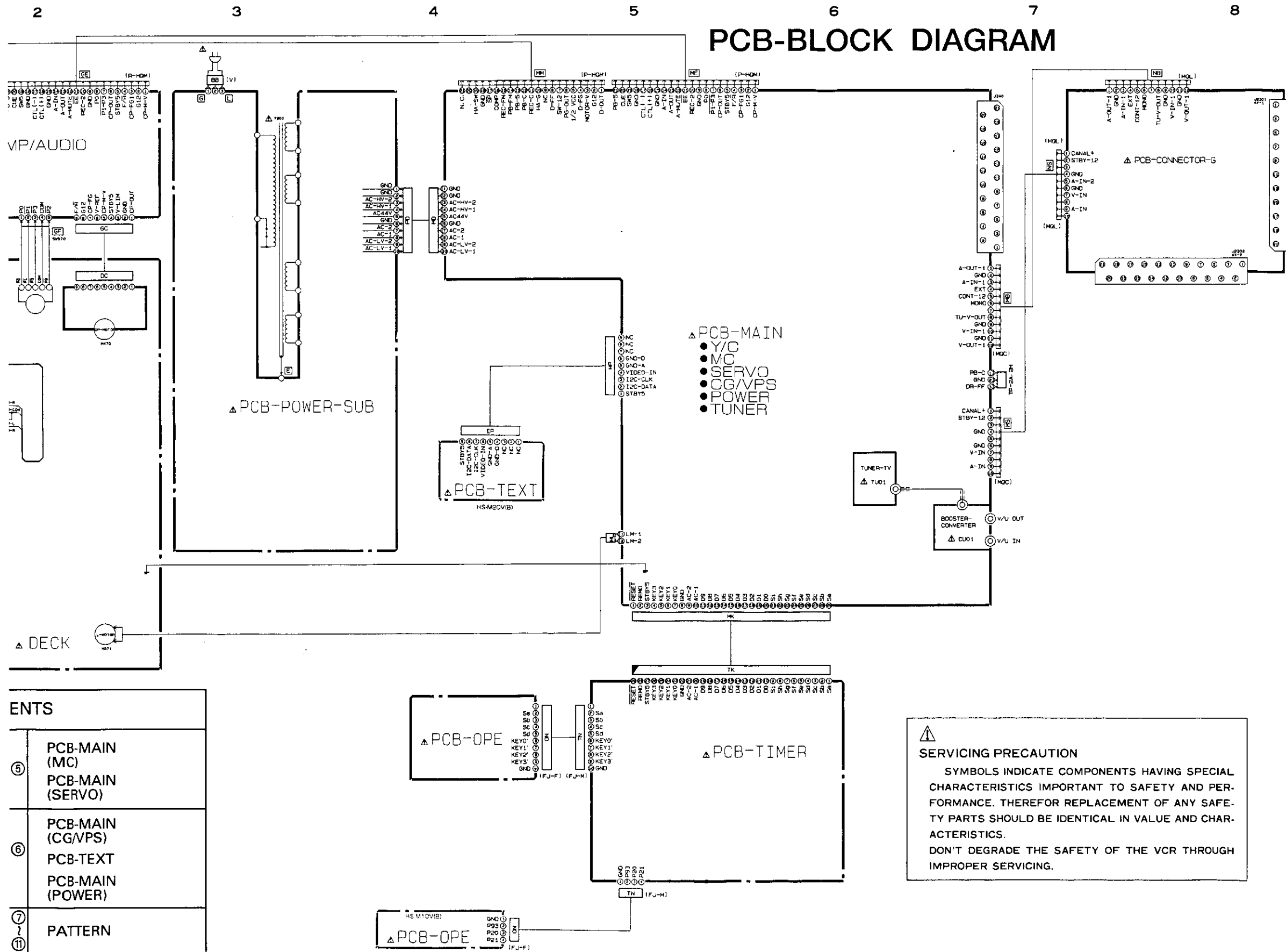

ENTS	
⑤	PCB-MAIN (MC) PCB-MAIN (SERVO)
⑥	PCB-MAIN (CG/VPS) PCB-TEXT PCB-MAIN (POWER)
⑦	PATTERN
⑪	PATTERN
⑫	TRANSMITTER REMOTE CONTROL

⚠️ SERVICING PRECAUTION

SYMBOLS INDICATE COMPONENTS HAVING SPECIAL CHARACTERISTICS IMPORTANT TO SAFETY AND PERFORMANCE. THEREFOR REPLACEMENT OF ANY SAFETY PARTS SHOULD BE IDENTICAL IN VALUE AND CHARACTERISTICS. DON'T DEGRADE THE SAFETY OF THE VCR THROUGH IMPROPER SERVICING.

HS-M10V(B)
HS-M20V(B)/V(G)/V(IR)

①

SCHEMATIC DIAGRAM

- NOTE**
- Each voltage should be within $\pm 20\%$ of the DC voltages measured with a digital voltmeter.
 - The voltages parenthesised are on SP recording mode. While those without parenthesised are on SP play back mode.
 - Waveforms were taken with standard colour bar signal.
 - TP6A, etc. show Test Points.

5. CAPACITORS

Value	Not indicated	PF, for numbers more than 1 μ F, for numbers less than 1
Dielectric Strength	Not indicated	:50V
Tolerance	Not indicated	$\pm 10\%$ No Tolerance is indicated for electrolytic capacitors and $\pm 20\%$
Sort	Parts except for chips	<ul style="list-style-type: none"> Not indicated : Ceramic capacitor (MP) : Polyester capacitor (PP) : Polypropylene film capacitor (ALM) : Aluminum electrolytic capacitor (TF) : Twin film capacitor (SC) : Semiconductor ceramic capacitor (MP) : Metalized paper (MPP) : Metalized plastic film capacitor (MMP) : Metalized polyester capacitor (MFPP) : Polyester polypropylene film capacitor (PS) : Styrol capacitor (TAN) or (TANT) : Tantalum capacitor (E) : Electrolytic capacitor (BP) or (NP) : Non polarized electrolytic capacitor
	Chips	<ul style="list-style-type: none"> Not indicated : Ceramic capacitor chip (E) : Electrolytic capacitor chip (BP) or (NP) : Non polarized electrolytic capacitor chip
Characteristic (only ceramic capacitor)	Not indicated	: F or B (high dielectric percentage) CH, SL, etc. : Temperature compensating types

6. Resistors

Value	Not indicated = Ω K = k Ω (1000 Ω) M = M Ω (1000k Ω)	
Wattage	Parts except for chips	Not indicated = 1/4W or 1/6W
	Chips	Not indicated = 1/10W
Tolerance	Not indicated = $\pm 5\%$ D = $\pm 0.5\%$ J = $\pm 5\%$ F = $\pm 1\%$ K = $\pm 10\%$	
Short	Parts except for chips	<ul style="list-style-type: none"> Not indicated : Carbon resistor (S) : Fixed composition resistor (MB) : Metal oxide film resistor (type B) (CE) : Cemented resistor (W) : Wire wound resistor (M) : Metal film resistor (MPC) : Metal plate cement resistor (ML) : Metal liner resistor
	Chip	Not indicated : Chip resistor

7. This is a basic schematic diagram. Some sets may be subject to modification according to engineering improvement.

SPECIFIC SYMBOL

	Zener Diode		Crystal unit
	Varicap		LE Diode
	Thermistor		Photo Diode
	Fusible Resistor		Ceramic filter
	PNP DIGITAL TRANSISTOR		
	NPN DIGITAL TRANSISTOR		

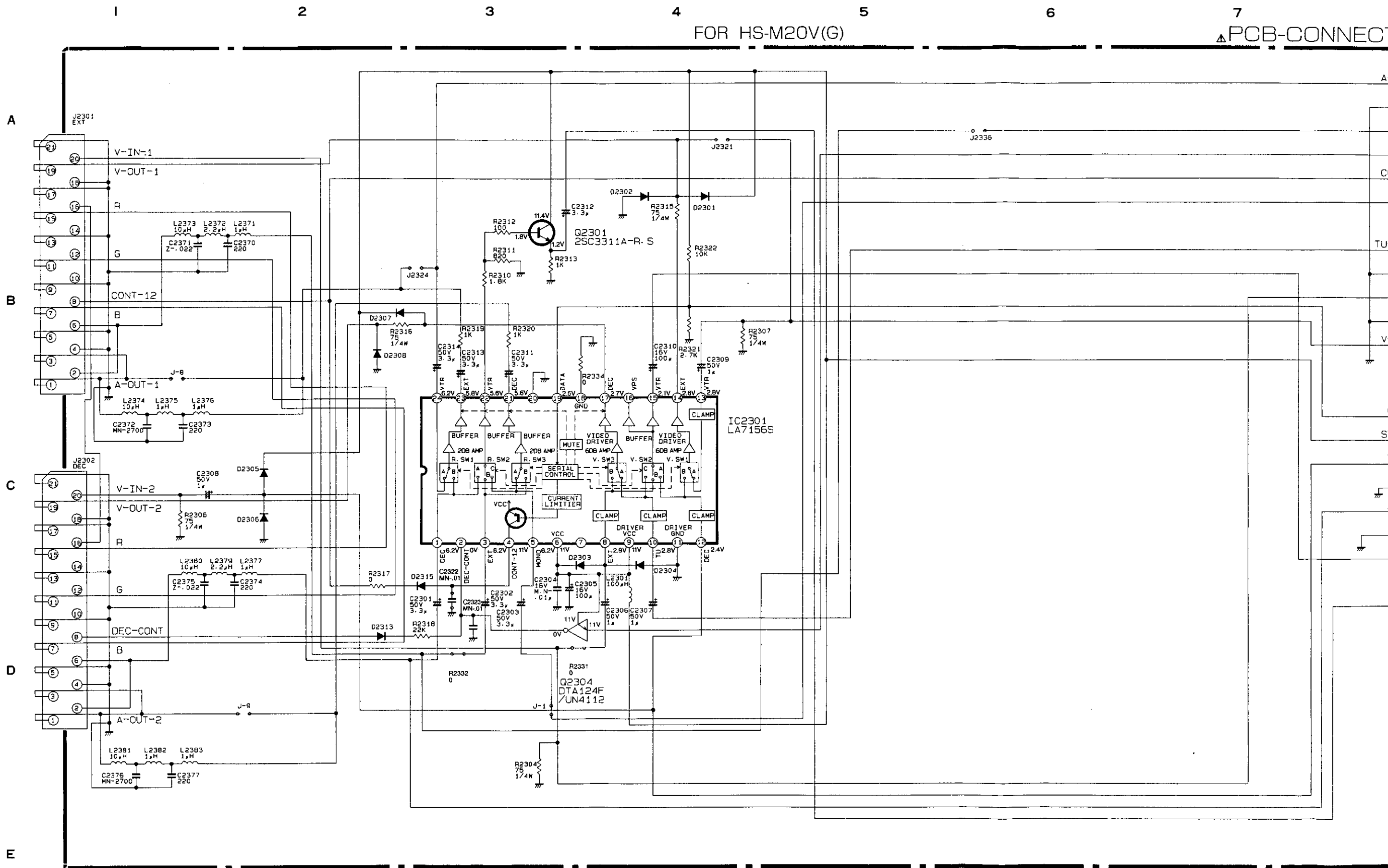

All diodes are 1SS252/1SS131 unless otherwise specified.

HS-M10V(B)
HS-M20V(B)/V(G)/V(IR)

2

FOR HS-M20V(G)

PCB-CONNECTOR

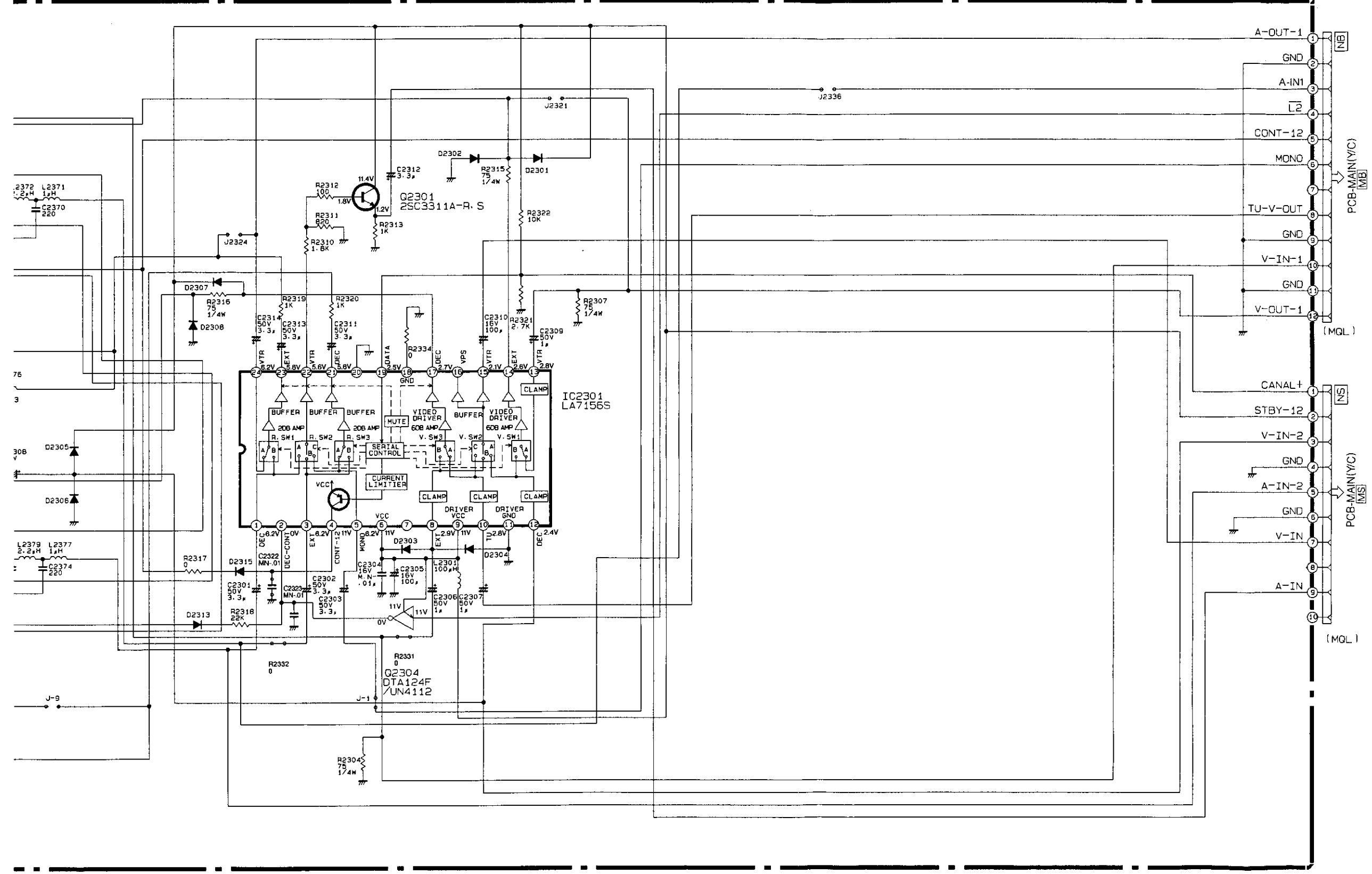

diodes are 1SS252/1SS131 unless otherwise specified.

A
B
C
D
E

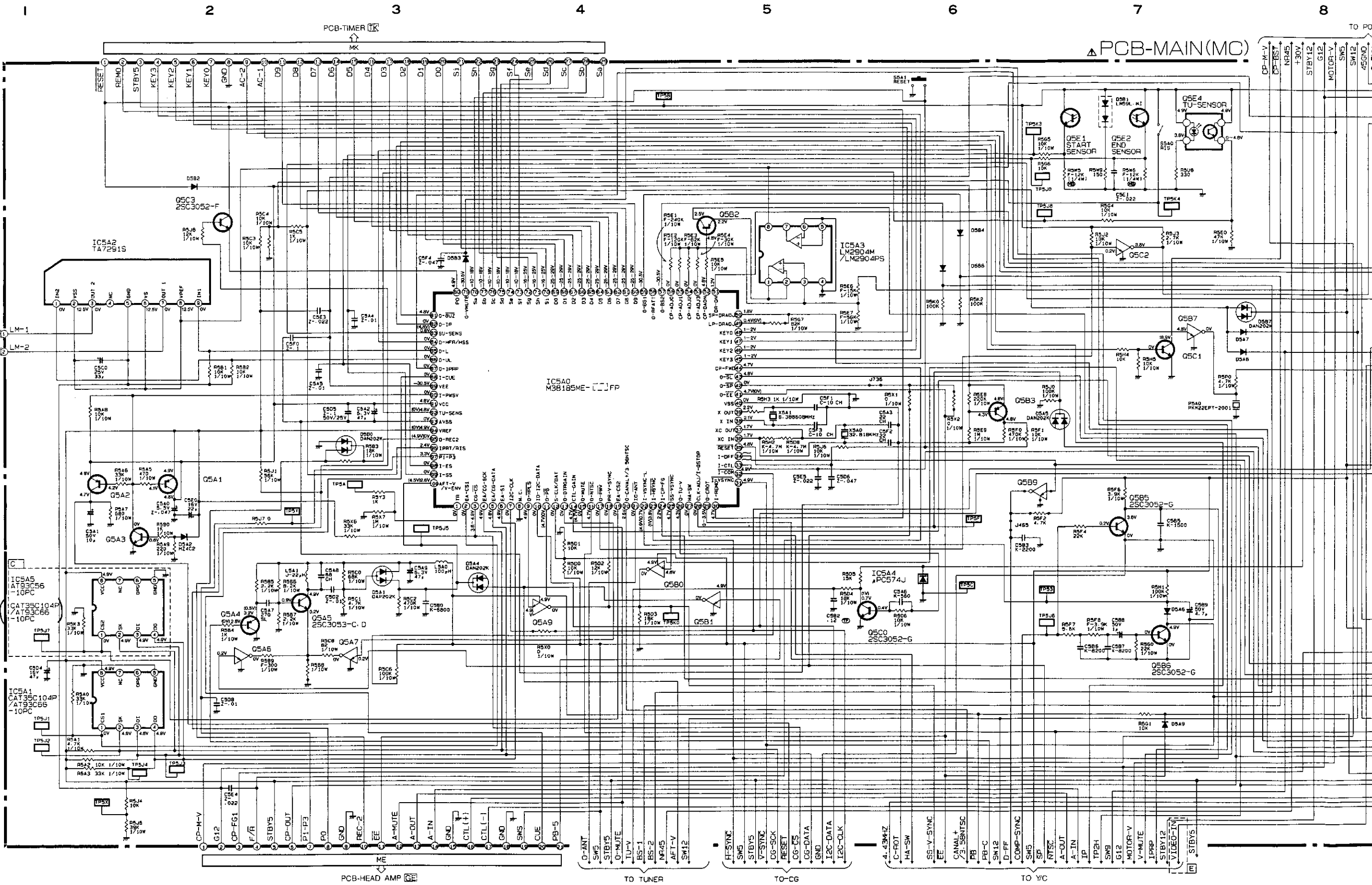

○: Employed X: Not employed

MODEL	SYMBOL NO	IC5A0	C AREA	R5B5	J736	R5G7	D AREA	E AREA	R5B8	R5X0	R5X2
HS-M20V(B)	066	○	○	220	○	○	○	○	100	○	X
HS-M20V(G)	053	○	○	330	X	X	X	X	100	○	○
HS-M20V(H)	066	X	○	220	○	○	X	X	100	X	X
HS-M10V(B)	066	○	○	220	○	○	X	X	100	X	X

All diodes are 1S5252/1S5131 unless otherwise specified.
 All NPN transistors are 2SC3052-E.F unless otherwise specified.
 All PNP transistors are 2SA1235-E.F unless otherwise specified.

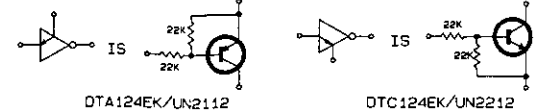

DTA124EK/UN2112 DTC124EK/UN2121

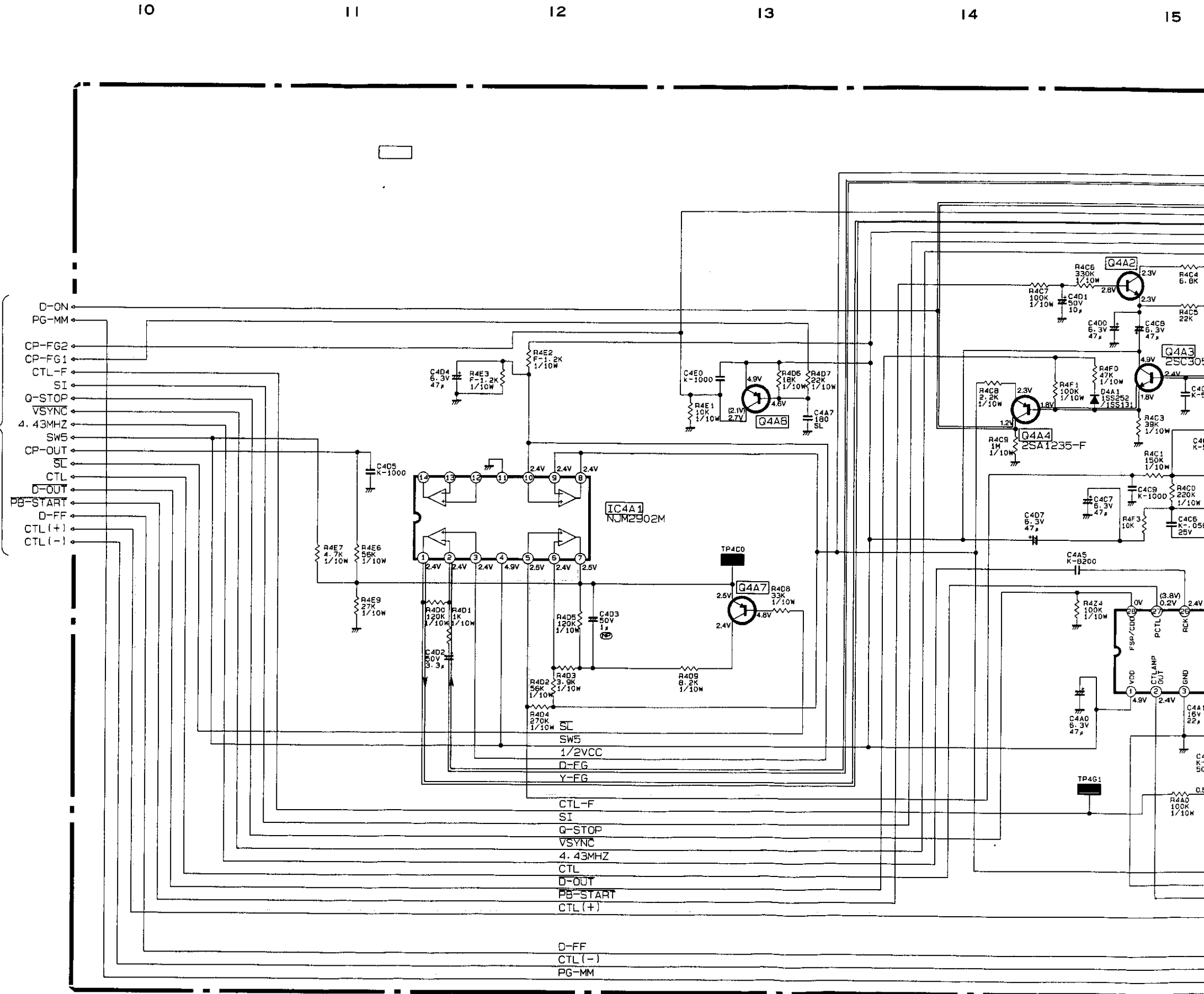
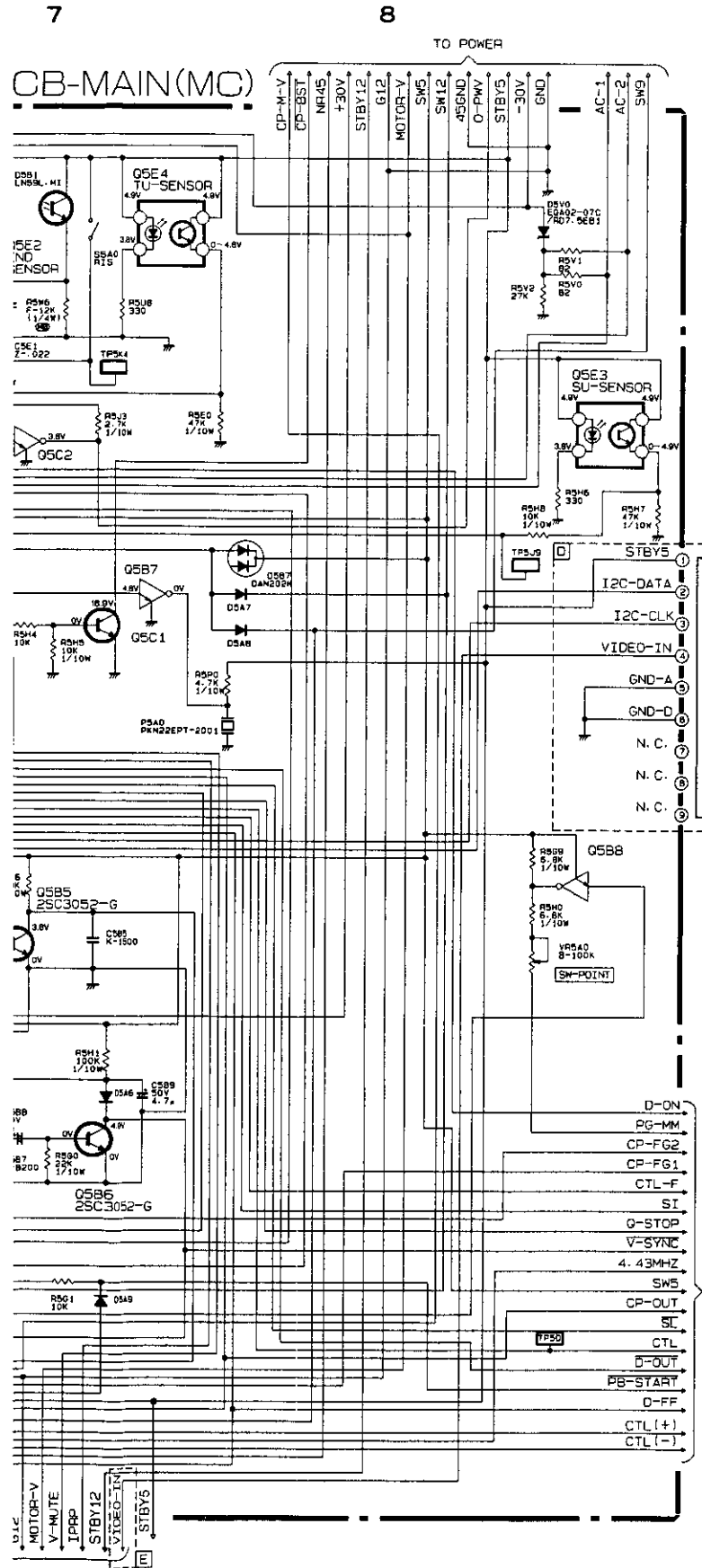

pecified.
 *wise specified.
 *wise specified.
 22K
 22K
 UN2212

All NPN transistors are 2SC3052-E.F unless otherwise specified.
 All PNP transistors are 2SA1235-E.F unless otherwise specified.

FOR HS-M10V(B) PCB-TIMER

X: No
SYMB
B)
G)
R)

A

B

C

D

E

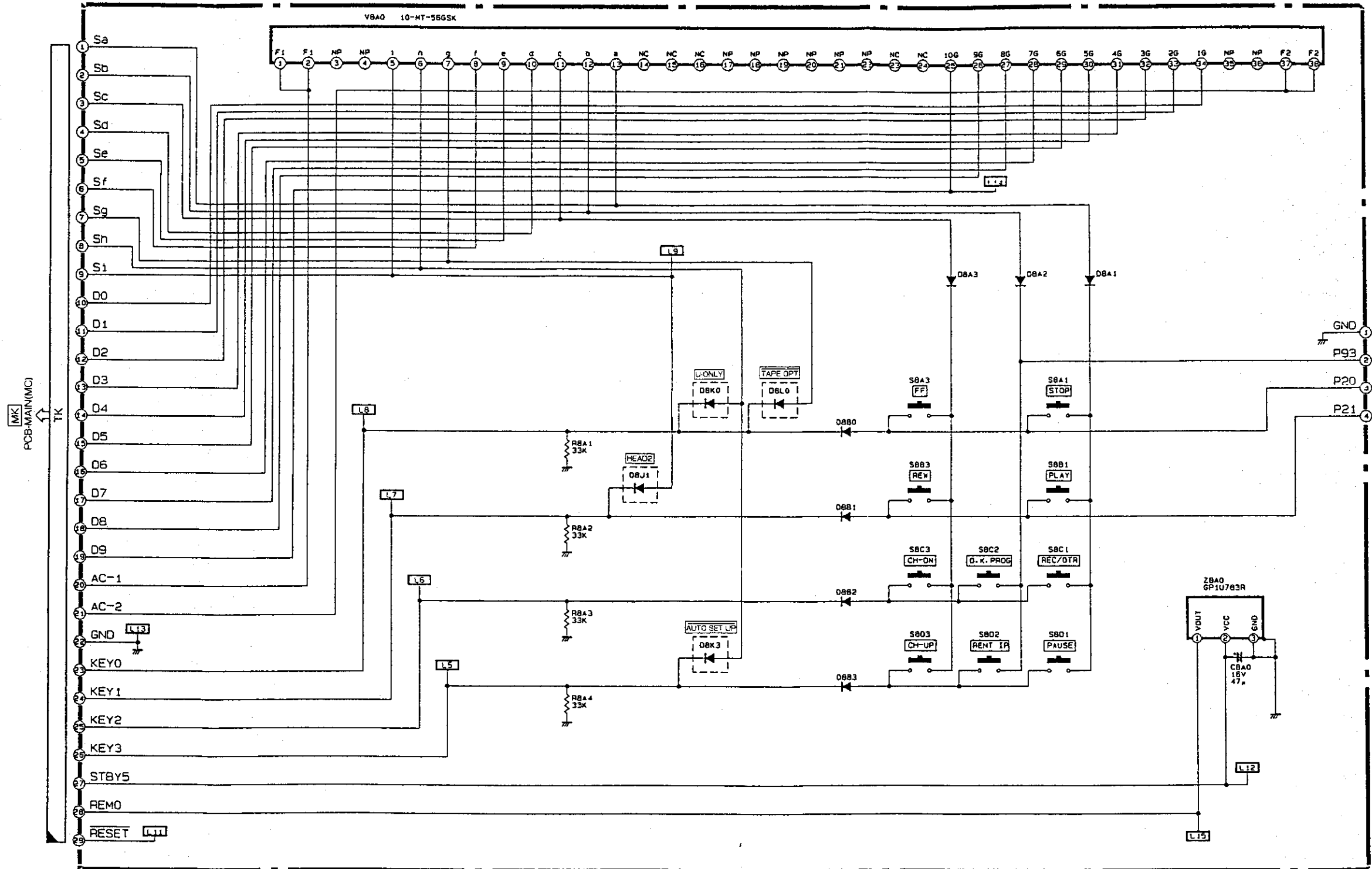

All diodes are unless otherwise

PCB-MAIN(TUNER/VIF)

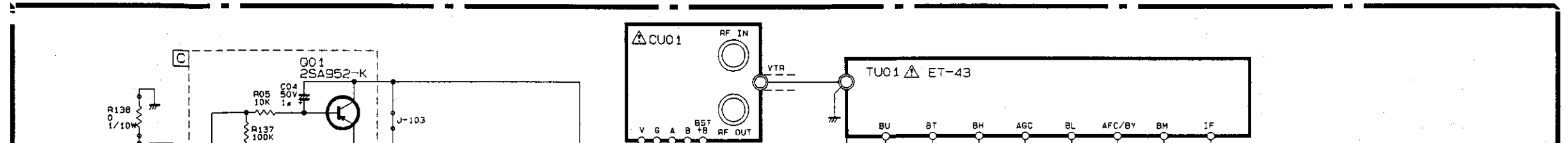

RESET

L15

PCB-MAIN(TUNER/VIF)

E
F
G
H
I
J

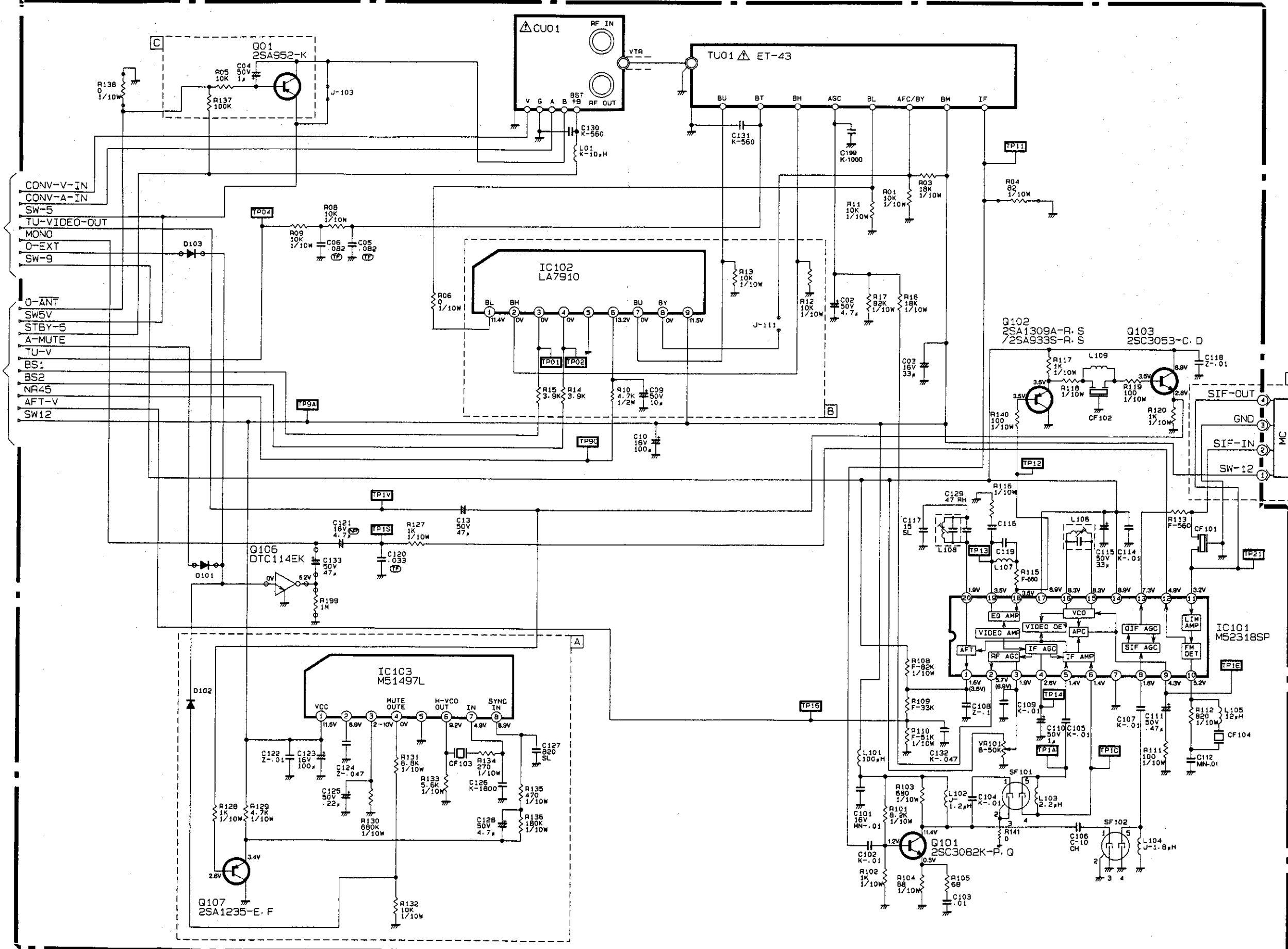

B-TIMER

7 8 9 10 11 12 13 14

FOR HS-M20V(B),V(G),V(IR) PCB-TIMER

○: Employed
 X: Not employed
 MODEL
 HS-M20
 HS-M20
 HS-M20

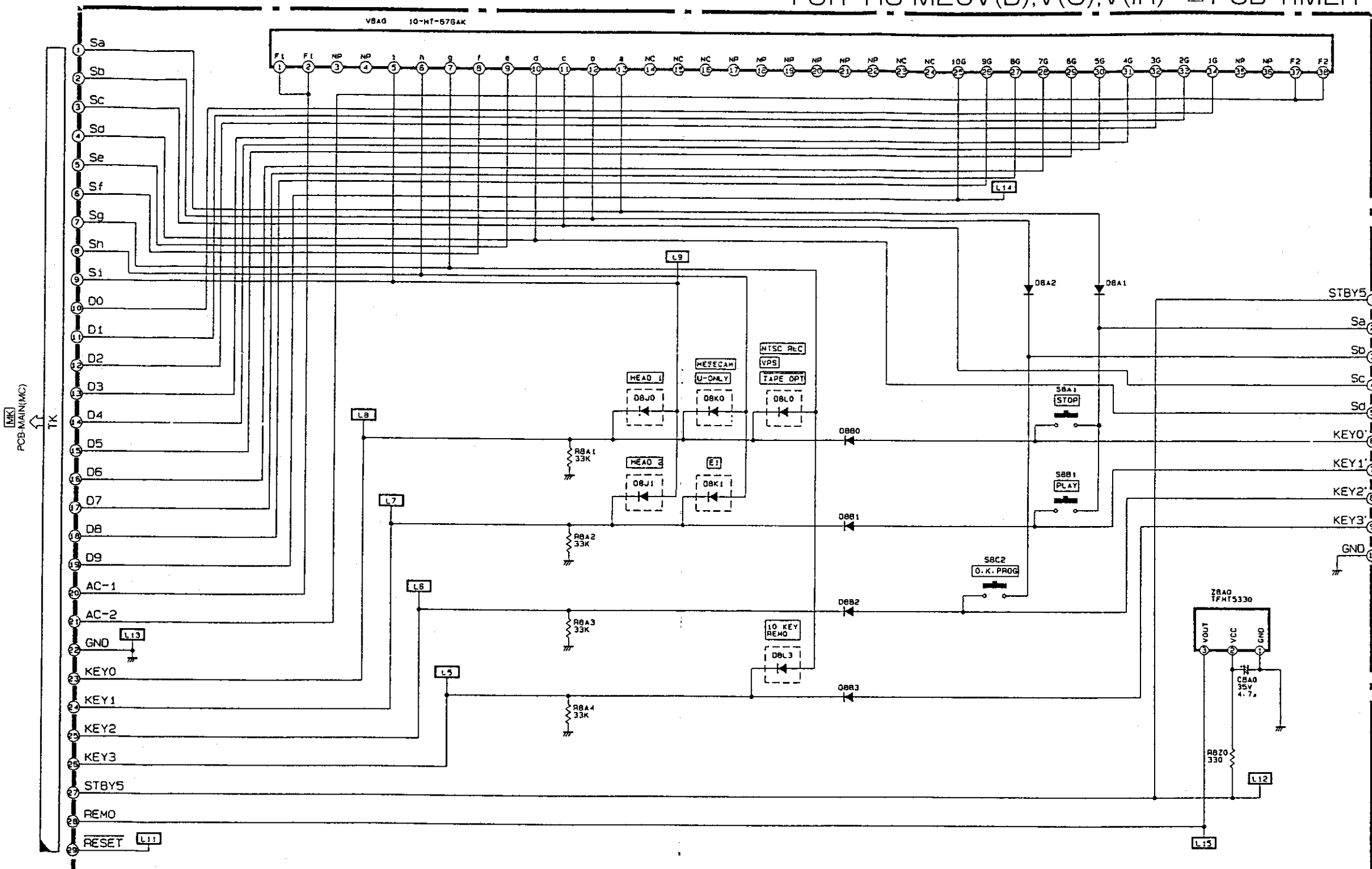
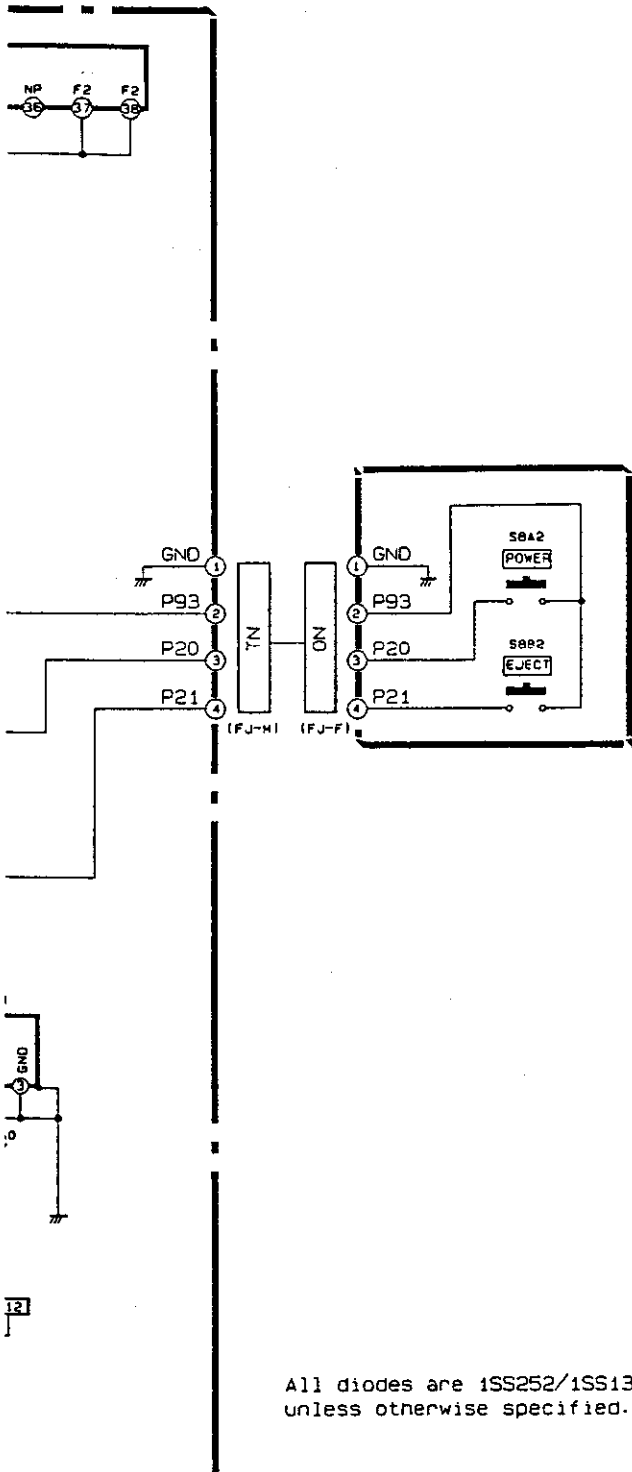

All diodes are 1SS252/1SS131 unless otherwise specified.

All diodes unless

○: Employed X: Not employed

	(M)	(B)	(P)	(IR)	(G)	(A)	(NZ)	(SA)	(EE)
A AREA	○	X	X	X	○	X	X	X	X
B AREA	○	X	○	○	○	○	○	○	○
C AREA	X	X	X	X	X	○	○	X	X
D AREA	X	X	X	X	X	X	X	X	○
L102	1.2μ	1.2μ	1.2μ	1.2μ	1.2μ	1.2μ	2.2μ	1.2μ	1.2μH

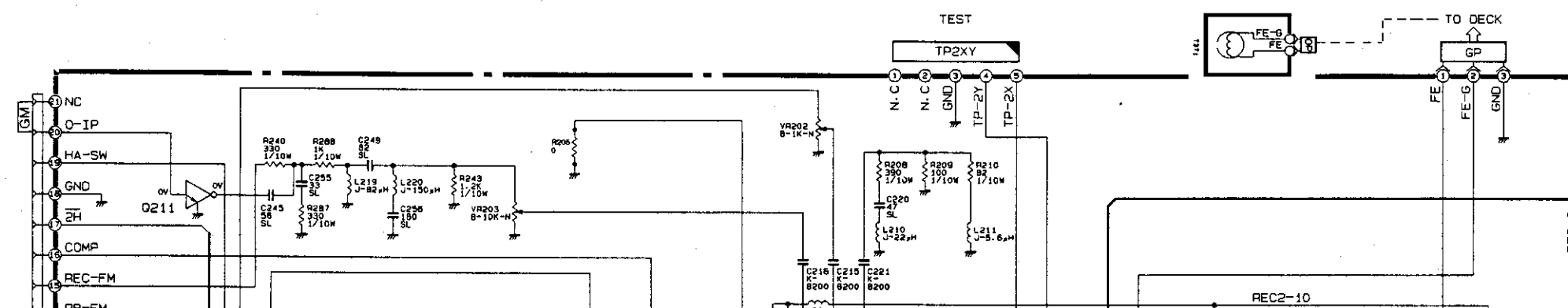

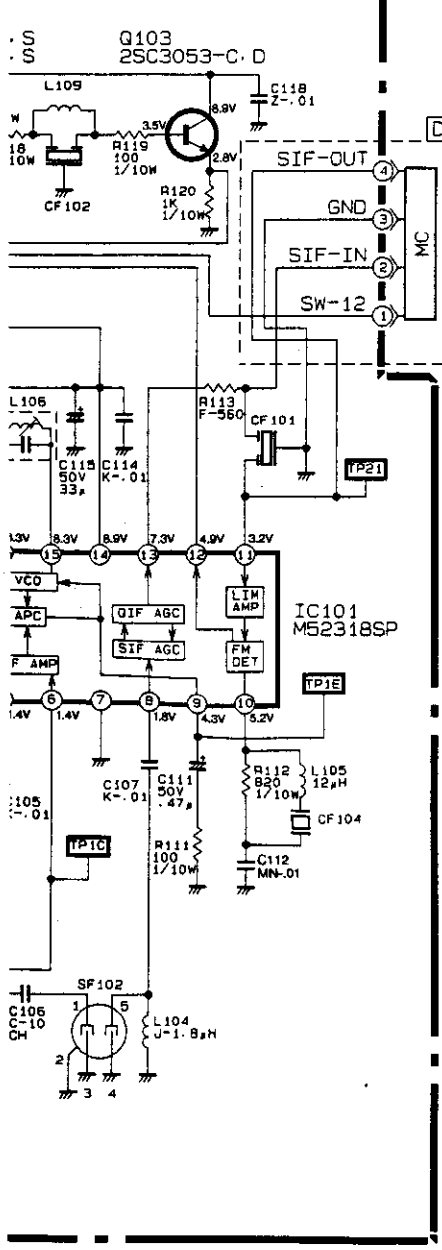

○ : Employed X : Not employed

	(Y)	(B)	(P)	(IR)	(G)	(A)	(NZ)	(SA)	(EE)
A AREA	○	X	X	X	○	X	X	X	X
B AREA	○	X	○	○	○	○	○	○	○
C AREA	X	X	X	X	X	○	○	X	X
D AREA	X	X	X	X	X	X	X	X	○
L102	1.2μ	1.2μ	1.2μ	1.2μ	1.2μ	1.2μ	2.2μ	1.2μ	1.2μH
R105	X	X	X	X	X	○	○	X	X
CF101	○	○	○	○	○	○	○	○	X
C103	X	X	X	X	X	○	○	X	X
C116	X	X	X	X	18SL	X	33P	X	1000P
C119	18SL	15SL	18SL	15SL	39SL	15SL	12SL	15SL	18SL
L109	J-5.6μH	J-8.2μH	J-5.6μH	J-8.2μH	J-5.6μH	J-5.6μH	J-5.6μH	J-5.6μH	J-5.6μH
L107	39μ	56μ	39μ	56μ	22μ	47μ	39μ	47μ	39μ
R113	F-560	F-560	F-560	F-560	F-560	F-560	F-560	F-560	0Ω
R118	F-150	F-390	F-150	F-330	F-330	F-180	F-220	F-180	F-150
R116	X	X	X	X	0Ω	X	0Ω	X	3.9K
D103	○	X	X	X	○	X	X	○	X
D101	○	X	X	X	○	X	X	○	○
Q106	○	X	X	X	○	X	X	○	X
C133	○	X	X	X	○	X	X	○	X
J103	○	○	○	○	○	X	X	○	○
R04	X	○	X	○	○	○	○	○	X
R138	○	○	○	○	○	X	X	○	○

TO PCB-SIF

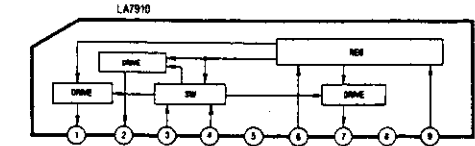

ALL DIODES ARE 1SS252/1SS131 UNLESS OTHERWISE SPECIFIED.

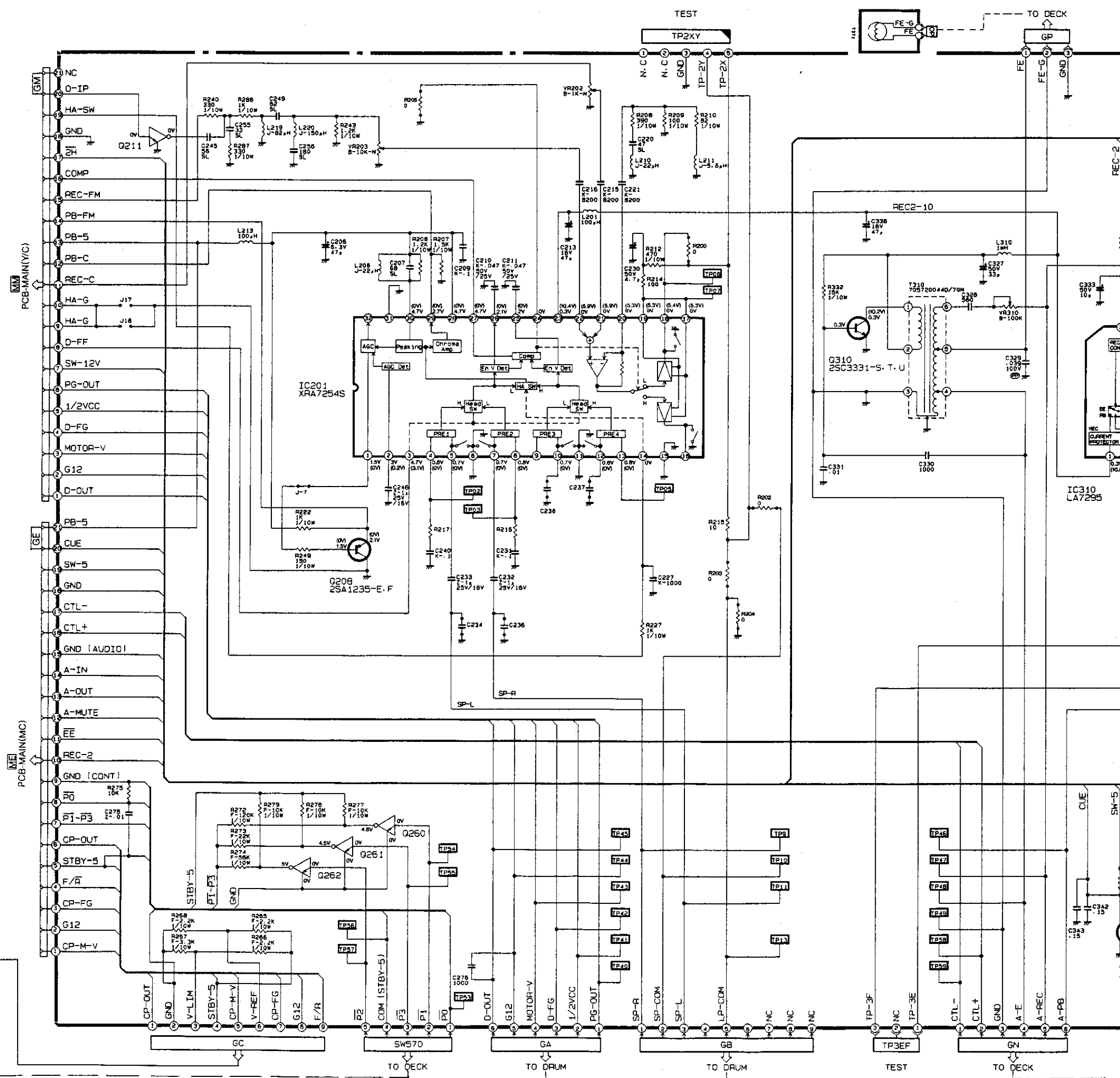
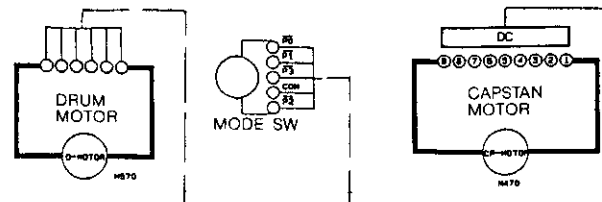
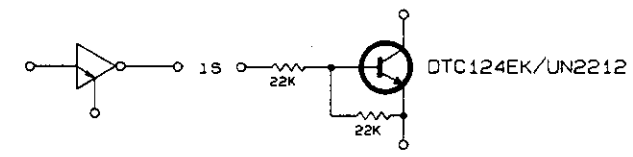

FOR HS-M20V(B),V(G),V(IR) Δ PCB-TIMER

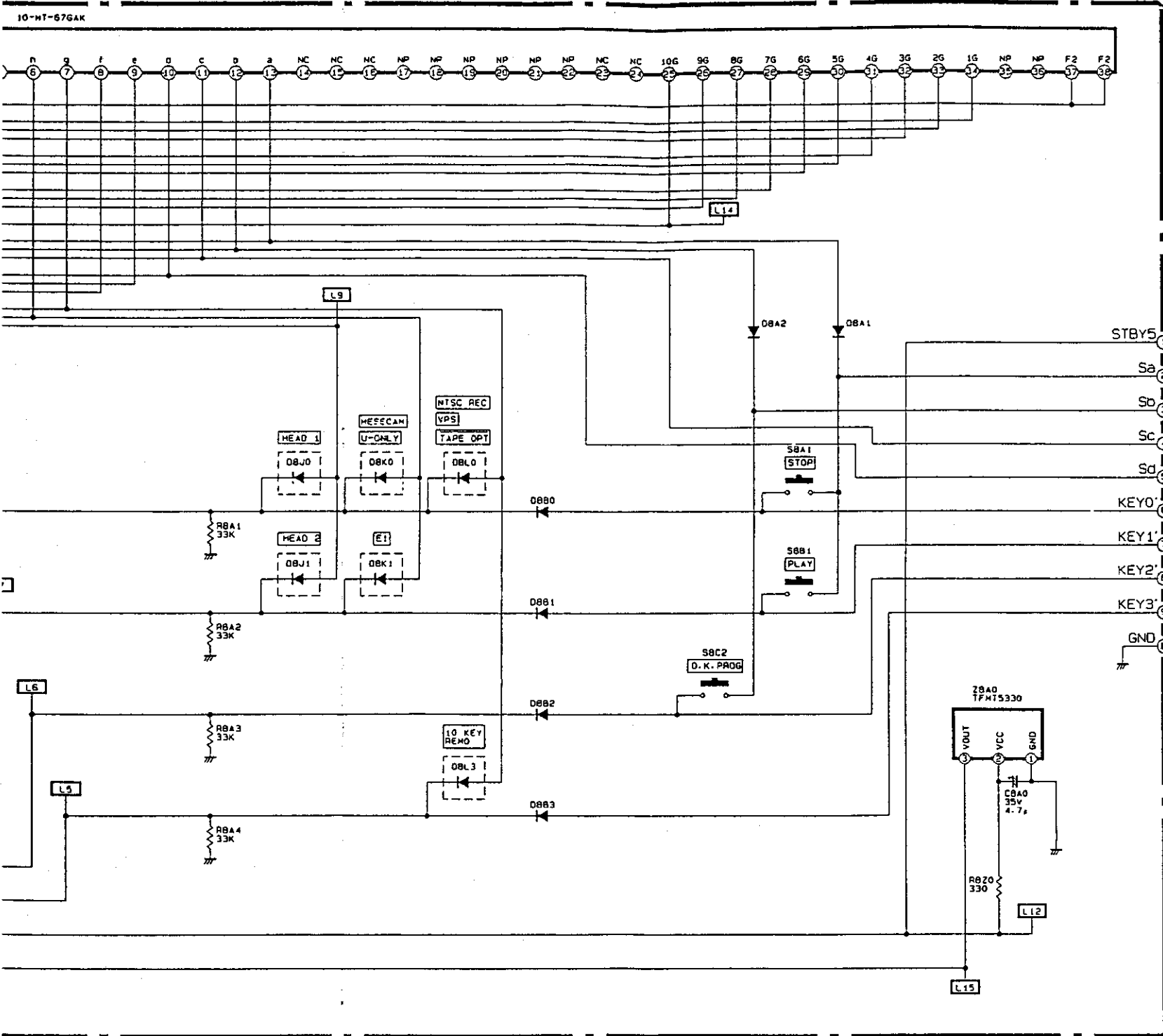

○: Employed X: Not employed

MODEL	SYMBOL	D8J0	D8J1	D8K0	D8K1	D8L0	D8L3	B AREA
HS-M20V(B)		X	○	○	X	X	X	○
HS-M20V(G)		○	X	○	○	○	○	X
HS-M20V(IR)		X	○	X	X	X	X	X

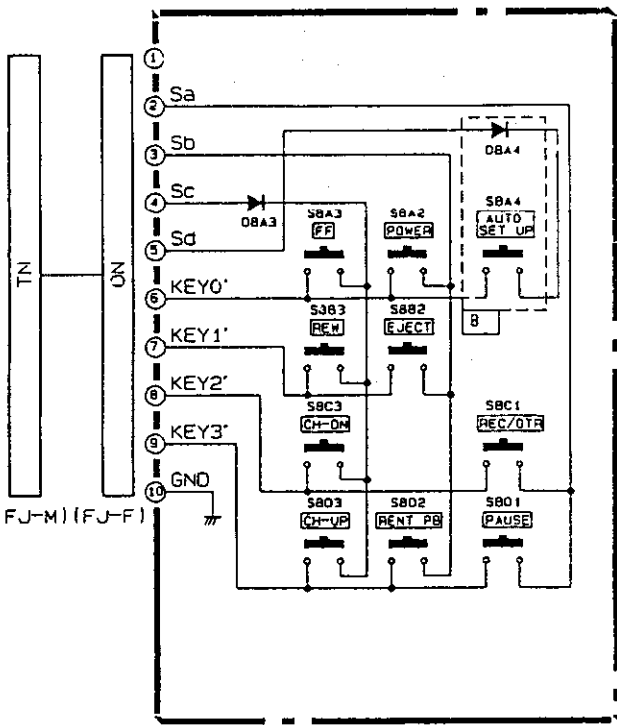

Z8A0 PREAMAP

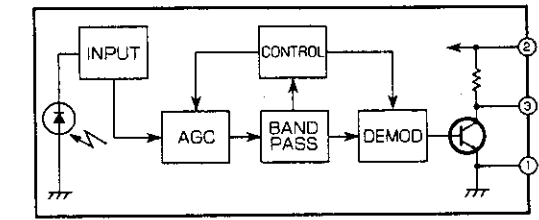

All diodes are 1SS252/1SS131 unless otherwise specified.

DRUM MOTOR

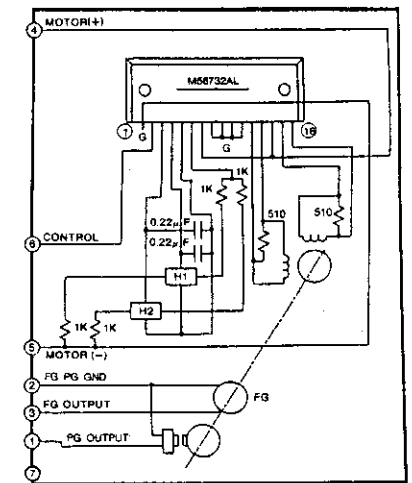

PCB-HEAD AMP/AUDIO

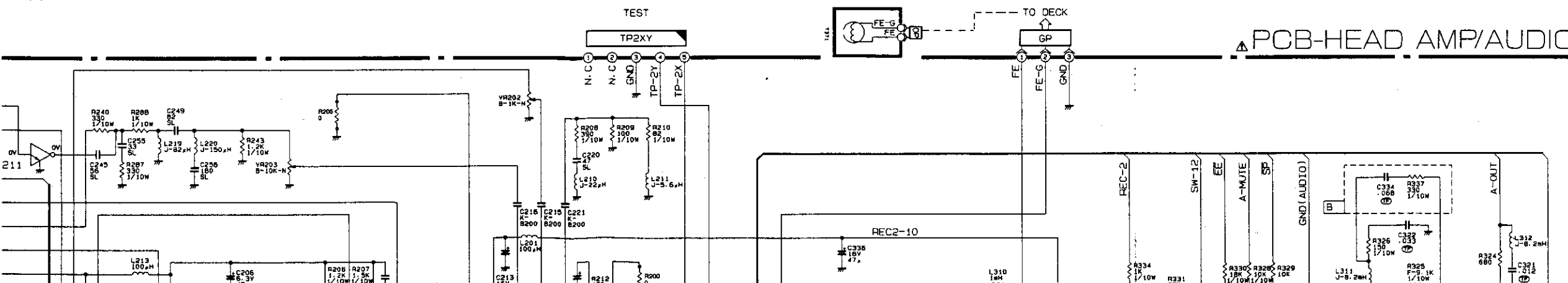

CAPSTAN MOTOR

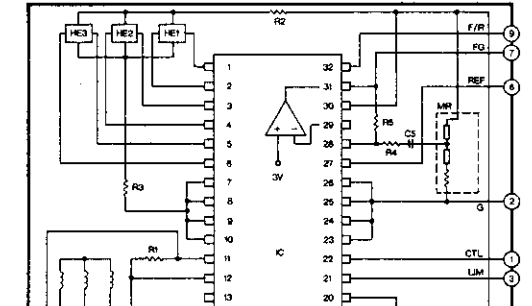

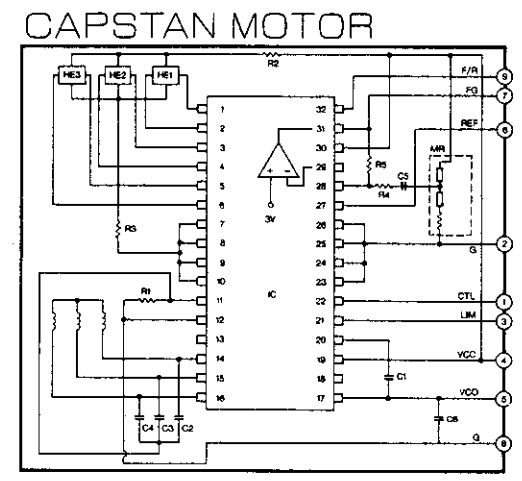
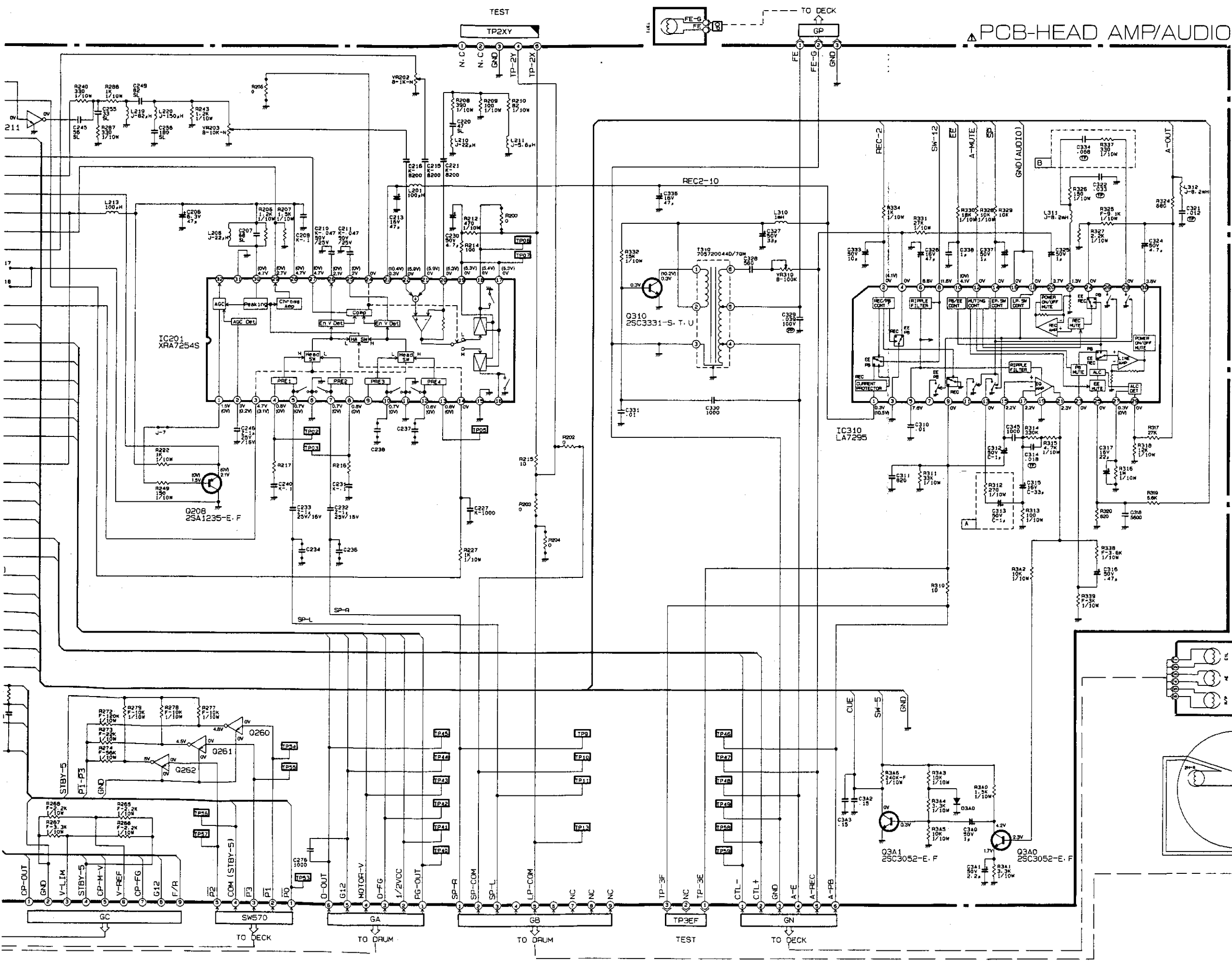

○ Employed X Not employed

ITEM	HS-M10V(B)	HS-M20V(B)	HS-M20V(G)
C345	X	○	
R329	○	X	
A AREA	○	X	
B AREA	○	X	
C234	58 SL	56 SL	
C236	47 SL	47 SL	
C237	8200	8200	
C337	○	X	
R217	390	680	
R216	330	560	
R205	○	○	
R202	○	○	
C238	8200	8200	

All diodes are 1SS252/1SS131 unless otherwise specified.

IS 2K DTC124EK

A
B
C
D
E
F

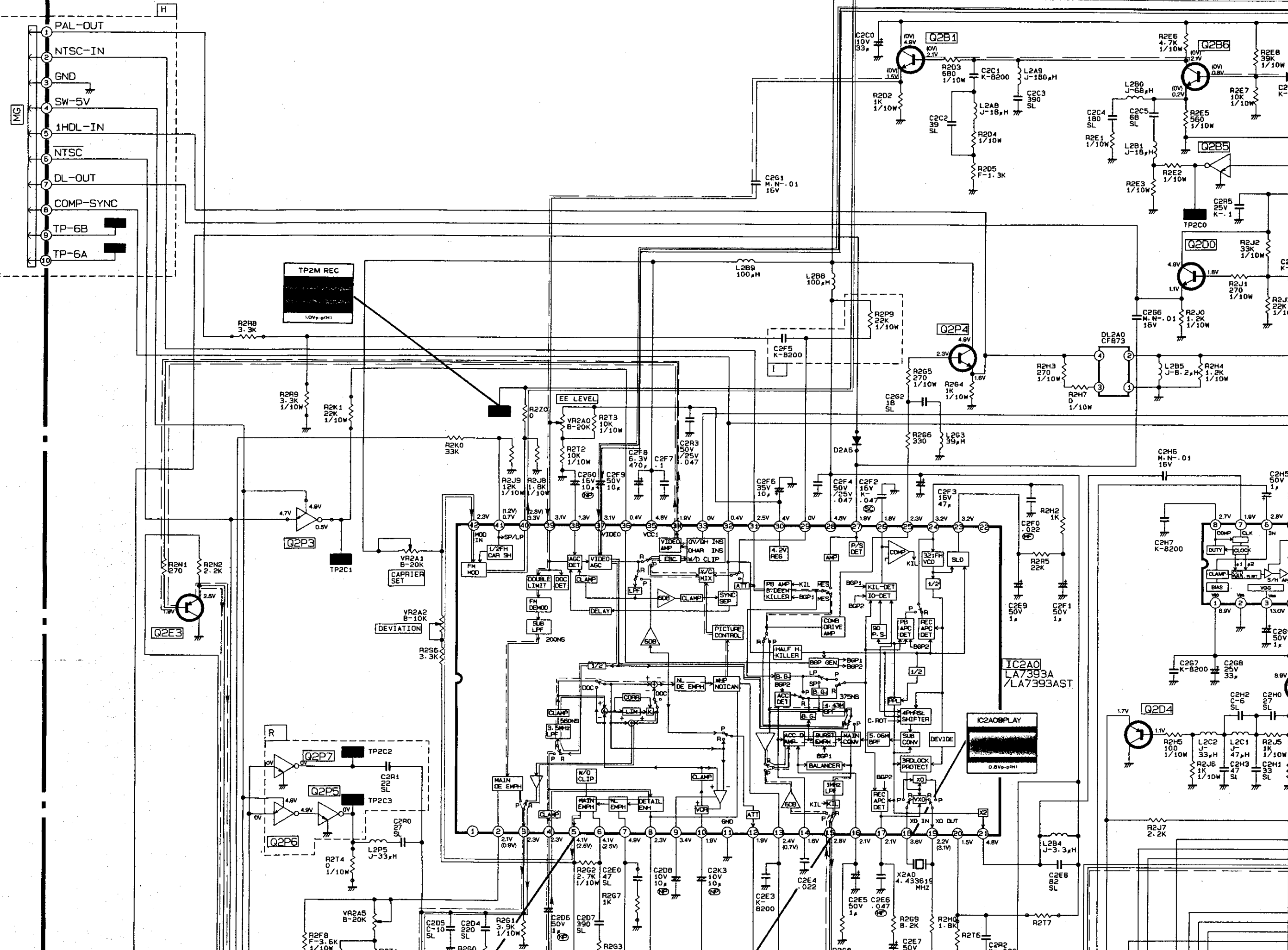

E
T
G
I

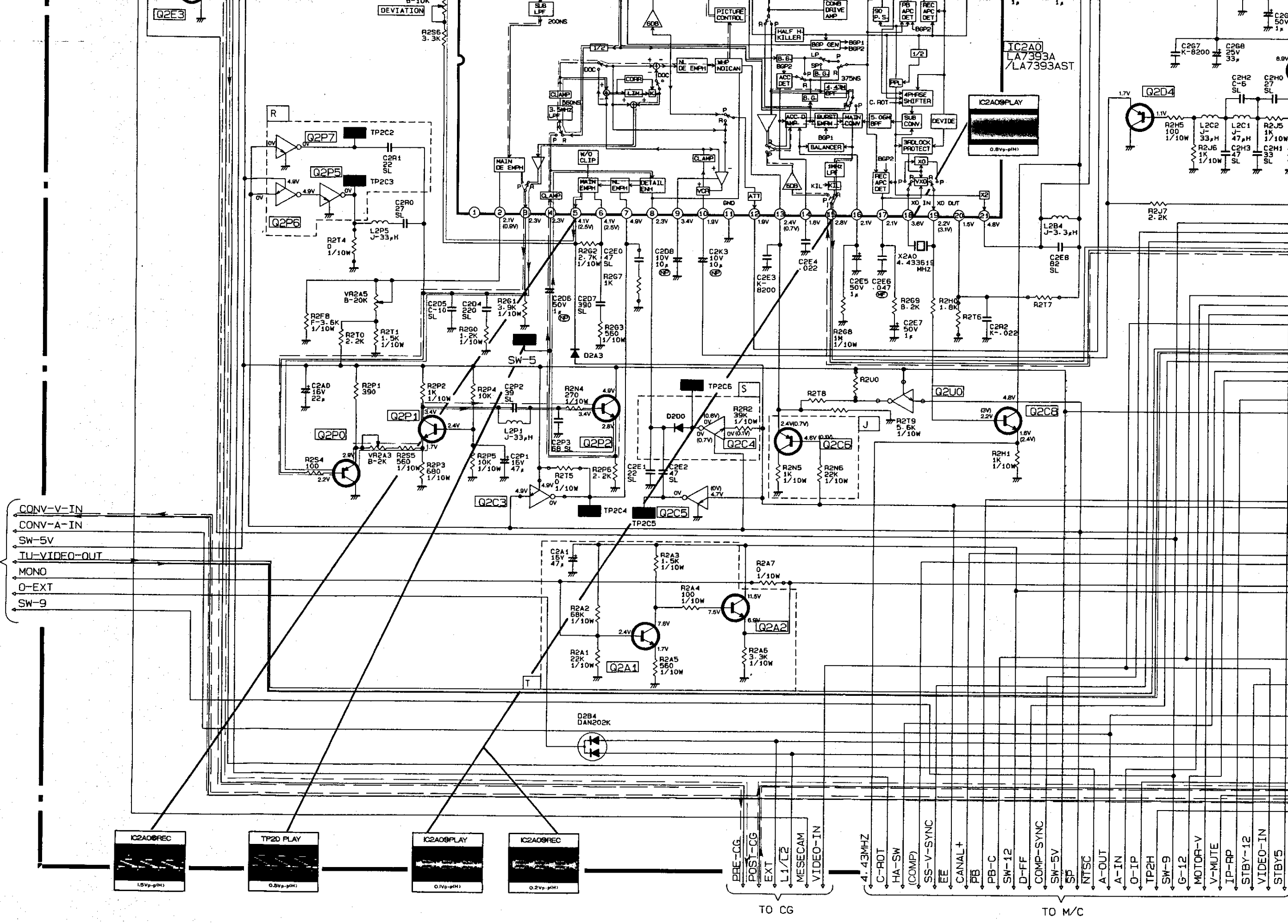

HS-M10V(B)
HS-M20V(B)/V(G)/V(IR)

PCB-MAIN(Y/C)

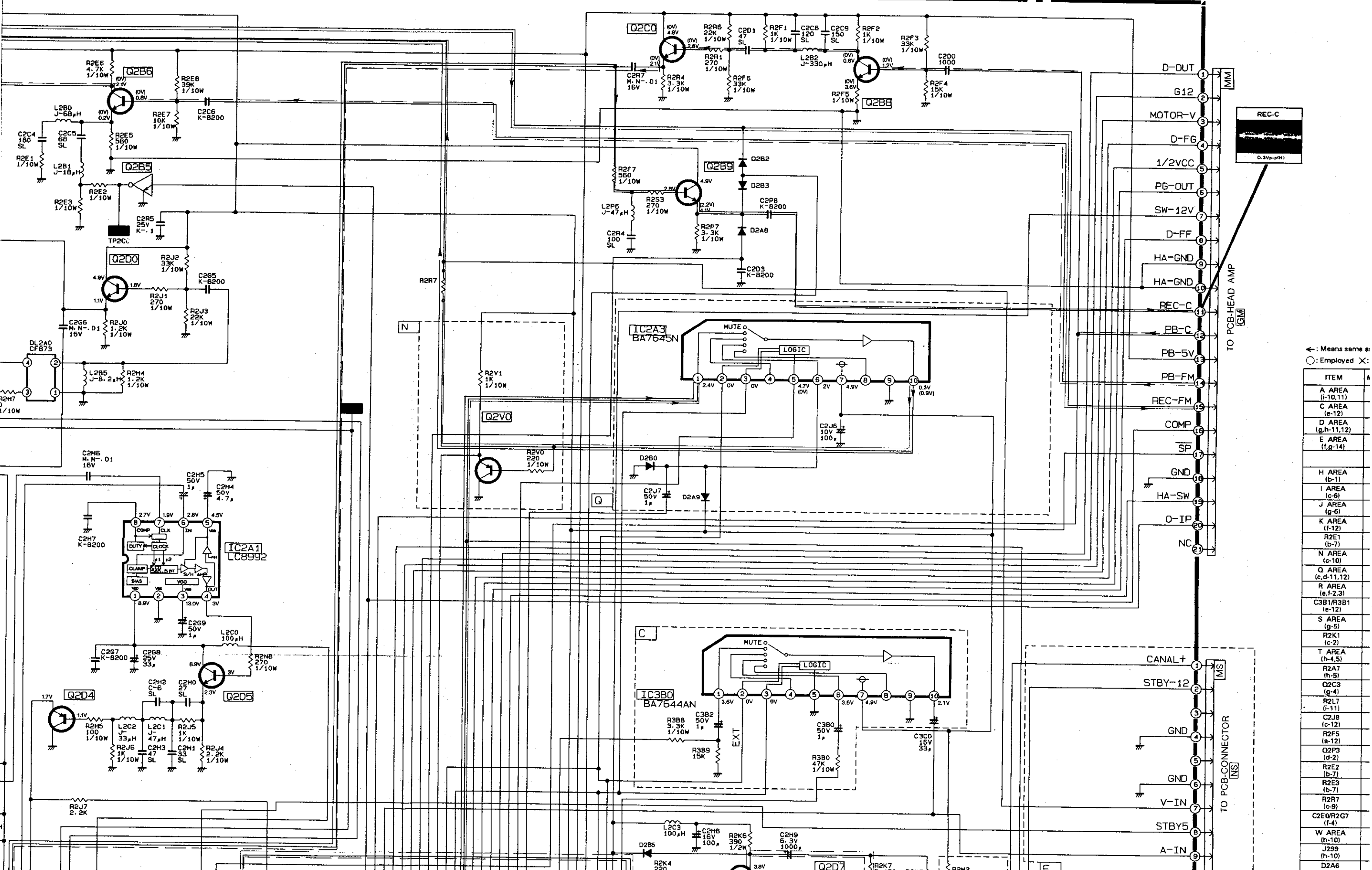

← : Means same as
 ○ : Employed X :

ITEM	A
A AREA (i-10,11)	
C AREA (e-12)	
D AREA (g,h-11,12)	
E AREA (f,g-14)	
H AREA (b-1)	
I AREA (c-6)	
J AREA (g-6)	
K AREA (f-12)	
N AREA (b-7)	
N AREA (c-10)	
Q AREA (c,d-11,12)	
R AREA (e,f-2,3)	
C3B1/R3B1 (e-12)	
S AREA (g-5)	
R2K1 (c-2)	
T AREA (h-4,5)	
R2A7 (h-5)	
Q2C3 (g-4)	
R2L7 (f-11)	
C2J8 (c-12)	
R2F5 (a-12)	
Q2P3 (d-2)	
R2E2 (b-7)	
R2E3 (b-7)	
R2R7 (c-9)	
C2E0/R2G7 (f-4)	
W AREA (h-10)	
J299 (h-10)	
D2A6	

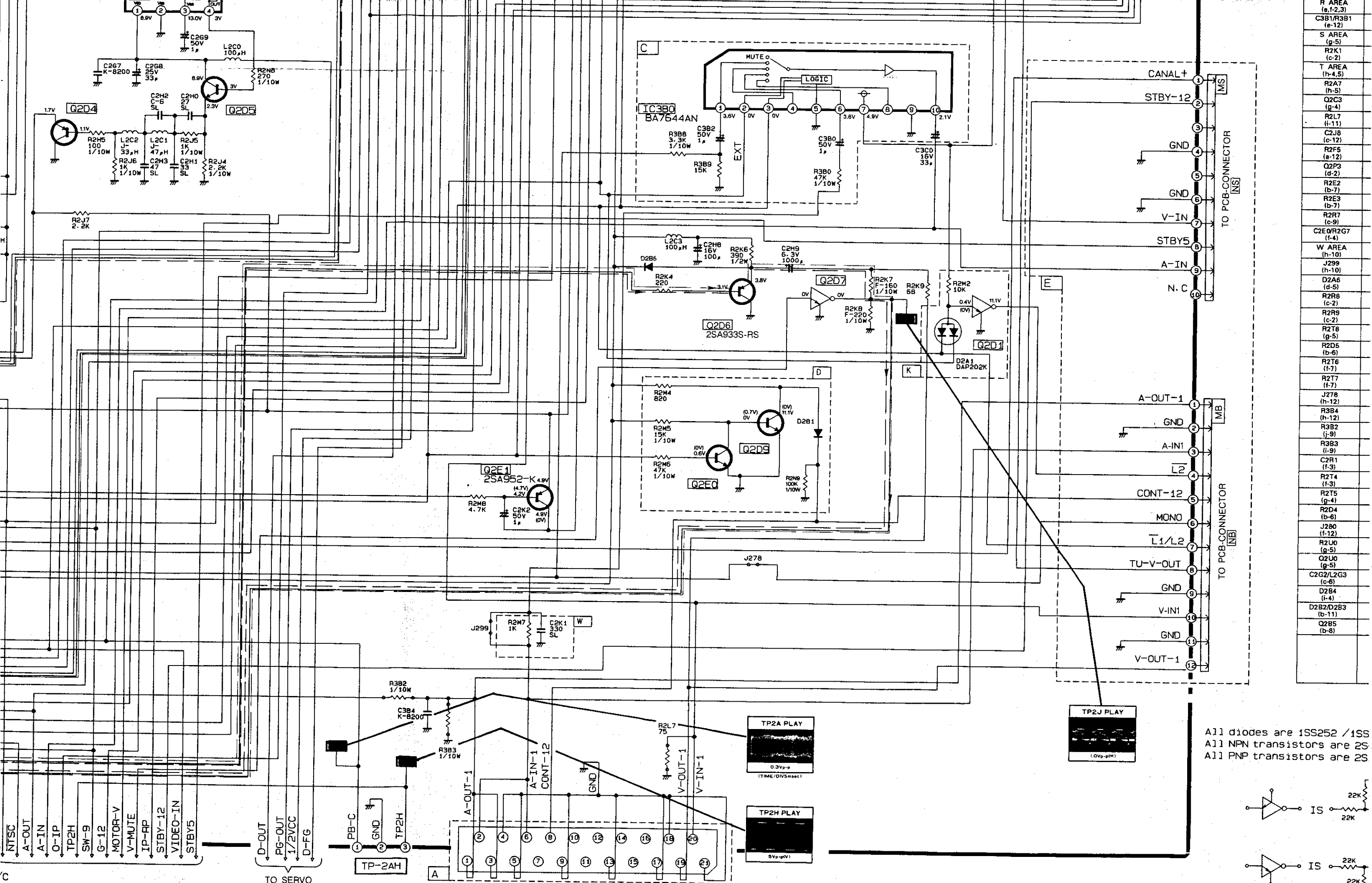

R AREA	(e-1,2,3)
C3B1/R3B1	(e-12)
S AREA	(g-5)
R2K1	(c-2)
T AREA	(h-4,5)
R2A7	(h-5)
Q2C3	(g-4)
R2L7	(i-11)
C2J8	(c-12)
R2F5	(a-12)
Q2P3	(d-2)
R2E2	(b-7)
R2E3	(b-7)
R2R7	(c-9)
C2E0/R2G7	(f-4)
W AREA	(h-10)
J299	(h-10)
D2A6	(d-5)
R2R8	(c-2)
R2R9	(c-2)
R2T8	(g-5)
R2D5	(b-6)
R2T6	(f-7)
R2T7	(f-7)
J278	(h-12)
R3B4	(h-12)
R3B2	(j-9)
R3B3	(i-9)
C2R1	(f-3)
R2T4	(f-3)
R2T5	(g-4)
R2D4	(b-6)
J280	(f-12)
R2U0	(g-5)
Q2U0	(g-5)
C2G2/L2G3	(c-6)
D2B4	(i-4)
D2B2/D2B3	(b-11)
Q2B5	(b-8)

All diodes are 1SS252 /1SS
 All NPN transistors are 2S
 All PNP transistors are 2S

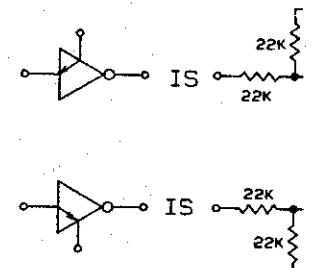

Recording of Luminance Signal
 Playback of Luminance Signal
 Recording of Color Signal
 Playback of Color Signal

PCB-MAIN(Y/C)

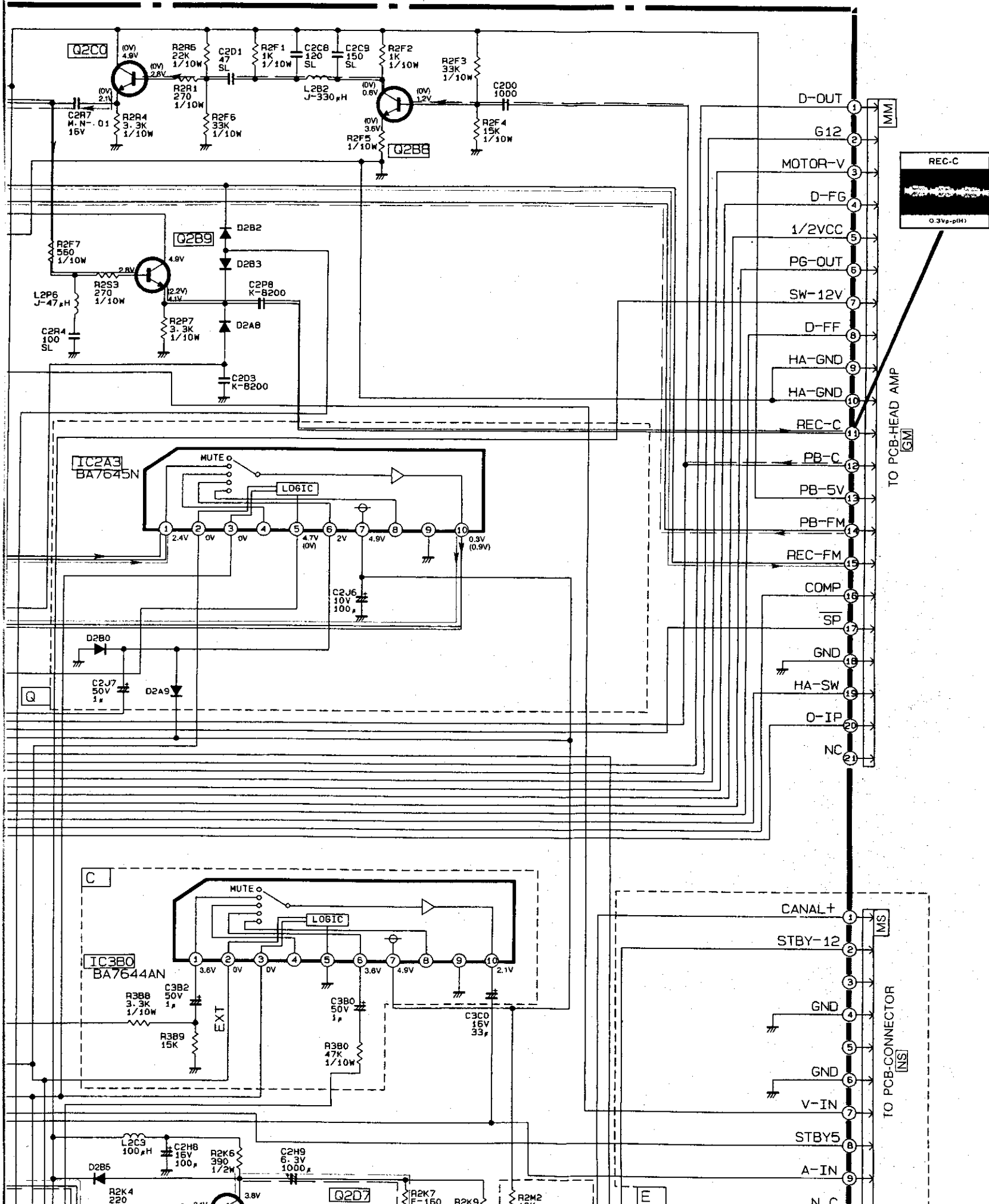

← : Means same as left side
 ○ : Employed X : Not employed

ITEM	M20V(B)	M20V(G)	M20V(IR)	M10V(B)
A AREA (i-10,11)	○	×	○	○
C AREA (e-12)	○	×	○	○
D AREA (g,h-11,12)	○	○	○	○
E AREA (f,g-14)	×	○	×	×
H AREA (b-1)	×	×	×	×
I AREA (c-6)	×	×	×	×
J AREA (g-6)	×	○	×	×
K AREA (f-12)	×	○	×	×
R2E1 (b-7)	2.7K	1.5K	2.7K	←
N AREA (c-10)	○	○	×	×
Q AREA (c,d-11,12)	○	×	○	○
R AREA (e,f-2,3)	○	×	○	○
C3B1/R3B1 (e-12)	×	×	×	×
S AREA (g-5)	○	×	○	○
R2K1 (c-2)	×	×	×	×
T AREA (h-4,5)	×	○	×	×
R2A7 (h-5)	○	×	○	○
Q2C3 (g-4)	○	×	○	○
R2L7 (i-11)	○	○	○	○
C2J8 (c-12)	×	×	×	×
R2F5 (a-12)	220	270	220	220
Q2P3 (d-2)	×	×	×	×
R2E2 (b-7)	270	220	270	×
R2E3 (b-7)	680	×	680	680
R2R7 (c-9)	220	0Ω (J633)	220	←
C2E0/R2G7 (f-4)	○	×	○	○
W AREA (h-10)	○	×	○	○
J299 (h-10)	×	×	×	×
D2A6 (d-5)	×	○	×	×

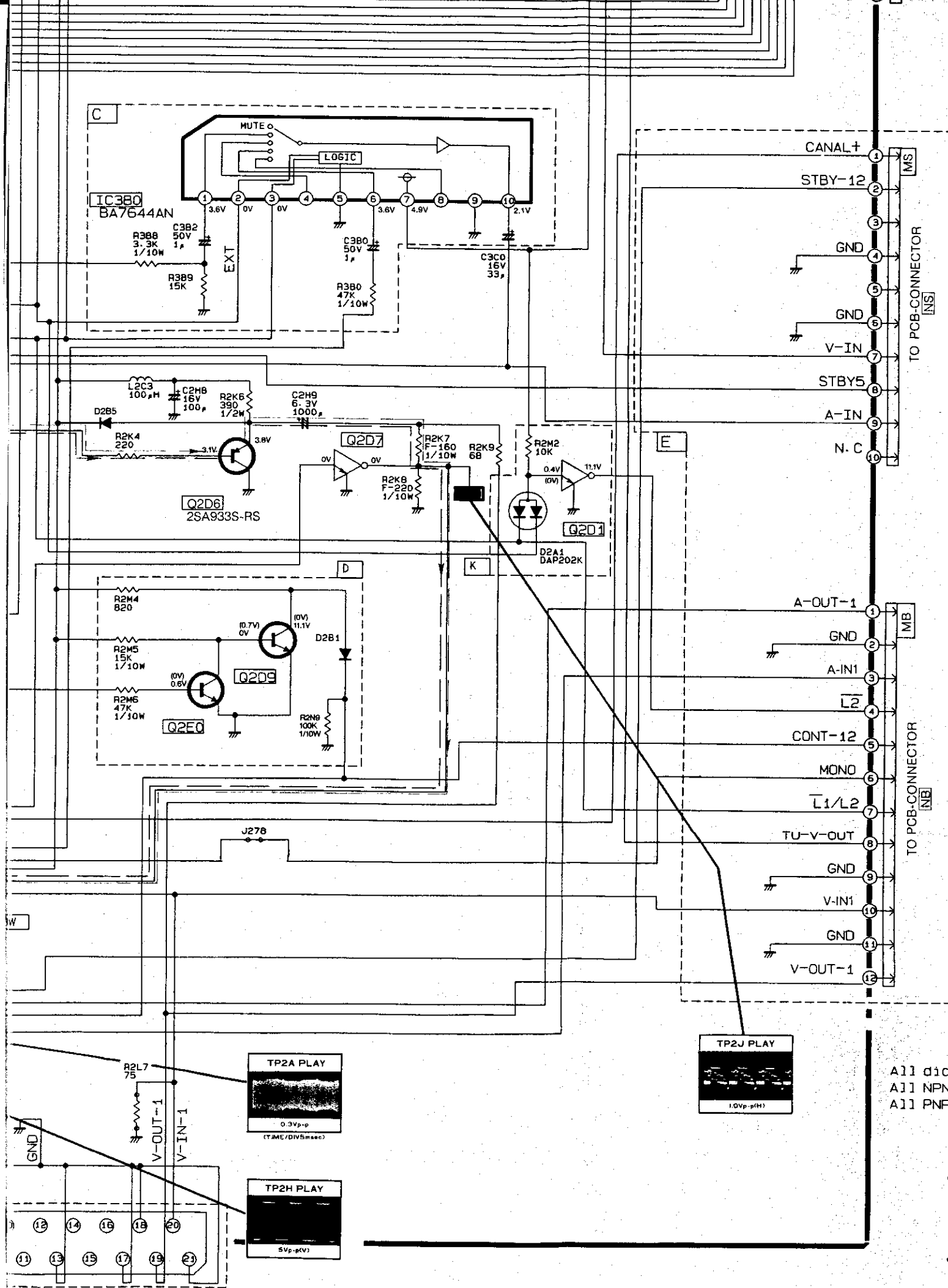

Q AREA (c,d-11,12)	○	×	○	○
R AREA (e,1-2,3)	○	×	○	○
C3B1/R3B1 (e-12)	×	×	×	×
S AREA (g-5)	○	×	○	○
R2K1 (c-2)	×	×	×	×
T AREA (h-4,5)	×	○	×	×
R2A7 (h-5)	○	×	○	○
Q2C3 (g-4)	○	×	○	○
R2L7 (i-11)	○	○	○	○
C2J8 (c-12)	×	×	×	×
R2F5 (a-12)	220	270	220	220
Q2P3 (d-2)	×	×	×	×
R2E2 (b-7)	270	220	270	×
R2E3 (b-7)	680	×	680	680
R2R7 (c-9)	220	0Ω (J633)	220	←
C2E0/R2G7 (f-4)	○	×	○	○
W AREA (h-10)	○	×	○	○
J299 (h-10)	×	×	×	×
D2A6 (d-5)	×	○	×	×
R2R8 (c-2)	×	×	×	×
R2R9 (c-2)	×	×	×	×
R2T8 (g-5)	4.7K	5.6K	4.7K	4.7K
R2D5 (b-6)	1K	1.2K	1K	1K
R2T6 (f-7)	×	2.2K	×	×
R2T7 (f-7)	×	3K	×	×
J278 (h-12)	×	○	×	×
R3B4 (h-12)	×	×	×	×
R3B2 (f-9)	0Ω	1.2K	0Ω	←
R3B3 (f-9)	4.7K	←	←	←
C2R1 (f-3)	15P	22P	15P	15P
R2T4 (f-3)	×	○	×	×
R2T5 (g-4)	×	○	×	×
R2D4 (b-6)	180	100	180	120
J280 (f-12)	×	×	×	×
R2U0 (g-5)	390	0	390	390
Q2U0 (g-5)	○	×	○	○
C2G2/L2G3 (c-6)	×	○	×	×
D2B4 (f-4)	×	○	×	×
D2B2/Q2B3 (b-11)	○	○	○	×
Q2B5 (b-8)	○	○	○	×
	HS-M20V(B)	HS-M20V(G)	HS-M20V(R)	HS-M10V(B)

All diodes are 1SS252 /1SS131 unless otherwise specified.
 All NPN transistors are 2SC3053-C,D unless otherwise specified.
 All PNP transistors are 2SA1235-E,F unless otherwise specified.

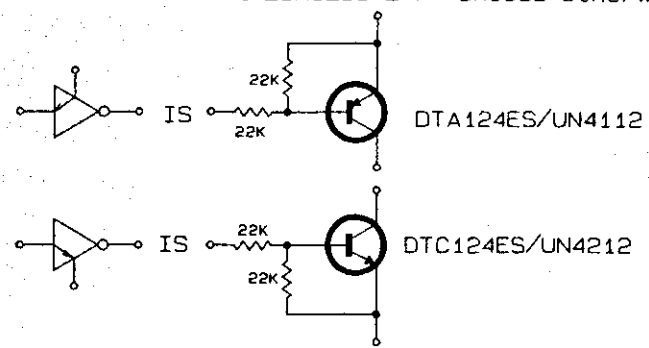

Recording of Luminance Signal
 Playback of Luminance Signal
 Recording of Color Signal
 Playback of Color Signal

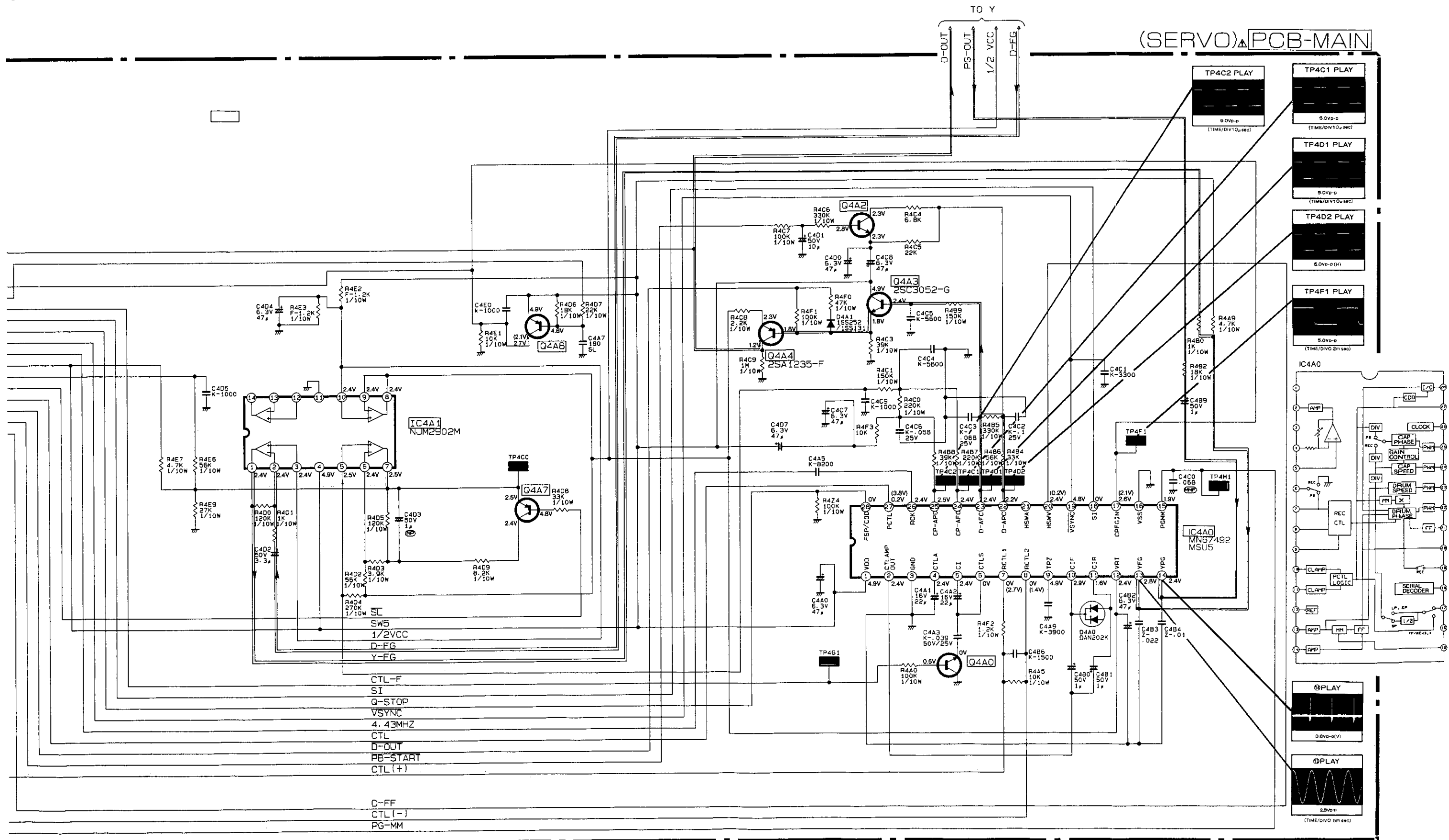

All NPN transistors are 2SC3052-E.F unless otherwise specified.
 All PNP transistors are 2SA1235-E.F unless otherwise specified.

— Drum Servo System

--- Capstan Servo System

HS-M10V(B)
 HS-M20V(B)/V(G)/V(IR)

△ PCB-MAIN(CG/VPS)

A
B
C
D

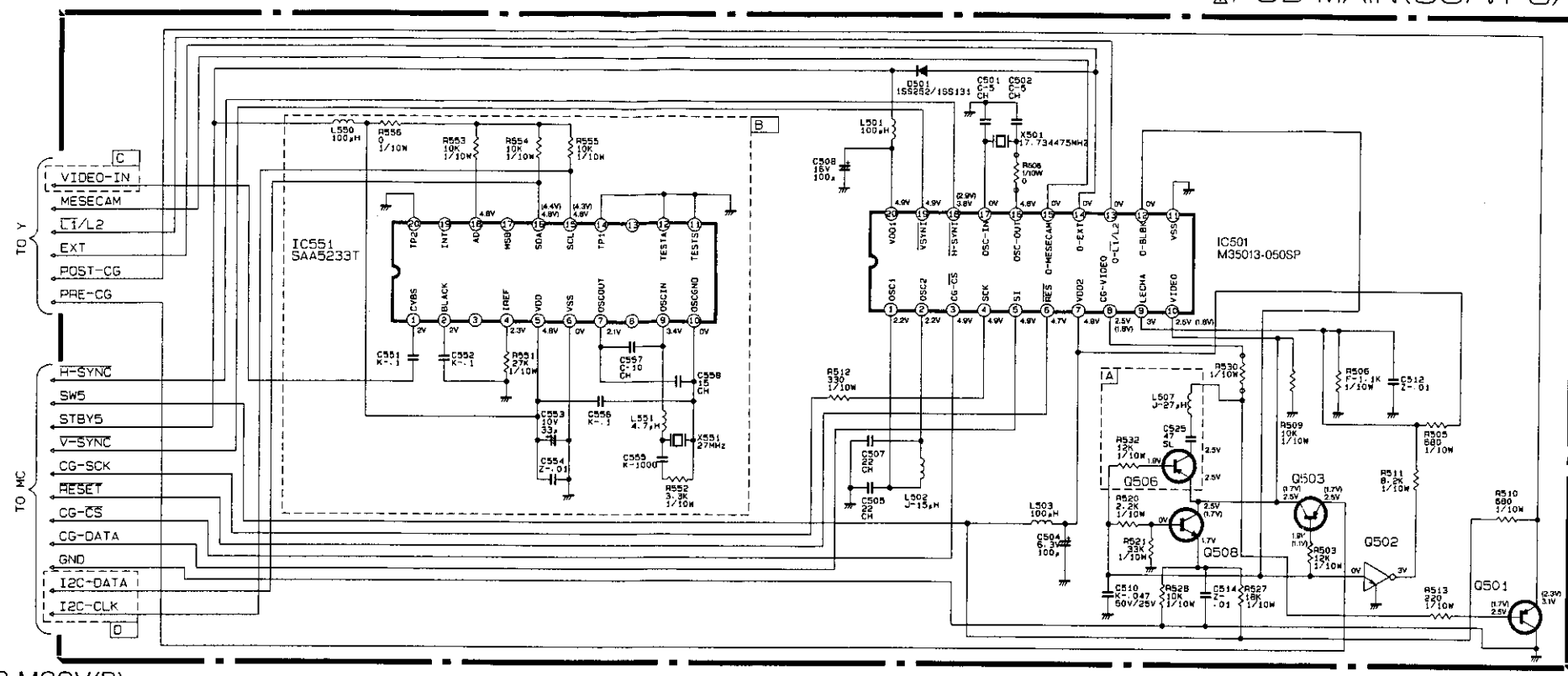

△ PCB-TEXT ONLY FOR HS-M20V(B)

C
D
E

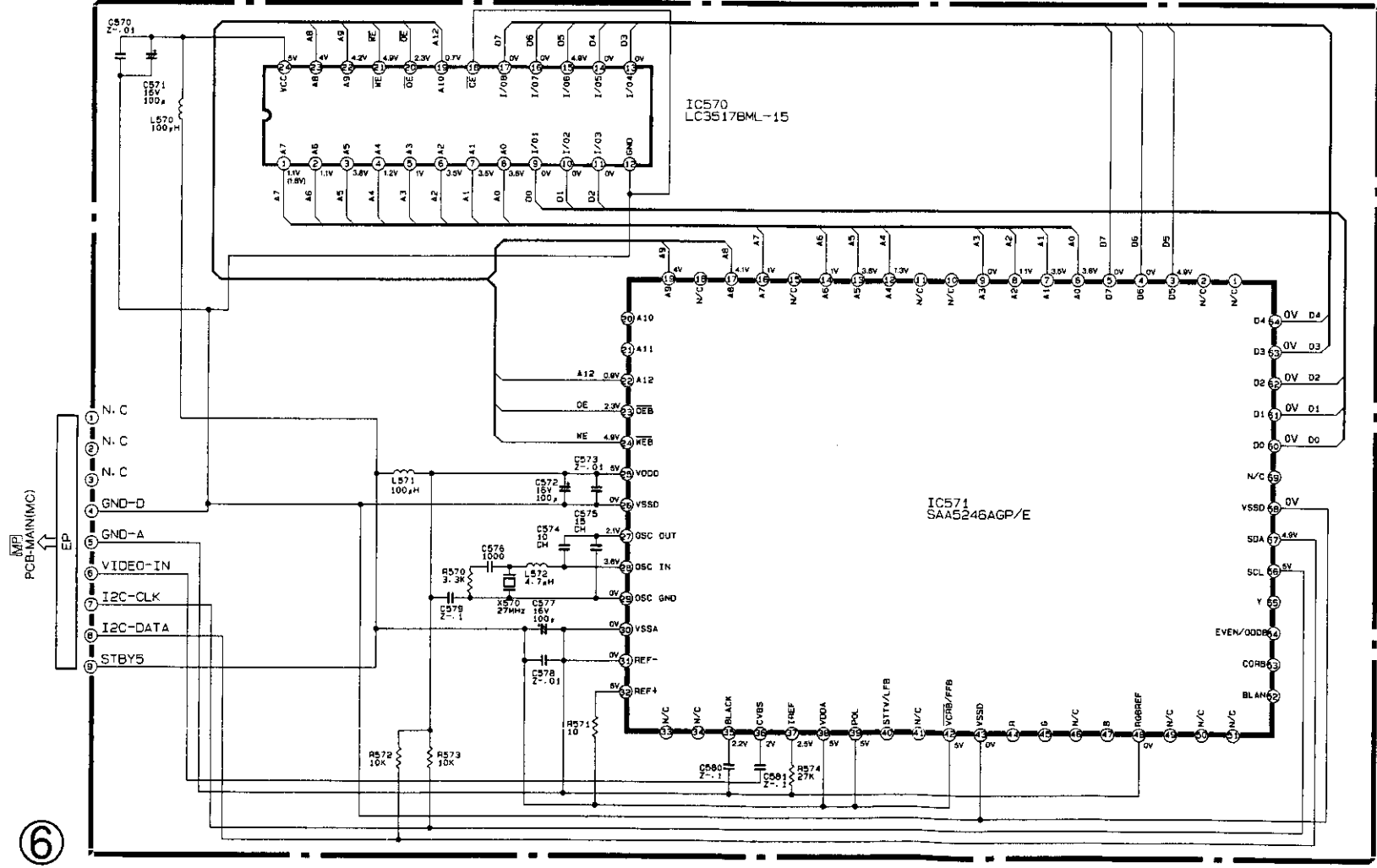

All NPN transistors are 2SC3052-E.F unless otherwise specified.
All PNP transistors are 2SA1235-E.F unless otherwise specified.

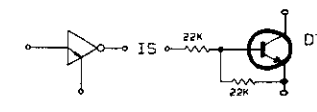

○: Employed X: Not employed

MODELS	SYMBOL NO.	A	B	C	D	L572	C575	R530
HS-M20V(B)		X	X	X	X	X	X	012
HS-M20V(G)		○	○	○	○	X	X	390
HS-M20V(IR),HS-M10V(B)		X	X	X	X	X	X	012

HS-M10V(B)
HS-M20V(B)/V(G)/V(IR)

⑥

PCB-MAIN(CG/VPS)

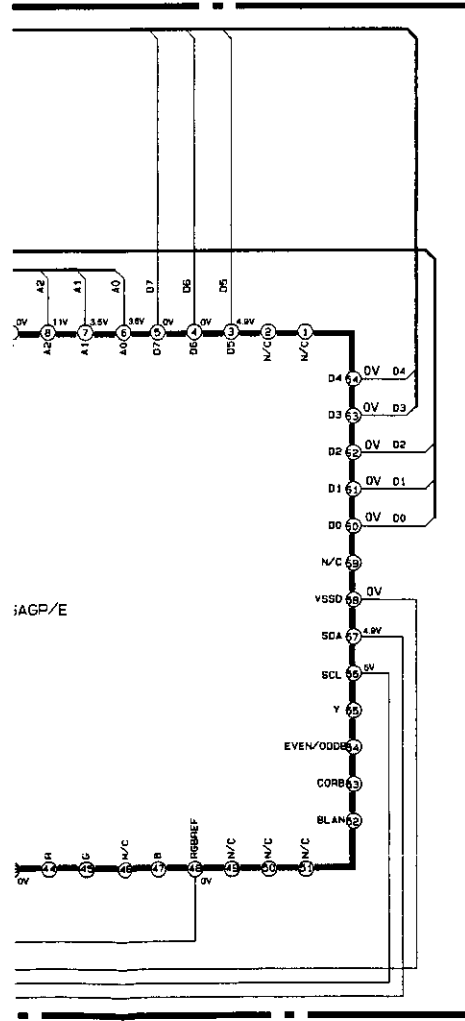
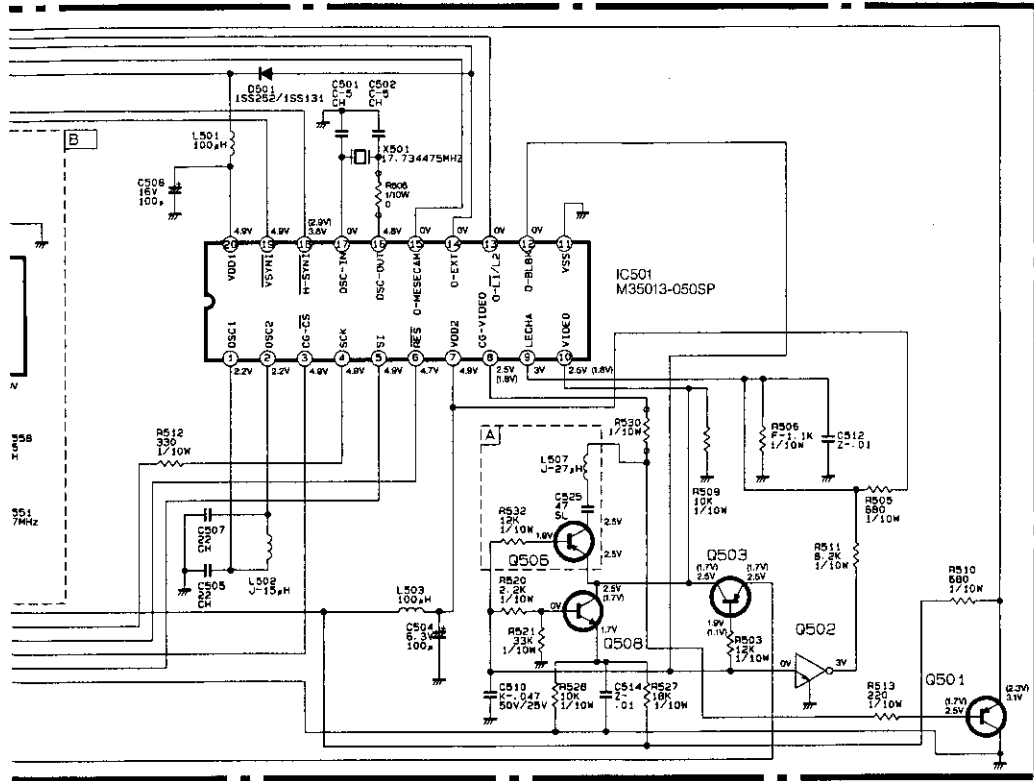

All NPN transistors are 2SC3052-E,F unless otherwise specified.
 All PNP transistors are 2SA1235-E,F unless otherwise specified.

○: Employed X: Not employed

MODELS	SYMBOL NO.	A	B	C	D	L572	C575	R530
HS-M20V(B)		X	X	X	X	X	X	042
HS-M20V(G)		○	○	○	○	X	X	390
HS-M20V(I),HS-M10V(B)		X	X	X	X	X	X	042

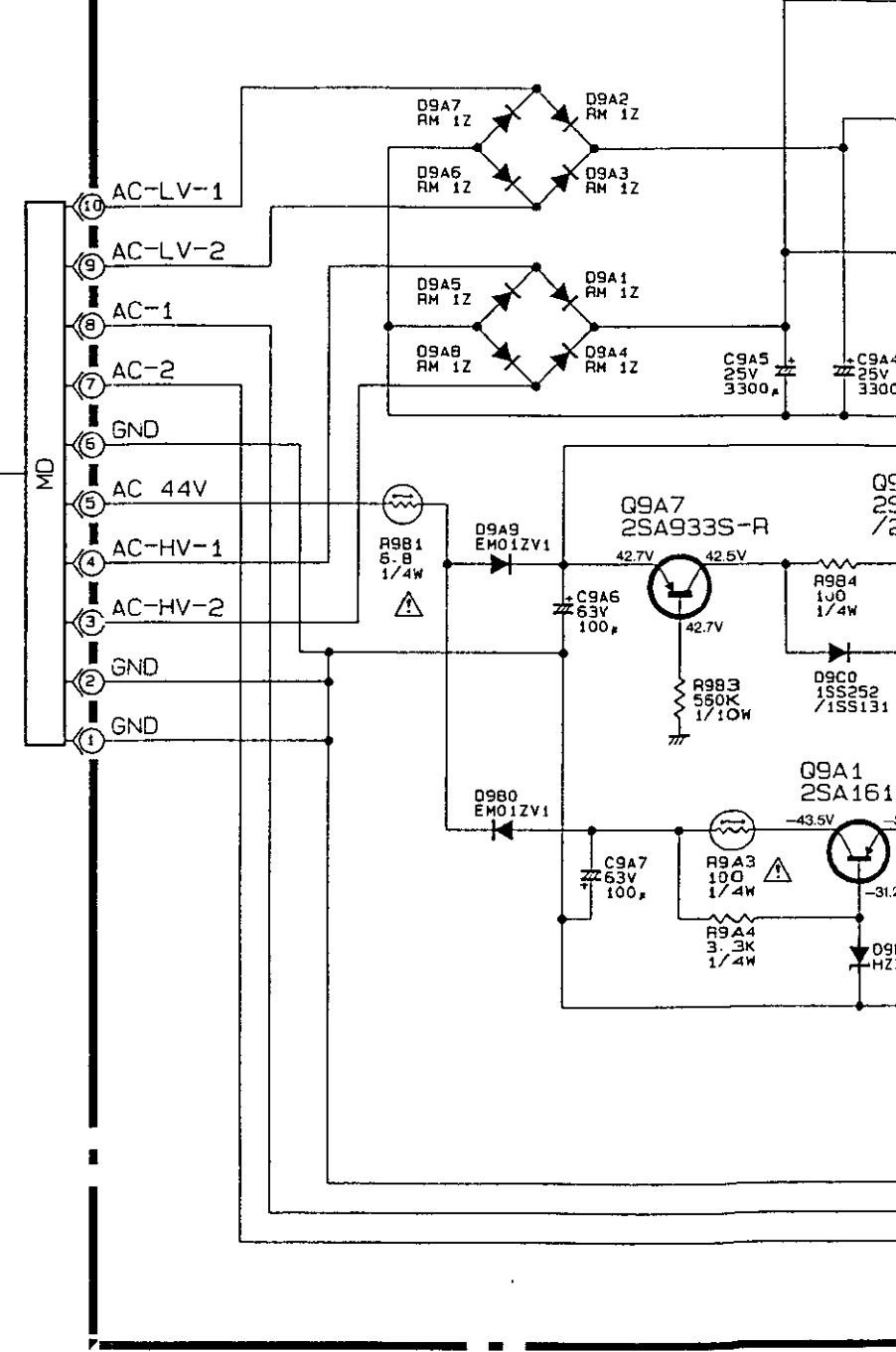
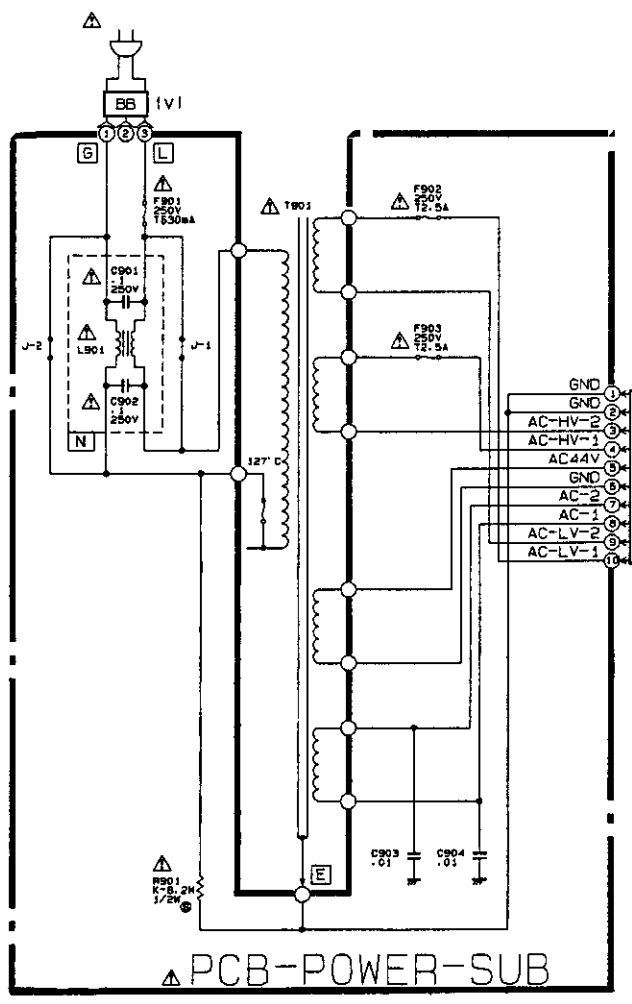
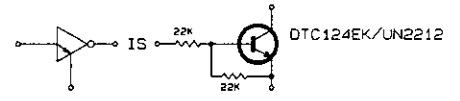

○: Employed X: Not employed

MODELS	SYMBOL NO.	R9B6	J3	R9B7	J4	B AREA	N AREA	J-1,J-2
HS-M10V(B)		X	○	○	X	X	X	○
HS-M20V(B)		X	○	○	X	X	X	○
HS-M20V(G)		○	X	X	○	○	○	X
HS-M20V(I)		○	X	X	○	X	X	○

PCB-MAIN(POWER)

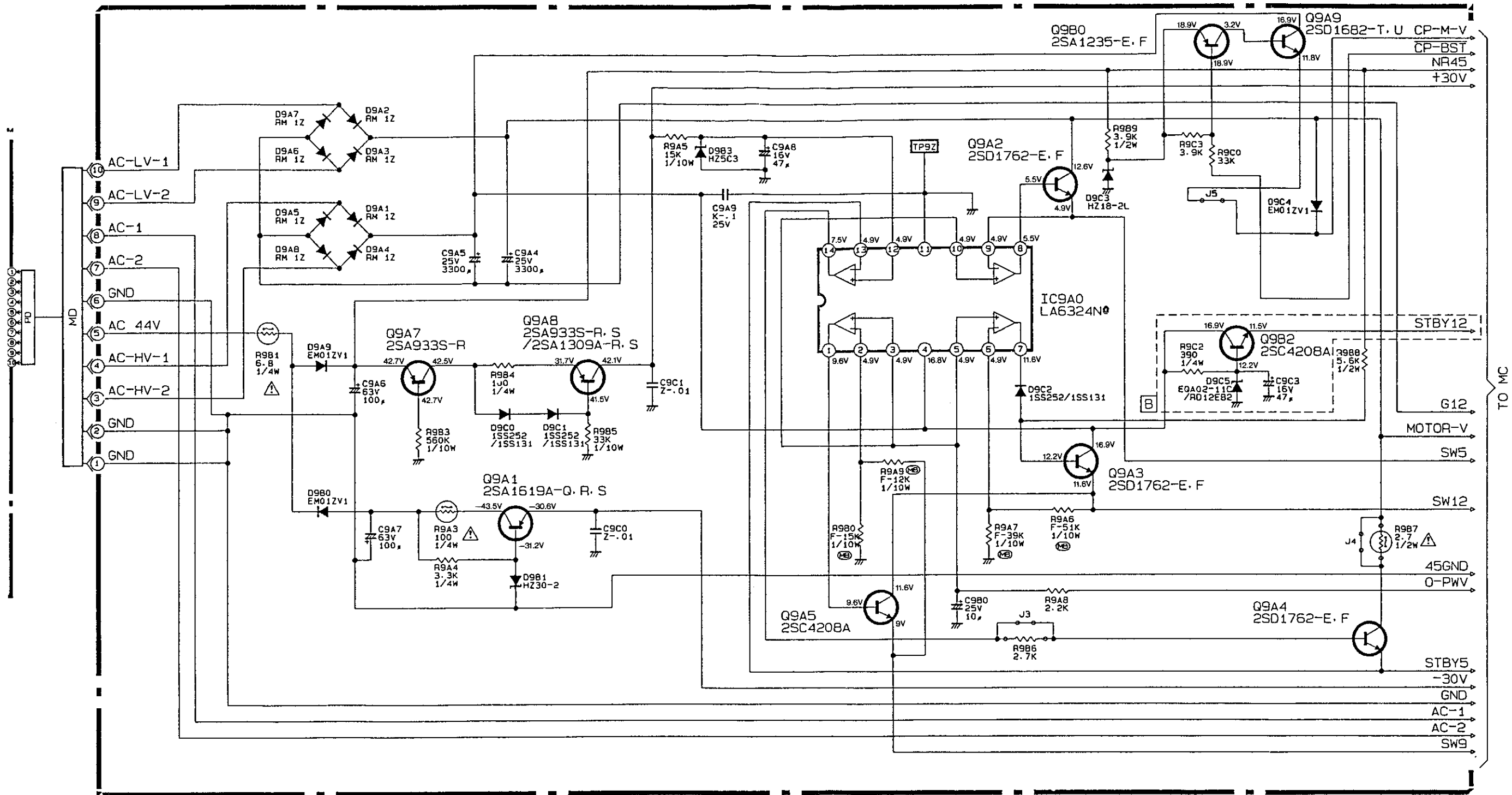

○: Employed X: Not employed

SYMBOL NO.	R9B6	J3	R9B7	J4	B AREA	N AREA	J-1,J-2
HS-M10V(B)	X	○	○	X	X	X	○
HS-M20V(B)	X	○	○	X	X	X	○
HS-M20V(G)	○	X	X	○	○	○	X
HS-M20V(IR)	○	X	X	○	X	X	○

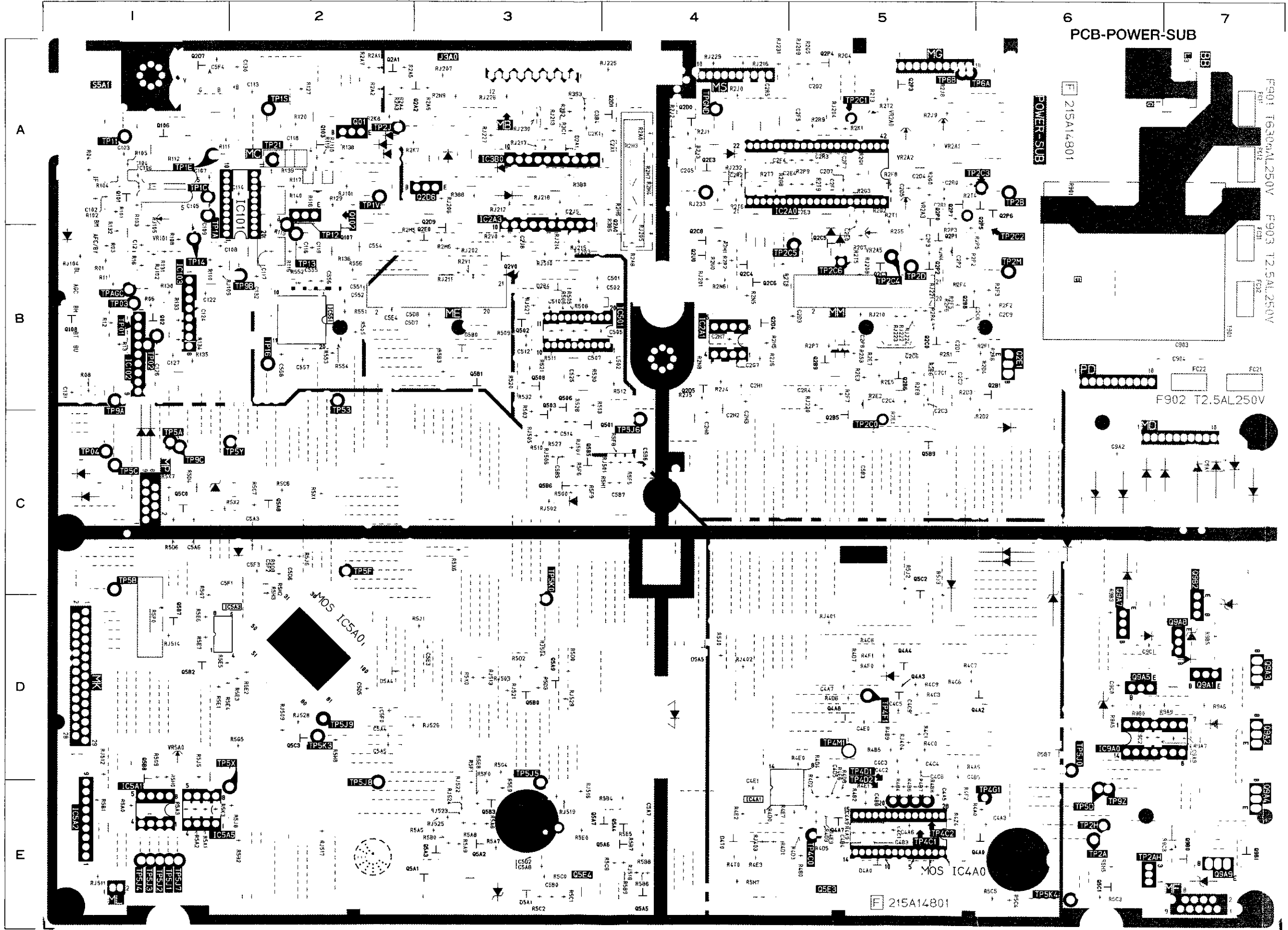

PCB-POWER-SUB

F901 T630AL250V
F903 T2.5AL250V

F902 T2.5AL250V

PCB-MAIN

PCB-M	SYMBOL	NO.
	C12	
	C102	
	C103	
	C104	
	C105	
	C106	
	C107	
	C108	
	C109	
	C113	
	C114	
	C116	
	C117	
	C118	
	C119	
	C122	
	C124	
	C126	
	C127	
	C130	
	C131	
	C132	
	C501	
	C502	
	C505	
	C507	
	C510	
	C512	
	C514	
	C525	
	C551	
	C552	
	C554	
	C555	
	C557	
	C558	
	C558	
	C903	
	C904	
	C2C1	
	C2C2	
	C2C3	
	C2C4	
	C2C6	
	C2C8	
	C2C9	
	C2D1	
	C2D3	
	C2D4	
	C2D5	
	C2D7	
	C2E0	
	C2E1	
	C2E3	
	C2E4	
	C2F4	
	C2F5	
	C2F7	
	C2G2	
	C2G5	

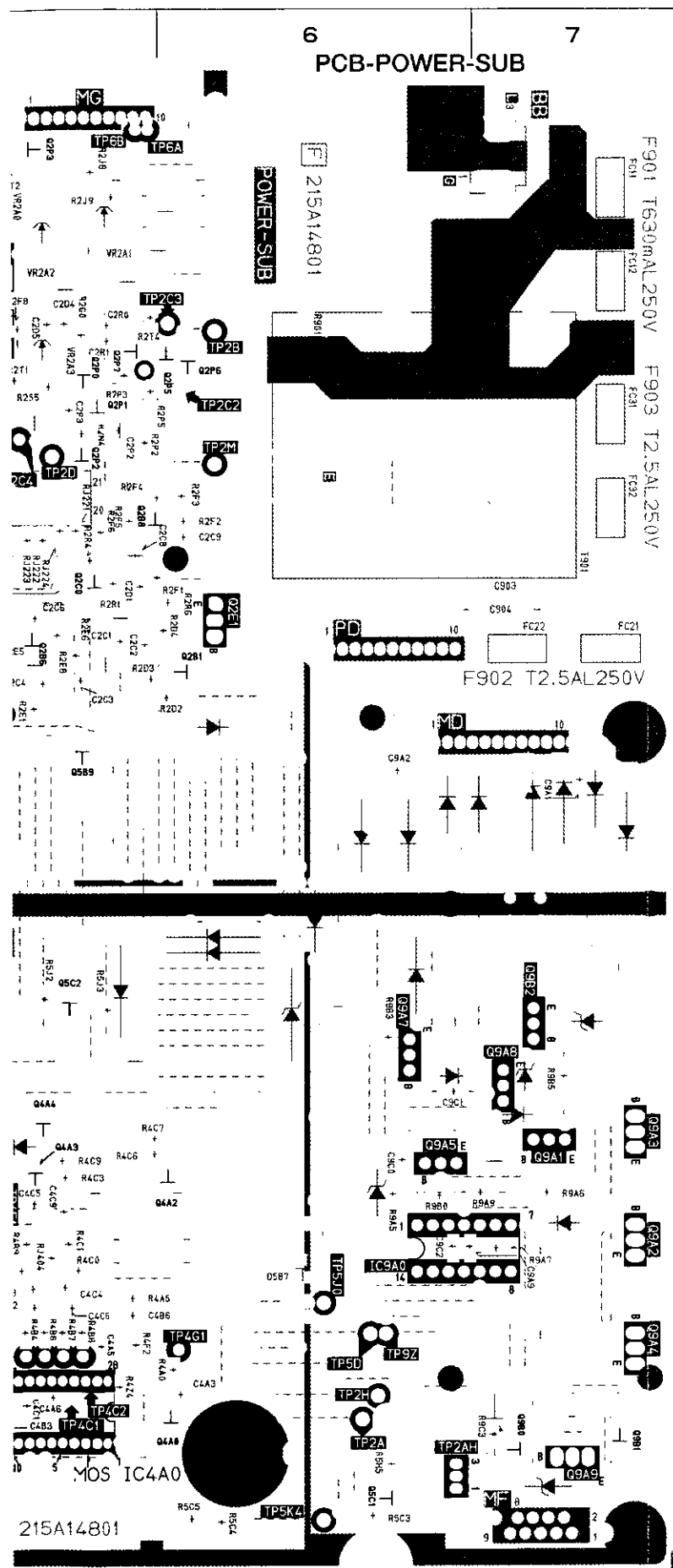

PCB-MAIN (SOLDER SIDE)

SYMBOL NO.	ADDRESS	SYMBOL NO.	ADDRESS	SYMBOL NO.	ADDRESS	SYMBOL NO.	ADDRESS	SYMBOL NO.	ADDRESS	SYMBOL NO.	ADDRESS	SYMBOL NO.	ADDRESS	SYMBOL NO.	ADDRESS		
C12	B-1	C2G7	B-4	C5F2	C-2	Q108	B-1	Q5B7	D-1	R509	B-3	R2J1	A-4	R4C3	D-5	R5D8	C-2
C102	A-1	C2H1	B-4	C5F3	C-2	Q501	C-3	Q5B8	D-1	R510	C-3	R2J2	A-4	R4C6	D-5	R5E0	E-3
C103	A-1	C2H2	C-4	C5F4	A-1	Q502	B-3	Q5B9	C-5	R511	B-3	R2J3	A-4	R4C7	D-5	R5E1	D-1
C104	A-1	C2H3	C-4	C9A1	C-7	Q503	B-3	Q5C0	C-1	R512	B-4	R2J4	B-4	R4C8	D-5	R5E2	D-2
C105	A-1	C2H7	B-4	C9A2	C-6	Q506	B-3	Q5C1	E-6	R513	B-3	R2J5	B-4	R4C9	D-5	R5E3	D-2
C106	A-1	C2J5	A-3	C9A9	D-7	Q508	B-3	Q5C2	C-5	R520	B-3	R2J6	B-4	R4D0	E-4	R5E4	D-1
C107	A-1	C2J8	B-3	C9C0	D-6	Q2A0	A-4	Q5C3	D-2	R521	B-3	R2J8	A-5	R4D1	E-4	R5E5	D-1
C108	B-1	C2K1	A-3	C9C1	D-6	Q2A1	A-2	Q5E3	E-5	R527	C-3	R2J9	A-5	R4D2	E-5	R5E6	D-1
C109	B-1	C2M0	C-4	C9C2	D-6	Q2A2	A-2	Q5E4	E-3	R528	C-3	R2K1	A-5	R4D3	E-5	R5E7	D-1
C113	A-2	C2P2	B-5			Q2B1	B-6	Q9A1	D-7	R530	B-3	R2K7	A-2	R4D4	D-5	R5E8	E-3
C114	A-2	C2P3	B-5	D2A1	A-3	Q2B5	C-5	Q9A2	D-7	R532	B-3	R2K8	A-2	R4D5	E-5	R5E9	E-3
C116	B-2	C2P8	B-5	D2B4	B-3	Q2B6	B-5	Q9A3	D-7	R551	B-2	R2M5	B-2	R4D6	D-5	R5F0	E-3
C117	B-2	C2R0	A-5	D4A0	E-5	Q2B8	B-5	Q9A4	E-7	R552	B-2	R2M6	B-3	R4D7	D-5	R5F1	E-3
C118	A-2	C2R1	A-5	D4T0	E-4	Q2B9	B-5	Q9A5	D-6	R553	B-2	R2N4	B-5	R4D8	E-5	R5F5	C-4
C119	B-2	C2R2	A-4	D5A1	E-3	Q2C0	B-5	Q9A7	D-6	R554	B-2	R2N5	B-4	R4D9	E-5	R5F6	C-3
C122	B-1	C2R3	A-5	D5A4	D-2	Q2C3	B-5	Q9A8	D-7	R555	B-2	R2N6	B-4	R4E0	D-5	R5F8	C-4
C124	B-1	C2R4	B-5	D5A5	D-4	Q2C4	B-4	Q9A9	E-7	R556	B-2	R2N8	B-4	R4E1	E-5	R5F9	C-3
C126	B-1	C2R5	A-4	D5B0	B-3	Q2C5	B-5	Q9B0	E-7	R901	A-6	R2N9	A-3	R4E2	E-4	R5G0	C-3
C127	B-1	C2X1	A-4	D5B7	D-6	Q2C6	B-4	Q9B1	E-7	R2A0	A-4	R2P2	B-5	R4E3	E-4	R5G4	D-3
C130	A-2	C3B4	A-3			Q2C8	B-4	Q9B2	C-7	R2A1	A-2	R2P3	B-5	R4E6	E-5	R5G5	D-2
C131	B-1	C4A3	E-6	F901	A-7	Q2D0	A-4			R2A2	A-2	R2P5	B-5	R4E7	E-4	R5G7	C-1
C132	B-2	C4A5	E-5	F902	B-7	Q2D1	A-4	R01	B-1	R2A3	A-2	R2P7	B-5	R4E9	E-5	R5G9	D-1
C501	B-3	C4A6	E-5	F903	B-7	Q2D4	B-4	R03	B-1	R2A4	A-2	R2P9	A-5	R4F0	D-5	R5H0	E-1
C502	B-3	C4A7	E-5			Q2D5	B-4	R04	A-1	R2A5	A-2	R2R1	B-5	R4F1	D-5	R5H2	C-2
C505	B-3	C4A9	E-5	FC11	A-7	Q2D6	A-3	R06	B-1	R2A6	A-3	R2R2	B-4	R4F2	E-5	R5H3	C-2
C507	B-3	C4B3	E-5	FC12	A-7	Q2D7	A-1	R08	B-1	R2A7	A-2	R2R4	B-5	R4T0	E-4	R5H5	E-6
C510	B-3	C4B4	E-5	FC21	B-7	Q2D9	B-3	R11	B-1	R2A8	B-4	R2R6	B-6	R4Z4	E-5	R5H7	E-4
C512	B-3	C4B6	D-5	FC22	B-7	Q2E0	B-3	R12	B-1	R2D2	B-5	R2R9	A-5	R5A0	E-1	R5H8	D-2
C514	C-3	C4B8	E-5	FC31	B-7	Q2E1	B-6	R13	B-1	R2D3	B-5	R2S3	B-5	R5A1	E-1	R5J0	D-4
C525	B-3	C4C1	E-5	FC32	B-7	Q2E3	A-4	R16	B-1	R2D4	B-5	R2S5	B-5	R5A2	E-1	R5J1	D-3
C551	B-2	C4C2	D-5			Q2P0	A-5	R101	A-1	R2E1	C-5	R2T1	A-5	R5A3	E-1	R5J2	C-5
C552	B-2	C4C3	D-5	IC101	A-2	Q2P1	B-5	R102	A-1	R2E2	B-5	R2T2	A-5	R5A5	E-3	R5J3	C-5
C554	B-2	C4C4	D-5	IC102	B-1	Q2P2	B-5	R103	A-1	R2E3	B-5	R2T4	A-5	R5A6	E-3	R5J5	D-1
C555	B-2	C4C5	D-5	IC103	B-1	Q2P3	A-5	R104	A-1	R2E5	B-5	R2T5	B-5	R5A7	E-3	R5J6	C-2
C557	B-2	C4C6	D-5	IC501	B-3	Q2P4	A-5	R105	A-1	R2E6	B-5	R2T6	A-4	R5A8	E-3	R5J8	E-2
C558	B-2	C4C7	D-5	IC551	B-2	Q2P5	A-5	R110	B-1	R2E7	B-5	R2T7	A-4	R5A9	E-3	R5K3	E-1
C903	B-7	C4C9	D-5	IC2A0	A-5	Q2P6	A-6	R111	A-1	R2E8	B-5	R2T8	B-4	R5B0	E-3	R5M1	C-3
C904	B-7	C4E0	D-5	IC2A1	B-4	Q2P7	A-5	R112	A-1	R2F1	B-5	R2T9	A-5	R5B1	E-1	R5P0	D-1
C2C1	B-5	C4E1	E-4	IC2A3	A-3	Q2U0	B-4	R115	B-2	R2F2	B-6	R2U0	B-4	R5B2	E-2	R5X0	D-3
C2C2	B-5	C5A2	D-2	IC3B0	A-3	Q2V0	B-3	R116	B-2	R2F3	B-6	R2V0	B-3	R5B3	B-3	R5X1	C-2
C2C3	B-5	C5A3	C-2	IC4A0	E-5	Q4A0	E-6	R117	A-2	R2F4	B-5	R2V1	B-3	R5B4	E-4	R5X2	C-1
C2C4	B-5	C5A5	D-2	IC4A1	E-4	Q4A2	D-5	R118	A-2	R2F5	B-5	R3B0	A-3	R5B5	E-4	R5X6	C-3
C2C6	B-5	C5A6	C-1	IC5A0	D-2	Q4A3	D-5	R119	A-2	R2F6	B-5	R3B2	A-3	R5B6	E-4	R5X7	C-1
C2C8	B-5	C5A7	E-4	IC5A1	E-1	Q4A4	D-5	R120	A-2	R2F7	B-5	R3B3	A-3	R5B7	E-4	R9A5	D-6
C2C9	B-6	C5A8	E-3	IC5A2	E-1	Q4A8	D-5	R127	A-2	R2F8	A-5	R3B5	A-4	R5B8	E-4	R9A6	D-7
C2D1	B-5	C5A8	E-3	IC5A3	D-1	Q5A1	E-3	R129	A-2	R2G0	A-5	R3B8	A-3	R5B9	E-4	R9A7	D-7
C2D3	B-4	C5B0	E-3	IC5A5	E-1	Q5A2	E-3	R130	B-1	R2G1	A-5	R3C1	A-3	R5C0	E-3	R9A9	D-7
C2D4	A-5	C5B3	C-5	IC9A0	D-6	Q5A3	E-3	R131	B-1	R2G2	A-5	R4A0	E-6	R5C1	E-3	R9B0	D-6
C2D5	A-5	C5B5	C-3			Q5A4	E-4	R132	B-1	R2G3	A-5	R4A5	D-5	R5C2	E-3	R9B3	C-6
C2D7	A-5	C5B6	C-4	J3A0	A-3	Q5A5	E-4	R133	B-1	R2G4	A-5	R4A9	E-5	R5C3	E-6	R9B5	D-7
C2E0	B-5	C5B7	C-4			Q5A6	E-4	R134	B-1	R2G5	A-5	R4B0	E-5	R5C4	E-6	R9C3	E-7
C2E1	A-5	C5D2	E-3	L502	B-4	Q5A7	E-3	R135	B-1	R2G7	B-5	R4B2	E-5	R5C5	E-6		
C2E3	A-5	C5D5	D-2			Q5A8	C-2	R136	B-2	R2G8	A-4	R4B4	E-5	R5C6	C-2	RJ101	A-2
C2E4	A-4	C5D6	C-2	Q01	A-2	Q5A9	D-3	R138	A-2	R2H1	B-4	R4B5	D-5	R5C7	C-2	RJ102	B-1
C2F4	A-4	C5D7	B-2	Q02	B-1	Q5B0	D-3	R139	A-2	R2H3	A-4	R4B6	E-5	R5C8	E-4	RJ104	B-1
C2F5	A-4	C5D8	B-2	Q101	A-1	Q5B1	B-3	R148	A-2	R2H4	A-4	R4B7	E-5	R5D0	D-3	RJ105	B-1
C2F7	A-5	C5E3	D-3	Q102	A-2	Q5B2	D-1	R503	C-3	R2H5	B-4	R4B8	E-5	R5D2	D-3	RJ109	B-1
C2G2	A-5	C5E4	B-2	Q103	A-2	Q5B3	E-3	R505	B-3	R2H6	A-4	R4B9	D-5	R5D3	D-3	RJ110	A-2
C2G5	A-4	C5F0	D-2	Q106	A-1	Q5B5	C-3	R506	B-3	R2H7	A-4	R4C0	D-5	R5D4	C-1	RJ201	B-4
		C5F1	C-2	Q107	B-2	Q5B6	C-3	R508	B-3	R2J0	A-4	R4C1	D-5	R5D6	C-1	RJ202	B-3

ADDRESS	SYMBOL NO.	ADDRESS	SYMBOL NO.	ADDRESS	SYMBOL NO.	ADDRESS	SYMBOL NO.	ADDRESS	SYMBOL NO.	ADDRESS	SYMBOL NO.	ADDRESS	SYMBOL NO.	ADDRESS	SYMBOL NO.	ADDRESS	SYMBOL NO.	ADDRESS
C-2	Q108	B-1	Q5B7	D-1	R509	B-3	R2J1	A-4	R4C3	D-5	R5D8	C-2	RJ203	B-3	S5A1	A-1	TP5J5	D-3
C-2	Q501	C-3	Q5B8	D-1	R510	C-3	R2J2	A-4	R4C6	D-5	R5E0	E-3	RJ204	A-5			TP5J6	C-4
A-1	Q502	B-3	Q5B9	C-5	R511	B-3	R2J3	A-4	R4C7	D-5	R5E1	D-1	RJ205	B-4	T901	B-7	TP5J7	E-1
C-7	Q503	B-3	Q5C0	C-1	R512	B-4	R2J4	B-4	R4C8	D-5	R5E2	D-2	RJ206	A-3			TP5J8	E-2
C-6	Q506	B-3	Q5C1	E-6	R513	B-3	R2J5	B-4	R4C9	D-5	R5E3	D-2	RJ207	A-3			TP5J9	D-2
D-7	Q508	B-3	Q5C2	C-5	R520	B-3	R2J6	B-4	R4D0	E-4	R5E4	D-1	RJ208	B-5			TP5K0	D-3
D-6	Q2A0	A-4	Q5C3	D-2	R521	B-3	R2J8	A-5	R4D1	E-4	R5E5	D-1	RJ209	A-4			TP5K3	D-2
D-6	Q2A1	A-2	Q5E3	E-5	R527	C-3	R2J9	A-5	R4D2	E-5	R5E6	D-1	RJ210	B-5			TP5K4	E-6
D-6	Q2A2	A-2	Q5E4	E-3	R528	C-3	R2K1	A-5	R4D3	E-5	R5E7	D-1	RJ211	B-3			TPAGC	B-1
	Q2B1	B-6	Q9A1	D-7	R530	B-3	R2K7	A-2	R4D4	D-5	R5E8	E-3	RJ212	A-3			TPGND	A-4
A-3	Q2B5	C-5	Q9A2	D-7	R532	B-3	R2K8	A-2	R4D5	E-5	R5E9	E-3	RJ213	A-3				
B-3	Q2B6	B-5	Q9A3	D-7	R551	B-2	R2M5	B-2	R4D6	D-5	R5F0	E-3	RJ214	B-3			VR101	B-1
E-5	Q2B8	B-5	Q9A4	E-7	R552	B-2	R2M6	B-3	R4D7	D-5	R5F1	E-3	RJ215	B-3			VR2A0	A-5
E-4	Q2B9	B-5	Q9A5	D-6	R553	B-2	R2N4	B-5	R4D8	E-5	R5F5	C-4	RJ216	A-4			VR2A1	A-5
E-3	Q2C0	B-5	Q9A7	D-6	R554	B-2	R2N5	B-4	R4D9	E-5	R5F6	C-3	RJ217	A-3			VR2A2	A-5
D-2	Q2C3	B-5	Q9A8	D-7	R555	B-2	R2N6	B-4	R4E0	D-5	R5F8	C-4	RJ218	A-3			VR2A3	A-5
D-4	Q2C4	B-4	Q9A9	E-7	R556	B-2	R2N8	B-4	R4E1	E-5	R5F9	C-3	RJ220	B-5			VR2A5	B-5
B-3	Q2C5	B-5	Q9B0	E-7	R901	A-6	R2N9	A-3	R4E2	E-4	R5G0	C-3	RJ221	B-5			VR5A0	D-1
D-6	Q2C6	B-4	Q9B1	E-7	R2A0	A-4	R2P2	B-5	R4E3	E-4	R5G4	D-3	RJ222	B-5				
	Q2C8	B-4	Q9B2	C-7	R2A1	A-2	R2P3	B-5	R4E6	E-5	R5G5	D-2	RJ223	B-5				
A-7	Q2D0	A-4			R2A2	A-2	R2P5	B-5	R4E7	E-4	R5G7	C-1	RJ224	B-5				
B-7	Q2D1	A-4	R01	B-1	R2A3	A-2	R2P7	B-5	R4E9	E-5	R5G9	D-1	RJ225	A-3				
B-7	Q2D4	B-4	R03	B-1	R2A4	A-2	R2P9	A-5	R4F0	D-5	R5H0	E-1	RJ226	A-3				
	Q2D5	B-4	R04	A-1	R2A5	A-2	R2R1	B-5	R4F1	D-5	R5H2	C-2	RJ227	A-3				
A-7	Q2D6	A-3	R06	B-1	R2A6	A-3	R2R2	B-4	R4F2	E-5	R5H3	C-2	RJ229	A-4				
A-7	Q2D7	A-1	R08	B-1	R2A7	A-2	R2R4	B-5	R4T0	E-4	R5H5	E-6	RJ230	A-3				
B-7	Q2D9	B-3	R11	B-1	R2A8	B-4	R2R6	B-6	R4Z4	E-5	R5H7	E-4	RJ231	A-4				
B-7	Q2E0	B-3	R12	B-1	R2D2	B-5	R2R9	A-5	R5A0	E-1	R5H8	D-2	RJ232	A-4				
B-7	Q2E1	B-6	R13	B-1	R2D3	B-5	R2S3	B-5	R5A1	E-1	R5J0	D-4	RJ233	A-4				
B-7	Q2E3	A-4	R16	B-1	R2D4	B-5	R2S5	B-5	R5A2	E-1	R5J1	D-3	RJ401	D-5				
	Q2P0	A-5	R101	A-1	R2E1	C-5	R2T1	A-5	R5A3	E-1	R5J2	C-5	RJ402	D-4				
A-2	Q2P1	B-5	R102	A-1	R2E2	B-5	R2T2	A-5	R5A5	E-3	R5J3	C-5	RJ403	E-4				
B-1	Q2P2	B-5	R103	A-1	R2E3	B-5	R2T4	A-5	R5A6	E-3	R5J5	D-1	RJ404	D-5				
B-1	Q2P3	A-5	R104	A-1	R2E5	B-5	R2T5	B-5	R5A7	E-3	R5J6	C-2	RJ501	C-3				
B-3	Q2P4	A-5	R105	A-1	R2E6	B-5	R2T6	A-4	R5A8	E-3	R5J8	E-2	RJ502	C-3				
B-2	Q2P5	A-5	R110	B-1	R2E7	B-5	R2T7	A-4	R5A9	E-3	R5K3	E-1	RJ503	D-3				
A-5	Q2P6	A-6	R111	A-1	R2E8	B-5	R2T8	B-4	R5B0	E-3	R5M1	C-3	RJ504	D-3				
B-4	Q2P7	A-5	R112	A-1	R2F1	B-5	R2T9	A-5	R5B1	E-1	R5P0	D-1	RJ505	C-3				
A-3	Q2U0	B-4	R115	B-2	R2F2	B-6	R2U0	B-4	R5B2	E-2	R5X0	D-3	RJ506	C-3				
A-3	Q2V0	B-3	R116	B-2	R2F3	B-6	R2V0	B-3	R5B3	B-3	R5X1	C-2	RJ507	C-3				
E-5	Q4A0	E-6	R117	A-2	R2F4	B-5	R2V1	B-3	R5B4	E-4	R5X2	C-1	RJ509	D-2				
E-4	Q4A2	D-5	R118	A-2	R2F5	B-5	R3B0	A-3	R5B5	E-4	R5X6	C-3	RJ510	B-3				
D-2	Q4A3	D-5	R119	A-2	R2F6	B-5	R3B2	A-3	R5B6	E-4	R5X7	C-1	RJ511	E-1				
E-1	Q4A4	D-5	R120	A-2	R2F7	B-5	R3B3	A-3	R5B7	E-4	R9A5	D-6	RJ512	D-1				
E-1	Q4A8	D-5	R127	A-2	R2F8	A-5	R3B5	A-4	R5B8	E-4	R9A6	D-7	RJ513	D-3				
D-1	Q5A1	E-3	R129	A-2	R2G0	A-5	R3B8	A-3	R5B9	E-4	R9A7	D-7	RJ514	D-1				
E-1	Q5A2	E-3	R130	B-1	R2G1	A-5	R3C1	A-3	R5C0	E-3	R9A9	D-7	RJ516	E-3				
D-6	Q5A3	E-3	R131	B-1	R2G2	A-5	R4A0	E-6	R5C1	E-3	R9B0	D-6	RJ517	E-2				
	Q5A4	E-4	R132	B-1	R2G3	A-5	R4A5	D-5	R5C2	E-3	R9B3	C-6	RJ518	E-4				
A-3	Q5A5	E-4	R133	B-1	R2G4	A-5	R4A9	E-5	R5C3	E-6	R9B5	D-7	RJ519	E-3				
	Q5A6	E-4	R134	B-1	R2G5	A-5	R4B0	E-5	R5C4	E-6	R9C3	E-7	RJ521	D-3				
B-4	Q5A7	E-3	R135	B-1	R2G7	B-5	R4B2	E-5	R5C5	E-6			RJ522	E-3				
	Q5A8	C-2	R136	B-2	R2G8	A-4	R4B4	E-5	R5C6	C-2			RJ523	E-3				
A-2	Q5A9	D-3	R138	A-2	R2H1	B-4	R4B5	D-5	R5C7	C-2			RJ524	E-3				
B-1	Q5B0	D-3	R139	A-2	R2H3	A-4	R4B6	E-5	R5C8	E-4			RJ525	E-3				
A-1	Q5B1	B-3	R148	A-2	R2H4	A-4	R4B7	E-5	R5D0	D-3			RJ526	D-3				
A-2	Q5B2	D-1	R503	C-3	R2H5	B-4	R4B8	E-5	R5D2	D-3			RJ527	B-3				
A-2	Q5B3	E-3	R505	B-3	R2H6	A-4	R4B9	D-5	R5D3	D-3			RJ528	D-2				
A-1	Q5B5	C-3	R506	B-3	R2H7	A-4	R4C0	D-5	R5D4	C-1			RJ529	D-3				
B-2	Q5B6	C-3	R508	B-3	R2J0	A-4	R4C1	D-5	R5D6	C-1								

PCB-MAIN [COMPONENT SIDE] (Except HS-M20V(G))

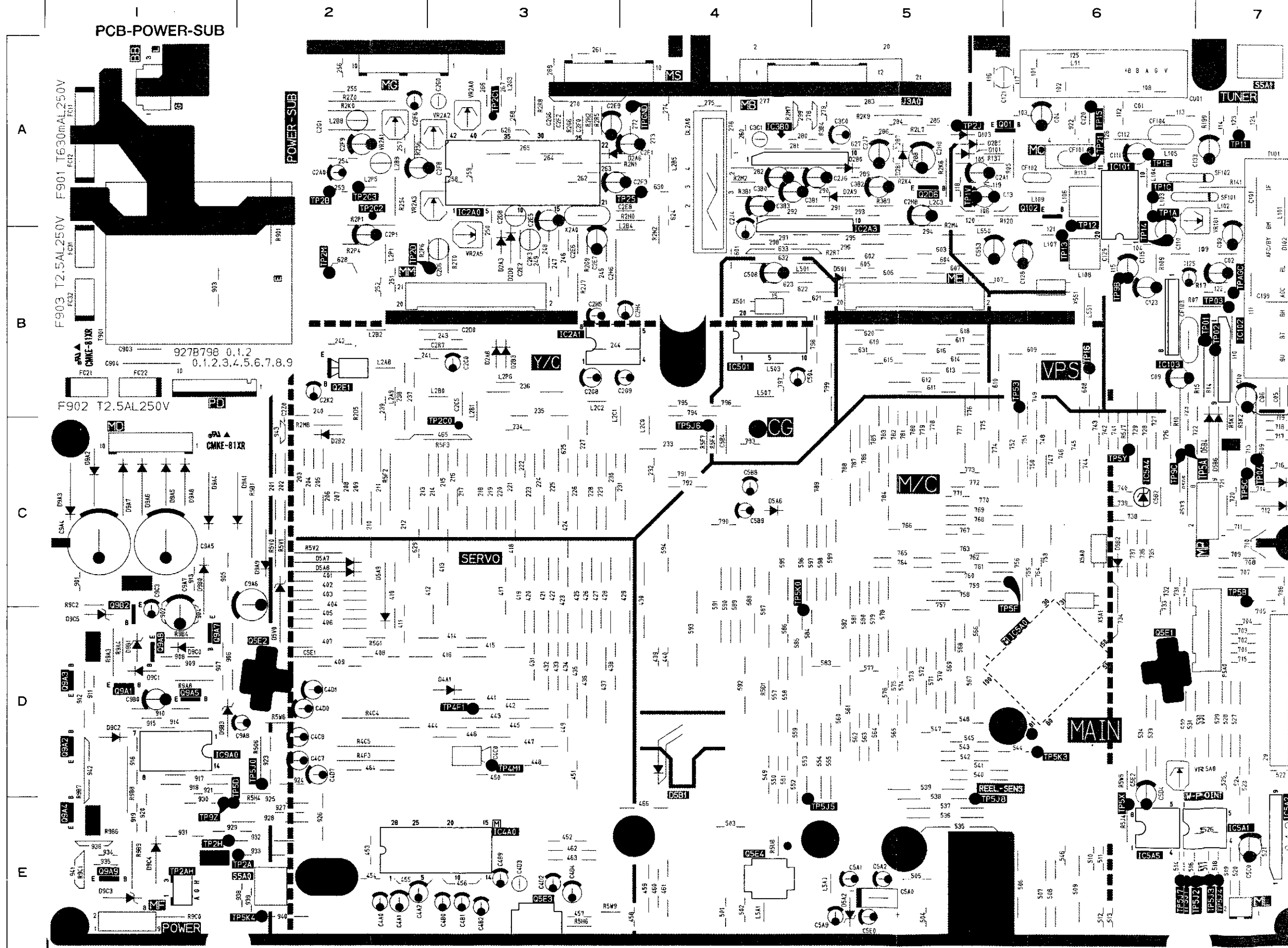

HS-M10V(B)
HS-M20V(B)/V(G)/V(IR)

8

PCB-MAIN

DE)

RESS	SYMBOL NO.	ADDRESS	SYMBOL NO.	ADDRESS
-1	Q01	A-5	TP2AH	E-1
-1	Q102	A-6	TP2C0	C-3
-1	Q2D6	A-5	TP2C1	A-3
-1	Q2E1	B-2	TP2C2	A-2
-1	Q5E1	D-6	TP2C3	A-2
	Q5E2	D-2	TP4F1	D-3
-6	Q5E3	E-3	TP4M1	D-3
-7	Q5E4	E-4	TP5J0	D-2
-6	Q9A1	D-1	TP5J1	E-6
-4	Q9A2	D-1	TP5J2	E-6
-3	Q9A3	D-1	TP5J3	E-7
-3	Q9A4	E-1	TP5J4	E-7
-4	Q9A5	D-1	TP5J5	E-4
-4	Q9A7	D-1	TP5J6	C-4
-3	Q9A8	D-1	TP5J7	E-6
-6	Q9A9	E-1	TP5J8	E-5
-7	Q9B2	D-1	TP5K0	D-4
			TP5K3	D-6
-6	S5A0	E-2	TP5K4	E-2
-6	S5A1	A-7	TPAGC	B-7
			TPGND	A-4
	SF101	A-6		
-5	SF102	A-6	TU101	B-7
-6	T901	B-1	VR101	A-6
-7			VR2A0	A-3
-7	TP01	B-7	VR2A1	A-2
-6	TP02	B-7	VR2A2	A-2
-6	TP03	B-7	VR2A3	A-2
-6	TP04	C-7	VR2A5	B-3
-6	TP11	A-7	VR5A0	D-6
-6	TP12	A-6		
-6	TP13	B-6	X501	B-4
-6	TP14	B-6	X551	B-6
-4	TP16	B-6	X2A0	A-3
-4	TP21	A-6	X5A0	C-6
-4	TP53	B-6	X5A1	C-6
-5	TP1A	A-6		
-6	TP1C	A-6		
-2	TP1E	A-6		
-2	TP1S	A-6		
-3	TP1V	A-5		
-3	TP2A	E-2		
-2	TP2B	A-2		
-3	TP2D	B-2		
-4	TP2H	E-1		
-2	TP2J	A-5		
-2	TP2M	B-2		
-4	TP2S	A-4		
-1	TP5A	C-6		
-3	TP5B	C-7		
-5	TP5C	C-7		
-3	TP5D	E-1		
-2	TP5F	C-5		
-2	TP5X	E-6		
-3	TP5Y	C-6		
-5	TP9A	B-7		
-4	TP9B	B-6		
	TP9C	C-6		
-7	TP9Z	E-1		

PCB-TIMER/OPE (HS-M10V(B) only)

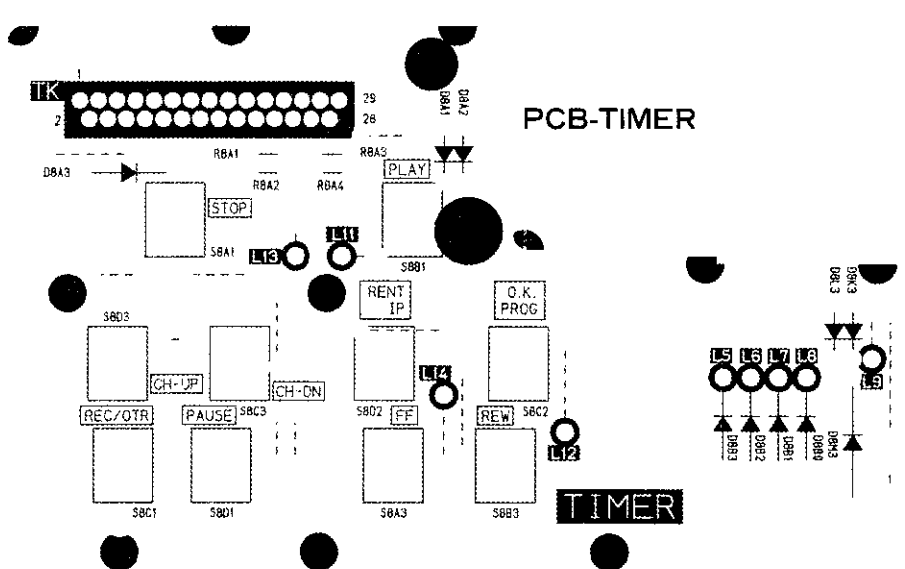

PCB-TIMER/OPE (Except HS-M10V(B))

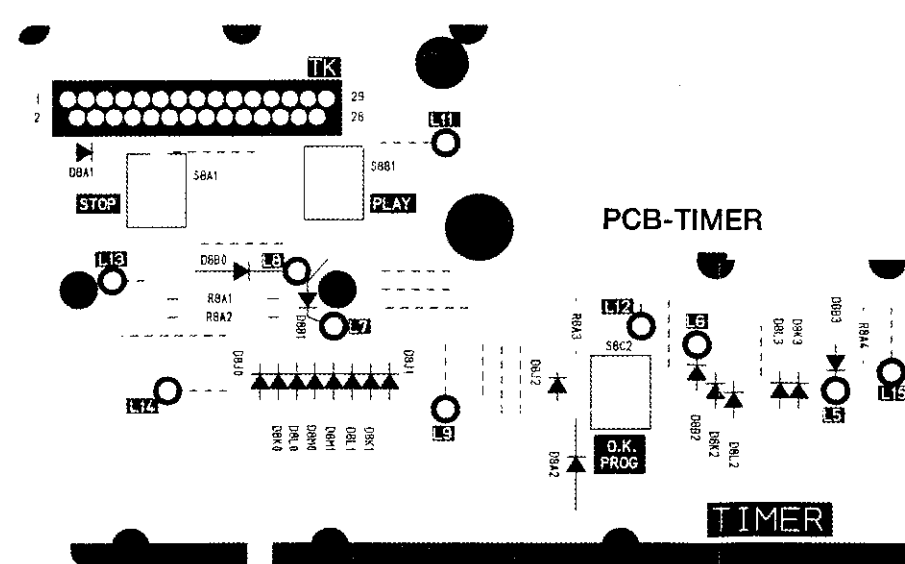

PCB-OPE

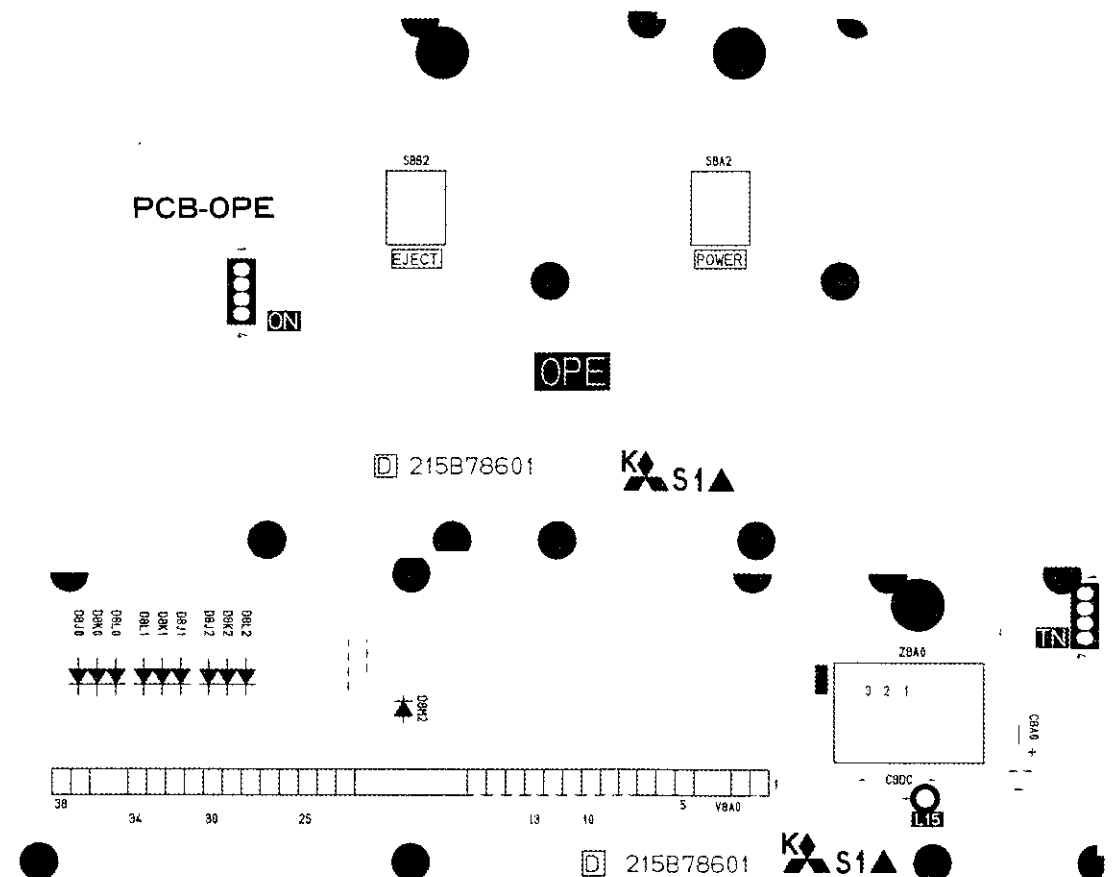

PCB-OPE (bottom section)

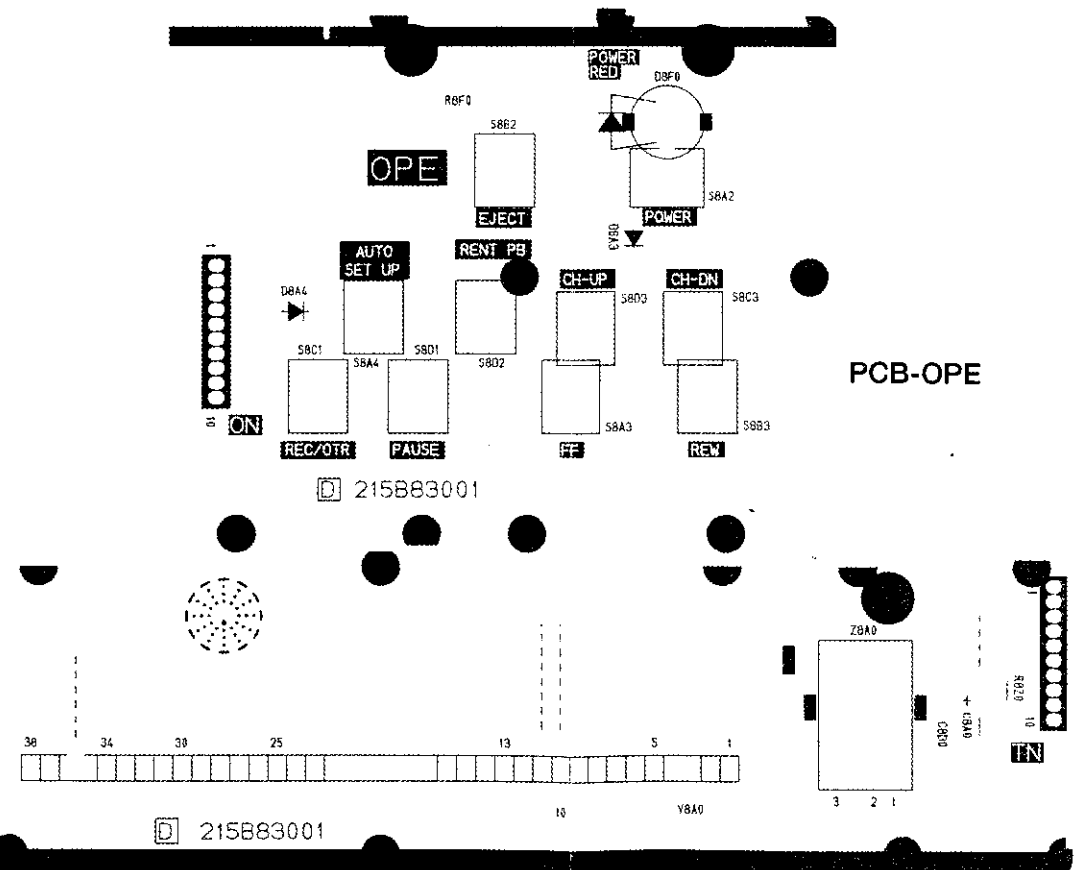

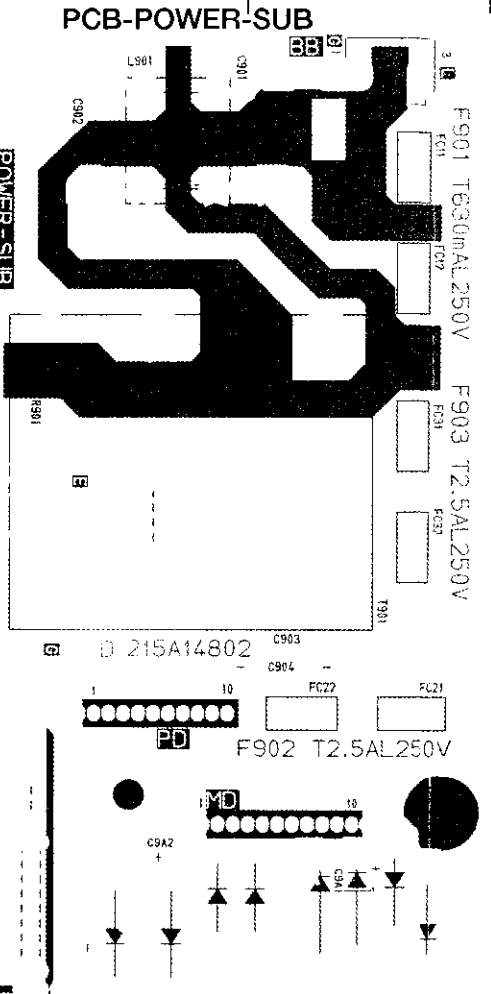
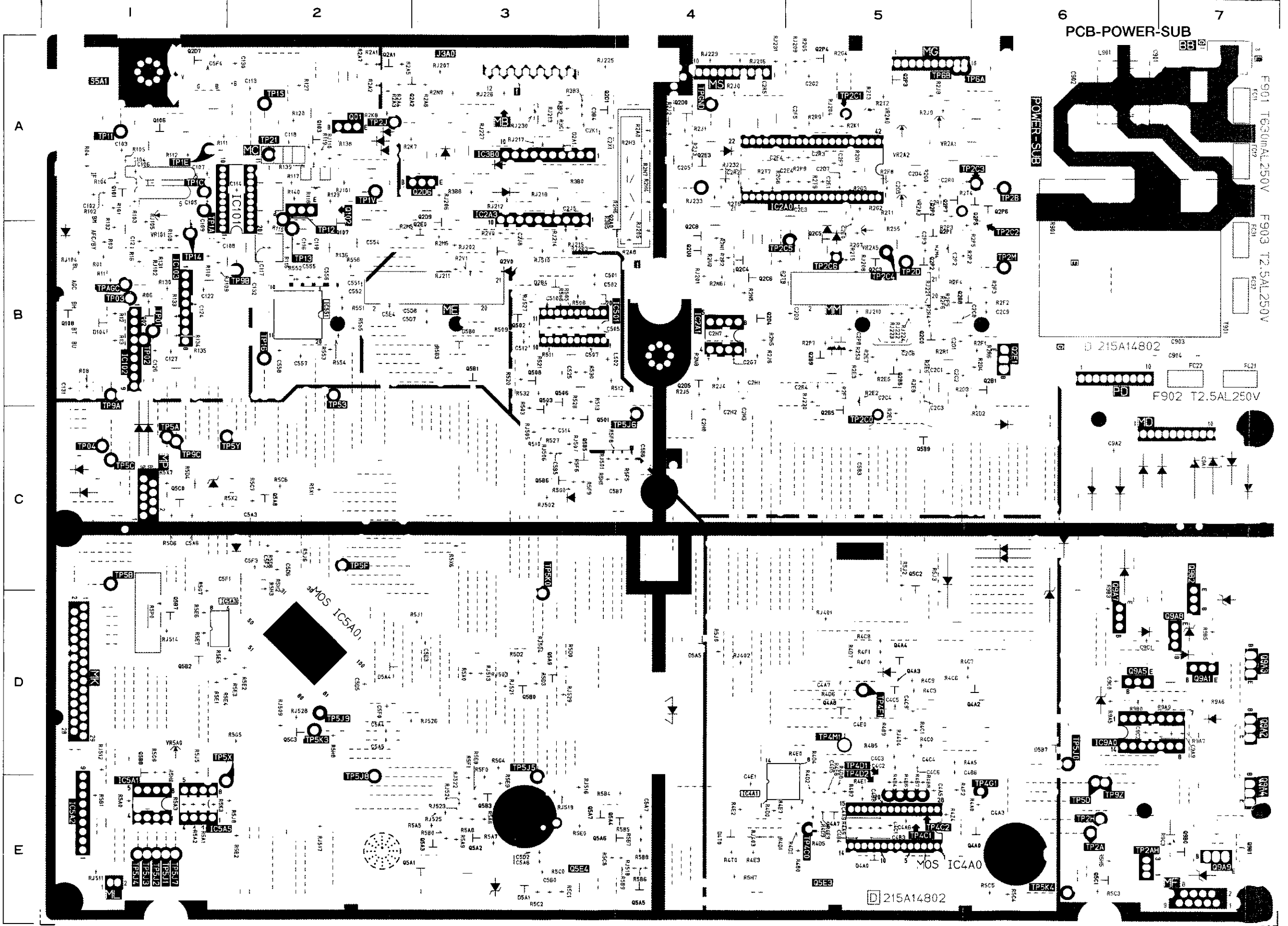

PCB-SYME NO	PCB-NO
C12	C12
C10:	C10:
C10:	C10:
C10:	C10:
C10:	C10:
C10:	C10:
C10:	C10:
C11:	C11:
C11:	C11:
C11:	C11:
C11:	C11:
C12:	C12:
C12:	C12:
C12:	C12:
C13:	C13:
C13:	C13:
C13:	C13:
C50:	C50:
C50:	C50:
C50:	C50:
C51:	C51:
C51:	C51:
C52:	C52:
C55:	C55:
C55:	C55:
C55:	C55:
C55:	C55:
C55:	C55:
C55:	C55:
C55:	C55:
C90:	C90:
C90:	C90:
C90:	C90:
C90:	C90:
C2C:	C2C:
C2C:	C2C:
C2C:	C2C:
C2C:	C2C:
C2C:	C2C:
C2D:	C2D:
C2D:	C2D:
C2D:	C2D:
C2E:	C2E:
C2E:	C2E:
C2E:	C2E:
C2F:	C2F:
C2F:	C2F:

ADDRESS	SYMBOL NO.	ADDRESS	SYMBOL NO.	ADDRESS	SYMBOL NO.	ADDRESS	SYMBOL NO.	ADDRESS	SYMBOL NO.	ADDRESS	SYMBOL NO.	ADDRESS	SYMBOL NO.	ADDRESS	SYMBOL NO.	ADDRESS	SYMBOL NO.	ADDRESS
C-2	Q103	A-2	Q5B2	D-1	R503	C-3	R2H6	A-4	R4B8	E-5	R5D2	D-3	RJ105	A-1	RJ525	E-3	TP4M1	D-5
C-2	Q106	A-1	Q5B3	E-3	R505	B-3	R2H7	A-4	R4B9	D-5	R5D3	D-3	RJ109	B-1	RJ526	D-3	TP5J0	D-6
C-2	Q107	B-2	Q5B5	C-3	R506	B-3	R2J0	A-4	R4C0	D-5	R5D4	C-1	RJ110	A-2	RJ527	B-3	TP5J1	E-1
A-1	Q108	B-1	Q5B6	C-3	R508	B-3	R2J1	A-4	R4C1	D-5	R5D6	C-1	RJ119	A-2	RJ528	D-2	TP5J2	E-1
C-7	Q501	C-3	Q5B7	D-1	R509	B-3	R2J2	A-4	R4C3	D-5	R5D8	C-2	RJ201	B-4	RJ529	D-3	TP5J3	E-1
C-6	Q502	B-3	Q5B8	E-1	R510	C-3	R2J3	A-4	R4C6	D-5	R5E0	E-3	RJ202	B-3			TP5J4	E-1
D-7	Q503	B-3	Q5B9	C-5	R511	B-3	R2J4	B-4	R4C7	D-5	R5E1	D-1	RJ203	B-3	S5A1	A-1	TP5J5	E-3
D-6	Q506	B-3	Q5C0	C-1	R512	B-4	R2J5	B-4	R4C8	D-5	R5E2	D-2	RJ204	A-5			TP5J6	C-4
D-6	Q508	B-3	Q5C1	E-6	R513	B-3	R2J6	B-4	R4C9	D-5	R5E3	D-2	RJ205	B-4	T901	B-6	TP5J7	E-1
D-6	Q2A0	B-4	Q5C2	C-5	R520	B-3	R2J8	A-5	R4D0	E-4	R5E4	D-2	RJ206	A-3			TP5J8	E-2
	Q2A1	A-2	Q5C3	D-2	R521	B-3	R2J9	A-5	R4D1	E-4	R5E5	D-1	RJ207	A-3	TP01	B-1	TP5J9	D-2
B-1	Q2A2	A-2	Q5E3	E-5	R527	C-3	R2K1	A-5	R4D2	E-5	R5E6	D-1	RJ208	B-5	TP02	B-1	TP5K0	D-3
A-3	Q2B1	B-6	Q5E4	E-3	R528	C-3	R2K7	A-2	R4D3	E-5	R5E7	D-1	RJ209	A-5	TP03	B-1	TP5K3	D-2
B-3	Q2B5	C-5	Q9A1	D-7	R530	B-3	R2K8	A-2	R4D4	D-5	R5E8	E-3	RJ210	B-5	TP04	C-1	TP5K4	E-6
E-5	Q2B6	B-5	Q9A2	D-7	R532	B-3	R2M5	B-2	R4D5	E-5	R5E9	E-3	RJ211	B-3	TP11	A-1	TPAGC	B-1
E-4	Q2B8	B-5	Q9A3	D-7	R551	B-2	R2M6	B-3	R4D6	D-5	R5F0	E-3	RJ212	A-3	TP12	A-2	TPGND	A-4
E-3	Q2B9	B-5	Q9A4	E-7	R552	B-2	R2N4	B-5	R4D7	D-5	R5F1	E-3	RJ213	A-3	TP13	B-2		
D-2	Q2C0	B-5	Q9A5	D-6	R553	B-2	R2N5	B-4	R4D8	E-5	R5F5	C-4	RJ214	B-3	TP14	B-1	VR101	A-1
D-4	Q2C3	B-5	Q9A7	D-6	R555	B-2	R2N6	B-4	R4D9	E-5	R5F6	C-3	RJ215	B-3	TP16	B-2	VR2A0	A-5
B-3	Q2C4	B-4	Q9A8	D-7	R556	B-2	R2N8	B-4	R4E0	D-5	R5F8	C-4	RJ216	A-4	TP21	A-2	VR2A1	A-5
D-6	Q2C5	B-5	Q9A9	E-7	R901	B-6	R2N9	A-3	R4E1	E-5	R5F9	C-3	RJ217	A-3	TP53	B-2	VR2A2	A-5
	Q2C6	B-4	Q9B0	E-7	R2A0	A-4	R2P2	B-5	R4E2	E-4	R5G0	C-3	RJ218	A-3	TP1A	A-1	VR2A3	A-5
A-7	Q2C8	B-4	Q9B1	E-7	R2A1	A-2	R2P3	B-5	R4E3	E-4	R5G4	D-3	RJ220	B-5	TP1C	A-1	VR2A5	B-5
B-7	Q2D0	A-4	Q9B2	C-7	R2A2	A-2	R2P5	B-5	R4E6	E-5	R5G5	D-2	RJ221	B-5	TP1E	A-1	VR5A0	D-1
B-7	Q2D1	A-4			R2A3	A-2	R2P7	B-5	R4E7	E-4	R5G7	D-1	RJ222	B-5	TP1S	A-2		
	Q2D4	B-4			R2A4	A-2	R2P9	A-5	R4E9	E-5	R5G9	D-1	RJ223	B-5	TP1V	A-2		
A-7	Q2D5	B-4	R01	B-1	R2A5	A-2	R2R1	B-5	R4F0	D-5	R5H0	E-1	RJ224	B-5	TP2A	E-6		
A-7	Q2D6	A-3	R03	B-1	R2A6	A-3	R2R2	B-4	R4F1	D-5	R5H1	C-4	RJ225	A-4	TP2B	A-6		
B-7	Q2D7	A-1	R04	A-1	R2A7	A-2	R2R4	B-5	R4F2	E-5	R5H2	C-2	RJ226	A-3	TP2D	B-5		
B-7	Q2D9	B-3	R06	B-1	R2A8	B-4	R2R6	B-6	R4T0	E-4	R5H3	D-2	RJ227	A-3	TP2H	E-6		
B-7	Q2E0	B-3	R08	B-1	R2D2	C-5	R2R9	A-5	R4Z4	E-5	R5H5	E-6	RJ229	A-4	TP2J	A-2		
B-7	Q2E1	B-6	R11	B-1	R2D3	B-5	R2S3	B-5	R5A0	E-1	R5H7	E-4	RJ230	A-3	TP2M	B-6		
	Q2E3	A-4	R12	B-1	R2D4	B-6	R2S5	B-5	R5A1	E-1	R5H8	D-2	RJ231	A-4	TP5A	C-1		
A-2	Q2P0	A-5	R13	B-1	R2E1	C-5	R2T1	A-5	R5A2	E-1	R5J0	D-4	RJ232	A-4	TP5B	C-1		
B-1	Q2P1	B-5	R16	B-1	R2E2	B-5	R2T2	A-5	R5A3	E-1	R5J1	D-3	RJ233	A-4	TP5C	C-1		
B-1	Q2P2	B-5	R101	A-1	R2E3	B-5	R2T3	A-5	R5A5	E-3	R5J2	C-5	RJ401	D-5	TP5D	E-6		
B-3	Q2P3	A-5	R102	A-1	R2E5	B-5	R2T4	A-5	R5A6	E-3	R5J3	C-5	RJ402	D-4	TP5F	C-2		
B-2	Q2P4	A-5	R103	A-1	R2E6	B-5	R2T5	B-5	R5A7	E-3	R5J5	D-1	RJ403	E-4	TP5X	E-1		
A-5	Q2P5	A-5	R104	A-1	R2E7	B-5	R2T6	A-4	R5A8	E-3	R5J6	C-2	RJ404	D-5	TP5Y	C-2		
B-4	Q2P6	A-6	R105	A-1	R2E8	B-5	R2T7	A-4	R5A9	E-3	R5J8	E-2	RJ501	C-4	TP6A	A-5		
A-3	Q2P7	A-5	R108	B-1	R2F1	B-6	R2T8	B-4	R5B0	E-3	R5K3	E-1	RJ502	C-3	TP6B	A-5		
A-3	Q2U0	B-4	R110	B-1	R2F2	B-6	R2T9	A-5	R5B1	E-1	R5P0	D-1	RJ503	D-3	TP9A	B-1		
E-5	Q2V0	B-3	R111	A-1	R2F3	B-6	R2U0	B-4	R5B2	E-2	R5X0	D-3	RJ504	D-3	TP9B	B-2		
E-4	Q4A0	E-6	R112	A-1	R2F4	B-5	R2V0	B-3	R5B3	B-3	R5X1	C-2	RJ505	C-3	TP9C	C-1		
D-2	Q4A2	D-5	R115	B-2	R2F5	B-5	R2V1	B-3	R5B4	E-4	R5X2	C-2	RJ506	C-3	TP9Z	E-6		
E-1	Q4A3	D-5	R116	B-2	R2F6	B-5	R3B0	A-3	R5B5	E-4	R5X6	C-3	RJ507	C-3	TP2AH	E-6		
E-1	Q4A4	D-5	R117	A-2	R2F7	B-5	R3B2	A-3	R5B6	E-4	R5X7	C-1	RJ509	D-2	TP2C0	C-5		
D-1	Q4A7	E-5	R118	A-2	R2F8	A-5	R3B3	A-3	R5B7	E-4	R9A5	D-6	RJ510	B-3	TP2C1	A-5		
E-1	Q4A8	D-5	R120	A-2	R2G0	A-5	R3B5	A-4	R5B8	E-4	R9A6	D-7	RJ511	E-1	TP2C2	A-5		
D-6	Q5A1	E-3	R127	A-2	R2G1	A-5	R3B8	A-3	R5B9	E-4	R9A6	D-7	RJ512	D-1	TP2C3	A-5		
	Q5A2	E-3	R129	A-2	R2G2	A-5	R3C1	A-3	R5C0	E-3	R9A7	D-7	RJ513	D-3	TP2C4	B-5		
A-3	Q5A3	E-3	R130	B-1	R2G3	A-5	R4A0	E-6	R5C1	E-3	R9A9	D-7	RJ514	D-1	TP2C5	B-4		
	Q5A4	E-4	R131	B-1	R2G4	A-5	R4A5	D-5	R5C2	E-3	R9B0	D-6	RJ516	E-3	TP2C6	B-5		
B-4	Q5A5	E-4	R132	B-1	R2G5	A-5	R4A9	E-5	R5C3	E-6	R9B3	D-6	RJ517	E-2	TP4C0	E-5		
A-6	Q5A6	E-4	R133	B-1	R2G7	B-5	R4B0	E-5	R5C4	E-6	R9B5	D-7	RJ518	E-4	TP4C1	E-5		
	Q5A7	E-3	R134	B-1	R2G8	A-4	R4B2	E-5	R5C5	E-6	R9C3	E-7	RJ519	E-3	TP4C2	E-5		
A-2	Q5A8	C-2	R135	B-1	R2H1	B-4	R4B4	E-5	R5C6	C-2			RJ521	D-3	TP4D1	E-5		
B-1	Q5A9	D-3	R136	B-2	R2H3	A-4	R4B5	D-5	R5C7	C-2			RJ522	E-3	TP4D2	E-5		
A-1	Q5B0	D-3	R138	A-2	R2H4	A-4	R4B6	E-5	R5C8	E-4			RJ523	E-3	TP4F1	D-5		
A-2	Q5B1	B-3	R139	A-2	R2H5	B-4	R4B7	E-5	R5D0	D-3			RJ524	E-3	TP4G1	E-6		

PCB-MAIN [COMPONENT SIDE] (HS-M20V(G) only)

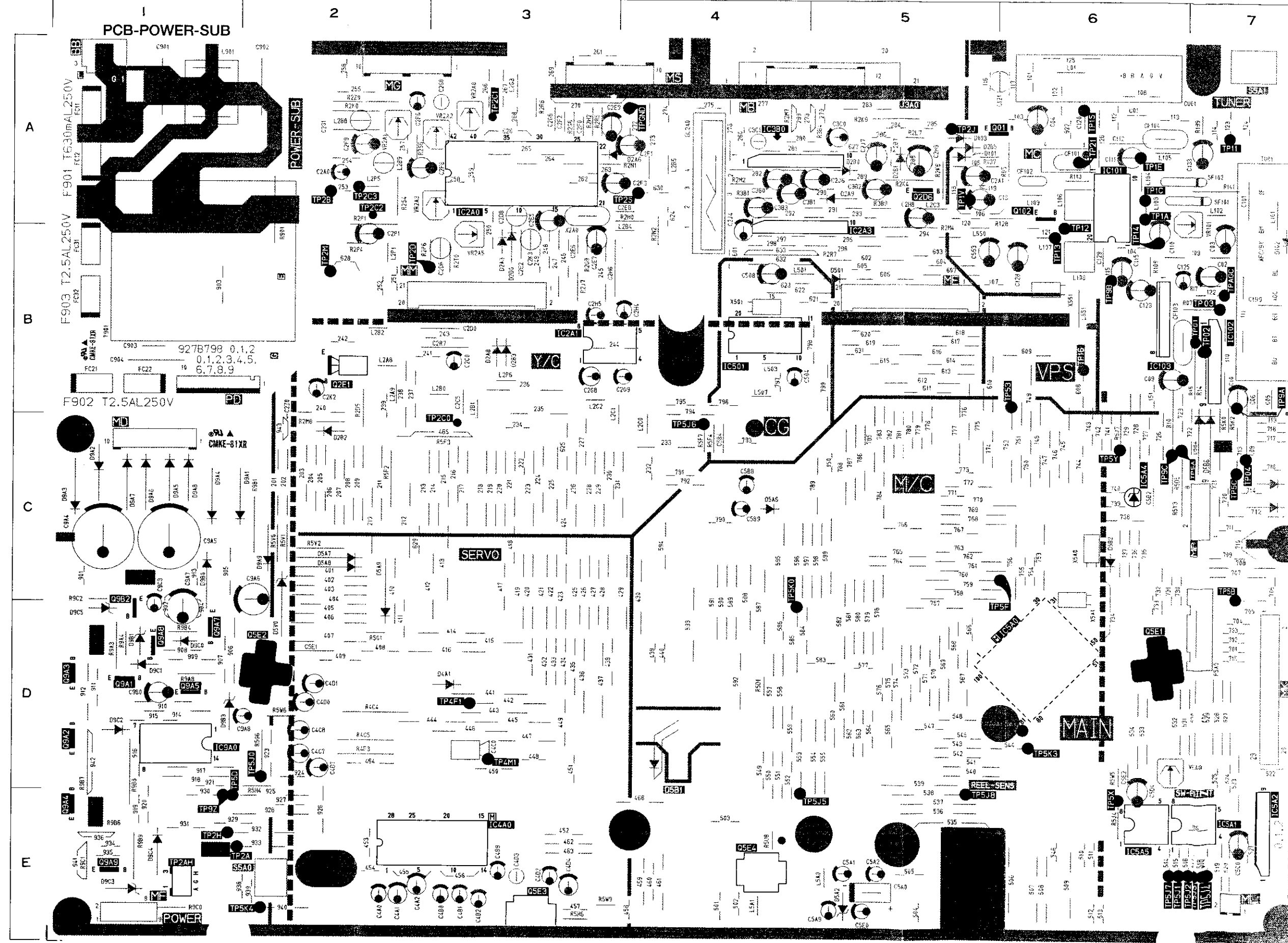

HS-M10V(B)
HS-M20V(B)/V(G)/V(IR)

10

PCB-MAIN

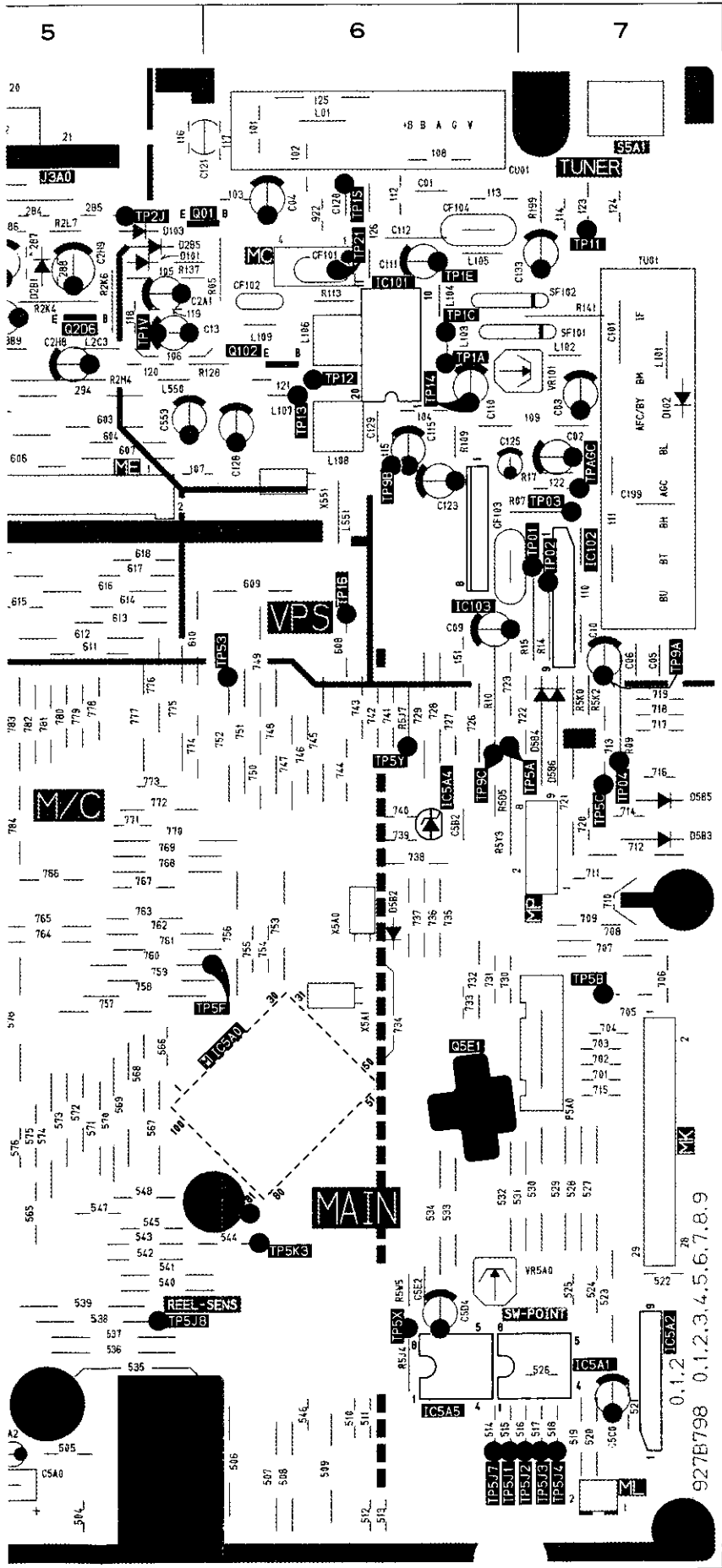

PCB-MAIN (COMPONENT SIDE)

SYMBOL NO.	ADDRESS	SYMBOL NO.	ADDRESS	SYMBOL NO.	ADDRESS	SYMBOL NO.	ADDRESS
CF101	A - 6	FC12	A - 1	Q102	A - 6	TP2C1	A - 3
CF102	A - 6	FC21	B - 1	Q2D6	A - 5	TP2C2	A - 2
CF103	B - 6	FC22	B - 1	Q5E1	B - 2	TP2C3	A - 2
CF104	A - 6	FC31	B - 1	Q5E2	D - 6	TP4F1	D - 3
		FC32	B - 1	Q5E3	D - 2	TP4M1	D - 3
CU01	A - 6			Q5E4	E - 3	TP5J0	D - 2
		IC101	A - 6	Q9A1	E - 4	TP5J1	E - 6
D101	A - 5	IC102	B - 7	Q9A2	D - 1	TP5J2	E - 6
D102	B - 7	IC103	B - 6	Q9A3	D - 1	TP5J3	E - 7
D103	A - 5	IC501	B - 4	Q9A4	E - 1	TP5J4	E - 7
D501	B - 5	IC2A0	A - 3	Q9A5	D - 1	TP5J5	E - 4
D2A3	B - 3	IC2A1	B - 3	Q9A7	D - 1	TP5J6	C - 4
D2A6	A - 3	IC2A3	A - 4	Q9A8	D - 1	TP5J7	E - 6
D2A8	B - 3	IC3B0	A - 4	Q9A9	E - 1	TP5K0	C - 4
D2A9	A - 5	IC4A0	E - 3	Q9B2	D - 1	TP5K3	D - 6
D2B0	A - 5	IC5A0	D - 6			TP5K4	E - 2
D2B1	A - 5	IC5A1	E - 6	S5A0	E - 2	TPAGC	B - 7
D2B2	C - 2	IC5A2	E - 7	S5A1	A - 7	TPGND	A - 4
D2B3	B - 3	IC5A4	C - 6				
D2B5	A - 5	IC5A5	E - 6	SF101	A - 6	TU01	B - 7
D2D0	B - 3	IC9A0	D - 1	SF102	A - 6		
D4A1	D - 3						
D5A2	E - 5	J3A0	A - 5				
D5A6	C - 4						
D5A7	C - 2	L01	A - 6				
D5A8	C - 2	L101	A - 7	T901	B - 1	VR101	A - 6
D5A9	C - 2	L102	A - 7			VR2A0	A - 3
D5B1	D - 4	L103	A - 6	TP01	B - 7	VR2A1	A - 2
D5B2	C - 6	L104	A - 6	TP02	B - 7	VR2A2	A - 3
D5B3	C - 7	L105	A - 6	TP03	B - 7	VR2A3	A - 3
D5B4	C - 7	L106	A - 6	TP04	C - 7	VR2A5	B - 3
D5B5	C - 7	L107	B - 6	TP11	A - 7	VR5A0	D - 6
D5B6	C - 7	L108	B - 6	TP12	A - 6		
D5V0	C - 2	L109	A - 6	TP13	B - 6	X501	B - 4
D9A1	C - 1	L501	B - 4	TP14	B - 6	X551	B - 6
D9A2	C - 1	L503	B - 4	TP16	B - 6	X2A0	A - 3
D9A3	C - 1	L507	B - 4	TP21	A - 6	X5A0	C - 6
D9A4	C - 1	L551	B - 6	TP53	B - 6	X5A1	C - 6
D9A5	C - 1	L901	A - 1	TP1A	A - 6		
D9A6	C - 1	L2A8	B - 2	TP1C	A - 6		
D9A7	C - 1	L2A9	B - 2	TP1E	A - 6		
D9A8	C - 1	L2A9	B - 2	TP1S	A - 6		
D9A9	C - 2	L2B1	B - 3	TP1V	A - 5		
D9B0	C - 1	L2B2	B - 2	TP2A	E - 2		
D9B1	D - 1	L2B4	B - 4	TP2B	A - 2		
D9B3	D - 1	L2B5	A - 4	TP2D	B - 2		
D9C0	D - 1	L2B8	A - 2	TP2H	E - 1		
D9C1	D - 1	L2B9	A - 2	TP2J	A - 5		
D9C2	D - 1	L2C0	C - 4	TP2S	A - 4		
D9C3	E - 1	L2C1	B - 3	TP5A	C - 6		
D9C4	E - 1	L2C2	B - 3	TP5B	C - 7		
D9C5	D - 1	L2C3	A - 5	TP5C	C - 7		
		L2G3	A - 3	TP5D	E - 1		
DL2A0	A - 4	L2P1	B - 2	TP5F	C - 5		
		L2P5	A - 2	TP5X	E - 6		
F901	A - 1	L2P6	B - 3	TP9A	B - 7		
F902	B - 1	L5A0	E - 5	TP9B	B - 6		
F903	B - 1	L5A1	E - 4	TP9C	C - 6		
				TP9Z	E - 1		
FC11	A - 1	Q01	A - 5	TP2AH	E - 1		
				TP2C0	C - 3		

PCB-CONNECTOR-G (SOLDER SIDE)

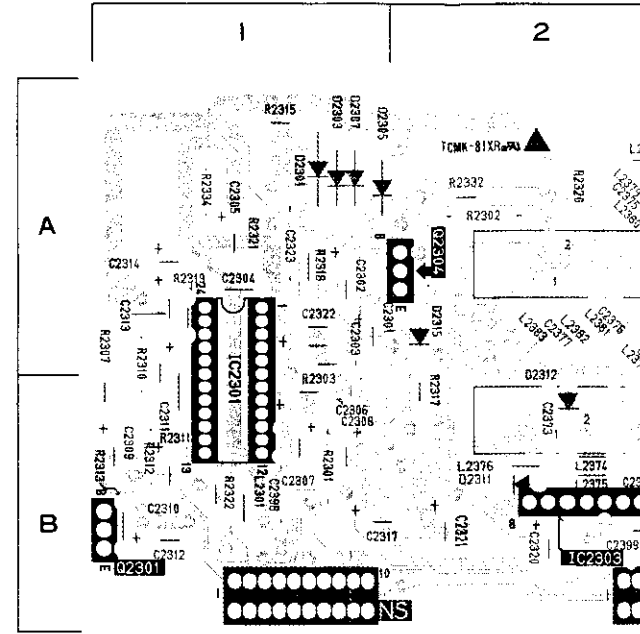

PCB-CONNECTOR-G (COMPONENT S)

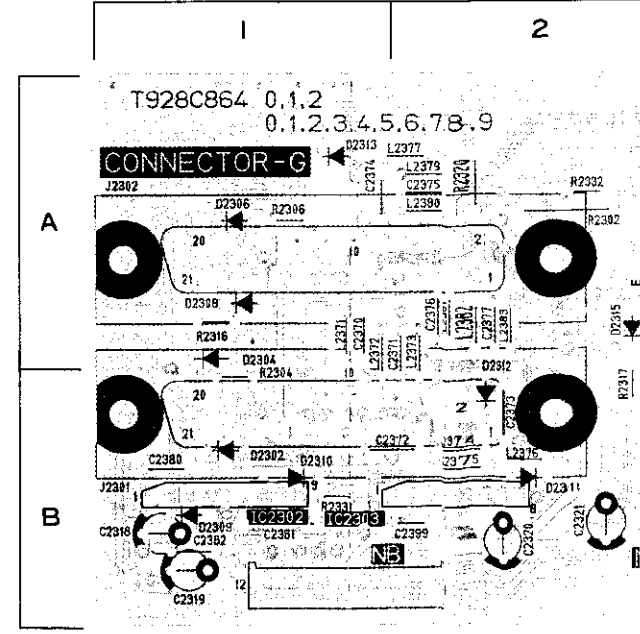

[SIDE]

ADDRESS	SYMBOL NO.	ADDRESS	SYMBOL NO.	ADDRESS
A-1	Q102	A-6	TP2C1	A-3
B-1	Q2D6	A-5	TP2C2	A-2
B-1	Q2E1	B-2	TP2C3	A-2
B-1	Q5E1	D-6	TP4F1	D-3
B-1	Q5E2	D-2	TP4M1	D-3
	Q5E3	E-3	TP5J0	D-2
A-6	Q5E4	E-4	TP5J1	E-6
B-7	Q9A1	D-1	TP5J2	E-6
B-6	Q9A2	D-1	TP5J3	E-7
B-4	Q9A3	D-1	TP5J4	E-7
A-3	Q9A4	E-1	TP5J5	E-4
B-3	Q9A5	D-1	TP5J6	C-4
A-4	Q9A7	D-1	TP5J7	E-6
A-4	Q9A8	D-1	TP5J8	E-5
E-3	Q9A9	E-1	TP5K0	C-4
D-6	Q9B2	D-1	TP5K3	D-6
E-6			TP5K4	E-2
E-7	S5A0	E-2	TPAGC	B-7
C-6	S5A1	A-7	TPGND	A-4
E-6				
D-1	SF101	A-6	TU01	B-7
	SF102	A-6		
A-5			VR101	A-6
	T901	B-1	VR2A0	A-3
A-6			VR2A1	A-2
A-7	TP01	B-7	VR2A2	A-3
A-7	TP02	B-7	VR2A3	A-3
A-6	TP03	B-7	VR2A5	B-3
A-6	TP04	C-7	VR5A0	D-6
A-6	TP11	A-7		
A-6	TP12	A-6	X501	B-4
B-6	TP13	B-6	X551	B-6
B-6	TP14	B-6	X2A0	A-3
A-6	TP16	B-6	X5A0	C-6
B-4	TP21	A-6	X5A1	C-6
B-4	TP53	B-6		
B-4	TP1A	A-6		
B-5	TP1C	A-6		
B-6	TP1E	A-6		
A-1	TP1S	A-6		
B-2	TP1V	A-5		
B-2	TP2A	E-2		
B-3	TP2B	A-2		
B-2	TP2D	B-2		
B-4	TP2H	E-1		
A-4	TP2J	A-5		
A-2	TP2S	A-4		
A-2	TP5A	C-6		
C-4	TP5B	C-7		
B-3	TP5C	C-7		
B-3	TP5D	E-1		
A-5	TP5F	C-5		
A-3	TP5X	E-6		
B-2	TP5Y	C-6		
A-2	TP9A	B-7		
B-3	TP9B	B-6		
E-5	TP9C	C-6		
E-4	TP9Z	E-1		
A-5	TP2AH	E-1		
	TP2C0	C-3		

PCB-CONNECTOR-G [SOLDER SIDE] (HS-M20V(G) only)

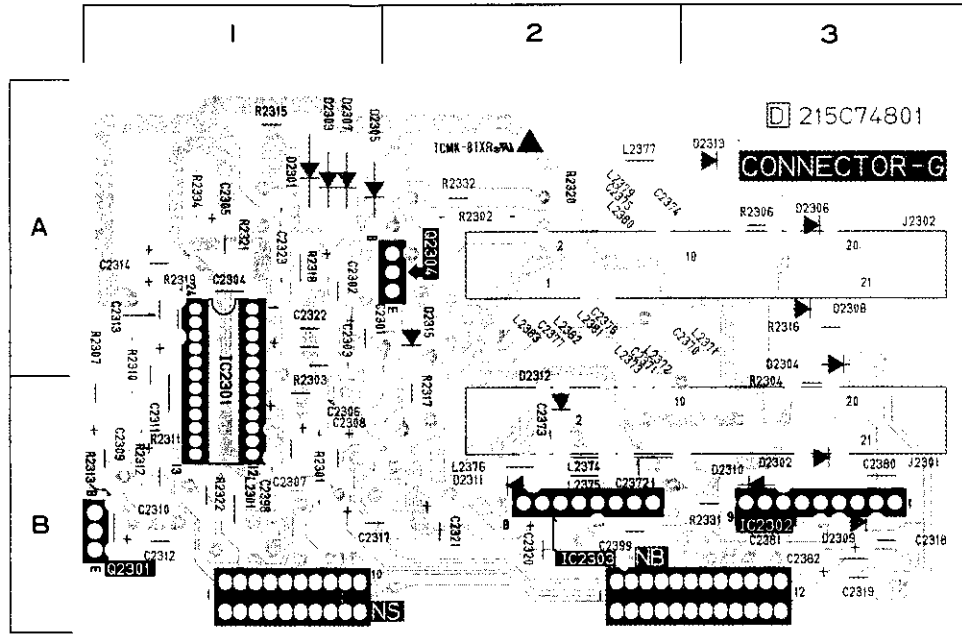

PCB-CONNECTOR-G [SOLDER SIDE]

SYMBOL NO.	ADDRESS	SYMBOL NO.	ADDRESS
D2301	A-1	L2373	A-2
D2302	B-3	L2374	B-2
D2303	A-1	L2375	B-2
D2304	A-3	L2376	B-2
D2305	A-1	L2377	A-2
D2306	A-3	L2379	A-2
D2307	A-1	L2380	A-2
D2308	A-3	L2381	A-2
D2309	B-3	L2382	A-2
D2310	B-3	L2383	A-2
D2311	B-2		
D2312	B-2	Q2301	B-1
D2313	A-3	Q2304	A-2
D2315	A-2		
IC2301	A-1		
IC2302	B-3		
IC2303	B-2		
J2301	B-3		
J2302	A-3		
L2301	B-1		
L2371	A-3		
L2372	A-2		

PCB-CONNECTOR-G [COMPONENT SIDE] (HS-M20V(G) only)

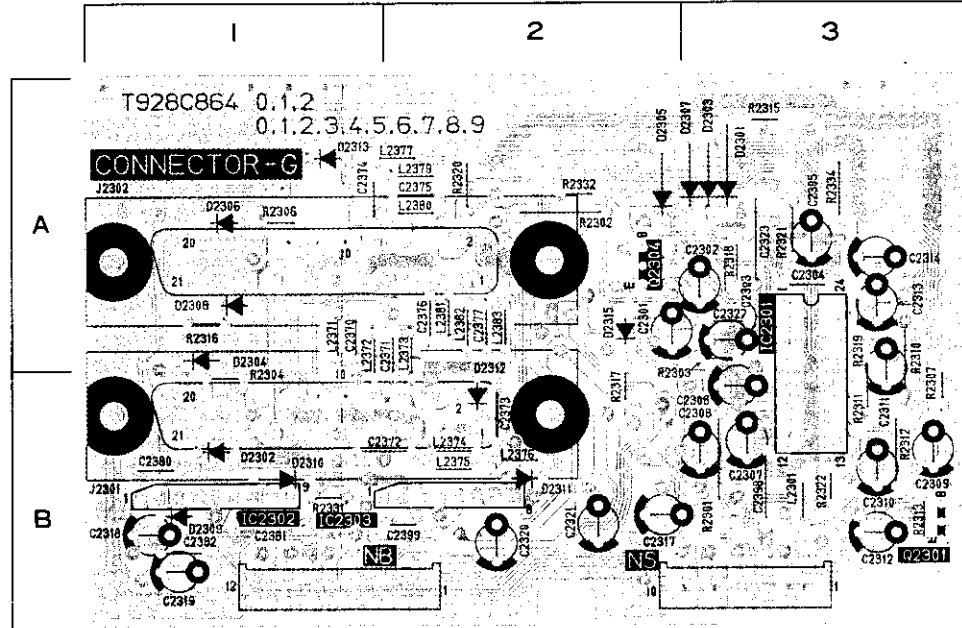

PCB-CONNECTOR-G [COMPONENT SIDE]

SYMBOL NO.	ADDRESS	SYMBOL NO.	ADDRESS
D2301	A-3	L2373	A-2
D2302	B-1	L2374	B-2
D2303	A-3	L2375	B-2
D2304	A-1	L2376	B-2
D2305	A-2	L2377	A-2
D2306	A-1	L2379	A-2
D2307	A-3	L2380	A-2
D2308	A-1	L2381	A-2
D2309	B-1	L2382	A-2
D2310	B-1	L2383	A-2
D2311	B-2		
D2312	B-2	Q2301	B-3
D2313	A-1	Q2304	A-2
D2315	A-3		
IC2301	A-3		
IC2302	B-1		
IC2303	B-1		
J2301	B-1		
J2302	A-1		
L2301	B-3		
L2371	A-1		
L2372	A-1		

PCB-TEXT (HS-M20V(B) only)

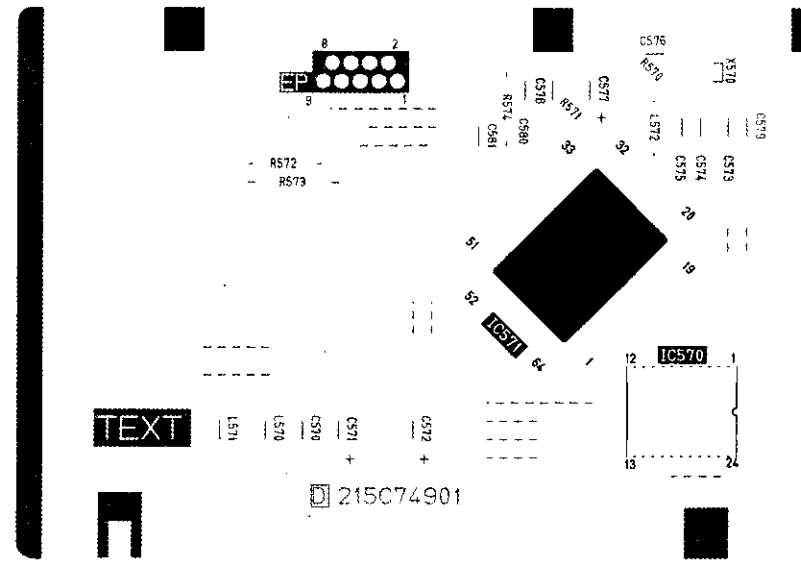

TRANSMITTER REMOTE CONTROL

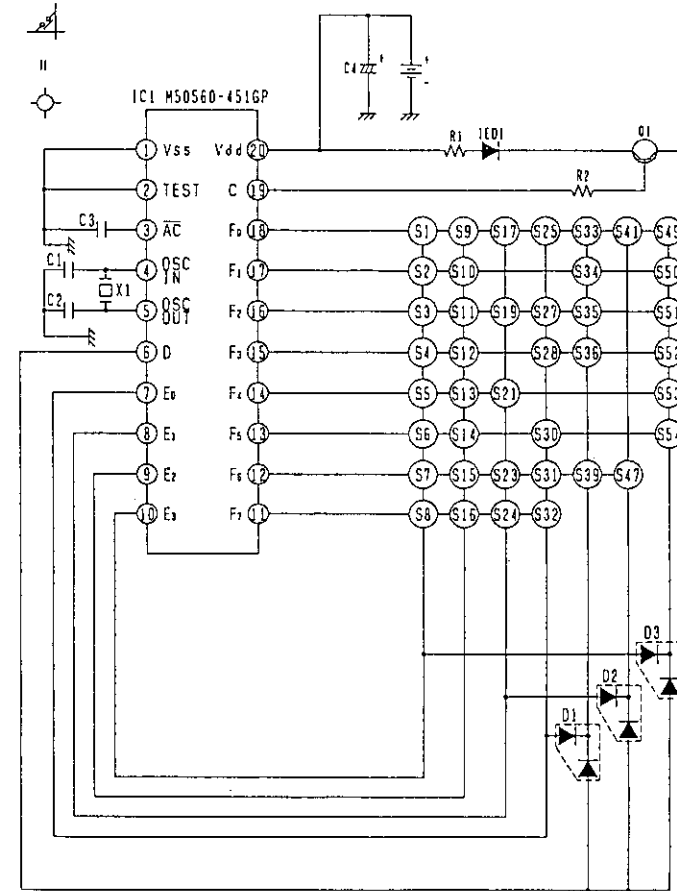

HS-M20V(B)
HS-M20V(IR)
HS-M10V(B)

TRANSMITTER REMOTE CONTROL

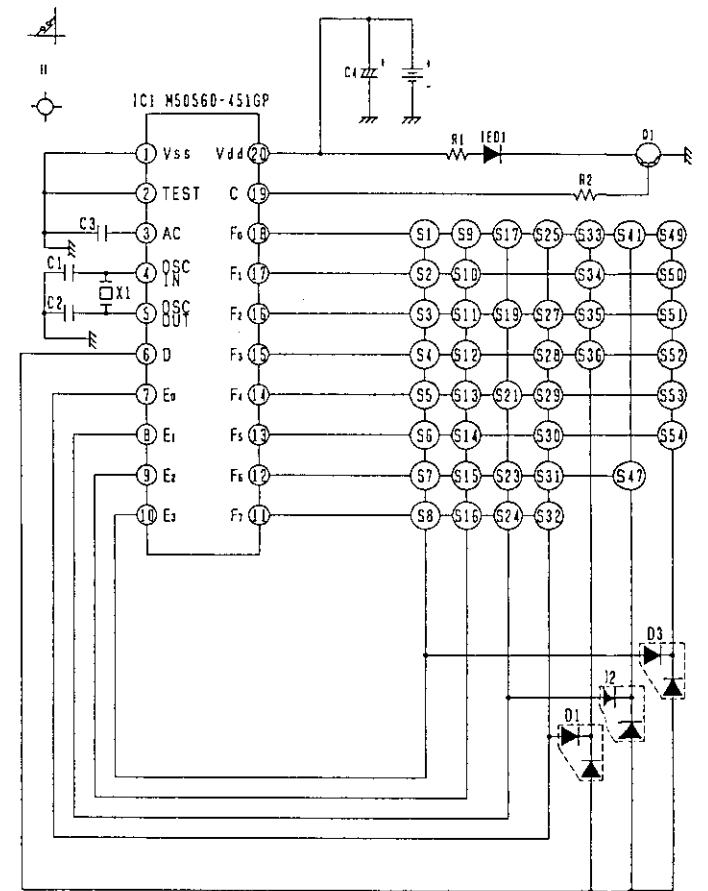

HS-M20V(G)

PCB-HA/AUDIO

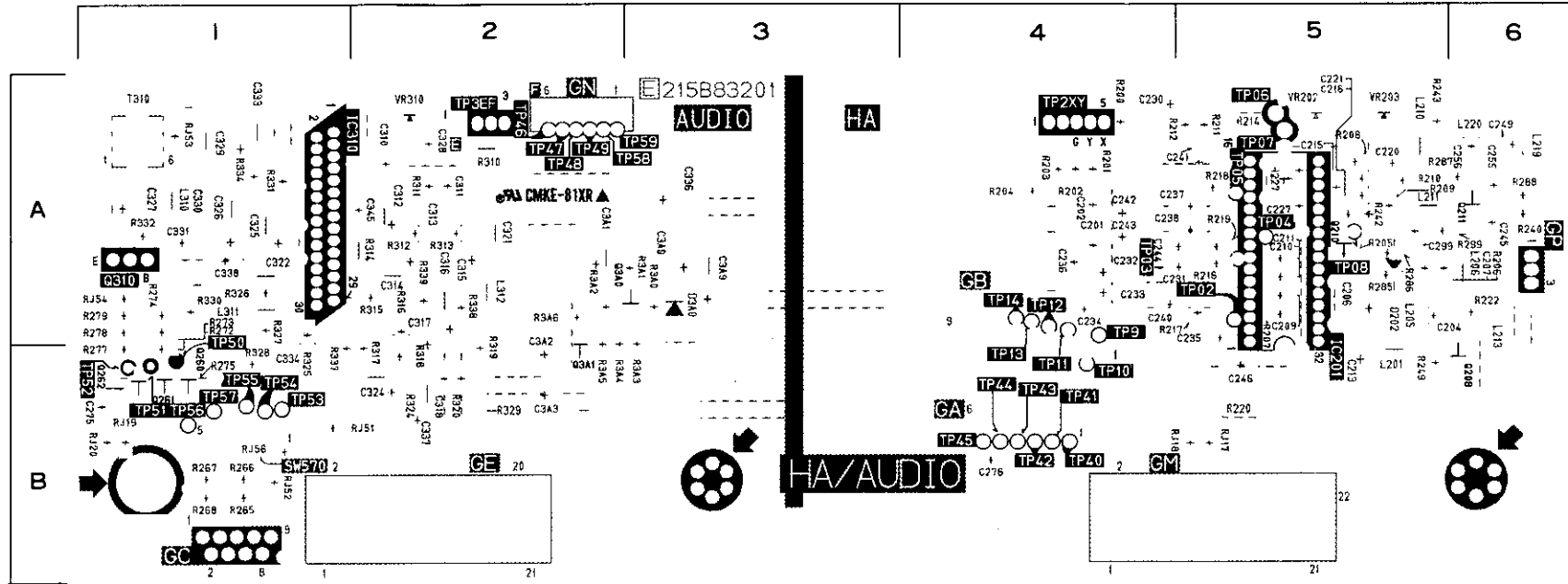

PCB-HA/AUDIO

SYMBOL NO.	ADDRESS	SYMBOL NO.	ADDRESS	SYMBOL NO.	ADDRESS	SYMBOL NO.	ADDRESS
C201	A-4	C345	A-2	R260	B-1	T310	A-1
C202	A-4	C3A0	A-3	R265	B-1		
C204	A-5	C3A1	A-2	R266	B-1	TP9	A-4
C206	A-5	C3A2	B-2	R267	B-1	TP02	A-5
C207	A-6	C3A3	B-2	R272	A-1	TP03	A-4
C209	A-5	C3A9	A-3	R273	A-1	TP04	A-5
C210	A-5			R274	A-1	TP05	A-5
C211	A-5	D202	A-5	R275	B-1	TP06	A-5
C213	B-5	D3A0	A-3	R277	B-1	TP07	A-5
C215	A-5			R278	A-1	TP08	A-5
C216	A-5	IC201	A-5	R279	A-1	TP10	B-4
C220	A-5	IC310	A-1	R285	A-5	TP11	A-4
C221	A-5			R286	A-5	TP12	A-4
C227	A-5	L201	B-5	R287	A-5	TP13	A-4
C230	A-4	L205	A-5	R288	A-6	TP14	A-4
C231	A-4	L206	A-6	R299	A-6	TP40	B-4
C232	A-4	L210	A-5	R310	A-2	TP41	B-4
C233	A-4	L211	A-5	R311	A-2	TP42	B-4
C234	A-4	L213	A-6	R312	A-2	TP43	B-4
C235	A-5	L219	A-6	R313	A-2	TP44	B-4
C236	A-4	L220	A-6	R314	A-2	TP45	B-4
C237	A-5	L310	A-1	R315	A-2	TP46	A-2
C238	A-5	L311	A-1	R316	A-2	TP47	A-2
C240	A-4	L312	A-2	R317	B-2	TP48	A-2
C241	A-5			R318	B-2	TP49	A-2
C242	A-4	Q208	B-6	R319	B-2	TP50	B-1
C243	A-4	Q210	A-5	R320	B-2	TP51	B-1
C244	A-4	Q211	A-6	R324	B-2	TP52	B-1
C245	A-6	Q260	B-1	R325	B-1	TP53	B-1
C248	B-5	Q261	B-1	R326	A-1	TP54	B-1
C249	A-6	Q262	B-1	R327	A-1	TP55	B-1
C255	A-6	Q310	A-1	R328	B-1	TP56	B-1
C256	A-6	Q3A0	A-3	R329	B-2	TP57	B-1
C275	B-1	Q3A1	B-2	R330	A-1	TP58	A-2
C276	B-4			R331	A-1	TP59	A-2
C299	A-5	R200	A-4	R332	A-1	TP2XY	A-4
C310	A-2	R201	A-4	R334	A-1	TP3EF	A-2
C311	A-2	R202	A-4	R337	B-1		
C312	A-2	R203	A-4	R338	A-2	VR202	A-5
C313	A-2	R204	A-4	R339	A-2	VR203	A-5
C314	A-2	R205	A-5	R3A0	A-3	VR310	A-2
C315	A-2	R206	A-6	R3A1	A-3		
C316	A-2	R207	A-5	R3A2	A-2		
C317	A-2	R208	A-5	R3A3	B-3		
C318	B-2	R209	A-5	R3A4	B-3		
C321	A-2	R210	A-5	R3A5	B-2		
C322	A-1	R211	A-5	R3A6	A-2		
C324	B-2	R212	A-5				
C325	A-1	R214	A-5	RJ17	B-5		
C326	A-1	R216	A-5	RJ18	B-5		
C327	A-1	R217	A-5	RJ19	B-1		
C328	A-2	R218	A-5	RJ20	B-1		
C329	A-1	R219	A-5	RJ51	B-2		
C330	A-1	R220	B-5	RJ52	B-1		
C331	A-1	R222	A-6	RJ53	A-1		
C333	A-1	R227	A-5	RJ54	A-1		
C334	B-1	R240	A-6	RJ56	B-1		
C336	A-3	R242	A-5				
C337	B-2	R243	A-6	SW570	B-1		
C338	A-1	R249	B-5				

AUDIO

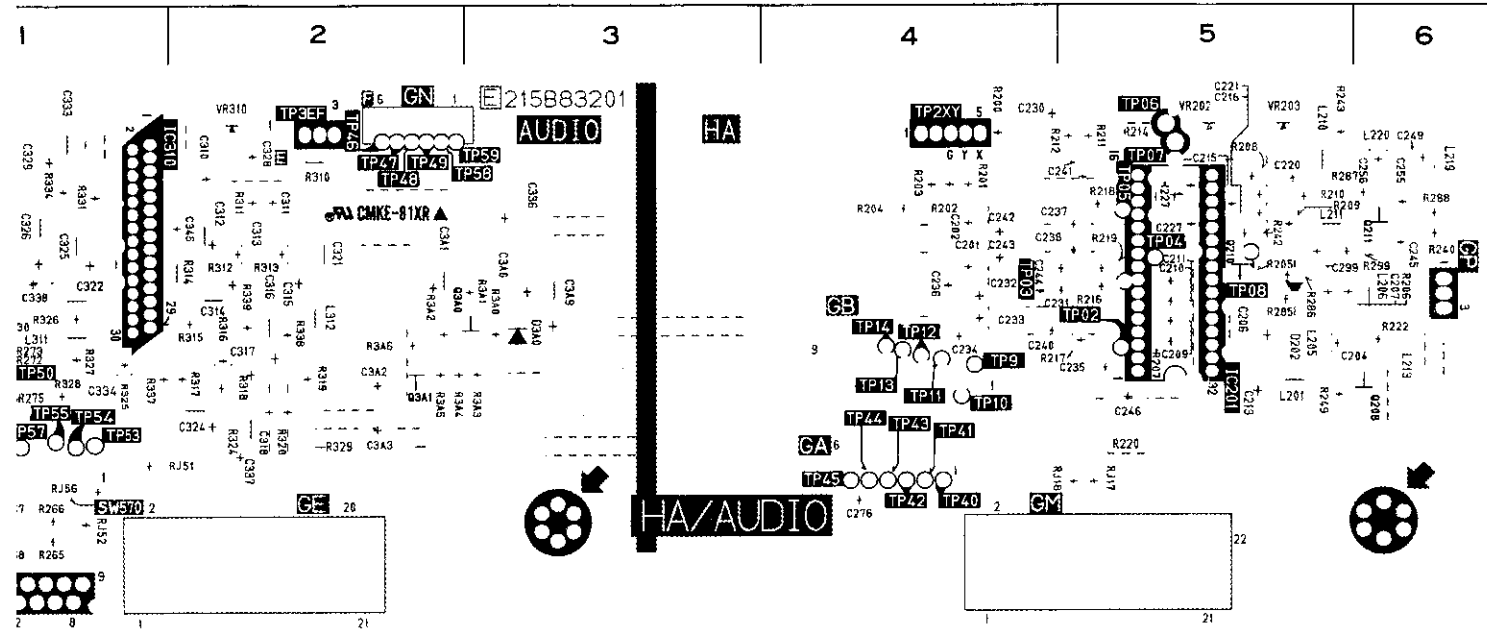

PCB-HA/AUDIO

SYMBOL NO.	ADDRESS
C201	A-4
C202	A-4
C204	A-5
C206	A-5
C207	A-6
C209	A-5
C210	A-5
C211	A-5
C213	B-5
C215	A-5
C216	A-5
C220	A-5
C221	A-5
C227	A-5
C230	A-4
C231	A-4
C232	A-4
C233	A-4
C234	A-4
C235	A-5
C236	A-4
C237	A-5
C238	A-5
C240	A-4
C241	A-5
C242	A-4
C243	A-4
C244	A-4
C245	A-6
C248	B-5
C249	A-6
C255	A-6
C256	A-6
C275	B-1
C276	B-4
C299	A-5
C310	A-2
C311	A-2
C312	A-2
C313	A-2
C314	A-2
C315	A-2
C316	A-2
C317	A-2
C318	B-2
C321	A-2
C322	A-1
C324	B-2
C325	A-1
C326	A-1
C327	A-1
C328	A-2
C329	A-1
C330	A-1
C331	A-1
C333	A-1
C334	B-1
C336	A-3
C337	B-2
C338	A-1

SYMBOL NO.	ADDRESS
C345	A-2
C3A0	A-3
C3A1	A-2
C3A2	B-2
C3A3	B-2
C3A9	A-3
D202	A-5
D3A0	A-3
IC201	A-5
IC310	A-1
L201	B-5
L205	A-5
L206	A-6
L210	A-5
L211	A-5
L213	A-6
L219	A-6
L220	A-6
L310	A-1
L312	A-2
Q208	B-6
Q210	A-5
Q211	A-6
Q260	B-1
Q261	B-1
Q262	B-1
Q310	A-1
Q3A0	A-3
Q3A1	B-2
R200	A-4
R201	A-4
R202	A-4
R203	A-4
R204	A-4
R205	A-5
R206	A-6
R207	A-5
R208	A-5
R209	A-5
R210	A-5
R211	A-5
R212	A-5
R214	A-5
R216	A-5
R217	A-5
R218	A-5
R219	A-5
R220	B-5
R222	A-6
R227	A-5
R240	A-6
R242	A-5
R243	A-6
R249	B-5

SYMBOL NO.	ADDRESS
R260	B-1
R265	B-1
R266	B-1
R267	B-1
R272	A-1
R273	A-1
R274	A-1
R275	B-1
R277	B-1
R278	A-1
R279	A-1
R285	A-5
R286	A-5
R287	A-5
R288	A-6
R299	A-6
R310	A-2
R311	A-2
R312	A-2
R313	A-2
R314	A-2
R315	A-2
R316	A-2
R317	B-2
R318	B-2
R319	B-2
R320	B-2
R324	B-2
R325	B-1
R326	A-1
R327	A-1
R328	B-1
R329	B-2
R330	A-1
R331	A-1
R332	A-1
R334	A-1
R337	B-1
R338	A-2
R339	A-2
R3A0	A-3
R3A1	A-3
R3A2	A-2
R3A3	B-3
R3A4	B-3
R3A5	B-2
R3A6	A-2
RJ17	B-5
RJ18	B-5
RJ19	B-1
RJ20	B-1
RJ51	B-2
RJ52	B-1
RJ53	A-1
RJ54	A-1
RJ56	B-1
SW570	B-1

SYMBOL NO.	ADDRESS
TP310	A-1
TP9	A-4
TP02	A-5
TP03	A-4
TP04	A-5
TP05	A-5
TP06	A-5
TP07	A-5
TP08	A-5
TP10	B-4
TP11	A-4
TP12	A-4
TP13	A-4
TP14	A-4
TP40	B-4
TP41	B-4
TP42	B-4
TP43	B-4
TP44	B-4
TP45	B-4
TP46	A-2
TP47	A-2
TP48	A-2
TP49	A-2
TP50	B-1
TP51	B-1
TP52	B-1
TP53	B-1
TP54	B-1
TP55	B-1
TP56	B-1
TP57	B-1
TP58	A-2
TP59	A-2
TP2XY	A-4
TP3EF	A-2
VR202	A-5
VR203	A-5
VR310	A-2

HS-M10V(B)
HS-M20V(B)/V(G)/V(IR)