

TANDBERG

TR 2075 MkII / TR2080

Service Manual

Contents

	Page
Changing and cleaning P/B selectors (switches)	2
Mechanical service	3
AM alignment procedure	4
AM circuit diagram	5
FM alignment procedure	6
FM circuit diagram — Stereo decoder diagrams	9
RIAA/input — P/B selectors, circuit diagram	11
Pre-Amp/Filter — Mode/Filter, circuit diagram	13
Power-Amplifier, circuit diagram	15



CHANGING OR CLEANING PUSH BUTTON SWITCHES

Occasionally the push button switches will need to be cleaned and lubricated to maintain trouble free action. A good cleaning agent should be applied sparingly with a fine brush. We recommend "Tandberg Klüberfett" or "Wählerfett" from our Service Department.

Alcohol or methylated spirit may also be used for cleaning, and vaseline may be used for lubrication afterwards.

NOTE! Avoid touching the contacts with your finger – it could cause corrosion.

Avoid using cleaning agents that could attack the metal parts.

NOTE! We have developed our own cleaning/lubricating agent, "Tandberg Contact Spray" in aerosols, and we recommend it for all types of contacts. These aerosols can be supplied from our district offices and subsidiary companies.

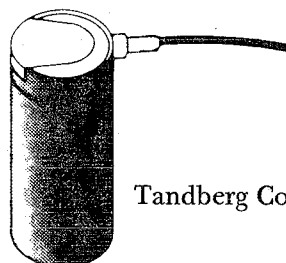

Tandberg Contact Spray

NOTE! Slide switches (mode selectors) are available complete as a replacement part.

If necessary, the switch can be cleaned, and the plunger or the contact unit can be changed. For these operations the switch must be dismantled.

DISMANTLING THE PLUNGER

- Pull the spring slightly forward so that the locking clip is free at the edge.
- Use tweezers as shown in the figure.
- Press the plunger right in. Push the locking clip backwards and lift it up.
NB! The locking pin lies loose in the locking clip.
- The plunger can be pulled out.
NB! The spring contact on the plunger are loose.

The spring is slightly conical so that if you remove it from the plunger, take care to replace it with the smallest end against front of the plunger.

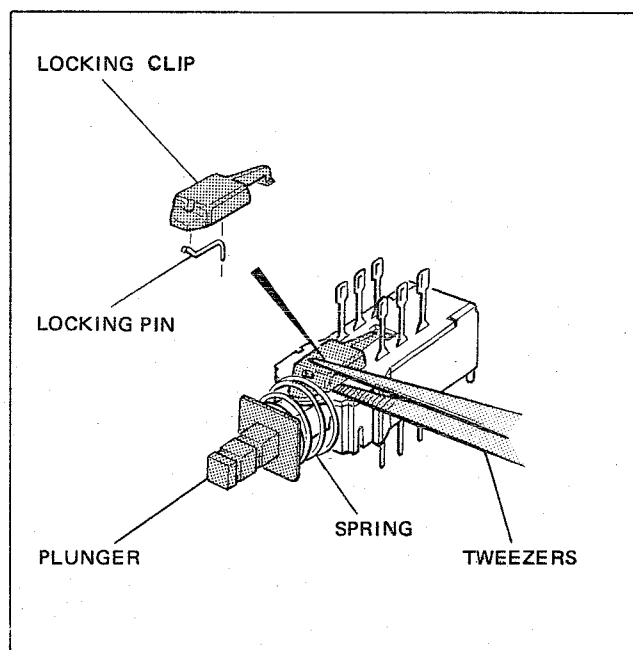

DISMANTLING

CABINET

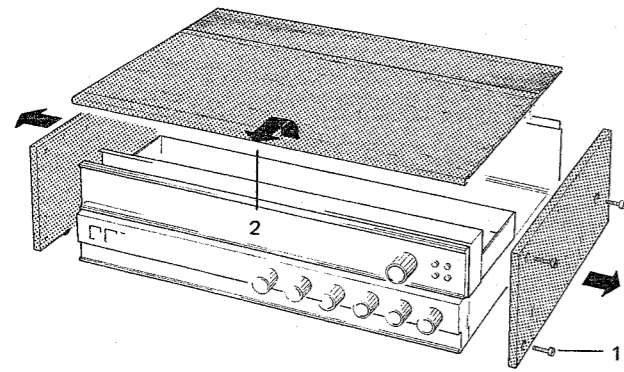

1. Remove 3 screws from each side panel.
2. Lift the top panel in front and pull the panel straight forward.

RIAA INPUT

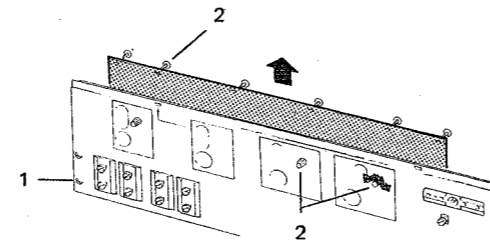

1. Remove the 6 mounting screws on the back panel.
2. Before you remove the 6 screws on the RIAA board, use some tape and secure the knobs to the back panel. Remove the 6 screws and pull the RIAA board away from the back panel and lift it straight up.

OUTPUT TRANSISTORS

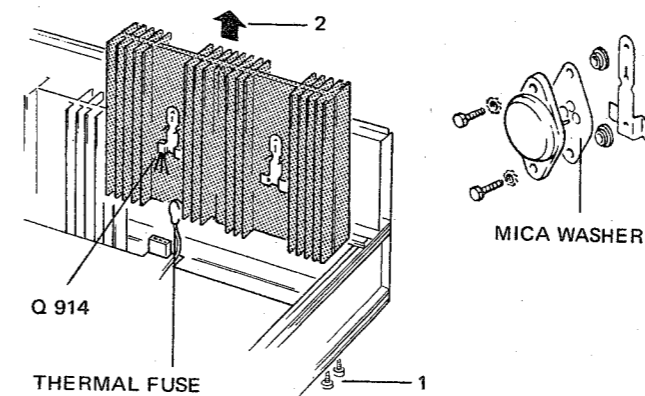

When changing the output transistors you should remove the complete corrugated heat sink for the channel in question.

1. Remove the 2 screws in the heat sink from underneath.
2. Pull the heat sink up.

NOTE! Q914 will come with the heat sink as it is pulled up, but the thermal fuse will remain hanging on the AF board.

NOTE! When assembling the output transistors we recommend to use "Thermal Compound Wakefield" on both sides of the mica washer. See Figure.

The compound can be obtained from our Service Dept. Use ordering No. 340245.

We do not recommend the use of "Silicon grease". If you must use Silicon grease, do not get it on the solder joints.

SCALE COVER/SCALE HOUSING AND METER LAMPS

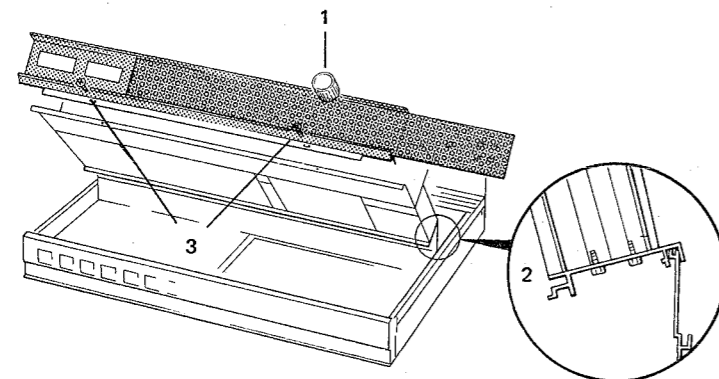

1. Loosen the screw in the tuner knob and pull the knob off. Pull the meter leads away from the FM/IF Tuner board.
2. Turn the tuner unit up into the vertical position.
3. Remove the 2 screws. Pull the scale housing forward. The meter lamps are accessible.

FM STEREO LAMP

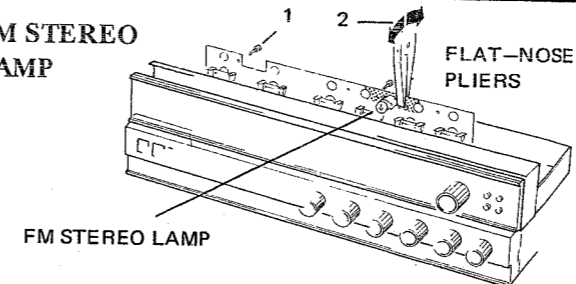

NOTE! The lamp unit and its lead are designed to be separated from the scale lamp board by a snap action.

1. Remove the four screws in the scale lamp board.
2. Loosen the board slightly so that you can insert a pair of flat-nose pliers beside the lamp. See Figure.

The scale lamp board and the stereo lamp are separately mounted.

NOTE! When removing the complete scale lamp board, you must first remove the screws on the MF/IF Tuner board.

SCALE DRIVE CORD

Before fitting a new drive cord you should loosen the screws on the AM board and pull off the leads so that the board is free.

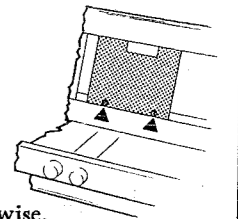

- Turn the pot. meter fully anti-clockwise.
- Pull cord end A through hole C from the back side. Pull cord end A until the eyelet on the cord comes out to the front side of hole C. Tape the cord securely as shown in the Figure.
- Lay cord end B in slot B in the cord wheel, then lay it in the back groove of the cord wheel and take 1 turn *anti-clockwise*. Tape the cord securely as shown in the Figure.
- Remove the tape from cord end A and lay the cord in slot A in the cord wheel. Then lay the cord in the front groove of the cord wheel and take 4 turns *clockwise*. Tape the cord again.
- Re-assemble the boards and the leads.
- Release the ends of the cord from the tape and complete the fitting of the cord as shown in the Figure.
- Assemble the scale pointer as shown in the Figure and set to the correct position on the scale.

THE SCALE

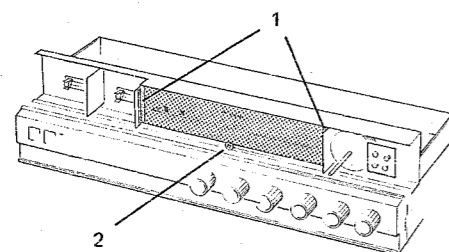

1. Remove the tape from both ends of the scale.
2. Remove the screw. Pull off the scale.

SCALE LAMPS

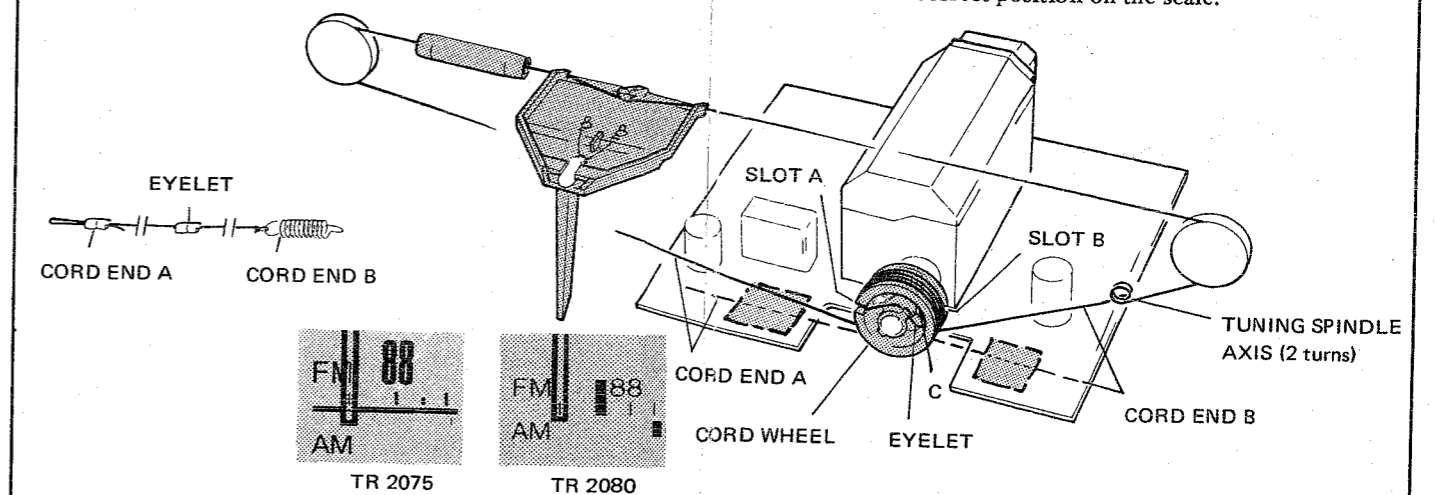
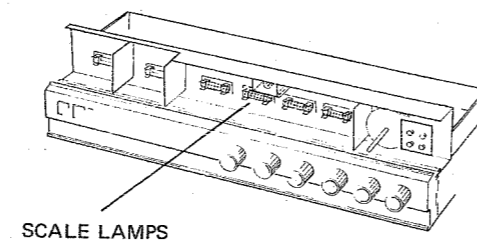

AM-ALIGNMENT PROCEDURE

Procedure	Receiver	Generator			Oscilloscope	Frequency counter	Circuits		Notes
	Frequency	Frequency	Modulation	Applied to M	Connected to M	Connected to M		Board No.	
1 A Oscilloscope with frequency counter						M2, see circuit diagram	L401 C402	A4	If available, use a frequency counter to obtain max. accuracy. Use a calibrated signal generator. NOTE! Check the dial pointer zero position, see Fig. 5.
1 B Oscillator	600 kHz 1400 kHz	600 kHz 1400 kHz	30%	* M3 via dummy ant. (Fig. 4)					
2 A AM-IF with wobbler	1400 kHz	Wobb.freq. — 1400 kHz	Unmodul.	* M3 via wobbler and dummy ant. (Fig. 3-4)	M1, see circuit diagram		L403 L404	A4	Adjust for max. curve height. See Fig. 6. The center frequency is determined by the fixed ceramic filter. Adjust for max. output.
2 B AM-IF without wobbler	1400 kHz	1400 kHz	30%	* M3 via dummy ant. (Fig. 4)					
3 A Antenna circuit, ferrite and HF circuit with wobbler	600 kHz 1400 kHz	Wobb.freq. — 600 kHz 1400 kHz	Unmodul.	* M3 via wobbler and dummy ant. (Fig. 3-4)	M1, see circuit diagram		**L3 - L402 C410 - C417	A4	Adjust for max. curve height. Adjust for max. output.
3 B Antenna circuit, ferrite and HF circuit without wobbler	600 kHz 1400 kHz	600 kHz 1400 kHz	30%	* M3 via dummy ant. (Fig. 4)					
4 Signal meter	1 MHz	1 MHz	30%	* M3 at/20 mV			R405	A4	Adjust to 15 on TR2075 MK II Adjust to 10 ² μV on TR2080

*M3, Antenna input.

**L3, Antenna circuit, ferrite.

Fig. 1 Alignment point, L3

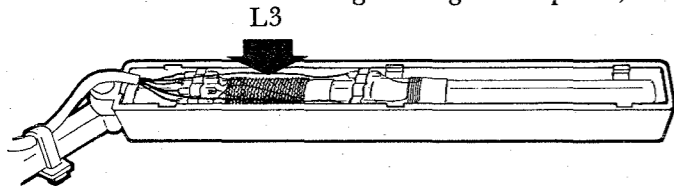
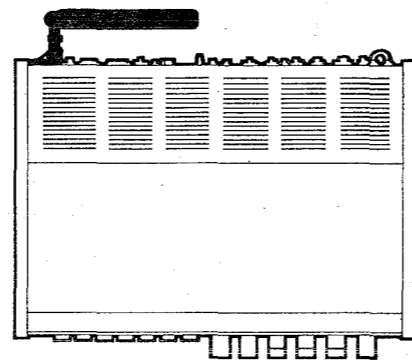

Fig. 2 Ferrite antenna

Adjust with ferrite ant. in position as shown in Figure.



A4

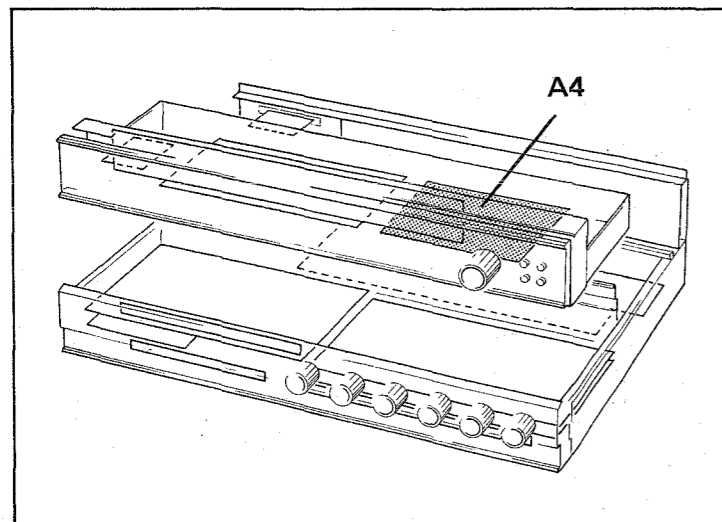

Fig. 3 Generator and wobbler

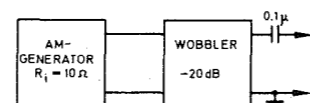

Fig. 4 Dummy antenna

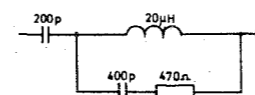

Fig. 5 Adjusting the dial pointer.

The end position of the scale cursor.

Note! Check FM scale accuracy.

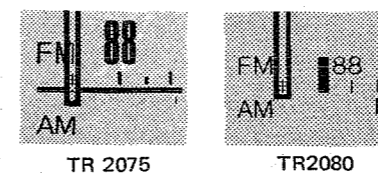
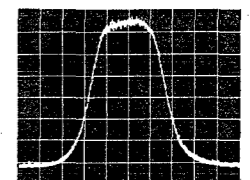
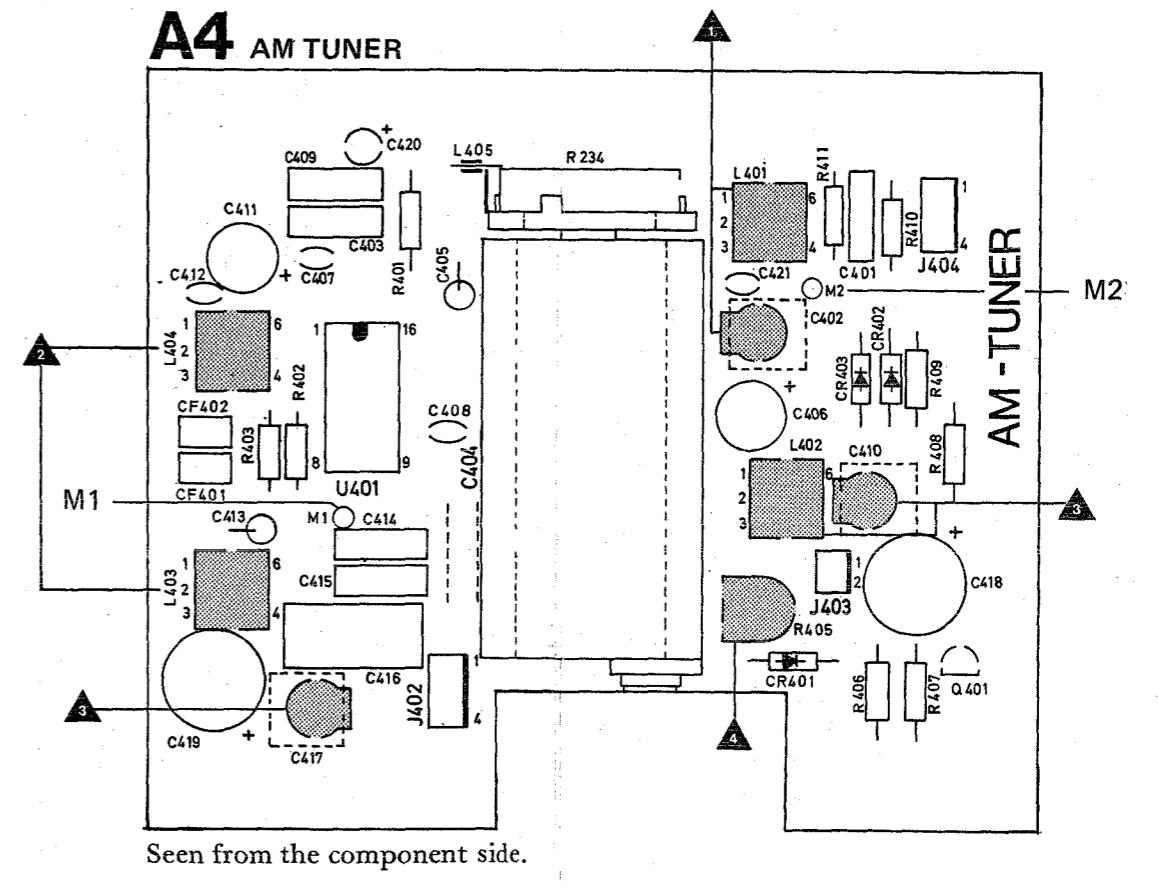
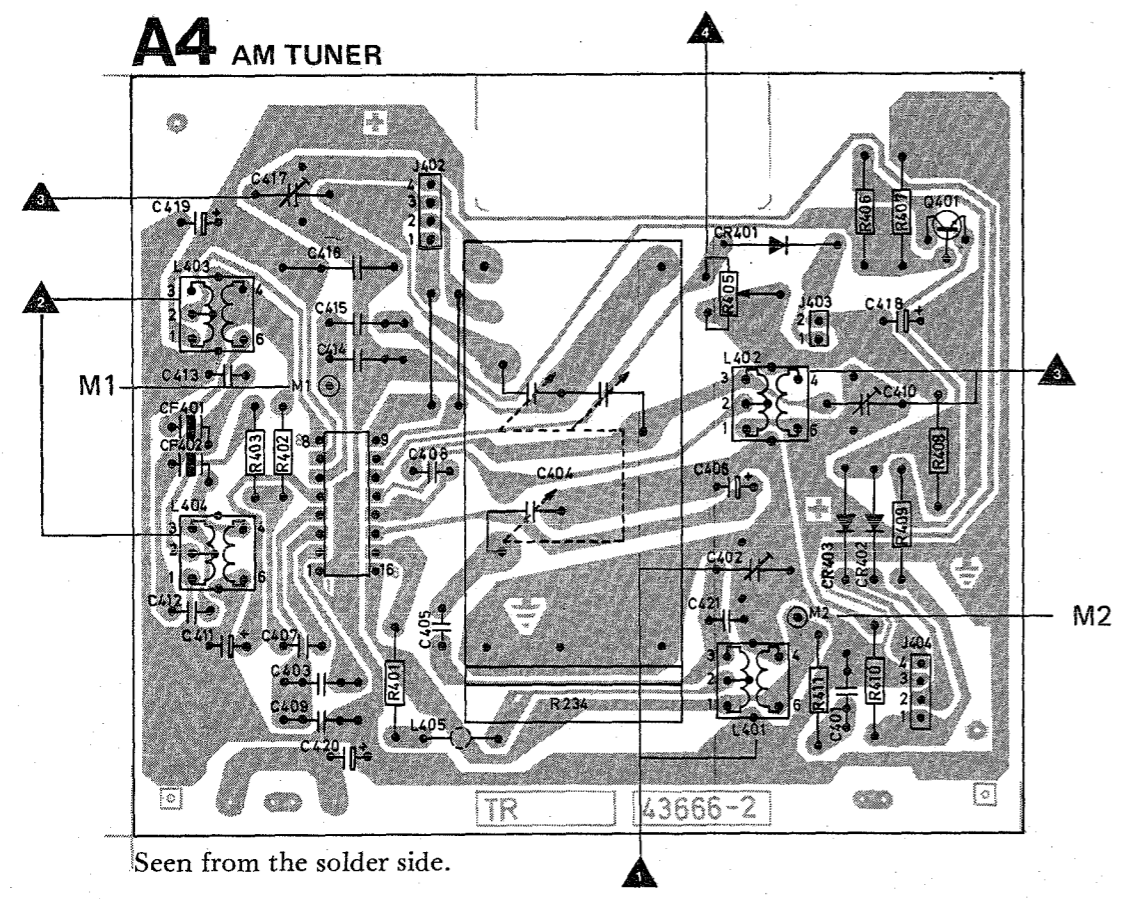
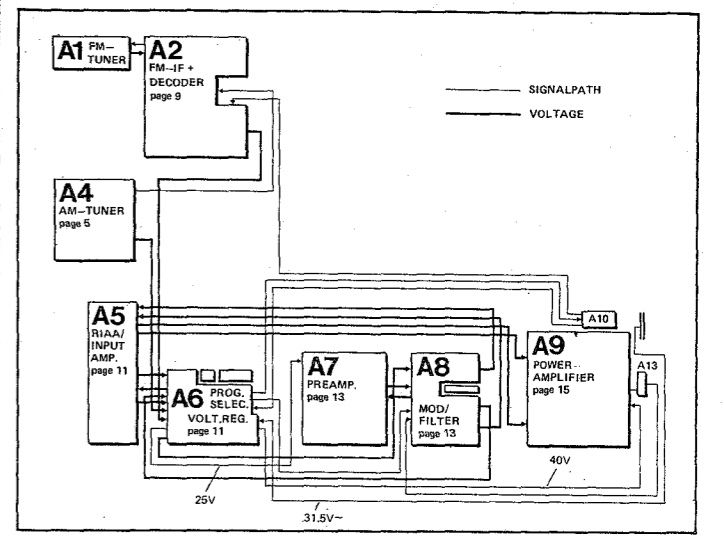
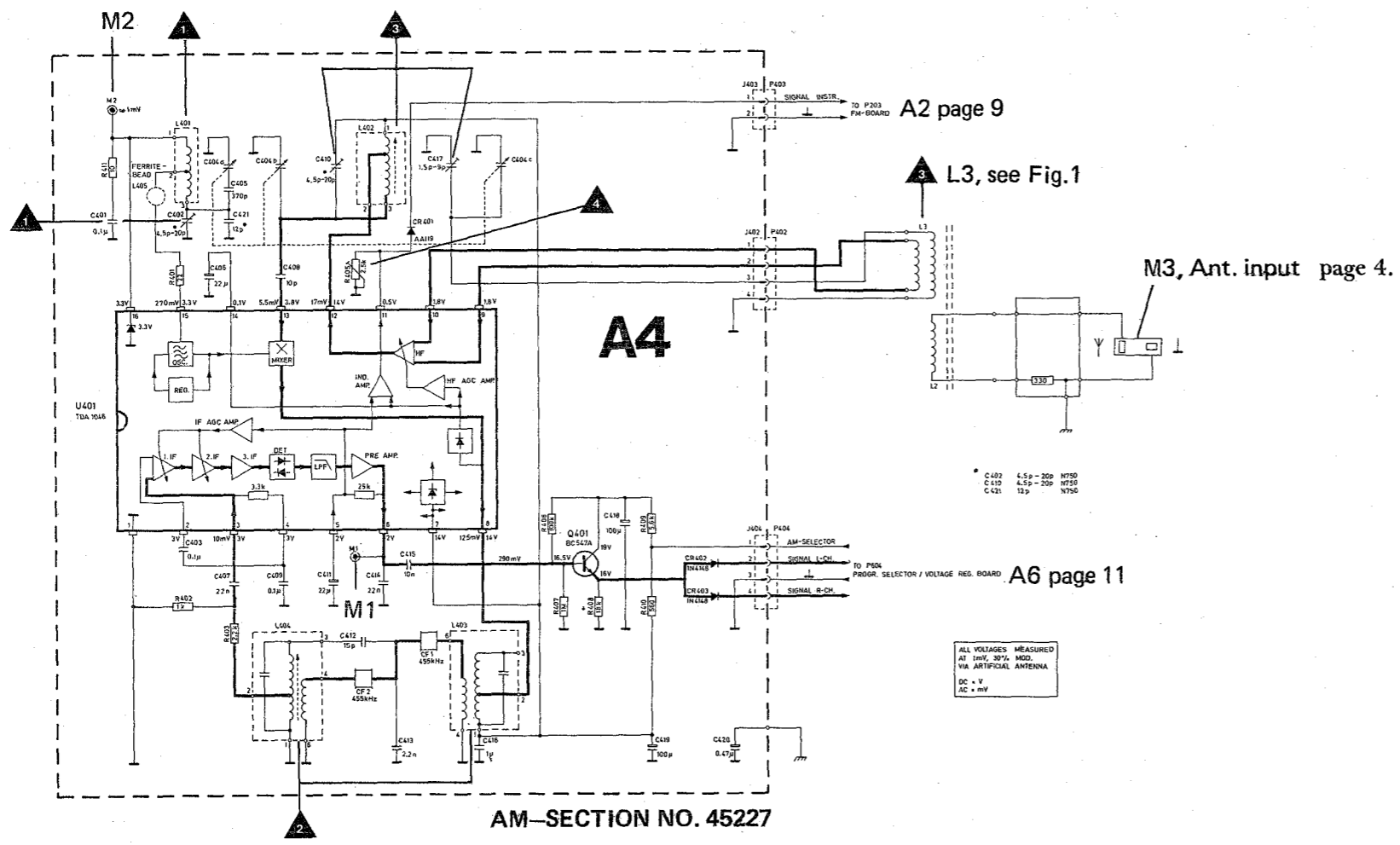

Fig. 6 AM-IF with wobbler

Signal applied to M3 via Fig. 3-4. Oscilloscope connected to M1





ALIGNMENT OF STEREO DECODER

Equipment needed:

FM stereo generator
Oscilloscope with sensitivity 5 mV/cm
Frequency counter
Selective voltmeter or a.c. voltmeter and 20 kHz low pass filter.

The decoder oscillator: 19 kHz

Apply a 1 mV signal from the FM stereo generator, unmodulated. (No pilot signal applied.)

— Adjust R304 so that the frequency counter connected to M301 indicates 19 kHz.

Alternative method without the frequency counter:

Apply a 1 mV signal from the FM stereo generator, modulation: 10% pilot signal.

— Turn R304 slowly from one extreme to the point where the stereo indicator lights up. Turn further in the same direction until the light goes out. Then turn in the opposite direction to set R304 in the middle of the range where the indicator lights.

Channel separation:

Apply a 1 mV signal from the FM stereo generator, modulation: 10% pilot signal. Modulate the right channel with 1 kHz at 30% deviation. Connect the oscilloscope to the TAPE OUT (L) socket.

— Adjust R323 to minimum deflection on the scope. Check this adjustment with the 1 kHz signal in the left channel and measure the output of the right channel.

Alternative method without the stereo generator:

— Adjust R323 for minimum signal in left (right) speaker when receiving a test FM stereo, transmission with signal in the right (left) channel only.

Muting and stereo/mono switching threshold:

Muting: Apply a 3 μ V signal from the FM-generator to the 75 ohm antenna input. Adjust the TUNING METER on the radio to center. Set R231 in the middle position and R229 fully clockwise (seen from component side). Turn R229 slowly counter-clockwise until the signal is recovered.

FM alignment procedure

Step	Alignment procedure	Receiver		Generator		Oscilloscope	Circuits		Notes
		Frequency	Frequency	Deviation	Applied to M	Connected to M	Adjust	Board No.	
5 ^A	25 V for varicap						R616	A6	Meter connected to M13. A6 page 11. Adjust to 25 V d.c. reading.
5 ^B	FM oscillator	90 MHz 105 MHz	90 MHz 105 MHz	± 22.5 kHz	*M1	**M4 via diode-probe. Fig. 10.	R204 C124	A2 A1	Check the position of the scale cursor (see Fig. 11). Check 95 MHz and 100 MHz.
6	Aerial circuit	90 MHz 105 MHz	90 MHz 105 MHz	± 200 kHz	*M1	**M4 via diode-probe. Fig. 10.	L101-L102-L103 L104,C104-C110 C112-C113	A1	Adjust for max. curve height (see Fig. 8).
7	FM - IF	90 MHz	90 MHz	± 200 kHz	*M1	**M4 via diode-probe. Fig. 10.	L107-L108	A1	Adjust for max. curve height and symmetry (see Fig. 8). FM - IF 10.6 - 10.8 MHz.
8	Discriminator	90 MHz	90 MHz	± 75 kHz	*M1 1 mV/75 ohm	***M5	L201-L202	A2	Dist./voltm. connected to M5, TAPE OUTPUT socket: Adjust L201 for max. output voltage. Afterwards adjust L202 for min. output voltage and min. distortion. See Fig. 9.
9	Center tuning meter	90 MHz	90 MHz	± 75 kHz	*M1 1 mV/75 ohm		R239	A2	Adjust for center position of the pointer, when the receiver is tuned to min. distortion. See step 8.
10 ^A 10 ^B	Signal meter	90 MHz	90 MHz	± 0 kHz	No signal. *M1, 1 mV/75 ohm		R236 R232	A2	Adjust to 0 on SIGNAL METER. Adjust to 20 on TR2075 MK II Adjust to $10^3 \mu$ V on TR2080

Stereo/mono switching threshold: Set R231 fully counter clockwise (seen from component side).

— Apply 0 μ V from the FM stereo generator to the 75 ohm antenna input modulated with 10% pilot signal.

Increase the signal from the FM-stereo generator from 0 μ V to 7,5 μ V. Turn R231 slowly clockwise until the stereo-indicator light comes on.

NOTE! The adjustments for muting and stereo/mono switching threshold interact.

Alternative method: Stereo/mono switching threshold:

If an FM-stereo generator is not available an ordinary FM-generator can be used for this adjustment.

— Apply a 7,5 μ V signal from the generator to the 75 ohm antenna input, modulated with 10 kHz, deviation 7.5 kHz (10%) (check the modulation frequency with a counter). Proceed as explained above.

* Antenna input (A1) page 9.
** See FM-IF Section (A2) page 9.
*** See Audio Section 1 (A5) page 11.

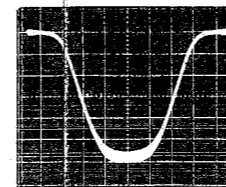

Fig. 8 FM-IF curve

Signal: $U_{in} = 150 \mu$ V/75 ohms, $f = 90$ MHz.
Dev. = ± 200 kHz applied to M1 via ant. plug.
Oscilloscope: Vert.: 5mV/div., Hor.: 50 kHz/div. connected to M4 via diodeprobe (Fig. 10).

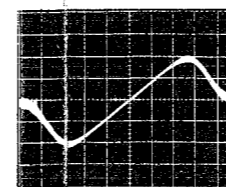

Fig. 9 Discriminator

Signal: $U_{in} = 2 \mu$ V/75 ohms, $f = 90$ MHz.
Dev. = ± 200 kHz applied to M1 via ant. plug.
Oscilloscope: Vert.: 1V/div. Hor.: 50 kHz/div. connected to M5.

Fig. 10 Diodeprobe

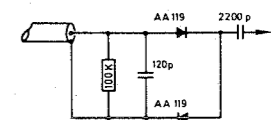
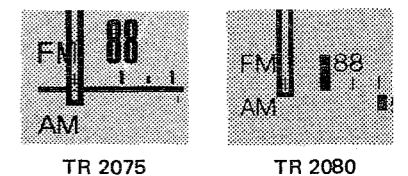
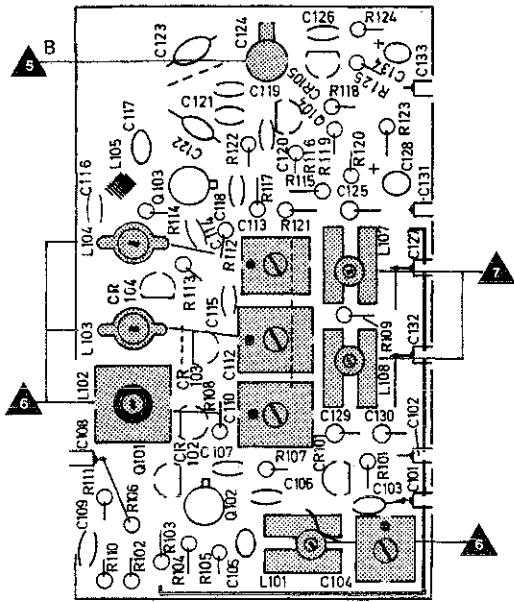

Fig. 11 Adjusting the dial pointer. The end position of the scale cursor.



A1 FM-TUNER



Seen from the component side.

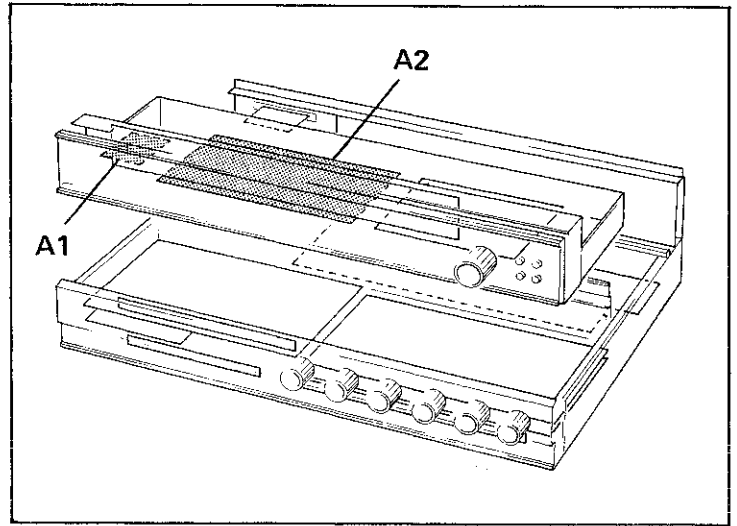

A2 FM-IF + DECODER

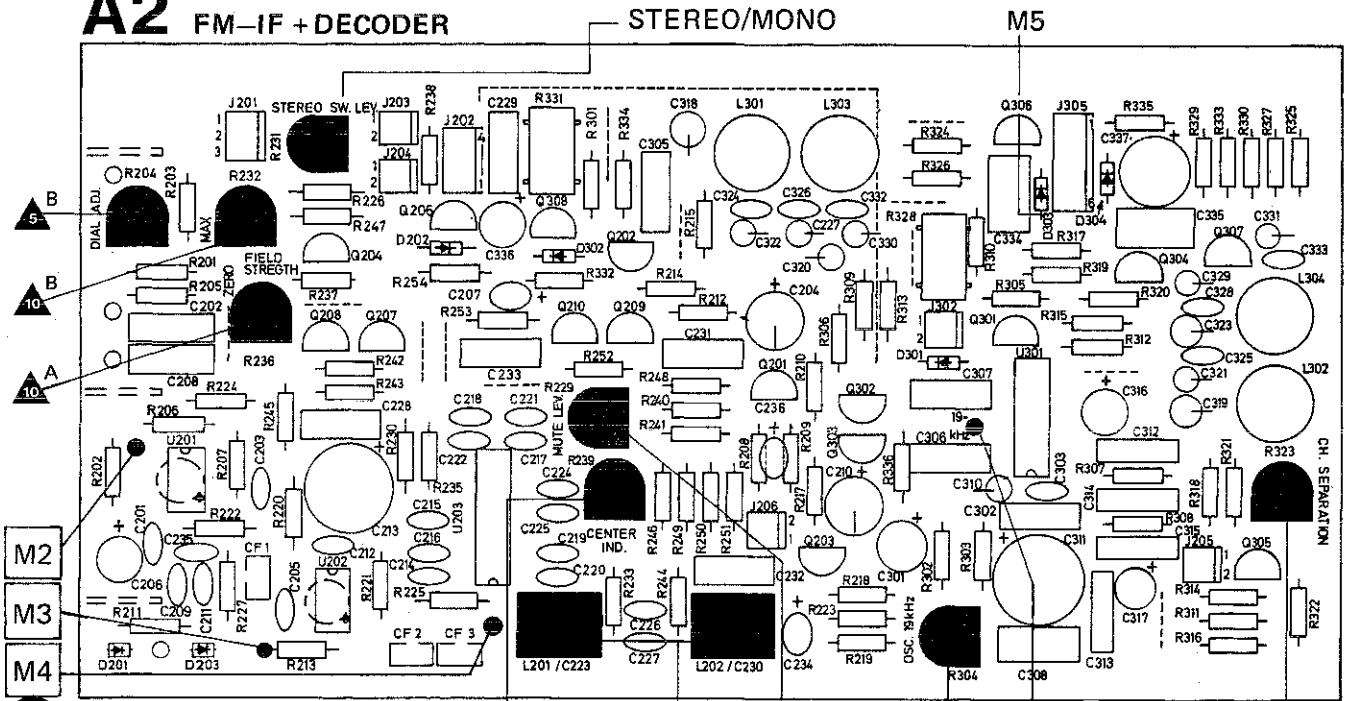

Seen from the component side.

MUTING

19 kHz
OSC.

M301

CHANNEL
SEP.

A1 FM TUNER

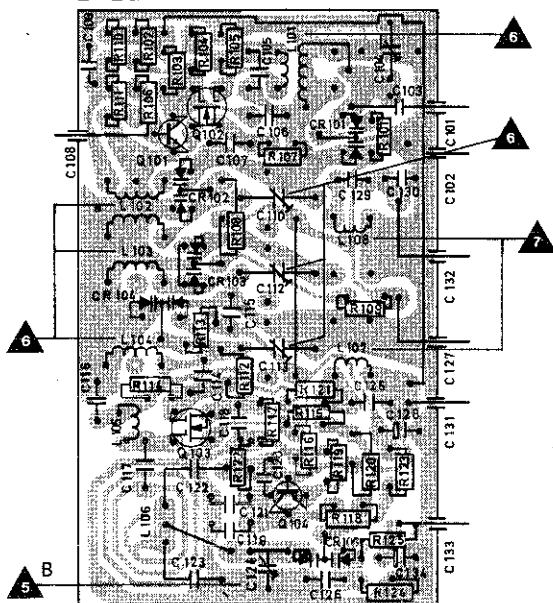

Seen from the solder side

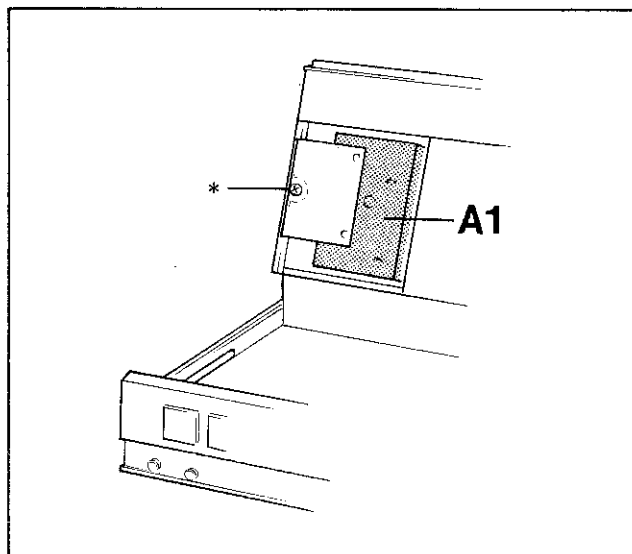

Fault finding on the FM TUNER

Turn the tuner unit up into vertical position.
 * Remove the screw shown in the figure.
 Remove the cover.

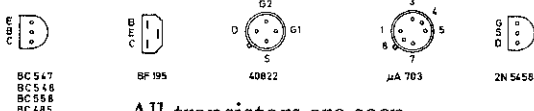

All transistors are seen from underneath

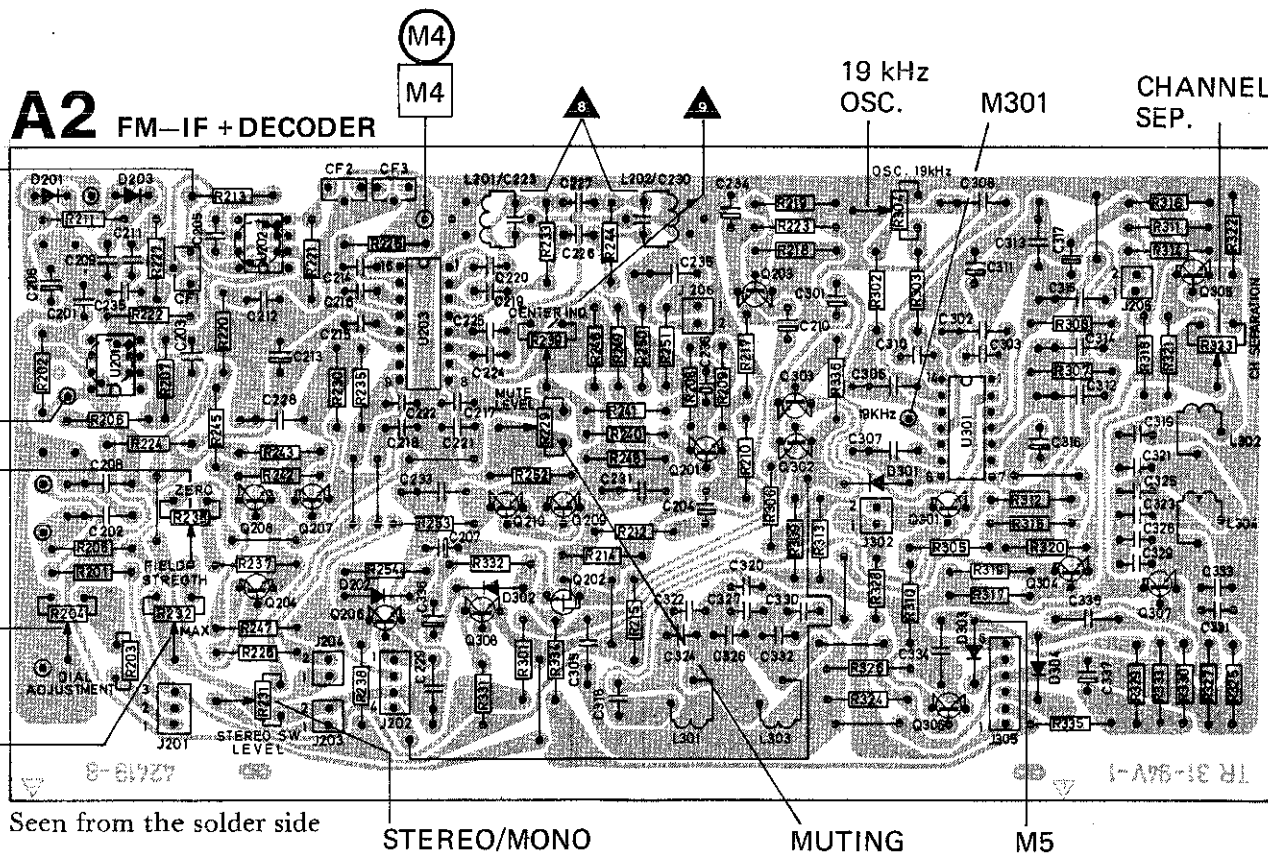

Seen from the solder side

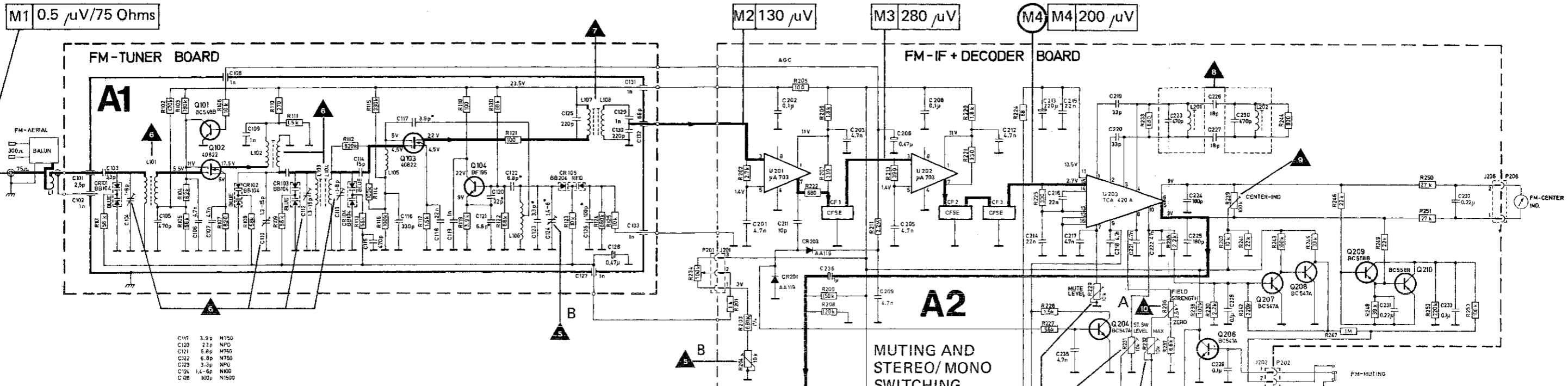

C107	3.3p	N750
C108	2.2p	N750
C109	5.6p	N750
C110	6.8p	N750
C111	3.3p	N750
C112	1.4-6p	N750
C113	100p	N1500
C114	100p	N1500
C115	100p	N1500
C116	100p	N1500
C117	3.3p	N750
C118	100p	N1500
C119	100p	N1500
C120	100p	N1500
C121	100p	N1500
C122	100p	N1500
C123	100p	N1500
C124	100p	N1500
C125	100p	N1500
C126	100p	N1500
C127	100p	N1500
C128	100p	N1500
C129	100p	N1500
C130	100p	N1500
C131	100p	N1500
C132	100p	N1500
C133	100p	N1500
C134	100p	N1500
C135	100p	N1500
C136	100p	N1500
C137	100p	N1500
C138	100p	N1500
C139	100p	N1500
C140	100p	N1500
C141	100p	N1500
C142	100p	N1500
C143	100p	N1500
C144	100p	N1500
C145	100p	N1500
C146	100p	N1500
C147	100p	N1500
C148	100p	N1500
C149	100p	N1500
C150	100p	N1500
C151	100p	N1500
C152	100p	N1500
C153	100p	N1500
C154	100p	N1500
C155	100p	N1500
C156	100p	N1500
C157	100p	N1500
C158	100p	N1500
C159	100p	N1500
C160	100p	N1500
C161	100p	N1500
C162	100p	N1500
C163	100p	N1500
C164	100p	N1500
C165	100p	N1500
C166	100p	N1500
C167	100p	N1500
C168	100p	N1500
C169	100p	N1500
C170	100p	N1500
C171	100p	N1500
C172	100p	N1500
C173	100p	N1500
C174	100p	N1500
C175	100p	N1500
C176	100p	N1500
C177	100p	N1500
C178	100p	N1500
C179	100p	N1500
C180	100p	N1500
C181	100p	N1500
C182	100p	N1500
C183	100p	N1500
C184	100p	N1500
C185	100p	N1500
C186	100p	N1500
C187	100p	N1500
C188	100p	N1500
C189	100p	N1500
C190	100p	N1500
C191	100p	N1500
C192	100p	N1500
C193	100p	N1500
C194	100p	N1500
C195	100p	N1500
C196	100p	N1500
C197	100p	N1500
C198	100p	N1500
C199	100p	N1500
C200	100p	N1500
C201	100p	N1500
C202	100p	N1500
C203	100p	N1500
C204	100p	N1500
C205	100p	N1500
C206	100p	N1500
C207	100p	N1500
C208	100p	N1500
C209	100p	N1500
C210	100p	N1500
C211	100p	N1500
C212	100p	N1500
C213	100p	N1500
C214	100p	N1500
C215	100p	N1500
C216	100p	N1500
C217	100p	N1500
C218	100p	N1500
C219	100p	N1500
C220	100p	N1500
C221	100p	N1500
C222	100p	N1500
C223	100p	N1500
C224	100p	N1500
C225	100p	N1500
C226	100p	N1500
C227	100p	N1500
C228	100p	N1500
C229	100p	N1500
C230	100p	N1500
C231	100p	N1500
C232	100p	N1500
C233	100p	N1500
C234	100p	N1500
C235	100p	N1500
C236	100p	N1500
C237	100p	N1500
C238	100p	N1500
C239	100p	N1500
C240	100p	N1500
C241	100p	N1500
C242	100p	N1500
C243	100p	N1500
C244	100p	N1500
C245	100p	N1500
C246	100p	N1500
C247	100p	N1500
C248	100p	N1500
C249	100p	N1500
C250	100p	N1500

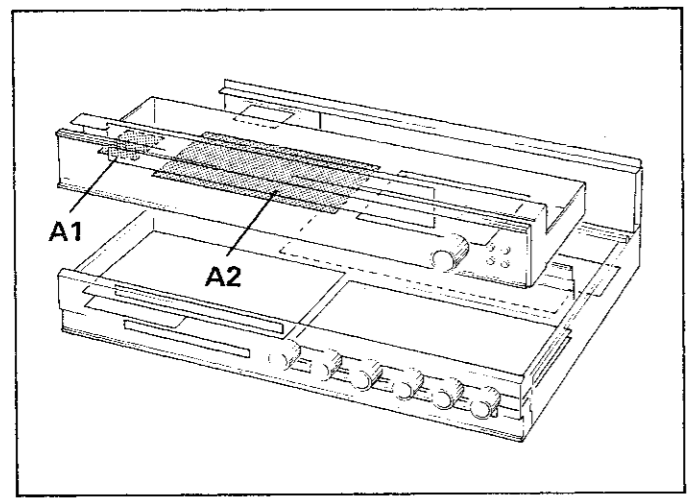
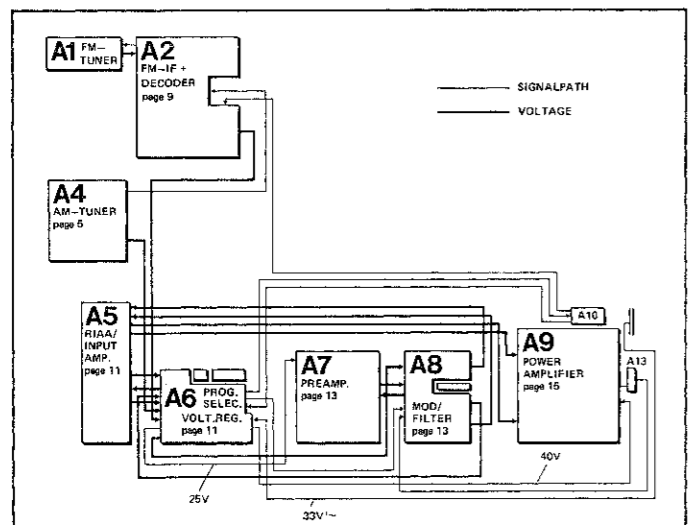

NOTE! The sensitivity measurements mentioned in the circuit diagram were made with a voltage divider in series with the sig. generator for M2, M3, and M4 (see figure below).

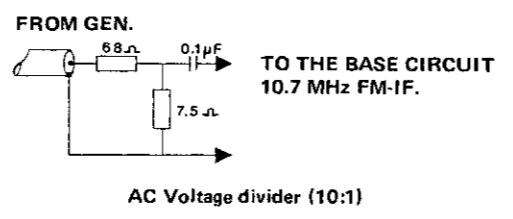

NOTE! The leads of the components in the voltage divider must be as short as possible.

THE MEASUREMENTS ARE MADE AS FOLLOWS:

- M5:** Out max. AF voltage, reduced by 3 dB.
- M1:** In 0.5 μ V from sig. generator, 100% modulation.
- M5:** Out max. AF voltage, reduced by 3 dB.
- M2:** In 130 μ V from sig. generator, 100% modulation.
- M5:** Out max. AF voltage, reduced by 3 dB.
- M3:** In 280 μ V from sig. generator, 100% modulation.
- M5:** Out max. AF voltage, reduced by 3 dB.
- M4:** In 200 μ V from sig. generator, 100% modulation.

NOTE! There can be a slight spread on the sensitivity measurement figures between different receivers.

*** NOTE!** When measuring only the sensitivity between M1 and M5 you can use the TAPE OUT (pin 1 or 4) socket as M5 to avoid dismantling the cabinet.

NOTE! When leading a signal from a sig. generator into the circuit, connect the generator positive and negative lead across the IC.

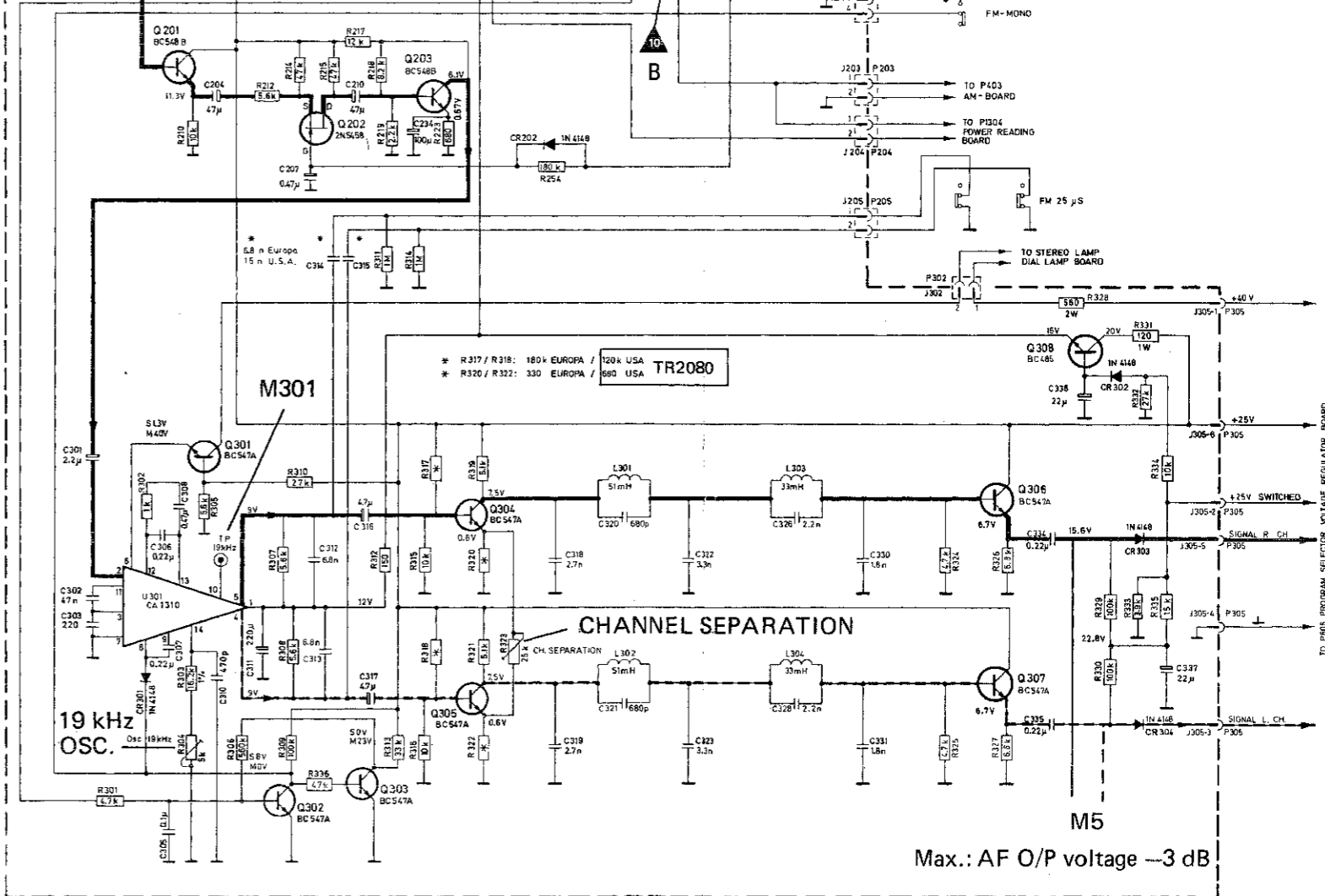

Max.: AF O/P voltage -3 dB

FM-SECTION NO. 45226

A5 RIAA/ INPUT AMP.

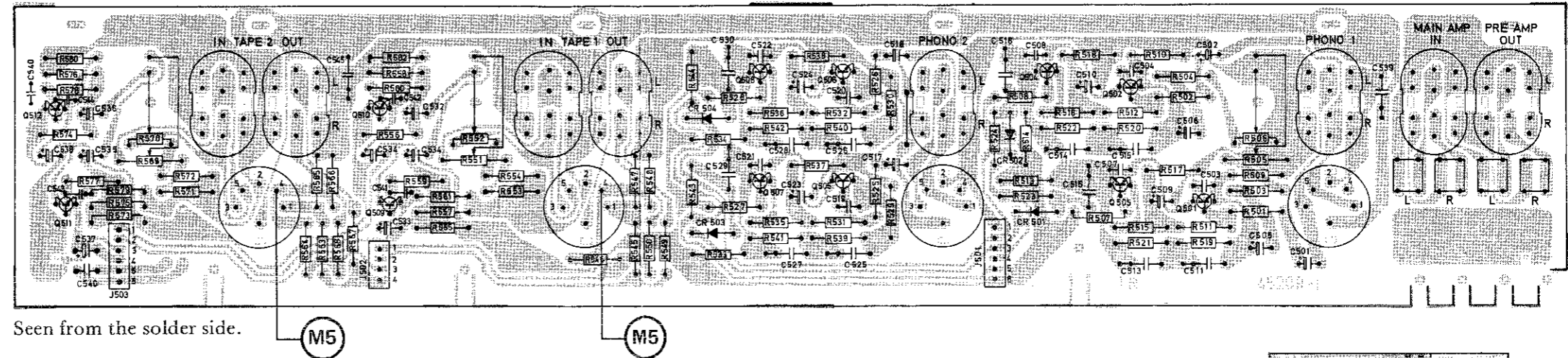

The transistors are seen from underneath.



Seen from the solder side.

"Pops" when switching the POWER OFF.
See page 15.

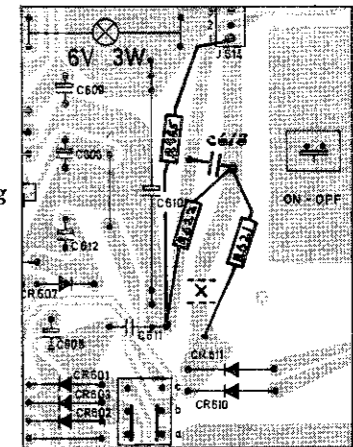

A6 PROGRAM SELECT/ VOLTAGE REG.

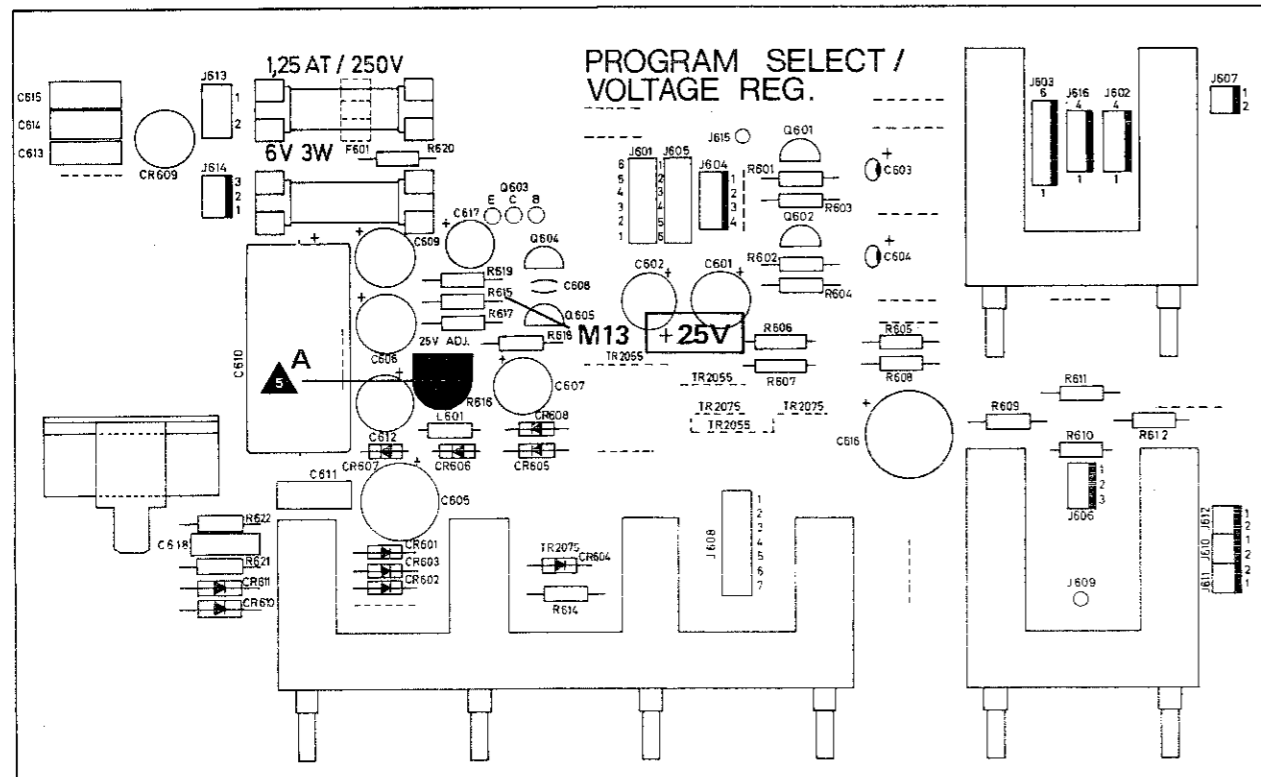

Seen from the component side.

A6 PROGRAM SELECT/ VOLTAGE REG.

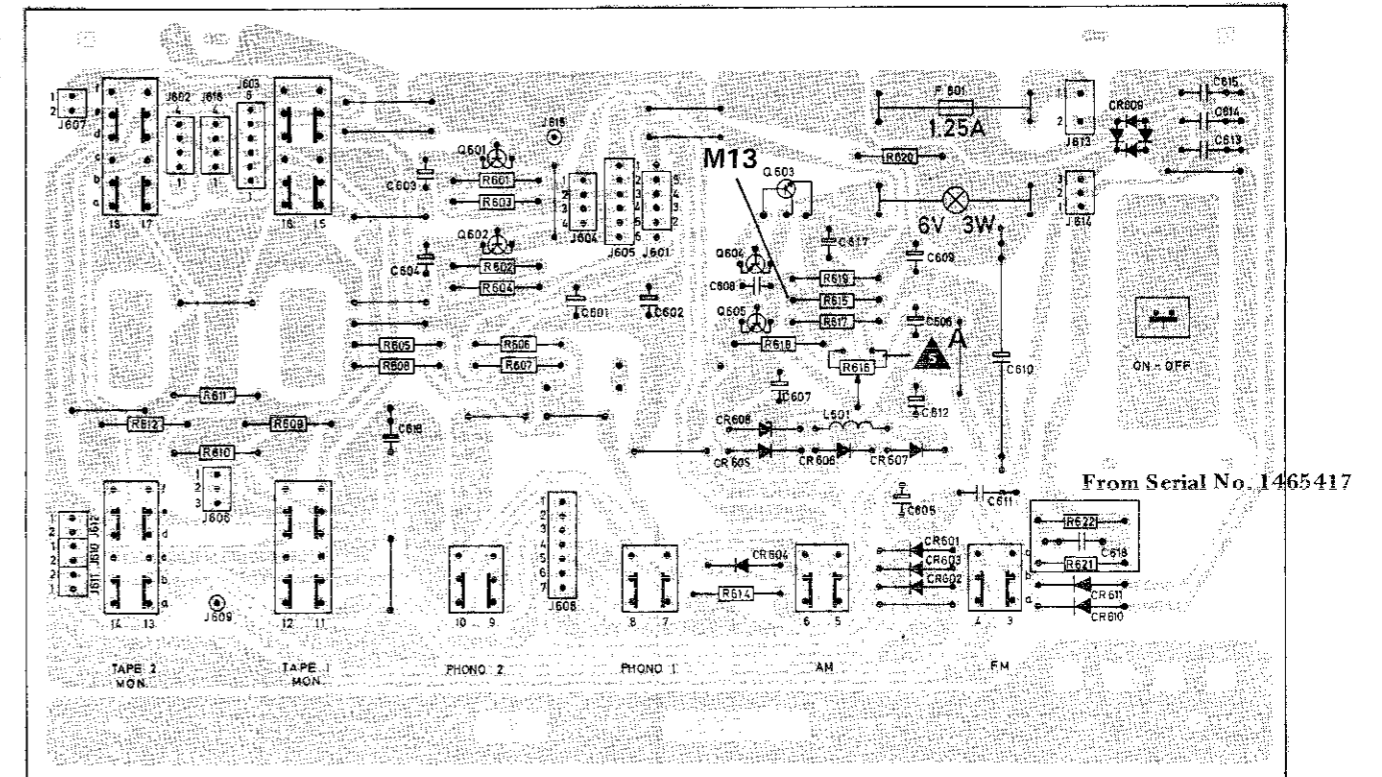

Seen from the solder side.

RIAA / INPUT AMP. BOARD

A5

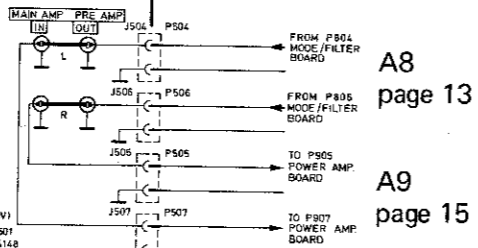
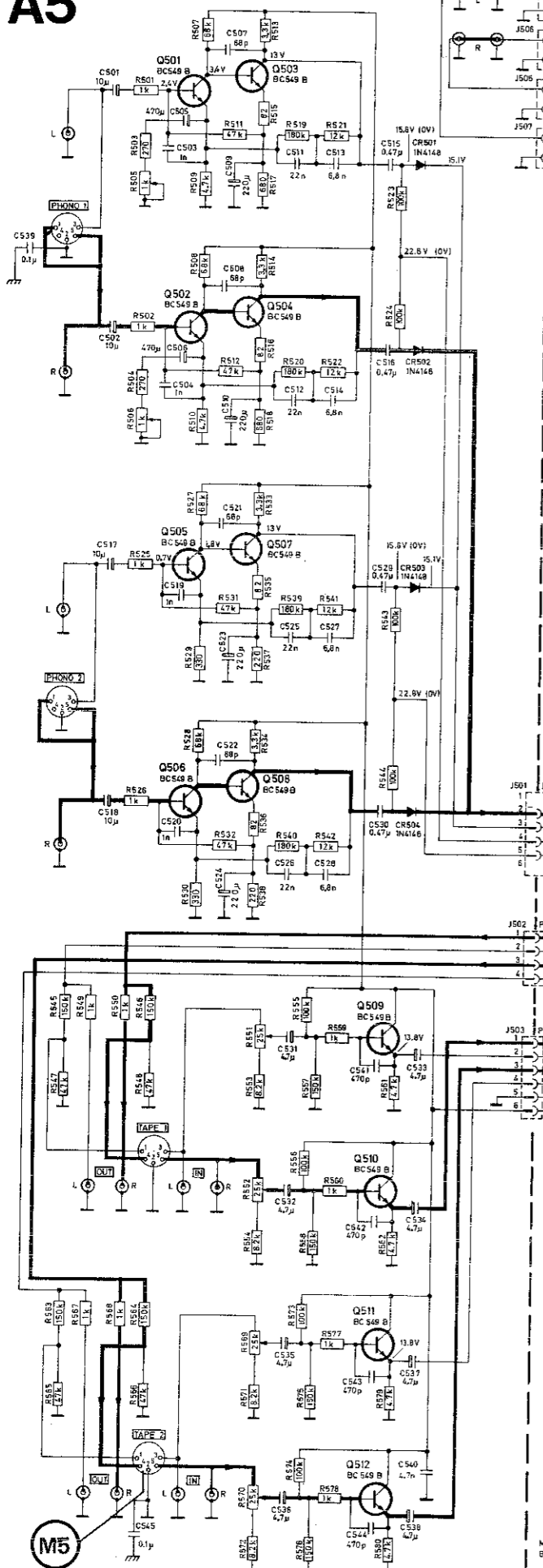

A8 page 13

A9 page 15

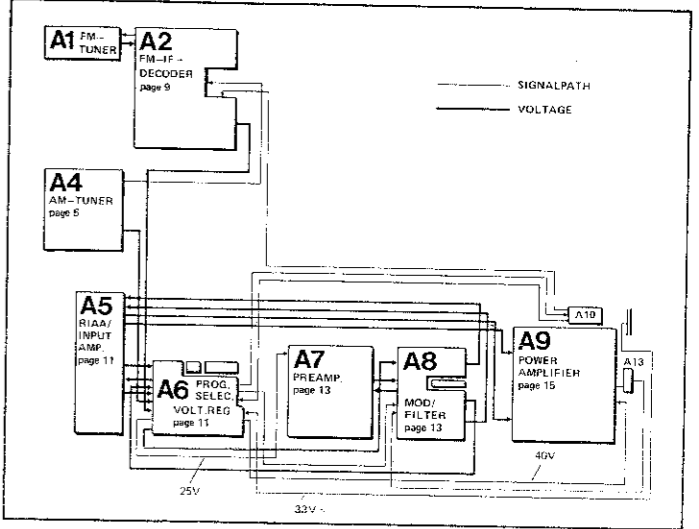
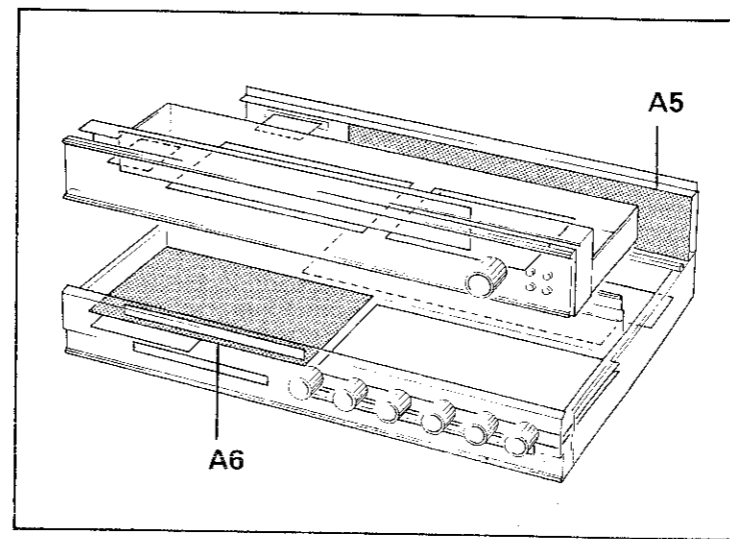

All selectors are shown in unoperated position.

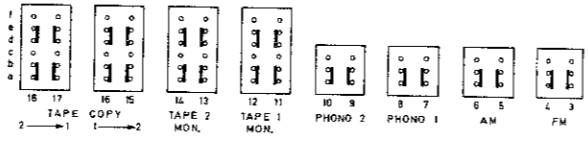

PROGRAM SELECT./VOLTAGE REG. BOARD

A6

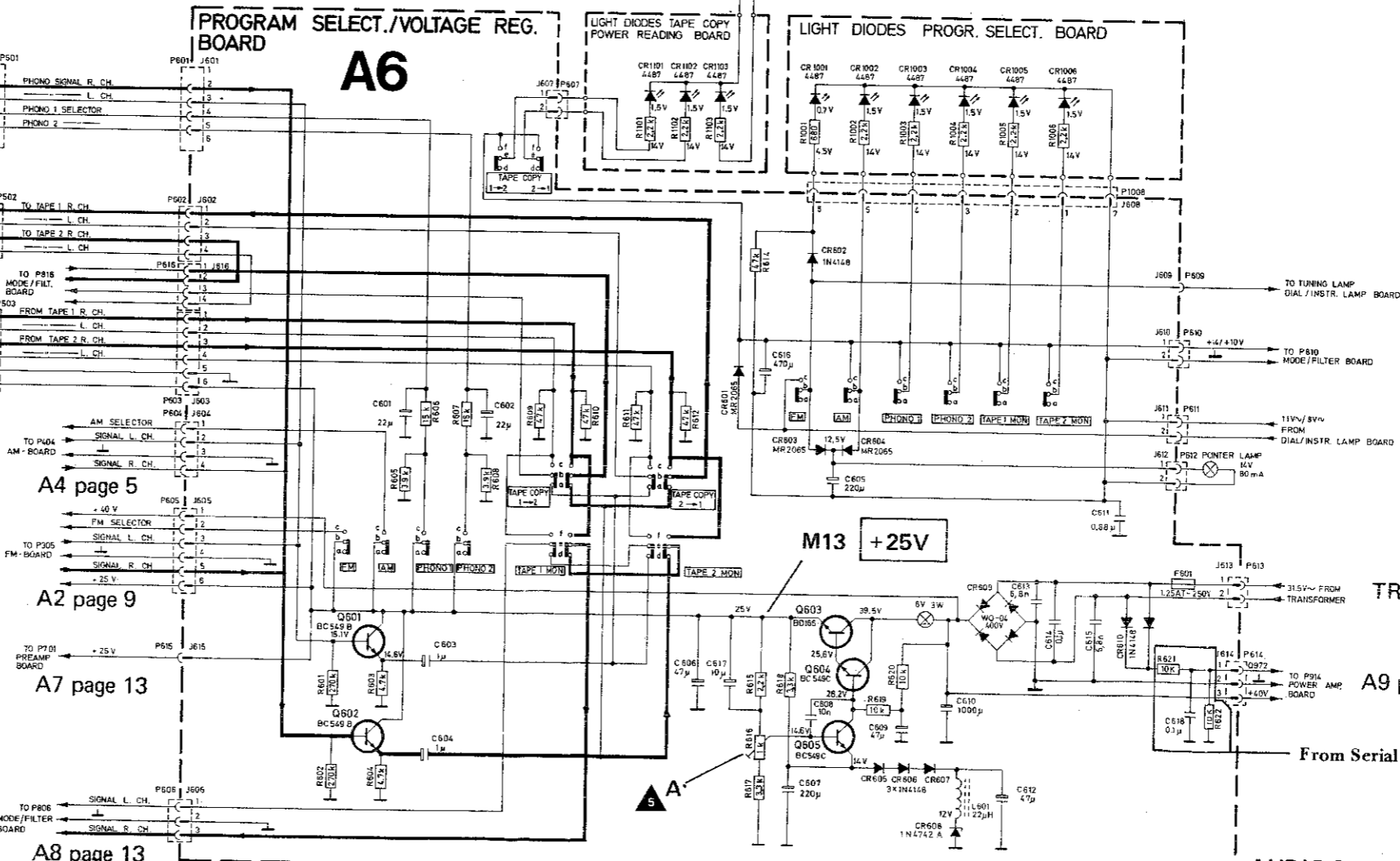

A4 page 5

A2 page 9

A7 page 13

A8 page 13

A10 page 15

A8 page 13

A10 page 15

TRAF0 page 15

A9 page 15

From Serial No. 1465417

A7 PREAMPLIFIER

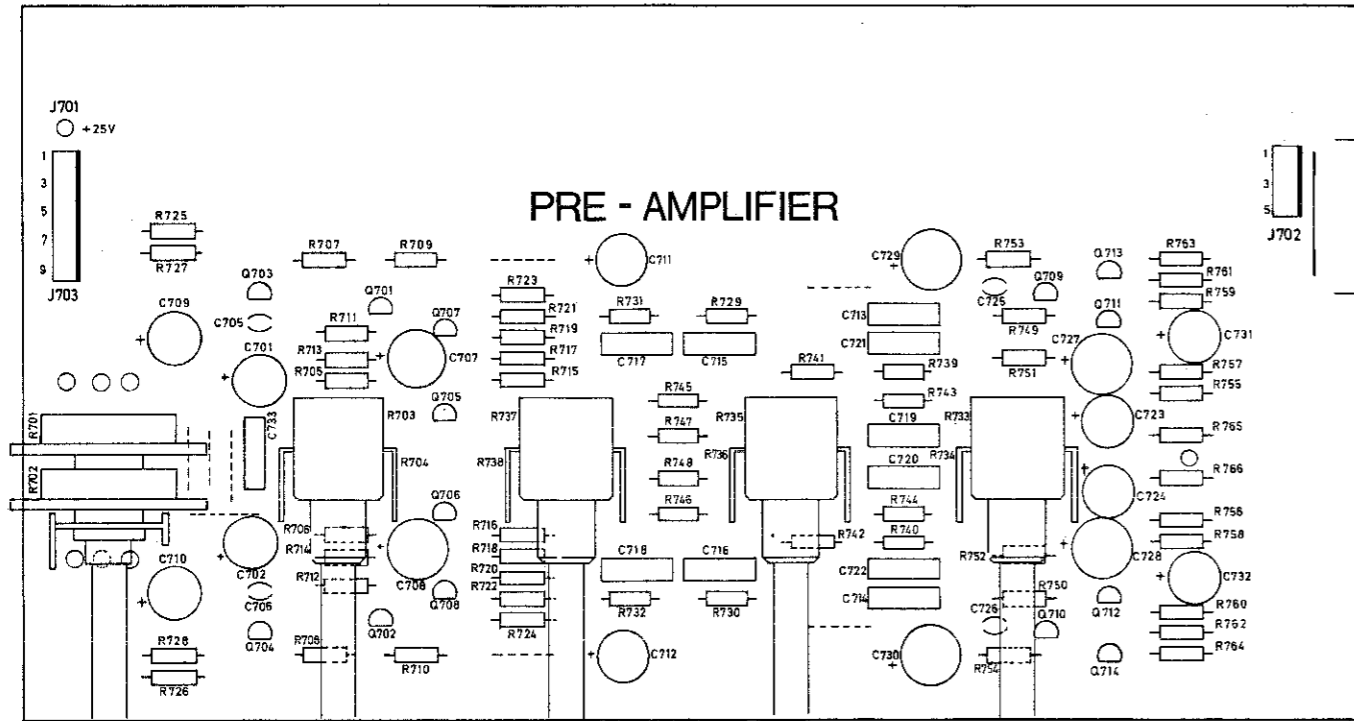

Seen from the component side.

A7 PREAMPLIFIER

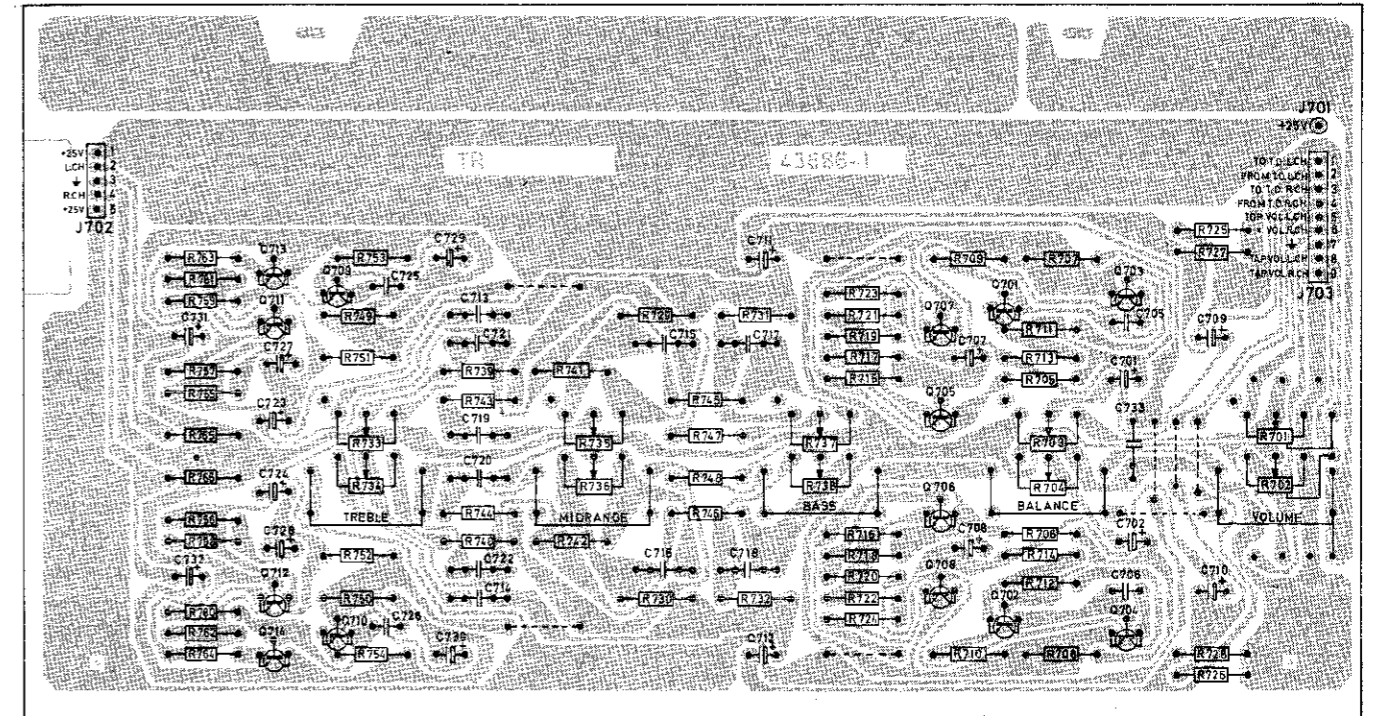

Seen from the solder side.

 The transistors are seen from underneath.

A8 MODE/FILTER

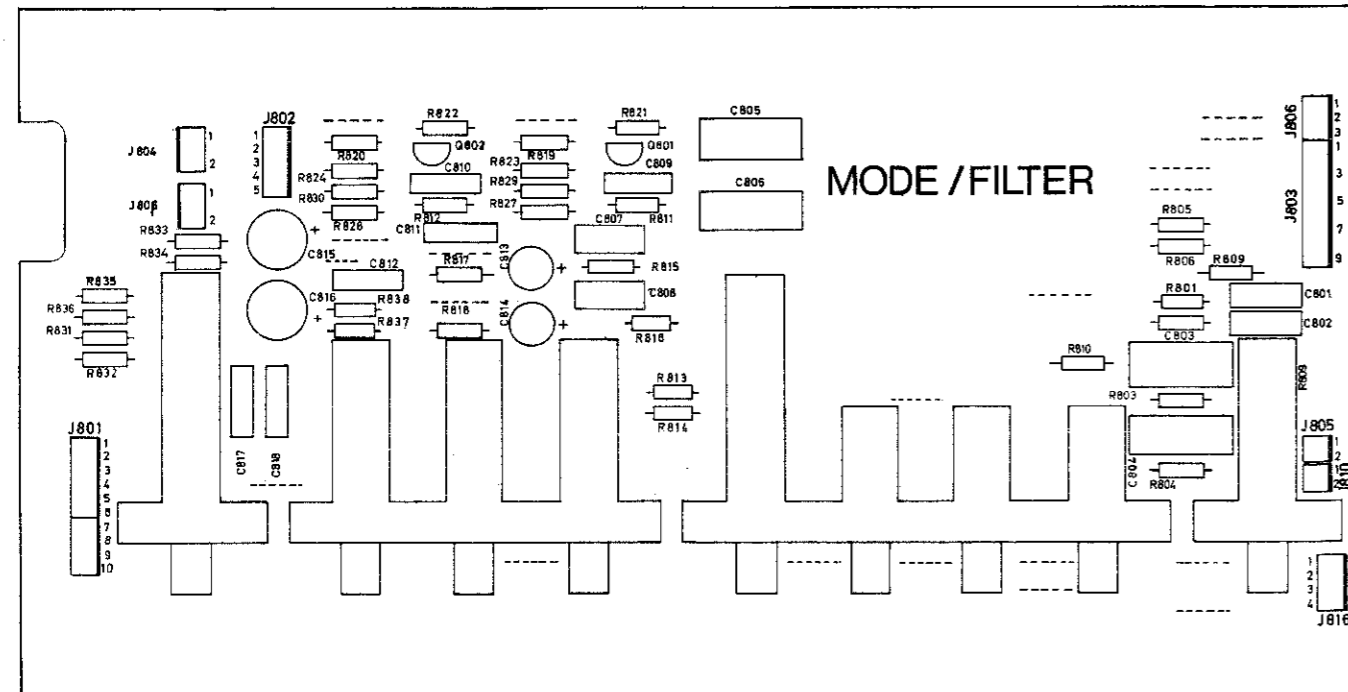

Seen from the component side.

A8 MODE/FILTER

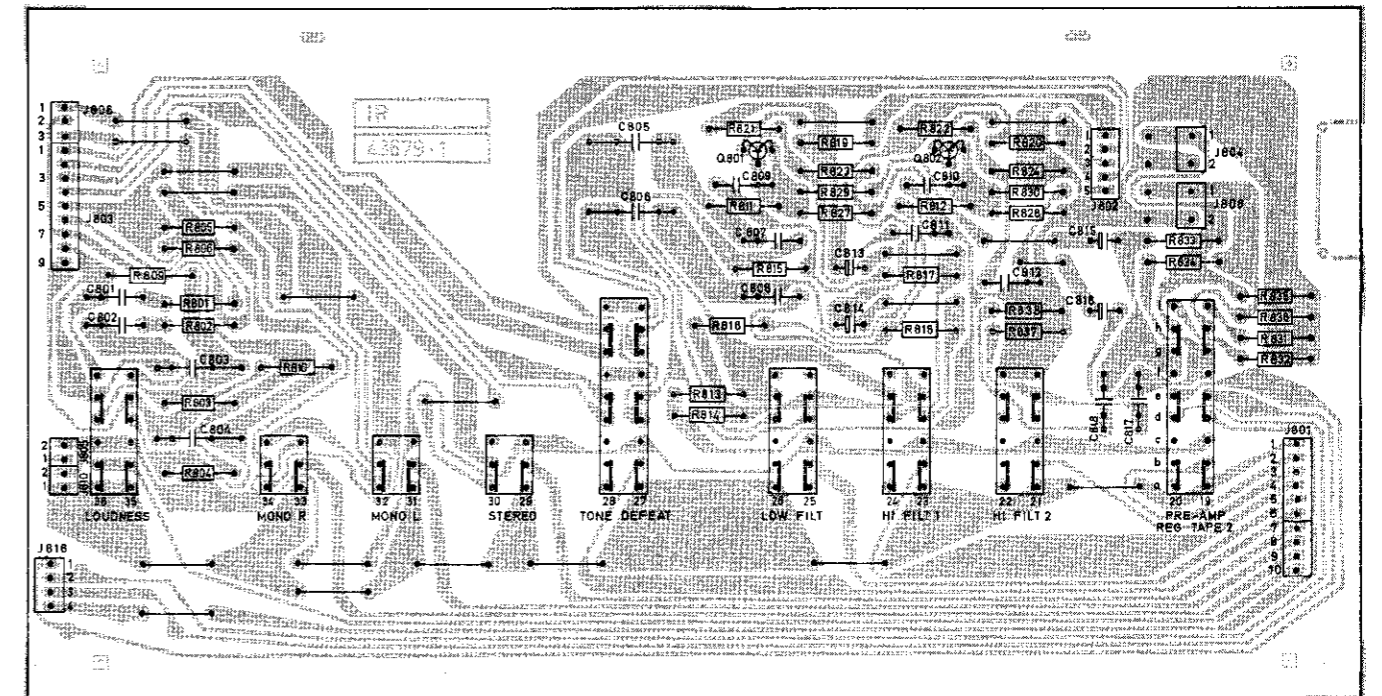

Seen from the solder side.

All selectors are shown in unoperated position.

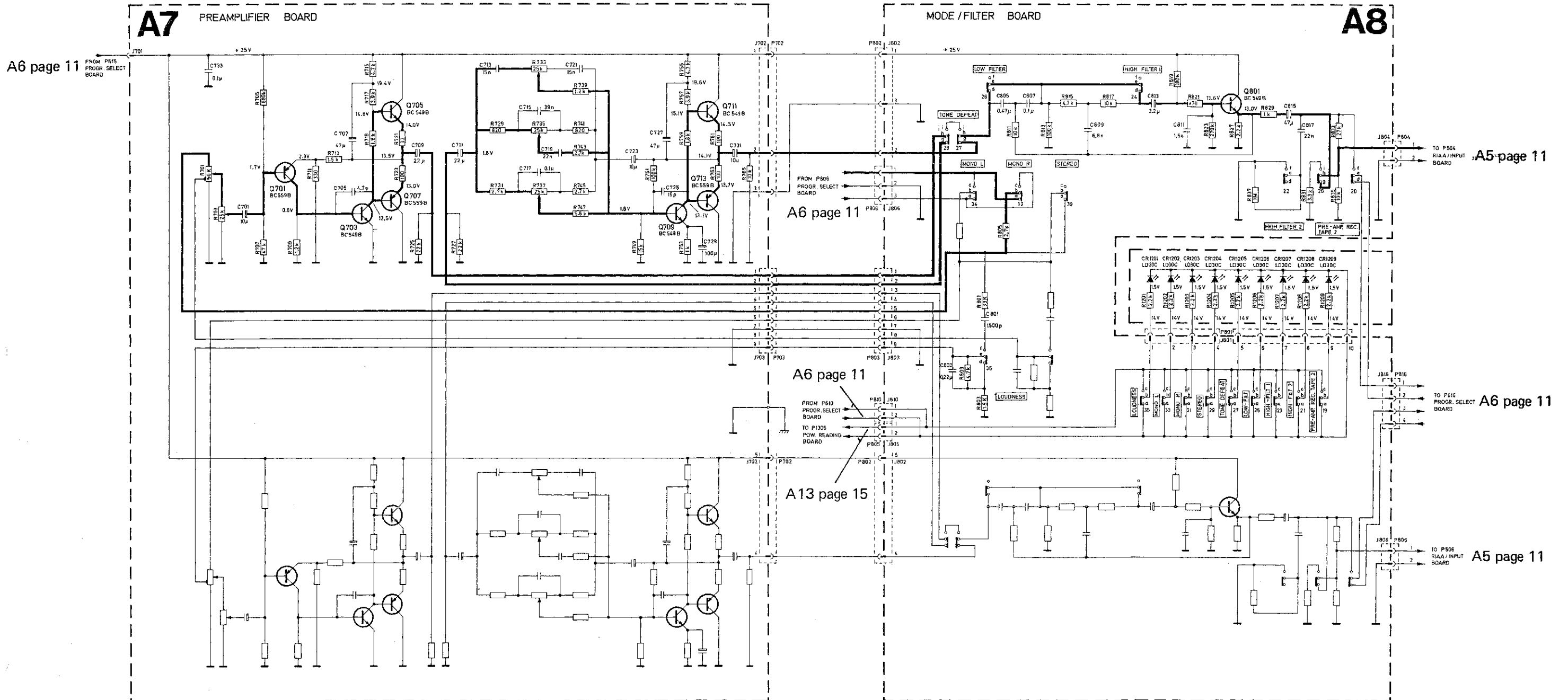
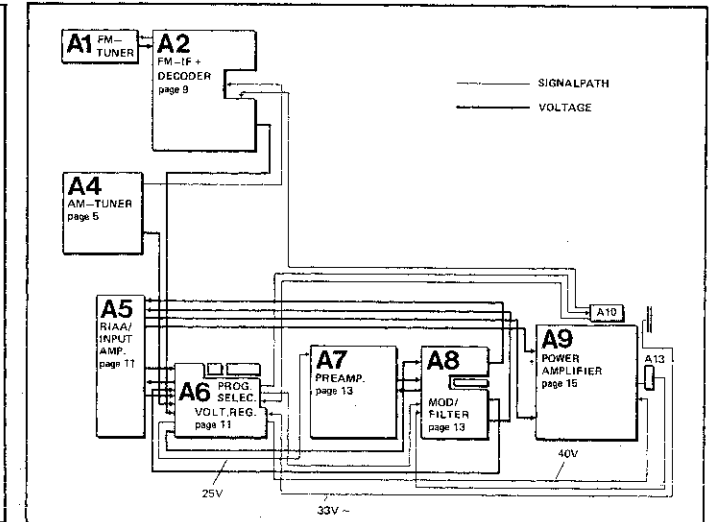
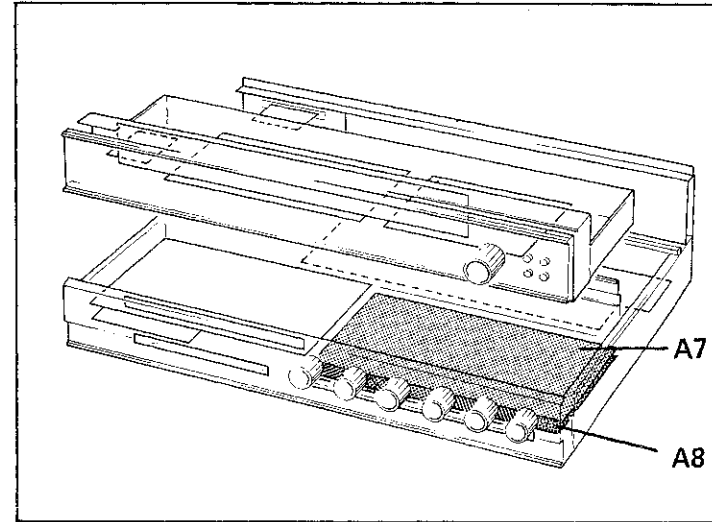
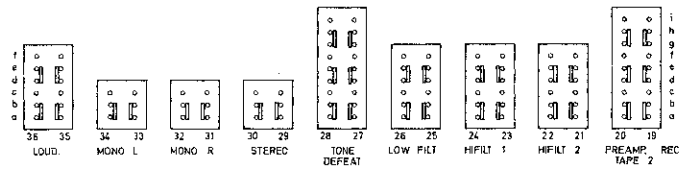

A13 POWER READING

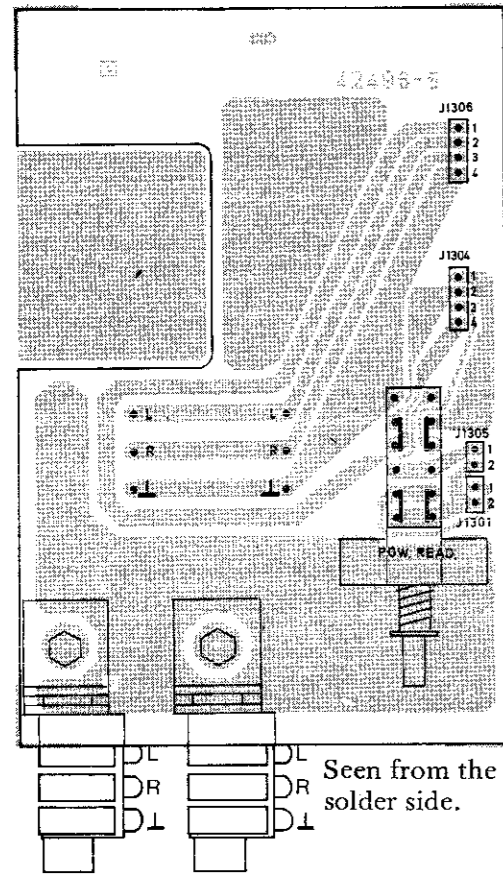

Seen from the solder side.

A9 POWER AMPLIFIER

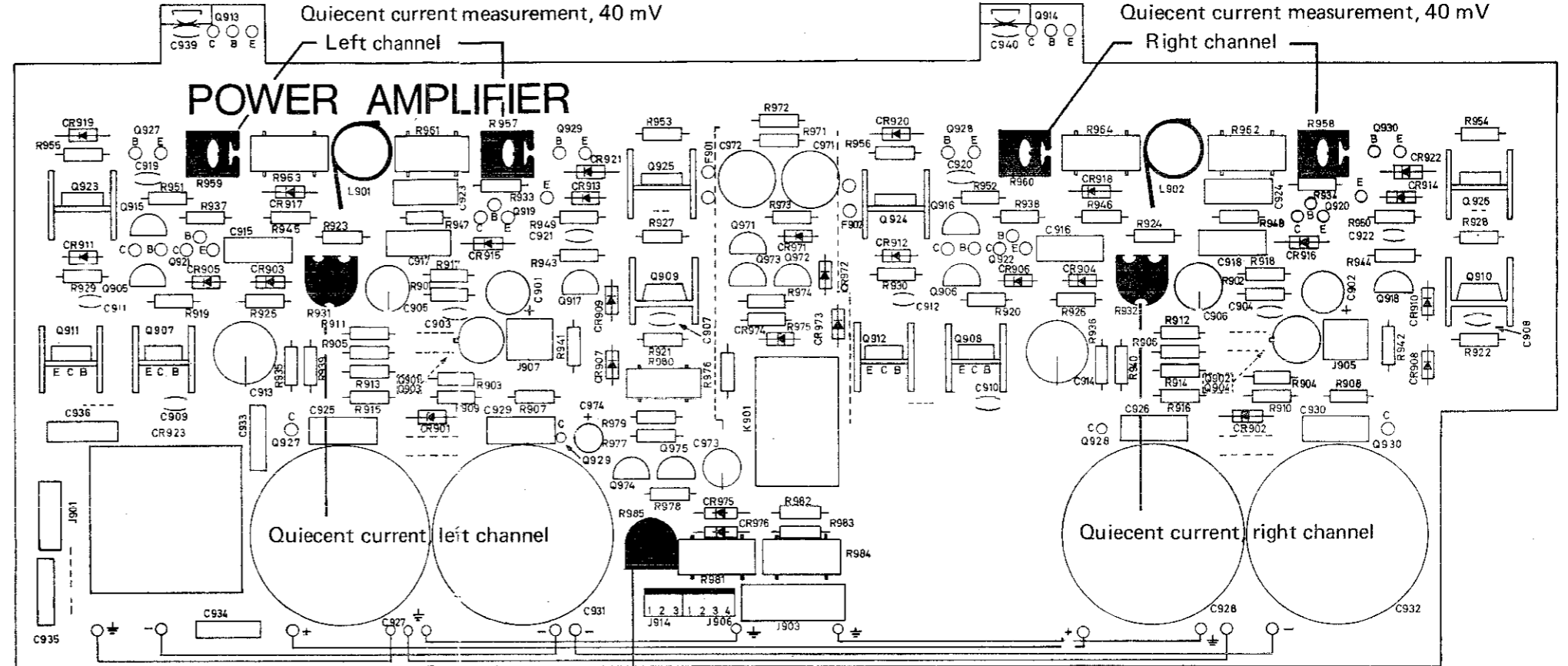

Seen from the component side

R985, POWER READING

A9 POWER AMPLIFIER

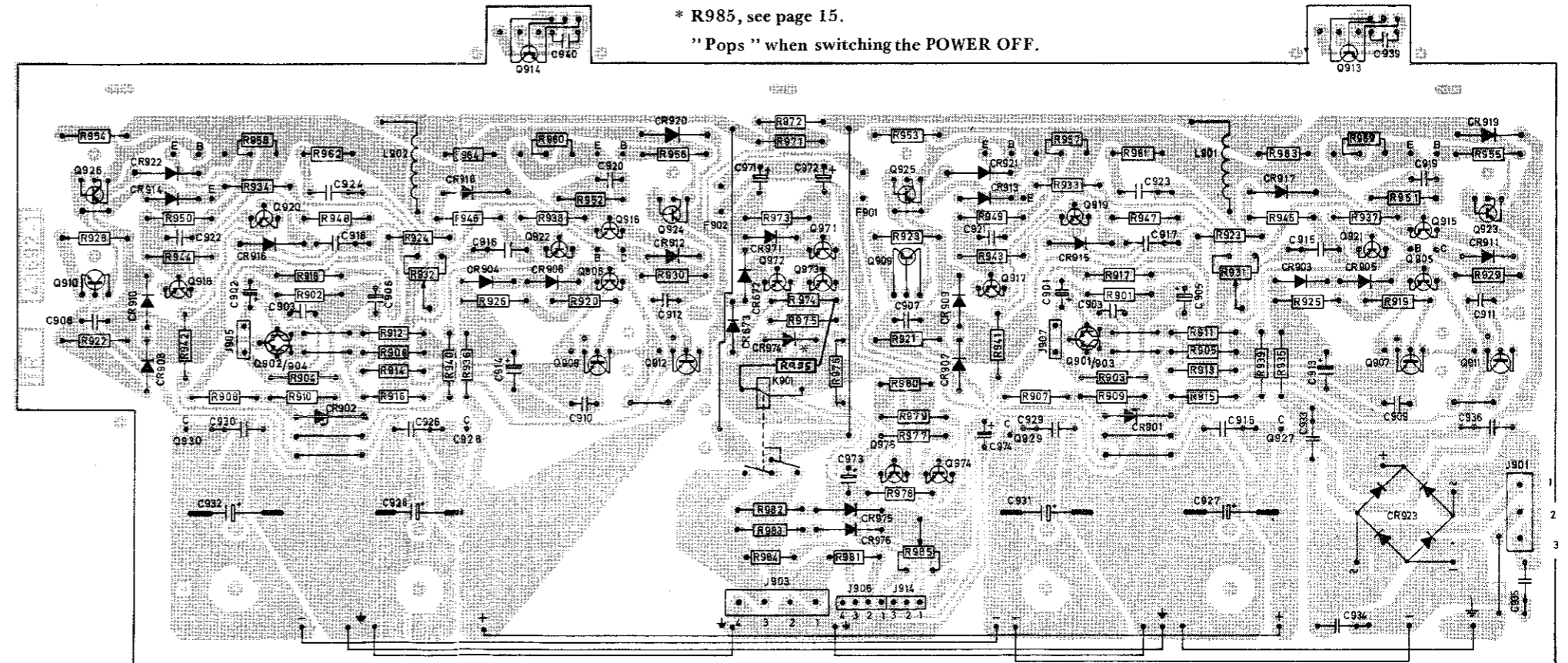

Seen from the solder side

- BC546
- BC556
- BC547
- BC548
- BC557
- BC558

The transistors are seen from underneath.

- BF 381
- 2SB528
- ZSC1583
- 2N 5030
- 2N 5030

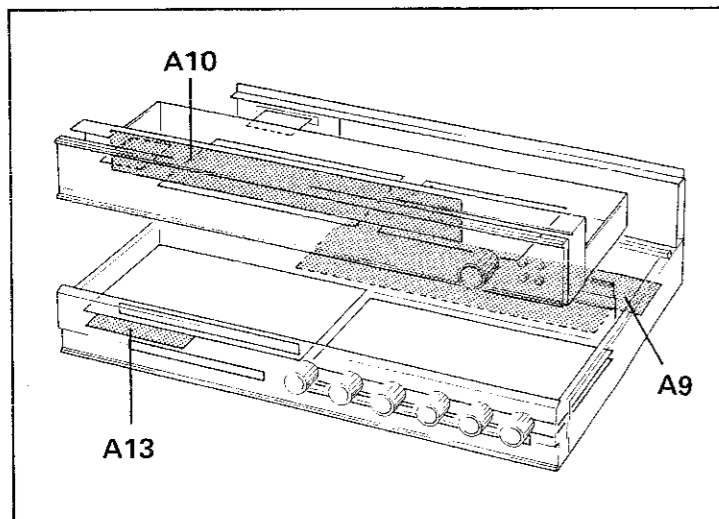

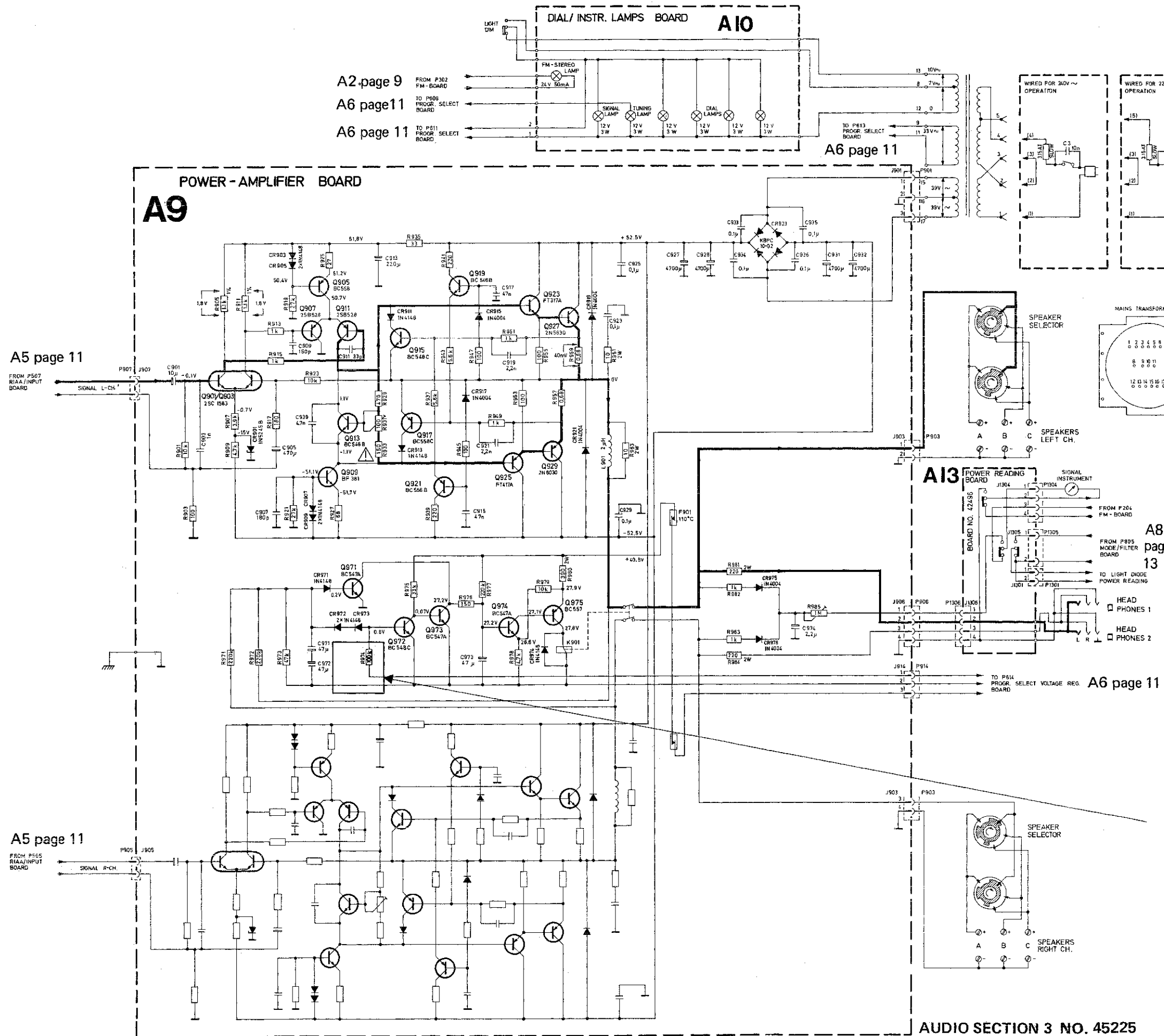

A2 page 9
A6 page 11
A6 page 11

A6 page 11

A5 page 11

FROM P507
RIAA INPUT BOARD

A5 page 11

FROM P505
RIAA INPUT BOARD

POWER READING

Output power indicator (SIGNAL meter).

Depress the button POWER READING. Apply a signal to TAPE 1 input and measure the a.c. voltage across the speaker output.

TR2075 MK II

Adjust the input voltage or the VOLUME until the output voltage is 25 volts.

Adjust R985 for the same reading on the SIGNAL meter.

TR2080

Adjust the input voltage or the VOLUME until the output voltage is 20 volts.

Adjust R985 to 50 (W) on the SIGNAL meter.

AF - ADJUSTMENTS.

Quiescent current.

The most convenient place to connect the voltmeter is between the top of emitter resistors R957/R959 (left channel) and R958/R960 (right channel) on the component side of the board.

After 10 minutes warm-up (with the volume control in minimum position), the voltage should be 40 mV. If necessary, adjust with R931 (left channel) and R932 (right channel).

" Pops " when switching the POWER OFF, to Serial No. 1465417.

R974, 470K, replace with 100K.

- * R985, 470K, remove.
- ** R621, 10K, new.
- ** R622, 10K, new.
- ** C618, 0.1μF, new.

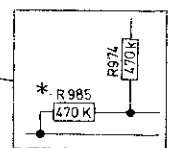

* R985 are mounted on the solder side on board A6, see page 10.
In some receivers the R985 are mounted on the solder side of board A9, see page 14.

** Solder R621, R622 and C618 on to the solder side on board A6, see page 10.
Cut the foil between the legs on R621.

AUDIO SECTION 3 NO. 45225