

1079077

Service Manual

TR-2075

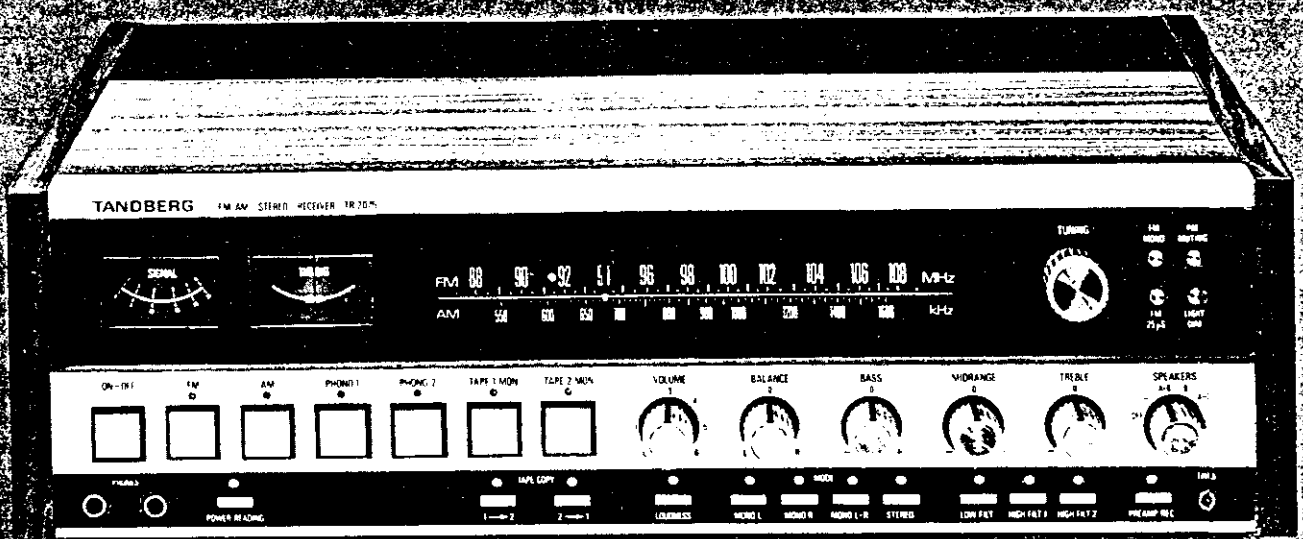

TANDBERG

MECHANICAL SERVICE

Removing the cabinet.

Unscrew the screws in the side plates and take the plates off. The top plate is then free to be removed as shown in the figure.

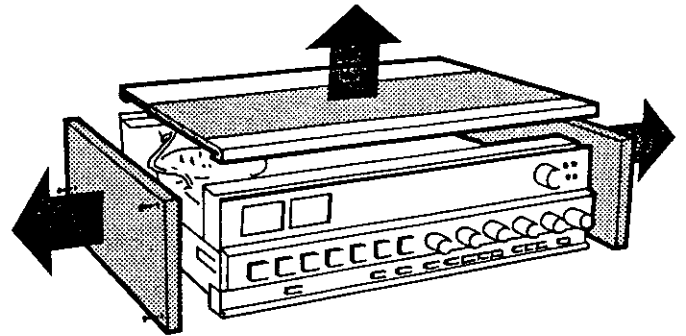

FM and AM tuner.

Swing the tuner up to the position shown in Figure 1. Put a screwdriver or similar into the hole in the cooling fin as shown in Figure 2.

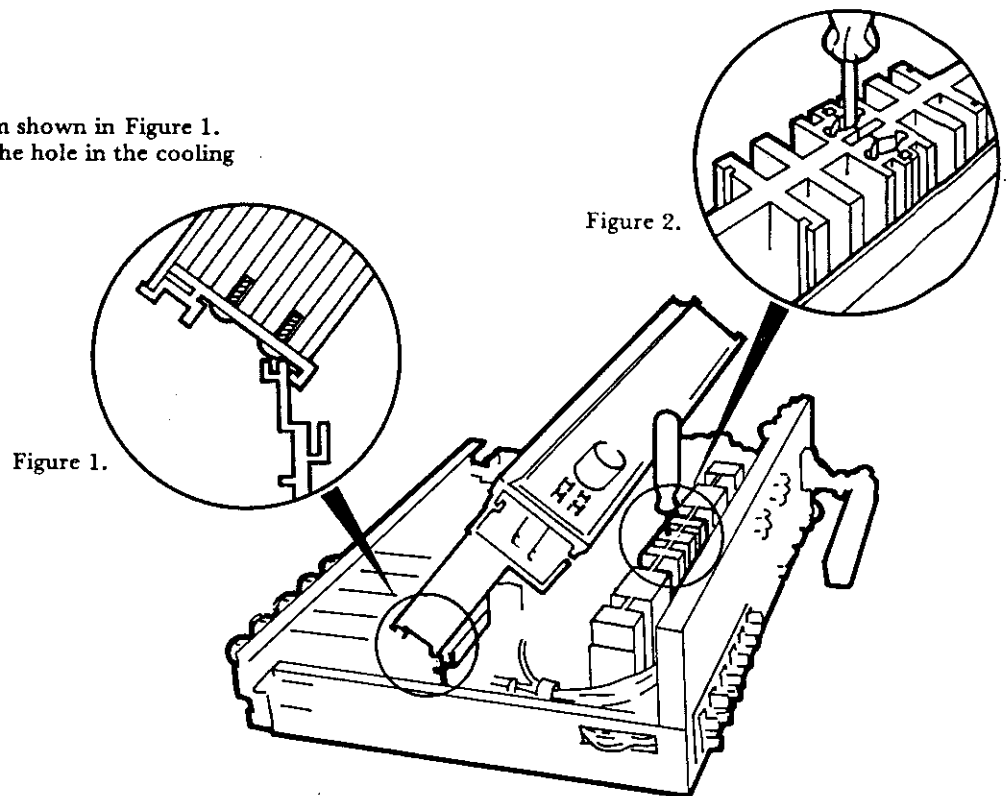

A7

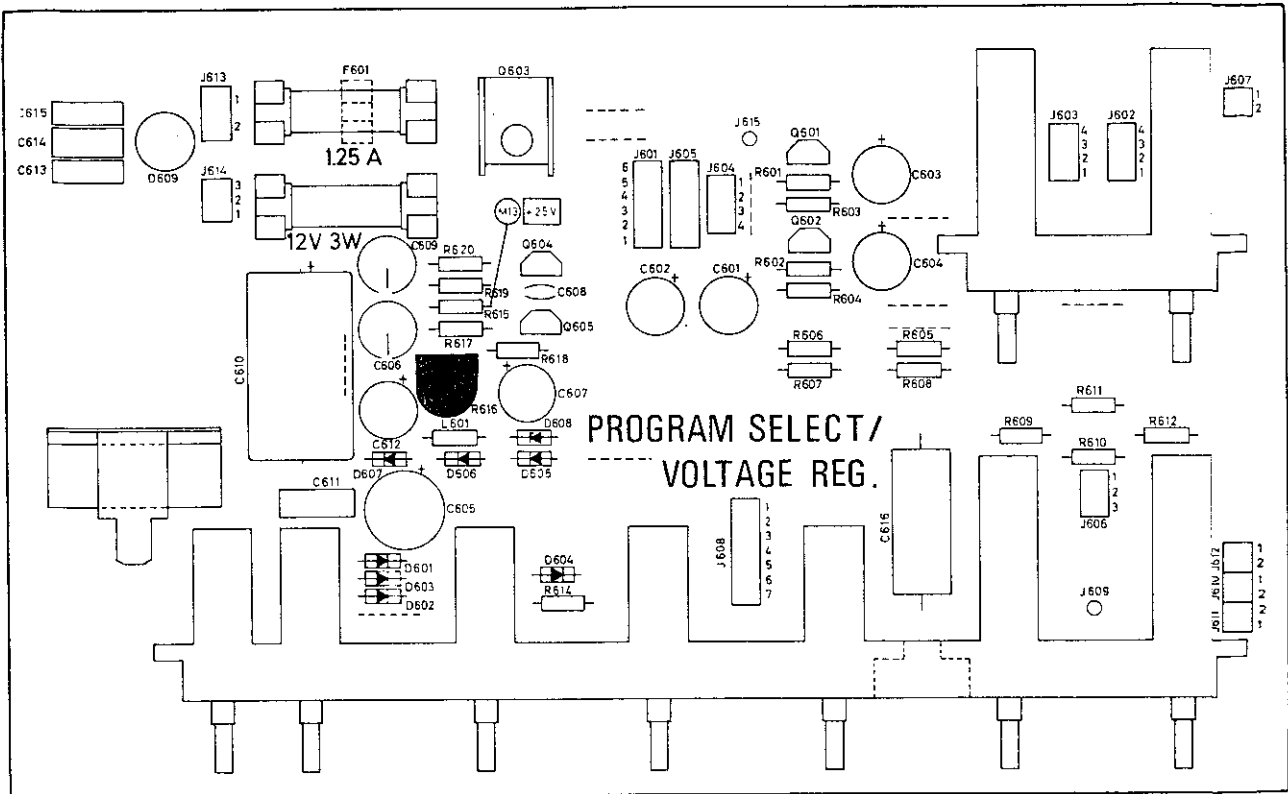

Seen from component side.

A7

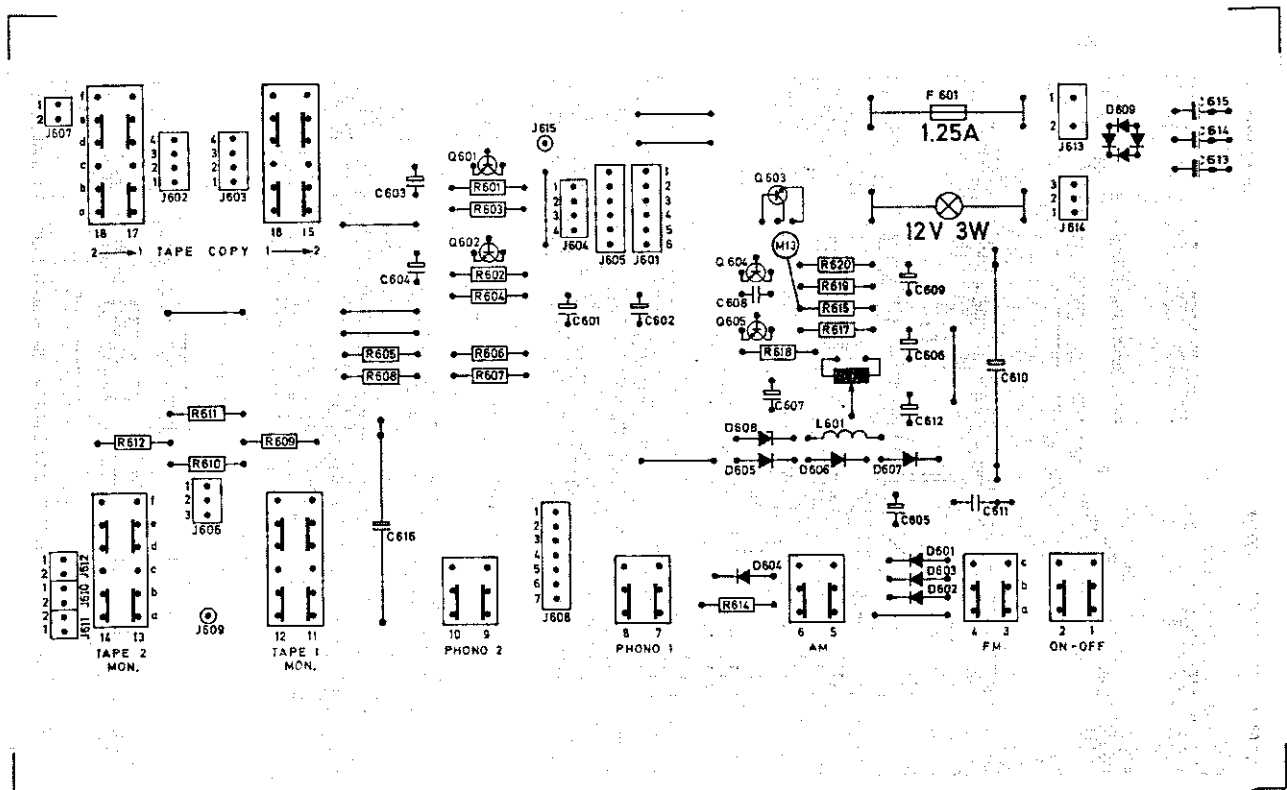

Seen from solder side.

Cord drive.

The cord drive is shown below.

Cord drive length: 115 cm. + spring (45,3" + spring).

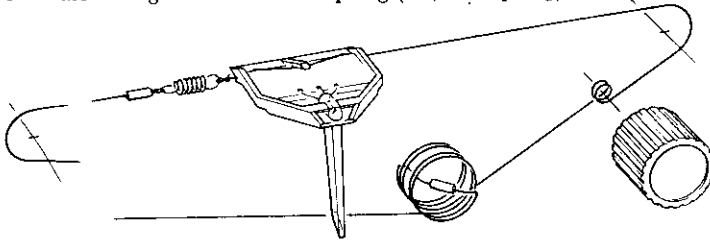

Positioning the pointer and adjusting the FM tuning potentiometer.

The tuning potentiometer is located at the rear end of the tuning capacitor and is accessible through a hole in the aluminium rail behind the capacitor. The following adjustment procedure presumes that the FM alignment, page 8, step 1 A has been carried out.

With the cord drive turned all the way to the left, position the pointer so that its left edge coincides with the mark below the letter M in FM. Then tune to 108 MHz on the dial and check that the voltage at terminal C121 on the tuner is 22 volts. If not, loosen the centre screw on the tuning potentiometer and adjust the potentiometer by moving the small plastic disc to achieve the correct voltage. Tighten the centre screw after the alignment.

NOTE! Before any other alignment in FM or AM-position check right positioning of pointer when cord drive is turned fully left.

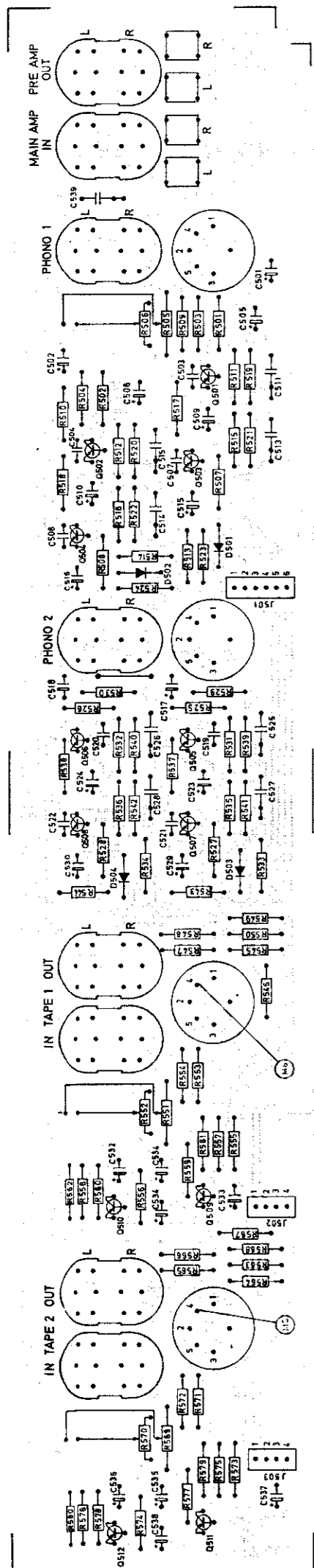

BOARD NO. 42449 RIAA/INPUT AMP.

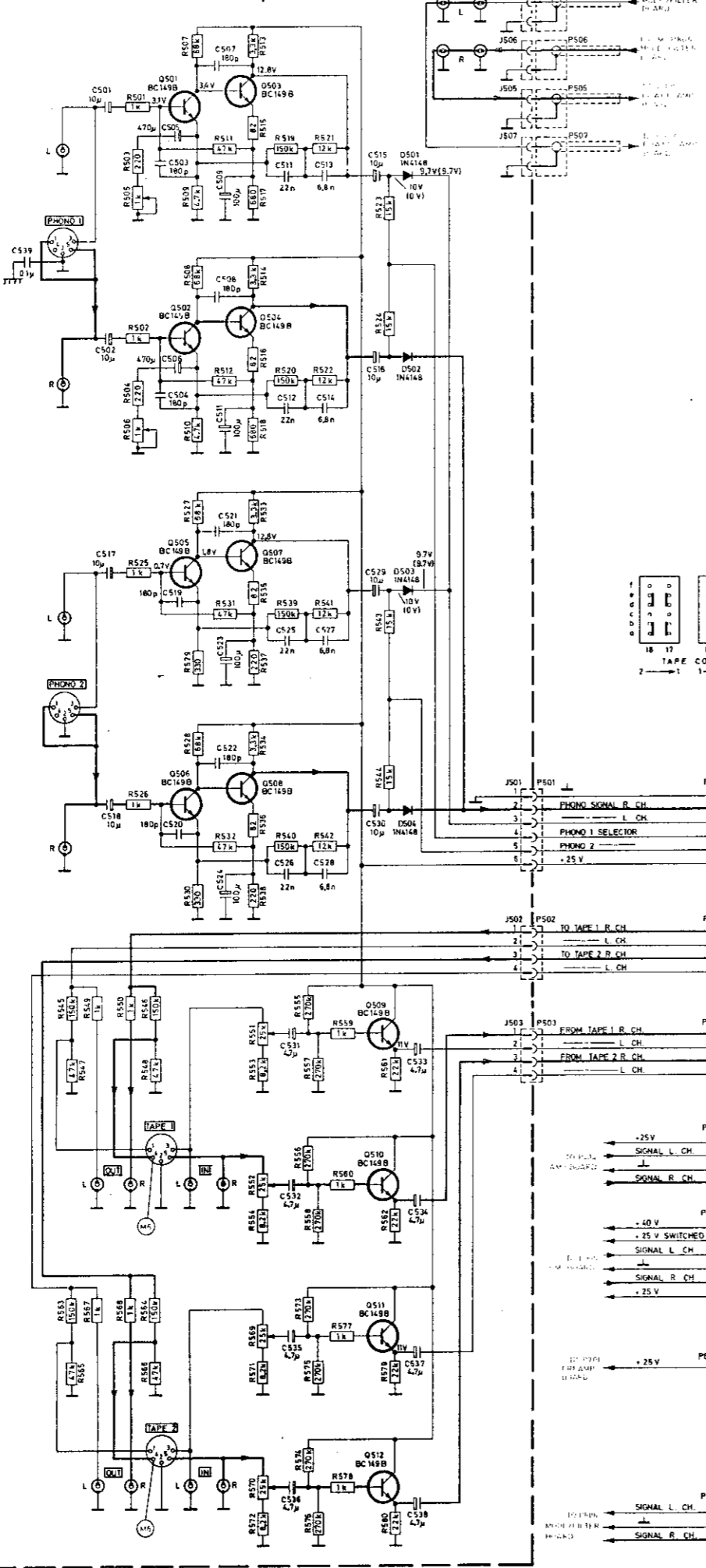

BOARD NO. 42425 PROGRAM SELECT/VOLTAGE REG.

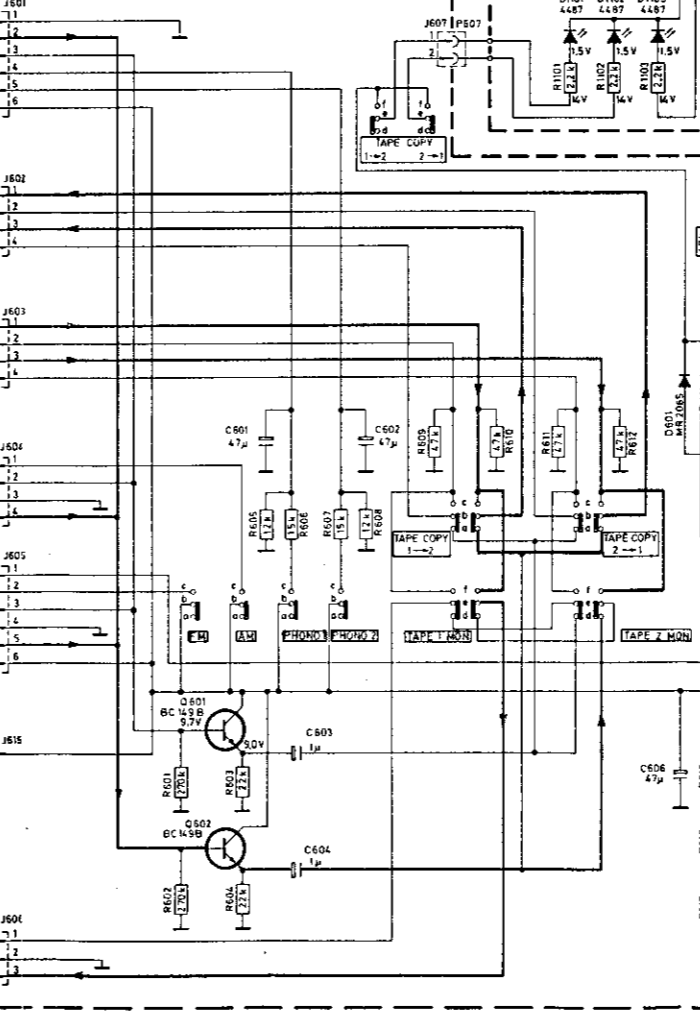

BOARD NO. 42522 LIGHT DIODES TAPE COPY POWER READING

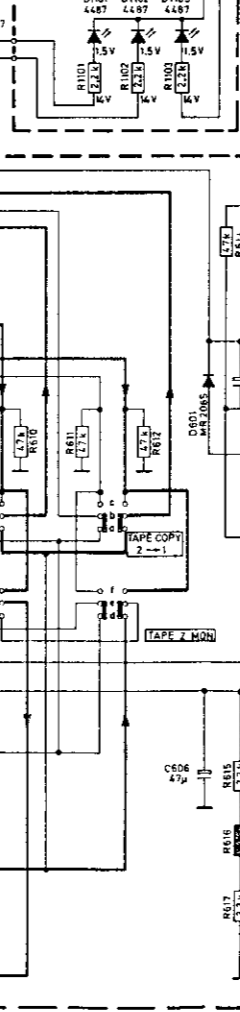

BOARD NO. 42518 LIGHT DIODES PROGR. SELECT.

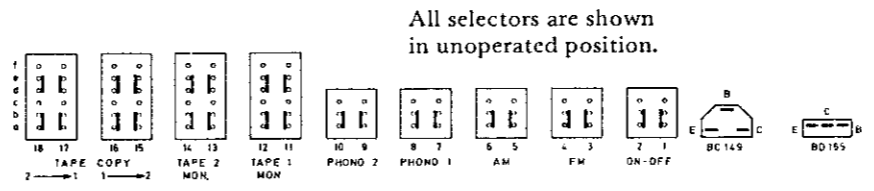
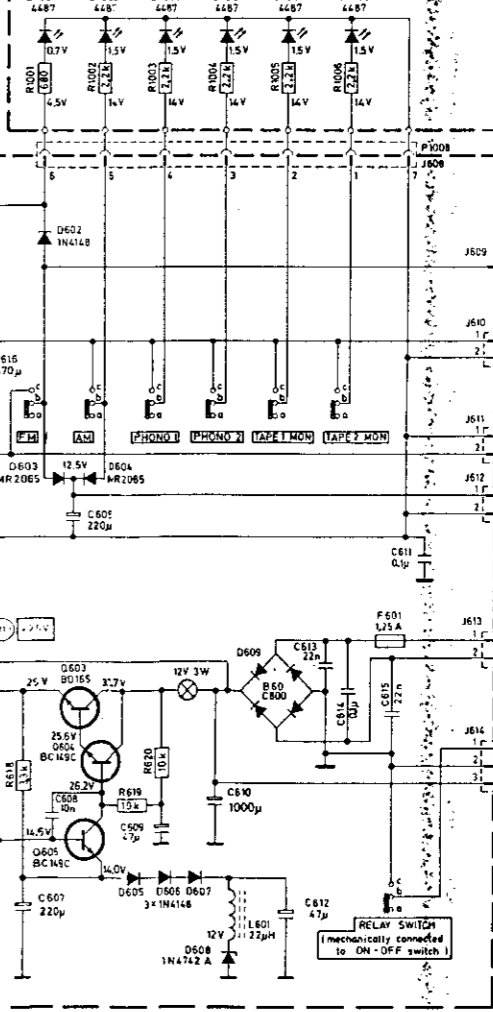

All selectors are shown in unoperated position.

Location.

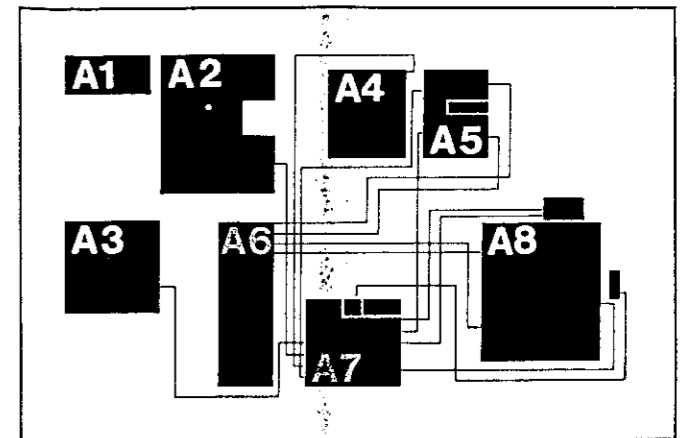

A6 Seen from solder side.

AM-alignment procedure

Step	Alignment procedure	Receiver	Generator			Outputmeter */ Oscilloscope	Circuits	Reading	Oscillator voltage	Notes
		Frequency	Frequency	Modulation	Applied to	Connected to	Adjust			
1	Operating point Q 404					M 11 *	R 413	2.2V DC		Use a VTVM of adequate accuracy.
2	AM-MF 3. MF(IF) AM-IF 2. MF(IF) 455 kHz 1. MF(IF)	1400 kHz	455 kHz	30%	M 10 via M 9 0.1 μF M 8 Fig. 6	M 12	L 409 L 408 - L 407 L 406 - L 405	Max. output		Use a marker (455 kHz) to obtain correct center frequency when aligning AM - IF. With wobbler, see Fig. 8.
3	455 kHz trap	518 kHz	455 kHz	30%	M 7 via dummy ant.	M 12	L 401 - L 402	Min. output		With Wobbler, see Fig. 9
4	Oscillator	600 kHz 1400 kHz	600 kHz 1400 kHz	30%	M 7 via dummy ant.	M 12	L 404 C 419	Adjust to beat frequency	Gate 2, Q 404: 1V	Use a calibrated signal generator, and further a marker (455 kHz) to avoid the alignment being influenced by the antenna circuit, and HF tuned circuit (L 403 - c 410).
5	Antenna circuit, ferrite and HF circuit.	600 kHz 1400 kHz	600 kHz 1400 kHz	30%	M 7 via dummy ant.	M 12	L 1 - C 402 L 403 - C 409	Max. output		Adjust with ferrite ant. in position as shown in Fig. 4/5.
6	Signal meter	1400 kHz	1400 kHz	30%	M 7 via dummy ant.		R 431	Max. meter reading		Signal voltage approx. 100 mV

Fig. 4.

Alignment point, L1 (step 5).

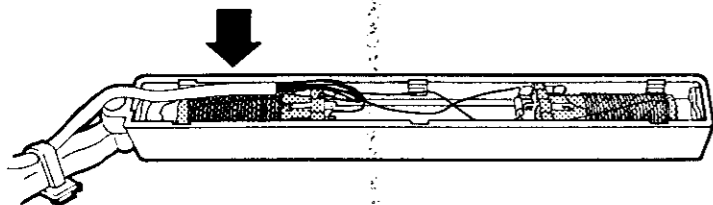

Fig. 5.

Adjust with ferrite ant. in position as shown in figure.

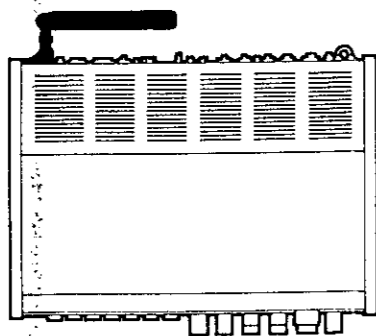
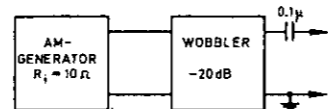
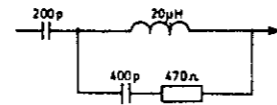

Fig. 6.



Signal generator and wobbler for AM-alignment with oscilloscope.

Fig. 7.



Dummy antenna. A capacitiv of 200 pF may be used.

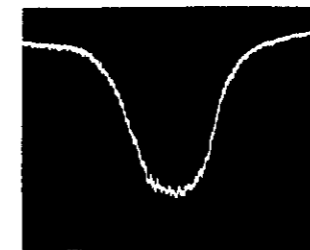

Fig. 8. MW.

Signal: $U_{in} = 100 \mu V$ via wobbler (Fig. 6/7) applied to M7.

Oscilloscope: Vert.: 200 mV/dev. Hor.: 2 kHz/dev., connected to M12.

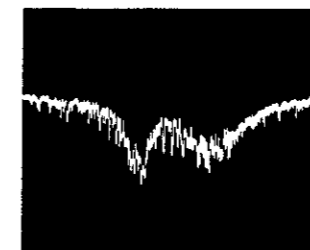
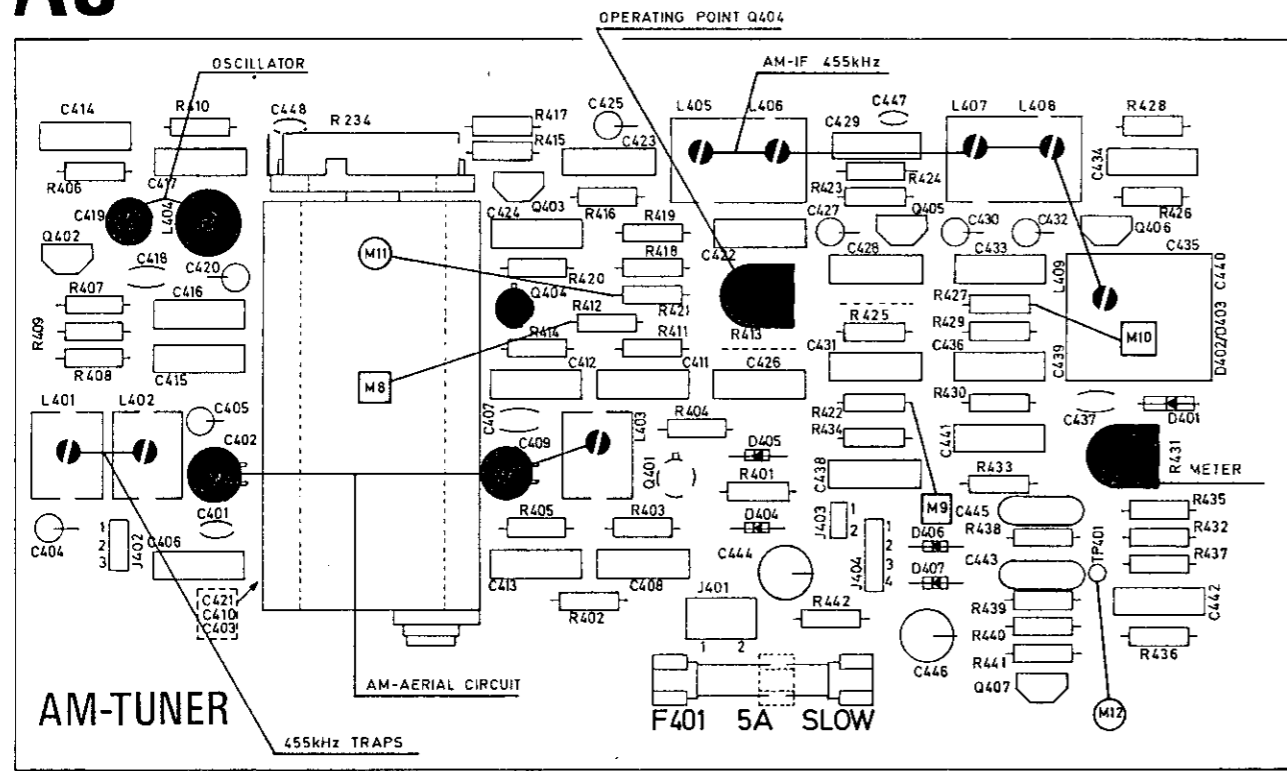

Fig. 9. 455 kHz trap.

Signal: $U_{in} = 200 mV$ via wobbler (Fig. 6/7) applied to M7.

Oscilloscope: Vert.: 50 mV/dev. Hor.: 2 kHz/dev., connected to M12.

A3



Seen from component side.

A3

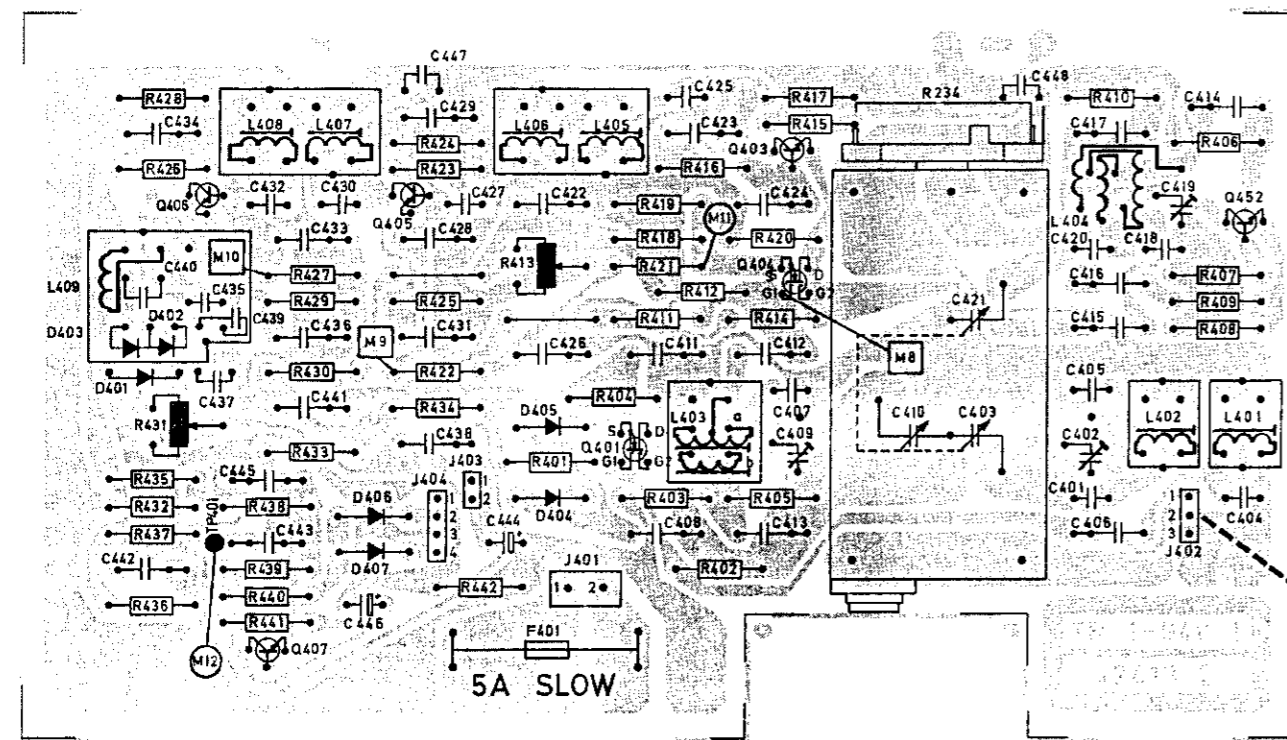

Seen from solder side.

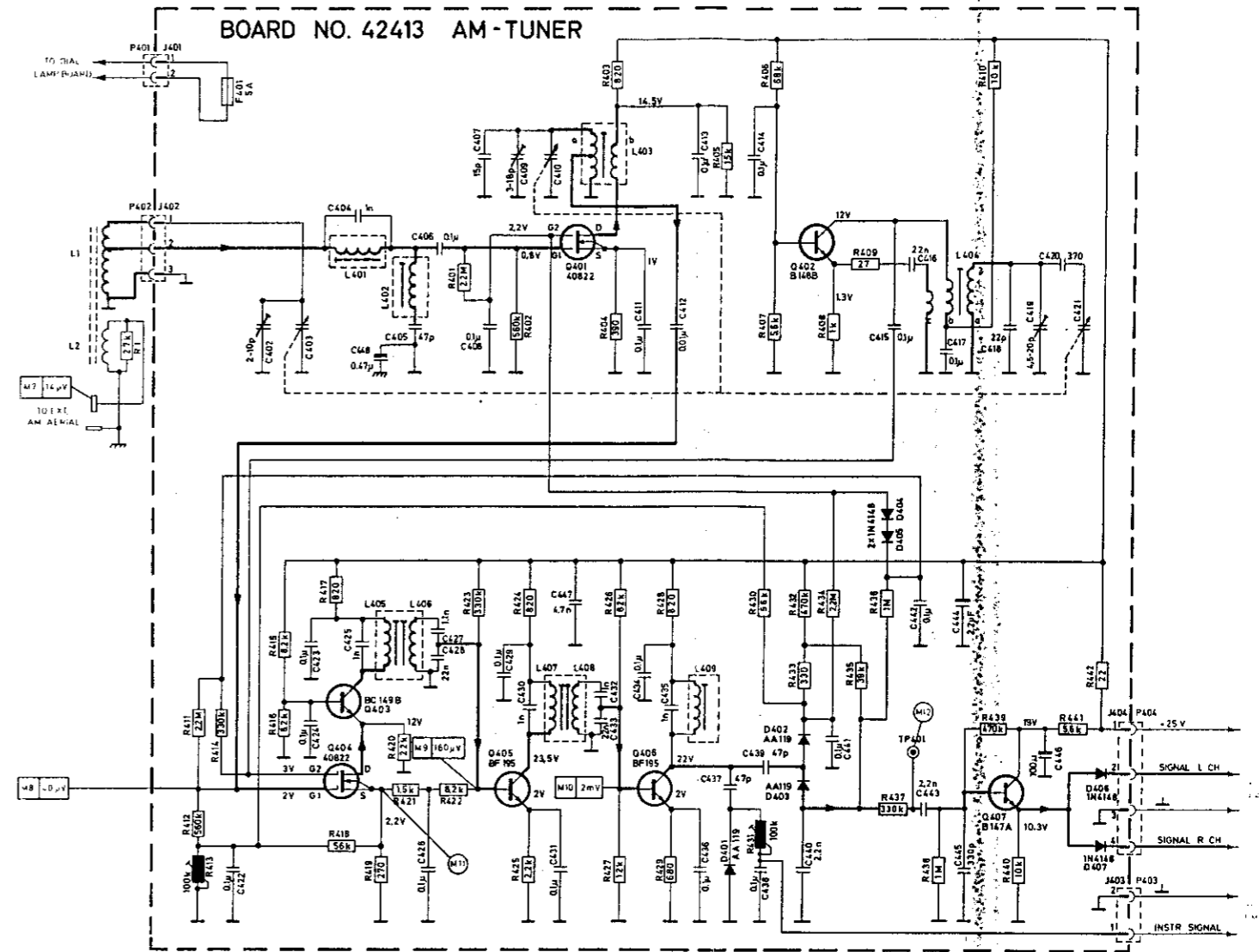

AM-SECTION - 42599

Location.

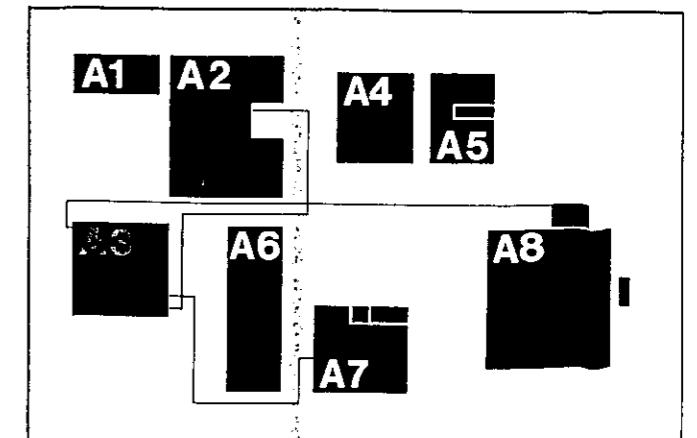

ALIGNMENT OF STEREO-DECODER

Equipment needed:

FM stereo generator
Oscilloscope with sensitivity 5 mV/cm
Frequency counter
Selective voltmeter or a.c. voltmeter and 20 kHz low pass filter.

Complete alignment:

The decoder oscillator: 19 kHz (see paragraph 1).
Channel separation (see paragraph 2).
19 kHz filter (see paragraph 3).
38 kHz suppression (see paragraph 4).
Stereo/mono switching threshold (see paragraph 5).
Definition: Pilotsignal 19 kHz (± 2 Hz).

1. The decoder oscillator: 19 kHz

Apply a 1 mV signal from the FM stereo generator, unmodulated. (No pilot signal applied).

Adjust R306 so that the frequency counter connected to M301 indicates 19 kHz.

Alternative method without the frequency counter:

Apply a 1 mV signal from the FM stereo generator, modulation: 10% pilotsignal.

Turn R306 slowly from one extreme to the point where the stereo indicator lights up. Turn further in the same direction until the light goes out. Then turn in the opposite direction to set R808 in the middle of the range where the indicator lights.

2. Channel separation:

Apply a 1 mV signal from the FM stereo generator, modulation: 10% pilotsignal. Modulate the right channel with 1 kHz at 30% deviation. Connect the oscilloscope to the TAPE OUT (L) socket.

Adjust R322 to minimum deflection on the scope. Check this adjustment with the 1 kHz signal in the left channel and measure the output of the right channel.

Alternative method without the stereo generator:

Adjust R332 for minimum signal in left (right) speaker when receiving a test FM stereo, transmission with signal in the right (left) channel only.

3. 19 kHz filter:

Apply a 1 mV signal from the FM stereo generator, modulation: 10% pilotsignal.

Adjust R334 and R338 (R335 and R339) alternatively for minimum signal at the left (right) TAPE OUT. Use a selective voltmeter or an a.c. voltmeter with a low pass filter at 20 kHz to avoid signal components at 38 kHz causing a false indication.

FM-alignment procedure

Step	Alignment procedure	Receiver	Generator			Oscilloscope	Circuits	Notes
		Frequency	Frequency	Deviation	Applied to	Connected to	Adjust	
1A	25V for varicap						R 616	Meter connected to M13 (Board A7). Adjust to 25V DC reading.
1B	FM - osc.	90 MHz 105 MHz	90 MHz 105 MHz	± 22.5 kHz	M 1	M 4 via diodeprobe Fig.10	R 203	Check 95 and 100 MHz.
2	Aerial circuit	90 MHz 105 MHz	90 MHz 105 MHz	± 200 kHz	M 1	M 4 via diodeprobe Fig.10	L101-L102-L103 C103-C107-C110	Adjust for max. curve height (see Fig.11)
3	FM - IF	90 MHz	90 MHz	± 200 kHz	M 1	M 4 via diodeprobe Fig.10	L 106 - L 107	Adjust for max. curve height and symmetry (see Fig.11) FM - IF 10.6 - 10.8 MHz.
4	Discriminator	90 MHz	90 MHz	± 75 kHz	M 1 1 mV/75 ohm	M 6 via Fig. 10	L 202 - L 203	Dist./voltm. connected to M6, TAPE OUTPUT socket: Adjust L203 for max. output voltage. Afterwards adjust L202 for min. output voltage and min. distortion. See Fig. 12.
5	Center tuning meter	90 MHz	90 MHz	± 75 kHz	M 1 1mV/75 ohm		R 233	Adjust for center position of the pointer. When the receiver is tuned to min. distortion. See step 4.
6	Signal indicator	90 MHz	90 MHz		M 1 50 mV/75 ohm		R 222	Adjust R 222 for max. meter reading at a signal voltage of about 50 mV.

4. 38 kHz suppression:

Apply a 1 mV signal from the FM stereo generator, modulated with 19 kHz.

Adjust R301 for minimum signal at TAPE OUT, measure wideband.

Note! Before aligning the 38 kHz suppression, paragraph 3 must be satisfied.

5. Stereo/mono switching threshold:

Apply a 10 μ V signal from the FM stereo generator to the 75 ohm antenna input and adjust the generator for 10% pilotsignal.

Set R220 fully counterclockwise (seen from the component side) and then turn R220 slowly clockwise until the stereo indicator lights up.

Alternative method:

If a FM stereo generator is not available an ordinary FM generator can be used for this adjustment. In this case it may be necessary to check the modulation frequency (19 kHz) with the frequency counter.

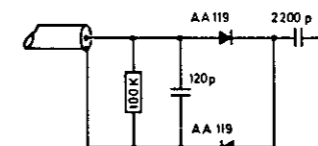

Fig. 10.
Diodeprobe.

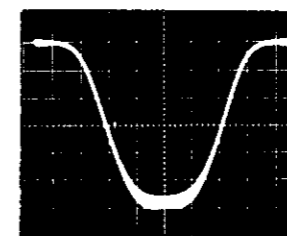

Fig. 11. FM-IF curve.

Signal: $U_{in} = 150 \mu\text{V}/75 \text{ ohms}$, $f = 90 \text{ MHz}$.
Dev. = $\pm 200 \text{ kHz}$ applied to M1 via ant. plug.

Oscilloscope: Vert.: 5 mV/dev., Hor.: 50 kHz/dev. connected to M4 via diodeprobe (Fig. 10).

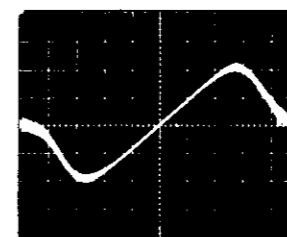
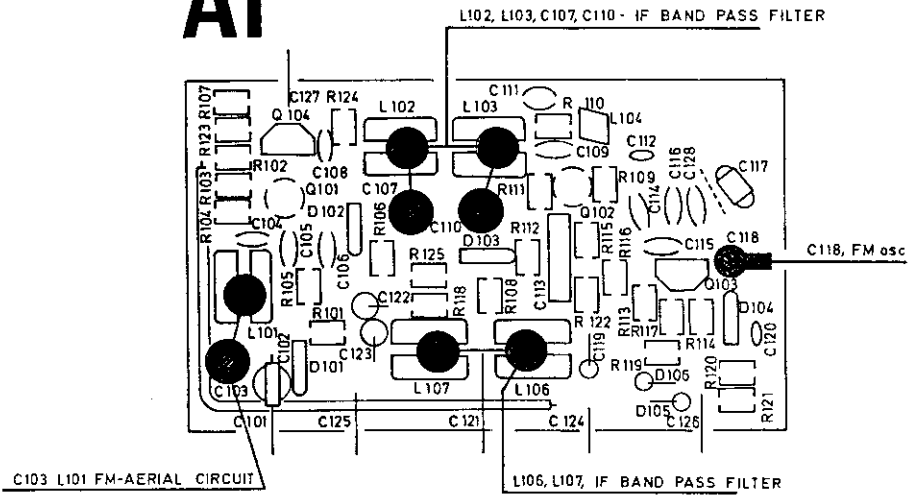

Fig. 12. Discriminator.

Signal: $U_{in} = 2 \mu\text{V}/75 \text{ ohms}$, $f = 90 \text{ MHz}$.
Dev. = $\pm 200 \text{ kHz}$ applied to M1 via ant. plug.

Oscilloscope: Vert.: 0.2 $\mu\text{V}/\text{dev.}$ Hor.: 50 kHz/dev. connected to M6.

A1



Seen from component side.

A2

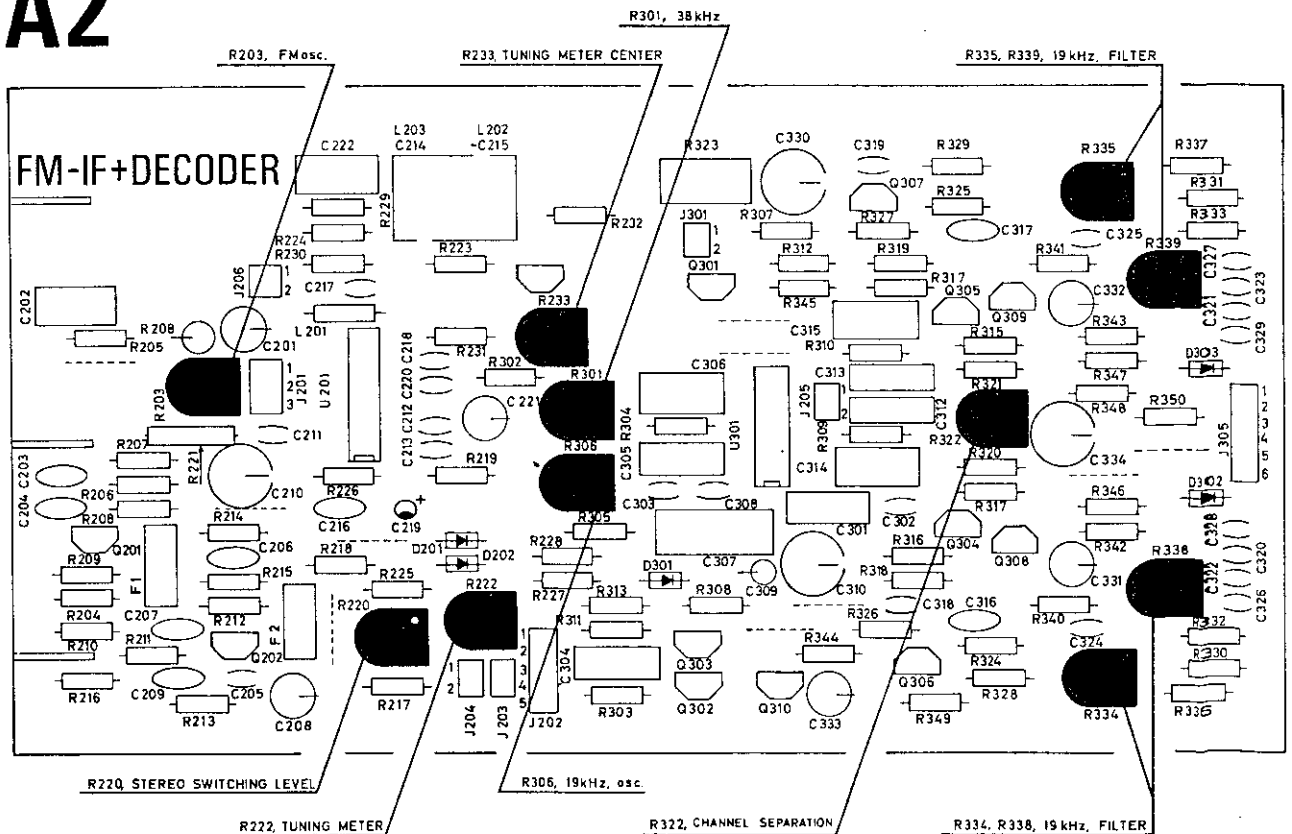

Seen from component side.

A1

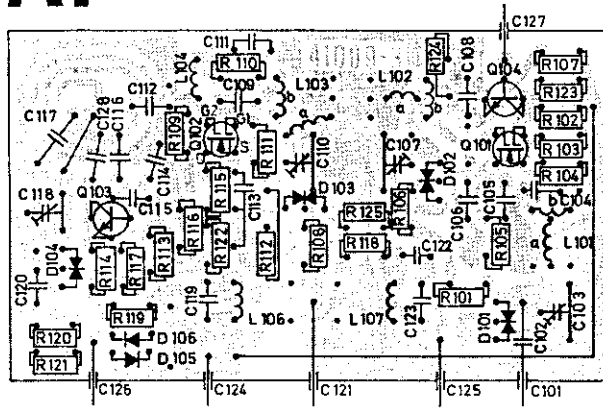

Seen from solder side.

A2

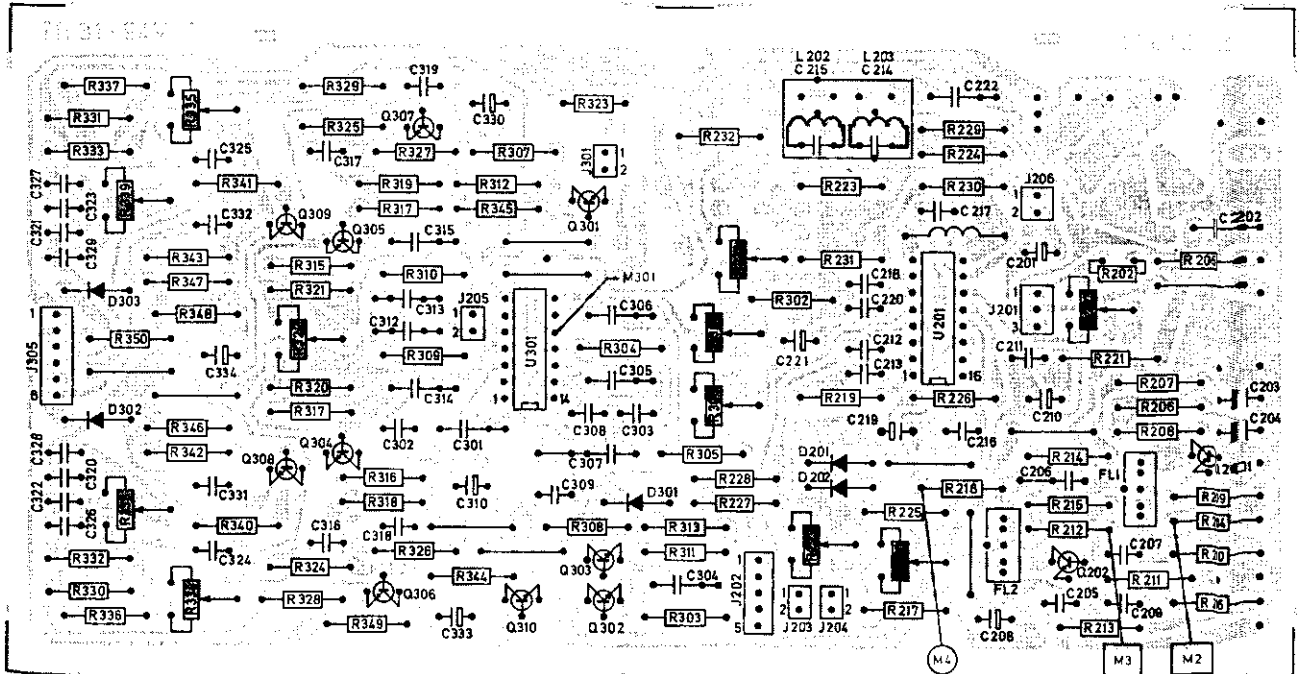

Seen from solder side.

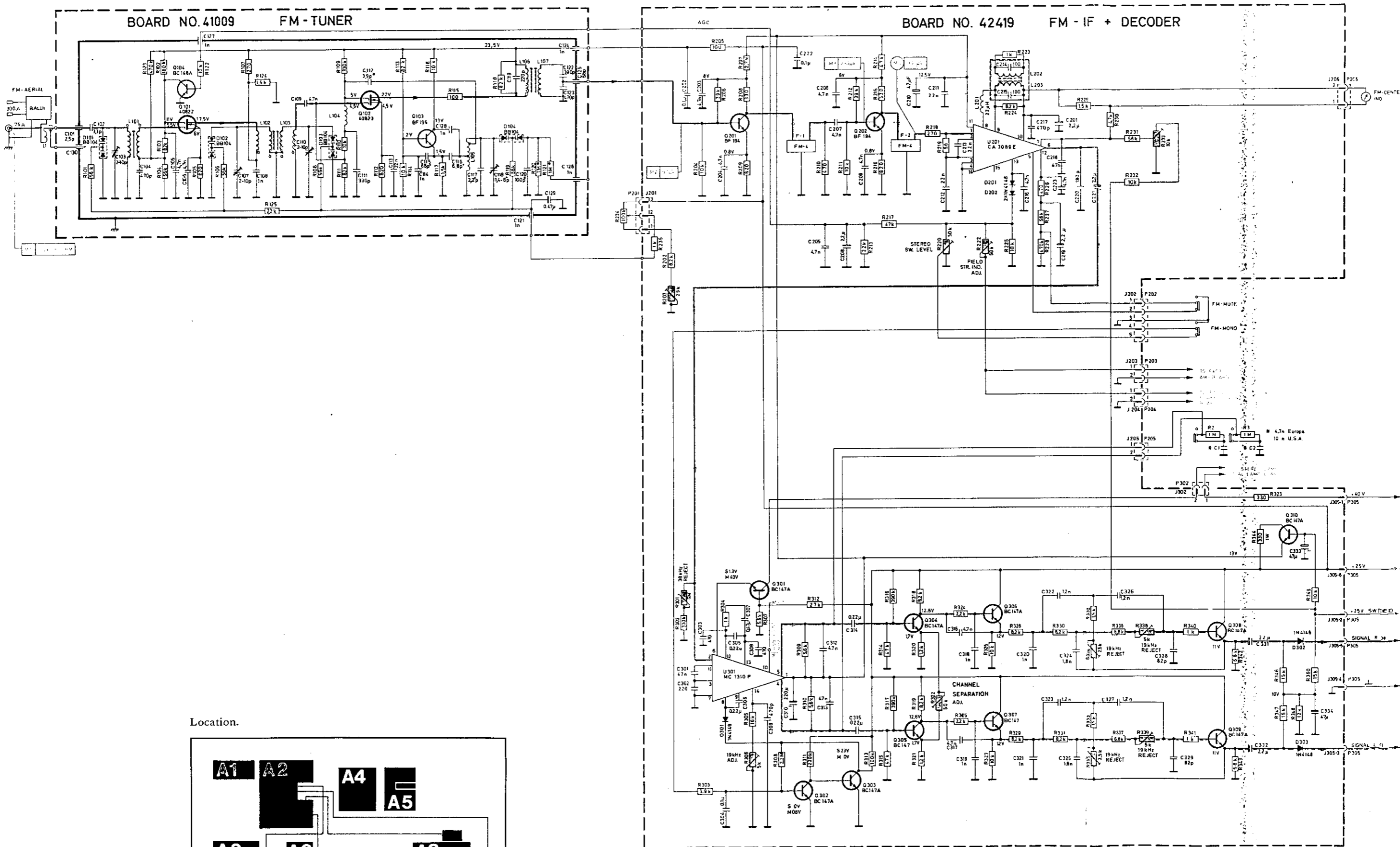

Location.

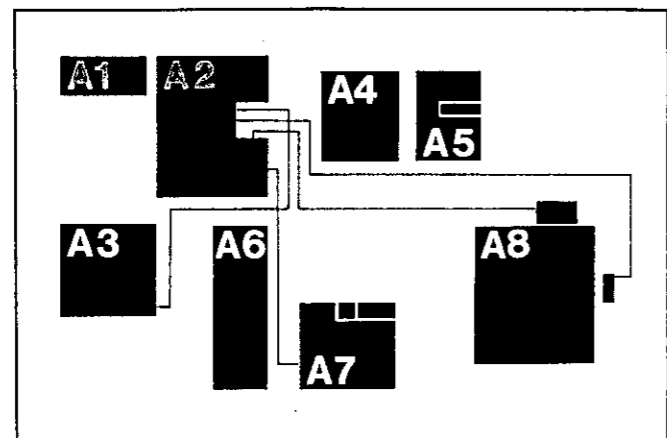

FM-IF SECTION - 42598

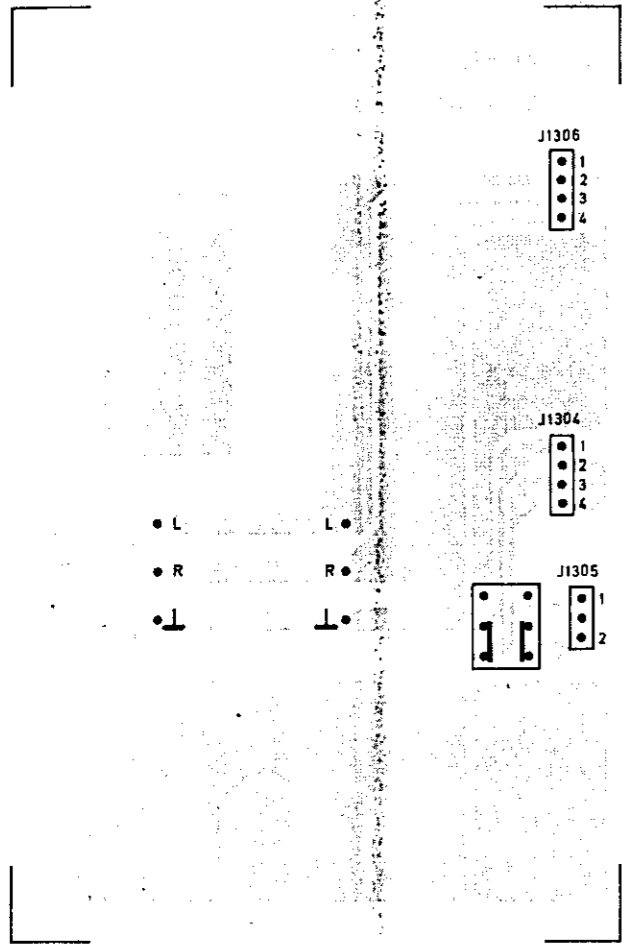

Seen from solder side. POWER READING BOARD

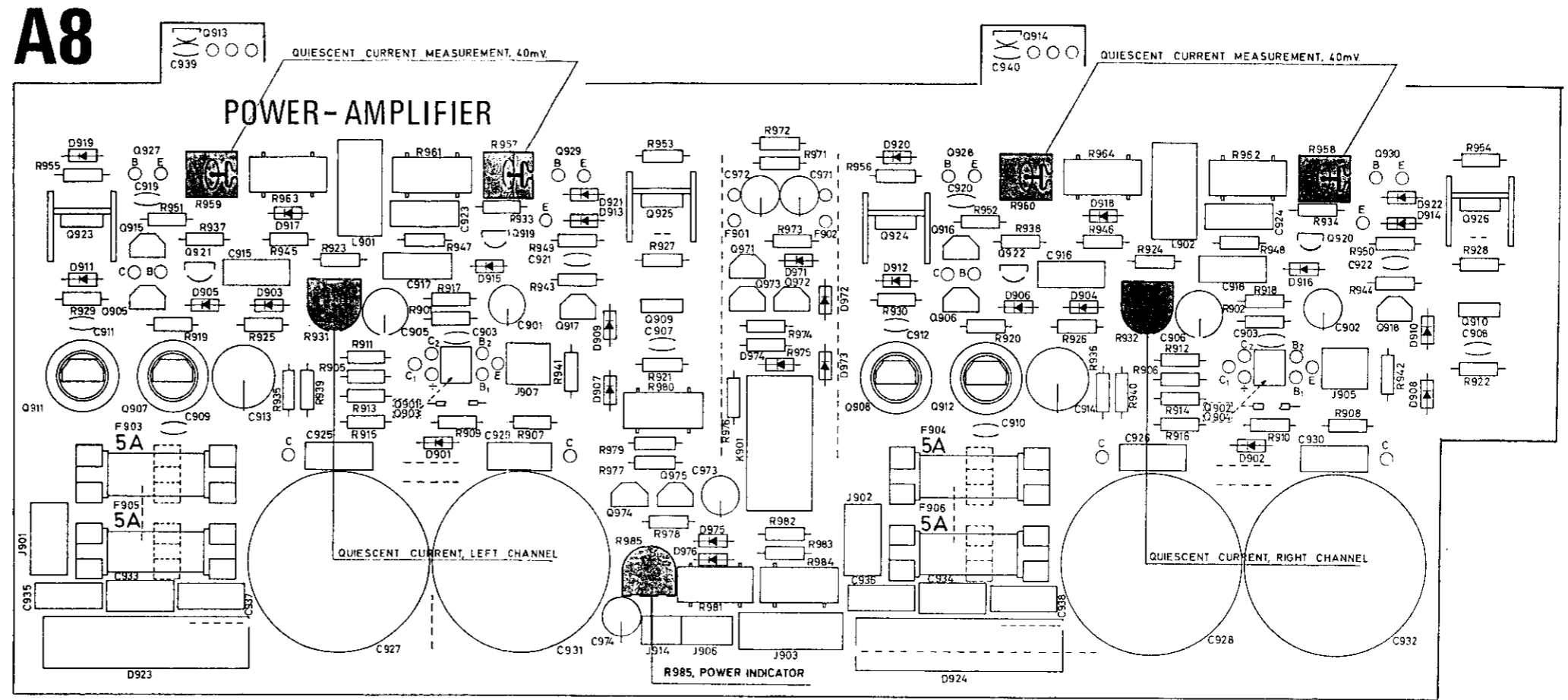

Seen from component side.

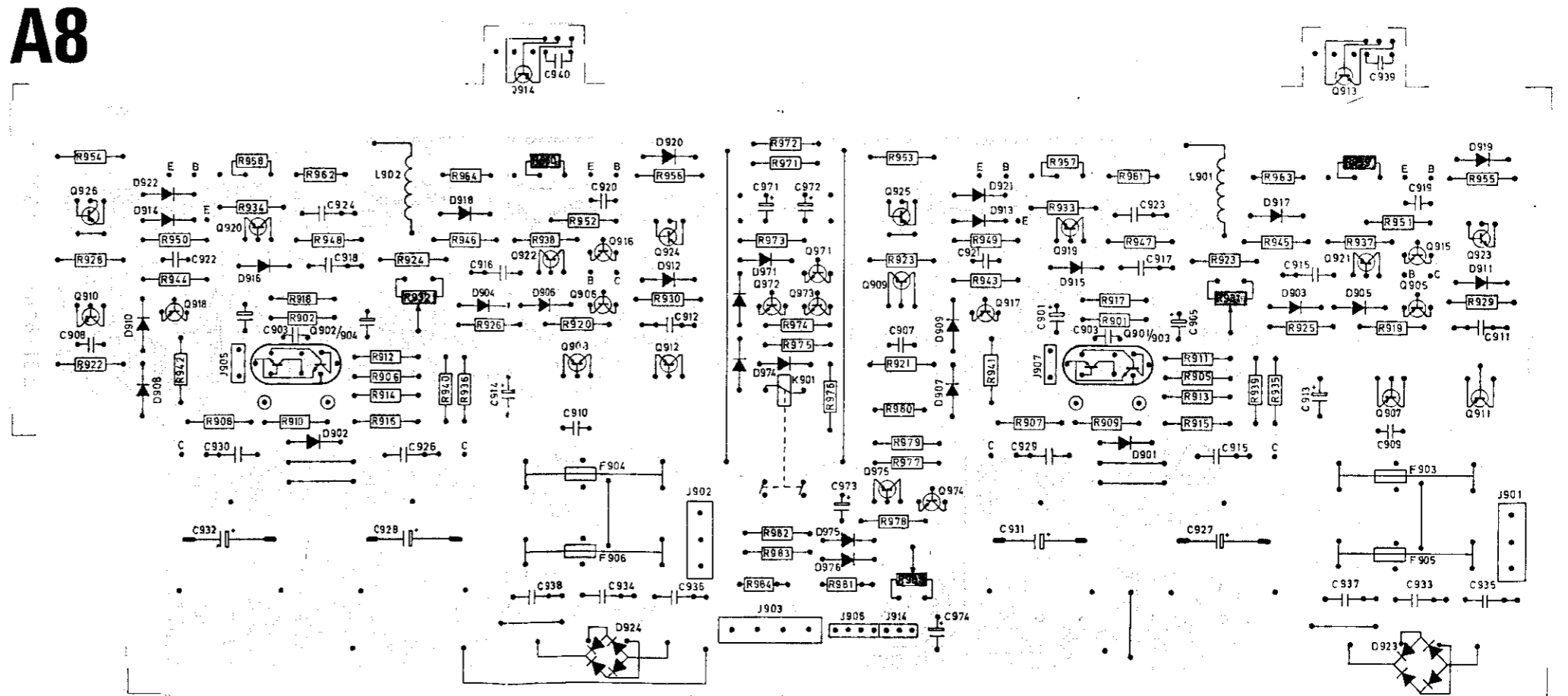

Seen from solder side.

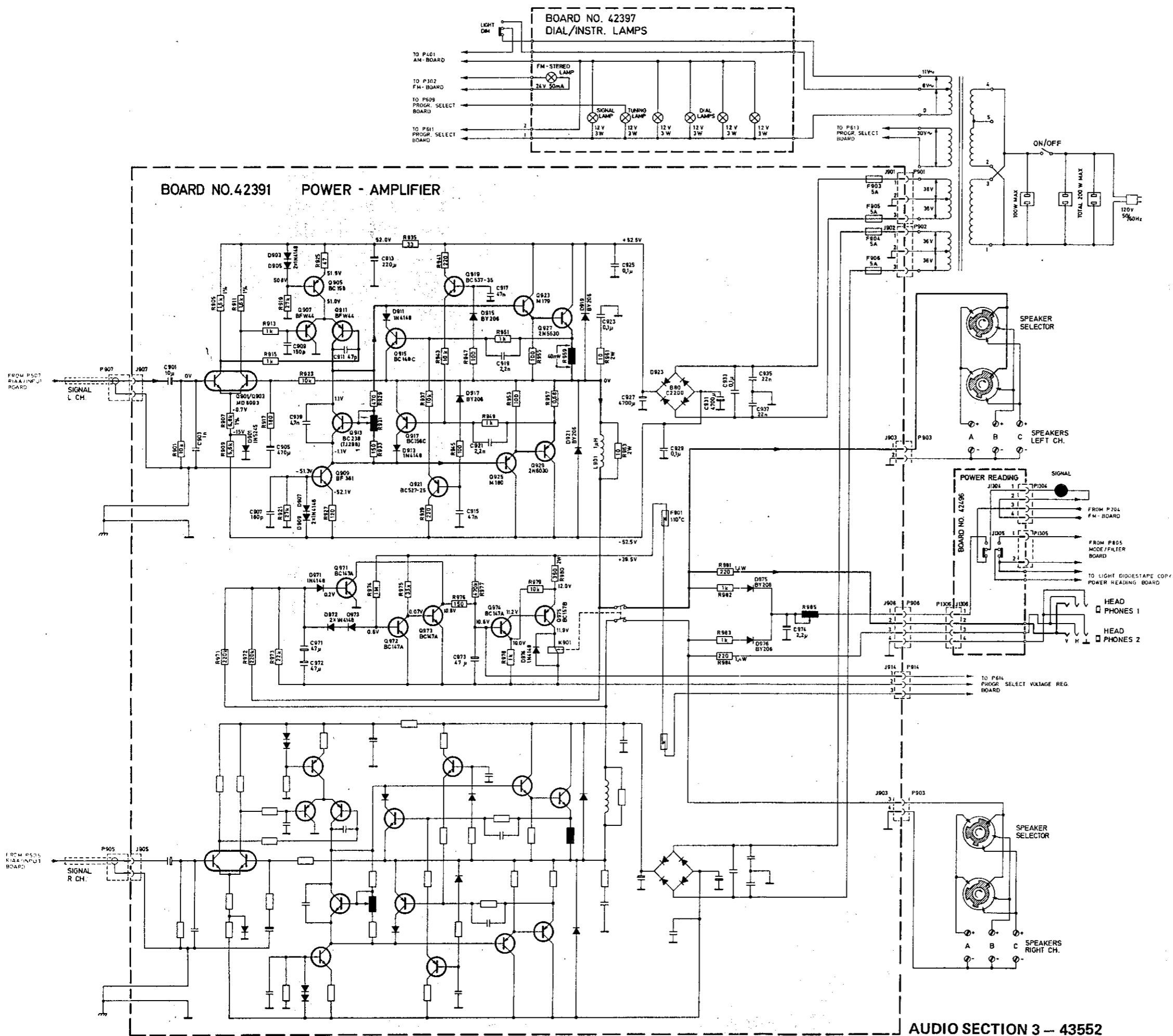

Location.

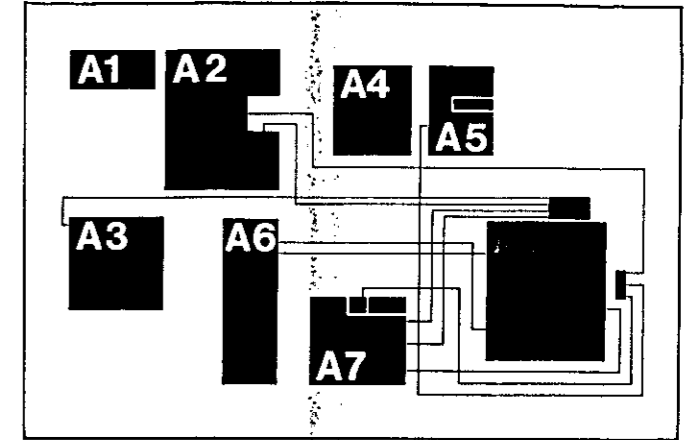

AF—adjustments.

Quiescent current.

Connect a DC VTVM across the emitter resistor R959 (left channel) and R960 (right channel). After 10 min. warm-up (with the volume control in minimum position), the voltage should be 40 mV. If necessary, adjust with R931 (left channel) and R932 (right channel). The most convenient place to connect the voltmeter is between the top of emitter resistors R959/R957 (left channel) and R960/R958 (right channel), on the component side of the board.

Output power indicator (SIGNAL meter).

Depress the button POWER READING. Apply a signal to TAPE 1 input and measure the a.c. voltage across the speaker output. Adjust the input voltage or the VOLUME until the output voltage is 25 volts. Adjust R985 for the same reading on the SIGNAL meter.

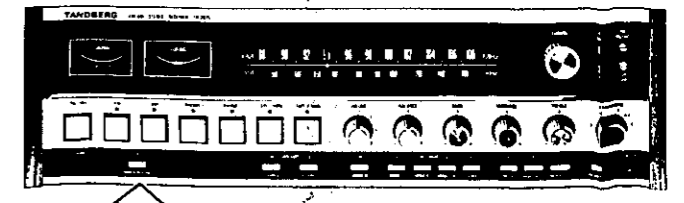

POWER READING

AUDIO SECTION 3 - 43552

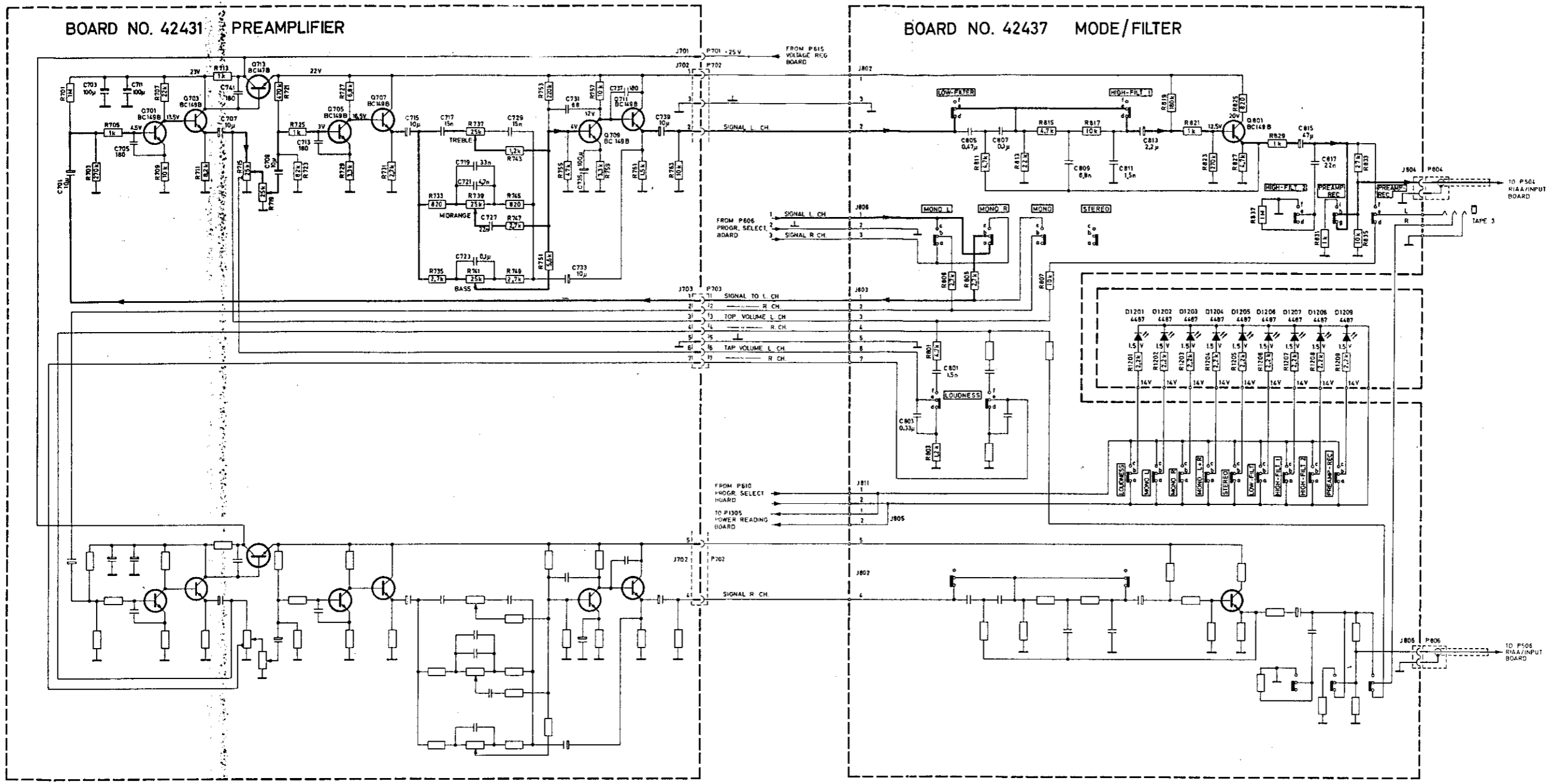

AUDIO SECTION 2 - 43551

Location.

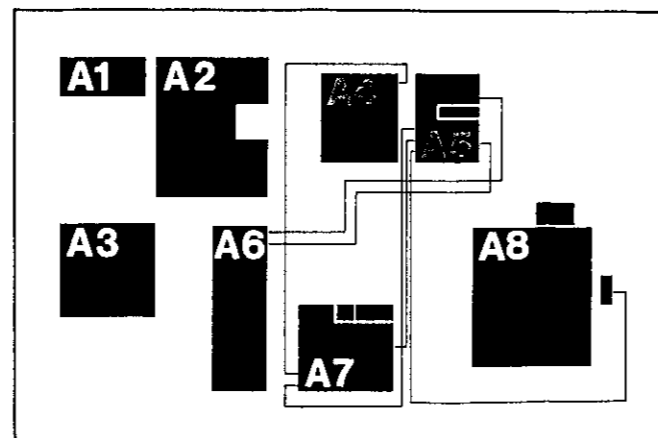

All selectors are shown in unoperated position.

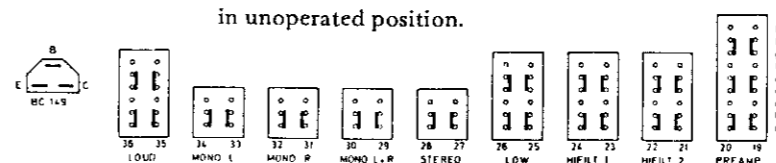

A4

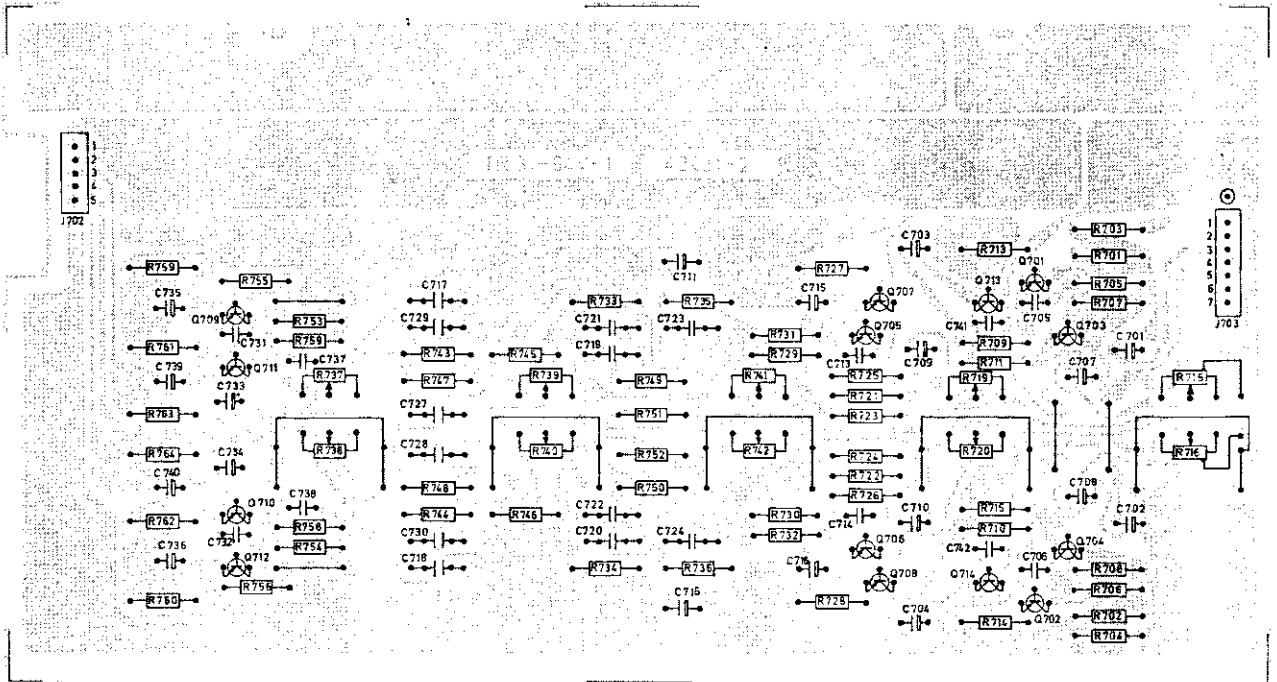

Seen from solder side.

A5

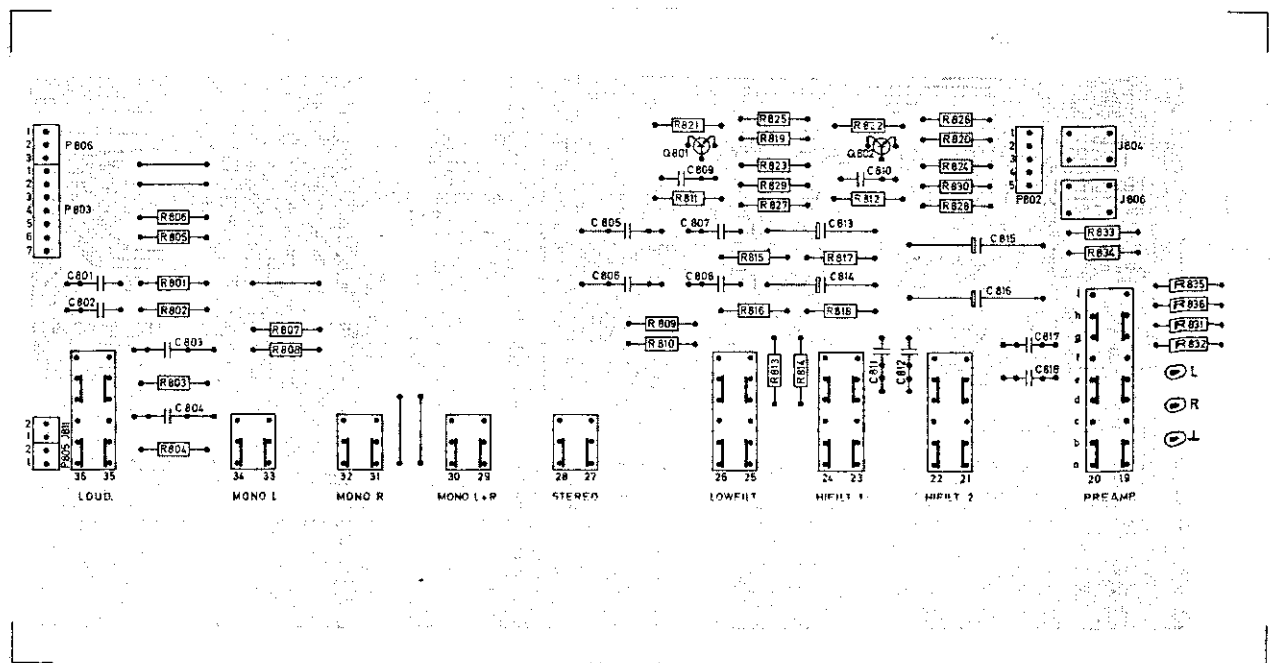

Seen from solder side.