

# TANDBERG

## TR-1040 A, TR-1055 Service Manual

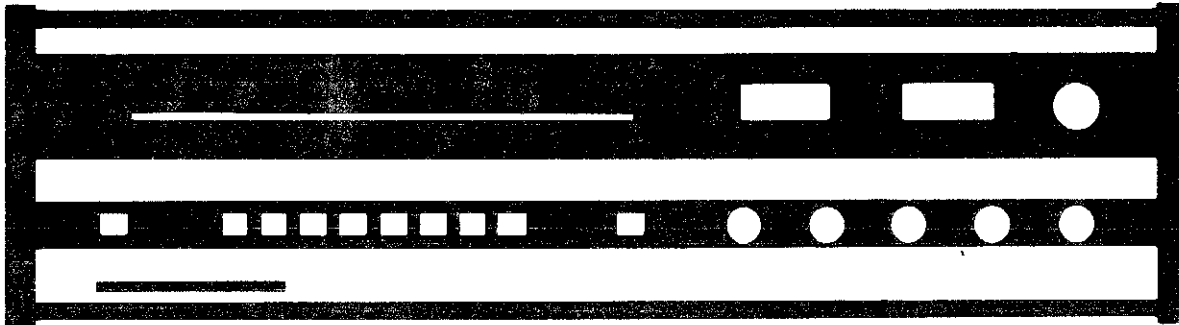

### CONTENTS

	Page
Mechanical service .....	2
Changing and cleaning p/b selectors (switches) .....	3
AM alignment procedure .....	4
AM circuit diagram .....	5
Alignment procedure for stereo decoder .....	6
FM alignment procedure .....	6
FM circuit diagrams — Stereo decoder diagram .....	9
Input/pre-amp circuit diagram .....	11
P/B selector board, circuit diagram .....	11
Tone control, circuit diagram .....	11
AF section, circuit diagram, TR-1040A .....	13
Power supply, circuit diagram, TR-1040A .....	13
AF section, circuit diagram, TR-1055 to Serial No. 1426400 .....	14
Power supply, circuit diagram, TR-1055 to Serial No. 1426400 .....	14
AF section, circuit diagram, TR-1055 from Serial No. 1426401 .....	17
Power supply, circuit diagram, TR-1055 from Serial No. 1426401 .....	17

## MECHANICAL SERVICE

### Removing the cabinet

Remove the screws in the side panels (two screws at the front and one screw at the back) and pull the panels off. Pull the top panel out sideways.

### Power supply board

The TR-1040A has 1 power supply board while the TR-1055 has 2 power supply boards. To gain access to the front screws of the power supply board the FM IF board should be loosened and tilted up at an angle.

### AF board

To remove the AF board, first remove the speaker connector panel which is held by 2 screws at the bottom. Then remove the 4 screws at the back of the AF board. Pull off all the connections and pull the board out backwards.

For electrical trouble shooting an extension board will be needed, obtainable from our service department stores. When changing the power transistors, follow the adjacent drawing.

### FM IF board

Remove the 4 screws on the front edge of the board. The board can now be lifted up for trouble shooting on the solder side and for easier access to the tone controls and the P/B selector board.

### Dismantling the front panel

Pull off the volume, balance, tone control, and speaker selector knobs after removing screws if necessary. (On the TR-1055 the speaker selector knob is held by an Allen [unbrako] screw).

The tuning knob is fixed to the flywheel axle inside the front panel by an Allen (unbrako) screw. When the tuning knob has been removed, the dial cover can be pulled sideways, and the 2 screws (1 on each side) behind the glass can be removed. Then remove the two screws behind the hinged flap. Release the two springs holding the AF indicator lamp housing.

There are two methods of fixing for the two meters. With the first method the meters will hang loose when the front panel is removed. When assembling the front panel on this type, the receiver must be tipped up to lie on its back. Lay the meter lenses onto the meters and put the front panel back into place.

With the second method of fixing, the meters are screwed to the front panel.

**NOTE!** Take care not to damage the pointer and the cardboard panel over the switch section when replacing the front panel.

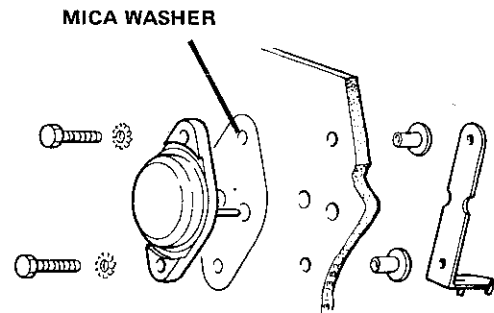

When fitting a power transistor, remember to put silicone grease on both sides of the mica washer.

### Changing the AF indicator lamps

1. Lift up the FM IF board to gain access to the lamp housing.
2. Remove the two springs holding the lamp housing.
3. Withdraw the lamp housing through the opening in the drive cord plate.
4. The plate holding the lamps is fixed to the lamp housing by two screws underneath. The 5 V, 115 mA lamps are soldered in place.

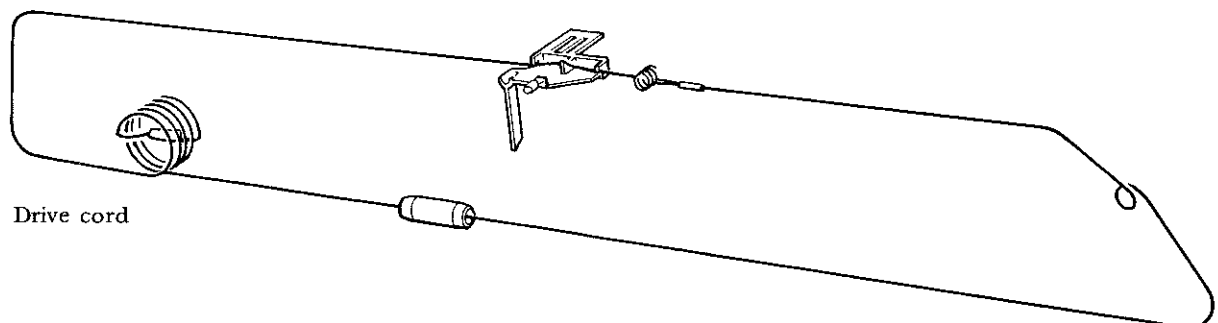
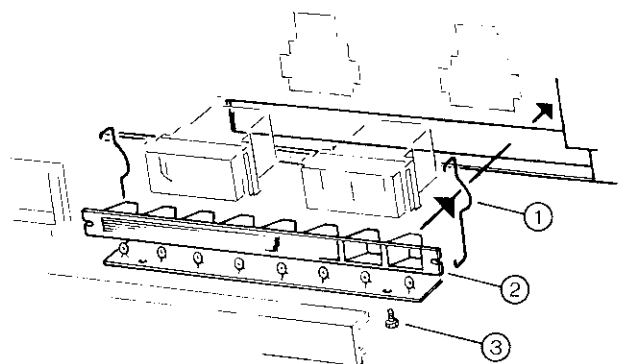

## CHANGING OR CLEANING PUSH BUTTON SWITCHES

Occasionally the push button switches will need to be cleaned and lubricated to maintain trouble free action. A good cleaning agent should be applied sparingly with a fine brush. We recommend "Tandberg Klüberfett" or "Wählerfett" from our Service Department.

Alcohol or methylated spirit may also be used for cleaning and vaseline may be used for lubrication afterwards.

**NOTE!** Avoid touching the contacts with your finger — it could cause corrosion.

Avoid using cleaning agents that could attack the metal parts.

**NOTE!** We have developed our own cleaning/lubricating agent, "Tandberg Contact Spray" in aerosols, and we recommend it for all types of contacts. These aerosols can be supplied from our district offices and subsidiary companies.

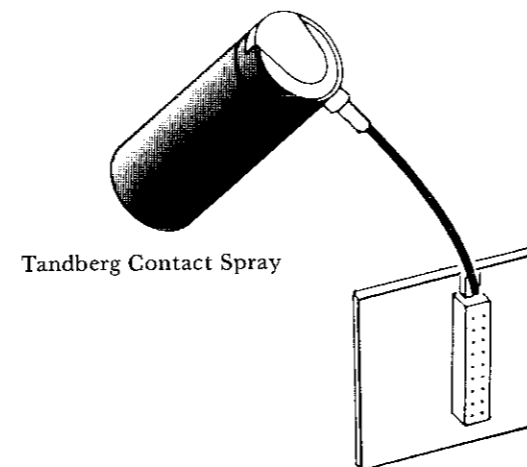

## MECHANICAL DISMANTLING

### Petrick switch — interlocking type

#### Plunger

Pull the locking plate slightly forward and push it across in the direction of the arrow so that it clears the locking tag. When the locking tag is pushed in the direction of the arrow, all the plungers, interlocked and independent, will spring out at the same time. Therefore hold your hand in front of them.

When re-assembling the switches, hold all the plungers in at the same time (with a plate) when the locking tag is pushed into the locking position.

**NOTE!** It pays to put one end of the locking plate up on the edge of the locking tag before you held the plungers in.

#### Switch housing

Unsolder the switch housing from the foil side. Unsolder any leads attached on the switch side. Clamp the tabs A together. The switch housing can now be removed.

#### Interlock return springs

To gain access to the interlock return springs you must first free the switch housing as described above. Return springs are not always fitted to interlocking switches.

### Petrick switch — independent type

#### Plunger

Dismantle in the same way as described above, in the paragraph called "Plunger".

#### Switch housing

The locking plate, return spring, and locking pin can be removed when the tabs A are clamped together. Otherwise, further dismantling should be carried out according to the description above in the paragraph called "Switch housing".

**NOTE!** Take care with the locking springs when you dismantle and assemble the switches, otherwise they could lose some of their tension.

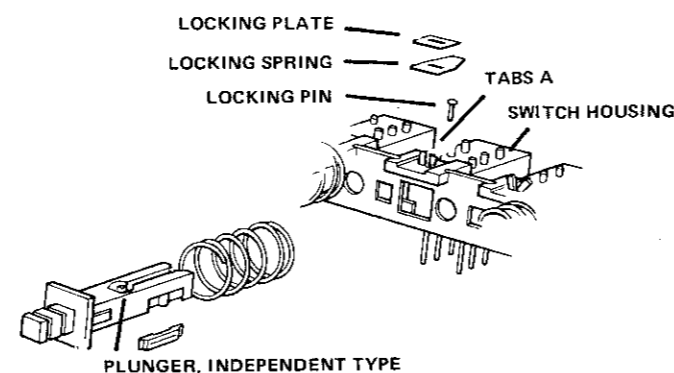
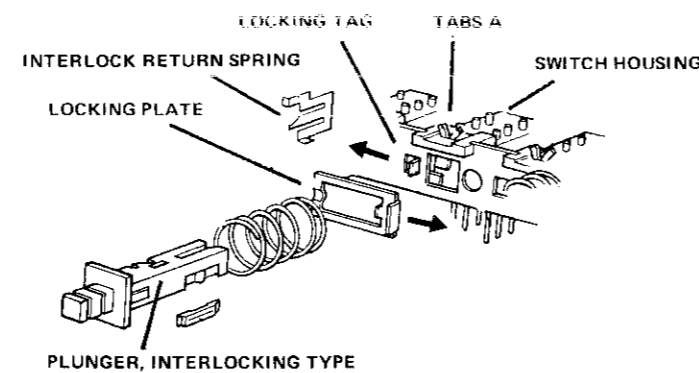

### Free-standing Petrick push button switch with independent locking

#### Plunger

Pull the front locking plate forward from one end (left and seen from the front) so that it sits on the edge of the switch carrier.

Push the back locking plate in the direction of the arrow and, at the same time, make sure that the plunger does not spring out.

#### Switch housing

Dismantle the switch housing according to the description for independent and interlocking switches in the paragraph "Switch housing".

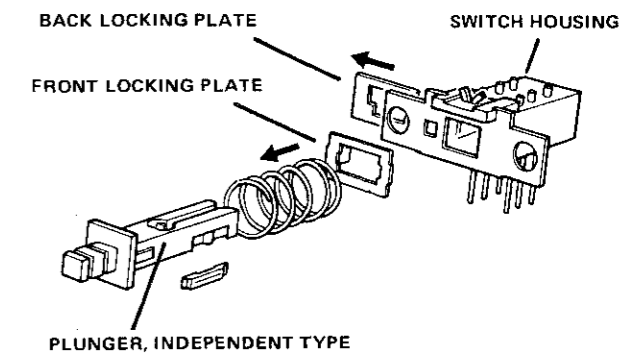

### Schadow switch — independent type

#### Plunger

Pull the spring forward and pull out the locking clip. To free the plunger you must first press in one of the other independent switches. When assembling the plunger, slightly press in one of the other independent switches so that the locking bar is pushed away from the locked position. Push the plunger into place. Replace the locking clip, back pin first.

#### Switch housing

Unsolder the switch housing from the foil side and unsolder any leads on the switch side. Clamp tabs A together. The switch housing can now be removed.

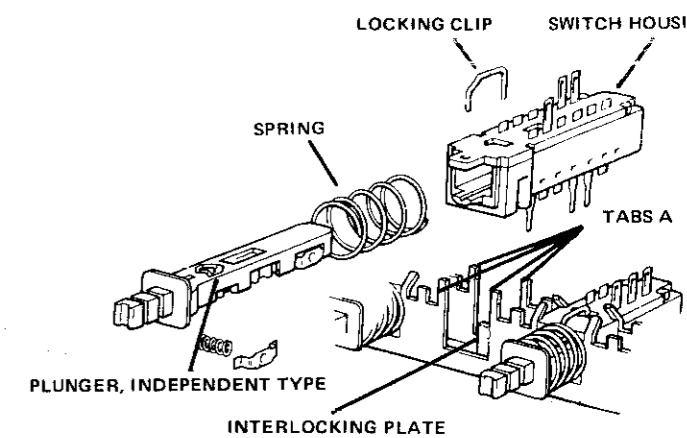

### Schadow switch — interlocking type

#### Plunger

Pull the spring forward and pull out the locking clip. The plunger can now be removed.

#### Switch housing

Dismantle in the same way as described above in the paragraph "Switch housing".

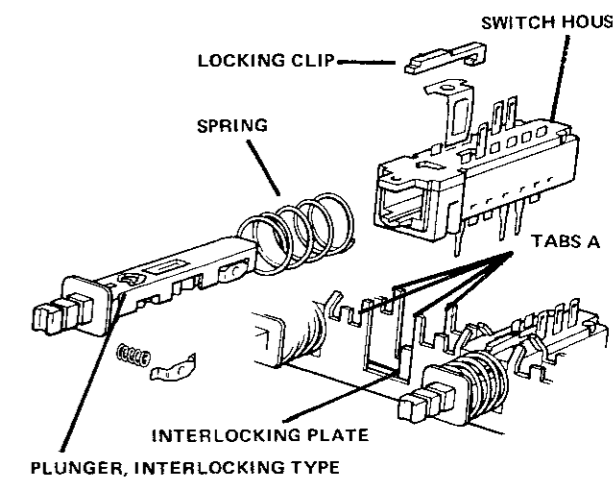

AM Alignment procedure

Step	Alignment procedure	Receiver		Signal Generator (Oscillator)			Oscilloscope	Voltmeter	Voltmeter circuit		Reading	Notes
		Frequency	Frequency	Modulation	Connected to <span style="border: 1px solid black; padding: 2px;">M</span>	Connected to <span style="border: 1px solid black; border-radius: 50%; padding: 2px;">M</span>	Connected to <span style="border: 1px solid black; border-radius: 50%; padding: 2px;">M</span>	Adjust	Board No.			
1	Working point Q452							M13	R457	A4	2.2 V	Release the screws in board A2 and tip it up. Connect the voltmeter probe directly on the transistor case. The case is connected to source. NOTE! Make sure that the receiver is not tuned in to a station when you make this adjustment.
2A	AM IF with wobulator		455 kHz + wobbl. freq.	unmodulated	M15 via 0.1 $\mu$ F (Figure 15)	M18			L405, L406 L407, L408, L409	A4	Figure 13 independent of volume	Check with a 455 kHz beat oscillator that it lies in the middle of the curve (Figure 13).
2B	AM IF without wobulator		455 kHz	30%	M15 via 0.1 $\mu$ F 50 $\mu$ V			M18			180 mV	Check with a 455 kHz beat oscillator (zero beat).
3A	455 kHz with wobulator	600 kHz	455 kHz + wobbl. freq.	unmodulated	M14*				L403, L404	A4	Min. amplitude	Check with a 455 kHz beat oscillator.
3B	455 kHz without wobulator		455 kHz	30%								
4	Oscillator	600 kHz 1400 kHz	600 kHz 1400 kHz	30%	M14*				L401 C452	A4 A4B		Check with a calibrated 455 kHz beat oscillator. Adjust C452 from solder side to zero beat.
5	Antenna circuit, ferrite antenna	600 kHz 1400 kHz	600 kHz 1400 kHz	30%	M14* 100 $\mu$ V			M18	L402b C457	A4C A4B	Max. output 110 mV Max. output 175 mV	Check with a 455 kHz beat oscillator. Adjust C457 from solder side to zero beat.
6	Meter field strength	1400 kHz	1400 kHz	30%	M14* 50 mV				R479	A4	90% deflection on meter	

M14\* - AM antenna input via dummy antenna (Figure 16).

Figure 13 AM-IF

Input signal = 100  $\mu$ V via wobulator (Figure 15) applied to M15.

Oscilloscope: Vert.: 200 mV/dev.  
Hor.: 2 kHz/dev., connected to M18

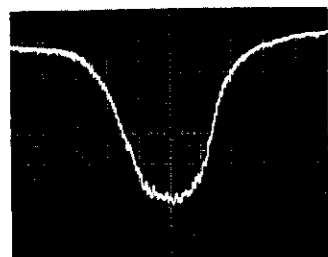

Figure 15

Signal generator and wobulator for AM alignment with oscilloscope.

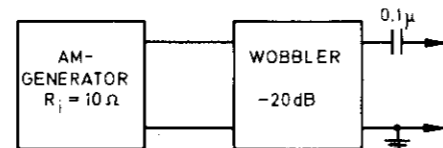
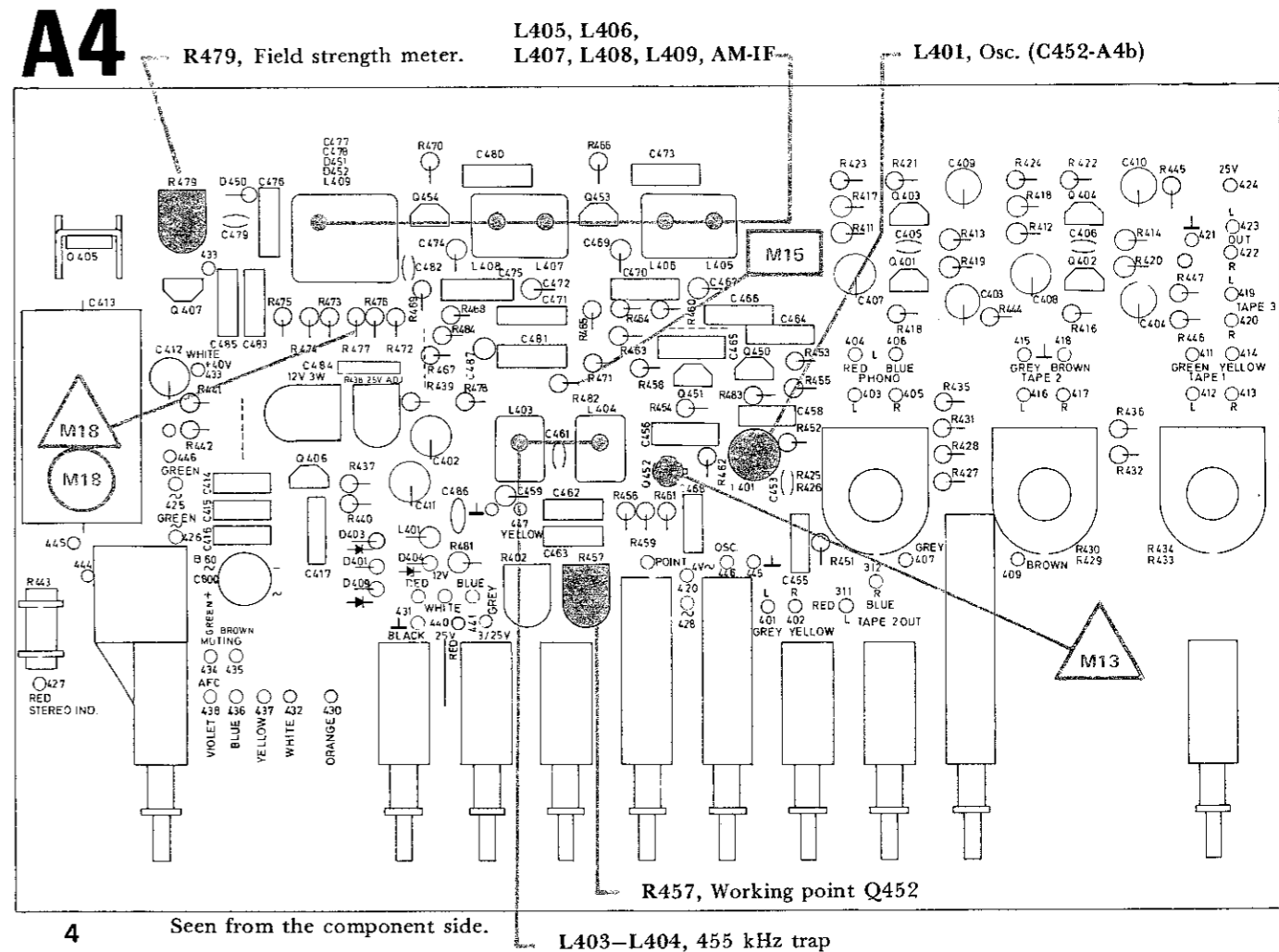
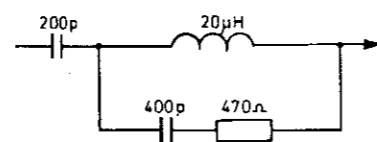
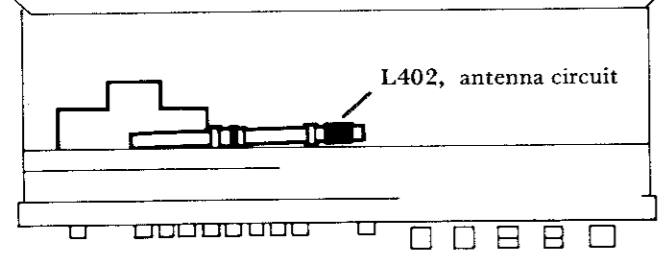

Figure 16

Standard dummy antenna.



# A4c



# A4b

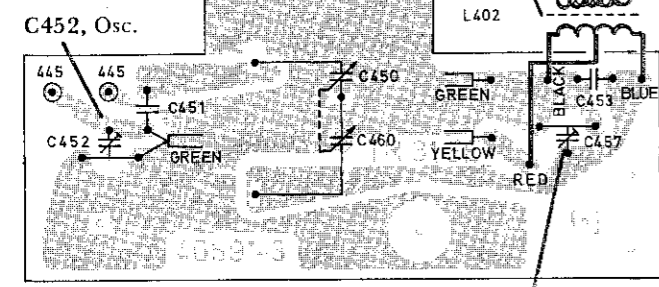

Trim from the solder side.

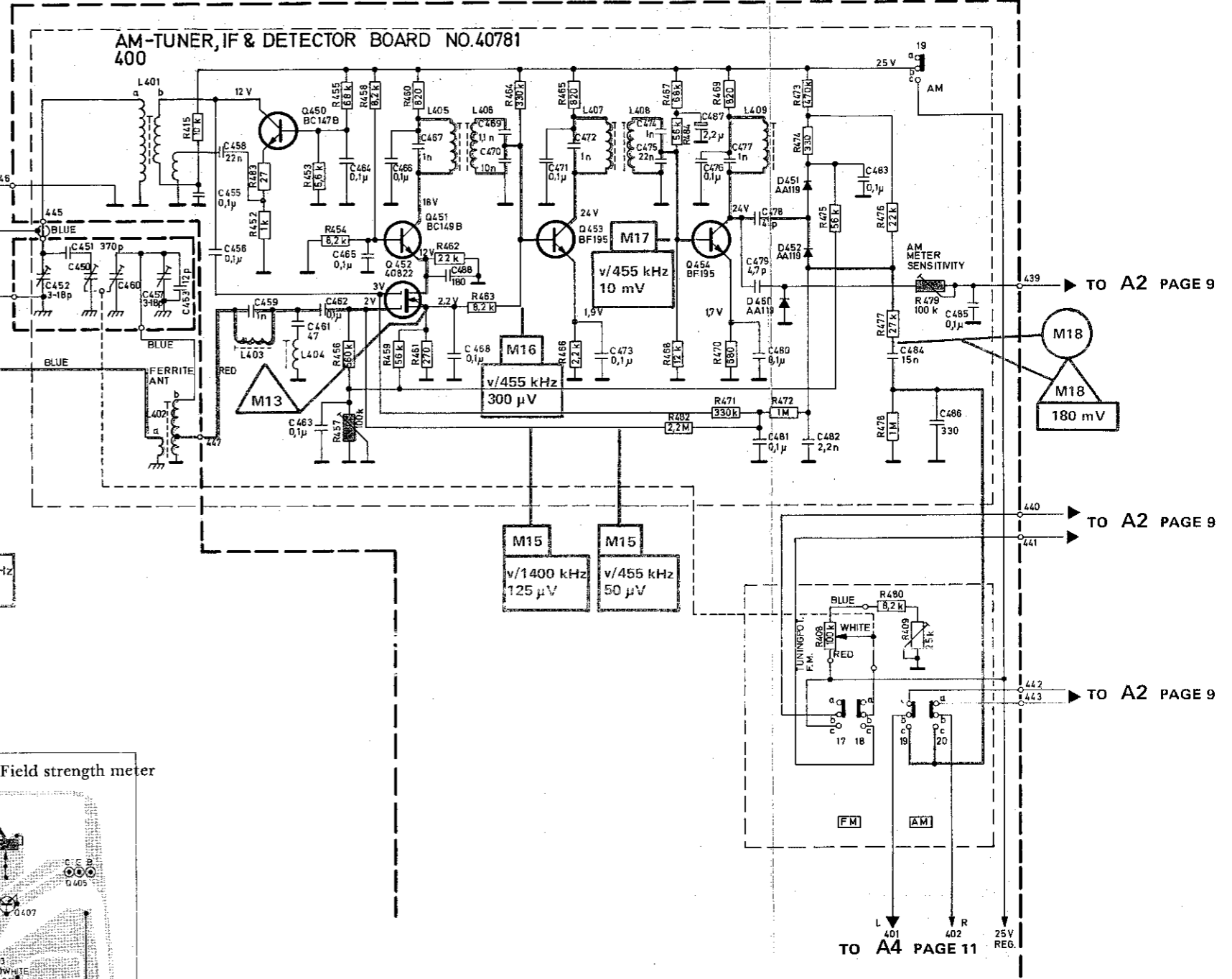

# A4

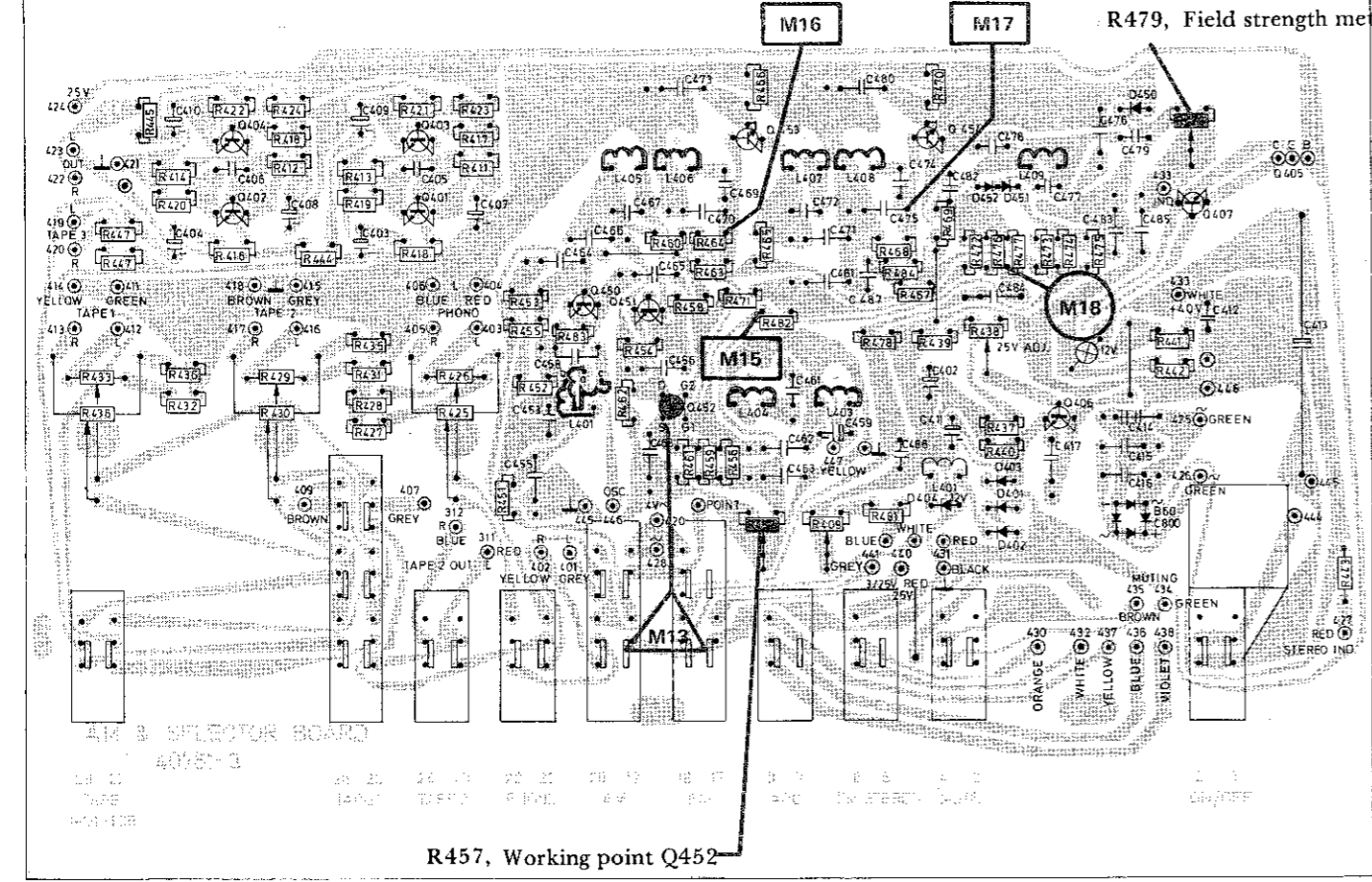

Seen from the solder side.

All the switches are shown in the unoperated position.

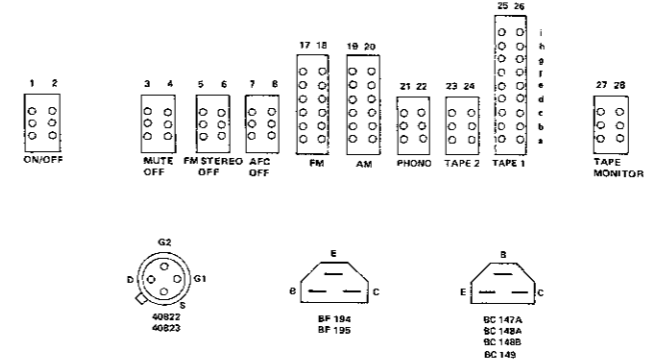

The transistors are shown from the underneath (lead or terminal side).

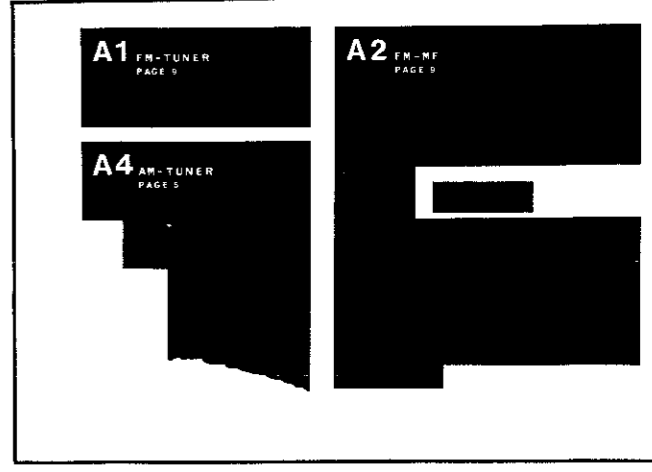

**ALIGNMENT PROCEDURE FOR STEREO DECODER**

**Measuring equipment required:**

FM stereo signal generator  
Oscilloscope (sensitivity 5 mV/cm)  
Frequency counter  
VTVM with 20 kHz LP filter or a selective VTVM

**Complete alignment**

Decoder oscillator: 19 kHz (see paragraph 1).  
Channel separation: (see paragraph 2).  
19 kHz filter: (see paragraph 3).  
Signal level for mono/stereo change over (see paragraph 4).  
Definition: Pilot signal 19 kHz ( $\pm 2$  kHz).

**1. Decoder oscillator: 19 kHz**

Apply 1 mV to the antenna input from the FM signal generator. No modulation (no 19 kHz).

Connect a frequency counter to M801 and adjust R808 until the counter indicates 19 kHz.

**Alternative:** Without using a frequency counter the oscillator can be adjusted by the following procedure. Apply 1 mV to the antenna input from an FM stereo signal generator, modulated by a 10% pilot signal. Turn R808 slowly from an end position to a position slightly past the position where the stereo indicator lamp comes on. Finely adjust R808 to the point where the pot. must be turned equally in both directions to get the lamps to go out.

**2. Channel separation**

Apply 1 mV to the antenna input from an FM stereo signal generator modulated with a 10% pilot signal. Modulate the right channel 90% with a 1 kHz signal. Connect an oscilloscope to the TAPE OUT socket for the left channel. Adjust R840 for minimum picture amplitude on the oscilloscope.

Change over the channels i.e. modulate the left channel and connect the oscilloscope to the TAPE OUT socket for the right channel. The right channel and the left channel should have the same curve amplitude on the oscilloscope.

**Alternative:** Without using a stereo signal generator you can adjust the channel separation by turning R840 until you get a minimum signal from the set's speaker on the right (or left) channel when the set is receiving a test transmission from an FM stereo transmitter. The test transmission must be modulated with a pilot signal and a signal in the left (right) channel.

**3. 19 kHz filter**

Apply 1 mV to the antenna input from an FM stereo signal generator modulated with a 10% pilot signal.

Adjust R833 and R835 (R834 and R836) alternately to get the min. 19 kHz signal on the TAPE OUT socket, left (right) channel, measured selectively. (Or with a LP filter at 20 kHz to remove the residue of the 38 kHz signal).

**FM Alignment procedure**

Step	Alignment procedure	Receiver	Signal Generator			Oscilloscope	Circuit		Notes
		Frequency	Frequency	Deviation	Connected to <span style="border: 1px solid black; padding: 0 2px;">M</span>	Connected to <span style="border: 1px solid black; border-radius: 50%; padding: 0 2px;">M</span>	Adjust	Board No.	
1	25 V for varicap diodes (D104)						R438	A4	Connect a d.c. voltmeter to M13 (board A2 must be tipped up and the measurement point reached from the foil side). Adjust to 25 V $\pm$ 0.2 V.
2	FM-IF	90 MHz	90 MHz	$\pm 200$ kHz	M1*	M4*	L106, L107	A1	Press the AFC button in. Adjust for max. curve amplitude and symmetry (Figure 13), FM-IF 10.6 to 10.8 MHz. The center frequency is determined by the fixed ceramic filter.
3	FM osc.	90 MHz 105 MHz	90 MHz 105 MHz	$\pm 200$ kHz	M1*	M4*	R409 C118	A4 A1	Check the position of the tuning pointer before alignment (see Figure 4). Check the coordination with 95 MHz and 100 MHz.
4	Antenna circuit	90 MHz 105 MHz	90 MHz 105 MHz	$\pm 200$ kHz	M1*	M4*	L101, L102, L103 C103, C107, C110	A1	Adjust for max. amplitude. Check the coordination with 95 MHz and 100 MHz.
5	Discriminator	90 MHz	90 MHz	$\pm 75$ kHz	M1* 1 mV/75 ohm	M4*	L202, L203	A3	For optimum alignment, the distortion from the signal generator should be less than 0.1%. If not, use the alternative method described below the table. Tune in to get symmetry on the IF curve. Connect a VTVM to TAPE OUT (M6). Adjust L203 for max. output voltage. Adjust L202 for min. output voltage. Then adjust to get min. distortion.
6	Center meter	90 MHz	90 MHz	$\pm 75$ kHz	M1* 1 mV/75 ohm	M4*	R234	A2	Adjust for center reading on the meter with the signal on. Then check that the center reading remains after the signal is removed by shorting C125 (A1) to ground.
7	AFC	90 MHz	90 MHz	$\pm 75$ kHz	M1*	M4*	R240	A2	Release the AFC button. Adjust R240 for center reading on the meter. Check that the center reading does not change as you push the AFC button in and out.
8	Field strength meter	90 MHz	90 MHz		M1* 10 mV/75 ohm		R224	A2	Adjust to get 90% of max. deflection.

M1\* - FM antenna input  
M4\* - Via diode probe (Figure 5) board A2.

**4. Signal level for mono/stereo switch-over**

Apply 10  $\mu$ V to the 75 ohm antenna input from an FM stereo signal generator modulated with a 10% pilot signal.

Turn R221 to an end position (anti-clockwise seen from the component side) and then turn it slowly clockwise until the stereo indicator lamp comes on.

**Alternative:** If an FM stereo signal generator is not available, use an ordinary signal generator. Apply 10  $\mu$ V to the 75 ohm antenna input from the FM signal generator modulated with 19 kHz, deviation 7.5 kHz. The 19 kHz should be checked against a frequency counter. Follow the same alignment procedure described in the preceding paragraph.

**Aligning the FM section**

See the FM alignment procedure in the table and the associated oscillograms.

**Figure 3 FM Selectivity**

INPUT SIGNAL = 150  $\mu$ V/75 ohms, f = 90 MHz, Deviation =  $\pm 200$  kHz applied to M1 via the antenna socket.  
OSCILLOSCOPE: Vert. defl.: 5 mV/div., Hor. def.: 50 kHz/div. applied to M4 via a diode probe (Figure 5).

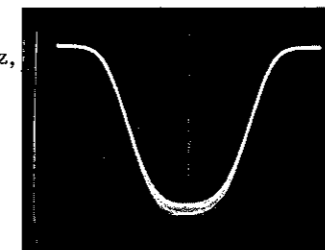

**Alternative: Discriminator**

Connect a VTVM to the TAPE OUT socket (M6). Tune in for a symmetrical IF curve. Trim L203 to get max. output voltage. Trim L202 to get min. output voltage. NOTE! Trim these coils very carefully.

**Figure 4 FM pointer position**

Check the pointer's zero position before trimming. It should lie in the middle of the "FM".

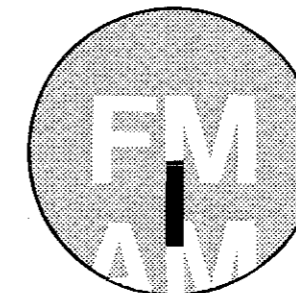

**Figure 5 Diode probe**

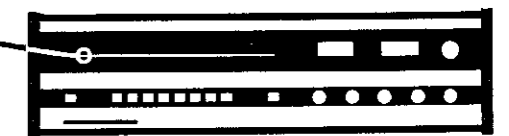
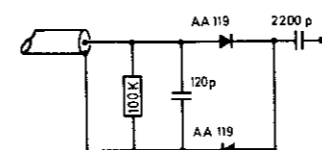

**A2**

**A1**

L102,L103,  
C107,C110, antenna circuits C118, FM-osc.

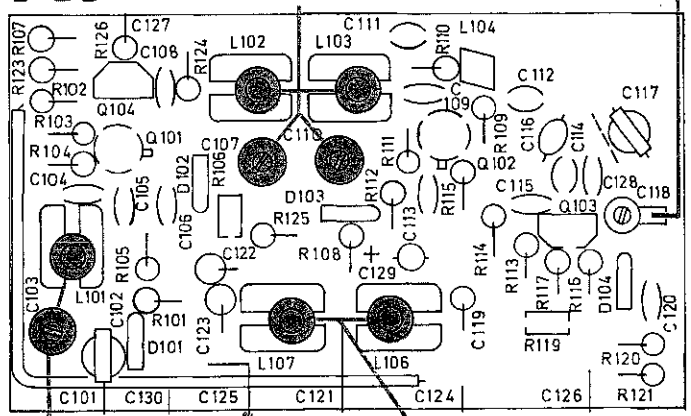

L101,C103, C125 L106,L107, FM-MF  
antenna circuit Seen from the component side.

**A4**

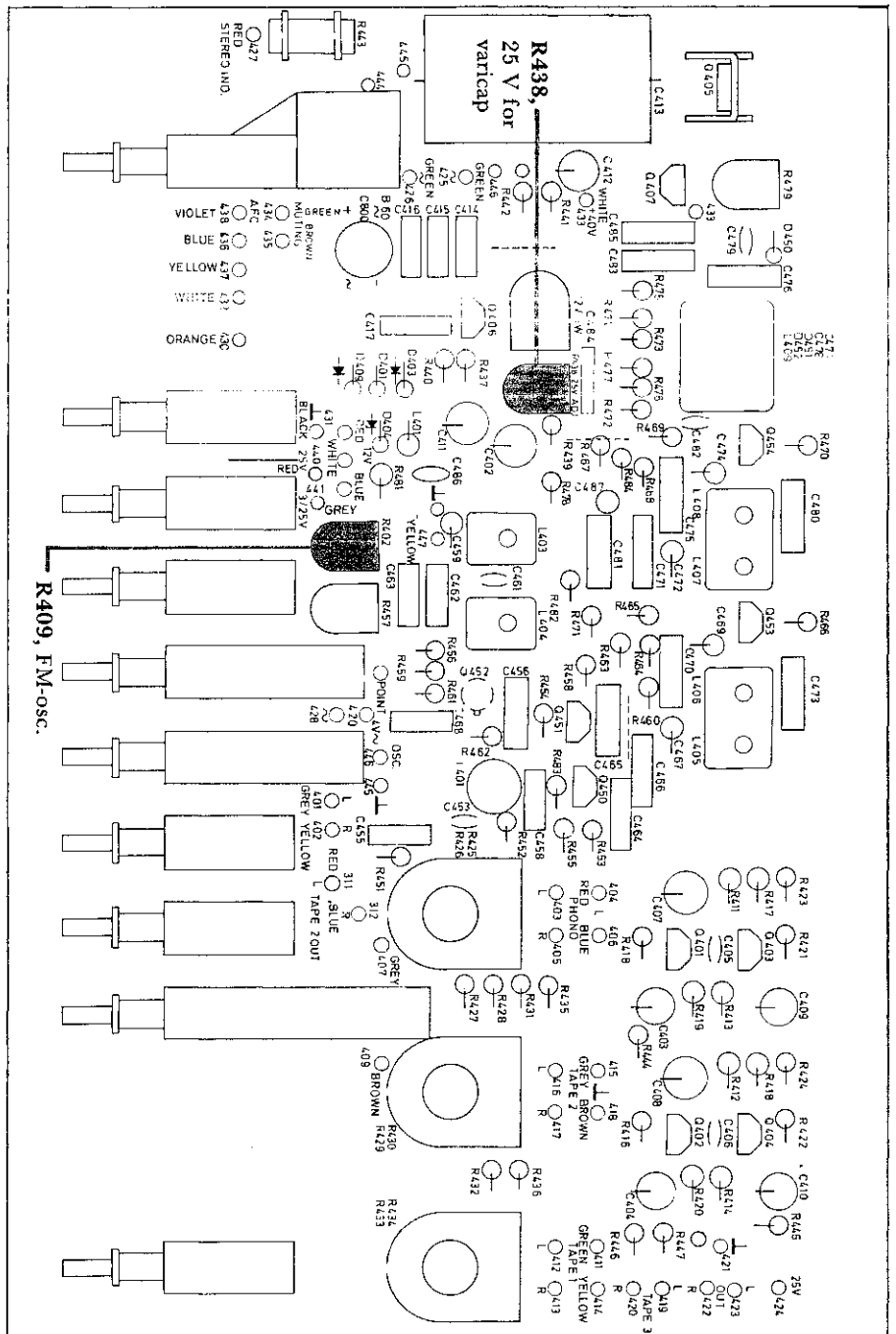

↑  
Seen from the component side.

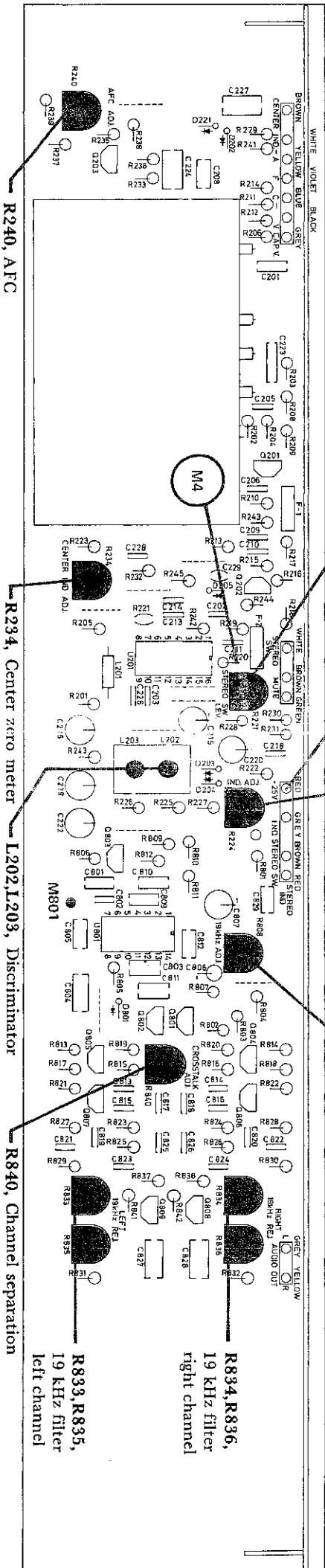

R221, Signal level mono/stereo switch-over M3  
R224, Field strength meter  
R808, 19 kHz  
R833, R835, 19 kHz filter right channel  
R834, R836, 19 kHz filter left channel  
R840, Channel separation

R240, AFC

R234, Center zero meter

R840, Channel separation

R833, R835, 19 kHz filter left channel

R834, R836, 19 kHz filter right channel

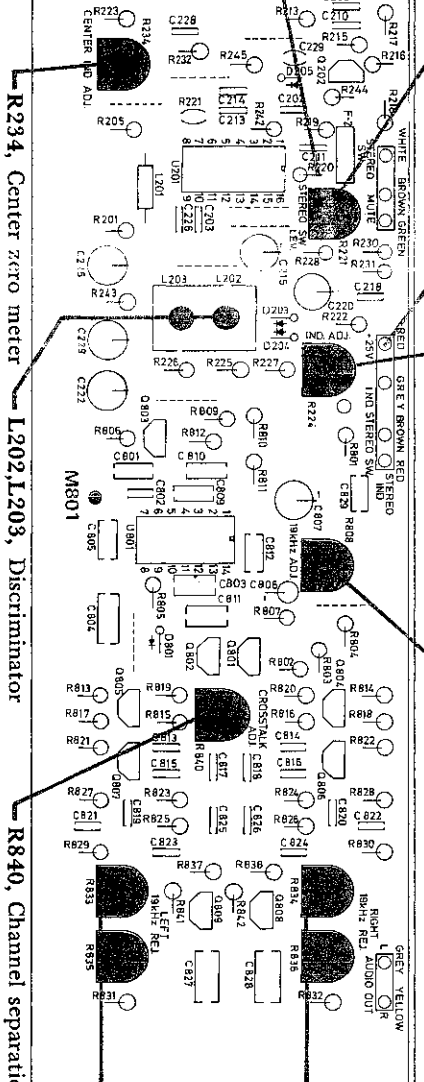
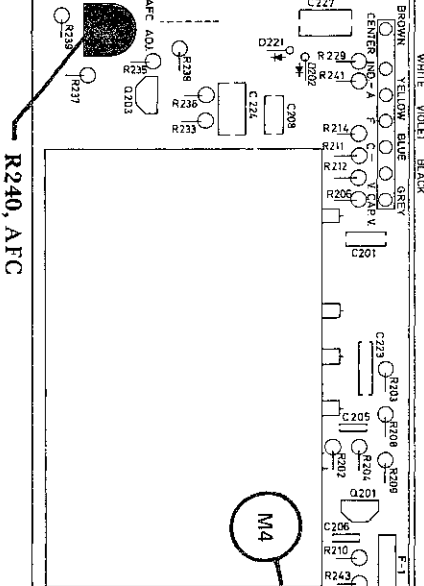

A1

L102, L103,  
C107, C110, Aerial circuit

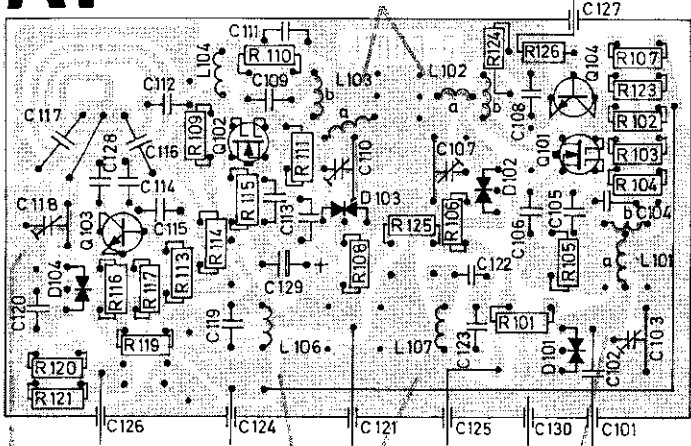

C118, FM-osc.      L106, L107, FM-IF      L101, C103,  
Seen from the solder side.      Aerial circuits

**VOLTAGE DIVIDER FOR MEASUREMENTS:**  
The amplification measurements M2, M3, and M4 marked in the circuit diagrams on page 9 have been made with a voltage divider in series with a signal generator as shown in the diagram below.

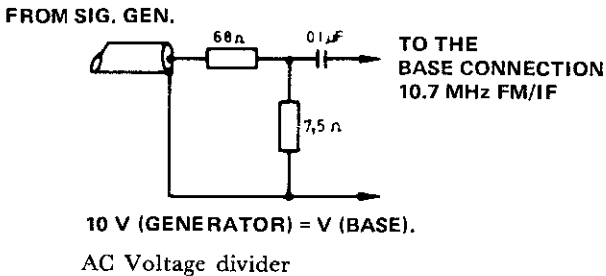

**NOTE!** The leads on the components in the circuit divider must be as short as possible.

M5: Max. AF voltage out, reduced by 3 dB.  
M1: Input 0.5 μV from signal generator.

M5: Max. AF voltage out, reduced by 3 dB.  
M2: Input 90 μV from signal generator.

M5: Max. AF voltage out, reduced by 3 dB.  
M2: Input 250 μV from signal generator.

M5: Max. AF voltage out, reduced by 3 dB.  
M4: Input 650 μV from signal generator.

**NOTE!** There may be a small spread in the amplification figures obtained from different receivers.

**SPREAD ON MEASUREMENTS:** When you are measuring the amplification between M1 and M5 it is easier to use the TAPE OUT socket (pin 1 or pin 4). This avoids dismantling the cabinet.

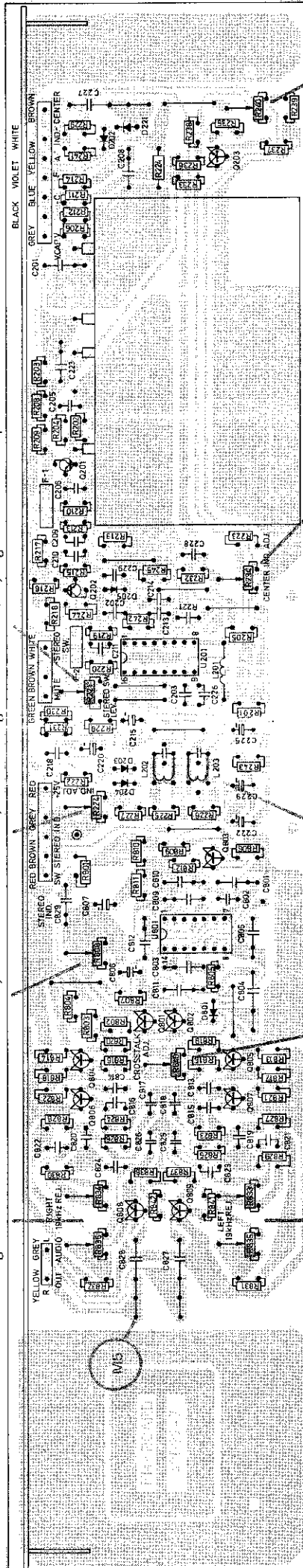

R834, R836,  
19 kHz filter,  
right channel

R833, R835,  
19 kHz filter,  
left channel

R224, Field strength meter

R808, 19 kHz

R834, R836,  
19 kHz filter,  
right channel

R202, L203, Discriminator

R234, Center zero meter

Seen from the solder side.

R240, AFC





# A4

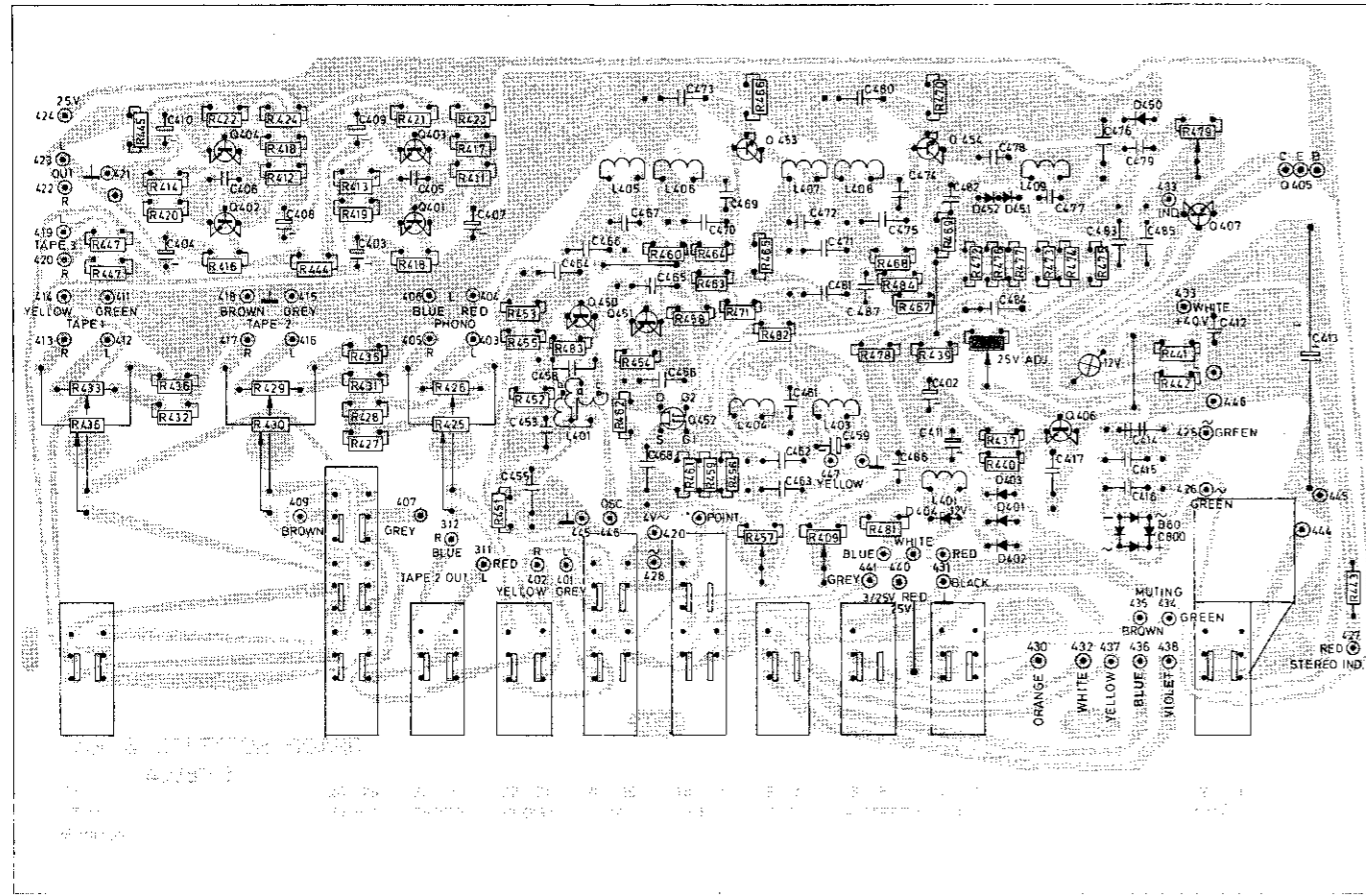

Seen from the solder side.

R438,  
25 V varicap

# A4

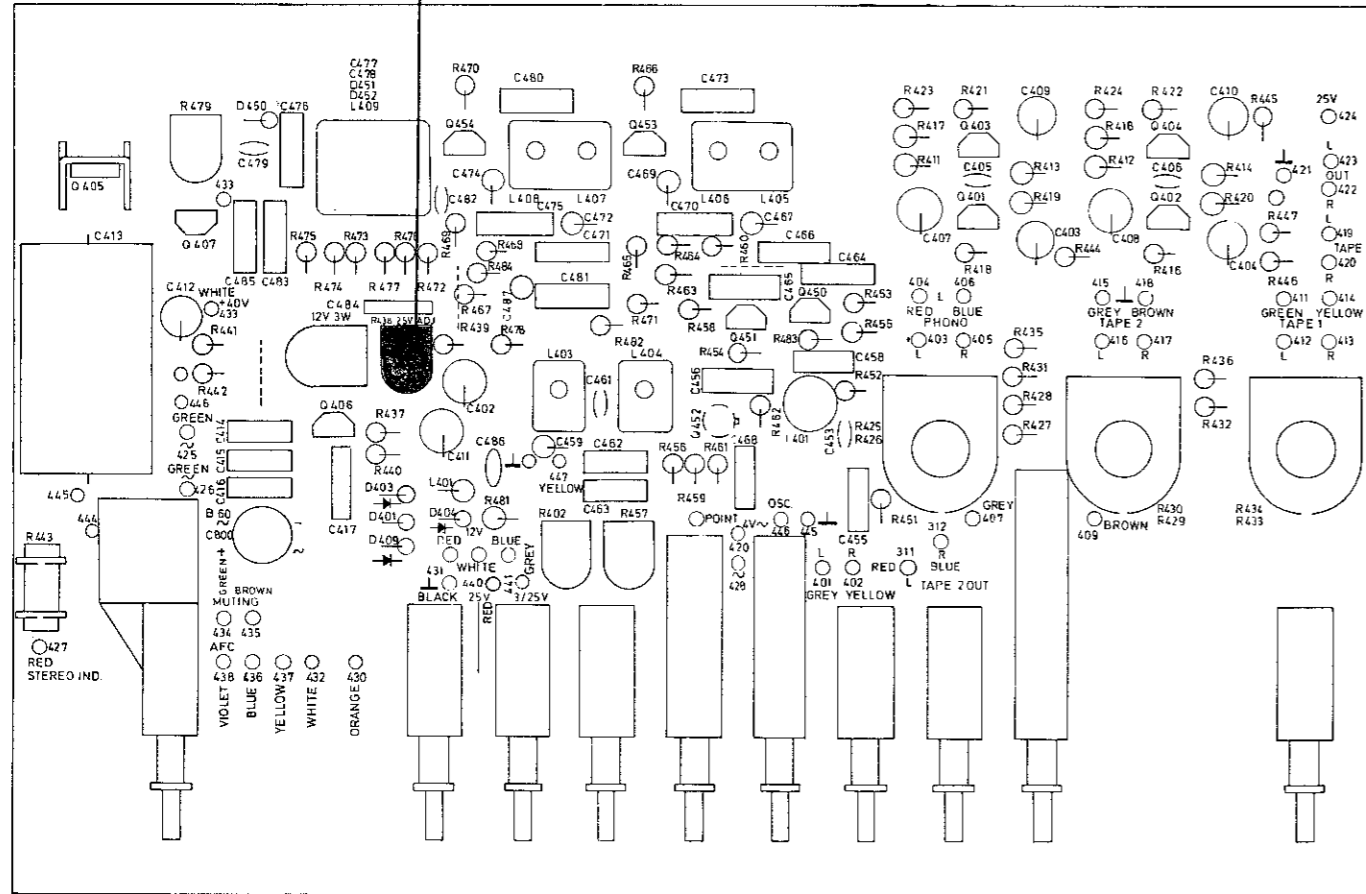

Seen from the component side.

# A3 TR-1040A, TR-1055

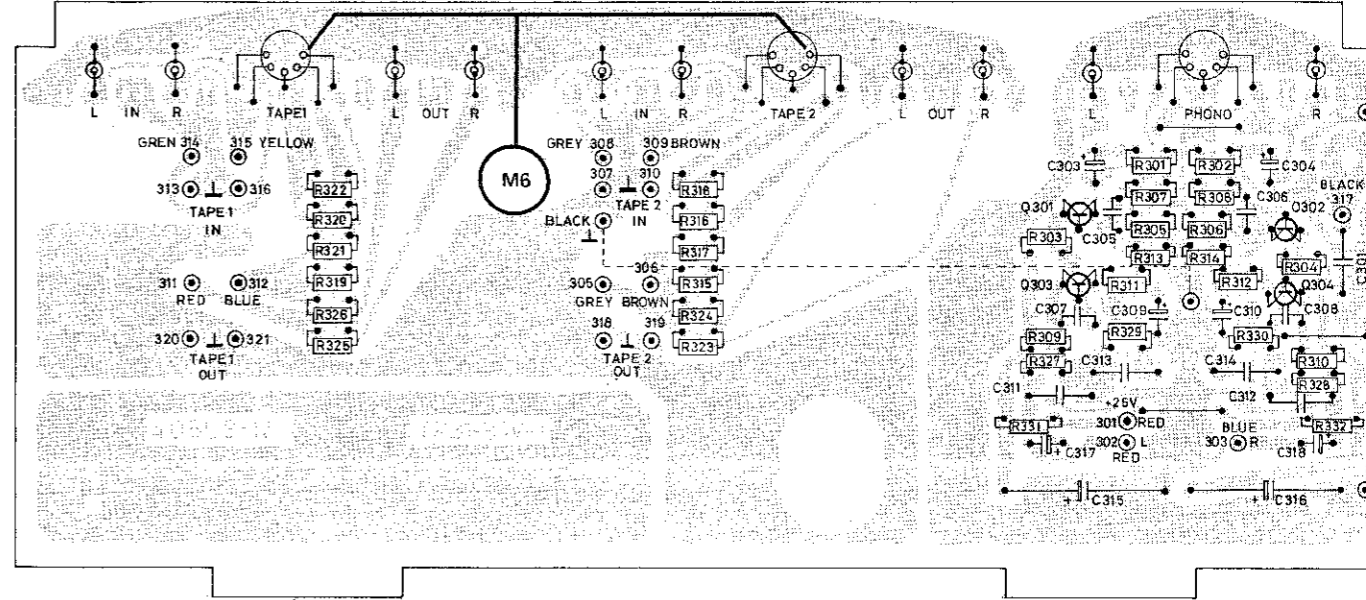

Seen from the solder side.

# A10

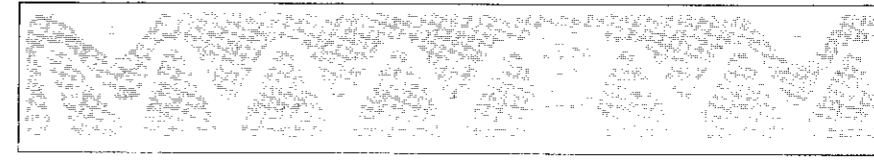

Seen from the solder side.

# A5

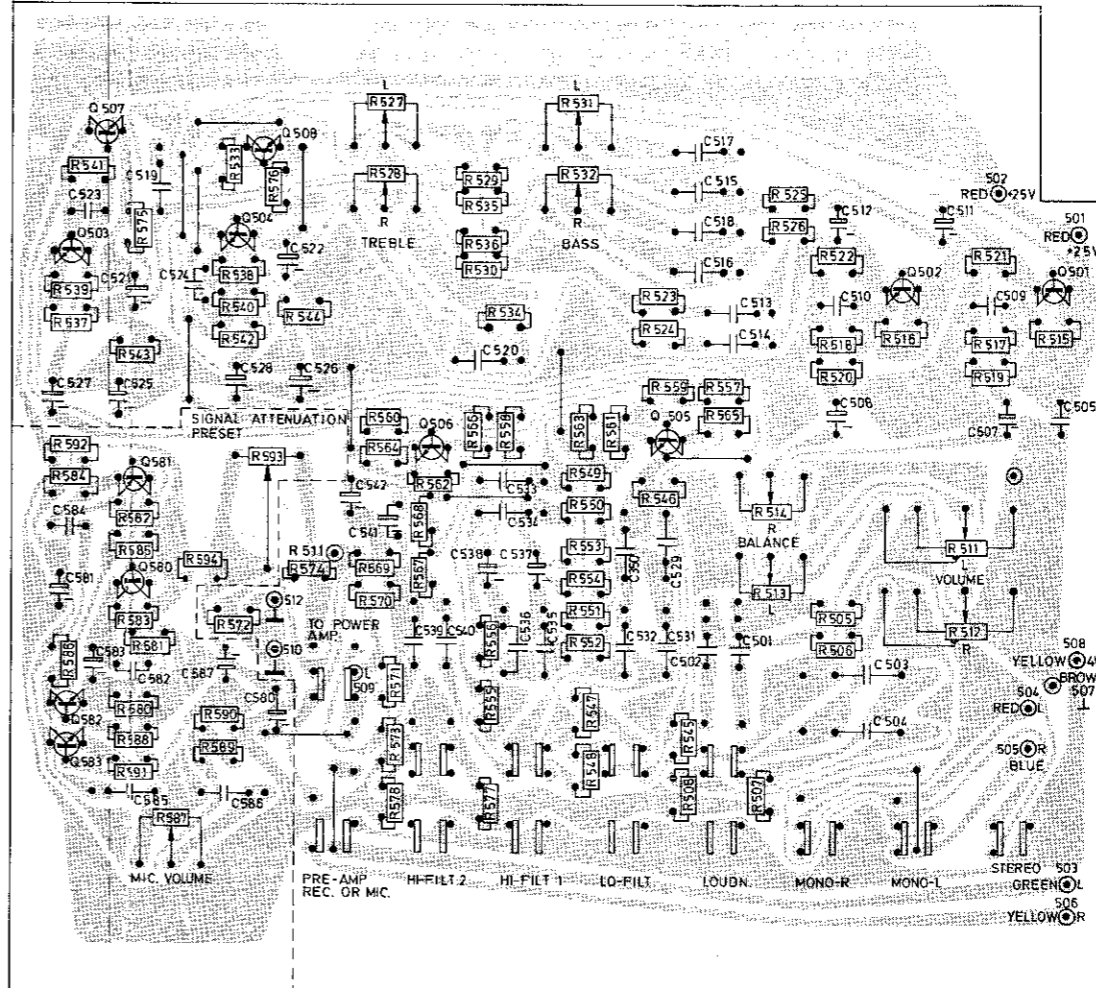

Seen from the solder side.

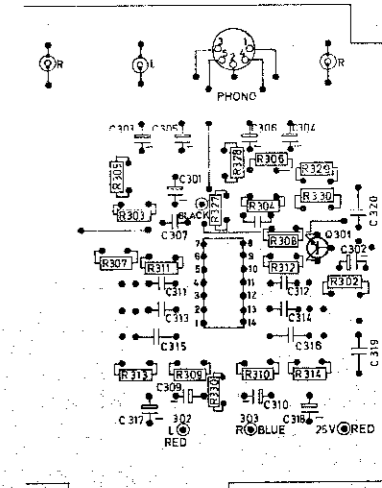

# A3 RIAA PRE-AMPLIFIER UP TO SERIAL NO. 1426000

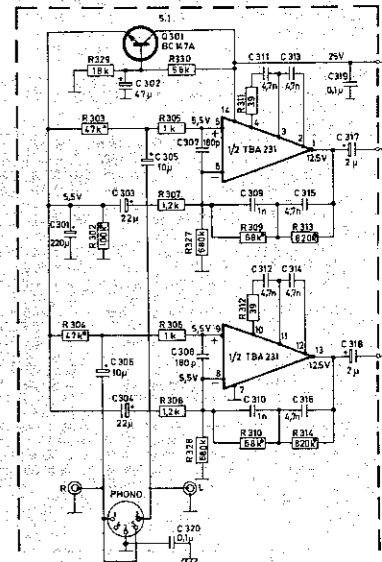

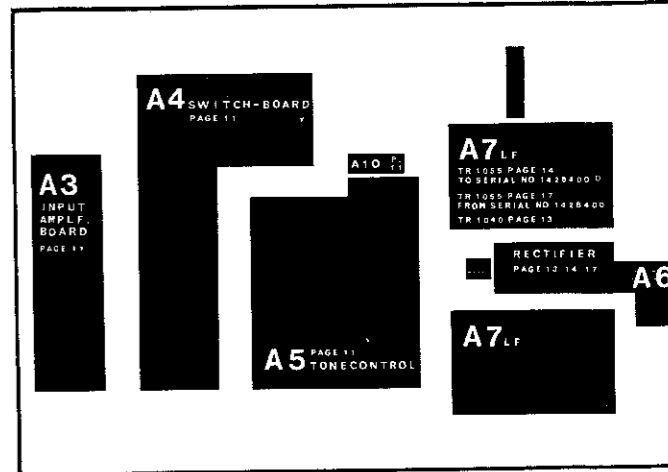

RESISTANCE VALUES ARE OHMS K=1000 M=1000000. RESISTORS ARE 05WATT OR LESS UNLESS OTHERWISE SPECIFIED. ALL SWITCHES ARE DRAWN IN UNOPERATED POSITION. ALL RESISTORS MARKED WITH A DOT ARE LOW NOISE TYPES. SWITCH-NOISE SUPPRESSOR

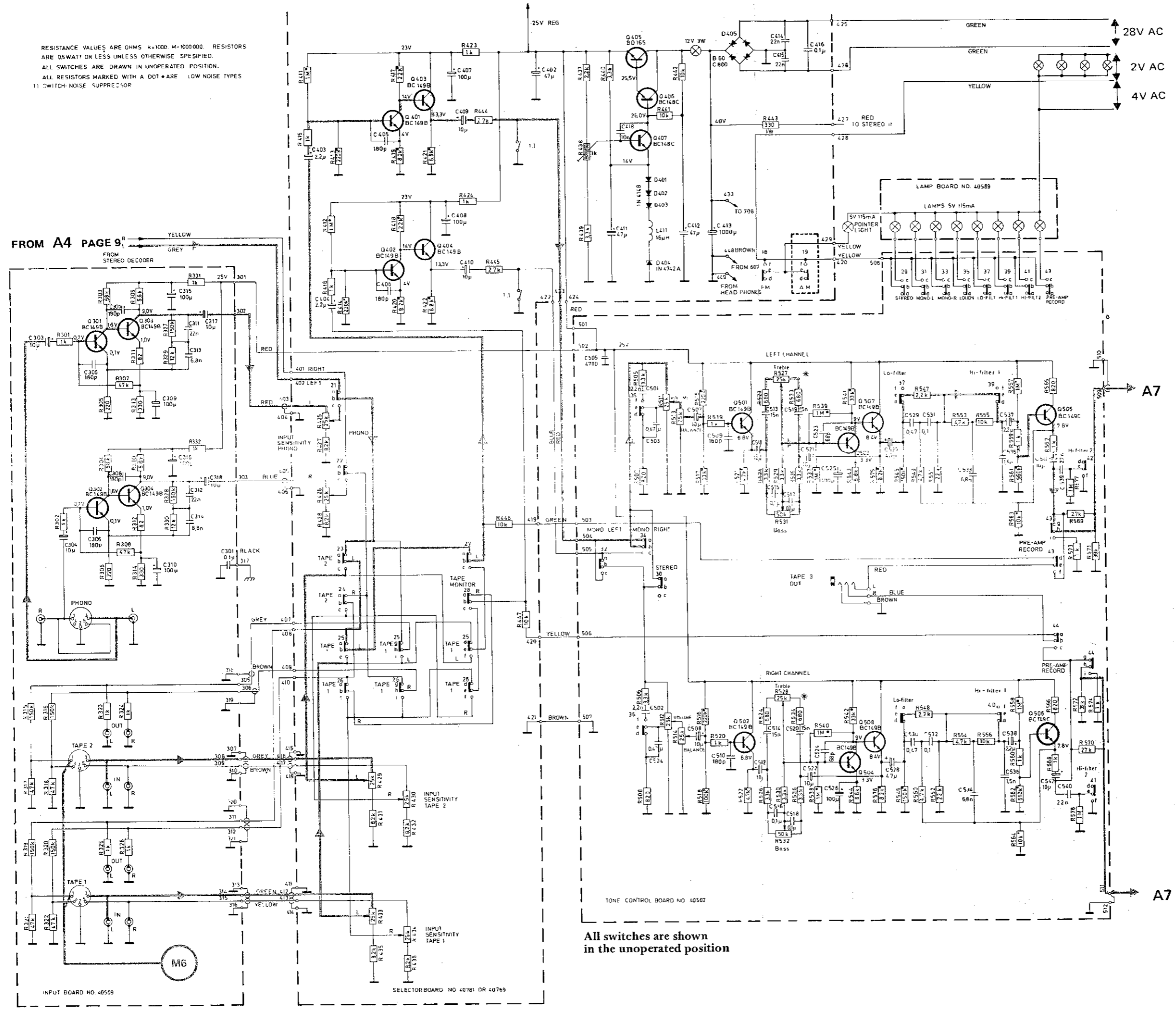

A7 LEFT CHANNEL → TR-1055 PAGE 14 TO SERIAL NO. 1426400  
 TR-1055 PAGE 17 FROM SERIAL NO. 1426401  
 TR-1040A PAGE 13

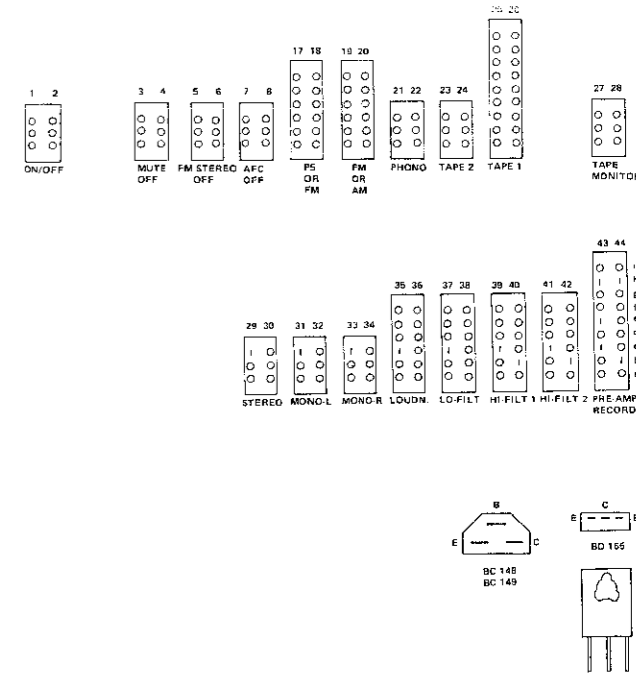

The transistors are shown from underneath

All switches are shown in the unoperated position

**A6**

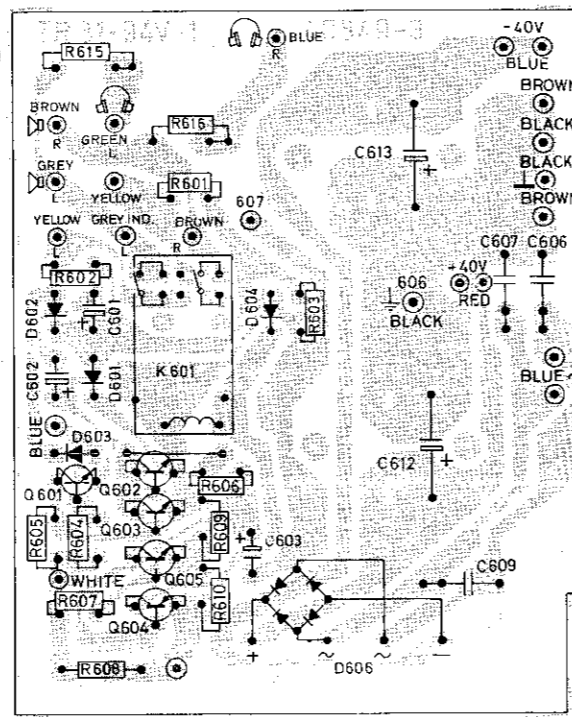

Seen from the solder side.

**A7**

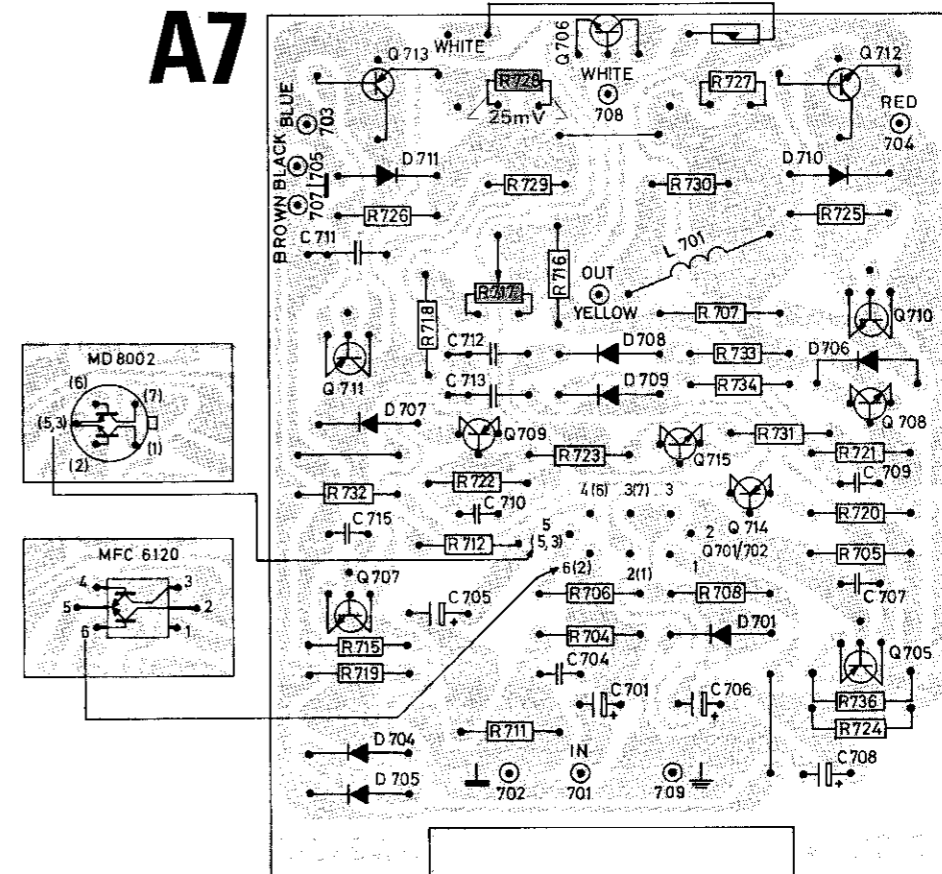

Seen from the solder side.

**A9**

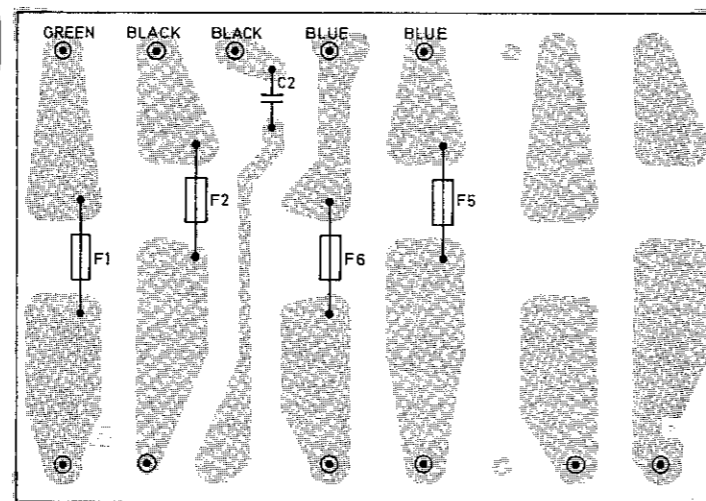

Seen from the solder side.

**A7**

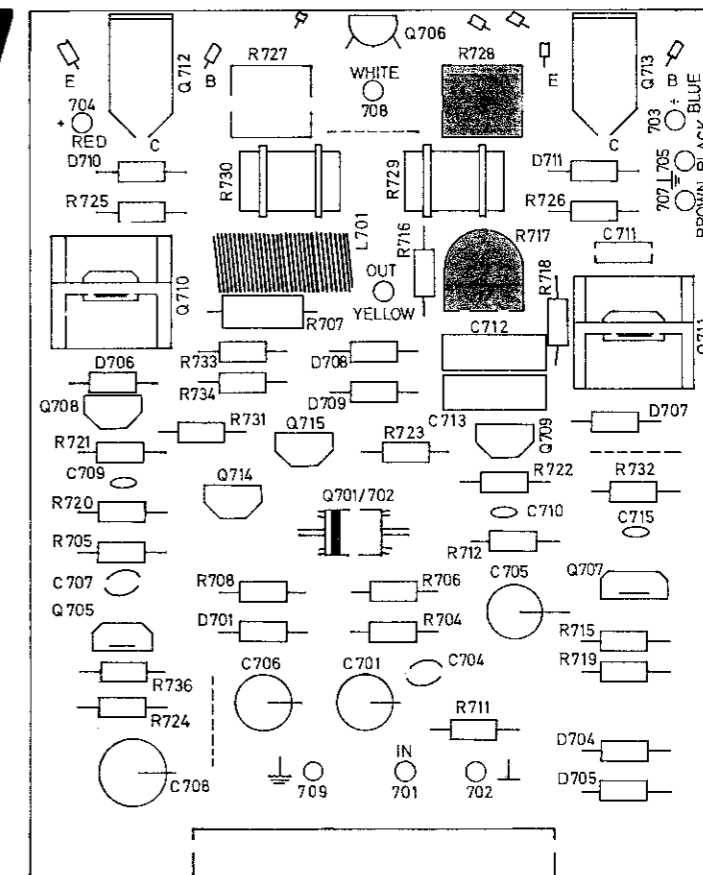

Seen from the component side.

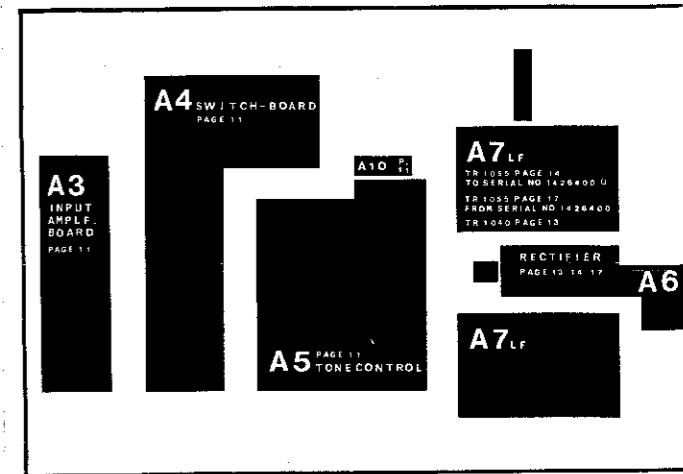
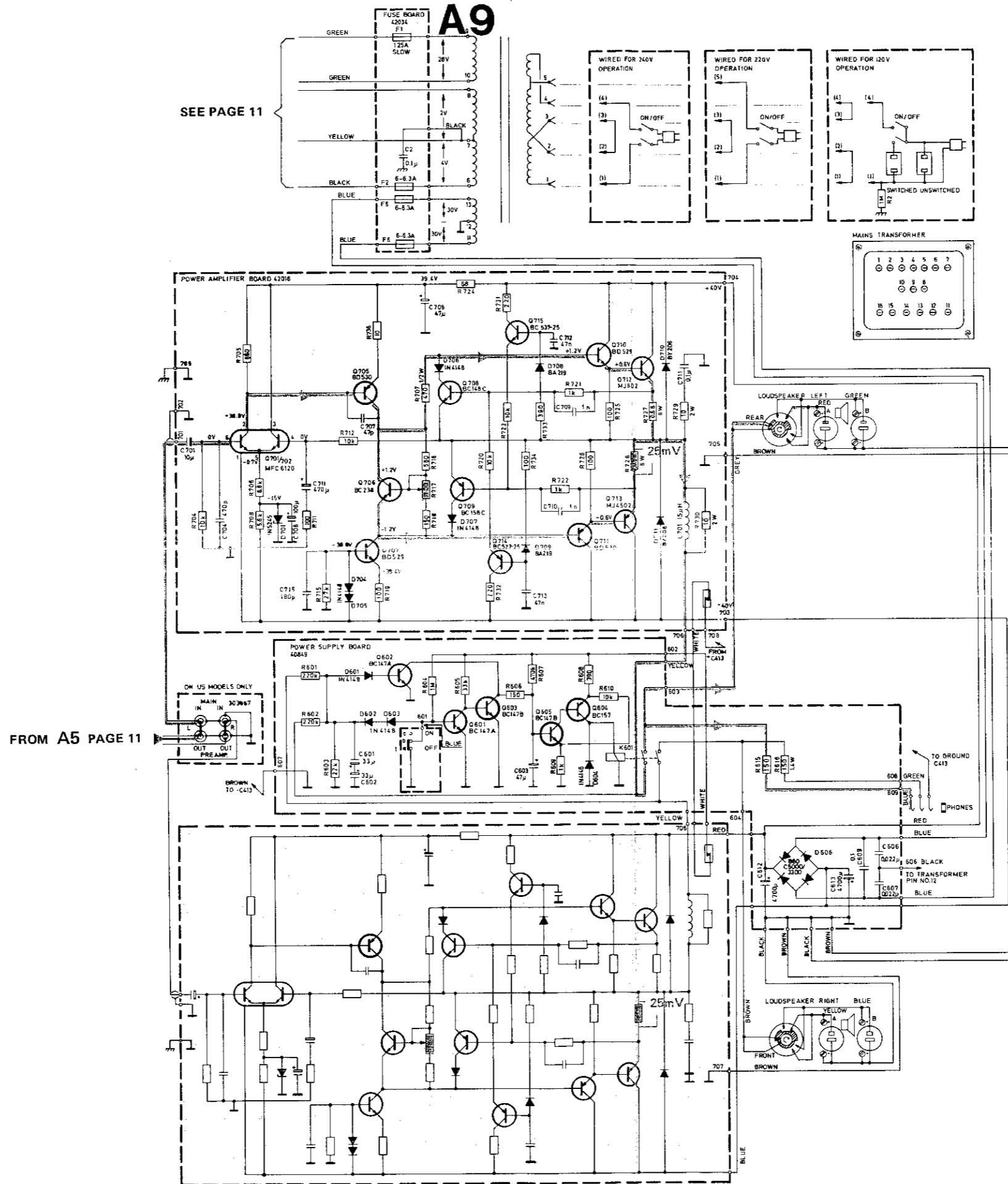

**Quiescent current.**

The quiescent current in both channels can be checked by measuring the voltage across R728. Immediately after power has been switched on and with the volume at minimum the voltage should be 25 mV. If necessary, adjust with R717. After 10 minutes warm-up the voltage will normally be 40 mV.

The most convenient place to connect the voltmeter is between the top of R727 and the top of R728 (on the component side of the board).

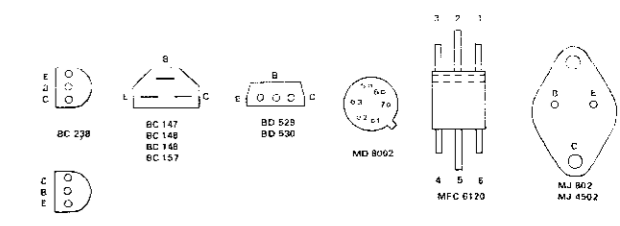

The transistors are seen from underneath

**A7**

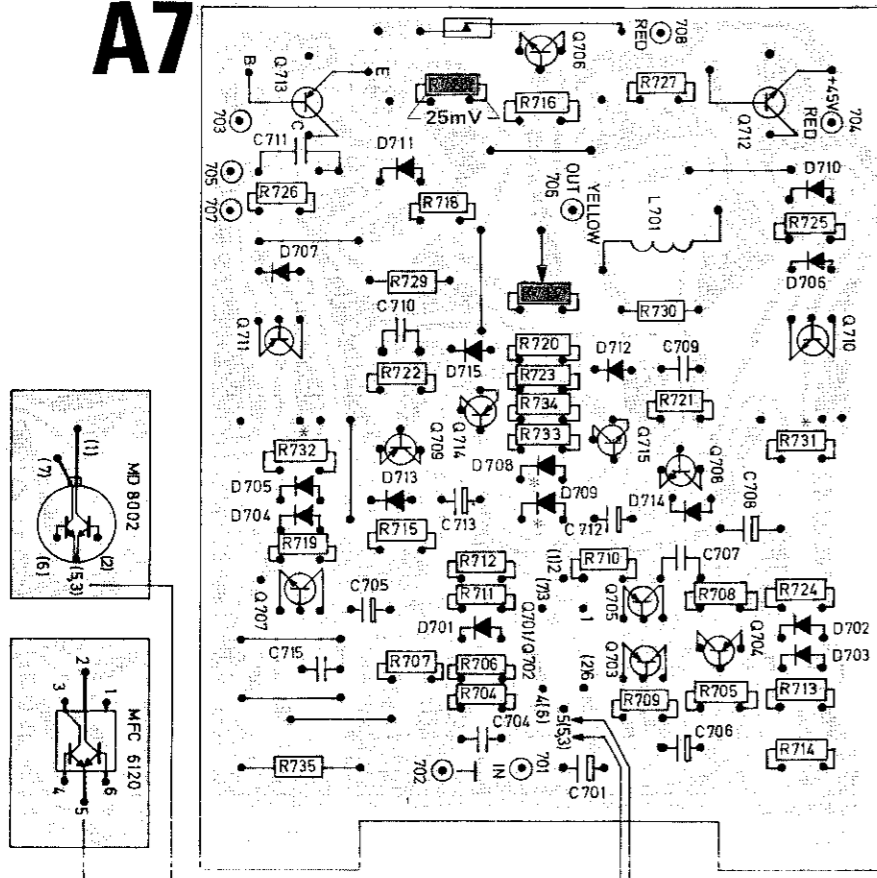

Seen from the solder side.

\*NOTE! If R731 or R732 is burnt  
D708 and D709 must be replaced with to BA219

**A7**

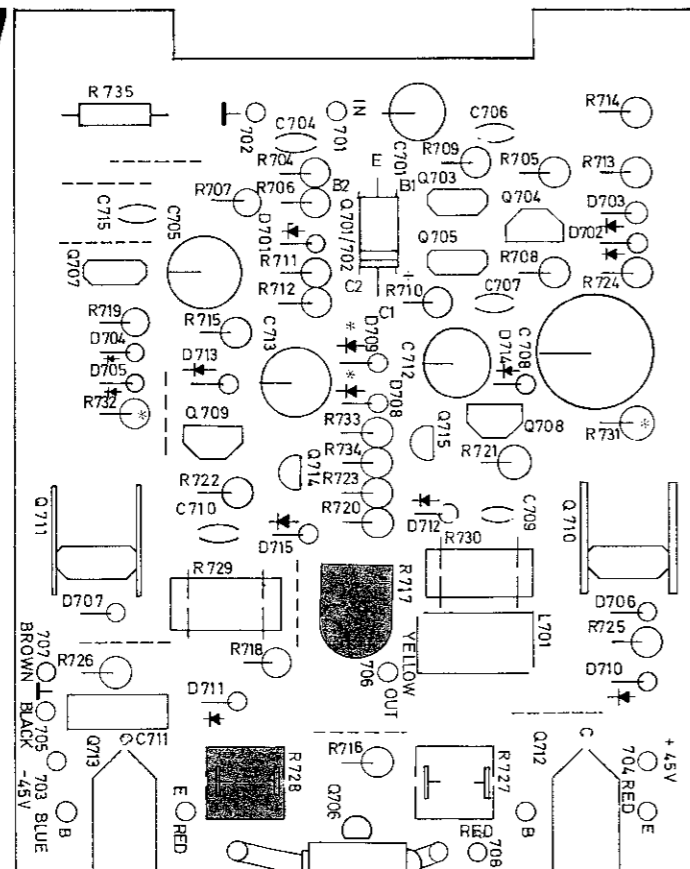

Seen from the component side.

**A9**

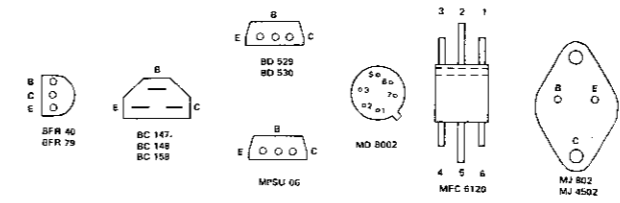

The transistors are shown from underneath  
(the lead or terminal side).

SEE PAGE 11

FROM A5 PAGE 11

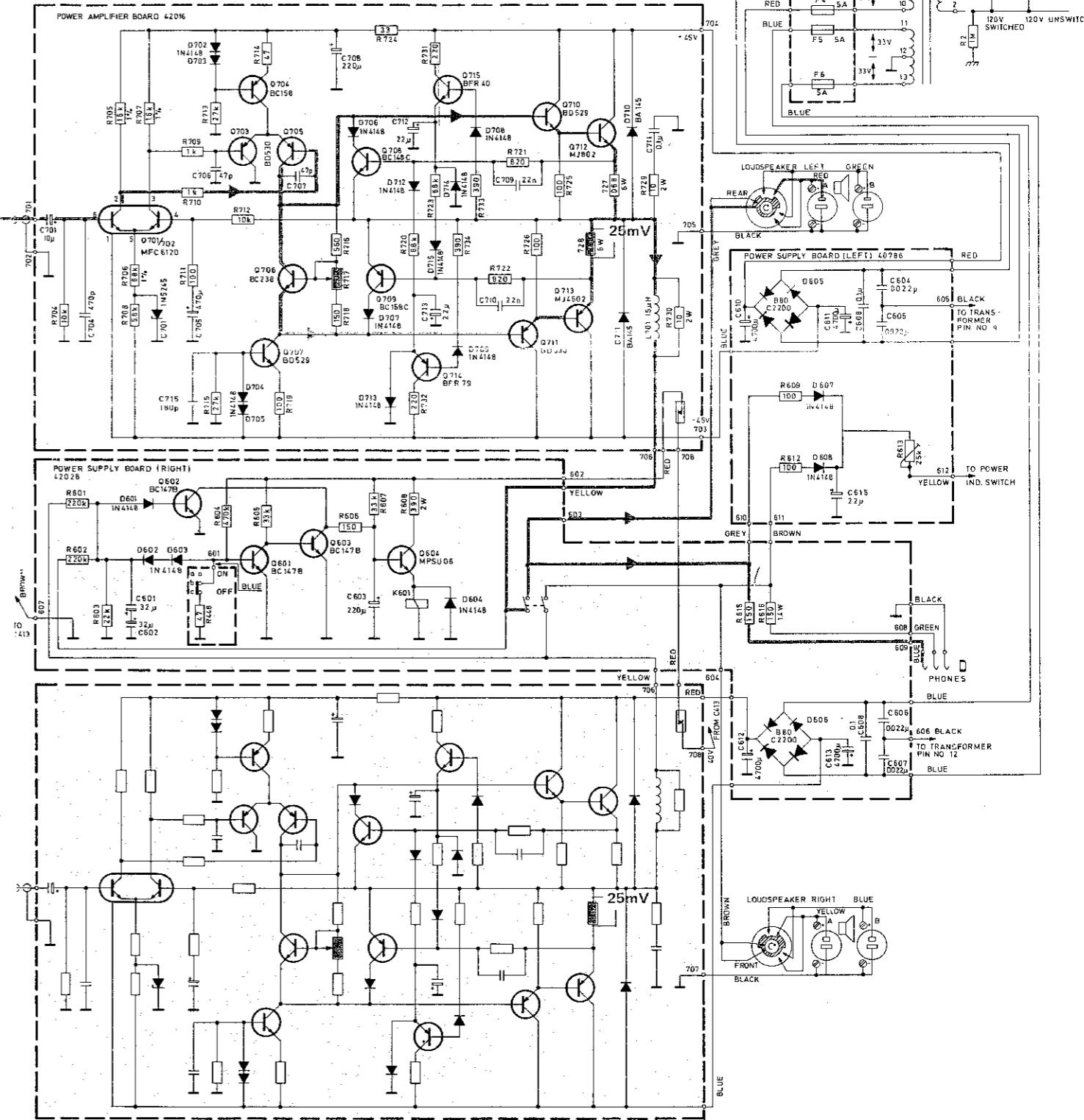



Quiescent current.

The quiescent current in both channels can be checked by measuring the voltage across R728. Immediately after power has been switched on and with the volume at minimum the voltage should be 25 mV. If necessary, adjust with R717. After 10 minutes warm-up the voltage will normally be 40 mV.

The most convenient place to connect the voltmeter is between the top of R727 and the top of R728 (on the component side of the board).

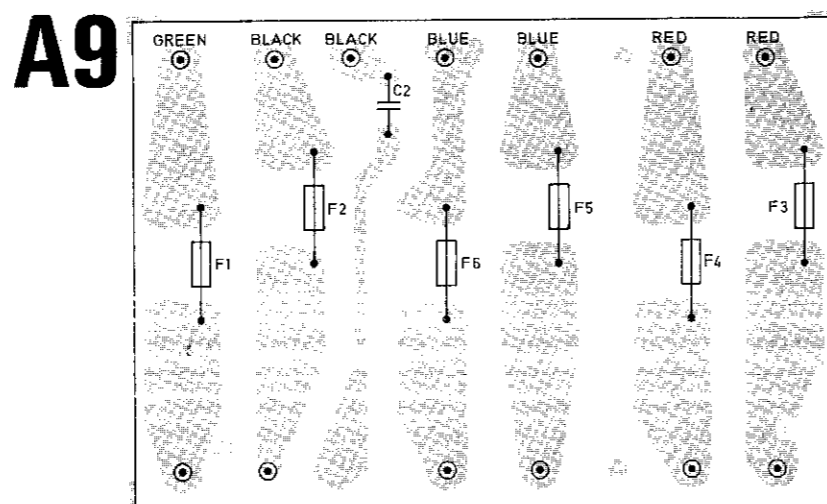
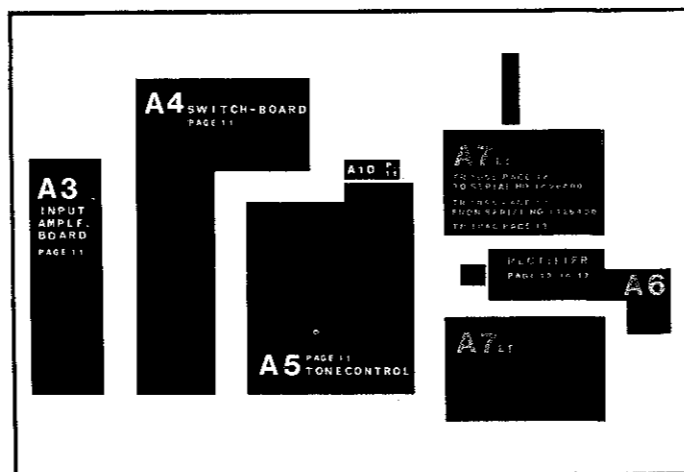

Seen from the solder side.

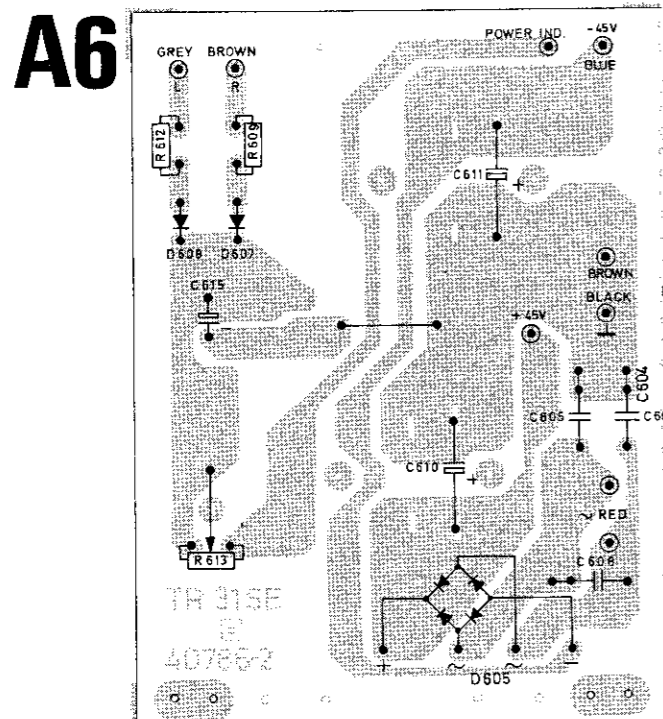

Seen from the solder side.

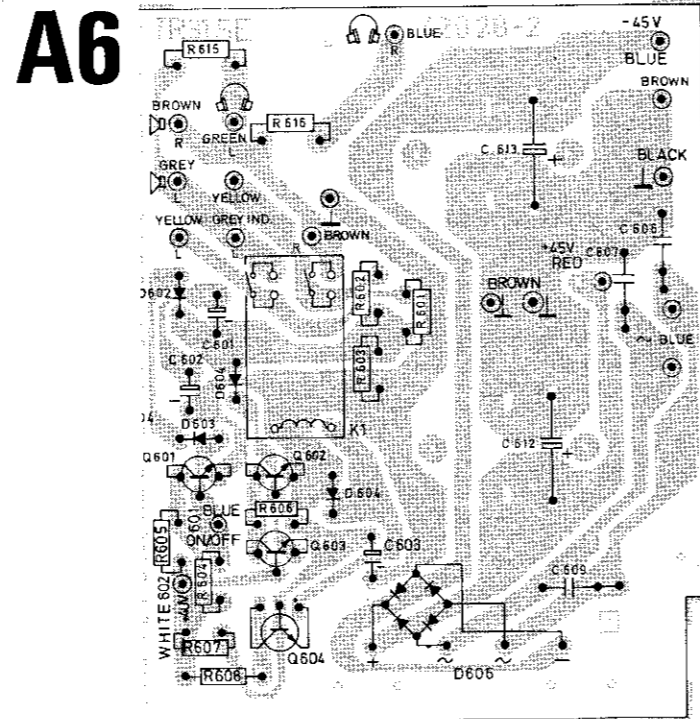

Seen from the solder side.

426400

NOTES:

NOTES:

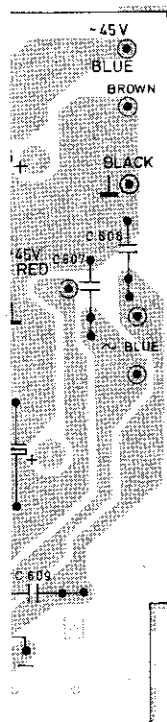
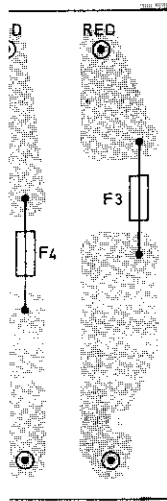



**A7**

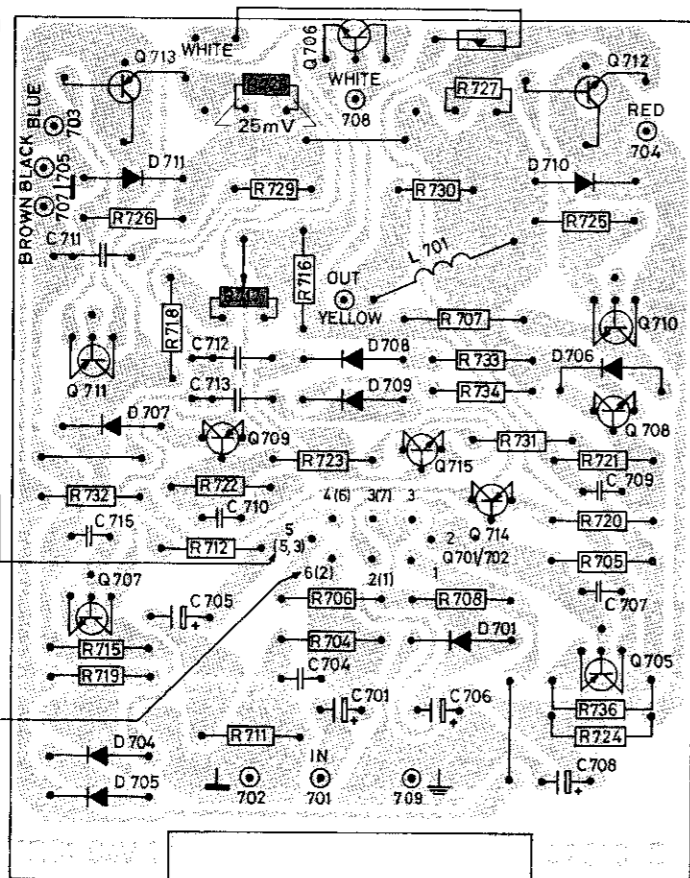

Seen from the solder side.

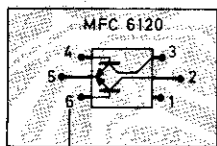
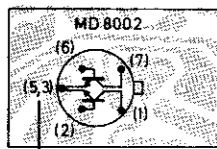

**A7**

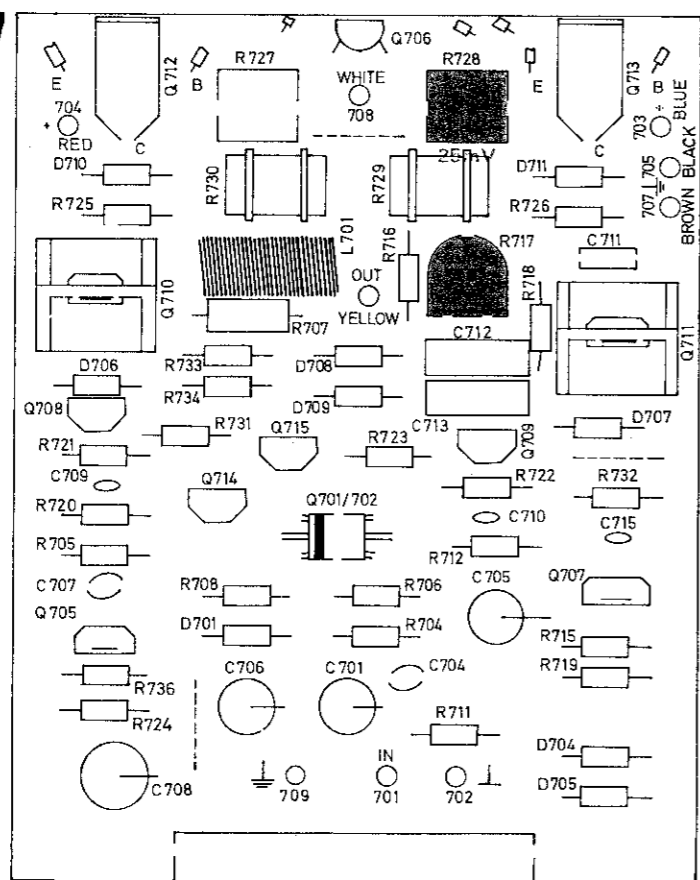

Seen from the component side.

**A9**

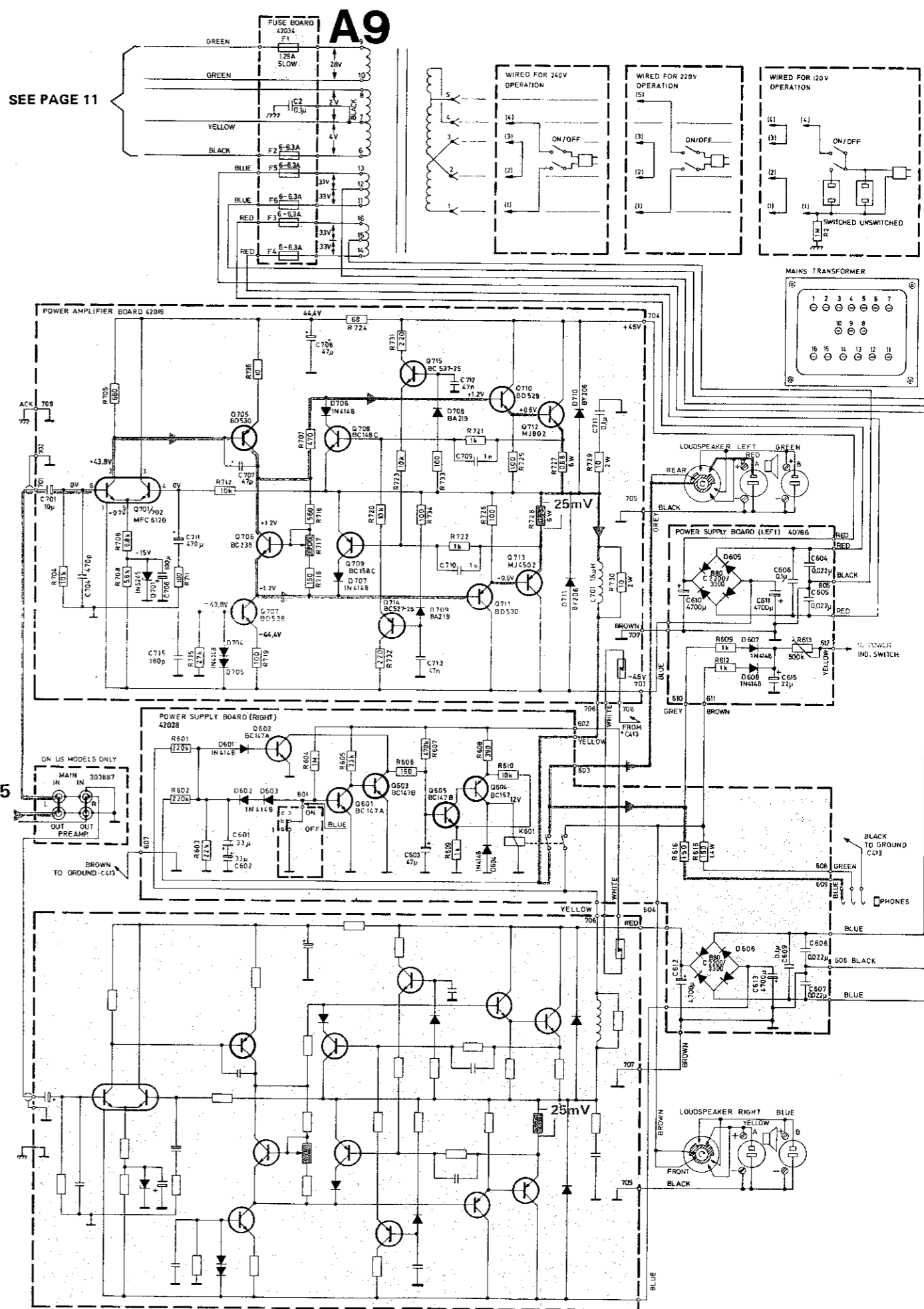

SEE PAGE 11

FROM A5  
PAGE 11

Qu  
Th  
me  
pow  
mu  
wit  
nor  
The  
bet  
por

**A**

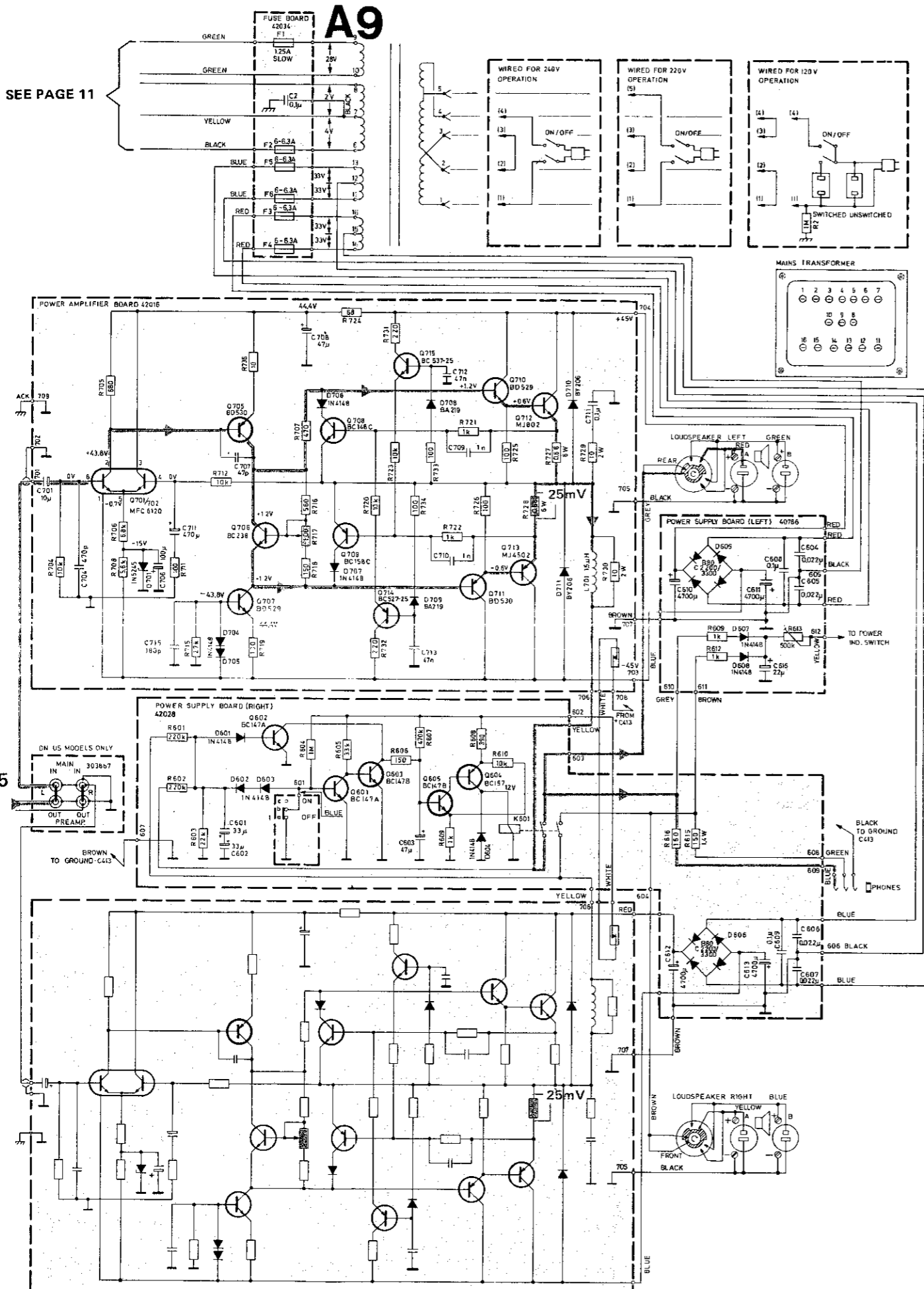

**Quiescent current.**

The quiescent current in both channels can be checked by measuring the voltage across R728. Immediately after power has been switched on and with the volume at minimum the voltage should be 25 mV. If necessary, adjust with R717. After 10 minutes warm-up the voltage will normally be 40 mV.

The most convenient place to connect the voltmeter is between the top of R727 and the top of R728 (on the component side of the board).

SEE PAGE 11

FROM A5 PAGE 11

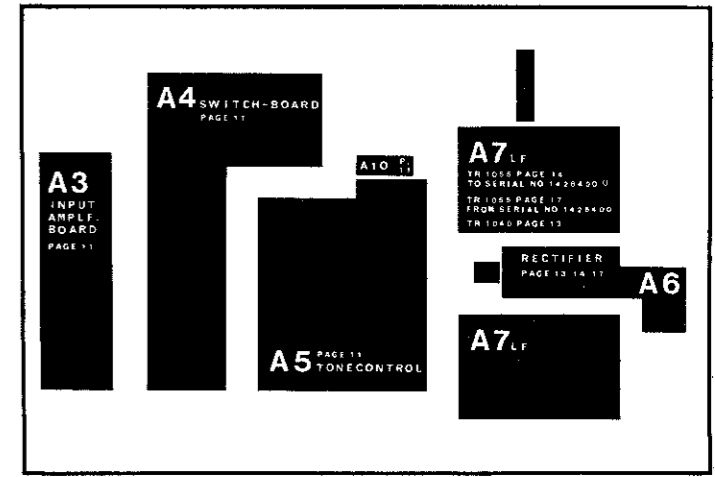

**A9**

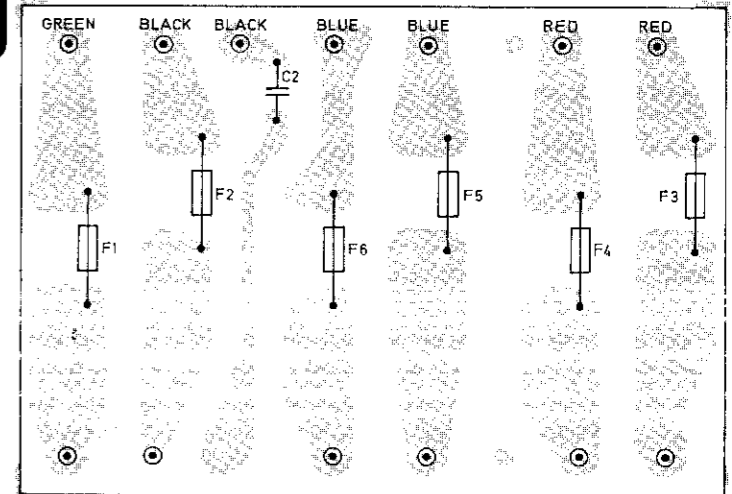

Seen from the solder side.

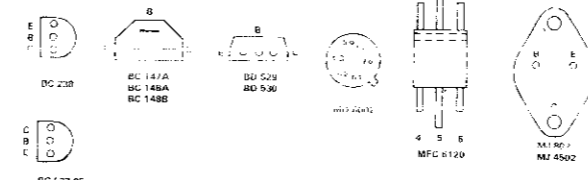

The transistors are seen from underneath (the lead or terminal side).

**A6**

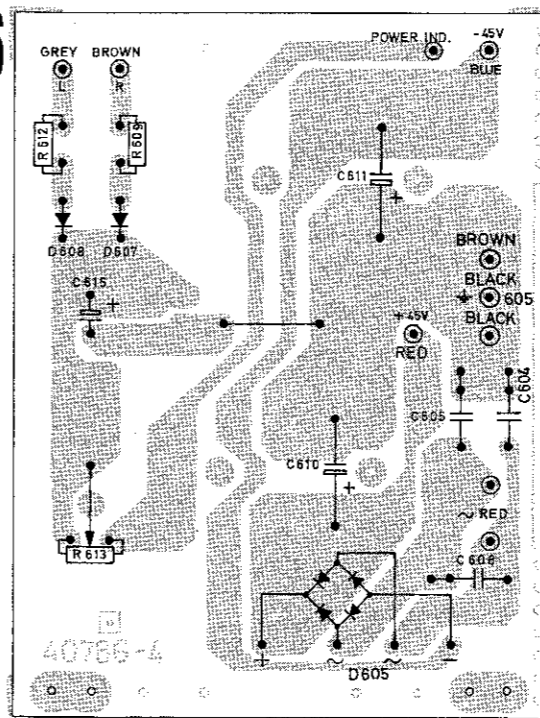

Seen from the solder side.

**A6**

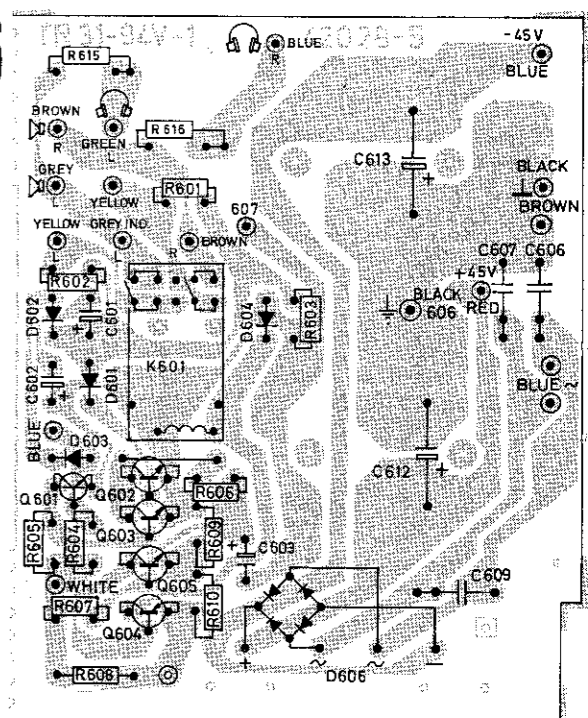

Seen from the solder side.