

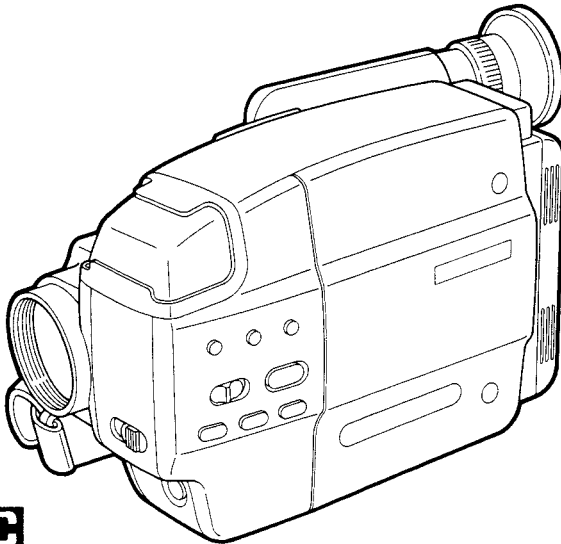

Service Manual

VIDEO CAMERA/RECORDER



MODEL

HS-CX7(A)
HS-CX7(B)
HS-CX7(E)



Only cassettes marked S-VHS-C or VHS-C can be used with this VIDEO CAMERA/RECORDER.

SPECIFICATION

Tape Format	: S-VHS-C and VHS-C 1/2" high-density video cassette tape	Pick Up	: 1/3"-format CCD
Power Source	: DC 6.0V	Minimum Required Illumination	: 7 lux
Power Consumption	: Approx. 7W	Lens	: F1.8, f6~48mm 8:1 power zoom lens with auto iris control Filter diameter 49 mm
Signal System	: PAL System	Viewfinder	: Electronic viewfinder with 0.6"black/white CRT
Video Recording System	: Azimuth helical scanning system	White Balance Adjustment	: Full-auto/selectable FIX, INDOOR or OUTDOOR
Luminance	: Frequency modulation recording	Operating Temperature	: 0°C ~ +40°C
Color Signal	: Low frequency conversion sub-carrier phase shift recording	Operating Humidity	: 30% ~ 80%
Hi-Fi Audio Recording System	: Azimuth helical scanning system, Frequency modulation, deep layer recording	Weight	: Approx. 590g
Linear Audio Track	: 1 track	Dimensions	: 105(W) x 112(H) x 155(D)mm
Tape Speed	: 23.39 mm/sec(SP mode) 11.70 mm/sec(LP mode)	AC POWER ADAPTER DA-M1(A,B,C)	
Record/Playback Time	: 45 min. with EC-45 cassette (SP mode) 90 min. with EC-45 cassette (LP mode)	Power Source	: AC 110 ~ 240V; 50/60Hz
Video Output	: 1.0 Vp-p, 75 ohm unbalanced AV OUT/EDIT socket	Power Consumption	: Approx. 19W
Audio Output	: -6dBs, 1k ohm unbalanced AV OUT/EDIT socket	Rated Output Voltage	: DC 6.0V
		Rated Output Current	: 1.8A(VIDEO CAMERA/RECORDER), 1.3A(Battery)
		Charging System	: Constant current, voltage controlled
		Dimensions	: 65(W) x 39.5(H) x 138(D)

● Weight and dimensions shown are approximate.

● Design and specifications are subject to change without notice.

MITSUBISHI ELECTRIC

CONTENTS

SAFETY PRECAUTIONS	1	4-7 Sync belt replacement	51
CONNECTION	3	4-8 Clutch unit replacement	51
DISASSEMBLY	4	4-9 A/C head replacement	52
1. Case(Outer)Disassembling Procedure	4	4-10 Pinch roller assembly and Pinch roller replacement	53
2. Disassembling Chassis unit	6	4-10-1 Pinch roller assembly replacement.....	53
3. Disassembling Case unit(L)	8	4-10-2 Pinch roller replacement	53
4. Disassembling Power knob of the Case unit(R) ..	10	4-11 Slant T replacement	54
5. Disassembling Eject knob of the Case unit(R)	10	4-12 Takeup guide arm replacement	55
6. Disassembling Release button of the Case unit(R)	10	4-13 Supply impedance roller replacement	55
7. Disassembling Other parts of the Case unit(R) ...	10	4-14 Capstan motor replacement	56
8. Disassembling Front panel unit	12	4-15 Supply tape guide assembly and Supply guide roller replacement	57
9. Disassembling AC Power Adapter	12	4-15-1 Supply tape guide assembly replacement	57
10. Disassembling EVF(Electronic View finder) unit	13	4-15-2 Supply guide roller replacement	57
11. Disassembling Camera unit	14	4-16 Takeup tape guide assembly and Takeup guide roller replacement	58
12. Disassembling Lens unit	15	4-16-1 Takeup tape guide assembly replacement	58
Replacing CCD Image Sensor	16	4-16-2 Takeup guide roller replacement	58
Table of Extension Jigs	17	4-17 Mode switch replacement	59
Using Extension Jigs	18	4-18 Cam T replacement	60
Adjusting VCR Unit Circuit	20	4-19 Tape guide stopper assembly replacement.....	61
Location of Adjustment Points(VCR Section)	22	5. ADJUSTMENTS	62
Power Supply Circuit	23	5-1 Back tension and Tension pole adjustment	62
Servo Circuit	23	5-2 FM envelope check and adjustment	63
Y/C Signal Circuit	24	5-2-1 Guide roller Check	63
Normal Audio Circuit	28	5-2-2 Supply guide roller height adjustment	63
Hi-Fi Audio Circuit	29	5-2-3 Takeup guide roller height adjustment	63
Character Display Circuit	30	5-3 Phase adjustment(coarse)	64
Adjusting Camera Unit Circuit	31	5-4 FM waveform flatness check	65
Location of adjustment Points (Camera Section)	34	5-5 A/C head adjustment	65
MECHANICAL ADJUSTMENT	45	5-5-1 A/C head height, azimuth and slant adjustment.....	65
1. Jigs and Measuring Instruments Required for Mechanism Adjustment	45	5-6 GR-lever roller tape running adjustment	66
1-1 Jigs for Adjustment	45	5-7 Phase adjustment(fine)	66
1-2 Other Tools and Measuring Instruments Required	45	KEY TO ABBREVIATIONS	67
1-3 Soldering points of lead wire	45	CHIP PARTS REPLACEMENT	68
2. CLEANING	46	PARTS LIST	69
2-1 Cleaning the video head	46	1. Outer parts	69
2-2 Cleaning the tape path system	46	2. Cabinet parts	70
2-3 Cleaning the reel disk driving system	46	3. Chassis Assembly Parts	71
3. HOW TO ATTACH THE MASTER PALANE	46	4. Case Assembly(Right side) Parts	72
4. HOW TO REPLACE THE PRINCIPAL PARTS ..	47	5. Case Assembly(Left side) Parts	73
4-1 Cassette housing replacement	47	6. EVF(Electronic View finder) unit Parts	74
4-2 Damper unit replacement	48	7. Camera Unit Parts	74
4-3 Drum assembly replacement	49	8. Front panel Assembly Parts	75
4-4 Loading motor replacement	49	9. AC Power Adapter Parts	75
4-5 Reel disk replacement	50	10. Packing Parts	76
4-6 Reel gear replacement	50	11. Electrical Parts	78
		12. AC Power Adapter Parts	96
		13. Deck Assembly	

SAFETY PRECAUTIONS

INTRODUCTION

This manual provides service information for the adjustments of mechanical and electrical operations. Due to design modifications, the servicing procedures and data given in this manual are subject to possible change without prior notice.

WARNING: Many of the programs broadcast by television stations are protected by copyright and Federal law imposes strict penalties for copyright infringement. Some motion picture companies have taken the position that home recording for noncommercial purposes is an infringement of their copyrights. Until the courts have ruled on the proper interpretation of the law as applied to home video recording, this equipment, if used to record copyrighted material, should be operated at user's own risk.

WARNING:
TO PREVENT FIRE OR SHOCK HAZARD, DO NOT EXPOSE THIS APPLIANCE TO RAIN OR MOISTURE.

This equipment should be used with DC 6V only.

CAUTION:

To prevent electric shocks and fire hazards, do not use any other power source.

The AC power adapter/battery charger should be used with:

AC120V; 60Hz in the USA and Canada, AC110/220/240V; 50/60Hz in other countries. (NTSC model)

AC110-240V; 50/60Hz. (PAL model)

CAUTION:

To prevent electric shocks and fire hazards, do not use any other power source.

X-RAY RADIATION

The primary source of X-ray radiation in this viewfinder is the picture tube. The tube used in this viewfinder is especially constructed to limit X-ray radiation emission. For continued X-ray radiation protection, the replacement tube must be the same type as the original. Mitsubishi approved one.

SAFETY NOTICE

Before returning VIDEO CAMERA/RECORDER to the customer a safety check of the entire VIDEO CAMERA/RECORDER should be made. The service technician must be sure that no protective device built into the instrument by the manufacturer has become defective or inadvertently damaged during servicing.

Observe all caution and safety related notes located on or inside the VIDEO CAMERA/RECORDER cabinet.

WARNING: Alterations of the design or circuitry of this VIDEO CAMERA/RECORDER should not be made.

Any design alterations or additions, such as circuit modifications, auxiliary speaker jacks, switches, grounding, active or passive circuitry, etc. use of unauthorized AC power adapter/charger, battery, cables, accessories, etc. may alter the safety characteristics of this VIDEO CAMERA/RECORDER and potentially create a hazardous situation for the user.

Any design alterations or unauthorized additions will invalidate the manufacturer's warranty and will further relieve the manufacturer of responsibility for personal injury or property damage resulting from them.

Do not lubricate any motors.

When reassembling the VIDEO CAMERA/RECORDER, always be certain that all the protective devices are put back in place, such as non-metallic control knobs, shield plate, etc.

When service is required, observe the original lead dress.

Components that indicate evidence of overheating or other electrical or mechanical damage should be replaced.

LEAKAGE CURRENT CHECK

Before returning the VIDEO CAMERA/RECORDER to the customer, it is recommended the leakage current be measured by the following methods.

1. Cold Check

With the AC plug removed from the AC source, place a jumper across the two AC plug prongs. Turn the AC switch on. Using an ohmmeter, connect one lead to the jumpered AC plug and touch the other lead to each exposed metal part (metal cabinet, screwheads, metal overlays, control shafts, etc.), particularly any exposed metal part having a return path to the chassis. Exposed metal parts having a return path to the chassis should have a minimum resistance reading of 1 megaohm. Any resistance below this value indicates an abnormality which requires corrective action. Exposed metal parts not having a return path to the chassis will indicate an open circuit.

2. Hot Check

The test sequence, with reference to the measuring circuit in Fig. 1 is as follows:

- (1) With switch S1 open, the VIDEO CAMERA/RECORDER is to be connected to the measuring circuit. Immediately after connection, the leakage current is measured using both positions of switch S2 and with the switching devices in the VIDEO CAMERA/RECORDER in all of their operating positions.
- (2) Switch S1 is then to be closed, energizing the VIDEO

CAMERA/RECORDER, and immediately after closing the switch, the leakage current is to be measured using both positions of switch S2, and with the switching devices in the VIDEO CAMERA/RECORDER in all of their operating positions.

Current measurements of items (1) and (2) are to be repeated after the VIDEO CAMERA/RECORDER has reached thermal stabilization.

The leakage current shall not be more than 0.5 milliamperes.

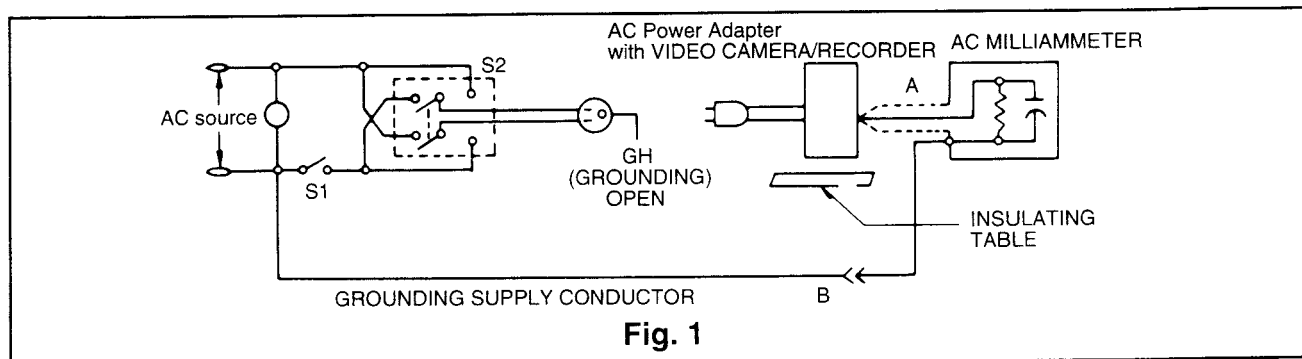

AC Leakage Test

Avoid shock hazards. Do not connect this VIDEO CAMERA/RECORDER to a TV antenna, cable or accessory that exhibits excessive leakage currents. If available, the television instrument or cable to which this VIDEO CAMERA/RECORDER is connected should have the antenna cold check and the leakage current hot check performed.

PRECAUTIONS

Handling and storage

- Avoid using the VIDEO CAMERA/RECORDER in the following places:
 - extremely hot, cold or humid places,
 - dusty places,
 - near appliances generating strong magnetic fields,
 - places subject to vibration, and
 - poorly ventilated areas.
- Be careful of moisture condensation.
- If you pour a cold liquid into a glass, water vapor in the air will condense on the surface of the glass. This is called moisture condensation.
- Moisture condensation on the head drum, one of the most critical parts of the VIDEO CAMERA/RECORDER, will cause damage to the tape.

- Moisture in the air will condense on the VIDEO CAMERA/RECORDER when you move the unit from a cold place to a warm place, after heating a cold room or under extreme humidity conditions. Avoid using the VIDEO CAMERA/RECORDER under these conditions.
- Handle the VIDEO CAMERA/RECORDER carefully.
- Do not place anything heavy on the VIDEO CAMERA/RECORDER.
- In case of transportation:
 - Avoid violent shocks to the VIDEO CAMERA/RECORDER during packing and transportation.
- Before packing, be sure to remove the cassette from the VIDEO CAMERA/RECORDER.

THIS SYMBOL INDICATES "FAST OPERATING FUSE".

Ce symbole indique un "fusible à fonctionnement rapide".

CAUTION: FOR CONTINUED PROTECTION AGAINST RISK OF FIRE, REPLACE ONLY WITH SAME TYPE 1.6A, 250V FUSE.

ATTENTION: Pour une protection permanente contre un risque d'incendie, ne remplacer qu'avec un fusible de 1.6A, 250V de même type.

CONNECTION

Connection to a TV without audio/video inputs

Disconnect the antenna cable from the back of the TV. Connect antenna cable to the RF IN terminal on the RF unit. If an antenna cable other than 75 ohm coaxial cable is to be used, install the matching transformer (300 ohm → 75 ohm).

Connect one end of the coaxial cable to the RF OUT terminal on the RF unit.

Connect the other end of the coaxial cable to the ANTENNA IN terminal of the TV set. If no 75 ohm terminal is available on the TV set, a VHF/UHF splitter must be used.

Connect the RF unit cable to the AV OUT/EDIT terminal on the VIDEO CAMERA/RECORDER.

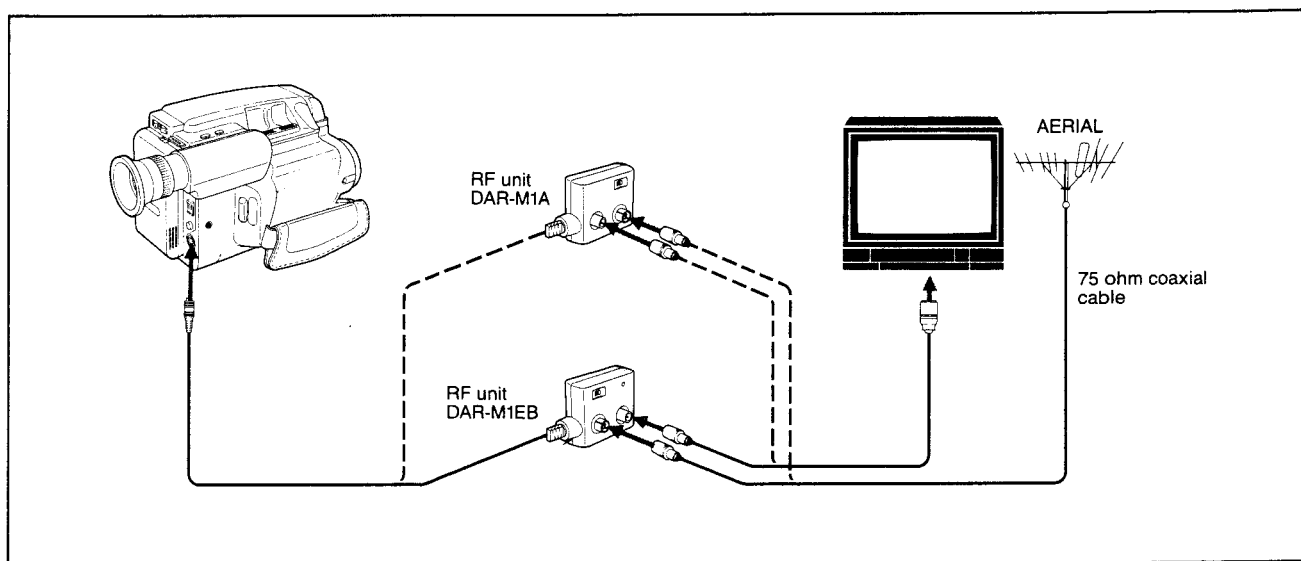

Connection to a TV with video/audio inputs

Connect the RCA type audio/video cable to the AV OUT/EDIT terminal on the VIDEO CAMERA/RECORDER. To do this, align the plug so that the arrow faces up and gently press it into place.

Connect the other side of the cable to the TV.

- AUDIO(L) : To AUDIO(L) IN terminal
- AUDIO(R) : To AUDIO(R) IN terminal
- VIDEO : To VIDEO IN terminal
(Do not connect this cable if you wish to connect a S-VIDEO cable.)
- EDIT : Do not connect

Connection to a TV with EURO AV socket

Connect the EURO AV cable to the AV OUT/EDIT terminal on the VIDEO CAMERA/RECORDER. To do this, align the plug so that the arrow faces up and gently press it into place.

Connect the other side of the cable to the EURO AV terminal on the TV.

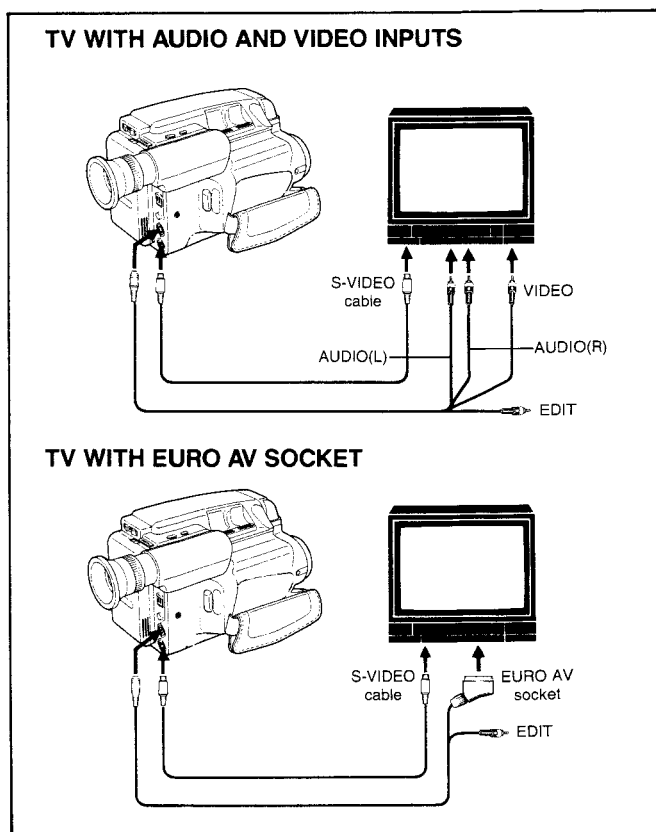

DISASSEMBLY

Warning : Detach the FPC cable according to procedures indicated in this manual, or do not touch the exposed terminal of the connector directly because they can cause malfunction. Open the connector for FPC cable in the order shown by the arrows in Fig. 1 to remove the connector. (To connect the FPC cable reverse procedures of this disassembly.)

Note : FPC connectors, VE, PD, VD, VG, VS, JS, JT must be performed arrow ① in Fig. 1 only.

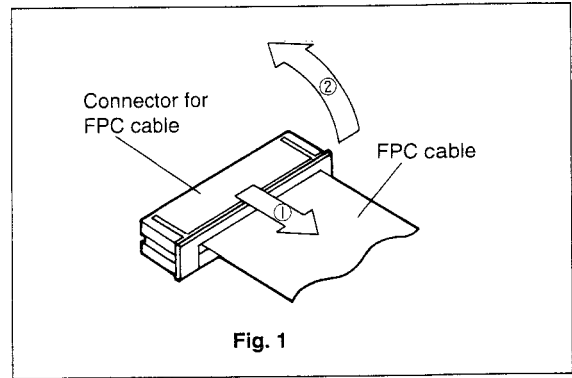

1. Case (Outer) Disassembling Procedure

Order	1 (possible in no order of these items)				2
Article name	Cassette housing	Microphone unit	Zoom switch	Tripod base	Case unit (L)
Symbol of removed No.	●	●	●	④	⑤
Screw & Terminal to be removed	Screws-2pcs.	Screw-1pc. Terminal-MN	Screw-1pc. Terminal-ZA	Screws-3pcs.	Screws-8pcs. Terminals-JS, JT
Order	3	4	5		
Article name	Front panel unit	Case unit (R)	Chassis assembly & Camera assembly		
Symbol of removed No.	⑥	●	⑧		
Screw & Terminal to be removed	Screws-2pcs.	Screws-2pcs. Terminal-RP	Screws-2pcs. Terminals-CA, SB		

Important :

1. Removing Microphone unit

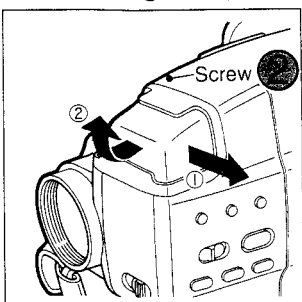

1. Remove the screw No. 2. (See figure above and the following page.)
2. Slide the Microphone unit to right slightly. Lift up the bottom of the microphone unit carefully.

Caution : Do not stretch the lead of connector MN in removing Microphone unit.

2. Removing Zoom switch

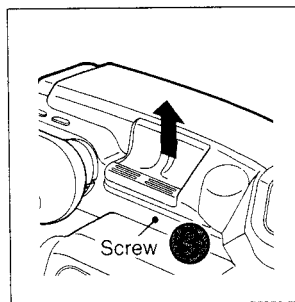

1. Remove the screw No. 3. (See figure above and the following page.)
2. Lift up carefully.

Caution : Do not stretch the lead of connector ZA in removing Microphone unit.

3. Removing Case unit

1. Remove the screw No. 5. (See figure above and the following page.)

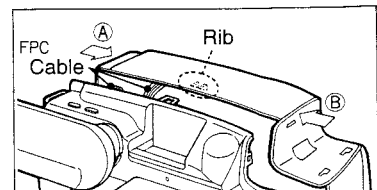

2. Press points A and B as shown by the arrows in the above figure then carefully detach the rib.
3. Hold the Case unit (L) slightly away from the Case unit (R), and remove it from the bottom cast and then the top of the unit.

Caution : Do not apply tension to two the FPC cables inside of the unit at the top.

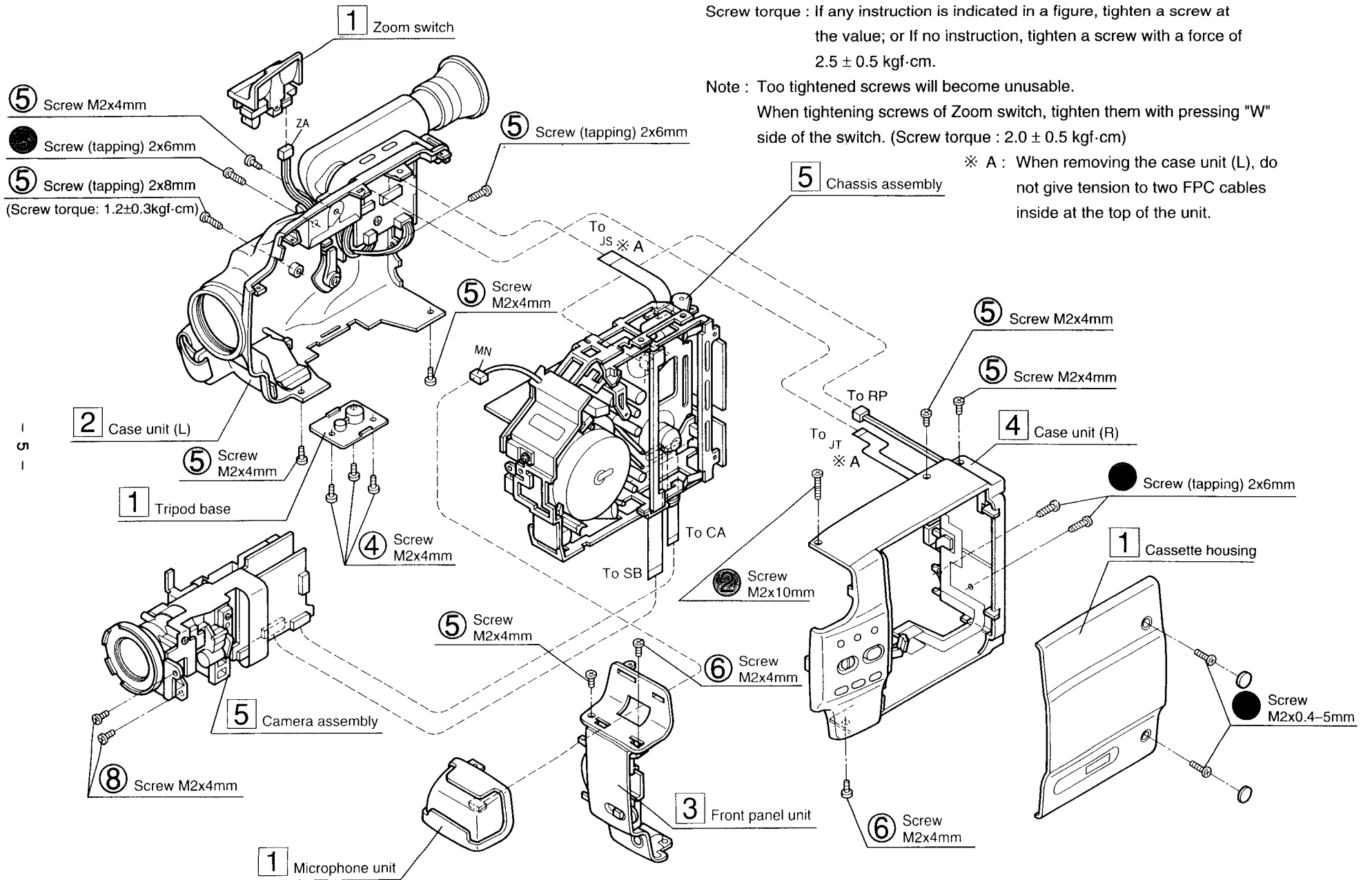

2. Disassembling Chassis Unit

Order	1	2	3	4	5
Article name	VTR - SUB PCB ASSY	Shield case	Camera SW ASSY	VTR PCB ASSY	Rear PCB ASSY
Symbol of removed No.			●	●	
Screw & Terminal to be removed	Terminals- PC, PD, PP, PQ		Screw-1pc. Terminal-VF	Screws - 6pcs. Terminals- VD, VE, VG, VL, VM	Terminal-RR

Important :

1. Attaching Shielded Case

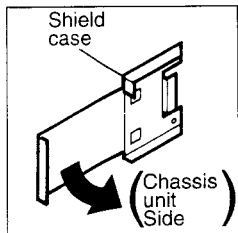

Press copper foil sheet to a direction shown by arrow in the figure to attach it the VTR PCB ASSY, avoid interfering with the FPC cable.

2. Attaching Chassis unit and Case unit (R)

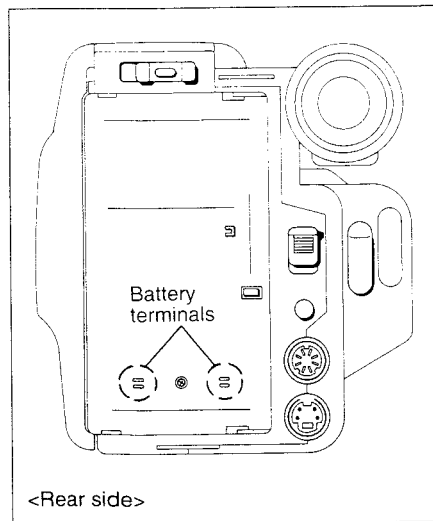

Insert battery terminals on the Rear PCB Assy in the holes of the back panel of the Case unit (R) to fit the Chassis unit into the Case unit (R).

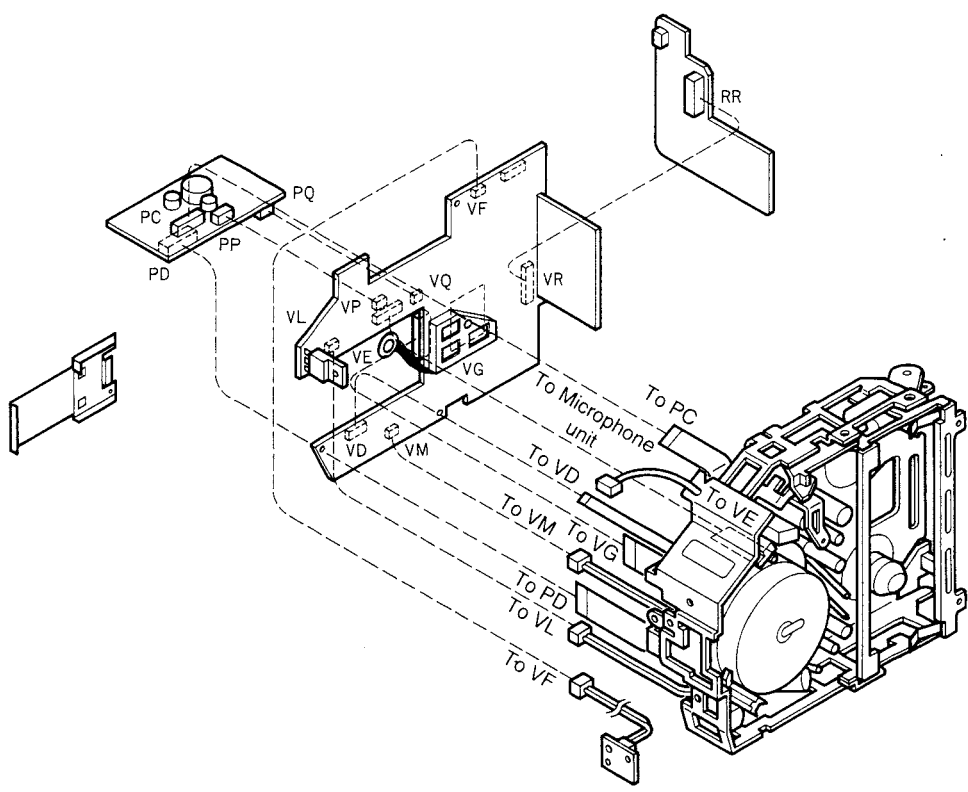
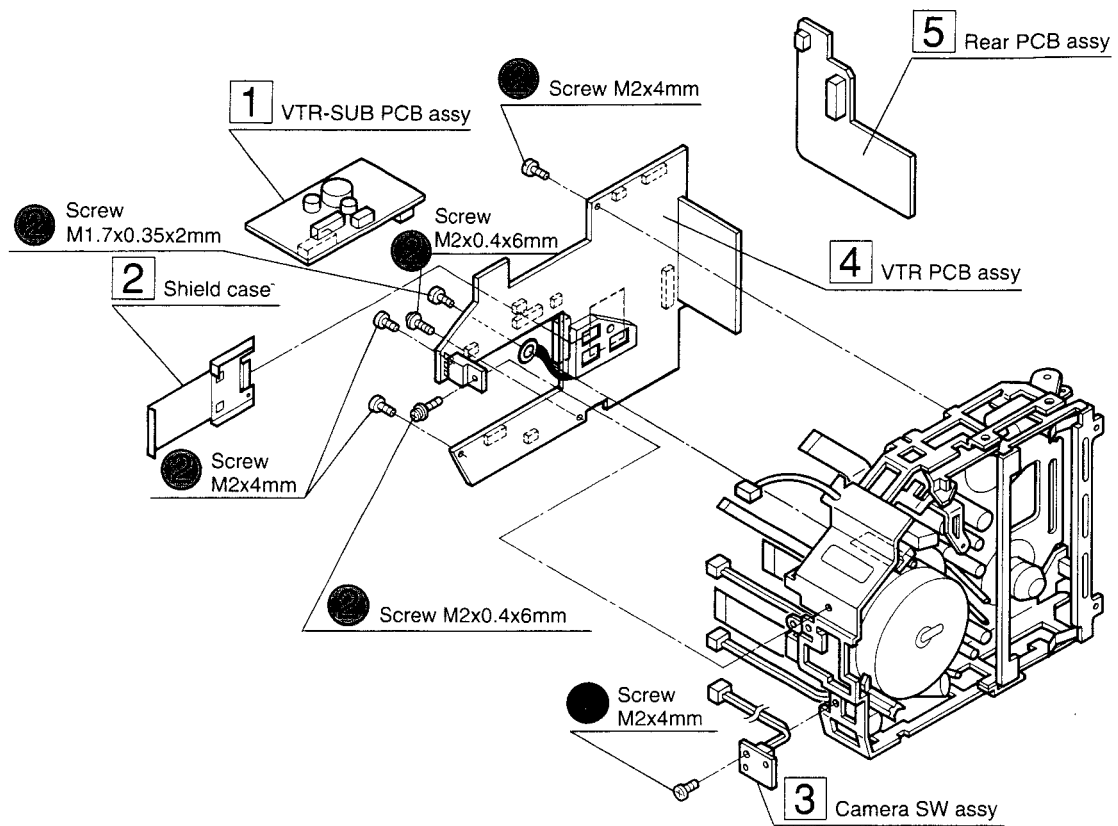

3. Disassembling Case unit (L)

Order	1	2	3	after 1	after 2
Article name	Retainer belt	VTR SW PCB assy	EVF unit	Grip belt	Trigger button
Symbol of removed No.	●	②	③		④
Screw & Terminal to be removed	Screw-1pc.	Screws-2pcs. Terminal-JB, JE	Screws-2pcs.		Screw-1pc.
Order	Possible in no order of these items				
Article name	Back up battery holder				
Symbol of removed No.	⑤				
Screw & Terminal to be removed	Screws-2pcs. Terminal-JB				

Important :

1. Leads of VTR PCB ASSY (Trigger bottom side)

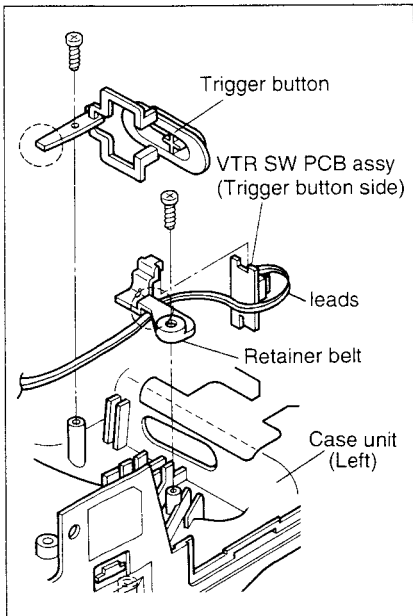

Put leads of VTR PCB ASSY (Trigger bottom side) between a rib of the trigger bottom and a retainer belt, and Case unit (L).

2. Attaching EVF Unit

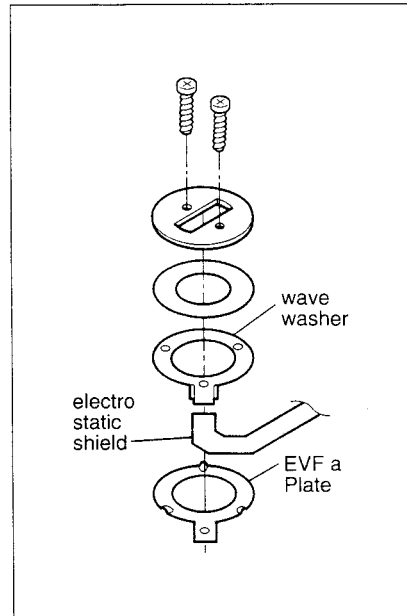

Attach the EVF unit while putting electrostatic shield taped on the Case unit (L) between a wave washer and EVF a plate. The convex side of the wave washer and EVF plate must be toward the upper side.

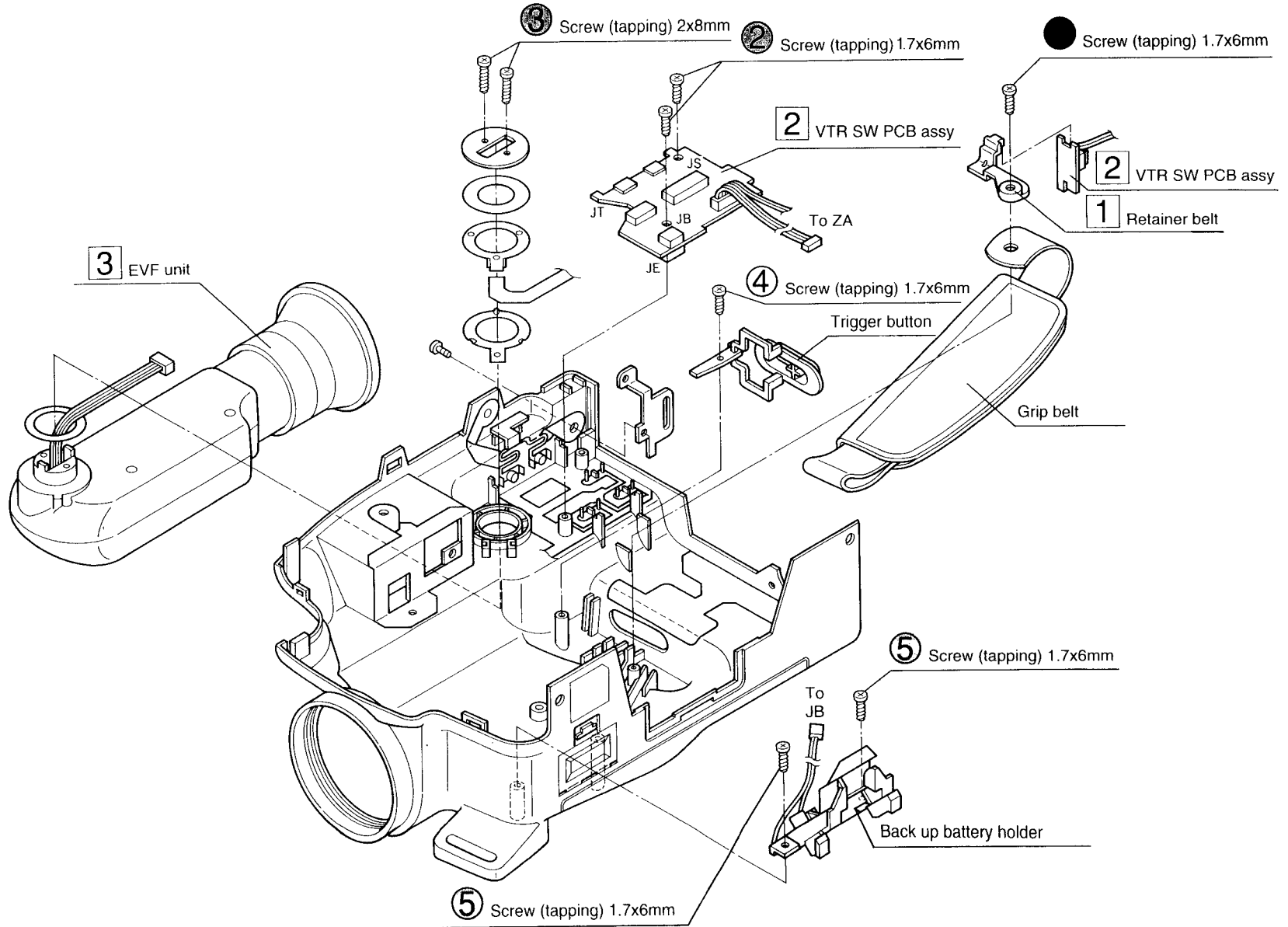

4. Disassembling Power knob of the Case unit (R)

Order	1	2
Article name	Power SW PCB assy	Power knob
Symbol of removed No.		/
Screw & Terminal to be removed	Screw-1pc.	/

5. Disassembling Eject knob of the Case unit (R)

Order	1	2
Article name	Eject spring	Eject knob
Symbol of removed No.	/	/
Screw & Terminal to be removed	/	/

6. Disassembling Release button of the Case unit (R)

Order	1	2
Article name	Battery spring	Release button
Symbol of removed No.		/
Screw & Terminal to be removed	Screw-1pc.	/

7. Disassembling Other parts of the Case unit (R)

Order	Possible in no order of these items		
Article name	Camera SW unit	Tape guide	Strap holder
Symbol of removed No.		④	⑤
Screw & Terminal to be removed	Screws-4pcs. Terminal-KT	Screw-1pc.	Screw-1pc.

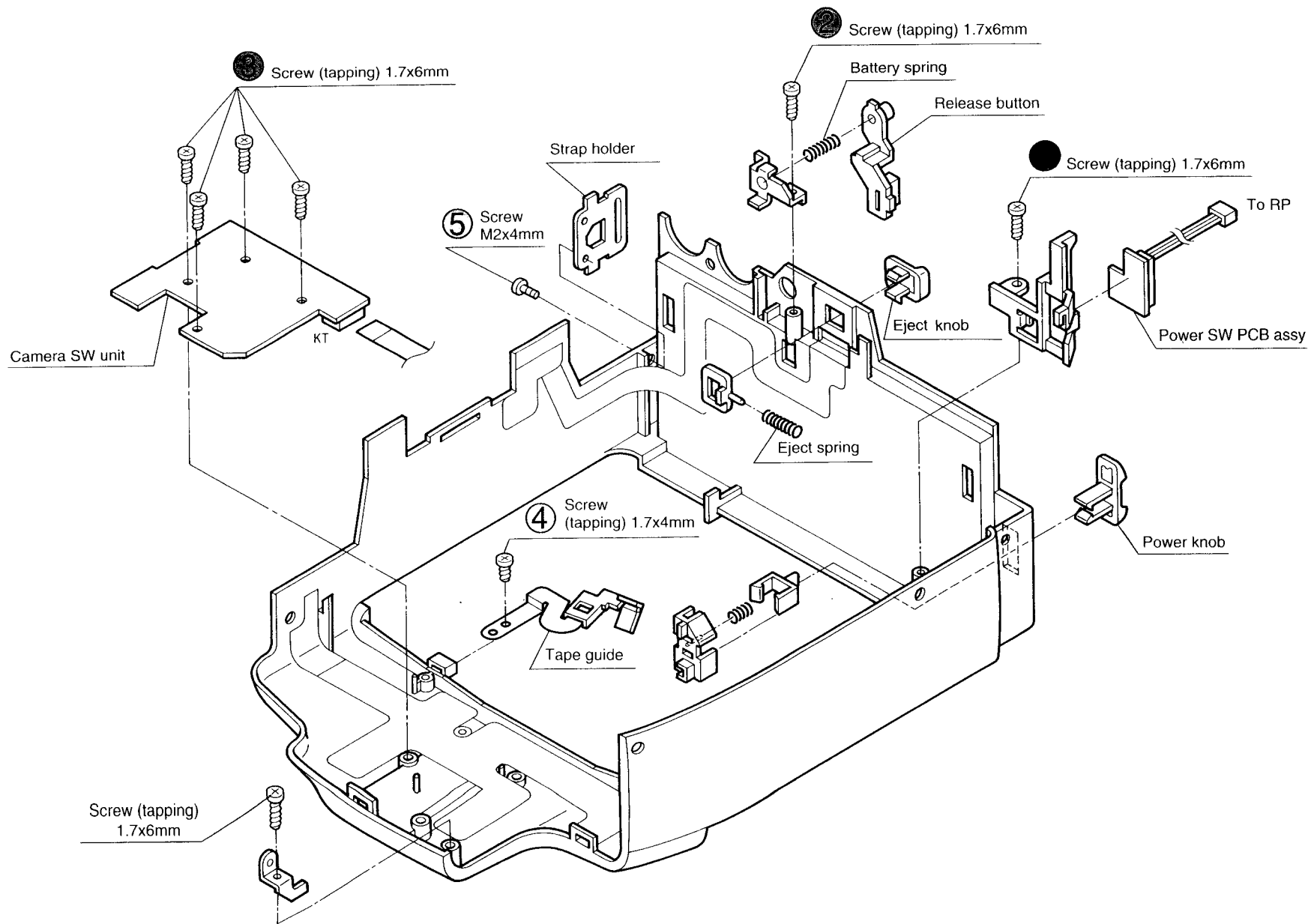

8. Disassembling Front Panel Unit

Order	1	2	3	4	5
Article name	Lens cover	Lens cover holder	Lens cover Spring	Knob holder	Lens cover knob
Symbol of removed No.		●	②		
Screw & Terminal to be removed		Screws - 3pcs.	Screw - 1pc.		

9. Disassembling AC Power Adapter

Order	1	2
Article name	Top cover	Bottom cover
Symbol of removed No.	●	②
Screw & Terminal to be removed	Screws - 2pcs.	Soldering - 2points points

Front Panel Unit

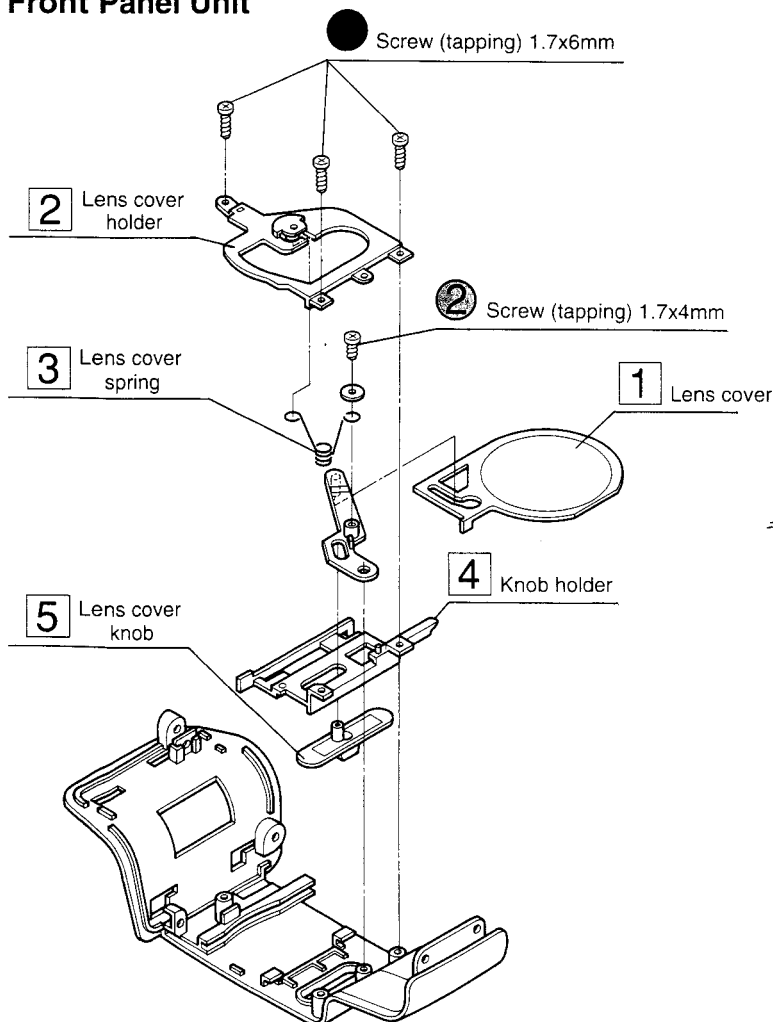

AC Power Adapter

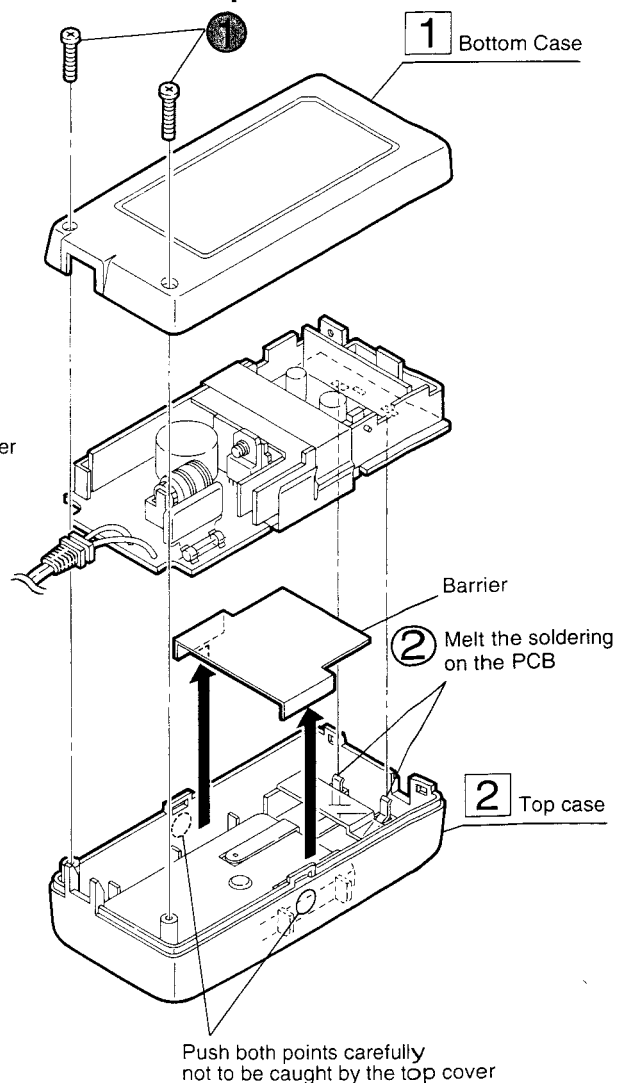

10. Disassembling EVF Unit

Order	1	2	3	4	5
Article name	Eye cap	EVF lens assy	Top case	Bottom case	EVF PCB assy
Symbol of removed No.			●		
Screw & Terminal to be removed			Screws - 2pcs.		Terminal - High-tension lead, DY socket CN2

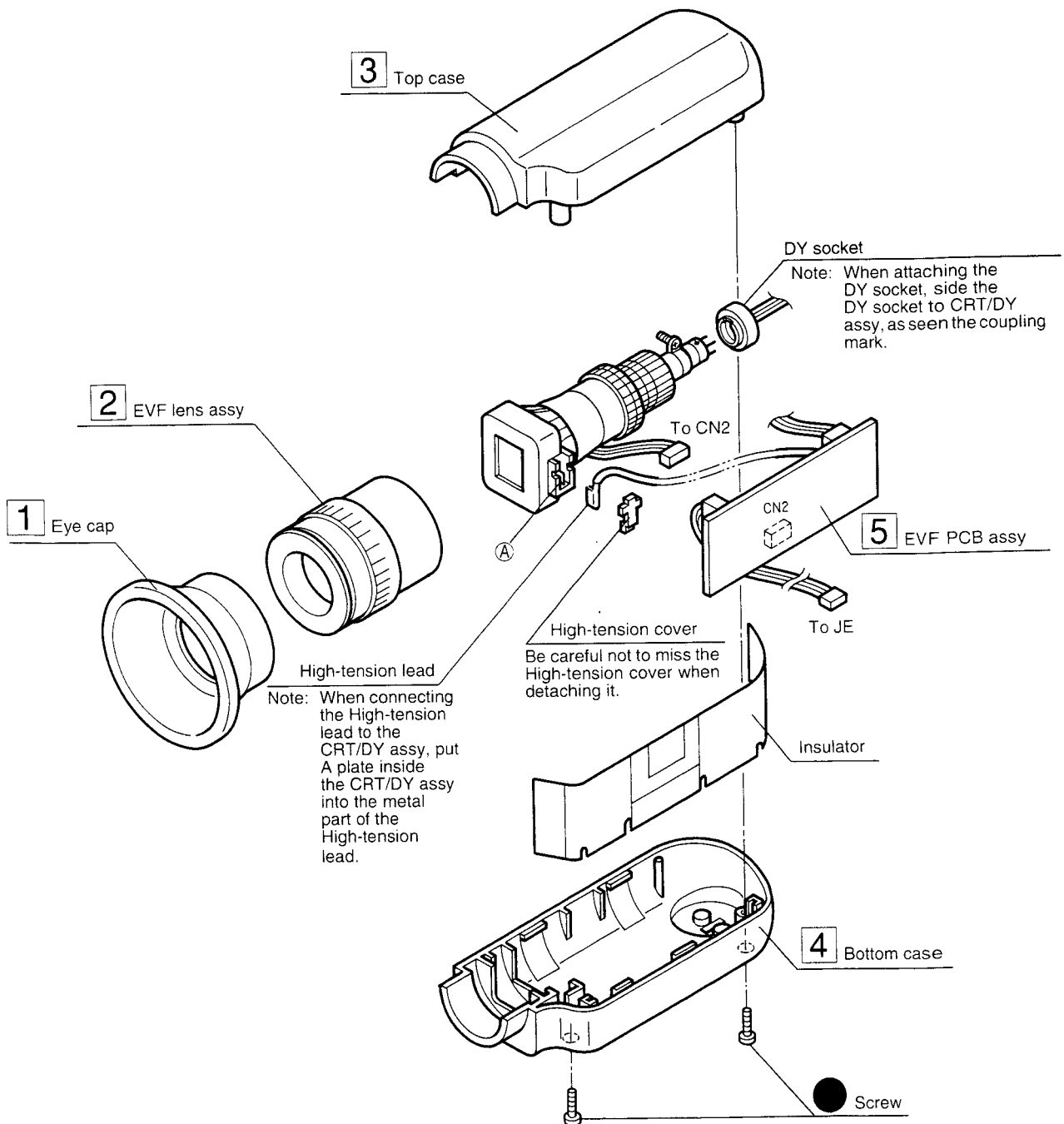

11. Disassembling Camera Unit

Order	1	2
Article name	CM PCB assy	SD/PC PCB assy
Symbol of removed No.		●
Screw & Terminal to be removed	Terminals- CB, CC, CD, CE	Screws-2pcs. Terminal-SA

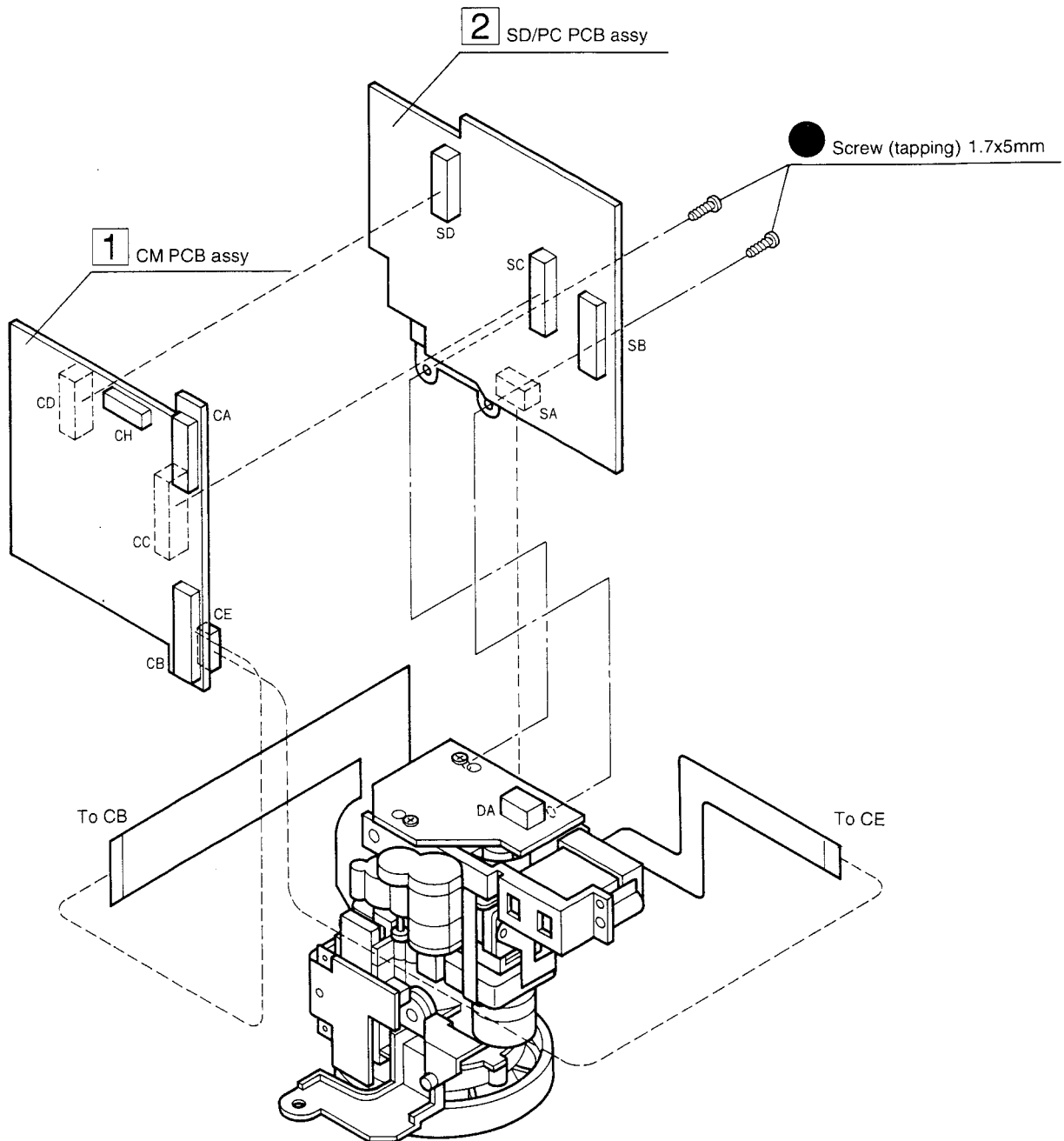

12. Disassembling Lens Unit

Order	1	2	3	4	5
Article name	CCD PCB assy	CCD assy	Optical filter protecting rubber	Optical filter	Lens holder-RL
Symbol of removed No.	●				●
Screw & Terminal to be removed	Screws-2pcs.				Screws-2pcs.
Order	6	7	possible in no order of these items		
Article name	Gyro-sens PCB assy	Lens holder-RR	Lens holder-FR	Lens holder-FL	
Symbol of removed No.	●	④	⑤	⑥	
Screw & Terminal to be removed	Screws-2pcs.	Screw-1pc.	Screw-1pc.	Screw-1pc.	

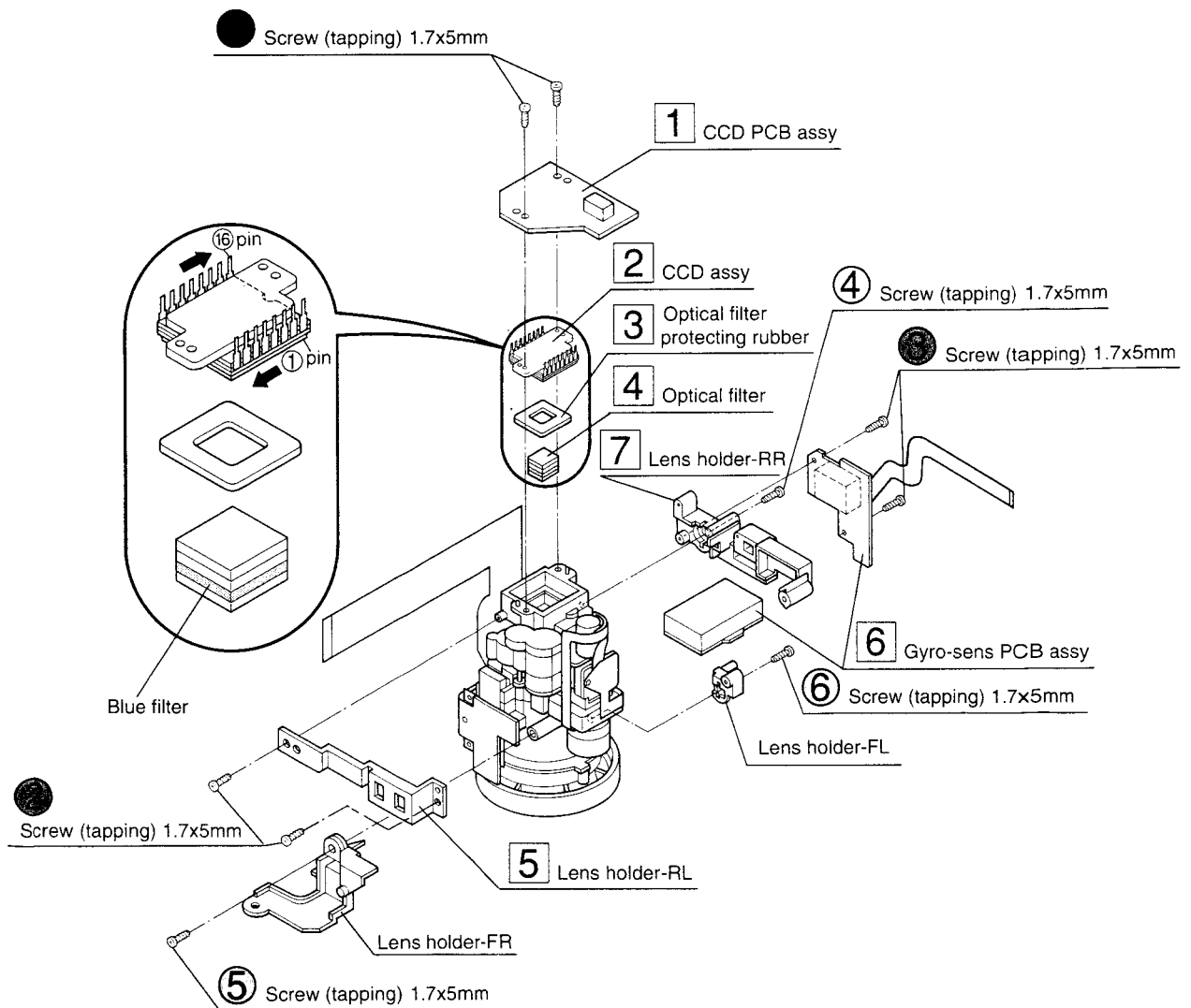

Replacing CCD Image Sensor

Caution : ● As the CCD image sensor is a C-MOS type semi-conductor, the soldering iron must be grounded.

- Do not soil, stain or injure the transparent glass and optical filter of the CCD image sensor.
If the CCD image sensor should be stained by finger print, wipe it off with silicone paper or chamois skin.
- When the CCD assy in soldered onto the PCB, do not apply excessive heat for a long time. The filter may be discolored by heat.

1. Removing

1. Take off the CCD PCB ASSY according to the disassembling procedures.
2. Remove sixteen terminals soldered on the CCD PCB ASSY to remove the CCD assy.

2. Attaching

Solder the CCD assy in the right direction on the CCD PCB ASSY.

TABLE OF EXTENSION JIGS

Extension Cable (FPC)

Connector	Parts No.
PD, PC, VS, to JS, VA to CA	859C543O20
VD	859C543O10
VG	859C543O40
VE, VB to SB	859C543O30



Joint Board

Connector	Parts No.
PD, PC	859C544O20
VD	859C544O10
VG	859C544O40
VE	859C544O30

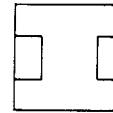

Board to Board

Connector	Parts No.
SD to CD	859C545O20
SC to CC	859C545O30
VQ to PQ, VP to PP	859C545O10

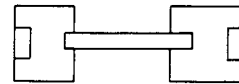

The following diagram illustrates how to connect the deck unit to the VTR PCB using the extension cable and Joint Board.

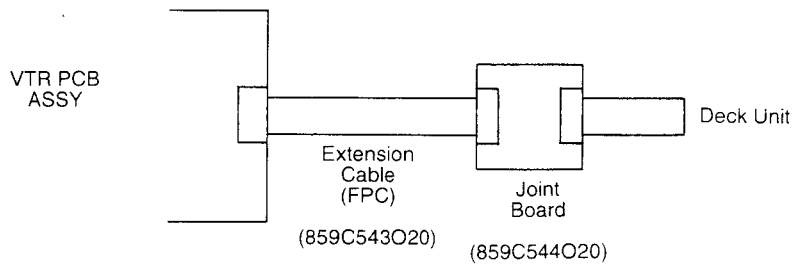

Processing Extension Cable (859C543O40, used for VG connector)

1. Apply proper length of copper foil tape to both sides of the extension cable.
2. Connect a lead between both sides of the copper foil tape and solder it on the both sides.
3. Solder another lead with clip on one side. The lead must be connected (5 cm max) from the nearest edge of the extension cable.
4. Wrap insulating tape around the copper foil tape.

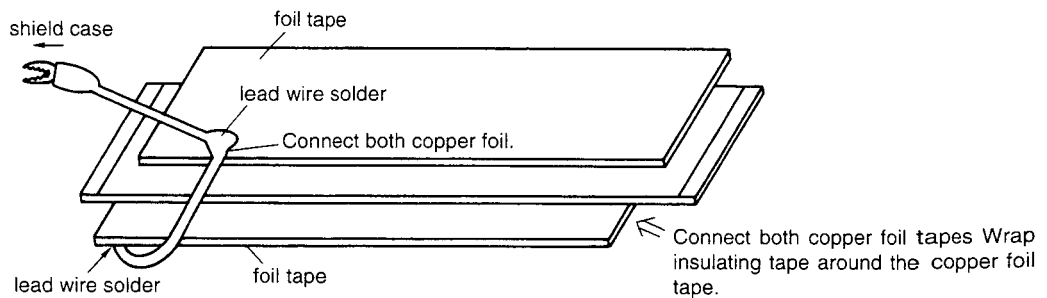

USING EXTENSION JIGS

Warning :

Use and apply a Regulated power source, 6V DC.

Camera Unit

1. Remove the Case unit (L) and the Front panel unit from the Camera unit.
2. Remove two fixed screws from the Camera unit.
3. Replace FPC cables between VB and SB, and VA and CA with extension jigs specified in table below to install the Camera unit. (See figure in the following page.)
4. Connect extension jigs specified in table below to connectors on the CM PCB and the SD/PC PCB, between connectors CD and SD, and CC and SC.

Note : Do not stretch FPC cables connected to connectors CB and CE excessively.

Extension Jigs :

Connector	Parts No.	Connector	Parts No.
VB to SB	859C543O30	CD to SD	859C545O20
VA to CA	859C543O20	CC to SC	859C545O30

2. VTR PCB ASSY

Warning:

Do not check the VTR PCB ASSY only removed from the Deck unit for over two hours.

If checking over two hours, attach a radiating plate to transistor Q5A2.

The transistor Q5A2 may be damaged if power on over two hours without a radiating plate.

1. Disassemble this VIDEO CAMERA/RECORDER according to disassembling procedures. Allocate each of the units or components. (See figure in the following page.)
2. Remove the Microphone unit and the Power switch from the Front panel switch to allocate them. (See figure in the following page.)
3. Connect the Deck unit to the VTR PCB ASSY with extension jigs shown in table below, connected to FPC cables.

Extension Jigs:

Connector	Parts No.	Connector	Parts No.
VG	859C543O40 , 859C544O40	PC	859C543O20 , 859C544O20
VE	859C543O30 , 859C544O30	PD	859C543O20 , 859C544O20
VD	859C543O10 , 859C544O10	VS-JS	859C543O20

Note : To minimize noise, wrap type No. 5 extension cable with copper foil sheet and connect it to a shielded case of the VTR PCB ASSY.

4. Connect the Deck unit to the shielded case with a lead, whose outer diameter of conductor is 0.76 mm min.
5. Connect each lead from the Loading motor and the Camera SW ASSY on the VTR PCB ASSY to connectors VL and VF on the Deck unit respectively.
6. Connect the VTR-SUB PCB ASSY to the VTR PCB ASSY with extension jigs shown in table below.

Extension Jigs:

Connector	Parts No.	Connector	Parts No.
VP to PP	859C545O10	PC	859C543O20 , 859C544O20
VQ to PQ	859C545O10	PD	859C543O20 , 859C544O20

Note : Put the VTR-SUB PCB ASSY onto a insulated table without crossing any extension jigs and the FPC cable of the drum, as noise will occur in the signal of the drum.

Deck Unit

1. Perform items 1 and 2 of "Camera unit" above.
2. Perform items 2, 3, 4 and 5 of "VTR PCB ASSY" above.

VTR-SUB PCB ASSY

1. Perform items 1, 2 and 3 of "Camera unit" above.
2. Perform item 6 only of "VTR PCB ASSY" above.

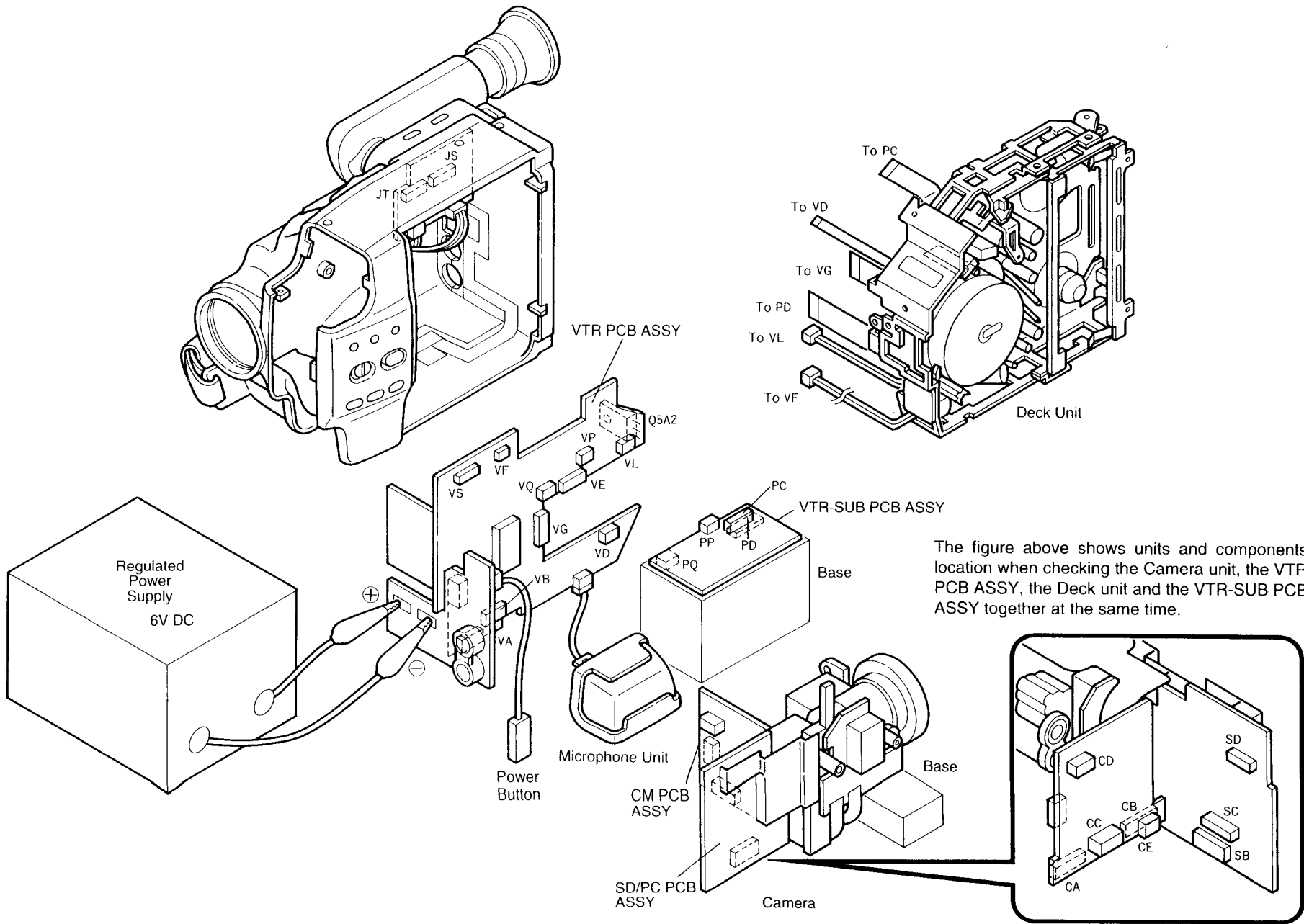



The figure above shows units and components location when checking the Camera unit, the VTR PCB ASSY, the Deck unit and the VTR-SUB PCB ASSY together at the same time.

Adjusting VCR Unit Circuit

1. Jigs and Measuring Instruments

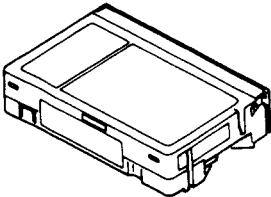
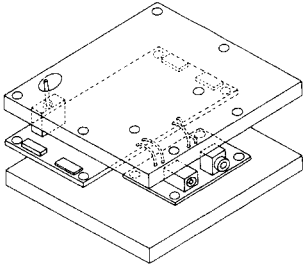
1-1 Jigs

Alignment Tape	Video Signal Input Jig	Pincers for Mini-connectors
See NOTE 1	859C398O70	859C395O30
		

NOTE 1

PC1KC (N-VHS Colour Bar)	:859C397O70
PC1KCS (S-VHS Colour Bar)	:859C397O80
PM6KE2CS (N-VHS 3H Monoscope)	:859C397O60
PM3KE6(CH1)C (N-VHS 6H Monoscope)	:859C399O40
PMXC (N-VHS 3H Monoscope)	:859C399O50

1-2 Tools and Measuring Instruments

1. Colour monitor (Colour TV: Use a monitor having two or more video input terminals.)
2. Oscilloscope
3. Colour bar generator
4. Frequency counter
5. Full set of general electric tools
6. Audio generator
7. Digital voltmeter
8. Carrier checker
9. Small screwdriver
10. Vector scope
11. Y/C Mix Adapter (859C398O90)

2. Precaution

VCR unit circuit often needs adjustment after replacing mechanical parts or the video heads.

If the electrical circuit is defective, locate the defective part using some appropriate instruments and repair or replace, and then adjust it.

Do not fiddle with any controls without verifying the cause of trouble.

Do not perform all adjustments, only adjust those pertaining to a specific problem.

When recording or playing, connect EVF to input V-SYNC to JE connector.

3. Standard Location and Connection

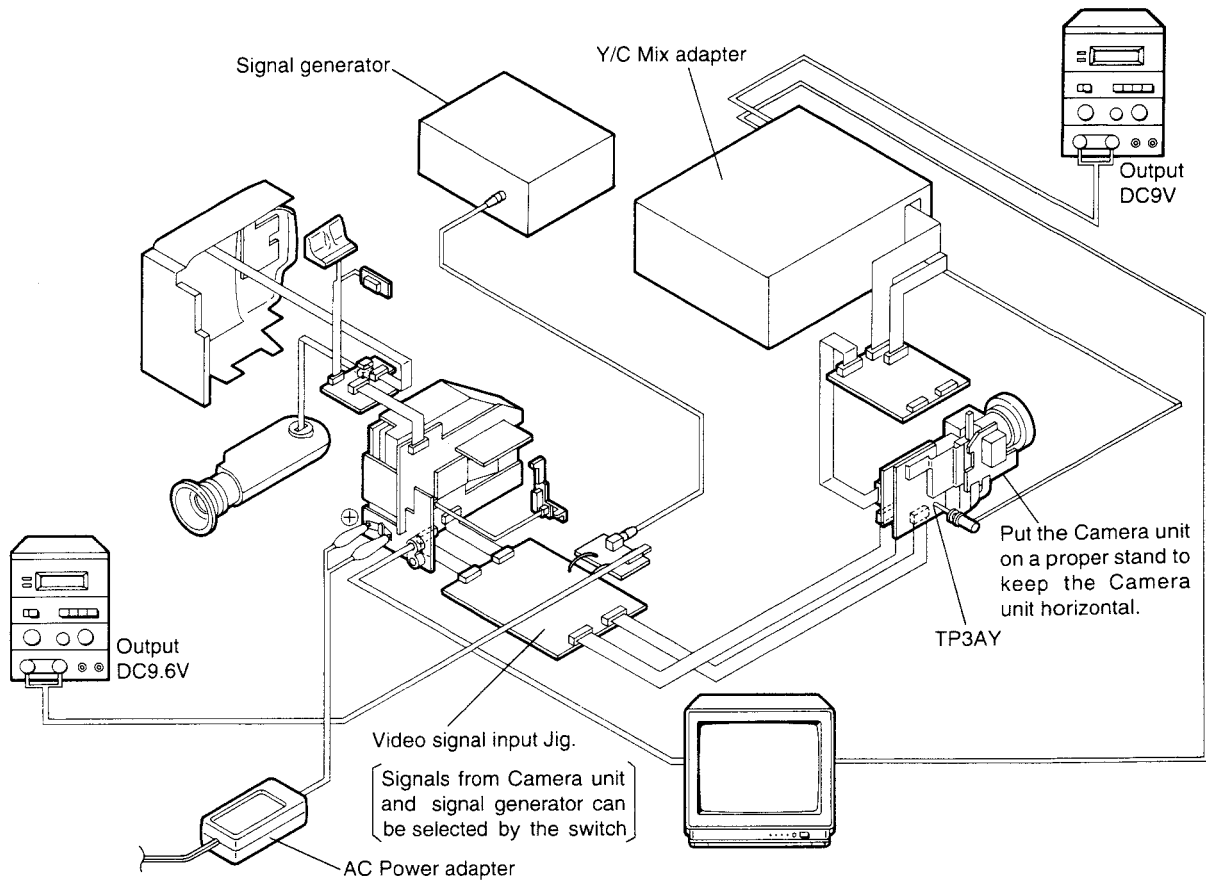

Note: Use the video signal input tool for inputting video signal.

4. Adjusting electronic volume with Y/C Mix adapter

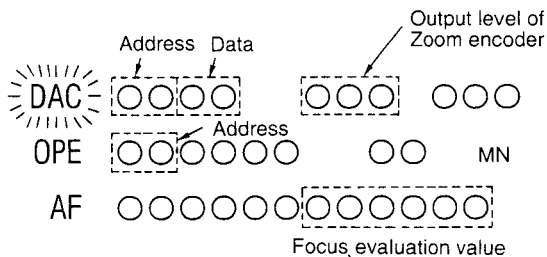

- Electronic volume adjustment requires connection of the Y/C Mix adapter.
- When displaying video output signal on a monitor, watch the display, shown in left figure, at the bottom on the screen. You should adjust electronic volume, watching this display on the screen.

4-1 Adjusting DAC Address

1. Turn EEPROM switch to WRITE side.
2. Press OPE•DAC button to blink "DAC" display.
3. Two-digit hexadecimal numbers displayed to the right of the "DAC" display shows the current address of DAC. When changing address number, press ADDRESS switch to (+) or (-) side once so that the number of address increases ± 1 , or keep pressing for continual change.
4. Two-digit hexadecimal numbers displayed to the right of the numbers of DAC address shows the content (data) of the current DAC address. When changing data of address, DATA switch to (+) or (-) side once so that the number of data increases 1, or keep pressing for continual change.
5. Press ADDRESS switch to (+) or (-) side to write the data to EEPROM.

Location of Adjustment Points (VCR Section)

PCB VTR (COMPONENT SIDE)

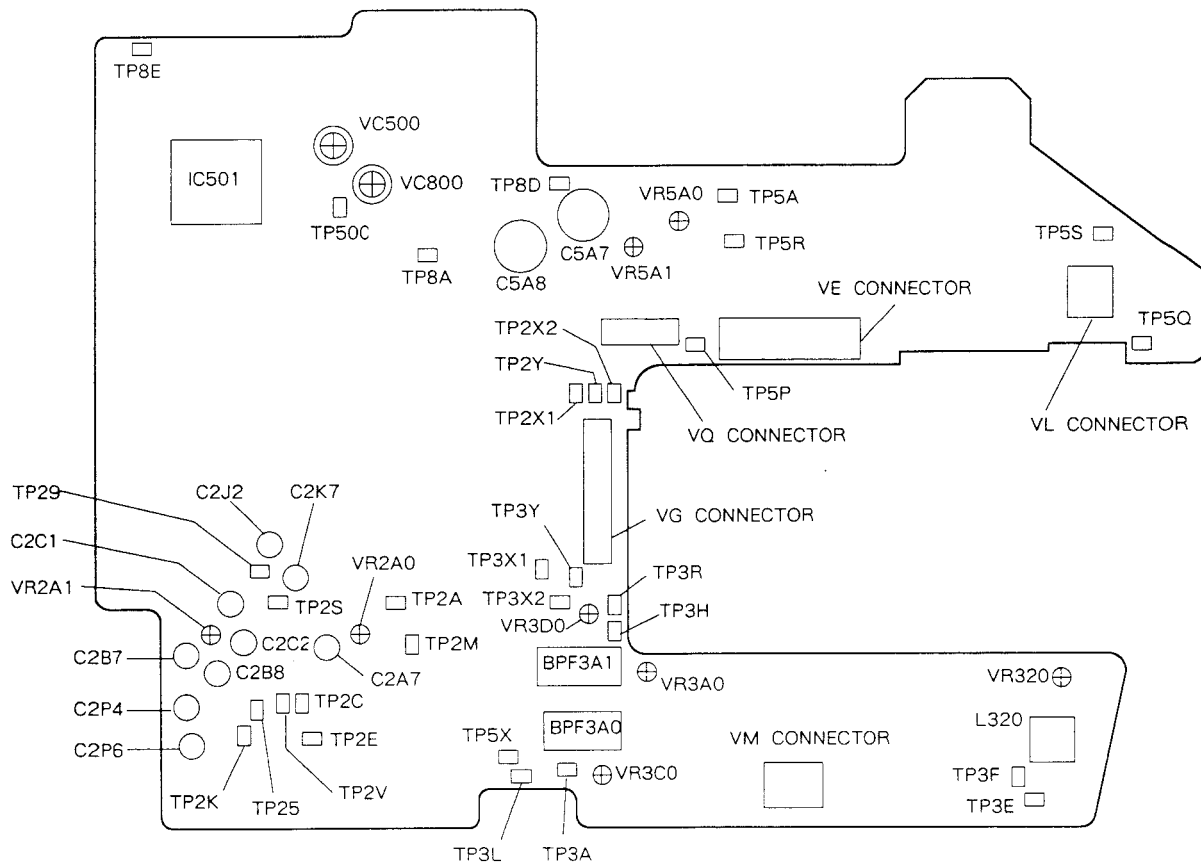

Note: Unless otherwise instructed, ground the head amp to the shield case.

[Power Supply Circuit] 1. Power Supply Voltage	Adjustment purpose: Setting power supply voltage of VCR and camera. Symptom when incorrectly adjusted: Malfunction.
----------------------------------------------------------	--------------------------------------------------------------------------------------------------------------------------------------

Measuring instrument and condition		VCR set up condition	
D.V.M		Input signal	Video signal (of camera out)
Test point	Positive : TP5Q Negative : TP5S	Using tape	A tape (VHS)
EXT trigger	—	VCR condition	SP REC (VHS)
Measurement range	—	Using jig.	—

Warning : Turn VR5A1 and VR902 to the mechanical centre point and power on.

1. Set a VCR to VHS mode.
2. Adjust VR5A1 so that the D.V.M is at $5.00 \pm 0.03V$.
3. Connect the positive of D.V.M to TP5X.
4. Adjust VR902 so that the D.V.M is at $8.50 \pm 0.03 V$.

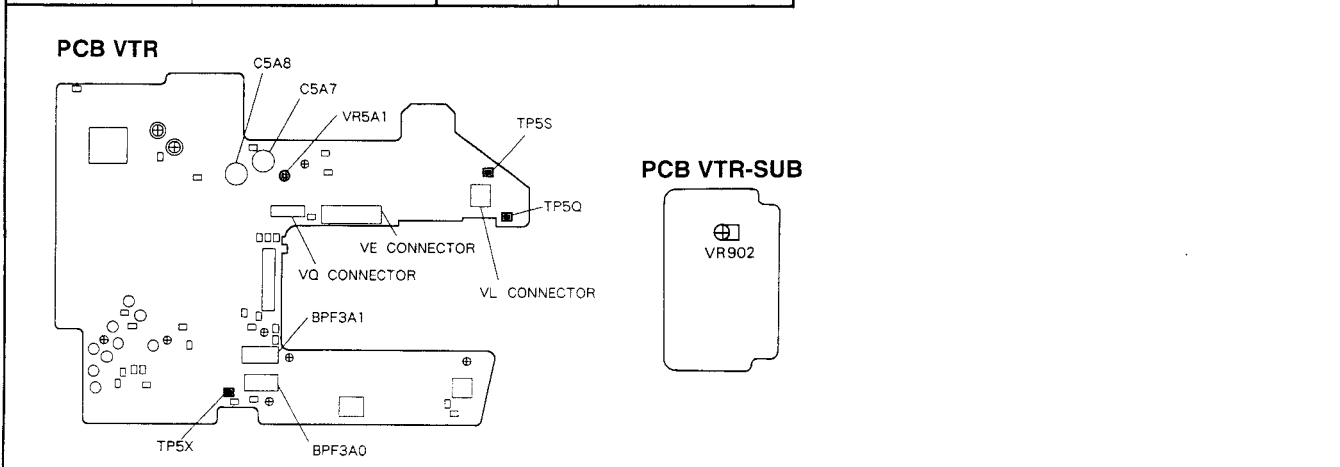

[Servo Circuit] 2. Playback Switching Point	Adjustment purpose: Video Head switch timing during playback. Symptom when incorrectly adjusted: Switching noise or jitter on the picture during playback.
-------------------------------------------------------	-----------------------------------------------------------------------------------------------------------------------------------------------------------------------------

Measuring instrument and condition		VCR set up condition	
Oscilloscope (Probe 10:1)		Input signal	—
Test point	AV OUT terminal (Video out)	Using tape	VHS Alignment tape (Colour bar)
EXT trigger	TP5A	VCR condition	SP Play back
Measurement range	DIV : 20 mV TIM : 50 μs	Using jig.	—

1. Connect TP5R to TP5S.
2. Set the oscilloscope's slope to (-).
3. Adjust VR5A0 so that the trigger point is located at $6.5 \pm 1.0 H$ before the vertical synchronizing signal.

Note: To recover digital tracking disconnect TR5R from TP5S and then turn off power.

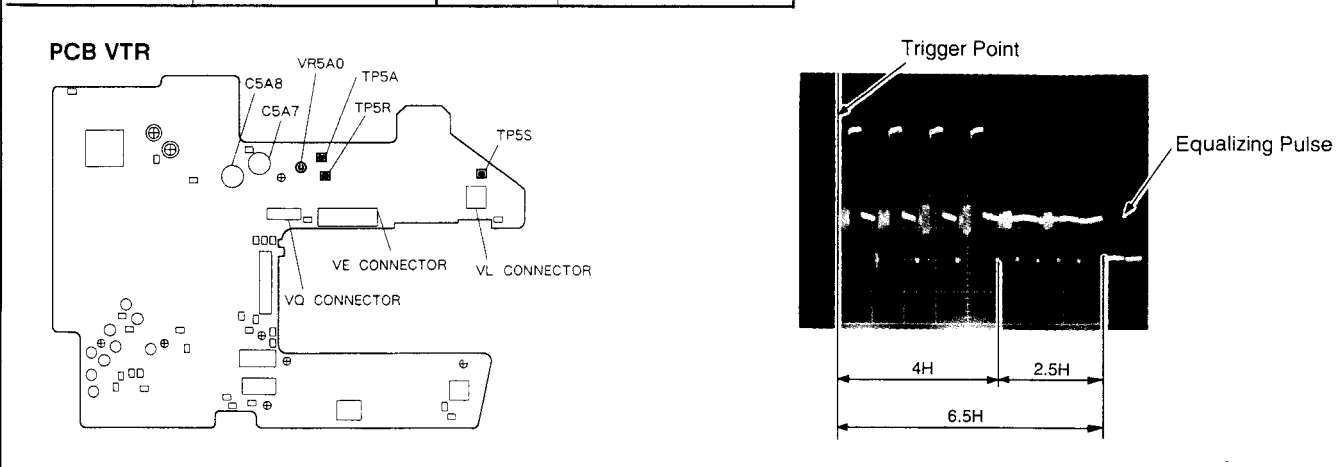

[Y/C Signal Circuit] 3. L.P.F Cut-Off Frequency	Adjustment purpose: Bandwidth of Low Pass Filter frequency to reject unnecessary signal during REC or PB. Symptom when incorrectly adjusted: Soft picture or poor S/N.
-----------------------------------------------------------	-----------------------------------------------------------------------------------------------------------------------------------------------------------------------------------------

Measuring instrument and condition		VCR set up condition	
Oscilloscope (Probe 10:1)		Input signal	Multiple burst
Test point	TP2V	Using tape	A tape (VHS)
EXT trigger	—	VCR condition	LP REC (VHS)
Measurement range	DIV : 10mV TIM : Variable	Using jig.	—

1. Set a VCR to VHS mode.
 2. Input Multiburst signal.
 3. When multiburst signal amplitude at 0.5MHz is "a" and "b" at 3.4MHz, adjust VR2A5 for b/a = 0.4, as shown below.
- Note: Some signal generator cannot provide correct 3.4MHz signal.
Signal at $3.4 \pm 0.3\text{MHz}$ may be permitted.
For location of the 3.4MHz signal, refer to the operation manual.

PCB VTR

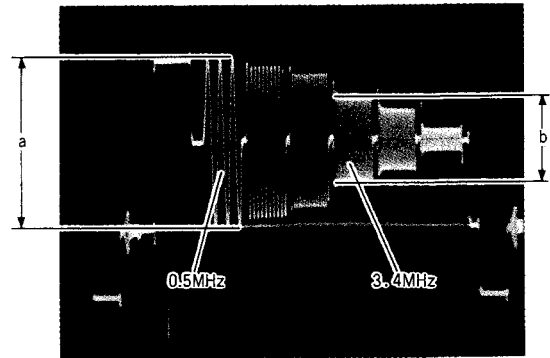
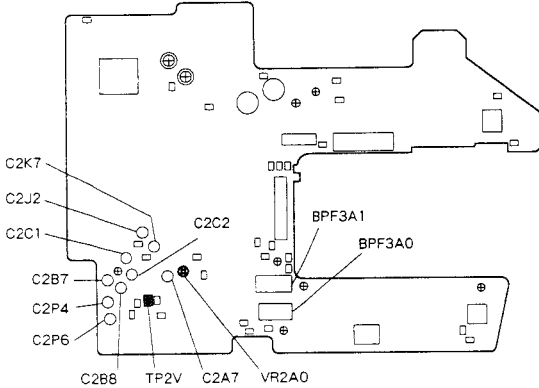

4. Signal Level	Adjustment purpose: Input level of equalizer during recording in VHS mode. Symptom when incorrectly adjusted: Poor sharpness of picture, white or black streaking.
------------------------	-------------------------------------------------------------------------------------------------------------------------------------------------------------------------------------

Measuring instrument and condition		VCR set up condition	
Oscilloscope (Probe 10:1)		Input signal	Split field stair step
Test point	TP25	Using tape	A tape (S-VHS)
EXT trigger	—	VCR condition	LP REC (S-VHS)
Measurement range	DIV : 10 mV TIM : 10 μs	Using jig.	—

1. Set a VCR to S-VHS mode.
2. Set DAC address to 1E.
3. Adjust data of DAC address (1E) so that the amplitude of oscilloscope's waveform is 300 mVp-p.
4. Set a VCR to VHS mode.
5. Set DAC address to 1F.
6. Adjust data of DAC address (1F) so that the amplitude of oscilloscope's waveform is 300 mVp-p.

PCB VTR

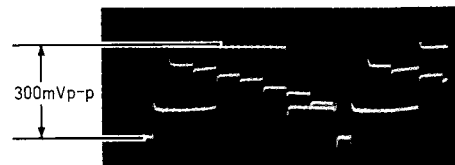
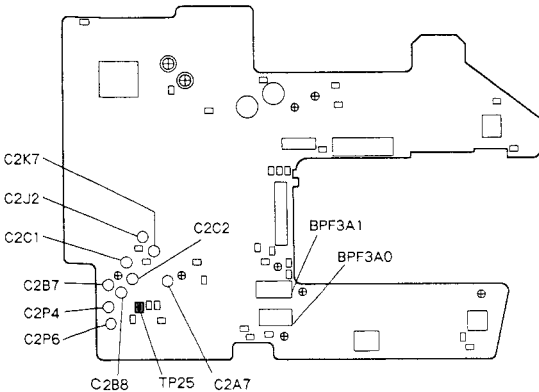

5. White Clip **Adjustment purpose:** Improve picture sharpness.
Symptom when incorrectly adjusted: Poor sharpness of picture, white or black streaking.

Measuring instrument and condition		VCR set up condition	
Oscilloscope (Probe 10:1)		Input signal	Split field stair step
Test point	TP2E	Using tape	A tape (S-VHS)
EXT trigger	—	VCR condition	LP REC (S-VHS)
Measurement range	DIV : 10 mV (Variable) TIM : 10 μs	Using jig.	—

1. Set a VCR to S-VHS mode.
2. Set DAC address to 20.
3. Adjust data of DAC address (20) so that overshoot of first transition in 100 % white area is 110%, where range from sync tip to white peak is assumed as 100 %.

PCB VTR

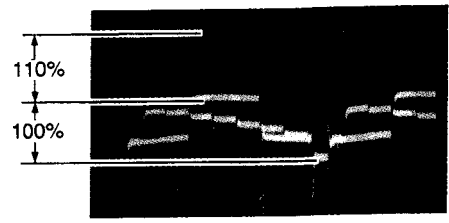
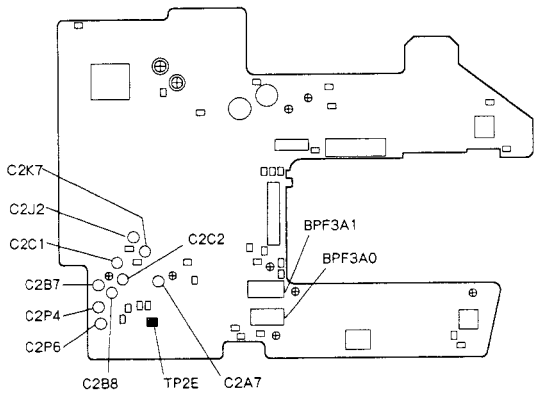

6. Carrier Set, Deviation **Adjustment purpose:** FM carrier frequency and frequency deviation.
Symptom when incorrectly adjusted: Too bright or too dark picture. Poor colour bar display, horizontal noise or out of sync.

Measuring instrument and condition		VCR set up condition	
Oscilloscope (Probe 1:1)		Input signal	Split field stair step
Test point	TP2M	Using tape	A tape (S-VHS)
EXT trigger	TP2S	VCR condition	LP REC (VHS)
Measurement range	DIV : 0.2 V TIM : 10 μs	Using jig.	Carrier checker

1. Set a VCR to VHS mode.
2. Observe TP2M via carrier checker.
3. Set DAC address to 25.
4. Adjust data of DAC address (25) so that frequency of sink tip is 3.8 MHz.

PCB VTR

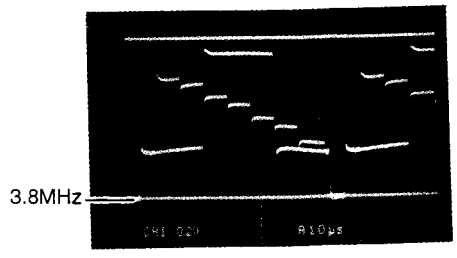
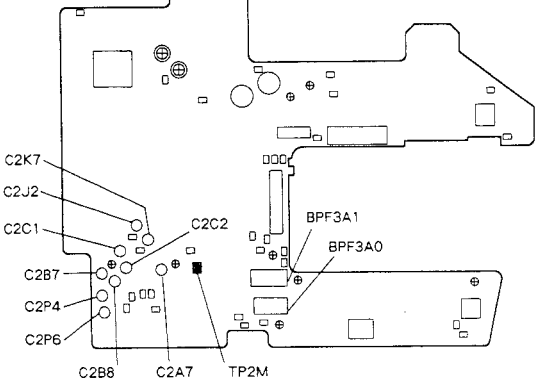

5. Set the VCR to S-VHS mode.
6. Set DAC address to 23.
7. Adjust data of DAC address (23) so that frequency of Sync tip is 5.4 MHz.

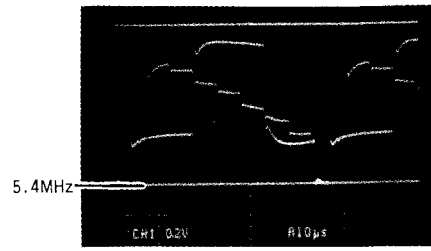
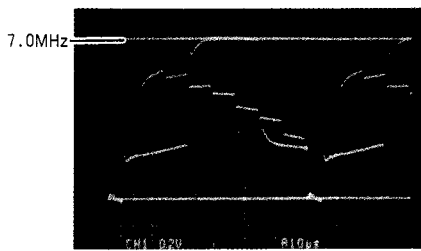

8. Adjust data of DAC address (1D) so that frequency of white peak is 7.0 MHz.

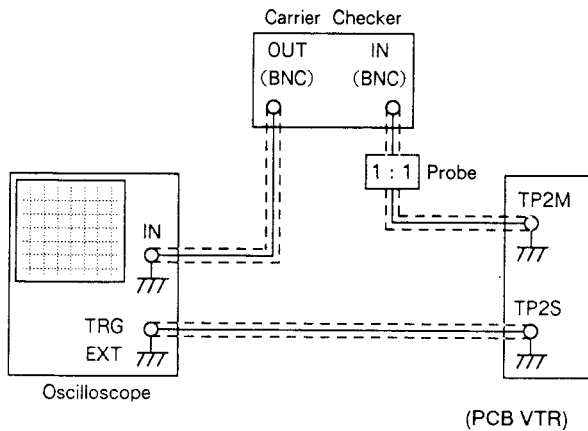

7. Chrominance Signal Recording Level

Adjustment purpose: Chrominance signal level during recording.

Symptom when incorrectly adjusted: Colour impurity or flicker of colour bars.

Measuring instrument and condition		VCR set up condition	
Oscilloscope (Probe 10:1)		Input signal	Video signal (of camera out)
Test point	TP2Y (GND : TP2X2)	Using tape	A tape (VHS)
EXT trigger	TP2S	VCR condition	LP REC (VHS)
Measurement range	DIV : 5 mV TIM : 2 μs	Using jig.	—

*This adjustment must be performed after finishing adjustments of all chroma signal processing circuit of the camera unit.

1. Set a VCR to VHS mode.
2. Connect TP2M to TP5Q.
3. Connect TP2X1 to TP2X2 via a capacitor (0.1μF).
4. Shade the camera's lens.
5. Set DAC address to 1C.
6. Adjust data of DAC address (1C) so that the minimum amplitude of burst is 20 mVp-p.

PCB VTR

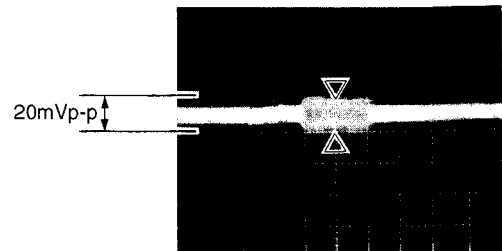
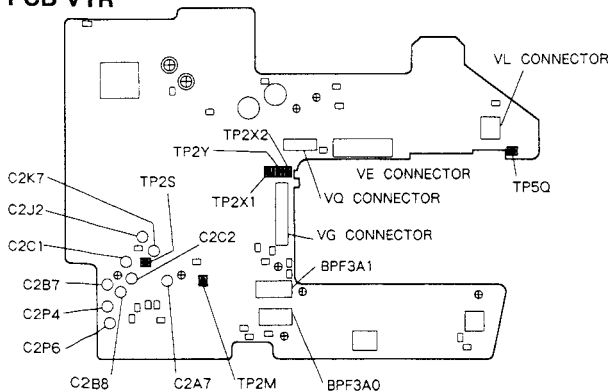

8. Luminance Signal Recording Level	Adjustment purpose: Luminance signal level during recording. Symptom when incorrectly adjusted: Lower luminance S/N or beat pattern.
-------------------------------------	-------------------------------------------------------------------------------------------------------------------------------------------------------

Measuring instrument and condition		VCR set up condition		<ol style="list-style-type: none"> 1. Set a VCR to S-VHS mode. 2. Connect TP2C to TP5Q through a resistance (1kΩ). 3. Connect TP2X1 to TP2X2 via a capacitor (0.1μF). 4. Set DAC address to 21. 5. Adjust data of DAC address (21) so that the amplitude of horizontal sync is 190 mVp-p.
Oscilloscope (Probe 10:1)		Input signal	Split field stair step	
Test point	TP2Y (GND : TP2X2)	Using tape	A tape (S-VHS)	
EXT trigger	TP2S	VCR condition	LP REC (S-VHS)	
Measurement range	DIV : 5 mV TIM : 2 μ s	Using jig.	—	

PCB VTR

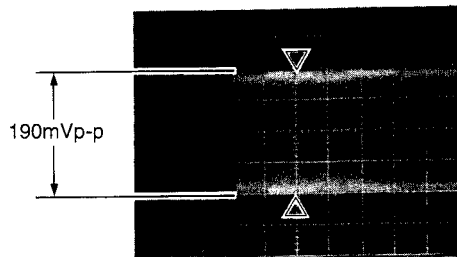
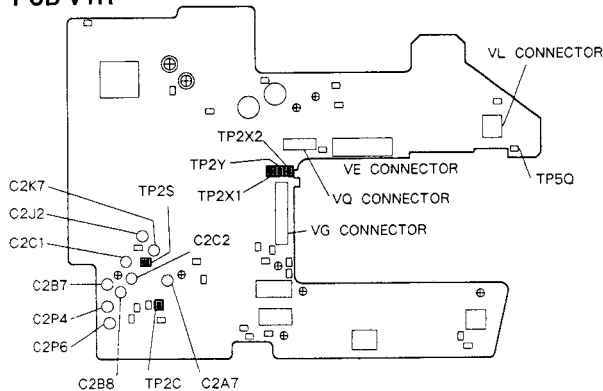

9. Playback Level	Adjustment purpose: Video output level during playback . Symptom when incorrectly adjusted: Poor colour bar display.
-------------------	---------------------------------------------------------------------------------------------------------------------------------------

Measuring instrument and condition		VCR set up condition		<ol style="list-style-type: none"> 1. Terminate the luminance signal output terminal at 75 Ω. 2. Set DAC address to 22. 3. Adjust data of DAC address (22) so that the amplitude of waveform is 1.0 Vp-p. 4. Set DAC address to 24. 5. Play a VHS alignment tape (color bar). 6. Adjust data of DAC address (24) so that the amplitude of waveform is 1.0 Vp-p.
Oscilloscope (Probe 10:1)		Input signal	—	
Test point	Y- OUT of S-terminal	Using tape	S-VHS Alignment tape (colour bar)	
EXT trigger	—	VCR condition	SP Playback (S-VHS)	
Measurement range	DIV : 20 mV TIM : 10 μ s	Using jig.	—	

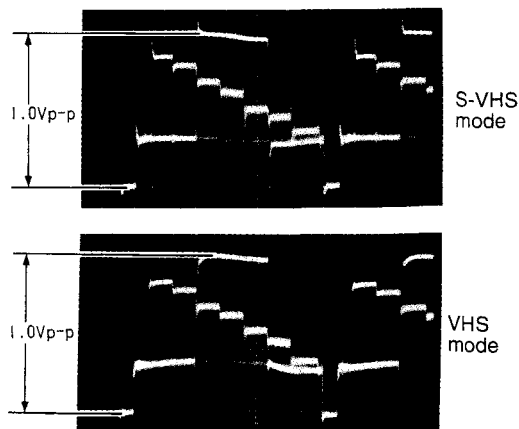

10. CCD Level	Adjustment purpose: Setting gain of Noise reduction circuit. Symptom when incorrectly adjusted: Lower video signal S/N.
---------------	------------------------------------------------------------------------------------------------------------------------------------------

Measuring instrument and condition		VCR set up condition	
Oscilloscope (Probe 10:1)		Input signal	—
Test point	TP2K	Using tape	VHS alignment tape (colour bar)
EXT trigger	—	VCR condition	SP Playback (VHS)
Measurement range	DIV : 10 mV TIM : 20 μs	Using jig.	—

1. Adjust VR2A1 so that the amplitude of waveform is the minimum.



PCB VTR

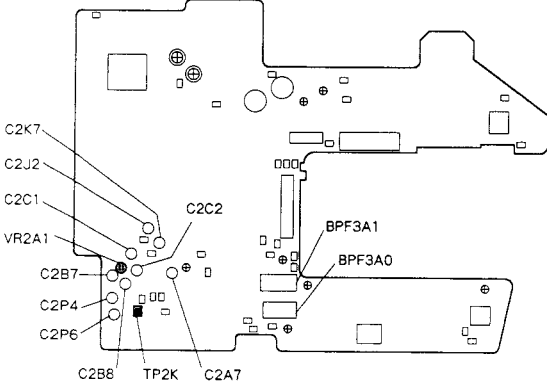

[Normal Audio Circuit] 11. Audio Bias Level	Adjustment purpose: Audio bias level during recording. Symptom when incorrectly adjusted: Poor audio response in high frequency area.
------------------------------------------------	--------------------------------------------------------------------------------------------------------------------------------------------------------

Measuring instrument and condition		VCR set up condition	
Audio Tester		Input signal	Stair step
Test point	TP3E TP3F	Using tape	A tape (VHS)
EXT trigger	—	VCR condition	SP REC (VHS)
Measurement range	—	Using jig.	High pass filter

1. Set a VCR to VHS mode.
2. Connect an electrolytic capacitor (16 V min./10 μF) between pin Nos. 1 and 3, and Nos. 2 and 3 of VM connector so that pin No. 3 is negative.
3. Observe TP3E and TP3F with high pass filter.
4. Confirm no influence on precision of the audio tester from monitors or TV set, and adjust VR320 so that the audio tester is at 2.4 mVrms.

Warnings : Do not contact the audio tester with a VCR. Never play a tape when the audio tester is connected to the VCR. (The audio amplifier will be overloaded.)

PCB VTR

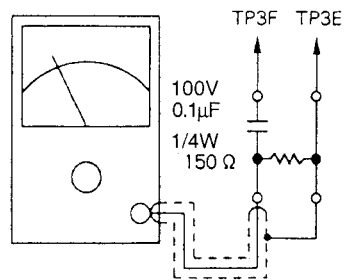
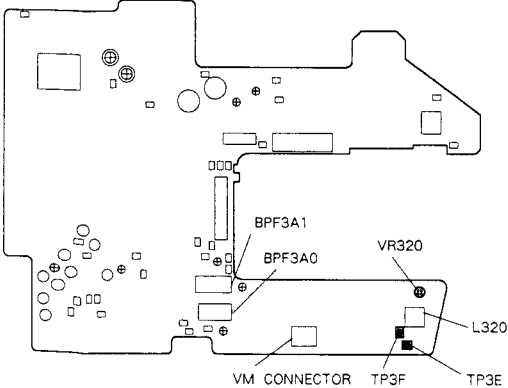

[Hi-Fi Audio Circuit]
12. Oscillating Frequency

Adjustment purpose: Setting FM carrier frequency of Hi-Fi audio signal.
Symptom when incorrectly adjusted: Buzz noise.

Measuring instrument and condition		VCR set up condition	
Frequency counter		Input signal	Stair step
Test point	TP3L TP3R	Using tape	A tape (VHS)
EXT trigger	—	VCR condition	SP REC (VHS)
Measurement range	—	Using jig.	—

1. Set a VCR to VHS mode.
2. Connect an electrolytic capacitor (16 V min./10 μ F) between pin Nos. 1 and 3, and Nos. 2 and 3 of VM connector so that pin No. 3 is negative.
3. Adjust VR3C0 so that frequency of TP3L is 1.400 MHz \pm 3.0 kHz.
4. Adjust VR3A0 so that frequency of TP3R is 1.800 MHz \pm 3.0 kHz.

PCB VTR

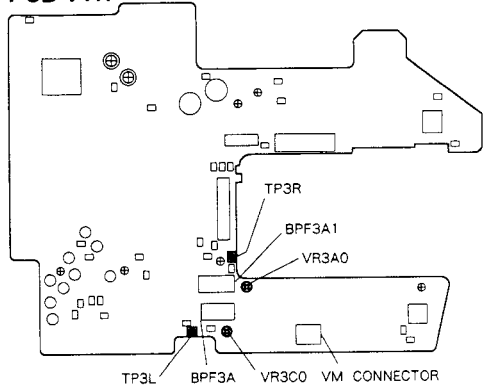

13. FM Recording Level

Adjustment purpose: Hi-Fi audio signal level during recording.
Symptom when incorrectly adjusted: Wow and flutter in audio signal or lower S/N in video signal.

Measuring instrument and condition		VCR set up condition	
Oscilloscope (Probe 10:1)		Input signal	Stair step
Test point	TP3Y	Using tape	A tape (VHS)
EXT trigger	TP3H	VCR condition	LP REC (VHS)
Measurement range	DIV : 10 mV TIM : 50 μ s	Using jig.	—

1. Set a VCR to VHS mode.
 2. Connect an electrolytic capacitor (16 V min./10 μ F) between pin Nos. 1 and 3, and Nos. 2 and 3 of VM connector so that pin No. 3 is negative.
 3. Connect ground of probe to TP3X1 through capacitor (0.1 μ F).
 4. Adjust VR3D0 so that the amplitude of waveform is 250 mVp-p.
- Note:** The earth of trigger must be connected to ground.

PCB VTR

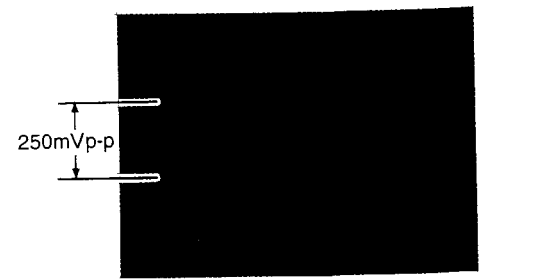
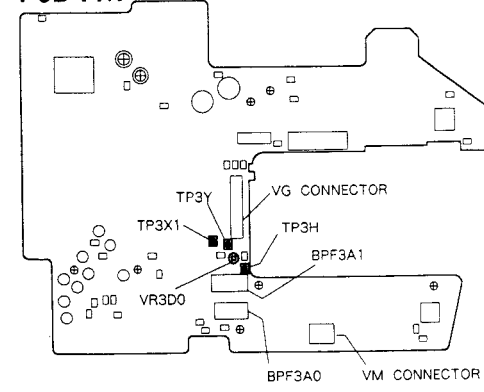

[Character display circuit] 14. PLL	Adjustment purpose: Reference clock level of character display circuit. Symptom when incorrectly adjusted: Character will flow in picture.
-----------------------------------------------	-------------------------------------------------------------------------------------------------------------------------------------------------------------

Measuring instrument and condition		VCR set up condition		1. Adjust VC500 so that the voltage is 2.0 ± 0.1 V DC.
D.V.M		Input signal	Video signal (of camera out)	
Test point	TP500	Using tape	—	
EXT trigger	—	VCR condition	Stop	
Measurement range	—	Using jig.	—	

PCB VTR

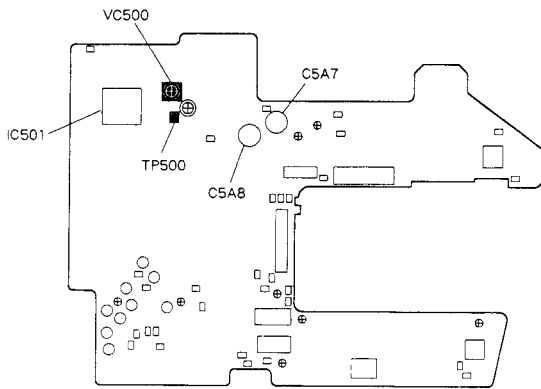

15. Character Display Position	Adjustment purpose: Location of character display position. Symptom when incorrectly adjusted: Characters will not be displayed in the regular position.
--------------------------------	---------------------------------------------------------------------------------------------------------------------------------------------------------------------------

Measuring instrument and condition		VCR set up condition		Caution : In this adjustment, the view finder must be connected to JE connector. 1. Short TP8D and TP8E to display one vertical line in the picture. 2. Adjust VC800 so that the vertical line lies on the centre line of centre cross signal.
—		Input signal	Centre cross signal	
Test point	—	Using tape	—	
EXT trigger	—	VCR condition	Stop	
Measurement range	—	Using jig.	—	

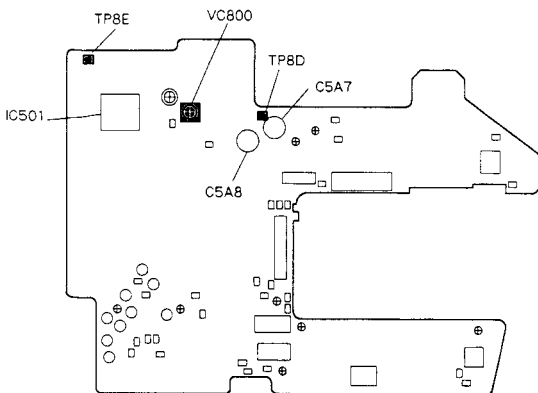

PCB VTR



Adjusting Camera Unit

1. Jigs and Measuring Instruments

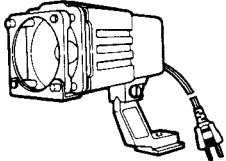
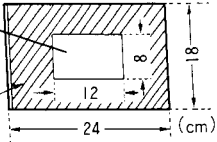
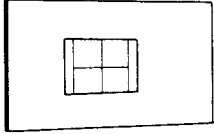
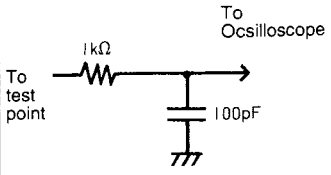
1-1 Jigs

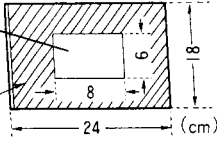
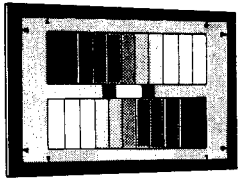
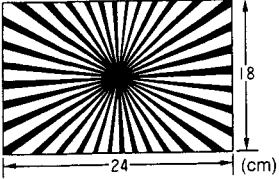
Halogen Light VLT-100 (3200 ± 50°K)	Window Chart (self-prepared)	Colour Chart (Reflection type) 859C397O4	Low Pass Filter (self-prepared)
	 <p>White paper Low Reflection Paper</p> <p>Stick black paper on a square corrugated board and white paper, 12(W)x8(H) cm, at the centre on the black paper.</p>		 <p>To test point</p> <p>To Oscilloscope</p>
Conversion Filter for Colour Temperature and Extinction filter (1/100)	J Chart (self-prepared)	Grey Scale Chart 859C361O10	Radial Chart (self-prepared)
 C2 (859C361O80) C12 (859C361O70) ND2 (859C362O40)	 <p>Stick From reverse Low Reflection Paper</p> <p>Make holes at the size of 8(W)x6(H) cm on both a board and black paper and stick white paper from the reverse.</p>		 <p>Narrower width between lines better.</p>

Note : Halogen light VLT-100 specified colour temperature at 3200°K available in adjustment.

1-2 Measuring Instruments

- Oscilloscope
- Vectorscope
- Illuminometer
- Digital voltmeter
- Colour monitor

2. Standard Location and Connection

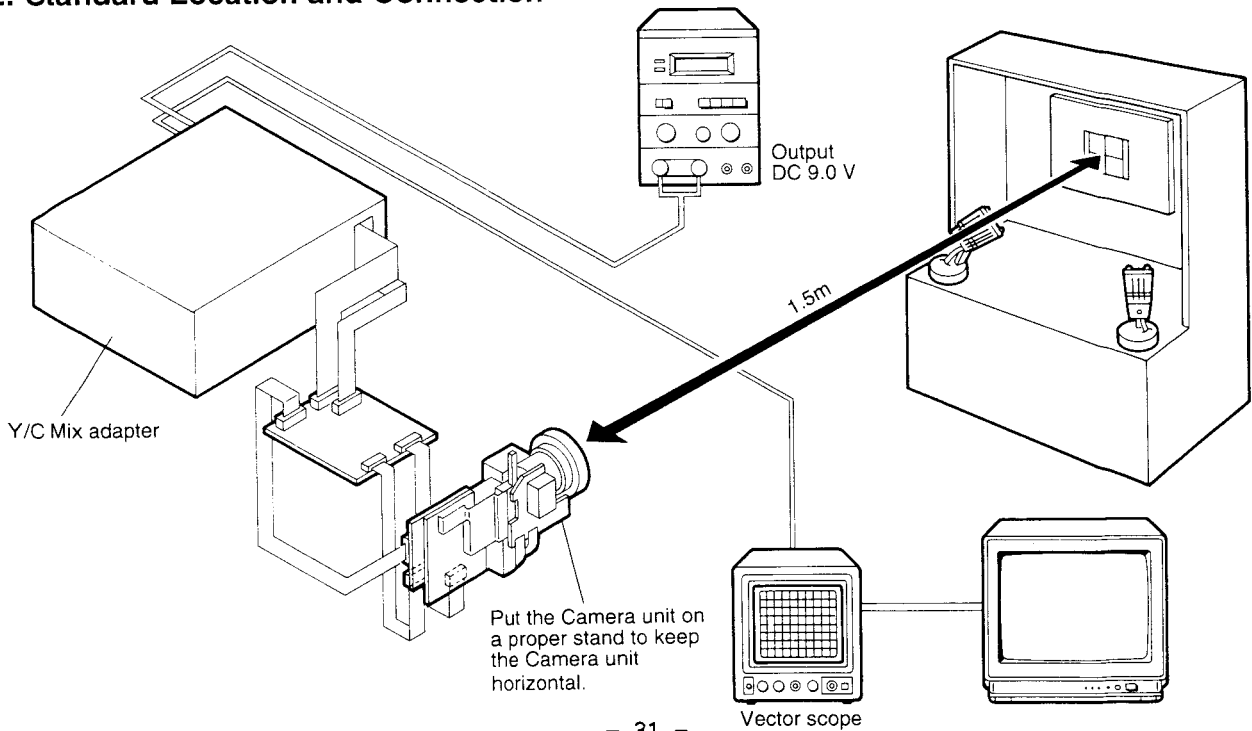

3. Preparation and Check Items

3-1 Preparation and Caution

1. You must use lamps with colour temperature at 3200°K to illuminate a chart used in adjustment, and set the lamps so that luminance on the surface of the chart is kept at about 2,000 lx. Install the illuminaires so that the chart is illuminated evenly (two or more light sources are preferable). If luminance on the surface of the chart is uneven, you cannot perform this adjustment properly.
2. When adjusting the Camera unit, you must adjust it without using any extension cable (without separating any unit of the VIDEO CAMERA/RECORDER), except where it's required.
3. Unless otherwise indicated in particular, distance between an object and the Camera unit is 1.5 m.

3-2 Adjusting Standard Angle of View

When shooting a chart in adjusting the Camera unit, unless otherwise indicated, shoot and adjust at the standard angle of view.

1. Shoot the Colour chart.
2. Connect the probe of oscilloscope to TP3AY or a video output terminal of the Y/C Mix adapter. Observe the waveform as shown right on the screen of oscilloscope.
3. Adjust the Power zoom button so that part A to B in the waveform are same as full effective range of horizontal signal.

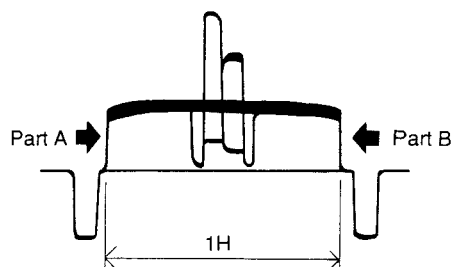

3-3 Adjusting White Balance with Y/C Mix Adapter

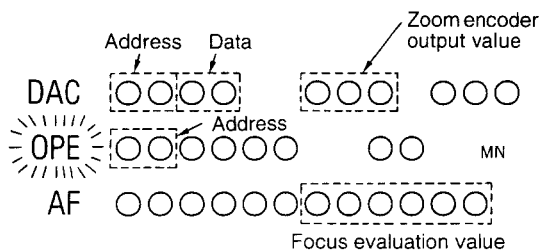

White balance has three modes : "Auto" (OPE address is "00"), "Outdoor" ("01"), "Indoor" ("02"). OPE address is two-digit hexadecimal numbers to right of "OPE" on the screen.

1. Press OPE•DAC button to blink "OPE" display.
2. Press DATA switch to (+) side so that OPE address is 02 (Indoor) and again 00.
3. Press DATA switch to (-) side so that OPE address is 01 (Outdoor) and again 00.

Note : When changing mode from Indoor to Outdoor or the reverse, the OPE address must be changed via "00". If OPE address is changed directly, for example, "01" to "02", the mode never be selected properly.

3-4 Standard Condition

1. Unless otherwise indicated in particular, set each function mode of the Camera unit in table listed below in adjustment.

Shutter	Standard (1/50 s)
Focus	Manual
Special effects	Off
Backlight compensation	Off
White balance	Indoor(3,200°K)

Press reset button of Y/C Mix adapter to set each mode of shutter, special effects, backlight compensation as shown in table above. Setting white balance mode as referred to item 3-3 above.

4. Adjusting Procedure for Camera Unit

The following shows all procedures to adjust each volume of the Camera unit.
You should perform some adjustment item(s) necessary for a trouble, not all.

1.

25 MHz Frequency

2.

Zoom Encoder and Photo Sensor

3.

Substrate voltage and Reset Voltage

4.

OB Offset

5.

ALC

6.

CCD Gain

7.

Setup Level

8.

APL

9.

Aperture Correction

10.

Chroma Gamma Leak

11.

R-Y and B-Y Offsets

12.

Chroma Offset and $f_H/2$ Offset

13.

White Balance

14.

Amplifier Output of Iris Hole Element

15.

Fsc

16.

Chroma VCO

17.

Chroma R-Y and B-Y Offset, and Burst Signal

18.

Camera APL

19.

Gain of R-Y and B-Y Chroma hue

Location of Adjustment Points (Camera section)

PCB SD/PC (COMPONENT SIDE)

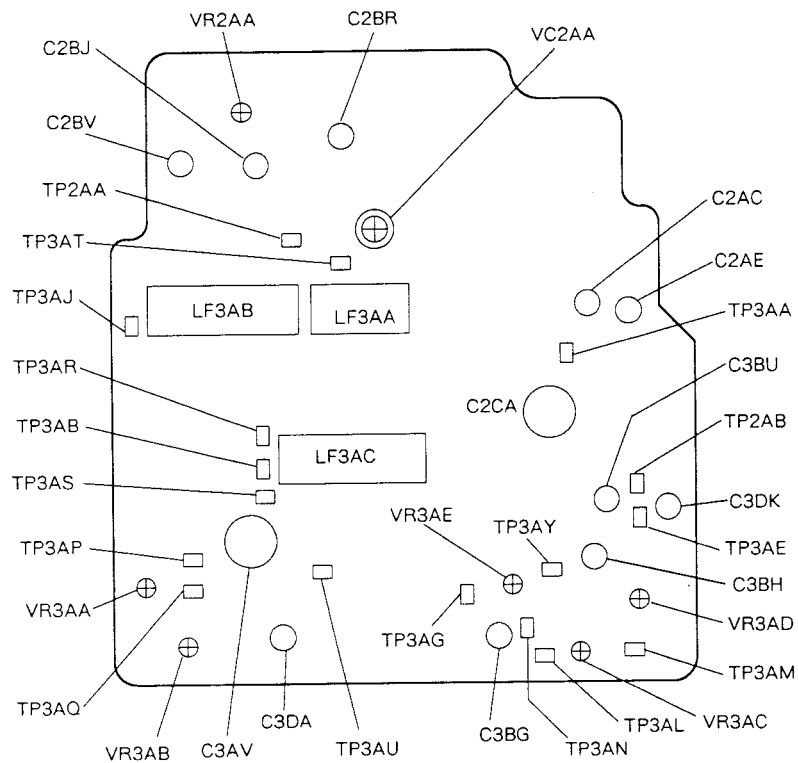

Note: Unless otherwise instructed, ground the shield case.

1. 25 MHz Frequency	<p>Adjustment purpose: Reference oscillator frequency for timing of CCD drive.</p> <p>Symptom when incorrectly adjusted: Disturbance of picture and colour content screen.</p>
---------------------	----------------------------------------------------------------------------------------------------------------------------------------------------------------------------------------------

Measuring instrument and condition	Frequency counter
Test point	TP2AA
EXT trigger	—
Measurement range	—
Chart used	—

1. Adjust VC2AA so that frequency of TP2AA is 25.750MHz ± 60Hz.

PCB SD/PC

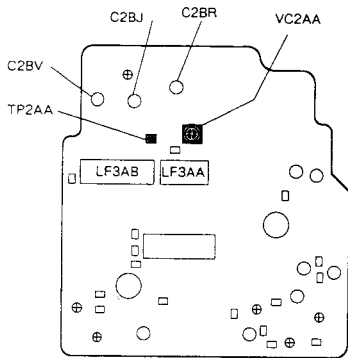

2. Zoom Encoder and Photo Sensor	<p>Adjustment purpose: Back focus of lens</p> <p>Symptom when incorrectly adjusted: Out of focus in zooming</p>
----------------------------------	-------------------------------------------------------------------------------------------------------------------------------

Measuring instrument and condition	—
Test point	—
EXT trigger	—
Measurement range	—
Chart used	Radial chart (or similar)

1. Locate and shoot the radial chart at a distance of 10 m min. from the Camera unit.
 2. Set DAC address to 32.
 3. Press a zoom button of Y/C Mix adapter to set zoom encoder output value to 232, where the zoom is at wide angle. (Refer to Page 32 Item 3-3)
 4. Set the focus to the best point with view and focus evaluation value, pressing manual button of Y/C Mix adapter. (The best focusing point is obtained where focusing is evaluated at the highest.)
 5. Press the zoom button for telephoto. Set the focus to the best point close to telephoto max. with view and focus evaluation value, when read the zoom encoder output value. (This zoom encoder output value is called "V".)
 6. Press TELE END button of Y/C Mix adapter to write data in EEPROM.
 7. Press the zoom button for wide angle. Set the focus to the best point with view and focus evaluation value, confirm that the zoom encoder output value ranges from V + y + 1 to V + y - 1. (See Certification number table below. The V is the Value at para 5.)
 8. Press WIDE END button of Y/C Mix adapter to write data in EEPROM.
- Note :** If not focusing in item 7, bring into focus with the manual button of Y/C Mix adapter. And then press WIDE END button to write data in EEPROM.
9. Press PHOTO SENS. button of Y/C Mix adapter to write data in EEPROM.
 10. Turn off the power and then on again.

Certification Number	Movement	Certification Number	Movement
396	203	410	210
397	203	411	210
398	204	412	211
399	204	413	211
400	205	414	212
401	205	415	212
402	206	416	213
403	206		
404	207		
405	207		
406	208		
407	208		
408	209		
409	209		

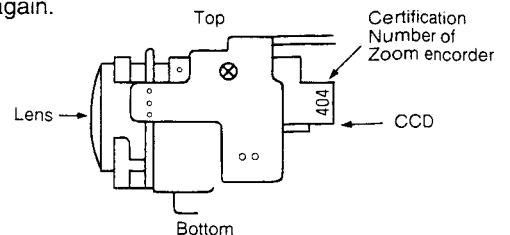

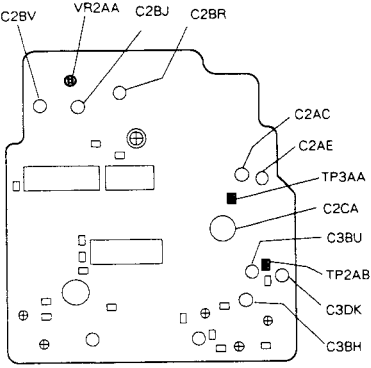
3. Substrate voltage and Reset Voltage		Adjustment purpose: Reference voltage for CCD drive. Symptom when incorrectly adjusted: S/N ratio lower or blooming
Measuring instrument and condition	Oscilloscope (Probe 10:1)	<ol style="list-style-type: none"> 1. Set data of DAC address 17 to FF. Open the iris. 2. Attach a 1/100 extinction filter onto lens of the Camera unit. 3. Shoot the J chart illuminated from the rear with a halogen light at the standard angle of view. 4. Move the location of the halogen light so that level of waveform of TP3AA is at 300 mVp-p. 5. Detach the extinction filter from the lens. 6. Adjust VR2AA so that blooming doesn't appear on the screen. 7. Change the test point from TP3AA to TP2AB. 8. Set DAC address to 09. 9. Decrease data value of DAC address 09 from FF. When waveform shows the maximum and the level changes no longer, stop decreasing the data value. <p>Note : If level of the waveform isn't higher, set the data value to FF.</p>
Test point	TP3AA	
EXT trigger	—	
Measurement range	DIV : 10 mV TIM : 10 μ s	
Chart used	J chart	
PCB SD/PC 		

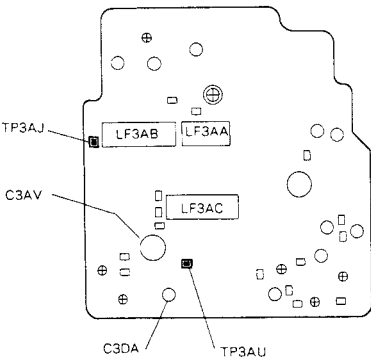
4. OB Offset		Adjustment purpose: Black colour level of CCD output signal Symptom when incorrectly adjusted: Black of CCD output signal will turn red or blue.
Measuring instrument and condition	Oscilloscope (Probe 10:1)	<ol style="list-style-type: none"> 1. Set DAC address to 0E. 2. Adjust data of DAC address 0E so that offset is at the minimum. <p>Note : If it is hard to observe the waveform because of poor S/N ratio, observe it with a specified low pass filter.</p>
Test point	TP3AJ	
EXT trigger	—	
Measurement range	DIV : 5 mV TIM : 10 μ s	
Chart used	Lens shaded	
PCB SD/PC 		

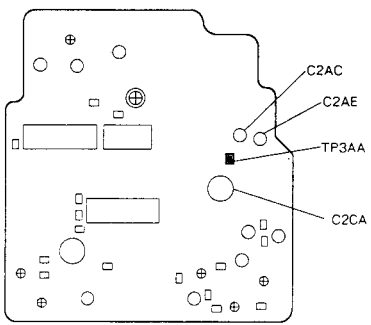
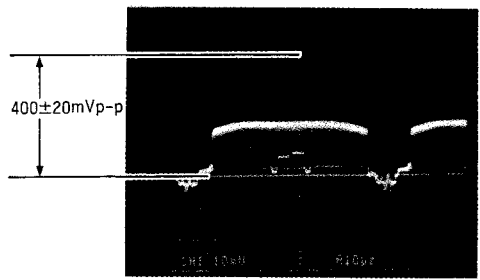
5. ALC		Adjustment purpose: Level of iris. Symptom when incorrectly adjusted: Poor gradation or whiten by excessive light.
Measuring instrument and condition	Oscilloscope (Probe 10:1)	<ol style="list-style-type: none"> 1. Observe TP3AA through the low pass filter. 2. Set DAC address to 17. 3. Adjust data of DAC address 17 so that white peak to pedestal level is at 400 ± 20 mVp-p.
Test point	TP3AA	
EXT trigger	—	
Measurement range	DIV : 10 mV TIM : 10 μ s	
Chart used	Colour chart	
<p>PCB SD/PC</p> 		

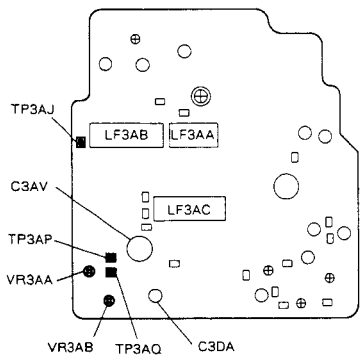
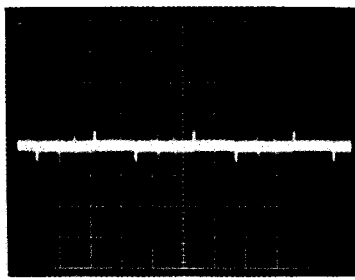
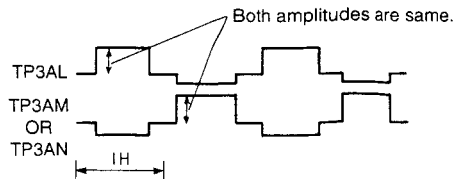
6. CCD Gain		Adjustment purpose: Gain of delay line of Y/C signal. Symptom when incorrectly adjusted: Too sharp or too soft profile in the horizontal on the screen.
Measuring instrument and condition	Oscilloscope (Probe 10:1)	<ol style="list-style-type: none"> 1. Adjust VR3AA so that the difference between TP3AJ and TP3AP with the oscilloscope is the minimum. Note : Where TP3AP is observed through low pass filter. 2. Change connection of CH-2 of oscilloscope from TP3AP to TP3AQ. Detach the low pass filter of TP3AP. 3. Adjust VR3AB so that the difference between TP3AJ and TP3AQ with the oscilloscope is the minimum. 4. Change connection of CH-1 of oscilloscope from TP3AJ to TP3AL and CH-2 from TP3AQ to TP3AM. 5. Set mode of white balance to "Outdoor" (OPE address : 01). 6. Adjust VR3AC so that the amplitude of signal from TP3AL and TP3AM are same at one point and the 1 H later. 7. Adjust VR3AD so that the amplitude of signal from TP3AL and TP3AN are same at one point and the 1 H later.
Test point	CH-1 : TP3AJ CH-2 : TP3AP	
EXT trigger	—	
Measurement range	DIV : 10 mV TIM : 10 μ s	
Chart used	Window chart	
<p>PCB SD/PC</p> 		 

7. Setup Level **Adjustment purpose:** Black level in video signal.
Symptom when incorrectly adjusted: Too bright or too dark picture.

Measuring instrument and condition	Oscilloscope (Probe 10:1)
Test point	TP3AY
EXT trigger	—
Measurement range	DIV : 10 mV TIM : 10 μs
Chart used	Lens shaded

1. Set DAC address to 13.
2. Adjust data of DAC address 13 so that the setup level is at 0 ± 14 mVp-p.

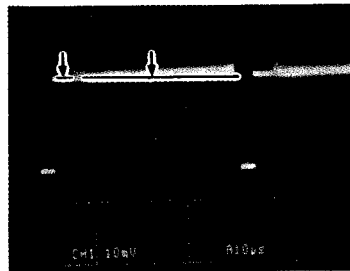

PCB SD/PC

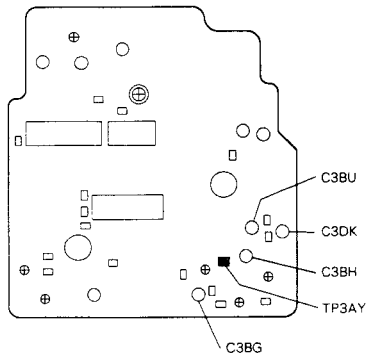

8. APL **Adjustment purpose:** AGC of video signal processing circuit.
Symptom when incorrectly adjusted: Too bright or too dark picture.

Measuring instrument and condition	Oscilloscope (Probe 10:1)
Test point	TP3AY
EXT trigger	—
Measurement range	DIV : 10 mV TIM : 10 μs
Chart used	Colour chart

1. Observe TP3AY through low pass filter.
2. Set DAC address to 0A
3. Adjust data of DAC address 0A so that level of background is at 400 ± 5 mVp-p.

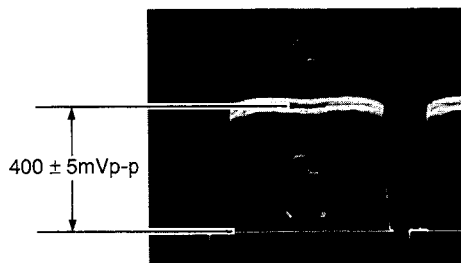

PCB SD/PC

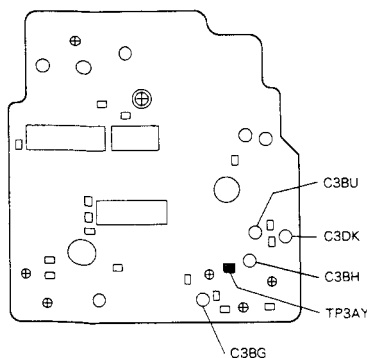

9. Aperture Correction		Adjustment purpose: Correction of profile correcting circuit. Symptom when incorrectly adjusted: Too sharp or too soft picture.
Measuring instrument and condition	—	<ol style="list-style-type: none"> 1. Set DAC address to 06. 2. Set data of DAC address 06 to 70. 3. Set DAC address to 07. 4. Set data of DAC address 07 to 88. 5. Set DAC address to 26. 6. Set data of DAC address 26 to 0C. 7. Set DAC address to 27. 8. Set data of DAC address 27 to 0C.
Test point	—	
EXT trigger	—	
Measurement range	—	
Chart used	—	

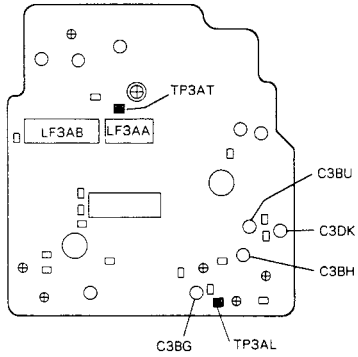
10. Chroma Gamma Leak		Adjustment purpose: Correcting leak of colour signal occurring with gamma control. Symptom when incorrectly adjusted: Colour impurity.
Measuring instrument and condition	Oscilloscope (Probe 10:1)	<ol style="list-style-type: none"> 1. Ground TP3AT at 100 μ F. 2. Set DAC address to 15. 3. Adjust data of DAC address 15 so that gamma leak is the minimum.
Test point	TP3AL	
EXT trigger	—	
Measurement range	DIV : 1 mV TIM : 10 μ s	
Chart used	Gray scale chart	
<p>PCB SD/PC</p> 		

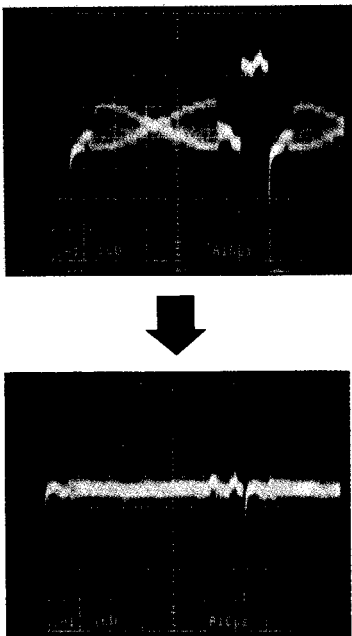

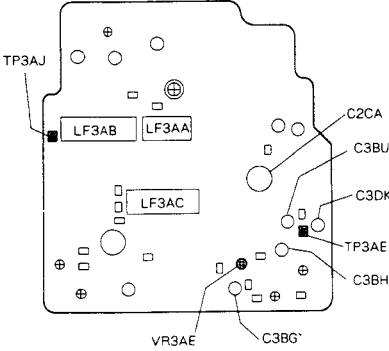
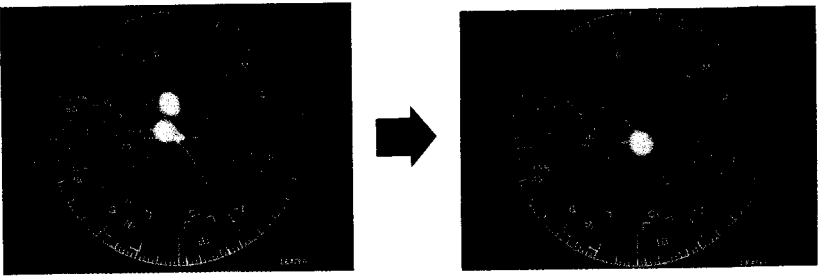
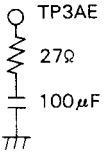
11. R-Y and B-Y Offsets		Adjustment purpose: Black level processed in colour-difference signal processing circuit.
		Symptom when incorrectly adjusted: Black in picture will turn red or blue.
Measuring instrument and condition	Vector scope	<ol style="list-style-type: none"> 1. Set mode of white balance to "Indoor" (OPE address : 02) 2. Ground TP3AE through a series with a resistance (27Ω) and a capacitor (100 μF). 3. Ground TP3AJ through a capacitor (100 μF). 4. Adjust VR3AE so that these two bright spots are overlapped and minimized. 5. Detach the capacitor in TP3AJ. 6. Set a vector scope to NTSC mode. 7. Adjust DAC addresses 0D and 0C so that the bright spot is at the centre of the vector scope.
Test point	Y/C Mix adapter Video output terminal	
EXT trigger	—	
Measurement range	GAIN : Max. SATURATION : 75 %	
Chart used	Lens shaded	
PCB SD/PC 		
		

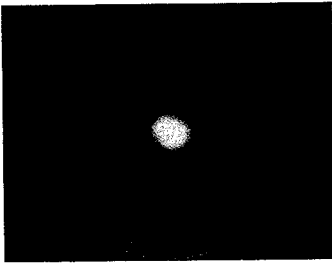
12. Chroma Offset and fh/2 Offset		Adjustment purpose: Black level before processing in colour-difference signal circuit.
		Symptom when incorrectly adjusted: Black in picture will turn red or blue.
Measuring instrument and condition	Vector scope	<ol style="list-style-type: none"> 1. Set mode of white balance to "Indoor" (OPE address : 02) 2. Adjust data of DAC addresses 10 and 0F so that bright spot is the closest to the centre of the vector scope.
Test point	Y/C Mix adapter Video output terminal	
EXT trigger	—	
Measurement range	GAIN : Max. SATURATION : 75 %	
Chart used	Lens shaded	
		

13. White Balance		<p>Adjustment purpose: Reference in displaying "white" on the screen.</p> <p>Symptom when incorrectly adjusted: icture will turn red or blue.</p>
Measuring instrument and condition	Vectorscope	<ol style="list-style-type: none"> 1. Set mode of white balance to "Indoor" (OPE address : 02) 2. Adjust DAC addresses 00 and 01 so that bright spot is at the centre of the vector scope. 3. Set mode of white balance to "Outdoor" (OPE address : 01) 4. Shoot the White chart with a colour filter (C2 + C12). 5. Adjust phase and gain of vectorscope so that burst signal spots at intersection of reference lines of burst and scale circle. 6. Adjust DAC addresses 02 and 03 so that bright spots is at the position in phot. below.
Test point	Y/C Mix adapter Video output terminal	
EXT trigger	—	
Measurement range	GAIN : Variable SATURATION : 75 %	
Chart used	White chart	

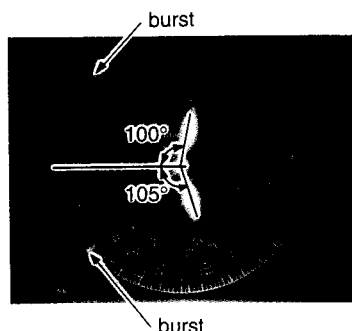

14. Amplifier Output of Iris Hole Element		<p>Adjustment purpose: Reading sensor voltage in both sides of iris.</p> <p>Symptom when incorrectly adjusted: Poor response of Auto focus.</p>
Measuring instrument and condition	—	<ol style="list-style-type: none"> 1. Set DAC address to 37. 2. Shoot a halogen light at a distance of about one metre from the Camera unit. After one second or more, press TELE END button of the Y/C Mix adapter to write the data in EEPROM. 3. Shade the lens. 4. After shading the lens for one second or more, press WIDE END button of to Y/C Mix adapter to write the data in EEPROM.
Test point	—	
EXT trigger	—	
Measurement range	—	
Chart used	—	

* Adjustments from item 15 on, must be performed with the camera connected to the VCR.

15. Fsc	Adjustment purpose: Frequency of reference frequency oscillator in colour signal processing circuit. Symptom when incorrectly adjusted: Poor colour display in picture.
---------	------------------------------------------------------------------------------------------------------------------------------------------------------------------------------------------

Measuring instrument and condition	Frequency counter
Test point	TP6J
EXT trigger	—
Measurement range	—
Chart used	—

1. Play back alignment tape (colour bar).
 2. Adjust VC6A1 so that the frequency is at 4.433635MHz \pm 30Hz.
Note : Do adjustment after the power supply turning on within one minute.

16. Chroma VCO	Adjustment purpose: Frequency of reference oscillator in low frequency colour signal processing circuit. Symptom when incorrectly adjusted: Poor colour display in picture.
----------------	----------------------------------------------------------------------------------------------------------------------------------------------------------------------------------------------

Measuring instrument and condition	Frequency counter
Test point	TP6X
EXT trigger	—
Measurement range	—
Chart used	Lens shaded

1. Set DAC address to 1A and the data to 00.
 2. Set DAC address to 19.
 3. Adjust data of DAC address 19 so that the frequency is at 613 \pm 3 kHz.
 4. Set data of DAC address 1A to FF.

PCB VTR

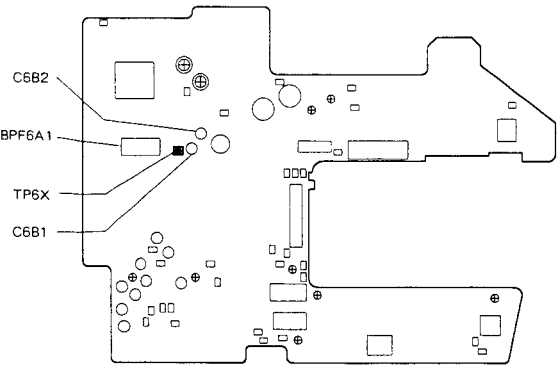

17. Chroma R-Y and B-Y Off set, and Burst Signal

Adjustment purpose: Setting white level in picture to the best and chroma level in video output signal to the regular.

Symptom when incorrectly adjusted: White in picture will turn blue or red. Or, colour signal will not displayed regularly.

Measuring instrument and condition	Vector scope
Test point	Video output terminal
EXT trigger	—
Measurement range	GAIN : Max. SATURATION : 75 %
Chart used	Colour chart

- Adjust DAC addresses 11 and 12 so that bright spot is the closest to the centre point of the vector scope.
- Set mode of vector scope to PAL. Rotate the gain to locate reference line of R-Y burst signal at the regular position on the vector scope.

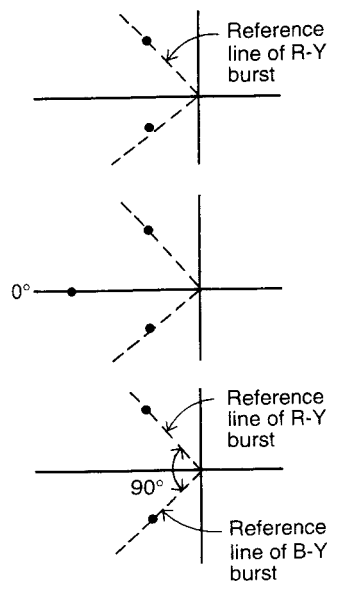
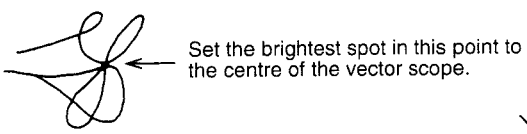

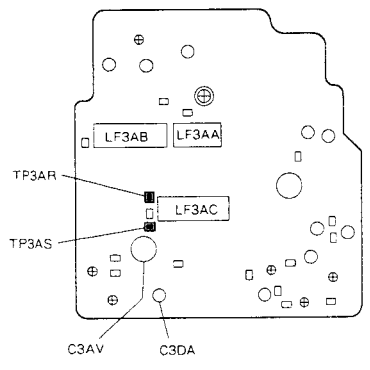

PCB SD/PC

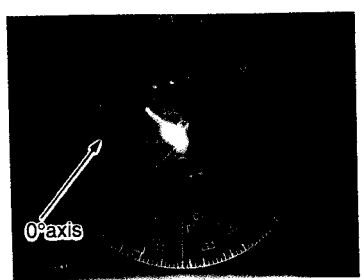
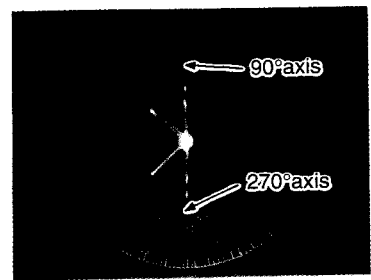

- Ground TP3AR through a capacitor (100 μ F).
- Set DAC address to 16.
- Adjust data of DAC address 16 so that bright spot is on the line 0°.
- Set DAC address to 1B.
- Adjust data of DAC address 1B so that the angle between spots of R-Y and B-Y burst signals is 90°.
- Detach the capacitor in TP3AR.

- Ground TP3AS through a capacitor (100 μ F).
 - Set DAC address to 18.
 - Adjust data of DAC address 18 so that the longest of luminescent lines around 90° -axis is lied on the axis.
 - Set DAC address to 1B.
 - Adjust data of DAC address 1B so that the longest of luminescent lines around 270° -axis is lied on the axis.
 - Detach the capacitor in TP3AS.
 - Repeat items 2 to 7.
 - Set mode of vectorscope to NTSC.
 - Set DAC address to 16.
 - Adjust data of DAC address 16 so that two bright spots of red are overlapped each other.
 - Set DAC address to 14.
 - Adjust data of DAC address 14 so that bright spot of burst signal is at 75%.
- * When there is no NTSC vector scope in the step 16~18, adjust it by the following method. Adjust data of DAC address 16 so that two bright spots of red are line symmetry to 0° -axis.



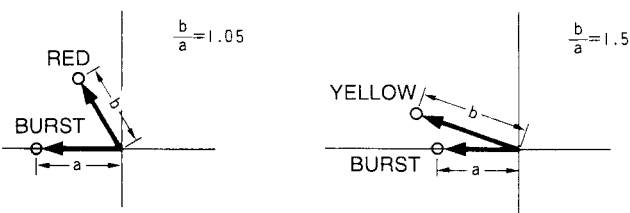

18. Camera APL		Adjustment purpose: Regular level of video signal. Symptom when incorrectly adjusted: Too bright or too dark picture.
Measuring instrument and condition	Oscilloscope (Probe 10:1)	<ol style="list-style-type: none"> Set DAC address to 0A. Adjust data of DAC address 0A so that background level is at 400 ± 5 mVp-p.
Test point	Video output terminal (75 Ω terminated)	
EXT trigger	—	
Measurement range	DIV : 10 mV TIM : 10 μ s	
Chart used	Colour chart	
		

19. Gain of R-Y and B-Y, and Chroma hue		Adjustment purpose: Gain of colour-difference signal and chroma hue of composite signal. Symptom when incorrectly adjusted: Colour signal will not be displayed on the screen regularly.
Measuring instrument and condition	Vectorscope	<ol style="list-style-type: none"> Set mode of white balance to "Indoor" (OPE address : 02). Set DAC address to 04. Adjust data of DAC address 04 so that the distance from the centre of vectorscope to bright spot of red is 1.05 times that of burst. Set DAC address to 05. Adjust data of DAC address 05 so that the distance from the centre of vectorscope to the bright spot of yellow is 1.5 times that of burst.
Test point	Video output terminal	
EXT trigger	—	
Measurement range	GAIN : regular SATURATION : 75 %	
Chart used	Colour chart	
		
<ol style="list-style-type: none"> Set DAC address to 0B. Adjust data of DAC address 0B so that phase of the spot of red is at $106 \pm 2^\circ$. Repeat the adjusting procedures above so that all values are set at the specified. <p>Note : Confirm that the phase of the spot of yellow is at $154 \pm 8^\circ$. If it is not, adjust data of DAC address 08.</p>		

MECHANICAL ADJUSTMENT

1. Jigs and Measuring Instruments Required for Mechanism Adjustment

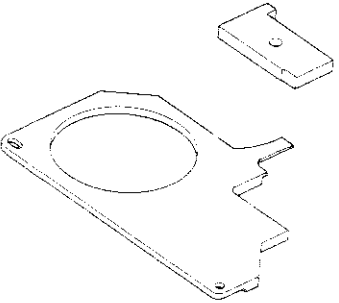
1-1. Jigs for Adjustment

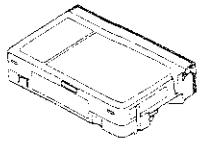
Master plane	Cassette torque meter	Alignment tape
859C398050	859C360010	PM6KE2C [859C397060] PM3KE6 (CH1)C35 [859C399070] PMX- C [859C399050]
		

1-2. Other Tools and Measuring Instruments Required

- ① Colour monitor (Colour TV)
- ② Oscilloscope
- ③ Hex key (1.5mm, 0.7mm)
- ④ Box driver (3.0mm)

1-3. Soldering points of lead wire

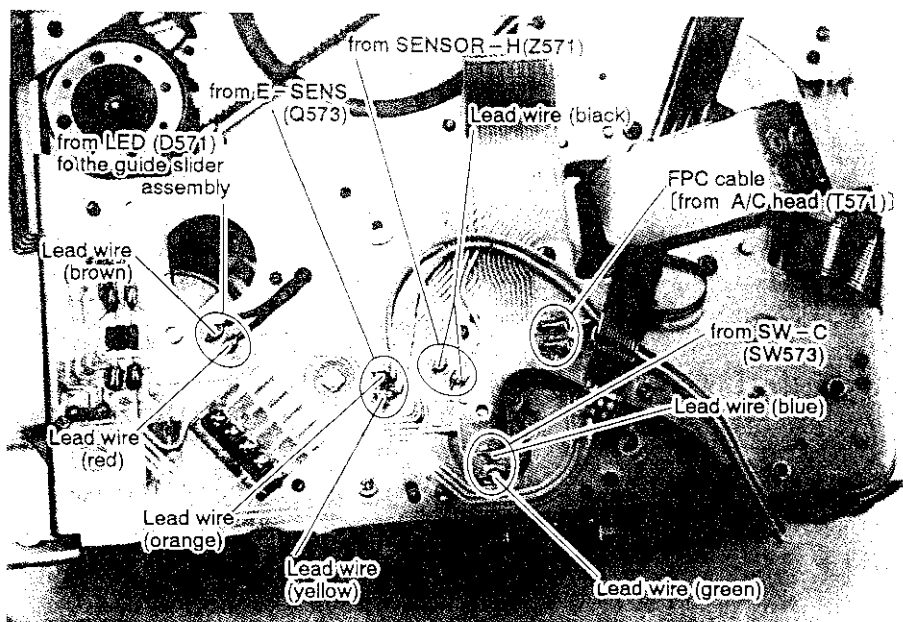

2. CLEANING

The following parts should be routinely cleaned as part of service or to maintain top performance.

2- 1 Cleaning the video heads

- ① Deposits of dust and similar foreign material on the head cause the head to fail to reproduce clear image. Hold a video head cleaning cloth dampened with cleaning solution, lightly against the drum. Holding the cloth, gradually rotate the drum counterclockwise.

Note:

Do not touch the head tips in to the upper drum. The head tip is very hard but not resistant against impact (particularly against force in vertical direction). Never move the head tip in vertical direction.

- ② Do not run a tape before the drum is fully dry. Residual solution may damage the tape.

2- 2 Cleaning the tape path system

The parts along the tape path, which need cleaning are listed below:

1. Regulator tension pole
2. Supply slant pole
3. Supply impedance pole
4. Supply tape guide pole
5. Supply guide roller
6. Drum assembly
7. Takeup guide roller
8. Takeup tape guide pole
9. Takeup slant pole
10. Takeup guide arm roller
11. A/C head
12. GR-lever roller
13. Capstan motor shaft
14. Pinch roller

Note:

Use a dry cleaning cloth to clean the supply guide roller and takeup guide roller. Do not use cleaning solution.

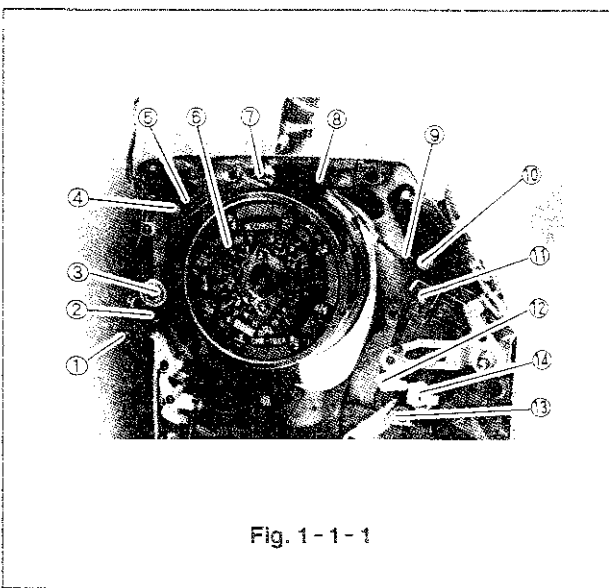

2- 3 Cleaning the reel disk driving system

- ① Clean the surface of the brake of the reel disk.
- ② Clean the reel disk drive member with a cleaning cloth dampened with cleaning solution.
- ③ Do not operate the mechanism before cleaned parts are dry.

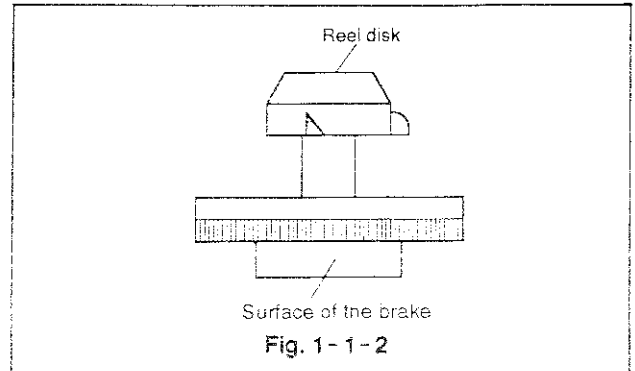

3. HOW TO ATTACH THE MASTER PLANE

- ① Remove the cassette housing (see para. 4-1, HOW TO REPLACE THE PRINCIPAL PARTS)
- ② Feed the loading motor with approx. 3.5 VDC and put the deck to loading condition.
- ③ Place the master plane on the main plate so that the positioning pin enters the positioning hole and the plane is off the drum.

Note:

When using the master plane, firmly hold it by pressing at the point A as shown in Fig. 2-1.

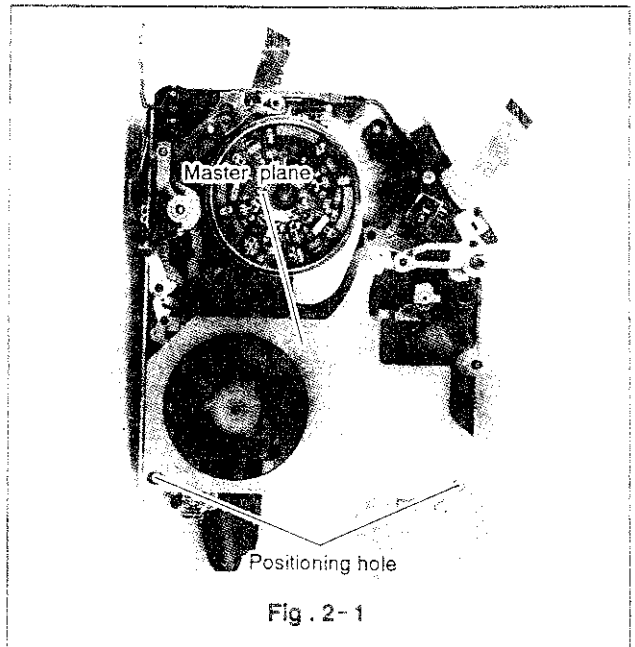

4. HOW TO REPLACE THE PRINCIPAL PARTS

4-1 Cassette housing replacement

Removal

- ① Set the cassette housing to eject mode.
- ② Remove two screws (a, b) holding the leaf switch.
- ③ Remove two screws (c, d) holding the cassette housing.
- ④ Slide the cassette housing toward you. Push the link on supply side and takeup side (Fig. 3-1-3 and 3-1-4) slightly to make clearance for the roller ; and remove the rollers from the grooves in the main plate. Remove the cassette housing.

Installation

- ① Set the cassette housing to eject mode.
- ② Push the link on supply side and takeup side (Figs. 3-1-3 and 3-1-4) slightly to make clearance for the roller; and insert the rollers into the grooves. Make sure that the sync shaft is under the fixing part of the leaf switch (see Fig. 3-1-6).
- ③ Referring to Fig. 3-1-5, engage the projection of the sync holder of cassette housing with the cutaway groove in the main plate.
- ④ Secure the cassette housing with screws c and d.
- ⑤ Secure the leaf switch with screws a and b.



Fig. 3-1-1

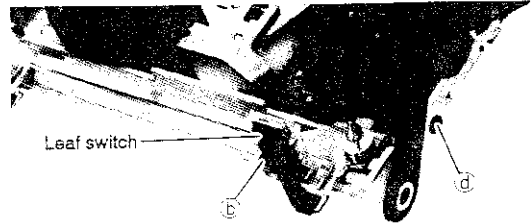

Fig. 3-1-2

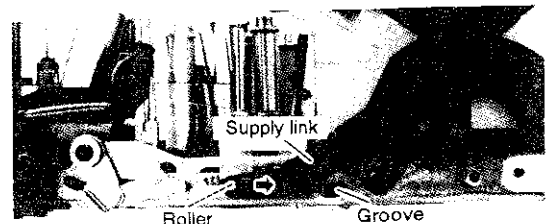

Fig. 3-1-3

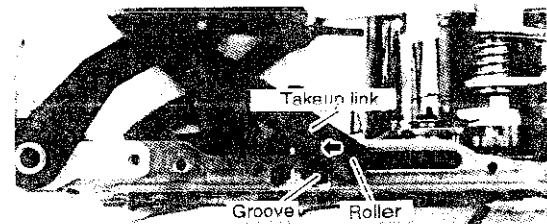

Fig. 3-1-4

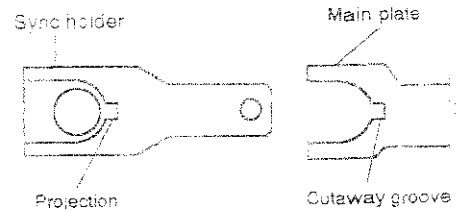

Fig. 3-1-5

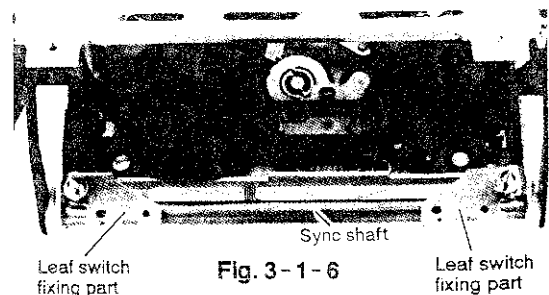

Fig. 3-1-6

4-2 Damper unit replacement

Removal

- ① Remove screws ① and ②. Remove the damper unit (damper section) by moving it in the direction of arrow.

Note:

Gears in the damper unit may fall away. Be careful not lose them.

- ② Remove the cassette housing (see para. 4-1).
- ③ Remove cut washers ③ and ④. Remove the link of supply side and takeup side from the bottom housing shaft.
- ④ Slide the supply arm to the rear end. While pushing the supply arm toward side, take out the bottom housing and damper unit (lever section) off respective groove.
- ⑤ Remove the cut washer ⑤ and then remove the damper unit (lever section).

Installation

- ① Attach the cut washer ⑤ and secure the damper unit (lever section).
- ② Put the roller of supply arm into the groove in the damper unit (lever section) and in the bottom housing.
- ③ Slide the link of the supply side and takeup side onto respective pins of the bottom housing, attach cut washers ③ and ④ and secure supply side link and takeup side link.
- ④ Lower the damper unit (lever section) ① and ② secure it with screws ① and ②.

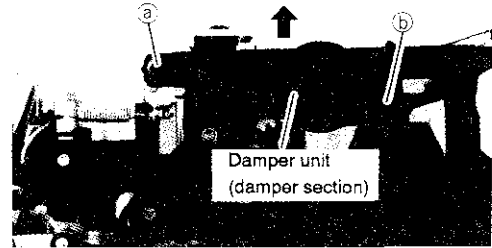

Fig. 3-2-1

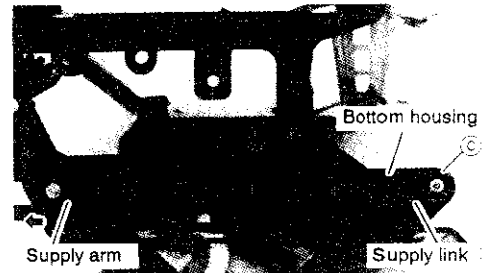

Fig. 3-2-2

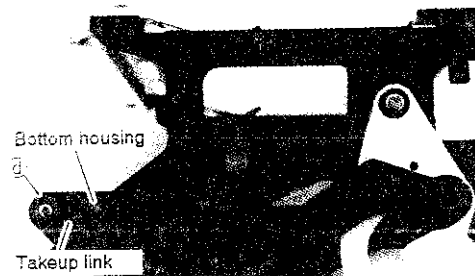

Fig. 3-2-3

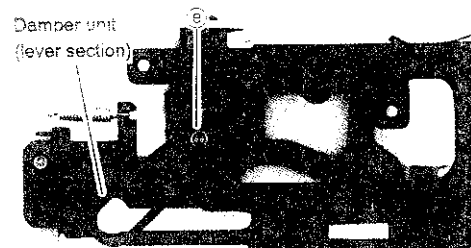

Fig. 3-2-4

4-3 Drum assembly replacement

Removal

- ① While supporting the drum assembly, remove screws ②, ③ and ④ that hold the assembly.
- ② Gradually lift up the drum assembly, take care to clear adjacent components.

Installation

- ① Insert two FPC cables from the drum assembly into the respective grooves in the main plate.
- ② Place the drum assembly on the main plate while taking care not to touch adjacent components. Align the positioning pin of the assembly with the positioning hole in the main plate.
- ③ Secure the drum assembly with screws ②, ③ and ④.

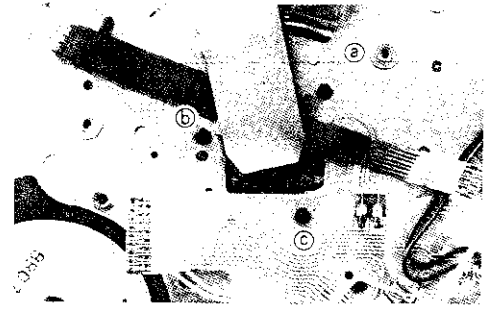

Fig. 3-3-1

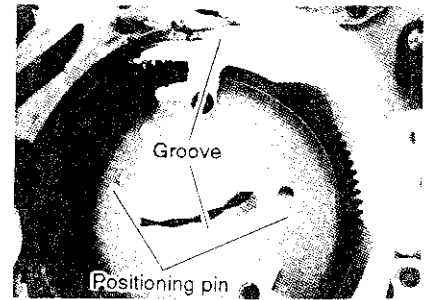

Fig. 3-3-2

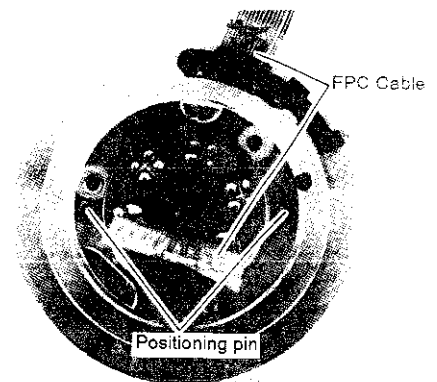

Fig. 3-3-3

4-4 Loading motor replacement

Removal

- ① Remove screws ② and ③ and then remove the loading motor.

Installation

- ① Verify that the motor holder is placed on the loading motor mounting area of the main plate.
- ② Engage the loading motor gear and idler gear S. Secure the motor with screws ② and ③.

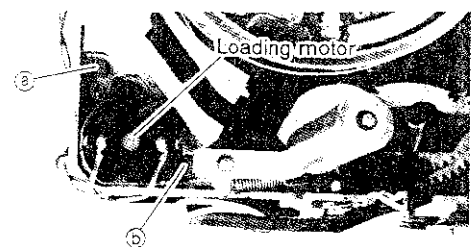

Fig. 3-4-1

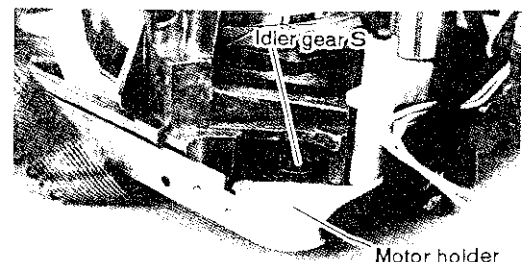

Fig. 3-4-2

4-5 Reel disk replacement

Removal

- ① Remove the cassette housing (see para. 4-1).
- ② Remove cut washer ③. Remove the reel disk from the shaft of the main plate.

Installation

- ① Make sure that two thrust washers are on the reel disk mounting shaft on the main plate.
- ② Gradually place the reel disk to the shaft of the main plate. Make sure that the tension belt is attached along the brake surface of the supply reel disk.
- ③ Attach the cut washer ③ and secure the reel disk.
- ④ Make sure that the reel disk turns smoothly.
- ⑤ Attach the master plane (see para. 3).
- ⑥ Place a height adjusting square on the master plane.
- ⑦ Slide the height measuring face of the square to the edge of the reel disk, and make sure that the reel disk turns smoothly at the face A of the square (upper face of measuring part) and will not turn at face B (lower surface of measuring Block).
- ⑧ If the result of step (7) is not acceptable, add or remove thrust washer(s) (material code: 552C006O10) under the reel disk.
- ⑨ Mount the cassette housing.

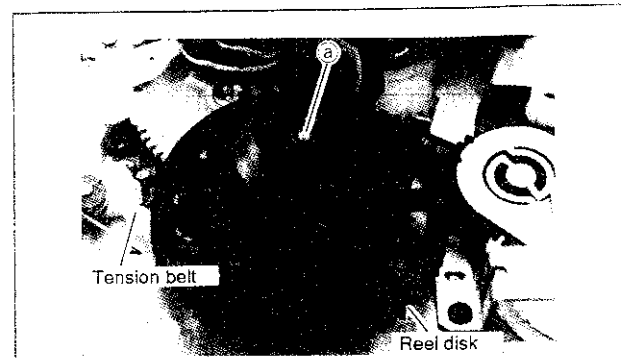

Fig. 3-5-1

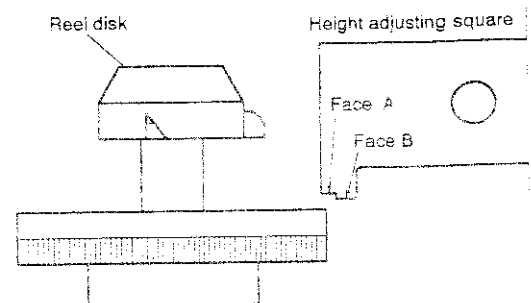
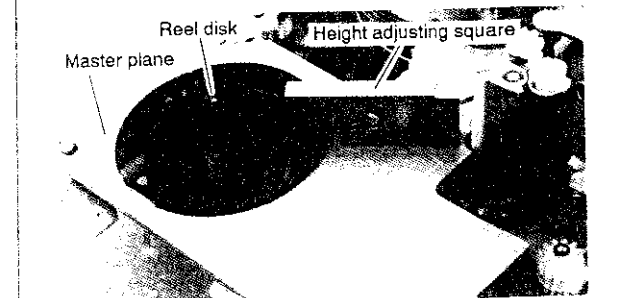

Fig. 3-5-2

4-6 Reel gear replacement

Removal

- ① Remove the cassette housing (see para. 4-1).
- ② Remove the cut washer ③ and then remove the gear TU1 from the main plate shaft.
- ③ Remove the cut washer ④ holding the reel gear.
- ④ Slightly move the clutch plate OFF in the direction of arrow and remove the reel gear from the main plate shaft.

Installation

- ① Make sure that the thrust washers are on the reel gear mounting shaft.
- ② Slightly move the clutch plate OFF in the direction of arrow and place the reel gear to the main plate shaft.
- ③ Secure the reel with the cut washer ④.
- ④ Make sure that the thrust washer is attached on the gear TU1 mounting shaft.
- ⑤ Place the gear TU1 to the mounting shaft on the main plate and secure the gear with the cut washer ③.
- ⑥ Mount the cassette housing.

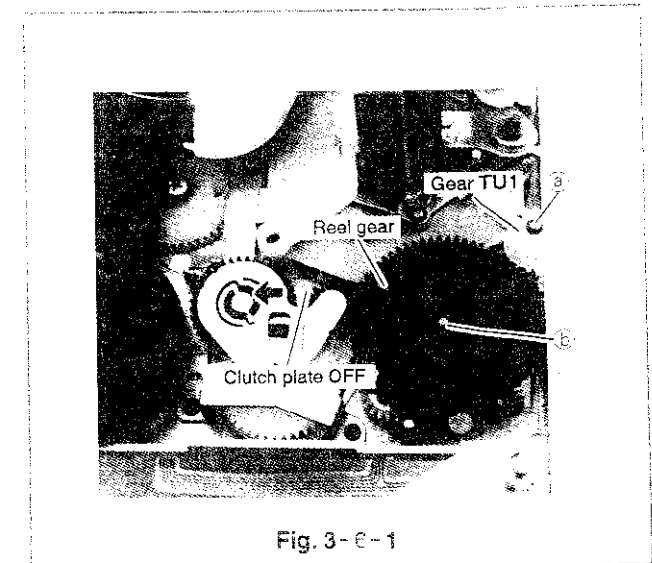

Fig. 3-6-1

4-7 Sync belt replacement

Removal

- ① Remove the cassette housing (see para. 4-1).
- ② Remove screws (a) and (b) that holding the idler unit.
- ③ Remove the sync belt from the capstan motor and idler unit.

Installation

- ① Attach the sync belt to the capstan motor and idler unit.
- ② Secure the idler unit with screws (a) and (b).
- ③ Mount the cassette housing.

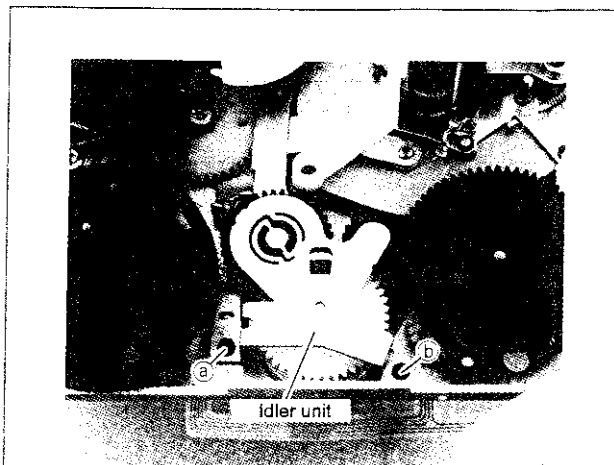

Fig. 3-7-1

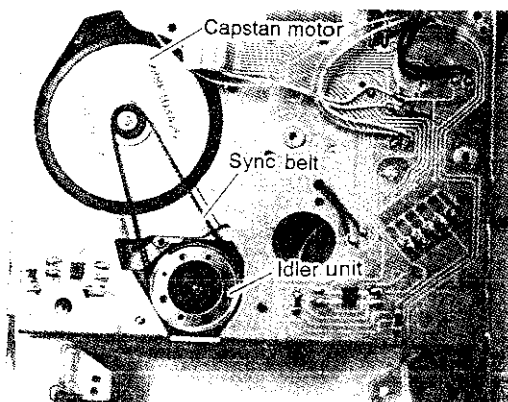

Fig. 3-7-2

4-8 Clutch unit replacement

Removal

- ① Remove the cassette housing (see para. 4-1).
- ② Remove all the parts described in para. 4-6 (Reel gear replacement).
- ③ Remove spring RS.
- ④ Remove the cut washer (a) and then remove the clutch unit from the main plate shaft and clutch plate OFF shaft.

Installation

- ① Attach the clutch unit to the main plate shaft and clutch plate OFF shaft.
- ② Secure the clutch unit with the cut washer (a).
- ③ Attach the spring RS.
- ④ Mount all the parts described in para. 4-6 (Reel gear replacement).
- ⑤ Mount the cassette housing.

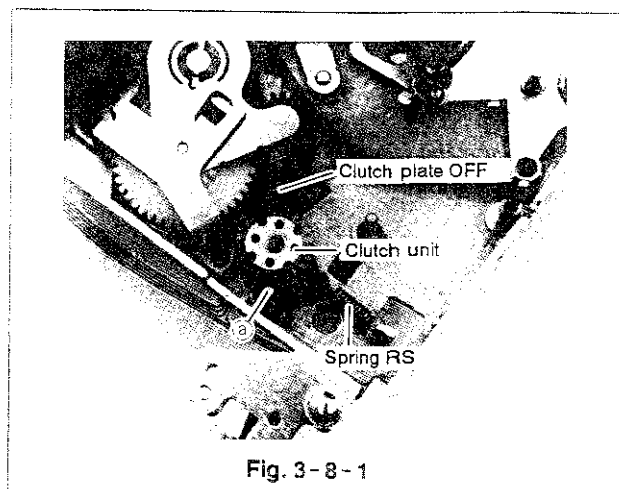

Fig. 3-8-1

4-9 A/C head replacement

Removal

- ① Remove the cassette housing (see para. 4-1).
- ② FPC cable connected to the A/C head is taped on the reverse side of the main plate with pressure sensitive adhesive double coated tape (see Fig. 3-9-1). Melt soldering of the FPC cable soldered on the FPC sensor assembly. Detach it from the tape carefully and take it off the slant T.

- ③ Remove nut S.
- ④ Pull the A/C head assembly gradually off the shaft on the capstan motor stator.

Note:

Removing the A/C head also loosens the A/C washer and spring G on the shaft. Take care not to lose them.

- ⑤ Pull the GR-lever roller and A/C arm spring off the A/C plate as shown in Fig. 3-9-3.
- ⑥ Remove screws ②, ⑤ and ③. Remove the A/C head and A/C plate spring from the A/C plate.
- ⑦ Desolder the lead wires at the A/C head.

Installation

- ① Solder the lead wires to the A/C head.
- ② Mount the A/C plate spring and A/C head on the A/C plate. Secure these parts with screws ②, ⑤ and ③ to the dimension shown in Fig. 3-9-4.
- ③ Place the A/C arm spring and GR-lever to the A/C plate shaft. For mounting status of the A/C arm spring, see Fig. 3-9-2.
- ④ Attach the A/C head assembly to the shaft of the capstan motor stator. To do so, move the GR-lever roller in the direction of arrow in Fig. 3-9-2. Orient the assembly so that the GR-lever tip R ④ is inside the main plate and the A/C head phase adjuster screw B ⑤ of the A/C plate is outside the main plate.
- ⑤ Tighten the nut S (temporary).
- ⑥ Install the master plane (see para. 3).
- ⑦ Place the height adjusting square on the master plane.
- ⑧ Adjust nut S so that the centre of the distance between measuring faces A and B of the square is at the same level as the edge of the lower flange of GR-lever roller. This is a critical adjustment since the distance between the A and B faces is small.

Note:

Check the adjustment by turning the GR-lever roller. It should rotate smoothly without touching the arm pinch.

- ⑨ Put the FPC cable connected to the A/C head through slant T. Tape it on the reverse of the Main plate with pressure sensitive adhesive double coated tape (see Fig. 3-9-1). Solder it on the FPC sensor assembly.
- ⑩ Mount the cassette housing.
- ⑪ Following the description in para. 5-5, A/C head adjustment.

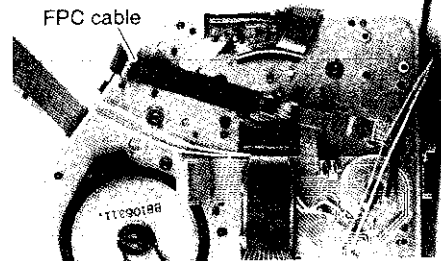

Fig. 3-9-1

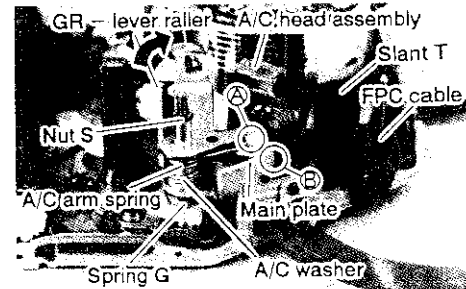

Fig. 3-9-2

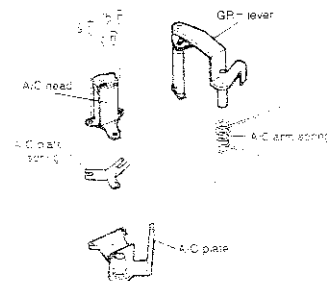

Fig. 3-9-3



Fig. 3-9-4

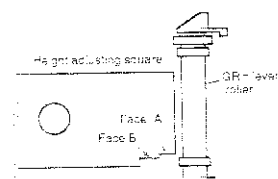
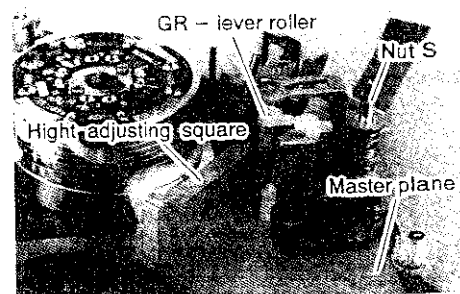

Fig. 3-9-5

4- 10 Pinch roller assembly and Pinch roller replacement

4- 10-1 Pinch roller assembly replacement

Removal

- ① Remove the cassette housing (see para. 4- 1).
- ② Remove the A/C head assembly (see para. 4- 9).
- ③ Pull out A/C washer and spring G off the A/C head mounting shaft.
- ④ Remove the cam gear TUG from the A/C head assembly mounting shaft.
- ⑤ Remove the pinch roller arm spring.
- ⑥ Remove screw ② and then pinch roller washer.
- ⑦ Remove the pinch roller assembly from the shaft on the capstan motor stator.

Installation

- ① Mount the pinch roller assembly on the shaft on the capstan motor stator. Be sure to position the pin at lower part of the pinch roller assembly to the part of the takeup guide arm shown in Fig.3-10-2.
- ② Attach the pinch roller washer to the pinch roller assembly. Secure the pinch roller with the screw ②.
- ③ The cam gear TUG has two positioning pins at the lower part. Attach the cam gear TUG to the takeup guide arm by first aligning the positioning pins with the positioning holes (Fig. 3- 10- 2) in the takeup guide.
- ④ Attach the spring G and A/C washer to the A/C head assembly mounting shaft.
- ⑤ Mount the A/C head assembly.
- ⑥ Mount the cassette housing.

4- 10-2 Pinch roller replacement

Removal

- ① Remove the cassette housing (see para. 4- 1).
- ② Set the deck to loaded status. Release the load just before the pinch roller touches the capstan motor shaft (see Fig. 3-10-3).
- ③ Move the GR-lever roller in the arrow - shown in Fig. 3-10-3, and then gradually remove the pinch roller cap.
- ④ Slide the pinch roller off the pinch roller arm shaft.

Installation

- ① Move the GR-lever roller in the direction of arrow.
- ② Make sure that the cam L-GR is attached on the pinch roller arm. Attach the pinch roller to the pinch roller arm shaft with orientation as shown in Fig. 3-10-4.
- ③ Attach the pinch roller cap to the pinch roller arm shaft with the orientation as shown in Fig. 3-10-4.

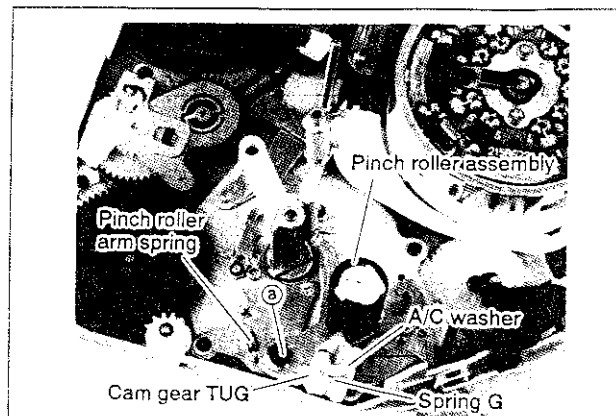

Fig. 3-10-1

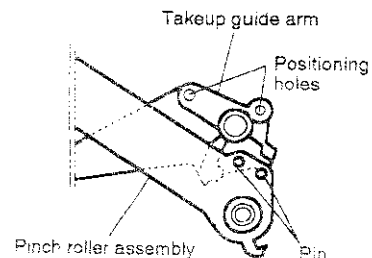

Fig. 3-10-2

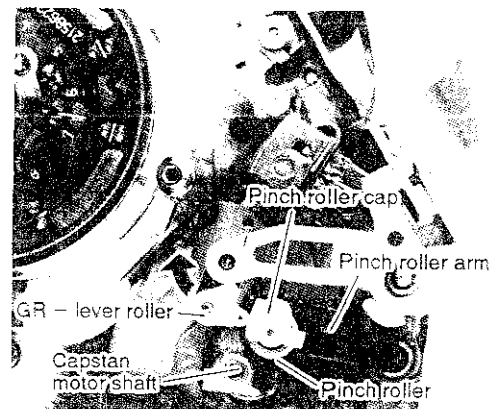

Fig. 3-10-3

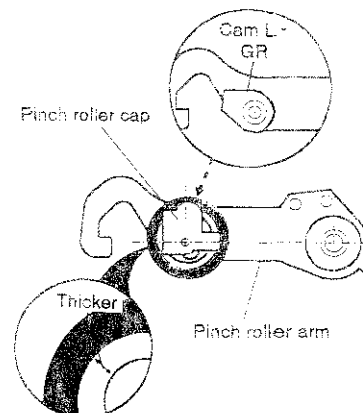

Fig. 3-10-4

4-11 Slant T replacement

Removal

- ① FPC cable connected to the A/C head is taped on the reverse of the main plate with pressure sensitive adhesive double coated tape (see Fig. 3-11-1). Detach it from the tape carefully and take it off the slant T.
- ② Remove screws ③ and ④, and then slant T.

Installation

- ① Make sure that the lock arm spring and lock lever T-B are mounted as shown in Fig. 3-11-3.
- ② Attach the slant T to the main plate shaft.
- ③ Secure the slant T with screws ③ and ④.
- ④ Put the FPC cable connected to the A/C head through slant T. Tape it on the reverse of the main plate with pressure sensitive adhesive double coated tape.

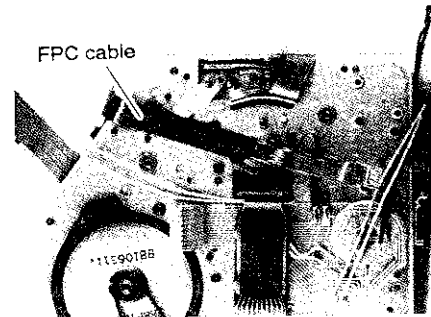

Fig. 3-11-1

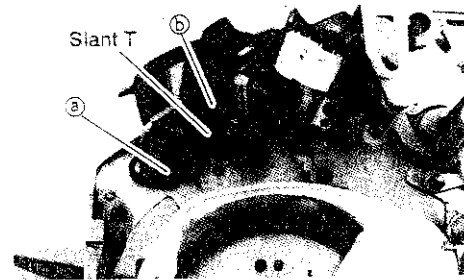

Fig. 3-11-2

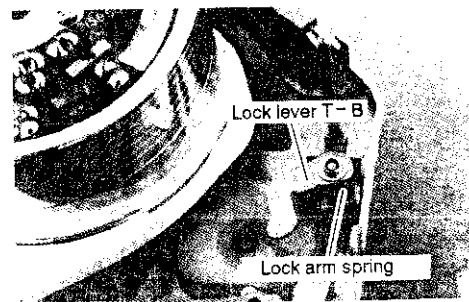

Fig. 3-11-3

4-12 Takeup guide arm replacement

Removal

- ① Remove the cassette housing (see para. 4-1).
- ② Remove the A/C head assembly (see para.4-9).
- ③ Remove all the components described in para. 4-10-1 (Pinch roller assembly replacement).
- ④ Remove all the components described in para. 4-11 (Slant T replacement).
- ⑤ Remove the takeup guide arm from the stator shaft of the capstan motor and pin of the cam lever T.

Installation

- ① Attach the takeup guide arm to the stator shaft of the capstan motor so that the positioning pin of the cam lever T fits into the positioning hole in the link rod.
- ② Attach all the components described in para. 4-11 (Slant T replacement).
- ③ Attach all the components described in para.4-10-1 (Pinch roller assembly replacement).
- ④ Mount the A/C head assembly.
- ⑤ Mount the cassette housing.

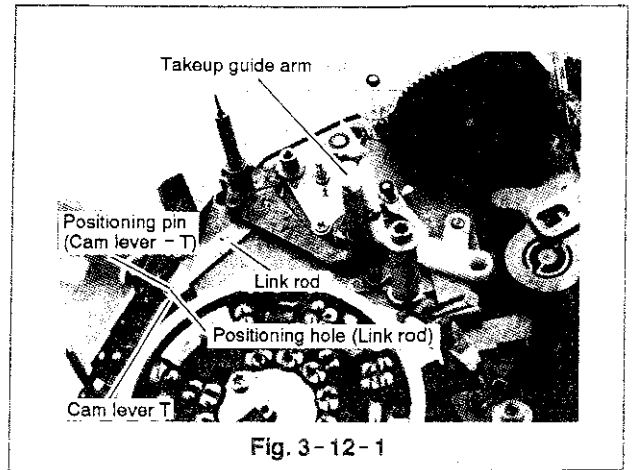

4-13 Supply impedance roller replacement

Removal

- ① Remove the screw ③ and then the tape end sensor.
- ② Remove the impedance spring.
- ③ Remove the cut washer ⑤. Pull the supply impedance roller assembly from the main plate shaft.

Installation

- ① Attach the supply impedance roller assembly to the main plate shaft and then secure the assembly with the cut washer ⑤.
- ② Attach the impedance roller spring.
- ③ Secure the tape end sensor assembly with the screw ③.

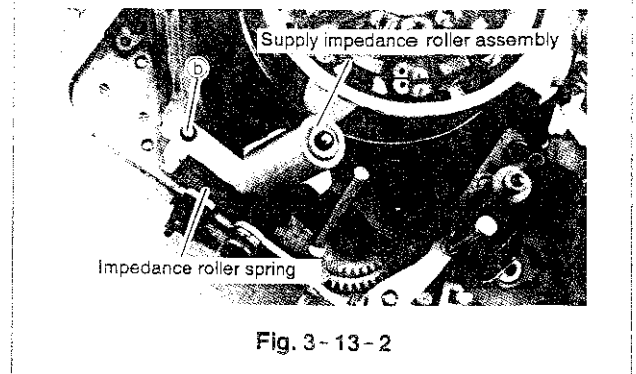
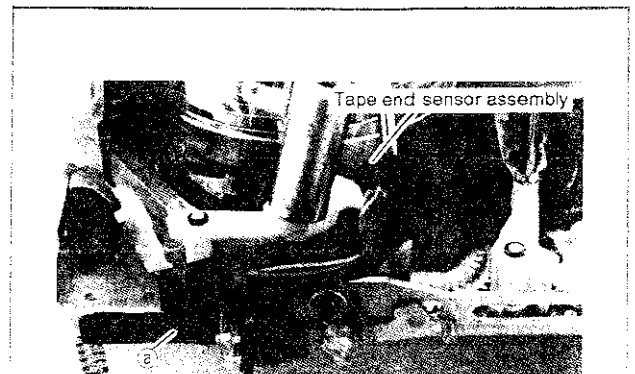

4-14 Capstan motor replacement

Removal

- ① Remove the cassette housing (see para. 4-1).
- ② Remove all the components described in para. 4-6 (Reel gear replacement).
- ③ Remove the A/C head assembly (see para. 4-9).
- ④ Remove all the components described in para. 4-10-1 (Pinch roller assembly replacement).
- ⑤ Remove all the components described in para. 4-11 (Slant T replacement).
- ⑥ Remove the lock lever T-B and lock arm spring.
- ⑦ Remove the takeup guide arm (see para. 4-12).
- ⑧ Remove screws ③ and ④ and the tape pilot unit.
- ⑨ Remove washer ⑤ and the sub pinch roller spring.
- ⑩ While slightly lifting up the pinch roller lever B, remove the pin roller links A and B.
- ⑪ Remove the sync belt (see para. 4-7).
- ⑫ Remove screws ⑥, ⑦ and ⑧ and then capstan motor.

Installation

- ① Pass the FPC cable of the capstan motor through the FPC entry hole in the main plate (Fig. 3-14-1) and under the pinch roller lever B; and then mount the capstan motor on the main plate.
- ② Secure the capstan motor with screws ⑥, ⑦ and ⑧.
- ③ Attach the sync belt.
- ④ While slightly lifting up the pinch roller lever B, insert the pin of the pinch roller link A into the hole of the pinch roller lever B. Mount the pinch roller links A and B.
- ⑤ Referring to Fig. 3-14-2, attach the sub pinch roller spring to the pinch roller link B. Secure the link B with the washer ⑤ shown in Fig. 3-14-1.
- ⑥ Secure the tape pilot unit with screws ③ and ④. Tighten screw ④ first.
- ⑦ Attach the takeup guide arm.
- ⑧ Attach the lock arm spring and lock lever T-B.
- ⑨ Attach all the components described in para. 4-11 (Slant T replacement).
- ⑩ Attach all the components described in para. 4-10-1 (Pinch roller assembly replacement).
- ⑪ Mount the A/C head assembly.
- ⑫ Attach all the components described in para. 4-6 (Reel gear replacement).
- ⑬ Mount the cassette housing.

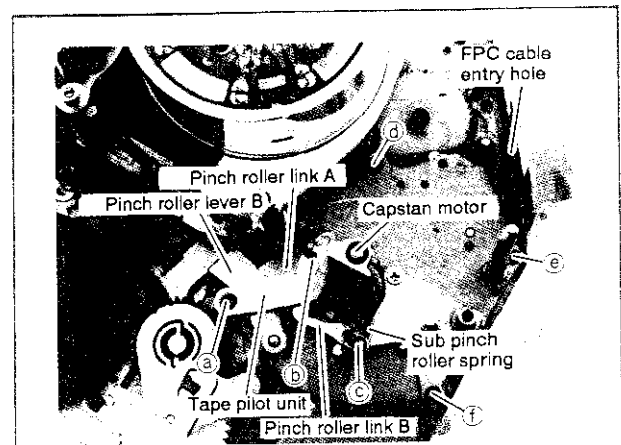

Fig. 3-14-1

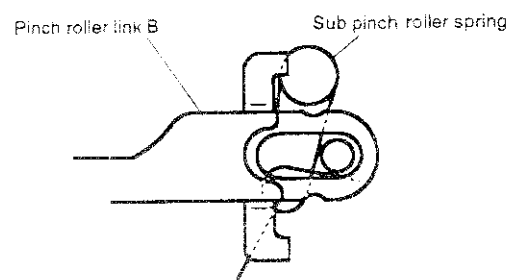

Fig. 3-14-2

4- 15 Supply tape guide assembly and Supply guide roller replacement

4- 15- 1 Supply tape guide assembly replacement

Removal

- ① Remove the cassette housing (see para. 4- 1).
- ② Remove the drum assembly (see para. 4- 3).
- ③ Remove the reel disk (see para. 4- 5).
- ④ Remove the supply impedance roller assembly (see para. 4- 13).
- ⑤ On the FPC sensor board, desolder the two lead wires from the LED of the guide slider assembly.
- ⑥ Remove the cut washer (a) and then regulator tension.
- ⑦ Remove screws (b), (c) and (d), and then guide slider assembly.
- ⑧ Remove the supply tape guide assembly from the supply lever by moving the tape guide in the direction of arrow (Fig. 3- 15- 3).

Installation

- ① Attach the supply tape guide assembly to the supply lever by moving the guide in the direction opposite to arrow in Fig. 3- 15- 3.
- ② Pass the two lead wires from the LED of the guide slider assembly through the hole in the main plate. Secure the guide slider with screws (b), (c) and (d).
- ③ Solder the two lead wires from the LED mounted on the guide slider assembly to the FPC sensor board.
- ④ Secure the regulator tension with the cut washer (a).
- ⑤ Attach the supply impedance roller assembly.
- ⑥ Mount the reel disk.
- ⑦ Mount the drum assembly.
- ⑧ Mount the cassette housing.

4- 15- 2 Supply guide roller replacement

Removal

- ① Remove the cassette housing (see para. 4- 1).
- ② Load the deck to a degree so that the set screw can be turned.
- ③ Loosen the set screw enough for the guide roller to turn easily.
- ④ Turn the supply guide roller counter - clockwise and remove it from the supply tape guide.

Installation

- ① Turn the supply guide roller fully clockwise three times to fix it to the supply tape guide.
- ② Lightly tighten the set screw.
- ③ Mount the cassette housing.
- ④ Following the description in para. 5- 2, check FM envelope and adjust it as necessary.

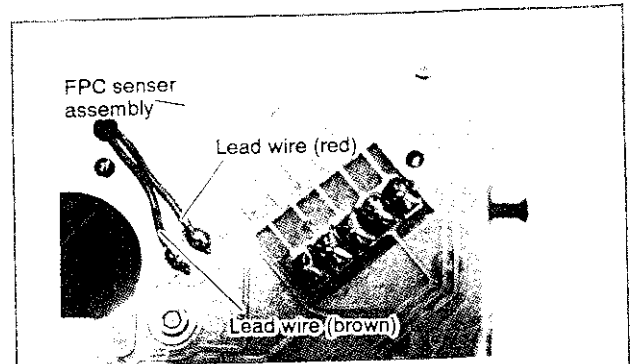

Fig. 3- 15- 1

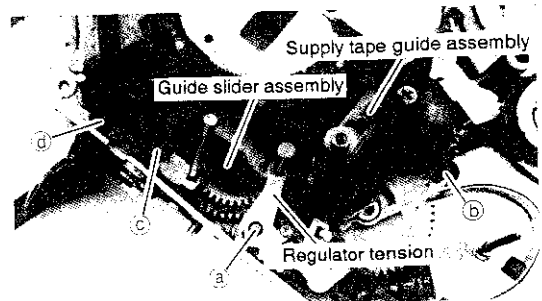

Fig. 3- 15- 2

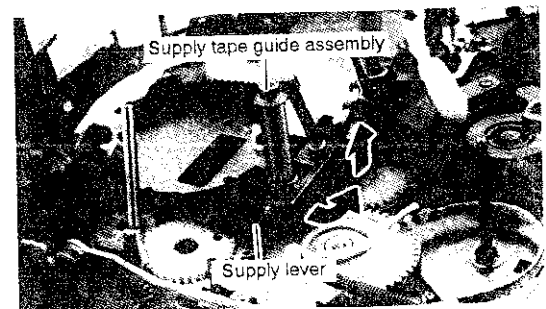

Fig. 3- 15- 3

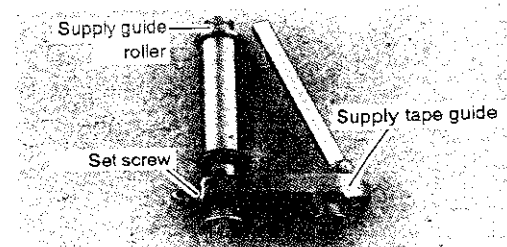

Fig. 3- 15- 4

4-16 Takeup tape guide assembly and Takeup guide roller replacement

4-16-1 Takeup tape guide assembly replacement

Removal

- 1 Remove the cassette housing (see para. 4-1).
- 2 Remove the drum assembly (see para. 4-3).
- 3 Remove screws ③ and ⑤ and then the guide slider T.
- 4 Slide the takeup tape guide assembly in the direction of arrow (Fig. 3-16-1) and remove it from the guide slider T.
- 5 Remove the cut washer ④ and then pull out the takeup tape guide assembly off the takeup arm shaft.

Installation

- 1 Attach the takeup guide assembly to the takeup arm shaft. Secure the takeup tape guide assembly with the cut washer ④.
- 2 Attach the takeup tape guide assembly to the guide slider T by sliding the guide in the direction opposite to the arrow shown in Fig. 3-16-1.
- 3 Attach the junction of guide sliders T and R as shown in Fig. 3-16-1. Secure the guide slider T with screws ③ and ⑤.

4-16-2 Takeup guide roller replacement

Removal

- 1 Remove the cassette housing (see para. 4-1).
- 2 Load the deck to a degree so that the set screw can be turned.
- 3 Loosen the set screw enough to allow the takeup guide roller to turn easily.
- 4 Turn the takeup guide roller counter-clockwise and remove it from the takeup tape guide.

Installation

- 1 Turn the takeup guide roller fully clockwise three times to fix it to the takeup tape guide.
- 2 Lightly tighten the set screw.
- 3 Mount the cassette housing.
- 4 Following the description in para. 5-2, check FM envelope and adjust it as necessary.

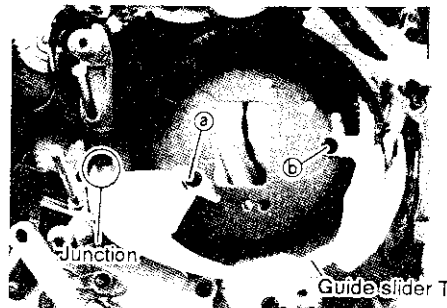

Fig. 3-16-1

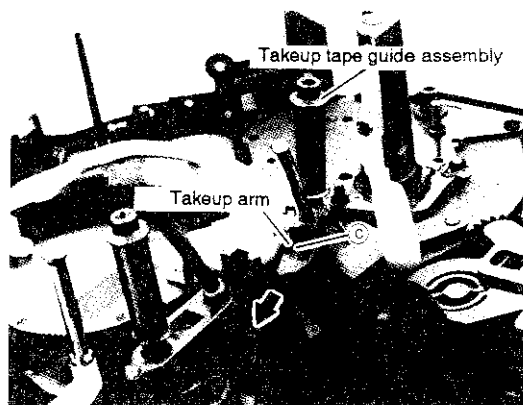

Fig. 3-16-2

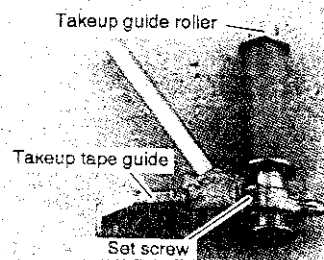

Fig. 3-16-3

4-17 Mode switch replacement

Removal

- ① Remove the cassette housing (see para. 4-1).
- ② Remove the drum assembly (see para. 4-3).
- ③ Remove the reel disk (see para. 4-5).
- ④ Remove the supply impedance roller assembly (see para. 4-14).
- ⑤ Following steps in para. 4-15-1 (Supply tape guide assembly replacement), remove the guide slider assembly.
- ⑥ Remove screws ③ and ④ and then the guide slider R.
- ⑦ Remove the tension spring 1.
- ⑧ Remove the cut washer ⑤ and then the tension spring 2 and tension holder from the main plate shaft.
- ⑨ Remove the cut washer ⑥ and then the regulator arm from the main plate shaft.
- ⑩ Desolder the 5 solder terminals of the mode switch on the FPC sensor board.
- ⑪ Remove screws ⑦ and ⑧, and then the mode switch.

Installation

- ① Make sure that the cam M positioning hole is aligned with the positioning hole in the main plate.
- ② Place the mode switch on the main plate so that the registration mark on the mode switch is aligned with that on the cam M. Secure the mode switch with screws ⑦ and ⑧. Check continuity between the mode switch common terminal (COM) and each of other terminals (P0-P3).

The results should be as follows:

- Between P0 continuity
- Between P1 open
- Between P2 continuity
- Between P3 open

- ③ Solder the 5 solder terminals of the mode switch to the FPC board.
- ④ Fix the regulator arm tension holder and tension spring 2 to the main plate shaft with cut washers ⑤ and ⑥.
- ⑤ Attach the tension spring 1.
- ⑥ Secure the guide slider R with screws ③ and ④.
- ⑦ Mount the guide slider assembly, following the steps in para. 4-15-1 (Supply tape guide assembly replacement).
- ⑧ Mount the supply impedance roller assembly.
- ⑨ Mount the reel disk.
- ⑩ Mount the drum assembly.
- ⑪ Mount the cassette housing.

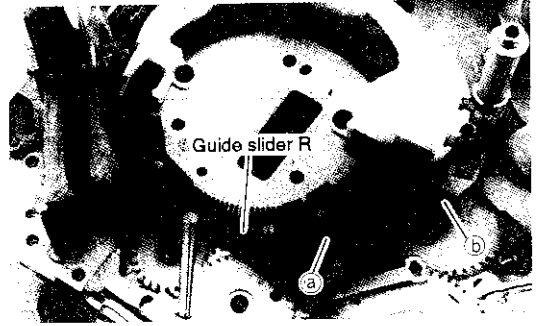

Fig. 3-17-1

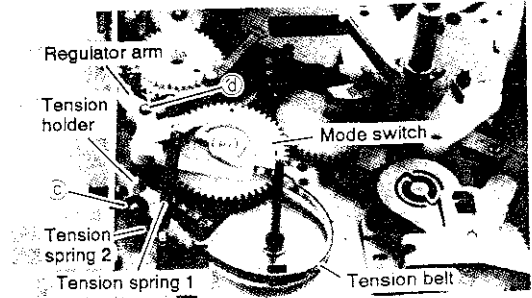

Fig. 3-17-2

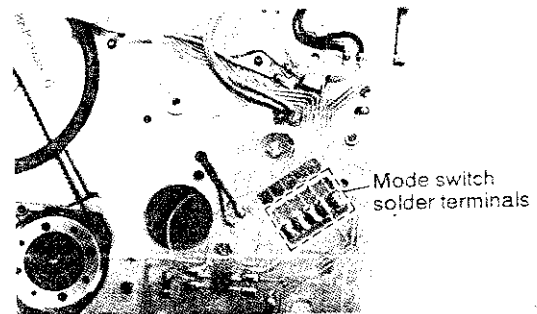

Fig. 3-17-3

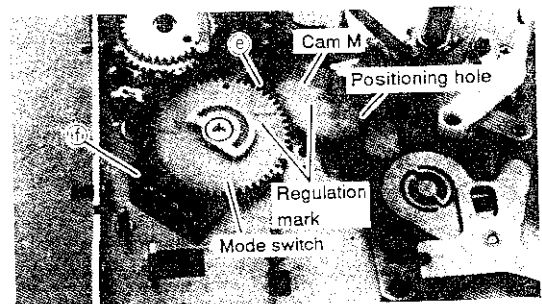

Fig. 3-17-4

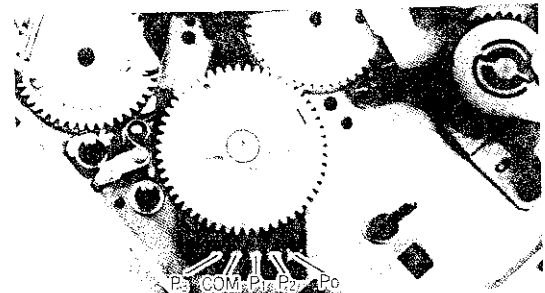

Fig. 3-17-5

4-18 Cam T replacement

Removal

- ① Remove the cassette housing (see para. 4-1).
- ② Remove the drum assembly (see para. 4-3).
- ③ Remove all the components described in para. 4-6 (Reel gear replacement).
- ④ Remove the sync belt (see para. 4-7).
- ⑤ Remove the A/C head assembly (see para. 4-9).
- ⑥ Remove the pinch roller assembly (see para. 4-10-1).
- ⑦ Remove all the components described in para. 4-11 (Slant T replacement).
- ⑧ Remove the takeup guide arm (see para. 4-12).
- ⑨ Remove all the components described in para. 4-14 (Capstan motor replacement).
- ⑩ Remove the spacer and cam lever T.
- ⑪ Remove the screw ⑩ and then cam T.

Installation

- ① Make sure that registration marks and positioning holes of components shown in Fig. 3-18-3 are aligned with corresponding mark and hole of the main plate. Secure the supply cam S and cam S.
- ② Make sure that the lock lever T-A is attached on the main plate shaft.
- ③ Align the positioning holes of lock lever T-A, main plate and cam T. Attach the cam T to the main plate mounting shaft. Make sure that the gears of the cam T and takeup ring unit are meshed with each other.
- ④ Secure the cam T with screw ⑩.
- ⑤ Attach the cam lever T and spacer to the main plate mounting shaft. Make sure that the cam T lower pin is in the groove in the cam T.
- ⑥ Mount all the components described in para. 4-14 (Capstan motor replacement)
- ⑦ Mount the takeup guide arm.
- ⑧ Mount all the components described in para. 4-11 (Slant T replacement).
- ⑨ Attach the pinch roller assembly.
- ⑩ Mount the A/C head.
- ⑪ Attach the sync belt.
- ⑫ Mount all the components described in para. 4-6 (Reel gear replacement).
- ⑬ Mount the drum assembly.
- ⑭ Mount the cassette housing.
- ⑮ Pull out the pin off the positioning hole in the supply cam S and cam S.

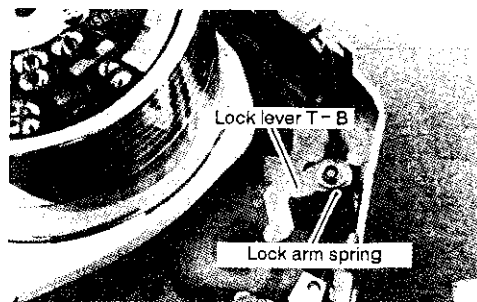

Fig. 3-18-1

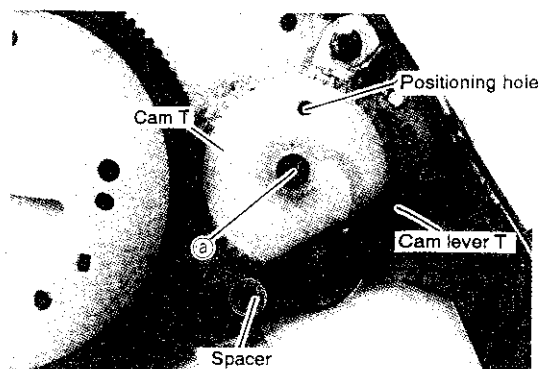

Fig. 3-18-2

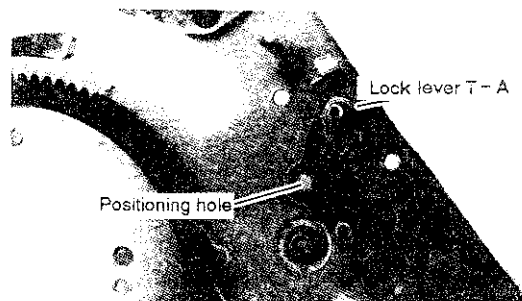

Fig. 3-18-3

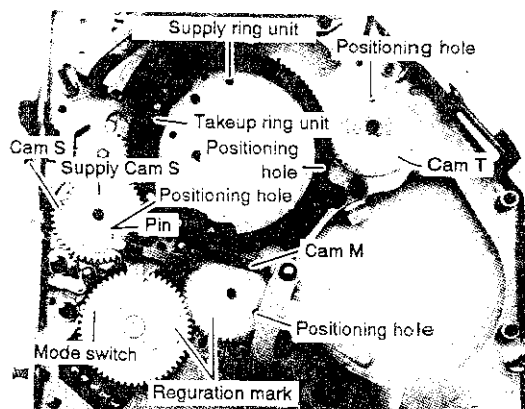

Fig. 3-18-4

4-19 Tape guide stopper assembly replacement

Removal

- ① Remove the cassette housing (see para. 4-1).
- ② Remove the drum assembly (see para. 4-3).
- ③ Remove one screw ① on the lower to dismount the tape guide stopper assembly and two screws ② and ③ on the upper of tape guide stopper assembly.

Installation

- ① Fix the tape guide stopper assembly with two screws ② and ③ on the upper and one screw ① on the lower.
- ② Mount the drum assembly.
- ③ Mount the cassette housing.

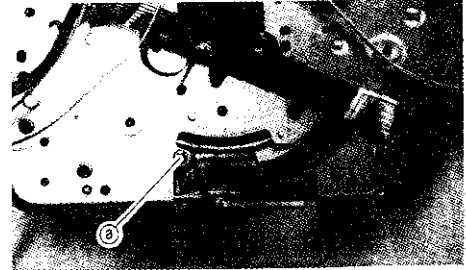

Fig. 3-19-1

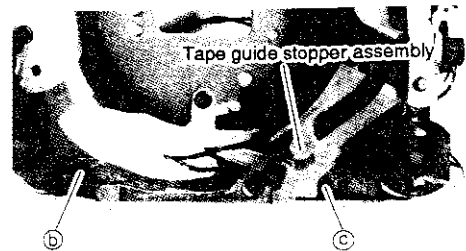

Fig. 3-19-2

5. ADJUSTMENTS

5-1 Back tension and Tension pole adjustment

- ① Set the unit to play mode.
- ② Measure the distance between the regulator tension pole and the internal surface of the main plate: should be 0.7 ± 0.2 mm (Fig. 4-1-1).
- ③ If the measurement is outside the range, adjust the regulator tension pole position adjuster screw for 0.7 ± 0.2 mm.
- ④ Set the back tension meter and set the unit to play mode.
- ⑤ When tape running becomes stable, read the back tension meter.
- ⑥ The reading should be 15 ± 3 g-cm.
- ⑦ If not, replace the tension spring 1 with a new one.
- ⑧ When tape running becomes stable, read the back tension meter, it should not vary 4 g-cm or more.
- ⑨ If the back tension varies more than 4 g-cm, the cause may be eccentric or defective reel disk. Replace with a new one.
- ⑩ After adjustment, record and play and check for no skew distortion and other parameters.

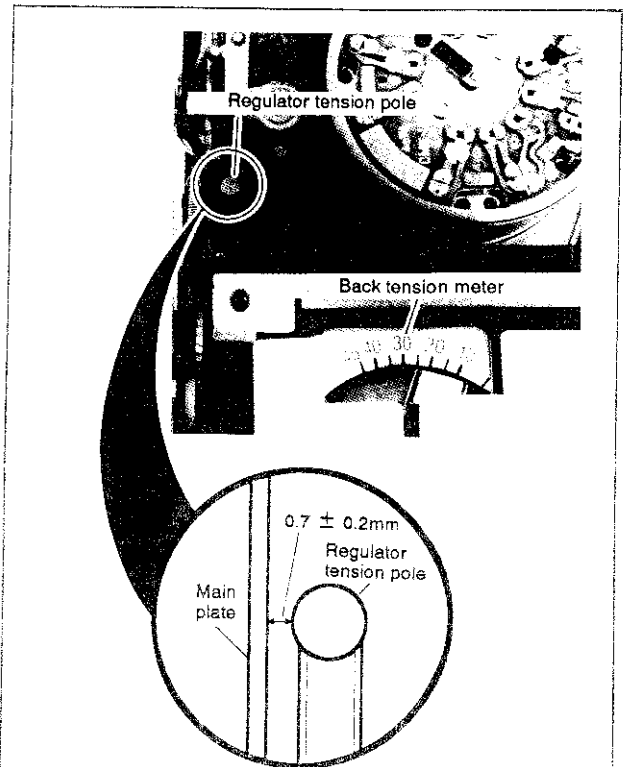

Fig. 4-1-1



Fig. 4-1-2

5-2 FM envelope check and adjustment

5-2-1 Guide roller check

- ① Play back the tape recorded using the recorder being tested.
- ② Visually check the tape at the supply and takeup guide rollers. There should be no gap between the lower face of the upper flange of the guide roller and the upper edge of the tape; and no wrinkle or crease.
- ③ Play an alignment tape (PM6KE2C).
- ④ Connect an oscilloscope to the TP2A. Trigger on the signal on TP5A.
- ⑤ Connect TP5R and TP5S to ground to force the digital tracking to enter preset mode.
- ⑥ Make sure that the both positive and negative peaks of the waveform are flat as shown in A of Fig. 4-2-1.
- ⑦ If the leading portion of FM waveform (supply side of the drum) is not flat (B, C of Fig. 4-2-1), adjust the height of the supply guide roller according to para. 5-2-2. If the period between adjacent FM waveforms is not flat (as waveforms D and E, drum takeup side), adjust the height of the takeup guide roller according to para. 5-2-3.

Note :

Turn the power off, and digital tracking mode will be set.

5-2-2 Supply guide roller height adjustment

- ① Loosen the set screw enough for the supply guide roller to turn easily.
- ② If the leading edge of the FM waveform (at drum supply side) looks like B in the figure, the height of the supply guide roller is low; if looks like C, the roller is high; adjust the height of the guide roller as described below, for obtaining flat waveform (A in the figure).
 - Counterclockwise to raise the roller
 - Clockwise to lower the roller
- ③ After adjustment, go to the phase adjustment (coarse).

5-2-3 Takeup guide roller height adjustment

- ① Loosen the set screw enough for the takeup guide roller to turn easily.
- ② If the period between adjacent FM waveforms (at drum takeup side) looks like D in the figure, the height of the takeup guide roller is low; If looks like E, the roller is high; adjust the height of the guide roller as described below, for obtaining flat waveform (A in the figure).
 - Counterclockwise to raise the roller
 - Clockwise to lower the roller
- ③ After adjustment, go to the phase adjustment (coarse).

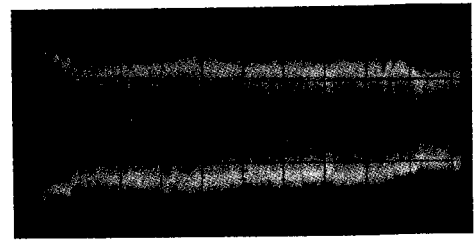

A

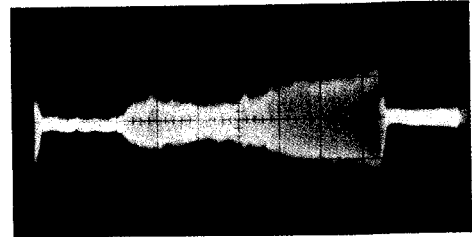

B

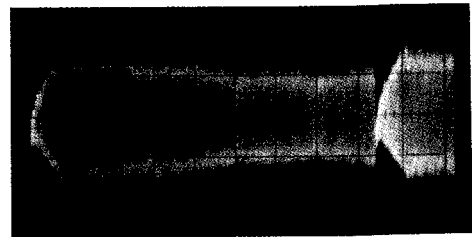

C

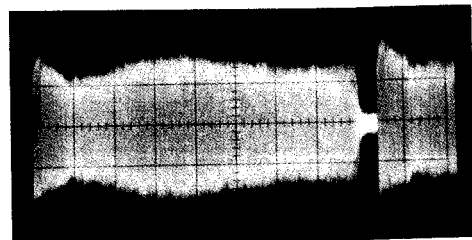

D

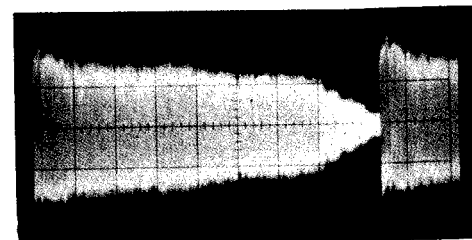

E

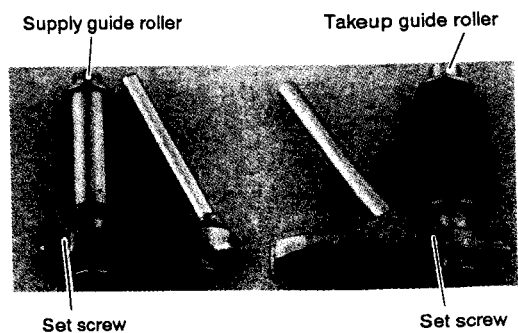

Fig. 4-2-1

5-3 Phase adjustment (coarse)

- ① Play the alignment tape (PMX-C).
- ② Connect the TP5R and TP5S of the PCB VTR to ground to force the digital tracking to enter preset mode.
- ③ Connect TP2A (PCB VTR) to CH-1, and audio output terminal to CH-2 of the oscilloscope. Trigger the scope on the signal from the TP5A (PCB VTR).
- ④ Absence of FM waveform and audio waveform should be almost coincidental (A of Fig.4-3-1).
- ⑤ If the absence of FM waveform and audio waveform is completely out of phase as shown in B or C of the figure, turn the phase adjuster screw clockwise until the FM waveform looks like the waveform in A.
- ⑥ Exchange the alignment tape (PMX-C) for an another one (PM6KE2C).
- ⑦ Fine tune the phase adjuster screw fo maximum FM wave amplitude without changing its phase with respect to that of audio signal.
- ⑧ After adjustment, apply locking material (paint or the like) to the phase adjuster screw.

Note :

Turn the power off, and digital tracking mode will be set.

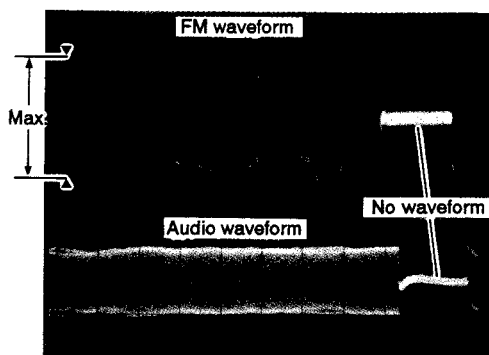

A

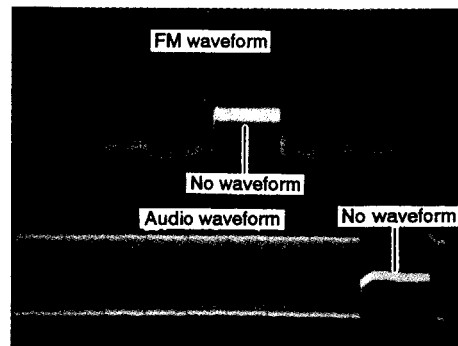

B

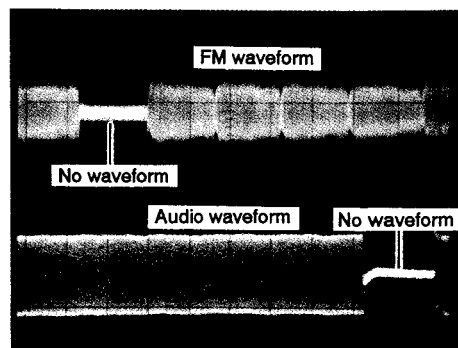

C

Fig. 4-3-1

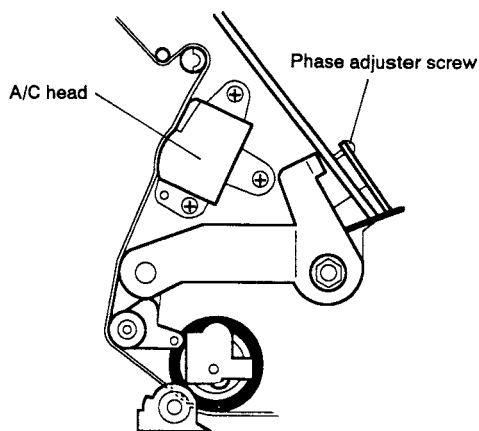

Fig. 4-3-2

5-4 FM waveform flatness check

- ① Play the alignment tape (PM6KE2C).
- ② Connect the oscilloscope to TP2A. Trigger on the TP5A output.
- ③ Connect the TP5R and TP5S of the VTR board to ground to force the digital tracking to enter the preset mode.
- ④ Press PAUSE button. This enters manual digital tracking mode, enabling manual adjustment of tracking.

Note :

Installing manual tracking adjustment Connect a variable resistor (200k Ω) between TP5S and TP5R.

This variable resistor is the manual tracking adjustment.

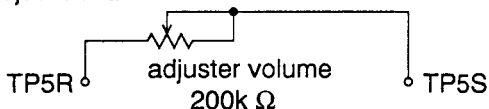

- ⑤ Turn the manual tracking adj., verify that the amplitude of the FM waveform varies while remaining flat.
- ⑥ Set the manual tracking for maximum amplitude. Adjust vertical gain of the oscilloscope so that the waveform amplitude equals 5 divisions on the scope graticule.
- ⑦ Adjust the manual tracking adj. so that the middle portion (Portion "b" in Fig. 4-4-1) of the waveform is 80% the maximum amplitude, i.e. 4 divisions of the scope graticule. Verify that the FM waveform amplitude at drum supply side (portion "a" in the figure) and takeup side (portion "b" in the figure) are at 3.2 divisions of graticule.
- ⑧ If these values are not met, repeat the adjustment steps.

Note :

Turn the power off, and digital tracking mode will be set.

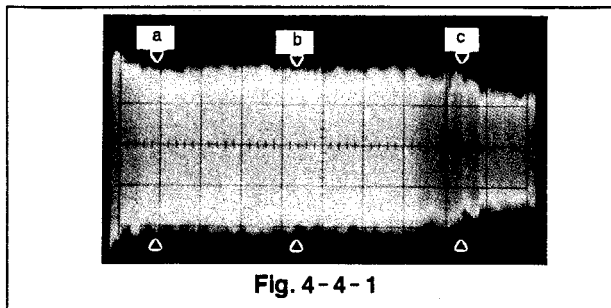

5-5 A/C head adjustment

5-5-1 A/C head height, azimuth and slant adjustment

- ① Play the tape recorded using the recorder being adjusted.
- ② Alternately adjust the A/C head height adjuster screw and azimuth screw (Ⓐ, Ⓑ in Fig. 4-5-1) so that the top edge of the tape comes just below the top of the audio head as shown in Fig. 4-5-2.
- ③ Play the alignment tape (PM6KE2C).

- ④ Connect the oscilloscope to an audio output terminal (CH R or L).
- ⑤ Alternately adjust A/C head height adjuster screw and azimuth adjuster screw (Ⓐ, Ⓑ) so that the audio output is maximum.
- ⑥ Play the tape used in step (1).
- ⑦ Verify that the tape position at the takeup guide arm roller is as shown in Fig. 4-5-4, "A" (lower tape edge is at the level of top face of the lower flange of the roller).
- ⑧ If the tape is positioned as shown in B or C of Fig. 4-5-4, adjust the A/C head slant adjuster screw (Ⓒ in Fig. 4-5-1) to bring the tape to the position shown in A of Fig. 4-5-4.

When it looks like B: turn the screw Ⓒ clockwise.

When it looks like C: turn the screw Ⓒ counterclockwise.

Note :

Because the tape will not quickly respond to height adjustment, turn the screw Ⓒ a little at a time, and then observe the tape for a while; and readjust as necessary.

- ⑨ After adjusting, disengage the tape. Reengage the tape and make sure that the tape comes at the position A of Fig. 4-5-4 in one second.
- ⑩ If the tape fails step ⑨, repeat steps ⑦ to ⑨.

Note :

One cycle of above steps may not bring satisfactory result. These steps may have to be repeated for fine tuning.

- ⑪ When the adjustment is complete, apply screw locking material (paint or the like) to A/C head adjuster screws Ⓐ, Ⓑ and Ⓒ.

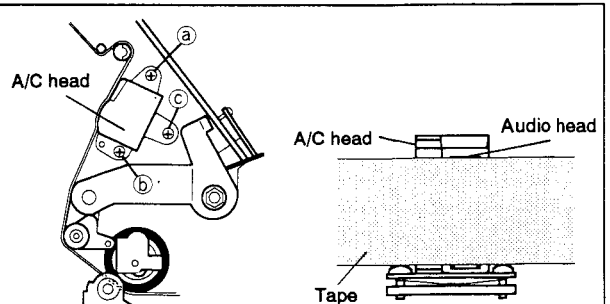

Fig. 4-5-1

Fig. 4-5-2

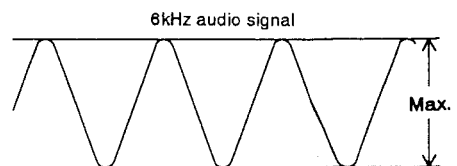

Fig. 4-5-3

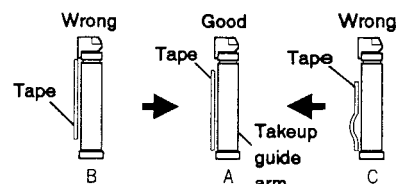

Fig. 4-5-4

5-6 GR-lever roller tape runing adjustment

Note:

This adjustment must follow the GR-lever roller height adjustment.

- ① Play a tape recorded using the recorder being adjusted.
- ② Observe status of the tape passing the GR lever roller against status illustrations in Fig. 4-6-1.
- ③ If the tape status looks like C or D in Fig. 4-6-1, adjust the GR-lever height adjuster nut shown in Fig. 4-6-2 so that the tape condition is A or B in Fig. 4-6-1.

Note:

Do not turn the GR-lever height adjuster nut more than 1/2 turn.

- ④ After adjustment, unload the tape. Load the tape again and set to play mode, and make sure the tape becomes status A or B in one second.
- ⑤ If not, repeat the step ③.

5-7 Phase adjustment (fine)

- ① Connect the oscilloscope to TP2A and trigger on the signal from the TP5A.
- ② Play the alignment tape. [PM3KE6(CH1)C35]
- ③ Connect the TP5R and TP5S of the VTR board to ground to force the digital tracking to enter the preset mode.
- ④ Adjust the phase adjuster screw so that the FM waveform is maximum.
- ⑤ Press PAUSE button. This enters manual digital tracking mode, enabling manual adjustment of tracking.

Note:

Installing manual tracking adjustment Connect a variable resistor (200k Ω) between TP5S and TP5R.

This variable resistor is the manual tracking adjustment.

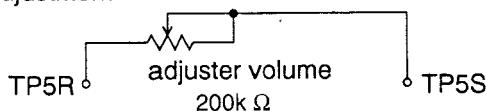

- ⑥ Adjust the manual tracking adj. so that the FM waveform is maximum amplitude. Adjust the vertical gain control of the oscilloscope so that the FM waveform swings across 5 divisions on the graticule.
- ⑦ Press the pause button. The digital tracking is now in preset mode.
- ⑧ Verify that the amplitude is 4.8 divisions or more on the scope graticule.
- ⑨ If the amplitude is lower than this value, clean the drum by following the steps of para. 2-1 (Cleaning the video heads).
- ⑩ Repeatedly load and unload a tape for use with the recorder, verify that the FM waveform won't vary.

Note :

Turn the power off, and digital tracking mode will be set.

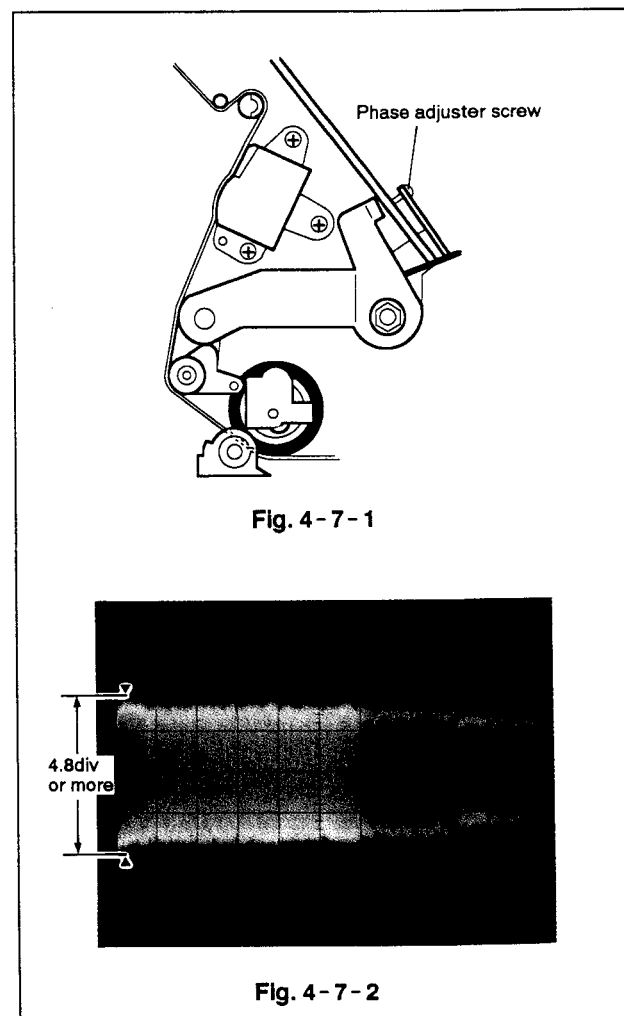
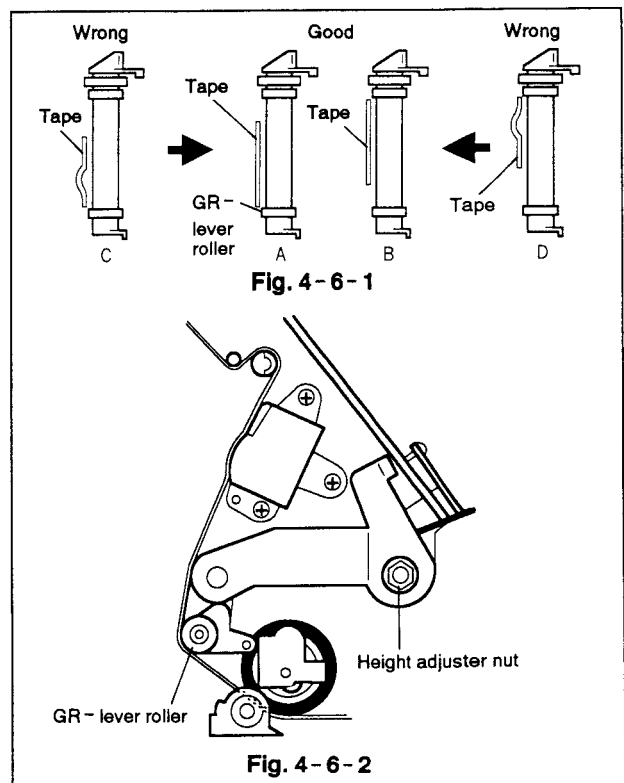

KEY TO ABBREVIATIONS

A/C	: Audio/Control	LIM	: Limiter
ACC	: Automatic Color Control	LPF	: Low-Pass Filter
A.E	: Audio Erase	LM	: Loading Motor
AFC	: Automatic Frequency Control	MDA	: Motor Drive Amplifier
AFT-D	: Automatic Fine Tuning Door Switch	MC	: Mechanical Control
AGC	: Automatic Gain Control	MIC	: Microphone
AL	: After Load	MOD	: Modulator
AMP	: Amplifier	N	: Not Normal
ANT	: Antenna	OPE	: Operation
A-PB	: Audio-Playback	OSC	: Oscillator
A-REC	: Audio-Recording	O-PWV	: ON/OFF Command from Remote Decoder
ALC	: Automatic Level Control	PB	: Play Back
B-FS	: Brake Forward Search	PG	: Pulse Generator
B-RS	: Brake Reverse Search	P/R-SW	: P.B/REC-SW
BPF	: Band-Pass Filter	PCB	: Printed Circuit Board
B/W	: Black and White	PIC	: Picture Control
BS	: Band SW	P/R	: Play/Record
CASS	: Cassette	PSC	: Pulse swallow control
CP	: Capstan	PWT-SET	: Power TV Set
CP-FG	: Capstan-Frequency Generator	PWV	: ON/OFF Command to B+ Switching Circuit
CP-F/R	: Capstan-Forward/Reverse	REC	: Recording
CP-M	: Capstan-Motor	REF	: Reference
CONV	: Converter	RIS	: Record Inhibit Switch
CTL	: Control	REW	: Rewind
C-LAMP	: Cassette Lamp	REG	: Regulator
C-I LAMP	: Cassette Indicator Lamp	RS	: Reverse Search
CE	: Chip Enable	REC-2	: Record Command for the Fine Editing Circuit
CE	: Not Chip Enable	R-FS	: Reel Drive Forward Search
CK	: Clock	R-P/R	: Reel Drive Play/Record
CL	: Clear	S/AL	: Stop After Load
CNT	: Counter	SL	: Slow
CP R-R	: Capstan Reverse Rotation	SLOK	: Slow OK
CS-1	: Cassette Switch 1	S/P	: Still/Pause
CS-2	: Cassette Switch 2	SS	: Start Sensor
DAL	: Delay-After Loading	SRV-REC	: Servo Record
DEMOD	: Demodulator	SS	: Not Speed Search
DET	: Detector	S-STOP	: Stop Command
DL	: Delay Line	STOK	: Still OK
DL-REV	: During Reverse	STW	: Stop Watch
DL-FWD	: During Forward	SENS	: Sensor
DOC	: Drop Out Compensator	STBY	: Stand By
DL-SL	: During Slow	TM	: Take up Motor
DL-SS	: During Not Speed Search	T-REC	: Timer-Record
DOP	: Drop Out Pulse	T.P	: Test Point
EF	: Emitter Follower	TR	: Transistor
EMPHA	: Emphasis	TU-P	: Tuner-Power
EQ	: Equalizer	UL	: Unload
EE	: Electronic-Electronic	VS	: Voltage Synthesizer
ES	: End Sensor	V.SYNC	: Vertical Sync
FE-H	: Full Erase Head	VCO	: Voltage Controlled Oscillator
FF	: Fast Forward	VXO	: Variable Crystal Oscillator
FG	: Frequency Generator	W/D	: White/Dark
FL-SW	: Front Loading SW	X'OSC	: Crystal Oscillator
FLM	: Front Loading Motor	Y/C	: Luminance/Chrominance
F/R-SW	: FF/Rewind Switch		
F/R	: Forward/Reverse		
FS	: Forward Search		
G	: Ground		
HE	: Hall Element		
H-LED	: Humidity-LED		
H-SENS	: Humidity-Sensor		
HPF	: High-Pass Filter		

CHIP PARTS REPLACEMENT

CHIP PARTS REPLACEMENT

Some resistors, shorting jumpers (0Ω resistor), ceramic capacitors, transistors and diodes are chip parts which are used for certain circuit elements. When replacing these parts, note the cautions as follows.

Cautions:

- Use fine tipped, well insulated soldering pencil (iron) about 30 watts and the tweezers.
- Melting the solder, remove the Chip Parts carefully not to tear off the copper foil of the printed circuit board.
- Discard removed chips; do not reuse them.
- Do not apply heat for more than 3 seconds to the new chip Parts.
- Avoid using a rubbing stroke when soldering.
- Take care not to scratch when soldering, or damage the Chip Parts.
- Supplementary cementing is not required.

1 Removal of chip Parts

(Resistors, capacitors, etc.)

- Grasp the part with tweezers. Melting the solder at both side alternately, remove the one side of the part with a twisting motion.
- Melt the solder at the other side and remove the part.

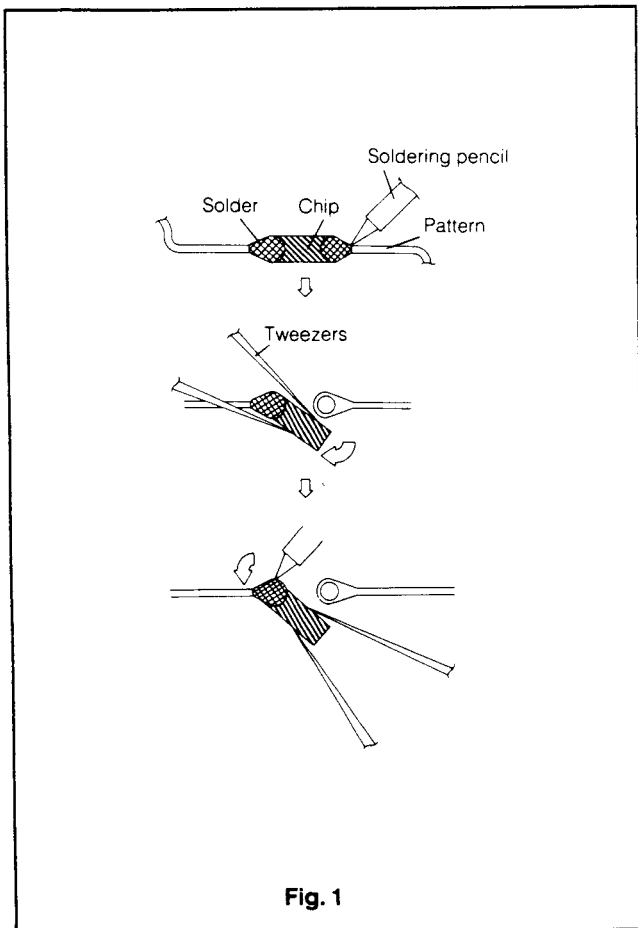

2 Removal of Chip Parts (Transistors)

- Melting the solder of one lead, Lift the side of that lead upward.
- Simultaneously melt the solder of the two remaining leads and lift the part to remove.

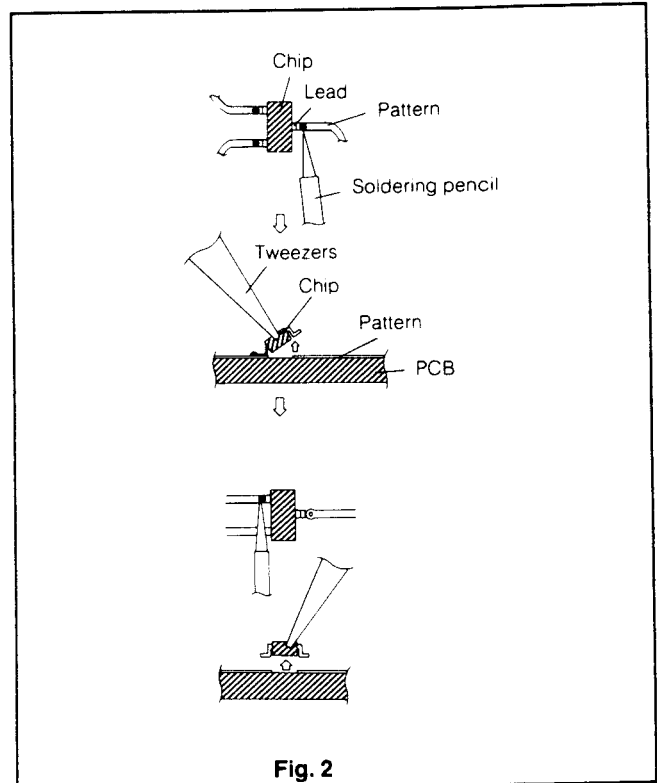

3 Replacement

- Presolder the contact points of the circuit pattern.
- Press the part downward with tweezers and apply the soldering pencil as shown in the figure.

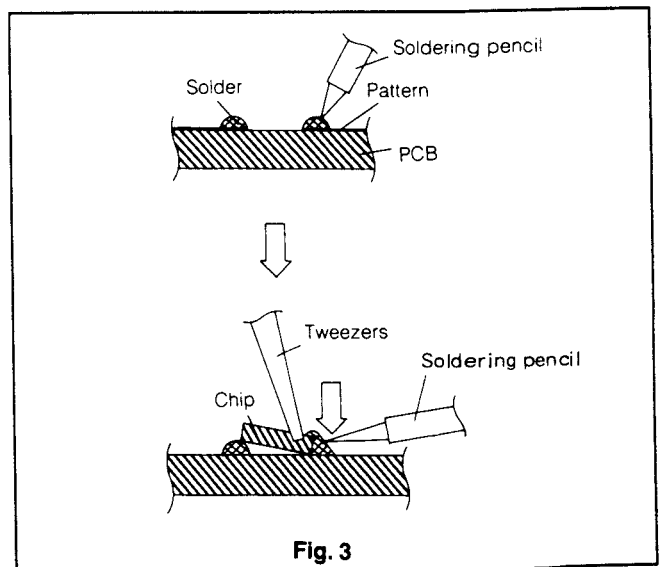

PARTS LIST

1.Outer parts

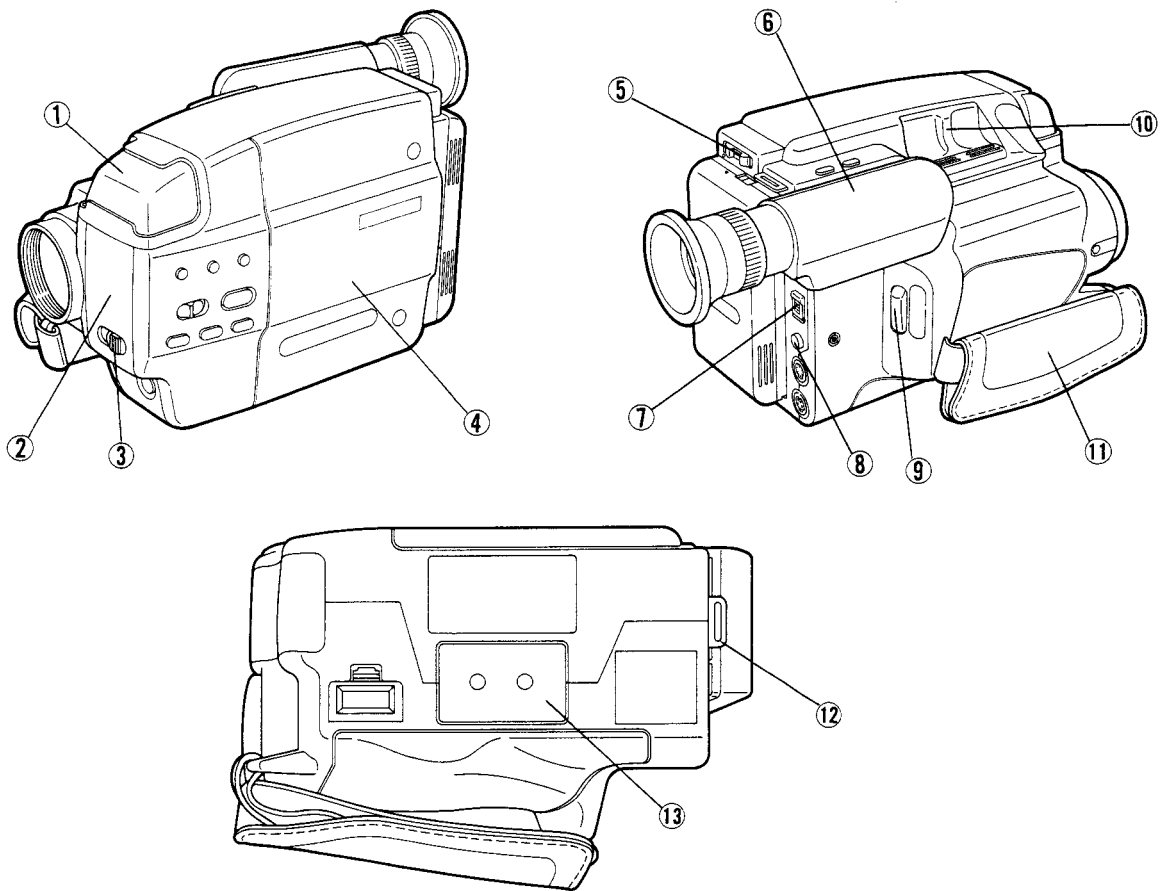

ITEM NO.	PARTS NO.	PARTS NAME	DESCRIPTION
1	485P017010	MICROPHONE UNIT	
2	701B233030	FRONT PANEL UNIT	
3	734D542010	LENS COVER KNOB	
4	702B828090	CASSETTE HOUSING	
5	704C803010	POWER KNOB	
6	939P438030	EVF UNIT	
7	704C804010	EJECT KNOB	
8	704C802010	RELEASE BUTTON	
9	704C800010	TRIGGER BUTTON	
10	439P030010	ZOOM SWITCH	
11	772C016020	GRIP BELT	
12	768D143010	STRAP HOLDER	
13	769C004010	TRIPOD BASE	

2. Cabinet parts

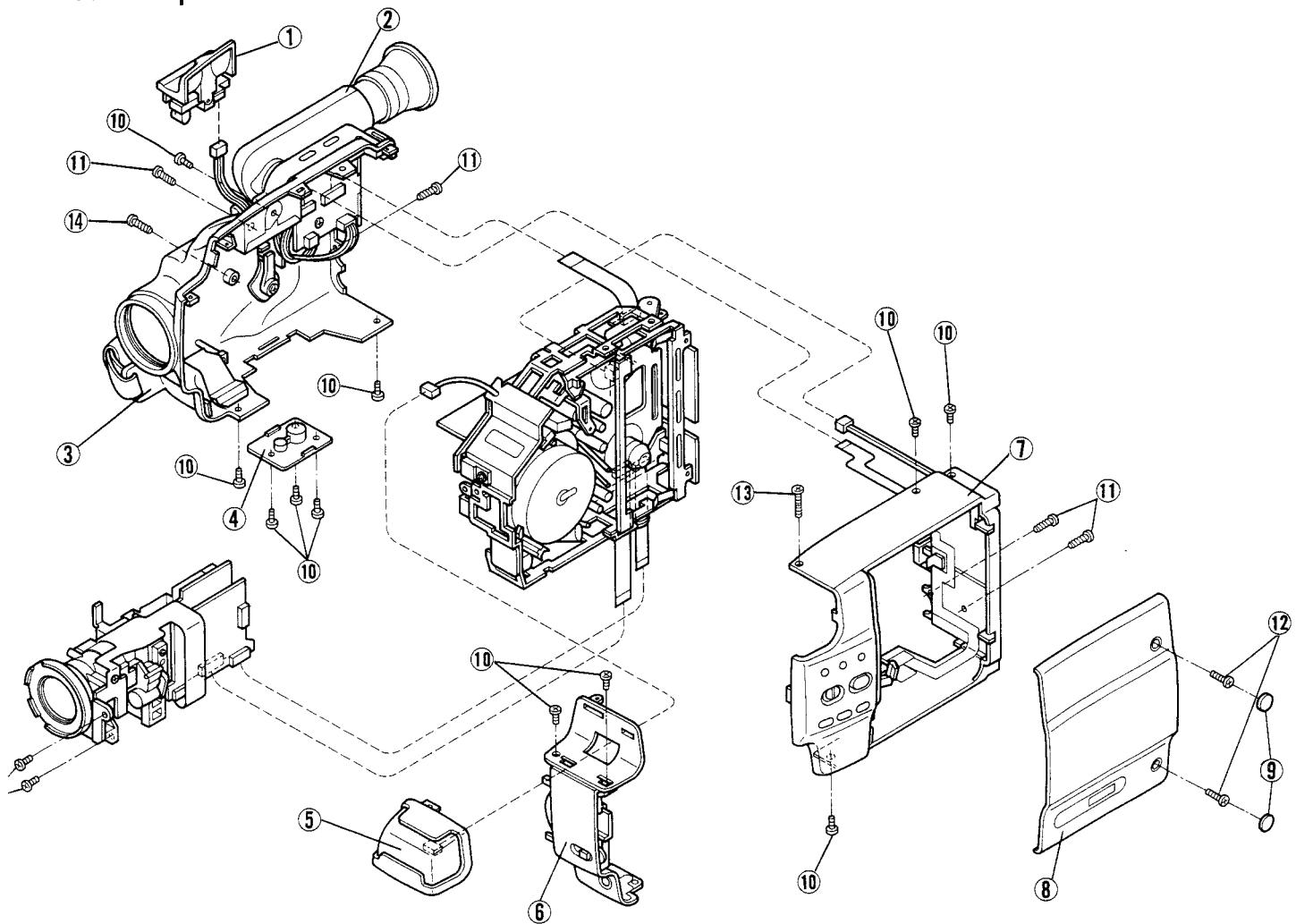

ITEM NO.	PARTS NO.	PARTS NAME	DESCRIPTION
1	439P030010	ZOOM SWITCH	
2	939P438030	EVF UNIT	
3	701B231090	CASE UNIT(L)	
4	769C004010	TRIPOD BASE	
5	485P017010	MICROPHONE UNIT	
6	701B233030	FRONT PANEL UNIT	
7	701B232040	CASE UNIT(R)	
8	702B828090	CASSETTE HOUSING	
9	722D008010	SEAL	
10	669D372010	SCREW	M2 × 4
11	669D410010	SCREW(TAPPING)	2 × 6
12	669D317030	SCREW	M2 × 0.4-5
13	669D372040	SCREW	M2 × 10
14	669D410020	SCREW(TAPPING)	2 × 8

3.Chassis Assembly Parts

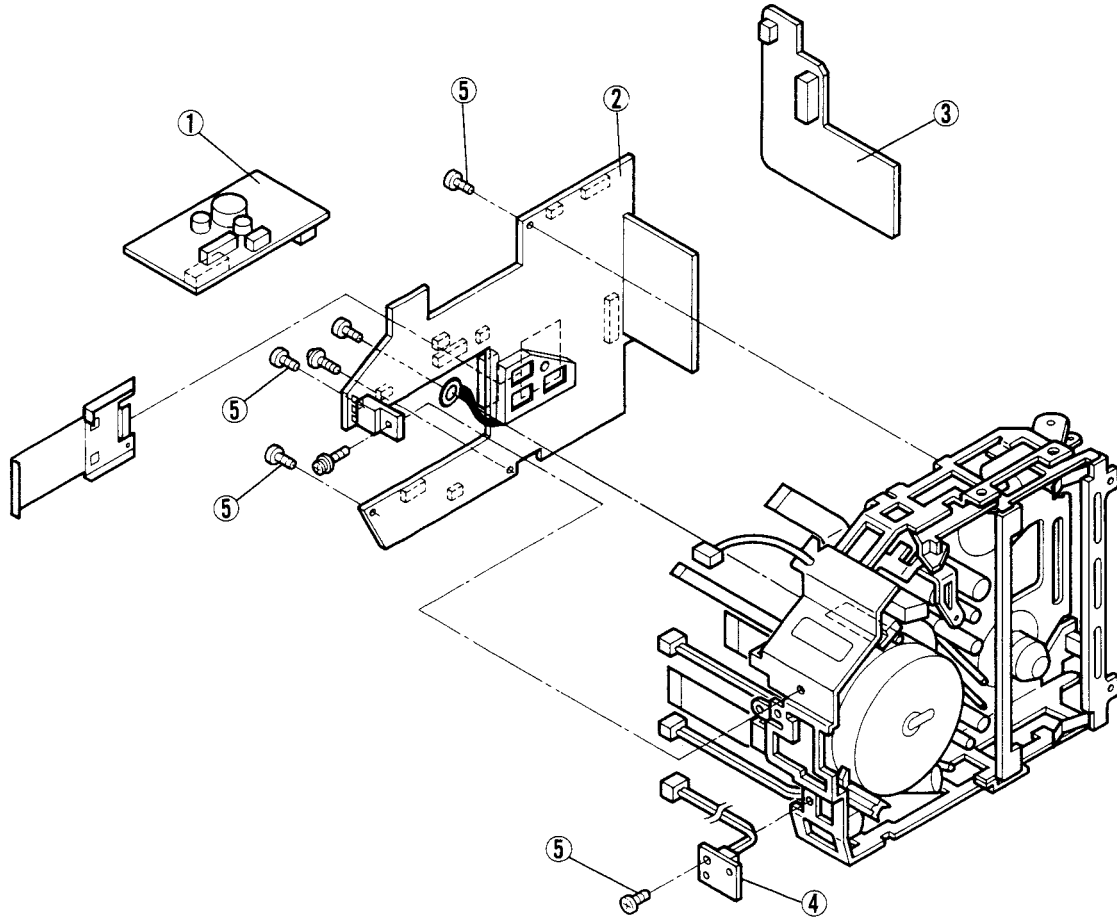

ITEM NO.	PARTS NO.	PARTS NAME	DESCRIPTION
1	928C719005	VTR-SUB PCB ASSY	
2	927B621001	VTR PCB ASSY	
3	928C795001	REAR PCB ASSY	
4	939P439020	CAMERA SW UNIT	FADE
5	669D372010	SCREW	M2×4
6	669D451010	SCREW	M2×0.4-6

4. Case Assembly(Right side) Parts

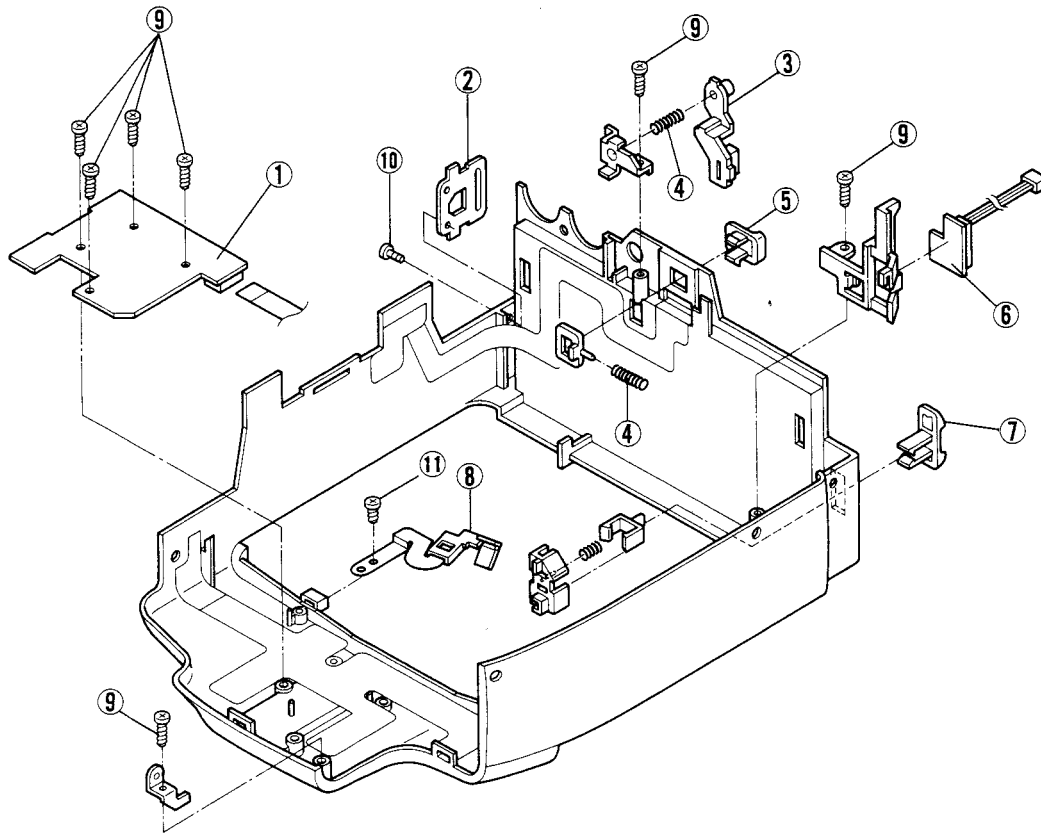

ITEM NO.	PARTS NO.	PARTS NAME	DESCRIPTION
1	939P439010	CAMERA SW UNIT	MENU +
2	768D143010	STRAP HOLDER	
3	704C802010	RELEASE BUTTON	
4	572D535010	EJECT SPRING	
5	704C804010	EJECT KNOB	
6	928C725001	POWER SW PCB ASSY	
7	704C803010	POWER KNOB	
8	621D767020	TAPE GUIDE	1.7×6 M2×4
9	669D435030	SCREW(TAPPING)	
10	669D372010	SCREW	
11	669D435010	SCREW(TAPPING)	1.7×4

5. Case Assembly(Left side) Parts

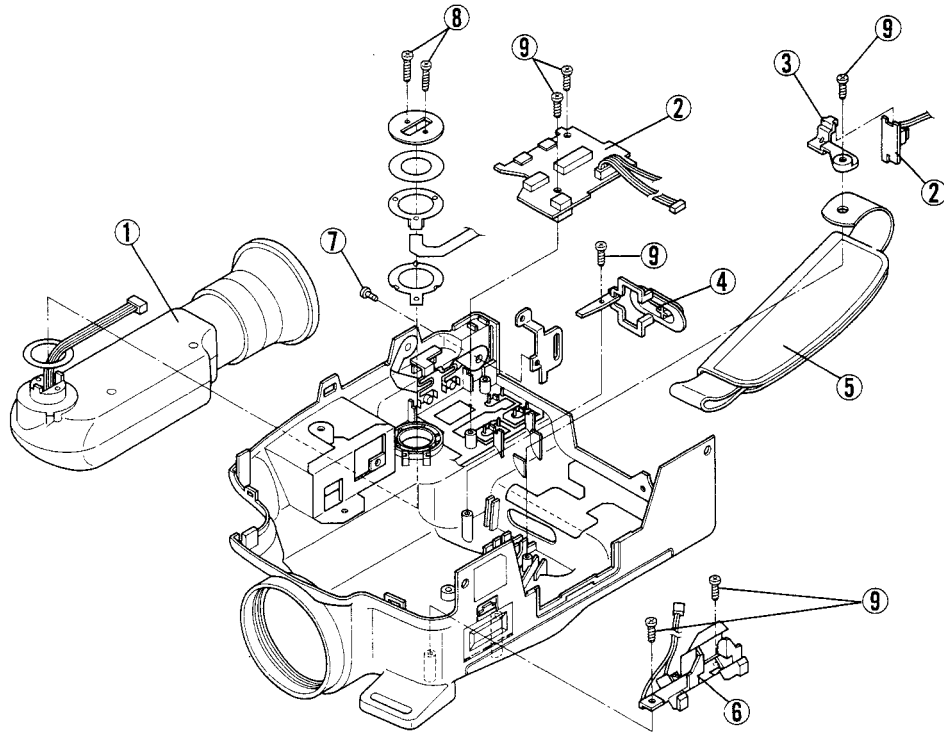

ITEM NO.	PARTS NO.	PARTS NAME	DESCRIPTION
1	939P438030	EVF UNIT	
2	928C746006	VTR SW PCB ASSY	
3	621C114010	RETAINER BELT	
4	704C800010	TRIGGER BUTTON	
5	772C016020	GRIP BELT	
6	701C026010	BACK UP BATTERY HOLDER	
7	669D372020	SCREW	M2×6
8	669D322070	SCREW(TAPPING)	2×8
9	669D435030	SCREW(TAPPING)	1.7×6

6.EVF(Electronic View Finder) unit Parts

7.Camera unit Parts

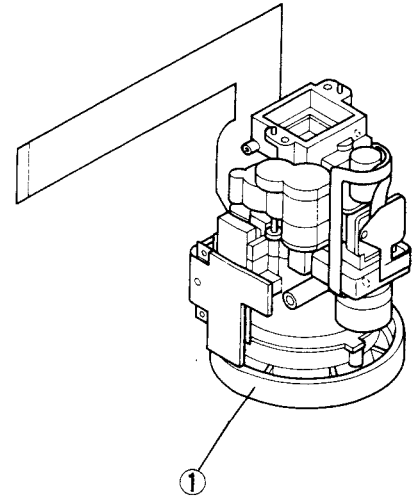
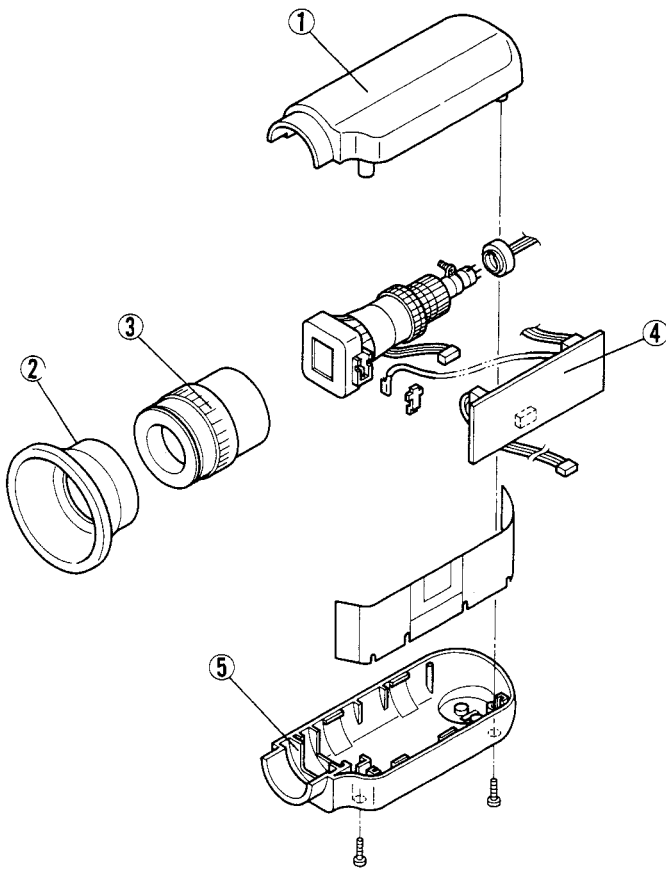

ITEM NO.	PARTS NO.	PARTS NAME	DESCRIPTION
EVF UNIT			
1	701D073050	TOP CASE	
2	765D039040	EYE CAP	
3	409D009070	LENS ASSY(EVF)	
4	928D041030	EVF PCB ASSY	
5	701D073060	BOTTOM CASE	
LENS UNIT			
1	490P093010	LENS UNIT	

8. Front panel Assembly Parts

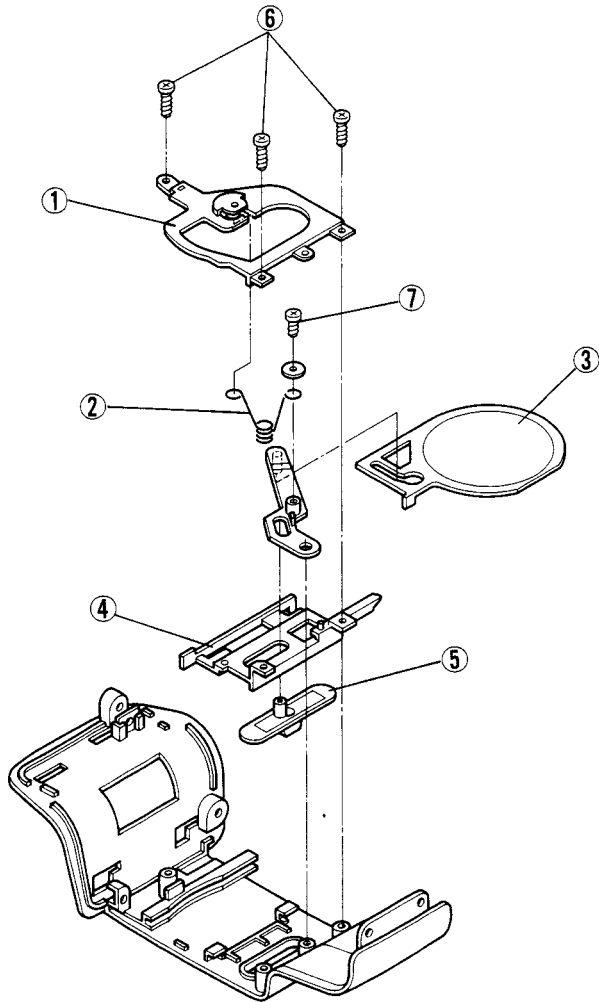

9. AC Power Adapter Parts

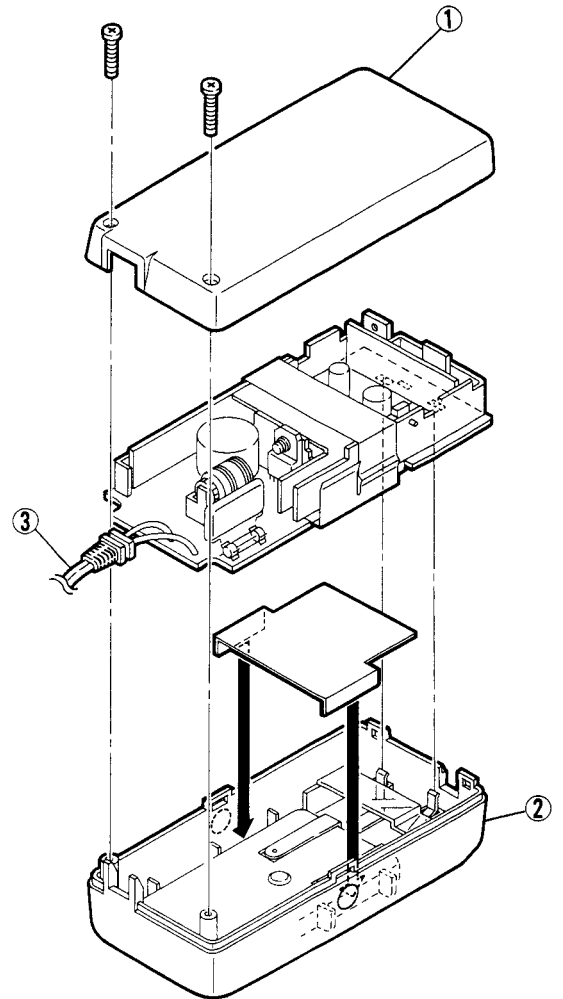

ITEM NO.	PARTS NO.	PARTS NAME	DESCRIPTION
FRONT PANEL UNIT			
1	621C125010	LENS COVER HOLDER	
2	572D573010	LENS COVER SPRING	
3	761D718010	LENS COVER	
4	621C149010	KNOB HOLDER	
5	734D542010	LENS COVER KNOB	
6	669D435030	SCREW(TAPPING)	1.7×6
7	669D435010	SCREW(TAPPING)	1.7×4
AC POWER ADAPTER			
1	700D029030	BOTTOM CASE	[E]
1	700D029040	BOTTOM CASE	[B]
1	700D029050	BOTTOM CASE	[A]
2	700D028030	TOP CASE	
3	242D410030	AC POWER CORD	[E]
3	242D410040	AC POWER CORD	[B]
3	242D410050	AC POWER CORD	[A]
<p>Note: Broken AC power cord must be exchanged with a new original power cord.</p>			

10.Packing Parts

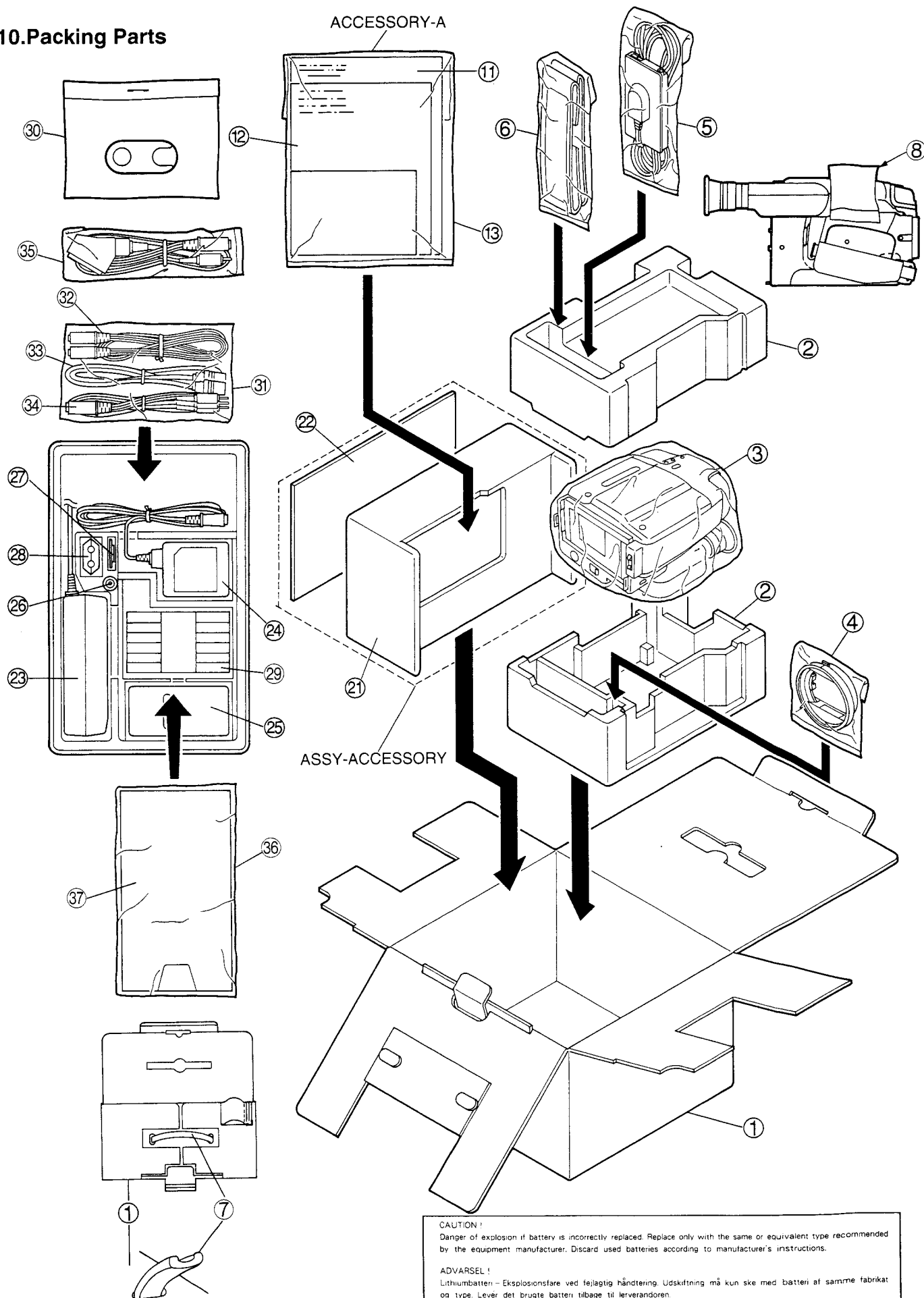

CAUTION !
 Danger of explosion if battery is incorrectly replaced. Replace only with the same or equivalent type recommended by the equipment manufacturer. Discard used batteries according to manufacturer's instructions.

ADVARSEL !
 Lithumbatteri – Eksplosionsfare ved fejlagtig håndtering. Udskiftning må kun ske med batteri af samme fabrikat og type. Lever det brugte batteri tilbage til leverandøren.

ITEM NO.	PARTS NO.	PARTS NAME	DESCRIPTION
PACKING PARTS			
1	801C129010	PACKING CASE	[E]
1	801C129020	PACKING CASE	[B]
1	801C129030	PACKING CASE	[A]
2	803A282010	PACKING CUSHION	
3	831D177070	PACKING BAG	
4	702C999010	ATTACHMENT RING	
5	939P437020	DC CABLE UNIT	
6	772P021020	SHOLDER BELT	
7	829D094010	QUICK HAND	
8	831D268020	CUSHION SHEET	
ACCESSORY - A			
11	872C041040	INSTRUCTION BOOK	[E]
11	872C041050	INSTRUCTION BOOK	[E]
11	872C041060	INSTRUCTION BOOK	[E]
12	851B930010	SHEET CAUTION	
13	831D181020	PACKING BAG	
ASSY - ACCESSORY			
21	803A283010	PACKING CUSHION	[E]
22	801C130060	PACKING SHEET	[B]
22	801C130070	PACKING SHEET	[A]
22	801C130080	PACKING SHEET	[E]
23	939P450010	AC ADAPTER	[E]
23	939P450020	AC ADAPTER	[B]
23	939P450030	AC ADAPTER	[A]
24	295P290010	RF CONVERTER	DAR-M1EB[B]
24	295P291010	RF CONVERTER	DAR-M1A[A]
25	939P455010	BATTERY PACK	BY-M1
26	-----	BATTERY	SUM-3(L) × 1
27	283P035020	BACK UP BATTERY	Lithium battery CR2025
28	451C072010	AC JACK	[E]
29	-----	C-VIDEO CASSETTE	SE-C30
30	761C462010	JACK CAP	
31	831D252010	PACKING BAG	
32	242D335060	S-CABLE	1.5m
33	242D231030	RF CABLE	1.5 m[B, A]
34	243C062010	AV CABLE	RCA PIN PLUG 4pcs. [A]
35	246C139010	AV CABLE	EURO AV + RCA PIN PLUG 1pc. [E, B]
36	831D252040	PACKING BAG	
37	908C137002	CASSETTE ADAPTER	

11. ELECTRICAL PARTS

SYMBOL NO.	PARTS NO.	PARTS NAME	DESCRIPTION	SYMBOL NO.	PARTS NO.	PARTS NAME	DESCRIPTION
INTEGRATED CIRCUITS				TRANSISTORS			
IC 2R1	274P121020	IC	MB88346B	IC803	263P440010	IC	S8054HNM-T1
IC201	272P548010	IC	AN3348FBP	IC902	272P547010	IC	MB3782PF-G-BND
IC2A1	272P672010	IC	M52351FP	TRANSISTORS			
IC2AA	263P567010	IC	MN5181	Q 200	260P857020	TRANSISTOR(C)	DTC144EU
IC2AB	263P566010	IC	MN3110SA	Q 201	260P852010	TRANSISTOR(C)	FMG2/XN1213
IC2AC	272P604010	IC	CXA1439M	Q 202	260P854020	TRANSISTOR(C)	2SC4098-P
IC2AD	263P220010	IC	SC7SU04F	Q 203	260P852010	TRANSISTOR(C)	FMG2/XN1213
IC2J1	272P489010	IC	VC2076MP	Q 205	260P854020	TRANSISTOR(C)	2SC4098-P
IC2P1	272P749010	IC	TL8819F	Q 221	260P877020	TRANSISTOR(C)	2SC4618-P
IC2R1	274P121020	IC	MB88346B	Q 222	260P877020	TRANSISTOR(C)	2SC4618-P
IC2001	272P668010	IC	AN3580SB	Q 223	260P877020	TRANSISTOR(C)	2SC4618-P
IC2002	272P546010	IC	MM1031XMR	Q 224	260P877020	TRANSISTOR(C)	2SC4618-P
IC300	272P375010	IC	BA7757BK	Q 225	260P877020	TRANSISTOR(C)	2SC4618-P
IC350	272P675010	IC	BA3308F	Q 226	260P877020	TRANSISTOR(C)	2SC4618-P
IC3A0	272P541010	IC	AN3935NFHP	Q 227	260P877020	TRANSISTOR(C)	2SC4618-P
IC3AA	272P700010	IC	AN2163FHP	Q 228	260P877020	TRANSISTOR(C)	2SC4618-P
IC3AB	274P054020	IC	MN3823S	Q 291	260P859050	TRANSISTOR(C)	2SA1576-R
IC3AC	274P053020	IC	MN3824S	Q 292	260P859050	TRANSISTOR(C)	2SA1576-R
IC3AD	274P121020	IC	MB88346B	Q 294	260P859050	TRANSISTOR(C)	2SA1576-R
IC3AE	274P121020	IC	MB88346B	Q 2A1	260P852010	TRANSISTOR(C)	FMG2/XN1213
IC401	272P485010	IC	LM2902DB	Q 2A3	260P857020	TRANSISTOR(C)	DTC144EU
IC401	272P485020	IC	NJM2902V	Q 2A4	260P857020	TRANSISTOR(C)	DTC144EU
IC402	272P205040	IC	LM2903DB	Q 2A6	260P854020	TRANSISTOR(C)	2SC4098-P
IC4AA	263P598010	IC	MN73033XRA	Q 2A9	260P857020	TRANSISTOR(C)	DTC144EU
IC4B0	272P540010	IC	VC5035	Q 2AA	260P870010	TRANSISTOR(C)	2SA1610Y34
IC4D0	272P542010	IC	LB1617M-TP-T1	Q 2AB	260P869010	TRANSISTOR(C)	2SC4176B35
IC4G0	272P705010	IC	LM2904DB	Q 2AC	260P870010	TRANSISTOR(C)	2SA1610Y34
IC500	263P370010	IC	LC3564PML-12-TER	Q 2AD	260P869010	TRANSISTOR(C)	2SC4176B35
IC501	263P564010	IC	BU2707K	Q 2AE	260P854030	TRANSISTOR(C)	2SC4098-Q
IC502	272P673010	IC	AN2355AP	Q 2AF	260P854030	TRANSISTOR(C)	2SC4098-Q
IC503	272P447010	IC	NJM2235M	Q 2AH	260P854030	TRANSISTOR(C)	2SC4098-Q
IC504	272P366020	IC	LM311DB	Q 2AJ	260P867050	TRANSISTOR(C)	2SD1949
IC505	274P070010	IC	SN74HC08DB	Q 2AK	260P859050	TRANSISTOR(C)	2SA1576-R
IC5A0	274P060010	IC	M37405M5-140FP	Q 2D0	260P854020	TRANSISTOR(C)	2SC4098-P
IC5A1	263P440010	IC	S8054HNM-T1	Q 2D1	260P857020	TRANSISTOR(C)	DTC144EU
IC5A2	272P674010	IC	M5237ML	Q 2D2	260P854020	TRANSISTOR(C)	2SC4098-P
IC5AA	274P001010	IC	M37450M8-470FP	Q 2DA	260P854030	TRANSISTOR(C)	2SC4098-Q
IC5AB	272P705010	IC	LM2904DB	Q 2F0	260P854020	TRANSISTOR(C)	2SC4098-P
IC5AC	272P485010	IC	LM2902DB	Q 2F1	260P857020	TRANSISTOR(C)	DTC144EU
IC5AE	272P703010	IC	LM2901DB	Q 2F2	260P859050	TRANSISTOR(C)	2SA1576-R
IC5D0	272P556010	IC	TA7291F(ER)	Q 2F4	260P854020	TRANSISTOR(C)	2SC4098-P
IC5EA	263P427010	IC	S-29181F	Q 2F5	260P859050	TRANSISTOR(C)	2SA1576-R
IC5FA	272P704010	IC	TB6503AF	Q 2H0	260P854020	TRANSISTOR(C)	2SC4098-P
IC5GA	263P596030	IC	CF79114PM	Q 2H2	260P859050	TRANSISTOR(C)	2SA1576-R
IC5LA	272P485010	IC	LM2902DB	Q 2H3	260P854020	TRANSISTOR(C)	2SC4098-P
IC5RA	272P357010	IC	RST529C	Q 2H4	260P859050	TRANSISTOR(C)	2SA1576-R
IC5ZA	272P358020	IC	TK10501M	Q 2P0	260P854020	TRANSISTOR(C)	2SC4098-P
IC6A1	272P748010	IC	AN2465NFHP	Q 2P1	260P854020	TRANSISTOR(C)	2SC4098-P
IC6AA	272P485010	IC	LM2902DB	Q 2V0	260P861050	TRANSISTOR(C)	2SA1577A-Q
IC6AB	263P217010	IC	SC14S66F	Q 2V1	260P861050	TRANSISTOR(C)	2SA1577A-Q
IC6AC	263P217010	IC	SC14S66F	Q 2000	260P854020	TRANSISTOR(C)	2SC4098-P
IC800	274P061010	IC	M37460M8-087FP	Q 2001	260P859050	TRANSISTOR(C)	2SA1576-R
IC801	263P373010	IC	S-81350HG-KD-T1	Q 2003	260P859050	TRANSISTOR(C)	2SA1576-R
IC802	263P375010	IC	S-80725AL-AN-T1				

SYMBOL NO.	PARTS NO.	PARTS NAME	DESCRIPTION	SYMBOL NO.	PARTS NO.	PARTS NAME	DESCRIPTION
Q 2004	260P855050	TRANSISTOR(C)	2SC4081	Q 5A3	260P858010	TRANSISTOR(C)	DTA114EU
Q 2005	260P859050	TRANSISTOR(C)	2SA1576-R	Q 5A4	260P855070	TRANSISTOR(C)	2SD1819A-Q
Q 2006	260P857020	TRANSISTOR(C)	DTC144EU	Q 5AA	260P854020	TRANSISTOR(C)	2SC4098-P
Q 2007	260P854020	TRANSISTOR(C)	2SC4098-P	Q 5AB	260P858010	TRANSISTOR(C)	DTA114EU
Q 2008	260P854020	TRANSISTOR(C)	2SC4098-P	Q 5AC	260P845010	TRANSISTOR(C)	IMX1
Q 300	260P856010	TRANSISTOR(C)	DTA144EU	Q 5AD	260P857020	TRANSISTOR(C)	DTC144EU
Q 301	260P844030	TRANSISTOR(C)	XN1501	Q 5AE	260P853010	TRANSISTOR(C)	FMA2/XN1113
Q 320	260P867060	TRANSISTOR(C)	2SD1949-R	Q 5AG	260P852010	TRANSISTOR(C)	FMG2/XN1213
Q 321	260P861050	TRANSISTOR(C)	2SA1577A-Q	Q 5D0	260P857020	TRANSISTOR(C)	DTC144EU
Q 350	260P844010	TRANSISTOR(C)	FMW1	Q 5FA	260P859050	TRANSISTOR(C)	2SA1576-R
Q 3A0	260P855060	TRANSISTOR(C)	2SC4081-S	Q 5FB	260P854030	TRANSISTOR(C)	2SC4098-Q
Q 3A1	260P855060	TRANSISTOR(C)	2SC4081-S	Q 5FC	260P854030	TRANSISTOR(C)	2SC4098-Q
Q 3AB	260P849010	TRANSISTOR(C)	IMZ1	Q 5FD	260P854030	TRANSISTOR(C)	2SC4098-Q
Q 3AC	260P849010	TRANSISTOR(C)	IMZ1	Q 5FG	260P859050	TRANSISTOR(C)	2SA1576-R
Q 3AD	260P854030	TRANSISTOR(C)	2SC4098-Q	Q 5FJ	260P855090	TRANSISTOR(C)	2SD1819A-S
Q 3AE	260P859050	TRANSISTOR(C)	2SA1576-R	Q 5FK	260P855090	TRANSISTOR(C)	2SD1819A-S
Q 3AF	260P849010	TRANSISTOR(C)	IMZ1	Q 5FL	260P859090	TRANSISTOR(C)	2SB1218A-S
Q 3AG	260P854030	TRANSISTOR(C)	2SC4098-Q	Q 5GA	260P845010	TRANSISTOR(C)	IMX1
Q 3AH	260P859050	TRANSISTOR(C)	2SA1576-R	Q 5KM	260P863010	TRANSISTOR(C)	IMT1
Q 3AJ	260P854030	TRANSISTOR(C)	2SC4098-Q	Q 5LB	260P855050	TRANSISTOR(C)	2SC4081
Q 3AK	260P854030	TRANSISTOR(C)	2SC4098-Q	Q 5LC	260P858010	TRANSISTOR(C)	DTA114EU
Q 3AL	260P859050	TRANSISTOR(C)	2SA1576-R	Q 6A1	260P852010	TRANSISTOR(C)	FMG2/XN1213
Q 3AM	260P849010	TRANSISTOR(C)	IMZ1	Q 6A3	260P857020	TRANSISTOR(C)	DTC144EU
Q 3AN	260P852010	TRANSISTOR(C)	FMG2/XN1213	Q 6A4	260P854020	TRANSISTOR(C)	2SC4098-P
Q 3AP	260P852010	TRANSISTOR(C)	FMG2/XN1213	Q 6A5	260P856010	TRANSISTOR(C)	DTA144EU
Q 3AQ	260P857020	TRANSISTOR(C)	DTC144EU	Q 6A6	260P849010	TRANSISTOR(C)	IMZ1
Q 3AR	260P849030	TRANSISTOR(C)	XN4601	Q 6A7	260P849010	TRANSISTOR(C)	IMZ1
Q 3AS	260P863010	TRANSISTOR(C)	IMT1	Q 6AA	260P845010	TRANSISTOR(C)	IMX1
Q 3AT	260P863010	TRANSISTOR(C)	IMT1	Q 6AB	260P855050	TRANSISTOR(C)	2SC4081
Q 3AU	260P845010	TRANSISTOR(C)	IMX1	Q 6AC	260P856010	TRANSISTOR(C)	DTA144EU
Q 3AV	260P845010	TRANSISTOR(C)	IMX1	Q 800	260P861060	TRANSISTOR(C)	2SA1577-R
Q 3AW	260P849010	TRANSISTOR(C)	IMZ1	Q 801	260P864010	TRANSISTOR(C)	2SK209GR
Q 3AX	260P854030	TRANSISTOR(C)	2SC4098-Q	Q 802	260P857030	TRANSISTOR(C)	UN5213
Q 3AY	260P854030	TRANSISTOR(C)	2SC4098-Q	Q 904	260P701010	TRANSISTOR(C)	2SA1213-Y
Q 3AZ	260P854030	TRANSISTOR(C)	2SC4098-Q	Q 905	260P701010	TRANSISTOR(C)	2SA1213-Y
Q 3BB	260P857020	TRANSISTOR(C)	DTC144EU	Q 906	260P701010	TRANSISTOR(C)	2SA1213-Y
Q 3BC	260P852010	TRANSISTOR(C)	FMG2/XN1213	DIODES			
Q 3BD	260P857020	TRANSISTOR(C)	DTC144EU	D 201	264P841030	DIODE(C)	MA132WA
Q 3BE	260P849010	TRANSISTOR(C)	IMZ1	D 202	264P841030	DIODE(C)	MA132WA
Q 3BF	260P845010	TRANSISTOR(C)	IMX1	D 203	264P841030	DIODE(C)	MA132WA
Q 3BG	260P854030	TRANSISTOR(C)	2SC4098-Q	D 204	264P841030	DIODE(C)	MA132WA
Q 3BH	260P849010	TRANSISTOR(C)	IMZ1	D 205	264P841030	DIODE(C)	MA132WA
Q 3BJ	260P854030	TRANSISTOR(C)	2SC4098-Q	D 206	264P814030	DIODE(C)	MA142WA
Q 3D0	260P857020	TRANSISTOR(C)	DTC144EU	D 207	264P814030	DIODE(C)	MA142WA
Q 404	260P851010	TRANSISTOR(C)	1MD2/XN4312	D 2A0	264P828010	DIODE(C)	DAN202U
Q 406	260P857020	TRANSISTOR(C)	DTC144EU	D 2A1	264P814030	DIODE(C)	MA142WA
Q 407	260P859030	TRANSISTOR(C)	2SA1576-S	D 2A2	264P814030	DIODE(C)	MA142WA
Q 500	260P857020	TRANSISTOR(C)	DTC144EU	D 2A3	264P843010	DIODE(C)	DA221/MA133
Q 501	260P844030	TRANSISTOR(C)	XN1501	D 2A4	264P843010	DIODE(C)	DA221/MA133
Q 571	268P044020	PHOTO INTERRUPTER		D 2A5	264P828010	DIODE(C)	DAN202U
Q 572	268P044020	PHOTO INTERRUPTER		D 2AA	264P837010	DIODE(C)	MA141K
Q 573	268P041010	PHOTO TRANSISTOR	PN147	D 2AD	264P837010	DIODE(C)	MA141K
Q 5A0	260P857020	TRANSISTOR(C)	DTC144EU	D 2AE	264P837010	DIODE(C)	MA141K
Q 5A1	260P855070	TRANSISTOR(C)	2SD1819A-Q	D 2AF	264P837010	DIODE(C)	MA141K
Q 5A2	260P484020	TRANSISTOR	2SB942-P				

SYMBOL NO.	PARTS NO.	PARTS NAME	DESCRIPTION	SYMBOL NO.	PARTS NO.	PARTS NAME	DESCRIPTION
D 2AG	264P837010	DIODE(C)	MA141K	FILTERS			
D 2AH	264P849010	DIODE(C)	MA728	499P018010		OPTICAL FILTER	SF101C4AA
D 2AJ	264P848010	DIODE(C)	MA110	BPF3A0	409P620010	BAND PASS FILTER(C)	RZV-397N
D 2AK	264P837010	DIODE(C)	MA141K	BPF3A1	409P621010	BAND PASS FILTER(C)	RZV-398N
D 2AL	264P814030	DIODE(C)	MA142WA	BPF6A1	409P552010	BAND PASS FILTER(C)	H355BSK-2042MYD
D 2J0	264P814030	DIODE(C)	MA142WA	CF800	299P148010	CERAMIC RESONATOR	KBR-4. 19MWS
D 2P0	264P814030	DIODE(C)	MA142WA	DE2000	409P652010	DELAY EQUALIZER(C)	
D 2000	264P814030	DIODE(C)	MA142WA	FL400	299P161010	FILTER	AFZR72YM38A1
D 2001	264P844050	DIODE(C)	RD 7. 5UMB2	LF2AA	409P705010	LOW PASS FILTER	PYV-812N
D 2002	264P844050	DIODE(C)	RD 7. 5UMB2	LF3AA	409P708010	LOW PASS FILTER	RZV-555N
D 2003	264P844050	DIODE(C)	RD 7. 5UMB2	LF3AB	409P707010	LOW PASS FILTER	RXV-205N
D 2004	264P844050	DIODE(C)	RD 7. 5UMB2	LF3AC	409P742010	LOW PASS FILTER	RXV-720N
D 2005	264P814030	DIODE(C)	MA142WA	LF3AE	409P706010	LOW PASS FILTER	RYV-80KN
D 2006	264P844050	DIODE(C)	RD 7. 5UMB2	LF3AF	409P714010	LOW PASS FILTER(C)	4US-TH354LA15794
D 2007	264P844050	DIODE(C)	RD 7. 5UMB2	LF3AG	409P719010	LOW PASS FILTER(C)	4FUSTH354LA15795
D 3A0	264P814030	DIODE(C)	MA142WA	LF3AH	409P706010	LOW PASS FILTER	RYV-80KN
D 3AB	264P833010	DIODE(C)	ND411G-2	LF5AA	409P733010	LOW PASS FILTER(C)	4FUSTH354LA15592
D 3MF	264P833010	DIODE(C)	ND411G-2	DELAY LINES			
D 500	264P845010	DIODE(C)	1SV223	DE2001	409P734010	DELAY EQUALIZER	
D 501	264P814030	DIODE(C)	MA142WA	DL6A1	337P185010	DELAY LINE	
D 571	264P526010	LIGHT EMITTING DIODE	LN57	COILS			
D 5A0	264P828010	DIODE(C)	DAN202U	L 200	325C147080	COIL (C)	180 μ H-J
D 5A1	264P814030	DIODE(C)	MA142WA	L 201	325C222050	COIL (C)	100 μ H-J
D 5CA	264P828010	DIODE(C)	DAN202U	L 202	325C221080	COIL (C)	27 μ H-J
D 5D0	264P828010	DIODE(C)	DAN202U	L 203	325C222020	COIL (C)	56 μ H-J
D 5FA	264P603010	DIODE(C)	U1GWJ44	L 204	325C147050	COIL (C)	100 μ H-J
D 5FB	264P603010	DIODE(C)	U1GWJ44	L 292	325C146030	COIL (C)	10 μ H-J
D 5FC	264P603010	DIODE(C)	U1GWJ44	L 293	325C146000	COIL (C)	5. 6 μ H-J
D 5FD	264P603010	DIODE(C)	U1GWJ44	L 2A2	325C221060	COIL (C)	18 μ H-J
D 5FE	264P814030	DIODE(C)	MA142WA	L 2A4	325C183010	COIL (C)	330 μ H-M
D 5LA	264P814030	DIODE(C)	MA142WA	L 2A5	325C222050	COIL (C)	100 μ H-J
D 6A0	264P828010	DIODE(C)	DAN202U	L 2AB	325C141050	COIL (C)	15 μ H-K
D 6A1	264P814030	DIODE(C)	MA142WA	L 2AC	325C240030	COIL (C)	1. 5 μ H-M
D 6A2	264P828010	DIODE(C)	DAN202U	L 2AD	325C141070	COIL (C)	22 μ H-K
D 6AA	264P828010	DIODE(C)	DAN202U	L 2AF	325C241070	COIL (C)	22 μ H-K
D 700	264P814030	DIODE(C)	MA142WA	L 2D1	325C243000	COIL (C)	270 μ H-K
D 701	264P814030	DIODE(C)	MA142WA	L 2D2	325C221070	COIL (C)	22 μ H-J
D 702	264P814030	DIODE(C)	MA142WA	L 2D2	325C221090	COIL (C)	33 μ H-J
D 703	264P814030	DIODE(C)	MA142WA	L 2F0	325C221090	COIL (C)	33 μ H-J
D 800	264P847010	DIODE(C)	MA741WA	L 2F1	325C221040	COIL (C)	12 μ H-J
D 801	264P846010	DIODE(C)	MA732	L 2F1	325C221070	COIL (C)	22 μ H-J
D 802	264P830020	DIODE(C)	DA204U	L 2F2	325C222000	COIL (C)	39 μ H-J
D 803	264P828010	DIODE(C)	DAN202U	L 2F3	325C221030	COIL (C)	10 μ H-J
D 805	264P814030	DIODE(C)	MA142WA	L 2H0	325C221090	COIL (C)	33 μ H-J
D 806	264P814030	DIODE(C)	MA142WA	L 2H1	325C222020	COIL (C)	56 μ H-J
D 807	264P828010	DIODE(C)	DAN202U	L 2H2	325C221070	COIL (C)	22 μ H-J
D 809	264P814030	DIODE(C)	MA142WA	L 2K1	325C222020	COIL (C)	56 μ H-J
D 903	264P814030	DIODE(C)	MA142WA	L 2P1	325C222050	COIL (C)	100 μ H-J
D 904	264P814030	DIODE(C)	MA142WA	L 2000	325C141060	COIL (C)	18 μ H-K
D 906	264P850010	DIODE(C)	MA720	L 320	409P695010	AUDIO BIAS OSC	
D 907	264P850010	DIODE(C)	MA720	L 321	325C242070	COIL (C)	150 μ H-K
D 908	264P850010	DIODE(C)	MA720	L 3A0	325C242050	COIL (C)	100 μ H-K

SYMBOL NO.	PARTS NO.	PARTS NAME	DESCRIPTION	SYMBOL NO.	PARTS NO.	PARTS NAME	DESCRIPTION
L 3AA	325C241070	COIL (C)	22 μ H-K	RESISTORS			
L 3AD	325C241070	COIL (C)	22 μ H-K	R 200	103P502030	RESISTOR (C)	1/20W 680 Ω -J
L 3AE	325C241070	COIL (C)	22 μ H-K	R 202	103P702050	METAL RESISTOR (C)	1/16W 1k Ω -J
L 3AF	325C241070	COIL (C)	22 μ H-K	R 203	103P704030	METAL RESISTOR (C)	1/16W 33k Ω -J
L 3AG	325C241070	COIL (C)	22 μ H-K	R 204	103P704000	METAL RESISTOR (C)	1/16W 18k Ω -J
L 3AH	325C241030	COIL (C)	10 μ H-K	R 205	103P702080	METAL RESISTOR (C)	1/16W 1.8k Ω -J
L 3AJ	325C242020	COIL (C)	56 μ H-K	R 206	103P702050	METAL RESISTOR (C)	1/16W 1k Ω -J
L 3AK	325C242020	COIL (C)	56 μ H-K	R 208	103P702050	METAL RESISTOR (C)	1/16W 1k Ω -J
L 500	325C141030	COIL (C)	10 μ H-K	R 209	103P701070	METAL RESISTOR (C)	1/16W 220 Ω -J
L 501	325C141030	COIL (C)	10 μ H-K	R 211	103P701030	METAL RESISTOR (C)	1/16W 100 Ω -J
L 502	325C181080	COIL (C)	27 μ H-K	R 212	103P702090	METAL RESISTOR (C)	1/16W 2.2k Ω -J
L 503	325C141010	COIL (C)	6.8 μ H-M	R 213	103P508040	RESISTOR (C)	1/20W 2.2 Ω -K
L 5AA	325C242020	COIL (C)	56 μ H-K	R 214	103P508040	RESISTOR (C)	1/20W 2.2 Ω -K
L 5AD	325C242040	COIL (C)	82 μ H-K	R 216	103P501060	RESISTOR (C)	1/20W 180 Ω -J
L 6A0	325C242090	COIL (C)	220 μ H-K	R 217	103P700010	METAL RESISTOR (C)	1/16W 10 Ω -J
L 6A1	325C221050	COIL (C)	15 μ H-J	R 218	103P703070	METAL RESISTOR (C)	1/16W 10k Ω -J
L 6A3	325C146050	COIL (C)	15 μ H-J	R 219	103P702000	METAL RESISTOR (C)	1/16W 390 Ω -J
L 6A4	325C141020	COIL (C)	8.2 μ H-M	R 220	103P702000	METAL RESISTOR (C)	1/16W 390 Ω -J
L 6A5	325C147090	COIL (C)	220 μ H-J	R 221	103P501060	RESISTOR (C)	1/20W 180 Ω -J
L 6A6	325C147070	COIL (C)	150 μ H-J	R 222	103P501070	RESISTOR (C)	1/20W 220 Ω -J
L 6A7	325C147030	COIL (C)	68 μ H-J	R 223	103P702040	METAL RESISTOR (C)	1/16W 820 Ω -J
L 6A8	325C147040	COIL (C)	82 μ H-J	R 224	103P500010	RESISTOR (C)	1/20W 10 Ω -J
L 800	325C181050	COIL (C)	15 μ H-K	R 225	103P702000	METAL RESISTOR (C)	1/16W 390 Ω -J
L 902	351P087010	CHOKE COIL	CD54 22MHz	R 226	103P702000	METAL RESISTOR (C)	1/16W 390 Ω -J
L 903	351P087010	CHOKE COIL	CD54 22MHz	R 227	103P501050	RESISTOR (C)	1/20W 150 Ω -J
L 904	351P088010	CHOKE COIL	CDR74 150MHz	R 228	103P703000	METAL RESISTOR (C)	1/16W 2.7k Ω -J
L 905	351P088010	CHOKE COIL	CDR74 150MHz	R 229	103P702000	METAL RESISTOR (C)	1/16W 390 Ω -J
L 906	325C242050	COIL (C)	100 μ H-K	R 230	103P702010	METAL RESISTOR (C)	1/16W 470 Ω -J
L 907	325C242050	COIL (C)	100 μ H-K	R 230	103P701080	METAL RESISTOR (C)	1/16W 270 Ω -J
L 908	351P087020	CHOKE COIL	CD54 120MHz	R 231	103P702090	METAL RESISTOR (C)	1/16W 2.2k Ω -J
TRANSFORMERS				R 232	103P700010	METAL RESISTOR (C)	1/16W 10 Ω -J
T 901	409P689010	TRANSFORMER	0353-105	R 233	103P703000	METAL RESISTOR (C)	1/16W 2.7k Ω -J
VARIABLE RESISTORS				R 234	103P702000	METAL RESISTOR (C)	1/16W 390 Ω -J
VR2A0	127C261010	VR-SEMI FIXED (C)	0.05W B50K	R 235	103P702090	METAL RESISTOR (C)	1/16W 2.2k Ω -J
VR2A1	127C261010	VR-SEMI FIXED (C)	0.05W B50K	R 236	103P702010	METAL RESISTOR (C)	1/16W 470 Ω -J
VR2AA	127C221030	VR-SEMI FIXED (C)	1/10W B200k Ω -N	R 236	103P701080	METAL RESISTOR (C)	1/16W 270 Ω -J
VR320	127C261020	VR-SEMI FIXED (C)	0.05W B100K	R 237	103P702010	METAL RESISTOR (C)	1/16W 470 Ω -J
VR3A0	127C260080	VR-SEMI FIXED (C)	0.05W B10K	R 237	103P701080	METAL RESISTOR (C)	1/16W 270 Ω -J
VR3A1	127C260060	VR-SEMI FIXED (C)	0.05W B3K	R 238	103P702000	METAL RESISTOR (C)	1/16W 390 Ω -J
VR3AA	127C220060	VR-SEMI FIXED (C)	1/10W B3k Ω -N	R 239	103P703000	METAL RESISTOR (C)	1/16W 2.7k Ω -J
VR3AB	127C220070	VR-SEMI FIXED (C)	1/10W B5k Ω -N	R 240	103P702090	METAL RESISTOR (C)	1/16W 2.2k Ω -J
VR3AC	127C220070	VR-SEMI FIXED (C)	1/10W B5k Ω -N	R 241	103P700010	METAL RESISTOR (C)	1/16W 10 Ω -J
VR3AD	127C220060	VR-SEMI FIXED (C)	1/10W B3k Ω -N	R 242	103P700010	METAL RESISTOR (C)	1/16W 10 Ω -J
VR3AE	127C220090	VR-SEMI FIXED (C)	1/10W B20k Ω -N	R 243	103P700010	METAL RESISTOR (C)	1/16W 10 Ω -J
VR3C0	127C260080	VR-SEMI FIXED (C)	0.05W B10K	R 244	103P702000	METAL RESISTOR (C)	1/16W 390 Ω -J
VR3C1	127C260060	VR-SEMI FIXED (C)	0.05W B3K	R 245	103P703000	METAL RESISTOR (C)	1/16W 2.7k Ω -J
VR3D0	127C260070	VR-SEMI FIXED (C)	0.05W B5K	R 246	103P702090	METAL RESISTOR (C)	1/16W 2.2k Ω -J
VR5A0	127C261020	VR-SEMI FIXED (C)	0.05W B100K	R 247	103P702010	METAL RESISTOR (C)	1/16W 470 Ω -J
VR5A1	127C260060	VR-SEMI FIXED (C)	0.05W B3K	R 247	103P701080	METAL RESISTOR (C)	1/16W 270 Ω -J
VR902	127C260050	VR-SEMI FIXED (C)	0.05W B2K	R 248	103P702020	METAL RESISTOR (C)	1/16W 560 Ω -J
				R 249	103P703040	METAL RESISTOR (C)	1/16W 5.6k Ω -J
				R 250	103P702070	METAL RESISTOR (C)	1/16W 1.5k Ω -J
				R 251	103P508040	RESISTOR (C)	1/20W 2.2 Ω -K
				R 252	103P508040	RESISTOR (C)	1/20W 2.2 Ω -K
				R 253	103P508040	RESISTOR (C)	1/20W 2.2 Ω -K

SYMBOL NO.	PARTS NO.	PARTS NAME	DESCRIPTION	SYMBOL NO.	PARTS NO.	PARTS NAME	DESCRIPTION
R 254	103P508040	RESISTOR(C)	1/20W 2.2Ω-K	R 2BJ	103P506010	RESISTOR(C)	1/20W 1MΩ-J
R 255	103P701070	METAL RESISTOR(C)	1/16W 220Ω-J	R 2BK	103P504030	RESISTOR(C)	1/20W 33kΩ-J
R 256	103P508040	RESISTOR(C)	1/20W 2.2Ω-K	R 2BL	103P504070	RESISTOR(C)	1/20W 68kΩ-J
R 257	103P508040	RESISTOR(C)	1/20W 2.2Ω-K	R 2BM	103P504030	RESISTOR(C)	1/20W 33kΩ-J
R 258	103P508040	RESISTOR(C)	1/20W 2.2Ω-K	R 2BN	103P501060	RESISTOR(C)	1/20W 180Ω-J
R 259	103P508040	RESISTOR(C)	1/20W 2.2Ω-K	R 2C0	103P704000	METAL RESISTOR(C)	1/16W 18kΩ-J
R 275	103P703040	METAL RESISTOR(C)	1/16W 5.6kΩ-J	R 2C1	103P509050	RESISTOR(C)	0Ω RM1608
R 279	103P702040	METAL RESISTOR(C)	1/16W 820Ω-J	R 2C3	103P704010	METAL RESISTOR(C)	1/16W 22kΩ-J
R 289	103P501010	RESISTOR(C)	1/20W 68Ω-J	R 2C4	103P503090	RESISTOR(C)	1/20W 15kΩ-J
R 290	103P502020	RESISTOR(C)	1/20W 560Ω-J	R 2C5	103P508040	RESISTOR(C)	1/20W 2.2Ω-K
R 291	103P503070	RESISTOR(C)	1/20W 10kΩ-J	R 2C6	103P508040	RESISTOR(C)	1/20W 2.2Ω-K
R 292	103P503090	RESISTOR(C)	1/20W 15kΩ-J	R 2C7	103P508040	RESISTOR(C)	1/20W 2.2Ω-K
R 293	103P501060	RESISTOR(C)	1/20W 180Ω-J	R 2C8	103P508040	RESISTOR(C)	1/20W 2.2Ω-K
R 294	103P501090	RESISTOR(C)	1/20W 330Ω-J	R 2CA	103P509050	RESISTOR(C)	0Ω RM1608
R 295	103P501010	RESISTOR(C)	1/20W 68Ω-J	R 2CB	103P502080	RESISTOR(C)	1/20W 2.7kΩ-J
R 296	103P508040	RESISTOR(C)	1/20W 2.2Ω-K	R 2CC	103P502050	RESISTOR(C)	1/20W 1kΩ-J
R 297	103P508040	RESISTOR(C)	1/20W 2.2Ω-K	R 2CD	103P501030	RESISTOR(C)	1/20W 100Ω-J
R 298	103P504070	RESISTOR(C)	1/20W 68kΩ-J	R 2CE	103P502090	RESISTOR(C)	1/20W 2.2kΩ-J
R 2A6	103P703070	METAL RESISTOR(C)	1/16W 10kΩ-J	R 2CF	103P503000	RESISTOR(C)	1/20W 2.7kΩ-J
R 2A7	103P505000	RESISTOR(C)	1/20W 120kΩ-J	R 2CG	103P501030	RESISTOR(C)	1/20W 100Ω-J
R 2A9	103P704020	METAL RESISTOR(C)	1/16W 27kΩ-J	R 2D0	103P703000	METAL RESISTOR(C)	1/16W 2.7kΩ-J
R 2AA	103P493080	METAL RESISTOR(C)	1/16W 3.6 K-F	R 2D1	103P701030	METAL RESISTOR(C)	1/16W 100Ω-J
R 2AB	103P495080	METAL RESISTOR(C)	1/16W 24K-F	R 2D2	103P702010	METAL RESISTOR(C)	1/16W 470Ω-J
R 2AC	103P506010	RESISTOR(C)	1/20W 1MΩ-J	R 2D3	103P702020	METAL RESISTOR(C)	1/16W 560Ω-J
R 2AD	103P502010	RESISTOR(C)	1/20W 470Ω-J	R 2D4	103P702040	METAL RESISTOR(C)	1/16W 820Ω-J
R 2AE	103P502010	RESISTOR(C)	1/20W 470Ω-J	R 2D5	103P704030	METAL RESISTOR(C)	1/16W 33kΩ-J
R 2AF	103P402050	RESISTOR(C)	1/10W 1kΩ-J	R 2D6	103P704000	METAL RESISTOR(C)	1/16W 18kΩ-J
R 2AG	103P502020	RESISTOR(C)	1/20W 560Ω-J	R 2D7	103P508040	RESISTOR(C)	1/20W 2.2Ω-K
R 2AH	103P502020	RESISTOR(C)	1/20W 560Ω-J	R 2D8	103P508040	RESISTOR(C)	1/20W 2.2Ω-K
R 2AJ	103P506010	RESISTOR(C)	1/20W 1MΩ-J	R 2DA	103P503040	RESISTOR(C)	1/20W 5.6kΩ-J
R 2AK	103P502000	RESISTOR(C)	1/20W 390Ω-J	R 2DB	103P501030	RESISTOR(C)	1/20W 100Ω-J
R 2AL	103P501040	RESISTOR(C)	1/20W 120Ω-J	R 2DC	103P509050	RESISTOR(C)	0Ω RM1608
R 2AM	103P501040	RESISTOR(C)	1/20W 120Ω-J	R 2DF	103P500040	METAL RESISTOR(C)	1/16W 18Ω-J
R 2AN	103P509050	RESISTOR(C)	0Ω RM1608	R 2DG	103P500040	METAL RESISTOR(C)	1/16W 18Ω-J
R 2AQ	103P509050	RESISTOR(C)	0Ω RM1608	R 2DH	103P501090	RESISTOR(C)	1/20W 330Ω-J
R 2AR	103P501030	RESISTOR(C)	1/20W 100Ω-J	R 2E0	103P702060	METAL RESISTOR(C)	1/16W 1.2kΩ-J
R 2AS	103P501030	RESISTOR(C)	1/20W 100Ω-J	R 2E1	103P702090	METAL RESISTOR(C)	1/16W 2.2kΩ-J
R 2AT	103P502040	RESISTOR(C)	1/20W 820Ω-J	R 2E2	103P501030	RESISTOR(C)	1/20W 100Ω-J
R 2AV	103P502010	RESISTOR(C)	1/20W 470Ω-J	R 2E3	103P701030	METAL RESISTOR(C)	1/16W 100Ω-J
R 2B1	103P492050	METAL RESISTOR(C)	1/16W 1.0kΩ-F	R 2E4	103P701030	METAL RESISTOR(C)	1/16W 100Ω-J
R 2B2	103P493070	METAL RESISTOR(C)	1/16W 3.3kΩ-F	R 2E5	103P504050	RESISTOR(C)	1/20W 47kΩ-J
R 2B3	103P504030	RESISTOR(C)	1/20W 33kΩ-J	R 2E6	103P706010	METAL RESISTOR(C)	1/16W 1MΩ-J
R 2B4	103P504010	RESISTOR(C)	1/20W 22kΩ-J	R 2E7	103P702050	METAL RESISTOR(C)	1/16W 1kΩ-J
R 2B5	103P493050	METAL RESISTOR(C)	1/16W 2.7kΩ-F	R 2EA	103P502080	RESISTOR(C)	1/20W 2.7kΩ-J
R 2B6	103P492010	METAL RESISTOR(C)	1/16W 680Ω-F	R 2EB	103P504020	RESISTOR(C)	1/20W 27kΩ-J
R 2B7	103P702010	METAL RESISTOR(C)	1/16W 470Ω-J	R 2F0	103P703030	METAL RESISTOR(C)	1/16W 4.7kΩ-J
R 2B8	103P701030	METAL RESISTOR(C)	1/16W 100Ω-J	R 2F1	103P703020	METAL RESISTOR(C)	1/16W 3.9kΩ-J
R 2B9	103P503040	RESISTOR(C)	1/20W 5.6kΩ-J	R 2F2	103P702070	METAL RESISTOR(C)	1/16W 1.5kΩ-J
R 2BA	103P501010	RESISTOR(C)	1/20W 68Ω-J	R 2F3	103P702050	METAL RESISTOR(C)	1/16W 1kΩ-J
R 2BB	103P509050	RESISTOR(C)	0Ω RM1608	R 2F4	103P702050	METAL RESISTOR(C)	1/16W 1kΩ-J
R 2BC	103P509050	RESISTOR(C)	0Ω RM1608	R 2F5	103P702040	METAL RESISTOR(C)	1/16W 820Ω-J [A, B]
R 2BD	103P503040	RESISTOR(C)	1/20W 5.6kΩ-J	R 2F5	103P703020	METAL RESISTOR(C)	1/16W 3.9kΩ-J [E]
R 2BE	103P500010	RESISTOR(C)	1/20W 10Ω-J	R 2F7	103P702020	METAL RESISTOR(C)	1/16W 560Ω-J
R 2BF	103P500090	RESISTOR(C)	1/20W 47Ω-J	R 2F8	103P702020	METAL RESISTOR(C)	1/16W 560Ω-J
R 2BG	103P509050	RESISTOR(C)	0Ω RM1608	R 2F9	103P702070	METAL RESISTOR(C)	1/16W 1.5kΩ-J

SYMBOL NO.	PARTS NO.	PARTS NAME	DESCRIPTION	SYMBOL NO.	PARTS NO.	PARTS NAME	DESCRIPTION
R 2G0	103P709050	METAL RESISTOR (C)	1/16W 0Ω	R 2007	103P502030	RESISTOR (C)	1/20W 680Ω-J
R 2G1	103P702050	METAL RESISTOR (C)	1/16W 1kΩ-J	R 2008	103P502030	RESISTOR (C)	1/20W 680Ω-J
R 2G2	103P702080	METAL RESISTOR (C)	1/16W 1.8kΩ-J	R 2009	103P508040	RESISTOR (C)	1/20W 2.2Ω-K
R 2G3	103P702050	METAL RESISTOR (C)	1/16W 1kΩ-J	R 2010	103P508040	RESISTOR (C)	1/20W 2.2Ω-K
R 2G4	103P704060	METAL RESISTOR (C)	1/16W 56kΩ-J	R 2011	103P501030	RESISTOR (C)	1/20W 100Ω-J
R 2G5	103P704060	METAL RESISTOR (C)	1/16W 56kΩ-J	R 2012	103P502050	RESISTOR (C)	1/20W 1kΩ-J
R 2G6	103P702050	METAL RESISTOR (C)	1/16W 1kΩ-J	R 2013	103P495030	METAL RESISTOR (C)	1/16W 15kΩ-F
R 2H0	103P703030	METAL RESISTOR (C)	1/16W 4.7kΩ-J	R 2014	103P492050	METAL RESISTOR (C)	1/16W 1.0kΩ-F
R 2H1	103P703020	METAL RESISTOR (C)	1/16W 3.9kΩ-J	R 2017	103P502030	RESISTOR (C)	1/20W 680Ω-J
R 2H2	103P702050	METAL RESISTOR (C)	1/16W 1kΩ-J	R 2018	103P501030	RESISTOR (C)	1/20W 100Ω-J
R 2H3	103P702020	METAL RESISTOR (C)	1/16W 560Ω-J	R 2019	103P491030	METAL RESISTOR (C)	1/16W 330Ω-F
R 2H4	103P702080	METAL RESISTOR (C)	1/16W 1.8kΩ-J	R 2020	109P117010	FUSE	0.025-M(3.15A)
R 2H6	103P702050	METAL RESISTOR (C)	1/16W 1kΩ-J	R 2021	103P491010	METAL RESISTOR (C)	1/16W 270Ω-F
R 2H7	103P702050	METAL RESISTOR (C)	1/16W 1kΩ-J	R 2022	103P503000	RESISTOR (C)	1/20W 2.7kΩ-J
R 2H8	103P702090	METAL RESISTOR (C)	1/16W 2.2kΩ-J	R 2023	103P503000	RESISTOR (C)	1/20W 2.7kΩ-J
R 2H9	103P702040	METAL RESISTOR (C)	1/16W 820Ω-J	R 2024	103P501030	RESISTOR (C)	1/20W 100Ω-J
R 2J0	103P493070	METAL RESISTOR (C)	1/16W 3.3kΩ-F	R 2025	103P503040	RESISTOR (C)	1/20W 5.6kΩ-J
R 2J1	103P493070	METAL RESISTOR (C)	1/16W 3.3kΩ-F	R 2026	103P492060	METAL RESISTOR (C)	1/16W 1.1kΩ-F
R 2J2	103P491070	METAL RESISTOR (C)	1/16W 470Ω-F	R 2027	103P492050	METAL RESISTOR (C)	1/16W 1.0kΩ-F
R 2J3	103P492090	RESISTOR (C)	1/16W 1.5kΩ-F	R 2028	103P503080	RESISTOR (C)	1/20W 12kΩ-J
R 2J4	103P492050	METAL RESISTOR (C)	1/16W 1.0kΩ-F	R 2029	103P504090	RESISTOR (C)	1/20W 100kΩ-J
R 2J5	103P492050	METAL RESISTOR (C)	1/16W 1.0kΩ-F	R 2031	103P494090	METAL RESISTOR (C)	1/16W 10kΩ-F
R 2J6	103P493000	METAL RESISTOR (C)	1/16W 1.6kΩ-F	R 2032	103P494070	METAL RESISTOR (C)	1/16W 8.2kΩ-F
R 2J7	103P701050	METAL RESISTOR (C)	1/16W 150Ω-J	R 2033	103P493090	METAL RESISTOR (C)	1/16W 3.9kΩ-F
R 2J8	103P702070	METAL RESISTOR (C)	1/16W 1.5kΩ-J	R 300	103P702090	METAL RESISTOR (C)	1/16W 2.2kΩ-J
R 2J9	103P701090	METAL RESISTOR (C)	1/16W 330Ω-J	R 301	103P703030	METAL RESISTOR (C)	1/16W 4.7kΩ-J
R 2K0	103P703010	METAL RESISTOR (C)	1/16W 3.3kΩ-J	R 302	103P704000	METAL RESISTOR (C)	1/16W 18kΩ-J
R 2K1	103P703010	METAL RESISTOR (C)	1/16W 3.3kΩ-J	R 303	103P702010	METAL RESISTOR (C)	1/16W 470Ω-J
R 2K2	103P508040	RESISTOR (C)	1/20W 2.2Ω-K	R 304	103P703050	METAL RESISTOR (C)	1/16W 6.8kΩ-J
R 2K3	103P508040	RESISTOR (C)	1/20W 2.2Ω-K	R 308	103P500010	RESISTOR (C)	1/20W 10Ω-J
R 2K4	103P502070	RESISTOR (C)	1/20W 1.5kΩ-J [A, B]	R 309	103P704010	METAL RESISTOR (C)	1/16W 22kΩ-J
R 2K4	103P502060	RESISTOR (C)	1/20W 1.2kΩ-J [E]	R 310	103P701040	METAL RESISTOR (C)	1/16W 120Ω-J
R 2L0	103P702050	METAL RESISTOR (C)	1/16W 1kΩ-J	R 311	103P705000	METAL RESISTOR (C)	1/16W 120kΩ-J
R 2P0	103P502070	RESISTOR (C)	1/20W 1.5kΩ-J	R 312	103P703040	METAL RESISTOR (C)	1/16W 5.6kΩ-J
R 2P1	103P493020	METAL RESISTOR (C)	1/16W 2kΩ-F	R 313	103P703010	METAL RESISTOR (C)	1/16W 3.3kΩ-J
R 2P2	103P491080	METAL RESISTOR (C)	1/16W 510Ω-F	R 314	103P503090	RESISTOR (C)	1/20W 15kΩ-J
R 2P3	103P702050	METAL RESISTOR (C)	1/16W 1kΩ-J	R 315	103P503010	RESISTOR (C)	1/20W 3.3kΩ-J
R 2P4	103P701030	METAL RESISTOR (C)	1/16W 100Ω-J	R 316	103P705000	METAL RESISTOR (C)	1/16W 120kΩ-J
R 2P5	103P508040	RESISTOR (C)	1/20W 2.2Ω-K	R 317	103P705000	METAL RESISTOR (C)	1/16W 120kΩ-J
R 2P6	103P508040	RESISTOR (C)	1/20W 2.2Ω-K	R 318	103P503020	RESISTOR (C)	1/20W 3.9kΩ-J
R 2P7	103P504070	RESISTOR (C)	1/20W 68kΩ-J	R 320	103P508040	RESISTOR (C)	1/20W 2.2Ω-K
R 2P8	103P501030	RESISTOR (C)	1/20W 100Ω-J	R 321	103P508040	RESISTOR (C)	1/20W 2.2Ω-K
R 2R0	103P508040	RESISTOR (C)	1/20W 2.2Ω-K	R 322	103P703050	METAL RESISTOR (C)	1/16W 6.8kΩ-J
R 2R1	103P508040	RESISTOR (C)	1/20W 2.2Ω-K	R 323	103P503000	RESISTOR (C)	1/20W 2.7kΩ-J
R 2V0	103P702080	METAL RESISTOR (C)	1/16W 1.8kΩ-J	R 324	103P502090	RESISTOR (C)	1/20W 2.2kΩ-J
R 2V1	103P703030	METAL RESISTOR (C)	1/16W 4.7kΩ-J	R 325	103P502000	RESISTOR (C)	1/20W 390Ω-J
R 2V2	103P702080	METAL RESISTOR (C)	1/16W 1.8kΩ-J	R 350	103P702090	METAL RESISTOR (C)	1/16W 2.2kΩ-J
R 2V3	103P703030	METAL RESISTOR (C)	1/16W 4.7kΩ-J	R 351	103P702090	METAL RESISTOR (C)	1/16W 2.2kΩ-J
R 2000	103P494070	METAL RESISTOR (C)	1/16W 8.2kΩ-F	R 354	103P703060	METAL RESISTOR (C)	1/16W 8.2kΩ-J
R 2001	103P493090	METAL RESISTOR (C)	1/16W 3.9kΩ-F	R 355	103P703060	METAL RESISTOR (C)	1/16W 8.2kΩ-J
R 2002	103P509090	RESISTOR (C)	1/20W 75Ω-J	R 356	103P704050	METAL RESISTOR (C)	1/16W 47kΩ-J
R 2003	103P491070	METAL RESISTOR (C)	1/16W 470Ω-F	R 357	103P704050	METAL RESISTOR (C)	1/16W 47kΩ-J
R 2004	103P491050	METAL RESISTOR (C)	1/16W 390Ω-F	R 358	103P704050	METAL RESISTOR (C)	1/16W 47kΩ-J
R 2005	103P509090	RESISTOR (C)	1/20W 75Ω-J	R 359	103P704050	METAL RESISTOR (C)	1/16W 47kΩ-J
R 2006	103P509090	RESISTOR (C)	1/20W 75Ω-J	R 360	103P703020	METAL RESISTOR (C)	1/16W 3.9kΩ-J

SYMBOL NO.	PARTS NO.	PARTS NAME	DESCRIPTION	SYMBOL NO.	PARTS NO.	PARTS NAME	DESCRIPTION
R 361	103P703020	METAL RESISTOR(C)	1/16W 3.9kΩ-J	R 3BX	103P503090	RESISTOR(C)	1/20W 15kΩ-J
R 362	103P501020	RESISTOR(C)	1/20W 82Ω-J	R 3BY	103P502060	RESISTOR(C)	1/20W 1.2kΩ-J
R 363	103P501020	RESISTOR(C)	1/20W 82Ω-J	R 3C0	103P495030	METAL RESISTOR(C)	1/16W 15kΩ-F
R 364	103P706040	METAL RESISTOR(C)	1/16W 1.8MΩ-J	R 3C1	103P493040	METAL RESISTOR(C)	1/16W 2.4Ω-F
R 365	103P701020	METAL RESISTOR(C)	1/16W 82Ω-J	R 3C2	103P504010	RESISTOR(C)	1/20W 22kΩ-J
R 366	103P502010	RESISTOR(C)	1/20W 470Ω-J	R 3C3	103P703030	METAL RESISTOR(C)	1/16W 4.7kΩ-J
R 367	103P703070	METAL RESISTOR(C)	1/16W 10kΩ-J	R 3C4	103P704010	METAL RESISTOR(C)	1/16W 22kΩ-J
R 368	103P703070	METAL RESISTOR(C)	1/16W 10kΩ-J	R 3C5	103P704050	METAL RESISTOR(C)	1/16W 47kΩ-J
R 3A0	103P503070	RESISTOR(C)	1/20W 10kΩ-J	R 3C6	103P702040	METAL RESISTOR(C)	1/16W 820Ω-J
R 3A1	103P493040	METAL RESISTOR(C)	1/16W 2.4Ω-F	R 3C7	103P702090	METAL RESISTOR(C)	1/16W 2.2kΩ-J
R 3A2	103P504010	RESISTOR(C)	1/20W 22kΩ-J	R 3CA	103P504060	RESISTOR(C)	1/20W 56kΩ-J
R 3A3	103P703030	METAL RESISTOR(C)	1/16W 4.7kΩ-J	R 3CB	103P503050	RESISTOR(C)	1/20W 6.8kΩ-J
R 3A4	103P704010	METAL RESISTOR(C)	1/16W 22kΩ-J	R 3CC	103P503070	RESISTOR(C)	1/20W 10kΩ-J
R 3A5	103P704050	METAL RESISTOR(C)	1/16W 47kΩ-J	R 3CD	103P503010	RESISTOR(C)	1/20W 3.3kΩ-J
R 3A6	103P702040	METAL RESISTOR(C)	1/16W 820Ω-J	R 3CF	103P503070	RESISTOR(C)	1/20W 10kΩ-J
R 3A7	103P702090	METAL RESISTOR(C)	1/16W 2.2kΩ-J	R 3CG	103P505040	RESISTOR(C)	1/20W 270kΩ-J
R 3AA	103P509050	RESISTOR(C)	0Ω RM1608	R 3CH	103P493080	METAL RESISTOR(C)	1/16W 3.6kΩ-F
R 3AC	103P503020	RESISTOR(C)	1/20W 3.9kΩ-J	R 3CJ	103P502070	RESISTOR(C)	1/20W 1.5kΩ-J [A, B]
R 3AD	103P504030	RESISTOR(C)	1/20W 33kΩ-J	R 3CJ	103P502090	RESISTOR(C)	1/20W 2.2kΩ-J [E]
R 3AF	103P503000	RESISTOR(C)	1/20W 2.7kΩ-J	R 3CK	103P504080	RESISTOR(C)	1/20W 82kΩ-J
R 3AH	103P504030	RESISTOR(C)	1/20W 33kΩ-J	R 3CL	103P503060	RESISTOR(C)	1/20W 8.2kΩ-J
R 3AJ	103P503070	RESISTOR(C)	1/20W 10kΩ-J	R 3CM	103P503090	RESISTOR(C)	1/20W 15kΩ-J
R 3AK	103P502050	RESISTOR(C)	1/20W 1kΩ-J	R 3CN	103P504020	RESISTOR(C)	1/20W 27kΩ-J
R 3AL	103P503060	RESISTOR(C)	1/20W 8.2kΩ-J	R 3CQ	103P501050	RESISTOR(C)	1/20W 150Ω-J
R 3AM	103P503090	RESISTOR(C)	1/20W 15kΩ-J	R 3CR	103P505030	RESISTOR(C)	1/20W 220kΩ-J
R 3AN	103P504040	RESISTOR(C)	1/20W 39kΩ-J	R 3CS	103P505030	RESISTOR(C)	1/20W 220kΩ-J
R 3AP	103P501070	RESISTOR(C)	1/20W 220Ω-J	R 3CT	103P503080	RESISTOR(C)	1/20W 12kΩ-J
R 3AQ	103P501070	RESISTOR(C)	1/20W 220Ω-J	R 3CU	103P501030	RESISTOR(C)	1/20W 100Ω-J
R 3AR	103P504050	RESISTOR(C)	1/20W 47kΩ-J	R 3CW	103P505000	RESISTOR(C)	1/20W 120kΩ-J
R 3AS	103P504050	RESISTOR(C)	1/20W 47kΩ-J	R 3CX	103P492040	RESISTOR(C)	1/16W 910Ω-F
R 3AT	103P502090	RESISTOR(C)	1/20W 2.2kΩ-J	R 3CY	103P503030	RESISTOR(C)	1/20W 4.7kΩ-J
R 3AU	103P502090	RESISTOR(C)	1/20W 2.2kΩ-J	R 3CZ	103P502050	RESISTOR(C)	1/20W 1kΩ-J
R 3AW	103P502050	RESISTOR(C)	1/20W 1kΩ-J	R 3D0	103P703010	METAL RESISTOR(C)	1/16W 3.3kΩ-J
R 3AX	103P504050	RESISTOR(C)	1/20W 47kΩ-J	R 3D1	103P504020	RESISTOR(C)	1/20W 27kΩ-J
R 3AY	103P505000	RESISTOR(C)	1/20W 120kΩ-J	R 3D2	103P503000	RESISTOR(C)	1/20W 2.7kΩ-J
R 3B0	103P504010	RESISTOR(C)	1/20W 22kΩ-J	R 3D3	103P702070	METAL RESISTOR(C)	1/16W 1.5kΩ-J
R 3BB	103P503070	RESISTOR(C)	1/20W 10kΩ-J	R 3D4	103P701050	METAL RESISTOR(C)	1/16W 150Ω-J
R 3BC	103P502080	RESISTOR(C)	1/20W 2.7kΩ-J	R 3D5	103P502090	RESISTOR(C)	1/20W 2.2kΩ-J
R 3BD	103P503080	RESISTOR(C)	1/20W 12kΩ-J	R 3D6	103P502090	RESISTOR(C)	1/20W 2.2kΩ-J
R 3BE	103P494060	METAL RESISTOR(C)	1/16W 7.5kΩ-F	R 3D7	103P702060	METAL RESISTOR(C)	1/16W 1.2kΩ-J
R 3BF	103P504000	RESISTOR(C)	1/20W 18kΩ-J	R 3D8	103P703050	METAL RESISTOR(C)	1/16W 6.8kΩ-J
R 3BG	103P506010	RESISTOR(C)	1/20W 1MΩ-J	R 3DA	103P502090	RESISTOR(C)	1/20W 2.2kΩ-J
R 3BH	103P505080	RESISTOR(C)	1/20W 560kΩ-J	R 3DB	103P494090	METAL RESISTOR(C)	1/16W 10kΩ-F
R 3BJ	103P504010	RESISTOR(C)	1/20W 22kΩ-J	R 3DD	103P494090	METAL RESISTOR(C)	1/16W 10kΩ-F
R 3BK	103P503070	RESISTOR(C)	1/20W 10kΩ-J	R 3DE	103P503060	RESISTOR(C)	1/20W 8.2kΩ-J
R 3BL	103P504070	RESISTOR(C)	1/20W 68kΩ-J	R 3DF	103P503030	RESISTOR(C)	1/20W 4.7kΩ-J
R 3BN	103P504000	RESISTOR(C)	1/20W 18kΩ-J	R 3DG	103P503070	RESISTOR(C)	1/20W 10kΩ-J
R 3BP	103P502010	RESISTOR(C)	1/20W 470Ω-J	R 3DH	103P502050	RESISTOR(C)	1/20W 1kΩ-J
R 3BQ	103P504050	RESISTOR(C)	1/20W 47kΩ-J	R 3DJ	103P503060	RESISTOR(C)	1/20W 8.2kΩ-J
R 3BR	103P494030	METAL RESISTOR(C)	1/16W 5.6kΩ-F	R 3DK	103P502020	RESISTOR(C)	1/20W 560Ω-J
R 3BS	103P495070	METAL RESISTOR(C)	1/16W 22kΩ-F	R 3DL	103P503070	RESISTOR(C)	1/20W 10kΩ-J
R 3BT	103P495070	METAL RESISTOR(C)	1/16W 22kΩ-F	R 3DM	103P502050	RESISTOR(C)	1/20W 1kΩ-J
R 3BU	103P503090	RESISTOR(C)	1/20W 15kΩ-J	R 3DN	103P503000	RESISTOR(C)	1/20W 2.7kΩ-J
R 3BV	103P502070	RESISTOR(C)	1/20W 1.5kΩ-J	R 3DP	103P502020	RESISTOR(C)	1/20W 560Ω-J
R 3BW	103P502070	RESISTOR(C)	1/20W 1.5kΩ-J	R 3DQ	103P494070	METAL RESISTOR(C)	1/16W 8.2kΩ-F

SYMBOL NO.	PARTS NO.	PARTS NAME	DESCRIPTION		SYMBOL NO.	PARTS NO.	PARTS NAME	DESCRIPTION
R 3DR	103P494090	METAL RESISTOR(C)	1/16W 10kΩ-F		R 3GH	103P501030	RESISTOR(C)	1/20W 100Ω-J
R 3DS	103P503060	RESISTOR(C)	1/20W 8.2kΩ-J		R 3GJ	103P492050	METAL RESISTOR(C)	1/16W 1.0kΩ-F
R 3DT	103P504050	RESISTOR(C)	1/20W 47kΩ-J		R 3GK	103P492050	METAL RESISTOR(C)	1/16W 1.0kΩ-F
R 3DU	103P504000	RESISTOR(C)	1/20W 18kΩ-J		R 3GL	103P496030	RESISTOR(C)	1/16W 39kΩ-F
R 3DV	103P504050	RESISTOR(C)	1/20W 47kΩ-J		R 3GM	103P502090	RESISTOR(C)	1/20W 2.2kΩ-J
R 3DW	103P505040	RESISTOR(C)	1/20W 270kΩ-J		R 3GN	103P503000	RESISTOR(C)	1/20W 2.7kΩ-J
R 3DX	103P504090	RESISTOR(C)	1/20W 100kΩ-J		R 3GP	103P503070	RESISTOR(C)	1/20W 10kΩ-J
R 3DY	103P502080	RESISTOR(C)	1/20W 2.7kΩ-J		R 3GQ	103P503070	RESISTOR(C)	1/20W 10kΩ-J
R 3DZ	103P502020	RESISTOR(C)	1/20W 560Ω-J		R 3GR	103P503080	RESISTOR(C)	1/20W 12kΩ-J
R 3EA	103P503010	RESISTOR(C)	1/20W 3.3kΩ-J		R 3GU	103P501070	RESISTOR(C)	1/20W 220Ω-J
R 3EB	103P503010	RESISTOR(C)	1/20W 3.3kΩ-J		R 3GV	103P502010	RESISTOR(C)	1/20W 470Ω-J
R 3EC	103P504050	RESISTOR(C)	1/20W 47kΩ-J		R 3GW	103P504010	RESISTOR(C)	1/20W 22kΩ-J
R 3ED	103P502080	RESISTOR(C)	1/20W 2.7kΩ-J		R 3GX	103P503070	RESISTOR(C)	1/20W 10kΩ-J
R 3EE	103P502020	RESISTOR(C)	1/20W 560Ω-J		R 3GY	103P502090	RESISTOR(C)	1/20W 2.2kΩ-J
R 3EF	103P496030	RESISTOR(C)	1/16W 39kΩ-F		R 3GZ	103P503030	RESISTOR(C)	1/20W 4.7kΩ-J
R 3EG	103P495000	METAL RESISTOR(C)	1/16W 11kΩ-F		R 3HA	103P502060	RESISTOR(C)	1/20W 1.2kΩ-J
R 3EH	103P503060	RESISTOR(C)	1/20W 8.2kΩ-J		R 3HB	103P504020	RESISTOR(C)	1/20W 27kΩ-J
R 3EK	103P503010	RESISTOR(C)	1/20W 3.3kΩ-J		R 3HC	103P502090	RESISTOR(C)	1/20W 2.2kΩ-J
R 3EL	103P494090	METAL RESISTOR(C)	1/16W 10kΩ-F		R 3HD	103P502090	RESISTOR(C)	1/20W 2.2kΩ-J
R 3EM	103P493080	METAL RESISTOR(C)	1/16W 3.6kΩ-F		R 3HE	103P504000	RESISTOR(C)	1/20W 18kΩ-J
R 3EQ	103P502070	RESISTOR(C)	1/20W 1.5kΩ-J		R 3HF	103P503090	RESISTOR(C)	1/20W 15kΩ-J
R 3ER	103P502050	RESISTOR(C)	1/20W 1kΩ-J		R 3HJ	103P501030	RESISTOR(C)	1/20W 100Ω-J
R 3EU	103P503070	RESISTOR(C)	1/20W 10kΩ-J		R 3HK	103P504090	RESISTOR(C)	1/20W 100kΩ-J
R 3EV	103P503020	RESISTOR(C)	1/20W 3.9kΩ-J		R 3HL	103P501030	RESISTOR(C)	1/20W 100Ω-J
R 3EW	103P503020	RESISTOR(C)	1/20W 3.9kΩ-J		R 3HM	103P501030	RESISTOR(C)	1/20W 100Ω-J
R 3EX	103P501070	RESISTOR(C)	1/20W 220Ω-J		R 3HN	103P501070	RESISTOR(C)	1/20W 220Ω-J
R 3EY	103P502080	RESISTOR(C)	1/20W 2.7kΩ-J		R 3HR	103P502030	RESISTOR(C)	1/20W 680Ω-J
R 3EZ	103P502050	RESISTOR(C)	1/20W 1kΩ-J		R 3HS	103P505090	RESISTOR(C)	1/20W 680kΩ-J
R 3FA	103P490070	METAL RESISTOR(C)	1/16W 180Ω-F		R 3HT	103P504090	RESISTOR(C)	1/20W 100kΩ-J
R 3FB	103P493010	METAL RESISTOR(C)	1/16W 1.8kΩ-F		R 3MF	103P502050	RESISTOR(C)	1/20W 1kΩ-J
R 3FC	103P493010	METAL RESISTOR(C)	1/16W 1.8kΩ-F		R 3VA	103P502030	RESISTOR(C)	1/20W 680Ω-J
R 3FD	103P503070	RESISTOR(C)	1/20W 10kΩ-J		R 400	103P503000	RESISTOR(C)	1/20W 2.7kΩ-J
R 3FE	103P502050	RESISTOR(C)	1/20W 1kΩ-J		R 401	103P504070	RESISTOR(C)	1/20W 68kΩ-J
R 3FF	103P502060	RESISTOR(C)	1/20W 1.2kΩ-J		R 402	103P505010	RESISTOR(C)	1/20W 150kΩ-J
R 3FG	103P501030	RESISTOR(C)	1/20W 100Ω-J		R 403	103P505050	RESISTOR(C)	1/20W 330kΩ-J
R 3FH	103P503020	RESISTOR(C)	1/20W 3.9kΩ-J		R 404	103P505010	RESISTOR(C)	1/20W 150kΩ-J
R 3FJ	103P503000	RESISTOR(C)	1/20W 2.7kΩ-J		R 405	103P503060	RESISTOR(C)	1/20W 8.2kΩ-J
R 3FK	103P501030	RESISTOR(C)	1/20W 100Ω-J		R 406	103P504030	RESISTOR(C)	1/20W 33kΩ-J
R 3FL	103P502050	RESISTOR(C)	1/20W 1kΩ-J	[E]	R 407	103P504030	RESISTOR(C)	1/20W 33kΩ-J
R 3FM	103P502070	RESISTOR(C)	1/20W 1.5kΩ-J		R 408	103P505010	RESISTOR(C)	1/20W 150kΩ-J
R 3FN	103P501030	RESISTOR(C)	1/20W 100Ω-J		R 409	103P503010	RESISTOR(C)	1/20W 3.3kΩ-J
R 3FP	103P493020	METAL RESISTOR(C)	1/16W 2kΩ-F		R 410	103P503030	RESISTOR(C)	1/20W 4.7kΩ-J
R 3FQ	103P502070	RESISTOR(C)	1/20W 1.5kΩ-J		R 411	103P504050	RESISTOR(C)	1/20W 47kΩ-J
R 3FR	103P503020	RESISTOR(C)	1/20W 3.9kΩ-J		R 412	103P504050	RESISTOR(C)	1/20W 47kΩ-J
R 3FS	103P502030	RESISTOR(C)	1/20W 680Ω-J		R 414	103P495020	METAL RESISTOR(C)	1/16W 13kΩ-F
R 3FT	103P503030	RESISTOR(C)	1/20W 4.7kΩ-J		R 415	103P495010	METAL RESISTOR(C)	1/16W 12kΩ-F
R 3FU	103P503030	RESISTOR(C)	1/20W 4.7kΩ-J		R 418	103P498020	METAL RESISTOR(C)	1/16W 240kΩ-F
R 3FW	103P503090	RESISTOR(C)	1/20W 15kΩ-J	[A, B]	R 421	103P504090	RESISTOR(C)	1/20W 100kΩ-J
R 3FW	103P504010	RESISTOR(C)	1/20W 22kΩ-J	[E]	R 422	103P503040	RESISTOR(C)	1/20W 5.6kΩ-J
R 3FX	103P504040	RESISTOR(C)	1/20W 39kΩ-J		R 423	103P501070	RESISTOR(C)	1/20W 220Ω-J
R 3FY	103P504090	RESISTOR(C)	1/20W 100kΩ-J		R 424	103P502050	RESISTOR(C)	1/20W 1kΩ-J
R 3FZ	103P505010	RESISTOR(C)	1/20W 150kΩ-J		R 425	103P505020	RESISTOR(C)	1/20W 180kΩ-J
R 3GE	103P496030	RESISTOR(C)	1/16W 39kΩ-F		R 426	103P504020	RESISTOR(C)	1/20W 27kΩ-J
R 3GF	103P503070	RESISTOR(C)	1/20W 10kΩ-J		R 427	103P705080	METAL RESISTOR(C)	1/16W 560kΩ-J
R 3GG	103P502090	RESISTOR(C)	1/20W 2.2kΩ-J		R 431	103P503040	RESISTOR(C)	1/20W 5.6kΩ-J

SYMBOL NO.	PARTS NO.	PARTS NAME	DESCRIPTION
R 432	103P503040	RESISTOR(C)	1/20W 5.6kΩ-J
R 433	103P503070	RESISTOR(C)	1/20W 10kΩ-J
R 434	103P506010	RESISTOR(C)	1/20W 1MΩ-J
R 435	103P509050	RESISTOR(C)	0Ω RM1608
R 439	103P504090	RESISTOR(C)	1/20W 100kΩ-J
R 443	103P494090	METAL RESISTOR(C)	1/16W 10kΩ-F
R 444	103P494090	METAL RESISTOR(C)	1/16W 10kΩ-F
R 44A	103P494010	METAL RESISTOR(C)	1/16W 4.7kΩ-F
R 4B0	103P505030	RESISTOR(C)	1/20W 220kΩ-J
R 4B1	103P505040	RESISTOR(C)	1/20W 270kΩ-J
R 4B2	103P504020	RESISTOR(C)	1/20W 27kΩ-J
R 4B3	103P502080	RESISTOR(C)	1/20W 2.7kΩ-J
R 4B4	103P497010	METAL RESISTOR(C)	1/16W 82kΩ-F
R 4B5	103P496030	RESISTOR(C)	1/16W 39kΩ-F
R 4B6	103P495000	METAL RESISTOR(C)	1/16W 11kΩ-F
R 4B7	103P508040	RESISTOR(C)	1/20W 2.2Ω-K
R 4B8	103P508040	RESISTOR(C)	1/20W 2.2Ω-K
R 4B9	103P508040	RESISTOR(C)	1/20W 2.2Ω-K
R 4BF	103P503030	RESISTOR(C)	1/20W 4.7kΩ-J
R 4C0	103P502050	RESISTOR(C)	1/20W 1kΩ-J
R 4C1	103P501050	RESISTOR(C)	1/20W 150Ω-J
R 4C2	103P508050	RESISTOR(C)	1/16W 2.7Ω-K
R 4C3	103P508050	RESISTOR(C)	1/16W 2.7Ω-K
R 4C4	103P508050	RESISTOR(C)	1/16W 2.7Ω-K
R 4C5	103P508050	RESISTOR(C)	1/16W 2.7Ω-K
R 4C6	103P501060	RESISTOR(C)	1/20W 180Ω-J
R 4C7	103P504030	RESISTOR(C)	1/20W 33kΩ-J
R 4C8	103P504010	RESISTOR(C)	1/20W 22kΩ-J
R 4CP	103P503030	RESISTOR(C)	1/20W 4.7kΩ-J
R 4D0	103P504020	RESISTOR(C)	1/20W 27kΩ-J
R 4D1	103P504030	RESISTOR(C)	1/20W 33kΩ-J
R 4D2	103P508040	RESISTOR(C)	1/20W 2.2Ω-K
R 4D3	103P508040	RESISTOR(C)	1/20W 2.2Ω-K
R 4D4	103P508040	RESISTOR(C)	1/20W 2.2Ω-K
R 4D6	103P501070	RESISTOR(C)	1/20W 220Ω-J
R 4G0	103P496050	METAL RESISTOR(C)	1/16W 47kΩ-F
R 4G1	103P496050	METAL RESISTOR(C)	1/16W 47kΩ-F
R 4G2	103P504050	RESISTOR(C)	1/20W 47kΩ-J
R 4G3	103P504060	RESISTOR(C)	1/20W 56kΩ-J
R 4G4	103P502050	RESISTOR(C)	1/20W 1kΩ-J
R 4G5	103P504020	RESISTOR(C)	1/20W 27kΩ-J
R 4G6	103P505040	RESISTOR(C)	1/20W 270kΩ-J
R 4G7	103P503070	RESISTOR(C)	1/20W 10kΩ-J
R 4G8	103P503070	RESISTOR(C)	1/20W 10kΩ-J
R 4JH	103P509050	RESISTOR(C)	0Ω RM1608
R 4JP	103P509050	RESISTOR(C)	0Ω RM1608
R 500	103P703070	METAL RESISTOR(C)	1/16W 10kΩ-J
R 501	103P702070	METAL RESISTOR(C)	1/16W 1.5kΩ-J
R 502	103P703070	METAL RESISTOR(C)	1/16W 10kΩ-J
R 503	103P505000	RESISTOR(C)	1/20W 120kΩ-J
R 504	103P504030	RESISTOR(C)	1/20W 33kΩ-J
R 505	103P504030	RESISTOR(C)	1/20W 33kΩ-J
R 506	103P503010	RESISTOR(C)	1/20W 3.3kΩ-J
R 507	103P495040	METAL RESISTOR(C)	1/16W 16kΩ-F
R 508	103P495030	METAL RESISTOR(C)	1/16W 15kΩ-F

SYMBOL NO.	PARTS NO.	PARTS NAME	DESCRIPTION
R 509	103P495020	METAL RESISTOR(C)	1/16W 13kΩ-F
R 510	103P495050	METAL RESISTOR(C)	1/16W 18kΩ-F
R 511	103P503000	RESISTOR(C)	1/20W 2.7kΩ-J
R 512	103P503040	RESISTOR(C)	1/20W 5.6kΩ-J
R 513	103P503090	RESISTOR(C)	1/20W 15kΩ-J
R 514	103P501080	RESISTOR(C)	1/20W 270Ω-J
R 515	103P503030	RESISTOR(C)	1/20W 4.7kΩ-J
R 516	103P503000	RESISTOR(C)	1/20W 2.7kΩ-J
R 517	103P503050	RESISTOR(C)	1/20W 6.8kΩ-J
R 518	103P503070	RESISTOR(C)	1/20W 10kΩ-J
R 519	103P504060	RESISTOR(C)	1/20W 56kΩ-J
R 520	103P503040	RESISTOR(C)	1/20W 5.6kΩ-J
R 521	103P505000	RESISTOR(C)	1/20W 120kΩ-J
R 522	103P495010	METAL RESISTOR(C)	1/16W 12kΩ-F
R 523	103P504030	RESISTOR(C)	1/20W 33kΩ-J
R 524	103P503010	RESISTOR(C)	1/20W 3.3kΩ-J
R 528	103P502080	RESISTOR(C)	1/20W 2.7kΩ-J
R 571	103P352020	RESISTOR(C)	1/8W 560Ω-J
R 572	103P359050	RESISTOR(C)	1/8W 0Ω
R 5A1	103P501020	RESISTOR(C)	1/20W 82Ω-J
R 5A2	103P501030	RESISTOR(C)	1/20W 100Ω-J
R 5A3	103P497030	METAL RESISTOR(C)	1/16W 100kΩ-F
R 5A4	103P498070	METAL RESISTOR(C)	1/16W 390kΩ-F
R 5A5	103P502080	RESISTOR(C)	1/20W 2.7kΩ-J
R 5A6	103P502080	RESISTOR(C)	1/20W 2.7kΩ-J
R 5A7	103P502090	RESISTOR(C)	1/20W 2.2kΩ-J
R 5A8	103P504050	RESISTOR(C)	1/20W 47kΩ-J
R 5A9	103P504050	RESISTOR(C)	1/20W 47kΩ-J
R 5AA	103P503070	RESISTOR(C)	1/20W 10kΩ-J
R 5AB	103P503070	RESISTOR(C)	1/20W 10kΩ-J
R 5AC	103P502090	RESISTOR(C)	1/20W 2.2kΩ-J
R 5AD	103P502090	RESISTOR(C)	1/20W 2.2kΩ-J
R 5AE	103P503030	RESISTOR(C)	1/20W 4.7kΩ-J
R 5AF	103P503030	RESISTOR(C)	1/20W 4.7kΩ-J
R 5AG	103P500070	RESISTOR(C)	1/20W 33Ω-J
R 5AH	103P494000	METAL RESISTOR(C)	1/16W 4.3kΩ-F
R 5AJ	103P501040	RESISTOR(C)	1/20W 120Ω-J
R 5AL	103P495040	METAL RESISTOR(C)	1/16W 16kΩ-F
R 5AM	103P495040	METAL RESISTOR(C)	1/16W 16kΩ-F
R 5AP	103P505030	RESISTOR(C)	1/20W 220kΩ-J
R 5AQ	103P504060	RESISTOR(C)	1/20W 56kΩ-J
R 5AR	103P505030	RESISTOR(C)	1/20W 220kΩ-J
R 5AS	103P504000	RESISTOR(C)	1/20W 18kΩ-J
R 5AT	103P504010	RESISTOR(C)	1/20W 22kΩ-J
R 5AU	103P504070	RESISTOR(C)	1/20W 68kΩ-J
R 5AV	103P504070	RESISTOR(C)	1/20W 68kΩ-J
R 5AW	103P504010	RESISTOR(C)	1/20W 22kΩ-J
R 5AX	103P504010	RESISTOR(C)	1/20W 22kΩ-J
R 5AY	103P504050	RESISTOR(C)	1/20W 47kΩ-J
R 5B1	103P504010	RESISTOR(C)	1/20W 22kΩ-J
R 5B2	103P504010	RESISTOR(C)	1/20W 22kΩ-J
R 5B3	103P504010	RESISTOR(C)	1/20W 22kΩ-J
R 5B4	103P504000	RESISTOR(C)	1/20W 18kΩ-J
R 5B5	103P502050	RESISTOR(C)	1/20W 1kΩ-J
R 5B6	103P506010	RESISTOR(C)	1/20W 1MΩ-J

SYMBOL NO.	PARTS NO.	PARTS NAME	DESCRIPTION	SYMBOL NO.	PARTS NO.	PARTS NAME	DESCRIPTION
R 5B7	103P504000	RESISTOR(C)	1/20W 18k Ω -J	R 5JQ	103P509050	RESISTOR(C)	0 Ω RM1608
R 5B8	103P504030	RESISTOR(C)	1/20W 33k Ω -J	R 5KE	103P502010	RESISTOR(C)	1/20W 470 Ω -J
R 5BA	103P504050	RESISTOR(C)	1/20W 47k Ω -J	R 5KL	103P501020	RESISTOR(C)	1/20W 82 Ω -J
R 5BB	103P504060	RESISTOR(C)	1/20W 56k Ω -J	R 5KM	103P509010	METAL RESISTOR(C)	1/16W 8.2 Ω -K
R 5BC	103P505030	RESISTOR(C)	1/20W 220k Ω -J	R 5LC	103P502090	RESISTOR(C)	1/20W 2.2k Ω -J
R 5BD	103P504050	RESISTOR(C)	1/20W 47k Ω -J	R 5LD	103P504050	RESISTOR(C)	1/20W 47k Ω -J
R 5BE	103P504060	RESISTOR(C)	1/20W 56k Ω -J	R 5LE	103P505050	RESISTOR(C)	1/20W 330k Ω -J
R 5BF	103P505030	RESISTOR(C)	1/20W 220k Ω -J	R 5LF	103P505020	RESISTOR(C)	1/20W 180k Ω -J
R 5BG	103P504050	RESISTOR(C)	1/20W 47k Ω -J	R 5LG	103P492010	METAL RESISTOR(C)	1/16W 680 Ω -F
R 5BH	103P504050	RESISTOR(C)	1/20W 47k Ω -J	R 5LH	103P495070	METAL RESISTOR(C)	1/16W 22k Ω -F
R 5BK	103P496030	RESISTOR(C)	1/16W 39k Ω -F	R 5LJ	103P494070	METAL RESISTOR(C)	1/16W 8.2k Ω -F
R 5C1	103P503070	RESISTOR(C)	1/20W 10k Ω -J	R 5LK	103P506050	RESISTOR(C)	1/20W 2.2M Ω -J
R 5C2	103P504050	RESISTOR(C)	1/20W 47k Ω -J	R 5LL	103P503030	RESISTOR(C)	1/20W 4.7k Ω -J
R 5C4	103P504020	RESISTOR(C)	1/20W 27k Ω -J	R 5LM	103P504060	RESISTOR(C)	1/20W 56k Ω -J
R 5CB	103P503030	RESISTOR(C)	1/20W 4.7k Ω -J	R 5LN	103P402000	RESISTOR(C)	1/10W 390 Ω -J
R 5D0	103P504050	RESISTOR(C)	1/20W 47k Ω -J	R 5LP	103P491080	METAL RESISTOR(C)	1/16W 510 Ω -F
R 5D1	103P504050	RESISTOR(C)	1/20W 47k Ω -J	R 5LQ	103P492090	RESISTOR(C)	1/16W 1.5k Ω -F
R 5D2	103P503070	RESISTOR(C)	1/20W 10k Ω -J	R 5LR	103P495010	METAL RESISTOR(C)	1/16W 12k Ω -F
R 5D3	103P503070	RESISTOR(C)	1/20W 10k Ω -J	R 5LS	103P497060	METAL RESISTOR(C)	1/16W 130k Ω -F
R 5E0	103P501070	RESISTOR(C)	1/20W 220 Ω -J	R 5LT	103P498040	METAL RESISTOR(C)	1/16W 300k Ω -F
R 5E1	103P503080	RESISTOR(C)	1/20W 12k Ω -J	R 5LU	103P497050	METAL RESISTOR(C)	1/16W 120k Ω -F
R 5E2	103P503010	RESISTOR(C)	1/20W 3.3k Ω -J	R 5LV	103P493070	METAL RESISTOR(C)	1/16W 3.3k Ω -F
R 5E3	103P504050	RESISTOR(C)	1/20W 47k Ω -J	R 5LW	103P495070	METAL RESISTOR(C)	1/16W 22k Ω -F
R 5E4	103P503070	RESISTOR(C)	1/20W 10k Ω -J	R 5LX	103P494090	METAL RESISTOR(C)	1/16W 10k Ω -F
R 5EA	103P504050	RESISTOR(C)	1/20W 47k Ω -J	R 5LY	103P495010	METAL RESISTOR(C)	1/16W 12k Ω -F
R 5ED	103P504010	RESISTOR(C)	1/20W 22k Ω -J	R 5LZ	103P502090	RESISTOR(C)	1/20W 2.2k Ω -J
R 5EF	103P503020	RESISTOR(C)	1/20W 3.9k Ω -J	R 5MA	103P508090	METAL RESISTOR(C)	1/16W 5.6 Ω -K
R 5FA	103P503020	RESISTOR(C)	1/20W 3.9k Ω -J	R 5MB	103P508090	METAL RESISTOR(C)	1/16W 5.6 Ω -K
R 5FB	103P494020	METAL RESISTOR(C)	1/16W 5.1k Ω -F	R 5MJ	103P509050	RESISTOR(C)	0 Ω RM1608
R 5FC	103P503070	RESISTOR(C)	1/20W 10k Ω -J	R 5MK	103P509050	RESISTOR(C)	0 Ω RM1608
R 5FD	103P502090	RESISTOR(C)	1/20W 2.2k Ω -J	R 5RA	103P503070	RESISTOR(C)	1/20W 10k Ω -J
R 5FE	103P501030	RESISTOR(C)	1/20W 100 Ω -J	R 5US	103P409050	RESISTOR(C)	1/10W 0 Ω
R 5FF	103P503070	RESISTOR(C)	1/20W 10k Ω -J	R 5ZA	103P493090	METAL RESISTOR(C)	1/16W 3.9k Ω -F
R 5FG	103P501070	RESISTOR(C)	1/20W 220 Ω -J	R 5ZB	103P492050	METAL RESISTOR(C)	1/16W 1.0k Ω -F
R 5FH	103P502050	RESISTOR(C)	1/20W 1k Ω -J	R 5ZC	103P495000	METAL RESISTOR(C)	1/16W 11k Ω -F
R 5FJ	103P503070	RESISTOR(C)	1/20W 10k Ω -J	R 6A0	103P502050	RESISTOR(C)	1/20W 1k Ω -J
R 5FK	103P501090	RESISTOR(C)	1/20W 330 Ω -J	R 6A1	103P502060	RESISTOR(C)	1/20W 1.2k Ω -J
R 5FL	103P502030	RESISTOR(C)	1/20W 680 Ω -J	R 6A2	103P502050	RESISTOR(C)	1/20W 1k Ω -J
R 5FN	103P503070	RESISTOR(C)	1/20W 10k Ω -J	R 6A3	103P504010	RESISTOR(C)	1/20W 22k Ω -J
R 5FQ	103P494020	METAL RESISTOR(C)	1/16W 5.1k Ω -F	R 6A4	103P504010	RESISTOR(C)	1/20W 22k Ω -J
R 5FS	103P503050	RESISTOR(C)	1/20W 6.8k Ω -J	R 6A5	103P502060	RESISTOR(C)	1/20W 1.2k Ω -J
R 5FT	103P503050	RESISTOR(C)	1/20W 6.8k Ω -J	R 6A6	103P501080	RESISTOR(C)	1/20W 270 Ω -J
R 5FU	103P502020	RESISTOR(C)	1/20W 560 Ω -J	R 6A8	103P504090	RESISTOR(C)	1/20W 100k Ω -J
R 5FV	103P502020	RESISTOR(C)	1/20W 560 Ω -J	R 6A9	103P504090	RESISTOR(C)	1/20W 100k Ω -J
R 5FW	103P502020	RESISTOR(C)	1/20W 560 Ω -J	R 6AA	103P503060	RESISTOR(C)	1/20W 8.2k Ω -J
R 5FX	103P501030	RESISTOR(C)	1/20W 100 Ω -J	R 6AC	103P505090	RESISTOR(C)	1/20W 680k Ω -J
R 5FY	103P503070	RESISTOR(C)	1/20W 10k Ω -J	R 6AF	103P505090	RESISTOR(C)	1/20W 680k Ω -J
R 5FZ	103P503070	RESISTOR(C)	1/20W 10k Ω -J	R 6AH	103P503060	RESISTOR(C)	1/20W 8.2k Ω -J
R 5GA	103P493020	METAL RESISTOR(C)	1/16W 2k Ω -F	R 6AJ	103P505090	RESISTOR(C)	1/20W 680k Ω -J
R 5GB	103P492080	RESISTOR(C)	1/16W 1.3k Ω -F	R 6AM	103P505090	RESISTOR(C)	1/20W 680k Ω -J
R 5GC	103P492080	RESISTOR(C)	1/16W 1.3k Ω -F	R 6AN	103P494090	METAL RESISTOR(C)	1/16W 10k Ω -F
R 5GD	103P501070	RESISTOR(C)	1/20W 220 Ω -J	R 6AP	103P495040	METAL RESISTOR(C)	1/16W 16k Ω -F
R 5GE	103P502050	RESISTOR(C)	1/20W 1k Ω -J	R 6AQ	103P502090	RESISTOR(C)	1/20W 2.2k Ω -J
R 5JH	103P509050	RESISTOR(C)	0 Ω RM1608	R 6AR	103P502090	RESISTOR(C)	1/20W 2.2k Ω -J
R 5JP	103P509050	RESISTOR(C)	0 Ω RM1608	R 6AS	103P500070	RESISTOR(C)	1/20W 33 Ω -J

SYMBOL NO.	PARTS NO.	PARTS NAME	DESCRIPTION	SYMBOL NO.	PARTS NO.	PARTS NAME	DESCRIPTION
R 6AT	103P500070	RESISTOR(C)	1/20W 33Ω-J	R 801	103P504090	RESISTOR(C)	1/20W 100kΩ-J
R 6AU	103P504090	RESISTOR(C)	1/20W 100kΩ-J	R 802	103P504050	RESISTOR(C)	1/20W 47kΩ-J
R 6AV	103P504090	RESISTOR(C)	1/20W 100kΩ-J	R 803	103P504050	RESISTOR(C)	1/20W 47kΩ-J
R 6AW	103P505090	RESISTOR(C)	1/20W 680kΩ-J	R 804	103P504050	RESISTOR(C)	1/20W 47kΩ-J
R 6B6	103P503030	RESISTOR(C)	1/20W 4.7kΩ-J	R 805	103P504050	RESISTOR(C)	1/20W 47kΩ-J
R 6B8	103P504010	RESISTOR(C)	1/20W 22kΩ-J	R 806	103P502090	RESISTOR(C)	1/20W 2.2kΩ-J
R 6B9	103P504010	RESISTOR(C)	1/20W 22kΩ-J	R 807	103P502090	RESISTOR(C)	1/20W 2.2kΩ-J
R 6BA	103P503060	RESISTOR(C)	1/20W 8.2kΩ-J	R 808	103P505030	RESISTOR(C)	1/20W 220kΩ-J
R 6BB	103P503060	RESISTOR(C)	1/20W 8.2kΩ-J	R 809	103P505030	RESISTOR(C)	1/20W 220kΩ-J
R 6C1	103P506050	RESISTOR(C)	1/20W 2.2MΩ-J	R 810	103P505030	RESISTOR(C)	1/20W 220kΩ-J
R 6C2	103P503090	RESISTOR(C)	1/20W 15kΩ-J	R 812	103P502050	RESISTOR(C)	1/20W 1kΩ-J
R 6C4	103P503070	RESISTOR(C)	1/20W 10kΩ-J	R 813	103P502060	RESISTOR(C)	1/20W 1.2kΩ-J
R 6C5	103P502050	RESISTOR(C)	1/20W 1kΩ-J	R 814	103P506050	RESISTOR(C)	1/20W 2.2MΩ-J
R 6C6	103P502070	RESISTOR(C)	1/20W 1.5kΩ-J	R 815	103P503070	RESISTOR(C)	1/20W 10kΩ-J
R 6C7	103P502050	RESISTOR(C)	1/20W 1kΩ-J	R 817	103P506010	RESISTOR(C)	1/20W 1MΩ-J
R 6C9	103P509050	RESISTOR(C)	0Ω RM1608	R 818	103P504050	RESISTOR(C)	1/20W 47kΩ-J
R 6D0	103P505010	RESISTOR(C)	1/20W 150kΩ-J	R 820	103P527030	METAL RESISTOR(C)	1/10W 100kΩ-D
R 6D2	103P509050	RESISTOR(C)	0Ω RM1608	R 822	103P527030	METAL RESISTOR(C)	1/10W 100kΩ-D
R 6D3	103P508040	RESISTOR(C)	1/20W 2.2Ω-K	R 824	103P502050	RESISTOR(C)	1/20W 1kΩ-J
R 6D4	103P508040	RESISTOR(C)	1/20W 2.2Ω-K	R 825	103P503070	RESISTOR(C)	1/20W 10kΩ-J
R 6D5	103P508040	RESISTOR(C)	1/20W 2.2Ω-K	R 829	103P503060	RESISTOR(C)	1/20W 8.2kΩ-J
R 6D6	103P508040	RESISTOR(C)	1/20W 2.2Ω-K	R 833	103P504090	RESISTOR(C)	1/20W 100kΩ-J
R 6D7	103P504030	RESISTOR(C)	1/20W 33kΩ-J	R 840	103P502090	RESISTOR(C)	1/20W 2.2kΩ-J
R 6D8	103P504060	RESISTOR(C)	1/20W 56kΩ-J	R 841	103P506070	RESISTOR(C)	1/16W 3.3MΩ-K
R 6D9	103P503050	RESISTOR(C)	1/20W 6.8kΩ-J [E]	R 842	103P506070	RESISTOR(C)	1/16W 3.3MΩ-K
R 6D9	103P703050	METAL RESISTOR(C)	1/16W 6.8kΩ-J [A, B]	R 843	103P506070	RESISTOR(C)	1/16W 3.3MΩ-K
R 6E0	103P504010	RESISTOR(C)	1/20W 22kΩ-J	R 852	103P502050	RESISTOR(C)	1/20W 1kΩ-J
R 6E1	103P509050	RESISTOR(C)	0Ω RM1608 [E]	R 853	103P502050	RESISTOR(C)	1/20W 1kΩ-J
R 6E2	103P509050	RESISTOR(C)	0Ω RM1608 [E]	R 854	103P502050	RESISTOR(C)	1/20W 1kΩ-J
R 6E3	103P504010	RESISTOR(C)	1/20W 22kΩ-J	R 855	103P503030	RESISTOR(C)	1/20W 4.7kΩ-J
R 6E4	103P503090	RESISTOR(C)	1/20W 15kΩ-J	R 856	103P502090	RESISTOR(C)	1/20W 2.2kΩ-J
R 6E5	103P504000	RESISTOR(C)	1/20W 18kΩ-J	R 860	103P703030	METAL RESISTOR(C)	1/16W 4.7kΩ-J
R 6E6	103P504050	RESISTOR(C)	1/20W 47kΩ-J	R 906	103P503070	RESISTOR(C)	1/20W 10kΩ-J
R 6E7	103P503070	RESISTOR(C)	1/20W 10kΩ-J	R 907	103P503010	RESISTOR(C)	1/20W 3.3kΩ-J
R 6F0	103P701030	METAL RESISTOR(C)	1/16W 100Ω-J [A, B]	R 908	103P505090	RESISTOR(C)	1/20W 680kΩ-J
R 6F1	103P703030	METAL RESISTOR(C)	1/16W 4.7kΩ-J	R 909	103P505010	RESISTOR(C)	1/20W 150kΩ-J
R 6F4	103P501030	RESISTOR(C)	1/20W 100Ω-J	R 910	103P505060	RESISTOR(C)	1/16W 390kΩ-J
R 6F5	103P503070	RESISTOR(C)	1/20W 10kΩ-J	R 911	103P496030	RESISTOR(C)	1/16W 39kΩ-F
R 6F6	103P493030	METAL RESISTOR(C)	1/16W 2.2kΩ-F [A, B]	R 912	103P495050	METAL RESISTOR(C)	1/16W 18kΩ-F
R 6F8	103P703070	METAL RESISTOR(C)	1/16W 10kΩ-J [A, B]	R 913	103P503090	RESISTOR(C)	1/20W 15kΩ-J
R 6F9	103P493030	METAL RESISTOR(C)	1/16W 2.2kΩ-F [A, B]	R 914	103P503070	RESISTOR(C)	1/20W 10kΩ-J
R 6R3	103P504060	RESISTOR(C)	1/20W 56kΩ-J	R 915	103P502000	RESISTOR(C)	1/20W 390Ω-J
R 6ZA	103P505070	RESISTOR(C)	1/20W 470kΩ-J	R 916	103P402010	RESISTOR(C)	1/10W 470Ω-J
R 6ZB	103P505070	RESISTOR(C)	1/20W 470kΩ-J	R 917	103P502000	RESISTOR(C)	1/20W 390Ω-J
R 6ZC	103P504050	RESISTOR(C)	1/20W 47kΩ-J	R 918	103P402010	RESISTOR(C)	1/10W 470Ω-J
R 6ZD	103P496080	METAL RESISTOR(C)	1/16W 62kΩ-F	R 919	103P501050	RESISTOR(C)	1/20W 150Ω-J
R 6ZE	103P496080	METAL RESISTOR(C)	1/16W 62kΩ-F	R 920	103P481070	METAL RESISTOR(C)	1/4W 220Ω-J
R 6ZF	103P496000	METAL RESISTOR(C)	1/16W 30kΩ-F	R 921	103P496010	METAL RESISTOR(C)	1/16W 33kΩ-F
R 6ZG	103P505070	RESISTOR(C)	1/20W 470kΩ-J	R 922	103P494010	METAL RESISTOR(C)	1/16W 4.7kΩ-J
R 6ZH	103P505070	RESISTOR(C)	1/20W 470kΩ-J	R 923	103P500090	RESISTOR(C)	1/20W 47Ω-J
R 6ZJ	103P504050	RESISTOR(C)	1/20W 47kΩ-J	CAPACITORS AND TRIMMERS			
R 6ZK	103P496080	METAL RESISTOR(C)	1/16W 62kΩ-F	C 200	154P355000	CAPACITOR(C)	SL50V 390pF-J
R 6ZL	103P496080	METAL RESISTOR(C)	1/16W 62kΩ-F	C 201	154P354020	CAPACITOR(C)	SL50V 180pF-J
R 6ZM	103P496000	METAL RESISTOR(C)	1/16W 30kΩ-F	C 202	154P353080	CAPACITOR(C)	SL50V 100pF-J
R 800	103P504020	RESISTOR(C)	1/20W 27kΩ-J				

SYMBOL NO.	PARTS NO.	PARTS NAME	DESCRIPTION	SYMBOL NO.	PARTS NO.	PARTS NAME	DESCRIPTION
C 203	141P140090	CAPACITOR (C)	B50V 1000pF-K	C 259	141P144020	CAPACITOR (C)	F16V 0.1 μ F-Z
C 204	154P351060	CAPACITOR (C)	SL50V 15pF-J	C 260	141P143080	CAPACITOR (C)	F50V 0.01 μ F-Z
C 205	141P141070	CAPACITOR (C)	B50V 4700pF-K	C 261	141P144020	CAPACITOR (C)	F16V 0.1 μ F-Z
C 207	154P354000	CAPACITOR (C)	SL50V 150pF-J	C 262	141P143080	CAPACITOR (C)	F50V 0.01 μ F-Z
C 208	141P136030	CAPACITOR (C)	F16V 1 μ F-Z	C 263	141P144020	CAPACITOR (C)	F16V 0.1 μ F-Z
C 209	141P136030	CAPACITOR (C)	F16V 1 μ F-Z	C 268	154P354040	CAPACITOR (C)	SL50V 220pF-J
C 211	141P135070	CAPACITOR (C)	F16V 1 μ F-Z	C 278	141P143080	CAPACITOR (C)	F50V 0.01 μ F-Z
C 212	141P135070	CAPACITOR (C)	F16V 1 μ F-Z	C 280	141P144020	CAPACITOR (C)	F16V 0.1 μ F-Z
C 213	141P135070	CAPACITOR (C)	F16V 1 μ F-Z	C 281	141P141080	CAPACITOR (C)	B50V 5600pF-K
C 214	141P144020	CAPACITOR (C)	F16V 0.1 μ F-Z	C 282	141P141070	CAPACITOR (C)	B50V 4700pF-K
C 215	141P144020	CAPACITOR (C)	F16V 0.1 μ F-Z	C 283	141P143080	CAPACITOR (C)	F50V 0.01 μ F-Z
C 216	154P355040	CAPACITOR (C)	SL25V 560pF-J	C 284	141P135080	CAPACITOR (C)	F25V 0.1 μ F-Z
C 217	141P143080	CAPACITOR (C)	F50V 0.01 μ F-Z	C 285	141P135070	CAPACITOR (C)	F16V 1 μ F-Z
C 218	154P355040	CAPACITOR (C)	SL25V 560pF-J	C 286	141P135070	CAPACITOR (C)	F16V 1 μ F-Z
C 219	141P143080	CAPACITOR (C)	F50V 0.01 μ F-Z	C 289	141P144020	CAPACITOR (C)	F16V 0.1 μ F-Z
C 220	141P144020	CAPACITOR (C)	F16V 0.1 μ F-Z	C 291	154P352040	CAPACITOR (C)	SL50V 33pF-J
C 221	141P135070	CAPACITOR (C)	F16V 1 μ F-Z	C 292	154P353060	CAPACITOR (C)	SL50V 100pF-J
C 222	141P144020	CAPACITOR (C)	F16V 0.1 μ F-Z	C 293	154P353060	CAPACITOR (C)	SL50V 100pF-J
C 223	141P135070	CAPACITOR (C)	F16V 1 μ F-Z	C 294	141P136030	CAPACITOR (C)	F16V 1 μ F-Z
C 224	141P144020	CAPACITOR (C)	F16V 0.1 μ F-Z	C 295	141P136030	CAPACITOR (C)	F16V 1 μ F-Z
C 225	154P355060	CAPACITOR (C)	SL25V 680pF-J	C 297	154P342030	CAPACITOR (C)	CH50V 33pF-J
C 226	141P143080	CAPACITOR (C)	F50V 0.01 μ F-Z	C 298	141P143080	CAPACITOR (C)	F50V 0.01 μ F-Z
C 227	141P144020	CAPACITOR (C)	F16V 0.1 μ F-Z	C 299	141P143080	CAPACITOR (C)	F50V 0.01 μ F-Z
C 228	141P144020	CAPACITOR (C)	F16V 0.1 μ F-Z	C 2A0	141P136030	CAPACITOR (C)	F16V 1 μ F-Z
C 229	154P355060	CAPACITOR (C)	SL25V 680pF-J	C 2A1	141P136030	CAPACITOR (C)	F16V 1 μ F-Z
C 230	141P143080	CAPACITOR (C)	F50V 0.01 μ F-Z	C 2A2	141P136030	CAPACITOR (C)	F16V 1 μ F-Z
C 231	141P144020	CAPACITOR (C)	F16V 0.1 μ F-Z	C 2A3	141P135080	CAPACITOR (C)	F25V0.1 μ F-Z
C 232	141P135070	CAPACITOR (C)	F16V 1 μ F-Z	C 2A4	141P143090	CAPACITOR (C)	F50V 0.022 μ F-ZZ
C 233	141P144020	CAPACITOR (C)	F16V 0.1 μ F-Z	C 2A5	154P342030	CAPACITOR (C)	CH50V 33pF-J
C 234	141P135070	CAPACITOR (C)	F16V 1 μ F-Z	C 2A6	154P344050	CAPACITOR (C)	CH25V 270pF-J
C 235	141P143080	CAPACITOR (C)	F50V 0.01 μ F-Z	C 2A7	181P509020	CAPACITOR (C)	04W35V 2.2 μ F-M
C 236	154P352040	CAPACITOR (C)	SL50V 33pF-J [A, B]	C 2A8	141P136030	CAPACITOR (C)	F16V 1 μ F-Z
C 236	154P353000	CAPACITOR (C)	SL50V 56pF-J [E]	C 2AA	141P143080	CAPACITOR (C)	F50V 0.01 μ F-Z
C 237	141P144020	CAPACITOR (C)	F16V 0.1 μ F-Z	C 2AB	141P143080	CAPACITOR (C)	F50V 0.01 μ F-Z
C 238	141P143080	CAPACITOR (C)	F50V 0.01 μ F-Z	C 2AC	181P509000	CAPACITOR (C)	04W 25V 4.7 μ F-M
C 239	141P135070	CAPACITOR (C)	F16V 1 μ F-Z	C 2AD	181P502040	CAPACITOR (C)	04W 16V 22 μ F-M
C 240	154P352020	CAPACITOR (C)	SL50V 27pF-J [A, B]	C 2AE	181P508080	CAPACITOR (C)	04W 16V 10 μ F-M
C 240	154P353000	CAPACITOR (C)	SL50V 56pF-J [E]	C 2AF	189P123070	CAPACITOR (C)	16V 10 μ F-M
C 241	141P144020	CAPACITOR (C)	F16V 0.1 μ F-Z	C 2AG	154P340080	CAPACITOR (C)	CH50V 7pF-C
C 242	141P135070	CAPACITOR (C)	F16V 1 μ F-Z	C 2AH	154P340060	CAPACITOR (C)	CH50V 5pF-C
C 243	141P143080	CAPACITOR (C)	F50V 0.01 μ F-Z	C 2AL	141P143080	CAPACITOR (C)	F50V 0.01 μ F-Z
C 244	154P352040	CAPACITOR (C)	SL50V 33pF-J [A, B]	C 2AM	141P143080	CAPACITOR (C)	F50V 0.01 μ F-Z
C 244	154P353000	CAPACITOR (C)	SL50V 56pF-J [E]	C 2AN	141P140090	CAPACITOR (C)	B50V 1000pF-K
C 245	141P143080	CAPACITOR (C)	F50V 0.01 μ F-Z	C 2AP	141P135080	CAPACITOR (C)	F25V 0.1 μ F-Z
C 246	154P352040	CAPACITOR (C)	SL50V 33pF-J [A, B]	C 2AQ	154P341050	CAPACITOR (C)	CH50V 15pF-J
C 246	154P353000	CAPACITOR (C)	SL50V 56pF-J [E]	C 2AU	141P143080	CAPACITOR (C)	F50V 0.01 μ F-Z
C 247	141P144020	CAPACITOR (C)	F16V 0.1 μ F-Z	C 2AV	154P341090	CAPACITOR (C)	CH50V 22pF-J
C 248	141P135070	CAPACITOR (C)	F16V 1 μ F-Z	C 2B0	141P135080	CAPACITOR (C)	F25V 0.1 μ F-Z
C 249	141P135070	CAPACITOR (C)	F16V 1 μ F-Z	C 2B1	154P342070	CAPACITOR (C)	CH50V 47pF-J
C 250	141P135070	CAPACITOR (C)	F16V 1 μ F-Z	C 2B2	141P143080	CAPACITOR (C)	F50V 0.01 μ F-Z
C 254	141P135070	CAPACITOR (C)	F16V 1 μ F-Z	C 2B4	154P334070	CAPACITOR (C)	CH50V 330pF-J
C 255	141P135070	CAPACITOR (C)	F16V 1 μ F-Z	C 2B5	141P135080	CAPACITOR (C)	F25V 0.1 μ F-Z
C 256	141P143080	CAPACITOR (C)	F50V 0.01 μ F-Z	C 2B6	141P136040	CAPACITOR (C)	F16V 2.2 μ F-Z
C 257	141P144020	CAPACITOR (C)	F16V 0.1 μ F-Z	C 2B7	181P509080	CAPACITOR (C)	04W 50V 1 μ F-M
C 258	141P143080	CAPACITOR (C)	F50V 0.01 μ F-Z	C 2B8	181P508070	CAPACITOR (C)	04W 16V 4.7 μ F-M

SYMBOL NO.	PARTS NO.	PARTS NAME	DESCRIPTION	SYMBOL NO.	PARTS NO.	PARTS NAME	DESCRIPTION
C 2B9	141P136040	CAPACITOR(C)	F16V 2.2 μ F-Z	C 2J2	181P508050	CAPACITOR(C)	04W 6.3V 22 μ F-M
C 2B8	154P341070	CAPACITOR(C)	CH50V 18pF-J	C 2J3	141P135070	CAPACITOR(C)	F16V 1 μ F-Z
C 2BC	154P342030	CAPACITOR(C)	CH50V 33pF-J	C 2J4	141P135070	CAPACITOR(C)	F16V 1 μ F-Z
C 2BD	141P133080	CAPACITOR(C)	F50V 0.01 μ F-Z	C 2J5	154P348040	CAPACITOR(C)	CH50V 150pF-G
C 2BE	141P143080	CAPACITOR(C)	F50V 0.01 μ F-Z	C 2J6	154P348040	CAPACITOR(C)	CH50V 150pF-G
C 2BF	154P341070	CAPACITOR(C)	CH50V 18pF-J	C 2J7	154P348040	CAPACITOR(C)	CH50V 150pF-G
C 2BG	154P342050	CAPACITOR(C)	CH50V 39pF-J	C 2J8	154P348040	CAPACITOR(C)	CH50V 150pF-G
C 2BH	141P143080	CAPACITOR(C)	F50V 0.01 μ F-Z	C 2J9	154P348060	CAPACITOR(C)	CH50V 220pF-G
C 2BJ	181P508050	CAPACITOR(C)	04W 6.3V 22 μ F-M	C 2K0	154P348010	CAPACITOR(C)	CH50V 82pF-G
C 2BK	141P143080	CAPACITOR(C)	F50V 0.01 μ F-Z	C 2K1	154P348070	CAPACITOR(C)	CH25V 270pF-G
C 2BL	141P135070	CAPACITOR(C)	F16V 1 μ F-Z	C 2K2	154P344010	CAPACITOR(C)	CH50V 180pF-J
C 2BM	141P143080	CAPACITOR(C)	F50V 0.01 μ F-Z	C 2K3	154P342070	CAPACITOR(C)	CH50V 47pF-J
C 2BN	141P135070	CAPACITOR(C)	F16V 1 μ F-Z	C 2K4	154P343090	CAPACITOR(C)	CH50V 150pF-J
C 2BQ	141P135010	CAPACITOR(C)	F25V 0.33 μ F-Z	C 2K5	154P343090	CAPACITOR(C)	CH50V 150pF-J
C 2BR	181P509090	CAPACITOR(C)	04W 50V 2.2 μ F-M	C 2K6	154P344050	CAPACITOR(C)	CH25V 270pF-J
C 2BS	141P135080	CAPACITOR(C)	F25V 0.1 μ F-Z	C 2K7	181P508070	CAPACITOR(C)	04W 16V 4.7 μ F-M
C 2BU	141P135070	CAPACITOR(C)	F16V 1 μ F-Z	C 2K8	154P354040	CAPACITOR(C)	SL50V 220pF-J
C 2BV	181P508050	CAPACITOR(C)	04W 6.3V 22 μ F-M	C 2K9	154P351060	CAPACITOR(C)	SL50V 15pF-J [A, B]
C 2C0	141P142010	CAPACITOR(C)	B25V 0.01 μ F-K	C 2K9	154P352020	CAPACITOR(C)	SL50V 27pF-J [E]
C 2C1	181P509090	CAPACITOR(C)	04W 50V 2.2 μ F-M	C 2P0	141P136030	CAPACITOR(C)	F16V 1 μ F-Z
C 2C2	181P509030	CAPACITOR(C)	04W 35V 3.3 μ F-M	C 2P1	141P136030	CAPACITOR(C)	F16V 1 μ F-Z
C 2C3	181P508050	CAPACITOR(C)	04W 6.3V 22 μ F-M	C 2P2	154P341090	CAPACITOR(C)	CH50V 22pF-J
C 2C5	141P135080	CAPACITOR(C)	F25V 0.1 μ F-Z	C 2P3	154P343030	CAPACITOR(C)	CH50V 82pF-J
C 2C7	154P342010	CAPACITOR(C)	CH50V 27pF-J	C 2P4	181P509020	CAPACITOR(C)	04W 35V 2.2 μ F-M
C 2C9	154P354020	CAPACITOR(C)	SL50V 180pF-J	C 2P5	141P136030	CAPACITOR(C)	F16V 1 μ F-Z
C 2CB	141P143080	CAPACITOR(C)	F50V 0.01 μ F-Z	C 2P6	181P509080	CAPACITOR(C)	04W 50V 1 μ F-M
C 2D0	141P136030	CAPACITOR(C)	F16V 1 μ F-Z	C 2P7	141P143080	CAPACITOR(C)	F50V 0.01 μ F-Z
C 2D1	141P136030	CAPACITOR(C)	F16V 1 μ F-Z	C 2R0	141P136030	CAPACITOR(C)	F16V 1 μ F-Z
C 2D2	154P354040	CAPACITOR(C)	SL50V 220pF-J	C 2R1	141P136030	CAPACITOR(C)	F16V 1 μ F-Z
C 2D3	154P351000	CAPACITOR(C)	SL50V 8pF-C [A, B]	C 2R2	141P135080	CAPACITOR(C)	F25V 0.1 μ F-Z
C 2D3	154P352020	CAPACITOR(C)	SL50V 27pF-J [E]	C 2V0	141P136030	CAPACITOR(C)	F16V 1 μ F-Z
C 2D4	154P352000	CAPACITOR(C)	SL50V 22pF-J [A, B]	C 2V1	141P136030	CAPACITOR(C)	F16V 1 μ F-Z
C 2D4	154P350080	CAPACITOR(C)	SL50V 6pF-C [E]	C 2000	141P143080	CAPACITOR(C)	F50V 0.01 μ F-Z
C 2D5	141P143080	CAPACITOR(C)	F50V 0.01 μ F-Z	C 2001	141P143080	CAPACITOR(C)	F50V 0.01 μ F-Z
C 2DA	141P143080	CAPACITOR(C)	F50V 0.01 μ F-Z	C 2002	141P143080	CAPACITOR(C)	F50V 0.01 μ F-Z
C 2DB	181P508070	CAPACITOR(C)	04W 16V 4.7 μ F-M	C 2003	141P136030	CAPACITOR(C)	F16V 1 μ F-Z
C 2DC	141P134010	CAPACITOR(C)	F50V 0.047 μ F-Z	C 2004	141P136030	CAPACITOR(C)	F16V 1 μ F-Z
C 2DD	141P134010	CAPACITOR(C)	F50V 0.047 μ F-Z	C 2006	181P508010	CAPACITOR(C)	04W 4V 220 μ F-M
C 2E0	154P351060	CAPACITOR(C)	SL50V 15pF-J	C 2007	181P509080	CAPACITOR(C)	04W 50V 1 μ F-M
C 2F0	141P143080	CAPACITOR(C)	F50V 0.01 μ F-Z	C 2009	181P508010	CAPACITOR(C)	04W 4V 220 μ F-M
C 2F1	154P351000	CAPACITOR(C)	SL50V 8pF-C	C 2010	181P508050	CAPACITOR(C)	04W 6.3V 22 μ F-M
C 2F2	154P352040	CAPACITOR(C)	SL50V 33pF-J [A, B]	C 2011	181P512020	CAPACITOR(C)	04W 16V 4.7 μ F-M
C 2F2	154P352020	CAPACITOR(C)	SL50V 27pF-J [E]	C 2012	141P136030	CAPACITOR(C)	F16V 1 μ F-Z
C 2F3	141P143080	CAPACITOR(C)	F50V 0.01 μ F-Z	C 2013	181P508070	CAPACITOR(C)	04W 16V 4.7 μ F-M
C 2F4	154P351080	CAPACITOR(C)	SL50V 18pF-J [A, B]	C 2015	141P143080	CAPACITOR(C)	F50V 0.01 μ F-Z
C 2F4	154P352000	CAPACITOR(C)	SL50V 22pF-J [E]	C 2016	181P508050	CAPACITOR(C)	04W 6.3V 22 μ F-M
C 2F5	154P351040	CAPACITOR(C)	SL50V 12pF-C	C 300	189P120050	CAPACITOR(C)	4V 22 μ F-M
C 2F6	154P340070	CAPACITOR(C)	CH50V 6pF-C	C 301	181P510070	CAPACITOR(C)	04W 10V 10 μ F-M BP
C 2H0	141P143080	CAPACITOR(C)	F50V 0.01 μ F-Z	C 302	141P135070	CAPACITOR(C)	F16V 1 μ F-Z
C 2H1	154P353040	CAPACITOR(C)	SL50V 82pF-J	C 305	154P354040	CAPACITOR(C)	SL50V 220pF-J
C 2H2	154P352060	CAPACITOR(C)	SL50V 39pF-J	C 306	189P125010	C-TANTALUM(C)	25V 0.47 μ F-M
C 2H3	154P351080	CAPACITOR(C)	SL50V 18pF-J	C 307	154P355060	CAPACITOR(C)	SL25V 680pF-J
C 2H4	154P351060	CAPACITOR(C)	SL50V 15pF-J	C 308	154P327000	CAPACITOR(C)	SL50V 2700pF-J
C 2J0	189P122010	CAPACITOR(C)	10V 2.2 μ F-M	C 309	189P120050	CAPACITOR(C)	4V 22 μ F-M
C 2J1	189P122010	CAPACITOR(C)	10V 2.2 μ F-M	C 310	141P132030	CAPACITOR(C)	B50V 0.015 μ F-K

SYMBOL NO.	PARTS NO.	PARTS NAME	DESCRIPTION	SYMBOL NO.	PARTS NO.	PARTS NAME	DESCRIPTION
C 311	181P508050	CAPACITOR (C)	04W 6.3V 22 μ F-M	C 3B1	181P508050	CAPACITOR (C)	04W 6.3V 22 μ F-M
C 312	141P135080	CAPACITOR (C)	F25V 0.1 μ F-Z	C 3B2	181P508050	CAPACITOR (C)	04W 6.3V 22 μ F-M
C 313	189P122010	CAPACITOR (C)	10V 2.2 μ F-M	C 3B3	141P135070	CAPACITOR (C)	F16V 1 μ F-Z
C 314	189P122010	CAPACITOR (C)	10V 2.2 μ F-M	C 3B5	141P134020	CAPACITOR (C)	F50V 0.1 μ F-Z
C 320	141P141040	CAPACITOR (C)	B50V 2700pF-K	C 3BA	141P135080	CAPACITOR (C)	F25V 0.1 μ F-Z
C 321	141P137080	CAPACITOR (C)	B25V 0.047 μ F-K	C 3BB	189P122010	CAPACITOR (C)	10V 2.2 μ F-M
C 323	154P354040	CAPACITOR (C)	SL50V 220pF-J	C 3BC	189P123010	CAPACITOR (C)	16V 1 μ F-M
C 324	189P096020	C-PLASTIC-PP	100V 3300pF-J	C 3BD	141P135080	CAPACITOR (C)	F25V 0.1 μ F-Z
C 325	141P136030	CAPACITOR (C)	F16V 1 μ F-Z	C 3BE	141P135080	CAPACITOR (C)	F25V 0.1 μ F-Z
C 352	181P509030	CAPACITOR (C)	04W 35V 3.3 μ F-M	C 3BF	141P135080	CAPACITOR (C)	F25V 0.1 μ F-Z
C 353	181P509030	CAPACITOR (C)	04W 35V 3.3 μ F-M	C 3BG	181P508050	CAPACITOR (C)	04W 6.3V 22 μ F-M
C 354	172P312070	CAPACITOR (C)	25V 0.15 μ F-J	C 3BH	181P508080	CAPACITOR (C)	04W 16V 10 μ F-M
C 355	172P312070	CAPACITOR (C)	25V 0.15 μ F-J	C 3BL	141P135070	CAPACITOR (C)	F16V 1 μ F-Z
C 356	172P312070	CAPACITOR (C)	25V 0.15 μ F-J	C 3BM	141P135080	CAPACITOR (C)	F25V 0.1 μ F-Z
C 357	172P312070	CAPACITOR (C)	25V 0.15 μ F-J	C 3BN	141P135070	CAPACITOR (C)	F16V 1 μ F-Z
C 358	154P353060	CAPACITOR (C)	SL50V 100pF-J	C 3BP	141P135080	CAPACITOR (C)	F25V 0.1 μ F-Z
C 359	154P353060	CAPACITOR (C)	SL50V 100pF-J	C 3BQ	189P121020	CAPACITOR (C)	6.3V 4.7 μ F-M
C 360	181P507080	CAPACITOR (C)	4V 33 μ F-M	C 3BR	189P121020	CAPACITOR (C)	6.3V 4.7 μ F-M
C 361	181P507080	CAPACITOR (C)	4V 33 μ F-M	C 3BS	141P143080	CAPACITOR (C)	F50V 0.01 μ F-Z
C 362	181P508070	CAPACITOR (C)	04W 16V 4.7 μ F-M	C 3BT	141P143080	CAPACITOR (C)	F50V 0.01 μ F-Z
C 363	181P500040	CAPACITOR (C)	6.3V 100 μ F-M	C 3BU	181P508050	CAPACITOR (C)	04W 6.3V 22 μ F-M
C 364	181P508050	CAPACITOR (C)	04W 6.3V 22 μ F-M	C 3BV	141P143080	CAPACITOR (C)	F50V 0.01 μ F-Z
C 3A0	189P120050	CAPACITOR (C)	4V 22 μ F-M	C 3C0	189P120050	CAPACITOR (C)	4V 22 μ F-M
C 3A1	154P326080	CAPACITOR (C)	SL50V 2200pF-J	C 3C1	154P326080	CAPACITOR (C)	SL50V 2200pF-J
C 3A2	189P120030	C-TANTALUM (C)	4V 10 μ F-M	C 3C2	189P120030	C-TANTALUM (C)	4V 10 μ F-M
C 3A3	141P142010	CAPACITOR (C)	B25V 0.01 μ F-K	C 3C3	141P142010	CAPACITOR (C)	B25V 0.01 μ F-K
C 3A4	189P122010	CAPACITOR (C)	10V 2.2 μ F-M	C 3C4	189P122010	CAPACITOR (C)	10V 2.2 μ F-M
C 3A5	181P507080	CAPACITOR (C)	4V 33 μ F-M	C 3C5	181P507080	CAPACITOR (C)	4V 33 μ F-M
C 3A6	141P136040	CAPACITOR (C)	F16V 2.2 μ F-Z	C 3C6	141P136040	CAPACITOR (C)	F16V 2.2 μ F-Z
C 3A7	172P341030	CAPACITOR (C)	16V 0.01 μ F-J	C 3C7	172P341030	CAPACITOR (C)	16V 0.01 μ F-J
C 3A8	141P138060	CAPACITOR (C)	B25V 0.22 μ F-K	C 3C8	141P138060	CAPACITOR (C)	B25V 0.22 μ F-K
C 3A9	141P136040	CAPACITOR (C)	F16V 2.2 μ F-Z	C 3C9	141P136040	CAPACITOR (C)	F16V 2.2 μ F-Z
C 3AA	141P135080	CAPACITOR (C)	F25V 0.1 μ F-Z	C 3CA	141P135070	CAPACITOR (C)	F16V 1 μ F-Z
C 3AB	141P144020	CAPACITOR (C)	F16V 0.1 μ F-Z	C 3CB	141P135070	CAPACITOR (C)	F16V 1 μ F-Z
C 3AC	141P143080	CAPACITOR (C)	F50V 0.01 μ F-Z	C 3CC	141P143080	CAPACITOR (C)	F50V 0.01 μ F-Z
C 3AD	141P144020	CAPACITOR (C)	F16V 0.1 μ F-Z	C 3CE	141P143080	CAPACITOR (C)	F50V 0.01 μ F-Z
C 3AE	141P135080	CAPACITOR (C)	F25V 0.1 μ F-Z	C 3CF	141P135080	CAPACITOR (C)	F25V 0.1 μ F-Z
C 3AF	141P135080	CAPACITOR (C)	F25V 0.1 μ F-Z	C 3CG	141P140090	CAPACITOR (C)	B50V 1000pF-K
C 3AG	141P135080	CAPACITOR (C)	F25V 0.1 μ F-Z	C 3CH	154P342070	CAPACITOR (C)	CH50V 47pF-J
C 3AH	141P135080	CAPACITOR (C)	F25V 0.1 μ F-Z	C 3CJ	154P342070	CAPACITOR (C)	CH50V 47pF-J
C 3AJ	141P135080	CAPACITOR (C)	F25V 0.1 μ F-Z	C 3CK	154P341050	CAPACITOR (C)	CH50V 15pF-J
C 3AK	141P135080	CAPACITOR (C)	F25V 0.1 μ F-Z	C 3CL	141P143080	CAPACITOR (C)	F50V 0.01 μ F-Z
C 3AL	189P121050	CAPACITOR (C)	6.3V 15 μ F-M	C 3CM	141P135070	CAPACITOR (C)	F16V 1 μ F-Z
C 3AM	141P135080	CAPACITOR (C)	F25V 0.1 μ F-Z	C 3CN	141P135070	CAPACITOR (C)	F16V 1 μ F-Z
C 3AN	141P143080	CAPACITOR (C)	F50V 0.01 μ F-Z	C 3CP	141P135080	CAPACITOR (C)	F25V 0.1 μ F-Z
C 3AP	141P135080	CAPACITOR (C)	F25V 0.1 μ F-Z	C 3CQ	141P140090	CAPACITOR (C)	B50V 1000pF-K
C 3AR	181P512020	CAPACITOR (C)	04W 16V 4.7 μ F-M	C 3CR	141P135080	CAPACITOR (C)	F25V 0.1 μ F-Z
C 3AS	141P135080	CAPACITOR (C)	F25V 0.1 μ F-Z	C 3CS	141P135080	CAPACITOR (C)	F25V 0.1 μ F-Z
C 3AT	141P135080	CAPACITOR (C)	F25V 0.1 μ F-Z	C 3CT	141P143080	CAPACITOR (C)	F50V 0.01 μ F-Z
C 3AU	141P135080	CAPACITOR (C)	F25V 0.1 μ F-Z	C 3D0	141P143080	CAPACITOR (C)	F50V 0.01 μ F-Z
C 3AW	141P143080	CAPACITOR (C)	F50V 0.01 μ F-Z	C 3D1	141P143080	CAPACITOR (C)	F50V 0.01 μ F-Z
C 3AX	141P135080	CAPACITOR (C)	F25V 0.1 μ F-Z	C 3D2	141P135070	CAPACITOR (C)	F16V 1 μ F-Z
C 3AY	189P122010	CAPACITOR (C)	10V 2.2 μ F-M	C 3D3	141P142010	CAPACITOR (C)	B25V 0.01 μ F-K
C 3AZ	154P343050	CAPACITOR (C)	CH50V 100pF-J	C 3D4	141P135080	CAPACITOR (C)	F25V 0.1 μ F-Z
C 3B0	141P135070	CAPACITOR (C)	F16V 1 μ F-Z	C 3D5	141P143080	CAPACITOR (C)	F50V 0.01 μ F-Z

SYMBOL NO.	PARTS NO.	PARTS NAME	DESCRIPTION	SYMBOL NO.	PARTS NO.	PARTS NAME	DESCRIPTION
C 3D6	141P143080	CAPACITOR(C)	F50V 0.01 μ F-Z	C 462	154P352000	CAPACITOR(C)	SL50V 22pF-J
C 3D7	154P354040	CAPACITOR(C)	SL50V 220pF-J	C 463	141P139030	CAPACITOR(C)	B25V 0.1 μ F-K
C 3D8	141P143080	CAPACITOR(C)	F50V 0.01 μ F-Z	C 500	141P142010	CAPACITOR(C)	B25V 0.01 μ F-K
C 3D9	141P143080	CAPACITOR(C)	F50V 0.01 μ F-Z	C 501	141P142010	CAPACITOR(C)	B25V 0.01 μ F-K
C 3DA	181P509000	CAPACITOR(C)	04W 25V 4.7 μ F-M	C 502	141P142010	CAPACITOR(C)	B25V 0.01 μ F-K
C 3DB	141P144000	CAPACITOR(C)	F25V 0.033 μ F-Z	C 503	141P135070	CAPACITOR(C)	F16V 1 μ F-Z
C 3DC	154P341010	CAPACITOR(C)	CH50V 10pF-C	C 505	154P343010	CAPACITOR(C)	CH50V 68pF-J
C 3DD	154P343050	CAPACITOR(C)	CH50V 100pF-J	C 506	141P142040	CAPACITOR(C)	B25V/16V 0.018 μ F-K
C 3DE	141P140090	CAPACITOR(C)	B50V 1000pF-K	C 507	141P139030	CAPACITOR(C)	B25V 0.1 μ F-K
C 3DF	141P135080	CAPACITOR(C)	F25V 0.1 μ F-Z	C 508	141P142070	CAPACITOR(C)	B25V/16V 0.033 μ F-K
C 3DG	141P135080	CAPACITOR(C)	F25V 0.1 μ F-Z	C 509	154P341030	CAPACITOR(C)	CH50V 12pF-J
C 3DJ	141P140010	CAPACITOR(C)	B50V 220pF-K	C 510	141P139030	CAPACITOR(C)	B25V 0.1 μ F-K
C 3DL	141P143080	CAPACITOR(C)	F50V 0.01 μ F-Z	C 511	141P139030	CAPACITOR(C)	B25V 0.1 μ F-K
C 3EC	141P144020	CAPACITOR(C)	F16V 0.1 μ F-Z	C 512	141P139030	CAPACITOR(C)	B25V 0.1 μ F-K
C 3VA	154P341010	CAPACITOR(C)	CH50V 10pF-C	C 513	181P508080	CAPACITOR(C)	04W 16V 10 μ F-M
C 401	181P508050	CAPACITOR(C)	04W 6.3V 22 μ F-M	C 514	141P139030	CAPACITOR(C)	B25V 0.1 μ F-K
C 402	181P508050	CAPACITOR(C)	04W 6.3V 22 μ F-M	C 515	141P139030	CAPACITOR(C)	B25V 0.1 μ F-K
C 403	141P132030	CAPACITOR(C)	B50V 0.015 μ F-K	C 516	141P139030	CAPACITOR(C)	B25V 0.1 μ F-K
C 404	141P140090	CAPACITOR(C)	B50V 1000pF-K	C 517	141P135070	CAPACITOR(C)	F16V 1 μ F-Z
C 405	141P140090	CAPACITOR(C)	B50V 1000pF-K	C 518	181P508080	CAPACITOR(C)	04W 16V 10 μ F-M
C 407	181P500030	CAPACITOR(C)	6.3V 47 μ F-M	C 519	141P142010	CAPACITOR(C)	B25V 0.01 μ F-K
C 408	181P500030	CAPACITOR(C)	6.3V 47 μ F-M	C 520	141P135070	CAPACITOR(C)	F16V 1 μ F-Z
C 409	141P137080	CAPACITOR(C)	B25V 0.047 μ F-K	C 521	141P135080	CAPACITOR(C)	F25V 0.1 μ F-Z
C 410	141P138050	CAPACITOR(C)	B25V 0.18 μ F-K	C 522	154P341030	CAPACITOR(C)	CH50V 12pF-J
C 412	181P508080	CAPACITOR(C)	04W 16V 10 μ F-M	C 523	141P143080	CAPACITOR(C)	F50V 0.01 μ F-Z
C 413	141P140020	CAPACITOR(C)	B50V 270pF-K	C 524	154P344010	CAPACITOR(C)	CH50V 180pF-J
C 414	181P508080	CAPACITOR(C)	04W 16V 10 μ F-M	C 525	141P140090	CAPACITOR(C)	B50V 1000pF-K
C 415	141P139010	CAPACITOR(C)	B25V 0.068 μ F-K	C 5A2	172P341090	CAPACITOR(C)	16V 0.033 μ F-J
C 418	189P122010	CAPACITOR(C)	10V 2.2 μ F-M	C 5A3	141P136030	CAPACITOR(C)	F16V 1 μ F-Z
C 419	141P139030	CAPACITOR(C)	B25V 0.1 μ F-K	C 5A4	154P341030	CAPACITOR(C)	CH50V 12pF-J
C 420	141P141050	CAPACITOR(C)	B50V 3300pF-K	C 5A5	154P341070	CAPACITOR(C)	CH50V 18pF-J
C 4AA	141P135080	CAPACITOR(C)	F25V 0.1 μ F-Z	C 5A6	141P137060	CAPACITOR(C)	B50V 0.033 μ F-K
C 4AB	154P343050	CAPACITOR(C)	CH50V 100pF-J	C 5A8	181P502060	CAPACITOR(C)	16V 47 μ F-M
C 4B0	141P136030	CAPACITOR(C)	F16V 1 μ F-Z	C 5AA	181P508050	CAPACITOR(C)	04W 6.3V 22 μ F-M
C 4B1	141P135080	CAPACITOR(C)	F25V 0.1 μ F-Z	C 5AB	141P135080	CAPACITOR(C)	F25V 0.1 μ F-Z
C 4B2	189P123010	CAPACITOR(C)	16V 1 μ F-M	C 5AC	141P135080	CAPACITOR(C)	F25V 0.1 μ F-Z
C 4B3	141P142010	CAPACITOR(C)	B25V 0.01 μ F-K	C 5AD	181P508050	CAPACITOR(C)	04W 6.3V 22 μ F-M
C 4B4	141P139030	CAPACITOR(C)	B25V 0.1 μ F-K	C 5AE	141P135080	CAPACITOR(C)	F25V 0.1 μ F-Z
C 4B5	181P509000	CAPACITOR(C)	04W 25V 4.7 μ F-M	C 5AG	141P135080	CAPACITOR(C)	F25V 0.1 μ F-Z
C 4B6	181P509000	CAPACITOR(C)	04W 25V 4.7 μ F-M	C 5AH	189P125030	CAPACITOR(C)	25V 1 μ F-M
C 4B7	181P509000	CAPACITOR(C)	04W 25V 4.7 μ F-M	C 5AJ	141P135080	CAPACITOR(C)	F25V 0.1 μ F-Z
C 4B8	154P343050	CAPACITOR(C)	CH50V 100pF-J	C 5AK	141P135080	CAPACITOR(C)	F25V 0.1 μ F-Z
C 4C0	141P134010	CAPACITOR(C)	F50V 0.047 μ F-Z	C 5AL	141P135070	CAPACITOR(C)	F16V 1 μ F-Z
C 4C1	154P355080	CAPACITOR(C)	SL25V 820pF-J	C 5AM	141P135070	CAPACITOR(C)	F16V 1 μ F-Z
C 4C2	181P509090	CAPACITOR(C)	04W 50V 2.2 μ F-M	C 5AN	141P135080	CAPACITOR(C)	F25V 0.1 μ F-Z
C 4C3	141P141050	CAPACITOR(C)	B50V 3300pF-K	C 5AP	141P135070	CAPACITOR(C)	F16V 1 μ F-Z
C 4C4	141P135080	CAPACITOR(C)	F25V 0.1 μ F-Z	C 5AQ	141P135070	CAPACITOR(C)	F16V 1 μ F-Z
C 4D0	141P135080	CAPACITOR(C)	F25V 0.1 μ F-Z	C 5AR	141P135080	CAPACITOR(C)	F25V 0.1 μ F-Z
C 4D1	141P135080	CAPACITOR(C)	F25V 0.1 μ F-Z	C 5AS	141P135080	CAPACITOR(C)	F25V 0.1 μ F-Z
C 4D2	141P135080	CAPACITOR(C)	F25V 0.1 μ F-Z	C 5AT	141P135070	CAPACITOR(C)	F16V 1 μ F-Z
C 4D3	141P136030	CAPACITOR(C)	F16V 1 μ F-Z	C 5AU	181P508050	CAPACITOR(C)	04W 6.3V 22 μ F-M
C 4D4	141P136030	CAPACITOR(C)	F16V 1 μ F-Z	C 5CB	154P341030	CAPACITOR(C)	CH50V 12pF-J
C 4D5	141P135080	CAPACITOR(C)	F25V 0.1 μ F-Z	C 5D0	181P500080	CAPACITOR(C)	04W 10V 33 μ F-M
C 4G0	141P139000	CAPACITOR(C)	B25V 0.056 μ F-K	C 5E0	154P353060	CAPACITOR(C)	SL50V 100pF-J
C 4G1	141P132010	CAPACITOR(C)	B50V 0.01 μ F-K	C 5E1	154P353060	CAPACITOR(C)	SL50V 100pF-J

SYMBOL NO.	PARTS NO.	PARTS NAME	DESCRIPTION	SYMBOL NO.	PARTS NO.	PARTS NAME	DESCRIPTION
C 5E2	154P353060	CAPACITOR (C)	SL50V 100pF-J	C 6B0	141P135000	CAPACITOR (C)	F25V 0.22 μ F-Z
C 5E3	154P353060	CAPACITOR (C)	SL50V 100pF-J	C 6B1	181P509080	CAPACITOR (C)	04W 50V1 μ F-M
C 5FA	154P343050	CAPACITOR (C)	CH50V 100pF-J	C 6B2	181P509080	CAPACITOR (C)	04W 50V1 μ F-M
C 5FB	154P343050	CAPACITOR (C)	CH50V 100pF-J	C 6B3	141P135000	CAPACITOR (C)	F25V 0.22 μ F-Z
C 5FC	154P344050	CAPACITOR (C)	CH25V 270pF-J	C 6B4	141P135000	CAPACITOR (C)	F25V 0.22 μ F-Z
C 5FD	141P135080	CAPACITOR (C)	F25V 0.1 μ F-Z	C 6B5	141P135000	CAPACITOR (C)	F25V 0.22 μ F-Z
C 5FE	141P135080	CAPACITOR (C)	F25V 0.1 μ F-Z	C 6B6	141P135000	CAPACITOR (C)	F25V 0.22 μ F-Z
C 5FG	154P342030	CAPACITOR (C)	CH50V 33pF-J	C 6B7	189P122050	CAPACITOR (C)	10V 10 μ F-M
C 5FH	154P342030	CAPACITOR (C)	CH50V 33pF-J	C 6B8	141P135070	CAPACITOR (C)	F16V 1 μ F-Z
C 5FL	141P135080	CAPACITOR (C)	F25V 0.1 μ F-Z	C 6B9	141P132020	CAPACITOR (C)	B50V 0.012 μ F-K
C 5FM	141P135080	CAPACITOR (C)	F25V 0.1 μ F-Z	C 6C0	189P122050	CAPACITOR (C)	10V 10 μ F-M
C 5FP	154P329020	CAPACITOR (C)	SL25V 4700pF-J	C 6C3	141P144020	CAPACITOR (C)	F16V 0.1 μ F-Z
C 5FQ	154P329020	CAPACITOR (C)	SL25V 4700pF-J	C 6C4	141P136040	CAPACITOR (C)	F16V 2.2 μ F-Z
C 5FS	141P135080	CAPACITOR (C)	F25V 0.1 μ F-Z	C 6C5	189P124040	CAPACITOR (C)	20V 2.2 μ F-M
C 5FT	141P141050	CAPACITOR (C)	B50V 3300pF-K	C 6C6	141P131080	CAPACITOR (C)	B50V 5600pF-K
C 5FU	181P500080	CAPACITOR (C)	04W 10V 33 μ F-M	C 6C7	154P340050	CAPACITOR (C)	CH50V 4pF-C
C 5FY	181P508050	CAPACITOR (C)	04W 6.3V 22 μ F-M	C 6D1	141P135080	CAPACITOR (C)	F25V 0.1 μ F-Z
C 5FZ	141P135080	CAPACITOR (C)	F25V 0.1 μ F-Z	C 6D2	141P144020	CAPACITOR (C)	F16V 0.1 μ F-Z
C 5GA	141P135080	CAPACITOR (C)	F25V 0.1 μ F-Z	C 6D3	141P135080	CAPACITOR (C)	F25V 0.1 μ F-Z
C 5GB	141P135080	CAPACITOR (C)	F25V 0.1 μ F-Z	C 6D4	154P341010	CAPACITOR (C)	CH50V 10pF-C
C 5GC	141P135070	CAPACITOR (C)	F16V 1 μ F-Z	C 6D5	141P136030	CAPACITOR (C)	F16V 1 μ F-Z
C 5GD	141P135080	CAPACITOR (C)	F25V 0.1 μ F-Z	C 6D6	141P136030	CAPACITOR (C)	F16V 1 μ F-Z
C 5GE	141P135070	CAPACITOR (C)	F16V 1 μ F-Z	C 6D7	141P136030	CAPACITOR (C)	F16V 1 μ F-Z
C 5KB	189P121010	CAPACITOR (C)	6.3V 3.3 μ F-M	C 6D8	141P136030	CAPACITOR (C)	F16V 1 μ F-Z
C 5LA	141P135080	CAPACITOR (C)	F25V 0.1 μ F-Z	C 6E0	154P343050	CAPACITOR (C)	CH50V 100pF-J
C 5LB	141P140090	CAPACITOR (C)	B50V 1000pF-K	C 6E1	189P122050	CAPACITOR (C)	10V 10 μ F-M
C 5LC	141P139030	CAPACITOR (C)	B25V 0.1 μ F-K	C 6E2	141P143080	CAPACITOR (C)	F50V 0.01 μ F-Z
C 5LD	141P135080	CAPACITOR (C)	F25V 0.1 μ F-Z	C 6E3	189P122050	CAPACITOR (C)	10V 10 μ F-M
C 5LE	141P135080	CAPACITOR (C)	F25V 0.1 μ F-Z	C 6E4	154P343010	CAPACITOR (C)	CH50V 88pF-J
C 5RA	141P135080	CAPACITOR (C)	F25V 0.1 μ F-Z	C 6E5	154P353000	CAPACITOR (C)	SL50V 56pF-J
C 5ZA	141P135090	CAPACITOR (C)	F25V 0.22 μ F-Z	C 6E7	154P342030	CAPACITOR (C)	CH50V 33pF-J
C 5ZB	141P135080	CAPACITOR (C)	F25V 0.1 μ F-Z	C 6E8	154P341010	CAPACITOR (C)	CH50V 10pF-C
C 6A0	141P139030	CAPACITOR (C)	B25V 0.1 μ F-K	C 6ZA	141P139010	CAPACITOR (C)	B25V 0.068 μ F-K
C 6A1	141P143080	CAPACITOR (C)	F50V 0.01 μ F-Z	C 6ZB	141P137080	CAPACITOR (C)	B25V 0.047 μ F-K
C 6A3	141P135080	CAPACITOR (C)	F25V 0.1 μ F-Z	C 6ZC	141P137080	CAPACITOR (C)	B25V 0.047 μ F-K
C 6A4	141P143080	CAPACITOR (C)	F50V 0.01 μ F-Z	C 6ZD	141P139030	CAPACITOR (C)	B25V 0.1 μ F-K
C 6A5	141P143080	CAPACITOR (C)	F50V 0.01 μ F-Z	C 6ZE	141P139010	CAPACITOR (C)	B25V 0.068 μ F-K
C 6A6	141P135080	CAPACITOR (C)	F25V 0.1 μ F-Z	C 6ZF	141P137080	CAPACITOR (C)	B25V 0.047 μ F-K
C 6A7	181P508000	CAPACITOR (C)	04W 4V 100 μ F-M	C 6ZG	141P137080	CAPACITOR (C)	B25V 0.047 μ F-K
C 6A8	154P344030	CAPACITOR (C)	CH50V 220pF-J	C 6ZH	141P139030	CAPACITOR (C)	B25V 0.1 μ F-K
C 6A9	181P509020	CAPACITOR (C)	04W 35V 2.2 μ F-M	C 800	141P144000	CAPACITOR (C)	F25V 0.033 μ F-Z
C 6AA	141P141080	CAPACITOR (C)	B50V 5600pF-K	C 801	141P143080	CAPACITOR (C)	F50V 0.01 μ F-Z
C 6AB	181P515000	ELECTROLYTIC-C (C)	35V 10 μ F-M	C 803	154P341050	CAPACITOR (C)	CH50V 15pF-J
C 6AD	141P137040	CAPACITOR (C)	B25V 0.022 μ F-K	C 804	154P341050	CAPACITOR (C)	CH50V 15pF-J
C 6AF	141P141080	CAPACITOR (C)	B50V 5600pF-K	C 805	154P342050	CAPACITOR (C)	CH50V 39pF-J
C 6AG	181P515000	ELECTROLYTIC-C (C)	35V 10 μ F-M	C 806	141P135070	CAPACITOR (C)	F16V 1 μ F-Z
C 6AJ	181P508050	CAPACITOR (C)	04W 6.3V 22 μ F-M	C 807	181P500080	CAPACITOR (C)	04W 10V 33 μ F-M
C 6AL	181P508050	CAPACITOR (C)	04W 6.3V 22 μ F-M	C 808	141P135070	CAPACITOR (C)	F16V 1 μ F-Z
C 6AM	141P137040	CAPACITOR (C)	B25V 0.022 μ F-K	C 809	181P500040	CAPACITOR (C)	6.3V 100 μ F-M
C 6AN	181P508050	CAPACITOR (C)	04W 6.3V 22 μ F-M	C 810	141P140090	CAPACITOR (C)	B50V 1000pF-K
C 6AP	181P508050	CAPACITOR (C)	04W 6.3V 22 μ F-M	C 812	141P140010	CAPACITOR (C)	B50V 220pF-K
C 6AQ	181P508050	CAPACITOR (C)	04W 6.3V 22 μ F-M	C 901	141P139030	CAPACITOR (C)	B25V 0.1 μ F-K
C 6AR	181P508050	CAPACITOR (C)	04W 6.3V 22 μ F-M	C 907	141P142010	CAPACITOR (C)	B25V 0.01 μ F-K
C 6AU	181P509050	CAPACITOR (C)	07W 50V 0.22 μ F-M	C 908	189P123010	CAPACITOR (C)	16V 1 μ F-M
C 6AV	181P509050	CAPACITOR (C)	07W 50V 0.22 μ F-M	C 909	141P141050	CAPACITOR (C)	B50V 3300pF-K

[E]

SYMBOL NO.	PARTS NO.	PARTS NAME	DESCRIPTION	SYMBOL NO.	PARTS NO.	PARTS NAME	DESCRIPTION
C 910	154P355060	CAPACITOR(C)	SL25V 680pF-J	TP 5P	299P136090	TEST POINT	1608
C 911	141P142010	CAPACITOR(C)	B25V 0.01 μF-K	TP 5Q	299P136090	TEST POINT	1608
C 917	181P502060	CAPACITOR(C)	16V 47 μF-M	TP 5R	299P136090	TEST POINT	1608
C 918	181P500080	CAPACITOR(C)	04W 10V 33 μF-M	TP 5S	299P136090	TEST POINT	1608
C 919	181P505000	CAPACITOR(C)	04W 35V 10 μF-M	TP 5X	299P136090	TEST POINT	1608
C 922	141P139030	CAPACITOR(C)	B25V 0.1 μF-K	TP 6J	299P136090	TEST POINT	1608
VC2AA	202P220010	CAPACITOR(C)	3pF-10pF	TP 6X	299P136090	TEST POINT	1608
VC500	202P220040	TRIMMER CAPACITOR(C)	9pF-40pF 4KA	TP 8A	299P136090	TEST POINT	1608
VC6A1	202P220030	C-TANTALUM(C)	7pF-30pF	TP 8D	299P136090	TEST POINT	1608
VC800	202P220050	TRIMMER CAPACITOR(C)	13pF-50pF 4K	TP 8E	299P136090	TEST POINT	1608
SWITCHES				TP S1	299P136090	TEST POINT	1608
	928D046001	CASSETTE SW ASSY		TP S2	299P136090	TEST POINT	1608
S 2000	432P088010	KEY BOARD SWITCH	EJECT	TP2AA	299P136090	TEST POINT	1608
S 711	432P094010	KEY BOARD SWITCH	FF	TP2AB	299P136090	TEST POINT	1608
S 713	432P093010	KEY BOARD SWITCH	PB	TP2X1	299P136090	TEST POINT	1608
S 715	432P094010	KEY BOARD SWITCH	REW	TP2X2	299P136090	TEST POINT	1608
S 717	432P093010	KEY BOARD SWITCH	STOP	TP3AA	299P136090	TEST POINT	1608
S 721	432P093010	KEY BOARD SWITCH	STILL	TP3AB	299P136090	TEST POINT	1608
S 725	432P090010	KEY BOARD SWITCH	START/SYOP	TP3AE	299P136090	TEST POINT	1608
S 730	431C074050	SLIDE SWITCH	POWER	TP3AG	299P136090	TEST POINT	1608
SW571	439P027010	LEAF SWITCH		TP3AJ	299P136090	TEST POINT	1608
SW572	439P027010	LEAF SWITCH		TP3AL	299P136090	TEST POINT	1608
SW573	439P013020	LIMIT SWITCH		TP3AM	299P136090	TEST POINT	1608
SW574	439P026010	MODE SWITCH		TP3AN	299P136090	TEST POINT	1608
MISCELLANEOUS				TP3AP	299P136090	TEST POINT	1608
	928C730001	A/C HEAD ASSY		TP3AQ	299P136090	TEST POINT	1608
	272P744010	IC-SENSOR-CCD	MN3727FE	TP3AR	299P136090	TEST POINT	1608
	440C227010	AV JACK		TP3AS	299P136090	TEST POINT	1608
	451C137010	EARPHONE JACK		TP3AT	299P136090	TEST POINT	1608
	215B511030	FPC CABLE	VA-CA	TP3AY	299P136090	TEST POINT	1608
	215B511040	FPC CABLE	VB-SB	TP3X1	299P136090	TEST POINT	1608
	215B511050	FPC CABLE	VS-JS	TP500	299P136090	TEST POINT	1608
M 571	288P103020	CAPSTAN MOTOR		TP5GA	299P136090	TEST POINT	1608
M 572	288P105020	LOADING MOTOR		TP5GD	299P136090	TEST POINT	1608
T 571	460P103020	A/C HEAD		TP5GU	299P136090	TEST POINT	1608
TP 25	299P136090	TEST POINT	1608	TP5HL	299P136090	TEST POINT	1608
TP 29	299P136090	TEST POINT	1608	X 2AA	285P164010	CRYSTAL RESONATOR	25.750MHz
TP 2A	299P136090	TEST POINT	1608	X 5A0	285P102030	CRYSTAL RESONATOR	7.9872MHz
TP 2C	299P136090	TEST POINT	1608	X 6A1	285P167010	CRYSTAL RESONATOR	HC-49/U-S
TP 2E	299P136090	TEST POINT	1608	X 800	285P054020	CRYSTAL RESONATOR	32.768KHz
TP 2K	299P136090	TEST POINT	1608	Z 571	299P168010	DEW SENSOR	SHS-A3
TP 2M	299P136090	TEST POINT	1608	Z 5A0	299P137010	PROTECTOR(C)	1A
TP 2S	299P136090	TEST POINT	1608	Z 5AA	299P137010	PROTECTOR(C)	1A
TP 2V	299P136090	TEST POINT	1608	Z 6AA	299P162010	ANGLE SENSOR	ENC-05S-01
TP 2Y	299P136090	TEST POINT	1608	Z 6AB	299P162010	ANGLE SENSOR	ENC-05S-01
TP 3A	299P136090	TEST POINT	1608	Z 901	299P137010	PROTECTOR(C)	1A
TP 3E	299P136090	TEST POINT	1608	Z 903	299P137040	SURGE ABSORBER	0.4A
TP 3F	299P136090	TEST POINT	1608	PRINTED CIRCUIT BOARD ASSY'S			
TP 3H	299P136090	TEST POINT	1608	928C722006	CCD PCB ASSY		
TP 3L	299P136090	TEST POINT	1608	928C724007	CM PCB ASSY		
TP 3R	299P136090	TEST POINT	1608	928D041030	EVF PCB ASSY		
TP 3Y	299P136090	TEST POINT	1608	928C749001	GYRO SENS PCB ASSY		
TP 5A	299P136090	TEST POINT	1608	928D065001	MF PCB ASSY		
				928C725001	POWER SW PCB ASSY		

SYMBOL NO.	PARTS NO.	PARTS NAME	DESCRIPTION	SYMBOL NO.	PARTS NO.	PARTS NAME	DESCRIPTION
	928C795001	REAR PCB ASSY					
	928C800001	SD/PC PCB ASSY					
	928C746006	VTR SW PCB ASSY					
	928D068001	TRAP PCB ASSY					
	927B621001	VTR PCB ASSY					
	928C719005	VTR-SUB PCB ASSY					

12. AC POWER ADAPTER

SYMBOL NO.	PARTS NO.	PARTS NAME	DESCRIPTION	SYMBOL NO.	PARTS NO.	PARTS NAME	DESCRIPTION
INTEGRATED CIRCUITS				F 101	283D086050	FUSE	250V 1.6A 19181 [E]
IC101	266D113040	IC	FA5311S	PC101	268D015020	PHOTO COUPLER	PS2652/2
IC201	267D001010	IC	AN8004TA	COSMETIC PARTS			
TRANSISTORS				242D410030		AC POWER CORD	[E]
Q 101	260D213040	TRANSISTOR	2SK1572	242D410040		AC POWER CORD	[B]
Q 201	260D213050	TRANSISTOR	2SB1299	242D410050		AC POWER CORD	[A]
Q 202	260D213060	TRANSISTOR	0.6W 20V	700D028030		TOP CASE	
DIODES				700D029030		BOTTOM CASE	[E]
D 101	264D141040	DIODE	1TWB60S	700D029040		BOTTOM CASE	[B]
D 102	264D141050	DIODE	ERA91-02/AL01Z	700D029050		BOTTOM CASE	[A]
D 103	264D141050	DIODE	ERA91-02/AL01Z	Note: Broken AC power cord must be exchanged with a new original power cord.			
D 104	264D121030	DIODE	ERA22-08 445012588				
D 201	264D141080	DIODE	90V-5A				
D 202	264D141090	DIODE	75V-0.15A				
PD201	264D124040	LIGHT EMITTING DIODE					
PD202	264D124040	LIGHT EMITTING DIODE					
ZD101	264D141060	DIODE	ZENER 4.7V				
ZD102	264D141070	DIODE	ZENER 24V				
ZD103	264D141070	DIODE	ZENER 24V				
ZD201	264D124050	DIODE	ZENER 5.1V				
COILS							
L 101	351D046010	CHOKO COIL	ELF18D290A				
L 102	351D046010	CHOKO COIL	ELF18D290A				
L 201	351D046020	CHOKO COIL	10MHz				
TRANSFORMERS							
T 101	350D041050	TRANSFORMER	ETB-22KA650X				
RESISTORS							
R 102	103P401030	RESISTOR(C)	1/10W 100-J				
R 104	103P400090	RESISTOR(C)	1/10W 47-J				
R 108	103P354090	RESISTOR(C)	1/8W 100K-J				
R 109	103P354090	RESISTOR(C)	1/8W 100K-J				
R 110	103P355030	RESISTOR(C)	1/8W 220K-J				
R 111	103P402000	RESISTOR(C)	1/10W 390-J				
R 113	103P403050	RESISTOR(C)	1/10W 6.8K-J				
R 115	103P354090	RESISTOR(C)	1/8W 100K-J				
R 116	103P354090	RESISTOR(C)	1/8W 100K-J				
R 117	103P355030	RESISTOR(C)	1/8W 220K-J				
R 118	103P355030	RESISTOR(C)	1/8W 220K-J				
R 119	103P355030	RESISTOR(C)	1/8W 220K-J				
R 201	103P401090	RESISTOR(C)	1/10W 330-J				
R 203	103P400050	RESISTOR(C)	1/10W 22-J				
R 206	103P405060	RESISTOR(C)	1/10W 390K-J				
CAPACITORS AND TRIMMERS							
C 110	185D070010	ELECTROLYTIC-C	400V 47M				
MISCELLANEOUS							
CN201	451D057020	JACK	DC-POWER				
F 101	283D086060	FUSE	250V 1.6A ET [A, B]				

CIRCUIT DIAGRAMS

PCB-CM

IC 4AA

PIN No.	
1	0.1V
2	—
3	—
4	—
5	—
6	0.5~1.5V
7	—
8	—
9	3~4V
10	—
11	—
12	—
13	—
14	4.8V
15	—
16	—
17	0V
18	—
19	—
20	0.1V
21	—
22	0V
23	—
24	—
25	4.8V
26	0.1V
27	0.8~1.5V
28	4.4V
29	0V
30	0V
31	—
32	—
33	—
34	0V
35	0V
36	0V
37	0V
38	2.4V
39	4.8V
40	—
41	—
42	0.4V
43	—
44	—

IC 5AA

PIN No.		PIN No.	
1	—	41	—
2	0V	42	0V
3	0~3V	43	4.7V
4	4.8V	44	0~2V
5	0V	45	0.3V
6	0V	46	0V
7	0V	47	0V
8	4.8V	48	~
9	0V	49	4.7V
10	~	50	4.8V
11	~	51	0V
12	4.8V	52	0V
13	0V	53	0V
14	4.7V	54	0V
15	4.8V	55	0V
16	4.8V	56	0V
17	4~5V	57	0V
18	0.5V	58	2.3V
19	0V	59	2.5V
20	—	60	2V
21	—	61	0V
22	—	62	4.8V
23	—	63	0V
24	—	64	3.6V
25	0V	65	4.3V
26	4.8V	66	4.8V
27	—	67	2.4V
28	2.2V	68	4.8V
29	—	69	4.8V
30	—	70	0V
31	—	71	4.8V
32	0V	72	4.8V
33	4.8V	73	0V
34	0V	74	0.5V
35	0V	75	4.8V
36	~	76	4.8V
37	0V	77	4.8V
38	4.8V	78	0V
39	0V	79	~
40	0.8~2V	80	—

IC 5EA

PIN No.	
1	—
2	4.8V
3	0V
4	4.8V
5	~
6	0.1V
7	0V
8	3V

IC 5GA

PIN No.		PIN No.	
1	4.8V	33	0.8~1.5V
2	4.8V	34	0.8~1.5V
3	4.8V	35	4.8V
4	2.1V	36	0.7V
5	4.8V	37	0V
6	—	38	0.6V
7	0V	39	0V
8	0.7V	40	0.7V
9	0V	41	0V
10	0V	42	0.6V
11	0V	43	0.6V
12	0V	44	0V
13	0V	45	0.7V
14	0V	46	0~1.5V
15	0V	47	0~1.5V
16	0V	48	1.2V
17	0~0.5V	49	4.8V
18	0.1V	50	0V
19	0.1V	51	0V
20	2.3V	52	0~1.2V
21	2.4V	53	4.8V
22	0V	54	0.8~2V
23	2V	55	2.2V
24	0V	56	4.8V
25	4.8V	57	0V
26	2.4V	58	2.1V
27	4.8V	59	-0.1V
28	0.4V	60	~
29	0.4V	61	0V
30	0.7V~1.2V	62	0V
31	0.6V~1.2V	63	0V
32	—	64	0V

IC 5FA

PIN No.	
1	—
2	1.9V
3	0V
4	4.8V
5	0~3V
6	—
7	0V
8	4.8V
9	—
10	—
11	0V
12	—
13	4.8V
14	6.5V
15	~
16	—
17	-0.1V
18	-0.1V
19	~
20	~
21	0.1V
22	—
23	0V
24	—
25	~
26	—
27	6.5V
28	4.8V
29	—
30	4.8V

IC 5LB

PIN No.	
1	1.8v
2	1.8v
3	0v
4	4.8v
5	4.8v

IC 5LA

PIN No.	
1	1.9V
2	2V
3	2V
4	4.8V
5	4.3V
6	1V
7	3.6V
8	1.8V
9	1.8V
10	1.8V
11	0V
12	1.9V
13	1.8V
14	3.6V

IC 5AB

PIN No.	
1	0V
2	0V
3	0V
4	0V
5	1.8V
6	1.8V
7	2.2V
8	4.8V

TRANSISTOR

SYMBOL	1	2	3	4	5
Q 5AE	1.8V	1.8V	0V	1.8V	0V
Q 5AG	1.8V	1.8V	0.1V	1.8V	0.1V

TRANSISTOR

SYMBOL	1	2	3	4	5	6
Q 5AC	4.8V	2.4V	1.8V	4.8V	4.8V	4.2V
Q 5GA	4.8V	1.3V	0.7V	4.8V	2.7V	2.1V

IC 5AE

PIN No.	
1	0V
2	0V
3	4.8V
4	1.8V
5	1.8V
6	1.8V
7	1.2V
8	2V
9	1.8V
10	1.8V
11	1.8V
12	0V
13	0V
14	0V

IC 5AC

PIN No.	
1	1.8V
2	1.8V
3	1.8V
4	4.8V
5	1.8V
6	1.9V
7	1.9V
8	1.8V
9	1.8V
10	1.8V
11	0V
12	1.8V
13	1.8V
14	1.8V

TRANSISTOR

SYMBOL	(E)	(B)	(C)
Q 5AB	4.8V	4.7V	4.8V
Q 5AD	0V	0.5~1.5V	1.2V
Q 5FC	0.7V	1.4V	1.6V
Q 5FD	2V	2.7V	4.8V
Q 5FE	2.5V	1.9V	0V
Q 5FG	2.5V	1.9V	0V
Q 5FH	0.6V	1.2V	4.8V
Q 5FJ	0.7V	1.2V	4.8V
Q 5FL	1.3V	0.7V	0V
Q 5LB	2.9V	3.6V	3.9V
Q 5LC	4.8V	4.8V	0V

IC 5ZA

PIN No.	
1	-0.1V
2	-0.1V
3	0V
4	6.5V
5	0.9V
6	—
7	0V
8	0V

PCB-GYRO-SENS (LENS CAP ON)

IC 6AA

PIN No.	
1	2.3V
2	2.3V
3	2.3V
4	4.9V
5	2.2V
6	2.3V
7	2.3V
8	2.3V
9	2.3V
10	2.2V
11	0V
12	2.3V
13	2.3V
14	2.4V

TRANSISTOR

SYMBOL	(E)	(B)	(C)
Q 6AB	2.3V	0V	4.9V
Q 6AC	4.9V	4.9V	0V

TRANSISTOR

SYMBOL	1	2	3	4	5	6
Q 6AA	4.9V	2.9V	2.3V	4.9V	3V	2.3V

SENSOR-DRIVE (LENS-CAP ON)

IC 2AB

PIN No.	
1	-7.1V
2	-7.1V
3	0.6V
4	0V
5	-0.1V
6	4.8V
7	0.1V
8	4.9V
9	0.1V
10	4.9V
11	—
12	4.7V
13	4.9V
14	4.7V
15	0V
16	15V
17	-6.7V
18	-6.7V
19	0.9V
20	18V

IC 2AD

PIN No.	
1	—
2	2.5V
3	0V
4	2.4V
5	4.9V

TRANSISTOR

SYMBOL	(E)	(B)	(C)
Q 2AC	8.4V	8.3V	5.6V
Q 2AJ	15V	15.6V	18V

PROCESS

(LENS CAP ON)

IC 3AA

PIN No.		PIN No.	
1	0V	41	1.9V
2	0.6V~1.2V	42	1.1V
3	1.8V	43	—
4	1V	44	1.8V
5	1.9V	45	0.7V
6	1.4V	46	3.1V
7	2.4V	47	1.9V
8	0V	48	1.8V
9	4.4V	49	1.8V
10	1.8V	50	3.2V
11	1.8V	51	2.1V
12	4.9V	52	2.2V
13	1.8V	53	1.8V
14	1.8V	54	4.9V
15	2.2V	55	—
16	1.9V	56	2.8V
17	1.9V	57	1.8V
18	1.6V	58	—
19	2.4V	59	1.8V
20	3.1V	60	1.8V
21	2.3V	61	1.8V
22	0V	62	—
23	—	63	2.5V
24	1.8V	64	0V
25	2.3V	65	1.2V
26	3.2V	66	1.7V
27	—	67	1V
28	1.8V	68	3V
29	1.8V	69	1V
30	3.2V	70	1.8V
31	1.9V	71	1.8V
32	3.2V	72	1.8V
33	2V	73	0.6V
34	1.8V	74	3.1V
35	1.9V	75	3.1V
36	1.8V	76	2.1V
37	—	77	1.9V
38	3.2V	78	1.8V
39	1.6V	79	2.9V
40	1.8V	80	2.1V

IC 3AB

PIN No.	
1	-2.4V
2	—
3	—
4	2.3V
5	2.5V
6	1.9V
7	—
8	—
9	—
10	0V
11	—
12	—
13	2.2V
14	—
15	4.9V
16	8.4V

IC 3AD

PIN No.	
1	0V
2	2.8V
3	1.8V
4	2.7V
5	1.6V
6	1.5V
7	1.1V
8	1.5V
9	3.1V
10	4.9V
11	4.9V
12	1.9V
13	1.4V
14	~
15	0V
16	4.8V
17	~
18	1.9V
19	1.9V
20	0V

IC 3AC

PIN No.	
1	0V
2	2.4V
3	8.4V
4	—
5	—
6	5V
7	2V
8	2.1V
9	2.1V
10	0V
11	2V
12	—
13	—
14	2.4V
15	2.5V
16	2.4V

IC 3AE

PIN No.	
1	0V
2	2.6V
3	0V
4	2.3V
5	2V
6	0.1V
7	0.1V
8	1.8V
9	3.3V
10	4.9V
11	4.9V
12	2.8V
13	2V
14	~
15	0V
16	4.7V
17	~
18	2.3V
19	1.6V
20	0V

TRANSISTOR

SYMBOL	(E)	(B)	(C)
Q 3AD	3V	3.6V	4.9V
Q 3AG	1.3V	2V	4.9V
Q 3AH	3V	2.4V	0V
Q 3AJ	3.1V	3.7V	4.9V
Q 3AK	1.8V	2.4V	4.9V
Q 3AL	1.8V	0V	0V
Q 3AQ	0V	4.8V	0V
Q 3AY	1.2V	1.8V	4.9V
Q 3AZ	1.8V	1V	1.8V
Q 3BB	1.8V	0.2V	1.8V
Q 3BD	0V	0V	1.8V
Q 3BG	1.3V	1.9V	4.9V
Q 3BJ	0V	0.1V	2~3V

TRANSISTOR

SYMBOL	1	2	3	4	5
Q 3AN	1.8V	1.8V	2~3V	1.8V	0V
Q 3AP	0V	0V	4.8V	0V	4.8V
Q 3BC	4.2V	0V	4.2V	0V	0V

TRANSISTOR

SYMBOL	1	2	3	4	5	6
Q 3AM	0V	7.7V	0V	8.4V	0.6V	0V
Q 3AS	0V	2.7V	2.4V	0V	1.8V	2.4V
Q 3AW	4.9V	1.2V	1.8V	0V	1.8V	1.2V
Q 3BF	4.9V	1.8V	1.2V	4.9V	0V	1.2V
Q 3BH	4.9V	3.1V	3.7V	0V	3.7V	3.1V

CHROMA

IC 6A1

Pin		Pin		Pin		Pin	
1	3.4V(3.8V)	17	2.1V	33	~	49	2.5V
2	0.5V	18	1.5V	34	0V	50	2.2V
3	2.6V	19	0V	35	0.4V	51	0V
4	0V	20	1.5V	36	4.8V	52	3V(2.6V)
5	0V	21	2.1V	37	~	53	5V
6	0V	22	2.1V	38	4.8V	54	5V
7	3V	23	1.6V(2.3V)	39	0.2V	55	0V
8	3.4V(3.8V)	24	2.1V	40	3.4V	56	2.3V(1.9V)
9	2.3V	25	0.9V	41	2.2V	57	0V
10	2.7V(4.2V)	26	4.8V(2.3V)	42	2.5V	58	3.1V
11	3V(4.1V)	27	0V(0.3V)	43	2.1V	59	2.8V
12	4.8V	28	0V	44	0V	60	2.9V
13	2V	29	0V	45	2.5V	61	4.8V
14	1.6V	30	0V(4.3V)	46	2.5V	62	2.6V
15	3V	31	0.4V	47	2.5V(1.8V)	63	4.2V(3V)
16	2.1V	32	0V	48	3V	64	1.6V

TRANSISTOR

SYMBOL	(E)	(B)	(C)
Q6A3	0V	0V	0.4V
Q6A4	4.2V	5V	5V
Q6A5	4.8V	0.1V(5V)	4.8V(2.3V)

TRANSISTOR

SYMBOL	1	2	3	4	5
Q6A1	0V(0.2V)	0V(0.3V)	2.6V(0V)	0V	2.6V(0V)

TELOP

IC 502

Pin	
1	—
2	0V
3	0.7V(1.6V)
4	0.7V(0.1V)
5	2.2V
6	5V
7	3.4V(2.6V)
8	—
9	—
10	1V(1.8V)
11	0.7V(1.6V)
12	0V
13	5V
14	0V
15	0V
16	—
17	—
18	1.6V
19	1.4V
20	0V
21	0.9V
22	0.9V
23	0.9V
24	—
25	—
26	1.6V
27	1.6V
28	1.4V
29	2.3V
30	0.7V(1.6V)
31	0.7V(1.6V)
32	—

IC 500

Pin	
1	—
2	1~3V
3	2~3V
4	2~3V
5	2~3V
6	2.5V
7	2.4V
8	2.5V
9	2V
10	2V
11	0.2V
12	0.2V
13	0.2V
14	0V
15	0.2V
16	0.2V
17	0.2V
18	0.2V
19	0.2V
20	0V
21	1~3V
22	0V
23	1~3V
24	2~3V
25	2~3V
26	0V
27	5V
28	5V

IC 501

Pin		Pin	
1	2.5V	23	5V
2	2.4V	24	0V
3	2.4V	25	0V
4	2~3V	26	5V
5	2~3V	27	—
6	2~3V	28	0V
7	1~3V	29	1~3V
8	—	30	2~3V
9	4.5V(5V)	31	1~3V
10	5V	32	0V
11	5V	33	1~3V
12	0V	34	0.2V
13	0V	35	0.2V
14	0V	36	0.3V
15	0V	37	0.3V
16	0V	38	0.3V
17	0V	39	5V
18	3.5V(0V)	40	2V
19	2.3V	41	2V
20	2.5V	42	0.2V
21	0V	43	0.2V
22	5V	44	0.2V

IC 503

Pin	
1	2.3V
2	0V
3	2.4V
4	0V
5	3V
6	5V
7	1.6V
8	0V

IC 505

Pin	
1	0V
2	5V
3	0V
4	0.4V
5	4.7V
6	0.3V
7	0V
8	0V
9	5V
10	0V
11	0V
12	5V
13	0V
14	5V

IC 504

Pin	
1	0V
2	1V(1.8V)
3	1.8V
4	0V
5	5V
6	5V
7	5V(1.7V)
8	5V

TRANSISTOR

SYMBOL	(E)	(E)	(E)
Q500	0V	0.2V	5V

TRANSISTOR

SYMBOL	1	2	3	4	5
Q501	5V	4.5V	0V	0V	0V

Y

IC 2A1

Pin		Pin		Pin		Pin	
1	2V	15	2.1V	29	5V	43	2.7V (0V)
2	2.5V	16	5V	30	2.4V	44	—
3	3.1V(4.2V)	17	2.4V	31	2.4V	45	3.4V
4	2.1V(4.2V)	18	—	32	3.7V (0.5V)	46	3.1V (4.3V)
5	2.7V	19	~	33	3V	47	5V
6	0.8V	20	0V	34	4.2V (1V)	48	5V
7	—	21	0V	35	3.6V (0V)	49	0.4V
8	0V	22	2.7V	36	4.3V (5V)	50	0V
9	2.8V	23	0V	37	2.5V (4V)	51	3.7V (2.1V)
10	2.8V	24	3.1V	38	3V	52	3.1V (0V)
11	1.7V	25	3.8V	39	0.4V (0V)	53	3.7V (2V)
12	2.3V	26	4.3V (3V)	40	2.5V (0.4V)	54	0.2V
13	—	27	0V	41	0.3V (0V)	55	2.1V
14	2.2V	28	4.8V	42	4.5V	56	2.7V

TRANSISTOR

SYMBOL	(E)	(B)	(C)
Q2P1	2.5V (0V)	3.3V (0V)	5V (0V)
Q2V0	5V	5V (4.2V)	0V (5V)
Q2V1	5V	4.3V (5V)	5V (0V)

IC 2P1

Pin	
1	—
2	0V
3	5V (0V)
4	3.3V (0V)
5	1.4V (0.1V)
6	2.6V (0V)
7	2.4V (0V)
8	—

IC 2R1

Pin	
1	0V
2	5V
3	2.3V
4	3.8V
5	2.1V
6	2.2V
7	2.3V
8	2.5V
9	5V
10	5V
11	5V
12	3V
13	3V
14	—
15	0V
16	4.7V
17	~
18	2.3V
19	2.5V
20	0V

HEAD-AMP

IC 201

Pin		Pin		Pin		Pin	
1	—	17	0.6V	33	0V (4-5V)	49	0~0.7V(0V)
2	0V (4.8V)	18	0V (3-5V)	34	1.4V	50	1.4V
3	—	19	0V	35	0~0.7V(0V)	51	4.8V
4	0V	20	0.6V	36	0.6V	52	~
5	2.4V (4V)	21	0~0.7V (~)	37	0V	53	~
6	4.7V	22	1.4V	38	0V (4-5V)	54	0~0.4V
7	—	23	0V (3-5V)	39	0.6V	55	5V (0V)
8	0V (1.6V)	24	1.4V	40	0~0.7V(0V)	56	0V (5V)
9	—	25	0~0.7V (~)	41	1.3V	57	0V (1.6V)
10	4.4V (0V)	26	0.6V	42	0V (4-5V)	58	0V (2.7V)
11	0~0.4V	27	0V (3-5V)	43	1.3V	59	0~0.6V(0.8V)
12	~	28	0V	44	0~0.7V(0V)	60	0~0.6V(0.7V)
13	~	29	0.6V	45	0.6V	61	3.8V
14	4.7V	30	0~0.7V (~)	46	0V	62	2.4V (4V)
15	1.4V	31	1.4V (1V)	47	0V (4-5V)	63	3.8V
16	0~0.7V (~)	32	0V (3-5V)	48	0.6V	64	3.8V

TRANSISTOR

SYMBOL	(E)	(B)	(C)
Q202	0V (0.9V)	0V (1.6V)	0V (3.1V)
Q205	0V (2.5V)	0V (3.1V)	0V (5V)
Q291	0V (2.6V)	0V (2.1V)	0V
Q292	0V (4.4V)	0V (3.8V)	0V
Q294	0V (4.4V)	0V (3.8V)	0V

OPERATION

IC 800

Pin		Pin		Pin		Pin	
1	5V	21	5V	41	0.1V	61	0V
2	5V	22	4.8V	42	5V (0V)	62	0V
3	0.7V	23	4.8V	43	4~5V (0V)	63	4.4V (0V)
4	3.2V	24	4~5V	44	0V	64	—
5	4.5V	25	0.5V (0V)	45	5V	65	0V
6	0V	26	0.4V	46	4.5V	66	0V
7	—	27	0V	47	5V	67	—
8	4.3V	28	5V	48	5V	68	—
9	5V	29	5V	49	0V	69	0V
10	4~5V	30	2.2V	50	0V	70	2~4V
11	5V	31	1.1V	51	4.8V	71	3~4V
12	5V	32	0V	52	4.9V	72	5V
13	5V	33	3~5V	53	5V	73	0V
14	0V	34	0~0.6V(0~1V)	54	4.5V (0V)	74	4~5V
15	0V (5V)	35	0~0.6V(0~1V)	55	—	75	0.3V
16	2~3V	36	0~0.6V(0~1V)	56	5V	76	5V
17	—	37	0~0.6V(0~1V)	57	0V	77	0V
18	—	38	0~0.6V(0~1V)	58	5V	78	0.1V
19	5V	39	—	59	5V (1.6V)	79	5V
20	5V	40	4.8V	60	5V	80	5V

TRANSISTOR

SYMBOL	(E)	(B)	(C)
Q802	0V	1.6V	0V

IC 803

Pin	
1	4.3V
2	5V
3	0V

IC 801

Pin	
1	5V
2	0V
3	6.5V

I/O REAR

IC 2001

Pin	
1	2.3V
2	0V
3	1V (3V)
4	0V
5	0V
6	5V
7	—
8	0V

IC 2002

Pin	
1	2V
2	5V
3	2.3V
4	0V

TRANSISTOR

SYMBOL	(E)	(B)	(C)
Q2000	0V (3V)	0V (2.4V)	0V
Q2001	2.5V	3.2V	3.7V
Q2004	2.4V	0V (3.1V)	5V
Q2006	0V	0V (5V)	0.7V (0V)

MIC-AMP

IC 350

Pin		Pin	
1	1.8V	8	—
2	0V	9	0V
3	—	10	1.8V
4	0V	11	—
5	4.8V	12	—
6	—	13	—
7	1.8V	14	—

TRANSISTOR

SYMBOL	1	2	3	4	5
Q350	0V	0V	0.6V	0V	0.6V

AUDIO

TRANSISTOR

SYMBOL	1	2	3	4	5
Q301	0V	0V	0.7V (-15.2V)	0V (-6V)	0.7 (-15.5V)

TRANSISTOR

SYMBOL	(E)	(B)	(C)
Q320	0V	0V	0V (4.5V)
Q3A0	0V	0V	0V
Q3A1	0V	0V	0V

IC 300

Pin		Pin	
1	2.5V	17	0V
2	2.5V	18	3.1V
3	—	19	—
4	2.5V	20	—
5	0V	21	—
6	—	22	0V
7	0V	23	0V
8	0.1V	24	2V
9	2.5V	25	0V
10	0.2V (5V)	26	2V
11	0V (5V)	27	5V
12	2.5V	28	2V
13	4.4V (0V)	29	5V
14	2.5V	30	2V
15	0V	31	2.5V
16	0V	32	2.5V

IC 3A0

Pin		Pin		Pin		Pin	
1	2.3V	17	2.5V	33	0V	49	2.3V
2	3.3V	18	2.5V	34	5V	50	0.2V (2V)
3	2.5V	19	2.5V	35	2.5V	51	3.1V (4.3V)
4	2.5V	20	0V	36	2.5V	52	0V (5V)
5	2.5V	21	2.5V	37	2.5V	53	0V
6	0.5V	22	2.5V	38	2.5V	54	2.7V (3.2V)
7	1.8V	23	—	39	2.5V	55	3.4V (0V)
8	0V	24	2.5V	40	2.5V	56	5V
9	2.5V	25	5V	41	0V	57	3.2V
10	2.5V	26	—	42	1.8V	58	0V
11	2.5V	27	2.5V	43	0.5V	59	2V (4.1V)
12	2.5V	28	5V	44	2.5V	60	—
13	2.5V	29	0V	45	2.5V	61	0V
14	2.5V	30	0V	46	2.5V	62	0V
15	—	31	2.5V	47	0V	63	3.1V (4.4V)
16	0.6V	32	2.5V	48	3.3V	64	0.1V (2V)

CONTROL

IC 401

Pin	
1	2.5v
2	2.5v
3	2.4v
4	5v
5	2.5v
6	2.5v
7	2.6v
8	1.5v
9	2.4v
10	2.4v
11	0v
12	1.6v
13	1.5v
14	1.5v

IC 5D0

Pin	
1	0V
2	—
3	—
4	0.2V
5	4.6V
6	—
7	0V
8	—
9	0V
10	—
11	5V
12	—
13	0.3V
14	—
15	6.5V
16	—

IC 5A1

Pin	
1	5V
2	5V
3	0V

IC 5A2

Pin	
1	1.2V
2	0V
3	5.7V

IC 5A0

Pin		Pin		Pin		Pin	
1	0V	21	5V	41	2.6V (0V)	61	2.5V
2	0V	22	0V	42	5V (0V)	62	2-3V (2.4V)
3	~ (0V)	23	~	43	~	63	0.7V (0V)
4	4.2V (1V)	24	~	44	0V	64	0V
5	~	25	0-0.4V	45	0V	65	0V (5V)
6	2-3V	26	5V	46	5V	66	0-0.4V
7	~	27	0V	47	0V	67	0V
8	~	28	5V	48	4.4V	68	0V (5V)
9	2.5V (-)	29	2.1V	49	0-0.4V	69	0V
10	—	30	1.1V (1.8V)	50	—	70	0V
11	—	31	—	51	2-3V	71	0-0.7V
12	5V	32	0V	52	~	72	0V
13	5V	33	0.1V (5V)	53	5V	73	5V
14	~	34	5V (0.1V)	54	5V	74	5V
15	0V	35	4.4V (0V)	55	0V	75	5V
16	~	36	4.4V	56	0V	76	4.8V
17	5V (0V)	37	0-0.4V	57	0-0.4V	77	0-0.4V (0V)
18	0V (5V)	38	0.5V (0V)	58	2-3V	78	5V
19	5V	39	0V (5V)	59	2.5V	79	~
20	5V	40	3.5 (0V)	60	2.5V	80	~

TRANSISTOR

SYMBOL	1	2	3	4	5
Q402	~	2-3V	1-2V	0V	~

TRANSISTOR

SYMBOL	1	2	3	4	5	6
Q404	2-3V	1-2V	5V	5V	1-2V	0V

TRANSISTOR

SYMBOL	(E)	(B)	(C)
Q406	0V	5V	0V
Q407	2.5V (-)	4.3V (-)	2.5V (-)
Q5A0	5V	0V	4.6V
Q5A1	0-0.5V	0-0.5V	6.5V
Q5A2	6.5V	5.8V	5V
Q5A4	0V	0.6V	0V

POWER / MDA

IC 4B0

Pin	
1	5V
2	0V
3	2.5V
4	2.5V
5	2.5V
6	1.5V
7	1V
8	1.5V
9	1.2V
10	4.4V
11	2.3V
12	1.2V
13	1.9V
14	1.3V
15	0V
16	1.3V
17	4.1V
18	1.3V
19	2.2V
20	2.1V
21	0.7V
22	0.7V
23	3.5V
24	3.5V
25	4.4V
26	2.5V
27	2.5V
28	2.5V
29	0.2V
30	1-2V

IC 4D0

Pin	
1	0V
2	0V
3	—
4	0-3V
5	0-3V
6	0-3V
7	0V
8	2.5V
9	6.5V
10	5V
11	5V
12	—
13	—
14	0V
15	0V
16	0V
17	0V
18	1.4V
19	0V
20	4.4V
21	2V
22	0.9V
23	1.7V
24	1.7V
25	1.7V
26	1.7V
27	1.7V
28	1.7V
29	0V
30	0V

IC 902

Pin	
1	2.5V
2	1.6V
3	1.2V
4	1.2V
5	1.2V
6	1.5V
7	2.5V
8	3.7V
9	0V
10	4.6V
11	1.7V
12	1.5V
13	1.2V
14	0V
15	5V
16	2.5V
17	1.4V
18	1.2V
19	4.9V
20	6.5V

TRANSISTOR

SYMBOL	(E)	(B)	(C)
Q904	6.5V	6.1V	2.6V
Q905	6.5V	6V	4.1V
Q906	6.5V	6.2V	0V

DECK ASSEMBLY ASSEMBLY DECK-I

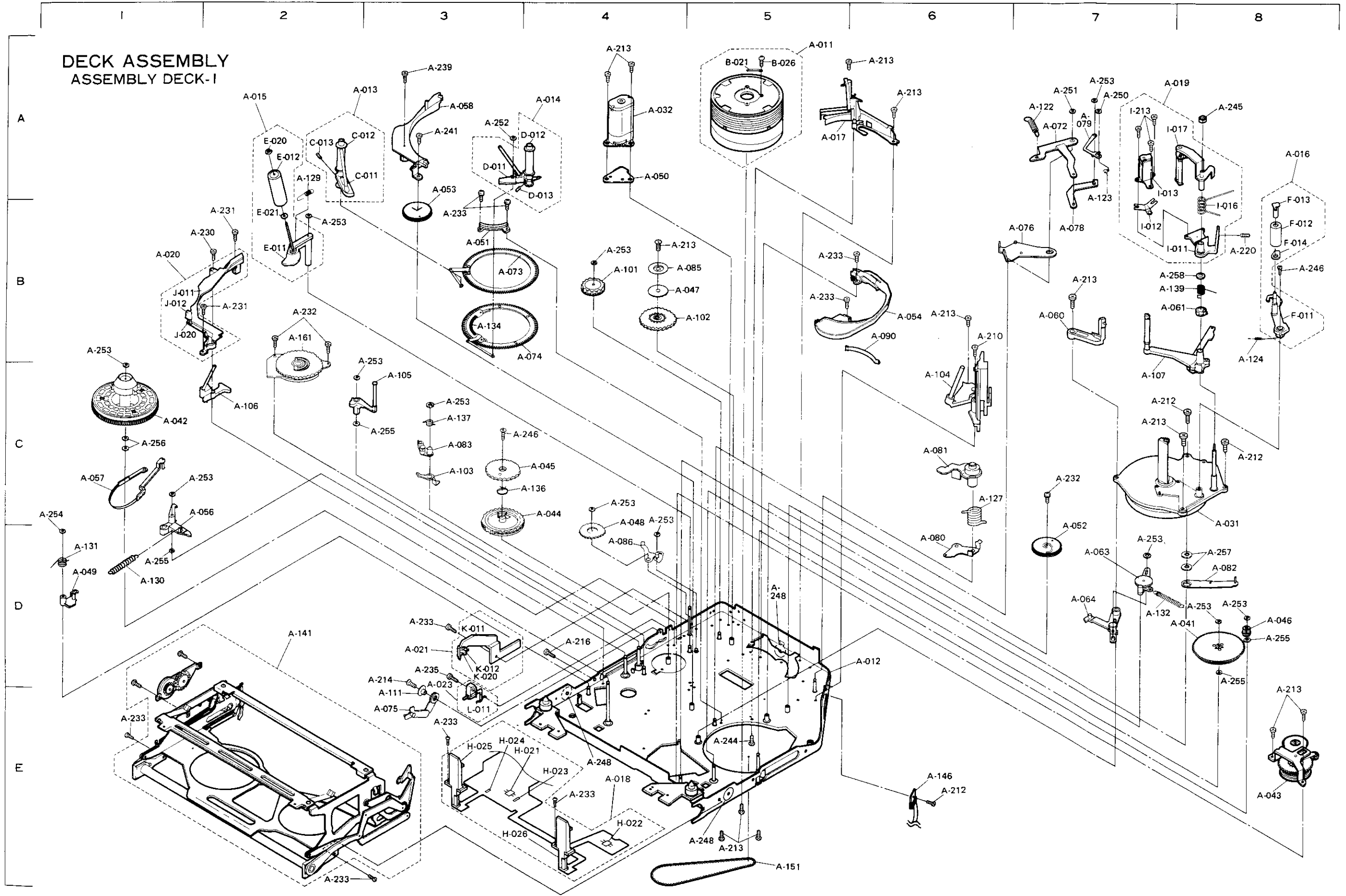

* Set

ITEM
A-011
B-021
B-026
A-012
A-013
C-011
C-012
C-013
A-014
D-011
D-012
D-013
A-015
E-011
E-012
E-020
E-021
A-016
F-011
F-012
F-013
F-014
A-017
A-018
H-021
H-022
H-023
H-024
H-025
H-026
A-019
I-011
I-012
I-013
I-016
I-017
I-213
A-020
J-011
J-012
J-020
A-021
K-011
K-012
K-020
A-023
L-011
A-031
A-032
A-041
A-042
A-043
A-044
A-045
A-046

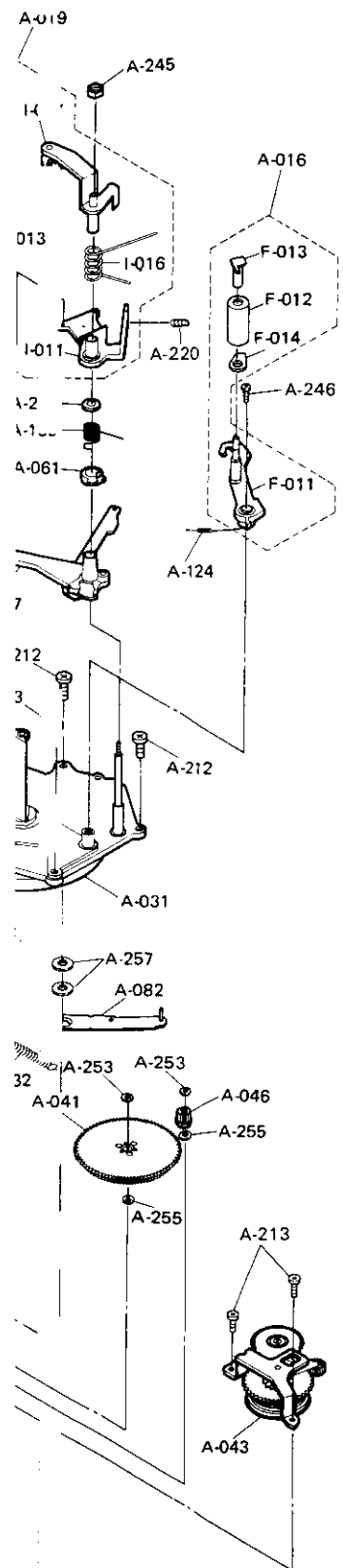

* Settled Service Parts

ITEM	PARTS No.	* ADDRESS	PARTS NAME	DESCRIPTION	Qt.
A-011	948B279006	○ A-5	ASSY-DRUM		01
B-021	299C028010	○ A-5	BRUSH		01
B-026	669D315020	A-5	SCREW	(M1. 7X0. 35-2)	01
A-012	948B280002	D-6	ASSY-PLATE-MAIN		01
A-013	948D029001	○ A-3	ASSY-TAPE-GUIDE-S		01
C-011	635B069010	○ A-3	TAPE-GUIDE-SP		01
C-012	522B050010	○ A-3	GUIDE-ROLLER-U2		01
C-013	669D419010	A-2	SET-SCREW	(M1. 4X0. 3)	01
A-014	948D030001	○ A-4	ASSY-TAPE-GUIDE-T		01
D-011	635B070010	○ A-3	TAPE-GUIDE-T		01
D-012	522B047010	○ A-4	GUIDE-ROLLER		01
D-013	669D419010	A-4	SET-SCREW	(M1. 4X0. 3)	01
A-015	948D031001	○ A-2	ASSY-IMP-ROLLER		01
E-011	641B443010	B-2	ARM-IMP		01
E-012	631D266010	A-2	ROLLER-IMP		01
E-020	552C009020	○ A-2	CUT-WASHER		01
E-021	552C001010	○ B-2	WASHER-THRUST		01
A-016	948D032001	○ A-8	ASSY-PINCH-ROLLER		01
F-011	591B706010	B-8	ARM-PINCH		01
F-012	522C086010	○ B-8	PINCH-ROLLER		01
F-013	641C995010	B-8	CAP-PINCH		01
F-014	621D801010	B-8	CAM-L-GR		01
A-017	948D033001	○ A-5	ASSY-STOPPER-TG		01
A-018	928C729001	○ E-4	ASSY-FPC-SENS		01
H-021	268P044020	○ E-3	PHOTO-INTERRUPTER	(Q571 ON2270. M1)	01
H-022	268P044020	○ E-4	PHOTO-INTERRUPTER	(Q572 ON2270. M1)	01
H-023	103P352020	○ E-4	CHIP METAL RESISTOR	(R571 1/8W 560Ω)	01
H-024	103P359050	○ E-3	CHIP METAL RESISTOR	(R572 1/8W 0Ω)	01
H-025	439P027010	○ E-3	SW-LEAF	(SW571)	01
H-026	439P027010	○ E-4	SW-LEAF	(SW572)	01
A-019	928C730001	○ A-8	ASSY-A/C-HEAD		01
I-011	593C082010	B-8	PLATE-AC		01
I-012	572D451010	B-7	SPRING-PLATE-AC		01
I-013	460P103020	○ A-7	HEAD-AC	(T571)	01
I-016	572D453010	B-8	SPRING-ARM-AC		01
I-017	596D532010	A-8	LEVER-GR		01
I-213	669D420040	A-7	SCREW	(M1. 7X0. 35X3)	03
A-020	928D039002	○ B-1	ASSY-GUIDE-SLIDER		01
J-011	641B431010	B-1	GUIDE-SLIDER-L		01
J-012	641C999010	B-1	HOLDER-LED		01
J-020	264P526010	○ B-1	DIODE-LE	(D571 LN-57)	01
A-021	928D040002	○ D-3	ASSY-E-SENS		01
K-011	641B457010	D-3	HOLDER-E-SENS		01
K-012	621D770010	D-3	COVER-E-SENS		01
K-020	268P041010	○ D-3	PHOTO-TRANSISTOR	(Q573 PN147)	01
A-023	928D046001	○ A-6	ASSY-SW-C		01
L-011	439P013020	○ E-3	SW-LIMIT	(SW573)	01
A-031	288P103020	○ C-8	MOTOR-CP	(M571)	01
A-032	288P105020	○ A-4	MOTOR-LOADING	(M572)	01
A-041	522B044010	○ D-8	GEAR-REEL		01
A-042	522B045010	○ C-1	REEL-DISK		01
A-043	522B046020	○ E-8	UNIT-IDLER		01
A-044	621C021010	○ C-4	CAM-S		01
A-045	621C022010	○ C-4	CAM-S-SP		01
A-046	621D711010	○ D-8	GEAR-TU1		01

* Settled Service Parts

ITEM	PARTS No.	* ADDRESS	PARTS NAME	DESCRIPTION	Qt.
A-047	621D718010	○ B-5	GEAR-GUIDE		01
A-048	621D721010	○ C-4	GEAR-LOAD-S		01
A-049	621D727010	D-1	HOLDER-TENS		01
A-050	621D728010	A-4	HOLDER-L-MO		01
A-051	621C068010	B-3	RING-GUIDE-SP		01
A-052	641B428020	○ C-7	CAM-T		01
A-053	641B429010	○ A-3	CAM-M		01
A-054	641B432010	B-6	GUIDE-SLIDER-T		01
A-056	621C090010	○ C-2	ARM-REGULATOR		01
A-057	641B437010	○ C-1	BELT-TENS		01
A-058	641B438010	A-3	GUIDE-SLIDER-R		01
A-060	621C156010	B-7	HOLDER-CP-CAS		01
A-061	641C984010	○ B-8	CAM-GEAR-TUG		01
A-063	522C088010	○ D-8	UNIT-CLUCH-2		01
A-064	593C199010	D-7	PLATE-CLUTCH-OFF2		01
A-072	591B705010	A-7	LEVER-PINCH-B		01
A-073	591B709010	○ B-3	UNIT-RING-S		01
A-074	591B710010	○ B-4	UNIT-RING-TU		01
A-075	591B711010	E-3	ARM-EJECT		01
A-076	593C011010	B-7	LEVER-PINCH-A		01
A-078	593C012010	B-7	LINK-PINCH-A		01
A-079	593C013010	A-7	LINK-PINCH-B		01
A-080	593C216010	D-6	LEVER-ROCK-T-A2		01
A-081	593C217010	C-6	LEVER-LOCK-T-B2		01
A-082	593C016010	D-7	LEVER-CAM-T		01
A-083	593C022010	C-3	SET-ARM-S		01
A-085	596D384010	○ B-5	STOPPER-RING-S		01
A-086	593C066010	D-4	LEVER-EJECT		01
A-090	596D445010	B-6	PLATE-SLIDER-T		01
A-101	635D065010	○ B-4	GEAR-IDLER-S		01
A-102	520D161010	○ B-5	GEAR-LOAD-1		01
A-103	635D067010	C-3	LEVER-TENS-OFF		01
A-104	641B538010	○ C-6	SLANT-T		01
A-105	641B499010	○ C-3	TENS-REGULATOR		01
A-106	641B531010	○ C-2	SLANT-SP		01
A-107	635B074020	○ C-7	GUIDE-ARM-TU		01
A-111	631D290010	E-3	SLEEVE-EJECT		01
A-122	572D454010	○ A-7	SPRING-PINCH		01
A-123	572D455010	A-7	SPRING-PINCH-SUB		01
A-124	572D456010	B-8	SPRING-ARM-PINCH		01
A-127	572D541010	○ C-6	SPRING-ARM-LOCK2		01
A-129	572D461010	A-2	SPRING-IMP		01
A-130	572D462010	D-1	SPRING-TENS-1		01
A-131	572D463010	D-1	SPRING-TENS-2		01
A-132	572D542010	E-8	SPRING-RS2		01
A-134	572D465010	B-3	SPRING-F		01
A-136	572D537010	C-4	SPRING-PUSH		01
A-137	572D468010	C-3	SPRING-PUSH2		01
A-139	572D516010	B-8	SPRING-G		01
A-141	591B712020	○ D-2	UNIT-C-HOU-U		01
A-146	299P168010	○ E-6	SENSOR-H	(Z571)	01
A-151	521D072010	○ E-5	BELT-SYNC		01
A-161	439P026010	○ B-2	SW-MODE	(SW574)	01
A-210	669D420010	B-6	SCREW	(M1. 7X0. 35X10)	01
A-212	669D420020	C-7	SCREW	(M1. 7X0. 35X2)	03
A-213	669D420040	E-6	SCREW	(M1. 7X0. 35X3)	13
A-214	669D420050	A-4	SCREW	(M1. 7X0. 35X4)	01
A-216	669D420070	B-4	SCREW	(M1. 7X0. 35X6)	01
A-220	669D405010	D-4	SCREW	(M1. 7X0. 35X3)	01
A-230	669D421010	B-2	SCREW	(M1. 7X0. 35X10)	01
A-231	669D421030	B-2	SCREW	(M1. 7X0. 35X2. 5)	02
A-232	669D421020	B-2 C-7	SCREW	(M1. 7X0. 35X2)	03

* Settled Service Parts

ITEM	PARTS No.	* ADDRESS	PARTS NAME	DESCRIPTION	Qt.
A-233	669D421040	B-3 B-5 D-3 E-1 E-2 E-3 E-4 D-3	SCREW	(M1. 7X0. 35X3)	09
A-235	669D421060	D-3	SCREW	(M1. 7X0. 35X5)	01
A-239	669D421090	A-3	SCREW	(M1. 7X0. 35X9)	01
A-241	669D344020	A-3	SCREW-FLANGE	(M1. 7X0. 35-2)	01
A-244	669D423060	E-5	SCREW	(M1. 4X0. 3 L=3. 5)	01
A-245	674D093010	A-8	NUT-S	(M2X0. 4)	01
A-246	669D443010	B-8 C-3	SCREW	(M1. 7X0. 35X3)	02
A-248	223D506010	D-4 E-4 E-5	SPACER		03
A-250	552C016010	A-7	WASHER		01
A-251	552C007010	○ A-7	CUT-WASHER		01
A-252	552C009010	○ A-3	CUT-WASHER		01
A-253	552C009020	○ A-7 B-1 B-2 B-3 B-4 C-2 C-3 C-4 D-8	CUT-WASHER		12
A-254	552C009040	○ C-1	CUT-WASHER		01
A-255	552C001010	○ C-3 D-8	WASHER-THRUST		04
A-256	552C006010	○ C-1	WASHER-THRUST		02
A-257	552C014010	D-7	WASHER-THRUST		02
A-258	683D120010	B-8	WASHER-AC		01

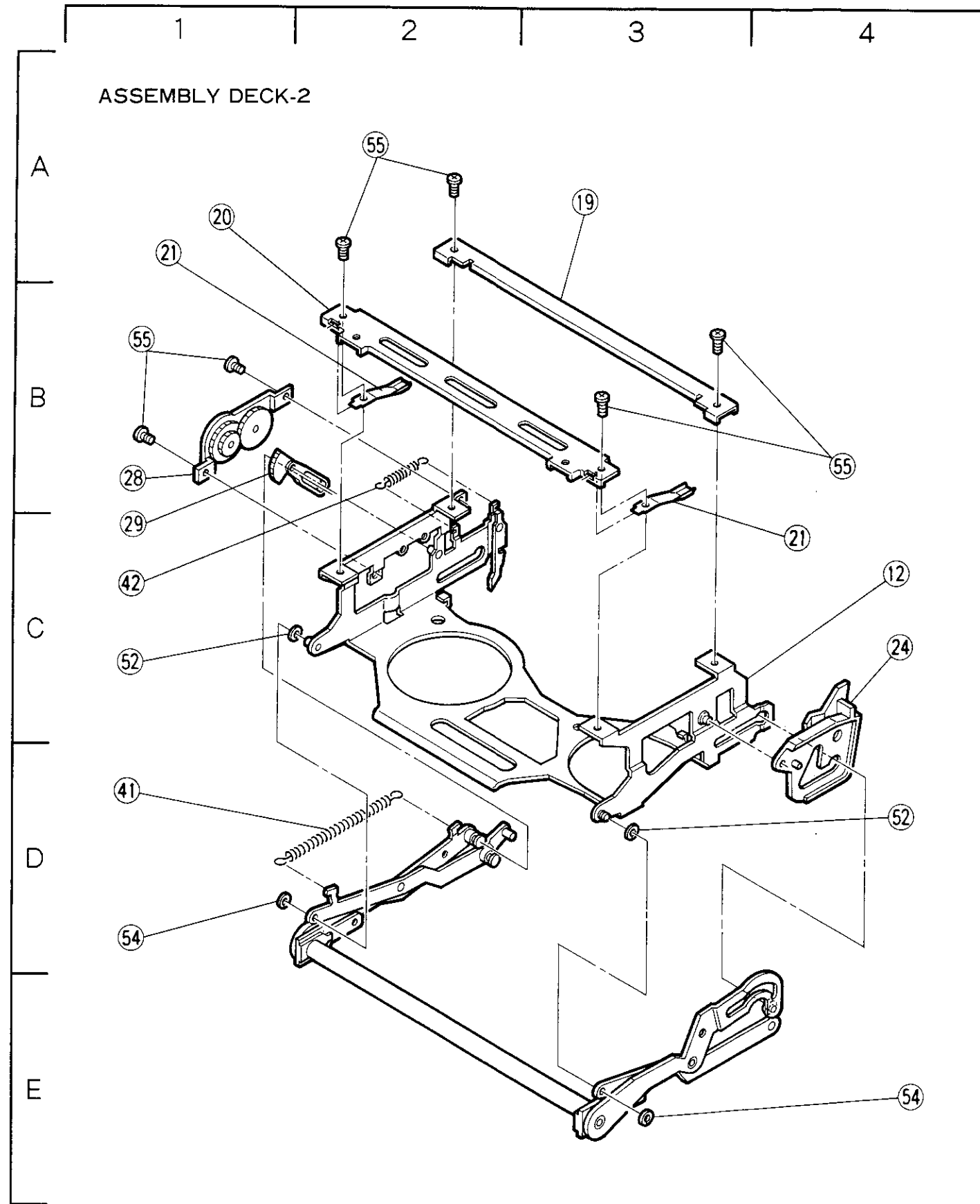

* Settled Service Parts

ITEM	PARTS No.	* ADDRESS	PARTS NAME	DESCRIPTION	Qt.
12	591B716020	C-4	BOTTOM-HOU-U		01
19	596D396010	A-3	PLATE-TOP-D		01
20	596D397010	A-1	PLATE-TOP-C		01
21	596D398010	A-1	PLATE-HOLD		02
28	621C049010	B-1	UNIT-DANPER		01
29	621D792010	○ C-1	LEVER-DANPER		01
41	572D473010	○ D-1	SPRING-LIFT		01
42	572D472010	○ C-1	SPRING-HOOK		01
52	-----	C-1	D-4	WASHER THRUST	02
54	-----	D-1	E-4	CUT-WASHER	02
55	-----	A-2	B-1	SCREW	M1.7
		B-4			06

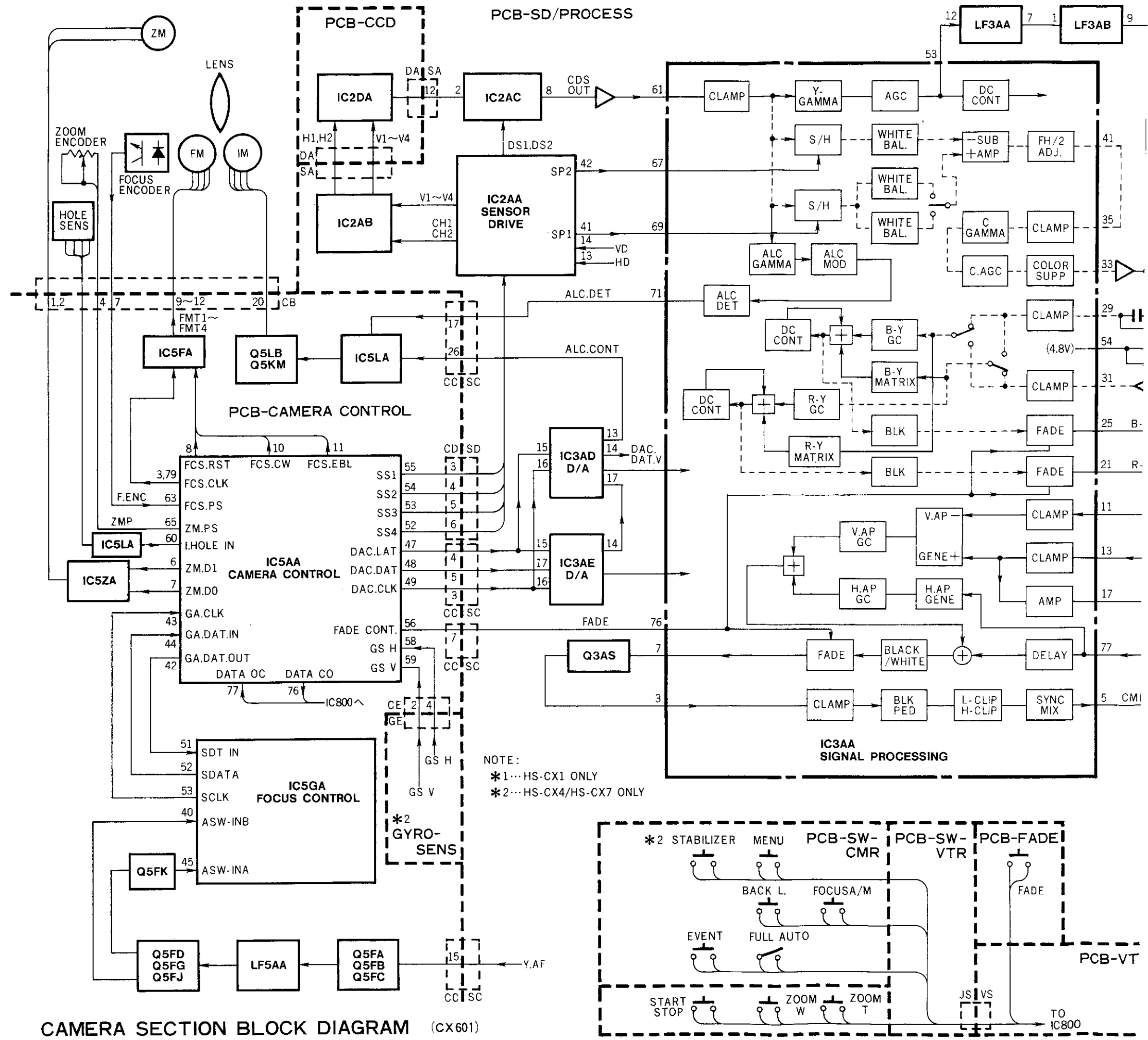

CAMERA SECTION BLOCK DIAGRAM (CX601)

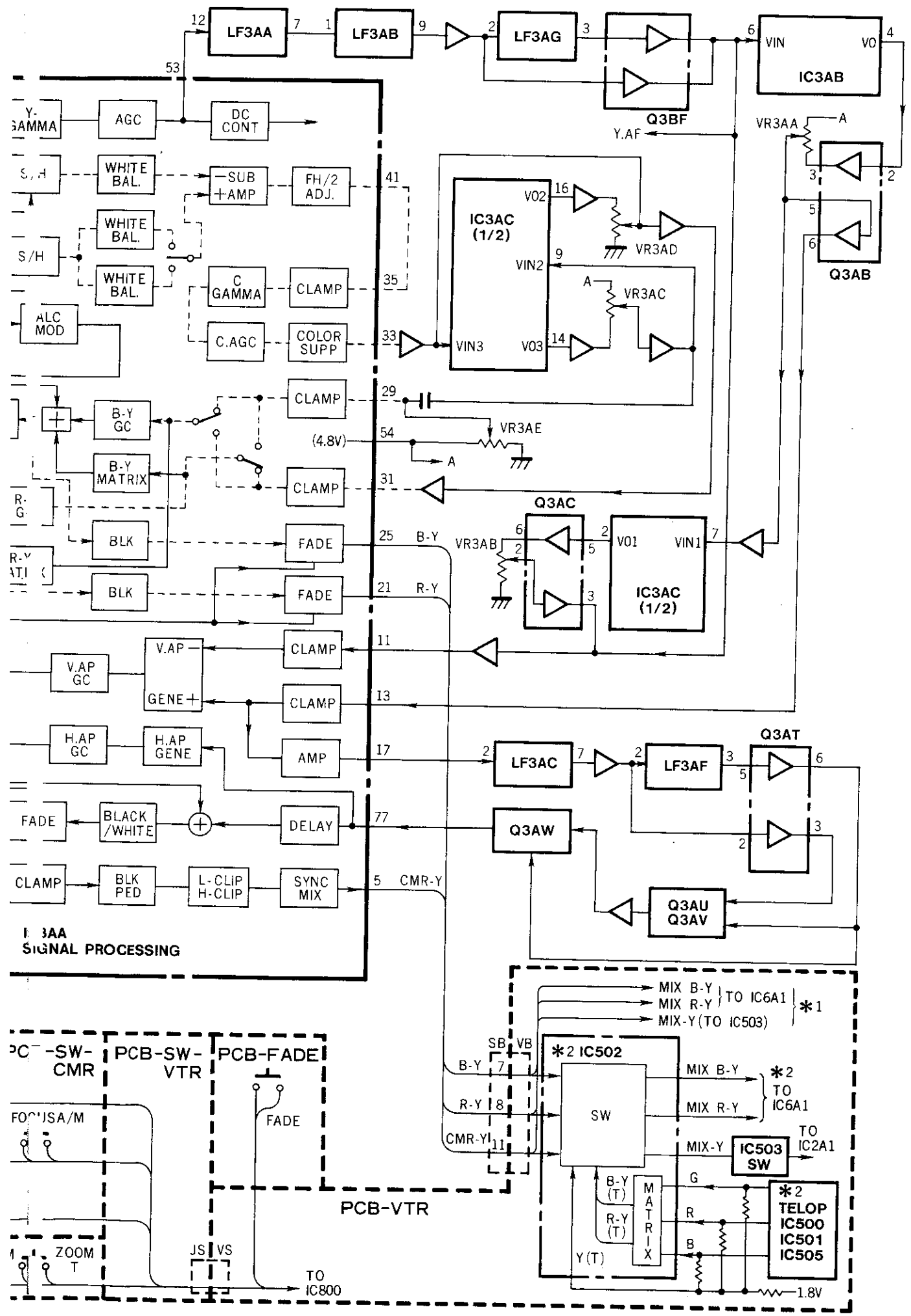

CAMERA CONTROL μ COMPUTER FUNCTION (IC 5AA)

PIN NO.	NAME	I/O	FUNCTION
2	LTR-BLK	O	Letter Box blanking pulse
3	FCS.CLK	O	Focus Lens drive pulse
4	P.DET	O	Special effect switch signal in Ski mode
5	ZM.SPD	O	Zoom speed control signal, high speed at "H"
6	ZM.D1	O	Zoom Lens is driven in the direction of "TELE"
7	ZM.D0	O	Zoom Lens is driven in the direction of "WIDE"
8	FCS.RST	O	fixed at "H"
10	FCS.CW	O	Focus Lens is driven in the direction of "∞" at "H"
11	FCS.EBL	O	Focus motor power is saved at "H"
12	ALC.CNTL	O	Iris control signal
13	27/36	I	jumper lead input to select Picture Element number of CCD.
14	RST_FL	O	"L" output for about 400 μsec synchronized with VD.
15	DL.PWR	O	Signal to rise 9V power supply
16	PAL/NTSC	I	jumper lead input to select PAL or NTSC.
17	S.STRB	I	Strobe signal input from operational microcomputer.
18	HD	I	H sync signal
19	VD	I	V sync signal
25	CNVSS	-	GND
26	RST	I	"L" input when μ computer is reset.
28	XIN	I	System Clock input
32	VSS	-	GND
33	LED.ON	O	"L" output to light LED for center detection
35	GA.HLSB	O	Stabilizer horizontal address data
36	SEL.1MFIL	O	Signal to select 1MHz or 600kHz (1MHZ at "H")
37	FCS.AREA	O	Signal to select Focus Area (fixed at "L")
38	HF.ENABL	O	Signal to select Stabilizer ON or OFF.
39	GA.STRB	O	Strobe signal output to IC 5GA
40	GA.READY	I	Ready signal input from IC 5GA
42	GA.DAT.OUT	O	Stabilizer address data output to IC 5GA
43	GA.CLK	O	Clock signal output to IC 5GA
44	GA.DAT.IN	I	Focus Evaluation data input from IC 5GA
45	E2.DAT.IN	I	Serial data input from EEPROM
46	E2.LAT	O	Chip select signal to EEPROM
47	DAC.LAT	O	Chip select signal to D/A converter
48	DAC.DAT	O	Data to D/A converter and EEPROM
49	DAC.CLK	O	Serial clock to D/A converter and EEPROM
50	WBLK.DIS	O	Special effect switch signal in Party mode

PIN NO.	NAME	I/O	FUNCTION
52	SS4	O	Shutter speed control signal
53	SS3	O	
54	SS2	O	
55	SS1	O	
56	B.COMP	I	White balance control input
57	R.COMP	I	
58	GS-H	I	Signal from Angular velocity sensor
59	GS-V	I	
60	I.HOLE.IN	I	Signal from Iris sensor
61	APLX	I	Signal from Y signal integration circuit
62	APL	I	
63	FCS.PS	I	Signal from Focus encoder.
64	ZM.PSX4	I	Signal from Zoom encoder
65	ZM.PS	I	
66	FADE.CNTL	O	Fader control signal output
67	FLK.CNTL	O	Flicker compensation signal output
68	DAVREF	I	Reference voltage input for D/A converter
69	ADVREF	I	Reference voltage input for A/D converter
70	AVSS	-	GND for D/A converter and A/D converter
71	AVCC	I	Power source input for A/D converter
72	VCC	I	Power source input for μ computer
73	VSS	-	GND
75	C.CLK	I	Serial data and clock between this μ computer and operation μ computer.
76	DATA.CO	O	
77	DATA.OC	I	
79	FCS.CLK	O	Focus Lens drive pulse

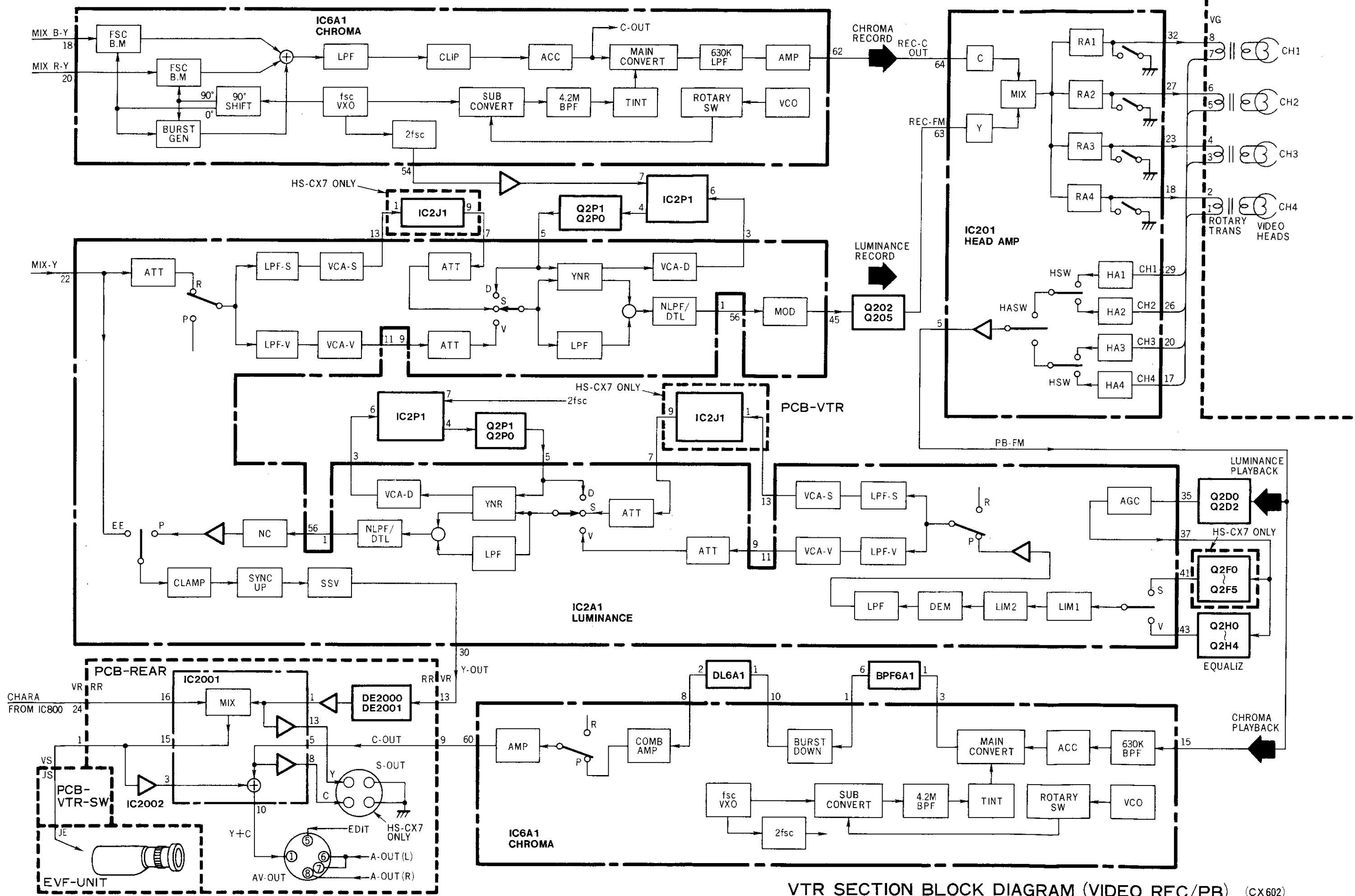

VTR SECTION BLOCK DIAGRAM (VIDEO REC/PB) (CX602)

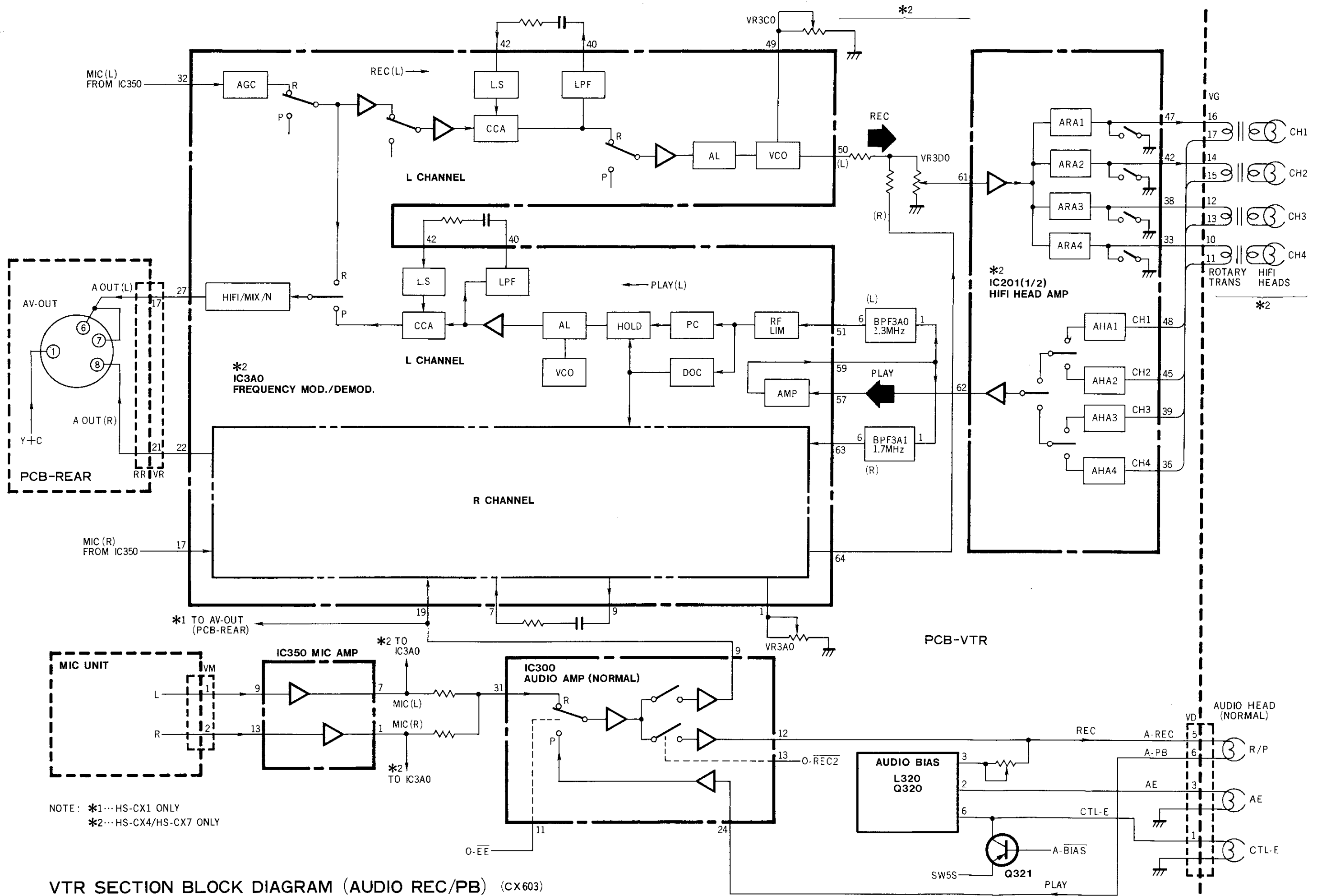

VTR SECTION BLOCK DIAGRAM (AUDIO REC/PB) (CX603)

A
B
C
D
E

1 2 3 4 5 6 7 8

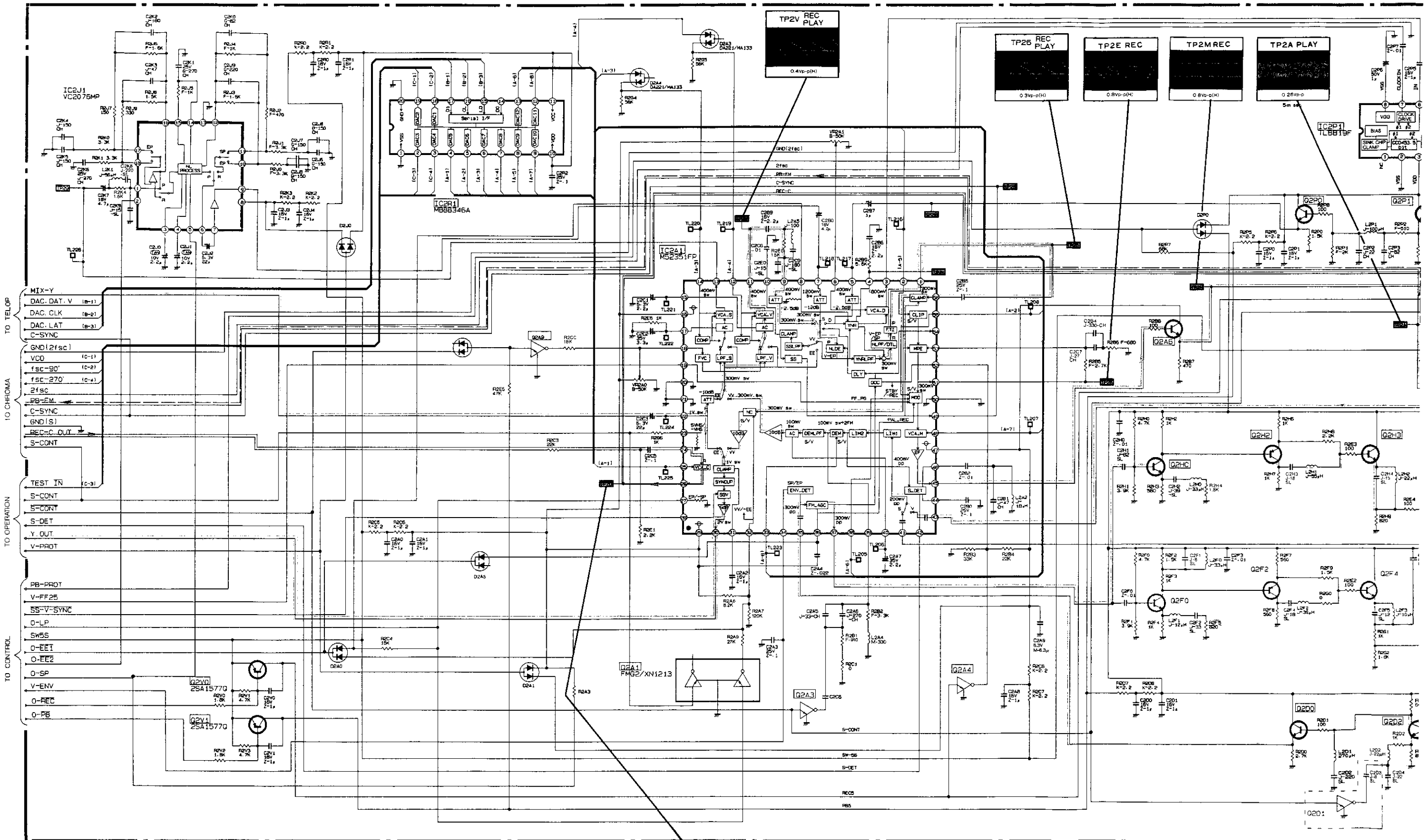

SYMBOL NO.	Q2A3	C2C8
MODELS	X	X
HS-CX7		

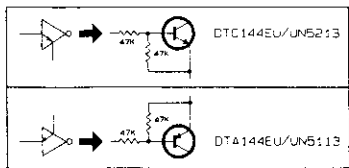

A-1	C-LEV	A-7	FM-LEV
A-2	DEV	A-8	PB-LEV
A-3	S-VHS-LEV	C-1	VCO
A-4	VHS-LEV	C-2	fsc-90°
A-5	CLIP-LEV	C-3	TEST IN
A-6	CAR-SET	C-4	fsc-270°

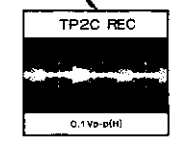

NOTE) PARTS WITHOUT INDICATION IN SCHEMATIC DIAGRAM.

- PNP TRANSISTORS ARE 2SA1576-R/2SB1218A-R
- NPN TRANSISTORS ARE 2SC4098-P/2SC3936-B
- PNP DIGITAL TRANSISTORS ARE DTA144EU/UN5113
- NPN DIGITAL TRANSISTORS ARE DTC144EU/UN5213



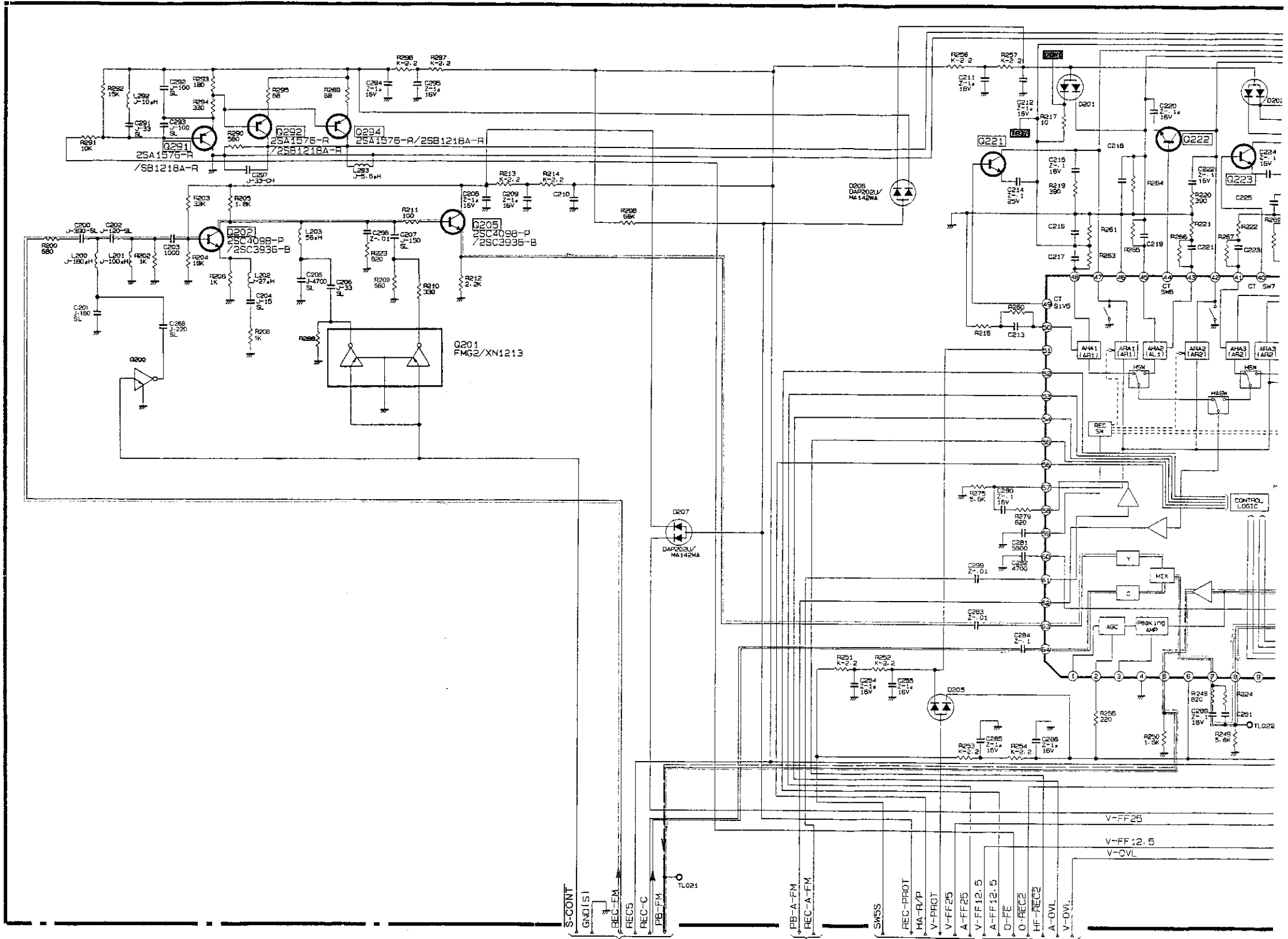
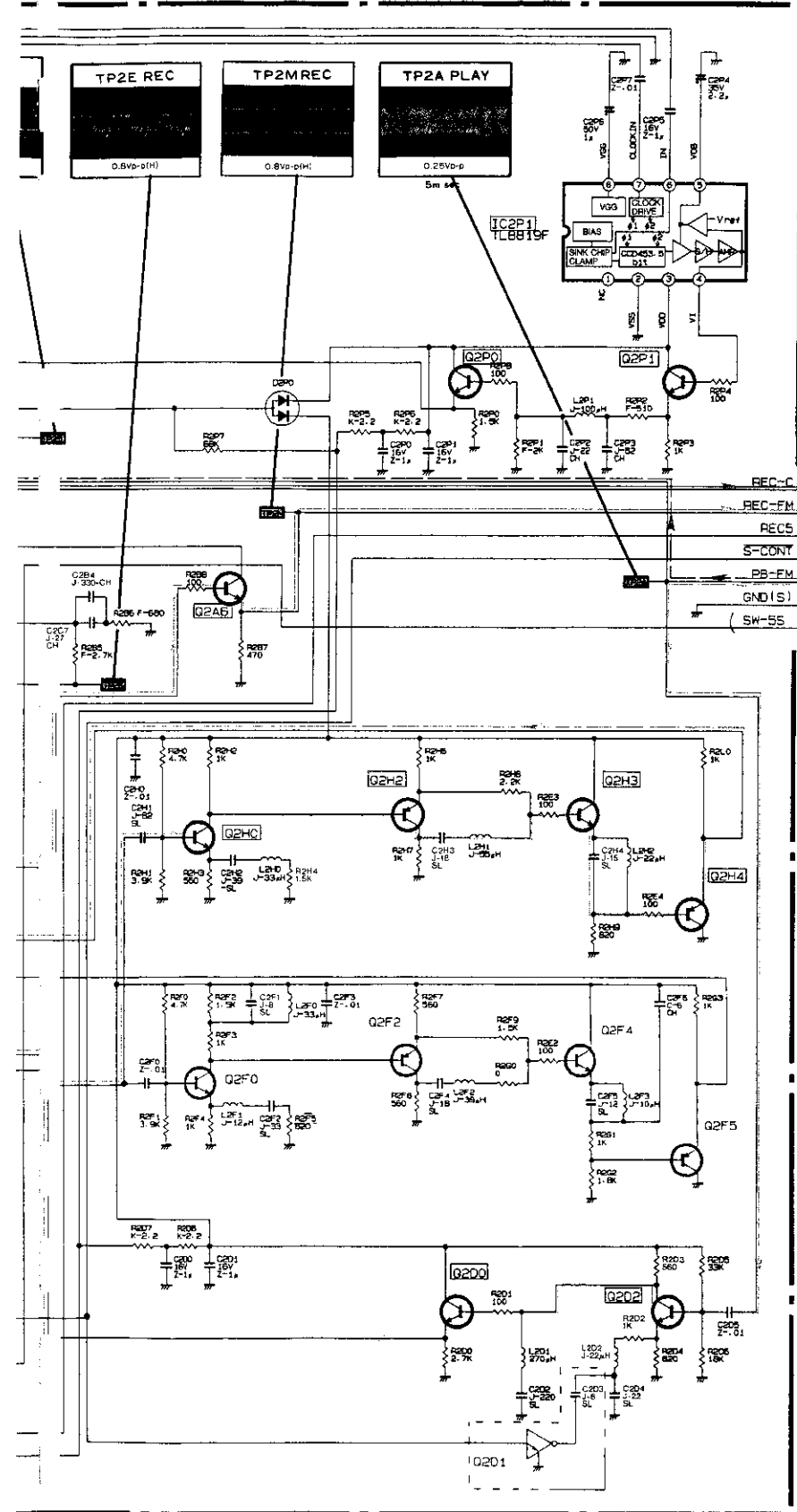

1/AGC.M.
 1/SE 218A-R
 1/SC3935-B
 1/44EU/UN5113
 1/44EU/UN5213

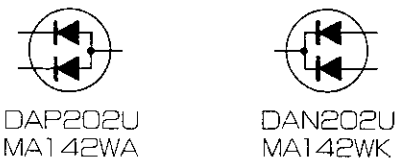

- Recording of Luminance Signal
- - - Playback of Luminance Signal
- · · Recording of Color Signal
- · · Playback of Color Signal

HEAD AMP		
SYMBOL NO.	R221	R222
MODEL		
HS-CX7	180	220

(HEAD AMP) PCB-VTR

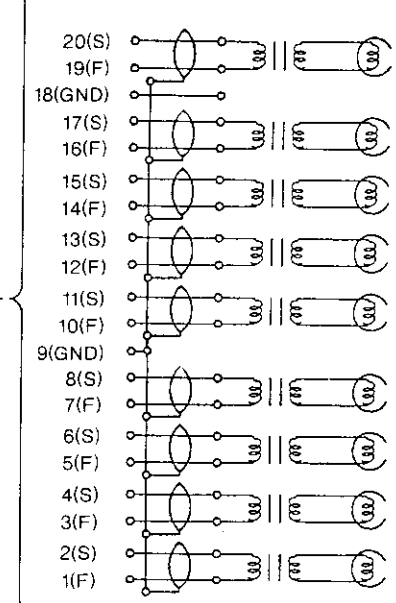
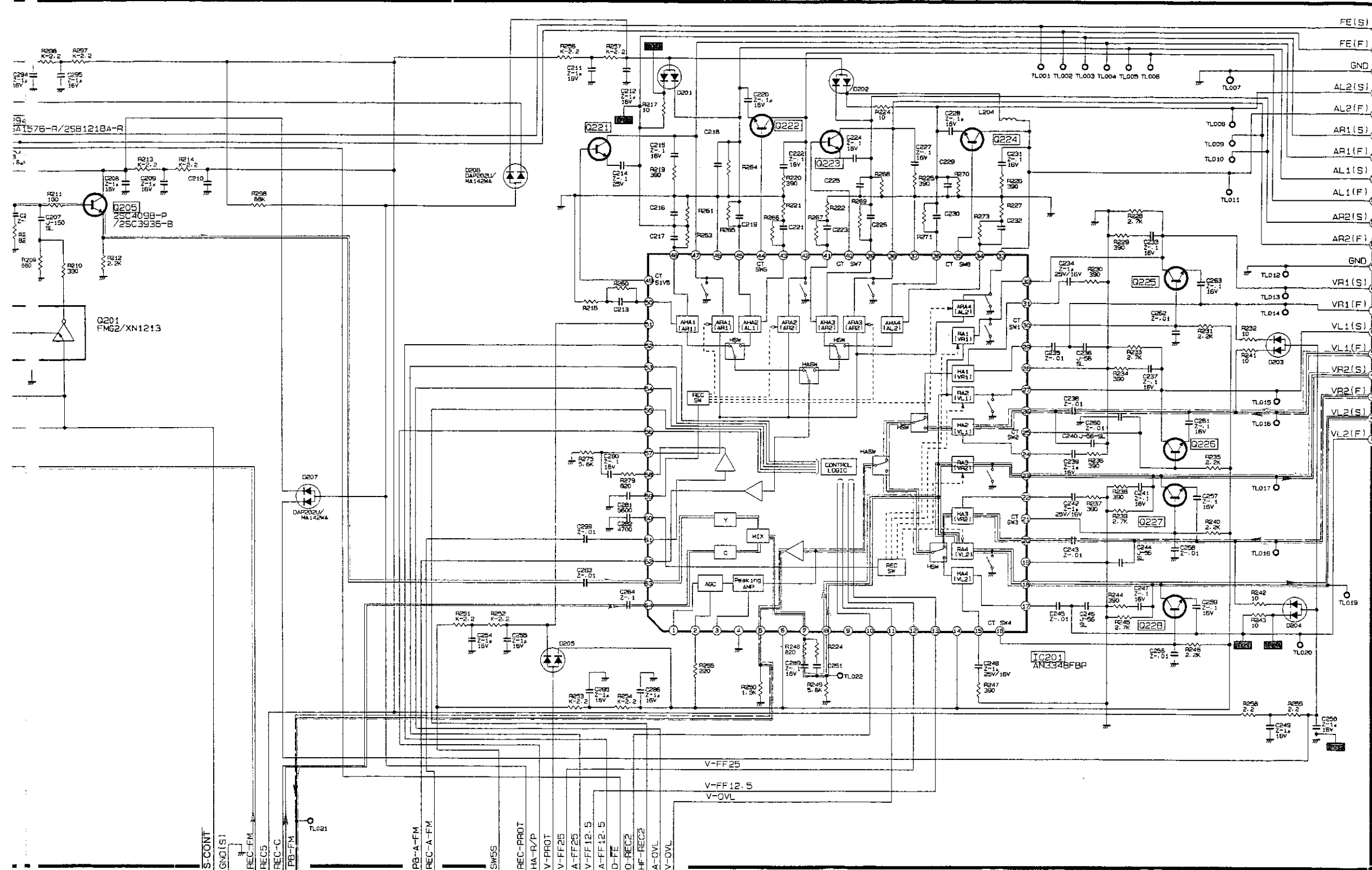

(HEAD AMP)
 NOTE: PARTS WITHOUT INDICATION IN SCHEMATIC DIAGRAM.
 ● NPN TRANSISTORS ARE 2SC4618-P/2SC4655-B
 ● PNP DIGITAL TRANSISTORS ARE DTA144EU/UN5113
 ● NPN DIGITAL TRANSISTORS ARE 2TC144EU/UN5213

HEAD AMP

SYMBOL NO	R221	R216	R222	C223	C232	R263	R261	R267	R271	L204	C230	C217	C218	R227
MODEL	R221	R216	R222	C223	C232	R263	R261	R267	R271	L204	C230	C217	C218	R227
	180	180	220	Z-1μ	Z-1μ	X	X	X	X	100μH	J-680 SL	Z-.01	J-560 SL	150

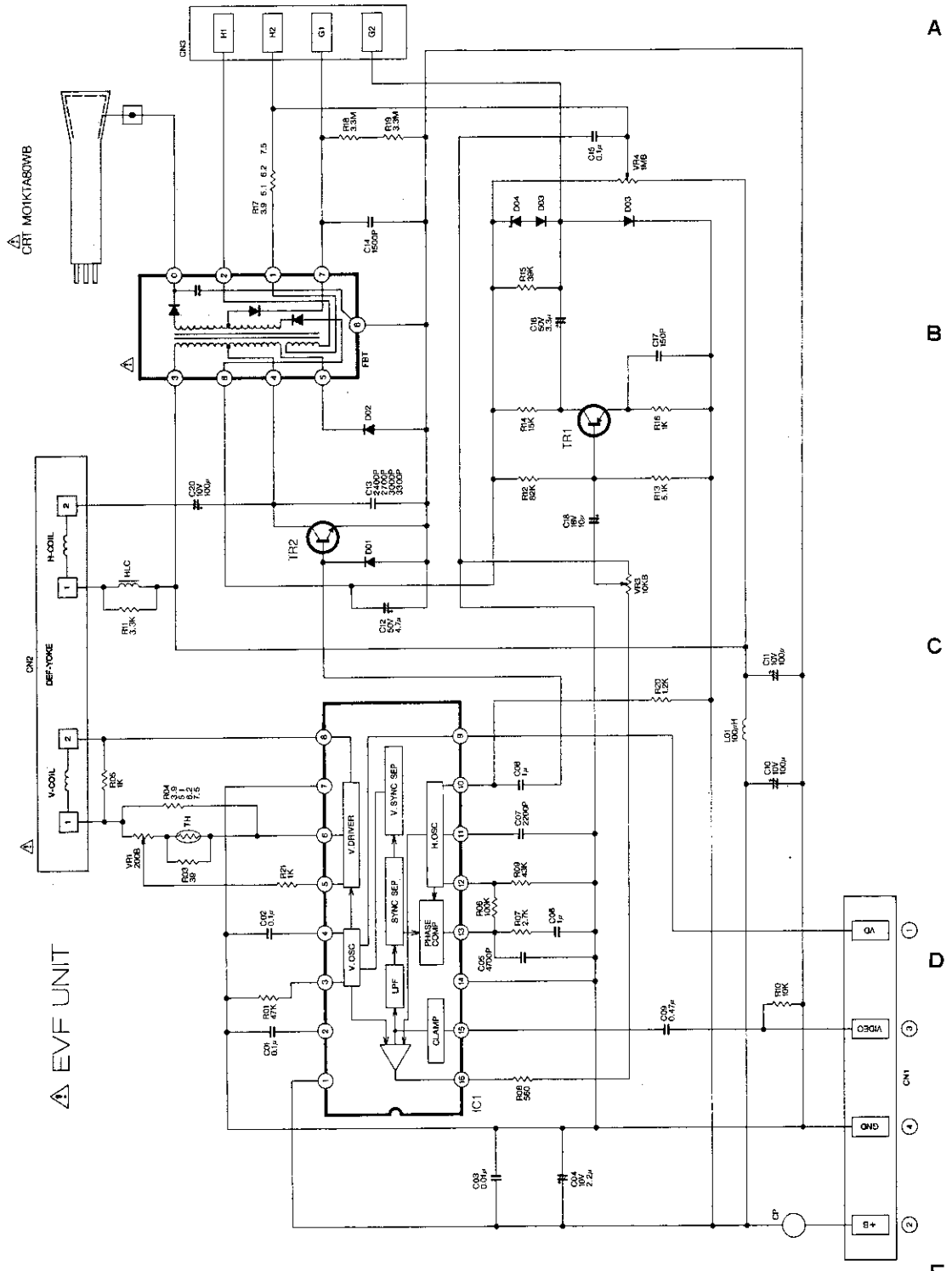

SYMBOL NO	R846	R847	R853	R854
MODEL				
HS-CX7	X	X	1kΩ	1kΩ

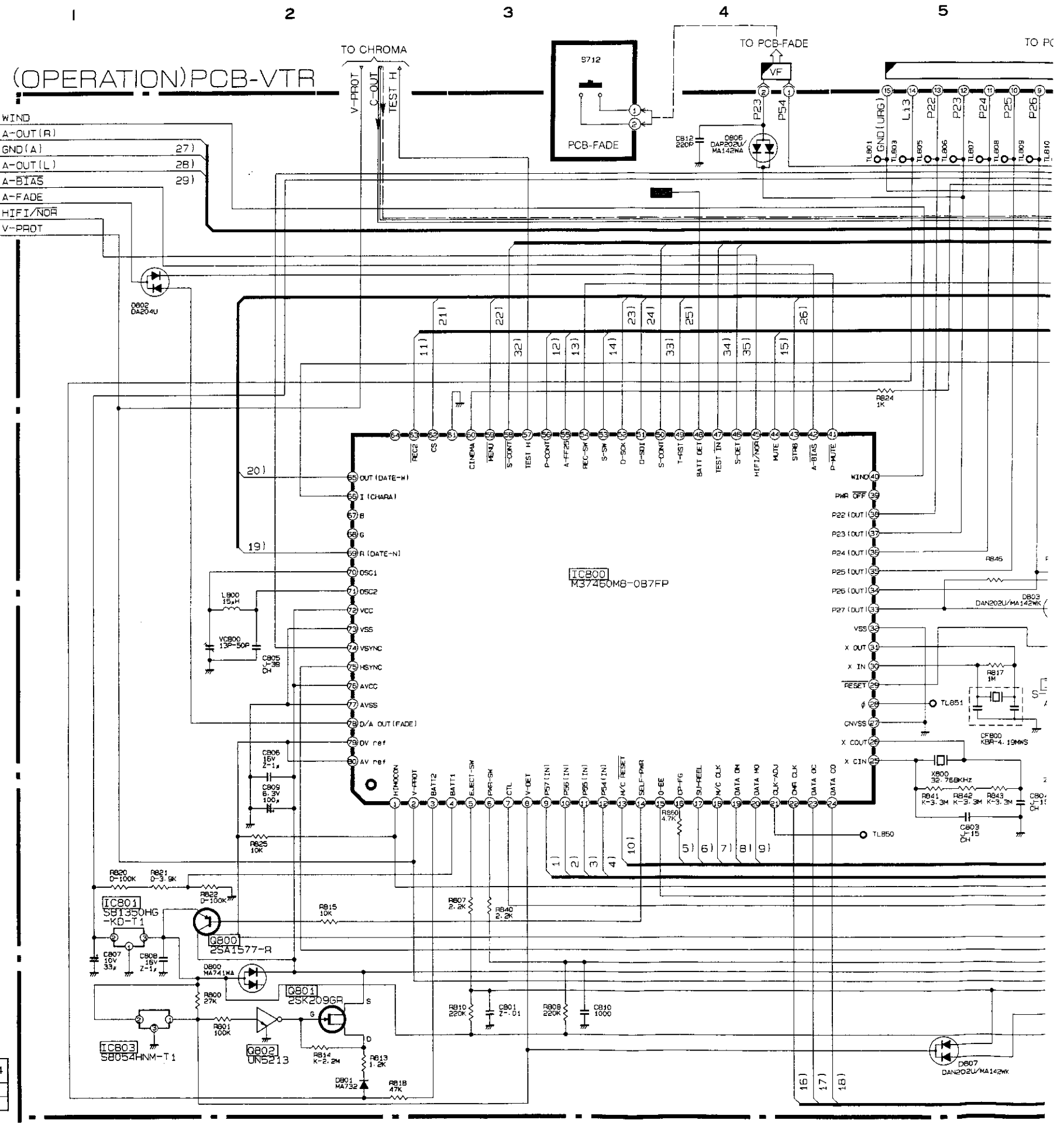

A
B
C
D
E

(OPERATION) PCB-VTR

- TO AUDIO
- WIND
- A-OUT (R) 27)
- GND (A)
- A-OUT (L) 28)
- A-BIAS 29)
- A-FADE
- HIFI/NOR
- V-PROT

TO CHROMA

TO PCB-FADE

TO PC

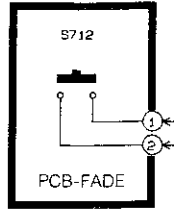

VF

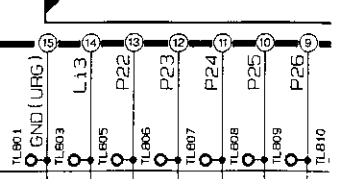

IC800
M37460MB-0B7FP

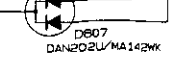
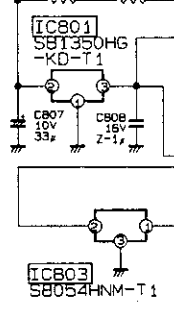

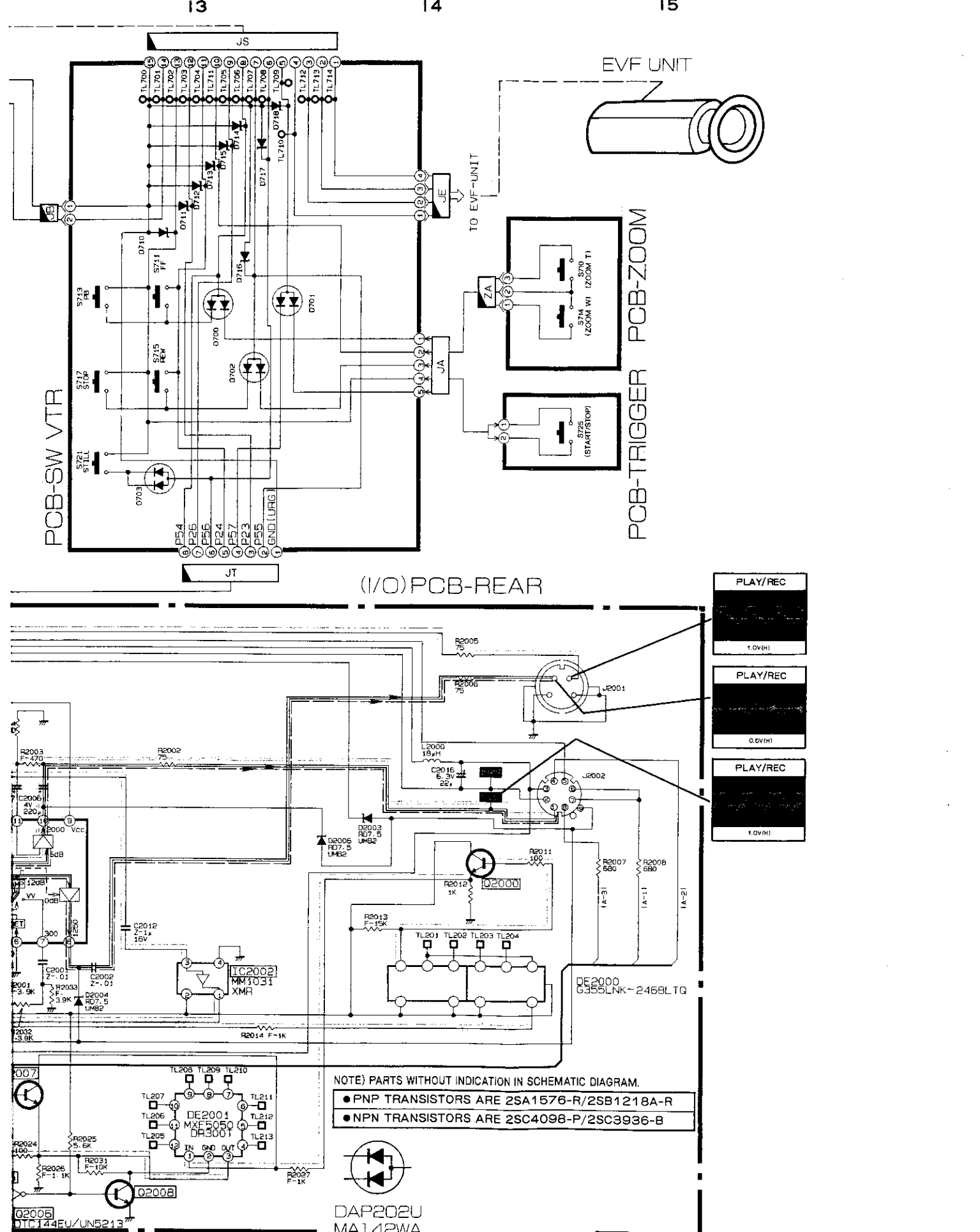
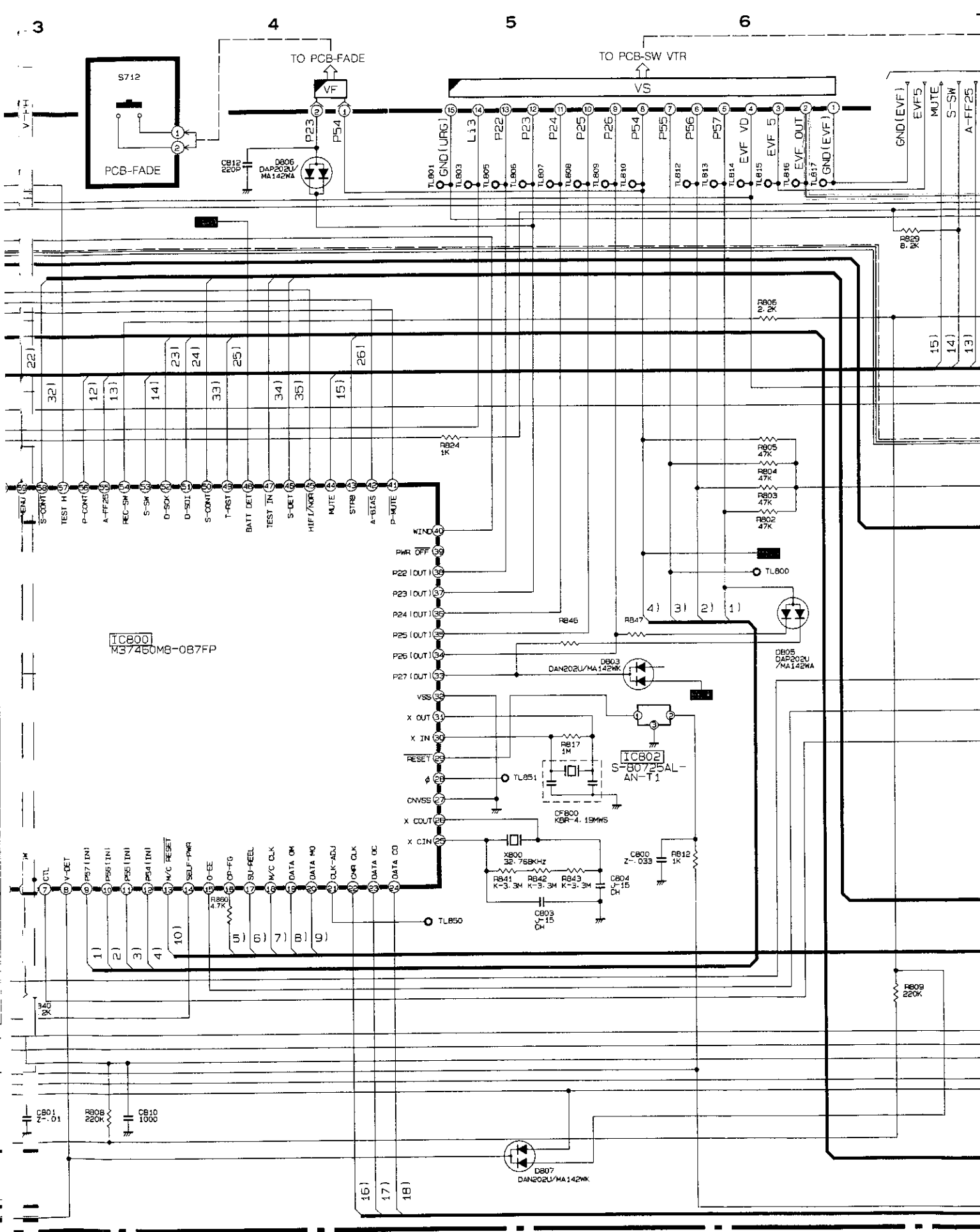

NOTE) PARTS WITHOUT INDICATION IN SCHEMATIC DIAGRAM.
 ● PNP TRANSISTORS ARE 2SA1576-R/2SB1218A-R
 ● NPN TRANSISTORS ARE 2SC4098-P/2SC3936-B

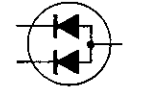

DAP202U
MA142WA

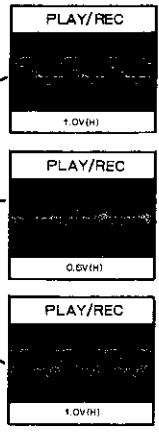
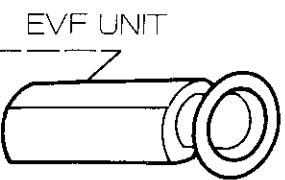

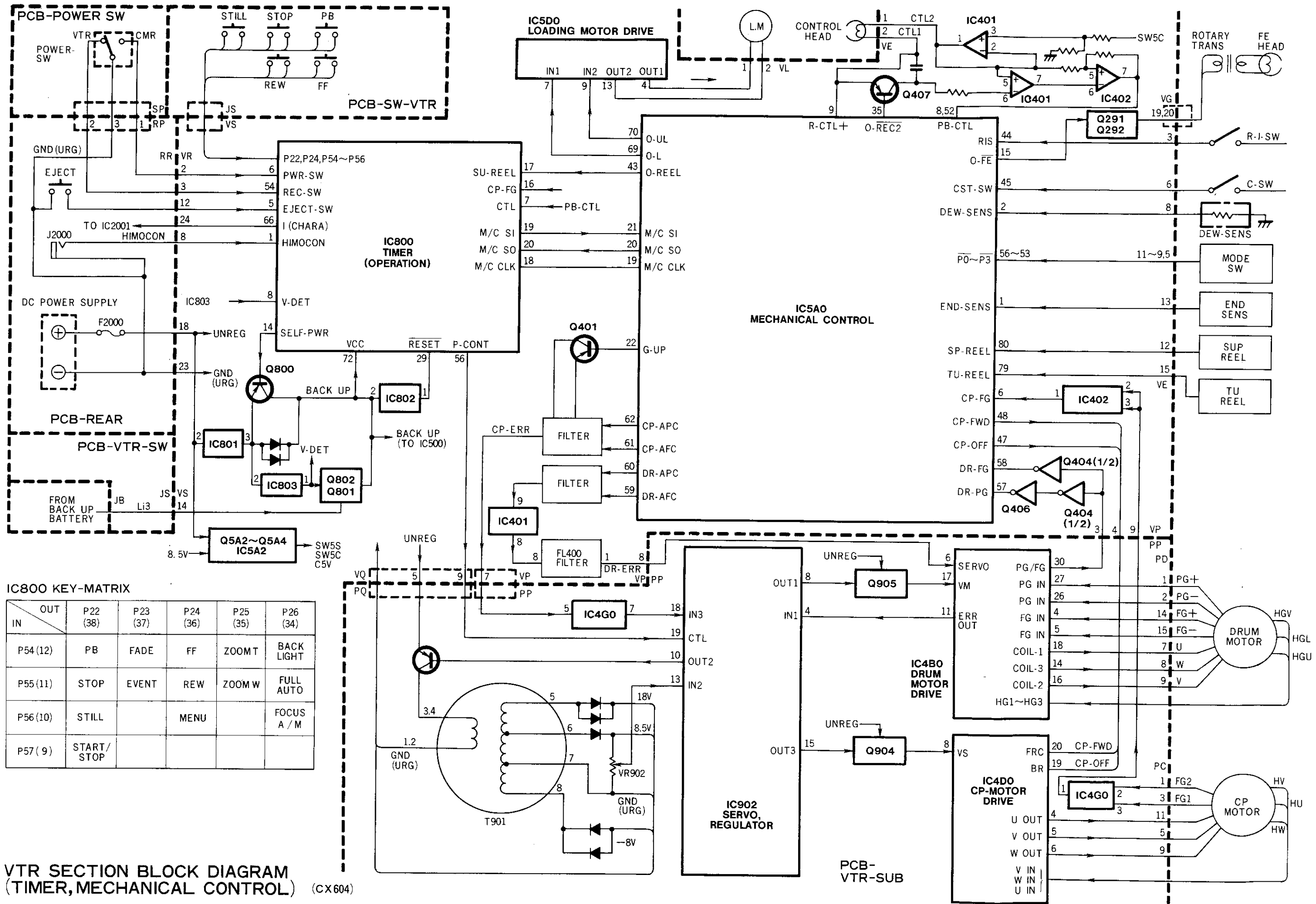

IC800 KEY-MATRIX

IN \ OUT	P22 (38)	P23 (37)	P24 (36)	P25 (35)	P26 (34)
P54 (12)	PB	FADE	FF	ZOOMT	BACK LIGHT
P55 (11)	STOP	EVENT	REW	ZOOM W	FULL AUTO
P56 (10)	STILL		MENU		FOCUS A/M
P57 (9)	START/STOP				

VTR SECTION BLOCK DIAGRAM (TIMER, MECHANICAL CONTROL) (CX604)

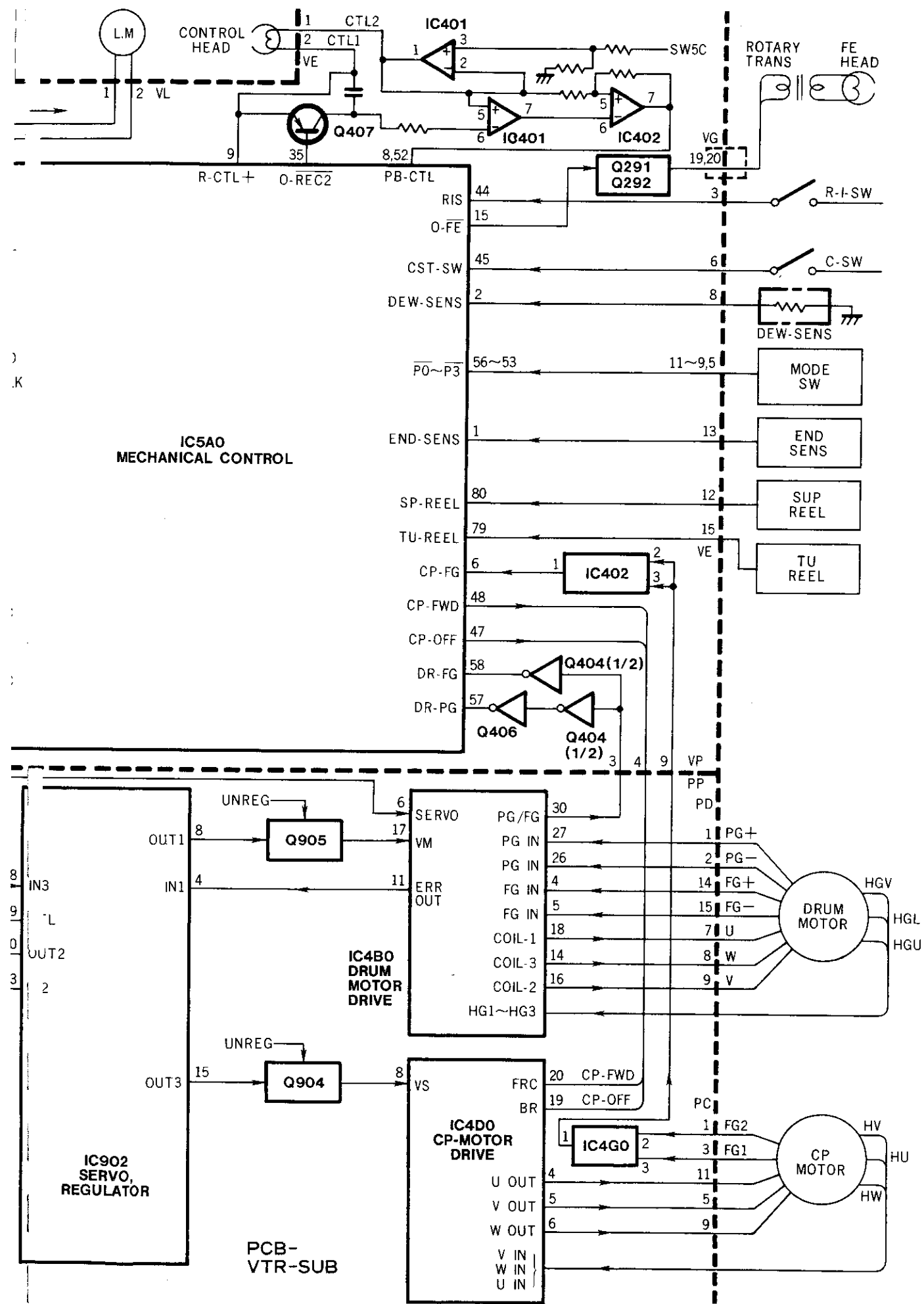

M/C μ COMPUTER FUNCTION (IC 5A0)

PIN NO.	NAME	I/O	FUNCTION
1	END-SENS	I	"H" input when tape end is detected.
2	DEW-SENS	I	"H" input when dew falls on the deck.
3	A-ENV	I	Playback Audio level signal
4	V-ENV	I	Playback Video level signal
5	A-FF25/ A-FF30	O	Audio Head switch signal
6	CP-FG	I	Capstan FG signal
7	V-FF25/ V-FF30	O	Video Head switch signal
8	CTL	I	Control signal from CTL Head
9	RECCTL+	O	Control signal to CTL Head
14	A-FF25/ A-FF30	O	Audio Head switch signal
15	O-FE	O	"L" output when FE Head is ON.
16	A-FF25 IN A-FF30 IN	I	Audio Head switch signal input
17	PB-PROT	I	PB-5V input
18	REC-PROT	I	REC-5V input
19	M/C CLK	I	
20	DATA SO	O	Serial data and clock between M/C and OPE μ computer.
21	DATA SI	I	
22	G-UP	O	Capstan motor control signal
23	V-FF12.5/ V-FF15	O	Video Head switch signal
24	A-FF12.5/ A-FF15	O	Audio Head switch signal
25	V-OVL	O	Control signal to Head Amp
26	VSYNC	I	V-Sync input
27	CNVSS	-	GND
28	RESET	I	"L" input when μ computer is reset.
29	X-IN	-	oscillator
30	X-OUT	-	
32	VSS	-	GND
33	O-PB	O	"L" output in Playback mode
34	O-REC	O	"L" output in Recording mode
35	O-REC2	O	REC control signal ("L" during Recording)
36	D-ON	O	"H" output when drum motor is ON.
37	A-OVL	O	Control signal to Head Amp
38	O-SP	O	"H" output in SP mode
39	O-PB2	O	"H" output in Playback mode
40	O-EE1	O	"L" output in EE mode (Recording or Stop mode)
41	O-EE2	O	
42	HF-REC2	O	"L" output during HiFi recording
43	O-REEL	O	Reel pulse output
44	RIS	I	Recording Inhibit signal ("L" input when recording is possible.)
45	CST-SW	I	Casset Housing is open at "H"

PIN NO.	NAME	I/O	FUNCTION
46	O-EDIT	O	"L" output in Editing mode
47	CP-OFF	O	"L" output when Capstan motor is ON.
48	CP-FWD	O	"H" output to drive Capstan motor forward direction
49	DR-PG IN	I	Drum PG signal input
51	DR-FG	I	Drum FG signal input
52	PB-CTL	I	Control signal from CTL Head
53	P3	I	Deck mode switch input
54	P2	I	
55	P1	I	
56	P0	I	
57	DR-PG	I	Drum PG signal input
58	DR-FG	I	Drum FG signal input
59	DR-AFC	O	Drum servo speed error output
60	DR-APC	O	Drum servo phase error output
61	CP-AFC	O	Capstan servo speed error output
62	CP-APC	O	Capstan servo phase error output
63	O-N	O	"H" output in special playback mode
64	O-LP	O	"H" output in LP mode
65	O-EE	O	"H" output in EE mode
66	ES-LED	O	pulse output to light ES-LED
67	O-MUTE	O	"H" output in special playback mode
68	O-REC	O	"H" output in Recording mode
69	O-L	O	Loading motor drive output
70	O-UL	O	
71	PG-MM	I	PG-MM control signal
72	AVSS	-	GND
73	VCC	I	Power source input
74	AVCC	I	
75	VREF	I	
76	SS-VSYNC	O	Quasi-sync signal for special playback
77	2/3PG OUT	O	Quasi-Drum PG signal output
78	TR-ADJ	O	TR-MM signal output
79	TU-REEL	I	Reel pulse input
80	SP-REEL	I	

CHIP PARTS SHAPES

(4-1)



DESCRIPTION	IMPRINTING	PARTS No.	SHAPES
CHIP TRANSISTOR			
2SA1235-F.G	MF, MG	260P802090	
2SA1576-R/2SB1218A-R 2SB1218A-Q	FR, BR BO	260P859020 260P859070	
2SA1576-R	FR	260P859050	
2SA1577-Q/2SB1219A-R	HQ, DR	260P861020	
2SA1577-Q 2SA1577-R	HQ HR	260P861050 260P861060	
2SA1610-Y34	Y34	260P870010	
2SC4081-Q/2SD1819A-Q	BQ, ZQ	260P855010	
2SC4081-R/2SD1819A-R 2SC4081-S/2SD1819A-S	BR, ZS BS, ZS	260P855020 260P855030	
2SC4098-P/2SC3936-B	AP, KB	260P854020	
2SC4098-Q/2SC3936-C	AQ, KC	260P854030	
2SC4176-B34	B34	260P869020	
2SC4176-B35	B35	260P869010	
2SD1819A-Q	ZQ	260P855070	
2SD1949-Q/2SD1820A-R	YQ, XR	260P867020	
2SD1949-R	YR	260P867060	
DTA144EU/UN5113	16, 6C	260P856010	
DTC114EK	24	260P808010	
DTC144EU/UN5213	26, 8C	260P857010	
DTC144EU	26	260P857020	
DTA114EU/UN5111	14, 6A	260P858010	
2SB798-DK	DK	260P482010	
2SB1114-ZL	ZL	260P847010	
2SC3736-OK	OK	260P866010	
2SD999-CK	CK	260P865010	
2SK209GR	XG	260P864010	
2SC2873-Y	MY	260P868010	
2SA1213-Y	NY	260P701010	
DTA124EU	15	260P871020	
DTC124EU	25	260P872020	
2SC4618-P/2SC4655-B DTA144EE/UN9113 DTC144EE/UN9213	AP, KB 16, 6C 26, 8C	260P877020 260P879010 260P880010	

(4-2)

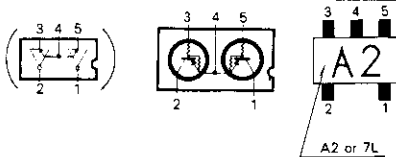
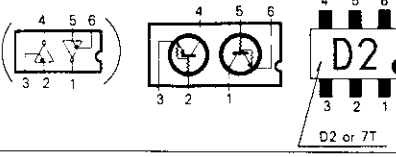
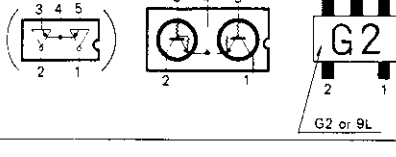
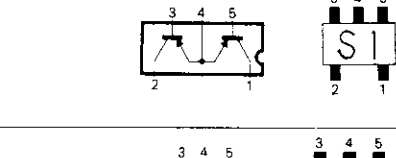
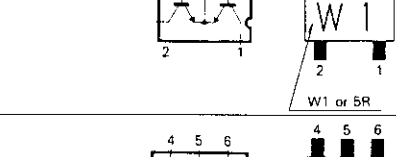
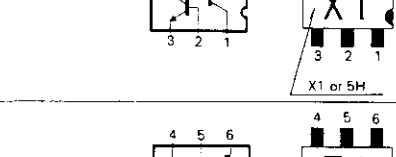
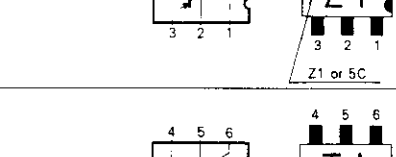
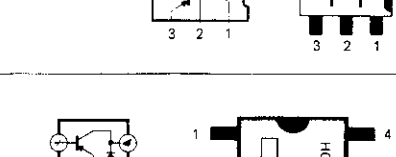

DESCRIPTION	IMPRINTING	PARTS No.	SHAPES
CHIP TRANSISTOR			
FMA2/XN1113	A2 or 7L	260P853010	
IMD2/XN4312	D2 or 7T	260P851010	
FMG2/XN1213	G2 or 9L	260P852010	
FMS1	S1	260P843010	
FMW1/XN1501	W1 or 5R	260P844020	
IMX1/XN4501	X1 or 5H	260P845020	
IMZ1/XN4601	Z1 or 5C	260P849020	
IMT1	T1	260P863010	
SAH02-VIL	H02	260P873010	

DESCRIPTION	IMPRINTING	PARTS No.	SHAPES
CHIP IC			
SC14S01F	C3	263P223010	
SC14S66F	C9	263P217010	
SC75U04F	E6	263P220010	
SC7500F	E1	263P230010	
S-81250HG-RD-T1	RD	272P360010	
NJM2406F	1	272P364010	
PST529C	T529C	272P357010	
S-80725AL-AN-T1 S-8054ALB-LM-T1 S-8054HNM	AN LM CQ	263P375010 272P362010 263P440010	
S-81215AG-RK-T1 /RH5RA16AA	RK or 6A	272P359010	
NJM2107F	2	272P592010	
M5236ML M5237ML	36 37	272P294010 272P674010	
S-81350HG-KD-T1	KD	263P373010	

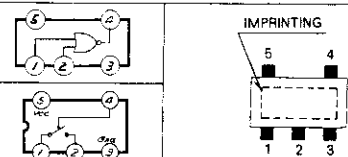
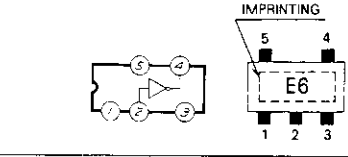
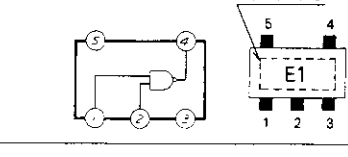
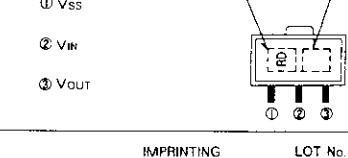
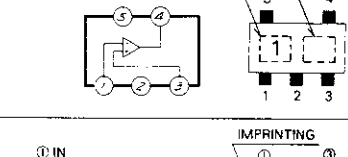
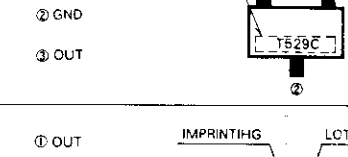
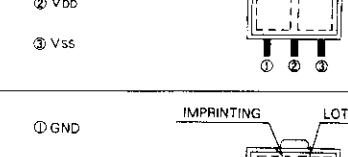
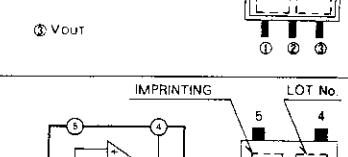
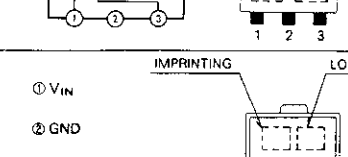
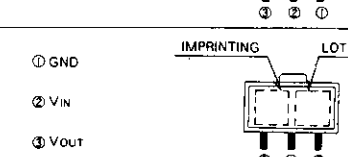

(4-2)

PARTS No.	SHAPES
TRANSISTOR	
2 P853010	
260P851010	
2 P852010	
260P843010	
2 P844020	
260P845020	
2 P849020	
260P863010	
2 P873010	

(4-3)

DESCRIPTION	IMPRINTING	PARTS No.	SHAPES
CHIP IC			
SC14S01F	C3	263P223010	
SC14S66F	C9	263P217010	
SC7SU04F	E6	263P220010	
SC7S00F	E1	263P230010	
S-81250HG-RD-T1	RD	272P360010	
NJM2406F	1	272P364010	
PST529C	T529C	272P357010	
S-80725AL-AN-T1	AN	263P375010	
S-8054ALB-LM-T1	LM	272P362010	
S-8054HNM	CQ	263P440010	
S-81215AG-RK-T1 /RH5RA16AA	RK or 6A	272P359010	
NJM2107F	2	272P592010	
M5236ML	36	272P294010	
M5237ML	37	272P674010	
S-81350HG-KD-T1	KD	263P373010	

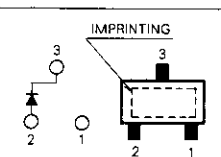
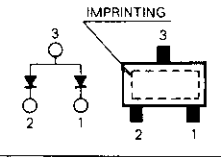
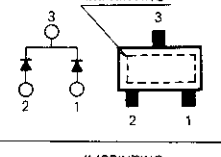
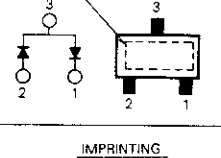
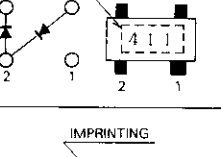
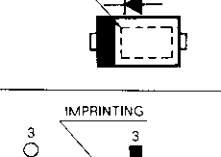
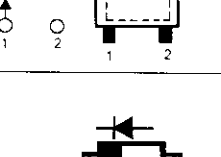
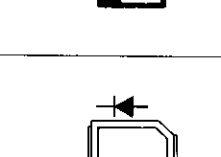
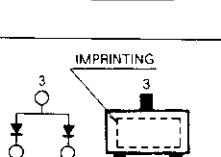
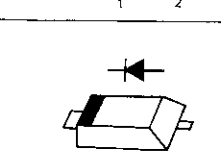
(4-4)

DESCRIPTION	IMPRINTING	PARTS No.	SHAPES
CHIP DIODE			
RD2.4MB	24	264P815010	
RD5.1MB1	511	264P815060	
RD6.8MB1	681	264P816040	
RD7.5MB2	752	264P816050	
RD10MB	100	264P816080	
RD11MB2	1102	264P816090	
DAP202U/MA142WA	P or MO	264P814010	
MA142WA	MO	264P814030	
MA132WA	MO	264P841030	
DAN202U/MA142WK	N or MU	264P828010	
DA204U	K	264P830020	
DA221/MA133	K, MP	264P843010	
ND411G-2	411	264P833010	
U1GWJ44	GW	264P603010	
SPB-54V	B54	264P831010	
SFPB-64V	B64	264P832010	
MA141K	MH	264P837010	
MA720	M2W	264P850010	
ISV205		264P838010	
ISV223		264P845010	
MA341		264P834010	
RD7.5UMB2		264P844050	
LN1351C		264P839010	
MA741WA	M2P	264P847010	
MA110	1A	264P848010	
MA728	2A	264P849010	
MA732	2C	264P846010	

PCB-INTERCONNECT

A

B

C

D

E

F

G

H

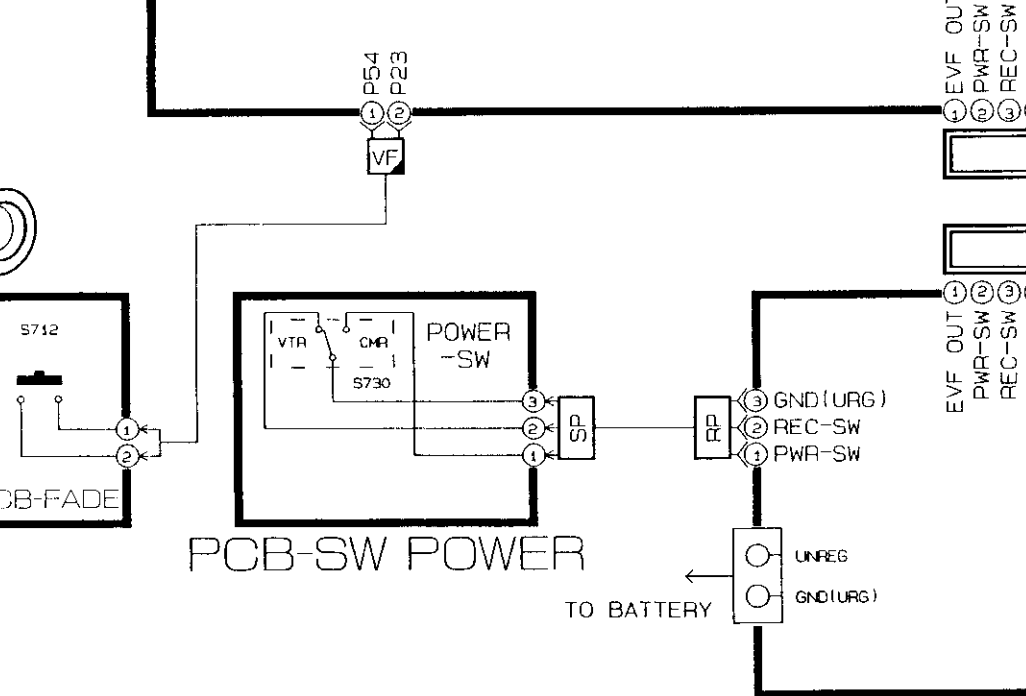
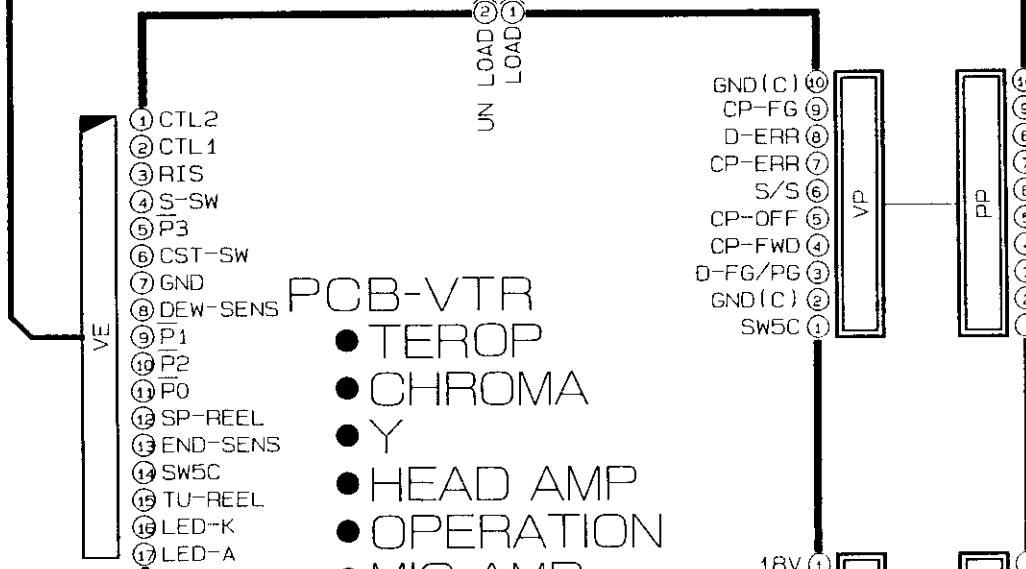
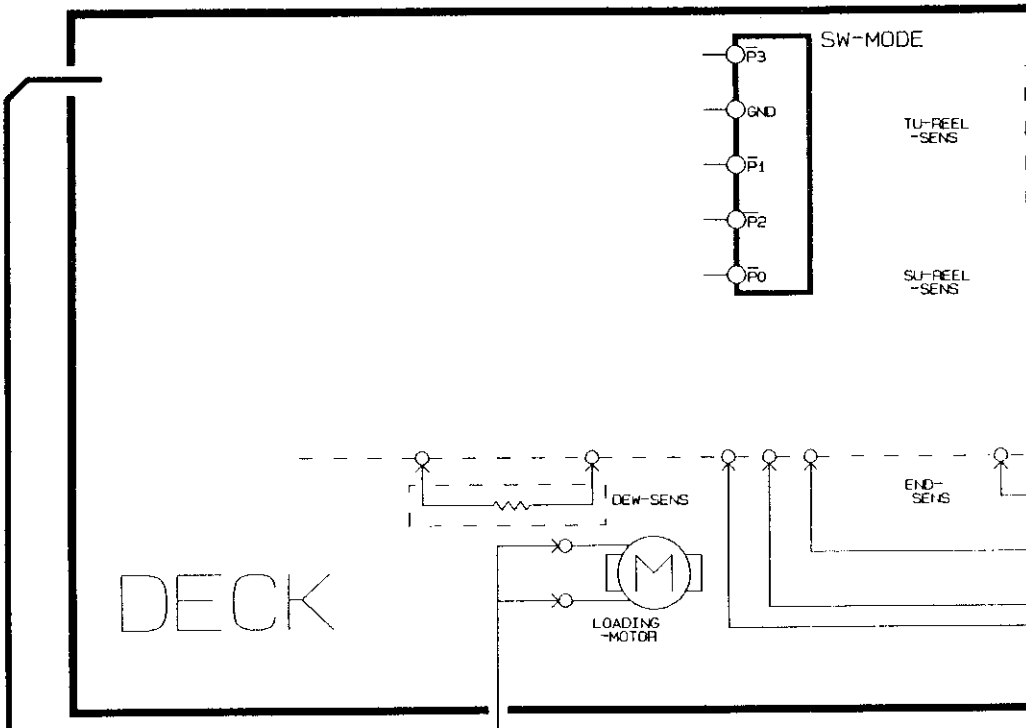
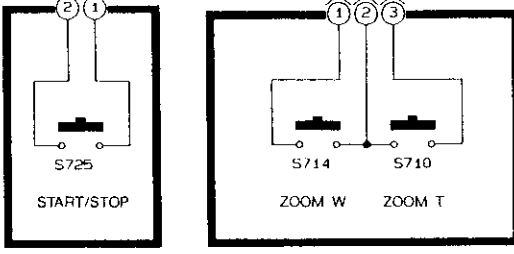
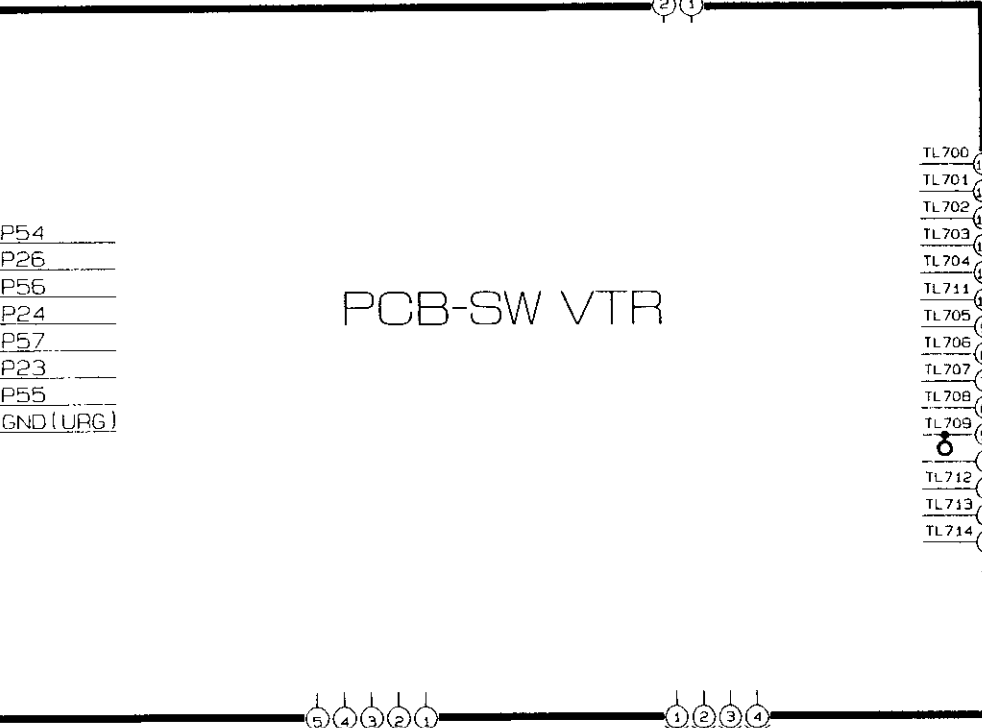
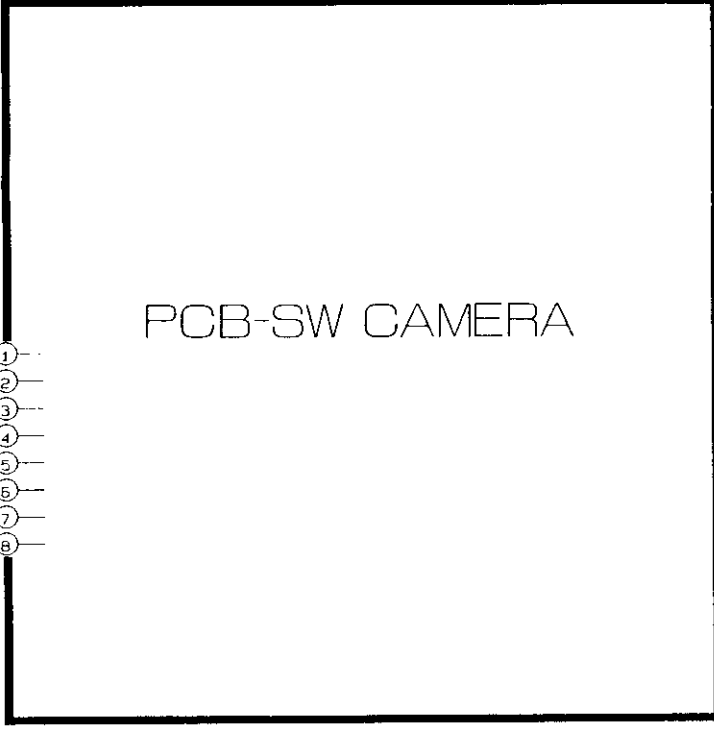

TO BATTERY BU

TO EVF-UNIT

TO BATTERY

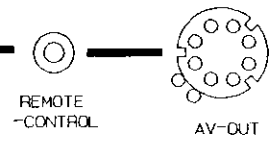
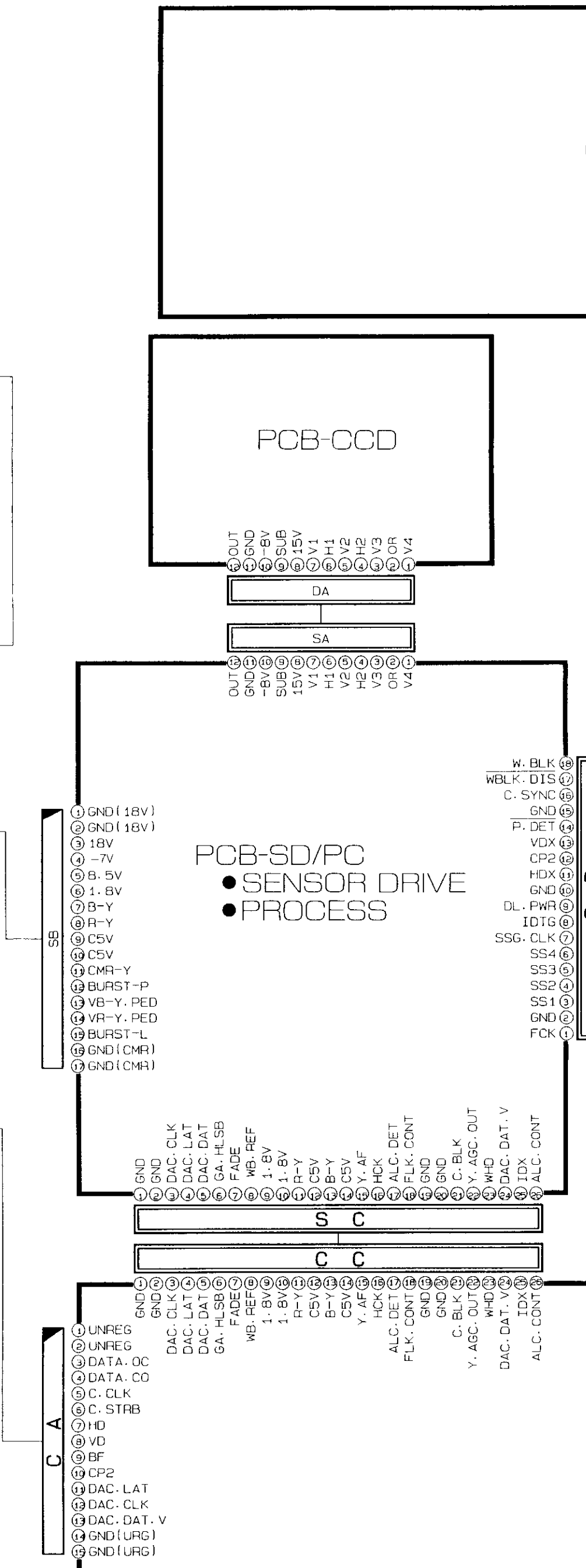
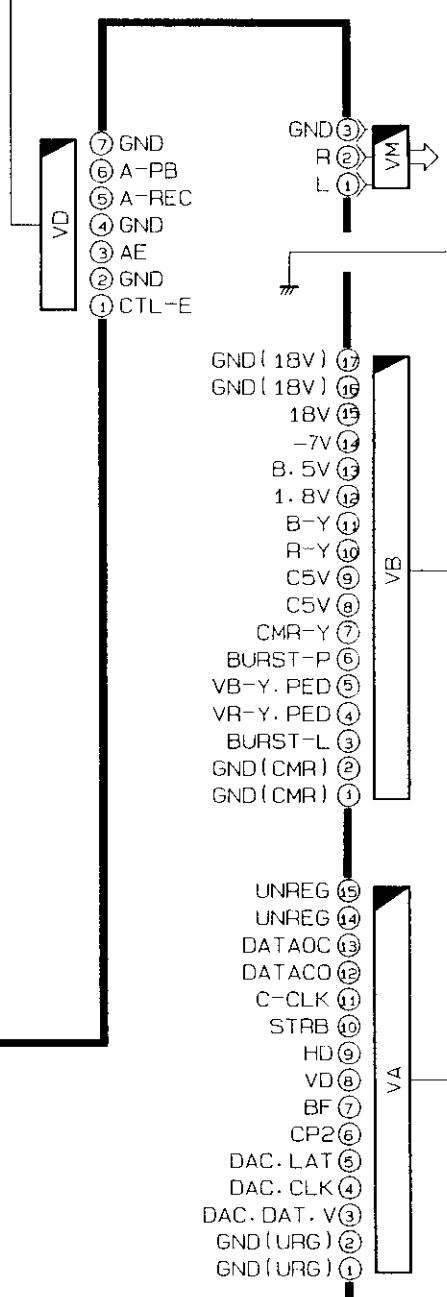
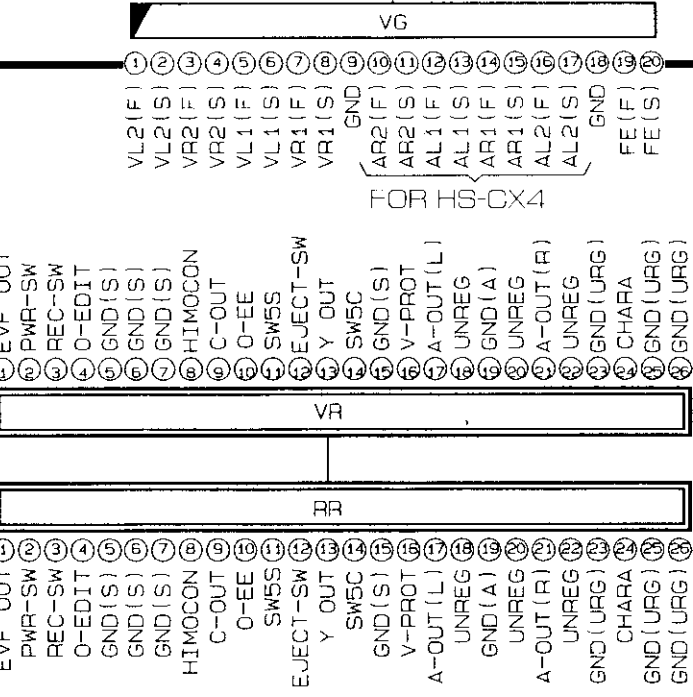
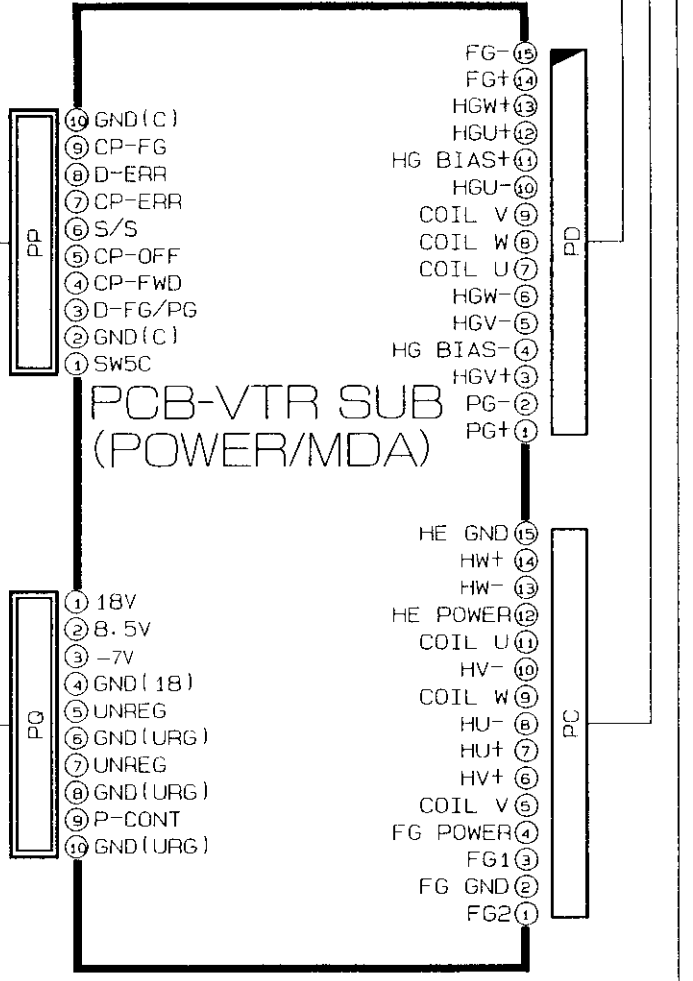
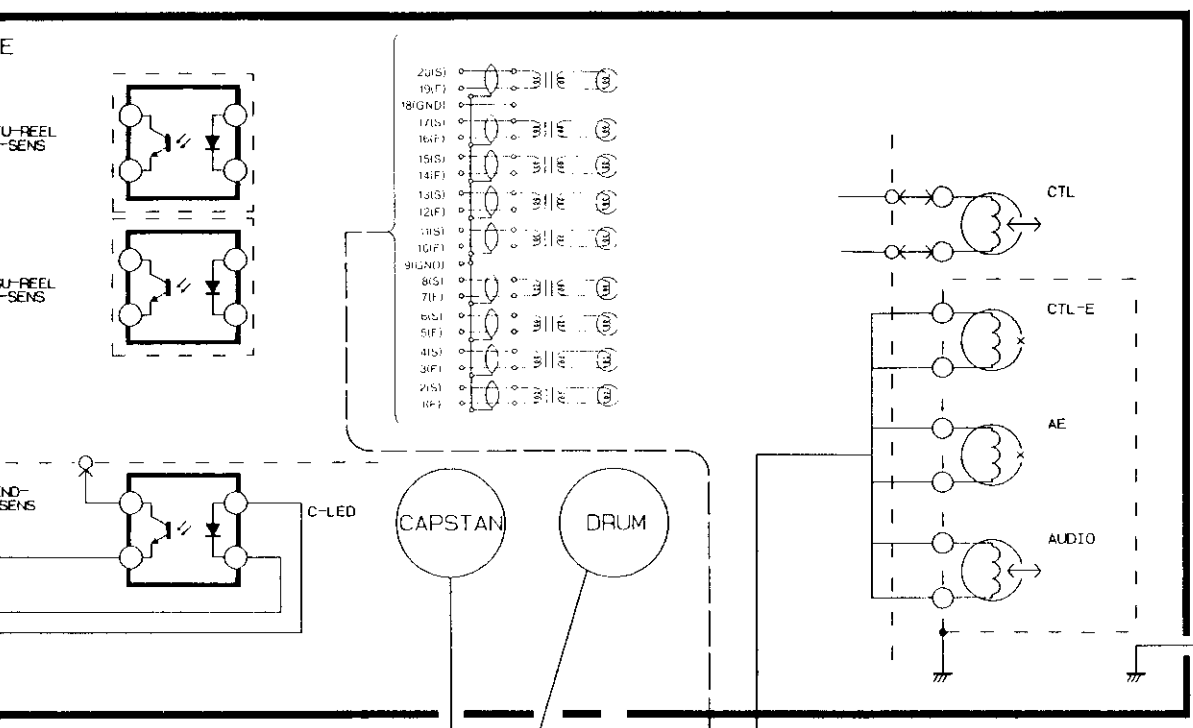

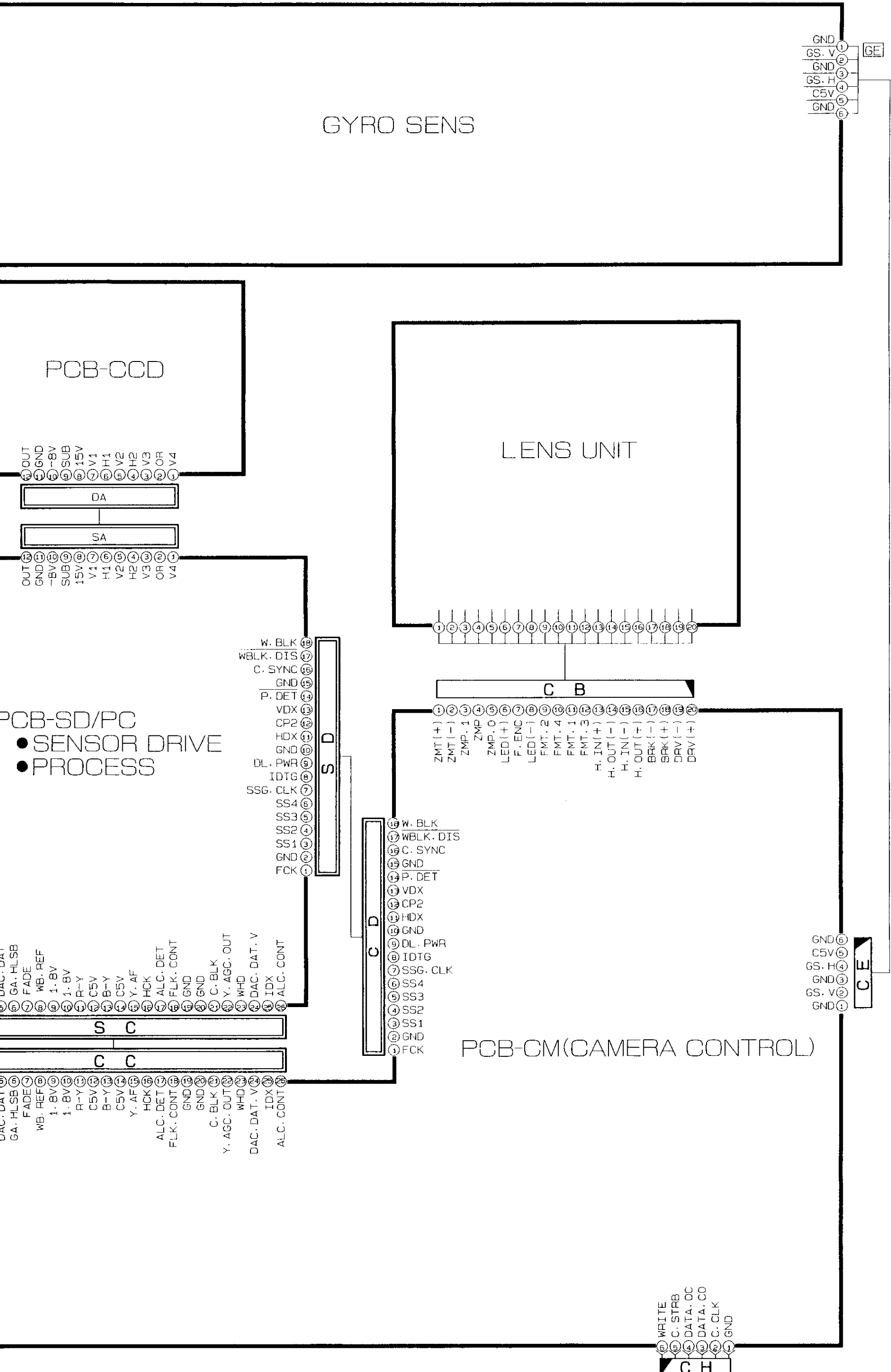

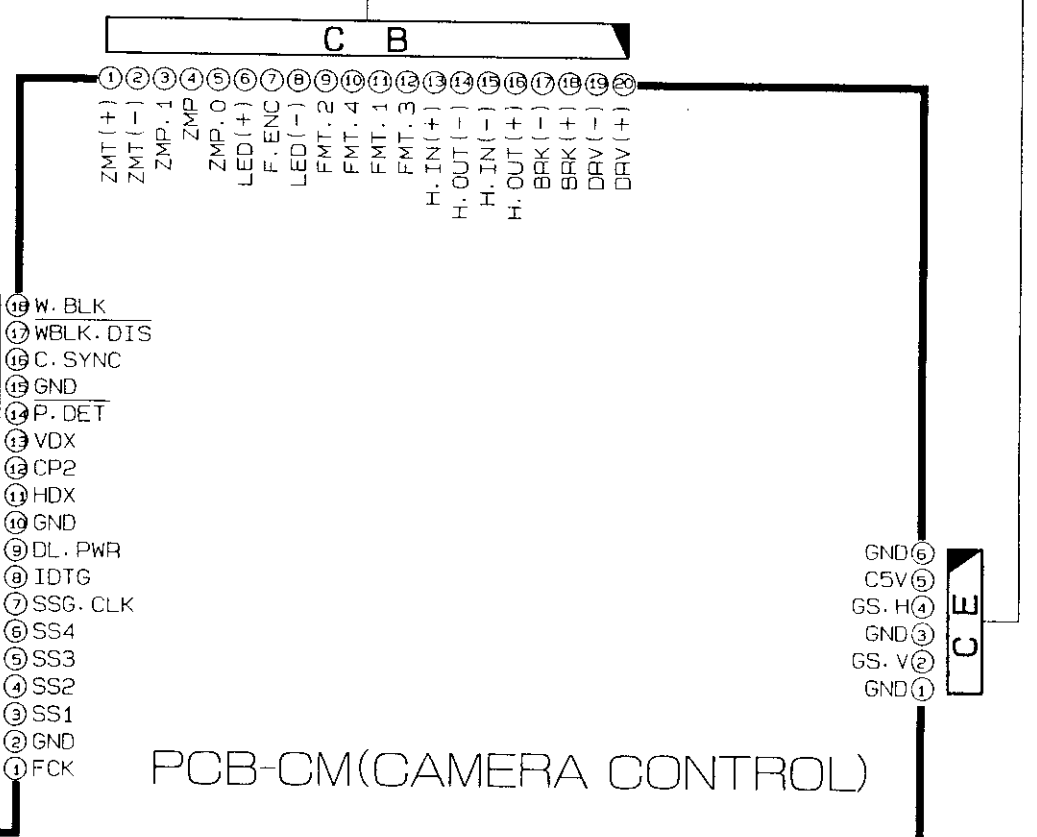
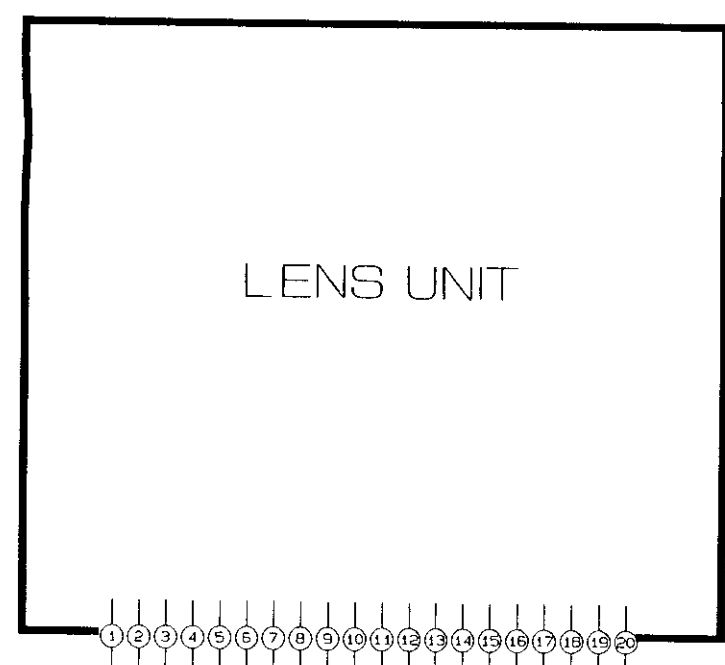
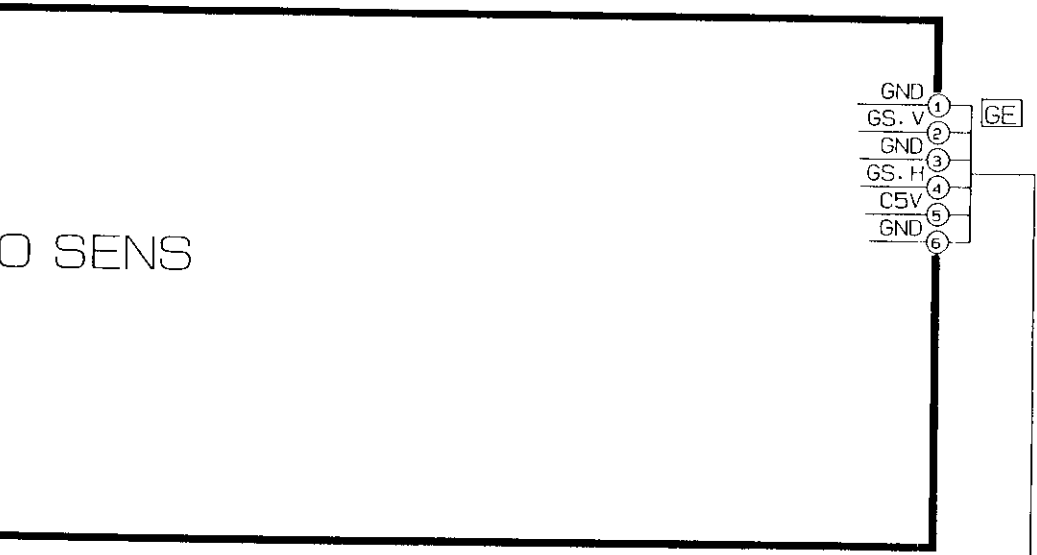

SCHEMATIC DIAGRAM

NOTE 1:

- DC voltages were measured from points indicated to the circuit ground with a Digital voltmeter.
- Waveforms of camera section were taken with the four color chart.
- Waveforms of VTR section were taken with standard color bar signal.
- The unit of resistance "ohm" entirely omitted. Accordingly, K=1000 ohms, M=1000K ohms.
- Resistors, not specifically designated, are R-M-chip resistors.
- The tolerance of resistor value, not specifically designated, is: ±5%.
- The unit of capacitance, not specifically designated, is: a) μF, for numbers less than 1 b) PF, for numbers more than 1
- Capacitors, not specifically designated are Ceramic chip capacitors except electrolytic capacitors.
- The marks of capacitors are as follows:
 - TAN : Tantalum capacitor
 - * : Electrolytic capacitor
- The tolerance of capacitor value, not specifically designated is: ±10% and J = ±5% K = ±10% M = ±20% P = $\begin{matrix} +100\% \\ -0\% \end{matrix}$ C = ±0.25PF D = ±0.5PF F = ±1PF Z = $\begin{matrix} +80\% \\ -20\% \end{matrix}$ N = ±30%
- Ceramic capacitors with the marks RH, UJ, SL, etc. are temperature compensating types.

SPECIFIC SYMBOL	
	Zener Diode
	LE Diode
	Photo Diode
	Crystal unit
	Ceramic filter

This is a basic schematic diagram. Some sets may be subject to modification according to engineering improvement.

⚠
SERVICING PRECAUTION

SYMBOLS INDICATE COMPONENTS HAVING SPECIAL CHARACTERISTICS IMPORTANT TO SAFETY AND PERFORMANCE. THEREFOR REPLACEMENT OF ANY SAFETY PARTS SHOULD BE IDENTICAL IN VALUE AND CHARACTERISTICS.

DON'T DEGRADE THE SAFETY OF THE VCR THROUGH IMPROPER SERVICING.

A
B
C
D
E
F
G
H

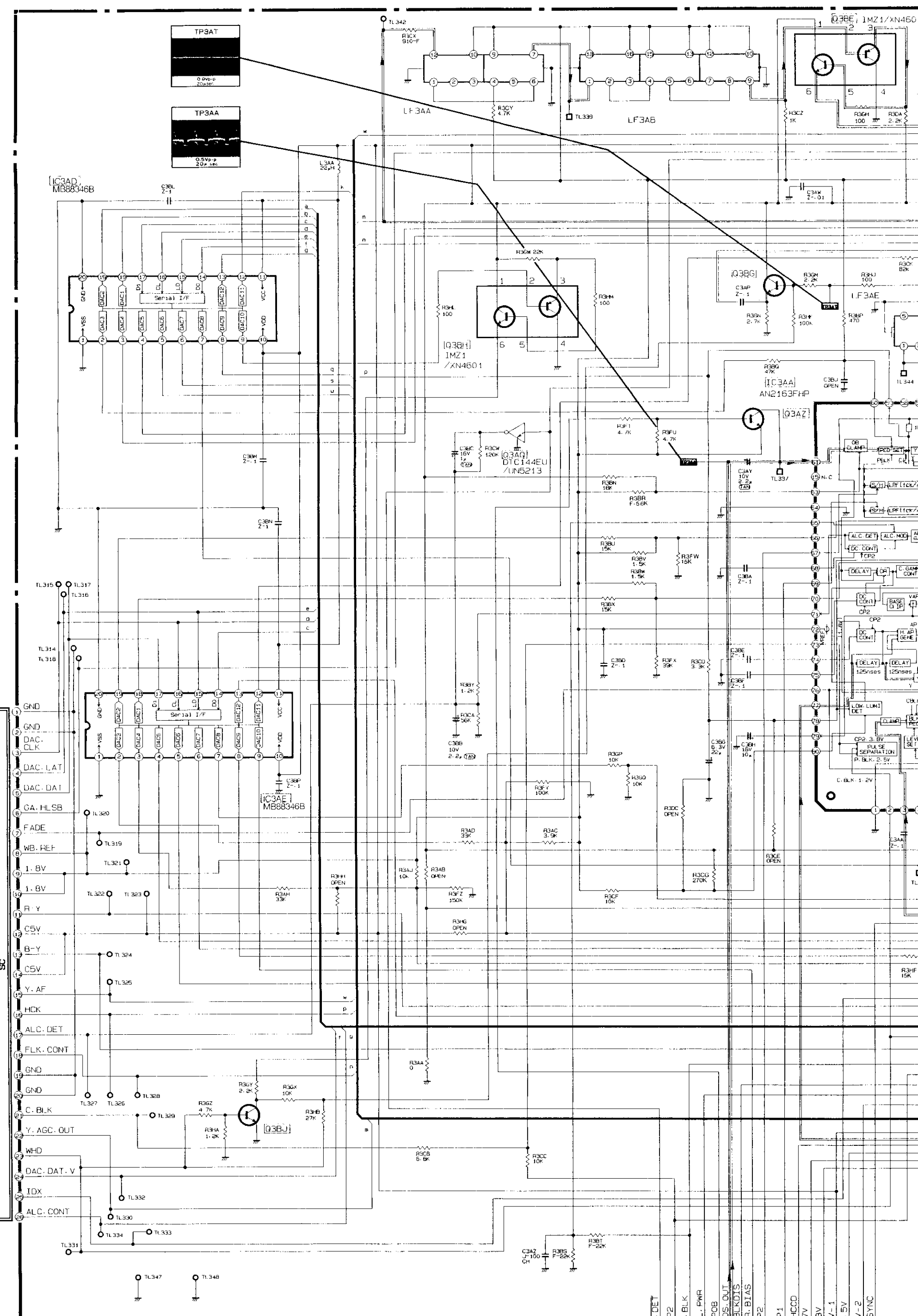

NOTE) PARTS WITHOUT INDICATION IN SCHEMATIC DIAGRAM.
 ● PNP TRANSISTORS ARE 2SA1576-R/2SB1218A-R
 ● NPN TRANSISTORS ARE 2SC4098-Q/ 2SC3936-C

TO SENSOR DRIVE

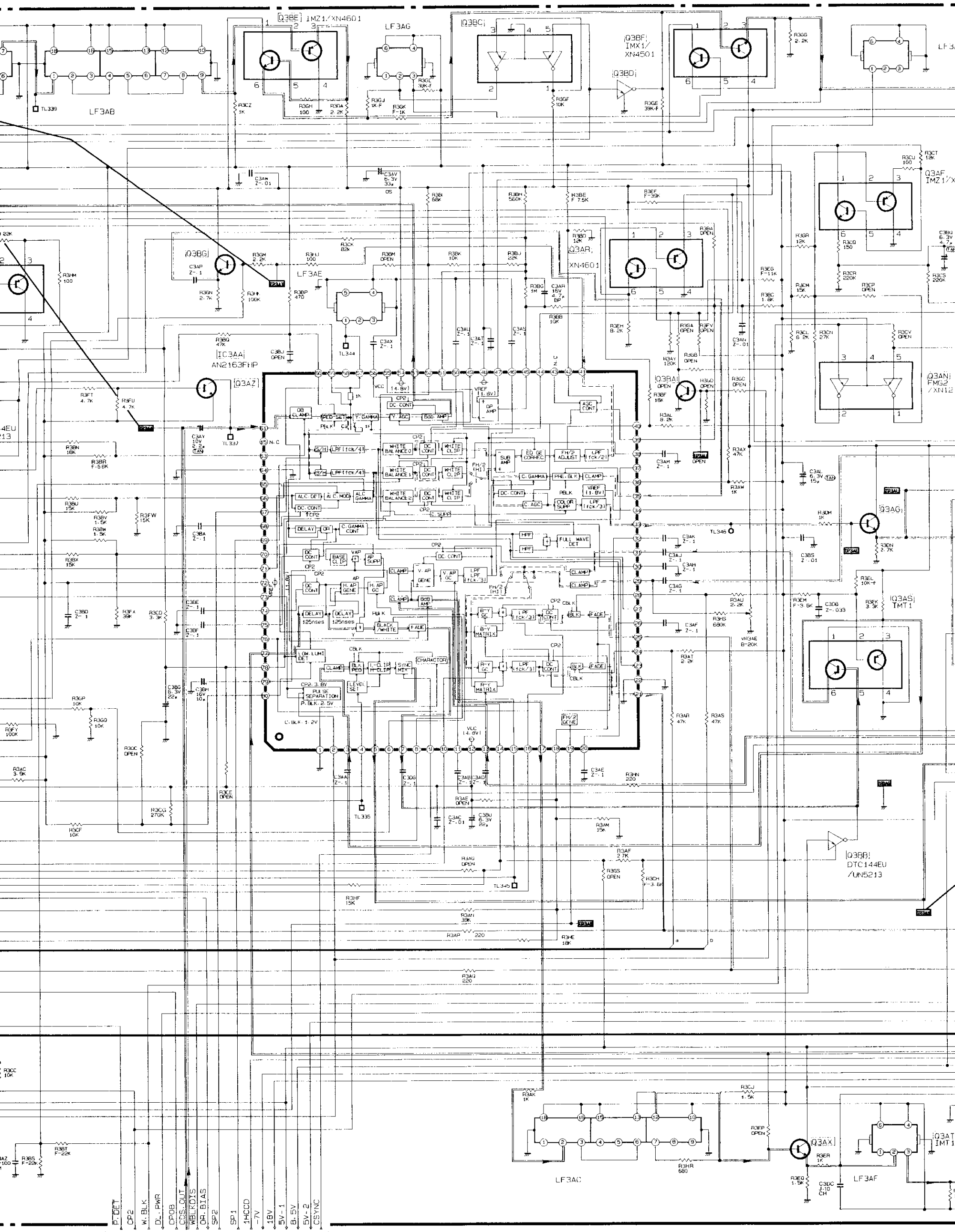

B. DET
 CP2
 W. BLK
 DL. PWR
 CPOB
 CDS. OUT
 WBLKDIS
 OR. BIAS
 SP2
 SP1
 1HCCD
 -7V
 18V
 5V-1
 8.5V
 5V-2
 CSYNC

TO SENSOR DRIVE

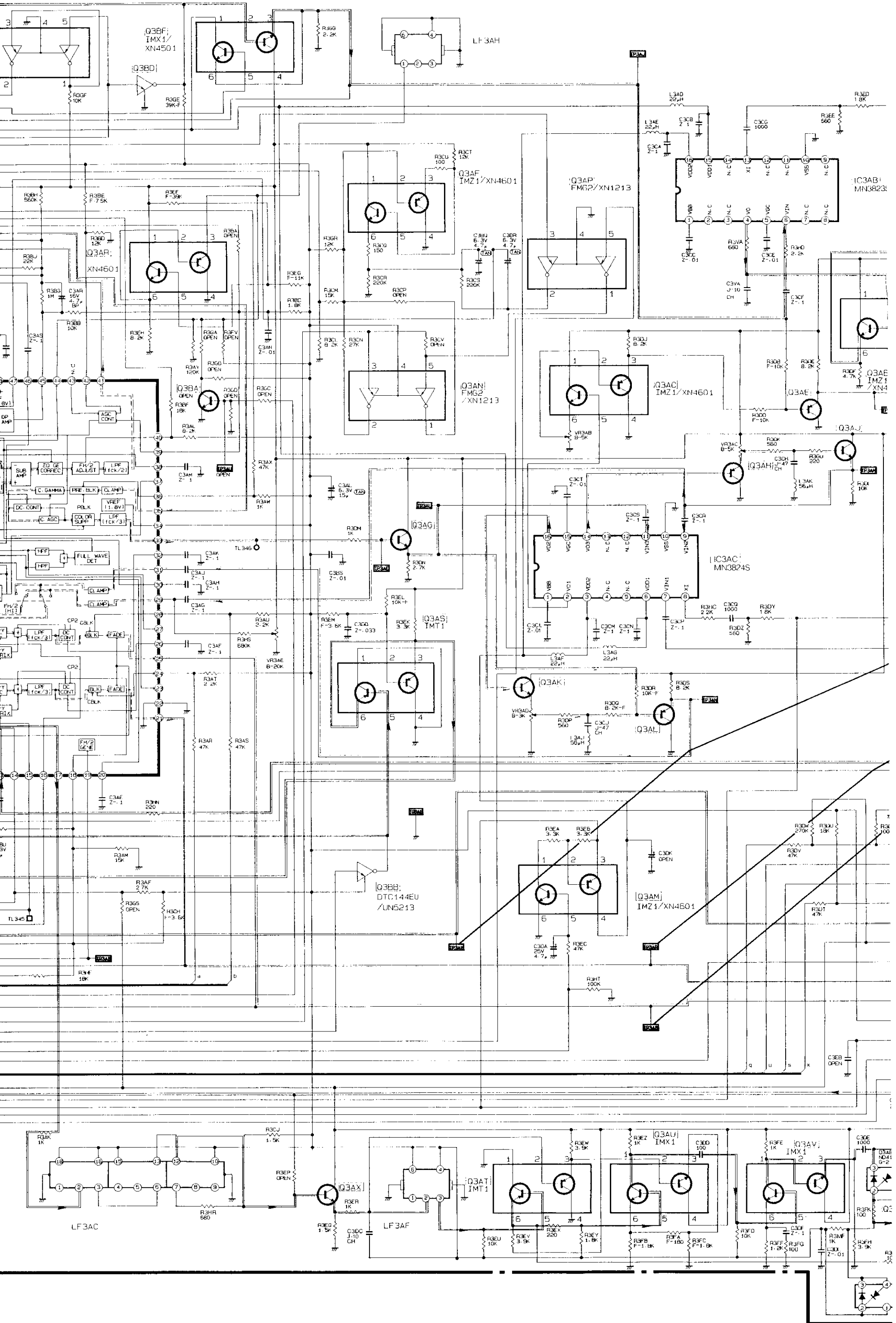

(PROCESS) PCB-S)/PC

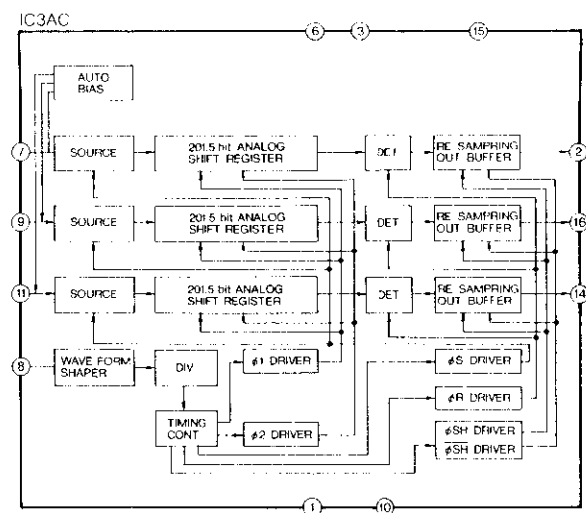
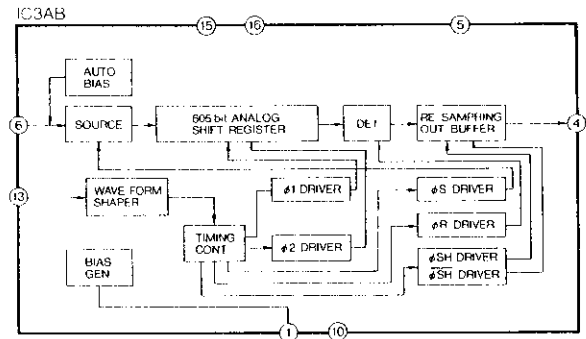
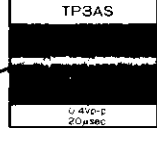
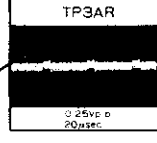
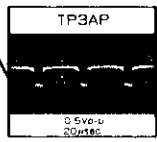
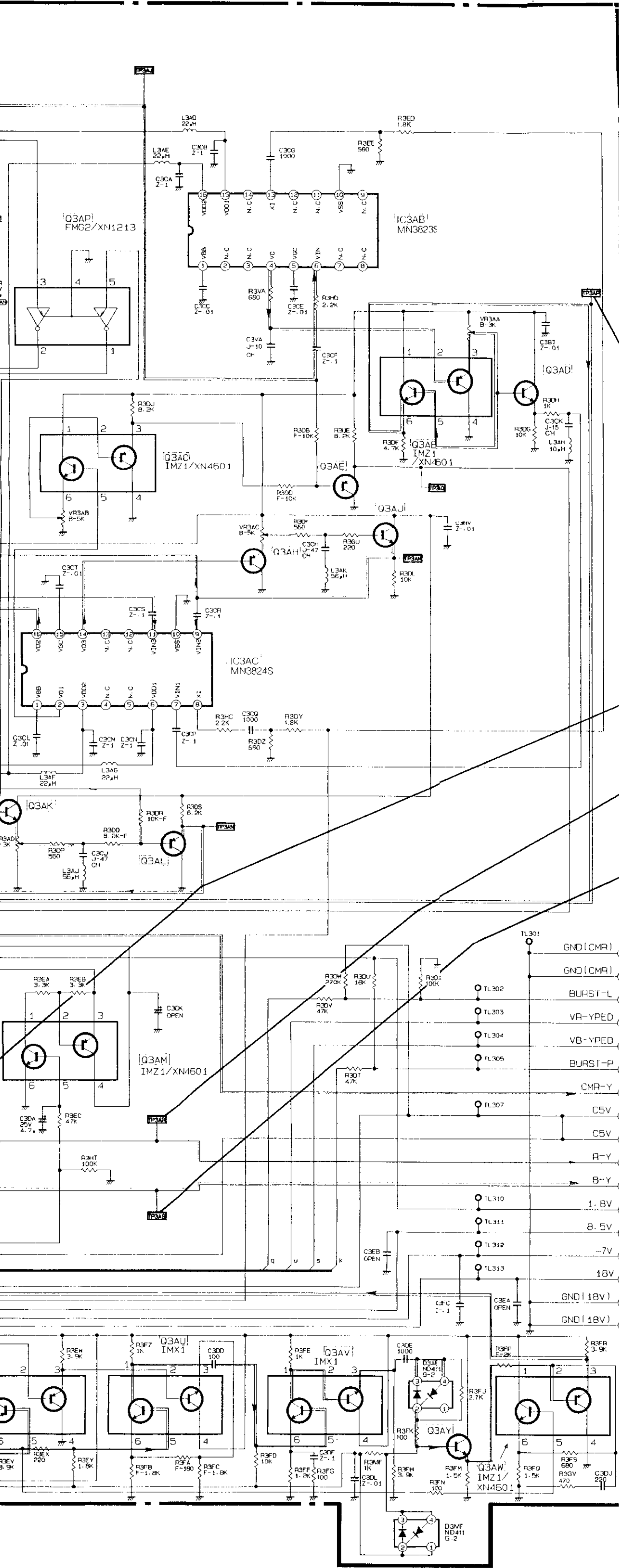

SB
[VB] TO PCB-VTR (CONTROL)

1

2

3

4

5

6

(PROCESSOR)

PCB-CM(CAMERA CONTROL)

A

B

C

D

E

F

G

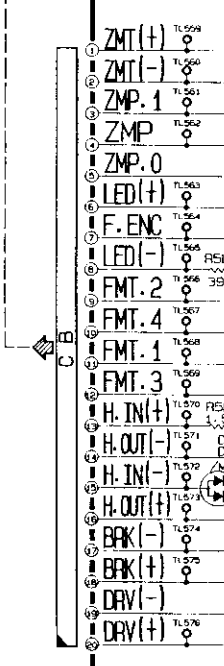
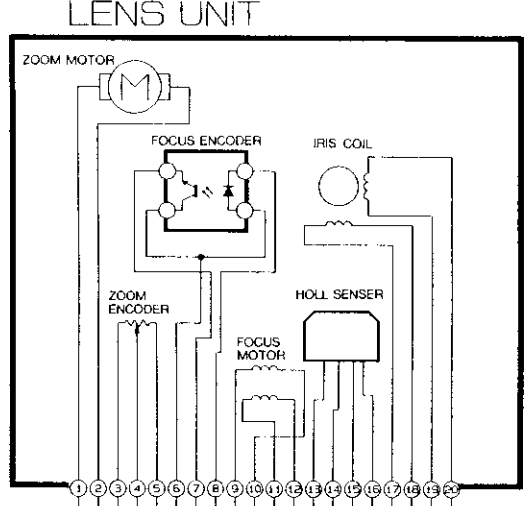
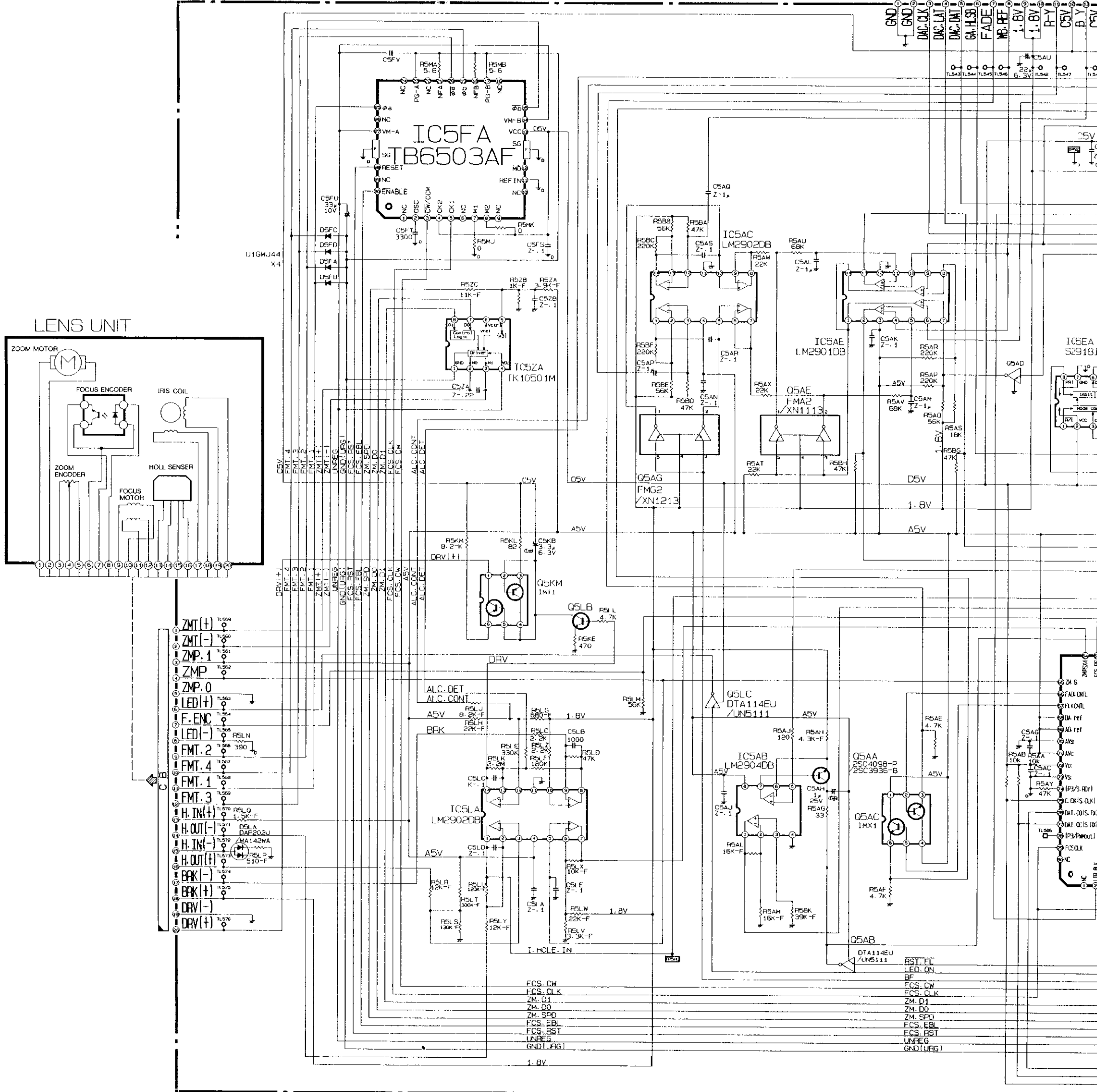

A
B
C
D
E
F
G

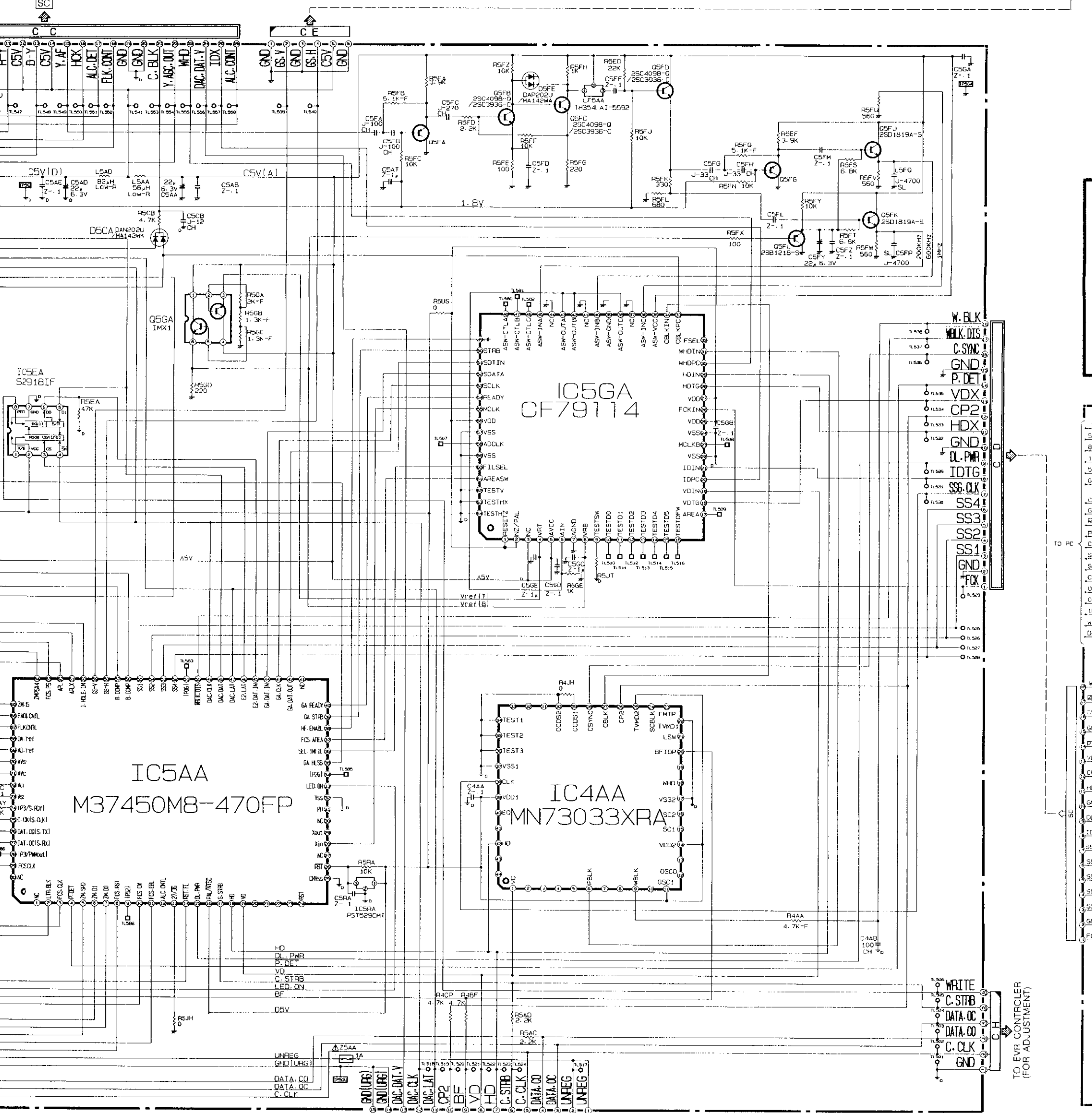

- (CAMERA CONTROL)
NOTE: PARTS WITHOUT INDICATION IN SCHEMATIC DIAGRAM.
- PNP TRANSISTORS ARE 2SA1576-R/2SB1819A-R
 - PNP TRANSISTORS ARE 2SC4081-R/2SD1218A-R
 - PNP DIGITAL TRANSISTORS ARE DTA144EU/UN5113
 - NPN DIGITAL TRANSISTORS ARE DTC144EU/UN5213

TO PC

TO EVR CONTROLLER (FOR ADJUSTMENT)

PCB-GYRO SENS

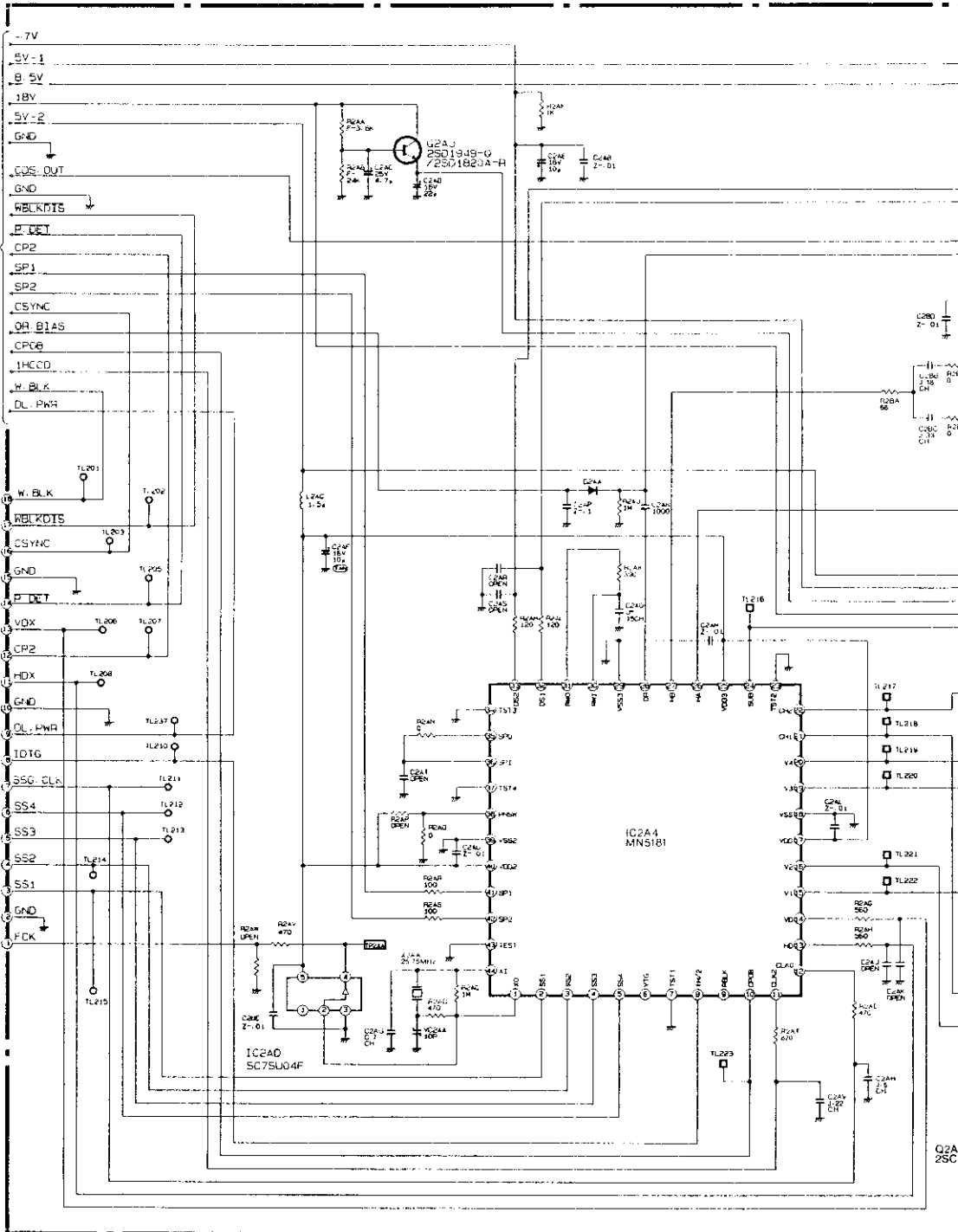
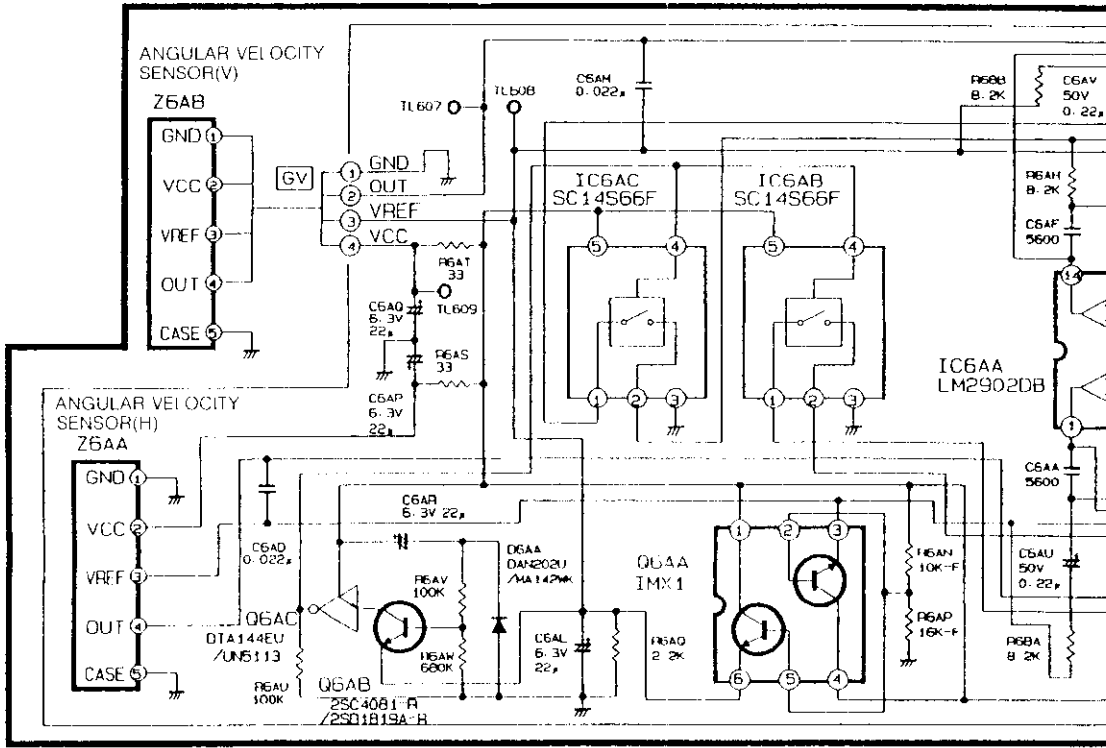

TO EVR CONTROLLER (FOR ADJUSTMENT)

GYRO SENS

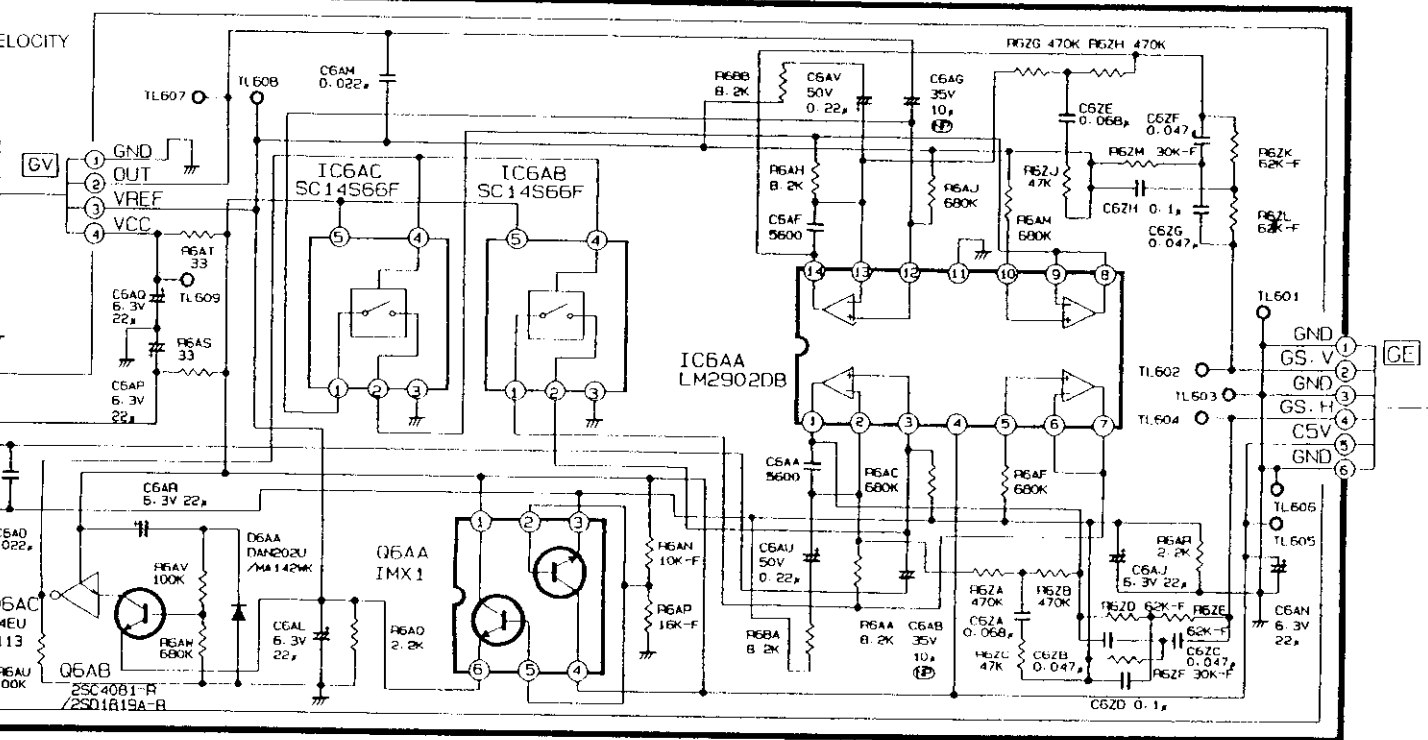

(SENSOR DRIVE)

NOTE) PARTS WITHOUT INDICATION IN SCHEMATIC DIAGRAM.

- DIODE ARE MA141K
- PNP TRANSISTORS ARE 2SA1576-R/2SB1218A-R
- NPN TRANSISTORS ARE 2SC4098-Q/2SC3936-C

(SENSOR DRIVE) PCB-SD/PC

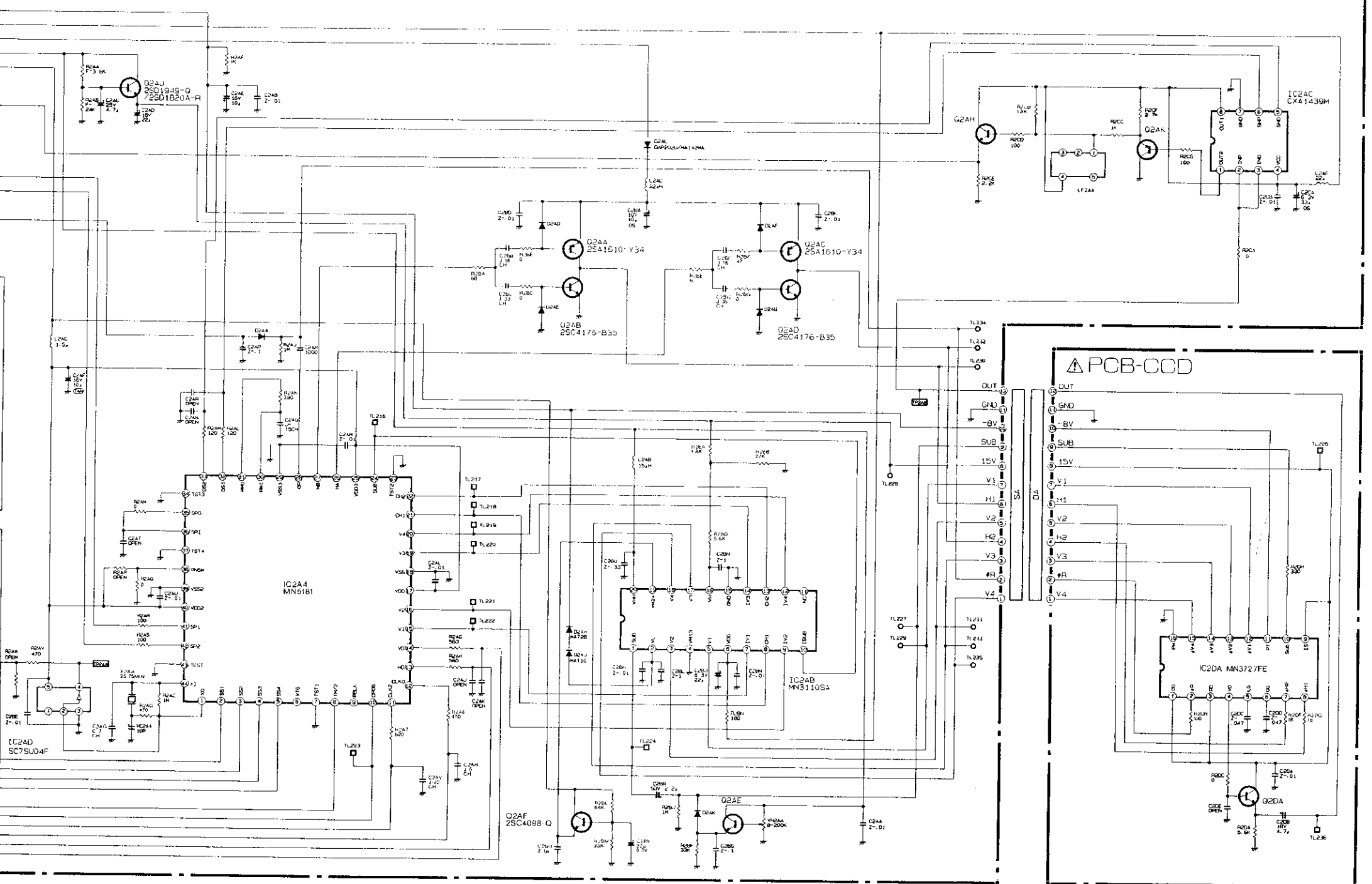

(MIC AMP)
PCB-VTR

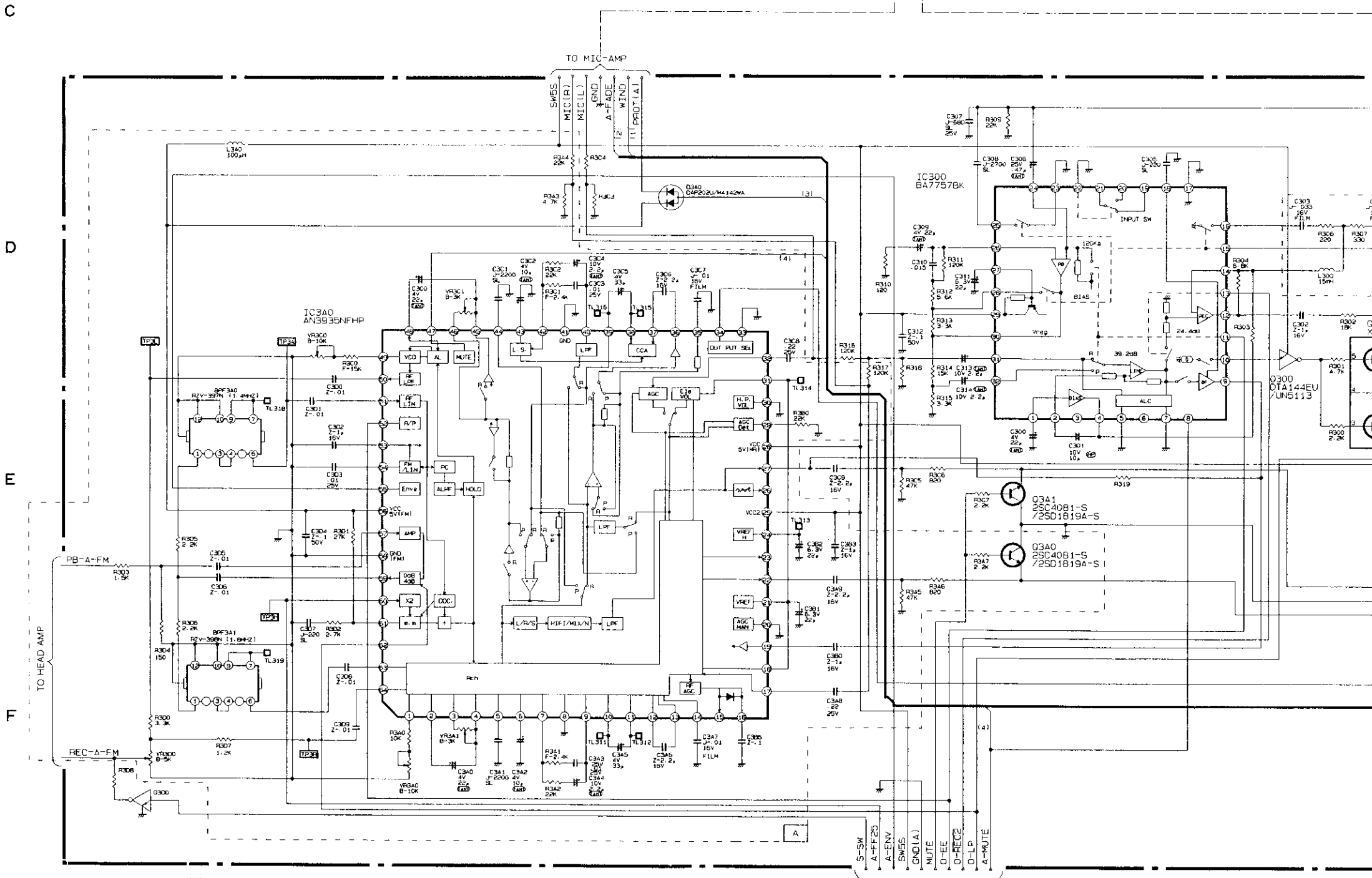
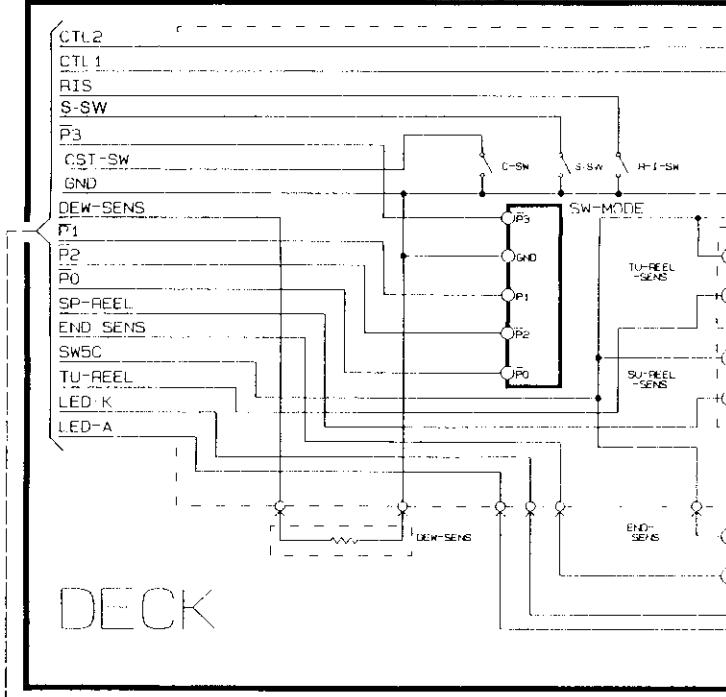
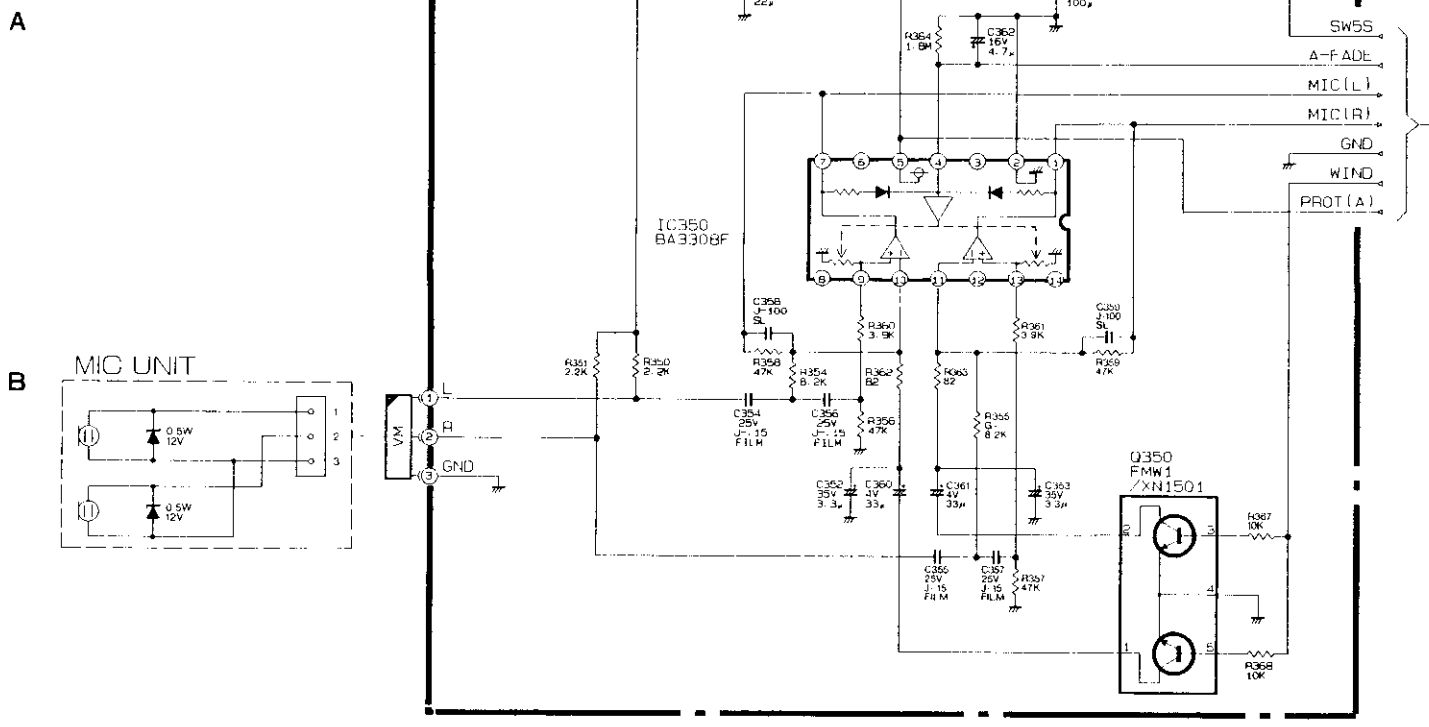

SYMBOL NO	R318	R3C4	R3C3	R319	A AREA	B AREA	R308	Q300	R303	
MODEL	HS-CX7	39K	22K	4.7K	X	O	X	4.7K	O	470

○ : Employed
X : Not employed

G

(DECK)

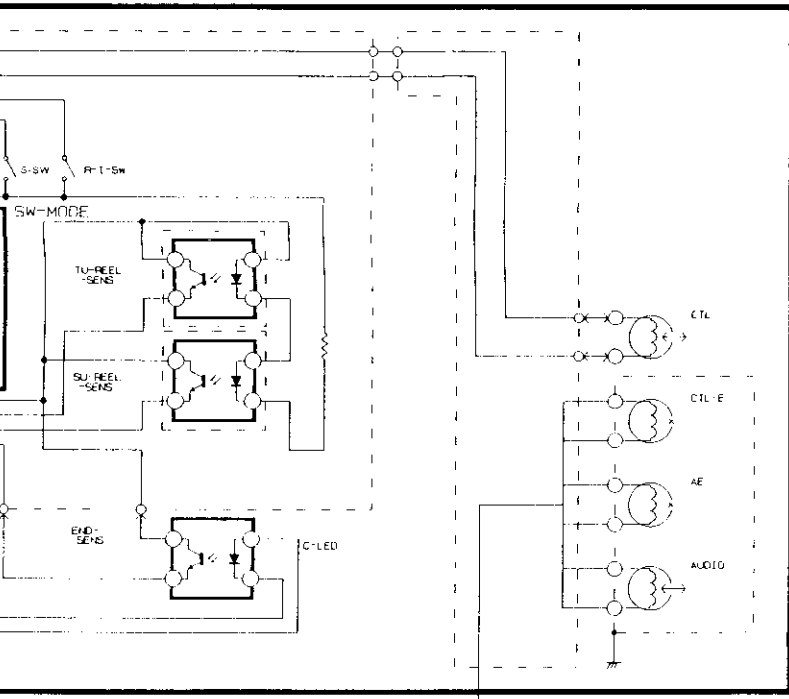

(AUDIO) PCB-VTR

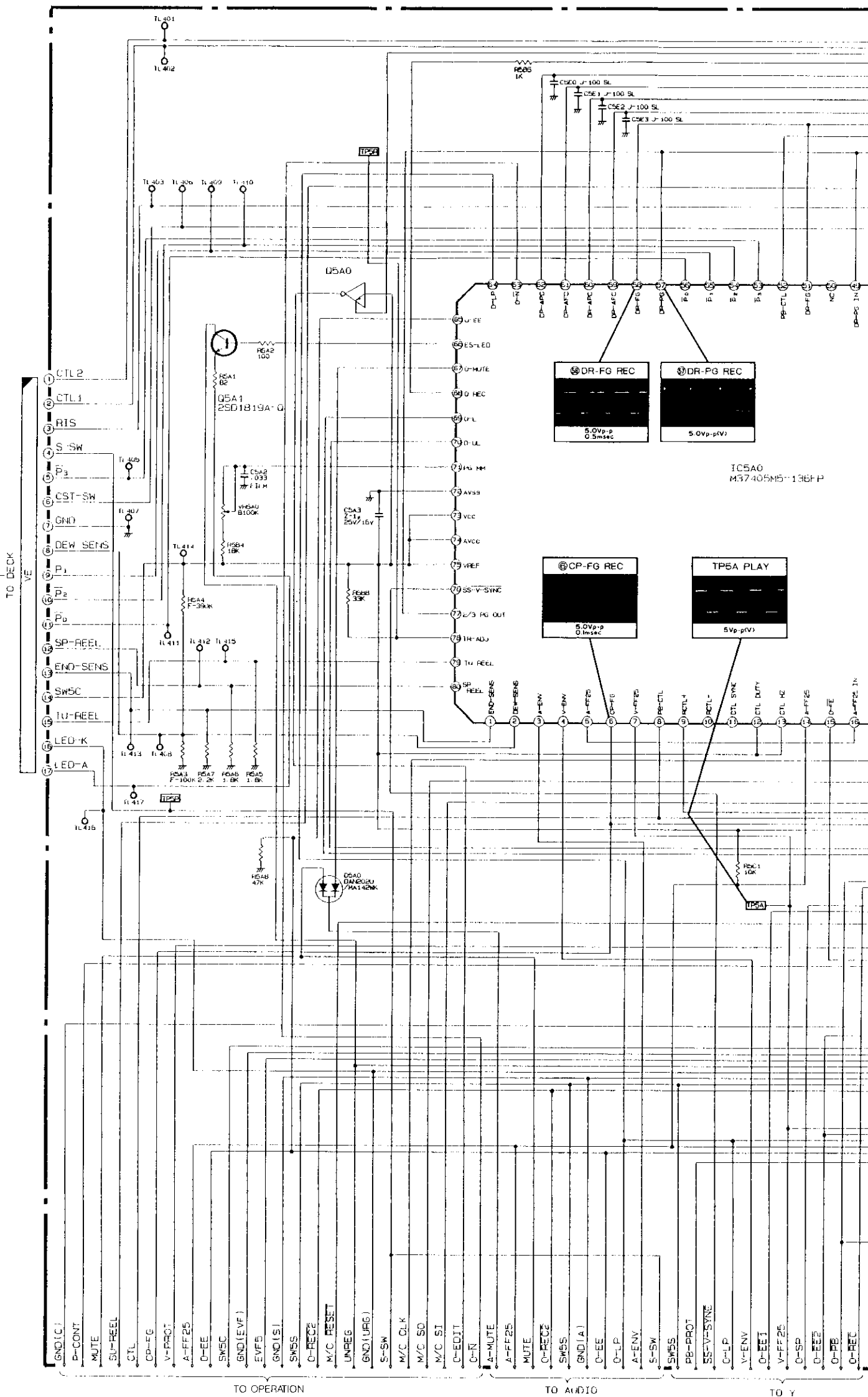
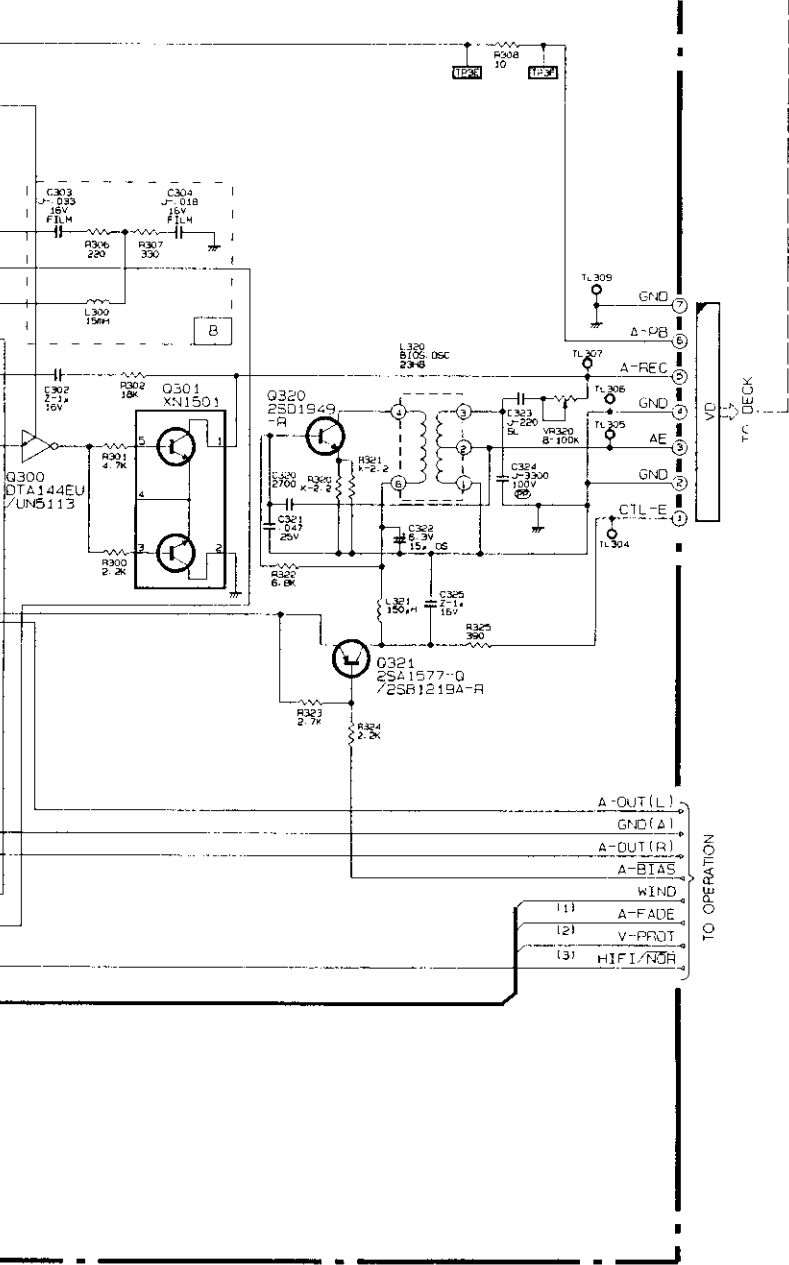

CP-APC REC
5.0Vp-p
0.2μsec

DR-APC REC
5.0Vp-p
10μsec

PB-CTL PLAY
5.0Vp-p(V)

DR-FG REC
5.0Vp-p
0.5μsec

DR-PG REC
5.0Vp-p(V)

CP-FG REC
5.0Vp-p
0.1μsec

IC5A0
M37405N5-138FP

TP5A PLAY
5Vp-p(V)

IC5A1
5B054H-NM-11

25A0
ECP24
1A

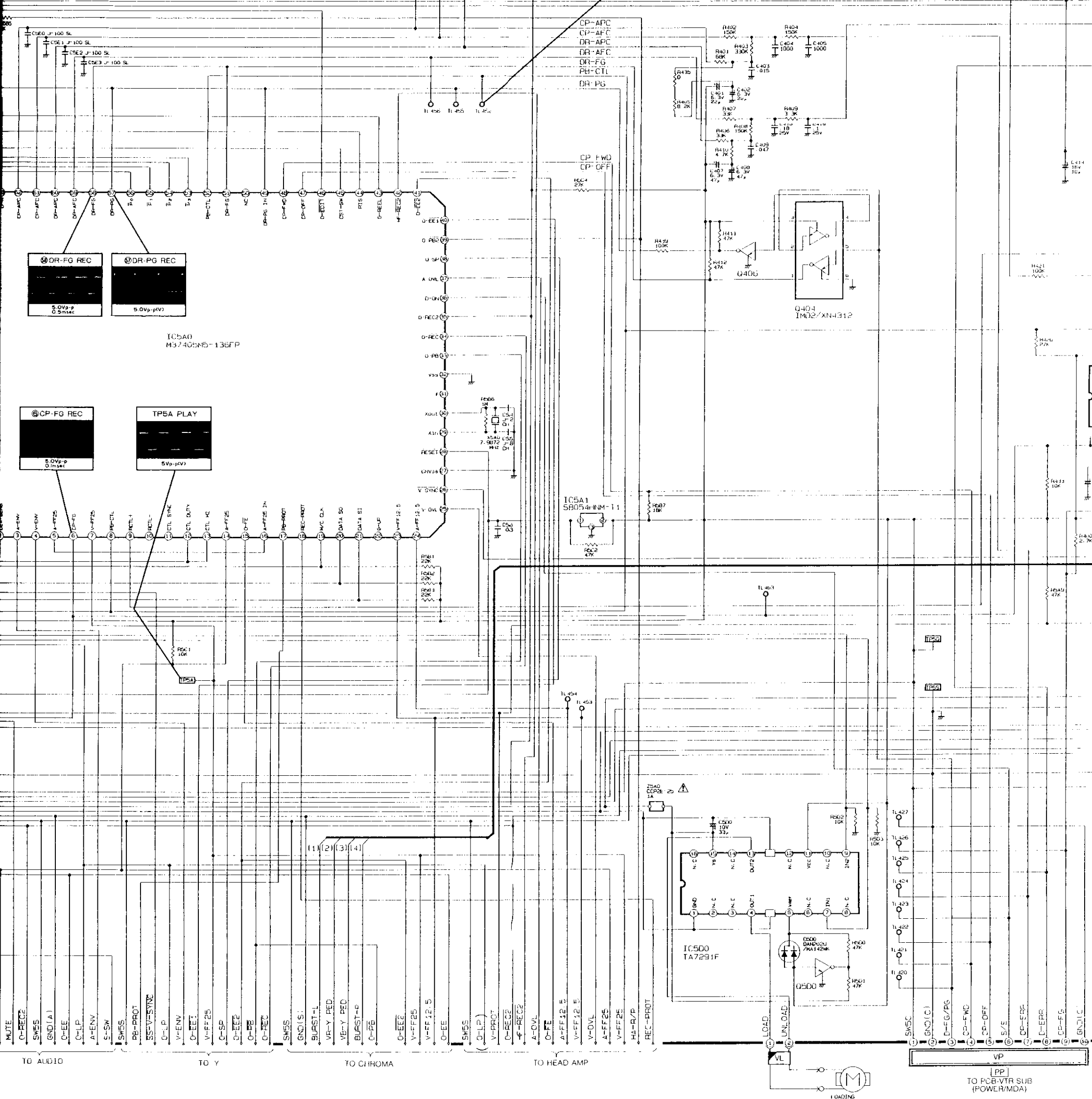
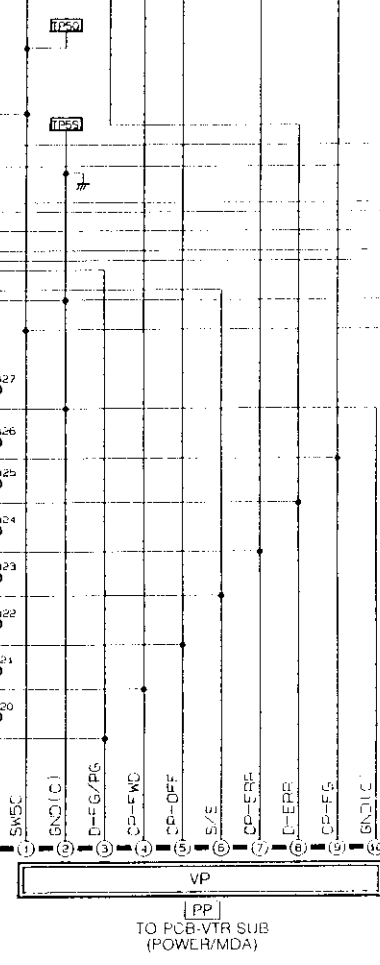
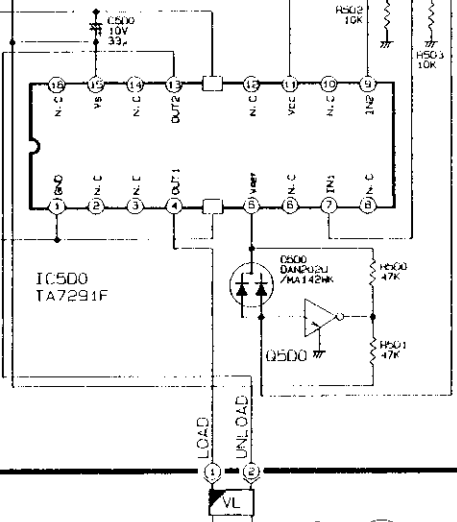

TO AUDIO

TO Y

TO CHROMA

TO HEAD AMP

VP
TO PCB-VTR SUB
(POWER/MDA)

(CONTROL)PCB-VTR

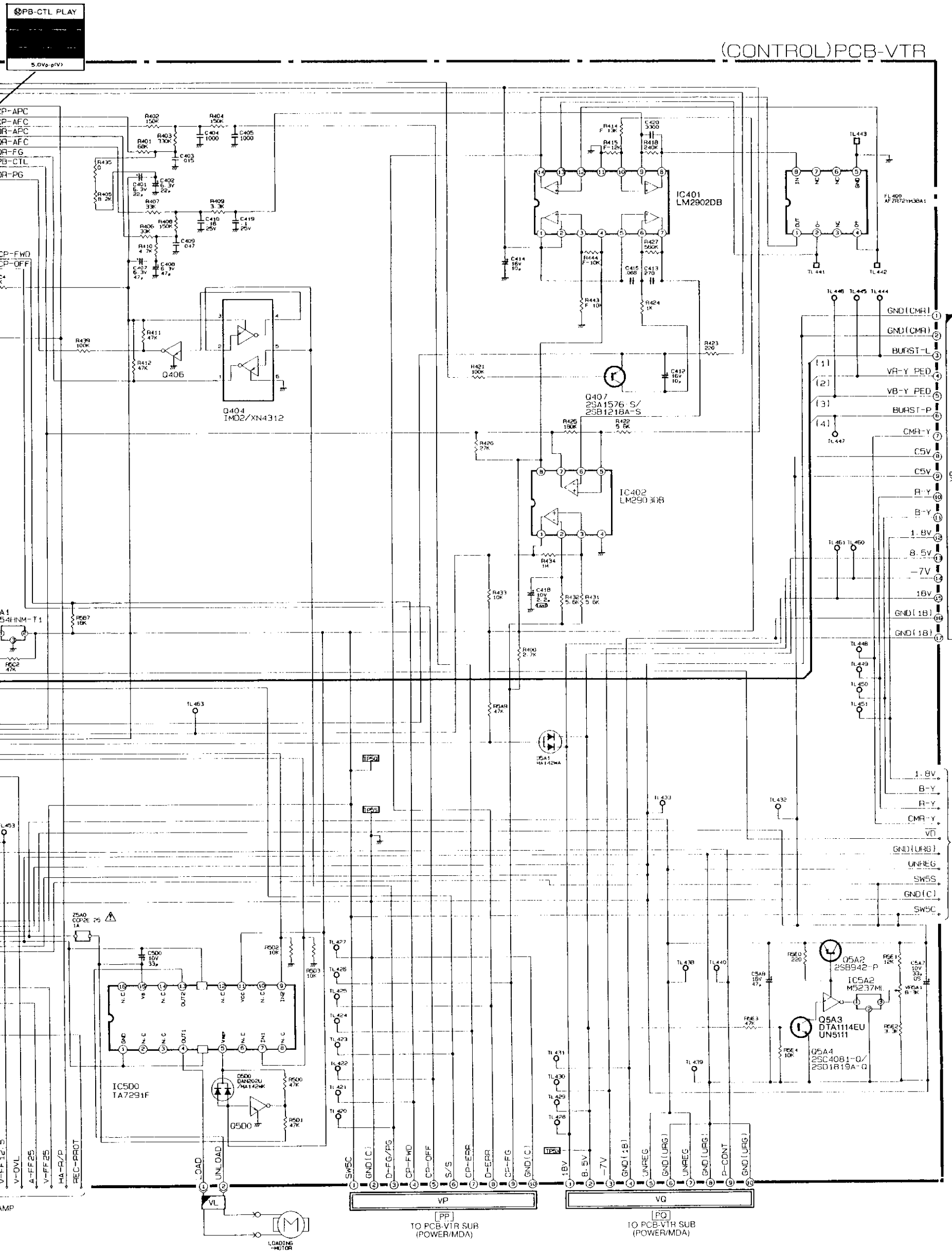

A
B
C
D
E
F

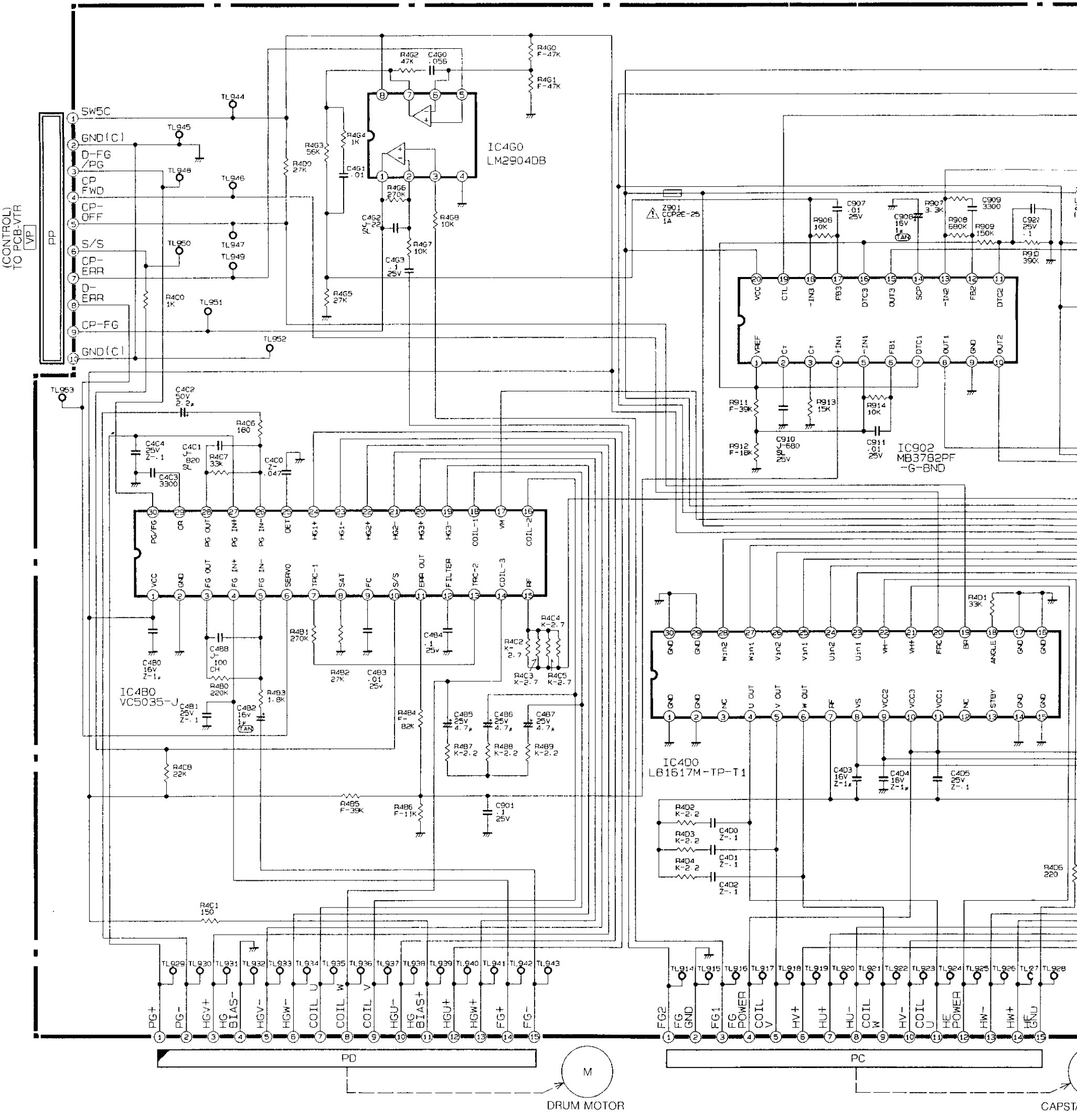

(POWER/MDA) PCB-VTR SUB

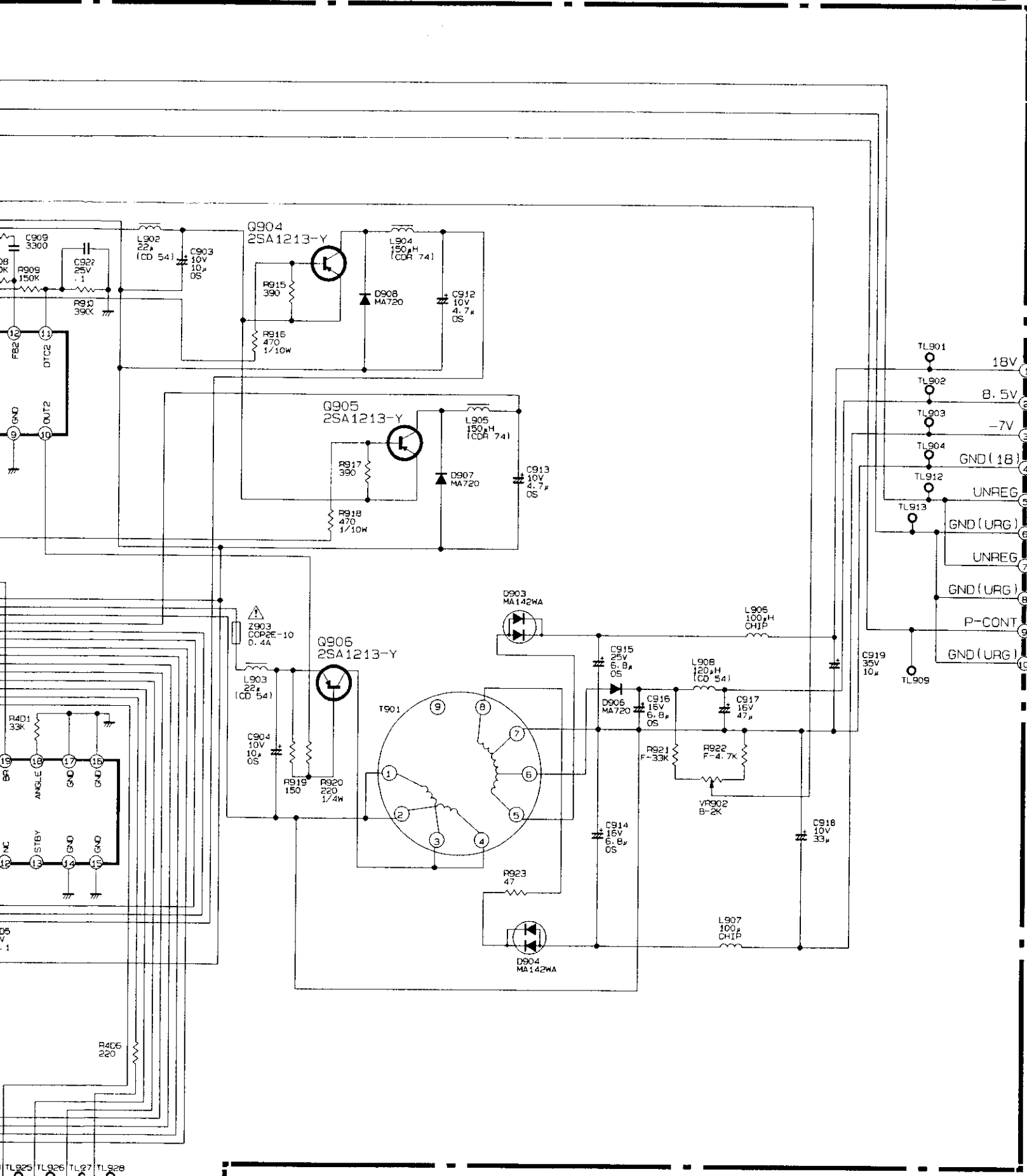

TO PCB-VTR (CONTROL)

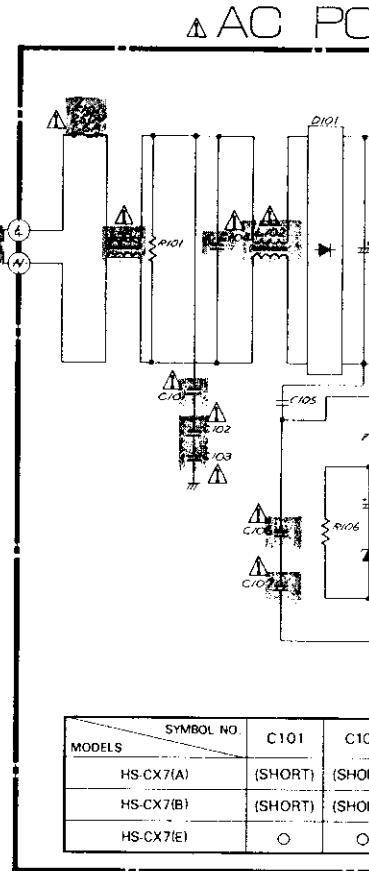

R SUB

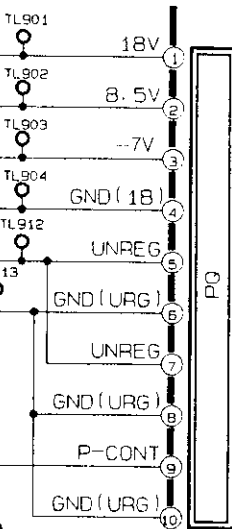

TO PCB-VTR (CONTROL)

AC POWER ADAPTER

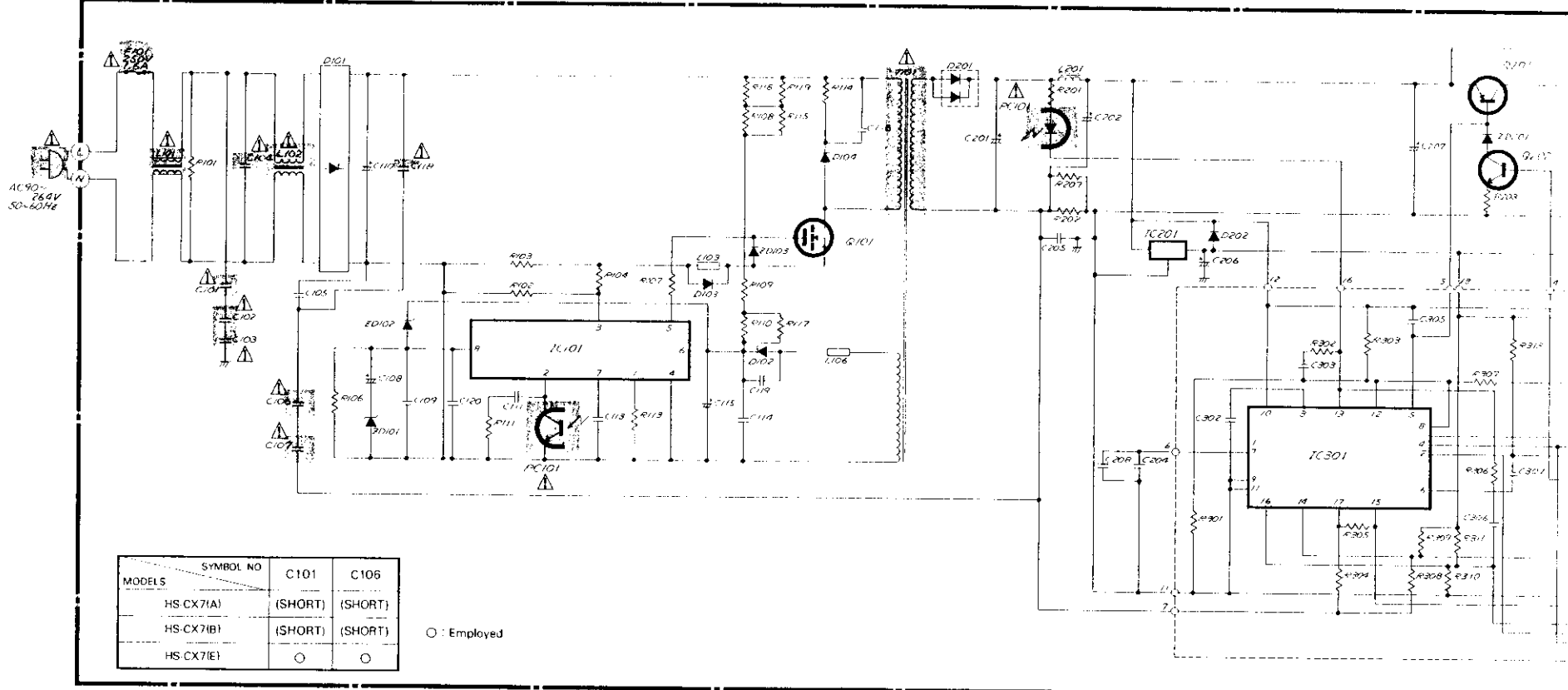

MODELS	SYMBOL NO	C101	C106
HS CX7(A)	(SHORT)	(SHORT)	(SHORT)
HS CX7(B)	(SHORT)	(SHORT)	(SHORT)
HS CX7(E)	○	○	○

○ : Employed

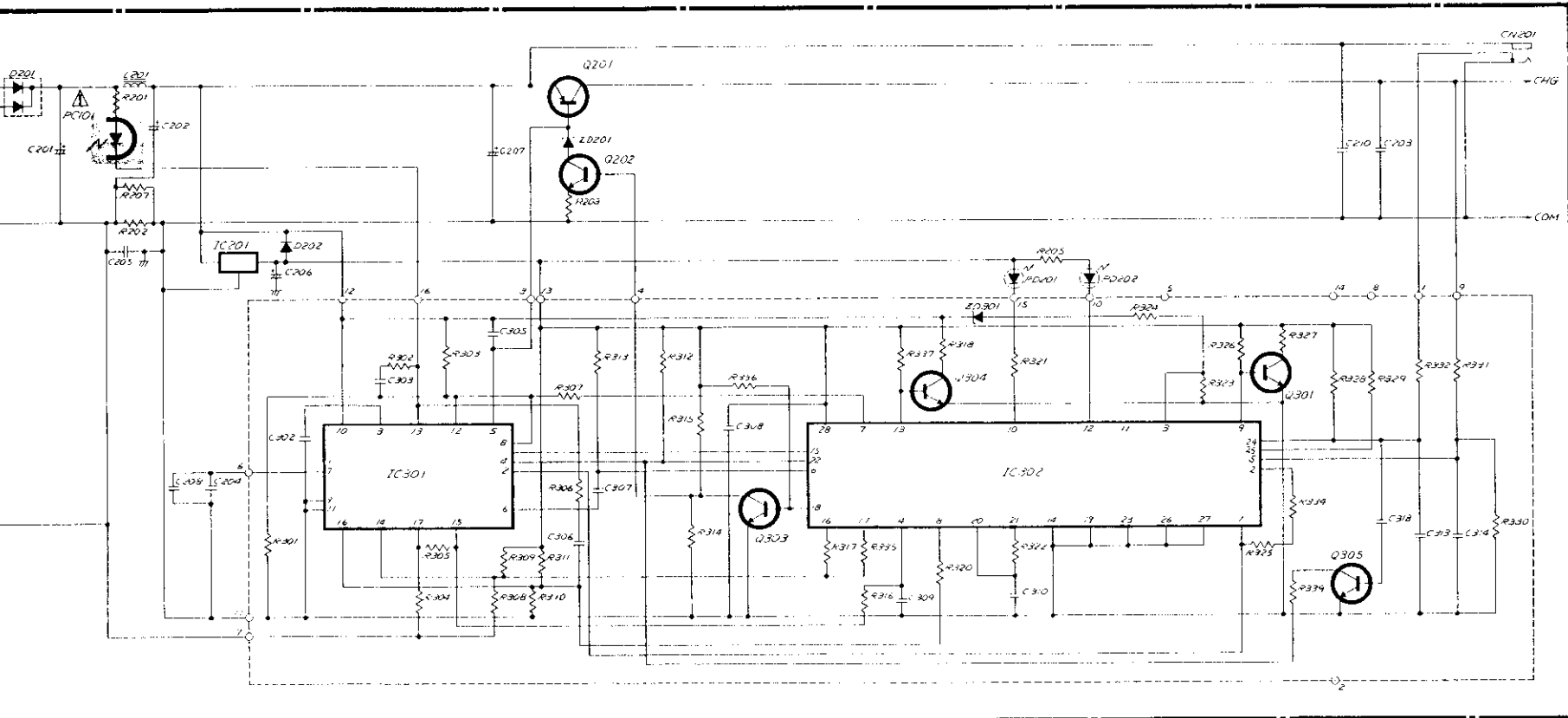

(TEROP)PCB-VTR

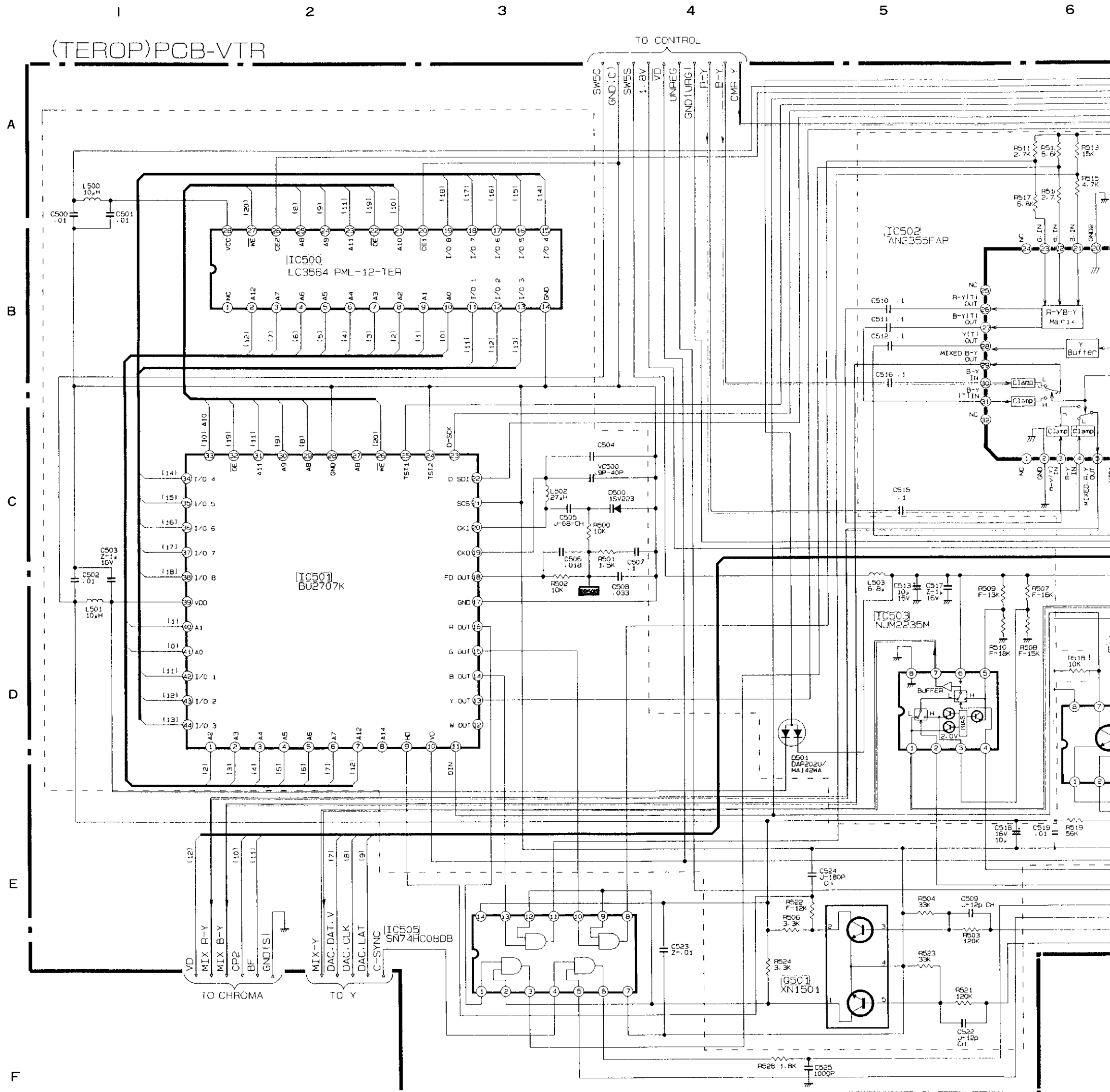

A

B

C

D

E

F

1

2

3

4

5

6

TO CONTROL

TO CHROMA

TO Y

IC500
LC3564 PML-12-TER

IC501
BU2707K

IC502
AN2355FAP

IC503
NUM2235M

IC504
SN74HC08DB

IC501
XN1501

IC LM

(CHROMA) PCB-VTR

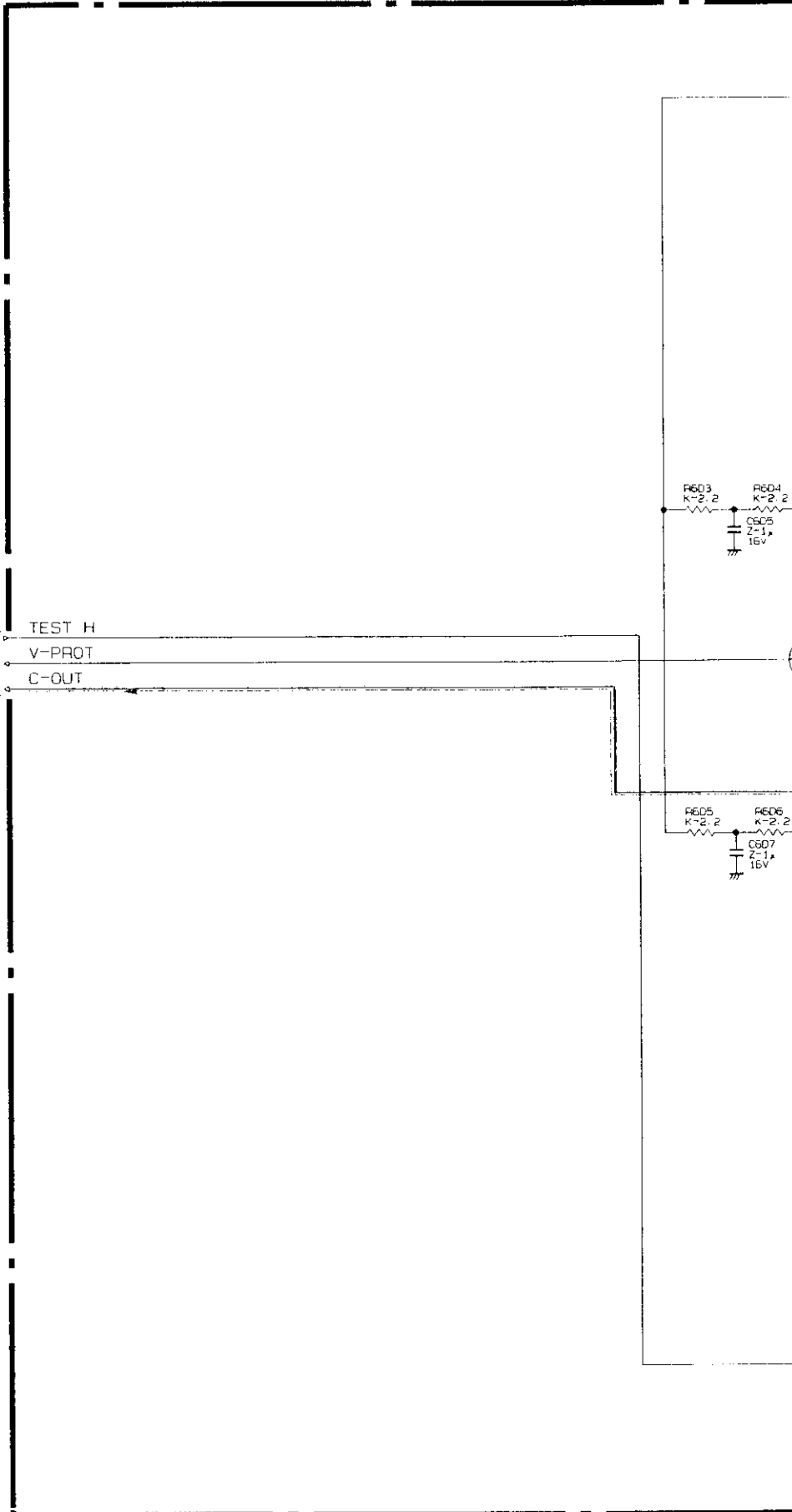
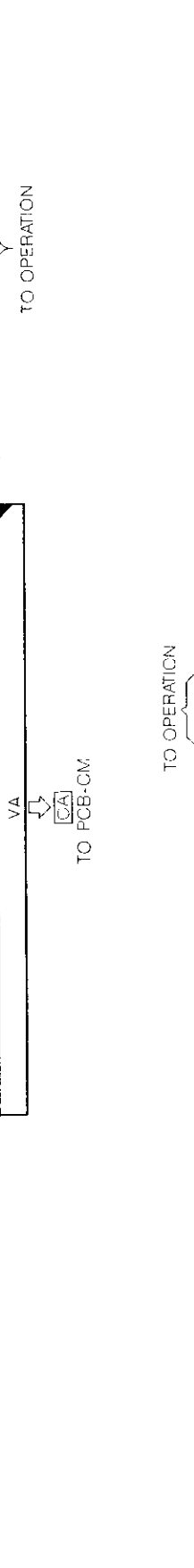
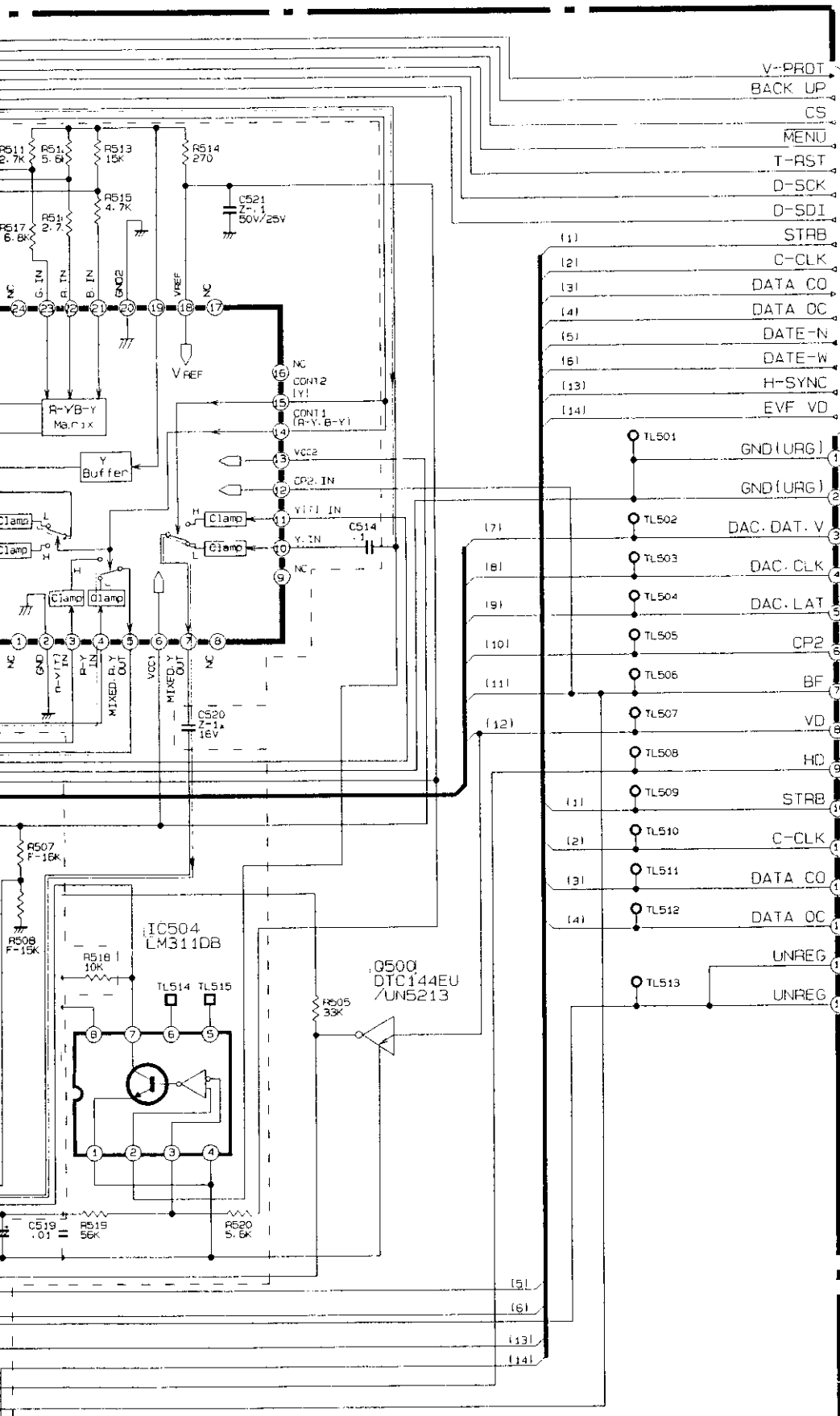

- NOTE) PARTS WITHOUT INDICATION IN SCHEMATIC DIAGRAM.
- PNP TRANSISTORS ARE 2SA1576-R/2SB1218A-R
 - NPN TRANSISTORS ARE 2SC4098-P/2SC3936-B
 - PNP DIGITAL TRANSISTORS ARE DTA144EU/UN5113
 - NPN DIGITAL TRANSISTORS ARE DTC144EU/UN5213

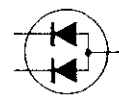

DAP20P
MA142WA

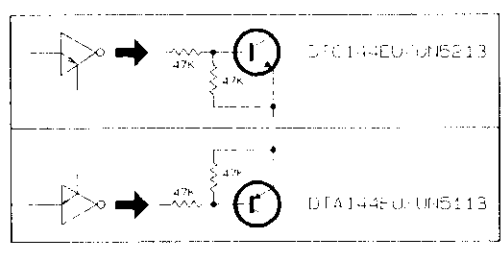
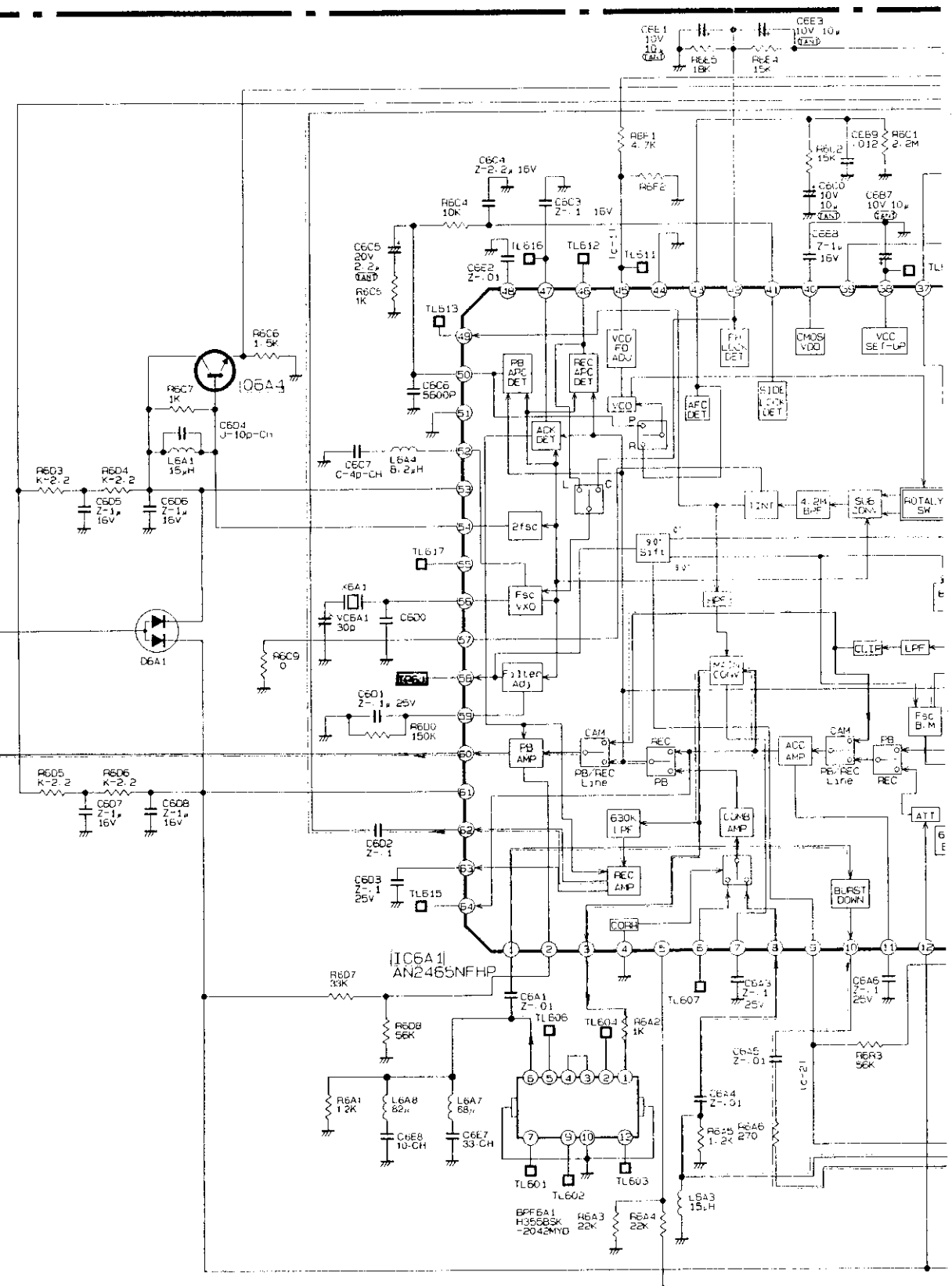

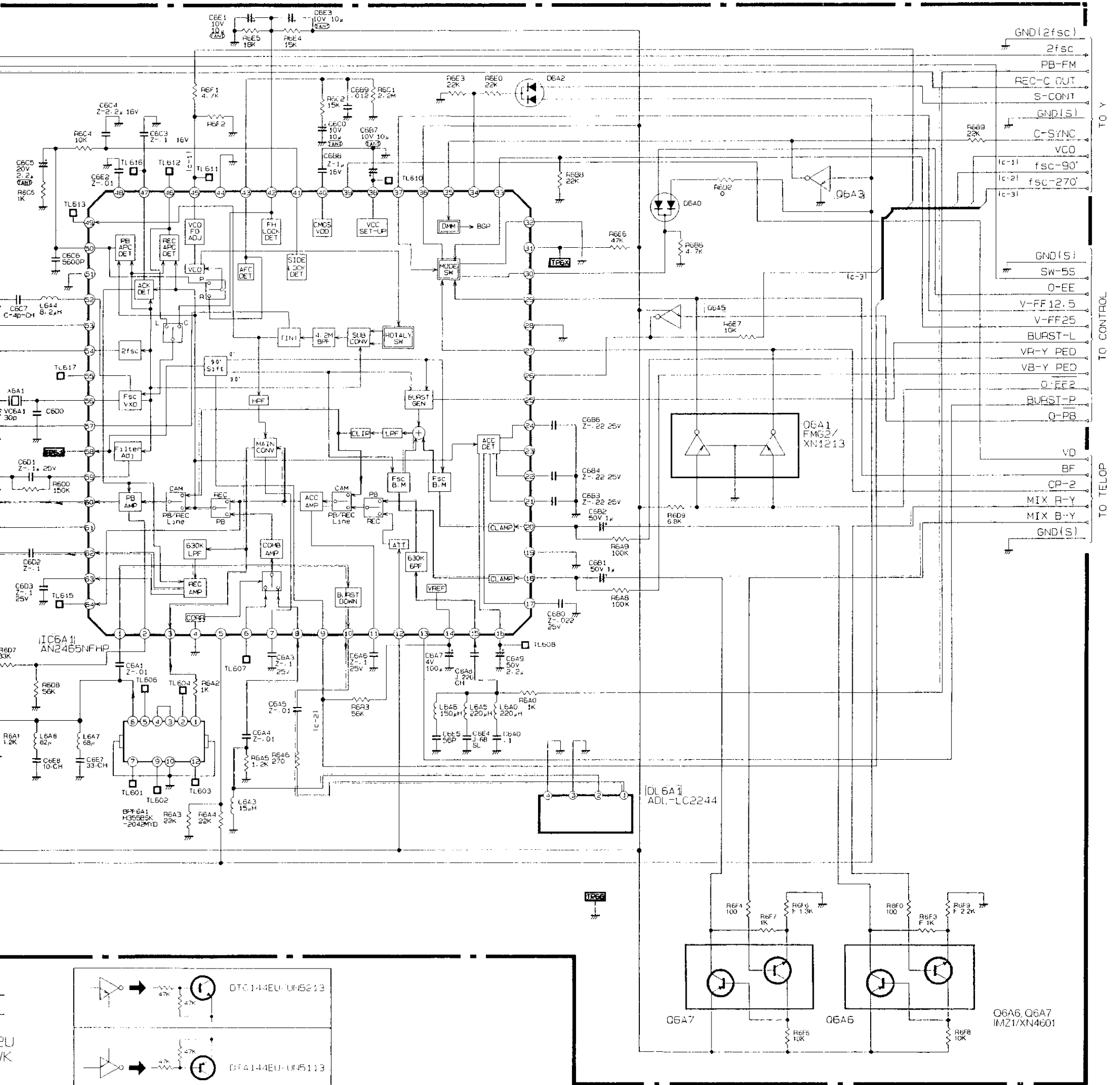

TO Y
TO CONTROL
TO TELOP

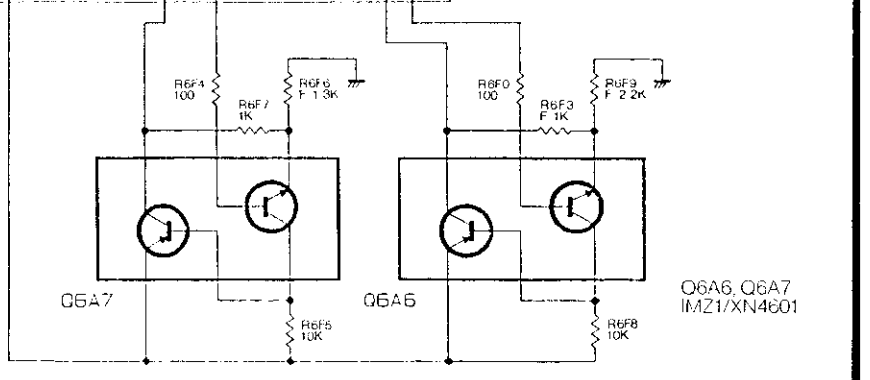
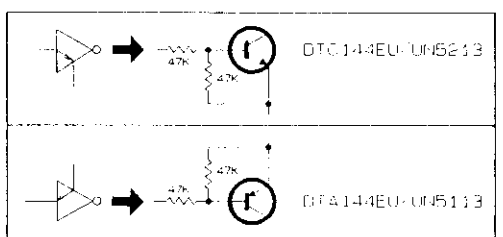

Q6A6, Q6A7
1M21/XN4601

514

PCB-VTR SUB(A SIDE)

PCB - VTR SUB (A SIDE)

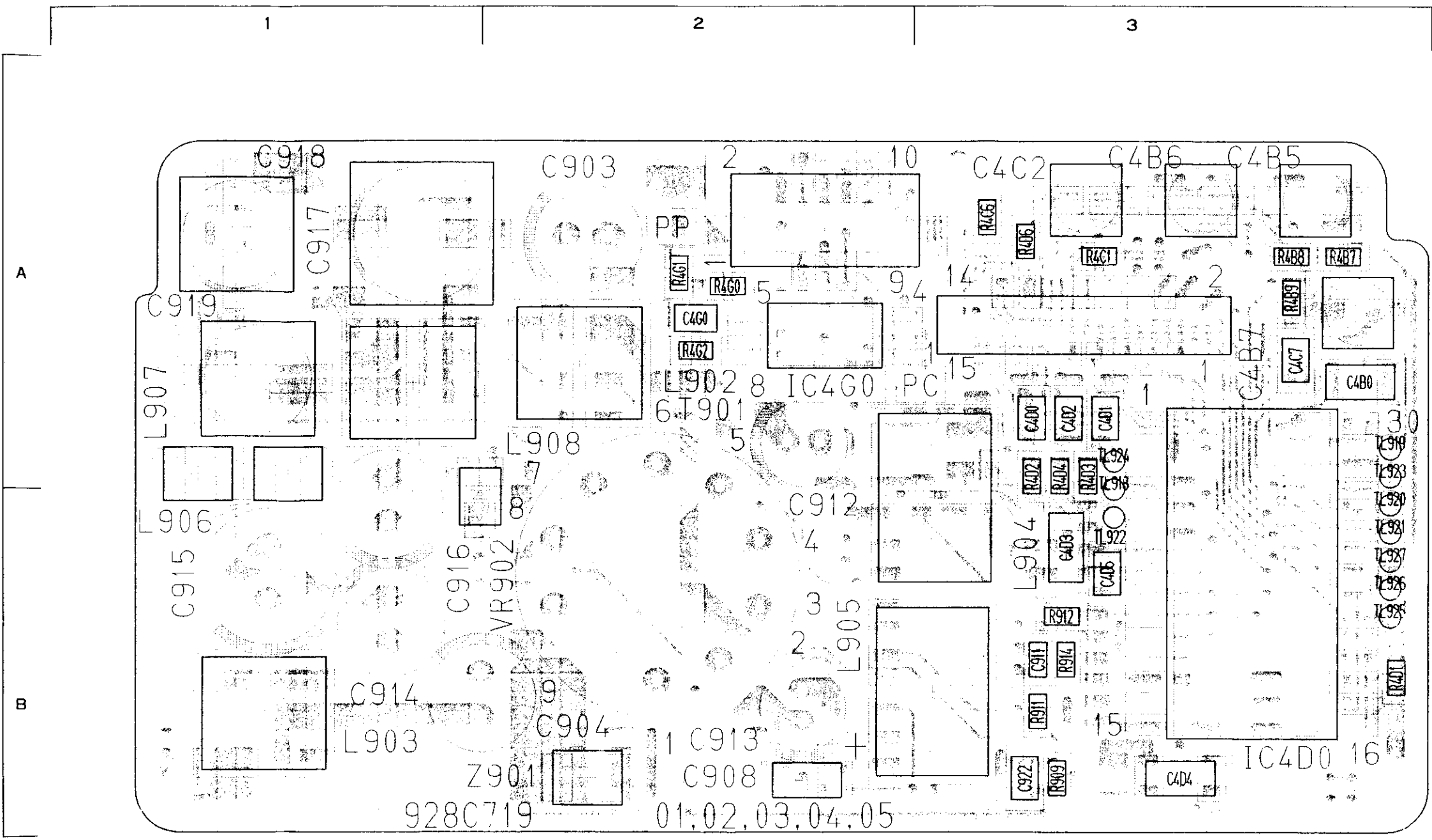

SYMBOL NO.	ADDRESS	SYMBOL NO.	ADDRESS
C4B0	A-3	L906	B-1
C4B5	A-3	L907	A-1
C4B6	A-3	L908	A-2
C4B7	A-3		
C4C2	A-3	R4B7	A-3
C4C7	A-3	R4B8	A-3
C4D0	A-3	R4B9	A-3
C4D1	A-3	R4C1	A-3
C4D2	A-3	R4C6	A-3
C4D3	B-3	R4D1	B-3
C4D4	B-3	R4D2	A-3
C4D5	B-3	R4D3	A-3
C4G0	A-2	R4D4	A-3
C903	A-2	R4D6	A-3
C904	B-2	R4G0	A-2
C908	B-2	R4G1	A-2
C911	B-3	R4G2	A-2
C912	B-2	R909	B-3
C913	B-2	R911	B-3
C914	B-1	R912	B-3
C915	B-1	R914	B-3
C916	B-1		
C917	A-1	T901	A-2
C918	A-1		
C919	A-1	VR902	B-2
C922	B-3		
		Z901	B-2
IC4D0	B-3		
IC4G0	A-2		
L902	A-2		
L903	B-1		
L904	B-3		
L905	B-2		

PCB-REAR(A SIDE)

PCB - REAR (A SIDE)

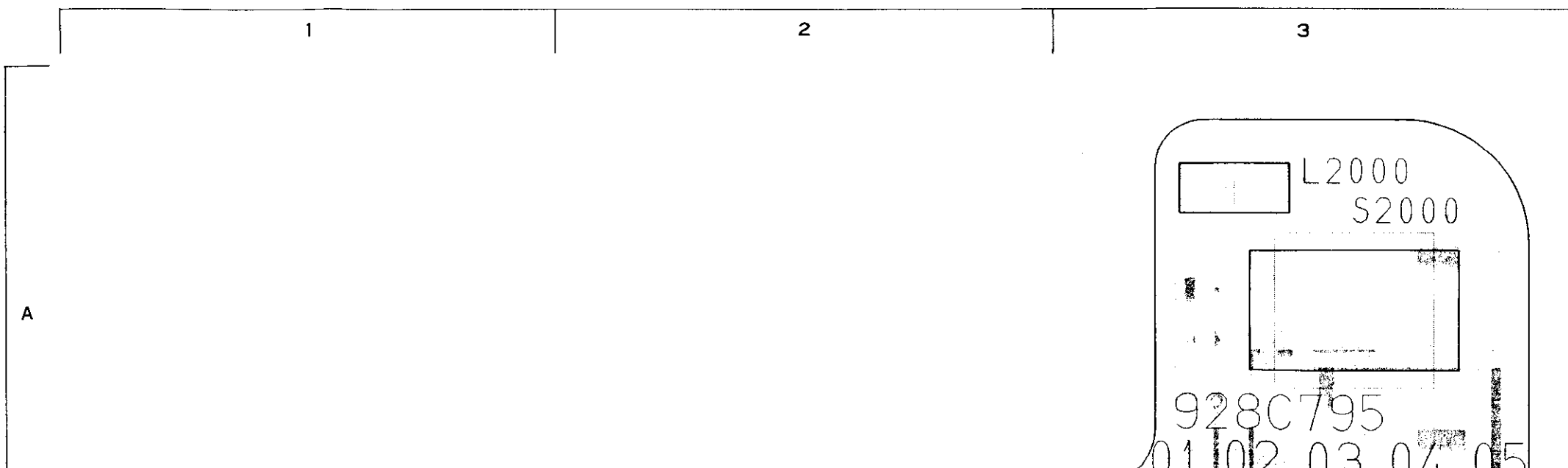

SYMBOL NO.	ADDRESS
C2000	C-2
C2001	C-2
C2006	C-3
C2007	C-3
C2009	B-3
C2010	C-2
C2011	C-2
C2012	C-2
C2013	C-2
C2016	A-3
D2006	C-2
DE2000	C-1
DE2001	C-1
IC2001	C-2
IC2002	C-2

A

B

C

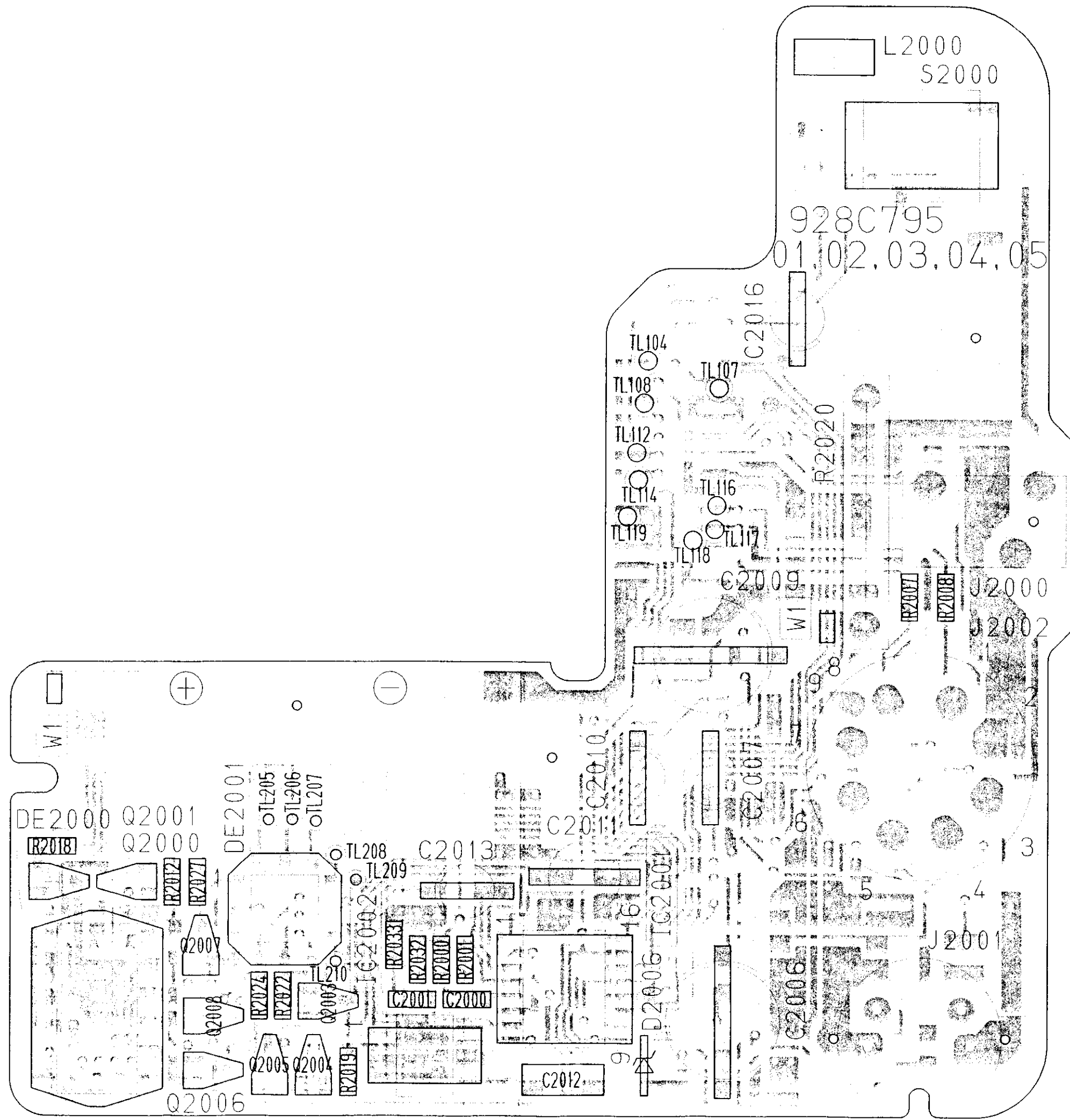

C2000	C-2
C2001	C-2
C2006	C-3
C2007	C-3
C2009	B-3
C2010	C-2
C2011	C-2
C2012	C-2
C2013	C-2
C2016	A-3
D2006	C-2
DE2000	C-1
DE2001	C-1
IC2001	C-2
IC2002	C-2
L2000	A-3
Q2000	C-1
Q2001	C-1
Q2003	C-1
Q2004	C-1
Q2005	C-1
Q2006	C-1
Q2007	C-1
Q2008	C-1
R2000	C-2
R2001	C-2
R2007	B-3
R2008	B-3
R2012	C-1
R2018	C-1
R2019	C-2
R2020	B-3
R2022	C-1
R2024	C-1
R2027	C-1
R2032	C-2
R2033	C-2
S2000	A-3

PCB-VTR SUB(B SIDE)

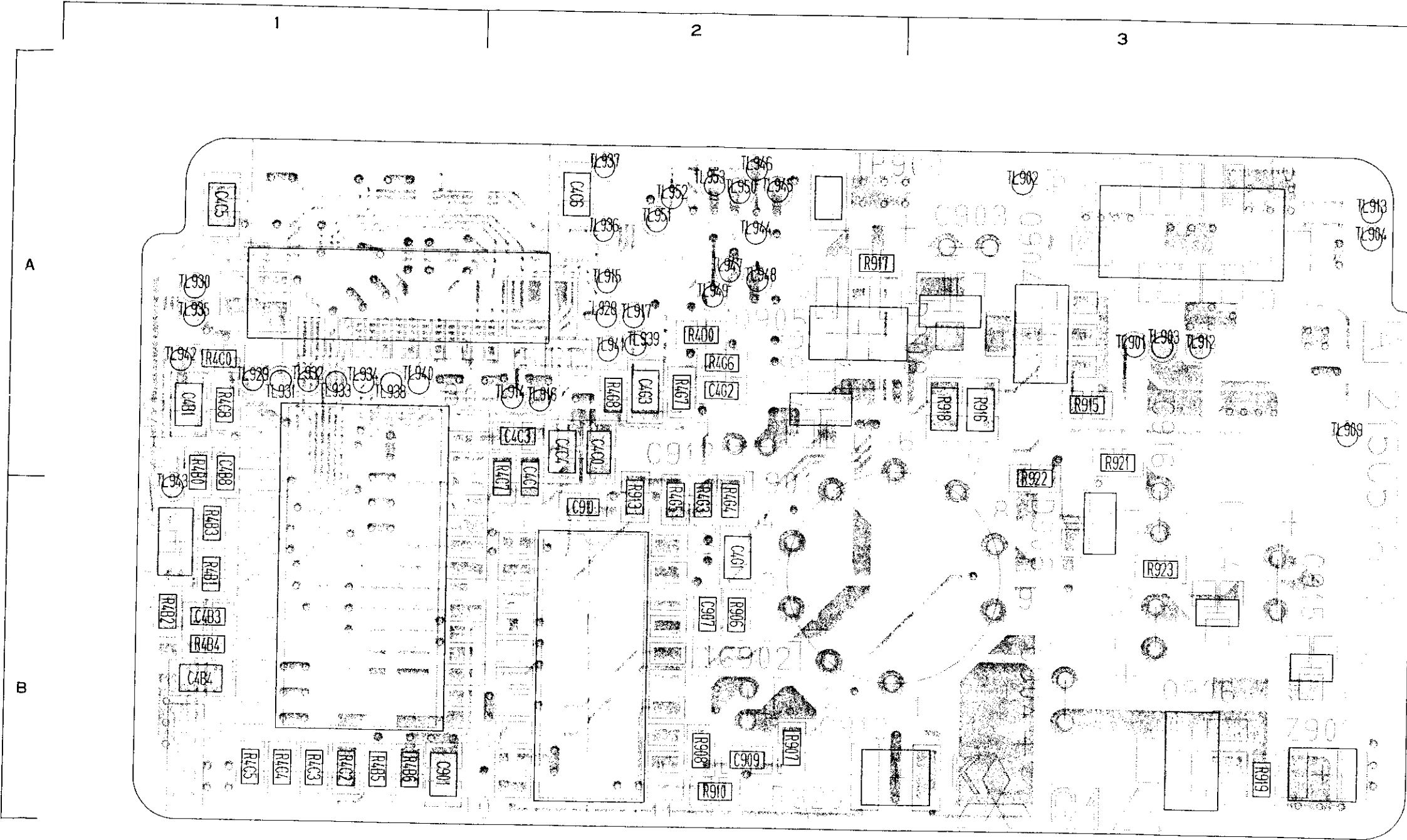

PCB - VTR SUB (B SIDE)

(5/7)

SYMBOL NO.	ADDRESS	SYMBOL NO.	ADDRESS
C481	A-1	R482	B-1
C482	A-1	R483	B-1
C483	B-1	R484	B-1
C484	B-1	R485	B-1
C488	A-1	R486	B-1
C4C0	A-2	R4C0	A-1
C4C1	A-2	R4C2	B-1
C4C3	A-2	R4C3	B-1
C4C4	A-2	R4C4	B-1
C4C5	A-1	R4C5	B-1
C4C6	A-2	R4C7	A-2
C4G1	B-2	R4C8	A-1
C4G2	A-2	R4D0	A-2
C4G3	A-2	R4G3	B-2
C901	B-1	R4G4	B-2
C903	A-3	R4G5	B-2
C904	B-3	R4G6	A-2
C907	B-2	R4G7	A-2
C909	B-2	R4G8	A-2
C910	B-2	R906	B-2
C912	A-2	R907	B-2
C913	B-2	R908	B-2
C914	B-3	R910	B-2
C915	B-3	R913	B-2
C916	A-3	R915	A-3
		R916	A-3
		R917	A-2
D903	B-3	R918	A-3
D904	B-3	R919	B-3
D906	B-3	R920	B-2
D907	A-2	R921	A-3
D908	A-3	R922	A-3
		R923	B-3
IC4B0	B-1		
IC902	B-2		
		T901	A-2
Q904	A-3		
Q905	A-2	TP900	A-2
Q906	B-3		
		Z903	B-3
R4B0	A-1		
R4B1	B-1		

PCB-REAR(B SIDE)

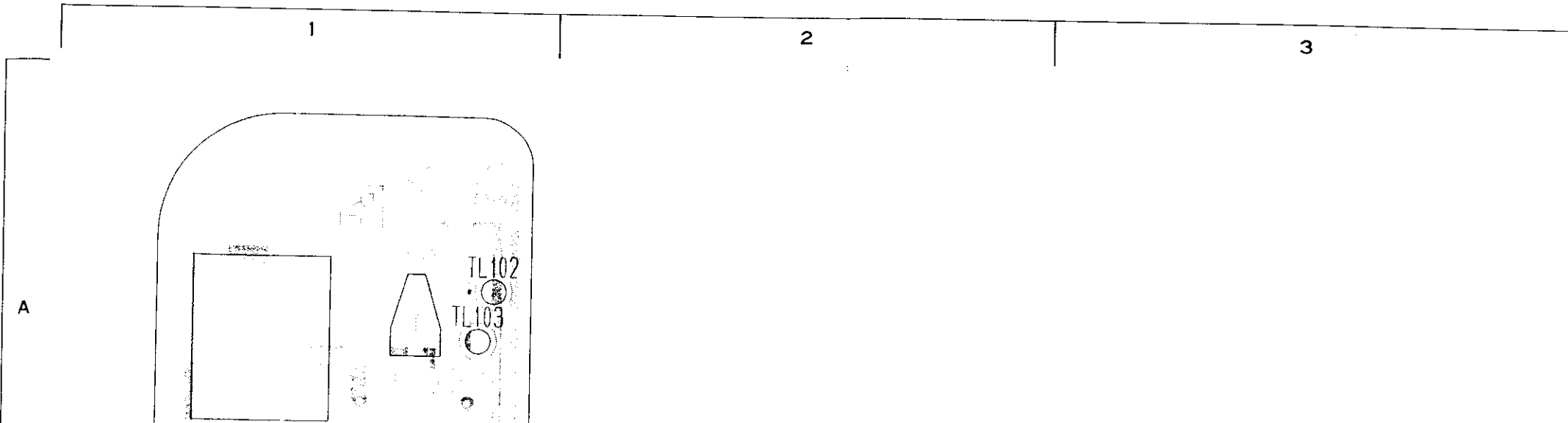

PCB - REAR (B SIDE)

SYMBOL NO.	ADDRESS
C2002	C-1
C2003	C-1
C2004	C-1
C2014	C-3
C2015	C-3
D2000	A-1
D2001	A-1
D2002	C-1
D2003	C-2
D2004	C-2
D2005	B-2
D2007	B-1
R2002	C-2

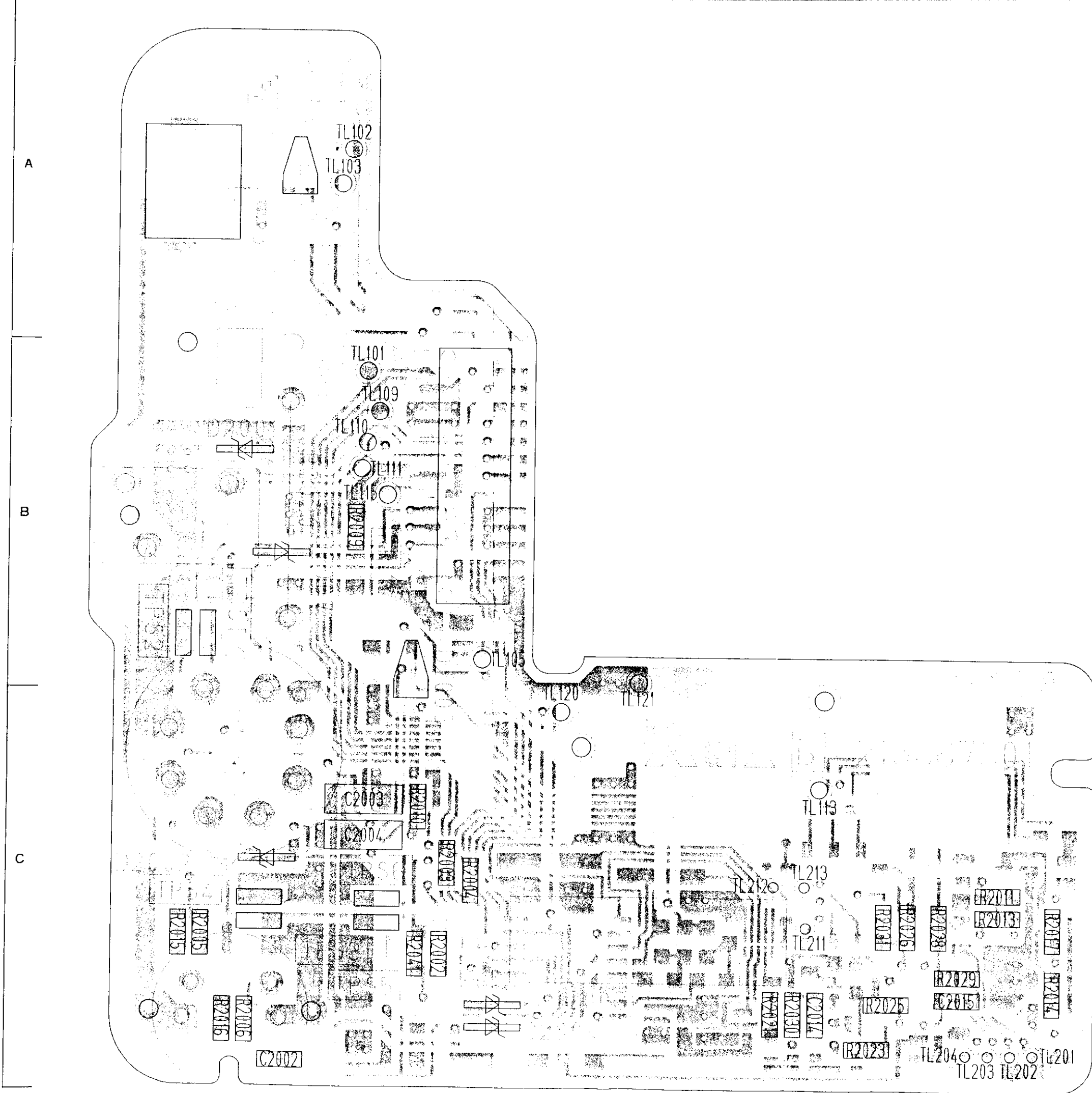

C2002	C-1
C2003	C-1
C2004	C-1
C2014	C-3
C2015	C-3
D2000	A-1
D2001	A-1
D2002	C-1
D2003	C-2
D2004	C-2
D2005	B-2
D2007	B-1
R2002	C-2
R2003	C-2
R2004	C-2
R2005	C-1
R2006	C-1
R2009	B-1
R2010	C-2
R2011	C-3
R2013	C-3
R2014	C-3
R2015	C-1
R2016	C-1
R2017	C-3
R2020	B-1
R2021	C-3
R2023	C-3
R2025	C-3
R2026	C-3
R2028	C-3
R2029	C-3
R2030	C-3
R2031	C-3
R2041	C-2
TPS1	B-1
TPS2	B-1
TPS3	C-1
TPS4	C-1
TPS5	C-1
TPS6	C-1

1

2

3

4

5

A

B

C

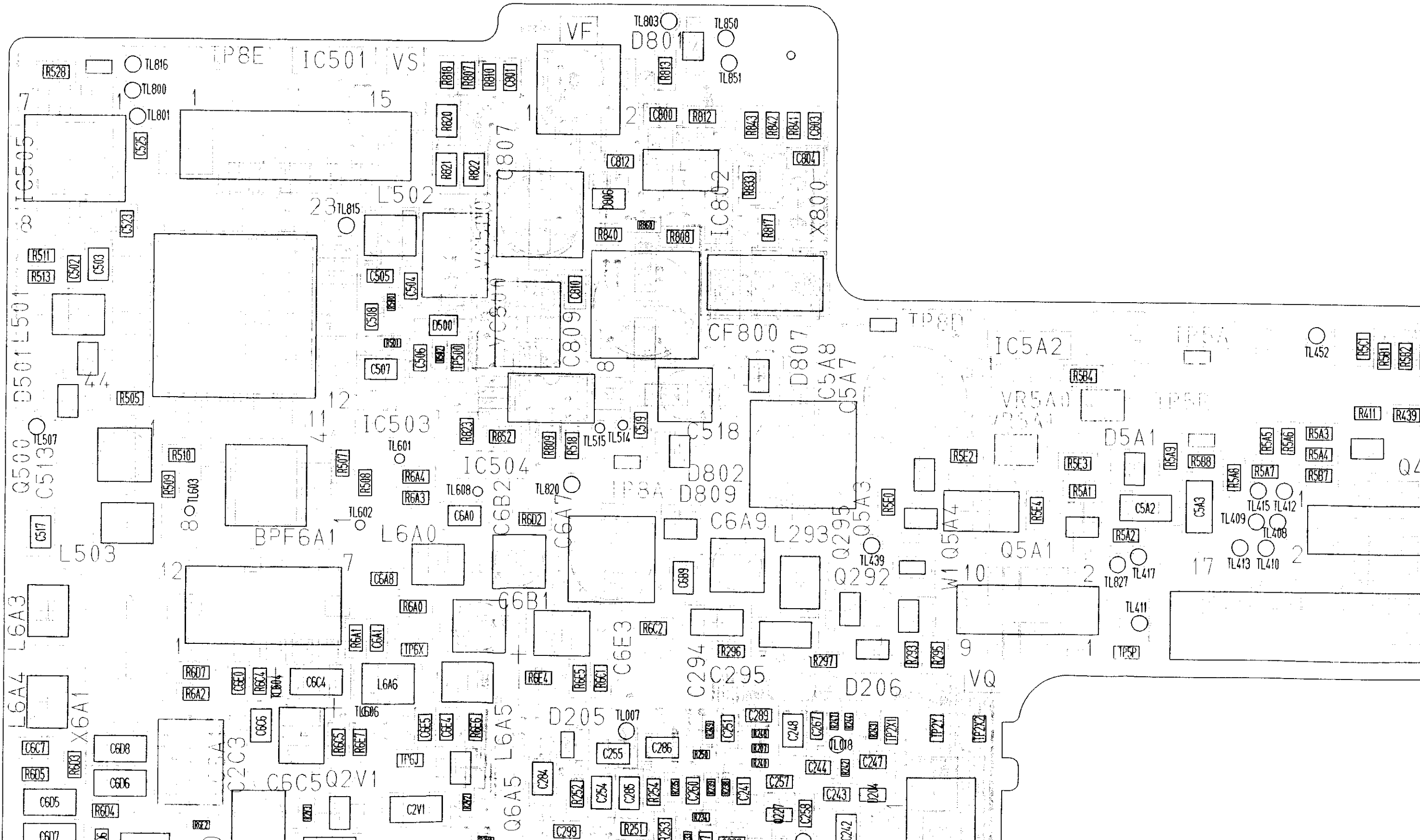



4

5

6

7



4

5

6

7

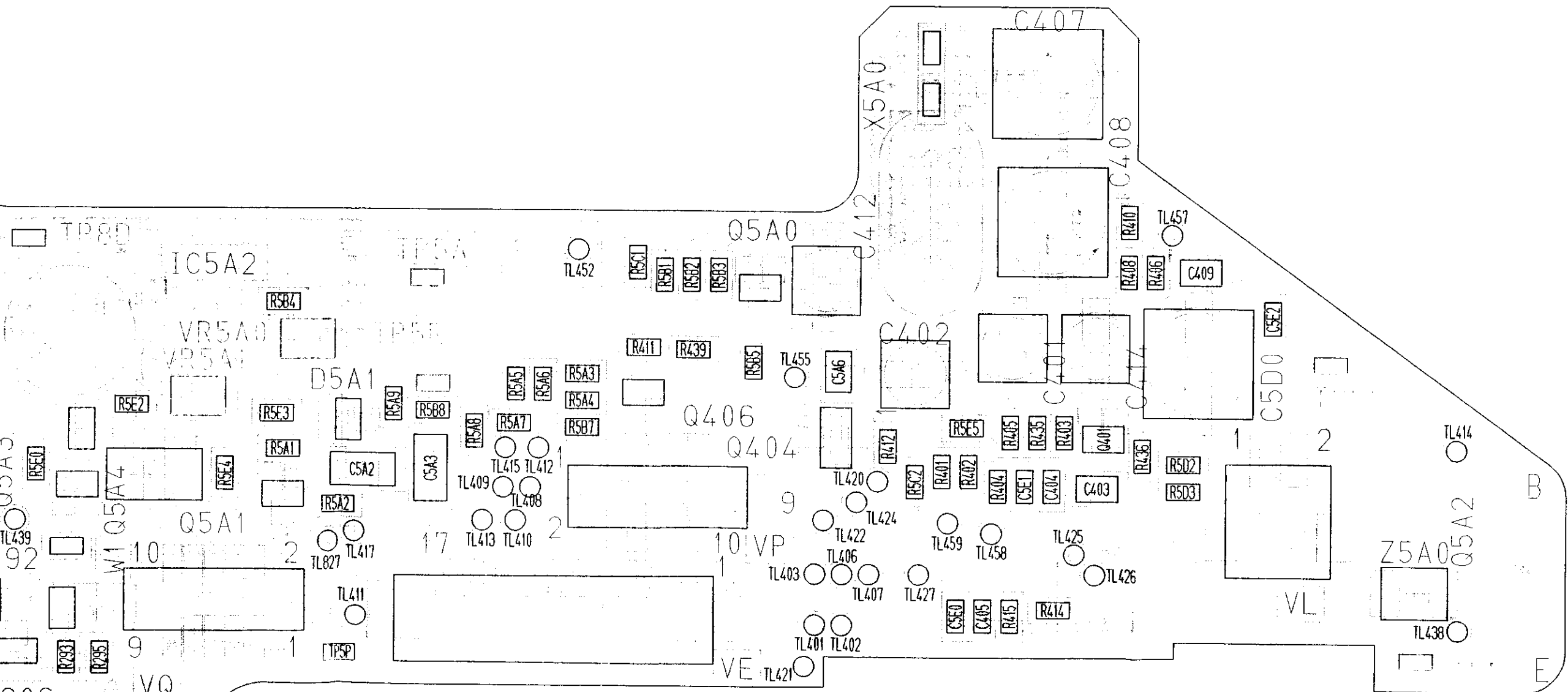

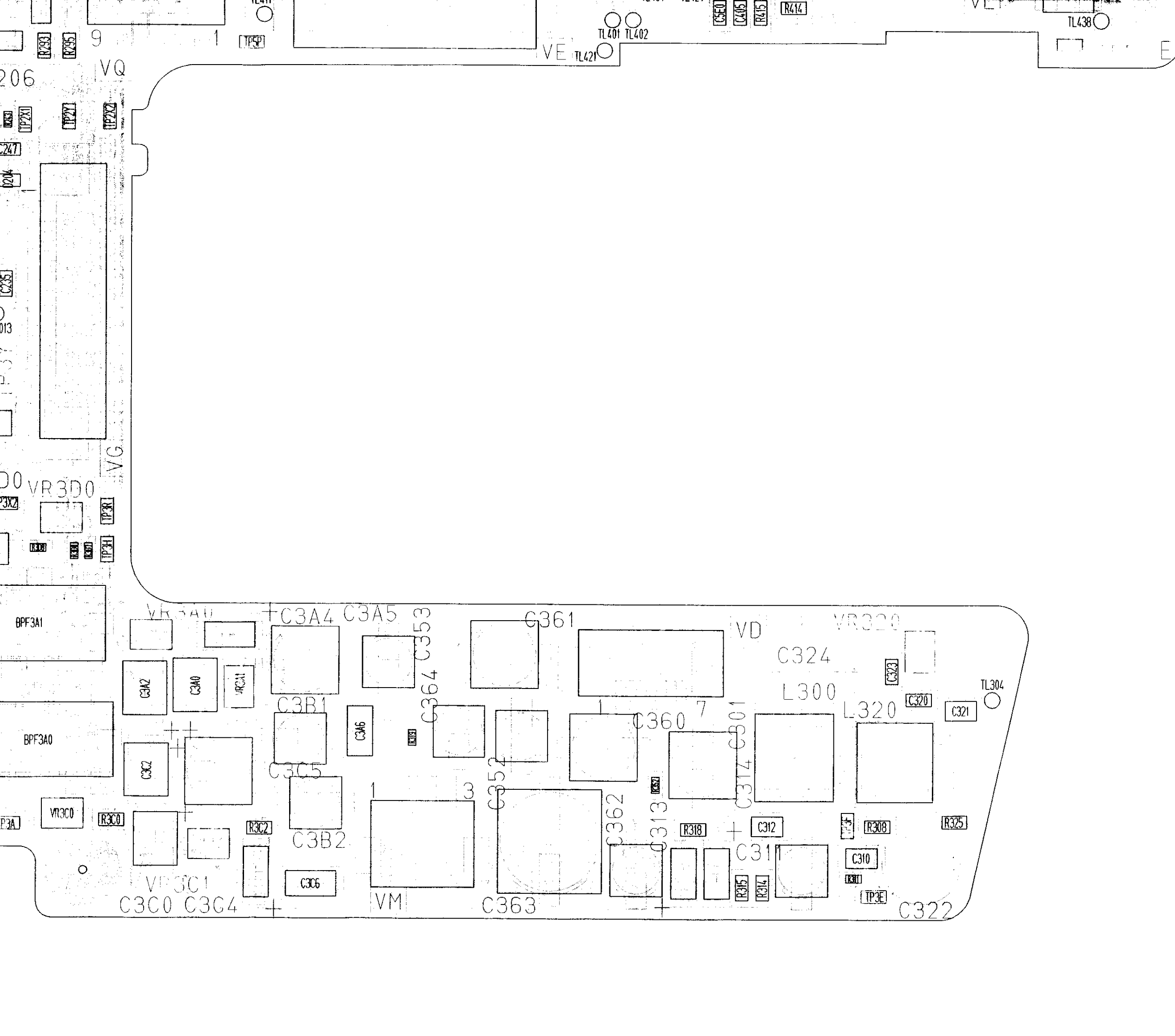

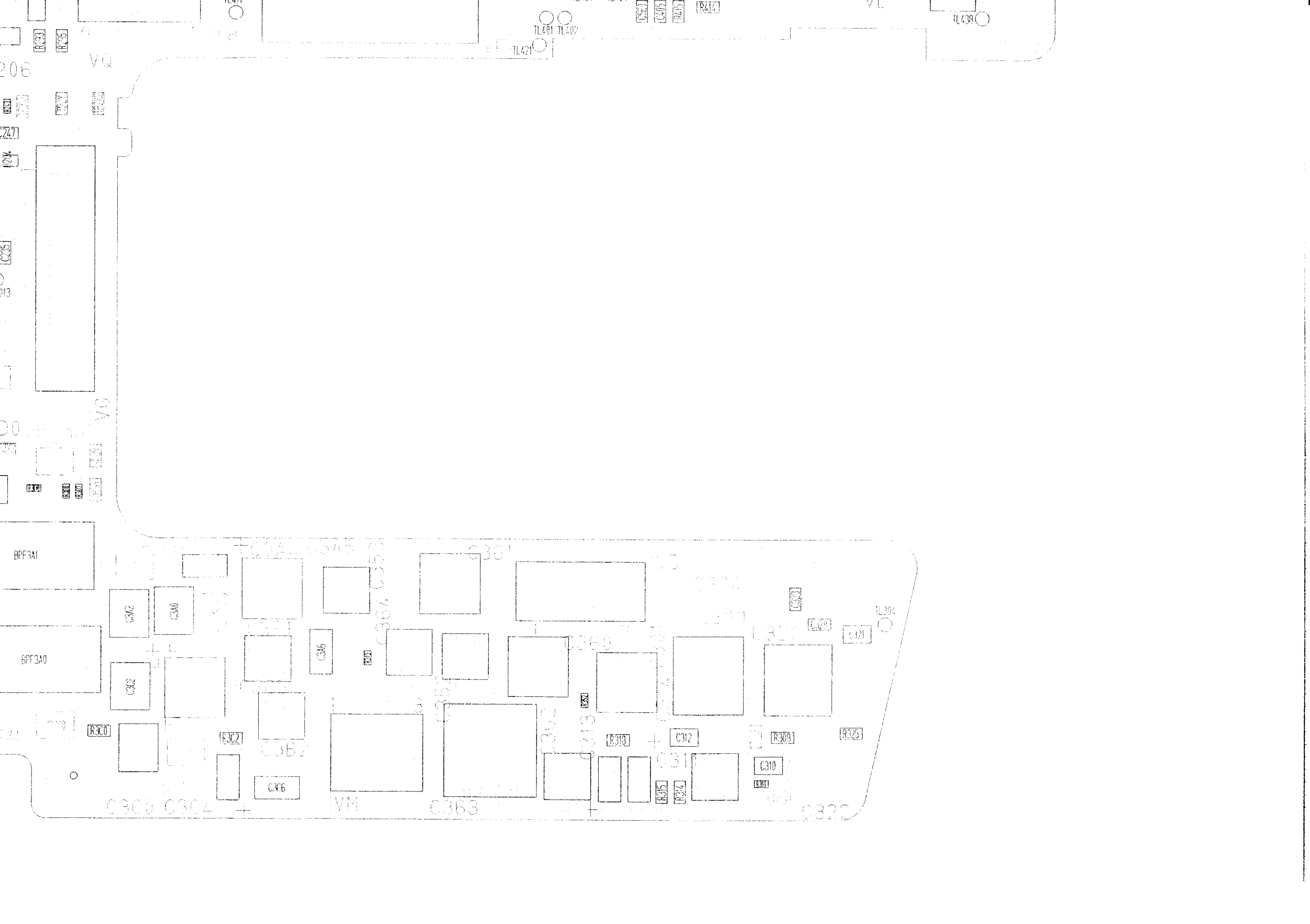

206

V0

247

244

235

213

200

V0

BPF3A1

BPF3A0

C3A2

C3A0

C3C2

C3B2

R300

R302

C3B2

C3B6

C300 C304

VM

C363

C3B2

R313

R319

C318

R315

R314

C312

C311

C310

R311

R309

R325

C320

C320

C321

C321

R325

C322

C322

C361

C361

C360

C367 C353

C3A5

C3A5

R317

C367

C367

C360

C360

C360

C360

TL304

TL421

TL401 TL402

C450 C445 R445 R444

TL439

0
0
0

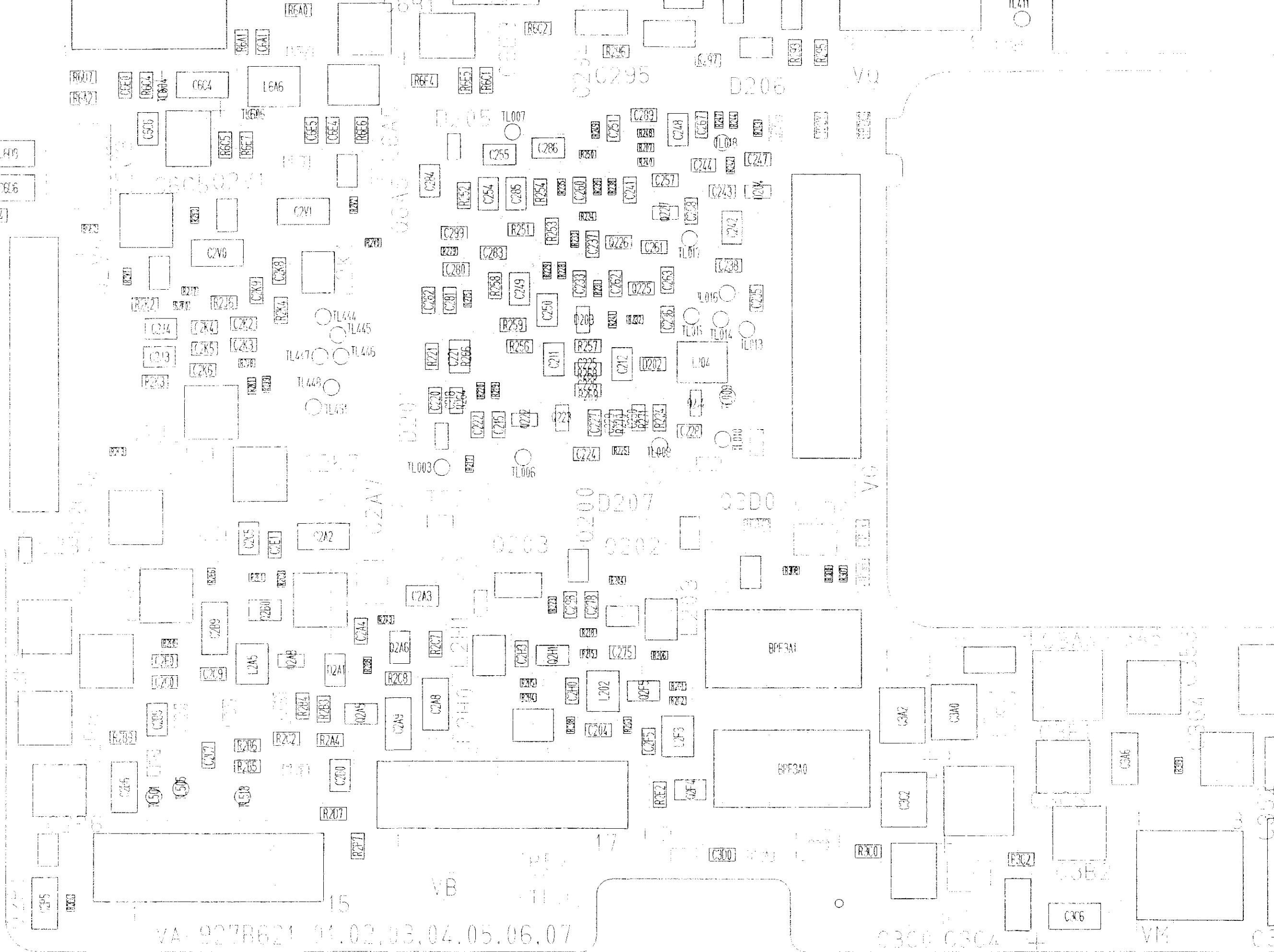

VA-9278621 01.02.03.04.05.06.07

15

VB

R300

R302

C306

VM

03

PCB -- VTR (A SIDE)

SYMBOL NO.	ADDRESS	SYMBOL NO.	ADDRESS	SYMBOL NO.	ADDRESS	SYMBOL NO.	ADDRESS	SYMBOL NO.	ADDRESS
BPF3A0	E-4	C2A8	E-2	C3B2	E-4	C801	A-2	Q225	D-3
BPF3A1	E-3	C2A9	E-2	C3C0	E-4	C803	A-3	Q226	C-3
BPF6A1	B-2	C2B0	E-2	C3C2	E-4	C804	A-3	Q227	C-3
		C2B5	E-2	C3C4	E-4	C807	A-2	Q292	C-3
C204	E-3	C2B6	E-1	C3C5	E-4	C809	B-2	Q295	B-3
C211	D-3	C2B7	D-1	C3C6	E-4	C810	B-2	Q2A5	E-2
C212	D-3	C2B8	E-1	C3D0	E-3	C812	A-3	Q2A6	E-2
C215	D-3	C2B9	E-2	C401	B-6			Q2A8	E-2
C218	D-2	C2C0	E-2	C402	B-6	CF800	B-3	Q2B0	D-2
C220	D-2	C2C1	D-1	C403	B-6			Q2F4	E-3
C221	D-2	C2C2	D-1	C404	B-6	D201	D-2	Q2F5	E-3
C222	D-3	C2C3	C-1	C405	C-6	D202	D-3	Q2H1	E-3
C224	D-3	C2C5	D-2	C407	A-6	D204	C-3	Q2P1	E-1
C225	D-3	C2C7	E-2	C408	B-6	D205	C-2	Q2V0	C-1
C226	D-3	C2C9	E-2	C409	B-6	D206	C-3	Q2V1	C-2
C227	D-3	C2E0	E-2	C412	B-5	D207	D-3	Q3A1	D-1
C228	D-3	C2E1	D-2	C414	B-6	D208	D-3	Q3D0	D-3
C229	D-3	C2F5	E-3	C502	B-1	D2A1	E-2	Q401	B-6
C230	D-3	C2H0	E-3	C503	B-1	D500	B-2	Q404	B-5
C233	C-3	C2H3	E-3	C504	B-2	D501	B-1	Q406	B-5
C235	D-3	C2J2	D-2	C505	B-2	D5A1	B-4	Q500	B-1
C236	D-3	C2J3	D-2	C506	B-2	D801	A-3	Q5A0	B-5
C237	C-3	C2J4	D-2	C507	B-2	D802	B-3	Q5A1	B-4
C238	C-3	C2K2	D-2	C508	B-2	D806	A-3	Q5A2	B-7
C241	C-3	C2K3	D-2	C513	B-1	D807	B-3	Q5A3	B-3
C242	C-3	C2K4	D-2	C517	B-1	D809	B-3	Q5A4	B-4
C243	C-3	C2K5	D-2	C518	B-3			Q6A5	C-2
C244	C-3	C2K6	D-2	C519	B-3	IC501	A-2		
C247	C-3	C2K7	D-2	C523	A-1	IC503	B-2	R204	D-3
C248	C-3	C2K8	C-2	C525	A-1	IC504	B-2	R206	E-3
C249	C-3	C2K9	C-2	C5A2	B-4	IC505	A-1	R207	C-3
C250	D-3	C2P4	E-1	C5A3	B-4	IC5A2	B-4	R208	E-3
C251	C-3	C2P5	E-1	C5A6	B-5	IC802	A-3	R215	E-3
C254	C-3	C2P6	E-1	C5A7	B-3			R217	D-3
C255	C-3	C2V0	C-2	C5A8	B-3	L202	E-3	R218	E-3
C257	C-3	C2V1	C-2	C5D0	B-6	L203	E-3	R219	D-3
C258	C-3	C301	E-6	C5E0	C-6	L204	D-3	R220	D-3
C260	C-3	C310	E-6	C5E1	B-6	L293	B-3	R221	D-2
C261	C-3	C311	E-6	C5E2	B-6	L2A5	E-2	R223	D-3
C262	C-3	C312	E-6	C6A0	B-2	L2F3	E-3	R224	D-3
C263	C-3	C313	E-5	C6A1	C-2	L2H0	E-3	R225	D-3
C267	C-3	C314	E-6	C6A2	B-2	L2H1	E-3	R228	C-3
C275	E-3	C320	E-6	C6A7	B-2	L2K1	C-2	R229	C-3
C278	D-3	C321	E-6	C6A8	C-2	L300	E-6	R231	D-3
C280	C-2	C322	E-6	C6A9	B-3	L320	E-6	R232	D-3
C281	D-2	C323	E-6	C6B1	C-2	L501	B-1	R233	C-3
C282	D-2	C324	E-6	C6B2	B-2	L502	A-2	R234	C-3
C283	C-3	C352	E-5	C6B9	C-3	L503	B-1	R235	C-3
C284	C-2	C353	E-5	C6C4	C-2	L6A0	B-2	R238	C-3
C285	C-3	C360	E-5	C6C5	C-2	L6A3	C-1	R239	C-3
C286	C-3	C361	E-5	C6C6	C-2	L6A4	C-1	R240	C-3
C289	C-3	C362	E-5	C6C7	C-1	L6A5	C-2	R241	D-3
C294	C-3	C363	E-5	C6D5	C-1	L6A6	C-2	R242	C-3
C295	C-3	C364	E-5	C6D6	C-1			R243	C-3
C298	D-3	C3A0	E-4	C6D7	C-1	Q200	D-3	R244	C-3
C299	C-2	C3A2	E-4	C6D8	C-1	Q202	D-3	R247	C-3
C2A2	D-2	C3A4	E-4	C6E0	C-1	Q203	D-3	R248	C-3
C2A3	D-2	C3A5	E-5	C6E3	C-3	Q222	D-3	R249	C-3
C2A4	E-2	C3A6	E-5	C6E5	C-2	Q223	D-3	R250	C-3
C2A7	D-2	C3B1	E-4	C800	A-3	Q224	D-3	R251	C-3

SYMBOL NO.	ADDRESS	SYMBOL NO.	ADDRESS	SYMBOL NO.	ADDRESS	SYMBOL NO.	ADDRESS
R252	C-2	R318	E-6	R5E2	B-3	TP3F	E-6
R253	C-3	R319	E-5	R5E3	B-4	TP3H	D-4
R254	C-3	R325	E-6	R5E4	B-4	TP3L	E-3
R256	D-3	R352	E-5	R5E5	B-6	TP3R	D-4
R257	D-3	R3A7	D-1	R6A0	C-2	TP3X1	D-3
R258	C-3	R3C0	E-4	R6A1	C-2	TP3X2	D-3
R259	D-3	R3C2	E-4	R6A2	C-1	TP3Y	D-3
R264	D-2	R3C6	D-1	R6A3	B-2	TP500	B-2
R266	D-2	R3C7	D-1	R6A4	B-2	TP5A	B-4
R268	D-3	R3D0	D-4	R6C1	C-3	TP5P	C-4
R269	D-3	R3D7	D-4	R6C2	C-3	TP5Q	C-7
R270	D-3	R3D8	D-4	R6C4	C-2	TP5R	B-4
R271	D-3	R401	B-6	R6C5	C-2	TP5S	B-7
R275	D-3	R402	B-6	R6D2	B-3	TP5X	E-3
R279	C-2	R403	B-6	R6D3	C-1	TP6G	D-1
R293	C-4	R404	B-6	R6D4	C-1	TP6J	C-2
R295	C-4	R405	B-6	R6D5	C-1	TP6X	C-2
R296	C-3	R406	B-6	R6D6	C-1	TP8A	B-3
R297	C-3	R408	B-6	R6D7	C-1	TP8D	B-4
R2A3	E-2	R410	B-6	R6E1	C-2	TP8E	A-1
R2A4	E-2	R411	B-5	R6E4	C-2		
R2B3	E-2	R412	B-6	R6E5	C-2	VC500	B-2
R2B4	E-2	R414	C-6	R6E6	C-2	VC6A1	C-1
R2B5	E-2	R415	C-6	R6E7	C-2	VC800	B-2
R2B6	E-2	R435	B-6	R6F2	C-1		
R2B8	E-2	R436	B-6	R6J7	C-2	VR2A0	D-2
R2B9	E-1	R439	B-5	R807	A-2	VR2A1	D-1
R2C2	E-2	R500	B-2	R808	A-3	VR320	E-6
R2C3	D-1	R501	B-2	R809	B-2	VR3A0	E-4
R2C7	E-2	R502	B-2	R810	A-2	VR3A1	E-4
R2C8	E-2	R505	B-1	R812	A-3	VR3C0	E-4
R2C9	D-2	R507	B-2	R813	A-3	VR3C1	E-4
R2D7	E-2	R508	B-2	R817	A-3	VR3D0	D-4
R2E0	E-2	R509	B-1	R818	A-2	VR5A0	B-4
R2E1	D-2	R510	B-1	R820	A-2	VR5A1	B-4
R2E2	E-3	R511	B-1	R821	A-2		
R2E6	D-2	R513	B-1	R822	A-2	X5A0	A-5
R2G1	E-3	R518	B-2	R823	B-2	X6A1	C-1
R2G2	E-3	R528	A-1	R833	A-3	X800	A-3
R2G3	E-3	R5A1	B-4	R840	A-3		
R2H4	E-3	R5A2	B-4	R841	A-3	Z5A0	B-7
R2H5	E-3	R5A3	B-5	R842	A-3		
R2J6	D-2	R5A4	B-5	R843	A-3		
R2J8	D-2	R5A5	B-5	R852	B-2		
R2J9	D-2	R5A6	B-5	R860	A-3		
R2K0	D-2	R5A7	B-5				
R2K1	D-2	R5A8	B-5	TP25	E-1		
R2K2	D-2	R5A9	B-4	TP29	D-2		
R2K3	D-2	R5B1	B-5	TP2A	D-2		
R2K4	D-2	R5B2	B-5	TP2C	E-2		
R2P4	E-1	R5B3	B-5	TP2E	E-2		
R2P7	E-2	R5B4	B-4	TP2K	E-1		
R2V0	C-2	R5B5	B-5	TP2M	D-2		
R2V1	C-1	R5B7	B-5	TP2S	D-2		
R2V2	C-2	R5B8	B-4	TP2V	E-2		
R2V3	C-2	R5C1	B-5	TP2X1	C-3		
R308	E-6	R5C2	B-6	TP2X2	C-4		
R311	E-6	R5D2	B-6	TP2Y	C-4		
R314	E-6	R5D3	B-6	TP3A	E-3		
R315	E-6	R5E0	B-3	TP3E	E-6		

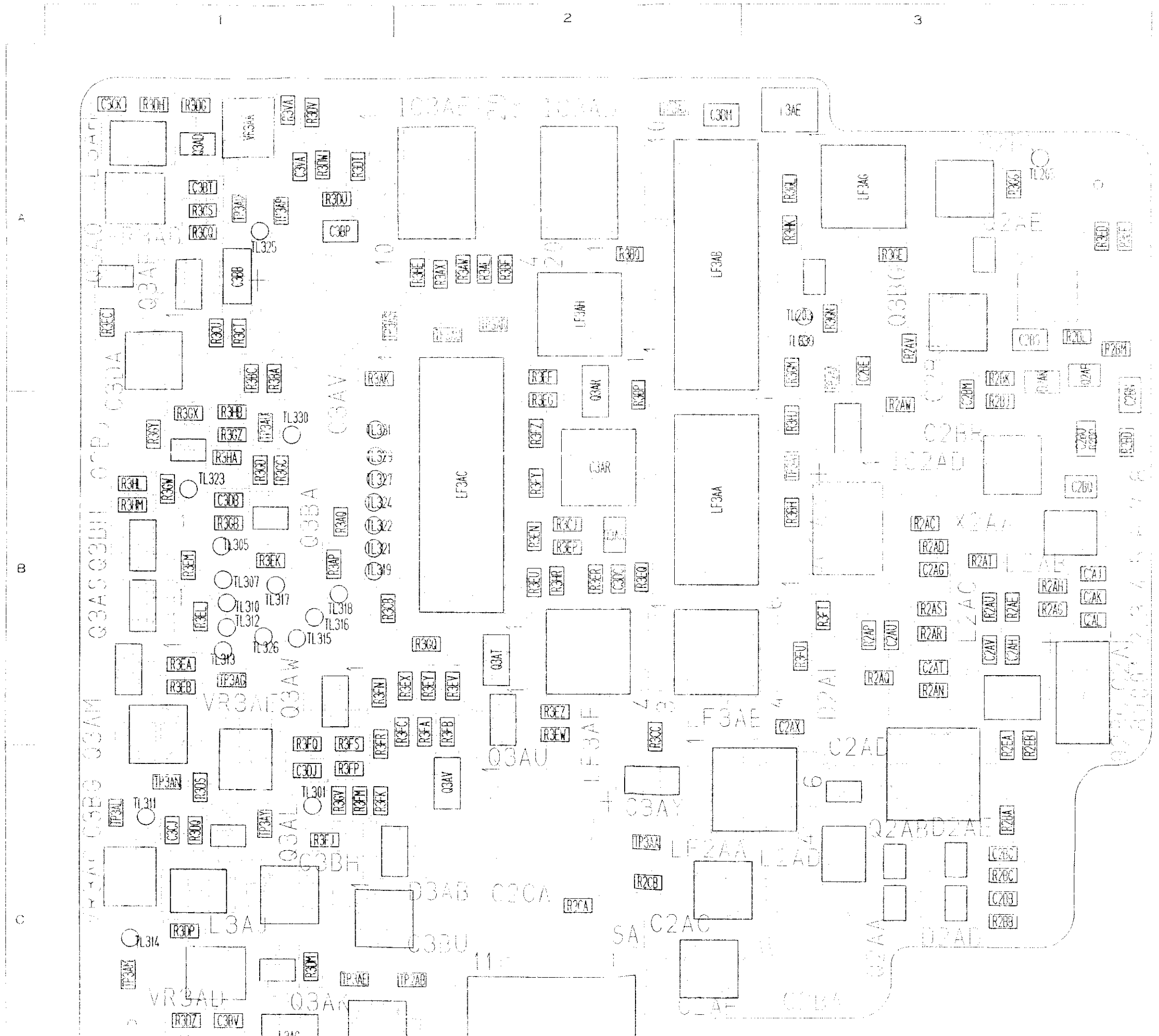

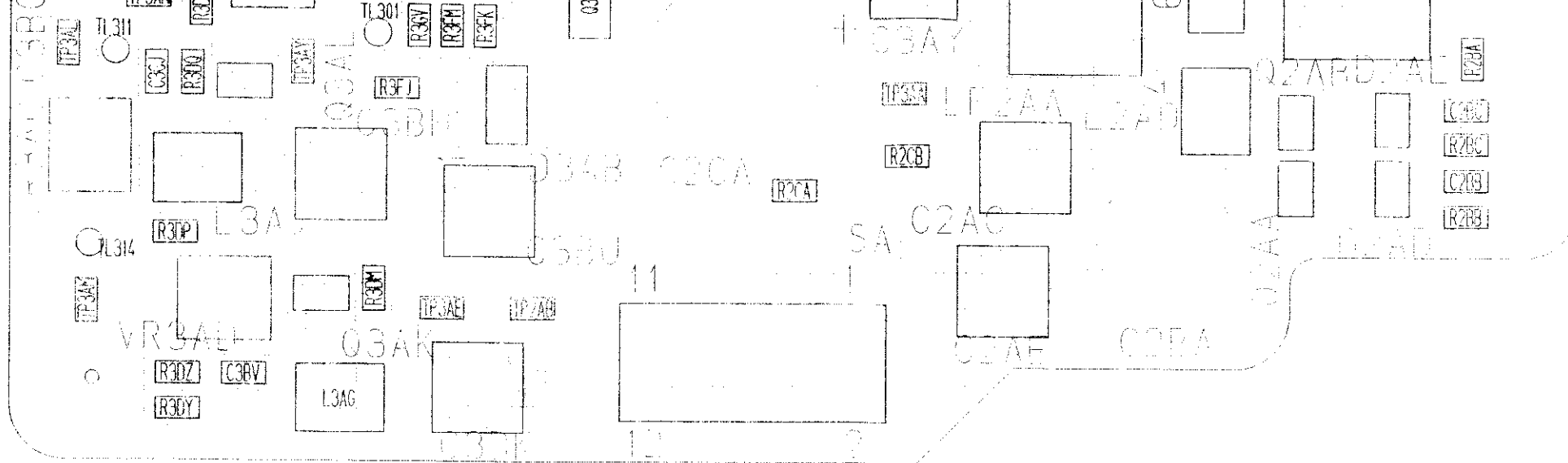

PCB-GYRO SENS(A SIDE)

PCB-GYRO SENS(B SIDE)

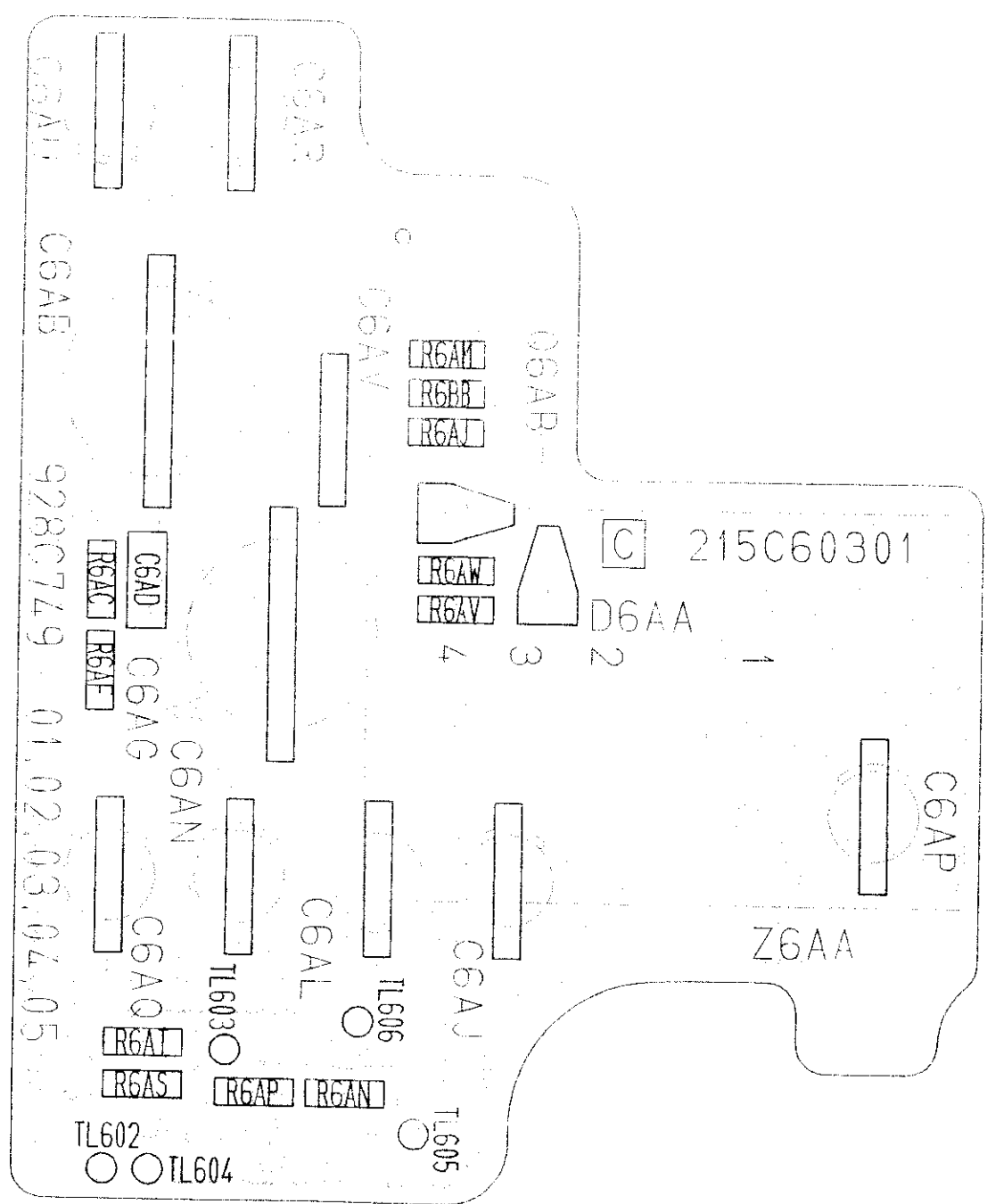
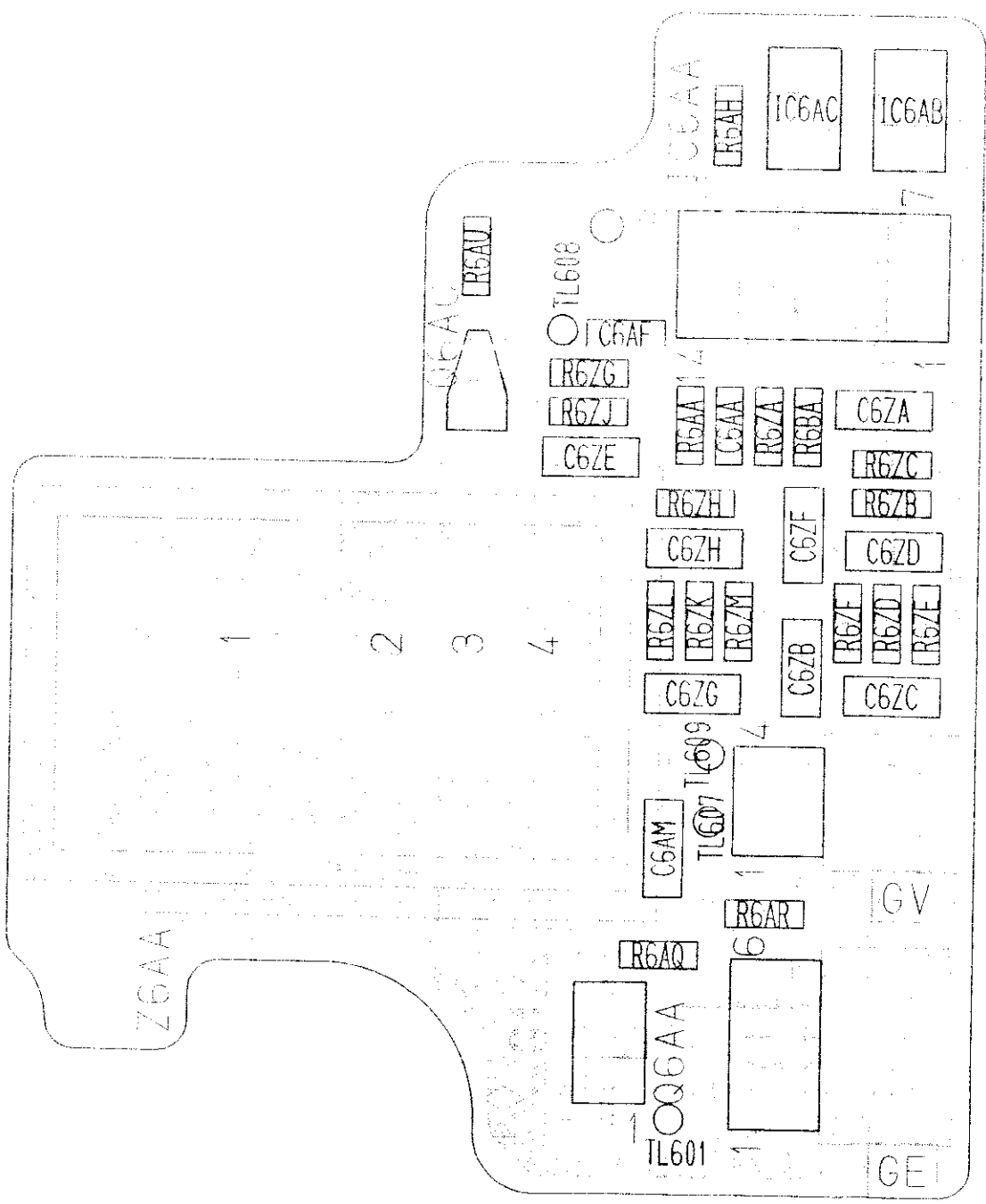

PCB 50/PC(B SIDE)

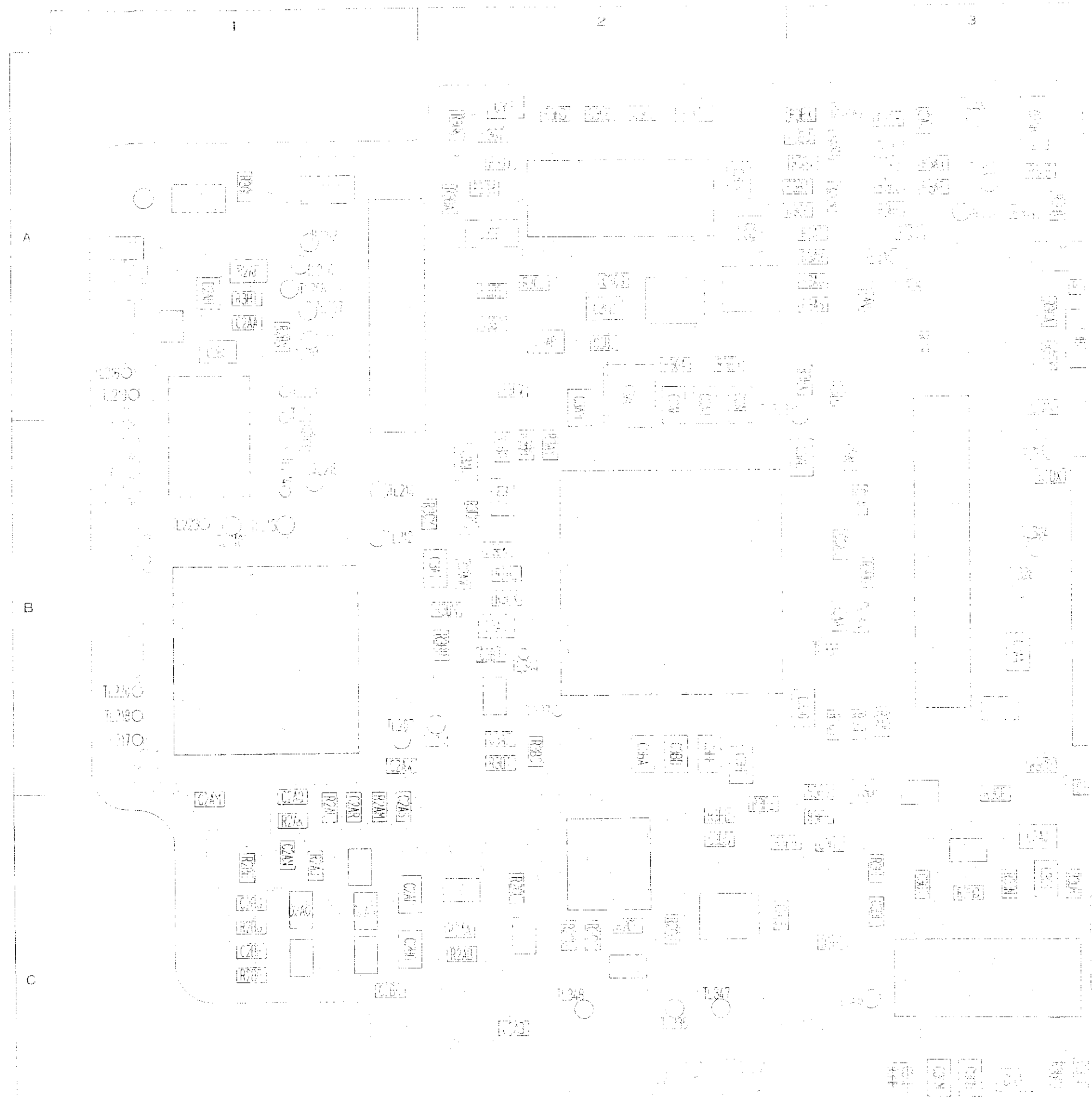

c



PCB-CCD(A SIDE)

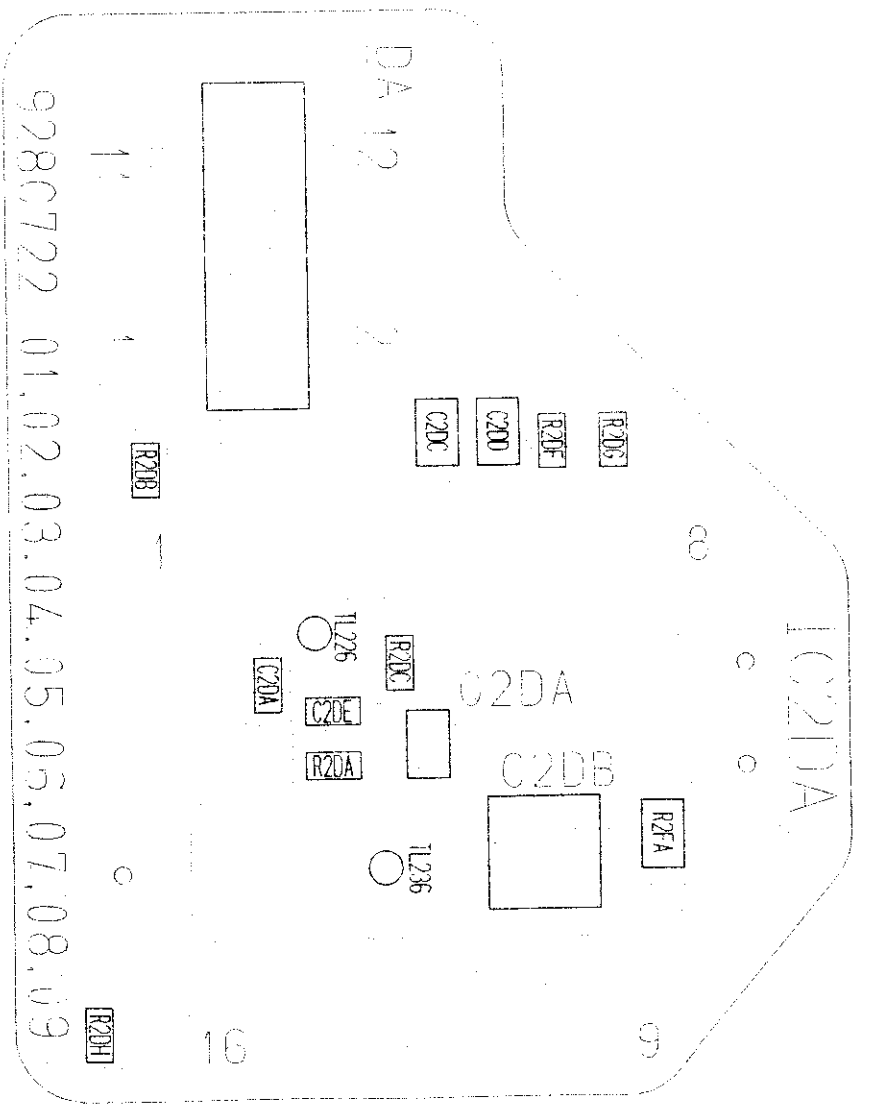

PCB-CCD(B SIDE)

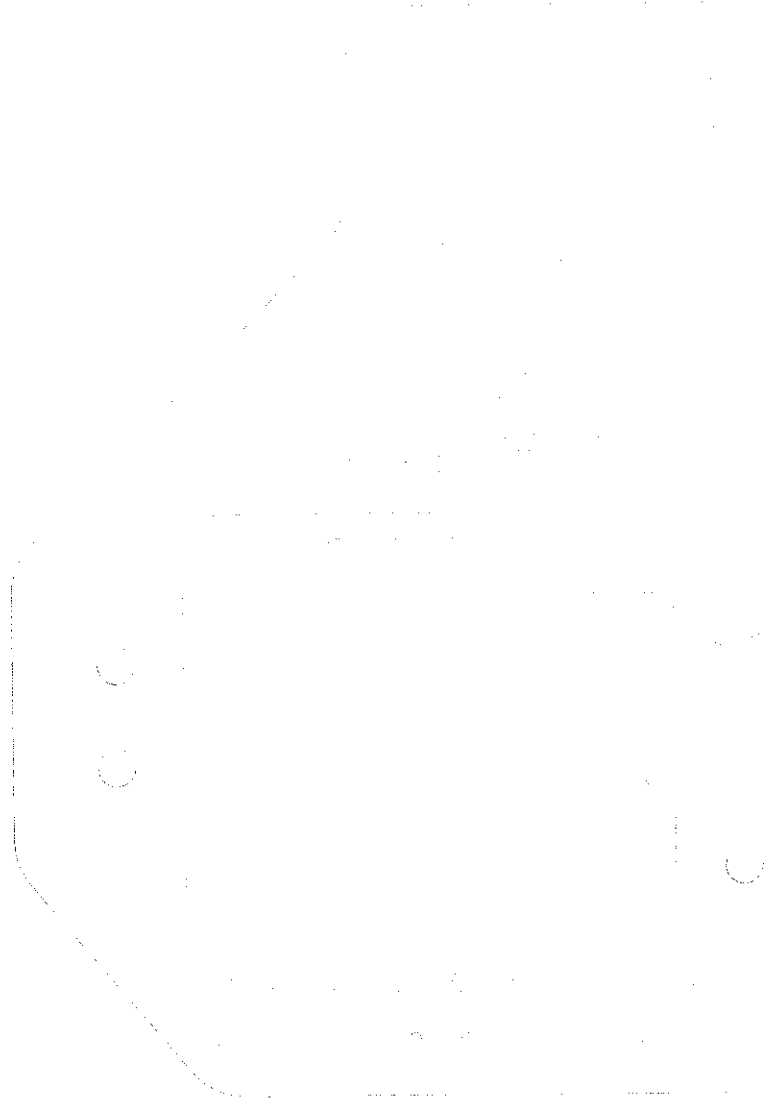

PCB - SD/PC (A SIDE)

SYMBOL NO.	ADDRESS	SYMBOL NO.	ADDRESS	SYMBOL NO.	ADDRESS	SYMBOL NO.	ADDRESS
C2AC	C-2	L3AG	C-1	R2EA	C-3	R3FP	C-1
C2AD	C-3	L3AH	A-1	R2EB	C-3	R3FQ	B-1
C2AE	C-2	L3AJ	C-1	R3AK	A-1	R3FR	B-1
C2AF	B-3			R3AL	A-2	R3FS	B-1
C2AG	B-3	LF2AA	C-2	R3AP	B-1	R3FT	B-3
C2AH	B-3	LF3AA	B-2	R3AQ	B-1	R3FU	B-3
C2AJ	B-3	LF3AB	A-2	R3AW	A-2	R3FY	B-2
C2AK	B-3	LF3AC	B-2	R3AX	A-2	R3FZ	B-2
C2AL	B-3	LF3AE	B-2	R3BA	A-1	R3GB	B-1
C2AT	B-3	LF3AF	B-2	R3BC	A-1	R3GC	B-1
C2AU	B-3	LF3AG	A-3	R3BF	A-2	R3GD	B-1
C2AV	B-3	LF3AH	A-2	R3BH	B-3	R3GE	A-3
C2AX	B-3			R3BP	B-2	R3GG	A-3
C2BA	C-3	Q2AA	C-3	R3BQ	A-2	R3GL	A-3
C2BB	C-3	Q2AB	C-3	R3CB	B-1	R3GM	A-3
C2BC	C-3	Q2AE	A-3	R3CC	B-2	R3GN	A-3
C2BE	A-3	Q2AF	A-3	R3CJ	B-2	R3GQ	B-2
C2BG	C-1	Q3AD	A-1	R3CD	A-1	R3GV	C-1
C2BJ	A-3	Q3AF	A-1	R3CS	A-1	R3GW	B-1
C2BM	B-3	Q3AK	C-1	R3CT	A-1	R3GX	B-1
C2BN	B-3	Q3AL	C-1	R3CU	A-1	R3GY	B-1
C2BQ	B-3	Q3AM	B-1	R3DG	A-1	R3GZ	B-1
C2BR	B-3	Q3AQ	A-1	R3DH	A-1	R3HA	B-1
C2BS	A-3	Q3AR	A-2	R3DM	C-1	R3HB	B-1
C2BU	B-3	Q3AS	B-1	R3DP	C-1	R3HE	A-2
C2BV	A-3	Q3AT	B-2	R3DQ	C-1	R3HJ	B-3
C2CA	C-2	Q3AU	C-2	R3DS	C-1	R3HK	A-3
C3AR	B-2	Q3AV	C-2	R3DT	A-1	R3HL	B-1
C3AV	B-1	Q3AW	B-1	R3DU	A-1	R3HM	B-1
C3AY	C-2	Q3AX	B-2	R3DV	A-1	R3HR	B-2
C3BH	C-1	Q3BA	B-1	R3DW	A-1	R3VA	A-1
C3BM	A-2	Q3BG	A-3	R3DY	C-1		
C3BP	A-1	Q3BH	B-1	R3DZ	C-1	TP2AA	A-3
C3BT	A-1	Q3BJ	B-1	R3EA	B-1	TP2AB	C-2
C3BU	C-2			R3EB	B-1	TP3AA	C-2
C3BV	C-1	R2AC	B-3	R3EC	A-1	TP3AB	A-2
C3CJ	C-1	R2AD	B-3	R3ED	A-3	TP3AE	C-1
C3CK	A-1	R2AE	B-3	R3EE	A-3	TP3AG	B-1
C3DA	A-1	R2AG	B-3	R3EF	A-2	TP3AJ	A-2
C3DB	B-1	R2AH	B-3	R3EG	B-2	TP3AL	C-1
C3DC	B-2	R2AN	B-3	R3EK	B-1	TP3AM	C-1
C3DD	A-1	R2AP	B-3	R3EL	B-1	TP3AN	C-1
C3DJ	C-1	R2AQ	B-3	R3EM	B-1	TP3AP	A-1
C3DK	C-1	R2AR	B-3	R3EN	B-2	TP3AQ	A-1
C3VA	A-1	R2AS	B-3	R3EP	B-2	TP3AR	A-2
		R2AT	B-3	R3EQ	B-2	TP3AS	A-1
D2AD	C-3	R2AU	B-3	R3ER	B-2	TP3AT	B-3
D2AE	C-3	R2AV	A-3	R3EU	B-2	TP3AU	B-1
D2AK	A-3	R2AW	B-3	R3EV	B-2	TP3AY	C-1
D2AL	B-3	R2BA	C-3	R3EW	B-2		
D3AB	C-2	R2BB	C-3	R3EX	B-2	VC2AA	B-3
		R2BC	C-3	R3EY	B-2		
IC2AD	B-3	R2BD	B-3	R3EZ	B-2	VR2AA	A-3
IC3AD	A-2	R2BJ	B-3	R3FA	B-2	VR3AA	A-1
IC3AE	A-2	R2BK	A-3	R3FB	B-2	VR3AB	A-1
		R2BL	A-3	R3FC	B-2	VR3AC	C-1
L2AB	B-3	R2BM	A-3	R3FJ	C-1	VR3AD	C-1
L2AC	B-3	R2BP	B-3	R3FK	C-1	VR3AE	B-1
L2AD	C-3	R2CA	C-2	R3FM	C-1		
L3AE	A-3	R2CB	C-2	R3FN	B-1	X2AA	B-3

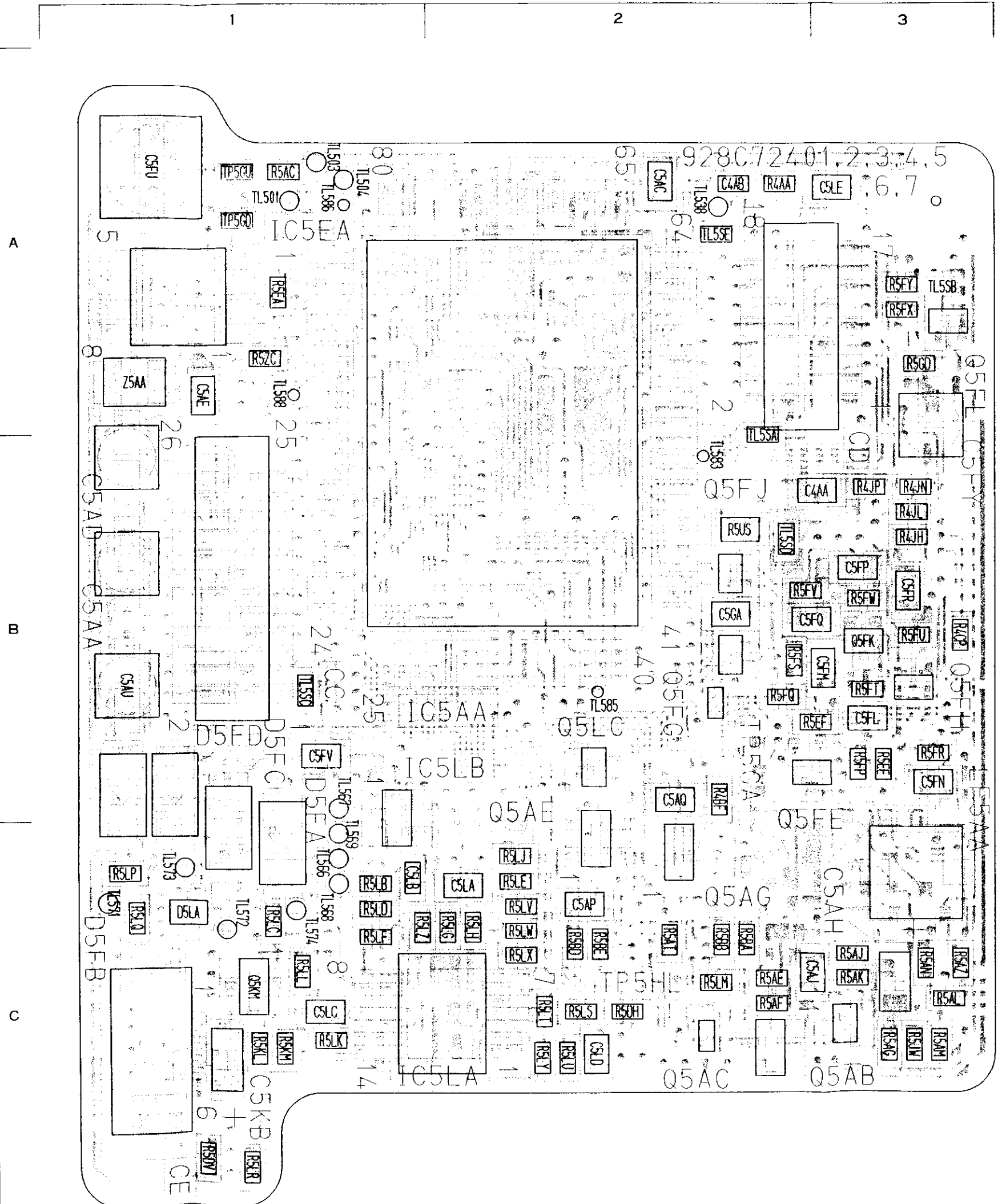

PCB - CM (A SIDE)

SYMBOL NO.	ADDRESS	SYMBOL NO.	ADDRESS	SYMBOL NO.	ADDRESS
C4AA	B-3	R4JP	B-3	TP5GA	B-2
C4AB	A-2	R5AC	A-1	TP5GD	A-1
C5AA	B-1	R5AE	C-2	TP5GU	A-1
C5AC	A-2	R5AF	C-2	TP5HL	C-2
C5AD	B-1	R5AG	C-3	Z5AA	A-1
C5AE	A-1	R5AJ	C-3		
C5AH	C-3	R5AK	C-3		
C5AJ	C-3	R5AL	C-3		
C5AP	C-2	R5AM	C-3		
C5AQ	B-2	R5AN	C-3		
C5AU	B-1	R5AT	C-2		
C5FL	B-3	R5AZ	C-3		
C5FM	B-3	R5BA	C-2		
C5FN	B-3	R5BB	C-2		
C5FP	B-3	R5BD	C-2		
C5FQ	B-3	R5BE	C-2		
C5FR	B-3	R5DH	C-2		
C5FU	A-1	R5DV	C-1		
C5FV	B-1	R5EA	A-1		
C5FY	B-3	R5EE	B-3		
C5GA	B-2	R5EF	B-3		
C5KB	C-1	R5FP	B-3		
C5LA	C-2	R5FQ	B-2		
C5LB	C-1	R5FR	B-3		
C5LC	C-1	R5FS	B-2		
C5LD	C-2	R5FT	B-3		
C5LE	A-3	R5FU	B-3		
		R5FV	B-2		
D5FA	B-1	R5FW	B-3		
D5FB	C-1	R5FX	A-3		
D5FC	B-1	R5FY	A-3		
D5FD	B-1	R5GD	A-3		
D5LA	C-1	R5JW	C-3		
		R5KL	C-1		
IC5AA	B-2	R5KM	C-1		
IC5EA	A-1	R5LB	C-1		
IC5LA	C-2	R5LC	C-1		
IC5LB	B-2	R5LD	C-1		
		R5LE	C-2		
LF5AA	B-3	R5LF	C-1		
		R5LG	C-2		
Q5AB	C-3	R5LH	C-2		
Q5AC	C-2	R5LJ	C-2		
Q5AE	B-2	R5LK	C-1		
Q5AG	C-2	R5LL	C-1		
Q5FE	B-2	R5LM	C-2		
Q5FG	B-2	R5LP	C-1		
Q5FH	B-3	R5LO	C-1		
Q5FJ	B-2	R5LR	C-1		
Q5FK	B-3	R5LS	C-2		
Q5FL	A-3	R5LT	C-2		
Q5KM	C-1	R5LU	C-2		
Q5LC	B-2	R5LV	C-2		
		R5LW	C-2		
R4AA	A-2	R5LX	C-2		
R4BF	B-2	R5LY	C-2		
R4CP	B-3	R5LZ	C-1		
R4JH	B-3	R5US	B-2		
R4JL	B-3	R5ZC	A-1		
R4JN	B-3				

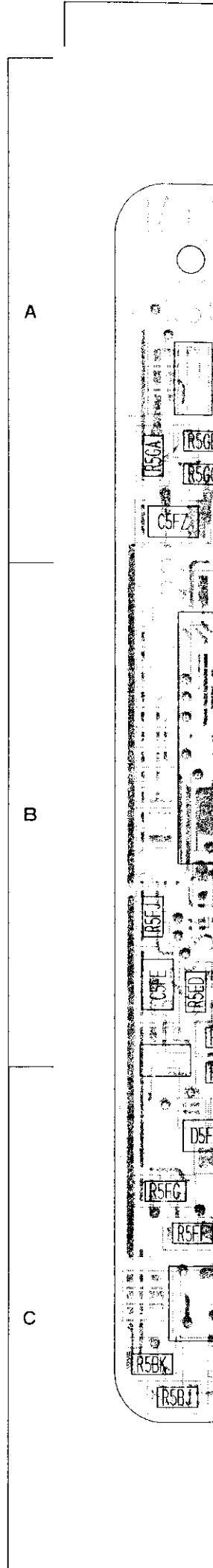

SYMBOL NO.	ADDRESS
4JP	B-3
5AC	A-1
5AE	C-2
5AF	C-2
5AG	C-3
5AJ	C-3
5AK	C-3
5AL	C-3
5AM	C-3
5AN	C-3
5AT	C-2
5AZ	C-3
5BA	C-2
5BB	C-2
5BD	C-2
5BE	C-2
5DH	C-2
5DV	C-1
5EA	A-1
5EE	B-3
5EF	B-3
5FP	B-3
5FQ	B-2
5FR	B-3
5FS	B-2
5FT	B-3
5FU	B-3
5FV	B-2
5FW	B-3
5FX	A-3
5FY	A-3
5GD	A-3
5JW	C-3
5KL	C-1
5KM	C-1
5LB	C-1
5LC	C-1
5LD	C-1
5LE	C-2
5LF	C-1
5LG	C-2
5LH	C-2
5LJ	C-2
5LK	C-1
5LL	C-1
5LM	C-2
5LP	C-1
5LQ	C-1
5LR	C-1
5LS	C-2
5LT	C-2
5LU	C-2
5LV	C-2
5LW	C-2
5LX	C-2
5LY	C-2
5LZ	C-1
5US	B-2
5ZC	A-1

SYMBOL NO.	ADDRESS
TP5GA	B-2
TP5GD	A-1
TP5GU	A-1
TP5HL	C-2
Z5AA	A-1

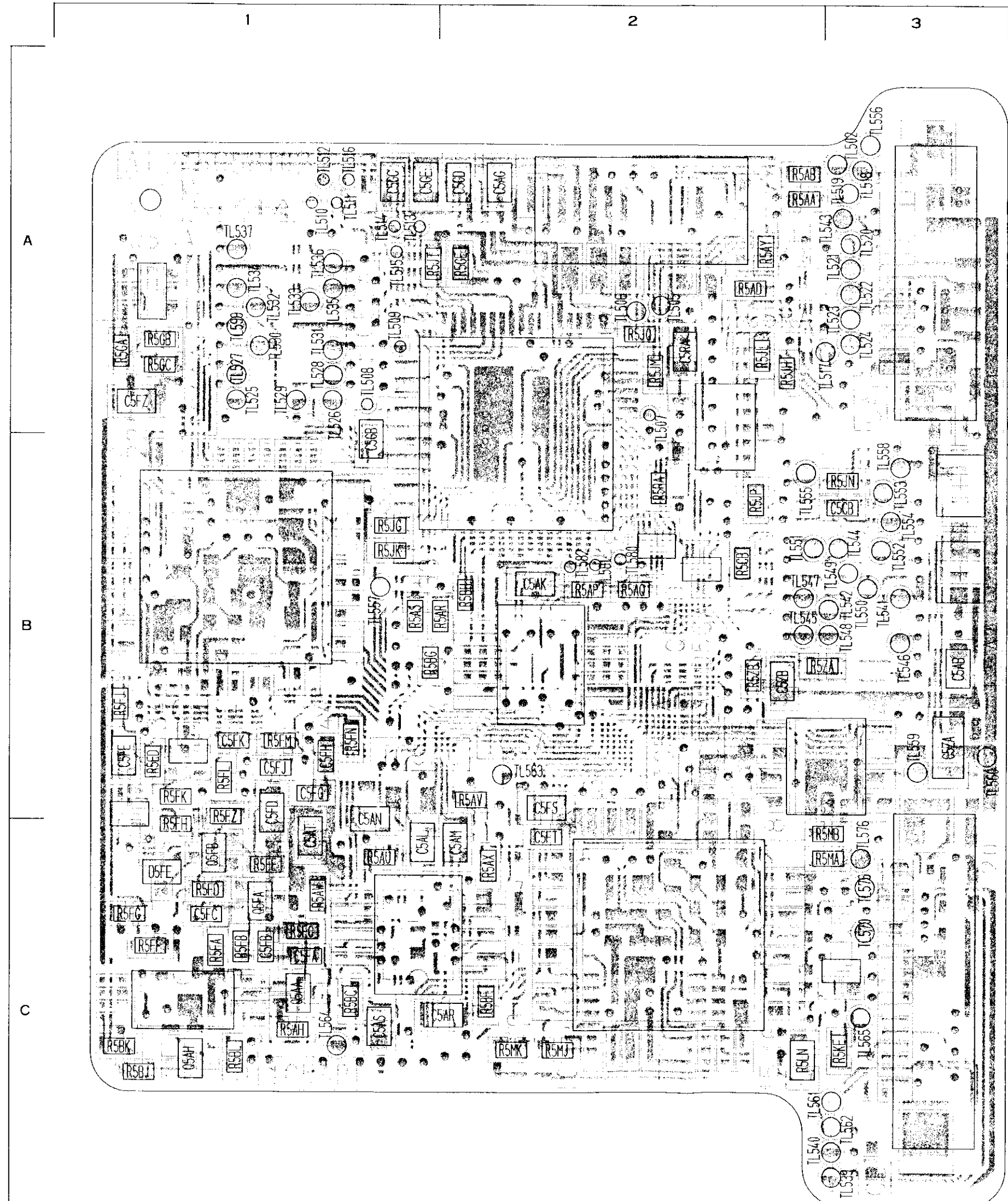

SYMBOL NO.	ADDRESS
C5AB	B-3
C5AG	A-2
C5AK	B-2
C5AL	C-1
C5AM	C-2
C5AN	B-1
C5AR	C-2
C5AS	C-1
C5AT	C-1
C5CB	B-3
C5FA	C-1
C5FB	C-1
C5FC	C-1
C5FD	B-1
C5FE	B-1
C5FG	B-1
C5FH	B-1
C5FJ	B-1
C5FK	B-1
C5FS	B-2
C5FT	C-2
C5FZ	A-1
C5GC	A-1
C5GD	A-2
C5GE	A-1
C5RA	A-2
C5ZA	B-3
C5ZB	B-2
D5CA	B-2
D5FE	C-1
IC4AA	A-1
IC5AB	C-1
IC5AC	B-1
IC5AE	B-2
IC5FA	B-2
IC5GA	A-1
IC5RA	A-2
IC5ZA	B-2
L5AA	B-3
L5AD	A-3
Q5AA	C-1
Q5AD	B-2
Q5AH	C-1
Q5FA	C-1
Q5FB	C-1
Q5FC	C-1
Q5FD	B-1
Q5GA	A-1
Q5LB	C-3
R4FE	C-1
R5AA	A-2
R5AB	A-2
R5AD	A-2
R5AH	C-1
R5AP	B-2

SYMBOL NO.	ADDRESS
R5AQ	B-2
R5AR	B-2
R5AS	B-1
R5AU	C-1
R5AV	B-2
R5AW	C-1
R5AX	C-2
R5AY	A-2
R5BC	C-1
R5BF	C-2
R5BG	B-1
R5BH	B-2
R5BJ	C-1
R5BK	C-1
R5BL	C-1
R5CB	B-2
R5ED	B-1
R5FA	C-1
R5FB	C-1
R5FC	C-1
R5FD	C-1
R5FF	C-1
R5FG	C-1
R5FH	C-1
R5FJ	B-1
R5FK	B-1
R5FL	B-1
R5FM	B-1
R5FN	B-1
R5FZ	B-1
R5GA	A-1
R5GB	A-1
R5GC	A-1
R5GE	A-2
R5JG	B-1
R5JH	A-2
R5JK	B-1
R5JL	A-2
R5JM	A-2
R5JN	B-3
R5JP	B-2
R5JQ	A-2
R5JT	A-1
R5KE	C-3
R5LN	C-2
R5MA	C-3
R5MB	C-3
R5MJ	C-2
R5MK	C-2
R5RA	B-2
R5ZA	B-3
R5ZB	B-2

LS	C-2		
LT	C-2		
LU	C-2		
LV	C-2		
LW	C-2		
LX	C-2		
LY	C-2		
LZ	C-1		
US	B-2		
ZC	A-1		

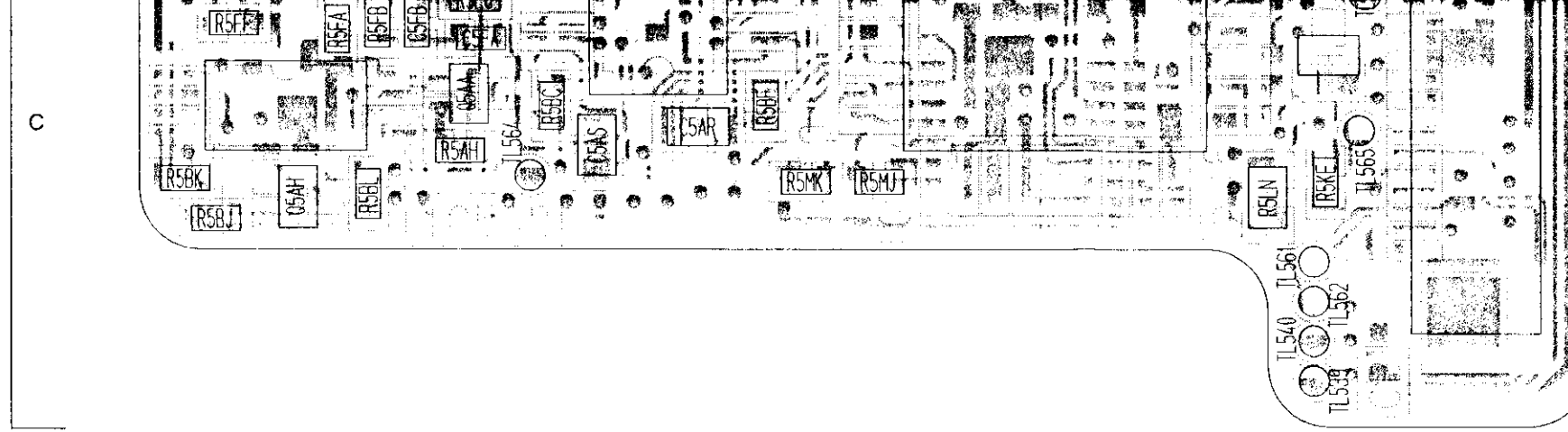

Q5FC	C-1	R5NA	B-2
Q5FD	B-1	R5ZA	B-3
Q5GA	A-1	R5ZB	B-2
Q5LB	C-3		
R4FE	C-1		
R5AA	A-2		
R5AB	A-2		
R5AD	A-2		
R5AH	C-1		
R5AP	B-2		

(SIDE)

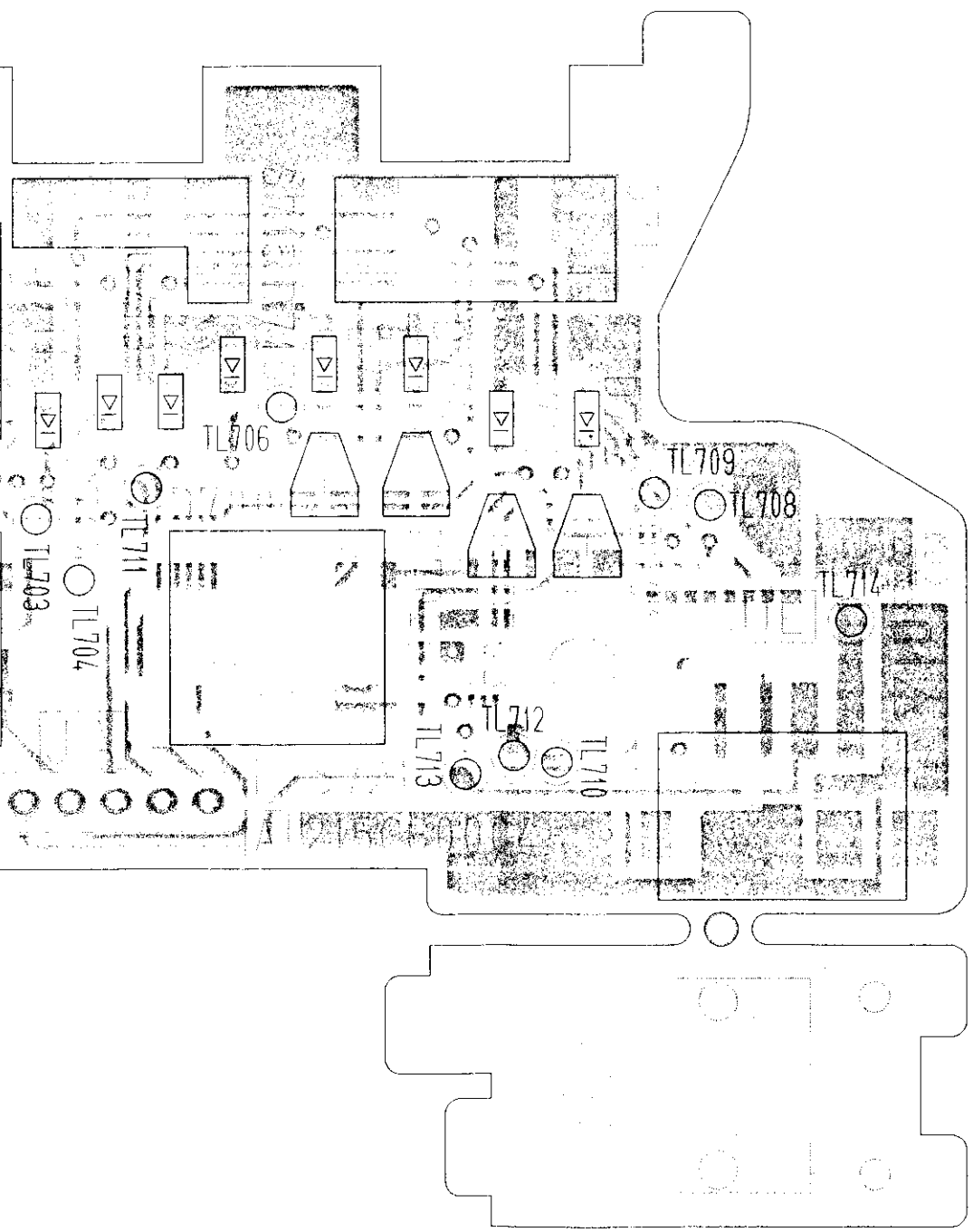

PCB-POWER SW(A SIDE)

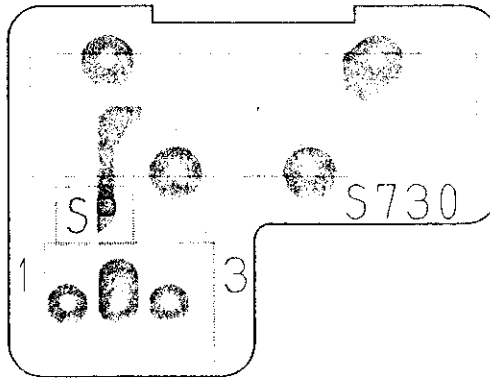

PCB-POWER SW(B SIDE)

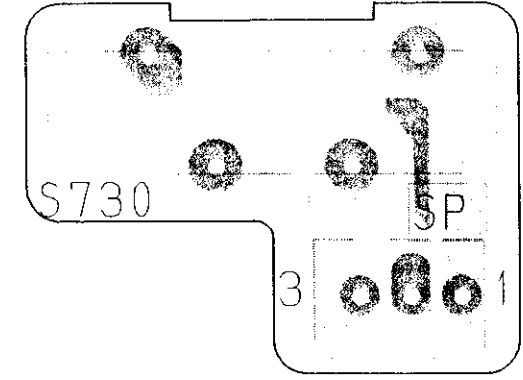

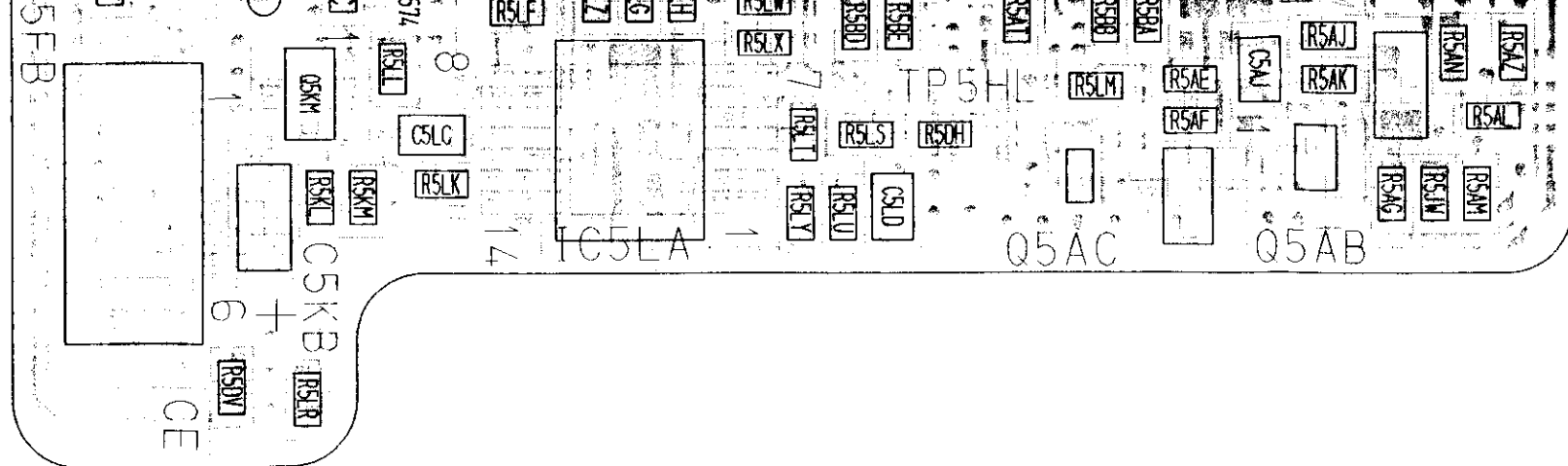

Q5FK	B-3	R5LS	C-2
Q5FL	A-3	R5LT	C-2
Q5KM	C-1	R5LU	C-2
Q5LC	B-2	R5LV	C-2
		R5LW	C-2
R4AA	A-2	R5LX	C-2
R4BF	B-2	R5LY	C-2
R4CP	B-3	R5LZ	C-1
R4JH	B-3	R5US	B-2
R4JL	B-3	R5ZC	A-1
R4JN	B-3		

PCB-VTR SW(A SIDE)

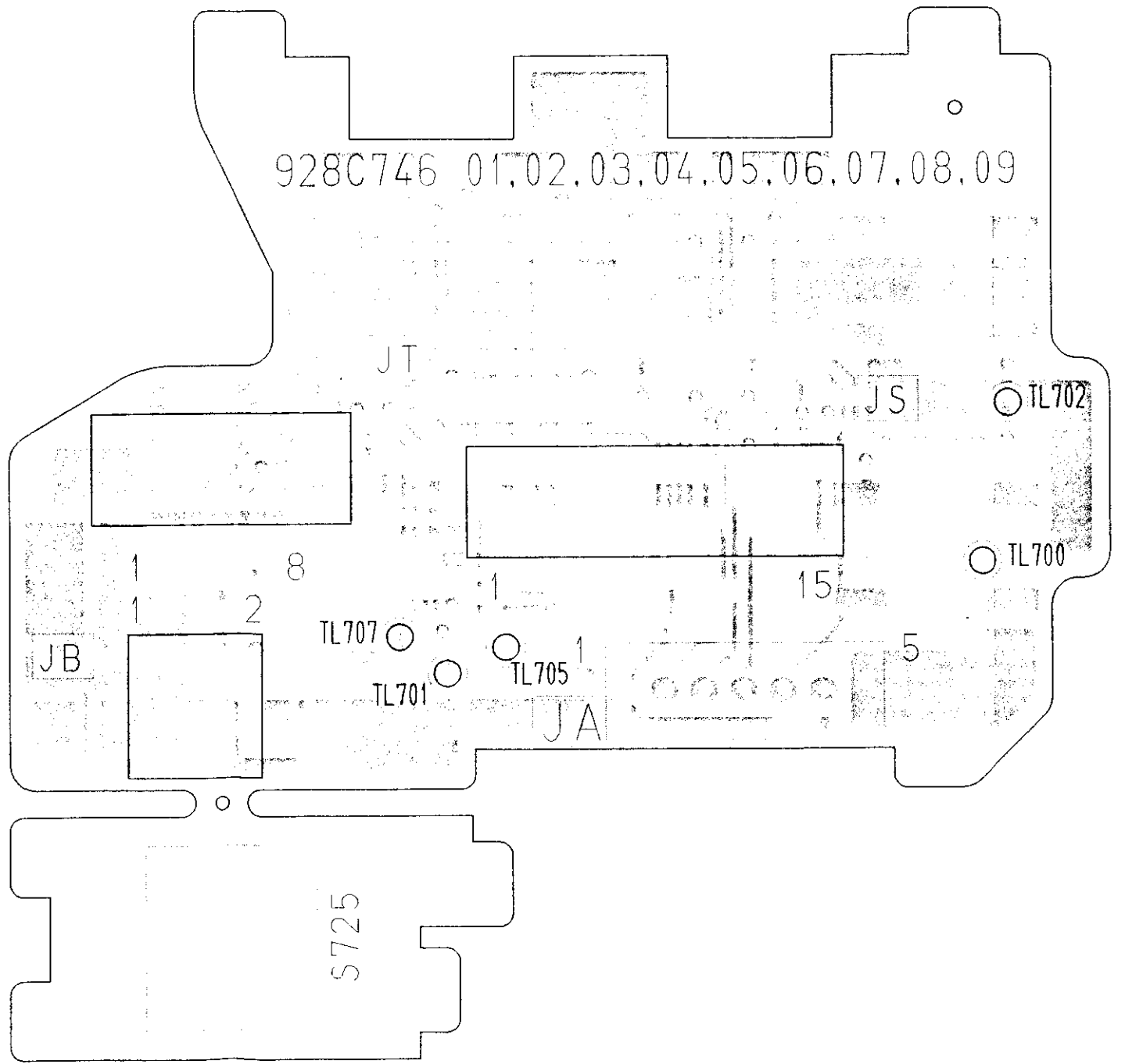

PCB-VTR SW(B SIDE)

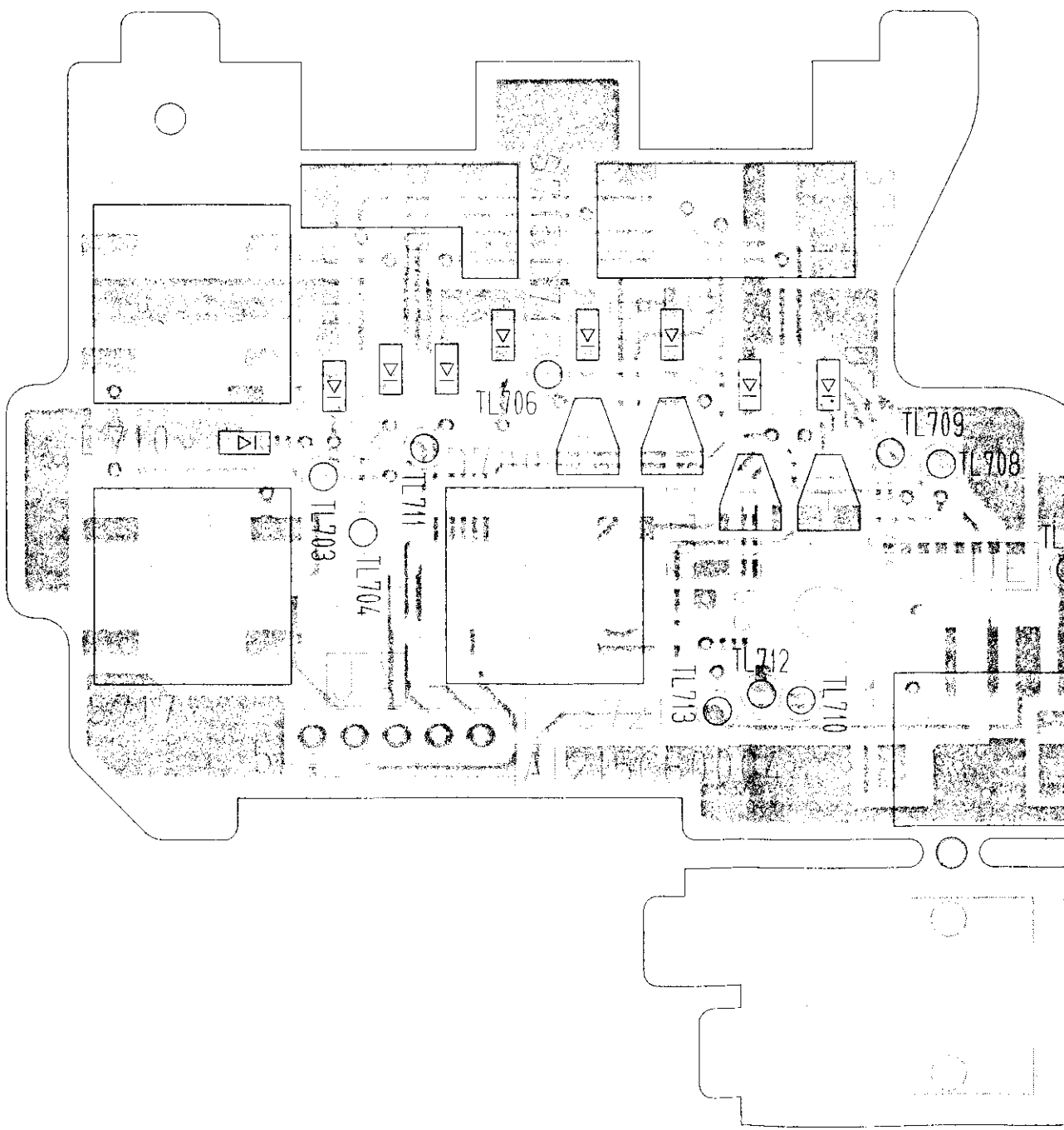

67

PCB-VTR(B SIDE)

1

2

3

4

5

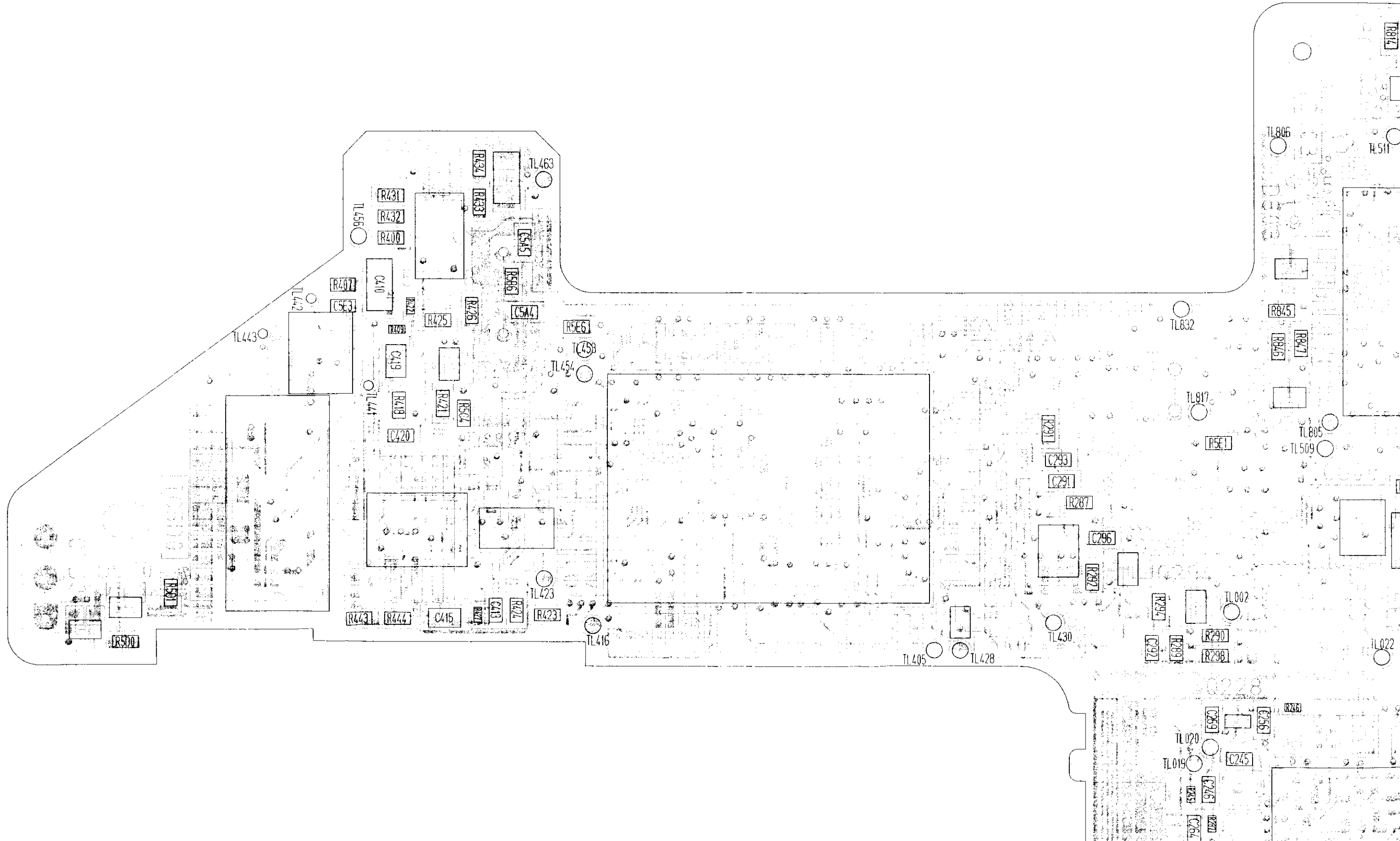

PCB - VTR (B SIDE)

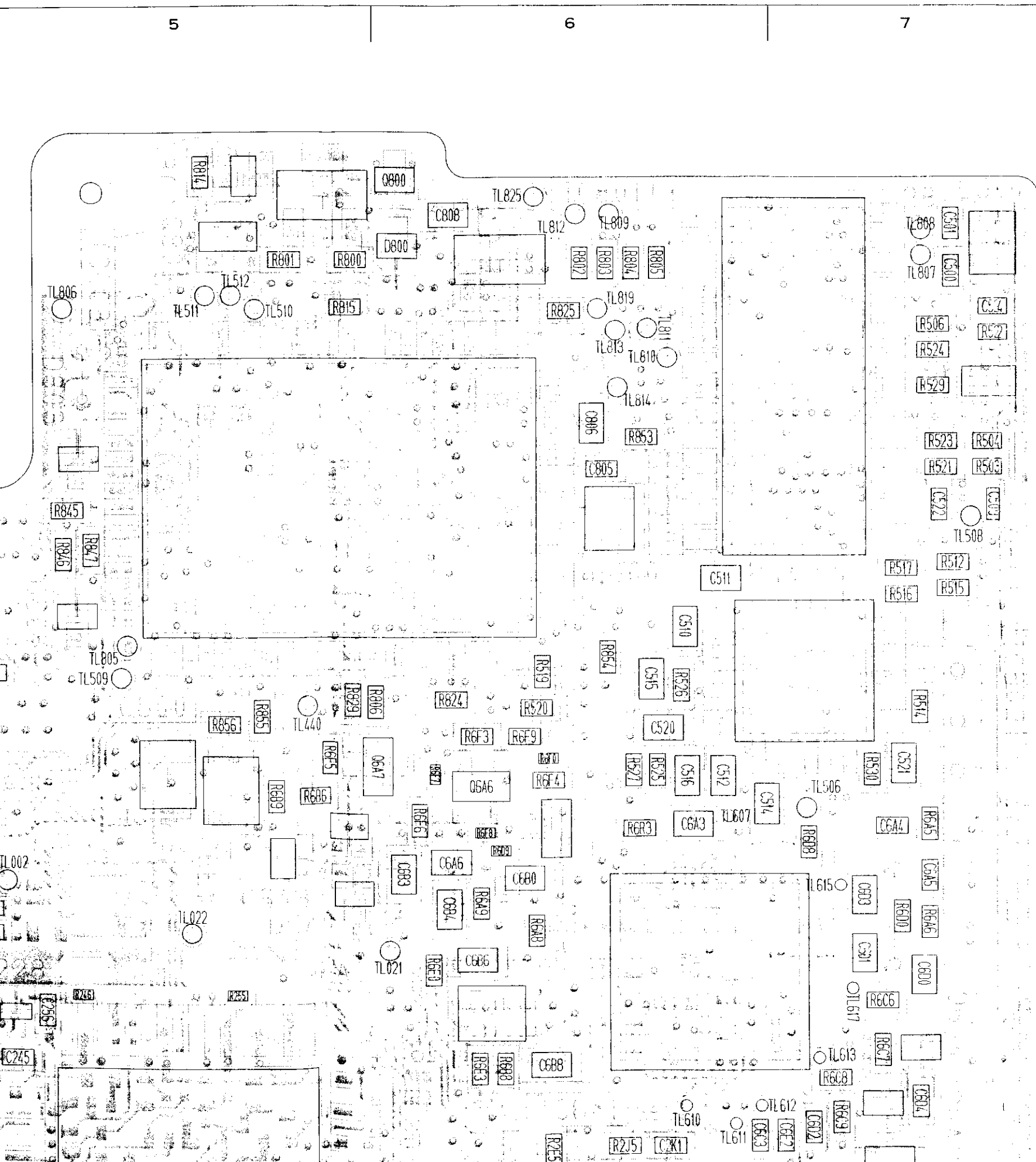

SYMBOL NO.	ADDRESS
C200	D-5
C201	D-5
C202	D-5
C203	D-5
C205	E-5
C206	D-5
C207	D-5
C208	D-4
C209	D-4
C210	D-4
C213	D-6
C214	D-5
C216	D-5
C217	D-5
C219	D-5
C223	D-5
C231	D-5
C232	D-5
C234	D-4
C239	C-4
C240	D-4
C245	C-5
C246	C-5
C256	C-5
C259	C-5
C264	C-4
C266	D-4
C268	D-5
C291	B-4
C292	C-4
C293	B-4
C296	B-4
C297	D-4
C2A0	D-7
C2A0	D-6
C2A5	E-6
C2A6	E-6
C2B1	E-6
C2B2	E-6
C2B3	E-6
C2B4	E-6
C2C6	E-6
C2C8	E-6
C2D0	E-6
C2D1	E-6
C2D2	E-5
C2D3	E-5
C2D4	E-5
C2D5	E-5
C2F0	E-5
C2F1	E-5
C2F2	E-5
C2F3	E-5
C2F4	E-5
C2F9	E-5
C2H1	E-5
C2H2	E-5
C2H4	D-5
C2J0	D-6
C2J1	D-6

SYMBOL NO.	ADDRESS
C2J5	D-7
C2J6	D-7
C2J7	D-7
C2J8	D-7
C2J9	D-6
C2K0	D-7
C2K1	C-6
C2P0	E-6
C2P1	E-6
C2P2	E-6
C2P3	E-6
C2P7	C-7
C2P8	E-6
C2R0	D-7
C2R1	D-7
C2R2	E-7
C300	E-2
C302	E-2
C303	E-2
C304	E-2
C305	E-2
C306	E-2
C307	E-2
C308	E-2
C309	E-2
C325	E-2
C355	E-3
C356	E-3
C357	E-3
C358	E-3
C359	E-2
C3A1	E-4
C3A3	E-4
C3A7	E-3
C3A8	E-3
C3A9	E-3
C3B0	E-3
C3B3	E-3
C3B5	E-3
C3C1	E-4
C3C3	E-3
C3C7	E-4
C3C8	E-3
C3C9	E-3
C3D1	E-4
C3D2	E-4
C3D3	E-4
C3D4	E-4
C3D5	E-4
C3D6	E-4
C3D7	E-4
C3D8	E-4
C3D9	E-4
C410	B-2
C413	C-2
C415	C-2
C418	A-2
C419	B-2
C420	B-2

SYMBOL NO.	ADDRESS
R2A7	D-5
R2A8	D-6
R2A9	D-6
R2B1	E-6
R2B2	E-6

SYMBOL NO.	ADDRESS
R2P6	E-6
R2P8	E-6
R2R0	D-7
R2R1	D-7
R300	F-2



C2F3	E-5	C3D8	E-4
C2F4	E-5	C3D9	E-4
C2F9	E-5	C410	B-2
C2H1	E-5	C413	C-2
C2H2	E-5	C415	C-2
C2H4	D-5	C418	A-2
C2J0	D-6	C419	B-2
C2J1	D-6	C420	B-2

SYMBOL NO.	ADDRESS
R2A7	D-5
R2A8	D-6
R2A9	D-6
R2B1	E-6
R2B2	E-6
R2B7	D-6
R2C0	D-6
R2C1	E-6
R2C4	D-6
R2C5	D-7
R2C6	D-7
R2D0	E-5
R2D1	E-5
R2D2	E-5
R2D3	E-6
R2D4	E-5
R2D5	E-5
R2D6	E-5
R2D8	E-6
R2E3	E-5
R2E4	D-5
R2E5	C-6
R2E7	E-5
R2E8	E-6
R2E9	E-6
R2F0	E-5
R2F1	E-5
R2F2	E-5
R2F3	E-5
R2F4	E-5
R2F5	E-5
R2F6	E-5
R2F7	E-5
R2F8	E-5
R2F9	E-5
R2G0	E-5
R2G4	E-6
R2G5	E-6
R2G6	D-6
R2G7	E-6
R2H0	E-5
R2H1	E-5
R2H2	E-5
R2H3	E-5
R2H6	E-5
R2H7	D-5
R2H8	E-5
R2H9	D-5
R2J0	D-7
R2J1	C-6
R2J2	D-6
R2J3	D-7
R2J4	D-7
R2J5	C-6
R2L0	E-5
R2P0	E-6
R2P1	E-6
R2P2	E-6
R2P3	E-6
R2P5	E-6

SYMBOL NO.	ADDRESS
R2P6	E-6
R2P8	E-6
R2R0	D-7
R2R1	D-7
R300	E-2
R301	E-2
R302	E-2
R303	E-2
R304	E-2
R306	E-2
R307	E-2
R309	E-2
R310	E-2
R312	E-2
R313	E-2
R316	E-2
R317	E-2
R320	E-2
R321	E-2
R322	E-2
R323	E-2
R324	E-2
R350	E-3
R351	E-3
R353	E-3
R354	E-3
R355	E-3
R356	E-3
R357	E-3
R358	E-3
R359	E-2
R360	E-3
R361	E-3
R362	E-3
R363	E-3
R364	E-2
R365	E-2
R366	E-3
R367	E-3
R368	E-3
R3A0	E-4
R3A1	E-4
R3A2	E-4
R3A3	E-3
R3A4	E-3
R3A5	E-3
R3A6	D-7
R3B0	E-3
R3C1	E-3
R3C3	E-3
R3C4	E-3
R3C5	E-3
R3D1	E-4
R3D2	E-4
R3D3	E-4
R3D4	E-4
R3D5	E-4
R3D6	E-4
R400	A-2
R407	B-2

C

D

E

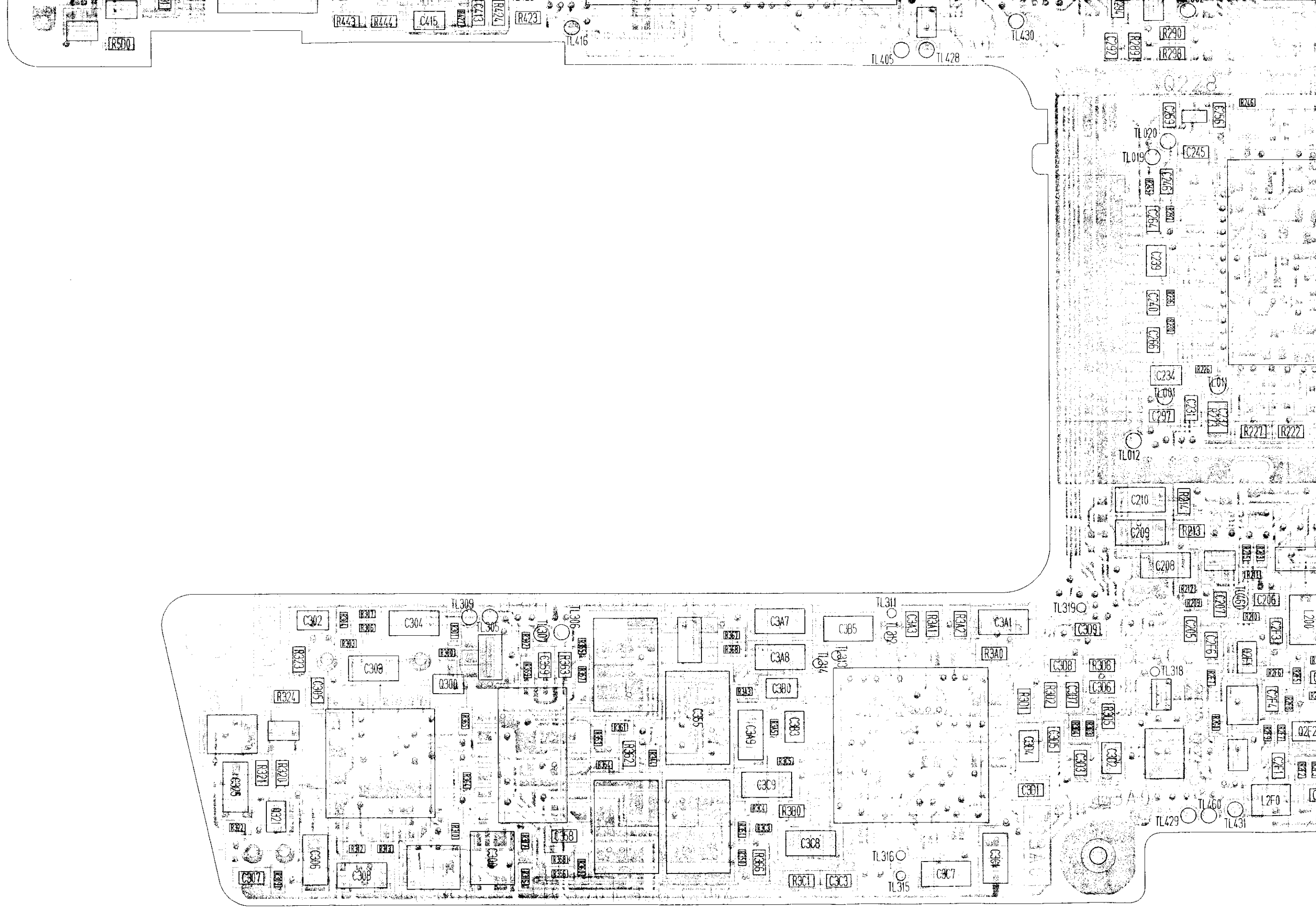

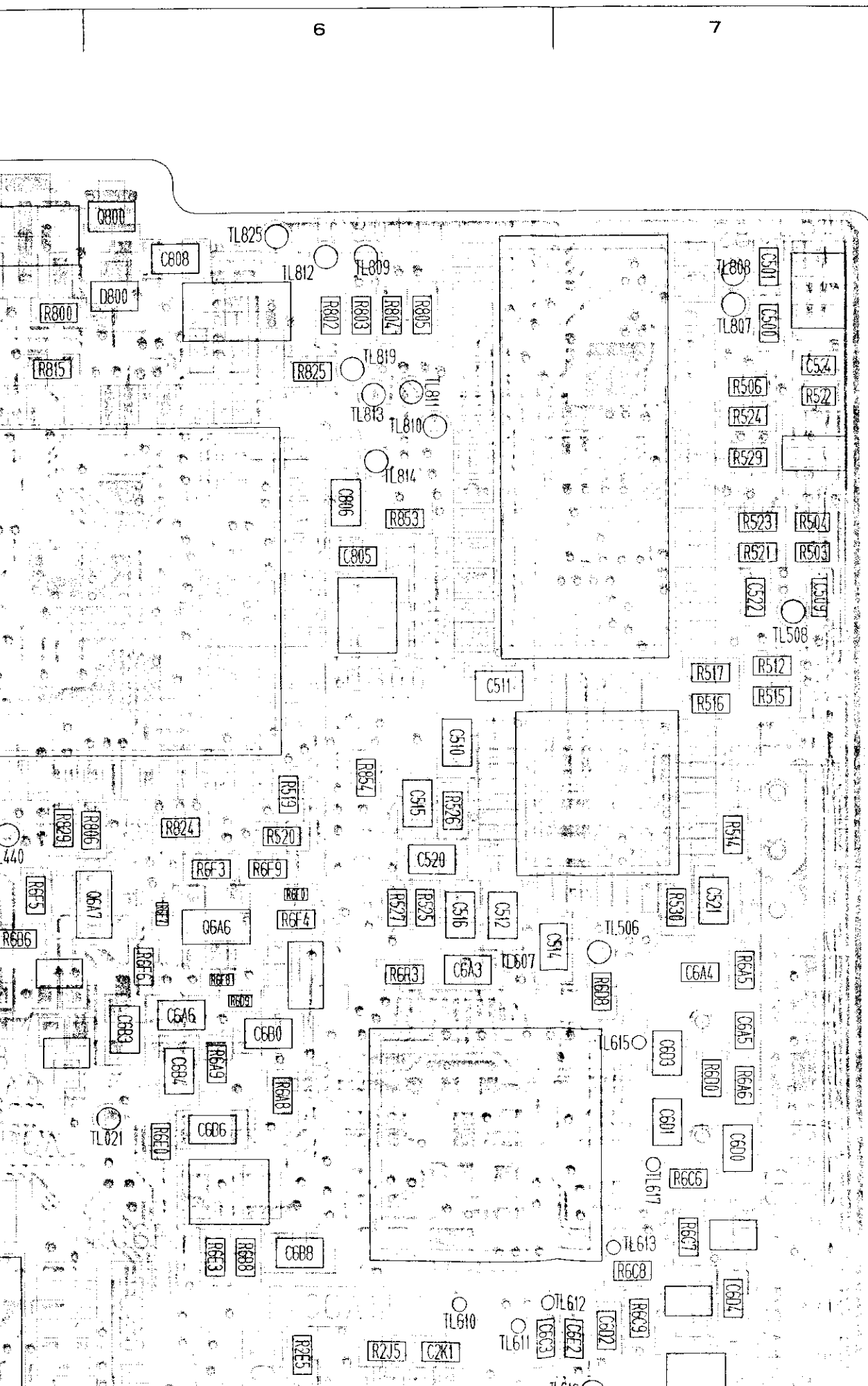

PCB - VTR (B SIDE)

SYMBOL NO.	ADDRESS	SYMBOL NO.	ADDRESS	SYMBOL NO.	ADDRESS	SYMBOL NO.	ADDRESS	SYMBOL NO.	ADDRESS
C200	D-5	C2J5	D-7	C500	A-7			Q2H0	E-5
C201	D-5	C2J6	D-7	C501	A-7	FL400	B-2	Q2H2	E-5
C202	D-5	C2J7	D-7	C509	B-7			Q2H3	E-5
C203	D-5	C2J8	D-7	C510	B-6	IC201	C-6	Q2H4	E-5
C205	E-5	C2J9	D-6	C511	B-6	IC2A1	D-6	Q2P0	E-6
C206	D-5	C2K0	D-7	C512	B-6	IC2J1	C-6	Q300	E-2
C207	D-5	C2K1	C-6	C514	B-6	IC2P1	E-7	Q301	E-2
C208	D-4	C2P0	E-6	C515	B-6	IC2R1	D-7	Q320	E-1
C209	D-4	C2P1	E-6	C516	B-6	IC300	E-2	Q321	E-2
C210	D-4	C2P2	E-6	C520	B-6	IC350	E-2	Q350	E-3
C213	D-6	C2P3	E-6	C521	B-7	IC3A0	E-4	Q3A0	D-7
C214	D-5	C2P7	C-7	C522	B-7	IC401	B-2	Q407	B-2
C216	D-5	C2P8	E-6	C524	A-7	IC402	A-2	Q501	B-7
C217	D-5	C2R0	D-7	C5A4	B-2	IC500	B-6	Q500	B-1
C219	D-5	C2R1	D-7	C5A5	A-2	IC502	B-7	Q6A1	C-6
C223	D-5	C2R2	E-7	C5E3	B-2	IC5A0	B-4	Q6A3	C-5
C231	D-5	C300	E-2	C6A3	B-6	IC5A1	B-2	Q6A4	C-7
C232	D-5	C302	E-2	C6A4	B-7	IC5D0	B-1	Q6A6	B-6
C234	D-4	C303	E-2	C6A5	C-7	IC6A1	C-6	Q6A7	B-6
C239	C-4	C304	E-2	C6A6	C-6	IC800	B-5	Q800	A-6
C240	D-4	C305	E-2	C6B0	C-6	IC801	A-6	Q801	A-5
C245	C-5	C306	E-2	C6B3	C-6	IC803	A-5	Q802	A-5
C246	C-5	C307	E-2	C6B4	C-6				
C256	C-5	C308	E-2	C6B5	C-6	L200	E-5	R200	D-5
C259	C-5	C309	E-2	C6B6	C-6	L201	D-5	R202	D-5
C264	C-4	C325	E-2	C6B7	C-6	L292	B-4	R203	D-5
C266	D-4	C355	E-3	C6B8	C-6	L2A2	E-6	R205	D-5
C268	D-5	C356	E-3	C6C0	B-5	L2A4	E-6	R209	D-5
C291	B-4	C356	E-3	C6C8	C-7	L2D1	E-5	R210	E-5
C292	C-4	C357	E-3	C6D0	C-7	L2D2	E-5	R211	D-5
C293	B-4	C358	E-3	C6D1	C-7	L2F0	E-5	R212	D-5
C296	B-4	C359	E-2	C6D2	C-7	L2F1	E-5	R213	D-5
C297	D-4	C3A1	E-4	C6D3	C-7	L2F2	E-5	R214	D-5
C2A0	D-7	C3A3	E-4	C6D4	C-7	L2H2	E-5	R216	D-5
C2A0	D-6	C3A7	E-3	C6E1	C-5	L2P1	E-6	R222	D-5
C2A5	E-6	C3A8	E-3	C6E2	C-7	L321	E-1	R226	D-5
C2A6	E-6	C3A9	E-3	C6E4	B-6	L3A0	E-4	R227	D-5
C2B1	E-6	C3B0	E-3	C803	A-5	L500	A-7	R236	C-5
C2B2	E-6	C3B3	E-3	C805	B-6	L6A1	C-7	R237	C-5
C2B3	E-6	C3B5	E-3	C806	A-6	L6A5	B-6	R237	D-5
C2B4	E-6	C3C1	E-4	C808	A-6	L800	B-6	R245	C-4
C2C6	E-6	C3C3	E-3					R246	C-5
C2C8	E-6	C3C7	E-4	D2A0	D-6	Q201	D-5	R255	C-5
C2D0	E-6	C3C8	E-3	D2A2	D-6	Q205	D-5	R260	D-6
C2D1	E-6	C3C9	E-3	D2A3	E-6	Q221	D-6	R261	D-5
C2D2	E-5	C3D1	E-4	D2A4	E-6	Q228	C-5	R263	D-5
C2D3	E-5	C3D2	E-4	D2A5	D-6	Q291	B-4	R265	D-5
C2D4	E-5	C3D3	E-4	D2J0	D-7	Q294	B-4	R267	D-5
C2D5	E-5	C3D4	E-4	D2P0	E-6	Q2A1	D-5	R280	D-5
C2F0	E-5	C305	E-4	D3A0	E-4	Q2A3	E-6	R287	B-4
C2F1	E-5	C3D6	E-4	D5A0	C-4	Q2A4	E-6	R289	C-4
C2F2	E-5	C3D7	E-4	D5D0	B-1	Q2A7	E-6	R290	C-5
C2F3	E-5	C3D8	E-4	D6A0	C-5	Q2A9	D-6	R291	B-4
C2F4	E-5	C3D9	E-4	D6A1	C-7	Q2D0	E-5	R292	B-4
C2F9	E-5	C410	B-2	D6A2	C-5	Q2D1	E-5	R294	C-4
C2H1	E-5	C413	C-2	D800	A-6	Q2D2	E-5	R298	C-5
C2H2	E-5	C415	C-2	D803	A-5	Q2F0	E-5	R299	C-5
C2H4	D-5	C418	A-2	D805	B-5	Q2F1	E-5	R2A3	D-6
C2J0	D-6	C419	B-2			Q2F2	E-5	R2A5	E-6
C2J1	D-6	C420	B-2	DL6A1	D-7	Q2F3	E-5	R2A6	D-6

SYMBOL NO.	ADDRESS
R2A7	D-5
R2A8	D-6
R2A9	D-6
R2B1	E-6
R2B2	E-6

SYMBOL NO.	ADDRESS
R2P6	E-6
R2P8	E-6
R2R0	D-7
R2R1	D-7
R300	E-2

SYMBOL NO.	ADDRESS
R409	B-2
R418	B-2
R421	B-2
R422	B-2
R423	C-2

SYMBOL NO.	ADDRESS
R6F4	B-6
R6F5	B-5
R6F6	B-6
R6F7	B-6
R6F8	B-6

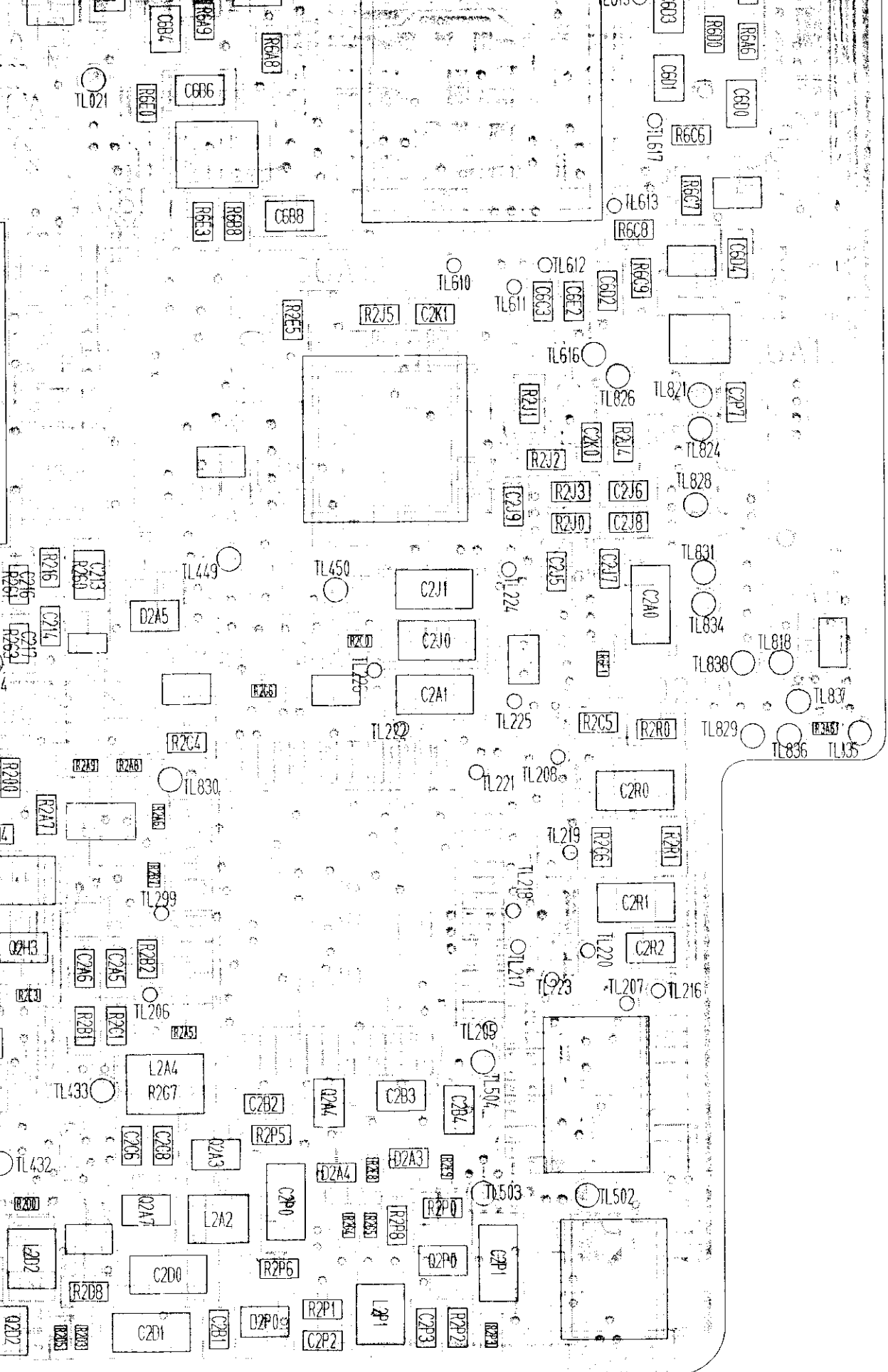

C2F4	E-5
C2F9	E-5
C2H1	E-5
C2H2	E-5
C2H4	D-5
C2J0	D-6
C2J1	D-6

C3D9	E-4
C410	B-2
C413	C-2
C415	C-2
C418	A-2
C419	B-2
C420	B-2

D6A1	C-7
D6A2	C-5
D800	A-6
D803	A-5
D805	B-5
DL6A1	D-7

Q2D0	E-5
Q2D1	E-5
Q2D2	E-5
Q2F0	E-5
Q2F1	E-5
Q2F2	E-5
Q2F3	E-5

R292	B-4
R294	C-4
R298	C-5
R299	C-5
R2A3	D-6
R2A5	E-6
R2A6	D-6

SYMBOL NO.	ADDRESS
R2A7	D-5
R2A8	D-6
R2A9	D-6
R2B1	E-6
R2B2	E-6
R2B7	D-6
R2C0	D-6
R2C1	E-6
R2C4	D-6
R2C5	D-7
R2C6	D-7
R2D0	E-5
R2D1	E-5
R2D2	E-5
R2D3	E-6
R2D4	E-5
R2D5	E-5
R2D6	E-5
R2D8	E-6
R2E3	E-5
R2E4	D-5
R2E5	C-6
R2E7	E-5
R2E8	E-6
R2E9	E-6
R2F0	E-5
R2F1	E-5
R2F2	E-5
R2F3	E-5
R2F4	E-5
R2F5	E-5
R2F6	E-5
R2F7	E-5
R2F8	E-5
R2F9	E-5
R2G0	E-5
R2G4	E-6
R2G5	E-6
R2G6	D-6
R2G7	E-6
R2H0	E-5
R2H1	E-5
R2H2	E-5
R2H3	E-5
R2H6	E-5
R2H7	D-5
R2H8	E-5
R2H9	D-5
R2J0	D-7
R2J1	C-6
R2J2	D-6
R2J3	D-7
R2J4	D-7
R2J5	C-6
R2L0	E-5
R2P0	E-6
R2P1	E-6
R2P2	E-6
R2P3	E-6
R2P5	E-6

SYMBOL NO.	ADDRESS
R2P6	E-6
R2P8	E-6
R2R0	D-7
R2R1	D-7
R300	E-2
R301	E-2
R302	E-2
R303	E-2
R304	E-2
R306	E-2
R307	E-2
R309	E-2
R310	E-2
R312	E-2
R313	E-2
R316	E-2
R317	E-2
R320	E-2
R321	E-2
R322	E-2
R323	E-2
R324	E-2
R350	E-3
R351	E-3
R353	E-3
R354	E-3
R355	E-3
R356	E-3
R357	E-3
R358	E-3
R359	E-2
R360	E-3
R361	E-3
R362	E-3
R363	E-3
R364	E-2
R365	E-2
R366	E-3
R367	E-3
R368	E-3
R3A0	E-4
R3A1	E-4
R3A2	E-4
R3A3	E-3
R3A4	E-3
R3A5	E-3
R3A6	D-7
R3B0	E-3
R3C1	E-3
R3C3	E-3
R3C4	E-3
R3C5	E-3
R3D1	E-4
R3D2	E-4
R3D3	E-4
R3D4	E-4
R3D5	E-4
R3D6	E-4
R400	A-2
R407	B-2

SYMBOL NO.	ADDRESS
R409	B-2
R418	B-2
R421	B-2
R422	B-2
R423	C-2
R424	C-2
R425	B-2
R426	B-2
R427	C-2
R431	A-2
R432	A-2
R433	A-2
R434	A-2
R443	C-2
R444	C-2
R500	C-1
R501	C-1
R503	B-7
R504	A-7
R506	A-7
R510	B-7
R512	B-7
R514	B-7
R515	B-7
R516	B-7
R517	B-7
R519	B-6
R520	B-6
R521	B-7
R522	A-7
R523	A-7
R524	A-7
R525	B-6
R526	B-6
R527	B-6
R529	A-7
R5B6	B-2
R5C4	B-2
R5E1	B-5
R608	B-7
R6A5	B-7
R6A6	C-7
R6A8	C-6
R6A9	C-6
R6B6	B-5
R6B8	C-6
R6B9	B-5
R6C6	C-7
R6C7	C-7
R6C8	C-7
R6C9	C-7
R6D0	C-7
R6D1	B-5
R6D9	B-6
R6E0	C-6
R6E3	C-6
R6F0	B-6
R6F1	D-7
R6F3	B-6

SYMBOL NO.	ADDRESS
R6F4	B-6
R6F5	B-5
R6F6	B-6
R6F7	B-6
R6F8	B-6
R6F9	B-6
R6R3	B-6
R800	A-5
R801	A-5
R802	A-6
R803	A-6
R804	A-6
R805	A-6
R806	B-6
R814	A-5
R815	A-5
R824	B-6
R825	A-6
R829	B-5
R845	B-5
R846	B-5
R847	B-5
R853	A-6
R854	B-6
R855	B-5
R856	B-5
TL456	A-2
TL463	A-2
TL806	A-5