

MODEL
HS-7496E
HS-7496E(B)

Only cassettes marked VHS can be used with this video cassette recorder.

SPECIFICATIONS

Tape Format	: VHS 1/2" width high-density video cassette tape	Audio Output	: -6dBs, 1k Ω unbalanced RCA plug																							
Power Source	: 100~230V \pm 10% AC ; 50Hz	Operating Temperature	: 41°F to 104°F																							
Power Consumption	: Approx. 20W	Relative Humidity	: MAX. 80%																							
Television System	: 625lines, 50fields PAL type colour system	Weight	: Approx. 4.5kg																							
Video Recording System	: 2 rotary heads, azimuth helical scanning system	Dimensions	: 425 (W) \times 93 (H) \times 315 (D) mm																							
Luminance Signal	: Frequency modulation recording	Display Position	: In any position																							
Colour Signal	: Low frequency conversion, sub-carrier phase shift recording	Timer Programme	: 8 programmes-Daily start and stop time for one week																							
Audio Recording System	: 1 full track head, recording system	Display Format	: Display mode 1: (Day)-(Month)-(Year) (Hour) (Minute) : (Second) (Alarm recording no.)																							
Erase	: 1 full track head		: Display mode 2: (Day)-(Month)-(Year) (Hour) (Day of week) (Alarm recording no.), (Hour) : (Minute) : (Second) (Recording mode)																							
Linear Audio Track	: 1 track	Battery Back Up	: Lasts 31 days																							
Fast Forward / Rewind Time	: Approx. 140sec. with E-180 cassette	Deck	: U Deck																							
Alarm Recording Time	: Timed: 15sec./ 30sec./ 45sec./ 1min./ 2min./ 5min./ 10min. Manual 1: Until the alarm reset switch is switched on. Manual 2: Until the alarm set switch is switched off.	Tape Speed and Recording Time (with E-180 cassette)																								
Video Input	: 1.0Vp-p, 75 Ω unbalanced BNC plug	<table border="1"> <thead> <tr> <th>Mode</th> <th>Time</th> <th>Speed (Drive)</th> <th>Recording interval</th> </tr> </thead> <tbody> <tr> <td>3H</td> <td>3hrs</td> <td>23.39mm/sec (Continuous)</td> <td>every field</td> </tr> <tr> <td>6H</td> <td>6hrs</td> <td>11.70mm/sec (Continuous)</td> <td>every field</td> </tr> <tr> <td>L18H</td> <td>18hrs</td> <td>3.90mm/sec (Continuous)</td> <td>3 fields</td> </tr> <tr> <td>72H</td> <td>78hrs</td> <td>0.260sec/field (Intermittent)</td> <td>13 fields</td> </tr> <tr> <td>96H</td> <td>102hrs</td> <td>0.340sec/field (Intermittent)</td> <td>17 fields</td> </tr> </tbody> </table>	Mode	Time	Speed (Drive)	Recording interval	3H	3hrs	23.39mm/sec (Continuous)	every field	6H	6hrs	11.70mm/sec (Continuous)	every field	L18H	18hrs	3.90mm/sec (Continuous)	3 fields	72H	78hrs	0.260sec/field (Intermittent)	13 fields	96H	102hrs	0.340sec/field (Intermittent)	17 fields
Mode	Time	Speed (Drive)	Recording interval																							
3H	3hrs	23.39mm/sec (Continuous)	every field																							
6H	6hrs	11.70mm/sec (Continuous)	every field																							
L18H	18hrs	3.90mm/sec (Continuous)	3 fields																							
72H	78hrs	0.260sec/field (Intermittent)	13 fields																							
96H	102hrs	0.340sec/field (Intermittent)	17 fields																							
Audio Input	: -8dBs, 50k Ω unbalanced RCA plug																									
Video Output	: 1.0Vp-p, 75 Ω unbalanced BNC plug																									

- Weight and dimensions shown are approximate.
- Design and specifications are subject to change without notice.

CONTENTS

CONNECTING WITH OTHER EQUIPMENT	1
CHECK PROCEDURE OF ELAPSED TIME	2
WARNING INDICATION	2
CONTROL INPUT/OUTPUT SIGNAL	4
CONTROL INPUT/OUTPUT SIGNALS AND CIRCUITS	5
MAINTENANCE GUIDE	7
DISASSEMBLY	8
HOW TO EXECUTE CIRCUIT BOARD SERVICE	11
DECK OPERATION CHECK	15
MECHANICAL ADJUSTMENTS TOOLS	16
ELECTRICAL ADJUSTMENTS TOOLS	17
ELECTRICAL ADJUSTMENTS	18
LOCATIONS	19
Servo Circuit Adjustments	20
Y/C signal Circuit Adjustments	20
Audio Circuit Adjustments	24
Timer Circuit Adjustments	25
MECHANICAL ADJUSTMENT AND REPLACEMENT	26
1. Cleaning the DECK	26
1-1 VIDEO HEAD	26
1-2 Tape Transport	26
1-3 REEL DISK Drive System	26
2. Replacement of Major Parts	27
2-1 GUIDE ARM (SP), CLEANING ARM, CLEANING ROLLER UNIT	27
2-2 STAY PLATE	27
2-3 BOTTOM UNIT	28
2-4 A/C HEAD UNIT	30
2-5 FE HEAD	30
2-6 SHUT LEVER UNIT	31
2-7 LAMP GUIDE, MODE POSITION GUIDE	32
2-8 TENSION SPRING, TENSION ARM, TENSION BELT UNIT	33
2-9 BRAKE SPRING (for MAIN BRAKE (SP)), MAIN BRAKE (SP), BRAKE SPRING (for MAIN BRAKE (TU)), MAIN BRAKE (TU)	35
2-10 REEL DISK (On SP side), REEL DISK (On TU side)	35
2-11 LOADING BELT, LOADING MOTOR ASSY	37
2-12 PINCH ARM CAP 2, PINCH ARM UNIT, PINCH GEAR ARM 2, PINCH CAM HOLDER, PINCH CAM SPRING, PINCH CAM LEVER, PINCH RACK SLIDER, PINCH CAM GEAR	38
2-13 GUIDE ARM ASSY (TU), GUIDE SPRING (TU), LOADING TG LEVER	41
2-14 REC SPRING, REC LEVER	43
2-15 REEL BELT, BELT PULLEY, SHIFT SPRING	44
2-16 CAPSTAN BRAKE SPRING, CAPSTAN BRAKE	45
2-17 MODE HOLDER, REEL LOCK LEVER, MODE GEAR, F/L DRIVE GEAR, F/L DRIVE LEVER, WORM PULLEY UNIT, LOADING WORM GEAR	45
2-18 CONTROL WIND LEVER, TENSION LEVER UNIT	49
2-19 PHOTO GUIDE UNIT (SP), PHOTO GUIDE UNIT (TU)	51
2-20 PLATE LD, LOADING GEAR, LAMP LOADING GEAR	52
2-21 CAM GEAR (TU)	52
2-22 PHOTO UNIT, REEL GEAR UNIT (TU), REEL GEAR UNIT (SP), LAMP LOADING GEAR	53
2-23 IDLER CENTER LEVER	55
2-24 PULLEY GEAR, IDLER UNIT	56
2-25 F/L ARM UNIT (SP)	56
2-26 F/L ARM UNIT (TU)	57
2-27 SYNC GEAR ASSY	58
2-28 F/L DOOR ARM	59
2-29 WIND LEVER UNIT	59
2-30 LOADING LOCK SPRING, LOADING LOCK LEVER	60
2-31 CAPSTAN MOTOR	61
2-32 CAM GEAR (SP)	62
2-33 LOADING ARM UNIT (TU), LOADING ARM UNIT (SP)	63

CONTENTS

2-34	CAM SPRING (C), CAM PLATE UNIT (C)	64
2-35	TAPE GUIDE ASSY (SP), TAPE GUIDE ASSY (TU)	65
2-36	GUIDE ROLLER (SP), GUIDE ROLLER (TU).....	66
2-37	DRUM CLAMPER, DRUM ASSY	67
2-38	DRUM MOTOR STATOR, BRUSH SPRING, ROTOR CASE, END RING, BRUSH, UPPER DRUM ASSY, SPACER.....	68
2-39	SHIFT LEVER	69
3.	Interchangeability Adjustment of the Mechanism.....	70
3-1	Adjustment of BACK TENSION and TENSION PIN Position.....	70
3-2	Check and Adjustment of the FM Envelope	71
3-2-1	GUIDE ROLLER Adjustment.....	71
3-2-2	Adjustment of GUIDE ROLLER (SP) Height	71
3-2-3	Adjustment of GUIDE ROLLER (TU) Height	71
3-2-4	Coarse Adjustment of Phase	72
3-2-5	Check of FM Waveform Flatness	72
3-2-6	Tape Running Condition at the GUIDE ROLLERS (check 1)	73
3-2-7	Tape Running Condition at the GUIDE ROLLERS (check 2)	73
3-3	Adjustment of A/C HEAD.....	74
3-3-1	Adjustment of A/C HEAD Slant	74
3-3-2	Adjustment of A/C HEAD Azimuth and Height	74
3-4	Adjustment of Phase	75
3-5	Adjustment of GUIDE ARM ASSY (TU) Height.....	76
4.	Servicing for Tape Jamming during the Loading Process.....	77

GLOSSARY OF ABBREVIATIONS.....	78
CHIP PARTS REPLACEMENT	79
Parts List.....	80
1. CABINET ASSEMBLY	80
2. PACKING PARTS	82
3. ELECTRICAL PARTS.....	84
4. DECK ASSEMBLY	
SCHEMATIC DIAGRAM	
PRINTED CIRCUIT BOARD PARTS LAYOUT	

CONNECTING WITH OTHER EQUIPMENT

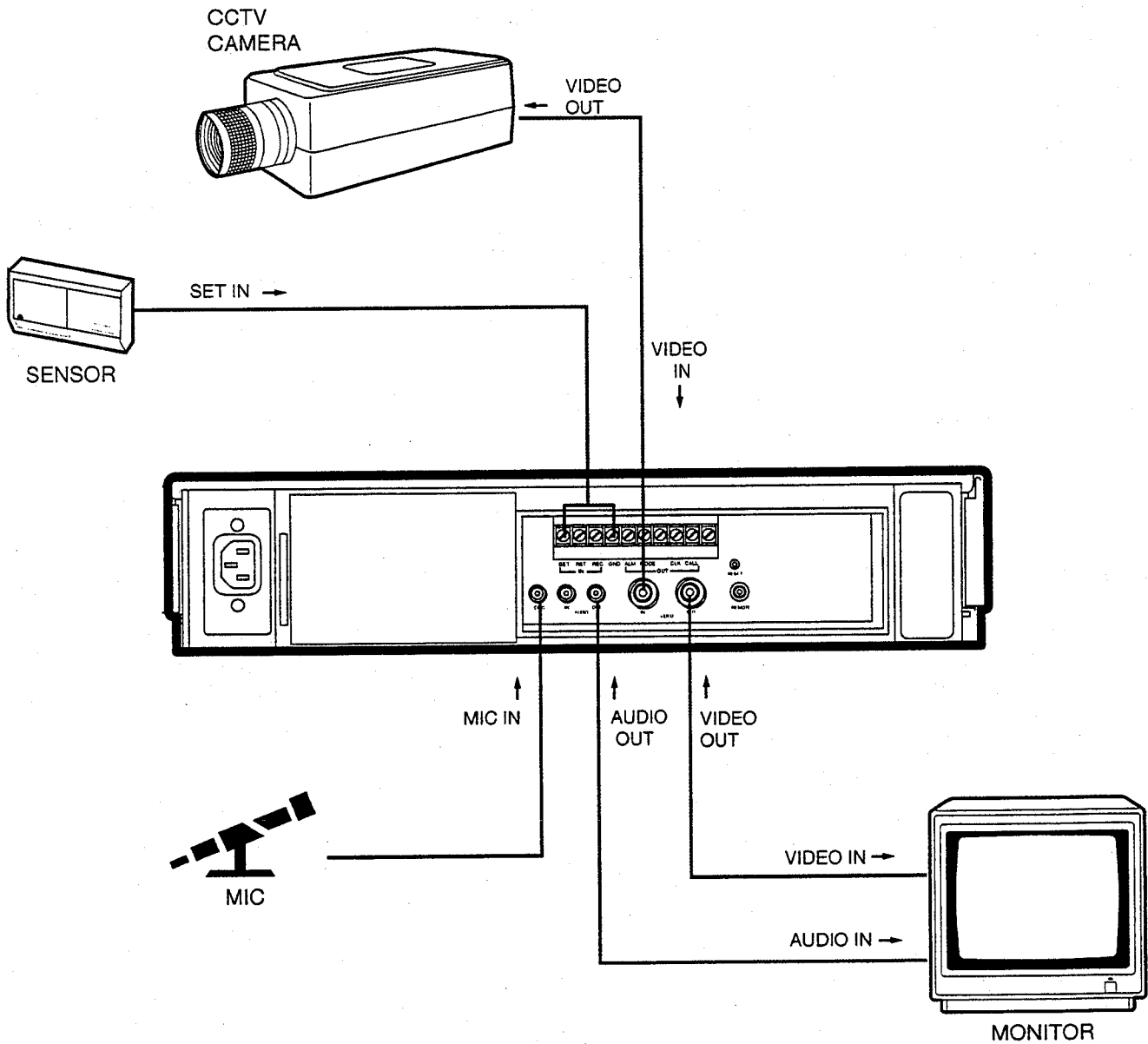

VERTICAL ADJUSTMENT (Correcting picture vibration at the top and bottom)

The picture vibration can be reduced or eliminated by the following steps.

- 1 If the vibration occurs in still, slow motion, fast playback (x2) or normal playback in 72H or 96H mode, playback a tape which is recorded in 3H or 6H mode with this VCR and press the PAUSE button.
If the vibration occurs during normal playback in L18H mode, playback a tape in each playback mode.
- 2 Press the VERTICAL ADJUST (+) or (-) button to reduce or eliminate the picture vibration.

MONITOR TO BE CONNECTED

- Connection with a CCTV monitor (for surveillance) is recommended.
- Connecting with some monitors may cause picture vibration and/or picture distortion at the top or bottom of the image during still or normal playback.
A domestic television monitor may be unable to provide a stable picture without vibration and distortion.

CHECK PROCEDURE OF ELAPSED TIME

<MAINTENANCE>	
POWER LOSS LIST	
ALARM LIST	
ALL MENU INITIALIZE	
POWER LOSS LIST CLEAR	
ALARM LIST CLEAR	
<REPEAT REC TIMES>	0
<ELAPSED TIME>	0H

1. Press the DISPLAY button to display the "MAIN MENU".
2. Turn the JOG to select the "MAINTENANCE".
3. Turn the SHUTTLE to right.
4. The "<ELAPSED TIME>" is displayed.
5. Press the DISPLAY button.

Note: The "<ELAPSED TIME>" counts up to 89,999 hours.

WARNING INDICATION

Self-Detection Function

This model has a function to detect internal malfunctions.

If any malfunction occurs inside the set, the state of malfunction is displayed on the fluorescent display or the monitor. Press the COUNTER-RESET button on the front panel for 10 seconds or more to indicate the latest malfunction. The number that indicates the type of the malfunction is displayed together with the warning indication "WRNG" on the fluorescent display.

Again press the COUNTER-RESET button for 10 seconds or over to cancel the indication.

No.	FLUORESCEN T DISPLAY	MONITOR	MALFUNCTION	STATE
				REMEDY
1	End	TAPE END	TAPE END DURING RECORDING	Tape stops at the tape end during recording. Rewind the tape or replace it by a new one.
3	---	NO SIGNAL	LOSS OF VIDEO SIGNAL INPUT	Leak of video signal continues for 5 secs or over during recording. Input the video signal or stop recording. *1
4	CLOG	---	Clogging	Clogging at the video head can not be removed. Remove the clogging or stop recording.
6	---	CHECK	LOADING MOTOR SYSTEM TROUBLE	Deck is on the wrong position during recording or when recording starts. Disassemble for repair.
7	---	CHECK	CAPSTAN MOTOR SYSTEM TROUBLE	Capstan motor does not rotate during recording. Disassemble for repair.
8	---	CHECK	DRUM MOTOR SYSTEM TROUBLE	Drum motor does not rotate during recording. Disassemble for repair.
5,9	---	CHECK	LOOSE TAPE	Tape is suffered from troubles such as looseness during recording. Disassemble for repair.
10	---	---	SHORT CIRCUIT	Power supply (SW5V, SW12V) short-circuit. Disassemble for repair.

*1: If the indication "WRNG" does not disappear even after the appropriate countermeasure, disassemble the set for repair.

1. TAPE END

<FIRST TIME SET UP>

The indication appears for the following conditions;
item "TAPE END", on the screen, is set to "STOP",
alarm is input once or more times while set to "ALM PROT", and
timer recording is implemented while it is set to "REWIND".

2. LOSS OF VIDEO SIGNAL INPUT

When the video signal is turned off during recording for 5 seconds or more, the "NO SIGNAL" appears on the monitor.

3. LOADING MOTOR SYSTEM TROUBLE

When a loading problem is detected, the intended mode is selected after returning the tape to the "CASSETTE-IN" position and loading it again. If the problem is not eliminated after this operation is repeated twice, the indication "CHECK" Appears on the monitor.

4. LOOSE TAPE

When looseness or transport error is detected, the following operation is made after the tape is returned to the "CASSETTE-IN" position and loaded again;

- When SP mode is selected for recording, the original mode is selected after recording at 3H mode for 5 secs.
- When LP mode is selected for recording, the original mode is selected after recording at 6H mode for 15 secs.

If the problem is not eliminated after this operation is repeated two times, the indication "CHECK" appears on the monitor.

5. CLOGGING

When the clogging at the video head can not be removed during the intermittent recording for more than 48 at the SP mode or more than 120H at the LP mode by operating the cleaning 4 times, Switch the SP mode to the LP mode or the LP mode to the SP mode for recording.

CONTROL INPUT/OUTPUT SIGNAL

No.	SIGNAL	Terminal	USAGE
1	SET INPUT	SET IN	Start alarm recording
2	RESET INPUT	RST IN	Finish alarm recording / Adjusting on screen
3	RECORD INPUT	REC IN	Start recording or series recording
4	MODE OUTPUT	MODE OUT	Indication of VCR selected mode
5	ALARM OUTPUT	ALM OUT	Output while alarm recording is under way
6	CLOCK OUTPUT	CLK OUT	Command camera switching
7	CALL OUTPUT	CALL OUT	External warning device or for series recording

Clock output cycle during recording (CLK OUT)

The clock output cycle during recording is variable according to the specified value of "CLOCK OUT" in REAR TERMINAL of MAIN MENU. Refer to the below table.

		Clock output cycle during recording											
Dividing Ratio Mode	Specified value of CLOCK OUT in REAR TERMINAL of MAIN MENU												
	1	2	3	4	5	10	15	20	25	30	50	60	FILED
3H/6H	If REC is selection : $(1/FF \text{ signal}) \times \text{dividing ratio.}$ If T/L REC is selected : Fixed at "H" level.						If REC is selected : $(1/FF \text{ signal}) \times 1/2.$ If T/L REC is selected : Fixed at "H" level.						
Except 3H/6H	Time lapse cycle \times dividing ratio.						Time lapse cycle. (dividing ratio fixed at 1.)						

CONTROL INPUT/OUTPUT SIGNALS AND CIRCUITS

■ SET/ RST/ REC IN terminals (screw)

Active: When input terminals are short-circuited to GND or "L" level voltage (0 - +1.6V) applied.
 Time for active: 0.1 sec or over.
 Non active: Open the input.

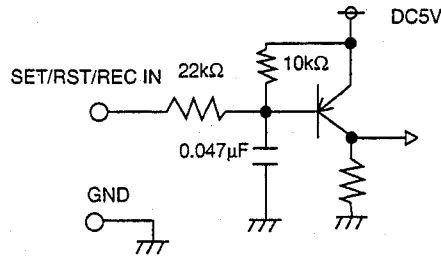

<Interface circuit inside the VCR>

■ ALM/ MODE/CALL OUT terminals (screw)

Active: "L" Level voltage (0 - +0.4V) output ; max. drive current 50mA(+5V DC)/
 10mA(+24V DC)
 Non active: Open; max. voltage +24V DC

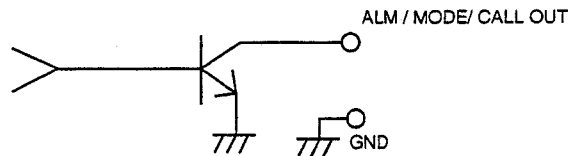

<Interface circuit inside the VCR>

■ CLK OUT terminals (screw)

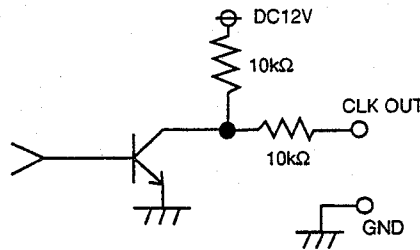

<Interface circuit inside the VCR>

CLK OUT signal

- When "F" is selected in REC of CLOCK OUT mode in 3H or 6H recording.

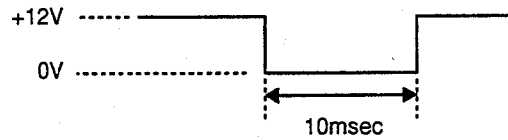

- During recording in L18H - 96H recording mode.

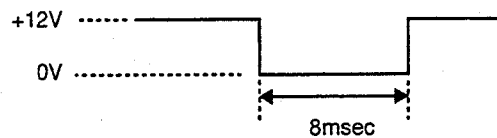

- When except "F" is selected in REC of CLOCK OUT mode in 3H or 6H recording.

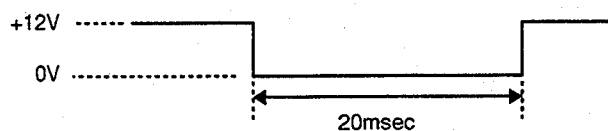

CONTROL INPUT/OUTPUT SIGNALS AND CIRCUITS

■ REMOTE jack

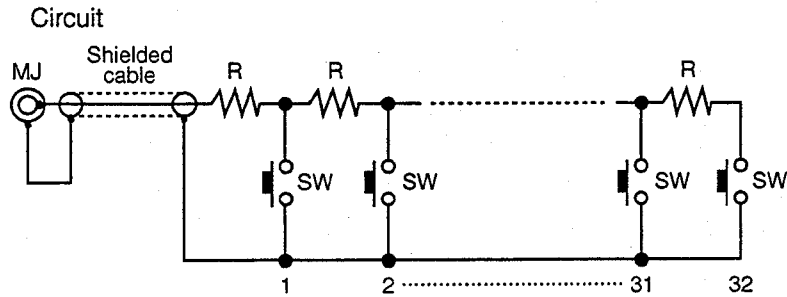

- 1) Resistor R: Metal film resistor 1/4W 33kohms $\pm 1\%$, temperature factor $\pm 100\text{ppm}/^\circ\text{C}$.
 - 2) Button switch: Momentary, ON resistor 200ohms or under.
 - 3) Connector MJ: Miniature jack, 2.5mm in diameter, comply with JISC6560.
- Operational conditions
- 1) Isolation resistor: 200Mohms or over (in connector MJ)
 - 2) Floating capacity: 0.1 μF or under (in connector MJ).
 - 3) Environmental temperature: 5-40 $^\circ\text{C}$ (common with VCR).
 - 4) Relative temperature: Max. 80% (common with VCR).

Remote control switch functions

Position	Function	Position	Function	Position	Function	Position	Function
1	STOP	9	3H	17	POWER ON/OFF	25	DOWN POSITION/SHIFT
2	RECORDING	10	6H	18	REVERSE FRAME SHIFT	26	UP POSITION/SHIFT
3	PAUSE	11	L18H	19	TIME DATE SEARCH	27	CLEAR
4	PLAYBACK	12	72H	20	INDEX SEARCH	28	START/END
5	REVERSE PLAYBACK	13	96H	21	(-)DISPLAY/SET	29	(-)REC/PLAY MODE
6	FORWARD FRAME SHIFT	14	---	22	(+)DISPLAY/SET	30	(+)REC/PLAY MODE
7	FAST FORWARD	15	---	23	LEFT POSITION/SHIFT	31	SKIP SEARCH
8	REWIND	16	---	24	RIGHT POSITION/SHIFT	32	TIMER RECORDING

■ Remote control (optional)

The optional remote control (R-7100) provides remote operation of the VCR. Before using the remote control, put the label on it as shown in Fig.

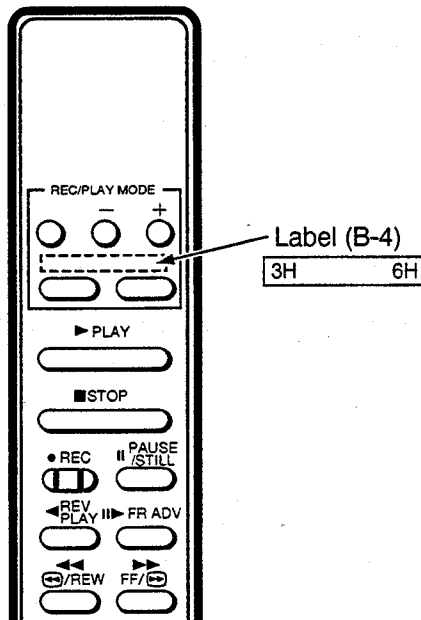

MAINTENANCE GUIDE

[○ : CLEANING ● : CHECK & ADJUSTMENT ⊙ : REPLACEMENT □ : GREASING]

SPECIFICATION	HOUR										
	500	1,000	1,500	2,000	2,500	3,000	3,500	4,000	4,500	5,000	10,000
ASSY DRUM *1	○	○	○	○	○	○	○	⊙	○	○	○
DRUM MOTOR	○	○	○	○	○	○	○	○	○	○	⊙
FE HEAD	○	○	○	○	○	○	○	○	○	○	⊙
A/C HEAD UNIT	○	○	○	○	○	○	○	○	○	○	⊙
TAPE PATH POLES *2	○	○	○	○	○	○	○	○	○	○	○
CAPSTAN SHAFT	○	○	○	○	○	○	○	○	○	○	○
REEL DISK	○	○	○	○	○	○	○	○	○	○	⊙
VIDEO HEAD *3	○	⊙	○	⊙	○	⊙	○	⊙	○	⊙	⊙
CAPSTAN MOTOR								⊙			
PINCH ARM UNIT								⊙			
LOADING BELT								⊙			
REEL BELT								⊙			
BCP2 UNIT								⊙			
REEL GEAR UNIT (SP, TU)								⊙			
MAIN BRAKE (SP, TU)								⊙			
TENSION BELT UNIT								⊙			
IDLER UNIT								⊙			
CLEANING ROLLER UNIT								⊙			
BRUSH *3								⊙			
LOADING MOTOR ASSY											⊙
LOADING MECHANISM											□
SERVO CIRCUIT *4								●			
Interchangeability Adjustment of the Mechanism								●			

- *1 Means the UPPER DRUM ASSY and LOWER DRUM ASSY.
- *2 Refer to 1. Cleaning the DECK of MECHANICAL ADJUSTMENT AND REPLACEMENT.
- *3 Included in the UPPER DRUM ASSY of the ASSY DRUM.
The exchange every 4,000hrs is recommended only for over 72Hr mode used.
- *4 Included in the PCB-MAIN.

Note : 1. Check tape running functions and performance such as picture and sound concerning each mode at inspection.
 2. Disassembly for repair is required when the operating time exceeds approx. 10,000hrs.
 3. ⊙ : Replace with new part at 4,000hrs or three years.

DISASSEMBLY

1. Removal of Top Cover

1. Remove the four Top Cover fastening screws (a) shown in Fig. 1 and remove the Top Cover in the direction shown by the arrow.

2. Removal of Front Panel

1. Remove the Top Cover.
(Refer to Para. 1 of the DISASSEMBLY.)
2. Remove the Jog Dial and the Shuttle Ring.
3. Unfasten the seven catches (b) shown in Fig. 1 and remove the Front Panel in the direction shown by the arrows.
4. Disconnect the Connector JJ shown in Fig. 1.

Note: Before installing the Front Panel, make sure that the lever is on the lower position. Push the cassette door open and install it.

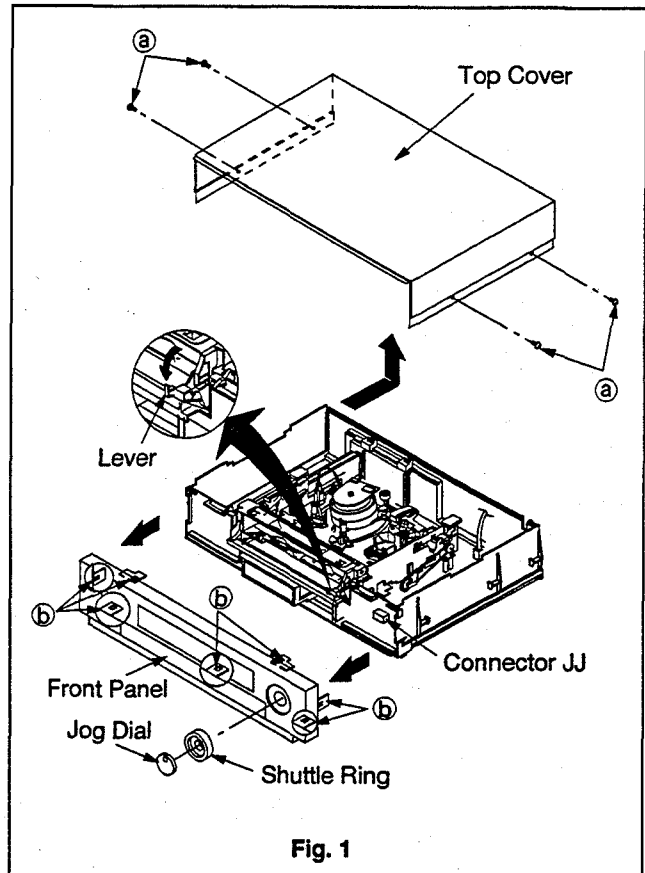

3. Removal of Bottom Panel

1. Turn the set upside down as shown in Fig. 2.
2. Remove the three fastening screws (a) shown in Fig. 2.
3. Push the one hook (b) toward inside. Slide the Bottom Panel backward to remove it, with taking care of the four catches (c).

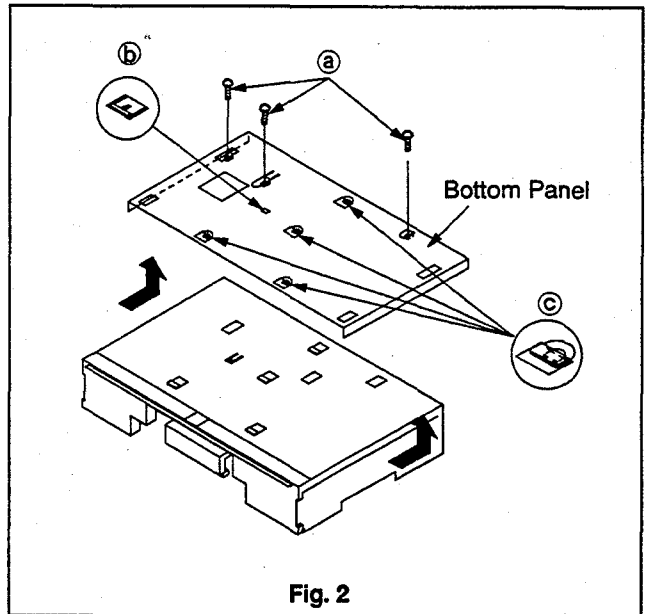

4. Removal of DECK ASSY

1. Remove the Top Cover.
(Refer to Para. 1 of the DISASSEMBLY.)
 2. Remove the Front Panel.
(Refer to Para. 2 of the DISASSEMBLY.)
 3. Remove the three screws (a) and the screw (b) shown in Fig. 3.
(When the Bottom Panel has been removed in Para. 3 of the DISASSEMBLY, remove the three screws (a).)
- Note:** Remove the screw with care because the Bottom Panel will deform if it remains.
4. Remove the three screws (c) shown in Fig. 4 and raise the Shield Plate upward to remove it.
 5. Remove the one screw (d) shown in Fig. 4 and remove the Ground Lead Wire.

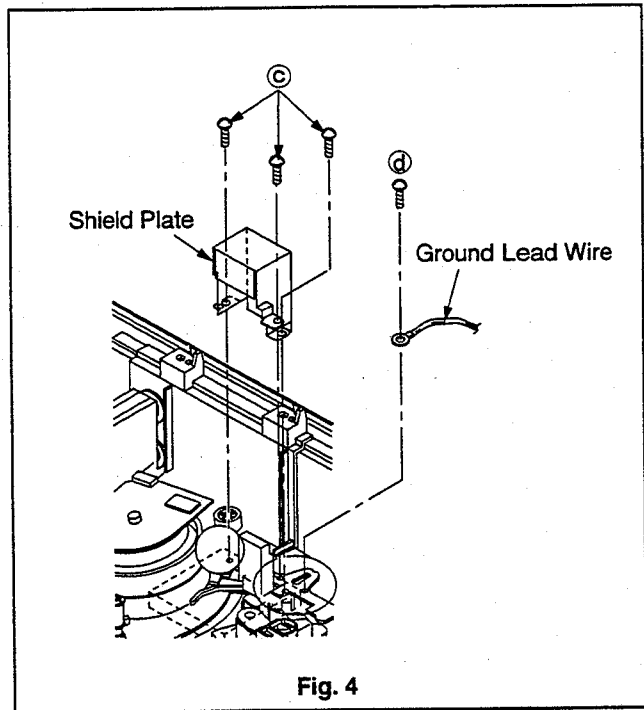
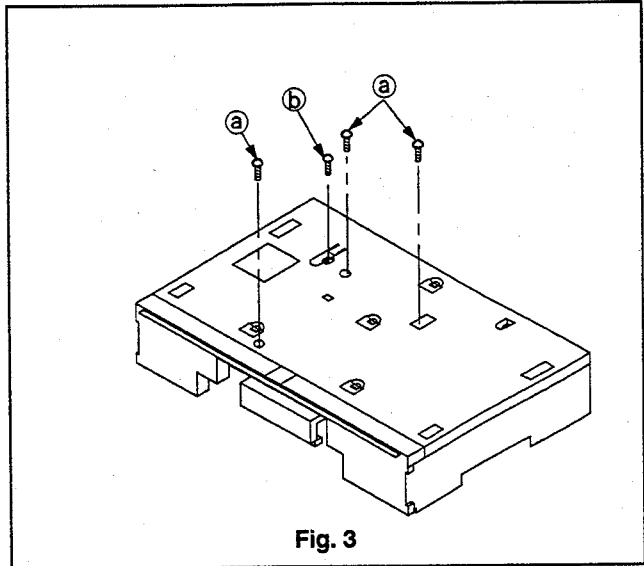

6. Remove the five screws (ⓐ) shown in Fig. 5.
7. Disconnect the Connectors MA, MD, MF, MH and ML.
8. Raise the DECK ASSY upward to remove it, paying attention to the Connector MC located under the DECK ASSY.

Note: During installation of DECK ASSY, check Connector DD which may be removed by side force. Do not use the Spacer to raise the DECK ASSY.

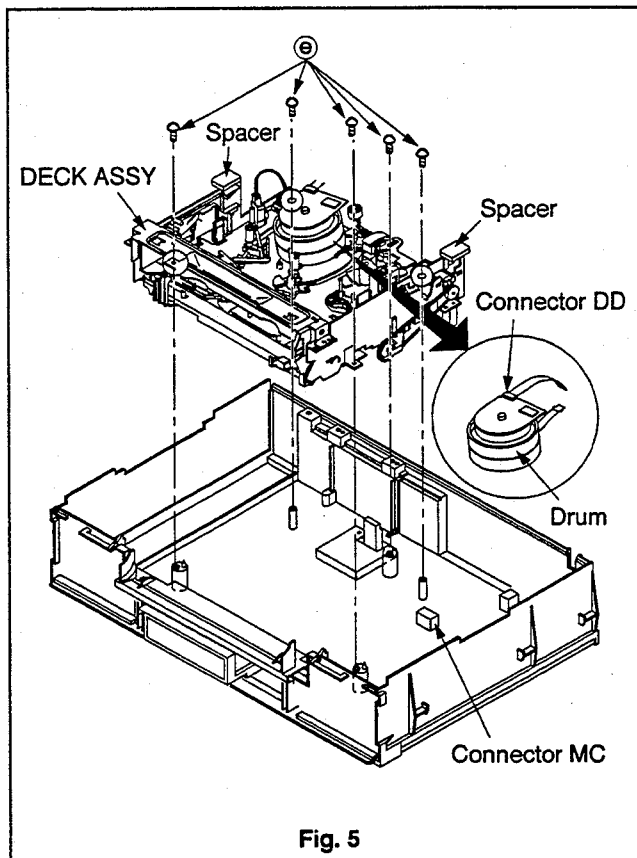

5. Removal of Insert Guide

1. Remove the DECK ASSY.
(Refer to Para. 4 of the DISASSEMBLY.)
2. Remove the two screws (ⓐ) shown in Fig. 6.
Raise the Insert Guide upward to remove it.

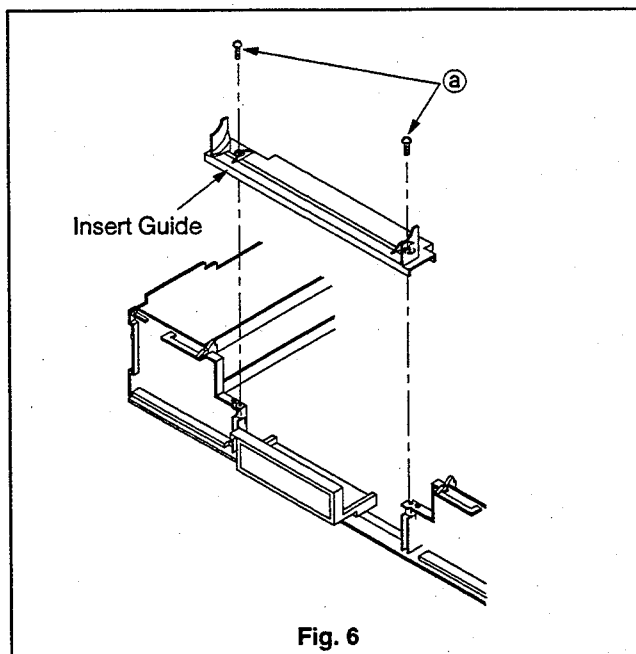

HOW TO EXECUTE CIRCUIT BOARD SERVICE

CAUTION: BEFORE ATTEMPTING TO REMOVE OR REPAIR ANY PCB, UNPLUG THE POWER CORD FROM THE A.C. SOURCE.

LOCATION OF PRINT CIRCUIT BOARDS

Note :

- Take caution when removing flat cables to prevent any contact problems.
- Connect and disconnect the flat cables at right angles to the connectors and make sure that they are completely secured.
- After servicing the PCB, reconnect the flat cable and leads.

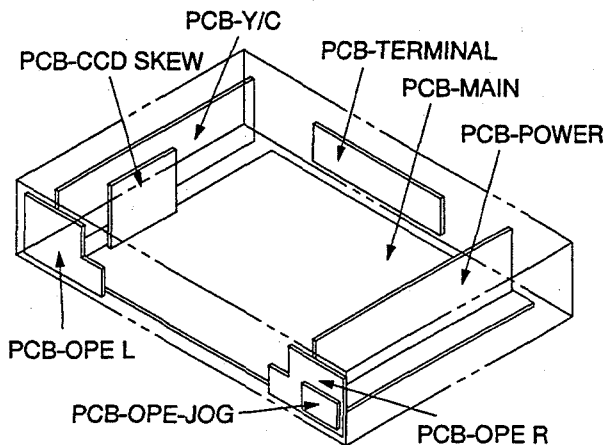

Fig. 7

1. PCB-OPE L

1. Remove the Top Cover.
(Refer to Para. 1 of the DISASSEMBLY.)
2. Remove the Front Panel.
(Refer to Para. 2 of the DISASSEMBLY.)
3. Unfasten the one catch (a) shown in Fig. 8 and rotate the PCB-OPE L in the direction shown by arrow (b) and remove it in the direction shown by arrow (c).

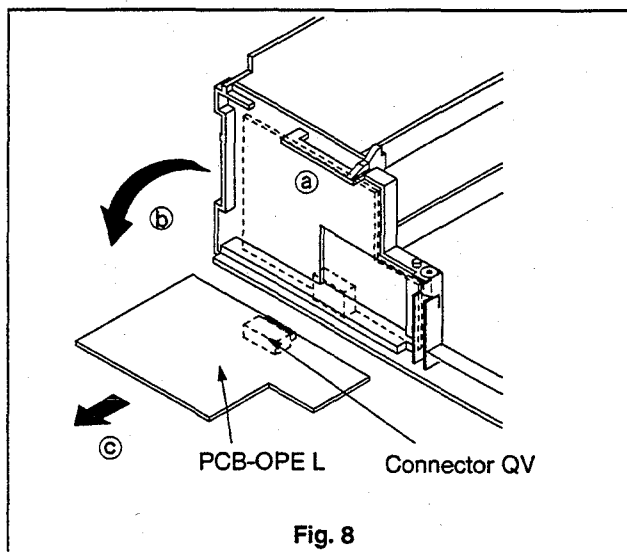

Fig. 8

2. PCB-OPE R

1. Remove the Top Cover.
(Refer to Para. 1 of the DISASSEMBLY.)
2. Remove the Front Panel.
(Refer to Para. 2 of the DISASSEMBLY.)
3. Unfasten the one catch (a) shown in Fig. 9 and rotate the PCB-OPE R in the direction shown by arrow (b) and remove it in the direction shown by arrow (c).

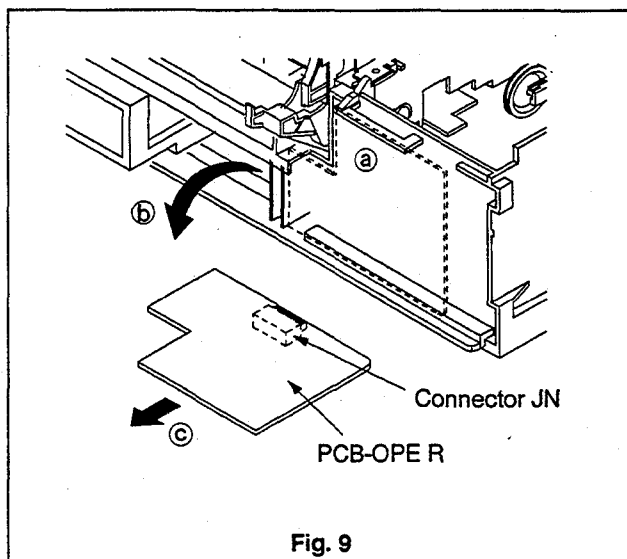
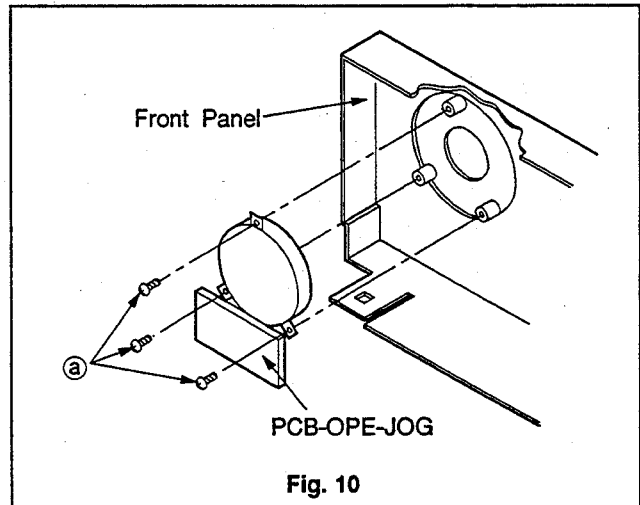

Fig. 9

3. PCB-JOG

1. Remove the Top Cover.
(Refer to Para. 1 of the DISASSEMBLY.)
2. Remove the Front Panel.
(Refer to Para. 2 of the DISASSEMBLY.)
3. Remove the three PCB-OPE-JOG fastening screws (a) shown in Fig. 10 and remove the PCB-OPE-JOG.



4. PCB-Y/C

1. Remove the Top Cover.
(Refer to Para. 1 of the DISASSEMBLY.)
2. Remove the one screw (a) shown in Fig. 11 and raise the Holder to remove it.
3. Disconnect the Connectors SR, SC and SS.
4. Remove the PCB-Y/C.

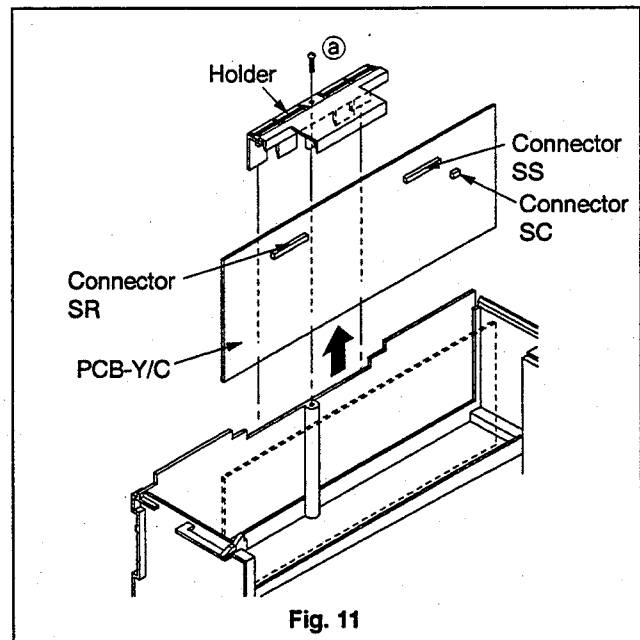

5. PCB-POWER

1. Remove the Top Cover.
(Refer to Para. 1 of the DISASSEMBLY.)
2. Remove the two screws (a) shown in Fig. 12 and raise the Holder to remove it.
3. Remove the one screw (b) shown in Fig. 12 and remove the Ground Lead Wire. (HS-7496E(B) only)
4. Remove the one screw (c) shown in Fig. 12 and remove the Power Cover.
5. Remove the one screw (d) shown in Fig. 12 and raise the PCB-POWER to remove it.

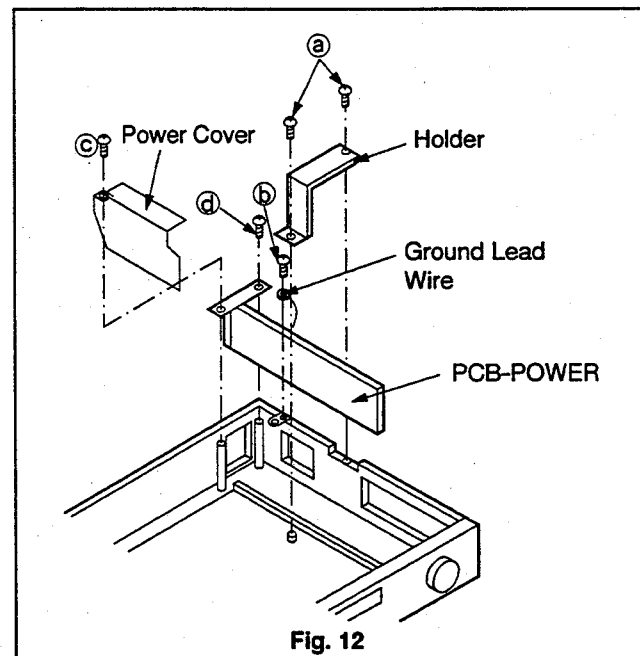

▣ Service of Transistor (Q901)

1. Disconnect the power plug.
2. Remove the one fastening screw (Ⓒ) shown in Fig. 13.

Note: Check that transistor (Q901) is connected to the Heat Sink before turning the power on. If the power is turned on without installing the Heat Sink, Q901 can be damaged.

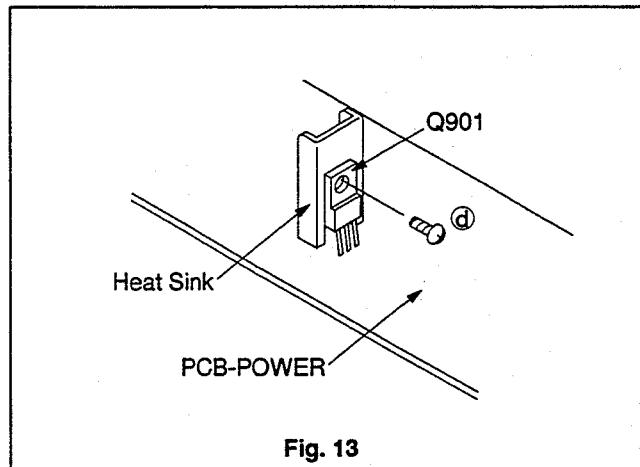

Fig. 13

6. PCB-MAIN

6-1. Removal of PCB-MAIN

1. Remove the DECK ASSY.
(Refer to Para. 4 of the DISASSEMBLY.)
2. Remove the Insert Guide.
(Refer to Para. 5 of the DISASSEMBLY.)
3. Remove the PCB-OPE R and PCB-OPE L.
(Refer to the preceding paragraph.)
4. Remove the three screws (Ⓐ) shown in Fig. 14.

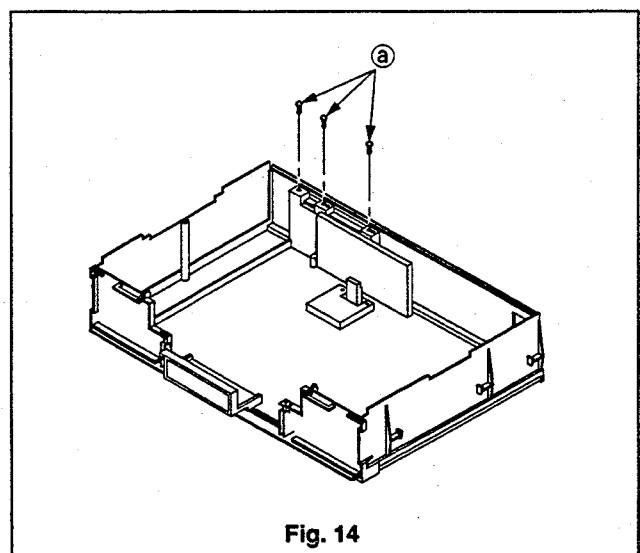

Fig. 14

▣ Service of Head Amp block

1. Unsolder the four soldered points of the Shield Case shown in Fig. 15 and remove it.
2. Unsolder the three soldered points of the Shield Plate shown in Fig. 15 and remove it.

Note: Before checking the operation, mount the Shield Case and the Shield Plate in their original position. If not connected, beat or picture malfunction may appear.

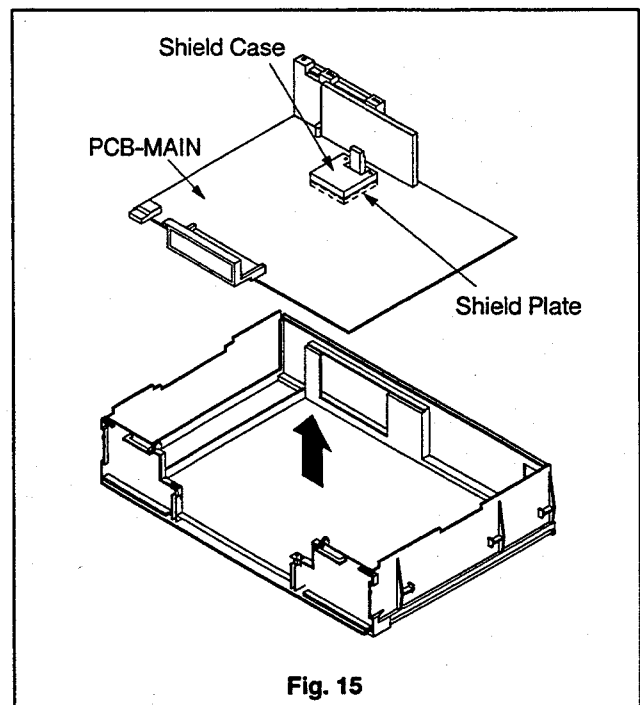
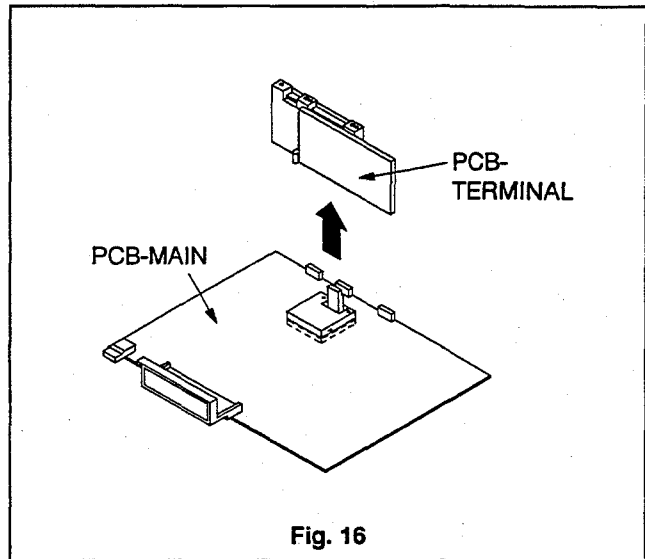

Fig. 15

6-2. Removal of PCB-TERMINAL

1. Remove the PCB-MAIN.
(Refer to the preceding paragraph.)
2. Remove the PCB-TERMINAL shown in Fig. 16.



6-3. Removal of Terminal Cover

1. Remove the PCB-MAIN.
(Refer to the preceding paragraph.)
2. Remove the PCB-TERMINAL.
(Refer to the preceding paragraph.)
3. Remove the five screws (a) shown in Fig. 17 and remove the Terminal Cover.

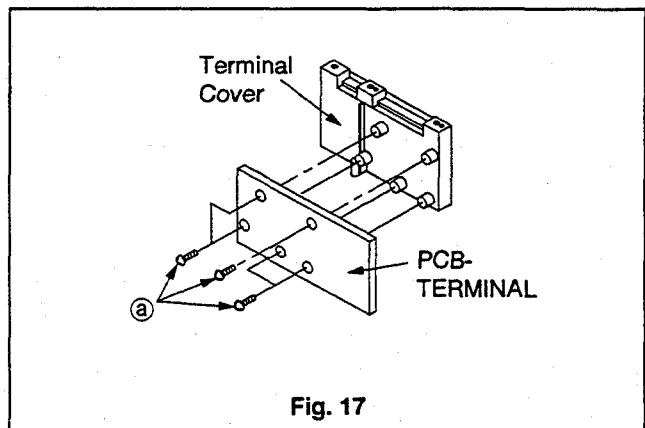

6-4. Removal of PCB-CCD SKEW

1. Remove the PCB-MAIN.
(Refer to the preceding paragraph.)
2. Disconnect the connector CC.
3. Pull the catches of holders to the direction shown by arrow (a) to remove the PCB-CCD SKEW shown in Fig. 18.

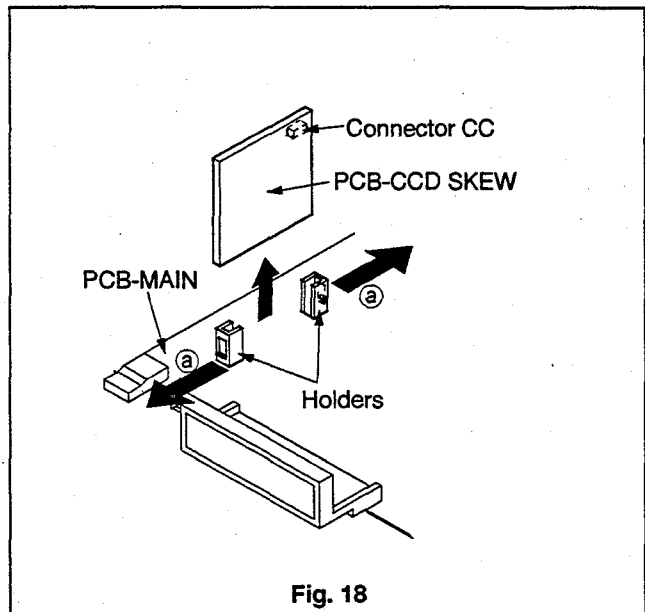

DECK OPERATION CHECK

Operation of the deck position and tape running systems can be checked according to the following method.

1. Unscrew all screws fastening the DECK ASSY and Shield Case.
2. Place the DECK ASSY on the Base Chassis so that the center of the rear side aligns with the boss and that the rear side of the supply side aligns with the screw hole as shown in Fig. 1. Raise the front side of the DECK ASSY and support it.

Note: The MODE DETECT SENSOR, START SENSOR, END SENSOR, REEL SENSOR and RECORD PROTECTION SENSOR cannot operate in this state.

- Parts on the DECK (LOADING BELT and REEL BELT) can be replaced.

3. Short TP5T and TP5X.

Note: Connect them before plugging in the set.

4. Turn the Power on.
5. Press the RESET button on the rear panel.
(The "LOCK" is displayed in fluorescent display.)
6. Insert the Video Cassette Tape.

Note: This check may damage the cassette tape.

Use a dummy cassette tape with a door or other tapes for test purpose only.

7. Press the TRACKING (+) and (-) buttons to check the deck position.
TRACKING (+) button : Operation in the loading direction.
TRACKING (-) button : Operation in the unloading direction.

8. Connect the Connector MC and the CAPSTAN MOTOR on the PCB-MAIN with the Extension cable (859C433080). Press the POSITION/VERTICAL ADJUST (+) and (-) buttons to check the operation of the tape running system.

Note: Take care that the two connectors of the Extension cable are attached in the same direction, without twisting the cable.

- (+) button : Forward rotation is implemented.
- (-) button : Reverse rotation is implemented.

• **Example :** Play back, REW/FF

1. Press the TRACKING (+) or (-) button to align the character PR or FR of the CAM GEAR (TU) with the positioning hole of the WORM PULLEY UNIT shown in Fig. 4.
PR : Play back position
FR : REW/FF position
2. For fast forward operation check, press the POSITION/VERTICAL ADJUST (+) button to make the CAPSTAN MOTOR rotate in the forward direction. For rewind operation check, press the POSITION/VERTICAL ADJUST (-) button to make the CAPSTAN MOTOR rotate in the reverse direction.

9. Open TP5T and TP5X.

10. Press the RESET button on the rear panel.

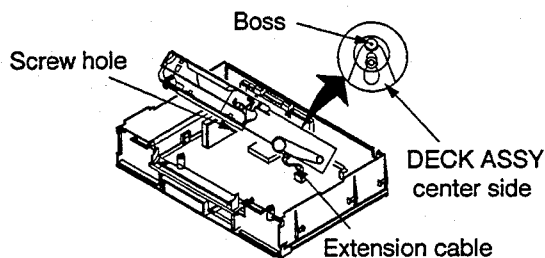

Fig. 1

PCB-MAIN (Component side)

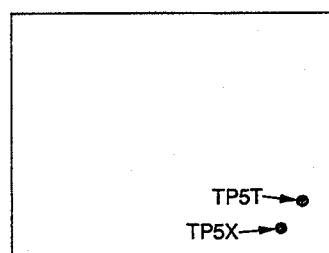

Fig. 2

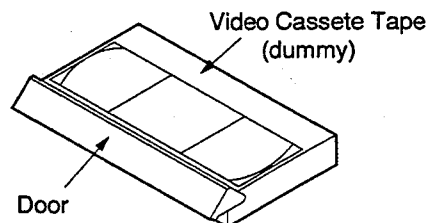

Fig. 3

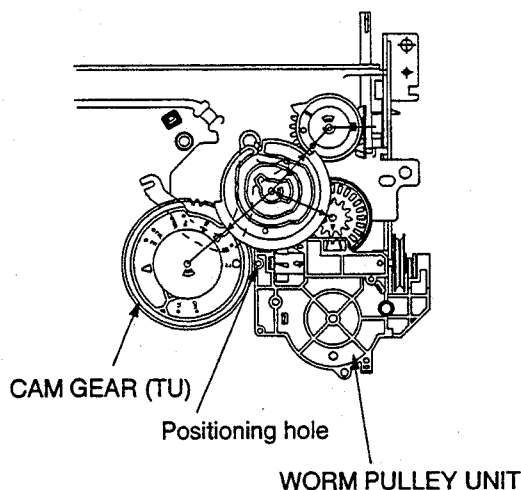
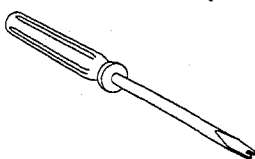
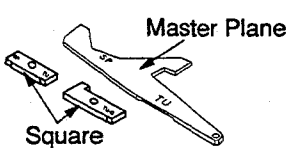
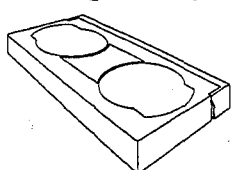
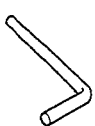
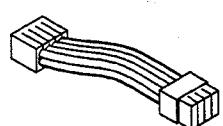
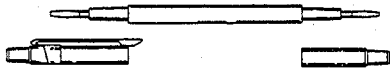
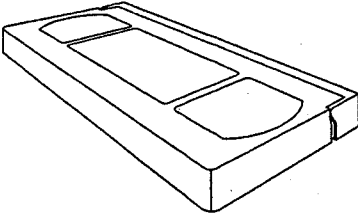

Fig. 4

MECHANICAL ADJUSTMENT TOOLS

	PURPOSE	METHOD
Adjustment Driver (859C259O80) 	For adjustment of guide rollers.	Carefully insert and adjust guide rollers.
Height adjusting Jig • Master Plane (859C342O20) • Square (859C433O60) 	The master plane and the square are used for measuring height and perpendicularity of the reel disk and Take up guide arm.	The gauge is applied to the part being measured.
Back Tension Gauge (859C345O80) 	The back tension gauge is used for measuring the tension of the tape on the supply side.	Load this gauge in the cassette housing and run in the play mode. Read the gauge indicator.
Cotton gloves	For changing, cleaning and handling of drum, heads and guides.	Use when handling all parts in the tape path.
Grease MULTEMP SH-A (859D055O80)	Lubrication of various parts.	To be applied as specified.
L SHARPED BOX DRIVER (859C433O70) 	The L SHARPED BOX DRIVER is used for tightening or removing screws which fasten the guide rollers.	Insert the screw and turn.
Extension Cable (859C433O80) 	For check of DECK operation.	Connect the MC connector and the CAPSTAN MOTOR.
Oil FLOIL (859D154O20)	Lubrication of various parts.	To be applied as specified.

ELECTRICAL ADJUSTMENT TOOLS

	PURPOSE	METHOD
<p>Adjustment Driver (859C338O00)</p> <p style="text-align: center;">767-M</p> 	<p>The adjustment driver is intended to adjust variable resistors, trimmers, transformers etc. in the circuitry.</p>	<p>Select a tip suitable for the particular head of the component concerned and adjust.</p>
<p>Alignment Tape</p> <p>(PS2 : 859C339O10) (PM6KH3 : 859C339O30) (PM3KE6(CH1) 25 : 859C568O50) (PMX : 859C568O70)</p> 	<p>Standard signals (VHS Standard) are recorded on the alignment tape and reproduced when required in the adjustment of Servo circuit and interchangeability alignment.</p>	<p>Install and run in the play mode, the same as for an ordinary tape.</p>

ELECTRICAL ADJUSTMENTS

Perform only the alignments required. If proper equipment is not available, do not attempt an alignment.

□ PRE-ADJUSTMENT SETTINGS

- * If otherwise specified, make adjustments under the following conditions.
- A-TAPE VHS TAPE (E-180) on the market.
- VIDEO Colour position.
- PICTURE VR (VR701) Centre click stop position.
- LOCK button OFF position.
- Display mode Non-characters display mode. (DISPLAY MODE 3 or 4)

□ MEASURING EQUIPMENT

- Oscilloscope (10:1 probe unless 1:1 specified.)
- Signal generator
- Audio tester
- Frequency counter
- Wired remote hand unit

□ TEST SIGNAL

Colour bar signal

In this manual, unless otherwise specified in particular, use the colour bar signal specified below.

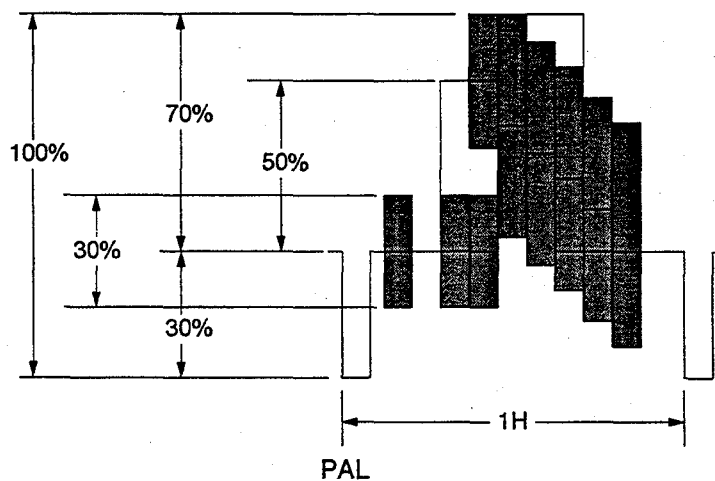

Split-Field colour bar (with 100% window)

LOCATIONS

PCB-MAIN (Component side)

REAR

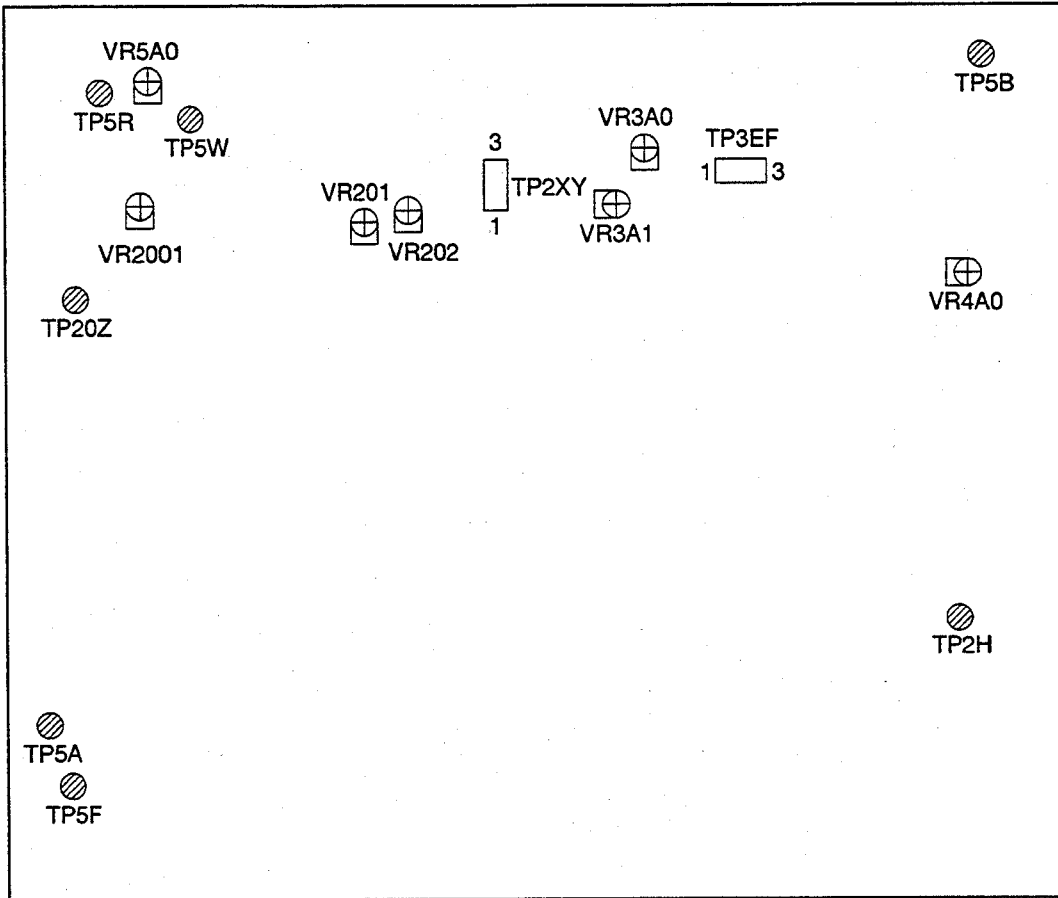

PCB-Y/C (Component side)

TOP

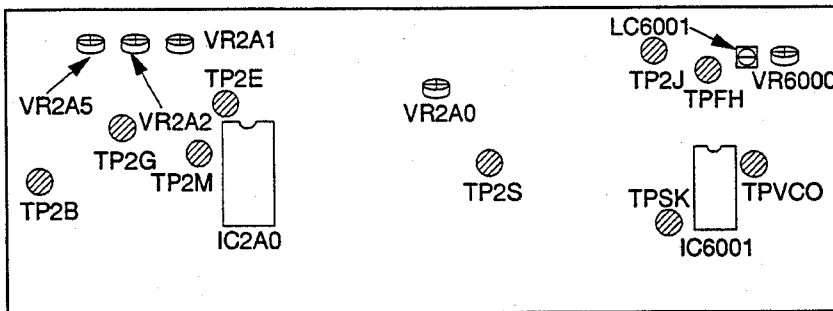

PCB-CCD SKEW (Component side) TOP

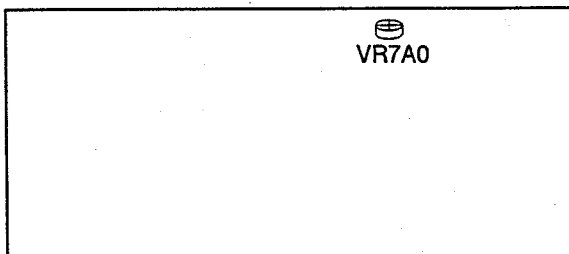

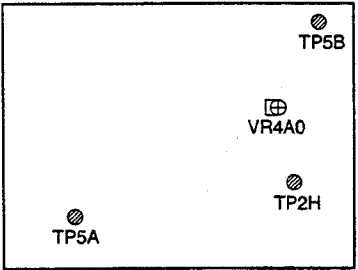
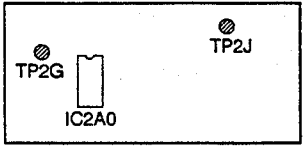
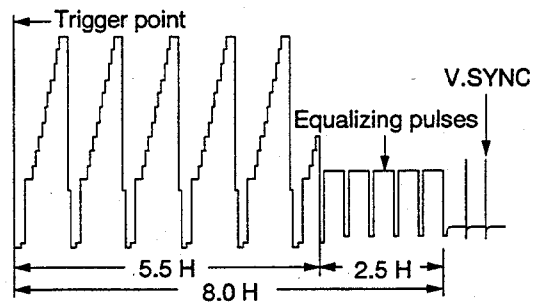
[Servo circuit] 1. Playback Switching Point (W4HEAD)		Adjustment purpose Video switch over timing during playback.
		Symptom when incorrectly adjusted Switching noise or jitter in the playback picture.
Measuring instrument and condition Oscilloscope		VCR set up condition Input signal ---
Test point TP2J		Using tape Alignment Tape (PS2, stair step)
EXT trigger TP2H		VCR condition 3H Playback
Measurement range DIV 20mV TIM 50µs		Using Jig ---
<ol style="list-style-type: none"> 1. Set the VCR to 3H PLAY mode. 2. Play an Alignment Tape. (PS2, stair step) 3. Push the TRACKING (+) and (-) buttons at the same time. 4. Short TP5A to TP5B. 5. Observe the waveform at TP2J. (The probe must be grounded to TP2G.) 6. Set the oscilloscope's slope to (-). 7. Adjust VR4A0 so that the trigger point is located at $8.0 \pm 1.0H$ before the vertical synchronising signal. 8. Open TP5A to TP5B. 		
PCB-MAIN (Component side) 		PCB-Y/C (Component side) 
		

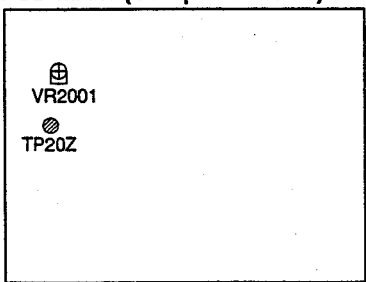
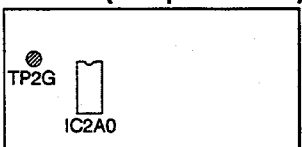
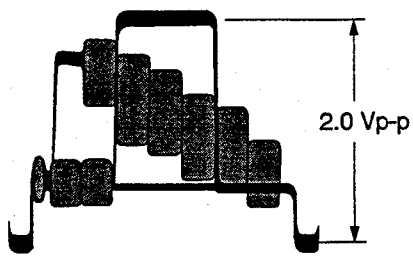
[Y/C signal circuit] 2. CG-AGC		Adjustment purpose Setting output level of the CG circuit.
		Symptom when incorrectly adjusted Too bright or too dark picture.
Measuring instrument and condition Oscilloscope		VCR set up condition Input signal Video signal (PAL Colour bar)
Test point TP20Z		Using tape ---
EXT trigger ---		VCR condition STOP
Measurement range DIV 50mV TIM 10µs		Using Jig ---
<ol style="list-style-type: none"> 1. Supply a video signal (PAL Colour bar). 2. Observe the waveform at TP20Z. (The probe must be grounded to TP2G.) 3. Adjust VR2001 so that the amplitude of waveform is 2.0Vp-p. 		
PCB-MAIN (Component side) 		PCB-Y/C (Component side) 
		

[Y/C signal circuit] 3. EE Out put Level	Adjustment purpose	To set output level of video signal at STOP mode.
	Symptom when incorrectly adjusted	Too bright or too dark image : incorrect colour.

Measuring instrument and condition		VCR set up condition	
Oscilloscope		Input signal	Video signal (PAL SPLIT FIELD)
Test point	TP2E TP2J	Using tape	---
EXT trigger	---	VCR condition	STOP
Measurement range	DIV 20mV TIM 10µs	Using Jig	---

1. Supply a video signal (PAL SPLIT FIELD).
2. Be certain that nothing is connected to the VIDEO OUT terminal.
3. Observe the waveform at TP2E.
(The probe must be grounded to TP2G.)
4. Adjust VR2A0 so that the amplitude of waveform is 0.48Vp-p.

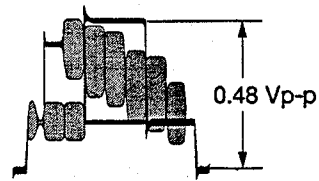

5. Observe the waveform at TP2J.
(The probe must be grounded to TP2G.)
6. Adjust VR7A0 so that the amplitude of waveform is 2.0Vp-p.

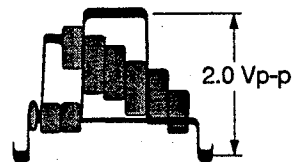

PCB-Y/C (Component side)

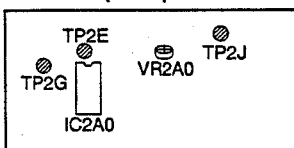

PCB-CCD SKEW (Component side)

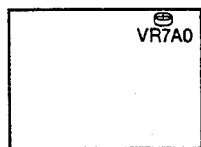

[Y/C signal circuit] 4. Carrier set, Deviation	Adjustment purpose	FM carrier frequency and deviation.
	Symptom when incorrectly adjusted	Too bright or too dark picture. Horizontal noise or less of sync.

Measuring instrument and condition		VCR set up condition	
Oscilloscope (Probe 1:1)		Input signal	Video signal (PAL Colour bar)
Test point	TP2M	Using tape	A Tape
EXT trigger	TP2S	VCR condition	3H REC
Measurement range	DIV 0.2V TIM 10µs	Using Jig	Carrier Checker

1. Supply a video signal (PAL Colour bar).
2. Set the VCR to 3H REC mode.
3. Observe the waveform at TP2M using a carrier checker.
(The probe must be grounded to TP2G.)
4. Adjust VR2A1 so that the sync tip is at 3.8MHz.
5. Adjust VR2A2 so that the peak white is at 4.8MHz.

PCB-Y/C (Component side)

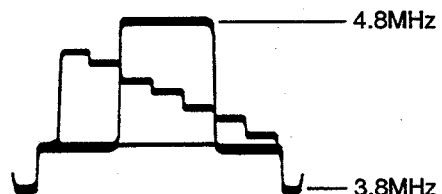
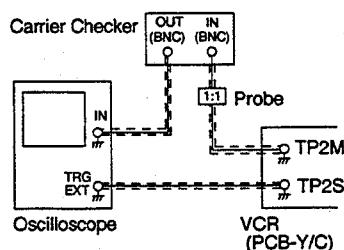
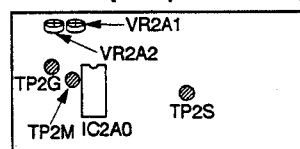

[Y/C signal circuit] 5. Y/C Recording Level	Adjustment purpose	Set the record level of the video and chroma signal.
	Symptom when incorrectly adjusted	Low luminance S/N, beats, colour bounding or flicker.

Measuring instrument and condition		VCR set up condition		<ol style="list-style-type: none"> 1. Remove the three screws and rise the Shield Plate upward to remove it as shown below. 2. Supply a video signal (PAL Colour bar). 3. Set the VCR to 6H REC mode. 4. Short TP2M to TP2B. 5. Be certain that nothing is connected to VIDEO OUT terminal. 6. Observe the waveform at TP2XY (pin ① (GND), pin ②). 7. Adjust VR201 so that the RED signal is 25mVp-p.
Oscilloscope (Probe 1:1)		Input signal	Video signal (PAL Colour bar)	
Test point	TP2XY (pin ①, pin ②)	Using tape	A Tape	
EXT trigger	---	VCR condition	6H REC	
Measurement range	DIV 5mV TIM 5μs	Using Jig	---	

PCB-MAIN (Component side)

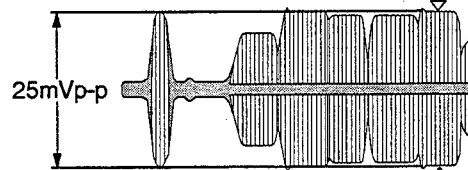
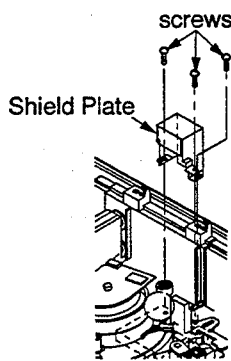
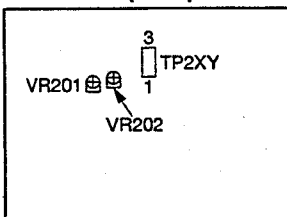

8. Set the oscilloscope's probe to 10 : 1.
9. Open TP2M to TP2B.
10. Adjust VR202 so that the amplitude of horizontal sync is 100mVp-p.

PCB-Y/C (Component side)

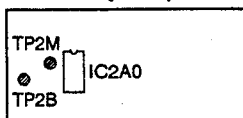

[Y/C signal circuit] 6. Playback Demodulation Sensitivity	Adjustment purpose	Setting each output level to the same when playing a tape recorded in VHS.
	Symptom when incorrectly adjusted	Both Y signal and colour signal will be played back incorrectly

Measuring instrument and condition		VCR set up condition		<ol style="list-style-type: none"> 1. Set the VCR to 3H PLAY mode. 2. Be certain that nothing is connected to the VIDEO OUT terminal. 3. Play an alignment tape (PS2, colour bar). 4. Observe the waveform at TP2J. (The probe must be grounded to TP2G.) 5. Adjust VR2A5 so that the amplitude of waveform is 2.1Vp-p.
Oscilloscope		Input signal	---	
Test point	TP2J	Using tape	Alignment Tape (PS2, colour bar)	
EXT trigger	---	VCR condition	3H Playback	
Measurement range	DIV 50mV TIM 10μs	Using Jig	---	

PCB-Y/C (Component side)

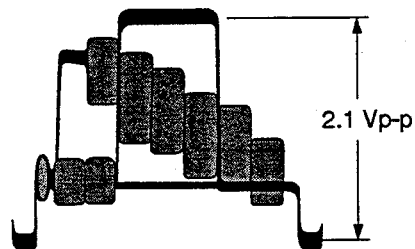
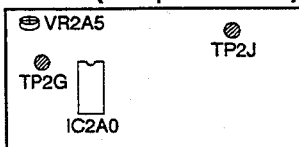

[Y/C signal circuit] 7. 2Fh VCO	Adjustment purpose	Picture distortion generated in forward speed search, reverse speed search and reverse playback in LP mode is detected.
	Symptom when incorrectly adjusted	Swing, noise or skew is noticeable on the screen in forward speed search, reverse speed search or reverse playback in LP mode.

Measuring instrument and condition		VCR set up condition	
DC Voltmeter		Input signal	---
Test point	TPVCO	Using tape	Alignment Tape (PS2, colour bar)
EXT trigger	---	VCR condition	3H Playback
Measurement range	---	Using Jig	---

1. Set the VCR to 3H PLAY mode.
3. Play an alignment tape (PS2, colour bar).
4. Observe the voltage at TPVCO.
5. Adjust VR6000 so that the DC voltage is $2.40 \pm 0.05V$.

PCB-Y/C (Component side)

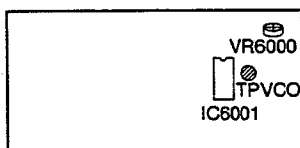

[Y/C signal circuit] 8. APC Error Phase	Adjustment purpose	Hue error generated in forward speed search, reverse speed search, and reverse playback.
	Symptom when incorrectly adjusted	No colour fault is caused in forward speed search, reverse search and reverse playback in LP mode.

Measuring instrument and condition		VCR set up condition	
Oscilloscope		Input signal	Video signal (PAL Colour bar)
Test point	CH1 : TPSK CH2 : TPFH	Using tape	A Tape
EXT trigger	TP2S	VCR condition	6H REC
Measurement range	DIV 50mV TIM 10μs	Using Jig	---

1. Supply a video signal (PAL Colour bar).
2. Set the VCR to 6H REC mode.
3. Still replay the tape recorded at the step 2 at 6H mode.
4. Connect CH1 of the oscilloscope to TPSK and CH2 to TPFH in the DUAL ALT mode.
5. Observe the wave form at TPSK and TPFH.
6. Adjust LC6001 so that time from ZERO cross point of the TPFH to Burst signal centre of TPSK is $30 \pm 3 \mu\text{sec}$.

PCB-Y/C (Component side)

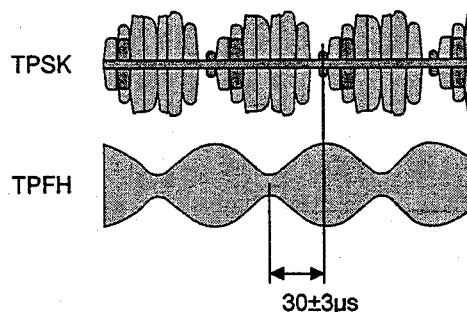
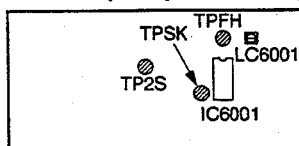

[Audio circuit] 9. Playback Audio Level	Adjustment purpose	Audio level during playback.
	Symptom when incorrectly adjusted	Too loud or too low audio level during playback.

Measuring instrument and condition		VCR set up condition	
Audio tester		Input signal	---
Test point	AUDIO OUT terminal	Using tape	Alignment Tape (PS2, colour bar)
EXT trigger	---	VCR condition	3H Playback
Measurement range	---	Using Jig	---

1. Set the VCR to 3H PLAY mode.
2. Play an alignment tape (PS2, colour bar).
3. Observe the audio level at AUDIO OUT terminal.
4. Adjust VR3A1 so that the audio output level is -6dBm.
Note: Check that the level fluctuation is less than ± 1 dB. If level fluctuation is over ± 1 dB then check the A/C HEAD slant adjustment.

PCB-MAIN (Component side)

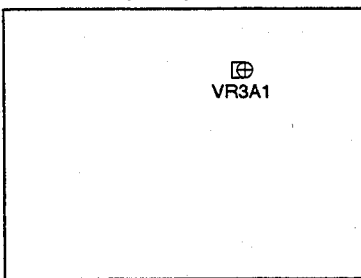

[Audio circuit] 10. Audio Bias level	Adjustment purpose	Audio bias level setting for record.
	Symptom when incorrectly adjusted	Poor audio response in high frequency area or distortion.

Measuring instrument and condition		VCR set up condition	
Audio tester		Input signal	---
Test point	TP3EF (pin ①, pin ③)	Using tape	A Tape
EXT trigger	---	VCR condition	3H REC
Measurement range	---	Using Jig	High pass filter

1. Insert the shorted RCA type Phono-plug into the AUDIO IN terminal.
2. Set the VCR to 3H REC mode.
3. Observe the audio level at TP3EF (pin ①, pin ③) with an Audio Tester using a high pass filter.
4. Confirm that the monitor TV etc. does not affect the indication of the Audio Tester and then adjust VR3A0 so that the level is 2.0mVr.m.s.
Note 1: Be sure that the audio tester housing never touches the VCR chassis.
Note 2: Never set the VCR to PLAY mode with the audio tester connected. (The audio amplifier will be over loaded.)

PCB-MAIN (Component side)

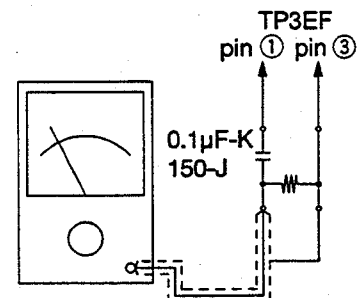
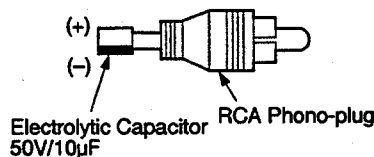
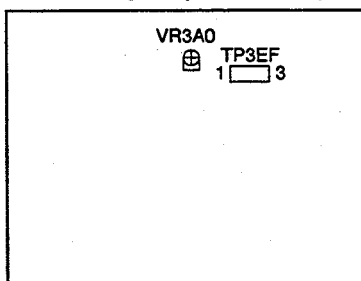

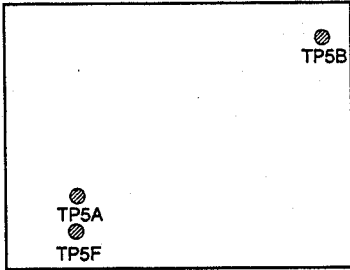
[Timer circuit] 11. Clock Frequency Correction	Adjustment purpose To set the accuracy of the clock. Symptom when incorrectly adjusted Poor clock accuracy.																					
<table border="1" style="width:100%; border-collapse: collapse;"> <thead> <tr> <th colspan="2">Measuring instrument and condition</th> <th colspan="2">VCR set up condition</th> </tr> </thead> <tbody> <tr> <td colspan="2">Frequency Counter</td> <td>Input signal</td> <td>---</td> </tr> <tr> <td>Test point</td> <td>TP5F</td> <td>Using tape</td> <td>---</td> </tr> <tr> <td>EXT trigger</td> <td>---</td> <td>VCR condition</td> <td>Power off</td> </tr> <tr> <td>Measurement range</td> <td>---</td> <td>Using Jig</td> <td>---</td> </tr> </tbody> </table>		Measuring instrument and condition		VCR set up condition		Frequency Counter		Input signal	---	Test point	TP5F	Using tape	---	EXT trigger	---	VCR condition	Power off	Measurement range	---	Using Jig	---	<ol style="list-style-type: none"> 1. Set the VCR to POWER off. (With the tape ejected from the VCR.) 2. Short TP5A to TP5B. (Confirm that the " REC " is displayed in fluorescent display.) 3. Observe the frequency at TP5F. 4. Be certain that the frequency is between 262.1000 ~ 262.1882kHz. 5. Use the Jog dial and Shuttle ring to enter the last three digits of the frequency counter reading (262.1@b@kHz). Transfer to next subordinate figure's position, turn the shuttle-ring to clockwise direction and enter the digits in @b@ sequence. 6. Push the REC button on the VCR. 7. Open TP5A to TP5B. (Confirm that the " REC " is not displayed in fluorescent display.)
Measuring instrument and condition		VCR set up condition																				
Frequency Counter		Input signal	---																			
Test point	TP5F	Using tape	---																			
EXT trigger	---	VCR condition	Power off																			
Measurement range	---	Using Jig	---																			
<p>PCB-MAIN (Component side)</p> 																						

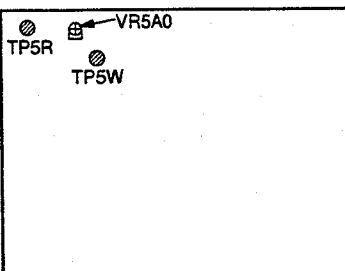
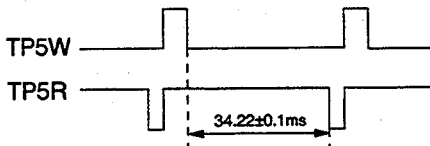
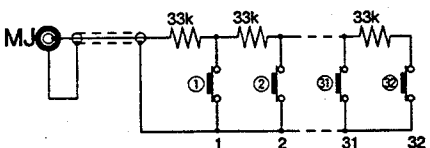
[Timer circuit] 12. Remote Control Circuit	Adjustment purpose Setting timing of each position of wired remote hand unit. Symptom when incorrectly adjusted Wrong operation.																					
<table border="1" style="width:100%; border-collapse: collapse;"> <thead> <tr> <th colspan="2">Measuring instrument and condition</th> <th colspan="2">VCR set up condition</th> </tr> </thead> <tbody> <tr> <td colspan="2">Oscilloscope</td> <td>Input signal</td> <td>---</td> </tr> <tr> <td>Test point</td> <td>TP5W TP5R</td> <td>Using tape</td> <td>---</td> </tr> <tr> <td>EXT trigger</td> <td>---</td> <td>VCR condition</td> <td>STOP</td> </tr> <tr> <td>Measurement range</td> <td>---</td> <td>Using Jig</td> <td>Wired remote hand unit</td> </tr> </tbody> </table>		Measuring instrument and condition		VCR set up condition		Oscilloscope		Input signal	---	Test point	TP5W TP5R	Using tape	---	EXT trigger	---	VCR condition	STOP	Measurement range	---	Using Jig	Wired remote hand unit	<ol style="list-style-type: none"> 1. Insert the wired remote hand unit into the REMOTE jack (When pushing the 32button, confirm that entire resistor value is $1056 \pm 0.2k\Omega$) 2. Connect TP5W to input CH1 and TP5R to input CH2. 3. Press " position32 " on the wired remote hand unit to adjust VR5A0 so that TP5R falls $34.22 \pm 0.1ms$ after TP5W falls. (Adjust VR5A0 by turning it clockwise.)
Measuring instrument and condition		VCR set up condition																				
Oscilloscope		Input signal	---																			
Test point	TP5W TP5R	Using tape	---																			
EXT trigger	---	VCR condition	STOP																			
Measurement range	---	Using Jig	Wired remote hand unit																			
<p>PCB-MAIN (Component side)</p> 																						
<div style="display: flex; align-items: center;">  </div> <div style="display: flex; align-items: center; margin-top: 10px;">  <div style="margin-left: 20px;"> <p>Wired remote hand unit</p> <p style="text-align: right;">Position No.</p> </div> </div>																						

MECHANICAL ADJUSTMENT AND REPLACEMENT

1. Cleaning the DECK

The following Parts require cleaning whenever serviced to maintain satisfactory performance.

1-1. VIDEO HEAD

1. Clean the VIDEO HEADS by the following method.
Dust and other foreign objects on the VIDEO HEADS disturb the normal play back picture.
Dampen a Video Head Cleaning Cloth with alcohol.
Hold the cloth against the DRUM and slowly turn the DRUM counterclockwise to clean.

Note : Do not directly touch the HEAD attached to the UPPER DRUM ASSY. The HEAD is very hard but brittle to impact, especially in the vertical direction.

Do not apply force in the vertical direction.

2. Allow residual alcohol to dry thoroughly before running a Tape. Otherwise, the liquid may stick to and damage the Tape.

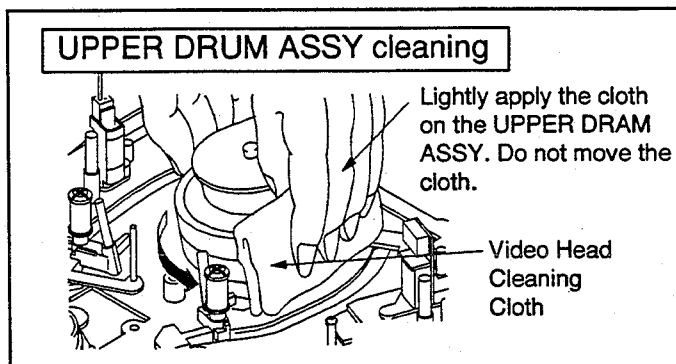

1-2. Tape Transport (Refer to Fig. 1.)

Clean the following Parts of the Tape Transport.

1. TENSION PIN
2. GUIDE POLE (SP)
3. FE HEAD
4. SLANT POLE (SP)
5. UPPER/LOWER DRUM ASSY
6. SLANT POLE (TU)
7. A/C HEAD
8. GUIDE POLE (TU)
9. CAPSTAN SHAFT
10. GUIDE PIN (TU)
11. GUIDE ROLLER (SP)
12. GUIDE ROLLER (TU)
13. PINCH ROLLER

1. Clean the Tape Transport using Gauze dampened with alcohol, except the GUIDE ROLLER (SP), GUIDE ROLLER (TU) and PINCH ROLLER which Dry Gauze should be used.
2. Allow residual alcohol to dry thoroughly before running a Tape. Otherwise the liquid may stick to and damage the Tape.

1-3. REEL DISK Drive System

1. Clean the REEL DISK braking surfaces and the REEL BELT.
2. Clean the REEL DISK drive system using Gauze dampened with alcohol, except the REEL BELT. Use Dry Gauze to clean the the REEL BELT.
3. Allow residual alcohol to dry thoroughly before operation.

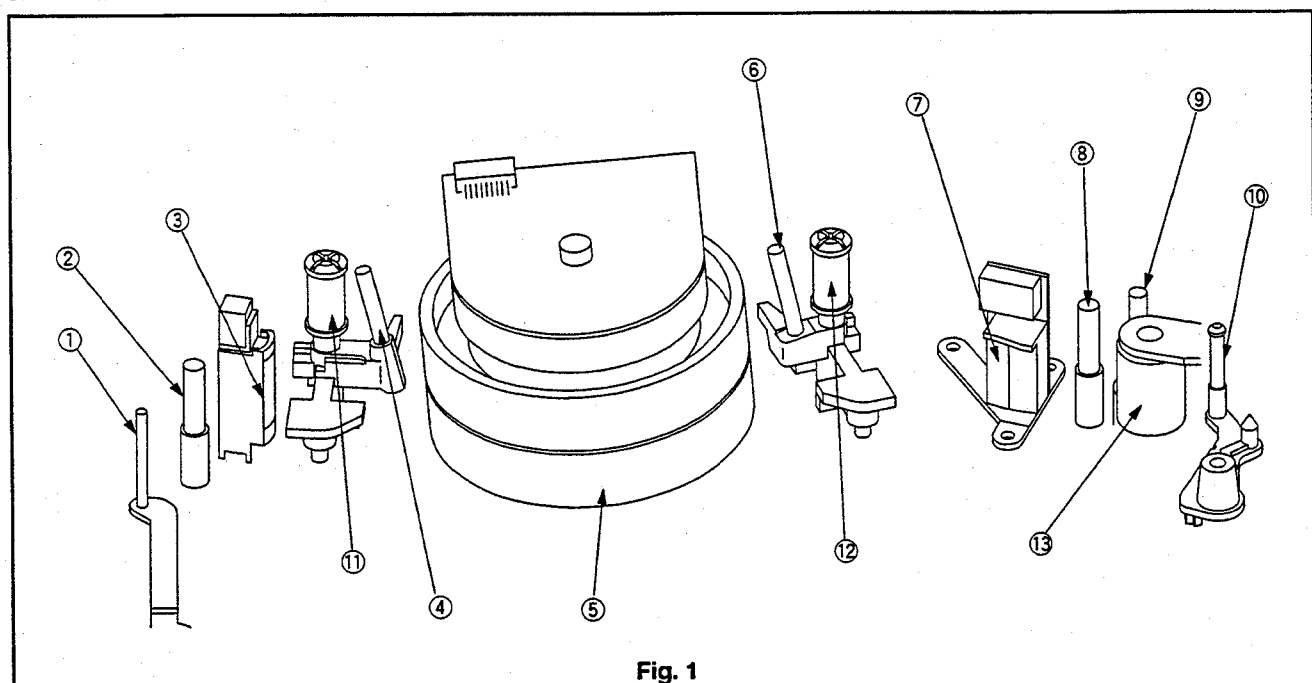

2. Replacement of Major Parts

2-1. GUIDE ARM (SP), CLEANING ARM, CLEANING ROLLER UNIT

SET POSITION : Normal

(Removal)

1. Disconnect the Lead Connector from the FE HEAD, which is clamped on the GUIDE ARM (SP) shown in Fig. 2-1.
2. Unfasten the Catch (Ⓐ) of the GUIDE ARM (SP) shown in Fig. 2-1 to remove the GUIDE ARM (SP).
3. Unfasten the Catch (Ⓑ) of the CLEANING ARM shown in Fig. 2-1 to remove the CLEANING ARM.
4. Unfasten the Catch (Ⓒ) of the CLEANING ARM shown in Fig. 2-1 to remove the CLEANING ROLLER UNIT from the CLEANING ARM.

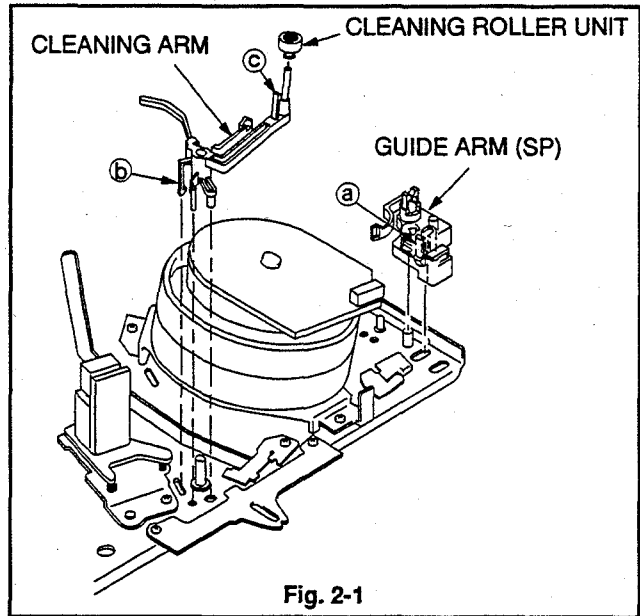

(Installation)

1. Install the CLEANING ROLLER UNIT shown in Fig. 2-1 to the CLEANING ARM.
2. Install the CLEANING ARM shown in Fig. 2-1.
3. Install the GUIDE ARM (SP) shown in Fig. 2-1.
4. Connect the Lead Connector from the FE HEAD.

2-2. STAY PLATE

SET POSITION : Normal

(Removal)

1. Unfasten a LID HOLDER PLATE fastening screw (Ⓐ) shown in Fig. 2-2. Remove the LID HOLDER PLATE.
2. Raise the STAY PLATE in the direction shown by arrow (A) so that it stands completely in vertical, as shown in Fig. 2-2. Remove the STAY PLATE in the direction shown by arrow (B).

(Installation)

1. Install the STAY PLATE and the LID HOLDER PLATE shown in Fig. 2-2.

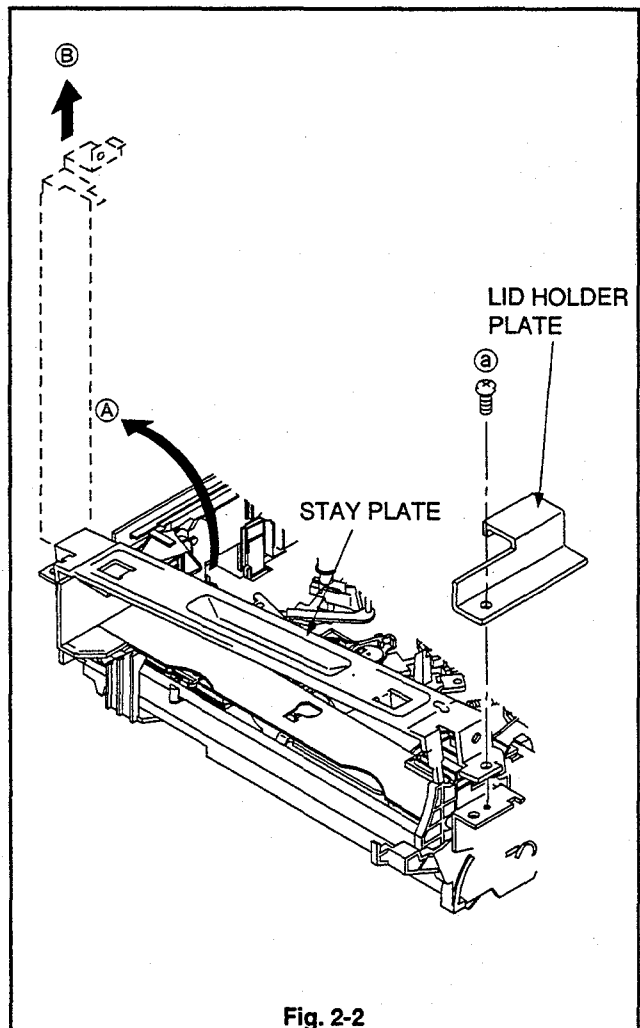

2-3. BOTTOM UNIT

SET POSITION : Normal

(Removal)

1. Remove the STAY PLATE. (Refer to Para. 2-2.)
2. Remove the BOTTOM UNIT in the direction shown by arrow as shown in Fig. 2-3-1.

(Installation)

1. Apply GREASE (MULTEMP SH-A) [859D055080] to the Groove of the MAIN PLATE ASSY specified in Fig. 2-3-5.
2. Apply GREASE (MULTEMP SH-A) [859D055080] to the BOTTOM UNIT specified in Fig. 2-3-5.
3. Move the LID HOOK (TU) shown in Fig. 2-3-2 in the direction shown by arrow (A).
4. Move the LID HOOK (TU) and the LID OPENER (TU) in the direction shown by arrow (B) in Fig. 2-3-3 so that the boss of the LID HOOK (TU) shown in Fig. 2-3-2 is inserted in the Matching Groove on the CASSETTE HOLDER (TU).
5. Move the LID OPENER (SP) of the BOTTOM UNIT in the direction shown by arrow (A) and hold it with your hand as shown in Fig. 2-3-3.
6. Insert a Cassette Tape in the BOTTOM UNIT shown in Fig. 2-3-3 with the LID OPENER (TU) held down with the hands.

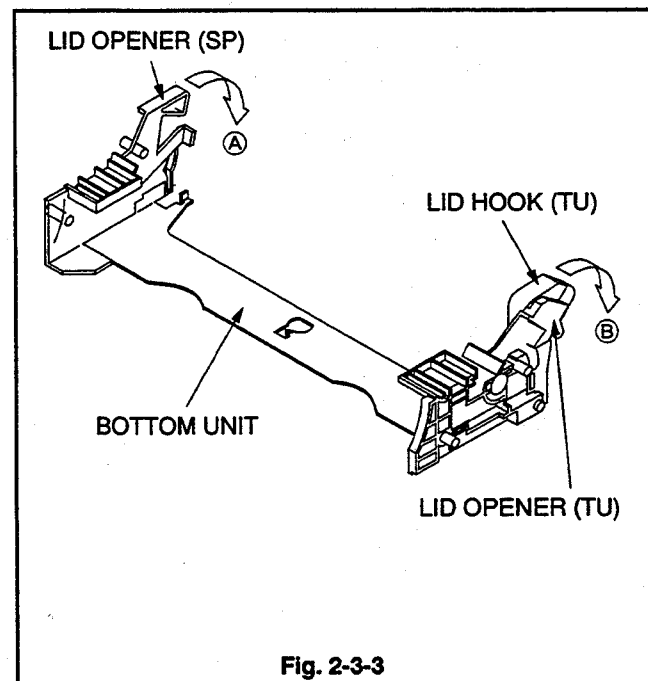
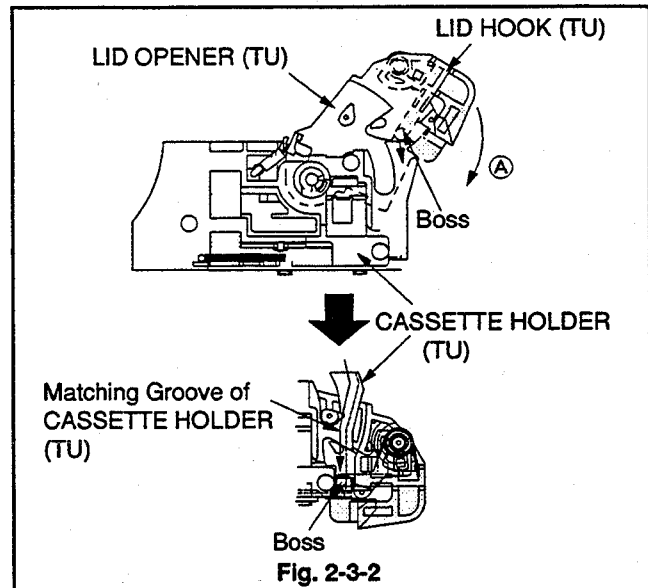
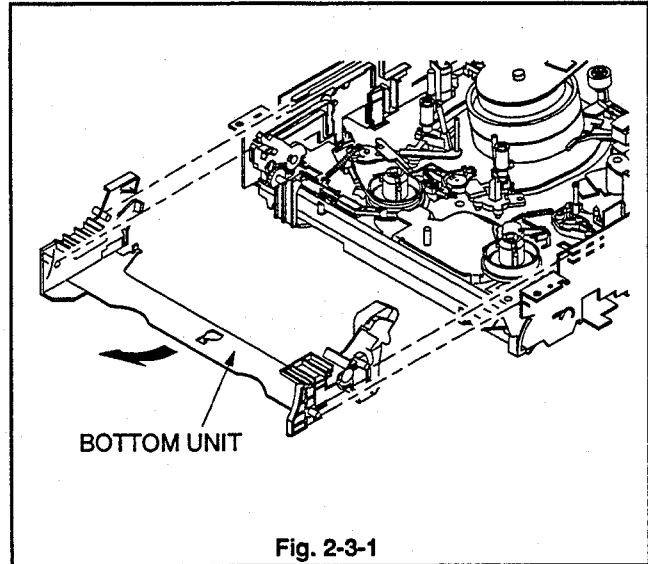

7. Make sure that the Catches of the LID HOOK (TU) and the LID OPENER (SP) shown in Fig. 2-3-4 are fastened on the Cassette Tape.
8. Install the BOTTOM UNIT so that its boss matches with the groove of the MAIN PLATE ASSY as shown in Fig. 2-3-5.
9. Remove the Cassette Tape.
10. Install the STAY PLATE. (Refer to Para. 2-2.)

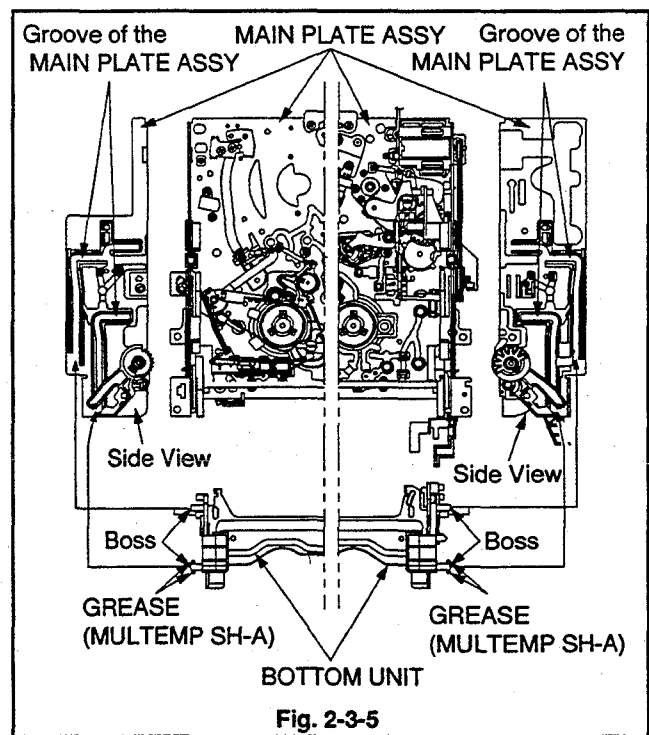
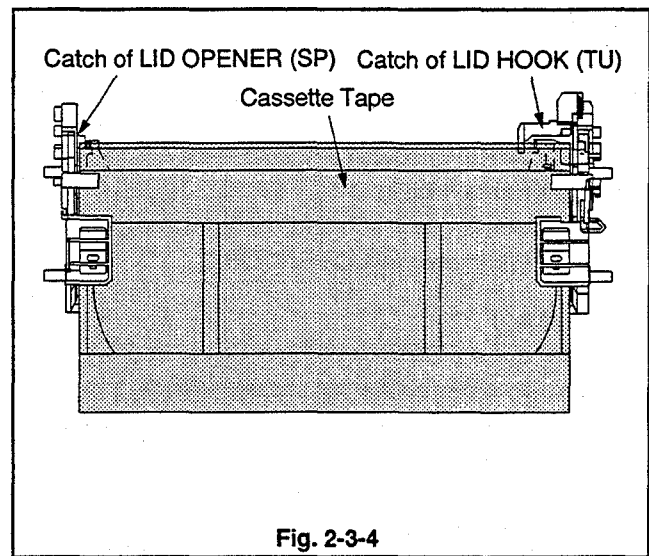

2-4. A/C HEAD UNIT

SET POSITION : Normal

(Removal)

1. Disconnect the Card Lead Wire of the A/C HEAD UNIT shown in Fig. 2-4-1.
2. Unscrew the two A/C HEAD UNIT fastening screws (a) to remove the A/C HEAD UNIT.

(Installation)

1. Install the A/C HEAD UNIT shown in Fig. 2-4-1.
- Note :** Do not touch the part shown in Fig.2-4-2.
If it is stained, clean it with alcohol.
2. Connect the Card Lead Wire of the A/C HEAD UNIT shown in Fig. 2-4-1.
 3. Perform "Adjustment of A/C HEAD" in Para. 3-3 and "Adjustment of Phase" in Para. 3-4 of "Interchangeability Adjustment of the Mechanism".

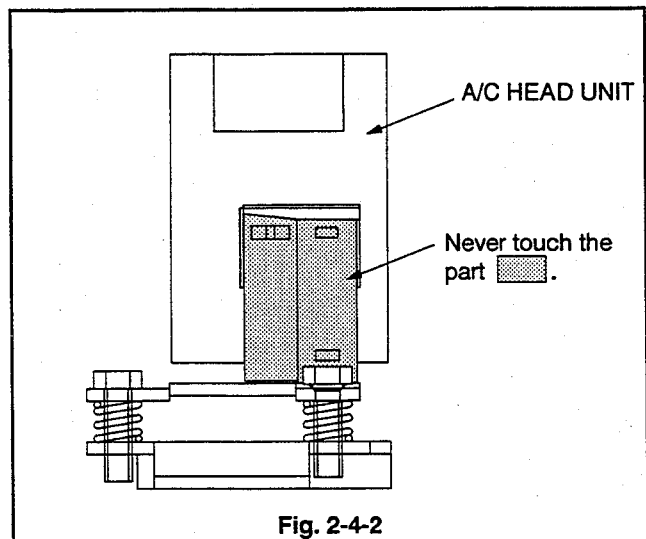
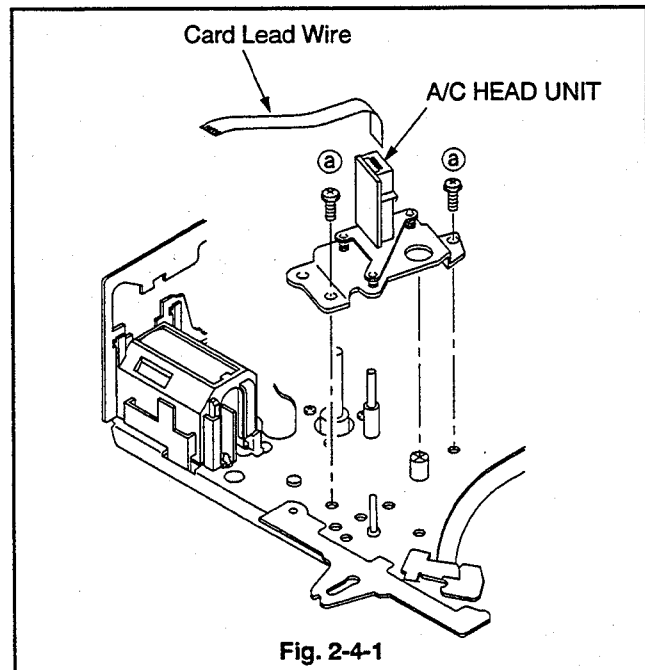

2-5. FE HEAD

SET POSITION : Normal

(Removal)

1. Disconnect the Lead Connector of the FE HEAD shown in Fig. 2-5-1.
2. Unscrew the FE HEAD fastening screw (a) to remove the FE HEAD.

(Installation)

1. Install the FE HEAD shown in Fig. 2-5-1.
- Note :** Do not touch the part shown in Fig. 2-5-2.
If it is stained, clean it with alcohol.
2. Connect the Lead Connector of the FE HEAD shown in Fig. 2-5-1.

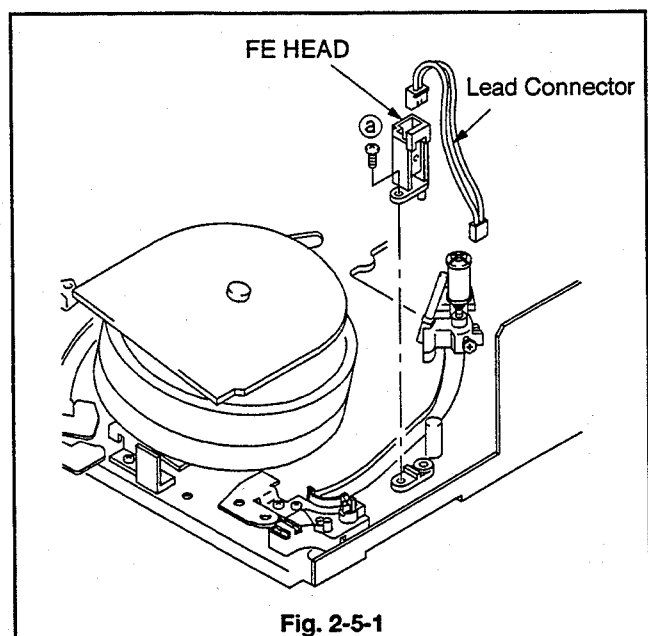

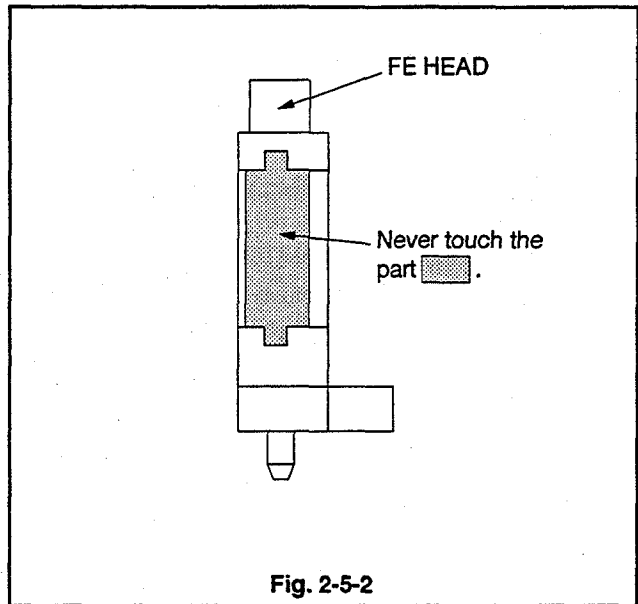

2-6. SHUT LEVER UNIT

SET POSITION : Normal

To access the SHUT LEVER UNIT, remove the :

- STAY PLATE (Para. 2-2)
- BOTTOM UNIT (Para. 2-3)

(Removal)

1. To remove the SHUT LEVER UNIT, unfasten the two Catches (㉓) of the SHUT LEVER UNIT shown in Fig. 2-6-1.

(Installation)

1. Apply GREASE (MULTEMP SH-A) [859D055O80] to the area specified in Fig. 2-6-1 on the MAIN PLATE ASSY.
2. Apply GREASE (MULTEMP SH-A) [859D055O80] to the area specified in Fig. 2-6-1 on the new SHUT LEVER UNIT.
3. Install the SHUT LEVER UNIT shown in Fig. 2-6-1.
4. Insert the spring of the SHUT LEVER UNIT under Groove of the MAIN PLATE ASSY shown in Fig. 2-6-2.
5. Make sure that the SHUT LEVER UNIT returns in the direction shown by arrow ㉔ when it is moved in the direction shown by arrow ㉓.

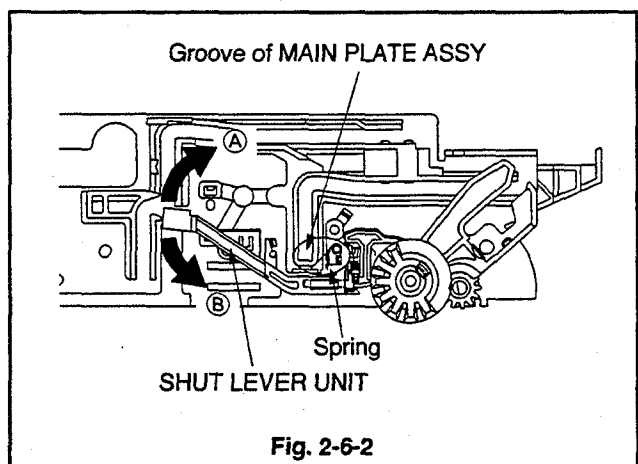
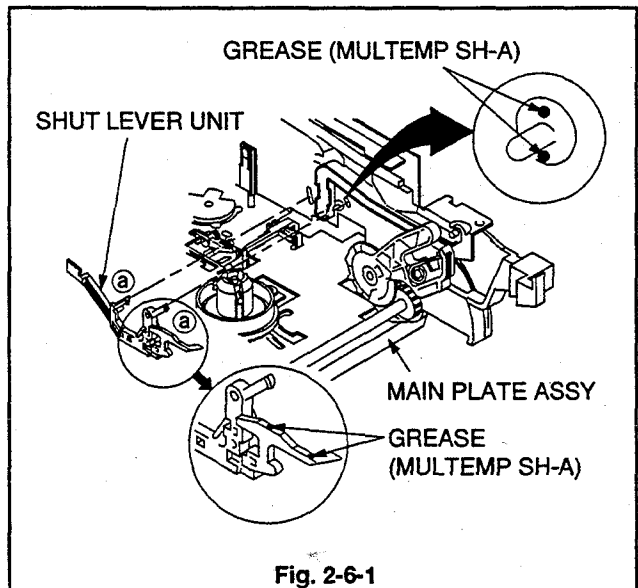

2-7. LAMP GUIDE, MODE POSITION GUIDE

SET POSITION : Normal

(Removal)

1. Unscrew the LAMP GUIDE fastening screw (a) shown in Fig. 2-7-1.
2. Unfasten the Catch (b) of the MAIN PLATE ASSY shown in Fig. 2-7-1 to remove the LAMP GUIDE.
3. Unfasten the Catch (c) of the MODE POSITION GUIDE shown in Fig. 2-7-1 to remove the MODE POSITION GUIDE.

(Installation)

1. Clean the Part A of the MODE POSITION GUIDE shown in Fig. 2-7-2 with the Video Head Cleaning Cloth.

Note : Never use alcohol or equivalent solvent.

2. Install the MODE POSITION GUIDE shown in Fig. 2-7-1.
3. Clean the Part B of the LAMP GUIDE shown in Fig. 2-7-2 with the Video Head Cleaning Cloth.

Note : Never use alcohol or equivalent solvent.

4. Install the LAMP GUIDE shown in Fig. 2-7-1.
5. Install the screw (a) shown in Fig. 2-7-1.
6. After installing the LAMP GUIDE and MODE POSITION GUIDE, clean the surface of them with the Video Head Cleaning Cloth.

Note : Never use alcohol or equivalent solvent.

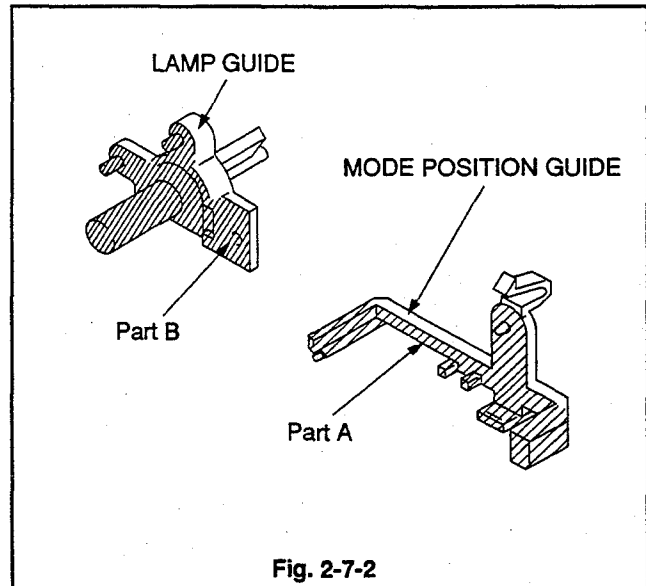
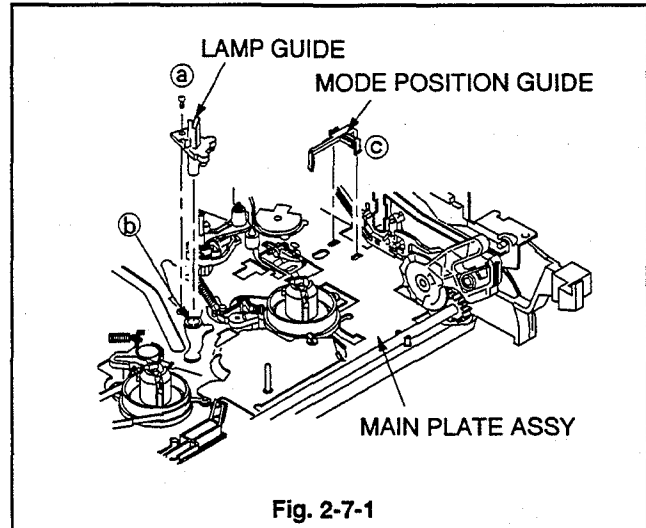

2-8. TENSION SPRING, TENSION ARM, TENSION BELT UNIT

SET POSITION : Normal

(Removal)

1. Remove the TENSION SPRING shown in Fig. 2-8-1.
2. Use a minus driver to move Part A of the MAIN PLATE ASSY, shown in Fig. 2-8-3, in the direction shown by arrow A.
3. Unfasten the two Catches (a) of the TENSION BELT UNIT shown in Fig. 2-8-1. Unfasten the Catch (b) of the MAIN PLATE ASSY. Remove the TENSION BELT UNIT with the TENSION ARM attached.
4. Unfasten the two Catches (c) of the TENSION BELT UNIT shown in Fig. 2-8-2 to remove the TENSION ARM.

(Installation)

1. Apply GREASE (MULTEMP SH-A) [859D055O80] to the area specified in Fig. 2-8-1 on the MAIN PLATE ASSY.
2. Attach the TENSION ARM on the TENSION BELT UNIT, refer to Fig. 2-8-2.
3. Fasten the TENSION BELT UNIT around the part of the REEL DISK (on SP side), refer to Fig. 2-8-3.

Note : Do not get GREASE or OIL on the TENSION BELT UNIT during installation.

4. Move the Part A of the spring of the TENSION LEVER UNIT, shown in Fig. 2-8-4, in the direction shown by arrow, and install the TENSION ARM in the position shown in Fig. 2-8-4.
5. Move the Part A of the MAIN PLATE ASSY in the opposite direction of arrow A so it enters the concave portion of the TENSION BELT UNIT, as shown in Fig. 2-8-3, and points to the centre of the REEL DISK (On SP side).
6. Install the TENSION SPRING shown in Fig. 2-8-1.
7. Perform "Adjustment of BACK TENSION and TENSION PIN Position" in Para. 3-1 of "Interchangeability Adjustment of the Mechanism".

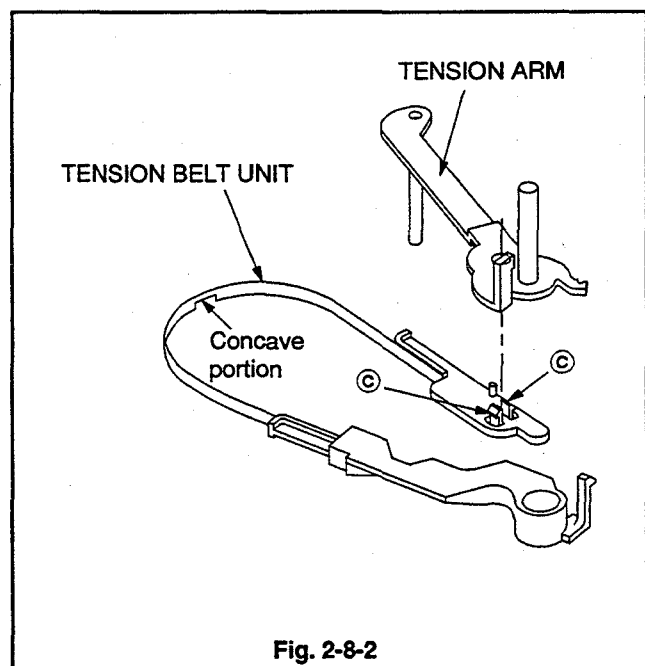
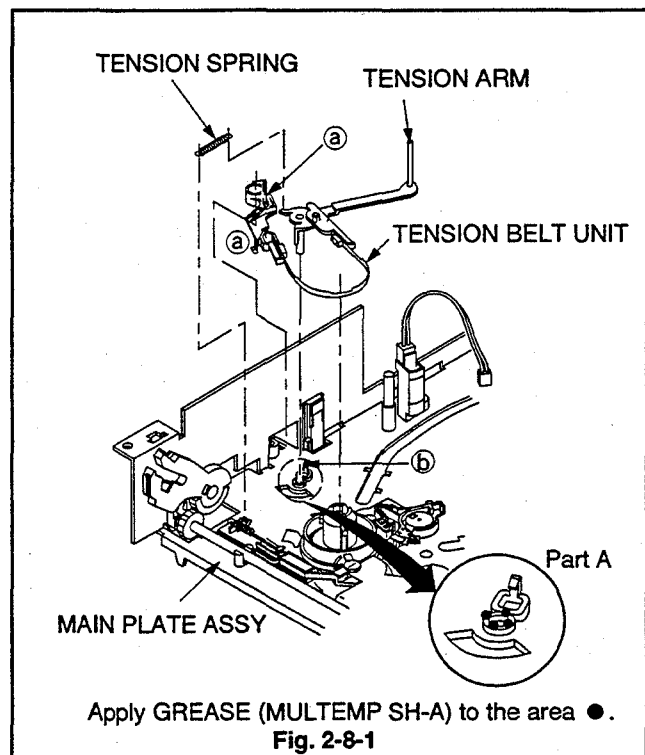

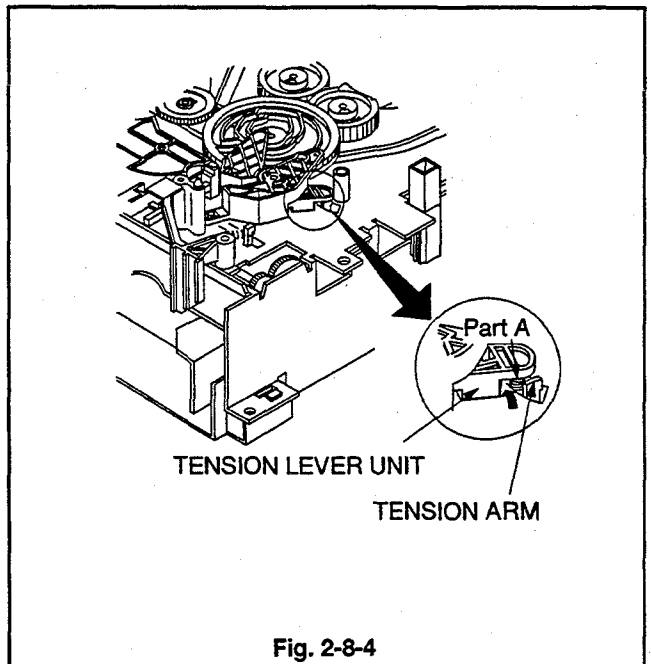
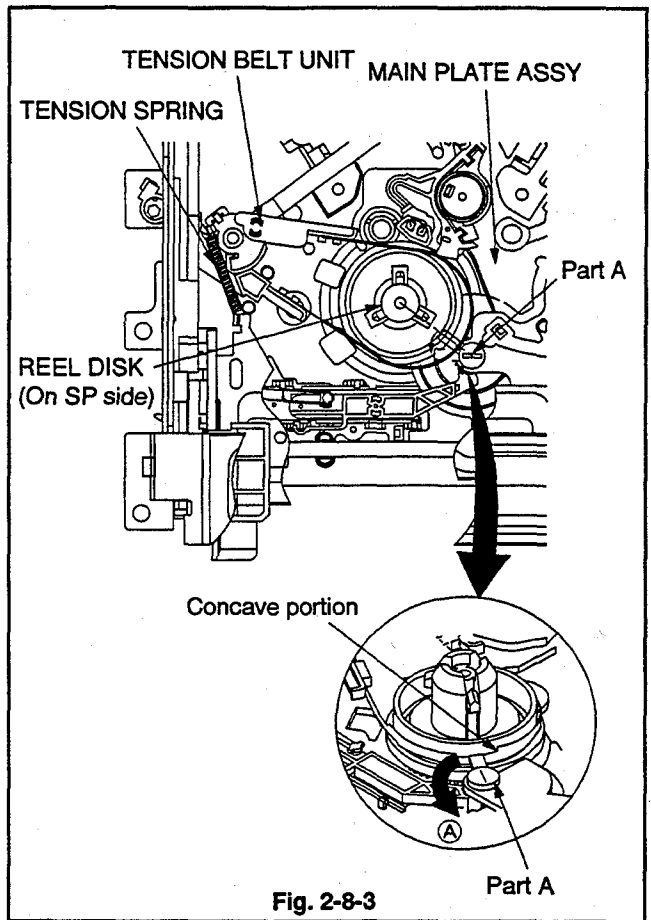

2-9. BRAKE SPRING (for MAIN BRAKE (SP)), MAIN BRAKE (SP), BRAKE SPRING (for MAIN BRAKE (TU)), MAIN BRAKE (TU)

SET POSITION : Normal

(Removal)

1. Remove the BRAKE SPRING (for MAIN BRAKE (SP)) shown in Fig. 2-9.
2. Use tweezers to unfasten Catch (a) of the MAIN BRAKE and remove the MAIN BRAKE (SP), refer to Fig 2-9.
3. Remove the BRAKE SPRING (for MAIN BRAKE (TU)) shown in Fig. 2-9.
4. Unfasten the Catch (b) of the MAIN BRAKE (TU) shown, in Fig. 2-9, to remove the MAIN BRAKE (TU).

(Installation)

1. Install the MAIN BRAKE (TU) shown in Fig. 2-9.
2. Install the BRAKE SPRING (for MAIN BRAKE (TU)) shown in Fig. 2-9.
3. Install the MAIN BRAKE (SP) shown in Fig. 2-9.
4. Install the BRAKE SPRING (for MAIN BRAKE (SP)) shown in Fig. 2-9.

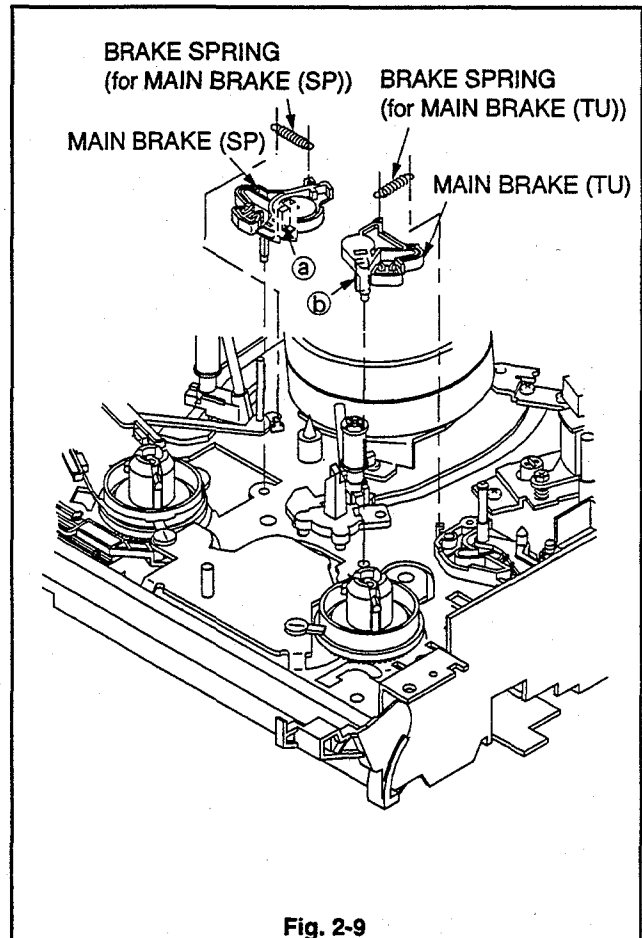

Fig. 2-9

2-10. REEL DISK (On SP side), REEL DISK (On TU side)

SET POSITION : Normal

To access the REEL DISK, remove the following parts :

- TENSION SPRING (Para. 2-8)
- TENSION ARM (Para. 2-8)
- TENSION BELT UNIT (Para. 2-8)

(Removal)

1. Move the MAIN BRAKE (SP) in the direction shown by arrow (A) hold it in that position. Remove the REEL DISK (On SP side) as shown in Fig. 2-10-1.
2. Use a minus driver to move Part B in the direction shown by arrow (B), as shown in Fig. 2-10-1.
3. Move the MAIN BRAKE (TU) in the direction shown by arrow (C) hold it in that position. Remove the REEL DISK (On TU side) as shown in Fig. 2-10-1.

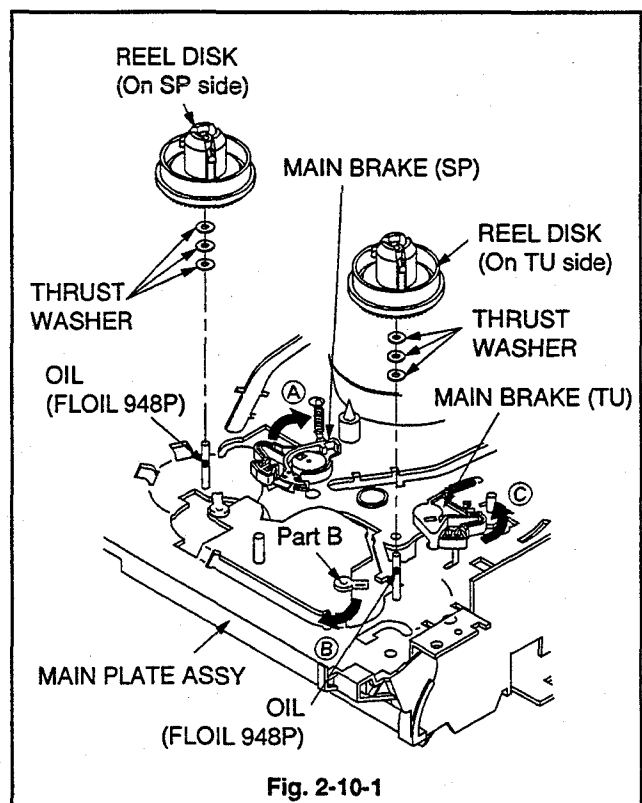

Fig. 2-10-1

(Installation)

1. Apply OIL (FLOIL 948P) [859D154O20] to the shaft, shown in Fig. 2-10-1, for the REEL DISK (On SP side) on the MAIN PLATE ASSY.
2. Install the REEL DISK (On SP side) shown in Fig. 2-10-1.
3. Place the height adjustment jig [MASTER PLANE] (859C342O20) shown in Fig. 2-10-2 in the reference position.
(Position the MASTER PLANE so that the points A, B and C of the MAIN PLATE ASSY support it.)
4. Place the height adjustment jig [SQUARE] (859C433O60) shown in Fig. 2-10-3 on the MASTER PLANE. Move it to the position shown in Fig. 2-10-3 and make sure that A can pass, but B cannot pass, under the REEL DISK (On SP side).
5. If the height of the REEL DISK (On SP side) is not correct, adjust the height by removing, or adding, a THRUST WASHER to the shaft, under the REEL DISK (On SP side).
 - If it is high, remove THRUST WASHER.
 - If it is low, add THRUST WASHER.
6. Install the TENSION BELT UNIT, TENSION ARM and TENSION SPRING.
(Refer to Para. 2-8 for the installation method.)
7. Make sure that the REEL DISK (On SP side), shown in Fig. 2-10-1 cannot come off.
8. Apply OIL (FLOIL 948P) [859D154O20] to the shaft, shown in Fig. 2-10-1, for the REEL DISK (On TU side) on the MAIN PLATE ASSY.
9. Install the REEL DISK (On TU side) shown in Fig. 2-10-1.
10. Install the height adjustment jig [MASTER PLANE] (859C342O20) shown in Fig. 2-10-3 in the reference position.
(Position the MASTER PLANE so that the points A, B and C of the MAIN PLATE ASSY support it.)
11. Place the height adjustment jig [SQUARE] (859C433O60) shown in Fig. 2-10-2 on the MASTER PLANE. Move it to the position shown in Fig. 2-10-4 and make sure that A can pass, but B cannot pass, under the REEL DISK (On TU side).
12. If the height of the REEL DISK (On TU side) is not correct, adjust the height by removing, or adding, a THRUST WASHER to the shaft under the REEL DISK (On TU side).
 - If it is high, remove THRUST WASHER.
 - If it is low, add THRUST WASHER.
13. Move Part B of the MAIN PLATE ASSY in the opposite direction of arrow ㊸, as shown in Fig. 2-10-1 so that it points to the centre of the REEL DISK (On TU side).
14. Make sure that the REEL DISK (On TU side) shown in Fig. 2-10-1 cannot come off.

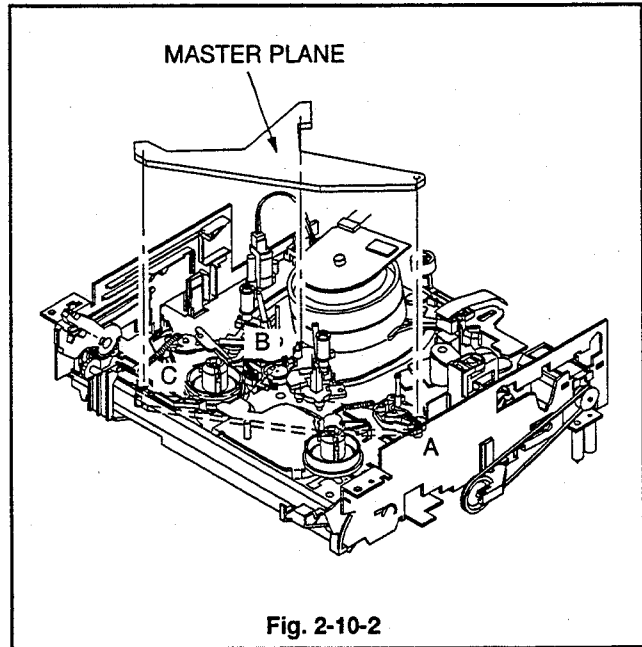

Fig. 2-10-2

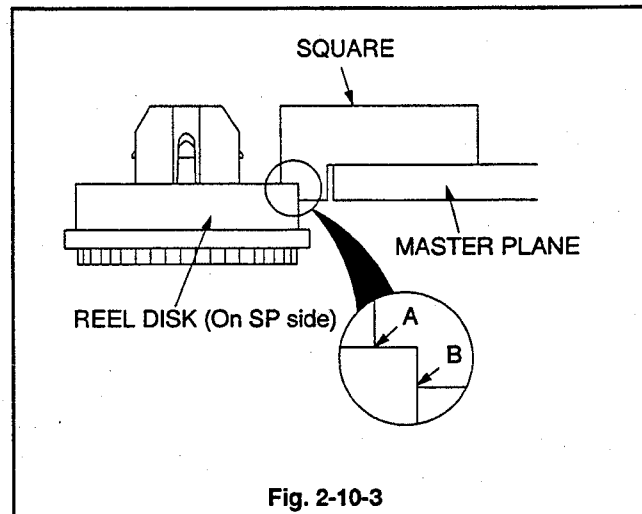

Fig. 2-10-3

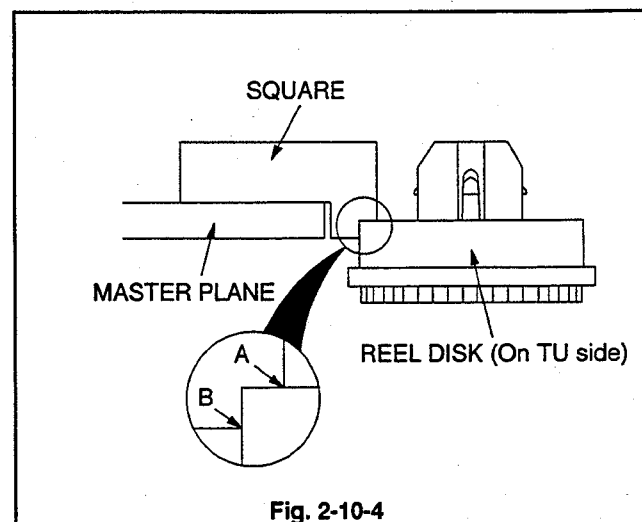

Fig. 2-10-4

2-11. LOADING BELT, LOADING MOTOR ASSY

SET POSITION : Normal

(Removal)

1. Remove the LOADING BELT shown in Fig. 2-11-1.
2. To remove the two LOADING MOTOR ASSY unfasten Catches (a) of the LOADING MOTOR ASSY, shown in Fig. 2-11-2, and unfasten the two Catches (b).

(Installation)

1. Install the LOADING MOTOR ASSY shown in Fig. 2-11-2.
2. Fasten the LOADING BELT shown in Fig. 2-11-1.

Note : Do not get GREASE or OIL on the LOADING BELT during installation.

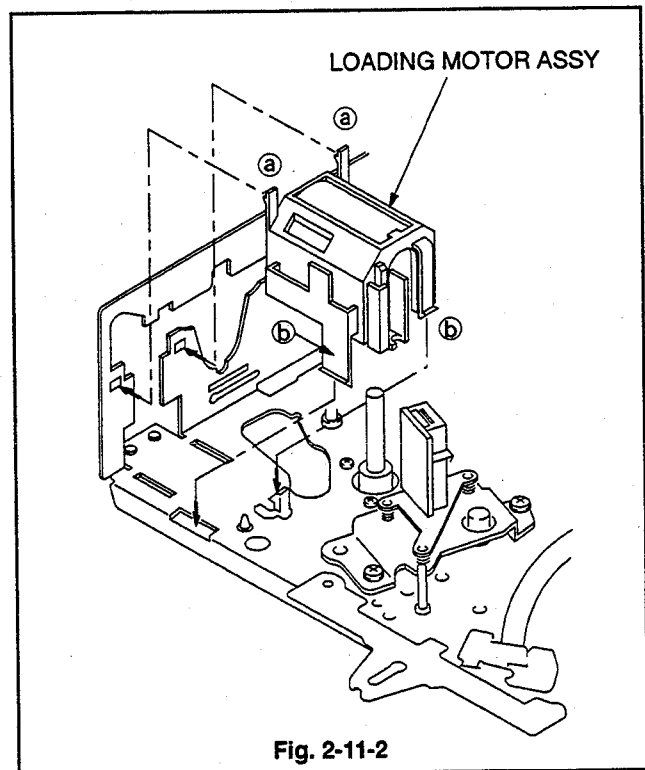
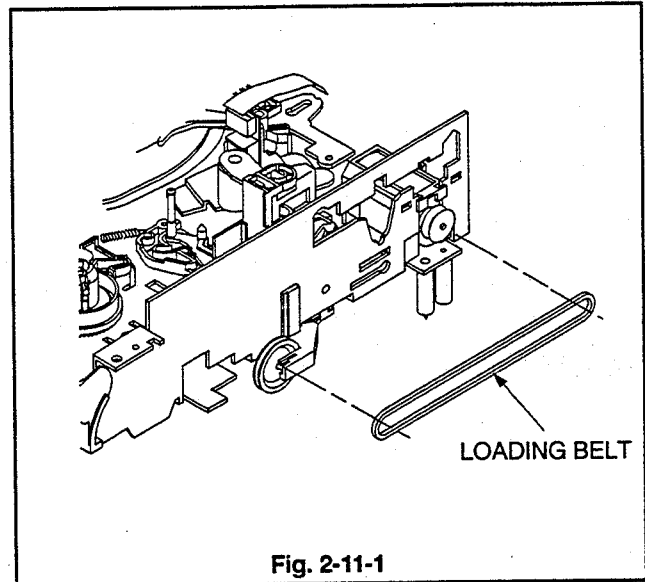

**2-12. PINCH ARM CAP 2,
PINCH ARM UNIT,
PINCH GEAR ARM 2,
PINCH CAM HOLDER,
PINCH CAM SPRING,
PINCH CAM LEVER,
PINCH RACK SLIDER,
PINCH CAM GEAR**

SET POSITION : Normal

(Removal)

1. Use tweezers to unfasten the two Catches (a) of the PINCH ARM CAP 2 shown in Fig. 2-12-1, and remove the PINCH ARM CAP 2.
2. Move the PINCH ARM UNIT in the direction shown by arrow (A) to remove it as shown in Fig. 2-12-1.
3. Remove the PINCH GEAR ARM 2 shown in Fig. 2-12-1.
4. Remove the PINCH CAM SPRING shown in Fig. 2-12-1.
5. Remove the PINCH CAM LEVER shown in Fig. 2-12-1.
6. Unfasten the Catch (b) of the PINCH RACK SLIDER shown in Fig. 2-12-1. Move the PINCH RACK SLIDER in the direction shown by arrow (B) to remove it.
7. Remove the screw (c) of the PINCH CAM HOLDER shown in Fig. 2-12-1, to remove the PINCH CAM HOLDER.
8. Remove the PINCH CAM GEAR shown in Fig. 2-12-1.

(Installation)

1. Apply GREASE (MULTEMP SH-A) [859D055O80] to the area specified in Fig. 2-12-2 on the new PINCH CAM GEAR.

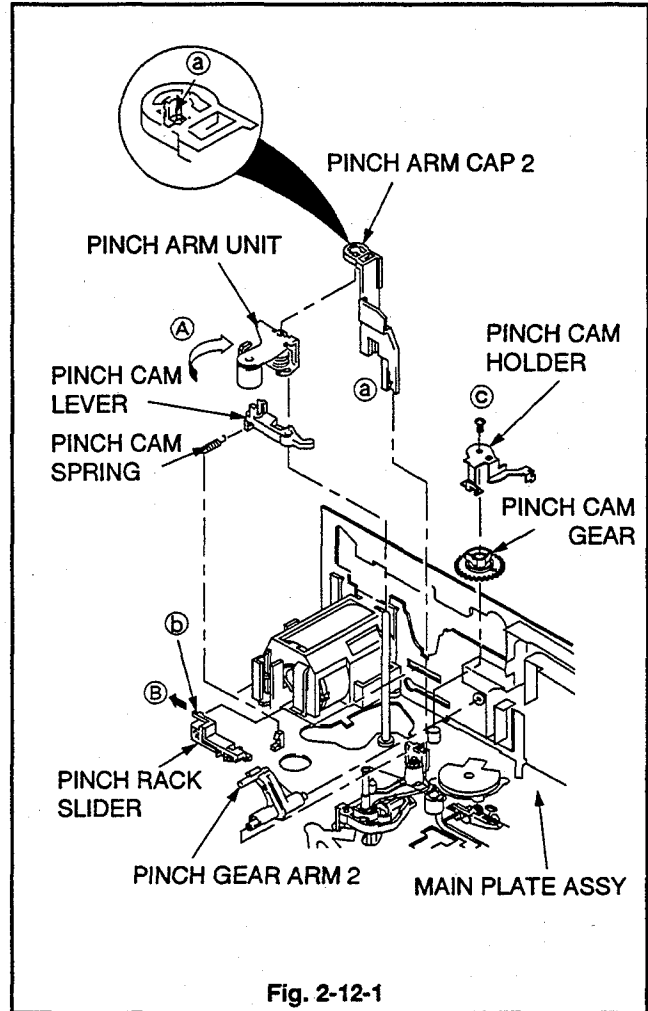

Fig. 2-12-1

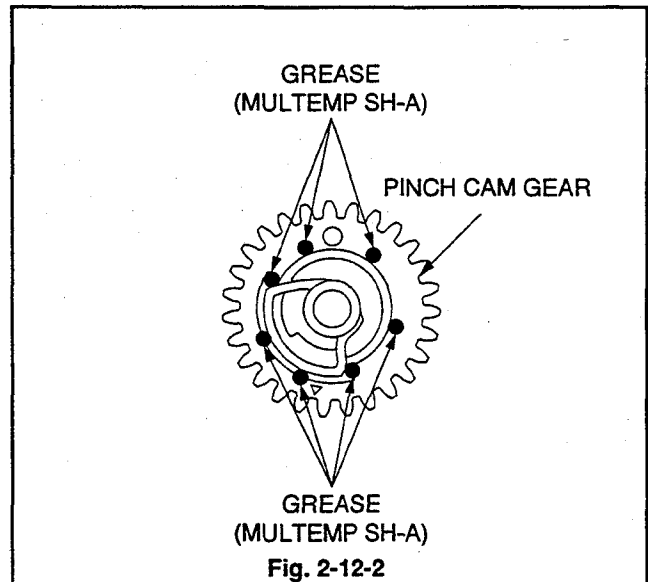
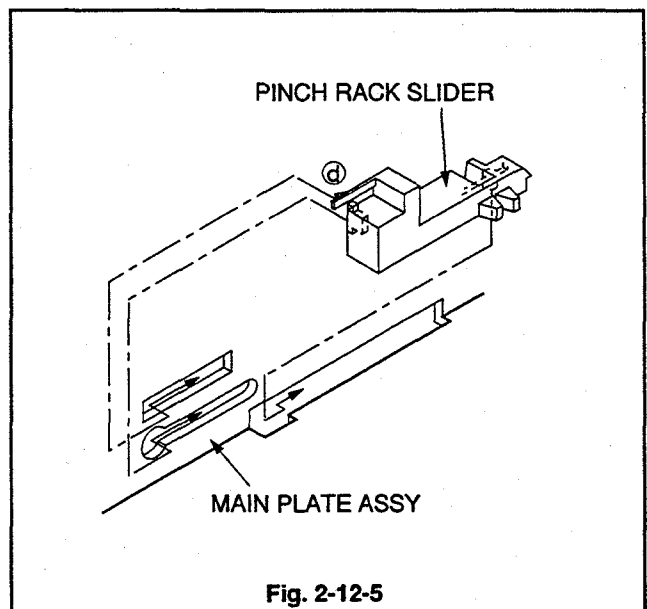
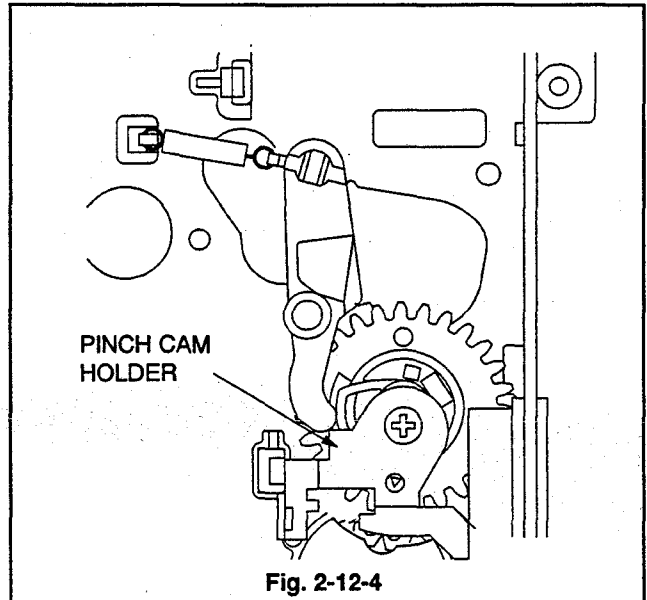
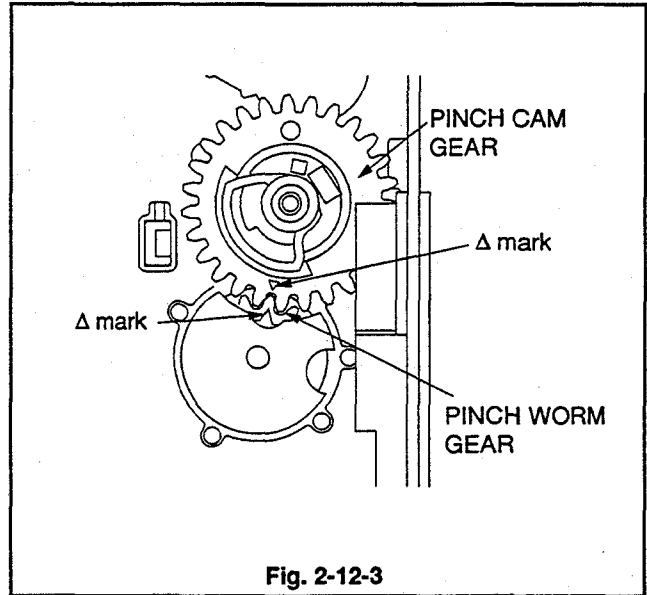
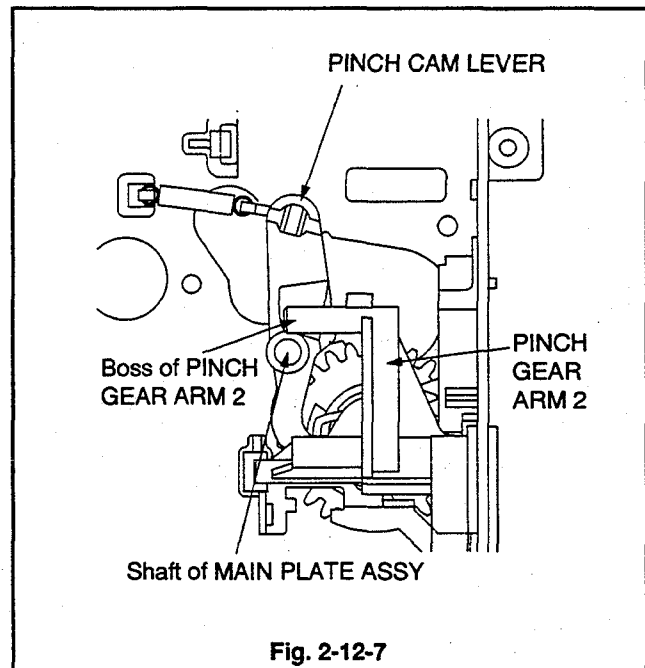
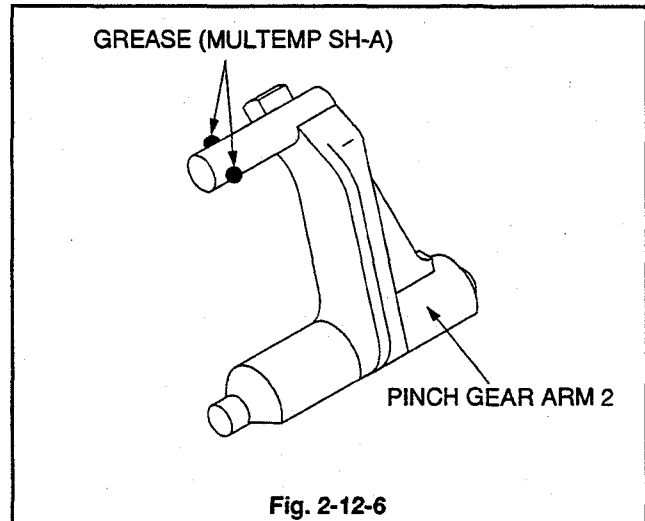

Fig. 2-12-2

2. Set the PINCH CAM GEAR so that the Δ mark on it matches with the Δ mark on the PINCH WORM GEAR as shown in Fig. 2-12-3 and install it.
3. Install the PINCH CAM HOLDER on the position shown in Fig. 2-12-4.
4. Move the PINCH RACK SLIDER in the direction shown by arrow in Fig. 2-12-5.
5. Make sure that the Catch (Ⓞ) of the PINCH RACK SLIDER enters the Hole of the MAIN PLATE ASSY, as shown in Fig. 2-12-5.
6. Install the PINCH CAM LEVER shown in Fig. 2-12-1.
7. Install the PINCH CAM SPRING shown in Fig. 2-12-1.



8. Apply GREASE (MULTEMP SH-A) [859D055O80] to the area specified in Fig. 2-12-6 on the new PINCH GEAR ARM 2.
9. Install the PINCH GEAR ARM 2 shown in Fig. 2-12-7 so that the boss of the PINCH GEAR ARM 2 and the shaft of the MAIN PLATE ASSY are positioned as shown.
10. Move the PINCH ARM UNIT in the opposite direction of arrow (A) to install it as shown in Fig. 2-12-1.
11. Install the PINCH ARM CAP 2 shown in Fig. 2-12-1.



2-13.GUIDE ARM ASSY (TU), GUIDE SPRING (TU), LOADING TG LEVER

SET POSITION : Normal

(Removal)

1. Remove the NYLON NUT, shown in Fig. 2-13-1 to remove the SL WASHER (a), the GUIDE ARM ASSY (TU) and GUIDE SPRING (TU).
2. Remove the CUT WASHER (b) holding the LOADING TG LEVER shown in Fig. 2-13-1.
3. To remove the two LOADING TG LEVER unfasten Catches (c) of the LOADING TG LEVER shown in Fig. 2-13-1.

(Installation)

1. Apply GREASE (MULTEMP SH-A) [859D055O80] to the area specified in Fig. 2-13-2 on the new LOADING TG LEVER.
2. Install the LOADING TG LEVER shown in Fig. 2-13-1.
3. Install the CUT WASHER (b) shown in Fig. 2-13-1 to fasten the LOADING TG LEVER.

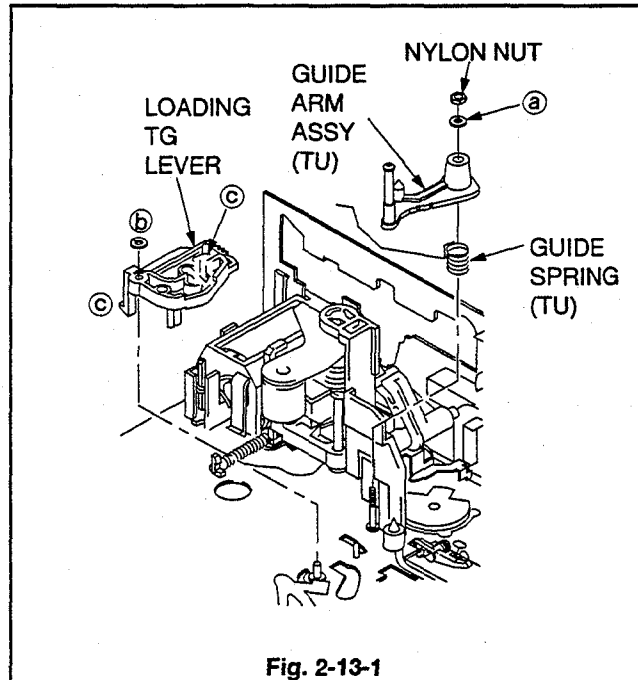

Fig. 2-13-1

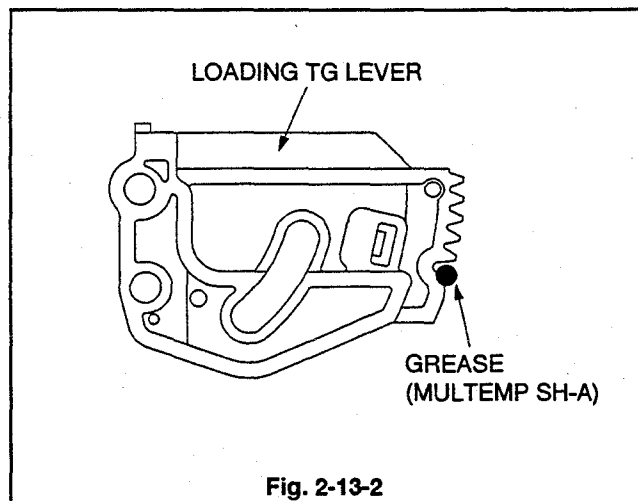
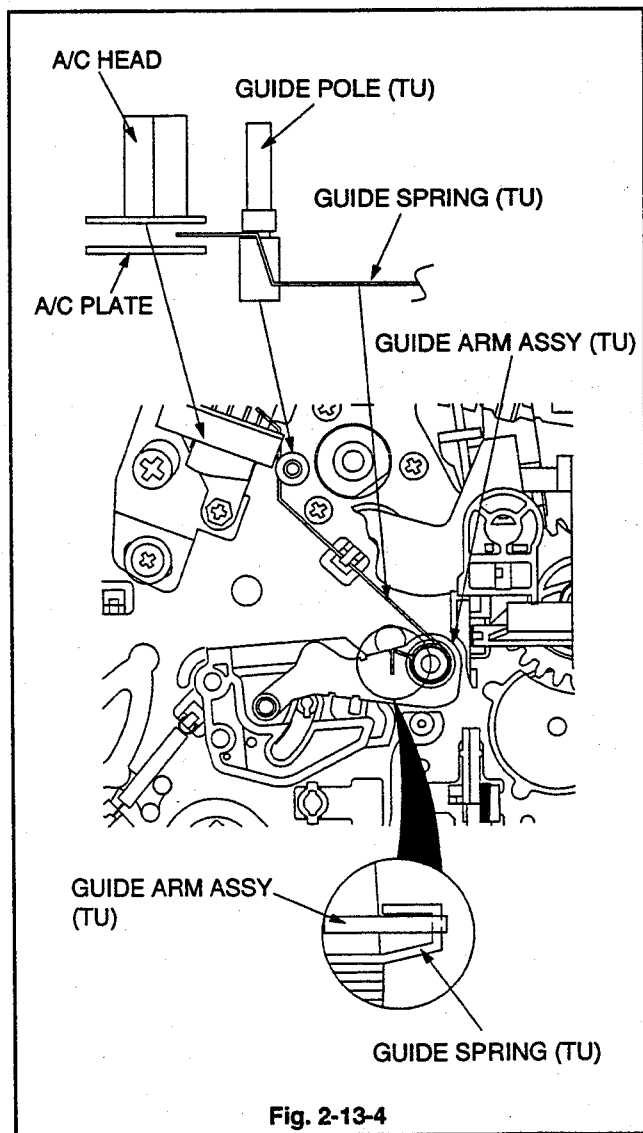
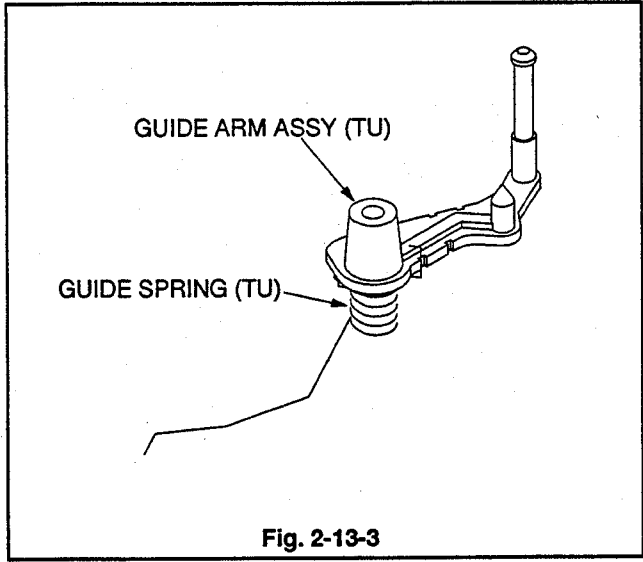
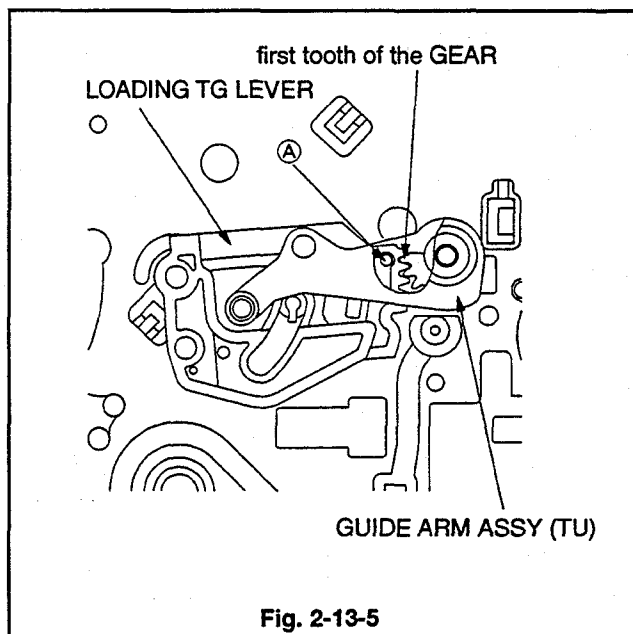

Fig. 2-13-2

4. Fix the GUIDE SPRING (TU) to the GUIDE ARM ASSY (TU) as shown in Fig. 2-13-3.
5. Fix the GUIDE ARM ASSY (TU) with the GUIDE SPRING (TU) attached, to the shaft of the MAIN PLATE ASSY, as shown in Fig. 2-13-1.
6. Install the GUIDE SPRING (TU) on the position shown in Fig. 2-13-4.



7. Install the GUIDE ARM ASSY (TU) so that the first tooth of the GEAR of the GUIDE ARM ASSY (TU), shown in Fig. 2-13-5, matches with Hole (A) of the LOADING TG LEVER.
8. Install the SL WASHER (A) and NYLON NUT shown in Fig. 2-13-1.
9. Perform "Adjustment of GUIDE ARM ASSY (TU) Height" in Para. 3-5 of "Interchangeability Adjustment of the Mechanism".



2-14. REC SPRING, REC LEVER

SET POSITION : Upside down

(Removal)

1. Remove the REC SPRING shown in Fig. 2-14.
2. Move the REC LEVER in the direction shown by arrow (A) until it strikes on the MAIN PLATE ASSY and remove it as shown in Fig. 2-14.

(Installation)

1. Insert the Catch of the REC LEVER, shown in Fig. 2-14, into the Hole of the MAIN PLATE ASSY and install the REC LEVER.
2. Install the REC SPRING shown in Fig. 2-14.

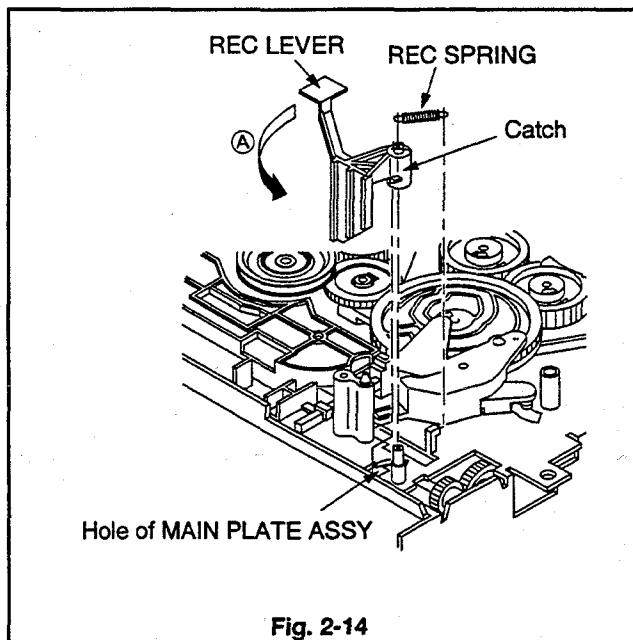

2-15. REEL BELT, BELT PULLEY, SHIFT SPRING

SET POSITION : Upside down

(Removal)

1. Remove the REEL BELT shown in Fig. 2-15.
2. Remove the CUT WASHER (a) fastening the BELT PULLEY shown in Fig. 2-15, and remove the BELT PULLEY.
3. Remove the SHIFT SPRING shown in Fig. 2-15.

(Installation)

1. Install the SHIFT SPRING shown in Fig. 2-15.
2. Fasten the BELT PULLEY shown in Fig. 2-15.
3. Install the CUT WASHER (a) shown in Fig. 2-15 to fasten the BELT PULLEY.
4. Install the REEL BELT shown in Fig. 2-15.

Note : Do not get GREASE or OIL on the REAL BELT during installation.

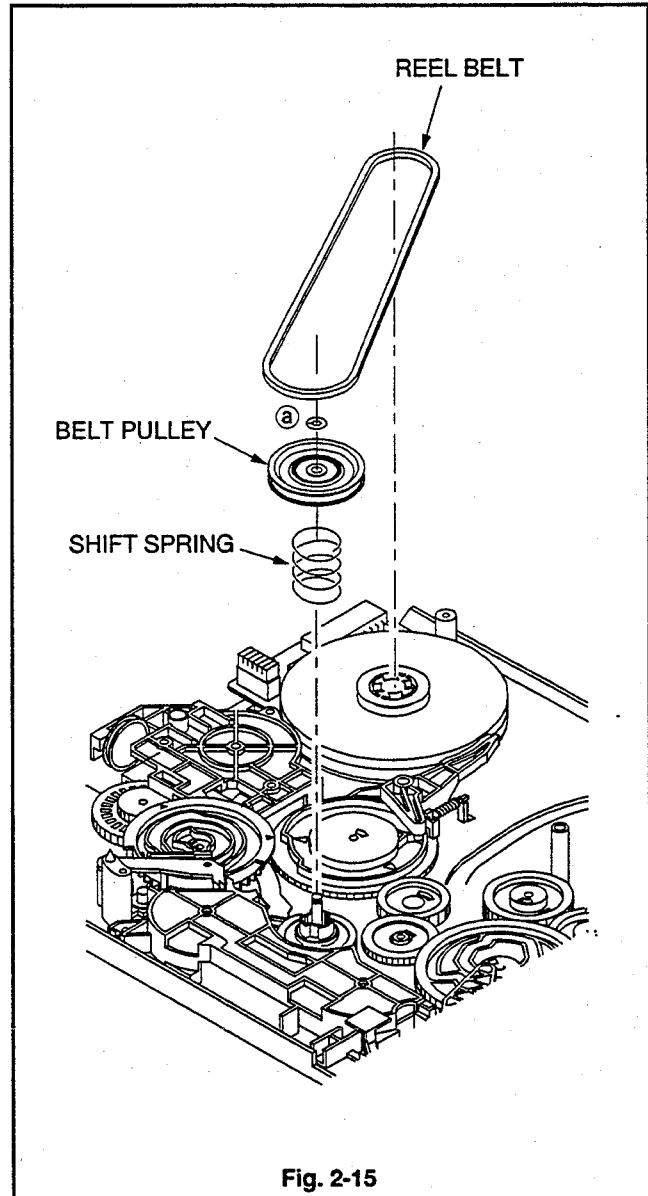

Fig. 2-15

2-16. CAPSTAN BRAKE SPRING, CAPSTAN BRAKE UNIT 2

SET POSITION : Upside down

To access CAPSTAN BRAKE SPRING and CAPSTAN BRAKE UNIT 2, remove the REEL BELT. (Para. 2-15)

(Removal)

1. Remove the CAPSTAN BRAKE SPRING shown in Fig. 2-16.
2. Remove the CUT WASHER (a) fastening the CAPSTAN BRAKE UNIT 2 shown in Fig. 2-16.
3. Use tweezers to unfasten Catch (b) on the surface of the CAPSTAN BRAKE UNIT 2 shown in Fig. 2-16, and remove the CAPSTAN BRAKE UNIT 2.

(Installation)

1. Install the CAPSTAN BRAKE UNIT 2 shown in Fig. 2-16.

Note : Do not get GREASE or OIL on the area specified in Fig. 2-16 during installation of the CAPSTAN BRAKE UNIT 2.

2. Install the CUT WASHER (a) shown in Fig. 2-16 to fasten the CAPSTAN BRAKE UNIT 2.
3. Install the CAPSTAN BRAKE SPRING shown in Fig. 2-16.

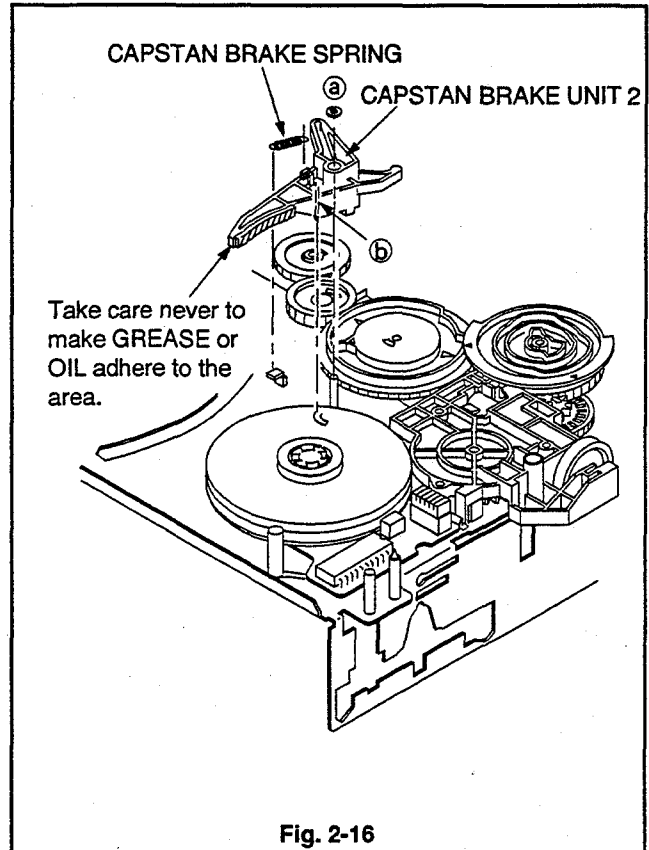

2-17. MODE HOLDER, REEL LOCK LEVER, MODE GEAR, F/L DRIVE GEAR, F/L DRIVE LEVER, WORM PULLEY UNIT, LOADING WORM GEAR

SET POSITION : Upside down

(Removal)

1. Use tweezers to unfasten Catch (a) on the surface of the REEL LOCK LEVER shown in Fig. 2-17-1, and remove the REEL LOCK LEVER.
2. Remove the MODE HOLDER fastening screw (b) shown in Fig. 2-17-1, and remove the MODE HOLDER.
3. Use tweezers to unfasten Catch (c) of the SNAP PIN shown in Fig. 2-17-1, and remove the SNAP PIN.
4. Use tweezers to Unfasten Catch (d) on the surface of the MODE GEAR, shown in Fig. 2-17-1, and remove the MODE GEAR.
5. Remove the F/L DRIVE GEAR, shown in Fig. 2-17-1, from the shaft of the MAIN PLATE ASSY.
6. Remove the F/L DRIVE LEVER shown in Fig. 2-17-1.

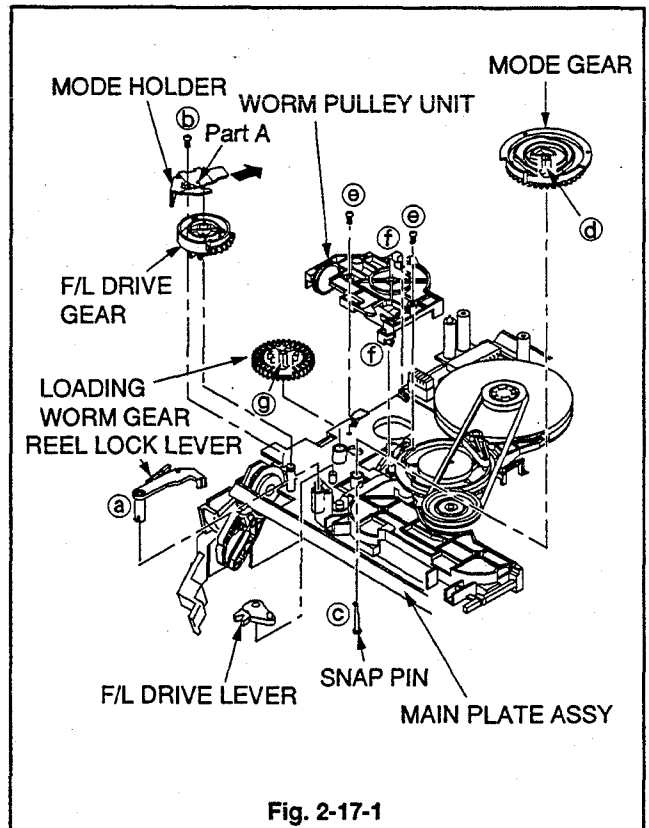

7. Remove the two WORM PULLEY UNIT fastening screws (⊙) shown in Fig. 2-17-1.
8. Remove the LOADING BELT.
(Refer to Para. 2-11 for the removal method.)
9. Unfasten the two Catches (Ⓢ) of the WORM PULLEY UNIT shown in Fig. 2-17-1 to remove the WORM PULLEY UNIT.
10. Unfasten the Catch (⊙) on the surface of the LOADING WORM GEAR, shown in Fig. 2-17-1, and remove the LOADING WORM GEAR.

(Installation)

1. Apply GREASE (MULTEMP SH-A) [859D055O80] to the area specified in Fig. 2-17-2 on the new LOADING WORM GEAR.
2. Install the LOADING WORM GEAR shown in Fig. 2-17-1.
3. Turn the WORM PULLEY shown in Fig. 2-17-3 so that the Round Hole on PINCH WORM GEAR matches with that on WORM HOLDER.
4. Install the WORM PULLEY UNIT so that the Δ mark on the LOADING WORM GEAR, shown in Fig. 2-17-4, matches with the Part A.
5. Fasten the LOADING BELT. (Refer to Para. 2-11.)
6. Install the F/L DRIVE LEVER shown in Fig. 2-17-1.

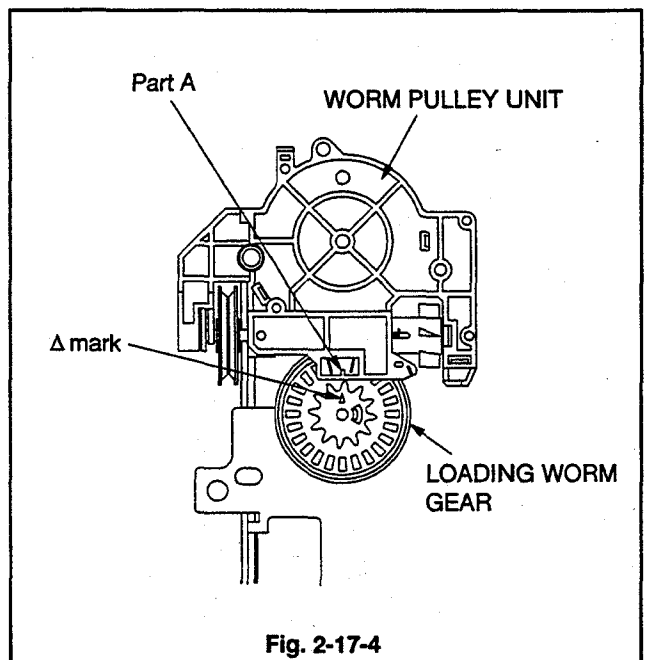
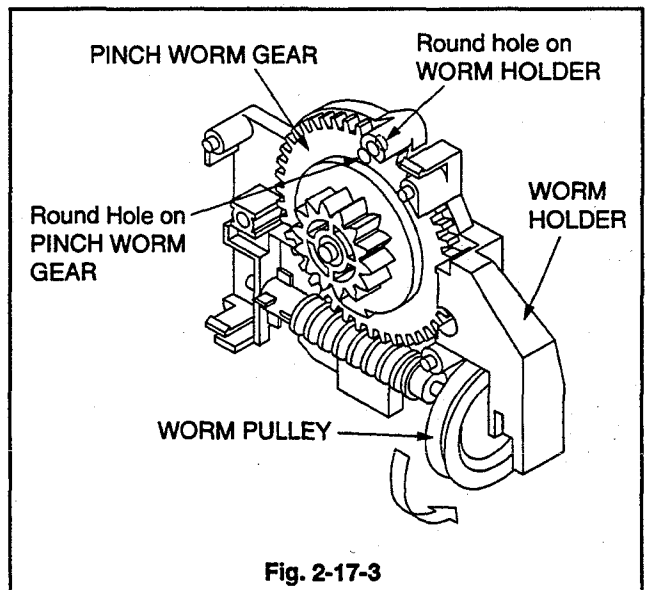
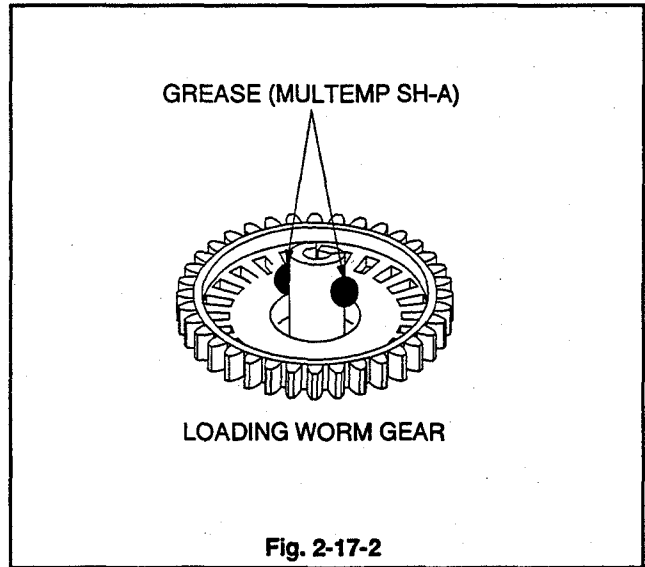

7. Fully move the F/L DRIVE LEVER shown in Fig. 2-17-5, in the direction shown by arrow (A).
8. Apply GREASE (MULTEMP SH-A) [859D055O80] to the area specified in Fig. 2-17-6 on the new F/L DRIVE GEAR.
9. Move the F/L ARM UNIT (TU) shown in Fig. 2-17-7, in the direction shown by arrow (A).

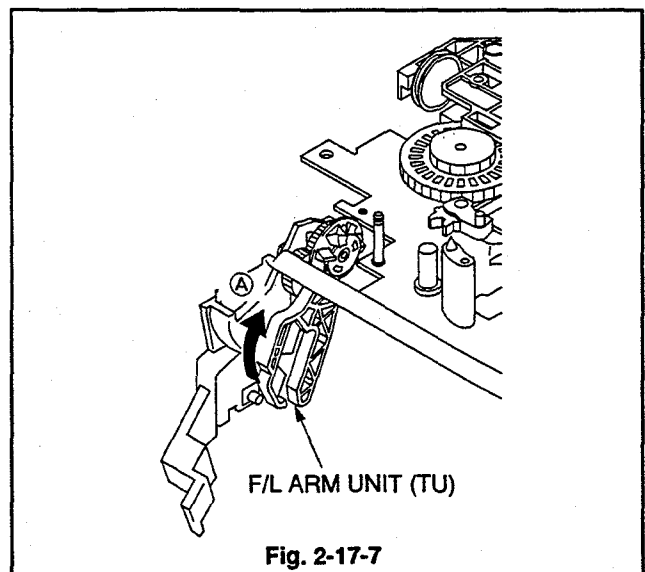
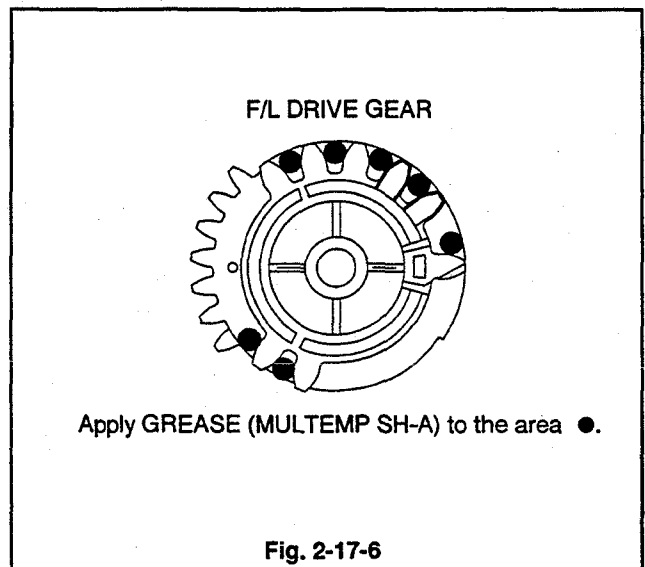
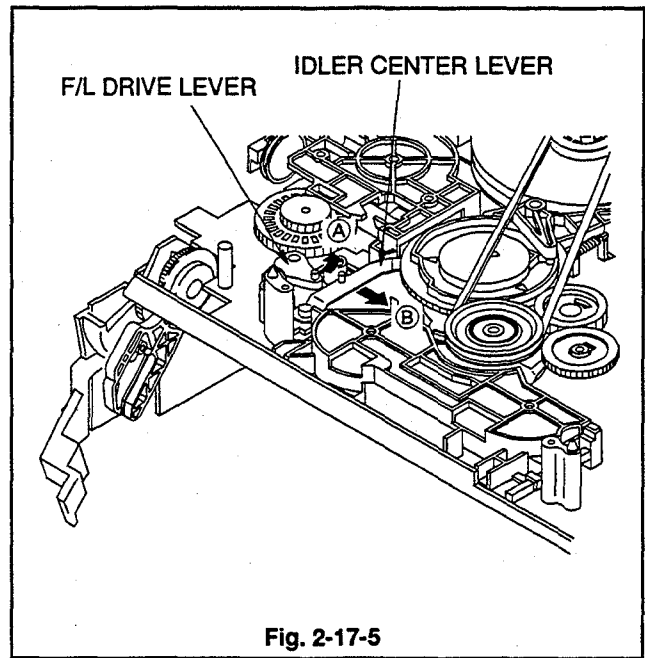

10. Install the F/L DRIVE GEAR so that the first tooth of the gear of the F/L ARM UNIT (TU) matches with the II mark on the F/L DRIVE GEAR, as shown in Fig. 2-17-8.
11. Fully move the IDLER CENTER LEVER, shown in Fig. 2-17-5, in the direction shown by arrow ㊟.
12. Apply GREASE (MULTEMP SH-A) [859D055O80] to the area shown in Fig. 2-17-9 on the new MODE GEAR.
13. Install the MODE GEAR shown in Fig. 2-17-10 so that ;
 - Δ mark on the Part A of the MODE GEAR matches with Δ mark on the Part B of the CAM GEAR (TU).
 - Δ mark on the Part C of the MODE GEAR points to the centre of the LOADING WORM GEAR.
 - Δ mark on the Part D of the MODE GEAR matches with the \circ mark on the Part E of the F/L DRIVE GEAR.
14. Make sure that the Δ mark on the PINCH WORM GEAR, shown in Fig. 2-12-3, matches with the Δ mark on the PINCH CAM GEAR .
15. Push the SNAP PIN, shown in Fig. 2-17-1, into the centre hole of the MODE GEAR.
16. Move the MODE HOLDER shown in Fig. 2-17-1, in the direction shown by arrow so that the Part A is fixed to the shaft of the MAIN PLATE ASSY and install it.

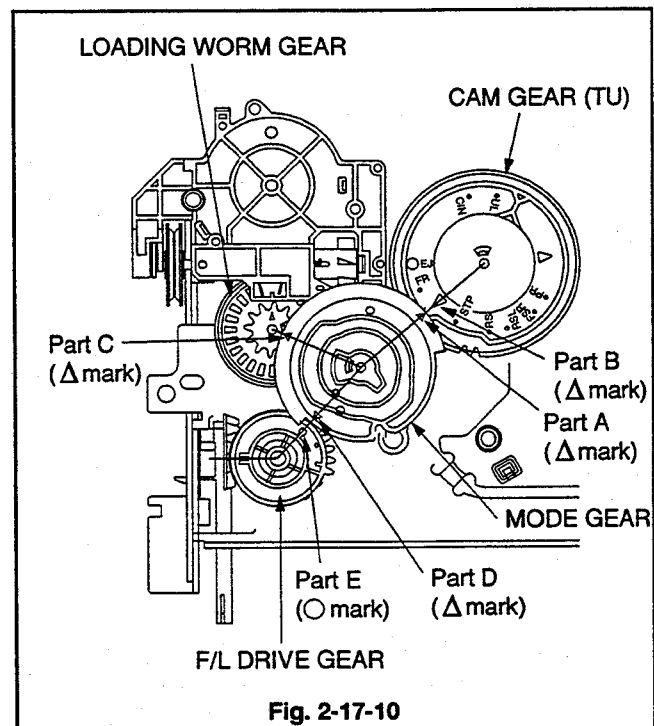
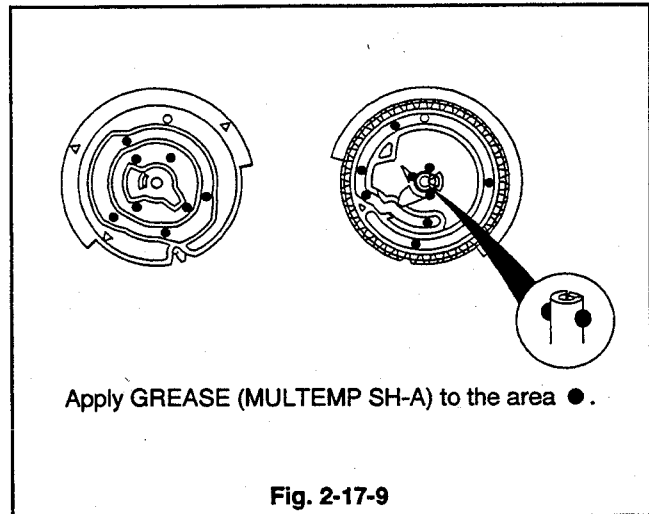
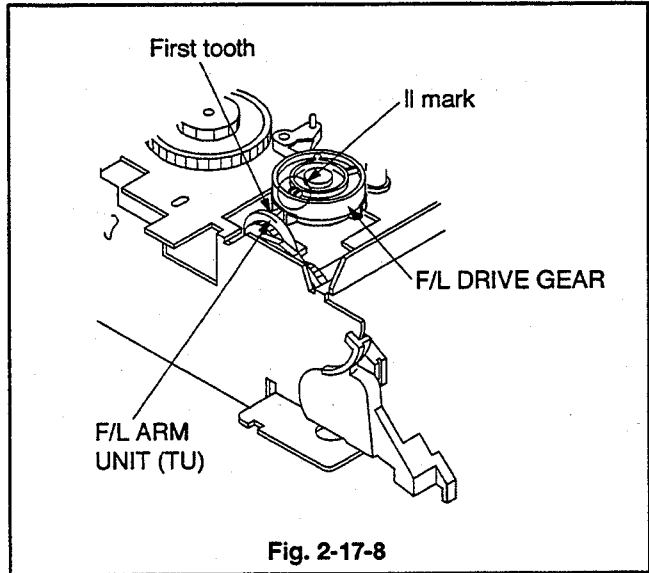

17. Install the REEL LOCK LEVER so that the pins on the Parts F and G of the REEL LOCK LEVER, shown in Fig. 2-17-11, enter the Cam Groove of the MODE GEAR.

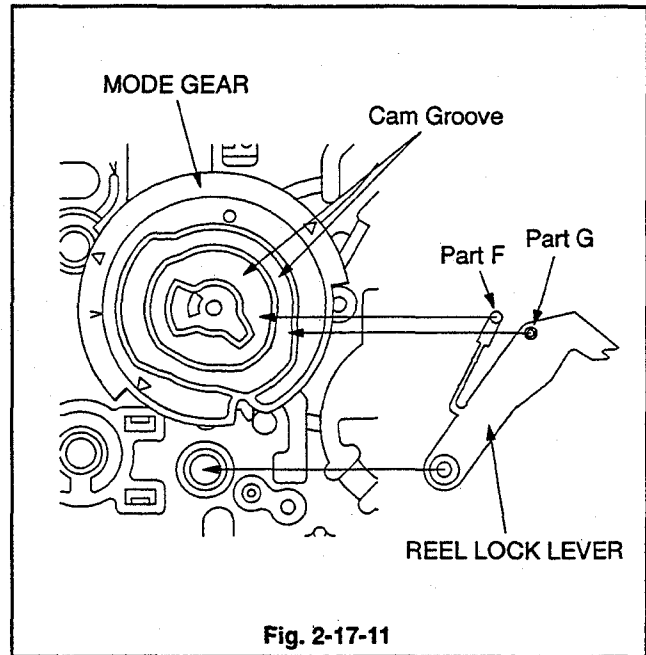

2-18. CONTROL WIND LEVER, TENSION LEVER UNIT

SET POSITION : Upside down

(Removal)

1. Use tweezers to unfasten Catch (Ⓐ) on the surface of the CONTROL WIND LEVER, shown in Fig. 2-18-1, and remove the CONTROL WIND LEVER.
2. Remove the TENSION LEVER UNIT shown in Fig. 2-18-1.

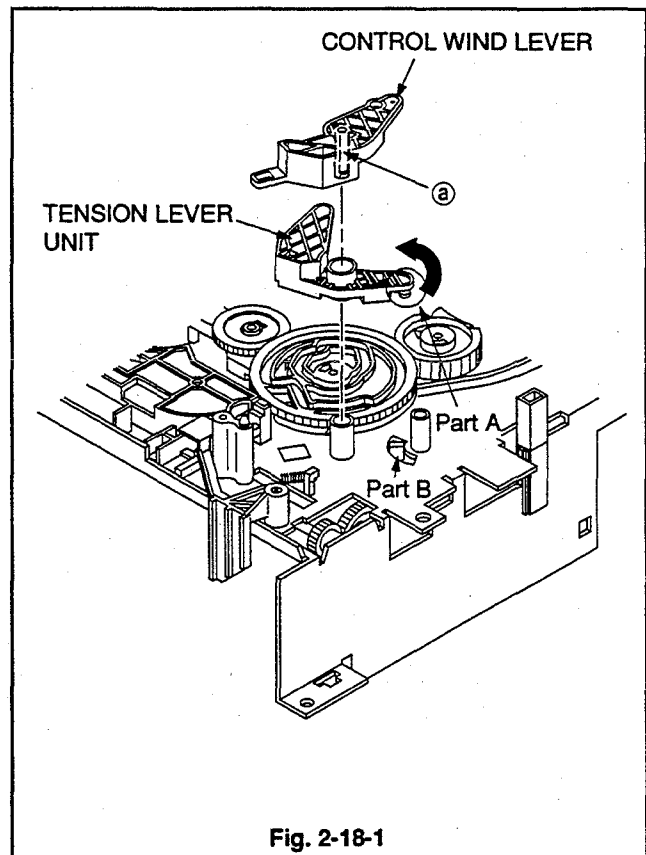

(Installation)

1. Apply GREASE (MULTEMP SH-A) [859D055O80] to the area specified in Fig. 2-18-2 on the new TENSION LEVER UNIT.
2. Install the TENSION LEVER UNIT shown in Fig. 2-18-1, by the following, procedure :
 - Make sure the pin on the Part A of the TENSION LEVER UNIT, shown in Fig. 2-18-3 enters the Cam Groove on the CAM GEAR (SP).
 - Move the Part A of the spring of the TENSION LEVER UNIT, shown in Fig. 2-18-1 in the direction shown by arrow. Install the TENSION LEVER UNIT so that the Part A of the spring is hooked to the Part B of the TENSION ARM.
3. Apply GREASE (MULTEMP SH-A) [859D055O80] to the area specified in Fig. 2-18-4 on the new CONTROL WIND LEVER.
4. Install the CONTROL WIND LEVER so that the pin on the Part B on the CONTROL WIND LEVER shown in Fig. 2-18-3, enters the Cam Groove on the CAM GEAR (SP), and that the pin of the Part D of the WIND LEVER UNIT enters the Hole of the Part C on the CONTROL WIND LEVER.

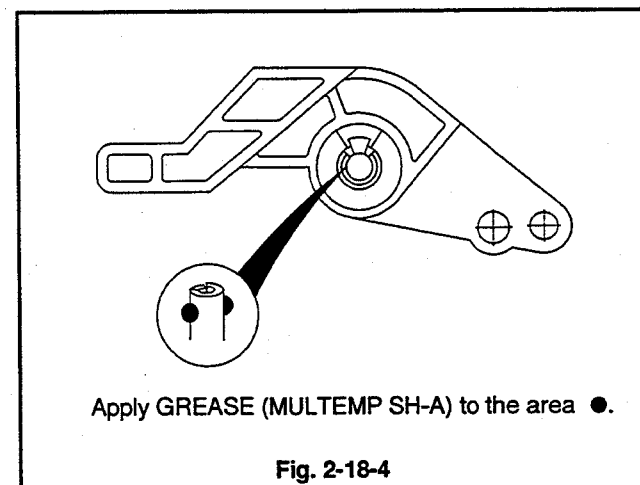
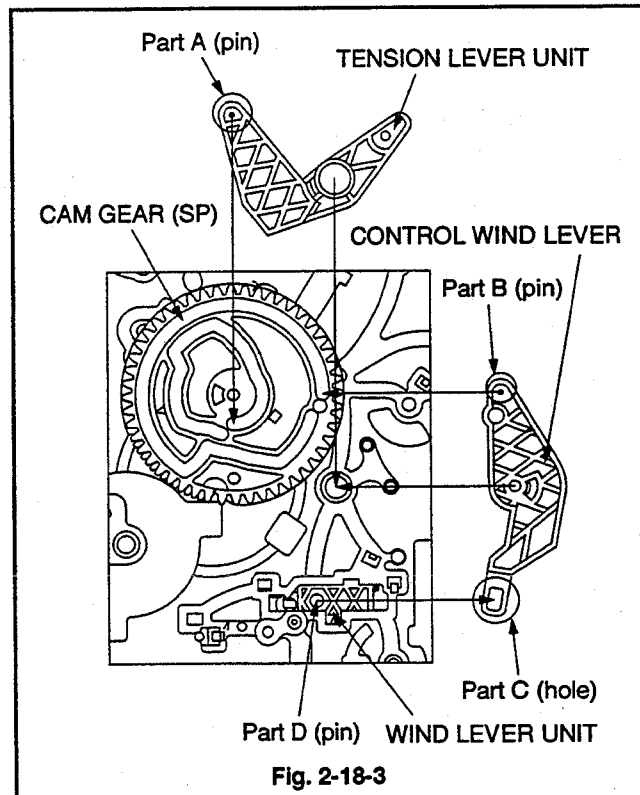
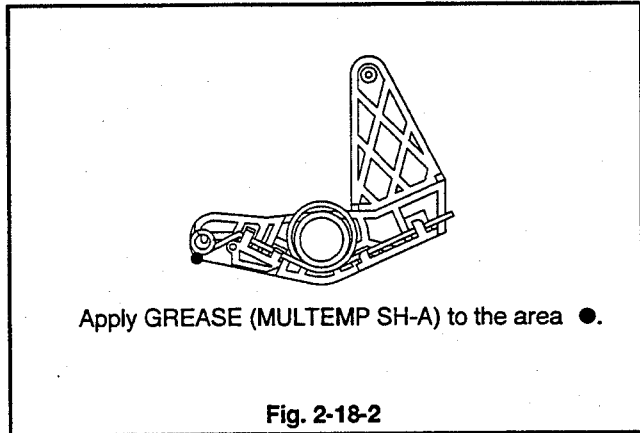

2-19. PHOTO GUIDE UNIT (SP), PHOTO GUIDE UNIT (TU)

SET POSITION : Upside down

To access PHOTO GUIDE UNIT(SP) and PHOTO GUIDE UNIT(TU), remove the following parts :

- LOADING BELT (Para. 2-11)
- MODE HOLDER (Para. 2-17)
- REEL LOCK LEVER (Para. 2-17)
- MODE GEAR (Para. 2-17)
- WORM PULLEY UNIT (Para. 2-17)

(Removal)

1. Use tweezers to unfasten Catch (Ⓐ) of the PHOTO GUIDE UNIT (SP), shown in Fig. 2-19-1, and remove the PHOTO GUIDE UNIT (SP) in the direction shown by arrow.
2. Remove the PHOTO GUIDE UNIT (TU), shown in Fig. 2-19-2, in the direction shown by arrow.

(Installation)

1. Push the PHOTO GUIDE UNIT (TU) into the DECK to the bottom, with the Part A shown in Fig. 2-19-2 toward the inside of DECK.

Note : Do not touch the transparent part A of the PHOTO GUIDE UNIT (TU).

2. Push the PHOTO GUIDE UNIT (SP) into the DECK so that the Catch (Ⓐ) is hooked, with the Part A shown in Fig. 2-19-1 toward the inside of DECK.

Note : Do not touch the transparent part A of the PHOTO GUIDE UNIT(SP).

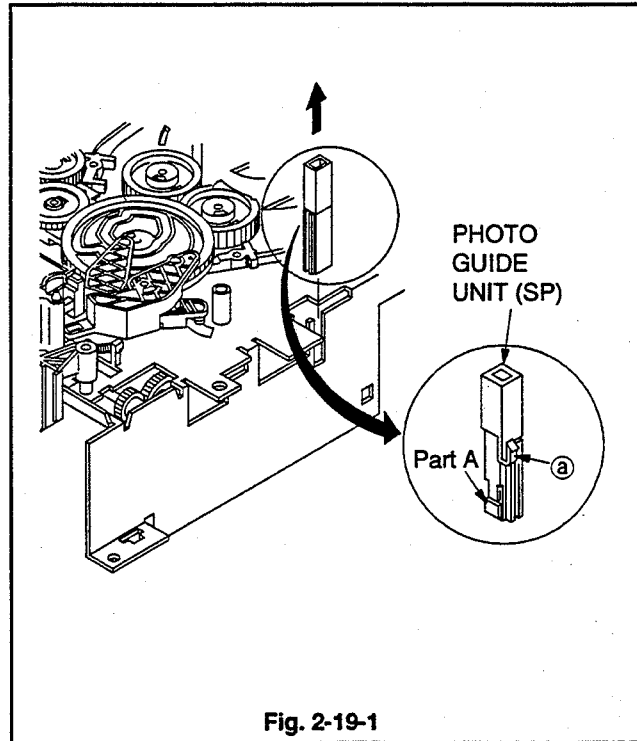

Fig. 2-19-1

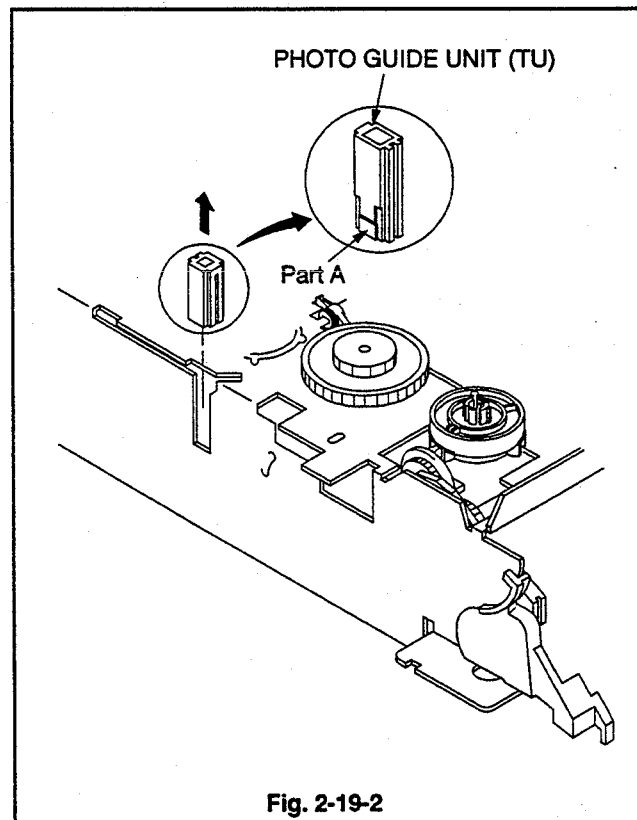

Fig. 2-19-2

2-20. PLATE LD, LOADING GEAR, LAMP LOADING GEAR

SET POSITION : Upside down

To access **LOADING GEAR** and **LAMP LOADING GEAR**, remove the following parts :

- LAMP GUIDE (Para. 2-7)
- REEL BELT (Para. 2-15)

(Removal)

1. Release the catches (©) of four **SNAP PIN LD**s securing **PLATE LD** as shown in Fig. 2-20-1, and remove **SNAP PIN LD**.
2. Use tweezers to unfasten Catch (Ⓐ) on the surface of the **LOADING GEAR**, shown in Fig. 2-20-1, and remove the **LOADING GEAR**.
3. Use tweezers to unfasten Catch (Ⓑ) on the surface of the **LAMP LOADING GEAR**, shown in Fig. 2-20-1, and remove the **LAMP LOADING GEAR**.

(Installation)

1. Install the **PLATE LD** and four **SNAP PIN LD**s shown in Fig. 2-20-1.
2. Apply **GREASE (MULTEMP SH-A)** [859D055O80] to the area specified in Fig. 2-20-2 on the new **LAMP LOADING GEAR**.
3. Install the **LAMP LOADING GEAR** shown in Fig. 2-20-1.
4. Apply **GREASE (MULTEMP SH-A)** [859D055O80] to the area specified in Fig. 2-20-2 on the new **LOADING GEAR**.
5. Install the **LOADING GEAR** shown in Fig. 2-20-1.

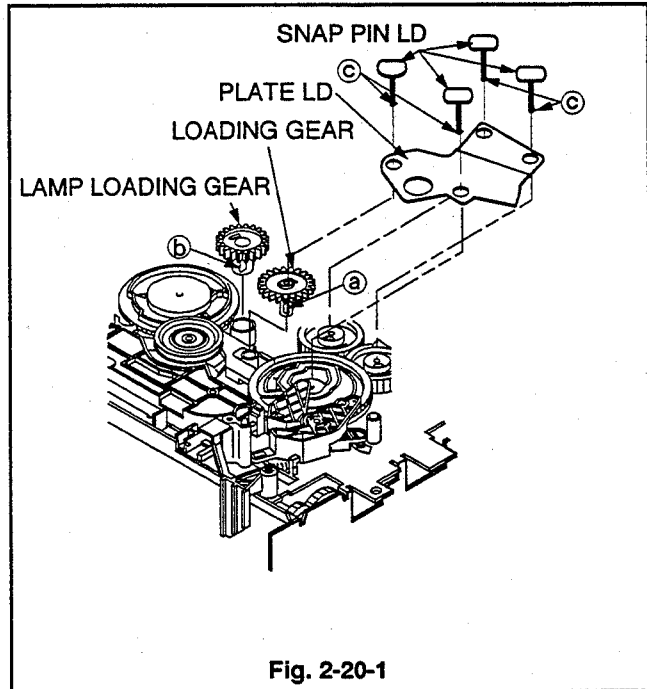

Fig. 2-20-1

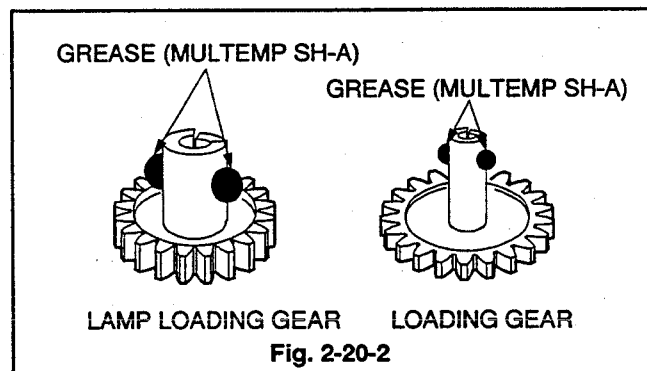

Fig. 2-20-2

2-21. CAM GEAR (TU)

SET POSITION : Upside down

To access the **CAM GEAR(TU)**, remove the following parts.

- **LOADING BELT** (Para. 2-11)
- **REEL BELT** (Para. 2-15)
- **CAPSTAN BRAKE SPRING** (Para. 2-16)
- **CAPSTAN BRAKE UNIT 2** (Para. 2-16)
- **MODE HOLDER** (Para. 2-17)
- **REEL LOCK LEVER** (Para. 2-17)
- **MODE GEAR** (Para. 2-17)

(Removal)

1. Use tweezers to unfasten the Catch (Ⓐ) on the surface of the **CAM GEAR (TU)**, shown in Fig. 2-21-1, and remove the **CAM GEAR (TU)**.

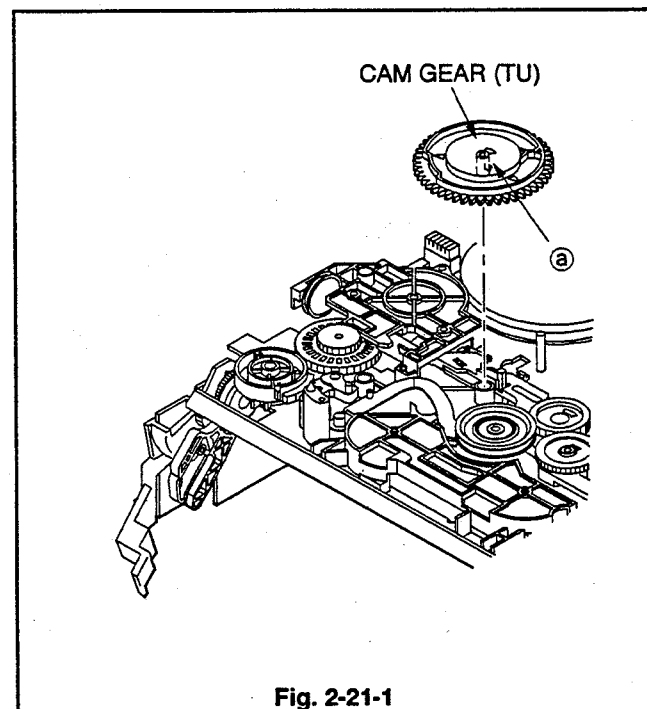

Fig. 2-21-1

(Installation)

1. Apply GREASE (MULTEMP SH-A) [859D055O80] to the area specified in Fig. 2-21-2 on the new CAM GEAR (TU).
2. Set the CAM GEAR (SP), shown in Fig. 2-21-3, so that the Δ mark on the Part A of it points to the centre of the LOADING GEAR.
3. Install the CAM GEAR (TU), shown in Fig. 2-21-3, so that the Δ mark on the Part B of it points to the centre of the LAMP LOADING GEAR.

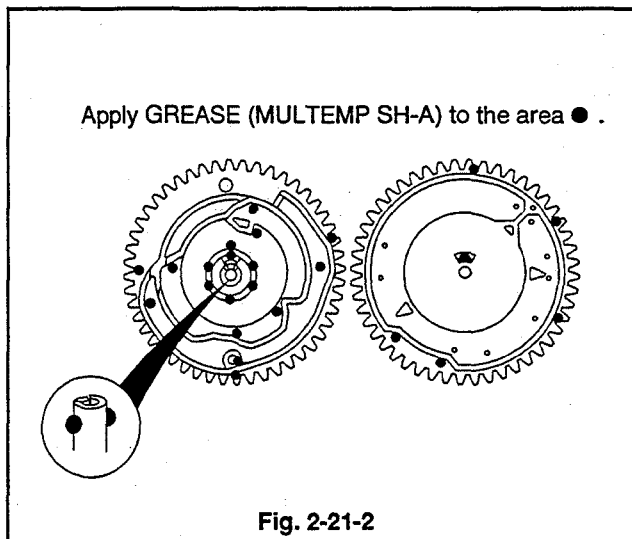

Fig. 2-21-2

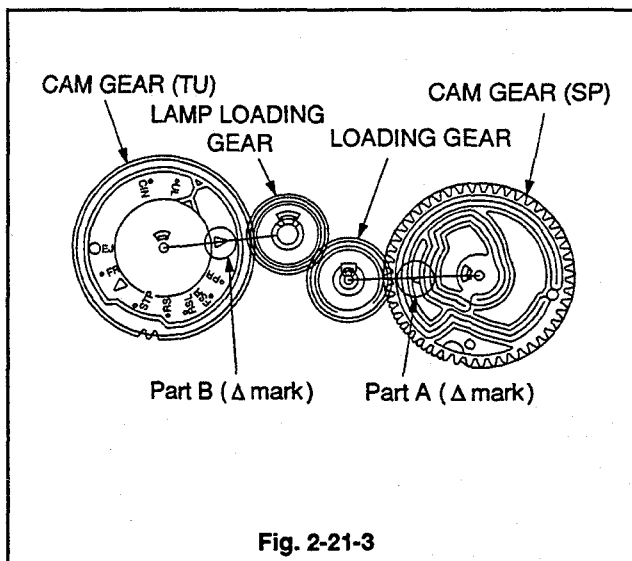

Fig. 2-21-3

**2-22. PHOTO UNIT,
REEL GEAR UNIT (TU),
REEL GEAR UNIT (SP)**

SET POSITION : Upside down

(Removal)

1. Move the REC LEVER, shown in Fig. 2-14-1, in the direction shown by arrow (A). Unfasten Catches (a) of the PHOTO UNIT, and Catches (b) of the MAIN PLATE ASSY, shown in Fig. 2-22-1, to remove the PHOTO UNIT.
2. Remove the REEL GEAR UNIT (TU) shown in Fig. 2-22-1.
3. Remove the REEL GEAR UNIT (SP) shown in Fig. 2-22-1.

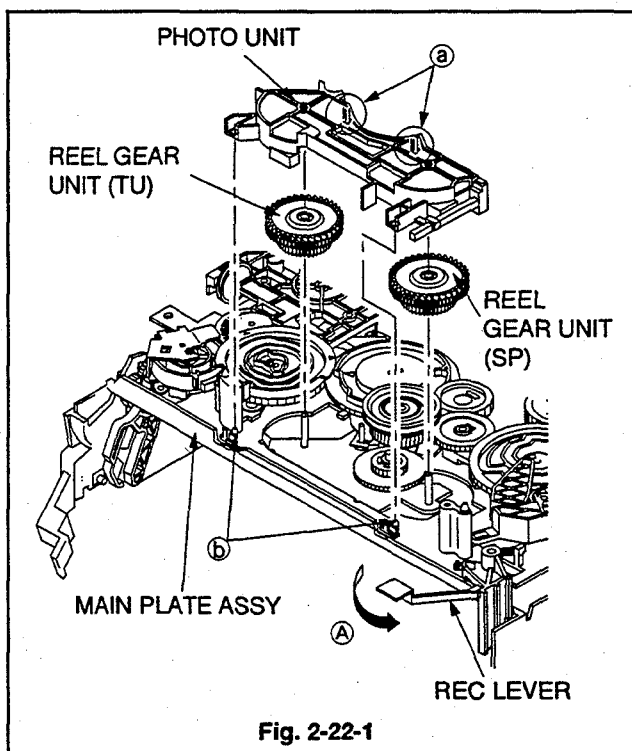

Fig. 2-22-1

(Installation)

1. Apply OIL (FLOIL 948P) [859D154O20] to the shaft on the MAIN PLATE ASSY, shown in Fig.2-22-2.
2. Install the REEL GEAR UNIT (SP) shown in Fig. 2-22-2.

Note : Make sure the colour of the spring is correct, refer to the table in Fig. 2-22-2, when installing the REEL GEAR UNIT (SP).

3. Apply OIL (FLOIL 948P) [859D154O20] to the shaft on the MAIN PLATE ASSY, refer to Fig.2-22-2.
4. Install the REEL GEAR UNIT (TU) shown in Fig. 2-22-1.

Note : Make sure the colour of the spring is correct. Refer to the table in Fig. 2-22-2, when installing the REEL GEAR UNIT(TU).

5. Apply a small quantity of OIL (FLOIL 948P) [859D154O20] to the area specified in Fig. 2-22-3 on the new PHOTO UNIT.
6. Install the PHOTO UNIT shown in Fig. 2-22-1.

Part Name	Colour of Spring
REEL GEAR UNIT (SP)	Gold
REEL GEAR UNIT (TU)	Silver

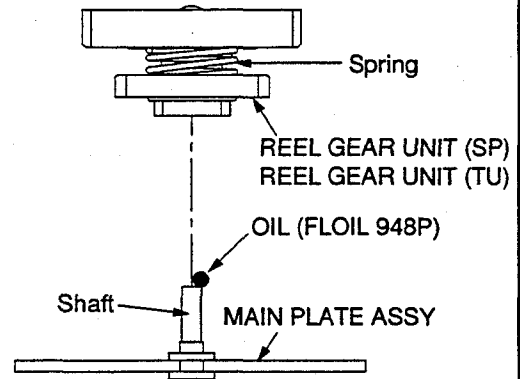

Fig. 2-22-2

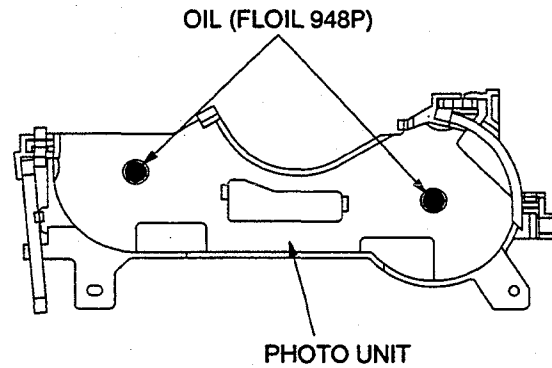

Fig. 2-22-3

2-23.IDLER CENTER LEVER

SET POSITION : Upside down

To access IDLER CENTER LEVER, remove the following Parts :

- LOADING BELT (Para. 2-11)
- REEL BELT (Para. 2-15)
- CAPSTAN BRAKE SPRING (Para. 2-16)
- CAPSTAN BRAKE UNIT 2 (Para. 2-16)
- MODE HOLDER (Para. 2-17)
- REEL LOCK LEVER (Para. 2-17)
- MODE GEAR (Para. 2-17)
- CAM GEAR (TU) (Para. 2-21)
- PHOTO UNIT (Para. 2-22)

(Removal)

1. Remove the IDLER CENTER LEVER shown in Fig. 2-23-1.

(Installation)

1. Insert the Part A of the IDLER CENTER LEVER, shown in Fig. 2-23-2 into the Part B of the IDLER UNIT, when installing the IDLER CENTER LEVER.

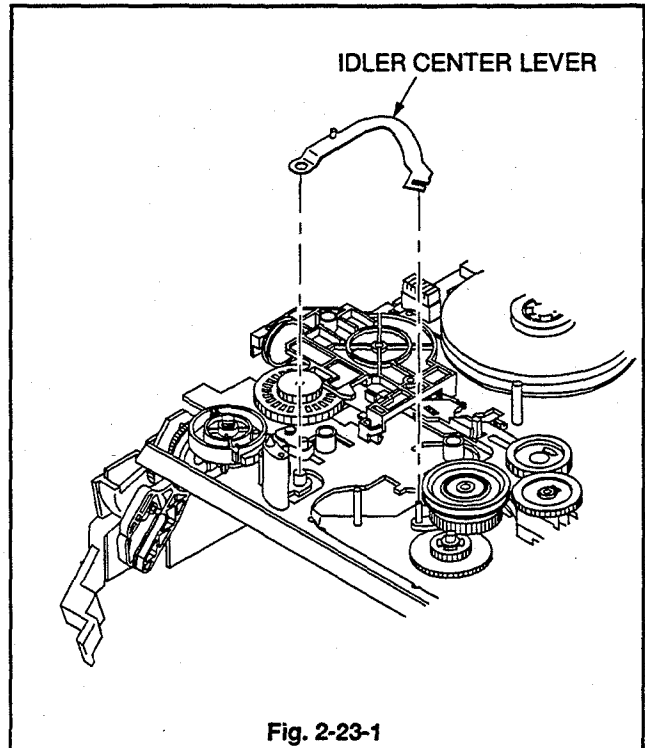

Fig. 2-23-1

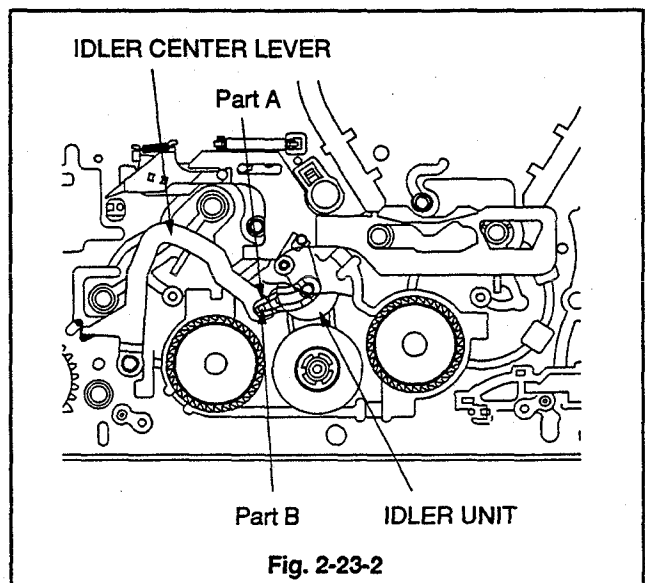

Fig. 2-23-2

2-24. PULLEY GEAR, IDLER UNIT

SET POSITION : Upside down

To access the PULLEY GEAR and IDLER UNIT, remove following parts :

- LOADING BELT (Para. 2-11)
- REEL BELT (Para. 2-15)
- CAPSTAN BRAKE SPRING (Para. 2-16)
- CAPSTAN BRAKE UNIT 2 (Para. 2-16)
- MODE HOLDER (Para. 2-17)
- REEL LOCK LEVER (Para. 2-17)
- MODE GEAR (Para. 2-17)
- CAM GEAR (TU) (Para. 2-21)
- PHOTO UNIT (Para. 2-22)
- IDLER CENTER LEVER (Para. 2-23)

(Removal)

1. Remove the PULLEY GEAR shown in Fig. 2-24.
2. Remove the IDLER UNIT shown in Fig. 2-24.

(Installation)

1. Apply OIL (FLOIL 948P) [859D154O20] to the shaft for the IDLER UNIT, shown in Fig.2-24.
2. Apply OIL (FLOIL 948P) [859D154O20] to the area specified in Fig. 2-24 on the new IDLER UNIT.
3. Install the IDLER UNIT shown in Fig. 2-24.
4. Install the PULLEY GEAR shown in Fig. 2-24.

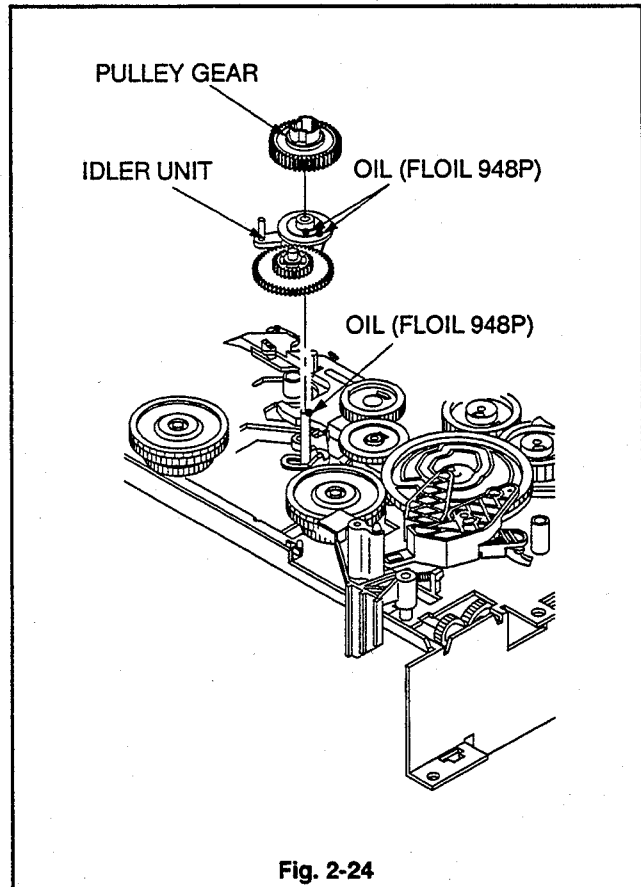

Fig. 2-24

2-25. F/L ARM UNIT (SP)

SET POSITION : Normal

To access the F/L ARM UNIT(SP), remove the following parts :

- STAY PLATE (Para. 2-2)
- BOTTOM UNIT (Para. 2-3)

(Removal)

1. Move the F/L ARM UNIT (SP) fully in the direction shown by arrow (A), as shown in Fig. 2-25-1.
2. Unfasten the Catch (a) of the F/L ARM UNIT (SP), shown in Fig. 2-25-1, to remove the F/L ARM UNIT (SP).

(Installation)

1. Move the F/L ARM UNIT (TU) fully in the direction shown by arrow (A), as shown in Fig. 2-26-1.
2. Install the F/L ARM UNIT (SP) so that the gear of the F/L ARM UNIT (SP) and that of the SYNC GEAR ASSY are engaged as shown in Fig. 2-25-2.

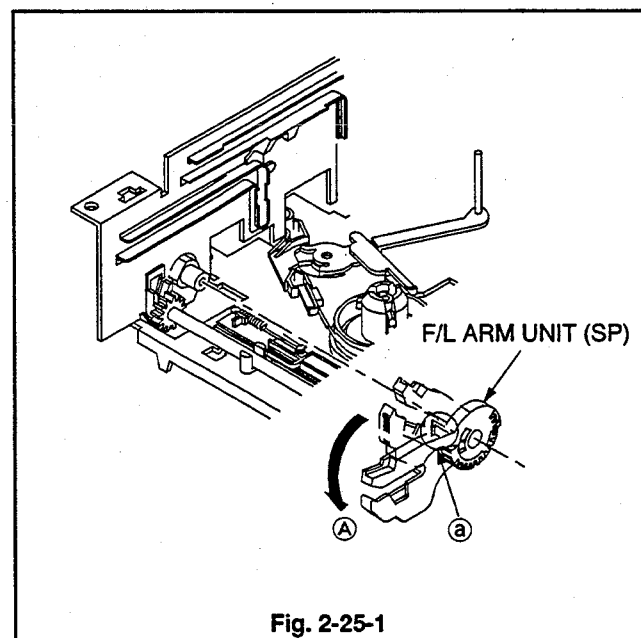
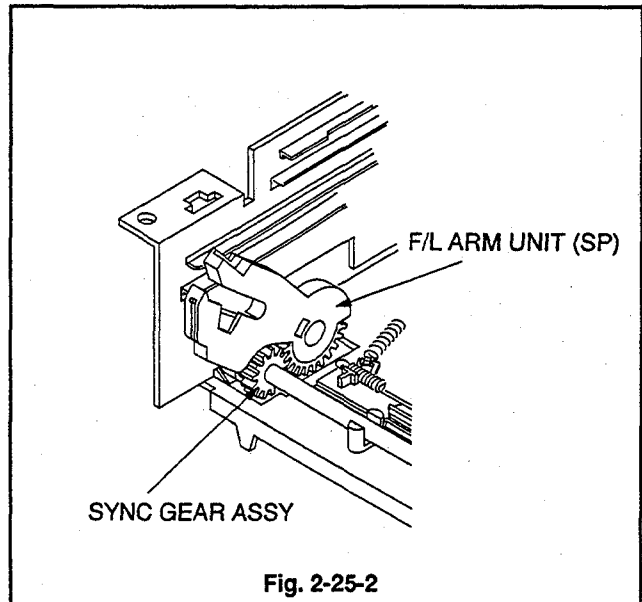

Fig. 2-25-1



2-26. F/L ARM UNIT (TU)

SET POSITION : Normal

To access the F/L ARM UNIT(TU), remove following parts :

- STAY PLATE (Para. 2-2)
- BOTTOM UNIT (Para. 2-3)
- LOADING BELT (Para. 2-11)
- MODE HOLDER (Para. 2-17)
- REEL LOCK LEVER (Para. 2-17)
- MODE GEAR (Para. 2-17)
- F/L DRIVE GEAR (Para. 2-17)
- F/L DRIVE LEVER (Para. 2-17)

(Removal)

1. Move the F/L ARM UNIT (TU) fully in the direction shown by arrow (A), as shown in Fig. 2-26-1.
2. Unfasten the Catch (a) of the F/L ARM UNIT (TU), shown in Fig. 2-26-1, to remove the F/L ARM UNIT (TU).

(Installation)

1. Move the F/L ARM UNIT (SP), shown in Fig. 2-25-1, fully in the direction shown by arrow (A).
2. Install the F/L ARM UNIT (TU) in the position shown in Fig. 2-26-2.

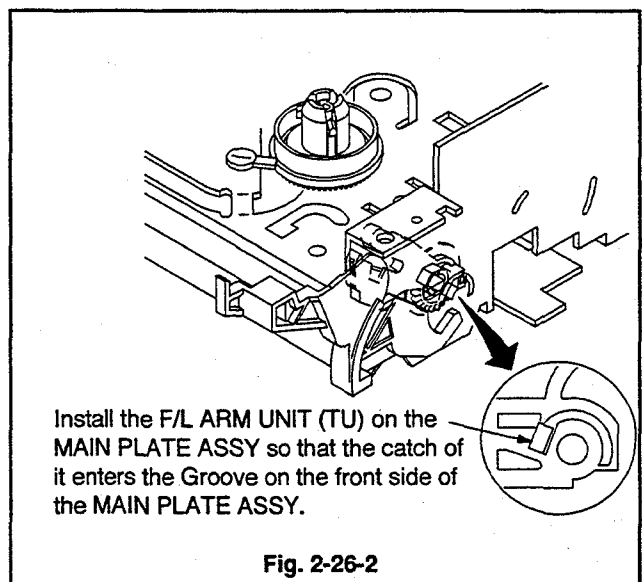
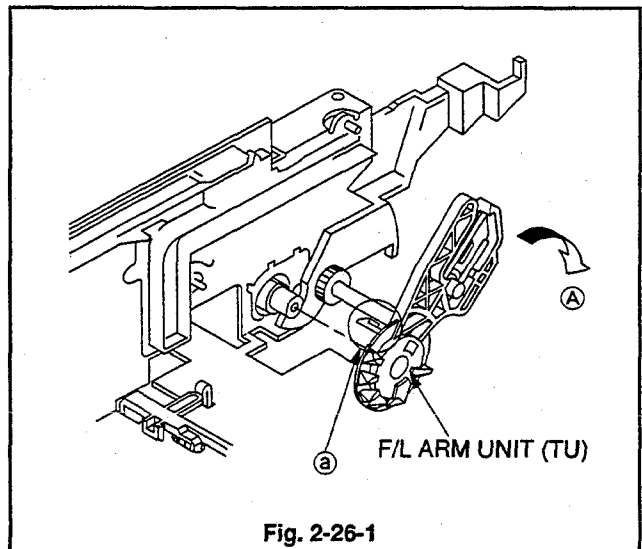

2-27. SYNC GEAR ASSY

SET POSITION : Normal

To access SYNC GEAR ASSY, remove the following parts :

- STAY PLATE (Para. 2-2)
- BOTTOM UNIT (Para. 2-3)
- LOADING BELT (Para. 2-11)
- MODE HOLDER (Para. 2-17)
- REEL LOCK LEVER (Para. 2-17)
- MODE GEAR (Para. 2-17)
- F/L DRIVE GEAR (Para. 2-17)
- F/L ARM UNIT (SP) (Para. 2-25)
- F/L ARM UNIT (TU) (Para. 2-26)

(Removal)

1. Unfasten the Catch (Ⓐ) of the MAIN PLATE ASSY as shown in Fig. 2-27-1. Move the SYNC GEAR ASSY in the direction shown by arrow Ⓐ to remove it.

(Installation)

1. Apply GREASE (MULTEMP SH-A) [859D055O80] to the area specified in Fig. 2-27-2 on the MAIN PLATE ASSY.
2. Move the SYNC GEAR ASSY, shown in Fig. 2-27-1, in the opposite direction against arrow Ⓐ to install it.

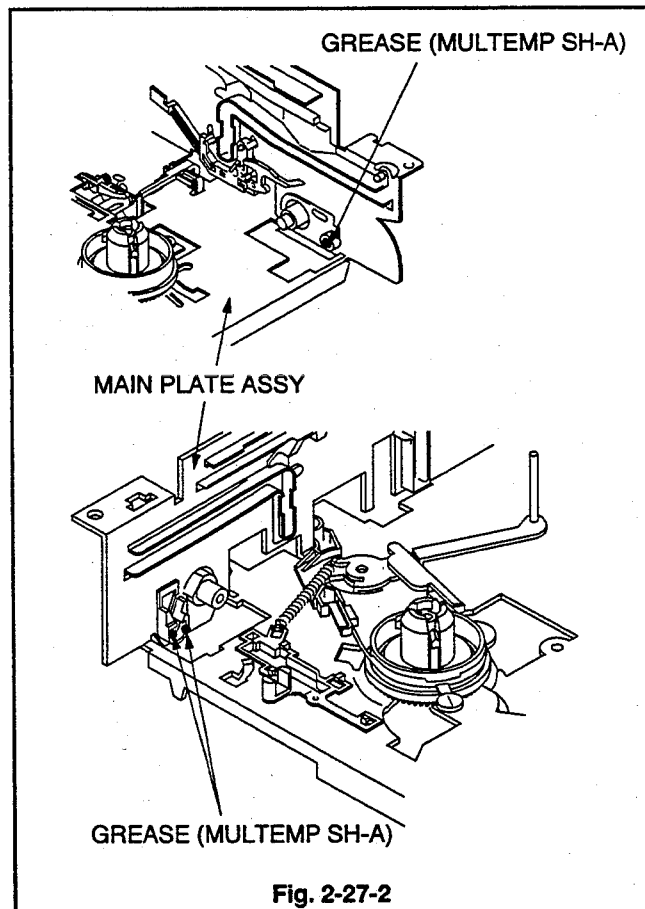
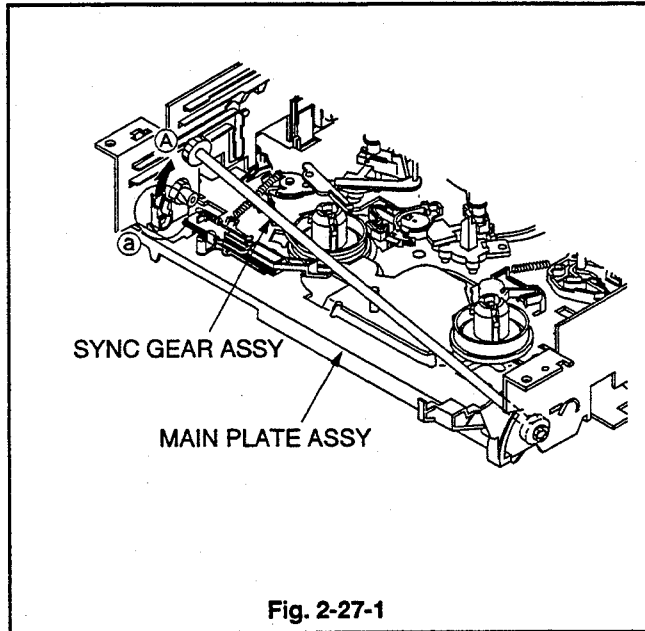

2-28. F/L DOOR ARM

SET POSITION : Normal

To access the F/L DOOR ARM, remove the following parts :

- STAY PLATE (Para. 2-2)
- BOTTOM UNIT (Para. 2-3)
- LOADING BELT (Para. 2-11)
- MODE HOLDER (Para. 2-17)
- REEL LOCK LEVER (Para. 2-17)
- MODE GEAR (Para. 2-17)
- F/L DRIVE GEAR (Para. 2-17)
- F/L ARM UNIT (SP) (Para. 2-25)
- F/L ARM UNIT (TU) (Para. 2-26)
- SYNC GEAR ASSY (Para. 2-27)

(Removal)

1. Remove the F/L DOOR ARM shown in Fig. 2-28.

(Installation)

1. Install the F/L DOOR ARM shown in Fig. 2-28.

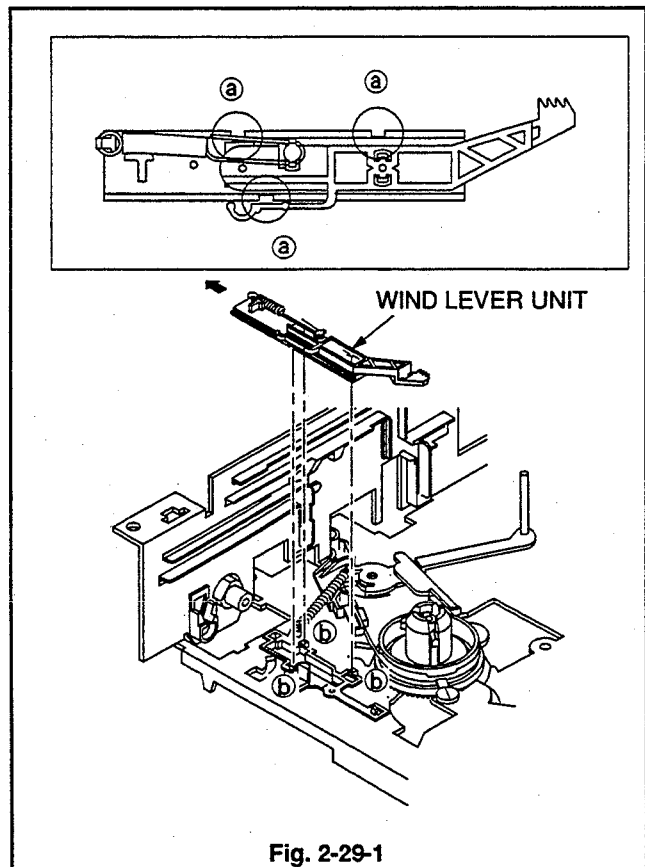
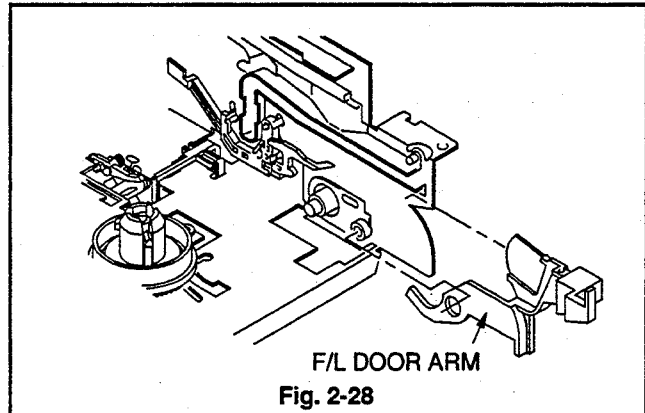

2-29. WIND LEVER UNIT

SET POSITION : Normal

To access the WIND LEVER UNIT, remove the following parts :

- STAY PLATE (Para. 2-2)
- BOTTOM UNIT (Para. 2-3)
- CONTROL WIND LEVER (Para. 2-18)

(Removal)

1. To remove, move the WIND LEVER UNIT in the direction of arrow, as shown in Fig. 2-29-1.

(Installation)

1. Apply GREASE (MULTEMP SH-A) [859D055O80] to the area specified in Fig. 2-29-2 on the MAIN PLATE ASSY.
2. Set the WIND LEVER UNIT so that each of three notches (a) matches with the corresponding Catches (b) on the MAIN PLATE ASSY, as shown in Fig. 2-29-1. Move the WIND LEVER UNIT in the opposite direction shown by arrow to install it.

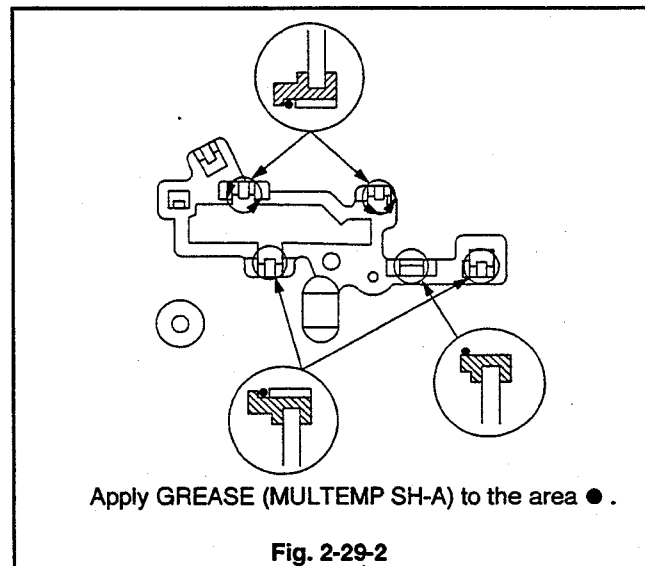

2-30. LOADING LOCK SPRING, LOADING LOCK LEVER

SET POSITION : Normal

To access the **LOADING LOCK SPRING** and **LOADING LOCK LEVER**, remove the following parts :

- **MODE POSITION GUIDE** (Para. 2-7)
- **LOADING BELT** (Para. 2-11)
- **MODE HOLDER** (Para. 2-17)
- **REEL LOCK LEVER** (Para. 2-17)
- **MODE GEAR** (Para. 2-17)
- **WORM PULLEY UNIT** (Para. 2-17)

(Removal)

1. Remove the **Part A** of the **LOADING LOCK SPRING**, shown in Fig. 2-30-1, through the **Hole of the MAIN PLATE ASSY**.
2. Move the **LOADING LOCK LEVER** in the direction shown by arrow **Ⓐ** while pushing the **Part B** of it to remove the **LOADING LOCK LEVER**, and **LOADING LOCK SPRING**, as shown in Fig. 2-30-1.

(Installation)

1. Attach the **LOADING LOCK SPRING** shown in Fig. 2-30-2 to the **LOADING LOCK LEVER**.
2. Move the **Part A** of the **LOADING LOCK SPRING**, shown in Fig. 2-30-2, in the direction shown by arrow **Ⓑ**. Hook the **Part A** of the **LOADING LOCK SPRING** on the **Catch** of the **Part B** of the **LOADING LOCK LEVER**.
3. Install the **LOADING LOCK LEVER** with the **LOADING LOCK SPRING** attached, shown in Fig. 2-30-1, on the **MAIN PLATE ASSY**.
4. Insert the **Part A** of the **LOADING LOCK SPRING**, shown in Fig. 2-30-1, into the **Hole of the LOADING LOCK SPRING**.

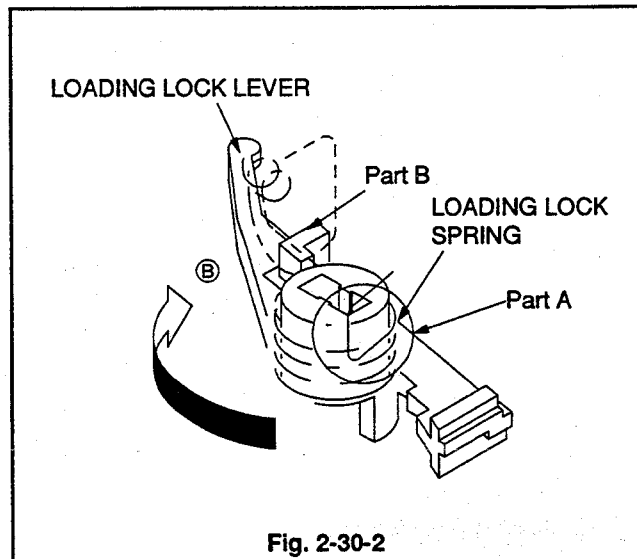
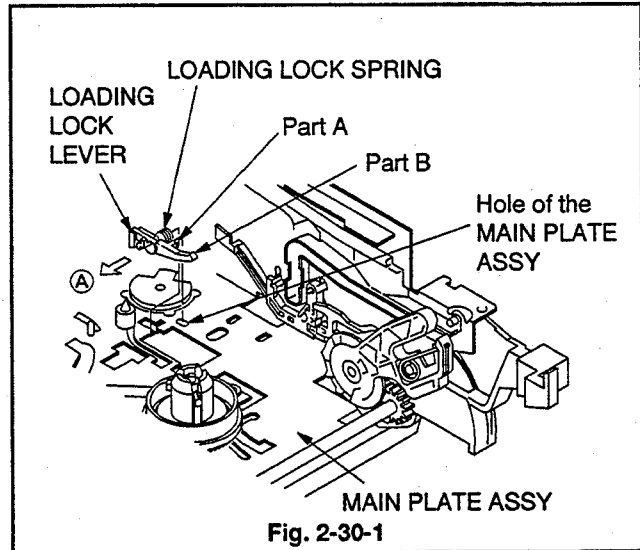

2-31. CAPSTAN MOTOR

SET POSITION : Normal

To access the CAPSTAN MOTOR, remove the REEL BELT (Para. 2-15) :

(Removal)

1. Remove the three CAPSTAN MOTOR fastening screws (a) shown in Fig. 2-31-1, and remove the CAPSTAN MOTOR.

(Installation)

1. Set the CAPSTAN MOTOR in the position shown in Fig. 2-31-2 to install it.

Note : Do not damage the shaft of the CAPSTAN MOTOR during installation.

2. Install three screws (a) shown in Fig. 2-31-1.

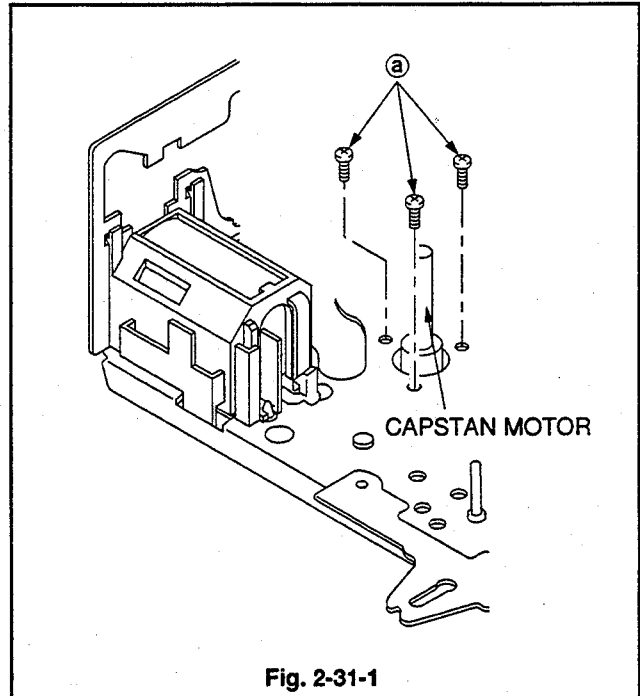

Fig. 2-31-1

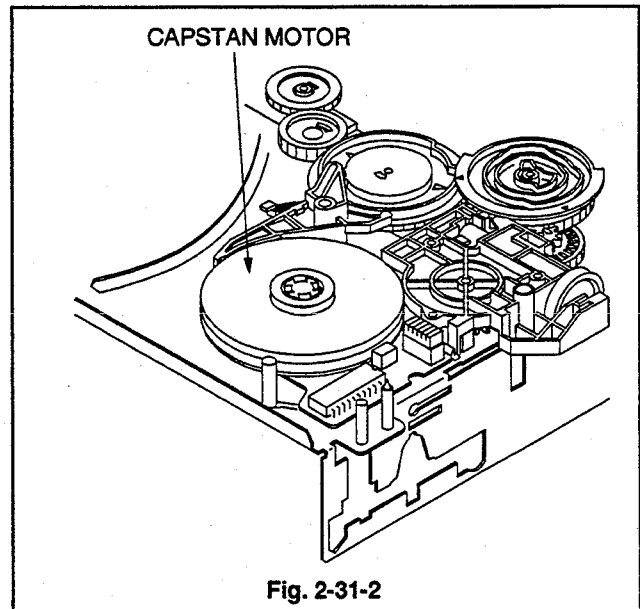

Fig. 2-31-2

2-32. CAM GEAR (SP)

SET POSITION : Upside down

To access the CAM GEAR(SP), remove the following parts :

- CONTROL WIND LEVER (Para. 2-18)
- TENSION LEVER UNIT (Para. 2-18)
- PLATE LD (Para. 2-20)
- LOADING GEAR (Para. 2-20)

(Removal)

1. Use tweezers to unfasten Catch (a) on the surface of the CAM GEAR (SP), shown in Fig. 2-32-1, and remove the CAM GEAR (SP).

(Installation)

1. Apply GREASE (MULTEMP SH-A) [859D055O80] to the area specified in Fig. 2-32-2 on the new CAM GEAR (SP).
2. Set the CAM GEAR (TU), shown in Fig. 2-32-3 so that the Δ mark on the Part B points to the centre of the LAMP LOADING GEAR.
3. Set the CAM GEAR (SP), shown in Fig. 2-32-3 so that the Δ mark on the Part A points to the centre of the boss for the LOADING GEAR.

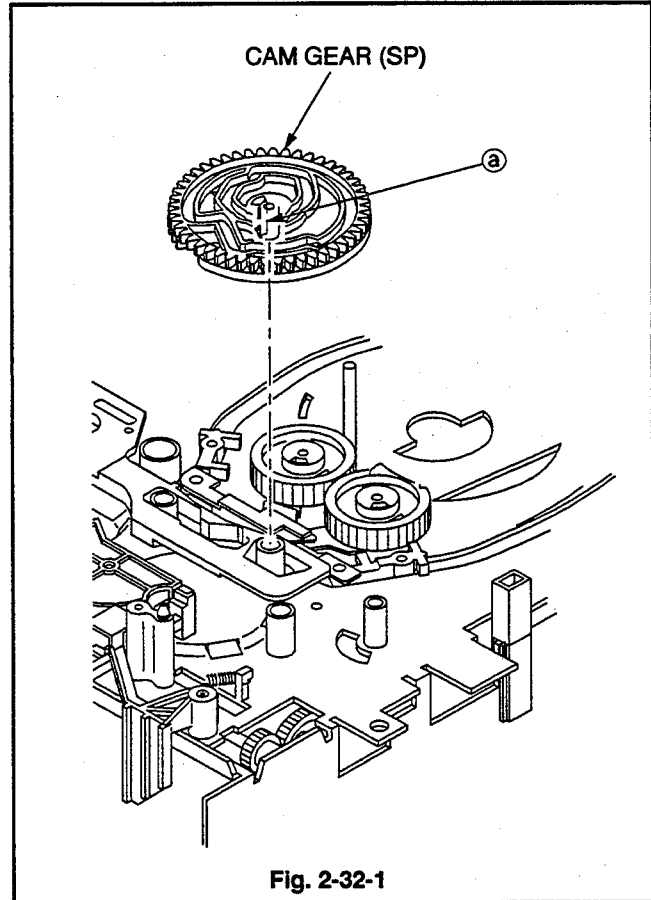

Fig. 2-32-1

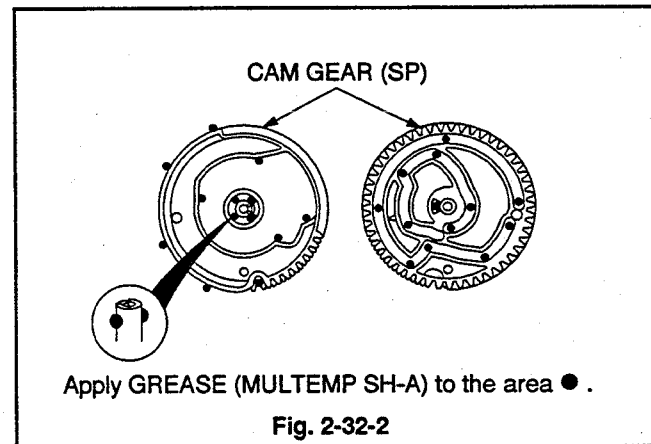

Fig. 2-32-2

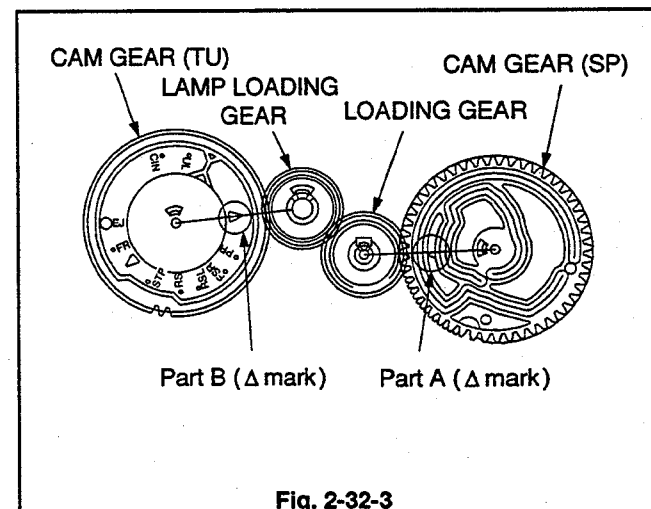

Fig. 2-32-3

2-33. LOADING ARM UNIT (TU), LOADING ARM UNIT (SP)

SET POSITION : Upside down

To access the LOADING ARM UNIT(TU) and LOADING ARM UNIT(SP), remove the following parts :

- CONTROL WIND LEVER (Para. 2-18)
- TENSION LEVER UNIT (Para. 2-18)
- PLATE LD (Para. 2-20)
- LOADING GEAR (Para. 2-20)
- CAM GEAR (SP) (Para. 2-32)

(Removal)

1. Remove the two MAIN PLATE SUPPORT fastening screws (a), shown in Fig. 2-33-1, and remove the MAIN PLATE SUPPORT.
2. Move the TAPE GUIDE ASSY (SP) and TAPE GUIDE ASSY (TU), shown in Fig. 2-33-1, to the fully loading position.
3. Use tweezers to unfasten Catch (b) on the surface of the LOADING ARM UNIT (TU) shown in Fig. 2-33-1 and remove the LOADING ARM UNIT (TU).
4. Use tweezers to unfasten Catch (c) on the surface of the LOADING ARM UNIT (SP), shown in Fig. 2-33-1, and remove the LOADING ARM UNIT (SP).

(Installation)

1. Apply GREASE (MULTEMP SH-A) [859D055O80] to the area specified in Fig. 2-33-2 on the new LOADING ARM UNIT (SP).
2. Install the LOADING ARM UNIT (SP) shown in Fig. 2-33-1.
3. Apply GREASE (MULTEMP SH-A) [859D055O80] to the area specified in Fig. 2-33-2 on the new LOADING ARM UNIT (TU).

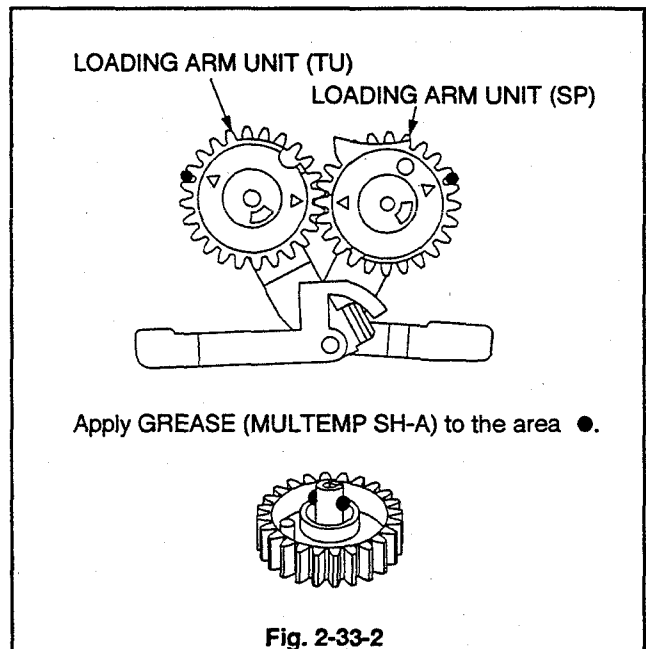
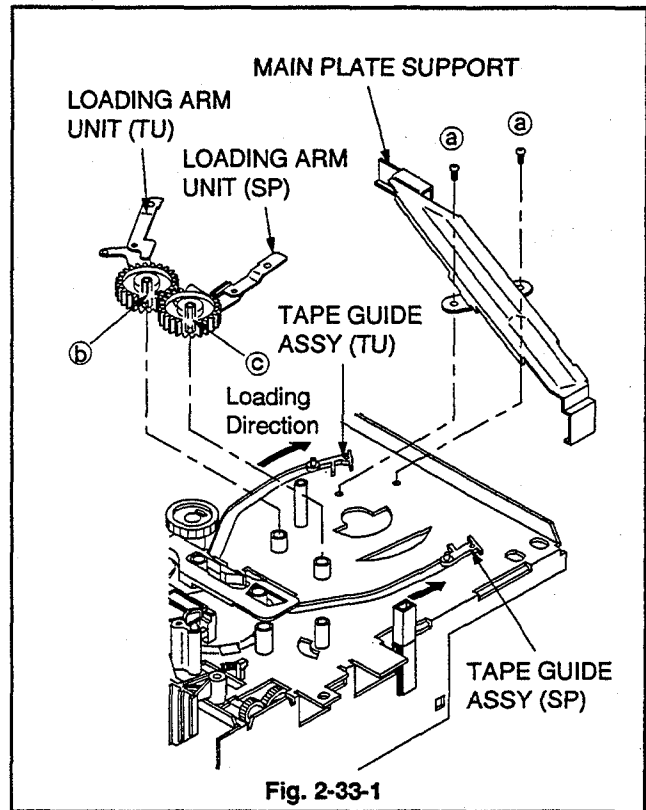

4. Set the LOADING ARM UNIT (TU) shown in Fig. 2-33-3 so that the Δ mark of it matches with the Δ mark of the LOADING ARM UNIT (SP) and install it.
5. Move the TAPE GUIDE ASSY (SP) and TAPE GUIDE ASSY (TU), shown in Fig. 2-33-1 fully to the unloading position.
6. Install the MAIN PLATE SUPPORT shown Fig. 2-33-1.

2-34. CAM SPRING (C), CAM PLATE UNIT (C)

SET POSITION : Upside down

To access the CAM SPRING(C) and CAM PLATE UNIT(C), remove the following parts :

- LAMP GUIDE (Para. 2-7)
- LOADING BELT (Para. 2-11)
- REEL BELT (Para. 2-15)
- CAPSTAN BRAKE SPRING (Para. 2-16)
- CAPSTAN BRAKE UNIT 2 (Para. 2-16)
- MODE HOLDER (Para. 2-17)
- REEL LOCK LEVER (Para. 2-17)
- MODE GEAR (Para. 2-17)
- WORM PULLEY UNIT (Para. 2-17)
- CONTROL WIND LEVER (Para. 2-18)
- TENSION LEVER UNIT (Para. 2-18)
- LOADING GEAR (Para. 2-20)
- LAMP LOADING GEAR (Para. 2-20)
- CAM GEAR (TU) (Para. 2-21)
- CAM GEAR (SP) (Para. 2-32)

(Removal)

1. Move the TAPE GUIDE ASSY (SP) and TAPE GUIDE ASSY (TU), shown in Fig. 2-33-1, to the fully loaded position.
2. Remove the CAM SPRING (C) shown in Fig. 2-34-1.
3. Move the CAM PLATE UNIT (C) in the direction shown by arrow (A) and remove it, as shown in Fig. 2-34-1.

(Installation)

1. Apply GREASE (MULTEMP SH-A) [859D055080] to the area specified in Fig. 2-34-2 on the new CAM PLATE UNIT (C).

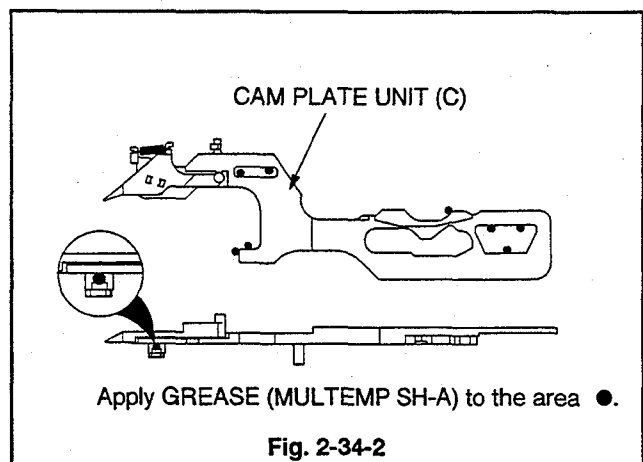
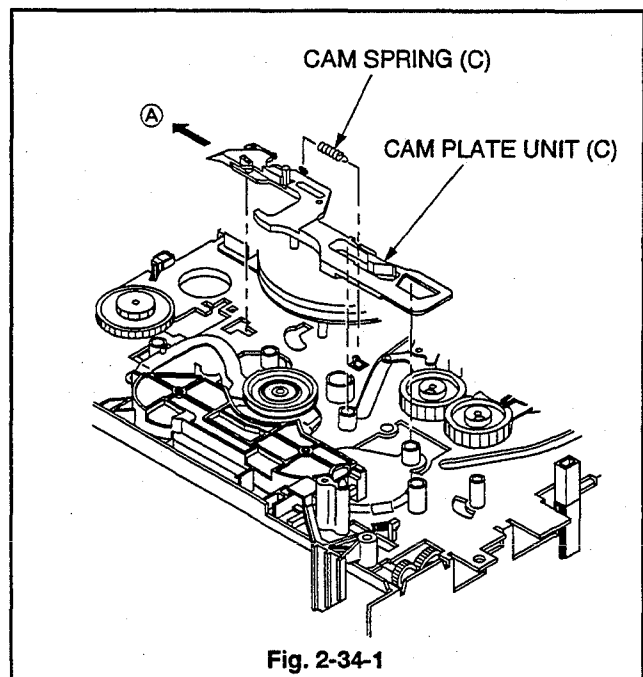
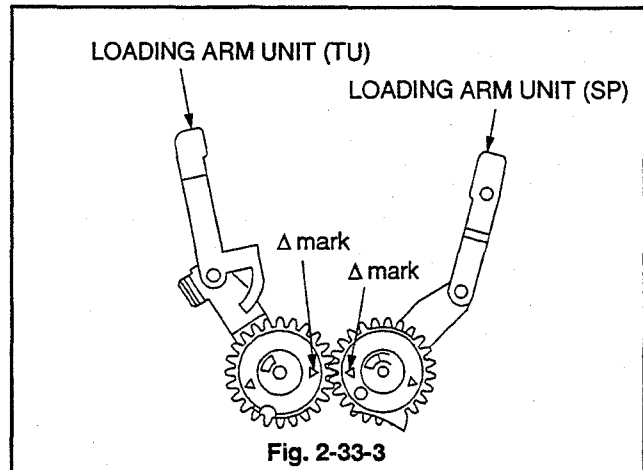

2. Install the CAM PLATE UNIT (C), shown in Fig. 2-34-3, so that the pin (a) of it enters the Part A of the SHIFT LEVER.
3. Install the CAM SPRING (C) shown in Fig. 2-34-1.
4. Move the TENSION ARM, shown in Fig. 2-34-4 fully in the direction shown by arrow. Move the TAPE GUIDE ASSY (SP) and TAPE GUIDE ASSY (TU), shown in Fig. 2-33-1 to the fully unloaded position.

2-35. TAPE GUIDE ASSY (SP), TAPE GUIDE ASSY (TU)

SET POSITION : Upside down

To access the TAPE GUIDE ASSY (SP), remove the following parts :

- LAMP GUIDE (Para. 2-7)
- LOADING BELT (Para. 2-11)
- REEL BELT (Para. 2-15)
- CAPSTAN BRAKE SPRING (Para. 2-16)
- CAPSTAN BRAKE UNIT 2 (Para. 2-16)
- MODE HOLDER (Para. 2-17)
- REEL LOCK LEVER (Para. 2-17)
- MODE GEAR (Para. 2-17)
- WORM PULLEY UNIT (Para. 2-17)
- CONTROL WIND LEVER (Para. 2-18)
- TENSION LEVER UNIT (Para. 2-18)
- LOADING GEAR (Para. 2-20)
- LAMP LOADING GEAR (Para. 2-20)
- CAM GEAR (TU) (Para. 2-21)
- CAM GEAR (SP) (Para. 2-32)
- LOADING ARM UNIT (TU) (Para. 2-33)
- LOADING ARM UNIT (SP) (Para. 2-33)
- CAM SPRING (C) (Para. 2-33)
- CAM PLATE UNIT (C) (Para. 2-34)

(Removal)

1. Move the TAPE GUIDE ASSY (SP), shown in Fig. 2-35-1, to the fully unloading position to remove it.
2. Move the TAPE GUIDE ASSY (TU), shown in Fig. 2-35-1, to the fully unloaded position to remove it.

(Installation)

1. Apply GREASE (MULTEMP SH-A) [859D055O80] to the area specified in Fig. 2-35-2 on the MAIN PLATE ASSY .
2. Install the TAPE GUIDE ASSY (TU) shown in Fig. 2-35-1.
3. Install the TAPE GUIDE ASSY (SP) shown in Fig. 2-35-1.
4. Perform interchangeability adjustment, item 3-2-1 (GUIDE ROLLER Adjustment) to item 3-2-5 (Adjustment of FM waveform Flatness).

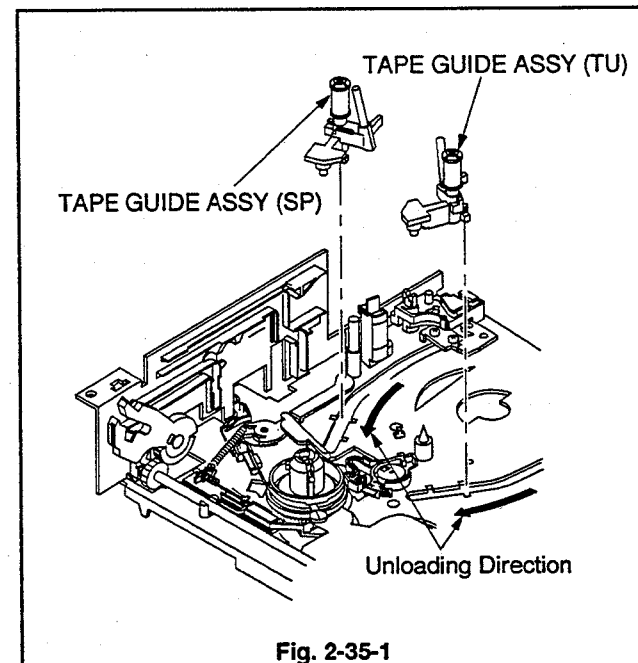
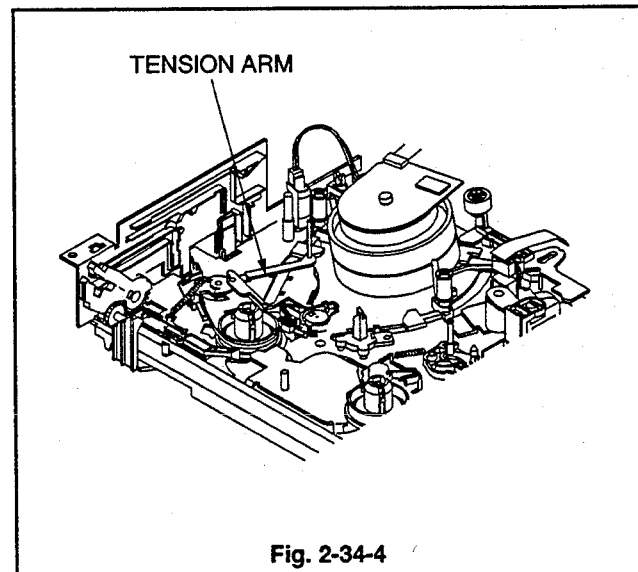
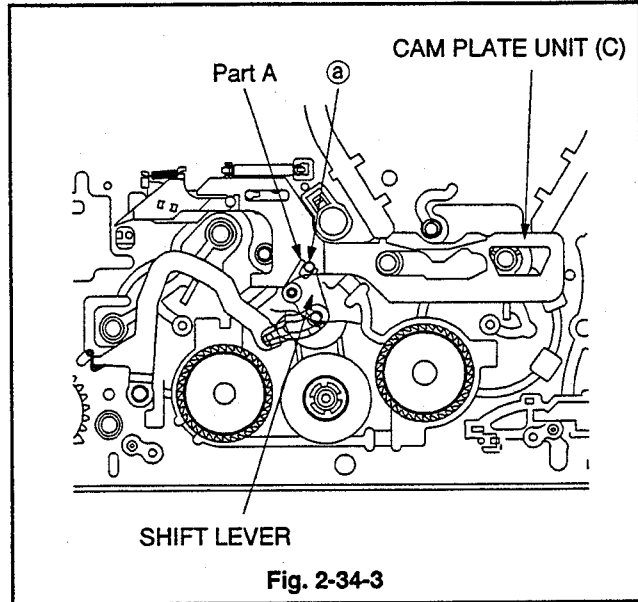

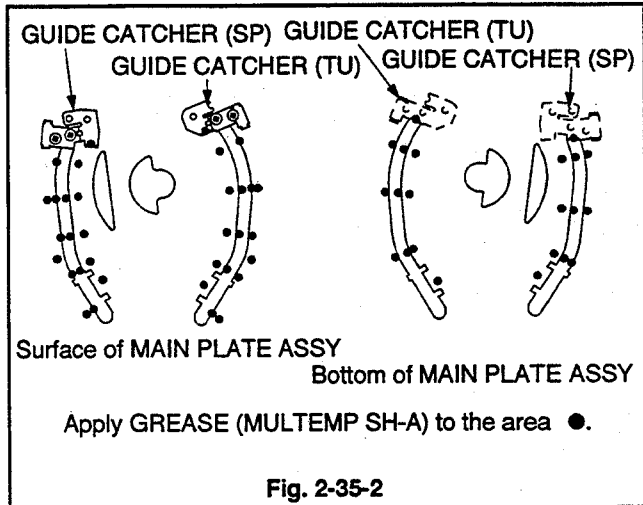

2-36. GUIDE ROLLER (SP), GUIDE ROLLER (TU)

(Removal)

1. Loosen the GUIDE ROLLER (SP) set screw (a) with an L SHAPED BOX DRIVER (859C433070) so that the GUIDE ROLLER (SP), shown in Fig. 2-36-1. Rotates freely.
2. Use the height adjustment screw driver to turn the GUIDE ROLLER (SP) height adjustment screw (b) counter-clockwise, and remove the GUIDE ROLLER (SP), refer to Fig. 2-36-1.
3. Loosen the GUIDE ROLLER (TU) set screw (c) with an L SHAPED BOX DRIVER (859C443070) so that the GUIDE ROLLER (TU) shown in Fig. 2-36-1. Rotates freely.
4. Turn the height adjustment screw (d), at the top of the GUIDE ROLLER (TU), counter-clockwise with a height Adjustment Driver to remove the GUIDE ROLLER (TU), refer to Fig. 2-36-1.

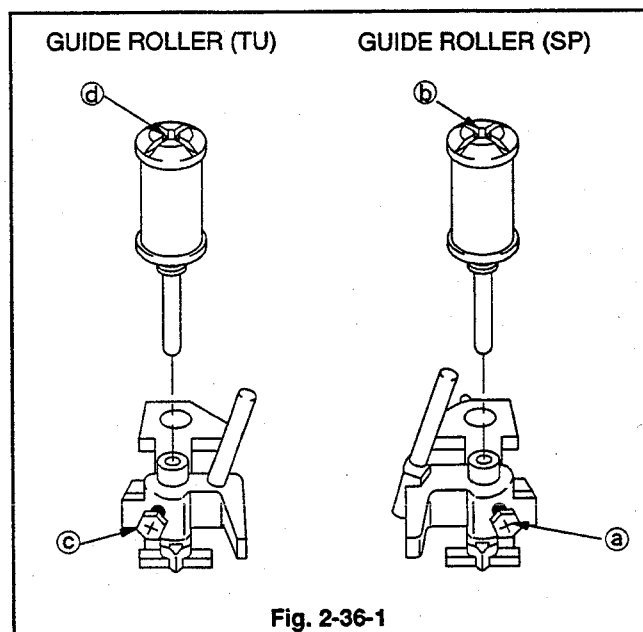

(Installation)

1. Insert the GUIDE ROLLER (TU) shown in Fig. 2-36-1 into the installation hole on the TAPE GUIDE ASSY (TU).
2. Turn the height adjustment screw (d) clockwise shown in Fig. 2-36-2, so that the GUIDE ROLLER (TU) is at a height of 25.2 mm above the Reference Plane.
3. Lightly tightened the GUIDE ROLLER (TU) set screw (c), shown in Fig. 2-36-1.
4. Insert the GUIDE ROLLER (SP), shown in Fig. 2-36-1, into the installation hole on the TAPE GUIDE ASSY (SP).
5. Turn the height adjustment screw (b) at the top of the GUIDE ROLLER (SP), clockwise shown in Fig. 2-36-2, so that the GUIDE ROLLER (SP) is at a height of 25.1 mm above the Reference Plane.

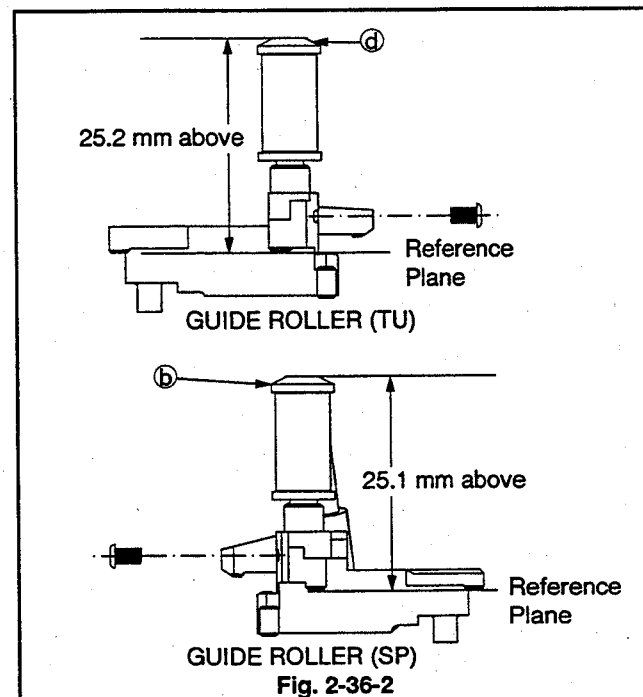

6. Lightly tightened the GUIDE ROLLER (SP) set screw (a) shown in Fig. 2-36-1.
7. Perform "Check and Adjustment of the FM Envelope" in Para. 3-2 of "Interchangeability Adjustment of the Mechanism".
8. Clean the GUIDE ROLLER (SP) and GUIDE ROLLER (TU) with Dry Gauze.

2-37. DRUM CLAMPER, DRUM ASSY

(Removal)

1. Disconnect the Card Lead Wire of the DRUM ASSY shown in Fig. 2-37-1.
2. Remove the two DRUM CLAMPER fastening screws (a) and (b), shown in Fig. 2-37-1, to remove the DRUM ASSY with the DRUM CLAMPER attached.
3. Move the DRUM CLAMPER in the direction shown by arrow to remove it from the DRUM ASSY, as shown in Fig. 2-37-2.
4. If the product is provided with the SHIM, shown in Fig. 2-37-1, remove and scrap it.

(Installation)

Note : When replacing the DRUM ASSY, do not install the shim.

1. Attach the DRUM CLAMPER shown in Fig. 2-37-2 to the DRUM ASSY.
2. Install the DRUM ASSY with the DRUM CLAMPER attached, shown in Fig. 2-37-1, on the MAIN PLATE ASSY.

Note : when installing the DRUM CLAMPER shown in Fig. 2-37-1, first install the screw (b) and then install the screw (a).

3. Connect the Card Lead Wire of the DRUM ASSY shown in Fig. 2-37-1.
4. Perform the "Playback Switching Point" adjustment described in ELECTRICAL ADJUSTMENT.
5. Perform "Interchangeability Adjustment of the Mechanism".
6. Clean the DRUM ASSY, shown in Fig. 2-37-1, with alcohol.

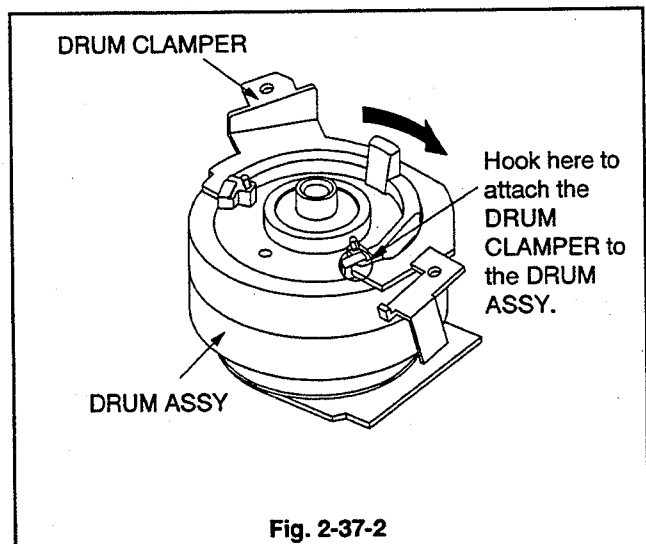
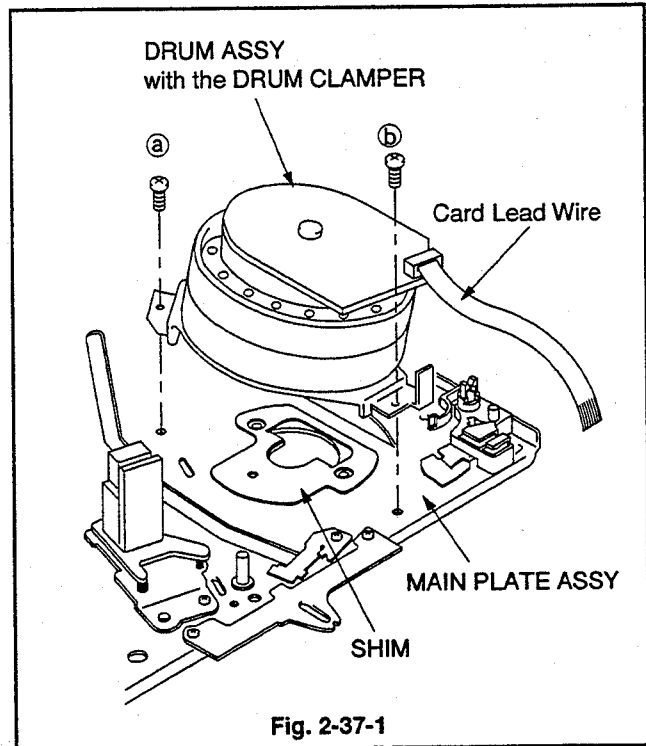

2-38. DRUM MOTOR STATOR, BRUSH SPRING, ROTOR CASE, END RING, BRUSH, UPPER DRUM ASSY, SPACER

SET POSITION : Normal.

(Removal)

1. Disconnect the Card Lead Wire of the DRUM ASSY shown in Fig. 2-38-1.
2. Remove the two DRUM MOTOR STATOR fastening screws (a), shown in Fig. 2-38-1, to remove the DRUM MOTOR STATOR.
3. Remove the two ROTOR CASE fastening screws (b), shown in Fig. 2-38-1, and remove the ROTOR CASE.
4. Loosen the END RING fastening screw (c) [hexagon screw] shown in Fig. 2-38-1, and remove the END RING.
5. Remove the BRUSH SPRING shown in Fig. 2-38-1.
6. Remove the BRUSH shown in Fig. 2-38-1.
7. Remove the UPPER DRUM ASSY shown in Fig. 2-38-1.
8. Remove the SPACER shown Fig. 2-38-1.

(Installation)

1. Install the SPACER shown in Fig. 2-38-1.

Note : Do not use any other SPACER than the one enclosed with the new UPPER DRUM ASSY for replacement.

2. Install the UPPER DRUM ASSY shown in Fig. 2-38-1.
3. Install the END RING shown in Fig. 2-38-1 so that the reference Hole (A) of the END RING is located in parallel with the rear line of the MAIN PLATE ASSY shown in Fig. 2-38-2.

(Install the reference Hole (A) to the right of the rear MAIN PLATE ASSY.)

4. Apply screw sealing agent to the END RING fastening screw (c) [hexagon screw] shown in Fig. 2-38-1.

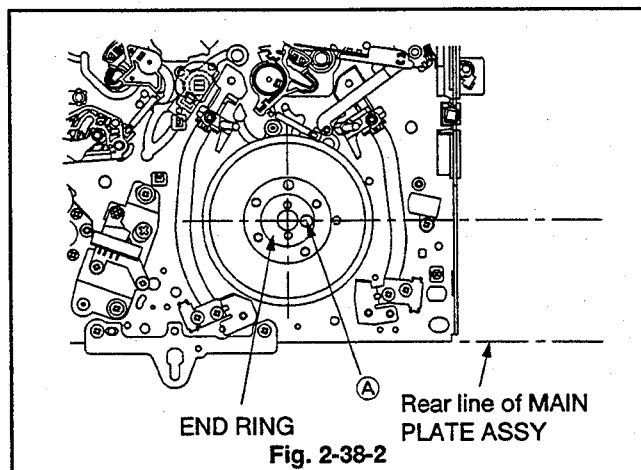
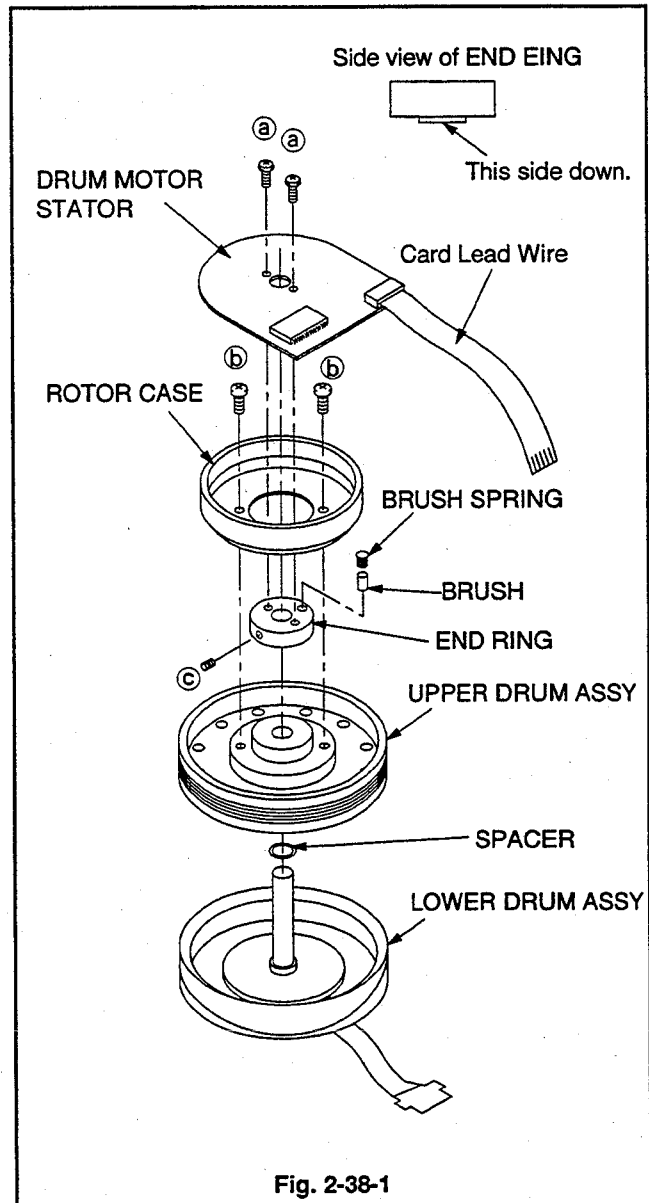

5. Install the ROTOR CASE shown in Fig. 2-38-1 so that the reference Holes (A) match each other at three points between the ROTOR CASE shown in Fig. 2-38-3 and the UPPER DRUM ASSY.
6. Install the BRUSH shown in Fig. 2-38-1.
7. Install the BRUSH SPRING shown in Fig. 2-38-1.
8. Install the DRUM MOTOR STATOR shown in Fig. 2-38-1.
9. Connect the Card Lead Wire of the DRUM ASSY shown in Fig. 2-38-1.
10. Perform the "Playback Switching Point" adjustment described in ELECTRICAL ADJUSTMENT.
11. Perform "Interchangeability Adjustment of the Mechanism".
12. Clean the DRUM ASSY with alcohol.

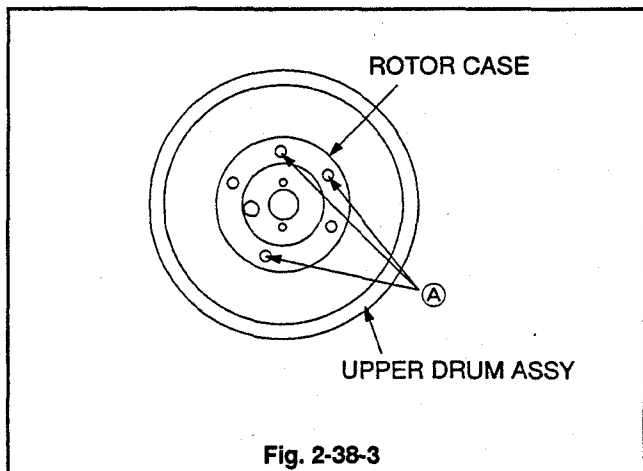

Fig. 2-38-3

2-39. SHIFT LEVER

SET POSITION : Normal

To access the SHIFT LEVER, remove the following parts :

- LAMP GUIDE (Para. 2-7)
- LOADING BELT (Para. 2-11)
- REEL BELT (Para. 2-15)
- CAPSTAN BRAKE SPRING (Para. 2-16)
- CAPSTAN BRAKE UNIT 2 (Para. 2-16)
- BELT PULLEY (Para. 2-15)
- SHIFT SPRING (Para. 2-15)
- MODE HOLDER (Para. 2-17)
- REEL LOCK LEVER (Para. 2-17)
- MODE GEAR (Para. 2-17)
- WORM PULLEY UNIT (Para. 2-17)
- CONTROL WIND LEVER (Para. 2-18)
- TENSION LEVER UNIT (Para. 2-18)
- LOADING GEAR (Para. 2-20)
- LAMP LOADING GEAR (Para. 2-20)
- CAM GEAR (TU) (Para. 2-21)
- PHOTO UNIT (Para. 2-22)
- IDLER CENTER LEVER (Para. 2-23)
- PULLEY GEAR (Para. 2-24)
- IDLER UNIT (Para. 2-24)
- CAM GEAR (SP) (Para. 2-32)
- CAM SPRING (C) (Para. 2-34)
- CAM PLATE UNIT (C) (Para. 2-34)

(Removal)

1. Remove the SHIFT LEVER shown in Fig. 2-39-1.

(Installation)

1. Apply GREASE (MULTEMP SH-A) [859D055O80] to the area of the new SHIFT LEVER shown in Fig. 2-39-2.
2. Install the SHIFT LEVER shown in Fig. 2-39-1.

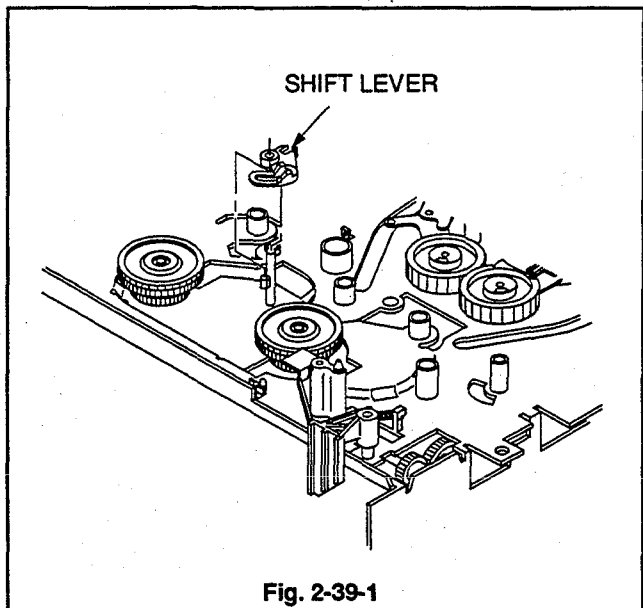

Fig. 2-39-1

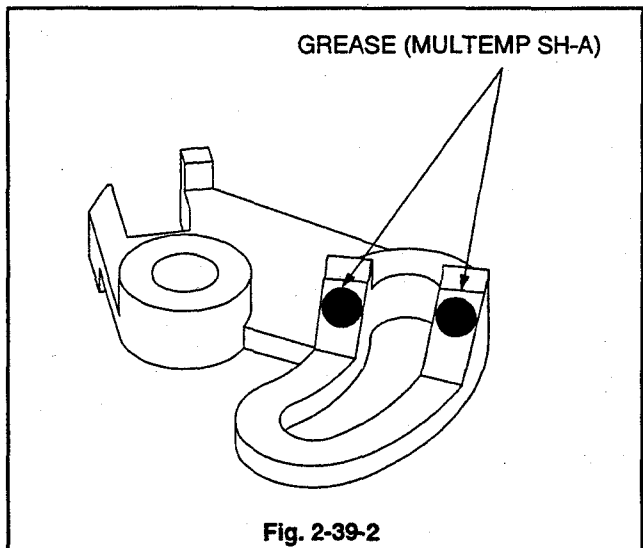

Fig. 2-39-2

3. Interchangeability Adjustment of the Mechanism

- Note 1 :** Tracking may need to be preset during interchangeability adjustment of the mechanism. Digital tracking is preset by short circuiting TP5A and TP5B on the PCB-MAIN.
- Note 2 :** The adjustments are performed in the play back mode, using the staircase signal of an Alignment Tape. Connect an oscilloscope to TP2A and external Trigger from TP2H, unless otherwise specified.

3-1. Adjustment of BACK TENSION and TENSION PIN Position

Run a Blank Tape for several minutes to break in the REEL DISKS and the transport before making the adjustment.

1. Play back an Alignment Tape. (3H mode)
[PM6KH3 : 859C339O30]
2. Make sure that the TENSION PIN is in the position shown in Fig. 3-1.
3. If the TENSION PIN is not in the position specified in Fig. 3-1, turn the boss to set the TENSION PIN to be in position.
4. Insert the Back Tension MEASURING JIG (859C345O80) and set the VCR to the play back mode.
5. Make sure that the reading of the BACK TENSION MEASURING JIG is within 50 ± 6 g/cm.

- Note :** Before the measurement, make sure that the Tape travel has become steady.
If the reading exceeds the specified value, replace the TENSION SPRING.
6. While Tape travel is steady, check visually to make sure that the vibration range of the TENSION PIN is 1 mm or less.
If the vibration range exceeds the specified value, replace the REEL DISK.

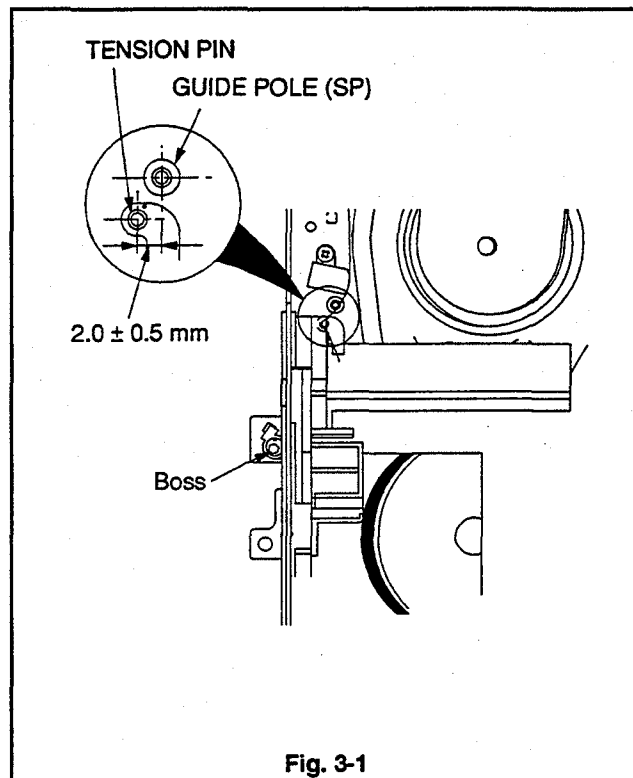

Fig. 3-1

3-2. Check and Adjustment of the FM Envelope

3-2-1. GUIDE ROLLER Adjustment

The Guide Rollers are secured by a hexagon screw, however, this screw, does not require to be loosened for adjustments to be made.

1. Play back an Alignment Tape. (3H mode)
[PM6KH3 : 859C339O30]
2. Preset tracking.
3. Make sure that the FM waveform is flat like (A).
4. Perform "Adjustment of GUIDE ROLLER (SP) Height" in Item 3-2-2 if the leading portion (the entry side of the DRUM) of the FM waveform is like (B) or (C). Perform "Adjustment of GUIDE ROLLER (TU) Height" in Item 3-2-3 if the trailing portion (the exit side of the DRUM) is like (D) or (E).

3-2-2. Adjustment of GUIDE ROLLER (SP) Height

1. Loosen the screw with an L SHAPED BOX DRIVER (859C433O70) slightly so that the GUIDE ROLLER (SP) rotates freely.
2. Observe the leading edge (the entry side of the DRUM) of the FM waveform. If it is like (B), the GUIDE ROLLER (SP) may be lower than the specified position, and if it is like (C), the GUIDE ROLLER (SP) may be higher. Turn the adjustment screw at the top of the GUIDE ROLLER (SP) so that the FM waveform becomes flat like (A).
 - Turn the adjusting screw counter-clockwise if the roller is low.
 - Turn the adjusting screw clockwise if the roller is high.
3. Tighten the Screw.
4. Perform "Coarse Adjustment of Phase" in Item 3-2-4.

3-2-3. Adjustment of GUIDE ROLLER (TU) Height

1. Loosen the screw with an L SHAPED BOX DRIVER (859C433O70) slightly so that the GUIDE ROLLER (TU) rotates freely.
2. Observe the trailing edge (the exit side of the DRUM) of the FM waveform. If it is like (D), the GUIDE ROLLER (TU) may be lower than the specified position, and if it is like (E), the GUIDE ROLLER (TU) may be higher. Turn the adjustment screw at the top of the GUIDE ROLLER (TU) so that the FM waveform becomes flat like (A).
 - Turn the adjusting counter-clockwise if the roller is low.
 - Turn the adjusting clockwise if the roller is high.
3. Tighten the set Screw with an L SHAPED BOX DRIVER (859C433O70).
4. Perform "Coarse Adjustment of Phase" in Item 3-2-4.

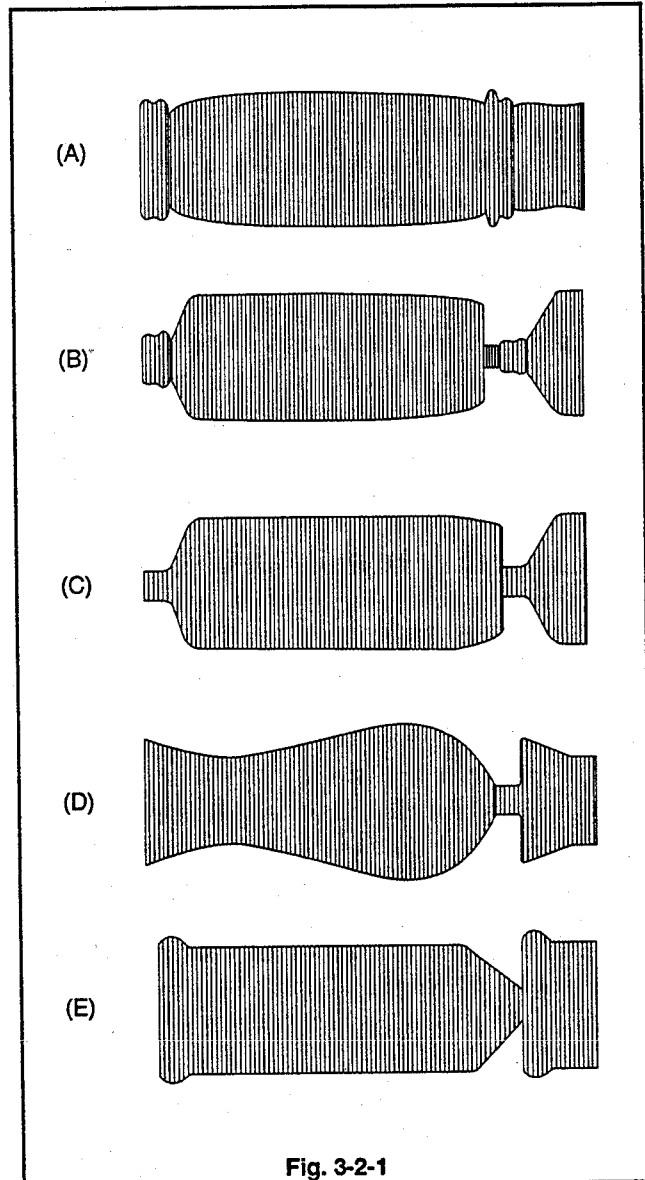

Fig. 3-2-1

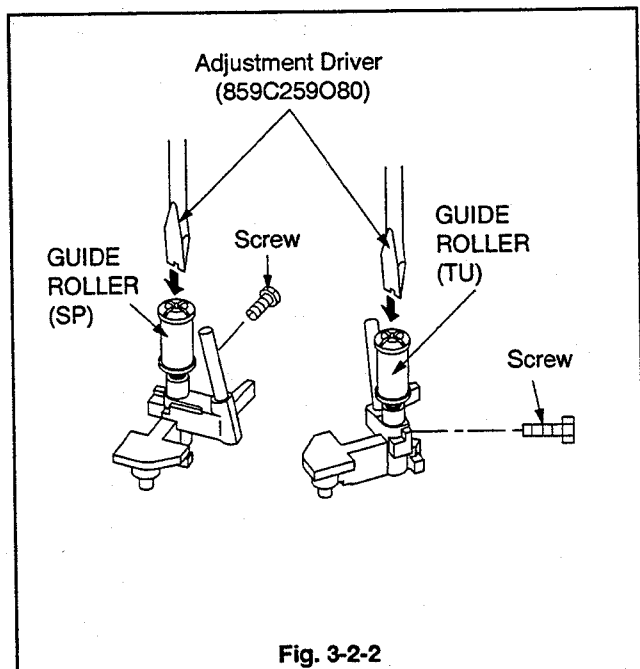
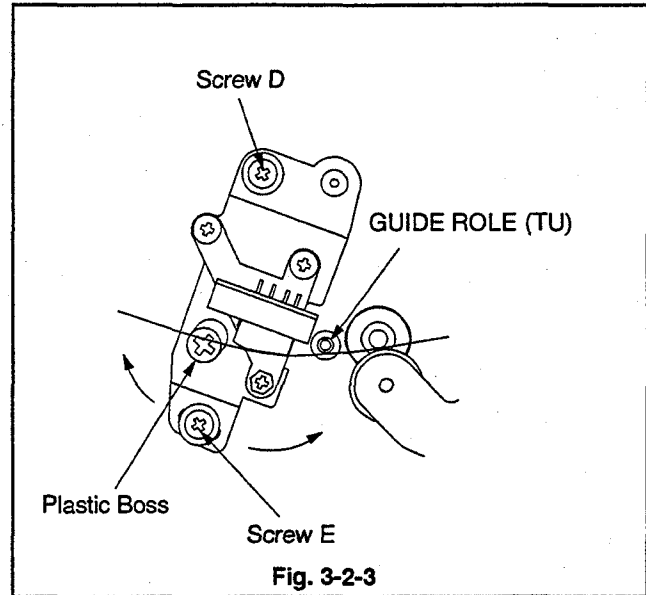

Fig. 3-2-2

3-2-4. Coarse Adjustment of Phase

1. Play back an Alignment Tape. (3H mode)
[PM6KH3 : 859C339O30]
2. Preset tracking. (Refer to Note 1 para 3.)
3. Check the FM waveform after performing "GUIDE ROLLER Adjustment" in Item 3-2-1.
4. If the amplitude of the FM waveform is narrow like (F) because of out of phase, adjust it to the maximum like (G) in Fig. 3-2-4, by the following procedure. Loosen the Screws D and E and insert a screw driver into the Plastic Boss of the MAIN PLATE ASSY. Move the A/C PLATE right and left to adjust the amplitude level of the FM waveform to the maximum. [Waveform G in Fig. 3-2-4]
5. Tighten the Screws D and E.



3-2-5. Check of FM Waveform Flatness

1. Play back an Alignment Tape. (3H mode)
[PM6KH3 : 859C339O30]
 2. Change tracking and make sure that the amplitude changes and the FM signal remains flat.
- Note :** Press the tracing (+) and (-) button during play back to adjust tracking.
3. Adjust the tracking so that the amplitude level of the FM waveform is maximum. Set the oscilloscope so that the amplitude level of the FM waveform is 5 divisions.
 4. Adjust tracking so that the peak value of the FM waveform is 4 divisions. Check if the FM waveforms (B), (C), (D) and (E) are within the specified values shown in Fig. 3-2-5.
 5. If the waveform is not within the specified value, repeat the procedure in Item 3-2 "Check and Adjustment of the FM Envelope" from the beginning.

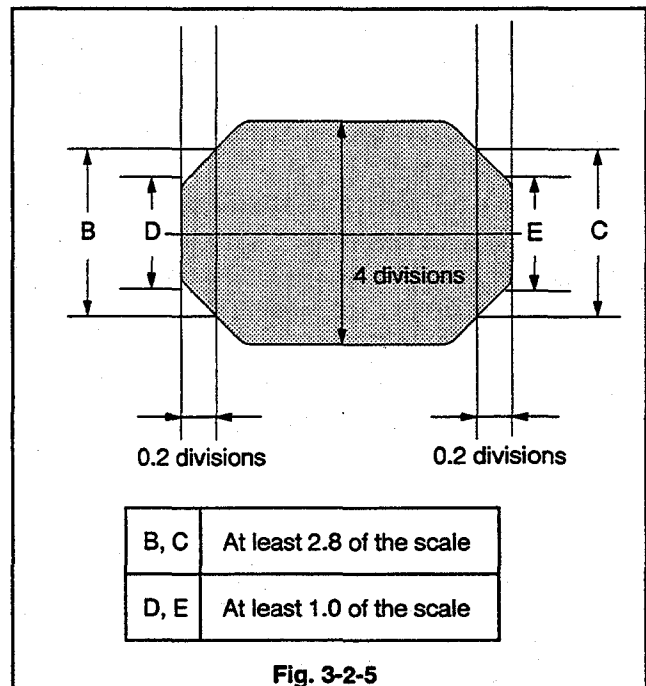
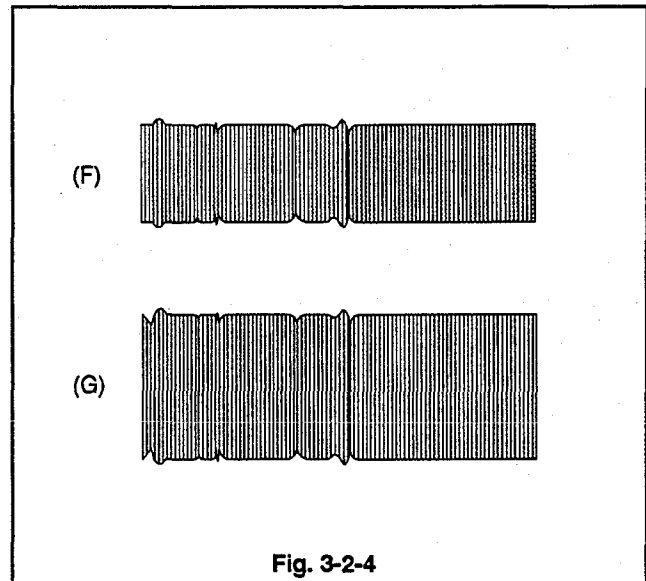

3-2-6. Tape Running Condition at the GUIDE ROLLERS (Check 1)

1. Play back an Alignment Tape. (3H mode)
[PM6KH3 : 859C339O30]
2. Visually check if there is a space between the Tape and the lower flanges of the GUIDE ROLLER (SP) and GUIDE ROLLER (TU).
3. If there is no space, replace the TAPE GUIDE ASSY (SP) and TAPE GUIDE ASSY (TU) according to Para. 2-35 in "Replacement of Major Parts".
4. Alternately load and unload the Tape several times, check that flatness of the FM waveform does not change.
5. If flatness changes, check the installation condition of the A/C HEAD. If it is abnormally installed, replace the A/C HEAD UNIT according to para. 2-4 and perform "Coarse Adjustment of Phase" in Item 3-2-4 again.

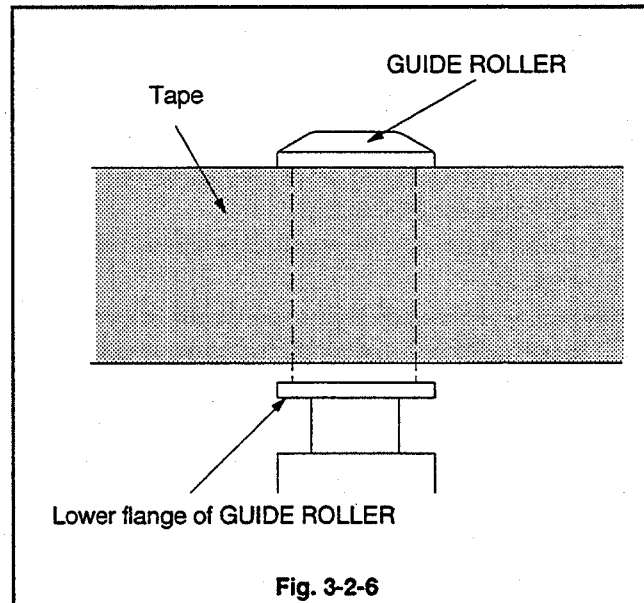

3-2-7. Tape Running Condition at the GUIDE ROLLERS (Check 2)

1. Play back an Alignment Tape. (3H mode)
[PM6KH3 : 859C339O30]
2. Lightly press and release the top of the GUIDE ROLLER (SP) and GUIDE ROLLER (TU). Check that the FM waveform is quickly restored to the previous level.
3. If the FM waveform is not restored to the previous level, replace the TAPE GUIDE ASSY (SP) and TAPE GUIDE ASSY (TU) according to para 2-35 in "Replacement of Major Parts".

3-3. Adjustment of A/C HEAD

3-3-1. Adjustment of A/C HEAD Slant

1. Play back a Blank Tape.
2. Slowly turn adjusting screw C counter-clockwise to slightly crease the bottom of the Tape at the flange portion of GUIDE POLE (TU).
3. Slowly return adjusting screw C to remove the crease.
4. Slowly turn the adjusting screw C counter-clockwise again and stop it just before the Tape is creased.

3-3-2. Adjustment of A/C HEAD Azimuth and Height

1. If the height of the CONTROL HEAD is different from the specified value in Fig. 3-3-2, adjust it with the adjusting screw A.
2. After adjustment with the screw A, perform "Adjustment of A/C HEAD Slant" in Item 3-3-1 again.
3. Connect the oscilloscope to the audio output terminal.
4. Play back an Alignment Tape. (3H mode)
[PM6KH3 : 859C339O30]
5. Adjust the audio output level to the maximum by turning the Azimuth adjusting screw B shown in Fig. 3-3-1.

After the adjustment, pull out the screw driver and check if the audio output level is 4.6 divisions or more, where the maximum audio output level is set to 5.

If the audio output level is less than 4.6, repeat the procedure 1~5.

6. Push the A/C HEAD to the right and left (in the direction A and A' in Fig. 3-3-1) and then release it. Check that the audio output level does not change. (Do not push the A/C HEAD such a degree that the audio output level is reduced less than 3/4 of its maximum value.)
7. Check that the change in the audio output level is less than 2 dB.
8. If the change exceeds 2 dB, perform "Adjustment of A/C HEAD Slant" in Item 3-3-1 and this adjustment.
9. If the above procedure proves to be unsatisfactory, replace the TAPE GUIDE ASSY (SP) and TAPE GUIDE ASSY (TU) according to Para. 2-35 (Replacement of Major Parts).

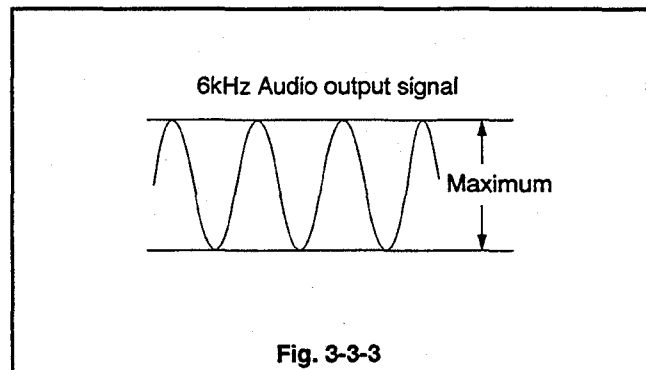
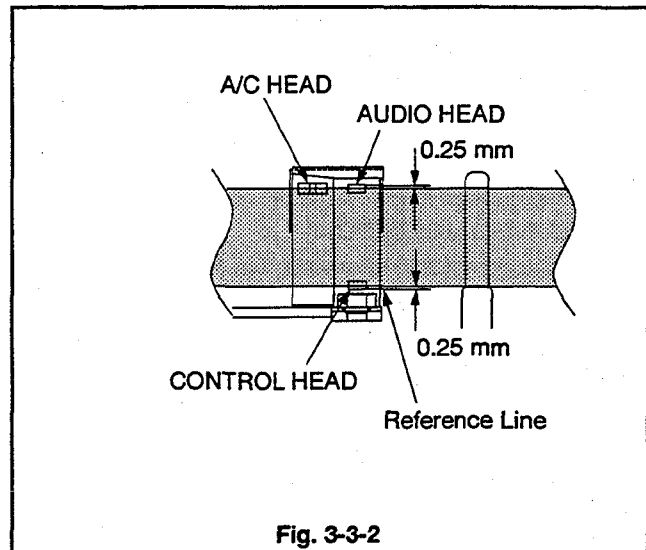
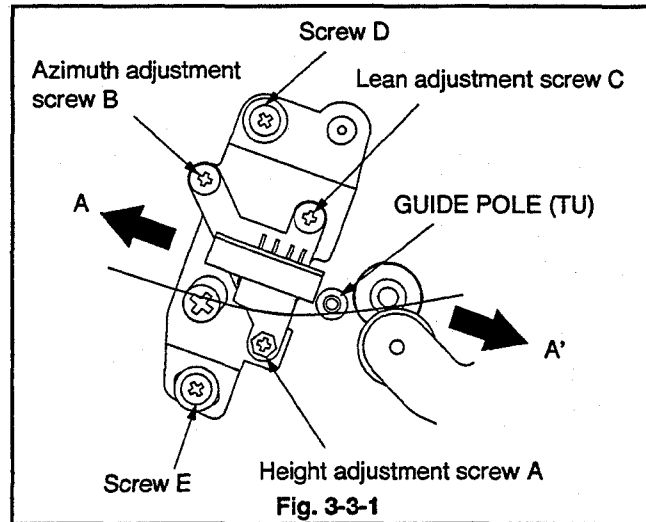

3-4. Adjustment of Phase

1. Set the VCR to the play back mode. (3H mode)
(Use the Alignment Tape specified below to perform adjustment 1~4).
[PM6KE2 35 : 859C568O90]
2. Preset tracking.
3. Loosen the Screws D and E and insert a screw driver into the Plastic Boss of the MAIN PLATE ASSY. Move the A/C PLATE right and left to adjust the FM output waveform to the maximum.
4. Tighten the screws D and E.
5. Play back the Alignment Tape. (3H mode)
[NMX : 859C568O60]
6. Connect TP2A (the FM waveform output) and the audio output terminal, to the oscilloscope. External Trig. from TP2H. Check that the missing portions of the FM waveform, and that of the Audio waveform are as shown in Fig. 3-4-2.
7. If they are not within the specified value, repeat the procedure 3.
8. Adjust manual tracking so the FM waveform is maximum, and set the oscilloscope so that the waveform is "5" divisions. (Refer to Note in para.3-2-5 about tracking adjustment.)
9. Preset tracking.
10. Check that the FM waveform on the oscilloscope is "4.8" or more divisions.
11. If the FM waveform is below "4.8" divisions after tracking preset, repeat this adjustment.
12. Push the A/C HEAD to the right and left (in the direction of A-A' in Fig. 3-4-1) and then release. Check that the amplitude of the FM waveform does not change from that before shifting the A/C HEAD.
13. When the FM waveform Varies in amplitude level, check the mounting position of the A/C HEAD UNIT. If the position is incorrect, correct the position following Item 2-4 "A/C HEAD UNIT" perform Item 3-3 "Adjustment of A/C HEAD" and repeat this adjustment from the beginning.
14. Alternately load and unload the Tape several times, check that the amplitude of the FM waveform does not change.

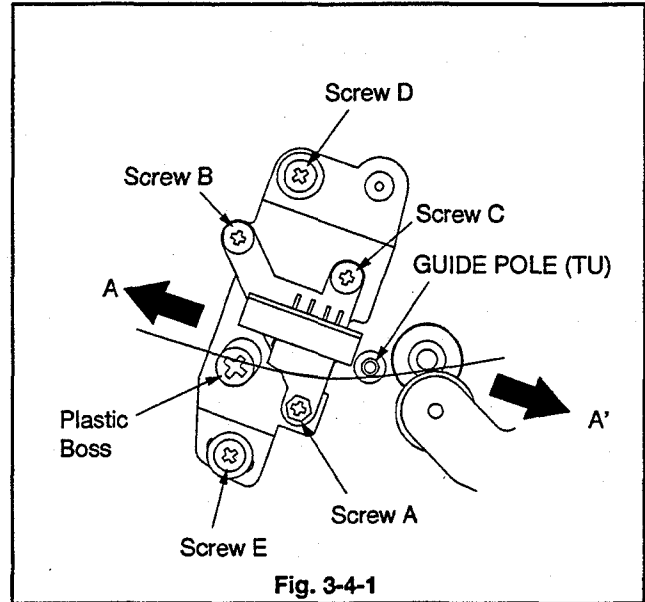

Fig. 3-4-1

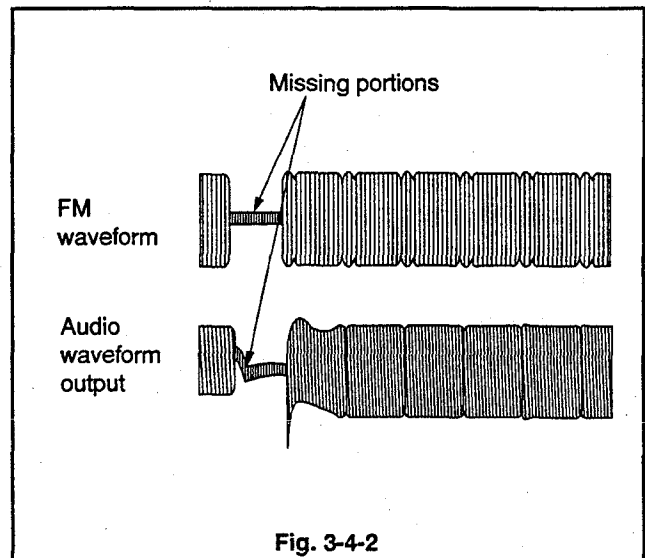

Fig. 3-4-2

3-5. Adjustment of GUIDE ARM ASSY (TU) Height

1. Run a final portion of E-240 Blank Tape in the reverse search mode.
2. Tighten the NYLON NUT of the GUIDE ARM ASSY (TU) with a box driver to lower the GUIDE ARM ASSY (TU) until the Tape is creased at the lower flange of the GUIDE POLE (TU). Then slowly return the NYLON NUT, stop it at the point where the crease is removed. (During adjustment, use an uncovered Cassette Tape, or raise the cover so that the adjustment is available.)

Note : During adjustment, turn the NYLON NUT in the loosening direction. Do not turn the NYLON NUT more than $\pm 1/2$ turn.

3. Eject and insert the Cassette Tape, and then set the VCR to the reverse search mode again. Check that the Tape is not creased at the lower flange of the GUIDE POLE (TU). If the crease is not removed, repeat the procedure 1~ 3.
4. Set the VCR to the play back mode and check that the Tape is not creased at the lower flange of the GUIDE POLE (TU). If the crease is present, repeat "Adjustment of A/C HEAD Slant" in Item 3-3-1 and the succeeding adjustments.
5. Run the start portion of E-180 Blank Tape in the forward search mode and check that the Tape is not creased at the GUIDE POLE (TU).

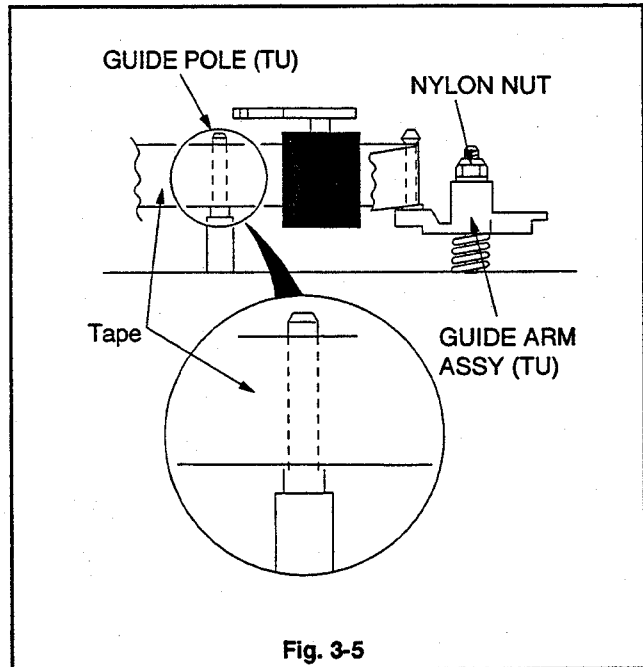

4. Servicing for Tape Jamming during the Loading Process

1. Remove the DECK ASSY.
2. If the Tape is caught in the mechanical parts, remove the Tape.
3. If the TAPE GUIDE ASSY (TU) and TAPE GUIDE ASSY (SP) are in the Tape unlocked position, turn the LOADING MOTOR ASSY shown in Fig. 4 in the direction shown by arrow Ⓐ and move the TAPE GUIDE ASSY (TU) and TAPE GUIDE ASSY (SP) fully in the unloaded position.
4. Turn the CAPSTAN MOTOR shown in Fig. 4 in the direction shown by arrow Ⓑ to wind the Tape up within the Cassette.
5. Turn the LOADING MOTOR ASSY shown in Fig. 4 in the direction shown by arrow Ⓐ to eject the Tape.

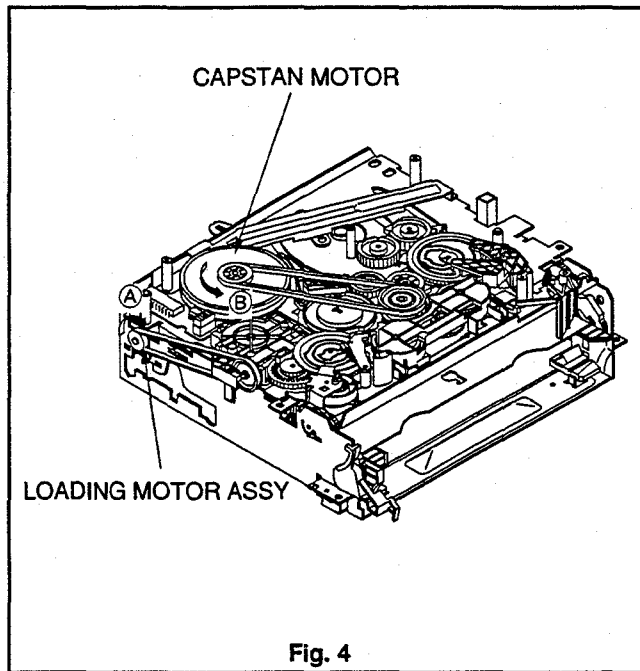

Fig. 4

GLOSSARY OF ABBREVIATIONS

A.E	: Audio Erase	HP	: Head Phone
A/C-H	: Audio / Control Head	HPF	: High-Pass Filter
A-FF	: Audio Flip Flop from Servo Circuit	LED	: Light Emitting Diode
A-PB	: Audio-Play Back	LIM	: Limiter
A-REC	: Audio-Recording	LM	: Loading Motor
ACC	: Automatic Chroma Control	LP	: Long Play
AFC	: Automatic Frequency Control	LPF	: Low-Pass Filter
AFT	: Automatic Fine Tuning	MC	: Mechanical Control
AGC	: Automatic Gain Control	MDA	: Motor Drive Amplifier
ALC	: Automatic Level Control	MIC	: Microphone
AMP	: Amplifier	MM	: Mono-Multivibrator
ANT	: Antenna	MOD	: Modulator
APC	: Automatic Phase Control	N	: Not Normal
ATT	: Attenuator	NL DEEMP	: Non Linear Deemphasis
B/W	: Black and White	NR	: Non Regulated or Noise Reduction
BPF	: Band-Pass Filter	O-PWV	: ON/OFF Command to supply B + Power
BS	: Band Switch	OPE	: Operation
BU	: Back Up	OSC	: Oscillator
C-LAMP	: Cassette Lamp	OTR	: One Touch Recording
C-ROT	: Chroma Rotation	P/R	: Playback/Record
CASS	: Cassette	P/R-SW	: Playback/Record-Switch
CE	: Chip Enable	PB	: Play Back
CG	: Character Generator	PCB	: Printed Circuit Board
CK	: Clock	PG	: Pulse Generator
CL	: Clear	PIC	: Picture Control
CNT	: Counter	PLL	: Phase Locked Loop
CONV	: Converter	PSC	: Pulse Swallow Control
CP	: Capstan	PWM	: Pulse Width Modulation
CP-F/R	: Capstan-Forward/Reverse	PWV	: ON/OFF Command to supply B + Power
CP-FG	: Capstan-Frequency Generator	REC	: Recording
CP-M	: Capstan-Motor	REC-1, REC-2	: Record Command for the PB/REC Control Circuit
CP-OUT	: Capstan Motor Control Out	REF	: Reference
CS	: Cassette Switch or Chip Select	REG	: Regulator
CTL	: Control	REM	: Remaining Time or Remote Control
D-FF	: Drum Flip Flop from Servo Circuit	REW	: Rewind
D-M	: Drum Motor	RIS	: Record Inhibit Switch
D-OUT	: Drum Motor Control Out	RS	: Reverse Search
DEMODO	: Demodulator	S/P	: Still/Pause
DET	: Detector	SENS	: Sensor
DL	: Delay Line	SL	: Slow
DOC	: Drop Out Compensator	SP	: Standard Play
DOP	: Drop Out Pulse	SP-SENS	: Supply Reel Sensor
DTR	: Digital Tracking	SS	: Start Sensor
EE	: Electronic-Electronic	STBY	: Stand By
EF	: Emitter Follower	T.P	: Test Point
EMPHA	: Emphasis	T-REC	: Timer-Record
EP	: Extended Play	TM	: Take up Motor
EQ	: Equalizer	TR	: Transistor or Tracking
ES	: End Sensor	TU-SENS	: Take Up Reel Sensor
F/R	: Forward/Reverse	UL	: Unload
F/R-SW	: FF/Rewind Switch	V-SYNC	: Vertical Synchronising Signal
FE-H	: Full Erase Head	VCO	: Voltage Controlled Oscillator
FF	: Fast Forward	VS	: Voltage Synthesizer
FG	: Frequency Generator	VXO	: Variable Crystal Oscillator
FL-SW	: Front Loading Switch	W/D	: White/Dark
FLCONT	: Flying Erase Head Control	X'OSC	: Crystal Oscillator
FLM	: Front Loading Motor	Y/C	: Luminance/Chrominance
FM	: Frequency Modulator	YNR	: Y Noise Reduction
FS	: Forward Search		
G	: Ground		
H-LED	: Humidity-LED		
H-SENS	: Humidity-Sensor		
H-SYNC	: Horizontal Synchronising Signal		
HA	: Head Amplifier		
HE	: Hall Element		

CHIP PARTS REPLACEMENT

CHIP PARTS REPLACEMENT

Some resistors, shorting jumpers (0Ω resistor), ceramic capacitors, transistors and diodes are chip parts. When replacing these parts, note the following cautions.

Cautions :

- Use fine tipped, well insulated soldering pencil (iron), about 30 watts, and tweezers.
- Melt the solder and remove the Chip Parts carefully not to tear off the copper foil of the printed circuit board.
- Discard removed chips ; do not reuse them.
- Do not apply heat for more than 3 seconds to new Chip Parts.
- Avoid using a rubbing stroke when soldering.
- Take care not to scratch, or damage the Chip Parts when soldering.
- Supplementary cementing is not required.

1. Removal of Chip Parts (Resistors, capacitors, etc.)

- Grasp the part with tweezers. Melt the solder at both sides alternately, remove one side of the part with a twisting motion.
- Melt the solder at the other side and remove the part.

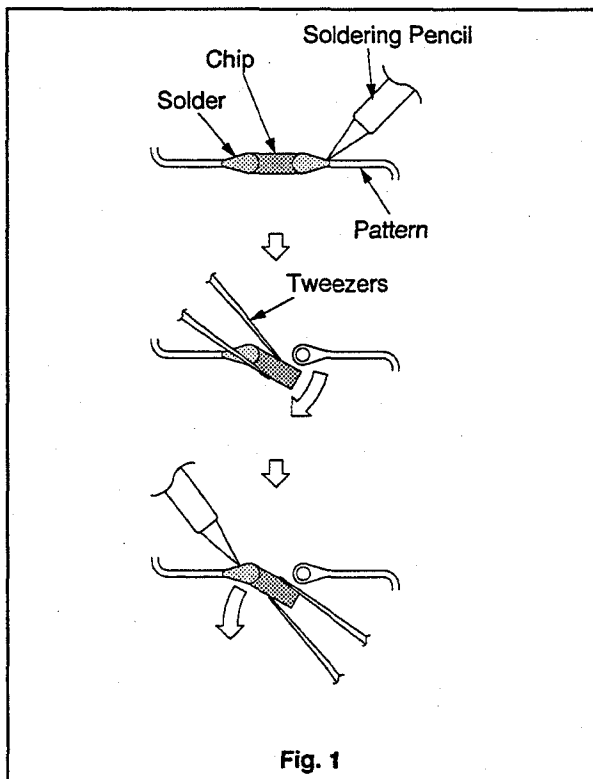

2. Removal of Chip Parts (Transistors)

- Melt the solder of one lead. Lift the side of that lead upward.
- Simultaneously melt the solder of the two remaining leads and lift the part from the PCB.

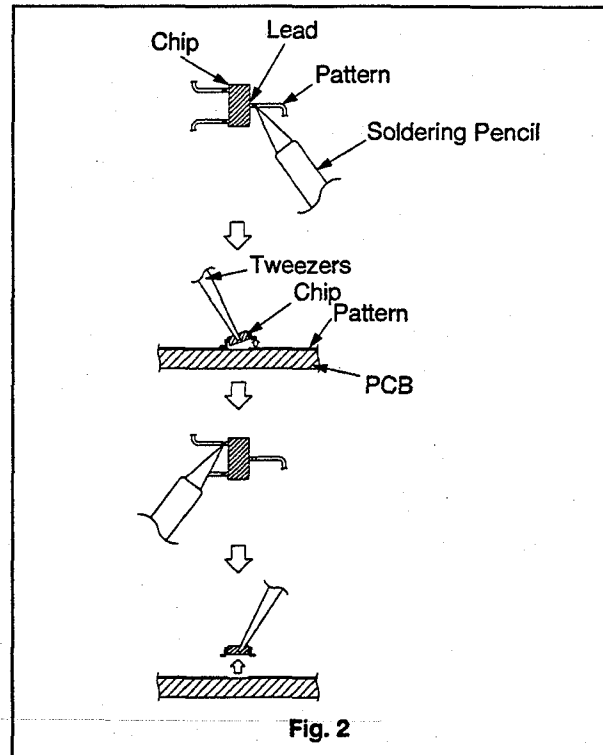

3. Replacement

- Presolder the contact points of the circuit pattern.
- Press the part downward with tweezers and apply the soldering pencil as shown in Fig. 3.

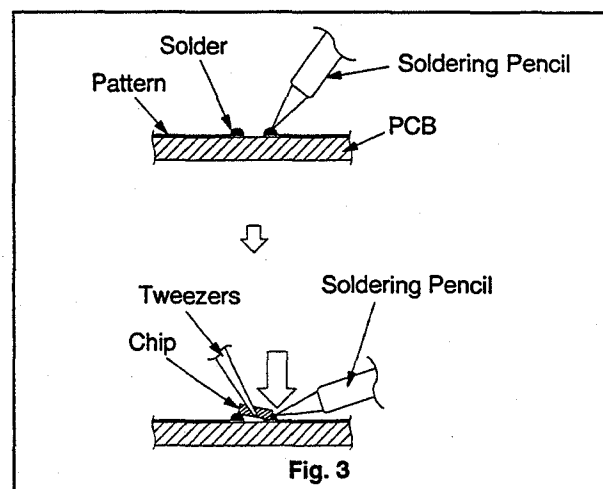

PARTS LIST

1. CABINET ASSEMBLY

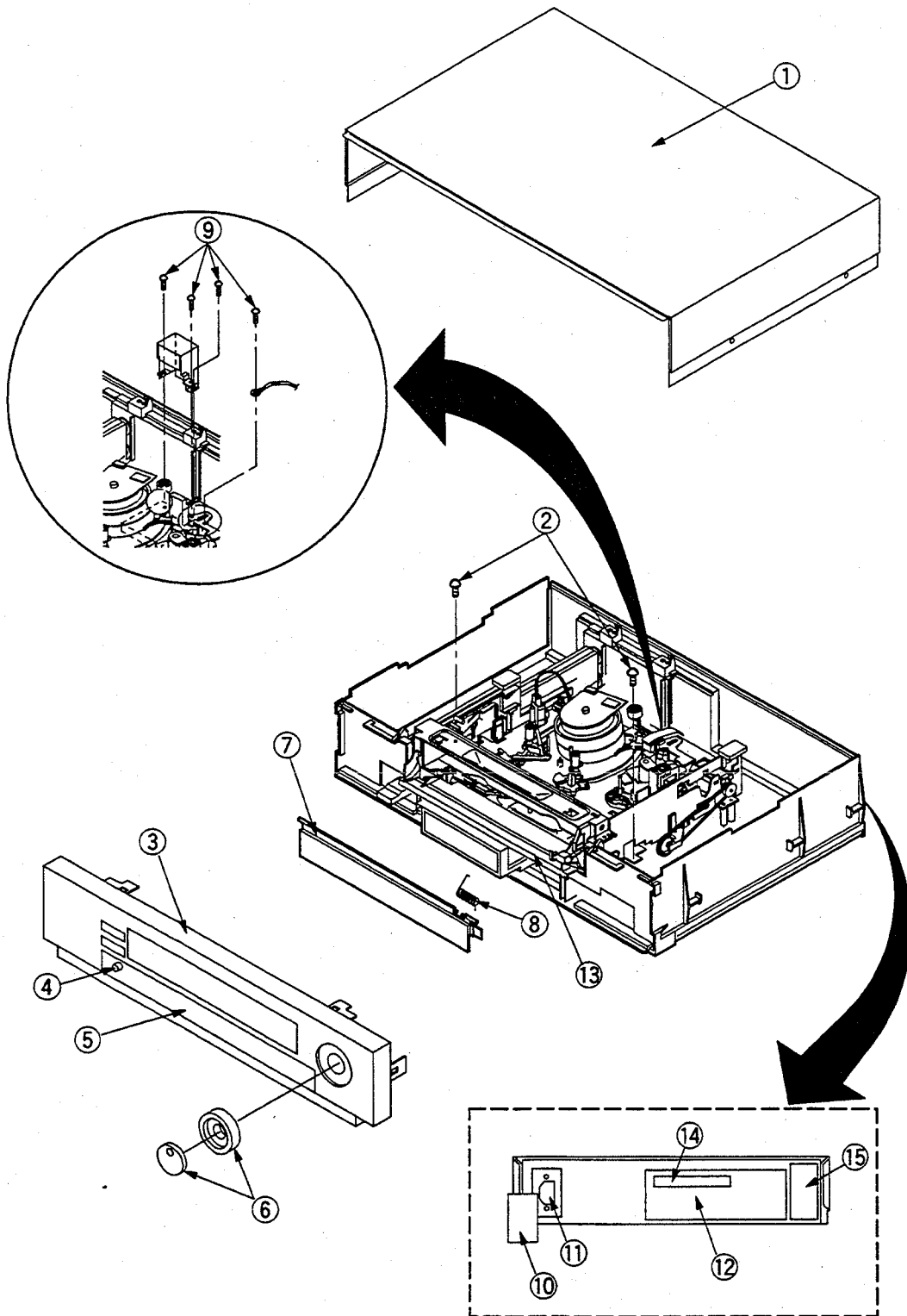

ITEM NO.	PARTS NO.	PARTS NAME	DESCRIPTION
CABINET ASSEMBLY			
1	968C047O01	TOP COVER ASSY	
2	669D221O40	SCREW	4 × 12 46LA005
3	968B044O15	FRONT ASSY	
4	734C035O10	CONTROL KNOB	
5	752C224O60	TIMER PLATE	
6	705D038O60	JOG/SHUTTLE ASSY	
7	752C226O10	CASSETTE DOOR ASSY	
8	572D385O10	F/L SPRING	
9	669D229O90	SCREW	M3.0 × 4 46LA005
10	761B313O20	INLET COVER	[HS-7496E]
10	761B313O10	INLET COVER	[HS-7496E(B)]
11	451C209O10	POWER JACK	[HS-7496E]
11	451C210O10	POWER JACK	[HS-7496E(B)]
12	761B312O20	TERMINAL COVER	
13	641D806O10	INSERT GUIDE	
14	440B128O10	TERMINAL BOARD	
15	760D608O10	CONTROL PLATE	

2. PACKING PARTS

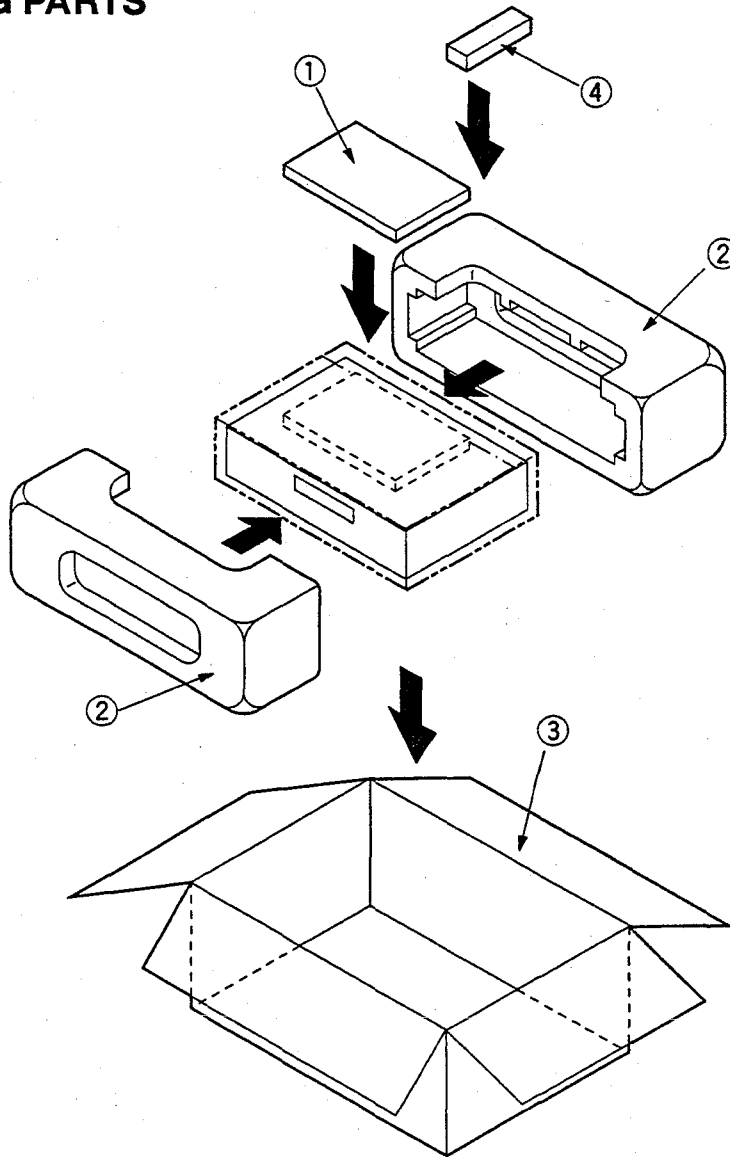

ACCESSORY

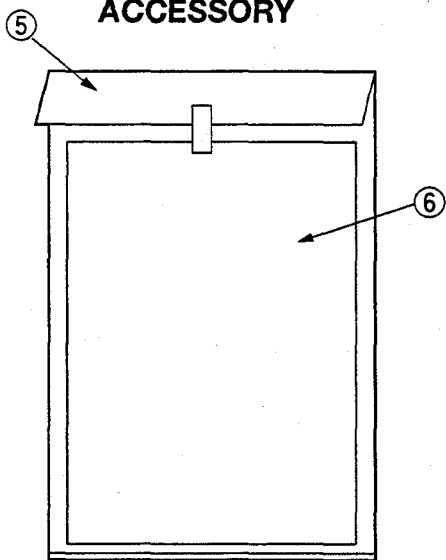

ITEM NO.	PARTS NO.	PARTS NAME	DESCRIPTION
PACKING PARTS			
1	-----	ACCESSORY	
2	803A480O10	CUSHION	
3	802B602O20	PACKING CASE	
4	242C209O80	AC POWER CORD	[HS-7496E]
4	246C221O10	AC POWER CORD	[HS-7496E(B)]
ACCESSORY			
5	831D302O10	PACKING BAG	(FOR ACCESSORY) 375X250 0.06T
6	872C190O20	INSTRUCTION BOOK	[HS-7496E]
6	872C190O80	INSTRUCTION BOOK	[HS-7496E(B)]

3. ELECTRICAL PARTS

SYMBOL No.	PARTS No.	PARTS NAME	DESCRIPTION	SYMBOL No.	PARTS No.	PARTS NAME	DESCRIPTION
INTEGRATED CIRCUITS							
IC201	270P080O10	IC	AN3341SC	Q 2C2	260P562O40	TRANSISTOR	2SA952-K
IC2A0	270P195O10	IC	LA7346	Q 2C3	260P804O30	CHIP TRANSISTOR	2SC3052-G
IC2A1	270P247O10	IC	LC89970M	Q 2C4	260P806O10	CHIP TRANSISTOR	DTA124EK
IC2001	275P084O10	MOS IC	μPD6458GT-101	Q 2C5	260P804O30	CHIP TRANSISTOR	2SC3052-G
IC2007	272P635O10	IC	AN3916-(LF)	Q 2C6	260P802O20	CHIP TRANSISTOR	2SA1235-F
IC300	272P200O10	IC	M5201FP	Q 2C7	260P804O30	CHIP TRANSISTOR	2SC3052-G
IC3A0	272P234O10	IC	LA7295	Q 2D0	260P805O30	CHIP TRANSISTOR	2SC3053-D
IC4A0	274P602O80	MOS IC	MN67492MTD5	Q 2D1	260P804O30	CHIP TRANSISTOR	2SC3052-G
IC4A1	263P053O20	MOS IC	TC4053BP	Q 2D2	260P805O30	CHIP TRANSISTOR	2SC3053-D
IC4A2	272P235O10	IC	TA7291S	Q 2D3	260P804O30	CHIP TRANSISTOR	2SC3052-G
IC4A3	272P079O10	IC	NJM2902M	Q 2J0	260P807O10	CHIP TRANSISTOR	UN2212
IC4A6	272P204O10	IC	LM2904M	Q 2J2	260P802O20	CHIP TRANSISTOR	2SA1235-F
IC501	274P561O10	MOS IC	μPD16311GC-AB6	Q 2J3	260P805O30	CHIP TRANSISTOR	2SC3053-D
IC5A0	275P111O20	MOS IC	M38185ME-254FP	Q 2J4	260P805O30	CHIP TRANSISTOR	2SC3053-D
IC5A1	270P070O10	MOS IC	AT93C56-10PC	Q 2J5	260P805O30	CHIP TRANSISTOR	2SC3053-D
IC5A2	263P708O20	MOS IC	TLC272CPS	Q 2J7	260P805O30	CHIP TRANSISTOR	2SC3053-D
IC5A3	263P328O10	MOS IC	MC14070BF	Q 2J8	260P805O30	CHIP TRANSISTOR	2SC3053-D
IC5A4	270P528O10	IC	PST7029MT	Q 2J9	260P805O30	CHIP TRANSISTOR	2SC3053-D
IC6000	270P387O10	IC	CXA1203M	Q 2K0	260P807O10	CHIP TRANSISTOR	UN2212
IC6001	270P384O10	IC	AN3592K	Q 2K3	260P802O30	CHIP TRANSISTOR	2SA1235-G
IC7A0	272P292O10	MOS IC	CXL1009P	Q 2M0	260P805O30	CHIP TRANSISTOR	2SC3053-D
IC7A1	272P687O10	IC	NJM2234L	Q 2M1	260P802O30	CHIP TRANSISTOR	2SA1235-G
IC7A2	272P687O10	IC	NJM2234L	Q 2M2	260P805O30	CHIP TRANSISTOR	2SC3053-D
IC7A3	274P758O10	MOS IC	TC7WU04F	Q 2M3	260P805O30	CHIP TRANSISTOR	2SC3053-D
IC7A4	274P758O10	MOS IC	TC7WU04F	Q 2M4	260P805O30	CHIP TRANSISTOR	2SC3053-D
IC7A5	274P758O10	MOS IC	TC7WU04F	Q 2N0	260P805O30	CHIP TRANSISTOR	2SC3053-D
IC7A6	274P758O10	MOS IC	TC7WU04F	Q 2N4	260P805O30	CHIP TRANSISTOR	2SC3053-D
IC901	272P500O20	IC	HA17431PA	Q 2N5	260P805O30	CHIP TRANSISTOR	2SC3053-D
				Q 2N6	260P807O10	CHIP TRANSISTOR	UN2212
				Q 2N7	260P807O10	CHIP TRANSISTOR	UN2212
TRANSISTORS				Q 2N8	260P807O10	CHIP TRANSISTOR	UN2212
Q 201	260P817O30	CHIP TRANSISTOR	2SA1037K-S	Q 2N9	260P807O10	CHIP TRANSISTOR	UN2212
Q 202	260P807O10	CHIP TRANSISTOR	UN2212	Q 2P1	260P805O30	CHIP TRANSISTOR	2SC3053-D
Q 203	260P807O10	CHIP TRANSISTOR	UN2212	Q 2P2	260P522O20	TRANSISTOR	2SC3068-AA
Q 204	260P807O10	CHIP TRANSISTOR	UN2212	Q 2P3	260P805O30	CHIP TRANSISTOR	2SC3053-D
Q 206	260P818O30	CHIP TRANSISTOR	2SC2412KS	Q 2P4	260P807O10	CHIP TRANSISTOR	UN2212
Q 207	260P818O30	CHIP TRANSISTOR	2SC2412KS	Q 2Q1	260P807O10	CHIP TRANSISTOR	UN2212
Q 208	260P807O10	CHIP TRANSISTOR	UN2212	Q 2001	260P817O30	CHIP TRANSISTOR	2SA1037K-S
Q 209	260P255O40	TRANSISTOR	2SA950-Y	Q 2007	260P818O30	CHIP TRANSISTOR	2SC2412KS
Q 210	260P807O10	CHIP TRANSISTOR	UN2212	Q 2008	260P818O30	CHIP TRANSISTOR	2SC2412KS
Q 211	260P817O30	CHIP TRANSISTOR	2SA1037K-S	Q 2009	260P817O30	CHIP TRANSISTOR	2SA1037K-S
Q 212	260P255O40	TRANSISTOR	2SA950-Y	Q 2010	260P818O30	CHIP TRANSISTOR	2SC2412KS
Q 213	260P807O10	CHIP TRANSISTOR	UN2212	Q 2011	260P818O30	CHIP TRANSISTOR	2SC2412KS
Q 2A5	260P806O10	CHIP TRANSISTOR	DTA124EK	Q 2013	260P805O30	CHIP TRANSISTOR	2SC3053-D
Q 2A6	260P806O10	CHIP TRANSISTOR	DTA124EK	Q 301	260P807O10	CHIP TRANSISTOR	UN2212
Q 2A7	260P807O10	CHIP TRANSISTOR	UN2212	Q 3A0	260P629O60	TRANSISTOR	2SC3331-S
Q 2A8	260P806O10	CHIP TRANSISTOR	DTA124EK	Q 3A1	260C676O30	TRANSISTOR	2SC3311A-S
Q 2B0	260P804O30	CHIP TRANSISTOR	2SC3052-G	Q 3A2	260C676O30	TRANSISTOR	2SC3311A-S
Q 2B1	260P804O30	CHIP TRANSISTOR	2SC3052-G	Q 3A3	260P807O10	CHIP TRANSISTOR	UN2212
Q 2B3	260P807O10	CHIP TRANSISTOR	UN2212	Q 3A4	260P806O10	CHIP TRANSISTOR	DTA124EK
Q 2B4	260P806O10	CHIP TRANSISTOR	DTA124EK	Q 3B0	260P818O30	CHIP TRANSISTOR	2SC2412KS
Q 2B5	260P807O10	CHIP TRANSISTOR	UN2212	Q 3B1	260P559O30	TRANSISTOR	2SC1740S-S
Q 2B8	260P807O10	CHIP TRANSISTOR	UN2212	Q 3B2	260P559O30	TRANSISTOR	2SC1740S-S
Q 2B9	260P806O10	CHIP TRANSISTOR	DTA124EK	Q 4A1	260P807O10	CHIP TRANSISTOR	UN2212
Q 2C0	260P802O20	CHIP TRANSISTOR	2SA1235-F	Q 4A2	260P818O30	CHIP TRANSISTOR	2SC2412KS
Q 2C1	260P802O20	CHIP TRANSISTOR	2SA1235-F	Q 4A3	260P818O30	CHIP TRANSISTOR	2SC2412KS

SYMBOL No.	PARTS No.	PARTS NAME	DESCRIPTION	SYMBOL No.	PARTS No.	PARTS NAME	DESCRIPTION
Q 4A5	260P818030	CHIP TRANSISTOR	2SC2412KS	DIODES			
Q 4A6	260P818030	CHIP TRANSISTOR	2SC2412KS				
Q 4A8	260P817030	CHIP TRANSISTOR	2SA1037K-S				
Q 4A9	260P817030	CHIP TRANSISTOR	2SA1037K-S				
Q 4B0	260P807010	CHIP TRANSISTOR	UN2212	D 2A0	264P568O10	DIODE	1SS252
Q 4B5	260P817030	CHIP TRANSISTOR	2SA1037K-S	D 2A1	264P568O10	DIODE	1SS252
Q 4B6	260P817030	CHIP TRANSISTOR	2SA1037K-S	D 2A2	264P568O10	DIODE	1SS252
Q 4B7	260P818030	CHIP TRANSISTOR	2SC2412KS	D 2A3	264P568O10	DIODE	1SS252
Q 5A3	260P802020	CHIP TRANSISTOR	2SA1235-F	D 2A4	264P568O10	DIODE	1SS252
Q 5A4	260P817030	CHIP TRANSISTOR	2SA1037K-S	D 2A5	264P568O10	DIODE	1SS252
Q 5A5	260P818030	CHIP TRANSISTOR	2SC2412KS	D 2A6	264P568O10	DIODE	1SS252
Q 5A6	260P806010	CHIP TRANSISTOR	DTA124EK	D 2001	264P104030	DIODE	HZ5C1
Q 5B1	260P817030	CHIP TRANSISTOR	2SA1037K-S	D 3A0	264P568O10	DIODE	1SS252
Q 5B2	260P817030	CHIP TRANSISTOR	2SA1037K-S	D 4A1	264P808O10	CHIP DIODE	DAN202K
Q 5B3	260P817030	CHIP TRANSISTOR	2SA1037K-S	D 4A3	264P390O10	CHIP DIODE	1SS123
Q 5B4	260P559O30	TRANSISTOR	2SC1740S-S	D 4A4	264P568O10	DIODE	1SS252
Q 5B5	260P559O30	TRANSISTOR	2SC1740S-S	D 4A5	264P500O20	DIODE	EM01Z
Q 5B6	260P559O30	TRANSISTOR	2SC1740S-S	D 4A6	264P568O10	DIODE	1SS252
Q 5B7	260P559O30	TRANSISTOR	2SC1740S-S	D 5A0	264P696O10	LIGHT EMITTING DIODE	SLR-932C-20-AB-T1 [E]
Q 5B8	260P806010	CHIP TRANSISTOR	DTA124EK	D 5A0	264P795O10	LIGHT EMITTING DIODE	SID1050CMT5 [EB]
Q 5B9	260P864O10	CHIP TRANSISTOR	2SK209GR	D 5A1	264P696O10	LIGHT EMITTING DIODE	SLR-932C-20-AB-T1 [E]
Q 5C0	260P807010	CHIP TRANSISTOR	UN2212	D 5A1	264P795O10	LIGHT EMITTING DIODE	SID1050CMT5 [EB]
Q 5C3	260P807010	CHIP TRANSISTOR	UN2212	D 5A2	264P342O70	DIODE	HZ4C2
Q 5C4	260P807010	CHIP TRANSISTOR	UN2212	D 5A3	264P568O10	DIODE	1SS252
Q 6006	260P818030	CHIP TRANSISTOR	2SC2412KS	D 5A4	264P696O20	LIGHT EMITTING DIODE	SLR-932A-20-B-T1 [E]
Q 6007	260P818030	CHIP TRANSISTOR	2SC2412KS	D 5A4	264P795O10	LIGHT EMITTING DIODE	SID1050CMT5 [EB]
Q 6008	260P817030	CHIP TRANSISTOR	2SA1037K-S	D 5A5	264P696O10	LIGHT EMITTING DIODE	SLR-932C-20-AB-T1 [E]
Q 6009	260P807010	CHIP TRANSISTOR	UN2212	D 5A5	264P795O10	LIGHT EMITTING DIODE	SID1050CMT5 [EB]
Q 6011	260P818030	CHIP TRANSISTOR	2SC2412KS	D 5A6	264P568O10	DIODE	1SS252
Q 6013	260P818030	CHIP TRANSISTOR	2SC2412KS	D 5A7	264P568O10	DIODE	1SS252
Q 6014	260P818030	CHIP TRANSISTOR	2SC2412KS	D 5B0	264P568O10	DIODE	1SS252
Q 6016	260P807010	CHIP TRANSISTOR	UN2212	D 5B1	264P568O10	DIODE	1SS252
Q 6017	260P818030	CHIP TRANSISTOR	2SC2412KS	D 5B2	264P808O10	CHIP DIODE	DAN202K
Q 6018	260P807010	CHIP TRANSISTOR	UN2212	D 5B3	264P568O10	DIODE	1SS252
Q 6101	260P845O30	CHIP TRANSISTOR	XN4501	D 5B4	264P568O10	DIODE	1SS252
Q 6102	260P818030	CHIP TRANSISTOR	2SC2412KS	D 5B5	264P568O10	DIODE	1SS252
Q 7A4	260P818010	CHIP TRANSISTOR	2SC2412KQ	D 5B6	264P568O10	DIODE	1SS252
Q 7A5	260P818010	CHIP TRANSISTOR	2SC2412KQ	D 5B7	264P568O10	DIODE	1SS252
Q 7A6	260P818010	CHIP TRANSISTOR	2SC2412KQ	D 5B8	264P568O10	DIODE	1SS252
Q 7A7	260P818010	CHIP TRANSISTOR	2SC2412KQ	D 5B9	264P568O10	DIODE	1SS252
Q 7A9	260P817030	CHIP TRANSISTOR	2SA1037K-S	D 5C0	264P568O10	DIODE	1SS252
Q 7B4	260P818010	CHIP TRANSISTOR	2SC2412KQ	D 5C1	264P568O10	DIODE	1SS252
Q 7B5	260P817030	CHIP TRANSISTOR	2SA1037K-S	D 5C2	264P568O10	DIODE	1SS252
Q 7B6	260P817030	CHIP TRANSISTOR	2SA1037K-S	D 5C3	264P568O10	DIODE	1SS252
Q 7C1	260P559O50	TRANSISTOR	2SC1740S-E	D 5C4	264P568O10	DIODE	1SS252
Q 901	261P038O10	TRANSISTOR	2SC4234	D 5C5	264P568O10	DIODE	1SS252
Q 902	260P522O20	TRANSISTOR	2SC3068-AA	D 6201	264P568O10	DIODE	1SS252
Q 903	260P629O10	TRANSISTOR	2SC3331-S	D 701	264P621O10	LIGHT EMITTING DIODE	SEL2210R TP2
Q 904	261P036O10	TRANSISTOR	2SB1548	D 7A0	264P104O50	DIODE	HZ9C1
Q 905	260P559O50	TRANSISTOR	2SC1740S-E	D 7B0	264P568O10	DIODE	1SS252
Q 906	260P630O10	TRANSISTOR	2SD2012	D 801	264P568O10	DIODE	1SS252
Q 907	260P559O50	TRANSISTOR	2SC1740S-E	D 802	264P568O10	DIODE	1SS252
Q 908	260C628O10	TRANSISTOR	2SA1619A-Q	D 803	264P568O10	DIODE	1SS252
Q 909	260P559O50	TRANSISTOR	2SC1740S-E	D 804	264P568O10	DIODE	1SS252
Q 910	260P560O40	TRANSISTOR	2SA933S-S	D 805	264P568O10	DIODE	1SS252
				D 806	264P568O10	DIODE	1SS252
				D 815	264P568O10	DIODE	1SS252
				D 816	264P568O10	DIODE	1SS252
				D 817	264P568O10	DIODE	1SS252

SYMBOL No.	PARTS No.	PARTS NAME	DESCRIPTION	SYMBOL No.	PARTS No.	PARTS NAME	DESCRIPTION
D 818	264P568010	DIODE	1SS252	L 2B5	325C167050	PEAKING COIL	100µH-J
D 819	264P568010	DIODE	1SS252	L 2B6	325C166050	PEAKING COIL	15µH-J
D 820	264P568010	DIODE	1SS252	L 2B7	325C167050	PEAKING COIL	100µH-J
D 901	264P508040	DIODE	S1WB(A)60	L 2G4	325C167050	PEAKING COIL	100µH-J
D 903	264P699010	DIODE	AP01C	L 2H0	325C167050	PEAKING COIL	100µH-J
D 904	264P825010	DIODE	ERA15-02	L 2H1	325C168030	PEAKING COIL	470µH-J
D 907	264P695040	DIODE	RK34	L 2J0	325C167050	PEAKING COIL	100µH-J
D 908	264P695060	DIODE	RK36	L 2J1	325C166080	PEAKING COIL	27µH-J
D 909	264P663010	DIODE	D1NL20U	L 2J2	325C167020	PEAKING COIL	56µH-J
D 910	264P663010	DIODE	D1NL20U	L 2J3	325C167050	PEAKING COIL	100µH-J
D 911	264P527030	DIODE	D1NS4/AK04	L 2J4	325C168000	PEAKING COIL	270µH-J
D 912	264P456070	DIODE	RD2.4EB	L 2J5	325C166010	PEAKING COIL	6.8µH-J
D 913	264P104040	DIODE	HZ30-2	L 2J6	325C166030	PEAKING COIL	10µH-J
D 914	264P291070	DIODE	HZ20-3	L 2J7	325C167090	PEAKING COIL	220µH-J
D 917	264P452030	DIODE	HZ5C3	L 2J8	325C166090	PEAKING COIL	33µH-J
D 918	264P568010	DIODE	1SS252	L 2K1	325C167050	PEAKING COIL	100µH-J
D 920	264P500020	DIODE	EM01Z	L 2N0	325C168010	PEAKING COIL	330µH-J
D 921	264P568010	DIODE	1SS252	L 2N2	325C167050	PEAKING COIL	100µH-J
D 924	264P568010	DIODE	1SS252	L 2Q2	325C167010	PEAKING COIL	47µH-J
D 926	264P488090	DIODE	RD16FB	L 2Q3	325C166070	PEAKING COIL	22µH-J
D 928	264P483070	DIODE	RD5.1FB1	L 2Q5	325C167050	PEAKING COIL	100µH-J
D 929	264P568010	DIODE	1SS252	L 2Q6	325C167050	PEAKING COIL	100µH-J
D 930	264P485060	DIODE	RD7.5FB2	L 2R4	325C167030	PEAKING COIL	68µH-J
D 933	264P500020	DIODE	EM01Z	L 2S1	325C168070	PEAKING COIL	1000µH-J
				L 2001	325C167050	PEAKING COIL	100µH-J
FILTERS				L 2002	325C166060	PEAKING COIL	18µH-J
L 5A0	409P777030	CHIP EMI FILTER	BLM21A10	L 2005	325C167050	PEAKING COIL	100µH-J
L 5A1	409P777030	CHIP EMI FILTER	BLM21A10	L 2007	325C167050	PEAKING COIL	100µH-J
L 5A2	409P777030	CHIP EMI FILTER	BLM21A10	L 2009	325C167050	PEAKING COIL	100µH-J
L 7A1	409P777030	CHIP EMI FILTER(TERMINAL PCB ASSY)	BLM21A10	L 2010	325C167040	PEAKING COIL	82µH-J
L 7A2	409P777030	CHIP EMI FILTER(TERMINAL PCB ASSY)	BLM21A10	L 3A0	321C113070	RF COIL	1000µH-K
L 7A3	409P777030	CHIP EMI FILTER(TERMINAL PCB ASSY)	BLM21A10	L 3A1	321C114080	RF COIL	8200µH-J
L 7A4	409P777030	CHIP EMI FILTER(TERMINAL PCB ASSY)	BLM21A10	L 4A0	325C167050	PEAKING COIL	100µH-J
L 7A5	409P777030	CHIP EMI FILTER(TERMINAL PCB ASSY)	BLM21A10	L 501	325C122050	PEAKING COIL	100µH-K
L 7A6	409P402030	EMI FILTER(CCD SKEW PCB ASSY)	FZ103N100	L 6002	325C167050	PEAKING COIL	100µH-J
L 7A6	409P777030	CHIP EMI FILTER(TERMINAL PCB ASSY)	BLM21A10	L 6003	325C167050	PEAKING COIL	100µH-J
L 7A7	409P777030	CHIP EMI FILTER(TERMINAL PCB ASSY)	BLM21A10	L 6005	325C167050	PEAKING COIL	100µH-J
L 901	351P038040	LINE FILTER	ELF-18D290HB	L 6008	325C167050	PEAKING COIL	100µH-J
LC2A1	409P364010	LOW PASS FILTER	H322LSQ-1768MAD	L 6009	325C167040	PEAKING COIL	82µH-J
				L 6011	325C167050	PEAKING COIL	100µH-J
COILS				L 6013	325C166030	PEAKING COIL	10µH-J
L 201	325C167050	PEAKING COIL	100µH-J	L 6101	325C167050	PEAKING COIL	100µH-J
L 202	325C167070	PEAKING COIL	150µH-J	L 6201	325C167040	PEAKING COIL	82µH-J
L 203	325C166090	PEAKING COIL	33µH-J	L 6202	325C166020	PEAKING COIL	8.2µH-J
L 204	325C167080	PEAKING COIL	180µH-J	L 7A0	325C100010	PEAKING COIL	1.0µH-K
L 2A1	321C112050	RF COIL	100µH-K	L 7A1	325C100010	PEAKING COIL(CCD SKEW PCB ASSY)	1.0µH-K
L 2A2	321C112050	RF COIL	100µH-K	L 7A2	325C100010	PEAKING COIL(CCD SKEW PCB ASSY)	1.0µH-K
L 2A5	325C167050	PEAKING COIL	100µH-J	L 7A3	325C100010	PEAKING COIL(CCD SKEW PCB ASSY)	1.0µH-K
L 2A6	325C167050	PEAKING COIL	100µH-J	L 7A4	325C100010	PEAKING COIL(CCD SKEW PCB ASSY)	1.0µH-K
L 2A7	325C167000	PEAKING COIL	39µH-J	L 7A5	325C100010	PEAKING COIL(CCD SKEW PCB ASSY)	1.0µH-K
L 2A8	325C167000	PEAKING COIL	39µH-J	L 7A7	325C107010	PEAKING COIL(CCD SKEW PCB ASSY)	47µH-J
L 2A9	325C166080	PEAKING COIL	27µH-J	L 7A8	325C100010	PEAKING COIL	1.0µH-K
L 2B0	325C166090	PEAKING COIL	33µH-J	L 7A9	325C100010	PEAKING COIL	1.0µH-K
L 2B1	325C166090	PEAKING COIL	33µH-J	L 7B0	325C100010	PEAKING COIL	1.0µH-K
L 2B2	325C167050	PEAKING COIL	100µH-J	L 7B5	325C105010	PEAKING COIL	1.0µH-J
L 2B3	325C167050	PEAKING COIL	100µH-J	L 7B6	325C105010	PEAKING COIL	1.0µH-J
				L 7B7	325C105010	PEAKING COIL	1.0µH-J

SYMBOL No.	PARTS No.	PARTS NAME	DESCRIPTION	SYMBOL No.	PARTS No.	PARTS NAME	DESCRIPTION
L 7B8	325C105010	PEAKING COIL	1.0μH-J	R 236	103P476000	CHIP RESISTOR	1/10W 30kΩ-F
L 7B9	325C105010	PEAKING COIL	1.0μH-J	R 237	103P403070	CHIP RESISTOR	1/10W 10kΩ-J
L 902	321C141090	RF COIL	33μH-K	R 238	103P401030	CHIP RESISTOR	1/10W 100Ω-J
LC6001	332P015010	HORIZ OSC COIL	K10-F5	R 240	103P402050	CHIP RESISTOR	1/10W 1kΩ-J
T 3A0	409P852030	BIAS OSCILLATOR COIL		R 241	103P401070	CHIP RESISTOR	1/10W 220Ω-J
TRANSFORMERS				R 242	103P403050	CHIP RESISTOR	1/10W 6.8kΩ-J
T 901	350P711020	POWER TRANSFORMER	ETS29AK2C6AC	R 243	103P402070	CHIP RESISTOR	1/10W 1.5kΩ-J
VARIABLE RESISTORS				R 244	103P402050	CHIP RESISTOR	1/10W 1kΩ-J
R 908	109C010010	SOLID RESISTOR	1/2W 1MΩ-K	R 245	103P401060	CHIP RESISTOR	1/10W 180Ω-J
VR201	127C380050	SEMIFIXED RESISTOR	1/5W B2kΩ-M	R 247	103P402050	CHIP RESISTOR	1/10W 1kΩ-J
VR202	127C380050	SEMIFIXED RESISTOR	1/5W B2kΩ-M	R 248	103P403050	CHIP RESISTOR	1/10W 6.8kΩ-J
VR2A0	127C480090	SEMIFIXED RESISTOR	1/5W B20kΩ+25%	R 249	103P403010	CHIP RESISTOR	1/10W 3.3kΩ-J
VR2A1	127C490090	SEMIFIXED RESISTOR	1/5W B20kΩ+25%	R 2A2	103P473080	CHIP RESISTOR	1/10W 3.6kΩ-F
VR2A2	127C480080	SEMIFIXED RESISTOR	1/5W B10kΩ+25%	R 2A3	103P402050	CHIP RESISTOR	1/10W 1kΩ-J
VR2A5	127C480090	SEMIFIXED RESISTOR	1/5W B20kΩ+25%	R 2A4	103P472050	CHIP RESISTOR	1/10W 1kΩ-F
VR2001	127C391010	SEMIFIXED RESISTOR	1/5W B50kΩ-M	R 2A5	103P473090	CHIP RESISTOR	1/10W 3.9kΩ-F
VR3A0	127C381020	SEMIFIXED RESISTOR	1/5W B100kΩ-M	R 2A6	103P403000	CHIP RESISTOR	1/10W 2.7kΩ-J
VR3A1	127C380080	SEMIFIXED RESISTOR	1/5W B10kΩ-M	R 2A7	103P402030	CHIP RESISTOR	1/10W 680Ω-J
VR4A0	127C391020	SEMIFIXED RESISTOR	1/5W B100kΩ-M	R 2A8	103P402050	CHIP RESISTOR	1/10W 1kΩ-J
VR5A0	127C390070	SEMIFIXED RESISTOR	1/5W B5kΩ-M	R 2B0	103P406010	CHIP RESISTOR	1/10W 1MΩ-J
VR6000	127C490090	SEMIFIXED RESISTOR	1/5W B20kΩ+25%	R 2B1	103P403060	CHIP RESISTOR	1/10W 8.2kΩ-J
VR701	129D167060	PCB VR	1/20W B5kΩ-15F CS	R 2B2	103P403030	CHIP RESISTOR	1/10W 4.7kΩ-J
VR7A0	127C490040	SEMIFIXED RESISTOR	1/5W B1kΩ+25%	R 2B3	103P402080	CHIP RESISTOR	1/10W 1.8kΩ-J
RESISTORS				R 2B4	103P402070	CHIP RESISTOR	1/10W 1.5kΩ-J
JP5A2	103P409050	CHIP RESISTOR	0.1W 0Ω(2125)	R 2B6	103P409050	CHIP RESISTOR	0.1W 0Ω(2125)
R 201	103P471070	CHIP RESISTOR	1/10W 470Ω-F	R 2B7	103P402050	CHIP RESISTOR	1/10W 1kΩ-J
R 204	103P471050	CHIP RESISTOR	1/10W 390Ω-F	R 2B8	103P403040	CHIP RESISTOR	1/10W 5.6kΩ-J
R 205	103P409090	CHIP RESISTOR	1/10W 75Ω-J	R 2B9	103P402070	CHIP RESISTOR	1/10W 1.5kΩ-J
R 206	103P400010	CHIP RESISTOR	1/10W 10Ω-J	R 2C0	103P402010	CHIP RESISTOR	1/10W 470Ω-J
R 207	103P400010	CHIP RESISTOR	1/10W 10Ω-J	R 2C2	103P402050	CHIP RESISTOR	1/10W 1kΩ-J
R 208	103P470010	CHIP RESISTOR	1/10W 100Ω-F	R 2C3	103P404010	CHIP RESISTOR	1/10W 22kΩ-J
R 209	103P470090	CHIP RESISTOR	1/10W 220Ω-F	R 2C4	103P403060	CHIP RESISTOR	1/10W 8.2kΩ-J
R 210	103P400010	CHIP RESISTOR	1/10W 10Ω-J	R 2C5	103P402080	CHIP RESISTOR	1/10W 1.8kΩ-J
R 211	103P400010	CHIP RESISTOR	1/10W 10Ω-J	R 2C6	103P471090	CHIP RESISTOR	1/10W 560Ω-F
R 212	103P470080	CHIP RESISTOR	1/10W 200Ω-F	R 2C7	103P401030	CHIP RESISTOR	1/10W 100Ω-J
R 213	103P471070	CHIP RESISTOR	1/10W 470Ω-F	R 2C9	103P403080	CHIP RESISTOR	1/10W 12kΩ-J
R 214	103P471060	CHIP RESISTOR	1/10W 430Ω-F	R 2D1	103P471030	CHIP RESISTOR	1/10W 330Ω-F
R 215	103P473030	CHIP RESISTOR	1/10W 2.2kΩ-F	R 2D3	103P470010	CHIP RESISTOR	1/10W 100Ω-F
R 216	103P472070	CHIP RESISTOR	1/10W 1.2kΩ-F	R 2D4	103P402050	CHIP RESISTOR	1/10W 1kΩ-J
R 217	103P402070	CHIP RESISTOR	1/10W 1.5kΩ-J	R 2D5	103P402050	CHIP RESISTOR	1/10W 1kΩ-J
R 218	103P402090	CHIP RESISTOR	1/10W 2.2kΩ-J	R 2D6	103P401080	CHIP RESISTOR	1/10W 270Ω-J
R 219	103P403070	CHIP RESISTOR	1/10W 10kΩ-J	R 2D7	103P401080	CHIP RESISTOR	1/10W 270Ω-J
R 221	103P409050	CHIP RESISTOR	0.1W 0Ω(2125)	R 2D9	103P404030	CHIP RESISTOR	1/10W 33kΩ-J
R 222	103P409050	CHIP RESISTOR	0.1W 0Ω(2125)	R 2E2	103P472010	CHIP RESISTOR	1/10W 680Ω-F
R 223	103P404000	CHIP RESISTOR	1/10W 18kΩ-J	R 2E3	103P472070	CHIP RESISTOR	1/10W 1.2kΩ-F
R 225	103P403050	CHIP RESISTOR	1/10W 6.8kΩ-J	R 2E4	103P472060	CHIP RESISTOR	1/10W 1.1kΩ-F
R 227	103P401070	CHIP RESISTOR	1/10W 220Ω-J	R 2E5	103P471070	CHIP RESISTOR	1/10W 470Ω-F
R 228	103P402050	CHIP RESISTOR	1/10W 1kΩ-J	R 2E6	103P403090	CHIP RESISTOR	1/10W 15kΩ-J
R 229	103P403010	CHIP RESISTOR	1/10W 3.3kΩ-J	R 2E7	103P404000	CHIP RESISTOR	1/10W 18kΩ-J
R 230	103P402060	CHIP RESISTOR	1/10W 1.2kΩ-J	R 2F0	103P402050	CHIP RESISTOR	1/10W 1kΩ-J
R 231	103P402060	CHIP RESISTOR	1/10W 1.2kΩ-J	R 2F1	103P402050	CHIP RESISTOR	1/10W 1kΩ-J
R 232	103P402060	CHIP RESISTOR	1/10W 1.2kΩ-J	R 2F2	103P471080	CHIP RESISTOR	1/10W 510Ω-F
R 233	103P403010	CHIP RESISTOR	1/10W 3.3kΩ-J	R 2F3	103P402090	CHIP RESISTOR	1/10W 2.2kΩ-J
R 235	103P409050	CHIP RESISTOR	0.1W 0Ω(2125)	R 2F4	103P401030	CHIP RESISTOR	1/10W 100Ω-J
R 236	103P476000	CHIP RESISTOR	1/10W 30kΩ-F	R 2F5	103P401030	CHIP RESISTOR	1/10W 100Ω-J
R 237	103P403070	CHIP RESISTOR	1/10W 10kΩ-J	R 2F6	103P402080	CHIP RESISTOR	1/10W 1.8kΩ-J
R 238	103P401030	CHIP RESISTOR	1/10W 100Ω-J				

SYMBOL No.	PARTS No.	PARTS NAME	DESCRIPTION	SYMBOL No.	PARTS No.	PARTS NAME	DESCRIPTION
R 2F7	103P401030	CHIP RESISTOR	1/10W 100Ω-J	R 2P2	103P403010	CHIP RESISTOR	1/10W 3.3kΩ-J
R 2F8	103P402090	CHIP RESISTOR	1/10W 2.2kΩ-J	R 2P3	103P473030	CHIP RESISTOR	1/10W 2.2kΩ-F
R 2F9	103P403030	CHIP RESISTOR	1/10W 4.7kΩ-J	R 2P4	103P472090	CHIP RESISTOR	1/10W 1.5kΩ-F
R 2G0	103P472050	CHIP RESISTOR	1/10W 1kΩ-F	R 2P5	103P409090	CHIP RESISTOR	1/10W 75Ω-J
R 2G3	103P402050	CHIP RESISTOR	1/10W 1kΩ-J	R 2Q0	103P402030	CHIP RESISTOR	1/10W 680Ω-J
R 2G5	103P404080	CHIP RESISTOR	1/10W 82kΩ-J	R 2Q1	103P401090	CHIP RESISTOR	1/10W 330Ω-J
R 2G6	103P409050	CHIP RESISTOR	0.1W 0Ω(2125)	R 2Q2	103P402050	CHIP RESISTOR	1/10W 1kΩ-J
R 2G7	103P402020	CHIP RESISTOR	1/10W 560Ω-J	R 2Q3	103P402070	CHIP RESISTOR	1/10W 1.5kΩ-J
R 2H1	103P402030	CHIP RESISTOR	1/10W 680Ω-J	R 2Q4	103P474050	CHIP RESISTOR	1/10W 6.8kΩ-F
R 2H2	103P402020	CHIP RESISTOR	1/10W 560Ω-J	R 2Q5	103P472060	CHIP RESISTOR	1/10W 1.1kΩ-F
R 2H3	103P403080	CHIP RESISTOR	1/10W 12kΩ-J	R 2Q6	103P409050	CHIP RESISTOR	0.1W 0Ω(2125)
R 2H4	103P402000	CHIP RESISTOR	1/10W 390Ω-J	R 2R0	103P401030	CHIP RESISTOR	1/10W 100Ω-J
R 2H5	103P402040	CHIP RESISTOR	1/10W 820Ω-J	R 2R1	103P403040	CHIP RESISTOR	1/10W 5.6kΩ-J
R 2H6	103P402090	CHIP RESISTOR	1/10W 2.2kΩ-J	R 2S0	103P403020	CHIP RESISTOR	1/10W 3.9kΩ-J
R 2H7	103P401090	CHIP RESISTOR	1/10W 330Ω-J	R 2S1	103P402090	CHIP RESISTOR	1/10W 2.2kΩ-J
R 2H8	103P402050	CHIP RESISTOR	1/10W 1kΩ-J	R 2S3	103P403030	CHIP RESISTOR	1/10W 4.7kΩ-J
R 2H9	103P402090	CHIP RESISTOR	1/10W 2.2kΩ-J	R 2S4	103P401030	CHIP RESISTOR	1/10W 100Ω-J
R 2J1	103P401070	CHIP RESISTOR	1/10W 220Ω-J	R 2S5	103P409050	CHIP RESISTOR	0.1W 0Ω(2125)
R 2J2	103P471090	CHIP RESISTOR	1/10W 560Ω-F	R 2S6	103P402030	CHIP RESISTOR	1/10W 680Ω-J
R 2J3	103P472040	CHIP RESISTOR	1/10W 910Ω-F	R 2S7	103P402090	CHIP RESISTOR	1/10W 2.2kΩ-J
R 2J6	103P402050	CHIP RESISTOR	1/10W 1kΩ-J	R 2S8	103P404010	CHIP RESISTOR	1/10W 22kΩ-J
R 2J7	103P470070	CHIP RESISTOR	1/10W 180Ω-F	R 2S9	103P403040	CHIP RESISTOR	1/10W 5.6kΩ-J
R 2J8	103P403020	CHIP RESISTOR	1/10W 3.9kΩ-J	R 2T0	103P402050	CHIP RESISTOR	1/10W 1kΩ-J
R 2J9	103P402050	CHIP RESISTOR	1/10W 1kΩ-J	R 2T9	103P402070	CHIP RESISTOR	1/10W 1.5kΩ-J
R 2K1	103P402020	CHIP RESISTOR	1/10W 560Ω-J	R 2U0	103P403060	CHIP RESISTOR	1/10W 8.2kΩ-J
R 2K2	103P402010	CHIP RESISTOR	1/10W 470Ω-J	R 2U1	103P403070	CHIP RESISTOR	1/10W 10kΩ-J
R 2K4	103P402050	CHIP RESISTOR	1/10W 1kΩ-J	R 2U2	103P401090	CHIP RESISTOR	1/10W 330Ω-J
R 2K5	103P403070	CHIP RESISTOR	1/10W 10kΩ-J	R 2U3	103P403080	CHIP RESISTOR	1/10W 12kΩ-J
R 2K6	103P403080	CHIP RESISTOR	1/10W 12kΩ-J	R 2U4	103P404010	CHIP RESISTOR	1/10W 22kΩ-J
R 2K7	103P402010	CHIP RESISTOR	1/10W 470Ω-J	R 2U5	103P409050	CHIP RESISTOR	0.1W 0Ω(2125)
R 2K8	103P402010	CHIP RESISTOR	1/10W 470Ω-J	R 2U6	103P402040	CHIP RESISTOR	1/10W 820Ω-J
R 2K9	103P402070	CHIP RESISTOR	1/10W 1.5kΩ-J	R 2U7	103P402050	CHIP RESISTOR	1/10W 1kΩ-J
R 2L0	103P402010	CHIP RESISTOR	1/10W 470Ω-J	R 2U8	103P402050	CHIP RESISTOR	1/10W 1kΩ-J
R 2L1	103P402070	CHIP RESISTOR	1/10W 1.5kΩ-J	R 2W1	103P401030	CHIP RESISTOR	1/10W 100Ω-J
R 2L2	103P402060	CHIP RESISTOR	1/10W 1.2kΩ-J	R 2W3	103P404060	CHIP RESISTOR	1/10W 56kΩ-J
R 2L3	103P402050	CHIP RESISTOR	1/10W 1kΩ-J	R 2W4	103P404060	CHIP RESISTOR	1/10W 56kΩ-J
R 2L4	103P401030	CHIP RESISTOR	1/10W 100Ω-J	R 2W5	103P402090	CHIP RESISTOR	1/10W 2.2kΩ-J
R 2L7	103P402040	CHIP RESISTOR	1/10W 820Ω-J	R 2Z1	103P403070	CHIP RESISTOR	1/10W 10kΩ-J
R 2L8	103P403020	CHIP RESISTOR	1/10W 3.9kΩ-J	R 2Z2	103P402050	CHIP RESISTOR	1/10W 1kΩ-J
R 2L9	103P409050	CHIP RESISTOR	0.1W 0Ω(2125)	R 2Z3	103P402050	CHIP RESISTOR	1/10W 1kΩ-J
R 2M0	103P402020	CHIP RESISTOR	1/10W 560Ω-J	R 2001	103P402080	CHIP RESISTOR	1/10W 1.8kΩ-J
R 2M1	103P402050	CHIP RESISTOR	1/10W 1kΩ-J	R 2002	103P403040	CHIP RESISTOR	1/10W 5.6kΩ-J
R 2M2	103P403010	CHIP RESISTOR	1/10W 3.3kΩ-J	R 2003	103P402050	CHIP RESISTOR	1/10W 1kΩ-J
R 2M3	103P402050	CHIP RESISTOR	1/10W 1kΩ-J	R 2004	103P401070	CHIP RESISTOR	1/10W 220Ω-J
R 2M4	103P402070	CHIP RESISTOR	1/10W 1.5kΩ-J	R 2007	103P401050	CHIP RESISTOR	1/10W 150Ω-J
R 2M5	103P401030	CHIP RESISTOR	1/10W 100Ω-J	R 2008	103P476090	CHIP RESISTOR	1/10W 68kΩ-F
R 2M6	103P402090	CHIP RESISTOR	1/10W 2.2kΩ-J	R 2009	103P409050	CHIP RESISTOR	0.1W 0Ω(2125)
R 2M9	103P401050	CHIP RESISTOR	1/10W 150Ω-J	R 2010	103P403040	CHIP RESISTOR	1/10W 5.6kΩ-J
R 2N0	103P404030	CHIP RESISTOR	1/10W 33kΩ-J	R 2011	103P402050	CHIP RESISTOR	1/10W 1kΩ-J
R 2N1	103P403090	CHIP RESISTOR	1/10W 15kΩ-J	R 2012	103P403030	CHIP RESISTOR	1/10W 4.7kΩ-J
R 2N2	103P402050	CHIP RESISTOR	1/10W 1kΩ-J	R 2013	103P403030	CHIP RESISTOR	1/10W 4.7kΩ-J
R 2N3	103P401070	CHIP RESISTOR	1/10W 220Ω-J	R 2027	103P476080	CHIP RESISTOR	1/10W 62kΩ-F
R 2N4	103P402050	CHIP RESISTOR	1/10W 1kΩ-J	R 2028	103P405030	CHIP RESISTOR	1/10W 220kΩ-J
R 2N5	103P404010	CHIP RESISTOR	1/10W 22kΩ-J	R 2031	103P475070	CHIP RESISTOR	1/10W 22kΩ-F
R 2N6	103P404030	CHIP RESISTOR	1/10W 33kΩ-J	R 2032	103P474090	CHIP RESISTOR	1/10W 10kΩ-F
R 2N7	103P401080	CHIP RESISTOR	1/10W 270Ω-J	R 2033	103P403030	CHIP RESISTOR	1/10W 4.7kΩ-J
R 2N8	103P403010	CHIP RESISTOR	1/10W 3.3kΩ-J	R 2034	103P478010	CHIP RESISTOR	1/10W 220kΩ-F

SYMBOL No.	PARTS No.	PARTS NAME	DESCRIPTION	SYMBOL No.	PARTS No.	PARTS NAME	DESCRIPTION
R 2035	103P401070	CHIP RESISTOR	1/10W 220Ω-J	R 4A9	103P403030	CHIP RESISTOR	1/10W 4.7kΩ-J
R 2036	103P402060	CHIP RESISTOR	1/10W 1.2kΩ-J	R 4B0	103P405020	CHIP RESISTOR	1/10W 180kΩ-J
R 2037	103P401070	CHIP RESISTOR	1/10W 220Ω-J	R 4B2	103P403070	CHIP RESISTOR	1/10W 10kΩ-J
R 2041	103P402080	CHIP RESISTOR	1/10W 1.8kΩ-J	R 4B5	103P404090	CHIP RESISTOR	1/10W 100kΩ-J
R 2042	103P401070	CHIP RESISTOR	1/10W 220Ω-J	R 4B6	103P409050	CHIP RESISTOR	0.1W 0Ω(2125)
R 2043	103P405030	CHIP RESISTOR	1/10W 220kΩ-J	R 4B7	103P403030	CHIP RESISTOR	1/10W 4.7kΩ-J
R 2044	103P403050	CHIP RESISTOR	1/10W 6.8kΩ-J	R 4B9	103P475010	CHIP RESISTOR	1/10W 12kΩ-F
R 2046	103P409050	CHIP RESISTOR	0.1W 0Ω(2125)	R 4C1	103P474090	CHIP RESISTOR	1/10W 10kΩ-F
R 301	103P404010	CHIP RESISTOR	1/10W 22kΩ-J	R 4C3	103P404030	CHIP RESISTOR	1/10W 33kΩ-J
R 302	103P403070	CHIP RESISTOR	1/10W 10kΩ-J	R 4C4	103P404030	CHIP RESISTOR	1/10W 33kΩ-J
R 303	103P404050	CHIP RESISTOR	1/10W 47kΩ-J	R 4C6	103P404000	CHIP RESISTOR	1/10W 18kΩ-J
R 304	103P402030	CHIP RESISTOR	1/10W 680Ω-J	R 4C8	103P404080	CHIP RESISTOR	1/10W 82kΩ-J
R 305	103P402050	CHIP RESISTOR	1/10W 1kΩ-J	R 4C9	103P402070	CHIP RESISTOR	1/10W 1.5kΩ-J
R 306	103P404070	CHIP RESISTOR	1/10W 68kΩ-J	R 4D1	103P403080	CHIP RESISTOR	1/10W 12kΩ-J
R 307	103P476020	CHIP RESISTOR	1/10W 36kΩ-F	R 4D2	103P404010	CHIP RESISTOR	1/10W 22kΩ-J
R 308	103P401030	CHIP RESISTOR	1/10W 100Ω-J	R 4D3	103P404030	CHIP RESISTOR	1/10W 33kΩ-J
R 309	103P403000	CHIP RESISTOR	1/10W 2.7kΩ-J	R 4D5	103P404030	CHIP RESISTOR	1/10W 33kΩ-J
R 310	103P403040	CHIP RESISTOR	1/10W 5.6kΩ-J	R 4D6	103P404090	CHIP RESISTOR	1/10W 100kΩ-J
R 311	103P403040	CHIP RESISTOR	1/10W 5.6kΩ-J	R 4D7	103P404030	CHIP RESISTOR	1/10W 33kΩ-J
R 312	103P404050	CHIP RESISTOR	1/10W 47kΩ-J	R 4D8	103P404060	CHIP RESISTOR	1/10W 56kΩ-J
R 313	103P403040	CHIP RESISTOR	1/10W 5.6kΩ-J	R 4D9	103P403010	CHIP RESISTOR	1/10W 3.3kΩ-J
R 314	103P403000	CHIP RESISTOR	1/10W 2.7kΩ-J	R 4E0	103P402090	CHIP RESISTOR	1/10W 2.2kΩ-J
R 315	103P403040	CHIP RESISTOR	1/10W 5.6kΩ-J	R 4E2	103P403030	CHIP RESISTOR	1/10W 4.7kΩ-J
R 317	103P751000	FUSE RESISTOR	1/4W 56Ω-J	R 4E3	103P404030	CHIP RESISTOR	1/10W 33kΩ-J
R 3A0	103P403070	CHIP RESISTOR	1/10W 10kΩ-J	R 4E4	103P404060	CHIP RESISTOR	1/10W 56kΩ-J
R 3A1	103P409050	CHIP RESISTOR	0.1W 0Ω(2125)	R 4E5	103P405050	CHIP RESISTOR	1/10W 330kΩ-J
R 3A2	103P404020	CHIP RESISTOR	1/10W 27kΩ-J	R 4E6	103P402060	CHIP RESISTOR	1/10W 1.2kΩ-J
R 3A3	103P403070	CHIP RESISTOR	1/10W 10kΩ-J	R 4E7	103P403070	CHIP RESISTOR	1/10W 10kΩ-J
R 3A4	103P401060	CHIP RESISTOR	1/10W 180Ω-J	R 4F1	103P403070	CHIP RESISTOR	1/10W 10kΩ-J
R 3A6	103P403060	CHIP RESISTOR	1/10W 8.2kΩ-J	R 4F2	103P403010	CHIP RESISTOR	1/10W 3.3kΩ-J
R 3A7	103P401040	CHIP RESISTOR	1/10W 120Ω-J	R 4F4	103P405030	CHIP RESISTOR	1/10W 220kΩ-J
R 3A8	103P400010	CHIP RESISTOR	1/10W 10Ω-J	R 4F6	103P405030	CHIP RESISTOR	1/10W 220kΩ-J
R 3B0	103P401030	CHIP RESISTOR	1/10W 100Ω-J	R 4F7	103P405010	CHIP RESISTOR	1/10W 150kΩ-J
R 3B1	103P403030	CHIP RESISTOR	1/10W 4.7kΩ-J	R 4F8	103P403070	CHIP RESISTOR	1/10W 10kΩ-J
R 3B2	103P402050	CHIP RESISTOR	1/10W 1kΩ-J	R 4F9	103P403070	CHIP RESISTOR	1/10W 10kΩ-J
R 3B3	103P402050	CHIP RESISTOR	1/10W 1kΩ-J	R 4G1	103P405030	CHIP RESISTOR	1/10W 220kΩ-J
R 3B4	103P406010	CHIP RESISTOR	1/10W 1MΩ-J	R 4G2	103P403090	CHIP RESISTOR	1/10W 15kΩ-J
R 3B6	103P404010	CHIP RESISTOR	1/10W 22kΩ-J	R 4G3	103P404000	CHIP RESISTOR	1/10W 18kΩ-J
R 3B7	103P401080	CHIP RESISTOR	1/10W 270Ω-J	R 4G5	103P405020	CHIP RESISTOR	1/10W 180kΩ-J
R 3C4	103P403070	CHIP RESISTOR	1/10W 10kΩ-J	R 4G6	103P405010	CHIP RESISTOR	1/10W 150kΩ-J
R 3C5	103P401060	CHIP RESISTOR	1/10W 180Ω-J	R 4G7	103P403030	CHIP RESISTOR	1/10W 4.7kΩ-J
R 3D0	103P402090	CHIP RESISTOR	1/10W 2.2kΩ-J	R 4G8	103P403040	CHIP RESISTOR	1/10W 5.6kΩ-J
R 3D1	103P402090	CHIP RESISTOR	1/10W 2.2kΩ-J	R 4H6	103P409050	CHIP RESISTOR	0.1W 0Ω(2125)
R 3D2	103P404060	CHIP RESISTOR	1/10W 56kΩ-J	R 4H8	103P474080	CHIP RESISTOR	1/10W 9.1kΩ-F
R 3E5	103P404000	CHIP RESISTOR	1/10W 18kΩ-J	R 4H9	103P475050	CHIP RESISTOR	1/10W 18kΩ-F
R 3E6	103P402050	CHIP RESISTOR	1/10W 1kΩ-J	R 4K2	103P404090	CHIP RESISTOR	1/10W 100kΩ-J
R 3G5	103P403070	CHIP RESISTOR	1/10W 10kΩ-J	R 4K4	103P404050	CHIP RESISTOR	1/10W 47kΩ-J
R 3G9	103P401030	CHIP RESISTOR	1/10W 100Ω-J	R 4K5	103P402050	CHIP RESISTOR	1/10W 1kΩ-J
R 3H0	103P401070	CHIP RESISTOR	1/10W 220Ω-J	R 4K6	103P402050	CHIP RESISTOR	1/10W 1kΩ-J
R 4A0	103P403040	CHIP RESISTOR	1/10W 5.6kΩ-J	R 4K7	103P402070	CHIP RESISTOR	1/10W 1.5kΩ-J
R 4A1	103P403020	CHIP RESISTOR	1/10W 3.9kΩ-J	R 501	103P404040	CHIP RESISTOR	1/10W 39kΩ-J
R 4A2	103P404090	CHIP RESISTOR	1/10W 100kΩ-J	R 5A1	103P405010	CHIP RESISTOR	1/10W 150kΩ-J
R 4A3	103P404010	CHIP RESISTOR	1/10W 22kΩ-J	R 5A2	103P405010	CHIP RESISTOR	1/10W 150kΩ-J
R 4A5	103P401030	CHIP RESISTOR	1/10W 100Ω-J	R 5A3	103P405010	CHIP RESISTOR	1/10W 150kΩ-J
R 4A6	103P401030	CHIP RESISTOR	1/10W 100Ω-J	R 5A5	103P404010	CHIP RESISTOR	1/10W 22kΩ-J
R 4A7	103P477010	CHIP RESISTOR	1/10W 82kΩ-F	R 5B0	103P401070	CHIP RESISTOR	1/10W 220Ω-J
				R 5B1	103P402050	CHIP RESISTOR	1/10W 1kΩ-J

SYMBOL No.	PARTS No.	PARTS NAME	DESCRIPTION	SYMBOL No.	PARTS No.	PARTS NAME	DESCRIPTION
R 5B2	103P402010	CHIP RESISTOR	1/10W 470Ω-J	R 5J9	103P404030	CHIP RESISTOR	1/10W 33kΩ-J
R 5B3	103P404090	CHIP RESISTOR	1/10W 100kΩ-J	R 5K0	103P404030	CHIP RESISTOR	1/10W 33kΩ-J
R 5B4	103P403000	CHIP RESISTOR	1/10W 2.7kΩ-J	R 5K1	103P404030	CHIP RESISTOR	1/10W 33kΩ-J
R 5B5	103P403070	CHIP RESISTOR	1/10W 10kΩ-J	R 5K2	103P404030	CHIP RESISTOR	1/10W 33kΩ-J
R 5C1	103P406010	CHIP RESISTOR	1/10W 1MΩ-J	R 5K3	103P404030	CHIP RESISTOR	1/10W 33kΩ-J
R 5C6	103P402050	CHIP RESISTOR	1/10W 1kΩ-J	R 5K4	103P404090	CHIP RESISTOR	1/10W 100kΩ-J
R 5C7	103P404010	CHIP RESISTOR	1/10W 22kΩ-J	R 5K5	103P404090	CHIP RESISTOR	1/10W 100kΩ-J
R 5C8	103P403070	CHIP RESISTOR	1/10W 10kΩ-J	R 5K6	103P404020	CHIP RESISTOR	1/10W 27kΩ-J
R 5C9	103P402050	CHIP RESISTOR	1/10W 1kΩ-J	R 5L4	103P403070	CHIP RESISTOR	1/10W 10kΩ-J
R 5D0	103P404010	CHIP RESISTOR	1/10W 22kΩ-J	R 5L5	103P403070	CHIP RESISTOR	1/10W 10kΩ-J
R 5D1	103P403070	CHIP RESISTOR	1/10W 10kΩ-J	R 5L6	103P403070	CHIP RESISTOR	1/10W 10kΩ-J
R 5D2	103P402050	CHIP RESISTOR	1/10W 1kΩ-J	R 5M0	103P403070	CHIP RESISTOR	1/10W 10kΩ-J
R 5D3	103P404010	CHIP RESISTOR	1/10W 22kΩ-J	R 5M1	103P403070	CHIP RESISTOR	1/10W 10kΩ-J
R 5D4	103P403070	CHIP RESISTOR	1/10W 10kΩ-J	R 5M2	103P409050	CHIP RESISTOR	0.1W 0Ω(2125)
R 5D5	103P404010	CHIP RESISTOR	1/10W 22kΩ-J	R 5M3	103P403070	CHIP RESISTOR	1/10W 10kΩ-J
R 5D6	103P409050	CHIP RESISTOR	0.1W 0Ω(2125)	R 5M4	103P403070	CHIP RESISTOR	1/10W 10kΩ-J
R 5D7	103P476000	CHIP RESISTOR	1/10W 30kΩ-F	R 5M5	103P409050	CHIP RESISTOR	0.1W 0Ω(2125)
R 5D8	103P476000	CHIP RESISTOR	1/10W 30kΩ-F	R 5M6	103P403070	CHIP RESISTOR	1/10W 10kΩ-J
R 5E0	103P476000	CHIP RESISTOR	1/10W 30kΩ-F	R 5M7	103P403070	CHIP RESISTOR	1/10W 10kΩ-J
R 5E1	103P475030	CHIP RESISTOR	1/10W 15kΩ-F	R 5M8	103P409050	CHIP RESISTOR	0.1W 0Ω(2125)
R 5E2	103P403070	CHIP RESISTOR	1/10W 10kΩ-J	R 5N2	103P403010	CHIP RESISTOR	1/10W 3.3kΩ-J
R 5E3	103P403070	CHIP RESISTOR	1/10W 10kΩ-J	R 5N4	103P402050	CHIP RESISTOR	1/10W 1kΩ-J
R 5E4	103P403070	CHIP RESISTOR	1/10W 10kΩ-J	R 5N5	103P404070	CHIP RESISTOR	1/10W 68kΩ-J
R 5E5	103P403070	CHIP RESISTOR	1/10W 10kΩ-J	R 5Q2	103P402010	CHIP RESISTOR	1/10W 470Ω-J
R 5E8	103P402060	CHIP RESISTOR	1/10W 1.2kΩ-J	R 5Q3	103P402010	CHIP RESISTOR	1/10W 470Ω-J
R 5E9	103P402090	CHIP RESISTOR	1/10W 2.2kΩ-J	R 5Q4	103P402010	CHIP RESISTOR	1/10W 470Ω-J
R 5F0	103P402090	CHIP RESISTOR	1/10W 2.2kΩ-J	R 5Q5	103P402010	CHIP RESISTOR	1/10W 470Ω-J
R 5F4	103P404050	CHIP RESISTOR	1/10W 47kΩ-J	R 5Q6	103P402010	CHIP RESISTOR	1/10W 470Ω-J
R 5F5	103P402050	CHIP RESISTOR	1/10W 1kΩ-J	R 5Q7	103P402010	CHIP RESISTOR	1/10W 470Ω-J
R 5F6	103P403080	CHIP RESISTOR	1/10W 12kΩ-J	R 5Q8	103P402010	CHIP RESISTOR	1/10W 470Ω-J
R 5F7	103P404000	CHIP RESISTOR	1/10W 18kΩ-J	R 5Q9	103P402010	CHIP RESISTOR	1/10W 470Ω-J
R 5F8	103P472060	CHIP RESISTOR	1/10W 1.1kΩ-F	R 5R0	103P402010	CHIP RESISTOR	1/10W 470Ω-J
R 5G0	103P409050	CHIP RESISTOR	0.1W 0Ω(2125)	R 5R1	103P402010	CHIP RESISTOR	1/10W 470Ω-J
R 5G3	103P403070	CHIP RESISTOR	1/10W 10kΩ-J	R 5R2	103P402010	CHIP RESISTOR	1/10W 470Ω-J
R 5G4	103P403030	CHIP RESISTOR	1/10W 4.7kΩ-J	R 5R3	103P402010	CHIP RESISTOR	1/10W 470Ω-J
R 5G5	103P402050	CHIP RESISTOR	1/10W 1kΩ-J	R 5R4	103P402010	CHIP RESISTOR	1/10W 470Ω-J
R 5G6	103P406090	CHIP METAL RESISTOR	1/10W 4.7MΩ-K	R 5R5	103P402010	CHIP RESISTOR	1/10W 470Ω-J
R 5G7	103P406090	CHIP METAL RESISTOR	1/10W 4.7MΩ-K	R 5R6	103P402010	CHIP RESISTOR	1/10W 470Ω-J
R 5G8	103P409050	CHIP RESISTOR	0.1W 0Ω(2125)	R 5R7	103P402010	CHIP RESISTOR	1/10W 470Ω-J
R 5G9	103P477010	CHIP RESISTOR	1/10W 82kΩ-F	R 5R8	103P402010	CHIP RESISTOR	1/10W 470Ω-J
R 5H0	103P476030	CHIP RESISTOR	1/10W 39kΩ-F	R 5R9	103P402010	CHIP RESISTOR	1/10W 470Ω-J
R 5H1	103P475060	CHIP RESISTOR	1/10W 20kΩ-F	R 5S0	103P402010	CHIP RESISTOR	1/10W 470Ω-J
R 5H2	103P479070	CHIP RESISTOR	1/10W 1MΩ-F	R 5S1	103P402010	CHIP RESISTOR	1/10W 470Ω-J
R 5H3	103P478050	CHIP RESISTOR	1/10W 330kΩ-F	R 5S2	103P402010	CHIP RESISTOR	1/10W 470Ω-J
R 5H4	103P479000	CHIP METAL RESISTOR	1/10W 510kΩ-F	R 5S3	103P402010	CHIP RESISTOR	1/10W 470Ω-J
R 5H5	103P403010	CHIP RESISTOR	1/10W 3.3kΩ-J	R 5S4	103P402010	CHIP RESISTOR	1/10W 470Ω-J
R 5H6	103P404090	CHIP RESISTOR	1/10W 100kΩ-J	R 6002	103P404010	CHIP RESISTOR	1/10W 22kΩ-J
R 5H8	103P404060	CHIP RESISTOR	1/10W 56kΩ-J	R 6003	103P404030	CHIP RESISTOR	1/10W 33kΩ-J
R 5J0	103P476050	CHIP RESISTOR	1/10W 47kΩ-F	R 6004	103P475050	CHIP RESISTOR	1/10W 18kΩ-F
R 5J1	103P475070	CHIP RESISTOR	1/10W 22kΩ-F	R 6005	103P475030	CHIP RESISTOR	1/10W 15kΩ-F
R 5J2	103P406010	CHIP RESISTOR	1/10W 1MΩ-J	R 6006	103P404090	CHIP RESISTOR	1/10W 100kΩ-J
R 5J3	103P476010	CHIP RESISTOR	1/10W 33kΩ-F	R 6007	103P404090	CHIP RESISTOR	1/10W 100kΩ-J
R 5J4	103P476010	CHIP RESISTOR	1/10W 33kΩ-F	R 6008	103P409050	CHIP RESISTOR	0.1W 0Ω(2125)
R 5J5	103P474090	CHIP RESISTOR	1/10W 10kΩ-F	R 6009	103P403030	CHIP RESISTOR	1/10W 4.7kΩ-J
R 5J6	103P474090	CHIP RESISTOR	1/10W 10kΩ-F	R 6010	103P409050	CHIP RESISTOR	0.1W 0Ω(2125)
R 5J7	103P404050	CHIP RESISTOR	1/10W 47kΩ-J	R 6011	103P404010	CHIP RESISTOR	1/10W 22kΩ-J
R 5J8	103P404030	CHIP RESISTOR	1/10W 33kΩ-J				

SYMBOL No.	PARTS No.	PARTS NAME	DESCRIPTION	SYMBOL No.	PARTS No.	PARTS NAME	DESCRIPTION
R 6012	103P403080	CHIP RESISTOR	1/10W 12kΩ-J	R 7C6	103P406010	CHIP RESISTOR	1/10W 1MΩ-J
R 6013	103P476080	CHIP RESISTOR	1/10W 62kΩ-F	R 7C7	103P405030	CHIP RESISTOR	1/10W 220kΩ-J
R 6014	103P401070	CHIP RESISTOR	1/10W 220Ω-J	R 7C8	103P402050	CHIP RESISTOR	1/10W 1kΩ-J
R 6015	103P405020	CHIP RESISTOR	1/10W 180kΩ-J	R 7D0	103P402050	CHIP RESISTOR	1/10W 1kΩ-J
R 6016	103P404090	CHIP RESISTOR	1/10W 100kΩ-J	R 7D1	103P404020	CHIP RESISTOR	1/10W 27kΩ-J
R 6027	103P402050	CHIP RESISTOR	1/10W 1kΩ-J	R 7D2	103P403090	CHIP RESISTOR	1/10W 15kΩ-J
R 6028	103P402050	CHIP RESISTOR	1/10W 1kΩ-J	R 7D3	103P403000	CHIP RESISTOR	1/10W 2.7kΩ-J
R 6030	103P402050	CHIP RESISTOR	1/10W 1kΩ-J	R 7E6	103P409050	CHIP RESISTOR	0.1W 0Ω(2125)
R 6031	103P402090	CHIP RESISTOR	1/10W 2.2kΩ-J	R 7E7	103P402050	CHIP RESISTOR	1/10W 1kΩ-J
R 6032	103P402050	CHIP RESISTOR	1/10W 1kΩ-J	R 7E8	103P406010	CHIP RESISTOR	1/10W 1MΩ-J
R 6033	103P402050	CHIP RESISTOR	1/10W 1kΩ-J	R 7G9	103P405010	CHIP RESISTOR	1/10W 150kΩ-J
R 6034	103P403000	CHIP RESISTOR	1/10W 2.7kΩ-J	R 7H0	103P404090	CHIP RESISTOR	1/10W 100kΩ-J
R 6035	103P402080	CHIP RESISTOR	1/10W 1.8kΩ-J	R 7H1	103P402060	CHIP RESISTOR	1/10W 1.2kΩ-J
R 6036	103P402060	CHIP RESISTOR	1/10W 1.2kΩ-J	R 7H2	103P402040	CHIP RESISTOR	1/10W 820Ω-J
R 6037	103P402050	CHIP RESISTOR	1/10W 1kΩ-J	R 7H3	103P402060	CHIP RESISTOR	1/10W 1.2kΩ-J
R 6038	103P402010	CHIP RESISTOR	1/10W 470Ω-J	R 7H4	103P402050	CHIP RESISTOR	1/10W 1kΩ-J
R 6039	103P402020	CHIP RESISTOR	1/10W 560Ω-J	R 7H5	103P401030	CHIP RESISTOR	1/10W 100Ω-J
R 6042	103P402030	CHIP RESISTOR	1/10W 680Ω-J	R 7H6	103P401030	CHIP RESISTOR	1/10W 100Ω-J
R 6043	103P402050	CHIP RESISTOR	1/10W 1kΩ-J	R 7H7	103P401030	CHIP RESISTOR	1/10W 100Ω-J
R 6044	103P402030	CHIP RESISTOR	1/10W 680Ω-J	R 7H8	103P401030	CHIP RESISTOR	1/10W 100Ω-J
R 6045	103P402030	CHIP RESISTOR	1/10W 680Ω-J	R 7H9	103P401070	CHIP RESISTOR	1/10W 220Ω-J
R 6046	103P402030	CHIP RESISTOR	1/10W 680Ω-J	R 901	109D036C40	COMPOSITION RESISTOR	1/2W 8.2MΩ-K
R 6047	103P404040	CHIP RESISTOR	1/10W 39kΩ-J	R 930	102P108060	WIRE RESISTOR	2W 3.3Ω-J
R 6048	103P404050	CHIP RESISTOR	1/10W 47kΩ-J	RJ 01	103P409050	CHIP RESISTOR	0.1W 0Ω(2125)
R 6049	103P402060	CHIP RESISTOR	1/10W 1.2kΩ-J	RJ 02	103P409050	CHIP RESISTOR	0.1W 0Ω(2125)
R 6050	103P404050	CHIP RESISTOR	1/10W 47kΩ-J	RJ 03	103P409050	CHIP RESISTOR	0.1W 0Ω(2125)
R 6054	103P472070	CHIP RESISTOR	1/10W 1.2kΩ-F	RJ 04	103P409050	CHIP RESISTOR	0.1W 0Ω(2125)
R 6061	103P403040	CHIP RESISTOR	1/10W 5.6kΩ-J	RJ 05	103P409050	CHIP RESISTOR	0.1W 0Ω(2125)
R 6063	103P403040	CHIP RESISTOR	1/10W 5.6kΩ-J	RJ 06	103P409050	CHIP RESISTOR	0.1W 0Ω(2125)
R 6064	103P402000	CHIP RESISTOR	1/10W 390Ω-J	RJ 07	103P409050	CHIP RESISTOR	0.1W 0Ω(2125)
R 6065	103P404030	CHIP RESISTOR	1/10W 33kΩ-J	RJ 08	103P409050	CHIP RESISTOR	0.1W 0Ω(2125)
R 6068	103P402050	CHIP RESISTOR	1/10W 1kΩ-J	RJ 09	103P409050	CHIP RESISTOR	0.1W 0Ω(2125)
R 6081	103P402050	CHIP RESISTOR	1/10W 1kΩ-J	RJ 10	103P409050	CHIP RESISTOR	0.1W 0Ω(2125)
R 6101	103P404050	CHIP RESISTOR	1/10W 47kΩ-J	RJ 11	103P409050	CHIP RESISTOR	0.1W 0Ω(2125)
R 6102	103P404040	CHIP RESISTOR	1/10W 39kΩ-J	RJ 12	103P409050	CHIP RESISTOR	0.1W 0Ω(2125)
R 6103	103P402020	CHIP RESISTOR	1/10W 560Ω-J	RJ 13	103P409050	CHIP RESISTOR	0.1W 0Ω(2125)
R 6104	103P402060	CHIP RESISTOR	1/10W 1.2kΩ-J	RJ 15	103P409050	CHIP RESISTOR	0.1W 0Ω(2125)
R 6105	103P402020	CHIP RESISTOR	1/10W 560Ω-J	RJ 16	103P409050	CHIP RESISTOR	0.1W 0Ω(2125)
R 6106	103P402050	CHIP RESISTOR	1/10W 1kΩ-J	RJ 17	103P409050	CHIP RESISTOR	0.1W 0Ω(2125)
R 6108	103P403020	CHIP RESISTOR	1/10W 3.9kΩ-J	RJ 18	103P409050	CHIP RESISTOR	0.1W 0Ω(2125)
R 6109	103P402050	CHIP RESISTOR	1/10W 1kΩ-J	RJ 19	103P409050	CHIP RESISTOR	0.1W 0Ω(2125)
R 6110	103P402090	CHIP RESISTOR	1/10W 2.2kΩ-J	RJ 21	103P409050	CHIP RESISTOR	0.1W 0Ω(2125)
R 6111	103P402050	CHIP RESISTOR	1/10W 1kΩ-J	RJ 22	103P409050	CHIP RESISTOR	0.1W 0Ω(2125)
R 6203	103P402080	CHIP RESISTOR	1/10W 1.8kΩ-J	RJ 23	103P409050	CHIP RESISTOR	0.1W 0Ω(2125)
R 7A0	103P406010	CHIP RESISTOR	1/10W 1MΩ-J	RJ 24	103P409050	CHIP RESISTOR	0.1W 0Ω(2125)
R 7A1	103P409050	CHIP RESISTOR	0.1W 0Ω(2125)	RJ 25	103P409050	CHIP RESISTOR	0.1W 0Ω(2125)
R 7A7	103P402040	CHIP RESISTOR	1/10W 820Ω-J	RJ 26	103P409050	CHIP RESISTOR	0.1W 0Ω(2125)
R 7A8	103P402020	CHIP RESISTOR	1/10W 560Ω-J	RJ 27	103P409050	CHIP RESISTOR	0.1W 0Ω(2125)
R 7A9	103P406010	CHIP RESISTOR	1/10W 1MΩ-J	RJ 28	103P409050	CHIP RESISTOR	0.1W 0Ω(2125)
R 7B0	103P409050	CHIP RESISTOR	0.1W 0Ω(2125)	RJ 29	103P409050	CHIP RESISTOR	0.1W 0Ω(2125)
R 7B8	103P406010	CHIP RESISTOR	1/10W 1MΩ-J	RJ 30	103P409050	CHIP RESISTOR	0.1W 0Ω(2125)
R 7B9	103P409050	CHIP RESISTOR	0.1W 0Ω(2125)	RJ 31	103P409050	CHIP RESISTOR	0.1W 0Ω(2125)
R 7C1	103P402050	CHIP RESISTOR	1/10W 1kΩ-J	RJ 32	103P409050	CHIP RESISTOR	0.1W 0Ω(2125)
R 7C2	103P402040	CHIP RESISTOR	1/10W 820Ω-J	RJ 33	103P409050	CHIP RESISTOR	0.1W 0Ω(2125)
R 7C3	103P402020	CHIP RESISTOR	1/10W 560Ω-J	RJ 34	103P409050	CHIP RESISTOR	0.1W 0Ω(2125)
R 7C4	103P471090	CHIP RESISTOR	1/10W 560Ω-F	RJ 35	103P409050	CHIP RESISTOR	0.1W 0Ω(2125)
R 7C5	103P471090	CHIP RESISTOR	1/10W 560Ω-F	RJ 36	103P409050	CHIP RESISTOR	0.1W 0Ω(2125)

SYMBOL No.	PARTS No.	PARTS NAME	DESCRIPTION	SYMBOL No.	PARTS No.	PARTS NAME	DESCRIPTION
RJ 37	103P409050	CHIP RESISTOR	0.1W 0Ω(2125)	C 253	141P135000	CHIP CAPACITOR	F25V 0.22μF-Z
RJ 38	103P409050	CHIP RESISTOR	0.1W 0Ω(2125)	C 256	141P133080	CHIP CAPACITOR	F50V 0.01μF-Z
RJ 41	103P409050	CHIP RESISTOR	0.1W 0Ω(2125)	C 2A2	154P324060	CHIP CAPACITOR	SL50V 270pF-J
RJ 42	103P409050	CHIP RESISTOR	0.1W 0Ω(2125)	C 2A4	154P325000	CHIP CAPACITOR	SL50V 390pF-J
RJ 43	103P409050	CHIP RESISTOR	0.1W 0Ω(2125)	C 2A5	154P322080	CHIP CAPACITOR	SL50V 47pF-J
RJ 44	103P409050	CHIP RESISTOR	0.1W 0Ω(2125)	C 2A8	141P133080	CHIP CAPACITOR	F50V 0.01μF-Z
RJ 45	103P409050	CHIP RESISTOR	0.1W 0Ω(2125)	C 2A9	141P137040	CHIP CAPACITOR	B25V 0.022μF-K
RJ 46	103P409050	CHIP RESISTOR	0.1W 0Ω(2125)	C 2B0	154P322000	CHIP CAPACITOR	SL50V 22pF-J
RJ 47	103P409050	CHIP RESISTOR	0.1W 0Ω(2125)	C 2B1	154P322080	CHIP CAPACITOR	SL50V 47pF-J
RJ 48	103P409050	CHIP RESISTOR	0.1W 0Ω(2125)	C 2B3	141P137080	CHIP CAPACITOR	B25V 0.047μF-K
RJ 49	103P409050	CHIP RESISTOR	0.1W 0Ω(2125)	C 2B5	141P137040	CHIP CAPACITOR	B25V 0.022μF-K
RJ 50	103P409050	CHIP RESISTOR	0.1W 0Ω(2125)	C 2B7	141P133080	CHIP CAPACITOR	F50V 0.01μF-Z
RJ 51	103P409050	CHIP RESISTOR	0.1W 0Ω(2125)	C 2C3	141P137080	CHIP CAPACITOR	B25V 0.047μF-K
RJ 52	103P409050	CHIP RESISTOR	0.1W 0Ω(2125)	C 2C4	141P137080	CHIP CAPACITOR	B25V 0.047μF-K
RJ 53	103P409050	CHIP RESISTOR	0.1W 0Ω(2125)	C 2C6	141P137080	CHIP CAPACITOR	B25V 0.047μF-K
RJ 1	103P409050	CHIP RESISTOR	0.1W 0Ω(2125)	C 2C7	141P139030	CHIP CAPACITOR	B25V 0.1μF-K
RJ 2	103P409050	CHIP RESISTOR	0.1W 0Ω(2125)	C 2D3	154P332010	CHIP CAPACITOR	CH50V 27pF-J
RJ 3	103P409050	CHIP RESISTOR	0.1W 0Ω(2125)	C 2D4	141P133080	CHIP CAPACITOR	F50V 0.01μF-Z
RJ 4	103P409050	CHIP RESISTOR	0.1W 0Ω(2125)	C 2D5	154P321060	CHIP CAPACITOR	SL50V 15pF-J
RJ 5	103P409050	CHIP RESISTOR	0.1W 0Ω(2125)	C 2D8	154P323000	CHIP CAPACITOR	SL50V 56pF-J
CAPACITORS AND TRIMMERS				C 2E0	154P321060	CHIP CAPACITOR	SL50V 15pF-J
C 201	141P133080	CHIP CAPACITOR	F50V 0.01μF-Z	C 2E1	141P139030	CHIP CAPACITOR	B25V 0.1μF-K
C 203	141P130090	CHIP CAPACITOR	B50V 1000pF-K	C 2F0	154P323080	CHIP CAPACITOR	SL50V 120pF-J
C 204	141P130090	CHIP CAPACITOR	B50V 1000pF-K	C 2F1	154P320050	CHIP CAPACITOR	SL50V 3pF-C
C 206	141P139030	CHIP CAPACITOR	B25V 0.1μF-K	C 2F2	154P322080	CHIP CAPACITOR	SL50V 47pF-J
C 207	141P135080	CHIP CAPACITOR	F25V 0.1μF-Z	C 2F3	154P320070	CHIP CAPACITOR	SL50V 5pF-C
C 208	141P135080	CHIP CAPACITOR	F25V 0.1μF-Z	C 2F4	141P133080	CHIP CAPACITOR	F50V 0.01μF-Z
C 210	141P139030	CHIP CAPACITOR	B25V 0.1μF-K	C 2F6	154P324060	CHIP CAPACITOR	SL50V 270pF-J
C 211	141P139030	CHIP CAPACITOR	B25V 0.1μF-K	C 2F7	154P322000	CHIP CAPACITOR	SL50V 22pF-J
C 213	141P135080	CHIP CAPACITOR	F25V 0.1μF-Z	C 2F8	154P324060	CHIP CAPACITOR	SL50V 270pF-J
C 216	141P139030	CHIP CAPACITOR	B25V 0.1μF-K	C 2F9	154P324020	CHIP CAPACITOR	SL50V 180pF-J
C 217	141P139030	CHIP CAPACITOR	B25V 0.1μF-K	C 2G0	141P133080	CHIP CAPACITOR	F50V 0.01μF-Z
C 218	154P333070	CHIP CAPACITOR	CH50V 120pF-J	C 2G1	154P322060	CHIP CAPACITOR	SL50V 39pF-J
C 219	141P135080	CHIP CAPACITOR	F25V 0.1μF-Z	C 2G2	141P133080	CHIP CAPACITOR	F50V 0.01μF-Z
C 220	141P135080	CHIP CAPACITOR	F25V 0.1μF-Z	C 2G3	141P133080	CHIP CAPACITOR	F50V 0.01μF-Z
C 221	154P333010	CHIP CAPACITOR	CH50V 68pF-J	C 2G5	141P133080	CHIP CAPACITOR	F50V 0.01μF-Z
C 222	141P139030	CHIP CAPACITOR	B25V 0.1μF-K	C 2H0	154P322060	CHIP CAPACITOR	SL50V 39pF-J
C 223	141P135080	CHIP CAPACITOR	F25V 0.1μF-Z	C 2H3	154P324040	CHIP CAPACITOR	SL50V 220pF-J
C 224	141P135080	CHIP CAPACITOR	F25V 0.1μF-Z	C 2H4	154P322040	CHIP CAPACITOR	SL50V 33pF-J
C 225	141P133080	CHIP CAPACITOR	F50V 0.01μF-Z	C 2J0	141P133080	CHIP CAPACITOR	F50V 0.01μF-Z
C 226	141P133080	CHIP CAPACITOR	F50V 0.01μF-Z	C 2J2	154P323000	CHIP CAPACITOR	SL50V 56pF-J
C 228	141P133080	CHIP CAPACITOR	F50V 0.01μF-Z	C 2J3	154P322060	CHIP CAPACITOR	SL50V 39pF-J
C 229	141P130090	CHIP CAPACITOR	B50V 1000pF-K	C 2J7	141P133080	CHIP CAPACITOR	F50V 0.01μF-Z
C 230	141P133080	CHIP CAPACITOR	F50V 0.01μF-Z	C 2J8	141P133080	CHIP CAPACITOR	F50V 0.01μF-Z
C 231	141P133080	CHIP CAPACITOR	F50V 0.01μF-Z	C 2J9	154P322040	CHIP CAPACITOR	SL50V 33pF-J
C 233	141P133080	CHIP CAPACITOR	F50V 0.01μF-Z	C 2K0	154P323000	CHIP CAPACITOR	SL50V 56pF-J
C 234	141P130090	CHIP CAPACITOR	B50V 1000pF-K	C 2K1	154P322080	CHIP CAPACITOR	SL50V 47pF-J
C 235	141P133080	CHIP CAPACITOR	F50V 0.01μF-Z	C 2K2	154P322040	CHIP CAPACITOR	SL50V 33pF-J
C 236	141P133080	CHIP CAPACITOR	F50V 0.01μF-Z	C 2K3	154P323020	CHIP CAPACITOR	SL50V 68pF-J
C 238	141P133080	CHIP CAPACITOR	F50V 0.01μF-Z	C 2K4	154P323000	CHIP CAPACITOR	SL50V 56pF-J
C 240	141P135080	CHIP CAPACITOR	F25V 0.1μF-Z	C 2K5	141P132000	CHIP CAPACITOR	B50V 8200pF-K
C 242	154P321080	CHIP CAPACITOR	SL50V 18pF-J	C 2K7	154P321040	CHIP CAPACITOR	SL50V 12pF-J
C 244	154P324080	CHIP CAPACITOR	SL50V 330pF-J	C 2M0	154P322080	CHIP CAPACITOR	SL50V 47pF-J
C 245	141P135080	CHIP CAPACITOR	F25V 0.1μF-Z	C 2M1	141P133080	CHIP CAPACITOR	F50V 0.01μF-Z
C 247	141P131000	CHIP CAPACITOR	B50V 1200pF-K	C 2M3	141P132000	CHIP CAPACITOR	B50V 8200pF-K
C 251	154P330090	CHIP CAPACITOR	CH50V 8pF-C	C 2M6	141P133080	CHIP CAPACITOR	F50V 0.01μF-Z

SYMBOL No.	PARTS No.	PARTS NAME	DESCRIPTION	SYMBOL No.	PARTS No.	PARTS NAME	DESCRIPTION
C 2M7	141P137040	CHIP CAPACITOR	B25V 0.022μF-K	C 4B7	141P130090	CHIP CAPACITOR	B50V 1000pF-K
C 2N0	141P132000	CHIP CAPACITOR	B50V 8200pF-K	C 4B8	141P131060	CHIP CAPACITOR	B50V 3900pF-K
C 2N1	154P324000	CHIP CAPACITOR	SL50V 150pF-J	C 4C0	141P139000	CHIP CAPACITOR	B25V 0.056μF-K
C 2N2	154P324000	CHIP CAPACITOR	SL50V 150pF-J	C 4C3	141P131080	CHIP CAPACITOR	B50V 5600pF-K
C 2N3	154P323020	CHIP CAPACITOR	SL50V 68pF-J	C 4C7	141P139030	CHIP CAPACITOR	B25V 0.1μF-K
C 2N5	141P132000	CHIP CAPACITOR	B50V 8200pF-K	C 4C8	141P139030	CHIP CAPACITOR	B25V 0.1μF-K
C 2N7	141P139030	CHIP CAPACITOR	B25V 0.1μF-K	C 4C9	141P131080	CHIP CAPACITOR	B50V 5600pF-K
C 2N8	141P133080	CHIP CAPACITOR	F50V 0.01μF-Z	C 4D1	141P130090	CHIP CAPACITOR	B50V 1000pF-K
C 2P0	141P132000	CHIP CAPACITOR	B50V 8200pF-K	C 4D2	141P130090	CHIP CAPACITOR	B50V 1000pF-K
C 2Q0	141P132000	CHIP CAPACITOR	B50V 8200pF-K	C 4D3	154P335010	CHIP CAPACITOR	CH50V 470pF-J
C 2Q2	141P132000	CHIP CAPACITOR	B50V 8200pF-K	C 4E1	154P335010	CHIP CAPACITOR	CH50V 470pF-J
C 2Q4	141P132000	CHIP CAPACITOR	B50V 8200pF-K	C 4E7	141P131050	CHIP CAPACITOR	B50V 3300pF-K
C 2Q5	141P132000	CHIP CAPACITOR	B50V 8200pF-K	C 4E9	141P132010	CHIP CAPACITOR	B50V 0.01μF-K
C 2Q6	154P321060	CHIP CAPACITOR	SL50V 15pF-J	C 4F0	141P131060	CHIP CAPACITOR	B50V 3900pF-K
C 2Q9	141P133080	CHIP CAPACITOR	F50V 0.01μF-Z	C 4F3	141P135000	CHIP CAPACITOR	F25V 0.22μF-Z
C 2R1	141P133080	CHIP CAPACITOR	F50V 0.01μF-Z	C 502	141P133090	CHIP CAPACITOR	F50V 0.022μF-Z
C 2R4	141P133080	CHIP CAPACITOR	F50V 0.01μF-Z	C 504	154P322080	CHIP CAPACITOR	SL50V 47pF-J
C 2R5	141P137080	CHIP CAPACITOR	B25V 0.047μF-K	C 5A0	141P133080	CHIP CAPACITOR	F50V 0.01μF-Z
C 2R6	141P133090	CHIP CAPACITOR	F50V 0.022μF-Z	C 5A1	141P133080	CHIP CAPACITOR	F50V 0.01μF-Z
C 2R7	141P139030	CHIP CAPACITOR	B25V 0.1μF-K	C 5A2	141P133080	CHIP CAPACITOR	F50V 0.01μF-Z
C 2U1	141P133080	CHIP CAPACITOR	F50V 0.01μF-Z	C 5A5	141P133080	CHIP CAPACITOR	F50V 0.01μF-Z
C 2U2	141P133080	CHIP CAPACITOR	F50V 0.01μF-Z	C 5A6	141P133090	CHIP CAPACITOR	F50V 0.022μF-Z
C 2U5	154P322000	CHIP CAPACITOR	SL50V 22pF-J	C 5A8	141P133090	CHIP CAPACITOR	F50V 0.022μF-Z
C 2U7	141P133080	CHIP CAPACITOR	F50V 0.01μF-Z	C 5B0	141P133090	CHIP CAPACITOR	F50V 0.022μF-Z
C 2W2	141P133080	CHIP CAPACITOR	F50V 0.01μF-Z	C 5B1	141P133080	CHIP CAPACITOR	F50V 0.01μF-Z
C 2002	141P133080	CHIP CAPACITOR	F50V 0.01μF-Z	C 5B2	141P133080	CHIP CAPACITOR	F50V 0.01μF-Z
C 2005	154P332050	CHIP CAPACITOR	CH50V 39pF-J	C 5B3	141P137080	CHIP CAPACITOR	B25V 0.047μF-K
C 2008	154P331030	CHIP CAPACITOR	CH50V 12pF-J	C 5B4	141P137080	CHIP CAPACITOR	B25V 0.047μF-K
C 2016	141P133080	CHIP CAPACITOR	F50V 0.01μF-Z	C 5B5	141P137080	CHIP CAPACITOR	B25V 0.047μF-K
C 2018	141P133080	CHIP CAPACITOR	F50V 0.01μF-Z	C 5B6	141P133080	CHIP CAPACITOR	F50V 0.01μF-Z
C 2019	154P323080	CHIP CAPACITOR	SL50V 120pF-J	C 5B7	141P133090	CHIP CAPACITOR	F50V 0.022μF-Z
C 2030	141P133080	CHIP CAPACITOR	F50V 0.01μF-Z	C 5B8	141P133090	CHIP CAPACITOR	F50V 0.022μF-Z
C 2050	141P133080	CHIP CAPACITOR	F50V 0.01μF-Z	C 5B9	141P133090	CHIP CAPACITOR	F50V 0.022μF-Z
C 2051	141P133080	CHIP CAPACITOR	F50V 0.01μF-Z	C 5C0	154P331070	CHIP CAPACITOR	CH50V 18pF-J
C 2055	154P331030	CHIP CAPACITOR	CH50V 12pF-J	C 5C1	154P331070	CHIP CAPACITOR	CH50V 18pF-J
C 2060	154P331010	CHIP CAPACITOR	CH50V 10pF-C	C 5C2	154P331010	CHIP CAPACITOR	CH50V 10pF-C
C 2061	154P322040	CHIP CAPACITOR	SL50V 33pF-J	C 5C3	154P331010	CHIP CAPACITOR	CH50V 10pF-C
C 2062	154P332050	CHIP CAPACITOR	CH50V 39pF-J	C 5C5	141P132010	CHIP CAPACITOR	B50V 0.01μF-K
C 2063	154P323060	CHIP CAPACITOR	SL50V 100pF-J	C 5C7	141P133090	CHIP CAPACITOR	F50V 0.022μF-Z
C 2064	141P139030	CHIP CAPACITOR	B25V 0.1μF-K	C 5C9	141P133080	CHIP CAPACITOR	F50V 0.01μF-Z
C 2065	141P133080	CHIP CAPACITOR	F50V 0.01μF-Z	C 5D5	141P139030	CHIP CAPACITOR	B25V 0.1μF-K
C 300	154P327040	CHIP CAPACITOR	SL50V 3900pF-J	C 5D6	141P139030	CHIP CAPACITOR	B25V 0.1μF-K
C 304	141P130040	CHIP CAPACITOR	B50V 390pF-K	C 5D7	141P136030	CHIP CAPACITOR	F16V 1μF-Z
C 309	154P323060	CHIP CAPACITOR	SL50V 100pF-J	C 6011	154P326060	CHIP CAPACITOR	SL50V 1800pF-J
C 3A1	141P133080	CHIP CAPACITOR	F50V 0.01μF-Z	C 6013	141P133080	CHIP CAPACITOR	F50V 0.01μF-Z
C 3A2	141P130090	CHIP CAPACITOR	B50V 1000pF-K	C 6015	154P323060	CHIP CAPACITOR	SL50V 100pF-J
C 3A3	141P130060	CHIP CAPACITOR	B50V 560pF-K	C 6021	141P133080	CHIP CAPACITOR	F50V 0.01μF-Z
C 3A8	141P131010	CHIP CAPACITOR	B50V 1500pF-K	C 6024	154P327020	CHIP CAPACITOR	SL50V 3300pF-J
C 3B9	141P137090	CHIP CAPACITOR	B25V 0.056μF-K	C 6025	141P139030	CHIP CAPACITOR	B25V 0.1μF-K
C 3D3	141P133080	CHIP CAPACITOR	F50V 0.01μF-Z	C 6036	141P133080	CHIP CAPACITOR	F50V 0.01μF-Z
C 3D4	141P138030	CHIP CAPACITOR	B25V 0.12μF-K	C 6039	141P133080	CHIP CAPACITOR	F50V 0.01μF-Z
C 3D5	141P137070	CHIP CAPACITOR	B25V 0.039μF-K	C 6040	154P324000	CHIP CAPACITOR	SL50V 150pF-J
C 4A0	141P132010	CHIP CAPACITOR	B50V 0.01μF-K	C 6041	154P321080	CHIP CAPACITOR	SL50V 18pF-J
C 4A1	141P132010	CHIP CAPACITOR	B50V 0.01μF-K	C 6042	154P321080	CHIP CAPACITOR	SL50V 18pF-J
C 4A5	141P137070	CHIP CAPACITOR	B25V 0.039μF-K	C 6043	141P133080	CHIP CAPACITOR	F50V 0.01μF-Z
C 4A7	154P326000	CHIP CAPACITOR	SL50V 1000pF-J	C 6046	154P322040	CHIP CAPACITOR	SL50V 33pF-J
C 4B5	141P130010	CHIP CAPACITOR	B50V 220pF-K	C 6047	154P322080	CHIP CAPACITOR	SL50V 47pF-J

SYMBOL No.	PARTS No.	PARTS NAME	DESCRIPTION	SYMBOL No.	PARTS No.	PARTS NAME	DESCRIPTION
C 6048	154P322080	CHIP CAPACITOR	SL50V 47pF-J	S 705	432P089020	KEY BOARD SWITCH	LOCK
C 6049	141P133080	CHIP CAPACITOR	F50V 0.01μF-Z	S 707	432P089020	KEY BOARD SWITCH	TRACKING (-)
C 6050	141P133080	CHIP CAPACITOR	F50V 0.01μF-Z	S 708	432P089020	KEY BOARD SWITCH	POSITION/STILL ADJ (-)
C 6057	141P131010	CHIP CAPACITOR	B50V 1500pF-K	S 709	431C079020	SLIDE SWITCH	COLOR B/W
C 6102	141P133080	CHIP CAPACITOR	F50V 0.01μF-Z	S 801	432P089020	KEY BOARD SWITCH	PAUSE
C 6103	141P133080	CHIP CAPACITOR	F50V 0.01μF-Z	S 802	432P089020	KEY BOARD SWITCH	TIMER REC
C 6104	154P320070	CHIP CAPACITOR	SL50V 5pF-C	S 803	432P089020	KEY BOARD SWITCH	MODE (-)
C 6106	141P133080	CHIP CAPACITOR	F50V 0.01μF-Z	S 804	432P089020	KEY BOARD SWITCH	COUNTER RESET
C 6107	141P133080	CHIP CAPACITOR	F50V 0.01μF-Z	S 805	432P089020	KEY BOARD SWITCH	PB
C 7A1	141P133080	CHIP CAPACITOR	F50V 0.01μF-Z	S 806	432P089020	KEY BOARD SWITCH	SKIP/INDEX MEMORY
C 7A2	141P133080	CHIP CAPACITOR	F50V 0.01μF-Z	S 807	432P089020	KEY BOARD SWITCH	MODE (+)
C 7A3	141P133080	CHIP CAPACITOR	F50V 0.01μF-Z	S 808	432P089020	KEY BOARD SWITCH	DISPLAY
C 7A4	141P133080	CHIP CAPACITOR	F50V 0.01μF-Z	S 809	432P089040	KEY BOARD SWITCH	STOP
C 7A5	141P137040	CHIP CAPACITOR	B25V 0.022μF-K	S 810	432P089040	KEY BOARD SWITCH	REC
C 7A8	154P321020	CHIP CAPACITOR	SL50V 10pF-C	S 8A1	439P023040	SWITCH	JOG/SHUTTLE
C 7A9	154P321020	CHIP CAPACITOR	SL50V 10pF-C	MISCELLANEOUS			
C 7B3	154P320070	CHIP CAPACITOR	SL50V 5pF-C	D 5A4	621C525010	LED HOLDER	
C 7B4	154P320090	CHIP CAPACITOR	SL50V 7pF-C	F 901	283D147040	FUSE	T2A
C 7B8	141P137040	CHIP CAPACITOR	B25V 0.022μF-K	J 3A1	451C108030	RCA PIN JACK	
C 7C0	141P137040	CHIP CAPACITOR	B25V 0.022μF-K	J 3A2	451C108030	RCA PIN JACK	
C 7C2	154P320090	CHIP CAPACITOR	SL50V 7pF-C	J 3A3	451C102010	MICROPHONE JACK	
C 7C6	154P321000	CHIP CAPACITOR	SL50V 8pF-C	J 7A1	440B128010	TERMINAL BOARD	
C 7C7	154P320090	CHIP CAPACITOR	SL50V 7pF-C	J 7A2	451C111010	JACK	
C 7C8	141P133080	CHIP CAPACITOR	F50V 0.01μF-Z	J 901	451C210010	POWER JACK	3P
C 7D5	141P133080	CHIP CAPACITOR	F50V 0.01μF-Z	J 902	451C209010	POWER JACK	2P
C 7D8	141P133080	CHIP CAPACITOR	F50V 0.01μF-Z	JJ KJ	243C155020	CARD LEAD WIRE	9PIN L=100
C 7E1	141P133080	CHIP CAPACITOR	F50V 0.01μF-Z	K 7A0	287P045010	RELAY	RA5W-OH-K
C 7E2	141P133080	CHIP CAPACITOR	F50V 0.01μF-Z	M 572	288P180010	CAPSTAN MOTOR	F2QKB26
C 7E5	141P133080	CHIP CAPACITOR	F50V 0.01μF-Z	MA DA	243C193030	CARD LEAD WIRE	7PIN L=120
C 7E7	141P133080	CHIP CAPACITOR	F50V 0.01μF-Z	MD DD	243C193020	CARD LEAD WIRE	7P L=100
C 7E8	141P133080	CHIP CAPACITOR	F50V 0.01μF-Z	MR SR	243C159020	CARD LEAD WIRE	17P L=100
C 7E9	141P133080	CHIP CAPACITOR	F50V 0.01μF-Z	MS SS	243C160020	CARD LEAD WIRE	19P L=100
C 7F0	141P133080	CHIP CAPACITOR	F50V 0.01μF-Z	PC901	268P079010	PHOTO COUPLER	PC123FY
C 7F9	154P320090	CHIP CAPACITOR	SL50V 7pF-C	Q 5A0	268P076010	PHOTO TRANSISTOR	SPS-1118C-T1
C 7G8	141P133080	CHIP CAPACITOR	F50V 0.01μF-Z	Q 5A0	621C526010	PHOTO HOLDER M	
C 7G9	141P133080	CHIP CAPACITOR	F50V 0.01μF-Z	Q 5A1	268P076010	PHOTO TRANSISTOR	SPS-1118C-T1
C 7H1	154P322000	CHIP CAPACITOR	SL50V 22pF-J	Q 5A2	268P076010	PHOTO TRANSISTOR	SPS-1118C-T1
C 7H2	154P322000	CHIP CAPACITOR	SL50V 22pF-J	Q 5A7	268P076010	PHOTO TRANSISTOR	SPS-1118C-T1
C 7H3	154P320040	CHIP CAPACITOR	SL50V 2pF-C	Q 5A7	621C527010	PHOTO HOLDER	
C 7H5	141P139030	CHIP CAPACITOR	B25V 0.1μF-K	Q 5A8	268P076010	PHOTO TRANSISTOR	SPS-1118C-T1
C 7H6	141P139030	CHIP CAPACITOR	B25V 0.1μF-K	Q 5A8	621C527010	PHOTO HOLDER	
C 7H7	141P139030	CHIP CAPACITOR	B25V 0.1μF-K	Q 5A9	268P076010	PHOTO TRANSISTOR	SPS-1118C-T1
C 7H8	154P324040	CHIP CAPACITOR	SL50V 220pF-J	Q 5A9	621C564010	LED HOLDER R	
C 7H9	154P324020	CHIP CAPACITOR	SL50V 180pF-J	Q 5B0	268P076010	PHOTO TRANSISTOR	SPS-1118C-T1
C 7J0	154P324040	CHIP CAPACITOR	SL50V 220pF-J	Q 5B0	621C527010	PHOTO HOLDER	
C 7J1	154P323060	CHIP CAPACITOR	SL50V 100pF-J	Q 5C1	268P076010	PHOTO TRANSISTOR	SPS-1118C-T1
C 7J2	154P324060	CHIP CAPACITOR	SL50V 270pF-J	Q 5C1	621C564010	LED HOLDER R	
C 901	189P153040	C-M-P-AC	AC250V 0.1μF-M	RV901	299P220020	SURGE SUPPRESSOR	DSS-302M
C 904	189P153040	C-M-P-AC	AC250V 0.1μF-M	SA901	299P198010	SURGE ABSORBER	ERZV07D471
C 909	189P094020	AC CERAMIC CAPACITOR	ACT4K E3300pF-M	SA902	265P100040	VARIATOR	ERZV10D471CS
SWITCHES				T 371	460P055050	FULL ERASE HEAD	
S 2A0	432P089040	KEY BOARD SWITCH	INITIAL RESET	V 5A0	253P128010	FLUOR DISPLAY TUBE	25U39115TA
S 701	432P089040	KEY BOARD SWITCH	EJECT	X 2A1	285P083010	CRYSTAL RESONATOR	4.43362MHz
S 702	432P089040	KEY BOARD SWITCH	POWER	X 2000	285P084010	CRYSTAL RESONATOR	17.7344MHz
S 703	432P089020	KEY BOARD SWITCH	TRACKING (+)	X 5A0	285P054010	CRYSTAL RESONATOR	32.768kHz
S 704	432P089020	KEY BOARD SWITCH	POSITION/STILL ADJ (+)	X 5A1	285P235010	CRYSTAL RESONATOR	8.3886MHz

[EB]
[E]

[EB]

[EB]

SYMBOL No.	PARTS No.	PARTS NAME	DESCRIPTION	SYMBOL No.	PARTS No.	PARTS NAME	DESCRIPTION
X7A0	285P279O10	CRYSTAL RESONATOR	16.384MHz				
X7A1	285P152O10	CRYSTAL RESONATOR	19.069MHz				
X7A2	285P084O10	CRYSTAL RESONATOR	17.7344MHz				
X7A3	285P106O10	CRYSTAL RESONATOR	25.75MHz				
PRINTED CIRCUIT BOARD ASSY'S							
	928C916O01	CCD SKEW PCB ASSY					
	925B034O06	MAIN PCB ASSY					
	928D391O01	OPE L PCB ASSY					
	928D392O12	OPE R PCB ASSY					
	925B014O02	POWER PCB ASSY	[E]				
	925B051O02	POWER PCB ASSY	[EB]				
	928C908O04	TERMINAL PCB ASSY					
	925B073O02	Y/C PCB ASSY					

[MEMO]

[MEMO]

[MEMO]

* Settled Service Parts

ITEM	PARTS NO.
B-011	948A194O02
B-012	948C338O01
B-014	948D059O01
B-015	948D060O01
B-016	948D062O01
B-017	928D350O01
B-024	460D017O10
B-029	621C551O10
B-033	593C817O10
B-037	621C557O10
B-041	460P055O50
B-042	521D096O10
B-054	641B790O10
B-055	621C505O10
B-056	635C104O10
B-058	635C108O10
B-062	641B844O10
B-063	621C532O10
B-064	621C498O10
B-065	621C529O10
B-066	593C923O10
B-067	621C486O10
B-073	641B788O20
B-078	597D572O10
B-079	641B782O10
B-081	641B863O10
B-082	641B864O10
B-083	621C530O10
B-084	641B785O10
B-092	593C800O10
B-093	593C801O10
B-094	592B274O10
B-095	592B280O10
B-099	622D615O10
B-101	572D844O10
B-103	572D858O10
B-106	572D839O10
B-107	572D840O10
B-109	572D843O10
B-121	674D081O20
B-151	515B001O20
B-152	515C001O30
B-153	515C001O40
B-154	621C533O10
B-201	669D224O10
B-202	669D285O40
B-203	669D224O30
B-204	669D476O20
B-211	552C017O20
B-213	552C018O70
B-214	683D114O40
F-011	948D083O01
F-021	522B061O10
F-031	669D506O90

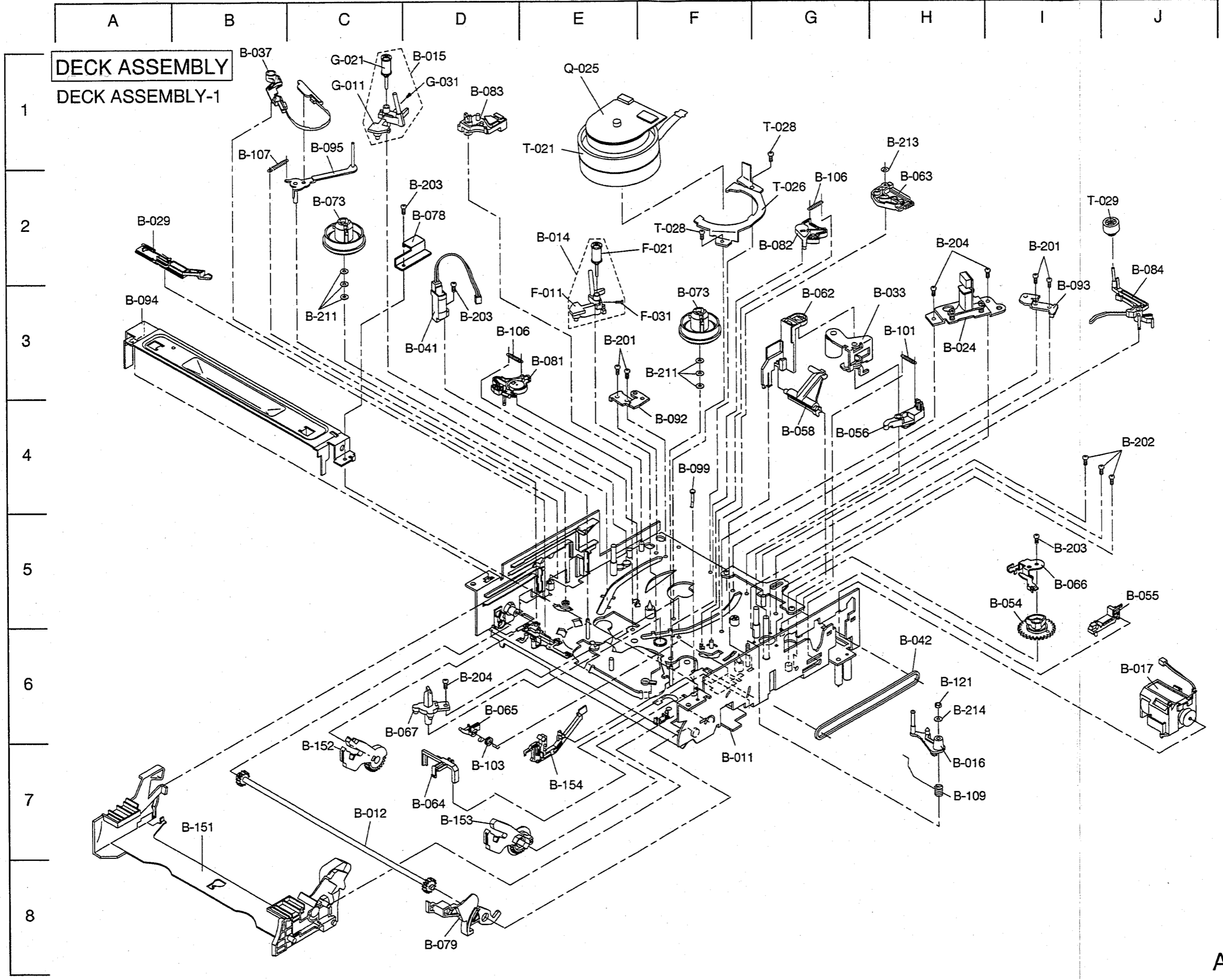

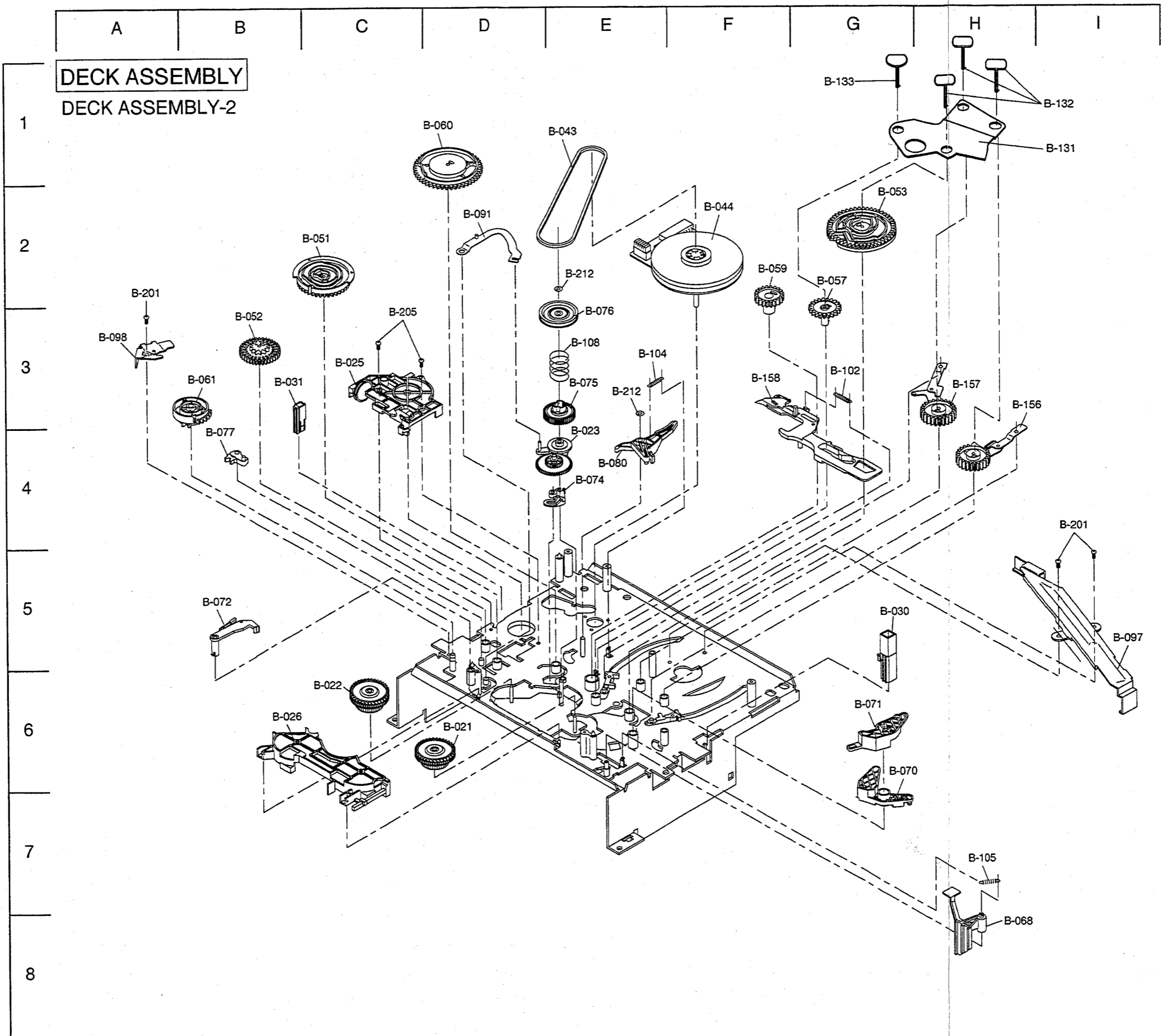

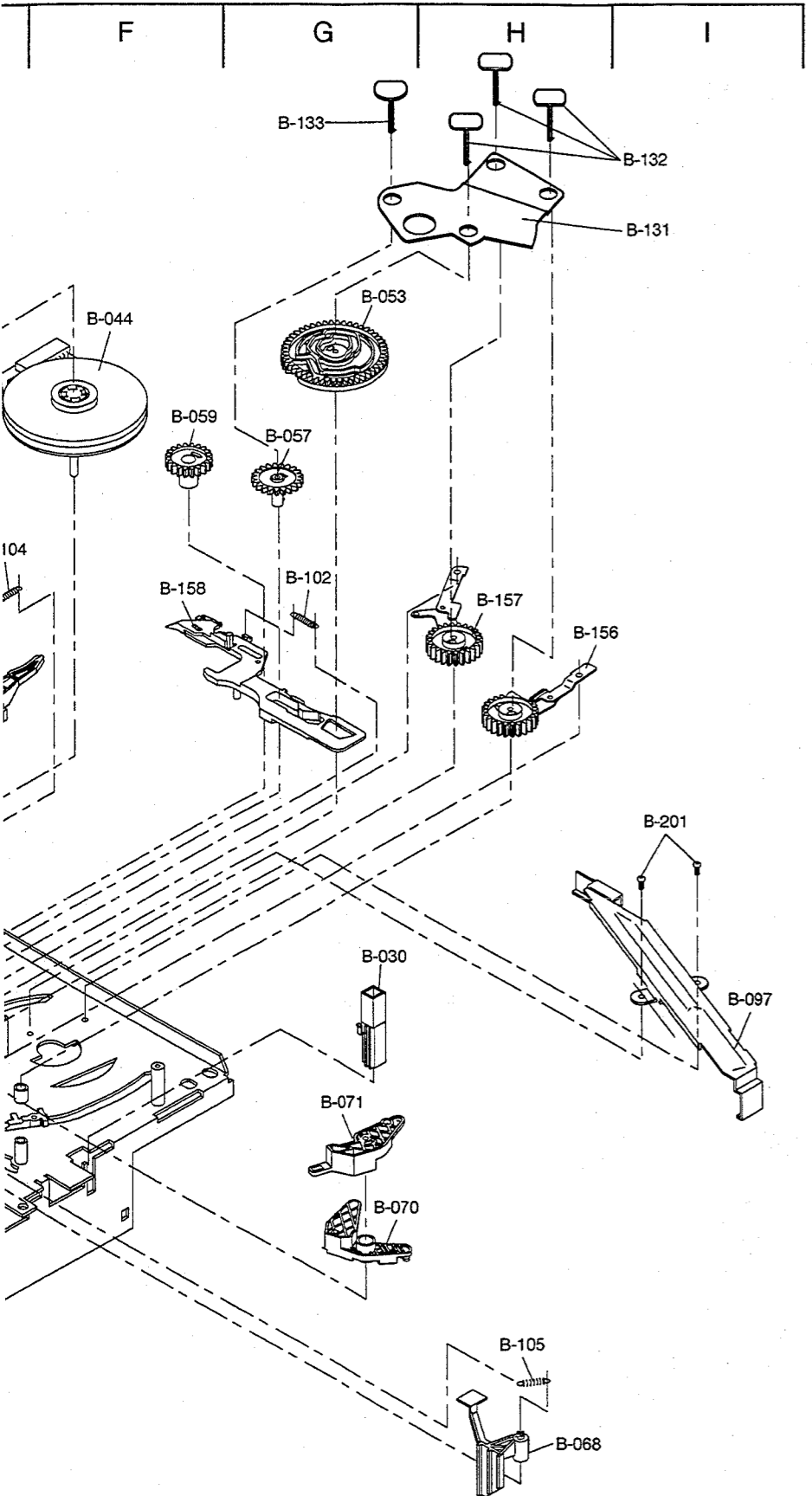

* Settled Service Parts

ITEM	PARTS NO.	*	ADDRESS	PARTS NAME	DESCRIPTION	Qt.	
B-021	641B805050	o	D-6	REEL GEAR UNIT (SP)	SUPPLY	1	
B-022	641B805060	o	C-6	REEL GEAR UNIT (TU)	TAKE UP	1	
B-023	621C536010	o	E-4	IDLER UNIT		1	
B-025	621C538020	o	C-3	WORM PULLEY UNIT		1	
B-026	641B827010	o	B-6	PHOTO UNIT		1	
B-030	622D585010	o	G-5	PHOTO GUIDE UNIT (SP)	SUPPLY	1	
B-031	622D586010	o	B-3	PHOTO GUIDE UNIT (TU)	TAKE UP	1	
B-043	521D097010	o	E-1	REEL BELT		1	
B-044	288P18C010	o	F-2	CAPSTAN MOTOR	F2QKB26 (M572)	1	
B-051	641B794020	o	C-2	MODE GEAR		1	
B-052	621C504010	o	B-3	LOADING WORM GEAR		1	
B-053	641B791020	o	G-2	CAM GEAR (SP)	SUPPLY	1	
B-057	621C503020	o	G-2	LOADING GEAR		1	
B-059	621C502010	o	F-2	LAMP LOADING GEAR		1	
B-060	641B792010	o	D-1	CAM GEAR (TU)	TAKE UP	1	
B-061	641B793010	o	B-3	F/L DRIVE GEAR		1	
B-068	641B817010	o	H-8	REC LEVER		1	
B-070	641B838020	o	G-6	TENSION LEVER UNIT		1	
B-071	621C508010	o	G-6	CONTROL WIND LEVER		1	
B-072	621C506010	o	B-5	REEL LOCK LEVER		1	
B-074	621C494010	o	E-4	SHIFT LEVER		1	
B-075	621C493010	o	E-3	PULLEY GEAR		1	
B-076	621C492010	o	E-3	BELT PULLEY		1	
B-077	635C106010	o	B-4	F/L DRIVE LEVER		1	
B-080	621C672010	o	E-4	CAPSTAN BRAKE UNIT 2		1	
B-091	593C799010	o	D-2	IDLER CENTER LEVER		1	
B-097	592B365010	o	I-5	MAIN PLATE SUPPORT		1	
B-098	593C903010	o	A-3	MODE HOLDER		1	
B-102	572D835010	o	G-3	CAM SPRING (C)		1	
B-104	572D962010	o	E-3	CAPSTAN BRAKE SPRING 3		1	
B-105	572D870010	o	H-7	REC SPRING		1	
B-108	572D865010	o	E-3	SHIFT SPRING		1	
B-131	594C063010	o	I-1	PLATE LD		1	
B-132	622D704010	o	I-1	SNAP PIN LD		3	
B-133	622D704020	o	G-1	SNAP PIN LD		1	
B-156	593C825020	o	H-3	LOADING ARM UNIT (SP)	SUPPLY	1	
B-157	593C826020	o	H-3	LOADING ARM UNIT (TU)	TAKE UP	1	
B-158	621C537010	o	F-3	CAM PLATE UNIT (C)		1	
B-201	669D224010	o	A-2	SCREW	2.6 x 6	3	
B-205	669D224050	o	C-3	SCREW	2.6 x 14	2	
B-212	552C018010	o	E-2	E-3	CUT WASHER	2.5 x 6.0 x 0.5	2

PCB-BLOCK DIAGRAM

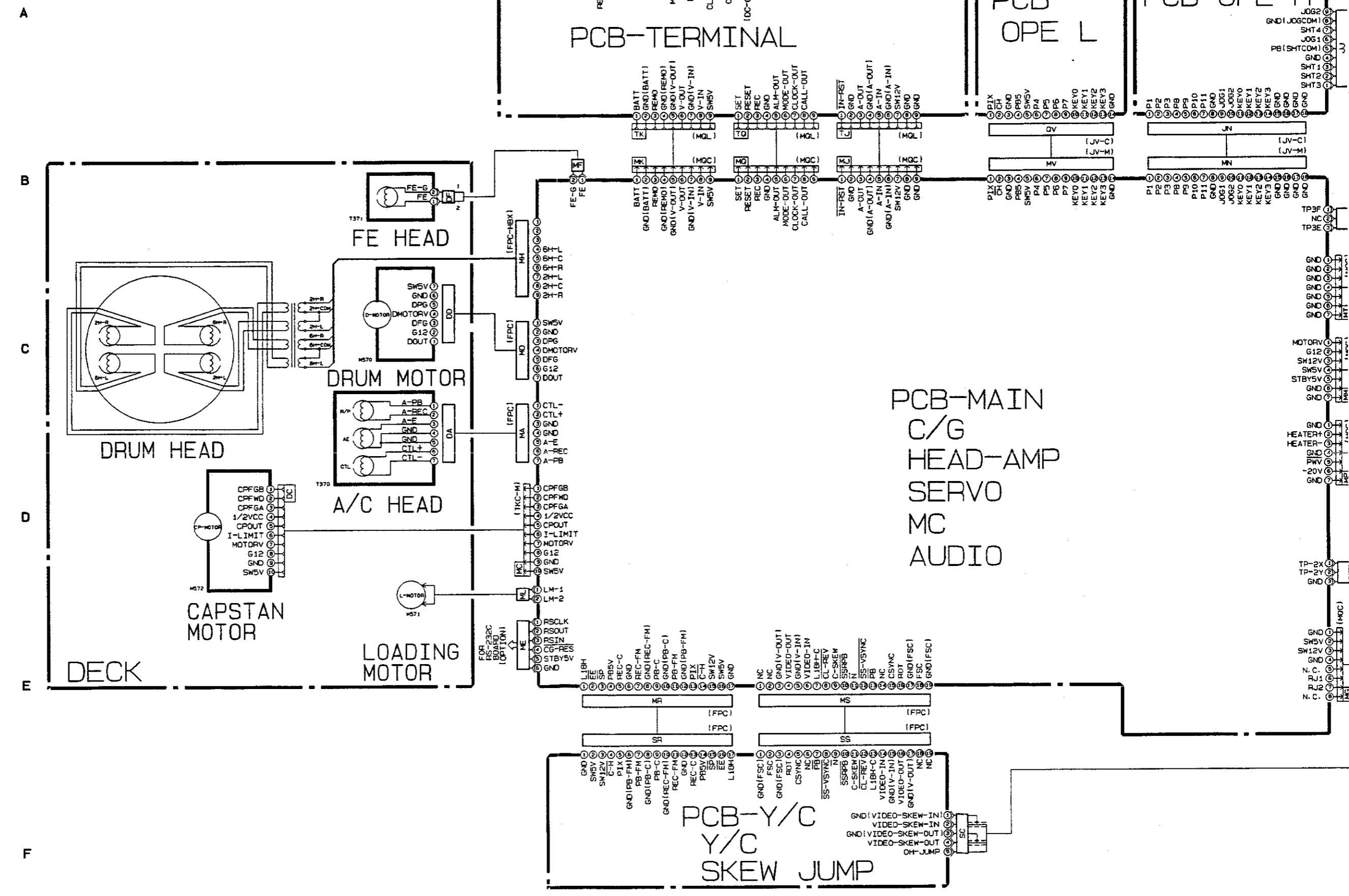

PCB-POWER

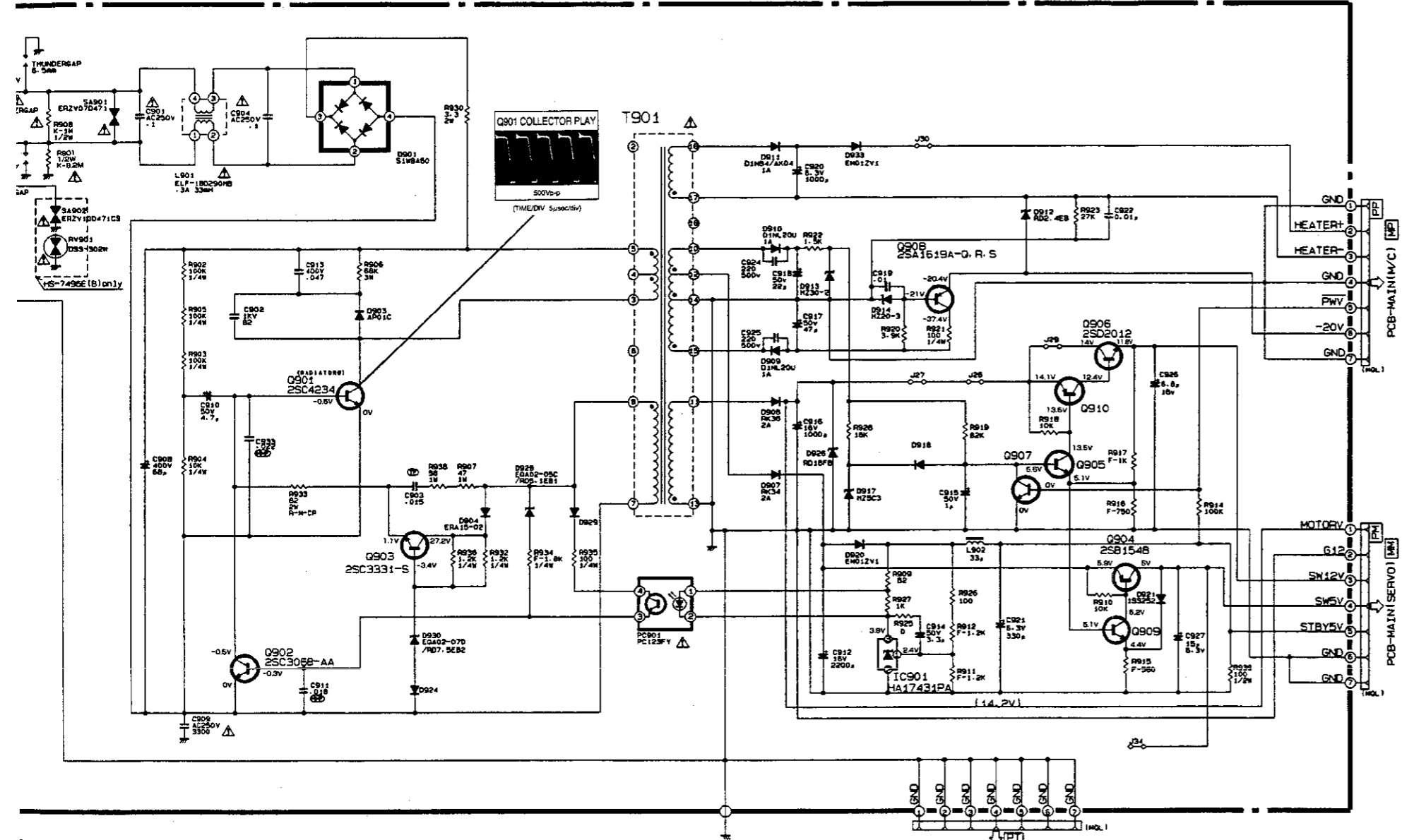

SCHEMATIC DIAGRAM

NOTE

- Each voltage should be within $\pm 20\%$ of the DC voltages measured with a digital voltmeter.
- The voltages parenthesised are on SP recording mode. While those without parenthesised are on SP play back mode.
- Waveforms were taken with standard colour bar signal.
- TP6A, etc. show Test Points.

5. Capacitors

Value	Not indicated	PF, for numbers more than 1 μF , for numbers less than 1
Dielectric Strength	Not indicated :50V	
Tolerance	Not indicated $\pm 10\%$	No Tolerance is indicated for electrolytic capacitors and $\pm 20\%$
Sort	Parts except for chips	Not indicated : Ceramic capacitor (MP) : Polyester capacitor (PP) : Polypropylene film capacitor (ALM) : Aluminum electrolytic capacitor (TE) : Twin film capacitor (SC) : Semiconductor ceramic capacitor (MP) : Metallized paper (MPP) : Metallized plastic film capacitor (MME) : Metallized polyester capacitor (MFPP) : Polyester polypropylene film capacitor (PS) : Styrol capacitor (TAN) or (TANT) : Tantalum capacitor (E) : Electrolytic capacitor (BP) or (NP) : Non polarized electrolytic capacitor
	Chips	Not indicated : Ceramic capacitor chip : Electrolytic capacitor : Non polarized electrolytic capacitor chip
Characteristic (only ceramic capacitor)	Not indicated : F or B (high dielectric percentage) CH, SL, etc. : Temperature compensating types	

6. Resistors

Value	Not indicated = Ω K = $k\Omega$ (1000 Ω) M = $M\Omega$ (1000 $k\Omega$)	
Wattage	Parts except for chips : Not indicated = 1/4W or 1/6W Chips : Not indicated = 1/10W	
Tolerance	Not indicated = $\pm 5\%$ D = $\pm 0.5\%$ J = $\pm 5\%$ F = $\pm 1\%$ K = $\pm 10\%$	
Sort	Parts except for chips	Not indicated : Carbon resistor (S) : Fixed composition resistor (MB) : Metal oxide film resistor (type B) (CE) : Cemented resistor (W) : Wire wound resistor (M) : Metal film resistor (MPC) : Metal plate cement resistor (ML) : Metal liner resistor
	Chip	Not indicated : Chip resistor

7. This is a basic schematic diagram. Some sets may be subject to modification according to engineering improvement.

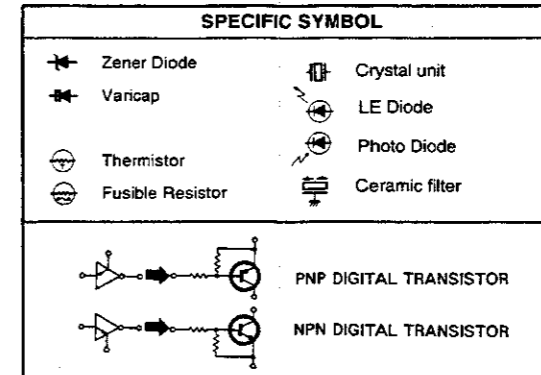

HS-7496E
HS-7496E(B)

CONTENTS	
①	PCB-BLOCK DIAGRAM PCB-POWER
②	PCB-MAIN (HEAD-AMP) (AUDIO) PCB-TERMINAL
③	PCB-Y/C (Y/C)
④	PCB-MAIN (MC)

⑤	PCB-MAIN (SERVO) (C/G) PCB-OPE L PCB-OPE R PCB-OPE-JOG
⑥	PCB-CCD SKEW PCB-Y/C (SKEW JUMP)
⑦	PRINTED CIRCUIT BOARD PARTS LAYOUT

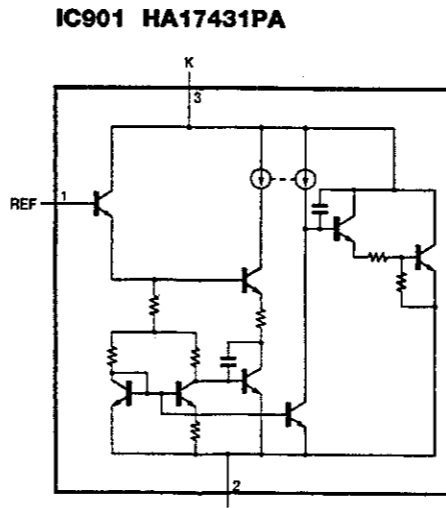

PN TRANSISTORS ARE 2SC1740B-E/2SC2803-G UNLESS OTHERWISE SPECIFIED
NP TRANSISTORS ARE 2SA1335-A-S/2SA1309-A-S UNLESS OTHERWISE SPECIFIED
TODES ARE 155252/155131 UNLESS OTHERWISE SPECIFIED

IG PRECAUTION
OLS INDICATE COMPONENTS HAVING SPECIAL
ERISTICS IMPORTANT TO SAFETY AND PER-
CE. THEREFOR REPLACEMENT OF ANY SAFE-
S SHOULD BE IDENTICAL IN VALUE AND CHAR-
TICS.
EGRADE THE SAFETY OF THE VCR THROUGH
R SERVICING.

(HEAD-AMP) ⚠ PCB-MAIN

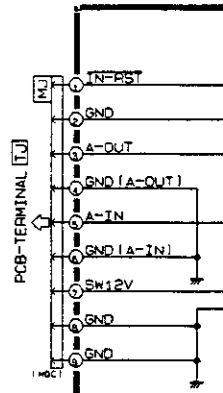
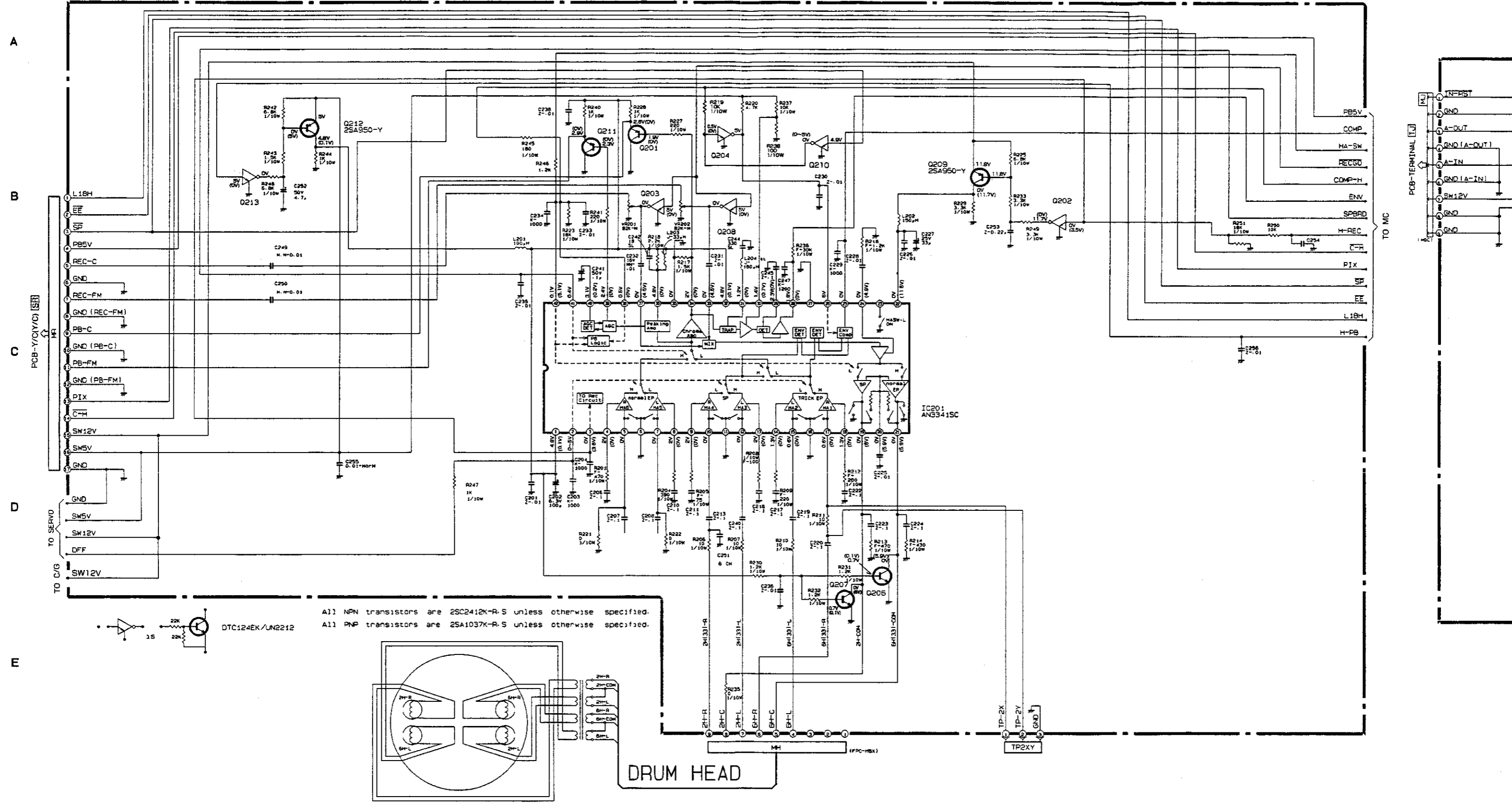

All NPN transistors are 2SC2412K-R-S unless otherwise specified.
 All PNP transistors are 2SA1037K-R-S unless otherwise specified.

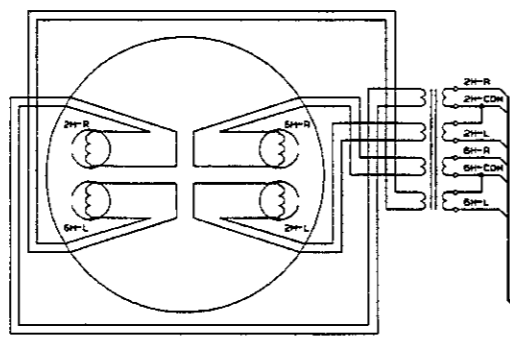
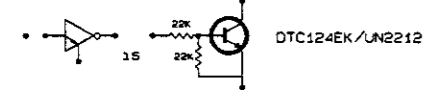

(AUDIO) PCB-MAIN

IAIN

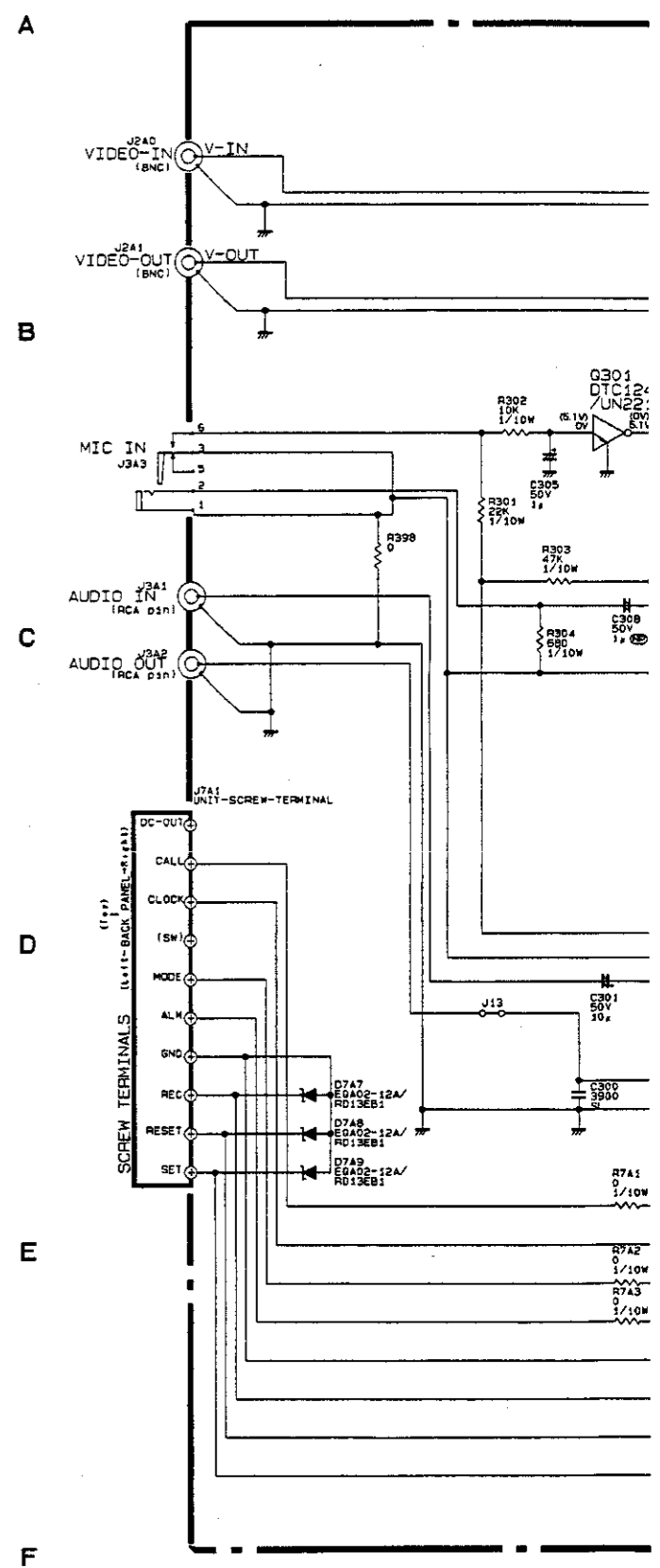
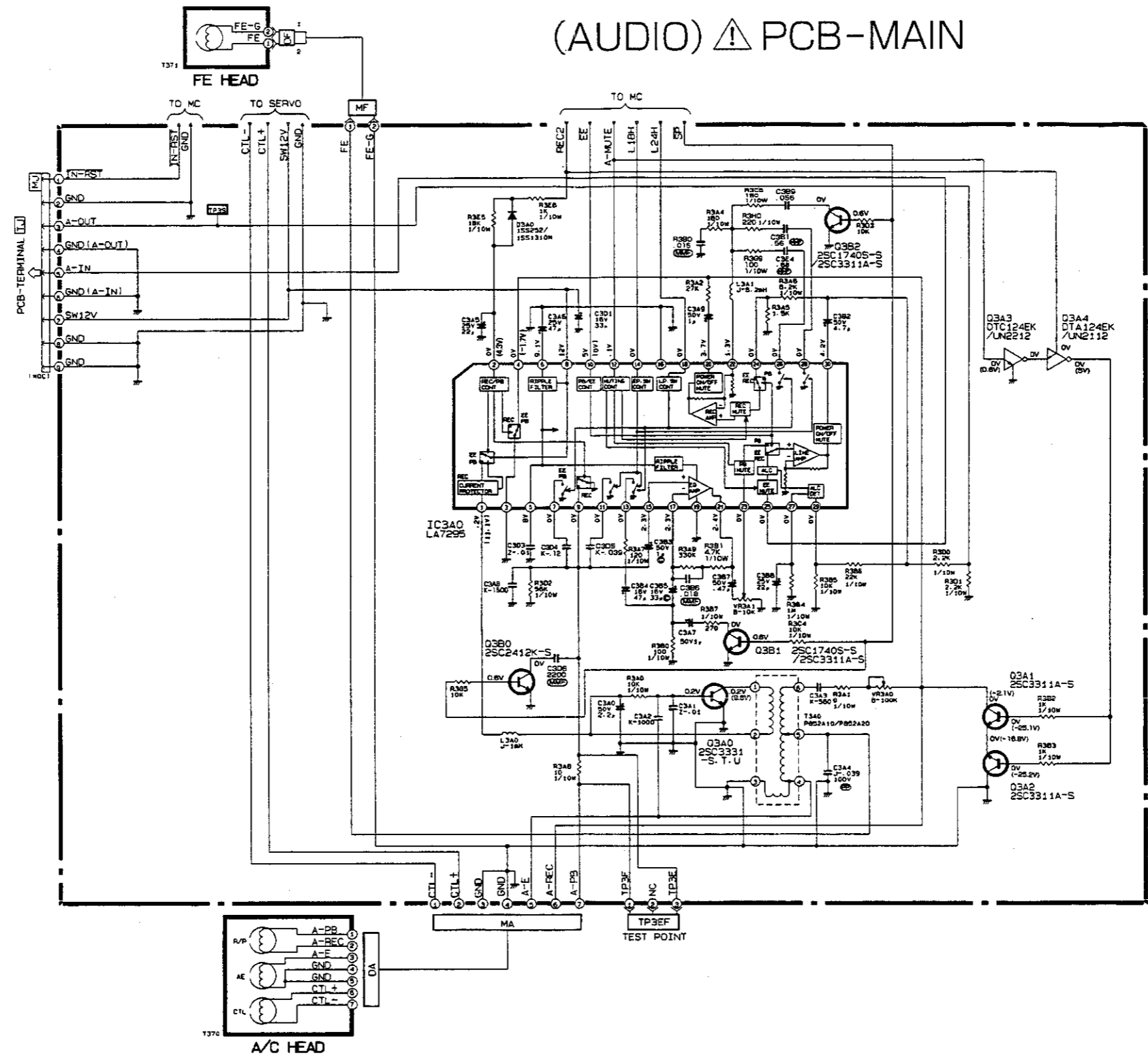
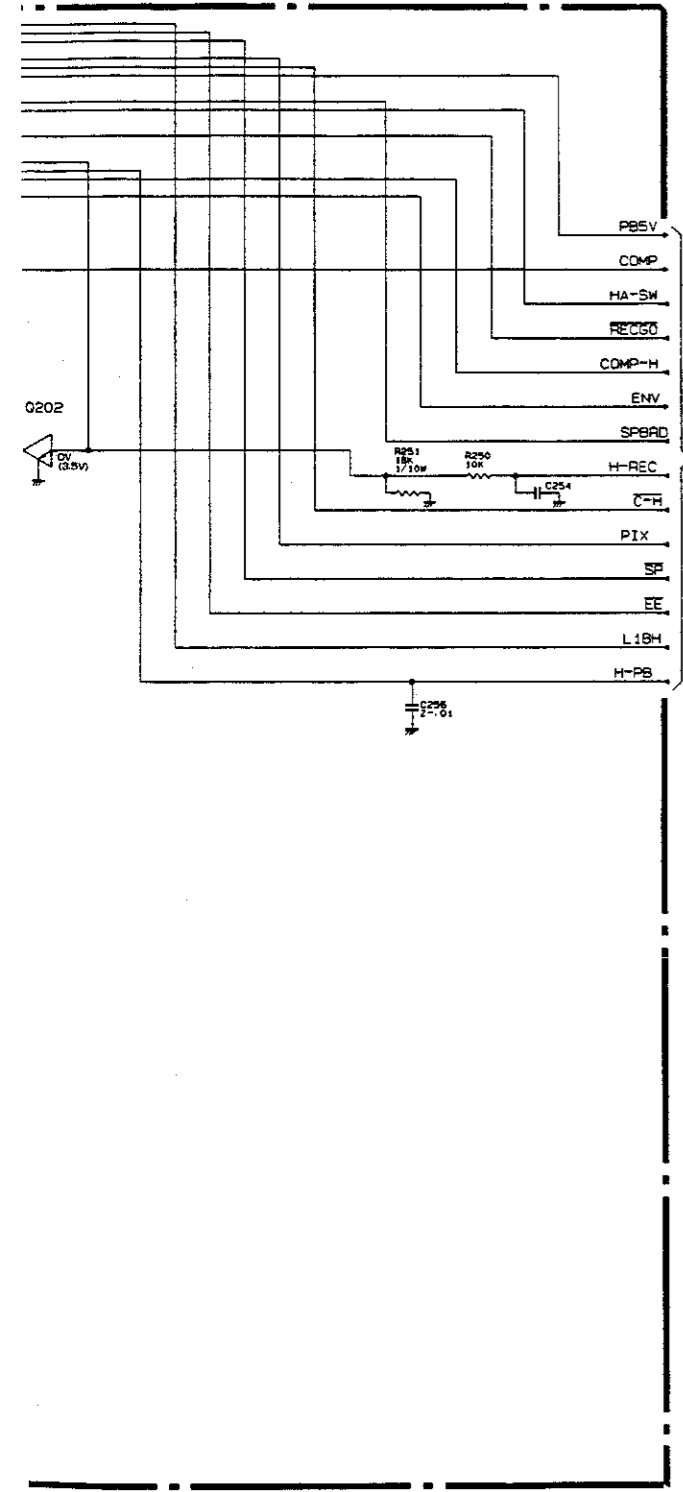

PCB-MAIN

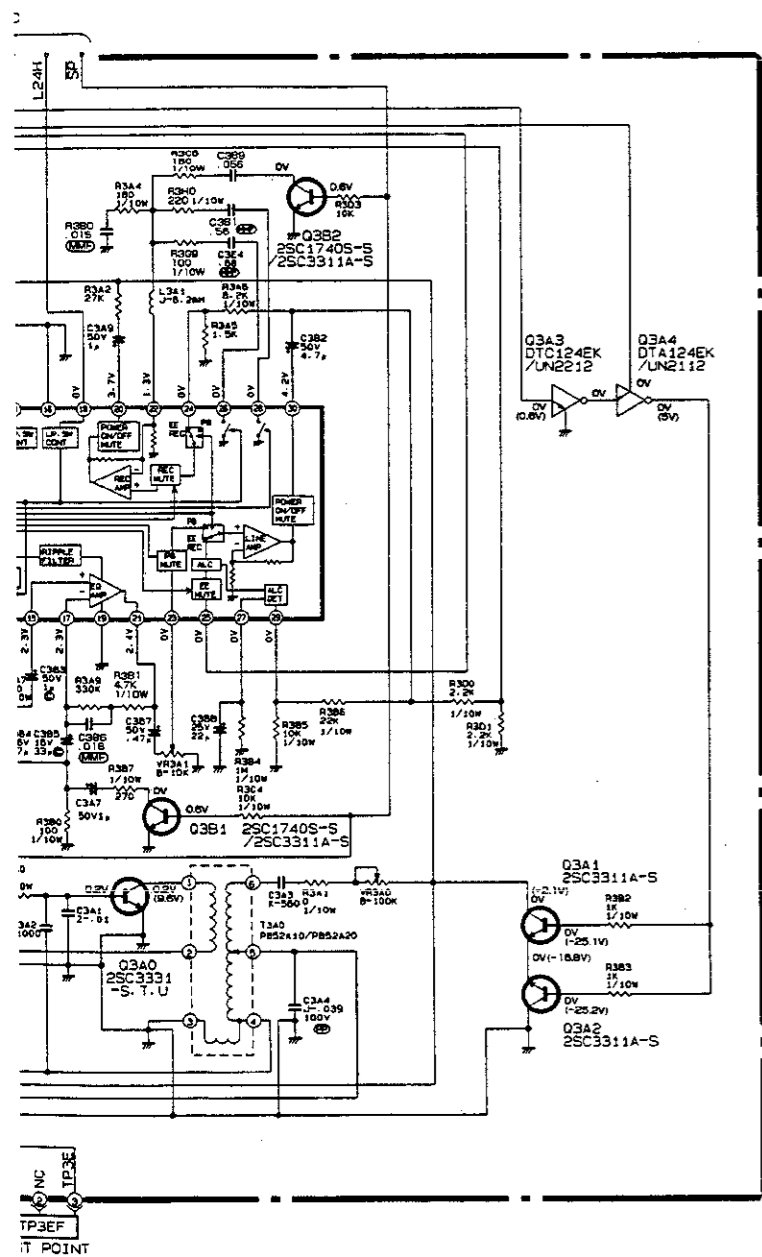

PCB-TERMINAL

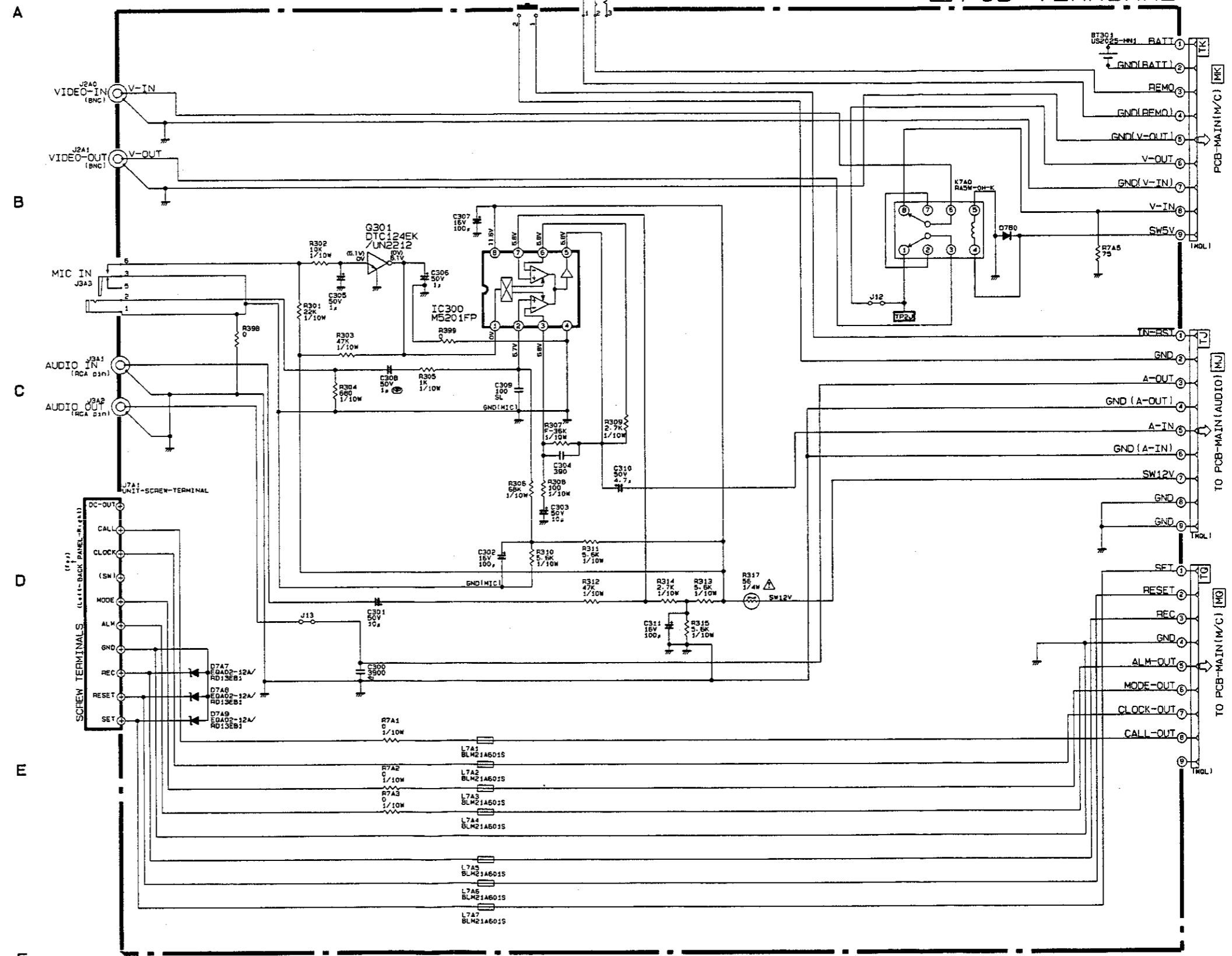

NOTE
 Unless otherwise specified resistors are 1/4W or 1/6W
 ALL DIODES ARE 1SS252/1SS131 UNLESS OTHERWISE SPECIFIED

PCB-MAIN

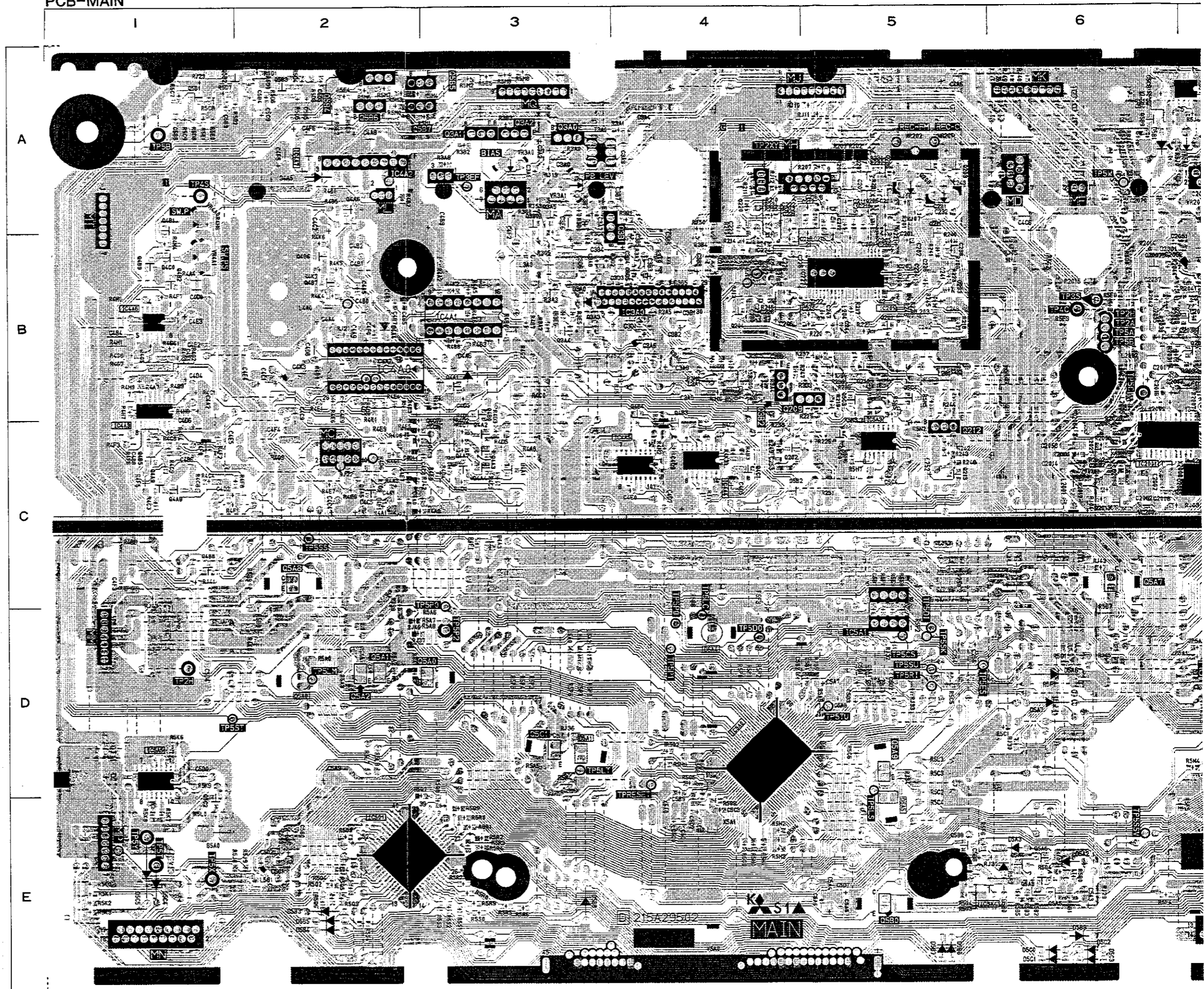

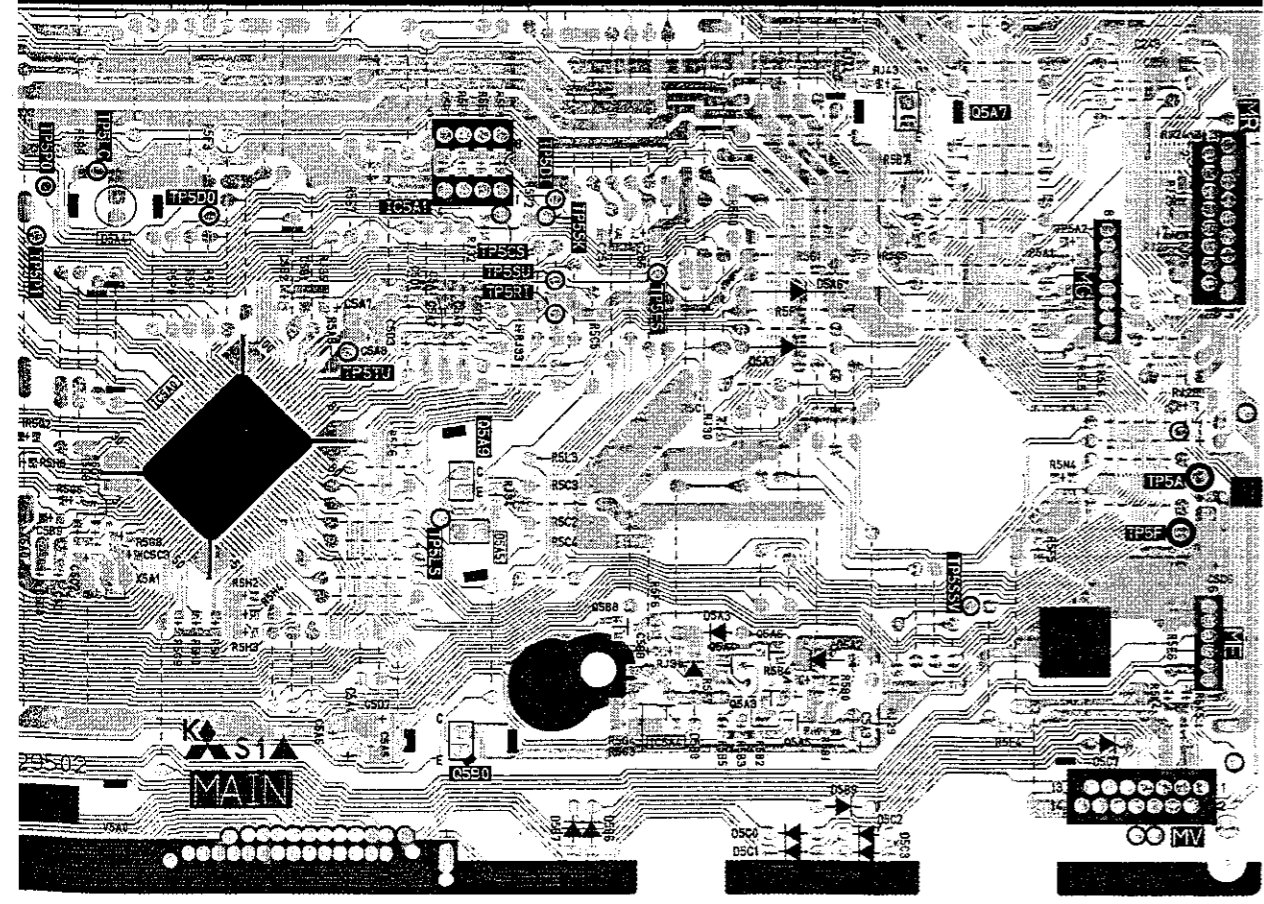
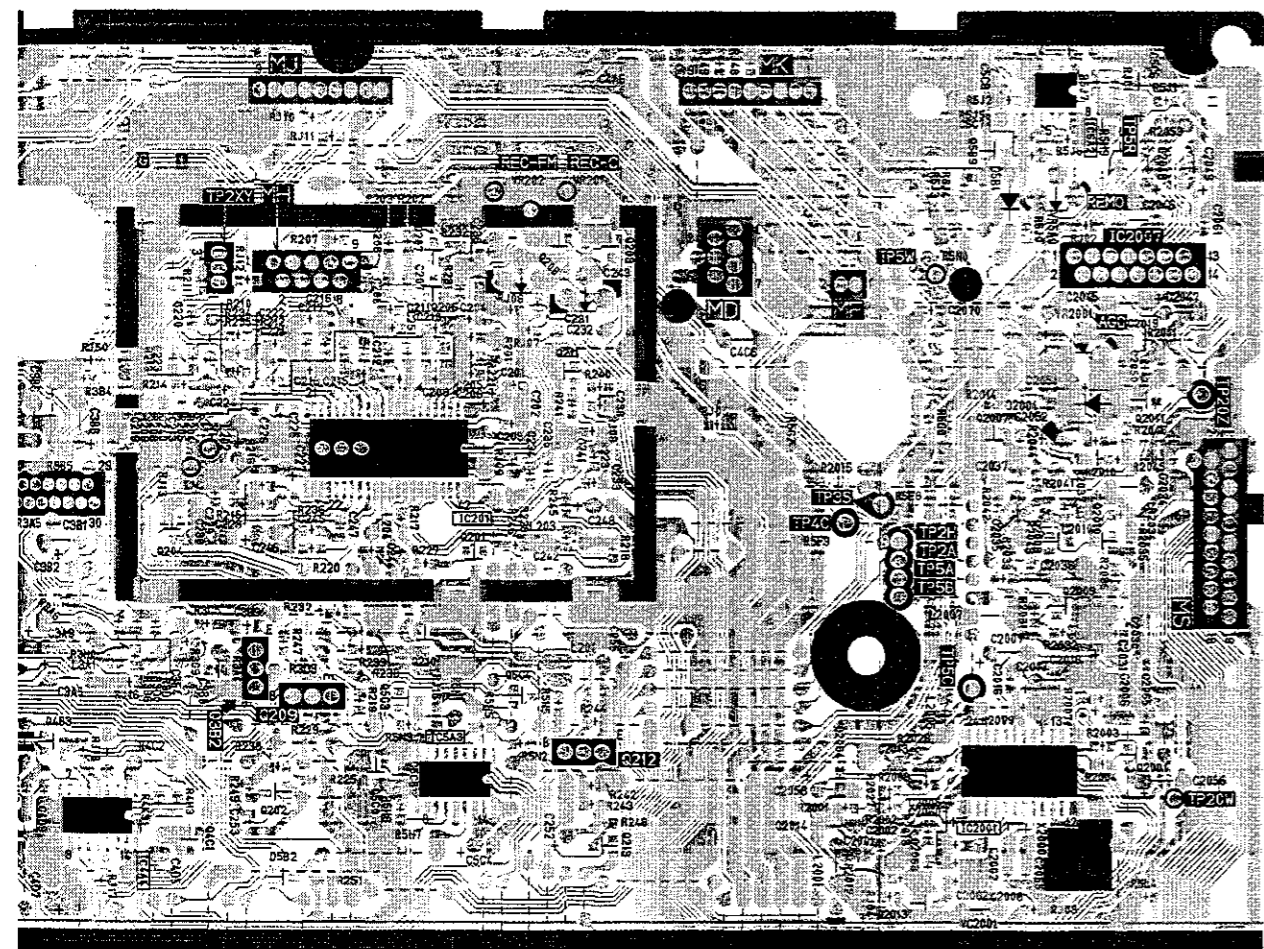

PCB-MAIN

SYMBOL NO.	ADDRESS	SYMBOL NO.	ADDRESS	SYMBOL NO.	ADDRESS	SYMBOL NO.	ADDRESS	SYMBOL NO.	ADDRESS	SYMBOL NO.	ADDRESS	SYMBOL NO.	ADDRESS		
B5A0	E-2	C231	A-5	C4B6	C-1	C5C4	C-5	IC5A4	E-5	Q3B0	A-3	R203	A-5	R3A6	B
C2001	C-6	C232	A-5	C4B7	B-2	C5C5	C-5	IC5A5	D-1	Q3B1	A-3	R2031	B-6	R3A7	B
C2002	C-6	C233	B-5	C4B8	C-1	C5C6	A-7			Q3B2	B-4	R2032	B-7	R3A8	A
C2005	C-6	C234	B-5	C4B9	A-3	C5C7	A-6	JP5A1	D-7	Q4A1	B-3	R2033	B-6	R3A9	B
C2006	B-7	C235	B-5	C4C0	C-3	C5C8	A-6	JP5A2	D-7	Q4A2	C-3	R2034	B-7	R3B0	A
C2007	B-6	C236	A-5	C4C1	B-2	C5C9	A-2			Q4A3	C-3	R2035	B-7	R3B1	A
C2008	C-6	C238	B-5	C4C2	A-2	C5D0	D-1	L2001	C-6	Q4A4	C-3	R2036	B-7	R3B2	A
C201	B-5	C240	A-5	C4C3	C-2	C5D1	D-5	L2002	C-6	Q4A5	C-2	R2037	B-7	R3B3	A
C2013	C-6	C241	B-5	C4C4	C-2	C5D2	D-5	L2005	C-6	Q4A6	A-2	R204	A-5	R3B4	B
C2014	C-6	C242	B-5	C4C5	C-2	C5D3	D-5	L2007	B-6	Q4A7	C-3	R2041	B-6	R3B5	B
C2016	B-6	C243	A-5	C4C6	A-6	C5D4	D-1	L201	B-5	Q4A8	C-1	R2042	B-6	R3B6	B
C2017	B-6	C244	B-5	C4C7	C-2	C5D5	A-2	L2010	B-7	Q4A9	C-1	R2043	B-6	R3B7	A
C2018	B-7	C245	B-5	C4C8	C-2	C5D6	E-7	L202	B-4	Q4B0	B-3	R2044	B-6	R3C4	B
C2019	B-7	C246	B-4	C4C9	B-2	C5D7	E-5	L203	B-5	Q4B1	A-1	R2045	B-7	R3C5	B
C202	B-5	C247	B-5	C4D0	B-1			L204	B-5	Q4B2	B-1	R2046	B-7	R3D0	B
C203	B-5	C248	B-5	C4D1	C-2	D2001	B-7	L3A0	B-3	Q4B3	C-4	R205	A-5	R3D1	B
C2030	B-7	C249	C-7	C4D2	C-1	D3A0	B-3	L3A1	B-4	Q4B4	C-4	R2053	A-7	R3D2	B
C2031	B-7	C250	C-7	C4D3	B-3	D4A1	C-3	L4A0	B-2	Q4B5	C-1	R206	A-5	R3D3	B
C2034	B-7	C251	A-5	C4D4	B-1	D4A3	C-3	L501	E-2	Q4B6	B-2	R207	A-5	R3E5	B
C2034	B-7	C252	C-5	C4D5	C-4	D4A4	B-2	L5A0	D-3	Q4B7	B-2	R208	A-5	R3E6	B
C2035	B-6	C253	C-4	C4D6	C-1	D4A5	A-2	L5A1	D-3	Q4B8	C-1	R209	A-5	R3G0	B
C2036	B-7	C254	D-5	C4D7	C-4	D4A6	B-3	L5A2	D-3	Q4B9	B-1	R210	A-4	R3G5	B
C2037	B-7	C255	B-5	C4D8	B-2	D5A0	D-2			Q4C0	B-1	R211	A-4	R3G9	B
C204	A-5	C256	D-5	C4D9	C-4	D5A1	D-3	MA	A-3	Q4C1	C-4	R212	A-4	R3H0	B
C2045	A-7	C3A0	A-3	C4E0	C-4	D5A2	E-6	MC	C-2	Q5A0	D-3	R213	A-4	R4A0	C
C2046	A-7	C3A1	A-3	C4E1	B-1	D5A3	E-6	MD	A-6	Q5A1	D-2	R214	B-4	R4A1	C
C2047	A-7	C3A2	A-3	C4E2	B-1	D5A4	D-4	ME	E-7	Q5A2	D-2	R215	B-4	R4A2	B
C2048	A-7	C3A3	A-4	C4E3	B-1	D5A5	E-5	MF	A-6	Q5A3	E-6	R216	B-4	R4A3	C
C2049	A-7	C3A4	A-4	C4E4	B-2	D5A6	D-6	MG	D-7	Q5A4	E-6	R217	B-5	R4A4	B
C205	A-5	C3A5	B-4	C4E5	C-2	D5A7	D-6	MH	A-4	Q5A5	E-6	R218	B-5	R4A5	B
C2050	B-7	C3A6	B-4	C4E7	C-2	D5B0	E-6	MJ	A-5	Q5A6	E-6	R219	B-5	R4A6	B
C2051	B-7	C3A7	A-3	C4E9	B-2	D5B1	A-6	MK	A-6	Q5A7	C-6	R220	B-5	R4A7	B
C2052	B-7	C3A8	B-3	C4F0	B-2	D5B2	C-4	ML	A-2	Q5A8	C-2	R221	B-5	R4A8	C
C2055	C-6	C3A9	B-4	C4F1	C-2	D5B3	E-2	MM	D-1	Q5A9	D-5	R222	A-5	R4A9	B
C2056	C-7	C3B0	B-4	C4F2	B-3	D5B4	E-2	MN	E-1	Q5B0	E-5	R223	B-5	R4B0	B
C2058	C-6	C3B1	B-4	C4F3	C-1	D5B5	E-2	MP	E-1	Q5B1	A-1	R225	C-5	R4B1	A
C206	A-5	C3B2	B-4	C4F4	C-2	D5B6	E-5	MQ	A-3	Q5B2	A-2	R227	B-5	R4B2	A
C2060	C-6	C3B3	B-4	C4F5	A-2	D5B7	E-5	MR	C-7	Q5B3	A-2	R228	B-5	R4B3	B
C2061	A-7	C3B4	B-3	C4F6	A-2	D5B8	E-3	MS	B-7	Q5B4	A-2	R229	B-5	R4B4	B
C2062	C-6	C3B5	B-4	C501	E-2	D5B9	E-6	MT	A-1	Q5B5	A-3	R230	A-5	R4B5	A
C2063	C-6	C3B6	B-4	C502	E-2	D5C0	E-6	MV	E-7	Q5B6	A-2	R231	A-5	R4B6	B
C2064	C-6	C3B7	A-3	C503	E-2	D5C1	E-6			Q5B7	A-3	R232	A-5	R4B7	B
C2065	B-7	C3B8	B-4	C504	E-2	D5C2	E-6	Q2001	C-7	Q5B8	E-5	R233	C-4	R4B8	C
C207	A-5	C3B9	B-4	C5A0	D-5	D5C3	E-6	Q2007	B-6	Q5B9	A-6	R234	A-4	R4B9	B
C2070	A-6	C3D1	B-4	C5A1	D-5	D5C4	E-1	Q2008	B-7	Q5C0	C-5	R235	B-4	R4C0	B
C208	A-5	C3D3	B-4	C5A2	D-5	D5C5	E-1	Q2009	B-7	Q5C1	D-3	R236	B-5	R4C1	B
C209	B-5	C3D4	B-4	C5A3	E-6	D5C7	E-7	Q201	B-5	Q5C2	E-1	R237	B-5	R4C2	C
C210	A-5	C3D5	B-4	C5A4	E-5			Q2010	B-7	Q5C3	B-5	R238	B-5	R4C3	C
C211	A-5	C3D6	B-3	C5A5	E-5	G	A-4	Q2011	B-7	Q5C4	B-5	R239	B-5	R4C4	C
C212	B-5	C3E4	B-4	C5A6	E-5			Q2013	C-6			R240	B-5	R4C5	C
C213	A-5	C3E6	B-3	C5A7	D-5	IC2001	C-6	Q202	C-4	R2001	C-6	R241	B-5	R4C6	C
C215	B-5	C4A0	C-2	C5A8	D-5	IC2007	A-7	Q203	A-5	R2002	C-6	R242	C-5	R4C7	C
C216	A-5	C4A1	C-2	C5A9	D-2	IC201	B-5	Q204	B-4	R2003	C-7	R243	C-5	R4C8	C
C217	A-5	C4A2	B-1	C5B0	E-2	IC3A0	B-3	Q206	A-5	R2004	C-7	R244	B-5	R4C9	C
C218	B-5	C4A3	B-2	C5B1	D-5	IC4A0	B-2	Q207	A-5	R2007	B-7	R245	B-5	R4D0	C
C219	A-5	C4A4	B-2	C5B2	D-4	IC4A1	B-3	Q208	A-5	R2008	C-6	R246	B-5	R4D1	C
C220	A-4	C4A5	B-2	C5B3	A-1	IC4A2	A-2	Q209	B-5	R2009	B-6	R247	B-4	R4D2	C
C221	B-4	C4A6	A-5	C5B4	A-2	IC4A3	B-1	Q210	B-5	R201	A-5	R248	C-5	R4D3	C
C222	A-4	C4A7	B-2	C5B5	A-2	IC4A4	C-4	Q211	B-5	R2010	B-7	R249	C-4	R4D4	C
C223	A-4	C4A8	A-2	C5B6	A-1	IC4A5	C-4	Q212	C-5	R2011	A-7	R250	D-5	R4D5	C
C224	B-4	C4A9	B-2	C5B7	D-5	IC4A6	B-1	Q213	C-5	R2012	C-6	R251	C-5	R4D6	C
C225	B-4	C4B0	B-2	C5B8	E-5	IC4A7	A-2	Q3A0	A-3	R2013	C-6	R3A0	A-3	R4D7	B
C226	B-4	C4B1	B-2	C5B9	E-4	IC501	E-2	Q3A1	A-3	R2014	B-7	R3A1	A-4	R4D8	B
C227	B-4	C4B2	B-2	C5C0	E-4	IC5A0	D-4	Q3A2	A-3	R2015	B-6	R3A2	B-3	R4D9	C
C228	B-4	C4B3	B-2	C5C1	E-4	IC5A1	D-5	Q3A3	B-3	R202	A-5	R3A3	B-3	R4E0	C
C229	B-4	C4B4	B-1	C5C2	E-4	IC5A2	A-7	Q3A4	B-3	R2027	C-6	R3A4	B-4	R4E1	B
C230	B-4	C4B5	B-2	C5C3	E-4	IC5A3	C-5	Q3A5	A-3	R2028	C-6	R3A5	B-4	R4E2	B

F
F
G
H
I
J

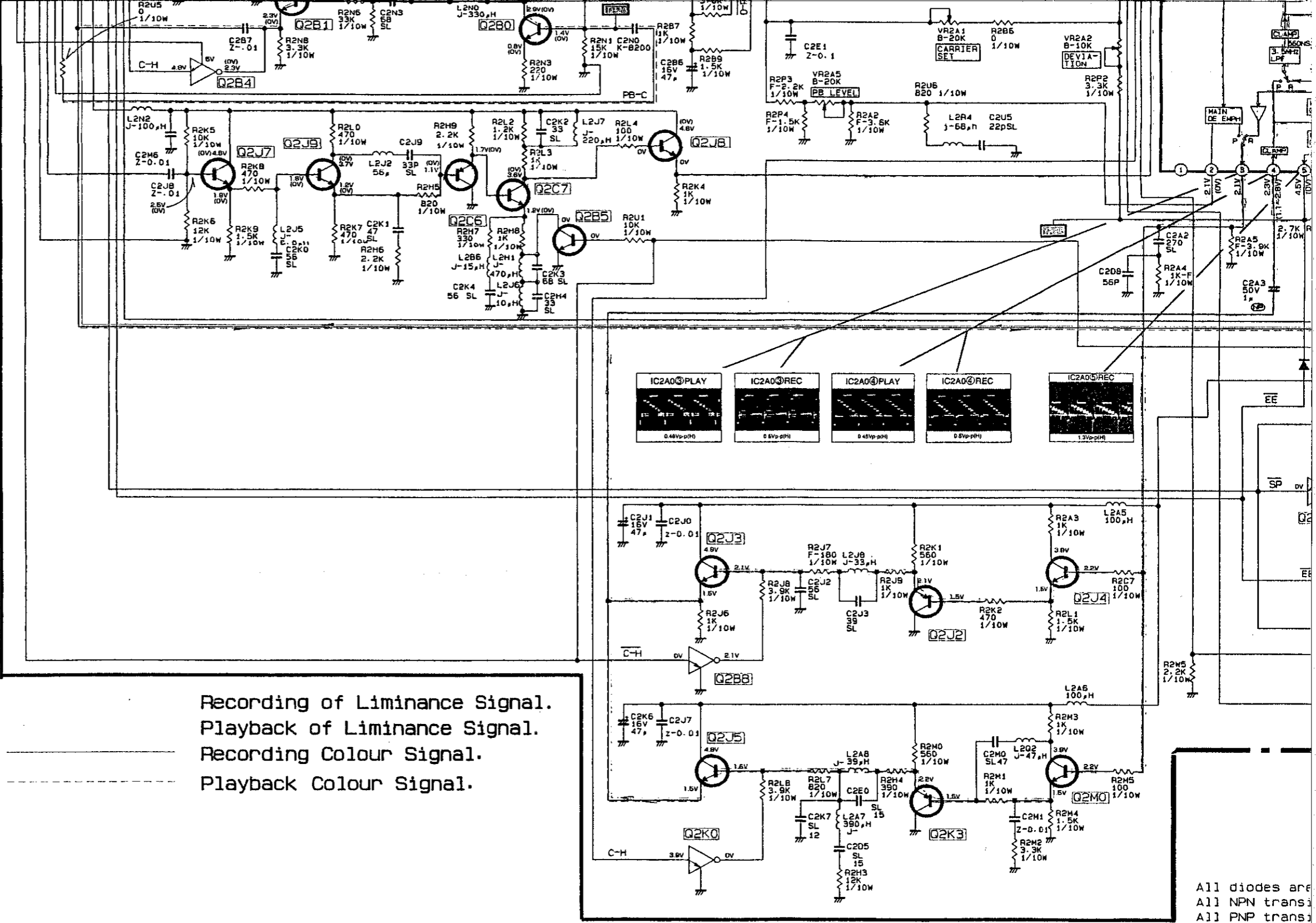

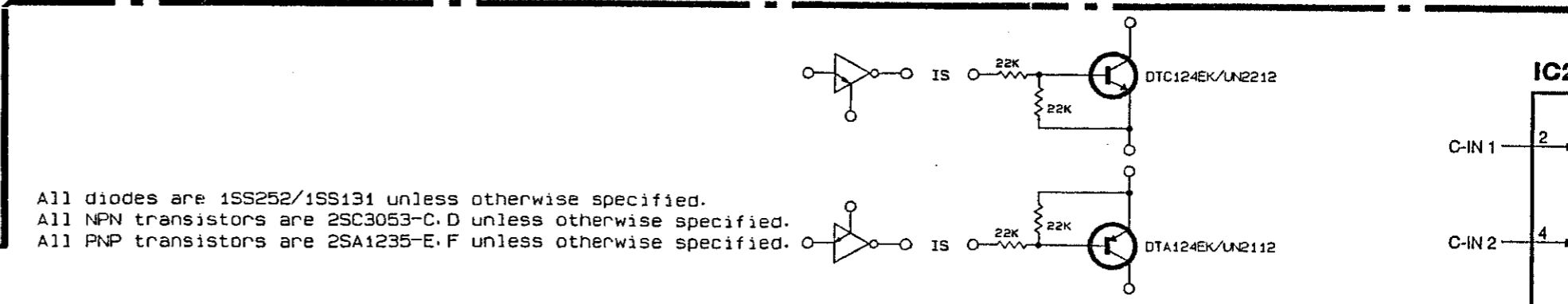
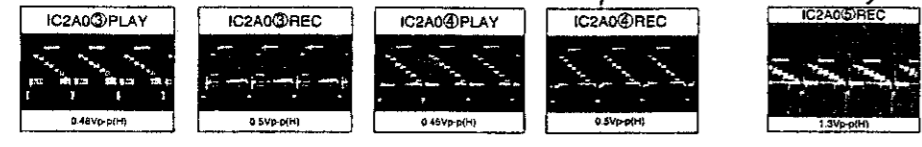
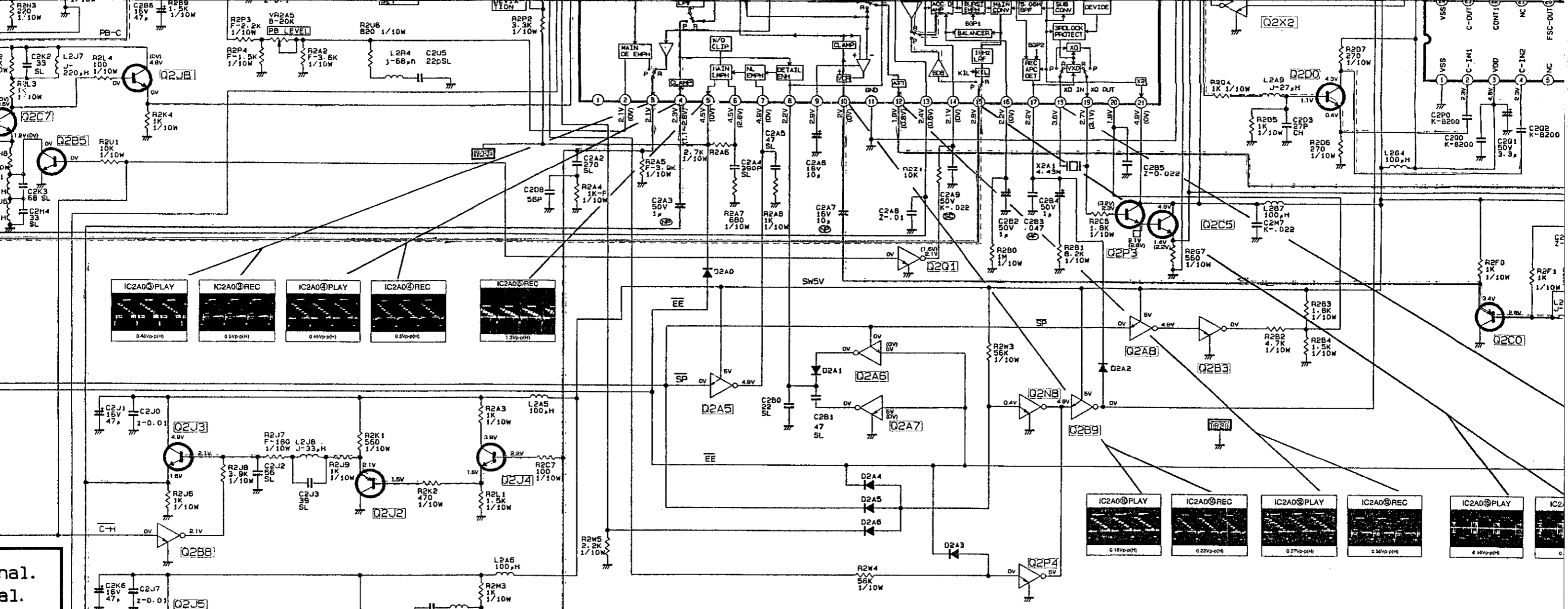

All diodes are 1SS252/1SS131 unless otherwise specified.
 All NPN transistors are 2SC3053-C.D unless otherwise specified.
 All PNP transistors are 2SA1235-E.F unless otherwise specified.

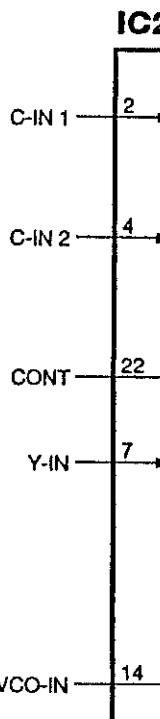

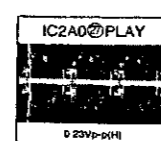
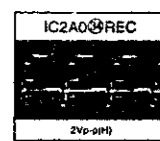
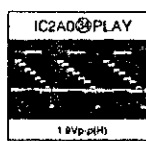

8

9

10

11

12

13

14

15

(Y/C) PCB-Y/C

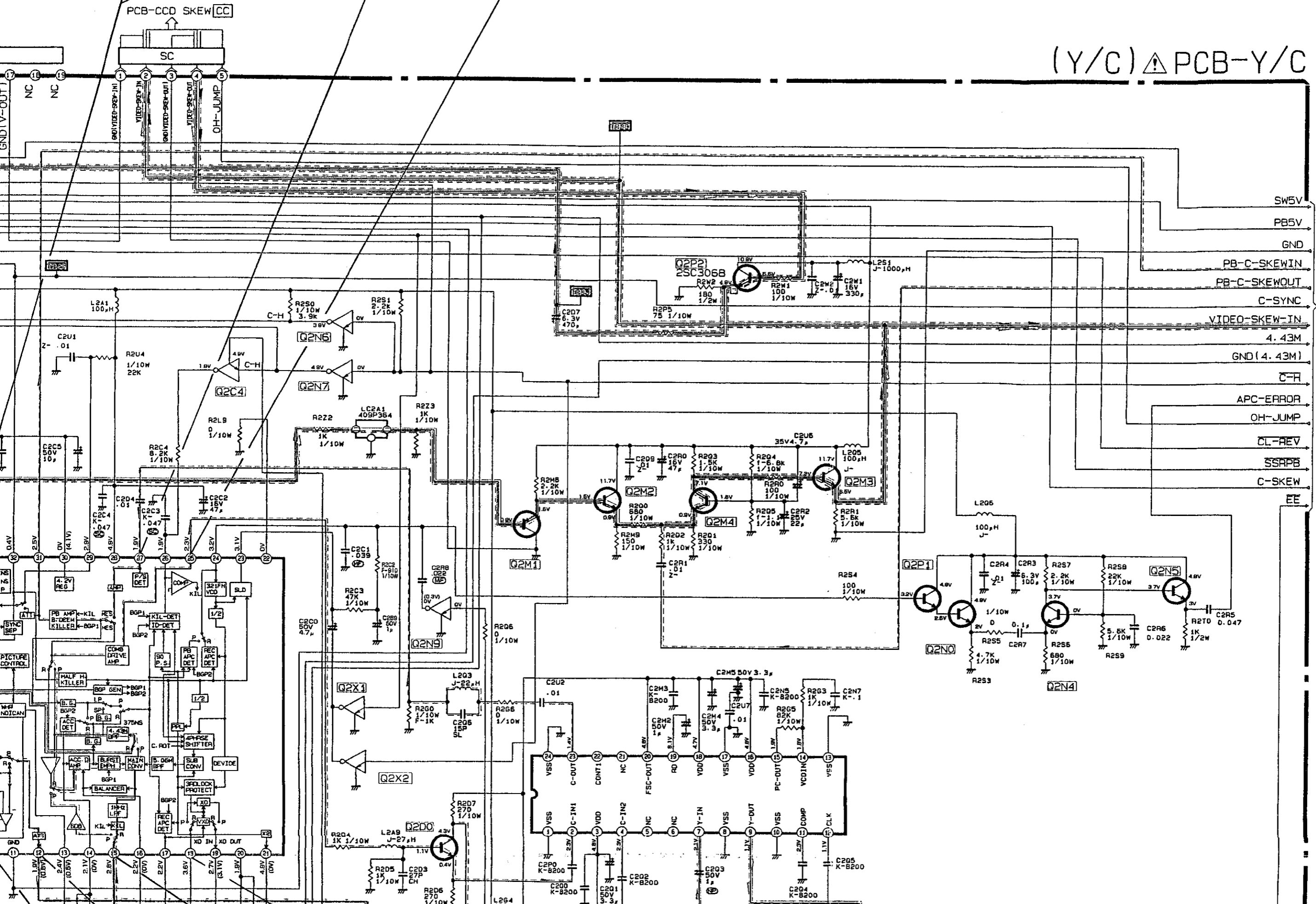

TO SKEW JUMP

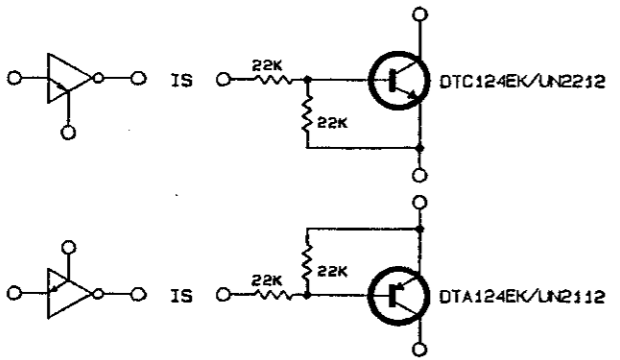
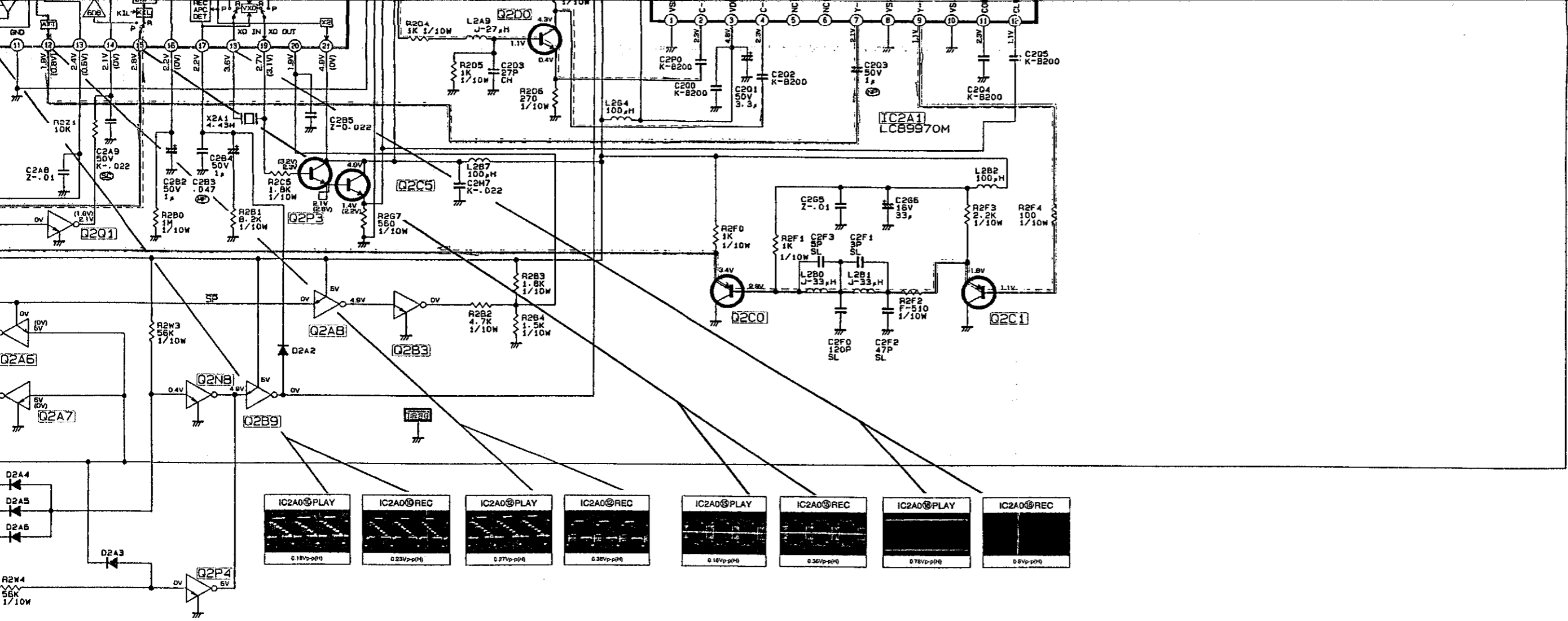

IC2A1 LC89970M

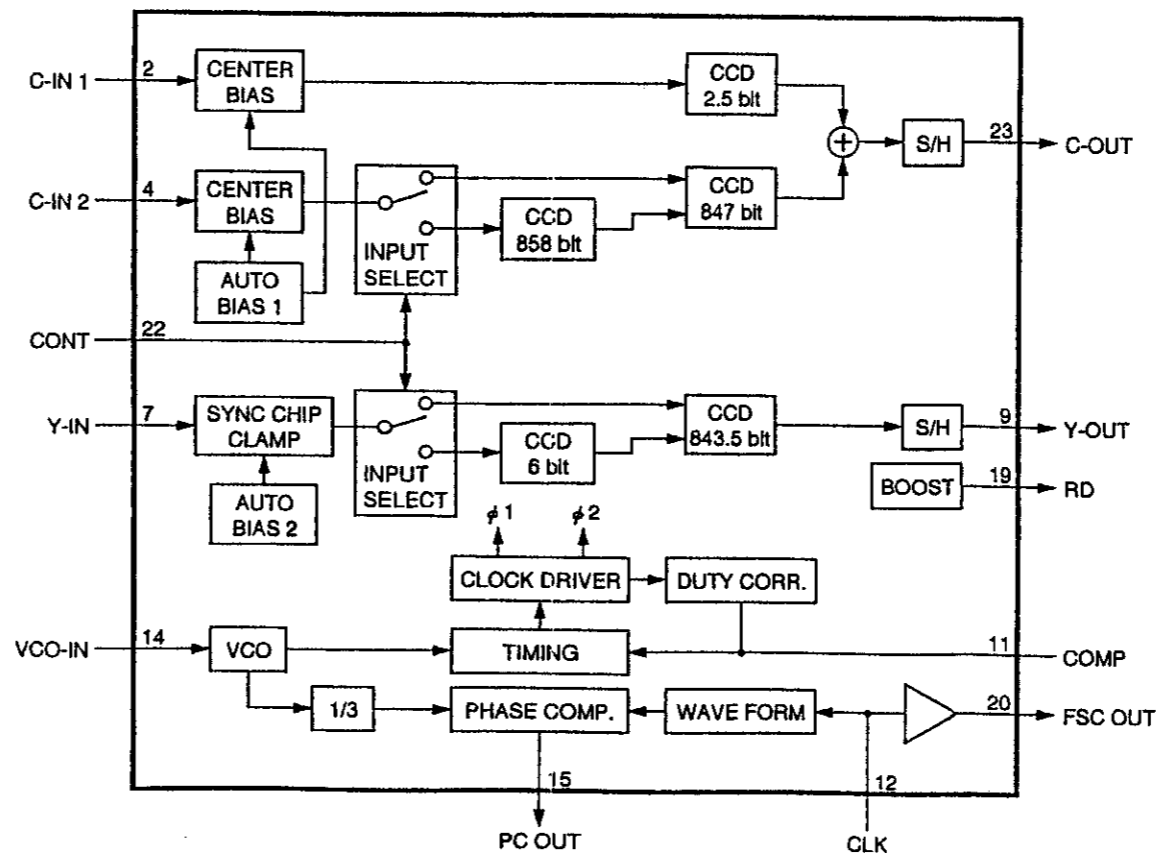

(MC) PCB-MAIN

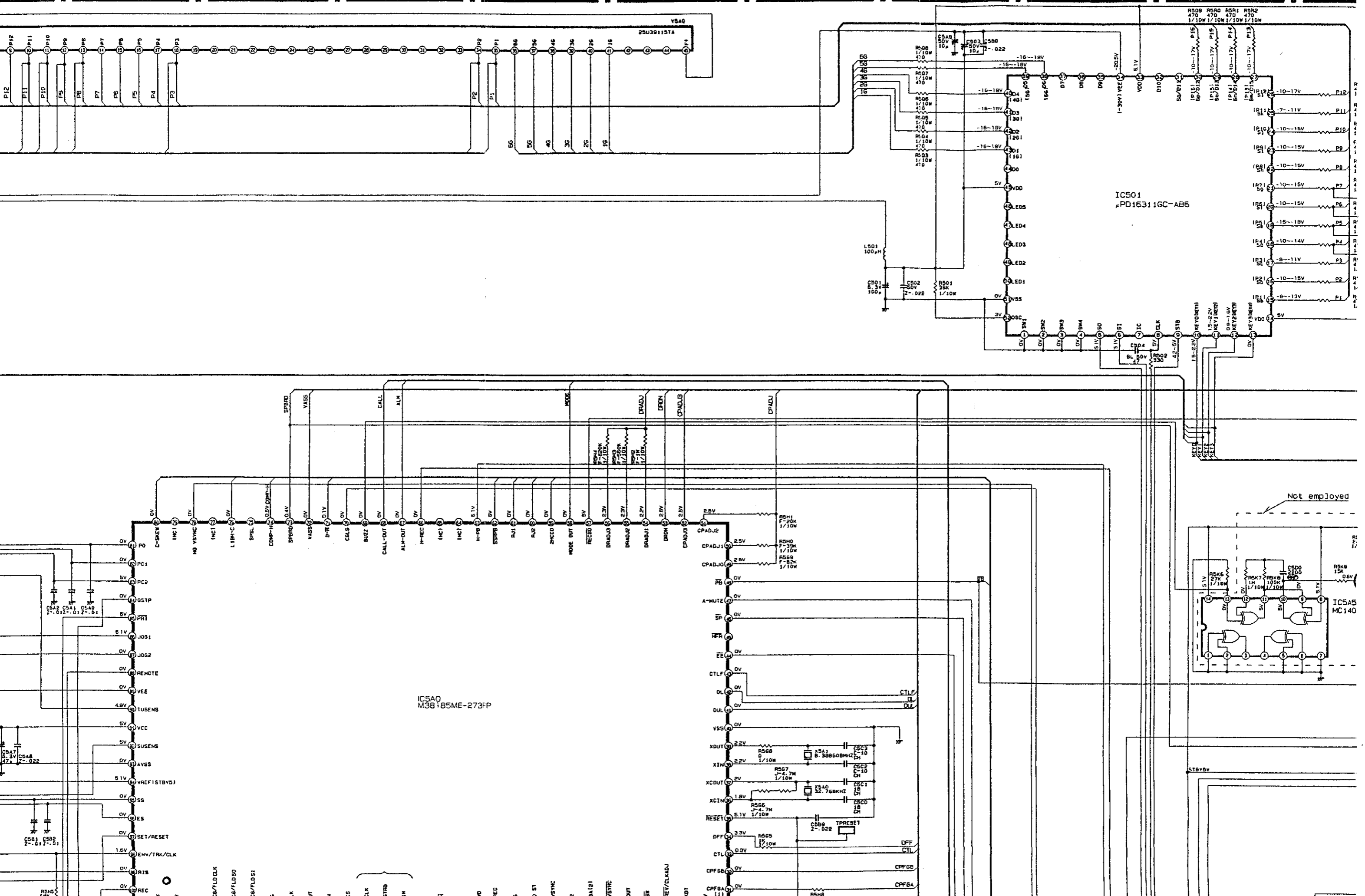

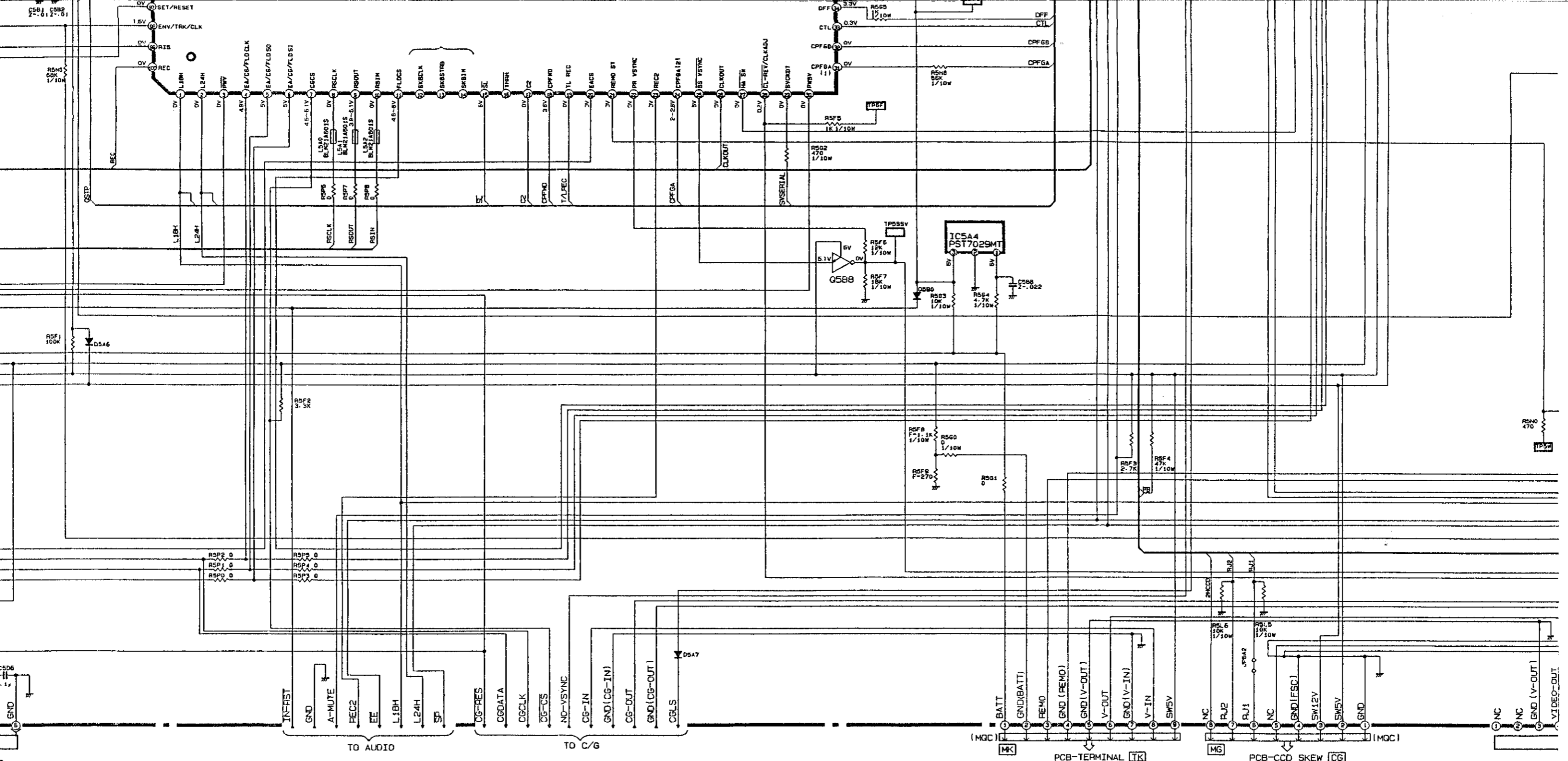

Note:
 Unless otherwise specified
 PNP transistors are 2SA1037K-R.S/2SB709AI-R.S
 NPN transistors are 2SC2412K-R.S/2SD601AI-R.S
 All diodes are 1SS252/1SS131
 PNP digital transistors are DTA124EK/UN2112
 NPN digital transistors are DTC124EK/UN2212

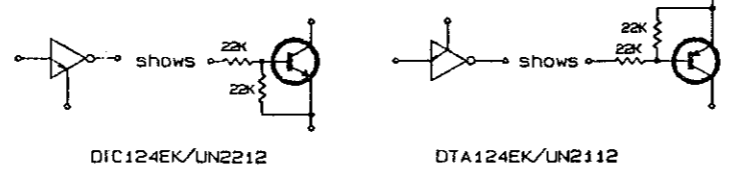

[IC-BLOCK DIAGRAMS (SERVO)(C/G)]

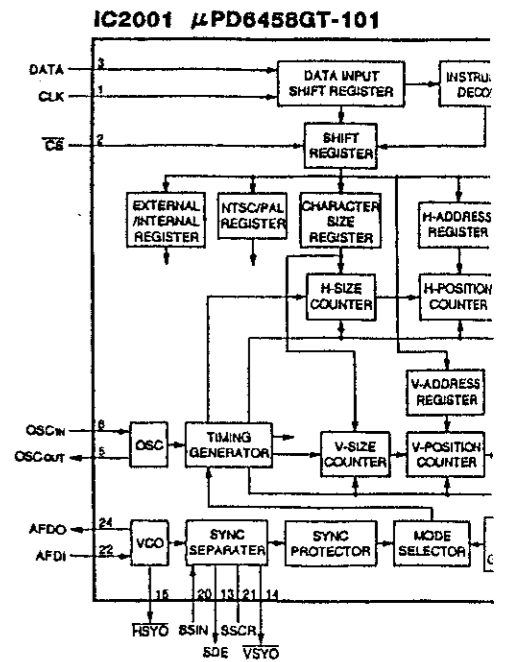
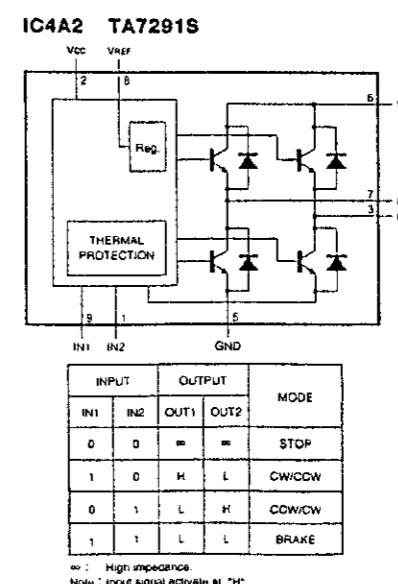
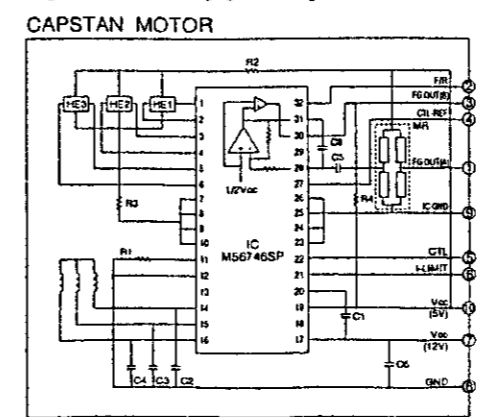
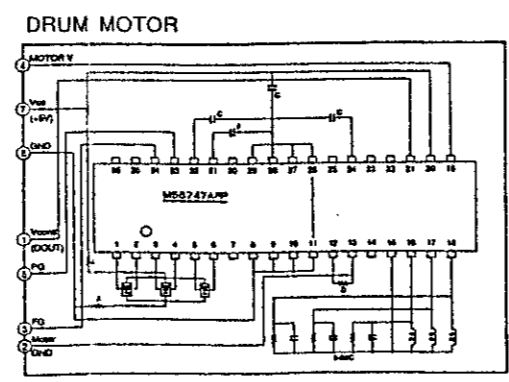
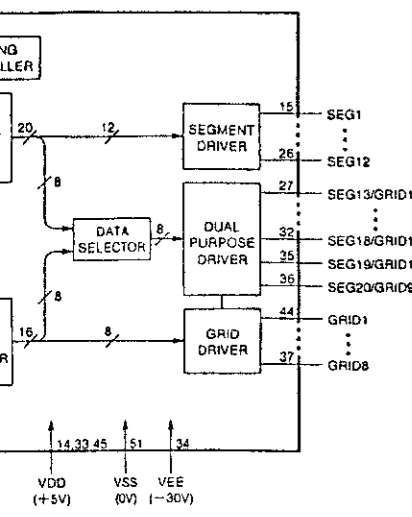

(MC) PCB-MAIN

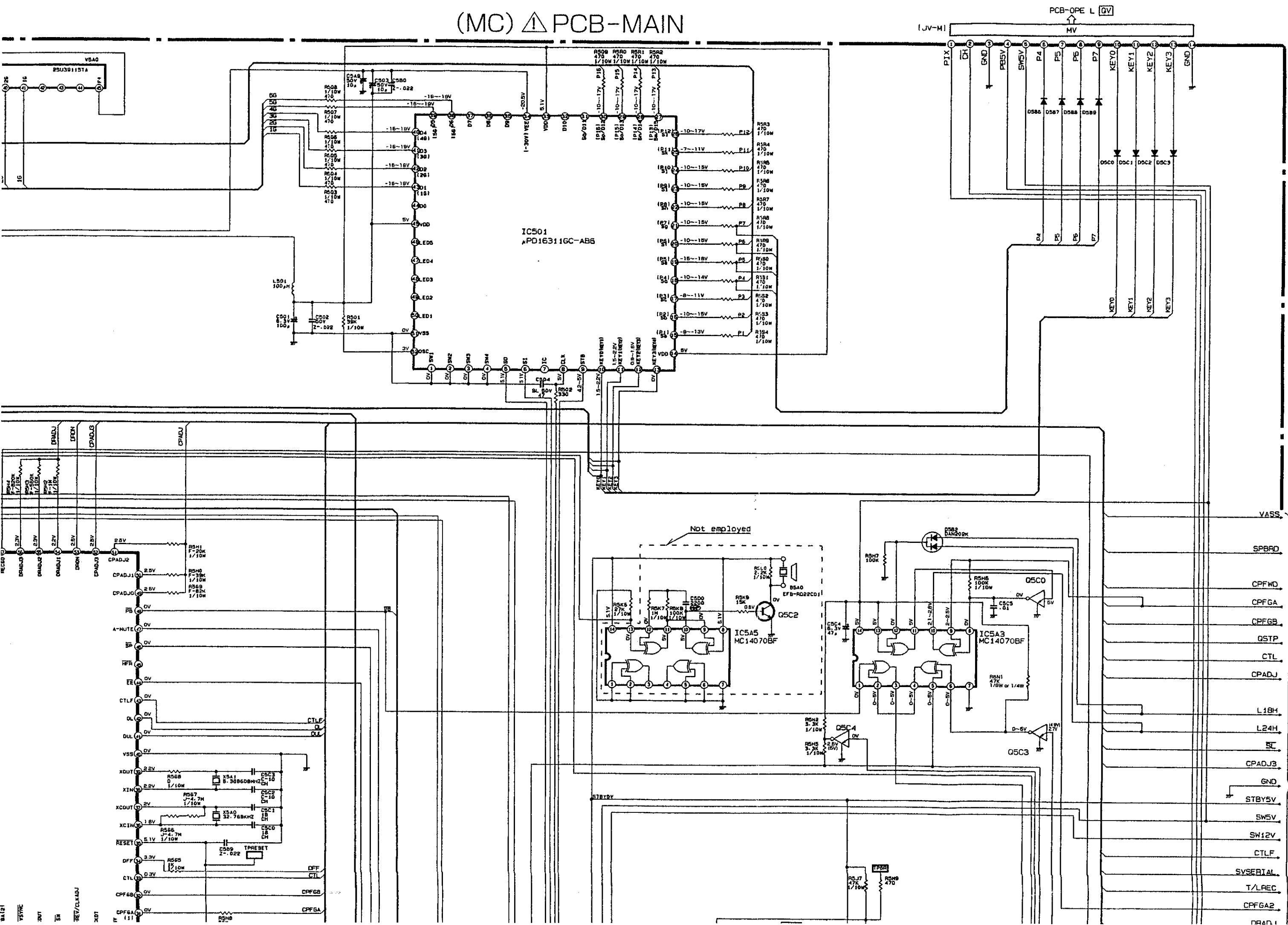

TO SERVO

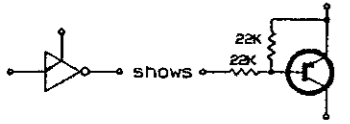
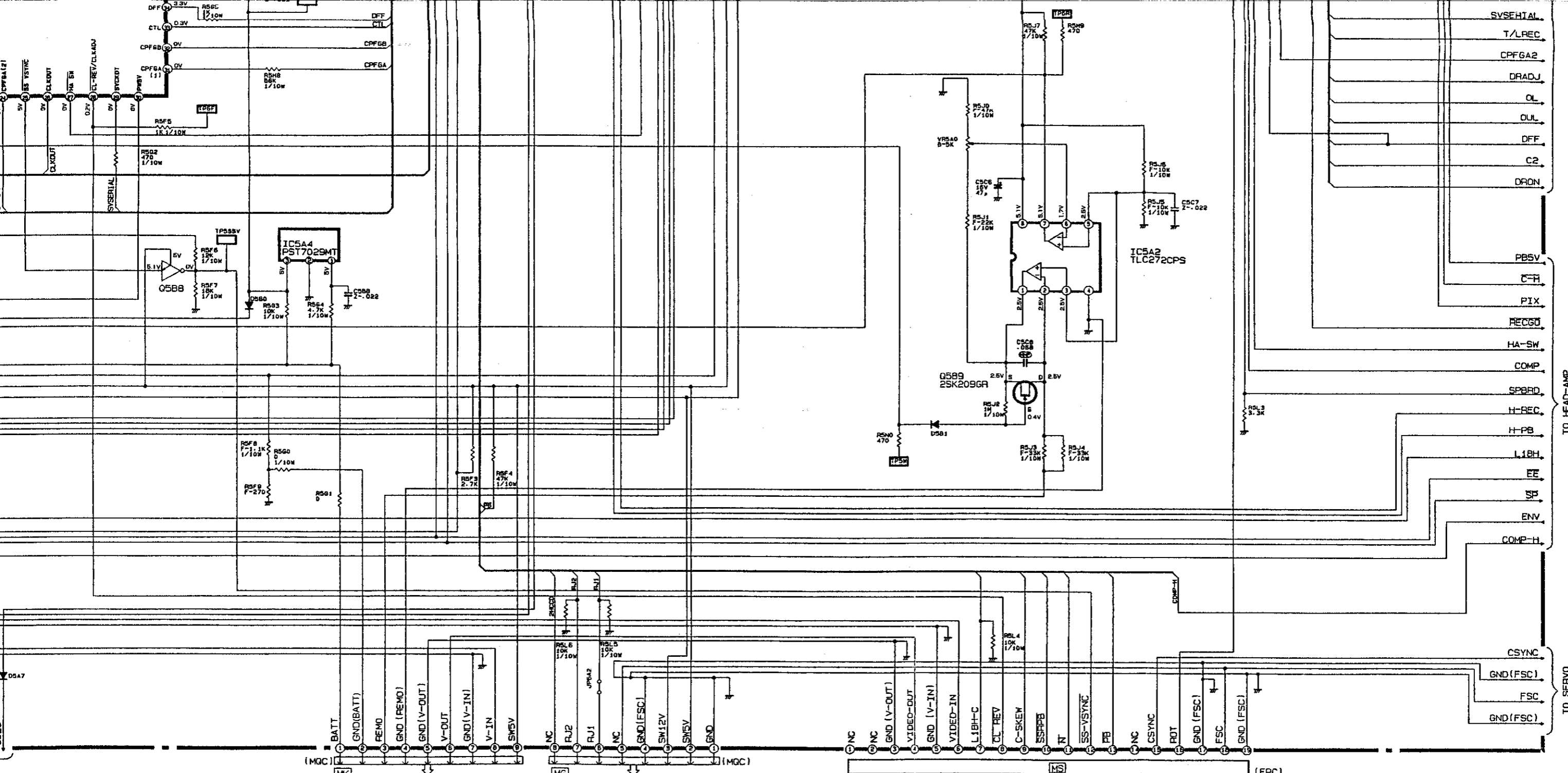

DTA124EK/UN2112

DIAGRAMS (SERVO)(C/G)

CAPSTAN MOTOR

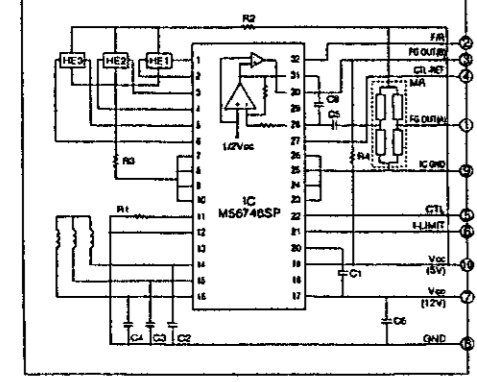

IC4A2 TA7291S

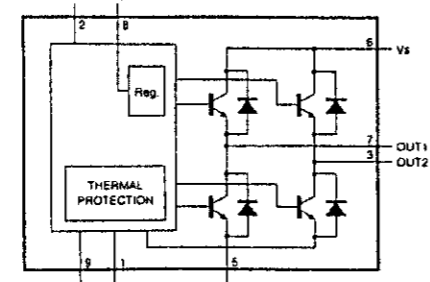

INPUT	OUTPUT	MODE
IN1	OUT1	STOP
IN2	OUT2	CW/CCW
0	L H	CCW/CW
1	L L	BRAKE

Note: Input signal activate at "H".

IC2001 μPD6458QT-101

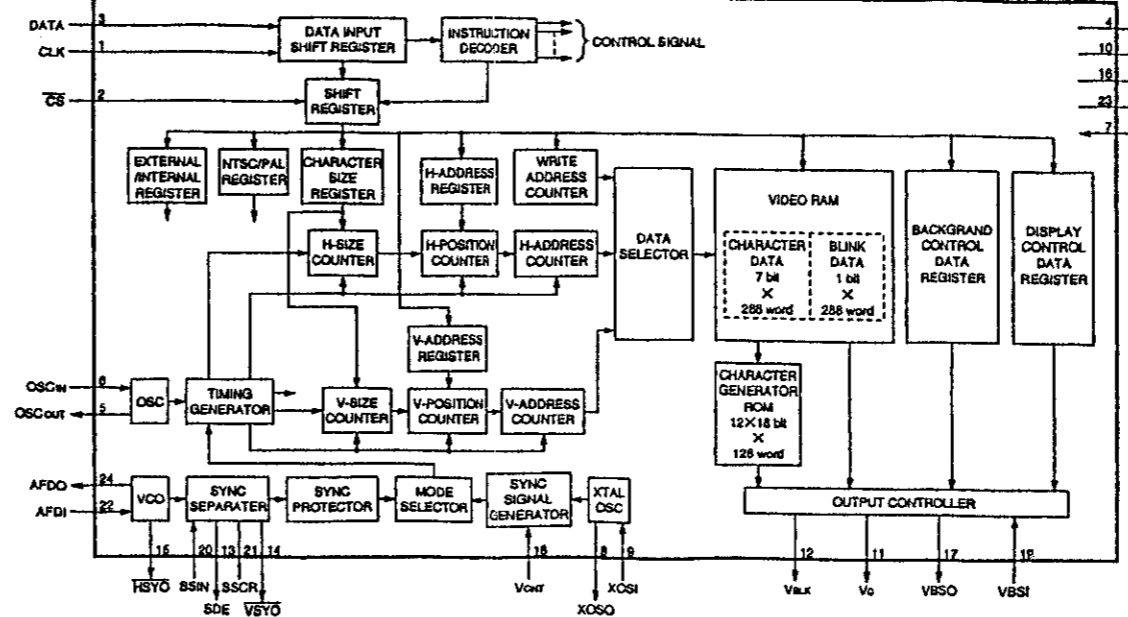

IC4A0 MN67492MTD5

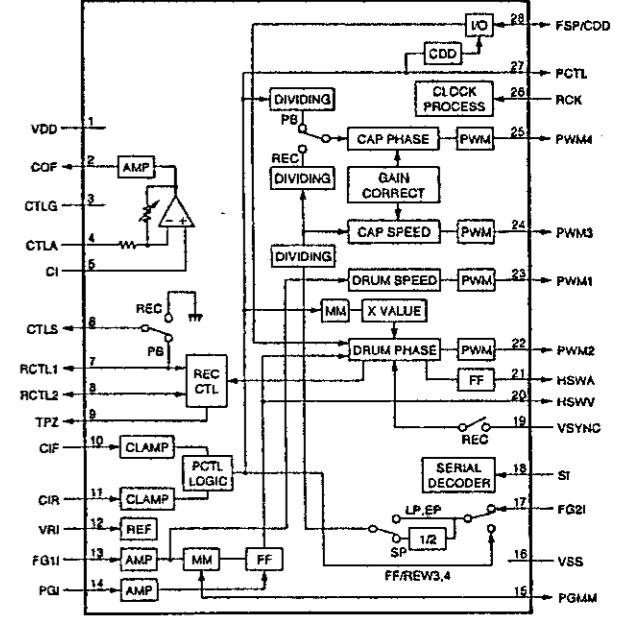

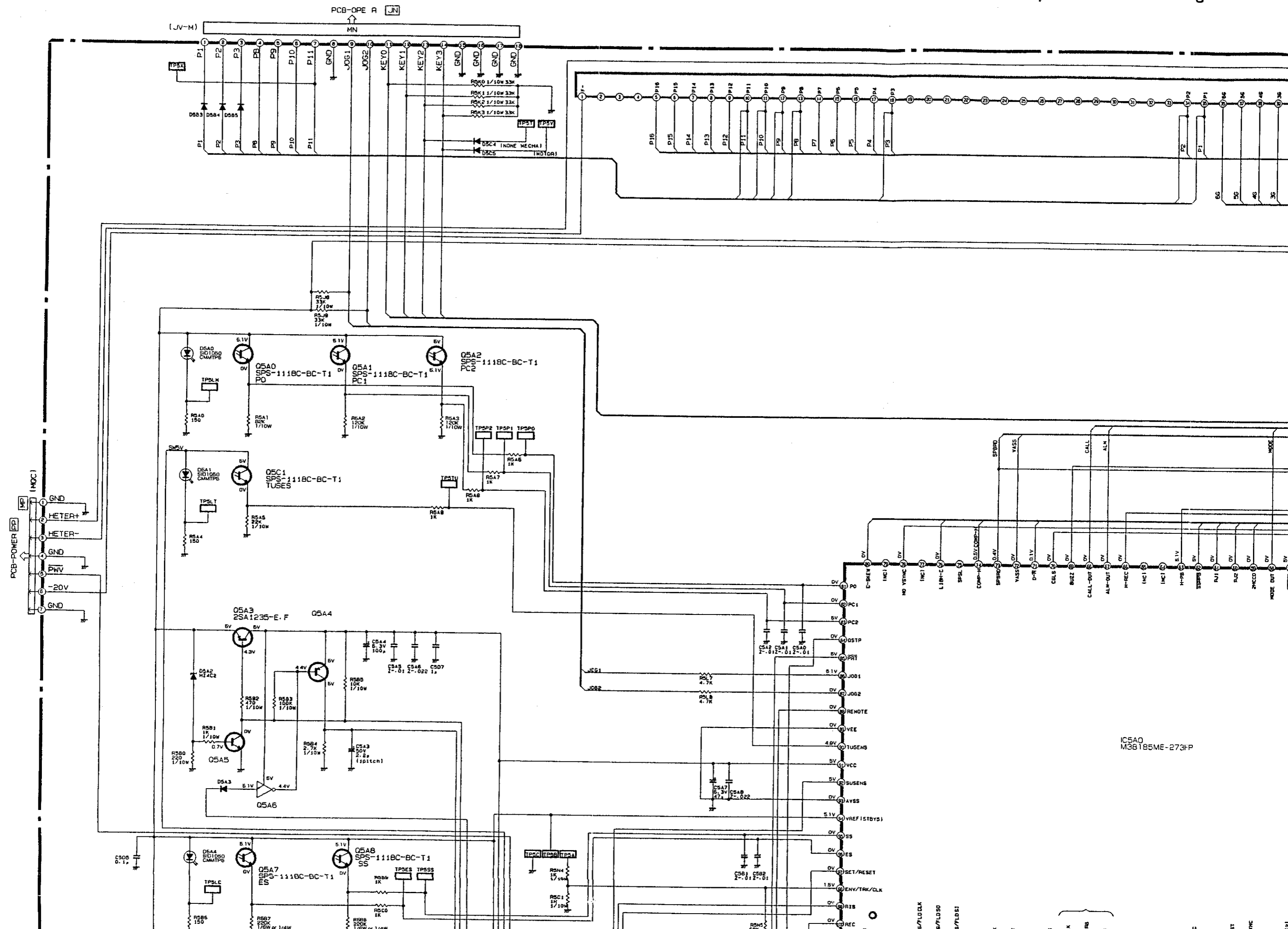

T
G
H
I
J

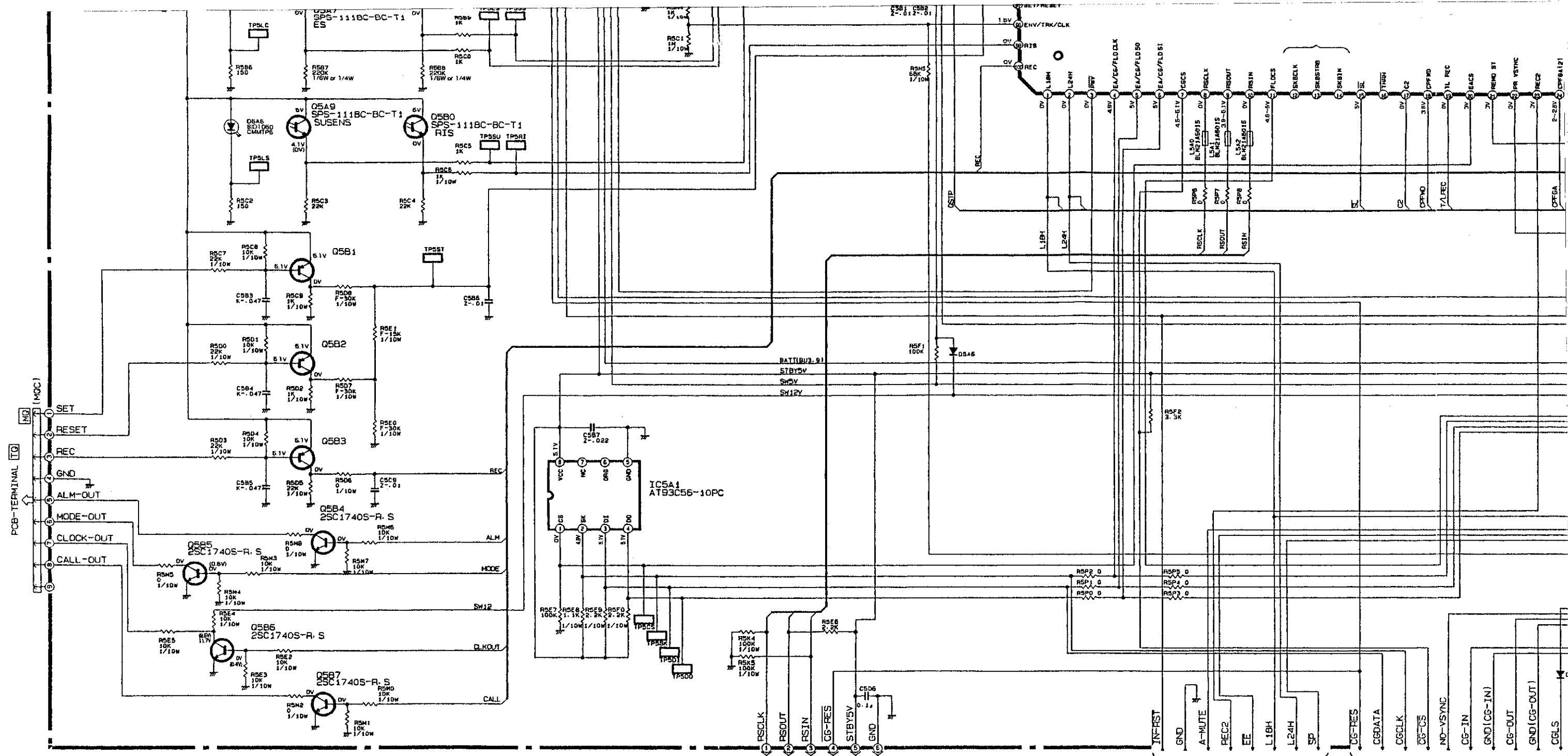

IC5A1 AT93C56-10PC (128word X 16bit)

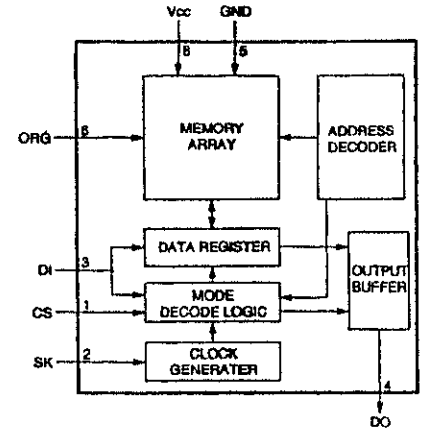

IC5A4 PST7029MT

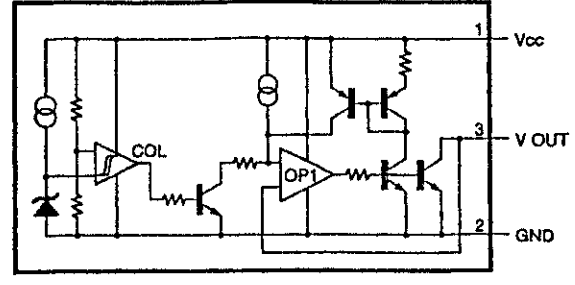

IC501 μPD16311GC-AB6

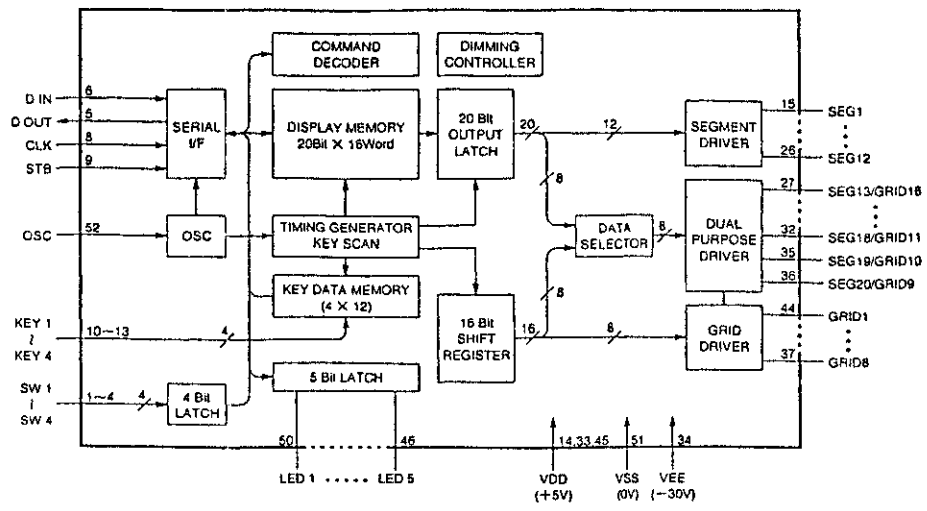

Note:
Unless otherwise specified
PNP transistors are 2SA1037K-R.S/2SB709AI-R.S
NPN transistors are 2SC2412K-R.S/2SD601AI-R.S
All diodes are 1SS252/1SS131
PNP digital transistors are DTA124EK/UN2212
NPN digital transistors are DTC124EK/UN2212

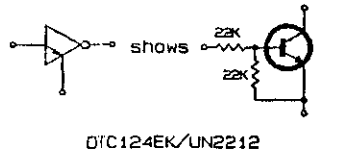

IC-BLOCK I

DRUM MOTOR

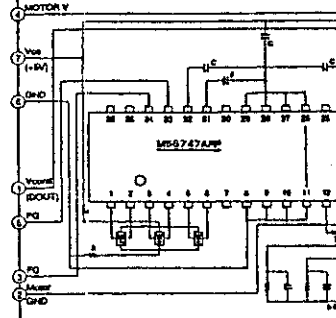

(SERVO) Δ PCB-MAIN

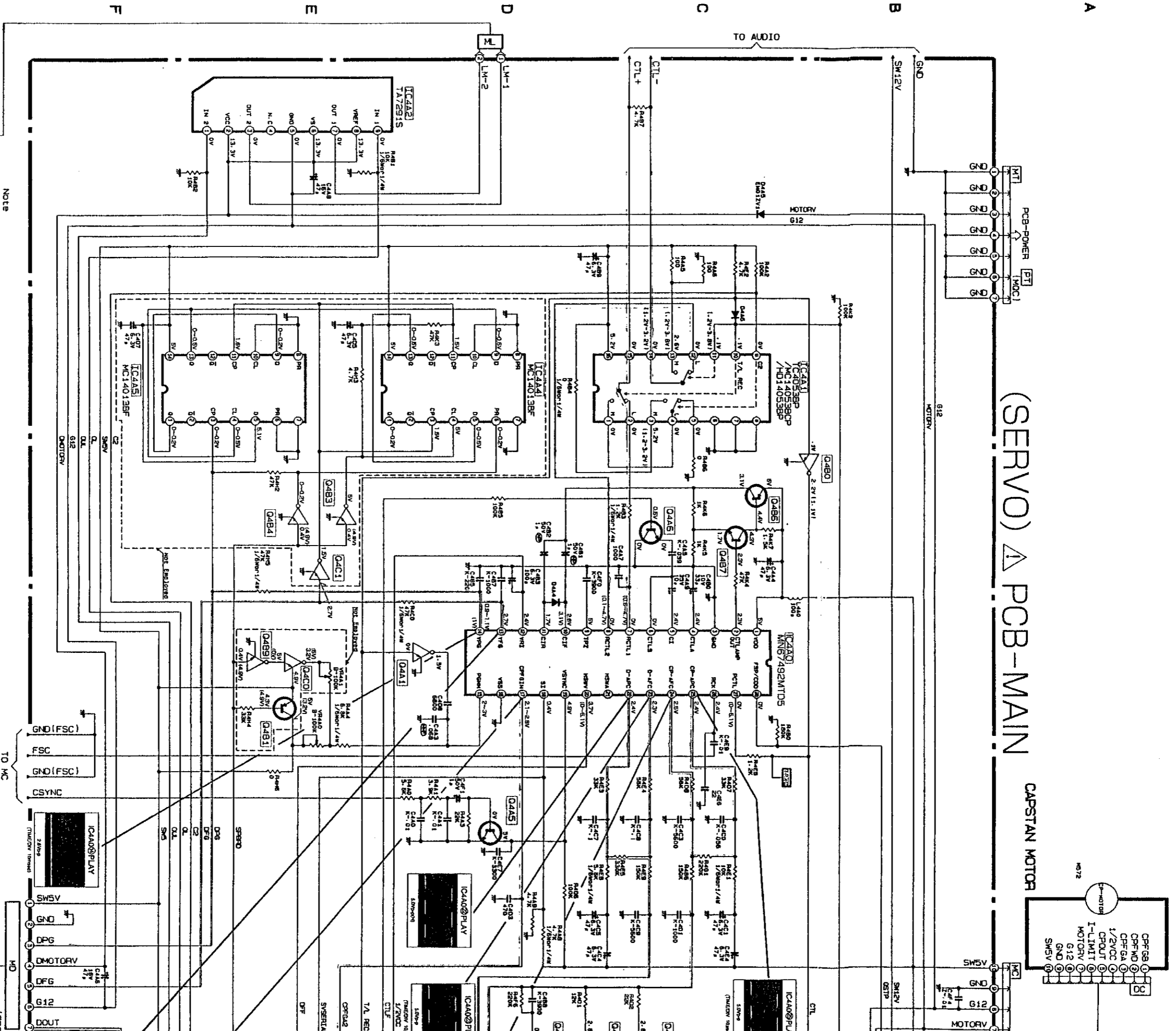

Note
 Unless otherwise specified
 NPN transistors are 2SC2412K-S
 PNP transistors are 2SA1037K-R, S
 NPN digital transistors are DTC124EK/UN2212
 Unless otherwise specified resistors are 1/10W
 Diodes are 1SS252/1SS1310M

Drum Servo System
 Capstan Servo System

IC-BLOCK DIAGRAM and MOTOR-CIRCUIT on the page before.

LOADING MOTOR

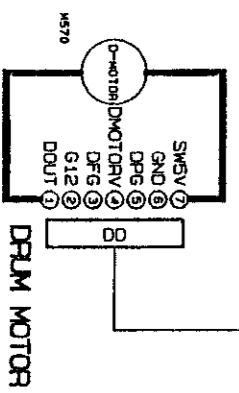
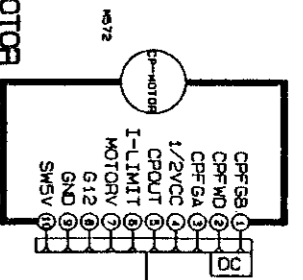
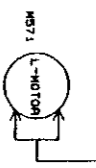

5

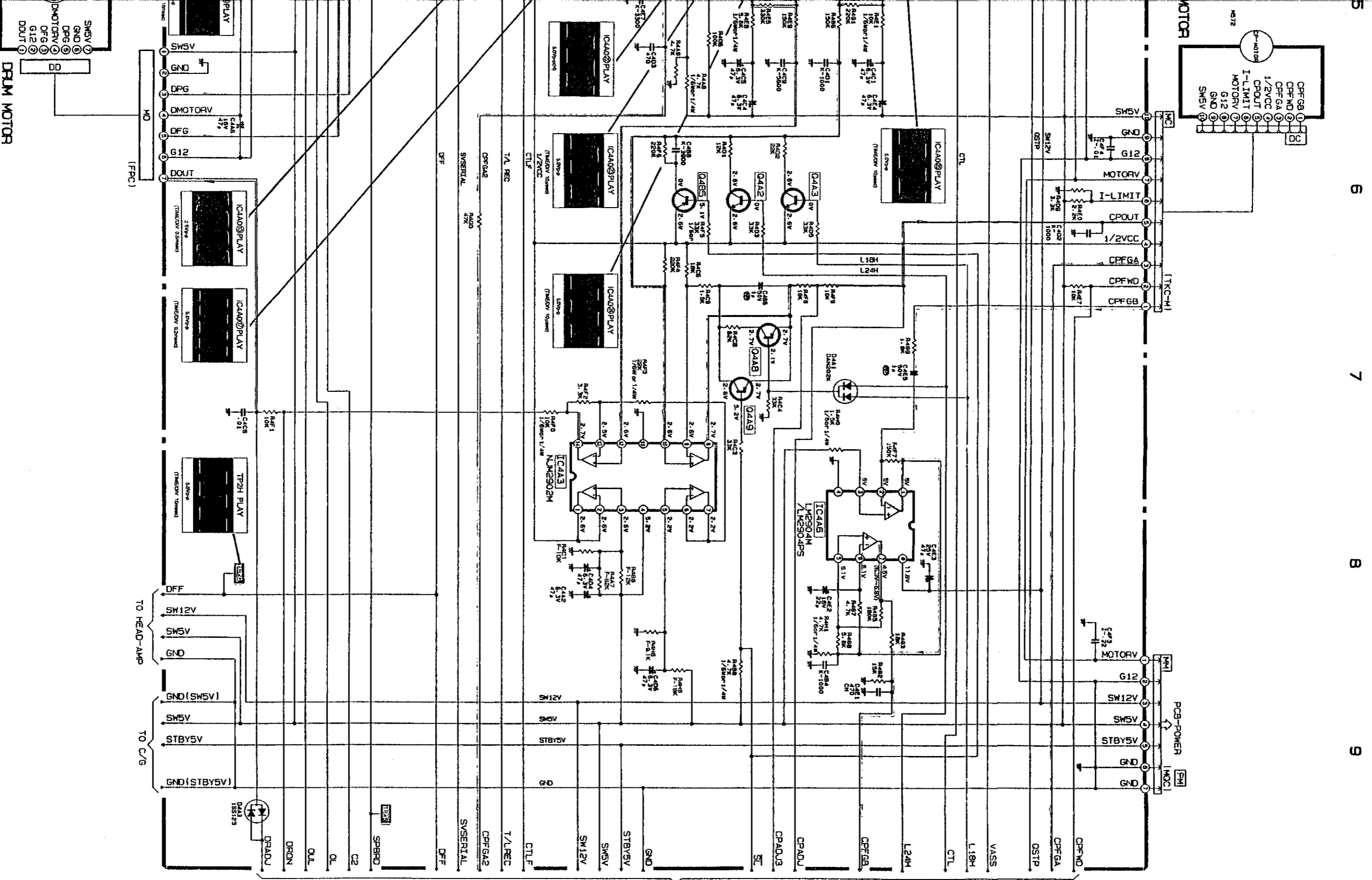

(C/G) PCB-MAIN

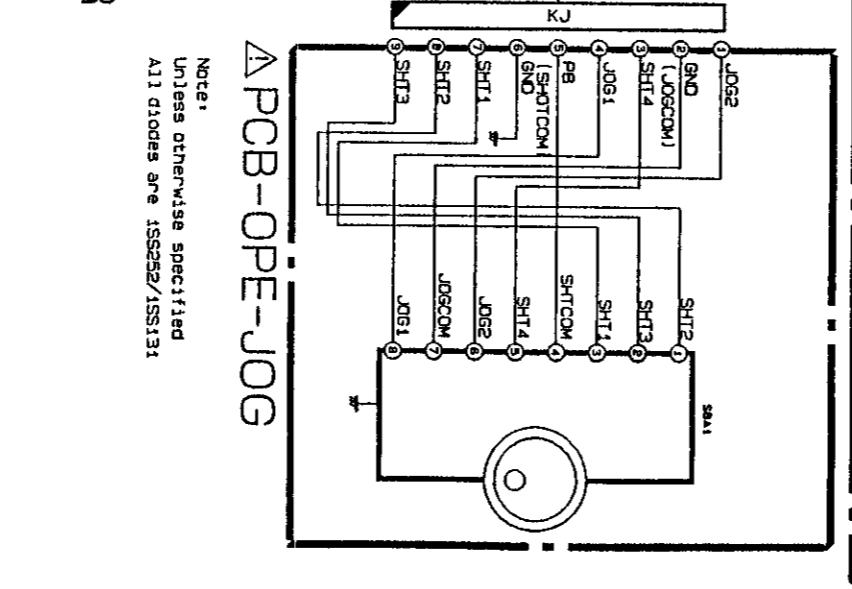
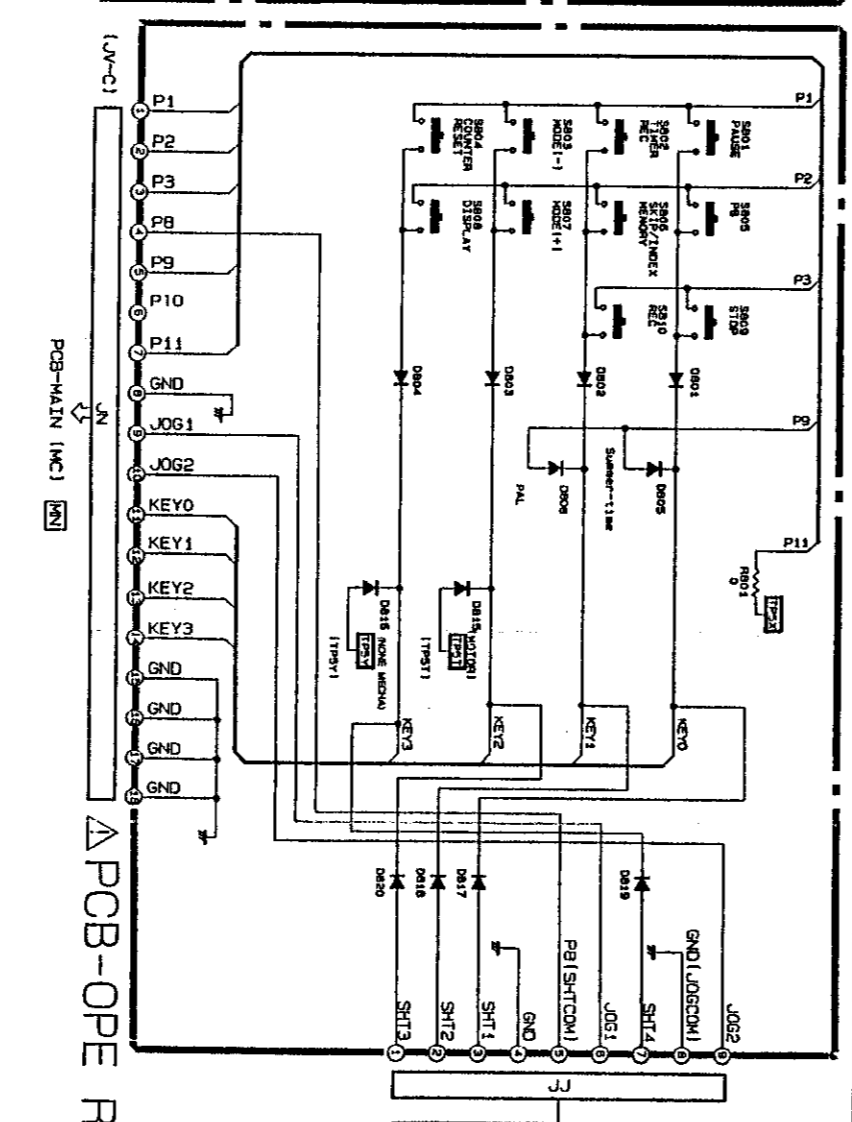
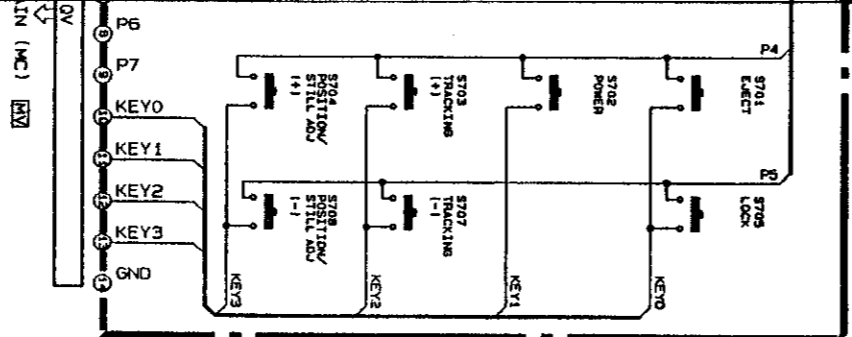
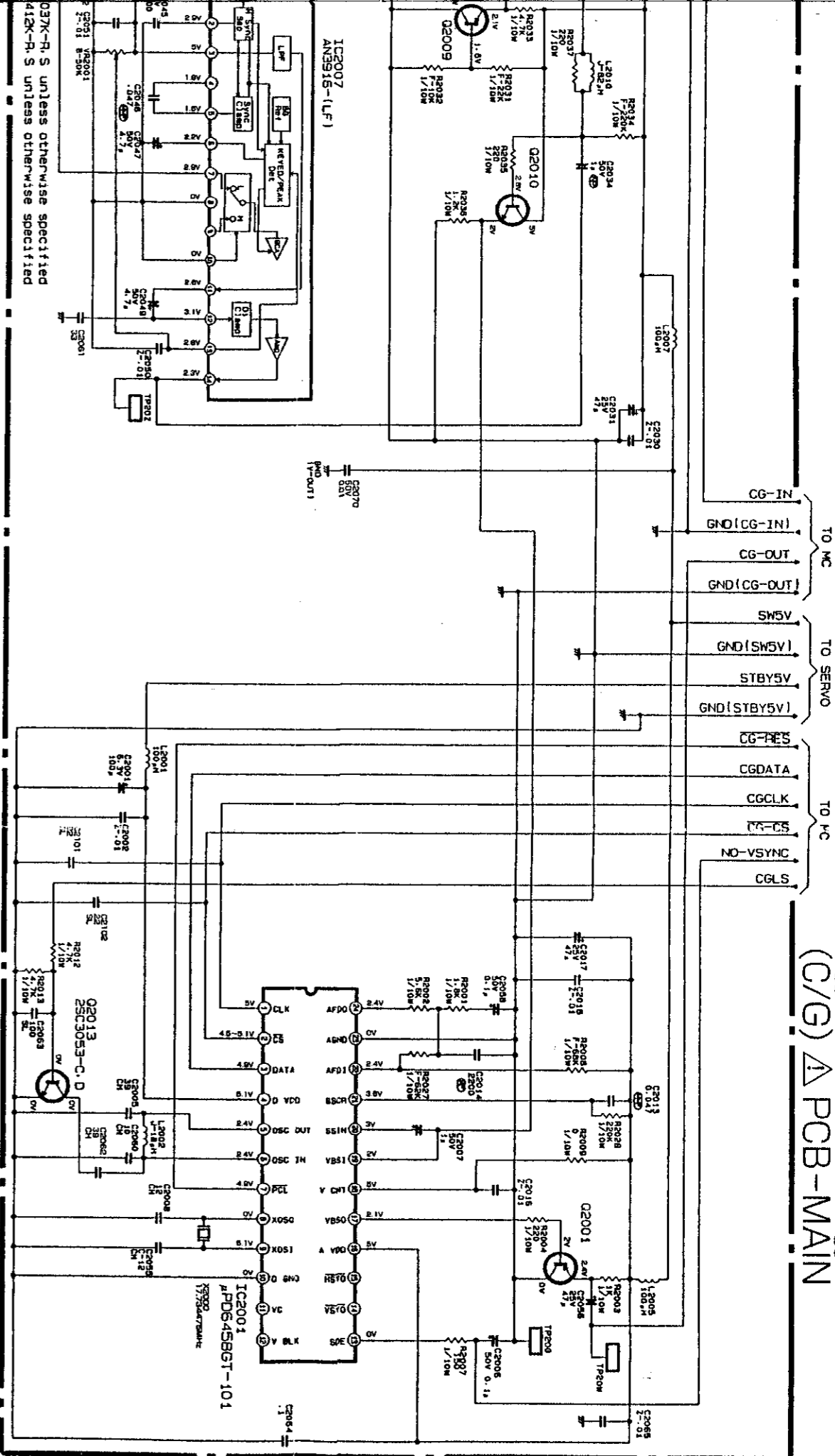

Note:
Unless otherwise specified
All diodes are 1SS252/1SS131

PCB-CCD SKEW

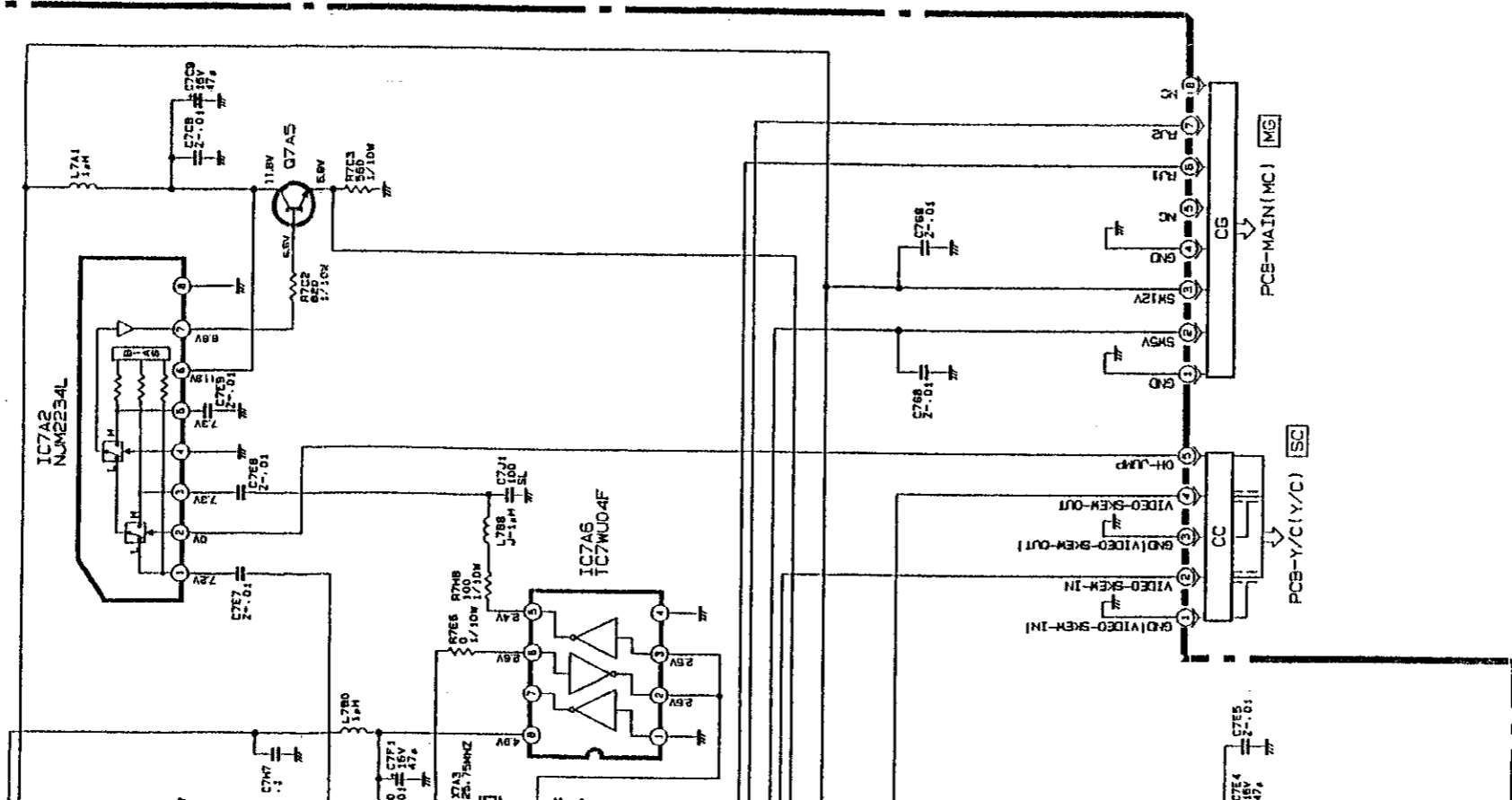

10M.

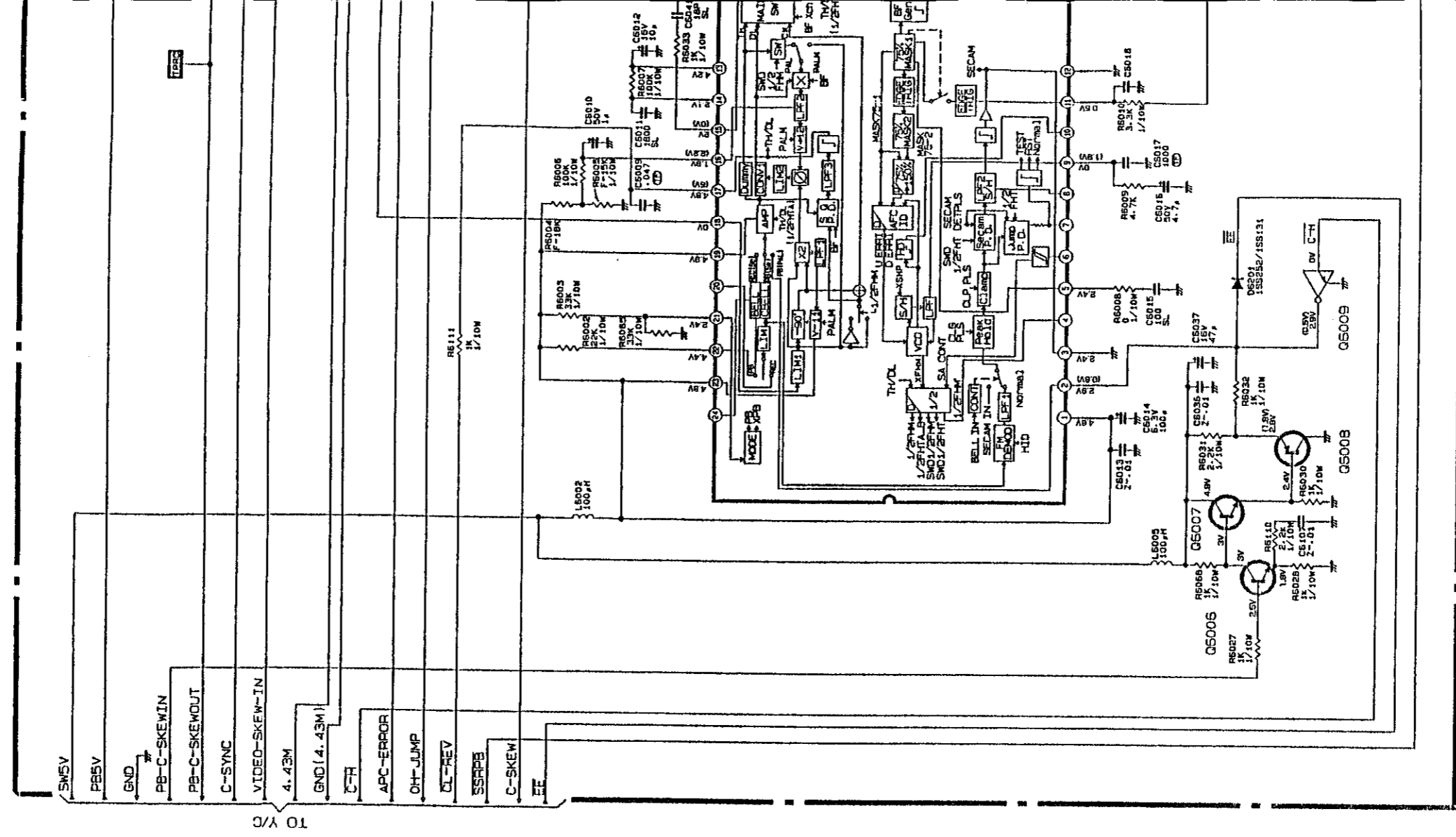

TO Y/C

1

2

3

4

5

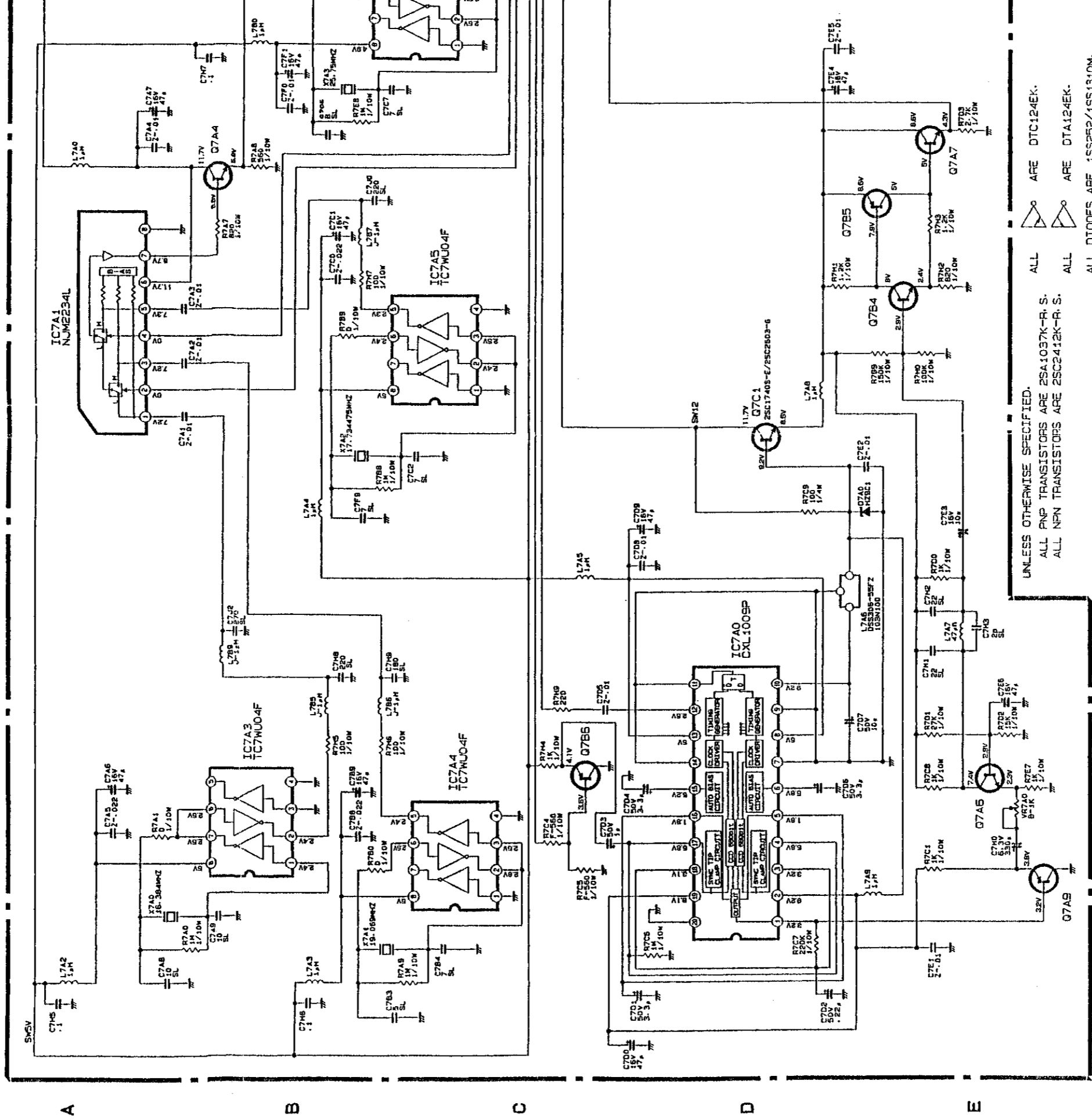

UNLESS OTHERWISE SPECIFIED.

ALL PNP TRANSISTORS ARE 2SA1037K-R. S.

ALL NPN TRANSISTORS ARE 2SC2412K-R. S.

ALL ARE DTC124EK.

ALL ARE DTA124EK.

ALL DIODES ARE 1SS252/1SS1310M.

PCB-CCD SKEW

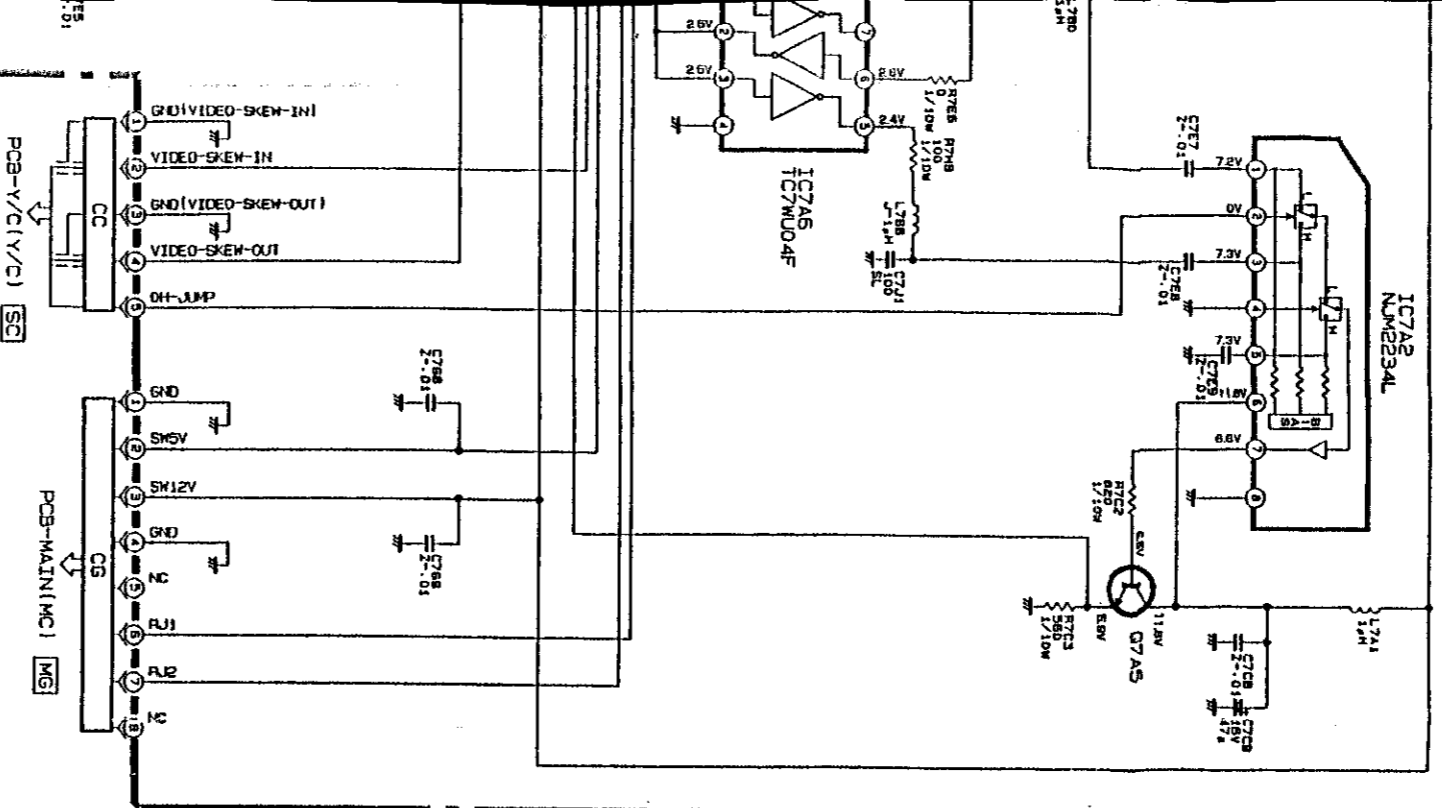

6

7

8

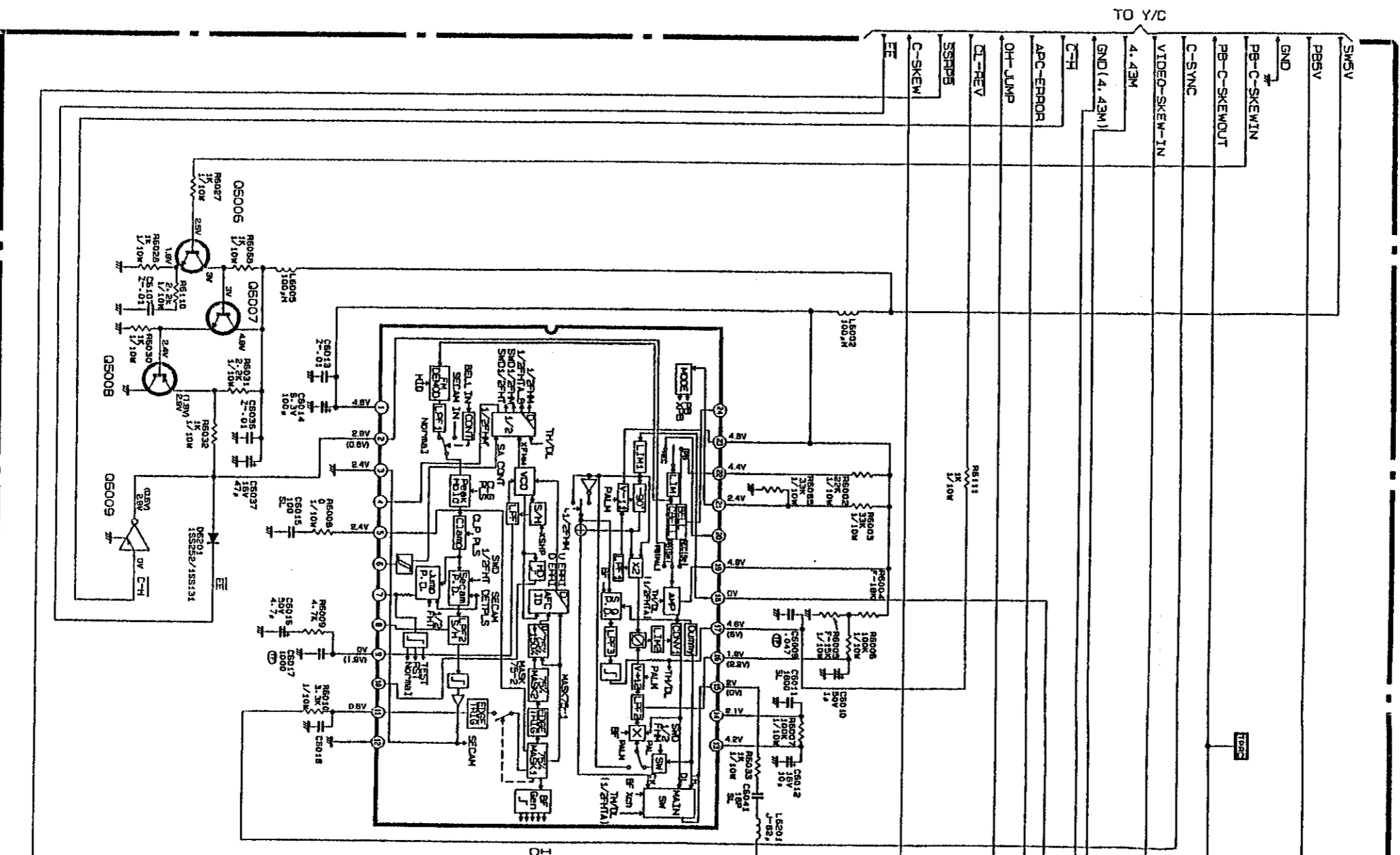

9

10

11

(SKEW JUMP) ΔPCB-Y/C

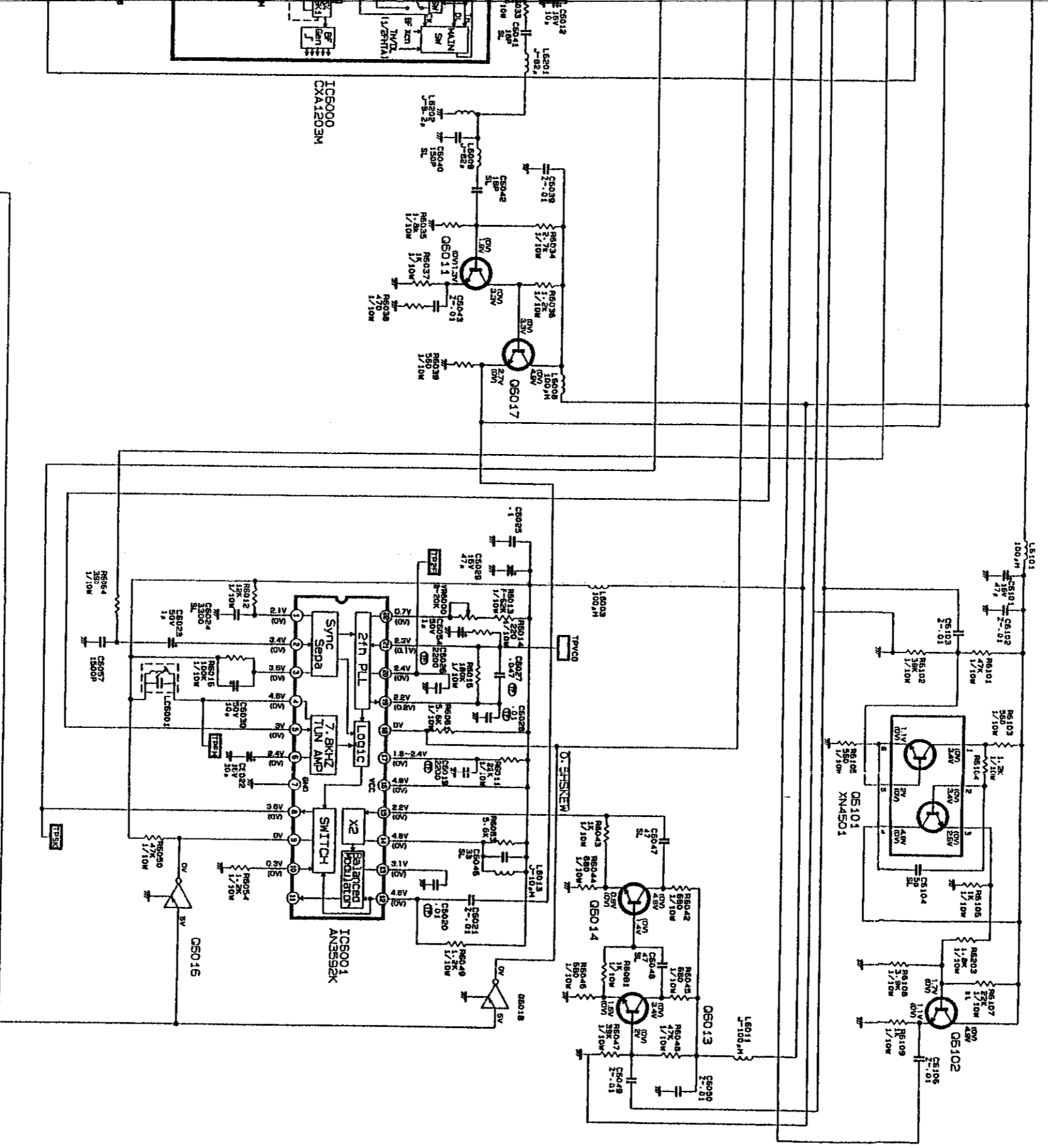

UNLESS OTHERWISE SPECIFIED,
 ALL PNP TRANSISTORS ARE 2SA1037K-R. S.
 ALL NPN TRANSISTORS ARE 2SC2412K-R. S.
 ALL Δ ARE DTC124EK.

PCB-Y/C [SOLDER SIDE]

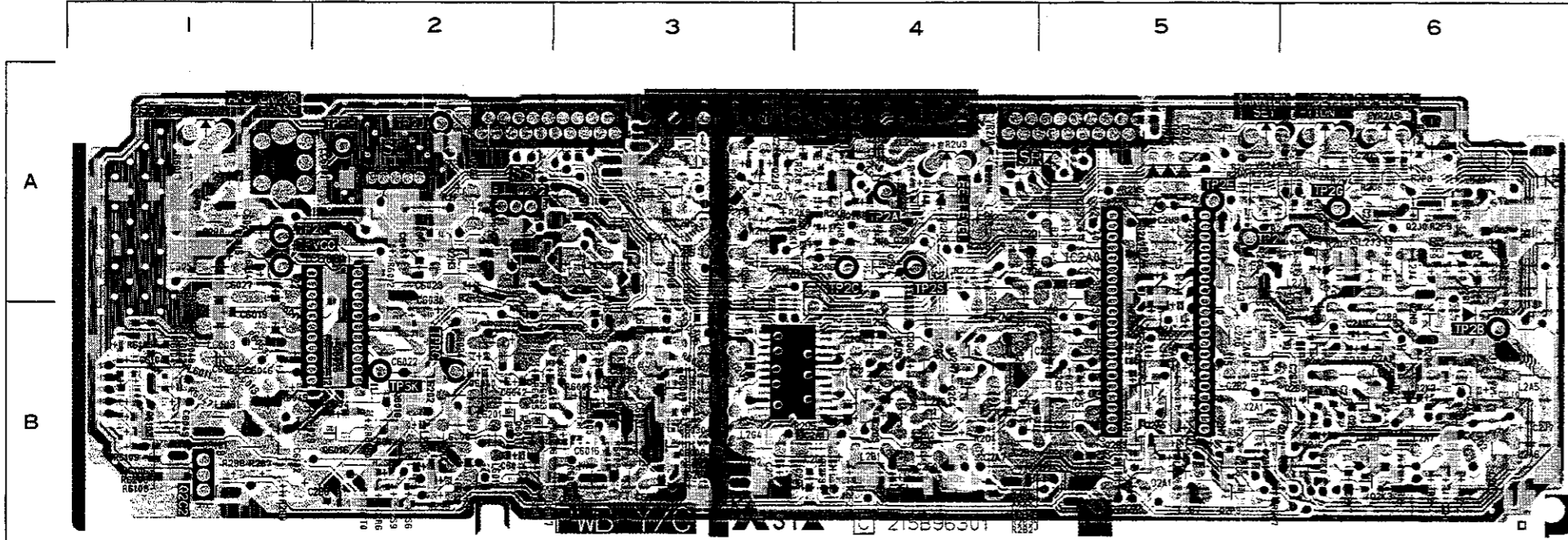

PCB-Y/C [SOLDER SIDE]

SYMBOL NO.	ADDRESS	SYMBOL NO.	ADDRESS	SYMBOL NO.	ADDRESS	SYMBOL NO.	ADDRESS	SYMBOL NO.	ADDRESS
C2A0	B-6	C2D2	B-4	C2K2	A-4	C2U1	B-5	C6040	B-
C2A1	B-5	C2D3	B-4	C2K3	A-3	C2U3	A-5	C6041	B-
C2A2	A-5	C2D5	B-6	C2K4	A-3	C2U4	A-4	C6042	B-
C2A3	A-5	C2D7	A-2	C2K5	A-4	C2U5	A-6	C6044	B-
C2A4	A-5	C2D8	A-5	C2K6	B-6	C2U6	A-3	C6046	B-
C2A5	B-5	C2E0	B-6	C2K7	B-6	C2U7	B-3	C6049	B-
C2A6	B-5	C2E1	A-5	C2M1	B-6	C2W1	A-3	C6050	B-
C2A7	B-4	C2F0	B-4	C2M2	B-3	C2W2	A-3	C6054	A-
C2A8	B-5	C2F1	B-4	C2M4	B-3	C2X1	B-6	C6057	A-
C2A9	B-5	C2F2	B-4	C2M5	B-3	C6009	B-3	C6101	B-
C2B0	B-5	C2F4	A-5	C2M6	A-4	C6010	B-3	C6102	B-
C2B1	B-5	C2F5	A-6	C2M7	B-5	C6012	B-2	C6103	B-
C2B2	B-5	C2F6	A-6	C2N4	A-3	C6013	B-3	C6104	B-
C2B3	B-5	C2F7	A-6	C2N8	A-3	C6014	B-3		
C2B4	B-6	C2F8	A-6	C2P0	B-4	C6015	B-3	D2A0	B-
C2B5	B-5	C2F9	A-6	C2Q0	B-4	C6016	B-3	D2A1	B-
C2B6	B-2	C2G1	A-6	C2Q1	B-4	C6017	B-3	D2A2	B-
C2B7	A-4	C2G3	A-6	C2Q3	B-4	C6019	B-1	D2A3	B-
C2B9	B-5	C2G4	A-6	C2Q4	B-4	C6020	B-1	D2A4	A-
C2C0	B-5	C2G5	B-4	C2Q5	B-4	C6022	B-2	D2A5	A-
C2C1	B-5	C2G6	B-4	C2Q6	B-4	C6023	A-2	D2A6	A-
C2C2	B-5	C2H0	A-6	C2Q9	A-1	C6025	B-2	D6201	B-
C2C3	B-5	C2H4	A-3	C2R0	A-1	C6026	A-1		
C2C4	B-5	C2J0	B-6	C2R1	B-3	C6027	A-1	IC2A0	A-
C2C5	B-5	C2J1	B-6	C2R2	A-3	C6028	A-1	IC2A1	B-
C2C6	B-5	C2J2	B-6	C2R3	B-2	C6029	B-2	IC6001	A-
C2C7	A-5	C2J7	B-6	C2R4	B-2	C6030	B-2		
C2C8	A-5	C2J8	A-4	C2R6	B-2	C6036	B-3	L2A0	B-
C2D0	A-5	C2K0	A-4	C2R7	B-2	C6037	B-3	L2A1	B-
C2D1	A-5	C2K1	A-4	C2R8	B-6	C6039	B-2	L2A2	A-

PCB-Y/C [COMPONENT SIDE]

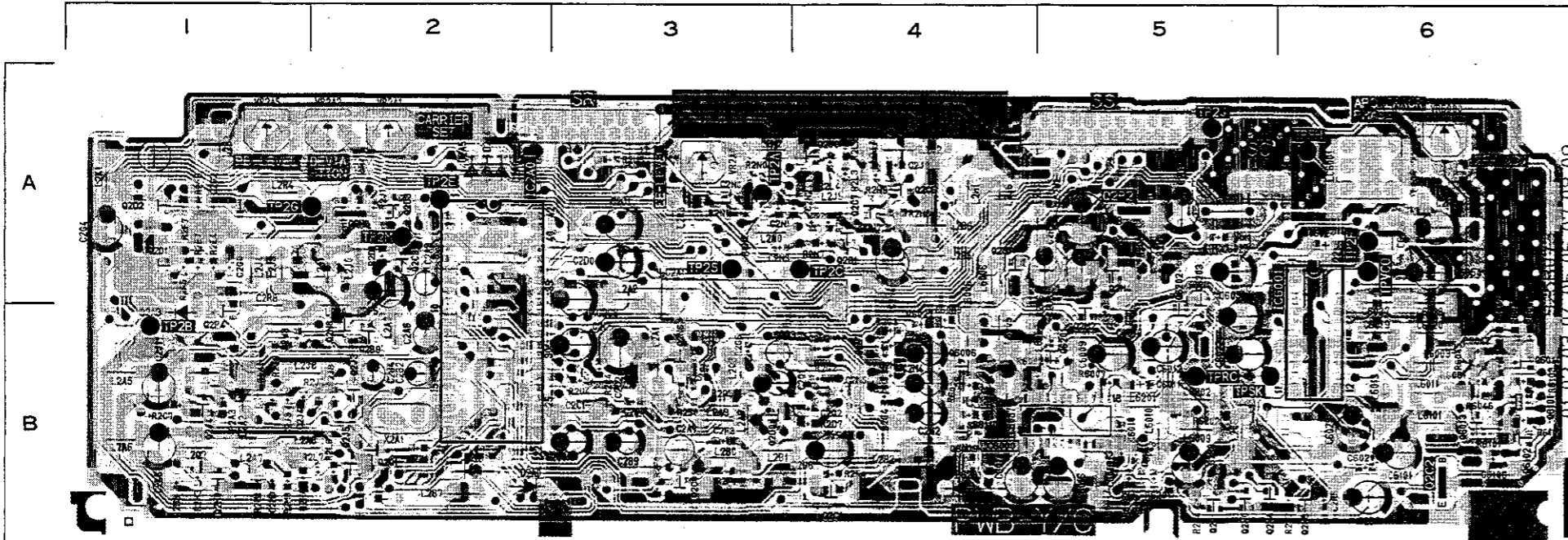

PCB-Y/C [COMPONENT SIDE]

SYMBOL NO.	ADDRESS	SYMBOL NO.	ADDRESS	SYMBOL NO.	ADDRESS	SYMBOL NO.	ADDRESS	SYMBOL NO.	ADDRESS
C2A3	A-2	C2M3	B-4	C6020	B-6	IC6000	B-5	L2J8	B-
C2A6	B-2	C2M4	B-4	C6021	B-6	IC6001	A-6	L2K1	A-
C2A7	B-3	C2M5	B-4	C6022	B-5			L2N0	A-
C2B2	B-2	C2N0	A-3	C6023	A-5	L2A0	B-2	L2N2	A-
C2B4	B-2	C2N1	A-3	C6024	A-6	L2A1	B-3	L2Q2	B-
C2B6	B-6	C2N2	A-4	C6026	A-6	L2A2	A-3	L2Q3	B-
C2B9	B-3	C2N3	A-3	C6027	A-6	L2A3	B-3	L2Q5	A-
C2C0	B-3	C2N4	A-4	C6028	A-6	L2A5	B-1	L2Q6	B-
C2C1	B-3	C2N5	B-4	C6029	B-6	L2A6	B-1	L2R3	A-
C2C2	B-3	C2N7	B-4	C6030	B-5	L2A7	B-1	L2R4	A-
C2C5	B-3	C2Q1	B-3	C6035	B-4	L2A8	B-1	L2S1	A-
C2C8	A-3	C2Q2	B-4	C6037	B-4	L2A9	B-3	L2T1	B-
C2D0	A-3	C2Q3	B-3	C6043	B-5	L2B0	B-3	L6002	B-
C2D1	A-3	C2R0	A-6	C6047	B-6	L2B1	B-3	L6003	B-
C2D4	B-3	C2R2	A-5	C6048	B-6	L2B2	B-4	L6005	B-
C2D7	A-5	C2R3	B-5	C6054	A-6	L2B3	A-1	L6006	B-
C2F3	B-3	C2R5	B-6	C6101	B-6	L2B5	A-4	L6008	A-
C2F5	A-2	C2R8	B-1	C6106	B-6	L2B6	A-4	L6009	B-
C2G0	A-1	C2U2	B-4	C6107	B-4	L2B7	B-2	L6010	B-
C2G2	A-1	C2U6	A-5			L2G4	B-4	L6011	B-
C2G4	A-1	C2W1	A-5	D2A0	B-3	L2H0	B-2	L6013	B-
C2G6	B-4	C6009	B-5	D2A1	B-2	L2H1	A-4	L6101	B-
C2H3	A-2	C6010	B-5	D2A2	B-1	L2J0	A-2	L6201	B-
C2J1	B-1	C6011	B-5	D2A3	B-1	L2J1	A-2	L6202	B-
C2J3	B-1	C6012	B-5	D2A4	A-2	L2J2	A-4		
C2J4	B-2	C6014	B-4	D2A5	A-2	L2J3	A-1	LC2A1	B-
C2J9	A-4	C6016	B-5	D2A6	A-2	L2J4	A-1	LC6001	A-
C2K6	B-1	C6017	B-5	D6201	B-4	L2J5	A-4		
C2M0	B-1	C6018	B-5			L2J6	A-4	Q2B1	A-
C2M2	B-4	C6019	B-6	IC2A0	A-2	L2J7	A-4	Q2B9	B-

01.02.03.04.05.06.07.08.09

ISS	SYMBOL NO.	ADDRESS	SYMBOL NO.	ADDRESS	SYMBOL NO.	ADDRESS	SYMBOL NO.	ADDRESS	SYMBOL NO.	ADDRESS	SYMBOL NO.	ADDRESS	SYMBOL NO.	ADDRESS	SYMBOL NO.	ADDRESS	SYMBOL NO.	ADDRESS	SYMBOL NO.	ADDRESS	SYMBOL NO.	ADDRESS		
	C2K2	A-4	C2U1	B-5	C6040	B-2	L2A3	B-4	L2Q5	A-1	Q2B3	B-5	R2A6	A-5	R2F3	B-4	R2P3	A-6	R6005	B-3	R6105	B-1		
	C2K3	A-3	C2U3	A-5	C6041	B-3	L2A5	B-6	L2Q6	B-2	Q2B4	A-4	R2A7	A-5	R2F6	A-6	R2P4	A-6	R6006	B-3	R6106	B-1	X2A1	B-6
	C2K4	A-3	C2U4	A-4	C6042	B-2	L2A6	B-6	L2R3	A-4	Q2B5	A-3	R2A8	B-5	R2F9	A-6	R2P5	A-2	R6008	B-3	R6108	B-1		
	C2K5	A-4	C2U5	A-6	C6044	B-2	L2A7	B-6	L2R4	A-6	Q2B8	B-6	R2B0	B-5	R2G0	B-4	R2Q1	A-2	R6009	B-3	R6109	B-1		
	C2K6	B-6	C2U6	A-3	C6046	B-1	L2A8	B-6	L2S1	A-3	Q2C2	B-1	R2B1	B-5	R2G5	B-3	R2Q2	B-3	R6011	B-1	R6111	B-3		
	C2K7	B-6	C2U7	B-3	C6049	B-1	L2A9	B-4	L2T1	B-6	Q2C4	B-4	R2B2	B-5	R2G7	B-6	R2Q5	A-3	R6012	A-2	R6203	B-1		
	C2M1	B-6	C2W1	A-3	C6050	B-1	L2B0	B-4	L6002	B-3	Q2C5	B-5	R2B3	B-5	R2H2	A-6	R2Q6	B-6	R6013	A-1				
	C2M2	B-3	C2W2	A-3	C6054	A-1	L2B1	B-4	L6003	B-1	Q2J0	A-6	R2B4	B-5	R2H3	B-6	R2R0	A-2	R6014	A-1	SC	A-2		
	C2M4	B-3	C2X1	B-6	C6057	A-2	L2B2	B-4	L6005	B-3	Q2J2	B-6	R2B6	A-6	R2H5	A-3	R2R1	A-2	R6015	A-1	SR	A-5		
	C2M5	B-3	C6009	B-3	C6101	B-1	L2B3	A-6	L6006	B-3	Q2J7	A-4	R2B7	B-1	R2H6	A-3	R2S3	B-2	R6016	B-2	SS	A-3		
	C2M6	A-4	C6010	B-3	C6102	B-1	L2B5	A-3	L6008	A-3	Q2J9	A-3	R2B8	B-1	R2J2	A-6	R2S5	B-2	R6030	B-3				
	C2M7	B-5	C6012	B-2	C6103	B-1	L2B6	A-3	L6009	B-2	Q2K0	B-6	R2B9	B-1	R2J3	A-6	R2S6	B-2	R6031	B-3	TP2A	A-4		
	C2N4	A-3	C6013	B-3	C6104	B-1	L2B7	B-5	L6010	B-2	Q2K3	B-6	R2C0	A-5	R2J6	B-6	R2S8	B-2	R6032	B-3	TP2B	B-6		
	C2N8	A-3	C6014	B-3			L2G4	B-3	L6011	B-1	Q2M3	A-2	R2C1	B-5	R2K2	B-6	R2S9	B-2	R6033	B-3	TP2C	A-4		
	C2P0	B-4	C6015	B-3	D2A0	B-5	L2H0	B-6	L6013	B-1	Q2N7	B-4	R2C2	B-5	R2K4	A-4	R2T0	B-2	R6034	B-2	TP2E	A-5		
	C2Q0	B-4	C6016	B-3	D2A1	B-5	L2H1	A-3	L6101	B-1	Q2N9	B-6	R2C3	B-5	R2K5	A-4	R2T9	A-5	R6035	B-2	TP2F	A-1		
	C2Q1	B-4	C6017	B-3	D2A2	B-6	L2J0	A-6	L6201	B-2	Q2P2	A-2	R2C5	B-5	R2K6	A-4	R2U0	A-5	R6036	B-3	TP2G	A-6		
	C2Q3	B-4	C6019	B-1	D2A3	B-6	L2J1	A-6	L6202	B-2	Q2P3	B-5	R2C6	A-6	R2K7	A-3	R2U1	A-3	R6039	B-2	TP2J	A-2		
	C2Q4	B-4	C6020	B-1	D2A4	A-5	L2J2	A-3			Q6007	B-3	R2C8	A-5	R2K8	A-4	R2U2	A-5	R6047	B-1	TP2M	A-5		
	C2Q5	B-4	C6022	B-2	D2A5	A-5	L2J3	A-6	LC2A1	B-4	Q6008	B-3	R2C9	A-5	R2K9	A-4	R2U3	A-4	R6048	B-1	TP2S	A-4		
	C2Q6	B-4	C6023	A-2	D2A6	A-5	L2J4	A-6	LC6001	A-1	Q6011	B-2	R2D2	A-5	R2L0	A-3	R2U6	A-6	R6049	B-1	TPFH	A-2		
	C2Q9	A-1	C6025	B-2	D6201	B-3	L2J5	A-4			Q6016	B-2	R2D3	A-6	R2L1	B-6	R2U7	A-4	R6050	B-2	TPRC	B-2		
	C2R0	A-1	C6026	A-1			L2J6	A-3	Q2A1	B-6	Q6017	B-3	R2D4	B-4	R2L9	B-5	R2U8	A-4	R6054	B-2	TPSK	B-2		
	C2R1	B-3	C6027	A-1	IC2A0	A-5	L2J7	A-4	Q2A2	B-6	Q6018	B-2	R2D6	B-4	R2M2	B-6	R2W2	A-2	R6061	B-1	TPVCO	A-1		
	C2R2	A-3	C6028	A-1	IC2A1	B-4	L2J8	B-6	Q2A3	B-6			R2D9	A-5	R2M4	B-6	R2W4	A-6	R6063	B-1				
	C2R3	B-2	C6029	B-2	IC6001	A-2	L2K1	A-6	Q2A5	B-5	R2E2	A-6	R2E2	A-6	R2M9	A-2	R2W5	A-5	R6064	A-2	VR2A0	A-4		
	C2R4	B-2	C6030	B-2			L2N0	A-4	Q2A6	B-5	R2A1	B-5	R2E3	A-6	R2N3	A-4	R2Z2	A-4	R6065	B-3	VR2A1	A-6		
	C2R6	B-2	C6036	B-3	L2A0	B-5	L2N2	A-4	Q2A7	B-6	R2A2	A-6	R2E5	A-6	R2N6	A-4	R2Z3	A-4	R6068	B-3	VR2A2	A-6		
	C2R7	B-2	C6037	B-3	L2A1	B-4	L2Q2	B-6	Q2A8	B-5	R2A4	A-5	R2E6	A-6	R2N8	A-4	R6003	B-3	R6102	B-1	VR2A5	A-6		
	C2R8	B-6	C6039	B-2	L2A2	A-5	L2Q3	B-4	Q2B0	A-4	R2A5	A-5	R2F2	B-4	R2P2	A-6	R6004	B-3	R6104	B-1	VR6000	A-1		

DEJ

ISS	SYMBOL NO.	ADDRESS	SYMBOL NO.	ADDRESS	SYMBOL NO.	ADDRESS	SYMBOL NO.	ADDRESS	SYMBOL NO.	ADDRESS	SYMBOL NO.	ADDRESS	SYMBOL NO.	ADDRESS	SYMBOL NO.	ADDRESS	SYMBOL NO.	ADDRESS	SYMBOL NO.	ADDRESS	SYMBOL NO.	ADDRESS	
	C6020	B-6	IC6000	B-5	L2J8	B-1	Q2C0	B-3	Q6014	B-6	R2J1	A-2	R2W1	A-5	TP2C	A-4							
	C6021	B-6	IC6001	A-6	L2K1	A-1	Q2C1	B-4	Q6101	B-6	R2J7	B-2	R2W2	A-5	TP2E	A-2							
	C6022	B-5			L2N0	A-3	Q2C2	B-6	Q6102	B-6	R2J8	B-2	R2W3	B-1	TP2F	A-6							
	C6023	A-5	L2A0	B-2	L2N2	A-3	Q2C3	A-2	Q6201	B-5	R2J9	B-1	R2Z1	B-2	TP2G	A-2							
	C6024	A-6	L2A1	B-3	L2Q2	B-1	Q2C6	A-4	Q6202	B-5	R2K1	B-1	R6002	B-5	TP2J	A-5							
	C6026	A-6	L2A2	A-3	L2Q3	B-3	Q2C7	A-4	Q6203	A-5	R2L2	A-4	R6007	B-5	TP2M	A-2							
	C6027	A-6	L2A3	B-3	L2Q5	A-6	Q2D0	B-3			R2L3	A-4	R6010	B-5	TP2S	A-3							
	C6028	A-6	L2A5	B-1	L2Q6	B-5	Q2D1	A-1	R2A3	B-1	R2L4	A-4	R6027	B-4	TPFH	A-6							
	C6029	B-6	L2A6	B-1	L2R3	A-3	Q2D2	A-1	R2C4	B-3	R2L7	B-2	R6028	B-4	TPRC	B-5							
	C6030	B-5	L2A7	B-1	L2R4	A-1	Q2D3	A-2	R2C7	B-1	R2L8	B-2	R6037	B-5	TPSK	B-6							
	C6035	B-4	L2A8	B-1	L2S1	A-5	Q2J3	B-2	R2D1	A-2	R2M0	B-1	R6038	B-5	TPVCO	A-6							
	C6037	B-4	L2A9	B-3	L2T1	B-1	Q2J4	B-1	R2D5	B-3	R2M1	B-1	R6042	B-6									
	C6043	B-5	L2B0	B-3	L6002	B-5	Q2J5	B-2	R2D7	B-4	R2M3	B-1	R6043	B-6	VR2A0	A-3							
	C6047	B-6	L2B1	B-3	L6003	B-6	Q2J8	A-4	R2E4	A-1	R2M5	B-1	R6044	B-6	VR2A1	A-2							
	C6048	B-6	L2B2	B-4	L6005	B-4	Q2M0	B-1	R2E7	A-1	R2M6	A-5	R6045	B-6	VR2A2	A-2							
	C6054	A-6	L2B3	A-1	L6006	B-4	Q2M1	A-4	R2F0	B-3	R2N0	A-3	R6046	B-6	VR2A5	A-1							
	C6101	B-6	L2B5	A-4	L6008	A-4	Q2M2	B-5	R2F1	B-3	R2N1	A-3	R6081	B-6									
	C6106	B-6	L2B6	A-4	L6009	B-5	Q2M4	A-5	R2F4	B-4	R2N2	A-3	R6101	B-6									
	C6107	B-4	L2B7	B-2	L6010	B-5	Q2N0	B-5	R2F5	A-1	R2N4	A-4	R6103	B-6									
			L2G4	B-4	L6011	B-6	Q2N4	B-6	R2F7	A-1	R2N5	A-4	R6107	B-6									
			L2H0	B-2	L6013	B-6	Q2N5	B-6	R2F8	A-1	R2N7	A-4	R6110	B-4									
			L2H1	A-4	L6101	B-6	Q2N6	B-3	R2G2	B-4	R2Q0	B-5	R6201	B-5									
			L2J0	A-2	L6201	B-5	Q2N8	B-2	R2G3	B-4	R2Q3	A-5	R6202	B-5									
			L2J1	A-2	L6202	B-5	Q2P1	B-5	R2G4	B-4	R2Q4	A-5											
			L2J2	A-4			Q2P2	A-5	R2G6	B-3	R2S0	B-3											
			L2J3	A-1	LC2A1	B-3	Q2P4	B-1	R2H1	A-2	R2S1	B-3											
			L2J4	A-1	LC6001	A-6	Q2Q1	B-2	R2H4	B-2	R2S4	B-5											
			L2J5	A-4			Q6006	B-4	R2H7	A-4	R2S7	B-6											
			L2J6	A-4	Q2B1	A-4	Q6009	B-4	R2H8	A-4	R2U4	B-3											
			L2J7	A-4	Q2B9	B-2	Q6013	B-6	R2H9	A-4	R2U5	A-3											

PCB-CCD SKEW

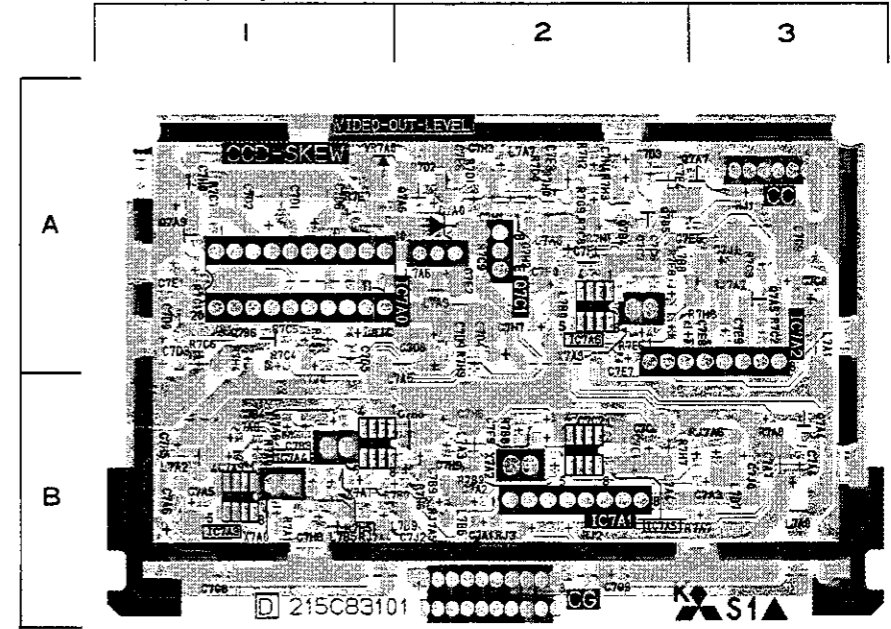

PCB-CCD SK

SYMBOL NO.	ADDRESS
C7A1	B-2
C7A2	B-2
C7A3	B-3
C7A4	B-3
C7A5	B-1
C7A6	B-1
C7A7	B-3
C7A8	B-1
C7A9	B-1
C7B3	B-1
C7B4	B-1
C7B8	B-2
C7C0	B-2
C7C1	B-2
C7C2	B-2
C7C6	A-2
C7C7	A-2
C7C8	A-3
C7C9	A-3
C7D0	A-1
C7D1	A-1
C7D2	A-1
C7D3	A-1
C7D4	A-2
C7D5	A-1
C7D6	A-1
C7D7	A-1
C7D8	A-2
C7D9	A-2

PCB-OPE R/OPE L

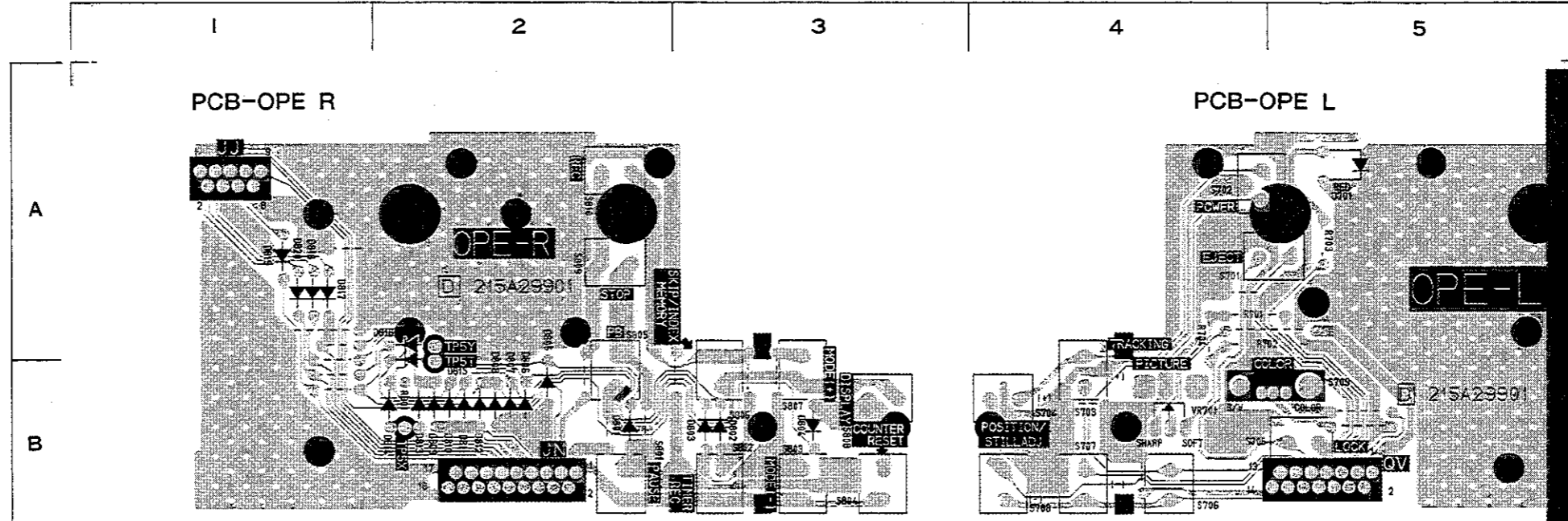

PCB-OPE R/OPE L

SYMBOL NO.	ADDRESS	SYMBOL NO.	AD
D701	A-5	R704	B-
D801	B-2	R801	B-
D802	B-3		
D803	B-3	S701	A-
D804	B-3	S702	A-
D805	B-2	S703	B-
D806	B-2	S704	B-
D807	B-2	S705	B-
D808	B-2	S706	B-
D809	B-2	S707	B-
D810	B-2	S708	B-
D811	B-2	S709	B-
D812	B-2	S801	B-
D813	B-2	S802	B-
D814	B-1	S803	B-
D815	B-1	S804	B-
D816	A-1	S805	B-
D817	A-1	S806	B-
D818	A-1	S807	B-
D819	A-1	S808	B-
D820	A-1	S809	A-
		S810	A-
JJ	A-1		
JN	B-2	TP5T	B-
		TP5X	B-
QV	B-5	TP5Y	A-
R701	A-4	VR701	B-
R702	A-5		
R703	A-5		

PCB-POWER [HS-7496E]

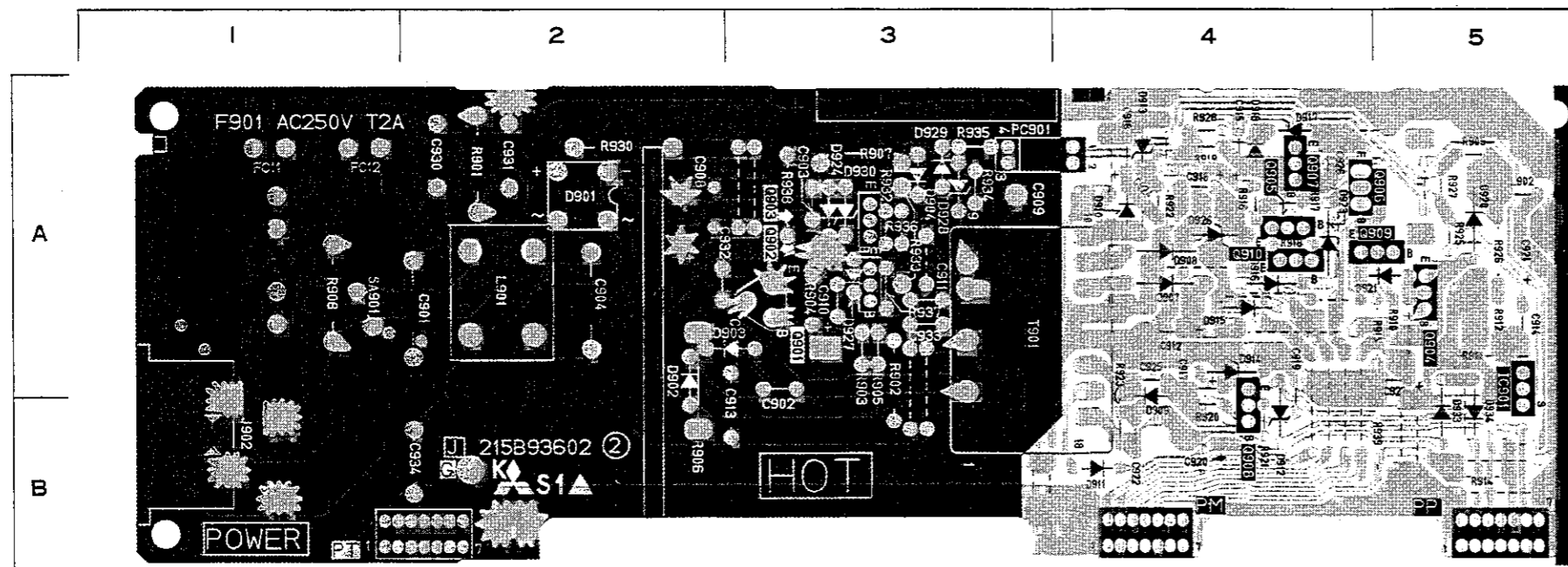

PCB-POWER [HS-7496E]

SYMBOL NO.	ADDRESS	SYMBOL NO.	ADDRESS	SYMBOL NO.	ADDRESS	SYMBOL NO.	ADDRESS
C901	A-2	D902	A-2	G	B-2	R905	A-3
C902	B-3	D903	A-2			R906	B-2
C903	A-3	D904	A-3	IC901	A-5	R907	A-3
C904	A-2	D907	A-4			R908	A-1
C908	A-2	D908	A-4	J902	B-1	R909	A-5
C909	A-4	D909	B-4			R910	A-5
C910	A-3	D910	A-4	L901	A-2	R911	A-5
C911	A-3	D911	B-4	L902	A-5	R912	A-5
C912	A-4	D912	B-4			R914	B-5
C913	B-2	D913	A-4	PC901	A-4	R915	A-4
C914	A-5	D914	A-4			R916	A-4
C915	A-4	D915	A-4	PM	B-4	R917	A-4
C916	A-4	D916	A-4	PP	B-5	R918	A-4
C917	A-4	D917	A-4	PT	B-1	R919	A-4
C918	A-4	D918	A-4			R920	B-4
C919	B-4	D920	A-5	Q901	A-3	R921	B-4
C920	B-4	D921	A-4	Q902	A-3	R922	A-4
C921	A-5	D923	A-4	Q903	A-3	R923	B-4
C922	B-4	D924	A-3	Q904	A-5	R925	A-5
C924	A-4	D926	A-4	Q905	A-4	R926	A-5
C925	A-4	D927	A-3	Q906	A-4	R927	A-5
C926	A-4	D928	A-3	Q907	A-4	R928	A-4
C927	A-5	D929	A-3	Q908	B-4	R930	A-2
C930	A-2	D930	A-3	Q909	A-4	R932	A-3
C931	A-2	D933	B-5	Q910	A-4	R933	A-3
C932	A-2	D934	B-5			R934	A-3
C933	A-3			R901	A-2	R935	A-3
C934	B-2	FC11	A-1	R902	B-3	R936	A-3
		FC12	A-1	R903	A-3	R937	A-3
D901	A-2			R904	A-3	R938	A-3

PCB-OPE R/OPE L

SYMBOL NO.	ADDRESS	SYMBOL NO.	ADDRESS
D701	A-5	R704	B-4
D801	B-2	R801	B-2
D802	B-3		
D803	B-3	S701	A-4
D804	B-3	S702	A-4
D805	B-2	S703	B-4
D806	B-2	S704	B-4
D807	B-2	S705	B-5
D808	B-2	S706	B-4
D809	B-2	S707	B-4
D810	B-2	S708	B-4
D811	B-2	S709	B-4
D812	B-2	S801	B-2
D813	B-2	S802	B-3
D814	B-1	S803	B-3
D815	B-1	S804	B-3
D816	A-1	S805	B-2
D817	A-1	S806	B-3
D818	A-1	S807	B-3
D819	A-1	S808	B-3
D820	A-1	S809	A-2
		S810	A-2
JJ	A-1		
JN	B-2	TP5T	B-2
		TP5X	B-2
QV	B-5	TP5Y	A-2
R701	A-4	VR701	B-4
R702	A-5		
R703	A-5		

PCB-TERMINAL

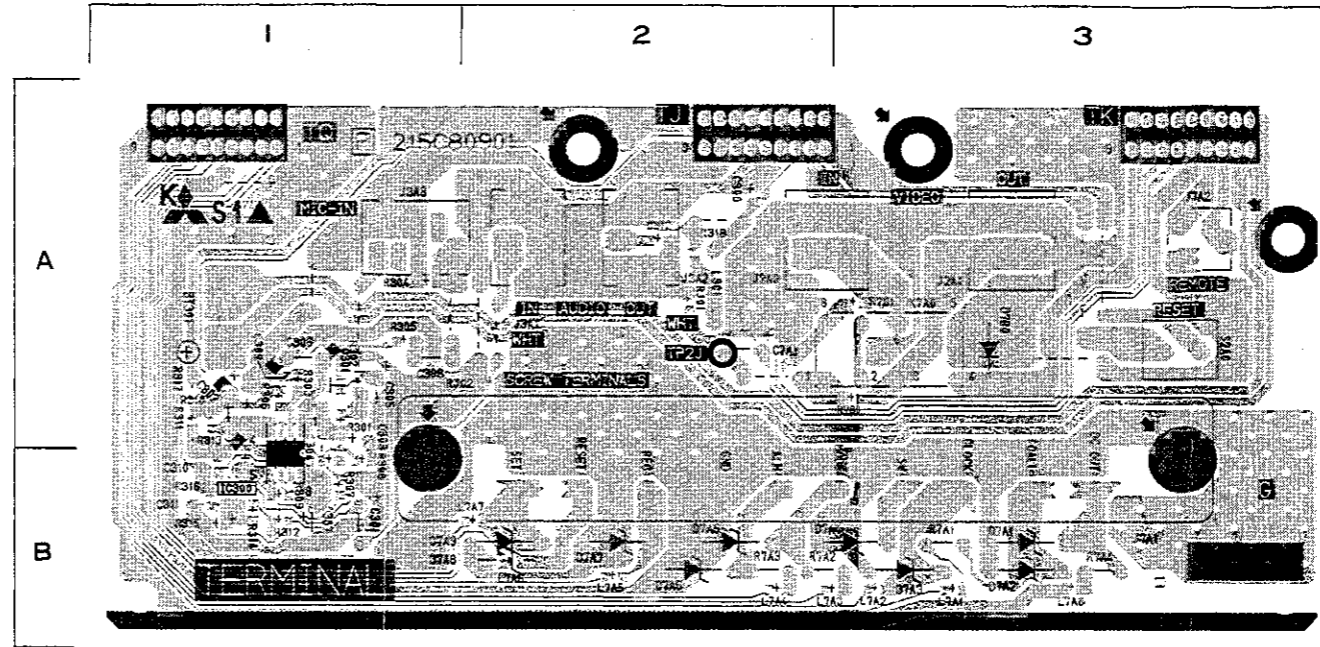

PCB-TERMINAL

SYMBOL NO.	ADDRESS	SYMBOL NO.	ADDRESS
BT301	A-1	J2A0	A-2
		J2A1	A-3
C300	A-2	J3A1	A-2
C301	B-1	J3A2	A-2
C302	A-1	J3A3	A-1
C303	B-1	J7A1	B-3
C304	B-1	J7A2	A-3
C305	A-1		
C306	A-1	K7A0	A-3
C307	B-1		
C308	A-1	L301	A-2
C309	A-1	L7A1	B-3
C310	B-1	L7A2	B-3
C311	B-1	L7A3	B-2
C312	A-2	L7A4	B-2
C7A1	A-2	L7A5	B-2
		L7A6	B-2
D7A1	B-3	L7A7	B-2
D7A2	B-3	L7A8	B-3
D7A3	B-3		
D7A4	B-3	Q301	A-1
D7A5	B-2		
D7A6	B-2	R301	A-1
D7A7	B-2	R302	A-1
D7A8	B-2	R303	A-1
D7A9	B-2	R304	A-1
D7B0	A-3	R305	A-1
		R306	A-1
		R307	B-1
IC300	B-1	R308	B-1

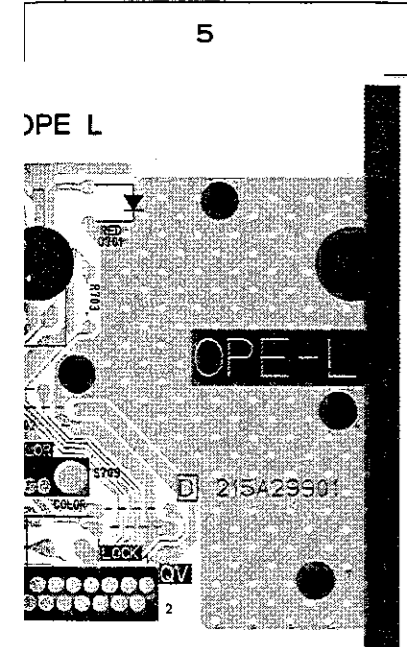

POWER (HS-7496E)

ADDRESS	SYMBOL NO.	ADDRESS	SYMBOL NO.	ADDRESS	SYMBOL NO.	ADDRESS
A-2	D902	A-2	G	B-2	R905	A-3
B-3	D903	A-2			R906	B-2
A-3	D904	A-3	IC901	A-5	R907	A-3
A-2	D907	A-4			R908	A-1
A-2	D908	A-4	J902	B-1	R909	A-5
A-4	D909	B-4			R910	A-5
A-3	D910	A-4	L901	A-2	R911	A-5
A-3	D911	B-4	L902	A-5	R912	A-5
A-4	D912	B-4			R914	B-5
B-2	D913	A-4	PC901	A-4	R915	A-4
A-5	D914	A-4			R916	A-4
A-4	D915	A-4	PM	B-4	R917	A-4
A-4	D916	A-4	PP	B-5	R918	A-4
A-4	D917	A-4	PT	B-1	R919	A-4
A-4	D918	A-4			R920	B-4
B-4	D920	A-5	Q901	A-3	R921	B-4
B-4	D921	A-4	Q902	A-3	R922	A-4
A-5	D923	A-4	Q903	A-3	R923	B-4
B-4	D924	A-3	Q904	A-5	R925	A-5
A-4	D926	A-4	Q905	A-4	R926	A-5
A-4	D927	A-3	Q906	A-4	R927	A-5
A-4	D928	A-3	Q907	A-4	R928	A-4
A-5	D929	A-3	Q908	B-4	R930	A-2
A-2	D930	A-3	Q909	A-4	R932	A-3
A-2	D933	B-5	Q910	A-4	R933	A-3
A-2	D934	B-5			R934	A-3
A-3			R901	A-2	R935	A-3
B-2	FC11	A-1	R902	B-3	R936	A-3
	FC12	A-1	R903	A-3	R937	A-3
A-2			R904	A-3	R938	A-3

PCB-POWER (HS-7496E(B))

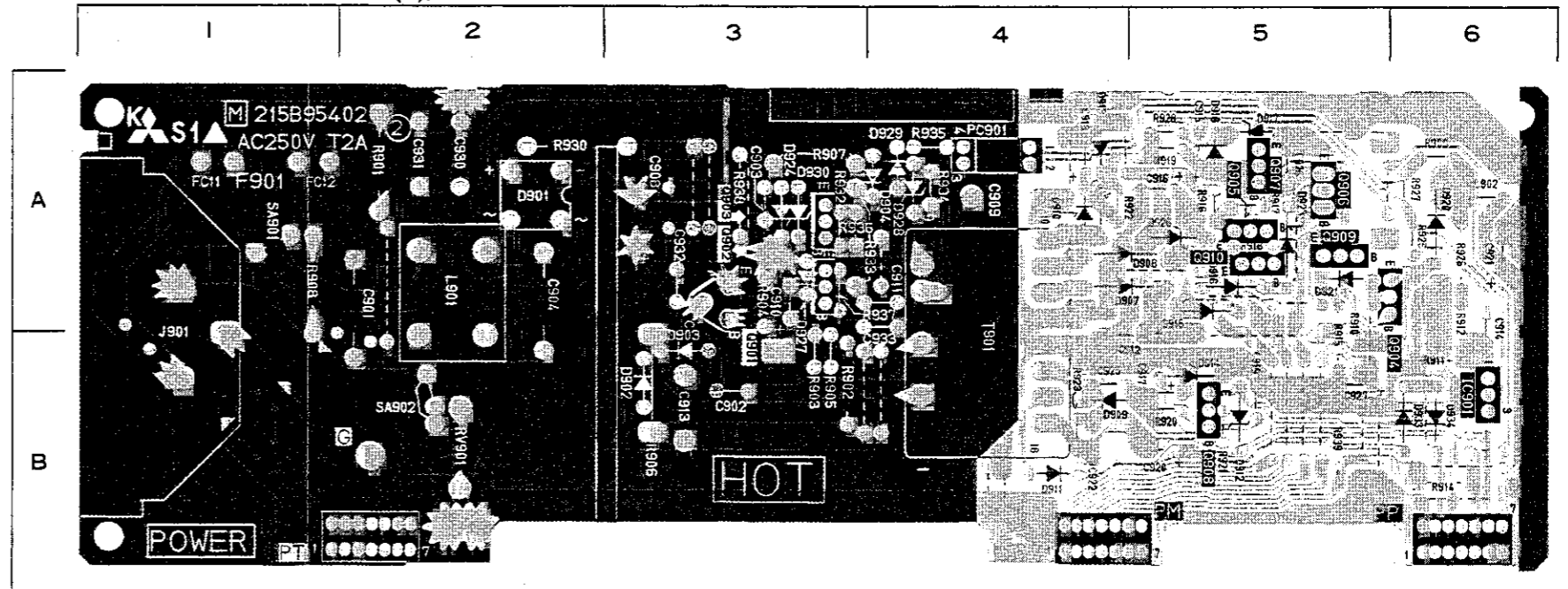

PCB-PC

SYMBOL NO.
C901
C902
C903
C904
C908
C909
C910
C911
C912
C913
C914
C915
C916
C917
C918
C919
C920
C921
C922
C924
C925
C926
C927
C930
C931
C932
C933
D901
D902

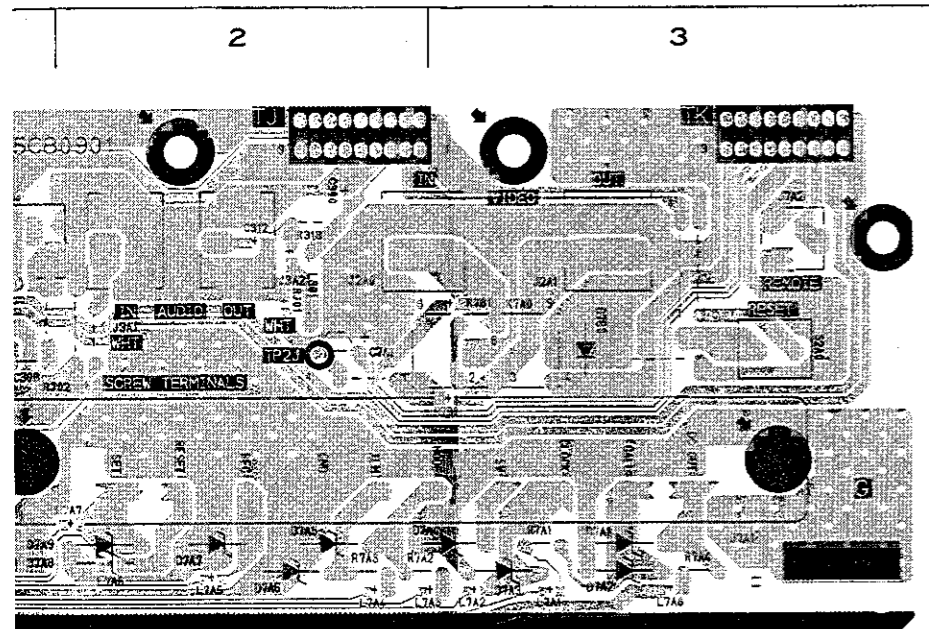

PCB-TERMINAL

SYMBOL NO.	ADDRESS	SYMBOL NO.	ADDRESS	SYMBOL NO.	ADDRESS
BT301	A-1	J2A0	A-2	R309	B-1
C300	A-2	J2A1	A-3	R310	A-1
C301	B-1	J3A1	A-2	R311	A-1
C302	A-1	J3A2	A-2	R312	B-1
C303	B-1	J3A3	A-1	R313	B-1
C304	B-1	J7A1	B-3	R314	B-1
C305	A-1	J7A2	A-3	R315	B-1
C306	A-1	K7A0	A-3	R316	B-1
C307	B-1	L301	A-2	R317	B-1
C308	A-1	L7A1	B-3	R318	A-2
C309	A-1	L7A2	B-3	R7A1	B-3
C310	B-1	L7A3	B-2	R7A2	B-2
C311	B-1	L7A4	B-2	R7A3	B-2
C312	A-2	L7A5	B-2	R7A4	B-3
C7A1	A-2	L7A6	B-2	R7B0	A-3
D7A1	B-3	L7A7	B-2	R7B1	A-3
D7A2	B-3	L7A8	B-3	RJ01	A-2
D7A3	B-3	Q301	A-1	RJ02	A-2
D7A4	B-3	R301	A-1	S2A0	A-3
D7A5	B-2	R302	A-1	TJ	A-2
D7A6	B-2	R303	A-1	TK	A-3
D7A7	B-2	R304	A-1	TP2J	A-2
D7A8	B-2	R305	A-1	TQ	A-1
D7A9	B-2	R306	A-1		
D7B0	A-3	R307	B-1		
IC300	B-1	R308	B-1		

PCB-OPE-JOG

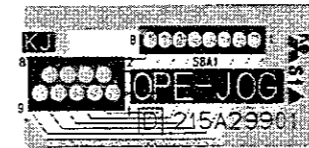

PCB-POWER [HS-7496E(B)]

SYMBOL NO.	ADDRESS	SYMBOL NO.	ADDRESS	SYMBOL NO.	ADDRESS	SYMBOL NO.	ADDRESS	SYMBOL NO.	ADDRESS
C901	B-2	D903	B-3			R906	B-3		
C902	B-3	D904	A-4	IC901	B-6	R907	A-4	RV901	B-2
C903	A-3	D907	A-5	J901	B-1	R908	B-2	SA901	A-1
C904	B-2	D908	A-5			R909	A-6	SA902	B-2
C908	A-3	D909	B-4	L901	A-2	R910	B-5		
C909	A-4	D910	A-4	L902	A-6	R911	B-6		
C910	A-3	D911	B-4	PC901	A-4	R912	B-6	T901	B-4
C911	A-4	D912	B-5			R914	B-6		
C912	B-5	D913	A-5	PM	B-4	R915	B-5		
C913	B-3	D914	B-5	PP	B-6	R916	A-5		
C914	B-6	D915	A-5	PT	B-2	R917	A-5		
C915	A-5	D916	A-5	Q901	A-3	R918	A-5		
C916	A-5	D917	A-5	Q902	A-3	R919	A-5		
C917	B-5	D918	A-5	Q903	A-3	R920	B-5		
C918	A-4	D920	A-6	Q904	A-6	R921	B-5		
C919	B-5	D921	A-5	Q905	A-5	R922	A-5		
C920	B-5	D923	A-5	Q906	A-5	R923	B-4		
C921	A-6	D924	A-3	Q907	A-5	R925	A-6		
C922	B-4	D926	A-5	Q908	B-5	R926	A-6		
C924	A-5	D927	A-3	Q909	A-5	R927	A-6		
C925	B-5	D928	A-4	Q910	A-5	R928	A-5		
C926	A-5	D929	A-4			R930	A-3		
C927	B-6	D930	A-3			R932	A-4		
C930	A-2	D933	B-6			R933	A-4		
C931	A-2	D934	B-6			R934	A-4		
C932	A-3			R901	A-2	R935	A-4		
C933	A-4	FC11	A-1	R902	B-4	R936	A-4		
		FC12	A-2	R903	B-3	R937	A-4		
D901	A-2	G	B-2	R904	A-3	R938	A-3		
D902	B-3			R905	B-3	R939	B-5		

496E(B)]

